

**Studies towards the total synthesis of pyxidatol C;  
New insights into the Cope rearrangement**

Jonathan David Osler

*Doctor of Philosophy*

**University of York**

**Chemistry**

*September 2014*

## Abstract

Studies towards the total synthesis of pyxidatol C **I**, isolated from the medicinal mushroom *Clavicornia pyxidata*, are described herein. Pyxidatol C **I** is a member of the africanane family of sesquiterpenes, which share a decahydro-1*H*-cyclopropa[*e*]azulene core structure. The synthetic strategy is shown below.

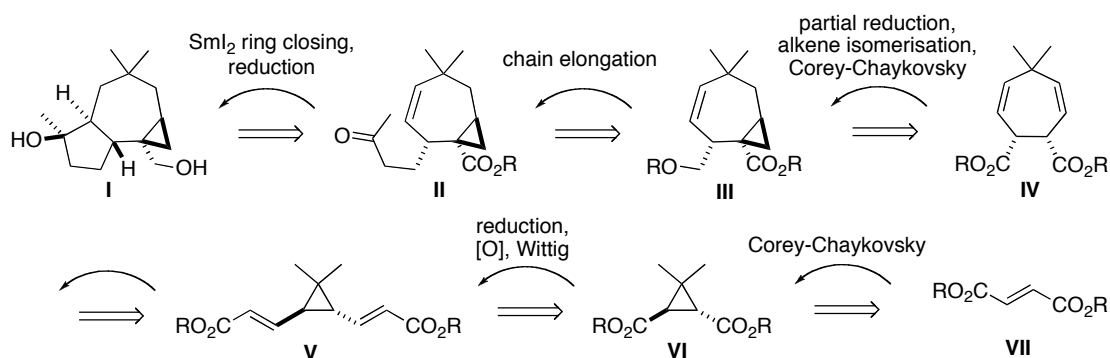

Chapter 1 provides an introduction while Chapter 2 outlines work on a desmethyl model system. A Cope rearrangement was used to prepare synthetic cycloheptadiene **IX**. Unfortunately, the analogous rearrangement using the *gem*-dimethyl substituted divinylcyclopropane **X** was unsuccessful. As such, the reactivity of a range of substituted divinylcyclopropanes towards the thermal Cope rearrangement was investigated (Chapter 3).

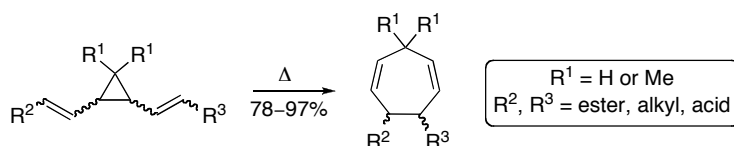
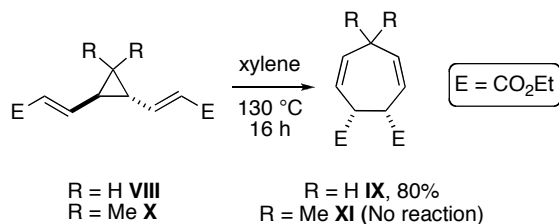

The effects of *gem*-dimethyl substitution on the cyclopropane, the

alkene geometry, the relative stereochemistry of the cyclopropane and the steric and electronic effects of a range of functional groups were all examined, and the methods developed were used to synthesise a range of functionalised 1,4-cycloheptadienes in high yields.

Chapters 4 and 5 describe studies towards the total synthesis of pyxidatol C. Advanced intermediates were prepared including ester **XII** and lactone **XIII** containing the requisite *gem*-dimethyl substituted 7-membered ring, the cyclopropane moiety and the methyl ketone side chain in place.

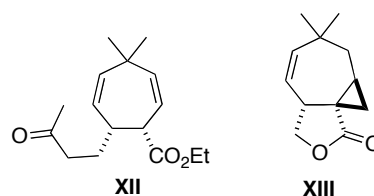

## Table of Contents

<b>Abstract</b>	ii
<b>Table of Contents</b>	iii
<b>List of Tables</b>	vi
<b>List of Figures</b>	vii
<b>Acknowledgements</b>	viii
<b>Author's Declaration</b>	ix
<b>Chapter 1</b> Introduction	1
1.1 Pyxidatol C and the Africananes	1
1.2 Structural Elucidation of Pyxidatol C	2
1.3 Biological Activity of Pyxidatol C	3
1.4 Proposed Biosynthesis of the Africananes	3
1.5 The First Synthesis of a Natural Africanane: Shirahuma's Synthesis of (±)-Africanol	4
1.6 White's Synthesis of (±)-Africanol Using the Oxy-Cope Rearrangement	5
1.7 Recent Syntheses of Africananes: Romo's Synthesis of Omphadiol	6
1.8 Pyxidatol C: Retrosynthetic Analysis	8
1.9 Asymmetric Synthesis	8
1.10 Taylor Group Methodologies	10
1.11 Preliminary Work on a Model System	11
1.12 Aims and Objectives	11
<b>Chapter 2</b> From the Desmethyl Model System to the <i>Gem</i> -Dimethyl System	12
2.1 Optimisation of Preliminary Work & Methyl Ketone Side-Chain Studies	12
2.2 Further Studies on the Model System: A Simmons-Smith Strategy	15
2.3 From the Desmethyl Model System to the <i>Gem</i> -Dimethyl System	21
2.4 The Ethoxide-Promoted Cope Rearrangement	22

<b>Chapter 3</b>	The Cope Rearrangement of <i>Gem</i> -Dimethyl Substituted Divinylcyclopropanes	26
3.1	Introduction	26
3.1.1	The Cope Rearrangement of Divinylcyclopropanes	26
3.1.2	Steric Effects in the Cope Rearrangement of Divinylcyclopropanes	27
3.2	The Cope Rearrangement of Diester <b>57a</b>	32
3.3	A Systematic Study into the Cope Rearrangement	33
3.4	Synthesis of Substrates (Divinylcyclopropanes <b>57a–57f</b> and <b>55a–55f</b> )	34
3.4.1	Synthesis of <i>Gem</i> -Dimethyl Divinylcyclopropanes ( <b>57a–57f</b> )	34
3.4.2	Synthesis of Desmethyl Divinylcyclopropanes ( <b>55a–55f</b> )	37
3.5	A Study into the Effect of <i>Gem</i> -Dimethyl Substitution on the Cope Rearrangement of Divinylcyclopropanes	42
3.6	Examining substituent effects on the Cope Rearrangement of <i>Cis-Gem</i> -Dimethyl Divinylcyclopropanes	50
<b>Chapter 4</b>	Towards the Total Synthesis of Pyxidatol C	54
4.1	Corey–Chaykovsky Strategy	54
4.2	Installing the Side-Chain	57
4.3	Simmons–Smith Strategy	59
4.4	Installing the Side-Chain; The Cyclic Ether Phenomenon	61
4.5	Installing the Side-Chain Before the Cope Rearrangement	67
4.6	Samarium Diiodide Ketone-Olefin Ring Closing Reaction	72
4.6.1	Background	72
4.6.2	Preparing Samarium Diiodide	72
4.6.3	Results	73
4.7	Conclusion	76
<b>Chapter 5</b>	Future Approach and Preliminary Studies	78
5.1	A Pauson-Khand Strategy	78
5.2	Preliminary Results Towards Alkyne <b>246</b>	80



<b>Chapter 6</b> Addendum: Total Synthesis of Pyxidatol C by G. Liang <i>et al.</i>	85
<b>Chapter 7</b> Experimental	87
7.1 General Experimental	87
7.2 Procedures & Compound Characterisation (Chapter 1 & Chapter 2)	88
7.3 Procedures & Compound Characterisation (Chapter 3)	112
7.4 Procedures & Compound Characterisation (Chapter 4)	143
7.5 Procedures & Compound Characterisation (Chapter 5)	165
<b>Appendix I</b>	171
<sup>1</sup> H- & <sup>13</sup> C-NMR Spectra for cycloheptadienes <b>58a</b> , <b>58b</b> , <b>88a</b> and <b>160-164</b>	
<b>Appendix II</b>	187
J. D. Osler, W. P. Unsworth, R. J. K. Taylor, <i>Org. Biomol. Chem.</i> , <b>2013</b> , <i>11</i> , 7587–7594. <sup>55</sup>	
<b>Abbreviations</b>	195
<b>References</b>	198

## List of Tables

<b>Table 1</b>	Optimisation of the isomerisation of lactone <b>60</b> to lactone <b>61</b>	12
<b>Table 2</b>	Summary of the cyclopropanation of <b>79</b>	18
<b>Table 3</b>	The base-catalysed Cope rearrangement of <b>57a</b>	23
<b>Table 4</b>	The Cope rearrangement on test substrates <b>55</b> and <b>57</b>	43
<b>Table 5</b>	The Cope rearrangement on test substrates <b>154–159</b>	52

## List of Figures

<b>Figure 1</b> Structures of pyxidatol A <b>1</b> , pyxidatol B <b>2</b> and pyxidatol C <b>3</b>	1
<b>Figure 2</b> Structures of pyxidatol C <b>3</b> , omphadiol <b>4</b> , africanol <b>5</b> and africanene <b>6</b>	1
<b>Figure 3</b> Structures of pyxidatol C <b>3</b> , omphadiol <b>4</b> and an acetylated derivative of omphadiol <b>7</b>	2
<b>Figure 4</b> Structures of pyxidatol C <b>3</b> , rosinone B <b>8</b> and tomeone F <b>9</b>	3
<b>Figure 5</b> The proposed reactive species in the Simmons-Smith cyclopropanation of allylic alcohols	18
<b>Figure 6</b> Potential destabilising steric interaction of gem dimethyl group toward cyclopropanation of the unfunctionalised alkene	20
<b>Figure 7</b> The symmetry-allowed chair and boat-like transition state for the Cope rearrangement of divinylcyclopanes.	27
<b>Figure 8</b> A diagram showing the potential destabilising steric interactions when <b>57a</b> adopts the required boat-like transition state ( <b>A</b> )	33
<b>Figure 9</b> The target substrates for a systematic study into the Cope rearrangement	33
<b>Figure 10</b> The <sup>1</sup> H NMR spectrum of <b>58a</b> with the peaks corresponding to the characteristic diastereotopic protons highlighted	41
<b>Figure 11</b> The <sup>1</sup> H NMR spectrum of <b>58b</b> with the characteristic homotopic protons highlighted	41
<b>Figure 12</b> Following the conversion of <b>57a</b> into <b>88a</b> by <sup>1</sup> H NMR spectroscopy at RT, 40 °C, 70 °C, 100°C and 130°C, showing complete conversion at 100 °C and signs of decomposition at 130 °C	44

## Acknowledgements

I would like to thank Richard for giving me the opportunity to work in his group and for the valuable advice and support he has given me throughout my PhD. I have very much enjoyed working with you.

I would also like to thank Will for his tireless guidance, helpful ideas, proof reading, support and friendship. All your efforts have been very much appreciated and will never be forgotten.

Thanks to all my lab-mates. I've really enjoyed sharing a laugh with you. The D216 cup rivalry, Mulligan, the myriad ethical discussions and the time spent mulling over curling world rankings were great. Special thanks to Graeme for looking after the labs, and us!

Finally, I would like to thank my friends for providing distractions from my research, and my parents for your constant support and encouragement in everything I do.

## Author's Declaration

The research presented in this Thesis was carried out at the University of York between October 2010 and December 2013. This work is, to the best of my knowledge, original except where due reference has been made to other workers. This work has not been presented for an award at this university, or any other university.

Part of the work disclosed herein has been published, during the project, in the below article:

J. D. Osler, W. P. Unsworth, R. J. K. Taylor, *Org. Biomol. Chem.*, **2013**, *11*, 7587–7594.<sup>55</sup>

# Chapter 1

## Introduction

### 1.1 Pyxidatol C and the Africananes

*Clavicornona pyxidata* is a wild mushroom used widely in traditional Chinese medicine for the treatment of gastric pain, dyspepsia, gout, and heat toxicity.<sup>1</sup> In 2008, Zheng *et al.*<sup>1</sup> reported the isolation of three novel sesquiterpene compounds from this medicinal mushroom, two belonging to the protoilludane family, pyxidatol A **1** and pyxidatol B **2**, and one belonging to the africanane family, pyxidatol C **3** (Figure 1).

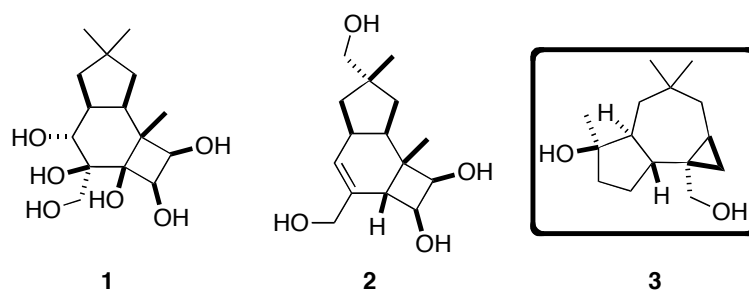

**Figure 1** Structures of pyxidatol A **1**, pyxidatol B **2** and pyxidatol C **3**.

The structure of pyxidatol C **3** is closely related to that of omphadiol **4** (Figure 2), first isolated by McMorris *et al.*<sup>2</sup> in 2000 from cultures of *Omphalutis illudens* and also isolated from *Clavicornona pyxidata* by Zheng *et al.*<sup>1</sup> Pyxidatol C belongs to the africanane family of sesquiterpenes, first found in africanol **5**<sup>3</sup> and later in africanene **6**.<sup>4</sup> The africananes are defined by their decahydro-1H-cyclopropa[e]azulene core structure (highlighted in red: Figure 2).

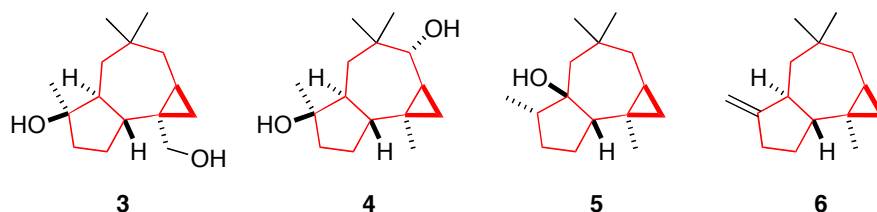
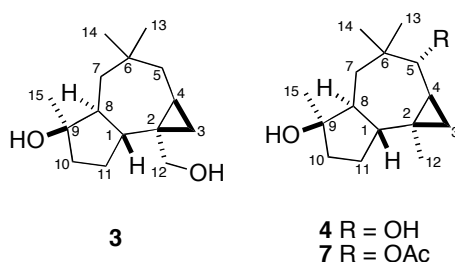

**Figure 2** Structures of pyxidatol C **3**, omphadiol **4**, africanol **5** and africanene **6** with the common decahydro-1H-cyclopropa[e]azulene core structure highlighted in red.

## 1.2 Structural Elucidation of Pyxidatol C

Pyxidatol C was isolated as a colourless oil. The molecular formula was determined as  $C_{15}H_{26}O_2$  using HRMS. The  $^{13}C$  NMR spectrum with DEPT revealed the presence of 15 signals: three  $CH_3$ , six  $CH_2$  (one oxygenated), three  $CH$ , and three quaternary C-atoms (one oxygenated). An IR absorption at  $3281\text{ cm}^{-1}$  suggested the presence of an OH group, which was supported by the  $^1H$  NMR and HSQC spectra which showed signals corresponding to two OH groups.<sup>1</sup>

A comparison of the  $^1H$  NMR and  $^{13}C$  NMR data of pyxidatol C, with the previously reported compound omphadiol **4**, revealed that the compounds share the same core structure. However the Me group (12) and CH-OH (5) in **4** were replaced by a  $HOCH_2$  (12) substituent and  $CH_2$  (5) in **3** (Figure 3).<sup>1</sup>



**Figure 3** Structures of pyxidatol C **3**, omphadiol **4** and an acetylated derivative of omphadiol **7** (Arbitrary atom numbering).

The absolute configuration of omphadiol **4** was determined from the X-ray crystal structure of a 3,5-dinitrobenzoate derivative.<sup>2</sup> Zheng *et al.*<sup>1</sup> also obtained a crystal structure of an acetylated derivative of omphadiol, **7**. The relative configuration of pyxidatol C was determined by comparison with **7**. Further evidence was provided by the observation of a ROESY correlation between H-C (8) and H-C (4), and H-C (12) and H-C (15), supporting their assigned *syn*-relationship (Figure 3).<sup>1</sup>

### 1.3 Biological Activity of Pyxidatol C

To date (other than the isolation paper) there have been no publications relating to pyxidatol C **3** (See Chapter 6: Addendum). However, the pharmacological activity of africanene **6** has been examined by Reddy *et al.*<sup>5</sup> It was found to show mild CNS depressant activity, dose-dependant hypotensive activity, and anti-inflammatory activity. Furthermore, africanene was found to exhibit cytotoxic activity against the Ehrlich ascites carcinoma and Dalton's lymphoma ascites tumour.<sup>5</sup>

Pyxidatol C **3** shares a common tetrasubstituted cyclopentane ring (highlighted in blue: Figure 4) with a large family of sesquiterpenes and diterpenes, many of which display potent biological activities.<sup>6</sup> Rossinone B **8**, for example shows anti-inflammatory, antiviral, and antiproliferative activities<sup>7,8</sup> and tomeone F **9** displays significant cytotoxicity against KB cells.<sup>9</sup>

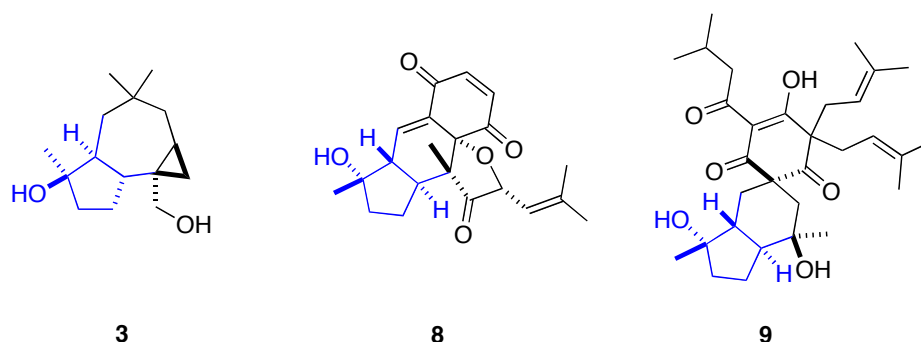
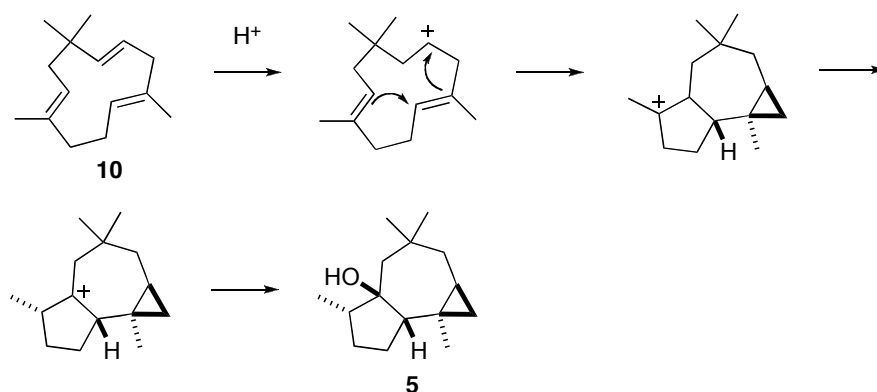

**Figure 4** Structures of pyxidatol C **3**, rossinone B **8** and tomeone F **9** with the common tetrasubstituted cyclopentane ring highlighted in blue.

### 1.4 Proposed Biosynthesis of the Africananes

$\alpha$ -Humulene **10** is an important biogenetic precursor of a large number of sesquiterpenes, particularly in fungi.<sup>10</sup> Although the biosynthesis of the africananes has not been established conclusively, biosynthetic pathways from  $\alpha$ -humulene have been proposed.<sup>11,12</sup> Braeckman *et al.*,<sup>11</sup> for example, proposed a biogenesis of africanol in their original isolation paper (Scheme 1).





**Scheme 1** Proposed biosynthesis of africanol **5** from  $\alpha$ -humulene **10**.<sup>11</sup>

Bohlmann and Zderol<sup>12</sup> reported the isolation and structural elucidation of the africanane sesquiterpene **12** (Scheme 2) and proposed a biogenetic derivation from  $\alpha$ -humulene derived epoxide **11**.

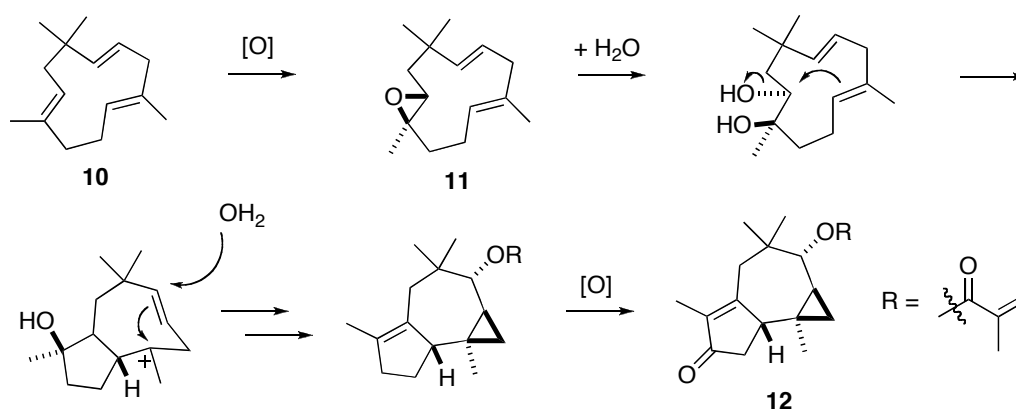

**Scheme 2** Proposed biosynthesis of sesquiterpene **12** from  $\alpha$ -humulene **10**.<sup>12</sup>

### 1.5 The First Synthesis of a Natural Africanane: Shirahama's Synthesis of ( $\pm$ )-Africanol

In 1980 Shirahama *et al.*<sup>13</sup> used the  $\alpha$ -humulene-derived epoxide **13** in their synthesis of ( $\pm$ )-africanol **5**. This was the first example of a chemical synthesis of a natural africanane (Scheme 3). They began with a transannular cyclisation of epoxide **13** by treating with trimethylsilyl trifluoromethanesulfonate followed by desilylation with KI in MeOH, obtaining a mixture of alcohols **14** and **15** in a 2:1 ratio. Following the

isolation of the desired isomer **15**, it was treated with  $\text{PBr}_3$  to give bromide **16** (retention is shown in the publication), which was then reduced using sodium in liquid ammonia furnishing olefin **17**. Epoxidation using *m*-CPBA delivered epoxide **18** and treatment with LDA afforded allylic alcohol **20**. Hydrogenation with Adam's catalyst concluded the synthesis of ( $\pm$ )-africanol **5**.

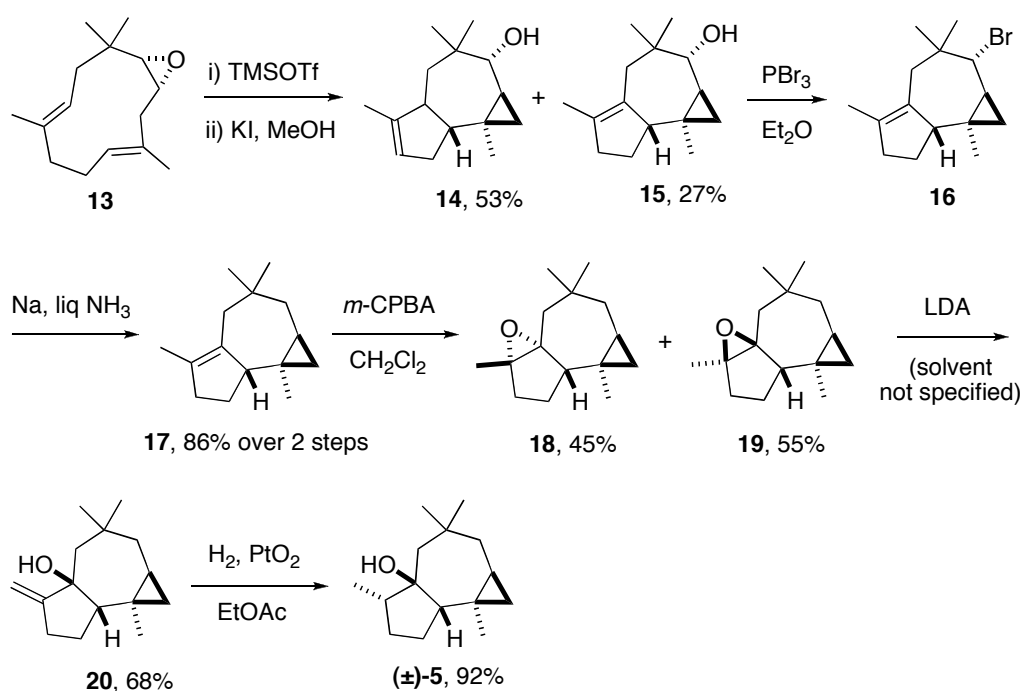

**Scheme 3** Synthesis of ( $\pm$ )-africanol **5** by Shirahama *et al.*<sup>13</sup>

### 1.6 White's Synthesis of ( $\pm$ )-Africanol Using the Oxy-Cope rearrangement

Africanol **5** has since been synthesised by many groups.<sup>14–18</sup> The next racemic total synthesis was reported by Paquette *et al.* in 1986<sup>16</sup> and the first asymmetric synthesis was reported by Tai *et al.*<sup>17</sup> in 1990. A six-step synthesis of ( $\pm$ )-africanol was developed by White and Fan in 1993,<sup>18</sup> which used a key anionic oxy-Cope rearrangement step (Scheme 4).

Conjugate addition of  $\text{Bu}_3\text{SnLi}$  into 2,5,5-trimethylcyclohex-2-enone **21** (prepared in 3 steps from commercially available dimedone),<sup>19</sup> followed by *in situ* trapping of the intermediate enolate with the vinyl cation equivalent (phenylseleno)acetaldehyde started White's synthesis of ( $\pm$ )-africanol.<sup>18</sup> This afforded a 1:1 mixture of

diastereomers **22** and **23**. The desired isomer **23** was isolable by chromatography. Elimination followed by Grignard addition into the ketone then furnished a single diastereomer of divinylcyclohexanol **25**. An anionic oxy-Cope rearrangement then led to the generation of compound **26**, which was unstable and was used without further purification. Na/naphthalene in THF promoted the cyclisation to the fused ring system **28** in 56% yield with only 6% of the unwanted diastereomer **27**. Finally Simmons–Smith cyclopropanation completed the synthesis affording ( $\pm$ )-africanol with exclusive addition on the less hindered *endo*-face.

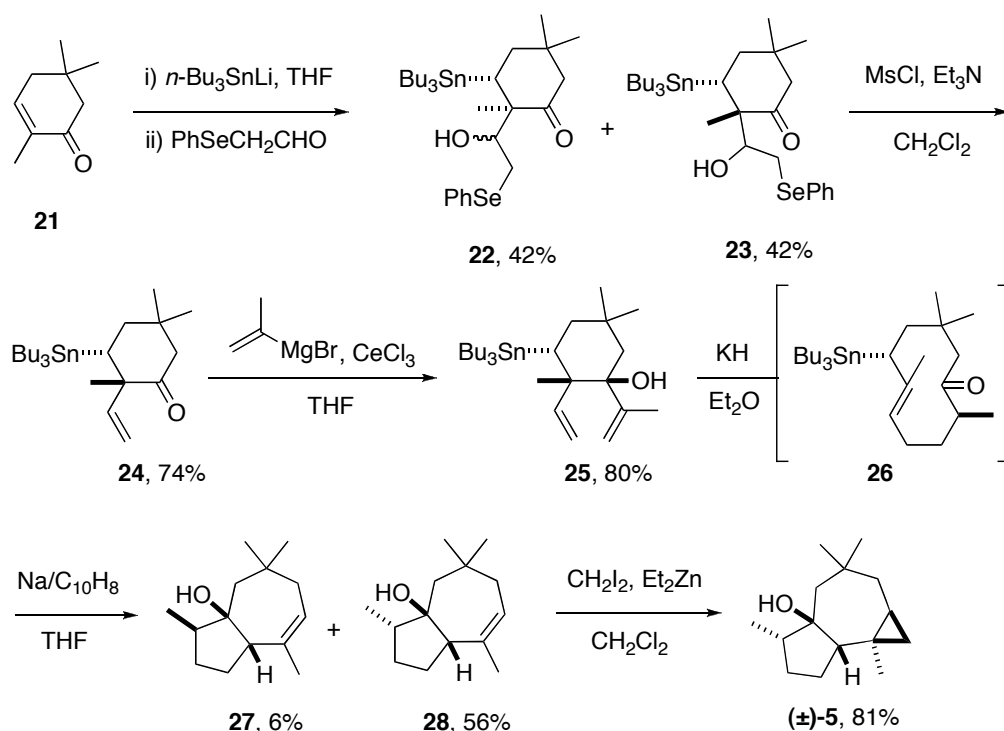

**Scheme 4** Synthesis of ( $\pm$ ) africanol **5** by White and Fan.<sup>18</sup>

### 1.7 Recent Syntheses of Africananes: Romo's Synthesis of Omphadiol

More recent synthetic routes towards members of the africanane family include Nakata's synthesis of epoxyafricanane<sup>20</sup> and Romo's synthesis of omphadiol,<sup>6</sup> both of which were published in 2011.

Romo *et al.*<sup>6</sup> prepared (+)-omphadiol **4** in 10 steps and in 18% overall yield (Scheme 5). Their elegant synthesis started with a  $[\text{Mn}^{\text{III}}(\text{dpm})_3]$ -catalysed hydration of the

enone moiety of (*R*)-carvone to afford hydroxy ketone **29**. Oxidative cleavage by periodic acid delivered keto-acid **30**. Upon activation of the carboxylic acid with tosyl chloride and the addition of 4-PPY as a nucleophilic catalyst, keto-acid **30** underwent an aldol lactonisation to give the unusual bicyclic lactone **31**. DIBAL reduction gave the corresponding diol that was then converted into the C7 bromide. A tosylation/bromination sequence, and subsequent acylation provided ester **32**. Alkylation using KHMDS, followed by quenching with excess MeI furnished the bicyclic  $\delta$ -lactone **33** bearing the requisite C6 *gem*-dimethyl moiety. The addition of allyllithium, which was derived from allyltriphenyltin, into lactone **33** gave the  $\beta,\gamma$ -unsaturated enone **34**. A tandem isomerisation/ring-closing metathesis (RCM) process using second generation Grubbs catalyst next gave cycloheptenone **35**. Finally, DIBAL reduction furnished allylic alcohol **36**, which underwent Simmons–Smith cyclopropanation to give synthetic (+)-omphadiol.<sup>6</sup>

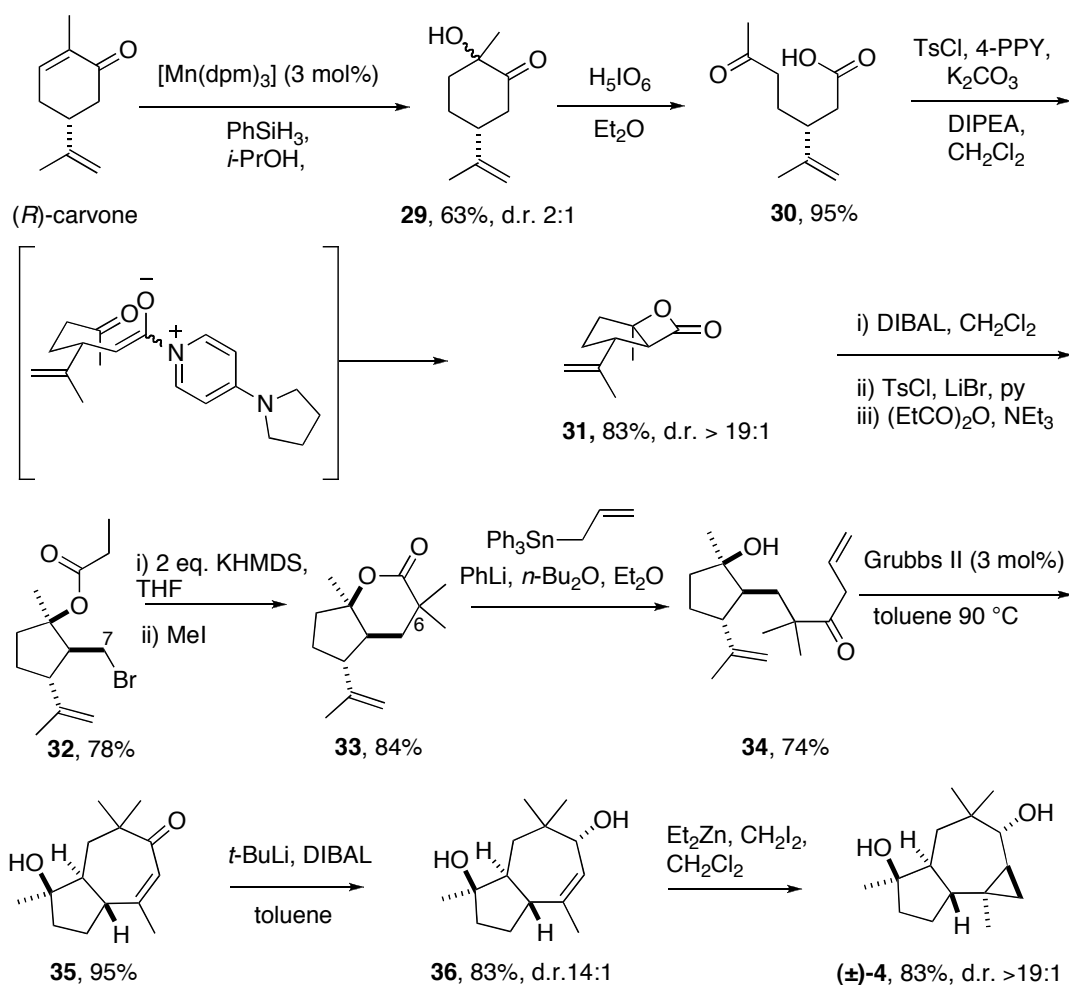

**Scheme 5** Synthesis of (+)-omphadiol **4** by Romo *et al.*<sup>6</sup>

## 1.8 Pyxidatol C: Retrosynthetic Analysis

Our aim was to apply established Taylor group methodologies in the total synthesis of pyxidatol C. A modified Corey–Chaykovsky protocol, developed within the Taylor group,<sup>20–23</sup> has been used previously to synthesise cyclopropane **41** where R = Et<sup>23</sup> which, it was hoped, could be readily converted into diester **40** *via* reduction followed by the group's tandem oxidation procedure (TOP, tandem MnO<sub>2</sub>-Wittig reaction).<sup>23,24</sup> It was then anticipated that the Cope rearrangement of **40**, would generate the 7-membered ring *meso*-compound **39** which, upon partial reduction and alkene isomerisation (thermodynamically driven by moving the alkene into conjugation) may undergo a second Corey–Chaykovsky reaction to install the cyclopropane moiety of **38**. It was envisioned that a Wittig reaction followed by selective reduction would install the methyl ketone side chain, and a key SmI<sub>2</sub>-mediated ring closing reaction would complete the synthesis.

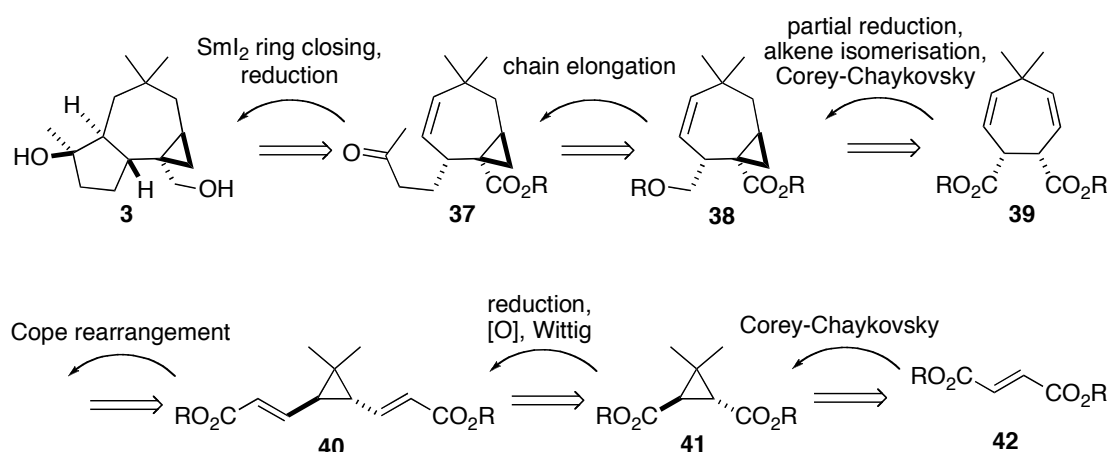

Scheme 6 Retrosynthetic strategy towards pyxidatol C.

## 1.9 Asymmetric Synthesis

It was planned that the synthesis could be rendered asymmetric by the desymmetrisation of either *meso*-compound **39** or *meso*-compound **40**. There is good precedent for related reactions, for example, the selective hydrolysis of bisacetate **43** using porcine pancreatic lipase (PPL) to generate enantio-enriched alcohol **44**, which was first described by Von Langen and Tolman (Scheme 7).<sup>25</sup>

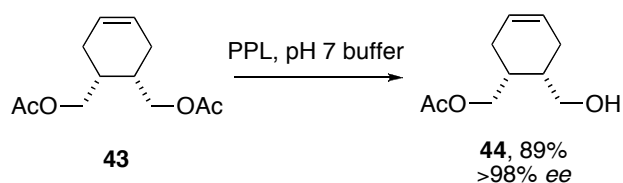

**Scheme 7** The desymmetrisation of **43** using PPL.<sup>25</sup>

We envisioned that a similar desymmetrisation could be applied to bisacetate **46**, which should be easily prepared from cycloheptadiene **39** in 2 steps (Scheme 8).

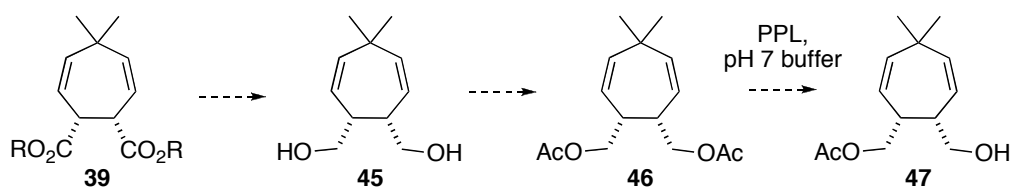

**Scheme 8** The planned desymmetrisation of **46** using PPL.

The monohydrolysis of **40** using pig liver esterase enzyme (PLE) is an alternative strategy. The monohydrolysis of cyclopropyl *meso*-diesters has previously been reported in the literature (e.g. **48**→**49**, Scheme 9).<sup>26</sup> Note that the monohydrolysis of the olefinic diester **40** is preferable to the monohydrolysis of diester **41** (cf. **48**), as this desymmetrisation comes at a later stage in the synthetic strategy.

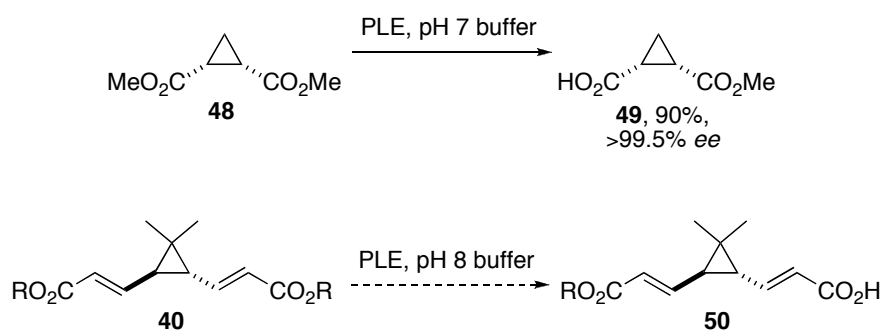

**Scheme 9** The desymmetrisation of **48** using PLE and the proposed desymmetrisation of **40** using PLE.<sup>26</sup>

## 1.10 Taylor Group Methodologies

In 2007, the Taylor group reported a *gem*-dimethylcyclopropanation procedure using triisopropyl-sulfoxonium tetrafluoroborate.<sup>20–23</sup> The cyclopropanation of diethyl fumarate (Scheme 10) has since been carried out to give **53**,<sup>23</sup> an intermediate in our retrosynthetic analysis of pyxidatol C.

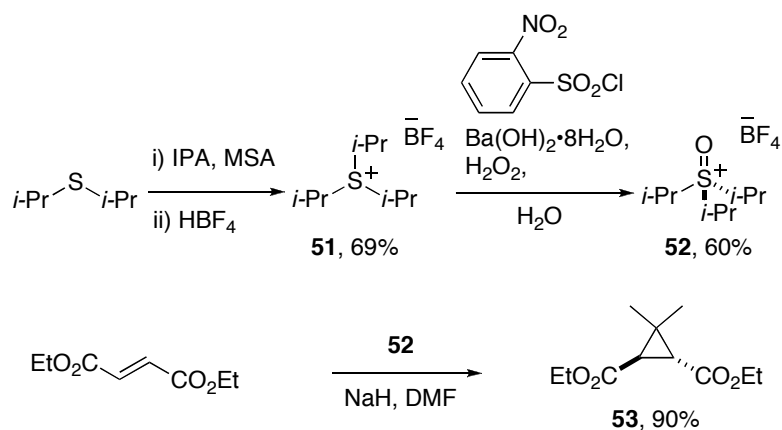

**Scheme 10** Taylor Group modified Corey–Chaykovsky protocol.<sup>20–23</sup>

The Taylor group's tandem MnO<sub>2</sub> oxidation then Wittig trapping process (TOP methodology) has been used previously to prepare **55**.<sup>24</sup> It was expected that this procedure could also be used to prepare the *gem*-dimethyl analogue, **57** (Scheme 11).

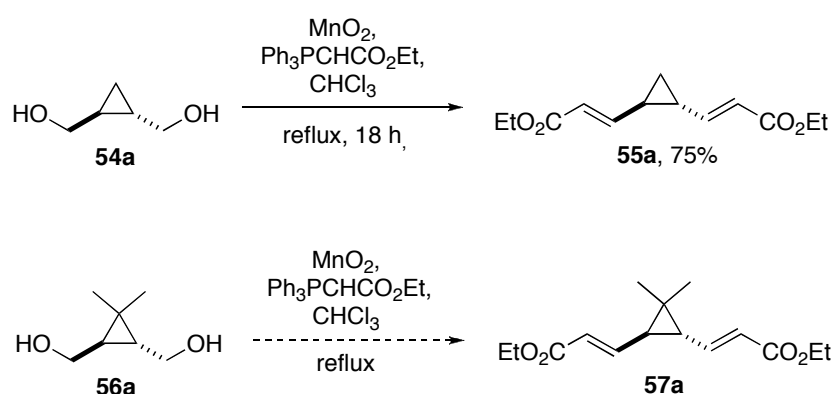

**Scheme 11** Taylor Group Tandem Oxidation Procedure (TOP).<sup>24</sup>

### 1.11 Preliminary Work on a Model System

Preliminary work in the group carried out by Unsworth<sup>27</sup> (Scheme 12), using a simplified desmethyl analogue, offered significant promise. Upon heating at 130 °C in xylene, the Cope rearrangement of **55** proceeded smoothly to give **58**. Reduction, followed by mono-oxidation then yielded lactone **60**, which was then isomerised to **61** under basic conditions. Finally a Corey-Chaykovsky reaction afforded **62** as a single diastereomer, which was believed to possess the relative stereochemistry required for pyxidatol C based on n.O.e experiments (an n.O.e enhancement between the cyclopropane  $\text{CH}_2$  and the  $\text{CHCH}_2\text{O}$  protons is observed, whereas no n.O.e enhancement is seen for the lactone  $\text{CH}_2$  protons with the cyclopropane  $\text{CH}_2$  protons).

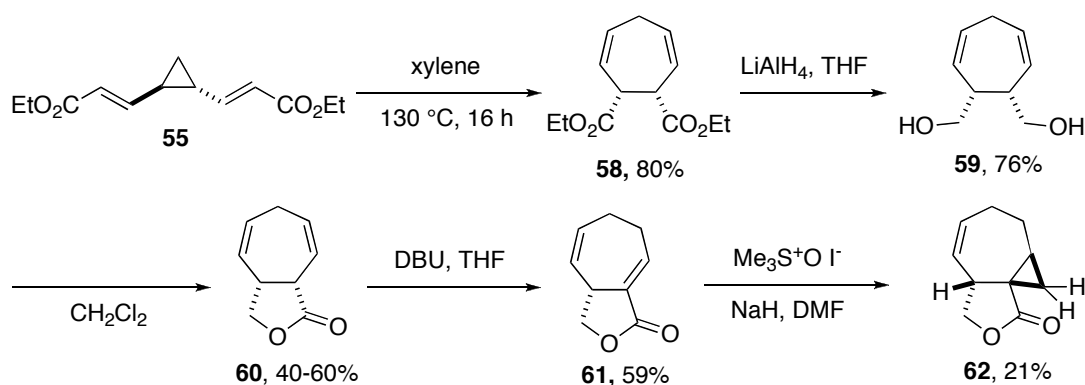

**Scheme 12** Preliminary work on a desmethyl model system.<sup>27</sup>

### 1.12 Aims and objectives

As outlined, a range of different approaches have been used to synthesise africanane natural products. We aimed to use established Taylor group methodologies in a total synthesis of the africanane, pyxidatol C.

Initial work would involve optimising Unsworth's preliminary work on the simplified desmethyl model system (Scheme 12) before applying this chemistry to the analogous *gem*-dimethyl pyxidatol C system.



## Chapter 2

### From the Desmethyl Model System to the *Gem*-Dimethyl System

#### 2.1 Optimisation of Preliminary Work & Methyl Ketone Side-Chain Studies

Initial work towards the synthesis of pyxidatol C involved repeating Unsworth's<sup>27</sup> preliminary studies (Scheme 12) with a view to optimising the low yielding steps. The route to lactone **60** was easily reproducible and thus attention focused on improving its isomerisation. This preliminary work showed that the unwanted lactone **63** was obtained upon heating compound **60** for 1 h at 70 °C. Unsworth had also established that by lowering the temperature to RT and decreasing the reaction time to 40 min, a 59% yield of lactone **61** along with a 30% yield of lactone **63** were isolated.<sup>27</sup> Lowering the temperature further to 0 °C was therefore considered a good starting point for further optimization and, pleasingly, after stirring lactone **60** for 2.5 h at 0 °C, the desired lactone **61** was isolated in a yield of 74%, an improvement of 15%. A small amount of the unwanted  $\alpha,\beta$ - $\gamma,\delta$ -unsaturated lactone **63** and the *trans*-epimer, lactone **64**, were also obtained in low yields (11% and 6% respectively).

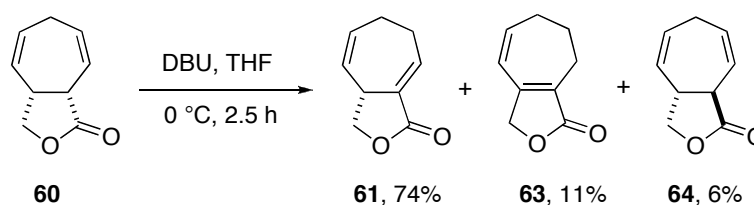

**Scheme 13** Optimised isomerisation conditions for the synthesis of lactone **61**.

Entry	Temperature (°C)	Reaction Time (min)	Ratio of Products <sup>a</sup>		
			<b>61</b>	<b>63</b>	<b>64</b>
1 <sup>27</sup>	70	60	0	1	0
2 <sup>27</sup>	RT	60	1.75	1	0
3	RT	40	1.75	0	1
4	0	30	1	0	1
5 <sup>b</sup>	0	150	8	1.5	1

<sup>a</sup>Ratio determined by analysis of the <sup>1</sup>H NMR spectra of the unpurified reaction mixtures.

<sup>b</sup>The compounds **61**, **63** and **64** were separated by flash column chromatography and the isolated yields are shown in Scheme 13.

**Table 1** Optimisation of the isomerisation of lactone **60** to lactone **61**.

Unfortunately, the cyclopropanation of **61** was harder to optimise. Using the Taylor group modified Corey-Chaykovsky cyclopropanation conditions<sup>23</sup> (**61** was reacted with NaH and trimethylsulfoxonium iodide in DMF at RT), furnished **62** in only 21% yield during preliminary work.<sup>27</sup> The same conditions were re-tested, but a similarly poor yield was obtained, with only 26% of cyclopropane **62** isolated. An alternative procedure<sup>28</sup> was tested using MTBD in acetonitrile at 60 °C but unfortunately this protocol furnished cyclopropane **62** in only 19% yield. However on a more positive note both the NaH/DMF and MTBD/MeCN reaction conditions, yielded only one diastereomer; its relative stereochemistry determined as that required for pyxidatol C *via* n.O.e (Scheme 14).<sup>27</sup> We were surprised by the low yields as the <sup>1</sup>H NMR spectra of the unpurified reaction mixtures showed very little evidence of decomposition. We considered that the sulfoxonium ylide was also adding into the enone from the other face but, rather than closing to form the other diastereomer, material was being lost as the salt. However by taking the <sup>1</sup>H NMR spectrum (D<sub>2</sub>O) of the aqueous extract no identifiable products were observed.

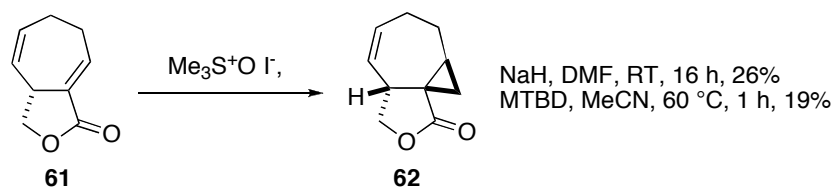

**Scheme 14** Corey-Chaykovsky cyclopropanation reactions.

Given the difficulties associated with the cyclopropanation of lactone **61** we planned instead to install the methyl ketone side-chain first with a view to testing the Corey-Chaykovsky cyclopropanation on ester **65** (Scheme 15).

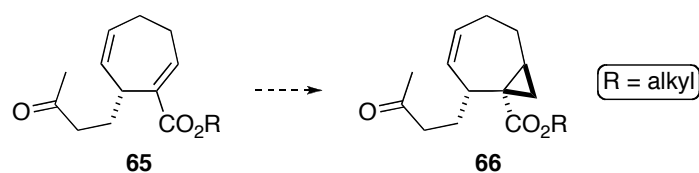

**Scheme 15** Cyclopropanation of ester **65**.

The initial strategy for installation of the side chain was *via* Wittig olefination, followed by selective reduction of the resulting  $\alpha,\beta$ -unsaturated ketone. This strategy was tested using lactol **67**, itself formed *via* the IBX oxidation of diol **59**. However, clean material could not be recovered from the reaction, even after flash column chromatography. Based on analysis of the  $^1\text{H}$  NMR spectrum of the unpurified reaction mixture, we speculated that isomerisation of the C1, C2 double bond into conjugation with the newly formed  $\alpha,\beta$ -unsaturated ketone was an unwanted side reaction (Scheme 16). We tentatively assigned the major component of the reaction mixture as **68** based on peaks at 7.12 (1H, d,  $J$  16.0 Hz, H-4), 6.48 (1H, t,  $J$  6.5 Hz, H-2), 6.15 (1H, d,  $J$  16.0 Hz, H-5) in the  $^1\text{H}$  NMR spectrum of the unpurified reaction mixture.

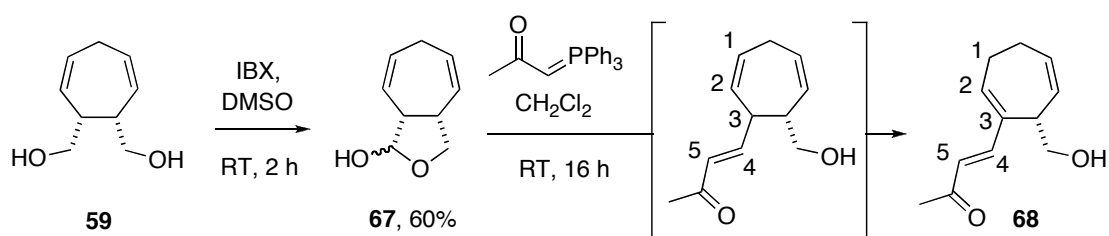

**Scheme 16** Installation of side-chain Wittig-reduction route.

An alternative strategy to introduce the side-chain was therefore tested on a model system. A cyclohexyl model system was chosen to test this alternative route. Iodination of cyclohexylmethanol using triphenylphosphine, imidazole and iodine in  $\text{CH}_2\text{Cl}_2$  provided iodide **69** in 62% yield. Then  $\beta$ -ketoester **70** was prepared in 72% yield by refluxing iodide **69**, NaH and *tert*-butyl 3-oxobutanoate in THF. Decarboxylation of  $\beta$ -ketoester **70** at reflux in benzene with *p*-TSA furnished ketone **71** in 85% yield and completed the installation of the desired side-chain into the cyclohexyl model system. This sequence was not tested on our desmethyl analogue of pyxidatol C but this chemistry would later be trialled on the *gem*-dimethyl, pyxidatol C system (Chapter 4).

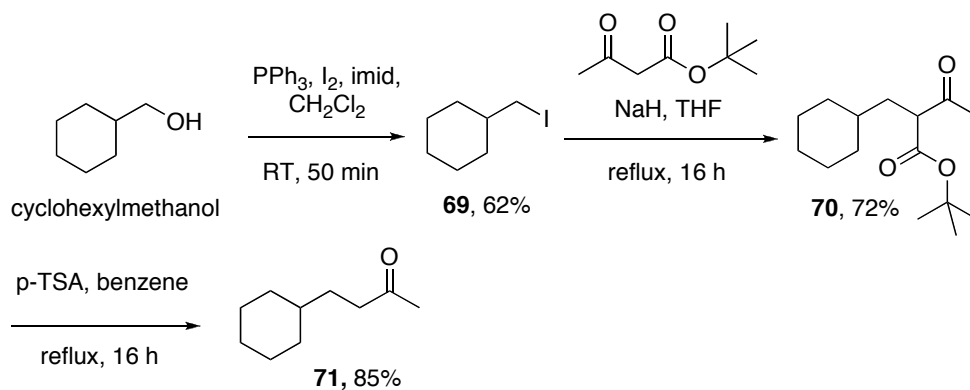

**Scheme 17** Installation of the side-chain *via* a  $\beta$ -ketoester route.

## 2.2 Further Studies on the Model System: A Simmons-Smith strategy

Given that difficulties were encountered using the Corey-Chaykovsky cyclopropanation, it was decided that an alternative method of cyclopropanation should be examined. It is well known<sup>29</sup> that in the Simmons-Smith reaction, the rate of cyclopropanation is faster for an allylic alcohol compared with an unfunctionalised alkene and we hoped to exploit this fact to achieve a regioselective cyclopropanation in our synthesis. DIBAL reduction of lactone **60** furnished diol **72** in 82% yield, providing a suitable test substrate for this Simmons-Smith reaction. However, treatment of diol **72** with diiodomethane and diethylzinc led only to a mixture of cyclopropanes **73**, **74** and bis cyclopropane **75** in poor yield. The trace presence of cyclopropane **75** is supported by HRMS. (Scheme 18).

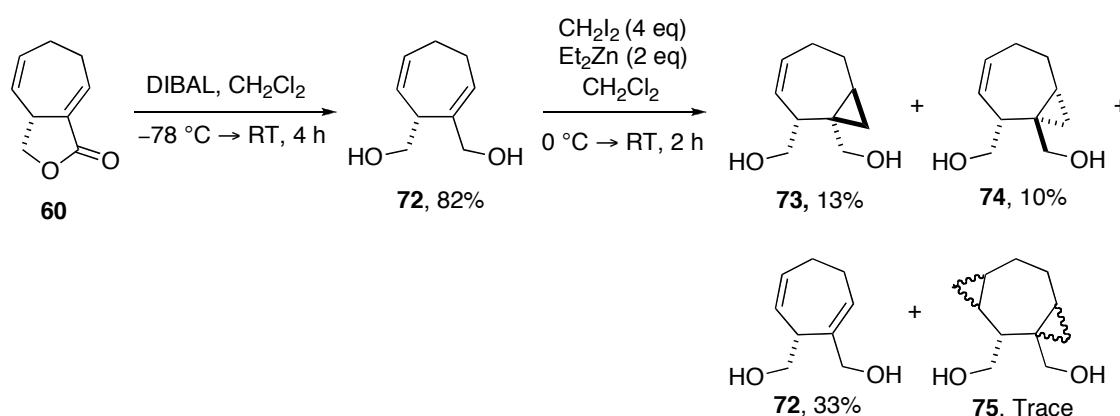

**Scheme 18** Simmons-Smith reaction on diol **72**.

The stereochemistry of cyclopropanes **73** and **74** in the Simmons-Smith reaction of diol **72** was confirmed by a comparison with the product of  $\text{LiAlH}_4$  reduction of lactone **62** (Scheme 19), where stereochemistry had already been confirmed by n.O.e (see Chapter 1.11, Scheme 12).

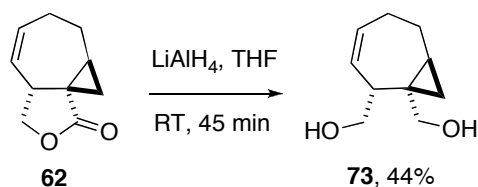

**Scheme 19**  $\text{LiAlH}_4$  reduction of lactone **62**.

Despite the poor yield and poor stereocontrol in the Simmons-Smith reaction of diol **72**, we could see sufficient scope for optimisation to believe that the reaction could be improved. For example zinc can coordinate to either alcohol of the diol **72** and we believed that protecting the non-allylic alcohol might improve the reaction.

The efficient mono-silylation of symmetric diols was established in 1986 by McDougal *et al.*<sup>30</sup> and was employed in the mono-TBS protection of diol **59** furnishing **76** in 89% yield. As outlined in Scheme 20, Dess–Martin oxidation provided the corresponding aldehyde **77** in 97% yield, which was isomerised to  $\alpha,\beta$ -unsaturated aldehyde **78** under basic conditions. Pleasingly, no unwanted side products were obtained and after 20 min at 0 °C and the desired aldehyde **78** was obtained in 77% yield. DIBAL reduction then afforded alcohol **79**, the required substrate for the Simmons-Smith reaction, in 64% yield.

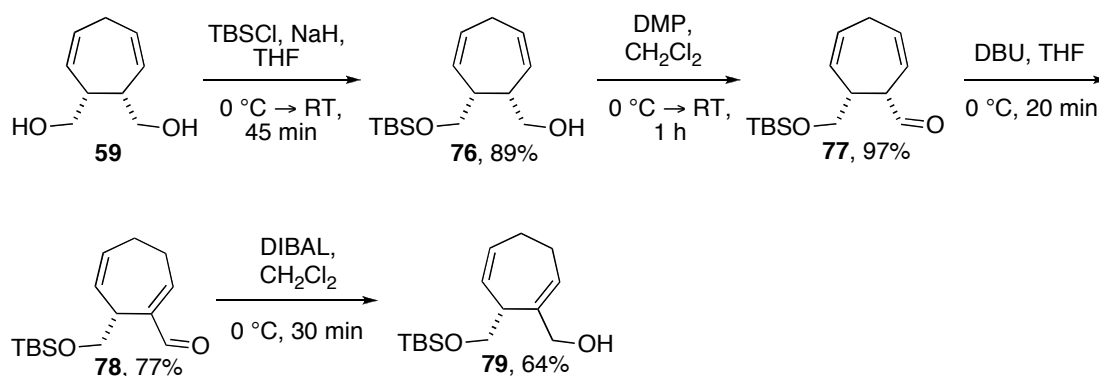

**Scheme 20** Mono-protection route to Simmons-Smith precursor **79**.

The Simmons-Smith cyclopropanation of alcohol **79** was, unfortunately, less straightforward. As outlined in Scheme 21, initial conditions trialled used four equivalents of diiodomethane and two equivalents of diethylzinc in CH<sub>2</sub>Cl<sub>2</sub> at RT. After 4 h, a ratio of 7:1 bis-cyclopropane **81** to cyclopropane **80** was observed by tentative analysis of the <sup>1</sup>H NMR spectrum of the unpurified reaction mixture. Consumption of the peaks corresponding to the double bonds of diene **79** at 5.95 (1H, t, *J* 6.5 Hz), 5.78–5.72 (1H, m) and 5.47 (1H, ddt, *J* 12.0, 6.5, 1.5 Hz) was observed alongside the appearance of cyclopropyl peaks at 0.98–0.84 (2H, m) and 0.74–0.60 (2H, m).

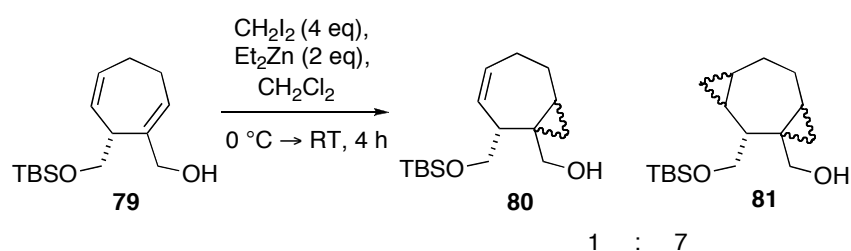

**Scheme 21** Simmons-Smith reaction on TBS protected alcohol **79**.

Unfortunately cyclopropanes **80** and **81** are indistinguishable by thin layer chromatography (tlc) and so the reaction progress could not be followed using this method. The reaction time was decreased to 30 min, after which time a ratio of 3:1 **81** to **80** was observed (Entry 2, Table 2). Between 10 and 20 min predominantly starting material was recovered (Entry 3 and 4, Table 2). The reaction temperature was lowered to 0 °C as we thought it would be easier to control the reaction and after 4 h at this temperature a ratio of 2.5:1 **81** to **80** was observed (Entry 5, Table 2), a promising result. However, reducing the reaction time had very little effect on the chemo-selectivity (Entry 6, Table 2). The reaction was attempted at –10 °C but even after 4 h there was no reaction (Entry 7, Table 2). Halving the number of equivalents of diiodomethane and diethylzinc, to two and one equivalents respectively, also resulted in no reaction after 4 h at RT (Entry 8, Table 2).

Entry <sup>a</sup>	Temperature (°C)	Reaction Time (min)	Ratio of Products <sup>b</sup>		
			<b>81</b>	<b>80</b>	<b>79</b>
1	RT	240	7	1	0
2	RT	30	3	1	0
3	RT	10	trace	1	5
4	RT	20	trace	1	4
5	0	240	2.5	1	0
6	0	30	2.5	1	0
7	-10 °C	240	0	0	1
8 <sup>c</sup>	RT	240	0	0	1

<sup>a</sup>Conditions (Entries 1–7): CH<sub>2</sub>I<sub>2</sub> (4 eq), Et<sub>2</sub>Zn (2 eq), CH<sub>2</sub>Cl<sub>2</sub>.

<sup>b</sup>Ratio of **80** to **81** determined by analysis of the <sup>1</sup>H NMR spectra of the unpurified reaction mixtures.

<sup>c</sup>Reaction carried out using only 2 equivalents of CH<sub>2</sub>I<sub>2</sub> and 1 equivalent of Et<sub>2</sub>Zn.

**Table 2** Summary of the cyclopropanation of **79**.

Given that we were unable to achieve good chemo-selectivity using standard Simmons-Smith conditions, a Charett modification<sup>31</sup> (which is also known to react faster with allylic alcohols than unfunctionalised alkenes) was trialled. The first step of the Simmons-Smith reaction using allylic alcohols is the generation of an iodomethylzinc alkoxide and computational studies by Nakamura *et al.*<sup>32</sup> suggest that the reactive species is likely to be a multimetallic aggregate, either a dimer or a tetramer (Figure 5). A dioxaborolane additive is used in the Charett reaction and computational studies by Wang *et al.*<sup>33</sup> suggest that the reactive species is a complex formed from dioxaborolane, Zn(CH<sub>2</sub>I)<sub>2</sub> and the alcohol (Figure 5).

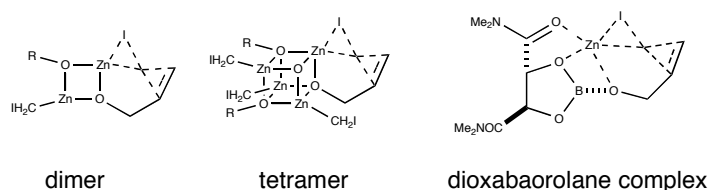

**Figure 5** The proposed reactive species in the Simmons-Smith cyclopropanation of allylic alcohols.<sup>32,33</sup>

It was hoped that this alternative reaction mechanism would improve the chemo-selectivity of our reaction but unfortunately this procedure only led to decomposition of substrate **79** (Scheme 22).

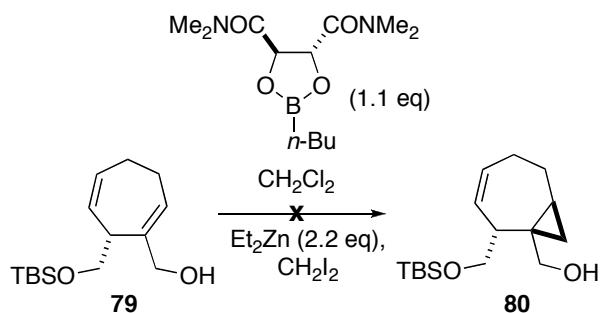

**Scheme 22** Simmons-Smith reaction on TBS protected alcohol **79** using a dioxaboralane additive.

A TBDPS variant of the route shown in Scheme 20 was attempted. It was anticipated that the extra bulk may provide some additional steric hindrance to the unwanted cyclopropanation on the unfunctionalised alkene. Pleasingly the synthesis of TBDPS-containing **85** proved as facile as its TBS analogue (Scheme 23), but unfortunately, the protecting group switch did not improve the chemo-selectivity for the cyclopropanation of **85**, which was found to be similarly poor to that of TBS variant **79**; the best result was a 2:1 ratio of bis-cyclopropane **87** to cyclopropane **86** (Scheme 23). The ratio of **87** to **86** was again determined by analysis of the  $^1\text{H}$  NMR spectra of the unpurified reaction mixtures. Consumption of the peaks corresponding to the double bonds of diene **85** at 5.97 (1H, dd,  $J$  7.5, 5.5 Hz), 5.74–5.69 (1H, m) and 5.51–5.45 (1H, m) was observed alongside the appearance of cyclopropyl peaks at 1.01–0.91 (2H, m) and 0.77–0.62 (2H, m).



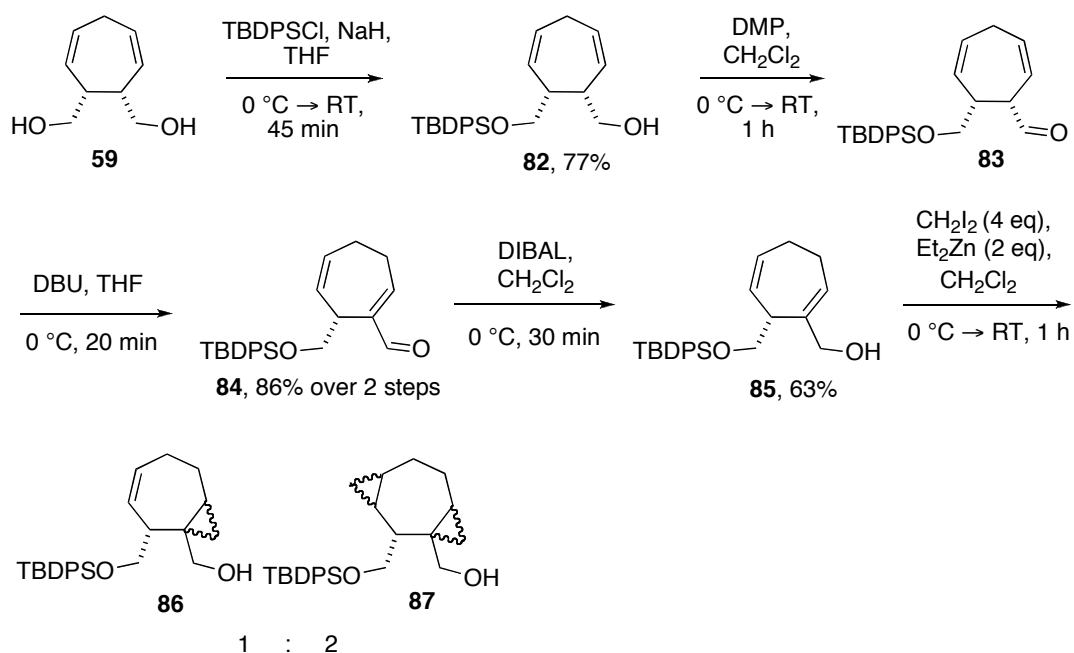

**Scheme 23** TBDPS Mono-protection route to Simmons-Smith precursor **85** and subsequent Simmons-Smith cyclopropanation.

As shown, we were unable to achieve good chemo-selectivity when using Simmons-Smith cyclopropanation on the desmethyl model system. However, we believed that the *gem*-dimethyl group on the analogous pyxidatol C system could influence this cyclopropanation. We thought it possible that the steric bulk of the cycloheptadiene dimethyl group might hinder the unwanted cyclopropanation on the unfunctionalised alkene (Figure 6) giving greater control over the regioselectivity of the cyclopropanation. Therefore, attention turned from the model system to preparation of the *gem*-dimethyl equivalent of alcohol **85**.

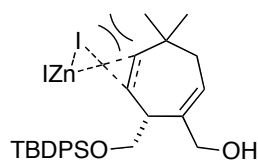

**Figure 6** Potential destabilising steric interaction of *gem* dimethyl group toward cyclopropanation of the unfunctionalised alkene.

### 2.3 From the Desmethyl Model System to the Gem-Dimethyl System

The requisite *gem*-dimethyl cyclopropane was made using a non-commercial sulfoxonium salt, necessitating the preparation of triisopropylsulfoxonium tetrafluoroborate **52**, which was prepared in two steps from commercially available diisopropyl sulfide. Badet and Julia<sup>34</sup> reported the synthesis of sulfonium salt **51** using IPA and MSA as a source of isopropyl cation to alkylate diisopropyl sulfide, which was followed by subsequent anion exchange with tetrafluoroboric acid. A protocol for the oxidation of this salt was developed within the Taylor group by Pugh,<sup>23</sup> based on work by Ciba-Geigy.<sup>35</sup> A sulfonoperoxic acid is formed *in situ* when *ortho*-nitrobenzenesulfonyl chloride, hydrogen peroxide and barium hydroxide are mixed, which oxidizes sulfonium salt **51** to sulfoxonium salt **52** (Scheme 24). With the sulfoxonium salt **52** in hand, Corey-Chaykovsky type cyclopropanation of diethyl fumarate was then performed, which gave *gem*-dimethyl cyclopropane **53** in 73% yield, although yields of 90% have been obtained for this reaction under these conditions, within the Taylor group.<sup>23</sup> LiAlH<sub>4</sub> reduction followed in 86% yield and finally a TOP reaction, furnished *E,E*-diester **57a** in 69% yield and *E,Z*-diester **57b** in 4% yield.

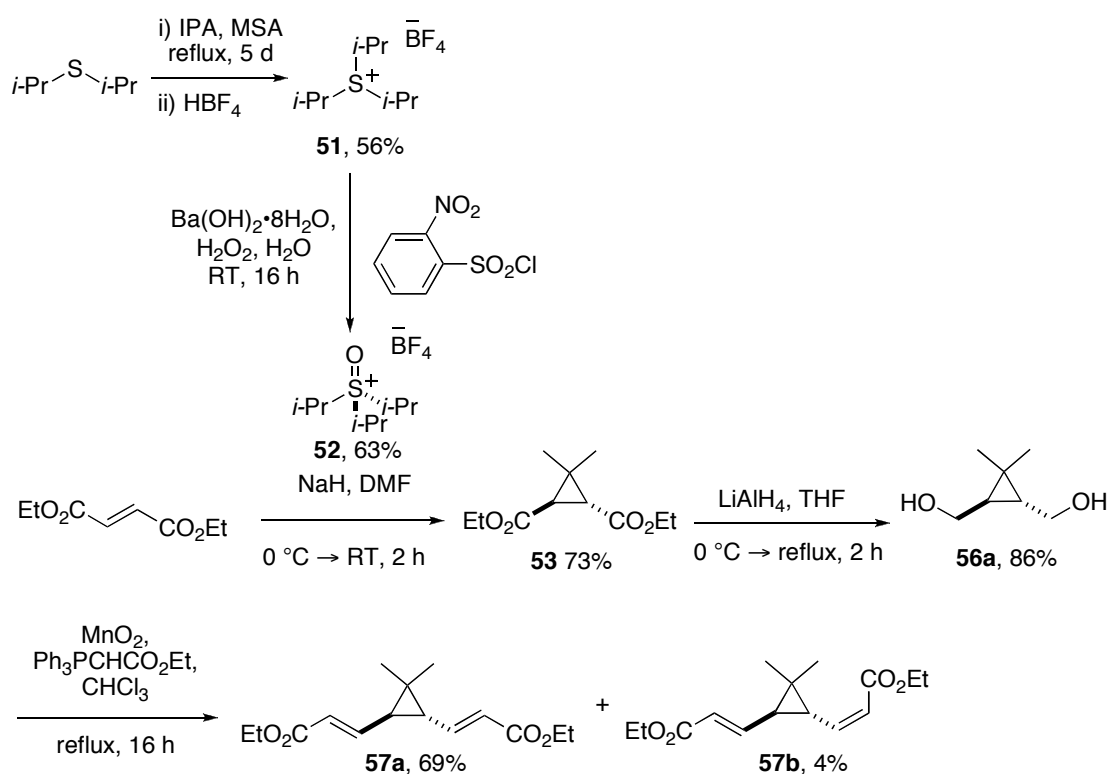

**Scheme 24** The synthesis of *gem*-dimethyl diester **57a** using Taylor group methodologies.

With diester **57a** in hand, we could now test the key step in our retrosynthesis, the Cope rearrangement, which we hoped would introduce the 7 membered ring found in pyxidatol C. We were very disappointed to find that, after following the same procedure as that for its desmethyl analogue **55a**, heating **57a** in xylene at 130 °C, only starting material was observed along with significant decomposition products in the <sup>1</sup>H NMR spectrum of the unpurified reaction mixture (Scheme 25).

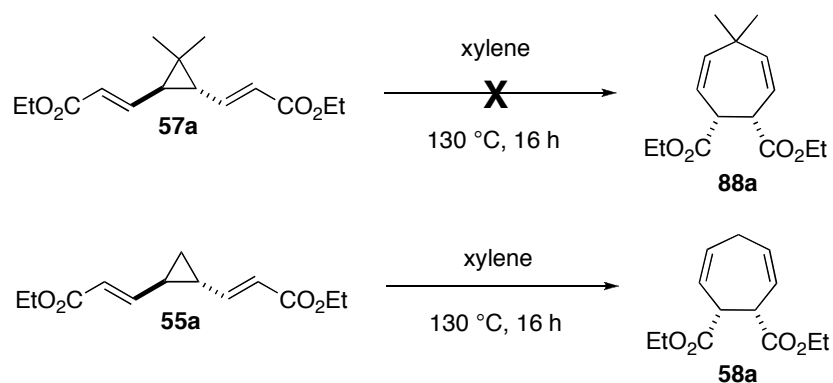

**Scheme 25** The unsuccessful thermal Cope rearrangement of **57a**.

#### 2.4 The Ethoxide-Promoted Cope Rearrangement

Disappointingly, *gem*-dimethyldivinylcyclopropane **57a** did not undergo the Cope rearrangement upon heating in xylene. We therefore considered an alternative strategy in which to encourage the Cope rearrangement. The Cope rearrangements of *trans*-divinylcyclopropanes are understood to proceed by first epimerising to the *cis*-cyclopropane before undergoing a rapid [3,3]-sigmatropic shift. With this in mind, it was thought that a base-catalysed epimerisation could facilitate the Cope rearrangement. DBU ( $pK_{aH}$  in water  $\sim 12$ ) in THF at 70 °C was attempted but there was no reaction. The stronger base, sodium ethoxide ( $pK_{aH}$  in water  $\sim 16$ ) in ethanol at 90 °C, was tested and pleasingly the Cope rearrangement was successful. Unfortunately, subsequent isomerisation of the double bonds into conjugation with the ester groups also occurred *in situ*, providing cycloheptadiene **89** in 80% yield (Scheme 26).

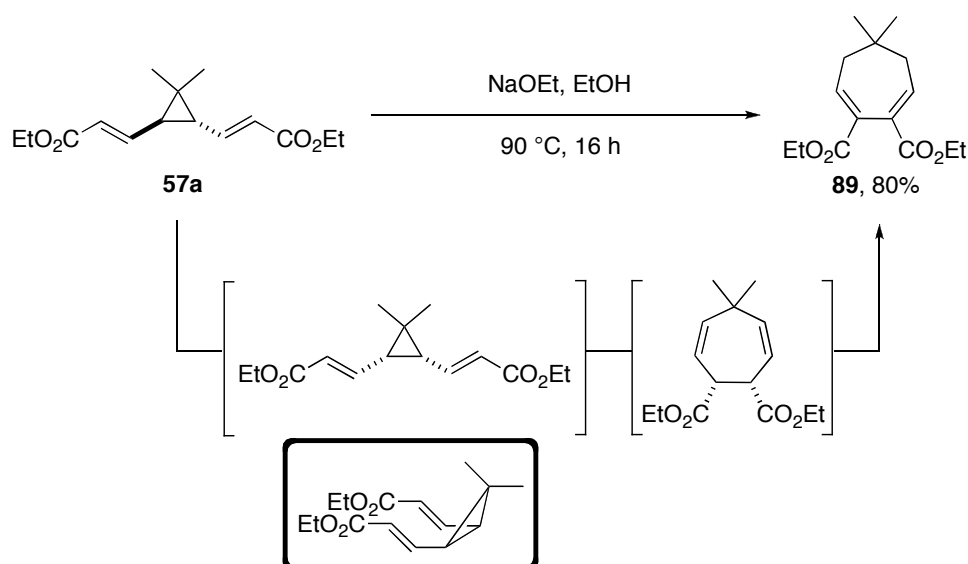

**Scheme 26** Ethoxide catalyzed Cope rearrangement and isomerisation to give **89**.

In order to confirm that the ethoxide base was indeed catalyzing the Cope rearrangement, and that the change in solvent from xylene to ethanol was not responsible for the observed Cope rearrangement, the reaction was attempted in the absence of base, using EtOH as the solvent. Thus, diester **57a** was heated in ethanol at 90 °C and as expected there was no reaction, confirming that the base was responsible for the Cope rearrangement. Under otherwise identical conditions to the reaction with sodium ethoxide, but at 50 °C and 70 °C, incomplete conversion into cycloheptadiene **89** was observed and so the initial conditions, using sodium ethoxide at 90 °C, were considered optimal for the synthesis of cycloheptadiene **89**.

Entry	Temperature (°C)	Solvent	Base	Ratio of Products <sup>a</sup>	
				<b>89</b>	<b>57a</b>
1	130	xylene	-	0	1 <sup>b</sup>
2	70	THF	DBU	0	1
3	90	EtOH	NaOEt	1	0
4	90	EtOH	-	0	1
5	50	EtOH	NaOEt	1	20
6	70	EtOH	NaOEt	1	10

<sup>a</sup>Ratio determined by analysis of the <sup>1</sup>H NMR spectra of unpurified reaction mixtures.

<sup>b</sup>Some decomposition was also observed.

**Table 3** The base-catalysed Cope rearrangement of **57a**.

While the Cope rearrangement of **57a** was achieved using NaOEt as an additive, the *in situ* isomerisation of the double bonds into conjugation with the ester groups was an unwanted side reaction. However, the isomerisation of one of the double bonds was necessary in the retrosynthetic plan. We therefore planned to exploit this isomerisation by preparing an unsymmetrical divinylcyclopropane **90** that could be subjected to the optimized conditions for the base-catalysed Cope rearrangement in the expectation of obtaining unsymmetrical cycloheptadiene **91** (Scheme 27). It was then hoped to synthesise alcohol **90** by monohydrolysis of diester **57a**, followed by borane reduction of the resulting acid **92**.

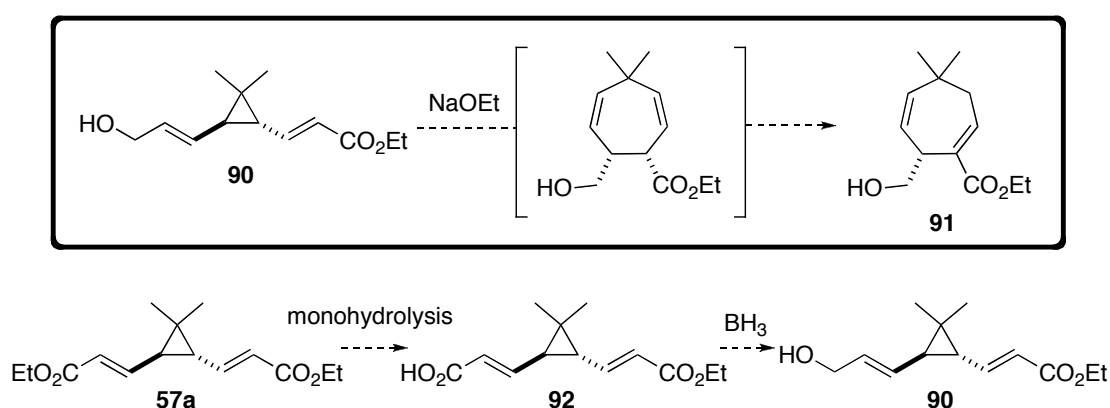

**Scheme 27** The synthetic strategy towards cycloheptadiene **91**.

Unfortunately, monohydrolysis proved troublesome; unsuccessful attempts using lithium hydroxide in ethanol<sup>36</sup> and sodium hydroxide in water/THF<sup>37</sup> led only to di-acid formation and an alternative strategy targeting protected hydroxyester **100** (Scheme 28) was planned instead, and this proved straightforward. Mono-TBS protection of diol **56a** furnished alcohol **93** in 65% yield which, following Dess–Martin oxidation, gave aldehyde **94** in 60% yield. Wittig olefination followed by DIBAL reduction afforded alcohol **96** in 79% yield. Benzyl protection with benzyl bromide gave **97** which was taken on crude to the next step. TBS cleavage with TBAF, then gave **98** in 44% over two steps. Dess–Martin oxidation (68% yield) followed by Wittig olefination (96% yield) furnished the required substrate **100** for testing the key mixed Cope reaction. We trialed the reaction using the established ethoxide conditions (Entry 3, Table 3) but, disappointingly, divinylcyclopropane **100** was unreactive under these conditions and starting material **100** was recovered from the reaction unchanged.

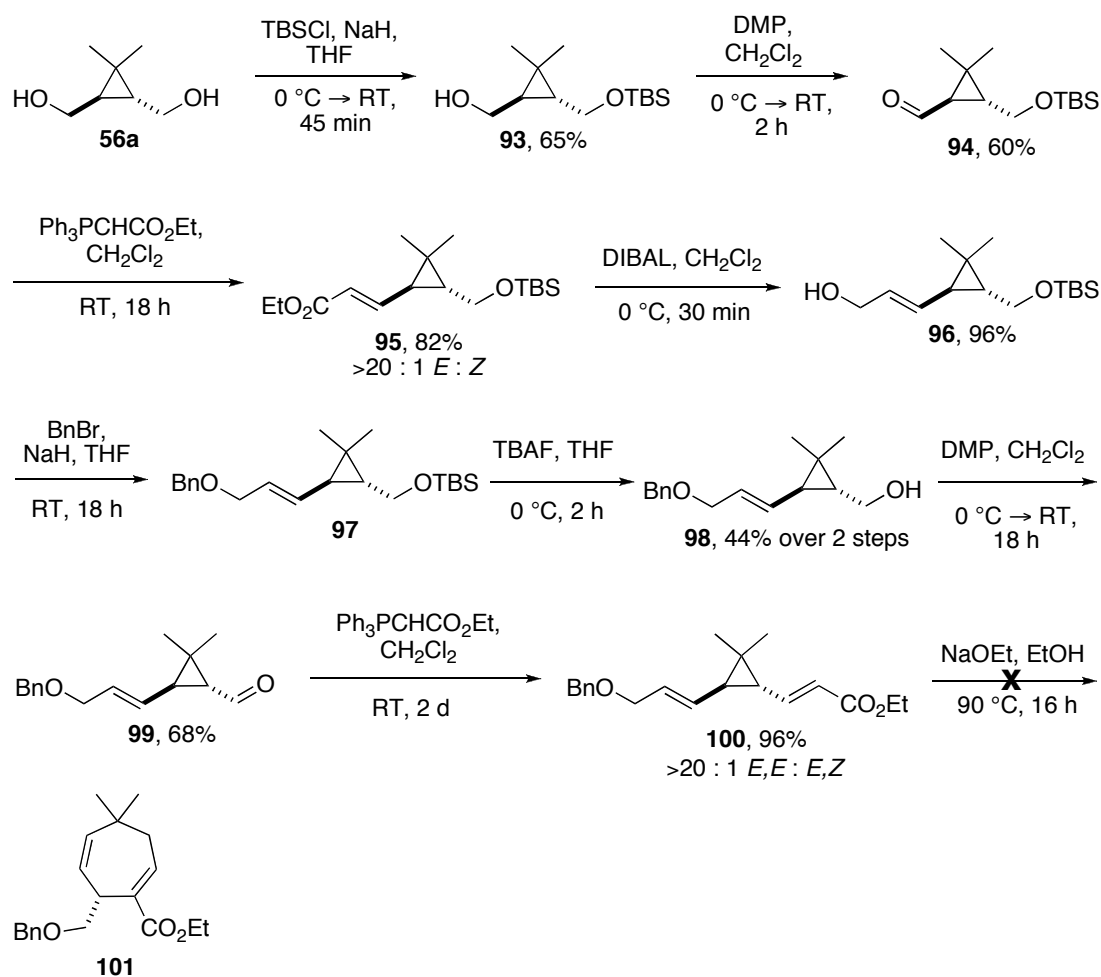

**Scheme 28** The synthesis of cyclopropane **100**.

In summary the Cope rearrangement of divinylcyclopropane **55** was successful (Scheme 25). However, under identical conditions, on the analogous *gem*-dimethyl pyxidatol C system it was unsuccessful (Scheme 25). The Cope rearrangement of a *gem*-dimethyl divinylcyclopropane was fundamental to the synthetic strategy for the synthesis of pyxidatol C and presented a significant challenge. Pleasingly, the Cope rearrangement was possible, using base-catalysed *trans/cis*-isomerisation, and despite leading to the unwanted cycloheptadiene **89** (Scheme 26), this result provided reason to be optimistic that this challenge could be overcome (Chapter 3).

# Chapter 3

## The Cope Rearrangement of *Gem*-Dimethyl Substituted Divinylcyclopropanes

### 3.1 Introduction

#### 3.1.1 The Cope rearrangement of divinylcyclopropanes

The thermal Cope rearrangement of divinylcyclopropanes was first described by Vogel in 1960, who reported the rearrangement of divinylcyclopropane **102a** to 1,4-cycloheptadiene **103** (Scheme 29).<sup>38–40</sup>

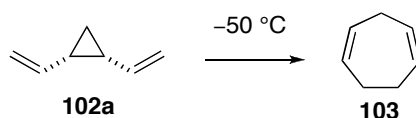

**Scheme 29** The Cope rearrangement of *cis*-divinylcyclopropane **102a**.

The rearrangement of *cis*-divinylcyclopropane **102a** to cycloheptadiene **103** is facile, even at  $-50\text{ }^{\circ}\text{C}$ . However, the rearrangement of its *trans*-analogue **102b** required temperatures of  $190\text{ }^{\circ}\text{C}$  (Scheme 30). The Cope rearrangements of *trans*-divinylcyclopropanes are understood to proceed *via* epimerisation to the *cis*-cyclopropane (at temperatures in the region of  $120\text{--}200\text{ }^{\circ}\text{C}$ ) before undergoing a rapid [3,3]-sigmatropic shift.<sup>41</sup>

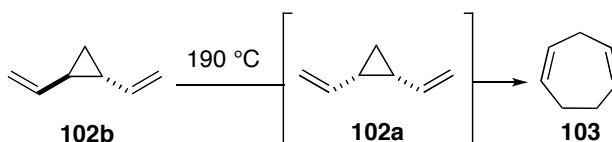

**Scheme 30** The Cope rearrangement of *trans*-divinylcyclopropane **102b** first reported by Vogel *et al.*

The Cope rearrangement of divinylcyclopropanes is symmetry allowed when it is suprafacial for all three components [ $\pi 2_s + \sigma 2_s + \pi 2_s$ ]. There are two possible transition state structures for an all-suprafacial reaction, one being chair-like and the other boat-like. The Cope rearrangement of divinylcyclopropanes proceeds *via* a boat-

like transition state<sup>41</sup> (Figure 7) because the chair-like transition state would lead to the formation of a highly strained ring containing two *trans*-double bonds.

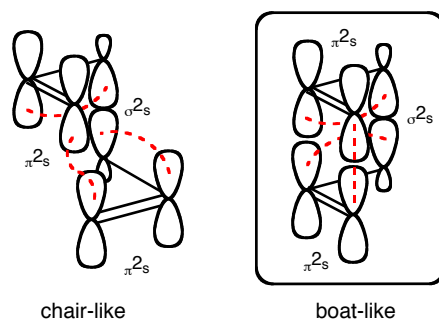

**Figure 7** The symmetry-allowed chair and boat-like transition state for the Cope rearrangement of divinylcyclopropanes.

### 3.1.2 Steric Effects in the Cope Rearrangement of Divinylcyclopropanes

Literature precedent shows that the stability of this boat-like transition state is highly sensitive to steric interactions.<sup>41–51</sup> Ohloff and Pickenhagen were the first to report this phenomenon (Scheme 31).<sup>42</sup> They found that diene **104a** underwent the Cope rearrangement at 15 °C whereas diene **104b** required the higher temperature of 75 °C in order to react. This was attributed to a destabilising steric interaction between the cyclopropyl moiety and the butyl group in the boat-like transition state of **104b**. Even higher temperatures (175 °C) were required before dienes **104c** and **104d** rearranged to generate cycloheptadiene **105**, because in their cases epimerisation to the *cis*-cyclopropane was also required.

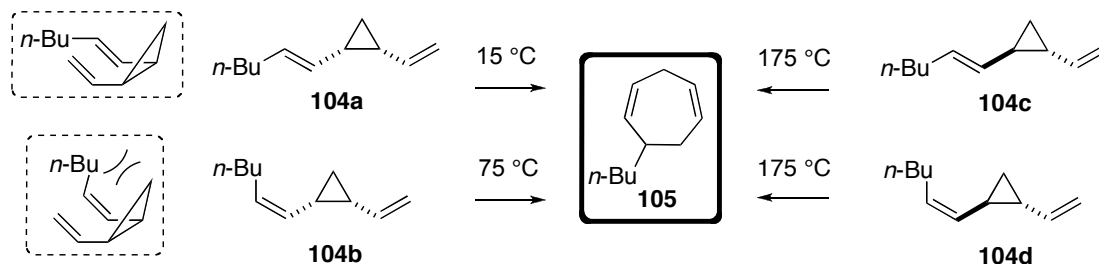

**Scheme 31** Work by Ohloff and Pickenhagen on the thermal Cope rearrangement.<sup>42</sup> Reactions were performed without solvent and yields and reaction times were not reported.



Baldwin *et al.*<sup>43,44</sup> tested the Cope rearrangements of compounds **106a**–**106c** (Scheme 32). They found that the *E,E*-diene **106a**, underwent the thermal Cope rearrangement at 178 °C giving cycloheptadiene **107a**. The Cope rearrangement of the *E,Z*-diene **106b** was also successful, this time at 179 °C, affording cycloheptadiene **107b**. Crucially, *Z,Z*-diene **106c**, did not undergo a Cope rearrangement; Baldwin proposed that the boat-like transition state for this rearrangement is higher in energy than that of the analogous *E,E/E,Z* variants because of two destabilising steric interactions between the methyl substituents and the cyclopropyl moiety. As such, the rearrangement does not take place even though *cis/trans*-isomerisation of the cyclopropane takes place.

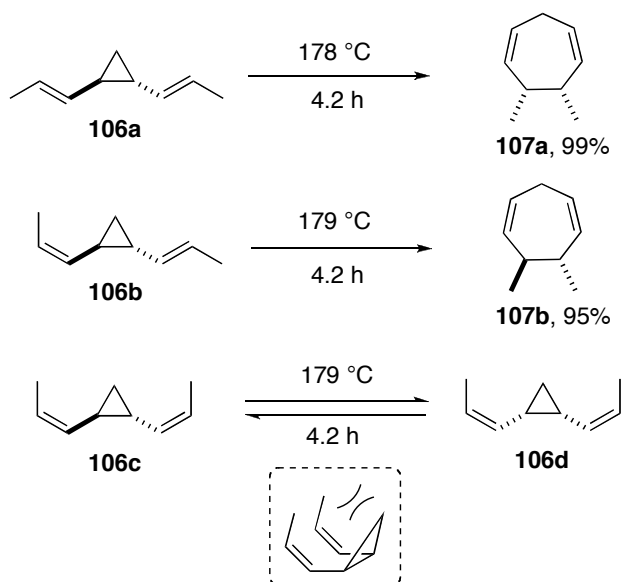

**Scheme 32** Work by Baldwin *et al.* on the thermal Cope rearrangement.<sup>43–44</sup> Reactions were performed without solvent.

Work by Schneider and Rau,<sup>45</sup> showed that the Cope rearrangement of diene **102a** to cycloheptadiene **103** occurs at a rate 5800 times faster than the conversion of diene **108** into cycloheptadiene **109** (Scheme 33). Again, a destabilising steric interaction between the methyl group in diene **108** and the cyclopropyl ring moiety in the transition state was used to explain this large difference in rate.

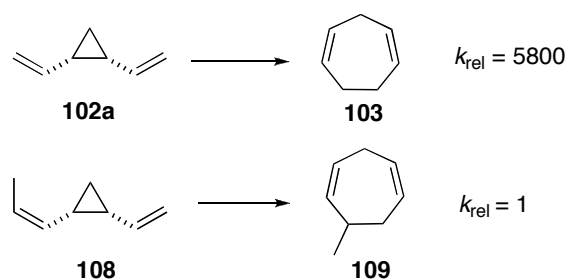

**Scheme 33** Work by Schneider and Rau on the thermal Cope rearrangement.<sup>45</sup> The solvent and the yields for the reactions were not reported.

Sasaki *et al.*<sup>46,47</sup> observed the profound effect a cyclopropyl *gem*-dimethyl group can have on the rearrangements of aza-divinylcyclopropanes. They found that the ‘aza-divinylcyclopropane’ rearrangement (which is still a [3,3]-sigmatropic rearrangement but not strictly a Cope rearrangement) of isocyanate **110** was extremely facile; in fact, they could not isolate vinylcyclopropyl isocyanate **110**, even when it was prepared at  $-45\text{ }^{\circ}\text{C}$ , and instead rearranged product **111** was isolated. However, they found that the ‘aza-divinylcyclopropane’ rearrangement of the *gem*-dimethyl analogue **112** required the far greater temperature of  $144\text{ }^{\circ}\text{C}$  before rearranged product **113** was observed even though the substituents are *cis*-orientated (Scheme 34).

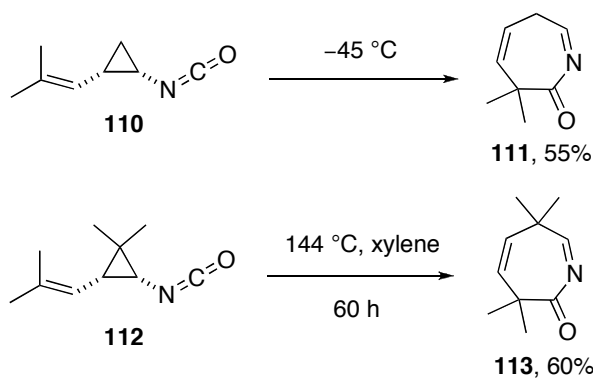

**Scheme 34** Work by Sasaki *et al.* on the ‘aza-divinylcyclopropane’ rearrangement.<sup>46</sup>

Müller *et al.*<sup>48</sup> report similar findings, in which a *gem*-dimethyl group had a similar effect on related ‘aza-divinylcyclopropane’ rearrangements; isocyanate **114** underwent rearrangement to product **115** at  $80\text{ }^{\circ}\text{C}$ , whereas the *gem*-dimethyl analogue **116** did not rearrange, even upon heating to  $144\text{ }^{\circ}\text{C}$ .

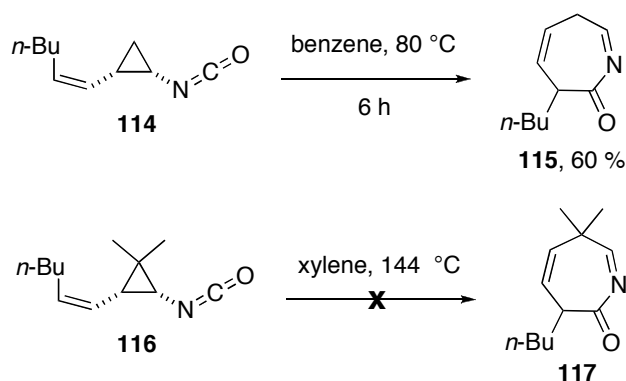

**Scheme 35** Work by Müller *et al.* on the ‘aza-divinylcyclopropane’ rearrangement.<sup>48</sup>

Further work by Sasaki *et al.*<sup>46</sup> showed that the *cis*-divinylcyclopropanes **118a** and **119a**, bearing a *gem*-dimethyl group, did not undergo the Cope rearrangement when heated to 144 °C and instead underwent *cis/trans*-isomerisation at the cyclopropane.

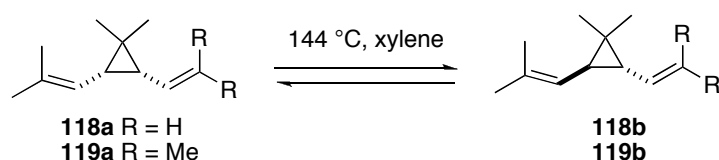

**Scheme 36** Work by Sasaki *et al.* on the thermal Cope rearrangement.<sup>47</sup>

An interesting Cope rearrangement of enone **120** was reported by Piers *et al.*,<sup>49–51</sup> in which after 4 h at 69 °C diene **120** was converted into cycloheptadiene **121** in 97% yield. The analogue **122a**, bearing a methyl substituent on the enone, was found to be far more stable, however; on heating diene **122a** to a far greater temperature (144 °C) isomerisation to the *trans*-isomer **122b** was found to compete with the Cope rearrangement and the ratio of the two products cycloheptadiene **123** and *trans*-diene **122b** was found to vary between 1.1:1 to 2.7:1.

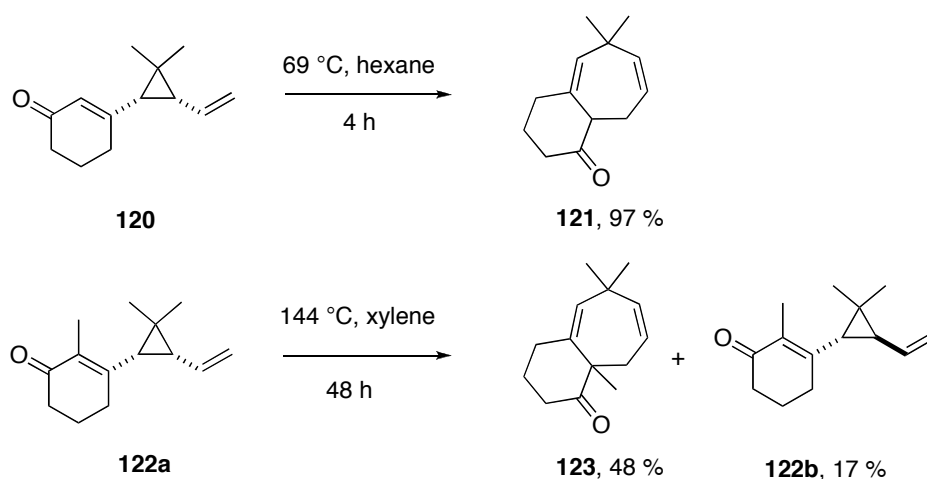

**Scheme 37** Work by Piers *et al.* on the thermal Cope rearrangement.<sup>49–51</sup>

The examples described above all demonstrate that the energy of the boat-like transition state in the Cope rearrangement of divinylcyclopropanes is highly sensitive to steric interactions. This may explain why in the vast majority of literature examples, the cyclopropane is substituted only with the two alkene groups involved in the rearrangement. Limited examples of the Cope rearrangement of trisubstituted cyclopropanes have also been reported, but these are far less common (e.g. **123**→**124**, Scheme 38).<sup>52</sup>

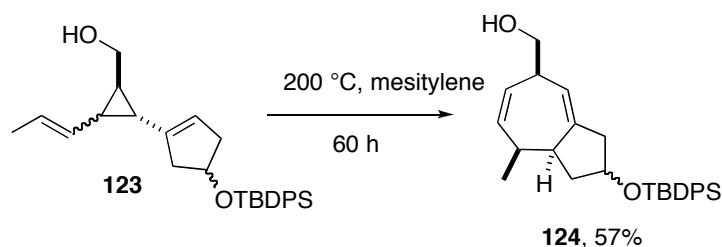

**Scheme 38** Work by Wollack *et al.* on the thermal Cope rearrangement.<sup>52</sup>

To the best of our knowledge, the only examples of tetrasubstituted cyclopropanes undergoing the Cope rearrangement, apart from the example described by Piers *et al.* (Scheme 37),<sup>49–51</sup> are of fused bicyclic systems (e.g. **125**→**126**, Scheme 39).<sup>53</sup> In these systems the compound is much more rigid and the conformation of the starting material allows the Cope rearrangement to occur more readily. The relief of ring strain is likely to be an additional driving force in these cases.

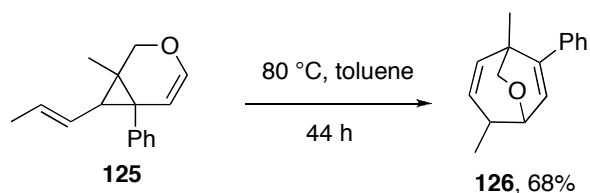

**Scheme 39** Work by Kim *et al.* on the thermal Cope rearrangement on a fused bicyclic system.<sup>53</sup>

### 3.2 The Cope Rearrangement of Diester **57a**

As outlined in Chapter two, we were able to prepare cycloheptadiene **58a** by heating diester **55a** in xylene for 16 h but the analogous reaction of diene **57a** was unsuccessful (Scheme 40).

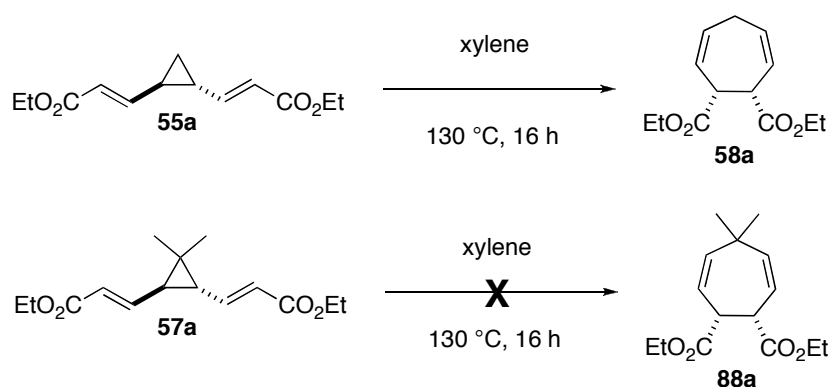

**Scheme 40** The Cope rearrangement of **55a** to give **58a** and the unsuccessful Cope rearrangement of **57a**.

Based on the literature precedent described in section 3.1, this result is not altogether unexpected as it is known that bulky substituents typically inhibit the Cope rearrangements of divinylcyclopropanes<sup>41–51</sup> by destabilising the boat-like transition state. A destabilising steric interaction between a *geminal* methyl group and the

double bond moiety in the transition state of diene **57a** (A, Figure 8) rearranging to cycloheptadiene **88a** is most likely the major obstacle to rearrangement explaining why the thermal Cope rearrangement is facile with the desmethyl substrate **55a** (B, Figure 8), but not with its *gem*-dimethyl equivalent **57a** (Scheme 40).

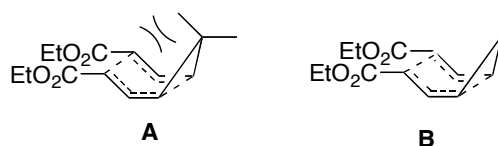

**Figure 8** A diagram showing the potential destabilising steric interactions when **57a** adopts the required boat-like transition state (A).

### 3.3 A Systematic Study into the Cope Rearrangement

We were surprised to discover that a study comparing the Cope rearrangements of a *gem*-dimethyl divinylcyclopropane with its non-methylated analogue has, to the best of our knowledge, not been reported in the literature. Thus, in order to better understand how steric effects influence our system, we planned a systematic study into the Cope rearrangement of the *gem*-dimethyl substrate **57** and desmethyl substrate **55**. We planned to prepare all of the possible *cis/trans* and *E/Z* isomers of **57** and **55** (Figure 9) and determine how readily they undergo the Cope rearrangement.

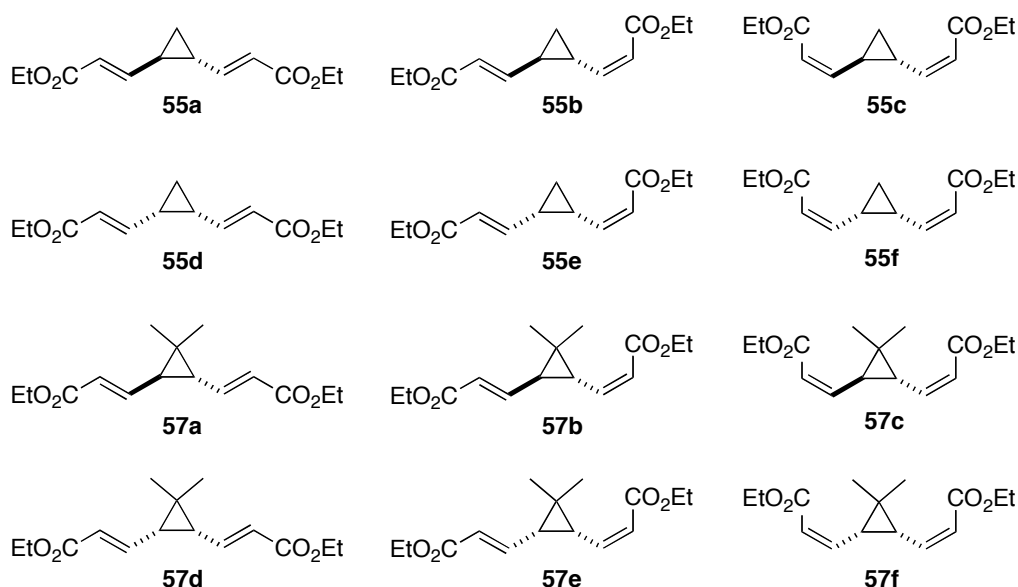
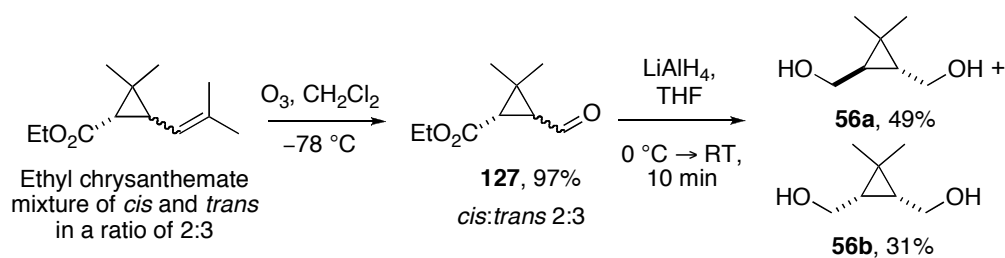

**Figure 9** The target substrates for a systematic study into the Cope rearrangement.

### 3.4 Synthesis of Substrates (Divinylcyclopropanes 57a–57f and 55a–55f)

#### 3.4.1 Synthesis of Gem-Dimethyl Divinylcyclopropanes (57a–57f)

Commercially available ethyl chrysanthemate was used to prepare diols **56a** and **56b** (which were separable by flash column chromatography) *via* ozonolysis followed by LiAlH<sub>4</sub> reduction (Scheme 41).



**Scheme 41** The synthesis of diols **56a** and **56b**.

*Trans*-diol **56a** was then subjected to Taylor group TOP chemistry (Section 1.10),<sup>24</sup> resulting in the preparation of two of the required substrates, *E,E*-diene **57a** and *E,Z*-diene **57b**, in 69% and 4% yield respectively (Scheme 42). The double bond geometry of both compounds (and indeed throughout) was confirmed by analysis of their  $J^3_{\text{H-H}}$  alkene coupling constants. Note that an alternative preparation of diol **56a** was also described earlier (see Scheme 24).

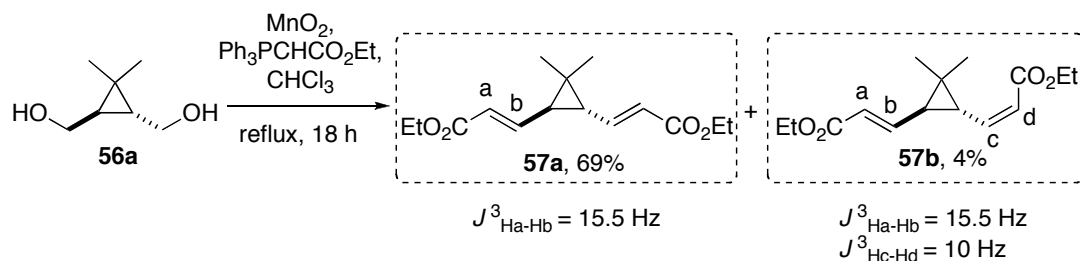

**Scheme 42** The synthesis of **57a** and **57b**. Previously described in Section 2.3.

The Still–Gennari modification<sup>54</sup> of the HWE reaction was used to prepare **57c**, following manganese dioxide oxidation of diol **56a** to generate dialdehyde **128** (Scheme 43).

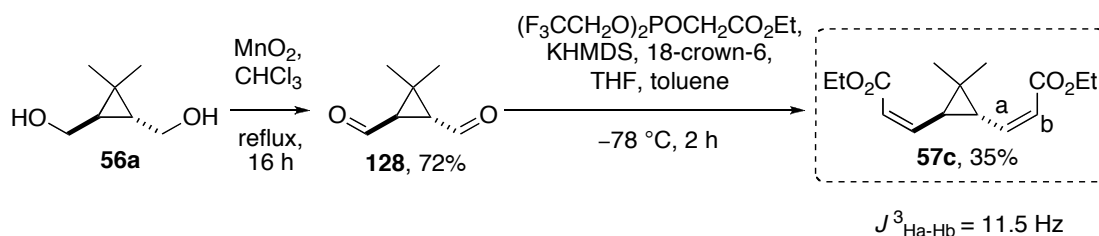

**Scheme 43** The synthesis of **57c** (> 20 : 1 *Z* : *E*).

A stepwise strategy was necessary for the synthesis of the *cis*-variants, because the oxidation of *cis*-diols, for example **56b**, results in lactone formation *via* lactol **129** (Scheme 44).

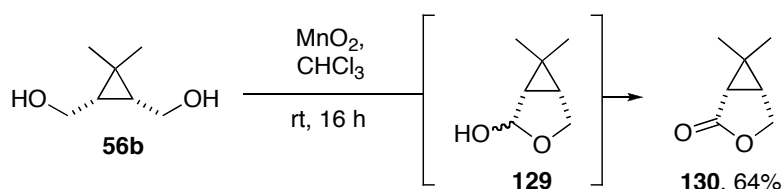

**Scheme 44**  $\text{MnO}_2$  oxidation of *cis*-cyclopropyl diols leads to lactone formation.

Using the ethyl chrysanthemate-derived diol **56a**, lactol **129** was prepared by IBX oxidation. Subsequent Wittig reaction furnished the desired compound **131**.

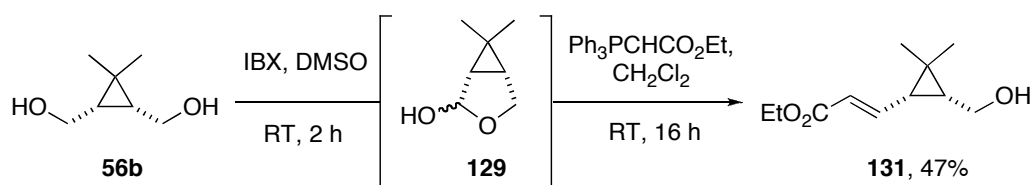

**Scheme 45** The synthesis of **131** via lactol **129** (> 20 : 1 *E* : *Z*).

However, poor yields and difficulties repeating the route shown above, led us to test an alternative synthesis of compound **131** (Scheme 46). Thus, the mono-TBS protection of **56b**, followed by a TOP reaction was straightforward, affording **133** in good yield. Unfortunately, TBS cleavage using TBAF led to oxy-Michael addition



giving rise to the unwanted tetrahydrofuran **134**. Pleasingly, this unwanted side-reaction was avoided by using an acidic source of fluoride (aqueous HF) furnishing the desired alcohol **131**. A TOP reaction was then performed, completing the synthesis of two of the required substrates; *E,E*-diene **57d** was obtained in 68% yield along with *E,Z*-diene **57e** in 16% yield. (Scheme 46).

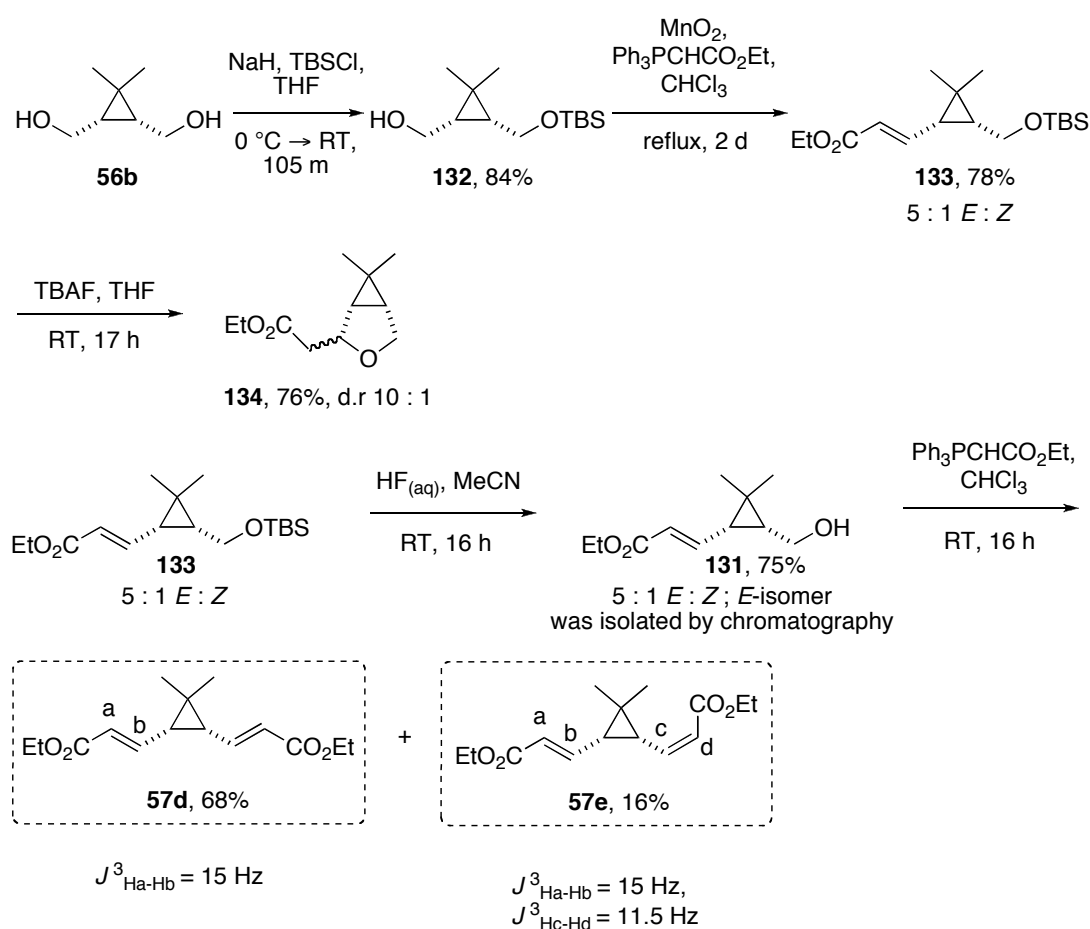

**Scheme 46** The synthesis of **57d** and **57e**.

The oxidation of alcohol **132** using  $\text{MnO}_2$  followed by a Still–Gennari reaction, silyl deprotection using HF (again, this was necessary to avoid oxy-Michael addition) and another  $\text{MnO}_2$  oxidation/Still–Gennari sequence afforded the final *gem*-dimethyl substrate, *Z,Z*-diene **57f** (Scheme 47).

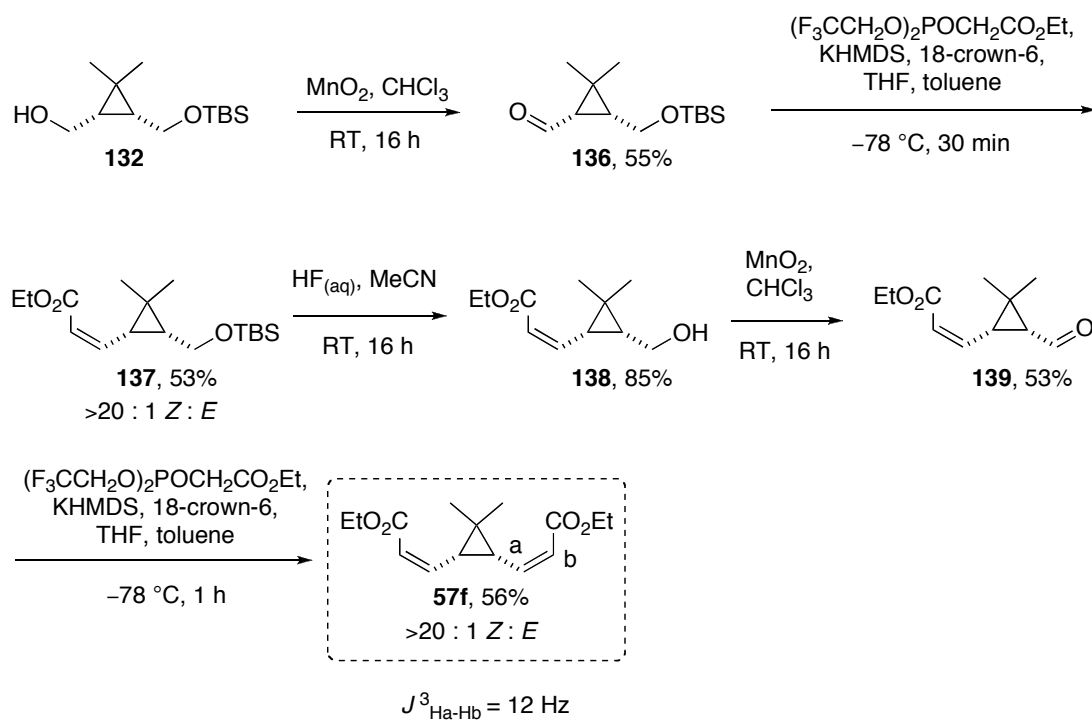

**Scheme 47** The synthesis of **57f**.

### 3.4.2 Synthesis of Desmethyl Divinylcyclopanes (**55a–55f**)

The *trans*-desmethyl divinylcyclopanes were prepared from commercially available diethyl *trans*-1,2-cyclopropanedicarboxylate;  $\text{LiAlH}_4$  reduction afforded diol **54a**, and the Taylor group's TOP chemistry was then used to prepare *E,E*-diene **55a** (Scheme 48).

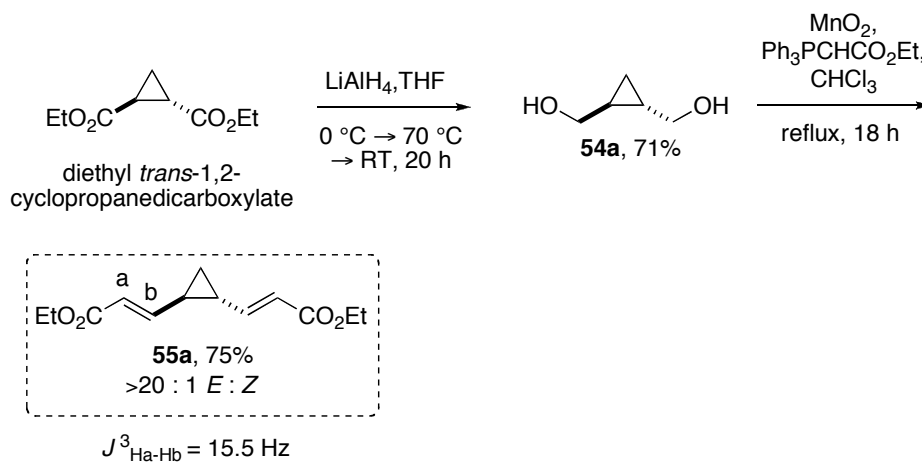

**Scheme 48** The synthesis of **55a**. Previously described in Section 1.10.

The synthesis of *E,Z*-diene **55b** began with mono-TBS protection of **54a**, followed by a TOP reaction furnishing ester **141**. TBS cleavage using TBAF furnished **142** (oxy-Michael addition cannot take place on the *trans*-cyclopropane system) and subsequent MnO<sub>2</sub> oxidation to form aldehyde **143** and a Still–Gennari reaction completed the synthesis of *E,Z*-diene **55b** (Scheme 49).

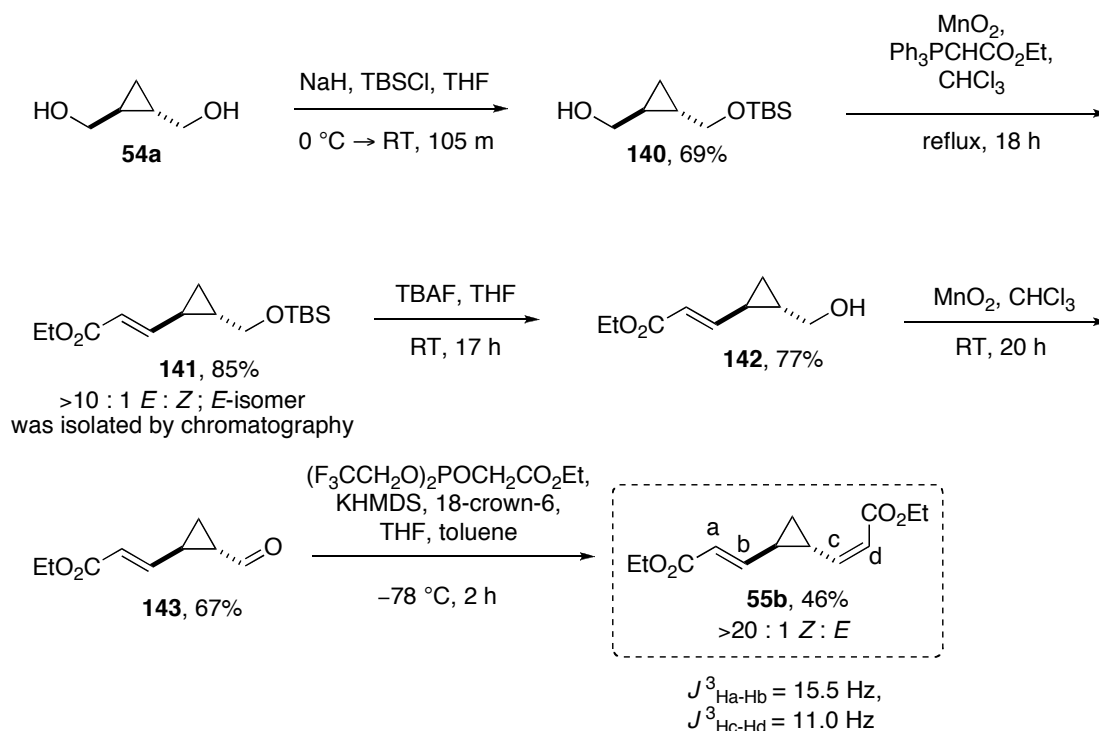

**Scheme 49** The synthesis of **55b**.

A double Still–Gennari modified HWE reaction was used to prepare **55c** after the MnO<sub>2</sub> oxidation of **54a** was used to generate dialdehyde **144** (Scheme 50).

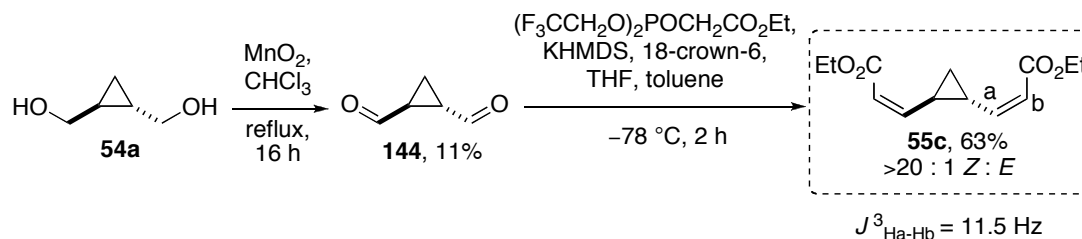

**Scheme 50** The synthesis of **55c**.

The *cis*-desmethyl substrates were prepared from diol **54b**, which was synthesised *via* the LiAlH<sub>4</sub> reduction of commercially available 3-oxabicyclo[3.1.0]hexane-2,4-dione. Mono-TBS protection of diol **54b**, followed by MnO<sub>2</sub> oxidation and a Wittig reaction

furnished ester **146**. TBS cleavage using aqueous HF provided alcohol **147** in good yield. MnO<sub>2</sub> oxidation then afforded aldehyde **148**. A Wittig reaction was then performed in an attempt to generate diester **55d**; however, while the intermediate presumably formed, it could not be isolated and instead underwent Cope rearrangement spontaneously *in situ*, furnishing cycloheptadiene **58a** in good yield (Scheme 51).

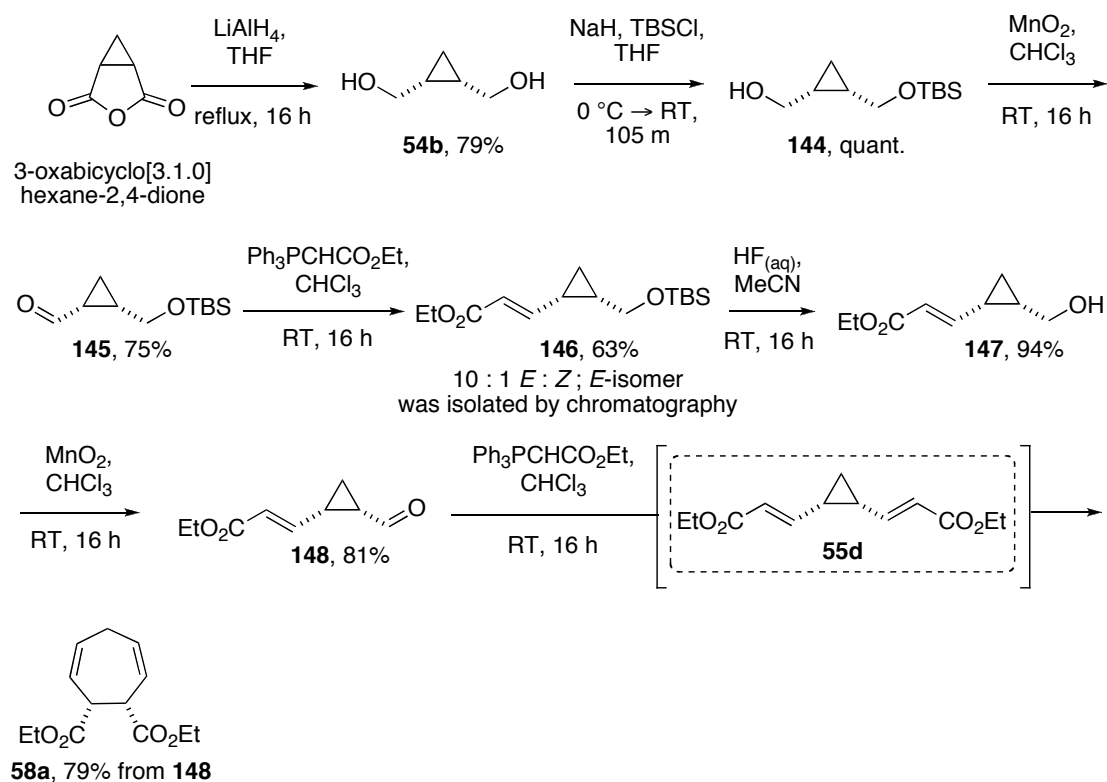

**Scheme 51** The synthesis of **58a** via **55d**.

A similar result was obtained during the attempted synthesis of *E,Z*-diene **55e**; the Still–Gennari reaction of compound **148** also afforded the Cope rearranged product **58b** at RT, presumably *via* divinylcyclopropane **55e** (Scheme 52).

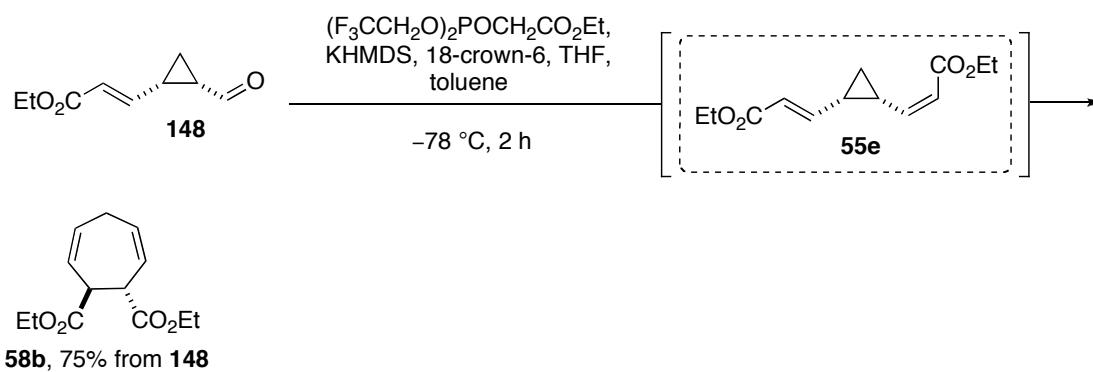

**Scheme 52** The synthesis of **58b** via **55e**.

A Still–Gennari reaction using aldehyde **145**, HF mediated silyl deprotection and another  $MnO_2$  oxidation and Still–Gennari reaction again led to the Cope rearrangement product **58a** at RT, presumably via the divinylcyclopropane **55f** which could not be isolated (Scheme 53).

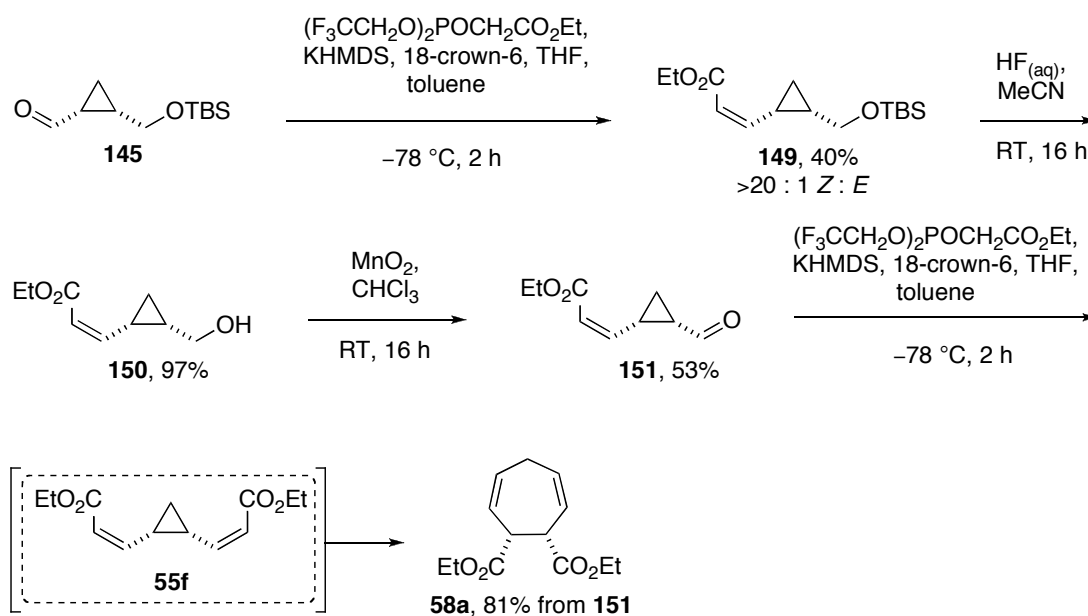

**Scheme 53** The synthesis of **58a** via **55f**.

By considering the symmetry of the two diastereomeric cycloheptadienes **58a** and **58b**, their stereochemistry could be inferred remarkably straightforwardly by analysis of their  $^1\text{H}$  NMR spectra. The spectrum of the *cis*-compound **58a** has two distinct peaks for the characteristic diastereotopic protons ( $J = 20$  Hz) shown in Figure 10.

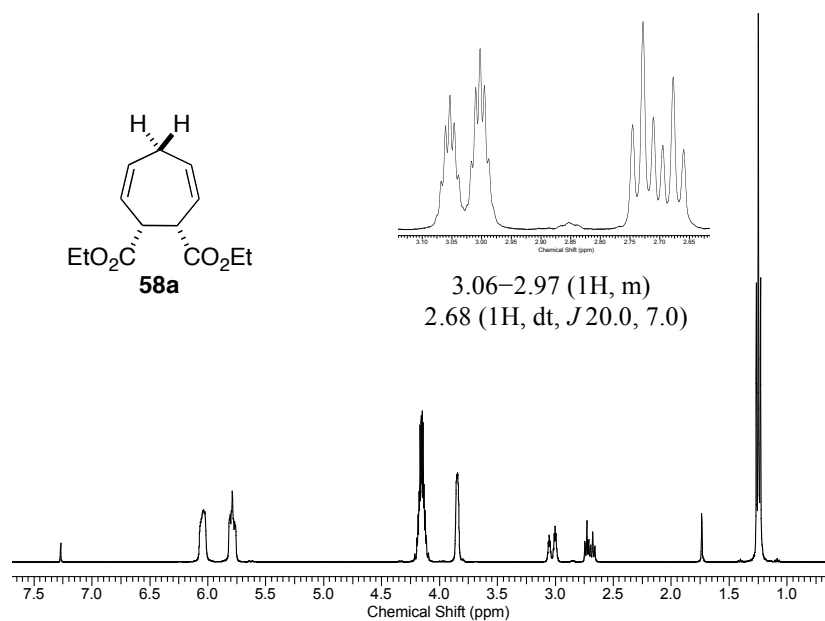

**Figure 10** The  $^1\text{H}$  NMR spectrum of **58a** with the peaks corresponding to the characteristic diastereotopic protons highlighted.

Conversely, the corresponding protons in the *trans*-compound are homotopic and thus appear as a single two proton resonance (Figure 11).

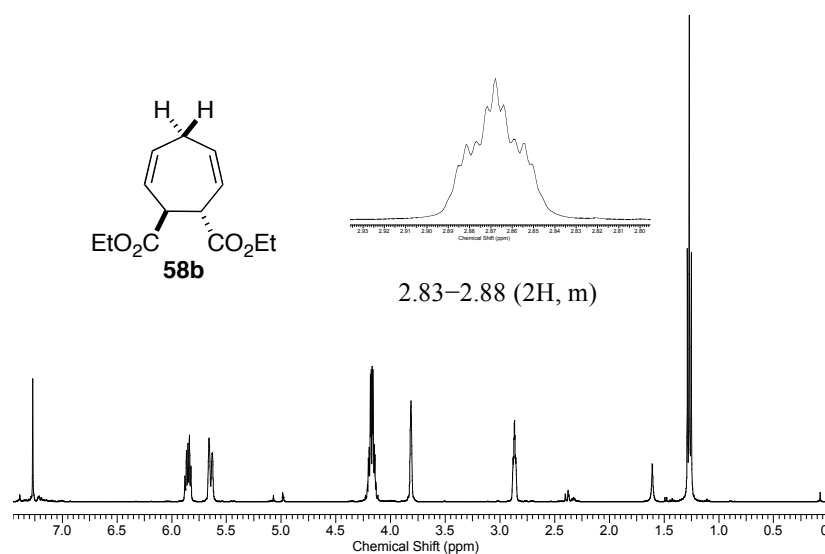

**Figure 11** The  $^1\text{H}$  NMR spectrum of **58b** with the characteristic homotopic protons highlighted.

### ***3.5 A Study into the Effect of Gem-Dimethyl Substitution on the Cope Rearrangement of Divinylcyclopropanes***

We next tested the Cope rearrangements of all of the *cis/trans* and *E/Z*-isomers of **55** and **57** as 0.19 mol dm<sup>-3</sup> solutions in xylene at 5 different temperatures: RT, 40 °C, 70 °C, 100 °C and 130 °C. Each substrate was stirred at these temperatures for 17 h before the percentage conversion was measured as a ratio of product to starting material, *via* analysis of the <sup>1</sup>H NMR spectra of the unpurified reaction mixtures. The results are summarised in Table 4 and are discussed in more detail in the following section.

Entry	Reagent	Product	% Conversion (17 h) <sup>a</sup>				
			Temperature				
			RT	40 °C	70 °C	100 °C	130 °C
1			0	0	0	20	100 <sup>b</sup>
2			0	0	0	20	100 <sup>b</sup>
3			0	0	0	0	80 <sup>b</sup>
4			100 <sup>c</sup>	-	-	-	-
5			100 <sup>c</sup>	-	-	-	-
6			100 <sup>c</sup>	-	-	-	-
7			0	0	0	0	0 <sup>b</sup>
8			0	0	0	0	0 <sup>b</sup>
9			0	0	0	0	0 <sup>b</sup>
10			0	30	90	100 <sup>d</sup>	100 <sup>b</sup>
11			0	0	0	0	0 <sup>b</sup>
12			0	0	0	0	0 <sup>b</sup>

<sup>a</sup>E = CO<sub>2</sub>Et. All reactions were carried out as 0.19 mol dm<sup>-3</sup> solutions in xylene. All reactions were carried out for 17 h. % Conversion was determined *via* <sup>1</sup>H NMR analysis of the unpurified reaction mixtures as a ratio of product to starting material.

<sup>b</sup>Some decomposition was also evident.

<sup>c</sup>The divinylcyclopropane could not be isolated at RT; the cycloheptadiene shown was instead isolated during the attempted preparation of the diene.

<sup>d</sup>Compound **88a** was isolated in 78% yield after flash column chromatography.

**Table 4** The Cope rearrangement on test substrates **55** and **57**.



The  $^1\text{H}$  NMR spectra for the key rearrangement of **57d** into **88a** at the 5 different temperatures are displayed in Figure 12. The spectra show that the reaction was complete after 17 h at 100 °C and show the decomposition that was evident after 17 h at 130 °C.

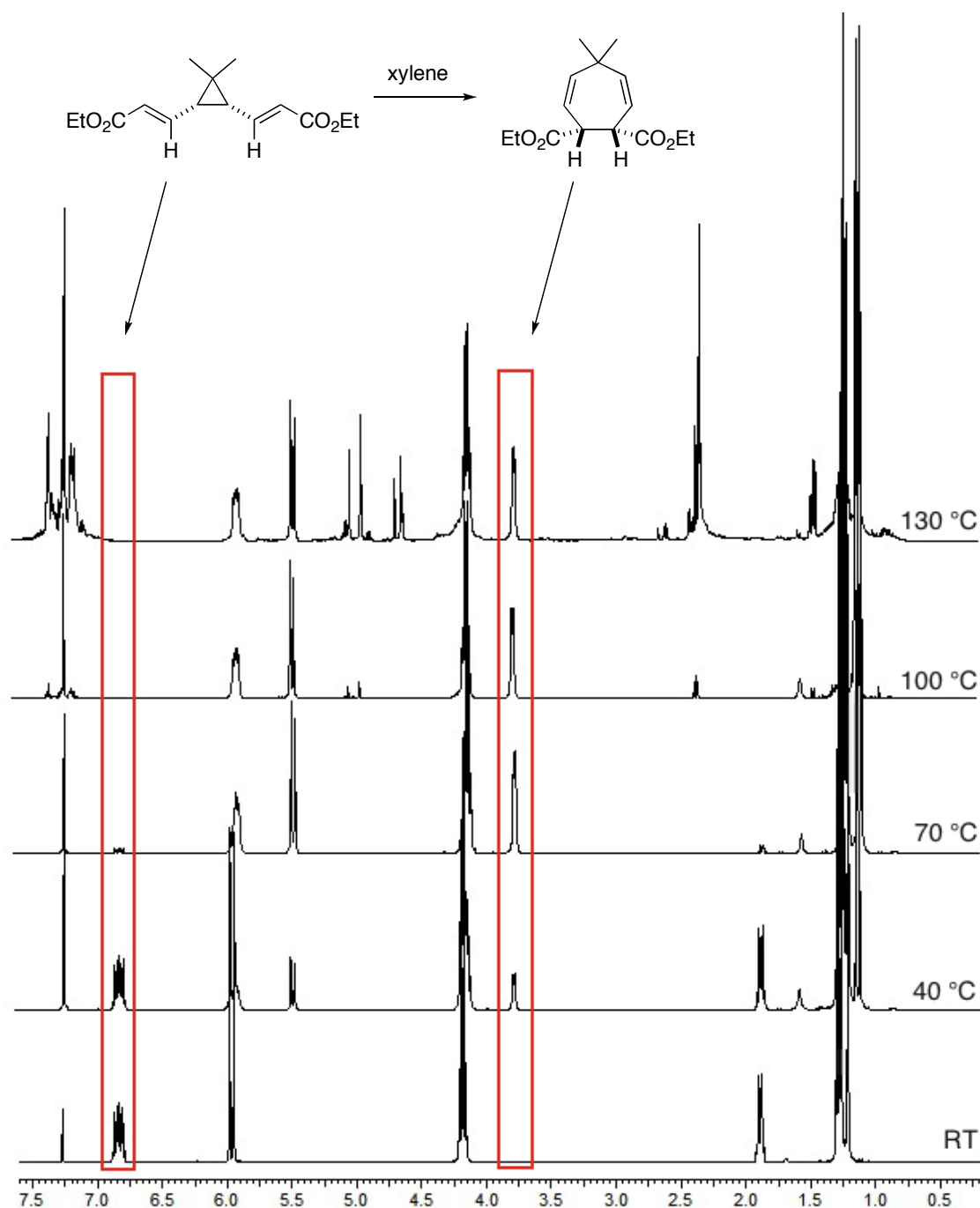
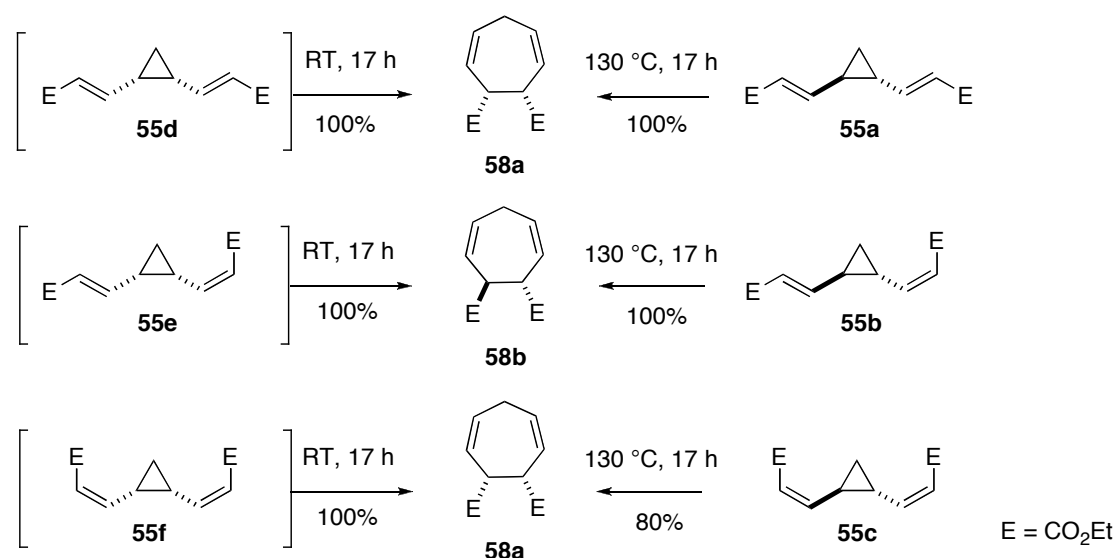

**Figure 12** Following the conversion of **57a** into **88a** by  $^1\text{H}$  NMR spectroscopy at RT, 40 °C, 70 °C, 100°C and 130°C, showing complete conversion at 100 °C and signs of decomposition at 130 °C.

The key findings of the study into the Cope rearrangement are: i) *cis*-divinylcyclopropanes undergo the Cope rearrangement more readily than *trans*-divinylcyclopropanes, ii) desmethyl divinylcyclopropanes undergo the Cope rearrangement more readily than their *gem*-dimethyl analogues, iii) divinylcyclopropanes with *E*-double bonds undergo the Cope rearrangement more readily than those with *Z*-double bonds, and iv) there is an increased barrier to epimerisation between *trans* and *cis*-divinylcyclopropanes in the *gem*-dimethyl series. These observations are illustrated below:

i) *cis*-Divinylcyclopropanes undergo the Cope rearrangement more readily than *trans*-divinylcyclopropanes

The desmethyl *cis*-divinylcyclopropanes **55d**, **55e** and **55f** could not be isolated at RT, and instead they underwent spontaneous Cope rearrangement under the conditions used for their formation (a TOP reaction at RT or a Still–Gennari reaction at RT, Table 4, Entries 4, 5, 6 & Scheme 54). In contrast, the desmethyl *trans*-divinylcyclopropanes **55a**, **55b** and **55c** were stable at RT and required temperatures of 100–130 °C before they underwent the Cope rearrangement (Table 4, Entries 1, 2, 3 & Scheme 54).



**Scheme 54** The contrasting Cope rearrangements of divinylcyclopropane **55**.

A single stereoisomer of product was observed in each case, with the stereochemical outcomes being consistent with a simple concerted thermal [3,3]-sigmatropic rearrangement in the *cis*-series of compounds (Table 4, entries 4–6) and *trans* to *cis*-isomerisation, followed by a concerted thermal [3,3]-sigmatropic rearrangement, in the *trans*-series (Table 4, entries 1–3). Thus, the high temperatures necessary to induce rearrangement in the *trans*-series appear to be associated with overcoming the energy barrier for *trans* to *cis*-epimerisation of the cyclopropane and not with the energy of the transition state of the Cope rearrangement itself.

A similar trend was seen in the analogous *gem*-dimethyl series: *cis*-divinylcyclopropane **57d** was fully converted into Cope product **88a** after 17 h at 100 °C (Table 4, Entry 10 & Scheme 55). In contrast, after 17 h at 130 °C *trans*-divinylcyclopropane **57a** did not undergo the Cope rearrangement (Table 4, Entry 7 & Scheme 55).

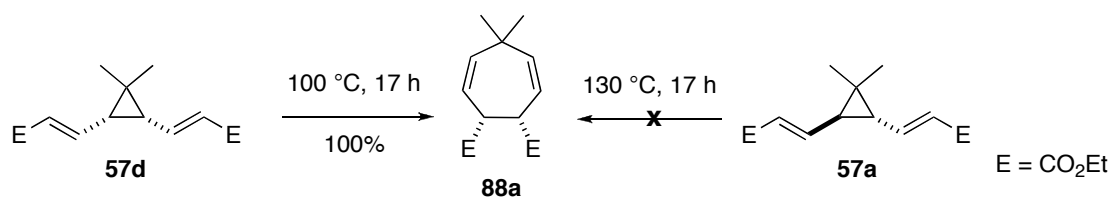

**Scheme 55** The contrasting Cope rearrangements of **57a** and **57d**.

ii) Desmethyl divinylcyclopropanes undergo the Cope rearrangement more readily than their *gem*-dimethyl analogues

These results support the findings described in Chapter 2, in which the reactions of desmethyl diene **55a** and *gem*-dimethyl diene **57a** were compared. The desmethyl divinylcyclopropanes **55d**, **55e** and **55f** all underwent the Cope rearrangement readily at RT. In contrast the corresponding *gem*-dimethyl variants **57e** and **57f** did not undergo the Cope rearrangement, even at 130 °C and while **57d** was converted into **88a**, it required 17 h at 100 °C in order for the reaction to reach completion (Table 4, Entries 4, 5, 6, 10, 11, 12 & Scheme 56).

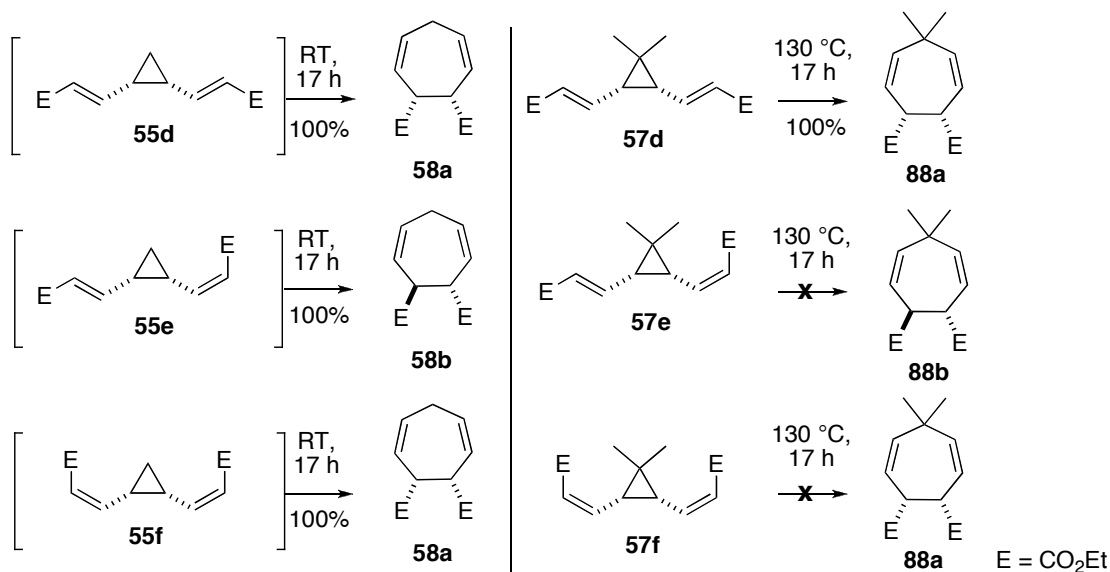

**Scheme 56** The contrasting Cope rearrangements of **55d**, **55e**, **55f**, **57d**, **57e** and **57f**.

iii) Divincyclopropanes with *E*-double bonds undergo the Cope rearrangement more readily than those with *Z*-double bonds.

The *gem*-dimethyl *cis*-divincyclopropane **57d** was fully converted into Cope product after 17 h at 100 °C. However, the *Z*-isomers **57e** and **57f** did not undergo the Cope rearrangement, even after 17 h at 130 °C (Table 4, Entries 10, 11, 12 & Scheme 57).

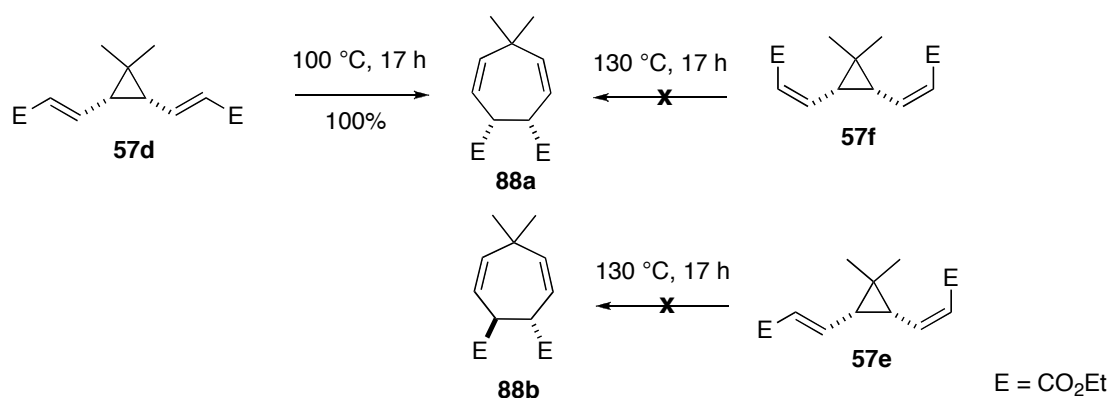

**Scheme 57** The contrasting Cope rearrangements of **57d**, **57e** and **57f**.

The same trend (albeit less pronounced) was also observed in the desmethyl series. The Cope rearrangements of **55a** and **55b** were complete after 17 h at 130 °C. By

contrast, only 80% conversion into Cope product **58a** was observed under the same conditions for **55c** (Table 4, Entries 1, 2, 3 & Scheme 58).

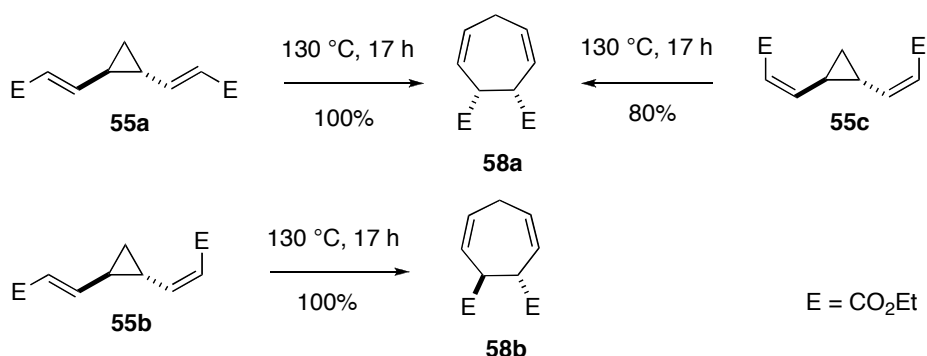

**Scheme 58** The contrasting Cope rearrangements of **55a**, **55b** and **55c**.

iv) There is an increased barrier to epimerisation between *trans* and *cis*-divinylcyclopropanes in the *gem*-dimethyl series.

This is without question the most surprising conclusion to be drawn from these studies. The *trans*-dimethyl substrates **57a**, **57b** or **57c** did not rearrange, even at 130 °C (Table 4, entries 7–9, Scheme 59) and, importantly, epimerisation to the corresponding *cis*-diesters was also not observed. The *cis*-*E,Z* and *cis*-*Z,Z*-substrates **57e** and **57f** also failed to react at 130 °C, with each remaining unchanged, again with no evidence of cyclopropane epimerisation (Table 4, entries 11–12). This suggests that the required transition state (Figure 8) is too high in energy for the Cope rearrangement to occur under the conditions screened, probably due to steric clashes, but also indicates that the *cis/trans*-epimerisation occurs less readily than in the non-methylated series of compounds. The *cis*-*E,E*-diester **57d** was significantly more reactive than either of compounds **57e** or **57f**; this substrate began to rearrange at temperatures as low as 40 °C and the rearrangement was complete after 17 h at 100 °C (Table 4, entry 10).

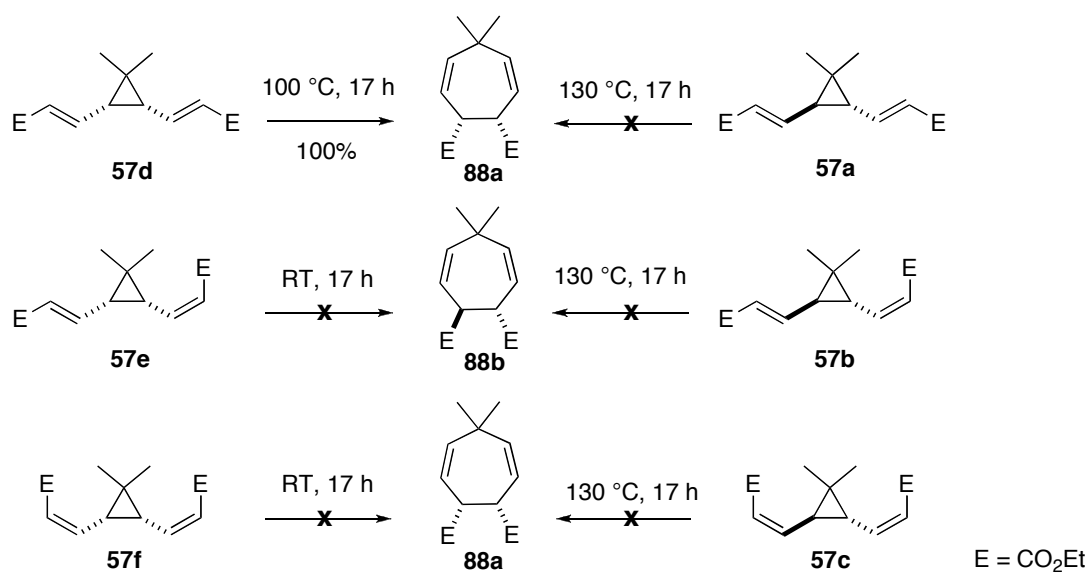

**Scheme 59** The contrasting Cope rearrangements of **57a**, **57b**, **57c**, **57d**, **57e** and **57f**.

This result sheds light on the reason why our original dimethyl *trans*-*E,E*-diester **57a** (Table 4, entry 7) failed to react; given that the Cope rearrangement of *cis*-*E,E*-diester **57d** (Table 4, entry 10) proceeded at temperatures as low as 40 °C, and that there was no evidence of any *cis/trans*-epimerisation in any of the diesters **57a–57f**, this suggests that the reaction of *trans*-*E,E* **57a** failed at the cyclopropane epimerisation stage, and not because of the high energy of the Cope rearrangement transition state as originally thought (Figure 8). In addition, the complete lack of *cis* to *trans*-epimerisation in any of the dimethyl substituted diesters **57a–57f** is in contrast to the unsubstituted diesters **55a–55c** (which must have epimerised otherwise their Cope rearrangements would not have taken place). Thus, we have shown that as well raising the energy of the Cope rearrangement transition state, *gem*-dimethyl substitution also retards the rate of cyclopropane epimerisation of the *trans*-cyclopropane substrates screened.

### 3.6 Examining substituent effects on the Cope Rearrangement of *Cis-Gem-Dimethyl Divinylcyclopropanes*

It is clear that *gem*-dimethyl substitution significantly retards the Cope rearrangements of divinylcyclopropanes. However, it appears that its effect on the *trans* to *cis*-isomerisation of the cyclopropane, and not its effect on the [3,3]-sigmatropic rearrangement itself, is the most significant barrier to reactivity. Pleasingly, from a synthetic viewpoint, the isomerisation problem is easily negated by starting from a *cis*-oriented divinylcyclopropane. To demonstrate this, we went on to synthesise a range of other *gem*-dimethyl-*cis-E,E*-functionalised cyclopropanes. Cyclopropane **154** was prepared using a tandem oxidation/Wittig reaction, followed by silyl cleavage using HF. Another tandem oxidation/Wittig reaction at RT afforded the *cis-E,E*-functionalised cyclopropane **154**.

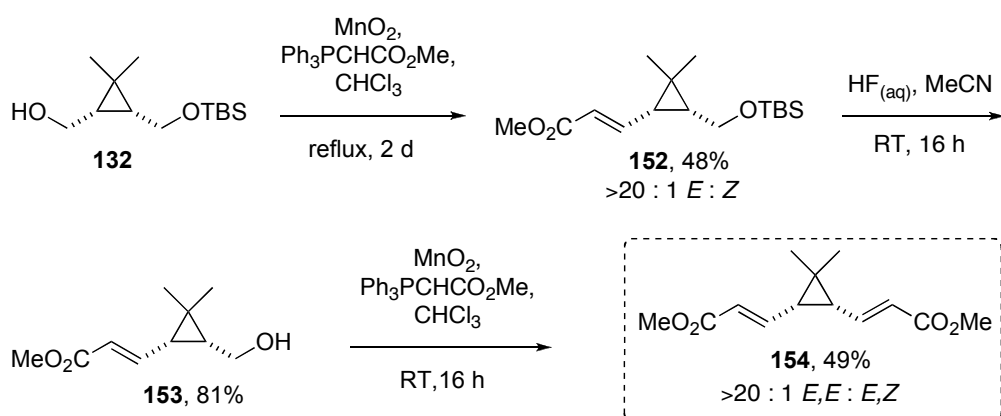

**Scheme 60** The synthesis of **154**.

The reduction of **154** using 2 equivalents of DIBAL gave a mixture of monoester **155** and diol **156**, which were easily separated by flash column chromatography.

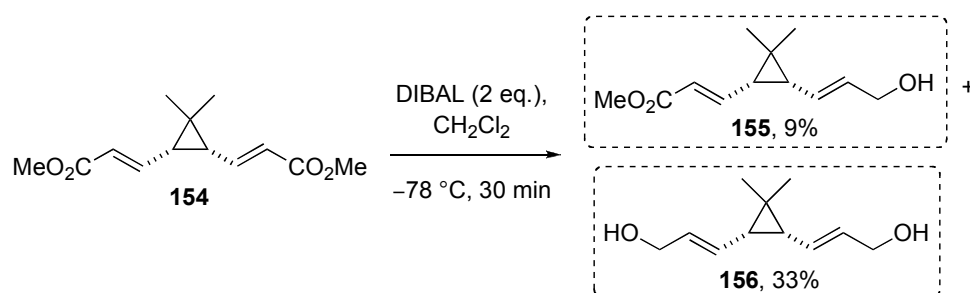

**Scheme 61** The synthesis of **155** and **156**.

TBS protection of diol **156** using 1.5 equivalent of TBSCl generated a mixture of TBS compounds **157** and **158**, which were easily separated by flash column chromatography.

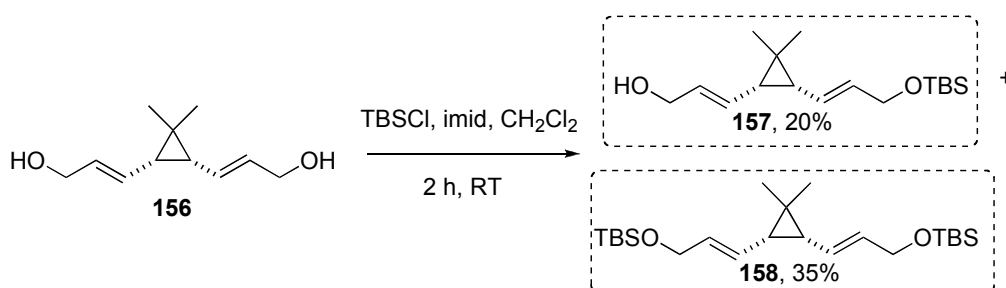

**Scheme 62** The synthesis of **157** and **158**.

Finally, the hydrolysis of diester **154** using NaOH in aq. THF (1:1) afforded cyclopropane **159**.

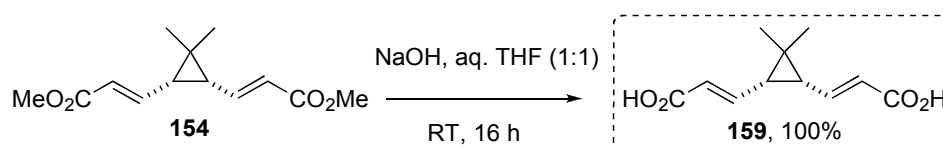

**Scheme 63** The synthesis of **159**.

We were pleased to find that all of these substrates **154–159** undergo the Cope rearrangement upon heating, generating 1,4-cycloheptadienes in high yields (78–97%, Table 5), with ester, alcohol, silyl ether and carboxylic acid substituents all being well tolerated. The rearrangements do not appear to be significantly affected by electronic effects, a point exemplified by the near-identical reactivity of the electron-deficient ester-substituted divinylcyclopropane **154** and the more electron-rich alcohol-substituted divinylcyclopropane **156** (entries 1 and 3, Table 5). Note that the product isolated from the Cope rearrangement of substrate **155** (entry 2, Table 5) was a lactone, presumably, formed *via* an intramolecular transesterification following the Cope rearrangement. The size of the substituents appears to be more significant; the addition of one **157** and then two **158** *tert*-butyldimethyl silyl groups to diol **156** led to a decrease in reactivity in each case (entries 4 and 5, Table 5). Diacid-substituted divinylcyclopropane **159** reacts more slowly still (entry 6, Table 5), but this reaction should not be compared directly to the other entries, as it was only sparingly soluble in the reaction solvent.



Entry	Reagent	Product	% Conversion			Isolated Yield <sup>a</sup> (%)
			Temperature (°C)	40	70	
1			30	100	100	83
2			0	100	100	84
3			30	90	100	83
4			30	70	100	86
5			0	30	100	88
6			0	10	100	97

<sup>a</sup>All reactions were carried out as 0.19 mol dm<sup>-3</sup> solutions in xylene. All reactions were carried out for 17 h. % Conversion was determined *via* analysis of the unpurified reaction mixtures. The isolated yields were obtained from the 100 °C experiments and include purification by column chromatography in each example except for diacid **165**.

**Table 5** The Cope rearrangement on test substrates **154–159**.

In conclusion, the rate-retarding effect of *gem*-dimethyl substitution on the Cope rearrangements of divinylcyclopanes has been demonstrated directly for the first time. An examination of the effects of alkene geometry and the relative stereochemistry of the cyclopropane have revealed that *gem*-dimethyl substitution significantly inhibits the *trans* to *cis*-isomerisation about the cyclopropyl ring, necessary for rearrangement to occur, relative to unsubstituted desmethyl analogues. Using the information accrued, a series of ideal substrates (*cis*-oriented on the cyclopropane with two *E*-alkenes) were synthesised and all underwent the desired

Cope rearrangement smoothly, affording a range of dimethylated substituted 1,4-cycloheptadienes in high yields. The findings of this study were recently published in *Organic and Biomolecular Chemistry*<sup>55</sup> (See Appendix for full paper).

Significantly, with respect to the synthesis of pyxidatol C, we showed that by preparing the *cis*-divinylcyclopropane **57d** we could access cycloheptadiene **88a**, the *gem*-dimethyl-pyxidatol C analogue of cycloheptadiene **58a** and therefore attention turned to completing its total synthesis (Chapter 4).

## Chapter 4

### Towards the Total Synthesis of Pyxidatol C

#### 4.1 Corey–Chaykovsky Strategy

A detailed study into the Cope rearrangements of *gem*-dimethyl divinylcyclopropanes revealed the importance of preparing a *cis*-divinylcyclopropane in the synthesis of *gem*-dimethyl substituted cycloheptadienes (Chapter 3). This led to the optimized synthesis of **88a**, an intermediate in the synthetic route towards pyxidatol C; the TOP reaction of **131** afforded **57d** in 68% yield, which was then converted into **88a** in 80% yield (Scheme 64). Toluene was used as the solvent in the Cope rearrangement of **57d**, in place of xylene, because it is easier to remove under *vacuo*. With the 7-membered ring component of the decahydro-1*H*-cyclopropa[*e*]azulene core structure of pyxidatol C in place attention turned to the installation of the cyclopropane moiety.

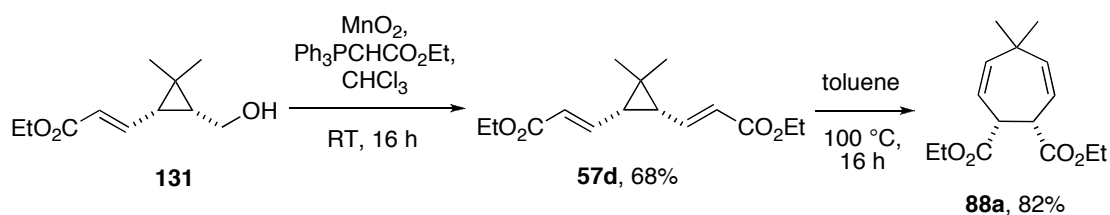

Scheme 64 Optimised synthesis of **88a**.

The general strategy devised for cyclopropanation was first to perform a partial reduction of diester **88a**, followed by alkene isomerisation and cyclopropanation (Scheme 65)

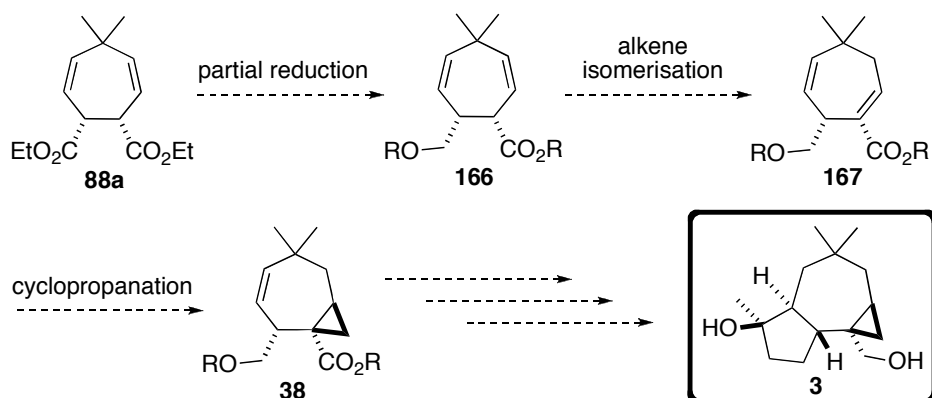

Scheme 65 General cyclopropanation strategy.

The Corey–Chaykovsky strategy trialled previously on the desmethyl model system was the first route to be tested on the *gem*-dimethyl system. LiAlH<sub>4</sub> reduction of **88a** was straightforward and was followed by TEMPO oxidation, affording lactone **161** (Scheme 66). The 69% yield for this step was reproducible, which was pleasing because on the desmethyl model system yields were inconsistent, ranging from 40–60% (Section 1.11).

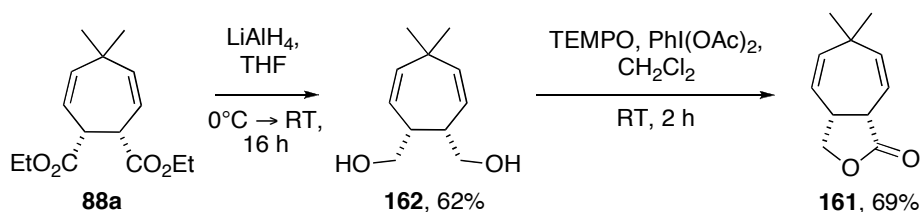

**Scheme 66** Synthesis of lactone **161**.

Unfortunately, base-promoted isomerisation of lactone **161** was harder to optimise than on the desmethyl model system. The initial conditions trialled (1 equivalent of DBU in THF at 0 °C for 1.5 h) resulted in the formation of a mixture of the desired lactone **168** and  $\alpha,\beta,\gamma,\delta$ -unsaturated lactone **169** in 71% overall yield in a ratio of 1:2.1 (Scheme 67).

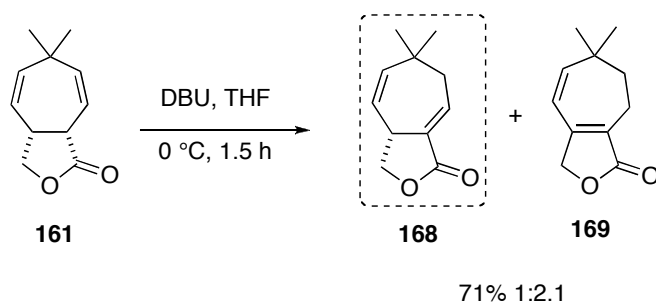

**Scheme 67** Initial conditions trialled for the isomerisation of lactone **168**.

In order to avoid isomerisation into  $\alpha,\beta,\gamma,\delta$ -unsaturated lactone **169**, the reaction time was reduced to 30 min affording  $\alpha,\beta$ -unsaturated lactone **168** in 30% yield, epimer **170** in 52% yield and starting material **161** in 7% yield. Epimer **170** could in turn be converted into the desired lactone **168** in 39% yield, thus allowing reproducible quantities of the target compound **168** to be obtained (Scheme 68).

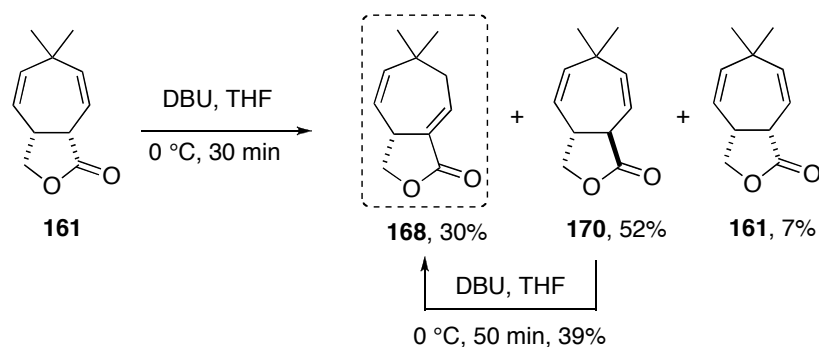

**Scheme 68** Optimised conditions for the synthesis of lactone **168**.

The Corey–Chaykovsky cyclopropanation of **168** was next attempted using trimethylsulfoxonium iodide (Corey’s salt) and sodium hydride in DMF. Pleasingly the desired cyclopropane **171** was formed as a single diastereomer (Scheme 69) with the relative stereochemistry shown to be that required for pyxidatol C by an n.O.e experiment (an n.O.e enhancement between the cyclopropane  $\text{CH}_2$  and the  $\text{CHCH}_2\text{O}$  protons was observed, whereas no n.O.e enhancement was observed for the lactone  $\text{CH}_2$  protons with the cyclopropane  $\text{CH}_2$ ). Unfortunately the yield was low, ranging from 5–20% using sodium hydride as the base in DMF. The solvent was changed to DMSO and cyclopropane **171** was formed in 11% yield. Using MTBD as the base in acetonitrile, cyclopropane **171** was formed in only 8% yield. The low yields were particularly disappointing given that the  $^1\text{H}$  NMR spectra of the unpurified reaction mixtures were clean and contained no evidence of either starting materials or side products. The fate of the rest of the material remains unclear; efforts were made to examine the contents of the aqueous extracts but no tractable material was found. This is the same problem that we observed using the analogous desmethyl lactone **61** (See Chapter 2.1).

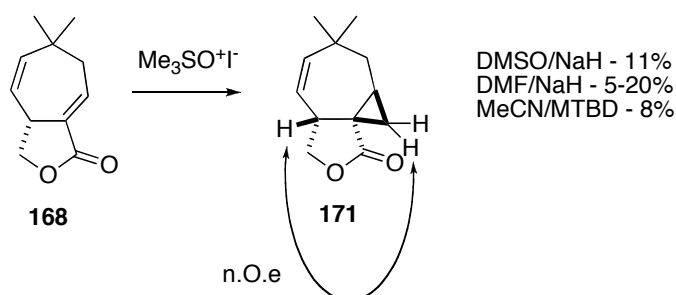

**Scheme 69** Synthesis of cyclopropane **171**

## 4.2 Installing the Side-Chain

Despite the disappointing yields for the cyclopropanation leading to compound **171**, we were able to continue the synthesis, with the aim of installing the methyl ketone side chain. We planned to install the side chain *via* reduction of lactone **171** to diol **172**, conversion of the less hindered alcohol into a leaving group, followed by alkylation (Scheme 70). This alkylation strategy had previously been tested on a cyclohexyl model system (Section 2.1).

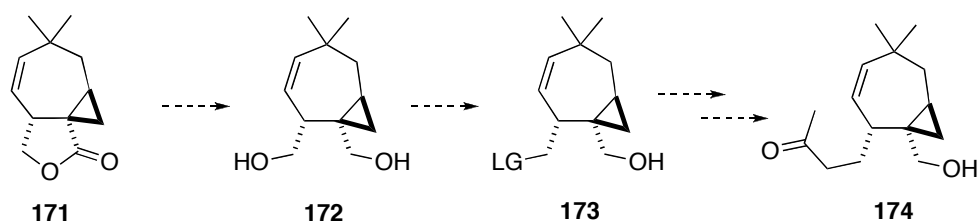

**Scheme 70** Installing the side chain to lactone **171**.

The reduction of lactone **171** with DIBAL was straightforward, affording diol **172**. Unfortunately, the attempted iodination of **172** was unsuccessful affording a complex mixture of products (Scheme 71). The major component of this mixture was tentatively assigned as cyclic ether **176** based on peaks at 5.22–5.20 (2H, m, H-4 & H-5), 4.03 (1H, dd,  $J$  11.5, 1.5 Hz, H-1a), 3.76 (2H, d,  $J$  7.0 Hz, H-2), 2.96 (1H, dd,  $J$  11.5, 1.0 Hz, H-1b) and 2.41 (1H, t,  $J$  7.0 Hz, H-3) in the  $^1\text{H}$  NMR spectrum of the unpurified reaction mixture, which are similar to those in a related compound **209** (see later, Section 4.4). Attempts to tosylate and mesylate diol **172** were also unsuccessful with clean starting material recovered in both cases. Cyclic ether formation may well have followed had the mesylation and tosylation been successful; therefore an alternative approach was sought.

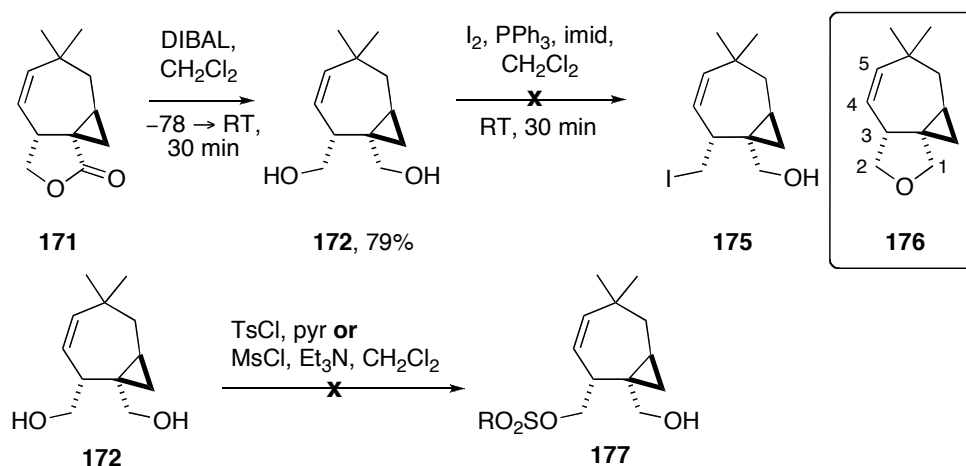

**Scheme 71** Synthesis of diol **172** and attempts to install a leaving group. The numbering of **176** is for characterisation purposes only and does not conform to IUPAC rules.

A lactone ring-opening strategy was tested as an alternative way of installing the leaving group, based on work by Olah *et al.* who reported the use of sodium iodide and methyltrichlorosilane to cleave a range of esters and lactones in good yield (Scheme 72).<sup>56</sup>

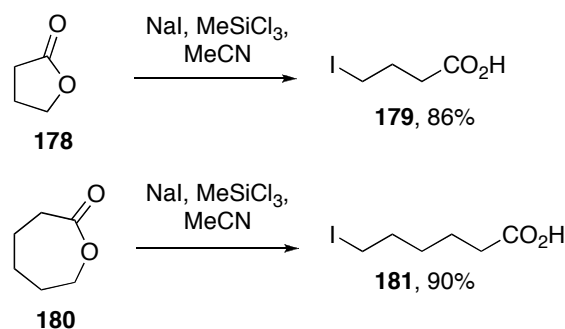

**Scheme 72** Studies by Olah *et al.*<sup>56</sup> into the dealkylative cleavage of esters and lactones using trichloromethylsilane and sodium iodide.

This strategy had the advantage of affording a carboxylic acid (rather than an alcohol) containing iodide, thus negating the undesired THF formation. Unfortunately attempts to cleave lactone **161**,  $\alpha,\beta$ -unsaturated lactone **168** and cyclopropyl lactone **171** using trichloromethylsilane and sodium iodide were all unsuccessful (Scheme 73) and clean starting material was recovered in each case. A related ring-opening strategy using thionyl bromide was also examined,<sup>57</sup> but again clean starting material was recovered when tested on lactones **168** and **171**. The reaction with lactone **161** formed the *trans*-epimer **170**, although there was evidence of trace formation of product **185** by mass

spectrometry [ $m/z$  (ESI):  $[MH^+]$   $C_{12}H_{18}^{79}BrO_2$ , 273.0503 and  $C_{12}H_{18}^{81}BrO_2$ , 275.0482]. Efforts were made to promote the ring-opening of lactone **161** by increasing the reaction time from 1 to 3 days and by heating to reflux instead of stirring at RT, but in each case only trace product formation was observed.

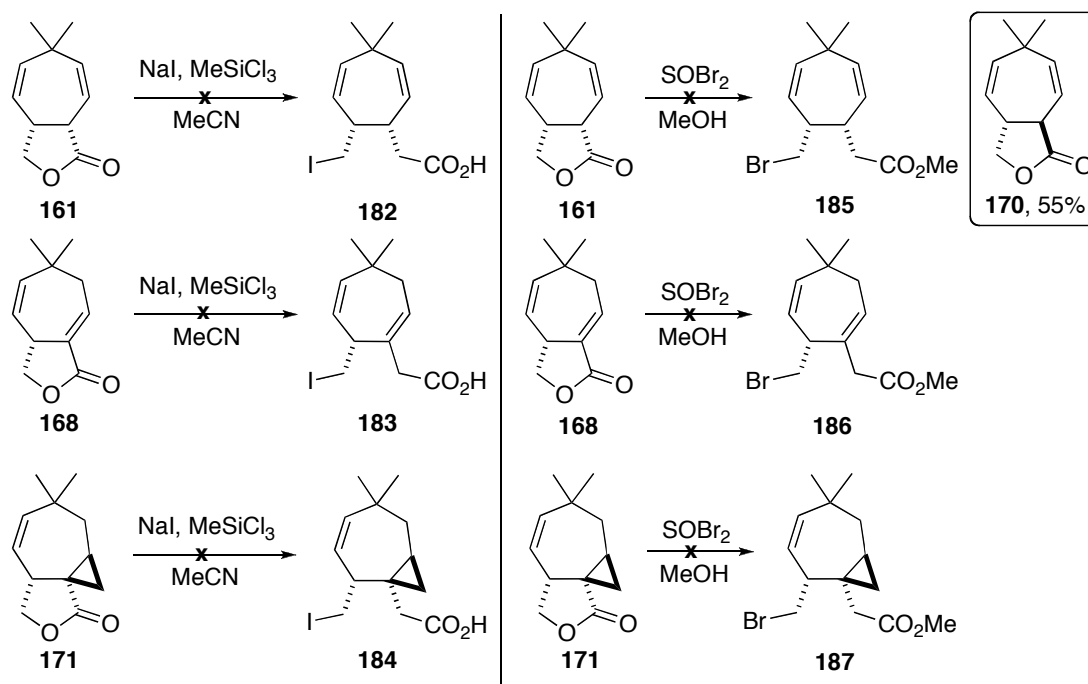

**Scheme 73** A ring-opening strategy to introduce a leaving group.

#### 4.3 Simmons–Smith Strategy

As an alternative to the Corey–Chaykovsky cyclopropanation, a Simmons–Smith strategy, previously tested on the desmethyl model system, was examined. The required substrate was formed easily *via* the mono-TBS protection of diol **162**, oxidation to generate aldehyde **188** using DMP, DBU-promoted isomerisation to  $\alpha,\beta$ -unsaturated aldehyde **189** and sodium borohydride reduction, furnishing alcohol **190** in a 62% yield over the four steps (Scheme 74).



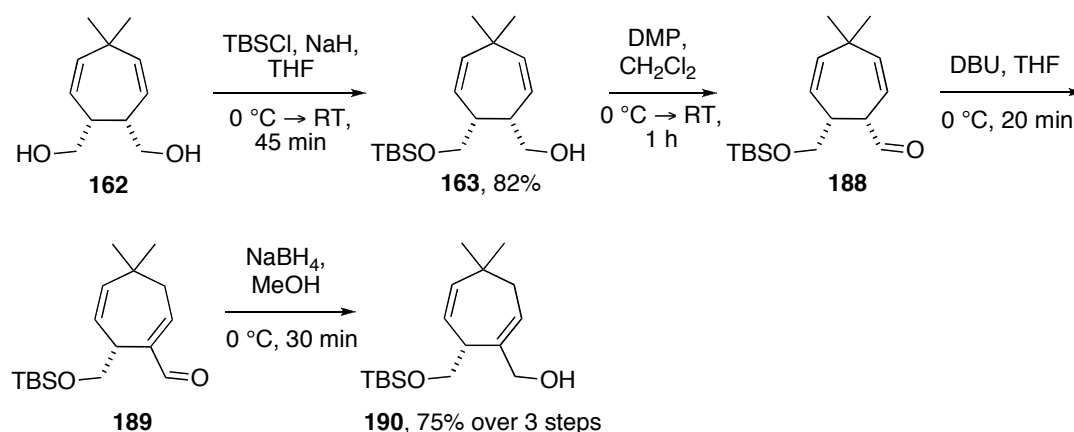

**Scheme 74** Synthesis of alcohol **190**.

As anticipated, the regioselectivity of the Simmons–Smith cyclopropanation was greater for the *gem*-dimethyl system relative to that of the desmethyl model system alcohol **79** (it was reasoned that the steric bulk of the cycloheptadiene dimethyl groups would hinder cyclopropanation on the unfunctionalised alkene, Section 2.2). Optimal conditions were found to be 4 equivalents of diiodomethane and 2 equivalents of diethylzinc in  $\text{CH}_2\text{Cl}_2$  at  $0\text{ }^\circ\text{C}$  for 40 min. This resulted in the synthesis of cyclopropane **191** in 32% yield and cyclopropane **192** in 27% yield, although trace impurities were evident in the  $^1\text{H}$  NMR spectrum of **191** and were attributed to the bis-cyclopropane **193** (supported by mass spectrometry [ $m/z$  (ESI):  $[\text{MNa}^+]$   $\text{C}_{19}\text{H}_{36}\text{NaO}_2\text{Si}$ , 347.2362]). The relative stereochemistry of cyclopropanes **191** and **192** was determined by TBS cleavage of cyclopropane **192** using TBAF to give diol **194**. The stereochemistry of diol **194** was confirmed by comparison with data for compound **172**, which was prepared *via* the Corey–Chaykovsky route (Scheme 69).

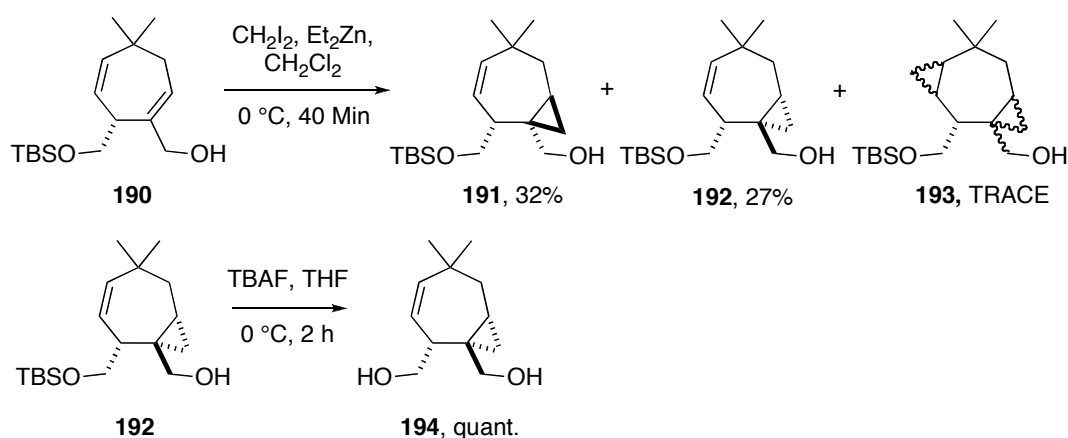

**Scheme 75** Simmons–Smith cyclopropanation of alcohol **190**.

#### 4.4 Installing the Side-Chain; The Cyclic Ether Phenomenon

Before installing the side chain, it was decided to protect the alcohol of **191** with a protecting group orthogonal to the TBS ether. It was hoped that this would allow cleavage of the TBS group followed by iodination without resulting in the unwanted formation of cyclic ether **176**. Unfortunately efforts to protect the alcohol as its benzyl ether were unsuccessful (Scheme 76); starting material **191** was recovered when benzyl bromide and NaH were used and decomposition was observed using the Dudley reagent.<sup>58</sup> Attempts to prepare the PMB ether **196**, TIPS ether **197** and methyl ether **198** were also all unsuccessful, with starting material **191** recovered in each case.

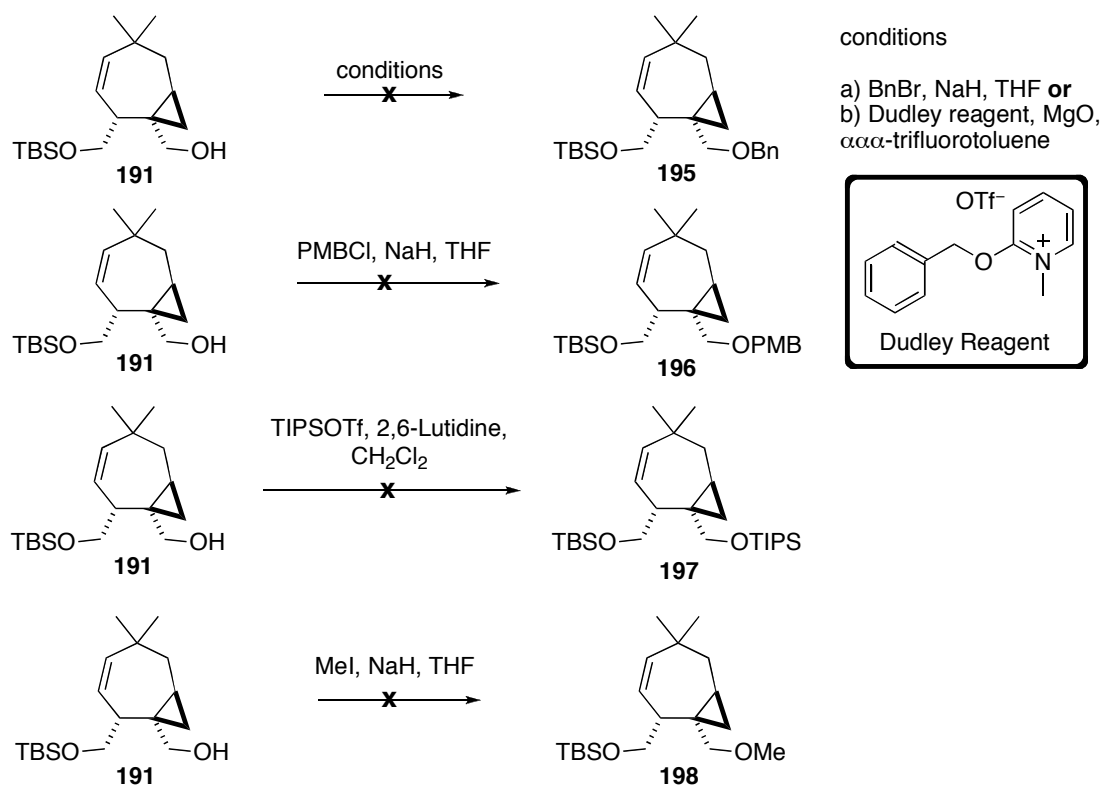

Scheme 76 Attempts to protect alcohol **191**.

It was concluded that the alcohol must be extremely sterically hindered (it is neopentyl). A new strategy of installing the side chain before carrying out the cyclopropanation was thus planned, so that protecting group manipulations could be carried out *before* the bulky cyclopropane was in place. Following protecting group

manipulations, we hoped to install the methyl ketone side chain to generate intermediate **201** (Scheme 77).

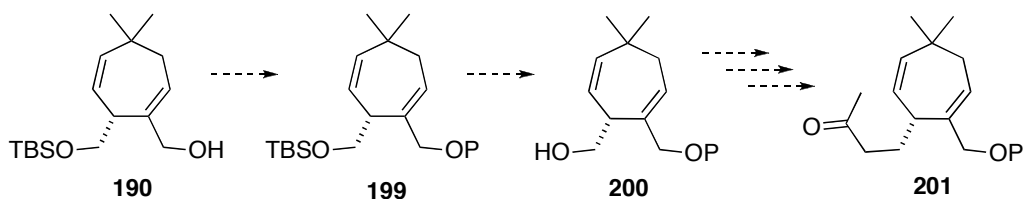

**Scheme 77** Synthetic strategy to install the side chain before attempting the cyclopropanation.

TIPS protection of TBS alcohol **190** was facile and TIPS containing compound **202** was obtained in 66% yield, corroborating our theory that the cyclopropane in **191** was a steric encumbrance to the alcohol protection on that system. However, we were unable to selectively cleave the TBS ether of **202**, and always observed the formation of a mixture of products (starting material was observed in the  $^1\text{H}$  NMR spectra of the unpurified reaction mixture and although clean material could not be isolated, HRMS indicated the presence of the corresponding diol in the unpurified reaction mixture).

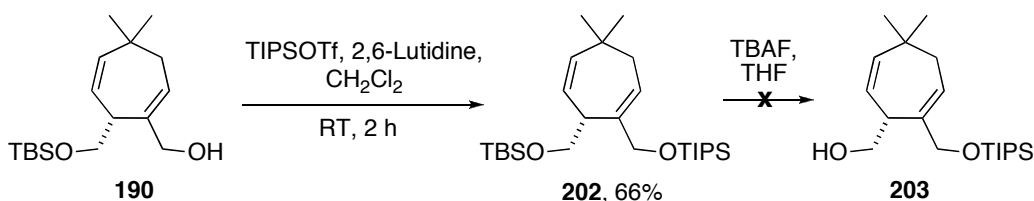

**Scheme 78** Attempt to selectively mono-deprotect TBS compound **202**.

We were also able to acetylate alcohol **190**, forming acetate **204** in quantitative yield. Unfortunately, during cleavage of the TBS group of **204** with TBAF, acetate migration between the two alcohol groups was observed, resulting in the formation of an inseparable mixture of mono-acetate compounds **205** and **206** in a 1:0.8 ratio, based on HRMS data [ $m/z$  (ESI): [ $\text{MNa}^+$ ]  $\text{C}_{13}\text{H}_{20}\text{NaO}_3$ , 247.1310] and the presence of two acetate methyl groups at 2.23 ppm and 2.38 ppm in the unpurified reaction mixture.

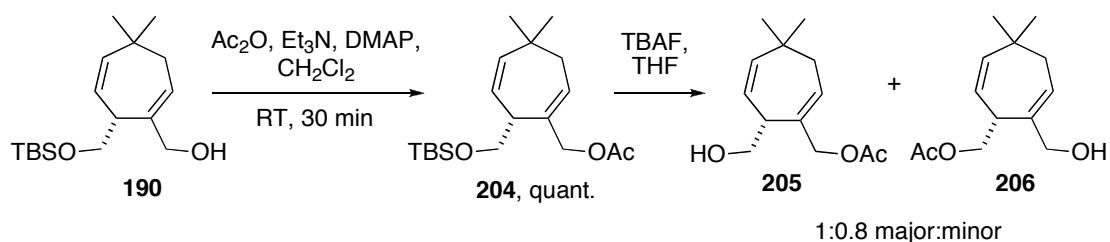

**Scheme 79** Attempt to selectively mono-deprotect TBS compound **204**.

In view of the various problems encountered during efforts to install orthogonal protecting groups, another change in the order of steps was planned. This involved the iodination of the alcohol of **163**, and the installation of the methyl ketone side chain before isomerisation of the alkene and cyclopropanation.

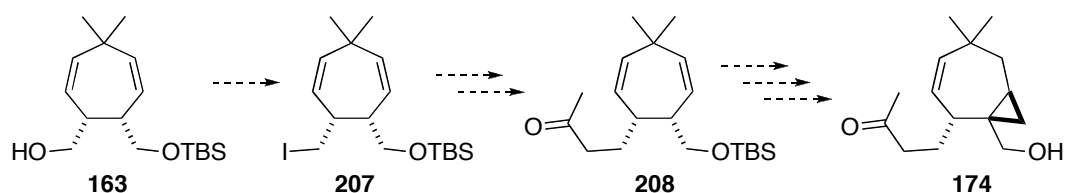

**Scheme 80** Synthetic strategy to install the side chain before isomerisation of the alkene.

Unfortunately the iodination of alcohol **163** did not go to plan. Surprisingly, the formation of the bis-TBS compound **164** and cyclic ether **209** were observed when alcohol **163** was treated with iodine, triphenylphosphine and imidazole (Scheme 81). The most likely explanation for this reactivity is that following iodination of the free alcohol, intramolecular nucleophilic attack from the oxygen of the TBS ether takes place generating an oxycation reactive intermediate, which can react with another molecule of alcohol **163** to form both the cyclic ether **209** and bis-TBS compound **164** (Scheme 81).

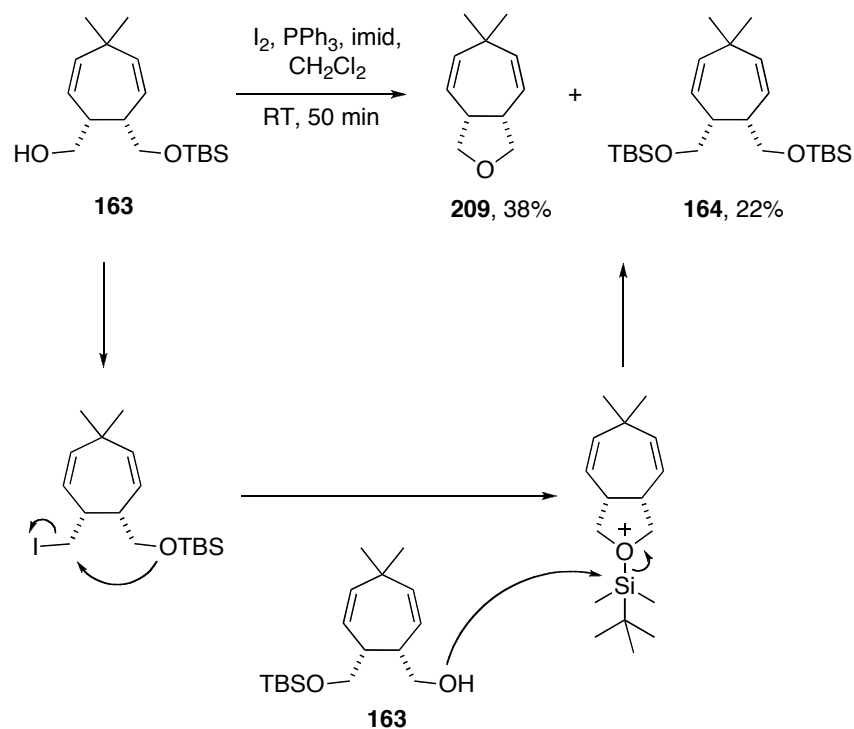

**Scheme 81** Attempted iodination of alcohol **163**.

The mono-protection of diol **162** with the bulkier, more stable silyl protecting group TBDPS was therefore considered. Mono-TBDPS protection of diol **162** furnished **210** in 95% yield, but under the same iodination conditions cyclic ether **209** and the bis-TBDPS compound **211** were again formed (Cyclic ether **209** was seen in the  $^1\text{H}$  NMR spectrum of the unpurified reaction mixture and the formation of **211** was inferred by HRMS).

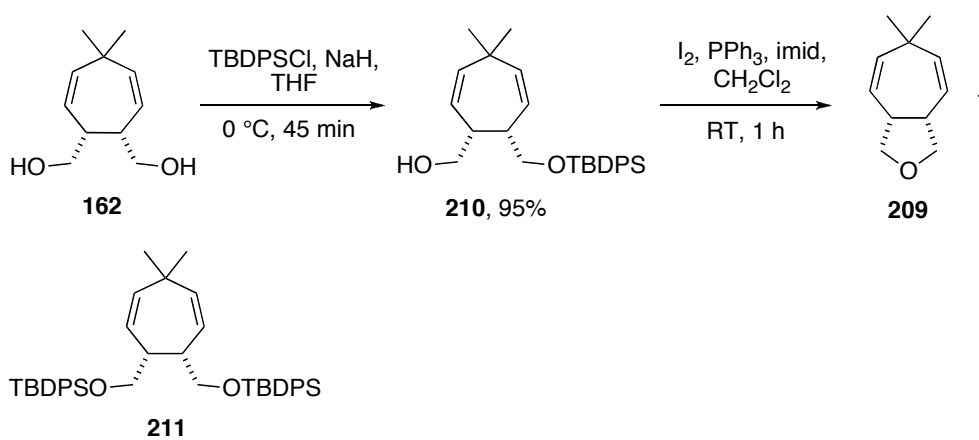

**Scheme 82** Mono-TBDPS protection of diol **162** and attempted iodination of alcohol **210**.

The mesylation of alcohol **210** was considered as an alternative to iodination. Pleasingly, mesylation was achieved in 83% yield using standard conditions but the subsequent alkylation with *t*-butyl acetoacetate and NaH in THF was unsuccessful and only starting material was recovered from the reaction after 16 h at reflux (Scheme 83).

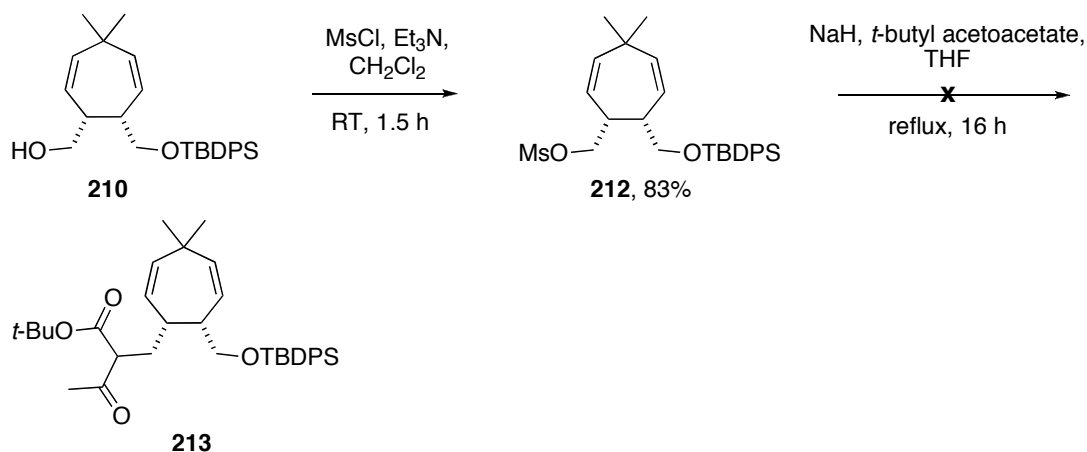

**Scheme 83** Mesylation and triflation approach to installing the sidechain.

A Finkelstein reaction<sup>59</sup> was therefore performed on mesylate **212** in an attempt to introduce the more reactive iodo-leaving group to facilitate the difficult alkylation. The desired iodide **214** is likely to have formed smoothly but unfortunately, only cyclic ether **209** was seen in the unpurified reaction mixture. Triflation of alcohol **210** was also attempted and once again the cyclic ether **209** was the only product seen in the unpurified reaction mixture.

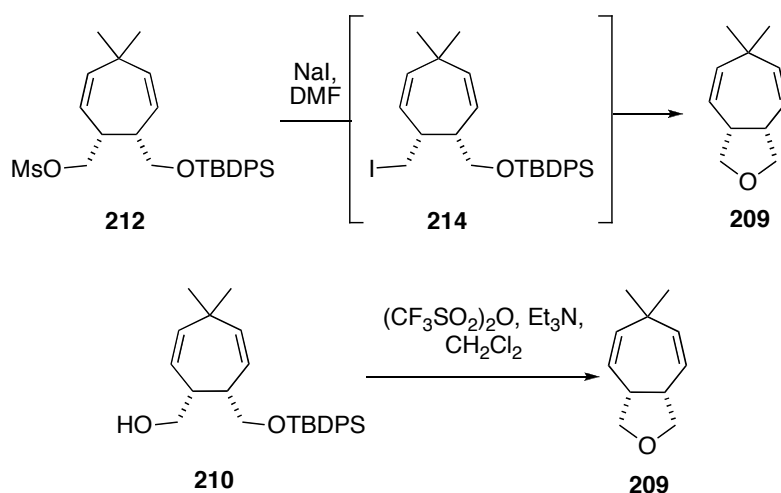

**Scheme 84** A Finkelstein and triflation approach to installing the sidechain.

In an effort to avoid cyclic ether formation during iodination, a PMB protecting group was considered. It was hoped that the PMB group would be more stable under the iodination reaction conditions than the TBS and TBDPS groups previously tested. Mono-protection of diol **162** as its PMB ether *via* the reduction of **215** was planned. Surprisingly under the acidic conditions necessary to prepare acetal **215**, cyclic ether **209** was formed again, presumably *via* an intramolecular S<sub>N</sub>2 reaction with loss of water. This result is particularly surprising given that H<sub>2</sub>O rarely acts as a leaving group in S<sub>N</sub>2 type processes. Mono-PMB ether **216** was therefore prepared using PMBCl and NaH in THF. Disappointingly (as judged by the analysis of the <sup>1</sup>H NMR spectrum of the unpurified reaction mixture) the attempted iodination of alcohol **162** led yet again to the predominant formation of cyclic ether **209**.

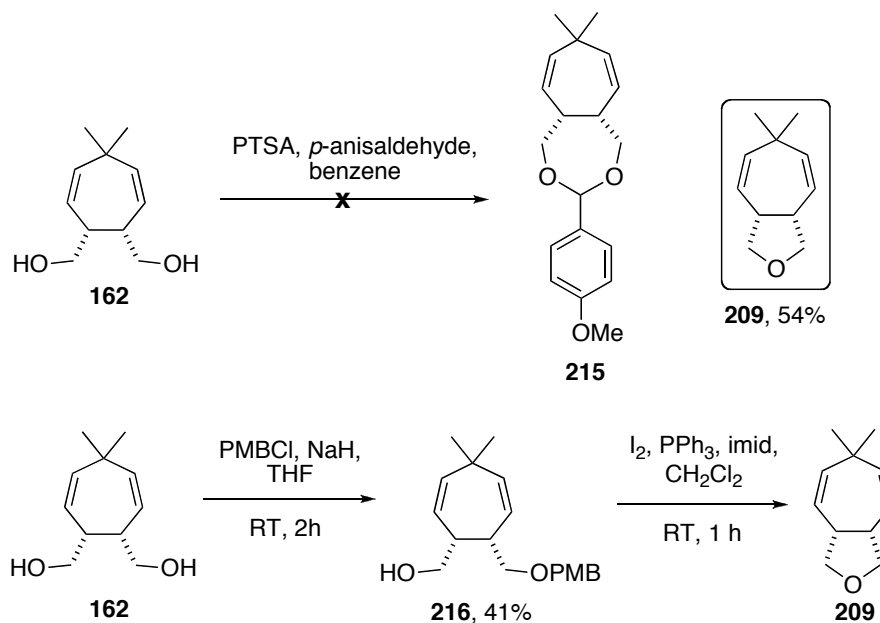

**Scheme 85** Mono-PMB protection of diol **162** and attempted iodination of alcohol **216**.

Given the previously described unwanted cyclic ether formations, this approach was abandoned. It was concluded that the alcohol groups are too prone to undergo THF formation for this strategy to succeed. It was surprising that the cyclic ether forms so readily such that the protecting groups, even PMB, are displaced. Given these setbacks the Wittig reaction, previously tested on the desmethyl system (Section 2.1) was re-examined.

During previous studies on the desmethyl model system, a Wittig reaction on lactol **67** was unsuccessful (Section 2.1, Scheme 16). However, we planned to investigate

the Wittig reaction using the *gem*-dimethyl aldehyde **217** (Scheme 86). Aldehyde **217** was prepared from alcohol **210** using DMP, in an 80% yield. Unfortunately, the Wittig reaction using 1-(triphenylphosphoranylidene)acetone in CH<sub>2</sub>Cl<sub>2</sub> at RT led to decomposition.

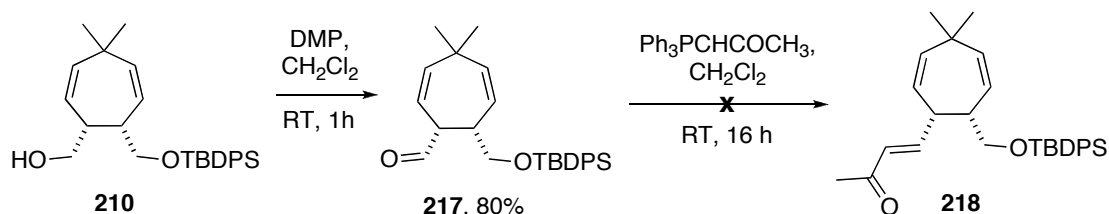

**Scheme 86** A Wittig approach to installing the side chain using aldehyde **217**.

#### 4.5 Installing the Side-Chain Before the Cope Rearrangement

As outlined in Section 4.4, many difficulties were encountered when attempting to install the methyl ketone side chain on the cycloheptadiene system. This led to another re-ordering of the synthetic strategy and the installation of the methyl ketone side chain before the Cope rearrangement was considered. By carrying out the Cope rearrangement of **219**, cycloheptadiene **220** could be prepared with the side chain already in place (Scheme 87).

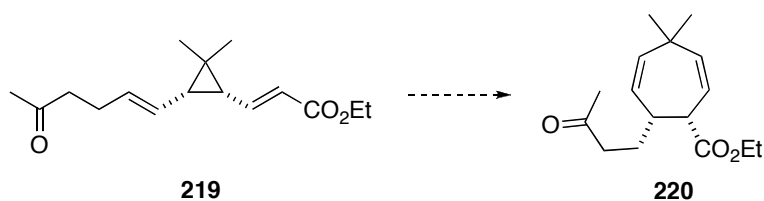

**Scheme 87** The Cope rearrangement of **219**.

The alkylation strategy tested on the cyclohexyl model system (Section 2.1) was trialled on divinylcyclopropyl alcohol **221**. DIBAL reduction of ester **133** furnished the requisite alcohol **221**, necessary to apply this halogenation, alkylation strategy (Scheme 88). Unfortunately attempts to iodinate, using iodine, triphenylphosphine and imidazole were unsuccessful, leading to decomposition. Bromination using carbon tetrabromide and triphenylphosphine also led to decomposition. Therefore an alternative approach towards the installation of the side chain was tested using alcohol **221**.



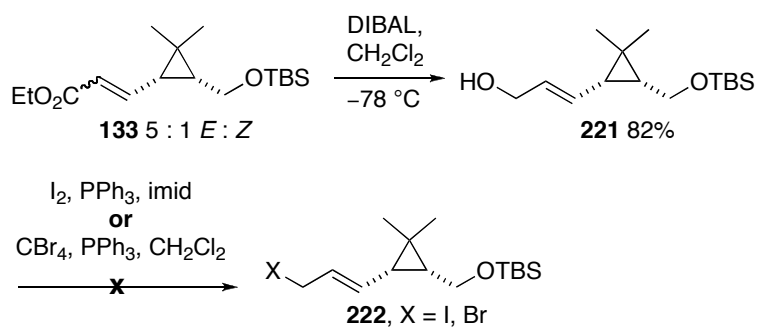

**Scheme 88** The attempted halogenation of alcohol **221**.

An alternative strategy for the introduction of the methyl ketone side chain was tested using Tsuji–Trost<sup>60,61</sup> chemistry (Scheme 89). Carbonate **223** was prepared from alcohol **221** using ethyl chloroformate, DMAP and pyridine. Carbonate **223** was then used without purification in the key Tsuji-Trost step. The reaction of carbonate **223** with tetrakis(triphenylphosphine)palladium(0) and *tert*-butyl 3-oxobutanoate afforded  $\beta$ -ketoester **224** in an excellent 92% yield over the two steps. Silyl cleavage was straightforward and furnished alcohol **225**, a potential substrate for a Taylor group TOP reaction. Disappointingly, this TOP reaction was unsuccessful and clean starting material was recovered from the reaction.

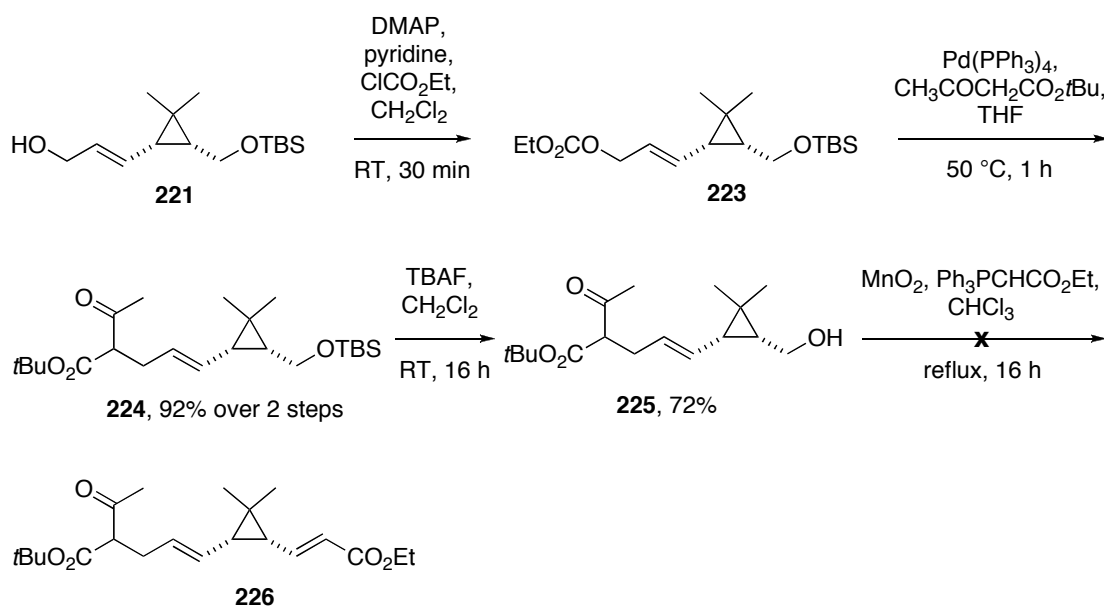

**Scheme 89** The Tsuji–Trost reaction of carbonate **223** and the attempted TOP reaction of alcohol **225**.

The oxidation, Wittig sequence was therefore completed in a step-wise manner. The  $\text{MnO}_2$  oxidation of **225** was unsuccessful and once again clean starting material was recovered from the reaction (Scheme 90). Pleasingly, Dess–Martin oxidation generated aldehyde **227** (Scheme 91) which was used without purification in the Wittig reaction with (carbethoxymethylene)triphenylphosphorane affording divinylcyclopropane **226** in 72% yield over two steps.

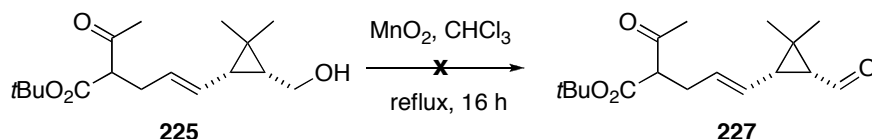

**Scheme 91** The unsuccessful  $\text{MnO}_2$  oxidation of alcohol **225**.

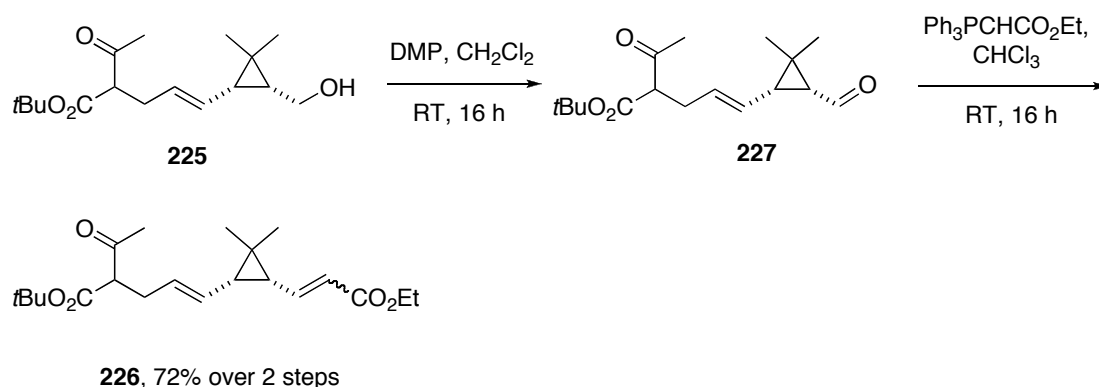

**Scheme 92** The step-wise Dess-Martin oxidation and Wittig reaction.

The decarboxylation of *t*-butyl ester **226** to furnish the desired divinylcyclopropane **219**, a substrate for the Cope rearrangement, was next planned (Scheme 92). However, attempts to promote decarboxylation of  $\beta$ -ketoester **226** using PTSA in benzene were unsuccessful, leading to decomposition of the material and when **226** was stirred in TFA, only traces of ketone **219** were evident by HRMS. The Cope rearrangement of  $\beta$ -ketoester **226** was therefore tested. This substrate was not considered ideal for the Cope rearrangement given its relatively high steric bulk but pleasingly the rearrangement was successful affording cycloheptadiene **228**. From here, decarboxylation of the  $\beta$ -ketoester using TFA was straightforward thus affording the key advanced cycloheptadiene intermediate **220** with the methyl ketone side chain already in place.

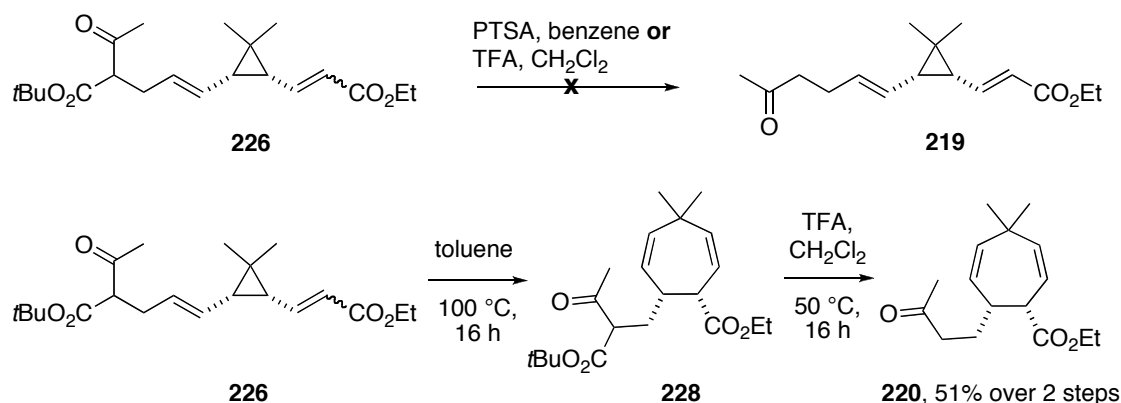

**Scheme 92** The Cope rearrangement of **226**.

With cycloheptadiene **220** in hand and the methyl ketone side chain in place, cyclopropanation and a ketone-olefin coupling reaction would complete the synthesis of the decahydro-1*H*-cyclopropa[*e*]azulene core structure common to the africananes.

The cyclopropane moiety has been successfully installed on related systems using both Corey–Chaykovsky chemistry and Simmons–Smith chemistry (Section 4.1 and Section 4.3). These established cyclopropanation conditions were next trialled on the more advanced cycloheptadiene intermediate **220**. Base-promoted isomerisation of the alkene of **220** into conjugation with the ethyl ester afforded the  $\alpha,\beta$ -unsaturated ester **229**, substrate for the Corey–Chaykovsky cyclopropanation (Scheme 93). Unfortunately cyclopropanation was unsuccessful using both the NaH/DMF conditions and MTBD/MeCN conditions; a complex mixture of decomposition products was observed in each case.

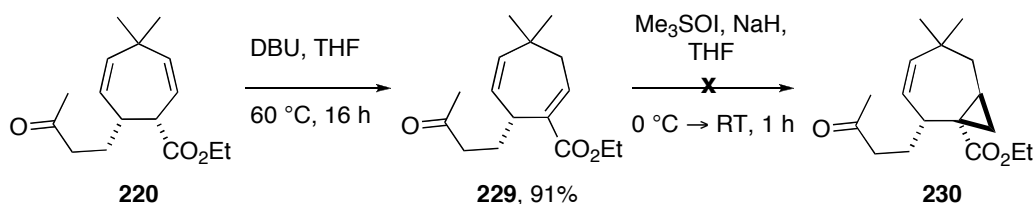

**Scheme 93** The DBU promoted isomerisation of **220**, and the failed Corey–Chaykovsky cyclopropanation of **229**.

It was considered possible that the free ketone in ester **229** was interfering with the reaction and as such, protection of the ketone as ketal **231** was attempted. Ketone **229**

was heated at reflux in toluene/ethylene glycol/PTSA under Dean–Stark conditions for 16 h, (Scheme 94) but unfortunately unreacted starting material was recovered from the reaction. As such, attention turned towards Simmons–Smith cyclopropanation chemistry.

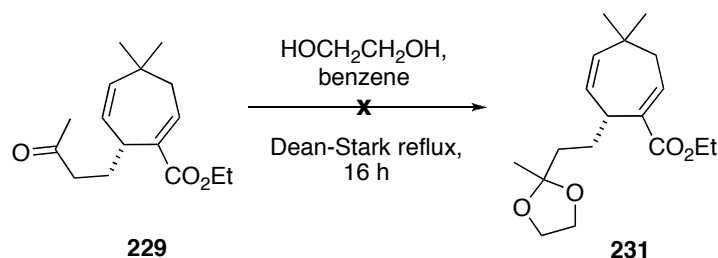

**Scheme 94** The unsuccessful ketal protection of ketone **229**.

DIBAL reduction of  $\alpha,\beta$ -unsaturated ester **229** afforded diol **232**, substrate for the Simmons–Smith cyclopropanation. However clean starting material was recovered from the reaction of allylic alcohol **232** with diethylzinc and diiodomethane.

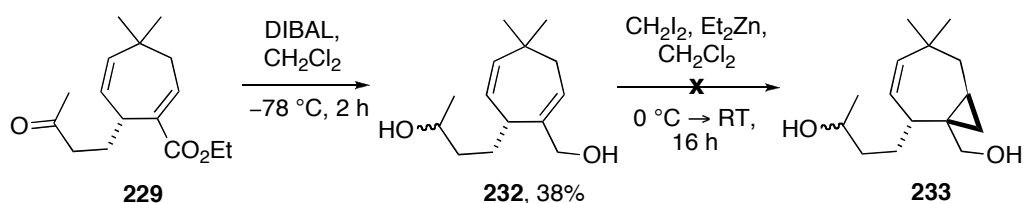

**Scheme 95** DIBAL reduction of **229** afforded diol **232** as predominantly a single diastereomer 10:1. The major diastereomer was isolated by flash column chromatography.

There is literature precedent for the high yielding and stereoselective Simmons–Smith cyclopropanation in the final step of the synthesis of other africananes.<sup>6,18</sup> Therefore, given the difficulties with cyclopropanation on this system, it was decided that preparing the 5 membered ring before cyclopropanation would be tested. The synthetic strategy for installation of the 5 membered ring was *via* a samarium diiodide ketone-olefin ring closing reaction.

## 4.6 Samarium Diiodide Ketone-Olefin Ring Closing Reaction

### 4.6.1 Background

The samarium diiodide mediated ketone-olefin coupling reaction of **220** into **234** was planned (Scheme 96). This type of coupling reaction has been shown to proceed *via* single electron reduction of the ketone to give a ketyl anionic radical followed by addition into the olefin, subsequent single electron reduction and protonation (Scheme 96).<sup>62</sup>

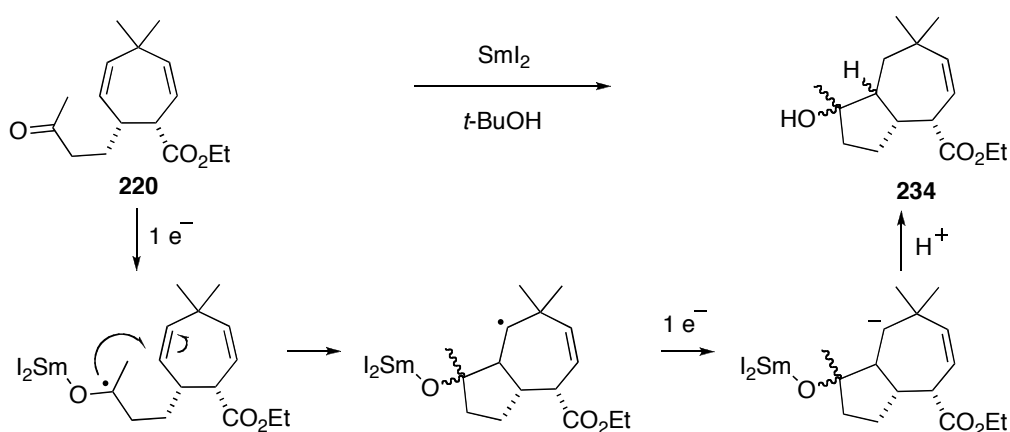

**Scheme 96** Mechanism for the  $\text{SmI}_2$  mediated ketone-olefin coupling reaction.

As such, 4 diastereomers of alcohol **234** are possible and it was expected, based on precedent for similar transformations, that the required *trans*-5/7 ring system with a *trans*-relationship between the relatively bulky methyl group (*cf.* the OH) and the 7 membered ring would predominate.<sup>62</sup> The four possible diastereomers are shown in Scheme 97 with the desired diastereomer **234a** boxed.

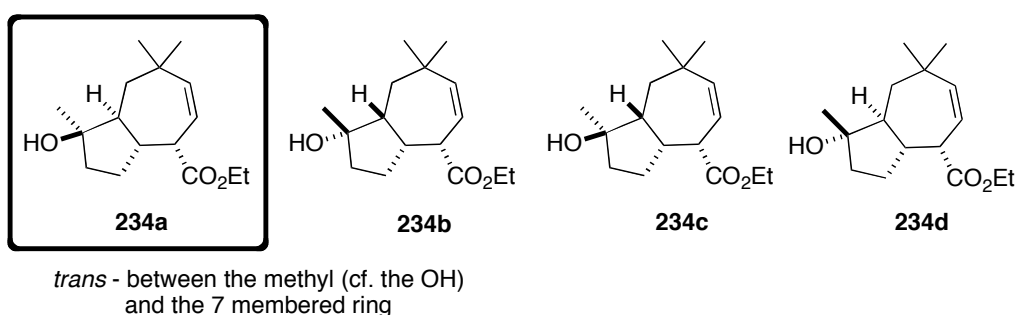

**Scheme 97** The 4 possible diastereomers from the ketone-olefin ring closing reaction with the desired diastereomer boxed.

#### 4.6.2 Preparing Samarium Diiodide

A solution of SmI<sub>2</sub> in THF was required to test this chemistry. Samarium diiodide is notoriously difficult to prepare and this proved to be the case in our hands. Fortunately, after several failed attempts at its preparation, a 2012 paper by Proctor *et al.* provided an answer. It describes how the major factor preventing the successful formation of SmI<sub>2</sub> is an oxide layer on the samarium metal.<sup>63</sup> By dry-stirring the samarium metal overnight under inert atmosphere the samarium is activated and the preparation of SmI<sub>2</sub> becomes straightforward using standard conditions.<sup>63</sup>

#### 4.6.3 Results

Clean starting material was recovered from the reaction of **220** with SmI<sub>2</sub> and *t*-BuOH in THF. This result was not entirely unexpected as the vast majority of literature SmI<sub>2</sub> ketone-olefin coupling reactions use HMPA as an additive.<sup>62,64-67</sup> Addition of HMPA to a solution of SmI<sub>2</sub> in THF enhances the reduction potential of SmI<sub>2</sub> by coordinating to the samarium metal center, producing the more powerful reductant [Sm(HMPA)<sub>6</sub>]<sup>2+</sup>2I<sup>-</sup>.<sup>68</sup>

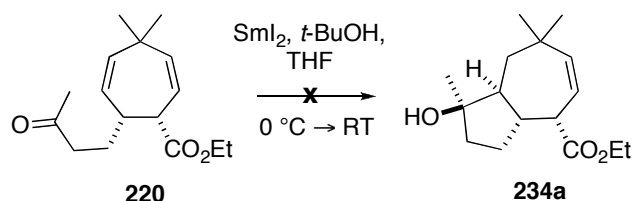

**Scheme 98** The SmI<sub>2</sub> ketone-olefin cyclisation of **220** without HMPA.

The reaction of **220** with SmI<sub>2</sub>, HMPA and *t*-BuOH was attempted, but this led to the formation of unknown compound **235**. Mass spectrometry suggests this compound is based on two molecules of the starting material (an unsymmetrical dimer) [*m/z* (ESI): [MNa<sup>+</sup>] C<sub>32</sub>H<sub>50</sub>NaO<sub>6</sub>, 553.3455], the IR shows a broad OH signal at 3400cm<sup>-1</sup> and the <sup>1</sup>H NMR and <sup>13</sup>C NMR spectra show that there are 4 alkene C-H environments and two ester C=O environments. Efforts were made to grow a crystal of the unknown compound but these were unsuccessful. In an attempt to avoid this dimerisation, the reaction was carried out at high dilution (3.7×10<sup>-4</sup> mol dm<sup>-3</sup>) but unfortunately the same product was recovered from this reaction.

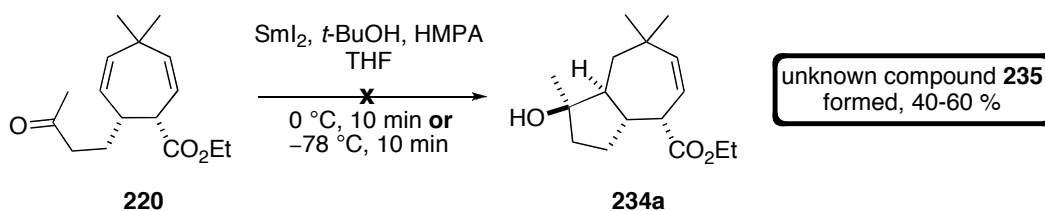

**Scheme 99** The  $\text{SmI}_2$  ketone-olefin cyclisation of **220** with HMPA.

A much simpler, cyclohexyl model ketone-olefin compound **239** was prepared in the hope that it would shed light on the reaction of **220** with  $\text{SmI}_2$ . Treatment of cyclohexene **236** with Schlosser's base<sup>69</sup> furnished alcohol **236** in 75% yield. The iodination/alkylation/decarboxylation strategy, which was previously optimized on cyclohexanol (Section 2.1), was straightforward furnishing ketone-olefin **239** in good yield.

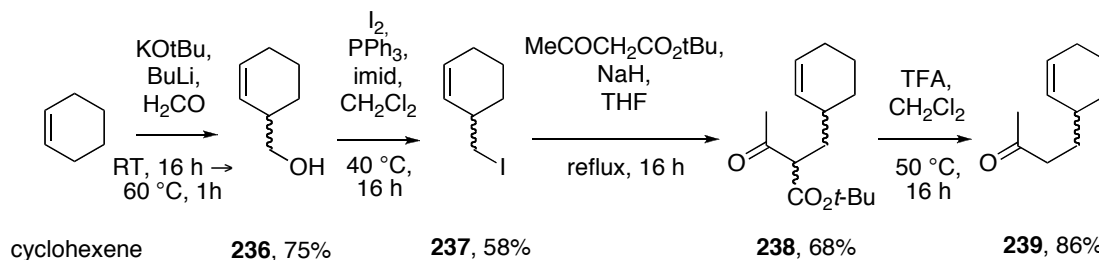

**Scheme 100** The preparation of model system ketone-olefin **239**.

The reaction of ketone-olefin **239** with  $\text{SmI}_2$  furnished an unidentifiable complex mixture of products. It had been hoped that this reaction would help in the elucidation of the unidentified dimer **235** but unfortunately, as there was no evidence of dimerisation by MS in the reaction of ketone-olefin **239** with  $\text{SmI}_2$  this was unhelpful.

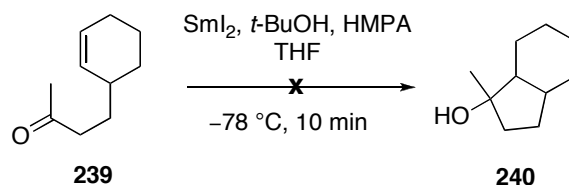

**Scheme 101** The  $\text{SmI}_2$  ketone-olefin cyclisation of **239**.

However, the ring closing reaction of ketone-olefin **238**, bearing the *t*-butyl ester group, furnished compound **241** as two isolable diastereomers in a yield of 43%. This

result is surprising as the steric bulk of the *t*-butyl ester moiety had been expected to hamper the reaction. The reaction was subsequently tested on the pyxidatol C analogue, *t*-butyl ester **228**, but again dimerisation was evident in the MS and the NMR spectra suggested formation of a *t*-butyl ester substituted analogue of the unidentified compound **235**.

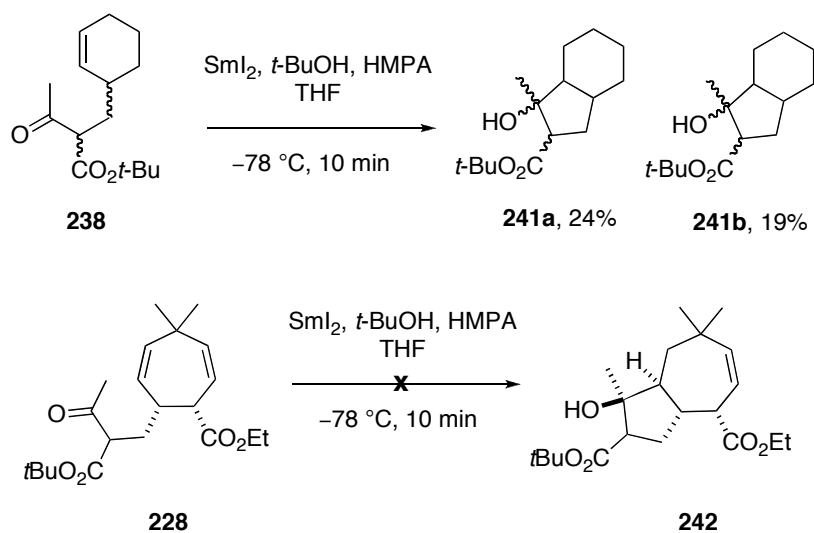

**Scheme 102** The  $\text{SmI}_2$  ketone-olefin cyclisation of *t*-butyl compound **238**.



## 4.7 Conclusion

Having successfully overcome the challenges associated with preparing the *gem*-dimethyl cycloheptadiene (Chapter 3), there have been some frustrating setbacks in our efforts to synthesise pyxidatol C. We were unable to avoid cyclic ether formation when attempting to install the methyl ketone side chain to the cycloheptadiene (Scheme 103).

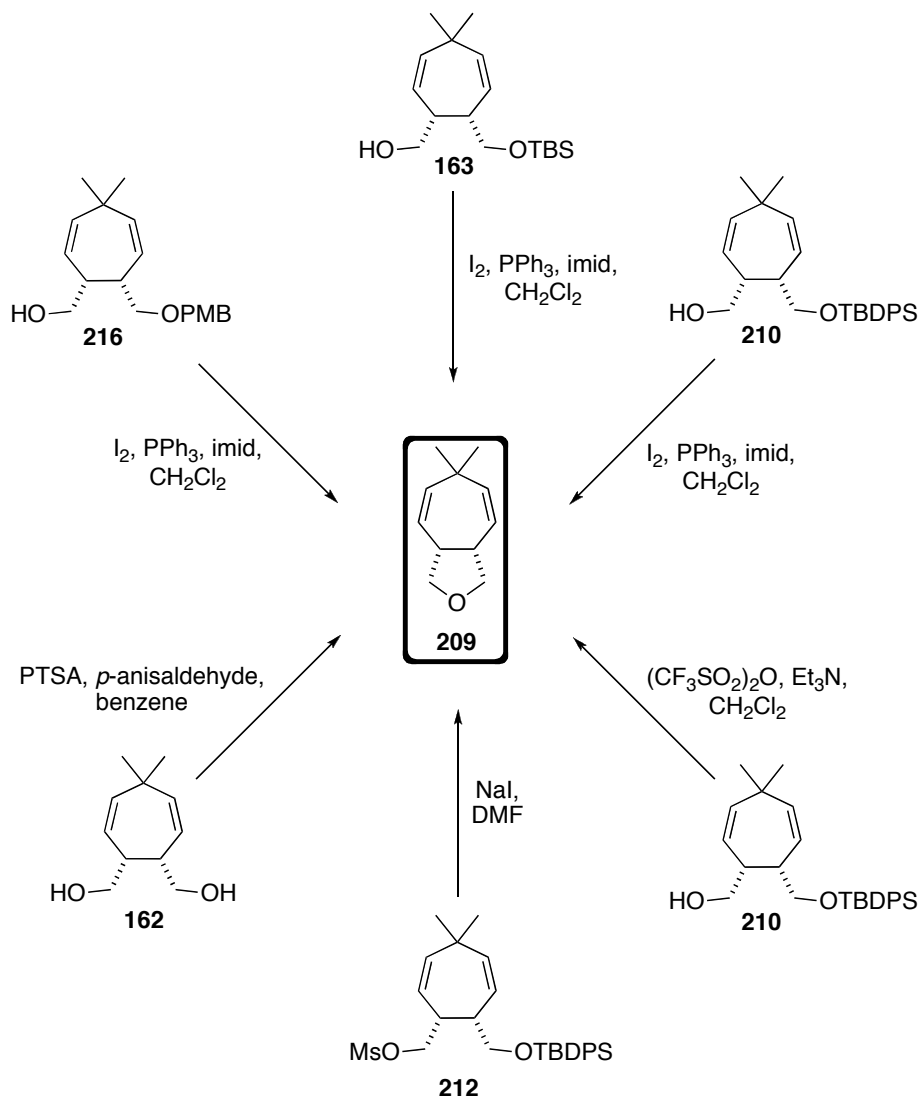

**Scheme 103** A review of the formation of unwanted cyclic ether **209**.

More positively, Tsuji–Trost chemistry was used to prepare methyl ketone **220** (Scheme 104), but the samarium diiodide promoted ketone-olefin cyclisation was unsuccessful.

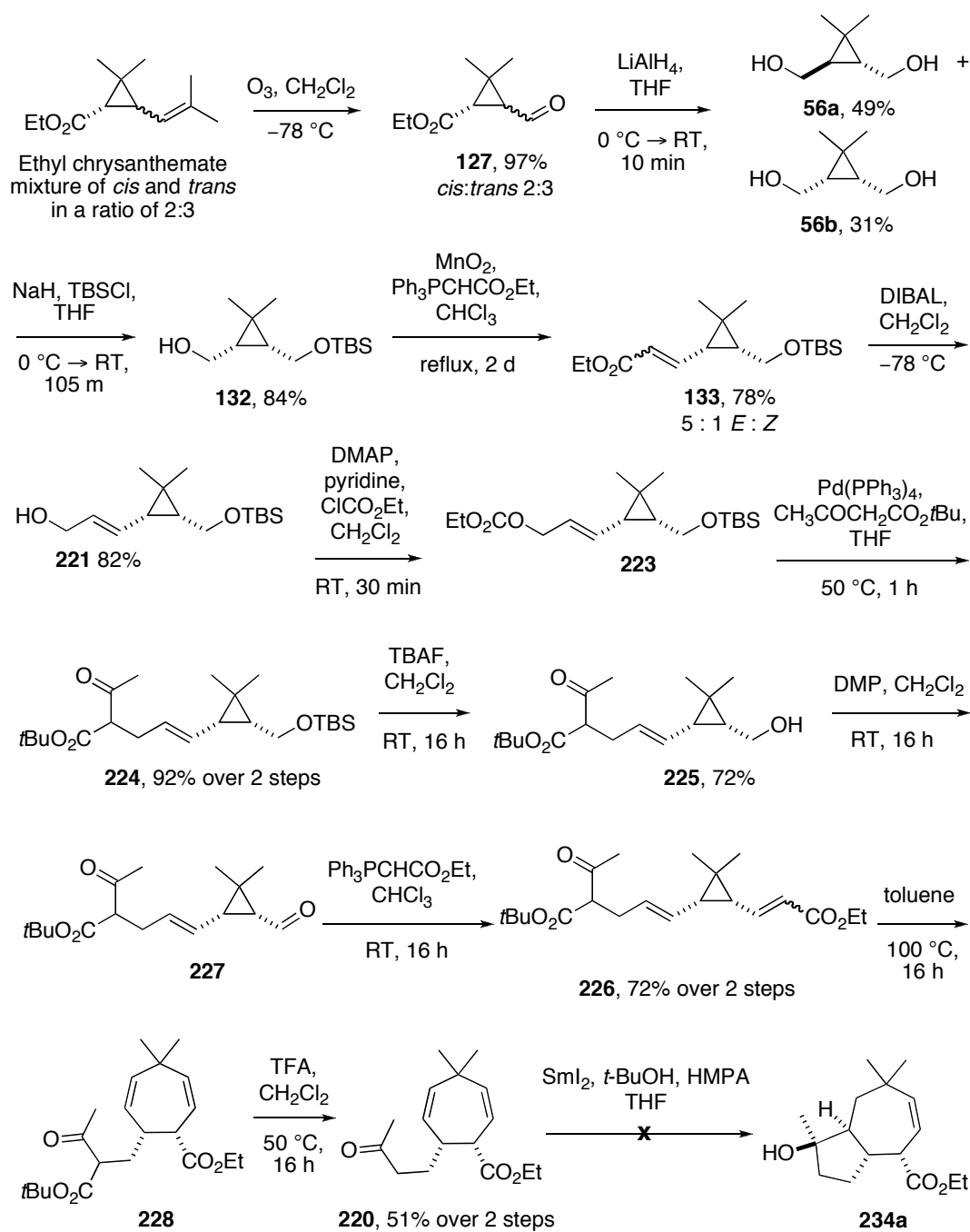

**Scheme 104** A review of the synthetic route to the advanced intermediate **220**.

In light of these setbacks, a 2001 paper by Kerr *et al.*<sup>71</sup> which uses Pauson–Khand chemistry in the synthesis of (+)-taylorione has led to the design of another alternative strategy for the installation of the 5 membered ring moiety, which is described in Chapter 5.

## Chapter 5

### Future Approach and Preliminary Studies

Studies into the Cope rearrangement enabled the synthesis of the *gem*-dimethyl containing 7-membered ring moiety present in the decahydro-1*H*-cyclopropa[*e*]azulene core structure of pyxidatol C (Chapter 3). The cyclopropane of this core structure has been installed using both Corey-Chaykovsky cyclopropanation and Simons-Smith cyclopropanation (Sections 4.1 & 4.3). The methyl ketone side chain was installed using Tsuji–Trost chemistry but unfortunately, the planned  $\text{SmI}_2$  ketone-olefin cyclisation reaction to form the 5-membered ring moiety present in pyxidatol C was unsuccessful (Scheme 104). Future work will focus on the development of a route to install this 5 membered ring moiety at an earlier stage in the synthesis. Preliminary scoping work and future plans are described below.

#### 5.1 A Pauson-Khand Strategy

Kerr *et al.* used Pauson-Khand chemistry in their synthesis of the cyclopentenone-containing compound (+)-taylorione (Scheme 105).<sup>70,71</sup> Coordination of hexacarbonyldicobalt to the alkyne of **243** is followed by a [2+2+1]-cycloaddition which furnished cyclopentenone **245**, an intermediate in the synthesis of (+)-taylorione. In one set of conditions, ethylene and carbon monoxide were used as reagents at 25 atm. In a second set of conditions, vinyl benzoate was used as an ethylene equivalent.<sup>70,71</sup>

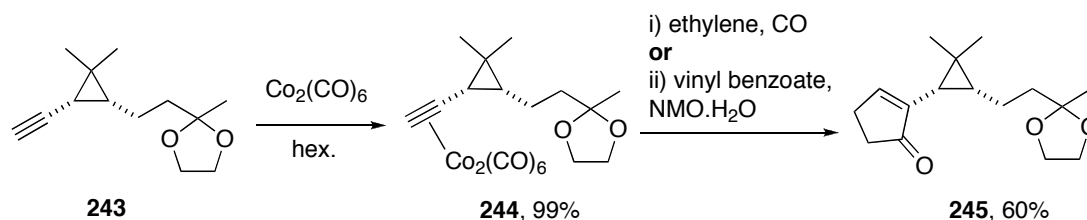

**Scheme 105** Pauson-Khand chemistry used in the synthesis of (+)-taylorione

It is expected that this methodology will be suitable for the preparation of the 5 membered ring present in pyxidatol C (Scheme 106). The Cope rearrangement of

cyclopropane **248** bearing a cyclopentenone moiety would furnish cycloheptadiene **249**. Then, a selective reduction of the electron-deficient alkene of **249**, followed by the addition of a methyl nucleophile into the ketone would furnish alcohol **234a**. Alkene isomerisation/cyclopropanation would then complete the total synthesis of pyxidatol C **3**.

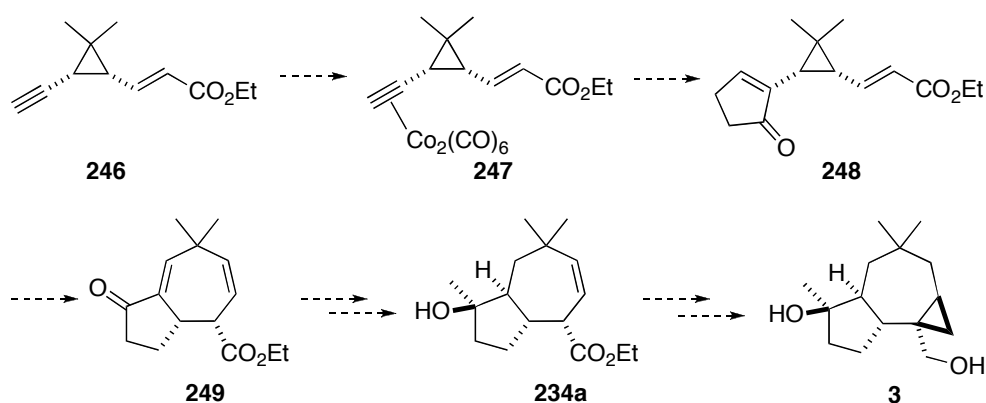

**Scheme 106** The proposed Pauson-Khand approach towards pyxidatol C **3**.

The Pauson-Khand reaction was tested on ethynylbenzene **250** by Kerr *et al.*<sup>71</sup> This chemistry was retested in order to confirm that it was reproducible in our hands (Scheme 107), and pleasingly it was easily repeated (using the vinyl benzoate, NMO.H<sub>2</sub>O conditions) both in terms of yield and purity. Alkynehexacarbonyldicobalt complex **251** was prepared in 95% yield, compared to 99% in the literature and cyclopentenone **252** was obtained in 75% yield compared to 80%.<sup>71</sup> Attention therefore turned to the preparation of alkyne **246**.

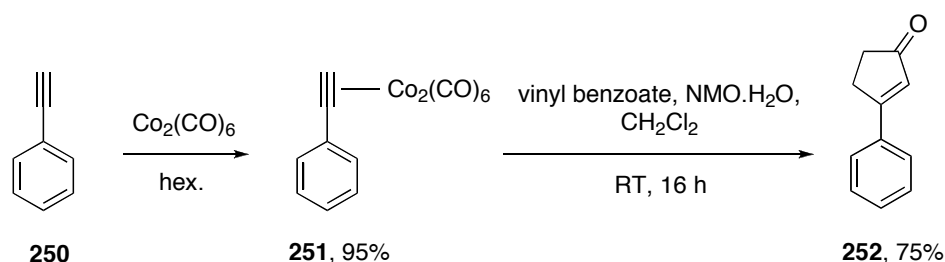

**Scheme 107** The ethynylbenzene model system.

## 5.2 Preliminary Results Towards Alkyne 246

Ohira-Bestmann chemistry<sup>72</sup> was considered to be the simplest way to prepare alkyne **246**. Aldehyde **253** was prepared *via* the MnO<sub>2</sub> oxidation of alcohol **131** but unfortunately the reaction with Ohira-Bestmann phosphonate **254** led only to a complex mixture of decomposition products (Scheme 108).

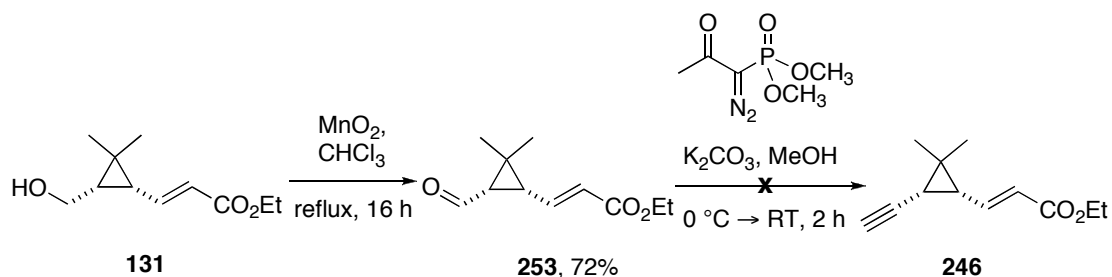

**Scheme 108** Ohira-Bestmann reaction using aldehyde **253**.

The Ohira-Bestmann reaction was therefore trialled on aldehyde **136** with a view to building in the unsaturated ester of **246** once the alkyne was in place. However, once again a complex mixture of decomposition products was obtained (Scheme 109). Rather than test a multitude of Ohira-Bestmann conditions, Corey-Fuchs chemistry<sup>73</sup> was trialled in its place.

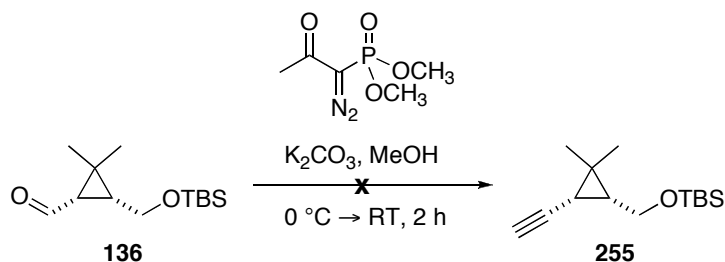

**Scheme 109** Ohira-Bestmann reaction using aldehyde **136**.

Dibromoalkene **256** was prepared from the reaction of aldehyde **253** with carbon tetrabromide and triphenylphosphine, in a moderate 48% yield (Scheme 110).

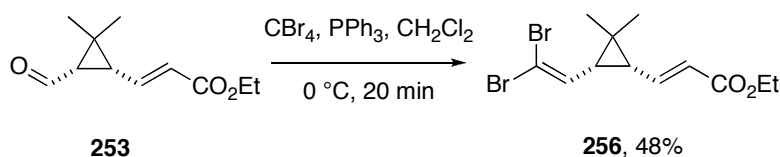

**Scheme 110** Corey-Fuchs reaction using aldehyde **253**.

It was hoped that the reaction of dibromoalkene **256** with *n*-BuLi would afford the desired alkyne **246**. However, a complex mixture of products, inseparable by flash column chromatography was obtained. A singlet at 1.95 ppm in the <sup>1</sup>H NMR spectrum of the unpurified reaction mixture indicated that an alkyne was present but analysis of the HRMS indicated that the desired alkyne **246** was not present in the reaction mixture. It is postulated that addition of the *n*Bu<sup>-</sup> nucleophile into the ester group instead afforded alkyne **257** which is supported by mass spectrometry [*m/z* (ESI): [MNa<sup>+</sup>] C<sub>18</sub>H<sub>30</sub>NaO, 285.2917].

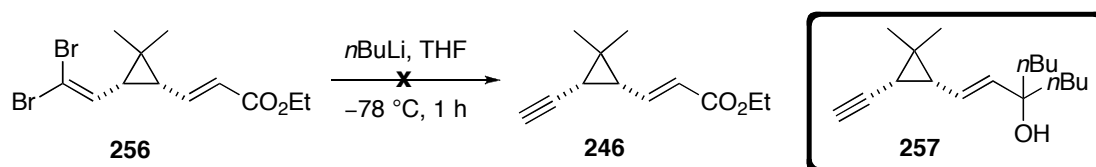

**Scheme 111** Formation of alkyne **257**.

Preparation of dibromoalkene **258** from TBS aldehyde **136** was trialled with a view to preparing the alkyne before the ester was in place, thus avoiding addition of the *n*Bu<sup>-</sup> nucleophile into the ethyl ester. Unfortunately, this reaction led to a complex mixture of decomposition products (Scheme 112) and so alternative strategies to avoid this addition were tested.

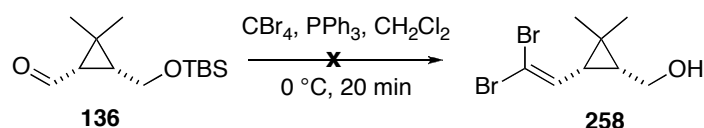

**Scheme 112** Corey-Fuchs reaction using aldehyde **136**.

It was hoped that reduction of the electrophilic ester moiety in **256** to give alcohol **259** would stop the side-reactions during alkyne formation. DIBAL reduction of ester **256** was straightforward but treatment with *n*BuLi again led to decomposition and no evidence of the formation of the desired product **260** (Scheme 113).

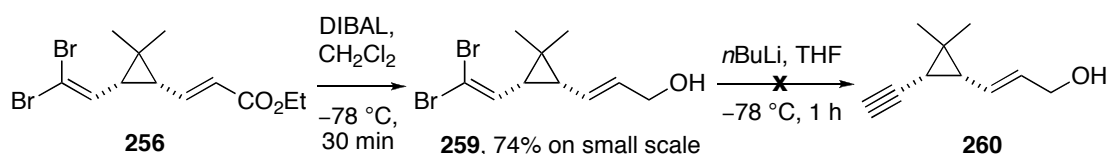

**Scheme 113** DIBAL reduction of **256**.

Alcohol **259** was to be protected as a silyl ether in order to avoid deprotonation of the free alcohol group by *n*BuLi because the resulting alkoxide could be a reactive intermediate in decomposition pathways. Unfortunately, the DIBAL reduction of ester **256** did not work well on scale up and only trace amounts of alcohol **259** were synthesized. With time limited, an alternative route towards silyl ether **265** was tested in place of optimizing the reduction of ester **256**. This strategy relied on the use of orthogonal protecting groups in the synthesis of silyl ether **265** (Scheme 114).

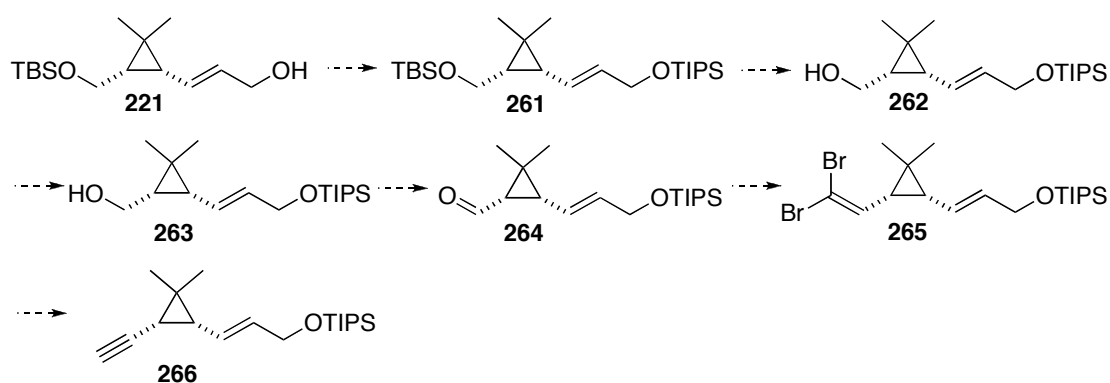

**Scheme 114** Using TIPS as an orthogonal protecting group.

TIPS protection of alcohol **221** proved to be straightforward. It was expected that TBAF would cleave the TBS ether of cyclopropane **261** selectively because the TIPS ether is more stable than TBS. However, desilylation using TBAF selectively cleaved the TIPS ether, in place of the desired TBS ether and TBS compound **221** was recovered from the reaction (Scheme 115).

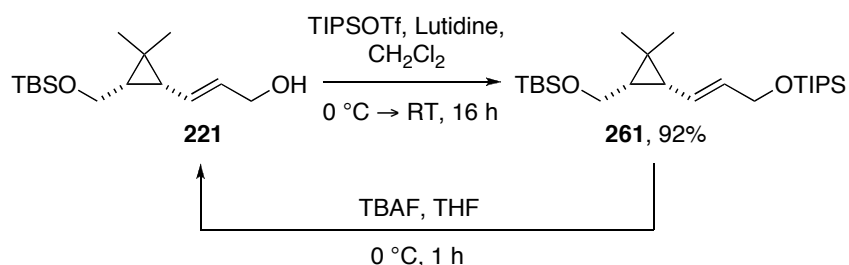

**Scheme 115** TIPS protection of alcohol **221** followed by unsuccessful TBS cleavage.

The relative stability of the TBS ether of cyclopropane **261** suggests that the silicon atom is more sterically hindered on the TBS than on the TIPS ether, probably due to

its proximity to the cyclopropane. With this in mind, it was hoped that the reaction of diol **267** with only 1 equivalent of TBSCl would give selectively mono-TBS protected compound **268**, but unfortunately a mixture of diol and bis-TBS compound was recovered from this reaction. This suggests that the mono-TBS protected compound **268** must silylate faster than diol **267**. Speculatively, this could be due to differences in the solubility of the mono-TBS protected compound **268** and the starting material diol **267** (Scheme 116).

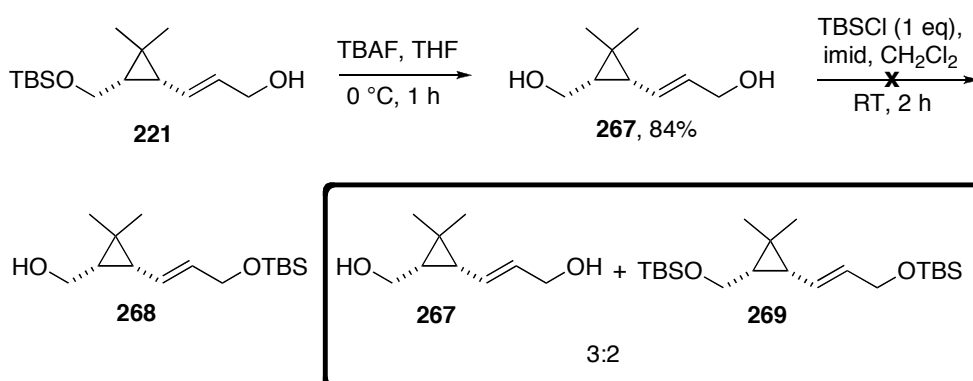

**Scheme 116** The unsuccessful mono-TBS protection of diol **267**.

Given the difficulties working with TIPS as an orthogonal protecting group, the use of a benzyl protecting group was planned. Pleasingly, benzyl protection of alcohol **221** was straightforward, as was silyl cleavage furnishing alcohol **270** in 64% yield over the two steps. Unfortunately oxidation with MnO<sub>2</sub> or DMP was unsuccessful (Scheme 117).

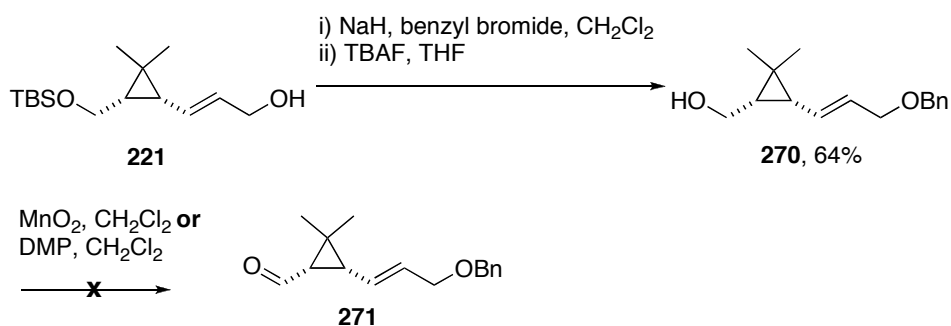

**Scheme 117** Benzyl protection followed by silyl deprotection of alcohol **221**.



The focus of future work will be to build on these preliminary studies to find an efficient synthesis of alkyne **246**, thus enabling us to test the proposed Pauson-Khand strategy towards pyxidatol C (Scheme 118).

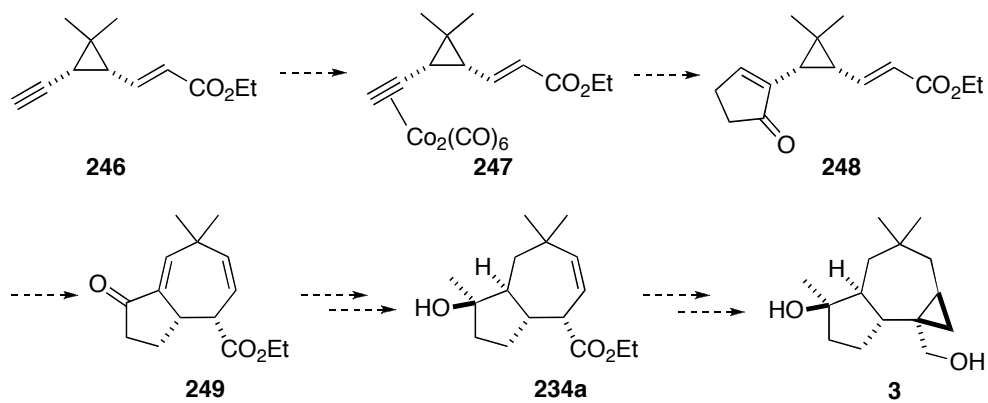

**Scheme 118** The proposed Pauson-Khand approach towards pyxidatol C **3**.

## Chapter 6

### Addendum

#### Total Synthesis of Pyxidatol C by G. Liang *et al.*<sup>74</sup>

Having completed all of the experimental and written work contained in this thesis, the total synthesis of pyxidatol C **3** was reported by G. Liang *et al.*<sup>74</sup> For completeness, details are given below.

Commercially available ketone **272** was converted to *trans*-decalin **273** in 45% yield using the aldol–Henry reaction cascade and subsequent Parikh–Doering oxidation.<sup>75</sup> The stereochemistry of **273** was unambiguously confirmed by single-crystal X-ray crystallographic analysis. The carbonyl group in **273** was protected as its acetal allowing palladium-catalyzed hydrogenation of the nitro group to afford the corresponding amine **275** in nearly-quantitative yield. The Tiffeneau–Demjanov rearrangement generated the desired *cis*-fused 5,7-carbocycle **276** in 62% yield with complete diastereocontrol.<sup>76</sup> A Corey–Chaykovsky epoxidation<sup>77</sup> and epoxide isomerization sequence yielded alcohol **278** as the single regioisomer shown.<sup>78</sup> Acetal hydrolysis with 1 N HCl in THF revealed ketone **279**. Addition of methyllithium then afforded the diol **280** in 59% yield; this reaction furnished a pair of separable diastereomers, with the minor diastereomer, which is not depicted in scheme 119 isolated in 15% yield. A Simmons–Smith cyclopropanation<sup>29</sup> of **280** completed the synthesis of pyxidatol C in 68% yield with excellent stereo-chemical control (d.r. > 19:1).<sup>74</sup>

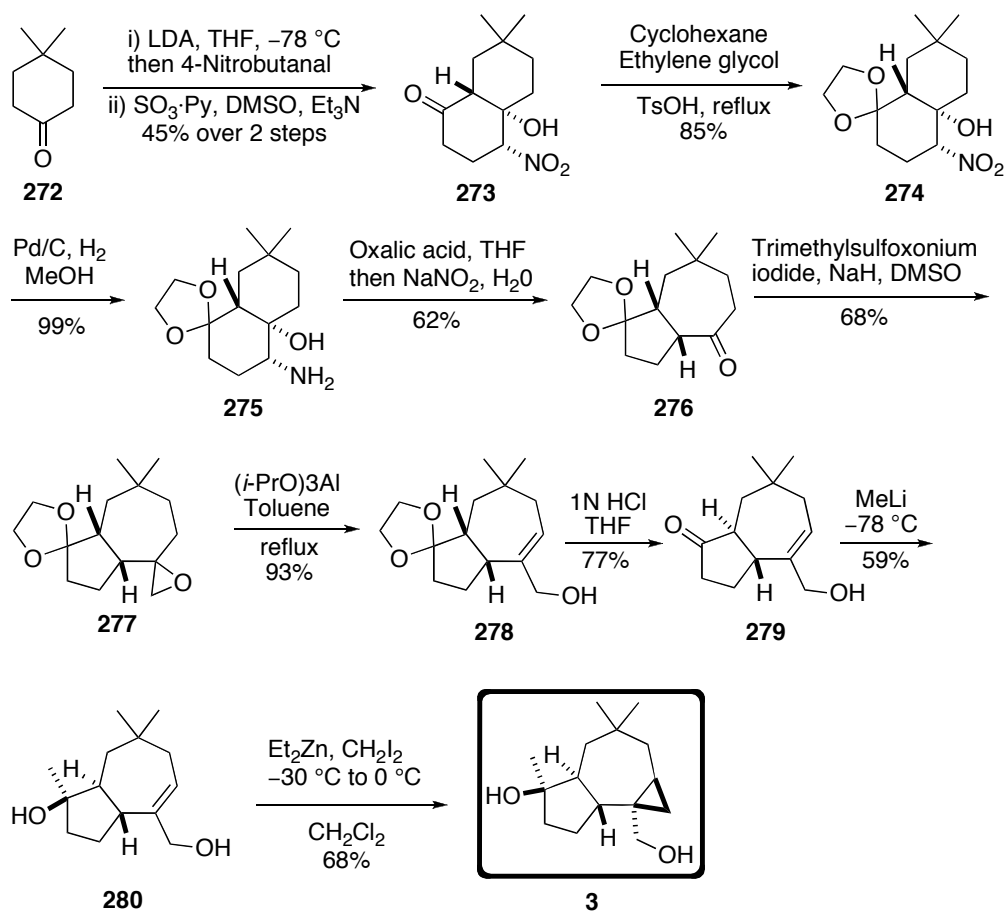

**Scheme 119** The total synthesis of pyxidatol C **3** by G.Liang *et al.*

## Chapter 7

### Experimental

#### 7.1 General Experimental

All reagents were purchased from commercial sources and were used without further purification.

Unless otherwise stated, all procedures were carried out under an atmosphere of argon. Where necessary, solvents were dried on an MBraun SPS solvent purification system. Anhydrous THF was obtained by distillation over sodium benzophenone. Hexane refers to n-hexane and pet. ether refers to light petroleum ether, bp 40–60 °C. Ethanol was dried according to the method of Lund and Bjerrum.<sup>79</sup> DMP was prepared using the procedure described by Boeckmann.<sup>80</sup>

Flash column chromatography was performed using Fluka silica gel 60 under positive pressure. Analytical thin layer chromatography was performed on aluminium sheets pre-coated with Merck silica gel 60 F<sub>254</sub> and visualised with ultraviolet light (254 nm), aqueous potassium permanganate or anisaldehyde solutions where appropriate.

<sup>1</sup>H NMR spectra were recorded on a JEOL ECX 400 (400 MHz) instrument. The chemical shift data is reported in parts per million (ppm) on the delta (δ) scale relative to tetramethylsilane (TMS) where δ<sub>TMS</sub> = 0.00 ppm. The number of protons (n) for a given resonance is indicated by nH. The multiplicity of each signal is indicated by: s (singlet), br s (broad singlet), d (doublet), t (triplet), q (quartet), m (multiplet). The coupling constants (*J*) are quoted to the nearest 0.5 Hz. The residual protic solvent (CHCl<sub>3</sub>) (δ<sub>H</sub>=7.26 ppm) was used as an internal reference. <sup>13</sup>C NMR spectra were recorded on a JEOL ECX 400 instrument at 100 MHz. The central signal of CDCl<sub>3</sub> (δ<sub>C</sub>=77.0 ppm) was used as an internal reference. <sup>13</sup>C spectra were verified using DEPT experiments and COSY and HSQC experiments were used for assignment purposes where necessary. Chemical shifts are reported to the nearest 0.01 ppm for <sup>1</sup>H NMR and to the nearest 0.1 ppm for <sup>13</sup>C NMR.

Infrared spectra were carried out on a ThermoNicolet IR100 spectrometer and are recorded as a thin film between NaCl discs. Absorption maxima are reported in wavenumbers ( $\text{cm}^{-1}$ ) and only selected absorbances are reported. Mass spectra and accurate mass measurements were obtained through the University of York mass spectrometry service and were recorded on a Bruker Daltonics, Micro-tof spectrometer. All melting points were taken on a Gallenkamp instrument.

All numbering of structures is for characterisation purposes only and does not conform to IUPAC rules.

## 7.2 Procedures & Compound Characterisation (Chapter 1 & Chapter 2)

### (±)-(1*S*,2*S*)-Cyclopropane-1,2-diyl dimethanol (**54a**)<sup>24</sup>

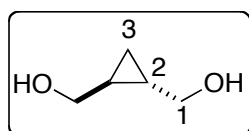

To a stirred suspension of  $\text{LiAlH}_4$  (4.17 g, 110 mmol) in THF (100 mL) at 0 °C was added a solution of diethyl *trans*-1,2-cyclopropanedicarboxylate (13.6 g, 73.1 mmol) in THF (25 mL), over a period of 1 h *via* a syringe pump. The reaction mixture was then heated at reflux at 70 °C for 2 h, before being cooled to RT and stirred for 18 h. After cooling to 0 °C the mixture was diluted with EtOAc (30 mL) and washed cautiously with sat.  $\text{NH}_4\text{Cl}$  (aq.) (30 mL). The resulting suspension was filtered, and the insoluble salts were washed with further portions of EtOAc ( $2 \times 50$  mL). The filtrate was concentrated under reduced pressure, and the residue taken up in EtOAc (50 mL). The solution was then dried ( $\text{MgSO}_4$ ), filtered and concentrated under reduced pressure to afford the title compound **54a** as a colourless oil. (5.30 g, 71%);  $R_f$  (1:1 pet. ether:EtOAc) 0.34;  $^1\text{H}$  NMR (400 MHz;  $\text{CDCl}_3$ )  $\delta$  3.73–3.60 (2 H, m, H-1a), 3.35–3.21 (2 H, m, H-1b), 0.99–1.07 (2 H, m, H-2), 0.46 (2 H, dt,  $J$  7.0, 2.5 H-3). Data in agreement with those reported in the literature.<sup>24</sup>

**(±)-(2*E*,2'*E*)-Diethyl 3,3'-cyclopropane-1*R*,2*R*-diyl)diprop-2-enoate (**55a**)<sup>24</sup>**

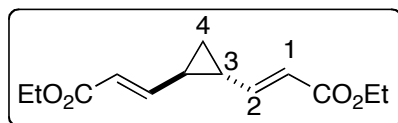

To a stirred solution of **54a** (8.67 g, 85.0 mmol) in CHCl<sub>3</sub> (510 mL) was added manganese oxide (148 g, 1.7 mol) and (carbethoxymethylene) triphenyl phosphorane (71.1 g, 204 mmol). The resulting suspension was stirred vigorously with heating to maintain gentle reflux for 18 h. After cooling to room temperature, the suspension was filtered through Celite, and washed with CHCl<sub>3</sub> (50 mL). The filtrate was concentrated under reduced pressure and diethyl ether (100 mL) was added to the yellow solid residue. This suspension was stirred at room temperature for 30 mins, and the resulting white precipitate (triphenylphosphine oxide) was removed by filtration and washed with pet. ether (75 mL). The filtrate was concentrated under reduced pressure to give the crude product. This was purified by flash column chromatography on silica gel, eluting with pet. ether:Et<sub>2</sub>O (4:1 → 2:1) to afford the title compound **55a** as a white solid (15.2 g, 75%); R<sub>f</sub> (4:1 pet. ether:Et<sub>2</sub>O) 0.41; <sup>1</sup>H NMR (400 MHz; CDCl<sub>3</sub>) δ 6.45 (2 H, dd, *J* 9.0, 15.5, H-2), 5.90 (2 H, d, *J* 15.5 H-1), 4.17 (4 H, q, *J* 7.0 CH<sub>3</sub>CH<sub>2</sub>O), 1.79–1.82 (2 H, m, H-3), 1.23–1.31 (8 H, m, CH<sub>3</sub>CH<sub>2</sub>O & H-4). Data in agreement with those reported in the literature.<sup>24</sup>

**(±)-(1*R*,2*S*,3*Z*,6*Z*)-Diethyl cyclohepta-3,6-diene-1,2-dicarboxylate (**58a**)**

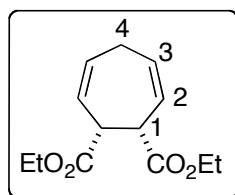

A stirred solution of **55** (5.01 g, 21.0 mmol) in xylene (50 mL) was heated at reflux at 130 °C for 16 h. After being cooled to RT the solution was concentrated under reduced pressure to give the crude product. This was purified by flash column chromatography on silica gel, eluting with pet. ether:Et<sub>2</sub>O (10:1 → 2:1) to afford the title compound **58a**, as a colourless oil (3.96 g, 80%); R<sub>f</sub> (20:1 pet. ether:EtOAc) 0.19; ν<sub>max</sub> (thin film)/cm<sup>-1</sup> 2981, 2937, 1735; <sup>1</sup>H NMR (400 MHz; CDCl<sub>3</sub>) δ 6.08–6.02 (2H, m, H-2), 5.82–5.76 (2H, m, H-3), 4.20–4.11 (4H, m, CH<sub>3</sub>CH<sub>2</sub>O), 3.86–3.84 (2H, m, H-1), 3.06–2.97 (1H, m, H-4a), 2.68 (1H, dt, *J* 20.0, 7.0 Hz H-4b), 1.25 (3H, t, *J* 7.0, CH<sub>3</sub>CH<sub>2</sub>O); <sup>13</sup>C NMR (101 MHz; CDCl<sub>3</sub>) δ 172.1 (CH<sub>3</sub>CH<sub>2</sub>OC=O), 129.4 (C-

3), 127.5 (C-2), 61.1 (OCH<sub>2</sub>CH<sub>3</sub>), 45.1 (C-1), 28.3 (C-4), 14.2 (OCH<sub>2</sub>CH<sub>3</sub>); m/z (ESI) 239 [MH<sup>+</sup>]; HRMS: calcd. for C<sub>13</sub>H<sub>19</sub>O<sub>4</sub>, 239.1278. Found: [MH<sup>+</sup>], 239.1271 (2.4 ppm error).

**(±)-(1*R*,2*S*,3*Z*,6*Z*)-Cyclohepta-3,6-diene-1,2-diylldimethanol (**59**)**

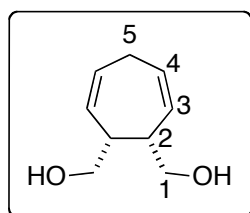

To a stirred suspension of LiAlH<sub>4</sub> (1.26 g, 33.2 mmol) in THF (75 mL) at RT was added **58** (3.96 g, 16.6 mmol) in THF (75 mL) via cannula. After 2 h the reaction was cooled to 0 °C and Na<sub>2</sub>SO<sub>4</sub>·10H<sub>2</sub>O was cautiously added until on further addition fizzing could no longer be observed. The aluminium salts were removed by filtration and washed with EtOAc (200 mL). The filtrate was concentrated under reduced pressure to give the crude product. This was purified by flash column chromatography on silica gel, eluting with pet. ether:EtOAc (4:1 → 1:1) to afford the title compound **59** as a colourless oil (1.94 g, 76%); R<sub>f</sub> (EtOAc) 0.44; ν<sub>max</sub> (thin film)/cm<sup>-1</sup> 3315, 3013, 2926, 2876, 1655; <sup>1</sup>H NMR (400 MHz; CDCl<sub>3</sub>) δ 5.79–5.57 (4H, m, H-3 & H-4), 3.77–3.58 (4H, m, H-1), 3.10–2.99 (1H, m, H-5a), 2.91–2.83 (2H, m, H-2), 2.73–2.64 (1H, m, H-5b); <sup>13</sup>C NMR (101 MHz; CDCl<sub>3</sub>) δ 130.3 (C-3 or C-4), 129.1 (C-3 or C-4), 64.0 (C-1), 44.1 (C-2), 29.8 (C-5); m/z (ESI): 177 [MNa<sup>+</sup>]; HRMS (ESI): calcd. for C<sub>9</sub>H<sub>14</sub>NaO<sub>2</sub>, 177.0886. Found: [MNa<sup>+</sup>], 177.0886 (0.0 ppm error).

**(±)-(3*aR*,4*Z*,7*Z*,8*aS*)-3,3*a*,6,8*a*-Tetrahydro-1*H*-cyclohepta[*c*]furan-1-one (**60**)**

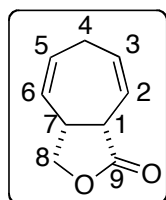

To a stirred solution of **59** (500 mg, 3.25 mmol) in CH<sub>2</sub>Cl<sub>2</sub> (18 mL) at RT was added PhI(OAc)<sub>2</sub> (2.62 g, 8.13 mmol) and TEMPO (508 mg, 0.325 mmol). After 2 h the reaction mixture was concentrated under reduced pressure to give the crude product. This was purified by flash column chromatography on silica gel, eluting with pet. ether:Et<sub>2</sub>O (10:1 → 1:1) to afford the title compound **60** as a colourless oil (240 mg, 49%); R<sub>f</sub> (1:1 pet. ether:Et<sub>2</sub>O) 0.42; ν<sub>max</sub> (thin film)/cm<sup>-1</sup> 3025, 2970, 2910, 1769; <sup>1</sup>H NMR (400 MHz;

CDCl<sub>3</sub>) δ 6.01–5.01 (2H, m, H-3 & H-5), 5.66 (1H, dddd, *J* 11.0, 5.0, 2.0, 1.0 Hz, H-6), 5.52–5.48 (1H, m, H-2), 4.31 (1H, dd, *J* 9.0, 5.5 Hz, H-8a), 4.19 (1H, dd, *J* 9.0, 3.5 Hz, H-8b), 3.52–3.44 (1H, m, H-1), 3.44–3.38 (1H, m, H-7), 2.98–2.87 (1H, m, H-4a), 2.77–2.67 (1H, m, H-4b); <sup>13</sup>C NMR (101 MHz; CDCl<sub>3</sub>) δ 176.4 (C-9), 133.4 (C-3 or C-5), 132.3 (C-3 or C-5), 127.8 (C-6), 122.7 (C-2), 72.7 (C-8), 43.3 (C-1 or C-7), 39.0 (C-1 or C-7), 27.2 (C-4); *m/z* (ESI): 173 [MNa<sup>+</sup>]; HRMS (ESI): calcd. for C<sub>9</sub>H<sub>10</sub>NaO<sub>2</sub>, 173.0573. Found: [MNa<sup>+</sup>], 173.0574 (0.7 ppm error).

**(±)-(R,4Z,8E)-3,3a,6,7-Tetrahydro-1H-cyclohepta[c]furan-1-one, (61)**

**& (±)-(Z)-3,6,7,8-Tetrahydro-1H-cyclohepta[c]furan-1-one (63) & (±)-**

**(3aR,4Z,7Z,8aR)-3,3a,6,8a-tetrahydro-1H-cyclohepta[c]furan-1-one (64)**

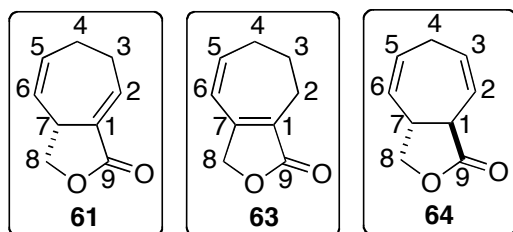

To a stirred solution of **60** (120 mg, 0.799 mmol) in degassed THF (24 mL) at 0 °C was added DBU (0.12 mL, 0.799 mmol). After 2h the reaction was quenched with NH<sub>4</sub>Cl (aq.) (30 mL), the organic layer was

separated and the aqueous layer extracted with portions of EtOAc (2 × 50 mL). The combined organic extracts were dried (MgSO<sub>4</sub>), filtered and concentrated under reduced pressure. The resulting crude product was purified by flash column chromatography on silica gel, eluting with pet. ether:Et<sub>2</sub>O (4:1) to afford the title compound **61** as a white solid (89 mg, 74%), **63** as a colourless oil (13 mg, 11%) and **64** (7 mg, 6%) as a colourless oil (assigned tentatively by <sup>1</sup>H NMR spectroscopy); **61** R<sub>f</sub> (1:2 pet. ether:Et<sub>2</sub>O) 0.54; mp 55-58 °C; ν<sub>max</sub> (thin film)/cm<sup>-1</sup> 3026, 2949, 2906, 2854, 1754, 1678; <sup>1</sup>H NMR (400 MHz; CDCl<sub>3</sub>) δ 6.96 (1H, dd, *J* 4.5, 9.5 Hz, H-2), 5.60 (1H, ddd, *J* 10.5, 2.5, 2.5 Hz, H-5), 5.98–5.90 (1H, m, H-6), 4.58 (1H, dd, *J* 9.0 Hz, H-8a), 4.24–4.13 (1H, m, H-7), 3.96 (1H, dd, *J* 9.0 Hz, H-8b), 2.60–2.47 (2H, m, H-3), 2.39–2.28 (1H, m, H-4a), 2.25–2.16 (1H, m, H-4b); <sup>13</sup>C NMR (101 MHz; CDCl<sub>3</sub>) δ 171.0 (C-9), 140.9 (C-2), 132.3 (C-5 or C-6), 130.0 (C-5 or C-6), 128.7 (C-1), 70.6 (C-8), 37.3 (C-7), 26.3 (C-3 or C-4), 25.0 (C-3 or C-4); *m/z* (ESI): 173 [MNa<sup>+</sup>]; HRMS (ESI): calcd. for C<sub>9</sub>H<sub>10</sub>NaO<sub>2</sub>, 173.0573. Found: [MNa<sup>+</sup>], 173.0571



(1.5 ppm error). **63**  $R_f$  (1: 2 pet. ether: Et<sub>2</sub>O) 0.51;  $\nu_{\max}$  (thin film)/cm<sup>-1</sup> 3020, 2928, 2850, 1752; <sup>1</sup>H NMR (400 MHz; CDCl<sub>3</sub>)  $\delta$  6.34 (1H, dt,  $J$  11.5, 5.5 Hz, H-5), 5.86 (1H, dt,  $J$  11.5, 1.5 Hz, H-6), 4.66 (2H, t,  $J$  2.5 Hz, H-8), 2.56–2.48 (4H, m, H-2 & H-4), 1.90–1.84 (2H, m, H-3); <sup>13</sup>C NMR (101 MHz; CDCl<sub>3</sub>)  $\delta$  175.1 (C-9), 153.3 (C-1 or C-7), 143.9 (C-5), 127.4 (C-1 or C-7), 119.0 (C-6), 70.9 (C-8), 32.0 (C-2 or C-4), 26.8 (C-2 or C-4), 22.4 (C-3).  $m/z$  (ESI): 173 [MNa<sup>+</sup>]; HRMS (ESI): calcd. for C<sub>9</sub>H<sub>10</sub>NaO<sub>2</sub>, 173.0573. Found: [MNa<sup>+</sup>], 173.0575 (1.5 ppm error). **64**  $R_f$  (1: 2 pet. ether: Et<sub>2</sub>O) 0.49; <sup>1</sup>H NMR (400 MHz; CDCl<sub>3</sub>)  $\delta$  6.43–5.22 (2H, m, H-3 & H-5), 5.97–5.76 (1H, m, H-6), 5.60–5.51 (1H, m, H-2), 4.43 (1H, dd,  $J$  9.5, 5.0 Hz, H-8a), 4.24 (1H, dd,  $J$  9.5, 3.5 Hz, H-8b), 3.75–3.65 (1H, m, H-1), 3.50–3.47 (1H, m, H-7), 3.01–2.84 (2H, m H-4).

**(±)-(3<sup>1</sup>S,4aS,8aR,Z)-4,4a,5,6-Tetrahydro-1H-isochromen-3(8aH)-one (62)**

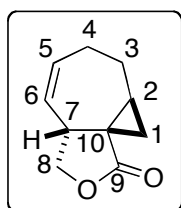

**Procedure 1:** To a suspension of NaH (27.0 mg, 0.675 mmol, 60% dispersion in mineral oil) in DMF (5 mL) at 0 °C was added trimethylsulfoxonium iodide (148 mg, 0.675 mmol). The reaction mixture was stirred for 5 min the dropwise addition of **61** (85 mg, 0.567 mmol) in DMF (5 mL). The solution was stirred at 0 °C for 5 mins before warming to RT and stirring for 16 h. Sat. NH<sub>4</sub>Cl (aq.) (10 mL) was then added followed by H<sub>2</sub>O (50 mL). The organic layer was separated and the aqueous layer extracted with portions of Et<sub>2</sub>O (2 × 60 mL). The combined organic extracts were dried (MgSO<sub>4</sub>), filtered and concentrated under reduced pressure. The resulting crude product was purified by flash column chromatography on silica gel, eluting with pet. ether:Et<sub>2</sub>O (4:1) to afford the title compound **62** as a colourless oil (24 mg, 26%); **Procedure 2:** To a stirred solution of MTBD (104 mg, 0.68 mmol) and trimethylsulfoxonium iodide (90 mg, 0.408 mmol) in MeCN (1 mL) was added **61** (51 mg, 0.340 mmol) in MeCN (1 mL). The reaction mixture was stirred at RT overnight. It was then concentrated under reduced pressure and the resulting crude product was purified by flash column chromatography on silica gel, eluting with pet. ether:Et<sub>2</sub>O (4:1) to afford the title compound **62** as a colourless oil (11 mg, 19%);  $R_f$  (1:1 pet.

ether:Et<sub>2</sub>O) 0.46;  $\nu_{\max}$  (thin film)/cm<sup>-1</sup> 3002, 2919, 1767; <sup>1</sup>H NMR (400 MHz; CDCl<sub>3</sub>)  $\delta$  5.71–5.66 (1H, m, H-5), 5.37 (1H, dd, *J* 11.5, 4.0 Hz, H-6), 4.50 (1H, dd, *J* 9.0, 7.0 Hz, H-8a), 4.28 (1H, dd, *J* 9.0, 1.0 Hz, H-8b), 3.14–3.10 (1H, m, H-7), 2.38–2.23 (3H, m, H-2 & H-4), 1.77–1.69 (1H, m, H-3a), 1.34–1.25 (2H, m, H-3b & H-1a), 0.99 (1H, dd, *J* 6.0, 4.0 Hz, H-1b); <sup>13</sup>C NMR (101 MHz; CDCl<sub>3</sub>)  $\delta$  179.7 (C-9), 133.3 (C-5), 129.9 (C-6), 74.1 (C-8), 39.9 (C-2), 30.2 (C-10), 29.4 (C-3 or C-4), 29.3 (C-3 or C-4), 24.3 (C-1), 22.9 (C-7); *m/z* (ESI): 187 [MNa<sup>+</sup>]; HRMS (ESI): calcd. for C<sub>10</sub>H<sub>12</sub>NaO<sub>2</sub>, 187.0730. Found: [MNa<sup>+</sup>], 187.0725 (2.7 ppm error).

**(±)-(3a*R*,4*Z*,7*Z*,8a*S*)-3,3a,6,8a-Tetrahydro-1*H*-cyclohepta[*c*]furan-1-ol (67)**

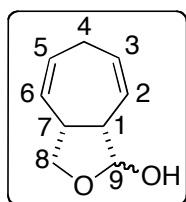

To a stirred solution of **59** (100 mg, 0.650 mmol) in anhydrous DMSO (2 mL) was added IBX (218 mg, 0.780 mmol) at RT. This was stirred for 2h before the addition of H<sub>2</sub>O (5 mL). The resulting mixture was filtered through celite, washed with CH<sub>2</sub>Cl<sub>2</sub> (10 mL) and water (2 mL). The filtrate was dried (MgSO<sub>4</sub>), filtered and concentrated under reduced pressure. The resulting crude product was purified by flash column chromatography on silica gel, eluting with pet. ether:Et<sub>2</sub>O (2:1) to afford the title compound **67** as a colourless oil and mixture of diastereomers in a ratio of major (A): minor (B), 2:1 (60 mg, 60%); *R<sub>f</sub>* (EtOAc) 0.63;  $\nu_{\max}$  (thin film)/cm<sup>-1</sup> 3397, 3017, 2941, 2885; <sup>1</sup>H NMR (400 MHz; CDCl<sub>3</sub>)  $\delta$  5.99–5.91 (1H, m, H-2 or H-3 or H-5 or H-6, A), 5.89–5.82 (1H, m, H-2 or H-3 or H-5 or H-6, A), 5.81–5.74 (1H, m, H-2 or H-3 or H-5 or H-6, A), 5.73–5.68 (1H, m, H-2 or H-3 or H-5 or H-6, B), 5.63–5.67 (1H, m, H-2 or H-3 or H-5 or H-6, B), 5.55–5.49 (1H, m, H-2 or H-3 or H-5 or H-6, A), 5.48–5.43, (2H, m, H-2 or H-3 or H-5 or H-6, B), 5.33 (1H, d, *J* 2.0 Hz, H-9, A), 5.29 (1H, dd, *J* 8.5, 5.0 Hz, H-9, B), 4.13 (1H, dd, *J* 8.0, 7.0 Hz, H-8a, A), 4.08 (1H, dd, *J* 8.5, 1.5 Hz, H-8a, B), 3.90 (1H, dd, *J* 8.5, 5.5 Hz, H-8b, B), 3.69 (1H, dd, *J* 8.0, 8.0 Hz, H-8b, A), 3.44 (1H, br s, OH, A), 3.36 (1H, br s, OH, B), 3.10–2.87 (4H, m, H-1 & H-7, A & B) 2.63 (2H, dd, *J* 7.0, 7.0 Hz, H-4, A), 2.58 (2H, dd, *J* 7.0, 7.0 Hz, H-4, B); <sup>13</sup>C NMR (101 MHz; CDCl<sub>3</sub>)  $\delta$  134.2 (C-2 or C-3 or C-5 or C-6, B), 133.8 (C-2 or C-3 or C-5 or C-6, A), 131.7 (C-2 or C-3 or C-5 or C-6, A), 130.7 (C-2 or C-3 or C-5 or C-6, B), 130.2, (C-2 or C-3 or C-5 or C-6, A) 127.8 (C-2 or C-3 or C-5 or C-6,

A), 127.6 (C-2 or C-3 or C-5 or C-6, B), 124.6 (C-2 or C-3 or C-5 or C-6, B), 103.8 (C-9, A), 99.2 (C-9, B), 75.1 (C-8, B), 72.6 (C-8, A), 48.5 (C-1, A), 47.8 (C-1, B), 40.1 (C-7, A), 38.8 (C-7, B), 27.7 (C-4, A), 27.4 (C-4, B);  $m/z$  (ESI): 175 [MNa<sup>+</sup>]; HRMS (ESI): calcd. for C<sub>9</sub>H<sub>12</sub>NaO<sub>2</sub>, 175.0730. Found: [MNa<sup>+</sup>], 175.0726 (2.6 ppm error).

### Iodomethyl(cyclohexane) (**69**)<sup>81</sup>

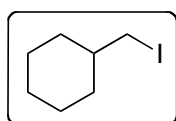

To a stirred solution of cyclohexylmethanol (500 mg, 4.38 mmol) in CH<sub>2</sub>Cl<sub>2</sub> (25 mL) at RT was added triphenylphosphine (1.72 g, 6.57 mmol), imidazole (447 mg, 6.57 mmol) and iodine (667 mg, 5.26 mmol). After stirring for 50 mins Na<sub>2</sub>S<sub>2</sub>O<sub>3</sub> (aq.) (25 mL) was added, the organic layer was separated and the aqueous layer extracted with further EtOAc (2 × 30 mL). The resulting crude product was purified by flash column chromatography on silica gel, eluting with pet. ether:EtOAc (30:1) to afford the title compound **69** as a colourless oil (608 mg, 62%);  $R_f$  (1:1 pet. ether:EtOAc) 0.78; <sup>1</sup>H NMR (400 MHz; CDCl<sub>3</sub>) δ 3.10 (2H, d,  $J$  6.5 Hz, CH<sub>2</sub>I), 1.88–1.84 (2H, m, CH-cyclohexyl), 1.72 (2H, m, CH-cyclohexyl), 1.65–1.58 (1H, m, CH-cyclohexyl), 1.48–1.37 (1H, m, CH-cyclohexyl), 1.31–1.07 (3H, m, CH-cyclohexyl), 0.94 (2H, m, CH-cyclohexyl) Data in agreement with those reported in the literature.<sup>81</sup>

### *tert*-Butyl 2-(cyclohexylmethyl)-3-oxobutanoate (**70**)

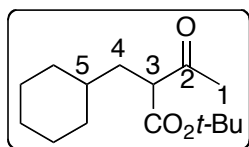

To a stirring suspension of NaH (5 mg, 0.134 mmol) in THF (0.75 mL) at 0 °C was added *t*-butyl 3-oxobutanoate (18 μL, 0.112 mmol). **69** (25 mg, 0.112 mmol) in THF (0.75 mL) was added to the reaction mixture dropwise over 1 minute before warming to RT over 1 h and heating for 16 h in a sealed tube wrapped in tin foil at 70 °C. The reaction was diluted with Et<sub>2</sub>O (5 mL), quenched with sat. NH<sub>4</sub>Cl (aq.) (3 mL) and the organic layer separated. The aqueous layer was extracted with further portions of Et<sub>2</sub>O (2 × 5 mL). The combined organic extracts were dried (MgSO<sub>4</sub>), filtered and concentrated under reduced pressure. The resulting crude product was purified by flash column

chromatography on silica gel, eluting with pet. ether:EtOAc (40:1) to afford the title compound **70** as a colourless oil (19 mg, 72%);  $R_f$  (20:1 pet. ether:EtOAc) 0.30;  $\nu_{\max}$  (thin film)/ $\text{cm}^{-1}$  2977, 2924, 2852, 1736, 1715;  $^1\text{H}$  NMR (400 MHz;  $\text{CDCl}_3$ )  $\delta$  3.41 (1H, dd,  $J$  8.0, 7.0 Hz, H-3), 2.19 (3H, s, H-1), 1.76–1.60 (7H, m,  $3 \times \text{CH}_2$  &  $\text{CH}$ ), 1.44 (9H, s,  $\text{C}(\text{CH}_3)_3$ ), 1.24–1.12 (4H, m,  $2 \times \text{CH}_2$ ), 0.90–0.84 (2H, m,  $\text{CH}_2$ );  $^{13}\text{C}$  NMR (101 MHz;  $\text{CDCl}_3$ )  $\delta$  204.0 ( $t\text{-BuOC}=\text{O}$ ), 169.5 (C-2), 81.8 ( $\text{C}(\text{CH}_3)_3$ ), 58.7 (C-3), 35.7 (C-5), 35.6 (C-4), 33.3 ( $\text{CH}_2$ ), 33.0 ( $\text{CH}_2$ ), 28.6 (C-1), 28.0 ( $\text{C}(\text{CH}_3)_3$ ), 26.5 ( $\text{CH}_2$ ), 26.3 ( $\text{CH}_2$ ), 26.3 ( $\text{CH}_2$ );  $m/z$  (ESI): 277 [ $\text{MNa}^+$ ]; HRMS (ESI): calcd. for  $\text{C}_{15}\text{H}_{26}\text{NaO}_3$ , 277.1774. Found: [ $\text{MNa}^+$ ], 277.1772 (1.3 ppm error).

#### 4-Cyclohexylbutan-2-one (**71**)<sup>82</sup>

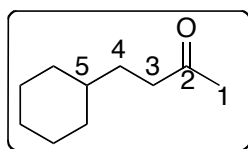

To a stirred solution of (**32**) (44 mg, 0.173 mmol) in benzene (1.5 mL) was added *p*-TSA (7 mg, 0.035 mmol). This was heated at reflux for 2.5h before the addition of sat.  $\text{NaHCO}_3$  (aq.) (2 mL) and  $\text{Et}_2\text{O}$  (2 mL). The organic layer was separated and the aqueous layer extracted with further portions of  $\text{Et}_2\text{O}$  ( $2 \times 5$  mL). The combined organic extracts were dried ( $\text{MgSO}_4$ ), filtered and concentrated under reduced pressure to afford the title compound **71** as a colourless oil (22 mg, 85%);  $R_f$  (10:1 pet. ether:EtOAc) 0.22;  $^1\text{H}$  NMR (400 MHz;  $\text{CDCl}_3$ )  $\delta$  2.42 (2H, t,  $J$  8.0 Hz, H-3), 2.13 (3H, s, H-1), 1.70–1.64 (5H, m,  $\text{CH}$ ), 1.48–1.42 (2H, m,  $\text{CH}$ ), 1.21–1.15 (4H, m,  $\text{CH}$ ), 0.91–0.82 (2H, m,  $\text{CH}$ ); Data in agreement with those reported in the literature.<sup>82</sup>

#### (±)-(R,2E,6Z)-Cyclohepta-2,6-diene-1,2-diylldimethanol (**72**)

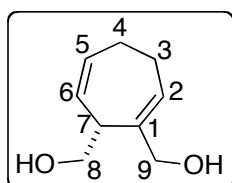

To a stirred solution of **60** (99 mg, 0.666 mmol) in  $\text{CH}_2\text{Cl}_2$  (3 mL) at  $-78$  °C was added DIBAL (3.33 mL, 3.33 mmol, 1M in hexanes). After 10 mins the reaction was warmed to RT. After 4 h the reaction mixture was diluted with  $\text{CH}_2\text{Cl}_2$  (5 mL) followed by the addition of sat. aq. Rochelle's salt (5 mL). The mixture was stirred overnight after which time, the organic layer was separated and the aqueous layer extracted with

further portions of  $\text{CH}_2\text{Cl}_2$  ( $2 \times 10$  mL). The combined organic extracts were dried ( $\text{MgSO}_4$ ), filtered and concentrated under reduced pressure to afford the title compound **72** as a colourless oil (84 mg, 82%);  $R_f$  (1:2 pet. ether: $\text{Et}_2\text{O}$ ) 0.21;  $\nu_{\text{max}}$  (thin film)/ $\text{cm}^{-1}$  3306, 3010, 2925, 2877, 1660;  $^1\text{H}$  NMR (400 MHz;  $\text{CDCl}_3$ )  $\delta$  5.95 (1H, t,  $J$  6.5 Hz, H-2), 5.78–5.72 (1H, m, H-5), 5.47 (1H, ddt,  $J$  12.0, 6.5, 1.5 Hz, H-6), 4.14–3.81 (2H, br s, OH), 3.97–3.96 (2H, m, H-9), 3.77 (1H, dd,  $J$  10.5, 8.5, H-8a), 3.70 (1H, dd,  $J$  10.5, 5.0, H-8b), 3.03–2.97 (1H, m, H-7), 2.54–2.43 (1H, m H-3a), 2.16–2.08 (3H, m, H-3b, H-4);  $^{13}\text{C}$  NMR (101 MHz;  $\text{CDCl}_3$ )  $\delta$  142.4 (C-1), 132.4 (C-5), 130.7 (C-2), 126.7 (C-6), 68.8 (C-9), 65.1 (C-8), 45.6 (C-7), 26.2 (C-3 or C-4), 25.5 (C-3 or C-4);  $m/z$  (ESI): 177 [ $\text{MNa}^+$ ]; HRMS (ESI): calcd. for  $\text{C}_9\text{H}_{14}\text{NaO}_2$ , 177.0886. Found: [ $\text{MNa}^+$ ], 177.0885 (0.1 ppm error).

**(±)-(1*S*,2*R*,7*S*,*Z*)-Bicyclo[5.1.0]oct-3-ene-1,2-diyl dimethanol (**73**) &**

**(±)-(1*R*,2*R*,7*R*,*Z*)-Bicyclo[5.1.0]oct-3-ene-1,2-diyl dimethanol (**74**)**

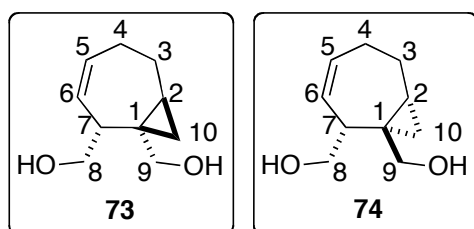

To a stirred solution of  $\text{Et}_2\text{Zn}$  (0.65 mL, 1 mol in hexanes, 0.650 mmol) in  $\text{CH}_2\text{Cl}_2$  (0.2 mL) at 0 °C was added diiodomethane (100  $\mu\text{L}$ , 1.30 mmol). This was stirred for 10 mins before the addition of **72** (45 mg, 0.292 mmol)

in  $\text{CH}_2\text{Cl}_2$  (0.2 mL) *via* cannula. The reaction was stirred at 0 °C for 10 mins, before warming to RT. After 2h the reaction was quenched by the addition of sat.  $\text{NH}_4\text{Cl}$  (aq.) (2mL). The organic layer was separated and the aqueous layer extracted with further portions of  $\text{CH}_2\text{Cl}_2$  ( $2 \times 5$  mL). The combined organic extracts were dried ( $\text{MgSO}_4$ ), filtered and concentrated under reduced pressure to afford the title compound **73** as a colourless oil (6 mg, 13%) and **74** as a colourless oil (5 mg, 10%); **73**  $R_f$  (1:2 pet. ether: $\text{Et}_2\text{O}$ ) 0.19;  $\nu_{\text{max}}$  (thin film)/ $\text{cm}^{-1}$  3301, 3012, 2928, 2880, 1640;  $^1\text{H}$  NMR (400 MHz;  $\text{CDCl}_3$ )  $\delta$  5.54–5.49 (1H, m, H-5), 5.41–5.36 (1H, ddt,  $J$  11.5, 4.0, 2.0 Hz, H-6), 3.97 (1H, dd,  $J$  11.5, 1.0 Hz, H-9a), 3.79–3.73 (2H, m, H-8), 3.22 (2H, br s, OH), 3.01 (1H, d,  $J$  11.5 Hz, H-9b), 2.58–2.49 (1H, m, H-7), 2.39–2.20 (2H, m, H-4), 2.05–1.98 (1H, m, H-3a), 1.65–1.53 (1H, m, H-3b), 0.78 (1H, dd,  $J$  8.5, 4.5 Hz, H-10a), 0.73–0.65 (1H, m, H-10b), 0.48 (1H, td,  $J$  4.5, 1.0 Hz, H-2).  $^{13}\text{C}$

NMR (101 MHz; CDCl<sub>3</sub>) δ 134.4 (C-5), 129.7 (C-6), 65.8 (C-9), 63.1 (C-8), 41.1 (C-7), 30.2 (C-3 or C-4), 29.5 (C-3 or C-4), 22.1 (C-1), 21.4 (C-2), 20.0 (C-10); 191 [MNa<sup>+</sup>]; HRMS (ESI): calcd. for C<sub>10</sub>H<sub>16</sub>NaO<sub>2</sub>, 191.1048. Found: [MNa<sup>+</sup>], 191.1050 (0.3 ppm error); **74** R<sub>f</sub> (1:2 pet. ether:Et<sub>2</sub>O) 0.17; ν<sub>max</sub> (thin film)/cm<sup>-1</sup> 3300, 3004, 2928, 2880, 1643; <sup>1</sup>H NMR (400 MHz; CDCl<sub>3</sub>) δ 5.66–5.50 (1H, m, H-5), 5.46 (1H, dddd, *J* 12.0, 6.5, 2.5, 1.5 Hz, H-6), 3.69–3.65 (1H, m, H-8a), 3.59 (1H, dd, *J* 11.0, 1.5 Hz, H-9a), 3.50–3.44 (1H, m, H-8b), 3.10 (1H, d, *J* 11.0 Hz, H-9b), 3.01–2.96 (1H, m, H-7), 2.4 (2H, br s, OH), 2.30–2.17 (2H, m, H-4), 1.96–1.86 (1H, m, H-3a), 1.50–1.39 (1H, m, H-3b), 0.87–0.82 (1H, m, H-10a), 0.67 (1H, td, *J* 5.0, 1.5 Hz, H-2), 0.60 (1H, dd, *J* 9.0, 5.0 Hz, H-10b). <sup>13</sup>C NMR (101 MHz; CDCl<sub>3</sub>) δ 135.2 (C-5), 130.3 (C-6), 69.5 (C-9), 65.1 (C-8), 38.1 (C-7), 30.0 (C-3 or C-4), 29.2 (C-3 or C-4), 23.3 (C-1), 20.9 (C-2), 20.3 (C-10); 191 [MNa<sup>+</sup>]; HRMS (ESI): calcd. for C<sub>10</sub>H<sub>16</sub>NaO<sub>2</sub>, 191.1048. Found: [MNa<sup>+</sup>], 191.1055 (1.4 ppm error)

**(±)-(1*R*,2*R*,7*R*,*Z*)-Bicyclo[5.1.0]oct-3-ene-1,2-diyl dimethanol (**73**)**

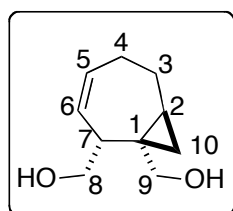

To a stirred solution of LiAlH<sub>4</sub> (16 mg, 0.426 mmol) in THF (2 mL) at 0 °C was added a solution of **62** (35 mg, 0.213 mmol) in THF (2 mL), *via* cannula. The reaction mixture was warmed to RT and stirred for 45 mins. After being cooled to 0 °C, Na<sub>2</sub>SO<sub>4</sub>·10H<sub>2</sub>O was cautiously added until on further addition fizzing could no longer be observed. The aluminium salts were removed by filtration and washed with EtOAc (15 mL). The filtrate was concentrated under reduced pressure to give the crude product. This was purified by flash column chromatography on silica gel, eluting with pet. ether:Et<sub>2</sub>O (4:1 → 1:1) to afford the title compound **73** as a colourless oil (16 mg, 44%); *For data see page 96.*

**(±)-((1*S*,2*Z*,5*Z*,7*R*)-7-((*tert*-Butyldimethylsilyloxy)methyl)cyclohepta-2,5-dienyl)methanol (**76**)**

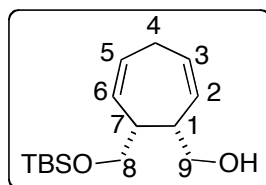

To a stirred solution of **59** (500 mg, 3.25 mmol) in THF (6 mL) was added NaH (156 mg, 3.90 mmol, 60% dispersion in

mineral oil) at RT and the reaction mixture stirred for 45 mins before the addition of TBSCl (588 mg, 3.90 mmol). After 2h the reaction was quenched with sat.  $K_2CO_3$  (aq.) (5 mL) followed by  $Et_2O$  (5 mL). The organic layer was separated and the aqueous layer extracted with further portions of  $Et_2O$  ( $2 \times 5$  mL). The combined organic extracts were dried ( $MgSO_4$ ), filtered and concentrated under reduced pressure. The resulting crude product was purified by flash column chromatography on silica gel, eluting with pet. ether:EtOAc (40:1  $\rightarrow$  5:1) to afford the title compound **76** as a colourless oil (775 mg, 89%);  $R_f$  (1:1 pet. ether:EtOAc) 0.72;  $\nu_{max}$  (thin film)/ $cm^{-1}$  3430, 3014, 2955, 2929, 2884, 2858;  $^1H$  NMR (400 MHz;  $CDCl_3$ )  $\delta$  5.77–5.69 (2H, m, H-2 or H-3 or H-5 or H-6), 5.66–5.64 (2H, m, H-2 or H-3 or H-5 or H-6), 3.84–3.80 (1H, m, H-8a or H-9a), 3.74 (1H, dd,  $J$  10.5, 8.0 Hz, H-8a or H-9a), 3.68–3.64 (1H, m, H-8b or H-9b), 3.56 (1H, dd,  $J$  10.5, 3.0 Hz, H-8b or H-9b), 3.07–3.00 (1H, m, H-4a), 2.89–2.85 (1H, m, H-1 or H-7), 2.80–2.76 (1H, m, H-1 or H-7), 2.71–2.62 (1H, m, H-4b), 0.91 (9H, s,  $C(CH_3)_3$ ), 0.10 (6H, s,  $SiCH_3$ );  $^{13}C$  NMR (101 MHz;  $CDCl_3$ )  $\delta$  130.8 (C-2 or C-3 or C-5 or C-6), 130.2 (C-2 or C-3 or C-5 or C-6), 129.1 (C-2 or C-3 or C-5 or C-6), 128.8 (C-2 or C-3 or C-5 or C-6), 64.5 (C-8 or C-9), 64.4 (C-8 or C-9), 44.4 (C-1 or C-7), 44.2 (C-1 or C-7), 29.8 (C-4), 26.0 ( $C(CH_3)_3$ ), 18.4 ( $C(CH_3)_3$ ),  $-5.4$  ( $SiCH_3$ ),  $-5.4$  ( $SiCH_3$ );  $m/z$  (ESI): 291 [ $MNa^+$ ]; HRMS (ESI): calcd. for  $C_{15}H_{28}NaO_2Si$ , 291.1751. Found: [ $MNa^+$ ], 291.1745 (2.2 ppm error).

**( $\pm$ )-(1*S*,2*Z*,5*Z*,7*R*)-7-((*tert*-Butyldimethylsilyloxy)methyl)cyclohepta-2,5-dienecarbaldehyde (**77**)**

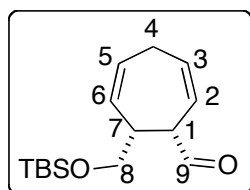

To a stirred solution of **76** (725 mg, 2.70 mmol) in  $CH_2Cl_2$  (27 mL), at 0 °C was added Dess-Martin Periodinane (1.72 g, 4.05 mmol). The reaction mixture was warmed to RT and allowed to stir for 1 h. It was then diluted with  $CH_2Cl_2$  (20 mL), and quenched with a 1:1 solution of sat.  $Na_2CO_3$  (aq.) and sat.  $Na_2S_2O_3$  (aq.) (40 mL). After vigorous stirring for 30 mins, the organic layer was separated and the aqueous layer extracted with further portions of  $CH_2Cl_2$  ( $2 \times 50$  mL). The combined organic extracts were dried ( $MgSO_4$ ), filtered and concentrated under reduced pressure to

afford the title compound **77** as a colourless oil (699 mg, 97%);  $R_f$  (5:1 pet. ether:EtOAc) 0.63;  $\nu_{\max}$  (thin film)/ $\text{cm}^{-1}$  2954, 2930, 2885, 2858, 1725, 1692;  $^1\text{H}$  NMR (400 MHz;  $\text{CDCl}_3$ )  $\delta$  9.62 (1H, br s, H-9) 6.00 (1H, ddd,  $J$  11.0, 5.5, 2.5, Hz, H-3 or H-5), 5.89–5.84 (1H, m, H-3 or H-5), 5.72–5.63 (2H, m, H-2 & H-6), 3.57 (2H, m, H-8), 3.41–3.38 (1H, m, H-1 or H-7), 3.18–3.14 (1H, m, H-1 or H-7), 3.10–3.02 (1H, m, H-4a), 2.78 (1H, dt,  $J$  21.0, 5.5 Hz, H-4b), 0.91 (9H, s,  $\text{C}(\text{CH}_3)_3$ ), 0.10 (6H, s,  $\text{SiCH}_3$ );  $^{13}\text{C}$  NMR (101 MHz;  $\text{CDCl}_3$ )  $\delta$  201.1 (C-9), 130.2 (C-2 or C-3 or C-5 or C-6), 129.2 (C-2 or C-3 or C-5 or C-6), 128.8 (C-2 or C-3 or C-5 or C-6), 125.1 (C-2 or C-3 or C-5 or C-6), 63.9 (C-8), 53.25 (C-1), 42.7 (C-7), 30.1 (C-4), 26.0 ( $\text{C}(\text{CH}_3)_3$ ), 18.4 ( $\text{C}(\text{CH}_3)_3$ ), -5.5 ( $\text{SiCH}_3$ ), -5.5 ( $\text{SiCH}_3$ ).

**(±)-(R,1E,5Z)-7-((tert-Butyldimethylsilyloxy)methyl)cyclohepta-1,5-dienecarbaldehyde (78)**

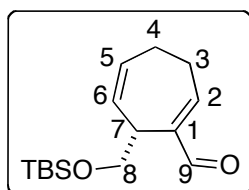

To a solution of **77** (685 mg, 2.57 mmol) in THF (24 mL) at 0 °C was added DBU (0.38 mL, 2.57 mmol). After 20 mins the reaction was quenched with  $\text{NH}_4\text{Cl}$  (aq.) (30 mL), the organic layer was separated and the aqueous layer extracted with portions of EtOAc ( $2 \times 50$  mL). The combined organic extracts were dried ( $\text{MgSO}_4$ ), filtered and concentrated under reduced pressure. The resulting crude product was purified by flash column chromatography on silica gel, eluting with pet. ether:EtOAc (20:1) to afford the title compound **78** as a colourless oil (525 mg, 77%);  $R_f$  (5:1 pet. ether:EtOAc) 0.59;  $\nu_{\max}$  (thin film)/ $\text{cm}^{-1}$  2954, 2929, 2887, 2857, 1689, 1649;  $^1\text{H}$  NMR (400 MHz;  $\text{CDCl}_3$ )  $\delta$  9.32 (1H, s, H-9), 6.95 (1H dd,  $J$  7.5, 5.5 Hz, H-2), 5.87–5.82 (1H, m, H-5), 5.66–5.60 (1H, m, H-6), 3.69–3.65 (2H, m, H-8), 3.64–3.61 (1H, m, H-7), 2.91–2.82 (1H, m, H-4a), 2.46–2.33 (2H, m, H-4b & H-3a), 2.22–2.14 (1H, m, H-3b), 0.86 (9H, s,  $\text{C}(\text{CH}_3)_3$ ), 0.02 (3H, s,  $\text{SiCH}_3$ ), 0.01 (3H, s,  $\text{SiCH}_3$ );  $^{13}\text{C}$  NMR (101 MHz;  $\text{CDCl}_3$ )  $\delta$  194.4 (C-9), 156.8 (C-2), 144.7 (C-1), 130.8 (C-5 or C-6), 128.6 (C-5 or C-6), 66.0 (C-8), 40.0 (C-7), 27.7 (C-3 or C-4), 26.1 ( $\text{C}(\text{CH}_3)_3$ ), 25.5 (C-3 or C-4), 18.4 ( $\text{C}(\text{CH}_3)_3$ ), -5.4 ( $\text{SiCH}_3$ ), -5.4 ( $\text{SiCH}_3$ );  $m/z$  (ESI): 289 [ $\text{MNa}^+$ ]; HRMS (ESI): calcd. for  $\text{C}_{15}\text{H}_{26}\text{NaO}_2\text{Si}$ , 289.1594. Found: [ $\text{MNa}^+$ ], 289.1583 (3.7 ppm error).



**(±)-((*R,1E,5Z*)-7-((*tert*-Butyldimethylsilyloxy)methyl)cyclohepta-1,5-dienyl)methanol (79)**

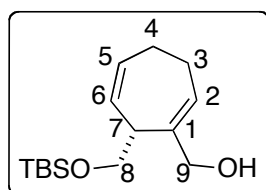

To a stirred solution of **78** (14 mg, 0.053 mmol) in CH<sub>2</sub>Cl<sub>2</sub> (2 mL) at 0 °C was added DIBAL (0.208 mL, 1M in hexanes). After 30 mins the reaction mixture was diluted with CH<sub>2</sub>Cl<sub>2</sub> (5 mL) and washed with Rochelle's salt (5 mL). The organic layer was separated and the aqueous layer extracted with portions of EtOAc (2 × 10 mL). The combined organic extracts were dried (MgSO<sub>4</sub>), filtered and concentrated under reduced pressure. The resulting crude product was purified by flash column chromatography on silica gel, eluting with pet. ether:Et<sub>2</sub>O (1:2) to afford the title compound **79** as a colourless oil (9 mg, 64%); R<sub>f</sub> (1:1 pet. ether:EtOAc) 0.75;  $\nu_{\max}$  (thin film)/cm<sup>-1</sup> 3337, 3010, 2927, 2856; <sup>1</sup>H NMR (400 MHz; CDCl<sub>3</sub>)  $\delta$  5.96–5.92 (1H, m, H-2), 5.79–5.73 (1H, m, H-6), 5.52–5.45 (1H, m, H-5), 4.01 (1H, dd, *J* 11.5, 4.0 Hz, H-9a), 3.94 (1H, dd, *J* 11.5, 6.0 Hz, H-9b), 3.83 (1H, dd, *J* 9.5, 9.5 Hz, H-8a), 3.72 (1H, dd, *J* 9.5, 5.0 Hz, H-8b), 3.21–3.16 (1H, m, H-7), 3.07–3.02 (1H, m, H-3 or H-4), 2.56–2.47 (1H, m, H-3 or H-4), 2.17–2.05 (3H, m, OH + H-3 or H-4), 0.91 (s, 9H, C(CH<sub>3</sub>)<sub>3</sub>), 0.09 (3H, s, SiCH<sub>3</sub>), 0.09 (3H, s, SiCH<sub>3</sub>); <sup>13</sup>C NMR (101 MHz; CDCl<sub>3</sub>)  $\delta$  143.6 (C-1), 132.4 (C-6), 128.5 (C-5), 124.6 (C-2), 68.3 (C-8), 64.8 (C-9), 42.9 (C-7), 26.4 (C-3 or C-4), 26.1 (C(CH<sub>3</sub>)<sub>3</sub>), 25.0 (C-3 or C-4), 18.4 (C(CH<sub>3</sub>)<sub>3</sub>), -5.5 (SiCH<sub>3</sub>), -5.5 (SiCH<sub>3</sub>) m/z (ESI): 291 [MNa<sup>+</sup>]; HRMS (ESI): calcd. for C<sub>15</sub>H<sub>28</sub>NaO<sub>2</sub>Si, 291.1751 Found: [MNa<sup>+</sup>], 291.1746 (1.1 ppm error).

**(±)-((*1S,2Z,5Z,7R*)-7-((*tert*-Butyldiphenylsilyloxy)methyl)cyclohepta-2,5-dienyl)methanol (82)**

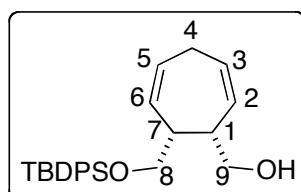

To a solution of **59** (100 mg, 0.650 mmol) in THF (3 mL) was added NaH (31 mg, 0.280 mmol, 60% dispersion in mineral oil) at RT and the reaction mixture stirred for 45 mins before the addition of TBDPSCI (0.17 mL, 0.650 mmol). After 45 mins the reaction was quenched with K<sub>2</sub>CO<sub>3</sub> (aq.) (5 mL) followed by Et<sub>2</sub>O (5 mL). The organic layer was separated and the aqueous layer extracted with

further portions of Et<sub>2</sub>O (2 × 5 mL). The combined organic extracts were dried (MgSO<sub>4</sub>), filtered and concentrated under reduced pressure. The resulting crude product was purified by flash column chromatography on silica gel, eluting with pet. ether:EtOAc (40:1 → 5:1) to afford the title compound **82** as a colourless oil (196 mg, 77%); R<sub>f</sub> (1:1 pet. ether:EtOAc) 0.73; ν<sub>max</sub> (thin film)/cm<sup>-1</sup> 3364, 3071, 3015, 2931, 2858, 1471, 1428; <sup>1</sup>H NMR (400 MHz; CDCl<sub>3</sub>) δ 7.71 (4H, ddd, *J* 8.0, 1.5, 0.5 Hz, Ar-H), 7.48–7.40 (6H, m, Ar-H), 5.82–5.71 (2H, m, H-2 or H-3 or H-5 or H-6), 5.63–5.51 (2H, m, H-2 or H-3 or H-5 or H-6), 3.84–3.71 (3H, m, H-8 or H-9), 3.61 (1H, dd, *J* 10.5, 4.0 Hz, H-8 or H-9), 3.07–2.96 (2H, m, H-1 or H-7 & H-4a), 2.88–2.80 (1H, m, H-1 or H-7), 2.64 (1H, ddd, *J* 20.5, 6.0, 6.0 Hz, H-4b), 1.09 (9H, s, C(CH<sub>3</sub>)<sub>3</sub>); <sup>13</sup>C NMR (101 MHz; CDCl<sub>3</sub>) δ 135.7 (Ar-CH), 135.7 (Ar-CH), 133.0 (Ar-CH), 133.0 (Ar-C), 130.9 (CH), 130.3 (CH), 130.0 (CH), 129.2 (CH), 128.8 (CH), 127.9 (CH), 65.2 (C-8 or C-9), 64.8 (C-8 or C-9), 43.8 (C-1 or C-7), 43.5 (C-1 or C-7), 29.7 (C-4), 26.9 (C(CH<sub>3</sub>)<sub>3</sub>), 19.2 (C(CH<sub>3</sub>)<sub>3</sub>); m/z (ESI): 415 [MNa<sup>+</sup>]; HRMS (ESI): calcd. for C<sub>25</sub>H<sub>32</sub>NaO<sub>2</sub>Si, 415.2069. Found: [MNa<sup>+</sup>], 415.2076 (2.5 ppm error).

**(±)-(1*S*,2*Z*,5*Z*,7*R*)-7-((*tert*-Butyldiphenylsilyloxy)methyl)cyclohepta-2,5-dienecarbaldehyde (**83**)**

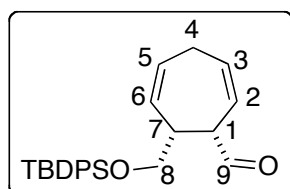

To a stirred solution of **82** (510 mg, 1.30 mmol) in CH<sub>2</sub>Cl<sub>2</sub> (13 mL), at 0 °C was added Dess-Martin Periodinane (827 mg, 1.95 mmol). The reaction mixture was warmed to RT and allowed to stir for 1 h. It was then diluted with CH<sub>2</sub>Cl<sub>2</sub> (15 mL), and quenched with a 1:1 solution of sat. Na<sub>2</sub>CO<sub>3</sub> (aq.) and sat. Na<sub>2</sub>S<sub>2</sub>O<sub>3</sub> (aq.) (30 mL). After vigorous stirring for 30 mins, the organic layer was separated and the aqueous layer extracted with further portions of CH<sub>2</sub>Cl<sub>2</sub> (2 × 30 mL). The combined organic extracts were dried (MgSO<sub>4</sub>), filtered and concentrated under reduced pressure to afford the title compound **83** as a colourless oil (511 mg, 100%) which was used in the next step without purification; R<sub>f</sub> (5:1 pet. ether:EtOAc) 0.81; <sup>1</sup>H NMR (400 MHz; CDCl<sub>3</sub>) δ 9.76 (1H, s, H-9), 7.63 (4H, ddd, *J* 8.0, 6.0, 1.5 Hz, Ar-H), 7.45–7.36 (6H, m, Ar-H), 6.06 (1H, ddd, *J* 11.0, 5.5, 3.0 Hz, H-2 or H-3 or H-5 or H-6), 5.88–5.83 (1H, m, H-2 or H-3 or H-5 or H-6), 5.62–5.60 (2H, m, H-2 or H-3 or H-5

or H-6), 3.65–3.52 (2H, m, H-8), 3.50–3.45 (1H, m, H-1), 3.24–3.20 (1H, m, H-7), 3.07–3.00 (1H, m, H-4a), 2.78–2.70 (1H, m, H-4b), 1.01 (9H, s, C(CH<sub>3</sub>)<sub>3</sub>); m/z (ESI): 391 [MH<sup>+</sup>]; HRMS (ESI): calcd. for C<sub>25</sub>H<sub>31</sub>O<sub>2</sub>Si, 391.2088. Found: [MH<sup>+</sup>], 391.2089 (0.3 ppm error).

**(±)-(R,1E,5Z)-7-((*tert*-Butyldiphenylsilyloxy)methyl)cyclohepta-1,5-dienecarbaldehyde (**84**)**

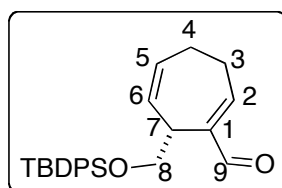

To a solution of **83** (480 mg, 1.23 mmol) in THF (40 mL) at 0 °C was added DBU (0.184 mL, 1.23 mmol). After 20 mins the reaction was diluted with EtOAc (30 mL), quenched with NH<sub>4</sub>Cl (aq.) (30 mL) and the organic layer separated. The aqueous layer was extracted with further portions of EtOAc (2 × 50 mL). The combined organic extracts were dried (MgSO<sub>4</sub>), filtered and concentrated under reduced pressure. The resulting crude product was purified by flash column chromatography on silica gel, eluting with pet. ether:Et<sub>2</sub>O (10:1) to afford the title compound **84** as a colourless oil (413 mg, 86%); R<sub>f</sub> (5:1 pet. ether:EtOAc) 0.72; ν<sub>max</sub> (thin film)/cm<sup>-1</sup> 3070, 3049, 3014, 2930, 2857, 1687, 1649, 1471, 1427; <sup>1</sup>H NMR (400 MHz; CDCl<sub>3</sub>) δ 9.30 (1H, s, H-9), 7.65 (4H, ddd, *J* 8.0, 6.0, 1.5 Hz, Ar-H), 7.43–7.35 (6H, m, Ar-H), 6.89 (1H, dd, *J* 7.5, 5.5 Hz, H-2), 5.86–5.81 (1H, m, H-5), 5.69–5.64 (1H, m, H-6), 3.78–3.75 (1H, m, H-7), 3.72–3.70 (2H, m, H-8), 2.81–2.73 (1H, m, H-3a), 2.38–2.26 (2H, m H-3b & H-4a), 2.18–2.14 (1H, m, H-4b), 1.02 (9H, s, C(CH<sub>3</sub>)<sub>3</sub>); <sup>13</sup>C NMR (101 MHz; CDCl<sub>3</sub>) δ 194.1 (C-9), 156.3 (C-2), 144.8 (C-1), 135.9 (C-5), 133.7 (Ar-C), 131.0 (Ar-CH), 129.7 (Ar-CH), 128.4 (C-6), 127.7 (Ar-CH), 66.4 (C-8), 39.3 (C-7), 27.5 (C-3 or C-4), 27.0 (C(CH<sub>3</sub>)<sub>3</sub>), 25.4 (C-3 or C-4), 19.4 (C(CH<sub>3</sub>)<sub>3</sub>); m/z (ESI): 413 [MNa<sup>+</sup>]; HRMS (ESI): calcd. for C<sub>25</sub>H<sub>30</sub>NaO<sub>2</sub>Si, 413.1907. Found: [MNa<sup>+</sup>], 413.1907 (0.8 ppm error).

**(±)-((*R*,1*E*,5*Z*)-7-((*tert*-Butyldiphenylsilyloxy)methyl)cyclohepta-1,5-dienyl)methanol (**85**)**

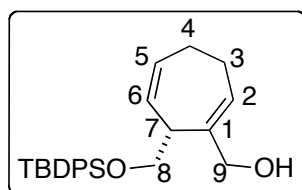

To a stirred solution of **84** (380 mg, 0.973 mmol) in CH<sub>2</sub>Cl<sub>2</sub> (11 mL) at 0 °C was added DIBAL (1.46 mL, 1M in hexanes). After 30 mins the reaction mixture was diluted with CH<sub>2</sub>Cl<sub>2</sub> (10 mL) and washed with Rochelle's salt (10 mL). The organic layer was separated and the aqueous layer extracted with portions of EtOAc (2 × 10 mL). The combined organic extracts were dried (MgSO<sub>4</sub>), filtered and concentrated under reduced pressure. The resulting crude product was purified by flash column chromatography on silica gel, eluting with pet. ether:EtOAc (10:1) to afford the title compound **85** as a colourless oil (240 mg, 63%); R<sub>f</sub> (5:1 pet. ether:EtOAc) 0.39; ν<sub>max</sub> (thin film)/cm<sup>-1</sup> 3378, 3071, 3013, 2920, 2857, 1472, 1427; <sup>1</sup>H NMR (400 MHz; CDCl<sub>3</sub>) δ 7.71 (4H, ddd, *J* 8.0, 6.0, 1.5 Hz, Ar-H), 7.47–7.38 (6H, m, Ar-H), 5.97 (1H, dd, *J* 7.5, 5.5 Hz, H-2), 5.74–5.69 (1H, m, H-5), 5.51–5.45 (1H, m, H-6), 4.10 (1H, d, *J* 12.0 Hz, H-9a), 4.00 (1H, d, *J* 12.0 Hz, H-9b), 3.86 (1H, dd *J* 9.5, 9.5 Hz, H-8a), 3.73 (1H, dd, *J* 9.5, 5.5 Hz, H-8b), 3.13 (1H, m, H-7), 2.78 (1H, br s, OH), 2.44–2.37 (1H, m H-3a), 2.11–2.01 (3H, m, H-3b + H-4), 1.08 (9H, s, C(CH<sub>3</sub>)<sub>3</sub>); <sup>13</sup>C NMR (101 MHz; CDCl<sub>3</sub>) δ 143.0 (C-1), 135.8 (Ar-CH), 135.8 (Ar-CH), 133.1 (Ar-C), 132.4 (C-5), 129.9 (Ar-CH), 128.5 (C-2), 127.9 (Ar-CH), 126.6 (C-6), 68.8 (C-8 or C-9), 66.5 (C-8 or C-9), 44.6 (C-7), 26.9 (C(CH<sub>3</sub>)<sub>3</sub>), 26.4 (C-3 or C-4), 25.2 (C-3 or C-4), 19.2 (C(CH<sub>3</sub>)<sub>3</sub>); m/z (ESI): 415 [MNa<sup>+</sup>]; HRMS (ESI): calcd. for C<sub>25</sub>H<sub>32</sub>NaO<sub>2</sub>Si, 415.2064. Found: [MNa<sup>+</sup>], 415.2058 (1.5 ppm error).

**Triisopropylsulfonium tetrafluoroborate (**51**)<sup>23</sup>**

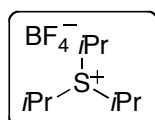

To a stirring solution of diisopropyl sulfide (7.3 mL, 0.049 mol) in *iso*-propyl alcohol (15 mL) was added methanesulfonic acid (32 mL, 500 mmol). The reaction was heated to reflux and held at temperature for 5 days. The brown solution was cooled to RT and tetrafluoroboric acid (31.5 mL, 500 mmol) added. The mixture was stirred for 15 mins, water (150 mL) and CH<sub>2</sub>Cl<sub>2</sub> (150 mL) were added and the organic layer separated. The aqueous layer was extracted with

further portions of  $\text{CH}_2\text{Cl}_2$  ( $2 \times 150$  mL). The combined organic extracts were dried ( $\text{MgSO}_4$ ), filtered and concentrated under reduced pressure to give an orange solid. This was suspended in  $\text{Et}_2\text{O}$  (100 mL) and filtered. The filtrand was washed with  $\text{Et}_2\text{O}$  ( $2 \times 50$  mL) to give a white precipitate, which was recrystallised from  $\text{MeOH}/\text{Et}_2\text{O}$  to afford the title compound **51** as a white solid (6.90 g, 56%);  $^1\text{H}$  NMR (400 MHz;  $\text{D}_2\text{O}$ )  $\delta$  3.88 (3H, septet,  $J$  7.0 Hz,  $\text{CH}$ ), 1.54 (18H, d,  $J$  7.0 Hz, 18H,  $\text{CH}_3$ ); Data in agreement with those reported in the literature.<sup>23</sup>

### Triisopropylsulfoxonium tetrafluoroborate (**52**)<sup>23</sup>

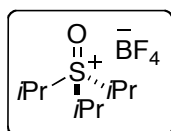

To a stirring solution of **51** (4.96 g, 20.0 mmol) in water (400 mL) at 0 °C was added 2-Nitrobenzenesulfonyl chloride (8.86 g, 40.0 mmol) followed by barium hydroxide octahydrate (18.9 g, 60.0 mmol) to give a cream suspension. Hydrogen peroxide (12.3 mL, 120.0 mmol) was added drop-wise over 1 h. The suspension was stirred for a further 1 h at 0 °C, warmed to RT and stirred for 18 h. The reaction mixture was filtered through celite, washed with water (100 mL) and concentrated under reduced pressure.  $\text{CH}_2\text{Cl}_2$  (250 mL) and ( $\text{MgSO}_4$ ) were added, the suspension filtered and the filtrate concentrated under reduced pressure to give the crude product. This was recrystallised from  $\text{MeOH}/\text{Et}_2\text{O}$  to afford the title compound **52** as a white solid (3.31 g, 63%);  $^1\text{H}$  NMR (400 MHz;  $\text{D}_2\text{O}$ )  $\delta$  4.43 (3H, septet,  $J$  7.0 Hz,  $\text{CH}$ ), 1.61 (18H, d,  $J$  7.0 Hz,  $\text{CH}_3$ ); Data in agreement with those reported in the literature.<sup>23</sup>

### (±)-(1*R*,2*R*)-Diethyl 3,3-dimethylcyclopropane-1,2-dicarboxylate (**53**)

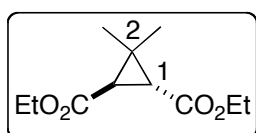

To a stirred solution of NaH (920 mg, 23.0 mmol, 60% dispersion in mineral oil) in DMF (150 mL) at 0 °C was added **52** (6.08 g, 23.0 mmol). This solution was allowed to stir for 5 mins before the drop-wise addition of a solution of diethyl fumarate (3.31 g, 19.2 mmol) in DMF (35 mL). The reaction mixture was allowed to stir at 0 °C for 5 mins before being warmed to RT and stirred for a further 2 h. It was diluted with  $\text{Et}_2\text{O}$  (115

mL), washed with sat.  $\text{NH}_4\text{Cl}$  (aq.) (100 mL), the organic layer separated and the aqueous layer extracted with further portions of  $\text{Et}_2\text{O}$  ( $2 \times 150$  mL). The combined organic extracts were dried ( $\text{MgSO}_4$ ), filtered and concentrated under reduced pressure. The resulting crude product was purified by flash column chromatography on silica gel, eluting with pet. ether: $\text{Et}_2\text{O}$  (7:1  $\rightarrow$  4:1) to afford the title compound **53** as a colourless oil (3.01 g, 73%);  $R_f$  (3:1 pet. ether: $\text{EtOAc}$ ) 0.59;  $\nu_{\text{max}}$  (thin film)/ $\text{cm}^{-1}$  2982, 1723;  $^1\text{H}$  NMR (400 MHz;  $\text{CDCl}_3$ )  $\delta$  4.20–4.08 (4H, m,  $\text{CH}_3\text{CH}_2\text{O}$ ), 2.21 (2H, s, H-1), 1.29 (6H, s,  $\text{CH}_3$ ), 1.27 (6H, t,  $J$  7.0,  $\text{CH}_3\text{CH}_2\text{O}$ );  $^{13}\text{C}$  NMR (101 MHz;  $\text{CDCl}_3$ )  $\delta$  170.6 ( $\text{C}=\text{O}$ ), 60.9 ( $\text{CH}_3\text{CH}_2\text{O}$ ), 33.7 (C-1), 30.4 (C-2), 20.5 ( $\text{CH}_3$ ), 14.4 ( $\text{CH}_3\text{CH}_2\text{O}$ );  $m/z$  (ESI): 215 [ $\text{MH}^+$ ]; HRMS (ESI): calcd. for  $\text{C}_{11}\text{H}_{19}\text{O}_4$ , 215.1278. Found: [ $\text{MH}^+$ ], 215.1283 (2.3 ppm error).

**(±)-((1*R*,2*R*)-3,3-Dimethylcyclopropane-1,2-diyl)dimethanol (56a)**

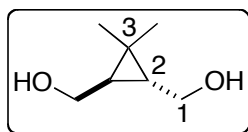

To a stirred solution of  $\text{LiAlH}_4$  (963 mg, 25.4 mmol) in THF (25 mL) at 0 °C was added a solution of **53** (3.63 g, 16.9 mmol) in THF (9 mL), over a period of 1 h *via* a dropping syringe. The reaction mixture was then heated at reflux at 70 °C for 2 h, before being cooled to RT and stirred for 18 h. After being cooled to 0 °C the mixture was diluted with  $\text{EtOAc}$  (6 mL), washed cautiously with sat.  $\text{NH}_4\text{Cl}$  (aq.) (6 mL). The resulting suspension was filtered, and the insoluble salts were washed with further portions of  $\text{EtOAc}$  ( $2 \times 10$  mL). The filtrate was concentrated under reduced pressure, and the residue taken up in  $\text{EtOAc}$  (10 mL). The solution was then dried ( $\text{MgSO}_4$ ), filtered and concentrated under reduced pressure to afford the title compound **56a** as a colourless oil. (1.89 g, 86%);  $R_f$  ( $\text{EtOAc}$ ) 0.23;  $\nu_{\text{max}}$  (thin film)/ $\text{cm}^{-1}$  3337, 2926, 2874;  $^1\text{H}$  NMR (400 MHz;  $\text{CDCl}_3$ )  $\delta$  3.77–3.69 (2H, m, H-1a), 3.59–3.50 (2H, m, H-1b), 2.23 (2H, broad s,  $\text{OH}$ ), 1.13 (6H, s,  $\text{CH}_3$ ), 0.85–0.79 (2H, m, H-2);  $^{13}\text{C}$  NMR (101 MHz;  $\text{CDCl}_3$ )  $\delta$  63.1 (C-1), 32.1 (C-2), 21.9 ( $\text{CH}_3$ ), 20.8 (C-3);  $m/z$  (ESI): 153 [ $\text{MNa}^+$ ]; HRMS (ESI): calcd. for  $\text{C}_7\text{H}_{14}\text{NaO}_2$ , 153.0886. Found: [ $\text{MNa}^+$ ], 153.0888 (–1.5 ppm error).

**Diethyl (±)-(2*E*,2'*E*)-3,3'-[(1*R*,2*R*)-3,3-dimethylcyclopropane-1,2-diyl]bisprop-2-enoate (**57a**) & Diethyl (±)-(2*Z*,2'*E*)-3,3'-[(1*R*,2*R*)-3,3-dimethylcyclopropane-1,2-diyl]bisprop-2-enoate (**57b**)**

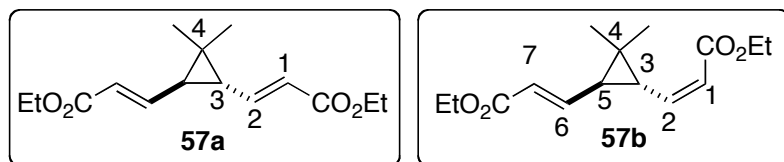

To a stirred solution of **56a** (934 mg, 7.17 mmol) in  $\text{CHCl}_3$  (70

mL) was added manganese (IV) dioxide (12.4 g, 143 mmol) and (carbethoxymethylene) triphenyl phosphorane (5.99 g, 17.2 mmol). The resulting suspension was stirred vigorously with heating to maintain gentle reflux for 18 h. After cooling to room temperature, the suspension was filtered through Celite, and washed with  $\text{CHCl}_3$  (25 mL). The filtrate was concentrated under reduced pressure to give the crude product. This was purified by flash column chromatography on silica gel, eluting with pet. ether:EtOAc (20:1) to afford the title compound **57a** as a white solid (1.31 g, 69%), and **57b** as a colourless oil (85 mg, 4%); **57a**  $R_f$  (1:1 pet. ether:Et<sub>2</sub>O) 0.38; mp 49–52 °C;  $\nu_{\text{max}}$  (thin film)/cm<sup>-1</sup> 2934, 1687, 1616; <sup>1</sup>H NMR (400 MHz;  $\text{CDCl}_3$ )  $\delta$ : 6.73–6.63 (2H, m, H-2), 5.91 (2H, d,  $J$  15.5, H-1), 4.17 (4H, q,  $J$  7.0,  $\text{CH}_3\text{CH}_2\text{O}$ ), 1.77–1.72 (2H, m, H-3), 1.27 (6H, t,  $J$  7.0,  $\text{CH}_3\text{CH}_2\text{O}$ ), 1.23 (6H, s, H-5 & H-6); <sup>13</sup>C NMR (101 MHz;  $\text{CDCl}_3$ )  $\delta$  166.4 ( $\text{C}=\text{O}$ ), 147.5 (C-2), 121.5 (C-1), 60.3 ( $\text{CH}_3\text{CH}_2\text{O}$ ), 38.5 (C-3), 30.3 (C-4), 22.4 (2 ×  $\text{CH}_3$ ), 14.4 ( $\text{CH}_3\text{CH}_2\text{O}$ );  $m/z$  (ESI): 267 [ $\text{MH}^+$ ]; HRMS: calcd. for  $\text{C}_{15}\text{H}_{23}\text{O}_4$ , 267.1591. Found: [ $\text{MH}^+$ ], 267.1581 (3.6 ppm error); **57b**  $R_f$  (1:1 pet. ether:Et<sub>2</sub>O) 0.39;  $\nu_{\text{max}}$  (thin film)/cm<sup>-1</sup> 2934, 1688, 1615; <sup>1</sup>H NMR (400 MHz;  $\text{CDCl}_3$ )  $\delta$  6.74 (1H, dd,  $J$  15.5, 10.0, H-6), 5.91 (1H, d,  $J$  15.5, H-5), 5.87–5.77 (2H, m, H-2 & H-1), 4.21–4.14 (4H, m,  $\text{CH}_3\text{CH}_2\text{O}$ ), 3.08 (1H, dd,  $J$  10.0, 5.0, H-5), 1.65 (1H, dd,  $J$  10.0, 5.0, H-3), 1.31–1.27 (6H, m,  $\text{CH}_3\text{CH}_2\text{O}$ ), 1.26 (3H, s,  $\text{CH}_3$ ), 1.21 (3H, s,  $\text{CH}_3$ ); <sup>13</sup>C NMR (101 MHz;  $\text{CDCl}_3$ )  $\delta$  166.8 ( $\text{C}=\text{O}$ ), 166.5 ( $\text{C}=\text{O}$ ), 148.3 (C-6 or C-2) 148.1 (C-6 or C-2), 121.2 (C-7 or C-1), 119.9 (C-7 or C-1), 60.3 ( $\text{CH}_3\text{CH}_2\text{O}$ ), 60.0 ( $\text{CH}_3\text{CH}_2\text{O}$ ), 39.7 (C-5), 35.6 (C-3), 30.6 (C-4), 22.6 ( $\text{CH}_3$ ), 22.3 ( $\text{CH}_3$ ), 14.5 ( $\text{CH}_3\text{CH}_2\text{O}$ ), 14.4 ( $\text{CH}_3\text{CH}_2\text{O}$ );  $m/z$  (ESI): 267 [ $\text{MH}^+$ ]; HRMS: calcd. for  $\text{C}_{15}\text{H}_{23}\text{O}_4$ , 267.1591. Found: [ $\text{MH}^+$ ], 267.1587 (1.1 ppm error).

**(±)-1,2-Diethyl 5,5 dimethylcyclohepta-1 (7),2-diene-1,2-dicarboxylate (89)**

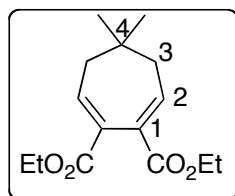

Sodium ethoxide (1 mL, 0.563 M), prepared in situ by the addition of sodium (129 mg, 5.63 mmol) to ethanol (10 mL) and stirring under argon for ~10 mins, was added to **57a** (100 mg, 0.375 mmol). The reaction mixture was heated to 90 °C and allowed to reflux for 18 h. After cooling to RT, the reaction mixture was concentrated under reduced pressure and CH<sub>2</sub>Cl<sub>2</sub> (10 mL) added. This was washed with sat. NH<sub>4</sub>Cl (aq.) (5 mL), the organic layer separated and the aqueous layer extracted with further portions of CH<sub>2</sub>Cl<sub>2</sub> (2 × 10 mL). The combined organic extracts were dried (MgSO<sub>4</sub>), filtered and concentrated under reduced pressure. The resulting crude product was purified by flash column chromatography on silica gel, eluting with pet. ether:EtOAc (9:1) to afford the title compound **89** as a colourless oil (80 mg, 80%) R<sub>f</sub> (1:1 pet. ether:EtOAc) 0.66;  $\nu_{\max}$  (thin film)/cm<sup>-1</sup> 2956, 1724; <sup>1</sup>H NMR (400 MHz; CDCl<sub>3</sub>)  $\delta$  7.40–7.37 (2H, m, H-2), 4.18 (4H, q, *J* 7.0, CH<sub>3</sub>CH<sub>2</sub>O), 1.86 (4H, d, *J* 7.5, H-3), 1.26 (6H, t, *J* 7.0, CH<sub>3</sub>CH<sub>2</sub>O), 1.03 (6H, s, CH<sub>3</sub>); <sup>13</sup>C NMR (101 MHz; CDCl<sub>3</sub>)  $\delta$  166.1 (C=O), 145.1 (C-2), 132.3 (C-1), 60.8 (CH<sub>3</sub>CH<sub>2</sub>O), 52.2 (C-4), 40.9 (C-3), 29.4 (CH<sub>3</sub>), 14.3 (CH<sub>3</sub>CH<sub>2</sub>O); *m/z* (ESI) 267 [MH<sup>+</sup>]; HRMS: calcd. for C<sub>15</sub>H<sub>23</sub>O<sub>4</sub>, 267.1591. Found: [MH<sup>+</sup>], 267.1586 (0.6 ppm error).

**(±)-((1*R*,3*R*)-3-((*tert*-Butyldimethylsilyloxy)methyl)-2,2-dimethylcyclopropyl)methanol (93)**

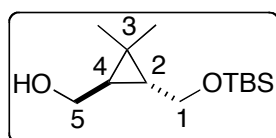

To a stirred solution of **56a** (824 mg, 6.33 mmol) in THF (13 mL) at RT was added NaH (253 mg, 6.33 mmol, 60% dispersion in mineral oil). After 45 mins, by which time a large amount of white precipitate had formed, TBSCl (954 mg, 6.33 mmol) was added. The reaction mixture was allowed to stir for a further 1 h before dilution with Et<sub>2</sub>O (15 mL). It was then washed with sat. K<sub>2</sub>CO<sub>3</sub> (aq.) (10 mL) and brine (10 mL), the organic layer separated and the aqueous layer extracted with further portions of Et<sub>2</sub>O (2 × 20 mL). The combined organic extracts were dried (MgSO<sub>4</sub>), filtered and concentrated under reduced pressure. The resulting crude product was purified by



flash column chromatography on silica gel, eluting with pet. ether:EtOAc (7:1 → 1:1) to afford the title compound **93** as a colourless oil (1.55 g, 65%);  $R_f$  (1:1 pet. ether:EtOAc) 0.46;  $\nu_{\max}$  (thin film)/ $\text{cm}^{-1}$  3392, 2954, 2929, 2858;  $^1\text{H}$  NMR (400 MHz;  $\text{CDCl}_3$ )  $\delta$  3.63–3.59 (4H, m, H-1 & H-5), 1.12 (3H, s,  $\text{CH}_3$ ), 1.11 (3H, s,  $\text{CH}_3$ ), 0.89 (9H, s,  $\text{C}(\text{CH}_3)_3$ ), 0.80–0.70 (2H, m, H-2 & H-4), 0.05 (6H, s,  $\text{SiCH}_3$ );  $^{13}\text{C}$  NMR (101 MHz;  $\text{CDCl}_3$ )  $\delta$  63.5 (C-1 or C-5), 63.4 (C-1 or C-5), 32.0 (C-2 or C-4), 31.9 (C-2 or C-4), 26.1 ( $\text{C}(\text{CH}_3)_3$ ), 21.9 ( $\text{CH}_3$ ), 21.8 ( $\text{CH}_3$ ), 20.8 (C-3), 18.4 ( $\text{C}(\text{CH}_3)_3$ ), –5.0 ( $\text{SiCH}_3$ ), –5.0 ( $\text{SiCH}_3$ );  $m/z$  (ESI) 267 [ $\text{MNa}^+$ ]; HRMS: calcd. for  $\text{C}_{13}\text{H}_{28}\text{NaO}_2\text{Si}$ , 267.1751. Found: [ $\text{MNa}^+$ ], 267.1748 (1.0 ppm error).

**(±)-(1*R*,3*R*)-3-((*tert*-Butyldimethylsilyloxy)methyl)-2,2-dimethylcyclopropanecarbaldehyde (**94**)**

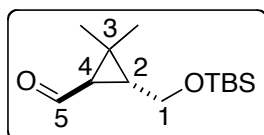

To a stirred solution of **93** (980 mg, 4.00 mmol) in  $\text{CH}_2\text{Cl}_2$  (40 mL), at 0 °C was added DMP (5.09 g, 12.0 mmol). The reaction mixture was warmed to RT and allowed to stir for 2 h.

It was then diluted with  $\text{CH}_2\text{Cl}_2$  (15 mL), and quenched with a 1:1 solution of sat.  $\text{Na}_2\text{CO}_3$  (aq.) and sat.  $\text{Na}_2\text{S}_2\text{O}_3$  (aq.) (15 mL). After vigorous stirring for 30 mins, the organic layer was separated and the aqueous layer extracted with further portions of  $\text{CH}_2\text{Cl}_2$  (2 × 20 mL). The combined organic extracts were dried ( $\text{MgSO}_4$ ), filtered and concentrated under reduced pressure. The resulting crude product was purified by flash column chromatography on silica gel, eluting with pet. ether:EtOAc (5:1 → 2:1) to afford the title compound **94** as a colourless oil (580 mg, 60%);  $R_f$  (1:1 pet. ether:EtOAc) 0.58;  $\nu_{\max}$  (thin film)/ $\text{cm}^{-1}$  2954, 2930, 2858, 1705;  $^1\text{H}$  NMR (400 MHz;  $\text{CDCl}_3$ )  $\delta$  9.35 (1H, d,  $J$  5.5, H-5), 3.77 (1H, dd,  $J$  11.0, 6.0, H-1a), 3.60 (1H, dd,  $J$  11.0, 8.0, H-1b), 1.93–1.88 (1H, m, H-4), 1.60–1.56 (1H, m, H-2), 1.30 (3H, s,  $\text{CH}_3$ ), 1.22 (3H, s,  $\text{CH}_3$ ), 0.89 (9H, s,  $\text{C}(\text{CH}_3)_3$ ), 0.05 (3H, s,  $\text{SiCH}_3$ ), 0.05 (3H, s,  $\text{SiCH}_3$ );  $^{13}\text{C}$  NMR (101 MHz;  $\text{CDCl}_3$ )  $\delta$  201.3 (C-5), 61.9 (C-1), 41.3 (C-4), 36.6 (C-2), 26.1 (C-3) 26.0 ( $\text{C}(\text{CH}_3)_3$ ), 22.2 ( $\text{CH}_3$ ), 21.4 ( $\text{CH}_3$ ), 18.4 ( $\text{C}(\text{CH}_3)_3$ ), –5.0 ( $\text{SiCH}_3$ ), –5.1 ( $\text{SiCH}_3$ );  $m/z$  (ESI) 243 [ $\text{MH}^+$ ]; HRMS: calcd. for  $\text{C}_{13}\text{H}_{27}\text{O}_2\text{Si}$ , 243.1775. Found: [ $\text{MH}^+$ ], 243.1770 (1.6 ppm error).

**(±)-(E)-Ethyl 3-((1R,3R)-3-((tert-butyl)dimethylsilyloxy)methyl)-2,2-dimethylcyclopropyl)prop-2-enoate (95)**

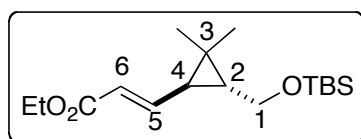

To a stirred solution of **94** (550 mg, 2.27 mmol) in  $\text{CH}_2\text{Cl}_2$  (25 mL) at RT was added carbethoxymethylene triphenylphosphorane (1.58 g, 4.54 mmol). After 18 h the solution was concentrated under reduced pressure and the crude product purified by flash column chromatography on silica gel, eluting with pet. ether:EtOAc (9:1) to afford the title compound **95** as a colourless oil (709 mg, 82%);  $R_f$  (5:1 pet. ether:EtOAc) 0.63;  $\nu_{\text{max}}$  (thin film)/ $\text{cm}^{-1}$  2954, 2930, 2858, 1724, 1641;  $^1\text{H NMR}$  (400 MHz;  $\text{CDCl}_3$ )  $\delta$  6.69 (1H, dd,  $J$  15.5, 10.0 Hz, H-5), 5.84 (1H, d,  $J$  15.5 Hz, H-6) 4.20–4.10 (2H, m,  $\text{CH}_3\text{CH}_2\text{O}$ ), 3.76 (1H, dd,  $J$  11.0, 6.0 Hz, H-1a), 3.57 (1H, dd,  $J$  11.0, 7.5 Hz, H-1b), 1.30–1.25 (2H, m, H-2 & H-4) 1.27 (3H, t,  $J$  7.0 Hz,  $\text{CH}_3\text{CH}_2\text{O}$ ), 1.17 (3H, s,  $\text{CH}_3$ ), 1.06 (3H, s,  $\text{CH}_3$ ), 0.87 (9H, s,  $\text{C}(\text{CH}_3)_3$ ), 0.04 (3H, s,  $\text{SiCH}_3$ ), 0.03 (3H, s,  $\text{SiCH}_3$ );  $^{13}\text{C NMR}$  (101 MHz;  $\text{CDCl}_3$ )  $\delta$  166.8 (C=O), 150.6 (C-5), 120.0 (C-6), 62.8 (C-1), 60.1 ( $\text{CH}_3\text{CH}_2\text{O}$ ), 37.3 (C-2 or C-4), 33.1 (C-2 or C-4), 26.5 (C-3), 26.0 ( $\text{C}(\text{CH}_3)_3$ ), 23.0 ( $\text{CH}_3$ ), 21.3 ( $\text{CH}_3$ ), 18.4 ( $\text{C}(\text{CH}_3)_3$ ), 14.5 ( $\text{CH}_3\text{CH}_2\text{O}$ ), -5.0 ( $\text{SiCH}_3$ ), -5.1 ( $\text{SiCH}_3$ );  $m/z$  (ESI) 313 [ $\text{MH}^+$ ]; HRMS: calcd. for  $\text{C}_{17}\text{H}_{33}\text{O}_3\text{Si}$ , 313.2193. Found: [ $\text{MH}^+$ ], 313.2185 (2.7 ppm error).

**(±)-(E)-3-((1R,3R)-3-((tert-Butyl)dimethylsilyloxy)methyl)-2,2-dimethylcyclopropyl)prop-2-en-1-ol (96)**

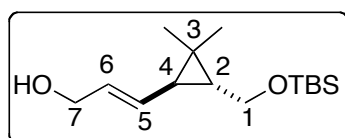

To a stirred solution of **95** (460 mg, 1.47 mmol) in  $\text{CH}_2\text{Cl}_2$  (15 mL) at 0 °C was added DIBAL (5.88 mL, 5.88 mmol, 1M in hexanes). After 30 mins the reaction mixture was diluted with  $\text{CH}_2\text{Cl}_2$  (35 mL) and washed with sat. aq. Rochelle's salt (20 mL). The organic layer was separated and the aqueous layer extracted with further portions of  $\text{CH}_2\text{Cl}_2$  (2 × 20 mL). The combined organic extracts were dried ( $\text{MgSO}_4$ ), filtered and concentrated under reduced pressure to afford the title compound **96** as a colourless oil (360 mg, 96%);  $R_f$  (1:1 pet. ether:EtOAc) 0.67;  $\nu_{\text{max}}$  (thin film)/ $\text{cm}^{-1}$  3368, 2929, 2859;  $^1\text{H NMR}$  (400 MHz;  $\text{CDCl}_3$ )  $\delta$  5.73–5.67 (1H, dt,  $J$  15.5, 6.0 Hz,

H-6), 5.44 (1H, dd,  $J$  15.5, 9.0, H-5), 4.09 (2H, dd,  $J$  6.0, 6.0 Hz, H-7), 3.79 (1H, dd,  $J$  11.0, 6.0 Hz, H-1a), 3.52 (1H, dd,  $J$  11.0, 8.5 Hz, H-1b), 1.26–1.08 (2H, m, H-2 & H-4), 1.23–1.18 (1H, t,  $J$  6.0 Hz, OH), 1.11 (3H, s, CH<sub>3</sub>), 1.07 (3H, s, CH<sub>3</sub>), 0.89 (9H, s, C(CH<sub>3</sub>)<sub>3</sub>), 0.05, (3H, s, SiCH<sub>3</sub>) 0.04 (3H, s, SiCH<sub>3</sub>); <sup>13</sup>C NMR (101 MHz; CDCl<sub>3</sub>) δ 133.4 (C-6), 128.8 (C-5), 64.0 (C-1), 63.4 (C-7), 34.7 (C-2 or C-4), 32.0 (C-2 or C-4), 26.1 (C(CH<sub>3</sub>)<sub>3</sub>), 23.1 (C-3), 22.7 (CH<sub>3</sub>), 21.3 (CH<sub>3</sub>), 18.4 (C(CH<sub>3</sub>)<sub>3</sub>), -4.9 (SiCH<sub>3</sub>), -5.0 (SiCH<sub>3</sub>);  $m/z$  (ESI) 293 [MNa<sup>+</sup>]; HRMS: calcd. for C<sub>15</sub>H<sub>30</sub>NaO<sub>2</sub>Si, 293.1907. Found: [MNa<sup>+</sup>], 293.1905 (0.1 ppm error).

**(±)-((1*R*,3*R*)-3-((*E*)-3-(Benzyloxy)prop-1-enyl)-2,2-dimethylcyclopropyl)methanol (98)**

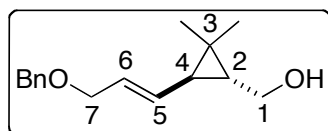

To a stirred solution of **96** (440 mg, 1.72 mmol) in THF (9 mL) at 0 °C was added NaH (103 mg, 2.58 mmol, 60% dispersion in mineral oil). This was warmed to RT and allowed to stir for 45 mins. This was re-cooled to 0 °C, benzyl bromide (307 μL, 2.58 mmol) was added and the reaction mixture was allowed to stir at RT for 18 h. The reaction mixture was diluted with Et<sub>2</sub>O (20 mL) and washed with sat. NH<sub>4</sub>Cl (aq.) (10 mL), the organic layer separated and the aqueous layer extracted with further portions of Et<sub>2</sub>O (2 × 20 mL). The combined organic phases were dried (MgSO<sub>4</sub>), filtered and concentrated under reduced pressure. The resulting crude product was dissolved in THF (17 mL) and the solution cooled to 0 °C before the addition of TBAF (3.4 mL, 1 M in THF). After 2 h the reaction mixture was diluted with Et<sub>2</sub>O (20 mL) and washed with sat. NH<sub>4</sub>Cl (aq.) (10 mL), the organic layer separated and the aqueous layer extracted with further portions of Et<sub>2</sub>O (2 × 20 mL). The combined organic extracts were dried (MgSO<sub>4</sub>), filtered and concentrated under reduced pressure. The resulting crude product was purified by flash column chromatography on silica gel, eluting with pet. ether:EtOAc (9:1 → 1:1) to afford the title compound **98** as a colourless oil (188 mg, 44%);  $R_f$  (1:1 pet. ether:EtOAc) 0.44;  $\nu_{\max}$  (thin film)/cm<sup>-1</sup> 3398, 2922, 2866, 1661; <sup>1</sup>H NMR (400 MHz; CDCl<sub>3</sub>) δ 7.36–7.26 (5H, m, Ar-CH), 5.68 (1H, ddd,  $J$  15.5, 6.5, 6.5 Hz, H-6), 5.47 (1H, dd,  $J$  15.5, 9.0 Hz, H-5), 4.50 (2H, s, C<sub>6</sub>H<sub>5</sub>CH<sub>2</sub>), 3.98 (2H, d,  $J$  6.5 Hz, H-7), 3.75 (1H, dd,  $J$  11.5, 6.5 Hz H-1a), 3.55 (1H, dd,  $J$  11.5,

8.5 Hz, H-1b), 1.42 (1H, br s, OH), 1.21–0.94 (2H, m, H-2 & H-4), 1.14 (3H, s, CH<sub>3</sub>), 1.10 (3H, s, CH<sub>3</sub>); <sup>13</sup>C NMR (101 MHz; CDCl<sub>3</sub>) δ 138.5 (Ar-C), 134.2 (C-6), 128.5 (Ar-CH), 127.9 (C-5), 127.7 (Ar-CH), 126.5 (Ar-CH) 72.0 (C<sub>6</sub>H<sub>5</sub>CH<sub>2</sub>), 70.9 (C-7), 63.3 (C-1), 34.6 (C-2 or C-4), 32.3 (C-2 or C-4), 23.2 (C-3), 22.6 (CH<sub>3</sub>), 21.3 (CH<sub>3</sub>); m/z (ESI): 269 [MNa<sup>+</sup>]; HRMS (ESI): calcd. for C<sub>16</sub>H<sub>22</sub>NaO<sub>2</sub>, 269.1512. Found: [MNa<sup>+</sup>], 269.1519 (1.4 ppm error).

**(±)-(1*R*,3*R*)-3-((*E*)-3-(Benzyloxy)prop-1-enyl)-2,2-dimethylcyclopropanecarbaldehyde (99)**

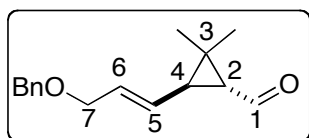

To a stirred solution of **98** (140 mg, 0.568 mmol) in CH<sub>2</sub>Cl<sub>2</sub> (6 mL), at 0 °C was added DMP (721 mg, 1.7 mmol). The reaction mixture was warmed to RT and allowed to stir for 18 h. It was then diluted with CH<sub>2</sub>Cl<sub>2</sub> (14 mL), and quenched with a 1:1 solution of sat Na<sub>2</sub>CO<sub>3</sub> (aq.) and sat. Na<sub>2</sub>S<sub>2</sub>O<sub>3</sub> (aq.) (10 mL). After vigorous stirring for 30 mins, the organic layer was separated and the aqueous layer extracted with further portions of CH<sub>2</sub>Cl<sub>2</sub> (2 × 10 mL). The combined organic extracts were dried (MgSO<sub>4</sub>), filtered and concentrated under reduced pressure. The resulting crude product was purified by flash column chromatography on silica gel, eluting with pet. ether:EtOAc (4:1) to afford the title compound **99** (139 mg, 68%); R<sub>f</sub> (2:1 pet. ether:EtOAc) 0.63; ν<sub>max</sub> (thin film)/cm<sup>-1</sup> 2923, 2852, 1699; <sup>1</sup>H NMR (400 MHz; CDCl<sub>3</sub>) δ 9.40 (1H, d, *J* 5.0 Hz, H-1), 7.37–7.26 (5H, m, Ar-CH), 5.80 (1H, ddd, *J* 15.5, 6.0, 6.0 Hz, H-6), 5.49 (1H, dd, *J* 15.5, 8.5 Hz, H-5), 4.51 (2H, s, C<sub>6</sub>H<sub>5</sub>CH<sub>2</sub>), 3.99 (2H, d, *J* 6.0 Hz, H-7), 2.33 (1H, dd, *J* 8.5, 5.0 Hz, H-4), 1.78 (1H, dd, *J* 5.0, 5.0 Hz, H-2), 1.32 (3H, s, CH<sub>3</sub>), 1.20 (3H, s, CH<sub>3</sub>); <sup>13</sup>C NMR (101 MHz; CDCl<sub>3</sub>) δ 200.3 (C-1), 138.3 (Ar-C), 130.0 (C-6), 129.3 (Ar-CH), 128.5 (Ar-CH), 127.9 (C-5), 127.79 (Ar-CH), 72.3 (C<sub>6</sub>H<sub>5</sub>CH<sub>2</sub>), 70.4 (C-7), 44.1 (C-4), 37.5 (C-2), 31.8 (C-3), 22.2 (CH<sub>3</sub>), 21.6 (CH<sub>3</sub>); m/z (ESI): 267 [MNa<sup>+</sup>]; HRMS (ESI): calcd. for C<sub>16</sub>H<sub>20</sub>NaO<sub>2</sub>, 267.1356. Found: [MNa<sup>+</sup>], 267.1355 (0.9 ppm error).

**(±)-(E)-Ethyl 3-((1R,3R)-3-((E)-3-(benzyloxy)prop-1-enyl)-2,2-dimethylcyclopropyl)prop-2-enoate (100)**

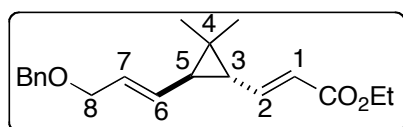

To a stirred solution of **99** (80 mg, 0.327 mmol) in  $\text{CH}_2\text{Cl}_2$  (25 mL) at RT was added carbethoxymethylene triphenylphosphorane (227 mg, 0.654 mmol). After stirring for 2 days the solution was concentrated under reduced pressure and the crude product purified by flash column chromatography on silica gel, eluting with pet. ether:EtOAc (9:1) to afford the title compound **100** as a colourless oil (99 mg, 96%);  $R_f$  (5:1 pet. ether:EtOAc) 0.41;  $\nu_{\text{max}}$  (thin film)/ $\text{cm}^{-1}$  2926, 1712, 1638;  $^1\text{H}$  NMR (400 MHz;  $\text{CDCl}_3$ )  $\delta$  7.38–7.26 (5H, m, Ar-CH), 6.69 (1H, dd,  $J$  15.5, 10.5 Hz, H-2), 5.88 (1H, d,  $J$  15.5 Hz, H-1), 5.73 (1H, ddd,  $J$  15.5, 6.0, 6.0 Hz, H-7), 5.48 (1H, dd,  $J$  15.5, 9.0 Hz, H-6), 4.50 (2H, s,  $\text{C}_6\text{H}_5\text{CH}_2$ ), 4.21–4.11 (2H, m,  $\text{CH}_3\text{CH}_2\text{O}$ ), 3.99 (2H, d,  $J$  6.0 Hz, H-8), 1.65 (1H, dd,  $J$  9.0, 5.0 Hz, H-5), 1.48 (1H, dd,  $J$  10.5, 5.0, Hz, H-3), 1.27 (3H, t,  $J$  7.0 Hz,  $\text{CH}_3\text{CH}_2\text{O}$ ), 1.19 (3H, s,  $\text{CH}_3$ ), 1.15 (3H, s,  $\text{CH}_3$ );  $^{13}\text{C}$  NMR (101 MHz;  $\text{CDCl}_3$ )  $\delta$  166.7 ( $\text{C}=\text{O}$ ), 149.4 (C-1 or C-2 or C-6 or C-7), 138.4 (Ar-C), 132.1 (C-1 or C-2 or C-6 or C-7), 128.5 (Ar-CH), 127.9 (Ar-CH), 127.8 (Ar-CH), 127.7 (C-1 or C-2 or C-6 or C-7), 120.4 (C-1 or C-2 or C-6 or C-7), 72.2 ( $\text{C}_6\text{H}_5\text{CH}_2$ ), 70.7 (C-8), 60.2 ( $\text{CH}_3\text{CH}_2\text{O}$ ), 38.4 (C-3 or C-5), 36.7 (C-3 or C-5), 28.3 (C-4), 22.5 ( $\text{CH}_3$ ), 22.2 ( $\text{CH}_3$ ), 14.5 ( $\text{CH}_3\text{CH}_2\text{O}$ );  $m/z$  (ESI): 337 [ $\text{MNa}^+$ ]; HRMS (ESI): calcd. for  $\text{C}_{20}\text{H}_{26}\text{NaO}_3$ , 337.1774. Found: [ $\text{MNa}^+$ ], 337.1772 (0.7 ppm error).

**7.3 Procedures & Compound Characterisation (Chapter 3)**

**Ethyl (±)-(1S,3R)-3-formyl-2,2-dimethylcyclopropanecarboxylate (127cis) & Ethyl (±)-(1R,3R)-3-formyl-2,2-dimethylcyclopropanecarboxylate (127trans)**<sup>83</sup>

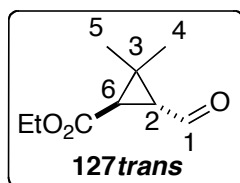
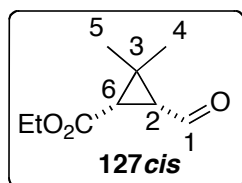

Oxygen was bubbled through a solution of ethyl chrysanthemate (10.0 g, 0.0510 mmol) in  $\text{CH}_2\text{Cl}_2$  (500 mL) at  $-78^\circ\text{C}$  for 5 min. Ozone was then bubbled through the solution until a sky blue colour could be seen (55 min), after which time oxygen was

bubbled through the solution for a further 5 min. DMS (37.4 mL, 0.510 mmol) was next added to the solution, which was then allowed to stir at RT overnight. The solution was concentrated under reduced pressure to give the crude product, which was purified by flash column chromatography on silica gel, eluting with pet. ether:EtOAc (10:1) to afford the title compound as a mixture of diastereomers (**127cis**:**127trans** 2:3) and as a colourless oil (8.23 g, 97%);  $R_f$  (20:1 pet. ether:EtOAc) 0.21;  $^1\text{H NMR}$  (400 MHz;  $\text{CDCl}_3$ ) **127cis**  $\delta$  9.70 (1H, d,  $J$  6.5, H-1), 4.08–4.16 (2H, m,  $\text{CH}_3\text{CH}_2\text{O}$ ), 2.08 (1H, d,  $J$  8.5, H-2 or H-6), 1.79 (1H, dd,  $J$  6.5, 6.5, H-2 or H-6), 1.56 (3H, s, H-4), 1.24 (3H t,  $J$  7.0,  $\text{CH}_3\text{CH}_2\text{O}$ ), 1.23 (3H, s, H-5); **127trans**  $\delta$  9.53 (1H, d,  $J$  3.5, H-1), 4.08–4.16 (2H, m,  $\text{CH}_3\text{CH}_2\text{O}$ ), 2.35–2.45 (2H, m, H-2 & H-6), 1.30 (3H, s, H-4), 1.26 (3H, s, H-5), 1.23 (3H, t  $J$  7.0,  $\text{CH}_3\text{CH}_2\text{O}$ ). Data in agreement with those reported in the literature.<sup>83</sup>

**[(1*R*,2*R*)-3,3-Dimethylcyclopropane-1,2-diyl]dimethanol (**56a**) & ( $\pm$ )-[(1*R*,2*S*)-3,3-Dimethylcyclopropane-1,2-diyl]dimethanol (**56b**)**

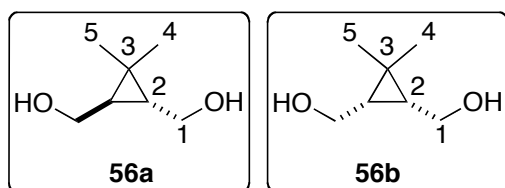

To a stirred suspension of  $\text{LiAlH}_4$  (7.30 g, 192 mmol) in THF (500 mL) at 0 °C was added **127** (16.4 g, 96.3 mmol) in THF (500 mL) *via* cannula. The reaction was warmed

to RT and stirred for 10 min. The reaction was cooled to 0 °C and water (7.3 mL) was added cautiously, followed by NaOH (aq. 15%) (7.3 mL) and water (21.9 mL). The aluminium salts were removed by filtration and washed with EtOAc (500 mL). The filtrate was concentrated under reduced pressure to give the crude product. This was purified by flash column chromatography on silica gel, eluting with EtOAc to afford the title compound **56a** as a colourless oil (6.22 g, 49%) and **56b** as a colourless oil (3.93 g, 31%); **56a** For data see page 105; **56b**  $R_f$  (EtOAc) 0.34;  $\nu_{\text{max}}$  (thin film)/ $\text{cm}^{-1}$  3342, 2987, 2929, 2887;  $^1\text{H NMR}$  (400 MHz;  $\text{CDCl}_3$ )  $\delta$  3.97 (2H, dd,  $J$  11.5, 5.5, H-1a), 3.50–3.46 (2H, m, H-1b), 2.83 (2H, broad s,  $\text{OH}$ ), 1.10–1.05 (2H, m, H-2), 1.07 (3H, s, H-4), 1.05 (3H, s, H-5);  $^{13}\text{C NMR}$  (101 MHz;  $\text{CDCl}_3$ )  $\delta$  59.7

(C-1), 29.2 (C-4), 29.1 (C-5), 20.2 (C-3), 15.6 (C-2); m/z (ESI): 153 [MNa<sup>+</sup>]; HRMS (ESI): calcd. for C<sub>7</sub>H<sub>14</sub>NaO<sub>2</sub>, 153.0886. Found: [MNa<sup>+</sup>], 153.0884 (1.3 ppm error).

**(2Z,2'Z)-Diethyl (±)-3,3'-((1R,2R)-3,3-dimethylcyclopropane-1,2-diyl)diprop-2-enoate (57c)**

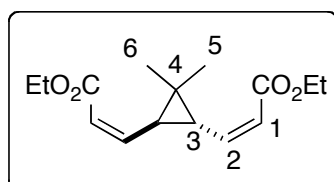

To a stirred solution of **56a** (1.80 g, 13.8 mmol) in CHCl<sub>3</sub> (150 mL) was added manganese (IV) dioxide (24.0 g, 276 mmol). The suspension was heated at reflux gently and after 16 h, the suspension was filtered through Celite, and washed with CHCl<sub>3</sub> (250 mL). The filtrate was concentrated under reduced pressure to give (1.25 g, 72%) of unpurified dialdehyde. (195 mg, 1.55 mmol) of the resulting dialdehyde was diluted with THF (8 mL). This was added, *via* cannula, to a solution of ethyl [bis(2,2,2-trifluoroethoxy)phosphoryl]acetate (1.33 mg, 4.00 mmol), 18-crown-6 (2.34 g, 9.02 mmol) and KHMDS (5.80 mL, 0.7 M in toluene, 3.45 mmol) at -78 °C. After 2 h the reaction was quenched with sat. NH<sub>4</sub>Cl (aq.) (15 mL), Et<sub>2</sub>O (25 mL) added and the organic layer separated. The aqueous layer was extracted with further portions of Et<sub>2</sub>O (2 × 25 mL) and the combined organic extracts were dried (MgSO<sub>4</sub>), filtered and concentrated under reduced pressure. The resulting crude product was purified by flash column chromatography on silica gel, eluting with pet. ether:EtOAc (10:1) to afford the title compound **57c** as a colourless oil (144 mg, 35%); R<sub>f</sub> (1:1 pet. ether:Et<sub>2</sub>O) 0.41; ν<sub>max</sub> (thin film)/cm<sup>-1</sup> 2934, 1688, 1604; <sup>1</sup>H NMR (400 MHz; CDCl<sub>3</sub>) δ 5.98–5.90 (2H, m, H-2), 5.80 (2H, d, *J* 11.5, H-1), 4.17 (4H, q, *J* 7.0, CH<sub>3</sub>CH<sub>2</sub>O), 3.04–3.00 (2H, m, H-3), 1.27 (6H, t, *J* 7.0, CH<sub>3</sub>CH<sub>2</sub>O), 1.23 (6H, s, H-5 & H-6); <sup>13</sup>C NMR (101 MHz; CDCl<sub>3</sub>) δ 167.0 (C=O), 149.3 (C-2), 119.3 (C-1), 59.9 (CH<sub>3</sub>CH<sub>2</sub>O), 37.0 (C-3), 30.9 (C-4), 22.5 (C-5 & C-6), 14.4 (CH<sub>3</sub>CH<sub>2</sub>O); m/z (ESI): 267 [MH<sup>+</sup>]; HRMS: calcd. for C<sub>15</sub>H<sub>23</sub>O<sub>4</sub>, 267.1591. Found: [MH<sup>+</sup>], 267.1583 (2.8 ppm error).

**(±)-(1*S*,5*R*)-6,6-Dimethyl-3-oxabicyclo[3.1.0]hexan-2-one (130)**<sup>84</sup>

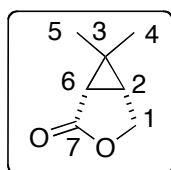

To a stirred solution of **56b** (180 mg, 1.38 mmol) in CHCl<sub>3</sub> (10 mL) was added manganese (IV) dioxide (2.40 g, 27.6 mmol). The suspension was stirred for 16 h, filtered through Celite and washed with CHCl<sub>3</sub> (20 mL). The filtrate was concentrated under reduced pressure to afford the title compound **130** (111 mg, 64%); R<sub>f</sub> (1:1 pet. ether:EtOAc) 0.38; <sup>1</sup>H NMR (400 MHz; CDCl<sub>3</sub>) δ 4.36 (1H, dd, *J* 10.0, 5.5 Hz, H-1a), 4.15 (1H, d, *J* 10 Hz, H-1b), 2.04 (1H, dd, *J* 6.0, 5.5 Hz, H-2), 1.95 (1H, d, *J* 6.0 Hz, H-6), 1.18 (3H, s, H-4), 1.17 (3H, s, H-5). Data in agreement with those reported in the literature.<sup>84</sup>

**Ethyl (±)-(2*E*)-3-[(1*S*,3*R*)-3-(hydroxymethyl)-2,2-dimethylcyclopropyl]prop-2-enoate (131)**

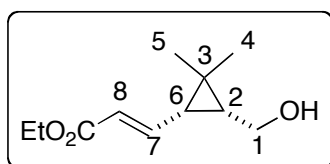

To a stirred solution of **56b** (3.93 g, 30.2 mmol) in anhydrous DMSO (150 mL) at RT was added IBX (10.1 g, 36.1 mmol). After 2 h the reaction was quenched with water (100 mL), filtered through celite and the filtrand washed with CH<sub>2</sub>Cl<sub>2</sub> (400 mL). The organic layer was separated and the aqueous layer extracted with portions of CH<sub>2</sub>Cl<sub>2</sub> (2 × 250 mL). The combined organic extracts were dried (MgSO<sub>4</sub>), filtered and concentrated under reduced pressure to give a colourless oil. This oil was diluted with CH<sub>2</sub>Cl<sub>2</sub> (200 mL) before the addition of (carboxymethylene)triphenylphosphorane (9.84 g, 28.2 mmol). The reaction was stirred at RT and after 16 h the solution was concentrated under reduced pressure and the crude product purified by flash column chromatography on silica gel, eluting with pet. ether:EtOAc (5:1) to afford the title compound **131** as a colourless oil (2.36 g, 47%); R<sub>f</sub> (5:1 pet. ether:EtOAc) 0.14; ν<sub>max</sub> (thin film)/cm<sup>-1</sup> 3372, 2938, 2910, 1683, 1613; <sup>1</sup>H NMR (400 MHz; CDCl<sub>3</sub>) δ; 6.76 (1H, dd, *J* 15.0, 11.0, H-7), 5.97 (1H, d, *J* 15.0, H-8), 4.17 (2H, q, *J* 7.0, CH<sub>3</sub>CH<sub>2</sub>O), 3.83 (1H, dd, *J* 11.5, 7.5, H-1a), 3.75 (1H, dd, *J* 11.5, 8.0, H-1b), 1.57 (1H, dd, *J* 11.0, 8.5, H-6), 1.50 (1H, br. s, OH), 1.42 (1H, dd, *J* 11.0, 8.0, H-2), 1.27 (3H, t, *J* 7.0, CH<sub>3</sub>CH<sub>2</sub>O), 1.19 (3H, s, H-5), 1.17 (3H, s, H-



4);  $^{13}\text{C}$  NMR (101 MHz;  $\text{CDCl}_3$ )  $\delta$  166.6 ( $\text{C}=\text{O}$ ), 146.7 (C-7), 122.0 (C-8), 60.3 ( $\text{CH}_3\text{CH}_2\text{O}$ ), 60.0 (C-1) 35.5 (C-2), 31.1 (C-6), 28.9 (C-5), 25.5 (C-3), 15.9 (C-4), 14.5, ( $\text{CH}_3\text{CH}_2\text{O}$ );  $m/z$  (ESI): 221 [ $\text{MNa}^+$ ]; HRMS: calcd. for  $\text{C}_{11}\text{H}_{18}\text{NaO}_3$ , 221.1148. Found: [ $\text{MNa}^+$ ], 221.1150 (−1.0 ppm error).

**(±)-[(1*S*,3*R*)-3-({*tert*-Butyl(dimethyl)silyl}oxy)methyl]-2,2-dimethylcyclopropyl]methanol (**132**)**

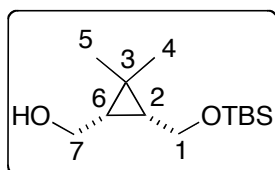

To a stirred solution of **56b** (276 mg, 2.12 mmol) in THF (4 mL) at 0 °C was added NaH (102 mg, 2.54 mmol, 60% dispersion in mineral oil). After 45 mins, by which time a large amount of white precipitate had formed, TBSCl (319 mg, 2.12 mmol) was added. The reaction mixture was warmed to RT and allowed to stir for a further 1 h before dilution with  $\text{Et}_2\text{O}$  (15 mL). It was then washed with sat.  $\text{NH}_4\text{Cl}$  (aq.) (10 mL) and brine (10 mL), the organic layer separated and the aqueous layer extracted with further portions of  $\text{Et}_2\text{O}$  ( $2 \times 20$  mL). The combined organic extracts were dried ( $\text{MgSO}_4$ ), filtered and concentrated under reduced pressure. The resulting crude product was purified by flash column chromatography on silica gel, eluting with pet. ether:EtOAc (20:1  $\rightarrow$  10:1) to afford the title compound **132** as a colourless oil (506 mg, 84%);  $R_f$  (1:1 pet. ether:EtOAc) 0.48;  $\nu_{\text{max}}$  (thin film)/ $\text{cm}^{-1}$  3346, 2885, 2842, 22816;  $^1\text{H}$  NMR (400 MHz;  $\text{CDCl}_3$ )  $\delta$  4.07–3.98 (1H, m, H-1a or H-7a), 3.89–3.80 (1H, m, H-1a or H-7a), 3.57–3.45 (2H, m, H-1b & H-7b), 2.97 (1H, br s, OH), 1.16–1.08 (1H, m, H-2 or H-6), 1.06 (3H, s, H-4), 1.04 (3H, s, H-5), 1.03–0.93 (1H, m, H-2 or H-6), 0.90 (9H, s,  $\text{SiC}(\text{CH}_3)_3$ ), 0.10 (3H, s,  $\text{SiCH}_3$ ), 0.08 (3H, s,  $\text{SiCH}_3$ );  $^{13}\text{C}$  NMR (101 MHz;  $\text{CDCl}_3$ )  $\delta$  60.6 (C-1 or C-7), 59.7 (C-1 or C-7), 29.9 (C-4), 29.2 (C-2 or C-6), 29.0 (C-2 or C-6), 26.0 ( $\text{SiC}(\text{CH}_3)_3$ ), 20.3 (C-3), 18.3 ( $\text{SiC}(\text{CH}_3)_3$ ), 15.7 (C-5) −5.1 ( $\text{SiCH}_3$ ), −5.3 ( $\text{SiCH}_3$ );  $m/z$  (ESI) 267 [ $\text{MNa}^+$ ]; HRMS: calcd. for  $\text{C}_{13}\text{H}_{28}\text{NaO}_2\text{Si}$ , 267.1751. Found: [ $\text{MNa}^+$ ], 267.1742 (3.1 ppm error).

**Ethyl (±)-(2*E*)-3-[(1*S*,3*R*)-3-({*tert*-butyl(dimethyl)silyl}oxy)methyl]-2,2-dimethylcyclopropyl]prop-2-enoate (**133<sub>E</sub>**) & Ethyl (±)-(2*Z*)-3-[(1*S*,3*R*)-3-({*tert*-butyl(dimethyl)silyl}oxy)methyl]-2,2-dimethylcyclopropyl]prop-2-enoate (**133<sub>Z</sub>**)**

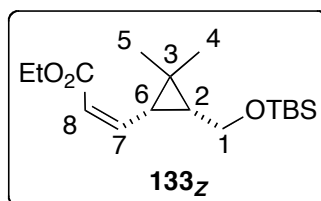
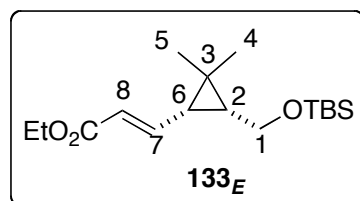

To a stirred solution of **132** (18.0 g, 73.5 mmol) in CHCl<sub>3</sub> (300 mL) was added manganese (IV) dioxide (63.9

g, 735 mmol) and (carbethoxymethylene) triphenyl phosphorane (30.7 g, 88.2 mmol). The resulting suspension was stirred vigorously with heating to maintain gentle reflux for 18 h. After cooling to room temperature, the suspension was filtered through Celite, and washed with CHCl<sub>3</sub> (500 mL). The filtrate was concentrated under reduced pressure to give the crude product. This was purified by flash column chromatography on silica gel, eluting with pet. ether:EtOAc (20:1) to afford the title compound as an inseparable mixture of **133<sub>E</sub>**/**133<sub>Z</sub>** isomers in a ratio of 5:1 and as a colourless oil (17.94 g, 78%); R<sub>f</sub> (20:1 pet. ether:EtOAc) 0.31; ν<sub>max</sub> (thin film)/cm<sup>-1</sup> 2910, 2884, 2813, 1690; <sup>1</sup>H NMR (400 MHz; CDCl<sub>3</sub>) **133<sub>E</sub>** δ 6.75 (1H, dd, *J* 15.0, 11.0, H-7), 5.93 (1H, d, *J* 15.0, H-8), 4.19–4.13 (2H, m, OCH<sub>2</sub>CH<sub>3</sub>), 3.77 (1H, dd, *J* 11.0, 7.5, H1a), 3.72 (1H, dd, *J* 11.0, 7.0, H-1b), 1.51 (1H, dd, *J* 11.0, 9.0, H-6), 1.39–1.32 (1H, m, H-2), 1.27 (3H, t, *J* 7.0, OCH<sub>2</sub>CH<sub>3</sub>), 1.16 (3H, s, H-4), 1.15 (3H, s, H-5), 0.87 (9H, s, SiC(CH<sub>3</sub>)<sub>3</sub>), 0.05 (3H, s, SiCH<sub>3</sub>), 0.04 (3H, s, SiCH<sub>3</sub>); **133<sub>Z</sub>** δ 5.98 (1H, dd, *J* 11.5, 11.5, H-7), 5.79 (1H, d, *J* 11.5, H-8), 4.19–4.13 (2H, m, OCH<sub>2</sub>CH<sub>3</sub>), 3.75–3.69 (1H, m, H-1a), 2.75 (1H, dd, *J* 11.0, 9.0, H-1b), 1.71–1.66 (1H, m, H-6 or H-2), 1.39–1.32 (1H, m, H-6 or H-2), 1.28 (3H, t, *J* 7.0, OCH<sub>2</sub>CH<sub>3</sub>), 1.16 (3H, s, H-4), 1.15 (3H, s, H-5), 0.87 (9H, s, SiC(CH<sub>3</sub>)<sub>3</sub>), 0.05 (3H, s, SiCH<sub>3</sub>), 0.04 (3H, s, SiCH<sub>3</sub>); <sup>13</sup>C NMR (101 MHz; CDCl<sub>3</sub>) **133<sub>E</sub>** δ 166.6 (CH<sub>3</sub>CH<sub>2</sub>OC=O), 147.7 (C-7), 121.3 (C-8), 60.1 (C-1), 60.1 (CH<sub>3</sub>CH<sub>2</sub>O), 35.6 (C-6 or C-2), 31.2 (C-4), 28.9 (C-6 or C-2), 26.0 (SiC(CH<sub>3</sub>)<sub>3</sub>), 25.4 (C-3), 18.4 (SiC(CH<sub>3</sub>)<sub>3</sub>), 15.9 (C-5), 14.5 (CH<sub>3</sub>CH<sub>2</sub>O), -5.0 (SiCH<sub>3</sub>), -5.1 (SiCH<sub>3</sub>); **133<sub>Z</sub>** δ 167.1 (CH<sub>3</sub>CH<sub>2</sub>OC=O), 148.1 (C-7), 119.5 (C-8), 60.0 (C-1), 59.8 (OCH<sub>2</sub>CH<sub>3</sub>), 35.6 (C-2), 29.0 (C-4), 28.1 (C-3), 26.0 (SiC(CH<sub>3</sub>)<sub>3</sub>), 25.6 (C-6), 18.4 (SiC(CH<sub>3</sub>)<sub>3</sub>), 15.6 (C-5), 14.5 (OCH<sub>2</sub>CH<sub>3</sub>), -5.0 (SiCH<sub>3</sub>), -5.0

(SiCH<sub>3</sub>); m/z (ESI) 335 [MNa<sup>+</sup>]; HRMS: calcd. for C<sub>17</sub>H<sub>32</sub>NaO<sub>3</sub>Si, 335.2013. Found: [MNa<sup>+</sup>], 335.2014 (−0.9 ppm error).

### Ethyl (±)-[(1*S*,5*R*)-6,6-dimethyl-3-oxabicyclo[3.1.0]hex-2-yl]acetate (**134**)

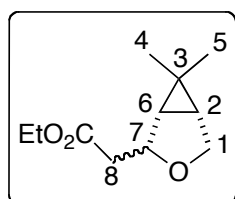

To a solution of **133** (102 mg, 0.327 mmol) in THF (5 mL) at 0 °C was added TBAF (0.491 mL, 1 M in THF, 0.491 mmol). After 17 h the reaction mixture was diluted with Et<sub>2</sub>O (5 mL) and washed with sat. NH<sub>4</sub>Cl (aq.) (5 mL), the organic layer separated and the aqueous layer extracted with further portions of Et<sub>2</sub>O (2 x 10 mL). The combined organic extracts were dried (MgSO<sub>4</sub>), filtered and concentrated under reduced pressure to give the crude product. This was purified by flash column chromatography on silica gel, eluting with pet. ether:EtOAc (5:1) to afford the title compound **88** as a colourless oil and in a diastereomeric ratio of 1:0.1 **134**<sub>major</sub>:**134**<sub>minor</sub> (49 mg, 76%); R<sub>f</sub> (1:1 pet. ether: Et<sub>2</sub>O) 0.47; ν<sub>max</sub> (thin film)/cm<sup>−1</sup> 2876, 2825, 1710; <sup>1</sup>H NMR (400 MHz; CDCl<sub>3</sub>) **134**<sub>major</sub> δ 4.28 (1H, dd, *J* 6.5, 6.5, H-7), 4.17 (1H, q, *J* 7.0, OCH<sub>a</sub>H<sub>b</sub>CH<sub>3</sub>), 4.16 (1H, q, *J* 7.0, OCH<sub>a</sub>H<sub>b</sub>CH<sub>3</sub>), 3.93 (1H, dd, *J* 8.5, 4.0, H-1a), 3.75 (1H, d, *J* 8.5, H-1b), 2.54–2.42 (2H, m, H-8), 1.45 (1H, dd, *J* 7.5, 4.0, H-2), 1.32 (1H, d, *J* 7.5, H-6), 1.26 (3H, t, *J* 7.0, OCH<sub>2</sub>CH<sub>3</sub>), 1.05 (3H, s, H-4), 1.01 (3H, s, H-5); **134**<sub>minor</sub> δ 4.49–4.43 (1H, m, H-7), 4.21–4.11 (2H, m, OCH<sub>2</sub>CH<sub>3</sub>), 3.89–3.84 (2H, m, H-1), 2.67 (1H, dd, *J* 15.0, 7.5, H-8a), (1H, dd, *J* 15.0, 6.0 (H-8b), 1.42–1.35 (2H, m, H-6 & H-2), 1.28 (3H, t, *J* 7.0, OCH<sub>2</sub>CH<sub>3</sub>), 1.20 (3H, s, H-4), 0.99 (3H, s, H-5); <sup>13</sup>C NMR (101 MHz; CDCl<sub>3</sub>) **134**<sub>major</sub> δ 171.4 (CH<sub>3</sub>CH<sub>2</sub>OC=O), 75.4 (C-7) 67.2 (C-1), 60.6 (CH<sub>3</sub>CH<sub>2</sub>O), 41.1 (C-8), 34.3 (C-6), 29.8 (C-2), 26.2 (CH<sub>3</sub>CH<sub>2</sub>O), 19.5 (C-3), 14.4 (C-4), 13.0 (C-5); **134**<sub>minor</sub> δ 171.4 (CH<sub>3</sub>CH<sub>2</sub>OC=O), 75.4 (C-7) 68.3 (C-1), 60.6 (CH<sub>3</sub>CH<sub>2</sub>O), 37.7 (C-8), 32.3 (C-6), 29.5 (C-2), 26.9 (CH<sub>3</sub>CH<sub>2</sub>O), 19.8 (C-3), 15.3 (C-4), 13.0 (C-5); m/z (ESI): 221 [MNa<sup>+</sup>]; HRMS: calcd. for C<sub>11</sub>H<sub>18</sub>NaO<sub>3</sub>, 221.1148. Found: [MNa<sup>+</sup>], 221.1154 (−2.2 ppm error).

**Ethyl (±)-(2*E*)-3-[(1*S*,3*R*)-3-(hydroxymethyl)-2,2-dimethylcyclopropyl]prop-2-enoate (**131**)**

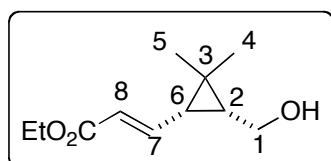

To a stirred solution of **133** (5:1 *E:Z*) (2.06 g, 6.59 mmol) in MeCN (65 mL) in a plastic container was added HF (0.41 mL, 48 wt % in water, 9.9 mmol). This was stirred at RT for 16 h before the addition of sat. NaHCO<sub>3</sub> (aq.) (50 mL). The solution was diluted with CH<sub>2</sub>Cl<sub>2</sub> (200mL), the organic layer was separated and the aqueous layer extracted with further portions of CH<sub>2</sub>Cl<sub>2</sub> (2 × 200 mL). The combined organic extracts were dried (MgSO<sub>4</sub>), filtered and concentrated under reduced pressure. The resulting crude product was purified by flash column chromatography on silica gel, eluting with pet. ether:EtOAc (2:1) to afford the title compound **131** as a colourless oil (0.984 g, 75%); *For data see page 115*

**(2*E*,2'*E*)-diethyl 3,3'-((1*R*,2*R*)-3,3-dimethylcyclopropane-1,2-diyl)diprop-2-enoate (**57d**) & (±)-(2*E*,2'*Z*)-diethyl 3,3'-((1*R*,2*S*)-3,3-dimethylcyclopropane-1,2-diyl)diprop-2-enoate (**57e**)**

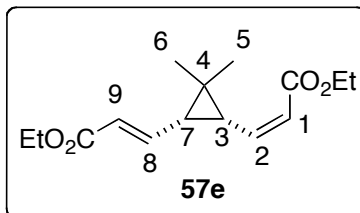
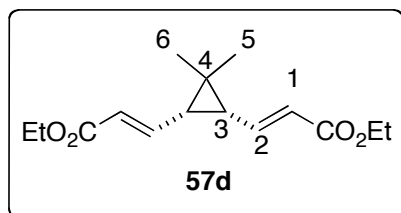

To a stirred solution of **131** (8.10 g, 40.9 mmol) in CHCl<sub>3</sub> (400 mL) was added manganese dioxide (35.6 g, 409 mmol), 4Å molecular sieves (35.6 g) and (carbethoxymethylene) triphenyl phosphorane (17.1 g, 49.1 mmol). After 16 h, the suspension was filtered through Celite, and washed with CHCl<sub>3</sub> (500 mL). The filtrate was concentrated under reduced pressure to give the crude product. This was purified by flash column chromatography on silica gel, eluting with pet. ether:EtOAc (40:1 → 20:1) to afford the title compound **57d** as a colourless oil (7.4 g, 68%) and **57e** as a colourless oil (1.73 g, 16%); **57d** R<sub>f</sub> (1:1 pet. ether:EtOAc) 0.62; ν<sub>max</sub> (thin film)/cm<sup>-1</sup> 2936, 2876, 1691, 1613; <sup>1</sup>H NMR (400 MHz; CDCl<sub>3</sub>) δ 6.90–6.76 (2H, m, H-2), 5.95 (2H, d, *J* 15.0, H-1), 4.17 (4H, q, *J* 7.0, OCH<sub>2</sub>CH<sub>3</sub>), 1.91–1.85 (2H, m, H-3), 1.28 (6H, t, *J* 7.0, OCH<sub>2</sub>CH<sub>3</sub>), 1.25 (3H, s, H-5), 1.21, (3H, s, H-6); <sup>13</sup>C NMR (101

MHz; CDCl<sub>3</sub>) δ 166.2 (CH<sub>3</sub>CH<sub>2</sub>OC=O), 145.4 (C-2), 123.0 (C-1), 60.3 (CH<sub>3</sub>CH<sub>2</sub>O), 36.6 (C-3), 29.6 (C-4), 28.6 (C-5), 16.7 (C-6), 14.4 (CH<sub>3</sub>CH<sub>2</sub>O); m/z (ESI) 289 [MNa<sup>+</sup>]; HRMS: calcd. for C<sub>15</sub>H<sub>22</sub>NaO<sub>4</sub>, 289.1410. Found: [MNa<sup>+</sup>], 289.1403 (2.3 ppm error); **57e** R<sub>f</sub> (15:1 pet. ether:EtOAc) 0.41; ν<sub>max</sub> (thin film)/cm<sup>-1</sup> 2936, 2913, 2881, 1688, 1612; <sup>1</sup>H NMR (400 MHz; CDCl<sub>3</sub>) δ 6.82 (1H, dd, *J* 15.0, 11.0, H-8), 6.10 (1H, dd, *J* 11.5, 11.5, H-2), 5.95 (1H, d, *J* 15.0, H-9), 5.87 (1H, d, *J* 11.5, H-1), 4.17 (2H, q, *J* 7.0, OCH<sub>2</sub>CH<sub>3</sub>), 4.16 (2H, q, *J* 7.0, OCH<sub>2</sub>CH<sub>3</sub>), 3.17 (1H, dd, *J* 11.5, 9.0, H-3), 1.94 (1H, dd, *J* 11.0, 9.0, H-7), 1.28 (3H, t, *J* 7.0, OCH<sub>2</sub>CH<sub>3</sub>), 1.27 (3H, t, *J* 7.0, OCH<sub>2</sub>CH<sub>3</sub>), 1.24 (3H, s, H-5), 1.23, (3H, s, H-6); <sup>13</sup>C NMR (101 MHz; CDCl<sub>3</sub>) δ 166.7 (CH<sub>3</sub>CH<sub>2</sub>OC=O), 166.4 (CH<sub>3</sub>CH<sub>2</sub>OC=O), 146.0 (C-2 or C-8), 145.9 (C-2 or C-8), 122.6 (C-0), 121.1 (C-1), 60.3 (OCH<sub>2</sub>CH<sub>3</sub>), 60.0 (OCH<sub>2</sub>CH<sub>3</sub>), 36.7 (C-7), 33.7 (C-3), 29.9 (C-4), 28.6 (C-5), 16.5 (C-6), 14.4 (OCH<sub>2</sub>CH<sub>3</sub>), 14.4 (OCH<sub>2</sub>CH<sub>3</sub>); m/z (ESI) 289 [MNa<sup>+</sup>]; HRMS: calcd. for C<sub>15</sub>H<sub>22</sub>NaO<sub>4</sub>, 289.1410. Found: [MNa<sup>+</sup>], 289.1406 (1.0 ppm error).

**(±)-(1*S*,3*R*)-3-({*tert*-Butyl(dimethyl)silyl}oxy)methyl)-2,2-dimethylcyclopropanecarbaldehyde (**136**)**

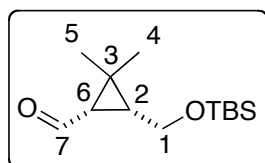

To a stirred solution of **132** (304 mg, 1.24 mmol) in CH<sub>2</sub>Cl<sub>2</sub> (10 mL) was added manganese (IV) dioxide (1.08 g, 12.4 mmol). and 4Å molecular sieves (1.08 g). After 16 h the suspension was filtered through Celite, and washed with CHCl<sub>3</sub> (50 mL). The filtrate was concentrated under reduced pressure to give the crude product. This was purified by flash column chromatography on silica gel, eluting with pet. ether:EtOAc (15:1) to afford the title compound **136** as a colourless oil (166 mg, 55%); R<sub>f</sub> (15:1 pet. ether:EtOAc) 0.17; ν<sub>max</sub> (thin film)/cm<sup>-1</sup> 2909, 2885, 2841, 1676; <sup>1</sup>H NMR (400 MHz; CDCl<sub>3</sub>) δ 9.50 (1H, d, *J* 5.5, H-7), 4.06 (1H, dd, *J* 11.5, 7.5, H-1a), 3.90 (1H, dd, *J* 11.5, 7.0, H-1b), 1.74–1.62 (2H, m, H-6 & H-2), 1.36 (3H, s, H-5), 1.20 (3H, s, H-4), 0.88 (9H, s, SiC(CH<sub>3</sub>)<sub>3</sub>), 0.05 (3H, s, SiCH<sub>3</sub>), 0.05 (3H, s, SiCH<sub>3</sub>); <sup>13</sup>C NMR (101 MHz; CDCl<sub>3</sub>) δ 201.3 (C-7), 58.6 (C-1), 39.0 (C-2 or C-6), 38.8 (C-2 or C-6), 29.8 (C-3), 29.1 (C-4), 26.0 (SiC(CH<sub>3</sub>)<sub>3</sub>), 18.4

(SiC(CH<sub>3</sub>)<sub>3</sub>), 15.3 (C-5), -5.1 (SiCH<sub>3</sub>); m/z (ESI) 265 [MNa<sup>+</sup>]; HRMS: calcd. for C<sub>13</sub>H<sub>26</sub>NaO<sub>2</sub>Si, 265.1594. Found: [MNa<sup>+</sup>], 265.1593 (0.1 ppm error).

**Ethyl (±)-(2Z)-3-[(1S,3R)-3-([*tert*-butyl(dimethyl)silyl]oxy)methyl]-2,2-dimethylcyclopropyl]prop-2-enoate (137)**

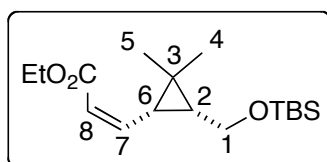

To a solution of ethyl [bis(2,2,2-trifluoroethoxy)phosphoryl]acetate (285 mg, 0.859 mmol) in THF (6 mL) was added 18-crown-6 (507 mg, 1.92 mmol). The solution was cooled to 0 °C and KHMDS (1.23 mL, 0.7 M in toluene, 0.859 mmol) was added cautiously. After 15 min the solution was cooled to -78 °C and **136** (160 mg, 0.661 mmol) in THF (3 mL) was added *via* cannula. After 30 min the reaction was quenched with sat. NH<sub>4</sub>Cl (aq.) (5 mL), Et<sub>2</sub>O (10 mL) added and the organic layer separated. The aqueous layer was extracted with further portions of Et<sub>2</sub>O (2 × 10 mL) and the combined organic extracts were dried (MgSO<sub>4</sub>), filtered and concentrated under reduced pressure. The resulting crude product was purified by flash column chromatography on silica gel, eluting with pet. ether:EtOAc (40:1) to afford the title compound **137** as a colourless oil (109 mg, 53%); R<sub>f</sub> (10:1 pet. ether:EtOAc) 0.57; ν<sub>max</sub> (thin film)/cm<sup>-1</sup> 2909, 2883, 2814, 1690, 1601; <sup>1</sup>H NMR (400 MHz; CDCl<sub>3</sub>) δ 5.98 (1H, dd *J* 11.5, 11.5, H-7), 5.79 (1H, d, *J* 11.5, H-8), 4.16 (2H, q, *J* 7.0, OCH<sub>2</sub>CH<sub>3</sub>), 3.74–3.71 (2H, m, H-1), 2.75 (1H, dd, *J* 11.5, 9.0, H-6), 1.40–1.34 (1H, m, H-2), 1.28 (3H, t, *J* 7.0, OCH<sub>2</sub>CH<sub>3</sub>), 1.18 (3H, s, H-4), 1.12 (3H, s, H-5), 0.87 (9H, s, SiC(CH<sub>3</sub>)<sub>3</sub>), 0.04 (6H, s, SiCH<sub>3</sub>); <sup>13</sup>C NMR (101 MHz; CDCl<sub>3</sub>) δ 167.1 (CH<sub>3</sub>CH<sub>2</sub>OC=O), 148.1 (C-7), 119.5 (C-8), 60.0 (C-1), 59.8 (OCH<sub>2</sub>CH<sub>3</sub>), 35.6 (C-2), 29.0 (C-4), 28.1 (C-3), 26.0 (SiC(CH<sub>3</sub>)<sub>3</sub>), 25.6 (C-6), 18.4 (SiC(CH<sub>3</sub>)<sub>3</sub>), 15.6 (C-5), 14.5 (OCH<sub>2</sub>CH<sub>3</sub>), -5.0 (SiCH<sub>3</sub>), -5.0 (SiCH<sub>3</sub>); m/z (ESI) 335 [MNa<sup>+</sup>]; HRMS: calcd. for C<sub>17</sub>H<sub>32</sub>NaO<sub>3</sub>Si, 335.2013. Found: [MNa<sup>+</sup>], 335.2006 (1.4 ppm error).

**Ethyl (±)-(2Z)-3-[(1S,3R)-3-(hydroxymethyl)-2,2-dimethylcyclopropyl]prop-2-enoate (138)**

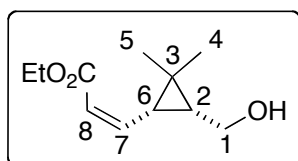

To a stirred solution of **137** (136 mg, 0.435 mmol) in MeCN (10 mL) in a plastic container was added HF (2 drops, 48 wt % in water). This was stirred at RT for 16 h before the addition of sat. NaHCO<sub>3</sub> (aq.) (5 mL). The solution was diluted with CH<sub>2</sub>Cl<sub>2</sub> (10 mL), the organic layer was separated and the aqueous layer extracted with further portions of CH<sub>2</sub>Cl<sub>2</sub> (2 × 10 mL). The combined organic extracts were dried (MgSO<sub>4</sub>), filtered and concentrated under reduced pressure. The resulting crude product was purified by flash column chromatography on silica gel, eluting with pet. ether:EtOAc (2:1) to afford the title compound **138** as a colourless oil (73 mg, 85%); R<sub>f</sub> (1:1 pet. ether:EtOAc) 0.38;  $\nu_{\max}$  (thin film)/cm<sup>-1</sup> 3372, 2939, 2883, 2827, 1689, 1601; <sup>1</sup>H NMR (400 MHz; CDCl<sub>3</sub>)  $\delta$  6.02 (1H, dd, *J* 11.5 10.5, H-7), 5.85 (1H, d, *J* 11.5, H-8), 4.17 (2H, q, *J* 7.0, OCH<sub>2</sub>CH<sub>3</sub>), 3.79 (1H, dd, *J* 11.5, 7.5, H-1a), 3.65 (1H, dd, *J* 11.5, 8.0, H-1b), 2.73–2.68 (1H, m, H-6), 1.47–1.39 (1H, m, H-2), 1.28 (3H, t, *J* 7.0, OCH<sub>2</sub>CH<sub>3</sub>), 1.19 (3H, s, H-4), 1.14 (3H, s, H-5); <sup>13</sup>C NMR (101 MHz; CDCl<sub>3</sub>)  $\delta$  167.1 (CH<sub>3</sub>CH<sub>2</sub>OC=O), 147.0 (C-7), 120.5 (C-8), 60.0 (C-1), 60.0 (OCH<sub>2</sub>CH<sub>3</sub>), 35.5 (C-2), 28.8 (C-6), 28.0 (C-5), 25.4 (C-3), 15.6 (C-4), 14.4 (OCH<sub>2</sub>CH<sub>3</sub>); *m/z* (ESI) 221 [MNa<sup>+</sup>]; HRMS: calcd. for C<sub>11</sub>H<sub>18</sub>NaO<sub>3</sub>, 221.1148. Found: [MNa<sup>+</sup>], 221.1140 (3.5 ppm error).

**Ethyl (±)-(2Z)-3-[(1S,3R)-3-formyl-2,2-dimethylcyclopropyl]prop-2-enoate (139)**

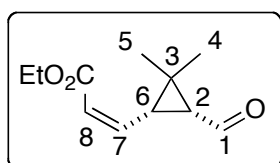

To a stirred solution of **138** (73 mg, 0.368 mmol) in CHCl<sub>3</sub> (5 mL) was added manganese (IV) dioxide (320 mg, 3.68 mmol) and 4Å molecular sieves (320 mg). After 12 h the suspension was filtered through Celite, and washed with CHCl<sub>3</sub> (25 mL). The filtrate was concentrated under reduced pressure to give the crude product. This was purified by flash column chromatography on silica gel, eluting with pet. ether:EtOAc (5:1) to afford the title compound **139** as a colourless oil (38 mg, 53%); R<sub>f</sub> (5:1 pet. ether:EtOAc) 0.34;  $\nu_{\max}$  (thin film)/cm<sup>-1</sup> 2911, 2876, 1689, 1610; <sup>1</sup>H NMR (400

MHz; CDCl<sub>3</sub>)  $\delta$  9.72 (1H, d, *J* 4.0, H-1), 6.55 (1H, dd, *J* 11.5, 10.5, H-7), 5.88 (1H, d, *J* 11.5, H-8), 4.16 (2H, q, *J* 7.0, OCH<sub>2</sub>CH<sub>3</sub>), 3.49–3.44 (1H, m, H-6), 2.21 (1H, dd, *J* 8.5, 4.0, H-2), 1.34 (3H, s, H-4), 1.30 (3H, s, H-5), 1.28 (3H, t, *J* 7.0, OCH<sub>2</sub>CH<sub>3</sub>); <sup>13</sup>C NMR (101 MHz; CDCl<sub>3</sub>)  $\delta$  199.9 (C-1), 166.7 (CH<sub>3</sub>CH<sub>2</sub>OC=O), 143.7 (C-7), 121.3 (C-8), 60.1 (OCH<sub>2</sub>CH<sub>3</sub>), 43.1 (C-2), 36.2 (C-6), 33.3 (C-3), 28.8 (C-4), 15.1 (C-5), 14.4 (OCH<sub>2</sub>CH<sub>3</sub>); *m/z* (ESI) 197 [MH<sup>+</sup>]; HRMS: calcd. for C<sub>11</sub>H<sub>17</sub>O<sub>3</sub>, 197.1172. Found: [MH<sup>+</sup>], 197.1167 (2.8 ppm error).

**Diethyl (2*Z*,2'*Z*)-3,3'-[(1*R*,2*S*)-3,3-dimethylcyclopropane-1,2-diyl]bisprop-2-enoate (57f)**

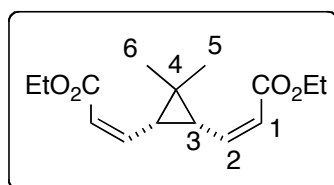

To a solution of ethyl [bis(2,2,2-trifluoroethoxy)phosphoryl]acetate (80 mg, 0.246 mmol) in THF (3 mL) was added 18-crown-6 (145 mg, 0.548 mmol). The solution was cooled to 0 °C and KHMDS (350  $\mu$ L, 0.7 M in toluene, 0.246 mmol) was added cautiously. After 15 min the solution was cooled to –78 °C and **139** (37 mg, 0.189 mmol) in THF (2 mL) was added *via* cannula. After 1 h the reaction was quenched with sat. NH<sub>4</sub>Cl (aq.) (5 mL), Et<sub>2</sub>O (10 mL) added and the organic layer separated. The aqueous layer was extracted with further portions of Et<sub>2</sub>O (2  $\times$  10 mL) and the combined organic extracts were dried (MgSO<sub>4</sub>), filtered and concentrated under reduced pressure. The resulting crude product was purified by flash column chromatography on silica gel, eluting with pet. ether:EtOAc (20:1) to afford the title compound **57f** as a colourless oil (28 mg, 56%); *R<sub>f</sub>* (1:1 pet. ether:Et<sub>2</sub>O) 0.71;  $\nu_{\text{max}}$  (thin film)/cm<sup>-1</sup> 2935, 2913, 2874, 1691, 1627; <sup>1</sup>H NMR (400 MHz; CDCl<sub>3</sub>)  $\delta$  6.08–6.01 (2H, m, H-2), 5.85 (2H, d, *J* 12.0, H-1), 4.16 (4H, q, *J* 7.0, OCH<sub>2</sub>CH<sub>3</sub>), 3.17–3.11 (2H, m, H-3), 1.28 (3H, s, H-5), 1.28 (6H, t, *J* 7.0, OCH<sub>2</sub>CH<sub>3</sub>), 1.17 (3H, s, H-6); <sup>13</sup>C NMR (101 MHz; CDCl<sub>3</sub>)  $\delta$  166.7 (CH<sub>3</sub>CH<sub>2</sub>OC=O), 146.0 (C-2), 121.0 (C-1), 60.0 (OCH<sub>2</sub>CH<sub>3</sub>), 33.7 (C-3), 30.2 (C-4), 28.8 (C-5), 16.3 (C-6), 14.4 (OCH<sub>2</sub>CH<sub>3</sub>); *m/z* (ESI) 267 [MH<sup>+</sup>]; HRMS: calcd. for C<sub>15</sub>H<sub>23</sub>O<sub>4</sub>, 267.1591. Found: [MH<sup>+</sup>], 267.1587 (1.1 ppm error).



**(±)-[(1*S*,2*S*)-2-({*tert*-Butyl(dimethyl)silyl}oxy)methyl]cyclopropyl]methanol  
(140)**

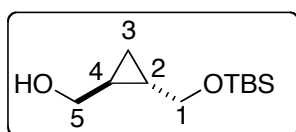

To a stirred solution of **54a** (1.00 g, 9.80 mmol) in THF (20 mL) at 0 °C was added NaH (472 mg, 11.8 mmol, 60% dispersion in mineral oil). After 45 mins, by which time a large amount of white precipitate had formed, TBSCl (1.48 g, 9.80 mmol) was added. The reaction mixture was warmed to RT and allowed to stir for a further 1 h before dilution with Et<sub>2</sub>O (25 mL). It was then washed with sat. NH<sub>4</sub>Cl (aq.) (20 mL) and brine (10 mL), the organic layer separated and the aqueous layer extracted with further portions of Et<sub>2</sub>O (2 × 20 mL). The combined organic extracts were dried (MgSO<sub>4</sub>), filtered and concentrated under reduced pressure. The resulting crude product was purified by flash column chromatography on silica gel, eluting with pet. ether:EtOAc (20:1 → 4:1) to afford the title compound **140** as a colourless oil (1.46 g, 69%); R<sub>f</sub> (EtOAc) 0.89; ν<sub>max</sub> (thin film)/cm<sup>-1</sup> 3315, 2909, 2884, 2842; <sup>1</sup>H NMR (400 MHz; CDCl<sub>3</sub>) δ 3.59 (1H, dd, *J* 10.5, 6.0) and 3.51–3.42 (3H, m, H-1 & H-5), 1.06–0.90 (2H, m, H-4 & H-2), 0.89 (9H, s, SiC(CH<sub>3</sub>)<sub>3</sub>), 0.53–0.40 (2H, m, H-3), 0.05 (6H, s, SiCH<sub>3</sub>); <sup>13</sup>C NMR (101 MHz; CDCl<sub>3</sub>) δ 66.6 (C-1 or C-5), 65.9 (C-1 or C-5), 26.0 (SiC(CH<sub>3</sub>)<sub>3</sub>), 19.5 (C-2 or C-4), 19.4 (C-2 or C-4), 18.4 (SiC(CH<sub>3</sub>)<sub>3</sub>), 7.9 (C-3), -5.1 (SiCH<sub>3</sub>); *m/z* (ESI) 217 [MH<sup>+</sup>]; HRMS: calcd. for C<sub>11</sub>H<sub>25</sub>O<sub>2</sub>Si, 217.1618. Found: [MH<sup>+</sup>], 217.1622 (-2.3 ppm error).

**Ethyl (±)-(2*E*)-3-[(1*R*,2*S*)-2-({*tert*-butyl(dimethyl)silyl}oxy)methyl]cyclopropyl]prop-2-enoate (141)**

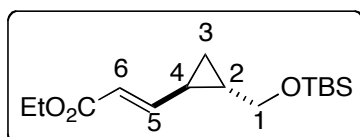

To a stirred solution of **140** (1.46 g, 6.75 mmol) in CHCl<sub>3</sub> (70 mL) was added manganese (IV) dioxide (5.87 g, 67.5 mmol) and (carbethoxymethylene) triphenyl phosphorane (2.82 g, 8.10 mmol). The resulting suspension was stirred vigorously with heating to maintain gentle reflux for 18 h. After cooling to room temperature, the suspension was filtered through Celite, and washed with CHCl<sub>3</sub> (100 mL). The filtrate was concentrated under reduced pressure to give the crude product.

This was purified by flash column chromatography on silica gel, eluting with pet. ether:EtOAc (40:1 → 10:1) to afford the title compound **141** as a colourless oil (1.63 g, 85%);  $R_f$  (10:1 pet. ether:EtOAc) 0.24;  $\nu_{\max}$  (thin film)/ $\text{cm}^{-1}$  2909, 2886, 2814, 1691, 1621;  $^1\text{H}$  NMR (400 MHz;  $\text{CDCl}_3$ )  $\delta$  6.48 (1H, dd,  $J$  15.5, 10.0, H-5), 5.85 (1H, d,  $J$  15.5), 4.17 (2H, q,  $J$  7.0,  $\text{CH}_3\text{CH}_2\text{O}$ ), 3.65–3.54 (2H, m, H-1), 1.54–1.47 (1H, m, H-4), 1.33–1.25 (1H, m, H-2), 1.27 (3H, t,  $J$  7.0  $\text{CH}_3\text{CH}_2\text{O}$ ), 0.96–0.90 (1H, m, H-3a), 0.88 (9H, s,  $\text{SiC}(\text{CH}_3)_3$ ), 0.84–0.79 (1H, m H-3b), 0.04 (6H, s,  $\text{SiCH}_3$ );  $^{13}\text{C}$  NMR (101 MHz;  $\text{CDCl}_3$ )  $\delta$  166.9 ( $\text{CH}_3\text{CH}_2\text{OC}=\text{O}$ ), 152.8 (C-5), 118.4 (C-6), 64.6 (C-1), 60.2 ( $\text{OCH}_2\text{CH}_3$ ), 26.1 ( $\text{SiC}(\text{CH}_3)_3$ ), 24.8 (C-2 or C-4), 19.6 (C-2 or C-4), 18.5 ( $\text{SiC}(\text{CH}_3)_3$ ), 14.5 ( $\text{OCH}_2\text{CH}_3$ ), 13.1 (C-3),  $-5.1$  ( $\text{SiCH}_3$ );  $m/z$  (ESI) 285 [ $\text{MH}^+$ ]; HRMS: calcd. for  $\text{C}_{15}\text{H}_{28}\text{O}_3\text{Si}$ , 285.1880. Found: [ $\text{MH}^+$ ], 285.1877 (1.2 ppm error).

#### Ethyl ( $\pm$ )-(2*E*)-3-[(1*R*,2*S*)-2-(hydroxymethyl)cyclopropyl]prop-2-enoate (**142**)

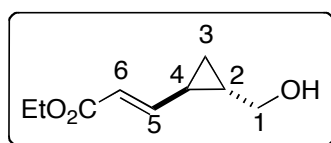

To a solution of **141** (1.60 g, 5.40 mmol) in THF (50 mL) at 0 °C was added TBAF (6.48 mL, 1 M in THF, 6.48 mmol). After 17 h the reaction mixture was diluted with  $\text{Et}_2\text{O}$  (50 mL) and washed with sat.  $\text{NH}_4\text{Cl}$  (aq.) (50 mL), the organic layer separated and the aqueous layer extracted with further portions of  $\text{Et}_2\text{O}$  ( $2 \times 50$  mL). The combined organic extracts were dried ( $\text{MgSO}_4$ ), filtered and concentrated under reduced pressure to give the crude product. This was purified by flash column chromatography on silica gel, eluting with pet. ether:EtOAc (2:1) to afford the title compound **142** as a colourless oil (704 mg, 77%);  $R_f$  (1:1 pet. ether:EtOAc) 0.59;  $\nu_{\max}$  (thin film)/ $\text{cm}^{-1}$  3374, 2938, 2893, 2830, 1687, 1670;  $^1\text{H}$  NMR (400 MHz;  $\text{CDCl}_3$ )  $\delta$  6.47 (1H, dd,  $J$  15.5, 10.0, H-5), 5.88 (1H, d,  $J$  15.5, H-6), 4.17 (2H, q,  $J$  7.0,  $\text{CH}_3\text{CH}_2\text{O}$ ), 3.60 (1H, dd,  $J$  11.5, 6.5, H-1a), 3.53 (1H, dd,  $J$  11.5, 7.0, H-1b), 1.57–1.49 (1H, m, H-2 or H-4), 1.43–1.35 (1H, m, H-2 or H-4), 1.27 (3H, t,  $J$  7.0  $\text{CH}_3\text{CH}_2\text{O}$ ), 0.96–0.86 (2H, m, H-3);  $^{13}\text{C}$  NMR (101 MHz;  $\text{CDCl}_3$ )  $\delta$  166.8 ( $\text{CH}_3\text{CH}_2\text{OC}=\text{O}$ ), 152.0 (C-5), 118.9 (C-6), 65.6 (C-1), 60.3 ( $\text{OCH}_2\text{CH}_3$ ), 24.8 (C-2 or C-4), 20.0 (C-2 or C-4), 14.4 ( $\text{OCH}_2\text{CH}_3$ ), 13.4 (C-3);  $m/z$  (ESI) 171 [ $\text{MH}^+$ ]; HRMS: calcd. for  $\text{C}_9\text{H}_{15}\text{O}_3$ , 171.1016. Found: [ $\text{MH}^+$ ], 171.1010 (3.8 ppm error).

### Ethyl (±)-(2E)-3-[(1R,2S)-2-formylcyclopropyl]prop-2-enoate (**143**)

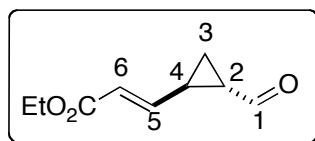

To a stirred solution of **142** (704 mg, 4.14 mmol) in  $\text{CHCl}_3$  (40 mL) was added manganese (IV) dioxide (3.60 g, 41.4 mmol) and 4Å molecular sieves (3.60 g). After 20 h the suspension was filtered through Celite, and washed with  $\text{CHCl}_3$  (100 mL). The filtrate was concentrated under reduced pressure to afford the title compound **143** as a colourless oil (468 mg, 67%);  $R_f$  (1:1 pet. ether:EtOAc) 0.72;  $\nu_{\text{max}}$  (thin film)/ $\text{cm}^{-1}$  2937, 2893, 2796, 1681, 1624;  $^1\text{H NMR}$  (400 MHz;  $\text{CDCl}_3$ )  $\delta$  9.31 (1H, d,  $J$  4.0, H-1), 6.42 (1H, dd,  $J$  15.5, 9.5, H-5), 5.97 (1H, d,  $J$  15.5, H-6), 4.17 (2H, q,  $J$  7.0,  $\text{CH}_3\text{CH}_2\text{O}$ ), 2.28–2.20 (1H, m, H-4), 2.17–2.10 (1H, m, H-2), 1.68–1.63 (1H, m, H-3a), 1.35–1.29 (1H, m, H-3b), 1.27 (3H, t,  $J$  7.0  $\text{CH}_3\text{CH}_2\text{O}$ );  $^{13}\text{C NMR}$  (101 MHz;  $\text{CDCl}_3$ )  $\delta$  198.7 (C-1), 166.2 ( $\text{CH}_3\text{CH}_2\text{OC}=\text{O}$ ), 147.4 (C-5), 121.7 (C-6), 60.6 ( $\text{OCH}_2\text{CH}_3$ ), 31.8 (C-2), 24.8 (C-4), 16.3 (C-3), 14.4 ( $\text{OCH}_2\text{CH}_3$ );  $m/z$  (ESI) 169 [ $\text{MH}^+$ ]; HRMS: calcd. for  $\text{C}_9\text{H}_{13}\text{O}_3$ , 169.0859. Found: [ $\text{MH}^+$ ], 169.0861 (−0.9 ppm error).

### Diethyl (±)-(2E,2'Z)-3,3'-(1R,2R)-cyclopropane-1,2-diylbisprop-2-enoate (**55b**)

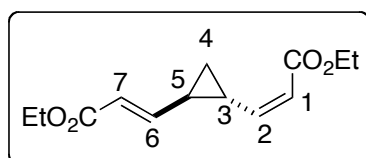

To a solution of ethyl [bis(2,2,2-trifluoroethoxy)phosphoryl]acetate (257 mg, 0.774 mmol) in THF (6 mL) was added 18-Crown-6 (457 mg, 1.73 mmol). The solution was cooled to 0 °C and KHMDS (1.10 mL, 0.7 M in toluene, 0.774 mmol) was added cautiously. After 15 min the solution was cooled to −78 °C and **143** (100 mg, 0.595 mmol) in THF (3 mL) was added *via* cannula. After 2 h the reaction was quenched with sat.  $\text{NH}_4\text{Cl}$  (aq.) (10 mL),  $\text{Et}_2\text{O}$  (20 mL) added and the organic layer separated. The aqueous layer was extracted with further portions of  $\text{Et}_2\text{O}$  (2 × 20 mL) and the combined organic extracts were dried ( $\text{MgSO}_4$ ), filtered and concentrated under reduced pressure. The resulting crude product was purified by flash column chromatography on silica gel, eluting with pet. ether:EtOAc (20:1) to afford the title compound **55b** as a colourless oil (65 mg, 46%);  $R_f$  (1:1 pet. ether: $\text{Et}_2\text{O}$ ) 0.56;  $\nu_{\text{max}}$  (thin film)/ $\text{cm}^{-1}$  2938, 2893, 2862, 1688, 1618;  $^1\text{H NMR}$  (400

MHz; CDCl<sub>3</sub>) δ 6.50 (1H, dd, *J* 15.5, 10.0, H-6), 5.88 (1H, d, *J* 15.5, H-7), 5.73 (1H, d, *J* 11.0, H-1), 5.50 (1H, dd, *J* 11.0, 11.0, H-2), 4.17 (2H, q, *J* 7.0, CH<sub>3</sub>CH<sub>2</sub>O), 4.15 (2H, q, *J* 7.0, CH<sub>3</sub>CH<sub>2</sub>O) 3.24–3.13 (1H, m, H-3), 1.78–1.68 (1H, m, H-5), 1.31–1.26 (1H, m, H-4a), 1.28 (3H, t, *J* 7.0 CH<sub>3</sub>CH<sub>2</sub>O), 1.26 (3H, t, *J* 7.0 CH<sub>3</sub>CH<sub>2</sub>O), 1.18–1.09 (1H, m, H-4b); <sup>13</sup>C NMR (101 MHz; CDCl<sub>3</sub>) δ 166.8 (CH<sub>3</sub>CH<sub>2</sub>OC=O), 166.4 (CH<sub>3</sub>CH<sub>2</sub>OC=O), 150.7 (C-2), 150.0 (C-6), 119.8 (C-7), 118.8 (C-1), 60.3 (OCH<sub>2</sub>CH<sub>3</sub>), 60.1 (OCH<sub>2</sub>CH<sub>3</sub>), 25.5 (C-5), 23.0 (C-3), 18.0 (C-4), 14.4 (OCH<sub>2</sub>CH<sub>3</sub>); *m/z* (ESI) 239 [MH<sup>+</sup>]; HRMS: calcd. for C<sub>13</sub>H<sub>19</sub>O<sub>4</sub>, 239.1278. Found: [MH<sup>+</sup>], 239.1276 (0.5 ppm error).

**(±)-(1*S*,2*S*)-Cyclopropane-1,2-dicarbaldehyde (**144**)<sup>85</sup>**

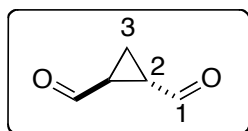

To a stirred solution of **54a** (2.00 g, 19.6 mmol) in CHCl<sub>3</sub> (150 mL) was added manganese (IV) dioxide (34.1 g, 392 mmol). The suspension was heated at reflux gently and after 16 h, the suspension was filtered through Celite, and washed with CHCl<sub>3</sub> (250 mL). The filtrate was concentrated under reduced pressure to afford the title compound **144** as a colourless oil (205 mg, 11%), which was used in the next step without further purification; *R<sub>f</sub>* (1:1 pet. ether:EtOAc) 0.54; <sup>1</sup>H NMR (400 MHz; CDCl<sub>3</sub>) δ 9.34–9.32 (2H, m, H-1), 2.57–2.49 (2H, m, H-2), 1.71–1.65 (2H, m, H-3). Data in agreement with those reported in the literature.<sup>85</sup>

**Diethyl (±)-(2'*Z*)-3,3'-(1*R*,2*R*)-cyclopropane-1,2-diylbisprop-2-enoate (**55c**)**

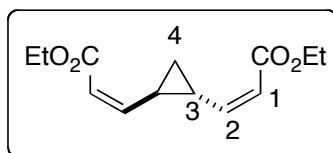

To a solution of ethyl [bis(2,2,2-trifluoroethoxy)phosphoryl]acetate (1.32 mg, 3.98 mmol) in THF (15 mL) was added 18-crown-6 (2.30 g, 8.87 mmol). The solution was cooled to 0 °C and KHMDS (5.70 mL, 0.7 M in toluene, 3.98 mmol) was added cautiously. After 15 min the solution was cooled to –78 °C and **144** (150 mg, 1.53 mmol) in THF (8 mL) was added *via* cannula. After 2 h the reaction was quenched with sat. NH<sub>4</sub>Cl (aq.) (15 mL), Et<sub>2</sub>O (25 mL) added and the organic layer separated. The aqueous layer was extracted with further portions of

Et<sub>2</sub>O (2 × 25 mL) and the combined organic extracts were dried (MgSO<sub>4</sub>), filtered and concentrated under reduced pressure. The resulting crude product was purified by flash column chromatography on silica gel, eluting with pet. ether:EtOAc (10:1) to afford the title compound **55c** as a colourless oil (192 mg, 63%); R<sub>f</sub> (10:1 pet. ether:EtOAc) 0.37; ν<sub>max</sub> (thin film)/cm<sup>-1</sup> 2935, 2885, 1691, 1612; <sup>1</sup>H NMR (400 MHz; CDCl<sub>3</sub>) δ 5.73 (2H, d, *J* 11.5, H-1), 5.60–5.53 (2H, m, H-2), 4.17 (4H, q, *J* 7.0, CH<sub>3</sub>CH<sub>2</sub>O), 3.18–3.10 (2H, m, H-3), 1.28 (6H, t, *J* 7.0, CH<sub>3</sub>CH<sub>2</sub>O), 1.20 (2H, t, *J* 7.0, H-4); <sup>13</sup>C NMR (101 MHz; CDCl<sub>3</sub>) δ 167.0 (CH<sub>3</sub>CH<sub>2</sub>OC=O), 151.4 (C-2), 118.4 (C-1), 60.0 (OCH<sub>2</sub>CH<sub>3</sub>), 23.4 (C-3), 18.3 (C-4), 14.4 (OCH<sub>2</sub>CH<sub>3</sub>); m/z (ESI) 239 [MH<sup>+</sup>]; HRMS: calcd. for C<sub>13</sub>H<sub>19</sub>O<sub>4</sub>, 239.1278. Found: [MH<sup>+</sup>], 239.1285 (−3.2 ppm error).

**(1*R*,2*S*)-Cyclopropane-1,2-diyl dimethanol (54b)**<sup>86</sup>

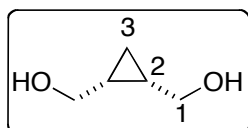

To a stirred suspension of LiAlH<sub>4</sub> (510 mg, 13.4 mmol) in THF (25 mL) at 0 °C was added 3-oxabicyclo[3.1.0]hexane-2,4-dione (1.00 g, 8.92 mmol) in THF (20 mL) *via* cannula. The reaction was heated to reflux and stirred for 16 h. The reaction was cooled to 0 °C and Na<sub>2</sub>SO<sub>4</sub>·10H<sub>2</sub>O was cautiously added until on further addition fizzing was no longer observed. The aluminium salts were removed by filtration and washed with EtOAc (100 mL). The filtrate was concentrated under reduced pressure to give the crude product. This was purified by flash column chromatography on silica gel, eluting with EtOAc to afford the title compound **54b** as a colourless oil. (723 mg, 79%); R<sub>f</sub> (EtOAc) 0.23; <sup>1</sup>H NMR (400 MHz; CDCl<sub>3</sub>) δ 4.15–4.08 (2H, m, H-1a), 3.31–3.21 (2H, m, H-1b), 2.20 (2H, br s, OH), 1.39–1.28 (2H, m, H-2), 0.81 (1H, dt, *J* 8.0, 5.0, H-3a), 0.22 (1H, dt, *J* 5.0, 5.0, H-3b). Data in agreement with those reported in the literature.<sup>86</sup>

**(±)-[(1*R*,2*S*)-2-({*tert*-Butyl(dimethyl)silyl}oxy)methyl]cyclopropyl]methanol  
(144)<sup>87</sup>**

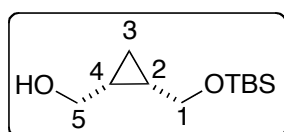

To a stirred solution of **54b** (720 mg, 7.06 mmol) in THF (14 mL) at 0 °C was added NaH (339 mg, 8.47 mmol, 60% dispersion in mineral oil). After 45 mins, by which time a large amount of white precipitate had formed, TBSCl (1.06 g, 7.06 mmol) was added. The reaction mixture was warmed to RT and allowed to stir for a further 1 h before dilution with Et<sub>2</sub>O (25 mL). It was then washed with sat. NH<sub>4</sub>Cl (aq.) (20 mL) and brine (10 mL), the organic layer separated and the aqueous layer extracted with further portions of Et<sub>2</sub>O (2 × 20 mL). The combined organic extracts were dried (MgSO<sub>4</sub>), filtered and concentrated under reduced pressure to afford the title compound **144** as a colourless oil (1.53 g, 100%), which was used in the next step without further purification; R<sub>f</sub> (EtOAc) 0.81; <sup>1</sup>H NMR (400 MHz; CDCl<sub>3</sub>) δ 4.15 (1H, dd, *J* 11.5, 5.5, H-1a or H-5a), 3.97 (1H, dd, *J* 12.0, 5.5, H-1a or H-5a), 3.26–3.20 (2H, m, H-1 & H-5) 1.43–1.30 (1H, m, H-4 or H-2), 1.30–1.18 (1H, m, H-4 or H-2), 0.92 (9H, s, SiC(CH<sub>3</sub>)<sub>3</sub>), 0.80–0.71 (1H, m, H-3a), 0.23–0.16 (1H, m, H-3b), 0.12 (3H, s, SiCH<sub>3</sub>), 0.10 (3H, s, SiCH<sub>3</sub>). Data in agreement with those reported in the literature.<sup>87</sup>

**(±)-[(1*R*,2*S*)-2-({*tert*-Butyl(dimethyl)silyl}oxy)methyl]cyclopropanecarbaldehyde  
(145)<sup>87</sup>**

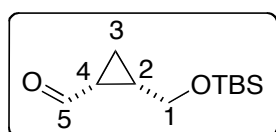

To a stirred solution of **144** (1.61 g, 7.44 mmol) in CHCl<sub>3</sub> (75 mL) was added manganese (IV) dioxide (6.47 g, 74.4 mmol) and 4Å molecular sieves (6.47 g). After 16 h the suspension was filtered through Celite, and washed with CHCl<sub>3</sub> (150 mL). The filtrate was concentrated under reduced pressure to afford the title compound **145** as a colourless oil (1.20 g, 75%), which was used in the next step without further purification; R<sub>f</sub> (1:1 pet. ether:EtOAc) 0.86; <sup>1</sup>H NMR (400 MHz; CDCl<sub>3</sub>) δ 9.41 (1H, d, *J* 5.0, H-5), 3.97 (1H, dd, *J* 11.0, 5.5, H-1a), 3.62 (1H, dd, *J* 11.0, 7.5, H-1b), 2.02–1.91 (1H, m, H-4 or H-2), 1.82–1.73 (1H, m, H-4 or H-2), 1.37–1.32 (1H, m, H-3a), 1.25–1.20 (1H, m, H-

3b), 0.87 (9H, s, SiC(CH<sub>3</sub>)<sub>3</sub>), 0.04 (3H, s, SiCH<sub>3</sub>), 0.03 (3H, s, SiCH<sub>3</sub>). Data in agreement with those reported in the literature.<sup>87</sup>

**Ethyl (±)-(2E)-3-[(1S,2S)-2-({tert-butyl(dimethyl)silyl}oxy)methyl]cyclopropyl]prop-2-enoate (146)**<sup>87</sup>

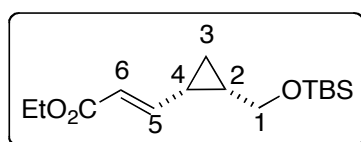

To a stirred solution of **145** (534 mg, 2.50 mmol) in CHCl<sub>3</sub> (25 mL) at RT was added (carbethoxymethylene) triphenyl phosphorane (1.04 g, 3.00 mmol). After 16 h the solution was concentrated under reduced pressure and the crude product purified by flash column chromatography on silica gel, eluting with pet. ether:EtOAc (40:1) to afford the title compound **146** as a colourless oil (471 mg, 63%); R<sub>f</sub> (20:1 pet. ether:EtOAc) 0.31; <sup>1</sup>H NMR (400 MHz; CDCl<sub>3</sub>) δ 6.72 (1H, dd, *J* 15.5, 10.5, H-5), 5.92 (1H, d, *J* 15.5, H-6), 4.17 (2H, q, *J* 7.0, CH<sub>3</sub>CH<sub>2</sub>O), 3.82 (1H, dd, *J* 11.0, 5.6, H-1a), (1H, dd, *J* 11.0 7.5, H-1b), 1.67–1.78 (1H, m, H-4 or H-2), 1.49–1.58 (1H, m, H-4 or H-2), 1.28 (3H, t, *J* 7.1, CH<sub>3</sub>CH<sub>2</sub>O), 1.09–1.16 (1H, m, H-3a), 0.89 (9H, s, SiC(CH<sub>3</sub>)<sub>3</sub>), 0.68–0.75 (1H, m, H-3b), 0.06 (3H, s, SiCH<sub>3</sub>), 0.05 (3H, s, SiCH<sub>3</sub>). Data in agreement with those reported in the literature.<sup>87</sup>

**Ethyl (±)-(2E)-3-[(1S,2S)-2-(hydroxymethyl)cyclopropyl]prop-2-enoate (147)**<sup>86</sup>

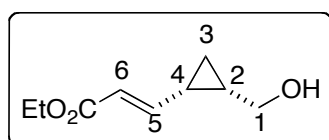

To a stirred solution of **146** (471 mg, 1.59 mmol) in MeCN (15 mL) in a plastic container was added HF (130 μL, 48 wt % in water, 3.18 mmol). This was stirred at RT for 16 h before the addition of sat. NaHCO<sub>3</sub> (aq.) (15 mL). The solution was diluted with CH<sub>2</sub>Cl<sub>2</sub> (10 mL), the organic layer was separated and the aqueous layer extracted with further portions of CH<sub>2</sub>Cl<sub>2</sub> (2 × 20 mL). The combined organic extracts were dried (MgSO<sub>4</sub>), filtered and concentrated under reduced pressure to afford the title compound **147** as a colourless oil (254 mg, 94%), which was used in the next step without further purification; R<sub>f</sub> (1:1 pet. ether: EtOAc) 0.42; <sup>1</sup>H NMR (400 MHz; CDCl<sub>3</sub>) δ 6.69 (1H, dd, *J* 15.5, 10.0, H-5), 5.95 (1H, d, *J* 15.5, H-6), 4.17 (2H, q, *J* 7.0, CH<sub>3</sub>CH<sub>2</sub>O), 3.82 (1H, ddd, *J* 11.5, 6.0, 1.5 H-1a), 3.50 (1H, dd, *J* 11.5, 8.5, H-

1b), 1.98 (1H, br s, OH), 1.81–1.70 (1H, m, H-4 or H-2), 1.63–1.52 (1H, m, H-4 or H-2), 1.25 (3H, t,  $J$  7.0, CH<sub>3</sub>CH<sub>2</sub>O), 1.20–1.13 (1H, m, H-3a), 0.72–0.65 (1H, m, H-3b). Data in agreement with those reported in the literature.<sup>86</sup>

### Ethyl (±)-(2*E*)-3-[(1*S*,2*S*)-2-formylcyclopropyl]prop-2-enoate (**148**)<sup>86</sup>

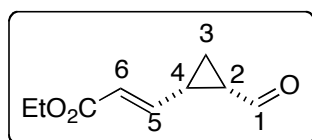

To a stirred solution of **147** (281 mg, 1.65 mmol) in CHCl<sub>3</sub> (15 mL) was added manganese (IV) dioxide (1.43 g, 16.5 mmol) and 4Å molecular sieves (1.43 g). After 16 h the suspension was filtered through Celite, and washed with CHCl<sub>3</sub> (50 mL). The filtrate was concentrated under reduced pressure to afford the title compound **148** as a colourless oil (224 mg, 81%), which was used in the next step without further purification;  $R_f$  (1:1 pet. ether: EtOAc) 0.57; <sup>1</sup>H NMR (400 MHz; CDCl<sub>3</sub>) δ 9.47 (1H, d,  $J$  4.5, H-1), 6.82 (1H, dd,  $J$  15.5, 9.5, H-5), 6.02 (1H, d,  $J$  15.5, H-6), 4.17 (2H, q,  $J$  7.0, CH<sub>3</sub>CH<sub>2</sub>O), 2.37–2.21 (2H, m, H-4 & H-2), 1.68–1.63 (1H, m, H-3a), 1.60–1.53 (1H, m, H-3b), 1.28 (3H, t,  $J$  7.0, CH<sub>3</sub>CH<sub>2</sub>O). Data in agreement with those reported in the literature.<sup>86</sup>

### Diethyl (1*R*,2*S*)-cyclohepta-3,6-diene-1,2-dicarboxylate (**58a**)

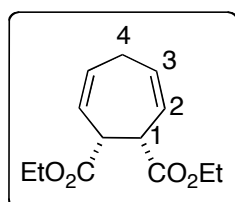

To a stirred solution of **148** (132 mg, 0.786 mmol) in CHCl<sub>3</sub> (10 mL) was added (carbethoxymethylene)triphenylphosphorane (329 mg, 0.943 mmol) at RT. After 16 h the solution was concentrated under reduced pressure at RT and the crude product purified by flash column chromatography on silica gel, eluting with pet. ether:EtOAc (20:1) to afford the title compound **58a** as a colourless oil (148 mg, 79%); *For data see page 89.*

### Diethyl (±)-(1*S*,2*S*)-cyclohepta-3,6-diene-1,2-dicarboxylate (**58b**)

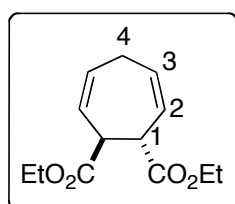

To a solution of ethyl [bis(2,2,2-trifluoroethoxy)phosphoryl]acetate (236 mg, 0.712 mmol) in THF (7 mL) was added 18-crown-6 (420 mg, 1.59 mmol). The



solution was cooled to 0 °C and KHMDS (1.02 mL, 0.7 M in toluene, 0.712 mmol) was added cautiously. After 15 min the solution was cooled to -78 °C and **148** (92 mg, 0.548 mmol) in THF (7 mL) was added *via* cannula. After 2 h the reaction was quenched with sat. NH<sub>4</sub>Cl (aq.) (10 mL), Et<sub>2</sub>O (20 mL) added and the organic layer separated. The aqueous layer was extracted with further portions of Et<sub>2</sub>O (2 × 20 mL) and the combined organic extracts were dried (MgSO<sub>4</sub>), filtered and concentrated under reduced pressure at RT. The resulting crude product was purified by flash column chromatography on silica gel, eluting with pet. ether:EtOAc (20:1) to afford the title compound **58b** as a colourless oil (98 mg, 75%); R<sub>f</sub> (10:1 pet. ether:EtOAc) 0.27; ν<sub>max</sub> (thin film)/cm<sup>-1</sup> 2978, 2936, 2893, 2862, 1710 <sup>1</sup>H NMR (400 MHz; CDCl<sub>3</sub>) δ 5.89–5.81 (2H, m, H-3), 5.66–5.60 (2H, m, H-2), 4.17 (4H, q, *J* 7.0, OCH<sub>2</sub>CH<sub>3</sub>), 3.83–3.77 (2H, m, H-1), 2.88–2.83 (2H, m, H-4), 1.26 (6H, t, *J* 7.0, CH<sub>3</sub>CH<sub>2</sub>O); <sup>13</sup>C NMR (101 MHz; CDCl<sub>3</sub>) δ 173.3 (CH<sub>3</sub>CH<sub>2</sub>OC=O), 130.8 (C-3), 127.0 (C-2), 61.1 (OCH<sub>2</sub>CH<sub>3</sub>), 45.5 (C-1), 27.5 (C-4), 14.3 (OCH<sub>2</sub>CH<sub>3</sub>); m/z (ESI) 239 [MH<sup>+</sup>]; HRMS: calcd. for C<sub>13</sub>H<sub>19</sub>O<sub>4</sub>, 239.1278. Found: [MH<sup>+</sup>], 239.1267 (3.8 ppm error).

**Ethyl (±)-(2Z)-3-[(1S,2S)-2-({*tert*-butyl(dimethyl)silyl}oxy)methyl]cyclopropyl]prop-2-enoate (**149**)**

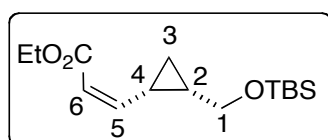

To a solution of ethyl [bis(2,2,2-trifluoroethoxy)phosphoryl]acetate (1.31 g, 4.04 mmol) in THF (40 mL) was added 18-crown-6 (2.38 g, 9.02 mmol). The solution was cooled to 0 °C and KHMDS (5.80 mL, 0.7 M in toluene, 4.04 mmol) was added cautiously. After 15 min the solution was cooled to -78 °C and **145** (665 mg, 3.11 mmol) in THF (40 mL) was added *via* cannula. After 2 h the reaction was quenched with sat. NH<sub>4</sub>Cl (aq.) (50 mL), Et<sub>2</sub>O (50 mL) added and the organic layer separated. The aqueous layer was extracted with further portions of Et<sub>2</sub>O (2 × 50 mL) and the combined organic extracts were dried (MgSO<sub>4</sub>), filtered and concentrated under reduced pressure. The resulting crude product was purified by flash column chromatography on silica gel, eluting with pet. ether:EtOAc (50:1) to afford the title compound **149** as a colourless oil (883 mg, 40%); R<sub>f</sub> (50:1 pet. ether:EtOAc) 0.18; ν<sub>max</sub> (thin film)/cm<sup>-1</sup> 2910, 2886, 2814, 1690, 1608; <sup>1</sup>H NMR (400

MHz; CDCl<sub>3</sub>) δ 5.91 (1H, dd, *J* 11.5, 11.5, H-5), 5.75 (1H, d, *J* 11.5, H-6), 4.17 (2H, q, *J* 7.0, OCH<sub>2</sub>CH<sub>3</sub>), 3.78 (1H, dd, *J* 11.0, 6.0, H-1a), 3.69 (1H, dd, *J* 11.0, 7.0, H-1b), 3.04–2.95 (1H, m, H-4), 1.59–1.49 (1H, m, H-2), 1.29 (3H, t, *J* 7.0, CH<sub>3</sub>CH<sub>2</sub>O), 1.24–1.15 (1H, m, H-3a), 0.88 (9H, s, (SiC(CH<sub>3</sub>)<sub>3</sub>)), 0.70–0.63 (1H, m, H-3b), 0.05 (6H, s, SiCH<sub>3</sub>); <sup>13</sup>C NMR (101 MHz; CDCl<sub>3</sub>) δ 167.2 (CH<sub>3</sub>CH<sub>2</sub>OC=O), 151.3 (C-5), 118.7 (C-6), 62.6 (C-1), 59.8 (OCH<sub>2</sub>CH<sub>3</sub>), 26.1 (SiC(CH<sub>3</sub>)<sub>3</sub>), 23.7 (C-2), 18.5 (SiC(CH<sub>3</sub>)<sub>3</sub>), 17.0 (C-4), 14.5 (OCH<sub>2</sub>CH<sub>3</sub>), 14.4 (C-3), –5.1 (SiCH<sub>3</sub>), –5.1 (SiCH<sub>3</sub>); *m/z* (ESI) 285 [MH<sup>+</sup>]; HRMS: calcd. for C<sub>15</sub>H<sub>29</sub>O<sub>3</sub>Si, 285.1880. Found: [MH<sup>+</sup>], 285.1880 (0.0 ppm error).

### Ethyl (±)-(2Z)-3-[(1S,2S)-2-(hydroxymethyl)cyclopropyl]prop-2-enoate (**150**)

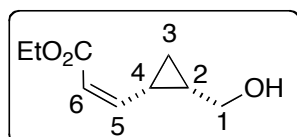

To a stirred solution of **149** (339 mg, 1.14 mmol) in MeCN (10 mL) in a plastic container was added HF (90 μL, 48 wt % in water, 2.28 mmol). This was stirred at RT for 16 h before the addition of sat. NaHCO<sub>3</sub> (aq.) (15 mL). The solution was diluted with CH<sub>2</sub>Cl<sub>2</sub> (15 mL), the organic layer was separated and the aqueous layer extracted with further portions of CH<sub>2</sub>Cl<sub>2</sub> (2 × 20 mL). The combined organic extracts were dried (MgSO<sub>4</sub>), filtered and concentrated under reduced pressure to afford the title compound **150** as a colourless oil (188 mg, 97%), which was used in the next step without further purification; *R<sub>f</sub>* (1:1 pet. ether: EtOAc) 0.43; *ν*<sub>max</sub> (thin film)/cm<sup>-1</sup> 3365, 2937, 2912, 2874, 1687, 1607; <sup>1</sup>H NMR (400 MHz; CDCl<sub>3</sub>) δ 5.89 (1H, dd, *J* 11.5, 10.0, H-5), 5.83 (1H, d, *J* 11.5, H-6), 4.19 (2H, q, *J* 7.0, OCH<sub>2</sub>CH<sub>3</sub>), 3.85 (1H, dd, *J* 11.5, 6.0, H-1a), 3.55 (1H, dd, *J* 11.5, 8.5, H-1b), 3.03–2.95 (1H, m, H-4), 1.69–1.39 (1H, m, H-2), 1.29 (3H, t, *J* 7.0, CH<sub>3</sub>CH<sub>2</sub>O), 1.28–1.23 (1H, m, H-3a), 0.67–0.62 (1H, m, H-3b); <sup>13</sup>C NMR (101 MHz; CDCl<sub>3</sub>) δ 167.0 (CH<sub>3</sub>CH<sub>2</sub>OC=O), 149.8 (C-5), 120.0 (C-6), 63.1 (C-1), 60.0 (OCH<sub>2</sub>CH<sub>3</sub>), 23.8 (C-2), 16.5 (C-4), 14.5 (C-3), 14.4 (OCH<sub>2</sub>CH<sub>3</sub>); *m/z* (ESI) 193 [MNa<sup>+</sup>]; HRMS: calcd. for C<sub>9</sub>H<sub>14</sub>NaO<sub>3</sub>, 193.0835. Found: [MNa<sup>+</sup>], 193.0833 (0.6 ppm error).

### Ethyl (±)-(2Z)-3-[(1S,2S)-2-formylcyclopropyl]prop-2-enoate (**151**)

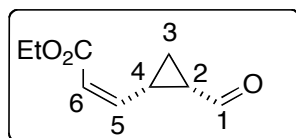

To a stirred solution of **150** (185 mg, 1.09 mmol) in  $\text{CHCl}_3$  (10 mL) was added manganese (IV) dioxide (948 mg, 10.9 mmol) and 4Å molecular sieves (948 mg). After 16 h the suspension was filtered through Celite, and washed with  $\text{CHCl}_3$  (50 mL). The filtrate was concentrated under reduced pressure. The resulting crude product was purified by flash column chromatography on silica gel, eluting with pet. ether:EtOAc (20:1) to afford the title compound **151** as a colourless oil (97 mg, 53%);  $R_f$  (20:1 pet. ether:EtOAc) 0.18;  $\nu_{\text{max}}$  (thin film)/ $\text{cm}^{-1}$  2938, 2894, 2861, 2803, 2699, 1685, 1613;  $^1\text{H}$  NMR (400 MHz;  $\text{CDCl}_3$ )  $\delta$  9.67 (1H, d,  $J$  3.5, H-1), 6.09 (1H, dd,  $J$  11.5, 10.5, H-5), 5.83 (1H, d,  $J$  11.5, H-6), 4.18 (2H, q,  $J$  7.0,  $\text{OCH}_2\text{CH}_3$ ), 3.67–3.56 (1H, m, H-4), 2.50–2.42 (1H, m, H-2), 1.60–1.52 (2H, m, H-3), 1.29 (3H, t,  $J$  7.0,  $\text{CH}_3\text{CH}_2\text{O}$ );  $^{13}\text{C}$  NMR (101 MHz;  $\text{CDCl}_3$ )  $\delta$  200.0 (C-1), 166.7 ( $\text{CH}_3\text{CH}_2\text{OC}=\text{O}$ ), 146.0 (C-5), 121.1 (C-6), 60.2 ( $\text{OCH}_2\text{CH}_3$ ), 31.1 (C-2), 23.9 (C-4), 17.3 (C-3), 14.4 ( $\text{OCH}_2\text{CH}_3$ );  $m/z$  (ESI) 191 [ $\text{MNa}^+$ ]; HRMS: calcd. for  $\text{C}_9\text{H}_{12}\text{NaO}_3$ , 191.0679. Found: [ $\text{MNa}^+$ ], 191.0676 (0.3 ppm error).

### Diethyl (1R,2S)-cyclohepta-3,6-diene-1,2-dicarboxylate (**58a**)

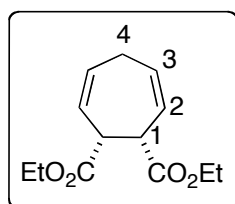

To a solution of ethyl [bis(2,2,2-trifluoroethoxy)phosphoryl]acetate (244 mg, 0.735 mmol) in THF (7 mL) was added 18-crown-6 (433 mg, 1.64 mmol). The solution was cooled to 0 °C and KHMDS (1.05 mL, 0.7 M in toluene, 0.735 mmol) was added cautiously. After 15 min the solution was cooled to -78 °C and **151** (95 mg, 0.565 mmol) in THF (7 mL) was added *via* cannula. After 2 h the reaction was quenched with sat.  $\text{NH}_4\text{Cl}$  (aq.) (10 mL),  $\text{Et}_2\text{O}$  (20 mL) added and the organic layer separated. The aqueous layer was extracted with further portions of  $\text{Et}_2\text{O}$  (2 × 20 mL) and the combined organic extracts were dried ( $\text{MgSO}_4$ ), filtered and concentrated under reduced pressure. The resulting crude product was purified by flash column chromatography on silica gel, eluting with pet. ether:EtOAc (20:1) to

afford the title compound **58a** as a colourless oil (109 mg, 81%); *For data see page 89*

**Methyl ( $\pm$ )-(*E*)-3-((1*S*,3*R*)-3-((*tert*-butyldimethylsilyloxy)methyl)-2,2-dimethylcyclopropyl)prop-2-enoate (**152**)**

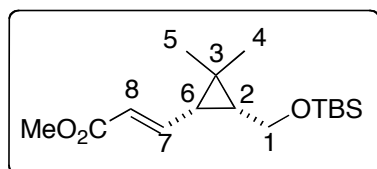

To a stirred solution of **132** (200 mg, 0.818 mmol) in  $\text{CHCl}_3$  (8 mL) was added manganese (IV) dioxide (711 mg, 8.18 mmol) and (methoxycarbonylmethylenetriphenylphosphorane) (328 mg, 0.982 mmol). The resulting suspension was stirred vigorously with heating to maintain gentle reflux for 48 h. After cooling to room temperature, the suspension was filtered through Celite, and washed with  $\text{CHCl}_3$  (20 mL). The filtrate was concentrated under reduced pressure to give the crude product. This was purified by flash column chromatography on silica gel, eluting with pet. ether:EtOAc (50:1) to afford the title compound **152** as a colourless oil *E:Z* < 20:1 (118 mg, 48%);  $R_f$  (10:1 pet.ether:EtOAc) 0.56;  $\nu_{\text{max}}$  (thin film)/ $\text{cm}^{-1}$  2908, 2814, 1696, 1242, 1066;  $^1\text{H NMR}$  (400 MHz;  $\text{CDCl}_3$ ) *E*  $\delta$  6.76 (1H, dd, *J* 15.0, 11.0, H-7), 5.93 (1H, d, *J* 15.0, H-8), 3.81–3.69 (2H, m, H-1), 3.71 (3H, s,  $\text{OCH}_3$ ), 1.57–1.48 (1H, m, H-6), 1.39–1.32 (1H, m, H-2), 1.16 (3H, s, H-4), 1.15 (3H, s, H-5), 0.87 (9H, s,  $\text{SiC}(\text{CH}_3)_3$ ), 0.05 (3H, s,  $\text{SiCH}_3$ ), 0.04 (3H, s,  $\text{SiCH}_3$ ) *Z*  $\delta$  5.99 (1H, dd, *J* 11.5, 11.5, H-7), 5.80 (1H, d, *J* 11.5, H-8), 4.00–3.86 (2H, m, H-1), 3.71 (3H, s,  $\text{OCH}_3$ ), 1.50–1.44 (2H, m, H-6 & H-2), 1.20 (3H, s, H-4), 1.19 (3H, s, H-5), 0.89 (9H, s,  $\text{SiC}(\text{CH}_3)_3$ ), 0.06 (6H, s,  $\text{SiCH}_3$ );  $^{13}\text{C NMR}$  (101 MHz;  $\text{CDCl}_3$ ) *E*  $\delta$  167.0 ( $\text{CH}_3\text{OC}=\text{O}$ ), 148.1 (C-7), 120.8 (C-8), 60.1 (C-1), 51.4 ( $\text{CH}_3\text{O}$ ), 35.7 (C-6 or C-2), 31.2 (C-4), 28.9 (C-6 or C-2), 26.0 ( $\text{SiC}(\text{CH}_3)_3$ ), 25.6 (C-3), 18.4 ( $\text{SiC}(\text{CH}_3)_3$ ), 15.9 (C-5), -5.1 ( $\text{SiCH}_3$ ), -5.1 ( $\text{SiCH}_3$ ); *m/z* (ESI): 321 [ $\text{MNa}^+$ ]; HRMS: calcd. for  $\text{C}_{16}\text{H}_{30}\text{NaO}_3\text{Si}$ , 321.1856. Found: [ $\text{MNa}^+$ ], 321.1852 (1.1 ppm error).

**Methyl ( $\pm$ )-(*E*)-3-((1*S*,3*R*)-3-(hydroxymethyl)-2,2-dimethylcyclopropyl)prop-2-enoate (**153**)**

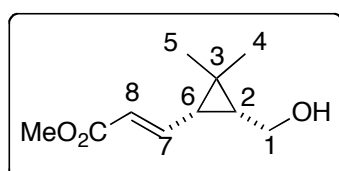

To a stirred solution of **152** (100 mg, 0.335 mmol) in MeCN (4 mL) in a plastic container was added HF (23

$\mu\text{L}$ , 48 wt % in water, 0.531 mmol). This was stirred at RT for 16 h before the addition of sat.  $\text{NaHCO}_3$  (aq.) (5 mL). The solution was diluted with  $\text{CH}_2\text{Cl}_2$  (10 mL), the organic layer was separated and the aqueous layer extracted with further portions of  $\text{CH}_2\text{Cl}_2$  ( $2 \times 10$  mL). The combined organic extracts were dried ( $\text{MgSO}_4$ ), filtered and concentrated under reduced pressure to afford the title compound **153** as a colourless oil  $E:Z < 20:1$  (50 mg, 81%), which was used in the next step without further purification;  $R_f$  (1:1 pet.ether:EtOAc) 0.47;  $\nu_{\text{max}}$  (thin film)/ $\text{cm}^{-1}$  3373, 2907, 1690, 1416;  $^1\text{H}$  NMR (400 MHz;  $\text{CDCl}_3$ )  $E$   $\delta$  6.78 (1H, dd,  $J$  15.0, 11.0, H-7), 5.98 (1H, d,  $J$  15.0, H-8), 3.87–3.73 (2H, m, H-1), 3.71 (3H, s,  $\text{OCH}_3$ ), 1.58 (1H, dd,  $J$  11.0, 9.0, H-6), 1.43 (1H, dd,  $J$  9.0, 7.5, H-2), 1.19 (3H, s, H-4), 1.18 (3H, s, H-5);  $Z$   $\delta$  6.78 (1H, dd,  $J$  11.5, 10.5, H-7), 5.87 (1H, d,  $J$  11.5, H-8), 3.87–3.73 (2H, m, H-1), 3.72 (3H, s,  $\text{OCH}_3$ ), 1.60–1.39 (2H, m, H-6 & H-2), 1.19 (3H, s, H-4), 1.18 (3H, s, H-5);  $^{13}\text{C}$  NMR (101 MHz;  $\text{CDCl}_3$ )  $\delta$  167.0 ( $\text{CH}_3\text{OC}=\text{O}$ ), 147.1 (C-7), 121.5 (C-8), 59.9 (C-1), 51.5 ( $\text{CH}_3\text{O}$ ), 35.5 (C-6 or C-2), 31.1 (C-4), 28.9 (C-6 or C-2), 25.7 (C-3), 15.9 (C-5);  $m/z$  (ESI): 207 [ $\text{MNa}^+$ ]; HRMS: calcd. for  $\text{C}_{10}\text{H}_{16}\text{NaO}_3$ , 207.0992. Found: [ $\text{MNa}^+$ ], 207.0989 (1.0 ppm error).

**Dimethyl (2*E*,2'*E*)-3,3'-((1*R*,2*S*)-3,3-dimethylcyclopropane-1,2-diyl)diprop-2-enoate (154)**

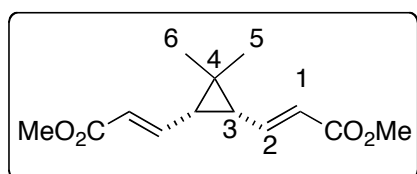

To a stirred solution of **153** (50 mg, 0.272 mmol) in  $\text{CHCl}_3$  (3 mL) at RT was added (methoxycarbonylmethylen)-triphenylphosphorane (109 mg, 0.326 mmol). After 16 h the solution was

concentrated under reduced pressure and the crude product purified by flash column chromatography on silica gel, eluting with pet. ether:EtOAc (20:1) to afford the title compound **154** as a colourless oil (32 mg, 49%);  $R_f$  (20:1 pet.ether:EtOAc) 0.18;  $\nu_{\text{max}}$  (thin film)/ $\text{cm}^{-1}$  2908, 2873, 1689, 1610, 1413;  $^1\text{H}$  NMR (400 MHz;  $\text{CDCl}_3$ )  $\delta$  6.89–6.78 (2H, m, H-2), 5.96 (2H, d,  $J$  15.5, H-1), 3.72 (6H, s,  $\text{OCH}_3$ ), 1.93–1.86 (2H, m, H-3), 1.26 (3H, s, H-5), 1.21, (3H, s, H-6);  $^{13}\text{C}$  NMR (101 MHz;  $\text{CDCl}_3$ )  $\delta$  166.6 ( $\text{CH}_3\text{OC}=\text{O}$ ), 145.7 (C-2), 122.5 (C-1), 51.6 ( $\text{CH}_3\text{O}$ ), 36.7 (C-3), 29.7 (C-4),

28.5 (C-5), 16.7 (C-6); m/z (ESI): 261 [MNa<sup>+</sup>]; HRMS: calcd. for C<sub>13</sub>H<sub>18</sub>NaO<sub>3</sub>, 261.1097. Found: [MNa<sup>+</sup>], 261.1096 (0.4 ppm error).

**Methyl (±)-(E)-3-((1S,3R)-3-((E)-3-hydroxyprop-1-enyl)-2,2-dimethylcyclopropyl)prop-2-enoate (155) & (2E,2'E)-3,3'-((1R,2S)-3,3-Dimethylcyclopropane-1,2-diyl)diprop-2-en-1-ol (156)**

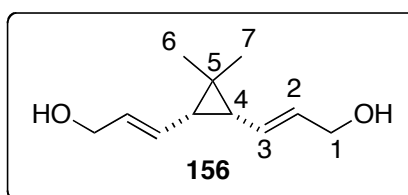
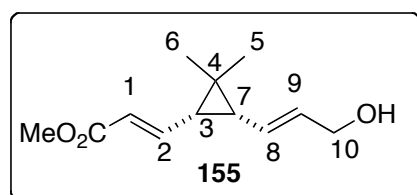

To a stirred solution of **154** (250 mg, 1.06 mmol) in

CH<sub>2</sub>Cl<sub>2</sub> (10 mL) at -78 °C was added DIBAL (2.10 mL, 2.10 mmol, 1M in hexanes). After 30 mins, MeOH (1 mL) was added and the reaction was warmed to RT, sat. aq. Rochelle's salt (5 mL) was added and the mixture was stirred overnight. The organic layer was separated and the aqueous layer extracted with further portions of CH<sub>2</sub>Cl<sub>2</sub> (2 x 20 mL). The combined organic extracts were dried (MgSO<sub>4</sub>), filtered and concentrated under reduced pressure to afford the crude compound, which was purified by flash column chromatography on silica gel, eluting with pet. ether: EtOAc (2: 1) to afford **155** as a colourless oil (21 mg, 9%) and **156** as a colourless oil (64 mg, 33%); **155** R<sub>f</sub> (2:1 pet.ether:EtOAc) 0.55; ν<sub>max</sub> (thin film)/cm<sup>-1</sup> 3357, 2906, 2876, 1689, 1610; <sup>1</sup>H NMR (400 MHz; CDCl<sub>3</sub>) δ 6.81 (1H, dd, *J* 15.0, 11.0, H-2), 5.94 (1H, d, *J* 15.0, H-1), 5.83 (1H, dt, *J* 15.0, 6.0, H-9), 5.60 (1H, ddt, *J* 15.0, 9.5, 1.5, H-8), 4.13 (2H, dd, *J* 6.0, 1.5, H-10), 3.72 (3H, s, OCH<sub>3</sub>), 1.81 (1H, dd, *J* 9.5, 8.5, H-7), 1.68 (1H, dd, *J* 11.0, 8.5, H-3), 1.19 (3H, s, H-5), 1.17 (3H, s, H-6); <sup>13</sup>C NMR (101 MHz; CDCl<sub>3</sub>) δ 167.0 (CH<sub>3</sub>OC=O), 147.7 (C-2), 132.0 (C-1), 128.2 (C-9), 121.3 (C-8), 63.8 (C-10), 51.5 (CH<sub>3</sub>O), 36.5 (C-7), 34.4 (C-3), 28.6 (C-5), 27.6 (C-4), 16.6 (C-6); m/z (ESI): 233 [MNa<sup>+</sup>]; HRMS: calcd. for C<sub>12</sub>H<sub>18</sub>NaO<sub>3</sub>, 233.1148. Found: [MNa<sup>+</sup>], 233.1143 (2.1 ppm error); **156** R<sub>f</sub> (2:1 pet.ether:EtOAc) 0.18; ν<sub>max</sub> (thin film)/cm<sup>-1</sup> 3284, 2954, 2899, 2821, 1356; <sup>1</sup>H NMR (400 MHz; CDCl<sub>3</sub>) δ 5.79 (2H, dt, *J* 15.0, 6.0, H-3), 5.56–5.48 (2H, m, H-2), 4.10 (4H, dd, *J* 6.0, 1.5, H-1), 1.58–1.52 (2H, m, H-4), 1.12 (3H, s, H-5), 1.09 (3H, s, H-6); <sup>13</sup>C NMR (101 MHz; CDCl<sub>3</sub>) δ 130.7 (C-3), 129.5 (C-2), 63.9 (C-1), 33.4 (C-4), 28.6 (C-7), 24.4 (C-5),

16.3 (C-6);  $m/z$  (ESI): 205 [MNa<sup>+</sup>]; HRMS: calcd. for C<sub>11</sub>H<sub>18</sub>NaO<sub>2</sub>, 205.1199. Found: [MNa<sup>+</sup>], 205.1192 (3.0 ppm error).

**(±)-(E)-3-((1S,3R)-3-((E)-3-(*tert*-butyldimethylsilyloxy)prop-1-enyl)-2,2-dimethylcyclopropyl)prop-2-en-1-ol (157) & (2E,2'E)-3,3'-((1R,2S)-3,3-Dimethylcyclopropane-1,2-diyl)bis(prop-2-ene-3,1-diyl)bis(oxy)bis(*tert*-butyldimethylsilane) (158)**

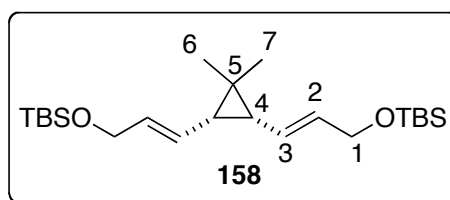
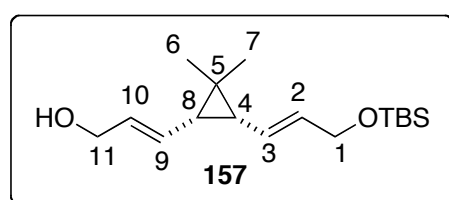

To a stirred solution of diol **156** (122 mg,

0.669 mmol) in CH<sub>2</sub>Cl<sub>2</sub> (10 mL) was added TBSCl (150 mg, 1.00 mmol) and imidazole (68 mg, 1.00 mmol). After 2 h aq. HCl (10 mL) was added. The organic layer was separated and the aqueous layer extracted with further portions of CH<sub>2</sub>Cl<sub>2</sub> (2 x 20 mL). The combined organic extracts were dried (MgSO<sub>4</sub>), filtered and concentrated under reduced pressure to afford the crude compound, which was purified by flash column chromatography on silica gel, eluting with pet. ether: Et<sub>2</sub>O (10: 1) to afford **157** as a colourless oil (40 mg, 20%) and **158** as a colourless oil (96 mg, 35%); **157** R<sub>f</sub> (10:1 pet.ether:Et<sub>2</sub>O) 0.28;  $\nu_{\max}$  (thin film)/cm<sup>-1</sup> 3346, 2882, 2813, 1441; <sup>1</sup>H NMR (400 MHz; CDCl<sub>3</sub>)  $\delta$  5.78 (1H, dt, *J* 15.0, 6.0, H-2 or H-10), 5.69 (1H, dt, *J* 15.0, 5.0, H-2 or H-10), 5.56–5.43 (2H, m, H-3 & H-9), 4.15 (2H, br d, *J* 5.0, H-1 or H-11), 4.09 (2H, br d, *J* 6.0, H-1 or H-11), 1.58–1.50 (1H, m, H-4 or H-8), 1.11 (3H, s, H-5), 1.09 (3H, s, H-6), 0.94–0.85 (1H, m H-4 or H-8), 0.905 (9H, s, SiC(CH<sub>3</sub>)<sub>3</sub>), 0.06 (6H, s, SiCH<sub>3</sub>); <sup>13</sup>C NMR (101 MHz; CDCl<sub>3</sub>)  $\delta$  131.0 (C-2 or C-10), 130.5 (C-2 or C-10), 130.1 (C-3 or C-9), 127.4 (C-3 or C-9), 64.1 (C-1 or C-11), 64.1 (C-1 or C-11), 33.4 (C-4 or C-8), 33.3 (C-4 or C-8), 28.7 (C-7), 26.1 (SiC(CH<sub>3</sub>)<sub>3</sub>), 24.3 (C-5), 18.6 (SiC(CH<sub>3</sub>)<sub>3</sub>), 16.3 (C-6), -5.0 (SiCH<sub>3</sub>)  $m/z$  (ESI): 319 [MNa<sup>+</sup>]; HRMS: calcd. for C<sub>17</sub>H<sub>32</sub>NaO<sub>2</sub>Si, 319.2064. Found: [MNa<sup>+</sup>], 319.2047 (4.9 ppm error); **158** R<sub>f</sub> (10:1 pet.ether:Et<sub>2</sub>O) 0.75;  $\nu_{\max}$  (thin film)/cm<sup>-1</sup> 2909, 2885, 2813; <sup>1</sup>H NMR (400 MHz; CDCl<sub>3</sub>)  $\delta$  5.68 (2H, dt, *J* 15.0, 5.5, H-3), 5.53–5.42 (2H, m, H-2), 4.18–4.08 (4H, m, H-1), 1.58–1.52 (2H, m, H-4), 1.12 (3H, s, H-5), 1.09 (3H, s,

H-6), 0.90 (18H, s, SiC(CH<sub>3</sub>)<sub>3</sub>), 0.06 (12H, s, SiCH<sub>3</sub>); <sup>13</sup>C NMR (101 MHz; CDCl<sub>3</sub>) δ 130.8 (C-3), 127.8 (C-2), 64.2 (C-1), 33.3 (C-4), 28.7 (C-7), 26.1 (SiC(CH<sub>3</sub>)<sub>3</sub>), 24.0 (C-5), 18.6 (SiC(CH<sub>3</sub>)<sub>3</sub>), 16.4 (C-6), -5.0 (SiCH<sub>3</sub>); m/z (ESI): 433 [MNa<sup>+</sup>]; HRMS: calcd. for C<sub>23</sub>H<sub>46</sub>NaO<sub>2</sub>Si<sub>2</sub>, 433.2929. Found: [MNa<sup>+</sup>], 433.2916 (3.2 ppm error).

**(2E,2'E)-3,3'-((1R,2S)-3,3-dimethylcyclopropane-1,2-diyl)diprop-2-enoic acid**  
**(159)**

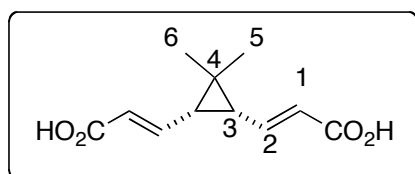

To a solution of **154** (71 mg, 0.298 mmol) in THF:H<sub>2</sub>O 1:1 (6 mL) was added NaOH (83 mg, 2.09 mmol). This was stirred at RT for 16 h before the addition of Et<sub>2</sub>O (10 mL). The Et<sub>2</sub>O layer was removed and the aq. layer was acidified with 10% aq. HCl (20 mL). The aqueous layer was extracted with of EtOAc (2 x 20 mL) and the combined organic extracts were dried (MgSO<sub>4</sub>), filtered and concentrated under reduced pressure to afford title compound **159**, without further purification as a light brown solid (62 mg, 100%);  $\nu_{\max}$  (thin film)/cm<sup>-1</sup> 2879, 2600 (br), 1679, 1627, 1421; <sup>1</sup>H NMR (400 MHz; DMSO) δ 5.93–5.85 (2H, m, H-2), 5.10 (2H, d, *J* 15.0, H-1), 1.21–1.14 (2H, m, H-3), 0.34 (3H, s, H-5), 0.30 (3H, s, H-6) <sup>13</sup>C NMR (101 MHz; DMSO) δ 167.1 (C=O), 146.0 (C-2), 123.8 (C-1), 36.3 (C-3), 29.8 (C-5), 28.4 (C-4), 16.8 (C-6); m/z (ESI): 433 [MNa<sup>+</sup>]; HRMS: calcd. for C<sub>11</sub>H<sub>14</sub>NaO<sub>4</sub>, 233.0790. Found: [MNa<sup>+</sup>], 233.0797 (2.2 ppm error).

### General Procedure for the Cope Rearrangement

A solution of divinylcyclopropane in xylene (0.19 mol dm<sup>-3</sup>) was heated to the temperature indicated and held at that temperature for 17 h. The solution was then concentrated in *vacuo*. The products in Table 5 were purified, by flash column chromatography, except for diacid **165**.



### Diethyl (1*R*,2*S*)-5,5-dimethylcyclohepta-3,6-diene-1,2-dicarboxylate (**88a**)

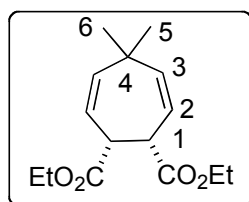

Synthesised from compound **57d** using the general procedure at 100 °C, affording the title compound **88a** as a colourless oil (78%);  $R_f$  (10:1 pet. ether: EtOAc) 0.25;  $\nu_{\max}$  (thin film)/ $\text{cm}^{-1}$  2961, 2920, 1735;  $^1\text{H NMR}$  (400 MHz;  $\text{CDCl}_3$ )  $\delta$  5.93 (2H, dd,  $J$  12.0, 6.0, H-2), 5.50 (2H, d,  $J$  12.0, H-3), 4.12–4.18 (4H, m,  $\text{OCH}_2\text{CH}_3$ ), 3.79 (2H, d,  $J$  6.0, H-1), 1.25 (6H, t,  $J$  7.0,  $\text{OCH}_2\text{CH}_3$ ), 1.16 (3H, s, H-5), 1.13 (3H, s, H-6);  $^{13}\text{C NMR}$  (101 MHz;  $\text{CDCl}_3$ )  $\delta$  172.0 (C=O), 140.0 (C-2), 123.2 (C-3), 61.1 ( $\text{OCH}_2\text{CH}_3$ ), 45.1 (C-1), 39.1 (C-4), 32.4 ( $\text{OCH}_2\text{CH}_3$ ), 29.3 (C-6), 14.3 (C-5);  $m/z$  (ESI): 289 [ $\text{MNa}^+$ ]; HRMS: calcd. for  $\text{C}_{15}\text{H}_{22}\text{NaO}_4$ , 289.1410. Found: [ $\text{MNa}^+$ ], 289.1411 (0.3 ppm error).

### Dimethyl (1*R*,2*S*)-5,5-dimethylcyclohepta-3,6-diene-1,2-dicarboxylate (**160**)

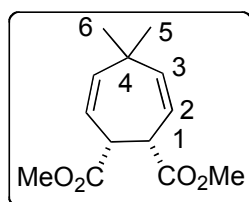

Synthesised from compound **154** using the general procedure at 100 °C, affording the title compound **160** as a colourless oil (36 mg, 83%);  $R_f$  (10:1 pet. ether: EtOAc) 0.23;  $\nu_{\max}$  (thin film)/ $\text{cm}^{-1}$  2974, 2912, 1718;  $^1\text{H NMR}$  (400 MHz;  $\text{CDCl}_3$ )  $\delta$  5.93 (2H, dd,  $J$  11.5, 6.5, H-2), 5.50 (2H, d,  $J$  11.5, H-3), 3.82 (2H, d,  $J$  6.5, H-1), 3.70 (6H, s,  $\text{OCH}_3$ ), 1.16 (3H, s, H-6), 1.12 (3H, s, H-5);  $^{13}\text{C NMR}$  (101 MHz;  $\text{CDCl}_3$ )  $\delta$  172.5 (C=O), 140.1 (C-2), 123.1 (C-3), 52.3 (C-1), 44.9 ( $\text{OCH}_3$ ), 39.1 (C-4), 32.5 (C-6), 29.3 (C-5);  $m/z$  (ESI): 239 [ $\text{MH}^+$ ]; HRMS: calcd. for  $\text{C}_{13}\text{H}_{19}\text{O}_4$ , 239.1278. Found: [ $\text{MH}^+$ ], 239.1269 (3.2 ppm error).

### (±)-(3*aR*,8*aS*)-6,6-Dimethyl-3,3*a*,6,8*a*-tetrahydro-1*H*-cyclohepta[*c*]furan-1-one (**161**)

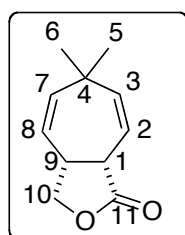

Synthesised from compound **155** using the general procedure at 100 °C, affording the title compound **161** as a light yellow solid (32 mg, 84%);  $R_f$  (EtOAc) 0.72; mp 29–32 °C;  $\nu_{\max}$  (thin film)/ $\text{cm}^{-1}$  2917, 2880, 2824, 1744;  $^1\text{H NMR}$  (400 MHz;  $\text{CDCl}_3$ )  $\delta$  5.67 (1H, ddd,  $J$  12.0, 2.0, 2.0, H-7 or H-3), 5.61 (1H, ddd,  $J$  12.0, 2.0, 2.0, H-7 or H-

3), 5.46 (1H, dd,  $J$  12.0, 5.0, H-8 or H-2), 5.31 (1H, dd,  $J$  12.0, 4.5, H-8 or H-2), 4.31 (1H, dd,  $J$  8.5, 6.0, H-10a), 4.12 (1H, dd,  $J$  8.5, 4.5, H-10b), 3.47–3.39 (2H, m, H-9 & H-1), 1.19 (3H, s, H-5), 1.15 (3H, s, H-6);  $^{13}\text{C}$  NMR (101 MHz;  $\text{CDCl}_3$ )  $\delta$  176.8 (C-11), 143.4 (C-7 or C-3), 142.6 (C-7 or C-3), 123.6 (C-8 or C-2), 118.6 (C-8 or C-2), 73.2 (C-10), 44.0 (C-9 or C-1), 39.7 (C-4), 38.2 (C-9 or C-1), 32.0 (C-5), 30.1 (C-6);  $m/z$  (ESI): 179 [ $\text{MH}^+$ ]; HRMS: calcd. for  $\text{C}_{11}\text{H}_{15}\text{O}_2$ , 179.1067. Found: [ $\text{MH}^+$ ], 179.1065 (1.0 ppm error).

**((1*R*,2*S*)-5,5-Dimethylcyclohepta-3,6-diene-1,2-diyl)dimethanol (162)**

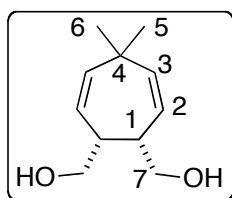

Synthesised from compound **156** using the general procedure at 100 °C, affording the title compound **162** as a colourless oil (15 mg, 83%);  $R_f$  (EtOAc) 0.43; mp 42–44 °C;  $\nu_{\text{max}}$  (thin film)/ $\text{cm}^{-1}$  3304, 3008, 2958, 2923, 2871;  $^1\text{H}$  NMR (400 MHz;  $\text{CDCl}_3$ )  $\delta$  5.57 (2H, dd,  $J$  12.0, 6.5, H-2), 5.43 (2H, d,  $J$  12.0, H-3), 3.72 (2H, dd,  $J$  11.0, 7.0, H-7a), 3.66 (2H, br s,  $\text{OH}$ ), 3.59 (2H, dd,  $J$  11.0, 3.0, H-7b), 2.81–2.76 (2H, m, H-1), 1.13 (3H, s, H-5), 1.08 (3H, s, H-6);  $^{13}\text{C}$  NMR (101 MHz;  $\text{CDCl}_3$ )  $\delta$  139.9 (C-3), 126.0 (C-2), 63.9 (C-7), 43.8 (C-1), 39.9 (C-4), 32.9 (C-5), 29.8 (C-6);  $m/z$  (ESI): 205 [ $\text{MNa}^+$ ]; HRMS: calcd. for  $\text{C}_{11}\text{H}_{18}\text{NaO}_2$ , 205.1199. Found: [ $\text{MNa}^+$ ], 205.1195 (0.7 ppm error).

**(±)-((1*R*,7*S*)-7-((*tert*-Butyldimethylsilyloxy)methyl)-4,4-dimethylcyclohepta-2,5-dienyl)methanol (163)**

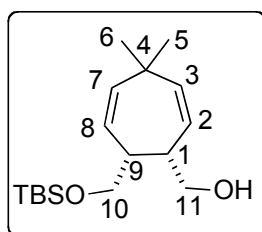

Synthesised from compound **157** using the general procedure at 100 °C, affording the title compound **163** as a colourless oil (10 mg, 86%);  $R_f$  (10:1 pet.ether:EtOAc) 0.52;  $\nu_{\text{max}}$  (thin film)/ $\text{cm}^{-1}$  3373, 2962, 2911, 2885, 2815;  $^1\text{H}$  NMR (400 MHz;  $\text{CDCl}_3$ )  $\delta$  5.58 (1H, dd,  $J$  11.5, 6.0, H-8 or H-2), 5.50 (1H, dd,  $J$  12.0, 6.5, H-8 or H-2), 5.45–5.37 (2H, m, H-7 & H-3), 3.74 (1H, dd,  $J$  10.5, 8.0, H-11a or H-10a), 3.65 (1H, dd,  $J$  11.5, 7.0, H-11a or H-10a), 3.57–3.51 (2H, m, H-11b & H-10b), 2.86–2.79 (1H, m, H-9 or H-1), 2.75–2.68 (1H, m, H-9 or H-1), 1.13 (3H,

s, H-6), 1.08 (3H, s, H-5), 0.91 (9H, s, SiC(CH<sub>3</sub>)<sub>3</sub>), 0.10 (6H, s, SiCH<sub>3</sub>); <sup>13</sup>C NMR (101 MHz; CDCl<sub>3</sub>) δ 140.1 (C-8 or C-2), 139.5 (C-8 or C-2), 126.5 (C-7 or C-3), 125.9 (C-7 or C-3), 64.4 (C-11 or C-10), 64.3 (C-11 or C-10), 44.0 (C-9 or C-1), 44.0 (C-9 or C-1), 39.8 (C-4), 33.0 (C-6), 29.7 (C-5), 26.0 (SiC(CH<sub>3</sub>)<sub>3</sub>), 18.4 (SiC(CH<sub>3</sub>)<sub>3</sub>), -5.4 (SiCH<sub>3</sub>); m/z (ESI): 319 [MNa<sup>+</sup>]; HRMS: calcd. for C<sub>17</sub>H<sub>32</sub>NaO<sub>2</sub>Si, 319.2064. Found: [MNa<sup>+</sup>], 319.2053 (2.4 ppm error).

**((1*R*,2*S*)-5,5-Dimethylcyclohepta-3,6-diene-1,2-diyl)bis(methylene)bis(oxy)bis(*tert*-butyldimethylsilane) (**164**)**

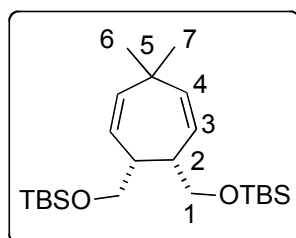

Synthesised from compound **158** using the general procedure at 100 °C, affording the title compound **164** as a colourless oil (17 mg, 88%); R<sub>f</sub> (40:1 pet. ether: Et<sub>2</sub>O) 0.76; ν<sub>max</sub> (thin film)/cm<sup>-1</sup> 2911, 2883, 2852, 2814; <sup>1</sup>H NMR (400 MHz; CDCl<sub>3</sub>) δ 5.48 (2H, dd, *J* 11.5, 6.0, H-3), 5.35 (2H, d, *J* 11.5, H-4), 3.66 (2H, dd, *J* 10.0, 7.0, H-1a), 3.58 (2H, dd, *J* 10.0, 7.0, H-1b), 2.73 (2H, ddd, *J* 7.0, 7.0, 6.0, H-2), 1.14 (3H, s, H-6), 1.09 (3H, s, H-7), 0.88 (18H, s, SiC(CH<sub>3</sub>)<sub>3</sub>), 0.03 (12H, s, SiCH<sub>3</sub>); <sup>13</sup>C NMR (101 MHz; CDCl<sub>3</sub>) δ 139.1 (C-4), 128.0 (C-3), 65.5 (C-1), 42.8 (C-2), 39.8 (C-5), 32.9 (C-6), 29.9 (C-7), 26.1 (SiC(CH<sub>3</sub>)<sub>3</sub>), 18.5 (SiC(CH<sub>3</sub>)<sub>3</sub>), -5.2 (SiCH<sub>3</sub>). m/z (ESI): 411 [MH<sup>+</sup>]; HRMS: calcd. for C<sub>23</sub>H<sub>47</sub>O<sub>2</sub>Si<sub>2</sub>, 411.3109. Found: [MH<sup>+</sup>], 411.3100 (1.1 ppm error).

**((1*R*,2*S*)-5,5-Dimethylcyclohepta-3,6-diene-1,2-dicarboxylic acid (**165**))**

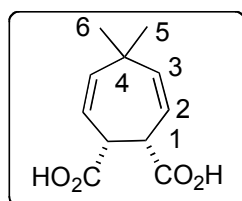

Synthesised from compound **159** using the general procedure at 100 °C, without chromatography, affording the title compound **165** as a light brown solid (22 mg, 97%); mp 130–132 °C; ν<sub>max</sub> (thin film)/cm<sup>-1</sup> 2963, 2927, 2600 (br), 1693; <sup>1</sup>H NMR (400 MHz; DMSO) δ 5.87–5.80 (2H, m, H-2), 5.40 (2H, d, *J* 12.0, H-3), 3.67 (2H, d, *J* 5.5, H-1), 1.12 (3H, s, H-6), 1.06 (3H, s, H-5); <sup>13</sup>C NMR (101 MHz; DMSO) δ 172.8 (C=O), 138.4 (C-2), 124.4 (C-3), 44.1 (C-1), 38.2 (C-4), 32.1 (C-6), 28.8 (C-5); m/z (ESI): 211 [MH<sup>+</sup>]; HRMS: calcd. for C<sub>11</sub>H<sub>15</sub>O<sub>4</sub>, 211.0965. Found: [MH<sup>+</sup>], 211.0971 (2.8 ppm error).

## 7.4 Procedures & Compound Characterisation (Chapter 4)

### Diethyl (1*R*,2*S*)-5,5-dimethylcyclohepta-3,6-diene-1,2-dicarboxylate (**88a**)

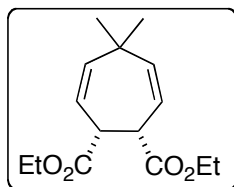

A stirred solution of **57d** (5.49 g, 20.6 mmol) in toluene (200 mL) was heated to 100 °C for 16 h. After being cooled to RT the solution was concentrated under reduced pressure to afford the title compound *cis*-**37**, as a colourless oil (4.50 g, 82%); *For data*

*see page 140*

### [(1*R*,2*S*)-5,5-Dimethylcyclohepta-3,6-diene-1,2-diyl]dimethanol (**162**)

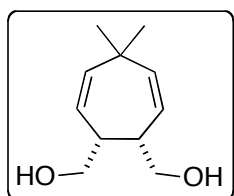

To a stirred suspension of LiAlH<sub>4</sub> (86 mg, 2.26 mmol) in THF (5 mL) at 0 °C was added **88a** (300 mg, 1.13 mmol) in THF (5 mL) *via* cannula. The reaction was warmed to RT and stirred for 16 h.

The reaction was cooled to 0 °C and Na<sub>2</sub>SO<sub>4</sub>·10H<sub>2</sub>O was cautiously added until on further addition fizzing could no longer be observed. The aluminium salts were removed by filtration and washed with EtOAc (20 mL). The filtrate was concentrated under reduced pressure to give the crude product. This was purified by flash column chromatography on silica gel, eluting with pet. ether:EtOAc (5:1 → 1:1) to afford the title compound **162** as a white solid (127 mg, 62%); *For data see page 141*

### (±)-(3*aR*,8*aS*)-6,6-Dimethyl-3,3*a*,6,8*a*-tetrahydro-1*H*-cyclohepta[*c*]furan-1-one (**161**)

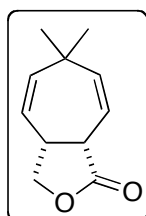

To a stirred solution of **162** (100 mg, 0.549 mmol) in CH<sub>2</sub>Cl<sub>2</sub> (5 mL) at RT was added PhI(OAc)<sub>2</sub> (441 mg, 1.37 mmol) and TEMPO (9 mg, 0.0576 mmol). After 2h the reaction mixture was concentrated under reduced pressure to give the crude product. This was purified by flash column chromatography on silica gel, eluting with pet. ether:Et<sub>2</sub>O (10:1 → 2:1) to afford the title compound **161** as a light yellow solid (68 mg, 69%); *For data see page 140*

(±)-(3*aR*)-6,6-Dimethyl-3,3*a*,6,7-tetrahydro-1*H*-cyclohepta[*c*]furan-1-one (**168**)  
& (±)-(3*aR*,8*aR*)-6,6-Dimethyl-3,3*a*,6,8*a*-tetrahydro-1*H*-cyclohepta[*c*]furan-1-one  
(**170**)

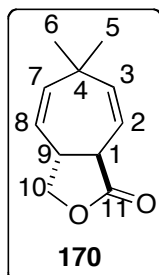
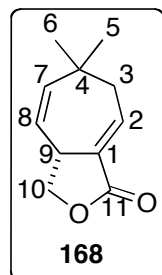

To a stirred solution of **161** (624 mg, 3.50 mmol) in THF (175 mL) at 0 °C was added DBU (0.52 mL, 3.50 mmol). After 30 min the reaction was quenched with NH<sub>4</sub>Cl (aq.) (100 mL), EtOAc (100 mL) was added, the organic layer was separated and the aqueous layer extracted with portions of EtOAc (2 × 100 mL). The combined organic extracts were dried (MgSO<sub>4</sub>), filtered and concentrated under reduced pressure. The resulting crude product was purified by flash column chromatography on silica gel, eluting with pet. ether:Et<sub>2</sub>O (4:1) to afford the title compound **168** as a colourless oil (185 mg, 30%) and **170** as a colourless oil (322 mg, 52%); **168** *R<sub>f</sub>* (1:1 pet. ether:Et<sub>2</sub>O) 0.48;  $\nu_{\max}$  (thin film)/cm<sup>-1</sup> 2915, 1731, 1663; <sup>1</sup>H NMR (400 MHz; CDCl<sub>3</sub>)  $\delta$  7.00–6.95 (1H, m, H-2), 5.44 (1H, ddd, *J* 12.0, 3.0, 1.5, H-8 or H-7), 5.18, (1H, dd, *J* 12.0, 2.0, H-8 or H-7), 4.56 (1H, dd, *J* 9.5, 8.5, H-10a), 4.00–3.92 (1H, m, H-9), 3.85 (1H, dd, *J* 8.5, 8.5, H-10b), 2.57 (1H, dddd, *J* 14.5, 6.0, 2.5, 0.5, H-3a), 2.22 (1H, dddd, *J* 14.5, 7.5, 1.0, 1.0, H-3b), 1.08 (3H, s, H-6), 1.01 (3H, s, H-5); <sup>13</sup>C NMR (101 MHz; CDCl<sub>3</sub>)  $\delta$  170.3 (C-11), 141.6 (C-8 or C-7), 139.2 (C-2), 131.8 (C-1), 122.5 (C-8 or C-7), 71.1 (C-10), 39.5 (C-3), 37.5 (C-9), 35.4 (C-4), 31.4 (C-6), 29.1 (C-5); *m/z* (ESI): 179 [MH<sup>+</sup>]; HRMS: calcd. for C<sub>11</sub>H<sub>15</sub>O<sub>2</sub>, 179.1067. Found: [MH<sup>+</sup>], 179.1066 (0.1 ppm error); **170** *R<sub>f</sub>* (1:1 pet. ether:Et<sub>2</sub>O) 0.45;  $\nu_{\max}$  (thin film)/cm<sup>-1</sup> 2969, 2916, 2878, 2824, 1754; <sup>1</sup>H NMR (400 MHz; CDCl<sub>3</sub>)  $\delta$  5.89 (1H, ddd, *J* 11.0, 3.0, 0.5, H-7 or H-3), 5.55–5.45 (3H, m, H-8, H-2 & H-7 or H-3), 4.44 (1H, ddd, *J* 8.5, 7.0, 0.5, H-10a), 3.92–3.85 (1H, m, H-10b), 3.26–3.13 (2H, m, H-9 & H-1), 1.17 (6H, s, H-5 & H-6); <sup>13</sup>C NMR (101 MHz; CDCl<sub>3</sub>)  $\delta$  176.7 (C-11), 141.1 (C-7 or C-3), 140.2 (C-7 or C-3), 122.3 (C-8 or C-2), 121.1 (C-8 or C-2), 70.4 (C-10), 44.3 (C-9 or C-1), 41.5 (C-9 or C-1), 41.1 (C-4), 31.6 (C-5), 31.5 (C-6); *m/z* (ESI): 179 [MH<sup>+</sup>]; HRMS: calcd. for C<sub>11</sub>H<sub>15</sub>O<sub>2</sub>, 179.1067. Found: [MH<sup>+</sup>], 179.1068 (–1.4 ppm error).

(±)-(3a*S*,4a*S*,8a*R*)-6,6-Dimethyl-1,4,4a,5,6,8a-hexahydrocyclopropa[1,7]cyclohepta[1,2-*c*]furan-3-one (**171**)

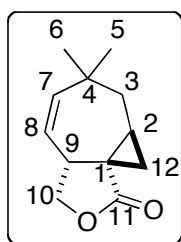

Procedure 1: To a suspension of NaH (33 mg, 0.815 mmol, 60% dispersion in mineral oil) in DMF (1.5 mL) at 0 °C was added trimethylsulfoxonium iodide (179 mg, 0.815 mmol). The reaction mixture was stirred for 5 min before the dropwise addition of **168** (121 mg, 0.679 mmol) in DMF (1.5 mL). The solution was stirred at 0 °C for a further 5 min before warming to RT and stirring for 16 h. Sat. NH<sub>4</sub>Cl (aq.) (5 mL) was then added followed by H<sub>2</sub>O (5 mL) and Et<sub>2</sub>O (15 mL). The organic layer was separated and the aqueous layer extracted with portions of Et<sub>2</sub>O (2 × 15 mL). The combined organic extracts were dried (MgSO<sub>4</sub>), filtered and concentrated under reduced pressure. The resulting crude product was purified by flash column chromatography on silica gel, eluting with pet. ether:Et<sub>2</sub>O (4:1) to afford the title compound **171** as a colourless oil (26 mg, 20%); Procedure 2: To a suspension of NaH (29 mg, 0.734 mmol, 60% dispersion in mineral oil) in DMSO (1 mL) at 0 °C was added trimethylsulfoxonium iodide (162 mg, 0.734 mmol). The reaction mixture was stirred for 5 min before the dropwise addition of **168** (109 mg, 0.612 mmol) in DMSO (1 mL). The solution was stirred at RT for 16 h. Sat. NH<sub>4</sub>Cl (aq.) (5 mL) was then added followed by H<sub>2</sub>O (5 mL) and Et<sub>2</sub>O (2 mL). The organic layer was separated and the aqueous layer extracted with portions of Et<sub>2</sub>O (2 × 2 mL). The combined organic extracts were dried (MgSO<sub>4</sub>), filtered and concentrated under reduced pressure. The resulting crude product was purified by flash column chromatography on silica gel, eluting with pet. ether:Et<sub>2</sub>O (4:1) to afford the title compound **171** as a colourless oil (15 mg, 11%); Procedure 3: To a stirred solution of MTBD (208 mg, 1.36 mmol) and trimethylsulfoxonium iodide (179 mg, 0.815 mmol) in MeCN (2 mL) was added **168** (121 mg, 0.679 mmol) in MeCN (2 mL). The reaction mixture was stirred at RT overnight. It was then concentrated under reduced pressure and the resulting crude product was purified by flash column chromatography on silica gel, eluting with pet. ether:Et<sub>2</sub>O (4:1) to afford the title compound **171** as a colourless oil (10 mg, 8%); R<sub>f</sub> (1:1 pet. ether:EtOAc) 0.43; ν<sub>max</sub> (thin film)/cm<sup>-1</sup> 2956, 2915, 2871, 2825, 1740; <sup>1</sup>H

NMR (400 MHz; CDCl<sub>3</sub>) δ 5.37 (1H, dd, *J* 12.0, 2.5, H-8 or H-7), 5.19 (1H, dd, *J* 12.0, 2.0, H-8 or H-7), 4.49 (1H, dd, *J* 9.0, 6.5, H-10a), 4.28 (1H, dd, *J* 9.0, 1.0, H-10b), 3.04–2.99 (1H, m, H-9), 2.05 (1H, ddd, *J* 14.0, 4.5, 2.5, H-3a), 1.82–1.73 (1H, m, H-2), 1.34 (1H, dd, *J* 9.0, 4.0, H-12a), 1.28 (1H, dd, *J* 14.0, 12.0, H-3b), 1.11 (3H, s, H-6), 1.01–0.98 (1H, m, H-12b), 0.99 (3H, s, H-5); <sup>13</sup>C NMR (101 MHz; CDCl<sub>3</sub>) δ 177.4 (C-11), 143.9 (C-8 or C-7), 126.5 (C-8 or C-7), 74.3 (C-10), 42.5 (C-3), 39.3 (C-9), 37.9 (C-4), 32.4 (C-2), 30.4 (C-1), 26.9 (C-6), 24.8 (C-12), 19.3 (C-5); *m/z* (ESI): 193 [MH<sup>+</sup>]; HRMS: calcd. for C<sub>12</sub>H<sub>17</sub>O<sub>2</sub>, 193.1223. Found: [MH<sup>+</sup>], 193.1222 (0.5 ppm error).

(±)-([1*S*,2*R*,7*S*]-5,5-Dimethylbicyclo[5.1.0]oct-3-ene-1,2-diyl]dimethanol (**172**)

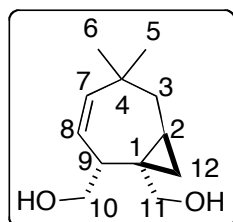

To a stirred solution of **171** (19 mg, 0.0990 mmol) in CH<sub>2</sub>Cl<sub>2</sub> (1 mL) at –78 °C was added DIBAL (0.50 mL, 0.495 mmol, 1M in hexanes). After 10 mins the reaction was warmed to RT and after 30 min the reaction mixture was diluted with CH<sub>2</sub>Cl<sub>2</sub> (2 mL) followed by the careful addition of sat. aq. Rochelle's salt (3 mL). The mixture was stirred overnight after which time, the organic layer was separated and the aqueous layer extracted with further portions of CH<sub>2</sub>Cl<sub>2</sub> (2 × 3 mL). The combined organic extracts were dried (MgSO<sub>4</sub>), filtered and concentrated under reduced pressure to afford the crude compound, which was purified by flash column chromatography on silica gel, eluting with pet. ether:Et<sub>2</sub>O (1:1) to afford the title compound **172** as a colourless oil (15 mg, 79%); *R<sub>f</sub>* (1:1 pet. ether:Et<sub>2</sub>O) 0.36; *ν*<sub>max</sub> (thin film)/cm<sup>-1</sup> 3285, 2951, 2909, 2873, 2807; <sup>1</sup>H NMR (400 MHz; CDCl<sub>3</sub>) δ 5.27–5.19 (2H, m, H-8 & H-7), 3.98 (1H, dd, *J* 11.5, 1.5, H-10a), 3.80–3.77 (2H, m, H-11), 3.04 (1H, dd, *J* 11.5, 1.0, H-10b), 2.46–2.39 (1H, m, H-9), 2.23 (2H, br s, OH), 1.78 (1H, ddd, *J* 14.5, 5.0, 2.0, H-3a), 1.57 (1H, dd, *J* 14.5, 11.5, H-3b), 1.05 (3H, s, H-6), 0.97 (3H, s, H-5), 0.94–0.73 (3H, m, H-12 & H-2); <sup>13</sup>C NMR (101 MHz; CDCl<sub>3</sub>) δ 141.2 (C-8 or C-7), 125.0 (C-8 or C-7), 69.1 (C-10), 64.8 (C-11), 42.8 (C-3), 40.0 (C-9), 38.9 (C-4), 32.3 (C-2), 31.0 (C-1), 27.7 (C-6), 19.0 (C-12), 18.1 (C-5); *m/z* (ESI): 219 [MNa<sup>+</sup>]; HRMS: calcd. for C<sub>12</sub>H<sub>20</sub>NaO<sub>2</sub>, 219.1356. Found: [MNa<sup>+</sup>], 219.1357 (–0.5 ppm error).

**(±)-[(1*S*,7*R*)-7-({*tert*-Butyl(dimethyl)silyl}oxy)methyl]-4,4-dimethylcyclohepta-2,5-dien-1-yl]methanol (**163**)**

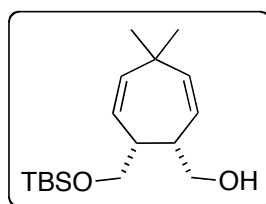

To a stirred solution of **162** (370 mg, 2.03 mmol) in THF (4 mL) was added NaH (100 mg, 2.44 mmol, 60% dispersion in mineral oil) at RT and the reaction mixture was stirred for 45 min before the addition of TBSCl (306 mg, 2.03 mmol). After 2 h the reaction was quenched with sat. NH<sub>4</sub>Cl (aq.) (5 mL) followed by Et<sub>2</sub>O (5 mL). The organic layer was separated and the aqueous layer extracted with further portions of Et<sub>2</sub>O (2 × 5 mL). The combined organic extracts were dried (MgSO<sub>4</sub>), filtered and concentrated under reduced pressure. The resulting crude product was purified by flash column chromatography on silica gel, eluting with pet. ether:EtOAc (40:1 → 1:1) to afford the title compound **163** as a colourless oil (495 mg, 82%); *For data see page 141*

**(±)-(1*S*,7*R*)-7-({*tert*-Butyl(dimethyl)silyl}oxy)methyl)-4,4-dimethylcyclohepta-2,5-diene-1-carbaldehyde (**188**)**

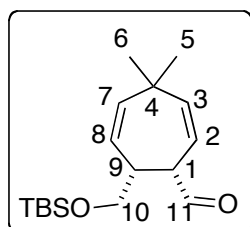

To a stirred solution of **163** (220 mg, 0.743 mmol) in CH<sub>2</sub>Cl<sub>2</sub> (10 mL), at 0 °C was added Dess–Martin Periodinane (636 mg, 1.50 mmol). The reaction mixture was warmed to RT and allowed to stir for 16 h. It was then diluted with CH<sub>2</sub>Cl<sub>2</sub> (10 mL), and quenched with a 1:1 solution of sat. Na<sub>2</sub>CO<sub>3</sub> (aq.) and sat. Na<sub>2</sub>S<sub>2</sub>O<sub>3</sub> (aq.) (40 mL). After vigorous stirring for 30 mins, the organic layer was separated and the aqueous layer extracted with further portions of CH<sub>2</sub>Cl<sub>2</sub> (2 × 25 mL). The combined organic extracts were dried (MgSO<sub>4</sub>), filtered and concentrated under reduced pressure to afford 200 mg of unpurified aldehyde **188**, which was used in the next step without further purification; R<sub>f</sub> (10:1 pet.ether:EtOAc) 0.71; <sup>1</sup>H NMR (400 MHz; CDCl<sub>3</sub>) δ 9.59 (1H, s, H-11) 5.86 (1H, dd, *J* 11.5, 5.0, H-8 or H-2), 5.60 (1H, ddd, *J* 11.5, 2.0, 2.0 H-7 or H-3), 5.56 (1H, dd, *J* 11.5, 6.5, H-8 or H-2), 5.42 (1H, ddd, *J* 11.5, 2.0, 2.0 H-7 or H-3), 3.56–3.53 (2H, m, H-10), 3.33–3.51 (1H, m, H-9 or H-1), 3.12–3.05



(1H, m, H-9 or H-1), 1.14 (3H, s, H-6), 1.12 (3H, s, H-5), 0.85 (9H, s, SiC(CH<sub>3</sub>)<sub>3</sub>), 0.00 (3H, s, SiCH<sub>3</sub>), -0.01 (3H, s, SiCH<sub>3</sub>).

**(±)-(7*R*)-7-([*tert*-Butyl(dimethyl)silyl]oxy)methyl)-4,4-dimethylcyclohepta-1,5-diene-1-carbaldehyde (**189**)**

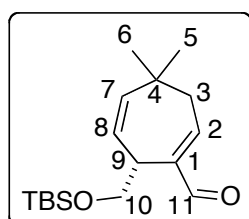

To a solution of **188** (200 mg, 0.675 mmol) in THF (20 mL) at 0 °C was added DBU (111 μL, 0.748 mmol). After 20 mins the reaction was quenched with NH<sub>4</sub>Cl (aq.) (20 mL), EtOAc (50 mL) was added and the organic layer was separated. The aqueous layer was extracted with portions of EtOAc (2 × 50 mL). The combined organic extracts were dried (MgSO<sub>4</sub>), filtered and concentrated under reduced pressure to afford 233 mg of unpurified aldehyde **189**, which was used in the next step without further purification; R<sub>f</sub> (5:1 pet. ether:Et<sub>2</sub>O) 0.53; <sup>1</sup>H NMR (400 MHz; CDCl<sub>3</sub>) δ 9.37 (1H, s, H-11) 6.87 (1H, dd, *J* 9.0, 5.5, H-2), 5.54 (1H, d, *J* 12.0, H-8 or H-7), 5.42 (1H, dd, *J* 12.0, 5.5, H-8 or H-7), 3.70–3.56 (3H, m, H-10 & H-9), 3.00 (1H, dd, *J* 13.5, 5.5 H-3a), 2.17 (1H, ddd, *J* 13.5, 9.0, 2.0 H-3b), 1.10 (3H, s, H-6), 1.00 (3H, s, H-5), 0.86 (9H, s, SiC(CH<sub>3</sub>)<sub>3</sub>), 0.02 (3H, s, SiCH<sub>3</sub>), 0.01 (3H, s, SiCH<sub>3</sub>).

**(±)-[(7*R*)-7-([*tert*-Butyl(dimethyl)silyl]oxy)methyl)-4,4-dimethylcyclohepta-1,5-dien-1-yl]methanol (**190**)**

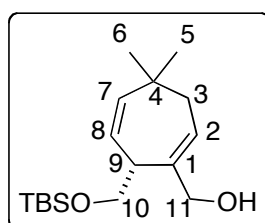

To a stirred solution of **189** (233 mg of crude material) in MeOH (10 mL) at 0 °C was added NaBH<sub>4</sub> (28 mg, 0.748 mmol). After 30 min the reaction mixture was diluted with CH<sub>2</sub>Cl<sub>2</sub> (25 mL) and quenched with NaHCO<sub>3</sub> (aq.) (5 mL). The organic layer was separated and the aqueous layer extracted with portions of CH<sub>2</sub>Cl<sub>2</sub> (2 × 25 mL). The combined organic extracts were dried (MgSO<sub>4</sub>), filtered and concentrated under reduced pressure. The resulting crude product was purified by flash column chromatography on silica gel, eluting with pet. ether:Et<sub>2</sub>O (5:1) to afford the title compound **190** as a colourless oil (165 mg, 75% over 3 steps); R<sub>f</sub> (5:1 pet. ether:Et<sub>2</sub>O) 0.18; ν<sub>max</sub> (thin film)/cm<sup>-1</sup> 3298, 2909, 2883, 2815; <sup>1</sup>H NMR (400 MHz;

CDCl<sub>3</sub>) δ 5.83 (1H, ddd, *J* 8.5, 6.0, 1.0, H-2), 5.43 (1H, ddd, *J* 12.0, 2.0, 1.0, H-8 or H-7), 5.32 (1H, dd, *J* 12.0, 7.0, H-8 or H-7), 4.06–3.94 (2H, m, H-10 or H-11), 3.79 (1H, dd, *J* 9.5, 9.5, H-10a or H-11a), 3.68 (1H, dd, *J* 9.5, 5.0, H-10a or H-11a), 3.04–2.97 (1H, m, H-9), 2.52 (1H, dd, *J* 14.0, 6.0, H-3a), 1.90 (1H, ddd, *J* 14.0, 8.5, 2.0, H-3b), 1.00 (3H, s, H-6), 0.98 (3H, s, H-5), 0.91 (9H, s, SiC(CH<sub>3</sub>)<sub>3</sub>), 0.10 (3H, s, SiCH<sub>3</sub>), 0.09 (3H, s, SiCH<sub>3</sub>); <sup>13</sup>C NMR (101 MHz; CDCl<sub>3</sub>) δ 142.9 (C-7), 140.4 (C-1), 127.4 (C-8), 121.6 (C-2), 68.5 (C-10), 65.0 (C-11), 44.1 (C-3), 43.1 (C-4), 33.3 (C-6), 29.8 (C-9), 28.9 (C-5), 26.1 (C(CH<sub>3</sub>)<sub>3</sub>), 18.5 (C(CH<sub>3</sub>)<sub>3</sub>), -5.5 (SiCH<sub>3</sub>), -5.5 (SiCH<sub>3</sub>); *m/z* (ESI): 319 [MNa<sup>+</sup>]; HRMS: calcd. for C<sub>17</sub>H<sub>32</sub>NaO<sub>2</sub>Si, 319.2064. Found: [MNa<sup>+</sup>], 319.2063 (0.2 ppm error).

(±)-[(1*S*,2*R*,7*S*)-2-({*tert*-Butyl(dimethyl)silyl}oxy)methyl]-5,5-dimethylbicyclo[5.1.0]oct-3-en-1-yl]methanol (**191**) & (±)-[(1*R*,2*R*,7*R*)-2-({*tert*-Butyl(dimethyl)silyl}oxy)methyl]-5,5-dimethylbicyclo[5.1.0]oct-3-en-1-yl]methanol (**192**)

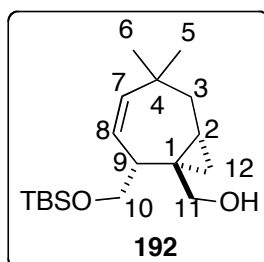
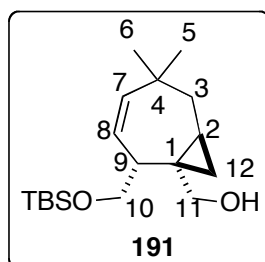

To a stirred solution of Et<sub>2</sub>Zn (170 μL, 1 M in hexanes, 0.170 mmol) in CH<sub>2</sub>Cl<sub>2</sub> (1 mL) at 0 °C was added diiodomethane (27 μL, 0.340 mmol). This was stirred for 10 min before the addition of **139** (25

mg, 0.0850 mmol) in CH<sub>2</sub>Cl<sub>2</sub> (1 mL) *via* cannula. The reaction was stirred at 0 °C for 30 min before it was quenched by the addition of sat. NH<sub>4</sub>Cl (aq.) (5 mL). The organic layer was separated and the aqueous layer extracted with further portions of CH<sub>2</sub>Cl<sub>2</sub> (2 × 10 mL). The combined organic extracts were dried (MgSO<sub>4</sub>), filtered and concentrated under reduced pressure. The resulting crude product was purified by flash column chromatography on silica gel, eluting with pet. ether:Et<sub>2</sub>O (15:1) to afford the title compound **191** as a colourless oil (8 mg, 32%) and **192** as a colourless oil (7 mg, 27%); **191** R<sub>f</sub> (4:1 pet. ether:Et<sub>2</sub>O) 0.21; ν<sub>max</sub> (thin film)/cm<sup>-1</sup> 3340, 2909, 2886, 2816; <sup>1</sup>H NMR (400 MHz; CDCl<sub>3</sub>) δ 5.25–5.15 (2H, m, H-7 & H-8), 3.82–3.73 (3H, m, H-10 & H-11), 3.04 (1H, d, *J* H-10b or H-11b), 2.37–2.31 (1H, m, H-9), 1.80–1.74 (1H, m, H-3a), 1.57–1.43 (1H, m, H-3b), 1.06 (3H, s, H-5), 0.98 (3H,

s, H-6), 0.92 (9H, s, SiC(CH<sub>3</sub>)<sub>3</sub>), 0.90–0.88 (1H, m, H-12a), 0.82–0.77 (2H, m, H-12b & H2), 0.10 (3H, s, SiCH<sub>3</sub>), 0.10 (3H, s, SiCH<sub>3</sub>); <sup>13</sup>C NMR (101 MHz; CDCl<sub>3</sub>) δ 140.9 (C-8), 125.0 (C-7), 68.9 (C-10 or C-11), 65.3 (C-10 or C-11), 48.2 (C-9), 42.7 (C-2), 40.2 (C-3), 39.0 (C-4), 32.3 (C-6), 30.7 (C-1), 27.7 (C-5), 25.9 (C(CH<sub>3</sub>)<sub>3</sub>), 19.3 (C-12), 18.3 (C(CH<sub>3</sub>)<sub>3</sub>), –5.3 (SiCH<sub>3</sub>), –5.3 (SiCH<sub>3</sub>); m/z (ESI): 333 [MNa<sup>+</sup>]; HRMS: calcd. for C<sub>18</sub>H<sub>34</sub>NaO<sub>2</sub>Si, 333.2220. Found: [MNa<sup>+</sup>], 333.2220 (0.0 ppm error); **192** R<sub>f</sub> (4:1 pet. ether:Et<sub>2</sub>O) 0.16; ν<sub>max</sub> (thin film)/cm<sup>-1</sup> 3354, 2910, 2884, 2814; <sup>1</sup>H NMR δ 5.38–5.28 (2H, m, H-7 & H-8), 3.54–3.50 (2H, m, H-10), 3.36 (1H, dd, *J* 10.0, 8.5, H-11a), 3.06 (1H, d, *J* 10.0, H-11b), 2.93–2.88 (1H, m, H-9), 1.84 (1H, ddd, *J* 14.0, 5.0, 2.0, H-3a), 1.44–1.22 (2H, m, H-3b & H-2), 1.09 (3H, s, H-5), 0.93 (3H, s, H-6), 0.89 (9H, s, SiC(CH<sub>3</sub>)<sub>3</sub>), 0.63–0.53 (2H, m, H-12), 0.06 (6H, s, SiCH<sub>3</sub>); <sup>13</sup>C NMR (101 MHz; CDCl<sub>3</sub>) δ 142.5 (C-8), 124.7 (C-7), 77.4 (C-9) 73.5 (C-11), 66.5 (C-10), 42.5 (C-2), 41.4 (C-3), 38.0 (C-4), 32.7 (C-5), 28.4 (C-1), 27.0 (C-6), 26.0 (C(CH<sub>3</sub>)<sub>3</sub>), 18.3 (C(CH<sub>3</sub>)<sub>3</sub>), 16.1 (C-12), –5.2 (SiCH<sub>3</sub>); m/z (ESI): 333 [MNa<sup>+</sup>]; HRMS: calcd. for C<sub>18</sub>H<sub>34</sub>NaO<sub>2</sub>Si, 333.2220. Found: [MNa<sup>+</sup>], 333.2222 (0.3 ppm error).

**(±)-[(1*R*,2*R*,7*R*)-5,5-Dimethylbicyclo[5.1.0]oct-3-ene-1,2-diyl]dimethanol (**194**)**

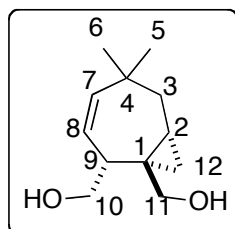

To a solution of **192** (6 mg, 0.0195 mmol) in THF (0.5 mL) at 0 °C was added TBAF (23 μL, 1 M in THF, 0.0230 mmol). After 2 h the reaction mixture was diluted with Et<sub>2</sub>O (5 mL) and washed with sat. NH<sub>4</sub>Cl (aq.) (2 mL), the organic layer separated and the aqueous layer extracted with further portions of Et<sub>2</sub>O (2 × 5 mL). The combined organic extracts were dried (MgSO<sub>4</sub>), filtered and concentrated under reduced pressure to afford the title compound **194** as a colourless oil (4 mg, 100%) which was assigned tentatively using <sup>1</sup>H NMR spectroscopy and HRMS; R<sub>f</sub> (EtOAc) 0.47; <sup>1</sup>H NMR (400 MHz; CDCl<sub>3</sub>) δ 5.42–5.29 (2H, m, H-8 & H-7), 3.60–3.55 (2H, m, H-10a & H-11a), 3.30 (1H, dd, *J* 10.5, 9.0, H-10b or H-11b), 3.12 (1H, d, *J* 11.0, H-10b or H-11b), 2.99–2.90 (1H, m, H-9), 1.86 (1H, ddd, *J* 14.5, 6.5, 1.5, H-3a), 1.34 (1H, dd, *J* 14.5, 12.0, H-3b), 1.09 (3H, s, H-6), 0.94 (3H, s, H-5), 0.93–0.84 (1H, m, H-2), 0.67 (1H, dd, *J* 9.0, 5.0, H-12a), 0.59 (1H, dd, *J* 5.0, 5.0, H-12b); m/z (ESI): 219

[MNa<sup>+</sup>]; HRMS: calcd. for C<sub>12</sub>H<sub>20</sub>NaO<sub>2</sub>, 219.1356. Found: [MNa<sup>+</sup>], 219.1358 (−1.0 ppm error).

**(±)-*tert*-Butyl{[(1*R*)-5,5-dimethyl-2-[(tripropan-2-ylsilyl)oxy]methyl]cyclohepta-2,6-dien-1-yl}methoxy}dimethylsilane (202)**

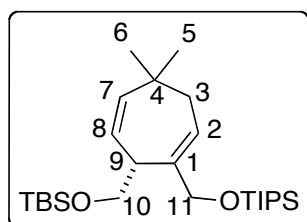

To a stirred solution of **190** (25 mg, 0.0850 mmol) in CH<sub>2</sub>Cl<sub>2</sub> (1.5 mL) at RT was added lutidine (25 μL, 0.213 mmol) and TIPSOTf (30 μL, 0.111 mmol). After 2 h the reaction was quenched by the addition of water (2 mL). The organic layer was separated and the aqueous layer extracted with further portions of CH<sub>2</sub>Cl<sub>2</sub> (2 × 5 mL). The combined organic extracts were dried (MgSO<sub>4</sub>), filtered and concentrated under reduced pressure. The resulting crude product was purified by flash column chromatography on silica gel, eluting with pet. ether:Et<sub>2</sub>O (40:1) to afford the title compound **202** as a colourless oil (25 mg, 66%) which was assigned tentatively using <sup>1</sup>H NMR spectroscopy and HRMS; R<sub>f</sub> (40:1 pet. ether:Et<sub>2</sub>O) 0.36; <sup>1</sup>H NMR (400 MHz; CDCl<sub>3</sub>) δ 5.85–5.79 (1H, m, H-2), 5.43–5.38 (2H, m, H-7 & H-8), 4.18–4.06 (2H, m, H-11), 3.77 (1H, dd, *J* 9.5, 7.0, H-10a), 3.71 (1H, dd, *J* 9.5, 7.0, H-10b), 2.78–2.70 (1H, m, H-9), 2.52 (1H, dd, *J* 14.0, 5.5, H-3a), 1.88 (1H, dd, *J* 14.0, 8.5, H-3b), 1.06 (18H, s, CH(CH<sub>3</sub>)<sub>2</sub>), 1.05 (3H, s, CH(CH<sub>3</sub>)<sub>2</sub>), 0.99 (3H, s, H-5), 0.98 (3H, s, H-6), 0.89 (9H, s, SiC(CH<sub>3</sub>)<sub>3</sub>), 0.04 (3H, s, SiCH<sub>3</sub>), 0.04 (3H, s, SiCH<sub>3</sub>); *m/z* (ESI): 475 [MNa<sup>+</sup>]; HRMS: calcd. for C<sub>26</sub>H<sub>52</sub>NaO<sub>2</sub>Si<sub>2</sub>, 475.3404. Found: [MNa<sup>+</sup>], 475.3409 (2.1 ppm error).

**(±)-[(7*R*)-7-({*tert*-Butyl(dimethyl)silyl}oxy)methyl]-4,4-dimethylcyclohepta-1,5-dien-1-yl]methyl acetate (204)**

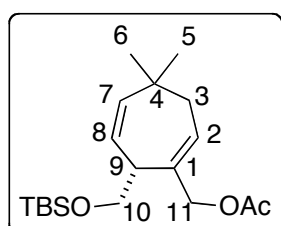

To a stirred solution of **190** (25 mg, 0.0850 mmol) in CH<sub>2</sub>Cl<sub>2</sub> (1 mL) at RT was added triethylamine (23 μL, 0.168 mmol), acetic anhydride (16 μL, 0.168 mmol) and DMAP (2 mg, 0.0170 mmol). After 30 min the reaction was quenched by the addition of sat. NH<sub>4</sub>Cl (aq.) (2 mL). The organic layer was

separated and the aqueous layer extracted with further portions of CH<sub>2</sub>Cl<sub>2</sub> (2 x 5 mL). The combined organic extracts were dried (MgSO<sub>4</sub>), filtered and concentrated under reduced pressure to afford the title compound **204** as a colourless oil (29 mg, 100%), which was assigned tentatively using <sup>1</sup>H NMR spectroscopy and HRMS; R<sub>f</sub> (4:1 pet. ether: Et<sub>2</sub>O) 0.77; <sup>1</sup>H NMR (400 MHz; CDCl<sub>3</sub>) δ 5.87–5.81 (1H, m, H-2), 5.46–5.41 (1H, m, H-7), 5.38 (1H, dd, *J* 12.0, 6.0, H-8), 4.55–4.45 (2H, m, H-10), 3.77 (1H, dd, *J* 9.50, 7.5, H-11a), 3.71 (1H, dd, *J* 9.5, 7.0, H-11b), 3.14–3.06 (1H, m, H-9), 2.52 (1H, dd, *J* 14.0, 6.5, H-3a), 2.06 (3H, s, OCOCH<sub>3</sub>), 1.88 (1H, ddd, *J* 14.0, 9.0, 1.5, H-3b), 1.00 (6H, s, H-5 & H-6), 0.88 (9H, s, SiC(CH<sub>3</sub>)<sub>3</sub>), 0.04 (3H, s, SiCH<sub>3</sub>), 0.04 (3H, s, SiCH<sub>3</sub>); m/z (ESI): 361 [MNa<sup>+</sup>]; HRMS: calcd. for C<sub>19</sub>H<sub>34</sub>NaO<sub>3</sub>Si, 361.2175. Found: [MNa<sup>+</sup>], 361.2179 (1.3 ppm error).

**(3a*R*,8a*S*)-6,6-Dimethyl-3,3a,6,8a-tetrahydro-1*H*-cyclohepta[*c*]furan (**209**) & **{[(1*R*,2*S*)-5,5-Dimethylcyclohepta-3,6-diene-1,2-diyl]bis(methanediyoxy)}bis[*tert*-butyl(dimethyl)silane] (**164**)****

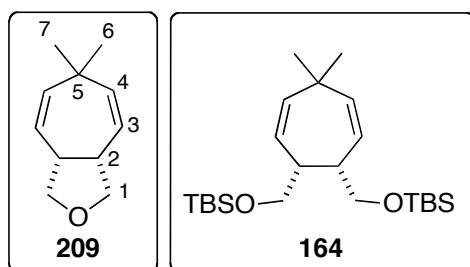

To a stirred solution of **163** (100 mg, 0.340 mmol) in CH<sub>2</sub>Cl<sub>2</sub> (3 mL) at RT was added triphenylphosphine (134 mg, 0.510 mmol), imidazole (35 mg, 0.510 mmol) and iodine (52 mg, 0.408 mmol). After stirring for 50 min,

Na<sub>2</sub>S<sub>2</sub>O<sub>3</sub> (aq.) (5 mL) was added, the organic layer was separated and the aqueous layer extracted with portions of CH<sub>2</sub>Cl<sub>2</sub> (2 x 10 mL). The resulting crude product was purified by flash column chromatography on silica gel, eluting with pet. ether:Et<sub>2</sub>O (30:1) to afford the title compound **164** as a colourless oil (31 mg, 22%) and **209** as a colourless oil (53 mg, 38%) **209** R<sub>f</sub> (15:1 pet. ether:Et<sub>2</sub>O) 0.32; <sup>1</sup>H NMR (400 MHz; CDCl<sub>3</sub>) δ 5.49 (2H, d, *J* 12.0, H-4), 5.32 (2H, dd, *J* 12.0, 4.0, H-3), 3.93 (2H, dd, *J* 7.5, 6.5, H-1a), 3.67 (2H, dd, *J* 7.5, 6.0, H-1b), 3.07–2.99 (2H, m, H-2), 1.20 (3H, s, H-6), 1.12 (3H, s, H-7); <sup>13</sup>C NMR (101 MHz; CDCl<sub>3</sub>) δ 140.9 (C-4), 125.4 (C-3), 74.6 (C-1), 42.5 (C-2), 38.2 (C-5), 32.7 (C-6), 30.0 (C-7); m/z (ESI): 165 [MH<sup>+</sup>]; HRMS: calcd. for C<sub>11</sub>H<sub>17</sub>O, 165.1274. Found: [MH<sup>+</sup>], 165.1280 (3.5 ppm error).

**164** For data see page 142

(±)-[(1*S*,7*R*)-7-({*tert*-Butyl(diphenyl)silyl}oxy)methyl]-4,4-dimethylcyclohepta-2,5-dien-1-yl]methanol (**210**)

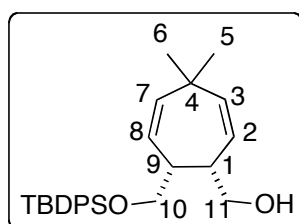

To a solution of **162** (200 mg, 1.10 mmol) in THF (3 mL) was added NaH (53 mg, 1.32 mmol, 60% dispersion in mineral oil) at 0 °C and the reaction mixture stirred for 45 mins before the addition of TBDPSCl (285  $\mu$ L, 1.10 mmol).

After 45 mins the reaction was quenched with  $K_2CO_3$  (aq.) (10 mL) followed by  $Et_2O$  (20 mL). The organic layer was separated and the aqueous layer extracted with further portions of  $Et_2O$  ( $2 \times 20$  mL). The combined organic extracts were dried ( $MgSO_4$ ), filtered and concentrated under reduced pressure. The resulting crude product was purified by flash column chromatography on silica gel, eluting with pet. ether:EtOAc (40:1  $\rightarrow$  1:1) to afford the title compound **210** as a colourless oil (440 mg, 95%);  $R_f$  (4:1 pet. ether:Et<sub>2</sub>O) 0.32;  $\nu_{max}$  (thin film)/ $cm^{-1}$  3301, 3024, 3003, 2964, 2913, 2887, 2815;  $^1H$  NMR (400 MHz;  $CDCl_3$ )  $\delta$  7.70–7.64 (4H, m, Ar-H), 7.48–7.35 (6H, m, Ar-H), 5.61 (1H, dd,  $J$  11.5, 6.0, H-2 or H-8), 5.44 (1H, d,  $J$  11.5, H-3 or H-7), 5.35 (1H, dd,  $J$  12.0, 6.0, H-2 or H-8), 5.30 (1H, d,  $J$  12.0, H-3 or H-7), 3.77 (1H, dd,  $J$  10.5, 8.5, H-10a or H-11a), 3.74 (1H, dd,  $J$  11.5, 6.5, H-10a or H-11a), 3.68 (1H, dd,  $J$  11.5, 4.5, H-10b or H-11b), 3.55 (1H, dd,  $J$  10.5, 4.0, H-10b or H-11b), 2.93–2.84 (1H, m, H-1 or H-9), 2.77–2.70 (1H, m, H-1 or H-9), 1.11 (3H, s, H-5), 1.07 (9H, s,  $SiC(CH_3)_3$ ), 1.03 (3H, s, H-6);  $^{13}C$  NMR (101 MHz;  $CDCl_3$ )  $\delta$  139.9 (C-8 or C-2), 139.9 (C-7 or C-3), 135.8 (Ar-CH), 135.7 (Ar-CH), 134.9 (C-8 or C-2), 133.0 (Ar-C), 132.9 (Ar-C), 130.0 (Ar-CH), 130.0 (Ar-CH), 129.8 (C-7 or C-3), 127.9 (Ar-CH), 127.9 (Ar-CH), 66.0 (C-11 or C-10), 65.0 (C-11 or C-10), 43.1 (C-9 or C-1), 39.7 (C-4), 32.9 (C-5), 29.7 (C-6), 27.0 ( $SiC(CH_3)_3$ ), 26.7 (C-9 or C-1), 19.3 ( $SiC(CH_3)_3$ ).  $m/z$  (ESI): 443 [ $MNa^+$ ]; HRMS: calcd. for  $C_{27}H_{36}NaO_2Si$ , 443.2377. Found: [ $MNa^+$ ], 443.2357 (4.4 ppm error).

**(±)-[(1*S*,7*R*)-7-({*tert*-Butyl(diphenyl)silyl}oxy)methyl]-4,4-dimethylcyclohepta-2,5-dien-1-yl]methyl methanesulfonate (**212**)**

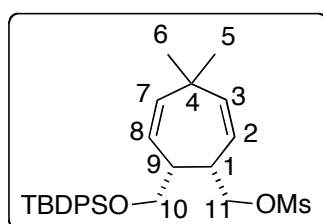

To a stirred solution of **210** (50 mg, 0.119 mmol) in CH<sub>2</sub>Cl<sub>2</sub> (2 mL) at RT was added triethylamine (50 μL, 0.357 mmol) and MsCl (14 μL, 0.179 mmol). After 1.5 h the reaction was quenched by the addition of sat. NH<sub>4</sub>Cl (aq.) (5 mL). The organic layer was separated and the

aqueous layer extracted with further portions of CH<sub>2</sub>Cl<sub>2</sub> (2 × 10 mL). The combined organic extracts were dried (MgSO<sub>4</sub>), filtered and concentrated under reduced pressure. The resulting crude product was purified by flash column chromatography on silica gel, eluting with pet. ether:Et<sub>2</sub>O (4:1) to afford the title compound **212** as a colourless oil (49 mg, 83%); R<sub>f</sub> (4:1 pet. ether:Et<sub>2</sub>O) 0.29; ν<sub>max</sub> (thin film)/cm<sup>-1</sup> 2967, 2914, 2887, 2850, 2815; <sup>1</sup>H NMR (400 MHz; CDCl<sub>3</sub>) δ 7.69–7.63 (4H, m, Ar-H), 7.46–7.35 (6H, m, Ar-H), 5.52 (1H, dd, *J* 12.0, 5.5, H-2 or H-8), 5.46 (1H, d, *J* 12.0, H-3 or H-7), 5.37 (1H, d, *J* 12.0, H-3 or H-7), 5.31 (1H, dd, *J* 12.0, 5.5, H-2 or H-8), 4.38–4.31 (2H, m, H-11), 3.71 (1H, dd, *J* 10.5, 9.0, H-10a), 3.60 (1H, dd, *J* 10.5, 5.5, H-10b), 3.16–3.08 (1H, m, H-1), 2.89 (3H, s, SO<sub>2</sub>CH<sub>3</sub>), 2.87–2.79 (1H, m, H-9), 1.13 (3H, s, H-5), 1.07 (3H, s, H-6), 1.06 (9H, s, SiC(CH<sub>3</sub>)<sub>3</sub>); <sup>13</sup>C NMR (101 MHz; CDCl<sub>3</sub>) δ 140.8 (C-8 or C-2), 140.2 (C-7 or C-3), 135.7 (Ar-CH), 135.7 (Ar-CH), 135.3 (C-8 or C-2), 134.9 (C-7 or C-3), 133.5 (Ar-C), 133.5 (Ar-C), 129.9 (Ar-CH), 129.8 (Ar-CH), 127.9 (Ar-CH), 127.9 (Ar-CH), 72.6 (C-11), 65.1 (C-10), 42.3 (C-1), 40.0 (C-4), 37.3 (SO<sub>2</sub>CH<sub>3</sub>), 32.6 (C-5), 29.6 (C-6), 27.0 (SiC(CH<sub>3</sub>)<sub>3</sub>), 26.7 (C-9), 19.3 (SiC(CH<sub>3</sub>)<sub>3</sub>). m/z (ESI): 521 [MNa<sup>+</sup>]; HRMS: calcd. for C<sub>28</sub>H<sub>38</sub>NaO<sub>4</sub>SSi, 521.2152. Found: [MNa<sup>+</sup>], 521.2153 (0.1 ppm error).

**(±)-[(1*R*,7*S*)-7-{{(4-Methoxybenzyl)oxy}methyl}-4,4-dimethylcyclohepta-2,5-dien-1-yl]methanol (**216**)**

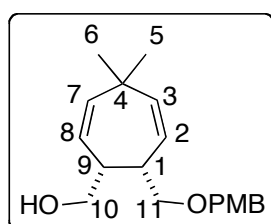

To a stirred solution of **162** (200 mg, 1.10 mmol) in THF (10 mL) was added NaH (53 mg, 1.32 mmol, 60% dispersion in mineral oil) at 0 °C After 30 min PMBCl (149 μL, 1.10 mmol)

was added and the reaction mixture was warmed to RT. After 2h the reaction was quenched with sat. NH<sub>4</sub>Cl (aq.) (10 mL) followed by Et<sub>2</sub>O (20 mL). The organic layer was separated and the aqueous layer extracted with further portions of Et<sub>2</sub>O (2 × 20 mL). The combined organic extracts were dried (MgSO<sub>4</sub>), filtered and concentrated under reduced pressure. The resulting crude product was purified by flash column chromatography on silica gel, eluting with pet. ether:Et<sub>2</sub>O (3:1 → 2:1) to afford the title compound **216** as a colourless oil (123 mg, 41%); R<sub>f</sub> (2:1 pet. ether:Et<sub>2</sub>O) 0.34;  $\nu_{\text{max}}$  (thin film)/cm<sup>-1</sup> 3349, 2959, 2912, 2858, 2822; <sup>1</sup>H NMR (400 MHz; CDCl<sub>3</sub>)  $\delta$  7.25 (2H, d, *J* 9.0, Ar-H), 6.88 (2H, d, *J* 9.0, Ar-H), 5.88–5.48 (2H, m, H-2 & H-8), 5.44–5.35 (2H, m, H-3 & H-7), 4.46 (2H, s, C<sub>6</sub>H<sub>4</sub>CH<sub>2</sub>), 3.80 (3H, s, C<sub>6</sub>H<sub>4</sub>OCH<sub>3</sub>), 3.64 (1H, dd, *J* 11.5, 7.0, H-10a or H-11a), 3.58 (1H, dd, *J* 9.5, 8.0, H-10a or H-11a), 3.54 (1H, dd, *J* 11.5, 4.0, H-10b or H-11b), 3.39 (1H, dd, *J* 9.5, 3.5, H-10b or H-11b), 2.87–2.76 (2H, m, H-1 & H-9), 1.13 (3H, s, H-5), 1.07 (3H, s, H-6); <sup>13</sup>C NMR (101 MHz; CDCl<sub>3</sub>)  $\delta$  159.5 (Ar-C), 139.9 (C-3 or C-7), 139.7 (C-3 or C-7), 129.7 (Ar-CH), 129.5 (Ar-C), 126.3 (C-2 or C-8), 126.2 (C-2 or C-8), 114.0 (Ar-CH), 73.2 (C<sub>6</sub>H<sub>4</sub>CH<sub>2</sub>), 71.1 (C-10 or C-11), 64.5 (C-10 or C-11), 55.5 (C<sub>6</sub>H<sub>4</sub>OCH<sub>3</sub>), 43.7 (C-1 or C-9), 41.6 (C-1 or C-9), 39.8 (C-4), 32.9 (C-5), 29.7 (C-6); *m/z* (ESI): 325 [MNa<sup>+</sup>]; HRMS: calcd. for C<sub>19</sub>H<sub>26</sub>NaO<sub>3</sub>, 325.1774. Found: [MNa<sup>+</sup>], 325.1770 (1.1 ppm error).

**(±)-(1*S*,7*R*)-7-({*tert*-Butyl(diphenyl)silyl}oxy)methyl)-4,4-dimethylcyclohepta-2,5-diene-1-carbaldehyde (**217**)**

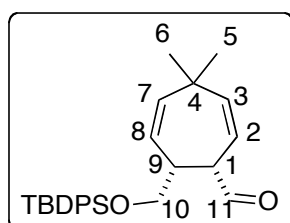

To a stirred solution of **210** (99 mg, 0.235 mmol) in CH<sub>2</sub>Cl<sub>2</sub> (5 mL), at 0 °C was added Dess–Martin periodinane (199 mg, 0.470 mmol). The reaction mixture was warmed to RT and allowed to stir for 1 h. It was then diluted with CH<sub>2</sub>Cl<sub>2</sub> (15 mL), and quenched with a 1: 1 solution of sat. Na<sub>2</sub>CO<sub>3</sub> (aq.) and sat. Na<sub>2</sub>S<sub>2</sub>O<sub>3</sub> (aq.) (30 mL). After vigorous stirring for 30 mins, the organic layer was separated and the aqueous layer extracted with further portions of CH<sub>2</sub>Cl<sub>2</sub> (2 × 30 mL). The combined organic extracts were dried (MgSO<sub>4</sub>), filtered and concentrated under reduced pressure to afford the title compound **217** as a colourless oil (78 mg, 80%) which was assigned



tentatively using  $^1\text{H}$  NMR spectroscopy;  $R_f$  (2:1 pet. ether:Et<sub>2</sub>O) 0.48;  $^1\text{H}$  NMR (400 MHz; CDCl<sub>3</sub>)  $\delta$  9.76 (1H, s, H-11), 7.69–7.61 (4H, m, Ar-H), 7.47–7.35 (6H, m, Ar-H), 5.94 (1H, dd,  $J$  11.5, 5.0, H-2 or H-8), 5.60 (1H, d,  $J$  11.5, H-3 or H-7), 5.50 (1H, dd,  $J$  12.0, 6.5, H-2 or H-8), 5.37 (1H, d,  $J$  12.0, H-3 or H-7), 3.62 (1H, dd,  $J$  9.5, 9.5, H-10a), 3.52 (1H, dd,  $J$  9.5, 4.5, H-10b), 3.43–3.39 (1H, m, H-1 or H-9), 3.20–3.13 (1H, m, H-1 or H-9), 1.13 (3H, s, H-5), 1.08 (3H, s, H-6) 1.01 (9H, s, SiC(CH<sub>3</sub>)<sub>3</sub>).

**(±)-(E)-3-((1S,3R)-3-((tert-Butyldimethylsilyloxy)methyl)-2,2-dimethylcyclopropyl)prop-2-en-1-ol (221)**

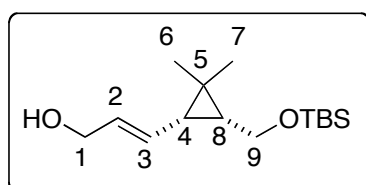

To a stirred solution of **133** (1.00 g, 3.20 mmol) in CH<sub>2</sub>Cl<sub>2</sub> (30 mL) at  $-78$  °C was added DIBAL (12.8 mL, 12.8 mmol, 1M in hexanes). After 10 mins the reaction was warmed to RT and after 30 min the reaction mixture was diluted with CH<sub>2</sub>Cl<sub>2</sub> (50 mL) followed by the careful addition of sat. aq. Rochelle's salt (30 mL). The mixture was stirred for 2 h after which time, the organic layer was separated and the aqueous layer extracted with further portions of CH<sub>2</sub>Cl<sub>2</sub> (2 × 100 mL). The combined organic extracts were dried (MgSO<sub>4</sub>), filtered and concentrated under reduced pressure to afford the crude compound, which was purified by flash column chromatography on silica gel, eluting with pet. ether:EtOAc (10:1) to afford the title compound **221** as a colourless oil (710 mg, 82%);  $R_f$  (10:1 pet. ether:EtOAc) 0.24;  $\nu_{\text{max}}$  (thin film)/cm<sup>-1</sup> 3346, 2929, 2858;  $^1\text{H}$  NMR (400 MHz; CDCl<sub>3</sub>)  $\delta$  5.83–5.74 (1H, m, H-2), 5.49–5.41 (1H, m, H-3), 4.08 (2H, d,  $J$  6.0, H-1), 3.70–3.66 (2H, m, H-9), 1.37 (1H, t,  $J$  9.5, H-4), 1.10 (3H, s, H-6), 1.08–1.01 (1H, m, H-8), 1.06 (3H, s, H-7), 0.88 (9H, s, SiC(CH<sub>3</sub>)<sub>3</sub>), 0.04 (6H, s, SiCH<sub>3</sub>);  $^{13}\text{C}$  NMR (101 MHz; CDCl<sub>3</sub>)  $\delta$  131.5 (C-3), 130.2 (C-2), 64.1 (C-1), 60.5 (C-9), 32.3 (C-6), 30.0 (C-4 or C-8), 28.9 (C-4 or C-8), 26.1 (SiC(CH<sub>3</sub>)<sub>3</sub>), 21.7 (C-5), 18.4 (SiC(CH<sub>3</sub>)<sub>3</sub>), 15.6 (C-7),  $-5.0$  (SiCH<sub>3</sub>),  $-5.0$  (SiCH<sub>3</sub>);  $m/z$  (ESI): 293 [MNa<sup>+</sup>]; HRMS: calcd. for C<sub>15</sub>H<sub>30</sub>NaO<sub>2</sub>Si, 293.1907. Found: [MH<sup>+</sup>], 293.1900 (2.6 ppm error).

**(±)-(E)-3-((1S,3R)-3-((*tert*-Butyldimethylsilyloxy)methyl)-2,2-dimethylcyclopropyl)allyl ethyl carbonate (223)**

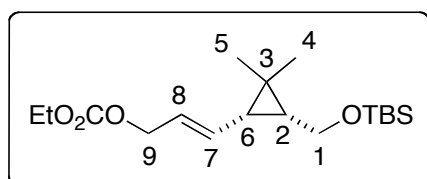

To a solution of alcohol **221** (420 mg, 1.55 mmol) in CH<sub>2</sub>Cl<sub>2</sub> (30 mL) at 0 °C was added DMAP (38 mg, 0.31 mmol) and pyridine (499 μL, 6.2 mmol).

This was stirred at 0 °C for 10 min before the addition of ethylchloroformate (505 mg, 4.65 mmol). The reaction was warmed to RT and after 30 min was quenched with a solution of sat. NH<sub>4</sub>CL (aq.) (30 mL). The organic layer was separated and the aqueous layer extracted with further portions of CH<sub>2</sub>Cl<sub>2</sub> (2 × 50 mL). The combined organic extracts were dried (MgSO<sub>4</sub>), filtered and concentrated under reduced pressure to afford the title compound **223** as a colourless oil which was used in the next step without further purification; R<sub>f</sub> (30:1 pet. ether:EtOAc) 0.31; ν<sub>max</sub> (thin film)/cm<sup>-1</sup> 2954, 2930, 2858, 1745; <sup>1</sup>H NMR (400 MHz; CDCl<sub>3</sub>) δ 5.73 (1H, dt, *J* 15.0, 6.5, H-8), 5.56 (1H, dd, *J* 15.0, 10.0, H-7), 4.58 (1H, dd, *J* 13.5, 6.5, H-9a), 4.55 (1H, dd, *J* 13.5, 6.5, H-9b), 4.18 (2H, q, *J* 7.0, CH<sub>3</sub>CH<sub>2</sub>O), 3.68 (1H, d, *J* 7.5 H-1a), 3.67 (1H, d, *J* 7.5 H-1b), 1.30 (3H, t, *J* 7.0, CH<sub>3</sub>CH<sub>2</sub>O), 1.11–1.08 (2H, m, H-2 & H-6), 1.10 (3H, s, H-5), 1.07 (3H, s, H-4), 0.88 (9H, s, SiC(CH<sub>3</sub>)<sub>3</sub>), 0.04 (6H, s, SiCH<sub>3</sub>); <sup>13</sup>C NMR (101 MHz; CDCl<sub>3</sub>) δ 155.2 (C=O), 134.3 (C-2), 124.3 (C-7), 68.7 (C-1), 64.0 (C-9), 60.4 (CH<sub>3</sub>CH<sub>2</sub>O), 32.7 (C-4), 30.1 (C-6 or C-2), 28.9 (C-6 or C-2), 26.1 (SiC(CH<sub>3</sub>)<sub>3</sub>), 22.1 (C-3), 18.4 (SiC(CH<sub>3</sub>)<sub>3</sub>), 15.7 (C-5), 14.4 (CH<sub>3</sub>CH<sub>2</sub>O), -5.0 (SiCH<sub>3</sub>), -5.0 (SiCH<sub>3</sub>); *m/z* (ESI): 365 [MNa<sup>+</sup>]; HRMS: calcd. for C<sub>18</sub>H<sub>34</sub>NaO<sub>4</sub>Si, 365.2119. Found: [MNa<sup>+</sup>], 365.2108 (2.1 ppm error).

**(±)-(E)-*tert*-Butyl 5-((1S,3R)-3-((*tert*-butyldimethylsilyloxy)methyl)-2,2-dimethylcyclopropyl)-2-ethanoylpent-4-enoate (224)**

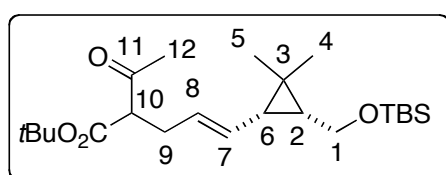

To a solution of carbonate **223** (1.55 mmol) in degassed THF at 0 °C was added *tert*-butyl 3-oxobutanoate (308 μL, 1.86 mmol) and

tetrakis(triphenylphosphine)palladium(0) (179 mg, 0.155 mmol). This reaction mixture was warmed to 45 °C and stirred for 1h. It was then concentrated under reduced pressure and the resulting crude product was purified by flash column chromatography on silica gel, eluting with pet. ether:EtOAc (30:1) to afford the title compound **224** as a colourless oil (584 mg, 92%) as a mixture of diastereomers in a ratio of ~ 1:1;  $R_f$  (30:1 pet. ether:EtOAc) 0.19;  $\nu_{\max}$  (thin film)/ $\text{cm}^{-1}$  2954, 2930, 2858, 1745, 1716;  $^1\text{H}$  NMR (400 MHz;  $\text{CDCl}_3$ )  $\delta$  5.50–5.40 (1H, m, H-8), 5.29–5.21 (1H, m, H-7), 3.70–3.57 (2H, m, H-1), 3.38–3.32 (1H, m, H-10), 2.53–2.47 (2H, m, H-9), 2.20 (3H, s, H-12), 1.45 (9H, s,  $\text{C}(\text{CH}_3)_3$ ), 1.28 (1H, dt,  $J$  9.0, 1.5, H-2), 1.06 (3H, s, H-5), 1.02 (3H, s, H-4), 1.00–0.96 (1H, m, H-6), 0.88 (9H, s,  $\text{SiC}(\text{CH}_3)_3$ ), 0.04 (6H, s,  $\text{SiCH}_3$ );  $^{13}\text{C}$  NMR (101 MHz;  $\text{CDCl}_3$ )  $\delta$  203.3, and 203.3 ( $\text{CH}_3\text{C}=\text{O}$ ), 168.7, and 168.7 ( $(\text{CH}_3)_3\text{COC}=\text{O}$ ), 129.6, and 129.6 (C-8), 127.1, and 127.0 (C-7), 82.0, and 82.0 ( $\text{C}(\text{CH}_3)_3$ ), 61.2, and 61.1 (C-10), 60.6, and 60.6 (C-1), 31.9, and 31.9 (C-5), 31.8, and 31.7 (C-9), 30.1, and 30.0 (C-6 or C-2), 29.2, and 29.1 (C-6 or C-2), 28.1, and 28.1 ( $\text{C}(\text{CH}_3)_3$ ), 26.1, and 26.1 ( $\text{SiC}(\text{CH}_3)_3$ ), 21.2, and 21.2 (C-3), 18.4, and 18.4 ( $\text{SiC}(\text{CH}_3)_3$ ), 15.7, and 15.7 (C-4), –4.9, and –4.9 ( $\text{SiCH}_3$ ), –5.0, and –5.0 ( $\text{SiCH}_3$ );  $m/z$  (ESI): 433 [ $\text{MNa}^+$ ]; HRMS: calcd. for  $\text{C}_{23}\text{H}_{42}\text{NaO}_4\text{Si}$ , 433.2745. Found: [ $\text{MNa}^+$ ], 433.2733 (2.9 ppm error).

**(±)-(E)-tert-Butyl 2-ethanoyl-5-((1S,3R)-3-(hydroxymethyl)-2,2-dimethylcyclopropyl)pent-4-enoate (**225**)**

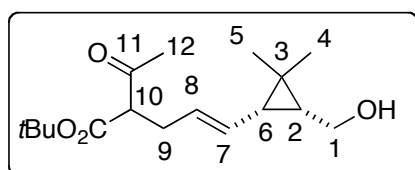

To a solution of **224** (167 mg, 0.421 mmol) in THF (4 mL) at 0 °C was added TBAF (505  $\mu\text{L}$ , 1 M in THF, 0.505 mmol). After 2 h the reaction mixture was diluted with  $\text{Et}_2\text{O}$  (5 mL) and washed with sat.  $\text{NH}_4\text{Cl}$  (aq.) (5 mL), the organic layer separated and the aqueous layer extracted with further portions of  $\text{Et}_2\text{O}$  ( $2 \times 10$  mL). The combined organic extracts were dried ( $\text{MgSO}_4$ ), filtered and concentrated under reduced pressure. The resulting crude product was purified by flash column chromatography on silica gel, eluting with pet. ether:EtOAc (1:1) to afford the title compound **225** as a colourless oil (86 mg, 72%) as a mixture of diastereomers and

enol/keto tautomers;  $R_f$  (1:1 pet. ether:Et<sub>2</sub>O) 0.24;  $\nu_{\max}$  (thin film)/cm<sup>-1</sup> 3444, 2980, 1714; <sup>1</sup>H NMR (400 MHz; CDCl<sub>3</sub>)  $\delta$  5.58–5.24 (2H, m, H-8 & H-7), 3.77–3.47 (2H, m, H-1), 3.41–3.35 (1H, m, H-10), 2.81–2.47 (2H, m, H-9), 2.22, 2.21, 2.20 (3H, s, H-12), 1.47, 1.44 (9H, s, C(CH<sub>3</sub>)<sub>3</sub>), 1.12–1.02 (2H, m, H-6 & H-2), 1.08 (3H, s, H-5), 1.06 (3H, s, H-4);  $m/z$  (ESI): 319 [MNa<sup>+</sup>]; HRMS: calcd. for C<sub>17</sub>H<sub>28</sub>NaO<sub>4</sub>, 319.1180. Found: [MNa<sup>+</sup>], 319.1868 (3.7 ppm error). Note that the compound exists as a mixture of diastereoisomers and enol/keto tautomers, therefore assignment of the <sup>13</sup>C NMR spectrum was complex and could not be assigned with confidence.

**(±)-(4E)-tert-Butyl 2-ethanoyl-5-((1S,3R)-3-(3-ethoxy-3-oxoprop-1-enyl)-2,2-dimethylcyclopropyl)pent-4-enoate (226)**

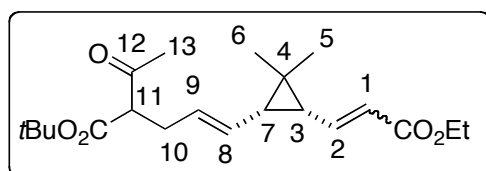

To a stirred solution of **225** (58 mg, 0.198 mmol) in CH<sub>2</sub>Cl<sub>2</sub> (2 mL), at 0 °C was added Dess-Martin periodinane (126 mg, 0.297 mmol). The reaction mixture was warmed to RT and allowed to stir overnight. It was then diluted with CH<sub>2</sub>Cl<sub>2</sub> (5 mL), and quenched with a 1:1 solution of sat. Na<sub>2</sub>CO<sub>3</sub> (aq.) and sat. Na<sub>2</sub>S<sub>2</sub>O<sub>3</sub> (aq.) (3 mL). After vigorous stirring for 30 mins, the organic layer was separated and the aqueous layer extracted with further portions of CH<sub>2</sub>Cl<sub>2</sub> (2 × 10 mL). The combined organic extracts were dried (MgSO<sub>4</sub>), filtered and concentrated under reduced pressure to afford aldehyde **227**. This was dissolved in CHCl<sub>3</sub> (5 mL) and (carbethoxymethylene) triphenyl phosphorane (83 mg, 0.238 mmol) was added. After 16 h the solution was concentrated under reduced pressure and the crude product purified by flash column chromatography on silica gel, eluting with pet. ether:EtOAc (5:1) to afford the title compound **226** as a colourless oil (52 mg, 72%) as a mixture of diastereomers and enol/keto tautomers;  $R_f$  (5:1 pet. ether:EtOAc) 0.29;  $\nu_{\max}$  (thin film)/cm<sup>-1</sup> 2980, 2954, 2930, 1714; <sup>1</sup>H NMR (400 MHz; CDCl<sub>3</sub>)  $\delta$  6.83–6.61 (1H, m, olefinic CH), 6.04–5.77 (1H, m, olefinic CH), 5.58–5.21 (2H, m, olefinic CH), 4.25–4.12 (2H, m, CH<sub>3</sub>CH<sub>2</sub>O), 3.42–3.30 (1H, m, H-11), 2.94–2.43 (2H, m, H-10), 2.23–2.18 (3H, m, H-13), 1.80–1.40 (2H, m, H-3 & H-7), 1.48–1.41 (9H, m, C(CH<sub>3</sub>)<sub>3</sub>), 1.30–1.25 (3H, m, CH<sub>3</sub>CH<sub>2</sub>O), 1.17–1.09 (6H, m,

H-5 &H-6);  $m/z$  (ESI): 387 [ $MNa^+$ ]; HRMS: calcd. for  $C_{21}H_{32}NaO_5$ , 387.2142. Found: [ $MNa^+$ ], 387.2413 (0.1 ppm error). Note that the compound exists as a mixture of diastereoisomers, *E/Z* isomers and enol/keto tautomers, therefore assignment of the  $^{13}C$  NMR spectrum was complex and could not be assigned with confidence.

**(±)-(1*S*,2*Z*,5*Z*,7*R*)-Ethyl 4,4-dimethyl-7-(3-oxobutyl)cyclohepta-2,5-dienecarboxylate (220)**

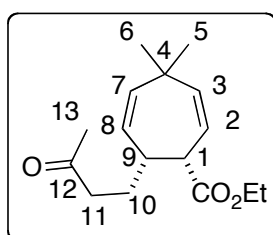

A stirred solution of **226** (1.00 g, 2.74 mmol) in toluene (100 mL) was heated to 100 °C for 16 h. After being cooled to RT the solution was concentrated under reduced pressure. The resulting light yellow oil was dissolved in  $CH_2Cl_2$  (50 mL) and stirred. TFA (2.8 mL) was then added and the reaction mixture was refluxed for a further 16 h before concentrating under reduced pressure. The resulting crude product was purified by flash column chromatography on silica gel, eluting with pet. ether:EtOAc (20:1) to afford the title compound **220** as a colourless oil (369 mg, 51%);  $R_f$  (20:1 pet. ether:EtOAc) 0.18;  $\nu_{max}$  (thin film)/ $cm^{-1}$  2954, 2930, 2858, 1745;  $^1H$  NMR (400 MHz;  $CDCl_3$ )  $\delta$  5.83 (1H, dd,  $J$  11.5, 6.0, H-2), 5.56 (1H, dd,  $J$  12.0, 7.0, H-8), 5.50 (1H, dt, 11.5, 2.0, H-3), 5.33 (1H, d, 12.0, H-7), 4.15 (2H, q,  $J$  7.0,  $CH_3CH_2O$ ), 3.67–3.58 (1H, m, H-1), 2.76–2.65 (1H, m, H-9), 2.53–2.35 (2H, m, H-11), 2.11 (3H, s, H-13), 1.79–1.63 (2H, m, H-10), 1.26 (3H, t,  $J$  7.0,  $CH_3CH_2O$ ), 1.13 (3H, s, H-5), 1.10 (3H, s, H-6);  $^{13}C$  NMR (101 MHz;  $CDCl_3$ )  $\delta$  208.9 (C=O), 173.2 ( $CH_3CH_2OC=O$ ), 139.9 (C-3), 139.2 (C-7), 128.7 (C-8), 123.2 (C-2), 60.9 ( $CH_3CH_2O$ ), 47.4 (C-1), 41.9 (C-11), 39.4 (C-4), 39.1 (C-9), 32.5 (C-5), 29.9 (C-13), 29.5 (C-6), 27.0 (C-10), 14.4 ( $CH_3CH_2O$ );  $m/z$  (ESI): 287 [ $MNa^+$ ]; HRMS: calcd. for  $C_{16}H_{24}NaO_3$ , 287.1618. Found: [ $MNa^+$ ], 287.1610 (2.0 ppm error).

**(±)-(R,1E,5Z)-Ethyl 4,4-dimethyl-7-(3-oxobutyl)cyclohepta-1,5-dienecarboxylate (229)**

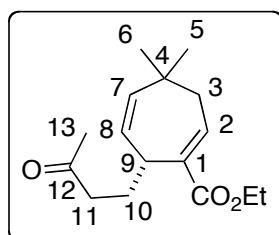

To a stirred solution of **220** (200 mg, 0.757 mmol) in degassed THF (8 mL) at 0 °C was added DBU (113 μL, 0.757 mmol). The reaction was heated to 60 °C and held at this temperature for 16 h. The reaction was then cooled to RT and the reaction mixture concentrated under reduced pressure. The resulting crude product was purified by flash column chromatography on silica gel, eluting with pet. ether:EtOAc (10:1) to afford the title compound **229** as a colourless oil (181 mg, 91%) which was assigned tentatively using <sup>1</sup>H NMR spectroscopy; R<sub>f</sub> (10:1 pet. ether:EtOAc) 0.38; <sup>1</sup>H NMR (400 MHz; CDCl<sub>3</sub>) δ 7.13 (1H, dd, *J* 9.5, 6.0, H-2), 5.43–5.36 (2H, m, H-8 & H-7), 4.21–4.15 (2H, m, CH<sub>3</sub>CH<sub>2</sub>O), 3.45–3.38 (1H, m, H-9), 2.56–2.38 (2H, m, H-11), 2.13 (3H, s, H-13), 1.92–1.83 (2H, m, H-3), 1.29 (3H, t, *J* 7.0, CH<sub>3</sub>CH<sub>2</sub>O), 1.16–1.10 (2H, m, H-10), 1.05 (3H, s, H-6), 0.98 (3H, s, H-5).

**4-((R,2E,6Z)-2-(Hydroxymethyl)-5,5-dimethylcyclohepta-2,6-dienyl)butan-2-ol (232)**

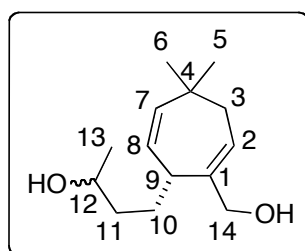

To a stirred solution of **229** (84 mg, 0.318 mmol) in CH<sub>2</sub>Cl<sub>2</sub> (3 mL) at -78 °C was added DIBAL (1.27 mL, 1.27 mmol, 1 M in hexanes). After 1 h the reaction mixture was diluted with CH<sub>2</sub>Cl<sub>2</sub> (5 mL) followed by the careful addition of MeOH (5 drops). The solution was warmed to RT and sat. aq. Rochelle's salt (5 mL) was added. It was stirred for 2 h after which time, the organic layer was separated and the aqueous layer extracted with further portions of CH<sub>2</sub>Cl<sub>2</sub> (3 × 10 mL). The combined organic extracts were dried (MgSO<sub>4</sub>), filtered and concentrated under reduced pressure to afford the crude compound. The major diastereomer was isolated by flash column chromatography on silica gel, eluting with pet. ether:EtOAc (1:1) to afford the title compound **232** as a colourless oil (27 mg, 38%). which was assigned tentatively using <sup>1</sup>H NMR spectroscopy; R<sub>f</sub> (1:1 pet.

ether:EtOAc) 0.18;  $^1\text{H}$  NMR (400 MHz;  $\text{CDCl}_3$ )  $\delta$  5.75 (1H, dd,  $J$  8.5, 6.5, H-2), 5.43 (1H, ddd,  $J$  12.0, 6.5, 2.5, H-8), 5.33 (1H, d,  $J$  12.0, H-7), 4.02–3.98 (2H, m, H-14), 3.85–3.74 (1H, m, H-12), 2.74–2.65 (1H, m, H-9), 2.56–2.50 (1H, m, H-3a), 1.95–1.84 (1H, m, H-3b), 1.82–1.43 (4H, m, H-10 & H-11), 1.20 (3H, d,  $J$  6.0, H-13), 1.00 (3H, s, H-5), 0.98 (3H, s, H-6).

### Cyclohex-2-enylmethanol (**236**)<sup>88</sup>

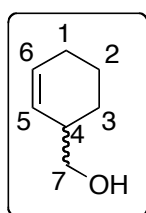

$n$ -BuLi (1.6 M in hexanes, 200 mL, 320 mmol) was added to a suspension of KOtBu (33.9 g, 302 mmol) in cyclohexene (270 mL, 2.7 mol). The reaction mixture was kept below 15 °C for a period of 2 h, and then allowed to warm to RT over 16 h. The resultant suspension was cooled to 0 °C and  $(\text{CH}_2\text{O})^n$  (9.98 g, 332 mmol) was added carefully. The reaction mixture was heated to 60 °C for 3 h, then cooled to 0 °C and quenched with sat. aq.  $\text{NaHCO}_3$  (200 mL). The mixture was extracted with  $\text{CH}_2\text{Cl}_2$  (3  $\times$  200 mL). The combined organic extracts were washed sequentially with sat. aq.  $\text{NaHCO}_3$  (200 mL) and brine (200 mL), dried and concentrated *in vacuo*. The resulting crude product was purified by flash column chromatography on silica gel, eluting with pet. ether:Et<sub>2</sub>O (1:1) to afford the title compound **236** as a pale yellow oil (25.5 g, 75%);  $R_f$  (1:1 pet. ether:Et<sub>2</sub>O) 0.19;  $^1\text{H}$  NMR (400 MHz;  $\text{CDCl}_3$ )  $\delta$  5.77–5.70 (1H, m, olefinic  $\text{CH}$ ), 5.57–5.48 (1H, m, olefinic  $\text{CH}$ ), 3.40 (2H, d,  $J$  6.5, H-7), 2.25–2.17 (1H, m, H-4), 1.92–1.86 (2H, m,  $\text{CH}_2$ ), 1.75–1.63 (2H, m,  $\text{CH}_2$ ), 1.53–1.47 (1H, m,  $\text{CH}_a$ ), 1.33–1.25 (1H, m,  $\text{CH}_b$ ). Data in agreement with those reported in the literature.<sup>88</sup>

### 3-(Iodomethyl)cyclohex-1-ene (**237**)<sup>89</sup>

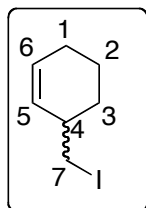

To a stirred solution of cyclohex-2-enylmethanol **236** (20 g, 178 mmol) in  $\text{CH}_2\text{Cl}_2$  (500 mL) at RT was added triphenylphosphine (69.8 g, 267 mmol), imidazole (18.1 g, 267 mmol) and iodine (27.1 g, 214 mmol). After stirring for 50 mins  $\text{Na}_2\text{S}_2\text{O}_3$  (aq.) (250 mL) was added, the organic layer was separated and the aqueous layer extracted with further EtOAc (2  $\times$

300 mL). The resulting crude product was purified by flash column chromatography on silica gel, eluting with pet. ether:EtOAc (30:1) to afford the title compound **237** as a colourless oil (22.9 g, 58%);  $R_f$  (1:1 pet. ether:EtOAc) 0.81;  $^1\text{H NMR}$  (400 MHz;  $\text{CDCl}_3$ )  $\delta$  5.82–5.77 (1H, m, olefinic  $\text{CH}$ ), 5.59–5.54 (1H, m, olefinic  $\text{CH}$ ), 3.21–3.10 (2H, m, H-7), 2.40–2.29 (1H, m, H-4), 2.00–1.83 (2H, m,  $\text{CH}_2$ ), 1.76–1.69 (2H, m,  $\text{CH}_2$ ), 1.61–1.50 (1H, m,  $\text{CH}_a$ ), 1.44–1.33 (1H, m,  $\text{CH}_b$ ); Data in agreement with those reported in the literature.<sup>89</sup>

### *tert*-Butyl 2-(cyclohex-2-enylmethyl)-3-oxobutanoate (**238**)

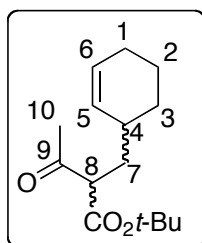

To a stirring suspension of NaH (1.00 g, 26.9 mmol) in THF (135 mL) at 0 °C was added *t*-butyl 3-oxobutanoate (3.62 mL, 22.5 mmol). **237** (5 g, 22.5 mmol) in THF (135 mL) was added to the reaction mixture over 20 minutes before warming to RT over 1 h and heating for 16 h at 70 °C. The reaction was diluted with  $\text{Et}_2\text{O}$  (500 mL), quenched with sat.  $\text{NH}_4\text{Cl}$  (aq.) (300 mL) and the organic layer separated. The aqueous layer was extracted with further portions of  $\text{Et}_2\text{O}$  (2 × 200 mL). The combined organic extracts were dried ( $\text{MgSO}_4$ ), filtered and concentrated under reduced pressure. The resulting crude product was purified by flash column chromatography on silica gel, eluting with pet. ether:EtOAc (40:1) to afford the title compound **238** as a colourless oil and inseparable mixture of 2 diastereomers **238a** & **238b** in a ratio ~ 1:1 (3.86 mg, 68%);  $R_f$  (20:1 pet. ether:EtOAc) 0.30;  $\nu_{\text{max}}$  (thin film)/ $\text{cm}^{-1}$  2968, 2932, 2884, 1712, 1689;  $^1\text{H NMR}$  (400 MHz;  $\text{CDCl}_3$ )  $\delta$  5.76–5.66 (1H, m, H-6<sub>A+B</sub>), 5.58–5.48 (1H, m, H-5<sub>A+B</sub>), 3.50–3.41 (1H, m, H-8<sub>A+B</sub>), 2.22 (3H, s, H-10<sub>A</sub>), 2.22 (3H, s, H-10<sub>B</sub>), 2.08–2.00 (1H, m, H-4<sub>A+B</sub>), 1.99–1.93 (2H, m,  $\text{CH}_{2A+B}$ ), 1.93–1.67 (4H, m, 2 ×  $\text{CH}_{2A+B}$ ), 1.46 (9H, s,  $\text{C}(\text{CH}_3)_{3A}$ ), 1.46 (9H, s,  $\text{C}(\text{CH}_3)_{3B}$ ), 1.30–1.13 (2H, m,  $\text{CH}_{2A+B}$ );  $^{13}\text{C NMR}$  (101 MHz;  $\text{CDCl}_3$ )  $\delta$  203.8 ( $\text{C}=\text{O}_A$ ), 203.8 ( $\text{C}=\text{O}_B$ ), 169.3 (*t*-BuOC=O<sub>A</sub>), 169.3 (*t*-BuOC=O<sub>B</sub>), 130.7 (C-5<sub>A</sub>), 130.3 (C-5<sub>B</sub>), 128.2 (C-6<sub>A</sub>), 128.1 (C-6<sub>B</sub>), 82.0 ( $\text{C}(\text{CH}_3)_{3A}$ ), 82.0 ( $\text{C}(\text{CH}_3)_{3B}$ ), 58.7 (C-8<sub>A</sub>), 58.7 (C-8<sub>B</sub>), 34.4 (C-7<sub>A</sub>), 34.4 (C-7<sub>B</sub>), 33.1 (C-4<sub>A</sub>), 33.1 (C-4<sub>B</sub>), 29.0 ( $\text{CH}_{2A}$ ), 28.7 ( $\text{CH}_{2B}$ ), 28.0 ( $\text{C}(\text{CH}_3)_{3A}$ ), 28.0 ( $\text{C}(\text{CH}_3)_{3B}$ ), 25.4 ( $\text{CH}_{2A}$ ), 25.3 ( $\text{CH}_{2B}$ ), 21.2 ( $\text{CH}_{2A}$ ), 21.2 ( $\text{CH}_{2B}$ );



m/z (ESI): 275 [MNa<sup>+</sup>]; HRMS (ESI): calcd. for C<sub>15</sub>H<sub>24</sub>NaO<sub>3</sub>, 275.1618 Found: [MNa<sup>+</sup>], 275.1606 (3.5 ppm error).

#### 4-(Cyclohex-2-enyl)butan-2-one (**239**)

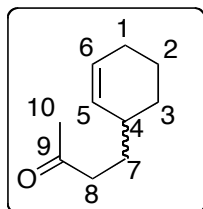

To a stirred solution of **238** (1.00 g, 3.96 mmol) in benzene (1.5 mL) was added p-TSA (160 mg, 0.802 mmol). This was refluxed for 2.5h before the addition of sat. NaHCO<sub>3</sub> (aq.) (50 mL) and Et<sub>2</sub>O (50 mL). The organic layer was separated and the aqueous layer extracted with further portions of Et<sub>2</sub>O (2 × 50 mL). The combined organic extracts were dried (MgSO<sub>4</sub>), filtered and concentrated under reduced pressure to afford the title compound **239** as a colourless oil (518 mg, 86%); R<sub>f</sub> (20:1 pet. ether:Et<sub>2</sub>O) 0.28; ν<sub>max</sub> (thin film)/cm<sup>-1</sup> 2971, 2884, 2817, 1759, 1670; <sup>1</sup>H NMR (400 MHz; CDCl<sub>3</sub>) δ 5.72–5.66 (1H, m, H-6), 5.52 (1H, dd, *J* 10.0, 2.0, H-5), 2.47 (2H, t, *J* 8.0, H-8) 2.15 (3H, s, H-10), 2.10–2.02 (1H, m, H-4), 2.00–1.92 (2H, m, CH<sub>2</sub>), 1.83–1.46 (4H, m, 2 × CH<sub>2</sub>), 1.30–1.14 (2H, m, CH<sub>2</sub>); <sup>13</sup>C NMR (101 MHz; CDCl<sub>3</sub>) δ 208.9 (C-9), 131.1 (C-5), 127.7 (C-6), 41.2 (C-8), 34.7 (C-4), 30.1 (C-10), 30.0 (CH<sub>2</sub>), 28.8 (CH<sub>2</sub>), 25.4 (CH<sub>2</sub>), 21.4 (CH<sub>2</sub>); m/z (ESI): 175 [MNa<sup>+</sup>]; HRMS: calcd. for C<sub>10</sub>H<sub>16</sub>NaO<sub>2</sub>, 175.1093 Found: [MNa<sup>+</sup>], 175.1094 (1.6 ppm error).

#### Samarium diiodide solution in THF (0.1 M)

To an oven dried RBF, equipped with a Teflon-coated magnetic stir bar, was added samarium metal (1.65 g, 11.0 mmol). This was left stirring at medium to high speed under a positive pressure of argon for 24 h. THF (45 mL) was added, followed by iodine (1.40 g, 5.5 mmol) dissolved in THF (10 mL). The reaction flask was heated at 60 °C for 18 h. The stirring was turned off and the solution of SmI<sub>2</sub> (0.1 M) was allowed to settle for 2 h.

### ***tert*-Butyl 1-hydroxy-1-methyloctahydro-1*H*-indene-2-carboxylate (**241**)**

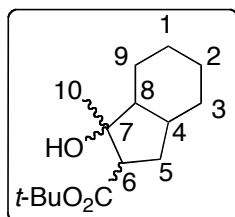

To a solution of ester **238** (42 mg, 0.166 mmol), *t*-BuOH (32  $\mu$ L, 0.332 mmol), HMPA (1.01 mL, 5.81 mmol) in THF (37 mL) at  $-78$   $^{\circ}$ C, was added SmI<sub>2</sub> (4.9 mL, 0.1 M in THF, 0.498 mmol) dropwise. The reaction was stirred for 10 minutes before the addition of sat. aq. NaHCO<sub>3</sub> (50 mL). The mixture was extracted with EtOAc (3  $\times$  25 mL). The combined organic extracts were dried (MgSO<sub>4</sub>) and concentrated *in vacuo*. The resulting crude product was purified by flash column chromatography on silica gel, eluting with pet. ether:EtOAc (10:1) to afford the title compound **241** as two isolated diastereomers **241a** and **241b** in a ratio of 1:0.8 (10 mg, 24%) and (8mg, 19%); **241a**; <sup>1</sup>H NMR (400 MHz; CDCl<sub>3</sub>)  $\delta$  2.7 (1H, t, *J* 9.0, H-6), 2.52–2.37 (1H, m, H-8) 2.16–2.04 (1H, m, H-4), 2.00–1.90 (1H, br s, OH), 1.86–1.76 (1H, m, CH<sub>2</sub>) 1.75–1.55 (5H, m, CH<sub>2</sub>), 1.46 (9H, s, C(CH<sub>3</sub>)<sub>3</sub>), 1.52–1.33 (2H, m, CH<sub>2</sub>), 1.25 (3H, s, H-10), 1.19–1.06 (2H, m, CH<sub>2</sub>); <sup>13</sup>C NMR (101 MHz; CDCl<sub>3</sub>)  $\delta$  173.9 (C=O), 84.1 (C(CH<sub>3</sub>)<sub>3</sub>), 80.7 (C-7), 57.5 (C-6), 51.6 (C-8), 35.3 (C-4), 30.6 (CH<sub>2</sub>), 28.3 (C(CH<sub>3</sub>)<sub>3</sub>), 26.9 (CH<sub>2</sub>), 25.1 (CH<sub>2</sub>), 22.7 (CH<sub>2</sub>), 22.3 (C-10), 20.9 (CH<sub>2</sub>); *m/z* (ESI): 277 [MNa<sup>+</sup>]; HRMS: calcd. for C<sub>15</sub>H<sub>26</sub>NaO<sub>3</sub>, 277.1774 Found: [MNa<sup>+</sup>], 277.1772 (0.6 ppm error); **241b**; <sup>1</sup>H NMR (400 MHz; CDCl<sub>3</sub>)  $\delta$  3.39 (1H, s, OH), 2.77 (1H, dd, *J* 11.5, 6.5, H-6), 2.04–2.1.76 (4H, m, H-8 & H-4 & CH<sub>2</sub>), 1.71–1.56 (6H, m, CH<sub>2</sub>), 1.47 (9H, s, C(CH<sub>3</sub>)<sub>3</sub>), 1.29 (3H, s, H-10), 1.28–0.70 (2H, m, CH<sub>2</sub>); <sup>13</sup>C NMR (101 MHz; CDCl<sub>3</sub>)  $\delta$  175.1 (C=O), 83.1 (C(CH<sub>3</sub>)<sub>3</sub>), 81.2 (C-7), 58.6 (C-6 or C-8), 51.1 (C-6 or C-8), 35.2 (C-4), 30.0 (CH<sub>2</sub>), 28.3 (C(CH<sub>3</sub>)<sub>3</sub>), 26.7 (CH<sub>2</sub>), 25.0 (CH<sub>2</sub>), 25.0 (CH<sub>2</sub>), 23.3 (C-10), 20.7 (CH<sub>2</sub>); *m/z* (ESI): 277 [MNa<sup>+</sup>]; HRMS: calcd. for C<sub>15</sub>H<sub>26</sub>NaO<sub>3</sub>, 277.1774 Found: [MNa<sup>+</sup>], 277.1767 (0.4 ppm error).

### **7.5 Procedures & Compound Characterisation (Chapter 5)**

#### **( $\pm$ )-Ethyl (2*E*)-3-[(1*S*,3*R*)-3-formyl-2,2-dimethylcyclopropyl]prop-2-enoate (**253**)**

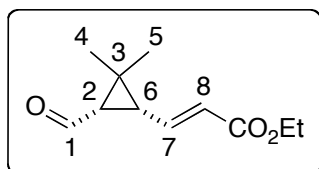

To a stirred solution of **131** (259 mg, 1.31 mmol) in CHCl<sub>3</sub> (13 mL) was added manganese (IV) dioxide (1.13 g, 13.1

mmol) and 4Å molecular sieves (1.13 g). After 16 h the suspension was filtered through Celite, and washed with CHCl<sub>3</sub> (50 mL). The filtrate was concentrated under reduced pressure to give the crude product. This was purified by flash column chromatography on silica gel, eluting with pet. ether:EtOAc (5:1) to afford the title compound **253** as a colourless oil (183 mg, 72%). R<sub>f</sub> (5:1 pet. ether:EtOAc) 0.19; ν<sub>max</sub> (thin film)/cm<sup>-1</sup> 2935, 2915, 2888, 1688, 1617; <sup>1</sup>H NMR (400 MHz; CDCl<sub>3</sub>) δ 9.62 (1H, d, *J* 5.0, H-1), 7.19 (1H, dd, *J* 15.5, 10.5, H-7), 5.99 (1H, d, *J* 15.5, H-8), 4.17 (2H, q, *J* 7.0, OCH<sub>2</sub>CH<sub>3</sub>), 2.14 (1H, dd, *J* 10.5, 8.5, H-6), 2.07 (1H, dd, *J* 8.5, 5.0, H-2), 1.40 (3H, s, H-4), 1.26 (3H, t, *J* 7.0, OCH<sub>2</sub>CH<sub>3</sub>), 1.25 (3H, s, H-5); <sup>13</sup>C NMR (101 MHz; CDCl<sub>3</sub>) δ 199.5 (C-1), 166.0 (CH<sub>3</sub>CH<sub>2</sub>O=C), 142.9 (C-7), 123.6 (C-8), 60.4 (CH<sub>3</sub>CH<sub>2</sub>O), 43.2 (C-2), 38.7 (C-6), 32.4 (C-3), 28.6 (C-5), 15.7 (C-4), 14.4 (CH<sub>3</sub>CH<sub>2</sub>O); m/z (ESI) 219 [MNa<sup>+</sup>]; HRMS: calcd. for C<sub>11</sub>H<sub>16</sub>NaO<sub>3</sub>, 219.0992. Found: [MNa<sup>+</sup>], 219.0991 (0.5 ppm error).

**(±)-(E)-ethyl 3-((1R,3R)-3-(2,2-dibromovinyl)-2,2-dimethylcyclopropyl)prop-2-enoate (256)**

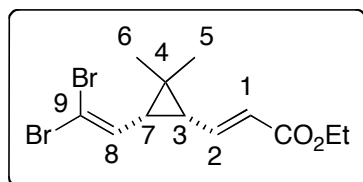

To a stirring solution of aldehyde **253** (2.04 g, 10.4 mmol) in CH<sub>2</sub>Cl<sub>2</sub> (100 mL) at 0 °C was added PPh<sub>3</sub> (15.0 g, 57.2 mmol) and CBr<sub>4</sub> (5.17 g, 15.6 mmol).

After 20 min the reaction mixture was filtered through a silica pad and washed through with Et<sub>2</sub>O (50 mL). The filtrate was concentrated under reduced pressure and the resulting crude product was purified by flash column chromatography on silica gel, eluting with pet. ether:EtOAc (60:1 → 40:1) to afford the title compound **256** as a colourless oil (1.76 g, 48%). R<sub>f</sub> (10:1 pet. ether:EtOAc) 0.44; ν<sub>max</sub> (thin film)/cm<sup>-1</sup> 2934, 1712, 1638; <sup>1</sup>H NMR (400 MHz; CDCl<sub>3</sub>) δ 6.67 (1H, dd, *J* 15.0, 10.5, H-2), 6.27 (1H, d, *J* 8.0, H-8), 5.96 (1H, d, *J* 15.0, H-1), 4.17 (2H, q, *J* 7.0, CH<sub>3</sub>CH<sub>2</sub>O), 1.89–1.77 (2H, m, H-3 & H-7), 1.27 (3H, t, *J* 7.0, CH<sub>3</sub>CH<sub>2</sub>O), 1.20 (3H, s, H-6), 1.17 (3H, s, H-5); <sup>13</sup>C NMR (101 MHz; CDCl<sub>3</sub>) δ 166.2 (C=O), 145.5 (C-2), 134.1 (C-7), 122.9 (C-1), 90.6 (C-9), 60.3 (CH<sub>3</sub>CH<sub>2</sub>O), 36.7 (C-3 or C-7), 34.1 (C-3 or C-7), 28.3 (C-5) 27.6 (C-4), 16.9 (C-6), 14.4

(CH<sub>3</sub>CH<sub>2</sub>O); m/z (ESI): 373 [MNa<sup>+</sup>]; HRMS: calcd. for C<sub>12</sub>H<sub>16</sub>Br<sub>2</sub>NaO<sub>2</sub>, 372.9409. Found: [MNa<sup>+</sup>], 372.9401 (1.0 ppm error).

**(±)-(E)-3-((1R,3R)-3-(2,2-Dibromovinyl)-2,2-dimethylcyclopropyl)prop-2-en-1-ol (259)**

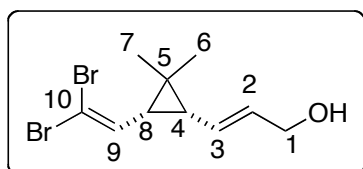

To a stirred solution of **256** (50 mg, 0.142 mmol) in CH<sub>2</sub>Cl<sub>2</sub> (2 mL) at -78 °C was added DIBAL (0.43 mL, 0.426 mmol, 1M in hexanes). After 1 h the reaction mixture was diluted with CH<sub>2</sub>Cl<sub>2</sub> (5 mL) followed by the careful addition of MeOH (2 drops). The solution was warmed to RT and sat. aq. Rochelle's salt (2 mL) was added. It was stirred for 2 h after which time, the organic layer was separated and the aqueous layer extracted with further portions of CH<sub>2</sub>Cl<sub>2</sub> (3 × 5 mL). The combined organic extracts were dried (MgSO<sub>4</sub>), filtered and concentrated under reduced pressure to afford the crude compound, which was purified by flash column chromatography on silica gel, eluting with pet. ether:EtOAc (20:1) to afford the title compound **259** as a colourless oil (32 mg, 74%) which was assigned tentatively using <sup>1</sup>H NMR spectroscopy and HRMS; R<sub>f</sub> (10:1 pet. ether:EtOAc) 0.34; <sup>1</sup>H NMR (400 MHz; CDCl<sub>3</sub>) δ 6.20 (1H, d, *J* 8.5, H-9), 5.83 (1H, dt, *J* 15.5, 6.5, H-2), 5.43 (1H, ddt, *J* 15.5, 9.0, 1.5 H-3), 4.14 (2H, dd, *J* 6.5, 1.5, H-1), 1.32–1.04 (2H, m, H-4 & H-8), 1.17 (3H, s, H-6), 1.09 (3H, s, H-7); HRMS: calcd. for C<sub>10</sub>H<sub>14</sub>Br<sub>2</sub>NaO<sub>2</sub>, 330.9309. Found: [MNa<sup>+</sup>], 330.9305 (0.3 ppm error).

**(±)-tert-Butyl(((1S,3R)-2,2-dimethyl-3-((E)-3-(triisopropylsilyloxy)prop-1-enyl)cyclopropyl)methoxy)dimethylsilane (261)**

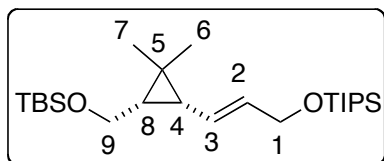

To a stirring solution of alcohol **221** (594 mg, 2.01 mmol) at 0 °C in CH<sub>2</sub>Cl<sub>2</sub> (20 mL), was added lutidine (0.698 mL, 6.03 mmol) and TIPS sulfonate (616 mg, 2.01 mmol). The reaction was warmed to RT and stirred for 10 min. The reaction mixture was diluted with CH<sub>2</sub>Cl<sub>2</sub> (20 mL) and washed with sat. NH<sub>4</sub>Cl (aq.) (10 mL),

the organic layer separated and the aqueous layer extracted with further portions of  $\text{CH}_2\text{Cl}_2$  ( $2 \times 20$  mL). The combined organic extracts were dried ( $\text{MgSO}_4$ ), filtered and concentrated under reduced pressure. The resulting crude product was purified by flash column chromatography on silica gel, eluting with pet. ether:EtOAc (60:1) to afford the title compound **261** as a colourless oil (790 mg, 92%);  $R_f$  (60:1 pet. ether:EtOAc) 0.27;  $\nu_{\text{max}}$  (thin film)/ $\text{cm}^{-1}$  2942, 2864;  $^1\text{H}$  NMR (400 MHz;  $\text{CDCl}_3$ )  $\delta$  5.68 (1H, dt,  $J$  15.0, 5.0, H-2), 5.46 (1H, ddt,  $J$  15.0, 10.0, 1.5, H-3), 4.20 (2H, dd,  $J$  5.0, 1.5, H-1), 3.73 (1H, dd,  $J$  11.0, 6.0, H-9a), 3.61 (1H, dd,  $J$  11.0, 8.5, H-9b), 1.11–1.02 (2H, m, H-4 & H-8), 1.09 (3H, s, H-6), 1.07 (18H, s,  $\text{SiCH}(\text{CH}_3)_2$ ), 1.06 (3H, s, H-7), 1.05 (3H, s,  $\text{SiCH}(\text{CH}_3)_2$ ), 0.89 (9H, s,  $\text{SiC}(\text{CH}_3)_3$ ), 0.04 (6H, s,  $\text{SiCH}_3$ );  $^{13}\text{C}$  NMR (101 MHz;  $\text{CDCl}_3$ )  $\delta$  130.5 (C-3), 126.8 (C-2), 64.1 (C-9), 60.7 (C-1), 32.1 (C-4 or C-8), 30.0 (C-4 or C-8), 26.1 ( $\text{SiC}(\text{CH}_3)_3$ ), 26.1 (C-6), 23.6 ( $\text{SiCH}(\text{CH}_3)_2$ ), 21.3 (C-5), 18.1 ( $\text{SiC}(\text{CH}_3)_3$ ), 15.6 (C-7), 12.2 ( $\text{SiCH}(\text{CH}_3)_2$ ), -5.0 ( $\text{SiCH}_3$ ), -5.0 ( $\text{SiCH}_3$ );  $m/z$  (ESI): 449 [ $\text{MNa}^+$ ]; HRMS: calcd. for  $\text{C}_{24}\text{H}_{50}\text{NaO}_2\text{Si}_2$ , 449.3242. Found: [ $\text{MNa}^+$ ], 449.3248 (1.0 ppm error).

**(±)-(E)-3-((1R,3S)-3-(Hydroxymethyl)-2,2-dimethylcyclopropyl)prop-2-en-1-ol (267)**

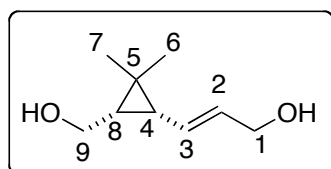

To a solution of **224** (731 mg, 2.70 mmol) in THF (30 mL) at 0 °C was added TBAF (3.24 mL, 1 M in THF, 3.24 mmol). After 2 h the reaction mixture was diluted with  $\text{Et}_2\text{O}$  (30 mL) and washed with sat.  $\text{NH}_4\text{Cl}$  (aq.) (30 mL), the organic layer separated and the aqueous layer extracted with further portions of  $\text{Et}_2\text{O}$  ( $2 \times 30$  mL). The combined organic extracts were dried ( $\text{MgSO}_4$ ), filtered and concentrated under reduced pressure. The resulting crude product was purified by flash column chromatography on silica gel, eluting with pet. ether:EtOAc (1:1) to afford the title compound **225** as a colourless oil (354 mg, 84%) which was assigned tentatively using  $^1\text{H}$  NMR spectroscopy;  $R_f$  (1:1 pet. ether:EtOAc) 0.18;  $^1\text{H}$  NMR (400 MHz;  $\text{CDCl}_3$ )  $\delta$  5.84 (1H, dt,  $J$  15.5, 6.0, H-2), 5.51 (1H, ddt,  $J$  15.5, 9.0, 1.5, H-3), 4.12 (2H, dd,  $J$  6.0, 1.5, H-1), 3.77 (1H, dd,  $J$  11.5, 7.5, H-9a), 3.68 (1H, dd,  $J$  11.5, 8.0, H-9b),

1.60–1.49 (1H, m, H-4 or H-8), 1.23–1.15 (1H, m, H-4 or H-8), 1.15 (3H, s, H-6), 1.11 (3H, s, H-7).

**(±)-*tert*-Butyl((*E*)-3-((1*R*,3*S*)-3-((*tert*-butyldimethylsilyloxy)methyl)-2,2-dimethylcyclopropyl)allyloxy)dimethylsilane (269)**

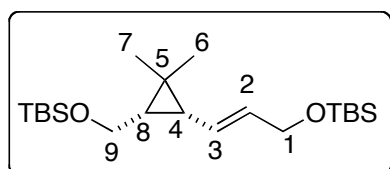

To a solution of **267** (100 mg, 0.641 mmol) in CH<sub>2</sub>Cl<sub>2</sub> (5 mL) was added TBS chloride (96.6 mg, 0.641 mmol) followed by imidazole (52.4 mg, 0.769 mmol).

After 2 h the reaction mixture was diluted with CH<sub>2</sub>Cl<sub>2</sub> (5 mL) and washed with sat. NH<sub>4</sub>Cl (aq.) (5 mL), the organic layer separated and the aqueous layer extracted with further portions of CH<sub>2</sub>Cl<sub>2</sub> (2 × 5 mL). The combined organic extracts were dried (MgSO<sub>4</sub>), filtered and concentrated under reduced pressure to afford a mixture of **267** and the title compound **269** as a yellow oil (178 mg) in a ratio of 3:2 which was assigned tentatively using <sup>1</sup>H NMR spectroscopy; **269**; R<sub>f</sub> (40:1 pet. ether:EtOAc) 0.22; <sup>1</sup>H NMR (400 MHz; CDCl<sub>3</sub>) δ 5.98 (1H, dt, *J* 15.5, 6.5, H-2), 5.57 (1H, ddt, *J* 15.5, 9.5, 1.5, H-3), 4.46 (2H, dd, *J* 6.5, 1.5, H-1), 3.99 (1H, dd, *J* 10.5, 7.0, H-9a), 3.62 (1H, dd, *J* 10.5, 7.5, H-9b), 1.50–1.42 (1H, m, H-4 or H-8), 1.19–1.07 (1H, m, H-4 or H-8), 1.13 (3H, s, H-6), 1.10 (3H, s, H-7), 0.98 (9H, s, SiC(CH<sub>3</sub>)<sub>3</sub>), 0.95 (9H, s, SiC(CH<sub>3</sub>)<sub>3</sub>), 0.16 (6H, s, SiCH<sub>3</sub>), 0.03 (6H, s, SiCH<sub>3</sub>).

**(±)-((1*S*,3*R*)-3-((*E*)-3-(Benzyloxy)prop-1-enyl)-2,2-dimethylcyclopropyl)methanol (270)**

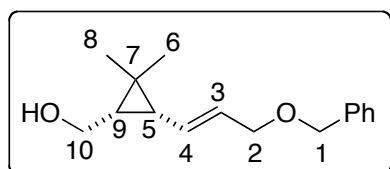

To a stirred solution of **221** (500 mg, 1.95 mmol) in THF (20 mL) at 0 °C was added NaH (117 mg, 2.93 mmol, 60% dispersion in mineral oil). This was

warmed to RT and allowed to stir for 45 mins. This was re-cooled to 0 °C, benzyl bromide (350 μL, 2.93 mmol) was added and the reaction mixture was allowed to stir at 40 °C for 18 h. The reaction mixture was diluted with Et<sub>2</sub>O (20 mL) and washed with sat. NH<sub>4</sub>Cl (aq.) (10 mL), the organic layer separated and the aqueous layer extracted with further portions of Et<sub>2</sub>O (2 × 20 mL). The combined organic phases

were dried ( $\text{MgSO}_4$ ), filtered and concentrated under reduced pressure. The resulting crude product was dissolved in THF (20 mL) and the solution cooled to 0 °C before the addition of TBAF (2.93 mL, 1 M in THF). After 2 h the reaction mixture was diluted with  $\text{Et}_2\text{O}$  (20 mL) and washed with sat.  $\text{NH}_4\text{Cl}$  (aq.) (10 mL), the organic layer separated and the aqueous layer extracted with further portions of  $\text{Et}_2\text{O}$  ( $2 \times 20$  mL). The combined organic extracts were dried ( $\text{MgSO}_4$ ), filtered and concentrated under reduced pressure. The resulting crude product was purified by flash column chromatography on silica gel, eluting with pet. ether:EtOAc (10:1) to afford the title compound **270** as a colourless oil (307 mg, 64%) which was assigned tentatively using  $^1\text{H}$  NMR spectroscopy;  $R_f$  (2:1 pet. ether:EtOAc) 0.57;  $^1\text{H}$  NMR (400 MHz;  $\text{CDCl}_3$ )  $\delta$  7.38–7.26 (5H, m, Ar-CH), 5.79 (1H, dt,  $J$  15.0, 6.5, H-3), 5.51 (1H, ddt,  $J$  15.0, 10.0, 1.5, H-4), 4.50 (2H, s, H-1), 3.98 (2H, dd,  $J$  6.5, 1.5, H-2), 3.74 (1H, dd,  $J$  11.5, 7.5, H-10a), 3.67 (1H, dd,  $J$  11.5, 8.0, H-10b), 1.48–1.43 (1H, m, H-5 or H-9), 1.19–1.14 (1H, m, H-5 or H-9), 1.12 (3H, s, H-6), 1.11 (3H, s, H-8).

## Appendix I

$^1\text{H}$ - &  $^{13}\text{C}$ -NMR Spectra for cycloheptadienes 58a, 58b, 88a and 160-164

*Diethyl (1R,2S)-cyclohepta-3,6-diene-1,2-dicarboxylate (58a)*

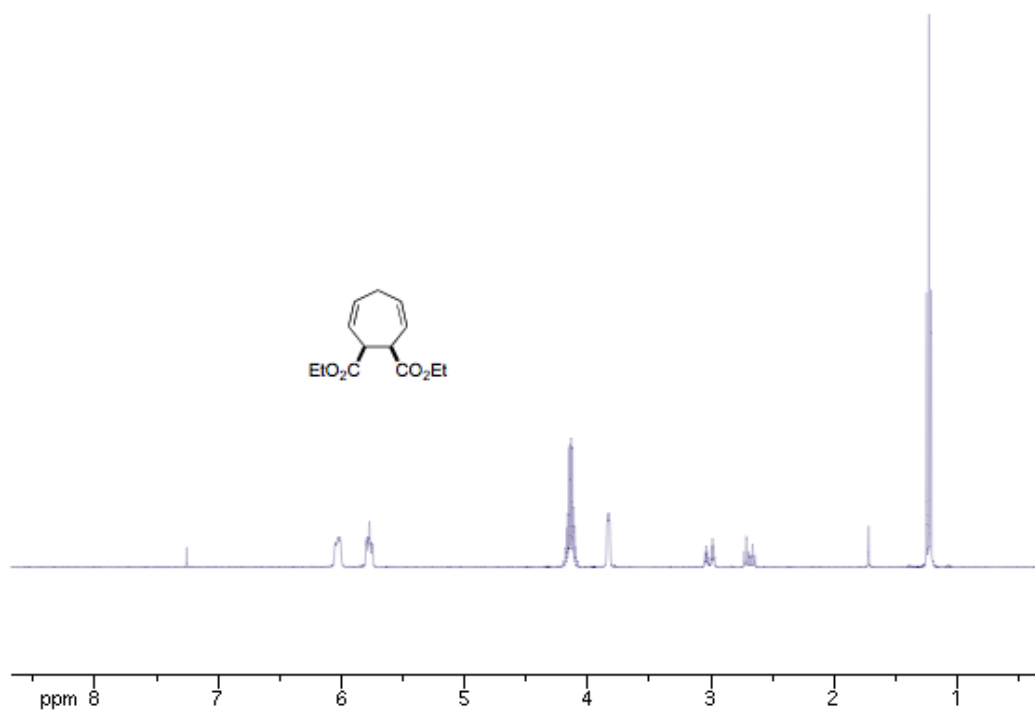



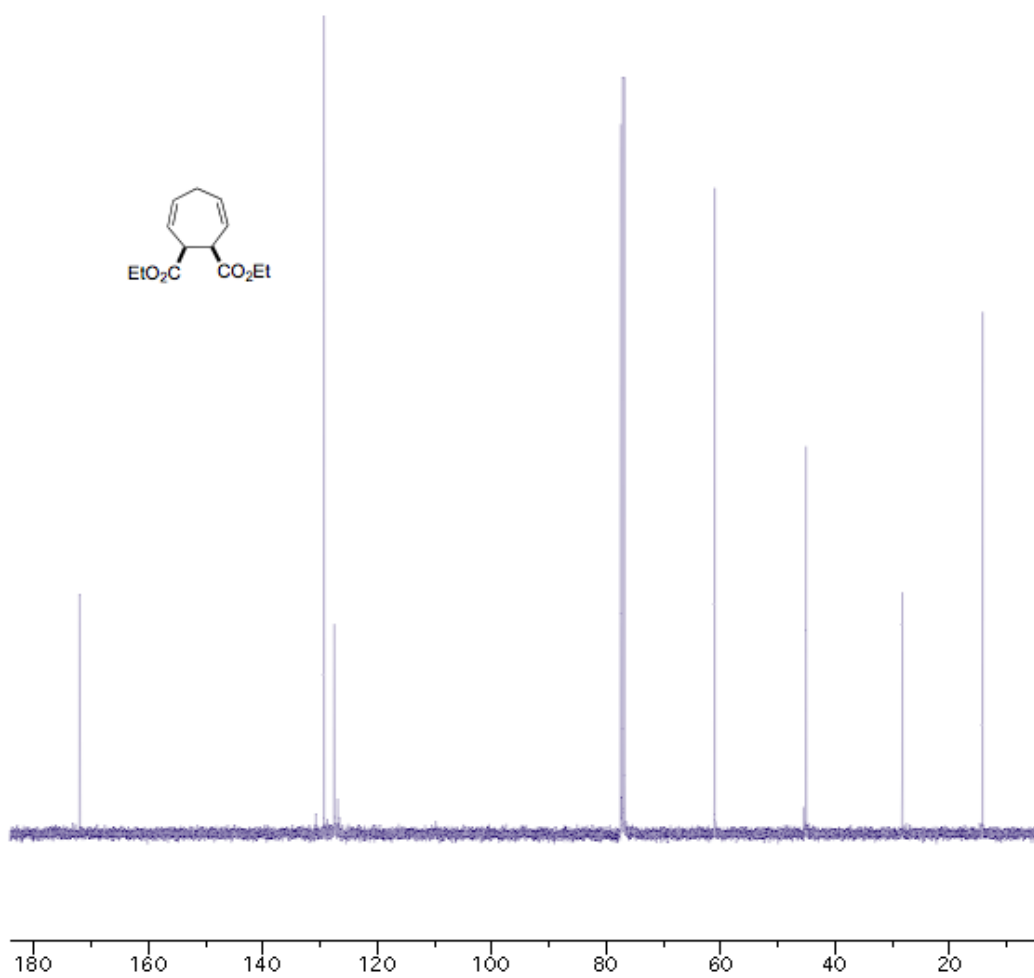
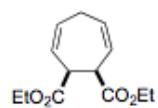

*Diethyl (±)-(1S,2S)-cyclohepta-3,6-diene-1,2-dicarboxylate (58b)*

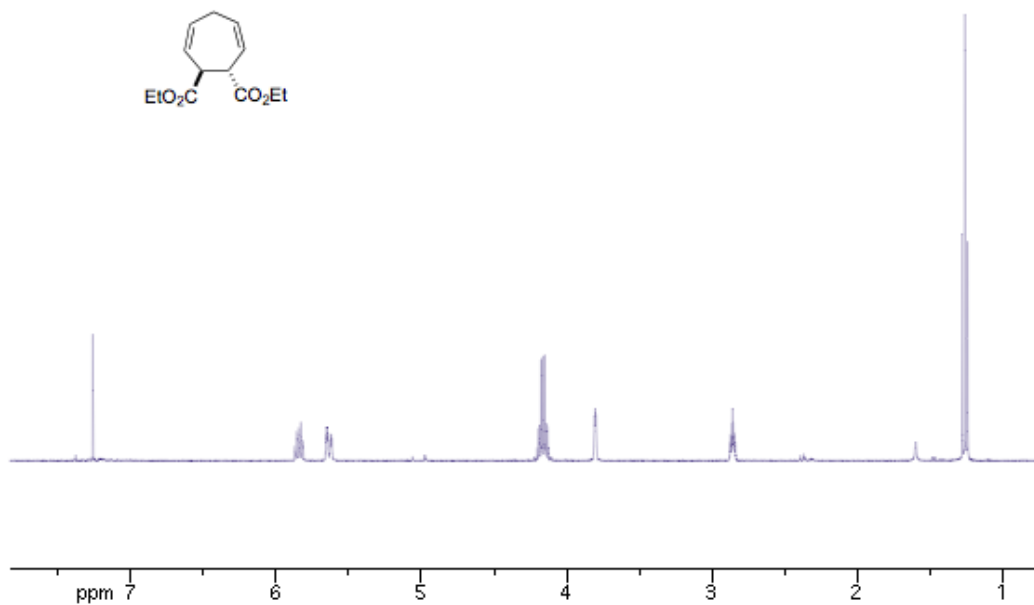
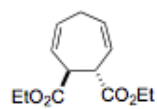

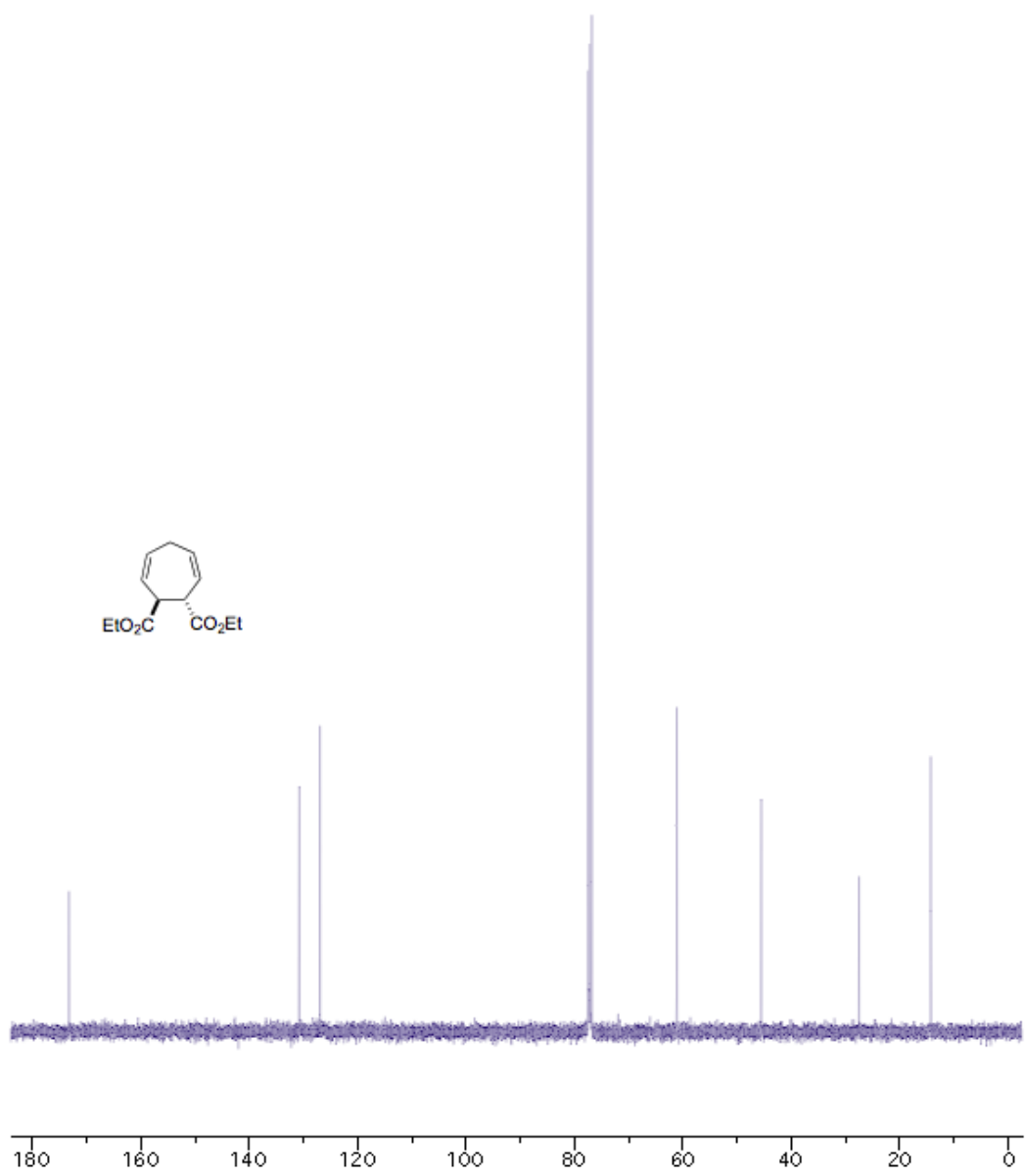

*Diethyl (1R,2S)-5,5-dimethylcyclohepta-3,6-diene-1,2-dicarboxylate (88a)*

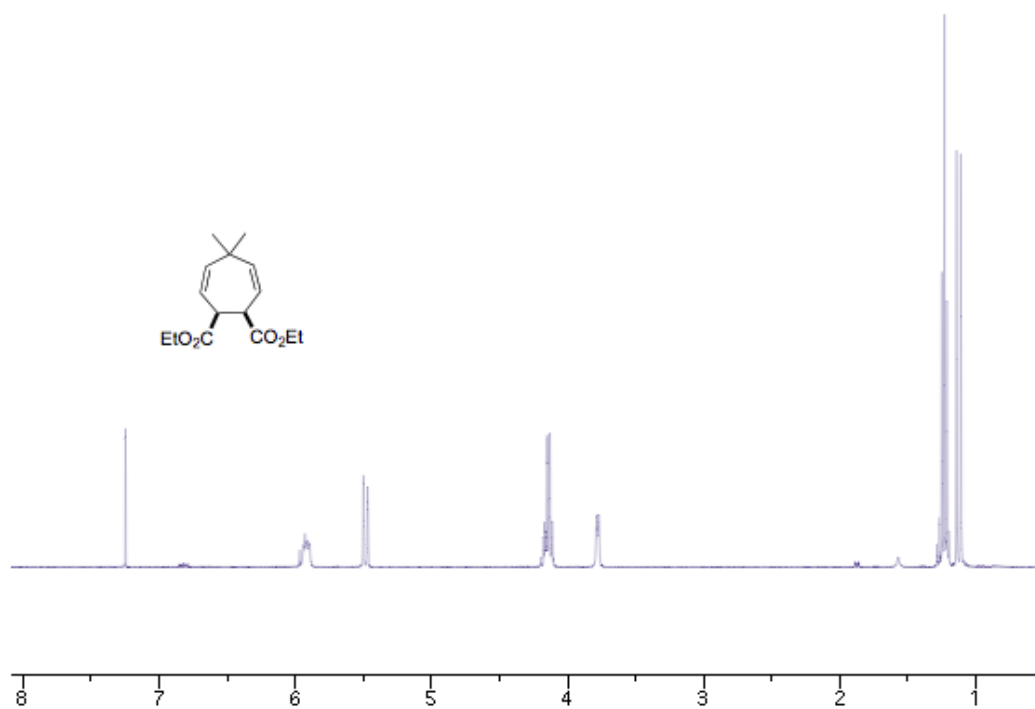

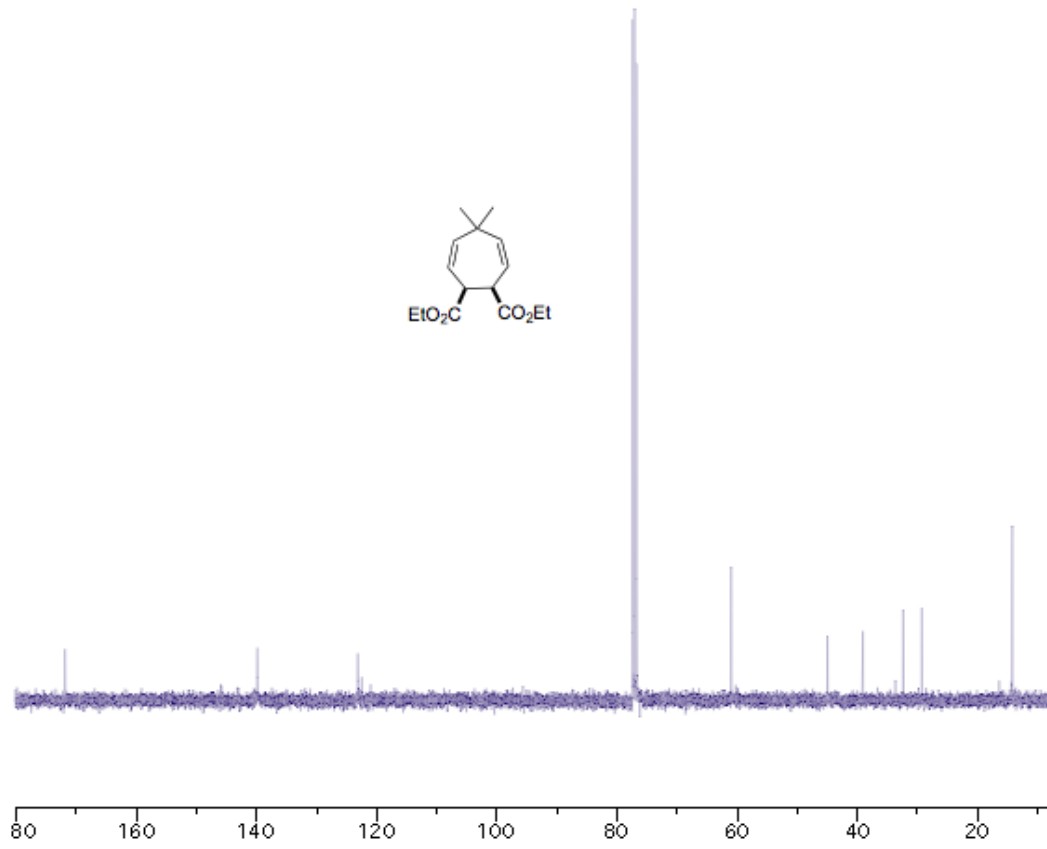
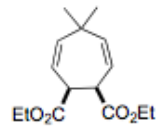

*Dimethyl (1R,2S)-5,5-dimethylcyclohepta-3,6-diene-1,2-dicarboxylate (160)*

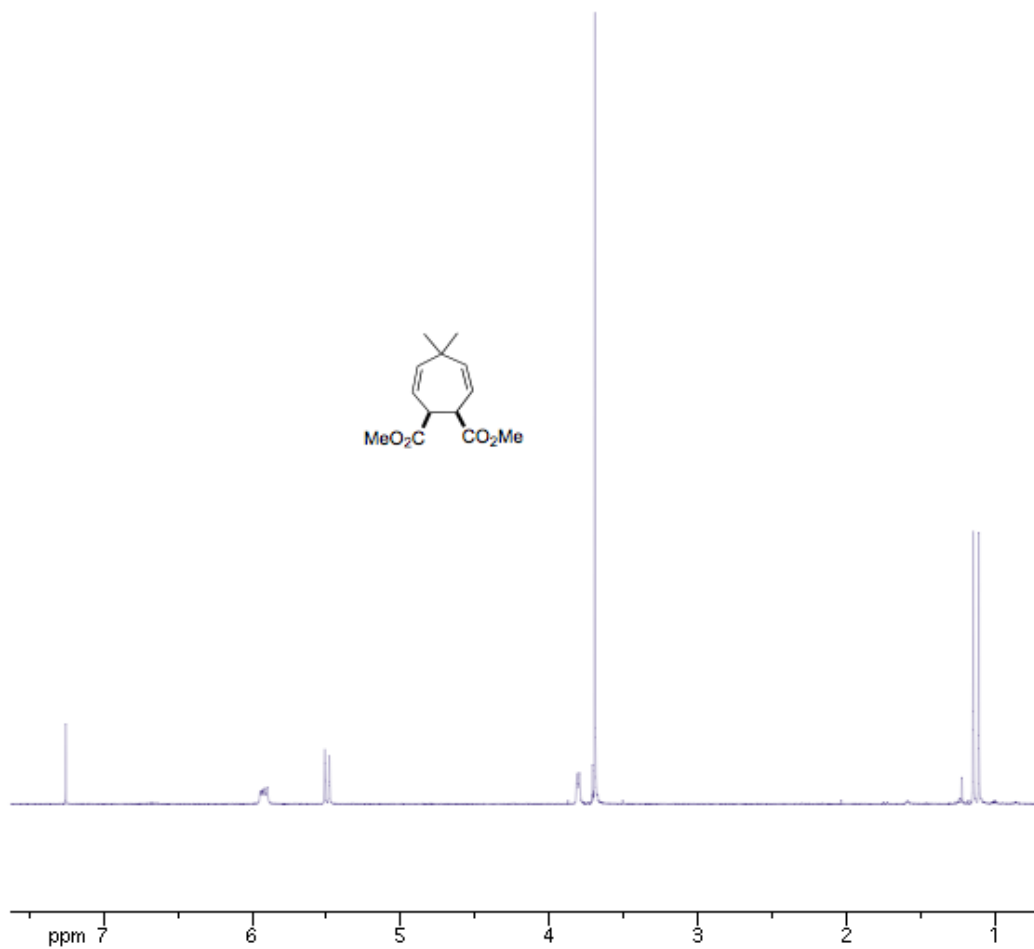

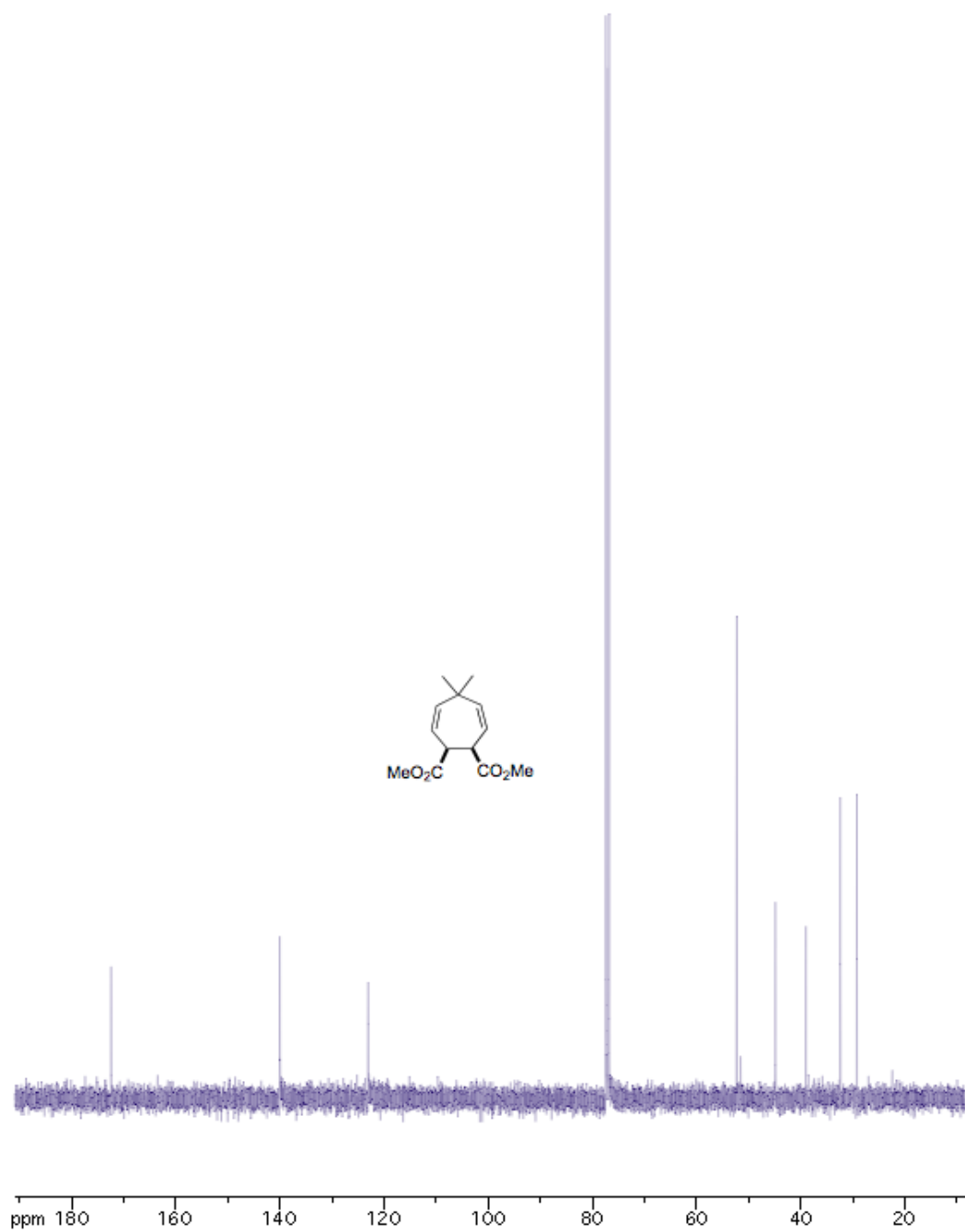

***(±)-(3aR,8aS)-6,6-Dimethyl-3,3a,6,8a-tetrahydro-1H-cyclohepta[c]furan-1-one***  
**(161)**

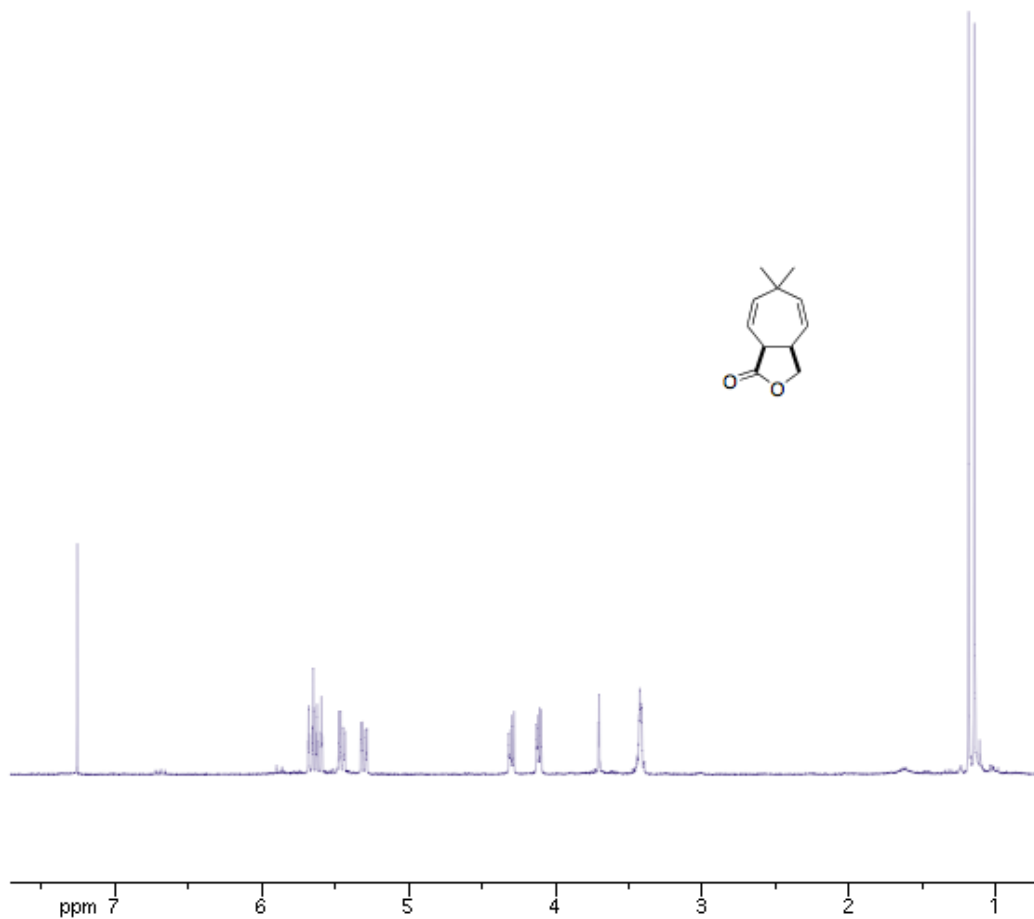



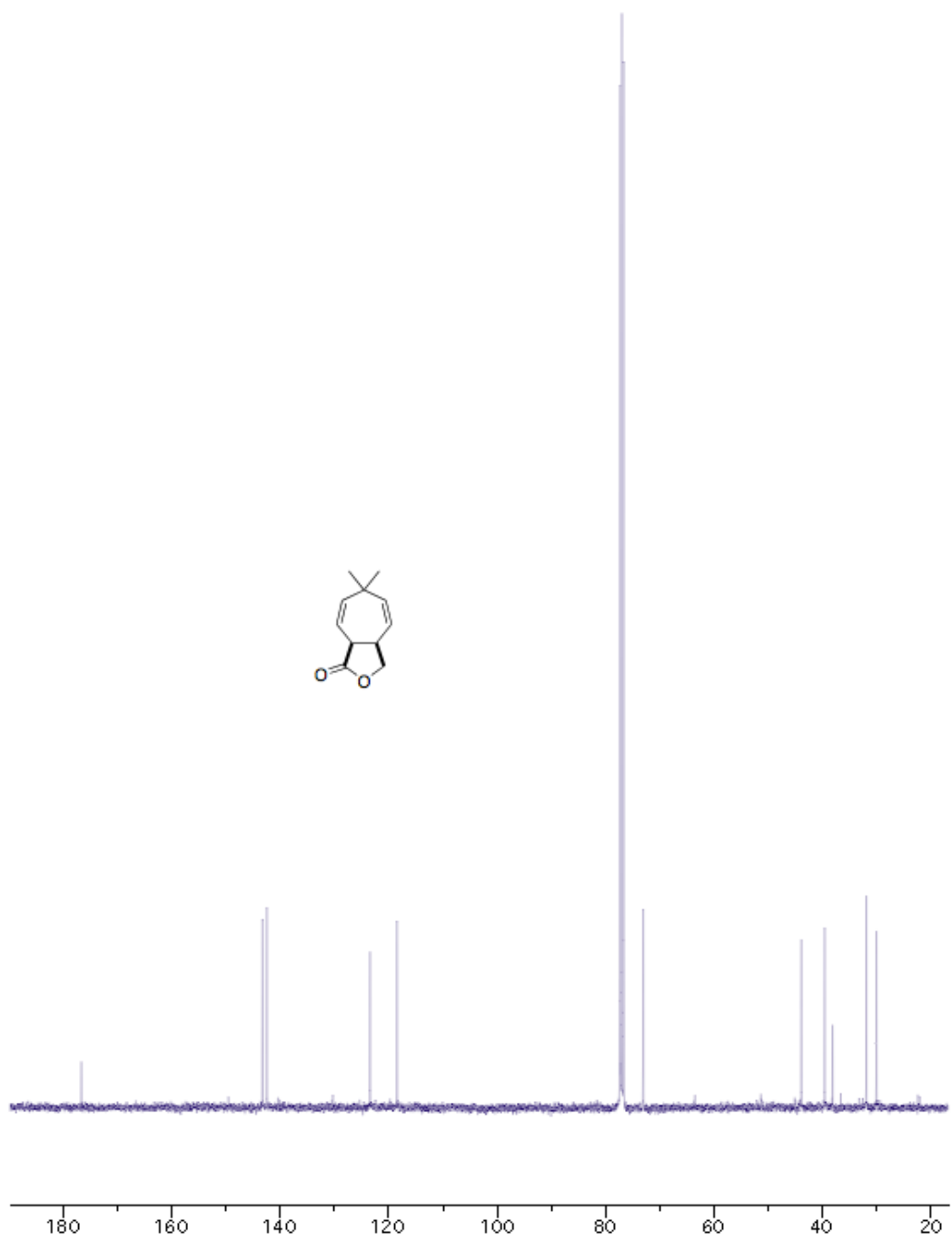

***((1R,2S)-5,5-Dimethylcyclohepta-3,6-diene-1,2-diyl)dimethanol (162)***

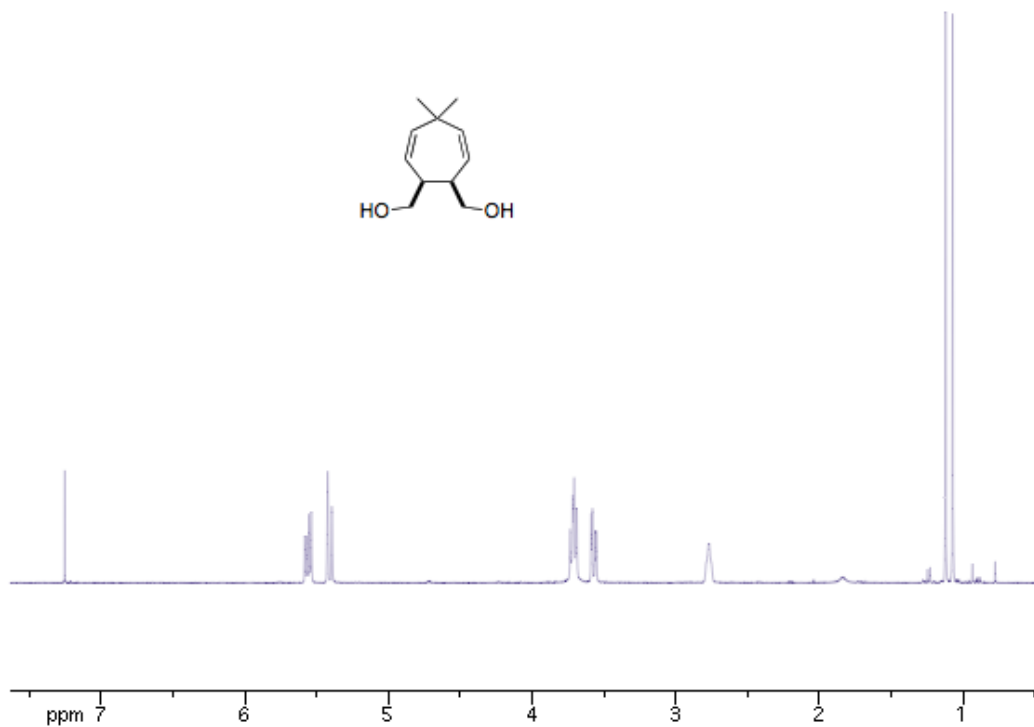
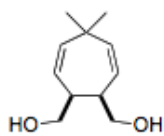

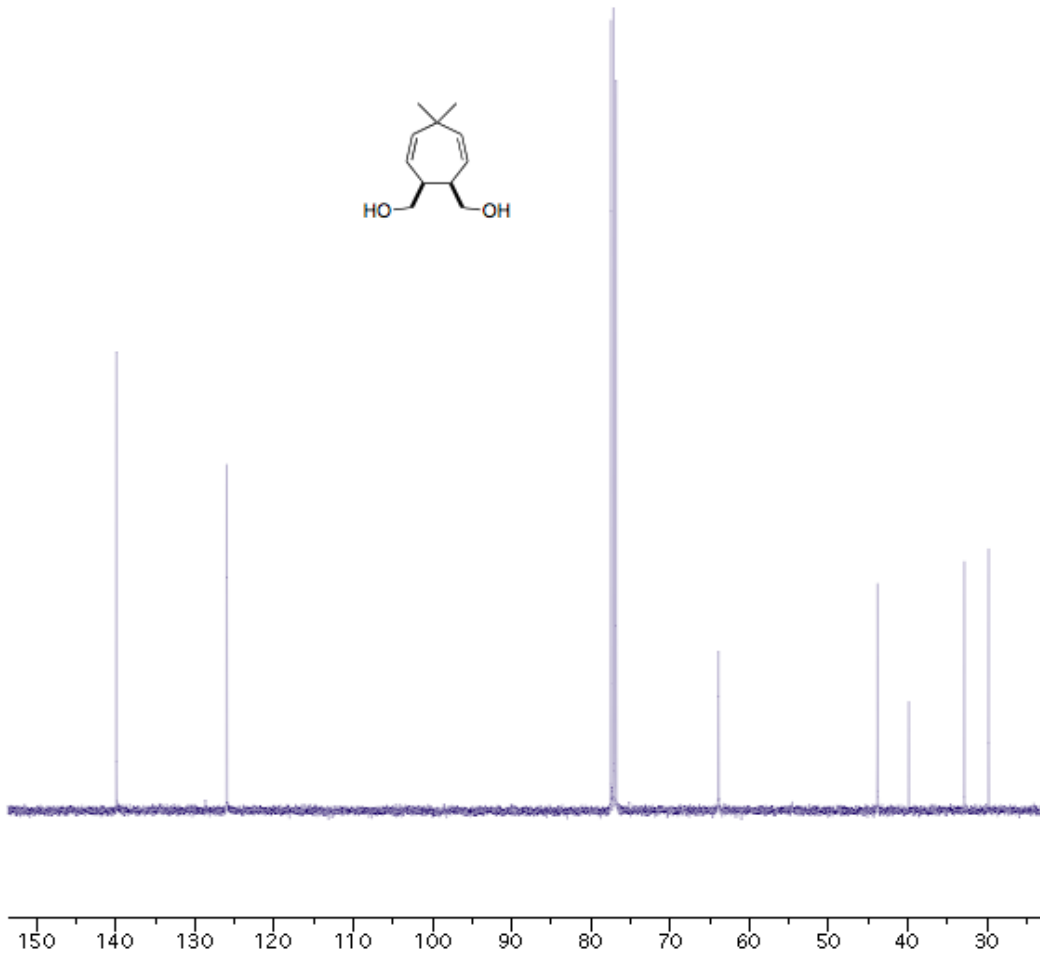
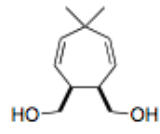

***(±)-((1R,7S)-7-((tert-Butyldimethylsilyloxy)methyl)-4,4-dimethylcyclohepta-2,5-dienyl)methanol (163)***



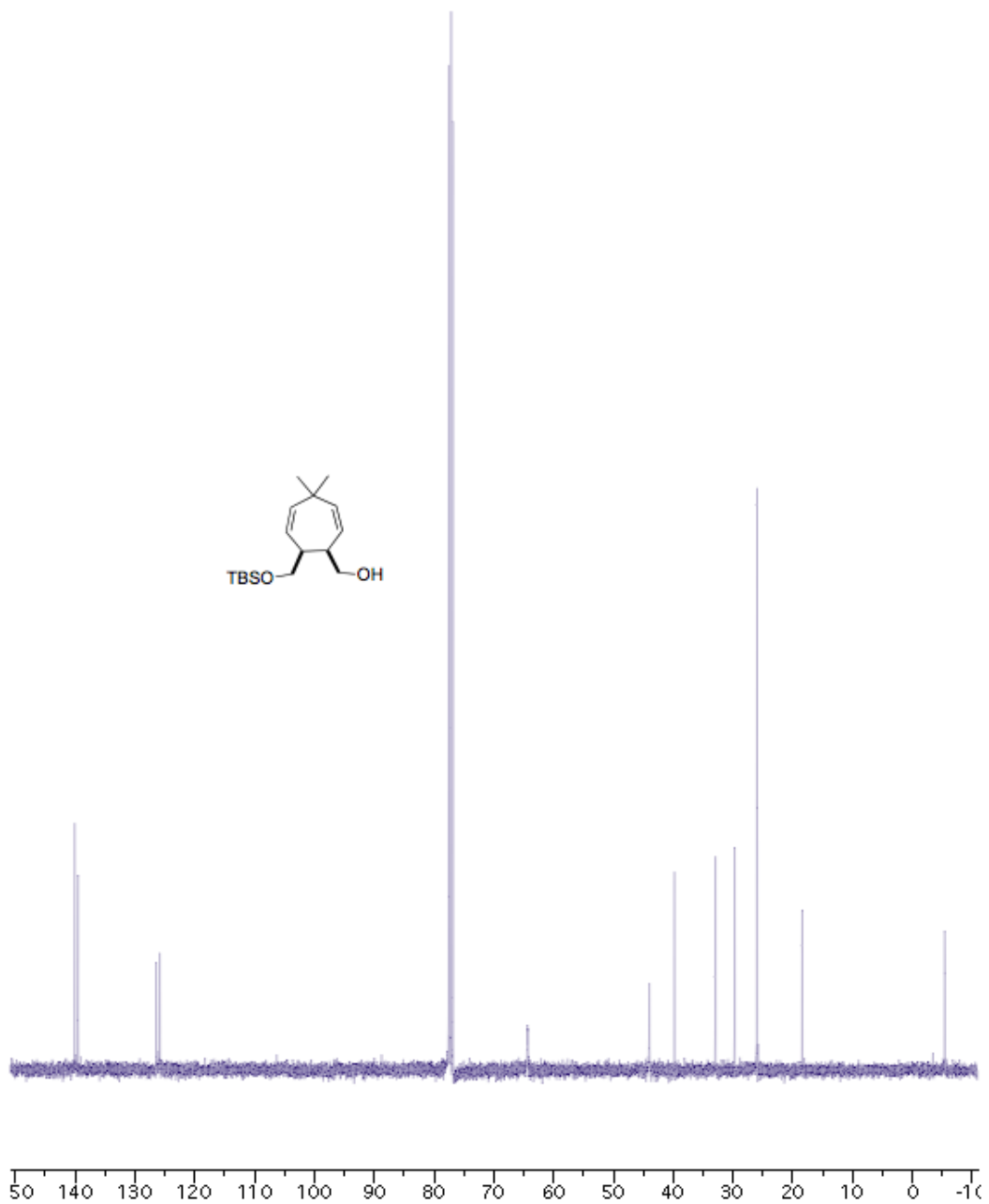

***((1R,2S)-5,5-Dimethylcyclohepta-3,6-diene-1,2-diyl)bis(methylene)bis(oxy)bis(tert-butyl)dimethylsilane (164)***

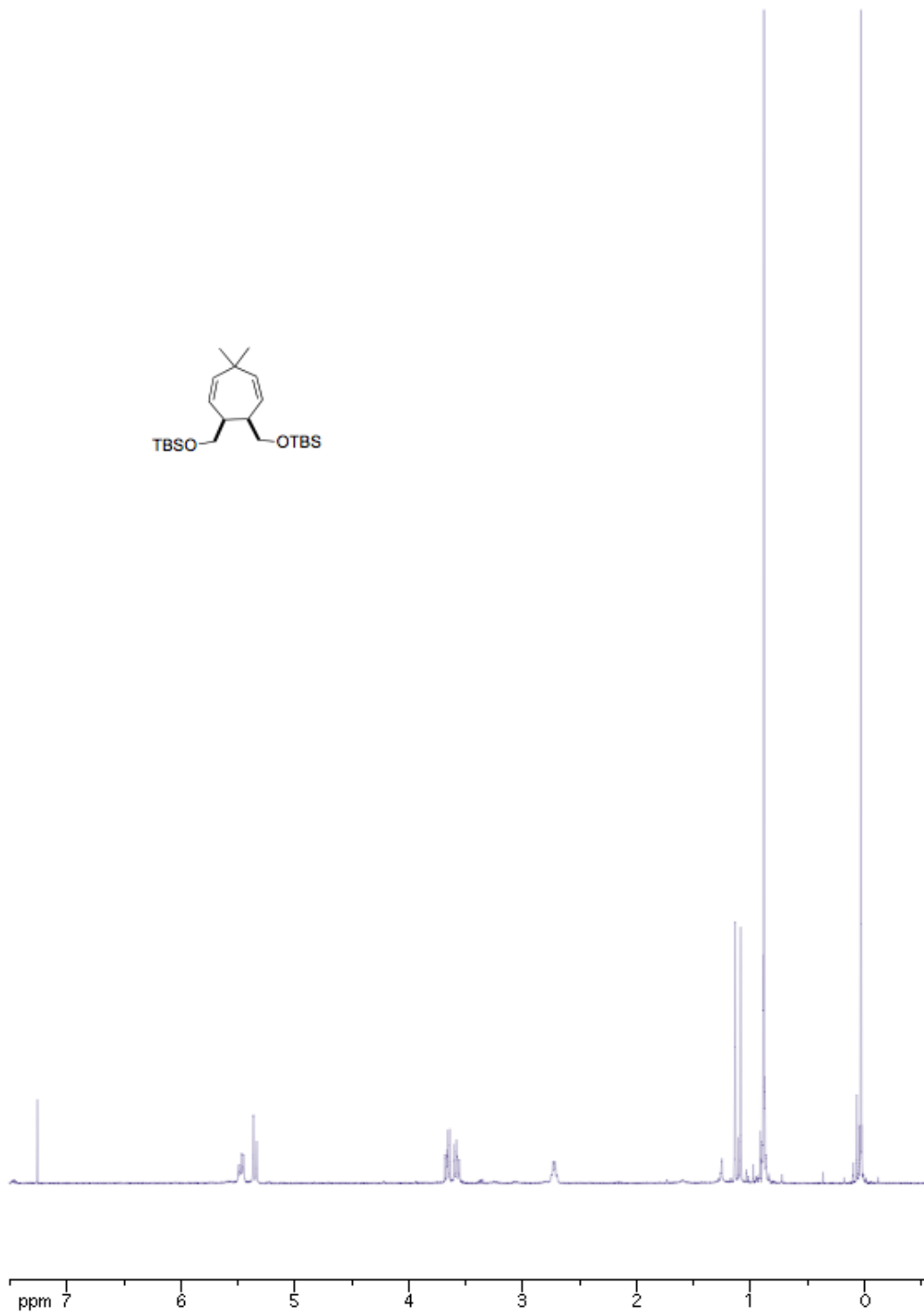
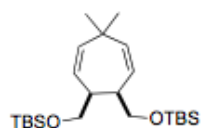

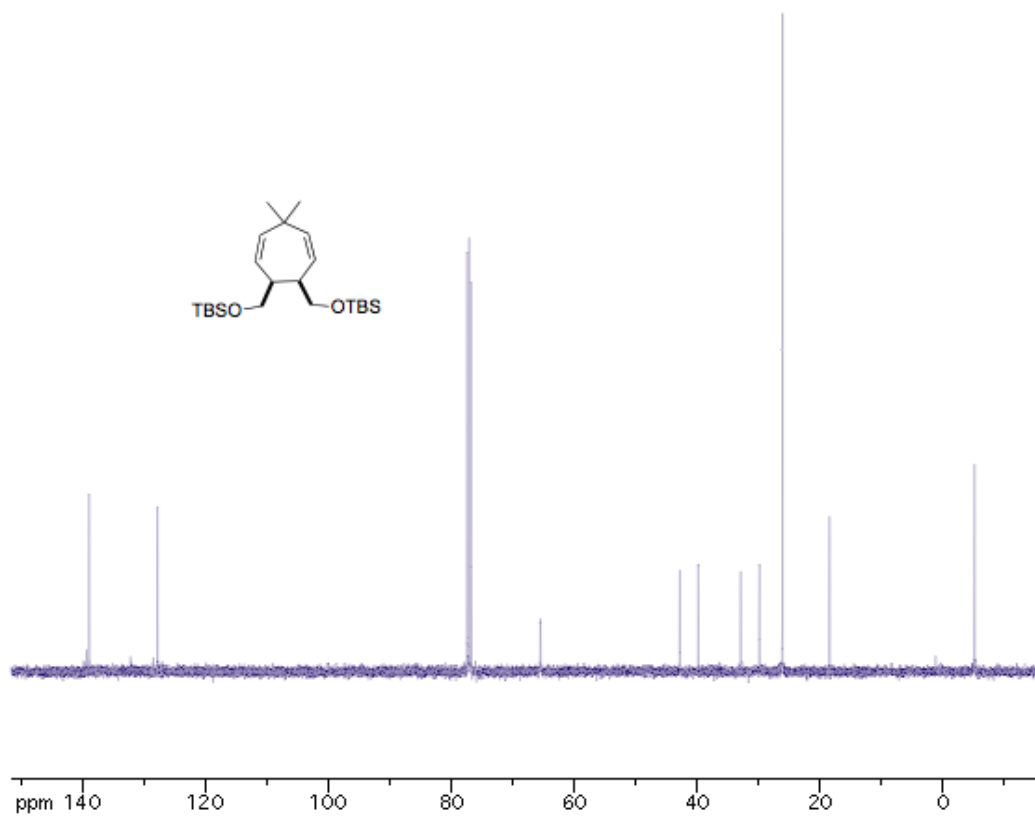

The Cope rearrangement of *gem*-dimethyl substituted divinylcyclopropanes†Cite this: *Org. Biomol. Chem.*, 2013, **11**, 7587

Jonathan D. Osler, William P. Unsworth and Richard J. K. Taylor\*

Received 7th August 2013,  
Accepted 23rd September 2013

DOI: 10.1039/c3ob41617h

www.rsc.org/obc

The reactivity of a range of substituted divinylcyclopropanes towards the thermal Cope rearrangement has been examined. The effects of *gem*-dimethyl substitution on the cyclopropane, the alkene geometry, the relative stereochemistry of the cyclopropane and the steric and electronic effects of a range of functional groups were all examined, and the methods developed were used to synthesise a range of functionalised 1,4-cycloheptadienes in high yields.

## Introduction

The thermal Cope rearrangement of a divinylcyclopropane was first described by Vogel in 1960 (Scheme 1).<sup>1</sup> The rearrangement normally proceeds *via* a [3,3]-sigmatropic rearrangement, including ring-opening of the strained cyclopropane moiety, leading to the convenient construction of 1,4-cycloheptadiene scaffolds from relatively simple starting materials. Numerous applications of this reaction have since appeared in the literature,<sup>2</sup> but in the majority of examples the cyclopropane moiety is substituted only with the two alkene groups involved in the rearrangement.<sup>3,4</sup> In this study we compare the reactivity of *gem*-dimethyl substituted divinylcyclopropanes with their unsubstituted analogues, examining the effects of alkene geometry, the relative stereochemistry of the cyclopropane and the steric and electronic effects of a range of functional groups.

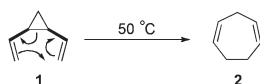
Scheme 1 Vogel's Cope rearrangement of divinylcyclopropane **1**.

## Results

Our interest in the Cope rearrangements of divinylcyclopropanes arose as an extension to our work concerning the use of tandem reaction sequences,<sup>5</sup> particularly those involving oxidation with manganese(IV) oxide.<sup>6</sup> As part of these studies,

Department of Chemistry, University of York, York, YO10 5DD, UK.  
E-mail: richard.taylor@york.ac.uk; Fax: +44 (0)1904 322516;  
Tel: +44 (0)1904 322606

†Electronic supplementary information (ESI) available: For experimental procedures, characterisation of compounds and NMR spectra. See DOI: 10.1039/c3ob41617h

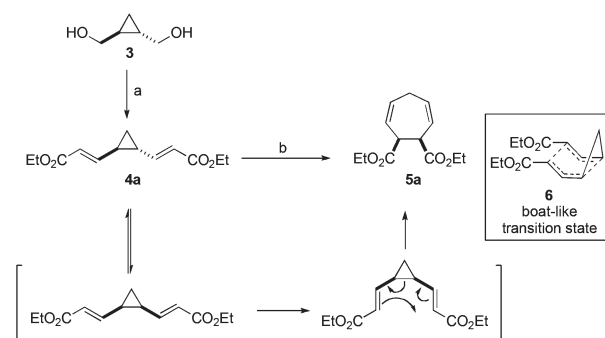

Scheme 2 The Cope rearrangement of diester **4a**. Reagents and conditions: (a) MnO<sub>2</sub>, CHCl<sub>3</sub>, Ph<sub>3</sub>PCHCO<sub>2</sub>Et, reflux, 75%,<sup>6d</sup> (b) xylene, 130 °C, 80%.

we reported the tandem oxidation and Wittig reaction of diol **3** that resulted in its conversion into *E,E*-diester **4a** in a high yielding, one-pot process.<sup>6d</sup> We have since discovered that heating the resulting *trans*-divinylcyclopropane in xylene at 130 °C results in its smooth conversion into 1,4-cycloheptadiene **5a**. The generally accepted mechanism for this process is presented (Scheme 2): a reversible epimerisation of *trans*-divinylcyclopropane **4a** to the corresponding *cis*-divinylcyclopropane takes place first, which is believed to proceed *via* a diradical opening of the cyclopropane.<sup>2,7</sup> The resulting *cis*-divinylcyclopropane then undergoes a thermal [3,3]-sigmatropic rearrangement *via* a boat-like transition state **6**.

Our group has also reported improved conditions for the formation of *gem*-dimethylcyclopropanes using triisopropylsulfoxonium tetrafluoroborate and sodium hydride.<sup>8</sup> Thus, using the reported procedure, dimethylcyclopropane **7** was synthesised in high yield and subsequent reduction with lithium aluminium hydride, followed by a tandem oxidation/Wittig reaction resulted in the formation of *E,E*-diester **9a**, as well as a small amount *E,Z*-diester **9b**. We then went on to attempt the Cope reaction of **9a** under the same conditions used for the rearrangement of its non-methylated analogue **4a** (130 °C in



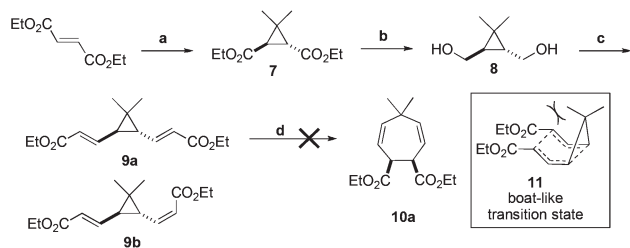

**Scheme 3** The formation of dimethylcyclopropanes **9a** and **9b** and the attempted Cope rearrangement. Reagents and conditions: (a)  $i\text{-Pr}_3\text{SO}^+\text{BF}_4^-$ , NaH, DMF, 73%. (b)  $\text{LiAlH}_4$ , THF, 86%. (c)  $\text{MnO}_2$ ,  $\text{Ph}_3\text{PCHCO}_2\text{Et}$ ,  $\text{CHCl}_3$ , reflux, **9a** 69%, **9b** 4%, (d) xylene, 130 °C, 0%.

xylene) but no reaction ensued and the starting material **9a** was recovered cleanly upon evaporation of the solvent (Scheme 3).

This result is not altogether unexpected, as a review of the related literature revealed that bulky substituents typically inhibit the Cope rearrangements of divinyl cyclopropanes,<sup>9–11</sup> by destabilising the previously invoked boat-like transition state (see **11**, Scheme 3). For example, it has been observed that substitution on the vinyl groups can retard the reaction significantly,<sup>9</sup> and that this effect is more pronounced for *Z*-substituents than *E*-substituents, as the ensuing steric clash with the cyclopropane moiety in the transition state is greater.<sup>9</sup> Far less is known about the effect of dimethyl substitution on the cyclopropane, however; indeed, to the best of our knowledge, there are no reports that directly compare the Cope rearrangements of divinyl dimethylcyclopropanes with their non-methylated analogues. The closest precedent was reported by Sasaki *et al.*<sup>10</sup> who found that methyl substitution on the ‘aza-divinylcyclopropanes’ **12** and **13** had a significant effect on their reactivity; the non-methylated variant **12** underwent [3,3]-sigmatropic rearrangement at RT, whereas its methylated analogue **13** required the far greater temperature of 144 °C before rearrangement occurred (Scheme 4).<sup>11</sup>

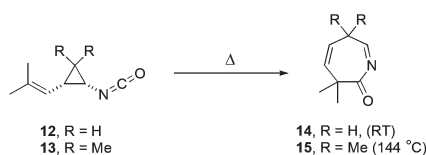

**Scheme 4** The [3,3]-sigmatropic rearrangement of cyclopropanes **12** and **13** (no yields reported).<sup>10</sup>

The preceding example (Scheme 4) demonstrates the profound effect that dimethyl substitution can have on the [3,3]-sigmatropic rearrangements of cyclopropane-containing systems. However, we were surprised to discover that our study is the first direct comparison of the Cope rearrangements of a divinyl dimethylcyclopropane with its non-methylated analogue. In view of this, we decided to investigate how dimethyl substitution affects such rearrangements, by synthesising all of the possible stereoisomers (*cis/trans* and *E,E/E,Z,Z,Z*) of the diesters **4** and **9** and examining their propensity to undergo Cope rearrangement.

The syntheses of two of the required diesters (**9a**, **9b**) are described above (Scheme 3) and the *Z,Z*-diester **9c** was readily

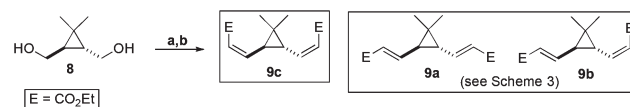

**Scheme 5** The synthesis of *gem*-dimethyl-*trans*-divinylcyclopropanes. Reagents and conditions: (a)  $\text{MnO}_2$ ,  $\text{CHCl}_3$ , reflux, 72%. (b)  $(\text{F}_3\text{CCH}_2\text{O})_2\text{POCH}_2\text{CO}_2\text{Et}$ , KHMDS, 18-crown-6, THF, toluene, 35% (>20 : 1 *Z* : *E*).

synthesised from diol **8**, *via* oxidation with manganese(IV) dioxide, followed by a Still–Gennari-modified Horner–Wadsworth–Emmons (HWE) olefination (Scheme 5).<sup>12</sup>

The synthesis of diester **4a** is described in Scheme 2. The *Z,Z*-diester **4c** was prepared from diol **3**, *via* oxidation with manganese(IV) dioxide, followed by a Still–Gennari-modified Horner–Wadsworth–Emmons (HWE) olefination (Scheme 6). The synthesis of *E,Z*-diester **4b** began with mono-TBS protection of diol **3**, and was followed by a tandem oxidation/Wittig reaction to install the *E*-alkene portion, furnishing compound **17**. Silyl cleavage using TBAF, manganese(IV) dioxide oxidation and Still–Gennari olefination was then used to install the *Z*-alkene and complete the synthesis (Scheme 6).

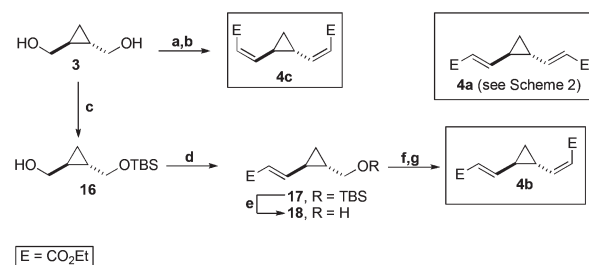

**Scheme 6** The synthesis of *trans*-divinylcyclopropanes. Reagents and conditions: (a)  $\text{MnO}_2$ ,  $\text{CHCl}_3$ , reflux, 11%. (b)  $(\text{F}_3\text{CCH}_2\text{O})_2\text{POCH}_2\text{CO}_2\text{Et}$ , KHMDS, 18-crown-6, THF, toluene, 63% (>20 : 1 *Z* : *E*). (c) NaH, TBSCl, THF, 69%. (d)  $\text{MnO}_2$ ,  $\text{Ph}_3\text{PCHCO}_2\text{Et}$ ,  $\text{CHCl}_3$ , reflux, 85% (>10 : 1 *E* : *Z*; *E*-isomer was isolated by chromatography). (e) TBAF, THF, 77%. (f) (a)  $\text{MnO}_2$ ,  $\text{CHCl}_3$ , reflux, 67%. (g)  $(\text{F}_3\text{CCH}_2\text{O})_2\text{POCH}_2\text{CO}_2\text{Et}$ , KHMDS, 18-crown-6, THF, toluene, 46% (>20 : 1 *Z* : *E*).

Similar reaction sequences were employed in the synthesis of the dimethyl *cis*-cyclopropane diesters **9d**, **9e**, and **9f**. To begin, subjecting ethyl chrysanthemate<sup>13</sup> to ozonolysis followed by reduction with lithium aluminium hydride afforded a mixture of *cis*-cyclopropane diol **19** and its *trans*-analogue **8**, which were readily separated by column chromatography. On all of the *cis*-cyclopropane diesters synthesised, the alkene components were installed sequentially, to avoid competing intramolecular cyclisation reactions. First, diol **19** was converted into mono-silyl ether **20** under standard conditions<sup>14</sup> and this common intermediate was then converted into either *E*-alkene **21** using our standard tandem oxidation/Wittig conditions or to *Z*-alkene **24** *via* oxidation and Still–Gennari olefination. Silyl cleavage of each of **21** and **24** using  $\text{HF}^{15}$  and oxidation/olefination in the same way completed the syntheses of the required cyclopropane diesters **9d**, **9e** and **9f** (Scheme 7).

The syntheses of the non-methylated *cis*-cyclopropane diesters **4d**, **4e**, and **4f** were completed using the same sequence

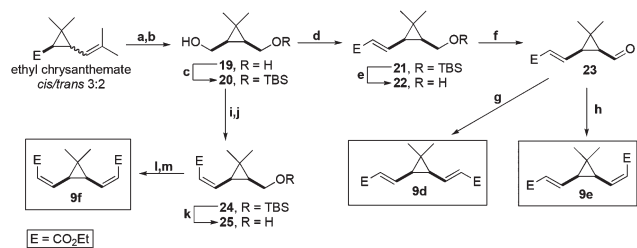

**Scheme 7** The synthesis of *cis-gem*-divinylcyclopropanes. Reagents and conditions: (a) O<sub>3</sub>, DCM, -78 °C then DMS, 97%. (b) LiAlH<sub>4</sub>, THF, 0 °C → RT, **19**, 31%, **8**, 49%. (c) NaH, TBSCl, THF 0 °C → RT, 84%. (d) MnO<sub>2</sub>, Ph<sub>3</sub>PCHCO<sub>2</sub>Et, CHCl<sub>3</sub>, reflux, 78% (5 : 1 *E* : *Z*). (e) HF, MeCN, 75% (5 : 1 *E* : *Z*; *E*-isomer was isolated by chromatography). (f) MnO<sub>2</sub>, CHCl<sub>3</sub>, reflux, 46%. (g) Ph<sub>3</sub>PCHCO<sub>2</sub>Et, CHCl<sub>3</sub>, RT, 47% (>10 : 1 *E* : *Z*; *E*-isomer was isolated by chromatography). (h) (F<sub>3</sub>CCH<sub>2</sub>O)<sub>2</sub>POCH<sub>2</sub>CO<sub>2</sub>Et, KHMDs, 18-crown-6, THF, toluene, 52% (>20 : 1 *Z* : *E*). (i) MnO<sub>2</sub>, CHCl<sub>3</sub>, reflux, 55%. (j) (F<sub>3</sub>CCH<sub>2</sub>O)<sub>2</sub>POCH<sub>2</sub>CO<sub>2</sub>Et, KHMDs, 18-crown-6, THF, toluene, 53% (>20 : 1 *Z* : *E*). (k) HF, MeCN, 85%. (l) MnO<sub>2</sub>, CHCl<sub>3</sub>, reflux, 53%. (m) (F<sub>3</sub>CCH<sub>2</sub>O)<sub>2</sub>POCH<sub>2</sub>CO<sub>2</sub>Et, KHMDs, 18-crown-6, THF, toluene, 56% (>20 : 1 *Z* : *E*).

of steps described in Scheme 7, with the exception that diol **27** was accessed readily *via* the reduction of cyclic anhydride **26**. Otherwise, the syntheses proceeded as above until the final step of the sequence; each of the target substrates **4d**, **4e**, or **4f** spontaneously undergo the Cope rearrangement at room temperature as they are generated, hence cycloheptadiene **5a** (from **4d** and **4f**) and cycloheptadiene **5b** (from **4e**) were instead obtained (Scheme 8).

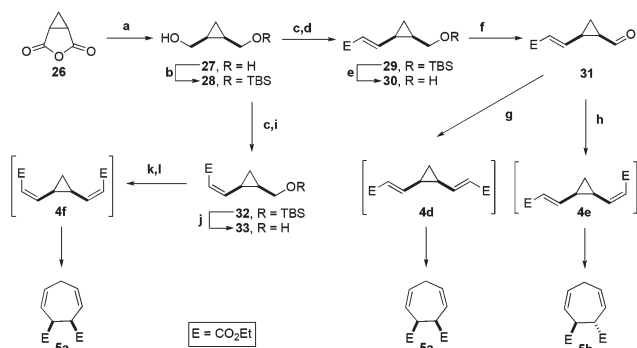

**Scheme 8** The synthesis of *cis*-divinylcyclopropanes. Reagents and conditions: (a) LiAlH<sub>4</sub>, THF, reflux, 79%. (b) NaH, TBSCl, THF 0 °C → RT, 100%. (c) MnO<sub>2</sub>, CHCl<sub>3</sub>, reflux 75%. (d) Ph<sub>3</sub>PCHCO<sub>2</sub>Et, CHCl<sub>3</sub>, 63% (>10 : 1 *E* : *Z*; *E*-isomer was isolated by chromatography). (e) HF, MeCN, 94%. (f) MnO<sub>2</sub>, CHCl<sub>3</sub>, 81%. (g) Ph<sub>3</sub>PCHCO<sub>2</sub>Et, CHCl<sub>3</sub>, RT, 79%. (h) (F<sub>3</sub>CCH<sub>2</sub>O)<sub>2</sub>POCH<sub>2</sub>CO<sub>2</sub>Et, KHMDs, 18-crown-6, THF, toluene 75%. (i) (F<sub>3</sub>CCH<sub>2</sub>O)<sub>2</sub>POCH<sub>2</sub>CO<sub>2</sub>Et, KHMDs, 18-crown-6, THF, toluene 40% (>20 : 1 *Z* : *E*). (j) HF, MeCN, 97%. (k) MnO<sub>2</sub>, CHCl<sub>3</sub>, reflux 53%. (l) (F<sub>3</sub>CCH<sub>2</sub>O)<sub>2</sub>POCH<sub>2</sub>CO<sub>2</sub>Et, KHMDs, 18-crown-6, THF, toluene 81%.

With the requisite substrates, **4a–f** and **9a–f**, in hand their propensity to undergo the Cope rearrangement was then examined. Each was stirred in xylene for 17 h at five different temperatures (RT, 40 °C, 70 °C, 100 °C, 130 °C) before removing the solvent *in vacuo*. The reaction conversion into product was then measured *via* analysis of the <sup>1</sup>H NMR spectra of the unpurified reaction mixtures as a ratio of product to starting material (Table 1).

**Table 1** The Cope rearrangement of divinylcyclopropane diesters

Entry	Reagent	Product	% Conversion (17 h)				
			Temperature (°C)				
			RT	40	70	100	130
1			0	0	0	20	100 <sup>a</sup>
2			0	0	0	20	100 <sup>a</sup>
3			0	0	0	0	80 <sup>a</sup>
4			100 <sup>b</sup>	—	—	—	—
5			100 <sup>b</sup>	—	—	—	—
6			100 <sup>b</sup>	—	—	—	—
7			0	0	0	0	0 <sup>a</sup>
8			0	0	0	0	0 <sup>a</sup>
9			0	0	0	0	0 <sup>a</sup>
10			0	30	90	100 <sup>c</sup>	100 <sup>a</sup>
11			0	0	0	0	0 <sup>a</sup>
12			0	0	0	0	0 <sup>a</sup>

E = CO<sub>2</sub>Et. All reactions were carried out as 0.19 mol dm<sup>-3</sup> solutions in xylene. All reactions were carried out for 17 h. % Conversion was determined *via* <sup>1</sup>H NMR analysis of the unpurified reaction mixtures as a ratio of product to starting material. <sup>a</sup> Some decomposition was also evident. <sup>b</sup> The divinylcyclopropane could not be isolated at RT; the cycloheptadiene shown was instead isolated during the attempted preparation of the diene. <sup>c</sup> Compound **10a** was isolated in 78% yield after flash column chromatography.

A number of conclusions can be drawn from these experiments. First, each of the unsubstituted *trans*-divinylcyclopropanes **4a**, **4b**, and **4c** underwent the Cope rearrangement only upon heating; a temperature of 130 °C was needed before the *trans*-*E,E* and *trans*-*E,Z*-substrates **4a** and **4b** rearranged (Table 1, entries 1–2) whereas only 80% conversion was observed in the more sterically encumbered *trans*-*Z,Z*-system **4c** under identical conditions (Table 1, entry 3). These results are in stark contrast to those of their *cis*-analogues **4d**, **4e**, and **4f** which rearrange spontaneously at room temperature during their generation (Table 1, entries 4–6). A single stereoisomer of product was observed in each case, with the stereochemical outcomes being consistent with a simple concerted thermal [3,3]-sigmatropic rearrangement in the *cis*-series of compounds (Table 1, entries 4–6) and *trans* to *cis*-isomerisation, followed by a concerted thermal [3,3]-sigmatropic rearrangement, in the *trans*-series (Table 1, entries 1–3). Thus, the high temperatures necessary to induce rearrangement in the *trans*-series appear to be associated with overcoming the energy barrier for *trans* to *cis*-epimerisation of the cyclopropane and not with the energy of the transition state of the Cope rearrangement itself.

The *trans*-dimethyl substrates **9a**, **9b** or **9c** did not rearrange, even at 130 °C (Table 1, entries 7–9) and, importantly, epimerisation to the corresponding *cis*-diesters was also not observed. The *cis*-*E,Z* and *cis*-*Z,Z*-substrates **9e** and **9f** also failed to react at 130 °C, with each remaining unchanged, again with no evidence of cyclopropane epimerisation (Table 1, entries 11–12). This suggests that the required transition state (**11**, Scheme 3) is too high in energy for the Cope rearrangement to occur under the conditions screened, probably due to steric clashes, but also indicates that the *cis/trans*-epimerisation occurs less readily than in the non-methylated series of compounds. Interestingly, the *cis*-*E,E*-diester **9d** was significantly more reactive than either of compounds **9e** or **9f**; this substrate began to rearrange at temperatures as low as 40 °C and the rearrangement was complete after 17 h at 100 °C (Table 1, entry 10). As before, a single stereoisomer of product was observed with the stereochemical outcome consistent with a concerted thermal [3,3]-sigmatropic rearrangement. Of course, the rearrangement occurred less readily than it did on the analogous desmethyl-*cis*-*E,E* substrate **4d** (Table 1, entry 4), as was expected, but the fact that it began to rearrange at temperatures as low as 40 °C is significant, given the dearth of examples on other divinyl dimethylcyclopropanes in the literature. This result also sheds light on the reason why our original dimethyl *trans*-*E,E*-diester **9a** (Table 1, entry 7) failed to react; given that the Cope rearrangement of *cis*-*E,E*-diester **9d** (Table 1, entry 10) proceeded at temperatures as low as 40 °C, and that there was no evidence of any *cis/trans*-epimerisation in any of the diesters **9a–9f**, this suggests that the reaction of *trans*-*E,E* **9a** failed at the cyclopropane epimerisation stage, and not because of the high energy of the Cope rearrangement transition state as originally thought.<sup>16</sup> In addition, the complete lack of *cis* to *trans*-epimerisation in any of the dimethyl substituted diesters **9a–9f** is in contrast to the

unsubstituted diesters **4a–4c** (which must have epimerised otherwise their Cope rearrangements would not have taken place). Thus, we have shown that as well raising the energy of the Cope rearrangement transition state, *gem*-dimethyl substitution also retards the rate of cyclopropane epimerisation of the *trans*-cyclopropane substrates screened.

It is clear that *gem*-dimethyl substitution significantly retards the Cope rearrangements of divinylcyclopropanes. However, it appears that its effect on the *trans* to *cis*-isomerisation of the cyclopropane, and not its effect on the [3,3]-sigmatropic rearrangement itself, is the most significant barrier to reactivity. Pleasingly, from a synthetic viewpoint, the isomerisation problem is easily negated by starting from a *cis*-oriented divinylcyclopropane. To demonstrate this, we then went on to synthesise a range of other dimethyl-*cis*-*E,E*-functionalised cyclopropanes (Scheme 9). Cyclopropane **35** was prepared using a tandem oxidation/Wittig reaction, followed by silyl cleavage using HF.<sup>15</sup> Another tandem oxidation/Wittig reaction at RT afforded the *cis*-*E,E*-functionalised cyclopropane **36**. The reduction of **36** using 2 equivalents of DIBAL gave a mixture of monoester **37** and diol **38**, and TBS protection of diol **38** using 1.5 equivalent of TBSCl generated a mixture of TBS compounds **39** and **40**. Finally, the hydrolysis of diester **36** afforded cyclopropane **41**.

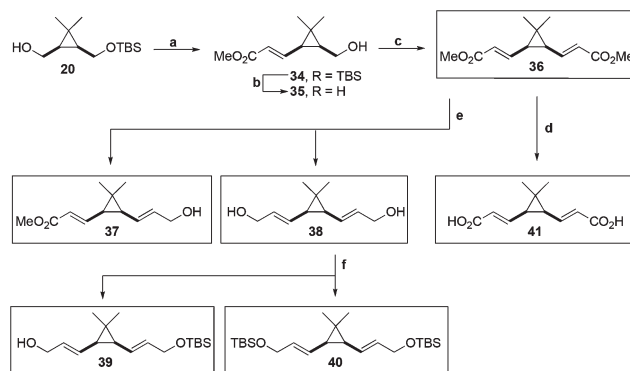

**Scheme 9** The synthesis of a range of dimethyl *cis*-*E,E* divinylcyclopropanes. Reagents and conditions: (a) MnO<sub>2</sub>, Ph<sub>3</sub>PCHCO<sub>2</sub>Me CHCl<sub>3</sub>, reflux 48% (>10:1 *E*:*Z*; *E*-isomer was isolated by chromatography). (b) HF, MeCN, 81%. (c) MnO<sub>2</sub>, Ph<sub>3</sub>PCHCO<sub>2</sub>Me CHCl<sub>3</sub>, RT, 49% (>10:1 *E*:*Z*; *E*-isomer was isolated by chromatography). (d) NaOH, THF, H<sub>2</sub>O, RT, 100%. (e) DIBAL (2 eq.), CH<sub>2</sub>Cl<sub>2</sub>, **37**, 9%, **38** 33%. (f) TBSCl (1.5 eq.), NaH, THF, **39** 20%, **40**, 35%.

We were pleased to find that all of these substrates **36–41** undergo the Cope rearrangement upon heating, generating 1,4-cycloheptadienes in high yields (83–97%, Table 2), with ester, alcohol, silyl ether and carboxylic acid substituents all being well tolerated. The rearrangements do not appear to be significantly affected by electronic effects, a point exemplified by the near-identical reactivity of the electron-deficient ester-substituted divinylcyclopropane **36** and the more electron-rich alcohol-substituted divinylcyclopropane **38** (entries 1 and 3). Note that the product isolated from the Cope rearrangement of substrate **37** (entry 2) was a lactone, presumably, formed *via* an intramolecular transesterification following the Cope

**Table 2** Substrate scope in the Cope rearrangement of substituted *gem*-dimethyl divinylcyclopropanes<sup>a</sup>

Entry	Reagent	Product	% Conversion			Isolated yield (%)
			Temperature (°C)			
			40	70	100	
1			30	100	100	83
2			0	100	100	92
3			30	90	100	83
4			30	70	100	86
5			0	30	100	88
6			0	10	100	97

<sup>a</sup> All reactions were carried out as 0.19 mol dm<sup>-3</sup> solutions in xylene. All reactions were carried out for 17 h. % Conversion was determined *via* analysis of the unpurified reaction mixtures. The isolated yields were obtained from the 100 °C experiments and include purification by column chromatography in each example except for diacid **47**.

rearrangement. The size of the substituents appears to be more significant; the addition of one **39** and then two **40** *tert*-butyldimethyl silyl groups to diol **38** led to a decrease in reactivity in each case (entries 3–5). Diacid-substituted divinylcyclopropane **41** reacts more slowly still (entry 6), but this reaction should not be compared directly to the other entries as compound **41** was only sparingly soluble in the reaction solvent.

## Conclusions

The rate-retarding effect of *gem*-dimethyl substitution on the Cope rearrangements of divinylcyclopropanes has been demonstrated directly for the first time. An examination of the effects of alkene geometry and the relative stereochemistry of the cyclopropane have revealed that *gem*-dimethyl substitution significantly inhibits the *trans* to *cis*-isomerisation about the cyclopropyl ring, necessary for rearrangement to occur, relative to unsubstituted analogues. Using the information accrued, a series of ideal substrates (*cis*-oriented on the cyclopropane with two *E*-alkenes) were synthesised and all underwent the desired Cope rearrangement smoothly, affording a range of dimethylated substituted 1,4-cycloheptadienes in high yields. Future work will focus on the application of this methodology

in the synthesis of natural products and pharmaceutically important targets.

## Experimental

### General remarks

Experimental procedures and data for the characterisation of Cope rearrangement products can be found below. Experimental procedures and characterisation data of all other compounds presented in this paper can be found in the ESI.† All reagents were purchased from commercial sources and were used without further purification. Where necessary, solvents were dried on an MBraun SPS solvent purification system. Anhydrous THF was obtained by distillation over sodium/benzophenone. Xylene refers to a mixture of *ortho*, *meta* and *para*-xylene and pet. ether refers to light petroleum ether, bp 40–60 °C. <sup>1</sup>H NMR spectra were recorded on a JEOL ECX 400 (400 MHz) instrument. <sup>13</sup>C NMR spectra were recorded on a JEOL ECX 400 instrument at 100 MHz. Infrared spectra were carried out on a Perkin Elmer FT-IR spectrometer UATR 2 or on a ThermoNicolet IR100 spectrometer (recorded as a thin film between NaCl discs). Mass spectra and accurate mass measurements were recorded on a Bruker Daltonics, Micro-tof spectrometer.



**Diethyl (1R,2S)-cyclohepta-3,6-diene-1,2-dicarboxylate (5a)**

**Procedure 1: from diethyl ( $\pm$ )-(2E,2'E)-3,3'-(1R,2R)-cyclopropane-1,2-diylbisprop-2-enoate 4a (Scheme 2).** A stirred solution of **4a** (5.01 g, 21.0 mmol) in xylene (50 mL) was refluxed at 130 °C for 16 h. After being cooled to RT the solution was concentrated under reduced pressure to give the crude product. This was purified by flash column chromatography on silica gel, eluting with pet. ether–EtOAc (20:1) to afford the title compound **5a**, as a colourless oil (3.96 g, 80%).

**Procedure 2: from ethyl ( $\pm$ )-(2E)-3-[(1S,2S)-2-formylcyclopropyl]prop-2-enoate 31 (Scheme 8).** To a stirred solution of **31** (132 mg, 0.786 mmol) in CHCl<sub>3</sub> (10 mL) at RT was added (carboxymethylene)triphenylphosphorane (329 mg, 0.943 mmol). After 16 h the solution was concentrated under reduced pressure at RT and the crude product purified by flash column chromatography on silica gel, eluting with pet. ether–EtOAc (20:1) to afford the title compound **5a** as a colourless oil (148 mg, 79%).

**Procedure 3: from ethyl ( $\pm$ )-(2Z)-3-[(1S,2S)-2-formylcyclopropyl]prop-2-enoate (Scheme 8).** To a solution of ethyl [bis(2,2,2-trifluoroethoxy)phosphoryl]acetate (244 mg, 0.735 mmol) in THF (7 mL) was added 18-crown-6 (433 mg, 1.64 mmol). The solution was cooled to 0 °C and KHMDs (1.05 mL, 0.7 M in toluene, 0.735 mmol) was added cautiously. After 15 min the solution was cooled to –78 °C and ethyl ( $\pm$ )-(2Z)-3-[(1S,2S)-2-formylcyclopropyl]prop-2-enoate (95 mg, 0.565 mmol) in THF (7 mL) was added *via* cannula. After 2 h the reaction was quenched with sat. NH<sub>4</sub>Cl (aq.) (10 mL), Et<sub>2</sub>O (20 mL) added and the organic layer separated. The aqueous layer was extracted with further portions of Et<sub>2</sub>O (2 × 20 mL) and the combined organic extracts were dried (MgSO<sub>4</sub>), filtered and concentrated under reduced pressure. The resulting crude product was purified by flash column chromatography on silica gel, eluting with pet. ether–EtOAc (20:1) to afford the title compound **5a** as a colourless oil (109 mg, 81%). *R*<sub>f</sub> (20:1 pet. ether–EtOAc) 0.19;  $\nu_{\max}$  (thin film)/cm<sup>-1</sup> 2981, 2937, 1735; <sup>1</sup>H NMR (400 MHz; CDCl<sub>3</sub>)  $\delta$  6.08–6.02 (2H, m), 5.82–5.76 (2H, m), 4.20–4.11 (4H, m), 3.86–3.84 (2H, m), 3.08–2.98 (1H, m), 2.75–2.66 (1H, m), 1.25 (6H, t, *J* 7.0); <sup>13</sup>C NMR (101 MHz; CDCl<sub>3</sub>)  $\delta$  172.0, 129.4, 127.5, 61.1, 45.1, 28.3, 14.2; *m/z* (ESI) 239 [MH<sup>+</sup>]; HRMS: calcd for C<sub>13</sub>H<sub>19</sub>O<sub>4</sub>, 239.1278. Found: [MH<sup>+</sup>], 239.1271 (2.4 ppm error).

**Diethyl ( $\pm$ )-(1S,2S)-cyclohepta-3,6-diene-1,2-dicarboxylate (5b)**

**From ethyl ( $\pm$ )-(2E)-3-[(1S,2S)-2-formylcyclopropyl]prop-2-enoate 31 (Scheme 8).** To a solution of ethyl [bis(2,2,2-trifluoroethoxy)phosphoryl]acetate (236 mg, 0.712 mmol) in THF (7 mL) was added 18-crown-6 (420 mg, 1.59 mmol). The solution was cooled to 0 °C and KHMDs (1.02 mL, 0.7 M in toluene, 0.712 mmol) was added cautiously. After 15 min the solution was cooled to –78 °C and **31** (92 mg, 0.548 mmol) in THF (7 mL) was added *via* cannula. After 2 h the reaction was quenched with sat. NH<sub>4</sub>Cl (aq.) (10 mL), Et<sub>2</sub>O (20 mL) added and the organic layer separated. The aqueous layer was extracted with further portions of Et<sub>2</sub>O (2 × 20 mL) and the

combined organic extracts were dried (MgSO<sub>4</sub>), filtered and concentrated under reduced pressure at RT. The resulting crude product was purified by flash column chromatography on silica gel, eluting with pet. ether–EtOAc (20:1) to afford the title compound **5b** as a colourless oil (98 mg, 75%). *R*<sub>f</sub> (10:1 pet. ether–EtOAc) 0.27;  $\nu_{\max}$  (thin film)/cm<sup>-1</sup> 2978, 2936, 2893, 2862, 1710 <sup>1</sup>H NMR (400 MHz; CDCl<sub>3</sub>)  $\delta$  5.89–5.81 (2H, m), 5.66–5.60 (2H, m), 4.17 (2H, q, *J* 7.0), 4.16 (2H, q, *J* 7.0), 3.83–3.77 (2H, m), 2.91–2.84 (2H, m), 1.26 (6H, t, *J* 7.0); <sup>13</sup>C NMR (101 MHz; CDCl<sub>3</sub>)  $\delta$  173.3, 130.8, 127.0, 61.1, 45.1, 27.5, 14.3; *m/z* (ESI) 239 [MH<sup>+</sup>]; HRMS: calcd for C<sub>13</sub>H<sub>19</sub>O<sub>4</sub>, 239.1278. Found: [MH<sup>+</sup>], 239.1267 (3.8 ppm error).

**General procedure for the Cope rearrangement**

A solution of divinylcyclopropane in xylene (0.19 mol dm<sup>-3</sup>) was heated to the temperature indicated and held at that temperature for 17 h. The solution was then concentrated *in vacuo*. The products in Table 2 were purified, by flash column chromatography, except for diacid 47.

**Diethyl (1R,2S)-5,5-dimethylcyclohepta-3,6-diene-1,2-dicarboxylate (10a)**

Synthesised from compound **9d** using the general procedure at 100 °C, affording the title compound **10a** as a colourless oil (78%); *R*<sub>f</sub> (10:1 pet. ether–EtOAc) 0.25;  $\nu_{\max}$  (thin film)/cm<sup>-1</sup> 2961, 2920, 1735; <sup>1</sup>H NMR (400 MHz; CDCl<sub>3</sub>)  $\delta$  5.93 (2H, dd, *J* 12.0, 6.0), 5.50 (2H, d, *J* 12.0), 4.12–4.18 (4H, m), 3.79 (2H, d, *J* 6.0), 1.25 (6H, t, *J* 7.0), 1.16 (3H, s), 1.13 (3H, s); <sup>13</sup>C NMR (101 MHz; CDCl<sub>3</sub>)  $\delta$  172.0, 140.0, 123.2, 61.1, 45.1, 39.1, 32.4, 29.3, 14.3; *m/z* (ESI): 289 [MNa<sup>+</sup>]; HRMS: calcd for C<sub>15</sub>H<sub>22</sub>NaO<sub>4</sub>, 289.1410. Found: [MNa<sup>+</sup>], 289.1411 (0.3 ppm error).

**Dimethyl (1R,2S)-5,5-dimethylcyclohepta-3,6-diene-1,2-dicarboxylate (42)**

Synthesised from compound **36** using the general procedure at 100 °C, affording the title compound **42** as a colourless oil (36 mg, 83%); *R*<sub>f</sub> (10:1 pet. ether–EtOAc) 0.23;  $\nu_{\max}$  (thin film)/cm<sup>-1</sup> 2974, 2912, 1718; <sup>1</sup>H NMR (400 MHz; CDCl<sub>3</sub>)  $\delta$  5.93 (2H, dd, *J* 11.5, 6.5), 5.50 (2H, d, *J* 11.5), 3.82 (2H, d, *J* 6.5), 3.70 (6H, s), 1.16 (3H, s), 1.12 (3H, s); <sup>13</sup>C NMR (101 MHz; CDCl<sub>3</sub>)  $\delta$  172.5, 140.1, 123.1, 52.3, 44.9, 39.1, 32.5, 29.3; *m/z* (ESI): 239 [MH<sup>+</sup>]; HRMS: calcd for C<sub>13</sub>H<sub>19</sub>O<sub>4</sub>, 239.1278. Found: [MH<sup>+</sup>], 239.1269 (3.2 ppm error).

**( $\pm$ )-(3aR,8aS)-6,6-Dimethyl-3,3a,6,8a-tetrahydro-1H-cyclohepta-[c]-furan-1-one (43)**

Synthesised from compound **37** using the general procedure at 100 °C, affording the title compound **43** as a colourless oil (32 mg, 84%); *R*<sub>f</sub> (10:1 pet. ether–EtOAc) 0.25;  $\nu_{\max}$  (thin film)/cm<sup>-1</sup> 3528, 2961, 1770; <sup>1</sup>H NMR (400 MHz; CDCl<sub>3</sub>)  $\delta$  5.69–5.59 (2H, m), 5.46 (2H, dd, *J* 12.0, 5.0), 5.31 (1H, dd, *J* 12.0, 4.0), 4.30 (1H, dd, *J* 8.5, 6.0), 4.12 (1H, dd, *J* 8.5, 4.5), 3.47–3.39 (2H, m), 1.19 (3H, s), 1.15 (3H, s); <sup>13</sup>C NMR (101 MHz; CDCl<sub>3</sub>)  $\delta$  176.9, 143.5, 142.6, 123.6, 118.6, 73.2, 44.0, 39.7, 38.3, 32.0, 30.2; *m/z* (ESI): 233 [MNa<sup>+</sup>]; HRMS: calcd for C<sub>11</sub>H<sub>14</sub>NaO<sub>2</sub>, 201.0891. Found: [MNa<sup>+</sup>], 201.0888 (1.2 ppm error).

**((1R,2S)-5,5-Dimethylcyclohepta-3,6-diene-1,2-diyl)dimethanol (44)**

Synthesised from compound **38** using the general procedure at 100 °C, affording the title compound **44** as a colourless oil (15 mg, 83%);  $R_f$  (EtOAc) 0.43; mp 42–44 °C;  $\nu_{\max}$  (thin film)/ $\text{cm}^{-1}$  3304, 3008, 2958, 2923, 2871;  $^1\text{H}$  NMR (400 MHz;  $\text{CDCl}_3$ )  $\delta$  5.57 (2H, dd,  $J$  12.0, 6.5), 5.43 (2H, d,  $J$  12.0), 3.72 (2H, dd,  $J$  11.0, 7.0), 3.66 (2H, br s), 3.59 (2H, dd,  $J$  11.0, 3.0), 2.81–2.76 (2H, m), 1.13 (3H, s), 1.08 (3H, s);  $^{13}\text{C}$  NMR (101 MHz;  $\text{CDCl}_3$ )  $\delta$  139.9, 126.0, 63.9, 43.8, 39.9, 32.9, 29.8;  $m/z$  (ESI): 205 [ $\text{MNa}^+$ ]; HRMS: calcd for  $\text{C}_{11}\text{H}_{18}\text{NaO}_2$ , 205.1199. Found: [ $\text{MNa}^+$ ], 205.1195 (0.7 ppm error).

**(±)-((1R,7S)-7-((tert-Butyldimethylsilyloxy)methyl)-4,4-dimethylcyclohepta-2,5-dienyl)methanol (45)**

Synthesised from compound **39** using the general procedure at 100 °C, affording the title compound **45** as a colourless oil (10 mg, 86%);  $R_f$  (10 : 1 pet. ether–EtOAc) 0.52;  $\nu_{\max}$  (thin film)/ $\text{cm}^{-1}$  3373, 2962, 2911, 2885, 2815;  $^1\text{H}$  NMR (400 MHz;  $\text{CDCl}_3$ )  $\delta$  5.58 (1H, dd,  $J$  11.5, 6.0), 5.50 (1H, dd,  $J$  12.0, 6.5), 5.45–5.37 (2H, m), 3.74 (1H, dd,  $J$  10.5, 8.0), 3.65 (1H, dd,  $J$  11.5, 7.0), 3.57–3.51 (2H, m), 2.86–2.79 (1H, m), 2.75–2.68 (1H, m), 1.13 (3H, s), 1.08 (3H, s), 0.91 (9H, s), 0.10 (6H, s);  $^{13}\text{C}$  NMR (101 MHz;  $\text{CDCl}_3$ )  $\delta$  140.1, 139.5, 126.5, 125.9, 64.4, 64.3, 44.0, 44.0, 39.8, 33.0, 29.7, 26.0, 18.4, –5.4;  $m/z$  (ESI): 319 [ $\text{MNa}^+$ ]; HRMS: calcd for  $\text{C}_{17}\text{H}_{32}\text{NaO}_2\text{Si}$ , 319.2064. Found: [ $\text{MNa}^+$ ], 319.2053 (2.4 ppm error).

**((1R,2S)-5,5-Dimethylcyclohepta-3,6-diene-1,2-diyl)bis(methylene)bis(oxy)bis(tert-butyl dimethylsilane) (46)**

Synthesised from compound **40** using the general procedure at 100 °C, affording the title compound **46** as a colourless oil (17 mg, 88%);  $R_f$  (40 : 1 pet. ether– $\text{Et}_2\text{O}$ ) 0.76;  $\nu_{\max}$  (thin film)/ $\text{cm}^{-1}$  2911, 2883, 2852, 2814;  $^1\text{H}$  NMR (400 MHz;  $\text{CDCl}_3$ )  $\delta$  5.48 (2H, dd,  $J$  11.5, 6.0), 5.35 (2H, d,  $J$  11.5), 3.66 (2H, dd,  $J$  10.0, 7.0), 3.58 (2H, dd,  $J$  10.0, 7.0), 2.73 (2H, ddd,  $J$  7.0, 7.0, 6.0), 1.14 (3H, s), 1.09 (3H, s), 0.88 (18H, s), 0.03 (12H, s);  $^{13}\text{C}$  NMR (101 MHz;  $\text{CDCl}_3$ )  $\delta$  139.1, 128.0, 65.5, 42.8, 39.8, 32.9, 29.9, 26.1, 18.5, –5.2;  $m/z$  (ESI): 411 [ $\text{MH}^+$ ]; HRMS: calcd for  $\text{C}_{23}\text{H}_{47}\text{O}_2\text{Si}_2$ , 411.3109. Found: [ $\text{MH}^+$ ], 411.3100 (1.1 ppm error).

**(1R,2S)-5,5-Dimethylcyclohepta-3,6-diene-1,2-dicarboxylic acid (47)**

Synthesised from compound **41** using the general procedure at 100 °C, without chromatography, affording the title compound **47** as a light brown solid (22 mg, 97%); mp 130–132 °C;  $\nu_{\max}$  (thin film)/ $\text{cm}^{-1}$  2963, 2927, 2600 (br), 1693;  $^1\text{H}$  NMR (400 MHz; DMSO)  $\delta$  5.87–5.80 (2H, m), 5.40 (2H, d,  $J$  12.0), 3.67 (2H, d,  $J$  5.5), 1.12 (3H, s), 1.06 (3H, s);  $^{13}\text{C}$  NMR (101 MHz; DMSO)  $\delta$  172.8, 138.4, 124.4, 44.1, 38.2, 32.1, 28.8;  $m/z$  (ESI): 211 [ $\text{MH}^+$ ]; HRMS: calcd for  $\text{C}_{11}\text{H}_{15}\text{O}_4$ , 211.0965. Found: [ $\text{MH}^+$ ], 211.0971 (2.8 ppm error).

## Notes and references

- (a) E. Vogel, *Angew. Chem.*, 1960, **72**, 4–26; (b) E. Vogel and K. H. Ott, *Justus Liebigs Ann. Chem.*, 1961, **644**, 172–188; (c) E. Vogel, *Angew. Chem., Int. Ed. Engl.*, 1963, **2**, 1–52.
- For reviews of the divinylcyclopropane–cycloheptadiene rearrangement see: (a) H. N. C. Wong, M.-Y. Hon, C.-W. Tse, Y.-C. Yip, J. Tanko and T. Hudlicky, *Chem. Rev.*, 1989, **89**, 165–198; (b) T. Hudlicky, R. Fan, J. W. Reed and K. G. Gadamasetti, *Org. React.*, 2004, **41**, 1–133.
- There are notable exceptions to this. For monocyclic examples see: (a) H. E. Morton, I. Nagakura, E. Piers and R. W. Thies, *Can. J. Chem.*, 1983, **61**, 1226–1238; (b) E. Piers and E. H. Reudiger, *Can. J. Chem.*, 1983, **61**, 1239–1247; (c) E. Piers, I. Nagakura and H. E. Morton, *J. Org. Chem.*, 1978, **43**, 3630–3631; (d) R. J. Gone, N. J. Wallock, S. Lindeman and A. W. Donaldson, *Tetrahedron Lett.*, 2009, **50**, 1023–1025; (e) R. K. Pandey, L. Wang, N. J. Wallock, S. Lindeman and W. A. Donaldson, *J. Org. Chem.*, 2008, **73**, 7236–7245; (f) N. J. Wallock, D. W. Bennett, T. Siddiquee, D. T. Haworth and A. W. Donaldson, *Synthesis*, 2006, 3639–3646.
- For other exceptions, using fused bicyclic systems see: (a) S. Y. Kim, Y. Park and Y. K. Chung, *Angew. Chem., Int. Ed.*, 2010, **122**, 425–428; (b) S. Kohmoto, N. Nakayama, J.-I. Takami, K. Kishikawa, M. Yamamoto and K. Yamada, *Tetrahedron Lett.*, 1996, **37**, 7761–7764; (c) T. Hudlicky, G. Sinae-Zingde, M. G. Natchus, B. C. Ranu and P. Papadopolous, *Tetrahedron*, 1987, **43**, 5685–5722.
- (a) J. Lubkoll, A. Millemaggi, A. Perry and R. J. K. Taylor, *Tetrahedron*, 2010, **66**, 6606–6612; (b) A. R. Burns, G. D. McAllister, S. E. Shanahan and R. J. K. Taylor, *Angew. Chem., Int. Ed.*, 2010, **49**, 5574–5577; (c) J. D. Cuthbertson, A. A. Godfrey and R. J. K. Taylor, *Synlett*, 2010, 2805–2807; (d) C. L. Moody, D. S. Pugh and R. J. K. Taylor, *Tetrahedron Lett.*, 2011, **52**, 2511–2514; (e) W. P. Unsworth, C. Kitsiou and R. J. K. Taylor, *Org. Lett.*, 2013, **15**, 258–261; (f) W. P. Unsworth, K. A. Gallagher, M. I. Jean, J. P. Schmidt, L. J. Diorazio and R. J. K. Taylor, *Org. Lett.*, 2013, **15**, 262–265; (g) W. P. Unsworth and R. J. K. Taylor, *Org. Biomol. Chem.*, 2013, DOI: 10.1039/C3OB41519H.
- (a) X. Wei and R. J. K. Taylor, *Tetrahedron Lett.*, 1998, **39**, 3815–3818; (b) L. Blackburn, X. Wei and R. J. K. Taylor, *Chem. Commun.*, 1999, **14**, 1337–1338; (c) X. Wei and R. J. K. Taylor, *J. Org. Chem.*, 2000, **65**, 616–620; (d) L. Blackburn, M. Lautens, G. D. McAllister, R. J. K. Taylor and M. Webster, *Org. Synth.*, 2008, **85**, 15–26.
- (a) S. J. Rhoads and N. R. Raulins, *Org. React.*, 1975, **22**, 1–252; (b) E. M. Milvitskaya, A. V. Tarakanova and A. F. Plate, *Chem. Rev.*, 1976, **45**, 469–478.
- (a) M. G. Edwards, R. J. Paxton, D. S. Pugh and R. J. K. Taylor, *Synlett*, 2007, 521–524; (b) M. G. Edwards, R. J. Paxton, D. S. Pugh and R. J. K. Taylor, *Synthesis*, 2008, 3279–3288.
- (a) G. Ohloff and G. Pickenhagen, *Helv. Chim. Acta*, 1969, 880–886; (b) C. Ullenius, P. W. Ford and J. E. Baldwin, *J. Am. Chem. Soc.*, 1972, **94**, 5910–5911; (c) C. Ullenius and

- J. E. Baldwin, *J. Am. Chem. Soc.*, 1973, **95**, 1542–1547;  
(d) M. P. Schneider and A. Rau, *J. Am. Chem. Soc.*, 1979, **101**, 4426–4427.
- 10 (a) T. Sasaki, S. Eguchi and M. Ohno, *J. Am. Chem. Soc.*, 1970, **92**, 3192–3194; (b) T. Sasaki, S. Eguchi and M. Ohno, *J. Org. Chem.*, 1972, **37**, 466–469.
- 11 P. Müller and H. Imogai, *Helv. Chim. Acta*, 1999, **82**, 315–322.
- 12 W. C. Still and C. Gennari, *Tetrahedron Lett.*, 1983, **24**, 4404–4408.
- 13 Ethyl chrysanthemate was purchased as a mixture (2 : 3) of *cis* and *trans*-diastereomers.
- 14 P. G. McDougal, J. G. Rice, Y. I. Oh and B. D. Condon, *J. Org. Chem.*, 1986, 3388–3390.
- 15 Silyl cleavage of **21**, **24**, **29**, **32** and **34** using TBAF rather than HF led to competing oxy-Michael addition.
- 16 Otherwise the Cope rearrangement would have taken place, as observed when *cis-E,E*-**9d** was heated at this, and indeed lower, temperature (Table 1, entry 10).

## Abbreviations

Ac	acetate
aq	aqueous
bp	boiling point
Bn	benzyl
br	broad (NMR)
CNS	central nervous system
COSY	correlation spectroscopy
d	doublet (NMR)
$\delta$	chemical shift
DBU	1,8-diazabicyclo[5.4.0]undec-7-ene
DCM	dichloromethane
DEPT	distortionless enhancement by polarization transfer
DIBAL	di- <i>iso</i> -butylaluminium hydride
DMAP	4-dimethylaminopyridine
DMF	<i>N,N</i> -dimethylformamide
DMP	Dess–Martin periodinane
DMSO	dimethyl sulfoxide
eq.	equivalent
ESI	electrospray ionization
Et	ethyl
EtOAc	ethyl acetate
g	gram(s)
h	hour(s)
HRMS	high-resolution mass spectrometry
HSQC	heteronuclear single quantum coherence
HWE	Horner–Wadsworth–Emmons
Hz	Hertz
<i>i</i>	<i>iso</i>
imid	imidazole
IBX	2-iodoxybenzoic acid
IPA	<i>iso</i> -propyl alcohol



IR	infrared
K	Kelvin
KHMDS	potassium hexamethyldisilazide
LDA	lithium diisopropylamide
<i>m</i>	<i>meta</i>
m	multiplet
M	molarity
<i>m</i> CPBA	<i>meta</i> -chloroperoxybenzoic acid
Me	methyl
mg	milligram(s)
min	minutes
mL	milliliter
mmol	millimoles
mp	melting point
Ms	methanesulfonyl
MS	mass spectrometry
MSA	methanesulfonic acid
MTBD	7-methyl-1,5,7-triazabicyclo[4.4.0]dec-5-ene
m/z	mass to charge ratio
<i>n</i>	<i>normal</i>
NMR	nuclear magnetic resonance
n.O.e	nuclear Overhauser effect
Nu	nucleophile
<i>p</i>	<i>para</i>
pet. ether	petroleum ether (light petroleum ether, bp 40–60°C)
Ph	phenyl
PIDA	(diacetoxyiodo)benzene
PMB	<i>p</i> -methoxybenzyl
ppm	parts per million
4-PPY	4-pyrrolidinopyridine
Py	Pyridine
<i>p</i> -TSA	<i>p</i> -toluenesulfonic acid
q	quartet (NMR)

RCM	ring-closing metathesis
R <sub>f</sub>	retention factor
ROESY	rotating-frame Overhauser effect spectroscopy
RT	room temperature
s	second(s); singlet (NMR)
sat.	saturated
S <sub>N</sub> 1	unimolecular nucleophilic substitution
S <sub>N</sub> 2	bimolecular nucleophilic substitution
t	triplet (NMR)
<i>t</i>	<i>tert</i>
TBAF	tetra- <i>n</i> -butylammonium fluoride
TBS	<i>tert</i> -butyldimethylsilyl
TBDPS	<i>tert</i> -butyldiphenylsilyl
TEMPO	2,2,6,6-tetramethylpiperidinyloxy
Tf	trifluoromethanesulfonyl
TFA	trifluoroacetic acid
THF	tetrahydrofuran
TIPS	triisopropylsilyl
tlc	thin layer chromatography
TOP	tandem oxidation procedure
UV	ultraviolet

## References

1. Y. B. Zheng, C-H. Lu, Z-H. Zheng, X-J. Lin, W-J. Su, Y-M. Shen, *Helv. Chim. Acta*, **2008**, 2174–2180.
2. T. C. McMorris, R. Lira, P. K. Gantzel, M. J. Kelner, R. Dawe, *J. Nat. Prod.*, **2006**, 63, 1557–1559.
3. B. Tursch, J. C. Braekman, D. Dalozze, P. Fritz, A. Kelecom, R. Karlsson, D. Losman, *Tetrahedron Lett.*, **1974**, 15, 747–750.
4. Y. Kashman, M. Bodner, J. S. Finer-Moore, J. Clardy, *Experientia*, **1980**, 36, 891–892.
5. B. S. G. Reddy, V. D. Rao, B. C. H. Rao, N. Dhananjaya, R. Kuttan, T. D. Babu, *Chem. Pharm. Bull.*, **1999**, 47, 1214–1220.
6. G. Liu, D. Romo, *Angew. Chem. Int. Ed.*, **2011**, 50, 7537–7540.
7. D. R. Appleton, C. S. Chuen, M. V. Berridge, V. L. Webb, B. R. Copp, *J. Org. Chem.*, **2009**, 74, 9195–9198.
8. Z-Y. Zhang, J. H. Chen, Z. Yang, Y-F. Tang, *Org. Lett.*, **2010**, 12, 5554–5557.
9. W. Hashida, N. Tanaka, Y. Kashiwada, M. Sekiya, Y. Ikeshiro, Y. Takaishi, *Phytochemistry*, **2008**, 69, 2225–2230.
10. X. Yang, M. L. Deinze, *J. Org. Chem.*, **1992**, 57, 4717–4722.
11. B. Tursch, J. C. Braekman, D. Dalozze, P. Fritz, D. Losman, *Tet. Lett.*, **1974**, 9, 747–750.
12. F. Bohlmann, C. Zdero, *Phytochemistry*, **1978**, 17, 1669–1671.
13. H. Shirahama, K. Hayano, Y. Kanemoto, S. Misumi, T. Ohtsuka, N. Hashiba, A. Furusaki, S. Murata, R. Noyori, T. Matsumoto, *Tetrahedron Lett.*, **1980**, 21, 4835–4838.
14. J. Cossy, S. BouzBouz, C. Mouzza, *Synlett*, **1998**, 621–622.
15. F. Marquez, A. De, J. T. B. Ferreira, E. Piers, *J. Braz. Chem. Soc.*, **2000**, 11, 502–511.
16. L. A. Paquette, W. H. Ham, *J. Am. Chem. Soc.*, **1987**, 109, 3025–3036.
17. T. Sugimura, T. Futagawa, A. Tai, *Chem. Lett.*, **1990**, 2295–2298.
18. W. Fan, J. B. White, *J. Org. Chem.*, **1993**, 58, 3557–3562.
19. E. J. Ellis, S. J. Dutcher, H. C. Heathcock, *J. Org. Chem.*, **1976**, 41, 2670–2676.

20. Y. Matsuda, Y. Endo, Y. Saikawa, M. Nakata, *J. Org. Chem.*, **2011**, *76*, 6258–6263.
21. M. G. Edwards, R. J. Paxton, D. S. Pugh, A. C. Whitwood, R. J. K. Taylor, *Synthesis*, **2008**, 3729–3288.
22. M. G. Edwards, R. J. Paxton, D. S. Pugh, R. J. K. Taylor, *Synlett*, **2007**, 521–524.
23. D. S. Pugh, *PhD Thesis*, University of York, **2011**.
24. L. Blackburn, M. Lautens, G. D McAllister, R. J. K. Taylor, M. Webster, *Org. Synth.*, **2008**, *85*, 15–26.
25. D. J. Von Langen, R. L. Tolman, *Tetrahedron: Asymmetry*, **1997**, *8*, 677.
26. R. Csuk, Y. von Scholz, *Tetrahedron*, **1994**, *50*, 10431–10442.
27. W. P. Unsworth, *Unpublished work*, University of York, **2011**.
28. R. Paxton, *PhD Thesis*, University of York, **2008**.
29. A. B. Charette, A. Beauchemin, *Org. React.*, **2001**, *58*, 3–65.
30. P. G. McDougal, J. G. Rico, Y. I. Oh, B. D. Condon, *J. Org. Chem.*, **1986**, 3388–3390.
31. A. B. Charette, H. J. Juteau, *J. Am. Chem. Soc.*, **1994**, *116*, 2651.
32. M. Nakamura, A. Hirai, E. Nakamura, *J. Am. Chem. Soc.*, **2003**, *125*, 2341–2350.
33. T. Wang, Y. Liang, Z-X. Yu, *J. Am. Chem. Soc.*, **2011**, *133*, 9343–9353.
34. B. Badet and M. Julia, *Tetrahedron Lett.*, **1979**, *20*, 1101–1104.
35. *United States Pat.*, 5576461, **1996**.
36. A. de Meijere, V. Bagutski, F. Zeuner, U. K. Fischer, V. Rheinberger, N. Mozner, *Eur. J. Org. Chem.*, **2004**, 3669–3678.
37. S. Niwayama, *J. Org. Chem.*, **2000**, *65*, 5834–5836.
38. E. Vogel, *Angew. Chem.*, **1960**, *72*, 4–26.
39. E. Vogel, K. H. Ott, K. Gajek, *Liebigs Ann. Chem.*, **1961**, *644*, 172–178.
40. E. Vogel, *Angew. Chem. Int. Ed.*, **1963**, *2*, 1–52.
41. For reviews of the divinylcyclopropane-cycloheptadiene rearrangement see: (a) H. N. C. Wong, M-Y. Hon, C-W. Tse, Y-C. Yip, J. Tanko and T. Hudlicky, *Chem. Rev.*, **1989**, *89*, 165–198; (b) T. Hudlicky, R Fan, J. W. Reed and K. G. Gadamasetti, *Org. React.*, **2004**, *41*, 1–133; (c) S. J. Rhoads and N. R. Raulins, *Org. React.*, **1975**, *22*, 1–252.

42. G. Ohloff, G. Pickenhagen, *Helv. Chim. Acta*, **1969**, 880–886.
43. C. Ullenius, P. W. Ford, J. E. Baldwin, *J. Am. Chem. Soc.*, **1972**, *94*, 5910–5911.
44. C. Ullenius, J. E. Baldwin, *J. Am. Chem. Soc.*, **1973**, *95*, 1542–1547.
45. M. P. Schneider, A. Rau, *J. Am. Chem. Soc.*, **1979**, *101*, 4426–4427.
46. T. Sasaki, S. Eguchi, M. Ohno *J. Am. Chem. Soc.*, **1970**, *92*, 3192–3194.
47. T. Sasaki, S. Eguchi, M. Ohno, *J. Org. Chem.*, **1972**, *37*, 466–469.
48. P. Müller, H. Imogai, *Helv. Chim. Acta*, **1999**, 315–322.
49. H. E. Morton, I. Nagakura, E. Piers, R. W. Thies, *Can. J. Chem.*, **1982**, *61*, 1226–1238.
50. E. Piers, E. H. Reudiger, *Can. J. Chem.*, **1983**, *61*, 1239–1247.
51. E. Piers, I. Nagakura, H. E. Morton, *J. Org. Chem.*, **1978**, *43*, 3630–3631.
52. For examples of the Cope rearrangement of trisubstituted cyclopropanes see:  
(a) R. J. Gone, N. J. Wallock, S. Lindeman, A. W. Donaldson, *Tetrahedron Lett.*, **2009**, *50*, 1023–1025; (b) R. K. Pandey, L. Wang, N. J. Wallock, S. Lindeman and W. A. Donaldson, *J. Org. Chem.*, **2008**, *73*, 7236–7245; (c) N. J. Wallock, D. W. Bennett, T. Siddiquee, D. T. Haworth, A. W. Donaldson, *Synthesis*, **2006**, 3639–3646.
53. For other exceptions, using fused bicyclic systems see: (a) S. Y. Kim, Y. Park, Y. K. Chung, *Angew. Chem. Int. Ed. Engl.*, **2010**, *122*, 425–428; (b) S. Kohmoto, N. Nakayama, J-I, Takami, K Kishikawa, M. Yamamoto and K Yamada, *Tetrahedron. Lett.*, **1996**, *37*, 7761–7764; (c) T. Hudlicky, G. Sinae-Zingde, M. G. Natchus, B. C. Ranu and P. Papadopolous, *Tetrahedron*, **1987**, *43*, 5685–5722.
54. W. C. Still, C. Gennari, *Tetrahedron Lett.*, **1983**, *24*, 4405–4408.
55. J. D. Osler, W. P. Unsworth, R. J. K. Taylor, *Org. Biomol. Chem.*, **2013**, *11*, 7587–7594.
56. G. A. Olah, A. Husain, B. P. Singh, A. K. Mehrotra, *J. Org. Chem.*, **1983**, *48*, 3667–3672.
57. O. Prezzavento, A. Campisi, C. Parenti, S. Ronsisvalle, G. Aricò, E. Arena, M. Pistolozzi, G. M. Scoto, C. Bertucci, A. Vanella, G. Ronsisvalle, *J. Med. Chem.*, **2010**, *53*, 5881–5885.

58. (a) K. W. C. Poon, G. B. Dudley, *J. Org. Chem.* **2006**, *71*, 3923–3927. (b) K. W. C. Poon, S. E. House, G. B. Dudley, *Synlett*, **2005**, 3142–3144.
59. H. Finkelstein, *Ber.*, **1910**, *43*, 1528–1532.
60. J. Tsuji, H. Takahashi, M. Morikawa, *Tetrahedron Lett.*, **1965**, *6*, 4387–4388.
61. B. M. Trost, T. J. Fullerton, *J. Am. Chem. Soc.*, **1973**, *95*, 292–294.
62. K. C. Nicolaou, S. P. Ellery, J. S. Chen, *Angew. Chem., Int. Ed.*, **2009**, *48*, 7140–7165.
63. M. Szostak, M. Spain, D. J. Procter, *J. Org. Chem.*, **2012**, *77*, 3049–3059.
64. M. G. Banwell, D. C. R. Hockless, M. D. McLeod, *New J. Chem.* **2003**, *27*, 50–59.
65. G. A. Molander, K. M. George, L. G. Monovich, *J. Org. Chem.*, **2003**, *68*, 9533–9540.
66. P. Chen, J. Wang, K. Liu, C. Li, *J. Org. Chem.*, **2008**, *73*, 339–341.
67. K. C. Nicolaou, A. Li, D. J. Edmonds, *Angew. Chem. Int. Ed.*, **2006**, *45*, 7086–7090.
68. R. J. Enemærke, T. Hertz, T. Skrydstrup, K. Daasbjerg, *Chem. Eur. J.*, **2000**, *6*, 3747–3754.
69. M. Schlosser, *Angew. Chem., Int. Ed.*, **2005**, *44*, 376–393.
70. J. G. Donkervoort, A. R. Gordon, C. Johnstone, W. J. Kerr, U. Lange, *Tetrahedron*, **1996**, *52*, 7391–7420.
71. W. J. Kerr, M. McLaughlin, P. L. Pauson, S. M. Robertson, *J. Organomet. Chem.*, **2001**, *630*, 104–117.
72. (a) S. Ohira, *Synth. Commun.* **1989**, *19*, 561–564. (b) S. Mueller, B. Liepold, G. J. Roth, H. J. Bestmann, *Synlett*, **1996**, 521–522.
73. E. J. Corey, P. L. Fuchs, *Tetrahedron Lett.* **1972**, *13*, 3769–3772.
74. L. Zhou, Y. Yao, W. Xu, G. Liang, *J. Org. Chem.*, **2014**, *79*, 5345–5350.
75. J. R. Parikh, W. v. E. Doering, *J. Am. Chem. Soc.*, **1967**, *89*, 5505–5507.
76. For a review of the Tiffeneau–Demjanov rearrangement see: P. A. S. Smith, D. R. Baer, *Org. React.*, **1960**, *11*, 157–188.
77. E. J. Corey, M. J. Chaykovsky, *J. Am. Chem. Soc.* **1965**, *87*, 1353–1364.
78. S. J. Danishefsky, J. J. Masters, W. B. Young, J. T. Link, L. B. Snyder, T. V. Magee, D. K. Jung, R. C. A. Isaacs, W. G. Bornmann, C. A. Alaimo, C. A. Coburn, M. J. D Grandi, *J. Am. Chem. Soc.*, **1996**, *118*, 2843–2859.

79. H. Lund, J. Bjerrum, *Chem. Ber.*, **1931**, *64*, 210–213.
80. R. K. Boeckmann, P. Shao, J. Mullins, *J. Org. Synth.*, **2004**, *10*, 696–702.
81. P. J. Kropp, N. J. Pienta, *J. Org. Chem.*, **1983**, *48*, 2084–2090.
82. D. Tsukamoto, Y. Shiraishi, T. Hirai, *J. Org. Chem.*, **2010**, *75*, 1450–1457.
83. P. A. Wender, A. J. Dyckman, *Org. Lett.*, **1999**, *1*, 2089–2092.
84. M. P. Doyle, W. R. Winchester, J. A. A. Hoorn, V. Lynch, S. H. Simonsen, R. Ghosh, *J. Am. Chem. Soc.*, **1993**, *115*, 9968–9978.
85. J. E. Baldwin, S. J. Gianciosi, **1992**, *114*, 9401–9408.
86. C. Hertweck, W. Boland, *J. Org. Chem.*, **2000**, *65*, 2458–2463.
87. I. Masato, A. Osaku, A. Shiibashi and T. Ikariya, *Org. Lett.*, **2007**, *9*, 1821–1824.
88. C. W. Bond, A. J. Cresswell, S. G. Davies, A. M. Fletcher, W. Kurosawa, J. A. Lee, P. M. Roberts, A. J. Russell, A. D. Smith, J. E. Thomson, *J. Org. Chem.*, **2009**, *74*, 6735–6748.
89. P. Knochel, T. Chou, H. G. Chen, Yeh, P. M. Chang, M. J. Rozema, *J. Org. Chem.*, **1989**, *54*, 5202–5204.