

**An Instrumental Phonetic Investigation of Timing  
Relations in Two-stop Consonant Clusters in Tripolitanian  
Libyan Arabic**

Abdurraouf Elhashmi Shitaw

Submitted in accordance with the requirements for the degree of Doctor  
of Philosophy

The University of Leeds

The School of Languages, Cultures and Societies  
Department of Linguistics and Phonetics

June 2014

The candidate confirms that the work submitted is his own and that appropriate credit has been given where reference has been made to the work of others.

This copy has been supplied on the understanding that it is copyright material and that no quotation from the thesis may be published without proper acknowledgement

© 2014 The University of Leeds and Abdurraouf Elhashmi Shitaw

The right of Abdurraouf Elhashmi Shitaw to be identified as the author of this work has been asserted by him in accordance with the Copyright, Designs and Patents Act 1988

## **Dedication**

I dedicate this work to my father, Elhashmi Shitaw, and to my mother, Fatima Shnaishah

## **Acknowledgement**

My greatest gratitude goes to Allah, without his help and blessings, I would have achieved nothing. My sincere appreciation goes to my first supervisor, Dr. Barry Heselwood, for implanting the love of phonetics and phonology in me during my MA, for his guidance and support the entire time of doing this work, for his patience, and for reading my thesis and making invaluable suggestions to improve it. I am in debt to you forever.

My special thanks go to my second supervisor, Dr. Leendert Plug, for his valuable comments, academic support and help with statistics. To my participants, the seven men and seven women, please know that I will always be grateful to each of you for your assistance in gathering the needed data for this thesis. To the Linguistics department and all the staff, particularly Karen Priestly, thank you for all your help and support over the duration of my time at the University of Leeds.

My most heartfelt thanks and appreciation go to my father, mother, brothers and sisters. Without their encouragement, love, and support the journey would have been much harder. I dedicate this work to my late beloved grandmother, for her prayers and love for me. You will always be in my prayers and thoughts; may your soul rest in peace.

I have been blessed and surrounded with many friends and I am grateful to have each of them in my life. I must give an extra special thank you to my all-time friend Susan Heilman for her support and sense of humour during the writing of this thesis and to my long-time friend and colleague, Aimen Ghummed, for all our discussions during the coffee breaks and the mutual support we have shared throughout the years. I wish you all the best in your thesis as well. Finally, I dedicate this work to all students of phonetics and phonology.

## Abstract

This study uses acoustic, electropalatographic and laryngographic data to investigate articulatory timing and the timing of voicing of single stops and two-stop consonant clusters in Tripolitanian Libyan Arabic. The theoretical framework which has been adopted in this investigation is based on Articulatory Phonology. An acoustic approach is also employed in this study to measure the duration of segments and overlap in clusters. Another objective of this research is to determine whether syllable position, place of articulation, including articulation sequence, the morphological structure, gender of the speaker and articulation rate will have an influence on the gestural coordination and the timing of voicing of Tripolitanian Libyan Arabic stops.

Fourteen native speakers of Tripolitanian Libyan Arabic produced fifty-eight mostly monosyllabic words that contain seven syllable-initial single stops, seven syllable-final single stops, twenty-seven syllable-initial two-stop clusters and seventeen syllable-final two-stop clusters in normal, fast and slow articulation rate. One speaker was recorded using Electropalatography and Laryngography. Measurements include duration of the hold phase of the stops, the duration of overlap/delay between two adjacent consonantal closures, the timing and duration of the voicing during the hold phase and the duration of VOT.

Statistical results show significant influence of syllable position, place of articulation, gender and speaking rate on the gestural coordination of two-stop clusters. In syllable-initial position, the pattern of coordination is characterised by an overlap between the two consonantal closures or by a short delay as a result of the release of the first stop. In syllable-final position, the pattern of coordination of two consonantal gestures is marked by a less cohesive coordination leading to the existence of an epenthetic vowel. These patterns of coordination varied as a function of place of articulation, gender of the speaker and the rate of articulation. Clusters with lingual stops are less overlapped compared to clusters containing bilabial stops. Male speakers produced longer hold phase durations and longer inter-consonantal intervals in comparison with female speakers. While in faster articulation rates the two consonantal gestures were reduced in duration and exhibited more gestural overlap, slow articulation

rate resulted in the opposite outcome. Results of the influences of articulation sequence and morphological structure of the cluster were less evident.

Finally, the duration of voice onset time and the timing and duration of voicing during the hold phase varied as a function of syllable position, place of articulation and articulation rate, with more voicing in syllable-final single stops than syllable-initial and an increase in voicing by the increase in articulation rate, and the opposite pattern is evident in slow articulation rate. The duration of VOT becomes longer as the place of articulation moves back and shorter when the articulation rate is increased. In slow speaking rate, VOT is longer.

## Tables of Contents

<b>Dedication .....</b>	<b>iii</b>
<b>Acknowledgement .....</b>	<b>iv</b>
<b>Abstract.....</b>	<b>v</b>
<b>Tables of Contents.....</b>	<b>vii</b>
<b>List of Figures.....</b>	<b>xiv</b>
<b>List of Tables .....</b>	<b>xxii</b>
<b>Abbreviations and Symbols.....</b>	<b>xxvii</b>
<b>Chapter One: Introduction and Background.....</b>	<b>1</b>
1.1 Structure of the Thesis .....	1
1.2 Purpose of the Study .....	2
1.3 Rationale for the Study.....	3
1.4 Arabic Language .....	4
1.4.1 Introduction .....	4
1.4.2 Linguistic Variation in Libya.....	7
1.4.3 Previous Studies on Libyan Arabic.....	10
1.4.4 Consonants in LA.....	12
1.4.4.1 Stops .....	13
1.4.4.2 Fricatives: .....	13
1.4.4.3 Nasals .....	14
1.4.4.4 Laterals .....	15
1.4.5 Consonant Clusters in TLA.....	16
1.4.5.1 VC vs. CV dialects .....	16
1.4.6 Assimilation in TLA .....	20
1.4.7 Vowels in TLA.....	20
1.4.8 Syllable Structure in TLA .....	24
1.4.9 Stress Patterns in TLA .....	27
<b>Chapter Two: Timing in speech production.....</b>	<b>29</b>
2.1 Introduction .....	29
2.2 The production of stops.....	29
2.3 Theories of timing in speech production.....	33
2.3.1 The nature of coarticulation .....	33
2.3.2 Keating's Articulatory Model .....	36
2.3.3 Articulatory Phonology Model .....	36
2.3.3.1 Articulatory timing .....	38
2.3.3.2 Rules of gestural phasing .....	40
2.3.4 Cues to gestural overlap .....	41
2.4 Factors that influence gestural coordination .....	42
2.4.1 The influence of place of articulation .....	42
2.4.2 The influence of syllable position (C-centre organisation).....	43
2.4.3 The influence of perceptual recoverability .....	45

2.4.4	The influence of physiological differences .....	45
2.4.5	The influence of articulation rate .....	47
2.4.6	The influence of speaking variability.....	50
2.4.7	Summary .....	51
2.5	The timing of voicing.....	52
2.5.1	Introduction .....	52
2.5.2	The mechanism of voicing .....	52
2.5.3	Voicing in stops .....	54
2.5.4	The timing of voicing in stop consonants .....	56
2.5.4.1	The timing of voicing in single stop consonants .....	56
2.5.4.2	The timing of voicing in two-stop consonant clusters ....	57
2.5.4.3	Voice onset time .....	59
2.6	Factors that influence the duration of VOT .....	60
2.6.1	The influence of place of articulation on VOT .....	60
2.6.2	The influence of the vowel on VOT .....	63
2.6.3	The influence of gender on VOT .....	64
2.6.4	The influence of speaking rate on VOT.....	65
2.6.5	Other factors that influence VOT .....	66
2.6.6	Summary of voicing.....	67
2.7	Conclusion .....	68
<b>Chapter Three: Methodology.....</b>		<b>70</b>
3.1	Introduction .....	70
3.2	Theoretical Framework .....	70
3.3	Research Questions and Hypotheses.....	71
3.4	The Participants.....	73
3.5	The Material .....	74
3.6	Procedures .....	77
3.7	Instrumentation and measurements.....	78
3.7.1	Electropalatography (EPG) .....	79
3.7.1.1	Limitations of using EPG .....	80
3.7.1.2	EPG measurements.....	81
3.7.1.3	Calculating Percentage of Contact .....	84
3.7.2	Audio recording .....	84
3.7.2.1	Acoustic Measurements .....	85
3.7.3	Laryngograph .....	87
3.7.3.1	Lx measurements.....	88
3.8	Statistical Analysis .....	90
3.8.1	The independent-sample <i>t</i> -test .....	91
3.8.2	The one-way ANOVA test (Analysis of variance) .....	92
3.8.3	The repeated-measures ANOVA test.....	92
3.9	Conclusion .....	92

<b>Chapter Four: EPG Results .....</b>	<b>94</b>
4.1 Introduction .....	94
4.2 Results of two lingual stop clusters in SI position .....	95
4.2.1 Coronal (plain and emphatic) + dorsal.....	95
4.2.2 Dorsal + coronal (plain and emphatic).....	97
4.3 Results of clusters containing /b/ in SI.....	99
4.3.1 /b/ + coronal (plain and emphatic) .....	99
4.3.2 /b/ + dorsal .....	102
4.3.3 Coronal (plain or emphatic) + /b/.....	103
4.3.4 Dorsal + /b/.....	104
4.4 Summary .....	105
4.5 Results of two lingual stop clusters in SF position .....	106
4.5.1 Coronal + dorsal.....	106
4.5.2 Dorsal + coronal.....	107
4.6 Results of clusters containing /b/ in SF.....	108
4.6.1 /b/ + coronal .....	109
4.6.2 /b/ + dorsal .....	110
4.6.3 Coronal + /b/ .....	111
4.6.4 Dorsal + /b/.....	112
4.7 The duration of ICI in words in isolation.....	113
4.8 The influence of syllable position .....	114
4.9 The influence of sequence of place of articulation .....	116
4.10 The influence of morphological structure .....	119
4.11 The influence of speaking rate .....	122
4.11.1 The influence of speaking rate on coronal + dorsal .....	123
4.11.1.1 SI coronal + dorsal .....	123
4.11.1.2 SF coronal + dorsal.....	123
4.11.2 The influence of speaking rate on dorsal + coronal .....	124
4.11.2.1 SI dorsal + coronal .....	124
4.11.2.2 SF dorsal + coronal.....	126
4.11.3 The influence of speaking rate on /b/ + coronal.....	127
4.11.3.1 SI /b/ + coronal .....	127
4.11.3.2 SF /b/ + coronal .....	128
4.11.4 The influence of speaking rate on /b/ + dorsal.....	129
4.11.4.1 SI /b/ + dorsal .....	129
4.11.4.2 SF /b/ + dorsal .....	129
4.11.5 The influence of speaking rate on coronal + /b/.....	130
4.11.5.1 SI coronal + /b/ .....	130
4.11.5.2 SF coronal + /b/ .....	130
4.11.6 The influence of speaking rate on dorsal + /b/.....	130

4.11.6.1	SI dorsal + /b/ .....	130
4.11.6.2	SI dorsal + /b/ .....	131
4.12	Discussion .....	131
4.13	Conclusion .....	137
<b>Chapter Five: Acoustic Results.....</b>		<b>139</b>
5.1	Introduction .....	139
5.2	The influence of place of articulation .....	139
5.2.1	The influence of place of articulation on HP duration of SI single stops .....	140
5.2.2	The influence of place of articulation on the timing of SI two-stop clusters .....	141
5.2.2.1	The release of C1 in SI clusters .....	142
5.2.2.2	The duration of SI coronal + dorsal clusters .....	142
5.2.2.3	The duration of SI dorsal + coronal clusters .....	144
5.2.2.4	The duration of SI /b/ + coronal clusters .....	145
5.2.2.5	The duration of SI /b/ + dorsal clusters .....	147
5.2.2.6	The duration of SI coronal + /b/ clusters .....	148
5.2.2.7	The duration of SI dorsal + /b/ clusters .....	149
5.2.3	Discussion and conclusion of the SI single- and two-stop cluster results .....	150
5.2.4	The influence of place of articulation on HP duration of SF single stops .....	152
5.2.5	The influence of place of articulation on the timing of SF two-stop clusters .....	153
5.2.5.1	The release of C1 in SF clusters .....	154
5.2.5.2	The duration of SF coronal + dorsal clusters .....	154
5.2.5.3	The duration of SF dorsal + coronal clusters .....	155
5.2.5.4	The dura .....	157
5.2.5.5	tion of SF /b/ + coronal clusters .....	157
5.2.5.6	The duration of SF /b/ + dorsal clusters .....	157
5.2.5.7	The duration of SF coronal + /b/ clusters .....	158
5.2.5.8	The duration of SF dorsal + /b/ clusters .....	158
5.2.6	The duration of ICI in words in isolation .....	159
5.2.7	Discussion and conclusion of the results for SF single and two-stop cluster .....	160
5.3	The influence of syllable position .....	162
5.4	The influence of articulation sequence .....	163
5.4.1	The influence of articulation sequence on SI clusters .....	163
5.4.2	The influence of articulation sequence on SF clusters .....	164
5.5	The influence of morphological structure on HP and on the duration of excrescent and intrusive vowel .....	165
5.6	The influence of gender of the speaker .....	166
5.6.1	The influence of gender on the HP duration of SI stops .....	166

5.6.2	The influence of gender on SI clusters.....	167
5.6.2.1	The influence of gender on the release of C1 in SI clusters.....	167
5.6.2.2	The influence of gender on the duration of the excrescent vowels in SI clusters.....	168
5.6.2.3	The influence of gender on the HP duration of SI clusters.....	169
5.6.3	The influence of gender on the HP duration of SF single stops ..	170
5.6.4	The influence of gender on SF stops.....	170
5.6.4.1	The influence on gender on the release of C1 in SF clusters.....	170
5.6.4.2	The influence on gender on the duration of epenthetic vowels in SF clusters .....	171
5.6.4.3	The influence of gender on the HP duration of SF clusters.....	172
5.6.5	The relation between gender and articulation sequence .....	172
5.7	Variability amongst and within speakers .....	173
5.7.1	Variability amongst and within speakers in SI single stops.....	173
5.7.2	Variability Amongst and Within Speakers in SF single stops .....	175
5.7.3	Variability amongst speakers in SI clusters .....	176
5.7.4	Variability amongst speakers in SF clusters .....	178
5.8	The influence of speaking rate .....	180
5.8.1	The influence of speaking rate on the HP duration of SI single stops	180
5.8.2	The influence of speaking rate on SI two-stop clusters .....	180
5.8.2.1	The influence of speaking rate on C1 release in SI two-stop clusters .....	180
5.8.2.2	The influence of speaking rate on SI HP duration .....	182
5.8.2.3	The influence of speaking rate on the duration of excrescent vowels in SI clusters.....	182
5.8.3	The influence of speaking rate on the duration of SF single stops	183
5.8.4	The influence of speaking rate on SF two-stop clusters .....	184
5.8.4.1	The influence of speaking rate on C1 release in SF clusters.....	184
5.8.4.2	The influence of speaking rate on SF HP duration.....	185
5.8.4.3	The influence of speaking rate on the duration of epenthetic vowels in SF clusters .....	186
5.9	Discussion .....	186
5.10	Conclusion .....	188
<b>Chapter Six: Timing of Voicing Results .....</b>		<b>191</b>
6.1	Introduction .....	191
6.2	The timing of voicing in syllable-initial single stops.....	192

6.3	The timing of voicing in syllable-final single stops.....	193
6.4	The timing of voicing in syllable-initial clusters .....	194
6.4.1	The timing of voicing in syllable-initial voiced + voiced.....	197
6.4.2	The timing of voicing in syllable-initial voiceless + voiceless....	199
6.4.3	The timing of voicing in syllable-initial voiced + voiceless.....	199
6.4.4	The timing of voicing in syllable-initial voiceless + voiced.....	201
6.5	The timing of voicing in syllable-final clusters .....	203
6.5.1	The timing of voicing in syllable-final voiced + voiced.....	204
6.5.2	The timing of voicing in syllable-final voiceless + voiceless.....	204
6.5.3	The timing of voicing in syllable-final voiced + voiceless.....	205
6.5.4	The timing of voicing in syllable-final voiceless + voiced.....	206
6.6	The influence of syllable position on timing of voicing .....	207
6.7	The influence of speaking rate .....	209
6.7.1	The influence of speaking rate on voicing of SI single stops .....	209
6.7.2	The influence of speaking rate on voicing of SF single stops.....	210
6.7.3	The influence of speaking rate on voicing of SI clusters .....	211
6.7.3.1	The influence of speaking rate on SI voiced + voiced clusters .....	211
6.7.3.2	The influence of speaking rate on voicing of SI voiceless + voiceless clusters .....	214
6.7.3.3	The influence of speaking rate on voicing of SI voiced + voiceless clusters .....	214
6.7.3.4	The influence of speaking rate on voicing of SI voiceless + voiced clusters .....	215
6.7.4	The influence of speaking rate on voicing of SF clusters .....	215
6.7.4.1	The influence of speaking rate on voicing SF Voiced + voiced.....	217
6.7.4.2	The influence of speaking rate on voicing of SF voiceless + voiceless .....	217
6.7.4.3	The influence of speaking rate on SF voiced + voiceless .....	217
6.7.4.4	The influence of speaking rate on SF voiceless + voiced .....	218
6.8	Discussion .....	218
6.9	Conclusion .....	220
<b>Chapter Seven: General Discussion and Conclusion.....</b>		<b>222</b>
7.1	Findings of the study .....	222
7.2	Limitations of the study .....	231
7.3	Suggestions for future research.....	232

<b>Appendix A: The influence of speaking rate on gestural coordination</b>	
<b>(EPG).....</b>	<b>233</b>
<b>Appendix B: The influence of speaking rate and gender on Duration</b>	
<b>(Acoustics).....</b>	<b>239</b>
<b>Appendix C: The influence of speaking rate on voicing (Lx) .....</b>	<b>249</b>
<b>Appendix D: Information sheet and consent forms .....</b>	<b>259</b>
<b>Appendix E: Word list.....</b>	<b>264</b>
<b>References .....</b>	<b>266</b>

## List of Figures

Figure 1.1 Countries where Arabic is an official or co-official language (Source: AraBbay.com). According to Owen (1993) the dotted line divides Eastern Arabic (EA) from Western Arabic (WA).....	6
Figure 1.2 A map of Libya showing its three dialectal areas, and the transitional area between Eastern and Western Arabic (The transition area is adapted from Owens 1983:116).....	8
Figure 1.3. The syllabic structure of the word /ktabt/ in TLA .....	25
Figure 1.4 The syllabic structure of TLA (based on Al-Ageli (1996:11)).....	27
Figure 2.1 A spectrogram of the word /taʃ/ ‘to start a fire’, showing the approach and hold phase, the release burst and voice onset time of /t/. .....	30
Figure 2.2 Schematic representation showing three overlapping phonetic gestures with anticipatory and perservatory (or carryover) coarticulation (adopted with modifications from Fowler and Saltzman 1993:184). .....	34
Figure 2.3 Landmarks in gestural lifespan (from Gafos 2002).....	37
Figure 2.4 The organisation of complex onset and codas in English, as proposed by the c-centre (from Marin and Pouplier 2010).....	43
Figure 2.5 the possible patterns of voicing in English consonant sequences (from Docherty 1992:40-41).....	58
Figure 3.1 EPG palate (right) with computer-generated display (left) showing a complete closure at the alveolar region (A) and a complete closure at the velar region (B). Black squares record tongue contact; white squares mean no contact. ....	79
Figure 3.2 EPG frames showing an overlap between a TB gesture and a following TT gesture.....	82
Figure 3.3 EPG frames showing a delay (ICI) between the release of the TB gesture and forming the closure by the TT gesture. The ICI lasts from frames 257-261 inclusive. ....	83
Figure 3.4 The HP duration of /d/ in the word /dam/ (left) and /d/ in the word /ʃad/ (right). ....	86

Figure 3.5 The duration of the HP of C1 and C2 and ICI in / tʰb/ in the word /tʰbaʃ/ (top), and the duration of C1 and C2 in /bg/ in the word /bgar/ (bottom) when C1 is not released. The tie-bar used in the bottom figure means overlapping closures (i.e. not a labial-velar stop as on the IPA chart). .....	86
Figure 3.6 The duration of VOT of /t/ in the word /taʃ/ (left) and the duration of prevoicing of /d/ in the word /dam/ (right). .....	87
Figure 3.7 Laryngograph processor with .....	88
Figure 3.8 The onset and offset of voicing relative to the onset and offset of HP in /bd/ in the word /bde:/. The Figure also shows the duration of VOT. ....	89
Figure 4.1 EPG frames and acoustic display for the cluster /tʰg/ (in /tʰgar/), showing a delay between the release of the TT constriction (vertical red line) and the formation of the following constriction by the TB gesture (vertical blue line). The ICI lasts for approximately 30ms (frames 457-459 inclusive). ....	96
Figure 4.2 EPG frames and acoustic display of the cluster /gt/ (in /gtal/), showing an overlap (black zigzag line) between the two closures of the TB (vertical blue line) and the TT (vertical red line) lasting for approximately 20ms (frames 372-373 inclusive). ....	98
Figure 4.3 EPG frames and acoustic display of the cluster /btʰ/ (in /btʰam/), showing a delay between the release of the labial closure (vertical green line) and formation of the closure by the TT gesture (vertical red line). The delay lasts for approximately 20ms. ....	100
Figure 4.4 EPG frames and acoustic display of the cluster /bdʰ/ (in /bdʰa:ʃa/, showing an overlap in zigzag pattern) between the TT closure (vertical red line/frame 115) and the labial release (dashed green line). ....	101
Figure 4.5 EPG frames and acoustic display of the cluster /bk/ (in /bke:/). The figure shows a delay between the LB release (vertical green line) and formation of the closure by the TB gesture (vertical blue line/frame 324). The delay lasts for approximately 20ms. ....	102

Figure 4.6 EPG frames acoustic display of the cluster /db/ (in /dbaf/). The figure shows an overlap (black zigzag line) between the TT closure (vertical red line/frame 332) and the labial closure (dashed green line).....	104
Figure 4.7 Acoustic display and EPG frames of the cluster /kb/ (in /kbas/). The labial closure (dashed green line) was formed before the release of the TB closure (vertical blue line/frame 218). As a result, C2 closure masked the acoustic release of C1.....	105
Figure 4.8 Acoustic display and EPG frames of the cluster /gt/ (in /wagt/), showing a long delay between the release of TB closure (vertical blue line/frame 257) and formation of the TT closure (vertical red line/frame 262). The duration of the ICI lasts for approximately 50ms (frames 257-261inclusive).....	108
Figure 4.9 Acoustic display and EPG printout of the cluster /bd/ (in /ʃabd/), showing a long delay between the release of labial closure (vertical green line) and formation of the closure by the TB gesture (vertical red line/frame 317). The ICI lasts between frames 314-316 inclusive. ....	109
Figure 4.10 EPG frames and acoustic display of the cluster /bk/ (in /habk/). The figure shows a long delay between the labial release (vertical green line) and formation of the closure by TB gesture (vertical blue line/frame 313). The ICI lasts for approximately 45ms (frames 309-312 inclusive).....	111
Figure 4.11 EPG frames acoustic and display and of the cluster /tʰb/ (in /ʃatʰb/). There is a long delay between the release of the TT closure (vertical red line/frame 419) and formation of the labial closure (vertical green line). The duration of the ICI lasts for approximately 50ms.....	111
Figure 4.12 EPG frames acoustic and display of the cluster /gb/ (in /nagb/). The figure shows a typical long delay between the TB release gesture (vertical blue line/frame 309) and formation of the labial closure (vertical green line). The duration of the ICI lasts for approximately 40ms.....	112
Figure 4.13 Acoustic display and EPG frames of the cluster /gt/ (in /gtal/), showing a short delay between the release of TB closure (vertical blue line/frame 319) and formation of the TT closure (vertical red line/frame 320). The duration of the ICI lasts for approximately 10ms.....	113

Figure 4.14 Acoustic display and EPG frames of the cluster /gt/ (in /wagt/), showing a long delay between the release of TB closure (vertical blue line/frame 273) and formation of the TT closure (vertical red line/frame 276). The duration of the ICI lasts for approximately 35ms (frames 273-275 inclusive)..... 114

Figure 4.15 Contact profile of syllable-initial /kt/ (in /ktab/), showing an overlap between the TB and the TT closures..... 115

Figure 4.16 Contact profile of syllable-final /kt/ (in /nakt/), showing a delay between the release of the TB closure and the formation of the closure by the TT gesture. .... 115

Figure 4.17 EPG frames and acoustic display for the cluster /kd/ (in /kdab/). There is a delay between the TB releasing gesture (vertical blue line/frame 100) and formation of the closure by the TT gesture (vertical red line/frame 102). The duration of the ICI is approximately 20ms. Both gestures have high percentage of contact..... 117

Figure 4.18 EPG frames and acoustic display for the cluster /dk/ (in /dkar/). There is an open transition between the TT releasing gesture (vertical red line/frame 151) and the formation of the closure by the TB (vertical blue line/frame 153). The duration of the ICI is approximately 20ms. .... 118

Figure 4.19 EPG frames and acoustic display of the cluster /bk/ (in /bkalma/), showing a total overlap between formation of the closure by the TB gesture (vertical blue line/frame 117) and the labial release (dashed vertical green line). .... 120

Figure 4.20 EPG frames of the cluster /gt/ (in /s<sup>h</sup>dagt/). There was an open transition, approximately 50ms (frames 166-170 inclusive) between the TB release (vertical blue line/frame 166) and the formation of the closure by the TT gesture (vertical red line/frame 171)..... 121

Figure 4.21 EPG frames and acoustic display of the cluster /tk/ (in /tkabir/), showing the TT gesture (red squares) and the TB gesture (blue diamonds) showing a considerable amount of overlap lasting for approximately 40ms (frames between 270-273 inclusive). .... 122

Figure 4.22 Acoustic display and EPG printout of the /gt/ cluster (in /gtal/) produced at fast speaking rate. The figure shows an overlap (in zigzag pattern) between the TB and the following TT closures lasting 20ms (frames 167–168). .....	125
Figure 4.23 Acoustic display and EPG frames of the cluster /kt/ (in /dʰakt/) produced at fast speaking rate. The two gestures show a more cohesive coordination compared to normal speaking rate. The ICI lasts for approximately 5ms. ....	126
Figure 4.24 EPG frames and acoustic display of the cluster /gt/ (in /wagt/) produced at fast speaking rate. Although C1 was released, the two gestures show a more cohesive coordination compared to normal speaking rate. The ICI lasts for approximately 8ms. ....	127
Figure 5.1 The coordination pattern of /dk/ in /dkar/ for speaker 1. A short ICI is seen (between the red vertical lines) because the two closures are not overlapped. ....	143
Figure 5.2 The coordination pattern of /kd/ in /kdab/ for speaker 2. A longer ICI is seen (between the red vertical lines) because the two gestures are less cohesive. ....	145
Figure 5.3 The coordination pattern of /btʰ/ in /btʰam/ for speaker 3. The absence of C1 release is an indication that the two closures are overlapped. ....	146
Figure 5.4 The coordination pattern of /btʰ/ in /btʰa:wa/ for MS 3. The gestural coordination is less cohesive meaning that a short ICI can be seen between the two closures. ....	146
Figure 5.5 The coordination pattern of /bk/ in /bke:/ for speaker M1. The short duration of the ICI shows that the two gestures are very cohesive. ....	148
Figure 5.6 HP duration of the coronal + dorsal, dorsal + coronal, /b/ + coronal, /b/ + dorsal, coronal + /b/ and dorsal + /b/ clusters, in addition to the ICI duration of each cluster type. ....	150
Figure 5.7 A comparison of HP duration of SI single stops (blue bars), SF single stops (red bars) and intervocalic geminate stops (green bars). ....	153

Figure 5.8 The coordination pattern of /gt/ in /wagt/ for speaker MS7. The gestural coordination shows a long delay between C1 release and the closure formation of C2. ....	156
Figure 5.9 The coordination pattern of /gtal/ left and /wagt/ right produced in isolation. ....	159
Figure 5.10 Duration of cluster HP and duration of ICI in SF coronal + dorsal, dorsal + coronal, /b/ + coronal, /b/ + dorsal, coronal + /b/, and dorsal + /b/ clusters. ....	161
Figure 6.1 Spectrogram (top), acoustic waveform (middle) and glottal waveform (bottom) showing voicing initiation of /b/ in the word /baχ/ (A), /d/ in the word /dam/ (B), /d <sup>s</sup> / in the word /d <sup>s</sup> am/ and /g/ in the word /gas <sup>s</sup> / (right). While in /b/, /d/ and /d <sup>s</sup> / the onset of glottal vibration is delayed after the onset of the HP, in /g/, it is timed to start at the onset of the HP. Vertical lines are inserted to mark the onset and offset of the HP. ....	193
Figure 6.2 Spectrogram (top), acoustic waveform (middle) and glottal waveform (bottom) showing an instance of the production of /gd/ in the word /gdar/. The figure shows fully uninterrupted voicing throughout C1, ICI and C2. There is also some reduction in the amplitude towards the offset of C2 HP. ....	197
Figure 6.3 Spectrogram (top), acoustic waveform (middle) and glottal waveform (bottom) for /bd <sup>s</sup> / in the word /bd <sup>s</sup> aʕa/. There is some delay in the initiation of voicing during the onset of /b/ HP; as a result C1 is partially devoiced. ....	198
Figure 6.4 Spectrogram (top), acoustic waveform (middle) and glottal waveform (bottom) for the cluster /bd/ in the word /bde:/. The figure shows a delay in voicing initiation in /b/, and an interruption of voicing before the release of /d/. ....	198
Figure 6.5 Spectrogram (top), acoustic waveform (middle) and glottal waveform (bottom) for the cluster /kt/ in the word /ktab/ showing complete voicelessness during the HP of C1 and C2 and the ICI. ....	199

Figure 6.6 Spectrogram (top), acoustic waveform (middle) and glottal waveform (bottom) for the cluster /dk/ in the word /dkar/. This figure shows that /d/ is completely devoiced as a result of regressive assimilation. ....	200
Figure 6.7 Spectrogram (top), acoustic waveform (middle) and glottal waveform (bottom) showing the cluster /gt/ in the word /gtal/. Voicing ceases just before the release of /g/, in anticipation of voiceless /t/.....	200
Figure 6.8 Spectrogram (top), acoustic waveform (middle) and glottal waveform (bottom) for the cluster /gtʰ/ in the word /gtʰaf/ showing continuous voicing through the HP of /g/ and ICI. Voicing ceases shortly after the onset of /tʰ/ HP. ....	201
Figure 6.9 Spectrogram (top), acoustic waveform (middle) and glottal waveform (bottom) for the cluster /tg/ in the word /tga:til/. The figure shows a fully voiced /t/ as a result of a regressive assimilation.....	201
Figure 6.10 Spectrogram (top), acoustic waveform (middle) and glottal waveform (bottom) for /kd/ in the word /kdab/ showing that the onset of voicing is timed to start during the ICI making each stop conserve its voicing specification. ....	202
Figure 6.11 Spectrogram (top), acoustic waveform (middle) and glottal waveform (bottom) of the cluster /tb/ in the word /tba:ʃir/. The figure shows a completely voiced /b/ as of result of a progressive assimilation.....	202
Figure 6.12 Spectrogram (top), acoustic waveform (middle) and glottal waveform (bottom) the cluster /bd/ in the word /ʃabd/. The figure shows the termination of voicing before the release of /b/ in anticipation of /h/.....	204
Figure 6.13 Spectrogram (top), acoustic waveform (middle) and glottal waveform (bottom) for the cluster /kt/ in the word /dʰakt/. The figure shows a voicing tail at the onset of C1 HP. There is no voicing during the rest of C1 HP, ICI is voiceless, and C2 HP is voice voiced.....	205
Figure 6.14 Spectrogram (top), acoustic waveform (middle) and glottal waveform (bottom) of the cluster /gtʰ/ in the word /magtʰ/. The figure shows continuous voicing from the vowel throughout the HP of C1 and ICI. Voicing ceases 22ms after the onset of C2 HP.....	205

Figure 6.15 Spectrogram (top), acoustic waveform (middle) and glottal waveform (bottom) of the cluster /bk/ in the word /ħabk/. The figure shows that voicing is terminated during C1 HP and resumed during the ICI. .... 206

Figure 6.16 Spectrogram (top), acoustic waveform (middle) and glottal waveform (bottom) of the cluster /tʰb/ in the word /fatʰb/. Voicing is terminated 20ms after the onset of C1 HP. Voicing is resumed during the ICI, but terminated before the release of C2. .... 206

Figure 6.17. Timing of voicing of mixed voicing specifications in SI and SF clusters. Onset of C1 closure occurs when the two lines converge, and the offset of C2 closure occurs when these diverge. The zigzag lines indicate voicing during the HP. The duration of the ICI is marked in red. .... 207

## List of Tables

Table 1.1 The consonants of TLA, their place and manner of articulation. ....	12
Table 1.2 The possible combinations of two-stop consonant clusters in syllable-initial position in TLA. When /b/ and /t/ are underlined, they function as a prefix.....	18
Table 1.3 The possible combinations of two-stop consonant clusters in syllable-final position in TLA. When /t/ is underlined, it functions as a suffix. ....	19
Table 1.4 Different types of assimilation in TLA from Elfitoury (1976: 23-24). In cases where /t/ is a prefix, * is used. The shaded examples are from Laradi (1983:34-35). ....	20
Table 1.5 Example of words containing /a:/ and /ɑ:/, in addition to their short counterparts /a/ and /ɑ:/ (adopted from Laradi (1983) and Abumdas (1985))......	21
Table 1.6 Syllabic templates for TLA (based on Laradi 1983:25). In the examples, syllables types are in bold. ....	26
Table 1.7 Words with different stress patterns.....	28
Table 2.1 Mean difference between the duration of the HP of single and geminate stops as produced by three speakers (Pickett <i>et al.</i> 1999:139-140). ....	48
Table 3.1 Age, gender and educational level of participants in the acoustic experiment. The mean age is 36 (33-43) for males and 29 (20-43) for females. ....	74
Table 3.2 SI and SF singleton stops in IPA transcription with glosses and target consonant underlined .....	75
Table 3.3 Words containing two-stop clusters in SI and SF position. Words with clusters containing a prefix or a suffix are placed between curved brackets. Shaded areas in the table mean that there are no SF clusters to match those in SI.....	76
Table 3.4 Criteria for voicing categories and the ratio of voicing in the HP. ....	90

Table 4.1 Average number of syllables per second, duration of HP of C1 and C2, duration of overlap (in minus) or delay (ICI) in syllable-initial coronal + dorsal stop clusters produced at normal speaking rate. Duration is given in ms. ....	95
Table 4.2 Average number of syllables per second, duration of C1 and C2 HP, and the duration of overlap (in minus) or delay (ICI) in syllable-initial dorsal + coronal stop clusters produced at normal speaking rate. Duration is given in ms. ....	97
Table 4.3 Average number of syllables per second, duration of C1 and C2 HP, and the overlap (*) or delay (ICI) in syllable-initial /b/ + coronal stop clusters produced at normal speaking rate. Where /b/ is a prefix, the LB and the TT closures are always overlapped. When the (+) sign is used, it means it is not possible to measure the exact duration of the HP due to the absence of the labial release. ....	100
Table 4.4 Average number of syllables per second, duration of C1 and C2 HP, and the overlap (*) or delay (ICI) in syllable-initial /b/ + dorsal stop clusters produced at normal speaking rate. ....	102
Table 4.5 Average number of syllables per second, duration of C1 and C2 HP, and the overlap (*) or the delay (ICI) in syllable-initial coronal + /b/ stop clusters produced at normal speaking rate. ....	103
Table 4.6 Average number of syllables per second, duration of C1 and C2 hold phase, and the overlap (*) or delay (ICI) in syllable-initial dorsal + /b/ stop clusters produced at normal speaking rate. ....	104
Table 4.7 Average number of syllables per second, duration of C1 and C2 HP, and the duration of the delay (ICI) in syllable-final coronal + dorsal stop clusters produced at normal speaking rate. ....	106
Table 4.8 Average number of syllables per second, duration of C1 and C2 HP, and the duration of delay (ICI) in SF dorsal + coronal stop clusters produced at normal speaking rate. ....	107
Table 4.9 Average number of syllables per second, duration of C1 and C2 HP, and the duration of delay (ICI) in syllable-final /b/ + dorsal clusters, produced in normal speaking rate. ....	110

Table 4.10 Mean ICI duration in SI and SF words recorded in isolation. For ease of comparison, the duration of ICI in clusters in words recorded in a carrier sentence is provided.....	113
Table 5.1 Mean duration and standard deviation of HP of SI single stops.....	140
Table 5.2 The release of C1 in SI two-stop clusters. ....	142
Table 5.3 Duration of C1 HP, ICI and C2 HP in SI coronal + dorsal stop clusters. ....	143
Table 5.4 The duration of C1 HP, ICI and C2 HP of SI dorsal + coronal single-stop clusters.....	144
Table 5.5 The duration of C1 HP, ICI and C2 HP of SI /b/ +coronal stop clusters. ....	145
Table 5.6 Duration of C1 HP, ICI and C2 HP of SI /b/ + dorsal single-stop clusters ....	147
Table 5.7 The duration of C1 HP, ICI and C2 HP of SI coronal + /b/ stop clusters ....	148
Table 5.8 The duration of C1 HP, ICI and C2 HP of SI dorsal + /b/ stop clusters. ....	149
Table 5.9 Mean duration and standard deviation of HP of SF single stop. ....	152
Table 5.10 The release of C1 in SF two-stop clusters.....	154
Table 5.11 Duration of C1 HP, ICI and C2 HP of SF coronal + dorsal stop clusters. ....	155
Table 5.12 Duration of C1 HP, ICI and C2 HP of SF dorsal + coronal stop clusters. ....	155
Table 5.13 Duration of C1 HP, ICI and C2 HP of SF /b/ + coronal stop clusters. ....	157
Table 5.14 Duration of C1 HP, ICI and C2 HP of SF /b/ + dorsal stop clusters. ...	157
Table 5.15 Mean ICI duration in SI and SF words recorded in isolation. For ease of comparison, the duration of ICI in clusters in words recorded in a carrier sentence is provided.....	159
Table 5.16 The duration of C1 HP, ICI, C2 HP and the overall duration of SI and SF clusters. ....	162
Table 5.17 The influence of articulatory sequence on the release of C1 and on the duration of excrescent vowels in SI clusters. ....	163

Table 5.18 The influence of sequence of articulation on the release of C1 and on the duration of epenthetic vowels in SF clusters.....	164
Table 5.19 The influence of morphological structure on the duration of HP and ICI in SI and SF clusters. ....	165
Table 5.20 The influence of gender on the duration of SI single stops. ....	166
Table 5.21 The influence of gender on the release of C1 in SI clusters. ....	167
Table 5.22 The influence of gender on the duration of excrescent vowels in SI clusters. ....	168
Table 5.23 The duration of C1 and C2 HP in SI position as produced by male and female speakers. ....	169
Table 5.24 The influence of gender on the HP duration of SF single stops. ....	170
Table 5.25 The influence of gender on the release of C1 in SI clusters. ....	170
Table 5.26 The influence of gender on the duration of epenthetic vowels in SF clusters. ....	171
Table 5.27 The duration of C1 and C2 HP in SF position as produced by male and female speakers. ....	172
Table 5.28 The relation between gender and articulation sequence. ....	172
Table 5.29 Variability amongst male and female speakers in the production of SI HP duration.....	174
Table 5.30 Variability amongst male and female speakers in the production of SI HP duration.....	175
Table 5.31 Variability amongst male and female speakers in the duration of HP of SI clusters. ....	176
Table 5.32 Variability amongst male and female speakers in the duration of excrescent vowel in SI clusters. ....	177
Table 5.33 Variability amongst male and female speakers in the duration of HP in SF clusters.....	178
Table 5.34 Variability amongst male and female speakers in the duration of epenthetic vowels in SF clusters. ....	180
Table 5.35 The influence of speaking rate on the release of C1 in SI clusters. ....	181
Table 5.36 The influence of speaking rate on SI clusters' HP duration. ....	182
Table 5.37 The influence of speaking rate on the duration of excrescent vowels in SI clusters. ....	183

Table 5.38 The influence of speaking rate on the release of C1 in SF clusters. ....	184
Table 5.39 The influence of speaking rate on the duration of HP in SF clusters....	185
Table 5.40 The influence of speaking rate on the duration of epenthetic vowels in SF clusters.....	186
Table 6.1 Mean duration, duration of voicing, percentage of voicing, number of periods, voicing category and VOT values of syllable-initial single stops. ....	192
Table 6.2 Mean duration, duration of voicing, percentage of voicing, number of periods, and voicing category of SF single stops. ....	194
Table 6.3. Mean duration of C1, ICI, and C2, duration and ratio of voicing in C1 and C2, number of periods, voicing category and VOT in voiced + voiced clusters (1-12) and voiceless + voiceless clusters (13-14). ....	195
Table 6.4. Mean duration of C1, ICI, and C2, duration and percentage of voicing in C1 and C2 , number of periods, voicing category and VOT in voiced + voiceless clusters (1-8) and voiceless + voiced clusters (9-14). ....	196
Table 6.5 Mean duration of C1, ICI, and C2, duration and percentage of voicing in C1 and C2, number of periods, voicing category in SF two- stop clusters.....	203
Table 6.6. Mean duration of clusters, duration of voicing, ratio of voicing, number of periods and voicing category of clusters with a range of voicing specifications in SI and SF positions. ....	208
Table 6.7 Mean HP duration, duration and percentage of voicing, number of periods, voicing category and VOT. While voiceless stops are completely voiceless, voiced stops are partially devoiced at normal and fast speaking rate, and devoiced at slow rate. ....	209
Table 6.8 Mean HP duration, duration and percentage of voicing, number of periods and voicing category. While voiceless stops are completely voiceless, voiced stops are voiced at normal and fast speaking rate, and become partially devoiced at slow rate. ....	210
Table 6.9 The Influence of speaking rate on duration and category of voicing in SI clusters with different voicing combinations. ....	213
Table 6.10 Influence of speaking rate on duration and category of voicing in SF clusters with different voicing combinations .....	216

## Abbreviations and Symbols

Abbreviations:

Abbreviation	Word(s)
LA	Libyan Arabic
TLA	Tripolitanian Libyan Arabic
BA	Benghazi Arabic
FA	Fezzani Arabic
SI	syllable-initial
SF	syllable-final
A-to-P	anterior-to-posterior
P-to-A	posterior-to-anterior
HP	hold phase
sig	significance
EPG	electropalatography
Lx	laryngograph
ICI	inter-consonantal Interval
C1	the first stop
C2	the second stop
Dur	duration
Syl	syllable
rlsd.	released
LB	labial
TT	tongue tip
TB	tongue body
clust.	cluster
VD	voiced
PD	partially devoiced
PV	partially voiced
DV	devoiced
VLS	voiceless

IPA notation is used throughout the thesis for phonetic and phonemic transcription.

# Chapter One: Introduction and Background

## 1.1 Structure of the Thesis

This thesis is organized into seven chapters. *Chapter One* presents the aims of the study, the rationale for choosing this topic. This chapter is also dedicated to the discussion of the consonant and vowel inventory of TLA, phonotactics and to the review of previous research conducted on TLA. *Chapter Two* is dedicated to the discussion of articulatory timing in speech production, including the timing of voicing, and the main factors that influence timing relations in stop production. *Chapter Three* presents the main questions and hypotheses, and discusses the methodology for this study including the theoretical framework (articulatory phonology), materials used and recording procedures. This chapter also shows how the measurements were taken in data gathered by every instrument. *Chapter Four* presents the results from the EPG measurements and discusses them in the light of the literature reviewed in Chapter Two and the hypotheses stated under coordination and speech rate in Chapter Three. *Chapter Five* presents and discusses the results from the acoustical measurements of duration and discusses these in the light of the literature reviewed in Chapter Two and the hypotheses stated under coordination, the influence of morphology and speech rate in Chapter Three. It also includes the results of the statistical analysis and a discussion of their significance. *Chapter Six* is dedicated to presenting and discussing Lx results for the timing of voicing in the light of the hypotheses stated under voicing and speech rate Chapter Three as well. *Chapter Seven* summarizes the main findings of the study, presents a general discussion, outlines the limitations of the study, and ends by suggesting possible directions for further research.

## 1.2 Purpose of the Study

The main purpose of the present research is to contribute to the body of knowledge about Libyan Arabic dialects, which to date have received little attention, and to pave the way for future research on the dialect spoken in the Libyan capital, Tripoli. This study adopts an articulatory and acoustic approach in order to investigate the temporal and spatial properties of two-stop consonant clusters in Tripolitanian Libyan Arabic (hereafter TLA). The thesis is motivated by three main questions. The first concerns how speakers of TLA coordinate the articulatory gestures in stop clusters. The second investigates how the laryngeal gesture is coordinated with supralaryngeal gestures. Finally, how syllable position, place of articulation, including sequence of articulation, morphological structure, gender of the speaker and speaking rate influence the gestural coordination of two-stop clusters.

EPG frames, spectrograms and Lx waveforms are used to measure articulatory timing and explore timing relations amongst the following categories:

- Syllable-initial (henceforth SI) single stops
- Syllable-final (henceforth SF) single stops
- Two-stop clusters in SI position (including those involving a prefix)
- Two-stop clusters in SF position (including those involving a suffix)

Examples of the timing relations investigated here include the ratio of hold phase (HP) duration of SI single stops to that of SF single stops, two-stop clusters to two individual single stops, voice onset time (VOT) for singletons to VOT of two-stop clusters. These measurements were used to test some hypotheses, stated in Chapter Three, regarding overlap and to answer the above research questions.

The objectives of this thesis are four-fold. First, it will describe the articulatory and the acoustic properties of stop consonants, and their permissible combinations in TLA SI and SF clusters. The second objective is to investigate how the articulatory gestures in two-stop clusters are organised and what role the place of articulation, sequence of articulation, syllable position, morphological structure, gender, and speaking rate play in the gestural coordination, the duration of the hold

phase (Henceforth HP), and the duration of the inter-consonantal interval (henceforth ICI). It is worth mentioning that this term will be used for now to refer to the vocalic segment that appears between the two stops regardless of its duration and voice. When ICI is used in tables, they refer to either excrescent or epenthetic vowels depending on syllable position, i.e. ICIs in onset position refer to excrescent vowels and ICIs in coda position refer to epenthetic vowels.

A related objective is to use electropalatography (EPG) to measure the spatial and temporal relations between the tongue and the hard palate in the production of two-stop consonant clusters, focusing in particular on lingual stops (coronal and dorsal). The final objective is to investigate the timing and duration of voicing in two-stop consonant clusters by using laryngography (henceforth Lx), and the influence of the factors stated above on its initiation and termination.

### **1.3 Rationale for the Study**

There are many reasons for choosing to undertake research in the area of Arabic phonetics. These include general reasons such as:

- The desire to contribute to the study of Arabic phonetics.
- The need to use different phonetic instruments that have not been used in TLA before. For example, Hassan and Heselwood (2011:10) stress the need to apply modern phonetic instruments to Arabic, in order to uncover the acoustic and articulatory patterns of this language.
- Investigating the acoustic properties resulting from the interaction of two stop consonants in particular.
- Investigating the influence of place of articulation, gender and articulation rate on the production of two-stop clusters.

TLA remains one of the most understudied dialects spoken in a capital city of the Arab world. Work carried out on Libyan Arabic in the 1970's and 1980's focused on its phonology, rather than its phonetics. This thesis is an attempt to shed more light on the articulatory and acoustic properties of stop consonants in TLA.

There is also a tendency in some of the existing studies to treat Libyan Arabic as one variety. As a result, there has been a lack of focus on the diverse dialects spoken in the country's vast regions.

The rationale of choosing timing in consonant clusters is the fact that consonant clustering is one of the features shared by many languages. After investigating the presence of consonant clusters in 104 languages spoken in different parts of the world, Locke (1983) concluded that some 48% of these languages have consonant clusters in SI and in SF position. For a language like Arabic which tends to avoid consonant clustering, it is worth investigating this feature when it exists. It is not clear whether TLA inherited this feature from its contact with other languages such as Berber, Turkish, and Italian. It is beyond the scope of this study to investigate the origin of consonant clustering in TLA. It is only concerned with the acoustic characteristics of two-stop clusters in TLA.

Another reason for conducting this study is that previous studies on TLA have not used instrumental phonetic tools such as EPG and Lx. There are many advantages of using multiple modern tools in phonetic research. Hassan and Heselwood (2011:9) point out that in the past, Arabic phoneticians relied mainly on observations and writing detailed descriptions of the sound system of Arabic. With modern phonetic instruments now becoming available, some of the areas in Arabic phonetics need to be revisited and investigated. In addition, when different phonetic instruments are used, they can provide more comprehensive data and yield to more reliable results.

This study will also explore the influence of gender on articulatory timing. To the best knowledge of the author, this study is the first to investigate female speech in TLA. This contributes to the research on how gender differences influence speech production in Arabic dialects.

## **1.4 Arabic Language**

### **1.4.1 Introduction**

Arabic is one of the most widely spoken languages in the world (Ryding 2005:1). It belongs to the Semitic family, a member of the Hamito-Semitic family

which belongs to a larger family known as the Afro-Asiatic group of languages (Watson 2002:1; Newman 2002: 65). Arabic is currently the fourth most widely spoken language in the world (<http://geography.about.com>) with more than 200 million speakers in twenty Arab countries stretching from Mauritania in North-West Africa to Oman in the Middle East. It is also used for mainly religious purposes by more than a billion non-Arab Muslims from many parts of the world (Ryding 2005:1).

The Arabic language is well known for its diglossia, the linguistic phenomenon whereby two varieties of a language are used to serve different purposes. Ferguson (1959:336) refers to “the superposed variety” [in the case of Arabic, this variety is Modern Standard Arabic (MSA), which evolved from Classical Arabic (CA), the language of the Holy Quran] and the low variety [this variety refers to Arabic dialects]. In Bentahila’s (1991:81) opinion, the main point of difference between the two varieties is that while the high variety is written, the low variety is spoken. However, the high variety is used in broadcast news and in formal speeches, whilst in modern times, short stories, popular poetry and plays, text messages, or emails may be written in the low variety as well. Despite the apparent binary distinction in contemporary times between the high and low varieties of Arabic, Versteegh (1997:131) observes that a certain amount of ‘mixing’ took place during the second stage of Arabicisation when Bedouin tribes from the Arabian Peninsula spread westwards across what was to become the Islamic empire from the seventh century to the twelfth century (Ryding 2005:3). Another type of Arabic language is emerging as a result of the interaction between MSA and Arabic dialects. Elgibali (1996) argues that this new linguistic variety combines features from both MSA and Arabic dialects. Ryding (2005:6) uses the term ‘cultivated spoken Arabic’ to refer to this variety of Arabic which forms a continuum, instead of the usual high vs. low binary division.

The division between high and low varieties of Arabic can be based on language use or may be the result of geographical or political boundaries. Figure 1.1 shows a map of the Arab countries where Arabic is an official or co-official language.

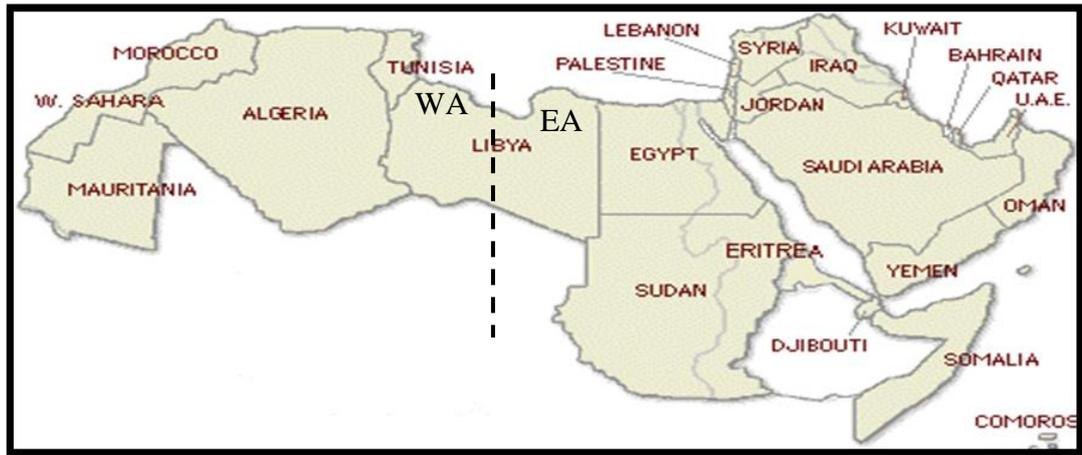

Figure 1.1 Countries where Arabic is an official or co-official language (Source: AraBbay.com). According to Owen (1993) the dotted line divides Eastern Arabic (EA) from Western Arabic (WA).

MSA is the variety used all over the Arab world by *Imams* delivering sermons in mosques, in television and radio broadcasting, and on formal occasions when a speech is being delivered. It is also usually the medium by which Arabs who speak very distinct dialects are able to communicate with each other. Varieties of Arabic can also be classified on a geographical basis. Thus Newman (2008:63) refers to Eastern and Western Arabic (EA and WA respectively) varieties which can be further sub-divided, see Figure 1.1 above, into dialects which correspond to nation states for example Egyptian Arabic, Lebanese Arabic, Jordanian Arabic, Libyan Arabic (henceforth LA), Moroccan Arabic, etc.

In addition to the above dialectal classification, Alorifi (2008:5) makes a clear distinction between EA and WA. EA includes those Arabic varieties spoken in the countries of the Arabian Peninsula, (Saudi Arabia, Bahrain, Kuwait, Qatar, the United Arab Emirates, Oman and Yemen) and Iraq, the Levant (Palestine, Syria, Lebanon and Jordan), and also Egypt, Sudan, Somalia, Djibouti and Comoros. WA, on the other hand, refers to those dialects found in Libya, Tunisia, Algeria, Morocco, and Mauritania. Alorifi (2008:6) identifies two further factors relevant to Arabic dialects. The first relates to the fact that there are significant differences between Bedouin and Urban dialectal varieties. The second factor is linked to religious differences which may lead to the formation of dialects which are associated with Muslim, Christian, and Jewish communities or with religious sects, e.g. Sunni and Shia.

As Miller (1986) explains, the question of whether Arabic dialects emerged from Classical Arabic is complicated. It is a well-established fact, however, that different Arabic dialects share many phonetic features with MSA and with each other (for example pharyngealisation). Dialectal variation can be found on three levels: vocabulary, grammar and pronunciation. This thesis is concerned with only the last of these levels as it is found in LA, and no attempt is made to investigate the other two levels.

On the phonetic level, different Arabic dialects have distinct vowel inventories and also display some variation in the realisation of consonants as well. For example, Al-Tamimi and Barkat-Defradas (2003:171) point out that Moroccan Arabic dialect has only five vowels, while Jordanian Arabic has as many as eight. In the case of consonants, Arabic dialects share the bulk of their consonants with MSA. However, variations between dialects exist. For example, some dialects have /θ/, /ð/ and /ð/, whereas in others these have been merged into /t/, /d/ and /d/ respectively (Corriente 1978:51).

#### **1.4.2 Linguistic Variation in Libya**

Geographical and historical factors played an important role in forming the linguistic variation which is apparent in contemporary Libya. The uniqueness of Libya's linguistic situation is the result of its geographical location. One of the largest countries in Africa, Libya occupies some 1,757,000 sq km, consisting of mostly desert areas in the south. With its coastline washed by the Mediterranean Sea, it lies in the heart of the Arab world sharing borders with Egypt in the east, Tunisia and Algeria in the west, Niger and Chad in the south, and Sudan in the south-east.

Libya has witnessed many eras of linguistic diversity in its history. It was influenced first by the Berber tribes, then the Phoenician merchants, or Punic, together with the Greeks, the Romans, and later the Arabs following the Islamic conquest in 643 C.E (Mattingly 1995:171). It was during the Islamic era that Arabic was introduced and gradually gained its position as the primary language. Libya was under the rule of the Ottoman Empire from 1517 to 1912 (Vandewalle 2012:16) Libya then became an Italian colony for nearly four decades during the nineteenth

century when several languages, including Berber, Hebrew, Arabic, Turkish, English and Italian were spoken in Libya (Simon 1989: 102).

During the Italian occupation, Libya was divided into three main provinces. The first of these, located in the north-west region of Libya, was known as Tripolitania and included Tripoli and the surrounding cities. The second province, Berga (or Cyrenaica) was located in the Eastern part of Libya. The third province, Fezzan, was situated in the south-west region of Libya. The three main dialectal areas correspond geographically to these three provinces as shown on the map of Libya in Figure 1.2.

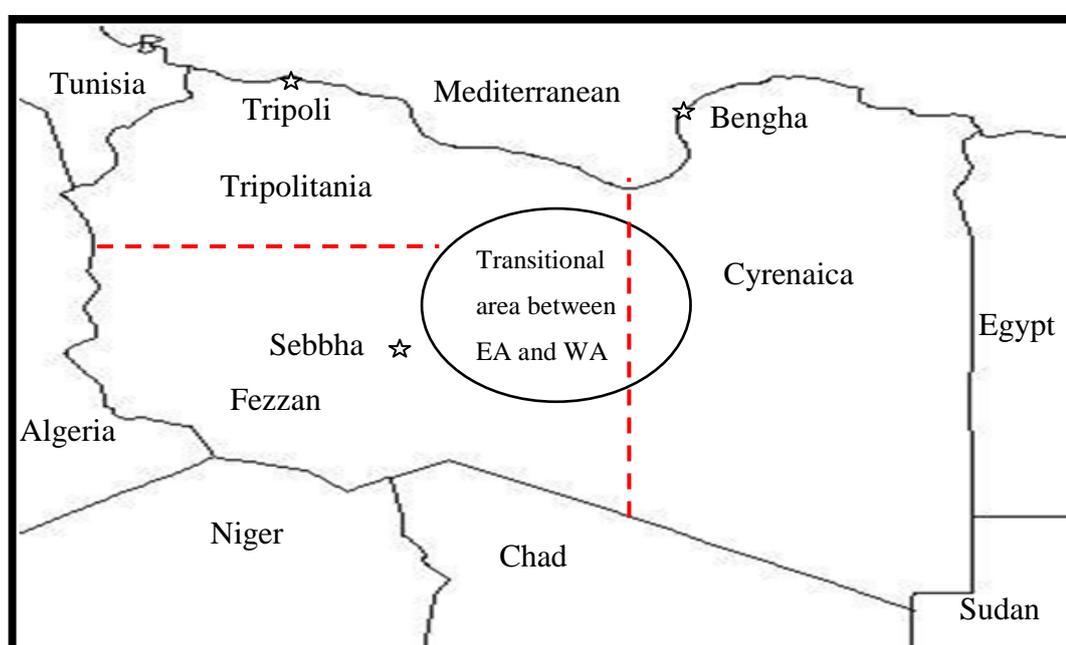

Figure 1.2 A map of Libya showing its three dialectal areas, and the transitional area between Eastern and Western Arabic (The transition area is adapted from Owens 1983:116).

Thus, Tripolitanian Libyan Arabic (henceforth TLA), Benghazi Arabic (BLA) and Fezzani Arabic (FLA) became the main dialectal areas in Libya. In this thesis, TLA is used to refer to the dialect spoken only in the capital Tripoli, i.e. it excludes the surrounding cities. Aurayieih (1981:1) states that differences relating to syntax, semantics, and lexis amongst these dialects are wider than they are for phonetics.

While TLA and FLA can be said to belong to the Western dialect or Maghribi area, BLA belongs to the Eastern dialect area (Chapin 2004:94-95). It is worth mentioning that a number of linguists including Owens (1983) and Ghazali *et al.* (2002) believe that the transitional area between EA and WA is in Libya on the boundaries between TLA and BLA, as shown in Figure 1.2. In addition to these main classifications, numerous Libyan sub-dialects exist within these three main areas. Mitchell (1993:4) refers to some of these sub-dialects, such as the Berber dialects, also known as ‘Tamazight’, which are spoken by tribes in the Jabal Nafusa area south of Tripoli. The Nafusi variety of Berber has its own dialects, including Zuara and Djerbi which exist close to the Libyan-Tunisian border (Lewis 2009). These varieties of Berber add to the complexity of the linguistic situation in Libya where Berber peoples have been mixing with Arabs for hundreds of years (Laradi 1983:7).

Other varieties of Berber are also spoken by Bedouins living in the Libyan Desert. While Tamasheq (or Tamachek) is spoken by the Tuareg, Berbers in Eastern Cyrenaica speak Awjilah (Lewis 2009). In addition, the Awlad Ali, one of the largest Arab tribes residing on the Eastern border in both Libya and Egypt, speak Arabic dialects (Evans-Pritchard 1949:47) that are more like Egyptian than Libyan (Mitchell 1993:4).

The main focus of this study, TLA, is spoken in Tripoli. Tripoli is the most densely populated city in the country with over two million residents (<http://arab.aljaryash/Arabic-3-14.html>). Given that Libya has just over six million inhabitants, this accounts for about one third of its population. Tripoli has always been the predominant city in Libya, and its importance increased during the years of the Italian occupation (Harrison 1976:399). As a result, it is the preferred destination for migrants from other cities in Libya and from neighbouring countries. Economic growth on the Libyan coast, particularly in Tripoli, continues to attract those seeking the chance of a better life, or, at the present time, hoping to cross the Mediterranean Sea to Europe. Different Arabic dialects from the east, west and south of Libya can be recognised when listening carefully to different speakers in Tripoli, in addition to other varieties of Arabic and African languages spoken in neighbouring countries.

To conclude, Libya has witnessed many linguistic changes over the centuries since the Islamic conquest originally brought Arabic to this country. Today, Libyans

speak their own distinctive variety of LA which, depending on the region, can be TLA, BLA, FLA or one of the other sub-dialects spoken there by the Berber or Bedouin peoples. Libyans are also exposed to, and can use MSA to differing degrees, depending on individual circumstances. The following section provides a brief review of the phonetic and phonological studies conducted on LA to date, and will cover both those which are of a general nature and those which have focused on specific dialects of LA.

### 1.4.3 Previous Studies on Libyan Arabic

In general, there is a shortage of publications on Arabic by Arabic linguists and phoneticians. Classical grammarians such as Al-Khali:l, in the first dictionary of the Arabic language *Kita:b Al-'Ayn*, and Si:bawayh in his meticulous account of Arabic *Al-Kita:b* founded the study of Arabic phonetics and both are still cited by modern academics (Rosenhouse 2007: 131). Today, despite advances in technology, computer science and software designed to analyse speech, Arabic phonetics is still understudied and needs further investigation using modern phonetic instruments<sup>1</sup>.

The same is true of LA dialects. The earliest research into languages in Libya was conducted by two Italian linguists, Griffini (1913) and Panetta (1943) respectively (cited in Laradi 1983:3). In the 1950s and 1960s, research on the phonetics and phonology of EA dialects in Libya was carried out by Mitchell (1952; 1957; 1960). In the late 1970s, however, the picture started to change. Libyan students were granted scholarships to pursue their studies abroad and some chose to investigate the grammar, discourse, phonetics and phonology of LA. Some of these are of relevance to this current study of TLA beginning with Elfitoury's (1976) doctoral dissertation which adopts a structural approach to analyse the grammatical structures of the Arabic dialect spoken in Tripoli. Swed's (1982) comparative study utilises a generative phonology framework to examine the processes of verb development in three different Arabic varieties spoken in national capitals: Tripoli dialect (Libya), Cairene Arabic (Egypt) and Baghdadi Arabic (Iraq).

---

<sup>1</sup> For more details about the use of modern phonetic instruments in studying Arabic phonetics, see Hassan and Heselwood (2011). The volume is devoted to the important role of modern phonetic instruments in studying Arabic phonetics.

In the same year, using a similar framework, a doctoral dissertation by Aurayieth (1982) investigated the phonology of the verb focusing in this case on Eastern LA. Both Abumdas (1985) and Elgadi (1986) also employ the framework of generative phonology in their respective studies. Abumdas (1985) investigated the phonology of LA as it is spoken in Zliten a city situated some 150 km east of Tripoli, whilst Elgadi (1986) analysed the phonology and morphology of TLA. Taking a different approach but still focusing on LA as spoken in the Tripoli region, Abdu (1988) investigated the semantic adaptation of Italian loanwords in this Arabic variety. Of particular interest here is Laradi's thesis (1983), probably the first instrumental phonetic study conducted on LA, which investigates the phenomenon of pharyngealization in Tripoli dialect. There are also the comments on Mitchell's (1960) works on Eastern Libyan Arabic by Owens (1980; 1984).

Studies conducted in the 1990s include Harrama's study (1993), which describes the morphological structure of Al-Jabal Al-Gharbi, or Western Mountain dialect, which is spoken in an area some 100 km south east of Tripoli. In addition, there is Al-Ageli's study (1996) which deals with the syllabic and metrical structure of TLA in the light of Optimality Theory. Later studies include the work of Ahmed (2008) which investigates the production and perception of Libyan Arabic vowels by speakers of Rayaina, a city which is situated in the Tripolitanian region, 142 km south of Tripoli (Ahmed 2008:103), and Kriba (2010) who focuses on pharyngealisation in Libyan Arabic. Kriba uses locus equations to investigate the distinction between plain vs. emphatic consonants. Elramli (2012) adopts a constraint-based approach to investigate assimilation in the phonology of Libyan Arabic. Elramli focuses on the dialect spoken in Misrata, a city located 200km east of Tripoli. Finally, Maiteq (2013) investigates the magnitude of anticipatory pharyngealisation in LA. Where relevant these works will be referred to in the following chapters as a useful source of general and specific information regarding the variety of Libyan Arabic used in Tripoli and elsewhere in the province of Tripolitania.

In the following sections, the consonants and vowels used in TLA are described and discussed, and an attempt is made to clarify the status of some disputed consonants and vowels. In addition, the possible combinations of two-stop consonant clusters, assimilation, syllable structure and stress rules are also

considered. Since the present study is restricted to the timing relations of two-stop consonant clusters in TLA, no attempt is made to examine other types of consonant clusters.

#### 1.4.4 Consonants in LA

Reviewing the studies conducted on LA, it becomes apparent that different studies claim different sizes of consonant inventory. While Elfitoury (1976:1) reports thirty-four consonants, Laradi (1983:11) and Elgadi (1986:5-6) identify twenty-eight and thirty consonants respectively. The reason behind this diversity is that different Libyan dialects vary in regard to the number of consonants they share with MSA. For example, some dialects, mainly Bedouin ones, preserve a number of consonants from MSA. Table 1.1 shows the consonants in TLA.

			Bilabial	Labio-dental	Dento-Alveolar	Post-alveolar	Velar	Uvular	Pharyngeal	Glottal
Stops	voiceless	plain			t		k		q	ʔ
		emph.			t <sup>ʕ</sup>					
	voiced	plain	b		d		g			
		emph.			d <sup>ʕ</sup>					
Fricatives	voiceless	plain		f	s	ʃ		χ	ħ	h
		emph.			s <sup>ʕ</sup>					
	voiced	plain			z	ʒ		ʁ	ʕ	
		emph.								
Nasals			m		n					
Laterals					l					
Tap or Trill										
Approximants			w							

Table 1.1 The consonants of TLA, their place and manner of articulation.

All three of the studies mentioned above agree that TLA has nine stops (/b/, /t/, /d/, /t<sup>ʕ</sup>/, /d<sup>ʕ</sup>/, /k/, /g/, /q/ and /ʔ/); eleven fricatives (/f/, /s/, /s<sup>ʕ</sup>/, /ʃ/, /ʒ/, /χ/, /ʁ/, /ħ/,

/ʕ/ and /h/); two nasals (/m/ and /n/); two laterals (/l/ and /lʕ/); one tap or trill (/r/) and two approximants (/w/ and /j/).

#### 1.4.4.1 Stops

In comparison to English, TLA, like MSA, has a larger inventory of stops, in both place and manner of articulation. These include the uvular /q/, and the emphatics /tʕ/ and /dʕ/, and the glottal stop /ʔ/. /q/ is commonly replaced by /g/ for example /qul/, ‘say!’ in MSA → /gu:l/ in TLA. Although it is widely said that /q/ exists only in the speech of educated people, it is fairly frequently used by most Libyans regardless of their education. Words like /qurʔa:n/ ‘Qur’an’, /qara:r/ ‘decision’, /qa:ʕida/ ‘base’, /ʕaqd/ ‘contract’ and /ʕaqd qira:n/ ‘marriage certificate’ are always pronounced with /q/. In TLA, /q/ is a lexically determined allophone of /g/, i.e. /g/ is used to replace it in certain context.

Laradi (1983:11) notes one of the common features of both TLA and other varieties of Libyan Arabic is the replacement of the glottal stop by a long vowel or approximant. Three examples are shown below:

Rule	example	Gloss
By /i:/	/biʔr/ → /bi:r/	‘well’
By /j/	/ʕa:ʔin/ → /ʕa:jin/	‘traitor’
By /w/	/ʔuðun/ → /widin/	‘an ear’

TLA does not have a voiceless bilabial stop /p/. In loanwords containing /p/, it is replaced by /b/, for example /penna/ (Italian for ‘pen’) is pronounced /be:nna/ in TLA.

#### 1.4.4.2 Fricatives:

Although Elfitoury (1976:3) states that /v/ is not frequently used in LA, Elgadi (1986:5) still includes it as a distinct phoneme. In words borrowed from Italian, it seems that when /v/ is intervocalic it is replaced by /w/. For example:

<b>Italian</b>	<b>TLA</b>	<b>Gloss</b>
/lavande'rja/	/wanda'ri:ja/	'laundry'
/la'vaddʒo, dʒi/	/la'wadʒu/	'car wash'
/lavan'dino/	/lawan'di:no/	'sink'

/v/ occurs in initial position in Italian or English loanwords; however, in TLA it is replaced by its voiceless counterpart /f/ as in the following examples:

**English:** /vɪdɪəʊ/ 'video' → /fi:dju:/ in TLA

**Italian:** /vait/ 'screw' → /fi:ti:/ in TLA

In an informal survey conducted by the researcher, a hundred Libyan speakers from Tripoli and the surrounding cities were asked how they would pronounce the loanwords 'video', 'Vaseline™', and 'viva', only 9% of the participants said they use /v/. In this case, it appears that it is the level of familiarity with English or other languages that use /v/, rather than the level of education, that determines the use of /v/ in loanwords.

According to Elfitoury (1976:3), the voiceless interdental fricative /θ/ and its voiced counterpart, /ð/, both found in MSA, are used in areas in the east and west of Libya. However, TLA lacks \*/θ/ and words realised with this sound in MSA are realised with \*/t/ in TLA to produce /tla:ta/ 'three' instead of /θalaθa/ and /ð/ corresponds with /d/ to produce /ha:da/ 'this' instead of /ha:ða/. In the case of /ðˢ/, this merges with /dˢ/ to produce /dˢulum/ 'injustice' instead of /ðˢulm/. This process is called "stopping" and it refers to the replacement of fricatives by homorganic stops (Roach 2000:56). The post-alveolar affricate \*dʒ is consistently reduced to /ʒ/ in TLA; as a result, it is excluded as a distinct consonant sound in this study.

#### **1.4.4.3 Nasals**

There are two nasals in TLA: /m/ and /n/. Some studies (for example Elfitoury 1976 and Elgadi 1986) include /mˢ/ in the consonant inventory of TLA.

Sometimes /n/ replaces /l/ as in the following examples:

MSA	TLA	Gloss
/ʔisma:ʕi:l/	/ʔisma:ʕi:n/	‘Ismael’
/silsila/	/sinsla/	‘chain’
/le:n/	/ne:n/	‘until’

/n/ is released as [ŋ] when it occurs adjacent to /g/ as in /ngu:l/ → [ŋgu:l] ‘we say’ (Laradi 1983:12).

#### 1.4.4.4 Laterals

In TLA, the emphatic /l<sup>s</sup>/ is less frequent than the non-emphatic /l/ (Laradi 1983:13). It exists in commonly used religious expressions such as /ʔalʕlʕa:h/ ‘Allah’ and related terms such as /inʕa:ʔa lʕlʕa:h/ ‘God willing’. Ferguson (1956:446) suggests that /l<sup>s</sup>/ should be treated as a distinct phoneme. However, there is no consensus on whether to treat it as a separate phoneme or as an allophone of /l/. Heselwood (1992) characterise it as a religiously determined allophone of /l/. Finally, /l/ sometimes replaces MSA /n/ as in: /findʒa:n/ → /findʒa:l/ ‘coffee cup’ and is sometimes itself replaced by /r/ as in: /le:t/ → /re:t/ ‘for wishing’.

Although /r/ is realized as a tap in TLA, it becomes a trill in final position. According to Elfitoury (1976:12), TLA has two taps: One is a dental tap that becomes a trill in final position for example [fa:r] ‘mouse’, whilst the other tap is velarised as in /ʕa:r/ ‘disgrace’. On the other hand, Laradi (1983: 14) states that depending on its position and whether it is doubled or not, /r/ in TLA can be realized as a tap or a trill. It seems that /r/ can become a tap when intervocalic or preceding a vowel for example /ʕrab/ ‘Arabs’, or a trill when in final position preceded by a vowel for example /marr/ ‘he passed’, or when followed by a consonant for example /ħarb/ ‘war’. The trill variant can be both an allophone of the tap or a geminate version of it. This variation is determined by the context. Additionally, this pattern of /r/ being realised as a tap when a singleton and a trill when a geminate is common across many languages including Italian (Ladefoged and Maddieson 1995:219-221).

Metathesis, that is the reversal of a sequence of sounds within the same word, occurs in TLA. Examples include:

	<b>MSA</b>	<b>TLA</b>	<b>Gloss</b>
/s/ and /f/	/nis <sup>s</sup> f/	/nufus <sup>s</sup> /	‘half’
/b/ and /d/	/dʒaḏaba/	/ʒbad/	‘to pull’
/q/ and /b/	/θuqb/	/t <sup>s</sup> ubug/	‘hole’

#### 1.4.5 Consonant Clusters in TLA

Before discussing consonant clustering in TLA, a distinction should be made between consonant clusters, consonant sequences and abutting consonants. Abercrombie (1967:76) points out that the term ‘consonant cluster’ is used to refer to two or more consecutive consonants occurring within one syllable. However, if these consonants extend to two syllables, the consonants are said to be in a sequence. In a sequence of three consonants, two of the consonants belong to the same syllable. The term ‘abutting’ refers to two adjacent consonants separated by a syllable boundary. For example, in a TLA word like /ʔinktab/ ‘it was written’, /nkt/ belongs to a sequence, /kt/ forms a cluster, whilst /nk/ are abutting consonants.

Compared to MSA, TLA is more permissive of consonant clustering, and Laradi (1983:26) argues that this feature has been inherited from the Berber languages which are still spoken in Libya. In this thesis, the focus is on two-stop consonant clusters which occur in SI and SF position in TLA. When the terms onset and coda are used, they also refer to SI and SF position.

##### 1.4.5.1 VC vs. CV dialects

Kiparsky (2003:147) makes a distinction between different Arabic dialects on the bases of their internal syllable structure. He divides Arabic dialects into VC, CV and C dialects. VC-dialects are those dialects mainly spoken in the Levant and Iraq. In these dialects, a remedy of a three consonant sequence is an epenthetic

vowel inserted before the second consonant. For example, a sequence of CCC is in /k**ab**tla/ 'I wrote for him' is rendered as CVCC in TLA as in /ktabitla/. These dialects are also known as onset dialects (Farwaneh (2009: 82). The second type of dialects is C-dialects. These dialects are spoken in North Africa, particularly in Morocco Tunis and Mauretania. According to Kiparsky (2003:147), these dialects have long clusters of only consonants, some of which are syllabic. The final dialect type is CV. These dialects are spoken in Egypt and Parts of Libya. A sequence of three consonants CCC as in /k**ab**tla/ is rendered as CCVC as in Cairene Arabic /ktabtilu/. These dialects are also known as coda dailects (Farwaneh (2009: 82)

It can be seen from Kiparsky's classification is that Cairene Arabic and TLA do not permit a sequence of three consonants (Broselow 1976: 1, cited in Watson 2002:64). As a result of being a CV dialect, Cairene Arabic speakers insert an epenthetic vowel after the second consonant. TLA, on the other hand is a VC dialects, because speakers of this dialects insert an epenthetic vowel after the first consonant (Kiparsky 2003:1). In this respect, the consonants preceding onset clusters and following coda clusters may have an influence on the gestural coordination of two-stop clusters in TLA. Before answering this question, it is worthwhile to have a look at the possible two-stop cluster combinations in TLA. Tables 1.2 and 1.3 below show the possible combinations of two stops in onset and in coda position respectively.

	<b>/b/</b>	<b>/t/</b>	<b>/d/</b>	<b>/tʰ/</b>	<b>/dʰ/</b>	<b>/k/</b>	<b>/g/</b>
<b>/b/</b>		<u>/b</u> ta:ri:x/ 'on (date)'	/bde:/ 'he started'	/btʰam/ 'he buttoned'	<u>b</u> dʰa:ʃa/ 'goods'	/bke:/ 'he cried'	/bgar/ 'cows'
<b>/t/</b>	/tba:ʃir/ 'you commence'		/tdu:m 'it endures'	/ttʰajib/ 'she cooks'	/tdʰurr/ 'it harms'	/tka:bir/ 'you (m/sing) insist'	/tga:til/ 'you (m/sing) fight'
<b>/d/</b>	/dbaʃ/ 'clothes'					/dkar/ 'male'	/dga:jig/ 'minutes'
<b>/tʰ/</b>	/tʰbaʃ/ 'he typed'						/tʰgar/ 'he tapped'
<b>/dʰ/</b>	/dʰbaba/ 'blur' or 'fog'						
<b>/k/</b>	/kbas/ 'he pressed'	/ktabt/ 'he wrote'	/kdab/ 'he lied'				
<b>/g/</b>	/gbal/ 'he agreed'	/gtal/ 'he killed'	/gdar/ 'he was able'	/gtʰaf/ 'he picked'	/gdʰe:/ 'he paid back'		

Table 1.2 The possible combinations of two-stop consonant clusters in syllable-initial position in TLA. When /b/ and /t/ are underlined, they function as a prefix.

	<b>/b/</b>	<b>/t/</b>	<b>/d/</b>	<b>/t̥/</b>	<b>/d̥/</b>	<b>/k/</b>	<b>/g/</b>
<b>/b/</b>		/ktabt/ 'I wrote'	/ʃabd/ 'a slave'	/rabt̥/ 'tying'	/gabd̥/ 'seizure'	/ħabk/ 'furious'	/t̥abg/ 'to make a hole'
<b>/t/</b>						/hatk/ 'violation'	/fatg/ 'hernia'
<b>/d/</b>	/kidb/ 'lying'						
<b>/t̥/</b>	/ʃat̥b/ 'cancelling'						
<b>/d̥/</b>	/d̥baba/ 'blur'						
<b>/k/</b>		/nakt/ 'unpacking'	/nakd/ 'boring'				
<b>/g/</b>	/nagb/ 'drilling'	/wagt/ 'time'	/ʃagd/ 'tying'	/magt̥/ 'a kind of rope'			

Table 1.3 The possible combinations of two-stop consonant clusters in syllable-final position in TLA. When /t/ is underlined, it functions as a suffix.

### 1.4.6 Assimilation in TLA

Assimilation is a term used to refer to the phonological process in which one sound changes into another due to the influence of a neighbouring sound(s). Elfitoury (1976: 23-24) identifies the some types of place and voice assimilation in TLA. These are presented in the following Table:

Rule		Example	Gloss
Non-velarized to velarized	(tʰ → tʰ)	/ʔittʰi:r/ → /ʔitʰtʰi:r/*	‘she flies’
Voiceless to voiced	(kg → gg)	/ʒa:kga: bil/ → /ʒa:gga: bil/	‘he came to you (sing) accepting’
	(tdʰ → dʰdʰ)	/tdʰu:g/ → /dʰdʰu:g/*	‘she tastes’
Voiced to voiceless	(gk → kk)	/tri:gkum/ → /tri:kkum/	‘your (pl) way’
	(dt → tt)	/gʃadt/ → /gʃatt/	‘I stayed’
place of articulation	(nl → ll)	/mninlik/ → /mnillik/	‘where did you get this from’
	(nf → mf)	/nfass/ → /mfass/	‘breath’
Others	(ts → ss)	/tsagmit/ → /ssagmit/*	‘it became straight’
Regressive assimilation	(lt → tt)	/ʃe:lt/ → /ʃe:tt/	‘family’
Progressive assimilation	(zʒ → zz)	/ʒo:z/ → /zo:z/	‘husband’

Table 1.4 Different types of assimilation in TLA from Elfitoury (1976: 23-24). In cases where /t/ is a prefix, \* is used. The shaded examples are from Laradi (1983:34-35).

Finally, Elgadi (1986:49) states that the definite article /l/ is assimilated to /s/, /θ/, /ʃ/, /ʒ/, /t/, /tʰ/, /d/, /dʰ/, /n/ and /r/. These sounds are coronal, which is why /l/ does not assimilate to sounds which are not coronal. However, Heselwood and Watson (2013) argue against this view, on the basis that assimilation (more) must be optional.

### 1.4.7 Vowels in TLA

Different studies conducted on LA have reported varying sizes of vowel inventory. While Elfitoury (1976, cited in Abumdas 1985:41) identifies eight

vowels, Aurayieth (1981:21) and Laradi (1983:15) respectively report nine. Abumdas (1985: 41) increases this number to ten vowels. All of the aforementioned studies have included the six vowels found in MSA namely /i/, /a/ and /u/, and their long counterparts /i:/, /a:/ and /u:/. In addition, they include /e:/ and /o:/, which correspond to the MSA diphthongs /aj/ and /aw/ respectively (Gairdner 1925: 42, cited in Ahmed 2008:81). However, Aurayieth (1982: 23) also includes /o/ citing the following examples: /ʔilbiso/ ‘they dressed’, /ʔimsiko/ ‘they held’, and /ʔigsimo/ ‘they shared’.

Responding to Aurayieth’s examples, Ahmed (2008: 84) argues that the short /o/ is just an allophone of /o:/ that only occurs in final position. He adds that when Aurayieth’s examples shown above are suffixed by the object pronoun /ha/, they preserve the long vowel /o:/ thus: /ʔilbiso:ha/ ‘they wore it’, /ʔimsiko:ha/ ‘they held it’, /ʔigsimo:ha/ ‘they shared it’. If Abumdas’s examples containing /o/ are suffixed, they also contain the long /o:/. In addition, the vowel in the examples containing /e/ are changed into either /e:/ or /a:/.

The status of the vowel /a/ in TLA has proved to be a controversial issue. One assumption is that there are two independent vowels, /a/ and /ɑ/, with the former occurring only in the vicinity of plain consonants while the latter occurs in the vicinity of emphatic consonants. An alternative proposal is that /ɑ/ is merely an allophone of /a/ occurring only in the vicinity of pharyngealised consonants. While Elgadi (1985:7) believes that [ɑ:] and its short counterpart [ɑ] are allophones of /a:/ and /a/ in the vowel inventory of TLA, Laradi (1983:15) reports that only /ɑ:/ exists as a distinct vowel in TLA. Abumdas (1985:47) also includes this vowel, /ɑ:/, and its short counterpart /ɑ/ as distinct vowels. Examples from Laradi (1983) and Abumdas (1985) are shown in Table 1.6 below:

Laradi (1983: 18)		Abumdas (1985:47)	
/a:/	/ɑ:/	/a:/	/ɑ:/
/da:r/ ‘he did’	/da:r/ ‘room’	/ba:bah/ ‘his door’	/ba:ba/ ‘father’
/ħa:r/ ‘puzzled’	/ħa:r/ ‘hot’	/χa:li/ ‘empty’	/χɑ:li/ ‘my uncle’

Table 1.5 Example of words containing /a:/ and /ɑ:/, in addition to their short counterparts /a/ and /ɑ/ (adopted from Laradi (1983) and Abumdas (1985)).

The difficulty with their conclusions is that /ɑ:/ and /ɑ/ do not occur in the vicinity of plain consonants, but only in the vicinity of the secondary emphatics /m<sup>ʕ</sup>/, /b<sup>ʕ</sup>/, /r<sup>ʕ</sup>/, /l<sup>ʕ</sup>/ and /n<sup>ʕ</sup>/. According to Erwin (1963:48), these sounds occur either in the vicinity of primary emphatic consonants or as a result of certain consonant combinations. The same author stresses that in the production of all emphatic sounds “the tongue is tenser, depressed in the middle, and raised at the back (Erwin 1969:49).

In explaining the nature of /ɑ/, Ghazali (1977:22) states that:

It is my opinion that one can conclude that the /ɑ/ in words not containing pharyngealized consonants is a target /ɑ/; that is, the perception of emphasis [...] is due to an underlying /ɑ/ and not to the fact that the neighbouring consonants are emphatic”. As a result, Ghazali adds “the North African dialects have developed two low vowel phonemes: /æ/ and /ɑ/” (1977:159).

Abumdas (1985:22), in additions, states that:

Since minimal pairs of secondary emphatics and plain consonants occur only in the environment of the low vowels A and a respectively, it is possible to deny the phonemic character of secondary emphatics in LA, attributing the emphatic feature to the neighbouring vowel(s).

Aurayieih (1982: 24) suggests that both the vowel and the consonant carry the emphasis. Although the exact status of /ɑ/ in the vicinity of secondary emphatic sounds remains questionable, it is beyond the scope of this thesis to address this issue in depth. In this thesis, for the sake of simplicity and convenience, [ɑ:] and [ɑ], will be treated as allophones of /ɑ:/ and /ɑ/. While /ɑ/ exists in the vicinity of plain consonants and primary emphatic consonants (that is /t<sup>ʕ</sup>/, /d<sup>ʕ</sup>/, /s<sup>ʕ</sup>/ and /z<sup>ʕ</sup>/), [ɑ] exists only in the vicinity of secondary emphatics. This classification includes all pharyngealised or velarised consonants apart from the aforementioned primary emphatics.

There are 8 vowels in TLA: three short vowels: /i/, /u/ and /ɑ/, together with five long ones: /i:/, /u:/, /ɑ:/, /o:/ and /e:/. TLA vowels can occur as the nucleus of closed and open syllables. In initial position, vowels are always preceded by a

glottal stop. Ahmed (2008: 201) points out that the long vowels are twice as long as the short vowels.

/i:/ is a front high long unrounded vowel. This vowel has many allophones depending on the surrounding consonants. Thus, in the vicinity of primary emphatic sounds, it is retracted as in the following examples: /t<sup>ʕ</sup>i:r/ ‘fly!’ and /ti:r/ ‘a small metal ball’.

/i/ is a front high short unrounded vowel with its context determining its allophones. Examples include: /s<sup>ʕ</sup>innara/ ‘fishing rod’ and /sija:ra/ ‘a car’.

/u:/ is a back high long rounded vowel which may occur in both initial and final position, as in the imperative /ʔu:ɡfu:/ ‘stand!’ It has many allophones depending on its context with examples including: /s<sup>ʕ</sup>u:r/ ‘a wall’ and /su:q/ ‘a market’.

/u/ is a back high short rounded vowel. This vowel may also occur in initial position, when it is preceded by a glottal stop, or in final position as in: /ʔumm/ ‘a mother’, and /ɡu:lu / ‘say!’ (imperative plural). Examples include: /s<sup>ʕ</sup>ull/ ‘boa’ and /sull/ ‘tuberculosis’.

/a:/ is front low long open vowel. It may occur in initial and final position as in /ʔa:hi/ ‘here it is’, and /ʕa:da:/ ‘habit’. Other examples include: /d<sup>ʕ</sup>a:r / ‘harmful’ and /da:r/ ‘he did’. In the vicinity of the secondary emphatic consonants /m<sup>ʕ</sup>/, /b<sup>ʕ</sup>/, /r<sup>ʕ</sup>/, /l<sup>ʕ</sup>/ and /n<sup>ʕ</sup>/, /a:/ is realised as [ɑ:]. Examples include: [ta:r<sup>ʕ</sup>] ‘revenge’ and [ma:r<sup>ʕ</sup>] ‘passing’.

/a/ is a front low short open vowel, occurring in both initial and final position as in /ʔarfaʕ/ ‘take it away!’, and /ʔamta/ ‘when’. Further examples include: /t<sup>ʕ</sup>all/ ‘he appeared’ and /tall/ ‘a coil’. /a/ occurs only in the vicinity of secondary emphatic consonants /m<sup>ʕ</sup>/, /b<sup>ʕ</sup>/, /r<sup>ʕ</sup>/, /l<sup>ʕ</sup>/ and /n<sup>ʕ</sup>/. The following examples are from Abumdas (1985:47): [b<sup>ʕ</sup>ab<sup>ʕ</sup>ah] ‘father’, [bal<sup>ʕ</sup>l<sup>ʕ</sup>ah] ‘by God’, and [ʔam] ‘to cover’.

/o:/ is a half-close long back vowel and it does not occur in final position in TLA. Examples include: /t<sup>ʕ</sup>o:r/ ‘phase’, /to:r/ ‘a bull’ and /ho:f/ ‘house’.

/e:/ is a half-close long front vowel which may occur in final position, replacing the MSA glottal stop sound as in /hasaʔ/ and /hse:/ ‘soup’. It sometimes alternates with /a/ as in /le:f/ or /la:f/ ‘why’, /be:f/ or /ba:f/ ‘to’ (or in some LA dialects ‘how much’), or with /i:/ as in /ki:f/ or /ke:f/ ‘how’. Examples of /e:/ in the vicinity of different consonants include: /d<sup>ʕ</sup>e:f/ ‘a quest’ and /be:ʕ/ ‘selling’.

In addition to these vowels, Elfitoury (1976:22) states that LA has eight diphthongs and divides these into two categories: fronting and retracting. The following examples are from Elfitoury (1976:22):

### Fronting

diphthongs	Example	Gloss
/ij/	/mija/	‘hundred’
/aj/	/hayra/	‘puzzled’ [feminine form]
/u:j/	/bu:j/	‘my father’
/a:y/	/fa:j/	‘nothing’

### Retracting

Diphthongs	Example	Gloss
/ew/	/zrew/	‘puppy’ [diminutive form]
/aw/	/ħawlit/	‘she tried’
/a:w/	/ʔa:wna:h/	‘there he is’
/ow/	/doww/	‘speech, argument’

#### 1.4.8 Syllable Structure in TLA

Unlike in phonology, where a syllable may be defined as “a complex unit made up of nuclear and marginal elements” (Laver 1994: 114), in phonetics there is no commonly agreed definition of what constitutes a syllable. There are, however, several theories which have been proposed to account for syllable structure. Before briefly discussing some of these theories and their limitations, it is worthwhile attempting to define what constitutes a syllable. In terms of internal structure, a syllable is divided into onset and rhyme. The onset refers to the consonant(s) preceding the nucleus, usually the vowel, which is the peak of the syllable. The rhyme branches into the nucleus and the coda, with the coda referring to the consonant(s) following the vowel. TLA allows a maximum of two consonants in an onset and in coda position. Thus, a three consonant sequence is broken by an

epenthetic vowel inserted before the second consonant (Kiparsky 2003; Watson 2007). Diagram 1.1 shows the syllable structure of the word /ktabt/ ‘I/you wrote’:

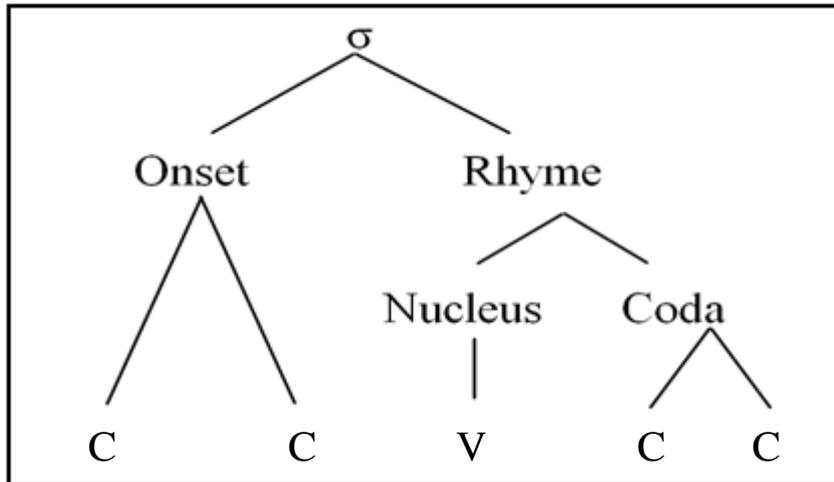

Figure 1.3. The syllabic structure of the word /ktabt/ in TLA

A syllable is considered to be open when it has no coda, i.e. it ends in a vowel, and closed when it ends in a consonant (Laver 1994: 32). Syllables can also be classified into ‘light and ‘heavy’. A heavy syllable consists of a long vowel, a geminate consonant, or a short vowel followed by a consonant cluster (Laver 1994:156). A light syllable has, at most, a short vowel followed by a single consonant or a short vowel in an open syllable (Laver 1994:517).

The sonority theory suggests that segments in a syllable are arranged according to their loudness on a sonority scale (Ladefoged and Johnson 2011: 146). On the sonority scale, vowels are more sonorous than consonants. With regard to vowels, open vowels are classed as being more sonorous than closed vowels. Consonants are divided into sonorants and obstruents, with sonorants being rated as more sonorous than obstruents. Within the group of obstruents, voiced consonants are more sonorous than voiceless ones. However, as Ladefoged and Johnson (2011: 246) note, the sonority scale is of limited validity in explaining some syllables. Thus, for example, in a word like /lbast/, there is only one vowel. However, it has two peaks /l/ and /a/. A modified version of the sonority theory is based on “peaks in prominence” (Ladefoged and Johnson 2011: 247). The phonotactic structure of

/lbast/ contains two prominent peaks (Heselwood 2007), or two phonetic syllables, namely /l/ and /bast/.

Another theory which has been used to explain syllable structure is Moraic Theory. In this theory, every constituent of the syllable equals a mora, which is represented by the symbol ‘μ’. According to Broselow (1976: 34) a light syllable is monomoraic, a heavy syllable bimoraic, and a superheavy syllable trimoraic.

With regard to syllable structure in MSA, there are two important rules of formation: (a) syllables never start with a vowel, and (b) they never have a consonant cluster in onset position. In addition to the five syllable types which are allowed in MSA (namely, CV, VC, CV:, CVC, and CVCC), Laradi (1983:25) argues that TLA also allows the syllable types shown in Table 1.4 below. It is worth mentioning that five of these syllable types can be found in MSA.

syllable type	Example	Gloss
VCC	/abb/	‘father’
CVC	/ <b>jar</b> ba/	‘soup’
CVCC	/b <b>int</b> /	‘a girl’
CCV:	/t <b>la</b> :ti:n/	‘thirty’
CCVC	/j <b>bah</b> na:h/	‘we saw him’
CCVCC	/s <b>raft</b> /	‘I knew’
CCCVC	/n <b>ftah</b> /	‘it opened’
CV:	/l <b>a</b> :/	‘no’
CV:CC	/s <b>a</b> :dd/	‘exception’
CCV:C	/k <b>ta</b> :b/	‘a book’
CCCV:C	/s <b>tra</b> :h/	‘he rested’

Table 1.6 Syllabic templates for TLA (based on Laradi 1983:25). In the examples, syllables types are in bold.

Elgadi (1986:56-57) states that TLA has a syllable structure in which the peak of the syllable consist of a short/long vowel or a diphthong. The onset may consist of up to three consonants, whilst the coda may have none, one or two consonants. He also includes CVVC /ba:b/ ‘door’, and CCCV /nkwe/ ‘to be cauterised’. Abumdas (1985:89) includes V as in /abe/ ‘he agreed’, V: as in /u:guf/ ‘stand up’, VC as in /aswad/ ‘black’. The first of his examples may be a dialect-specific item, not used in TLA. The other two examples offered by Abumdas,

however, can be preceded by a glottal stop followed by a vowel, which prevents a sequence of three consonants in syllable-onsets.

Al-Ageli (1996:11) summarises the syllable structure of TLA as in Figure 1.4. He also adds another syllable template CCVV as in /ʒni:/ ‘guinea/ ‘pound’.

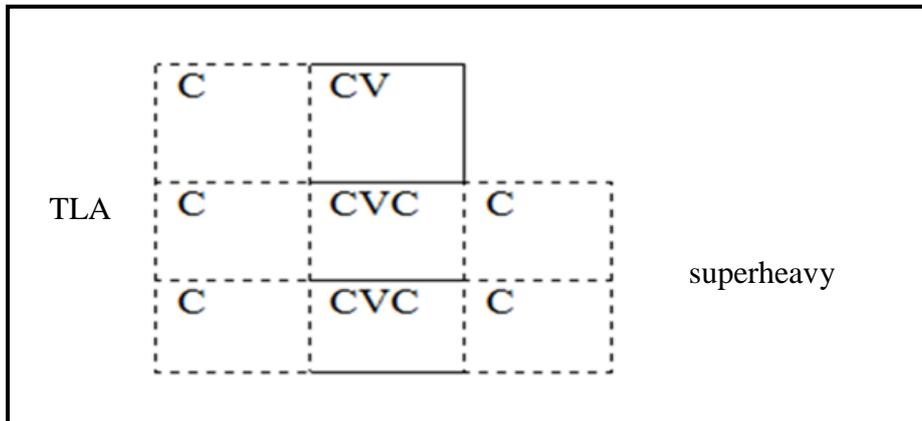

Figure 1.4 The syllabic structure of TLA (based on Al-Ageli (1996:11)).

The main issue to notice about Al-Ageli’s analysis is that he does not include more than two consonants in onset position. In fact, Al-Ageli (1996:112) argues that the three consonant clusters in onset position are derived by prefixation or infixation to Class VII verbs, for example, and not underlying in TLA. For more details on syllable and metrical structure of TLA, see Al-Ageli (1996). This thesis supports the view that TLA allows up to two consonants in onset and in coda position. A sequence of more than two consonants can only occur across word boundary.

#### 1.4.9 Stress Patterns in TLA

Three patterns of stress have been identified in TLA. Firstly, monosyllabic words are always stressed (Laradi 1983:35; Elgadi 1986:75).

Examples:

- /ʒa:b/                    ‘he brought’
- /ʕidd/                    ‘count!’
- /ʕbrid/                   ‘it became cold’
- /ʕla:f/                    ‘why’

Secondly, disyllabic words follow different rules depending on the weight of the syllable, with stress being attracted to the heavy syllable or to the first syllable, if both syllables are light. (Elfitoury 1976: 22; Laradi 1983:35; Elgadi 1986:75). In Table 1.8 below, List A includes examples of stress falling on the syllable containing a long vowel or a geminate, whilst list B contains examples of stress falling on the first syllable when there are two light syllables. When the two syllables are heavy, the stress falls on the ultimate syllable, as in /mi:'za:n/ 'scale', /du:'la:b/ 'closet' and /ba:'zi:n/ 'a traditional dish'.

A		B	
Example	Gloss	Example	Gloss
/ba:rid/	'cold'	/'kabda/	'liver'
/jin'ga:l/	'can be said'	/'ʕurfah/	'he knew him'
/'ra:ʒil/	'man'	/'maktib/	'office'
/'li:bi/	'Libyan'	/'habil/	'rope'
/'li:mi/	'orange colour'	/'kammil/	'he finished'
/ʃar'fu:r/	'stones'	/'jurbuʕ/	'he ties'
/tʕa'bu:r/	'queue'	/'ʔahmir/	'red'
/'ʃwa:raʕ/	'streets'	/'tʕanzra/	'cooking pot'

Table 1.7 Words with different stress patterns.

Thirdly, in words of more than two syllables, stress falls on the rightmost heavy syllable:

Example	Gloss
/sʕu:'ni:ya/	'bowl'
/ba'tʕa:la/	'unemployment'
/kar'tʕo:ni/	'cardboard'
/batʕa'ni:ja/	'blanket'
/faraʃi:ja/	'lady's coat'
/tal'la:ʒa/	'refrigerator'
/maħal'la:t/	'shops'
/mħal'bi:ja/	'rice pudding'

## **Chapter Two: Timing in speech production**

### **2.1 Introduction**

This chapter is dedicated to the literature review which will mainly focus on timing in speech production. This is divided into two main parts with each one addressing a key issue. The first is articulatory timing and the second is the timing of voicing. In the first part, well-known theories of speech production including the window model of coarticulation and Articulatory Phonology Theory are discussed. The nature of coarticulation and coordination in consonant clusters will also be discussed. The main factors that influence the coordination of articulatory gestures during the production of speech are then discussed, with a special focus on timing in stop consonant clusters. These factors include place of articulation (including sequence of articulation), syllable position, morphological structure, gender and speaking rate. Other factors such as variability between speakers are also reviewed. The second part of the chapter is dedicated to reviewing the timing of voicing in speech production. It will provide an overview of the mechanism of voicing and the difference between voiceless and voiced stops. Finally, the influence of place of articulation, the voicing quality, syllable position and speaking rate on the timing of voicing in the production of SI and SF single stop and SI and SF two-stop clusters will be considered. With respect to the factors that influence the duration of VOT, only place of articulation and articulation rate will be investigated.

### **2.2 The production of stops**

Stops are the most frequently found consonantal sounds in languages throughout the world (Henton *et al.* 1992:98). Their production is characterised by completely stopping the flow of air from escaping through the oral cavity. There are three phases involved in the production of stops: ‘approach’, ‘hold’, and ‘release’ (Ashby and Maidment 2005:56). Other terms used to describe these phases are the ‘shutting phase’, ‘closure phase’ and ‘opening phase’ (Abercrombie 1967:140). In the first phase, the active articulator, i.e. the lower lip or the tongue forms a

constriction against a passive articulator to prevent the air from escaping. This can be achieved by the lower lip closing against the upper one (in the case of English [p] and [b]) the tip of the tongue being placed against the alveolar ridge (in the case of [t] and [d]) or by the back of the tongue being placed against the velum (in the case of [k] and [g]). The second phase starts when contact is made and pressure begins to build up behind the constriction place. Depending on the identity of the stop, the vocal fold may or may not vibrate. The last phase entails the opening or release phase when the active articulator moves away from its target causing the release of the pressure. Throughout this thesis, the term ‘approach phase’, ‘hold phase’ (HP) and ‘release phase’ which are shown in Figure 2.1 will be used to refer to these three phases in the production of oral stops.

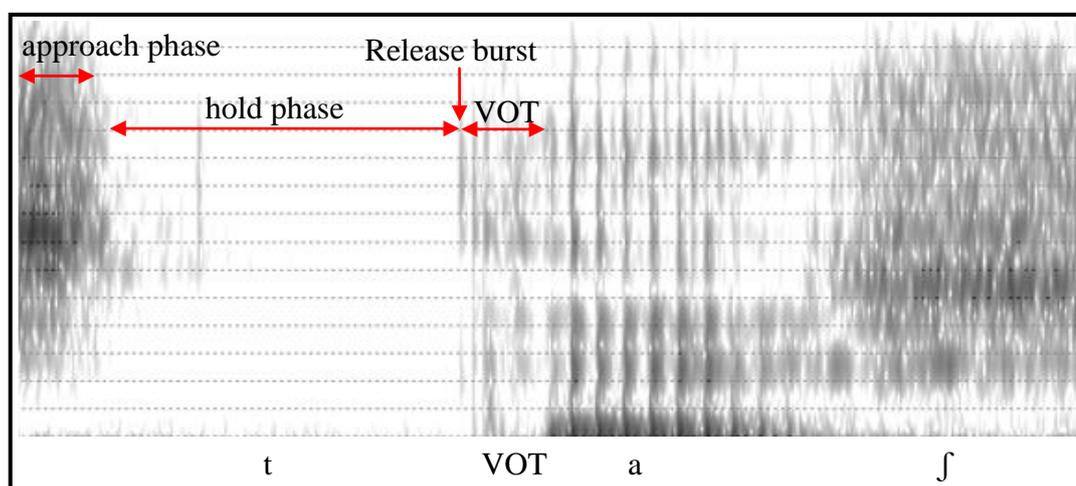

Figure 2.1 A spectrogram of the word /taf/ ‘to start a fire’, showing the approach and hold phase, the release burst and voice onset time of /t/.

In TLA, stops are formed by making the obstruction of the air at the lips, post-dental region, velar, uvula or the glottis. The oral stops which participate in forming a cluster in onset and coda in TLA are /b/, /t/, /d/, /t<sup>s</sup>/, /d<sup>s</sup>/, /k/ and /g/. In this thesis, /q/ and are excluded because /q/ has distribution that is restricted to coda position only. /ʔ/, in addition, is always preceded by a vowel, preventing it from forming clusters in onset position. Table 1.1 (page 12) describes voice, place and manner of articulation of these stops. It is worth mentioning that /t<sup>s</sup>/ and /d<sup>s</sup>/, in addition to having the post-dental as the primary place of articulation, have a secondary place of articulation resulting from the “contraction of the pharynx either

by a retraction of the root of the tongue, or by lateral compression of the faucal pillars and some raising of the larynx, or a combination of these” (Catford 1977:193).

Stop consonants have different acoustic properties which differentiate them on the basis of their place of articulation. These include the duration of the HP, the formant transitions and the spectrum of the release burst. The acoustic characteristics of oral stops correspond to the three stages mentioned above. In his acoustic analysis of Arabic speech, Shaheen (1979:82) states that the movement of the articulators during the first stage affects “the short-time energy spectrum”. Since there is no activity in the second phase, the HP or the closure, this appears on spectrograms as an absence of energy, except for voiced stops where some energy appears at the base line. In the last phase, the release burst, the intensity of the release burst is sometimes very weak; and as a result it is very difficult to isolate this from the frication that follows (Repp and Lint 1988:323). Different acoustic properties are also the result of different places of articulation of stops (Shaheen 1979:83). While a flat spectrum, usually with frequencies above 4000 Hz, is the characteristic of post-dental stops /t/ and /d/, the frequency position of the energy in /k/ and /g/ is concentrated between 2000-4000Hz. However, the frequency range is dependent on whether the vowel following it is front or back (Delattre *et al.* 1962:104). Finally, bilabial stops occupy the frequency range of 500-1500 Hz. The low energy in bilabial stops is the result of their weak release burst which is due to the lack of a chamber in front of the release (Henderson and Repp 1981:71).

In addition to differing in their acoustic properties, stop consonants vary in the duration of the HP. Abdelli-Beruh (2009:76) studied the duration of the HP of different stops in different contexts. He found out that the average HP duration for /b/ is longer than that for alveolar and velar voiced stops. Following a voiced context, the average HP durations of bilabial and alveolar stops were significantly longer than the average HP duration for velar. The overall conclusion is that bilabial stops have significantly longer HP durations and shorter VOT lags when compared to alveolar and velar stops (Abdelli-Beruh 2009:77). The voicing in the HP, in addition to the transition to and from the vowel, and the release burst, are the main cues to identifying the stop (Halle *et al.* 1957: 107). Finally, with regard to the duration of the HP and the duration of the following vowel, according to Fowler

(1992:143) “vowel durations and closure durations vary inversely in voiced and voiceless obstruents”. This relation, however, has not been noted in all languages (Keating 1985). The duration of vowels is not measured in the current study, only the duration and nature of the inter-consonantal-interval (ICI) is investigated.

The place of articulation of the stop also determines the properties of its release burst. In a controlled study Zue (1980:63) investigated the acoustic properties of stop consonants. He states that for /t/, the release burst occupies the frequency region of about 2000 Hz, and for /k/ preceding a back vowel, there are two bursts; one is in the mid-frequency region, and another at higher frequencies. For bilabial stops, the burst tends to be weak and difficult to detect.

There are other factors that distinguish stops from each other. For example, the extent and direction of formant transitions, the duration of the closure, and aspiration. Regarding formant transitions, the first formant (F1) of vowels preceding stops is determined by the size of the constriction (William 1996). The first formant increases when the constriction area increases and decreases when this decreases. The rate and extent of transitions of the second and third formant (F2 and F3 respectively), depend on the quality of the vowel: the further back it is, the lower the formant frequencies (Zhao 2003:18). For example, F2 and F3 of a back vowel preceding a bilabial stop have a slight decrease. F2 of the same vowel increases before alveolar and velar stops, while F3 decreases. Following a back vowel, transitions from these stops do the opposite (Stevens 2000).

Aspiration is the last criterion that distinguishes one stop from another. Ladefoged (2001: 44) defines aspiration as “a period of voicelessness after the stop articulation and before the start of the vowel”. Zue (1976:75) draws a distinction between aspiration and the friction noise of the release burst. While the noise made by aspiration is generated close to the glottis, the noise source of the friction is situated in front of the constriction. Acoustically, aspiration interacts with formant transitions. For example, F2 transitions of bilabial and alveolar stops preceding [a] start at considerably higher frequencies than those of unaspirated sibilants (Repp and Lin 1988:127). In TLA, /t/ and /k/ may be aspirated (Laradi 1983:12); however, they are not as aspirated as English stops. The duration of VOT will be discussed in 2.5 below.

## **2.3 Theories of timing in speech production**

In its simplest form, speech production is the transformation of commands into articulatory gestures. This seems straightforward and easy to capture. However, in reality, the production of speech is one of the most complex aspects of human behaviour to analyse and understand. One of the reasons behind this complexity is that speech is a highly variable process employing different timing patterns (Gaitenby 1965). The main challenge lies in finding out how this timing is implemented in speech.

Phoneticians and phonologists have tried to formulate theories that can account for phenomena such as coarticulation and assimilation but this has proved to be a difficult task for two main reasons. Firstly, human speech is made up of sounds that cannot be easily untangled into distinct elements (Kühnert and Nolan 1999:11). Sounds interact with each other, influencing the way they are produced. As a result, there is no one-to-one correspondence between the movement of the articulators and the resulting acoustic signal. There are transitions between sounds in which it is difficult to establish where one sound ends and another starts. This is the result of the fact that articulatory gestures overlap in time and space so that one sound starts before the articulators have been disengaged in the production of another (Hardcastle 1981: 51).

The second reason for this difficulty is the number of contributory factors which influence the duration of segments and how they are coordinated in an utterance. These include contextual factors, prosodic factors, the nature of the articulators (their size and velocity), the position of the utterance, the gender of the speaker, and their speaking style. This complexity represents the main challenge facing the formulation of any speech production model aiming to account for how sounds are timed in speech.

### **2.3.1 The nature of coarticulation**

Torres (2002:9) defines coarticulation as “a purely phonetic phenomenon that takes place in all human languages and involves articulatory adaptation of a segment to its phonetic environment without altering its phonological features”. In

the process of coarticulation, the articulation of one sound affects the articulation of another sound as a result of many factors. Two sounds may overlap in time and space and the degree of this overlap is determined by the articulators involved in the articulation of the two sounds. For example, in clusters of two stops, there are two consecutive constrictions. These could involve a constriction at the lips followed by a constriction at the alveolar ridge or velar, or any other permissible combination of these. The location of the constriction is affected by the following vowel. If this is a front vowel, the constriction is anterior, and if it is a back vowel, the constriction is posterior (Stevens 2000), but not for labials where the tongue tends to be in neutral position.

There are two types of coarticulation: anticipatory and perservatory (or carryover). In the former the articulators adjust their position and the speed they have to travel at in anticipation of the following sound(s). The latter refers to the production of a sound while the articulators are still engaged with the production of the preceding sound (Henke 1966). Figure 2.2 shows these two types of coarticulation. Finally, coarticulation can be influenced by many factors such as speech rate (Amerman *et al.* 1970) and the nature of the language itself (Boyce 1990). It is worth pointing out that in the latter case, coarticulation is not purely phonetic, but partly phonological.

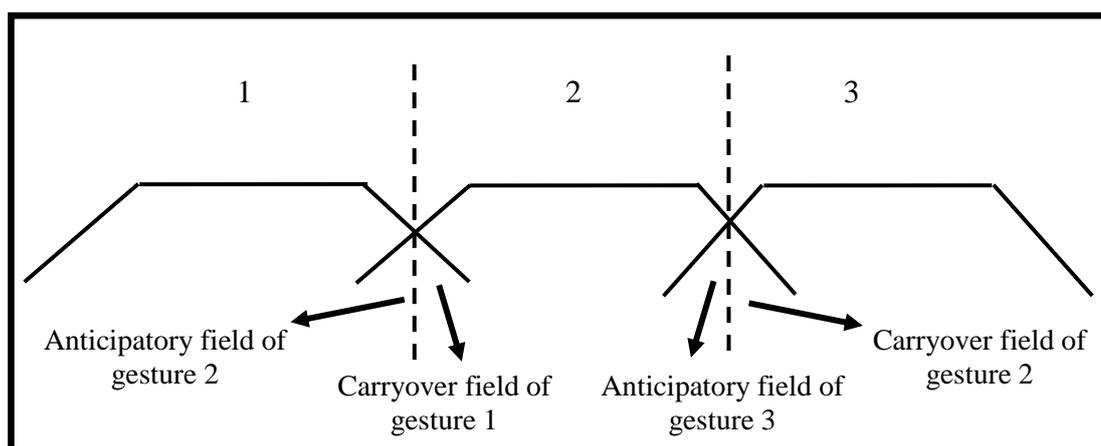

Figure 2.2 Schematic representation showing three overlapping phonetic gestures with anticipatory and perservatory (or carryover) coarticulation (adopted with modifications from Fowler and Saltzman 1993:184).

Coarticulation is not random. Each language allows a particular degree of coarticulation. One of the most important factors influencing coarticulation is the articulatory constraint on the gestures involved. It has been proven that sounds are different in their degree of coarticulatory resistance. For example, Öhman (1966) proposes that consonants and vowels form two different categories with consonants being a way of starting and ending vowels. He further argues that consonants are more resistant to coarticulatory effects than vowels, i.e. the vocalic gesture is more prone to compromise than the consonantal gesture.

Fowler (1980) identifies two important models of speech production to account for coarticulation and the patterns of timing in speech, namely: extrinsic timing theories and intrinsic timing theories. In extrinsic timing theories, phonemes are looked at as timeless units. They exist only in the lexicon of the speaker and the listener. Phonemes can be described using the manner of their articulation or the resulting acoustic signal. The variation of these phonemes, allophones, is further divided into those which are language specific, and those resulting from the physiological limitation of speech.

In intrinsic timing theories, on the other hand, timing is derived from the dynamics of a muscle group (Fowler 1980, 1986). Time is an important component that is implanted within each segment. Unlike extrinsic timing theories which do not lend themselves to empirical analysis to account for anticipatory coarticulation, intrinsic timing theories can provide an explanation of how two segments overlap in time, by viewing segments as dynamic units. There are numerous models of speech production that adopt the intrinsic timing framework. Among these models are Perkell's Multi-stage Model (1980), Bell-Berti and Harris's Temporal Model (1981), Keating's Articulatory Model (1990), and Browman and Goldstein's Articulatory Phonology Model (1986). Because the last two models are relevant to the kind of analysis intended in this thesis, they will be discussed in the following section.<sup>2</sup>

---

<sup>2</sup> For more details on speech production models, see Fowler (1980), Kelso *et al.* (1986) Saltzman and Munhall (1989).

### **2.3.2 Keating's Articulatory Model**

This model is also known as the window model of coarticulation. It was developed by Keating (1985, 1988, and 1990) to account for the temporal and spatial variability of speech production. Keating (1990) assumes that sounds have different production limits beyond which they cannot expand. Keating (1990:455) states that:

For a given physical articulatory dimension, such as jaw position or tongue backness, each feature value of a segment has associated with it a range of possible spatial values, i.e. a minimum and a maximum value that the observed value must fall within [...]. For some segments this window is very narrow, reflecting little contextual variation; for others it is very wide, reflecting extreme contextual variation.

Despite the fact that Keating's window model opens new insights into articulatory organisation and tries to relate phonetics to phonology, the model is criticised by some phoneticians and phonologists. For example, Stevens (1990:475) states that "it may be difficult at this time to develop a theory that will predict the precision or window size required for positioning articulatory structures for sequences of segments in an utterance". In addition, Fowler (1990:478) rejects that "phonological and phonetic generalizations are of the same sort and should be characterized in the same way by formal rules".

How timing is implemented in this model is another source of criticism. Although Keating (1990) refers to inherent timing in this model, Byrd (1996:6) argues that coarticulatory timing is not fully explained in this model and it is considered to be a dimension derived from outside the model. The spatial coordination between two segments, however, is governed by phonological rules. The displacement of phonemes is planned and the relation between this spatial displacement and variability is what motivates this model (Byrd 1994:233).

### **2.3.3 Articulatory Phonology Model**

This section outlines the main concepts of Articulatory Phonology, its claims, why it is important to investigate timing in speech production and how it views

timing in speech production. It will also review previous work which adopts this model of timing in consonant clusters. Articulatory Phonology was proposed by Browman and Goldstein (1986, 1988, 1989 and 1990a, 1990b, 1992) to account for coarticulation, insertion and deletion in speech production. In Articulatory Phonology, gestures are understood to be the central element of contrast between two lexical items (Browman and Goldstein 1992:23). An articulatory gesture is defined as “a spatio-temporal unit, consisting of the attainment of some constriction at some location in the vocal tract” (Gafos 2002:270). Gestures are invariant in time i.e. each gesture has an intrinsic time or duration and can exist even when there is no acoustic evidence. Gestures can also overlap in time and the amount of overlap or delay between gestures can account for processes such as assimilation and epenthesis. According to Gafos (2002:7) an articulatory gesture has the following landmarks: onset, target, c-centre, release and release offset. Figure 2.3 shows the landmarks of an articulatory gesture.

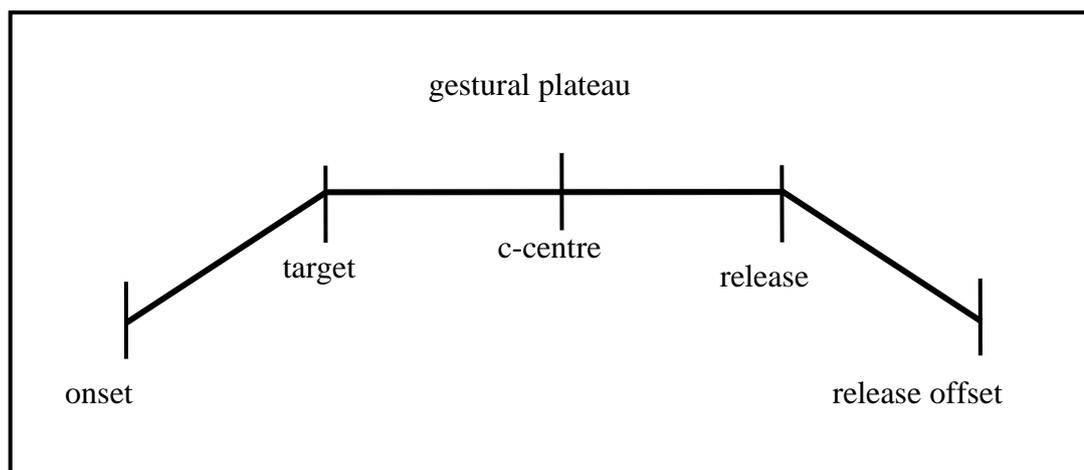

Figure 2.3 Landmarks in gestural lifespan (from Gafos 2002).

The onset refers to the onset of movement of the articulator towards a particular target. The articulator then achieves its target for some time before the release starts. The mid-point between attaining the target and starting the release is called the c-centre. This is when the articulator reaches the maximum contact. The release is when the articulator starts to disengage from the target. Finally, the release offset marks the end of the gesture.

The term “gestural constellation” is used to refer to the pattern of a set of gestures (Browman and Goldstein 1986:2). Thus, within this approach, “phonotactics” describes the possible combination of gestural constellations while “gestural score” refers to the organization of the gestural units of a word (Byrd 1996:140).

### **2.3.3.1 Articulatory timing**

According to Browman and Goldstein (1989: 211) articulatory gestures are organised according to an internal timing pattern. A set of phasing rules governs the spatiotemporal coordination of these gestures in a given utterance. The timing patterns in a given language play a crucial role in securing intelligibility and naturalness (Carlson *et al.* 1979). It is also crucial in revealing how speech is organised (Lindblom 1975).

Lisker and Abramson (1996:389) point out the importance of segmental timing in language acquisition. The organisation of articulatory gestures in released vs. unreleased stop is also governed by timing. For example when one stop is followed by another, the acoustic release of the first stop is determined by the time that the closing gesture of the second one reaches its target (Browman and Goldstein 1986). When the first stop is not acoustically released, it means that the two closures overlap in time.

Byrd (1994) emphasizes the importance of speech timing in both phonology and phonetics. The diversity of lexical representations, for example, is the result of differences in articulatory timing (Byrd 1994: 143). Different languages apply different timing patterns that distinguish them from each other. For example, languages differ regarding their rhythm. While some languages are said to employ “stress-timing”, others are said to follow “syllable-timing” (Hoequist 1983). In addition, different languages apply different timing patterns when it comes to the duration of vowels in relation to consonants. For example, it is well documented that vowels are longer before voiced consonants. The length of this duration, however, is significant in English (Flege 1988), less significant in French (Mack 1982), and of no significance in Arabic (Flege 1979).

Consonant clusters in English are characterised by an overlap between the two consonantal gestures (Browman and Goldstein 1990a, Zsiga 1995, Byrd 1994, 1996). This is the result of forming the closure of C2 before the closure of C1 is released (Zsiga 2003:403). Browman and Goldstein (1989b) compared the gestural patterns of what they call “canonical forms” to the same forms observed in connected speech. They concluded that the two forms differ with respect to the magnitude of the gestures and in the amount of overlap between these gestures, there being greater magnitude and less overlap in the canonical forms (Browman and Goldstein 1989a :214).

A considerable amount of work has been conducted on articulatory timing of English consonant clusters, and how it is influenced by many factors. Byrd and Tan (1996) carried out an EPG study to investigate the articulatory timing of consonant clusters in fast speech. They speculated that there were two possibilities, namely (1) as a function of the increase in speaking rate the duration of the segments will decrease and (2) a decrease in the gesture duration is accompanied by more gestural overlap. Their results confirm the assumptions that by the increase in articulation rate, gestures exhibit more overlap and shorter durations.

Within the framework of gestural coordination of consonant clusters, Gafos (2002) explains that vowel and consonant insertion can be explained as gestural mistiming. In addition, Hall (2003) uses the term “intrusive vowels” or ‘excrescent vowels’ (Hall 2011), to account for the acoustic element that can be seen in sequences containing a guttural, as a result of mistiming. She also differentiates between epenthetic and intrusive vowels on the basis of their duration. Epenthetic vowels are longer in duration and voiced. They become shorter in fast articulation. On the other intrusive vowels are shorter and they disappear in fast articulation rate (2003:3).

There have only been a few studies on timing in Arabic. It has been observed that in certain circumstances a vowel-like element appears in onset sequences in Moroccan Arabic (Harrell *et al.* 2004). While Dell and Elmedlaoui (2002), and Gafos (2002) analyse this vocoid as a transition between the two consonantal gestures, Boudlal (2001) interprets it as a short vowel. In one of the recent studies on the relationship between syllable structure and temporal patterns, Gafos *et al.* (2009) used 3-D Electromagnetic Articulometry to distinguish between complex onsets

(e.g. CCV) and simplex onsets (e.g. C#CV, where ‘#’ indicates a syllable boundary) in Moroccan Arabic. Their results support the simplex onsets proposal, i.e., that a vocalic element is inserted at the syllable boundary. In a recent study, Gafos *et al.* (2011) uses electromagnetic articulography to investigate the timing patterns in Moroccan Arabic by analysing the stability of timing intervals. Their results reveal that “consonants added before a consonant-vowel sequence are not parsed in the same constituent as that consonant-vowel sequence” (Gafos *et al.* 2011:29).

### 2.3.3.2 Rules of gestural phasing

In Articulatory Phonology, gestures are organised in time and space according to certain phasing rules. These phasing rules determine the way these gestures are coordinated. For example, they may allow overlap in time depending on certain factors that will be discussed later in this chapter. When a gesture seems to be deleted or assimilated by another, there is sometimes some evidence that it is still articulated at the same place (Browman and Goldstein 1990).

In general, there are two kinds of gestural coordination: “open transition” and “close transition” (Bloomfield 1933). Whilst in the former, there is an acoustic release intervening between the two gestures, in the latter there is no release as a result of forming the closure of the second gesture before, or at the same time as, the release of the first gesture. These notions correspond to total synchronicity and a very long delay. Depending on the gestures involved, this total synchronicity, or overlap, may result in assimilation (the perceptual loss of one of the consonants). On the other hand, this delay might lead to the perception of intrusive vowels (Hall 2003, Davidson 2005, Davidson and Roon 2008), particularly if the vowel is voiced.

Variability in articulatory timing and phasing rules was also observed by Byrd (1996). Using EPG to investigate the gestural coordination of stop + stop, stop + /s/, and /s/ + stop in the word boundaries, Byrd found that phasing rules may result in gestural reduction or overlap between the two gestures. When there is no acoustic evidence of a segment, they argue that gestures may lose magnitude and become “acoustically obscured” (Browman and Goldstein 1990b: 360), i.e. not deleted from the gestural score but they have no observable realisation (Heselwood 2013:165-166).

### 2.3.4 Cues to gestural overlap

There are many cues to gestural overlap. These include the duration of the HP, the acoustic release of the first consonant (C1) in a cluster/sequence and formant transitions from and into the vowel. While a missing release burst is a universal cue to gestural overlap, the duration of the HP can be considered language-specific. The duration of the closure interval can be used to determine if there is an overlap between the gestures of the two stops. Zhao (2003:23) suggests that comparing the closure interval of the two stops in the cluster to the sum of their duration when they are single can in comparable contexts reveal the amount of overlap. If the durations are relatively equal, there is no overlap, but when the two durations become shorter, it can be suggested that this reduction is the result of the overlap between the two gestures.

A missing burst of C1 suggests an overlap between the two closures of the stops. In this overlap, the closure of C2 is formed before the release of C1. As a result, the release is suppressed by a following closure (Zhao 2003:23). When C1 is released, the duration and the quality of the interval can reveal the extent of overlap between the gestures. For example, when there is considerable overlap, the quality of the resulting interval is like that of a schwa, but when this overlap is small, the interval is more likely to be a copy of a surrounding vowel (Hall 2003:3). If there is an overlap between the two closures, then there is no vowel interval.

The mechanism involved in the production of two-stop clusters is different from that of single stops. In VCCV, where CC is not a geminate, formant transitions can be used to determine if there is overlap between the two stops or not. For example, Zhao (2003:22) states that:

[If] differences in formant movements into the C1 closure exist and is C2-dependent, then such evidence would suggest that the formation of the C2 closure began before the release of C1. The extent of the overlap may be inferred from the magnitude of the C1- or C2-dependent deviations in the formant movements”.

Because this thesis is concerned with investigating only SI and SF clusters, not intervocalic clusters, this cue is not tested. Finally, gestural reduction, or “the ease of articulation” (June 1995:27), may also provide some evidence about the pattern of

coordination. For example, investigating changes of oral pressure during the production of /pk/, Jun (1996:89) found out that some tokens displayed partial gestural reduction, while others showed gestural overlap without any reduction. Gestural reduction is motivated by word frequency; the higher this is the more likely that the gestures undergo reduction (Lin *et al.* 2011).

## **2.4 Factors that influence gestural coordination**

There is a large volume of published studies investigating the factors affecting timing in speech production in different languages. The aim of this section is to review some of these factors influencing the duration and coordination of articulatory gestures. These factors include place of articulation, syllable position, perceptual recoverability, gender, speaking rate and stress.

### **2.4.1 The influence of place of articulation**

Place of articulation has been shown to play a role in how consonantal gestures are coordinated. Kühnert and Hoole (2006) suggest that the influence of place of articulation could be the result of certain constraints. For example, Byrd (1994) conducted an EPG study to uncover the timing patterns of heterorganic English consonant sequences within and across word boundaries. Her results show a clear influence of place and manner of articulation on the gestural coordination.

The order of place of articulation can also affect the way gestures are coordinated. The order of place of articulation can be A-to-P or P-to-A. In the former, the place of articulation moves from bilabial to alveolar or velar or from alveolar to velar. P-to-A order of articulation is the opposite. Kochetov and Goldstein (2005) showed that P-to-A sequences (/kt/ and /tp/) in Russian showed less temporal overlap than A-to-P sequences (/tk/ and /pt/). They concluded that as when C2 constriction is anterior to C1 constriction, C2 constriction is likely to prevent the acoustic release of C1. As a result, less overlap is allowed in P-to-A articulation to ensure C1 release and enhance perception (Chitoran *et al.* 2002).

In addition to place of articulations, manner of articulation is likely to influence the degree of gestural coordination. For example, Byrd (1994) examined what she called the "local time", which refers to the coordination pattern within the sequence, and "the global time" which refers to the phasing pattern of the sequence in relation to the preceding and following vowels. Her main finding is that two-stop sequences showed more gestural overlap in comparison to sequences containing /s/.

#### 2.4.2 The influence of syllable position (C-centre organisation)

Syllable position is one of the main factors that play a role in the way consonantal gestures are organised. Syllable-initial (henceforth SI) clusters have been described as having particular spatial and temporal characteristics distinguishing them from syllable-final (henceforth SF) clusters (Browman and Goldstein 1988). Throughout this thesis SI and SF will be used to refer to the onset and coda clusters. SI clusters display greater spatial displacement and exhibit stability compared to SF clusters (Pouplier and Marin 2008).

SI clusters are also said to exhibit the so-called c-centre organisation in which consonantal gestures are organised globally with the vowel gesture (Browman and Goldstein 1988; Byrd 1994). SF clusters, on the other hand, are said to be organised locally. Figure 2.4 shows the timing patterns of SI and SF consonant clusters as proposed by the c-centre hypothesis.

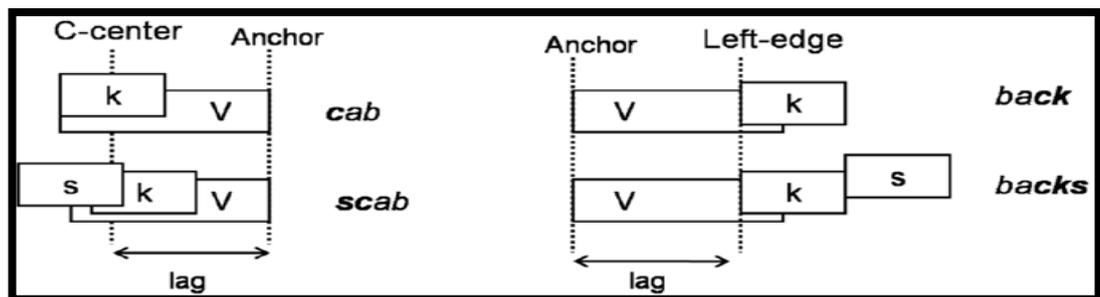

Figure 2.4 The organisation of complex onset and codas in English, as proposed by the c-centre (from Marin and Pouplier 2010).

The consonants in a complex onset are coupled with the vowel in an in-phase relation (Browman and Goldstein 2000) and are in a competitive mode with each

other to avoid the two consonantal closures overlapping and to secure the perceptual recoverability of C1 by releasing it (Chitoran *et al.* 2002). The c-centre for SI clusters has been confirmed for a number of languages, including English (Byrd 1996; Marin and Pouplier 2010), Italian (Hermes *et al.* 2008), Romanian (Marin 2013), and French (Kühnert and Hoole 2006). Conversely, SF clusters do not form a global organisation with the preceding vowel, they are in an anti-phase relation with the vowel and they are not in competitive mode with each other (Browman and Goldstein 2000). Figure 2.4 above shows that in onset position, the lag between the mid-point of a single consonant and the offset of the vowel equals that between the mid-point of a cluster of two consonants and the same anchor point. This means that when consonants are added before the vowel, the lag remains stable. On the other hand, in coda clusters, this is not the case. The gestures here are not organised globally with the vowel, but rather locally (Marin and Pouplier 2010:281).

SF clusters are also described as showing a reduction in magnitude (duration) and percentage of contact (Byrd 1994:210). Using EPG, many studies have been conducted to investigate clusters in SI and SF positions. These studies report that clusters in SI position show high percentage of contact compared to those in SF positions. For example, Byrd (1994) noted that /d/ and /g/ have more lingual palatal contact when they occur initially than when they occur finally. SI clusters exhibit c-centre organization and stability, while SF clusters did not conform to the c-centre organization, and showed more variability. Finally, Keating *et al.* (1999) reported the same results for /t/ and /d/.

Kochetov (2006) studies the effect of syllable position and magnitude of gestures on the organization of SI and SF in Russian. He used the palatal and non-palatalised voiceless labial stops /p<sup>i</sup>/ and /p/, and the palatalised /j/. He concluded that there was a great difference between the same clusters in different positions. However, Kochetov (2006:565) stressed that the difference between the same sequences in different syllable position could be related to the fact that different languages apply different patterns of organization of the same gestures.

The position of the syllable extends to affect not only coordination, but also duration. Oller (1972) conducted a study to determine the effect of syllable position on segment duration. For consonants, he found out that final syllable consonants

were longer than medial syllable consonants by 20-30ms. He also found out that this lengthening could be motivated by perception.

According to Krakow (1999) the reason for these differences lies in the way these syllables are articulated in different positions. While syllables in initial position exhibit tighter constrictions and stability, a number of studies reported that there is some weakening in the constriction or loss of the stop completely in syllables occurring in final position (Manuel and Vatikiotis-Bateson 1988, Kent and Read 1992). The difference between the articulation of SI and SF clusters could also be explained in the light of some phonological processes where coda consonants are more prone to weaken, or disappear, than onset consonants. Examples include the deletion of final /n/ in French (Rochet 1976) and final /s/ in Spanish (Sayahi 2005).

### **2.4.3 The influence of perceptual recoverability**

The degree of overlap permitted between articulatory gestures is also influenced by perception. Chinton *et al.* (2002) conducted a magnetometer study on Georgian consonant clusters to investigate the relation between the amount of overlap and perceptual recoverability. They concluded that overlap between stop closures is not allowed in SI position, because there is a need to enhance perception. In addition, Kühnert and Hoole (2006) support the view that less overlap is required to ensure perceptual recoverability. Finally, Dell and Elmedlaoui (2002:231) explain that in two heterorganic stops in Moroccan Arabic an “audible release” is required between the two closures.

### **2.4.4 The influence of physiological differences**

Laver and Trudgill (1991:237) propose three main markers to identify speech. There include physical, social, and physiological factors. The first marker focuses on the influence of physical differences such as gender, shape of vocal tract and age on speech production. As the name suggests, the second marker is concerned with sociophonetic factors that influence speech. The final marker concentrates on the physiological aspects of speech. In this thesis, only the first factor is investigated.

Besides the above mentioned factors that influence the coordination of articulatory gestures, the gender of the speaker can affect the spatial and temporal properties of gestures. It is well-documented in the literature that men's speech is acoustically different from that of women. This is due to the physiological fact that women have a vocal tract which is approximately on average 20% shorter than that of men (Simpson 2001: 2153). Moreover, he states that physiological differences in the size and dimensions of the vocal tract between males and females result in differences in the temporal and spatial properties of speech sounds (Simpson 2001: 2163). More specifically, gender differences influence the duration of the vowel attainment of articulatory targets, and the speed of the articulators (Simpson 2002: 417). Gender differences also affect the dimensions of the vowel space (Henton 1995). Although there are other factors that differentiate between men's and women's speech, only acoustic differences will be investigated here.

In a controlled laboratory experiment, Whiteside (1996) conducted a study to investigate the influence of gender on linguistic and stylistic conventions. Whiteside found evidence that men tend to produce shorter utterances in sentence-final positions compared to women. Whiteside (1996) attributes this variation to the observation that men tended to either omit or reduce both vowels and consonants, whilst women tend to fully pronounce segments. The same study also examined the speech of 29 male and 25 female speakers, and found differences in the duration of vowels for male and female speakers. Females' vowels are on average 11% longer than those of their male counterparts. Whiteside (1996) concluded that women tend to speak slower than males.

Kuehn and Moll (1976) investigated the relationship between the size of the vocal tract, the amount of displacement and the velocity of the articulators. Their results confirmed that subjects with larger vocal tracts exhibited both larger displacements and greater velocity. In addition, Byrd (1993) investigating the TIMIT database, An Acoustic-Phonetic Continuous Speech Corpus, confirmed previous findings that men speak faster than women. Byrd also found out that women showed greater variability than men.

#### 2.4.5 The influence of articulation rate

There is some debate about the definition of speech tempo, and whether speaking rate or articulation rate is the right term to use. Tsao *et al* (2006:1156) define articulation rate as “the number of output units per unit of time”. Jacewicz (2009:235) makes a distinction between speech/speaking rate and articulation rate. He states that because it focuses on general characteristics of speech, the former includes pauses and intervals between segments and focuses more on the speaker. The latter on the other hand, does not include pauses and places more emphasis on the how segments are produced. Throughout this thesis the term “articulation rate” will be used to refer to change in the rate at which segments are articulated.

There is a large volume of published studies describing the influence of articulation rates on inter-gestural coordination. Bauer *et al.* (2010) tested the duration of gestures and the velocity of articulators using electromagnetic articulography (EMA). Their results showed onset durations varied significantly as a function of active articulators. This is the result of the inertia of the three major speech organs: jaw, tongue (tip and back), and the lower lip. In general, the lower lip and the tongue-tip are relatively faster than the tongue-back (Hirose and Sawashima1982:105). However, Hirose and Sawashima add that the distance the articulators need to travel and the place of the tracking device should also be taken into consideration. Finally, the vowel context has also been shown to influence the velocity of articulators (Gay 1974: 48).

A number of studies investigated the influence of articulation rate on segment duration. For example, using electromyographic (EMG) data, Gay (1981) reported a decrease in segment duration and an increase in the velocity of articulators at a fast articulation rate. The increase in articulation rate also results in target undershoot where articulators fail to reach their targets due to restrictions on their speed, particularly at a fast speaking rate (Lindblom 1963). One of the most important influences of speaking rate on inter-gestural coordination is the increase in the amount of gestural overlap reported in many studies such as Byrd and Tan (1993), although some studies claim that the relative timing of some gestures remains stable despite the change in speaking rate (Kent and Netsell 1971, Kent and Moll 1975). The contradictory results of the relationship between the increase in

speaking rate and target undershoot could be related to variability between speakers (Flege 1988).

Investigating the difference between single and geminate stops, Manuel (1990) argues that since duration is the key distinction between single and geminate consonants, and since duration is affected by speaking rate, it follows then that this duration decreases as speaking rate increases. For perceptual reasons, however, speakers may control the duration of segments to make sure that the acoustic characteristics remain unchanged. In the case of single and geminate stops, speakers may limit how much duration should be reduced in geminates to ensure the two categories can be distinguished by listeners.

Arvaniti (1999) investigated the duration of the single and geminate sonorants /m/, /n/, /l/, and /r/ in Cypriot Greek and compared them to standard Greek. Except for /r/, increasing the speaking rate had a clear effect on segment duration. The duration decreased as speaking rate increased.

Pickett *et al.* (1999) conducted a production experiment to investigate the duration of single and geminate stops in Italian to determine if duration is the only acoustic difference between these two categories. Another aim of their study was to see how the duration of single and geminate stops is influenced by speaking rate. They concluded that there was a significant difference between the duration of single and geminate stops in Italian. In addition, they found that in slow speaking rate, the difference between the two categories decreased. The difference also decreased more in fast rate. Table 2.1 summarises the mean differences between single and geminate stops in words produced in isolation, at three different speaking rates. Pickett *et al.* (1999) also concluded that the distinction between single and geminate stops on the basis of their duration can be taken as a cue to differentiate between the two categories. An increase in speaking rate results in a decrease in the mean difference between the two categories.

Speaker	Slow	Normal	Fast
Speaker 1	175	93	58
Speaker 2	135	105	94
Speaker 3	168	133	97

Table 2.1 Mean difference between the duration of the HP of single and geminate stops as produced by three speakers (Pickett *et al.* 1999:139-140).

According to Browman and Goldstein (1990b: 360) an increase in speaking rate results in an increase in the speed of the articulators, a decrease in gestural magnitude, in time and space, and an increase in the amount of overlap. In casual production of stop consonants, the articulators achieve their targets to form a closure and maintain it. However, at fast speech rate, due to their fast movements in a short time, the articulators may fail to copy the same gestures of normal speech rate. As a result, they approximate their targets, undershoot them, or reduce the duration of contact. Changes in speech rate affect achievement of the target place of articulation (displacement), duration of segments, the velocity of articulators and the degree of articulation (Gay 1981:148). All of these factors result in a reduction in the degree of constriction leading to more overlap between the gestures (Davidson 2005:82).

There is, however, some argument about how much of an increase in speech rate will result in a certain degree of overlap. A fundamental question to ask at this point is whether gestural overlap is dependent on the speaking rate, or whether different speakers adopt different speaking rates meaning that the resulting gestures may or may not overlap. Davidson (2005:95) supports this idea and states that there are two types of speakers. The first type increases the gestural overlap when they increase their speech rate whilst the speech of the second type is characterised by gestural overlap regardless of their speech rate. In addition, Gay *et al.* (1974:47) state that the jaw movement in fast speech is the same as that in slow speech. The only difference is in the decrease in overall displacement as the speaking rate increases. They concluded that speaking rate influences “the duration and the size of muscle contraction” (Gay *et al.* 1974:48).

In the case of stops, speech rate has an influence on achieving the target place of articulation. Gay *et al.* (1974) investigated the influence of speech rate on the production of bilabial consonants /b/ and /w/ at a fast speaking rate. They reported an increase in muscle activity as well as in the movement of the lips. Regarding the tongue movement in fast speech rate, there was a decrease in tongue displacement and a decrease in the muscle activity. They concluded that at a fast speech rate, gestures require a change in duration and muscle activity.

As for the overlap between the supralaryngeal and the laryngeal gestures, Munhall and Löfqvist (1992) conducted a study to investigate the contact of voiceless consonant clusters at word boundary. They concluded that at a slow rate of

speech, the two consonants had separate gestures for the opening of the glottis, but in fast speaking rates, as a result of overlap between the gestures of the two consonants, there is only one gesture. Finally, in the production of labialvelars, where two places of articulation are achieved synchronically, Yehouenou (1998:40) states that when speaking rate is increased, there is an incomplete closure at the velum in labiovelar stops. Despite the reduction of the percentage of contact, the target was still achieved. Because the lower lip is a separate articulator, the constriction at the lips is not influenced by the retraction of the tongue. However, the general pattern is characterised by a decrease in duration as speaking rate is increased.

Duez (1999) examined how the duration of syllables, consonants and vowels vary as a function of their articulation rate and position in phrases and utterances. He concluded that vowels are more prone than consonants to suffer shortening. There was also a significant variation among speakers in the duration of sentences at normal and fast speaking rate. The duration decreases as speaking rate increases.

#### **2.4.6 The influence of speaking variability**

An opposite argument to the view that gestural overlap is purely physiological is provided by Jun (1996). He states that the amount of overlap between gestures or the reduction in their magnitude can be controlled by the speaker. In addition, Zsiga (1994:139) noticed that the increase in speaking rate is not always accompanied by an increase in the amount of overlap. Finally, Flege's (1988: 99) study of gestural timing and overlap correlated with speech rate sheds light on the matter. He concludes that the amount of overlap and reduction may not be related to the increase or decrease in speaking rate.

Additionally, the social class of the speaker has been found to influence speech production. In their study to investigate the influence of gender on the production of the plain coronal /t/ and its emphatic sibling /t<sup>ʕ</sup>/, Khattab *et al.* (2006:157) concluded that gender of the speaker in addition to his/her cultural background are likely to affect the production of emphatic /t<sup>ʕ</sup>/.

Finally, the process of assimilation has been found to be optional. Heselwood *et al.* (2011) used electropalatographic and acoustic data to investigate the

assimilation of word-final /l/ to word-initial /r/ in three female native speakers of Syrian Arabic. Although their results show that assimilation can be complete at fast speaking rate and gradient in slow and normal articulation rate, they found out that the process of assimilation is optional at all speaking rate: normal, slow and fast Heselwood *et al.* (2011:63).

#### **2.4.7 Summary**

This section investigated timing in speech production and how it is influenced by factors such as place of articulation, syllable position, gender and speaking rate. Timing has been found to be a very important component in speech production. How time is employed in speech can account for many phonetic phenomena. Different theories and models have tried to explain how speech units are timed in speech. The Articulatory Phonology Model as proposed by Browman and Goldstein provides a gestural approach to investigate and account for coarticulation, insertion and deletion in speech. The main concepts of articulatory phonology are gestures, phasing rules and timing. Different languages apply different phasing rules and different timing patterns to allow for certain degrees of gestural overlap or delays between gestures. These patterns are influenced by many factors. Syllable position has been found to be an important factor in determining how two consonantal gestures are organised. In general, SI clusters exhibit more gestural overlap than SF. The place of articulation, including sequence of articulation, has been also found to influence the coordination of gestures with more overlap in A-to-P compared to B-to-A.

Other factors that are crucial to the coordination pattern are perception, gender of the speaker and speaking rate. For the sake of perception, a speaker may opt for less overlap. Due mainly to physiological differences, male and female speakers have been found to exhibit different durational and spatial patterns. Finally, an increase in articulation rate, which results in an increase in the velocity of the articulation, leads to the possibility of gestural overlap. Slow articulation rate is likely to result in the opposite.

## **2.5 The timing of voicing**

### **2.5.1 Introduction**

This section focuses on the mechanism of voicing, the timing of voicing, and the factors that influence voicing in speech production. It begins with an overview of the voicing mechanism, particularly the laryngeal mechanism involved in the production of voiceless and voiced stops, and how these laryngeal activities are coordinated with supralaryngeal activities. The section also discusses VOT duration of single and two-stop clusters. Voicing assimilation in stop clusters is also discussed. The rest of the section provides a review of the main factors that influence voicing during the HP and the duration of VOT. These factors include place of articulation, syllable position, gender, the influence of vowel and stress. The main objective is to determine the patterns of timing of voicing with respect to supraglottal articulators. As in other studies of voicing in obstruents (e.g. Docherty 1992), the stops will be referred to as either voiced or voiceless.

### **2.5.2 The mechanism of voicing**

The subglottal airway is below the vocal folds whilst the supraglottal airway is above these. In order for voicing to occur there must be a pressure difference between these airways. A pair of vocal folds in the larynx attach anteriorly inside the thyroid cartilage and posteriorly to the left and right arytenoid cartilages. The space between these two folds is called the glottis. When the vocal folds are apart or abducted, the glottis is open. When the vocal folds are together or adducted, the airway to the lungs is sealed. Vocal folds must be adducted in order for voicing to occur.

In his myoelastic-aerodynamic theory of voice production, Van den Berg (1958) states that in order to initiate and maintain vocal fold vibration, a difference between subglottal and supraglottal air pressure must be secured. His theory states that when the air is sucked into the lungs, the vocal folds are abducted and lax. Intrinsic laryngeal muscle activities bring the vocal folds together and this adduction blocks the air-stream coming from the lungs. When the subglottal pressure increases to the point where the trans-glottal pressure is high, the air coming from the lungs

through the bronchi will force the vocal folds to be blown apart to let the air pass. The vocal folds will resist this force by trying to shut again. This activity is repeated as long as the pressure of air coming from the lungs is sufficient. When the pressure finally drops, the vocal folds are abducted again (Laver 1980:96).

Catford (1977:107) states that laryngeal features are gradual in nature, covering the spectrum from complete voicelessness, when the vocal folds are abducted, to a glottal stop, when the vocal folds are adducted. In order for voicing to take place, a number of conditions must be fulfilled such as the vocal fold should tense and the subglottal pressure should be around 2-3 cm Ho<sub>2</sub> (Catford 1977:98).

Subglottal pressure increases during exhalation. When the subglottal pressure is greater than the supraglottal pressure the result is a pressure drop across the glottis. According to the myoelastic-aerodynamic theory, the vocal folds will only vibrate when this pressure drop across the glottis is present. The high pressure will force the lower portion of the vocal folds to separate first while the upper portion remains together. As the air continues to travel, the upper portion of the vocal folds begin to separate, opening the glottis. The elasticity of the vocal folds first brings the lower portion of the vocal folds back to a medial position, which lowers the transglottal pressure. This decrease in pressure pulls the lower portion of the vocal folds inward, with the upper portion lagging behind. As the upper portion of the vocal folds comes together the glottis is sealed. The vocal folds rapidly cycle through this vibratory pattern. The generation of sound due to the vibration of vocal folds is known as phonation (Behrman 2007).

Laver (1994: 187) points out that the larynx is capable of producing a wide range of different modes of phonation. In this chapter, only those laryngeal activities that are relevant for the description of voicing in stop consonants are discussed. The opening of the glottis during the production of voiceless obstruents is controlled by two muscles: the cricoarytenoid is used to abduct the vocal folds and the interarytenoid to adduct them (Hirose 1976). Voicing can be prolonged by lowering the larynx or expanding the cheeks to allow for more air to flow into the supraglottal chamber (Torres 2002).

### 2.5.3 Voicing in stops

Maddieson (1984: 28) states that 88.9 percent of the world's languages have voice contrasts amongst their sounds. To ensure the voice distinction, the production of oral stops entails the coordination of many articulatory systems at the same time. The process of stop consonant production starts by directing the air to the oral cavity by raising the soft palate. A closure will then be formed by movements of the tongue, the lips and the jaws. The final stage is controlling the movement of the vocal folds which are abducted in the production of voiceless stops and adducted in the production of voiced stops. On this basis, stop consonants can be distinguished by the state of the vocal folds. In speech they can be voiced and voiceless sounds. Voiceless sounds have an absence of vocal fold vibration. Voiced sounds are characterised by the presence of vocal fold vibration seen as periodicity in the speech wave. In stop consonants, the vocal folds remain stiff; in the case of /p/, /t/ and /k/, they do not vibrate, in the case of /b/, /d/ and /g/, they do.

The coordination of oral and laryngeal gestures during the production of stop sounds is one of the most complex stages in the production of stops. In order for the oral pressure to take place and increase, the active articulators, tongue or lips, should form a closure at the appropriate place of articulation. To prevent the air from escaping from the nasal cavity, another closure is secured by raising the velum. The glottis will then adjust, depending on whether the stop is voiceless or voiced. In the case of voiceless stops, for example, the vocal folds are tense to prevent them from vibrating during the HP (Löfqvist 1992:16).

Löfqvist and Yoshioka (1984) investigated the interarticulator timing of Swedish voiceless obstruents. They state that in aspirated stops, the glottal closing is delayed till after the release of the stop, while in unaspirated stops, the opening takes place before the release. That is why on spectrograms, voiceless stops show no voicing during the HP, whereas with voiced stops, voicing can be seen along the baseline of spectrograms during the HP.

Docherty (1992:8) describes three laryngeal features during the production of oral stops. These features correspond with the closure phase, the release phase, and the offset of release. During the first stage, if the stop is voiceless, there is no laryngeal activity. On a spectrogram, this stage is characterised by a complete silence. If the stop is voiced, however, there is some "low periodicity" in the

waveform. During the second stage, there is higher intensity in voiceless stops compared to the voiced ones. This is due to the amount of air escaping at the release burst. During the last stage, due to the velocity of the articulators in moving apart from each other, the intra-oral pressure drops very fast.

According to Summerfield (1981) timing is of the utmost importance in establishing the contrast in stop voicing specifications. Docherty (1992:16) explains some timing patterns of the coordination between the glottis and the closure in voiced aspirated stops and in voiceless post aspirated stops. While in the first example the opening gesture of the glottis takes place towards the end of the oral pressure, in the second example the glottal abduction takes place at around the same time as the closure. That is why the sound is characterised as voiceless. Moreover, in post-pausal SI position, English stop voicing is characterised by three main patterns. Voicing either commences during the HP, at the release of the HP, or is delayed to start after the release phase (Docherty 1992:23). While the first two patterns characterise voiced stops, the last pattern is a typical feature of voiceless stops in English.

To produce the right kind of stop, there must be coordination between the oral and laryngeal gestures. Löfqvist (1992:16) explains some timing patterns of the coordination between the glottis and the closure in voiced and voiceless stops. In the former, the vocal fold may be vibrating at the onset of closure, but in voiceless stops, the vocal folds are stiff producing a voiceless sound.

In addition to the difference in the state of the vocal folds, stop consonants can be contrasted according to their length. Voiceless stops tend to have longer HP duration than their voiced counterpart due to the fact that voicing cannot continue once the pressure has equalised (Henton *et al.* 1992: 67-68). If the duration of the HP of voiced stops is as long as that of their voiceless counterparts, the subglottal and oral pressure would be the same, and the voicing will be terminated (Torres 2002: 6). Finally, voiced and voiceless stops differ in the amount of air produced. While the volume of air produced in voiceless stops is about 80 ml, it is 50 ml in voiced stops (Warren 1996). However, this depends on the place of articulation of the stop.

Regarding the relation between the duration of the HP and voicing, Westbury and Keating (1986) examined the nature of voiced and voiceless stops in different

phonetic contexts. They found that in intervocalic position, stops are naturally voiced if their HP is short. If the closure is long, intervocalic stops tend to show a voiced-voiceless pattern. Westbury and Keating (1986) state it is more likely for stop voicing to occur in the medial/intervocalic position than in the initial or final position due largely to the fact that voicing depends on the difference between subglottal and supraglottal pressures.

#### **2.5.4 The timing of voicing in stop consonants**

This section reviews the timing of voicing in single stops and two-stop consonant clusters in English. It will also discuss VOT. Finally, this section reviews the influence of the place of articulation, vowel context, gender, and speaking rate on the voicing quality.

##### **2.5.4.1 The timing of voicing in single stop consonants**

In SI voiced stops, the timing of voicing starts either during the closure phase, or after release of the stop. The terms “pre-voicing” or “voicing lead” are used to refer to the former, while “voicing lag” is used for the latter (Docherty 1992:29). Regarding the pattern speakers employ when producing SI voiced stops, studies have reported inconsistent results. While Lisker and Abramson (1964) noticed that the pre-voicing pattern was dominant in comparison with the short lag, other studies (e.g. Westbury 1979) reported similar proportions between the pre-voicing and the short lag.

In an intervocalic position, voiced stops are characterised by uninterrupted voicing through the closure phase. Westbury (1979) reports that voicing in voiced stops occurring in intervocalic position was interrupted in only 3% of his tokens. In SF position, voiced stops can either be completely voiced, partially voiced as a result of ceasing voicing before the release phase, or devoiced. Roach (1983:33) points out that in SI and SF position, voiced stops are often not voiced. There is only some voicing in SF voiced stops.

When voiceless stops occur in intervocalic position, there is evidence in the literature of a voicing tail. I.e. voicing from the preceding vowel continues into the

closure phase of the stop. For example, Suomi (1980) reports a continuation of the voicing by 10ms through the HP of voiceless stops. In addition, Westbury (1979) noted a longer voicing interval continuing from the previous vowel. Other studies that confirm this pattern in voiceless stops include Keating (1984).

In TLA, /b/, /d/, /d<sup>h</sup>/ and /g/ are voiced, /t/ and /k/ are voiceless aspirated and /t<sup>h</sup>/ is a voiceless unaspirated emphatic plosive.

#### **2.5.4.2 The timing of voicing in two-stop consonant clusters**

In their paper examining consonant clusters in American English Yoshioka *et al.* (1981) point out that in order to understand the laryngeal coarticulation in stop clusters, it is very helpful to examine voiceless consonant sequences, because this will provide the main organisational principles governing how gestures interact with each other. The vocal folds remain stiff for voiceless ones and lax for voiced stops. When both stops are voiced or voiceless, the state of the vocal folds remains the same throughout. However, the state of the glottis changes when the two stops are different. For example, if C1 is voiced and C2 is voiceless, when C1 is released the glottis will start to expand, and the vocal folds will stiffen. On the other hand, if C1 is voiceless, and C2 is voiced, the glottis will start to close and the vocal folds will become lax after the release of C1 in anticipation of the voiced stop (Zhao 2003:21).

Since the main focus of this section is to investigate the timing of voicing in two-stop consonant clusters and how this is coordinated with the three phases of the production of stops, Figure 2.5 below (from Docherty 1992:40-41) shows the possible patterns of voicing in English consonant sequences.

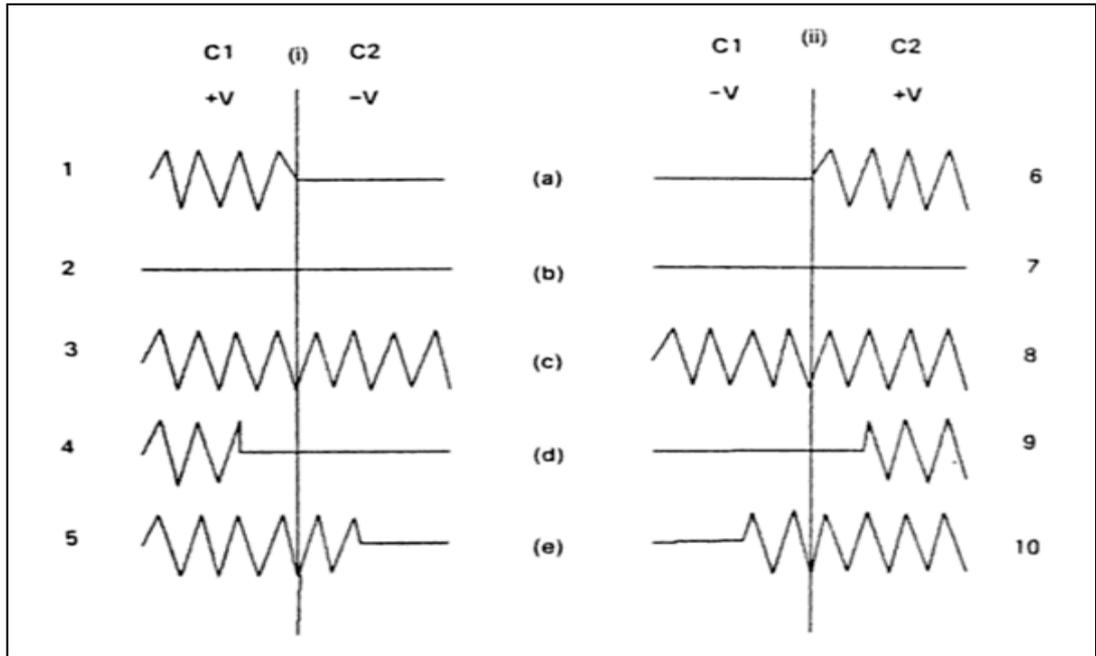

Figure 2.5 the possible patterns of voicing in English consonant sequences (from Docherty 1992:40-41).

From Figure 2.5, it can be seen that if C1 is voiced and C2 is voiceless, there are five possible patterns. In the first, both stops will retain their voicing quality, i.e. no voice assimilation will take place. In the second pattern, the first stop will become devoiced as a result of regressive assimilation. In the third pattern, voicing will continue from C1 through the HP of C2. As a result, C2 becomes voiced due to progressive assimilation. In the fourth pattern, if voicing is ceased before the release of C1, this becomes partially voiced. The last pattern occurs when voicing from C1 continues to the HP of C2, but ceases before the release of C2. In this case, C2 becomes partially voiced.

If C1 is voiceless and C2 is voiced, there are also five possible patterns of voicing in the cluster. In the first pattern both stops keep their voicing quality. In the second pattern, as a result of progressive assimilation, C2 becomes devoiced. In the third pattern, regressive assimilation will result in a voiced C1. In the fourth pattern, C2 is partially devoiced, and the voicelessness of C1 continues to the closure phase of C2 where there is prevoicing before the release of C2. In the final pattern, voicing starts during C1 closure making C1 partially voiced.

Numerous studies on the mechanism of the larynx during the production of speech have been conducted. Using fiberoptic filming, Fujimura and Sawashima

(1971) investigated laryngeal coordination in two-stop clusters in American English. However, they covered only a few clusters. Another study that used transillumination of the larynx and aerodynamic records to investigate Swedish voiceless stops was conducted by Löfqvist (1977). Löfqvist investigated Icelandic voiceless stops. His results concluded that clusters of two voiceless stop consonants can be produced with either one or two glottal opening and closing gestures. Gósy (1999) points out that Hungarian has a rule of voicing assimilation whereby obstruent clusters come to share the voiced/voiceless specification of their rightmost member across word boundaries as well as within words.

Concerning the magnitude of laryngeal gestures, Romero (1999) showed that single voiced stops have the highest levels of voicing; in other words, they have the smallest glottal opening. Voiceless consonant clusters, on the other hand, have the lowest level of voicing, that is, they have the greatest glottal opening.

#### **2.5.4.3 Voice onset time**

Voice onset time (VOT) is probably one of the most prominent acoustic characteristics in stops. Lisker and Abramson (1967:1) define VOT as “the time interval between the burst that marks the release of stop closure and the onset of quasiperiodicity which reflects laryngeal vibration”. In the literature VOT is referred to as having different categories depending on the time of voicing. When the voicing starts before the release, it is referred to as “voicing lead”. In this case, VOT is measured as negative. When voicing starts after the release, it is referred to as “voicing lag”, and VOT is then measured as positive. When voicing coincides with the release, VOT is referred to as zero (MacKay 1987:93-4). “Short lag” is when voicing starts up to 25ms after the release, and “long lag” is when voicing starts more than 25ms and up to 100ms or more after the release (Lisker and Abramson 1964: 389). It has been argued that all languages can be said to fall into one of these two categories, either having prevoicing and short lag, or short lag and long lag (Kessinger and Blumstein 1997). However, some languages, e.g. Arabic, allow the two categories. They have short lag in voiceless emphatic /t<sup>ʕ</sup>/, but long lag in voiceless plain /t/ (Khattab *et al.* 2006:135; Heselwood 1996:31).

Lisker and Abramson (1964) distinguish between the different VOT durations of English stops. They state that /b/, /d/, and /g/ are produced with short VOTs, or with prevoicing in some instances. On the other hand, the English voiceless stops /p/, /t/, and /k/ have longer VOT values. Docherty (1992) confirms that in English, /p/, /t/ and /k/ have a long lag (30-100ms) whilst /b/, /d/ and /g/ have a short lag (0-25ms).

There have not been many studies focusing on the investigation of VOT in Arabic dialects. Amongst the available literature is Rahim and Kasim's (2009:39) spectrographic study which investigated the influence of vowel context on the duration of VOT in Mosuli. Their results show that VOT for voiceless stops is longer before a close vowel than before a nonclose vowel. Voiced stops, however, were not influenced by the vowel context. The results also showed a clear influence of place of articulation on VOT duration with the later becomes longer in velar stops

TLA and English stops differ in their place of articulation and in VOT. While English has a two-way voicing distinction between long lag and prevoicing, TLA has a two-way voicing distinction between short lag and prevoicing. Long lag has also been reported for /k/ (Laradi 1983:12).

## **2.6 Factors that influence the duration of VOT**

There are many factors that can influence the duration of VOT. Such factors include the place of articulation of the stop, gender of the speaker, speaking rate, vowel quality, position of the stop, stress, and the number of syllables in a word. In the following sections, these factors will be reviewed and discussed.

### **2.6.1 The influence of place of articulation on VOT**

In general, /b/, /d/, and /g/ in English are produced with a short-lag VOT (Keating 1984:88) whilst English /p/, /t/ and /k/ are produced with a long delay of voicing (Lisker and Abramson 1964). Variation in VOT duration is the result of the place of the constriction. The general view is that the duration of VOT increases as the place of articulation shifts from an anterior place of articulation to a posterior

one, i.e. VOT for /p/ is shorter than that of /t/, and VOT for /t/ is shorter than that for /k/ (Lisker and Abramson 1964, 1967).

Docherty (1992) conducted a study on timing of voicing in British obstruents and found that of the three places of articulation, bilabial stops have the shortest VOT lag. As the point of articulation of the stop moves from bilabial to velar, the value of VOT increases indicating an effect of place of articulation on VOT (Lisker and Abramson 1994). Docherty (1992) also found that short-lag VOT in /b/ was significantly shorter than that for /g/.

In addition, Abdelli-Beruh (2009) investigated the influence of place of articulation on the short-lag VOT, closure duration, the voiceless interval, percentages of phonated closure in post-voiced and post-voiceless contexts in Parisian French. She found out that the average short-lag VOT duration is longer in velar stops. The average short-lag VOT of bilabial stops was significantly shorter than that for velars. In accounting for this variation, it has been stated that different amounts of pressure cause different values of VOT (Klatt 1975) and the more rapidly this pressure drops, the earlier the initiation of voicing will start (Lisker and Abramson 1967).

Yavaş (2009) tested the influence of place of articulation and vowel on VOT of English and discovered a correlation between the place of articulation and VOT. His results confirm previous findings that the duration of VOT becomes longer as the place of articulation is moved backwards. However, this pattern was not confirmed between alveolar and velars when followed by low vowels. Even when controlling for all these factors, Allen *et al.* (2003) states that different speakers have different VOTs.

Despite the apparent influence of place of articulation on the duration of VOT, some results reported no significant results. For example, Docherty (1992) did not find any significant difference between VOT duration for /d/ and /g/. In the same lines, Mitleb (2009:135), investigating the influence of place of articulation on VOT in Arabic, found that there is no difference in VOT duration between /t/ and /k/. Their results could be influenced by the speaker or the context. In sum, the influence of place of articulation on VOT is evident and well-documented in the literature, however, it is variable. The question raised at this point is why VOT varies as a function of place of articulation.

Cho and Ladefoged (1999) discuss the possible reasons behind the variations in VOT duration as a function of the place of articulation. They mention the volume of the cavity relative to the place of constriction, the velocity of the articulators, and the size of the contact area. The smaller cavity behind the place of constriction of velar stops results in higher pressure. Compared to the pressure behind the other two places of constriction, namely the lips and the tip of the tongue and the alveolar ridge, this pressure needs a longer time to drop and allow the vocal folds to start to vibrate.

Along these lines, the VOT has been also found to vary as a function of pharyngealisation. Abudaljuh (2010) conducted an experiment to see the effect of gender on the production of emphasis in Jordanian Arabic, using CVC pairs of words in which the consonant in the onset position was emphatic or plain. He found that the VOT for voiceless emphatic stops was significantly shorter than the VOT for plain stops. His results also revealed that emphasis was more evident in the speech of males than it is in the speech of females. The size of the cavity in front of the constriction place is also relevant in this respect. The air in this cavity will hinder the high pressure from dropping fast and reaching the point where the pressure is sufficient for the vocal folds to vibrate (Hardcastle 1973).

Despite the assumptions that both the lips and the tongue move at a very high velocity at the onset of closure, and that the vowel context is what makes the tongue slower (Löfqvist and Gracco 2002:2811), it is a well-known fact that the size and velocity of speech articulators are not the same. The lower lip is always faster than the tongue to initiate a movement towards a target (Löfqvist 2006:2883). In addition, the movement of the back of the tongue has lower velocity in comparison to the tongue tip and the lower lip (Roon et al 2007:409).

But let us now account for the difference in VOT between [p<sup>h</sup>] and [k<sup>h</sup>]. Because of the high velocity of the lower lip, it takes less time to decrease the transglottal pressure and start the vibration. On the other hand, due to the slow velocity of the back of the tongue, more time is needed for the right pressure to be reached and for the vocal folds to start to vibrate (Hardcastle 1973, Klatt 1975, Kuehn and Moll 1976). However, it is also possible to have unaspirated/short lag [k] in many languages such as Japanese (Riney et al. 2007).

Abdelli-Beruh (2009:67) identifies two factors that control the onset of vocal fold vibrations. These are the rate of decrease in the intra-oral pressure after the release of the stop, and the rate of increase in volume velocity of the air flow through the glottis. This is in agreement with Stevens (1999) who argues that a more plausible explanation for the variation of VOT duration is the size of the contact area between the active and the passive articulators forming the constriction. The size of the contact area decreases as the place of articulation moves from back to front. It follows then that the larger this contact area is the more time is needed to allow for the articulatory to be disengaged completely. This will slow down the rate at which the transglottal pressure drops, which means more time for the vocal folds to vibrate.

With regard to the interarticulator phasing, Löfqvist (1992:15) states that there is a weak correlation between VOT and interarticulator phasing. There are, however, other factors in addition to interarticulator phasing that have an effect on the duration of VOT. These include “glottal opening, transglottal pressure and airflow, and vocal fold tension” Löfqvist (1992:15). To sum up, Ladefoged and Maddieson (1995:622) conclude that the variation is very difficult to explain, because there could be more than one reason responsible for this difference.

### **2.6.2 The influence of the vowel on VOT**

The second factor that affects VOT is the quality of the vowel. Klatt (1975) measured the duration of VOT and the duration of the different stop bursts in word-initial consonant clusters. The results show a clear influence of the following vowel on VOT duration. The duration of VOT is longer when the following vowel is high in comparison with contexts where mid and low vowels followed. In addition, Ohala (1981) reported that the mean VOT value for /pi/ was double that of /pa/. Finally, the quality of the vowel, whether it is tense or lax, has an effect on VOT. Weismer (1979) states that VOT is longer when the following vowel is tense as opposed to when it is lax. In this thesis, the vowel context is kept consistent by using the open low vowel /a/.

### 2.6.3 The influence of gender on VOT

The physiological differences between males and females have also been found to influence the duration of VOT. These physiological differences include the shape of the glottis, the size of the vocal tract, the thickness of the vocal folds, and differences in speaking styles (Shue and Iseli 2008:4493). The difference between the speech of males and females emerges during preadolescence (Lee *et al.* 1999), the most noticeable difference between the two genders being the size of the vocal tract. Simpson (2001) has shown that differences in the average vocal tract dimensions of males and females result in differences in the spatial and temporal properties of sounds. It has been also suggested that physiological differences in the glottis and vocal tract can also be influenced by age differences (Mattingly 1966). These differences are manifested in the duration of VOT.

There are, however, contradicting results of the influence of gender on VOT. For example, Morris *et al.* (2008) compared the VOT values produced by male and female speakers of English. Although there was a significant difference between VOT values as a function of the vowel, there was no significant difference between VOT values for males and females. Other studies, on the other hand, have noted longer VOTs in adult females when compared to males. Swartz (1992) examined the influence of gender on VOT. The results of analysis for eight males and eight females showed significant differences between the two groups, particularly in /t/ and /d/, where male speakers produced a shorter VOT compared to female speakers. In addition, Whiteside *et al.* (2004) measured the duration of VOT for a sample of females and found out that they produced longer VOTs than the males in the study. The results were more significant when women had “high hormonal levels” suggesting that these differences may be motivated by hormones.

In Smith’s (1979) study using English-speaking adults, ten males and ten adults produced 12 CVC words in isolation. After analysing the VOT duration of the two groups, Smith concluded that the percentages of prevoicing and short lag between the two groups were about the same. However male participants produced longer VOTs for initial /d/ and /g/. In addition, Whiteside and Irving (1997) used English stops in stressed syllables and in word-initial and prevocalic position to investigate the influence of gender on VOT. Their target words were produced by five males (aged 25-37) and five females (aged 28-38). The results of their analysis

revealed that female speakers produced longer VOT values compared to male speakers. In addition, Ryalls *et al.* (1997) investigated VOT production by twenty males and females, African American and Caucasian American speakers of English who produced the six stops (/p/, /t/, /k/, /b/, /d/, /g/) with the vowels /i/, /a/, and /u/. Significant gender differences were found in the results with female speakers producing longer VOT.

The age of the speaker is another factor that has been found to be important in influencing voicing quality and VOT duration. Sweeting and Baken (1982) looked at the influence of age on VOT. They used three groups, each consisting of ten speakers. The participants in the first group were aged 25-39; those in the second group were aged 65-74, whilst speakers in the last group were over 75. All groups produced the words 'beat', 'Pete', and 'bead' in a carrier sentence. Results showed that with the increase in age, there was an increase in variability within the participants leading to more variability between the groups.

Finally, Khattab *et al.* (2006) investigated the influence of gender on the production of /t/ and /tʰ/ in Jordanian Arabic. Results of their study show that female participants produced longer VOT duration. Another study by Albarak (2008) investigated the sociophonetic factors influencing emphasis in Syrian Arabic. Female participants showed large but not significant differences between VOT values for /t/ and /tʰ/.

#### **2.6.4 The influence of speaking rate on VOT**

Previous studies on English voicing have shown that the duration of VOT varies as a function of speaking rate (Miller and Baer 1983, Miller *et al.* 1986). There is an inverse relationship between VOT duration and speaking rate. In other words, a decrease in speaking rate results in an increase in VOT duration, and vice-versa. However, changes in speaking rate do not have the same influence on different categories of voicing. Morris *et al.* (2008:316) confirmed that VOT becomes shorter as speech rate increases, but found no significant change in the duration of the short lag.

Pind (1995: 293) conducted an experiment on the influence of speaking rate on VOT and quantity in Icelandic stop consonants. He found out that when the rate

of speaking is slowed, longer VOTs were produced for both aspirated and unaspirated stops. However, the influence of speaking rate on these categories was not equal, being more evident in aspirated stops.

Kessinger and Blumstein (1997) investigated the extent to which fast and slow speaking rates affect the distribution and mean values of VOT in French, Thai and English. They used CV(C) words in isolation where the first consonant is either a bilabial or an alveolar. Their results show that the change in speaking rate did not have any effect on the short lag value of VOT. However, changing the speaking rate affected the long lag VOT in Thai and English, and the pre-voiced consonants in Thai and French. This influence made the two categories overlap.

Schmidt and Flege (1996) carried out a study on bilinguals and monolinguals of English and Spanish to investigate the influence of speech rate on the production of stops. Regardless of the language, the four groups showed similar patterns in fast, normal, and slow speech rate. However, as expected, the values of VOT in the English and Spanish monolingual groups were different. Finally, Summerfield (1981) examined the influence of speech rate on the perception of voiceless /p/, /t/ and /k/, and their voiced siblings /b/, /d/ and /g/. At a slow speech rate, the target words were more likely to be identified as voiced i.e. as the rate of articulation slows down, longer voicing durations are produced.

### **2.6.5 Other factors that influence VOT**

There are other factors that can play a role in the variation of VOT duration. These include speaker variability, the position of the stop, number of syllables, voicing of consonants in the same syllable, and stress. Allen *et al.* (2003) tested the VOT of voiceless stops in monosyllabic words to see the influence of speaker variability. His results revealed that the value of VOT differed from one speaker to another, and that the rate of speech of the speakers was variable as well. The position of the stop in an utterance, whether it is in a list or embedded in a sentence, has also been said to influence the value of VOT. A study by Lisker and Abramson (1964) revealed that VOT for words produced in isolation was longer than when the words were produced in a sentence.

The number of syllables influences the duration of VOT. Klatt (1975) observed that VOT of stops in monosyllabic words was 8% longer than VOT of stops in disyllabic words. Another factor influencing the duration of VOT is the voicing of neighbouring segments. Weismer (1979) noticed that the voicing of the consonant in syllable-final CVC affects the VOT of the syllable-initial stop in the same syllable. The VOT value of the onset stop was longer if the coda stop is voiced, as compared to when it is voiceless.

Finally, stress has been found to influence VOT. In their study, Lisker and Abramson (1967) used both words in isolation and words in sentences, and found that in stressed syllables there is a longer lag in the value of VOT, which is not the case for unstressed syllables. In syllables bearing the final sentence stress, the value of VOT increased even more. Lisker and Abramson (1967) further noticed that the VOT value was longer when the following vowel was stressed than when it was unstressed.

#### **2.6.6 Summary of voicing**

The second section of this chapter reviewed the mechanism of voicing and how it is coordinated with supralaryngeal gestures during the production of single and two-stop clusters. The laryngeal gesture is one of the complicated gestures in speech marking the distinction between voiceless and voiced stops. While in the former the vocal folds are abducted so that air can pass freely between them, the latter is marked by the vocal folds being adducted so that they can vibrate during the production of voiced stops. The timing of voicing is influenced by many factors such as the place of articulation, the voicing of the surrounding sounds, gender and speaking rate. VOT is one of the most important characteristics in stops consonants. It can be measured as positive when voicing starts after the release of the stops, and as negative when voicing starts during the HP. VOT has been found to be influenced by place of articulation with VOT duration is longer as the place of articulation moves back. VOT also varies as a function of vowel context, gender, articulation rate and stress.

## 2.7 Conclusion

This chapter reviewed the relevant literature on articulatory timing and timing of voicing in speech production. It also reviewed the main factors that influence gestural coordination and the initiation of voicing in speech sounds, particularly stop consonants. Stop consonants have different acoustic properties depending on their place of articulation. The main differences are the duration of the HP and VOT. In short, bilabial stops have longer HPs, but shorter VOTs.

The production of speech is one of the most complex human skills to analyse and understand because sounds are fused together in such a way that it is almost impossible to determine where one sound ends and another starts. Articulatory phonology is an attempt to clarify some of the ambiguity of speech production. The basic unit consists of articulatory gestures which overlap in time and space, and are affected by many factors. Place of articulation, including the order of articulation, is one of the main factors affecting the coordination of gestures. In general, less overlap is allowed in P-to-A order of articulation. The position of the sequence also affects how its gestural components are coordinated with SI sequences being organised differently from SF ones. Perception has also proved to be a factor in gestural coordination. When there is a risk of misunderstanding, less overlap is adopted. The influence of gender has a physiological and social basis. Men are said to produce shorter utterances and omit more than women. Finally, speaking rate influences the coordination of articulatory gestures. In general, an increase in speaking rate results in an increase in the velocity of the articulators and a decrease in the duration and magnitude of the gesture.

The second part of the chapter reviewed the mechanism and timing of voicing in single and two-stop clusters. It also considered some studies on VOT and the factors that are responsible for variation in the initiation of voicing. In order for voicing to take place, several requirements need to be met. These include the correct amount of transglottal pressure, suitable velocity of the articulators and the air, the size of the glottal opening and the stiffness of the vocal folds.

Stop consonants can be distinguished on the basis of vocal fold activity during the HP. In general the vocal folds vibrate for /b/, /d/, /d<sup>h</sup>/ and /g/, but not for /t/, /t<sup>h</sup>/ and /k/. Voicing during the HP is referred to as pre-voicing. The duration from the

release to the start of voicing is known as VOT. Depending on the duration, VOT is referred to as short or long lag.

VOT duration is influenced by many factors, including place of articulation, the vowel context, gender, speaking rate and other factors such as syllable count and stress. The place of the constriction is one of the most important factors, the general pattern being that VOT duration increases as the place of the constriction moves from front to back. The size of the cavity behind/in front of the constriction, the velocity of the articulators and the size of the contact area are among the main explanations advanced to account for VOT variation. The vowel context influences VOT as well, as longer VOT durations were observed when high vowels followed. The gender of the speaker also affects VOT duration with females having been found to produce longer VOT duration than males. As for speaking rate, the duration of VOT increases at a slow speaking rate, and decreases at a fast speaking rate. It seems that the amount of the pressure behind the constriction, the velocity of the articulators and finally the velocity of the air all play an important role in VOT duration. Finally, there are other factors such as the number of syllables in the word and stress that have been found to influence the duration of VOT.

## **Chapter Three: Methodology**

### **3.1 Introduction**

This chapter reviews the methodology adopted in this thesis. It discusses the methodological issues such as the theoretical framework, material, participants, instrumentation and measurements. Three different instrumental techniques of recording and measuring the data are used in this thesis, namely electropalatography (EPG) to investigate the coordination of articulatory gestures, spectrography to investigate the acoustic and durational properties of the target sound(s), and finally, laryngography (Lx) to investigate the timing of voicing. Depending on the techniques, different measurements are discussed in this section. The Statistical Package for the Social Sciences (SPSS) was used to analyse the data and different tests such as the independent-sample *t*-test, one-way ANOVA and repeated measures ANOVA were employed to investigate any significant differences in the data.

### **3.2 Theoretical Framework**

This thesis adopts the articulatory phonology framework as formulated by Browman and Goldstein (1986) and developed by Byrd (1996) and Gafos (2002). This framework links phonology with phonetics on the premise that both form complementary descriptions of the same system (Tatham 1995:85). Sounds are looked at in terms of the gestures that constitute different variables of the vocal tract during the production of speech. Such variables describe the location of constriction (i.e. the tongue tip and body, the lips, the glottis, and the velum) and the degree of constriction (closed, critical, narrow, mid or wide) (Gafos 2002). Another instrumental method advanced in this thesis addresses articulatory and acoustic phonetics. This method is concerned with the production of speech sounds and their acoustic characteristics including voicing.

### 3.3 Research Questions and Hypotheses

Answering questions related to speech production has always two main difficulties. The first arises from the fact that it is not always straightforward to clearly observe the behaviour of the articulators involved, or the overlap between the gestures of two consonants. The second difficulty is that variability in speech production is the result of many factors such as the context (which includes place of articulation, manner of articulation and voicing of the consonants), prosodic structure and speaking rate.

The aim of this study is to investigate how speakers of TLA coordinate the articulatory gestures of SI and SF two-stop clusters in TLA. Another aim is to investigate the patterns of the timing of the glottal opening with respect to the closure and release gesture of the stop, and what will happen when the two stops do not agree in voicing.

The main research question is: what is the influence of place of articulation, sequence of articulation, syllable position, morphological structure, gender and articulation rate on the gestural organization of SI and SF two-stop consonant clusters? The extent of the difference in the coordination pattern, in SI and SF clusters, between male and female speakers is also investigated. The hypotheses tested in Chapter four, five and six can be divided into four main themes: coordination, morphology, speech rate and voicing as follows. Under each of these themes, there may be a number of related hypotheses.

#### Coordination

- The place of articulation of C1 and C2 will affect the duration of their HP. This hypothesis is also tested for single stops in SI and SF position.
- SI two-stop consonant clusters will exhibit more intergestural cohesion than SF two-stop clusters, leading to more overlap in onset than in coda.
- Consonant clusters with two lingual stops will exhibit more overlap than lingual-bilabial, or bilabial-lingual clusters. This hypothesis is based on the assumption that when the tongue is the only active articulator in the gestures of two stops in a consonant cluster, the two gestures will be more overlapped

than when the lip (LB) gesture is followed by a tongue-tip (TT) or tongue-back (TB) gesture or vice-versa.

- Posterior-to-anterior (P-to-A) sequence of articulations will have more gestural overlap than anterior-to-posterior (A-to-P) articulation. When a posterior closure is followed by an anterior one, the release of the first closure may be hindered by the second closure, if this was formed before the release. On the other hand, if there is an anterior closure followed by another posterior closure, the release of the front closure is secured so that even if the closure at the posterior region was formed first, the front closure will still be released.
- Since more overlap is expected in two lingual stops and in clusters with A-to-P sequence of articulation, it follows then that the duration of ICI in these contexts will be shorter.

### Morphology

- The morphological structure of SI and SF clusters will influence the gestural coordination pattern. This hypothesis is based on the assumption that where C1 and C2 are tautomorphemic (belonging to the same root) will have less gestural overlap than when C1 and C2 are heteromorphemic (not belonging to the same root). In other words, when C1 is a prefix, the two consonantal gestures are less likely to show overlap than when it is not a prefix. In SF position, when C2 is a suffix, it is less likely to overlap with C1 than when it is not.

### Speech rate

- The pattern of coordination in different articulation rates may be influenced by the place of articulation and gender of the speaker. This hypothesis assumes that an increase in the articulation rate will result in a decrease in the HP duration in an increase in gestural overlap (less C1 release and shorter ICIs) in SI and SF two stop clusters. On the other hand, slow articulation rate is expected to have the opposite effect on these clusters, i.e. longer HP durations and less gestural overlap (more C1 releases and longer ICIs).

- Based on the physiological difference between males and females, the two groups (males and females recruited in this study) are expected to exhibit different HP durations and different gestural coordination patterns (Different patterns of C1 release and different ICI duration).
- This hypothesis is related to the influence of articulation rate on voicing. It supposes that an increase in articulation rate results in longer voice durations relative to the HP duration. In slow articulation rate, the opposite is assumed.
- An increase in articulation rate is expected to result in shorter VOT duration and the opposite is expected in slow articulation rate.

### Voicing

- This hypothesis is adopted from (Westbury's 1975). It states that the degree of voicing adaptation in stop clusters may be determined by the voicing characteristics of single stops.
- The duration of VOT will vary as a function of place of articulation. The further back the place of articulation is, the longer the VOT duration will be.
- The voicing quality of first and second stop in the consonant cluster will determine the voice quality of the ICI. When the two stops are voiced, it is hypothesized that the ICI will be voiced, and if the two stops are voiceless, the ICI is expected to be voiceless. The voice quality of the second stop in the cluster will play a more important role than the first stop in determining the voice quality of the ICI.

### **3.4 The Participants**

Fourteen TLA participants took part in this study. The criteria for inclusion of participants were being born and raised in Tripoli, and using TLA for everyday conversations. It is worth mentioning that four of the participants were not living in Tripoli during the time of the recording, and that three participants do not speak English at all. The rest of participants could speak English with different degrees of proficiency from pre-intermediate to advance. One of the male participants, aged 35 years' old, was recorded using EPG and Lx. Fourteen participants, seven males (including the EPG and Lx participant) and seven females, were recorded for the acoustic analysis. The age range for those participants at the time of data collection

was 20-43. The average age for male participants was 36 years and 29 years for female participants. All participants were informally interviewed to verify that they speak TLA (that their accent contained no other accent features) and to ensure that they did not have a history of any speech or listening disorders. After the speakers were recruited, they were asked to read the description of the research (provided in Arabic and English (Appendix D) and sign a consent form (Appendix D). None of the participants was informed about the main purpose of the experiment. All participants were offered compensation for their time. Information about participants is presented in Table 3.1.

Speakers	Age	Gender	Level of Education
MS1	36	M	MA
MS2	33	M	MA
MS3	35	M	PhD
MS4	36	M	PhD candidate
MS5	35	M	PhD candidate
MS6	43	M	PhD candidate
MS7	33	M	MA
FS1	43	F	BA
FS2	41	F	BA
FS3	38	F	BA
FS4	23	F	BA
FS5	20	F	Undergraduate
FS6	20	F	Undergraduate
FS7	20	F	Undergraduate

Table 3.1 Age, gender and educational level of participants in the acoustic experiment. The mean age is 36 (33-43) for males and 29 (20-43) for females.

From now on, male speakers (1-7) will be referred to as MS1-MS7 and female speakers (1-7) will be referred to as speaker FS1-FS7.

### 3.5 The Material

The recorded material was divided into four main groups. The first group consists of 7 CVC syllables with one of the stops /b/, /t/, /d/, /tʰ/, /dʰ/, /k/ and /g/ in SI position (14x7x3=294). The second group contains the same single stops in SF

position (14x7x3=294). All of the words are verbs except for the nouns /dam/, /bat<sup>s</sup>/, /jak/ and /hag/. Table 3.2 shows the target words in the singleton (SI and SF).

SI single stops		SF single stops	
Word	Gloss	Word	Gloss
/ba <sup>x</sup> /	“he sprayed”	/ha <sup>b</sup> /	“he loved”
/ta <sup>f</sup> /	“he lit a fire”	/na <sup>t</sup> /	“he yelled”
/da <sup>m</sup> /	“blood”	/fa <sup>d</sup> /	“he caught”
/ta <sup>b</sup> /	“he kicked”	/ba <sup>t<sup>s</sup></sup> /	“ducks”
/d <sup>s</sup> am/	“he packed”	/sa <sup>d<sup>s</sup></sup> /	“he bit”
/ka <sup>r</sup> /	“he towed”	/ja <sup>k</sup> /	“suspicion”
/qa <sup>s</sup> /	“he cut”	/ha <sup>g</sup> /	“right”

Table 3.2 SI and SF singleton stops in IPA transcription with glosses and target consonant underlined

In the third group, there are 27 words containing two-stop clusters in SI position (27x14x3=1134). Depending on the place of articulation, these are divided into 6 groups as follows: coronal + dorsal, dorsal + coronal, /b/ + coronal, /b/ + dorsal, coronal + /b/, and finally dorsal + /b/. These cluster types can be sub-divided into two further categories. The first category consists of 18 words with the target cluster (C1 + C2) are part of the root. The second category consists of nine words where C1 is the prefix /b/ (6 words) or the prefix /t/ (3 words). Table 3.3 presents words with SI and SF two-stop clusters. In this table, words with clusters containing a prefix are placed between curved brackets. Apart from words containing a prefix and /dga:jig/, /bd<sup>s</sup>a:sa/ and /d<sup>s</sup>ba:ba/, all words are monosyllabic.

Cluster type	SI two-stop clusters		SF two-stop clusters	
	Word	Gloss	Word	Gloss
coronal + dorsal clusters	/dkar/*	‘male’		
	/dga:jig/*	‘minutes’		
	/t <sup>s</sup> gar/*	‘he tapped’		
	(/tka:bir/)	‘you brag’	/hatk/ <sup>x</sup>	‘violation’
	(/tga:til/)	‘you fight’	/fatg/ <sup>x</sup>	‘hernia’
dorsal + coronal clusters	/ktab/*	‘he wrote’	/nakt/ <sup>x</sup> (/d <sup>s</sup> hakt/)	‘unpacking’ ‘you laughed’
	/kdab/*	‘he lied’	/nakd/	‘boring’
	/gtal/*	‘he killed’	/waqt/ <sup>x</sup>	‘time’

			(/s <sup>ɕ</sup> dagt/)	‘I/you told the truth’
	/gt <sup>ɕ</sup> af/*	‘he picked’	/magt <sup>ɕ</sup> /	‘a kind of ropes’
	/gdar/*	‘he was able’	/ʒagd/	‘knotting’
/b/ + coronal	/bde:/* (/bda:faʒ/)	‘he started’ ‘with a motive’	/ʒabd/	‘slave’
	/bt <sup>ɕ</sup> am/* (/bt <sup>ɕ</sup> a:wa/)	‘he buttoned’ ‘with a pan’	/rabt <sup>ɕ</sup> /	‘tying’
	(/bd <sup>ɕ</sup> a:ʒa/) (/bd <sup>ɕ</sup> arba/)	‘goods’ ‘with a strike’	/gabd <sup>ɕ</sup> /	‘arresting’
	(/bta:ri:x/)	‘on the date’	(/ktabt/)	‘I/you wrote’
/b/+ + dorsal	/bke:/* (/bkalma/)	‘he cried’ ‘with a word’	/habk/	‘angirly’
	/bgar/* (/bgalbna/)	‘cows’ ‘with our heart’	/t <sup>ɕ</sup> abg/*	‘drilling’
coronal + /b/	(/tba:ʒir/)	‘you commence’		
	/dbaʒ/*	‘clothes’		
	/t <sup>ɕ</sup> baʒ/*	‘he typed’	/ʒat <sup>ɕ</sup> b/	‘delete’
coronal + /b/	/d <sup>ɕ</sup> baba/*	‘fog’		
	/kbas/*	‘he pressed’		
	/gbal/*	‘he accepted’	/nagb/*	‘puncturing’

Table 3.3 Words containing two-stop clusters in SI and SF position. Words with clusters containing a prefix or a suffix are placed between curved brackets. Shaded areas in the table mean that there are no SF clusters to match those in SI.

In the fourth group of words, there are 17 words with SF two-stop clusters (17x14x3=714). The group is divided into the same 6 cluster types adopted in SI clusters. This group can also be sub-divided into those containing no suffixes (14 words) and those with the /t/ suffix (3 words). Words with a suffix are placed between curved brackets in Table 3.3.

All words with a SI or SF cluster are arranged on the basis of order of place of articulation. Words can contain A-to-P or P-to-A articulation. In the former, C1 is either a bilabial or an alveolar followed by a velar, or a bilabial followed by an alveolar. P-to-A articulation presents the opposite pattern. It is worth noting that not all the clusters are lingual stops. Words marked with (\*) have a corresponding word with the opposite order of place of articulation in SI position, whilst those marked with (x) have a corresponding word with the opposite order of place of articulation in SF position.

In order to help keep the sample consistent, the same lists of words were used when conducting the EPG and the Lx recording. There is another advantage of

using the same lists which relates to the vowel. According to Byrd (1994:312), using the vowel /a/ has two advantages. First, it makes the velar constriction anterior, so that it is more easily recognizable on the EPG palate. Second, it minimises vocalic lingua-palatal contact.

### 3.6 Procedures

The participants were asked to read each target word embedded in the carrier sentence: “*matgu:li:sh \_\_\_\_\_ halba*” meaning “Don’t say \_\_\_\_\_ many times”. There are many reasons for using a carrier sentence. First, it is used to avoid the gemination of singleton stops in pre-pausal position. Second, a carrier sentence helps maintain the same articulation rate, minimise variation of stress and intonation patterns. Third, it helps when taking accurate measurements. For example, the sounds preceding and following the target words, namely /ʃ/ and /h/, work as a marker both for the onset of the HP for initial stop consonants and for the offset of HP for SF final stops.

To investigate that the gestural coordination of the SI clusters is not influenced by the preceding consonant in the carrier sentence (/ʃ/) or the following consonant (/h/) for SF clusters, words containing SI and SF clusters were recorded in isolation. Although it is not always possible to measure the duration of the C1 hold phase, recording in isolation is very help when it comes to investigating the duration of ICI in only two-stop clusters.

Apart from /nakd/, /magtʕ/, all the chosen words have a high frequency in TLA, and the participants were expected to have no difficulty in producing and perceiving them. However, reading the material from the cards posed an important methodological issue: interference from Modern Standard Arabic (MSA). Since TLA is not usually written, unlike MSA, it was possible that participants would be influenced by their knowledge of the orthographic system of MSA when reading the target words. To avoid this influence, the words were written in Arabic script on a series of 20 x 5 cm cards without any diacritics indicating how they should be vocalised. The participants had a chance to practise pronouncing these and to annotate the cards with diacritics and short vowels if they wished. From these practices, the researcher was satisfied that all participants used TLA pronunciations.

Once ready, the participants read the carrier sentences with the target word at three different articulation rates: normal, fast and slow. To produce normal speech rate, participants were instructed to speak as though talking to a friend or a family member. For fast speaking rate, all participants were asked to speak rapidly, but to ensure that they did not misarticulate. For slow speaking rate, participants were asked to speak “carefully and clearly” (Pickett *et al.* 1999:138) without inserting any pauses between or within words (Kewley-Port and Luce 1984). Since stress influences the duration of segments, participants were advised not to speak loud or emphasise any part of the carrier sentence. This is to avoid comparing a segment in a stressed syllable with one in an unstressed syllable.

The data for each speaker was collected in a single session. The microphone was placed 15-20 cm to the right or left of the speakers’ lips to avoid “popping”. A three-second pause was left between each sentence to allow the participant’s tongue and lips to return to their neutral position, and to keep the speech rate consistent with the advised speaking rate. There was about a 10 minute-break between the recordings. All recordings were then carefully monitored to make sure that all the participants had adopted approximately the same rate. If participants had not produced some sentences at the speech rate required or had made any mistakes, such as pausing or failing to achieve the correct pronunciation, they were asked to repeat these items at the end of their session.

### **3.7 Instrumentation and measurements**

In this study, the articulatory analysis was based on data obtained from three different instruments: audio recordings, EPG and Lx recordings. Each of these tools proved useful in providing particular insights when attempting to answer the research questions. Later, the advantages and disadvantages of these tools are discussed and a rationale is provided for the choice of these tools in relation to the research objectives of this thesis.

### 3.7.1 Electropalatography (EPG)

Electropalatography (EPG) is one of the most useful techniques for studying lingual coarticulation (Butcher and Weiher, 1976; Hardcastle, 1984). It is used to provide information about the spatial and temporal contacts between the tongue and the palate and this is what distinguishes it from other phonetic instruments, making it suitable for the purposes of this thesis. The only EPG data used in this study were produced by the researcher. This custom-made artificial palate, known as “the articulate palate”, is very thin and fits against the speaker’s own hard palate. Figure 3.1 shows the EPG palate used in this study.

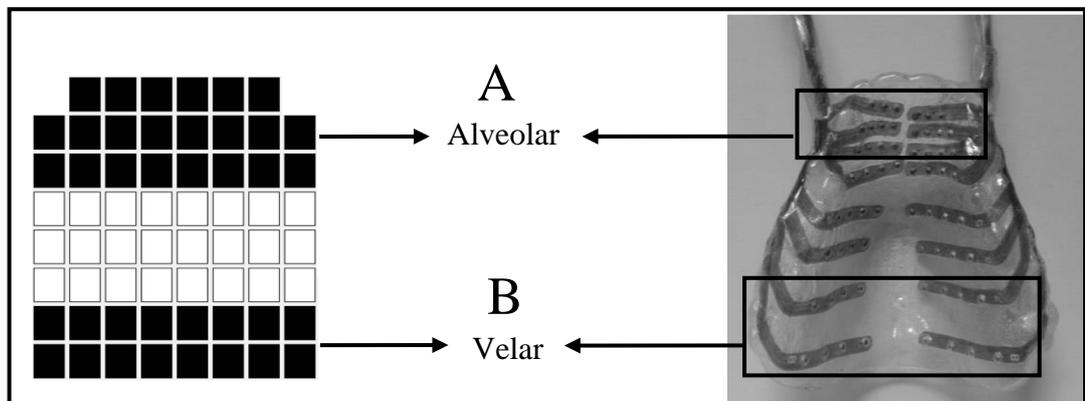

Figure 3.1 EPG palate (right) with computer-generated display (left) showing a complete closure at the alveolar region (A) and a complete closure at the velar region (B). Black squares record tongue contact; white squares mean no contact.

The articulate palate contains 62 electrodes equally distributed on both sides. These are arranged in eight rows, seven of these containing eight electrodes, whilst the front row contains only six. The front three rows (1-3) measure alveolar region contact, the next three rows (4-6) measure palatal region contact, while the last two rows (7-8) measure velar region contact (*Articulate Assistant User Guide 2003-2007*: 31).

Regarding the number of electrodes, Fougeron *et al.* (2000) compared how the lingual-palatal information varies as a function of the number and distribution of electrodes. They concluded that although more information is provided by pseudopalates with more electrodes, the information provided by the pseudopalate with 62 electrodes is good enough to give clear articulatory patterns.

The palate is connected to a ‘multiplexer’ which is in turn connected to EPG serial interface SPI V.2.0 with a palate scanner EPG3.V2. This scanner is then plugged into a PC. The software ‘Articulate Assistant’ was used to analyse the recording. This software displays the place and time of the tongue contacts with the palate. Every frame at 10ms intervals shows real-time articulatory events aligned with acoustic information (spectrogram and waveform display) about these contacts. The tongue-palate contact patterns can be analysed and presented in tables and graphs (*Articulate Assistant User Guide 2003-2007*: 31).

### **3.7.1.1 Limitations of using EPG**

EPG is one of the oldest and most widely used instrument in linguistics and speech therapy. It has the following advantages:

- It is very easy to use; it does not require an expert to operate. However, the person analysing the data needs to be phonetically trained.
- It provides accurate information about the position of the tongue when it is in contact with the palate, making it both suitable and convenient for investigating intergestural coordination of two lingual stop clusters.
- The data are easy to interpret and convert into tables and charts.

The articulate palate used in this study has some advantages over the Reading palate. For example, the velar closure in the articulate palate is better than the original Reading palate ([www.Articulateinstruments.com/Information](http://www.Articulateinstruments.com/Information)). Moreover, the former is lighter, thinner, and shock resistant. It can also provide lateral contact information on the palate sides, and grips around the teeth very well. Despite the above advantages, the following drawbacks have been also noted:

- EPG is relatively expensive for large-scale studies involving many participants.
- It is considered to be an invasive tool.
- Perhaps the most serious restriction of using the articulate palate is that it does not record the bilabial closure. As a result, it is not

suitable for investigating intergestural coordination when one of the stops is bilabial.

- It may fail to provide any information about the magnitude of the tongue-back gesture when this is posterior.
- It may influence the production of some sounds.
- Finally, the 10ms interval between frames may not capture shorter articulatory events.

The articulate palate, in particular, has some drawbacks such as the cables which may influence lip-rounding. It also covers the teeth which may influence the production of dental stops. Despite these limitations, the role of EPG as an instrument in investigating timing in lingual stops remains vital and its limitations are not as problematic as they may seem for the following reasons:

- Since the main aim of this thesis is to investigate the intergestural coordination in two-stop clusters, the position of the tongue when it is not in contact is less important in this study. The most important cue is tracing the build-up of the constriction until it is formed, reaching the maximum contact and then being released.
- In the case of clusters containing /b/, the spectrograms aligned with these frames can be, to some extent, used to infer the pattern of coordination
- The vowel /a/ is used to provide an anterior constriction that is captured by the last two rows of electrodes in the velar region.
- Finally, in respect to the claim that EPG influences the production of sounds, such influence has been proven to be insignificant (e.g. Hardcastle 1972).

### **3.7.1.2 EPG measurements**

All clusters in SI position were followed by the open vowel /a/. Using this vowel helps to minimise the interference with the trajectory of the consonantal

gestures (Chitoran *et al.* 2002:11), and to control the contextual effect of the vowel environment (Dixit and Flege 1991 and Byrd 1993). For each cluster, four EPG measurements were made. These are (1) onset and offset of closure for C1, (2) onset and offset of closure for C2, (3) the amount of overlap between the closure of C1 and C2, and finally, (4) the amount of delay between the release of C1 and formation of the closure of C2. It is worth noting that C1 and C2 refer to the first and second stops in a cluster, regardless of syllable position.

The onset of closure of C1 or C2 was measured from the first frame in which the tongue-tip (TT) or the tongue-body (TB) gesture reached the target and formed a complete closure. The onset of gesture frames, the frames before a complete seal is formed, are not counted. The offset of closure of C1 or C2 is marked by the first frame where the closure seal at the alveolar or velar region is broken. It is worth mentioning that the measurement of the duration includes the duration of the HP only. In other words, it excludes the duration of VOT in SI clusters and the release of C2 in SF clusters.

The amount of overlap was measured by how many frames there were in which there was a simultaneous closure of C1 and C2 at the alveolar and velar regions. The greater the number of frames with a simultaneous constriction, the more overlap between the two closures. Figure 3.2 shows the EPG measurements of the onset and offset of closure of a TB gesture followed by a TT gesture when there is an overlap between the two closures.

Another measurement that is used only in EPG is the number of syllables per second. The duration of each repetition was calculated from the onset of the acoustic signal to the pause when the speaker finishes the sentence. This duration was then divided by the number of syllables in each sentence.

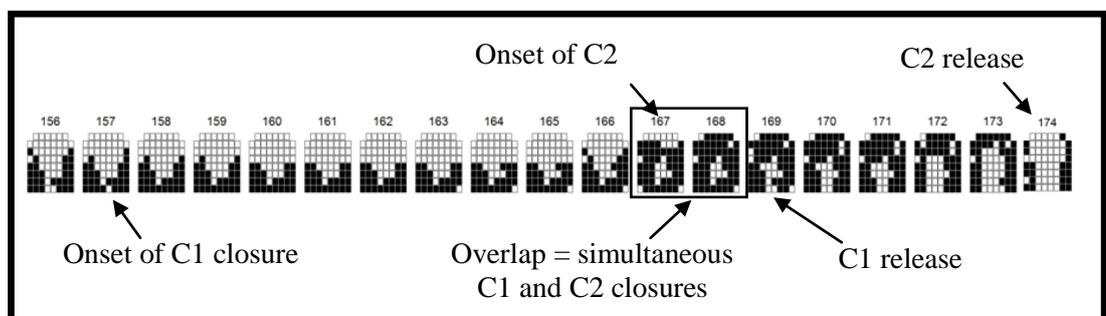

Figure 3.2 EPG frames showing an overlap between a TB gesture and a following TT gesture.

Finally, when there is no overlap, the ICI frames were defined as the frames between the release of C1, where the seal is broken, and the formation of the closure for C2, where a new seal is complete. ICI frames are characterised by having no complete alveolar or velar seal. An increase in the number of these frames reflects a lesser degree of overlap between the two gestures. Figure 3.3 shows the measurements for onset and offset of closure of TB gesture followed by a TT gesture when there is a delay between these two closures.

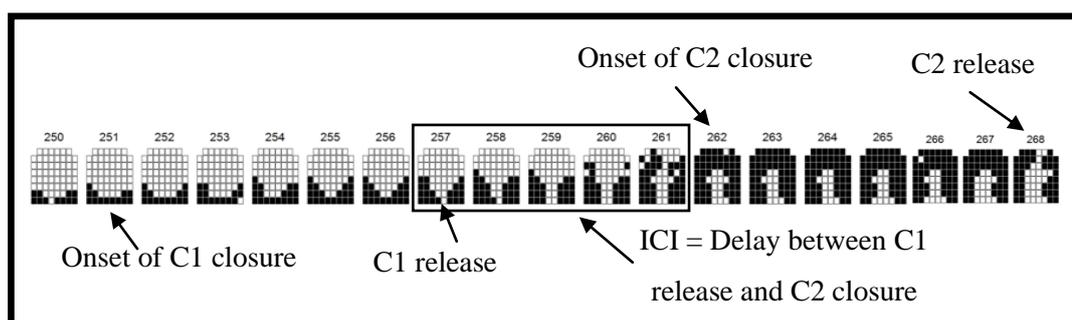

Figure 3.3 EPG frames showing a delay (ICI) between the release of the TB gesture and forming the closure by the TT gesture. The ICI lasts from frames 257-261 inclusive.

When C1 is /b/, the acoustic release of /b/ relative to the formation of the closure of the lingual stop is the main criterion used to determine whether there is an overlap or not. For example, in /b/ + coronal stops, the absence of the labial (LB) acoustic release is evidence that the TT closure took place before the LB release. i.e., the two closures overlap. On the other hand, if the LB closure is released before formation of the closure by the TT, then the two closures do not overlap. While shorter ICIs between the two closures indicate more overlap between the two gestures, longer ICIs mean that the two gestures are less overlapped or more pulled apart.

In cases where the duration of ICI is less than 10ms, this means that the EPG frames show neither an overlap, nor do they show a delay, i.e. no overlap or delay.

### **3.7.1.3 Calculating Percentage of Contact**

The EPG frames were divided into three regions depending on the place of articulation. These were the alveolar region (first three rows), the palatal region (next three rows) and the velar region (last two rows). The number of electrodes contacted in each region was calculated and converted to a percentage depending on the total number of electrodes in that region. For example, if the tongue was in contact with 22 electrodes in the alveolar region, the percentage of contact is 100%. A 100% contact in the velar region, on the other hand, only requires the tongue to be in contact with 16 electrodes. It is worth mentioning that the percentage of contact in the velar region, despite closure formation, is rarely 100%. This means only the last row may have a complete seal.

The percentages of contact in the two lingual gestures were aligned on an Excel spread sheet and plotted frame by frame and the frames with a complete closure were identified. Although the percentage of contact at any given frame was calculated, more importance was placed on the onset and offset of closure. The percentage of contact proved very helpful when investigating the influence of syllable position. Finally, the duration of the HP of the gesture was also calculated from the number of frames with complete seal

### **3.7.2 Audio recording**

Audio recording is one of the oldest tools used to record speech. It has many advantages. Unlike some of the instruments mentioned above which must be operated and analysed by technical experts, audio recording requires no specialized expertise. This means that researchers can recruit a large number of participants. In addition, this method is non-invasive and does not require long preparations and sessions. Because the device is portable, researchers can record participants anywhere. Finally, the acoustic signal displayed in spectrograms and waveforms can be analyzed to deduce different articulatory movements such as the HP and the release.

There are some important disadvantages to using audio recordings. First, there is the background noise which can arise from surroundings. This can be reduced by recording in a sound-proof room, if possible, or in a quiet place. The second

disadvantage is the fact that the behaviour of the articulators cannot be fully inferred from the acoustic signal. For example, in a two-stop cluster, when C1 is not released because it has been acoustically masked by C2 closure, it is not possible to tell when it was released. However, these limitations can be overcome by following instructions on how to make a good audio recording, and by using other phonetic instruments.

In this experiment, the data was collected and digitised using Praat software (available at: <http://www.fon.hum.uva.nl/praat/>) in the recording room of the phonetic laboratory at the Department of Linguistics and Phonetics, University of Leeds. Where this was not possible (for example, when participants were outside Leeds), data were recorded in a quiet room away from electric appliances or devices in order to avoid interference with the recorder and to ensure the best possible quality. Data were recorded using the Marantz PM67, at 44,000 Hz sampling rate, together with the Sennheiser Evolution E865, a super-cardioid pre-polarised condenser microphone. Recording sessions took 30-45 minutes.

### **3.7.2.1 Acoustic Measurements**

Wide-band spectrograms and waveforms generated by Praat software were used to obtain visual measurements of stop consonants. The same acoustic measurements of consonants and vowels were used throughout the thesis. These included: (1) the duration of the HP of SI and SF singleton stops, (2) the duration of the HP of C1 and C2 in SI and SF two-stop clusters, (3) the duration of the inter-consonantal interval (ICI) in SI and SF clusters and (4) the duration of VOT. It is worth mentioning that C1 and C2 refer to the first and second stop in the cluster, regardless of syllable position.

The duration of HP of SI singleton stops was measured from the zero crossing at end of frication of /ʃ/, where there is no noticeable frication, to the start of the aperiodic energy to the first spike of the release burst (Davidson and Roon 2008). It is worth noting that the duration of VOT was not included in the duration of the HP. In SF position, the HP of singleton stops was measured from the end of periodicity of the vowel, the point where the amplitude drops, to the release burst. The release phase of stops in SF position may sometimes be difficult to determine

because of the /h/ sound which followed. Figure 3.4 shows the measurements of the SI and SF HP of singleton stops.

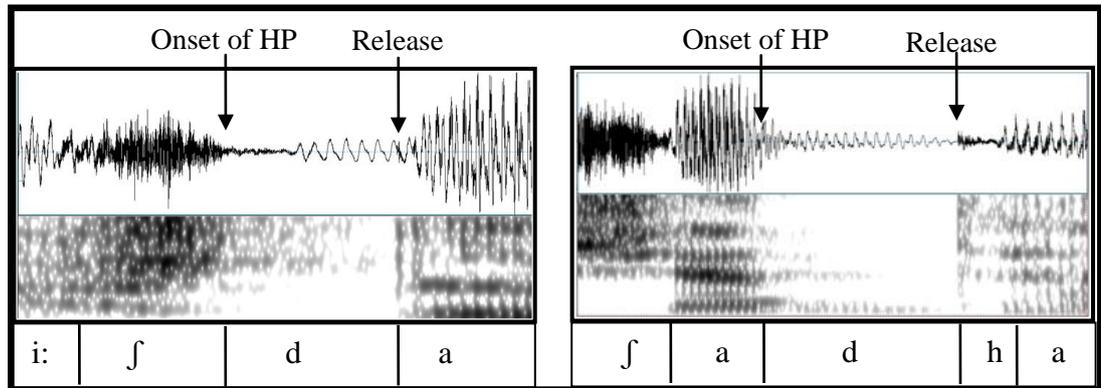

Figure 3.4 The HP duration of /d/ in the word /dam/ (left) and /d/ in the word /fad/ (right).

The same procedures were followed when measuring the HP of C1 and C2 in two-stop clusters in SI and SF position. Figure 3.5 shows these durations.

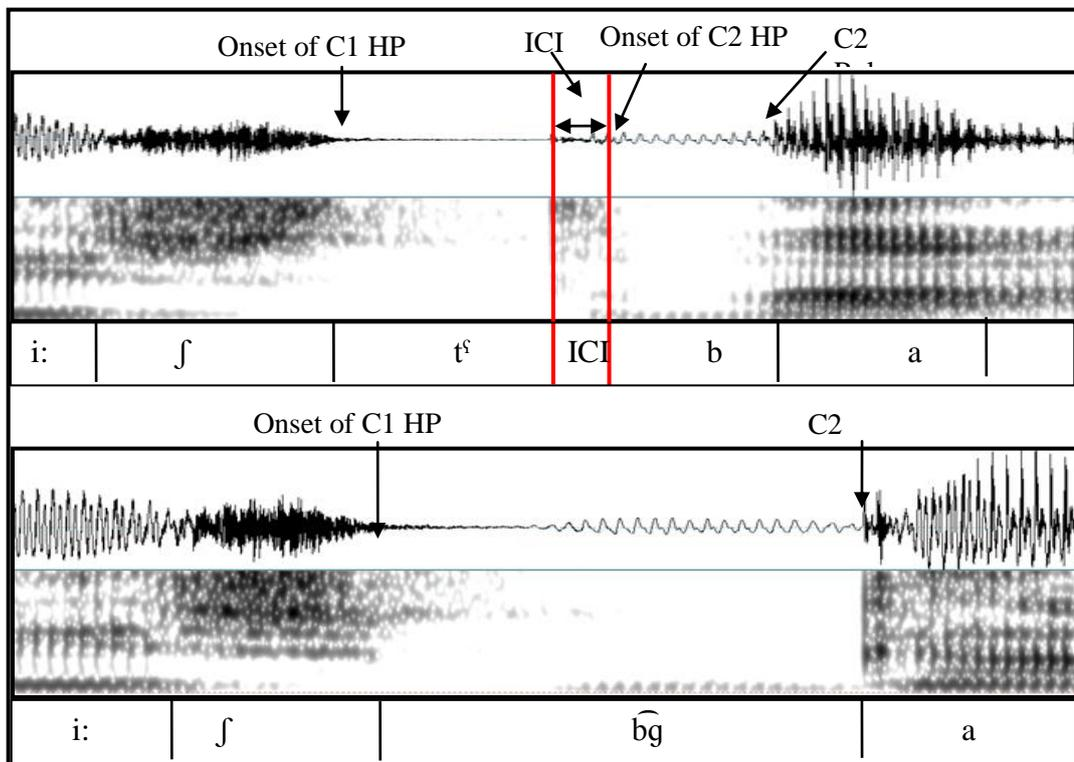

Figure 3.5 The duration of the HP of C1 and C2 and ICI in /tʰb/ in the word /tʰbaʃ/ (top), and the duration of C1 and C2 in /bg/ in the word /bgaʃ/ (bottom) when C1 is not released. The tie-bar used in the bottom figure means overlapping closures (i.e. not a labial-velar stop as on the IPA chart).

Special attention, however, was paid to whether the C1 was released or not and whether any vocalic element was produced after the release. If C1 was released, the duration of the ICI was measured from the release burst of C1 to the onset of C2 HP. If C1 was not released, the duration of the HP was measured from the end of frication of the preceding /f/ to the release burst of C2.

The last measurement was the duration of VOT. Figure 3.6 shows the measurement of VOT in voiceless and voiced stops. VOT was measured from the release burst to the start of periodicity in the case of voiceless stops. In voiced stops, when voicing often starts during the HP, it was measured from the onset of vocal folds vibration to the release burst. VOT was measured only in SI position and it will be discussed in the next chapter.

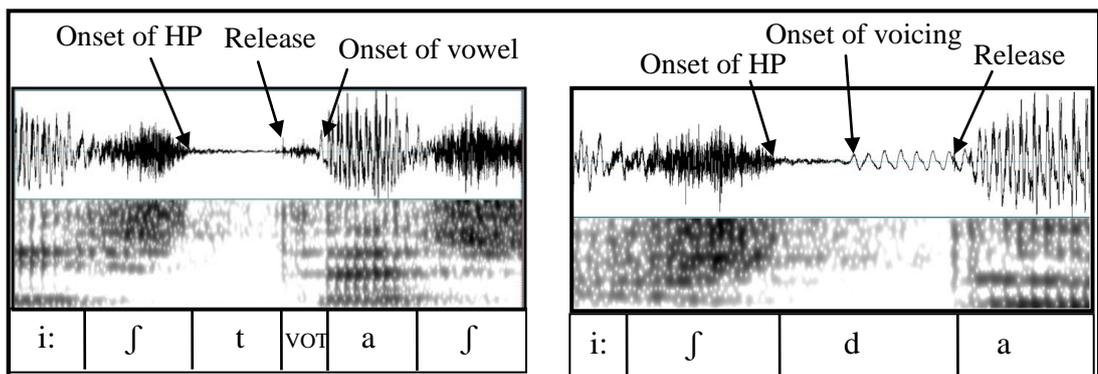

Figure 3.6 The duration of VOT of /t/ in the word /taf/ (left) and the duration of prevoicing of /d/ in the word /dam/ (right).

### 3.7.3 Laryngograph

The Laryngograph (abbreviated to Lx) is an instrument used to record the activities of the vocal folds during the production of speech. The Lx does not provide the dimensions of the glottal aperture. That is why the term “laryngograph” is used instead of “glottograph” (Fourcin and Abberton 1977: 116). The vibration of the vocal folds is recorded by two electrodes that can be fitted around the speaker’s neck, as can be seen in Figure 3.7 below. This instrument has the following advantages:

- It is very convenient for tracking the onset and offset of voicing.

- It is physiologically safe (Rothenberg and Mashie 1988:338).
- It is non-invasive.
- It is not affected by noise, so recording can take place anywhere (Fourcin 2000).
- It provides the number of cycles and glottal waveform
- It provides acoustic information (waveforms and spectrograms) aligned with vocal fold activity.



Figure 3.7 Laryngograph processor with electrodes that strap around the neck.

The only disadvantage of using the Lx is that if the electrodes are not placed in the right position, the resulting waveform may be distorted. In this case it is very difficult to analyse. This disadvantage can be overcome by ensuring that the electrodes are placed correctly and that the movement of the waveform is monitored during recording.

### 3.7.3.1 Lx measurements

The Lx measurements included duration of voicing, the number of periods, the duration of the HP and the duration of VOT. The number of periods was obtained from the Multidimensional Voice Profile (MDVP) function in the speech studio software. The rest of the measurements were obtained visually from the glottal waveform. In SI voiced stops, VOT was measured from the onset of periodicity during the HP to the release of the stop. If the stop is voiceless (or devoiced) the

duration of VOT is taken from the release burst to the first vocalic voicing pulse (Abramson 1977). The duration of VOT depends on the onset of voicing. If voicing started before the release, VOT was measured as negative (-) and if voicing started after the release, VOT was measured in positive (+). When voicing started at the release, VOT was zero. In SF singleton stops, voicing was measured from the offset of the vowel to the cessation of voicing. Figure 3.8 shows the voicing measurements.

The duration of voicing in SI two-stop clusters was measured from the onset to the offset of vocal fold vibration during the HP of C1. In C2, the duration of voicing is measured from the onset of voicing in the HP to the release of the stop.

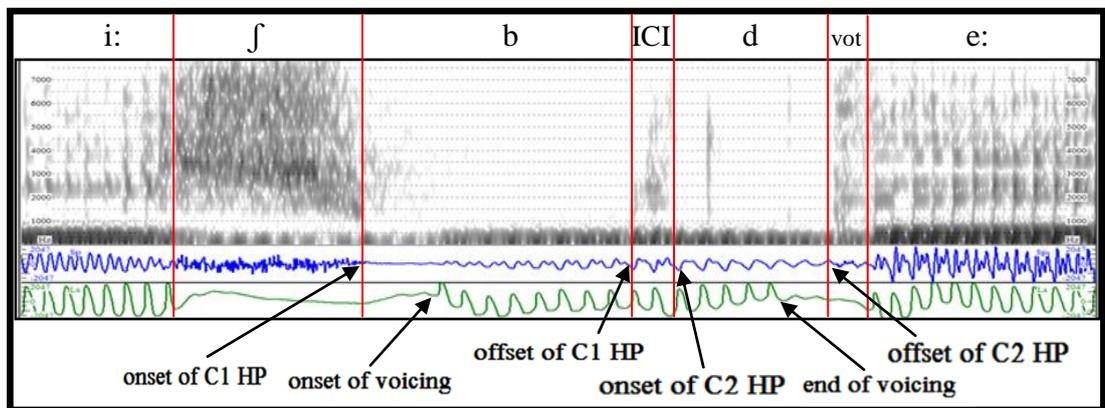

Figure 3.8 The onset and offset of voicing relative to the onset and offset of HP in /bd/ in the word /bde:/. The Figure also shows the duration of VOT.

In SF, the duration of voicing in C1 is measured from the offset of the vowel to the cessation of voicing. C2 voicing is measured from the onset of voicing in the HP to the release of the stop. Special attention was paid to the voicing of the ICI in SI and in SF position. The voicing category was either voiced or voiceless. Table 3.4 classifies the main voicing categories which are based on the ratio of voicing during the HP of the stops.

Voicing category	Percentage of voicing	Abbreviation
Voiceless (for voiceless stops)	0-24% of the HP is voiced	VLS
Devoiced (for voiced stops)	0-24% of the HP is voiced	DV
Partially voiced (for voiceless and voiced stops)	25-49% of the HP is voiced	PV

Partially Devoiced (for voiced stops)	50-74% of the HP is voiced	PD
Voiced (for voiceless and voiced stops)	75-100% of the HP is voiced	VD

Table 3.4 Criteria for voicing categories and the ratio of voicing in the HP.

### 3.8 Statistical Analysis

When taking all the measurements, data were firstly fed into Microsoft Office Excel 2010. It was then transferred into the statistical software IBM SPSS 2.0 for Windows to test whether the data are normally distributed or not. If the data were normally distributed, parametric tests were used. If the data were not normally distributed, non-parametric tests were used. Another purpose of using statistical analysis was to obtain the descriptive data such as the mean and standard deviation.

In addition to testing for the distribution of the data and obtaining descriptive statistics, the purpose of conducting the statistical analysis was to test the hypotheses stated in Chapter Three, and to determine if there were any significant differences in the data. The main variables evaluated were the duration of the HP of the stop(s) and the duration of the ICI. The influence of place of articulation, syllable position, morphological structure, sex-based differences, speaking rate and variability (where relevant) on these durations is also investigated. Within each variable, a number of timing relations were investigated as follows:

1- The influence of place of articulation includes testing:

- The duration of HP of single and two stop clusters.
- The duration of VOT for SI single and two stop clusters.
- The influence of order of place of articulation (by comparing A-to-P vs. P-to-A) on duration and pattern of coordination.

2- The influence of syllable position includes comparing:

- The duration of HP of single and two-stop clusters in SI and in SF
- The amount of overlap in SI and in SF.
- The duration of ICI in SI and in SF

3- The influence of morphological structure on the gestural coordination:

- The duration of HP of C1 and C2 in tautomorphic and heteromorphic cluster.
- The duration of ICI in these two environments.

4- The influence of gender includes the following tests:

- The duration of HP of single and two-stop clusters in SI and SF position (as produced by males and females)
- The amount of overlap between C1 and C2 closure, or the duration of ICI when C1 is released (as produced by males and females).
- The duration of VOT as produced by males vs. females.

5- The influence of speaking rate includes testing:

- The duration of HP of single and two-stop clusters in SI and SF position in fast and slow speaking rate to see the amount of decrease and increase in the HP duration.
- The duration of ICI in fast and slow speaking.
- VOT in different speaking rates.
- The relationship between speaking rate and gender.

In addition to testing the influence of the above factors, another aim of conducting the statistical analysis was to test for variability between and within males and females. The following was the main test used to conduct the statistical analysis. The null hypothesis (the assumption), was that there is no significant difference between any two groups (or more) compared. Values were considered significant if  $P \leq 0.05$ .

### **3.8.1 The independent-sample *t*-test**

This test is used to compare the mean of two different conditions between two groups or within a speaker. For example, to see whether there is any significant difference between the duration of /b/ in SI and the duration of /b/ in SF. To conduct this test, two variables are needed. In the above example, the place of articulation is the categorical or independent variable, whilst the HP duration of SI or SF /b/ is the continuous or dependent variable.

### **3.8.2 The one-way ANOVA test (Analysis of variance)**

This test is conducted to see if there is any significant difference between more than two groups of variables. For example, it is used here to test if there is any significant difference in the duration of ICI produced in different cluster types (e.g. /bt/, /kd/, /tb/ etc.). The cluster type is the independent factor whilst the duration of different ICIs was the dependent factor. The difference between this test and the previous one lies in the number of cases under the dependent variable. While the independent sample *t*-test is used to compare the mean duration of ICI in two clusters only, the one-way ANOVA is used to compare the duration of ICI in more than two clusters. The one-way ANOVA is used to test if there were any significant differences between VOT values of the different voiceless singleton stops /t/, /tʰ/ and /k/.

### **3.8.3 The repeated-measures ANOVA test**

In general, this test is used to investigate any significant differences within one sample on different occasions. It was used here to test the variability within speakers when producing the three repetitions. In the repeated measures ANOVA, data are usually collected on different occasions to test the difference between them (Kerr *et al.* 2002:120). In this experiment, however, the data to be compared were collected on one occasion. Another reason for using this test was to determine whether the male or the female group was more variable.

## **3.9 Conclusion**

This chapter discussed the methodology adopted in this thesis. It presented the theoretical framework, material, participants, instrumentation and measurements. It also discussed the advantages and disadvantages of different instrumental techniques that can be used when investigating speech production. Three main instruments were used in this thesis: Electropalatography, spectrography and laryngography. Electropalatography was judged most suitable for investigating the coordination of articulatory gestures of clusters of two lingual stops because it is able to capture

intergestural coordination. However, it cannot be used when one of the stops in the cluster is bilabial. Thus, a second tool, spectrography, was used to investigate the acoustic properties of target stop(s). This less invasive tool is considered useful for large-scale studies with large numbers of participants. Finally, laryngography is used to investigate the timing of voicing. All three instruments together were able to cover the areas to be investigated in this study. The Statistical Package for the Social Sciences (SPSS) was used to investigate any significant differences in the data produced. Three tests were used: The independent sample *t*-test, the one-way ANOVA and the repeated-measures ANOVA. The following three chapters will present and discuss the results of the EPG, acoustic and Lx analysis. The EPG results are presented first because it is the only instrument that can provide information about the duration of overlap between two lingual stops.

## Chapter Four: EPG Results

### 4.1 Introduction

The Electropalatography (EPG) results discussed in this chapter were drawn from the analysis of the speech of one TLA participant. They provide the patterns of intergestural coordination and duration of clusters of two lingual stops and clusters containing /b/ in SI and SF position. This chapter also discusses how the place of articulation of C1 and C2, their syllable position, sequence of articulation, morphological structure and change in speaking rate influence the pattern of intergestural coordination, i.e. the amount of overlap or delay between the two consonantal closures in each cluster. The results for two lingual stop clusters are divided into two groups: (1) coronal (plain and emphatic) + dorsal and (2) dorsal + coronal (plain and emphatic). The clusters containing /b/ are divided into four groups: (1) bilabial + coronal (plain and emphatic), (2) bilabial + dorsal, (3) coronal (plain and emphatic) + bilabial, and finally (4) dorsal + bilabial. Results of the acoustic analysis and the timing of voicing will be presented separately and discussed in Chapter Five and Chapter Six.

In this chapter, the following hypotheses (1-6 and 9) are tested

- SI two-stop consonant clusters will exhibit more intergestural cohesion than SF
- The place of articulation of C1 and C2 will affect the duration of their HP.
- Consonant clusters with two lingual stops will exhibit more overlap than lingual-bilabial, or bilabial-lingual clusters
- P-to-A sequence of articulations will have more gestural overlap than A-to-P articulation.
- The duration of ICI in two lingual stops and in P-to-A sequence of articulation will be shorter.
- SI and SF clusters where C1 and C2 are tautomorphic will have less gestural overlap than when C1 and C2 are heteromorphic.

- Finally, an increase in the articulation rate will result in a decrease in the HP duration and an increase in gestural overlap (fewer C1 releases and shorter ICIs) in SI and SF two stop clusters, and a decrease in speaking rate is expected to have the opposite effect.

## 4.2 Results of two lingual stop clusters in SI position

This section presents the results relating to the coordination of the articulatory gestures of two lingual stops in SI position. In these clusters, the constrictions of the two stops are made at two different places of articulation: the alveolar and the velar regions. For example, in clusters consisting of coronal + dorsal, a tongue-tip (TT) gesture is followed by a tongue-body (TB) gesture, as in /dg/, /dk/, /tk/, /tg/ and /t<sup>ɕ</sup>g/. In dorsal + coronal clusters, a TB gesture is followed by a TT gesture, as in /gt/, /gd/, /kt/, /gt<sup>ɕ</sup>/ and /gd<sup>ɕ</sup>/.

### 4.2.1 Coronal (plain and emphatic) + dorsal

Results of the duration of SI coronal + dorsal clusters are presented in Table 4.1. In /tka:bir/ and /tga:til/, C1 is a prefix.

	Word	Syl. per sec.	Dur. of C1 HP	Dur. of Overlap	Dur. Of ICI	Dur. of C2 HP	Dur. of cluster
1.	/dkar/	3.5	117	--	20	86	223
2.	/dga:jig/	3.9	120	--	20	97	237
3.	/t <sup>ɕ</sup> gar/	4.5	93	--	30	76	199
4.	/tga:til/	3.5	78	--	20	95	193
5.	/tka:bir/	4.3	84	20	--	100	204
	Average	3.9	98	20	23	91	211

Table 4.1 Average number of syllables per second, duration of HP of C1 and C2, duration of overlap (in minus) or delay (ICI) in syllable-initial coronal + dorsal stop clusters produced at normal speaking rate. Duration is given in ms.

The average number of syllables per second is 3.9. The average duration of C1 and C2 is 98ms and 91ms respectively. The average duration of coronal + dorsal clusters is 211ms. The duration of C1 HP is longer than the duration of C2 HP,

except for the clusters /tk/ and /tg/. It is worth noting that in these clusters C1 is a prefix.

Apart from /tk/ where the two closures overlap for approximately 20ms, the pattern of intergestural coordination in coronal + dorsal clusters is characterised by a 20-30ms delay between the release of the TT constriction and the formation of the following constriction by the TB gesture. For example, in the clusters /dk/ (in /dkar/) and /dg/ (in /dga:jig/), there is a short delay between the release of C1 and formation of the closure for C2. However, the two consonantal gestures have a high percentage of contact, particularly in /dk/ where the gesture for /k/ was initiated during the HP of /d/. A further observation on these clusters relates to the voicing of the release of C1. While in /dg/ the ICI is voiced, in /dk/ it is voiceless.

The cluster /t<sup>ɕ</sup>g/ (in /t<sup>ɕ</sup>gar/) consists of an emphatic coronal + a dorsal stop. Figure 4.1 below shows the pattern of intergestural coordination and percentage of contact in this cluster.

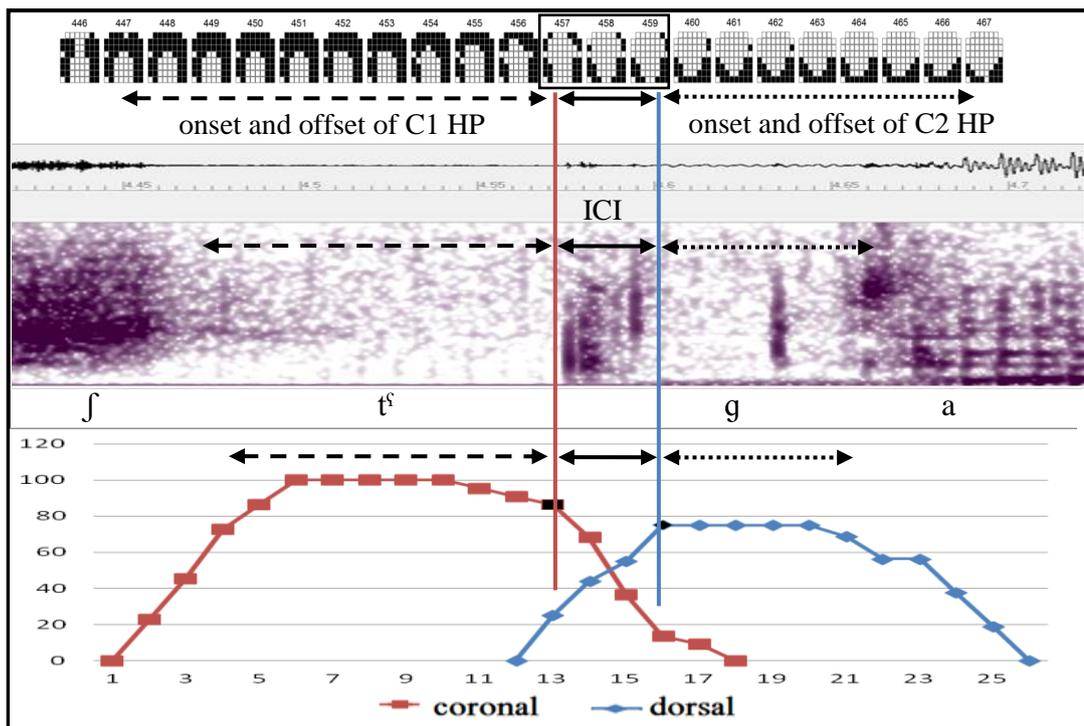

Figure 4.1 EPG frames and acoustic display for the cluster /t<sup>ɕ</sup>g/ (in /t<sup>ɕ</sup>gar/), showing a delay between the release of the TT constriction (vertical red line) and the formation of the following constriction by the TB gesture (vertical blue line). The ICI lasts for approximately 30ms (frames 457-459 inclusive).

Figure 4.1 above shows the same pattern of coordination in which the two closures do not overlap. Moreover, the two gestures show different percentages of contact. While the TT closure has the maximum percentage of contact during the HP, the TB gesture shows a lower percentage of contact as a result of the reduction in the size of the contact area.

#### 4.2.2 Dorsal + coronal (plain and emphatic)

Results of the duration of SI dorsal + coronal clusters are presented in Table 4.2. The average number of syllables per second is 4.4. In comparison with coronal + dorsal clusters, there are more syllables per second. The average duration of C1 is 107ms, and the average duration of C2 is 88ms. As in coronal + dorsal clusters, the duration of C1 HP tends to be longer. The mean duration of the clusters is 192ms, some 19ms shorter than that for coronal + dorsal clusters.

	Word	Syl. per sec.	Dur. of C1 HP	Dur. of Overlap	Dur. Of ICI	Dur. of C2 HP	Dur. of cluster
1.	/ktab/	4.5	95	20	--	98	173
2.	/kdab/	4.8	103	--	10	65	178
3.	/gtal/	4.7	110	20	--	97	187
4.	/gt <sup>ɬ</sup> af/	3.9	124	--	20	97	241
5.	/gdar/	4.3	104	10	--	85	179
Average		4	107	17	15	88	192

Table 4.2 Average number of syllables per second, duration of C1 and C2 HP, and the duration of overlap (in minus) or delay (ICI) in syllable-initial dorsal + coronal stop clusters produced at normal speaking rate. Duration is given in ms.

The average duration of overlap in dorsal + coronal clusters is 17ms. However, not all of the clusters exhibited an overlap between the two closures. While the two consonantal closures in /kt/, /gt/ and /gd/ showed an overlap lasting 10-20ms, /kd/ and /gt<sup>ɬ</sup>/ were less tightly coordinated, leading to a 10-20ms delay between the release of the TB closure and formation of the closure by the TT gesture.

Results of the temporal and spatial analysis of these clusters, where the two closures overlap, show that the two gestures are tightly coordinated and produced

with a considerable amount of overlap. Figure 4.2 below shows the gestural coordination of /gt/ (in /gtal/). In this figure, the TT gesture was initiated in frame 371 and formed a complete seal by frame 372, two frames before the release made by the TB in frame 374. There is a high percentage of contact in the velar region throughout the HP of the coronal stop. This evidence suggests that the two consonantal gestures are very cohesive. In clusters where the two closures do not overlap, there is a 10-20ms ICI. Although these clusters are P-to-A sequences of articulation, where less overlap may be assumed to enhance perception, they showed overlap. The influence of articulation sequence as a factor in gestural organisation will be presented in section 4.7.

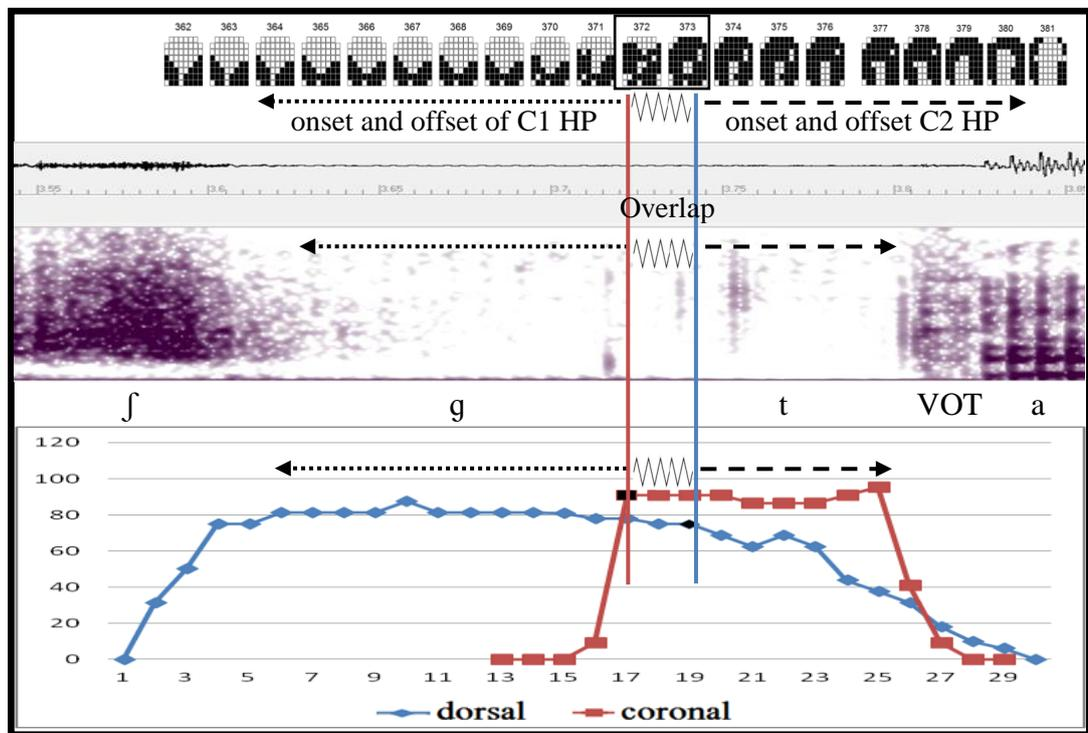

Figure 4.2 EPG frames and acoustic display of the cluster /gt/ (in /gtal/), showing an overlap (black zigzag line) between the two closures of the TB (vertical blue line) and the TT (vertical red line) lasting for approximately 20ms (frames 372-373 inclusive).

The TB and the TT gestures of /k/ and /t/ (in /ktabt/) are also very cohesive. Here, the duration of overlap between the two closures is 20ms. In addition, the two gestures show the maximum percentage of contact in both the velar and alveolar regions. The last cluster showing gestural overlap is /gd/ (in /gdar/). These two

gestures are less cohesive than /gt/ and /kt/. The closure of /d/ was formed just 10ms before the release of /g/ i.e. the two closures overlap in only one EPG frame. Although this pattern of coordination led to the obliteration of C1 release, there is not much amount of overlap between the two closures. In the cluster /gt<sup>s</sup>/ (in /gt<sup>s</sup>af/), the pattern of coordination is less cohesive than all SI clusters. The two gestures in /gd<sup>s</sup>/ and /kd/ allow the presence of a 20ms ICI between the two consonantal closures. The last SI dorsal + coronal cluster to be considered in this section is /kd/. Although the TB and the TT closures do not overlap, there is a high percentage of contact in the velar region, even after the release of /g/. This indicates that the two gestures are produced with tight coordination.

### 4.3 Results of clusters containing /b/ in SI

This section presents the timing results of clusters containing /b/ + a lingual stop (coronal or dorsal). The results are divided into four groups as follows: /b/ + coronal (/bd/ /bt/ /bd<sup>s</sup>/ and /bt<sup>s</sup>/), /b/ + dorsal (/bg/ and /bk/), coronal + /b/ (/db/ /t<sup>s</sup>b/ and /d<sup>s</sup>b/) and finally dorsal + /b/ (/gb/). The acoustic release of /b/ relative to the closure of the following lingual stop, or the lingual release relative to the onset of the bilabial closure, is taken as an evidence as to what pattern is employed.

In all clusters consisting of /b/ + a lingual stop or lingual + /b/, and showing an overlap between the two consonantal closures, there is no direct observation of the duration of overlap between the two closures, nor is there any way to calculate the HP duration of /b/. In the tables showing the duration of clusters containing /b/ below, an asterisk (\*) indicates that there is an overlap between the two closures of C1 and C2, but this cannot be measured. A plus sign (+) is used when the duration of /b/ cannot be measured acoustically.

#### 4.3.1 /b/ + coronal (plain and emphatic)

There are 7 clusters consisting of a labial (LB) gesture followed by a TT gesture. The results of their duration are shown in Table 4.3 below. In /bta:ti:ɣ/, /bda:faɕ/, /bt<sup>s</sup>awa/ and /bd<sup>s</sup>arba/, /b/ is a prefix.

	Word	Syl. per sec.	Dur. of C1 HP	Dur. of Overlap	Dur. Of ICI	Dur. of C2 HP	Dur. of cluster
1.	/bde:/	3.5	100	--	30	60	190
2.	/bt <sup>ʰ</sup> am/	3.6	104	--	20	100	224
3.	/bd <sup>ʰ</sup> aʃa/	4.3	120+	*	--	100	220
4.	/bta:ti:ɣ/	4.1	80+	*	--	80	160
5.	/bda:faʃ/	4.3	110+	*	--	80	190
6.	/bt <sup>ʰ</sup> awa/	4.5	110+	*	--	90	200
7.	/bd <sup>ʰ</sup> arba/	4.3	120+	*	--	70	190
	Average	4.0	106+	*	25	83	196

Table 4.3 Average number of syllables per second, duration of C1 and C2 HP, and the overlap (\*) or delay (ICI) in syllable-initial /b/ + coronal stop clusters produced at normal speaking rate. Where /b/ is a prefix, the LB and the TT closures are always overlapped. When the (+) sign is used, it means it is not possible to measure the exact duration of the HP due to the absence of the labial release.

The average number of syllables per second is 4.0. The average duration of C1 and C2 HP is 106+ and 83ms in that order. As seen in previous cluster types, the duration of C1 HP is longer. There are two patterns of intergestural coordination when C1 is /b/. In /bd/ (in /bde:/ and /bt<sup>ʰ</sup>/ (in /bt<sup>ʰ</sup>am/). The pattern of coordination of /bt<sup>ʰ</sup>/ (in /bt<sup>ʰ</sup>am/) is shown in Figure 4.3.

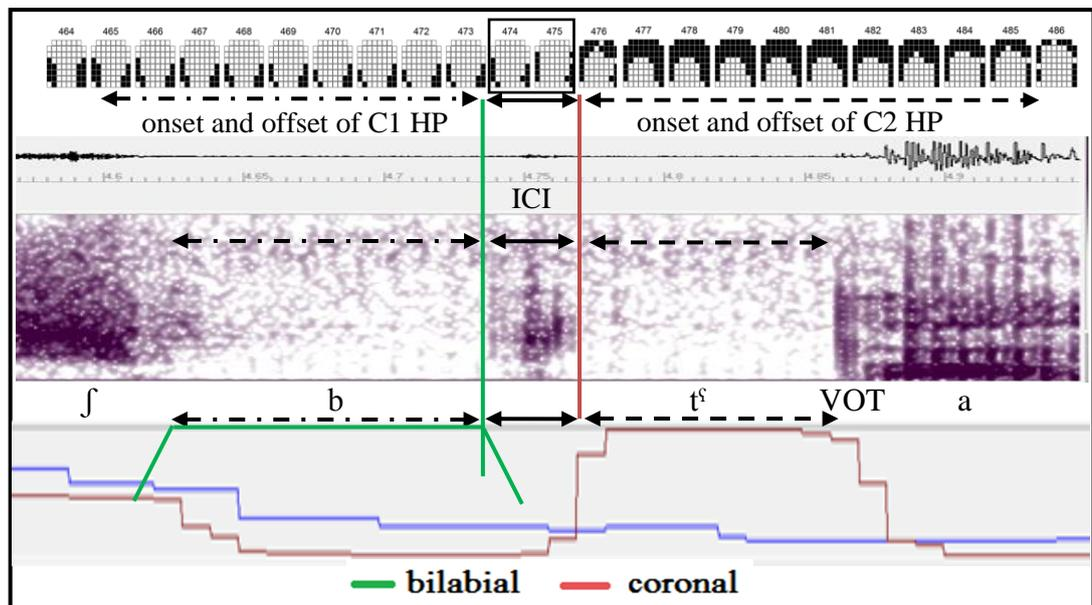

Figure 4.3 EPG frames and acoustic display of the cluster /bt<sup>ʰ</sup>/ (in /bt<sup>ʰ</sup>am/), showing a delay between the release of the labial closure (vertical green line) and formation of the closure by the TT gesture (vertical red line). The delay lasts for approximately 20ms.

In the previous figure, the LB closure and the following TT closure do not overlap. As a result, there is a delay between the two closures. The duration of ICI is 30ms and 20ms respectively.

In /bd<sup>s</sup>/ (in /bd<sup>s</sup>aʕa/, however, there is an overlap between the two closures. The absence of C1 release indicates that the two gestures are blended together into one long HP and could be released together. In Figure 4.4 below, which displays EPG frames and an acoustic display of /bd<sup>s</sup>/ (in /bd<sup>s</sup>a:ʕa/), the LB closure is not released immediately after the formation of the dorsal closure. As a result, the two closures are overlapped. The green dashed line is speculative because it is not possible to determine exactly when the LB closure was released.

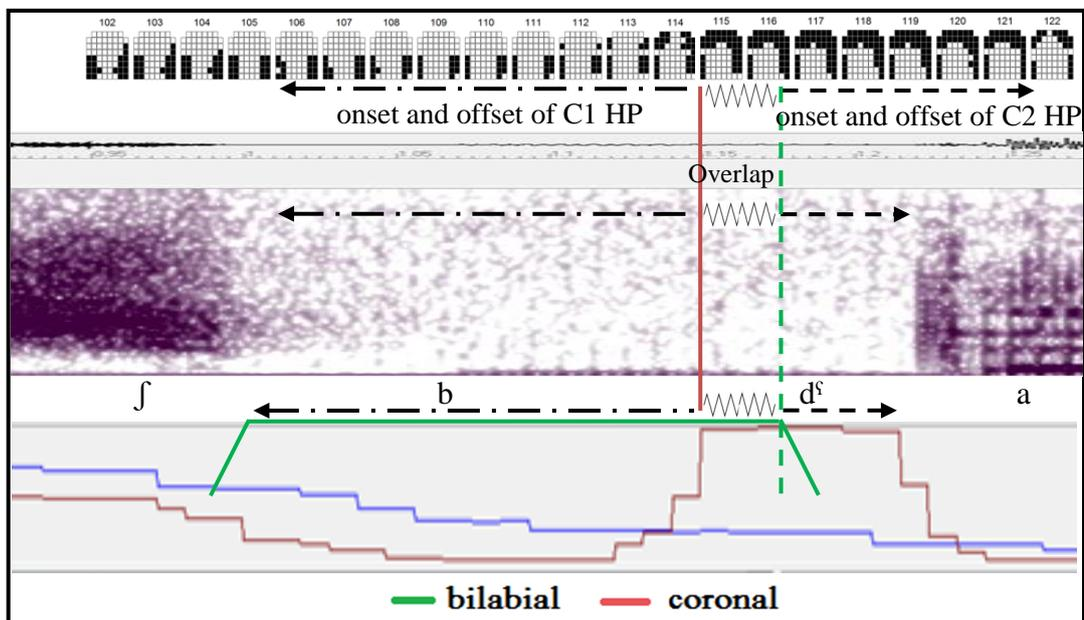

Figure 4.4 EPG frames and acoustic display of the cluster /bd<sup>s</sup>/ (in /bd<sup>s</sup>a:ʕa/, showing an overlap in zigzag pattern) between the TT closure (vertical red line/frame 115) and the labial release (dashed green line).

The coordination of the two gestures in /bt/, /bd/, /bt<sup>s</sup>/ and /bd<sup>s</sup>/ where /b/ is a prefix, follows the same pattern of overlap observed in /bd<sup>s</sup>aʕa/. The closure of C2 was formed before the release of C1. As a result, the two gestures are coordinated in such a manner that there is no ICI

### 4.3.2 /b/ + dorsal

The results of the duration of SI /b/ + dorsal clusters are shown in Table 4.4 below. In /bkalma/ and /bgalbna/, /b/ is a prefix.

	Word	Syl. per sec.	Dur. of C1 HP	Dur. of Overlap	Dur. Of ICI	Dur. of C2 HP	Dur. of cluster
1.	/bke:/	3.4	100	--	20	110	230
2.	/bgar/	3.6	120	--	20	90	230
3.	/bkalma/	4.4	100+	*	--	90	170
4.	/bgalbna/	4.1	90	--	20	80	170
	Average	3.9	103	*	20	93	200

Table 4.4 Average number of syllables per second, duration of C1 and C2 HP, and the overlap (\*) or delay (ICI) in syllable-initial /b/ + dorsal stop clusters produced at normal speaking rate.

The average number of syllables per second is 3.9. The average duration of C1 is 103+, and the average duration of C2 is 93. The average duration of these clusters is 200ms. The general pattern is characterised by the release of C1 as in Figure 4.5 below.

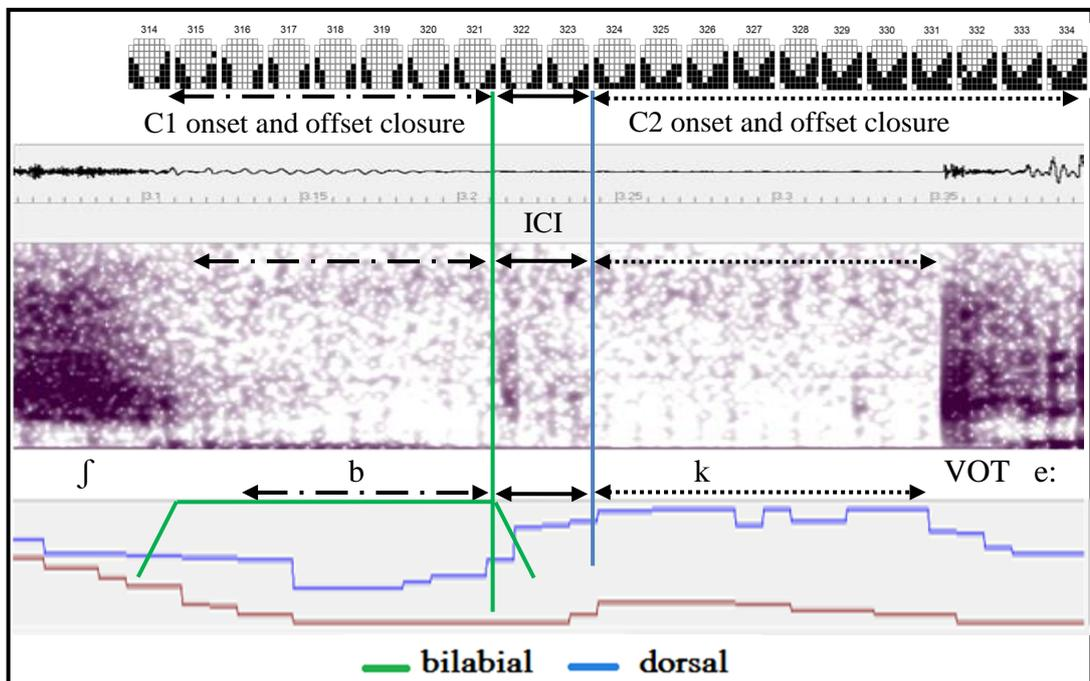

Figure 4.5 EPG frames and acoustic display of the cluster /bk/ (in /bke:/). The figure shows a delay between the LB release (vertical green line) and formation of the closure by the TB gesture (vertical blue line/frame 324). The delay lasts for approximately 20ms.

The figure shows the coordination pattern of /bk/ in /bke:/. Although the TB gesture was initiated before the release of the LB closure, the TB closure was achieved after the release of /b/. The average duration of the ICI in /b/ + dorsal clusters is 15ms. This duration was measured from spectrograms, because EPG does not record the closure of the LB gesture. This is not the case in /bk/ in /bkalma/ where the TB gesture reached its target before the LB release

The last cluster consisting of /b/ + a dorsal is /bg/ in the words /bgar/ and /bgalbna/). Although the TB gesture in both examples was initiated before the release of /b/, the closure was achieved after the LB release. The average duration of the ICI is 20ms.

### 4.3.3 Coronal (plain or emphatic) + /b/

Table 4.5 below shows the results of the duration of SI coronal + /b/ clusters.

In /tba:ʃir/, /t/ is a prefix.

	Word	Syl. per sec.	Dur. of C1 HP	Dur. of Overlap	Dur. Of ICI	Dur. of C2 HP	Dur. of cluster
1.	/tba:ʃir/	4.1	70	--	20	80	180
2.	/dbaʃ/	3.3	130	*	--	130+	260
3.	/t <sup>ɕ</sup> baʃ/	3.7	90	--	20	100	220
4.	/d <sup>ɕ</sup> baba/	4.0	140	*	--	120+	260
Average		3.8	107	*	20	108	230

Table 4.5 Average number of syllables per second, duration of C1 and C2 HP, and the overlap (\*) or the delay (ICI) in syllable-initial coronal + /b/ stop clusters produced at normal speaking rate.

The average number of syllables is 3.8 syllables per second. The average duration of clusters consisting of coronal + /b/ is 230ms. This duration makes this cluster type the longest. The average duration of C1 and C2 is 107 and 108+ms respectively. While /tb/ and /t<sup>ɕ</sup>b/ are characterized by a delay between the release of the TT closure and formation of the LB closure, /db/ and /d<sup>ɕ</sup>b/ show an overlap between these two closures. The average duration of ICI in clusters with no overlap is 20ms. Figure 4.6 shows how the two gestures of /db/ (in /dbaʃ/) are blended

together into one long HP and one release, evidence of overlap between the two closures. The dashed vertical green line is speculative.

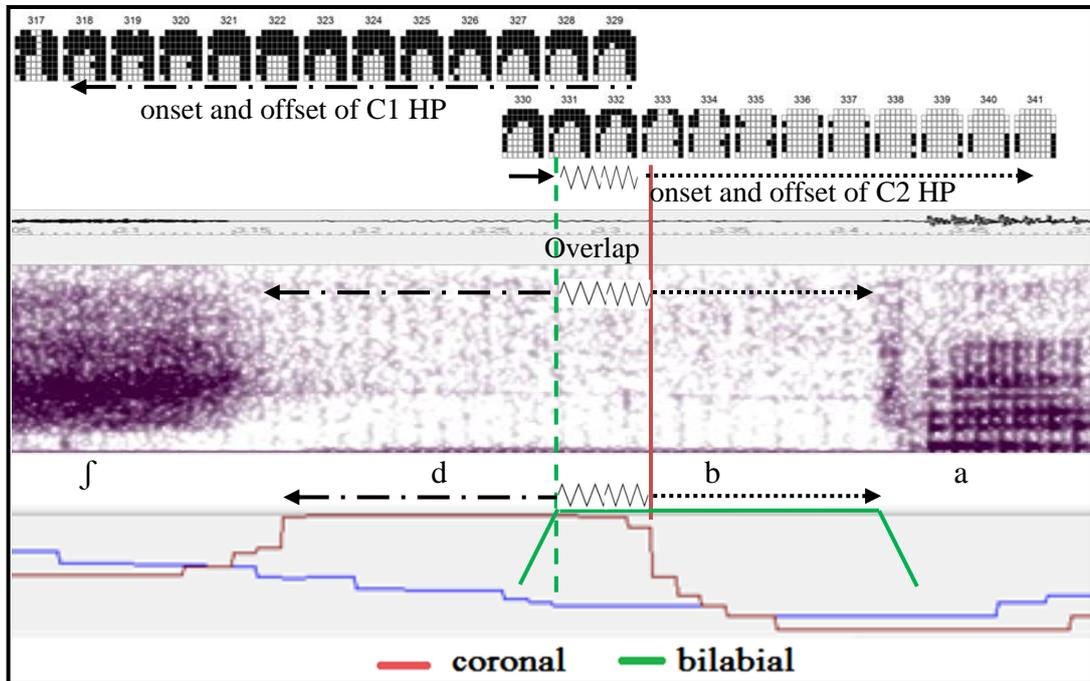

Figure 4.6 EPG frames acoustic display of the cluster /db/ (in /dbaf/). The figure shows an overlap (black zigzag line) between the TT closure (vertical red line/frame 332) and the labial closure (dashed green line).

In /t<sup>h</sup>b/ and /tb/, on the other hand, the two gestures are less tightly coordinated because the formation of the TT closure was delayed until the LB closure was released. This leads to a 20ms ICI between the two consonantal closures.

#### 4.3.4 Dorsal + /b/

The results of the duration of SI dorsal + /b/ clusters are shown in Table 4.6.

	Word	Syl. per sec.	Dur. of C1 HP	Dur. of Overlap	Dur. Of ICI	Dur. of C2 HP	Dur. of cluster
1.	/kbas	3.4	110	*	--	90+	230
2.	/gbal/	3.5	90	*	--	80+	200
Average		3.4	100	*	--	85+	215

Table 4.6 Average number of syllables per second, duration of C1 and C2 hold phase, and the overlap (\*) or delay (ICI) in syllable-initial dorsal + /b/ stop clusters produced at normal speaking rate.

The average number of syllables is 3.4 syllables per second. In /kb/ and /gb/, the average duration of the cluster is 215ms. The average duration of C1 and C2 is 100 and 85+ms. respectively. The gestural coordination in SI position /kb/ and /gb/ is characterised by the formation of the LB closure while the dorsal constriction is still maintained. As a result, C1 release is absent and the two closures are overlapped. Figure 4.7 shows the coordination pattern of /kb/ (in /kbas/).

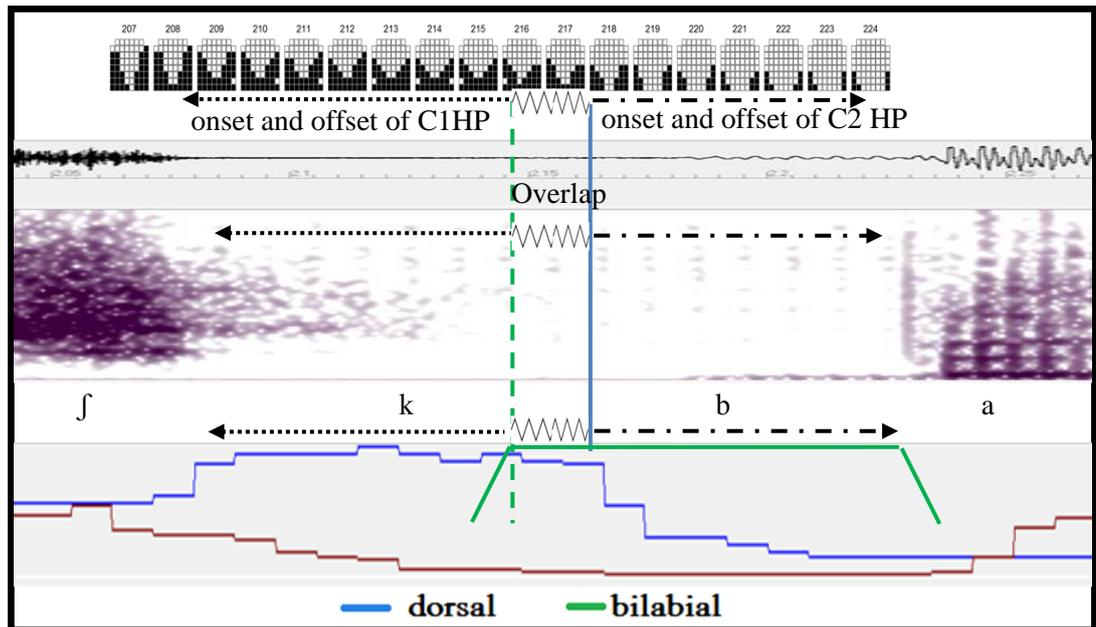

Figure 4.7 Acoustic display and EPG frames of the cluster /kb/ (in /kbas/). The labial closure (dashed green line) was formed before the release of the TB closure (vertical blue line/frame 218). As a result, C2 closure masked the acoustic release of C1.

#### 4.4 Summary

In all SI clusters, the duration of HP of C1 tends to be longer than that of C2. The pattern of gestural coordination varied from a total overlap between the two closures to a delay of 10-30ms. The duration of the clusters ranged from 192ms to 230ms. These durational differences do not indicate the intergestural coordination. Dorsal + /b/ showed more gestural cohesion than /b/ + dorsal. Clusters containing two lingual stops, coronal + dorsal and dorsal + coronal, showed less overlap than clusters containing /b/.

## 4.5 Results of two lingual stop clusters in SF position

The clusters discussed in this section consist of two lingual stops in SF position. These include coronal + dorsal clusters, where a TT gesture is followed by a TB gesture as in /tk/ (in /hatk/) and /tg/ (in /fatg/). In dorsal + coronal clusters a TB gesture is followed by a TT gesture as in /kt/ (in /nakt/), /kd/ (in /nakd/), /gt/ (in /wagt/), /gd/ (in /ʁagd/), /gtʰ/ (in /magtʰ/), /gt/ (in sdʰdagt/) and finally /kt/ (in /dʰhakt/). Apart from /wagt/, when C2 is /t/ it is always a suffix.

### 4.5.1 Coronal + dorsal

Table 4.7 below shows the results of the duration of SF coronal + dorsal clusters.

	Word	Syl. per sec.	Dur. of C1 HP	Dur. of Overlap	Dur. Of ICI	Dur. of C2 HP	Dur. of cluster
1.	/hatk/	4.3	80	--	40	70	190
2.	/fatg/	4.2	70	--	55	94	218
	Average	4.3	75	--	48	82	204

Table 4.7 Average number of syllables per second, duration of C1 and C2 HP, and the duration of the delay (ICI) in syllable-final coronal + dorsal stop clusters produced at normal speaking rate.

There are two examples of a coronal followed by a dorsal in SF position. These are /tk/ (in /hatk/) and /tg/ (in /fatg/). The average number of syllables per second is 4.3. More syllables per second were produced in SF coronal + dorsal in comparison with SI. The average duration of C1 and C2 is 75 and 82 respectively. The average duration of these clusters is 204ms. There are two interesting observations in SF coronal + dorsal clusters compared to their SI counterparts. The first is that the duration of C1 and C2 decreased in comparison with SI C1 and C2. The second observation is that the two SF consonantal closures do not overlap. There is a long delay between the release of the TT gesture and formation of the closure by the TB gesture. The average duration of ICI in this context is 48ms.

#### 4.5.2 Dorsal + coronal

Results of the duration of SF dorsal + coronal clusters are presented in Table 4.8 below. In /sd<sup>s</sup>dagt/ and /d<sup>s</sup>hakt/, /t/ is a suffix.

	Word	Syl. per sec.	Dur. of C1 HP	Dur. of Overlap	Dur. Of ICI	Dur. of C2 HP	Dur. of cluster
1.	/nakt/	4.9	90	--	40	80	200
2.	/nakd/	5.0	90	--	40	85	201
3.	/wagt/	4.4	65	--	50	60	175
4.	/ʃagd/	4.5	80	--	40	70	180
5.	/magt <sup>s</sup> /	3.9	60	--	55	77	192
6.	/s <sup>s</sup> dagt/	4.2	50	--	50	78	178
7.	/d <sup>s</sup> hakt/	4.5	70	--	50	91	211
	Average	4.5	72	--	46	77	191

Table 4.8 Average number of syllables per second, duration of C1 and C2 HP, and the duration of delay (ICI) in SF dorsal + coronal stop clusters produced at normal speaking rate.

The average number of syllables per second is 4.5 which is similar to SI (4.4 syllables per second). The duration of these clusters ranges between 175-211ms with an average of 191ms. The average duration of C1 and C2 is 72 and 77ms respectively. It is obvious that C1 and C2 are shorter when they are in SF. The average duration of the ICI is 46ms. In SF dorsal + coronal stop clusters, there is no overlap between the two closures.

In general there is a relatively long delay between the release of the TB gesture and formation of the closure by the TT gesture. This leads to the presence of a vocalic element separating the two closures. The duration of this ICI varies from 40ms in /kt/, /kd/ and /gd/, to 50ms in /gt/ and /kt/, and 55ms in /gt<sup>s</sup>/. In addition, the TB gesture is reduced in magnitude, i.e. the size of the contact area between the TB and the velar is smaller. It seems that there is less of an attempt by the two gestures /g/ and /t/ to overlap in SF than in SI. The coordination of the two gestures of /g/and /t/ (in /wagt/) is shown in Figure 4.8 below.

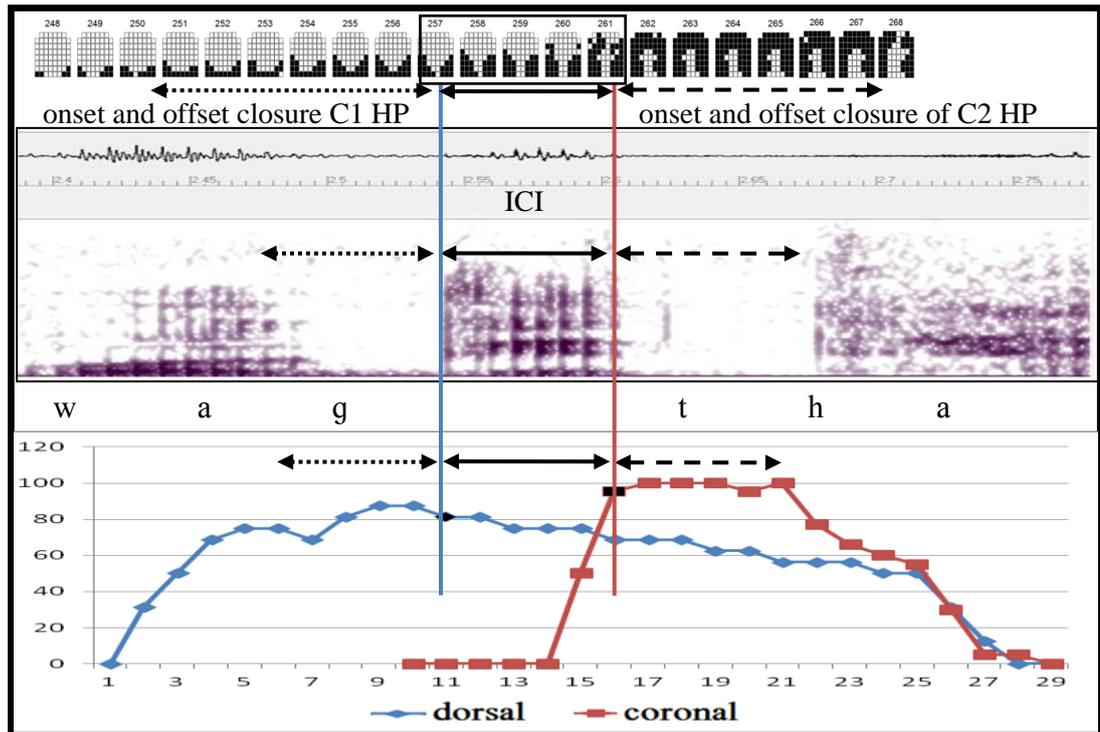

Figure 4.8 Acoustic display and EPG frames of the cluster /gt/ (in /wagt/), showing a long delay between the release of TB closure (vertical blue line/frame 257) and formation of the TT closure (vertical red line/frame 262). The duration of the ICI lasts for approximately 50ms (frames 257-261 inclusive).

In /d<sup>h</sup>akt/, the TB gesture is reduced, has a lower percentage of contact, and the two gestures are pulled apart, leading to the creation of a vocalic element. This ICI is voiceless due to the voicing of the adjacent consonants.

#### 4.6 Results of clusters containing /b/ in SF

In this section, results of the timing of clusters consisting /b/ + a lingual stop in SF position are discussed. As in section 4.3, the results are divided into four groups as follows: (1) /b/ + coronal, (2) /b/ + dorsal, (3) coronal + /b/ and finally (4) dorsal + /b/.

#### 4.6.1 /b/ + coronal

Examples of /b/ + coronal clusters are /bt/ (in /ktabt/), /bt<sup>s</sup>/ (in /rabt<sup>s</sup>/), /bd/ (in /ʃabd/) and /bd<sup>s</sup>/ (in /gabds/). Table 4.9 below shows the results of the duration of SF /b/ + coronal clusters.

	Word	Syl. per sec.	Dur. of C1 HP	Dur. of Overlap	Dur. Of ICI	Dur. of C2 HP	Dur. of cluster
1.	/ktabt/	4.4	65	--	40	63	168
2.	/rabt <sup>s</sup> /	3.9	104	--	35	87	226
3.	/ʃabd/	3.7	80	--	37	91	206
4.	/gabds/	3.7	83	--	46	79	208
Average		3.9	83	--	40	80	202

The average number of syllables per second is 3.9. The average duration of C1 and C2 is 83 and 80ms in that order. The average duration of ICI is 40ms. The average duration of these clusters is 202ms. It seems that the average duration of the clusters, including the ICI, remains relatively the same regardless of syllable position. In SF /bd/ (in /ʃabd/) shown in Figure 4.9, the two gestures are as overlapped as in SI clusters.

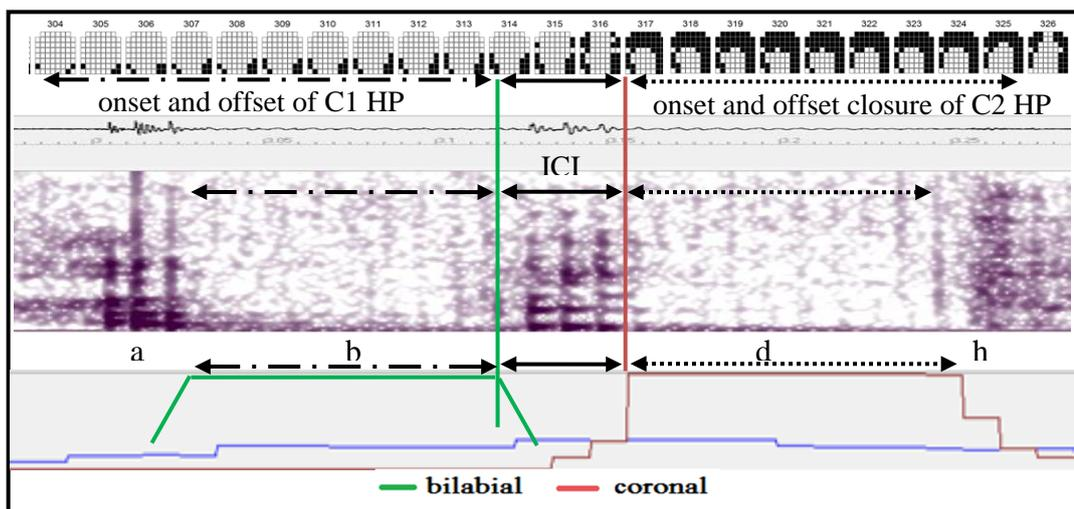

Figure 4.9 Acoustic display and EPG printout of the cluster /bd/ (in /ʃabd/), showing a long delay between the release of labial closure (vertical green line) and formation of the closure by the TB gesture (vertical red line/frame 317). The ICI lasts between frames 314-316 inclusive.

The less tight coordination pattern in the previous figure of /bd/ in /ʃabd/ gives rise to a long ICI between the two closures. The duration of the ICI is 37ms. It is also obvious that the TT gesture is large in magnitude.

Although another SF /b/ + coronal cluster, /bt/, is the shortest in comparison with the rest of the clusters, its pattern of gestural coordination is consistent with longer clusters such as /btʰ/, where the two gestures are pulled apart. In /b/ + coronal clusters, the duration of the ICI is 35-46ms. Another interesting observation relates to clusters where C2 is emphatic. Here, there is more contact between the back of the tongue and the palate.

#### 4.6.2 /b/ + dorsal

There are two clusters consisting of /b/ + dorsal stops: /bk/ and /bg/. Their durational results are presented in Table 4.10 below.

	Word	Syl. per sec.	Dur. of C1 HP	Dur. of Overlap	Dur. Of ICI	Dur. of C2 HP	Dur. of cluster
1.	/habk/	3.7	83	--	45	74	202
2.	/tʰabg/	3.8	80	--	40	67	187
	Average	3.8	82	--	43	71	195

Table 4.9 Average number of syllables per second, duration of C1 and C2 HP, and the duration of delay (ICI) in syllable-final /b/ + dorsal clusters, produced in normal speaking rate.

The average number of syllables per second is 3.8. The average duration of C1 and C2 is 82 and 75ms. The average duration of the ICI is 43ms. The average duration of the two clusters is 195ms. In SF position, the coordination is typical to other clusters in SF positions, i.e. the two gestures are pulled apart giving rise to a long ICI between the two gestures. Figure 4.10 shows the pattern of coordination of /bk/ in SF position.

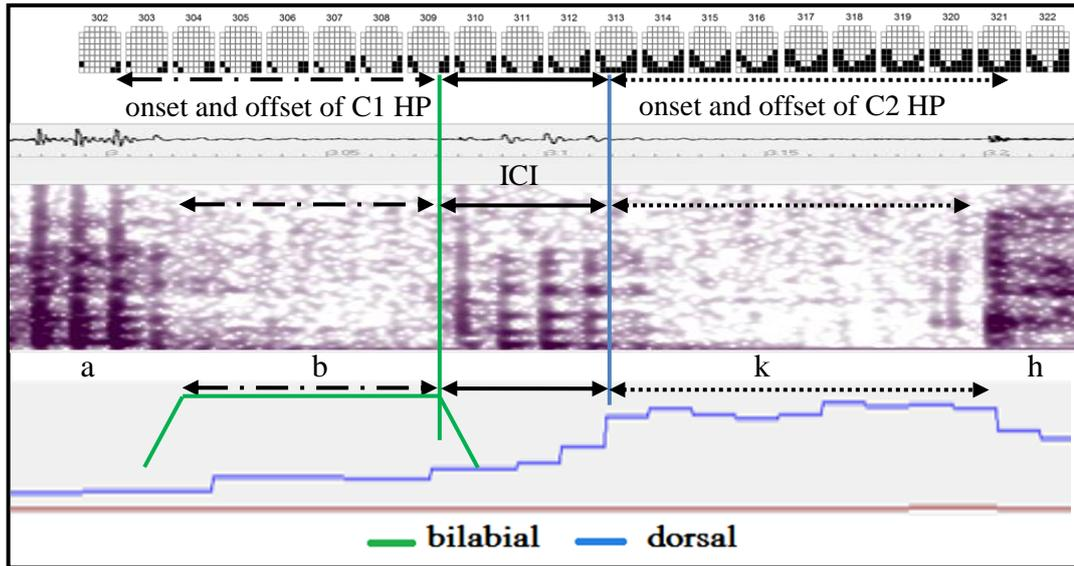

Figure 4.10 EPG frames and acoustic display of the cluster /bk/ (in /habk/). The figure shows a long delay between the labial release (vertical green line) and formation of the closure by TB gesture (vertical blue line/frame 313). The ICI lasts for approximately 45ms (frames 309-312 inclusive).

#### 4.6.3 Coronal + /b/

/t<sup>h</sup>b/ is the only cluster where a coronal stop is followed by /b/. Figure 4.11 illustrates the pattern of coordination of SF this cluster.

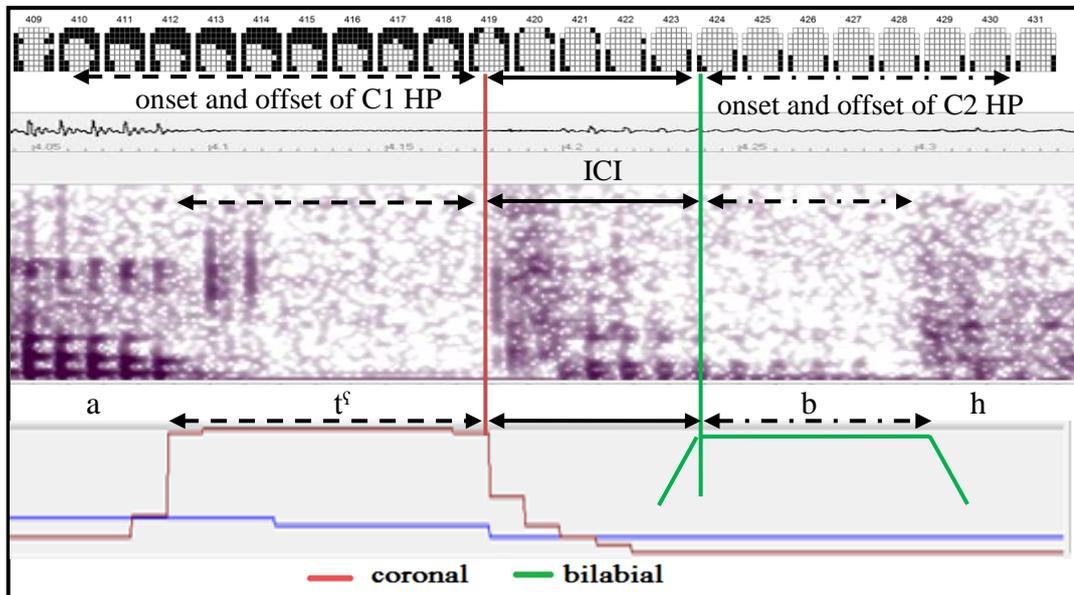

Figure 4.11 EPG frames acoustic and display and of the cluster /t<sup>h</sup>b/ (in /ʃat<sup>h</sup>b/). There is a long delay between the release of the TT closure (vertical red line/frame 419) and formation of the labial closure (vertical green line). The duration of the ICI lasts for approximately 50ms.

The average number of syllables is 3.9 per second. The duration of C1 and C2 in this cluster is 70 and 77ms respectively. The duration of the ICI is 50ms. The overall duration of the cluster is 197ms. One noticeable observation is the high percentage of contact during the HP of the coronal stop. Despite the high degree of magnitude, the two closures are separated. In fact, it is obvious that the two gestures are less tightly coordinated in comparison to the same gestures in SI position.

#### 4.6.4 Dorsal + /b/

The cluster /gb/ (in /nagb/) is the only dorsal + /b/ cluster. The average number of syllables per second is 4.1. The duration of the HP of C1 and C2 is 87 and 79ms respectively. The duration of the ICI is 40ms. The duration of the cluster /gb/ (in /nagb/) is 206ms. The pattern of coordination of the two gestures is typical to that of SF clusters. i.e. there is no overlap between the two closures which are separated by a longer ICI in comparison with the same cluster in SI. The pattern of coordination of this cluster is shown in Figure 4.12 below.

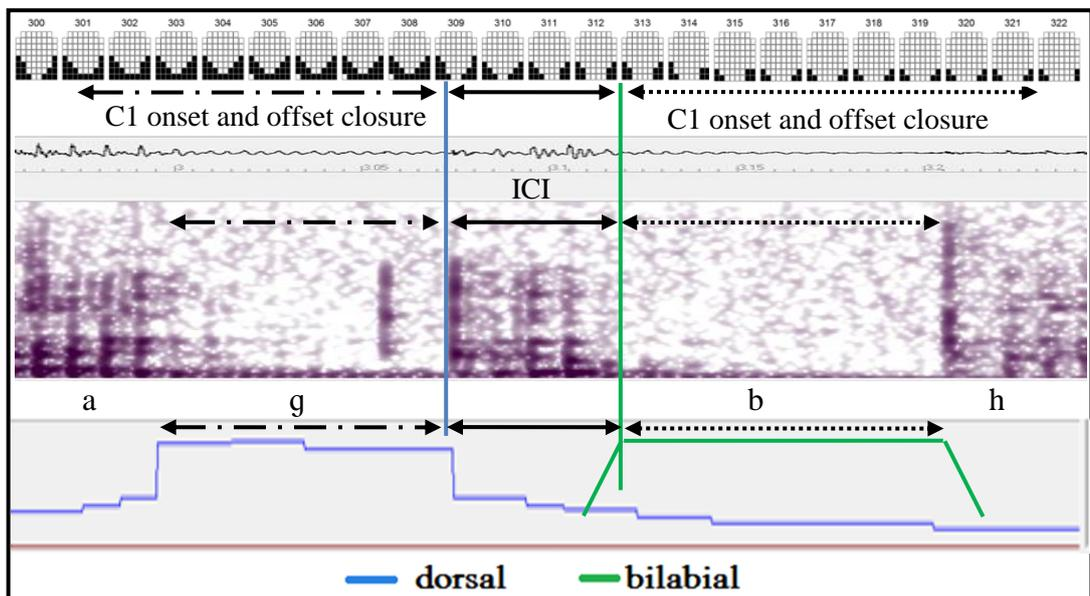

Figure 4.12 EPG frames acoustic and display of the cluster /gb/ (in /nagb/). The figure shows a typical long delay between the TB release gesture (vertical blue line/frame 309) and formation of the labial closure (vertical green line). The duration of the ICI lasts for approximately 40ms.

#### 4.7 The duration of ICI in words in isolation

The duration of ICI in clusters recorded in words in isolation is presented in Table 4.11.

Cluster type	ICI duration in SI clusters (in isolation)	ICI duration in SI clusters (in a carrier sentence)	ICI duration in SF clusters (in isolation)	ICI duration in SF clusters (in a carrier sentence)
Coronal + dorsal	20	23	50	47
Dorsal + coronal	10	15	40	64
/b/ + coronal	17	25	43	40
/b/ + dorsal	27	20	56	43
Coronal + /b/	22	20	47	43
Dorsal + /b/	24	0	42	50
Average	20	17	46	48

Table 4.10 Mean ICI duration in SI and SF words recorded in isolation. For ease of comparison, the duration of ICI in clusters in words recorded in a carrier sentence is provided.

When compared to the duration of ICI in clusters in words recorded in a carrier sentence, there are no significant differences between the two contexts. The only clusters type where the ICI duration was shorter in words recorded in isolation is SF dorsal + coronal clusters. Despite these differences, the pattern of gestural coordination remains the same in both cases where the coordination of SI clusters favours short delays, Figure 4.13, and the coordination of SF clusters is characterised by a long delay between the two closures as in Figure 4.14 below.

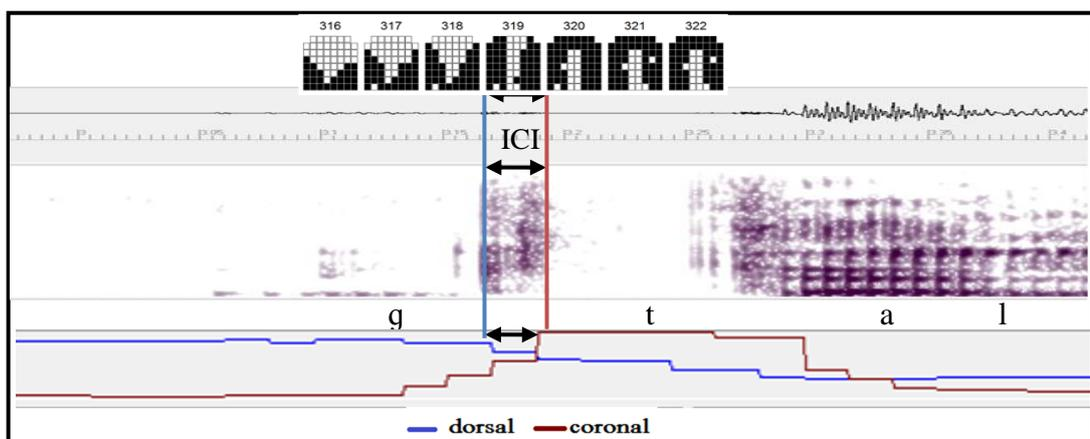

Figure 4.13 Acoustic display and EPG frames of the cluster /gt/ (in /gtal/), showing a short delay between the release of TB closure (vertical blue line/frame 319) and formation of the TT closure (vertical red line/frame 320). The duration of the ICI lasts for approximately 10ms.

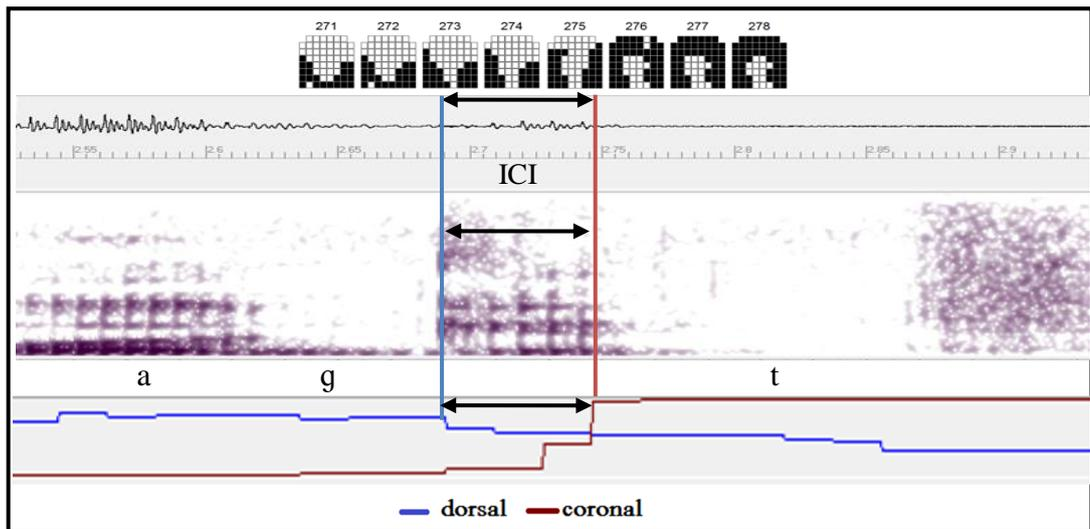

Figure 4.14 Acoustic display and EPG frames of the cluster /gt/ (in /wagt/), showing a long delay between the release of TB closure (vertical blue line/frame 273) and formation of the TT closure (vertical red line/frame 276). The duration of the ICI lasts for approximately 35ms (frames 273-275 inclusive).

#### 4.8 The influence of syllable position

The principal observation regarding the influence of syllable position on the pattern of intergestural coordination is that in SI, the coordination pattern always favours either a total overlap or a short delay lasting 5-30ms between the two consonantal closures. In SF, on the other hand, the pattern of coordination is characterised by the lack of overlap between the two consonantal closures. The typical pattern is a 30-55ms delay between these two closures.

Results show that the duration of overlap or delay between the release of C1 closure and the formation of the closure for C2 in SI and SF varied, depending on the place of articulation. For example, the clusters /kt/, /gt/, /gd/, /bd<sup>s</sup>/ and /gb/ exhibited an overlap in SI position lasting 10-20ms. In SF, the same cluster exhibited a 30-50ms delay between the two closures. Figure 4.15 shows the pattern coordination of SI /kt/ and Figure 4.16 shows the pattern coordination of the same cluster in SF position.

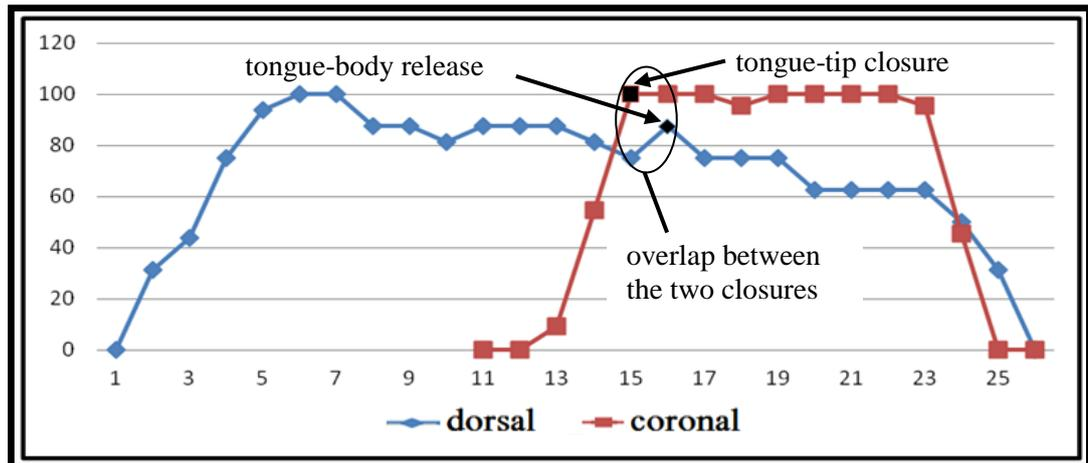

Figure 4.15 Contact profile of syllable-initial /kt/ (in /ktab/), showing an overlap between the TB and the TT closures.

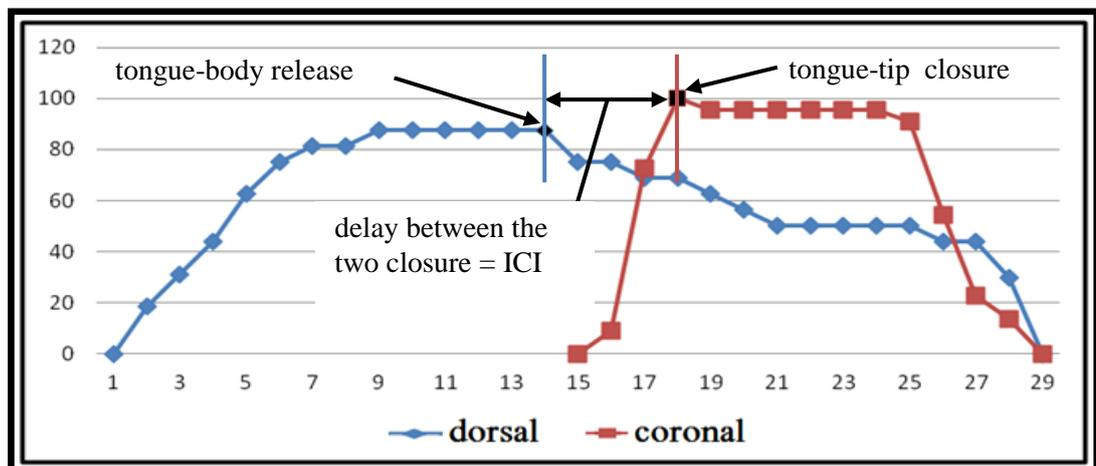

Figure 4.16 Contact profile of syllable-final /kt/ (in /nakt/), showing a delay between the release of the TB closure and the formation of the closure by the TT gesture.

In clusters containing /b/, there was an overlap between the two consonantal closures as well. However, it was not possible to mark the release of /b/. Thus in these cases the duration of overlap was marked with (+). The shortest ICI in SF was 30ms in the cluster /kt/ (in /nakt/), and the longest 55ms in the cluster /gt<sup>s</sup>/ (in /magt<sup>s</sup>/).

Clusters in which there was no overlap regardless of syllable position are /kd/, /gt<sup>s</sup>/, /bd/, /bt<sup>s</sup>/, /bg/, and /bk/. However, the duration of the delay between the release of the first closure and formation of the following closure varied as a function of syllable position. In SI position, the duration of ICI was 10-30ms. On the other hand, in SF position the duration of ICI was 30-55ms.

#### 4.9 The influence of sequence of place of articulation

Examples containing A-to-P sequence of articulation are bilabial + coronal (/bd/, /bt<sup>s</sup>/ and /bd<sup>s</sup>/), coronal + dorsal (/dk/, /dg/ and /t<sup>s</sup>g/ in SI, and /tk/ and /tg/ in SF), and bilabial + dorsal (/bk/ and /bq/). Examples containing a P-to-A sequence of articulation are coronal + bilabial (db/, /t<sup>s</sup>b/, /d<sup>s</sup>b/), dorsal + coronal (/kd/, /gd/ and /gt<sup>s</sup>/ and in SF /kt/ /gt/), and dorsal + bilabial (/kb/, /qb/). Underlined clusters are found in both SI and SF position. Other clusters that have A-to-P vs. P-to-A sequences, but with C1 as a prefix, were /tk/ vs. /kt/, /tg/ vs. /gt/ and /bt/ vs. /tb/.

There were three different patterns of intergestural coordination as a function of articulation sequence. These were: less overlap in P-to-A articulation sequence, no influence of articulation sequence and finally more overlap in A-to-P. In the first pattern, the intergestural coordination seems to be influenced by the sequence of articulation. In general, clusters with a P-to-A sequence of articulation showed more overlap or tighter gestural coordination than clusters with A-to-P sequence of articulation. For example, while P-to-A clusters /gd/, /db/ /kb/ and /qb/ were characterised by an overlap between the two closures, their A-to-P counterparts showed no overlap. There was a total difference of some 20-30ms in the amount of overlap between the two sequences of articulation. Even when there was no overlap between the two closures, as in /t<sup>s</sup>g/ vs. /gt<sup>s</sup>/, the P-to-A sequence of articulation exhibited tighter coordination between the two consonantal gestures. This was evident in the duration of the ICI in both contexts (30ms in /t<sup>s</sup>g/ vs. 20ms in /t<sup>s</sup>g/).

In the second pattern, the articulation sequence did not show any influence on the intergestural coordination. For example, in /bd<sup>s</sup>/ in /bd<sup>s</sup>a:ʃa/ and /d<sup>s</sup>b/ (in /d<sup>s</sup>baba/), C1 was not released in both clusters and the two closures overlapped. Moreover, the TT gesture has a high magnitude

In the third pattern, A-to-P articulation seemed to exhibit tighter coordination between the two consonantal gestures. For example, in the A-to-P sequence of articulation /bt<sup>s</sup>/ (in /bt<sup>s</sup>am/), the pattern was marked by more cohesive coordination between the two gestures in comparison with the P-to-A sequence /t<sup>s</sup>b/ (in /t<sup>s</sup>baʃ/). The duration of the ICI was 20 in /bt<sup>s</sup>/ and 30ms in /t<sup>s</sup>b/.

Despite the observation that the pattern is usually characterised by more overlap in P-to-A sequences, some A-to-P sequences did show more overlap. When

C1 was released in /dk/ and /kd/, although there was the same number of open frames between the release of C1 and formation of the closure of C2, the acoustic duration of ICI showed that A-to-P /dk/ was produced with tighter coordination compared to P-to-A /kd/. Figure 4.17 and 4.18 show the coordination of /dk/ and /kd/ in SI position.

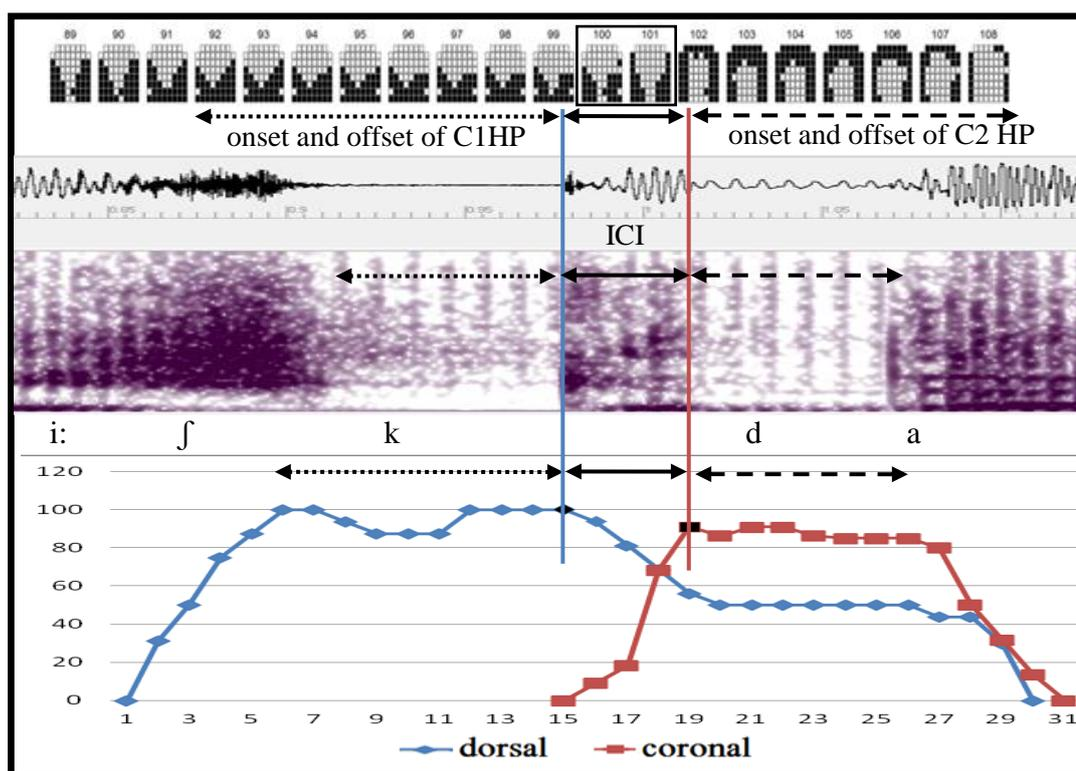

Figure 4.17 EPG frames and acoustic display for the cluster /kd/ (in /kdab/). There is a delay between the TB releasing gesture (vertical blue line/frame 100) and formation of the closure by the TT gesture (vertical red line/frame 102). The duration of the ICI is approximately 20ms. Both gestures have high percentage of contact.

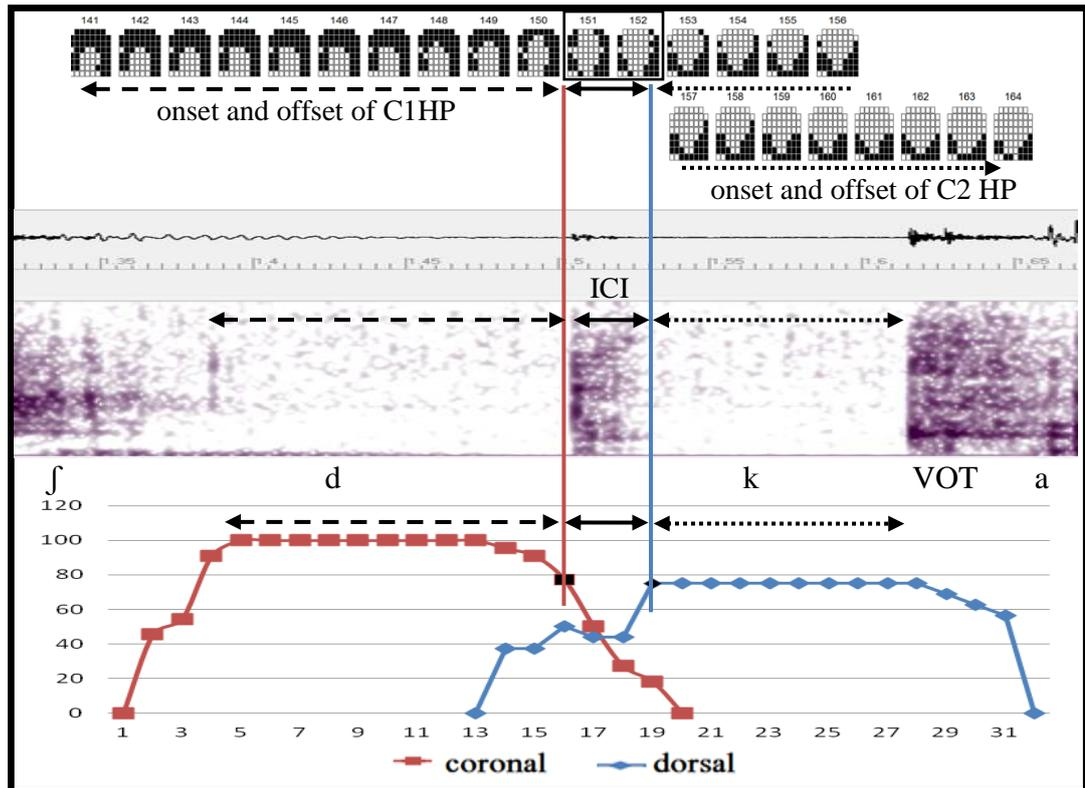

Figure 4.18 EPG frames and acoustic display for the cluster /dk/ (in /dkar/). There is an open transition between the TT releasing gesture (vertical red line/frame 151) and the formation of the closure by the TB (vertical blue line/frame 153). The duration of the ICI is approximately 20ms.

In SF position, the sequence of articulation influence on coordination was not consistent in all the clusters. There were three different patterns. The first pattern showed P-to-A sequence as having tighter coordination compared to A-to-P. For example, /kt/ (in /nakt/) and /gt/ (in /wagt/) showed tighter gestural coordination when compared to /tk/ (in /hatk/) and /tg/ (in /fatg/). The duration of the ICI was 30-50ms in the P-to-A context compared to 40-55ms in the A-to-P one. In the second pattern, the sequence of articulation seemed to have no influence on the coordination. Both /bg/ and /gb/ showed the same intergestural coordination pattern. The duration of the ICI was 40ms in both. In the last pattern, A-to-P /bt<sup>h</sup>/ showed tighter coordination between the two consonantal gestures in comparison with /t<sup>h</sup>b/. While the duration of the ICI in the former is 35ms, in the latter it was 50ms.

#### 4.10 The influence of morphological structure

This section investigates the coordination pattern of SF two-stop clusters containing a suffix. The aim is to determine whether or not the morphological structure has an influence on coordination by comparing these clusters to the same cluster when SI C1 or SF C2 is part of the root. The clusters to be discussed are /bd/ (in /bde:/) ‘he started’ vs. /bd/ (in /bda:faʃ/) ‘with a motive’, /bdʰ/ (in /bdʰa:ʃa/) ‘goods’ vs. /bdʰ/ (in /bdʰarba/) ‘with a strike’, /btʰ/ (in /btʰam/) ‘he buttoned’ vs. /btʰ/ (in /btʰa:wa/) ‘by a pan’, /bk/ (in /bke:/) ‘he cried’ vs. /bk/ (in /bkalma/) ‘with a word’, /bg/ (in /bgar/) ‘cows’ vs. /bg/ (in /bgalbna/) ‘with our heart’, and finally /gt/ (in /wagt/) ‘time’ vs. /gt/ (in /sʰdagt/) ‘you sing. told the truth’. In all of these pairs, the second word contains a preposition /b/ as prefix as. In the last pair, the second word contains a suffix /t/.

Analysis of the results showed that the morphological structure seemed to have an influence on the intergestural coordination pattern of /bd/, /btʰ/ and /bk/. For example, in /bde:/ where /b/ is not a prefix, there is a 30ms delay between the release of the LB closure and the formation of the closure by the TT gesture. On the other hand, in /bda:faʃ/, where /b/ is a prefix, the release of /b/ was masked by the formation of the closure for coronal closure /d/. As a result, the two closures overlapped. In another cluster, /btʰ/, there were also two different coordinations depending on the identity of /b/. While in /btʰam/, the duration of ICI was 20ms; in /btʰawa/ the two closures are overlapped. In the last cluster, /bk/, the influence of the same pattern of morphology can be observed. In /bke:/ the duration of ICI was 20ms but in /bkalma/, there was no /b/ release. The percentage of contact in the dorsal region was high throughout the cluster, an indication that the two gestures are overlapped. Figure 4.5 (page 102) shows the coordination pattern of /bk/ (in /bke:/) and Figure 4.19 below shows that for /bk/ (in /bkalma/).

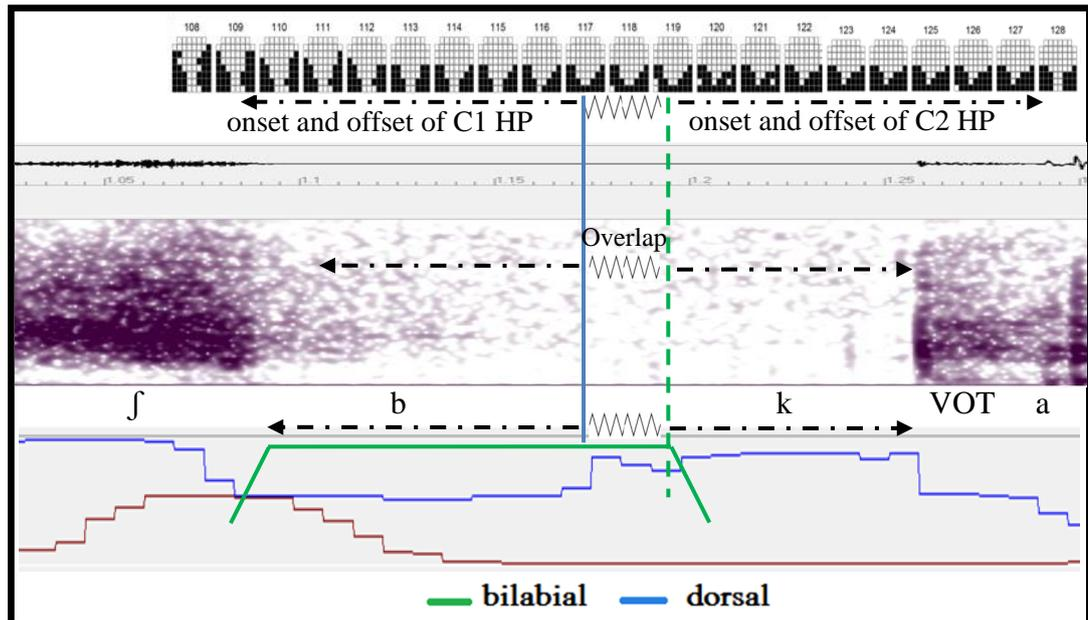

Figure 4.19 EPG frames and acoustic display of the cluster /bk/ (in /bkalma/), showing a total overlap between formation of the closure by the TB gesture (vertical blue line/frame 117) and the labial release (dashed vertical green line).

Morphology did not seem to have an influence on the pattern of gestural coordination in SI /bd<sup>s</sup>/ and /bg/, and in SF /gt/. In the coordination of /bd<sup>s</sup>/ (in /bd<sup>s</sup>arba/ and /bd<sup>s</sup>a3a/), the TT gesture reached its target before the release of the /b/. As a result, the release is not acoustically visible, as the two closures overlapped. Another example in which the morphological structure did not seem to have an influence is /bg/ (in /bgar/ and /bgalbna/). In both contexts there was a delay between the two closures. The duration of ICI was 20ms.

In SF /gt/ (in /s<sup>s</sup>dagt/ and /wagt/), there is no difference between the coordination of SF /gt/ whether /t/ was a suffix or not. Figure 4.20 below shows the coordination of the same gestures in /s<sup>s</sup>dagt/ and Figure 4.8 (page 108) shows how the TB and the TT gestures in /gt/ (in /wagt/) are coordinated. In both clusters the duration of the ICI, which separates the two consonantal closures, is 50ms. It is worth mentioning that the two gestures are also shorter, particularly /g/ which shows some reduction compared to its percentage of contact in /wagt/.

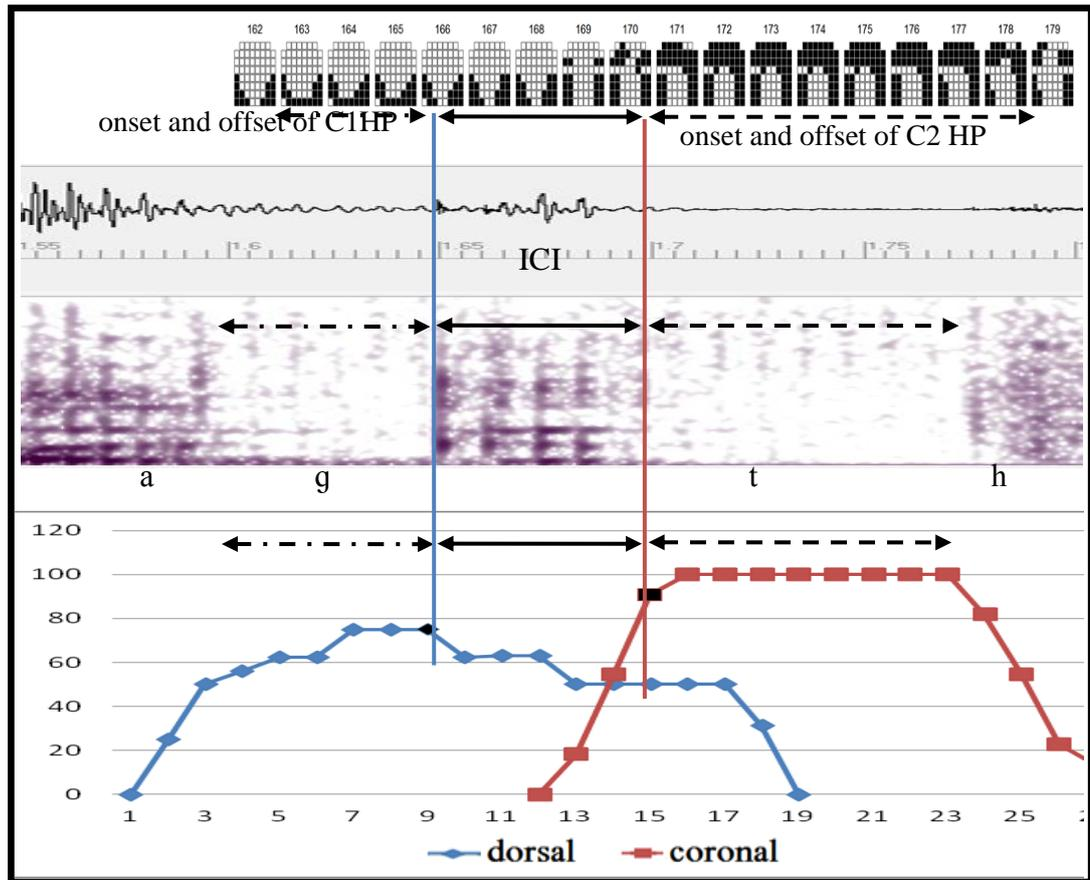

Figure 4.20 EPG frames of the cluster /gt/ (in /s<sup>d</sup>adt/). There was an open transition, approximately 50ms (frames 166-170 inclusive) between the TB release (vertical blue line/frame 166) and the formation of the closure by the TT gesture (vertical red line/frame 171).

When /t/ is a prefix, there is no cluster in which /t/ was part of the root. However, there are two clusters that are worth discussing. These are /tk/ and /tg/. In /tk/ and /tg/, where /t/ was a prefix, the two gestures are very cohesive. In /tk/, the two gestures exhibit a high percentage of contact and an overlap lasting for 40ms. Figure 4.21 shows the coordination of the two gestures in /tka:bir/.

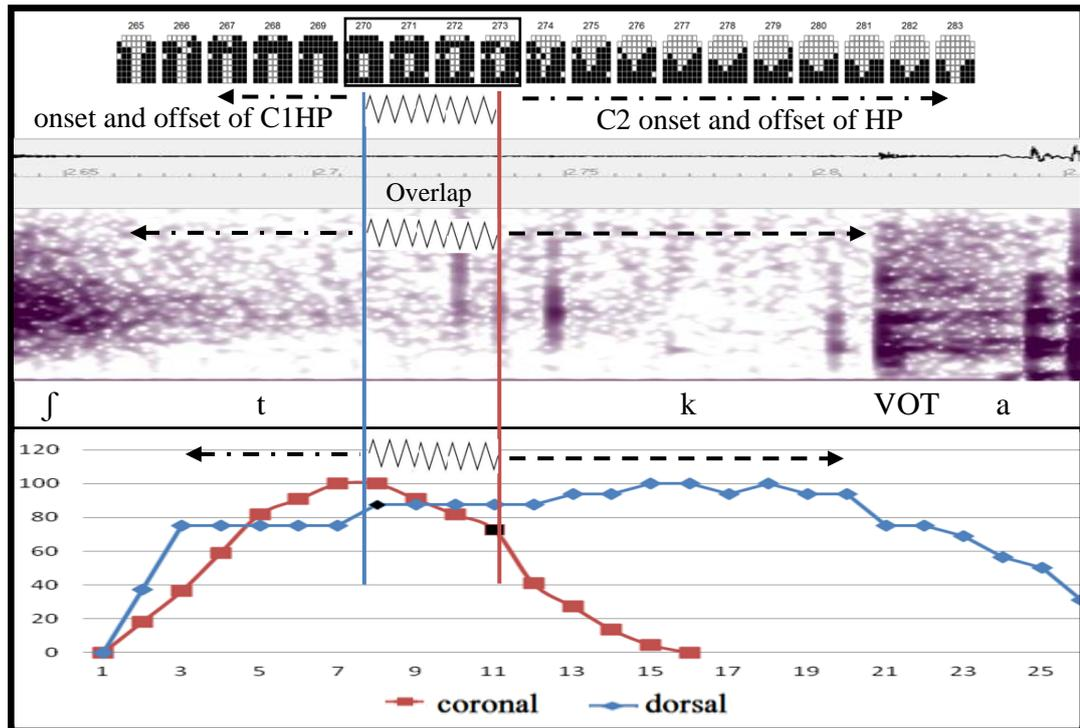

Figure 4.21 EPG frames and acoustic display of the cluster /tk/ (in /tkabir/), showing the TT gesture (red squares) and the TB gesture (blue diamonds) showing a considerable amount of overlap lasting for approximately 40ms (frames between 270-273 inclusive).

In /tg/, the two gestures were less cohesive leading to the release of C1 just before the formation of the closure of C2. It seems that when the C1 and C2 agree in voicing, they are more likely to be overlapped than when they do not agree in their voicing.

#### 4.11 The influence of speaking rate

This section presents the influence of speaking rate on the patterns of gestural coordination. The same place of articulation classification which was adopted in the previous sections is used here too. For ease of comparison, results of the influence of fast and slow speaking rate on SI and SF clusters are combined together.

In general, an increase in speaking rate results in a decrease in the overall duration of the cluster, an increase in the duration of overlap between the two closures, a more cohesive coordination, and a reduction in the percentage of contact. A decrease in the speaking rate, on the other hand, leads to an increase in the overall

duration of the cluster and a less cohesive pattern between the two gestures. However, different clusters are not identical in their sensitivity to change in speaking rate. Place of articulation and syllable position seem to play an important role in determining the pattern of coordination in different speaking rates.

#### **4.11.1 The influence of speaking rate on coronal + dorsal**

##### **4.11.1.1 SI coronal + dorsal**

The average number of syllables per second increased from 3.9 syllables in normal speaking rate to 5.6 syllables per second at fast speaking rate. The average duration of SI coronal + dorsal clusters decreased from 211ms to 135 (a 35% decrease ranging from 100ms in /dg/ (in /dga:jig/) to 170ms in /dk/ (in /dkar/). The intergestural coordination pattern between the two closures ranges from 10ms overlap in /dk/ and /dg/ to 10ms delay in /t<sup>h</sup>g/ and /tg/. In /tk/ there was no overlap or delay between the TT releasing gesture and the formation of the closure by the TB gesture. In other words, the frame of release was immediately followed by the frame of closure. In this case, the duration of ICI is less than 10ms (the duration of one frame).

At slow speaking rate, on the other hand, the average number of syllables has decreased from 3.9 to 2.1 per second. The average duration of the clusters increased from 211 to 329ms (a 33% increase, ranging from 236ms for /tk/ to 433ms for /dg/. The average duration of ICI decreased from 14 to 8ms (-20ms for /tk/, and 20ms for /dk/ and /t<sup>h</sup>g/. This was because the two gestures in /tg/ and /dg/ showed more overlap at slow speaking rate. This result failed to support the hypothesis under speech rate which states that a decrease in articulation rate will result in a longer ICI duration.

##### **4.11.1.2 SF coronal + dorsal**

In SF coronal + dorsal clusters produced at fast speaking rate, the average number of syllables increased from 4.3 to 6.2 syllables per second. The average duration of these clusters decreased from 204 to 130ms (a 37% decrease, ranging

from 114ms for /tk/ to 145ms for /tg/. It is obvious that C1 and C2 had shorter duration in SF, and were subject to more reduction as a result of the increase in speaking rate. This was particularly noticeable in the duration of ICI which decreased from an average of 47ms at normal speaking rate to 20ms at fast speaking rate (10ms for /tk/ to 30ms for /tg/).

At slow speaking rate, the average number of syllables in sentences containing SF coronal + dorsal stop cluster has decreased from an average of 4.3 to 2.5 per second. The average duration of the clusters increased from 204 to 296ms (a 31% increase in overall cluster duration). The average duration of the ICI also increased from an average of 47ms to 58ms (55ms for /tk/ and 60ms for /tg/). The speech rate hypothesis which states that by the decrease in articulation rate, the duration of segments becomes longer is validated here. This is the result of the articulators having more time dedicated to the production.

#### **4.11.2 The influence of speaking rate on dorsal + coronal**

##### **4.11.2.1 SI dorsal + coronal**

In SI dorsal + coronal clusters produced at fast speaking rate, the average number of syllables increased from 4.4 to 5.8 syllables per second. The average duration of these clusters decreased from 192 to 137ms (a 28% decrease in overall cluster duration, ranging between 122ms for /kd/, and 150ms for /gt<sup>s</sup>/). The average duration of overlap increased as a result of the increase in speaking rate from 4ms at normal speaking rate to 15ms (0 for /gt<sup>s</sup>/ and -20 for /gt/). Figure 4.22 below shows the pattern of gestural coordination of /gt/ (in /gtal/) produced at fast speaking rate. The same pattern noticed in normal speaking rate (see figure 4.2, page 98) is observed in fast speaking rate.

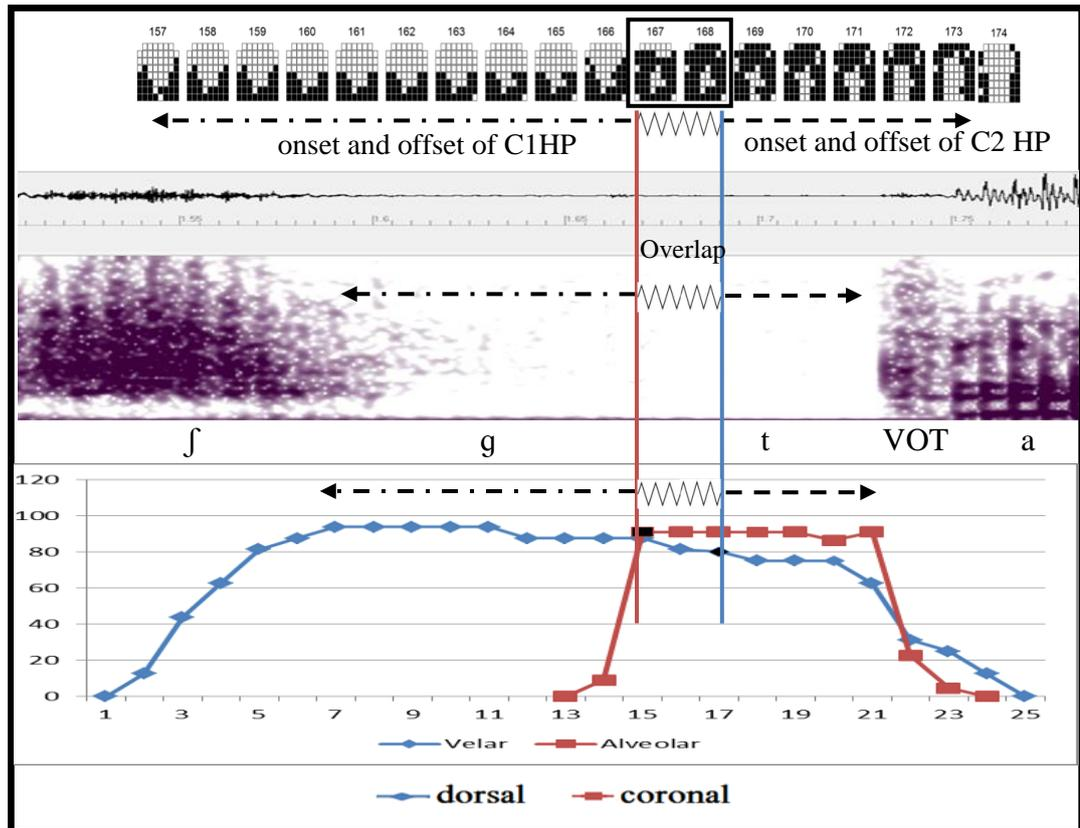

Figure 4.22 Acoustic display and EPG printout of the /gt/ cluster (in /gtal/) produced at fast speaking rate. The figure shows an overlap (in zigzag pattern) between the TB and the following TT closures lasting 20ms (frames 167–168).

The increase in gestural overlap was more evident in /kd/ and /gt<sup>ɕ</sup>/ where the two closures did not overlap in normal speaking rate. As a result of the decrease in speaking rate, on the other hand, the average number of syllables decreased from 4.4 to 2.3 per second. The average duration of the clusters increased from 192ms to 380ms (a 46% increase in the overall duration of the cluster, ranging from 220ms for /kt/ to 472ms for /gt/). As a result of this increase in the duration of the clusters, the duration of ICI increased from an average of 4ms overlap at normal speaking rate to an average of 18ms delay at slow speaking rate (-30 for /kt/ and 40ms for both /gt/ and /gt<sup>ɕ</sup>/). It is worth noting that the cluster /kt/ showed overlap at slow speaking rate. This is an evident that slow speaking rate does not always entail less overlap.

#### 4.11.2.2 SF dorsal + coronal

Results of the influence of fast speaking rate on the intergestural coordination of SF dorsal + coronal stops show that the average number of syllables increased from 4.5 to 6.6 per second. The average duration of these clusters decreased from 191ms to 126ms (ranging between 106ms in /kt/ to 134ms in /kd/, a 36% decrease in the overall cluster duration). The average duration of the ICI decreased from 42ms to 17ms (0 for /kt/ 8ms for /d<sup>h</sup>akt/, presented in figure 4.23 below, 8ms for /gt/ in /wagt/, presented in figure 4.24, and 30ms (in /magt<sup>s</sup>/).

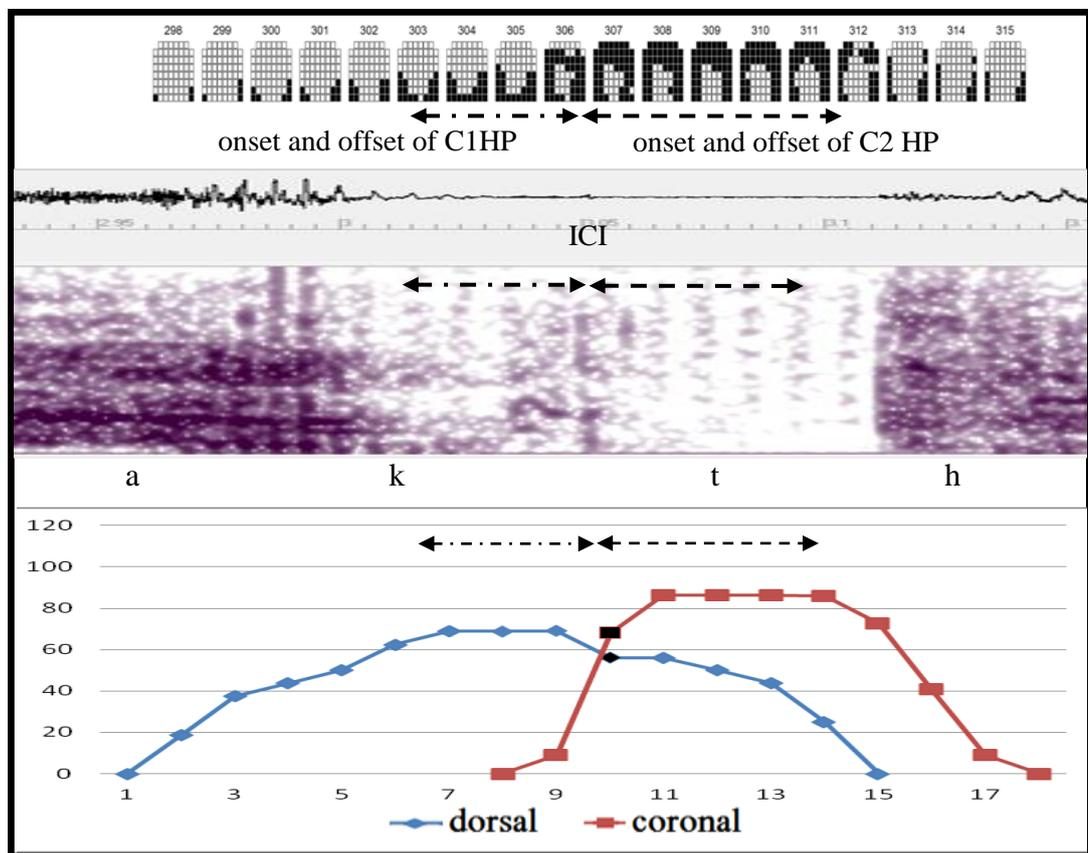

Figure 4.23 Acoustic display and EPG frames of the cluster /kt/ (in /d<sup>h</sup>akt/) produced at fast speaking rate. The two gestures show a more cohesive coordination compared to normal speaking rate. The ICI lasts for approximately 5ms.

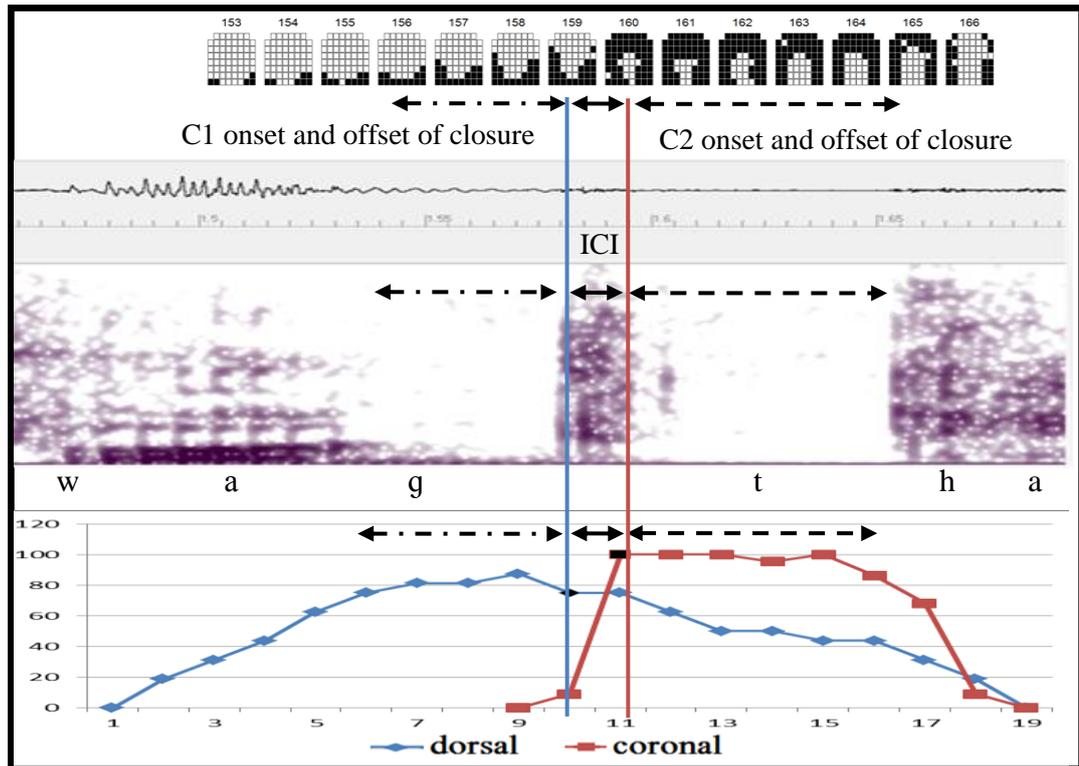

Figure 4.24 EPG frames and acoustic display of the cluster /gt/ (in /wagt/) produced at fast speaking rate. Although C1 was released, the two gestures show a more cohesive coordination compared to normal speaking rate. The ICI lasts for approximately 8ms.

At slow speaking rate, the average number of syllables increased from 4.5 to 2.5 per second. The average duration of these clusters increased from 195ms to 325ms (a 39% increase, ranging between 298ms for /kt/ to 400ms for /gt/). The duration of the ICI increased from 42ms to 67ms (63ms for /gt/ [in /wagt/] and 86ms for /gt/ [in /s<sup>h</sup>dagt/]). Contrary to previous observations that SF clusters decreased in duration, the SF dorsal + coronal showed a longer duration as a result of the decrease in speaking rate compared to their SI counterpart.

### 4.11.3 The influence of speaking rate on /b/ + coronal

#### 4.11.3.1 SI /b/ + coronal

In SI /b/ + coronal clusters, the average number of syllables increased from 4.1 to 6.1 per second at fast speaking rate. The average duration of these clusters

decreased from 196ms to 118ms (a 39% decrease in the overall cluster duration, ranging from 102ms for /bt/ to 157ms for /bd/). The duration of the ICI decreased from an average of 7ms to a complete overlap at fast speaking rate. This was particularly evident in /bd/ and /bt<sup>s</sup>/. However, in /bd/ where /b/ is not a prefix, there was a 10ms delay between the two closures.

At slow speaking rate, the average number of syllables decreased from 4.1 to 2.0 per second. The average duration of the clusters increased from 196ms to 379ms (a 48% increase in the average duration of the cluster, ranging between 339ms for /bt<sup>s</sup>/ (in /bt<sup>s</sup>a:wa/) to 453ms for /bt<sup>s</sup>/ (in /bt<sup>s</sup>am/). The duration of the ICI increased from 7ms to 33ms (27ms for /bt<sup>s</sup>/ (in /bt<sup>s</sup>a:wa/) and 45ms for /bd<sup>s</sup>/ (in /bd<sup>s</sup>aʕa/). This is an indication that the two gestures became less cohesive as a result of the decrease in speaking rate. This result is in agreement with the speech rate hypothesis advanced in ChapterThree.

#### **4.11.3.2 SF /b/ + coronal**

Results of the influence of fast speaking rate on the intergestural coordination of SF b + coronal stops show that the average number of syllables increased from 3.9 to 5.7 per second. The average duration of the target clusters decreased from 202ms to 135ms (a 33% decrease in the overall duration of the cluster ranging between 103ms for /bt/ to 149ms for /bd/). The ICI duration decreased from 39ms to 25ms (10ms for /bt/ [in /ktabt/] and 30ms for /bt<sup>s</sup>/, /bd/ and /bd<sup>s</sup>/).

At slow speaking rate, the average number of syllables decreased from 3.9 syllables at normal speaking rate to 2.2 per second. The average duration of SF /b/ + coronal clusters increased from 202ms to 355ms (a 43% increase in the average cluster duration, ranging from 336ms for /bt/ to 367ms for /bt<sup>s</sup>/). The duration of the ICI also increased from 39ms to 74ms (62ms for /bt/ [in /ktabt/] and 86ms for /bt<sup>s</sup>/).

#### **4.11.4 The influence of speaking rate on /b/ + dorsal**

##### **4.11.4.1 SI /b/ + dorsal**

The increase in speaking rate resulted in an increase in the number of syllables per second from 3.9 to 5.8 per second. The average duration of the SI /b/ + dorsal decreased from 200ms to 144ms (a 23% increase in the overall duration of the cluster ranging from 120ms for /bg/ (in /bgalbna/) to 158ms for /bg/ (in /bgar/)). The duration of ICI decreased from 15ms to total overlap in all /b/ + dorsal clusters produced at fast speaking rate. This means that the two consonantal gestures in these SI /b/ + dorsal clusters became more cohesive as a result of the increase in speaking rate.

As a result of slow speaking rate, the average number of syllables decreased from 3.9 to 2.0 per second. The average duration of the clusters increased from 200ms to 380ms [ranging from 305ms for /bg/ (in /bgalbna/) and 420ms for /bg/ (in /bgar/)], 49% increase check). The duration of the ICI also increased from 15ms to 26ms [18ms for /bk/ (in /bkalma/) and 31ms for /bg/ (in /bgalbna/)].

##### **4.11.4.2 SF /b/ + dorsal**

In sentences containing /b/ + dorsal clusters produced at a fast speaking rate, there was an increase in the number of syllables from 3.8 to 5.4 per second. As a result, the overall duration of these clusters decreased from 195ms to 144ms (a 27% increase in the overall duration of the cluster, ranging from 147 for /bg/ to 153ms for /bk/). The average duration of ICI decreased from 43ms to 23ms (16ms for /bk/ and 20ms for /bg/).

At slow speaking rate, the average number of syllables decreased from 3.8 to 2.6 per second. The average duration of the SF /b/ + dorsal stops produced at slow speaking rate increased from 200ms to 368ms (a 45% increase in the overall duration of the cluster, ranging from 380ms for /bg/ to 401ms for /bk/). The average duration of ICI increased from 43ms to 84ms (86ms for /bk/ and 95ms for /bg/). This is a sign that the two gestures are pulled apart at slow speaking rate.

#### **4.11.5 The influence of speaking rate on coronal + /b/**

##### **4.11.5.1 SI coronal + /b/**

The average number of syllables increased from 3.8 to 5.5 per second. The average duration of the target clusters decreased from 230ms to 153ms (a 37% decrease in the average duration of the cluster, ranging from 117ms for /tb/ and 173ms for /t<sup>s</sup>b/). The duration of ICI decreased from 15ms at normal speaking rate to total overlap in all coronal + /b/ produced at a fast speaking rate. This is evidence that the two gestures became more cohesive as a function of the increase in speaking rate.

On the other hand, the decrease in speaking rate resulted in a decrease in number of syllables from 3.8 to 2.5 per second. The duration of the cluster increased from 230 to 408ms (a 38% increase in the average duration of the cluster, ranging from 320ms for /t<sup>s</sup>b/ to 450ms for /d<sup>s</sup>b/). The duration of ICI increased from 15ms to 31ms (22ms for / d<sup>s</sup>b/ to 38ms for /t<sup>s</sup>b/).

##### **4.11.5.2 SF coronal + /b/**

At a fast speaking rate, the coordination of /t<sup>s</sup>b/ (in /fat<sup>s</sup>b/) was characterised by an increase from 3.9 to 5.6 syllables per second. The average duration of the cluster has decreased from 197 to 129 (a 35% decrease in the average duration of the cluster). The duration of ICI decreased from 50ms to 10ms.

At slow speaking rate, the coordination of /t<sup>s</sup>b/ (in /fat<sup>s</sup>b/) was characterised by a decrease from 3.9 to 2.7 syllables per second. The average duration of the cluster has increased from 197ms to 405ms (a 51% increase in the total duration of the cluster). The duration of ICI increased from 50ms to 87ms.

#### **4.11.6 The influence of speaking rate on dorsal + /b/**

##### **4.11.6.1 SI dorsal + /b/**

Results of the influence of the increase in speaking rate on the intergestural coordination of SI dorsal + /b/ clusters show that the number of syllables increased

from 3.4 to 5.3 syllables per second. The average duration of the syllables decreased from 215ms to 142ms (91ms for /kb/ to 183ms for /gb/, a decrease of 35%). The pattern of intergestural coordination remained characterised by a total overlap in both clusters. These results suggest that if two gestures are normally produced with overlap in normal speaking rate, their coordination pattern is likely to remain stable in fast speaking rate

At slow speaking rate, the average number of syllables decreased from 3.8 to 2.4 per second. The average duration of the clusters decreased from 215ms to 375ms (a 39% increase in the overall duration of the cluster). The duration of the ICI increased from 33ms to 40ms (22ms for /gb/ to 46ms for /kb/).

#### **4.11.6.2 SI dorsal + /b/**

Finally, the influence of articulation rate on SF dorsal + /b/ clusters show that at fast speaking rate, /gb/ (in /nagb/) is characterised by an increase in the number of syllables per second from 4.1 to 5.4. The average duration of the cluster decreased from 206ms to 135ms (a 34% decrease in the average duration of the cluster). The duration of ICI remained 40ms regardless of the increase in speaking rate. In other words, the pattern of coordination was not influenced the increase in articulation rate.

At slow speaking rate, on the other hand, the coordination of /gb/ (in /nagb/) was characterised by a decrease in the number of syllables per second, from 4.1 to 2.8 per second. The average duration of the cluster increased from 206ms to 365ms (a 44% decrease in the average duration of the cluster). The duration of ICI increased from 40ms to 70ms.

## **4.12 Discussion**

The present results suggest that there are two general patterns of gestural coordination in two-stop clusters in TLA. The first takes place in SI clusters. This pattern is characterised by either an overlap or a short delay between the two closures. The second pattern takes place in SF clusters. This pattern is marked by a

longer delay that separates the two closures. Based on duration, the delay between the two closures seems to fall under two categories. These are excrescent and epenthetic. While the former is short (Hall 2003, Davidson 2005, Davidson and Roon 2008; Dell and Elmedlaoui 2002) and exists as a result of gestural mistiming (Hall 2003) or to ensure perception (Chitoran *et al.* 2002), the latter is triggered by the three consonant sequence which is not permissible in TLA.

These patterns are evident even when the target clusters were recorded in words in isolation. This suggests that the coordination patterns are largely determined by syllable position. SI clusters are very cohesive as a result of the overlap, or the short delay, between the closures of C1 and C2, i.e. the formation of the closure for C2 usually takes place before the release of C1 or a short time after the release. A question to be asked here is why an epenthetic vowel is not inserted before C1 in SI clusters, i.e. having a consonant in the carrier sentence, /ʃ/, maximises the sequence to three consonants, a scenario that TLA does not permit. There are two explanations for this. The first is that all participants were asked not to pause or leave any gaps between the words in the carrier sentence. However, in some case, there was in fact a short vocoid before C1. The second explanation is the long vowel occurring just before the clusters. This vowel helped to block the epenthetic vowel that should have been inserted before C2.

In addition, SI two-lingual clusters exhibit a high percentage of contact, particularly in the alveolar region, an indication that the mechanism involved in their production is different from that for SF clusters which exhibit less cohesive coordination between the two gestures. The epenthetic vowel in SF clusters is the result of the phonotactics of TLA which does not permit a sequence of three consonants. Due to the following /h/ in the carrier sentence, an epenthetic vowel is inserted before C2. This coordination supports the views advanced by Kiparsky (2003) and Watson (2007) that TLA is a VC dialect. As a result of the epenthetic vowel in SF clusters, the two gestures become less cohesive. This is evident in the reduction exhibited by the lingual gestures, particularly in the velar region. To sum up, regardless of the number of consonants, the general coordination pattern is consistent.

The variation of gestural coordination could be related to the fact that SI clusters are articulated differently from SF clusters. This is in agreement with

previous literature on the effect of syllable position on gestural coordination (e.g. Browman and Goldstein 1988; Pouplier and Marin 2008; Marin and Pouplier 2010; Kochetov 2006; Krakow 1999). Other reasons such as perception (Goldstein *et al.* 2007) and stress patterns (Tilsen 2011) could also play a role in the way these gestures were coordinated. Other explanations could be the size and velocity of the different articulators involved in the production of these clusters (Bauer *et al.* (2010). For example, although the retraction of the tongue towards the back of the mouth in /tʰg/ should facilitate more overlap between the two gestures, by shortening the distance that the back of the tongue needs to travel, the two closures do not overlap. This could be related to the frequency of the word. Because the word has a low frequency it could be that it was produced with less overlap to ensure its perceptual recoverability.

Another noticeable difference between SI and SF is the duration of the HP of C1 and C2. In SI, the duration of C1 and C2 HP tends to be longer than that of SF. This result does not support Oller (1972) results which report longer HP durations in for SF stops. The duration of excrescent vowel in SI clusters is shorter than that of the epenthetic vowel in SF. In SF, the duration of C1 and C2 is shorter because the two gestures are not tightly coordinated. As a result, they allow the presence of a long transition between the two closures. This distinction between excrescent, or intrusive, and epenthetic vowels is observed and studied by many researchers (e.g. (Hall 2003; Davidson 2005; Davidson and Roon 2008)

It seems that there is some sort of a trading relationship between the duration of C1 and C2 HP and the duration of excrescent/epenthetic vowels in both syllable positions. Longer C1 and C2 HPs in SI require shorter excrescent vowels, and shorter C1 and C2 HPs in SF require longer epenthetic vowels.

However, in /tʰb/, the duration of excrescent and epenthetic vowel is the same regardless of syllable position. A possible explanation is that the vocal tract configuration during the production of emphatic sounds makes it difficult for the lips to maintain any closure before the emphatic sound is released. The influence of emphatic sounds can be seen in those clusters in which they are positioned as C2. Here, the higher percentage of contact in the velar region during the production of clusters containing emphatic stops could be an indication that the TB gesture is

influenced by the retraction of the tongue towards the back of the mouth during the production of the emphatic stops.

The influence of emphatic stops can be seen in the difference between /gt/ and /gt<sup>s</sup>/. There is more contact in the velar region for /gt<sup>s</sup>/ than /gt/. There are two possible explanations for this. The first is that the phasing of /gt<sup>s</sup>/ is more constrained than that of /gt/. Since emphatics have a dorsal gesture in addition to a coronal one, i.e. have a secondary articulation, it could be that in anticipation of the following gesture for /t<sup>s</sup>/, the back of the tongue remains retracted even after the release of /g/. Another possibility is the velocity of the back of the tongue. When the back of the tongue was moving slowly, the percentage of contact decreased very slowly. Although the two gestures, /g/ and /t<sup>s</sup>/, are cohesive, the closure for /t<sup>s</sup>/ took place after the release of /g/.

Another example of the influence of the velocity of the articulators and the distance they have to travel on the coordination pattern can be seen when C1 is /b/. Here when /b/ is a prefix, it is almost always overlapped with the following TT, but when it is followed by a TB gesture, the labial closure is always released first. This could be the result of the velocity of the TT and TB gesture. The TT is faster to achieve its target before the TB gesture.

The sequence of articulation is related to the place of articulation of C1 and C2. The results show that the A-to-P sequence of articulation showed more overlap and shorter excrescent vowels compared to P-to-A clusters. These results are not in agreement with those obtained by Kochetov and Goldstein (2005) who reported less overlap in A-to-P sequence of articulation.

Although in A-to-P clusters (/b/ + coronal and /b/ + dorsal) there is no obstruction to the release of the labial closure, due to the lack of another anterior closure, both closures, the labial and coronal or the dorsal, are overlapped. On the other hand, in P-to-A, although the C1 closure is expected to be released, due to the need to enhance the perceptual recoverability of the word (Chitoran *et al.* 2002), it is masked by C2 closure. That is why the cluster appears on spectrogram as one long HP followed by one acoustic release. This could be attributed to the fact that the phasing rules of TLA favour overlap.

Other reasons could be the velocity of the articulators or when the word frequency is high (Lin *et al.* 2011). Since the labial, coronal and dorsal gestures each have different velocities; the coordination of the cluster is determined by the velocity of the formation of the closure of C2. For example, the retraction of tongue in an A-to-P sequence articulation is faster than fronting in a P-to-A articulation sequence.

While clusters like /kt/ showed an overlap between the two closures lasting for 20ms, the dorsal closure in /kd/ was released before the formation of the following coronal closure. The pattern of coordination in these clusters could be motivated by the voicing of the two gestures. It may be the case that to facilitate the start of voicing of C2 in /kd/, C1 intraoral pressure is released so that voicing can be easily initiated. In /kt/ where the two stops are voiceless, there is no need to release the intraoral pressure because there is no voicing. The last fact which could have motivated the release is the fact that /d/ is actually /ð/ in Modern Standard Arabic, i.e. it was originally a fricative not a stop. In anticipation of just a narrowing (or partial closure) of the air, the /k/ was released.

Another instance where voicing seems to play a role is in /dk/ and /dg/. When /d/ is released, the excrescent vowel is voiceless. This could be due to the voicing of adjacent consonants, or the fact that the laryngeal gesture of /g/ in /dg/ caused a delay in the formation of the closure of C2, and led to the insertion of a voiced excrescent. In SF the epenthetic vowel is mostly voiced, because the adjacent stops are voiced. When the adjacent consonants are voiceless as in SF /kt/, the epenthetic vowel is voiceless. Duration may also provide another explanation as to why the epenthetic vowel in SF is mostly voiced. The longer duration of this vowel allows sufficient time for the vocal folds to start vibrating, particularly if C2 is voiced.

Another factor that could account for the variation in the gestural coordination of two-stop clusters concerns whether the cluster is in a disyllable or monosyllable word. For example, there is more overlap in the disyllabic word /btʕa:wa/ as compared to the monosyllabic /btʕam/, because articulatory gestures in disyllabic words are coordinated in such a manner that overlap between consonantal gestures is allowed. This explanation is in support to Tilsen (2013) that more gestural overlap is observed in disyllabic words.

As a result of the increase in speaking rate, the duration of both SI and SF clusters decreased. A strong relationship between speaking rate and segment duration has been reported in the literature (e.g. Lindblom 1963; Gay 1981; Arvaniti; 1999; Pickett *et al.* 1999; Miller 1981), but not with some studies which reported no significant influence of articulation rate on segment duration (e.g. Gay *et al.* 197; Kent and Netsell 1971, Kent and Moll 1975).

Because SI clusters were already overlapped at normal speaking rate, they remained stable when the speaking rate was increased. However, the two gestures of /k/ and /d/ exhibited greater overlap at fast speaking rate. Results of the influence of fast articulation rate do not support the view that fast articulation rate does not always entail less overlap (e.g. Zsiga 1994; Flege's 1988; or reduction (Flege's 1988). However, the decrease in the duration of the epenthetic vowel in SF clusters is the result of the two gestures becoming overlapped or more cohesive. The shorter duration of the epenthetic vowel in SF clusters produced at fast speaking supports this conclusion. This is evidence that the two gestures are more cohesive at a fast speaking rate.

In SF clusters, the TB gestures decreased more markedly in magnitude and a showed a lower percentage of contact at a fast speaking rate. This result is in line with previous work on gestural reduction reported by June (1995). The demand on the articulators to achieve their targets within a certain time frame could result in target undershoot. The reason why the same reduction is not observed in SI could be attributed to many factors such as the "domain-initial strengthening" (Keating *et al.* 2004). It could be also related to the longer duration and shorter transitions which led to the tighter coordination observed in SI.

However, more overlap was also observed at slow speaking rate. For example, /tg/ and /dq/ overlapped more at a slow speaking rate. It is important to point out that slow articulation does not always lead to less overlap. Rather, this relates to the coordination and velocity of the articulators. In addition, it is the distance between the two points of articulation that determines the pattern of gestural coordination.

#### 4.13 Conclusion

The patterns of intergestural coordination of two-stop consonant clusters in TLA, and how this coordination is influenced by factors such as syllable-position, place of articulation, sequence of articulation, morphological structure and speaking rate, were presented and discussed. Based on these results it can be stated that syllable position is the main factor that influences the coordination of two-stop closures. In general, there are two patterns of intergestural coordination in SI and one pattern in SF. The first SI pattern consists of /b/ + a TB or a TT gesture, or vice-versa. This pattern is characterised by the absence of C1 release as a result of the overlap between the two closures. The first SI pattern also involves a TB gesture followed by TT gesture. This pattern exhibits an overlap between the two closures in some clusters. C1 is released at the same timing of the formation of the closure of C2. This pattern is stable, and less sensitive to the change in speaking rate. In the second SI pattern, there is a short delay between the release of C1 and the formation of the closure of C2. This pattern leads to a short delay between the two closures. In all these patterns, when either C1 or C2 is emphatic, less overlap is observed.

In SF position, the pattern of coordination is characterised by a long delay between the release of the closure of C1 and the formation of the closure of C2, regardless of the place of articulation of the two stops. This gives rise to an epenthetic vowel separating the two closures. This epenthetic vowel has been observed in Arabic dialects which do not favour consonant clusters (see Hall 2013). This epenthetic vowel is mostly voiced, unless it occurs between two voiceless stops.

The pattern of coordination has also been found to be influenced by the sequence of articulation and speaking rate. SI two-lingual clusters in a A-to-P sequence of articulation exhibited more overlap than P-to-A articulation. Clusters with /b/+ coronal and /b/ + dorsal seemed to be less influenced by sequence of articulation. In SF position, the sequence of articulation did not seem to play any significant role in the intergestural coordination.

The influence of speaking rate showed that SI clusters increased in overlap as speaking rate increased, and decreased in overlap as the speaking rate decreased, apart from those clusters where a TB gesture was followed by a TT gesture. This

applies to most clusters in SI and SF positions. However, some clusters such as /gt/, /bt<sup>h</sup>/ and /gb/ were more resistant to change in speaking rate i.e. their pattern remained stable. Other clusters such as /tg/, /dg/, /kt/, /tk/, /gt<sup>h</sup>/, /kb/, bd/, /db/, /bg/, /kd/ were sensitive to the change in speaking rate.

Other factors that may have influenced the intergestural coordination are the morphological structure, voicing of the stops and the number of syllables in the word. Results of intergestural coordination show that it could be influenced by whether the two stops are tautomorphemic or not. More overlap was seen in clusters where C1 was not part of the root of the word. The number of syllables influences the amount of overlap, with disyllabic words showing tighter coordination. Finally, a cluster of two stops sharing the same voicing quality are more likely to overlap than clusters in which C1 or C2 shows a different voicing quality.

## Chapter Five: Acoustic Results

### 5.1 Introduction

This chapter presents and discusses the results of the acoustic measurements of single stops in SI and SF position and two-stop clusters in SI and SF position. The results reveal the influence of place of articulation, syllable position, articulatory sequence, morphology, gender and speaking rate on the timing relations and gestural coordination of two-stop clusters. The chapter also presents results of the relationship between gender and speaking rate as well as variability amongst and within speakers (males and females). The Shapiro-Wilk test for normality was used to test the distribution of the data. Then, all the data were subjected to the appropriate statistical tests such as the independent-samples *t*-test, the one-way ANOVA and the repeated-measures ANOVA. The mean difference is considered significant at the level of 0.05 ( $p \leq 0.05$ ). The results of the timing of voicing in two-stop clusters are presented and discussed in Chapter Six.

### 5.2 The influence of place of articulation

The influence of place of articulation on the production of stops is presented here. Results relating to the influence of place of articulation on SI and SF single stops are presented first. Unless otherwise stated, results include both groups of participants, males and females, and include only the duration of the HP. Results of the influence of place of articulation on the production of SI and SF two-stop clusters are presented and discussed next. These measurements include the duration of the HP of both C1 and C2 and the duration of the inter-consonantal interval (ICI). The purpose is to check the validity of Hypotheses (1-10) by revealing how the articulatory gestures of two-stop clusters are organized. The duration of the HP of single stops and the duration of the ICI are used to determine the degree of reduction/overlap in different clusters. For example, shorter cluster HP duration in comparison with that of single stops could be the result of overlap. In addition, the

absence of C1 release and the short ICI when C1 is released are clear signs of gestural overlap. The results also show how C1 and C2 place of articulation, articulatory sequence, morphological structure, gender and speaking rate influence cluster duration and the degree of overlap between the two consonantal gestures. Unless otherwise stated, none of the cluster durations include the duration of the ICI. The results will be discussed in the light of the hypotheses presented in Chapter Three.

### 5.2.1 The influence of place of articulation on HP duration of SI single stops

The average HP duration and standard deviation of SI single stops, as produced by males and females, are presented in Table 5.1.

	N	Mean	Std. Deviation	Std. Error	Interval of means	
					Lower Bound	Upper Bound
/b/	42	71	13	2	67	75
/t/	42	57	13	2	53	61
/d/	42	66	15	2	61	70
/t <sup>ɬ</sup> /	42	67	14	2	62	71
/d <sup>ɬ</sup> /	42	74	22	3	68	81
/k/	42	66	15	2	61	70
/g/	42	63	19	3	57	69
Total	294	66	17	1	64	68

Table 5.1 Mean duration and standard deviation of HP of SI single stops.

The average HP duration of SI single stops is 66ms (between 57ms for /t/ and 74ms for /d<sup>ɬ</sup>/). Coronal stops, with the exception of /d<sup>ɬ</sup>/, tend to have a shorter HP compared to the dorsal stops /k/ and /g/ and the bilabial stop /b/. Results of a one-way ANOVA test revealed significant differences between the HP duration of SI single stops. For example, /t/ is significantly shorter than /b/ (P = 0.01) and /d<sup>ɬ</sup>/ (P = 0.00) and /g/ is significantly shorter than /d<sup>ɬ</sup>/ (P = 0.03).

The average HP duration based on the place of articulation is 71ms for /b/, 66ms for coronal stops, including emphatics, and 65ms for dorsal stops. The HP duration tends to decrease as the place of articulation moves further back. This pattern is compatible with earlier findings by Lisker and Abramson (1967) and Klatt (1975). Voiceless stops usually have a shorter HP duration. This applies to coronal

stops, but not to dorsal stops since the HP duration of /k/ is longer than that of /g/. The mean HP duration of SI voiceless single stops is 63ms, and the mean duration of the HP of their voiced counterparts is 69ms. These results are not in line with Suen and Beddoes (1974) who reported longer durations of the silent interval of voiceless stops in English. It is worth mentioning that this is only the duration of the HP. When the duration of VOT is added, the average duration of voiceless stops becomes 88ms and the average duration of voiced stops increases to 79ms.

### 5.2.2 The influence of place of articulation on the timing of SI two-stop clusters

As in the previous chapter, SI two-stop clusters are divided into six types on the basis of three articulatory gestures, namely, the labial (LB) gesture, the tongue-tip (TT) gesture and the tongue-back (TB) gesture. Results for the following types of clusters are presented here:

coronal + dorsal	/dkar/, /dga:jig/, /t <sup>s</sup> gar/, /tka:bir/, /tga:til/
dorsal + coronal	/ktab/, /kdab/, /gtal/, /gt <sup>s</sup> af/, /gdar/
/b/ + coronal	/bde:/, /bt <sup>s</sup> am/, /bd <sup>s</sup> aʃa/, /bta:ti:ɣ/, /bda:faʃ/, /bt <sup>s</sup> awa/, /bd <sup>s</sup> arba/
/b/ + dorsal	/bke:/, /bgar/, /bkalma/, /bqalbna/
coronal + /b/	/tba:ʃir/, /dbaʃ/, /t <sup>s</sup> baʃ/, /d <sup>s</sup> ba:ba/
dorsal + /b/	/kbas/, /gbal/

These results include the HP duration of C1 and C2, the release of C1 and the duration of the ICI when C1 is released. It will also present the results of overlap in the clusters by calculating the sum of C1 + C2 HP and compare these to the duration of the HP of the two stops as singletons to determine the degree of reduction which could be the result of overlap.

### 5.2.2.1 The release of C1 in SI clusters

Table 5.2 shows the percentages of release vs. not release of C1 in SI two-stop clusters.

Cluster Type	N	Release of C1 in SI two-stop clusters			
		Released	Percentage	Not released	Percentage
coronal + dorsal	210	170	81%	40	19%
dorsal + coronal	210	184	88%	26	12%
/b/ + coronal	294	150	51%	144	49%
/b/ + dorsal	168	87	52%	81	48%
coronal + /b/	168	103	61%	65	39%
dorsal + /b/	84	67	80%	17	20%
Total	1134	761	67%	373	33%

Table 5.2 The release of C1 in SI two-stop clusters.

In all cluster types, C1 was released in 67% of the total 1134 tokens and was not released in 33% of them. The highest percentage of C1 releases is in dorsal + coronal 88% and coronal + dorsal 81%. Dorsal + /b/ and coronal + /b/ follow with 80% and 61% respectively. Finally, /b/ + dorsal and /b/ + coronal clusters have the least percentage of releases with 52% and 51%. In terms of gestural coordination, the higher percentages of releases are interpreted as having less overlap between the two closures. On the other hand, clusters with less C1 releases are interpreted as having more overlap between the two closures because of forming the closure of C2 before the release of C1.

### 5.2.2.2 The duration of SI coronal + dorsal clusters

There are five clusters consisting of a coronal followed by a dorsal stop. The acoustic measurements are presented in Table 5.3.

	N	Dur. of C1 HP	Dur. of ICI	Dur. of C2 HP	Dur. of Cluster	Std Dev.	Cluster HP	Single Stops HPs
/dkar/	42	71	16	61	148	26	132	122
/dga:jig/	42	64	14	58	136	21	122	129
/t <sup>s</sup> gar/	42	76	18	69	163	32	145	130
/tka:bir/	42	54	18	58	130	20	112	123

/tga:til/	42	54	18	56	128	26	110	120
Total	210	64	17	60	141	25	124	125

Table 5.3 Duration of C1 HP, ICI and C2 HP in SI coronal + dorsal stop clusters.

It can be seen from the data in Table 5.3 that the average duration of C1 HP is 64ms (ranges 54-76ms). The average duration of C2 HP is 60ms (58-69ms). Results of the one-way ANOVA show that there are some significant differences between the HP duration of C1 and C2 ( $P = 0.00$ ). Apart from /tk/ and /tg/, the duration of C1 HP tends to be longer than that of C2. However, results of the independent samples *t*-test show that there are no significant differences between the average duration of HP of C1 and C2 ( $P = 0.06$ ). When the duration of the HP of C1 + C2 was compared to the C1 and C2 as SI singletons, there is some reduction in the HP duration in /dg/, /tk/, and /tg/, but it was not the case in /dk/ and /tʰg/.

In those instances where the coronal stop was released, the average duration of the ICI is 17ms (14-18ms). Figure 5.1 shows the pattern of coordination of the cluster /dk/ in /dkar/ and how the two closures are separated by a short ICI.

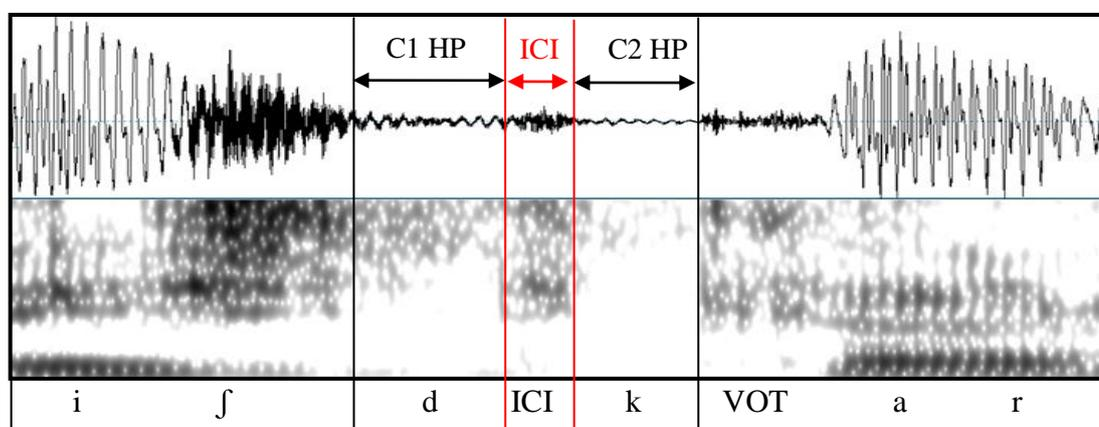

Figure 5.1 The coordination pattern of /dk/ in /dkar/ for speaker 1. A short ICI is seen (between the red vertical lines) because the two closures are not overlapped.

No significant differences were found between ICI durations ( $P = 0.45$ ). This means that the two gestures in all coronal + dorsal clusters follow a similar pattern of gestural coordination. When the ICI duration was added to the total duration of

the clusters, results show some significant differences between these clusters ( $P = 0.00$ ).

### 5.2.2.3 The duration of SI dorsal + coronal clusters

Table 5.4 shows the results of the acoustic measurements of SI dorsal + coronal single-stop clusters.

	N	Dur. of C1 HP	Dur. of ICI	Dur. of C2 HP	Dur. of Cluster	Std Dev.	Cluster HP	Single Stops HPs
/ktab/	42	63	12	76	151	24	139	123
/kdab/	42	63	18	67	148	25	130	122
/gtal/	42	67	15	71	153	33	138	120
/gtʰaf/	42	65	15	71	151	21	136	130
/gdar/	42	63	18	64	145	20	127	129
Total	210	64	16	70	150	25	134	125

Table 5.4 The duration of C1 HP, ICI and C2 HP of SI dorsal + coronal single-stop clusters.

The average duration of C1 HP is 64ms (63-67ms). The average duration of C2 HP is 70ms (64-76ms). Unlike coronal + dorsal clusters, where C1 HP was longer, in dorsal + coronal clusters, C1 HP is shorter. While there are no significant differences between the durations of C1 HP ( $P = 0.64$ ), results of the one-way ANOVA test show that there are some significant differences between HP durations of C2 ( $P = 0.01$ ) and between HP durations of C1 and C2 ( $P = 0.00$ ).

Dorsal + coronal clusters showed the highest percentage of C1 release in all cluster types. The average duration of the ICI is 16ms (12-18). Figure 5.2 shows the pattern of coordination of the cluster /kd/ in /kdab/ and how the two closures are separated by a longer ICI compared to coronal + dorsal. This means that the two consonantal gestures in the clusters where the duration of the ICI is shorter show greater overlap compared to the gestures separated by longer ICIs. These results can also be discussed in the light of articulation sequence which will be presented in the following sections.

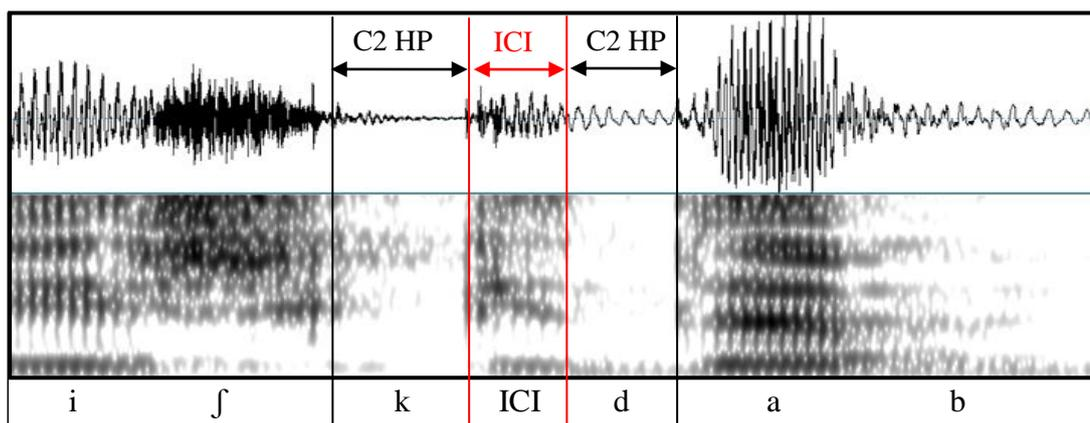

Figure 5.2 The coordination pattern of /kd/ in /kdab/ for speaker 2. A longer ICI is seen (between the red vertical lines) because the two gestures are less cohesive.

It is worth mentioning that there were no significant differences between the ICI durations ( $P = 0.07$ ) and no significant differences between the coordination patterns in these clusters. Considering the overall duration of each cluster without the ICI duration, there are some significant differences between the clusters' HP ( $P = 0.03$ ). When the duration of the ICI is added to the overall cluster duration, these differences disappear ( $P = 0.41$ ). This could be interpreted in the light of the trading relationship between consonants and vowels.

#### 5.2.2.4 The duration of SI /b/ + coronal clusters

Table 5.5 below shows the acoustic measurements of SI /b/ + coronal stop clusters.

	N	Dur. of C1 HP	Dur. of ICI	Dur. of C2 HP	Dur. of Cluster	Std Dev.	Cluster HP	Single Stops HPs
/bde:/	42	81	5	56	142	38	137	137
/bt <sup>h</sup> am/	42	75	4	63	142	36	138	138
/bd <sup>h</sup> a:ʃa/	42	64	2	66	132	27	130	145
/bta:ri:x/	42	57	13	63	133	31	120	128
/bda:faʃ/	42	66	7	56	129	18	122	137
/bt <sup>h</sup> a:wa/	42	66	9	65	140	23	131	138
/bd <sup>h</sup> arba/	42	64	5	58	127	36	122	145
Total	294	68	6	61	135	32	129	138

Table 5.5 The duration of C1 HP, ICI and C2 HP of SI /b/ +coronal stop clusters.

As Table 5.5 shows, the average duration of C1 is 68ms (57-81ms), and the average duration of C2 HP is 61ms (56-66ms). Again in this cluster type, the HP of C1 is longer. Results of the one-way ANOVA test show that there are significant differences between the HP duration of C1 ( $P = 0.00$ ), the HP duration of C2 ( $P = 0.01$ ) and between the average HP duration of C1 and C2 HP ( $P = 0.00$ ). The average duration of ICI is 6ms (2-13ms). Compared to the previous clusters, the LB and the TT are very cohesively coordinated so that C1 is not always released. Figure 5.3 shows how the TT closing gesture was formed before the LB releasing gesture and Figure 5.4 illustrates how the TT closure was delayed until after the release of the LB gesture.

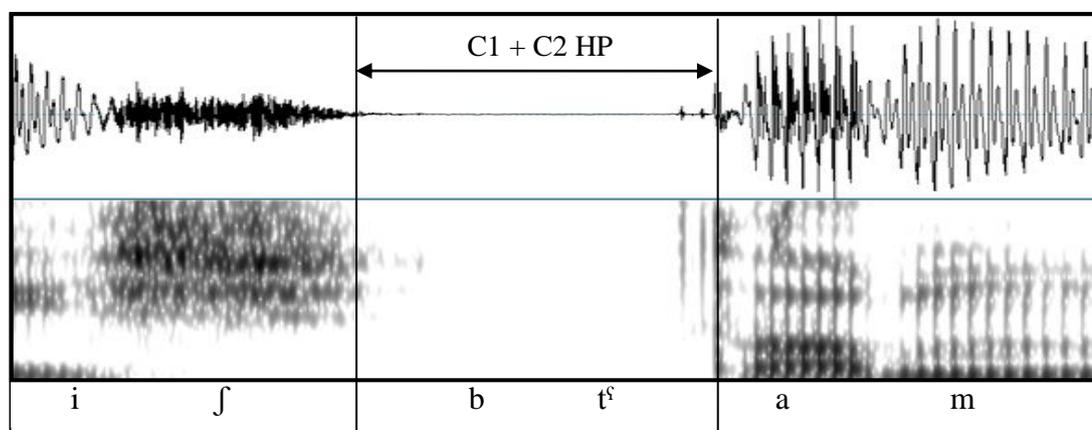

Figure 5.3 The coordination pattern of /btʰ/ in /btʰam/ for speaker 3. The absence of C1 release is an indication that the two closures are overlapped.

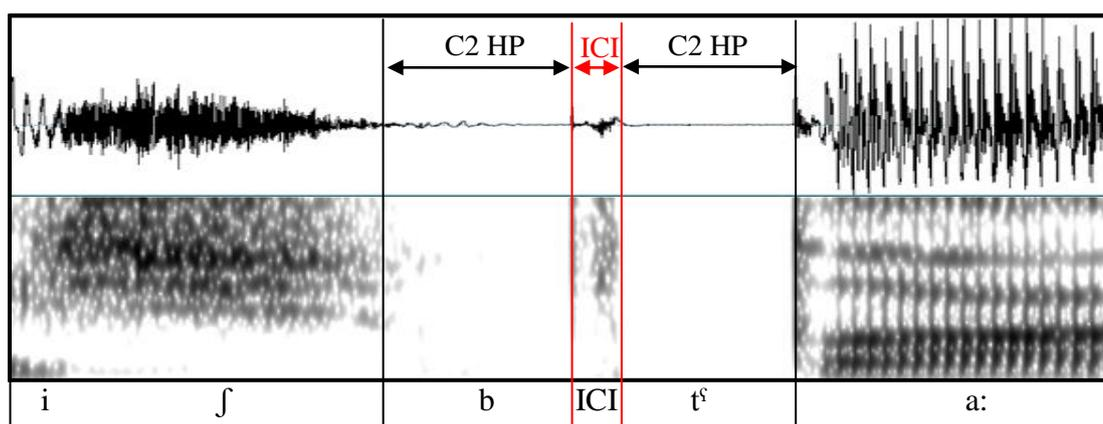

Figure 5.4 The coordination pattern of /btʰ/ in /btʰa:wa/ for MS 3. The gestural coordination is less cohesive meaning that a short ICI can be seen between the two closures.

There are significant differences between the ICI durations ( $P = 0.00$ ). The shorter the ICI is, the more overlapped the two gestures are. Thus, the two gestures in clusters like /bʰam/ and /bdʰa:ʃa/ have a greater overlap than the gestures in /bʰa:wa/ and /bta.ri:x/. Despite these differences in overlap, there are no significant differences between the clusters' duration without the ICI ( $P = 0.33$ ). When the ICI duration is added, the differences between the clusters become significant ( $P = 0.00$ ).

### 5.2.2.5 The duration of SI /b/ + dorsal clusters

Results of the acoustic measurements of SI /b/ + dorsal stop clusters are presented in Table 5.6.

	N	Dur. of C1 HP	Dur. of ICI	Dur. of C2 HP	Dur. of Cluster	Std Dev.	Cluster HP	Single Stops HPs
/bke:/	42	67	5	70	142	26	137	137
/bgar/	42	73	6	60	139	36	133	134
/bkalma/	42	64	4	59	127	24	123	137
/bgalbna/	42	62	6	53	121	26	115	134
Total	168	66	5	60	131	30	126	136

Table 5.6 Duration of C1 HP, ICI and C2 HP of SI /b/ + dorsal single-stop clusters

From Table 5.6, it can be seen that the average duration of C1 HP is 66ms (62-73ms), and the average duration of C2 HP is 60ms (53-70ms). There are no significant differences between the HP durations of C1 ( $P = 0.12$ ), but there are some differences between the HP durations of C2 ( $P = 0.00$ ) and those of C1 and C2 ( $P = 0.00$ ). The average ICI duration is 5ms (4-6ms). There are no significant differences between the ICI durations ( $P = 0.80$ ). The ICI duration indicates that the two gestures are very cohesive, as Figure 5.5 below illustrates, and the statistical results (being not significant) show that the coordination pattern is similar in this cluster type.

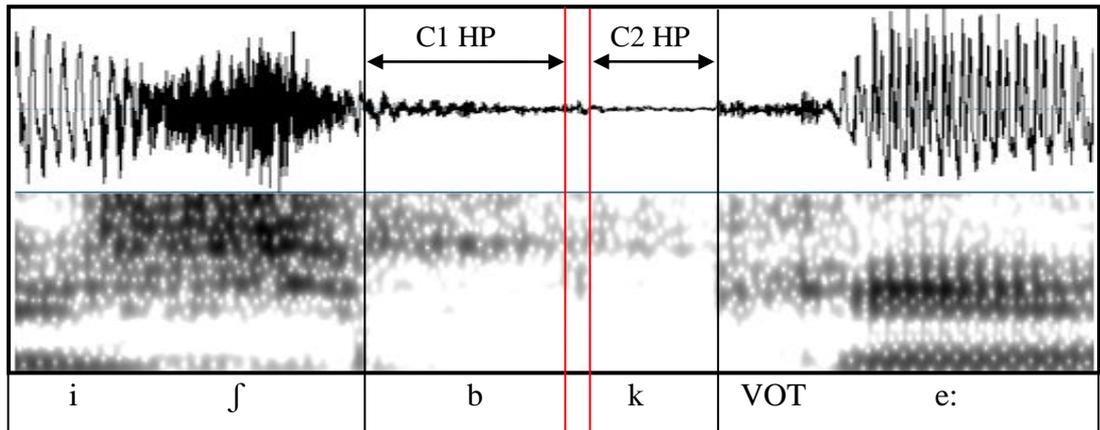

Figure 5.5 The coordination pattern of /bk/ in /bke:/ for speaker M1. The short duration of the ICI shows that the two gestures are very cohesive.

There are no significant differences between the average duration of these clusters' HP ( $P = 0.07$ ). However, significant differences between the duration of these clusters emerge when the duration of the ICI is added to the overall duration ( $P = 0.00$ ).

### 5.2.2.6 The duration of SI coronal + /b/ clusters

Results of the acoustic measurements of SI coronal + /b/ stop clusters are presented in Table 5.7.

	N	Dur. of C1 HP	Dur. of ICI	Dur. of C2 HP	Dur. of Cluster	Std Dev.	Cluster HP	Single Stops HPs
/tba:ʃɪr/	42	57	13	63	133	31	120	128
/dbaʃ/	42	71	8	64	143	28	135	138
/t <sup>h</sup> baʃ/	42	70	9	71	150	34	141	138
/d <sup>h</sup> baba/	42	74	7	74	155	30	148	145
Total	168	72	8	70	149	31	141	141

Table 5.7 The duration of C1 HP, ICI and C2 HP of SI coronal + /b/ stop clusters

The average duration of C1 HP in coronal + /b/ clusters is 72ms (57-74ms) and the average duration of C2 HP is 70ms (63-74ms). The one-way ANOVA results show that there are significant differences between the durations of C1 HP ( $P = 0.00$ ) and those of C2 HP ( $P = 0.04$ ) but not between C1 and C2 HPs ( $P = 0.97$ ).

The average duration of the ICI is 8ms (7-13ms). No statistically significant results were found for ICI durations ( $P = 0.09$ ), which means that the two gestures exhibited a similar coordination pattern. When the ICI duration is excluded, the average duration of the clusters' HP is 141ms. Here, there are some significant differences between the clusters' HPs ( $P = 0.00$ ). When the duration of the ICI is added, the significant differences between the clusters disappear ( $P = 0.36$ ).

### 5.2.2.7 The duration of SI dorsal + /b/ clusters

Results of the acoustic measurements of SI dorsal + /b/ stop cluster are presented in Table 5.8.

	N	Dur. of C1 HP	Dur. of ICI	Dur. of C2 HP	Dur. of Cluster	Std Dev.	Cluster HP	Single Stops HPs
/kbas/	42	59	14	79	152	22	138	137
/gbal/	42	71	8	74	153	26	145	134
Total	84	65	11	77	153	24	142	136

Table 5.8 The duration of C1 HP, ICI and C2 HP of SI dorsal + /b/ stop clusters.

The average duration of C1 HP is 65ms and the average duration of C2 HP is 77ms. Results of the independent-samples *t*-test show that there are significant differences between the duration of C1 HP in the two clusters ( $P = 0.00$ ), but not between the HP durations of C2 ( $P = 0.32$ ). However, when the C1 HP duration is compared to the C2 HP duration, significant differences are evident ( $P = 0.00$ ).

The average duration of the ICI is 11ms (8-14ms). There is a significant difference between the ICI durations ( $P = 0.00$ ), which means that the two gestures are coordinated differently in the two clusters with greater overlap in /gb/. The overall duration of the cluster is 153ms. Here, there are no significant differences between the duration of the two clusters ( $P = 0.13$ ), even when the ICI duration is excluded, the difference remains not significant ( $P = 0.70$ ).

### 5.2.3 Discussion and conclusion of the SI single- and two-stop cluster results

From the results, it can be seen that the duration of the HP of single stops decreases as the place of articulation moves from anterior to posterior. The HP duration of bilabial and coronal stops tends to be longer than that of dorsal stops and the differences are significant. This result supports the hypothesis under coordination which states that place of articulation will influence the HP duration of single stops. The results also support previous literature that place of articulation influence the HP duration of the stop (Byrd 1994). These durational differences could be related to the amount of time the pressure takes to build up in different places of articulation. It takes longer in /b/, due to the larger size of the mouth cavity, and not as long in the case of dorsal stops where the pressure builds up faster and is released earlier.

A summary of the cluster HP durations of the six types of clusters and the duration of the ICI for each cluster type is presented in Figure 5.6.

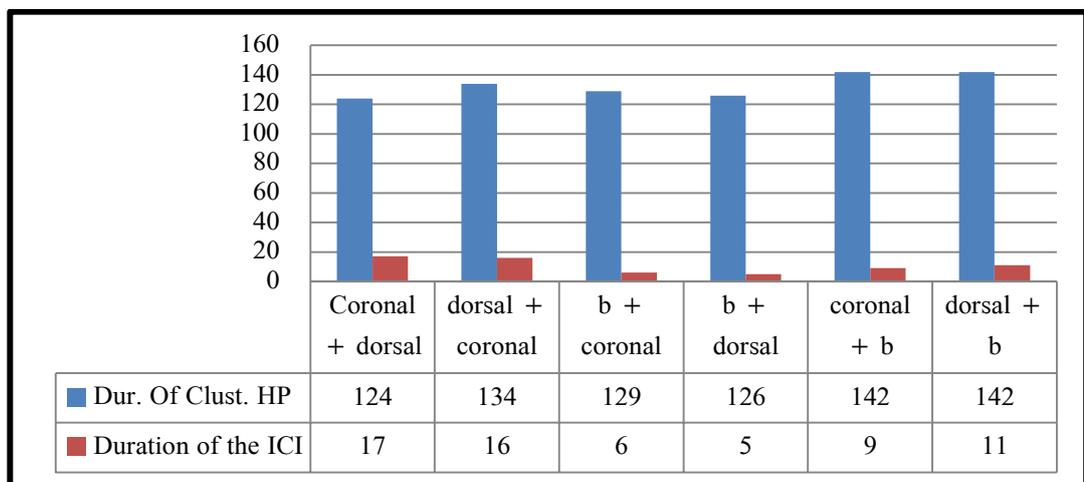

Figure 5.6 HP duration of the coronal + dorsal, dorsal + coronal, /b/ + coronal, /b/ + dorsal, coronal + /b/ and dorsal + /b/ clusters, in addition to the ICI duration of each cluster type.

In SI two-stop clusters, the duration of C1 HP tends to be longer, except when C1 is dorsal. The difference between C1 and C2 HP duration is significant, but not in coronal + /b/ clusters. As for the release of C1 in SI clusters, the highest

percentage of releases is in dorsal + coronal 88% and the lowest percentage of releases is in /b/ + coronal 51%. It seems that the articulatory gestures in clusters consisting of two lingual clusters are less cohesive, and clusters where C1 is /b/ are the most cohesive of all the cluster types. The nature and velocity of the articulators involved could be the reason for the diversity in the coordination pattern (Bauer *et al.* 2010). While in coronal + dorsal and dorsal + coronal clusters, the tongue is the only articulator, the rest of the clusters have the lips as the second articulator. It follows then that it is difficult for the tongue to achieve the second closure without the release of the first one, particularly with the low velocity of the TB gesture. In the case of clusters containing /b/, there are two independent articulators, the closures of which closures can easily overlap.

There is no significant difference between the HP duration of C1 in all cluster types ( $P = 0.18$ ) and there are some significant differences between C2 HP duration in different clusters ( $P = 0.00$ ). The fact that there is no significant difference between C1 HP durations could be related to stress i.e. C1 is always stressed in the same manner. On the other hand, differences in C2 HPs could be related to the number of syllables in the word.

As shown in the EPG results, the ICI falls under two categories depending on syllable position: excrescent (short delays) and epenthetic (long delays). These two patterns have been observed in studies such as (Hall's 2003, Davidson's 2005, Davidson and Roon's 2008 and Dell and Elmedlaoui's 2002). The duration of the excrescent vowel varies from one cluster type to another. These significant differences between the duration of the excrescent vowel in different clusters indicate that the gestures are coordinated differently. For example, the gestures in /b/ + dorsal clusters showed a greater overlap compared to coronal + dorsal clusters. Further evidence of different coordination patterns being employed in SI clusters is that differences between the cluster HP durations became more significant when the duration of the excrescent vowel was added ( level of significance increased from  $P = 0.01$  to  $P = 0.00$ ).

#### 5.2.4 The influence of place of articulation on HP duration of SF single stops

The average HP duration and standard deviation of SF single stops are provided in Table 5.9.

	N	Mean	Std Deviation	Std. Error	Interval of Means	
					Lower Bound	Upper Bound
/b/	42	128	30	5	119	138
/t/	42	133	25	4	125	140
/d/	42	130	25	4	122	137
/t <sup>ʰ</sup> /	42	145	23	4	138	153
/d <sup>ʰ</sup> /	42	127	23	4	120	134
/k/	42	137	26	4	128	145
/g/	42	120	18	3	115	126
Total	294	131	25	1	128	134

Table 5.9 Mean duration and standard deviation of HP of SF single stop.

The average duration of HP of SF single stops is 131ms (ranges between 120ms for /g/ and 145ms for /t<sup>ʰ</sup>/). For bilabial /b/, the average duration is 128ms, for coronal stops, the average duration is 134ms, and for dorsal stops, the average duration is 128ms. The average duration of the HP of SF voiced stops is 126ms and the average duration of their voiceless counterparts is 138ms. It is worth observing that SF voiced stops tend to have shorter HP durations in comparison to their voiceless siblings.

The place of articulation has some influence only on the HP duration of SF single stops. The results of the one-way ANOVA test show that the HP of /t<sup>ʰ</sup>/ is significantly longer than /d<sup>ʰ</sup>/ (P = 0.01) and /g/ is significantly shorter than /t<sup>ʰ</sup>/ (P = 0.00) and /k/ (P = 0.03). These results are in line with Oller (1972) who observed that final consonants are 20-30ms longer. However, the amount of the increase in this case is about double. (The average duration of all SI stops is 66ms and 131ms for all SF stops). The ratio of SI stops to SF stops is 1:1.8 for /b/, 1:2.3 for /t/, 1:2 for /d/, 1:2.2 for /t<sup>ʰ</sup>/, 1:1.7 for /d<sup>ʰ</sup>/, 1:2.1 for /k/, and 1:1.9 for /g/. The results of a one-way ANOVA show that these differences are significant (P = 0.00). The duration of the HP of single stops in SF position was also compared to that of geminate stops<sup>3</sup>.

<sup>3</sup> Geminate stops in intervocalic position were recorded in this study, but they were excluded for time constraints. The word list can be found in Appendix E and the participants are the same ones recruited in the study. It is worth mentioning that only the duration of geminates was measured.

Figure 5.7 shows this comparison. The average duration of geminates /bb/, /tt/, /dd/ and /d<sup>s</sup>d<sup>s</sup>/ was longer than that of their SF single counterparts. However, results of the independent-samples *t*-test shows no significant differences in the HP duration of the two groups (P = 0.08).

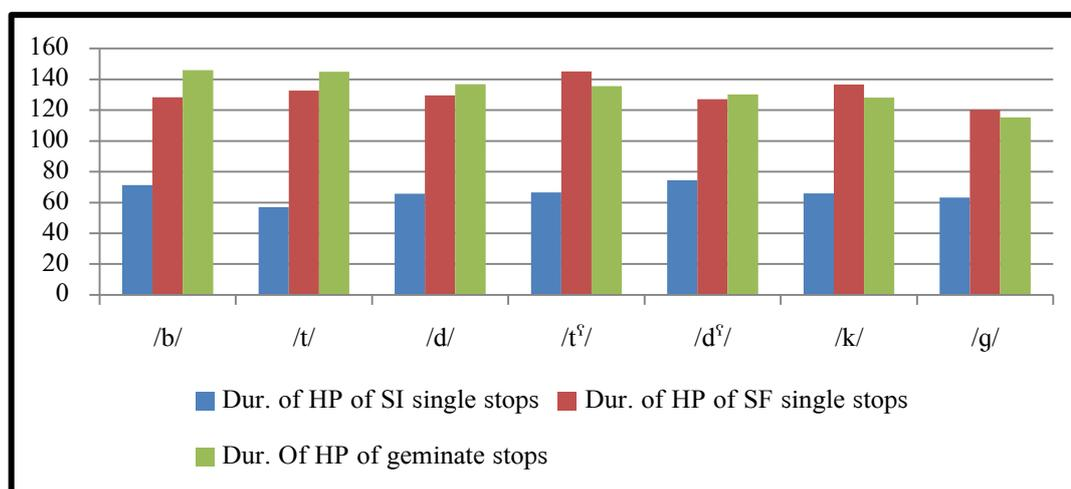

Figure 5.7 A comparison of HP duration of SI single stops (blue bars), SF single stops (red bars) and intervocalic geminate stops (green bars).

From Figure 5.7, it is apparent that intervocalic geminate stops and SF single stops have approximately the same HP duration. Heselwood and Watson (2013:51) use the term ‘pseudo-geminates’ to these final long consonants. The HP of SI single stops, on the other hand, is significantly shorter.

### 5.2.5 The influence of place of articulation on the timing of SF two-stop clusters

Depending on the place of articulation, SF two-stop clusters can be divided into six cluster types. These are:

coronal + dorsal: /hatk/, /fatg/

dorsal + coronal: /nakt/, /nakd/, /wagt/, /ʒagd/, /magt<sup>s</sup>/, /sd<sup>s</sup>dagt/, /d<sup>s</sup>hakt/

/b/ + coronal: /ktabt/, /rabt<sup>s</sup>/, /ʒabd/, /gabds/

/b/ + dorsal:        /habk/, /tʰabg/  
 coronal + /b/:        /fatʰb/  
 dorsal + /b/:        /nagb/

The total number of tokens is 714. This section presents the results of C1 release, the duration of the HP of C1 and C2, and the duration of the ICI.

### 5.2.5.1 The release of C1 in SF clusters

In all SF cluster types, C1 was released in 94% of the total number of utterances and was not released in only 6% of them. The highest percentage of C1 releases is in coronal + /b/ (100%) and clusters of two lingual clusters (coronal + dorsal (98%) and dorsal + coronal (97%). Clusters with less percentage of C1 release include dorsal + /b/ (95%), /b/ + coronal (89%) and /b/ + dorsal (85%). Table 5.10 shows the percentages of release vs. non-release of C1 in SF clusters

	N	Release of C1 in SF Two-Stop Clusters			
		Released	Percentage	Not Released	Percentage
coronal + dorsal	84	82	98%	2	2%
dorsal + coronal	294	284	97%	10	3%
/b/ + coronal	168	150	89%	18	11%
/b/ + dorsal	84	71	85%	13	15%
coronal + /b/	42	42	100%	0	0%
dorsal + /b/	42	40	95%	2	5%
Total	714	669	94%	45	6%

Table 5.10 The release of C1 in SF two-stop clusters.

From the percentages of C1 releases, it is apparent that the gestural coordination of two gestures in SF is less cohesive. The release of C1 in SF shows that the two gestures in SF favour the release of C1 over overlap.

### 5.2.5.2 The duration of SF coronal + dorsal clusters

There are two clusters that consist of a coronal + a dorsal stop in SF position. The acoustic measurements of these clusters are presented in Table 5.11.

	N	Dur. of C1 HP	Dur. of ICI	Dur. of C2 HP	Dur. of Cluster	Std Dev.	Cluster HP	SF C1 HP	SF C2 HP
/hatk/	42	61	39	66	166	21.932	127	133	137
/fatg/	42	81	31	75	188	22.673	156	133	120
Total	84	71	35	71	177	37.516	142	133	129

Table 5.11 Duration of C1 HP, ICI and C2 HP of SF coronal + dorsal stop clusters.

The average duration of C1 is 71ms (61-81ms) and the average duration of C2 HP is also 71ms (66-75ms). Results of the of the one-way ANOVA show that there are significant differences between the durations of C1 HP ( $P = 0.00$ ) and between C2 HP ( $P = 0.01$ ). However, the independent-samples *t*-test result shows no significant difference between the HP of C1 and C2 ( $P = 0.86$ ).

The average duration of the ICI of SF coronal + dorsal clusters is 35ms (31-39). There is a significant difference between the duration of the ICI of SF coronal + dorsal clusters ( $P = 0.002$ ), which means that the two gestures are not organised in the same pattern. Shorter ICI durations imply that the two gestures have a greater overlap. When considering the duration of the cluster HP without the ICI, there is a significant difference between the two clusters ( $P = 0.041$ ). When the ICI duration is included in the overall duration of the cluster, the difference becomes more significant ( $P = 0.00$ ).

### 5.2.5.3 The duration of SF dorsal + coronal clusters

Results of the acoustic measurements of SF dorsal + coronal stop clusters are presented in Table 5.12.

	N	Dur. of C1 HP	Dur. of ICI	Dur. of C2 HP	Dur. of Cluster	Std Dev.	C1+C2 HP	C1 HP	C2 HP
/nakt/	42	61	39	66	166	21	127	137	133
/nakd/	42	81	31	75	188	22	156	137	130
/wagt/	42	64	41	64	169	28	128	120	133
/magt <sup>s</sup> /	42	65	39	77	182	28	142	120	145
/ʃagd/	42	67	39	67	173	29	134	120	130
/s <sup>s</sup> dagt/	42	67	33	66	166	28	133	120	133
/d <sup>h</sup> akt/	42	61	39	66	166	21	127	137	133
Total	294	67	37	69	173	29	136	127	134

Table 5.12 Duration of C1 HP, ICI and C2 HP of SF dorsal + coronal stop clusters.

The average duration of C1 HP is 67ms (61-81ms) and the average duration of C2 HP is 69ms (64-75ms). There are significant differences between the HP durations of C1 ( $P = 0.00$ ) and between C2 HP ( $P = 0.00$ ). However, the independent-samples  $t$ -test results show no significant differences between the HP durations of C1 and C2 ( $P = 0.85$ ).

The average duration of the ICI in this cluster type is 37ms (31-41ms). Figure 5.8 illustrates how the two consonantal gestures of /g/ and /t/ in SF position are less cohesive in comparison with SI.

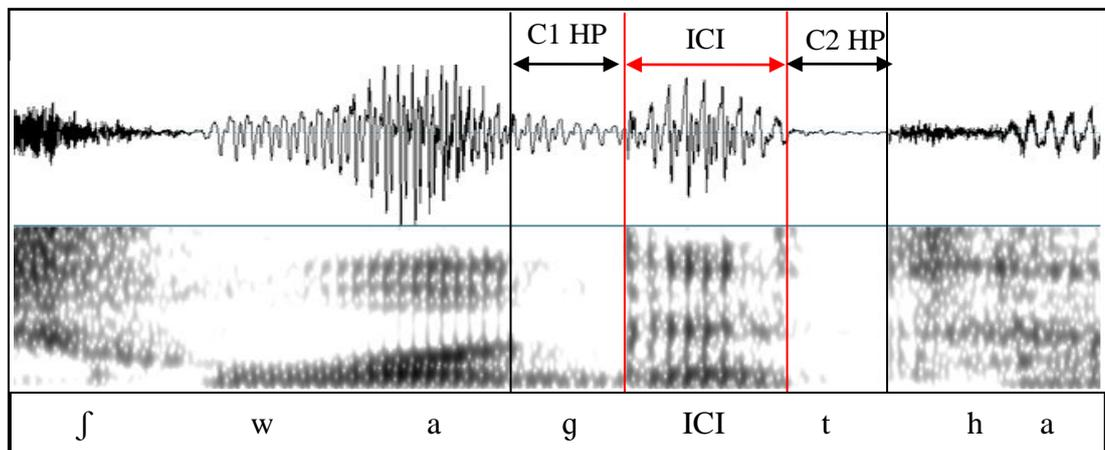

Figure 5.8 The coordination pattern of /gt/ in /wagt/ for speaker MS7. The gestural coordination shows a long delay between C1 release and the closure formation of C2.

There are significant differences between the ICI durations of SF dorsal + coronal clusters ( $P = 0.03$ ). Whether the duration of the ICI is included in the overall duration of the clusters or not, results of the one-way ANOVA test show significant differences between these clusters ( $P = 0.00$ ).

#### 5.2.5.4 The dura

#### 5.2.5.5 Duration of SF /b/ + coronal clusters

Results of the acoustic measurements of SF /b/ + coronal stop clusters are presented in Table 5.13.

	N	Dur. of C1 HP	Dur. of ICI	Dur. of C2 HP	Dur. of Cluster	Std Dev.	C1+C2 HP	C1 HP	C2 HP
/ktabt/	42	65	27	67	160	28	132	128	133
/ʁabd/	42	68	37	61	166	27	129	128	130
/rabtʰ/	42	64	38	68	170	26	132	128	145
/gabdʰ/	42	69	39	58	166	21	127	128	127
Total	168	67	35	63	165	29	130	128	134

Table 5.13 Duration of C1 HP, ICI and C2 HP of SF /b/ + coronal stop clusters.

The average duration of C1 HP is 67ms (64-69ms) and the average duration of C2 HP is 63 (58-68ms). There are no significant differences between the durations of C1 HP ( $P = 0.35$ ), but there are some significant differences between those of C2 HP ( $P = 0.02$ ). The difference between the HP duration of C1 and C2 is not significant either ( $P = 0.07$ ).

The average duration of the ICI is 35ms (27-39ms). There are significant differences between the ICI durations ( $P = 0.00$ ). These significant differences indicate that the way the bilabial gesture is coordinated with the coronal gesture is not the same. The shorter the ICI duration is, the more cohesive the two gestures are. There are significant differences between the cluster durations with or without the ICI duration ( $P = 0.00$ ).

#### 5.2.5.6 The duration of SF /b/ + dorsal clusters

Results of the acoustic measurements of SF /b/ + dorsal stop clusters are presented in Table 5.14.

	N	Dur. of C1 HP	Dur. of ICI	Dur. of C2 HP	Dur. of Cluster	Std. Dev.	C1+C2 HP	C1 HP	C2 HP
/habk/	42	67	38	73	177	24	140	128	137
/tʰabg/	42	69	39	58	166	19	127	128	120
Total	84	68	38	65	172	22	133	128	129

Table 5.14 Duration of C1 HP, ICI and C2 HP of SF /b/ + dorsal stop clusters.

The average duration of C1 HP is 68ms (67-69ms) and that of C2 HP 65ms (58-73ms). There are no significant differences between the duration of C1 ( $P = 0.35$ ), but there is a significant difference between the durations of C2 HP ( $P = 0.00$ ). There was no significant difference between the durations of the HP of C1 and C2 ( $P = 0.23$ ). The average duration of the ICI in /b/ + dorsal clusters is 38.5ms (38-39ms). There is no significant difference between the ICI durations ( $P = 0.621$ ) in the two clusters. When the duration of the ICI is excluded from the overall cluster duration, the independent-samples *t*-test results show that there are no significant differences between the two clusters ( $P = 0.09$ ). When the ICI duration is added, the differences become more significant ( $P = 0.02$ ).

#### **5.2.5.7 The duration of SF coronal + /b/ clusters**

/t<sup>h</sup>b/ is the only cluster in which a coronal is followed by /b/ in SF position. In this cluster, the average duration of C1 HP is 69ms and the average duration of C2 HP is 60ms. Statistical tests show significant differences between C1 and C2 HP. The average duration of the ICI duration is 39ms. The cluster HP duration is 127ms. The average duration of C1 as a singleton is 145ms and that of C2 as a singleton is 128ms. When the duration of the ICI is added, the overall duration becomes 166ms.

#### **5.2.5.8 The duration of SF dorsal + /b/ clusters**

/gb/ is the only cluster in which a dorsal is followed by /b/ in SF position. In this cluster, the average duration of C1 HP is 68ms and the average duration of C2 HP is 69ms. No significant differences were found between C1 and C2 HP duration. The average duration of the ICI duration is 38ms. The cluster HP duration is 137ms. The average duration of C1 as a singleton is 120ms and the average duration of C2 as a singleton is 128ms. When the duration of the ICI is added, the overall duration becomes 175ms.

### 5.2.6 The duration of ICI in words in isolation

As stated in the methodology chapter, words containing SI and SF clusters were also recorded in isolation. The main aim is to verify whether the inter-gestural coordination pattern of these clusters will be influenced by the preceding consonant, in the case of SI clusters, and the following consonant, in the case of SF clusters. Results of the duration of ICI in SI and SF are presented in Table 5.15. For ease of comparison, the duration of ICI in clusters recorded in a carrier sentence are presented.

Cluster type	ICI duration in SI clusters (in isolation)	ICI duration in SI clusters (in a carrier sentence)	ICI duration in SF clusters (in isolation)	ICI duration in SF clusters (in a carrier sentence)
Coronal + dorsal	19	17	59	35
Dorsal + coronal	23	16	54	37
/b/ + coronal	21	6	47	35
/b/ + dorsal	16	5	41	38
Coronal + /b/	16	9	46	39
Dorsal + /b/	19	11	46	38
Average	19	11	49	37

Table 5.15 Mean ICI duration in SI and SF words recorded in isolation. For ease of comparison, the duration of ICI in clusters in words recorded in a carrier sentence is provided.

As can be seen from the Table 5.15 the duration of the ICI seems to fall under the same categories depending on syllable position. Whether the ICI exists in clusters recorded in isolated words or in a carrier sentence does not affect the coordination pattern, i.e. shorter delays in SI clusters regardless of the preceding consonants, compared to longer ones in SF, despite the absence of a following consonant. Figure 5.9 shows the pattern of gestural coordination of the cluster /gt/ in SI and SF.

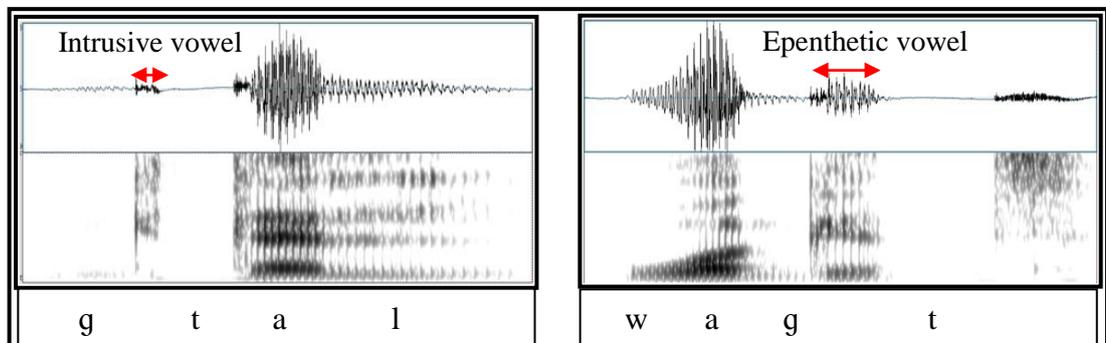

Figure 5.9 The coordination pattern of /gtal/ left and /wagt/ right produced in isolation.

It is worth noting that the duration of ICI in SI and SF clusters in words recorded in isolation seems to be longer than those recorded in a carrier sentence. This variation can be explained in the light of ‘connected speech process’ (Jones 1969) where consonants are assimilated (Barry 1992), or deleted (Farnetani and Recasens 1997) and vowels are reduced (Lindblom 1963).

### **5.2.7 Discussion and conclusion of the results for SF single and two-stop cluster**

The HP duration of SF single stops seems to be less variable compared to that of SI. The place of articulation has less influence on the HP duration. The most striking result to emerge from the acoustic analysis is the significantly longer HP of SF single stops in comparison to that of SI. This distinction has been observed in the literature (e.g. Heselwood and Watson 2013).

In monosyllabic major class words in TLA, as is likely to be the case in many other Arabic dialects too, there appears to be quantity complementarity. If the vowel is long, then the coda consonant must be short (e.g. [baat] ‘spent the night’), and if the vowel is short then either the coda consonant must be long (e.g. [bat:] ‘broadcasting’), or there has to be a cluster of two consonants (e.g. [wagt]). The rhyme structures ‘short V + short C’, ‘long V: + long C’ and ‘long V: + CC cluster’ are unattested in monosyllabic major class words. One consequence of this situation is that, in the context of occurring after a short vowel, there is no contrast possible between a singleton and a geminate consonant. The consonant that occurs typically has duration similar to what is expected in a geminate consonant, but, as Heselwood & Watson (2013: 51) argue, we cannot really call it a true geminate unless it is in a position where it can contrast phonologically with a true singleton. They call such consonants ‘pseudo geminates’. While we can legitimately neither call them singletons nor geminates, we can nevertheless point out that they comprise a single articulatory gesture in contrast to clusters which comprise two successive gestures potentially separable by an ICI. That is to say, pseudo geminates, like true geminates but unlike false and fake geminates, conform to the ‘geminate inseparability’ (Gafos 2002: 274) criterion and cannot be interrupted by an ICI. We are therefore justified in

saying that there is a single coda consonant in a word such as *bat* provided we make it clear that it is contextually lengthened. In light of the above, these words will therefore be represented phonologically in transcription with a single consonant symbol; in allophonic transcriptions they will be represented with length marks.

In SF two-stop clusters, there is a tendency for C1 HP to be longer than C2 HP. However, when C1 is a dorsal stop, the HP duration of this stop is always shorter. Regarding the release of C1 in SF position, the results are very striking. C1 was released in 94% of the instances and not released in only 6%. In coronal + /b/, C1 was released in every case. The cluster where a coronal is followed by /b/ showed the least releases with C1 released in 85% of the total number of utterances. The release and non-release factor can be considered as evidence that the pattern of coordination favours the release of C1 making the two gestures less cohesive.

Summary of the durations of HP in SF clusters and the duration of the epenthetic vowel in each type of cluster are presented in figure 5.10.

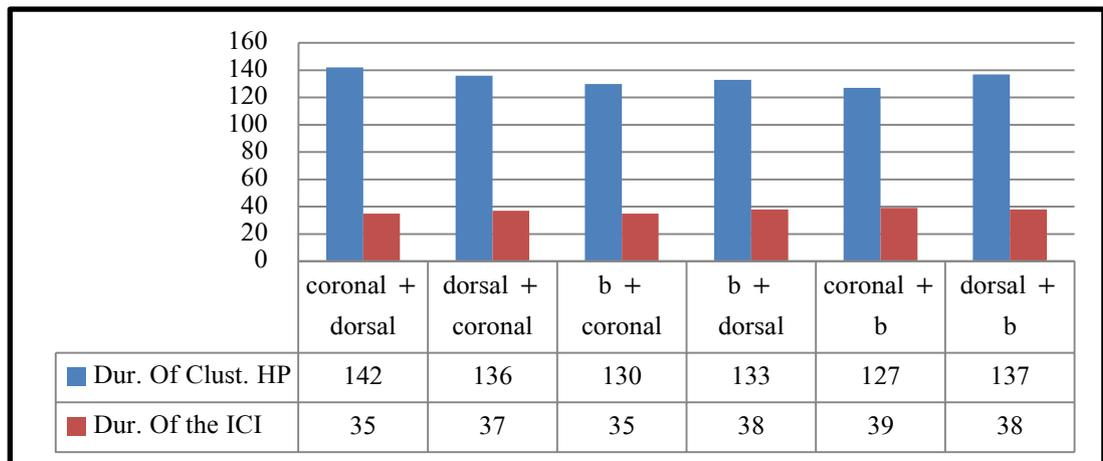

Figure 5.10 Duration of cluster HP and duration of ICI in SF coronal + dorsal, dorsal + coronal, /b/ + coronal, /b/ + dorsal, coronal + /b/, and dorsal + /b/ clusters.

There are some significant differences between C1 HP durations and C2 HP durations ( $P = 0.00$ ). Although the duration of the ICI seemed to be stable across all cluster types, the one-way ANOVA results show significant differences between ICI durations in different cluster types. Despite these differences, the general pattern of coordination always favours epenthetic vowels compared to SI clusters. Whether

this duration of the epenthetic vowel is included in the overall cluster duration or not, differences between the clusters remain significant ( $P = 0.00$ ).

These results are in agreement with the EPG results which show that regardless of the consonant preceding SI clusters and the consonant following SF clusters, the coordination pattern is the same: Excrescent vowels in SI clusters as a result of a tighter gestural coordination, and an epenthetic vowel in SF clusters as a result of less cohesive gestural coordination.

### 5.3 The influence of syllable position

Only the clusters /gt/, /gt<sup>ɚ</sup>/, /gd/, bd/, /bt<sup>ɚ</sup>/, /bd<sup>ɚ</sup>/, /bk/, /bg/, /t<sup>ɚ</sup>b/ and /gb/ can be found in SI and SF position. Results of the duration of C1 HP, ICI, C2 HP and the overall duration of these clusters are presented in Table 5.16. This table also shows the significance level of difference between the clusters' HPs, the clusters' duration including the ICI, and between the ICI duration in SI and SF clusters.

Cluster	Syllable-Initial				Syllable-Final				Level of Significance		
	C1	ICI	C2	Cluster	C1	ICI	C2	Cluster	HPs	Clusters	ICIs
/gt/	67	15	71	153	64	41	64	169	0.09	0.03	0.00
/gt <sup>ɚ</sup> /	65	15	71	151	65	39	77	182	0.24	0.00	0.00
/gd/	63	18	64	145	67	39	67	173	0.17	0.00	0.00
/bd/	81	5	56	142	68	37	61	166	0.26	0.00	0.00
/bt <sup>ɚ</sup> /	75	4	63	142	64	38	68	170	0.41	0.00	0.00
/bd <sup>ɚ</sup> /	64	2	66	132	69	39	58	166	0.41	0.00	0.00
/bk/	67	5	70	142	67	38	73	177	0.55	0.00	0.00
/bg/	73	6	60	139	69	39	58	166	0.36	0.00	0.00
/t <sup>ɚ</sup> b/	70	9	71	150	69	39	60	168	0.013	0.00	0.00
/gb/	71	8	74	153	68	38	69	175	0.118	0.00	0.00
Average	70	9	67	145	67	39	66	171	0.266	0.003	0.00

Table 5.16 The duration of C1 HP, ICI, C2 HP and the overall duration of SI and SF clusters.

In SI position, the average C1 HP duration is 70ms (63-81ms). In SF, the average HP duration of C1 is 67ms (64-69ms). The average HP duration of C2 HP in SI is 67ms (56-74ms) and the average HP duration of C2 in SF is 66ms (58-77ms). With the exception of /t<sup>ɚ</sup>b/ where the position of the cluster has a significant influence on the C1 + C2 HP duration ( $P = 0.01$ ), there are no significant differences

between C1 + C2 HP in SI position (145ms) and C1 + C2 in SF position (137ms) ( $P = 0.26$ ). This means there is no influence of syllable position on cluster HP duration.

The average duration of the excrescent vowel in SI clusters is 9ms (2-18ms) and the average duration of the epenthetic in the same cluster but in SF position is 39ms (37-41ms). There are significant differences between the duration of the excrescent vowel in SI and the epenthetic vowel in SF position ( $P = 0.00$ ). This is more evident in clusters where C1 is /b/. The difference between cluster duration, which was not significant when only the HP was measured, became significant when the ICI duration is added to the overall duration of the cluster. This means that the two gestures in SI and SF are not coordinated in the same manner. While in SI the two gestures are very cohesive allowing only excrescent vowels (2-18ms), in SF position, the two consonantal gestures are pulled apart giving rise to a longer epenthetic vowel (37-41ms). These results are in agreement with Browman and Goldstein's (1988) findings that onset and coda clusters are organized differently.

## 5.4 The influence of articulation sequence

### 5.4.1 The influence of articulation sequence on SI clusters

Another factor investigated here is the articulation sequence. The articulation sequence can be A-to-P or P-to-A. Results of the influence of articulatory sequence on the release of C1 and on the duration of excrescent vowels SI clusters are presented in Table 5.17.

Clust.	Anterior-to-posterior				Posterior-to-anterior					Sig.
	C1 rlsd	C1 not rlsd	ICI	Std Dev.	Clust.	C1 rlsd	C1 not rlsd	ICI	Std Dev.	
/dk/	37 (88%)	5 (12%)	16	9	/kd/	37 (88%)	5 (12%)	18	11	0.42
/dg/	35 (83%)	7 (17%)	14	11	/gd/	39 (93%)	3 (7%)	18	11	0.56
/t <sup>h</sup> g/	39 (93%)	3 (7%)	18	9	/gt <sup>h</sup> /	37 (88 %)	5 (12%)	15	9	0.18
/db/	25 (60%)	17 (40%)	5	7	/bd/	24 (57%)	18 (43%)	8	13	0.11
/bt <sup>h</sup> /	20 (48%)	22 (52%)	4	8	/t <sup>h</sup> b/	30 (71%)	12 (29%)	9	8	0.03
/bd <sup>h</sup> /	12 (29%)	30 (71%)	2	5	/d <sup>h</sup> b/	17 (40%)	25 (60%)	7	11	0.08
/bk/	33 (79%)	9 (21%)	5	6	/kd/	39 (93%)	3 (7%)	14	10	0.00
/bg/	18 (43%)	24 (57%)	6	11	/gb/	28 (67%)	14 (33%)	8	8	0.22
Total	219 (65%)	117 (35%)	8	8		251 (75%)	85 (25%)	12	10	0.20

Table 5.17 The influence of articulatory sequence on the release of C1 and on the duration of excrescent vowels in SI clusters.

The average instances of C1 release varies as a function of the articulation sequence. While in A-to-P clusters, the percentage of C1 release is 65%, in P-to-A clusters, this percentage increases to 75%. This is particularly evident in /bt<sup>s</sup>/ vs. /t<sup>s</sup>b/ and /bg/ vs. /gb/. The independent samples *t*-test results show that there are no significant differences between A-to-P clusters /dk/, /dg/, /t<sup>s</sup>g/, /db/ and /bg/, and their P-to-A counterparts /kd/ (P = 0.42), /gd/ (P = 0.561), /gt<sup>s</sup>/ (P = 0.18), /bd/ (P = 0.11) and /bg/ (P = 0.22). This means that the articulation sequence does not play any significant role in the way these gestures are coordinated in each cluster. However, there are significant differences between A-to-P clusters /bt<sup>s</sup>/, /bd<sup>s</sup>/ and /bk/, and their P-to-A counterparts /t<sup>s</sup>b/ (P = 0.00), /d<sup>s</sup>b/ (P = 0.00) and /kb/ (P = 0.00). The shorter duration of the excrescent vowels in A-to-P clusters indicates that the two gestures have a greater overlap in that order of articulation. Since this duration is significantly longer in these P-to-A clusters, it follows then that the two gestures are less cohesive.

#### 5.4.2 The influence of articulation sequence on SF clusters

There are four SF clusters with opposite sequence of articulation. A comparison in C1 release and the duration of the epenthetic vowels between these clusters is presented in Table 5.18.

Clust.	Anterior-to-posterior				Posterior-to- anterior					Sig.
	C1 rlsd	C1 not rlsd	ICI	Std Dev.	Clust.	C1 rlsd	C1 not rlsd	ICI	Std Dev.	
/tk/	40 (95%)	2 (5%)	43	8	/kt/	40 (95%)	2 (5%)	39	12	0.05
/tg/	40 (95%)	2 (5%)	31	11	/gt/	40 (95%)	2 (5%)	41	16	0.00
/bt <sup>s</sup> /	42 (100%)	0 (0%)	37	13	/t <sup>s</sup> b/	42 (100%)	0 (0%)	39	11	0.50
/bg/	40 (95%)	2 (5%)	39	11	/gb/	40 (95%)	2 (5%)	38	17	0.85
Total	162 (96%)	6 (4%)	38	11	Total	162 (96%)	6 (4%)	39	14	0.35

Table 5.18 The influence of sequence of articulation on the release of C1 and on the duration of epenthetic vowels in SF clusters.

The average instances of C1 release in the SF position does not vary as a function of the articulation sequence. In both articulation sequences, the percentage of C1 releases is 96%. This means C1 is not released in only 4% of the total number of tokens. While this pattern of C1 release indicates that there is no significant

difference between clusters of opposite articulation sequence, the duration of the epenthetic vowels shows some significant differences in the pattern of coordination. The independent-samples *t*-test shows that the sequence of articulation influences the duration of ICI in /tk/ vs. /kt/ ( $P = .005$ ) and /tg/ vs. /gt/ ( $P = 0.00$ ). While in the former a greater overlap is observed in the P-to-A cluster, the latter shows the opposite i.e. greater overlap in the A-to-P cluster. Results of /bt/ vs. /t<sup>h</sup>b/ and /bg/ vs. /gb/ show no influence of the articulation sequence on the coordination pattern.

### 5.5 The influence of morphological structure on HP and on the duration of excrement and intrusive vowel

Table 5.19 compares the duration of HP of C1 and C2 and the duration of ICI when C1 and C2 are tautomorphemic (belonging to the same root) to when they are heteromorphemic (not belonging to the same root). Apart from /wagt/ vs. /s<sup>h</sup>dagt/, the rest of these clusters are in SI position.

Tautomorphemic					Heteromorphemic				
N		Dur. of C1 HP	Dur. of ICI	Dur. of C2 HP	N		Dur. of C1 HP	Dur. of ICI	Dur. of C2 HP
42	/bde:/	81	5	56	42	/bda:faʃ/	66	7	56
42	/bd <sup>h</sup> a:ʃa/	64	2	66	42	/bd <sup>h</sup> arba/	64	5	58
42	/bt <sup>h</sup> am/	75	4	63	42	/bt <sup>h</sup> a:wa/	66	9	65
42	/bke:/	67	5	70	42	/bkalma/	64	4	59
42	/bgar/	73	6	60	42	/bgalbna/	62	6	53
Average		72	4	63	Average		64	6	58
42	/wagt/	64	41	64	42	/s <sup>h</sup> dagt/	67	33	66

Table 5.19 The influence of morphological structure on the duration of HP and ICI in SI and SF clusters.

In SI tautomorphemic clusters, the average duration of C1 HP is 72ms, and the average duration of C2 HP is 64ms. The average duration of the excrement vowel is 4ms. In heteromorphemic clusters, on the other hand, the average duration of C1 HP is 64ms and 58ms for C2. The average duration of the excrement vowel is 6ms. In SF tautomorphemic /gt/, the average HP duration for both C1 and C2 is

64ms. The average duration of the epenthetic vowel is 41ms. In SF heteromorphemic /gt/ the average duration of C1 HP is 67ms and that of C2 HP is 58ms. The average duration of the epenthetic vowel is 33ms.

While tautomorphemic clusters seem to be more cohesive in SI position, (with shorter ICIs), heteromorphemic clusters show a shorter HP duration and relatively longer excrescent vowels. Results of the independent-samples *t*-test show some significant differences in HP duration, but not in the duration of the excrescent vowels. In SF position, results from the same test show that there are no significant difference in the HP duration between the two clusters, whereas there are significant differences in the duration of epenthetic vowels ( $P = 0.01$ ).

## 5.6 The influence of gender of the speaker

This section reports the results of the influence of gender on the duration of the HP of single stops (in SI and SF position), the duration of HP of C1 and C2 in SI and SF clusters, in addition to the release of C1, and the duration of the excrescent and epenthetic vowels (as produced by males and females). The results of the relationship between gender and sequence of articulation will then be discussed.

### 5.6.1 The influence of gender on the HP duration of SI stops

Table 5.20 compares the HP duration of SI single stops as produced by male and female speakers.

SI single stops	Males				Females			
	N	Mean	Std Dev.	Std Error	N	Mean	Std Dev.	Std Error
/b/	21	81	11	2	21	62	6	1
/t/	21	63	14	3	21	51	10	2
/d/	21	74	16	3	21	58	10	2
/tʰ/	21	76	10	2	21	57	10	2
/dʰ/	21	89	18	4	21	59	13	3
/k/	21	68	18	4	21	63	10	2
/g/	21	73	19	4	21	53	14	3
Total	147	75	17	1	147	58	11	1

Table 5.20 The influence of gender on the duration of SI single stops.

The results of the HP duration of SI single stops show that the two groups (males and females) are different. The average HP duration of SI single stops for males is 75ms and for females 58ms. While the longest HP produced by male speakers is /d<sup>ɬ</sup>/, for female speakers it is /k/. Male speakers tend to produce longer HPs at all places of articulation when compared to female speakers. This difference is not the result of speaking rate differences, because the speaking rate of the two groups was normal. Despite these differences, the two groups tend to share some durational patterns. For example, in both groups /t<sup>ɬ</sup>/ has the shortest HP duration and show similar patterns in the duration of /d<sup>ɬ</sup>/ and /b/.

## 5.6.2 The influence of gender on SI clusters

### 5.6.2.1 The influence of gender on the release of C1 in SI clusters

Results of the influence of gender on the release of C1 in SI clusters are presented in Table 5.21 below.

Cluster type	Males			Females			Sig.
	N	C1 rlsd	C1 not rlsd	N	C1 rlsd	C1 not rlsd	
Coronal+ dorsal	105	81 (77%)	24 (23%)	105	89 (85%)	16 (15%)	0.16
Dorsal + coronal	105	103 (98%)	2 (2%)	105	81 (77%)	24 (23%)	0.00
/b/ + coronal	147	94 (64%)	53 (36%)	147	56 (38%)	91 (62%)	0.00
/b/ + dorsal	84	54 (64%)	30 (36%)	84	33 (39%)	51 (61%)	0.00
Coronal + /b/	84	56 (67%)	28 (33%)	84	47 (56%)	37 (44%)	0.15
Dorsal + /b/	42	36 (86%)	6 (14%)	42	31 (74%)	11 (26%)	0.17
Average	567	424 (75%)	143 (25%)	567	337 (59%)	230 (41%)	0.08

Table 5.21 The influence of gender on the release of C1 in SI clusters.

In general, male speakers did not release C1 in 25% of the instances containing SI two-stop clusters. In comparison, female speakers did not release C1 in 41% of the same clusters. Apart from coronal + dorsal clusters where female speakers produced more C1 releases (85% compared to 77% by males), in all the rest of the clusters, female speakers produced fewer C1 releases. For males and females, the highest percentage of non-released C1 is in /b/ + coronal (36% for male speakers and 62% for female speakers), followed by that in /b/ + dorsal clusters (36% for male speakers and 61% for female speakers).

The highest percentage of C1 releases by male speakers is in clusters containing two lingual stops. For example, in dorsal + coronal, male speakers released C1 98% of the total number. For female speakers, more releases took place in coronal + dorsal clusters. There are significant differences in C1 release between the two groups in dorsal + coronal and /b/ + dorsal with male speakers having more C1 releases.

### 5.6.2.2 The influence of gender on the duration of the excrescent vowels in SI clusters

The two groups also differ in regards to the duration of the excrescent vowels in SI position. Table 5.22 presents these durations as produced by the male and female groups.

Cluster type	N	Males			Females			Sig.
		Dur. of ICI	Std Dev.	Std Error	Dur. of ICI	Std Dev.	Std Error	
Coronal + Dorsal	105	17	10	1	17	10	1	0.90
Dorsal + Coronal	105	18	10	1	13	10	1	0.00
/b/ + Coronal	147	10	13	1	3	6	0	0.00
/b/ + Dorsal	84	8	13	1	2	5	1	0.00
Coronal + /b/	84	12	13	1	7	8	1	0.00
Dorsal + /b/	42	12	9	1	10	10	1	0.17
Total	567	13	12	1	9	10	0	0.18

Table 5.22 The influence of gender on the duration of excrescent vowels in SI clusters.

While the average duration of excrescent vowels produced by male speakers is 13ms (8-18ms), the average duration of excrescent vowels produced by female speakers is 9ms (2-17ms). For both groups, longer durations of excrescent vowels are observed in lingual stop clusters, and shorter durations are in clusters where C1 is /b/. While there are no significant differences between the two groups in the duration of excrescent vowels found in coronal + dorsal ( $P = 0.90$ ) and in dorsal + /b/ ( $P = 0.17$ ), results from the independent-samples *t*-test show that there are significant differences in the duration of excrescent vowels between the two groups in dorsal + coronal ( $P = 0.02$ ), /b/ + coronal ( $P = 0.00$ ), /b/ + dorsal ( $P = 0.01$ ) and coronal + /b/ ( $P = 0.01$ ). Differences in the duration of excrescent vowels between

male and female speakers are an indication of gender differences in the way the gestures of two-stop clusters are coordinated in SI position.

### 5.6.2.3 The influence of gender on the HP duration of SI clusters

Gender also seems to have an effect on the HP duration of two-stop clusters. Male speakers produced longer C1 and C2 HP duration compared to female speakers. Table 5.23 below presents the duration of C1 and C2 HP as produced by male and female speakers.

Cluster type	Males			Females			Sig.
	C1 HP	C2 HP	Clust. HP	C1 HP	C2 HP	Clust. HP	
Coronal + dorsal	73	60	133	54	61	115	.000
Dorsal + coronal	69	74	143	59	66	125	.000
/b/ + coronal	74	65	139	61	57	118	.000
/b/ + dorsal	73	63	136	60	57	117	.000
Coronal + /b/	77	71	148	58	65	123	.000
Dorsal + /b/	74	78	152	59	75	134	.002
Average	73	69	142	59	64	123	.000

Table 5.23 The duration of C1 and C2 HP in SI position as produced by male and female speakers.

The average duration of C1 HP produced by male speakers is 73ms (69-74ms) and that for female speakers is 59ms (54-61ms). The C1 HP duration produced by male speakers was longer by 14ms. In addition, the duration of C2 HP as produced by male speakers is 69ms (60-78ms) as compared to 64ms (61-75ms) for female speakers. The average of cluster HP is 142ms for male speakers and 123ms for female speakers. Results of the independent-samples *t*-test show significant difference between the two groups in all cluster types. It is worth noting that while males produced longer C1 HP duration compared to C2 HP, females produced shorter C1 HP duration in comparison to C2.

### 5.6.3 The influence of gender on the HP duration of SF single stops

A comparison between male and female speakers in the duration of HP of SF single stops is presented in Table 5.24 below.

SF single stops	Males				Females			
	N	Mean	Std Dev.	Std Error	N	Mean	Std Dev.	Std Error
/b/	21	131	36	8	21	125	23	5
/t/	21	129	28	6	21	137	20	4
/d/	21	128	27	6	21	131	23	5
/tʰ/	21	149	28	6	21	142	18	4
/dʰ/	21	134	28	6	21	121	14	3
/k/	21	140	33	7	21	133	18	4
/g/	21	127	21	5	21	114	12	3
Total	147	134	30	2	147	129	20	2

Table 5.24 The influence of gender on the HP duration of SF single stops.

The influence of gender on the duration of the HP of SF singleton stops is surprising. For both groups, the duration of the HP is shortest for /g/, and longest for /tʰ/. Another interesting observation is that unlike the case of SI single stops, female speakers produced longer HP durations in voiceless and voiced alveolar /t/ and /d/. For the rest of SF single stops, male participants tended to produce longer HPs.

### 5.6.4 The influence of gender on SF stops

#### 5.6.4.1 The influence on gender on the release of C1 in SF clusters

Results of the influence of gender on the release of C1 in SF clusters are presented in Table 5.25 below.

Cluster type	Males			Females			Sig.
	N	C1 rlsd	C1 not rlsd	N	C1 rlsd	C1 not rlsd	
Coronal + dorsal	42	42 (100%)	0 (0%)	42	40 (95%)	2 (5%)	0.16
Dorsal + coronal	147	146 (99%)	1 (1%)	147	138 (94%)	9 (6%)	0.10
/b/ + coronal	84	83 (99%)	1 (1%)	84	67 (80%)	17 (20%)	0.00
/b/ + dorsal	42	40 (95%)	2 (5%)	42	31 (74%)	11 (26%)	0.00
Coronal + /b/	21	21 (100%)	0 (0%)	21	17 (81%)	4 (19%)	0.42
Dorsal + /b/	21	21 (100%)	0 (0%)	21	19 (90%)	2 (10%)	0.16
Average	357	353 (99%)	4 (1%)	357	312 (87%)	45 (13%)	0.14

Table 5.25 The influence of gender on the release of C1 in SI clusters.

In general, male speakers did not release C1 in only 1% of the instances of SF two-stop clusters. Female speakers, on the other hand, did not release C1 in 13% of the same clusters. In all SF clusters, female speakers tended to produce fewer C1 releases. For males, the highest percentage of non-released C1 is in /b/ + dorsal (5%). For female speakers, this is also /b/ + dorsal (26%). The difference between the two groups in C1 release is significant when C1 is a bilabial.

#### 5.6.4.2 The influence on gender on the duration of epenthetic vowels in SF clusters

The average duration of epenthetic vowels in SF clusters as produced by male and female speakers is presented in Table 5.26.

Cluster type	Males				Females			Sig.
	N	Dur. of ICI	Std Dev.	Std Error	Dur. of ICI	Std Dev.	Std Error	
Coronal + dorsal	42	35	12	2	35	12	2	0.88
Dorsal + coronal	147	38	15	1	37	12	1	0.41
/b/ + coronal	84	36	14	2	35	12	1	0.71
/b/ + dorsal	42	38	13	2	38	9	1	0.82
Coronal + /b/	21	40	10	2	38	11	2	0.63
Dorsal + /b/	21	40	15	3	37	19	4	0.59
Total	357	39	14	1	36	12	1	0.10

Table 5.26 The influence of gender on the duration of epenthetic vowels in SF clusters.

Regarding the duration of the epenthetic vowel when C1 is released, there seems to be no significant difference between the two groups. While the average duration of epenthetic vowel as produced by male speakers is 39ms (35-40ms), that average for female speakers is 36ms (35-38ms). Unlike in SI position where both groups showed some significant differences in the duration of excrescent vowels, there are no significant differences in the duration of epenthetic vowels between the two groups in SF position ( $P > 0.05$ ).

### 5.6.4.3 The influence of gender on the HP duration of SF clusters

Results of the duration of C1 and C2 HP as produced by male and female speakers are presented in Table 5.27 below.

Cluster type	Males			Females			Sig.
	C1 HP	C2 HP	Clust. HP	C1 HP	C2 HP	Clust. HP	
Coronal+ dorsal	69	75	144	74	67	141	0.91
Dorsal + coronal	66	72	138	68	66	133	0.25
/b/ + coronal	70	63	133	63	64	127	0.19
/b/ + dorsal	70	65	135	66	66	132	0.46
Coronal + /b/	71	61	132	67	58	126	0.63
Dorsal + /b/	67	73	139	69	66	135	0.58
Average	69	68	137	68	64	132	0.50

Table 5.27 The duration of C1 and C2 HP in SF position as produced by male and female speakers.

The average duration of C1 HP produced by male speakers is 69ms (66-71ms) and that for female speakers is 68ms (63-74ms). In addition, C2 HP duration as produced by male speakers is 68ms (61-75ms) compared to 64ms for female speakers (58-67ms). The average of cluster HP is 137ms for male speakers and 132ms for female speakers. Results of the independent-samples *t*-test show no significant differences between both groups in all SF cluster types ( $P = > 0.05$ ).

### 5.6.5 The relation between gender and articulation sequence

Results of the relationship between gender and articulation sequence are presented in Table 5.28.

Anterior-to-posterior					Posterior-to-anterior				
Cluster	N	Male ICI	Female ICI	Sig.	Cluster	N	Male ICI	Female ICI	Sig.
/dk/	42	17	15	1.00	/kd/	42	22	14	0.00
/dg/	42	18	10	0.04	/gd/	42	16	19	0.65
/t <sup>h</sup> g/	42	16	19	0.70	/gt <sup>h</sup> /	42	18	12	0.05
/bd/	42	8	2	0.00	/db/	42	12	4	0.00
/bt <sup>h</sup> /	42	7	1	0.00	/t <sup>h</sup> b/	42	12	7	0.00
/bd <sup>h</sup> /	42	3	0	0.02	/d <sup>h</sup> b/	42	11	3	0.00
/bk/	42	6	3	0.04	/kb/	42	14	14	0.95
/bg/	42	8	3	0.01	/gb/	42	11	11	0.79
Total	336	10	7	0.22		336	15	11	0.30

Table 5.28 The relation between gender and articulation sequence.

There are some significant differences in the coordination of A-to-P and P-to-A between the two groups. Apart from /dk/ and /t<sup>h</sup>g/ where there was no gender influence on the gestural coordination, gender seems to play a role in the coordination of A-to-P clusters. Female speakers seem to have tighter coordination in A-to-P sequences in comparison to the male group ( $P < 0.05$ ). In a P-to-A articulation, results of the comparison between the two groups show that apart from /gd/, /kb/ and /gb/ where there was no difference between the two groups ( $P = 0.62$ ,  $0.95$  and  $0.79$  respectively), statistical results show that female speakers have more cohesive coordination in the P-to-A sequence of articulation ( $P \leq 0.05$ ).

Within each group, there has been some influence of the sequence of articulation on the duration of the cluster and the duration of the excrescent vowel. Male speakers produced significantly longer /gb/ compared to /bg/, and significantly longer /bk/ clusters compared /kb/. Statistical results show that there are also significant differences in A-to-P vs. P-to-A articulation produced by female speakers.

Regarding the duration of excrescent vowels in the two sequences of articulation as produced by each group, the male group shows a tendency to produce shorter durations (more gestural overlap) in A-to-P compared to P-to-A. The only cluster where P-to-A exhibits more overlap is /gd/. On the other hand, the female group only produced longer ICIs in A-to-P /dk/ and /t<sup>h</sup>g/. For the remaining stop clusters, the P-to-A stop clusters showed a longer ICI duration. Most of these results are not in line with previous findings showing that P-to-A articulation has less gestural overlap than A-to-P.

## **5.7 Variability amongst and within speakers**

### **5.7.1 Variability amongst and within speakers in SI single stops**

Table 5.29 below presents results of the variability amongst speakers in the production of SI HP durations. Results of the SI HP duration as produced by the male group showed that the range of data is 75ms (45-125ms). The average of the standard deviation is 17. There are significant differences amongst speakers in this group. MS1 tended to produce shorter HP in comparison with MSs 2, 3 and 5 ( $P =$

0.00). Variability within speakers in this group also shows some differences. In general, MS1 and MS3 showed less variability in comparison with MS6 and MS7.

speakers	N	Mean	Std Dev.	Std Error	95% Confidence Interval for Mean		Minimum	Maximum
					Lower Bound	Upper Bound		
MS1	21	66	9	2	62	70	45	86
MS2	21	73	14	3	67	79	51	104
MS3	21	92	15	3	85	99	65	125
MS4	21	72	12	3	67	77	50	94
MS5	21	81	14	3	75	88	51	101
MS6	21	79	15	3	72	86	46	115
MS7	21	62	19	4	53	70	52	106
Total	147	75	17	1	72	78	45	125
FS1	21	60	15	3	53	67	42	84
FS2	21	57	10	2	52	61	45	82
FS3	21	48	10	2	43	52	50	68
FS4	21	56	9	2	52	60	49	73
FS5	21	60	9	2	56	64	47	77
FS6	21	65	10	2	60	69	42	86
FS7	21	58	9	2	54	62	41	75
Total	147	58	11	1	56	59	41	86

Table 5.29 Variability amongst male and female speakers in the production of SI HP duration.

Amongst the speakers of the female group, the range of data is 44ms (42-86ms). The average standard deviation is 11. The female group shows less variability than the male group but there are significant differences within the female group. In general, FS3 produced shorter HP durations compared to FS5, FS6 and FS7. Within-speaker variability results show that F1 displayed more variability compared to the rest of the group.

The level of variability varies as a function of place of articulation. Results show less speaker variability for /t/ and /k/ and more for /b/, /d/ and /d<sup>ɣ</sup>/. The most significant differences amongst the speakers seem to be in voiced single stops, and the least in voiceless singletons except for /t<sup>ɰ</sup>/. The repeated measures ANOVA results of variability within speakers show some significant differences within each speaker i.e. there are significant differences between the three repetitions for each speaker.

### 5.7.2 Variability Amongst and Within Speakers in SF single stops

Table 5.30 below presents the results of the variability amongst speakers in the duration of HP of SF single stops.

speakers	N	Mean	Std Dev.	Std Error	95% Confidence Interval for Mean		Minimum	Maximum
					Lower Bound	Upper Bound		
MS1	21	97	12	3	92	103	74	126
MS2	21	151	19	4	143	160	119	190
MS3	21	158	15	3	152	165	138	196
MS4	21	122	19	4	114	130	83	150
MS5	21	150	18	4	142	158	116	187
MS6	21	155	19	4	146	164	119	192
MS7	21	103	20	4	94	112	99	134
Total	147	134	17	2	129	139	74	196
FS1	21	126	12	3	121	132	104	152
FS2	21	110	17	4	102	118	84	138
FS3	21	118	9	2	114	122	99	135
FS4	21	129	14	3	123	135	104	150
FS5	21	146	23	5	136	157	110	195
FS6	21	132	21	5	122	141	96	172
FS7	21	143	18	4	134	151	104	173
Total	147	129	20	2	126	132	84	195

Table 5.30 Variability amongst male and female speakers in the production of SI HP duration.

Variability in the duration of the HP amongst male speakers shows that the range of data is 122ms (74-196ms). The average of the standard deviation is 17. There are significant differences amongst the male speakers in this group. MS1 and MS7 produced significantly shorter HP durations ( $P = 0.00$ ). None of the speakers in this group showed any significant variability within their repetitions.

Amongst the speakers in the female group, the range of data is 111ms (84-195ms). As was the case for SI stops, in SF the female group showed less variability compared to the male group. The average standard deviation is 20. The female speakers showed more variability in their SF clusters and there are significant differences amongst them. FS2 tends to produce shorter HP durations compared to FS5 and FS7. Within-speaker variability results show that FS5, FS6 and FS7 were more variable in their HP durations.

In SF position, speakers showed variability in all places of articulation, particularly /t/ and /k/.

### 5.7.3 Variability amongst speakers in SI clusters

Table 5.31 below presents the results of variability amongst speakers in the HP duration of SI clusters.

speakers	N	Mean	Std Dev.	Std Error	95% Confidence Interval for Mean		Minimum	Maximum
					Lower Bound	Upper Bound		
MS1	81	120	22	2	115	125	132	184
MS2	81	157	22	2	152	162	114	209
MS3	81	153	24	3	147	158	105	228
MS4	81	131	33	4	124	138	115	179
MS5	81	165	18	2	161	169	107	204
MS6	81	158	23	3	153	163	122	205
MS7	81	124	16	2	121	128	102	168
Total	567	144	29	1	142	146	102	228
FS1	81	122	20	2	118	127	95	177
FS2	81	115	21	2	110	120	77	166
FS3	81	114	21	2	109	118	89	172
FS4	81	110	15	2	106	113	102	144
FS5	81	138	19	2	134	142	115	183
FS6	81	123	30	3	117	130	96	208
FS7	81	141	16	2	137	144	104	180
Total	567	123	23	1	121	125	89	208

Table 5.31 Variability amongst male and female speakers in the duration of HP of SI clusters.

Variability in the duration of the HP of SI clusters amongst male speakers shows that the range of duration is 126ms (102-228). The standard deviation is 29. There are significant differences amongst the male speakers. MS1 and MS7 tend to produce significantly shorter HP duration ( $P \leq 0.05$ ). The repeated measures ANOVA results show no significant differences in variability within the male speakers' repetitions.

The range of the HP duration produced by female speakers is 119ms (89-208ms). There are significant differences amongst the female speakers. FS4 produced significantly shorter HP duration (109ms) while HP duration for FS7 is significantly longer (140ms). The standard deviation is 23. This means that the female group shows less variability than the male group. Variability results for individuals show that the female group was less variable in their cluster HP duration.

Table 5.32 presents the variability results amongst speaker production of excrescent vowels in SI position. In the male group, the duration of excrescent vowel ranges from 0-38ms with a mean of 14ms. The standard deviation is 12. There are significant differences amongst male speakers. While M1 produced the shortest excrescent vowel duration (3ms), M2 produced significantly longer durations (23ms). Variability tests for individual speakers show that M2 and M7 exhibit more variability than the other males.

	N	Mean	Std Dev.	Std Error	95% Confidence Interval for Mean		Minimum	Maximum
					Lower Bound	Upper Bound		
MS1	81	3	6	1	2	4	0	28
MS2	81	23	17	2	19	26	0	38
MS3	81	18	11	1	15	20	0	29
MS4	81	8	10	1	6	11	0	36
MS5	81	15	10	1	13	17	0	33
MS6	81	8	9	1	6	10	0	38
MS7	81	14	11	1	12	17	0	25
Total	567	13	12	1	12	14	0	38
FS1	81	15	10	1	12	17	0	30
FS2	81	7	10	1	5	9	0	25
FS3	81	8	9	1	6	10	0	36
FS4	81	8	8	1	6	10	0	28
FS5	81	9	8	1	7	11	0	29
FS6	81	5	10	1	3	7	0	33
FS7	81	6	9	1	4	8	0	25
Total	567	8	10	0	7	9	0	36

Table 5.32 Variability amongst male and female speakers in the duration of excrescent vowel in SI clusters.

Regarding variability in the excrescent vowel duration amongst female speakers, results show that the range of duration is (0-36ms) and the standard

deviation is 10. There are significant differences amongst this group. While FS1 produced significantly longer excrescent vowels (15ms), FS6 produced the shortest (5ms).

#### 5.7.4 Variability amongst speakers in SF clusters

Results of the variability amongst speakers in the duration of the HP are presented in Table 5.33 below.

speakers	N	Mean	Std Dev.	Std Error	95% Confidence Interval for Mean		Minimum	Maximum
					Lower Bound	Upper Bound		
MS1	51	135	29	4	126	143	96	198
MS2	51	147	15	2	143	151	117	171
MS3	51	148	28	4	140	156	106	198
MS4	51	153	25	3	146	160	112	206
MS5	51	150	22	3	144	156	135	177
MS6	51	190	25	4	183	197	156	249
MS7	51	125	19	3	120	131	103	166
Total	357	150	30	2	147	153	96	249
FS1	51	124	22	3	117	130	91	171
FS2	51	125	24	3	118	132	112	191
FS3	51	141	19	3	136	147	105	175
FS4	51	138	22	3	132	144	96	180
FS5	51	168	23	3	161	174	134	208
FS6	51	154	24	3	147	161	97	191
FS7	51	154	18	3	149	159	108	190
Total	357	143	22	1	141	146	91	208

Table 5.33 Variability amongst male and female speakers in the duration of HP in SF clusters.

Variability amongst male speakers in the duration of the HP of SF clusters shows that the range of duration is 153ms (96-249), with a standard deviation of 30. There are significant differences amongst the male speakers. MS7 tends to produce significantly short HP durations (125ms). Variability results for individual speakers show that M1 displays a greater variability range than other male speakers.

The range of the HP duration produced by female speakers is 117ms (91-208ms), the standard deviation being 23. There are significant differences amongst

the female speakers, with FS1 producing significantly shorter HP duration (123ms) and F6 producing significantly longer cluster HP duration (171ms). The standard deviation is 22, showing that this group displays less variability. Results for individual speaker variability show that all female speakers exhibited greater variability in their HP duration.

The variability amongst speakers in the duration of the epenthetic vowel is presented in Table 5.34 below. The duration of epenthetic vowels in SF clusters ranges from 0-92ms, with a standard deviation of 14. There are significant differences in the duration of epenthetic vowels amongst male speakers ( $P \leq .05$ ). MS6 and MS7 produced the longest and the shortest ICI (22 and 53 respectively). Results also show that MS3 and MS5 display more variability than other male speakers.

Regarding the variability in the duration of epenthetic vowel amongst female speakers, the female group is less variable than the male group. The ICI duration ranges from 0-75ms, with a standard deviation of 12. There are significant differences in the duration of epenthetic vowels. While FS2 produced the shortest HP (an average of 33ms), FS7 has produced the longest (an average of 45ms). In addition, there were differences in variability of individual female speakers. While FS6 showed greater variability, FS1 and FS4 were less variable than the others.

speakers	N	Mean	Std Dev.	Std Error	95% Confidence Interval for Mean		Minimum	Maximum
					Lower Bound	Upper Bound		
MS1	51	35	13	2	31	39	17	92
MS2	51	35	11	2	32	38	15	58
MS3	51	35	13	2	31	39	0	55
MS4	51	38	10	1	36	41	0	60
MS5	51	38	12	2	35	42	19	69
MS6	51	22	12	2	19	25	0	46
MS7	51	53	9	1	50	55	31	75
Total	357	37	14	1	35	38	0	92
FS1	51	30	8	1	28	33	4	42
FS2	51	30	15	2	26	35	0	73
FS3	51	35	11	2	32	38	0	57
FS4	51	32	9	1	30	35	10	50
FS5	51	38	12	2	35	41	23	59
FS6	51	48	14	2	44	52	0	75

FS7	51	38	7	1	36	40	24	52
Total	357	36	12	1	35	37	0	75

Table 5.34 Variability amongst male and female speakers in the duration of epenthetic vowels in SF clusters.

## 5.8 The influence of speaking rate

### 5.8.1 The influence of speaking rate on the HP duration of SI single stops

Both speaking rates, fast and slow, have an influence on the duration of the HP of singleton stops in onset position. As speaking rate increases, the duration of the HP decreases. The amount of decrease is 22% for /b/, 23% for /t/, 20% for /d/, 25% for /t<sup>s</sup>/, 28% for /d<sup>s</sup>/, 19% for /k/ and finally 24% for /g/. On the other hand, as the speaking rate decreases, the duration of the HP increases. The amount of increase is 31% for /b/, 46% for /t/, 44% for /d/, 44% for /t<sup>s</sup>/, 35% for /d<sup>s</sup>/, 46% for /k/ and finally 44% for /g/. It is worth mentioning that the two groups remain stable at a fast speaking rate, and display more variability at a slow speaking rate. Moreover, the amount of decrease in HP duration at fast speaking rate is less than the amount of increase in HP duration at slow speaking rate.

### 5.8.2 The influence of speaking rate on SI two-stop clusters

#### 5.8.2.1 The influence of speaking rate on C1 release in SI two-stop clusters

A summary of the influence of speaking rate on C1 release vs. non-release in SI clusters is presented in Table 5.35 below. The total number of tokens for each speaking rate (fast, normal and slow) is 1134. For each speaking rate the number of C1 release vs. non-release is presented as both a number and a percentage.

Cluster type	N	Normal		Fast		Slow	
		C1 released	C1 not released	C1 released	C1 not released	C1 released	C1 not released
Coronal + dorsal	210	170 (81%)	40 (19%)	181 (86%)	29 (14%)	185 (88%)	25 (12%)

Dorsal + coronal	210	184 (88%)	26 (12%)	163 (78%)	47 (22%)	189 (90%)	21 (10%)
/b/ + coronal	294	150 (51%)	144 (49%)	101 (34%)	193 (66%)	181 (62%)	113 (38%)
/b/ + dorsal	168	87 (52%)	81 (48%)	92 (55%)	76 (45%)	108 (64%)	60 (36%)
Coronal + /b/	168	103 (61%)	65 (39%)	55 (33%)	113 (67%)	141 (84%)	27 (16%)
Dorsal + /b/	84	67 (80%)	17 (20%)	44 (52%)	40 (52%)	75 (89%)	9 (11%)
Average	1134	761 (67%)	373 (33%)	636 (56%)	498 (44%)	879 (78%)	255 (22%)

Table 5.35 The influence of speaking rate on the release of C1 in SI clusters.

For sake of convenience, a summary of the results of normal speaking rates are presented first, followed by results for fast, then slow speaking rate. At normal speaking rate, the percentage of C1 released is 67% of the total number. The highest percentage of C1 release is in dorsal + coronal (88%) and in coronal + dorsal (81%). On the other hand, /b/ + coronal and /b/ + dorsal show the highest percentage of C1 not released (49% and 48% respectively). At fast speaking rate, the percentage of C1 releases decreased to 56%. It is worth noting that the percentage of C1 releases increased to 86% in coronal + dorsal clusters and to 89% in /b/ + dorsal clusters. With regard to fast speaking rate resulting in less C1 release, the coronal + /b/ cluster produced the most striking results where the percentage of non-released C1 decreased to 67% of the total utterances.

The percentage of C1 releases at slow speaking rate increased from an average of 67% at normal speaking rate to 78% at slow speaking rate. Higher percentages of C1 releases are evident in dorsal + coronal (90%), dorsal + /b/ (89%) and coronal + dorsal (88%). While results of the influence of fast articulation rate are not in support of the speech rate hypothesis which assumes that an increase in the articulation rate will result in a decrease in the HP duration in an increase in gestural overlap (less C1 release and shorter excrescent vowels) and a decrease in articulation rate will result in the opposite, results of the influence of slow speaking rate do confirm the hypothesis. This indicates that the two gestures become looser at slow speaking rate. However, /b/ + coronal clusters show some resistance to this pattern.

### 5.8.2.2 The influence of speaking rate on SI HP duration

Results of the influence of speaking rate on the duration of cluster HP is presented in Table 5.36.

Cluster type	Normal		Fast		Slow	
	Cluster HP	Std Dev.	Cluster HP decrease	Std Dev.	Cluster HP increase	Std Dev.
Coronal + dorsal	124	32	103 (17%)	25	185 (49%)	46
Dorsal + coronal	134	25	103 (23%)	18	186 (39%)	40
/b/ + coronal	129	32	102 (21%)	22	213 (65%)	70
/b/ + dorsal	126	30	101 (20%)	23	203 (61%)	54
Coronal + /b/	136	33	107 (21%)	21	204 (50%)	50
Dorsal + /b/	141	24	111 (21%)	22	194 (38%)	44
Average	131	29	105 (20%)	22	197 (50%)	51

Table 5.36 The influence of speaking rate on SI clusters' HP duration.

As can be seen in Table 5.38, the duration of SI clusters HP decreases at fast speaking rate, and increases at slow speaking rate. The average duration of decrease at fast speaking rate is 20%. Coronal + dorsal clusters show some resistance to this increase in speaking rate, compared to dorsal + coronal. Other clusters showed relatively the same percentage of HP reduction. The standard deviation shows that the duration of the cluster becomes less variable at fast speaking rate.

As a result of the decrease in speaking rate, the average duration of the cluster HP increases by 50%. The standard deviation shows that, in addition to this increase, the speakers become more variable. With a 65% increase in the HP duration, /b/ + coronal clusters are more influenced by this increase. In dorsal + /b/ clusters the percentage of decrease is 38%. This means that again A-to-P clusters are more resistant to the change in speaking rate.

### 5.8.2.3 The influence of speaking rate on the duration of excrescent vowels in SI clusters

Table 5.37 presents the results of the influence of speaking rate on the duration of the excrescent vowels in SI clusters.

Cluster type	Normal		Fast		Slow	
	Dur. Of ICI	Std Dev.	Dur. Of ICI	Std Dev.	Dur. Of ICI	Std Dev.
Coronal + dorsal	17	10	12	9	24	14
Dorsal + coronal	16	10	11	9	23	15
/b/ + coronal	6	7	2	4	12	14
/b/ + dorsal	5	9	3	4	10	12
Coronal + /b/	9	11	4	7	19	16
Dorsal + /b/	11	9	5	7	19	14
Average	11	9	6	7	18	14

Table 5.37 The influence of speaking rate on the duration of excrescent vowels in SI clusters.

At fast speaking rate, all SI excrescent vowels decrease from an average of 11ms to an average of 6ms. This means that the consonantal gestures show greater overlap, or a more cohesive coordination pattern, as a result of the increase in speaking rate. At slow speaking, rate on the other hand, the duration of the excrescent vowels increases from an average of 11 at normal speaking rate to 18ms. /b/ + a lingual stop clusters and coronal + /b/ clusters are more influenced by a decrease in speaking rate. The increase of the duration of excrescent vowels at slow speaking rate is an indication that the two consonantal gestures become less overlapped at slow speaking rate.

### 5.8.3 The influence of speaking rate on the duration of SF single stops

In SF clusters, the change in speaking rate has an influence on the HP duration of SF single stops. At fast speaking rate, there is a slight decrease in the duration when compared to SI single stops, except for /t/ which remains stable. The amount of decrease is 14% for /b/, 13% for /t/, 19% for /d/, 19% for /t<sup>h</sup>/, 17% for /d<sup>h</sup>/, 22% for /k/ and finally 24% for /g/. At fast speaking rate, speakers show less variability when producing onset /b/, /t/ and /d/, but greater variability in the rest.

At slow speaking rate, the duration of the HP increases as expected. The amount of increase is 55% for /b/, 61% for /t/, 50% for /d/, 63% for /t<sup>h</sup>/, 58% for /d<sup>h</sup>/, 61% for /k/ and finally 58 % for /g/. The amount of increase is 31% for /b/, 46% for /t/, 44% for /d/, 44% for /t<sup>h</sup>/, 35% for /d<sup>h</sup>/, 46% for /k/ and finally 44% for /g/. It is clear that some stops are more resistant to changes in speaking rate than others. In addition, speakers show greater variability in all SF single stops except for /d/. At

slow speaking rate, speakers display less variability in /t/, /d/ and /tʰ/ compared to normal speaking rate. Speakers show less variability in /t/, /d/ and /tʰ/.

#### 5.8.4 The influence of speaking rate on SF two-stop clusters

##### 5.8.4.1 The influence of speaking rate on C1 release in SF clusters

A summary of the influence of speaking rate on C1 release vs. non-release in SF clusters is presented in Table 5.38.

Cluster type	N	Normal		Fast		Slow	
		C1 released	C1 not released	C1 released	C1 not released	C1 released	C1 not released
coronal + dorsal	84	82 (98%)	2 (2%)	71 (85%)	13 (15%)	81 (96%)	3 (4%)
dorsal + coronal	294	284 (97%)	10 (3%)	273 (93%)	21 (7%)	278 (95%)	16 (5%)
/b/ + coronal	168	150 (89%)	18 (11%)	147 (88%)	21 (13%)	155 (92%)	13 (8%)
/b/ + dorsal	84	71 (85%)	13 (15%)	71 (85%)	13 (15%)	78 (93%)	6 (7%)
coronal + /b/	42	42 (100%)	0 (0%)	40 (95%)	2 (5%)	41 (98%)	1 (2%)
dorsal + /b/	42	40 (95%)	2 (5%)	38 (90%)	4 (10%)	42 (100%)	0 (0%)
Average	714	669 (94%)	45 (6%)	640 (90%)	74 (10%)	675 (95%)	39 (5%)

Table 5.38 The influence of speaking rate on the release of C1 in SF clusters.

At fast speaking rate, the average percentage of C1 release in SF clusters is 90%, a decrease of 4% in comparison with that of normal speaking rate. However, this decrease is not significant compared to the SI clusters. The release of C1 appears more noticeable in coronal + dorsal clusters, but /b/ + dorsal clusters remain stable. At slow speaking rate, the average percentage of C1 releases is 95%. There is no significant difference between this and average percentage for normal speaking rate. In clusters consisting of two-lingual stops and in coronal + /b/ clusters, the percentage of C1 release decreases in comparison with normal speaking rate. This means that in these clusters, the decrease in speaking rate does not always imply a decrease in the percentage of C1 release. These results support the speech rate

hypothesis, which states that a decrease in articulation rate will result in more instances of C1 release.

#### 5.8.4.2 The influence of speaking rate on SF HP duration

The influence of speaking rate on the duration of HP of SF clusters is shown in Table 5.39 below.

Cluster type	N	Normal		Fast		Slow	
		Cluster HP	Std Dev.	Cluster HP	Std Dev.	Cluster HP	Std Dev.
coronal + dorsal	84	142	37	107 (25%)	21	211 (49%)	57
dorsal + coronal	294	136	29	105 (23%)	19	194 (43%)	50
/b/ + coronal	168	130	29	107 (18%)	19	198 (52%)	40
/b/ + dorsal	84	133	22	108 (19%)	23	191 (44%)	46
coronal + /b/	42	127	30	113 (11%)	24	235 (85%)	67
dorsal + /b/	42	137	28	104 (24%)	19	202 (47%)	48
Average	714	134	29	107 (20%)	21	205 (53%)	51

Table 5.39 The influence of speaking rate on the duration of HP in SF clusters.

The results in Table 5.38 show that the average duration of SF clusters HP decreases at fast speaking rate, and increases at slow speaking rate. The average percentage of decrease at fast speaking rate is 20%, the same amount of decrease as in SI clusters. However, in this case it is not coronal + dorsal clusters which are more resistant to the increase in speaking rate, but coronal + /b/. Coronal + dorsal show they are more influenced by an increase in speaking rate. The standard deviation shows that the duration of SF clusters is more variable at fast speaking rate than at the same speaking rate in SI position.

As a result of the decrease in speaking rate, the average duration of the cluster HP increases by 53%. The standard deviation, 51, shows that, in addition to this increase, variability between speakers has also increased. Coronal + /b/ clusters are more influenced by this decrease. The average HP duration increase in coronal + /b/ clusters is 85% which is almost double. In dorsal + coronal clusters the percentage of decrease is 43%. The increase in the HP duration in SF means that the two gestures present less overlap at slow speaking rate.

### 5.8.4.3 The influence of speaking rate on the duration of epenthetic vowels in SF clusters

Results of the influence of speaking rate on the duration of epenthetic vowels in SF position are presented in Table 5.40.

Cluster type	Normal		Fast		Slow	
	ICI Dur.	Std Dev.	ICI Dur.	Std Dev.	ICI Dur.	Std Dev.
coronal + dorsal	35	13	24	11	56	23
dorsal + coronal	39	15	29	10	57	24
/b/ + coronal	35	12	22	11	55	18
/b/ + dorsal	38	11	30	13	53	22
coronal + /b/	39	11	22	10	50	19
dorsal + /b/	38	17	36	9	57	24
Average	37	13	27	11	54	22

Table 5.40 The influence of speaking rate on the duration of epenthetic vowels in SF clusters.

At fast speaking rate, the duration of the epenthetic vowels in all clusters has decreased from an average of 37ms to an average of 27ms. This means that the consonantal gestures become more cohesive as a result of the increase in speaking rate. The epenthetic vowels in /b/ + coronal clusters is shorter compared to those in dorsal + coronal clusters. At slow speaking rate, the duration of the epenthetic vowels increases from an average of 37ms at normal speaking rate to 54ms. There are no significant differences between the duration of epenthetic vowels in SF clusters which means that the gestural coordination pattern was almost the same.

## 5.9 Discussion

In this section, results of the influence of syllable position, sequence of articulation, morphological structure, gender and speaking rate are discussed in the light of the literature review. In the results, syllable position was found to influence the HP duration of the cluster. This is the result of the mechanism involved in the production of SI clusters compared to SF. The force of articulation in SI is stronger leading to longer duration. It is also well documented in the literature that SI consonants are organised differently from SF (Browman and Goldstein 1988; Pouplier and Marin 2008; Marin and Pouplier 2010; Kochetov 2006).

The difference in duration between the excrescent vowel in SI and the epenthetic vowel in SF has also been observed in the literature (e.g. Hall 2003; Davidson 2005; Davidson and Roon 2008; Dell and Elmedlaoui 2002). Because the tight gestural coordination in SI, the two gestures either overlap or coordinate in such a manner to allow the release of C1. In SF, on the other hand, the two gestures are pulled apart as a result of the epenthetic vowels inserted. This insertion of this vowel is motivated by the phonotactics of TLA which does not allow a sequence of three consonants. This vowel is inserted before C2, because TLA is a VC language (Kiparsky 2003; Watson 2007).

Not in agreement with previous literature on the influence of articulation sequence on gestural coordination and C1 release (Chitoran *et al.* 2002); sequences with P-to-A place of articulation had more C1 releases than A-to-P. The shorter duration of the excrescent vowels in A-to-P sequence suggest that the two gestures are more overlapped in this context than it is in P-to-A. This could be motivated by the need to release C1 when it is posterior to ensure perception. Frequency of the word could be also a factor determining gestural overlap. The fact that in SF there was no significant influence of the sequence of articulation on the duration of epenthetic vowels supports these conclusions.

Results also showed that excrescent vowels were longer in heteromorphemic clusters compared to tautomorphemic. This result suggests that the morphological structure influences the gestural coordination patterns. However, the shorter HP duration of C1 and C2 could be analysed as a trading relationship between consonants and vowels, i.e. shorter HP durations allow for longer durations of excrescent vowels, and vice-versa.

The gender influence in the results is in agreement with previous studies where differences in speech production were due physiological differences (Laver and Trudgill 1991; Simpson 2001; Kuehn and Moll 1976) Vowel space (Henton 1995).

Female speakers produced fewer C1 releases in SI clusters, shorter HP durations and shorter excrescent vowels when C1 was released and shorter epenthetic vowels in SF. The results indicate that there are some sex-based differences in the way articulatory gestures are coordinated in TLA. Since there are not any gender studies in LA, these results could not be verified. However, results of

the study are not in agreement with those obtained by previous studies on gender influence on segment duration. In these results, male speakers were found to produce shorter segments than female speaker (Whiteside 1996) and speak faster (Byrd 1993).

Finally, the influence of articulation rate on the duration of segments, consonants and vowels is well-documented in the literature (e.g. Lindblom 1963). The velocity of the articulators which increases in fast speaking rate (Browman and Goldstein (1990b) is determined by their inertia (Bauer *et al.* 2010). Results of the influence of fast speaking rate are in agreement with previous studies (e.g. Gay 1981; Arvaniti 1999; Pickett *et al.* 1999) which found that by the increase of speaking rate, the duration of segments decrease. However, the results do not support studies which found no significant influence of articulation rate on segment duration (e.g. Gay *et al.* 1974:47; Kent and Netsell 1971; Kent and Moll 1975).

## **5.10 Conclusion**

This chapter has presented and discussed the results from the acoustic analysis. These results include those for singletons and two-stop clusters. Measurements for single stops include the duration of the HP and how it is influenced by place of articulation. It emerged that place of articulation has a significant influence on the HP duration of SI single stops. This duration decreases as the place of articulation moves further back. The most significant finding with regard to SF single stops is the significantly longer HP duration they display in comparison to their SI counterparts.

In SI two-stop clusters, the HP duration of C1 tends to be longer than that of C2. The most striking result for SI clusters is that C1 is not always released due to the tight coordination of the two gestures involved. C2 closure is formed before, or at, the release of the C1 closure. When C1 is released, the duration of the excrescent vowel is shorter. There are some significant differences in the HP duration of C1 and C2, C1 release and in the duration of excrescent vowels for different cluster types.

More releases and longer excrescent vowel durations were found in two lingual stop clusters. There may be many reasons for these differences. Since the

tongue is the only articulator involved in the production of these clusters, unlike those cases when tongue and lips are articulators, it may be difficult to make the TT and TB gestures overlap.

Results of SF two-stop clusters show that the HP duration of C1 and C2 is not as significantly different as for SI clusters. There are two important results in SF clusters. The first is that C1 is released most of the time in comparison with SI. The second is the significantly longer epenthetic vowels duration of SF compared to SI clusters. Unlike SI two-stop clusters where the two gestures involved show a considerable amount of gestural overlap, the two gestures in SF clusters are less cohesive allowing the presence of a longer epenthetic vowels. These findings support the results from previous literature that syllable position has an influence on the way gestures are coordinated (Krakow 1999).

Results of the influence of articulation sequence on the coordination of gestures in SI and SF show that A-to-P clusters display more gestural overlap in comparison to P-to-A clusters. In SF clusters, on the other hand, the articulation sequence did not show the same influence on gestural coordination.

As for the influence of the morphological structure on gestural coordination, the statistical results show some differences in SI HP duration but not in the duration of excrescent vowels between tautomorphemic and heteromorphemic clusters. In SF, where only two clusters were compared, results show more overlap in the heteromorphemic cluster.

Gender, a factor that is investigated only in the acoustic data, was found to be an important factor in the duration of HP, release of C1, and the duration of excrescent vowels. In SI and SF positions, male speakers were found to produce longer HP duration, more C1 release and longer duration of excrescent vowels in comparison with the female speakers. This implies that male speakers apply different gestural coordination patterns to those of female speakers. In addition, gender appears to have less influence on the articulation sequence.

Results also show some variability within the two groups of speakers and for individual speakers. Male speakers are more variable in SI single stops, but the female group shows more variability in SF stops. In SI and SF two-stop clusters, the male group are more variable in the HP duration of C1 and C2 and in the duration of the epenthetic vowel in comparison with the female group.

Finally, speaking rate was found to influence the HP duration and the gestural coordination of two-stop clusters in both SI and SF clusters. Although an increase in the articulation rate does not always involve more overlap between the two gestures and a decrease will lead to looser coordination, the general pattern suggests that as speaking rate increases, duration of the HP decreases, and the opposite is true. The amount of decrease at fast speaking rate is less than the amount of increase in the HP duration at slow speaking rate. Some clusters are more resistant to changes in speaking rate. The number of C1 releases decreased as the speaking rate is increased. When C1 is released, the duration of the excrescent vowel becomes shorter. This is the result of the two gestures becoming more cohesive at fast speaking rate compared to the looser coordination pattern at slow speaking rate.

## Chapter Six: Timing of Voicing Results

### 6.1 Introduction

The last chapter, Chapter Five, presented and discussed the results of the acoustic analysis of single and two-stop clusters in SI and SF position. The purpose of this chapter is to present the findings about the timing of voicing. The results show how the laryngeal activities are co-ordinated with supralaryngeal activities i.e. at what point in the HP voicing is initiated in phonologically voiced stops. The results also show the influence of the voicing specification, place of articulation, syllable position, and speaking rate on the timing of voicing and VOT duration. The results are divided into four sections: the results from SI single stops, SF single stops, SI two-stop clusters, and SF two-stop clusters. In the first three sections, the results include the duration of the HP, the duration of voicing (periodicity) during the HP, voicing ratios (i.e. proportion of voicing in the HP), the number of periods, the voicing category and finally the duration of VOT for SI single stops. The next two sections present the results of the timing of voicing in SI and SF two-stop clusters. These include the duration of the HP of C1 and C2, the duration of ICI, the duration of voicing in C1 and C2, the ratio of voicing in the HP of C1 and C2, the number of periods in C1, ICI and C2, the voicing category of C1, the ICI and C2, and finally the duration of VOT in SI two-stop clusters.

The aim is to reveal the co-ordination of onset/offset of voicing with the onset/offset of the HP and the ratio of voicing in the HP of C1 and C2. The results of voicing in single stops are then compared to the results of voicing in two-stop clusters to test Westbury's (1975) hypothesis, stated under voicing, that the degree of voicing adaptation in stop clusters is determined by the voicing characteristics of single stops.

## 6.2 The timing of voicing in syllable-initial single stops

The results of timing of voicing in SI single stops are presented in Table 6.1.

	SI single stops	Dur. of HP	Dur. of voicing	% of voicing	No. of periods	Voicing category	VOT
VD	/ba <sub>x</sub> /	122	-38	31%	3	PV	0
	/da <sub>m</sub> /	105	-47	45%	4	PV	0
	/d <sup>h</sup> a <sub>m</sub> /	95	-55	58%	4	PD	0
	/ga <sub>s</sub> <sup>h</sup> /	78	-60	77%	5	VD	7
	Mean	100	-50	50%	4	PD	7
VLS	/ta <sub>f</sub> /	76	0	0%	0	VLS	21
	/t <sup>h</sup> a <sub>b</sub> /	92	0	0%	0	VLS	31
	/ka <sub>r</sub> /	81	0	0%	0	VLS	39
	Mean	83	0	0%	0	VLS	30

Table 6.1 Mean duration, duration of voicing, percentage of voicing, number of periods, voicing category and VOT values of syllable-initial single stops.

The mean duration of voiced stops is 100ms. and the mean duration of voicing is 50ms (50% of the total duration). The average number of periods during the HP of voiced stops is 4. SI single voiced stops are different in two main aspects: the duration of voicing, which includes the number of periods, and the timing of voicing. While the duration of the HP decreases as the place of articulation moves from front to back, the duration of voicing and the number of periods increase. 77% of the HP of /g/ is voiced, compared to 31% of the HP of /b/. Single voiced stops also differ with regard to the timing of voicing initiation. In /b/, /d/ and /d<sup>h</sup>/, laryngeal timing has a consistent pattern where voicing is initiated after the onset of closure, and continues throughout the HP. As a result, the onset of closure is devoiced. In /g/, on the other hand, voicing is always co-ordinated with the onset of the HP, and is frequently terminated before its release. When /g/ is devoiced or partially voiced, the average VOT is 7ms.

In voiceless stops, /t/, /t<sup>h</sup>/ and /k/, the mean duration of the HP is 83ms. It is shorter than the HP in voiced stops by 27ms. This is not in agreement with previous literature (Henton *et al.* 1992: 67-68) who reported longer HP durations for voiceless stops. Voicing ceases at the offset of the preceding vowel, and does not start until after the release of the stop. As a result, glottal pulsing is always absent during the HP of SI voiceless single stops. The VOT value is 21, 31 and 39ms respectively. It is worth noting that VOT value increases as the place of articulation

moves from front to back. This result confirms the hypothesis stated under voicing that the place of articulation of the stop influences the duration of VOT. Figure 6.1 shows the difference between these two patterns of voicing initiation in SI single stops.

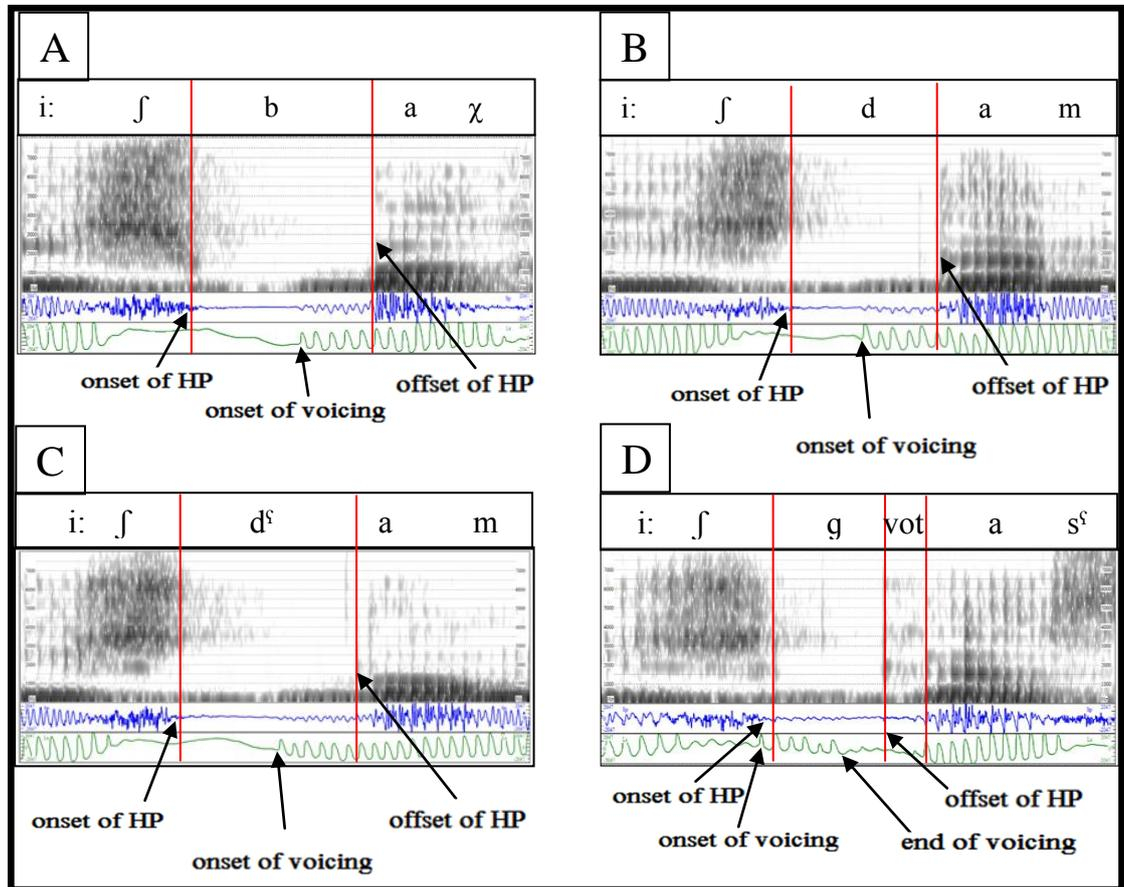

Figure 6.1 Spectrogram (top), acoustic waveform (middle) and glottal waveform (bottom) showing voicing initiation of /b/ in the word /bay/ (A), /d/ in the word /dam/ (B), /d<sup>s</sup>/ in the word /d<sup>s</sup>am/ and /g/ in the word /gas<sup>s</sup>/ (right). While in /b/, /d/ and /d<sup>s</sup>/ the onset of glottal vibration is delayed after the onset of the HP, in /g/, it is timed to start at the onset of the HP. Vertical lines are inserted to mark the onset and offset of the HP.

### 6.3 The timing of voicing in syllable-final single stops

The results of voicing in SF stops are presented in Table 6.2.

SF single stops	Dur. of HP	Dur. of voicing	% of voicing	No. of periods	Voicing category
/hab/	195	119	61%	11	PD
/jad/	179	134	75%	14	PD
/ʃad <sup>s</sup> /	185	158	85%	16	VD
/hag/	182	167	92%	17	VD
Mean	185	145	78%	15	VD

/nat/	182	0	0%	0	VLS
/bat <sup>s</sup> /	175	0	0%	0	VLS
/ɸak/	186	0	0%	0	VLS
Mean	182	0	0%	0	VLS

Table 6.2 Mean duration, duration of voicing, percentage of voicing, number of periods, and voicing category of SF single stops.

The mean duration of the HP of SF voiced stops is 185ms. The mean duration of voicing is 145ms of this duration (78%). The ratio of HP of SI voiced single stops to SF is 1:1.8. The further back the place of articulation is, the longer the voicing duration and the more periods there will be during the HP. As for the timing of voicing in SF single stops, unlike in SI where voicing initiation is coordinated to start at two different times, in SF single stops, voicing always continues from the preceding vowel and is terminated before the release of the stop. Despite the fact that the HP in SF voiced stops is longer, approximately double in duration, the vocal folds continue to vibrate for longer in SF voiced stops (78% in comparison to 54%). Finally, the mean duration of voiceless stops in SF position is 182ms. The ratio of HP of SI voiceless stops to SF is 1:2.1. There is no voicing during the HP of SF /t/, /t<sup>s</sup>/ and /k/.

#### 6.4 The timing of voicing in syllable-initial clusters

This section reports the results of timing of voicing in SI two-stop clusters. Based on the (phonological) voicing specification of the two members of the cluster, voiced or voiceless, the section is divided onto four main sections: results of voiced + voiced and voiceless + voiceless, presented in Table 6.3, and results of voiced + voiceless, and voiceless + voiced presented in and Table 6.4.

	SI two-stop clusters	Dur. of C1	Dur. of voicing	%	No. of periods	Voicing category	C1 release	Dur. of ICI	No. of periods	Voicing category	Dur. of C2	Dur. of voicing	%	No. of periods	Voicing category	VOT
1.	/bde:/	123	-95	77%	6	VD	rlsd	17	2	VD	81	-68	84%	6	VD	27
2.	/bd <sup>s</sup> aʃa/	115	-80	70%	8	VD	rlsd	13	1	VD	71	-48	68%	7	PD	16
3.	/bgar/	100	-100	100%	8	VD	rlsd	9	0	VLS	63	-45	71%	6	PD	32
4.	/gbal/	115	-110	96%	8	VD	rlsd	8	0	VLS	90	90	100%	9	VD	10
5.	/gdar/	85	-85	100%	8	VD	rlsd	20	0	VD	84	-70	83%	7	VD	17
6.	/dbaʃ/	104	-40	38%	5	PV	not rlsd	-	-	-	91	-56	62%	4	PD	4
7.	/d <sup>s</sup> baba/	95	-20	21%	1	DV	not rlsd	-	-	-	125	-124	99%	9	VD	0
8.	/dga:yig/	113	-91	81%	7	VD	rlsd	18	1	VD	59	-59	100%	6	VD	3
9.	/gd <sup>s</sup> e:/	88	-87	99%	8	VD	rlsd	18	2	VD	99	-95	96%	10	VD	0
10.	/bdafaʃ/	96	-36	38%	2	PV	rlsd	6	0	VD	67	-58	87%	5	VD	0
11.	/bd <sup>s</sup> arba/	83	-64	77%	7	VD	not rlsd	-	-	-	83	-57	69%	5	PD	10
12.	/bgalbna/	91	-43	47%	3	PV	rlsd	3	0	VD	70	-64	91%	6	VD	18
	Mean	101	-66	65%	6	PD	--	12	1	VD	82	-62	76%	7	VD	11
13.	/ktabt/	77	0	0%	0	VLS	rlsd	26	0	VLS	73	0	0%	0	VLS	18
14.	/tka:bir/	78	0	0%	0	VLS	rlsd	20	0	VLS	65	0	0%	0	VLS	33
	Mean	78	0	0%	0	VLS	--	23	0	VLS	69	0	0%	0	VLS	26

Table 6.3. Mean duration of C1, ICI, and C2, duration and ratio of voicing in C1 and C2, number of periods, voicing category and VOT in voiced + voiced clusters (1-12) and voiceless + voiceless clusters (13-14).

	SI two-stop clusters	Dur. of C1	Dur. of voicing	%	No. of periods	Voicing category	C1 Release	Dur. of ICI	No of periods	Voicing category	Dur. of C2	Dur. of voicing	%	No. of periods	Voicing category	VOT
1.	/bt <sup>h</sup> am/	93	0	0%	0	DV	rlsd	14	0	VLS	80	0	0	0	VLS	19
2.	/bke:/	98	0	0%	0	DV	rlsd	11	0	VLS	75	0	0	0	VLS	50
3.	/dkar/	99	0	0%	0	DV	rlsd	16	0	VLS	77	0	0	0	VLS	38
4.	/gtal/	85	-38	45%	3	PV	rlsd	17	0	VLS	89	0	0	0	VLS	16
5.	/gt <sup>h</sup> af/	80	-80	100%	7	VD	rlsd	20	1	VD	88	0	0	0	VLS	23
6.	/btari: χ/	86	0	0%	0	DV	rlsd	10	0	VLS	49	0	0	0	VLS	25
7.	/bt <sup>h</sup> awa/	87	0	0%	0	DV	rlsd	8	0	VLS	65	1	2	0	VLS	19
8.	/bkalma/	87	0	0%	0	DV	rlsd	4	0	VLS	53	0	0	0	VLS	37
Mean		89	-15	17%	1	DV	--	13	0	VLS	72	0	0	0	VLS	28
9.	/t <sup>h</sup> baʃ/	85	0	0%	0	VLS	not rlsd	-	-	-	105	-67	64	0	PD	10
10.	/t <sup>h</sup> gar/	102	0	0%	0	VLS	rlsd	15	0	VLS	82	-74	90	7	VD	3
11.	/kbas/	71	0	0%	0	VLS	not rlsd	-	-	-	91	-17	19	0	DV	6
12.	/kdab/	82	0	0%	0	VLS	rlsd	29	2	VD	80	-78	98	8	VD	0
13.	/tba:ʃir/	73	0	0v	0	VLS	rlsd	11	0	VLS	80	0	0	0	DV	6
14.	/tga:til/	71	71	100%	10	VD	rlsd	24	3	VD	69	-69	100	11	VD	0
Mean		81	0	0%	0	VLS	--	19	0	VLS	85	-51	60	3	VD	7

Table 6.4. Mean duration of C1, ICI, and C2, duration and percentage of voicing in C1 and C2 , number of periods, voicing category and VOT in voiced + voiceless clusters (1-8) and voiceless + voiced clusters (9-14).

#### 6.4.1 The timing of voicing in syllable-initial voiced + voiced

In voiced + voiced clusters, the mean duration of C1 HP is 101ms. Voicing is maintained for 66ms of this duration. The mean duration of C2 HP is 82ms, with voicing continuing for an average of 62ms. While 65% of the C1 HP is voiced, the ratio of voicing in the C2 HP duration is 75%. C1 is released 70% of the total repetitions. When it is released, the mean duration of ICI is 12ms. The average number of periods is six for C1, one for the ICI and seven for C2. While C1 falls into the category of partially devoiced, ICI and C2 are voiced.

There are three patterns in this voicing combination. In the first, C1, ICI and C2 are all completely voiced. This means over 75% of the duration of the cluster is voiced. This group includes /gb/, /gd/, /bg/ and /gd<sup>h</sup>/. Voicing is co-ordinated to start with the onset of C1 HP and continues through C2 HP. Voicing sometimes fades out before the release of C2, and resumes again after the release as seen in Figure 6.2. The ICI is voiced in /gd/ and /gd<sup>h</sup>/, but not in /gb/. Voicing is sometimes terminated before the release of C2 as in /bgar/. In this case, the average duration of VOT is 32ms.

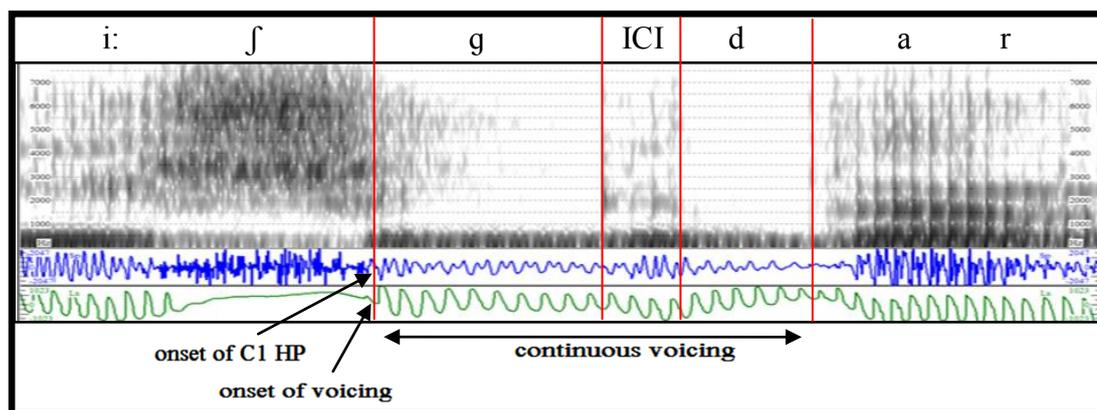

Figure 6.2 Spectrogram (top), acoustic waveform (middle) and glottal waveform (bottom) showing an instance of the production of /gd/ in the word /gdar/. The figure shows fully uninterrupted voicing throughout C1, ICI and C2. There is also some reduction in the amplitude towards the offset of C2 HP.

The second pattern is characterized by a delay in the initiation of voicing. As a result, the onset of C1 HP is devoiced. When voicing starts, it continues uninterrupted to the release of C2. This pattern includes /d<sup>s</sup>b/, bd<sup>s</sup>/ and /dg/. The difference between all these clusters is in the duration of prevoicing, i.e. how early voicing is initiated before C1 release. The voicing lead in C1 is 15-23ms in /d<sup>s</sup>baba/, 44-62ms in /bd<sup>s</sup>aʃa/, 53-79ms in /dga:jig/. Voicing then continues uninterrupted through C2 HP. When C1 is released, the ICI is always voiced. Figure 6.3 shows an instance of this pattern of voicing in /bd<sup>s</sup>/ in the word /bd<sup>s</sup>aʃa/.

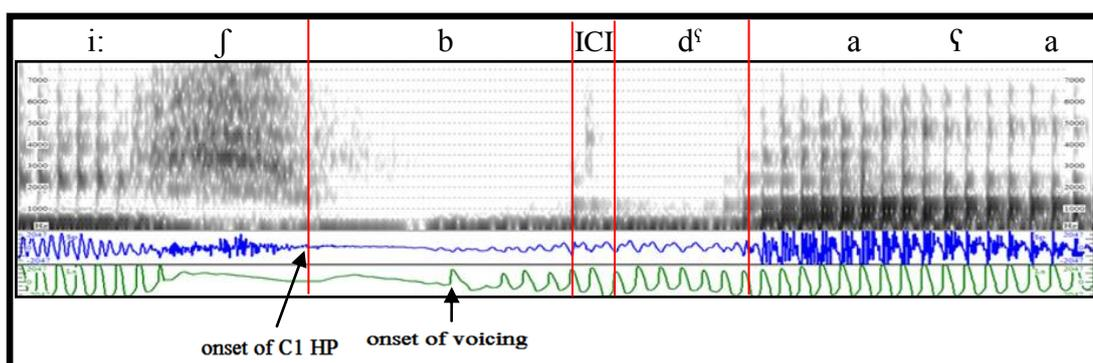

Figure 6.3 Spectrogram (top), acoustic waveform (middle) and glottal waveform (bottom) for /bd<sup>s</sup>/ in the word /bd<sup>s</sup>aʃa/. There is some delay in the initiation of voicing during the onset of /b/ HP; as a result C1 is partially devoiced.

In the last pattern of voiced + voiced clusters, voicing is initiated 41-60ms before the release of C1. As a result, C1 is just partially devoiced. Voicing then starts and continues throughout the rest of C1 HP, ICI and the onset of C2 HP where it is terminated 39-79ms before the release of C2. This pattern is observed in /bd/, /db/ and /bd<sup>s</sup>/. Mean duration of VOT is just 10ms. Figure 6.4 shows the time of voicing for the cluster /bd/ in /bde:/.

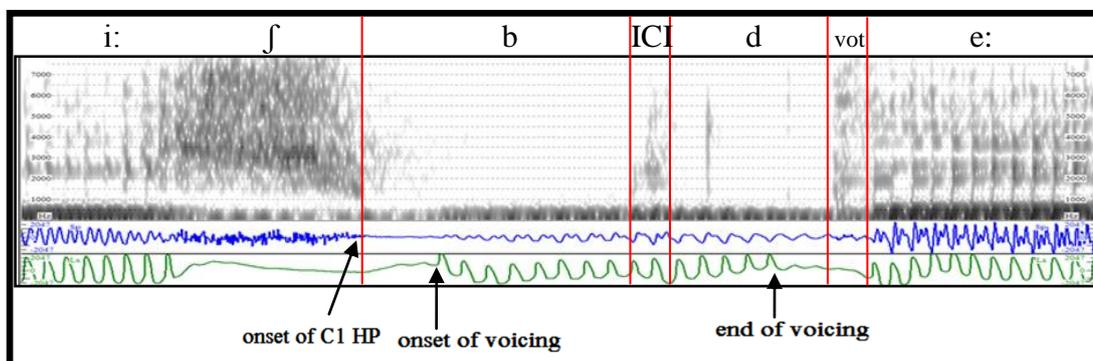

Figure 6.4 Spectrogram (top), acoustic waveform (middle) and glottal waveform (bottom) for the cluster /bd/ in the word /bde:/. The figure shows a delay in voicing initiation in /b/, and an interruption of voicing before the release of /d/.

### 6.4.2 The timing of voicing in syllable-initial voiceless + voiceless

In clusters consisting of two voiceless stops, /tk/ and /kt/, there is no voicing during the HP of C1 and C2. When C1 is released, the ICI is always voiceless. It is worth noting that /k/ has a longer VOT, 33ms, compared to that for /t/, 18ms. The pattern of voicing in voiceless + voiceless stop clusters is shown in Figure 6.5.

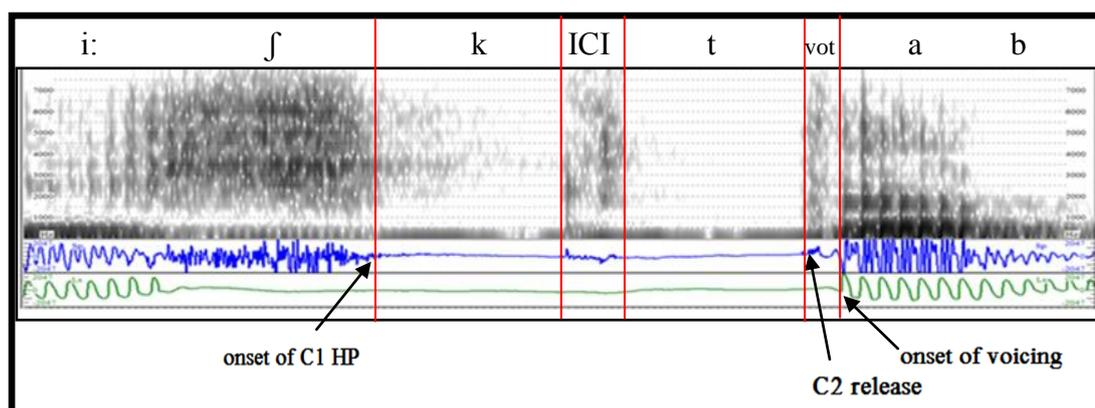

Figure 6.5 Spectrogram (top), acoustic waveform (middle) and glottal waveform (bottom) for the cluster /kt/ in the word /ktab/ showing complete voicelessness during the HP of C1 and C2 and the ICI.

It is worth mentioning that when /t/ is singleton in SI position, it has a longer HP duration to when it occurs as C2 in a cluster. Single /k/, on the other hand, does not show such a tendency.

### 6.4.3 The timing of voicing in syllable-initial voiced + voiceless

When a voiced stop is followed by a voiceless one, there is a variety of voicing patterns. In the first pattern, C1 HP is completely devoiced as a result of a regressive, or anticipatory, assimilation. These clusters where C1 is /b/ include: /bt/, /btʰ/, /bk/ and /dk/. The mean duration of VOT for C2 is 28ms. It is worth mentioning that /k/ has longer VOT durations in comparison to /t/. Figure 6.6 below shows an instance of regressive voice assimilation to voicelessness of the clusters /dk/ in the word /dkab/.

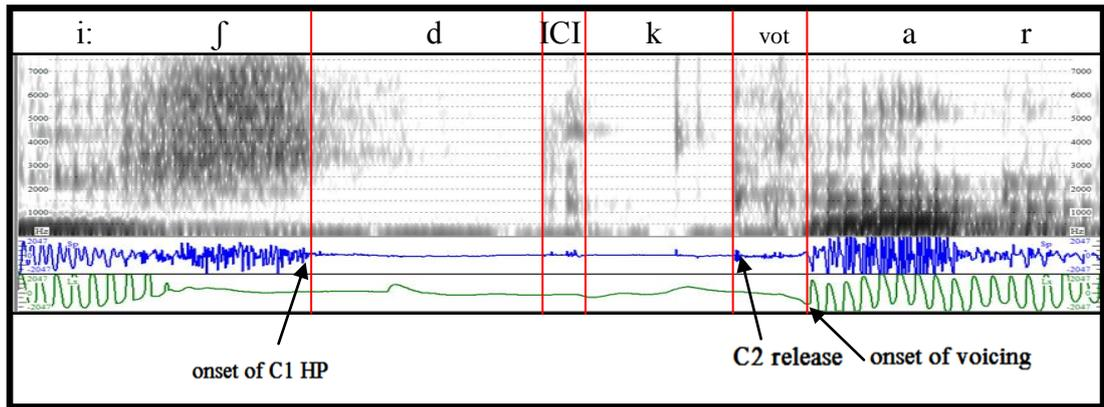

Figure 6.6 Spectrogram (top), acoustic waveform (middle) and glottal waveform (bottom) for the cluster /dk/ in the word /dkar/. This figure shows that /d/ is completely devoiced as a result of regressive assimilation.

In the second pattern, shown in Figure 6.7, voicing starts at the onset of C1 HP. It is frequently terminated before the release of C1, which is usually /g/. The average number of periods is three. When C1 is released, the ICI is voiceless. C2 HP is always voiceless.

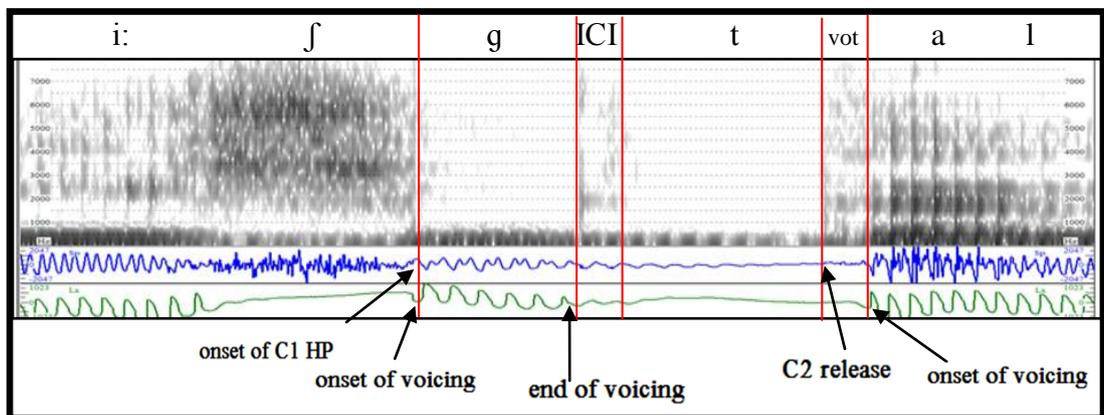

Figure 6.7 Spectrogram (top), acoustic waveform (middle) and glottal waveform (bottom) showing the cluster /gt/ in the word /gtal/. Voicing ceases just before the release of /g/, in anticipation of voiceless /t/.

In the third pattern, presented in Figure 6.8, voicing is initiated at the onset of C1 HP, and sustained to the onset of C2 HP where it is terminated. The average number of periods is seven. This pattern results in a voiced ICI. Apart from a brief voicing tail of 10-13ms, there is no voicing during C2 HP. It can be clearly seen from the last two figures that voicing is sustained for longer when C2 is /tʰ/ than

when it is /t/. The last two patterns supports Westbury's (1975) hypothesis that voicing adaptation in stop clusters may be determined by the voicing characteristics of single stops.

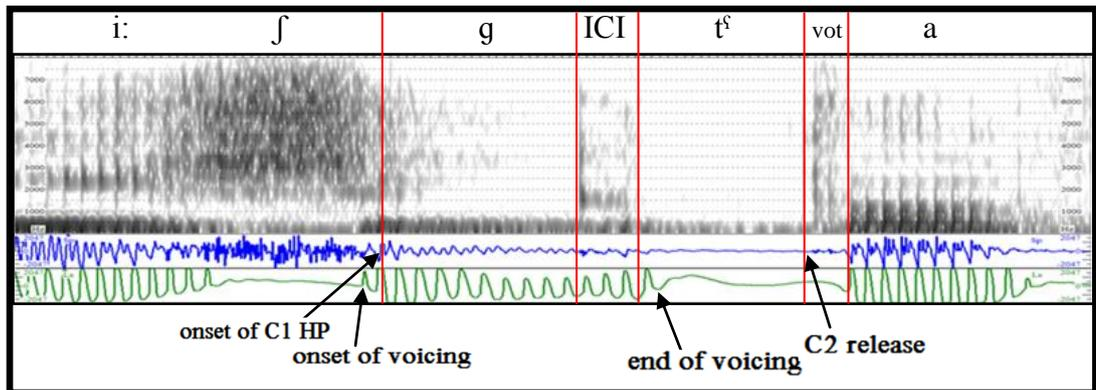

Figure 6.8 Spectrogram (top), acoustic waveform (middle) and glottal waveform (bottom) for the cluster /gtʰ/ in the word /gtʰaf/ showing continuous voicing through the HP of /g/ and ICI. Voicing ceases shortly after the onset of /tʰ/ HP.

#### 6.4.4 The timing of voicing in syllable-initial voiceless + voiced

The first pattern of voicing in voiceless + voiced clusters is shown in Figure 6.9. In the cluster /tg/, C1 is voiced as a result of a regressive assimilation. C1, ICI and C2 are all fully voiced. The average number of periods in C1, ICI and C2 is nine, three and ten respectively.

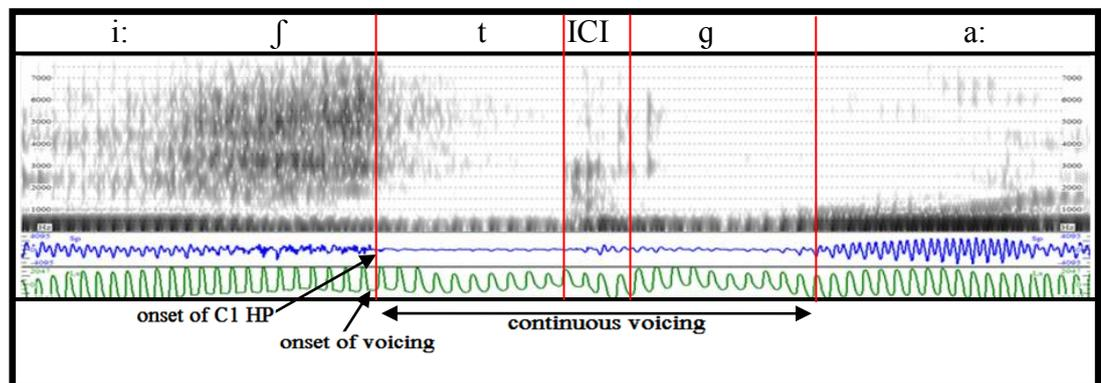

Figure 6.9 Spectrogram (top), acoustic waveform (middle) and glottal waveform (bottom) for the cluster /tg/ in the word /tga:til/. The figure shows a fully voiced /t/ as a result of a regressive assimilation.

The second pattern is apparent in the clusters /t<sup>h</sup>b/, /t<sup>h</sup>g/ and /kd/. Except for one occasion when /b/ in /t<sup>h</sup>b/ has a 33-42ms voicing lead, C1 HP is always voiceless. This causes the ICI to be voiceless as well. In /t<sup>h</sup>g/ and /kd/, voicing of C2 is initiated during the ICI as can be seen in Figure 6.10 below. This is another example supporting Westbury's (1975) hypothesis that the degree of voicing adaptation in stop clusters may be determined by the voicing characteristics of single stops.

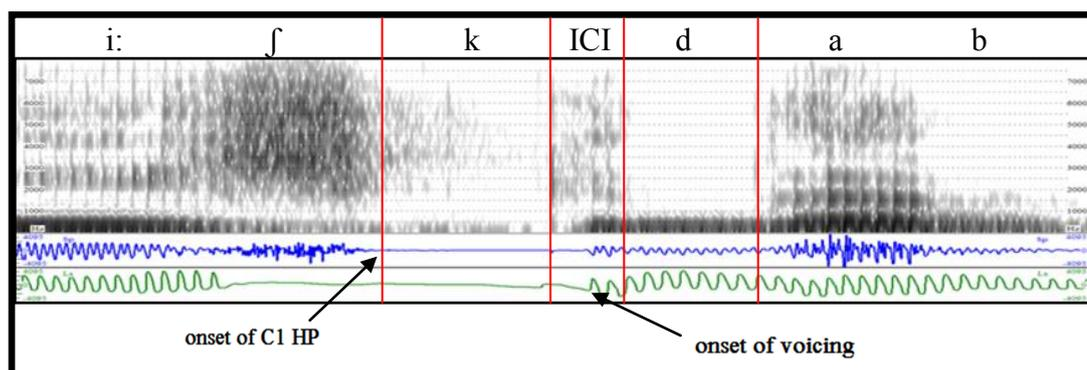

Figure 6.10 Spectrogram (top), acoustic waveform (middle) and glottal waveform (bottom) for /kd/ in the word /kdab/ showing that the onset of voicing is timed to start during the ICI making each stop conserve its voicing specification.

In the final voicing pattern, C2 is completely devoiced as a result of a progressive voicing assimilation. Apart from /b/, in /kb/, which has a voicing lead of 48ms in one occasion, C2 is always devoiced. The mean duration of VOT is 6ms. Figure 6.11 shows an example of progressive voicing assimilation in the cluster /tb/ in /tba:ʃir/. The ICI is voiceless too.

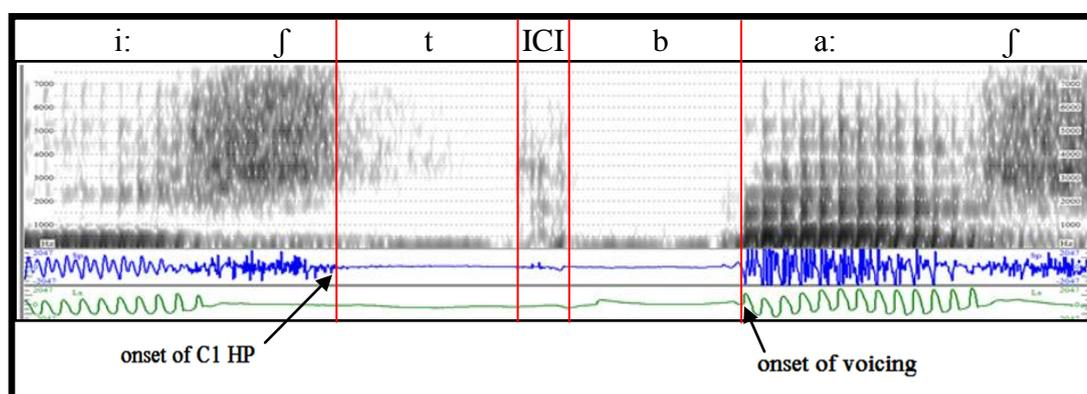

Figure 6.11 Spectrogram (top), acoustic waveform (middle) and glottal waveform (bottom) of the cluster /tb/ in the word /tba:ʃir/. The figure shows a completely voiced /b/ as of result of a progressive assimilation.

## 6.5 The timing of voicing in syllable-final clusters

Results of the timing of voicing in SF clusters are presented in Table 6.5.

	SF two-stop clusters	Dur. of C1	Dur. of voicing	%	No. of periods	Voicing	C1 Release	Dur. of ICI	No. of periods	Voicing	Dur. of C2	Dur. of voicing	%	No. of periods	Voicing
1.	/ʕabd/	90	-73	81%	6	VD	1	37	4	VD	82	-48	59%	4	PD
2.	/gabds/	58	-58	100%	6	VD	1	26	3	VD	69	-67	97%	5	VD
3.	/tʰabg/	70	-70	100%	7	VD	1	31	4	VD	65	-64	98%	6	VD
4.	/nagb/	77	-76	99%	9	VD	1	37	5	VD	96	-94	98%	6	VD
5.	/ʕagd/	71	-70	99%	8	VD	1	32	4	VD	71	-54	76%	5	PD
	Mean	73	-69	95%	7	VD	1	33	4	VD	77	-65	84%	5	VD
6.	/hatk/	89	8	9v	0	VLS	1	33	0	VLS	65	0	0%	0	VLS
7.	/dʰhakt/	80	16	20%	0	VLS	1	25	0	VLS	82	0	0%	0	4
	Mean	85	12	14v	0	VLS	1	29	0	VLS	74	0	0%	0	4
8.	/rabtʰ/	78	-54	69%	6	PD	1	34	4	VD	90	0	0%	1	VLS
9.	/habk/	68	-68	100%	7	PD	1	27	3	VD	90	-35	39%	0	VLS
10.	/wagt/	64	-64	100%	8	VD	1	35	4	VD	70	0	0%	2	VLS
11.	/magtʰ/	72	-70	97%	8	VD	1	42	4	VD	86	0	0%	1	VLS
12.	/ktabt/	77	-56	73%	5	PD	1	35	0	VLS	100	0	0%	0	VLS
	Mean	72	-62	86%	7	VD	1	35	3	VD	87	-7	8%	1	VLS
13.	/ʃatʰb/	80	0	0%	1	VLS	1	24	2	VD	109	-56	51%	6	PD

Table 6.5 Mean duration of C1, ICI, and C2, duration and percentage of voicing in C1 and C2, number of periods, voicing category in SF two-stop clusters.

### 6.5.1 The timing of voicing in syllable-final voiced + voiced

There is a variety of voicing patterns in SF clusters. As in SI, the timing of voicing is determined by the phonological voicing specifications of the two elements in the cluster, i.e. the clusters are divided into four groups: voiced + voiced, voiceless + voiceless, voiced + voiceless and voiceless + voiced. There is only one pattern in voiced + voiced SF two-stop clusters. In this pattern, C1, the ICI and C2 fall under the voiced category. However, there are some differences in the ratio of voicing in the HP of C2. Voicing is terminated 23-29ms before the release of C2 in /bd/, 38-49ms in /gb/, 13-25ms in /bd<sup>h</sup>/, 27-32ms in /gd/, and 10-15ms in /bg/. The average number of periods is seven in C1, four in the ICI and five in C2. It is worth mentioning that the duration of voicing is shorter when C2 is /b/ or /d/ than when it is /d<sup>h</sup>/ and /g/. Figure 6.12 shows the voicing pattern for /bd/ in /ʃabd/. It can be clearly seen that the duration of the ICI is longer in SF in comparison to that of SI. More periods are apparent as well.

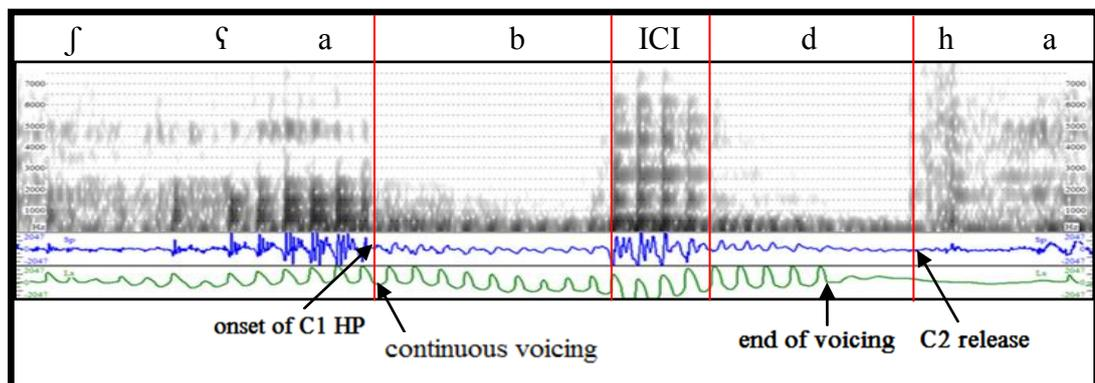

Figure 6.12 Spectrogram (top), acoustic waveform (middle) and glottal waveform (bottom) the cluster /bd/ in the word /ʃabd/. The figure shows the termination of voicing before the release of /b/ in anticipation of /h/.

### 6.5.2 The timing of voicing in syllable-final voiceless + voiceless

In voiceless + voiceless clusters, voicing continues from the vowel for 12-18ms throughout the HP of C1. Due to the fact that C1 and C2 are both voiceless, the ICI is voiceless as well. Figure 6.13 shows an instance of complete voicelessness during the production of /kt/ in the word /d<sup>h</sup>akt/. It is worth mentioning that /t/ is a

subject pronoun, voiceless, and preceded by /k/, a root-final stop which is voiceless as well.

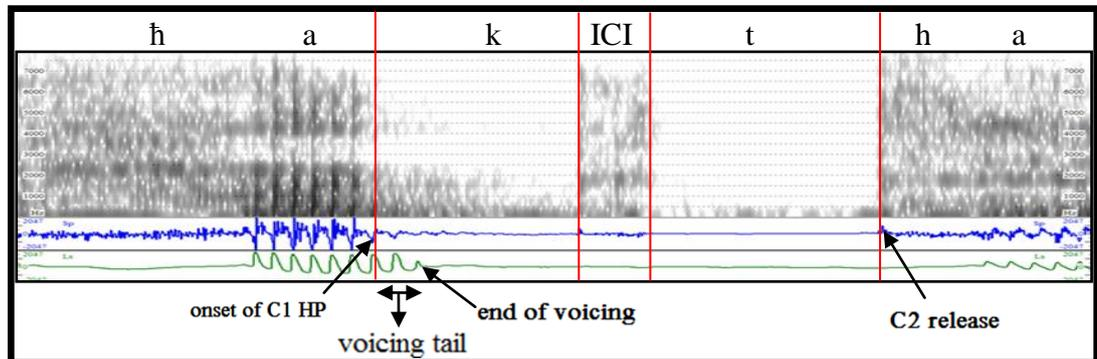

Figure 6.13 Spectrogram (top), acoustic waveform (middle) and glottal waveform (bottom) for the cluster /kt/ in the word /dʰakt/. The figure shows a voicing tail at the onset of C1 HP. There is no voicing during the rest of C1 HP, ICI is voiceless, and C2 HP is voice voiced.

### 6.5.3 The timing of voicing in syllable-final voiced + voiceless

In clusters composed of a voiced + a voiceless stop, there are two patterns of voicing. In the first one, C1 and the ICI are fully voiced. Voicing is maintained after the onset of C2 HP for 10-20ms in /btʰ/, 10-15ms in /gt/ and 18-25ms in /gtʰ/. While the average number of periods in C1 is seven, in C2 it is only one. In this pattern, voicing is terminated shortly after the onset of C2 HP. The ICI is 35ms and it is voiced. The timing of voicing in the cluster /gtʰ/ in /magtʰ/ is shown in Figure 6.14.

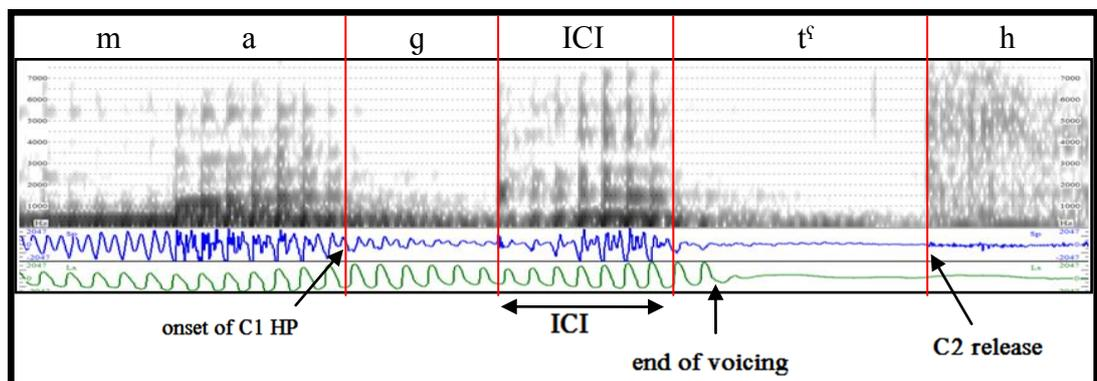

Figure 6.14 Spectrogram (top), acoustic waveform (middle) and glottal waveform (bottom) of the cluster /gtʰ/ in the word /magtʰ/. The figure shows continuous voicing from the vowel throughout the HP of C1 and ICI. Voicing ceases 22ms after the onset of C2 HP.

In the second pattern, voicing is terminated 23-37ms before the release of C1 in /bk/, and 13-23ms in /bt/. There is a short interval of voicelessness before the vocal folds resume vibrating during the ICI only. There is no voicing during the HP of C2. ICI is 9-26ms in /ktabt/. Figure 6.15 shows the timing of voicing of the cluster /bk/ in the word /h**ab**k/. ICI is 9-26ms in /ktabt/. Figure 6.15 shows the timing of voicing of the cluster /bk/ in the word /h**ab**k/.

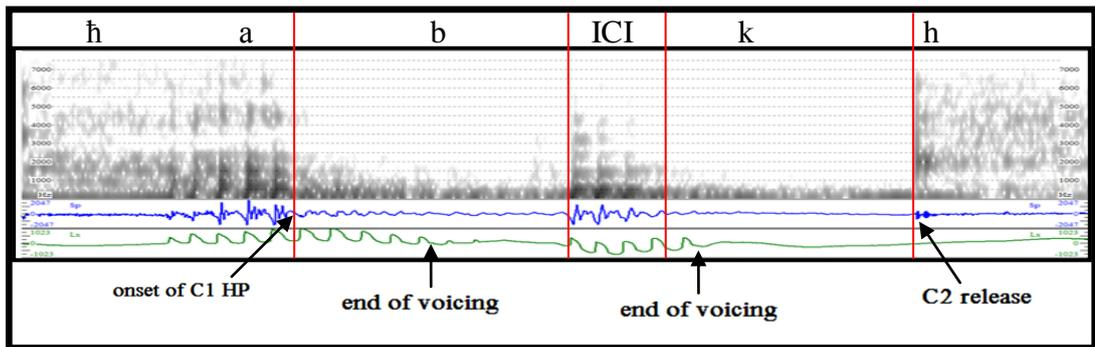

Figure 6.15 Spectrogram (top), acoustic waveform (middle) and glottal waveform (bottom) of the cluster /bk/ in the word /habk/. The figure shows that voicing is terminated during C1 HP and resumed during the ICI.

#### 6.5.4 The timing of voicing in syllable-final voiceless + voiced

In this pattern, apart from a voicing tail, C1 HP is voiceless. Voicing starts during the ICI and continues for 38 -51ms throughout the HP of C2 but it ceases before the release in anticipation of /h/. The average number of periods in the C2 HP is six compared to only one in C1 and two in the ICI. Figure 6.16 shows the timing of voicing of /t<sup>s</sup>b/ in the word /fat<sup>s</sup>b/.

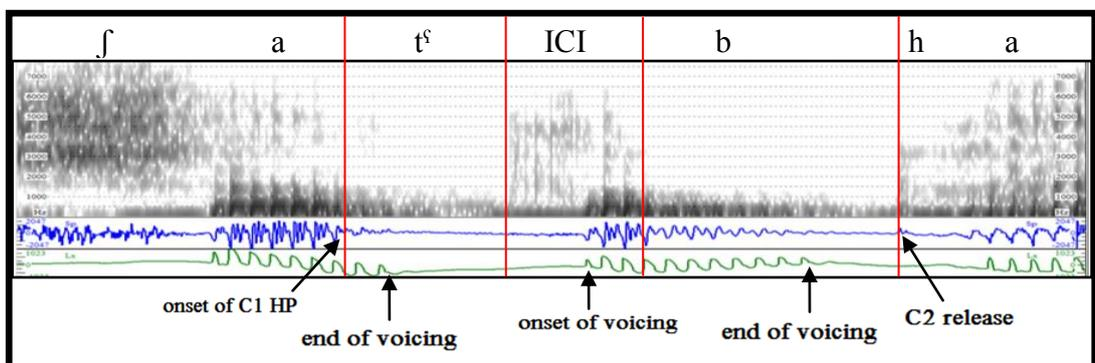

Figure 6.16 Spectrogram (top), acoustic waveform (middle) and glottal waveform (bottom) of the cluster /t<sup>s</sup>b/ in the word /fat<sup>s</sup>b/. Voicing is terminated 20ms after the onset of C1 HP. Voicing is resumed during the ICI, but terminated before the release of C2.

## 6.6 The influence of syllable position on timing of voicing

This section compares the results of timing for voicing in SI Voiced + voiced clusters (/bd/, /bd<sup>s</sup>/, /bg/, /gb/ and /gd/), voiceless + voiceless (/kt/ and /tk/), voiced + voiceless (/bt<sup>s</sup>/, /bk/, /bt/, /gt/ and /gt<sup>s</sup>/) and voiceless + voiced (/kd/ and /t<sup>s</sup>b/) to the same clusters in SF position. The patterns of voicing are shown in Figure 6.17 and the durational results are summarised in Table 6.6. For ease of comparison, clusters with the same voicing specification are placed next to each other, regardless of their syllable-position.

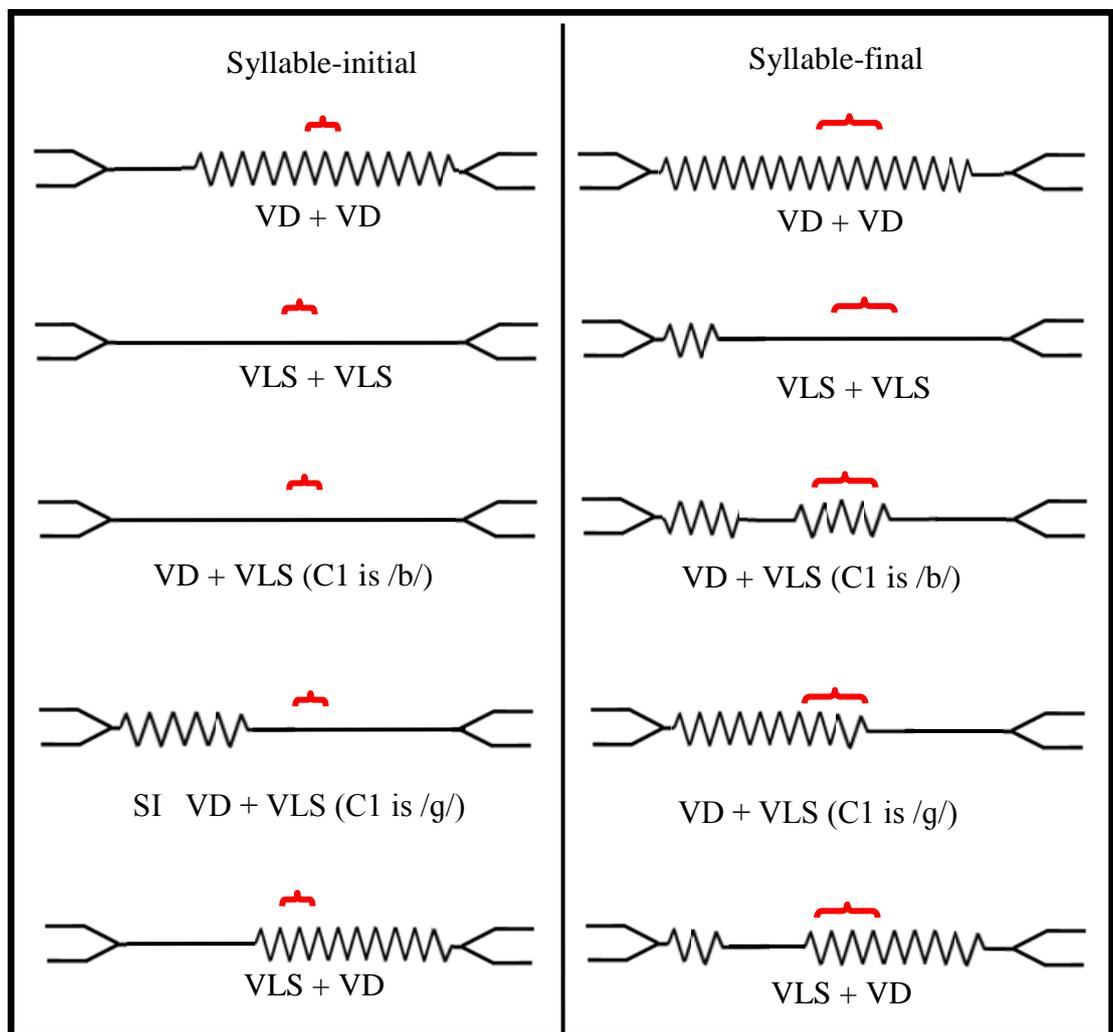

Figure 6.17. Timing of voicing of mixed voicing specifications in SI and SF clusters. Onset of C1 closure occurs when the two lines converge, and the offset of C2 closure occurs when these diverge. The zigzag lines indicate voicing during the HP. The duration of the ICI is marked in red.

Voicing specification	Syllable position	Dur. of cluster	Dur. of voicing	% of voicing	No. of periods	Voicing category
VD + VD	SI	199	-158	79%	11	VD
	SF	182	-167	91%	16	VD
VLS + VLS	SI	188	0	0%	0	VLS
	SF	195	44	23%	6	VLS
VD + VLS	SI	179	24	13%	2	DV
	SF	190	98	52%	11	PD
VLS + VD	SI	205	102	50%	9	PD
	SF	200	60	30%	7	PV

Table 6.6. Mean duration of clusters, duration of voicing, ratio of voicing, number of periods and voicing category of clusters with a range of voicing specifications in SI and SF positions.

For voiced + voiced clusters, results show that SI clusters are longer by an average of 17ms. However, voicing is maintained for longer in SF clusters. The ratio of voicing in the total duration of the SF cluster is higher by 12%. The total number of periods from the onset of C1 closure to the release of C2 in SF position is higher.

In voiceless + voiceless combination, SF clusters are longer by an average of 7ms. Apart from a voicing tail at the onset of C1 HP in SF position, and the longer duration of the ICI, there is no difference in the timing of voicing between SI and SF. In voiced + voiceless combination, SF clusters are longer by 11ms. While in SI the duration of voicing is 24ms (13% of the cluster), in SF, the duration of voicing is 98ms (52% of the cluster). The overall voicing category of SI is devoiced, but in SF it is partially devoiced. Finally, voiceless + voiced combinations have different voicing patterns that are determined by syllable position. The duration of SI voiceless + voiced is longer than that in SF by 5ms. The duration of voicing is also longer in SI, some 102ms (50%) compared to 60ms (30%) in SF). The average number of periods in SI is nine, but only seven in SF. This marks voiceless + voiced SI clusters as partially devoiced and SF clusters PV. This is the only combination where SI clusters have more voicing in comparison to SF.

Despite, these differences, it seems that SI clusters are more prone to assimilation, both progressive and regressive, when compared to SF clusters which may only undergo some devoicing due to the following /h/.

## 6.7 The influence of speaking rate

This section presents the results of the influence of fast and normal speaking rates on the timing and ratio of voicing in the HP of single and geminate stops, and during C1 and C2 in SI and SF clusters. The hypothesis, stated under voicing, which assumes longer voicing durations as speaking rate increases and shorter voicing durations as it decreases, is tested here.

### 6.7.1 The influence of speaking rate on voicing of SI single stops

Results of the influence of speaking rate on voicing in SI single stops are presented in Table 6.7.

CV	SI voiced single stops			SI voiceless single stops		
	Normal	Fast	Slow	Normal	Fast	Slow
Dur. of HP	100	68	159	83	71	143
Dur. of voicing	-50	-39	-31	0	0	0
% of voicing	50%	57%	19%	0%	0%	0%
No. of periods	4	6	3	0	0	0
Voicing category	PD	PD	DV	VLS	VLS	VLS
VOT	7	14	14	30	19	33

Table 6.7 Mean HP duration, duration and percentage of voicing, number of periods, voicing category and VOT. While voiceless stops are completely voiceless, voiced stops are partially devoiced at normal and fast speaking rate, and devoiced at slow rate.

At fast speaking rate, the duration of the HP decreased by 32%. However, the duration of voicing increased from 50% at normal speaking rate to 57%. This increase was accompanied by an increase in the number of periods. Despite the fact that there was apparently more voicing during the HP at fast speaking rate, the voicing category remains partially voiced. When voiced single stops were devoiced, particularly /b/ which is always completely devoiced, the mean duration of VOT increased to 14ms. At slow speaking rate, on the other hand, the duration of the HP increased by 37%. The duration of voicing during the HP decreased to 19%.

Moreover, as the number of periods decreased, voiced stops at slow speaking rate were produced as devoiced. The mean duration of VOT is 14ms.

For SI voiceless stops, the duration of HP decreased by 14% at fast speaking rate, and increased by 42% at slow speaking rate. A consistent pattern of laryngeal timing was observed in all speaking rates i.e. there were no voicing activities during the HP. The VOT duration decreased from an average of 30ms at normal speaking rate to 19ms at fast rate, and increased to 33ms at slow rate. This influence was more evident in /k/ where the duration of VOT decreased from 39ms to 27ms at fast, and increased to 57ms at slow rate. Those results support the speech rate hypothesis about the influence of speaking rate on VOT duration and in agreement with finding in previous (e.g. Miller and Baer 1983; Miller *et al.* 1986; Pind 1995; Morris *et al.* 2008)

### 6.7.2 The influence of speaking rate on voicing of SF single stops

Results of the influence of speaking rate on SF single stops are presented in Table 6.8.

VC	SF voiced single stops			SF voiceless single stops		
	Normal	Fast	Slow	Normal	Fast	Slow
Dur. of HP	185	120	297	182	133	287
Dur. of voicing	145	96	194	0	0	0
% of voicing	78%	80%	65%	0%	0%	0%
No. of periods	15	11	14	0	0	0
Voicing categ.	VD	VD	PD	VLS	VLS	VLS

Table 6.8 Mean HP duration, duration and percentage of voicing, number of periods and voicing category. While voiceless stops are completely voiceless, voiced stops are voiced at normal and fast speaking rate, and become partially devoiced at slow rate.

The HP of SF voiced single stops decreased by 35% at fast speaking rate (a greater decrease compared to SI). The duration of voicing during the HP has increased by 2%. Although the number of periods decreased from 15 to 11, the fast

rate did not influence the voicing category of SF voiced stops, i.e. they remained voiced. SF voiceless clusters produced at fast speaking rate did not show any voicing during their HP.

As for the influence of slow rate on the timing of voicing in SF single voiced stops, there was an increase of 38% in the duration of HP. However, the percentage of voicing decreased to 65%, and the number of periods was 14. In SF voiceless single stops, the duration of the HP decreased by 27% at fast speaking rate, and increased by 37% at slow speaking rate. The HP for both rates is completely voiceless.

### **6.7.3 The influence of speaking rate on voicing of SI clusters**

#### **6.7.3.1 The influence of speaking rate on SI voiced + voiced clusters**

Table 6.9 shows the results of timing of voicing in SI clusters. The table is divided into four main sections depending on the voicing specifications of C1 and C2. For ease of comparison, every section is divided into results for normal, fast and slow speaking rate. At fast speaking rate, there was a decrease in C1 duration by 40%. However, the percentage of voicing during the HP increased by 2% only (65% at normal rate to 67% at fast). The number of periods decreased from 5 to 4. The voicing category remained stable as partially devoiced. The duration of the ICI decreased, and its voicing quality changed from voiced to voiceless. As for C2, the HP duration decreased by 34%. The percentage of voicing increased to 81%, and the number of periods remained the same. When C2 is devoiced, the duration of VOT decreased from 11ms to 6ms.

At slow speaking rate, there was an increase of 19% in the duration of the HP. The ratio of voicing decreased to 49% of the HP, and the number of periods remained the same as at normal rate. As a result of the decrease in voicing, the voicing category of C1 changed from VD to PV. The voicing category of the ICI is voiced, as at normal speaking rate. C2 HP duration increased by 34%, but the ratio of voicing in the HP duration increased from 76% to 81%. At slow speaking rate, C2 HP increased by 44%, but the ratio of voicing decreased to only 61% of the HP

duration. This led to a change in the voicing category of C2 from voiced to PD. Finally, the number of periods decreased from 11 to nine.

C1C2V	Voiced + voiced			Voiceless + voiceless			Voiced + voiceless			Voiceless + voiced		
	Slow	Normal	Fast	Slow	Normal	Fast	Slow	Normal	Fast	Slow	Normal	Fast
Dur. of C1 HP	125	101	61	99	78	58	109	89	58	104	81	59
Dur. of voicing in C1 HP	61	-66	40	0	0	34	19	-15	18	0	0	14
% of Voicing in C1HP	49%	65%	67%	0%	0%	59%	17%	17%	31%	0%	0%	23%
No. of periods in C1 HP	5	5	4	0	0	4	1	1	2	0	0	1
Voicing category of C1	PV	PD	PD	VLS	VLS	VLS	DV	DV	PD	VLS	VLS	VLS
C1 release	rlsd	rlsd	not rlsd	rlsd	-	rlsd	rlsd	rlsd	rlsd	rlsd	rlsd	rlsd
Dur. of ICI	13	12	9	26	23	10	17	13	12	23	19	15
No. of periods in ICI	1	1	1	1	0	1	0	0	0	0	0	0
Voicing of ICI	VD	VD	VLS	0	VLS	VLS	VLS	VLS	VLS	VLS	VLS	VLS
Dur. of C2 HP	110	82	54	81	69	54	97	72	55	99	85	58
Dur. of voicing in C2 HP	67	-62	44	0	0	38	0	0	8	59	-39	18
% of voicing in C2 HP	61%	76%	81%	0%	0%	70%	0%	0	14%	59%	46	32%
No. of periods in C1 HP	5	6	6	0	0	4	0	0	1	3	3	2
Voicing category of C2	PD	VD	VD	VLS	VLS	VLS	VLS	VLS	VLS	PD	PV	PV
VOT	9	11	6	44	26	7	40	28	20	9	7	9

Table 6.9 The Influence of speaking rate on duration and category of voicing in SI clusters with different voicing combinations.

### **6.7.3.2 The influence of speaking rate on voicing of SI voiceless + voiceless clusters**

In voiceless + voiceless clusters produced at fast rate, there was a decrease of 26% in C1 HP. There are no voicing activities during C1 HP. The duration of the ICI decreased in duration, but remained voiceless. C2 HP decreased by 22%, and remained voiceless. The VOT duration decreased from 26ms to 7ms at fast speaking rate. At slow rate, C1 HP duration increased by 21%, ICI increased to 26ms and C2 HP duration increased by 15%. The HP of C1 and C2, and the ICI durations are all voiceless. The VOT value increased from an average of 26ms at normal to 44ms at slow speaking rate. This is more evident when C2 is /k/. Here, VOT duration increased from an average of 33ms to 57ms. This result confirms the hypothesis under speech rate advanced in Chapter Three.

### **6.7.3.3 The influence of speaking rate on voicing of SI voiced + voiceless clusters**

At fast speaking rate, C1 HP decreased by 35%, but the percentage of voicing increased from 17% to 31%. The number of periods increased as well. While at normal articulation rate the voicing category of C1 was devoiced, at fast rate, it became partially devoiced. C1 was not released 33%. When it was released, the duration of ICI remained roughly the same in duration, and retained its voicing specification. C2 HP decreased by 24%. The percentage of voicing during HP increased to 14%. The VOT duration decreased from 28ms to 20ms.

At slow speaking rate, the HP of C1 increased by 18%, but voicing remained the same, 17% of the total duration of the HP. The ICI increased in duration, but remained voiceless. The HP of C2 increased by 26%. There was no voicing activity during the HP of C2. The duration of VOT increased from 28ms at normal rate to 40ms at slow rate. /g/ in /gtʰ/, which was voiced at normal rate, became devoiced at slow rate (progressive assimilation is more effective at slow speaking rate). There is a tendency to devoicing at slow speaking rate. The mean VOT value increased from 28ms at normal to 40ms at slow speaking rate. Again, the increase is more evident when C2 is /k/.

#### **6.7.3.4 The influence of speaking rate on voicing of SI voiceless + voiced clusters**

C1 HP decreased at fast speaking rate by 27%. The percentage of voicing increased to 23% of the HP. However, C1 remained voiceless. The duration of the ICI decreased and remained voiceless as well. C2 HP decreased by 28%. The percentage of voicing decreased to 32% of the total duration of HP. VOT duration increased to 9ms.

At slow speaking rate, the duration of C1 HP increased by 21%. The HP is completely voiceless. The duration of ICI increased in duration and remained voiceless. C2 HP increased in duration by 14%, and the percentage of voicing increased by 59%. This was the first instance where the duration of voicing increased at slow speaking rate. The voicing category of /b/ changed from partially voiced to partially devoiced.

#### **6.7.4 The influence of speaking rate on voicing of SF clusters**

Results of the influence of articulation rate on the timing and duration of voicing in SF clusters are presented in Table 6.10.

VC1C2	Voiced + voiced			Voiceless + voiceless			Voiced + voiceless			Voiceless + voiced		
	Slow	Normal	Fast	Slow	Normal	Fast	Slow	Normal	Fast	Slow	Normal	Fast
Dur. of C1 HP	92	73	54	115	85	53	93	72	49	110	80	59
Dur. of voicing in C1 HP	67	-69	54	0	12	12	78	-62	43	0	0	9
% of voicing in C1HP	73%	95%	100%	0%	14%	23%	84%	86%	86%	0	0%	15%
No. of periods in C1 HP	5	7	8	1	0	2	6	7	6	0	1	1
Voicing category Of C1	PD	VD	VD	VLS	VLS	VLS	VD	VD	VD	VLS	VLS	VLS
C1 release	rlsd	rlsd	rlsd	rlsd	rlsd	rlsd	rlsd	rlsd	rlsd	rlsd	rlsd	rlsd
Dur. of ICI	46	33	23	31	29	18	51	29	18	25	24	19
No. of periods in ICI	4	4	3	2	0	0	5	3	1	3	2	1
Voicing category of ICI	VD	VD	VD	VLS	VLS	VLS	VD	VD	VD	VD	VD	VLS
Dur. of C2 HP	88	77	51	118	74	47	101	87	58	132	109	62
Dur. of voicing in C2 HP	77	-65	45	0	0	0	0	-7	0	71	-56	54
% of voicing in C2 HP	87%	84%	89%	0%	0%	0%	0%	8%	0%	54%	51%	87%
No. of periods in C1 HP	6	5	5	0	0	0	1	1	0	5	6	6
Voicing category of C2	VD	VD	VD	VLS	VLS	VLS	VLS	VLS	VLS	PD	PD	VD

Table 6.10 Influence of speaking rate on duration and category of voicing in SF clusters with different voicing combinations

#### **6.7.4.1 The influence of speaking rate on voicing SF Voiced + voiced**

In SF voiced + voiced clusters, the duration of C1 HP decreased by 26%, and the percentage of voicing increased from 95% to 100%. The number of periods increased from seven to eight. The ICI decreased in duration from 33ms to 23ms, and the number of periods also decreased from four to three. Despite the decrease in duration, the ICI remained voiced. The duration of C2 HP has decreased by 34%. Voicing increased from 84% to 89%. The number of periods remained the same. Apart from /bd/ and /gb/, where /b/ was partially devoiced, C1, ICI and C2 were all completely voiced.

At slow speaking rate, C1 HP increased by 21%. While 96% of C1 HP was voiced, only 73% of C1 duration at slow speaking rate was voiced. If the increase in duration is ignored, it appears that voicing lasts for the same time at both speaking rates. Voicing category changed from VD to PV.

#### **6.7.4.2 The influence of speaking rate on voicing of SF voiceless + voiceless**

The duration of C1 HP decreased by 38%, and the duration of voicing increased to 23%. There is a voicing tail of 12ms, and two periods, at the onset of C1 HP. The ICI decreased in duration, but remained voiceless. C2 HP decreased by 30%, but there was no voicing activity during the HP. At slow speaking rate, C1 HP decreased by 26%. There was no voicing during the HP of C1, and the ICI, which increased in duration. C2 HP increased in duration by 37%, but it remained completely voiceless. Voicing tail observed at normal speaking rate did not exist at slow speaking rate.

#### **6.7.4.3 The influence of speaking rate on SF voiced + voiceless**

At fast speaking rate, C1 HP decreased by 42% and the percentage of voicing remained the same as at normal speaking rate i.e. 86%. The number of periods decreased to six. The ICI decreased in duration, but remained voiced. C2 HP decreased by 33%, but there was no voicing activity in C2 HP. At slow speaking rate, C2 HP decreased by 23% and the percentage of voicing in proportion to the

overall HP decreased by 2%. The ICI increased in duration by 51%, and it was voiced. The duration C2 HP has increased by 14%. Apart from a voicing tail, C2 HP was completely voiceless.

#### **6.7.4.4 The influence of speaking rate on SF voiceless + voiced**

At fast speaking rate, C1 HP decreased by 26%, but voicing increased by 15%. However, C1 is still voiceless. The ICI decreased in duration, and in the number of periods as well. It was voiceless. The HP of C2 decreased by 43%, and the percentage of voicing increased to 87%. As a result, C2 became voiced. At slow speaking rate, C1 HP decreased by 27% and there was no voicing activity. The duration of ICI increased to 25ms, and increased in the number of periods from two to three. The HP of C2 increased by 17%. The percentage of voicing in addition increased to 54% of C2 HP which remained partially devoiced.

### **6.8 Discussion**

The duration of the HP and the duration of voicing during this HP for SI and SF single stops and C1 and C2 in SI and SF clusters have been analysed. Results from SI single stops revealed that voiced stops are very considerably different from SF single stops in terms of their HP duration, ratio of voicing and time at which voicing is initiated. This can be explained by the mechanism involved in the production of stop consonants at different places of articulation. The initiation and termination of voice is highly determined by the critical amount of transglottal pressure (Van Alphen *et al.* 2004). The more posterior the stop is, the earlier the right pressure is reached. In the case of /b/, for example, it takes longer for pressure to build up in comparison to /g/. On the other hand, the higher the intraoral pressure during the HP, the more likely it will prevent the initiation of voicing (Brutel-Vuilmet and Fuchs 2008). These results support the hypothesis that the place of articulation influences the timing and duration of voicing.

Results of SI voiceless stops confirm the results obtained from previous research (e.g. Lisker *et al.* 1969) who observed that there is no glottal vibration

during the HP of voiceless stops, except for occasional voicing tails. Results of the influence of place of articulation on VOT were consistent with previous research which demonstrated that the further back the place of articulation, the longer the VOT duration is (e.g. Lisker and Abramson 1964). This can be explained by the velocity of the articulators during the release of the closure. It takes longer for the back of the tongue to release the closure compared to the lips which are faster. Slow velocity will result in a delay in reaching the right amount of pressure for the initiation of voicing (see Cho and Ladefoged 1999)

In voiced + voiced stop clusters, there is shorter pre-voicing during the HP of C1 compared to C2. The reason could be attributed to the difference in the time needed to initiate voicing in both. While in the former, the pressure needs time to build to the right amount to excite the vocal folds, in the latter, the pressure is already high (Westbury and Keating 1986, Slifka 2000).

The question of why /g/ in /gtal/ does not undergo regressive assimilation, and instead, it retains its voicing quality particularly at the onset of its HP, could be explained by the fact that different stops have different degrees of voicing co-articulation resistance or aggressiveness (Recasens and Mira 2012). In this respect, /b/ is less resistant than /g/, or /g/ is more aggressive than /b/. check Janest's book page 259

When C2 is voiced, voicing is sometimes terminated before the release of the stop, because of the drop in the transglottal pressure. In this case, the volume and the velocity of the air coming from the lungs is not sufficient to make the vocal folds vibrate.

In voiced + voiceless, the excrescent vowel is voiceless. This could be attributed to the fact that in anticipation of the voiceless stop, vocal fold vibration is terminated before the release, or the release helped to accelerate the drop in the transglottal pressure. In some examples, the excrescent vowel is voiceless because it is short i.e. there is not enough time for the vocal folds to start vibrating. However, when C2 /t<sup>s</sup>/ is preceded by /g/ as in /gt<sup>s</sup>af/, the vocal folds continue to vibrate for longer in comparison to /gtal/. In this case, voicing is prolonged due to the more constricted vocal tract during the production of /gt<sup>s</sup>/. It could be that the constriction facilitated longer voicing, because it helped to keep the transglottal pressure high for longer.

The influence of speaking rate on the duration and timing of voicing can be explained in the light of the pressure and velocity of the air coming from the lungs. Higher intraoral pressure has been found at fast speaking rates compared to slow speaking rate (Arkebauer *et al.* 1967). Another factor related to the amount of transglottal pressure is the duration of the HP. The longer the HP is, the more likely it is to become devoiced.

## 6.9 Conclusion

The analysis of HP duration and the ratio of voicing in the HP reported in this chapter shows that the timing and duration of voicing is dependent on the phonological voicing specification of the stop(s), place of articulation, syllable position and speaking rate.

Results of the influence of place of articulation reveal that this factor plays an important role in the ratio of voicing during the HP of SI and SF single and two-stop clusters. The role place of articulation plays is the result of the mechanism involved in the production of the stop(s). The results have also shown that voiceless stops exhibited a tendency to resist voicing assimilation during their production. The reason behind this pattern is that the onset of glottal abduction in voiceless stops is co-ordinated with the onset of HP. In voiced stops, on the other hand, there is considerable variation in the duration and timing of pre-voicing due to the influence of place of articulation.

Voicing assimilation in clusters with mixed voicing specification was frequent. TLA applies more regressive assimilation to voicelessness, particularly when C1 is /b/ and /d/. However, /tg/ shows a regressive assimilation of voice. Clusters with /tʰ/ and /dʰ/ showed longer timing of voicing in comparison to those clusters with /t/ and /d/. Westbury's hypothesis that the voicing characteristics of single stops determines the degree of voicing adaptation in stop clusters seems to hold in the case of clusters in a certain place, syllable position and with a particular voicing specification.

Another factor that is crucial to the timing and duration of voicing is syllable position. Apart from where SI voiceless + voiced clusters have a longer duration of voicing, it seems that SF clusters are more resistant to devoicing compared to SI. The last factor that is found to influence the duration and timing of voicing is

speaking rate. The duration of voicing during the HP of single and clusters of two stops varied as a function of change in the speaking rate to different degrees. As the duration of the HP decreased, the voicing component increases in proportion to the overall duration of the HP. At slow speaking rate, as the duration of the HP increases, voicing decreases. These results confirm the hypothesis that an increase in speech rate results in longer voice durations. These results are consistent with the results obtained by Malécot (1969). However, there may be other factors that influence the duration of voicing such as controlling the time of voicing by lowering the glottis (the increase of cavity volume above the glottis can increase the duration of voicing), stress, and the number of syllables.

## Chapter Seven: General Discussion and Conclusion

### 7.1 Findings of the study

This thesis aimed to investigate the timing relations of single and two-stop clusters in TLA, a variety of Libyan Arabic spoken in Tripoli, Libya's capital city. The investigation focused on how speakers of TLA co-ordinate two-stop gestures in coronal + dorsal, dorsal + coronal, /b/ + coronal, /b/ + dorsal, coronal + /b/ and dorsal + /b/ clusters. The investigation also focused on the influence of place of articulation, syllable position (syllable-initial SI vs. syllable-final SF), sequence of articulation, morphological structure, gender, and articulation rate on the duration of the HP, the pattern of gestural co-ordination, and the duration of the inter-consonantal interval. Finally, the thesis aimed to shed some light on the voicing in clusters consisting of voiced + voiced, voiceless + voiceless, voiced + voiceless and finally voiceless + voiced combinations by focusing on the timing, the duration and the quality of voicing during the HP of the stops, and the quality of the excrescent/epenthetic vowel in clusters consisting of different voicing characteristics.

In order to address this study's research questions and hypotheses, data were gathered using multiple phonetic instruments: Electropalatography (EPG), spectrography and laryngography (Lx). Due to its ability to record contact between the tongue and the palate, EPG was used to investigate the co-ordination of articulatory gestures of clusters of two lingual stops. There was one speaker in the EPG experiment. The second technique, spectrography, was used to investigate the durational properties of two-stop clusters. A total of 14 native speakers of TLA (seven males and seven females) were recruited for this experiment, given that another aim of the study was to investigate gender difference and variability among speakers and within individual performances. Finally, laryngography was used to investigate the timing of voicing and its duration during the hold phase (HP) of single and two-stop clusters in SI and SF position. Here, one speaker was also used to investigate the timing of voicing. In addition to these instruments, the Statistical Package for the Social Sciences (SPSS) was used to investigate any significant

differences in the data. All of these tools were used to address the study's research questions and the hypotheses stated in Chapter Three under three main topics: coordination, morphology, articulation rate and voicing.

The data included seven single stops in SI, seven single stops in SF position, twenty-seven two-stop clusters in SI position and seventeen two-stop clusters in SF position. The data covered all stop consonants in TLA and almost all possible combinations of two-stop clusters in SI and SF position.

Results from the EPG analysis show that the intergestural co-ordination of two-stop consonant clusters in TLA exhibits a variety of patterns depending on the place of articulation of the stops and their syllable position. The results yielded strong evidence that place of articulation and syllable position plays a major role in the co-ordination of two-stop consonantal gestures. These findings support the hypotheses about coordination which state that SI two-stop consonant clusters will exhibit more intergestural cohesion than SF and agree with previous results (e.g. Browman and Goldstein 1988; Pouplier and Marin 2008; Marin and Pouplier 2010; Kochetov 2006) that SI and SF consonant clusters are organised differently.

There were two patterns of intergestural co-ordination in SI and one in SF. The first pattern includes clusters consisting of a labial (LB) gesture followed by a tongue-back (TB) gesture or a tongue-tip (TT) gesture, or vice versa. This was characterised by a considerable amount of overlap between the two stop closures. Due to one of the limitations of EPG, it was not possible to measure the duration of this overlap. The first SI pattern is also seen in clusters where a TB gesture is followed by a TT gesture. This pattern exhibited an overlap lasting 10-20ms between the two closures in some clusters. The time of the release of C1 coincided with the time of forming the closure for C2. This pattern was stable, and less sensitive to changes in speaking rate. In the second SI pattern, the formation of the closure of C2 does not take place until after the release of C1. As a result, a short excrescent vowel can be seen between the two closures (10-30ms). This distinction between excrescent, or intrusive, and epenthetic vowels has been observed and described in the literature of timing in speech production (e.g. Hall 2003). Here, the excrescent vowel exists in the vicinity of gutturals as a result of gestural mistiming.

In regards to the absence of this vowel before SI clusters, there are two possible explanations. The first is that all participants were advised not to pause

between the words in the carrier sentence. As a result, on some occasions, a cluster of three consonants can be seen on spectrograms. The second explanation could be the long vowel occurring just before the clusters. This vowel helped to block the epenthetic vowel that should have been inserted before C2. Recordings of the target words in isolation yielded to the same patterns in SI and SF position.

In all SI clusters, less overlap was observed when either C1 or C2 was emphatic. The gestural phasing of clusters containing an emphatic stop is more constrained than those containing only plain stops. Given that emphatics have a secondary articulation, this might have influenced the coordination of clusters where they occur as either C1 or C2. Another explanation is related the velocity of the TB gesture.

In SF two-stop clusters, there was only one pattern of co-ordination. This pattern was characterised by a less cohesive co-ordination between the two consonantal gestures giving rise to a long epenthetic vowel interval lasting 30-55ms. This pattern was stable, i.e. it did not seem to be affected by the place of articulation of the two stops or by the sequence of articulation. The existence of this epenthetic vowel is partially triggered by the following /h/ in the carrier sentence. Due to the fact that TLA does not permit a sequence of three consonants and that it is a VC dialect (Kiparsky 2003; Watson 2007), when a sequence of three consonants occur across word boundary, an epenthetic vowel is inserted before C2. The same results were seen when the target words were recorded in isolation. There was also less gestural magnitude of SF two-stop clusters in comparison with SI. Similar results were obtained by June (1995). The reason why the same reduction is not observed in SI could be attributed to many factors such as the “domain-initial strengthening” (Keating *et al.* 2004) which the production of SI segments is more cohesive.

In general, results of the acoustic analysis are in support of the coordination hypothesis that the place of articulation has a significant influence on the duration of the HP of single stops in SI position. The HP duration decreased as the place of articulation moved back. However, the hypothesis does not hold for single stops in SF position, i.e. the place of articulation did not influence the duration of the HP. All SF single stops were characterised by their significantly longer HP durations in comparison with SI single stops. It is worth mentioning that SF single stops are considered single on the basis that their production involves a single gesture.

In SI two-stop clusters, the most striking result was the occasional absence of C1 release. Due to the cohesive co-ordination of the two gestures, closure formation of C2 took place before C1 release. When C1 was released, the pattern only allowed for short excrescent vowel lasting 2-18ms. There were some significant differences between the HP duration of C1 and C2 with the HP duration of the former tending to be longer. There were also significant differences in C1 release with clusters containing two lingual stops showing more C1 releases in comparison with those clusters containing /b/. These results did not confirm the hypothesis which states that clusters containing two lingual stops will exhibit more gestural overlap than clusters containing /b/. The nature of the articulator(s) involved is the main reason behind this variation. While in two-lingual stop clusters the tongue is the only articulator, in clusters with /b/, there are two independent articulators which can easily form two simultaneous closures.

The duration of excrescent vowels varied as a function of cluster type. Longer excrescent vowel durations were more apparent in clusters containing two lingual stops. This is not in agreement with our hypothesis about coordination where shorter excrescent vowel durations were expected in two lingual stop clusters. The place of articulation and the velocity of articulators are two reasons which help to explain this variation. Other possible explanations of factors governing the way articulatory gestures were organised include stress, number of syllables and word frequency.

Results of the duration of the HP of C1 and C2 in SF position showed that they were not as significantly different as was the case in SI. In addition, the release of C1 and in the duration of the epenthetic vowel varied as a function of syllable position. The co-ordination pattern of SF two-stop clusters appeared to favour the release of C1 over the overlap between the two closures. Like SI clusters, fewer C1 releases were found in clusters containing /b/. In SF two-stop clusters, longer durations of epenthetic vowel durations were also observed. Unlike SI two-stop clusters where a considerable amount of gestural overlap was observed, SF clusters were less cohesive, allowing the presence of an epenthetic vowel (27-41ms). These findings were in agreement with the EPG results of the target words recorded in isolation and confirmed results from previous literature that syllable position has a strong influence on how articulatory gestures are co-ordinated.

Results of the timing and ratio of voicing during the HP of SI and SF single stops, and the HP of C1 and C2 in SI and SF two-stop clusters in TLA are also interesting. While voiceless single stops exhibited a tendency to resist voicing during their HP, voiced single stops showed considerable variation in the duration and timing of prevoicing. This could be attributed to the place of articulation of the stops and how this affects the speed at which pressure drops. While pressure drops faster in bilabial stops, leading to earlier initiation of voicing, it drops at a slower rate in velar stops, leading to a delay in reaching the right pressure to initiate voicing. This variation is in agreement with Docherty (1992) who reported different patterns of voicing in English.

Finally, the duration of VOT was found to vary as a function of place of articulation. The duration of VOT increased as the place of articulation moved from anterior to posterior. The place of articulation of the stop is the main reason behind this variation. This result confirms previous results (e.g. Lisker and Abramson 1964; Docherty 1992; Abdelli-Beruh 2009; Löfqvist and Gracco 2002).

In clusters with mixed voicing specification, voicing assimilation was frequent. It was established that TLA applies more regressive assimilation to voicelessness, particularly when C1 is /b/ and /d/. However, regressive assimilation of voice was also applied in clusters such as when a voiceless C1 /t/ is followed by a voiced C2 /g/. In SI /gt/, /t<sup>h</sup>g/ and /kd/, Westbury's hypothesis regarding the relation between voicing in single consonants and voicing adaptation in clusters seemed to hold. The place of articulation of the stop(s) plays an important role in the ratio of voicing during the HP. This is the result of the mechanism involved in the production of stop(s) and the volume of trapped air behind the place of constriction. Emphatic stops /t<sup>h</sup>/ and /d<sup>h</sup>/ showed longer timing of voicing in comparison to clusters with /t/ and /d/. It may be the case that the secondary constriction involved in the production of emphatic stops slows the rate at which the pressure drops. As a result, the vocal folds continue to vibrate for longer.

Lx results showed that syllable position is a crucial factor to the timing and duration of voicing during the HP. Apart from SI voiceless + voiced voicing combinations, where stops showed longer duration of voicing, results showed that SF two-stop clusters were more resistant to devoicing compared to the same cluster in SI. The voicing quality of the excrescent/epenthetic vowel seems to be

determined by syllable position. While in SI position, the excrescent vowel is often voiceless, in SF the epenthetic vowel is always voiced except for some occasions when it occurs between two voiceless stops. This could have been influenced by differences in duration between the Excrescent and epenthetic vowels. As a result of being short, there is a very short time for the vocal folds to initiate voicing, particularly when both stops are voiceless. In the case of epenthetic vowels, their duration makes them voiced even between voiceless stops.

In addition, the sequence of articulation and the morphological structure of the cluster were found to have less consistent influence on the co-ordination pattern of two-stop clusters. EPG results showed that SI two lingual stop clusters with A-to-P sequence of articulation exhibited more overlap than P-to-A articulation. On the other hand, A-to-P clusters where a LB gesture was followed by either a TT or a TB gesture seemed to be less influenced by the sequence of articulation. In SF position, however, the sequence of articulation did not seem to play any role in the intergestural co-ordination. In confirmation of these results, the acoustic data showed that A-to-P clusters in SI display more gestural overlap in comparison to P-to-A clusters. In SF clusters, as in the EPG results, the articulation sequence did not show any significant influence on gestural co-ordination and on the duration of the epenthetic vowels. These results did not support the coordination hypothesis where more overlap was expected in P-to-A than A-to-P sequences of articulation. Additionally, shorter excrescent vowel durations were expected in P-to-A sequences of articulation, not in A-to-P. This result does not support those obtained by Kochetov and Goldstein (2005) who reported less overlap in A-to-P.

Another factor that had a variable influence on the intergestural co-ordination is the morphological structure of the cluster. EPG results showed more overlap was seen in heteromorphemic clusters than in tautomorphemic clusters. However, the morphological structure has only a limited effect on the way the gestures are organised. In fact, it could be other factors are responsible for these variations. For example, since most heteromorphemic clusters are in disyllabic words, it follows then that the number of syllables may have influenced the degree of overlap, i.e. disyllabic words are expected to show tighter co-ordination (Tilsen 2013:5).

The acoustic results showed that the morphological structure of the cluster seems to have some influence on the intergestural co-ordination pattern of /bd/, /bt<sup>ɕ</sup>/

and /bk/ with more gestural overlap in tautomorphemic clusters than in heteromorphemic. The longer duration of the excrescent vowels in heteromorphemic clusters compared to tautomorphemic support the hypothesis on the influence of the morphological structure on gestural coordination. However, the morphological structure did not seem to have the same influence on the pattern of gestural coordination in SI /bd<sup>s</sup>/ and /bg/, and in SF /gt/. These results partially support the hypothesis about the influence of morphology in which more gestural overlap was predicted in tautomorphemic than in heteromorphemic clusters. Factors as word frequency and place of articulation may have played a role in the pattern of coordination.

Sex-based differences, which were only investigated in the acoustic data, were found to be an influential factor in determining the duration of HP, release of C1 and the duration of the excrescent and epenthetic vowels. Sex-based differences are well documented in the literature. There are physiological differences between males and females (e.g. Laver and Trudgill 1991; Simpson 2001; Kuehn and Moll 1976), differences in vowel space (Henton 1995), and differences in segment duration (Whiteside 1996) and differences in articulation rate (Byrd 1993).

In SI positions, male speakers were found to produce longer HP duration, more C1 releases, and longer durations of excrescent vowels in comparison with the female speakers. Despite the observation that gender of the speaker had less influence on the articulation sequence, the results are in agreement with the hypothesis under articulation rate which assumed that male and female speakers apply different gestural co-ordination patterns. In SF, however, gender of the speaker was found to have less influence on the HP duration and the duration of the epenthetic vowels. Part of these results is in support of the articulation rate hypotheses.

Acoustic results also showed some variability within each group of speakers and for individual speakers. Male speakers exhibited more variability in SI single stops, but the female group showed more variability in SF single stops. In SI and SF two-stop clusters, the male group were more variable in the HP duration of C1 and C2 and in the duration of the excrescent and epenthetic vowels in comparison with the female group. An unexpected finding in this study is that male speakers were generally more variable than female speakers.

The influence of speaking rate was apparent in the EPG, acoustic and Lx data. In the EPG results, the duration of overlap between the two-stop gestures in SI and SF increased at fast speaking rate and decreased at slow speaking rate. However, different clusters varied in the amount of overlap they allow. While /tg/, /dg/, /kt/, /tk/, /gt<sup>h</sup>/, /kb/, bd/, /db/, /bg/, /kd/ were sensitive to the change in speaking rate, /gt/, /bt<sup>h</sup>/ and /gb/ were more resistant to this. The increase in speaking rate has also resulted in a reduction in the percentage of contact, particularly in the velar region. These results support the previous finding that by the increase in the articulation rate, it becomes difficult for the articulators to achieve their targets and maintain a contact. As a result, gestural reduction, or in some cases target undershoot, is more likely to take place in faster articulation rate.

In the acoustic data, the increase in speaking rate resulted in a decrease in the HP duration of SI and SF single stops. This reduction varied from one stop to another. The place of articulation and the articulator(s) involved are the main reasons of this variation. Moreover, fast speaking rate was found to influence the HP duration of C1 and C2, and the gestural co-ordination of two-stop clusters in both SI and SF clusters. As speaking rate increased, duration of the HP of C1 and C2 decreased. The percentage of C1 release also decreased at fast speaking rate. When C1 was released, the duration of the excrescent and epenthetic vowels became shorter. When less time is dedicated to the production of clusters, the duration of segments is expected to decrease. More gestural overlap has also been reported in the literature. The more C1 and C2 are overlapped, the more likely C2 will mask the release of C1. When this is not the case, C2 closure is formed just after the release of C1. This leads to shorter excrescent vowels.

At slow speaking rate, the duration of the HP of SI and SF single stops increased sharply as a result of the longer time spent in articulation. In two-stop clusters in SI and SF position, a decrease in speaking rate resulted in an increase in the HP duration of C1 and C2, and an increase in the duration of the excrescent and epenthetic vowels. This is the result of the looser co-ordination pattern employed at slow speaking rate. The observation that the amount of decrease at fast speaking rate is less than the amount of increase in the HP duration at slow speaking rate was an unexpected finding in the study. However, these results support previous research

findings that speakers become less variable at fast speaking rate. This could be due to the fact that in shorter durations, there is less time to have variations.

In general, results of the influence of speaking rate on the HP duration, the release of C1 and the duration of the excrescent and epenthetic vowels support the hypotheses advanced under articulation rate and support previous results on the influence of fast articulation rate segment duration (e.g. Lindblom 1963; Gay 1981; Arvaniti; 1999; Pickett *et al.* 1999) and on muscle activity (Gay *et al.* 1974).

Despite the fact some clusters did not seem to be influenced by the increase in speaking rate, the two consonantal gestures became more cohesive, leading to less C1 releases and shorter durations of excrescent vowels. At slow speaking rate where the percentage of C1 release was expected to increase, some hypotheses about the influence of speech rate do not seem to hold. This could be interpreted as meaning that a decrease in articulation rate does not necessarily entail a looser gestural coordination. This particular result adds evidence to those obtained by Gay *et al.* (1974), Kent and Netsell (1971) and Kent and Moll (1975), that fast speaking rate does not influence segment duration.

Regarding the influence of speaking rate on voicing, it was established that the timing and duration of voicing in SI and SF single stops and in SI and SF two-stop clusters varied as a function of change in the speaking rate. At fast speaking rate, as the duration of the HP decreased, the voicing component increased relative to the overall duration of the HP. At slow speaking rate, as the duration of the HP increased, the duration of voicing decreased. These results confirm the hypothesis advanced under speech rate that an increase in speech rate results in longer voice durations. These results are consistent with previous results. However, there could be other physiological or prosodic factors which might affect the timing and duration of voicing. Finally, the duration of VOT decreased in fast speaking rate and increased in slow speaking rate. This is in support to the inverse relationship between VOT and speaking rate (Miller and Baer 1983; Miller *et al.* 1986; Pind 1995), but not in agreement with Kessinger and Blumstein (1997).

The influence of voicing quality on gestural coordination may suggest that sharing the same voicing quality might facilitate more overlap between the two consonantal gestures than with two gestures with a different voicing quality. If the glottal state has to change between two stops not sharing the same voicing quality, it

may be easier for the glottal to do so if the glottal gesture is synchronised with the articulatory gesture. However, more clusters with different voicing specification in mono/disyllable words need to be investigated, in order to prove these assumptions.

Results from this study show the importance of timing in speech production. They also show the validity of the gestural approach depicted in articulatory phonology as a crucial framework in studying timing in speech production. Results also prove the validity and reliability of using different phonetic instruments to capture the coordination pattern and the acoustic results (Hassan and Heselwood 2011).

## **7.2 Limitations of the study**

Within the current study, several limitations need to be acknowledged. These limitations are related to the study itself and to the instruments used. Although the thesis examined the influence of a variety of factors on the timing relations of single and two-stop clusters, the study did not investigate other factors such as vowel context and stress, which may have had an influence as well. In addition, due to the large quantity of data and to time constraints, the thesis did not investigate the influence of gender on the timing and the durations of voicing.

Finally, regarding the use of EPG, there is only one limitation. The EPG is not designed to record bilabial closures in clusters containing /b/. As a result, it was not possible to record the duration of overlap between a TT/TB and a LB closure.

Despite the above limitations, the study managed to focus on one of the unexplored areas in Libyan Arabic dialects. It shed some light on the nature of timing in single and two-stop clusters in TLA, one of the understudied dialects in Libya. To the knowledge of the researcher, this thesis is the first to focus on timing relations, including the influence of morphological structure on the gestural coordination of two-stop clusters in TLA, using a variety of instruments. It is the first to use EPG and Lx to investigate TLA. Finally, it is the first to investigate the influence of gender on timing relations of stop(s) in TLA. It is hoped that it will provide some insights and assist in future research on other dialects in Libya. It may also help researchers to understand the differences amongst other regional Arabic dialects.

### 7.3 Suggestions for future research

The current investigation of timing in two-stop consonant clusters is by no means comprehensive. Further investigation and experimentation into articulatory timing and the timing of voicing in TLA are strongly recommended. Additional studies using more advanced instruments, such as real time MRI and electromagnetic articulography, are needed in order to reveal more timing relations in stops and other consonants in TLA, and to take into consideration other factors that may or may not influence these timing relations. Future research could therefore focus on the following areas:

- Since the production of emphatic consonants is different from non-emphatic ones, it would be very interesting to investigate possible influence of pharyngealisation on timing of emphatic stops.
- Further research in the area of gestural co-ordination could usefully investigate the possible influence of voicing on the degree of gestural overlap.
- In addition to using EPG, future research could use other techniques such as ultrasound to obtain a clearer idea of the nature of gestural co-ordination.
- This thesis focused only on TLA. In order to gain a clearer understanding of timing patterns in LA, a comparative study involving other dialects such as BA and FA could be undertaken as well.
- Future studies could focus on the quality of the excrescent vowels in SI and the epenthetic ones in SF position.
- A perceptual experiment could be conducted to explore whether the deletion of the excrescent vowels in SI and the epenthetic vowels in SF affects the perception of words.
- Since the investigation of the influence of morphology was restricted to only some clusters, future research could focus on the influence of the morphological structure using clusters other than stops.

## Appendix A: The influence of speaking rate on gestural coordination (EPG)

### 1) The influence of fast speaking rate

#### A) Two stop clusters in SI

	Word	Syl. per sec.	Dur. of C1 HP	Dur. of Overlap	Dur. Of ICI	Dur. of C2 HP	Dur. of cluster	percentage of decrease
1.	/dkar/	4.9	90	10	--	80	170	24%
2.	/dga:jig/	5.8	40	10	--	50	100	58%
3.	/t <sup>h</sup> gar/	5.3	70	--	10	65	145	27%
4.	/tka:bir/	6.0	50	--	0	70	120	41%
5.	/tga:til/	6.1	40	--	10	90	140	27%
Average		5.6	58	10	10	71	135	35%

The influence of fast speaking rate on SI coronal + dorsal clusters.

	Word	Syl. per sec.	Dur. of C1 HP	Dur. of Overlap	Dur. Of ICI	Dur. of C2 HP	Dur. of cluster	percentage of decrease
1.	/ktab/	6.0	65	20	--	72	129	28%
2.	/kdab/	6.0	67	20	--	75	122	29%
3.	/gtal/	6.0	95	25	--	75	145	22%
4.	/gt <sup>h</sup> af/	5.1	80		0	70	150	38%
5.	/gdar/	6.0	89	15	--	65	139	22%
Average		5.8	79			71	137	28

The influence of fast speaking rate on SI dorsal + coronal clusters.

	Word	Syl. per sec.	Dur. of C1 HP	Dur. of Overlap	Dur. Of ICI	Dur. of C2 HP	Dur. of cluster	percentage of decrease
1.	/bde:/	5.3	117	--	10	40	157	17%
2.	/bt <sup>h</sup> am/	5.4	85+	*	--	40	125	44%
3.	/bd <sup>h</sup> aʃa/	6.0	89+	*	--	50	139	37%
4.	/bta:ti:ɣ/	6.1	42+	*	--	60	102	36%
5.	/bda:faʃ/	6.0	64+	*	--	45	109	43%
6.	/bt <sup>h</sup> awa/	6.2	63+	*	--	60	123	39%
7.	/bd <sup>h</sup> arba/	6.2	82+	*	--	40	122	36%
Average		6.1	70	0	10	48	118	39%

The influence of fast speaking rate on SI /b/ + coronal clusters.

	Word	Syl. per sec.	Dur. of C1 HP	Dur. of Overlap	Dur. Of ICI	Dur. of C2 HP	Dur. of cluster	percentage of decrease
1.	/bke:/	5.3	23+	*		110	133	42%
2.	/bgar/	5.1	98+	*		60	158	31%
3.	/bkalma/	6.1	65+	*		70	153	10%
4.	/bqalbna/	6.2	20+	*		100	120	29%
Average		5.8	61	0		77	144	23%

The influence of fast speaking rate on SI /b/ + dorsal clusters.

	Word	Syl. per sec.	Dur. of C1 HP	Dur. of Overlap	Dur. Of ICI	Dur. of C2 HP	Dur. of cluster	percentage of decrease
1.	/tbaʃir/	5.3	50+	*	--	67+	117	35%
2.	/dbaʃ/	5.3	60+	*	--	73+	133	49%
3.	/tʰbaʃ/	5.0	80+	*	--	93+	173	21%
4.	/dʰbaba/	6.1	70+	*	--	83+	153	41%
Average		5.5	70	0	--	83	153	0.37

The influence of fast speaking rate on SI coronal + /b/ clusters.

	Word	Syl. per sec.	Dur. of C1 HP	Dur. of Overlap	Dur. Of ICI	Dur. of C2 HP	Dur. of cluster	percentage of decrease
1.	/kbas/	5.3	40+	*	--	51+	91	60%
2.	/gbal/	5.0	130+	*	--	53+	183	9%
Average		5.3	80	0	--	62	142	35%

The influence of fast speaking rate on SI dorsal + /b/ clusters.

#### B) Two-stop clusters in SF (Fast)

	Word	Syl. per sec.	Dur. of C1 HP	Dur. of Overlap	Dur. Of ICI	Dur. of C2 HP	Dur. of cluster	percentage of decrease
1.	/hatk/	7.0	49	--	10	55	114	40%
2.	/fatg/	5.3	50	--	30	65	145	33%
Average		6.2	50	--	20	60	130	37%

The influence of fast speaking rate on SF coronal + dorsal clusters.

	Word	Syl. per sec.	Dur. of C1 HP	Dur. of Overlap	Dur. Of ICI	Dur. of C2 HP	Dur. of cluster	percentage of decrease
1.	/nakt/	7.2	68	--	15	49	132	33%
2.	/nakd/	7.2	63	--	15	56	134	32%
3.	/wagt/	6.6	55	--	8	60	123	34%
4.	/ʕagd/	7.2	60	--	8	60	128	38%
5.	/magtʕ/	5.3	44	--	30	53	127	34%
6.	/sdʕdɔgt/	6.7	52	--	16	51	119	33%
7.	/dʕhakt/	6.9	51	--	8	35	106	50%
Average		6.6	54	--	17	54	126	36%

The influence of fast speaking rate on SF dorsal + coronal clusters.

	Word	Syl. per sec.	Dur. of C1 HP	Dur. of Overlap	Dur. Of ICI	Dur. of C2 HP	Dur. of cluster	percentage of decrease
1.	/ktabt/	5.8	53	--	10	40	103	39%
2.	/rabtʕ/	5.6	64	--	30	54	148	35%
3.	/ʕabd/	5.8	67	--	30	52	149	28%
4.	/gabdʕ/	5.4	50	--	30	60	140	33%
Average		5.7	59	--	25	52	135	33%

The influence of fast speaking rate on SF /b/ + coronal clusters.

	Word	Syl. per sec.	Dur. of C1 HP	Dur. of Overlap	Dur. Of ICI	Dur. of C2 HP	Dur. of cluster	percentage of decrease
1.	/habk/	5.1	67	--	16	70	153	24%
2.	/tʕabg/	5.3	83	--	20	44	147	21%
Average		5.4	65	--	23	56	144	27%

The influence of fast speaking rate on SF /b/ + dorsal clusters.

	Word	Syl. per sec.	Dur. of C1 HP	Dur. of Overlap	Dur. Of ICI	Dur. of C2 HP	Dur. of cluster	percentage of decrease
1.	/ʕatʕb/	5.6	55	--	10	64	129	35%

The influence of fast speaking rate on SF /tʕb/ in /ʕatʕb/

	Word	Syl. per sec.	Dur. of C1 HP	Dur. of Overlap	Dur. Of ICI	Dur. of C2 HP	Dur. of cluster	percentage of decrease
1.	/nagb/	5.4	45	--	40	50	135	34%

The influence of fast speaking rate on SF /gb/ in /nagb/.

2) The influence of slow speaking rate

A) The influence of slow speaking rate on SI clusters

	Word	Syl. per sec.	Dur. of C1 HP	Dur. of Overlap	Dur. Of ICI	Dur. of C2 HP	Dur. of cluster	percentage of decrease
1.	/dkar/	2.7	230	--	20	144	394	43%
2.	/dga:yig/	2.1	183	--	10	240	433	45%
3.	/t <sup>h</sup> gar/	2.8	140	--	20	153	313	36%
4.	/tka:bir/	2.2	116	20	--	140	236	14%
5.	/tga:til/	2.2	110	--	10	148	268	28%
Average		2.4	156			165	329	33%

The influence of slow speaking rate on SI coronal + dorsal clusters.

	Word	Syl. per sec.	Dur. of C1 HP	Dur. of Overlap	Dur. Of ICI	Dur. of C2 HP	Dur. of cluster	percentage of decrease
1.	/ktab/	2.6	150	30	--	100	220	21%
2.	/kdab/	2.3	282	--	30	118	430	59%
3.	/gtal/	2.1	327	--	40	105	472	60%
4.	/gt <sup>h</sup> af/	2.3	239	--	40	116	395	39%
5.	/gdar/	2.5	253	--	10	122	385	54%
Average		2.3	250	--		112	380	46%

The influence of slow speaking rate on SI dorsal + coronal clusters.

	Word	Syl. per sec.	Dur. of C1 HP	Dur. of Overlap	Dur. Of ICI	Dur. of C2 HP	Dur. of cluster	percentage of decrease
1.	/bde:/	2.3	238	--	35	120	393	52%
2.	/bt <sup>h</sup> am/	1.8	183	--	35	235	453	51%
3.	/bd <sup>h</sup> aʃa/	1.9	235	--	45	122	402	45%
4.	/bta:ti:χ/	2.2	146	--	30	102	278	42%
5.	/bda:faʃ/	1.9	258	--	30	123	411	54%
6.	/bt <sup>h</sup> awa/	2.2	133	--	27	179	339	41%
7.	/bd <sup>h</sup> arba/	2.0	217	--	29	131	377	50%
Average		2.0	201	--	33	145	379	48%

The influence of slow speaking rate on SI /b/ + coronal.

	Word	Syl. per sec.	Dur. of C1 HP	Dur. of Overlap	Dur. Of ICI	Dur. of C2 HP	Dur. of cluster	percentage of decrease
1.	/bke:/	2.3	137	--	27	162	326	29%
2.	/bgar/	2.0	192	--	30	198	420	45%
3.	/bkalma/	2.0	172	--	18	224	414	59%
4.	/bgalbna/	2.2	116	--	31	158	305	44%
Average		2.0	160	--	26	193	380	49%

The influence of slow speaking rate on SI /b/ + dorsal clusters.

	Word	Syl. per sec.	Dur. of C1 HP	Dur. of Overlap	Dur. Of ICI	Dur. of C2 HP	Dur. of cluster	percentage of decrease
1.	/tbaʃɪr/	2.7	141	--	30	154	325	45%
2.	/dbaʃ/	2.5	290	--	34	129	453	43%
3.	/tʰbaʃ/	2.7	174	--	38	108	320	31%
4.	/dʰbaba/	2.2	269	--	22	159	450	42%
Average		2.5	244	--	31	132	408	38%

The influence of slow speaking rate on SI coronal + bilabial.

	Word	Syl. per sec.	Dur. of C1 HP	Dur. of Overlap	Dur. Of ICI	Dur. of C2 HP	Dur. of cluster	percentage of decrease
1.	/kbas	2.3	197	--	46	110	353	35%
2.	/gbal/	2.4	224	--	22	119	365	45%
Average		2.4	222	--	33	120	375	39%

The influence of slow speaking rate on SI dorsal + bilabial clusters.

B) The influence of slow speaking rate on SF clusters:

	Word	Syl. per sec.	Dur. of C1 HP	Dur. of Overlap	Dur. Of ICI	Dur. of C2 HP	Dur. of cluster	percentage of decrease
1.	/hatk/	2.5	134	--	55	98	287	34%
2.	/fatg/	2.4	100	--	60	144	304	28%
Average		2.5	117	--	58	121	296	31%

The influence of slow speaking rate on SF coronal + dorsal clusters

	Word	Syl. per sec.	Dur. of C1 HP	Dur. of Overlap	Dur. Of ICI	Dur. of C2 HP	Dur. of cluster	percentage of decrease
1.	/nakt/	2.8	175	--	59	99	333	40%
2.	/nakd/	2.8	135	--	70	117	322	38%
3.	/wagt/	2.2	216	--	63	121	400	56%
4.	/ʃagd/	2.3	173	--	62	127	362	50%
5.	/magtʰ/	2.6	142	--	83	105	330	42%
6.	/sdʰdagt/	2.4	139	--	86	90	315	43%
7.	/dʰhakt/	2.5	138	--	77	83	298	29%
Average		2.5	147	--	67	111	325	39%

The influence of slow speaking rate on SF dorsal + coronal clusters.

	Word	Syl. per sec.	Dur. of C1 HP	Dur. of Overlap	Dur. Of ICI	Dur. of C2 HP	Dur. of cluster	percentage of decrease
1.	/ktabt/	2.2	166	--	62	120	352	52%
2.	/rabtʰ/	2.1	118	--	86	160	367	38%
3.	/ʃabd/	2.0	144	--	67	150	365	44%

4.	/gab <sup>s</sup> /	2.4	150	--	80	102	336	38%
Average		2.2	145	--	74	133	355	43%

The influence of slow speaking rate on SF bilabial + coronal clusters.

	Word	Syl. per sec.	Dur. of C1 HP	Dur. of Overlap	Dur. Of ICI	Dur. of C2 HP	Dur. of cluster	percentage of decrease
1.	/habk/	2.5	142	--	86	169	401	50%
2.	/t <sup>s</sup> abg/	2.6	158	--	95	123	380	51%
Average		2.6	149	--	84	132	368	45%

The influence of slow speaking rate on SF bilabial + dorsal clusters.

	Word	Syl. per sec.	Dur. of C1 HP	Dur. of Overlap	Dur. Of ICI	Dur. of C2 HP	Dur. of cluster	percentage of decrease
1.	/fat <sup>s</sup> b/	2.7	150		87	164	405	51%

The influence of slow speaking rate on SF /t<sup>s</sup>b/ in /fat<sup>s</sup>b/.

	Word	Syl. per sec.	Dur. of C1 HP	Dur. of Overlap	Dur. Of ICI	Dur. of C2 HP	Dur. of cluster	percentage of decrease
1.	/nagb/	2.8	149	--	70	142	365	44%

The influence of slow speaking rate on SF /gb/ in /nagb/.

## Appendix B: The influence of speaking rate and gender on Duration (Acoustics)

### 1) The influence of fast speaking rate

#### A) On the duration of single stop:

SI single stops		All		Males		Females	
		Dur. of HP	Std. Dev.	Dur. of HP	Std. Dev.	Dur. of HP	Std. Dev.
1.	/b/	58	15	67	15	48	6
2.	/t/	43	12	43	14	42	11
3.	/d/	52	15	55	17	48	12
4.	/t <sup>s</sup> /	51	16	59	16	43	11
5.	/d <sup>s</sup> /	54	13	57	15	51	11
6.	/k/	53	13	55	13	51	13
7.	/g/	48	13	51	15	46	9
Average		51	14	55	15	47	10

The influence of fast speaking rate on HP duration of SI single stops.

SF single stops		All		Males		Females	
		Dur. of HP	Std. Dev.	Dur. of HP	Std. Dev.	Dur. of HP	Std. Dev.
1.	/b/	110	21	113	25	106	15
2.	/t/	114	26	108	34	119	13
3.	/d/	101	27	99	35	104	16
4.	/t <sup>s</sup> /	116	28	113	36	118	19
5.	/d <sup>s</sup> /	103	23	99	27	108	18
6.	/k/	106	24	101	25	112	21
7.	/g/	99	21	98	27	99	12
Average		107	24	104	30	109	16

The influence of fast speaking rate on HP duration of SF single stops.

B) The influence of fast speaking rate on C1 and C2 HP duration and duration of ICI in SI clusters:

coronal + dorsal		All					Male					Females				
		Dur of C1	Dur Of IV	Dur Of C2	Total	Std Dev.	Dur of C1	Dur Of IV	Dur Of C2	Total	Std Dev.	Dur of C1	Dur Of IV	Dur Of C2	Total	Std Dev.
1.	/dkar/	48	9	47	105	26	56	11	51	117	19	41	8	44	92	26
2.	/dga:jig/	50	14	49	113	29	54	13	46	113	34	46	15	51	112	25
3.	/t <sup>h</sup> gar/	54	13	60	127	27	62	13	54	129	28	46	14	66	126	28
4.	/tka:bir/	41	7	41	90	23	47	7	45	100	21	35	7	38	80	21
5.	/tga:til/	43	11	48	102	19	47	9	51	107	20	39	13	46	98	16
Average		47	11	49	107	25	53	11	49	113	24	41	11	49	102	23

The influence of fast speaking rate on the duration C1 and C2 HP and duration of ICI in SI coronal + dorsal clusters.

dorsal + coronal		All					Male					Females				
		Dur of C1	Dur Of IV	Dur Of C2	Total	Std Dev.	Dur of C1	Dur Of IV	Dur Of C2	Total	Std Dev.	Dur of C1	Dur Of IV	Dur Of C2	Total	Std Dev.
1.	/ktabt/	68	34	55	157	27	53	26	66	145	29	66	34	68	168	25
2.	/kdab/	47	14	62	123	31	47	15	53	115	28	47	13	71	131	31
3.	/gtal/	48	11	54	113	22	50	12	51	113	26	47	9	57	113	18
4.	/gt <sup>h</sup> af/	47	11	56	114	20	49	11	58	118	22	45	10	55	110	18
5.	/gdar/	48	12	55	115	20	50	14	54	119	19	46	10	55	111	21
Average		52	16	56	124	23	50	16	56	122	24	50	15	61	127	22

The influence of fast speaking rate on C1 and C2 HP duration and duration of ICI in SI dorsal + coronal clusters.

bilabial + coronal		All					Male					Females				
		Dur of C1	Dur Of IV	Dur Of C2	Total	Std Dev.	Dur of C1	Dur Of IV	Dur Of C2	Total	Std Dev.	Dur of C1	Dur Of IV	Dur Of C2	Total	Std Dev.
1.	/bde:/	60	3	48	111	28	64	3	53	121	30	57	3	43	102	22
2.	/bt <sup>h</sup> am/	54	2	46	102	23	63	3	47	114	23	45	1	44	90	15

3.	/bd <sup>h</sup> afa/	53	1	46	100	17	59	1	47	107	17	47	1	44	92	14
4.	/bta:ti:ɣ/	45	1	41	86	18	51	1	44	96	16	38	0	38	77	15
5.	/bda:faʃ/	49	1	47	98	20	52	1	48	102	23	47	0	46	94	17
6.	/bt <sup>h</sup> awa/	55	3	50	108	19	60	2	49	112	16	49	4	52	105	20
7.	/bd <sup>h</sup> arba/	55	1	51	107	24	55	1	49	105	29	56	2	52	110	20
Average		53	2	47	102	21	58	2	48	108	22	48	2	46	96	18

The influence of fast speaking rate on C1 and C2 HP duration and duration of ICI in SI bilabial + coronal clusters.

bilabial + dorsal		All					Male					Females				
		Dur of C1	Dur Of IV	Dur Of C2	Total	Std Dev.	Dur of C1	Dur Of IV	Dur Of C2	Total	Std Dev.	Dur of C1	Dur Of IV	Dur Of C2	Total	Std Dev.
1.	/bke:/	56	3	50	109	21	66	4	50	120	21	46	3	50	98	15
2.	/bgar/	50	2	46	97	28	61	2	51	114	27	40	2	40	81	16
3.	/bkalma/	52	4	46	102	27	64	4	47	115	22	40	4	44	89	25
4.	/bgalbna/	53	3	61	116	35	59	3	79	141	31	47	3	42	91	17
Average		53	3	51	106	28	63	3	57	123	25	43	3	44	90	18

The influence of fast speaking rate on C1 and C2 HP duration and duration of ICI in SI bilabial + dorsal clusters.

coronal + bilabial		All					Male					Females				
		Dur of C1	Dur Of IV	Dur Of C2	Total	Std Dev.	Dur of C1	Dur Of IV	Dur Of C2	Total	Std Dev.	Dur of C1	Dur Of IV	Dur Of C2	Total	Std Dev.
1.	/tba:ʃir/	45	6	62	114	25	50	4	55	109	19	41	8	70	119	29
2.	/dbaʃ/	51	4	53	108	20	56	6	56	118	21	46	3	50	98	13
3.	/t <sup>h</sup> baʃ/	53	5	59	117	22	62	6	60	128	20	43	5	57	105	19
4.	/d <sup>h</sup> baba/	53	2	54	108	24	58	3	57	118	28	47	1	50	98	13
Average		51	4	57	112	23	57	5	57	118	22	44	4	57	105	19

The influence of fast speaking rate on C1 and C2 HP duration and duration of ICI in SI coronal + bilabial clusters.

dorsal + bilabial		All					Male					Females				
		Dur of C1	Dur Of IV	Dur Of C2	Total	Std Dev.	Dur of C1	Dur Of IV	Dur Of C2	Total	Std Dev.	Dur of C1	Dur Of IV	Dur Of C2	Total	Std Dev.
1.	/kbas/	53	5	58	115	26	57	6	63	126	27	50	3	52	105	22
2.	/gbal/	51	5	60	116	21	55	5	66	126	21	48	4	54	106	17
Average		52	5	59	116	24	56	6	65	126	24	49	4	53	106	20

The influence of fast speaking rate on C1 and C2 HP duration and duration of ICI in SI dorsal + bilabial clusters.

C) The influence of fast speaking rate on C1 and C2 HP duration and duration of ICI in SF clusters:

coronal + dorsal		All					Male					Females				
		Dur of C1	Dur Of IV	Dur Of C2	Total	Std Dev.	Dur of C1	Dur Of IV	Dur Of C2	Total	Std Dev.	Dur of C1	Dur Of IV	Dur Of C2	Total	Std Dev.
1.	/fatg/	65	36	53	154	8	72	41	56	170	8	57	30	51	138	7
2.	/hatk/	51	26	66	143	5	57	27	67	151	5	45	24	65	135	9
Average		58	31	60	149	7	65	34	62	161	7	51	27	58	137	8

The influence of fast speaking rate on C1 and C2 HP duration and duration of ICI in SF coronal + dorsal clusters.

dorsal + coronal		All					Male					Females				
		Dur of C1	Dur Of IV	Dur Of C2	Total	Std Dev.	Dur of C1	Dur Of IV	Dur Of C2	Total	Std Dev.	Dur of C1	Dur Of IV	Dur Of C2	Total	Std Dev.
1.	/nakt/	61	29	61	151	8	67	33	70	170	1	56	25	52	133	4
2.	/nakd/	59	42	51	152	3	67	43	47	157	5	51	41	55	148	2
3.	/wagt/	49	30	52	131	16	47	31	50	128	19	51	30	53	134	12
4.	/ʕagd/	54	31	52	136	16	51	33	51	136	16	57	28	52	137	16
5.	/magtʕ/	50	27	54	131	21	50	29	53	132	21	50	25	54	130	20
6.	/sdʕdagt/	52	23	53	128	18	49	25	48	122	19	56	21	58	135	15
7.	/dʕhakt/	52	22	52	126	16	48	24	49	121	17	55	20	56	131	14
Average		54	29	54	136	14	54	31	53	138	14	54	27	54	135	12

The influence of fast speaking rate on C1 and C2 HP duration and duration of ICI in SF dorsal + coronal clusters

bilabial + coronal		All					Male					Females				
		Dur of C1	Dur Of IV	Dur Of C2	Total	Std Dev.	Dur of C1	Dur Of IV	Dur Of C2	Total	Std Dev.	Dur of C1	Dur Of IV	Dur Of C2	Total	Std Dev.
1.	/ktabt/	55	18	55	129	19	54	18	49	121	18	56	18	62	137	17
2.	/rabtʰ/	52	24	52	127	21	50	27	49	126	20	53	20	55	128	22
3.	/ʁabd/	54	22	51	127	16	54	21	53	128	18	54	22	49	125	17
4.	/gabdtʰ/	56	23	52	132	17	58	23	53	134	19	55	24	51	130	15
Average		54	22	53	129	18	54	22	51	127	19	55	21	54	130	18

The influence of fast speaking rate on C1 and C2 HP duration and duration of ICI in SF bilabial + coronal clusters.

bilabial + dorsal		All					Male					Females				
		Dur of C1	Dur Of IV	Dur Of C2	Total	Std Dev.	Dur of C1	Dur Of IV	Dur Of C2	Total	Std Dev.	Dur of C1	Dur Of IV	Dur Of C2	Total	Std Dev.
1.	/habk/	55	30	60	145	24	55	29	48	132	17	55	31	71	157	24
2.	/tʰabg/	55	30	46	132	17	57	32	38	127	10	54	28	55	137	20
Average		55	30	53	139	21	56	31	43	130	14	55	30	63	147	22

The influence of fast speaking rate on C1 and C2 HP duration and duration of ICI in SF bilabial + dorsal clusters.

coronal + bilabial		All					Male					Females				
		Dur of C1	Dur Of IV	Dur Of C2	Total	Std Dev.	Dur of C1	Dur Of IV	Dur Of C2	Total	Std Dev.	Dur of C1	Dur Of IV	Dur Of C2	Total	Std Dev.
1.	/ʃatʰb/	60	22	53	135	26	61	23	50	134	24	59	21	56	136	29

The influence of fast articulation rate on C1 and C2 HP duration and duration of ICI in SF /tʰb/ in /ʃatʰb/.

dorsal + bilabial		All					Male					Females				
		Dur of C1	Dur Of IV	Dur Of C2	Total	Std Dev.	Dur of C1	Dur Of IV	Dur Of C2	Total	Std Dev.	Dur of C1	Dur Of IV	Dur Of C2	Total	Std Dev.
1.	/nagb/	52	36	52	140	23	49	34	49	133	21	55	38	54	148	22

The influence of fast articulation rate on C1 and C2 HP duration and duration of ICI in SF /gb/ in /nagb/.

2) The influence of slow speaking rate on the duration of stop

A) The influence of fast articulation rate on single stops:

SI single stops		All		Males		Females	
		Dur. of HP	Std. Dev.	Dur. of HP	Std. Dev.	Dur. of HP	Std. Dev.
1.	/b/	171	68	121	36	220	55
2.	/t/	184	84	241	74	126	47
3.	/d/	170	97	84	15	255	62
4.	/tʰ/	164	69	220	44	108	32
5.	/dʰ/	188	88	115	27	261	64
6.	/k/	162	67	217	47	107	23
7.	/g/	154	66	97	23	211	41
Average		170	77	156	38	184	46

The influence of fast articulation rate on HP duration of SI single stops.

SI single stops		All		Males		Females	
		Dur. of HP	Std. Dev.	Dur. of HP	Std. Dev.	Dur. of HP	Std. Dev.
1.	/b/	179	65	131	38	228	47
2.	/t/	185	88	250	74	119	35
3.	/d/	170	69	118	44	222	47
4.	/tʰ/	167	70	223	44	110	37
5.	/dʰ/	162	72	110	37	215	59
6.	/k/	167	70	218	50	115	45
7.	/g/	163	69	123	45	204	65
Average		170	72	168	47	173	48

The influence of fast articulation rate on HP duration of SF single stops.

B) The influence of slow speaking rate on C1 and C2 HP duration and duration of ICI in SI two-stop clusters:

coronal + dorsal		All					Male					Females				
		Dur of C1	Dur Of IV	Dur Of C2	Total	Std Dev.	Dur of C1	Dur Of IV	Dur Of C2	Total	Std Dev.	Dur of C1	Dur Of IV	Dur Of C2	Total	Std Dev.
1.	/dkar/	101	24	90	215	40	111	27	92	230	42	91	22	88	200	32
2.	/dga:jig/	88	26	76	191	50	103	36	80	219	46	73	16	73	162	35
3.	/t <sup>s</sup> gar/	109	22	89	220	57	127	28	93	248	47	91	15	85	192	52
4.	/tka:bir/	84	27	79	189	32	88	23	79	190	36	79	31	79	189	28
5.	/tga:til/	90	23	83	196	46	101	22	87	211	46	79	23	80	182	42
Average		94	24	83	202	45	106	27	86	220	43	83	21	81	185	38

The influence of slow speaking rate on C1 and C2 HP duration and duration of ICI in SI coronal + dorsal clusters.

dorsal + coronal		All					Male					Females				
		Dur of C1	Dur Of IV	Dur Of C2	Total	Std Dev.	Dur of C1	Dur Of IV	Dur Of C2	Total	Std Dev.	Dur of C1	Dur Of IV	Dur Of C2	Total	Std Dev.
1.	/ktab/	109	66	85	260	33	135	52	131	318	27	112	62	109	283	36
2.	/kdab/	91	20	93	204	45	108	25	99	232	33	73	16	87	176	37
3.	/gtal/	92	24	94	211	36	102	26	94	222	34	83	23	93	199	35
4.	/gt <sup>s</sup> af/	91	26	101	218	47	101	34	103	238	45	81	17	99	198	42
5.	/gdar/	95	20	86	201	37	99	24	87	210	38	90	16	85	191	33
Average		96	31	92	219	40	109	32	103	244	35	88	27	95	209	37

The influence of slow speaking rate on C1 and C2 HP duration and duration of ICI in SI dorsal + coronal clusters.

bilabial + coronal		All					Male					Females				
		Dur of C1	Dur Of IV	Dur Of C2	Total	Std Dev.	Dur of C1	Dur Of IV	Dur Of C2	Total	Std Dev.	Dur of C1	Dur Of IV	Dur Of C2	Total	Std Dev.
1.	/bde:/	112	14	90	215	46	121	14	94	229	44	102	14	85	201	44
2.	/bt <sup>s</sup> am/	115	11	104	230	84	137	15	121	273	98	92	8	87	188	34

3.	/bd <sup>ɬ</sup> aɸa/	108	10	111	229	79	115	16	135	266	88	101	3	87	191	47
4.	/bta:ti:ɣ/	85	11	80	176	51	90	18	87	195	40	80	4	74	158	55
5.	/bda:faɸ/	97	13	90	200	53	113	18	104	235	35	82	7	76	165	43
6.	/bt <sup>ɬ</sup> awa/	103	18	102	222	52	115	23	108	245	40	90	13	96	199	54
7.	/bd <sup>ɬ</sup> arba/	102	10	89	202	53	110	16	96	222	41	95	5	82	181	57
Average		103	12	95	211	60	114	17	106	238	55	92	8	84	183	48

The influence of slow speaking rate on C1 and C2 HP duration and duration of ICI in SI bilabial + coronal clusters.

bilabial + dorsal		All					Male					Females				
		Dur of C1	Dur Of IV	Dur Of C2	Total	Std Dev.	Dur of C1	Dur Of IV	Dur Of C2	Total	Std Dev.	Dur of C1	Dur Of IV	Dur Of C2	Total	Std Dev.
1.	/bke:/	96	11	90	197	49	113	13	86	212	46	80	9	94	183	49
2.	/bgar/	97	9	122	228	60	113	15	95	224	44	81	3	149	233	73
3.	/bkalma/	85	16	82	183	42	94	23	85	203	40	77	8	78	163	34
4.	/bgalbna/	81	14	86	181	43	87	21	93	201	40	75	7	79	160	38
Average		90	13	95	197	49	102	18	90	210	43	78	7	100	185	49

The influence of slow speaking rate on C1 and C2 HP duration and duration of ICI in SI bilabial + dorsal clusters.

coronal + bilabial		All					Male					Females				
		Dur of C1	Dur Of IV	Dur Of C2	Total	Std Dev.	Dur of C1	Dur Of IV	Dur Of C2	Total	Std Dev.	Dur of C1	Dur Of IV	Dur Of C2	Total	Std Dev.
1.	/tbaɸir/	92	22	96	211	41	101	23	97	221	30	83	22	95	200	49
2.	/dbaɸ/	97	21	93	210	36	109	28	89	226	30	84	13	97	195	35
3.	/t <sup>ɬ</sup> baɸ/	109	16	116	241	61	126	16	112	254	47	92	16	120	228	72
4.	/d <sup>ɬ</sup> baba/	100	19	97	216	52	112	29	98	240	47	88	9	96	193	47
Average		100	20	101	220	48	112	24	99	235	39	87	15	102	204	51

The influence of slow speaking rate on C1 and C2 HP duration and duration of ICI in SI coronal + bilabial clusters.

dorsal + bilabial		All					Male					Females				
		Dur of C1	Dur Of IV	Dur Of C2	Total	Std Dev.	Dur of C1	Dur Of IV	Dur Of C2	Total	Std Dev.	Dur of C1	Dur Of IV	Dur Of C2	Total	Std Dev.
1.	/kbas/	92	19	96	207	50	107	23	99	229	39	77	16	94	186	52
2.	/gbal/	103	20	97	220	43	113	24	98	235	42	93	15	96	204	38
Average		98	20	97	214	47	110	24	99	232	41	85	16	95	195	45

The influence of slow speaking rate on C1 and C2 HP duration and duration of ICI in SI dorsal + bilabial clusters.

C) The influence of slow speaking rate on C1 and C2 HP duration and duration of ICI in SF two-stop clusters:

coronal + dorsal		All					Male					Females				
		Dur of C1	Dur Of IV	Dur Of C2	Total	Std Dev.	Dur of C1	Dur Of IV	Dur Of C2	Total	Std Dev.	Dur of C1	Dur Of IV	Dur Of C2	Total	Std Dev.
1.	/fatg/	123	70	90	283	22	125	77	115	317	27	121	62	65	248	16
2.	/hatk	107	69	77	252	19	116	67	86	269	9	97	71	67	235	29
Average		115	70	84	268	21	121	72	101	293	18	109	67	66	242	23

The influence of slow speaking rate on C1 and C2 HP duration and duration of ICI in SF coronal + dorsal clusters.

dorsal + coronal		All					Male					Females				
		Dur of C1	Dur Of IV	Dur Of C2	Total	Std Dev.	Dur of C1	Dur Of IV	Dur Of C2	Total	Std Dev.	Dur of C1	Dur Of IV	Dur Of C2	Total	Std Dev.
1.	/nakt/	100	62	100	262	14	121	55	119	295	25	78	69	81	228	3
2.	/nakd/	95	79	83	257	17	113	74	101	287	6	78	84	64	226	27
3.	/wagt/	78	63	108	249	42	83	61	108	252	48	73	64	108	245	36
4.	/ʕagd/	91	57	106	254	55	96	56	108	259	64	87	58	105	250	44
5.	/magtʕ/	76	57	114	246	41	74	55	112	241	47	78	58	116	251	35
6.	/dʕhakt/	85	49	106	240	52	88	55	107	251	58	81	43	105	229	44
7.	/sdʕdagt/	98	42	111	251	57	114	43	111	268	59	82	41	111	233	50
Average		89	58	104	251	40	98	57	109	265	44	80	60	99	237	34

The influence of slow speaking rate on C1 and C2 HP duration and duration of ICI in SF dorsal + coronal clusters.

bilabial + coronal		All					Male					Females				
		Dur of C1	Dur Of IV	Dur Of C2	Total	Std Dev.	Dur of C1	Dur Of IV	Dur Of C2	Total	Std Dev.	Dur of C1	Dur Of IV	Dur Of C2	Total	Std Dev.
1.	/ktabt/	95	39	116	251	56	101	44	123	267	57	90	34	110	234	52
2.	/rabt <sup>s</sup> /	85	52	126	263	46	94	50	128	272	57	76	53	124	254	29
3.	/ʁabd/	86	55	110	251	45	90	57	116	263	51	82	52	104	239	35
4.	/gabdt <sup>s</sup> /	86	55	113	254	36	88	55	119	263	30	83	56	107	246	41
Average		88	50	116	255	46	93	52	122	266	49	83	49	111	243	39

The influence of slow speaking rate on C1 and C2 HP duration and duration of ICI in SF bilabial + coronal clusters.

bilabial + dorsal		All					Male					Females				
		Dur of C1	Dur Of IV	Dur Of C2	Total	Std Dev.	Dur of C1	Dur Of IV	Dur Of C2	Total	Std Dev.	Dur of C1	Dur Of IV	Dur Of C2	Total	Std Dev.
1.	/habk/	89	51	107	247	47	97	52	113	262	57	82	50	100	232	28
2.	/t <sup>s</sup> abg/	87	55	99	241	51	94	55	103	251	59	80	55	95	230	40
Average		88	53	103	244	49	96	54	108	257	58	81	53	98	231	34

The influence of slow speaking rate on C1 and C2 HP duration and duration of ICI in SF bilabial + dorsal clusters.

coronal + bilabial		All					Male					Females				
		Dur of C1	Dur Of IV	Dur Of C2	Total	Std Dev.	Dur of C1	Dur Of IV	Dur Of C2	Total	Std Dev.	Dur of C1	Dur Of IV	Dur Of C2	Total	Std Dev.
1.	/fat <sup>s</sup> b/	113	50	122	285	69	128	47	126	300	68	98	52	118	269	68

The influence of slow speaking rate on C1 and C2 HP duration and duration of ICI in SF /t<sup>s</sup>b/ in /fat<sup>s</sup>b/.

dorsal + bilabial		All					Male					Females				
		Dur of C1	Dur Of IV	Dur Of C2	Total	Std Dev.	Dur of C1	Dur Of IV	Dur Of C2	Total	Std Dev.	Dur of C1	Dur Of IV	Dur Of C2	Total	Std Dev.
1	/nagb/	86	57	116	259	53	81	54	124	259	45	90	60	109	258	61

The influence of slow speaking rate on C1 and C2 HP duration and duration of ICI in SF /gb/ in /nagb/

### Appendix C: The influence of speaking rate on voicing (Lx)

1) The influence of fast speaking rate on voicing:

A) The influence of fast articulation rate on single stops

SI single stops		Dur. of HP	Dur. of voicing	% of voicing	No. of periods	Voicing category	VOT
1.	/bay/	84	0	0%	0	DV	7
2.	/dam/	68	61	90%	9	VD	3
3.	/d <sup>h</sup> am/	70	69	99%	8	VD	0
4.	/qas <sup>h</sup> /	48	25	52%	2	PD	25
Average		68	39	57%	6	PD	14
5.	/taf/	60	0	0%	0	VLS	17
6.	/t <sup>h</sup> ab/	79	0	0%	0	VLS	12
7.	/kar/	75	0	0%	0	VLS	27
Average		71	0	0%	0	VLS	19

The influence of fast speaking rate on voicing on SI single stops

SF single stops		Dur. of HP	Dur. of voicing	% of voicing	No. of periods	Voicing category
1.	/hab/	133	93	70%	10	PD
2.	/fad /	117	100	85%	8	VD
3.	/ʕad <sup>h</sup> /	130	102	78%	13	VD
4.	/hag/	101	87	86%	11	VD
Average		120	96	80%	11	VD
5.	/nat/	131	0	0%	0	VLS
6.	/bat <sup>h</sup> /	137	0	0%	0	VLS
7.	/ʕak/	130	0	0%	0	VLS
Average		133	0	0%	0	VLS

The influence of fast speaking rate on voicing of SF single stops.

B) The influence of fast speaking rate on voicing of SI two-stop clusters:

SI VD + VD		C1 Dur.	Dur. of voicing	%	prds	Voicing category	Release C1	ICI Dur	Prds	Voicing category	C2 Dur	Dur of voicing	%	Prds	Voicing category	VOT
1.	/bde:/	57	38	67%	1	PD	2	-	-	-	54	30	56%	6	PD	12
2.	/bd <sup>h</sup> aʃa/	58	45	78%	0	VD	2	-	-	-	58	45	78%	10	VD	9
3.	/bgar/	72	28	39%	3	PV	1	6	0	VLS	47	45	96%	5	VD	5
4.	/gbal/	60	60	100%	7	VD	2	-	-	-	63	63	100%	7	VD	0
5.	/gdar/	47	47	100%	6	VD	1	13	2	VD	53	47	89%	6	VD	7
6.	/dbaʃ/	78	17	22%	2	DV	1	7	0	VLS	61	30	49%	3	PV	3
7.	/d <sup>h</sup> baba/	64	46	72%	7	PD	2	-	-	-	68	67	99%	8	VD	0
8.	/dga:jig/	59	59	100%	7	VD	1	14	2	VD	38	26	68%	2	PD	24
9.	/bda:faʃ/	50	31	62%	4	PD	2	0	-	-	50	35	70%	5	PD	0
10.	/bd <sup>h</sup> arba/	53	22	42%	3	PV	2	0	-	-	53	42	79%	6	VD	0
11.	/bgalbna/	73	47	64%	6	PD	1	6	1	VLS	42	42	100%	4	VD	8
Average		61	40	67%	4	PD	2	9	1	VLS	54	44	81%	6	VD	6

The influence of fast speaking rate on voicing of SI VD + VD two-stop clusters

SI VLS + VLS		C1 Dur.	Dur. of voicing	%	prds	Voicing category	Release C1	ICI Dur	Prds	Voicing category	C2 Dur	Dur of voicing	%	Prds	Voicing category	VOT
1.	/ktabt/	47	0	0%	0	VLS	1	15	0	VLS	48	0	0%	0	VLS	15
2.	/tka:bir/	54	0	0%	0	VLS	1	13	0	VLS	50	0	0%	0	VLS	25
Average		58	34	59%	0	VLS	1	10	1	VLS	54	38	70%	0	VLS	7

The influence of fast speaking rate on voicing of SI VLS + VLS two-stop clusters.

SI VD + VLS		C1 Dur.	Dur. of voicing	%	prds	Voicing category	Release C1	ICI Dur	Prds	Voicing category	C2 Dur	Dur of voicing	%	Prds	Voicing category	VOT
1.	/bt <sup>s</sup> am/	62	0	0%	0	DV	2	-	-	-	62	0	0%	0	VLS	18
2.	/bke:/	77	0	0%	0	DV	1	11	0	VLS	63	0	0%	0	VLS	32
3.	/dkar/	52	47	90%	4	VD	1	12	0	VLS	55	0	0%	0	VLS	19
4.	/gtal/	70	22	31%	2	PV	1	13	0	VLS	50	0	0%	0	VLS	33
5.	/gt <sup>s</sup> af/	44	23	52%	3	PD	1	12	0	VLS	71	0	0%	1	VLS	22
6.	/bta.ri:ɣ/	49	0	0%	0	DV	2	-	-	-	44	0	0%	0	VLS	20
7.	/bt <sup>s</sup> awa/	61	0	0%	0	DV	2	-	-	-	61	0	0%	0	VLS	13
8.	/bkalma/	59	50	85%	2	VD	1	12	0	VLS	46	9	20%	0	VLS	28
Average		58	18	31%	2	PD	1	12	0	VLS	55	8	14%	1	VLS	20

The influence of fast speaking rate on voicing of SI VD + VLS two-stop clusters.

SI VLS + VD		C1 Dur.	Dur. of voicing	%	prds	Voicing category	Release C1	ICI Dur	Prds	Voicing category	C2 Dur	Dur of voicing	%	Prds	Voicing category	VOT
1.	/t <sup>s</sup> baʃ/	70	0	0%	0	VLS	2	-	-	-	70	35	50%	4	PD	-33
2.	/t <sup>s</sup> gar/	58	0	0%	0	VLS	2	-	-	-	64	11	17%	1	DV	-4
3.	/kbas/	80	0	0%	0	VLS	1	17	0	VLS	71	68	96%	8	VD	0
4.	/kdab/	55	0	0%	0	VLS	1	20	1	VLS	70	58	83%	8	VD	0
5.	/tba:ʃir/	52	0	0%	0	VLS	2	-	-	-	56	0	0%	0	DV	10
6.	/tqa.til/	52	50	96%	4	VD	1	18	1	VD	40	32	80%	3	VD	0
Average		59	14	23%	1	VLS	1	15	0	VLS	58	18	32%	2	PV	9

The influence of fast speaking rate on voicing of SI VLS + VD two-stop clusters.

C) The influence of fast speaking rate on voicing on SF two-stop clusters:

<b>SF VD + VD</b>		Dur of C1	Dur of voicing	%	No. of periods	Voicing category	C1 Release	Dur of ICI	No. of periods	Voicing category	Dur of C2	Dur of voicing	%	No. of periods	Voicing category
1.	/ʃabd/	54	53	98%	8	VD	1	10	1	VD	47	39	83%	4	VD
2.	/gabdʰ/	50	50	100%	7	VD	1	15	2	VD	51	46	90%	5	VD
3.	/tʰabg/	70	70	100%	10	VD	1	27	4	VD	42	42	100%	5	VD
4.	/nagb/	50	50	100%	7	VD	1	31	5	VD	69	50	72%	6	PD
5.	/ʃagd/	46	46	100%	7	VD	1	30	4	VD	48	48	100%	5	VD
Average		54	54	100%	8	VD	1	23	3	VD	51	45	89%	5	VD

The influence of fast speaking rate on voicing of SF VD + VD two-stop clusters.

<b>SF VLS + VLS</b>		Dur of C1	Dur of voicing	%	No. of periods	Voicing category	C1 Release	Dur of ICI	No. of periods	Voicing category	Dur of C2	Dur of voicing	%	No. of periods	Voicing category
1.	/hatk/	57	10	18%	1	VLS	1	20	0	VLS	44	0	0%	0	VLS
2.	/nakt/	48	3	7%	0	VLS	1	38	1	PD	51	0	0%	0	VLS
3.	/dʰhakt/	48	13	27%	2	VLS	1	15	0	VLS	50	0	0%	0	VLS
Average		53	12	23%	2	VLS	1	18	0	VLS	47	0	0%	0	VLS

The influence of fast speaking rate on voicing of SF VLS + VLS two-stop clusters.

<b>SF VD + VLS</b>		Dur of C1	Dur of voicing	%	No. of periods	Voicing category	C1 Release	Dur of ICI	No. of periods	Voicing category	Dur of C2	Dur of voicing	%	No. of periods	Voicing category
1.	/rabtʰ/	54	54	100%	6	VD	1	10	0	VLS	69	0	0%	0	VLS
2.	/habk/	66	66	100%	8	VD	1	11	0	VLS	69	0	0%	0	VLS
3.	/wagt/	45	45	100%	7	VD	1	24	3	VD	58	0	0%	0	VLS
4.	/magtʰ/	50	50	100%	7	VD	1	21	2	VD	56	0	0%	0	VLS
5.	/ktabt/	45	8	18%	1	DV	1	16	0	VLS	50	0	0%	0	VLS

6.	/s <sup>h</sup> dagt/	36	36	100%	5	VD	1	24	3	VD	45	0	0%	0	VLS
Average		49	43	86%	6	VD	1	18	1	VD	58	0	0%	0	VLS

The influence of fast speaking rate on voicing of SF VD + VLS two-stop clusters.

	<b>SF VD + VLS</b>	Dur of C1	Dur of voicing	%	No. of periods	Voicing category	C1 Release	Dur of ICI	No. of periods	Voicing category	Dur of C2	Dur of voicing	%	No. of periods	Voicing category
1.	/fat <sup>h</sup> b/	59	9	15%	1	VLS	1	19	1	VLS	62	54	87%	6	VD
2.	/fatg/	51	6	11%	0	VLS	1	48	4	VD	55	43	78%	4	VD
3.	/nakd/	55	0	0%	0	VLS	1	43	2	PD	55	36	67%	3	PD
Average		55	5	9%	0	VLS	1	37	2	PD	57	44	77%	4	VD

The influence of fast speaking rate on voicing of SF VLS + VD two-stop clusters.

2) The influence of slow Speaking rate:

A) The influence of slow speaking rate on voicing of single stops:

SI single stops		Dur. of HP	Dur. of voicing	% of voicing	No. of periods	Voicing category	VOT
1.	/baɣ/	145	11	8%	1	DV	0
2.	/dam/	175	40	23%	3	DV	7
3.	/dʰam/	184	72	39%	7	PV	0
4.	/gasʰ/	133	0	0%	0	DV	48
Average		159	31	19%	3	DV	14
5.	/taf/	130	0	0%	0	VLS	25
6.	/tʰab/	155	0	0%	0	VLS	16
7.	/kar/	143	0	0%	0	VLS	57
Average		143	0	0%	0	VLS	33

The influence of slow speaking rate on voicing of SI single stops

SF single stops		Dur. of HP	Dur. of voicing	% of voicing	No. of periods	Voicing category
1.	/hab/	312	128	41%	9	PV
2.	/ʃad /	295	208	71%	12	PD
3.	/ʒadʰ/	279	195	70%	15	PD
4.	/hag/	303	245	81%	19	VD
Average		297	194	65%	14	PD
5.	/nat/	293	0	0%	0	VLS
6.	/batʰ/	293	0	0%	0	VLS
7.	/ʃak/	274	0	0%	0	VLS
Average		287	0	0%	0	VLS

The influence of slow speaking rate on voicing of SF single stops

B) The influence of slow speaking rate on voicing of SI two-stop clusters:

SI VD + VD	HP of C1	Dur. of voicing	%	prds	Voicing category	C1 Release	ICI Dur	Prds	Voicing category	HP of C2	Dur of voicing	%	Prds	Voicing category	VOT
1. /bde:/	157	110	70%	6	PD	1	14	1	VD	104	86	83%	6	VD	5
2. /bd <sup>h</sup> aʃa/	141	25	18%	2	DV	1	7	0	VLS	142	49	35%	4	PV	5
3. /bgar/	117	69	59%	5	PD	2	-	-	-	110	63	57%	5	PD	19
4. /gbal/	133	120	90%	9	VD	1	14	1	VLS	113	49	43%	3	PV	0
5. /gdar/	89	89	100%	7	VD	1	21	2	VD	90	68	76%	5	VD	17
6. /dbaʃ/	125	68	54%	4	PD	1	6	0	VLS	109	34	31%	3	PV	0
7. /d <sup>h</sup> baba/	126	71	56%	5	PD	2	-	-	-	124	58	47%	4	PV	5
8. /dga:yig/	133	43	32%	3	PV	1	14	1	VD	96	69	72%	3	PD	11
9. /bdafaʃ/	123	0	0%	7	DV	1	15	1	VD	96	68	71%	5	PD	16
10. /bd <sup>h</sup> arba/	127	0	0%	0	DV	1	9	1	VLS	126	114	90%	8	VD	4
11. /bgalbna/	122	44	36%	3	PV	1	9	1	VLS	83	39	47%	3	PD	25
Average	125	61	49%	5	PV	1	13	1	VD	110	67	61%	5	PD	9

The influence of slow speaking rate on voicing of SI VD + VD two-stop clusters.

SI VLS + VLS	HP of C1.	Dur. of voicing	%	prds	Voicing category	Release C1	ICI Dur	Prds	Voicing category	HP of C2	Dur of voicing	%	Prds	Voicing category	VOT
1. /ktabt/	93	0	0%	0	VLS	1	28	0	0	95	0	0%	0	VLS	31
2. /tka:bir/	105	0	0%	0	VLS	1	24	2	0	67	0	0%	0	VLS	57
Average	99	0	0%	0	VLS	1	26	1	0	81	0	0%	0	VLS	44

The influence of slow speaking rate on voicing of SI VLS + VLS two-stop clusters

SI VD + VLS		HP of C1	Dur. of voicing	%	prds	Voicing category	Release C1	ICI Dur	Prds	Voicing category	HP of C2	Dur of voicing	%	Prds	Voicing category	VOT
1.	/bt <sup>h</sup> am/	143	0	0%	0	DV	1	20	0	VLS	113	0	0%	0	VLS	26
2.	/bke: /	124	0	0%	0	DV	1	13	0	VLS	84	0	0%	0	VLS	61
3.	/dkar/	96	71	74%	5	PD	1	19	0	VLS	106	0	0%	1	VLS	26
4.	/gtal/	123	18	15%	1	DV	1	21	0	VLS	83	0	0%	0	VLS	65
5.	/gt <sup>h</sup> af/	82	59	72%	4	PD	1	28	0	VLS	98	0	0%	0	VLS	24
6.	/btari: χ/	87	0	0%	0	DV	1	6	0	VLS	77	0	0%	0	VLS	36
7.	/bt <sup>h</sup> awa/	114	0	0%	0	DV	1	15	0	VLS	117	0	0%	0	VLS	32
8.	/bkalma/	105	0	0%	0	DV	1	15	0	VLS	96	0	0%	0	VLS	47
Average		109	19	17%	1	DV	1	17	0	VLS	97	0	0%	0	VLS	40

The influence of slow speaking rate on voicing of SI VD + VLS two-stop clusters

SI VLS + VD		HP of C1	Dur. of voicing	%	prds	Voicing category	Release C1	ICI Dur	Prds	Voicing category	HP of C2	Dur of voicing	%	Prds	Voicing category	VOT
1.	/t <sup>h</sup> baʃ/	112	0	0%	0	VLS	1	14	0	VLS	94	90	96%	3	VD	0
2.	/t <sup>h</sup> gar/	92	0	0%	0	VLS	1	28	0	VLS	106	8	8%	0	DV	0
3.	/kbas/	108	0	0%	0	VLS	1	20	0	VLS	104	92	88%	5	VD	27
4.	/kdab/	120	0	0%	0	VLS	1	26	1	VD	100	100	100%	8	VD	0
5.	/tba:ʃir/	102	0	0%	0	VLS	1	22	0	VLS	99	20	20%	1	DV	3
6.	/tga:til/	89	0	0%	0	VLS	1	27	0	VLS	89	42	47%	2	PV	24
Average		104	0	0%	0	VLS	1	23	0	VLS	99	59	59%	3	PD	9

The influence of slow speaking rate on voicing of SI VLS + VD two-stop clusters.

C) The influence of slow speaking rate on voicing of SF two-stop clusters:

<b>SF VD + VD</b>		HP of C1	Dur of voicing	%	No. of periods	Voicing category	C1 Release	Dur of ICI	No. of periods	Voicing category	HP of C2	Dur of voicing	%	No. of periods	Voicing category
1.	/ʃabd/	96	0	0%	0	DV	1	53	VD	4	83	60	72%	4	PD
2.	/gabdʰ/	91	91	100%	7	VD	1	42	VD	4	97	97	100%	6	VD
3.	/tʰabg/	99	71	72%	5	PV	1	33	VD	3	80	80	100%	7	VD
4.	/nagb/	86	86	100%	7	VD	1	48	VD	5	93	93	100%	8	VD
5.	/ʃagd/	88	88	100%	7	VD	1	55	VD	5	86	53	62%	3	PD
Average		92	67	73%	5	PD	1	46	VD	4	88	77	87%	6	VD

The influence of slow speaking rate on voicing of SF VD + VD two-stop clusters

<b>SF VLS + VLS</b>		HP of C1	Dur of voicing	%	No. of periods	Voicing category	C1 Release	Dur of ICI	No. of periods	Voicing category	HP of C2	Dur of voicing	%	No. of periods	Voicing category
1.	/hatk/	89	0	0%	0	VLS	1	22	VLS	0	119	0	0%	0	VLS
2.	/nakt/	105	0	0	0	VLS	1	80	4	PD	100	0	0	0	VLS
3.	/dʰhakt/	140	0	0%	1	VLS	1	39	VLS	4	117	0	0%	0	VLS
Average		115	0	0%	1	VLS	1	31	VLS	2	118	0	0%	0	VLS

The influence of slow speaking rate on voicing of SF VLS + VLS two-stop clusters

<b>SI VD + VLS</b>		HP of C1	Dur of voicing	%	No. of periods	Voicing category	C1 Release	Dur of ICI	No. of periods	Voicing category	HP of C2	Dur of voicing	%	No. of periods	Voicing category
1.	/rabtʰ/	96	41	43%	2	PV	1	51	VD	5	126	0	0%	1	VLS
2.	/hʌbk/	67	67	100%	6	VD	1	53	VD	4	74	0	0%	0	VLS
3.	/wagt/	96	96	100%	8	VD	1	42	VD	4	88	0	0%	0	VLS
4.	/magtʰ/	93	93	100%	8	VD	1	57	VD	5	96	0	0%	1	VLS

5.	/ktabt/	99	66	67%	4	PD	1	48	VD	4	114	0	0%	0	VLS
6.	/s <sup>h</sup> dagt/	104	104	100%	9	VD	1	53	VD	5	109	0	0%	1	VLS
Average		93	78	84	6	VD	1	51	VD	5	101	0	0%	1	VLS

The influence of slow speaking rate on voicing of SF VD + VLS two-stop clusters

SI VLS + VD		HP of C1	Dur of voicing	%	No. of periods	Voicing category	C1 Release	Dur of ICI	No. of periods	Voicing category	HP of C2	Dur of voicing	%	No. of periods	Voicing category
1.	/jat <sup>h</sup> b/	105	0	0	0	VLS	1	80	4	PD	100	55	55%	4	PV
2.	/fatg/	87	0	0	0	VLS	1	77	6	VD	92	83	92	6	VD
3.	/nakd/	97	6	5	0	VLS	1	71	4	PD	85	56	65	4	PD
Average		96	2	2	0	VLS	1	76	5	PD	92	65	53	5	PV

The influence of slow speaking rate on voicing of SF VLS + VD two-stop clusters

## **Appendix D: Information sheet and consent forms**

### a) Information sheet (English)

#### Information sheet

Title of the research project: An Instrumental Phonetic Investigation of Timing Relations of Two-stop Consonant Clusters in Tripolitanian Libyan Arabic

Researcher: Abdurraouf E shitaw

Phone no. 07845525576

Email address: [ml07ahs@leeds.ac.uk](mailto:ml07ahs@leeds.ac.uk)

Date: 03/05/2011

Dear .....,

You are being invited to participate in a research project. Before deciding whether to participate or not, I would like you to read the summary of this research, and answers to the questions: why have you been chosen to take part in this research? What will you be asked to do? How long will your participation take? and what will happen if you decided to withdraw from the research after taking part? If there is anything that needs explanation or if you have any questions, please feel free to contact me. You can also discuss any of the issues concerning this research with anyone you like.

#### The purpose of the research:

This research aims to provide a thorough description of the temporal patterns of two-stop clusters in syllable-initial and syllable-final clusters in Tripolitanian Libyan Arabic. To investigate these patterns, some words said by native speakers of Libyan Arabic will be recorded using a professional recorder. In this case, you are eligible to take part because you are a native speaker of Libyan Arabic. The recording will then be analysed using computer software. The results of the analysis will reveal the patterns of gestural coordination adopted by speakers of Tripolitanian Libyan Arabic.

The research will shed more light on the Libyan dialect, and will hopefully contribute to future research. It may also help learners who seek to speak Libyan Arabic.

About your participation:

You have been chosen because you are a native speaker of Libyan Arabic, which is the main focus of this research. You will be asked to read some sentences in normal, fast and slow speaking rate. Your speech will be recorded then analysed on a computer. The recording session will take between 30-45 min max. It is a one-time session. There is no risk in participating in this research, and you can decide not to participate, or withdraw from the research within two months of your participation. Your participation will be kept confidential. No names will be used in the research, and you will not be identified by anyone.

If you have any questions, please do not hesitate to contact me any time

Thank you very much for having the time to read this

Best wishes

b) Information sheet (Arabic)

معلومات عن بحث

عنوان البحث:

اسم الباحث: عبد الرؤوف الهاشمي شيتاو

رقم الهاتف: 07845525576

عنوان البريد الإلكتروني: [ml07ahs@leeds.ac.uk](mailto:ml07ahs@leeds.ac.uk)

التاريخ: 18/01/2012

أعزائي المحترمين,, بعد التحية

أنتم مدعون للمشاركة في بحث علمي عن اللهجة الليبية, وقبل أن تقرروا المشاركة في البحث, أتمنى ان تقرءوا الأتي والذي هو إجابة عن الأسئلة الآتية: لماذا تم اختيارك, ما المطلوب منك إذا وافقت على المشاركة, كم من الوقت ستستغرق المشاركة, وماذا سيحصل لو انك قررت سحب مشاركتك. تستطيع مناقشة هذا الموضوع مع أي شخص تريد, ولو احتجت أي توضيحات أرجو الاتصال بي في أي وقت.

طبيعة البحث:

يهدف البحث لدراسة شاملة للعلاقات الزمنية بين الاصوات الانفجارية في مقطع صوتي واحد في اللهجة العربية في طرابلس ليبيا. ويهدف البحث للإجابة عن الأسئلة الآتية: ما انواع هذه العلاقات بين الاصوات الانفجارية المتجاورة في مقطع واحد؟ ما مدى استقرار هذه العلاقات وكيف يؤثر موقع الاصوات في الكلمة عليها.

للإجابة على هذه الأسئلة سيتم تسجيل بعض الجمل وتحليلها على جهاز الحاسوب. سيساهم هذا البحث في تسليط بعض الضوء على اللهجة الليبية وقد يساهم أيضا في مساعدة من يحاول تعلم اللهجة الليبية.

بخصوص مشاركتك:

لقد تم اختيارك لأنك متحدث أصلي للهجة الليبية والتي هي محور هذا البحث. سيطلب منك في حالة الموافقة على المشاركة قراءة بعض الجمل والتي ستسجل وتحلل على الحاسوب. سيستغرق التسجيل حوالي 30-45 دقيقة. ولا يشكل هذا التسجيل إي خطر عليك ستضل المعلومات كلها سرية ولن يتم الإشارة إلى أي أسماء في البحث و يمكنك سحب مشاركتك في أي وقت تشاء.

في حالة وجود أي سؤال أو استفسار, أرجو الاتصال بي على رقم الهاتف أو البريد الإلكتروني المبين

بالأعلى

شكراً لقراءة هذا الملخص

أفضل التمنيات

c) Consent form (English)

Title of Research Project: An Instrumental Phonetic Investigation of Timing Relations in Two-stop Consonant Clusters in Tripolitanian Libyan Arabic

Name of Researcher: Abdurraouf Elhashmi Shitaw

Initial the box if you agree with the statement to the left

- 1 I confirm that I have carefully read the description of the above project dated \_\_\_\_\_ and I have had the opportunity to ask questions about the project.
- 2 I understand that my participation is voluntary and that I am free to withdraw at any time without giving any reason and without there being any negative consequences. In addition, I reserve the right not to answer any questions, without the need to explain why.
- 3 I understand that all my personal information will be completely confidential and that it may be quoted, will be described and analysed.   
All data will be presented with complete anonymity using initials or numbers, not names.
- 4 I agree that my recordings can be used in future research
- 5 I agree to take part in the above research project and will inform the principal investigator should my contact details change.

\_\_\_\_\_  
Name of participant                      Date                      Signature  
(or legal representative)

\_\_\_\_\_  
Lead researcher                      Date                      Signature

d) Consent form (Arabic)

طلب موافقة للمشاركة في بحث علمي

عنوان البحث: : دراسة صوتية معمليّة لدراسة العلاقات الزمنية بين الاصوات الانفجارية المتجاورة في مقطع واحد في اللهجة العربية الليبية في طرابلس  
اسم الباحث: عبدالرؤوف الهاشمي شيتاو  
في حالة الموافقة على الفقرات الآتية، الرجاء وضع الأحرف الأولى من اسمك في المربع

- 1- أؤكد أنني قرأت جيداً وفهمت محتوى البحث العلمي بعنوان "تحليل طيفي للصوامت في" اللهجة العربية الليبية"، المسجل بتاريخ \_\_\_\_\_ وقد أتيت لي الفرصة للسؤال عن هذا البحث.
- 2- أفهم أن مشاركتي تمت بمليء إرادتي وأنه بإمكانني الانسحاب من البحث في أي وقت ومن دون الضرورة لإعطاء أي أسباب ومن دون أي نتائج سلبية. بالإضافة لذلك، بإمكانني الامتناع عن إجابة أي سؤال أو أسئلة معينة من دون الحاجة لذكر لأسباب الرفض.
- 3- أفهم أن مشاركتي ستظل سرّاً. و أعطيت الحرية للباحث في الرجوع إلى مشاركتي من دون ترميز، الاقتباس منها، ووصفها وتحليلها. أفهم أن اسمي لن يربط بمادة البحث، وسوف يستخدم الباحث أرقام وليس أسماء للإشارة إلى مشاركتي.
- 4- أوافق على ان تستخدم هذه التسجيلات في البحوث المستقبلية.
- 5- أوافق على مشاركتي في البحث المذكور أعلاه وسأبلغ الباحث في حالة تغيير عنوان سكني أو رقم هاتفي.

_____	_____	_____
التوقيع	التاريخ	اسم المشارك
_____	_____	_____
التوقيع	التاريخ	اسم الباحث

عند إنهاء توقيع هذا الطلب من الجميع يجب إعطاء نسخة منه إلى الشخص المشارك في البحث. كما يعطى المشارك نسخة عن ملخص البحث وعن أي وثيقة تم استخدامها في هذه المشاركة. يجب أيضاً حفظ نسخة من هذه الموافقة مع البحث وفي مكان أمين.

أسم المتقدم بالطلب: عبدالرؤوف الهاشمي شيتاو

## Appendix E: Word list

### A) Syllable-initial and syllable-final single stops

SI single stops			SF single stops		
	Word	Gloss		Word	Gloss
بخ	/baχ/	‘he sprayed’	حب	/ħab/	‘he loved’
تش	/taʃ/	‘he lit a fire’	نت	/nat/	‘he yelled’
دم	/dam/	‘blood’	شد	/ʃad/	‘he caught’
طب	/tʰab/	‘he kicked’	بط	/batʰ/	‘docks’
ضم	/dʰam/	‘he packed’	عض	/ʕadʰ/	‘he bit’
كر	/kar/	‘he towed’	شك	/ʃak/	‘suspicion’
قص	/qasʰ/	‘he cut’	حق	/ħaq/	‘right’

### B) Syllable-initial and syllable-final two-stop clusters

SI two-stop clusters			SF two-stop clusters		
Arabic	Word	Gloss	Arabic	Word	Gloss
دكر	/dkar/	‘male’			
دقائق	/dga:jig/	‘minutes’			
طقر	/tʰgar/	‘he tapped’			
تكابر	(/tka:bir/)	‘you brag’	هتك	/hatk/	‘violation’
تقاتل	(/tga:til/)	‘you fight’	فتق	/fatg/	‘hernia’
كتبت	/ktab/	‘he wrote’	نكت	/nakt/	‘unpacking’
كذب	/kdab/	‘he lied’	ضحكت	(/dʰhakt/)	‘you laughed’
قتل	/gtal/	‘he killed’	نكد	/nakd/	‘boring’
طقر	/gtʰaf/	‘he picked’	وقت	/wagt/	‘time’
قدر	/gdar/	‘he was able’	صدقت	(/sʰdagt/)	‘I/you told the truth’
بدي	/bde:/	‘he started’	مقط	/magtʰ/	‘a kind of ropes’
بدافع	/bda:faʕ/	‘with a motive’	عقد	/ʕagd/	‘knotting’
بطم	/btʰam/	‘he buttoned’	عبد	/ʕabd/	‘slave’
بطاوة	(/btʰa:wa/)	‘with a pan’	ربط	/rabtʰ/	‘tying’
بضاعة	(/bdʰa:ʕa/)	‘goods’	قبض	/gabdʰ/	‘arresting’
بضربة	(/bdʰarba/)	‘with a strike’	كتبت	(/ktabt/)	‘I/you wrote’
بتاريخ	(/bta:ri:x/)	‘on the (date)’	حكيت	/ħabk/	‘angrily’
بكي	/bke:/	‘he cried’	طبقت	/tʰabg/	‘drilling’
بكلمة	(/bkalma/)	‘with a word’			
بقر	/bgar/	‘cows’			
بقالبنا	(/bqalbna/)	‘with our heart’			
تباشير	(/tba:ʃir/)	‘you commence’			
دبش	/dbaʃ/	‘clothes’			
طبع	/tʰbaʕ/	‘he typed’	شطب	/ʃatʰb/	‘delete’
ضبابة	/dʰbaba/	‘fog’			
كبس	/kbas/	‘he pressed’			
قبل	/qbal/	‘he accepted’	نقب	/nagb/	‘puncturing’

C) Intervocalic geminate stops

Intervocalic geminate stops		
Arabic	Word	Gloss
دَبَّاح	/dabbah/	'he slaughtered'
وَتَّأ	/watta/	'he prepared'
هَدَّأ	/hadda/	'he slowed down'
قَطَّع	/gat <sup>t</sup> ʿaʃ/	'he cut'
عَطَّمَ	/ʕad <sup>d</sup> ʿam/	'he blessed'
بَكَّأ	/bakka/	'he made cry'
نَقَّب	/naggib/	'he punctured'

## References

- Abdelli-Beruh, N. (2009). Influence of place of articulation on some acoustic correlates of the stop voicing contrast in Parisian French. *Journal of Phonetics*, **37** (1), 66-78.
- Abdu, H. (1988). *Italian Loanwords in Colloquial Libyan Arabic as Spoken in the Tripoli Region*. PhD. dissertation, University of Arizona.
- Abercrombie, D. (1967). *Elements of general phonetics*. Edinburgh: Edinburgh University Press.
- Abudalbh, M (2010). *Effects of Gender on the Production of Emphasis in Jordanian Arabic: A Sociophonetic Study*. MA. dissertation, University of Kansas.
- Abumdas, A. (1985). *Libyan Arabic phonology*. PhD. dissertation, University of Michigan.
- Ahmed, A. (2008). *Production and perception of Libyan Arabic vowels*. PhD. dissertation, Newcastle University.
- Al-Ageli, H. (1995). *Syllabic and Metrical Structure in Tripolitanian Arabic: A Comparative Study in Standard and Optimality Theory*. PhD. dissertation, University of Essex.
- Amerman, J. and R. Daniloff (1970). Lip and jaw coarticulation for the phoneme /æ/. *Journal of Speech and Hearing Research*, **13**, 147-161.
- Al-Masri, M. and A. Jongman (2004). Acoustic correlates of emphasis in Jordanian Arabic: Preliminary results. *Proceedings of the 2003 Texas Linguistics Society Conference*, 96–106.
- Al-Masri, M. (2009). *The acoustic and perceptual correlates of emphasis in urban Jordanian Arabic*. PhD. dissertation, University of Kansas.
- Allen, J., J. Miller and D. DeSteno (2003). Individual talker differences in voice-onset-time. *Journal of the acoustical society of America*, **113**, 544-552.
- Alorifi, F. (2008). *Automatic identification of Arabic dialects using hidden Markov models*. PhD. dissertation, University of Pittsburgh.
- Alphen, V., M. Petra and R. Smits (2004). Acoustical and perceptual analysis of the voicing distinction in Dutch initial plosives: the role of prevoicing. *Journal of Phonetics*, **32**, 455-491.

- Al-Tamimi, J. and M. Barkat-Defradas (2003). Inter-dialectal and inter-individual variability in production and perception. I. Ferrando, J. and A. Cádiz (eds), *A preliminary study in Jordanian and Moroccan Arabic. Proceedings of the 5th Conference in AIDA*. Universidad de Cádiz, 171-186.
- Arkebauer H., T. Hixon and J. Hardy (1967). Peak intraoral air pressures during speech. *Journal of speech hear research*, **10**,196-208.
- Articulate Assistant User Guide 2003-2007.
- Arvaniti, A. (1999). Effects of speaking rate on the timing of single and geminate sonorants. *Proceedings of the XIVth International Congress of Phonetic Sciences*, **1**, 599-602. San Francisco.
- Ashby, M. and J. Maidment (2005). *Introducing phonetic science*. Cambridge: Cambridge University Press.
- Aurayie, A. (1982). The phonology of the verb in Libyan Arabic. PhD. dissertation, University of Washington.
- Barry, M. (1992). Palatalisation, assimilation and gestural weakening in connected speech. *Speech communication*, **11**(4), 393-400.
- Bauer, D., J. Kannampuzha, P. Hoole and B.Kröger (2010). Gesture duration and articulator velocity in plosive-vowel-transitions. *In Development of Multimodal Interfaces: Active Listening and Synchrony*, 346–353). Springer Berlin Heidelberg.
- Behrman, A. (2007). *Speech and Voice Science*. Plural Inc.
- Bell-Berti, F. and K. Harris (1981). A temporal model of speech production. *Phonetica*, **38** (1-3), 9-20.
- Bentahila, A. (1991). Standards for Arabic: One, Two or Many? *Indian Journal of Applied Linguistics*, **17**, 69–88.
- Bengochea, J. (2007). Place of Articulation and Consonantal Strength. *CamLing*, 154–161.
- Berg, J. (1958). Myoelastic-aerodynamic theory of voice production. *Journal of Speech and Hearing Research*, **3** (1): 227-244.
- Berry, J. (2011). Speaking Rate Effects on Normal Aspects of Articulation: Outcomes and Issues. *SIG 5 Perspectives on Speech Science and Orofacial Disorders*, **21** (1), 15-26.

- Blevins, J. and A. Garrett (2004). The evolution of metathesis. In B. Hayes, R. Kirchner, and D. Steriade (Eds.). *Phonetically based phonology*, 117-156. Cambridge: Cambridge University Press.
- Bloomfield, L. (1933). *Language*. New York: Henry Holt.
- Boudlal, A (2001). *Constraint interaction in the phonology and morphology of Casablanca Moroccan Arabic*. PhD. dissertation, Mohammed V University, Rabat.
- Boyce (1990). Coarticulatory organization for lip-rounding in Turkish and English. *Journal of the Acoustical Society of America*, **88**, 2584-2595.
- Broselow, E. (1976). The Phonology of Egyptian Arabic. Ann Arbor: Michigan.
- Browman, C. and L. Goldstein (1986). Towards an articulatory phonology. *Phonology yearbook*, **3** (21), 9-252.
- Browman, C. and L. Goldstein (1988). Some notes on syllable structure in articulatory phonology. *Phonetica*, **45** (2-4), 140-155.
- Browman, C. and L. Goldstein (1989a). Articulatory gestures as phonological units. *Phonology*, **6** (2), 201-251.
- Browman, C. and L. Goldstein (1989b). Gestural structures and phonological patterns. *Haskins Laboratories Status Report on Speech Research*, 1-23.
- Browman, C. and L. Goldstein (1990a). Gestural specification using dynamically-defined articulatory structures. *Journal of Phonetics*, **18** (3), 299-320.
- Browman, C. and L. Goldstein (1990b). Tiers in articulatory phonology, with some implications for casual speech. In J. Kingston and M. Beckman, *Papers in laboratory phonology I: Between the grammar and physics of speech*. Cambridge: Cambridge University Press, 341-376.
- Browman, C. and L. Goldstein (1992). Articulatory phonology: An overview. *Phonetica*, **49**, 155-180.
- Browman, C. and L. Goldstein (2000). Competing constraints on intergestural coordination and self-organization of phonological structures. *Les Cahiers de l'ICP. Bulletin de la communication parlée*, **5**, 25-34.
- Brutel-Vuilmet, C. Fuchs and S. Fuchs (2008). Rate effects on aerodynamics of intervocalic stops: Evidence from real speech data and model data. In Zygis, M. and S. Fuchs (eds.), *ZAS Papers in Linguistics* **49. Papers in Phonetics and Phonology**, 1-21.

- Butcher, A. and E. Weiher (1976). An electropalatographic investigation of coarticulation in VCV sequences. *Journal of Phonetics*, **4**, 59-74.
- Butcher, A. (1989) Measuring coarticulation and variability in tongue contact patterns. *Clinical linguistics and phonetics*, **3**, 39-47.
- Byrd, D. (1993). 54,000 American stops. *UCLA Working Papers in Phonetics*, **83**, 97-116.
- Byrd, D. (1994). *Articulatory timing in English consonant sequences*. PhD. dissertation, University of California, Los Angeles.
- Byrd, D. (1996a). Influences on articulatory timing in consonant sequences. *Journal of Phonetics*, **24** (2), 209-244.
- Byrd, D. and C. Tan (1996b). Saying consonant clusters quickly. *Journal of Phonetics*, **24**(2), 263–282.
- Carlson, R., B. Grandstrom, and D. Klatt (1979). Some notes on the perception of temporal patterns in speech. *In Proceedings of the Ninth International Congress of Phonetic Sciences*, **1**, 260-267.
- Chapin, H. (2004). *Libya*. Montana:US, Kessinger Publishing Co.
- Chitoran, I., L. Goldstein, and D. Byrd (2002). Gestural overlap and recoverability: Articulatory evidence from Georgian. In C. Gussenhoven, N. Warner and N. Warner (eds.), *Papers in Laboratory Phonology 7*. Mouton de Gruyter, 419-448.
- Cho, T. and P. Ladefoged (1999). Variation and universals in VOT: evidence from 18 languages. *Journal of Phonetics*, **27**(2), 207-229.
- Catford, J. (1977). *Fundamental Problems in Phonetics*. Edinburgh: Edinburgh University Press.
- Corriente, F. (1978). DL doublets in classical Arabic as evidence of the process of De-Lateralisation of DAD and development of its standard reflex. *Journal of Semitic Studies*, **23** (1), 50-55.
- Davidson, L. (2005). Addressing phonological questions with ultrasound. *Clinical Linguistics & Phonetics*, **19**, 619-633.
- Davidson, L. and K. Roon (2008). Durational correlates for differentiating consonant sequences in Russian. *Journal of the International Phonetic Association*, **38**, 137-165.

- De Jong, K., B. Lim, B. K. Nagao (2004). The perception of syllable affiliation of singleton stops in repetitive speech. *Language and speech*, **47**, 241-266.
- Delattre, P., A. Berman and F. Cooper (1962). Formant transitions and loci as acoustic correlates of place of articulation in American fricatives. *Studia linguistica*, **16** (1-2), 104-122.
- Dell, F. and M. Elmedlaoui (2002). *Syllables in Tashlhiyt Berber and in Moroccan Arabic* (Vol. 2). Taylor & Francis US.
- Dixit, R. and J. Flege (1991). Vowel context, rate, and loudness effects on linguapalatal contact patterns in Hindi retroflex /ʈ/. *Journal of Phonetics*, **19**, 213-229.
- Docherty, G. (1992). *The Timing of voicing in British English obstruents*. Berlin: Foris Publications.
- Duez, D. (1999). Effects of articulation rate on duration in read French speech. In *EUROSPEECH'99*, 715-718.
- El-fitoury, A. (1976). *A descriptive grammar of Libyan Arabic*. PhD. dissertation, Washington, Georgetown University.
- Elgadi, A. (1986). *Tripolitanian Arabic phonology and morphology: A generative approach*. PhD. dissertation, Georgetown University.
- Elgibali, A. (1996). *Understanding Arabic: essays in contemporary Arabic linguistics in honor of El-Said Badawi*. Cairo, Egypt: American University in Cairo Press.
- Erwin, W. (1963). *A short reference grammar of Iraqi Arabic*. Georgetown University Press.
- Evans-Pritchard, E. E. (1949). *The Sanusi of Cyrenaica*. Oxford: Clarendon Press.
- Farnetani, E. and D. Recasens (1997). Coarticulation and connected speech processes. In W. Hardcastle, J. Laver, J. and F Gibbon (Eds.) *The handbook of phonetic sciences* (Vol. 79). John Wiley and Sons.
- Farwaneh, S. (2009). Towards a typology of Arabic dialects: The role of final consonantality. *Journal of Arabic and Islamic Studies*, **9**, 82-109.
- Ferguson, C. (1959). Diglossia. *Word*, **15**, 325-333.
- Flege, J. (1979). *Phonetic interference in second language acquisition*. Phd. dissertation. Indiana University

- Flege, J. (1988). The development of skill in producing word-final English stops: Kinematic parameters. *Journal of the acoustical society of america*, **84**: 1639-1652.
- Fougeron, C., Y. Meynadier, and D. Demolin, (2000). 62 vs. 96 electrodes: a comparative analysis of Reading and Kay Elemetrics EPG pseudo-palates. In *Proceedings of Seminar on Speech Production: Models and Data-CREST Workshop on Models on Speech Production: Motor Planning and Articulatory Modelling*, 1-4.
- Fourcin, A. and E. Abberton (1977). Laryngograph studies of vocal-fold vibration. *Phonetica*, **34** (4), 313-315.
- Fourcin, A. (2000). Precision stroboscopy, voice quality and electrolaryngography. *Voice Quality Measurement*. San Diego, CA: Singular Publishing Group.
- Fowler, C. (1980). Coarticulation and theories of extrinsic timing. *Journal of Phonetics*, **8**, 113-133.
- Fowler, C. (1986). An event approach to the study of speech perception. *Journal of Phonetics*, **14**, 3-28.
- Fowler, C. (1990). Some regularities in speech are not consequences of formal rules: comments on Keating's paper. In J. Kingston and M. Beckman (Eds.). *Papers in Laboratory Phonology: Between the Grammar and Physics of Speech* (Vol. 1), 476-489. Cambridge University Press.
- Fowler, C. (1992). Vowel duration and closure duration in voiced and unvoiced stops: There are no contrast effects here. *Journal of Phonetics*, **20** (1), 143-165.
- Fowler, C. and E. Saltzman (1993). Coordination and coarticulation in speech production. *Speech Communication*, **36** (2, 3), 171-195.
- Fujimura, O. and M. Sawashima, (1971). Consonant sequences and laryngeal control. *Annual Bulletin, Research Institute of Logopedics and Phoniatrics, University of Tokyo* 5, 1-6.
- Gafos, A. (2002). A grammar of gestural coordination. *Natural language and linguistic theory*, **20**, 269–337.
- Gafos, A., J. Shaw, P. Hoole and C. Zeroual (2009). Syllabification in Moroccan Arabic: Evidence from patterns of temporal stability in articulation. *Phonology*, **26**, 187-215.

- Gafos, A., P. Hoole and C. Zeroual (2011). Preliminary study of Moroccan Arabic word-initial consonant clusters and syllabification using electromagnetic articulography. In Z. Hassan and B. Heselwood (Eds.) *Instrumental Studies in Arabic Phonetics*, **319**, 29-45.
- Gairdner, W. (1925). *The phonetics of Arabic*. London: Oxford University Press.
- Gaitenby, J. (1965). The elastic word. *Haskins Laboratories Status Report on Speech Research SR-2*. New Haven, 2, 1-3.
- Gay, T., T. Ushijima, H. Hirose, and F. Cooper (1974). Effects of speaking rate on labial consonant-vowel articulation. *Journal of phonetics*, **2**, 47-63.
- Gay, T. (1981). Mechanisms in the control of speech rate, *Phonetica*, **38**, 148-158.
- Gay, T. (1974). A cinefluorographic study of vowel production. *Journal of Phonetics*, **2**, 255-266.
- Ghazali, S. (1977). Back consonants and backing coarticulation in Arabic. PhD. dissertation, University of Texas at Austin.
- Ghazali, S., R. Hamdi and Melissa Barkat (2002). Speech rhythm variation in Arabic dialects. *Proceedings from Speech Prosody 2002, Aix-en-Provence, France*, April 11-13, 2002, 331-334. From ISCA Archive. Available at: <http://citeseerx.ist.psu.edu/viewdoc/summary?doi=10.1.1.2.6127>
- Gósy, M. (1999). Predictability of voicing assimilation in speech production. *Proceedings of the 14th International Congress of Phonetic Sciences*, 1905-1908, San Francisco.
- Griffini, E. (1913). *L'Arabo parlato della Libia*. Milano: Ulrico Hoepli.
- Hall, N. (2003). Gestures and segments: *Vowel intrusion as overlap*. PhD. dissertation, University of Haifa.
- Hall, N. (2011). Vowel Epenthesis. In van Oostendorp, Marc; Ewen, Colin J.; Hume, Elizabeth; Rice, Keren (eds.). *The Blackwell Companion to Phonology*. Malden, MA & Oxford: Wiley-Blackwell, pp. 1576-1596.
- Hall, N. (2013). Acoustic differences between lexical and epenthetic vowels in Lebanese Arabic. *Journal of Phonetics*, **41** (2), 133-143.
- Halle, M., G. Hughes, and P. Radley (1957). Acoustic properties of stop consonants. *Journal of the acoustical society of America*, **1**, 107-116.

- Hardcastle, J. (1984). New methods of profiling lingual-palatal contact patterns with electropalatography. *Phonetics Laboratory University of Reading Work in Progress*, **4**, 1-40.
- Hardcastle, W. (1972). The use of electropalatography in phonetic research. *Phonetica*, **25**, 197-215.
- Hardcastle, W. (1973). Some observations on the tense-lax distinction in initial stops in Korean. *Journal of Phonetics*, **1**, 263-272.
- Hardcastle, W. (1981). Experimental studies in lingual coarticulation. In R. Asher, and E. Henderson (eds.), *Phonetics Laboratory University of Reading Work in Progress*, **3**, 51-78.
- Hardcastle, W. (1985). Some phonetic and syntactic constraints on lingual coarticulation during /kl/ sequences. *Speech Communication*, **4**, 247-263.
- Harrell, R., S. Richard and L. Brunot (2004). *A short reference grammar of Moroccan Arabic*. Washington, D.C.: Georgetown University Press.
- Harrama, A. (1993). *Libyan Arabic morphology: Al-Jabal dialect*. PhD. dissertation, University of Arizona.
- Harrison, R. (1967). Migrants in the City of Tripoli. *American Geographical society*, **57**, 397-423.
- Hassan, Z. and B. Heselwood (Eds.) (2011). *Instrumental studies in Arabic phonetics* (Vol. 319). John Benjamins Publishing.
- Henke, W. (1966). *Dynamic articulatory model of speech production using computer simulation*. PhD. dissertation, Massachusetts Institute of Technology
- Henton, C., P. Ladefoged and I. Maddieson (1992). Stops in the world's languages. *Phonetica*, **49**, 65-101.
- Henton, C. (1995). Cross-language variation in the vowels of female and male speakers. *Proceedings of the 8th International Congress of Phonetic Sciences, Stockholm*. Vol **4**, 420-423
- Hermes, A., M. Grice, D. Mücke and H. Niemann (2008). Articulatory indicators of syllable affiliation in word initial consonant clusters in Italian. *Proceedings of the 8th International Seminar on Speech Production*, pp. 433-436.

- Hertrich, I. and H. Ackermann (1995). Coarticulation in slow speech: durational and spectral analysis. *Language and Speech*, **38** (2), 159-187.
- Heselwood, B. (1992). *Extended axiomatic functionalist phonology: an exposition with application to Modern Standard Arabic*. PhD Thesis, University of Ulster.
- Heselwood, B. (1996). Glottal states and emphasis in Baghdadi and Cairene Arabic: synchronic and diachronic aspects. *University of Durham Center for Middle Eastern and Islamic Studies, Occasional Paper*, (53).
- Heselwood, B. (2007). Schwa and the phonotactics of RP English. *Transactions of the Philological Society*, 105, **2**, 148-187.
- Heselwood, B., S. Howard and R. Ranjous (2011). Assimilation of /l/ to /r/ in Syrian Arabic. In Z. Hassan and B. Heselwood (eds), *Instrumental Studies in Arabic Phonetics*. Amsterdam: John Benjamins, 63-98.
- Heselwood, B. (2013). *Phonetic Transcription in Theory and Practice*. Edinburgh University Press.
- Heselwood, B. and J. Watson (2013). The Arabic definite article does not assimilate. *Leeds Working Papers in Linguistics & Phonetics* **18**, 34-53.
- Hirose, H. (1976). Posterior cricoarytenoid as a speech muscle. *Ann. Rhinol. Laryngol*, **85**, 334-342.
- Hirose, H. and M. Sawashima, (1982). Velocity of articulatory movements in normal and dysarthric subjects. *Folia Phoniatrica et Logopaedica*, **34**(4), 210-215.
- Hoequist, C. (1983). Syllable duration in stress-, syllable- and mora-timed languages. *Phonetica*, **40**(3), 203-237.
- Hong, K., H. Kim and S. Niimi (2002). Laryngeal gestures during stop production using high speed digital images. *Journal of Voice*, **16**, 207-214.
- Huggins, A. (1978). Speech timing and intelligibility. *Requiem Attention and Performance*, **7**, 278-297.
- Jacewicz, E., R. Fox, C. O'Neill and J. Salmons (2009). Articulation rate across dialect, age, and gender. *Language variation and change*, **21**(02), 233-256.
- Jones, D. (1969). *The pronunciation of English*. Cambridge University Press.
- Jun, J. (1995). *Perceptual and articulatory factors in place assimilation: An Optimality Theoretic approach*. PhD. UCLA.

- Jun, J. (1996). Place assimilation is not the result of gestural overlap: evidence from Korean and English. *Phonology*, **13**, 377-407.
- Jun, S. (1993). *The Phonetics and Phonology of Korean Prosody*. PhD. dissertation, Ohio State University, Columbus, Ohio.
- Keating, P. (1984). Universal phonetics and the organisation of grammars. *UCLA Working Papers in Phonetics*, **59**, 35-49.
- Keating, P. (1985a). Linguistic and nonlinguistic effects on the perception of vowel duration. *UCLA Working Papers in Phonetics*, **60**, 20-39.
- Keating, P. (1985b). Universal phonetics and the organization of grammars. In V. Fromkin (ed.), *Phonetic Linguistics*. Academic Press, 115-132
- Keating, P. (1988). Palatals as complex segments: X-ray evidence. *UCLA Working Papers in Phonetics*, **69**, 77-91.
- Keating, P. (1990). The window model of coarticulation: Articulatory evidence. In J. Kingston and M. Beckman (eds.), *Papers in Laboratory Phonology I: Between the Grammar and Physics of Speech*, 451-470. Cambridge: Cambridge University Press.
- Kelso, J., E. Saltzman and B. Tuller (1986). The dynamical perspective on speech production: Data and theory. *Journal of Phonetics*.
- Kent, R. and R. Netsell (1971). Effects of stress contrasts on certain articulatory parameters. *Phonetica*, **24** (1), 23-44.
- Kent, R. and K. Moll (1975). Articulatory timing in selected consonant sequences. *Brain and Language*, **2**, 304-323.
- Kent, R. and C. Read (1992). *The acoustic analysis of speech*. San Diego, Calif.: Singular Pub. Group.
- Kerr, A. W., H. Hall and S. Kozub (2002). *Doing statistics with SPSS*. Sage.
- Kewley-Port, D. and P. Luce (1984). Time-varying features of initial stop consonants in auditory running spectra: A first report. *Perception & psychophysics*, **35**(4), 353-360.
- Kessinger, R. and S. Blumstein (1997). Effects of speaking rate on voice-onset time in Thai, French, and English. *Journal of Phonetics*, **25** (2), 143-168.
- Khattab, G., F. Al-Tamimi and B. Heselwood, (2006). Acoustic and auditory differences in the /t/- /T/ opposition in male and female speakers of

- Jordanian Arabic. In S. Boudelaa (Ed.), *Perspectives on Arabic Linguistics XVI: Papers from the sixteenth annual symposium on Arabic linguistics*, 131–160. Cambridge, UK: John Benjamins.
- Kiparsky, P. (2003). Syllables and moras in Arabic. In Caroline Féry & Ruben van de Vijver (eds.) *The syllable in Optimality Theory*. Cambridge: Cambridge University Press. pp147-182.
- Klatt, D. (1975). Voice onset time, friction, and aspiration in word-initial consonant clusters. *Journal of speech and hearing research*, **18**, 686-706.
- Koenig, L. (2000). Laryngeal factors in voiceless consonant production in men, women, and 5-year-olds. *Journal of speech language and hearing research*, **43**, 1211–1228.
- Kohler, K. J. (1992). Gestural reorganization in connected speech: a functional viewpoint on ‘articulatory phonology. *Phonetica*, **49** (3-4), 205-211.
- Kochetov, A. and L. Goldstein (2005). Position and place effects in Russian word-initial and word-medial clusters. *Journal of the Acoustical Society of America*, **117** (4), Pt. 2. 2571.
- Kochetov, A. (2006). Syllable Position Effects and Gestural Organization: Articulatory Evidence from Russian. In L. Goldstein, D. Whalen, and C. Best Papers (eds.), *Laboratory Phonology VIII*, 565–588. Berlin: Mouton.
- Krakow, R. (1999). Physiological organization of syllables: a review. *Journal of Phonetics*, **27**, 23-54.
- Kriba, H. (2010). *Acoustic parameters of emphasis in Libyan Arabic*. PhD. dissertation, University of Newcastle Upon Tyne.
- Kuehn, D. and K. Moll (1976). A cineradiographic study of VC and CV articulatory velocities. *Journal of Phonetics*, **4**, 303-320.
- Kühnert, B. and F. Nolan (1999). The origin of coarticulation. In W, Hardcastle, and N. Hewlett (eds.), *Coarticulation: Theory, Data, and Techniques*. UK: Cambridge University Press.
- Kühnert, B. and P. Hoole (2006). Cohésion temporelle dans les groupes C1/l/initiaux en français. *Actes des XXVIe Journées d'Etude sur la Parole*. 545-548, 2006.
- Ladefoged, P. and I. Maddieson (1995). *The sounds of the world's languages*. Oxford: Blackwell.

- Ladefoged, P. (2001). *A course in Phonetics*. Fort Worth: Harcourt College Publishers.
- Ladefoged, P. and K. Johnson (2011). *A course in phonetics*. Boston: Massachusetts.
- Laradi, W. (1983). *Pharyngealization in Libyan (Tripoli) Arabic: an instrumental study*. PhD. dissertation, Edinburgh: University of Edinburgh.
- Laver, J. (1994). *Principles of phonetics*. Cambridge: Cambridge University Press.
- Laver, J. (1980). *The phonetic description of voice quality*. Cambridge: Cambridge University Press.
- Laver, J. and P. Trudgill (1991). Phonetic and linguistic markers in speech. In J. Laver (ed.), *The Gift of Speech: Readings in the analysis of speech and voice*. Edinburgh: Edinburgh University Press. 235-264.
- Lee, S., B. Quigley, M. Nesler, A. Corbett and J. Tedeschi (1999). Development of a self-presentation tactics scale. *Personality and Individual Differences*, **26**, 701-722.
- Lewis, P. (2009). *Ethnologue report for Nafus: Ethnologue: Languages of the World, sixteenth edition*. Retrieved 15/01, 2011, from [http://www.ethnologue.org/show\\_language.asp](http://www.ethnologue.org/show_language.asp).
- Lin, S., P. Beddor and A. Coetzee (2011). Gestural reduction and sound change: An ultrasound study. In *ICPhS XVII: Proceedings of the 17th International Congress of Phonetic Sciences*. 1250-1253.
- Lindblom, B. (1963). Spectrographic study of vowel reduction. *Journal of the acoustical society of America*, **35** (11), 1773-1781.
- Lindblom, B. (1975). Some Temporal Regularity of Spoken Swedish. In Fant, G. and M. Tatham (eds.), *Auditory Analysis and Perception of Speech*. Academic Press, 387-396.
- Lindblom, B. (1983). Economy of speech gestures. In MacNeilage, P. (Ed.), *The production of speech*, 217-246. New York: Springer Verlag.
- Lisker, L., and A. Abramson (1964). A cross-language study of voicing in initial stops: Acoustical measurements. *Word*, **20**, 384-422.
- Lisker, L. and A. Abramson (1967). Some effects of context on voice onset time in English stops. *Language and Speech*, **10**, 1-28.

- Lisker, L., A. Abramson, F. Cooper and M. Schvey (1969). Transillumination of the larynx in running speech. *Journal of the Acoustical Society of America*, **45**, 1544-1546.
- Löfqvist, A. (1977). Articulatory programming in Swedish obstruent clusters (In swedish) *Nysvenska Studier*, **57**, 95-104.
- Löfqvist, A and H. Yoshioka (1981). Interarticulator programming in stop production. *Phonetica*, **38**, 21-34.
- Löfqvist, A. and H. Yoshioka, (1984). Intrasegmental timing: Laryngeal-oral coordination in voiceless consonant production. *Speech Communication*, **3** (4), 279-289.
- Löfqvist, A. (1992). Acoustic and aerodynamic effects of interarticulator timing in voiceless consonants. *Language and Speech*, **35**, 15-28.
- Löfqvist, A. and V. Gracco (2002). Control of oral closure in lingual stop consonant production. *The Journal of the Acoustical Society of America*, **111**(6), 2811-2827.
- Löfqvist, A. (2006). Interarticulator programming: Effects of closure duration on lip and tongue coordination in Japanese. *The Journal of the Acoustical Society of America*, **120** (5), 2872-2883.
- Mack, M. (1982). Voicing-dependent vowel duration in English and French: Monolingual and bilingual production. *Journal of the acoustical society of America*, **71**, 173-178.
- MacKay, I. (1987). *Phonetics: The science of speech production*. Little, Brown.
- Maddieson, I. (1984). *Patterns of sounds*. Cambridge, UK: Cambridge University Press
- Maddieson, I. (1993). Investigating Ewe articulations with electromagnetic articulography. *Forschungsberichte, Institut für Phonetik und Sprachliche Kommunikation der Universität München*, **31**, 182-214.
- Malécot, A. (1969). The lenis-fortis opposition: Its physiological parameters. *Journal of the Acoustical Society of America*, **47**, 1588-1592.
- Manuel, S. (1990). The role of contrast in limiting vowel-to-vowel coarticulation in different languages. *Journal of the acoustical society of America*, **88**, 1286-98.

- Marin, S. and M. Pouplier (2008). Organization of Complex Onsets and Codas in American English: Evidence for a Competitive Coupling Model. *Proceedings of the 8th International Seminar of Speech Production*, Strasbourg.
- Marin, S. and M. Pouplier (2010). Temporal organization of complex onsets and codas in American English: testing the predictions of a gestural coupling model. *Motor Control*, **14** (3), 380-407.
- Maiteq, T. B. (2013). Prosodic constituent structure and anticipatory pharyngealisation in Libyan Arabic.
- Mattingly, D. (1995). *Tripolitania*. London: Batsford.
- Mattingly, G. (1966). Speaker variation and vocal tract size. *Journal of the Acoustical Society of America*, **39**, 1219-1219.
- Mitleb, F. (2001). Voice onset time of Jordanian Arabic stops. *Journal of the Acoustical Society of America*, **109**(5), 133-135.
- Miller, A. (1986). The origin of the modern Arabic sedentary dialects: An evaluation of several theories. *Al-Arabiyya*, **19**, 47-74.
- Miller, J. and T. Baer (1983). Some effects of speaking rate on the production of /b/ and /w/. *The Journal of the Acoustical Society of America*, **73**(5), 1751-1755.
- Mitchell, T. (1952). The active principle in an arabic dialect of Cyrenaica. *Bulletin of the school of oriental and African studies*, **14**, 11-33.
- Mitchell, T. (1957). The language of buying and selling in Cyrenaica: A situational statement. In T. F. Mitchell (Ed.), *Principles of Firthian linguistics*, 167-200. London: Longman.
- Mitchell, T. (1960). Prominence and syllabification in Arabic. *Bulletin of the School of Oriental and African Studies*, **2**, 369-389.
- Mitchell, T. (1993). *Pronouncing Arabic II*. Oxford, Clarendon.
- Morris, R., C. McCrea and K. Herring (2008). Voice onset time differences between adult males and females: isolated syllables. *Journal of Phonetics*, **36**, 308-317.
- Munhall K. and A. Löfqvist (1992). Gestural aggregation in speech: laryngeal gestures. *Journal of Phonetics*, **20**, 93-110.

- Munhall, K. and E. Vatikiotis-Bateson (1998). The moving face during speech communication. In R. Campbell, B. Dodd, and D. Burnham (eds.) *Hearing by Eye, Part 2: The Psychology of Speech reading and Audiovisual Speech*. Psychology Press, London.
- Newman, D. (2002). The phonetic status of Arabic within the world's languages: the uniqueness of the lughat al-daad. *Antwerp Papers in Linguistics*, **100**, 65-75.
- Newman, D. (2008). The phonetics of Arabic. Work in progress. Available at: [http://www.kau.edu.sa/Files/0001063/files/2826\\_phon5.pdf](http://www.kau.edu.sa/Files/0001063/files/2826_phon5.pdf). (10-06-2014)
- Öhman, S. (1966). Coarticulation in VCV utterances: Spectrographic measurements. *Journal of the acoustical society of America*, **39**, 151-168.
- Oller, D. (1973). The effect of position in utterance on speech segment duration in English. *Journal of the Acoustical Society of America*, **54**, 1235-1247.
- Owens, J. (1980). The syllable as prosody: A re-analysis of syllabification in eastern Libyan Arabic. *Bulletin of the School of Oriental and African studies*, **43**, 277-287.
- Owens, J. (1983). Libyan Arabic dialects. *Orbis*, **32**, 97-117.
- Owens, J. (1984). *A short reference grammar of eastern Libyan Arabic*. Wiesbaden, Harrassowitz
- Ohala, J. (1981a). Articulatory constraints on the cognitive representation of speech. In T. Myers, J. Laver, and J. Anderson (eds.). *The cognitive representation of speech*, 111-122. Amsterdam: North Holland.
- Panetta, E. (1943). *L'arabo parlato a Bengasi* (Vol. 1). Libreria dello stato.
- Perkell, J. (1980). Phonetic features and the physiology of speech production. 337-372.
- Pickett, E., S. Blumstein and M. Burton (1999). Effects of Speaking Rate on the Singleton/Geminate Consonant Contrast in Italian. *Phonetica*, **56**, 135-157.
- Pind, J. (1995). Speaking rate, voice-onset time, and quantity: The search for higher-order invariants for two Icelandic speech cues. *Perception & Psychophysics*, **57**(3), 291-304.
- Petursson, M. (1978). Jointure au niveau glottal. *Phonetica*, **35**, 65-85.
- Praat software. Retrieved 02/10/2010, from: <http://www.fon.hum.uva.nl/praat/>. Retrieved 25/07/2011, from: [www.articulateinstruments.com/Information](http://www.articulateinstruments.com/Information)

- Rahim, A. and Z. Kasim (2009). A Spectrographic study of voice onset time in Arabic. *Journal of Education and Science*, **16** (2), 28-41.
- Recasens, D. and M. Mira (2013). Voicing assimilation in Catalan three-consonant clusters. *Journal of Phonetics*, **41**, 264-280.
- Repp, B. and H. Lin (1989). Effects of preceding context on discrimination of voice onset times. *Perception & psychophysics*, **45** (4), 323-332.
- Riney, T., N. Takagi, K. Ota and Y. Uchida (2007). The intermediate degree of VOT in Japanese initial voiceless stops. *Journal of Phonetics*, **35** (3), 439-443.
- Roach, P. (1983). *English phonetics and phonology*. Cambridge, UK: Cambridge University Press.
- Roach, P. (2000). *English Phonetics and Phonology: A Practical Course*. 3rd ed. Cambridge University Press, Cambridge: England.
- Robert, H. (1967). Migrants in the City of Tripoli, Libya. *Geographical review*, **57**, 397-423.
- Rochet, B. (1976). *The formation and evolution of the French nasal vowels*. Tübingen: MaxNiemeyer).
- Romero, J. (1999). The effect of voicing assimilation on gestural coordination. *Proceedings of the 14th International Congress of Phonetic Sciences*, 1793-1796, San Francisco.
- Roon, K., A. Gafos, P. Hoole and C. Zeroul (2007). Influence of articulator an manner of stiffness. *Proceedings 16th ICPHS 2007*, 409-412.
- Rothenberg, M. and J. Mahshie (1988). Monitoring vocal fold abduction through vocal fold contact area. *Journal of Speech and Hearing Research*, **31**, 338-351.
- Rosenhouse, J. (2007). Arabic Bedouin dialects and their classification. *Conference on Features, Methods and Models of Classification*. Montpellier. France.
- Ryalls, J., A. Zipprer, P. Baldauff (1997). A preliminary investigation of the effects of gender and race on voice onset time. *Journal of speech and hearing research*, **40**, 642-645.
- Ryding, K. (2005) *A Reference Grammar of Modern Standard Arabic*. Cambridge: Cambridge University Press.
- Salam, F., and Embarki, M. (2012). Gender and acoustic variation: cases of vowels in Arabic Libyan of Tripoli. In *Sociolinguistics Symposium 19*.

- Saltzman, E. and K. Munhall (1989). A dynamical approach to gestural patterning in speech production. *Ecological Psychology*, **1** (4), 333-382.
- Sayahi, L. (2005). Final/s/retention and deletion in Spanish: the role of the speaker's type of competence. *Language Sciences*, *27*(5), 515-529.
- Schmidt, A. and J. Flege (1995). Effects of speaking rate changes on native and non-native speech production. *Phonetica*, **52**(1), 41-54.
- Shaheen, K. (1979). *The acoustic analysis of Arabic speech*. PhD. dissertation, University coll. North Wales.
- Shue, Y. and M. Iseli (2008). The role of voice source measures on automatic gender classification. *Proceedings of ICASSP*, 4493-4496.
- Simon, R. (1989). Language change and socio-Political transformations: The case of Nineteenth- and Twentieth-Century Libyan Jews. *Jewish History*, **4**,101-121.
- Simpson, A. (2002). Gender-specific articulatory-acoustic relations in vowel sequences. *Journal of Phonetics*, **30** (3), 417-435.
- Simpson, A. (2001). Dynamic consequences of differences in male and female vocal tract dimensions. *Journal of the Acoustical Society of America*, **109**, 2153-2164.
- Slifka, J. (2000). *Respiratory constraints on speech production at prosodic boundaries*. PhD. dissertation, Massachusetts Institute of Technology.
- Smith, P. (1979). Sex markers in speech. In K. Scherer and H. Giles (Eds.). *Social markers in speech*. Cambridge: Cambridge University Press.
- Stetson, R. (1951). *Motor phonetics*. Amsterdam: North-Holland.
- Stevens, K. (1990). Some factors influencing the precision required for articulation. In J. Kingston and M. Beckman (Eds.). *Papers in Laboratory Phonology: Between the Grammar and Physics of Speech* (Vol. 1), 471-475. Cambridge University Press.
- Stevens, K. (2000). *Acoustic phonetics*. MIT press.
- Suen, C. and M. Beddoes (1974). The silent interval of stop consonants. *Language and speech*, **17** (2), 126-134.
- Summerfield, Q. (1981). Articulatory rate and perceptual constancy in phonetic perception. *Journal of Experimental Psychology: Human Perception and Performance*, **7** (5), 1074-1095.

- Suomi, K. (1980). Voicing in English and Finnish stops. PhD. dissertation, University of Turku.
- Swartz, B. (1992). Gender differences in voice onset time. *Journal of Perceptual and motor skills*, **75**, 983-992.
- Swed, A. (1977). Al-khawas Attarkibiyya li-Lahjat Tarabulus al-Gharb. Unpublished MA. dissertation. University of Cairo.
- Sweeting, P. and R. Baken (1982). Voice onset time in a normal-aged population. *Journal of Speech and Hear Research*, **25**, 129-134.
- Tatham, M. (1995). Dynamic articulatory phonology and the supervision of speech production. *Proceedings of ICPPhS*. Stockholm:Royal Institute of Technology.
- Tilsen, S. (2013). A dynamical model of hierarchical selection and coordination in speech planning. *PloS one*, 8(4), e62800.
- Torres, N. (2002). *Voicing assimilation in Catalan and English*. Universitat Autònoma de Barcelona.
- Tsao, Y., G. Weismer and K. Iqbal (2006). Interspeaker variation in habitual speaking rate: Additional evidence. *Journal of Speech, Language, and Hearing Research*, **49**, 1156-1164.
- Van Alphen, J., O. Seehausen and F. Galis (2004). Speciation and radiation in African haplochromine cichlids. In Dieckmann, U., M. Doebeli, J. Metz and D. Tautz (eds), *Adaptive Speciation*, 173–191. Cambridge: Cambridge University Press.
- Vandewalle, D. (2012). *A history of modern Libya*. Cambridge University Press.
- Versteegh, K. (1997). *The Arabic language*. Edinburgh: Edinburgh University Press.
- Warren, D. (1996). Regulation of speech aerodynamics. In N. Lass (ed.), *Principles of Experimental Phonetics* . St Louis: Mosby, 46-92.
- Watson, J. (2002). *The phonology and morphology of Arabic*. Oxford: Oxford University press.
- Watson, J. (2007). Syllabification patterns in Arabic dialects: long segments and mora sharing. *Phonology*, **24**, 335-356.
- Weisruer, G. (1979). Sensitivity of voice onset time measures to certain segmental features in speech production. *Journal of Phonetics*, **7**, 197-204.

- Whiteside, S. (1996). Temporal-based acoustic-phonetic patterns in read speech: Some evidence for speaker sex differences. *Journal of the International Phonetic Association*, **26**, 23-40.
- Whiteside, S. and C. Irving (1997). Speakers' sex differences in voice onset time. *Journal of perceptual and motor skills*, **85**, 459-463.
- Whiteside, S. and J. Marshall (2001). Developmental trends in voice onset time: some evidence for sex differences. *Phonetica*, **58**, 196-210.
- Whiteside, S., L. Henry, and R. Dobbin (2004). Sex differences in voice onset time: a developmental study of phonetic context effects in British English. *The Journal of the Acoustical Society of America*, **116** (2), 1179-1183.
- Wrench, A. Articulate Instruments. Retrieved 25-7-2011, from [www.articulateinstruments.com/Information](http://www.articulateinstruments.com/Information).
- Westbury, J. (1975). The status of regressive voicing assimilation as a rule of Russian. *Texas Linguistic Forum*, **1**, 131-144.
- Westbury, J. and P. Keating (1986). On the naturalness of stop consonant voicing. *Journal of Linguistics*, **22**, 145-166.
- Yavaş, M. (2009). Factors influencing the VOT of English long lag stops and interlanguage phonology. *Recent Research in Second Language Phonetics/Phonology: perception and production*. Cambridge Scholars Publishing, 244-255.
- Yehouenou, B. (1998). A study of the effect of speech rate on the articulation of labiovelar stop consonants in fongbe: an EPG and aerodynamic approach. *sciences sociales et humaines*, **00**, 30-42.
- Yoshioka, H., A. Löfqvist and H. Hirose (1981). Laryngeal adjustment in the production of consonant clusters and geminates in American English. *Journal of the Acoustical Society of America*, **70** (6), 1615-1623.
- Zhao, S. (2003). *Gestural overlap of stop-consonant sequence*. PhD. dissertation, Massachusetts Institute of Technology.
- Zsiga, E (1994). Acoustic evidence for gestural overlap in consonant sequences. *Journal of Phonetics*, **22**, 121-140.
- Zsiga, E. (1995). An acoustic and electropalatographic study of lexical and post-lexical palatalisation in American English. In B. Connell and A. Arvaniti

(eds.), *Phonology and Phonetic Evidence. Papers in Laboratory IV*.  
Cambridge: Cambridge University Press, 282-302.

Zsiga, E. (2003). Articulatory timing in a second language: Evidence from Russian and English. *Studies in Second Language Acquisition*, **25**, 399-432.

Zue, V. (1976). *Acoustic characteristics of stop consonants: A controlled study*.  
Bloomington, Ind.: Indiana University Linguistics Club

Internet resources:

Retrieved 11/11, 2010, from: [WWW.AraBbay.com](http://WWW.AraBbay.com).

Retrieved 15/11/2010, from: <http://arab.aljayyash/Arabic-3-14.html>.