

# **A Modular Catalytic Approach Towards Pyridine and Quinolone Synthesis**

Mary Esther Gunn

The University of Leeds  
School of Chemistry

May 2013

Submitted in accordance with the requirements for the degree of Doctor of Philosophy.





The candidate confirms that the work is her own and that appropriate credit has been given where reference has been made to the work of others.

This copy has been supplied on the understanding that it is copyright material and that no quotation from the thesis may be published without proper acknowledgement.

© The University of Leeds  
Mary Esther Gunn





## **Acknowledgements**

Firstly, I would like to thank Steve for his guidance and advice over the past three and a half years: for all the ideas and for proofreading my reports and presentations. Thanks also to my industrial supervisor Steve Wailes for his ideas and for the support he gave me whilst on my three-month placement in Jealott's Hill.

Thanks as well to the teaching, support and stores staff at Leeds and Syngenta, particularly Tanya Morinka-Covell, Simon Barrett, Martin Huscroft and Ian Blakeley and anyone else who might have helped me with my project, especially the cleaner who rescued me when I got locked in the basement!

For funding, I'd like to thank the EPSRC and Syngenta.

Most importantly thanks to the Marsden group members past and present who have helped and encouraged me throughout: Angela, Emma, Sophie, Jarle, Paolo, Liam, David, Theresa, Nicky, John, James, Nic, Dan, Roberta and all the masters students. You guys have made doing a PhD fun. Also to Fraser for all the banter and being a listening ear when it felt like it was all going wrong and to the rest of the Fishwicks for all the lunchtime chat.

Finally a massive thank you to my family and friends, especially those at Leeds Vineyard who have been my Leeds family throughout: for all the house moves and dinners, listening to my rants and for reminding me that there are other things to life.

## Abstract

*N*-Containing heterocycles such as substituted pyridines and 2-quinolones are commonly found in drugs and agrochemicals; however, classical methods towards their synthesis often lead to limited substitution patterns. We recently described the first examples of the organocatalytic intramolecular aza-Wittig reaction in the synthesis of azoles and azines from isocyanates. The work described herein is divided into three chapters detailing attempts to expand the scope of the use of isocyanates in heterocycle synthesis.

The first chapter describes the development of multicomponent synthesis of substituted pyridines incorporating the intermolecular catalytic aza-Wittig and Diels–Alder reactions; in total 31 exemplar pyridines were prepared in up to 52% yield. The reaction works well for electron-poor and heteroaromatic aldehydes, electron-rich and electron-poor cinnamic acids and push-pull enamines to give a range of substitution patterns. The use of commercially available starting materials and catalytic phosphine oxide means the process offers distinct advantages over classical methods.

The development of a tandem catalytic aza-Wittig/electrocyclisation process towards benzothienopyridines was also investigated. To this end benzothienoimines and azatrienes were prepared, however, the electrocyclic ring closure of the azatrienes was non-trivial with low yields of the desired pyridines even under harsh conditions.

The final chapter outlines the preparation of substituted 2-quinolones from readily available urea starting materials by two methods. The first is a two-pot three-step process incorporating urea-directed oxidative Heck reaction, isocyanate formation and electrocyclisation; in total 9 exemplar 2-quinolones were prepared in up to 61% overall yield. The second is a two-pot three-step process incorporating Heck reaction, isocyanate formation and electrocyclisation; 10 exemplar 2-quinolones were prepared in up to 59% overall yield. The use of the urea directing-group in the subsequent isocyanate formation negates the necessity for acyl azides and means no further manipulation is required to remove the directing group after 2-quinolone synthesis.

## Contents

<b>Acknowledgements</b> .....	<b>i</b>
<b>Abstract</b> .....	<b>ii</b>
<b>Contents</b> .....	<b>iii</b>
<b>Abbreviations</b> .....	<b>v</b>
<b>1.0 Introduction</b> .....	<b>1</b>
1.1 Aza Diels–Alder reactions .....	1
1.2 Mechanism of imino Diels–Alder reactions .....	2
1.3 Inverse electron-demand imino Diels–Alder reactions.....	3
1.4 2-Azadienes in Diels–Alder reactions.....	4
1.5 The synthesis of 2-azadienes.....	7
1.6 The aza-Wittig reaction.....	10
1.7 Mechanism of the aza-Wittig reaction .....	10
1.8 Intermolecular aza-Wittig reactions.....	12
1.9 Developing a catalytic aza-Wittig reaction.....	13
1.9.1 Mechanistic studies .....	16
1.9.2 Catalyst screening .....	17
1.9.3 Isocyanate substrate scope .....	19
1.10 Previous work .....	20
1.11 Project Aims.....	26
<b>2.0 Development of a two-pot process towards substituted pyridines</b> .....	<b>28</b>
2.1 Intermolecular catalytic aza-Wittig reactions .....	28
2.2 Optimisation of intermolecular aza-Wittig reaction .....	29
2.3 Preparation of vinyl isocyanates .....	32
2.4 Variation of the aldehyde.....	39
2.5 Variation of the $\alpha,\beta$ -unsaturated carboxylic acid .....	42
2.6 Variation of the enamine.....	44
2.7 Alternative methods for isocyanate formation.....	45

2.8 Conclusion .....	47
<b>3.0 Attempts to prepare heterocyclic pyridines via tandem aza-Wittig/electrocyclisation reactions .....</b>	<b>51</b>
3.1 Introduction .....	51
3.2 Results and Discussion.....	53
3.3 Preparation of heteroaromatic imines .....	56
3.4 Conclusion .....	59
<b>4.0 Development of a two-pot process towards substituted quinolones.....</b>	<b>60</b>
4.1 Oxidative Heck reactions .....	60
4.2 Mechanistic aspects.....	61
4.3 Ureas as directing groups.....	62
4.4 2-Quinolones .....	63
4.5 Examples of C–H activation in 2-quinolone synthesis .....	65
4.6 Electrocyclisation of isocyanates.....	66
4.7 Generation of Isocyanates.....	69
4.8 Mechanism of urea hydrolysis .....	71
4.9 Project aims.....	72
4.10 Proof of concept.....	73
4.11 Optimisation of the oxidative Heck reaction .....	74
4.12 Optimisation of electrocyclisation reactions.....	75
4.13 Substrate scope – oxidative Heck conditions.....	80
4.14 Optimisation of Heck reactions.....	83
4.15 Conclusions .....	87
<b>5.0 Experimental .....</b>	<b>90</b>
5.1 General Experimental Techniques .....	90
5.2 Experimental Procedures .....	91
<b>6.0 References .....</b>	<b>150</b>



## Abbreviations

Ac	Acetyl
Aq.	Aqueous
Ar	Aromatic
Bn	Benzyl
BQ	Benzoquinone
br	Broad
<sup>n</sup> Bu	<i>normal</i> -Butyl
<sup>t</sup> Bu	<i>tert</i> -Butyl
cat.	Catalytic
CDI	Carbonyl diimidazole
C	Celsius
<i>o</i> -DCB	<i>ortho</i> -Dichlorobenzene
DCE	Dichloroethane
DG	Directing group
DMF	Dimethyl formamide
DMAP	Dimethylaminopyridine
DPPA	Diphenylphosphorylazide
d	Doublet
EDG	Electron-donating group
Eq.	Equivalents
ES	Electrospray
ESI	Electrospray ionisation
Et	Ethyl
EWG	Electron-withdrawing group
h	Hours
HOMO	Highest occupied molecular orbital
HRMS	High resolution mass spectrometry
IR	Infra-red
L.A.	Lewis acid
LCMS	Liquid chromatography mass spectrometry
Lit.	Literature
LUMO	Lowest occupied molecular orbital
μW	Microwave
<i>m</i>	meta
m	Multiplet

M	Molar
<i>m</i> CPBA	<i>meta</i> -chloroperbenzoic acid
Me	Methyl
MeCN	Acetonitrile
Min	Minutes
MOM	Methoxymethyl ether
m.p.	Melting point
MS	Molecular sieves
n.d.	Not defined
NEt <sub>3</sub>	Triethylamine
NMR	Nuclear magnetic resonance spectroscopy
<i>o</i>	ortho
[O]	Oxidation
<i>p</i>	para
Ph	Phenyl
PhMe	Toluene
PPh <sub>3</sub>	Triphenylphosphine
ppm	Parts per million
<sup><i>i</i></sup> Pr	<i>iso</i> -Propyl
Pyr	Pyridyl
q	Quartet
quat.	Quaternary carbon
quin	Quintet
rt	Room temperature
s	Singlet
t	Triplet
TBAF	Tetrabutylammonium fluoride
TEBA	Triethylbutylammonium chloride
Temp.	Temperature
Tf	Triflate
TFA	Trifluoroacetic acid
THF	Tetrahydrofuran
Tol	Tolyl
Ts	Tosyl
UV	Ultraviolet

## 1.0 Introduction

*N*-Containing heterocycles are found widely in both natural and synthetic compounds that exhibit a diverse range of biological activities.<sup>1-4</sup> A recent survey has shown that >90% of all drug molecules contain a nitrogen atom and amongst those which feature heteroaromatic rings, the pyridine moiety is one of the most commonly occurring.<sup>5</sup> As a result it is found in many of the best-selling drugs and agrochemicals such as the herbicide imazamox **1** and the drug, esomeprazole **2** a proton pump inhibitor used to treat a number of intestinal disorders including gastroesophageal reflux disease and gastric ulcers (Figure 1.1).

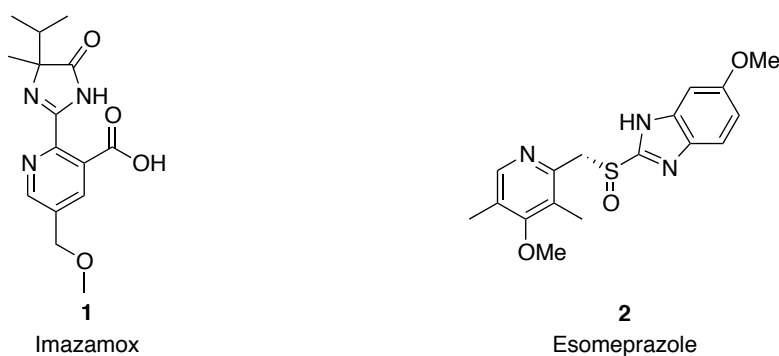

Figure 1.1

This prevalence in biologically active molecules has led to the development of many synthetic approaches towards pyridines. Classically, condensation reactions such as the Hantzsch synthesis<sup>6</sup> or Bohlmann–Rahtz reaction<sup>7</sup> have been used to prepare pyridines. Whilst these methods are well established, certain substitution patterns are difficult to prepare and the mechanisms often require the presence of multiple electron-withdrawing groups in substrates and hence, products.<sup>5</sup> More recent developments have included [4+2] cycloaddition approaches towards pyridine synthesis. 2-Azadienes are useful precursors for pyridine synthesis in [4+2] cycloaddition reactions; however, their use has been limited by a lack of general method for their synthesis.

### 1.1 Aza Diels–Alder reactions

After the discovery of the Diels–Alder reaction, the prospect of introducing heteroatoms into any of the positions in a six-membered ring became an interesting challenge for organic chemists.<sup>8</sup> Hetero Diels–Alder reactions have since become a key reaction in the synthesis of heterocycles and natural products.<sup>9</sup> The aza Diels–Alder has three basic variants: one where the nitrogen is incorporated into the dienophile; the second where the nitrogen is in the 1-position of the diene; and the third where the nitrogen is in the 2-position of the diene (Figure 1.2). It is

possible therefore, to change the position of substituents depending on the system used, thus giving a range of substitution patterns.

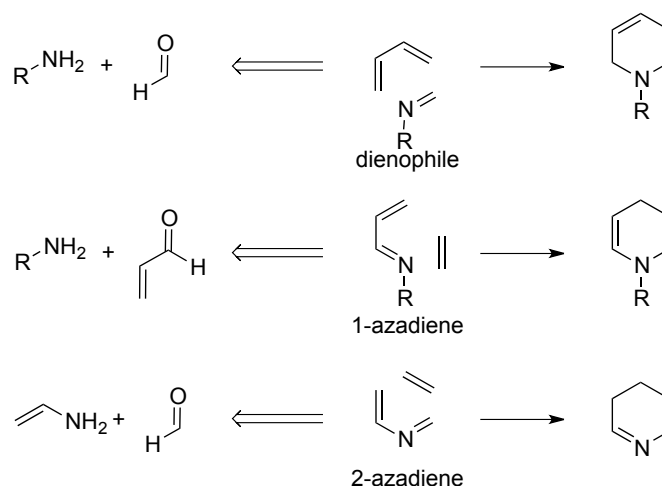

Figure 1.2

Retrosynthesis of the imine dienophile and 1-azadiene gives a nucleophilic nitrogen species and an aldehyde; hence imine formation should be a relatively simple condensation reaction. In the case of the 2-azadiene, however, a non-nucleophilic nitrogen species (enamine) would be required; this will be unreactive with aldehydes. An alternative method for their synthesis, such as the aza-Wittig reaction is therefore required.

## 1.2 Mechanism of imino Diels–Alder reactions

As with the all-carbon Diels–Alder reaction the electronic properties of the diene and dienophile are important with both  $\text{HOMO}_{\text{diene}}$ -controlled normal electron-demand (where the diene is electron-rich and dienophile electron-poor) and  $\text{LUMO}_{\text{diene}}$ -controlled inverse electron-demand reactions known. Although cycloadditions with imine dienophiles can be concerted or go through a stepwise Mannich–Michael reaction sequence,<sup>10</sup> *ab initio* computational studies of reactions of 2-azadienes show that the reaction goes through a concerted mechanism.<sup>11</sup> This is indicated by the presence of a single, asynchronous transition state where the forming C–C bonds differ in length by 0.13 Å (Figure 1.3).<sup>10</sup>

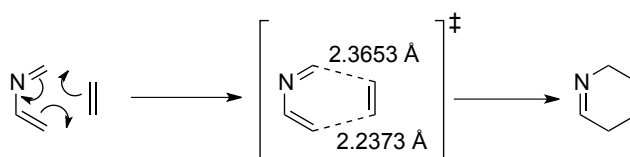

Figure 1.3

The substitution of a CH in butadiene **3** for a nitrogen atom in azadiene **4** lowers the energy of the molecular orbitals, thus increasing the azadiene's electrophilicity favouring participation in the inverse electron-demand reaction (Figure 1.4).<sup>9</sup> Additionally, examination of the energies of the molecular orbitals of butadiene **3**, 2-azadiene **4** and substituted 2-azadiene **5** shows that changing the substituents on the azadiene can have a significant effect on the energy of the molecular orbitals.<sup>12</sup> This can allow both normal and inverse electron-demand reactions to be accessed by substitution with electron-donating and electron-withdrawing groups respectively.

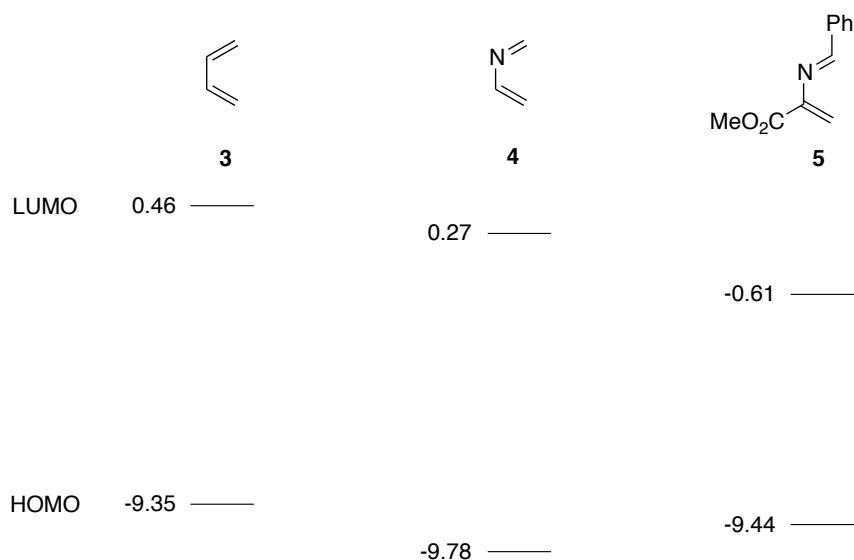
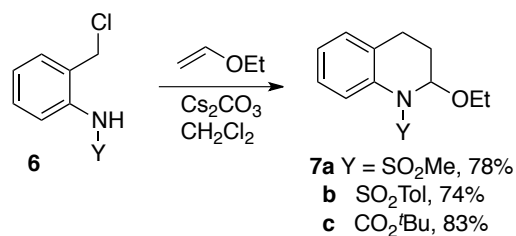

Figure 1.4

Lewis acid coordination to the nitrogen lowers the molecular orbital energies further, thus lowering the activation energy for reactions to occur although coordination of the Lewis acid results in a more asynchronous transition state.<sup>13</sup>

### 1.3 Inverse electron-demand imino Diels–Alder reactions

Reversing the electronics to give inverse electron-demand reactions is much simpler with an imino Diels–Alder reaction than its all carbon analogue due to the electron-poor nature of imines.<sup>14</sup> Despite this many examples of imino Diels–Alder reactions with 1-azadienes and 2-azadienes have involved the use of electron-donating groups to reverse the electron-deficient nature of the azadiene and allow normal electron-demand reactions to occur. In the case of 1-azadienes introducing electron-withdrawing substituents to the N-1 or C-3 positions enhances the reactivity towards electron-rich dienophiles. Steinhagen and Corey demonstrated this with both *N*-acyl and *N*-sulfonyl groups in the synthesis of tetrahydroquinolines **7a-c** (Scheme 1.1).<sup>15</sup> Here base-induced elimination of hydrogen chloride from **6** formed the azadiene, which reacted with ethyl vinyl ether to give the tetrahydroquinoline products **7a-c**.



Scheme 1.1

Inverse electron-demand Diels–Alder reactions of 1,2,4-triazines reacting as 2-azadienes have been well studied,<sup>16–20</sup> with an elegant example described by Taylor *et al.* in the synthesis of louisianins A–D **11–14**.<sup>11</sup> A common pyridine intermediate **10** was constructed through the [4+2] cycloaddition reaction between electron-deficient triazine **8**, which acts as an azadiene, and enamine **9** (Scheme 1.2).

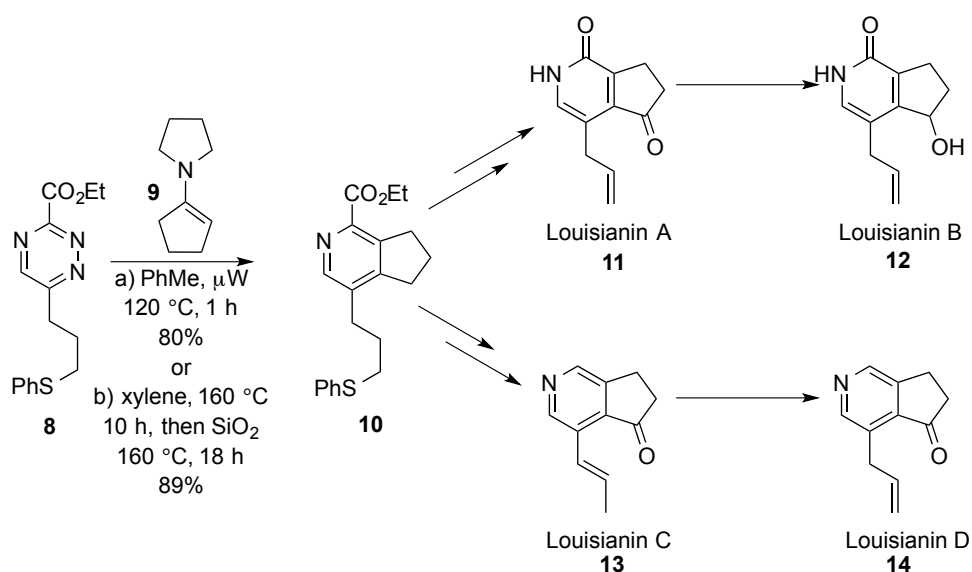

Scheme 1.2

### 1.4 2-Azadienes in Diels–Alder reactions

Despite the inherently electron-poor nature of 2-azadienes, their use in Diels–Alder reactions has largely been limited to the use of electron-rich azadienes with electron-poor dienophiles in normal electron-demand Diels–Alder reactions. One early example of an inverse electron-demand Diels–Alder reaction was described by Barluenga *et al.* who showed that electron-poor azadienes **15** undergo [4+2] cycloaddition reactions with electron-rich enamines **9a** and **9b** to give tetrahydropyridines **16** (Scheme 1.3).<sup>21</sup> Acid-induced elimination and subsequent aromatisation gave the pyridines **17** in excellent yields.

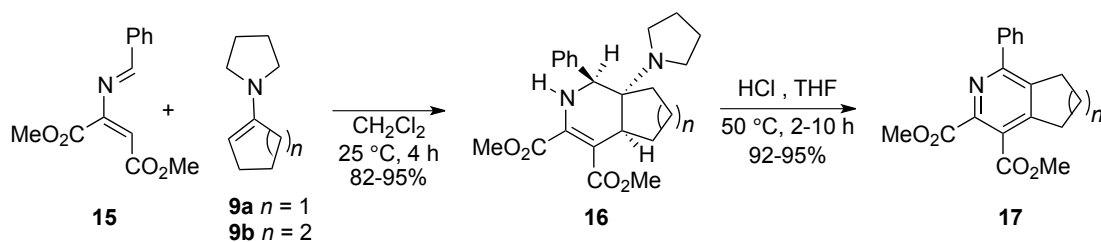

Scheme 1.3

To extend the scope of these reactions Palacios *et al.* used electron-deficient azadienes **18** in [4+2] cycloaddition reactions with the strained olefins, *trans*-cyclooctene **19a** and *cis,trans*-cyclooctadiene **19b** (Scheme 1.4) to give bicyclic compounds **20**, **21** in good yield.<sup>21</sup> However, when using the less-strained olefin, norbornadiene, the use of lithium perchlorate in diethyl ether was required for reaction to occur and yields were lower.

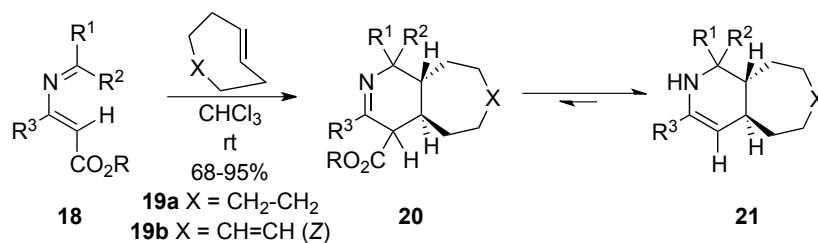

Scheme 1.4

Palacios and co-workers continued their investigations into [4+2] cycloadditions of 2-azadienes using neutral azadienes **22** with enamines **9** (Scheme 1.5).<sup>22</sup> Good to excellent yields of the desired pyridines **25** were prepared, even with a  $\beta$ -enamino ester (where  $\text{R}^3 = \text{CO}_2\text{Et}$ ), which has previously reported to be an unreactive dienophile with heterocyclic azadienes such as 1,2,3-triazines.<sup>23</sup> With this enamine, higher temperatures and an additional separate oxidation step using *p*-benzoquinone were required. When 3-pyridylsubstituted azadienes **22** were used an additional product was formed. Tandem [2+2+2] cycloaddition of the azadiene **22** with two molecules of enamine **9a** gave the tricyclic pyridine **27** alongside the desired pyridine **25**.

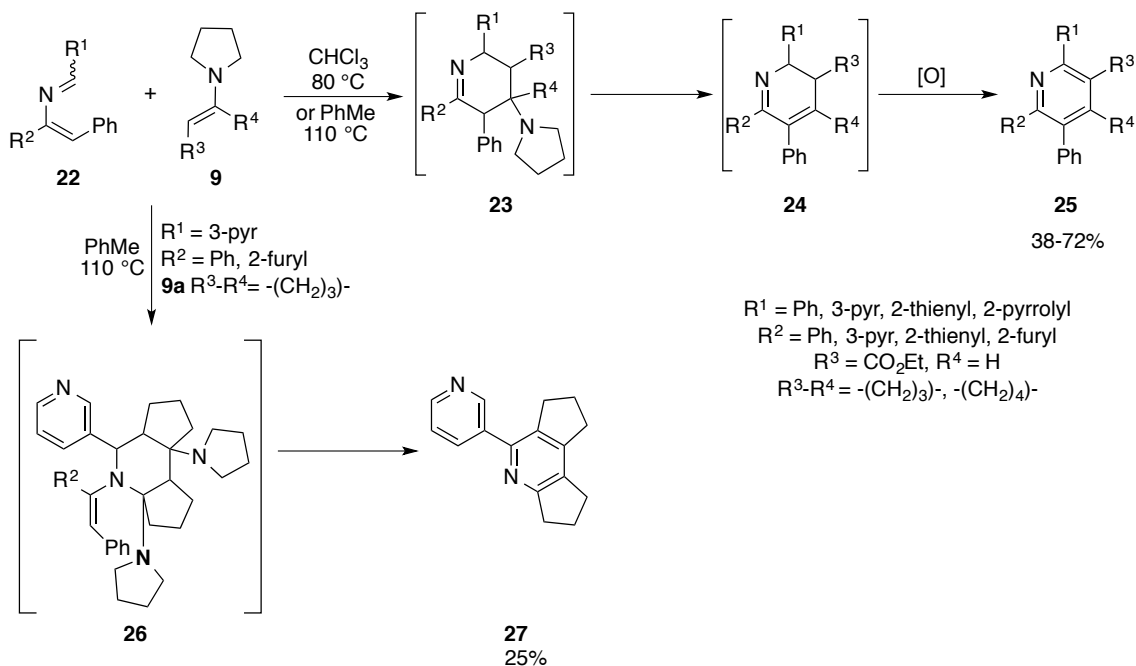

Scheme 1.5

More recently, the first preparation of fluoroalkylated pyridines from azadiene precursors **28** has been demonstrated by Palacios and co-workers.<sup>24</sup> The introduction of fluorinated groups to organic molecules is very useful since the biological properties of the molecules are often dramatically changed. Using fluorinated precursors is often a more useful method of preparing fluorinated compounds than direct fluorination since the regioselectivity can be more easily controlled. Fluoroalkyl 2-azadienes **28** were prepared from fluoroalkyl *N*-vinylic iminophosphoranes with ethyl glyoxylate in yields up to 90% and used *in situ* in Diels–Alder reactions with enamines **9**, to give the desired pyridines **29**. The substituents on the enamines could affect the outcome of the reaction since with enamine **9b**, oxidation did not occur under the reaction conditions. Instead a mixture of compounds was obtained and the dihydropyridine **31** could be oxidised to give the aromatised product **29** (Scheme 1.6). With enamine **9c** on the other hand, elimination and oxidation occurred under the reaction conditions to give pyridine **29** directly.



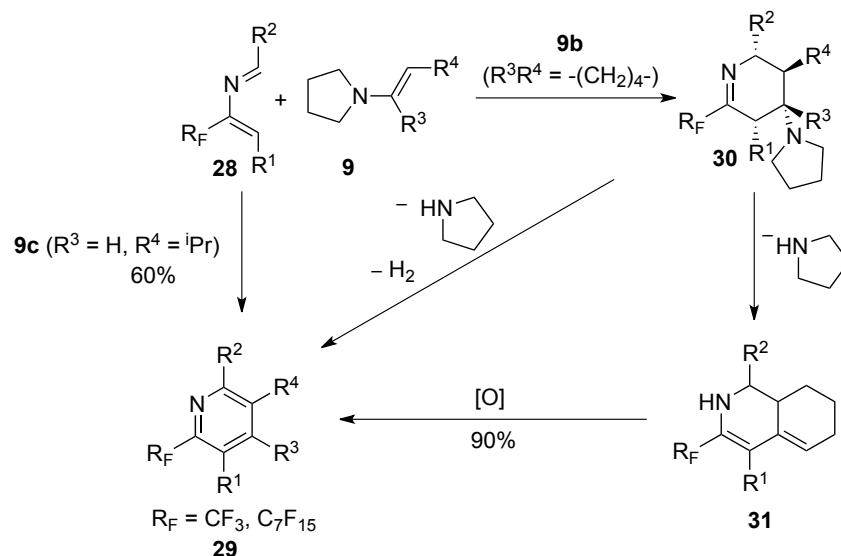

Scheme 1.6

The incorporation of perfluoroalkyl substituents by this method led to unexpected results. Instead of the expected pyridine **35**, the pyridine **37** obtained had a different substituent (Scheme 1.7). This result could be explained by loss of pyrrolidine and dehydrofluorination from the [4+2] cycloadduct **33** followed by tautomerism of intermediate **36**.<sup>25</sup>

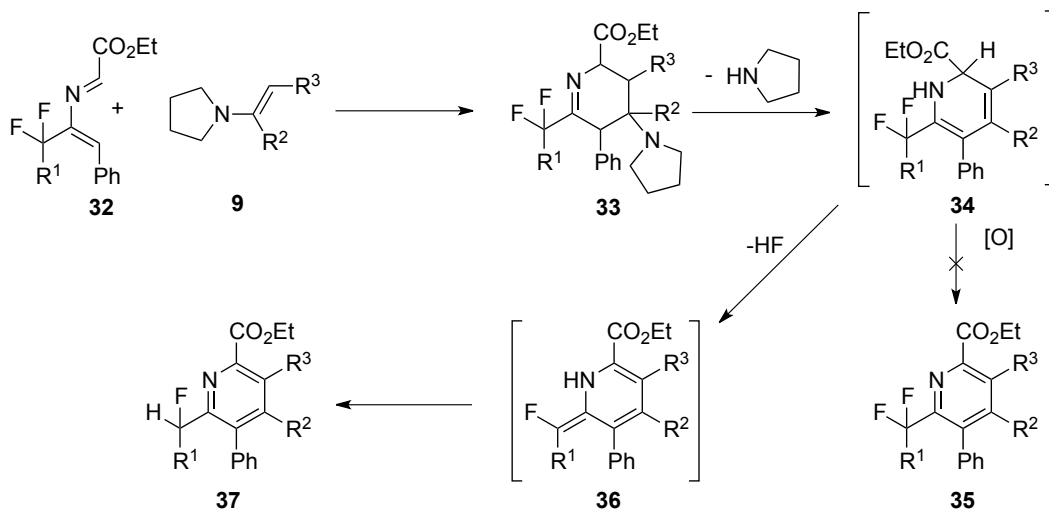

Scheme 1.7

### 1.5 The synthesis of 2-azadienes

Whilst azadienes are the most commonly used heterodienes in organic synthesis, their synthetic utility relies on prior activation.<sup>9</sup> This can be achieved by substitution using electron-rich or electron-poor substituents. However, there is a paucity of methods towards their synthesis, especially towards electron-deficient azadienes. Barluenga *et al.* described a synthesis of azadienes **40** from silyl imines **38** and activated acetylenes (Scheme 1.8).<sup>14</sup> Fluoride-induced

desilylation generated the azadienes from intermediate **39** in good yields. Whilst this gave azadienes in good yields the unstable nature of the starting imines and the requirement for very electron-deficient alkynes has prevented the wider uptake of this method.

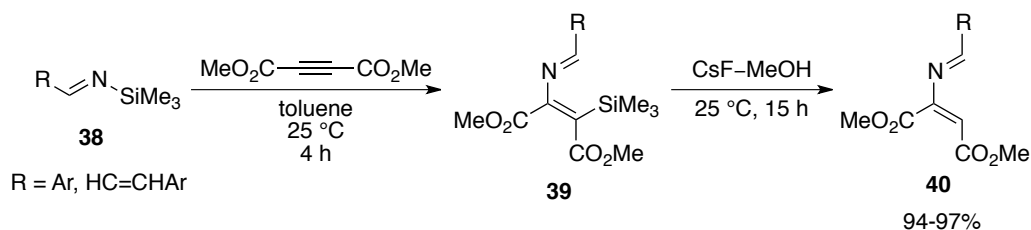

*Scheme 1.8*

Khlebnikov and co-workers reported a completely different approach towards azadienes from the reaction between 3-aryl-2*H*-azirines **41** and rhodium carbenoid **42** (Scheme 1.9).<sup>26</sup> Isomerisation of the resulting azirinium ylide **43** gave the 2-azadiene **44**. When an excess of diazoester was used with unsubstituted azirines **41** ( $R^1$  and  $R^2 = H$ ) 3,4-dihydro-2*H*-pyrroles **47** were also formed. Unexpectedly when the highly polarised azirinium ylide **41** ( $R = CO_2Me$ ;  $R^1 = R^3 = Ph$ ;  $R^2 = H$ ) was used, none of the desired azadiene was observed; instead azetine **45** arising from electrocyclic ring closure of the azadiene was the major product.

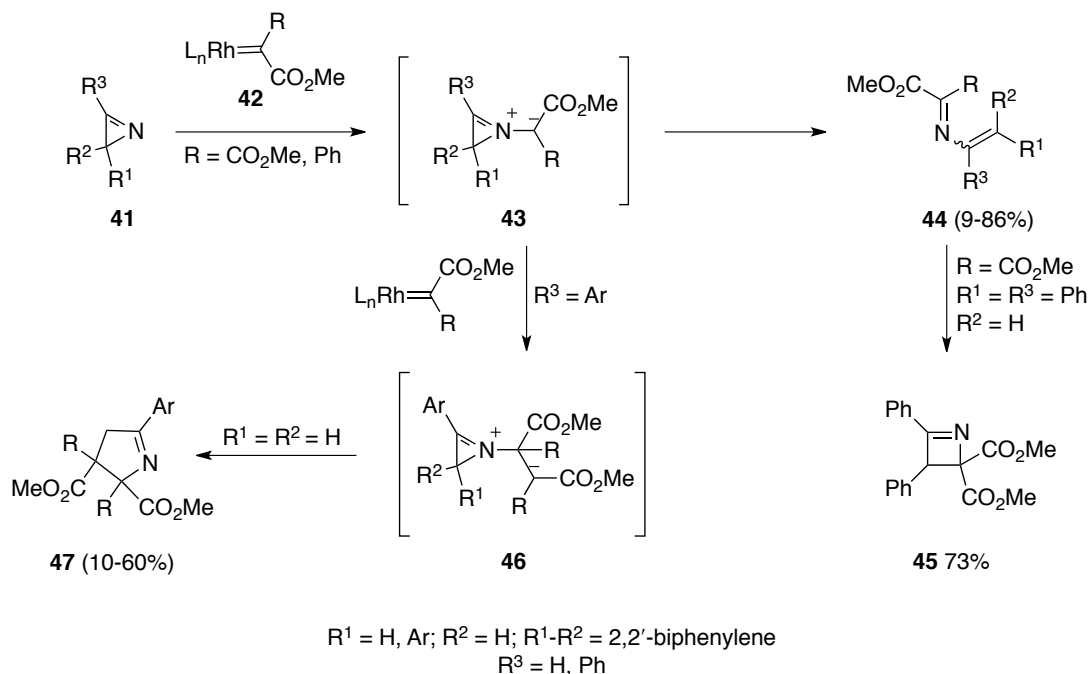

*Scheme 1.9*

The aza-Wittig reaction is a powerful tool in the synthesis of azadienes due to the mild conditions used. The first example of preparing azadienes using the aza-Wittig reaction was reported by Palacios *et al.*<sup>27</sup> *N*-Vinyllic iminophosphoranes **48** were obtained by Staudinger

reaction of azidoacrylates with phosphines and used in the reaction with aldehydes to give electron-deficient 2-aza-1,3-dienes **49** in yields >86% (Scheme 1.10).

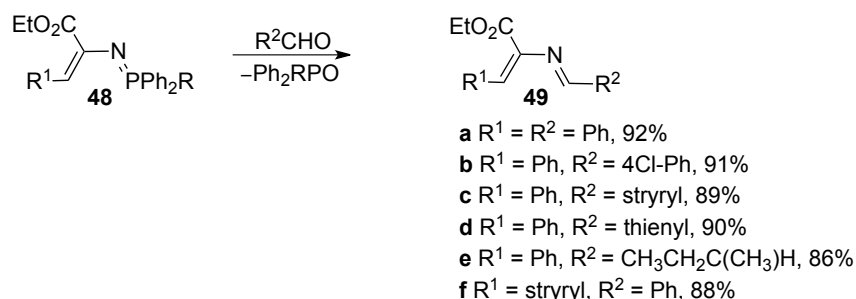

Scheme 1.10

The synthesis of electron-deficient 2-azadienes has been extended through the use of electron-poor aldehydes such as ethyl glyoxylate. Reaction of the iminophosphoranes **50** with ethyl glyoxylate and diethyl malonate gave the azadienes **51** in high yields (Scheme 1.11). The azadienes **51** proved to be unstable to both chromatography and distillation and were therefore used without isolation in [4+2] cycloaddition reactions with enamines.<sup>21</sup>

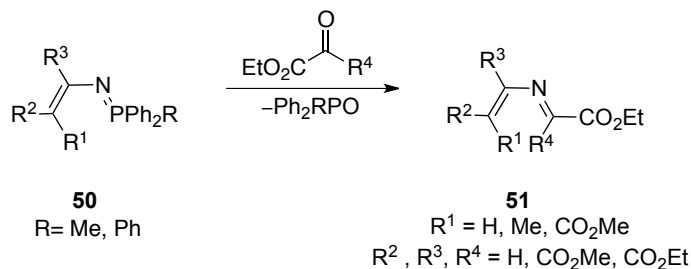

Scheme 1.11

A recent development was the synthesis of fluoroalkylated 2-aza-1,3-butadienes **55** from fluoroalkylated *N*-vinylic iminophosphoranes **54**.<sup>24</sup> Fluorine-containing heterocycles have increasing importance in the pharmaceutical and agrochemical industries so the synthesis of fluoroalkyl-substituted azadienes is particularly useful. Phosphorus ylides **52** and perfluoroalkyl nitriles **53** were used to prepare the *N*-vinylic iminophosphoranes **54** via [2+2] cycloaddition followed by ring opening. Aza-Wittig reaction with ethyl glyoxylate in CHCl<sub>3</sub> at room temperature gave the corresponding azadienes **55** which were used *in situ* due to their instability to distillation and chromatography (Scheme 1.12).

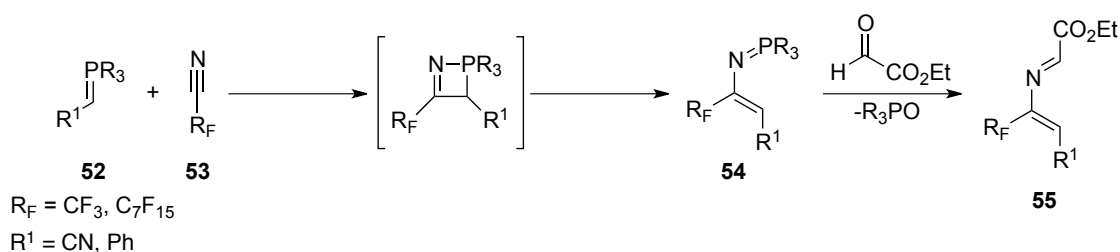

Scheme 1.12

## 1.6 The aza-Wittig reaction

The aza-Wittig reaction, a nitrogen analogue of the classical Wittig reaction, is a useful reaction for the formation of C=N bonds under mild, neutral conditions (Scheme 1.13).<sup>28</sup> It is usually preceded by a Staudinger reaction of organic azides **56** with a phosphorus(III) reagent **57** that generates iminophosphoranes (also called phosphazenes or phosphine imines) **58** *in situ* with loss of nitrogen. This iminophosphorane **58** is analogous to the phosphorus ylide used in the classic Wittig reaction.

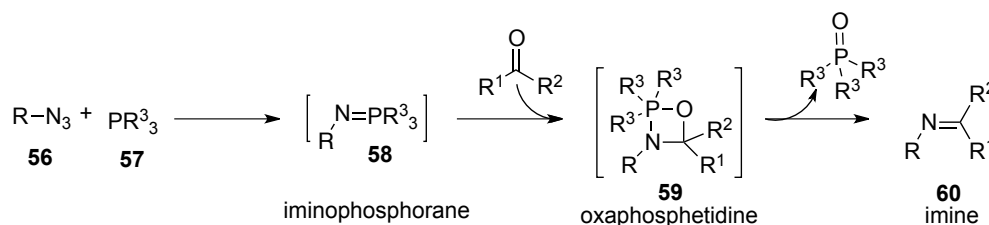

Scheme 1.13

The reactivity of iminophosphoranes **58** is dependent on both the substituents on the nitrogen and phosphorus atoms since this affects the degree of polarisation of the phosphorus-nitrogen bond.<sup>29, 30</sup> Condensation of iminophosphoranes **58** with carbonyl compounds generates imines **60** and a phosphine oxide by-product. Formation of the latter provides the enthalpic driving force of the reaction due to the strength of the phosphorus-oxygen bond formed. Unfortunately, it is the formation of this by-product that is one of the biggest inconveniences of the aza-Wittig reaction since it is difficult to separate from the product.<sup>28</sup>

## 1.7 Mechanism of the aza-Wittig reaction

Whilst the mechanism of the Wittig reaction has been extensively investigated, there has been relatively little attention paid to the mechanism of the aza-Wittig reaction. This is due in part to the difficulty in isolating unstable intermediates, an important aspect in the elucidation of reaction mechanism.<sup>28</sup> Despite this, Kawashima *et al.* used bulky substituents to allow synthesis

and isolation of 1,2- $\lambda^5$ -oxazaphosphetidine intermediates **62** in crystalline form (Scheme 1.14)<sup>31</sup> whose structure was confirmed by X-ray crystallography. Thermolysis of **62** gave the corresponding imine **63** and phosphine oxide **64**, proving its intermediacy in the aza-Wittig reaction. The structure of intermediate **62** is not surprising since similarities between the Wittig and aza-Wittig reactions have been reported previously.<sup>32</sup>

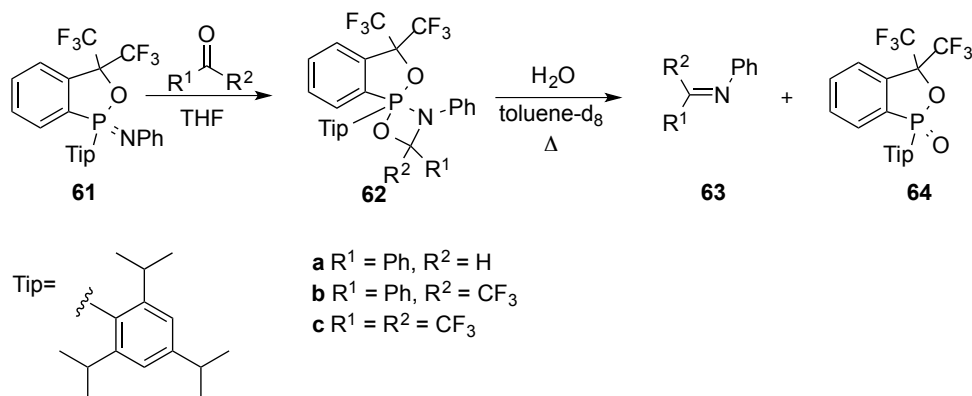

Scheme 1.14

Computational studies have shown that the aza-Wittig reaction proceeds *via* a [2+2] cycloaddition/cycloreversion sequence. In this, the oxazaphosphetidine intermediate is formed directly (Scheme 1.15),<sup>33-35</sup> not *via* a charged betaine intermediate as early studies suggested.<sup>36</sup>

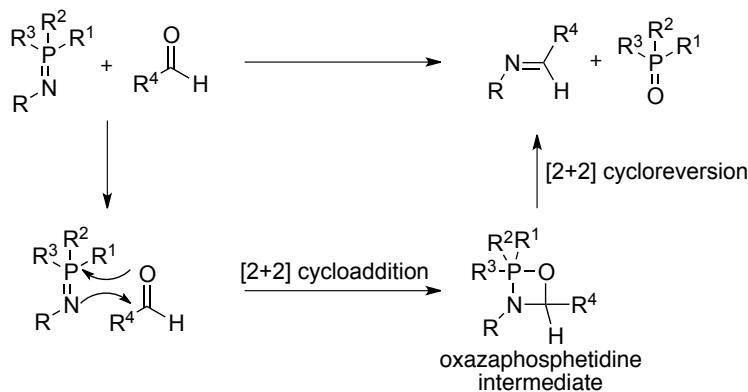

Scheme 1.15

Unlike the classical Wittig reaction, the stereochemical outcome of the reaction is dependent on the second, not first step of the reaction because the activation energy required for the [2+2] cycloreversion step is much greater than that required for configurational changes in the oxazaphosphetidine intermediates.<sup>37</sup> As a result (*E*)-imines are formed almost exclusively in the reaction between *N*-alkyl or *N*-aryliminophosphoranes and alkyl or aryl aldehydes.

## 1.8 Intermolecular aza-Wittig reactions

The aza-Wittig reaction has become an important route towards heterocyclic ring systems due to the mild and neutral nature of the reaction conditions to give generally good yields of product. Both intra- and intermolecular variants of the aza-Wittig reaction are known, although the former has received more attention recently due to its ability to generate *N*-heterocycles in an efficient one-step process with good functional group tolerance.<sup>36-38</sup>

The intermolecular aza-Wittig reaction has been utilised in the synthesis of a variety of heterocycles to good effect. The synthesis of substituted pyridine and pyrimidine rings is of particular interest since these are found in many natural and synthetic biologically active molecules. Tandem aza-Wittig/cyclisation reactions have found particular use in the synthesis of natural products containing pyridine and pyrimidine rings.<sup>37</sup> The total synthesis of variolin B **67**, a marine alkaloid with anti-tumoral properties, is one such example (Scheme 1.16).<sup>39</sup> Here a tandem aza-Wittig carbodiimide formation/cyclisation process was used. Aza-Wittig reaction between iminophosphorane **65** and  $\alpha$ -methylbenzyl isocyanate followed by intramolecular nucleophilic trapping provides a 2-aminopyrimidine ring in almost quantitative yield to give the central core of the product in intermediate **66**. A second 2-aminopyrimidine was introduced at the 3-position of the azaindole and final demethylation and *N*-deprotection was carried out to give the product, variolin B **67**.

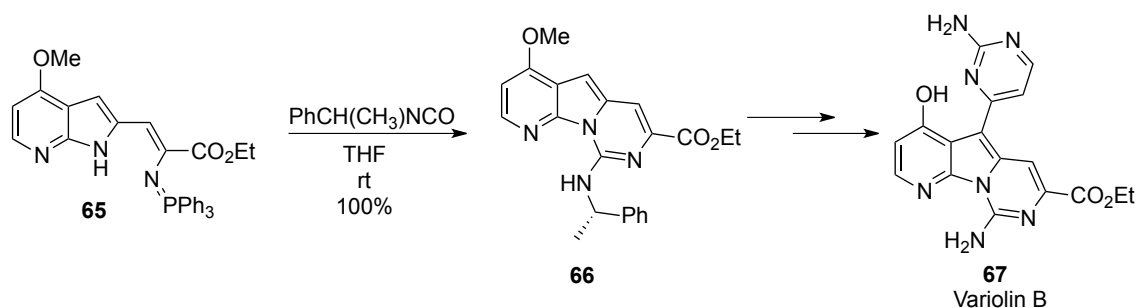

Scheme 1.16

Molina *et al.* utilised the intermolecular aza-Wittig reaction to prepare a highly substituted pyridine ring in the core of two azafluoranthene alkaloids.<sup>40</sup> The carbon skeletons of rufesine **70a** and imelutine **70b** were prepared in four steps from iminophosphorane **68** *via* tandem aza-Wittig/electrocyclic ring closure followed by intramolecular oxidative biaryl coupling of the quinolone **69**. Here the aza-Wittig reaction was used to assemble the quinoline ring found in the core of the molecules (Scheme 1.17).

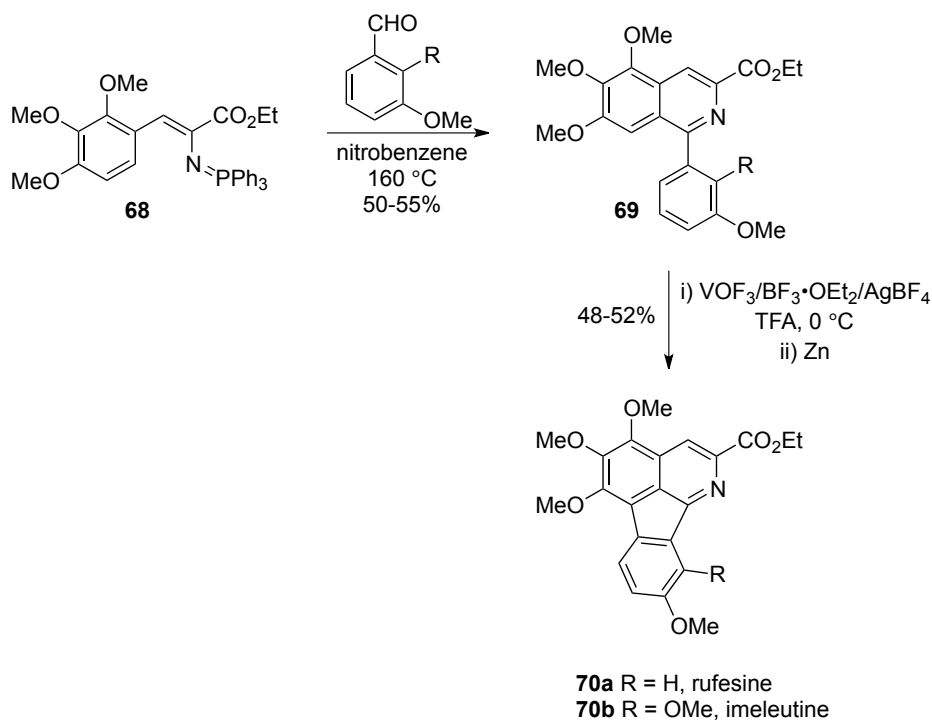

Scheme 1.17

The intermolecular aza-Wittig reaction is also useful for the synthesis of reactive substrates such as amines, amides, enamines, carbodiimides, isocyanates and isothiocyanates. Isocyanates and isothiocyanates are highly reactive heterocumulene derivatives and therefore can take part in tandem or domino reactions towards heterocyclic compounds.<sup>28</sup>

### 1.9 Developing a catalytic aza-Wittig reaction

Whilst the aza-Wittig reaction is useful for the construction of C=N bonds under mild conditions,<sup>28</sup> its uptake into industrial application has been limited by the necessity to prepare and use organic azides as precursors to the iminophosphorane. In addition, the formation of phosphine oxide may be the driving force of the reaction but produces substantial amounts of relatively high molecular weight residual waste that is often difficult to separate from the desired products.<sup>41</sup> In order to reduce the environmental impact of this process a variant that is catalytic in phosphorus would therefore be desirable. This poses a significant challenge due to the requirement to chemoselectively reduce the phosphine oxide by-product into phosphorus(III) reagents in the presence of aldehyde starting materials and imine products. There are two conceptually different approaches to this problem that differ in their methods of achieving turnover (Scheme 1.18). The first (a redox-driven process) recognises that most phosphorus(V) reagents are formed *in situ* from phosphorus(III) reagents such as phosphines

and relies on reduction of the generated phosphine oxide to achieve turnover (A, Scheme 1.18). The second (a redox-neutral process) bypasses the requirement for reducing agents by directly converting the phosphine by-product into the active phosphorus(V) reagent (B, Scheme 1.18).<sup>42</sup>

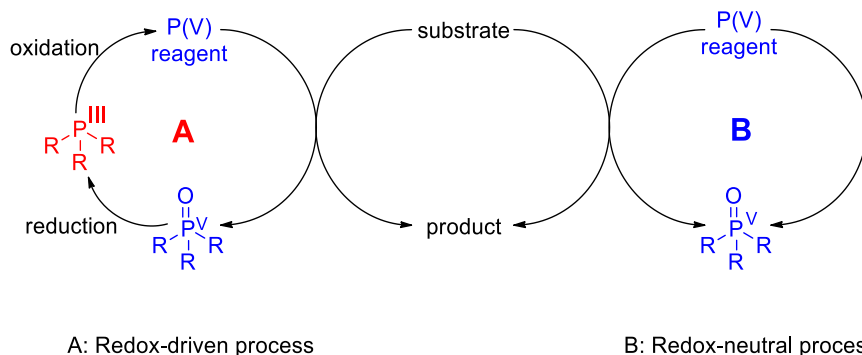

Scheme 1.18

The first example of the redox-driven process was found by O'Brien and co-workers in the first Wittig reaction catalytic in phosphorus (Scheme 1.19).<sup>43</sup> Here they showed that diphenylsilane **72** is a competent reducing agent for phosphine oxide **71** whilst being mild enough to leave other functional groups intact in the synthesis of alkenes **78**.

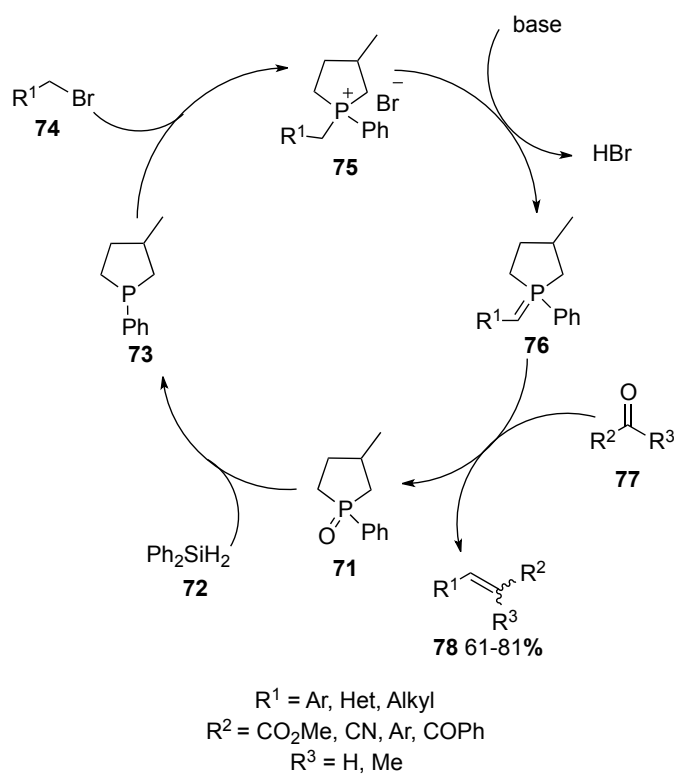

Scheme 1.19



This approach has been utilised further in the development of catalytic Appel and Staudinger reactions by the van Delft group and Woerpel in the reduction of silyl peroxides (Scheme 1.20).<sup>44-46</sup> A challenge still remains in transferring this to a catalytic aza-Wittig reaction, since the imines produced can be easily reduced by silanes<sup>47</sup> and the expense of the silane reducing agents makes them less conducive to large-scale synthesis.

**Catalytic Appel reaction:**

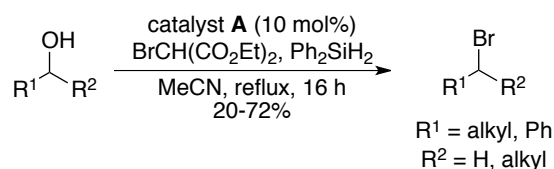

**Catalytic Staudinger reaction:**

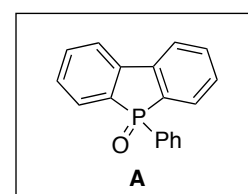
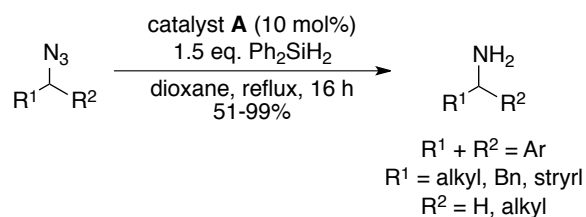

**Catalytic reduction of silyl peroxides:**

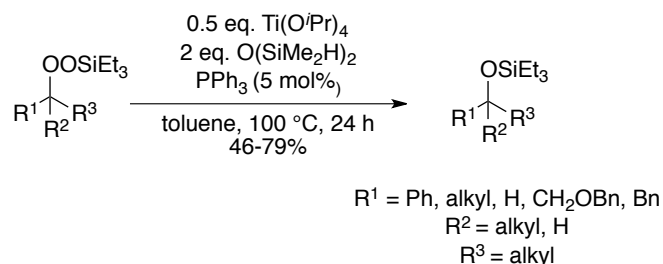

*Scheme 1.20*

Precedent for the redox-neutral process came from Monagle and co-workers in 1962 who demonstrated that carbodiimides can be prepared by the phosphine oxide-catalysed self-condensation of isocyanates.<sup>48</sup> In this case the proposed phosphorus(V) reagent is iminophosphorane **81**, formed *via* a metathesis reaction between the phosphine oxide **80** and isocyanate **79**, eliminating carbon dioxide. The iminophosphorane **81** then reacts with a further molecule of isocyanate **79** by an intermolecular aza-Wittig reaction to produce the carbodiimide **82** and regenerate catalyst **80** (Scheme 1.21). Importantly this shows that iminophosphoranes – the precursors for aza-Wittig reactions – can be prepared and subsequently reacted in a catalytic

fashion. Indeed, this has been utilised in intramolecular aza-Wittig reactions to generate heterocycles in the Marsden group.<sup>49</sup>

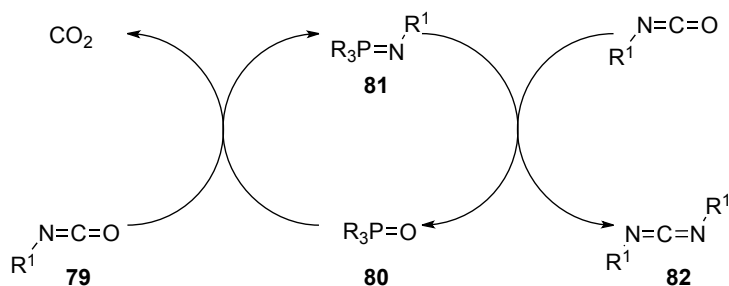

Scheme 1.21

An alternative approach to generating phosphorus(V) reagents in a redox-neutral fashion was demonstrated by Denton *et al.* in the catalytic Appel reaction (Scheme 1.22).<sup>42</sup> Here, oxalyl chloride **83** and triphenylphosphine oxide **84** were used to generate the active phosphorus(V) species **86** with nucleophilic chloride, which upon addition of the alcohol **87** formed the desired chloride **89** through alkoxyphosphonium salt **88**. Use of lithium bromide allowed exchange of chlorine for bromine to furnish the brominated product **89**.

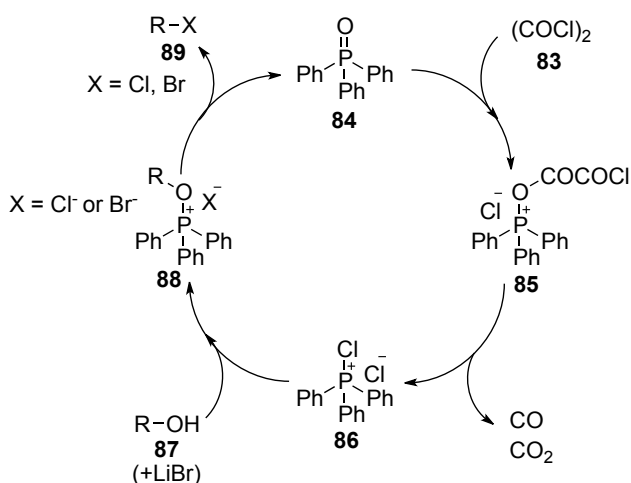

Scheme 1.22

### 1.9.1 Mechanistic studies

Monagle's proposed catalytic cycle (Scheme 1.21) was supported by Staudinger's work on iminophosphoranes where he showed that triphenylphosphine phenylimide reacts with carbon dioxide in a reversible fashion to give phenyl isocyanate and triphenylphosphine oxide (Scheme 1.23).<sup>50</sup> He then showed that triphenylphosphine phenylimide reacts with phenyl isocyanate to give diphenyl carbodiimide and triphenylphosphine oxide.

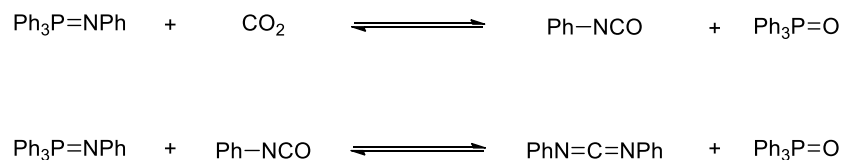

Scheme 1.23

Monagle *et al.* continued to probe the mechanism of the reaction using kinetic studies to show the reaction is first order with respect to both the isocyanate and catalyst for over 95% of the reaction.<sup>51</sup> The kinetic results were consistent with formation of the iminophosphorane being the rate-determining step followed by rapid reaction with another molecule of isocyanate to furnish the carbodiimide and regenerate the catalyst. In addition, a negative entropy of activation ( $\Delta S = -37.9 \pm 3.9$  eu) indicated a highly ordered transition state. Use of <sup>18</sup>O-enriched phosphine oxide gave <sup>18</sup>O-enriched carbon dioxide, whose abundance dropped off rapidly until natural abundance was observed after ~6% of the reaction had occurred.<sup>52</sup> This indicated that the carbon dioxide produced obtains one of its oxygen atoms from the phosphine oxide that was regenerated unlabelled. Based on these results they postulated that nucleophilic attack of the phosphine oxide to the isocyanate generates a four-membered transition state, which decomposes to the iminophosphorane and is driven by the extrusion of carbon dioxide. Reaction of the iminophosphorane and isocyanate in a similar manner produces the carbodiimide and regenerates the catalyst (Scheme 1.24).

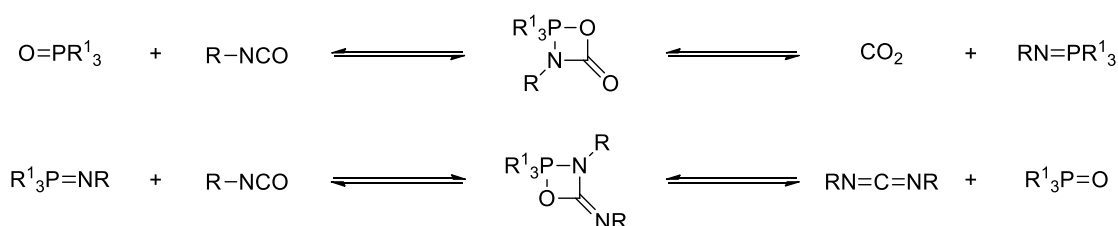

Scheme 1.24

To confirm the reversibility of the reaction, carbon dioxide was passed through a solution of ditolylcarbodiimide in the presence of phosphine oxide in benzene giving tolyl isocyanate whose presence was confirmed by infra-red and the addition of *tert*-butylamine to give the corresponding urea.<sup>48</sup>

### 1.9.2 Catalyst screening

According to Monagle, the most important requirement for catalytic activity is the polarised phosphorus-oxygen bond.<sup>48</sup> In particular, those with a higher dipole moment and hence greater

negative charge on the oxygen should be even more effective than the phosphine oxides. To this end the catalytic activity of a number of arsine, amine and stilbene oxides were screened.<sup>53</sup> As expected trimethylamine oxide displayed no catalytic activity in this reaction since this would require a transition state with pentavalent nitrogen. Moreover, the phosphine, arsine and stilbene oxides followed the predicted trend, with triphenylarsine oxide (dipole moment = 5.50 D) as the most reactive whilst triphenylphosphine oxide (dipole moment = 4.31D) was least, however, none were found to be more active than cyclic phosphine oxides **90a** and **90b** (Figure 1.5).<sup>48</sup> Of these, the phenyl derivative, despite being less reactive, is much more readily available and therefore the catalyst of choice.

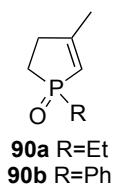

Figure 1.5

The increased activity of cyclic phosphine oxides was later confirmed by Frøyen and co-workers,<sup>54</sup> who compared a variety of phosphine oxides in the self-condensation of phenyl isocyanates, finding that the cyclic analogues reacted approximately 1000 faster. It has been proposed that this is due to the relief of ring strain in the formation of the iminophosphorane, where, to form the transition state a change from tetrahedral to trigonal bipyramidal geometry must occur. This has been shown previously in phosphate ester hydrolysis,<sup>55, 56</sup> where it was suggested that since the endocyclic C-P-C angle in cyclic phospholane oxides has a much greater deviation from the optimal 109° tetrahedral geometry than their acyclic analogues (95° compared to 105°), it is more energetically favourable to move to the trigonal bipyramidal geometry (where the C-P-C angle is 90°) in this case. Upon formation of the iminophosphorane rates of reaction for cyclic and acyclic phosphine oxides produced carbodiimides at similar rates. In their work on the catalytic Appel reaction van Delft and co-workers showed that this was particular to five-membered cycles since smaller ring sizes were unstable and the efficiency of reaction drops off rapidly when the ring size was increased (<20% conversion after 3h for six-membered phosphine oxide compared to quantitative conversion in the same time for the five-membered variants).<sup>44</sup> To widen the scope of catalysts available they prepared aromatic phospholanes **91a-b** (Figure 1.6), which they found to be significantly more active than **90a**, however, these require multi-step procedures for synthesis so **90b** still remains a valuable catalyst.

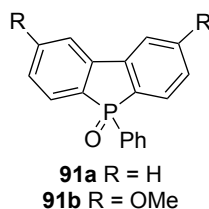
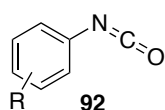

Figure 1.6

### 1.9.3 Isocyanate substrate scope

Monagle quickly established that aryl isocyanates react much faster in the self-condensation reactions than aliphatic isocyanates.<sup>48</sup> To investigate this further Guberman *et al.* explored the electronic effects of aromatic substituents on the rate of reaction of phenyl isocyanates **92a-f** (Table 1.1).<sup>57</sup>

Table 1.1



Entry	R	Rate <sup>a,b</sup>
1 (a)	<i>o</i> -Cl	2.3
2 (b)	H	11.2
3 (c)	<i>p</i> -Cl	18.0
4 (d)	<i>m</i> -Cl	32.9
5 (e)	<i>m</i> -CF <sub>3</sub>	33.8
6 (f)	<i>m</i> -NO <sub>2</sub>	66.5

a: Units: mol<sup>-1</sup>s<sup>-1</sup>; b: reactions carried out in benzene

These results showed that when the electrophilicity of the isocyanate increases, either inductively or by delocalisation of electron density, the rate of the reaction increases. This can be explained by examining the reaction mechanism where attack of a nucleophilic species onto the carbonyl of the isocyanate occurs in the rate-determining iminophosphorane formation. Thus reaction of *m*-nitrophenyl isocyanate (Entry 6) occurs almost 70 times faster than phenyl isocyanate (Entry 2). The presence of *ortho* substituents hinders the reactions as can be seen in the case of *o*-chlorophenyl isocyanate (Entry 1). The decreased rate of reaction in this case can be attributed to the steric effect of the chlorine atom on the approach of the phosphine oxide.

### 1.10 Previous work

The self-condensation of isocyanates to carbodiimides was the first example of an intermolecular catalytic aza-Wittig reaction.<sup>48</sup> However, despite the widespread use of the intramolecular aza-Wittig reaction in the synthesis of heterocycles<sup>28</sup> no examples of a catalytic variant had been reported. With this in mind, it was proposed that use of an isocyanate with pendant carbonyl in the formation of an iminophosphorane could then allow interception with the carbonyl *via* an intramolecular aza-Wittig reaction, to generate a heterocycle (Scheme 1.25). It was hoped that the intramolecular reaction could be favoured over the self-condensation of the isocyanate to carbodiimide by dilution (Scheme 1.25, unwanted).

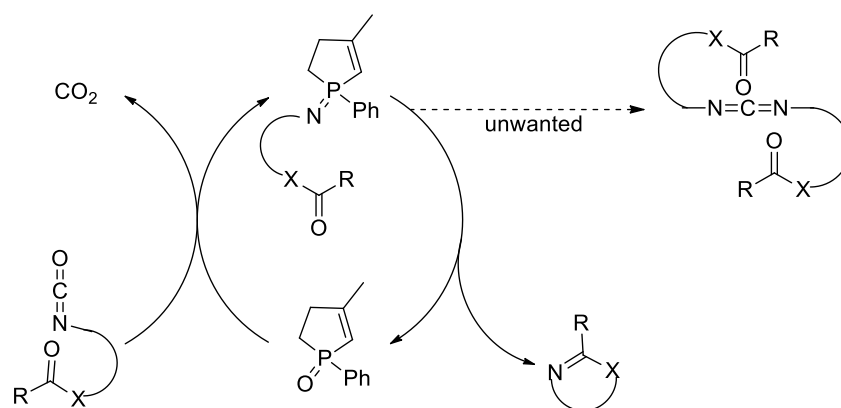

Scheme 1.25

Preliminary investigations focused on the synthesis of 6-alkoxyphenanthridine **94a** (Scheme 1.26) which was prepared in 71% yield by treating isocyanate **93a** with 25 mol% of catalyst **90b** in refluxing toluene.<sup>49, 58</sup>

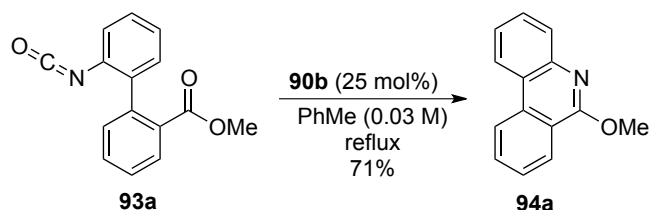

Scheme 1.26

To investigate alternative substrates isocyanates were prepared *via* a three-step synthesis from diphenic anhydride (Scheme 1.27). Ring-opening using alcohol or amine gave the corresponding acid **95** that was converted to the acyl azide **96** upon addition of DPPA and triethylamine. Subsequent Curtius rearrangement afforded the isocyanate **93**, which could be treated, without further purification, with catalyst **90b** in toluene under reflux to obtain the phenanthridines **94a-d**.

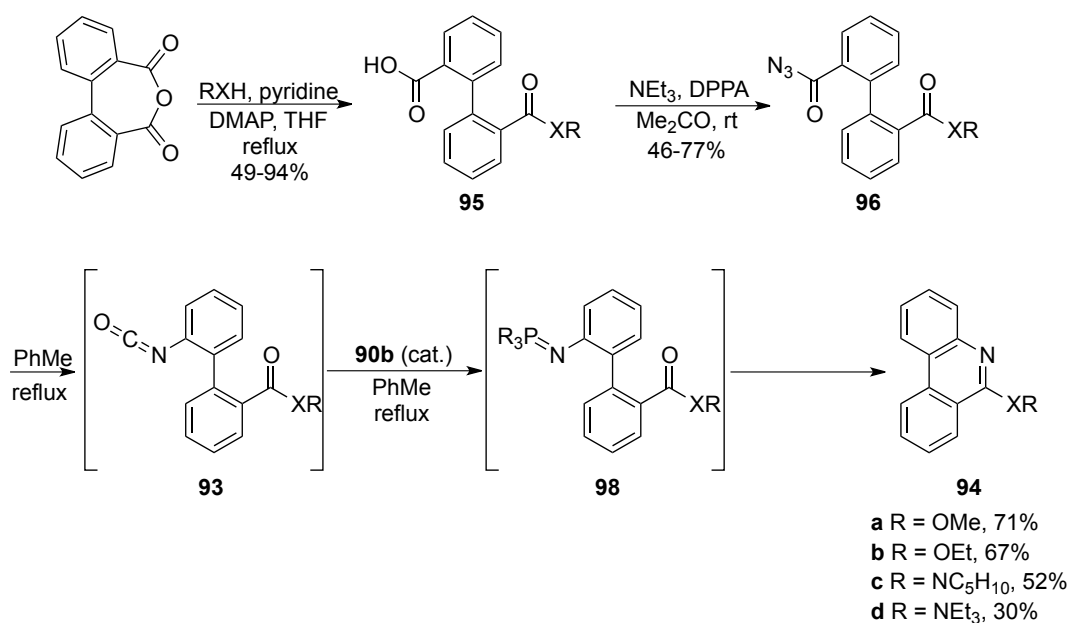

Scheme 1.27

Further experimentation showed that catalyst loadings could be reduced to 5 mol% at higher concentrations (0.1 M) leading to improved yield. With extended reaction times catalyst loadings could be reduced down to 1 mol% with no loss in yield. This reaction was also extended to the use of amide substrates **94c** and **94d**, although these less electrophilic starting materials required higher catalyst loadings to achieve sufficient cyclisation.

Having exemplified the reaction for six-membered heterocycles (azines), work proceeded onto the application of this process in the synthesis of five-membered heterocycles (azoles). Benzoxazoles are prevalent in both natural products and pharmaceutical targets<sup>59-61</sup> and the salicylic acid precursors are widely available, therefore these were a desirable target. The isocyanate precursors **99** were prepared *via* Curtius rearrangement of the corresponding acyl azides, prepared from treatment of the acylated salicylic acids with DPPA and NEt<sub>3</sub>. Initially, these were subjected to the optimal conditions used for phenanthridine synthesis (5 mol% **90b** at 0.1 M concentration), however, this led to significant carbodiimide formation *via* the competing self-condensation of the isocyanates, so a more dilute reaction (0.03 M) was carried out (Table 1.2). The reaction was exemplified in the synthesis of 15 benzoxazoles **100** prepared in good to moderate yields.

Table 1.2

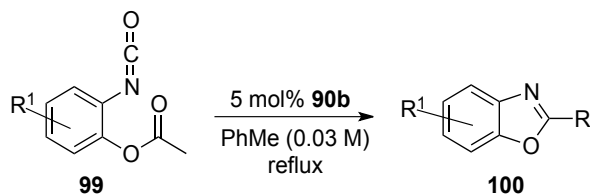

Entry	R <sup>1</sup>	R	Yield of 100 (%) <sup>a</sup>
1 (a)	H	Ph	87
2 (b)		4-FC <sub>6</sub> H <sub>4</sub>	70
3 (c)		4-MeOC <sub>6</sub> H <sub>4</sub>	62
4 (d)		2-Furyl	77
5 (e)		Me	82 <sup>b</sup>
6 (f)		<sup>n</sup> C <sub>6</sub> H <sub>13</sub>	45 <sup>b</sup>
7 (g)		CH(Me)C <sub>3</sub> H <sub>17</sub>	65 <sup>b</sup>
8 (h)	4-OMe	Ph	70 <sup>b</sup>
9 (i)		2-Furyl	38
10 (j)	3-OMe	Ph	70 <sup>b</sup>
11 (k)		4-FC <sub>6</sub> H <sub>4</sub>	62
12 (l)		4-OMeC <sub>6</sub> H <sub>4</sub>	59
13 (m)	5-F	Ph	51
14 (n)		4-FC <sub>6</sub> H <sub>4</sub>	48
15 (o)	4-Cl	Me	26

a: Isolated yield from acyl azide precursor to **100**; b: 3 mol% catalyst loading.

Following the successful implementation of the organocatalytic aza-Wittig reaction to phenanthridines and benzoxazoles, it was hoped this could be applied to a wider array of benzo-fused 1,3-azoles, including benzimidazoles. Preliminary investigations using the previous conditions, however, led to significant quantities of the carbodiimide by-product and only modest yields of the desired benzimidazole products **104a-c** (Scheme 1.28).<sup>58</sup> Upon further examination it was found that this was due in part to the propensity of the *ortho*-substituted benzoyl azide precursors **102a-c** to undergo Curtius rearrangement at room temperature.<sup>62</sup> Instability of the isocyanates **103** on silica gel led to significant loss of yield during purification.



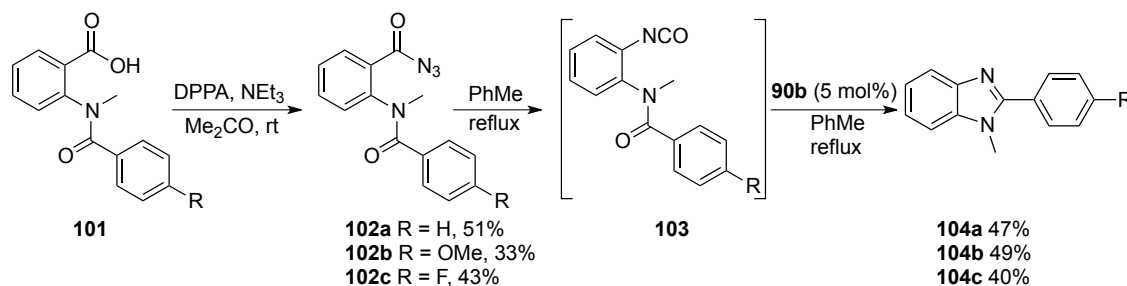

Scheme 1.28

To improve the overall yield of the process, an alternative synthesis of the acyl azides **102** that would eliminate the necessity for chromatographic purification was sought. Thus acyl azides **102a-c** were prepared in high yields (81-93%) by treatment of the acids **101a-c** with carbonyl diimidazole, followed by addition of aqueous sodium azide solution. Whilst some Curtius rearrangement still occurred, aqueous work-up sufficiently removed any impurities negating the requirement for chromatography. This in combination with a more dilute aza-Wittig reaction gave increased yields of the benzimidazoles **104a-c** (47, 43, 53% over 3 steps compared to 23, 14 and 20% respectively). The optimal conditions (preparation of the acyl azides using carbonyl diimidazole and sodium azide followed by aza-Wittig at 0.02 M with 5 mol% **90b**) were then used to prepare a further 17 examples (Table 1.3) in good yields.

Table 1.3

Entry	R <sup>1</sup>	R <sup>2</sup>	Yield of <b>104</b> (%)
1 ( <b>d</b> )	Ph	Me	38
2 ( <b>e</b> )		(CH <sub>2</sub> ) <sub>5</sub> CH <sub>3</sub>	48 <sup>a</sup>
3 ( <b>f</b> )		(CH <sub>2</sub> ) <sub>2</sub> CH=CH <sub>2</sub>	43
4 ( <b>g</b> )		CF <sub>3</sub>	91 <sup>b</sup>
5 ( <b>h</b> )		4-O <sub>2</sub> NC <sub>6</sub> H <sub>4</sub>	60 <sup>a</sup>
6 ( <b>i</b> )		4-NCC <sub>6</sub> H <sub>4</sub>	72 <sup>a</sup>
7 ( <b>j</b> )	Me	CF <sub>3</sub>	63
8 ( <b>k</b> )		4-O <sub>2</sub> NC <sub>6</sub> H <sub>4</sub>	87 <sup>a</sup>
9 ( <b>l</b> )		4-NCC <sub>6</sub> H <sub>4</sub>	78 <sup>a</sup>
10 ( <b>m</b> )		3,5-O <sub>2</sub> NC <sub>6</sub> H <sub>3</sub>	78 <sup>a</sup>
11 ( <b>n</b> )	4-FC <sub>6</sub> H <sub>4</sub>	CF <sub>3</sub>	76

12 (o)	3-F <sub>3</sub> CC <sub>6</sub> H <sub>4</sub>	Me	36 <sup>a</sup>
13 (p)		CF <sub>3</sub>	61 <sup>a</sup>
14 (q)	2-CH <sub>3</sub> -3-ClC <sub>6</sub> H <sub>3</sub>	CF <sub>3</sub>	63 <sup>a</sup>
15 (r)	4-CH <sub>3</sub> C <sub>6</sub> H <sub>4</sub>	CF <sub>3</sub>	70 <sup>a</sup>
16 (s)		4-O <sub>2</sub> NC <sub>6</sub> H <sub>4</sub>	64 <sup>a</sup>
17 (t)	5-FIC <sub>6</sub> H <sub>4</sub>	CF <sub>3</sub>	78 <sup>a</sup>
18 (u)		4-O <sub>2</sub> NC <sub>6</sub> H <sub>4</sub>	63 <sup>a</sup>

a: reaction run at 0.01 M; b: reaction run at 0.03 M

To confirm the role of the phosphine oxide catalyst in the synthesis of the heterocycles the formation of 2-methylbenzoxazole was studied using an *in situ* IR probe (ReactIR). Prior to addition of the catalyst, the reaction profile (Figure 1.7) shows that the intensity of isocyanate (2254 cm<sup>-1</sup>) and ester (1779 cm<sup>-1</sup>) stretches remains constant. These rapidly disappeared with first order kinetics upon addition of the catalyst with new stretches at 1455, 1578 and 1617 cm<sup>-1</sup> corresponding to the products steadily increasing. The signal at 1188 cm<sup>-1</sup> was thought to correspond to a reactive intermediate due to its initial growth upon catalyst addition then disappearance as the reaction progresses.

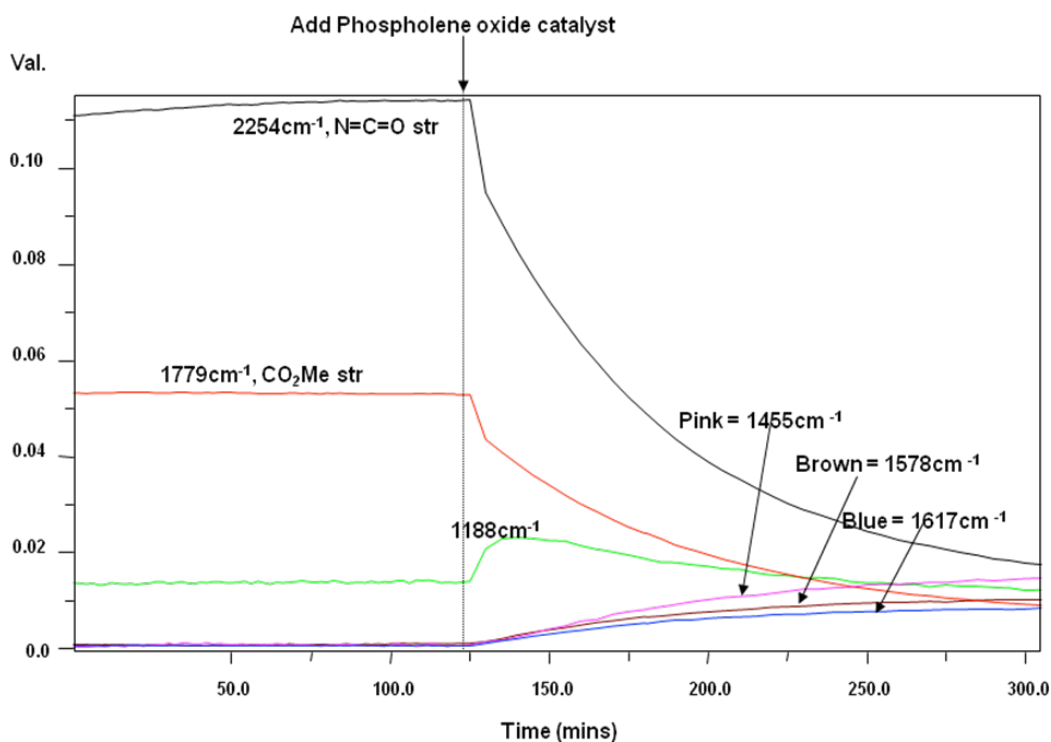

Figure 1.7

This work demonstrates the first examples of the organocatalytic intramolecular aza-Wittig reaction and has been exemplified in both azole and azine synthesis. It provides a novel and

potentially useful approach towards 6-alkoxyphenanthridines, the core of many benzophenanthridine alkaloids. In addition, the synthesis of 2-substituted benzoxazoles from salicylic acid precursors of which there are over 1800 commercially available provides an alternative feedstock from 2-aminophenol derivatives (320 available) used in many classical syntheses.

### 1.11 Project Aims

The aim of the project is to develop a one-pot process towards pyridine and pyrimidine rings utilising intermolecular catalytic aza-Wittig and cyclisation reactions.

Firstly, the catalytic aza-Wittig reaction will be extended to the intermolecular reaction between vinyl isocyanates **105** and aldehydes **107** to prepare 2-azadienes **108** for use in cyclisation reactions (Scheme 1.29). The conditions for this reaction will be developed and optimised in order to minimise formation of the carbodiimide by-product, either by controlled addition of the isocyanate **105** or the use of excess aldehyde **107**, an approach utilised by Monagle *et al.* during mechanistic studies of isocyanate self-condensation.<sup>48</sup>

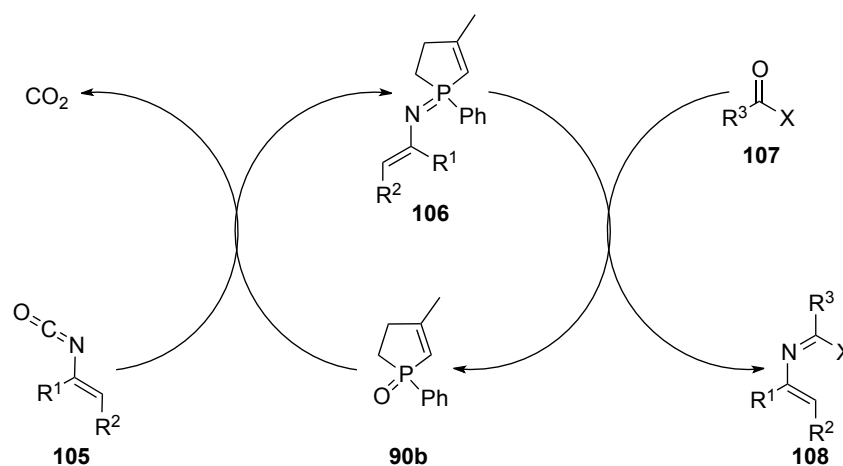

Scheme 1.29

Two different cyclisation methods shall be used to prepare substituted pyridines. Firstly, imino Diels–Alder reactions of 2-azadienes will be investigated. Vinyl isocyanates **105** shall be prepared according to literature procedures<sup>63–65</sup> and used in the catalytic aza-Wittig reaction to give 2-azadienes **108**. Electron-poor 2-azadienes **108** will be used in the inverse electron-demand Diels–Alder reaction with electron-rich enamines **9** (Scheme 1.30).

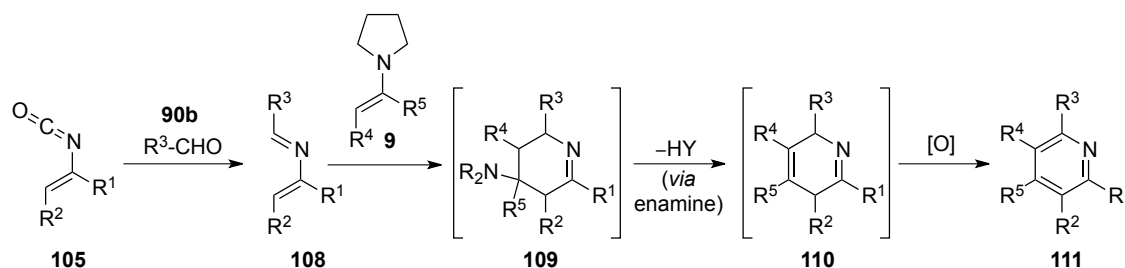

Scheme 1.30

Secondly, electrocyclisation reactions of azatrienes will be investigated. Heteroaryl isocyanates such as benzothiophene, benzofuran and indole isocyanates **113** shall be prepared by the Curtius

rearrangement of acyl azides **112** and used in the catalytic aza-Wittig reaction with  $\alpha,\beta$ -unsaturated aldehydes **114** to give azatrienes **115**. Azatrienes can then undergo electrocyclic ring closures under thermal or photochemical conditions to give dihydropyridines and products oxidised to give pyridines **116** (Scheme 1.31).<sup>1-3, 66-68</sup>

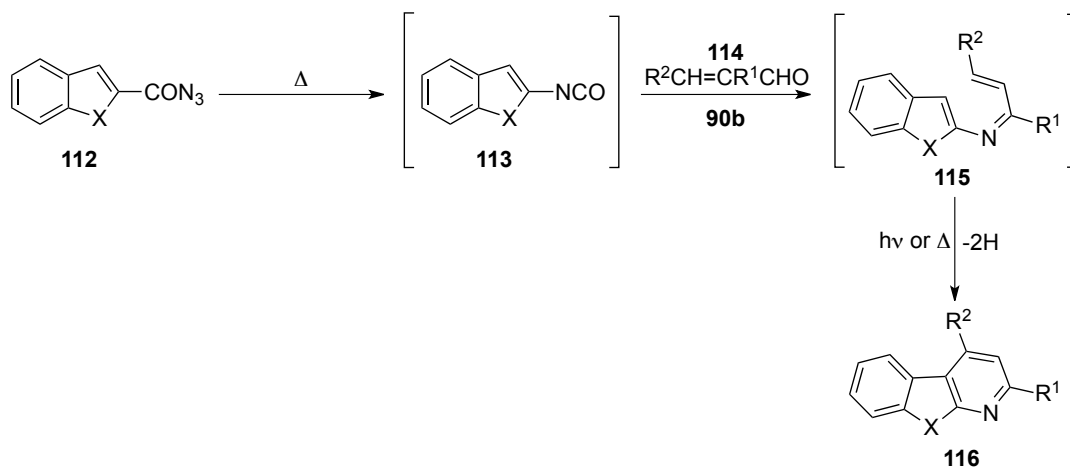

*Scheme 1.31*

The aza-Wittig/cyclisation reactions will then be telescoped to give a one-pot process.

## 2.0 Development of a two-pot process towards substituted pyridines

### 2.1 Intermolecular catalytic aza-Wittig reactions

The intramolecular catalytic aza-Wittig reaction has been established and used to prepare a number of heterocycles,<sup>49, 58, 62, 69</sup> however, the intermolecular variant was conceptually more difficult. Previously, the desired unimolecular aza-Wittig reaction to the pendant carbonyl was favoured over the bimolecular process (carbodiimide formation) by dilution. In the case of the intermolecular reaction there are two competing bimolecular processes, firstly between the iminophosphorane and the aldehyde, secondly between the iminophosphorane and a second molecule of the isocyanate (Scheme 2.1).

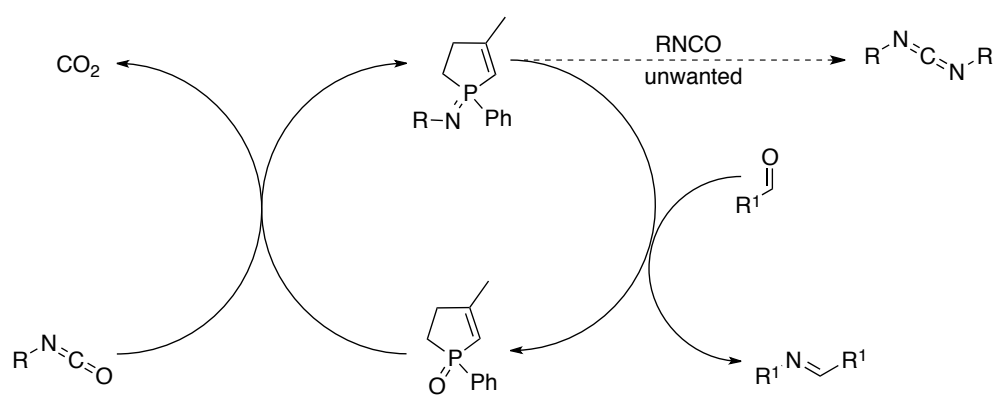

Scheme 2.1

Although Monagle and Campbell's early work on intermolecular catalytic aza-Wittig reactions mostly focused on self-condensation reactions of isocyanates to form carbodiimides, one example involving reaction with an aldehyde in the aza-Wittig step was explored (Scheme 2.2). However, although benzaldehyde **118** was used as a solvent, the reaction was low yielding for imine **118**.<sup>48</sup>

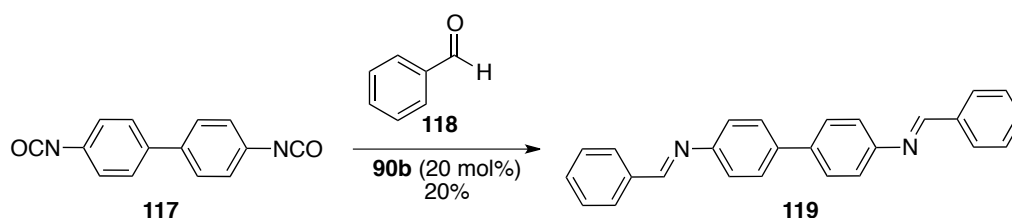

Scheme 2.2

Despite this the development of a catalytic intermolecular aza-Wittig that utilises carbonyl functionalities such as aldehydes to intercept the iminophosphorane is appealing. This could provide a neutral method of preparing imines whose syntheses are non-trivial such as *N*-tosyl imines (whose syntheses require high loadings of Lewis acid catalysts such as TiCl<sub>4</sub> which are

often incompatible with other functional groups)<sup>70</sup> and azadienes (whose synthesis requires organic azides). Previous work in our group therefore led to a mild procedure for the preparation of a number of *N*-tosyl imines **120a-f** in excellent yields (Scheme 2.3).<sup>62</sup> The commercial availability of *N*-tosyl isocyanate, and ability to carry substrates forward without the need for purification offers significant advantages over classical procedures.

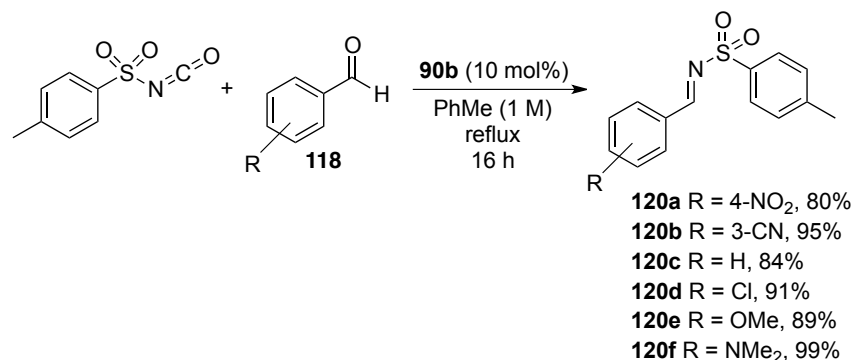

Scheme 2.3

It is noteworthy that tosyl isocyanate was found to be less reactive than phenyl isocyanates, generally requiring significantly longer reaction times (4 h compared to 30 minutes). This is somewhat surprising since the electron-withdrawing *p*-tosyl group would be expected to enhance the rate of iminophosphorane formation (postulated to be the rate-determining step).<sup>57</sup> However, it is possible in this case, that the electron-withdrawing sulfonyl group may decrease the nucleophilicity of the iminophosphorane sufficiently to reduce the rate of reaction between aldehyde and iminophosphorane, thus making imine formation the rate-determining step.

## 2.2 Optimisation of intermolecular aza-Wittig reaction

Initially we sought to gain an understanding of how the reaction conditions could affect the system with more reactive aryl isocyanates. Hence, the reaction between commercially available phenyl isocyanate **92b** and benzaldehyde **118** was chosen as a model reaction (Scheme 2.4), to avoid the need to prepare vinyl isocyanates. Initially the reaction conditions from the previously developed intramolecular process were used since these had been used successfully for a number of substrates.<sup>49, 58, 62</sup>

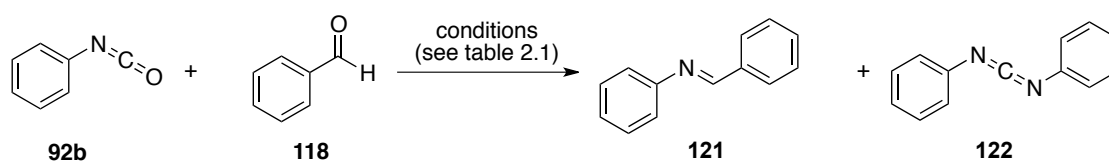

Scheme 2.4

At first, the isocyanate **92b** was added over a short period of time to a solution of catalyst **90b** and benzaldehyde **118** in toluene at reflux using IR spectroscopy on sampled aliquots of the reaction mixture to monitor the course of the reaction. This gave the imine **121** in 71% conversion (calculated by integration of the  $^1\text{H}$  NMR of the crude product rather than as an isolated yield because the imines are unstable to column chromatography). Absorbance at  $2140\text{ cm}^{-1}$  in the IR spectrum and signals for the unreacted benzaldehyde **118** in the  $^1\text{H}$  NMR spectrum at the end of the reaction indicated that the undesired carbodiimide **122** had also been formed by competing self-condensation of phenyl isocyanate **92b**.

In order to reduce the formation of the undesired carbodiimide **122**, thereby potentially increasing the amount of desired imine **121** prepared, 36 reactions were carried out varying concentration, catalyst loading, slow addition time and equivalents of reagents. The most significant results of these experiments are summarised in Table 2.1 and show a number of trends:

- When no catalyst was present, no imine formation was observed (Table 2.1, entry 1).
- Increasing the addition time of isocyanate **92b** using a syringe pump increases the ratio of imine **121** formed compared to carbodiimide **122** (Table 2.1, entries 3, 4).
- Increasing the reaction time without slow addition of phenyl isocyanate **92b** increases the ratio of imine **121** formed compared to carbodiimide **122** (Table 2.1, entries 3, 5).
- At 1 M concentration with slow addition of the isocyanate **92b** over 5 hours, the catalyst loading could be decreased with no detrimental effect on the yield of the imine **121** (Table 2.1, entries 6, 7).
- Distilling the benzaldehyde **118** prior to reaction increases the conversion to imine **121** (Table 2.1, entries 3, 5).



Table 2.1

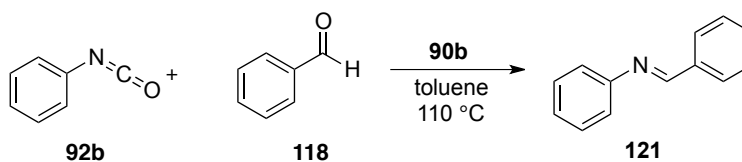

Entry	Conc./ mol l <sup>-1</sup>	Mol % catalyst	Addition time <sup>a</sup>	% conversion <sup>b</sup>
1	1	0	-	0 <sup>c</sup>
2	0.2	10	-	0.5
3	1	10	-	71
4	1	10	5 h	86
5	1	10	- <sup>c</sup>	86 <sup>d</sup>
6	1	1	5 h	>99 <sup>d</sup>
7	1	5	5 h	>99 <sup>d</sup>

a: reactions were carried out for 15 minutes until IR showed disappearance of the isocyanate absorbance (2259 cm<sup>-1</sup>); b: calculated from ratio of benzaldehyde **118** to imine **121** in crude <sup>1</sup>H NMR; c: reaction time 5 hours after phenyl isocyanate addition.; d: benzaldehyde **118** distilled prior to reaction.

Some trends from this data are worthy of comment; by increasing the addition time of phenyl isocyanate **92b** using a syringe pump, the amount present in the reaction vessel at any given time was reduced, so there was less isocyanate available for self-condensation to occur. Hence, the ratio of imine **121** compared to carbodiimide **122** was improved. However, adding the isocyanate **92b** in one portion and increasing the reaction time also increased the conversion to imine **121** compared to carbodiimide **122**. This was unexpected because the IR spectrum of the reaction mixture suggested the reaction had gone to completion as there was no isocyanate absorbance. It was later found that this was due to the reaction of the carbodiimide by-product **122** with the catalyst and the aldehyde to give the imine **121**. This is discussed further in chapter 3.

To explore the effect of different substituents on the aldehyde, several substrates were investigated using the optimal reaction conditions; dropwise addition over 5 hours of 1.1 equivalents of the isocyanate **92b** to distilled aldehyde at 1 M concentration in toluene heated at reflux (Table 2.2). The substituents on the aryl aldehydes **123** had a significant effect on the rate of formation of the imine **124**. The presence of an electron-donating methoxy group in the *para*-position saw the rate of conversion to imine **124** decrease significantly with longer reaction times required. Accordingly, reaction times were significantly reduced when using benzaldehydes **123d-e** with strongly electron-withdrawing substituents; high conversions to imine **124** were seen within 15 minutes. Pivaldehyde was also screened in an attempt to move

away from aromatic aldehydes. However, no imine formation was observed and the major product was found to be carbodiimide. However, the highly electrophilic aldehyde, ethyl glyoxylate gave 70% conversion to imine **124e** after 5 hours. Reaction of an  $\alpha,\beta$ -unsaturated aldehyde (cinnamaldehyde **123f**) was examined but this gave only a modest conversion to imine, with higher quantities of carbodiimide observed.

Table 2.2

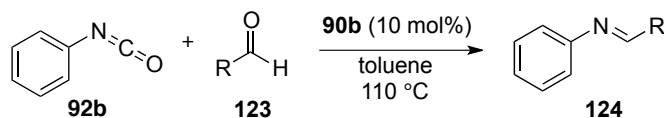

Entry	<b>122</b>	<b>R</b>	<b>% Yield 124</b>
1	<b>a</b>	4-MeOC <sub>6</sub> H <sub>4</sub>	50
2	<b>b</b>	4-BrC <sub>6</sub> H <sub>4</sub>	97
3	<b>c</b>	4-F <sub>3</sub> CC <sub>6</sub> H <sub>4</sub>	>99
4	<b>d</b>	4-O <sub>2</sub> NC <sub>6</sub> H <sub>4</sub>	80 <sup>a</sup>
5	<b>e</b>	CO <sub>2</sub> Et	70 <sup>a</sup>
6	<b>f</b>	HC=CHPh	33
7	<b>g</b>	<sup>t</sup> Bu	0

a: No dropwise addition of isocyanate **92b**.

### 2.3 Preparation of vinyl isocyanates

Having developed and optimised the intermolecular aza-Wittig reaction on a simple system, attempts were made to prepare vinyl isocyanates to allow the study of azadiene synthesis. Although it has been reported by Rigby and co-workers that vinyl isocyanates are readily prepared *via* Curtius rearrangement of acyl azides,<sup>63</sup> these substrates are highly reactive and rarely isolated. Their formation can be monitored by IR spectroscopy by disappearance of the azide signal at 2140-2150 cm<sup>-1</sup> and appearance of the isocyanate signal at 2270-2250 cm<sup>-1</sup>.<sup>71</sup> Preliminary experiments focused on the isocyanate-ester **127** since 2-azadienes bearing ester substituents have previously been used in inverse electron-demand Diels–Alder reactions with enamines.<sup>21, 25, 28, 29</sup> Thus, the electron-poor fumarate half ester **125** was prepared in 69% yield from maleic anhydride and benzyl alcohol (Scheme 2.5) with *in situ* isomerism occurring in the reaction medium to give the *trans*-isomer exclusively.<sup>72</sup> However, upon addition of carbonyl diimidazole and 5 M sodium azide solution (aq) the <sup>1</sup>H NMR spectrum of acyl azide **126** was unexpectedly complicated and no isocyanate signal was observed in the IR spectrum upon heating in toluene.

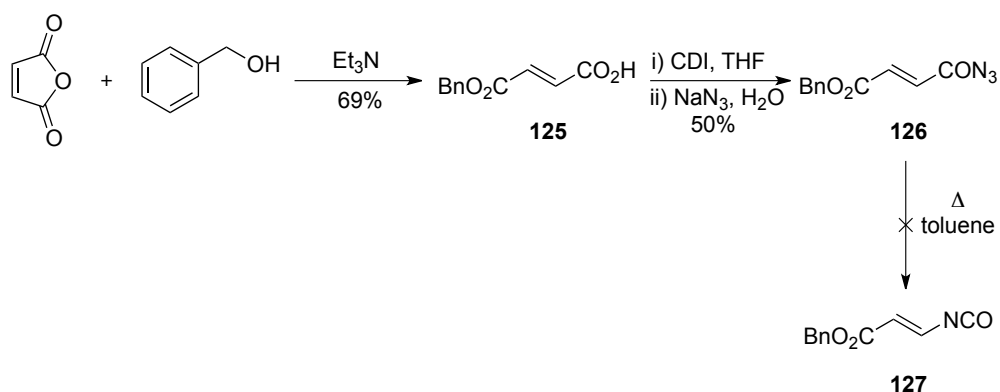

Scheme 2.5

Whilst Kricheldorf has reported the preparation of  $\beta$ -isocyanatoacrylic acid esters **128** and their reversible isomerisation into oxazinones **129** (Scheme 2.6),<sup>73</sup> the isocyanate **128** was not isolated from solution. A later report by Byerley *et al.* stated that the isocyanate **128** was difficult to prepare and isolate due to the fast rate of cyclisation to **129**.<sup>74</sup> However, in our hands no absorbance for the oxazinone ( $1770\text{ cm}^{-1}$ )<sup>73</sup> was observed by IR during the Curtius rearrangement of **125** and a complex mixture was observed by  $^1\text{H}$  NMR.

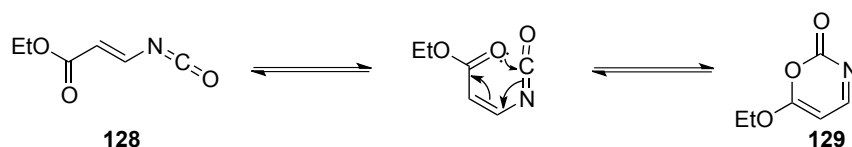

Scheme 2.6

To avoid the potential competing formation of the oxazinone **129** an alternative substrate was sought. Styryl isocyanate **132** has been used in the synthesis of pyridones *via* cyclocondensations with enamines,<sup>64, 75</sup> and the starting carboxylic acid, cinnamic acid is commercially available. Formation of acyl azide **131** proceeded smoothly and subsequent Curtius rearrangement showed the expected isocyanate signal at  $2259\text{ cm}^{-1}$  in the IR spectrum (Scheme 2.7).

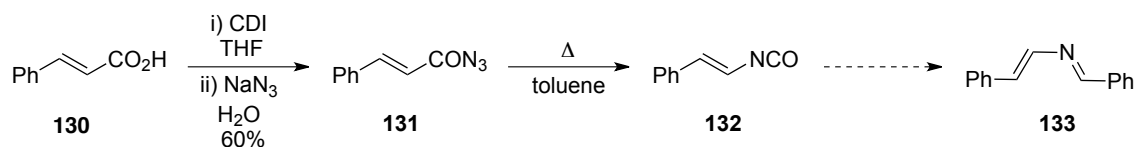

Scheme 2.7

Having obtained the desired isocyanate **132**, benzaldehyde and 3-methyl-1-phenylphospholene oxide catalyst **90b** were added to attempt the catalytic aza-Wittig reaction. However, despite the isocyanate signal disappearing by IR, no azadiene was seen in the  $^1\text{H}$  NMR spectrum of the crude reaction mixture.

According to literature reports, acyclic vinylic isocyanates are often problematic reaction partners due to a propensity to polymerise.<sup>64, 65, 75</sup> Therefore, a more stable cyclic vinyl isocyanate, 1-cyclohexenyl isocyanate, was chosen. To increase the thermal stability of the corresponding acyl azide (and so reduce the risk of explosion), the 4-*t*-butyl derivative was prepared.<sup>76</sup> A report by Vitnik *et al.* describes a one-pot procedure towards 1-cyclohexenyl carboxylic acids from cyclohexanones with isolated yields up to 95%.<sup>77</sup> Whilst the 4-*t*-butyl-1-cyclohexenyl carboxylic acid **134** was obtained by this method, yields were variable and generally less than 50% (Scheme 2.8). Potentially, this could be due to insufficient mixing of the biphasic reaction mixture since yields decreased upon scaling the reaction from 1 mmol (44%) to 20 mmol (29%).

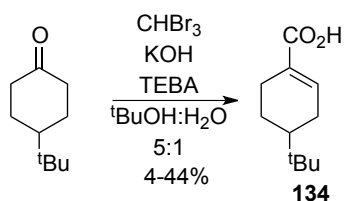

Scheme 2.8

Vinyl isocyanate **136** was then generated *via* Curtius rearrangement of the corresponding acyl azide **135** by heating in toluene under reflux. Whilst the presence of the vinyl isocyanate **135** was observed by IR spectroscopy, confirmation of the stability and yield of the product was sought. A common method for the confirmation of the formation of isocyanates is the addition of alcohols to form the corresponding carbamates.<sup>78</sup> Accordingly, benzyl alcohol was added to the reaction mixture, giving a 16% yield of the carbamate **137** (Scheme 2.9). It was observed in these reactions that whilst the acyl azide **135** appears to be pure by <sup>1</sup>H NMR, several *t*-butyl peaks were observed after the reaction. The use of *d*<sub>8</sub>-toluene as solvent for the Curtius rearrangement allowed a <sup>1</sup>H NMR of the isocyanate **136** to be obtained. This also showed a number of peaks in the *t*-butyl region suggesting that a number of side reactions were occurring during the Curtius rearrangement, leading to low yields of the isocyanate **136**. It is known that vinyl isocyanates readily polymerise,<sup>79, 80</sup> even at room temperature, therefore it is likely that, after Curtius rearrangement, isocyanate polymerisation reactions were occurring.

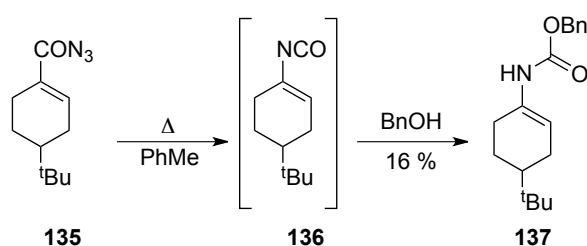

Scheme 2.9

Two methods of reducing polymerisation side-reactions were envisaged: (i) adding the reagents prior to the Curtius rearrangement to allow immediate trapping, thus reducing the amount of isocyanate available to polymerise (a strategy used successfully in the synthesis of benzothienopyridines, chapter three); (ii) use of a more dilute Curtius rearrangement, which should reduce the bimolecular interactions between isocyanate molecules that can lead to polymerisation<sup>81</sup> (previously reactions had been carried out at 1 M concentration according to the optimal conditions for the aza-Wittig reaction). This in turn might facilitate a dropwise addition of isocyanate to the other aza-Wittig reagents – namely the phospholene oxide catalyst and aldehyde. Whilst the former method was successful in the synthesis of benzyl carbamate **138**, increasing the yield to 52%, it did not translate to azadiene formation. However, to our delight, a solution of isocyanate **132** prepared by thermolysis of a 0.1 M solution of acyl azide **131**, not only gave a 66% yield of carbamate **138** (path A, Scheme 2.10), but dropwise addition over 2 hours to a mixture of the catalyst **90b** and 4-trifluoromethylbenzaldehyde in refluxing toluene gave azadiene **139** in 50% conversion (carbodiimide by-product observed by IR, path B, Scheme 2.10).

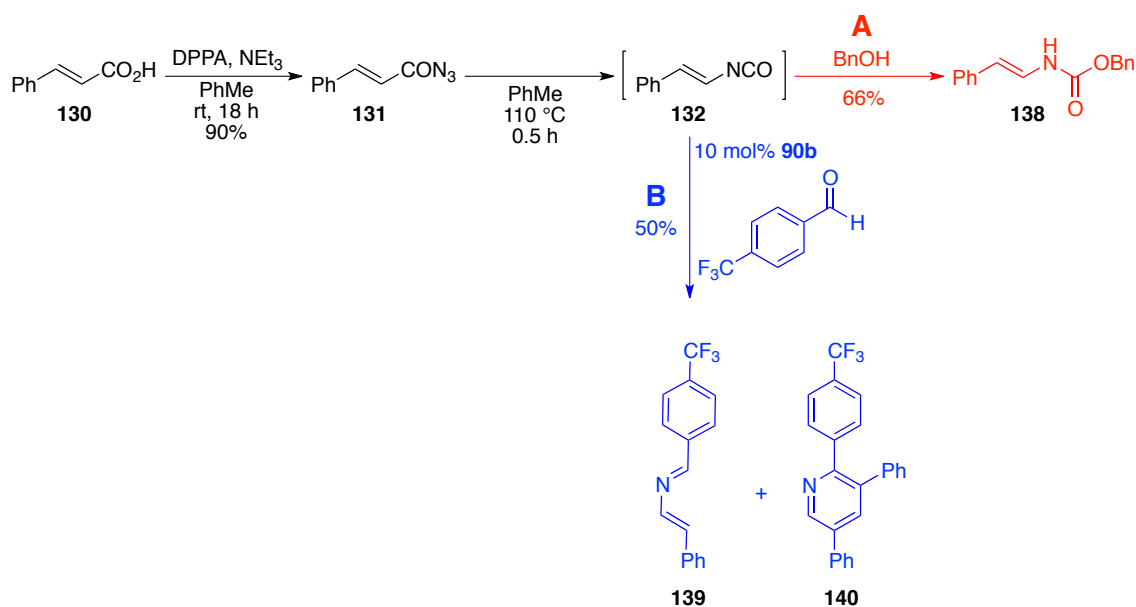

Scheme 2.10

It was observed that a pyridine by-product **140** was formed in small amounts during the aza-Wittig reaction. This can be attributed to the dimerisation of the azadiene **139**, where it acts as both a diene and dienophile in a [4+2] cycloaddition as reported by Palacios *et al.* (Scheme 2.11).<sup>22</sup>

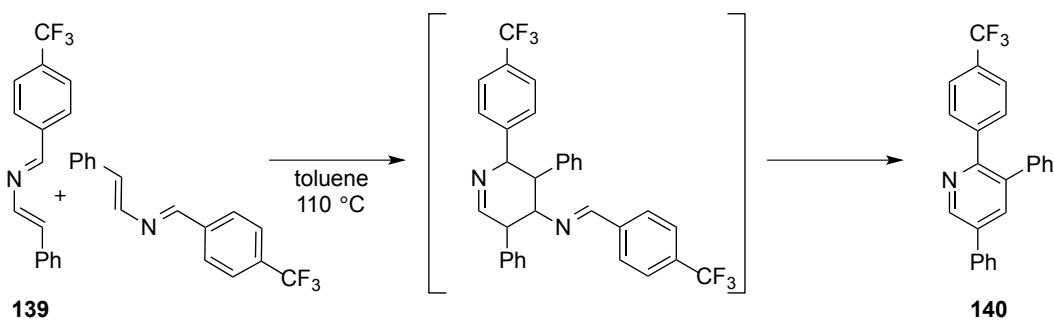

Scheme 2.11

Whilst this indicated that dimerisation of the 2-azadiene **139** could be a potential issue, it was hoped that, upon addition of a more reactive enamine dienophile, this side-reaction would be limited. Indeed when the enamine **141** was added after consumption of the isocyanate **130** (monitored by IR spectroscopy) the desired pyridine **142** was formed, but in a disappointing 5% yield (Scheme 2.12). It is noteworthy that the enamine cannot be added prior to isocyanate consumption since the reaction between vinyl isocyanates and enamines has been documented to occur at room temperature.<sup>63, 64</sup>

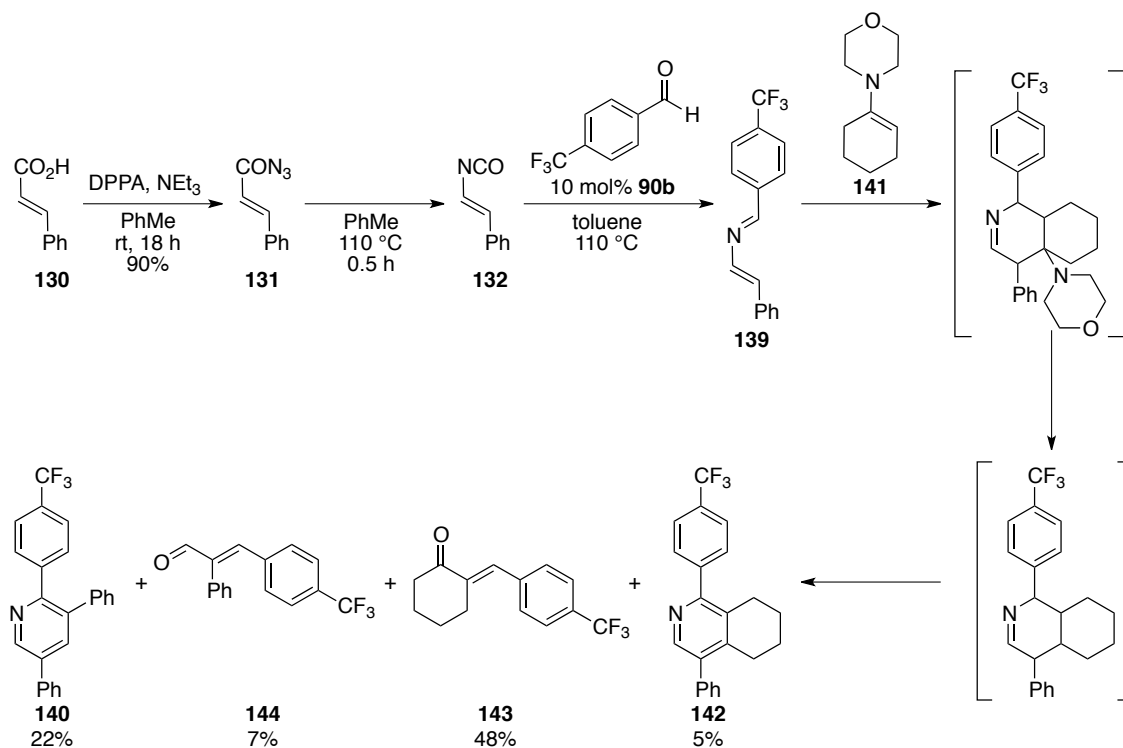

Scheme 2.12

Two further products were identified, the cyclohexanone derivative **143**, formed by reaction of unreacted aldehyde and enamine **141** and the interesting alkene **144**. It was speculated that this formed by a [2+2] electrocycloaddition of the azadiene **139** to give the azetine intermediate **145**, as the reverse reaction has been previously observed by Khlebnikov *et al.* in their work on 2H-

azetines.<sup>26</sup> Hydrolysis of the intermediate azetine **145** would give the alkene **144** (Scheme 2.13). It was hoped that by heating a more dilute solution of the azadiene **139**, the intramolecular cyclisation would be favoured, supporting the proposed mechanism. Thus, a 0.1 M solution of the azadiene was heated. However, only 10% of the alkene **144** was isolated with 40% of pyridine **140**.

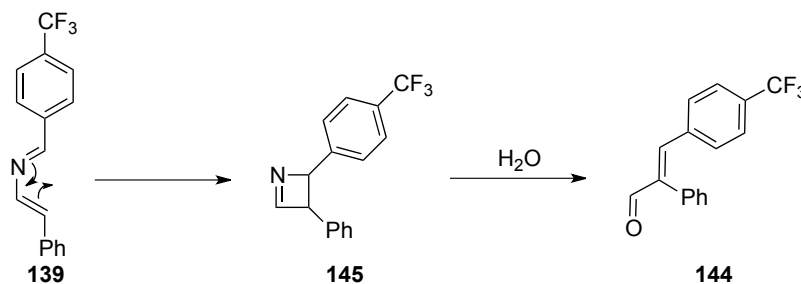

Scheme 2.13

Clearly to increase the yield of the desired pyridine and develop the methodology for a broader array of substrates, both the aza-Wittig and Diels–Alder steps required optimisation. To improve the conversion in aza-Wittig reactions a two-fold strategy was employed. Firstly, the Curtius rearrangement was carried out at 0.2 M concentration to increase the concentration of the isocyanate solution. Previously, it had been found that increasing the concentration of the aza-Wittig reaction increased the conversion to imine over carbodiimide. Using these conditions, the isocyanate could be prepared with no significant polymerisation side reactions observed in the  $^1\text{H}$  NMR. Secondly, the reaction time of the aza-Wittig reaction was reduced in order to limit the formation of dimerised product **140**. It was found that slow addition over 2 hours was sufficient to avoid oligomerisation and self-condensation, giving the azadiene **136** in 85% conversion (with 5% dimerised pyridine **140** as judged by integration of the  $^1\text{H}$  NMR signals).

Having established reaction conditions for the aza-Wittig step, we turned our attention to the Diels–Alder. Enamine **9d** was found to be more reactive than the cyclohexenyl enamine **141** used previously, although a significant amount (31%) of the pyridine by-product **140** was still observed. It was envisaged that the use of a Lewis acid could be beneficial since this would lower the LUMO of the azadiene, bringing it closer in energy to the HOMO of the enamine, thus increasing the yield of pyridine **146a** versus pyridine **140**. Whilst the yield of pyridine **146a** was not improved (Table 2.3, entry 4), the yield of the pyridine by-product **140** decreased giving a 1:1 ratio of products. The use of molecular sieves has also been shown to be beneficial in similar reactions by Taylor *et al.*,<sup>82</sup> and their use improved the yield of pyridine **146a** to 23% (Table 2.3, entry 5) giving a product ratio of 2.56:1 (**146a**:**140**).

Table 2.3

Entry	Temperature	Time	Additive	% Yield	
				146a <sup>a</sup>	140 <sup>a</sup>
1	110 °C	18 h	-	12	31
2	110 °C	18 h	3 Å MS	16	20
3	rt	4 days	-	4	31
4	rt	18 h	1 eq. BF <sub>3</sub> ·OEt <sub>2</sub>	11	11
5	rt	2 h	1 eq. BF <sub>3</sub> ·OEt <sub>2</sub> + 3 Å MS	23	9

a: Yield calculated from cinnamic acid **130**.

To determine if the yield of pyridine **146a** could be improved further, a screen of Lewis acids was carried out (Table 2.4) and MgBr<sub>2</sub> found to give the highest conversions (Table 2.4, entry 4). The number of equivalents of the Lewis acid was also investigated and it was found that one equivalent was optimal (Entries 1-3). However, in the case of NbCl<sub>5</sub>, the equivalents could be lowered to 0.1 with no loss in yield (Entry 7). It is important to note that this process encompasses six steps; the yields were calculated from the cinnamic acid starting material.



Table 2.4

Entry	Lewis acid	Eq. L.A.	% Yield 146a <sup>a,b</sup>	% Yield 140 <sup>a</sup>
1	BF <sub>3</sub> ·OEt <sub>2</sub>	1	27 (57)	9
2	BF <sub>3</sub> ·OEt <sub>2</sub>	2	11 (23)	n.d.
3	BF <sub>3</sub> ·OEt <sub>2</sub>	0.5	17 (37)	n.d.
4	MgBr <sub>2</sub>	1	38 (83)	3
5	Sc(OTf) <sub>3</sub>	1	25 (58)	6
6	Yb(OTf) <sub>3</sub>	1	8 (20)	2
7	NbCl <sub>5</sub>	1 or 0.1	29 (55)	10
8	AlCl <sub>3</sub>	1	17 (31)	10
9	SnCl <sub>4</sub>	1	11 (20)	8
10	FeCl <sub>3</sub>	1	26 (45)	12
11	Ti(O <sup><i>i</i></sup> Pr) <sub>4</sub>	1	12 (19)	15
12	Y(OTf) <sub>3</sub>	1	17 (26)	7

a: yields calculated from cinnamic acid; b: values in parentheses show conversion from azadiene as judged by integration by <sup>1</sup>H NMR.

## 2.4 Variation of the aldehyde

With suitable reaction conditions in place we sought to explore the substrate scope of the reaction by screening a variety of aldehydes (Scheme 2.14, Table 2.5). Preliminary investigations commenced with benzaldehydes since these had previously given high conversions in the synthesis of aldimines **124**. Hence, pyridines **146b-k** were readily prepared in the following manner: the crude acyl azides isolated after an aqueous work-up were subjected to subsequent Curtius rearrangement at 0.2 M in toluene to give vinyl isocyanate solution, whose dropwise addition over 2 hours to a refluxing 1 M of 1.1 equivalents benzaldehyde and 10 mol% catalyst **90b** in toluene afforded the azadiene **147**. Addition of 2 equivalents of the enamine **9d**, 4 Å molecular sieves and 1 equivalent magnesium bromide to the azadiene **147** afforded the pyridines **146b-k** after stirring overnight at room temperature.

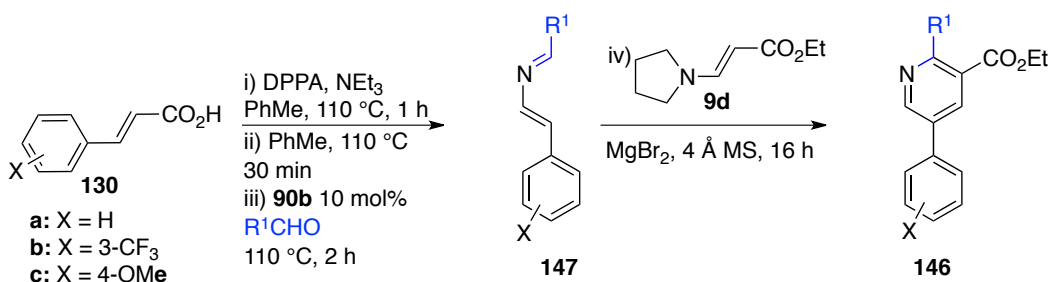

Scheme 2.14

Table 2.5

Entry	X	R <sup>1</sup>	Yield <b>146</b> (%) <sup>a</sup>
1 ( <b>b</b> )	H	Ph	11
2 ( <b>c</b> )		4-MeOC <sub>6</sub> H <sub>4</sub>	0
3 ( <b>d</b> )		4-NCC <sub>6</sub> H <sub>4</sub>	20
4 ( <b>e</b> )		4-ClC <sub>6</sub> H <sub>4</sub>	12
5 ( <b>f</b> )		4-MeCOC <sub>6</sub> H <sub>4</sub>	12
6 ( <b>g</b> )		2-BrC <sub>6</sub> H <sub>4</sub>	33
7 ( <b>h</b> )		3-O <sub>2</sub> NC <sub>6</sub> H <sub>4</sub>	26
8 ( <b>i</b> )		4-pyridyl	34
9 ( <b>j</b> )	3-CF <sub>3</sub>	3-O <sub>2</sub> NC <sub>6</sub> H <sub>4</sub>	29 <sup>b</sup>
10 ( <b>k</b> )	4-OMe	3-O <sub>2</sub> NC <sub>6</sub> H <sub>4</sub>	38
11 ( <b>l</b> )		CO <sub>2</sub> Et	13

a: yields from carboxylic acid **147** across six steps; b: 5% Pd/C added after Diels–Alder reaction and heated under reflux for 6 hours.

The reaction of 4-cyanobenzaldehyde proceeded in 20% yield (Table 2.5, entry 3) showing electron-withdrawing groups worked well in these reactions as was previously observed in the synthesis of aldimines **124a-f**. The reaction with 4-anisaldehyde was less successful (Entry 2), presumably a consequence of decreased electrophilicity at the carbonyl. The reactions with 2-bromobenzaldehyde and 3-nitrobenzaldehyde both gave good yields (Entries 6 and 7) showing that *ortho*- and *meta*-substituents can be tolerated in the reaction. Given the disappointing outcome with pivaldehyde in the reaction with phenyl isocyanate **92b** (Section 2.2), no attempt was made to prepare an alkyl derivative; however, ethyl glyoxylate once again proved a success (Entry 11). An  $\alpha,\beta$ -unsaturated aldehyde (cinnamaldehyde) was also examined; however, no azadiene **147** was observed, perhaps unsurprisingly given the lower reactivity in the synthesis of aldimine **124f** with phenyl isocyanate **92b**. The encouraging yield from the reaction with 4-pyridinecarboxaldehyde (Entry 8) led us to investigate reactions of a variety of heterocyclic aldehydes which gave the desired pyridines **146** in good yields (Table 2.6). Having the ring nitrogen in the 2-position in the case of pyridine and 3-position in the case of isoquinoline was found to be detrimental and only a trace of the desired pyridines **146o** and **146v** were observed (Table 2.6, entries 3 and 10).

Table 2.6

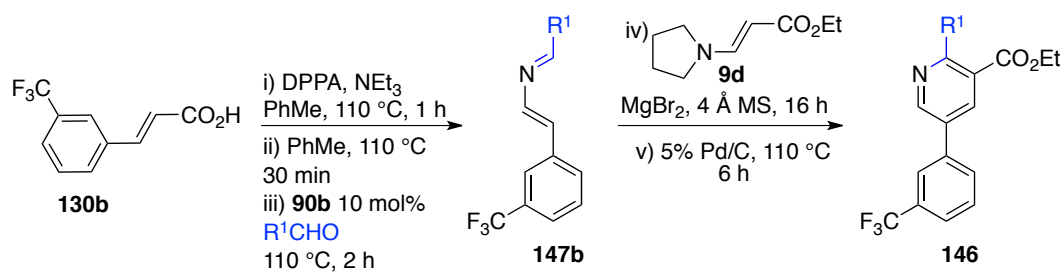

Entry	R <sup>1</sup>	Yield 146 (%) <sup>a</sup>
1 (m)		29
2 (n)		32
3 (o)		trace
4 (p)		52
5 (q)		32
6 (r)		12
7 (s)		39
8 (t)		38
9 (u)		16
10 (v)		0

a: yield from cinnamic acid

## 2.5 Variation of the $\alpha,\beta$ -unsaturated carboxylic acid

The scope of this six-step approach was next investigated with respect to the  $\alpha,\beta$ -unsaturated carboxylic acid. The high yield obtained with 4-pyridinecarboxaldehyde prompted us to use this as the aldehyde component in the reactions (Table 2.7). It was found that electron-donating and electron-withdrawing groups on the cinnamic acids are both well tolerated (Table 2.7, entries 1 and 2). In the case of electron-withdrawing trifluoromethyl groups it was found that significant amounts of the dihydropyridine remained at the end of the reaction and so 5% Pd/C was added after 18 hours and the reaction heated at 110 °C for 6 hours to oxidise the intermediate dihydropyridine to the pyridine. Whilst the pyridylacrylic acid worked well (Entry 5) it was found that trying to incorporate a furan at the R<sup>4</sup> position gave a complex mixture of products (Entry 6). To ensure this was not due to the intolerance of furan to Lewis acids, the reaction was repeated without magnesium bromide but none of the desired pyridine was observed. Introducing substitution at the R<sup>5</sup> position was successful with both phenyl and methyl groups used in place of the hydrogen (Entries 3 and 4), but at the expense of a drop in the yield of the pyridines. A particularly interesting example of this was **150g**, where use of 4-*t*-butyl-1-cyclohexenyl carboxylic acid gave alkyl substituents at both R<sup>4</sup> and R<sup>5</sup> positions.

Table 2.7

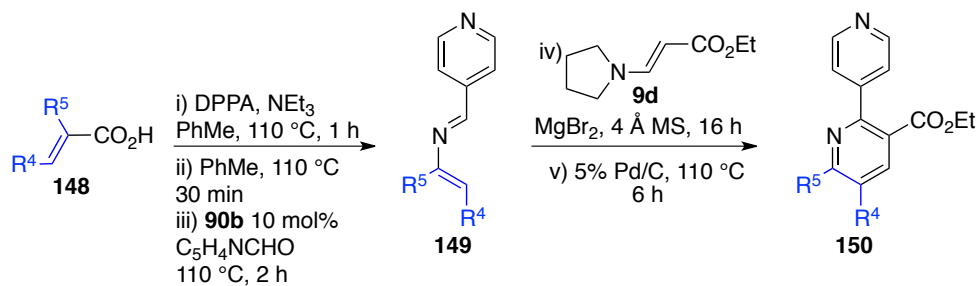

Entry	R <sup>4</sup>	R <sup>5</sup>	Yield <b>150</b> (%) <sup>a</sup>
1 ( <b>a</b> )	3-CF <sub>3</sub> C <sub>6</sub> H <sub>4</sub>	H	48
2 ( <b>b</b> )	4-OMeC <sub>6</sub> H <sub>4</sub>	H	49 <sup>b</sup>
3 ( <b>c</b> )	Ph	Ph	18
4 ( <b>d</b> )	Ph	Me	15
5 ( <b>e</b> )	3-Pyr	H	49
6 ( <b>f</b> )	2-Furyl	H	Complex mixture
7 ( <b>g</b> )	-(CH <sub>2</sub> ) <sub>2</sub> <sup>t</sup> BuCH <sub>2</sub> -		10 <sup>b</sup>

a: Yields calculated from cinnamic acid; b: Step (v) not required

A paper by Palacios *et al.* describes a remarkable rearrangement between neutral azadienes with either an aromatic substituent in the 3-position or no substituents in both 3- and 4-positions, and enamine **9d** (Scheme 2.15).<sup>83</sup> Here, the expected pyridine **152** arising from [4+2] cycloaddition

was observed in refluxing xylene. Interestingly, when the reaction was carried out in refluxing toluene or in the presence of lithium perchlorate in ether at room temperature, an alternative pyridine **155** was observed. They postulated this result arises due to a [2+2] cycloaddition-cycloreversion sequence between azadiene **151** and enamine **9d** through intermediate **153**.

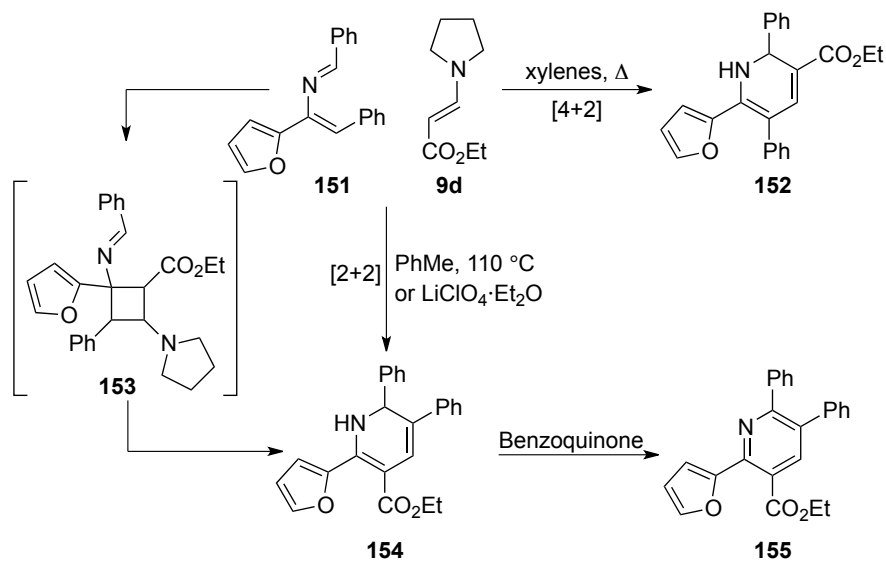

Scheme 2.15

To confirm the regiochemical outcome and investigate if this rearrangement was occurring in our process, NOESY spectra of pyridines **150c-d** were obtained. Interaction between the ethoxy methylene protons and protons of the pyridyl substituent arising from the aldehyde (displayed by arrow) showed that the pyridine arising from [4+2] cycloaddition had been prepared (Figure 2.1) since no such interaction can occur in the [2+2] products.

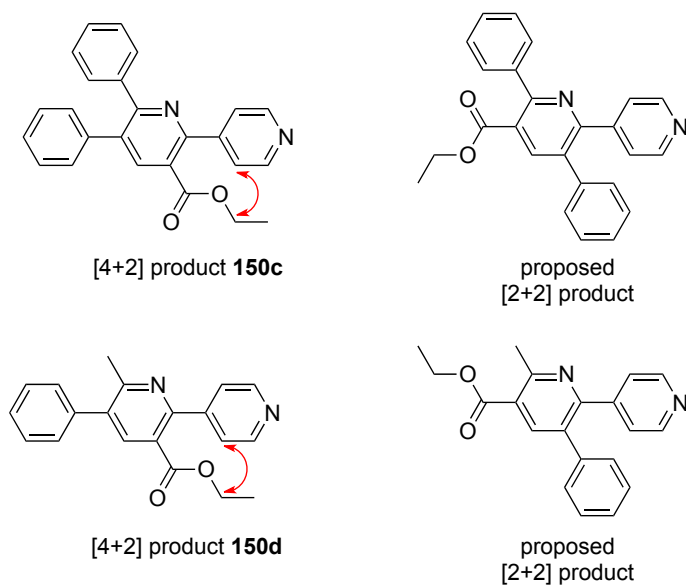
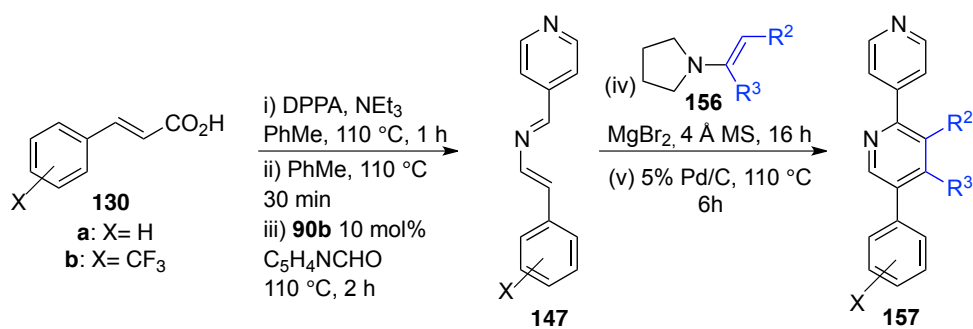

Figure 2.1

## 2.6 Variation of the enamine

The final positions to explore were those contributed by the enamine. As stated earlier, it was found that electron-withdrawing groups in the R<sup>2</sup> position give higher yields of pyridine **146a**, possibly due to the decreased pK<sub>a</sub> of the adjacent hydrogen in the tetrahydropyridine intermediate, making elimination easier. Thus, enamines with electron-withdrawing groups were investigated (Table 2.8). One example using cyclopentenyl enamine **9a** (Entry 4) was screened since this has been reported to be more reactive than the cyclohexenyl derivative **9b**.<sup>84</sup> Disappointingly, purification proved difficult leading to a poor yield of pyridine **157d**.

Table 2.8



Entry	X	R <sup>2</sup>	R <sup>3</sup>	Yield <b>157</b> (%) <sup>a</sup>
1 (a)	3-CF <sub>3</sub>	SO <sub>2</sub> Tol	H	14
2 (b)	3-CF <sub>3</sub>	COMe	H	42
3 (c)	3-CF <sub>3</sub>	CO <sub>2</sub> Et	Me	23
4 (d)	H	-(CH <sub>2</sub> ) <sub>3</sub> - <sup>c</sup>		5 <sup>b</sup>

a: Yields calculated from cinnamic acid; b: Step (v) not required; c: enamine **9a** used.

Reaction of the methyl ketone derivative gave good yields of pyridine (Table 2.8, entry 3). The yield decreased with sulfonyl groups in the R<sup>3</sup> position (Entries 1 and 2). It was found that R<sup>2</sup> could also be a methyl group (Entry 4), although as seen with the carboxylic acids, this increased steric bulk leads to some loss in yield.

Although, a range of different substitution patterns were available using the developed methodology a desirable feature would be the ability to prepare a pentasubstituted pyridine, since the steric hindrance between substituents makes these more difficult to prepare. Hence, the reaction between  $\alpha$ -methylcinnamic acid, 4-pyridinecarboxaldehyde and enamine **156c** (Scheme 2.16) was explored. Unfortunately, despite a mass observed at 333.1 in the LCMS, which corresponds to the desired pyridine **159**, less than 0.6% of an impure sample was obtained after chromatographic purification.

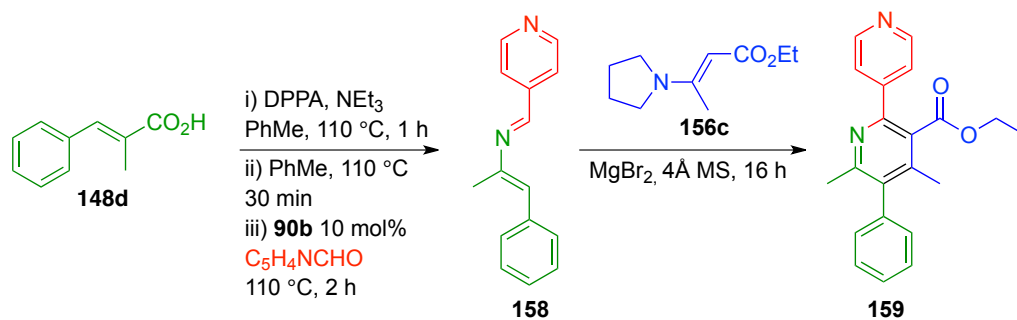

Scheme 2.16

## 2.7 Alternative methods for isocyanate formation

Although the catalytic aza-Wittig reaction no longer requires organic azides as iminophosphorane precursors, the use of acyl azides is still a necessity in the synthesis of vinyl isocyanates. Whilst acyl azides can be handled safely on small-scale, they still present issues upon scale-up due to their potentially explosive nature. Therefore we sought a method that could reduce the necessity for acyl azide handling and isolation.

During the course of this work, Carreira *et al.* reported a catalytic aza-Wittig reaction between a vinyl isocyanate and 9,10-phenanthrenequinone in the presence of catalytic triphenylarsonium oxide to generate 2,2-diarylphenanthro-(9,10)-[2H]-[1,4]-oxazines **160a-d** (Scheme 2.17).<sup>85</sup> To avoid polymerisation side-reactions and isolating acyl azides they developed a one-pot procedure, which goes directly from the  $\alpha,\beta$ -unsaturated acids to the oxazine product. It was envisaged therefore, that a similar method could be used for the preparation of our azadienes.

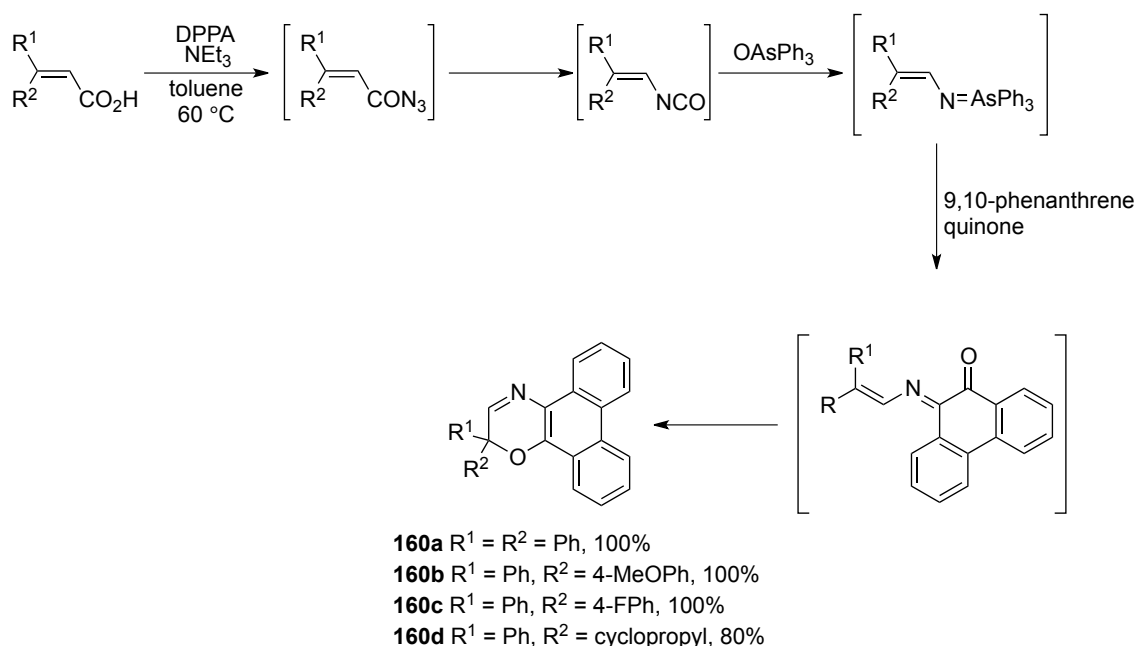

Scheme 2.17

Accordingly, a solution of cinnamic acid, diphenyl phosphoryl azide, triethylamine, 10 mol% catalyst **90b** and 4-trifluoromethylbenzaldehyde in toluene (0.2 M) was heated under reflux for one hour (Scheme 2.18). However, none of the desired azadiene was observed, only a complex mixture of products suggesting that polymerisation was the major reaction occurring. Lowering the temperature and concentration of the reaction according to the conditions developed by Carreira *et al.* was not beneficial since no Curtius rearrangement occurred at 60 °C and only a trace of the azadiene observed at 0.08 M.

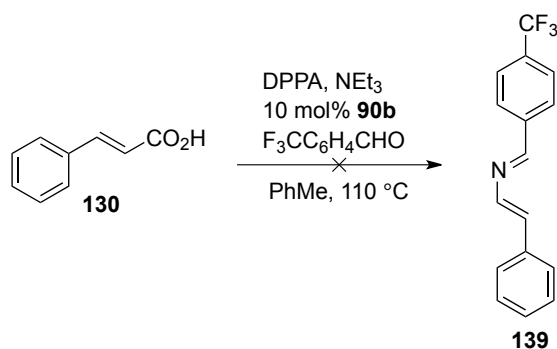

Scheme 2.18

Recently a report by Booker-Milburn *et al.* described the use of hindered ureas as masked isocyanates. They observed that bulky ureas such as diisopropyl ureas would rearrange to form carbamates in the presence of methanol, presumably going through an isocyanate intermediate.<sup>86</sup> The ability to use a variety of different nucleophiles including amines and thiols supported the formation of an isocyanate intermediate. It was postulated that this phenomenon could be utilised to generate a vinyl isocyanate avoiding the use of acyl azide precursors. A recent result, generated within our group, demonstrated that a hindered urea could be heated and intermediate isocyanate trapped by the phospholene oxide catalyst, generating an iminophosphorane which subsequently reacted with 3-nitrobenzaldehyde to give aldimine **161** in high conversions (Scheme 2.19). These hindered ureas could be prepared *via* a Lossen rearrangement of the corresponding benzoic acids<sup>87</sup> and it was hoped that a similar method for preparing a vinyl substrate could be utilised.

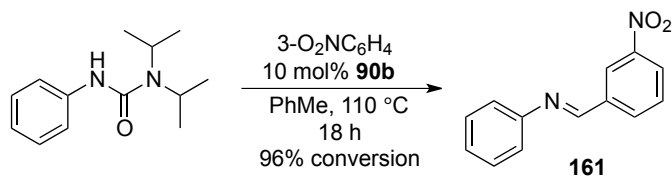

Scheme 2.19

The excellent conversion to imine supported the proposal that an isocyanate intermediate was involved and suggested that *in situ* generation of a vinyl isocyanate from a hindered urea might



be possible. Thus, urea **162** was prepared, initially *via* amine trapping of the isocyanate generated by Curtius rearrangement since the feasibility of aza-Wittig reaction of isocyanates generated from hindered vinyl ureas was as yet unknown. Heating the urea with phospholene catalyst **90b** and 4-pyridylbenzaldehyde in toluene at 110 °C gave none of the desired azadiene (Scheme 2.20), instead polymerisation products were observed at both 1 M (the optimum concentration for aldimine **147i** formation) and 0.2 M concentrations. In addition, an attempt to trap the isocyanate using benzyl alcohol to examine the yield of the reaction furnished only 8% of the desired carbamate **138**.

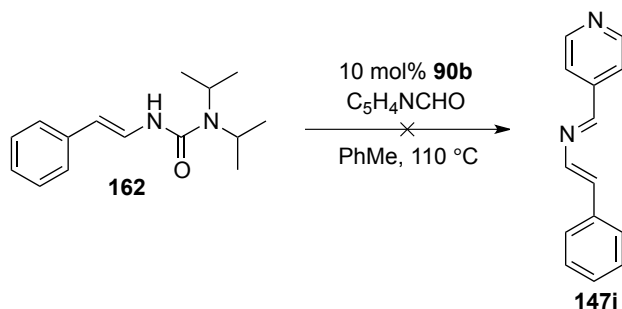

Scheme 2.20

## 2.8 Conclusion

In summary, studies towards the development of a multicomponent synthesis of substituted pyridines have led to a two-pot six-step procedure from commercially available starting materials. The reaction works well for electron-poor and heteroaromatic aldehydes; electron-rich and electron-poor cinnamic acids including those with  $\beta$ -substituents; and push-pull enamines to give a range of substitution patterns (Figure 2.2); 31 exemplar pyridines were prepared in up to 52% yield.

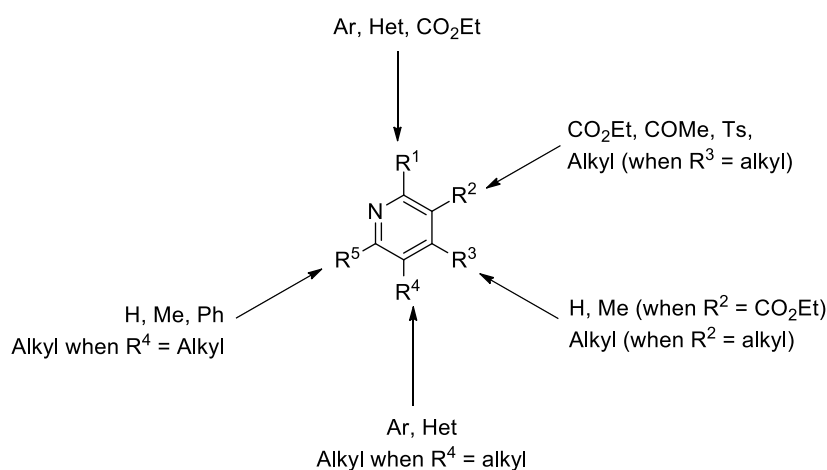
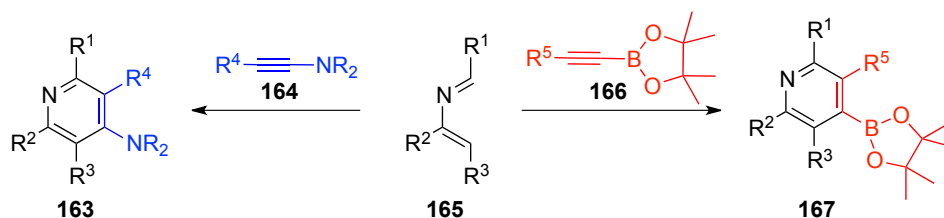

Figure 2.2

To develop the methodology further, an investigation into the use of electron-rich alkynes as dienophiles in the Diels–Alder reactions would be beneficial since this could allow alternative

substitution patterns to be prepared (Scheme 2.21). Harrity and co-workers have shown the use of alkynyl boronate esters **166** as dienophiles with 1,4-oxazin-2-ones in [4+2] cycloadditions to prepare pyridine boronic esters **167**.<sup>88</sup> This provides a valuable coupling partner for Suzuki reactions and allows further functionalisation enabling library generation. In addition, ynamines **164** are known to act as dienophiles in [4+2] cycloadditions,<sup>89</sup> which would allow the introduction of an amine substituent.



Scheme 2.21

An alternative method towards introducing amine substituents would be *via* Lossen rearrangement of a hydroxamic acid or Curtius rearrangement of the acyl azide prepared by hydrolysis of the ester group in the R<sup>2</sup> position of pyridines **146a-w**.

Some alternative methods towards isocyanate synthesis have been investigated. However, a route that avoids the handling and isolation of acyl azides would be desirable. Buchwald *et al.* recently reported a novel palladium-catalysed method for the preparation of unsymmetrical ureas.<sup>90</sup> Here aryl isocyanates were prepared *via* palladium-catalysed cross-coupling between aryl chlorides and triflates with sodium cyanate, then trapped using an amine nucleophile. It was also applied to the synthesis of vinyl isocyanate **169** (Scheme 2.22). This provides an alternative isocyanate synthesis that avoids the requirement for acyl azide precursors. Whilst this has only been applied to the synthesis of ureas, it can be envisaged that addition of the phospholene oxide catalyst and an aldehyde may lead to generation of the iminophosphorane and subsequently an azadiene.

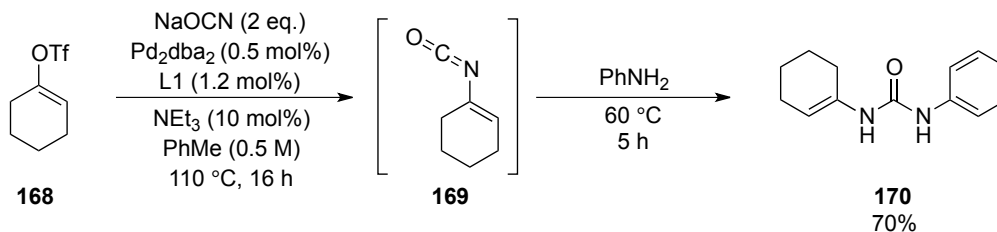

Scheme 2.22

An alternative route towards the safer handling of acyl azides is the utilisation of flow based techniques, which offer many advantages over normal batch processes.<sup>91-94</sup> For example, highly hazardous or reactive intermediates can be handled under controlled and highly reproducible

conditions since only a small amount of reagent is present in the reactor at any given time. A continuous flow process has been developed in the Ley group that allows *in situ* generation and reaction of acyl azides by mixing a solution of the carboxylic acid, triethylamine and the nucleophile with a solution of DPPA and passing through a convection heater (Scheme 2.23).<sup>93</sup> By passing the resulting solution through an immobilised trimethylamine equivalent followed by a sulfonic acid resin any acid and base impurities were removed from the mixture thereby removing the requirement for chromatographic purification. This process not only avoids the safety risks associated with acyl azides but also allows immediate trapping of the reactive isocyanate intermediates. Following this, a reaction column containing an ion-exchange resin with immobilised azide ions (an azide ion-exchange monolith) was developed for flow reactors and used to convert acyl chlorides to isocyanates *via* the corresponding acyl azide.<sup>92</sup> These monoliths could be regenerated by elution with sodium azide solution to restore their original loadings and reactivity.

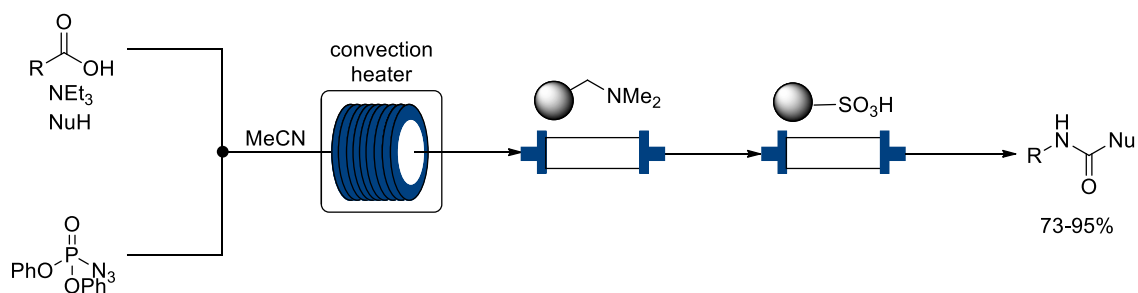

Scheme 2.23

The ability to prepare and use acyl azides and their corresponding isocyanates in this manner, and the continuous nature of the process could allow subsequent slow addition of the isocyanate to phosphine oxide catalyst and an aldehyde. Indeed, a monolith supported version of triphenylphosphine has been developed for flow reactors by Ley and co-workers.<sup>94</sup> They demonstrated its application in the Staudinger aza-Wittig reaction in the synthesis of imines **172** (Scheme 2.24). Initially, azides were generated *in situ* and carried on directly (from aniline with trimethylsilyl azide and *tert*-butyl nitrite for aryl azides, method A, or alkyl bromides **171** for alkyl azides using the previously developed azide monolith, method B). The azides were passed onto the triphenylphosphine monolith to form an immobilised iminophosphorane intermediate (Step 1) allowing any excess azide and other impurities to be washed to waste. Further impurities could be removed by washing with an appropriate solvent (Step 2). Finally a solution of aldehyde or ketone (0.1-1.0 M in THF or MeCN-THF 1:1) was passed through the iminophosphorane monolith generating an imine in excellent conversion (Step 3).

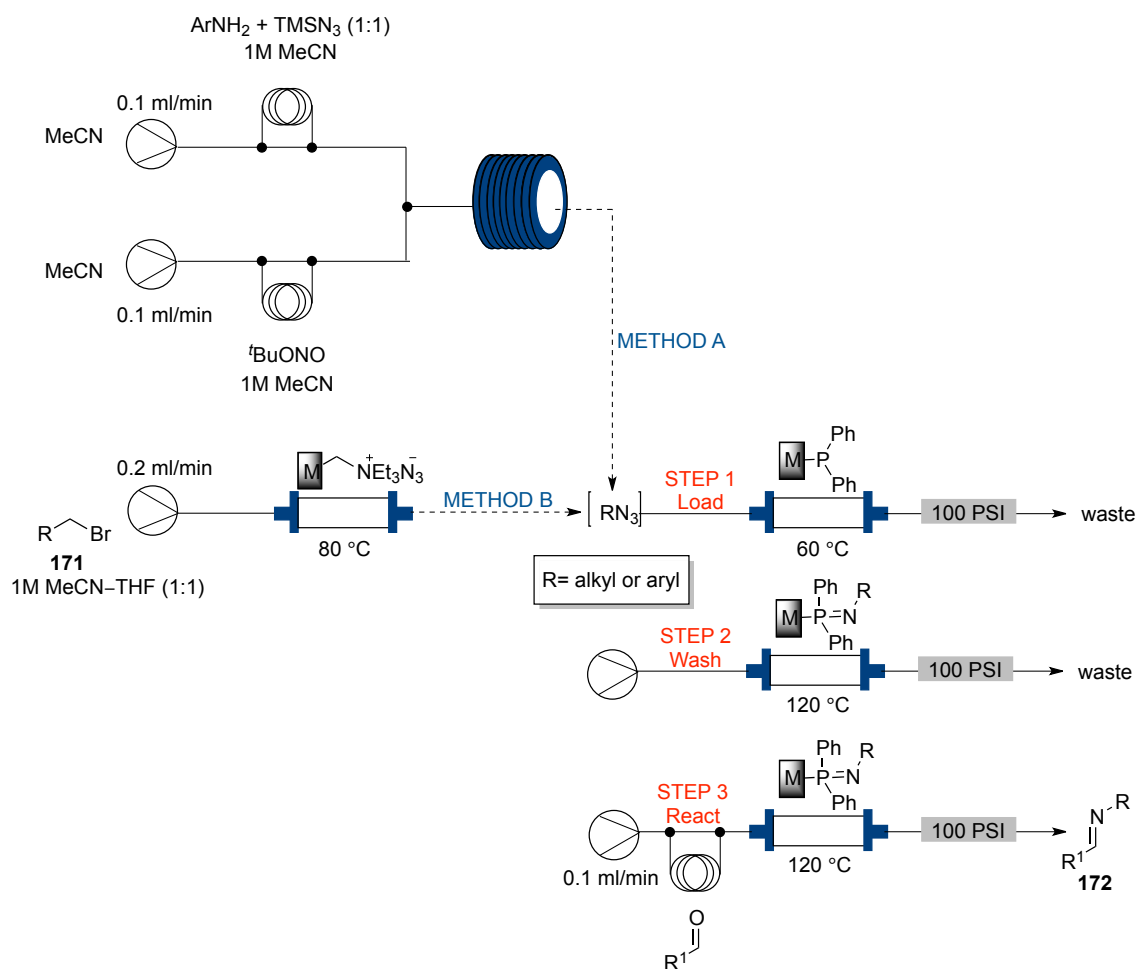

Scheme 2.24

Whilst this offers significant advantages over conventional aza-Wittig reactions since the phosphine oxide by-product remains supported and no contamination of the products was observed, the level of phosphine available for reaction decreases over time as phosphine oxide levels increase. A solid-supported phosphine oxide could be advantageous since this would not require regeneration after reaction, thereby increasing the lifetime of the monolith.

### 3.0 Attempts to prepare heterocyclic pyridines *via* tandem aza-Wittig/electrocyclisation reactions

#### 3.1 Introduction

Azatrienes can be used as key intermediates in dihydropyridine and pyridine synthesis due to their ability to undergo electrocyclisation reactions under thermal or photochemical conditions.<sup>66, 95</sup> The use of vinyliminophosphoranes and  $\alpha,\beta$ -unsaturated carbonyls in the aza-Wittig reaction has led to a mild, pH neutral method towards their synthesis and the development of tandem aza-Wittig/electrocyclisation methodologies.<sup>28, 36, 38</sup> These have been exemplified in the synthesis of a variety of heterocycles including pyridines and pyrimidines,<sup>28, 36, 38, 96</sup> such as the synthesis of the frameworks of the alkaloids eudistomycin A and M **181** and lavendamycin **182** (Scheme 3.1) by Molina and co-workers.<sup>97</sup>

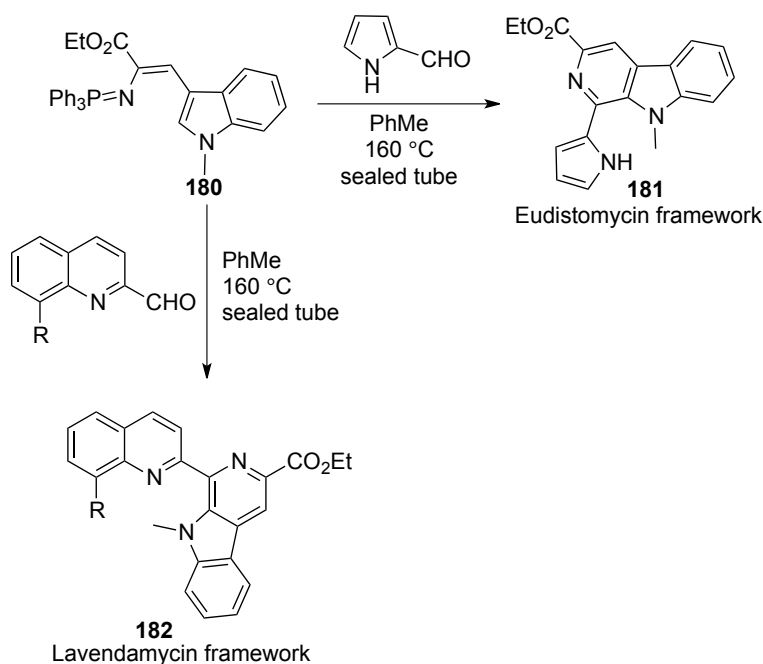

Scheme 3.1

Of particular interest is the preparation of benzothieno-, benzofuopyridines and carbolines since the heteroaryl amines that would be required for their preparation by classical syntheses are often unstable and difficult to prepare.<sup>98-103</sup> Furthermore, they have interesting biological properties including anti-allergenic and anti-inflammatory properties.<sup>1, 3</sup> Early approaches towards these substrates tended to be difficult and low-yielding due to multi-step procedures, instability of intermediates and starting materials that are not easily accessible.<sup>104-110</sup> Spagnolo *et al.* demonstrated the first use of tandem aza-Wittig/electrocyclisation reactions as a mild, high-yielding route to benzo[*b*]thienopyridines **185** (Scheme 3.2).<sup>111</sup>

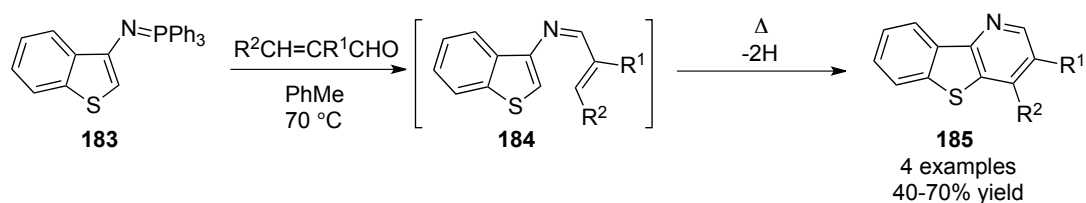

Scheme 3.2

One disadvantage to this method was the requirement to synthesise heteroaryl azides as precursors to the iminophosphorane. This involved halogen-metal exchange of the bromobenzothiophene **186**, treatment of the lithiated derivative with tosyl azide and subsequent fragmentation of the triazene-lithium salts using tetrasodium pyrophosphate (Scheme 3.3). Whilst the 3-azidobenzothiophene could be prepared in 85% yield this route was very low-yielding for 2-azidobenzothiophene **187** which also proved to be unstable at room temperature.<sup>68</sup>

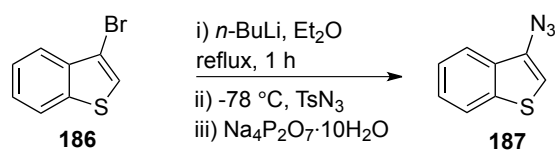

Scheme 3.3

More recently the tandem aza-Wittig/electrocyclisation strategy has been extended to further include benzo[*b*]thiophene derivative<sup>1, 3, 66</sup>  $\alpha$ -carbolines (pyrido[2,3-*b*]indoles)<sup>1</sup> and benzo[4,5]furo[3,2-*b*]pyridines (Scheme 3.4).<sup>2</sup>

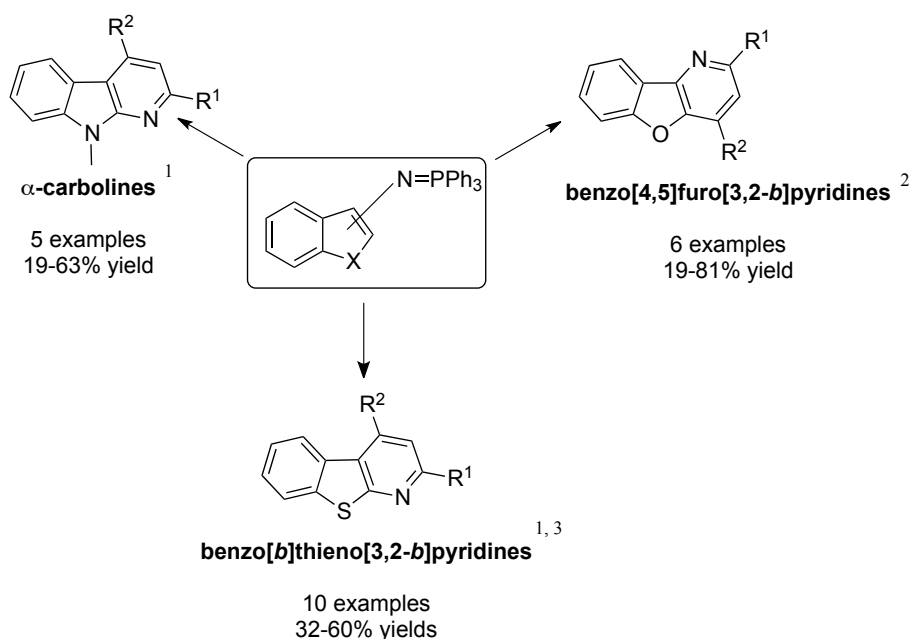

Scheme 3.4

Based on these findings and the previous success in the catalytic aza-Wittig reaction between phenyl isocyanate and variously substituted benzaldehydes, it was envisaged that a tandem catalytic aza-Wittig/electrocyclisation methodology could be developed using heteroaryl isocyanates.

### 3.2 Results and Discussion

To prepare an azatriene we first needed to understand how an  $\alpha,\beta$ -unsaturated aldehyde would behave in the catalytic aza-Wittig reaction. Hence, preliminary investigations involved the optimisation of the reaction between a simple aryl isocyanate and an  $\alpha,\beta$ -unsaturated aldehyde in the presence of the phospholene oxide catalyst **90b** (Scheme 3.5). The reaction between phenyl isocyanate **92b** and cinnamaldehyde **123f** was chosen as a suitable test reaction as both reagents are readily available.

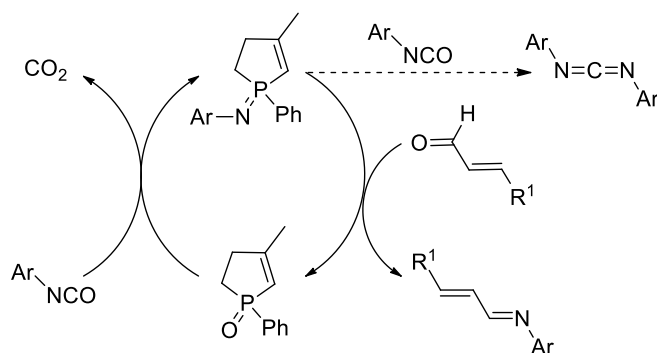

Scheme 3.5

The initial reaction conditions for the intermolecular catalytic aza-Wittig reaction were as developed previously; 1.1 equivalents isocyanate **92b** were added dropwise over 5 hours to a 1 M solution of aldehyde **123f** and 10 mol% catalyst **90b** in toluene under reflux for 6 hours. These conditions gave the imine **124f** in 33% conversion (Scheme 3.6) as judged by the examination of the integrals of the aldehyde versus imine signals in the  $^1\text{H}$  NMR spectrum of the crude reaction mixture.

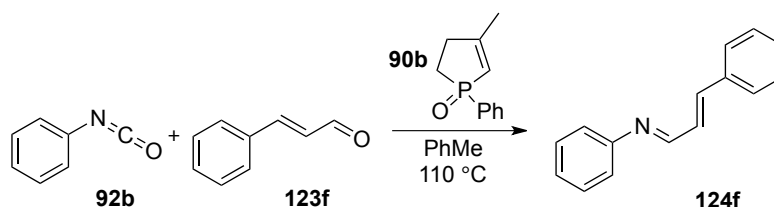

Scheme 3.6

The presence of unreacted aldehyde **123f** in the  $^1\text{H}$  NMR spectrum and a signal at  $2139\text{ cm}^{-1}$  in the IR spectrum indicated that self-condensation of the isocyanate to carbodiimide was a significant side-reaction. To decrease the formation of carbodiimide, thereby increasing the

potential formation of the desired imine **124f**, several reactions were carried out varying concentration, reaction time, equivalents of aldehyde **123f** and addition time of the isocyanate **92b**. The most significant of these experiments are summarised in Table 3.1 and show that the formation of imine versus carbodiimide (measured indirectly by the integration of the  $^1\text{H}$  NMR signals of the aldehyde and imine) could be favoured in a number of ways: increasing addition time of the isocyanate (entries 1 and 2), use of higher equivalents of aldehyde (entries 2 and 3) and use of higher concentration (entries 3 and 4).

Table 3.1

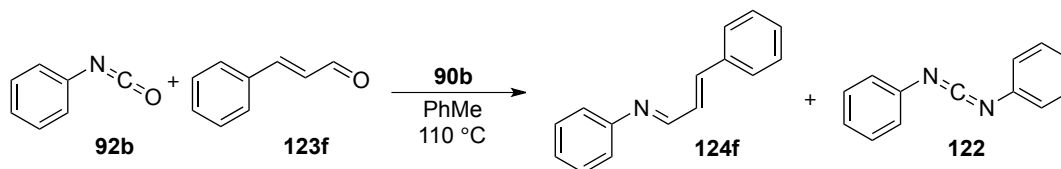

Entry	Conc./mol l <sup>-1</sup>	Eq. RCHO	Mol % catalyst	Addition time/hours	Reaction time/hours <sup>b</sup>	% conversion <sup>a</sup>
1	1	1	10	4	4.25	16
2	1	1	10	6	6.25	25
3	1	2	10	6	6.25	40
4	2	2	10	6	6.25	80
5	1	1	10	-	6	33
6	1	1	10	-	18	40 <sup>c</sup>
7	2	2	10	-	18	96

a: calculated from ratio of aldehyde **123f** to imine **124f** in crude  $^1\text{H}$  NMR; b: reaction time includes slow addition of isocyanate; c: aldehyde **123f** distilled prior to reaction.

The optimal reaction conditions for these substrates involved heating a 2 M solution of isocyanate **92b** with two equivalents of aldehyde **123f** and 10 mol% phospholene oxide catalyst **90b** in toluene under reflux for 18 hours, without the need for slow addition (entry 7).

Surprisingly, it was observed that the formation of imine versus carbodiimide could be increased by increasing the reaction time, without the necessity for slow addition of the isocyanate (Table 3.1, entry 4). Since the isocyanate starting material had been consumed after 6 hours (shown by the disappearance of the IR signal at 2259 cm<sup>-1</sup>) we postulated that the carbodiimide by-product **122** must be reacting after its formation. This gave two conceivable pathways for increased imine formation: (i) the carbon dioxide produced from the reaction of the isocyanate **92b** and phospholene oxide catalyst **90b** had remained in solution, allowing the reverse reaction to occur and thus regenerating the isocyanate **92b**, as reported by Kurzer *et al.*, (path A, Scheme 3.7)<sup>112</sup> or (ii) the carbodiimide reacted with the phospholene oxide catalyst



**90b**, generating the iminophosphorane intermediate and allowing further reaction with the aldehyde **123f** to take place (path B, Scheme 3.7).

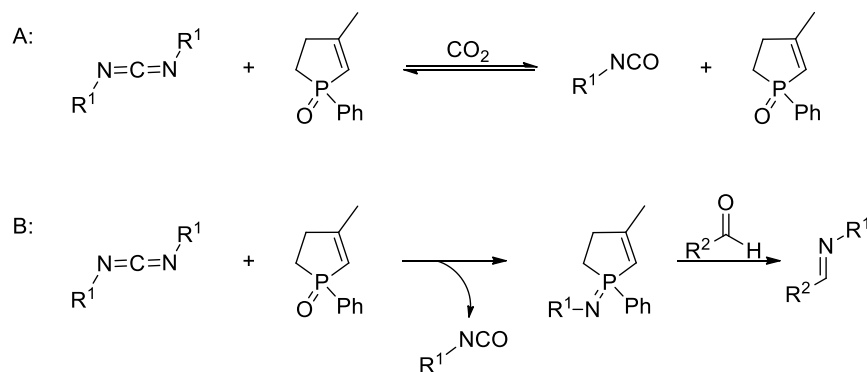

Scheme 3.7

Extrapolations of experimental solubility data shows that CO<sub>2</sub> has poor solubility in toluene at atmospheric pressure,<sup>113</sup> therefore we decided to test the latter theory by preparing the carbodiimide and then subjecting it to our aza-Wittig conditions. Hence, diphenyl carbodiimide **122** was prepared in quantitative conversion from phenyl isocyanate in the presence of the phospholene oxide catalyst (Scheme 3.8).

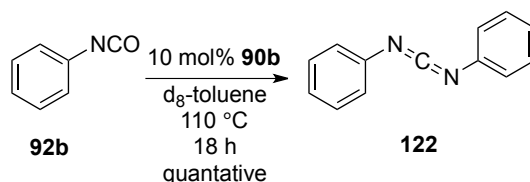

Scheme 3.8

Having established that no isocyanate remained after carbodiimide formation, (disappearance of the isocyanate signal at 2259 cm<sup>-1</sup> in the IR spectrum and  $\delta_c$  133.7 ppm in the <sup>13</sup>C NMR) benzaldehyde **118** and the catalyst were added and to our delight imine **121** was formed in 28% conversion (Scheme 3.9).

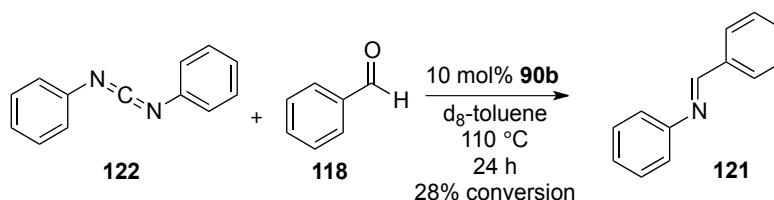

Scheme 3.9

To confirm that no carbon dioxide remaining from the carbodiimide formation was involved in imine formation, commercially available ditolylcarbodiimide **188** was used under the same reaction conditions to give imine **189** in 75% conversion after 48 hours (Scheme 3.10). Whilst Yamamoto *et al.* reported the uncatalysed reaction of carbodiimides and aldehydes to give

imines at 200 °C,<sup>114</sup> to the best of our knowledge this is the first example using a phospholene oxide catalyst in this transformation, allowing a reduction in the reaction temperature from 200 °C to 110 °C and increasing conversions from 33% to 75%.

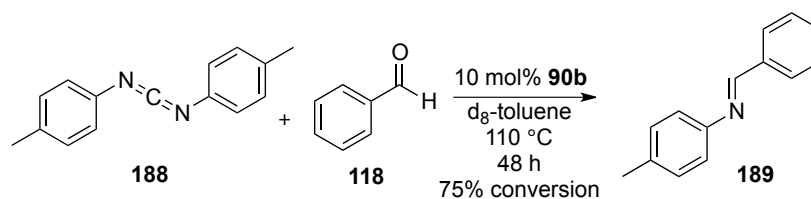

Scheme 3.10

### 3.3 Preparation of heteroaromatic imines

Having established the reaction conditions for the aza-Wittig reaction with  $\alpha,\beta$ -unsaturated aldehydes, the synthesis of heteroaromatic isocyanates was investigated. To verify the stability and yield of the benzothiophene isocyanate **192** we first attempted the synthesis of benzothiophene carbamate **193**. The acyl azide **191** was obtained in 67% yield *via* a mixed anhydride approach and upon heating, the IR spectrum showed disappearance of the acyl azide signal at 2143  $\text{cm}^{-1}$  and appearance of the isocyanate signal at 2261  $\text{cm}^{-1}$  after 2 hours. However, when benzyl alcohol was added, only 11% of the carbamate **193** was isolated alongside a complex mixture of inseparable compounds (Scheme 3.11) suggesting that a number of side-reactions were occurring, either before or after the Curtius rearrangement.

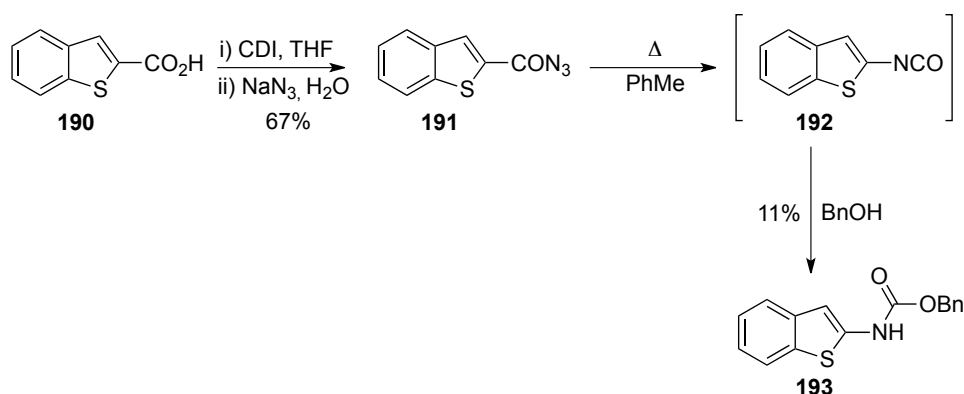

Scheme 3.11

A report by Fakhr *et al.*<sup>115</sup> suggested that higher yields of carbamate might be obtained if the alcohol was added prior to the Curtius rearrangement, because this would allow immediate trapping of the isocyanate. This would indicate whether the isocyanate was being fully formed and then undergoing side reactions, or if the Curtius rearrangement was the problem. Accordingly, the acyl azide and alcohol were heated under reflux for 1.5 hours and the carbamate **193** obtained in 67% isolated yield. In this case, a less complicated  $^1\text{H}$  NMR analysis

of the crude product suggested that previously the isocyanate had been formed but was undergoing decomposition before the alcohol was added.

Having established the carbamate synthesis was viable, we anticipated a one-pot Curtius rearrangement/aza-Wittig reaction would be possible. Indeed, upon reaction of the benzo[*b*]thiophenyl acyl azide **191** with phospholene oxide catalyst **90b** and benzaldehyde **118**, the imine proton signal at  $\delta_{\text{H}}$  8.50 ppm was observed in the  $^1\text{H}$  NMR spectra of crude reaction mixture, showing 83% conversion to imine **194a** (Scheme 3.12). By the same method imine **194b** was prepared with quantitative conversion, and 42% isolated yield.

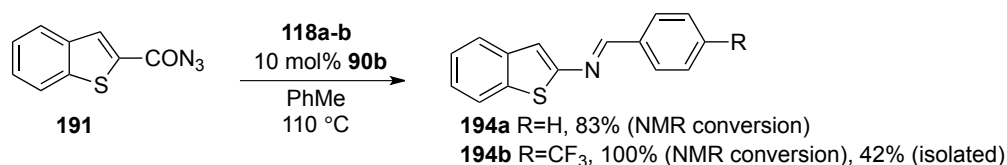

Scheme 3.12

Encouraged by this, we proceeded on to the synthesis of an azatriene. Hence, a solution of acyl azide **191**, cinnamaldehyde **123f** and the phospholene oxide **90b** in toluene was heated at 110 °C for 48 hours (Scheme 3.13). Although both the azatriene **195** and pyridine **196** were observed by LCMS and  $^1\text{H}$  NMR, isolated yields were low with only 4% of each product obtained after column chromatography. Since literature procedures generally required high temperatures and sealed tube conditions it was thought that these might help promote the  $6\pi$ -electrocyclisation.<sup>3, 66</sup> Thus, the reaction mixture was heated in a microwave vial at 160 °C for 1 hour after completion of the aza-Wittig step. Although some improvement in the yield was observed it was still a disappointing 8% (conversion to imine was 40% by  $^1\text{H}$  NMR analysis).

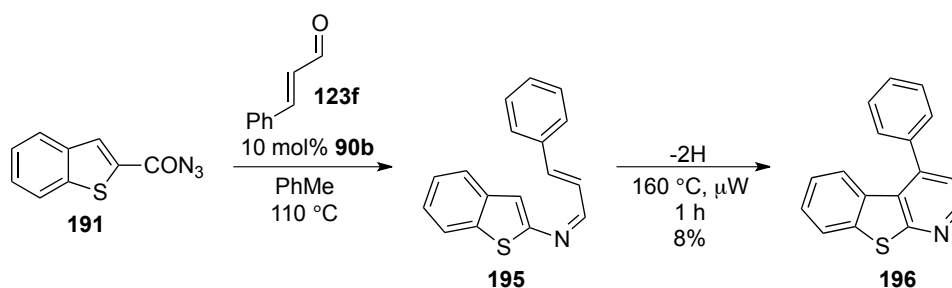

Scheme 3.13

Reports by Spagnolo *et al.* have shown that benzo[*b*]thiophenes substituted in the 3-position have a lower activation barrier for electrocyclisation to occur.<sup>1, 3, 66, 111</sup> Hence, 3-benzo[*b*]thiopheneazido carboxylate **198** was prepared from the carboxylic acid **197** in 96% yield and heated in toluene in the presence of cinnamaldehyde and phospholene oxide **90b** to generate the aldimine **199** in 29% conversion as judged by the  $^1\text{H}$  NMR of the intermediate.

Subsequently, the aldimine **199** was heated in the microwave at 160 °C for 1 hour to give the desired pyridine **200** in 13% yield, with unreacted aldehyde **123f** and a complex mixture of inseparable compounds (Scheme 3.14). This disappointing yield and the presence of unreacted aldehyde suggested that the aza-Wittig step might also be problematic.

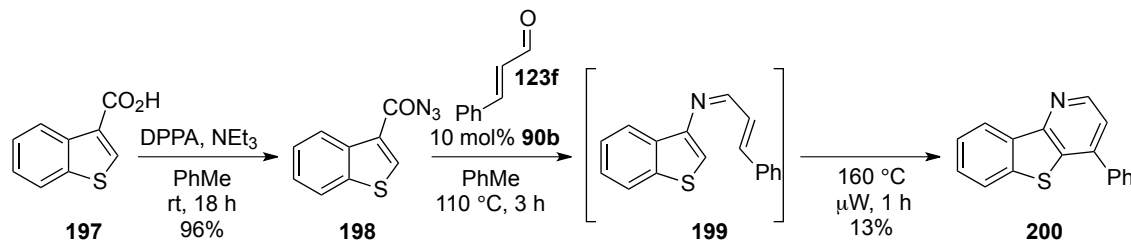

Scheme 3.14

As described in chapter 2, lowering the concentration of Curtius rearrangements was essential for the efficient formation of vinyl isocyanates, and we thought that the same principle could be applied here. If the benzothienylisocyanates could be successfully prepared at the lower concentration, dropwise addition of the heteroaryl isocyanate would be possible in the subsequent catalytic aza-Wittig reactions, thus potentially allowing higher conversions to imine. Hence, imine **195** was prepared in 37% conversion by <sup>1</sup>H NMR and used in an electrocyclic ring closure to give 2-phenylbenzothienopyridine **196** in 12% isolated yield (Scheme 3.15).

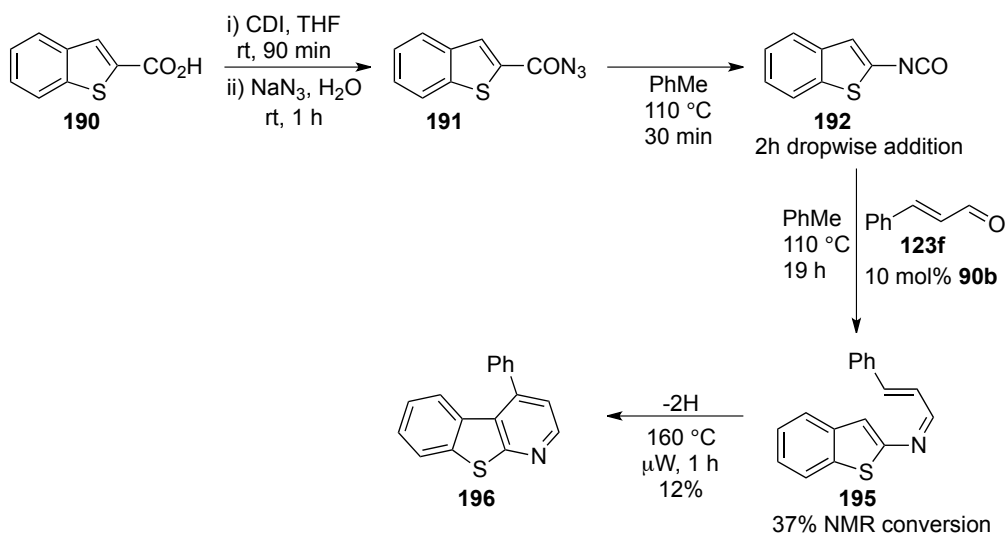

Scheme 3.15

To extend this methodology, the reactions with non-benzofused thiophenes were explored. Initially, commercially available 2-isocyanatothiophene **201** was added to a solution of the catalyst **90b** and cinnamaldehyde in toluene; however, a dark brown oil was rapidly formed and no imine was observed by <sup>1</sup>H NMR analysis upon completion (IR spectroscopy was used to monitor the consumption of isocyanate during the reaction). To establish whether an aza-Wittig reaction would be feasible with this isocyanate, a more reactive aldehyde (benzaldehyde) was

used. Heating the isocyanate **201** with benzaldehyde **118a** and the catalyst **90b** gave the imine **202** in 30% conversion as judged by  $^1\text{H}$  NMR as before. This was further increased to 80% conversion by slow addition of the isocyanate over 5 hours (Scheme 3.16).

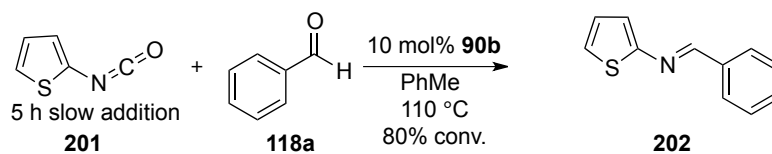

Scheme 3.16

Using these latter conditions the  $\alpha,\beta$ -unsaturated aldimine **203** was prepared from cinnamaldehyde and 2-isocyanatothiophene **201** in 20% isolated yield (44% conversion by  $^1\text{H}$  NMR). However, no electrocyclisation of **203** was observed on heating, even after heating at 160 °C for 1 hour in the microwave (Scheme 3.17) instead only unreacted starting material was observed.

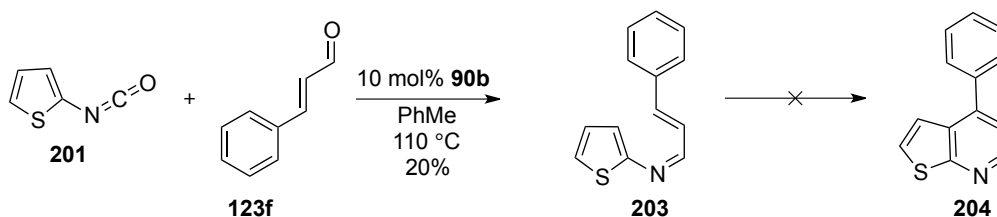

Scheme 3.17

### 3.4 Conclusion

The results described above suggest the rate of intermolecular aza-Wittig reaction of an iminophosphorane and an  $\alpha,\beta$ -unsaturated aldehyde is slow compared with the rate of reaction between the same iminophosphorane and benzaldehydes. This led to lower yields of imine and therefore, of the derived pyridines. In addition, the electrocyclic ring closure of heterocyclic azatrienes is non-trivial since even under harsh conditions full conversion is not achieved.

An alternative approach by Funicello and co-workers towards benzothienylpyridines was the use of UV light to promote electrocyclic ring closure of azatrienes **205** in the synthesis of benzo[*b*]thieno[2,3-*b*]pyridines **206** (Scheme 3.18).<sup>3, 66, 111</sup> Further studies into the use of UV light to promote the electrocyclic ring closure reaction could therefore be carried out.

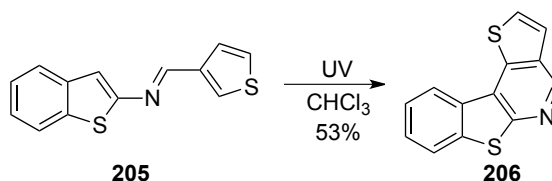

Scheme 3.18

## 4.0 Development of a two-pot process towards substituted quinolones

### 4.1 Oxidative Heck reactions

Palladium-catalysed Heck and cross-coupling reactions are particularly valuable reactions in synthetic organic chemistry. However, the requirement to prefunctionalise starting materials and generation of stoichiometric halide salts waste are significant drawbacks to these reactions.<sup>116</sup> The ability to insert palladium directly into a carbon–hydrogen bond, circumventing the use of aryl halides has thus emerged as a field of great interest.

Moritani and Fujiwara pioneered palladium-mediated C–H activation Heck reactions as early as 1967, detailing a reaction between benzene **210** and styrene **211** to give stilbene **212**.<sup>117</sup> While the initial reaction used stoichiometric palladium(II) chloride, a catalytic variant swiftly followed, although the yield was modest and catalytic turnovers were low (Scheme 4.1).<sup>118</sup> The lack of regiocontrol with substituted benzenes and large excess of benzene required meant further investigation was necessary and it has taken many years for the reaction to find more widespread interest.



Scheme 4.1

Fujiwara and co-workers continued their investigations into the activation of C–H bonds, finding that regeneration of Pd<sup>II</sup> from Pd<sup>0</sup> was a key step in the catalytic cycle; therefore choice of an effective oxidant was crucial for catalyst turnover to occur. It was found that *tert*-butyl hydroperoxide was a suitable oxidant in the reaction between benzene **210** and (*E*)-ethyl cinnamate **213** giving a 72% yield of the desired trisubstituted alkene **214** with only 1 mol% Pd(OAc)<sub>2</sub> (Scheme 4.2).<sup>119</sup> The addition of benzoquinone enhanced the reaction considerably and it was proposed this had a two-fold role: formation of Pd<sup>0</sup>–BQ complexes stabilise the Pd<sup>0</sup> species, preventing aggregation to Pd black, and also mediate the oxidation of Pd<sup>0</sup> to Pd<sup>II</sup>.

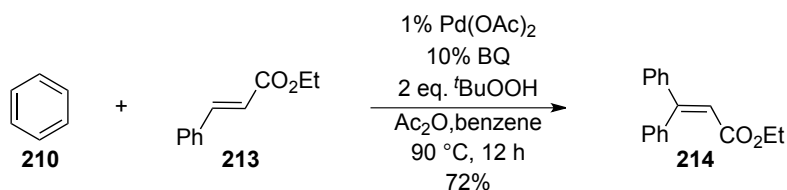

Scheme 4.2

The issue of regiocontrol can be circumvented by the use of molecules with C–H bonds of different reactivity and this strategy has been applied to a number of heterocycles.<sup>120</sup> In substituted benzene systems the difference in reactivity between C–H bonds is usually less pronounced, therefore the use of coordinating directing groups such as amides, pyridines and acetanilides has become widely employed.<sup>121</sup> The coordination ability of these groups directs the transition metal to the adjacent C–H bond, activating it with high levels of regioselectivity (Figure 4.1).

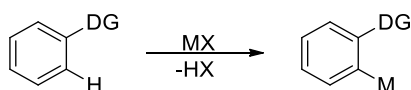
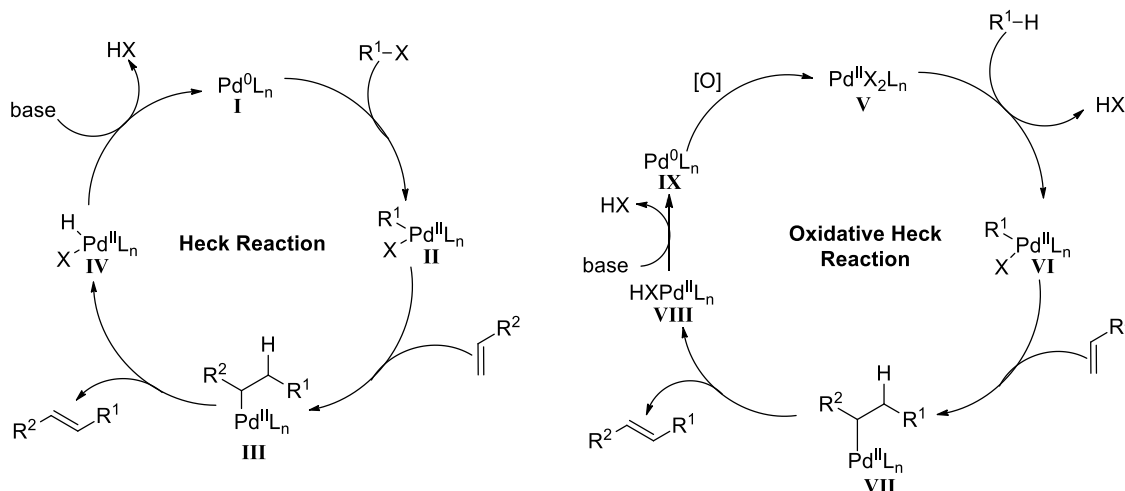

Figure 4.1

Directing groups do have their limitations: additional steps are required to install and remove them (if they are not part of the target molecule) and the substitution pattern is restricted since functionalisation usually occurs in the *ortho*-position. Manipulating the directing group for further functionalisation can therefore be beneficial and has been used effectively.<sup>122-125</sup>

## 4.2 Mechanistic aspects

The classic Heck reaction involves the coupling reaction between an aryl/vinyl halide and an olefin to generate a substituted alkene.<sup>126</sup> The catalytic cycle proceeds *via* oxidative insertion of  $\text{Pd}^0\text{L}_n$  **I** into the C–X bond of the aryl/vinyl halide. Coordination of the olefin to the generated  $\text{Pd}^{\text{II}}$  species **II** is followed by bond insertion to give the palladium complex **III**. Subsequent  $\beta$ -hydride elimination generates the substituted alkene product and  $\text{Pd}^{\text{II}}$  species **IV**, which is reduced with extrusion of the halide salt by addition of a base to regenerate the active  $\text{Pd}^0\text{L}_n$  catalyst **I** (Scheme 4.3).<sup>127</sup>



Scheme 4.3

The catalytic cycle for the oxidative Heck reaction, although similar has two distinct differences. Firstly, the Pd<sup>II</sup> species **V** is required for insertion into the C–H bond, rather than Pd<sup>0</sup>L<sub>n</sub> as seen previously. Secondly, the Pd<sup>0</sup> species **IX** formed after reductive elimination requires an oxidant to reform the active Pd<sup>II</sup> species **V**, completing the cycle (Scheme 4.3).<sup>117</sup>

### 4.3 Ureas as directing groups

Booker-Milburn *et al.* demonstrated that trisubstituted ureas are effective directing groups in 1,2-carboamination reactions of dienes to give indolines (Scheme 4.4).<sup>128</sup> The reaction proceeds *via* an oxidative Heck-type reaction between the C–H bond *ortho*- to the urea **215** and the diene **217** through the palladacycle **216**. Subsequent cyclisation proceeds by attack of the nitrogen onto the newly formed  $\eta^3$ -allyl Pd<sup>II</sup> intermediate **218** to give the indoline **219** and Pd<sup>0</sup>L<sub>n</sub>; oxidation of the latter regenerates the catalyst for further reaction. The presence of TsOH was essential for reaction and it was postulated that this was due to the formation a more active palladium tosylate species. Indeed, reaction with [Pd(MeCN)<sub>2</sub>(OTs)<sub>2</sub>] gave **219a** in 85% yield with no requirement for added TsOH. Furthermore, with this catalyst system the use of molecular sieves as a drying agent can be employed, negating the necessity for Ac<sub>2</sub>O in the reaction mixture.

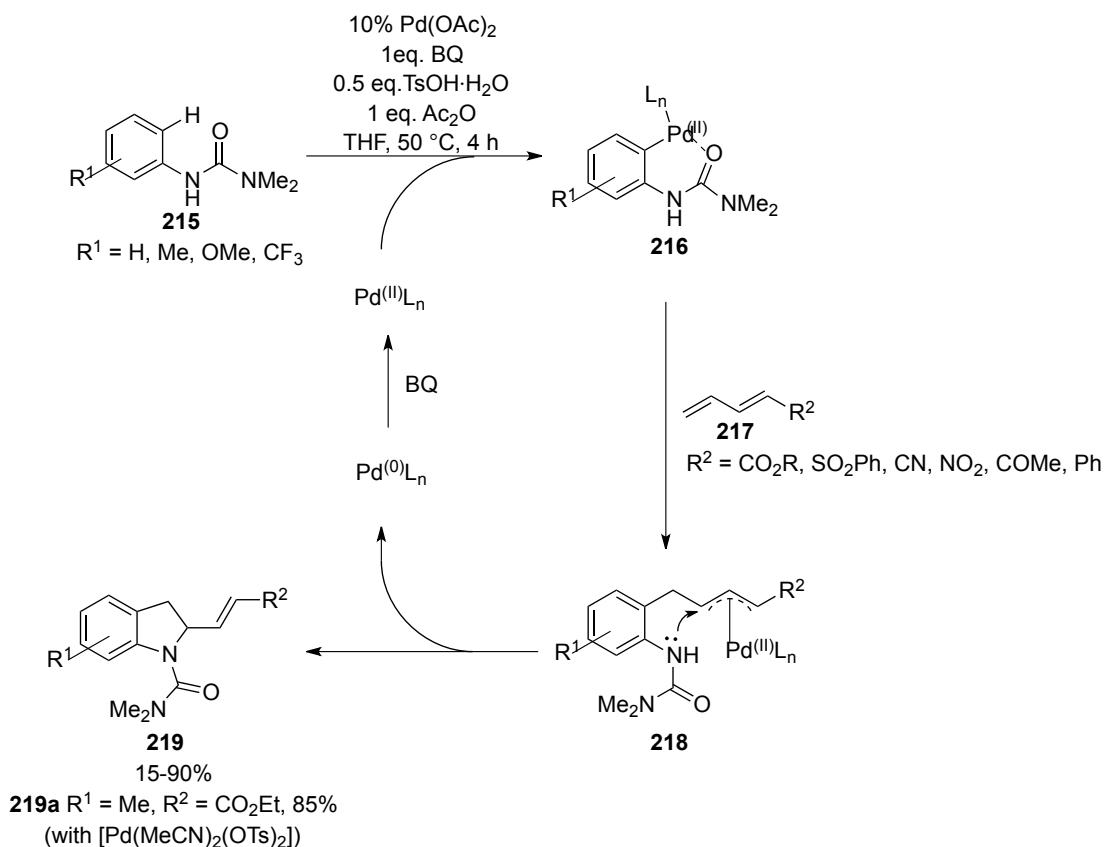

Scheme 4.4



As a continuation of this work, Booker-Milburn and co-workers explored the reactivity of the palladacycle **216** with a number of coupling partners, albeit stoichiometrically (Scheme 4.5).<sup>129</sup> In addition, a catalytic process for the synthesis of cyclic imidates **221** and methyl anthranilates **220** was developed and the catalyst shown to be effective even at ambient temperature. The powerful activating effect of the urea directing group was demonstrated, in comparison with the acetanilide, for the formation of methyl anthranilate **220** (88% compared to 0% respectively). Further work by Brown *et al.* confirmed the greater reactivity of ureas over acetanilides.<sup>130</sup>

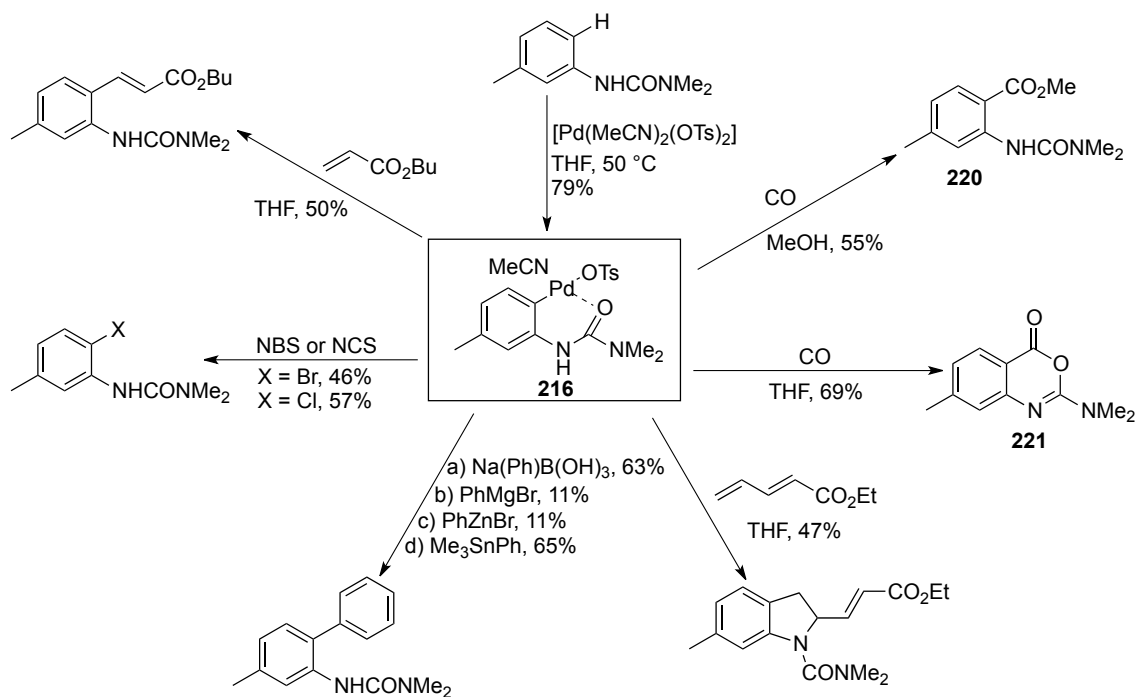

Scheme 4.5

The powerful directing effect of the urea and the ability to remove it under mild conditions (hydrolysis in water at 100 °C)<sup>128</sup> makes it an attractive group for C–H insertions.

#### 4.4 2-Quinolones

2-Quinolones are an important class of *N*-heterocycles which exhibit a range of biological activities and are found in many natural products,<sup>131</sup> pharmaceuticals<sup>132-134</sup> and agrochemicals (Figure 4.2).<sup>135, 136, 137, 138</sup> Furthermore, they are valuable intermediates in organic synthesis since they can be easily transformed into haloquinolines for further functionalisation.<sup>139, 140</sup>

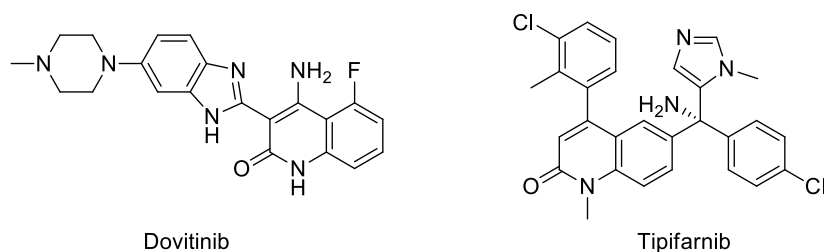
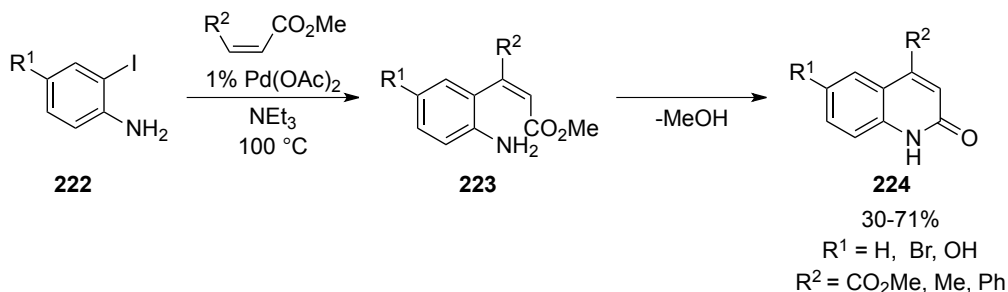

Figure 4.2

Classical condensation routes towards the synthesis of 2-quinolones suffer from harsh reaction conditions, unstable starting materials, low yields and problems with regioselectivity,<sup>141</sup> so there is a need for more efficient and environmentally benign processes. An early example of a mild transition metal-catalysed process was reported by Heck *et al.* where 2-iodoanilines **222** react with *cis*-alkenes in the presence of Pd(OAc)<sub>2</sub> and undergo subsequent cyclisation to give the 2-quinolones **224** (Scheme 4.6).<sup>142</sup> Despite this early work, only a few examples of transition metal-catalysed processes towards substituted 2-quinolones have been developed.<sup>143-151</sup>



Scheme 4.6

Disubstituted 2-quinolones have typically been more difficult to prepare, leading to a paucity of methods towards their synthesis.<sup>152-154</sup> Larock *et al.* reported that a carbonylative annulation reaction between 2-iodoanilines **225** and alkynes **226** in the presence of Pd(OAc)<sub>2</sub> and CO gives 3,4-disubstituted 2-quinolones **227** and **228** (Scheme 4.7).<sup>145</sup> Choice of the nitrogen-protecting group was crucial with alkoxy carbonyl, tosyl and trifluoroacetyl groups being the most effective and the reaction conditions facilitating removal of the protecting group. Controlling the regioselectivity of the reaction was an issue, with mixtures of regioisomers formed from unsymmetrical alkynes. In addition, the process is very sensitive to steric hindrance, with bulky substituents leading to sluggish reactions and low yields.

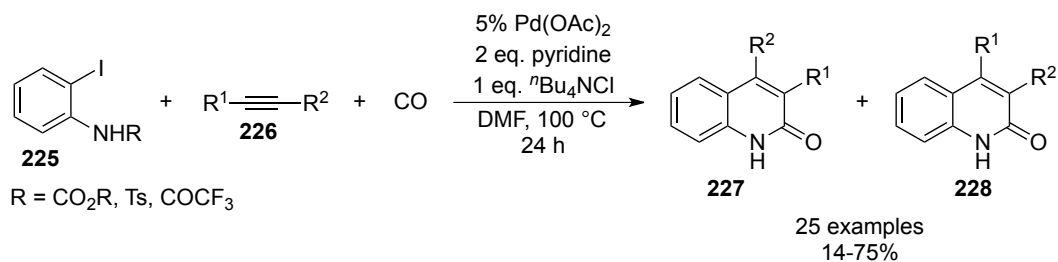

Scheme 4.7

#### 4.5 Examples of C–H activation in 2-quinolone synthesis

The development of C–H activation reactions towards 2-quinolones is an attractive prospect since this would negate the requirement for aryl halide precursors. One of the challenges faced is the difficulty in carbon–nitrogen bond formation through C–H activation; a reaction less studied than carbon–carbon, carbon–oxygen and carbon–halogen bond formations.<sup>146, 155</sup> Nevertheless, Yu *et al.* reported the first C–H activation approach towards 2-quinolones **230** from *N*-alkoxyhydroxamic acids **229**. However, only two examples were prepared (Scheme 4.8) using their intramolecular approach.<sup>147</sup>



Scheme 4.8

More recently Doi and co-workers have developed palladium-catalysed C–H amidations of 3-arylacrylamides **231** leading to 4-aryl quinolones **232**.<sup>146</sup> They extended this methodology to an oxidative Heck/intramolecular C–H amidation sequence from cinnamamides and arylboronic acids (Scheme 4.9).<sup>148</sup> Whilst this demonstrates the ability to prepare 2-quinolones using formal C–H insertion reactions, the requirement of a super-stoichiometric copper/silver oxidant system and the limited substrate scope mean this approach is relatively unattractive.

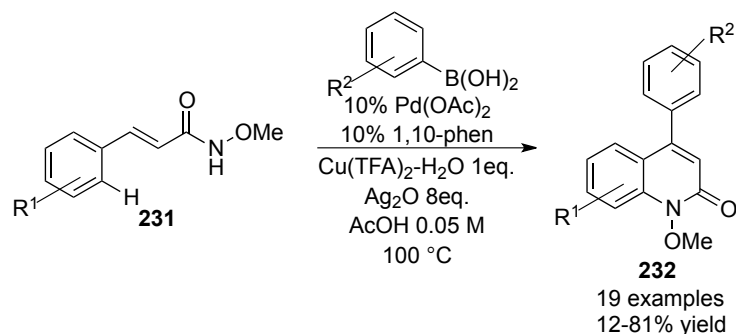

Scheme 4.9

A copper-catalysed C–H amidation of 3-arylacrylamides **233** described by Fabrizi *et al.* eliminates the need for stoichiometric oxidants since they found oxygen (air) sufficient for reoxidation of the catalyst.<sup>149</sup> By taking advantage of the steric effects of *ortho*-substituents in the R<sup>1</sup> position, a cyclisation process that was selective for quinolone **234** over its isomer **235** was developed (Scheme 4.10).

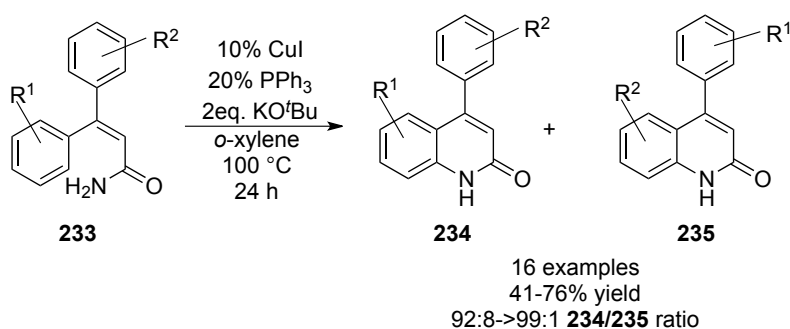

Scheme 4.10

#### 4.6 Electrocyclisation of isocyanates

An alternative method for the synthesis of 2-pyridones and 2-quinolones is the electrocyclisation of dienyl isocyanates. These reactions have not found widespread application due to the requirement of high temperatures in most cases and the hazardous conditions required to form the starting materials. In particular, the isocyanate precursors have typically been generated *via* Curtius rearrangement of the corresponding acyl azides<sup>156-158</sup> or phosgenation of amines.<sup>159, 160</sup> Washburne *et al.* demonstrated an early example of this reaction; the formation of the desired pyridine **239** was compromised by competing polymerisation of the isocyanate **238** (Scheme 4.11).<sup>156</sup>

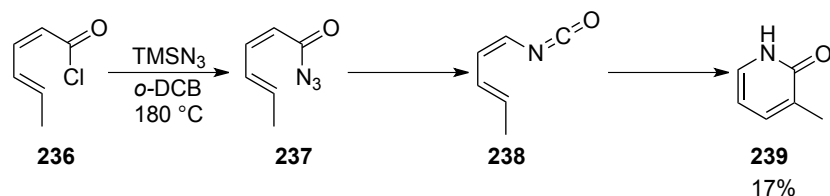

Scheme 4.11

This approach has found application in the synthesis of isocryptolepine, an indolo[3,2-*c*]quinoline alkaloid with antimalarial properties. In Hayashi's total synthesis, microwave-assisted tandem Curtius rearrangement and electrocyclisation reaction was the key step (Scheme 4.12).<sup>161</sup> Use of a MOM-protecting group was essential for high conversion to the quinolone **240** because urea formation between the indole nitrogen and the isocyanate became a significant side-reaction for the unprotected derivative. Having established a high-yielding procedure for the synthesis of the quinolone, isocryptolepine **241** was obtained in 54% overall yield across nine steps.

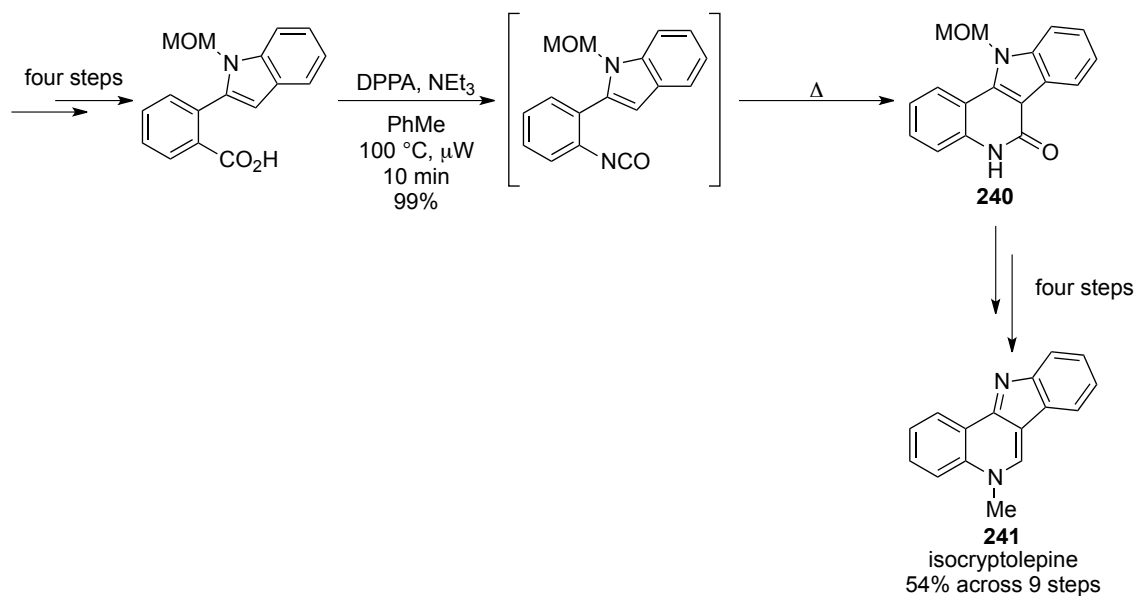

Scheme 4.12

A novel method for the preparation of dienyl isocyanates was developed by Overman and co-workers in the synthesis of 2-pyridones (Scheme 4.13).<sup>162, 163</sup> Here, pseudoureas **242** were prepared *via* base-catalysed condensation of cyanopyrrolidine and secondary propargylic alcohols. Upon heating the pseudoureas in refluxing xylene they observed formation of diene **245** and the pyridone **248**, formed through electrocyclic ring closure of the isocyanate intermediate **246**. Addition of piperidine to the reaction formed the expected piperidinyl urea in 17% confirming the intermediacy of the isocyanate **246**. The reaction worked well for alcohols with alkyl groups in the R<sup>2</sup> position, however, yields decreased when aryl groups or a proton were used.

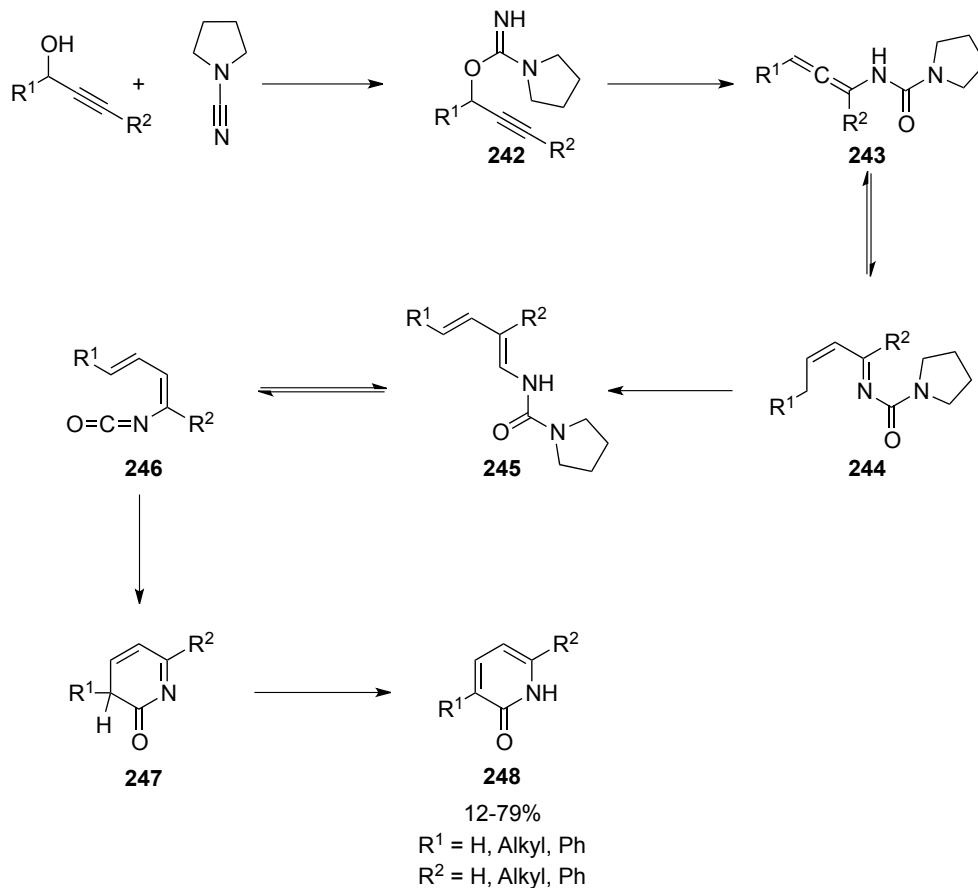

Scheme 4.13

More recently, Kobayashi *et al.* demonstrated an alternative approach, preparing isocyanates **251** by oxidation of isocyanides **250** using *m*CPBA (Scheme 4.14).<sup>152</sup> Electrocyclisation ensued under the reaction conditions to give the 2-quinolones **252** in good yields. Whilst this gave the desired substrates under mild conditions, the method was limited to 2-quinolones with a hydrogen or methyl group in the 3-position with no electrocyclisation observed with the 3-phenyl derivative.

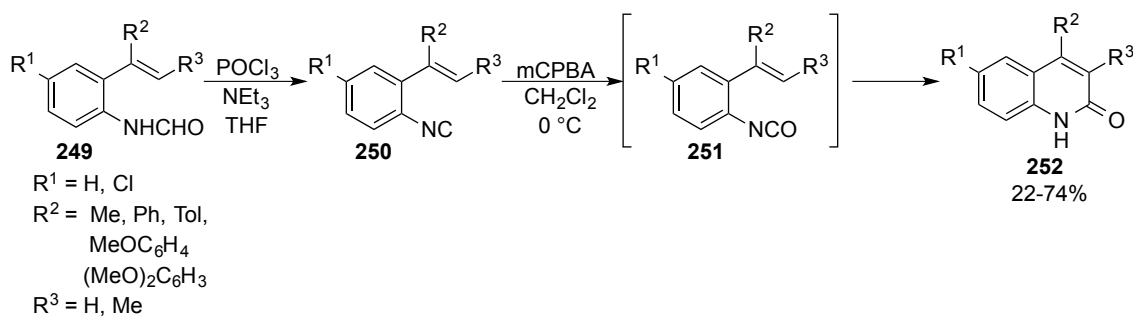

Scheme 4.14

Kinetic studies by Dolbier *et al.* showed that the electrocyclisation of styryl isocyanates exhibits first-order behaviour with respect to the 2-isocyanatostyrene with computational studies

supporting the reaction proceeding through a late-stage transition state **254** (Scheme 4.15). The electrocyclicisation step (step A, Scheme 4.15) was found to be rate-determining since the addition of base (which would enhance the rate of proton elimination in step B) had no significant effect on the rate of reaction. Computational data indicated that the reaction was not a classic, disrotatory  $6\pi$  electrocyclic ring closure reaction. Rather, the vinyl group was twisted out of the plane by  $28.2^\circ$  of the aromatic ring (compared to  $33.0^\circ$  for the normal electrocyclic process), thus orientating the terminal  $p$ -orbital for overlap with the carbonyl  $\pi$ -bond instead of the C=N  $\pi$ -bond as would be expected for a classic, disrotatory process. This orientation of the transition state suggests the reaction goes through a pseudopericyclic process where non-bonding and bonding orbitals interchange roles;<sup>164-166</sup> in this case one of the carbonyl non-bonding pairs becomes a bonded pair as the new  $\sigma$ -bond is formed.

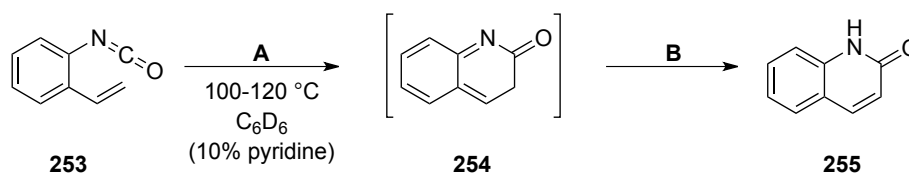

Scheme 4.15

#### 4.7 Generation of Isocyanates

Classical methods for isocyanate generation such as Curtius rearrangement of acyl azides and phosgenation of amines suffer from the use of toxic and hazardous reagents, limiting their use in large scale synthesis.<sup>167</sup> The development of flow engineering has made these routes more accessible,<sup>168</sup> however, the use of alternative methods with fewer associated safety hazards is desirable. In recent years a number of new methods towards isocyanate synthesis have been developed. Dubé *et al.* reported a carbonyl diimidazole-mediated Lossen rearrangement of hydroxamic acids to generate carbamates and ureas in excellent yields at low temperatures (Scheme 4.16).<sup>87</sup> The reaction proceeds through dioxazolone intermediate **257** that upon heating releases  $\text{CO}_2$  to give the isocyanate, which can be trapped by nitrogen- or oxygen-centred nucleophiles. This offers a mild, scalable route towards isocyanates. The reaction is limited by the availability of the hydroxamic acid precursors and the need for electron-rich arenes for rearrangement to occur.

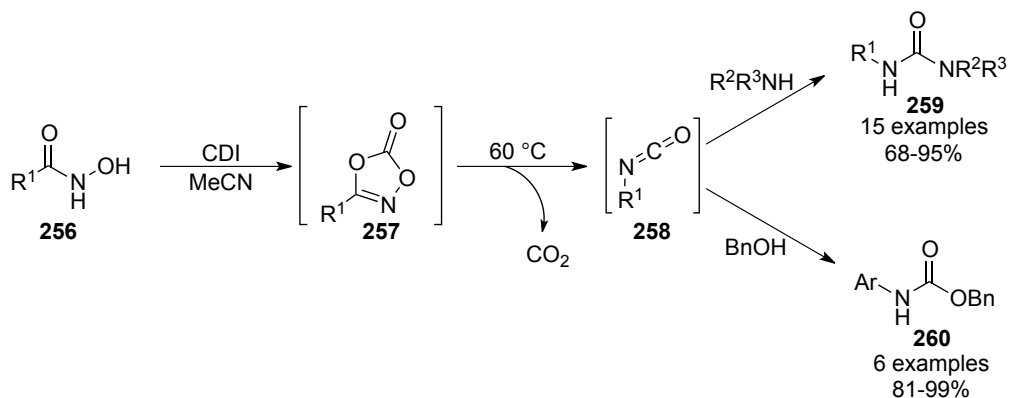

Scheme 4.16

Zhdankin and Hu independently reported the mild synthesis of ureas and carbamates from amides through an isocyanate intermediate using a Hofmann rearrangement mediated by a hypervalent iodine species (PhINTs and PhIO respectively).<sup>169, 170</sup> Zhdankin *et al.* demonstrated the intermediacy of the isocyanate in this process by isolation of *p*-tolyl isocyanate **264** in an 80% yield which they propose is formed *via* 1,2-aryl shift to a nitrenium nitrogen atom formed from amidoiodane **262** (Scheme 4.17). Electron-rich and electron-poor benzamides as well as alkyl amides were high-yielding for formation of the methyl carbamates. Hu *et al.* expanded on this showing that the reactions were general for a range of amine and alcohols in excellent yields.

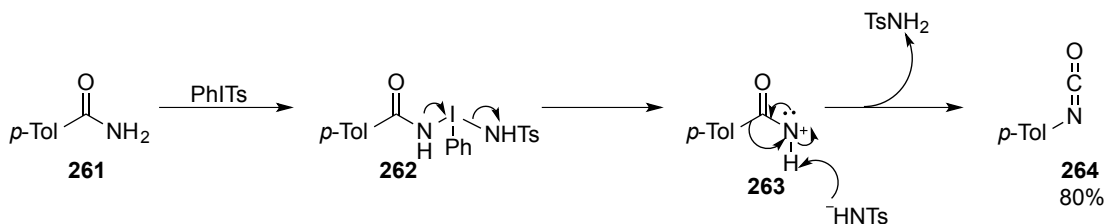

Scheme 4.17

A palladium-catalysed method for the generation of isocyanates from aryl chlorides and triflates was recently reported by Buchwald *et al.*<sup>90</sup> Here, arylisocyanurate palladium complexes were generated from the aryl chloride (or triflate), Pd<sub>2</sub>(dba)<sub>3</sub>, ligand and sodium cyanate. Reductive elimination to give the aryl isocyanate **266** occurs upon heating the palladacycle to 60 °C for 110 minutes in the presence of bromobenzene (used to trap the resulting Pd(0) species). Subsequent amine addition gives unsymmetrical tri- and disubstituted ureas **267** in good yields (Scheme 4.18).



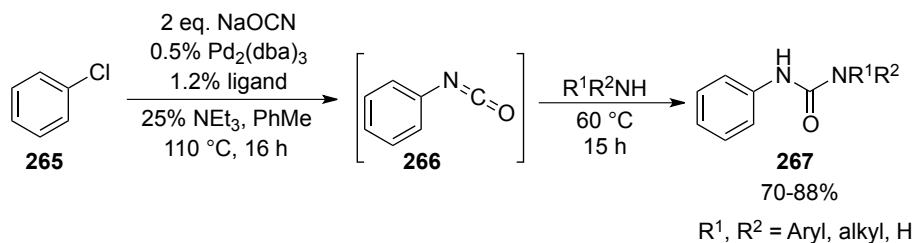

Scheme 4.18

During their studies into Pd<sup>II</sup>-catalysed *ortho*-carbonylation of alkyl aryl ureas, Booker-Milburn *et al.* observed that an *N,N*-diisopropyl urea underwent slow hydrolysis to the corresponding aniline at 100 °C. Upon further investigation it was found that heating hindered *N,N*-disubstituted ureas in methanol gave carbamates, leading to the proposal that an isocyanate intermediate was involved.<sup>171</sup> A variety of nucleophiles can be used to intercept the isocyanate intermediate generating a range of carbamates, ureas and thiocarbamates **268** (Scheme 4.19). The ready availability of anilines for the synthesis of hindered ureas makes this an attractive route towards isocyanates.

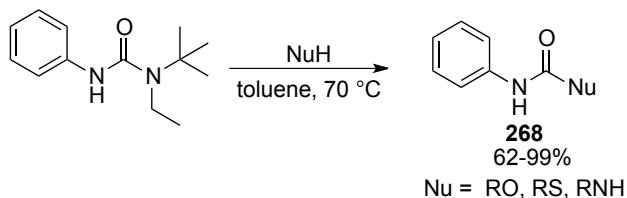

Scheme 4.19

#### 4.8 Mechanism of urea hydrolysis

The hydrolysis of *N*-aryl ureas has been the subject of a number of detailed mechanistic studies, with the general consensus that expulsion of R<sub>2</sub>NH from the zwitterionic species Ar–N=C(O<sup>−</sup>)–NR<sub>2</sub>H<sup>+</sup> **270** leads to the formation of *N*-aryl isocyanates **271**.<sup>172-178</sup> O'Connor and co-workers' pioneering work indicated that water acts as a proton transfer agent to generate the zwitterionic species through a six-membered transition state **269** (Scheme 4.20) in neutral and mildly acidic media.<sup>172-174</sup> In addition, Capossa *et al.* have demonstrated that both acidic and basic buffers enhance the reactivity of the reactions suggesting that either can act as a proton transfer agent in the formation of the zwitterionic species.<sup>177</sup> More recently, computational studies have shown that lowest-energy path for the extrusion of ammonia from urea in water involves a hydrogen transfer mediated by one water molecule *via* a H<sub>3</sub>N<sup>+</sup>C(O<sup>−</sup>)=NH zwitterion.<sup>179</sup>

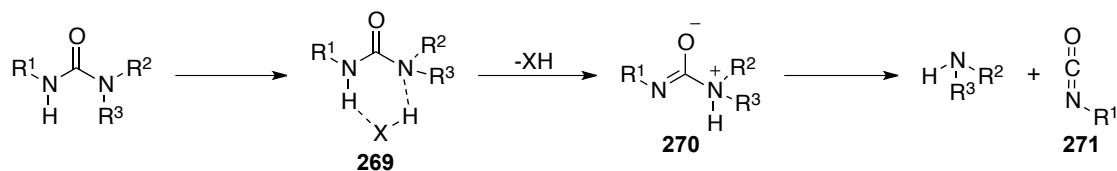

Scheme 4.20

This mechanism does not, however, account for the formation of isocyanates from ureas when no proton transfer agent is present, as is the case in Overman's rearrangement of ureas to form pyridines through an isocyanate intermediate.<sup>162, 163</sup> Indeed, Booker-Milburn also demonstrated that isocyanate generation is possible with no protic source available,<sup>86</sup> suggesting that a proton transfer agent is not a requirement, but that it can accelerate the reaction. There are two plausible explanations for isocyanate generation without a proton transfer agent: firstly generation of the zwitterionic intermediate **270** through intermolecular hydrogen transfer between two hydrogen-bonded urea molecules **272** (Scheme 4.21); secondly spontaneous collapse of the urea molecule upon heating followed by proton-transfer.

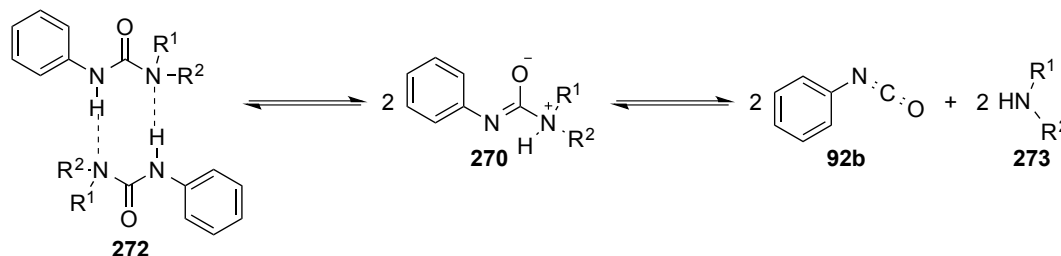

Scheme 4.21

#### 4.9 Project aims

The aim of the project was to develop a one-pot process towards 2-quinolones from aryl ureas.

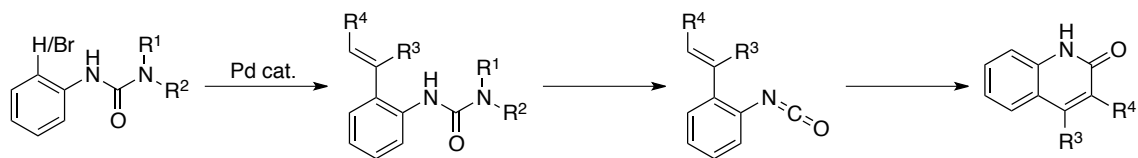

Scheme 4.22

Initially, the isocyanate formation and electrocyclisation reactions would be investigated to prepare 2-quinolones from bulky ureas. Secondly the use of a bulky urea in a C–H activated Heck reaction would be explored and conditions optimised. By telescoping the reaction a one-pot preparation of 2-quinolones from aryl ureas could be developed (Scheme 4.22).

#### 4.10 Proof of concept

To determine if the isocyanate formation and subsequent cyclisation would give the desired quinolone, the alkene **275** first had to be prepared. This was obtained *via* a Heck reaction of 2-bromoaniline with styrene in the presence of palladium acetate and tri-*o*-tolylphosphine to give the aniline **274** in 75% yield. Treatment of **274** with diisopropylcarbonyl chloride and triethylamine gave the alkene **275** in 50% yield. A 0.2 M solution of the urea in 1:1 toluene/MeCN was then heated in the microwave for 1 hour at 150 °C to give the quinolone **276a** in 18% yield (Scheme 4.23). Dilution of the reaction mixture to 0.1 M increased the yield to 55% presumably since this favoured intramolecular cyclisation over recombination of the isocyanate and diisopropylamine. Aniline **274** was also isolated in 33% yield after the electrocyclic cyclisation, indicating that further isocyanate was formed, and hydrolysed during or after the reaction.

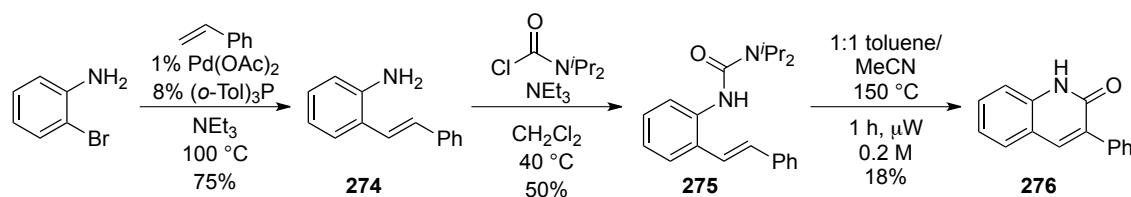

Scheme 4.23

To ensure the reaction was not substrate-dependent, and to aid development of an oxidative Heck approach, the sequence was repeated using butyl acrylate as the Heck coupling partner since this is widely used in oxidative Heck reactions. Hence, quinolone **279a** was prepared in 34% yield (Scheme 4.24). Aniline **277** was also observed in 24% yield alongside a complex mixture of products. The LCMS contained a peak for a compound of mass 487 that suggested the urea **280** had also been formed; this could be due to attack of the aniline **277** onto the isocyanate.

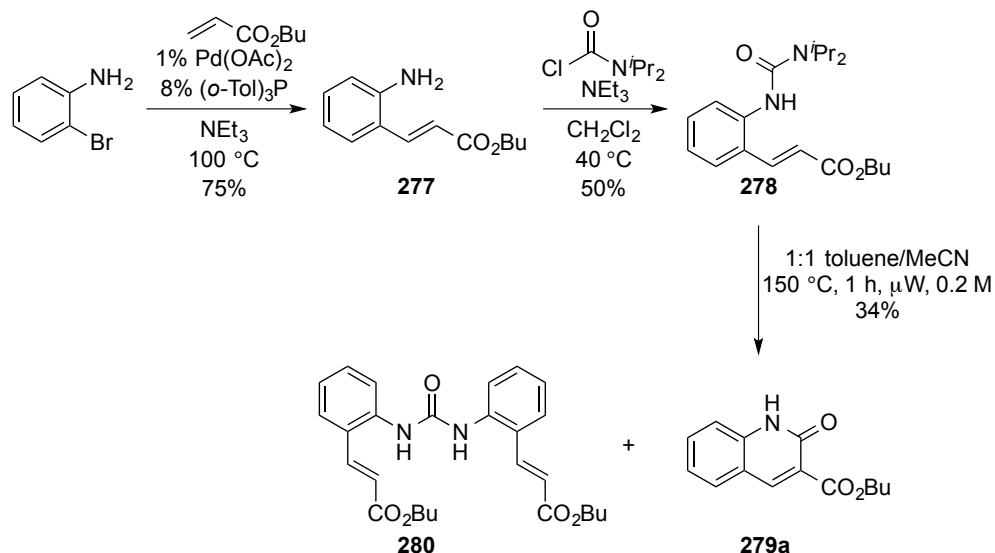

Scheme 4.24

It is noteworthy that whilst the isocyanate is formed at 70 °C,<sup>171</sup> in our hands only unreacted starting material was observed upon heating the urea **275** in toluene at 110 °C for 16 hours. It is likely that the isocyanate is formed reversibly, but that the electrocyclisation requires elevated temperatures, hence the only product observed is formed by the recombination of isocyanate and amine to give the starting material.

Although this method worked well for preparing the ureas on a small scale (1 mmol), scaling the reaction to 5 mmol saw formation of a number of by-products which were inseparable from the product by both chromatographic purification and trituration. Examination of the LCMS chromatogram indicated that the urea **280** arising from isocyanate formation and subsequent trapping with aniline **277** was a significant by-product. The difficulties in preparing larger quantities of the urea starting material **278** led us to investigate the oxidative Heck reaction before continuing optimisation of the electrocyclisation step.

#### 4.11 Optimisation of the oxidative Heck reaction

Booker-Milburn and co-workers reported that  $[\text{Pd}(\text{MeCN})_2(\text{OTs})_2]$  is an efficient catalyst in urea-directed C–H insertions.<sup>129</sup> The palladacycle formed reacts with a range of coupling partners, including butyl acrylate, albeit in modest yields. This ability to use ureas as directing groups in the stoichiometric oxidative Heck reaction has been extended to the catalytic reaction by Brown *et al.*,<sup>130</sup> but only the dimethyl urea was investigated. Since use of the hindered diisopropyl urea was important for facile isocyanate formation this was the initial substrate we examined. However, when we attempted this reaction using diisopropyl urea **281** and 10 mol%  $[\text{Pd}(\text{MeCN})_2(\text{OTs})_2]$  only recovered starting material was observed (Scheme 4.25).

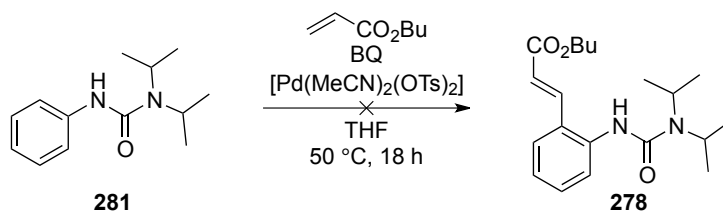

Scheme 4.25

During Booker-Milburn and coworkers investigation into urea-directed C–H insertions using  $[\text{Pd}(\text{MeCN})_2(\text{OTs})_2]$  a variety of urea derivatives were explored, including the diisopropyl urea.<sup>129</sup> The increased steric bulk on the urea was found to be detrimental to the C–H activation. Overman *et al.* have reported rearrangement reactions of pyrrolidinyl pseudo-ureas to give isocyanates (Scheme 4.13, section 4.6).<sup>162, 163</sup> The decreased steric bulk of the pyrrolidinyl group should be beneficial for C–H insertions, and hence the oxidative Heck reaction was repeated

with pyrrolidinyl urea **282a** to give the alkene **283a** in 44% yield (Table 4.1, entry 1). A significant amount of palladium black was observed at the end of the reaction and so a number of reactions were attempted to improve the yield of alkene: changing the equivalents of benzoquinone (Entries 3, 4 and 5), order of addition (Entries 1, 2 and 3) and solvent (Entries 2 and 6). It was found that pre-mixing the catalyst and urea and changing the solvent to MeCN were beneficial (Entries 3 and 7) to obtain the alkene in 93% yield.

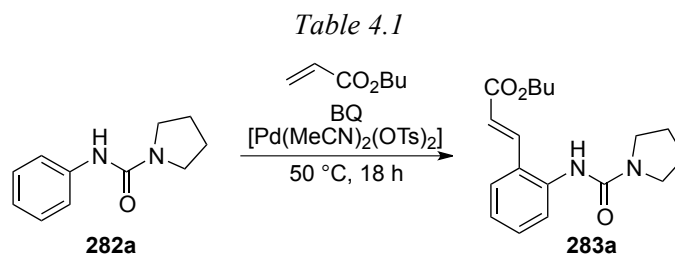

Entry	Order of Addition	Equivalents BQ	Solvent	% Yield <b>283a</b>
1	No premix	1.2	THF	44
2	Urea + Pd premix	1.2	THF	35
3	10% Urea + Pd premix	1.2	THF	47
4	Urea + Pd premix	1.5	THF	51
5	Urea + Pd premix	2	THF	46
6	Urea + Pd premix	1.2	MeCN	74
7	Urea + Pd premix	1.5	MeCN	93

#### 4.12 Optimisation of electrocyclisation reactions

The success of the oxidative Heck reactions prompted us to attempt the electrocyclisation on this new substrate. Unfortunately using the conditions developed for the diisopropyl derivative, (heating the alkene in 1:1 toluene/MeCN at 150 °C in the microwave for 1 hour) yielded none of the desired quinolone, with only unreacted starting material observed. In the report by Overman *et al.* xylene was used as a reaction solvent, therefore it was thought that this might be a suitable solvent for the reaction.<sup>162</sup> It was found that the alkene **283a** was not soluble in xylene; however, heating the alkene **283a** in a mixture of xylene and acetonitrile at 170 °C in a microwave vial for 1 hour gave the desired quinolone **279a** in 12% yield (Scheme 4.26). In addition, Overman and co-workers showed that the yield of pyridones from pseudoureas was improved by the addition of 2-4 equivalents of *N,N*-diisopropylethylamine at 140 °C in xylene.<sup>163</sup> Hence it was thought that addition of a non-nucleophilic amine such as triethylamine could be beneficial, however, no reaction was observed under these conditions by <sup>1</sup>H NMR or LCMS.

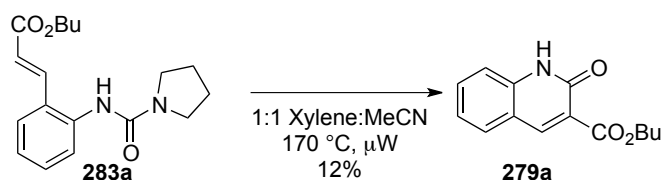

Scheme 4.26

To increase the yield of the quinolones further we next sought to determine if there was optimum steric bulk for the urea, small enough to allow C–H activation to occur, but large enough for isocyanate formation to occur readily. Only three ureas were prepared since it quickly became apparent that, upon reaction with butyl acrylate, benzoquinone and  $[\text{Pd}(\text{MeCN})_2(\text{OTs})_2]$ , the yields dropped rapidly with increased steric bulk (Table 4.2) with even a piperidinyl urea giving only 28% of the desired alkene **285a** (Table 4.2, Entry 1).

Table 4.2

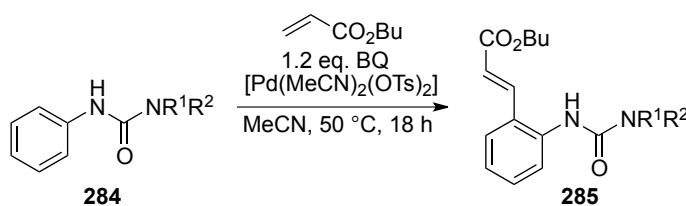

Entry	R <sup>1</sup>	R <sup>2</sup>	% Yield 285
1 (a)	Piperidine		28
2 (b)	2-Methylpiperidine		5
3 (c)	<sup>i</sup> Pr	<sup>i</sup> Pr	N.R.

The requirement for a relatively sterically unhindered urea in the C–H activation led us to reinvestigate the electrocyclicisation of the pyrrolidinyl ureas. In particular, conditions requiring lower temperatures were desirable. Booker-Milburn *et al.* proposed that isocyanate formation is accelerated through expulsion of  $\text{R}_2\text{NH}$  from a zwitterion of the form  $\text{Ar}-\text{N}=\text{C}(\text{O})-\text{NR}_2\text{H}^+$  mediated by a X–H unit where X has a lone pair of electrons.<sup>86</sup> It was postulated that addition of an X–H species such as an alcohol could therefore be beneficial since these have previously been shown to enhance reactivity in the hydrolysis of ureas.<sup>177</sup> Thus, *tert*-butanol was added to the alkene **283a** and the reaction mixture heated to 150 °C as before. Surprisingly, no reaction was observed, with only starting material recovered (Scheme 4.27).

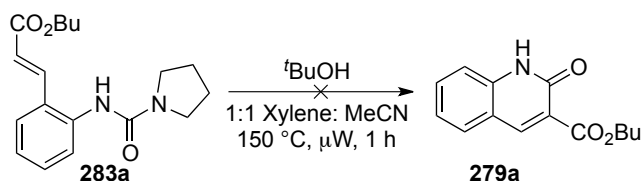

Scheme 4.27

We speculated that palladium's affinity for nitrogen might enhance the formation of the isocyanate intermediate in a similar manner to an X–H species, allowing generation of the zwitterionic intermediate. In addition, the initial aim of the project was to develop a one-pot process incorporating oxidative Heck, isocyanate formation and electrocycloisatn reactions. Hence, a mixture of the alkene **283a** with 10 mol% [Pd(MeCN)<sub>2</sub>(OTs)<sub>2</sub>] in a 1:1 mixture of xylene and acetonitrile was heated to 150 °C under microwave conditions. Whilst only 5% of the desired product **279a** was observed, the yield was increased to 37% by elevating the temperature to 200 °C (Scheme 4.28).

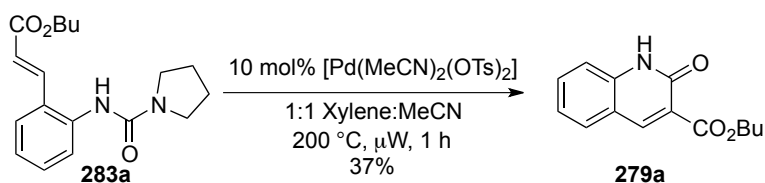

Scheme 4.28

Although this demonstrated that the quinolone **279a** could be prepared in modest yields, the high temperatures required were undesirable. A report by Washburne *et al.* indicated that the yield of pyridones generated *via* electrocycloisatn of isocyanates can be increased by a solvent swap from xylene to *o*-dichlorobenzene.<sup>156</sup> Hence, alkene **283a** was heated in *o*-dichlorobenzene at 150 °C in a microwave vial at 0.1 M. Initially no palladium catalyst was added since this would indicate if the catalyst was still required in *o*-dichlorobenzene. After 15 minutes LCMS indicated the presence of the desired quinolone **279a** and after one hour <sup>1</sup>H NMR indicated 20% conversion to quinolone **279a** by examination of the integrals of the alkene versus the quinolone (Scheme 4.29). When the temperature was reduced further to 100 °C, no reaction was observed.

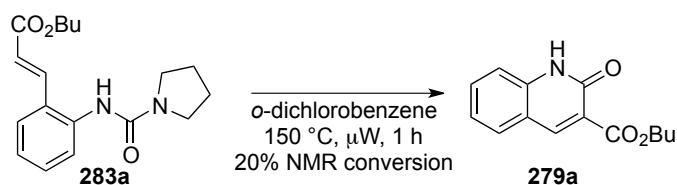

Scheme 4.29

Given the success of adding the palladium catalyst in previous reactions it was hoped that this could improve the conversion further. Hence, alkene **283a** was heated in *o*-dichlorobenzene with 10 mol% [Pd(MeCN)<sub>2</sub>(OTs)<sub>2</sub>] at 150 °C under microwave conditions. After 1 hour a 30% conversion to quinolone **279a** was observed by <sup>1</sup>H NMR and by heating for a further 2 hours the quinolone **279a** was isolated in 65% yield (Scheme 4.30).

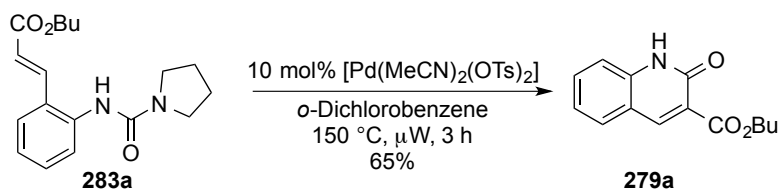

Scheme 4.30

With this result in hand, a variety of palladium catalysts were screened to see if yields could be increased by the use of an alternative palladium source (Table 4.3). A mixture of acetonitrile and *o*-dichlorobenzene was used since this is required for the one-pot reactions, however, it can be seen that the conversion to quinolone **279a** is reduced in comparison to *o*-dichlorobenzene alone (Entries 1 and 2). It can be seen that Pd(dba)<sub>2</sub> had no catalytic effect in the reaction (Entry 5) suggesting that palladium(II) sources are better than palladium(0). Whilst PdCl<sub>2</sub> and PdCl<sub>2</sub>(MeCN)<sub>2</sub> both showed some catalytic activity (Entries 3 and 4), neither was as effective as the [Pd(MeCN)<sub>2</sub>(OTs)<sub>2</sub>] catalyst used for C–H insertion reactions (Entries 7 and 8).

Table 4.3

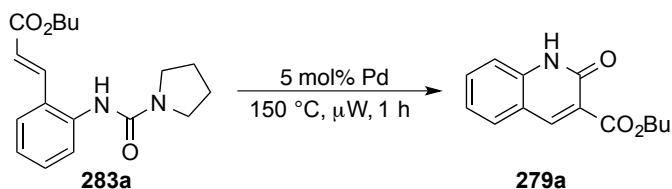

Entry	Solvent	Additive	% Conversion <b>279a</b> <sup>a</sup>
1	<i>o</i> -DCB/MeCN 4:1	-	4
2	<i>o</i> -DCB/MeCN 4:1	Pd(OAc) <sub>2</sub>	6
3	<i>o</i> -DCB/MeCN 4:1	PdCl <sub>2</sub>	11
4	<i>o</i> -DCB/MeCN 4:1	PdCl <sub>2</sub> (MeCN) <sub>2</sub>	12
5	<i>o</i> -DCB/MeCN 4:1	Pd(dba) <sub>2</sub>	3
6	<i>o</i> -DCB/MeCN 4:1	PdCl <sub>2</sub> (PPh <sub>3</sub> ) <sub>2</sub>	6
7	<i>o</i> -DCB/MeCN 4:1	Pd(MeCN) <sub>2</sub> (OTs) <sub>2</sub>	15
8	<i>o</i> -DCB/MeCN 4:1	10 % Pd(MeCN) <sub>2</sub> (OTs) <sub>2</sub>	30

a: calculated by comparison of <sup>1</sup>H NMR integrals of alkene **283a** versus quinolone **279a**.

Having established conditions for alkene and quinolone formation and found that the same catalyst is effective for both processes, a one-pot reaction was attempted. Thus alkene **283a** was prepared from urea **282a** using the previously optimised conditions. Upon completion, *o*-dichlorobenzene was added and the reaction mixture heated at 150 °C under microwave conditions. Although some product was observed by LCMS the reaction had not gone to



completion, even after heating in a microwave vial for 6 hours. Addition of further 2.5 mol%  $[\text{Pd}(\text{MeCN})_2(\text{OTs})_2]$  was required to obtain a 42% yield of the quinolone **279a** (Scheme 4.31). An alternative approach using conventional heating for 48 hours at 150 °C gave 65% yield of the quinolone **279a** but again required an additional 2.5 mol%  $[\text{Pd}(\text{MeCN})_2(\text{OTs})_2]$ .

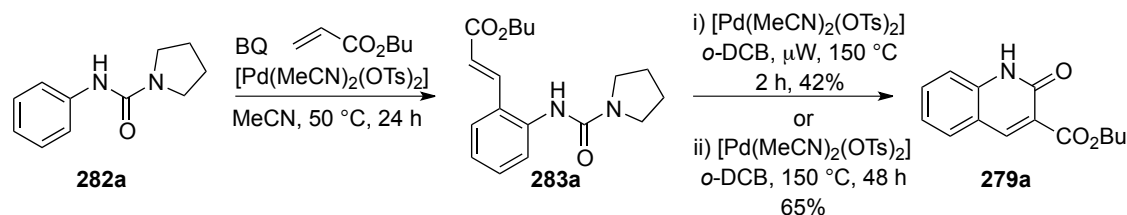

Scheme 4.31

Attention then turned to exploring the substrate scope of the reaction using the optimised reaction conditions: addition of 1.5 equivalents of butyl acrylate to a solution of the urea, 10 mol%  $[\text{Pd}(\text{MeCN})_2(\text{OTs})_2]$  and 1.2 equivalents of benzoquinone in acetonitrile at 50 °C; followed after 24 hours, by addition of 5 mol%  $[\text{Pd}(\text{MeCN})_2(\text{OTs})_2]$  and *o*-dichlorobenzene with heating to 150 °C for 3 hours under microwave conditions. When the one-pot reaction was attempted with alternative ureas **282b-d**, however, low yields of the desired quinolones **279b-d** were obtained with the major product being the alkenes **283b-d** and unreacted starting material (Scheme 4.32).

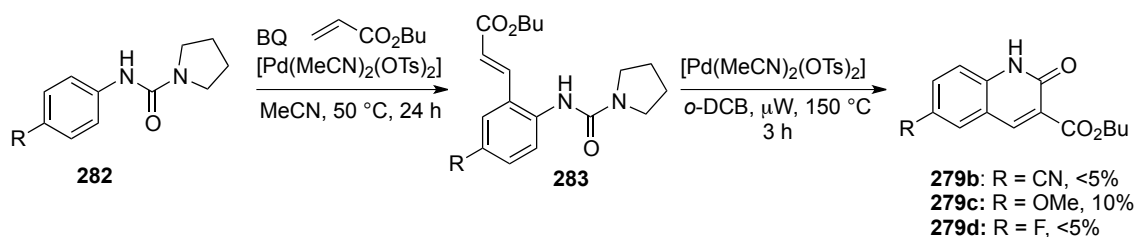

Scheme 4.32

The presence of traces of the corresponding aniline after some reactions suggested that the isocyanate was being formed, but that it was reacting with water upon exposure to air during filtration. Since the yields of the prepared quinolones were nearly equivalent to the amount of palladium present it was proposed that the palladium in these cases was acting as an amine scavenger, and hence the use of solid-supported sulfonyl chloride as an amine scavenger was explored (Table 4.4).

Table 4.4

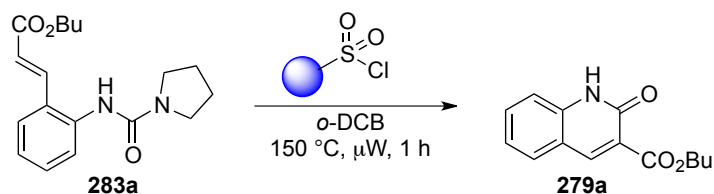

Entry	Conc. (M)	Scale (mg)	Vial size	Resin	% Conversion <sup>a</sup>
					<b>276b</b>
1	0.04	25	10 mL	Polystyrene	99
2	0.08	25	10 mL	Polystyrene	70
3	0.08	150	10 mL	Polystyrene	trace
4	0.08	150	35 mL	Polystyrene	75
5	0.08	150	35 mL	Silica	37

a: calculated by comparison of <sup>1</sup>H NMR integrals of alkene **283a** and quinolone **279a**.

While quantitative conversion could be achieved at 0.04 M, the conversion to quinolone **279a** decreased when the concentration was increased to allow reactions to be carried out on larger scale (Entry 2). Interestingly when the reaction was repeated on a larger scale, only a trace of quinolone was obtained (Entry 3). It was observed that the resin floated at the surface and the larger volume of solvent required for the scaled-up reaction meant that sufficient stirring was not achieved. To overcome this, a wider microwave vial was used allowing an even distribution of the resin, and increasing the conversion (Entry 4). In addition, a silica-supported scavenger was used since this should have a higher density and finer particles, and hence it should be more evenly distributed in the vial, however, the conversion decreased to 37% in this case (Entry 5).

#### 4.13 Substrate scope – oxidative Heck conditions

With the electrocyclisation conditions developed we decided to explore the substrate scope of the reaction. It was found, as described in section 4.14, that yields were improved when the alkene was isolated before isocyanate formation/electrocyclisation rather than carrying the reaction forward in a one-pot process. This could be due to the presence of acetonitrile that appeared to inhibit electrocyclisation reactions (4% conversion with 4:1 *o*-dichlorobenzene: MeCN, versus 20% conversion with *o*-dichlorobenzene alone). Therefore 2-quinolones **279** were prepared using the optimised reaction conditions: addition of butyl acrylate and benzoquinone to a pre-stirred solution of the urea and [Pd(MeCN)<sub>2</sub>(OTs)<sub>2</sub>] at 60 °C followed by heating at 60 °C for 24 hours gave the alkenes **283**. Heating a 0.04 M solution of the alkenes

**283** with sulfonyl chloride supported on polystyrene resin in *o*-dichlorobenzene under microwave conditions at 150 °C for 1 hour gave the 2-quinolones **279** (Table 4.5).

Table 4.5

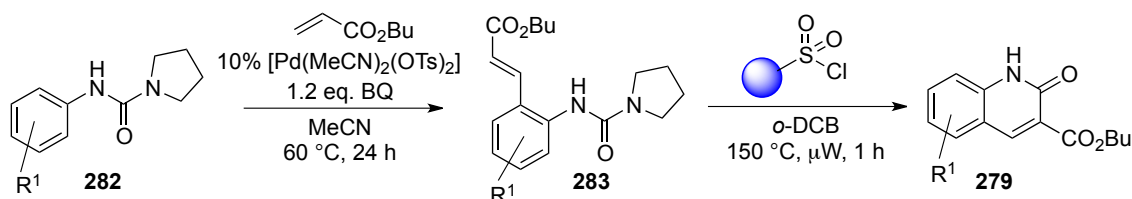

Entry	R <sup>1a</sup>	% Yield	
		Alkene <b>283</b>	Quinolone <b>279</b>
1 (a)	H	93	66
2 (e)	4-Me	70	22
3 (f)	3-Me	68	32
4 (d)	4-F	69	18
5 (g)	4-OMe	81	0
6 (h)	2-OMe	70	0

a: this is the position of R<sup>1</sup> on the starting material not product.

It was found that the unsubstituted urea **282a** gave the best results with butyl acrylate (Entry 1) and electron-donating groups were not beneficial in the electrocyclisation reactions (Entries 2 and 3). Whilst the Heck reaction proceeded smoothly for phenyl vinyl sulfone (80% yield) no electrocyclisation reaction occurred using the prepared alkene. Heck reaction with methyl vinyl ketone, gave only recovered starting material and polymerised alkene (Scheme 4.33).

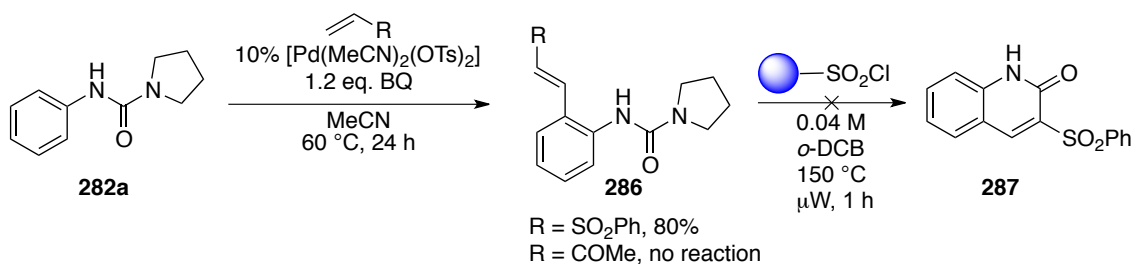

Scheme 4.33

Reactions with dimethyl acrylamide were higher-yielding (Table 4.6), with the *meta*-methoxy derivative giving the highest yield (Entry 2). Interestingly, when *ortho*- or *para*-methoxy groups were present (Table 4.5, entries 5 and 6), no electrocyclisation occurred and only the corresponding aniline was observed after reaction.

Table 4.6

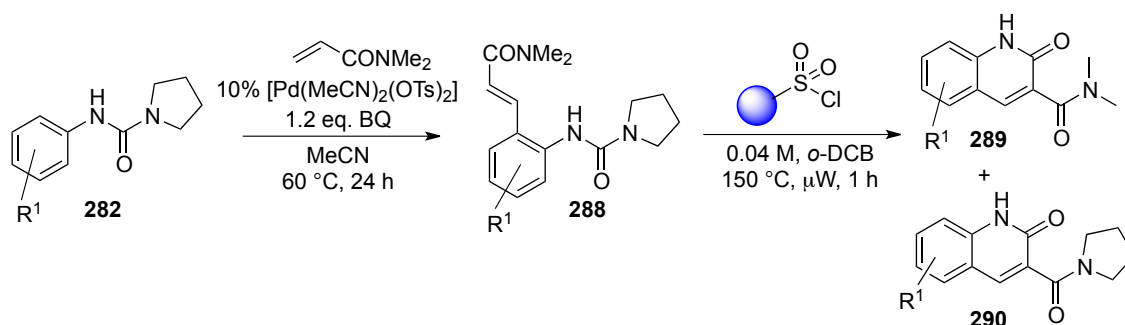

Entry	R <sup>1</sup>	% Yield Alkene	% Yield <sup>a</sup>	% Yield <sup>a</sup>
		288	289	290
1 (a)	H	69	60	4
2 (b)	3-OMe	77	70	28
3 (c)	3-Me	28	42	8
4 (d)	4-Me	74	35	4
5 (e)	4-CO <sub>2</sub> Et	18	31	16

a: Yields calculated from <sup>1</sup>H NMR integrals of **289** and **290** after chromatographic purification.

It was observed in the reactions with acrylamide that quinolone by-product **290** was also formed (Figure 4.3). It has been reported by Mucsi *et al.* that in closed systems transamidation reactions can occur even at room temperature.<sup>180</sup> Therefore, it is possible that quinolone **290** is formed *via* a transamidation reaction with pyrrolidine released during isocyanate formation. Whilst this product was observed in the crude <sup>1</sup>H NMR of the reaction using butyl acrylate, conversions were low; hence, none of the quinolone by-product was isolated.

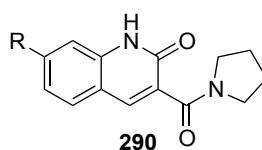
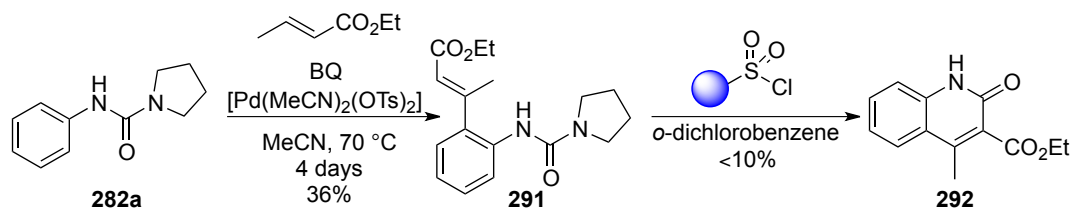

Figure 4.3

Disubstituted alkenes such as ethyl crotonate were less reactive in the oxidative Heck reactions. These were of particular interest since this would expand the substrate scope further and Kobayashi *et al.* reported that electrocyclisations of *o*-isocyanatostyrenes that are substituted in the 4-position can occur even at room temperature.<sup>152</sup> However, only 36% of the desired alkene **291** was obtained, even after 4 days. In addition, the cyclisation reaction was inefficient: despite a mass corresponding to the product being observed in the LCMS, less than 10% of the desired quinolone **292** product was obtained as an inseparable mixture with the starting urea **282a** (Scheme 4.34).



Scheme 4.34

To expand the product scope further, using electron-neutral alkenes such as styrenes (which were unreactive in the oxidative Heck reaction with urea directing groups) an additional process was developed alongside this methodology using 2-bromophenyl ureas under standard Heck conditions.

#### 4.14 Optimisation of Heck reactions

Initially the reaction of *N*-(2-bromophenyl)-*N',N'*-diisopropyl ureas **293** was explored since it was hoped that steric hindrance would be less of a problem in this case and the subsequent isocyanate formation can proceed at lower temperatures than the pyrrolidine derivatives (70 °C versus 140 °C).<sup>86, 162</sup> Given the issues with purification in preparing the starting alkenyl urea *via* Heck reaction of 2-bromoaniline and subsequent urea formation with diisopropyl carbamoyl chloride (Section 4.10), an alternative sequence was proposed, with the Heck reaction after the urea formation. Hence, urea **293** was prepared in 64% yield *via* treatment of 2-bromoaniline with diisopropylcarbamoyl chloride and triethylamine at room temperature. Subsequent Heck reaction using styrene gave alkene **275** in 28% yield and subsequent heating gave the quinolone **276a** in 31% yield (Scheme 4.35). In the interest of time, this methodology was developed alongside the oxidative Heck reactions, therefore the electrocyclosation was carried out in 1:1 acetonitrile/toluene since *o*-dichlorobenzene had not yet been found as the optimum solvent.

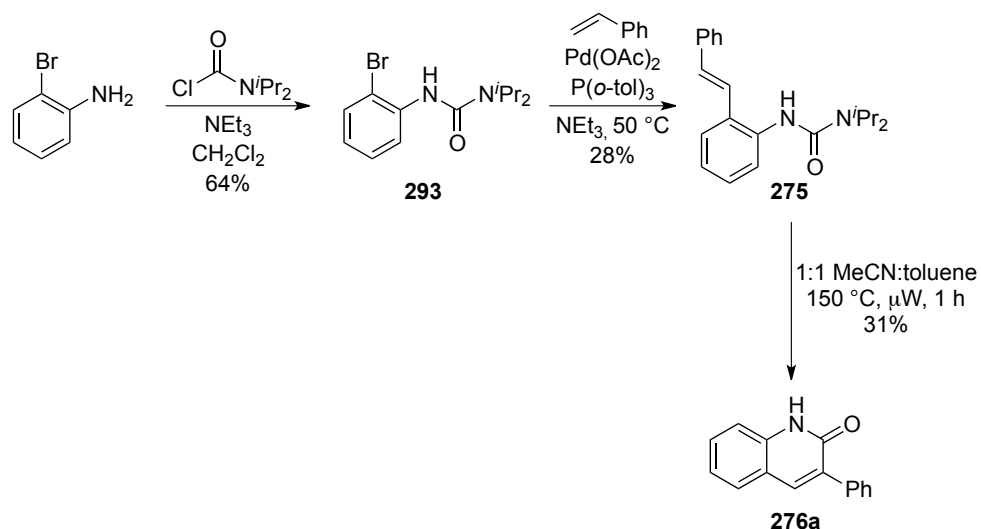

Scheme 4.35

By increasing the temperature of the Heck reaction to 70 °C and performing the reactions in one-pot the overall yield of quinolone **276a** was improved to 20% from the urea **293** (Scheme 4.36, compared to 9% above). Attempts to further improve the yield by changing the equivalents and type of base in the Heck reaction were unsuccessful, with aniline **274** observed as the major product. It was proposed that this could be due to the ability of the diisopropyl urea to generate the isocyanate at 70 °C, and thus isocyanate formation was occurring during the Heck reaction and under the reaction conditions being hydrolysed to the aniline.

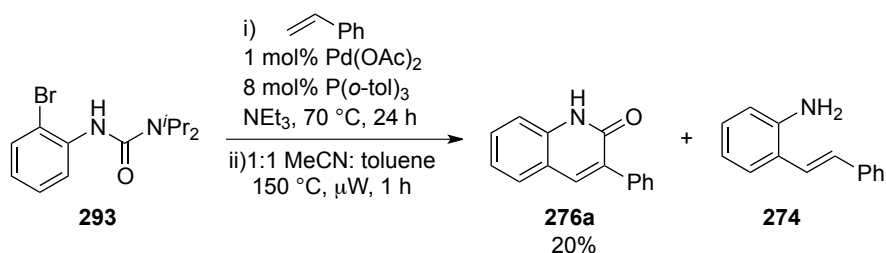

Scheme 4.36

It has been shown that high temperatures are often required in Heck reactions to form the active catalyst, which is often in the form of palladium nanoparticles.<sup>181, 182</sup> To investigate the use of higher temperatures in the Heck reactions, isocyanate formation would have to occur at higher temperature to avoid aniline formation. Hence, the use of pyrrolidine ureas was once more explored. To prepare the brominated derivatives of the pyrrolidine ureas **282**, 2-bromoaniline was stirred with pyrrolidinyl carbamoyl chloride in the presence of triethylamine (Scheme 4.37). This gave a disappointing 5% yield of the urea. The pyrrolidinyl carbamoyl chloride was difficult to handle and hydrolysed easily, thus an alternative route towards the brominated ureas was sought.

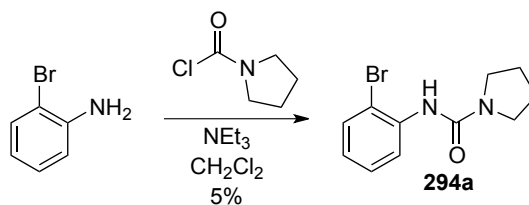

Scheme 4.37

Dubé *et al.* have reported that ureas can be formed from the hydroxamic acid *via* carbonyl diimidazole mediated Lossen rearrangement at 60 °C.<sup>87</sup> Thus the hydroxamic acid **295a** was prepared in 91% yield by treatment of 2-bromobenzoic acid with oxalyl chloride and DMF in dichloromethane at room temperature and reaction of the resulting acid chloride with hydroxylamine hydrochloride and potassium carbonate at 0 °C. After heating the hydroxamic acid **295a** to 60 °C with carbonyl diimidazole, addition of pyrrolidine gave the urea **294a** in 90% yield (Scheme 4.38).

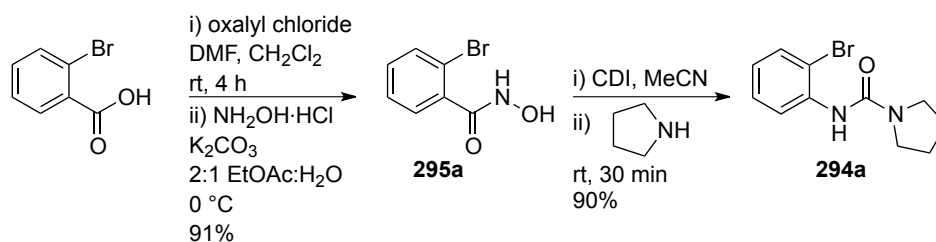

Scheme 4.38

With an efficient urea synthesis in hand, one-pot quinolone synthesis commenced using the optimised conditions: heating the urea **294a** in a solution of 1 mol% palladium acetate, 8 mol% phosphine ligand and triethylamine in refluxing toluene overnight then addition of the amine scavenger and *o*-dichlorobenzene followed by microwave reaction at 150 °C for 1 hour. Whilst the desired quinolones **276** were prepared, yields were modest (Scheme 4.39, Table 4.7).

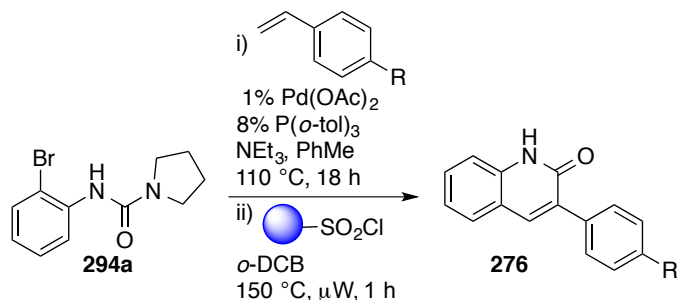

Scheme 4.39

Table 4.7

Entry	R	% Yield 276
1 (a)	H	24
2 (b)	OMe	26
3 (c)	CF <sub>3</sub>	18

In order to determine if the low yields were due to the Heck reaction, electrocycisation or the one-pot conditions, reactions were carried out in a sequential two-pot process with isolation of the alkene after the Heck reaction. This gave higher yields of the desired quinolones **276a-c** (46%, 33% and 47% respectively) showing that a two-step process was beneficial in this case. The substrate scope of the reaction was explored, using substituted styrenes, acrylates and acrylamide (Table 4.8).

Table 4.8

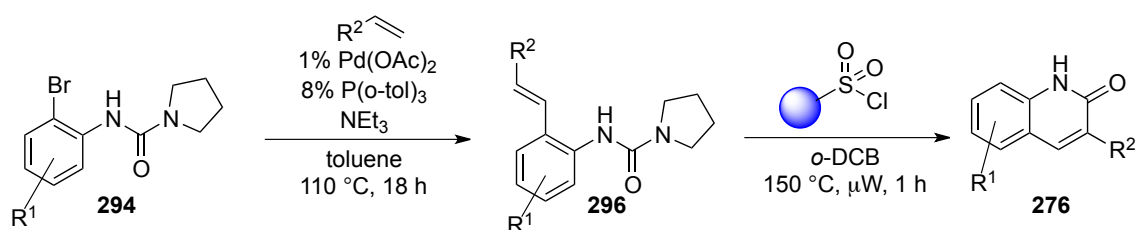

Entry	R <sup>1</sup>	R <sup>2</sup>	% Yield	
			Alkene 296	Quinolone 276
1 (a)	H	Ph	81	57
2 (b)	H	4-MeOC <sub>6</sub> H <sub>4</sub>	63	53
3 (c)	H	4-CF <sub>3</sub> C <sub>6</sub> H <sub>4</sub>	80	59
4 (d)	H	3-MeO <sub>2</sub> CC <sub>6</sub> H <sub>4</sub>	53	55
5 (e)	3-OMe	Ph	63	37
6 (f)	4-Me	Ph	29	20
7 (g)	4-F	Ph	58	24
8 (h) <sup>a</sup>	H	CO <sub>2</sub> Bu	89	66
9 (i)	H	CO <sub>2</sub> Me	10 <sup>b</sup>	63
10 (j) <sup>c</sup>	H	CONMe <sub>2</sub>	76	60 <sup>d</sup>

a: quinolone **279a** formed; b: from *trans*-methoxymethyl acrylate and iodated urea; c: quinolone **289a** formed; d: obtained as 15:1 mixture with **290a**.

Adding substituents around the aromatic ring hindered the electrocycisation reactions with lower yields of quinolone observed (Entries 5-7). However, the reaction worked well for the unsubstituted urea **294a**. In this case no electron-withdrawing substituents on the aromatic ring could be explored since the benzoic acid precursors were unavailable commercially. Although



the reaction worked well for styrenes (Entries 1-4), acrylate (Entry 8) and acrylamide (Entry 10), no Heck reaction was observed with 1-pentene or acrylonitrile. In addition, the Heck reaction went smoothly in the case of 4-vinylpyridine however, only a trace of the quinolone was observed by  $^1\text{H}$  NMR and none of the desired product was isolated.

Literature reports show that 2-quinolones substituted with a methoxy or hydroxy group in the 4-position often have high biological activity.<sup>183-185</sup> It was therefore proposed that a 4-methoxy substituent could be introduced using *trans*-methoxymethyl acrylate in the Heck reaction. Whilst Yamanaka has reported the use of  $\beta$ -alkoxy acrylates in Heck reactions, aryl iodides were used as the coupling partner and there are no literature reports using an aryl bromide.<sup>186</sup> Thus, the iodo derivative of the urea **294** was prepared. However, Heck reaction between the *trans*-methoxymethyl acrylate and 2-iodophenyl urea in the presence of palladium acetate and *o*-tritolylphosphine saw loss of the methoxy group and gave only low yields of the alkene **296i** (Entry 9, Scheme 4.40).

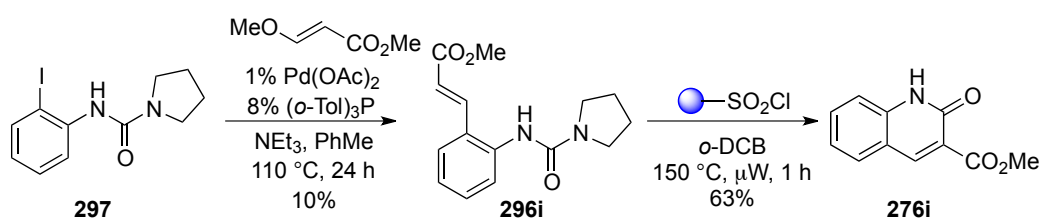

Scheme 4.40

It has been reported that quinolones can react with sulfonyl chlorides such as tosylates.<sup>187-189</sup> Thus to ensure no quinolone was bound to the resin after electrocyclisation the filtered resin was heated in a 1 M solution of TBAF for 4 hours at 70 °C since this has been reported to cleave the N-S bond of solid-supported sulfonamides under mild conditions.<sup>190</sup> No quinolone was observed by  $^1\text{H}$  NMR analysis of the resulting residue, which was solely unreacted TBAF.

#### 4.15 Conclusions

In summary, studies towards the development of a process towards substituted 2-quinolones have led to two procedures from readily available starting materials (Scheme 4.41). The first is a two-pot, three-step process incorporating urea-directed oxidative Heck reaction, isocyanate formation and electrocyclisation to give 9 exemplar 2-quinolones in up to 61% overall yield. The reaction works well for electron-deficient alkenes such as acrylates and acrylamides, but electron-withdrawing substituents on the aromatic ring significantly decrease the yield of the oxidative Heck reaction. The second is a two-pot three step process incorporating Heck

reaction, isocyanate formation and electrocyclisation; 10 exemplar quinolones were prepared in up to 59% overall yield.

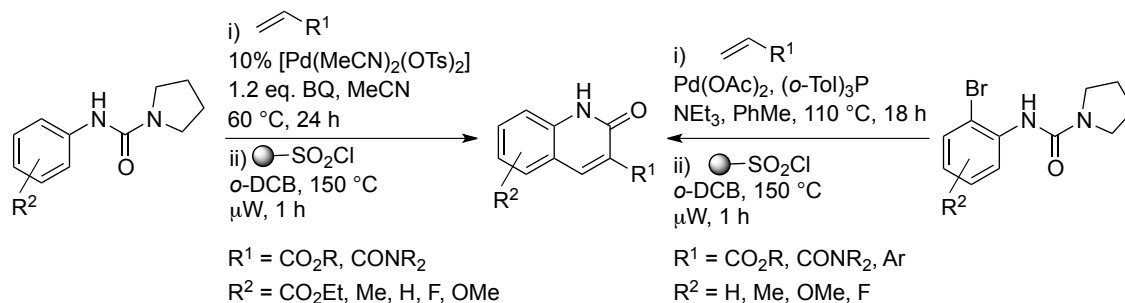

Scheme 4.41

To extend the methodology further investigations into the use of disubstituted alkenes in the Heck reaction would be beneficial, since this would give access to 3,4-disubstituted 2-quinolones. Whilst 3,4-disubstituted 2-quinolones are often found in biologically active compounds there is a paucity of methods towards their preparation.<sup>145</sup> Disubstituted alkenes are more difficult substrates in Heck reactions due to a low reactivity towards typical catalysts, however, Fu and Littke have reported a palladium-catalysed Heck reaction between aryl chlorides and bromides and mono- and disubstituted alkenes under mild reaction conditions using a Pd<sub>2</sub>(dba)<sub>3</sub>/P(<sup>t</sup>Bu)<sub>3</sub> catalyst system.<sup>191</sup> They found that use of a bulky amine base Cy<sub>2</sub>NMe was crucial for reactivity. The reactivity of chlorinated and brominated aryl ureas in Heck reactions could therefore be investigated and upon formation of the disubstituted alkenes electrocyclisation reactions explored. It has been reported that disubstituted alkenes are more reactive in electrocyclisation reactions with isocyanates,<sup>152, 157</sup> hence, the reaction conditions could be optimised to give a milder process towards 3,4-disubstituted 2-quinolones (Scheme 4.42).

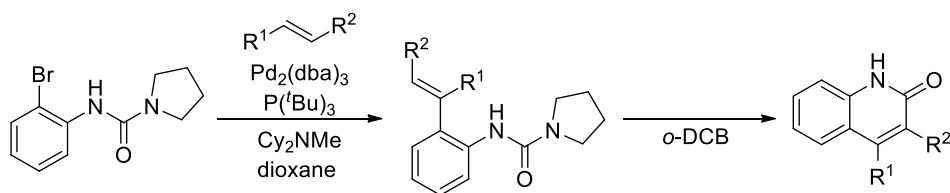

Scheme 4.42

The use of microwave reactors in small scale synthesis has enhanced many organic syntheses due to the ability to quickly and efficiently heat the reaction mixture, leading to reduced reaction times and often increased yields and product purity.<sup>192</sup> Unfortunately, translating this to large-scale processes is difficult since the ability to rapidly heat and cool cannot be transferred to larger volumes. Recently the development of a microwave-assisted continuous flow-reactor has been demonstrated by Kappe *et al.* and Larhed *et al.* allowing microwave reactions to be carried

out on larger scale.<sup>192-194</sup> This allows the benefits associated with flow-chemistry - the ability to generate and handle reactive and hazardous reagents such as isocyanates in a controlled and reproducible manner<sup>92, 93</sup> - with the ability to use the high temperature and pressure conditions provided by microwave conditions. It can be envisaged this could be utilised in the synthesis of 2-quinolones, allowing rapid and controlled isocyanate formation with subsequent microwave-assisted electrocyclicisation (Scheme 4.43). Since only small quantities of intermediates are present in solution at any given time the formation of by-products could also be reduced.

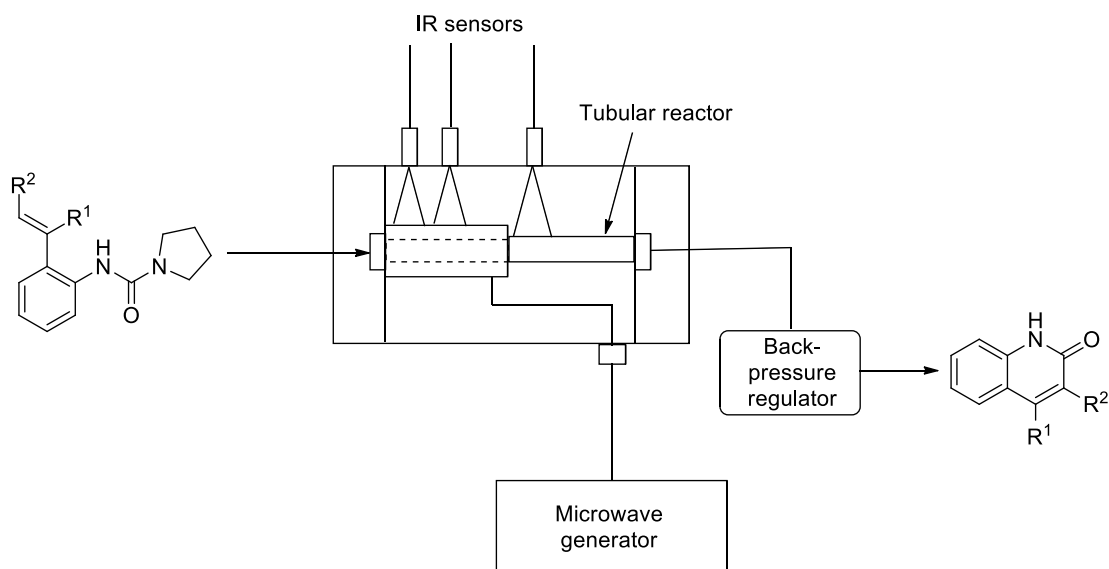

Scheme 4.43

## 5.0 Experimental

### 5.1 General Experimental Techniques

#### Instrumentation

Proton ( $^1\text{H}$ ) and carbon ( $^{13}\text{C}$ ) magnetic resonance spectra were recorded using a Bruker DPX 300, a Bruker DRX 500 or a Bruker Avance 500 spectrometer using an internal deuterium lock.  $^1\text{H}$  NMR chemical shifts ( $\delta$ ) are quoted in ppm downfield of trimethylsilane.  $^{13}\text{C}$  NMR spectra were recorded with broadband proton decoupling at 75 MHz or 150 MHz. Assignments were made on the basis of chemical shift and coupling data, using  $^1\text{H}$ - $^{13}\text{C}$  HMQC, DEPT, HMBC and nOe experiments where necessary. Infra-red spectra were recorded on a Perkin Elmer Spectrum One FT-IR spectrometer, with absorption reported in wavenumbers ( $\text{cm}^{-1}$ ). Mass spectra were recorded on a Bruker HCT Ultra LCMS instrument or a Bruker MicroTOF spectrometer using electrospray ionisation (ESI). Melting points were determined on a Reichert hot stage apparatus and are uncorrected.

#### Experimental Procedures

All reactions were carried out under an inert atmosphere of nitrogen using oven-dried glassware, unless stated. Microwave reactions were carried out using CEM Explorer or CEM Discover microwave reactors. Toluene, acetonitrile, dichloromethane and tetrahydrofuran were dried prior to use using a Pure Solv MD solvent purification system. Xylene was distilled before use from 4 Å molecular sieves. Benzaldehydes were distilled before use. Diphenyl phosphoryl azide was purchased from Apollo Scientific. All other solvents and reagents were purchased from commercial sources and were used without purification. Flash column chromatography was performed using Fischer Matrix silica gel (35-70  $\mu\text{m}$ ) or using pre-packed Biotage or Redisep silica cartridges running using Biotage Isolera or Redisep Flashmaster machines. Thin-layer chromatography was conducted using pre-coated silica plates (Merck silica Kieselgel 60F<sub>254</sub>). Spots were visualised using UV fluorescence ( $\lambda_{\text{max}} = 254 \text{ nm}$ ) and chemical staining with potassium permanganate, bromocresol green or iodine. All chromatography eluents were BDH GPR grade and used without purification. Petrol refers to light petroleum (b.p. 40-60 °C).

*CAUTION:* All azides should be treated as potentially explosive and were routinely prepared and handled behind a blast shield using glassware free from contamination with transition metals. Residual sodium azide (from aqueous work-ups) was quenched by stirring with 20% aq.  $\text{NaNO}_2$  (40% excess) followed by dropwise addition of 20% aq.  $\text{H}_2\text{SO}_4$ .

## 5.2 Experimental Procedures

### General Procedure A for the preparation of imines

3-Methyl-1-phenyl-2-phospholene-1-oxide (10 mol%) and the benzaldehyde in toluene (0.2 mL/mmol) were heated under reflux with stirring. A solution of phenyl isocyanate (1.1 equivalents) in toluene (0.80 mL/mmol) was added dropwise by syringe pump over 5 hours. The reaction mixture was stirred under reflux until isocyanate consumption was complete (monitored by IR for disappearance of phenyl isocyanate signal at 2261  $\text{cm}^{-1}$ ). An aliquot was taken and solvents removed *in vacuo* to determine the ratio of imine to benzaldehyde by  $^1\text{H}$  NMR.

### *N*-[(1*E*)-Phenylmethylene]aniline **121**

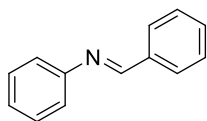

Prepared by general procedure A from benzaldehyde (100  $\mu\text{L}$ , 1.0 mmol) and phenyl isocyanate (120  $\mu\text{l}$ , 1.1 mmol) to afford the imine **121** as yellow oil (99:1 imine:aldehyde ratio).

$\delta_{\text{H}}$  ( $\text{CDCl}_3$ , 300 MHz) signals for imine only; 8.41 (1H, s,  $\text{N}=\text{CH}$ ), 7.92-7.84 (2H, m, *ArH*), 7.46-7.40 (3H, m, *ArH*), 7.40-7.33 (2H, m, *ArH*), 7.23-7.17 (3H, m, *ArH*);  $\delta_{\text{C}}$  ( $\text{CDCl}_3$ , 75 MHz) signals for imine only: 160.5 ( $\text{N}=\text{CH}$ ), 152.1 (quat.), 136.3 (quat.), 131.5 (*ArCH*), 129.3 (*ArCH*), 128.9 (*ArCH*), 128.9 (*ArCH*), 126.0 (*ArCH*), 121.0 (*ArCH*);  $\nu_{\text{max}}/\text{cm}^{-1}$  (thin film) of the crude reaction mixture; 3344, 3026, 2918, 2138 ( $\text{N}=\text{C}=\text{N}$ ), 1703, 1627 ( $\text{C}=\text{N}$ ), 1596, 1495, 1449, 1310, 1191, 1073, 1028.

Spectroscopic data was consistent with literature values.<sup>195</sup>

### *N*-[(1*E*)-(4-Methoxyphenyl)methylene]aniline **124a**

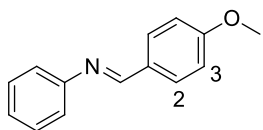

Prepared by general procedure A from *p*-anisaldehyde (120  $\mu\text{L}$ , 1.0 mmol) and phenyl isocyanate (120  $\mu\text{l}$ , 1.1 mmol) to afford the imine **124a** as yellow oil (50:50 imine:aldehyde ratio).

$\delta_{\text{H}}$  (300 MHz,  $\text{CDCl}_3$ ) signals for imine only; 8.39 (1H, s,  $\text{N}=\text{CH}$ ), 7.85 (2H, d,  $J$  8.7 Hz, H2), 7.39-7.35 (2H, m, *ArH*), 7.20-7.16 (3H, m, *ArH*), 7.00 (2H, d,  $J$  8.7 Hz, H3), 3.89 (3H, s,  $\text{CH}_3$ );  $\delta_{\text{C}}$  ( $\text{CDCl}_3$ , 75 MHz) signals for imine only: 162.3 ( $\text{N}=\text{CH}$ ), 159.5 (quat.), 152.5 (quat.), 132.0 (quat.), 130.4 (*ArCH*), 129.0 (*ArCH*), 125.6 (*ArCH*), 120.8 (*ArCH*), 114.2 (*ArCH*), 55.4 ( $\text{CH}_3$ );  $\nu_{\text{max}}/\text{cm}^{-1}$  (thin film) of the crude reaction mixture; 3026, 2919, 2734, 2140 ( $\text{N}=\text{C}=\text{N}$ ), 1942, 1858, 1803, 1699, 1603 ( $\text{C}=\text{N}$ ), 1495, 1459, 1379, 1260, 1204, 1160, 1081, 1030..

Spectroscopic data was consistent with literature values.<sup>196</sup>

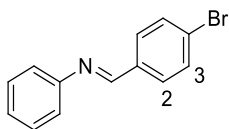
***N*-[(1*E*)-(4-Bromophenyl)methylene]aniline **124b****

Prepared by general procedure A from *p*-bromobenzaldehyde (0.18 g, 1.0 mmol) and phenyl isocyanate (120  $\mu$ l, 1.1 mmol) to afford the imine **124b** as a brown solid (97:3 imine:aldehyde ratio).

$\delta_{\text{H}}$  (CDCl<sub>3</sub>, 300 MHz) signals for imine only; 8.41 (1H, s, N=CH), 7.78 (2H, d, *J* 8.0 Hz, H3), 7.61 (2H, d, *J* 8.0 Hz, H2), 7.43-7.38 (2H, m, ArH), 7.24-7.17 (3H, m, ArH);  $\delta_{\text{C}}$  (CDCl<sub>3</sub>, 75 MHz) signals for imine only: 159.0 (N=CH), 151.7 (quat.), 135.2 (quat.), 132.1 (ArCH), 130.2 (ArCH), 129.3 (ArCH), 126.4 (ArCH), 125.9 (quat.), 121.0 (ArCH);  $\nu_{\text{max}}/\text{cm}^{-1}$  (thin film) of the crude reaction mixture; 3027, 2920, 2734, 2140 (N=C=N), 1942, 1858, 1802, 1710, 1604 (C=N), 1589, 1495, 1460, 1379, 1203, 1081, 1030.

Spectroscopic data was consistent with literature values.<sup>197</sup>

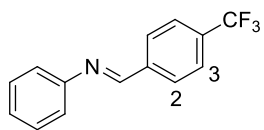
***N*-[(1*E*)-(4-Trifluoromethylphenyl)methylene]aniline **124c****

Prepared by general procedure A from trifluoromethylbenzaldehyde (140  $\mu$ L, 1.0 mmol) and phenyl isocyanate (120  $\mu$ l, 1.1 mmol) to afford the imine **124c** as a yellow solid (99:1 imine:aldehyde ratio).

$\delta_{\text{H}}$  (CDCl<sub>3</sub>, 300 MHz) signals for imine only; 8.50 (1H, s, N=CH), 8.02 (2H, d, *J* 8.0 Hz, H3), 7.72 (2H, d, *J* 8.0 Hz, H2), 7.40 (2H, d, *J* 8.2 Hz, ArH), 7.31-7.27 (3H, m, ArH);  $\nu_{\text{max}}/\text{cm}^{-1}$  (thin film) of the crude reaction mixture; 3027, 2920, 2140 (N=C=N), 1713, 1590 (C=N), 1495, 1462, 1380, 1324, 1204, 1170, 1132, 1064.

Spectroscopic data was consistent with literature values.<sup>198</sup>

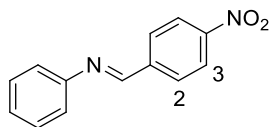
***N*-[(1*E*)-(4-Nitrophenyl)methylene]aniline **124d****

Phenyl isocyanate (120  $\mu$ l, 1.1 mmol) was added to a solution of 4-nitrobenzaldehyde (0.15 g, 1.0 mmol) and 3-methyl-1-phenyl-2-phospholene-1-oxide (19 mg, 10 mol%) in toluene under reflux. The reaction mixture was stirred under reflux until isocyanate consumption was complete (15 minutes, monitored by IR for disappearance of phenyl isocyanate signal at 2261  $\text{cm}^{-1}$ ). An aliquot was taken and solvents removed *in vacuo* to afford the imine **124d** as a yellow solid (80:20 imine:aldehyde ratio).

$\delta_{\text{H}}$  (CDCl<sub>3</sub>, 300 MHz) signals for imine only; 8.56 (1H, s, N=CH), 8.33 (2H, d, *J* 8.9 Hz, H3), 8.08 (2H, d, *J* 8.9 Hz, H2), 7.47-7.39 (2H, m, ArH), 7.29-7.23 (3H, m, ArH);  $\delta_{\text{C}}$  (CDCl<sub>3</sub>, 75 MHz) signals for imine only: 157.3 (N=CH), 150.8 (quat.), 149.2 (quat.), 141.5 (quat.), 129.4 (ArCH), 129.3 (ArCH), 127.0 (ArCH), 123.9 (ArCH), 120.9 (ArCH);  $\nu_{\text{max}}/\text{cm}^{-1}$  (thin film) of the crude reaction mixture; 3026, 2919, 2734, 2139 (N=C=N), 1710, 1602 (C=N), 1525, 1495, 1460, 1378, 1345, 1201, 1081, 1029.

Spectroscopic data was consistent with literature values.<sup>199</sup>

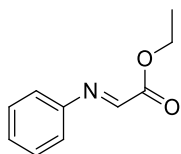
**Ethyl 2-(phenylimino)acetate 124e**

Phenyl isocyanate (110  $\mu\text{l}$ , 1.0 mmol) was added to a stirred solution of ethyl glyoxylate (150  $\mu\text{l}$ , 1.5 mmol) and 3-methyl-1-phenyl-2-phospholene-1-oxide (19 mg, 0.1 mmol) in toluene under reflux. The reaction mixture was heated under reflux for 5 hours then cooled to room temperature and solvents removed *in vacuo* to give imine **124e** as yellow oil (70:30 imine:aldehyde ratio).

$\delta_{\text{H}}$  ( $\text{CDCl}_3$ , 300 MHz) signals for imine only; 7.82 (1H, br s,  $\text{N}=\text{CH}$ ), 7.35-7.25 (5H, m,  $\text{ArH}$ ), 4.36 (2H, q,  $J$  7.2 Hz,  $\text{CH}_2$ ), 1.34 (3H, t,  $J$  7.2 Hz,  $\text{CH}_3$ );  $\nu_{\text{max}}/\text{cm}^{-1}$  (thin film) of the crude reaction mixture; 3026, 2982, 1748, 1627, 1603, 1495, 1371, 1346, 1295, 1213, 1096, 1029.

Spectroscopic data was consistent with literature values.<sup>200</sup>

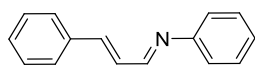
***N*-[(1*E*)-Cinnamylmethylene]aniline 124f**

Phenyl isocyanate (0.22 mL, 2.00 mmol), phospholene oxide (38 mg, 0.20 mmol) and cinnamaldehyde (0.50 mL, 4.00 mmol) in toluene (1.0 mL) were heated under reflux for 18 hours. The reaction mixture was cooled to room temperature and evaporated *in vacuo* to give the imine **124f** as a brown solid (83:17 imine:aldehyde ratio).

$\delta_{\text{H}}$  (300 MHz,  $\text{CDCl}_3$ ); 8.28 (1H, dd,  $J$  7.2, 1.5 Hz,  $\text{N}=\text{CH}$ ), 7.54-7.50 (2H, m,  $\text{CH}=\text{CH}$ ), 7.40-7.34 (5H, m,  $\text{ArH}$ ), 7.40-7.34 (5H, m,  $\text{ArH}$ );  $\nu_{\text{max}}/\text{cm}^{-1}$  (thin film) of crude reaction mixture; 3062, 3030, 2816, 2743, 2138 ( $\text{N}=\text{C}=\text{N}$ ), 1957, 1884, 1806, 1674, 1626, 1585, 1545, 1486, 1449, 1294, 1251, 1203, 1125, 1072.

Spectroscopic data was consistent with literature values.<sup>201</sup>

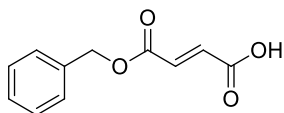
***trans*-3-Benzoyloxycarbonylacrylic acid 125<sup>72</sup>**

Prepared by the method of Schoenecker *et al.*<sup>72</sup> Triethylamine (3.1 ml, 22.4 mmol) was added dropwise to a stirred solution of maleic anhydride (2.0 g, 20.4 mmol) in benzyl alcohol (3.1 ml, 20.4 mmol) and the reaction mixture stirred at room temperature for 2 hours. Water (20 ml) was added and the aqueous phase washed with  $\text{CH}_2\text{Cl}_2$  (20 ml  $\times$  3) then acidified with 1 M HCl and extracted with  $\text{CH}_2\text{Cl}_2$  (20 ml  $\times$  3). The combined organic extracts were washed with brine (30 ml), dried ( $\text{MgSO}_4$ ), filtered and evaporated under reduced pressure to give the ester **125** as a colourless solid (1.46 g, 69%).

M.p. = 48-51  $^{\circ}\text{C}$  ( $\text{CHCl}_3$ );  $\delta_{\text{H}}$  ( $\text{CDCl}_3$ , 300 MHz); 7.40 (5H, s,  $\text{C}_6\text{H}_5$ ), 6.50 (1H, d,  $J$  12.8 Hz,  $\text{CH}=\text{CH}'$ ), 6.40 (1H, d,  $J$  12.8 Hz,  $\text{CH}=\text{CH}'$ ), 5.31 (2H, s,  $\text{CH}_2\text{Ph}$ );  $\delta_{\text{C}}$  ( $\text{CDCl}_3$ , 75 MHz); 167.3 ( $\text{C}=\text{O}$ ), 164.9 ( $\text{C}=\text{O}$ ), 136.1 ( $\text{CH}=\text{CH}'$ ), 135.4 ( $\text{CH}=\text{CH}'$ ) 133.9 (quat.), 129.2 ( $\text{ArCH}$ ), 129.0

(ArCH), 128.8 (ArCH), 68.6 (s, CH<sub>2</sub>);  $\nu_{\max}/\text{cm}^{-1}$  (thin film); 3054, 2987, 2685, 2410, 2305, 1736, 1635, 1421, 1265, 1066, 1028.

Spectroscopic data was consistent with literature values.<sup>72</sup>

#### 4-*tert*-Butylcyclohexenyl-1-carboxylic acid **134**<sup>77</sup>

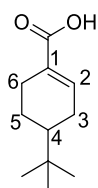

Prepared by modified method of Vitnik *et al.*<sup>77</sup> Bromoform (5.7 ml, 64.8 mmol) was added in 1 ml portions to a stirred solution of 4-*tert*-butylcyclohexanone (2.5 g, 16.2 mmol), potassium hydroxide (13.6 g, 243.0 mmol) and benzyltriethylammonium bromide (0.44 g, 1.6 mmol) in *tert*-butanol (40 ml) and water (8 ml) and the biphasic mixture stirred

vigorously for 24 hours at room temperature. Water (50 ml) and EtOAc (25 ml) were added, the phases separated and the organic phase washed with water (25 ml  $\times$  3). The aqueous phase and washings were extracted with EtOAc (25 ml  $\times$  3). The aqueous phase was acidified with 1 M HCl (aq.) and extracted with EtOAc (25 ml  $\times$  3). The combined organic extracts were washed with brine, dried (MgSO<sub>4</sub>), filtered and evaporated *in vacuo* to give yellow solid. The product was purified by column chromatography (SiO<sub>2</sub>, 3:1 petrol–EtOAc) and recrystallised from CHCl<sub>3</sub> to give the carboxylic acid **134** as colourless plates (0.81 g, 27%).

M.p. = 181–184 °C (CHCl<sub>3</sub>, Lit.<sup>77</sup> = 182–183 °C);  $\delta_{\text{H}}$  (300 MHz, CDCl<sub>3</sub>); 7.16–7.10 (1H, dd, *J* 5.4, 2.0 Hz, H2), 2.55–2.44 (1H, m, *HH'*6), 2.35–2.21 (1H, m, *HH'*3), 2.21–2.04 (1H, m, *HH'*6), 1.88–2.04 (2H, m, *HH'*3 and *HH'*5), 1.22–1.35 (1H, tdd, *J* 12.8, 4.6, 2.0 Hz, H4), 1.16 (1H, td, *J* 11.7, 4.6 Hz, *HH'*5), 0.89 (9H, s, <sup>t</sup>Bu);  $\delta_{\text{C}}$  (75 MHz, CDCl<sub>3</sub>); 173.5 (C=O), 143.5 (C1), 130.0 (C2), 43.5 (CH<sup>t</sup>Bu), 32.5 (CMe<sub>3</sub>), 29.7 (CH<sub>2</sub>), 27.6 (CH<sub>3</sub>), 25.6 (CH<sub>2</sub>), 23.9 (CH<sub>2</sub>);  $\nu_{\max}/\text{cm}^{-1}$  (solid, diamond); 3600–2300 (OH), 2868, 1800 (C=O), 1422, 1362, 1268, 1173, 1088, 1040.

Spectroscopic data was consistent with literature values.<sup>77</sup>

#### General Procedure B for the preparation of acyl azides

A solution of the carboxylic acid and carbonyl diimidazole (CDI, 1.1 equivalents) in THF (2.0 ml/mmol) were stirred at room temperature for 75 minutes. A solution of 5M aq. sodium azide (8.0 equivalents) was added and the biphasic mixture stirred vigorously for 2 hours, then poured into water (10 ml) and the aqueous phase extracted with CHCl<sub>3</sub> (10 ml  $\times$  3). The combined organic extracts were washed with brine (20 ml), dried (MgSO<sub>4</sub>), filtered and evaporated *in vacuo* at room temperature to give the acyl azide which was used without purification. Excess sodium azide in the aqueous phase was quenched by reaction with nitrous acid, formed by sequential addition of sodium nitrite and sulfuric acid (the order of addition is important since reaction of sulfuric acid and sodium azide generates poisonous and explosive HN<sub>3</sub>).<sup>69</sup>





### General Procedure C for the preparation of acyl azides

A solution of the carboxylic acid, diphenylphosphoryl azide (DPPA, 0.9 equivalents) and triethylamine (NEt<sub>3</sub>, 1.0 equivalent) in toluene (2.0 ml/mmol) was stirred at room temperature for 18 hours. The reaction mixture was diluted with EtOAc (15 ml) and washed with saturated solution NaHCO<sub>3</sub> (15 ml), followed by water (2 × 15 ml) and brine (15 ml). The organic phase was dried (MgSO<sub>4</sub>), filtered and evaporated *in vacuo* at room temperature to give the acyl azide which was used without further purification.

#### 4-*tert*-Butylcyclohexenyl-1-carbonyl azide **135**

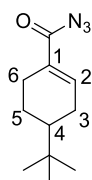

Prepared by general procedure B from 4-*tert*-butylcyclohexenyl-1-carboxylic acid (0.18 g, 1.0 mmol), CDI (0.18 g, 1.1 mmol) and sodium azide (0.52 g, 8.0 mmol). Removal of the solvents gave the acyl azide **135** as colourless oil (0.15 g, 73%).

$\delta_{\text{H}}$  (300 MHz, CDCl<sub>3</sub>); 7.11-7.06 (1H, m, H2), 2.57-2.45 (1H, m, *HH'*6), 2.35-2.22 (1H, m, *HH'*3), 2.18-2.05 (1H, m, *HH'*6), 2.04-1.88 (2H, m, *HH'*3 and *HH'*5), 1.26 (1H, tdd, *J* 12.8, 5.1, 2.0 Hz, H4), 1.13 (1H, td, *J* 12.3, 5.1 Hz, *HH'*5), 0.88 (9H, s, <sup>t</sup>Bu);  $\nu_{\text{max}}/\text{cm}^{-1}$  (thin film); 3155, 2963, 2141 (N<sub>3</sub>), 1680 (C=O), 1643, 1265, 1216, 1171, 1096.

#### (*2E*)-3-Phenylprop-2-enoyl azide **131**

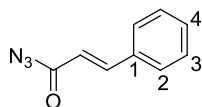

Prepared by general procedure C from cinnamic acid (0.15 g, 1.0 mmol), DPPA (200  $\mu$ l, 0.9 mmol) and NEt<sub>3</sub> (0.15 ml, 1.0 mmol). Removal of the solvents gave the acyl azide **131** as a colourless solid (0.14 g, 81%).

$\delta_{\text{H}}$  (300 MHz, CDCl<sub>3</sub>) of crude material; 7.76 (1H, d, *J* 16.4 Hz, COCH), 7.56-7.53 (2H, m, H2), 7.43-7.40 (3H, m, H3, H4), 6.43 (1H, d, *J* 15.9 Hz, ArCH=C);  $\nu_{\text{max}}/\text{cm}^{-1}$  (thin film); 3401, 2977, 2144 (N<sub>3</sub>), 2043, 1740, 1650, 1455, 1277, 1178, 1064.

Spectroscopic data was consistent with literature values.<sup>202</sup>

#### Benzyl (*2E*)-4-azido-4-oxobut-2-enoate **126**

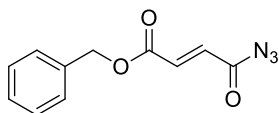

Prepared by general procedure C from *trans*-3-benzyloxycarbonylacrylic acid (0.21 g, 1.0 mmol), DPPA (200  $\mu$ l, 0.9 mmol) and NEt<sub>3</sub> (0.15 ml, 1.0 mmol). Removal of the solvents

gave the acyl azide **126** as an orange oil (0.12 g, 50%).

$\delta_{\text{H}}$  (300 MHz, CDCl<sub>3</sub>); 7.40-7.35 (5H, m, ArH), 6.94 (1H, d, *J* 15.7 Hz, C=CH), 6.83 (1H, d, *J* 15.7 Hz, C=CH), 5.24 (2H, s, CH<sub>2</sub>);  $\nu_{\text{max}}/\text{cm}^{-1}$  (thin film); 3401, 2977, 2144 (N<sub>3</sub>), 2043, 1740, 1650, 1455, 1277, 1178, 1064.

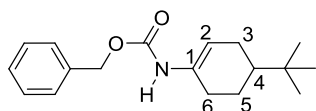
**4-tert-Butylcyclohex-1-enyl-carbamic acid benzyl ester 137**

A solution of acyl azide (0.17 g, 0.80 mmol) in toluene (5.0 ml) was heated under reflux for 30 minutes until IR showed disappearance of the azide signal at  $2142\text{ cm}^{-1}$  and appearance of the isocyanate signal at  $2259\text{ cm}^{-1}$ . The isocyanate solution was cooled to room temperature, benzyl alcohol (0.20 ml, 2.0 mmol) was added and the reaction mixture heated under reflux for 1 hour until IR showed the reaction had gone to completion (disappearance of the isocyanate signal). The reaction mixture was reduced *in vacuo* to give pale orange oil which was purified by column chromatography ( $\text{SiO}_2$ , 95:5 petrol–EtOAc) to give the carbamate **137** as a colourless solid (0.15 g, 66%).

M.p. =  $72\text{--}74\text{ }^\circ\text{C}$  ( $\text{CHCl}_3$ , Lit.<sup>203</sup> =  $72.2\text{--}74.8\text{ }^\circ\text{C}$ )  $\delta_{\text{H}}$  (300 MHz,  $\text{CDCl}_3$ ); 7.43–7.29 (5H, m, ArH), 5.88–5.74 (2H, br m, H<sub>2</sub> + NH), 5.11 (2H, s,  $\text{CH}_2\text{Ar}$ ), 2.28–2.04 (3H, m,  $\text{CH}_2$ ), 1.78–1.93 (2H, m,  $\text{CH}_2$ ), 1.31–1.20 (2H, m,  $\text{CH}_2$ , H<sub>4</sub>), 0.87 (9H, s, <sup>t</sup>Bu);  $\delta_{\text{C}}$  (300 MHz,  $\text{CDCl}_3$ ); 154.7 (C=O), 136.4 (quat.), 131.8 (quat.), 128.5 (ArCH), 128.1 (ArCH), 128.0 (ArCH), 110.2 (C<sub>2</sub>), 66.5 ( $\text{OCH}_2$ ), 47.3 (C<sub>4</sub>), 35.6 ( $\text{CH}_2$ ), 32.3 (quat.), 27.6 (<sup>t</sup>Bu), 27.5 ( $\text{CH}_2$ ), 22.8 ( $\text{CH}_2$ ); *m/z* (ESI); 288.2 [ $\text{M}+\text{H}$ ]<sup>+</sup>.

Spectroscopic data was consistent with literature values.<sup>203</sup>

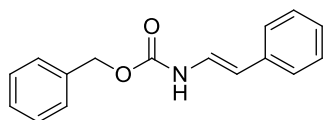
**(E)-Benzyl styrylcarbamate 138**

A solution of the acyl azide **131** (0.14 g, 0.96 mmol) in toluene (10.0 ml) was heated under reflux for 15 minutes until IR showed disappearance of the acyl azide signal at  $2146\text{ cm}^{-1}$  and appearance of the isocyanate signal at  $2259\text{ cm}^{-1}$ . The isocyanate solution was cooled to room temperature and benzyl alcohol (0.5 ml, 12 mmol) added and reaction mixture stirred at room temperature for 40 minutes until IR showed the reaction had gone to completion (disappearance of the isocyanate signal). The reaction mixture was reduced *in vacuo* to give a pale yellow solid. Purification by column chromatography ( $\text{SiO}_2$ , 6:1 petrol–EtOAc) gave the carbamate **138** as colourless solid (0.16 g, 66%).

M.p. =  $93\text{--}94\text{ }^\circ\text{C}$  ( $\text{CHCl}_3$ , Lit.<sup>204</sup> =  $94\text{ }^\circ\text{C}$ );  $\delta_{\text{H}}$  (300 MHz,  $\text{CDCl}_3$ ); 7.36–7.26, (5H, m, ArH), 7.24–7.16 (4H, m, ArH), 7.15–7.05 (1H, m, ArH), 6.91 (1H, d, *J* 12.3 Hz, HNHC=CH), 5.98 (1H, d, *J* 14.5 Hz, HNHC=CH), 3.76 (1H, br s, NH), 3.69 (2H, s,  $\text{CH}_2$ );  $\nu_{\text{max}}/\text{cm}^{-1}$  (thin film); 3396, 3305, 3085, 2872, 1740, 1661, 1604, 1494, 1460, 1379, 1214, 1179, 1081, 1030; HRMS ( $\text{ES}^+$ ) *m/z* [ $\text{M}+\text{Na}$ ]<sup>+</sup> requires 276.0995 for  $\text{C}_{16}\text{H}_{15}\text{NNaO}_2$ , found: 276.0983.

Spectroscopic data was consistent with literature values.<sup>204</sup>

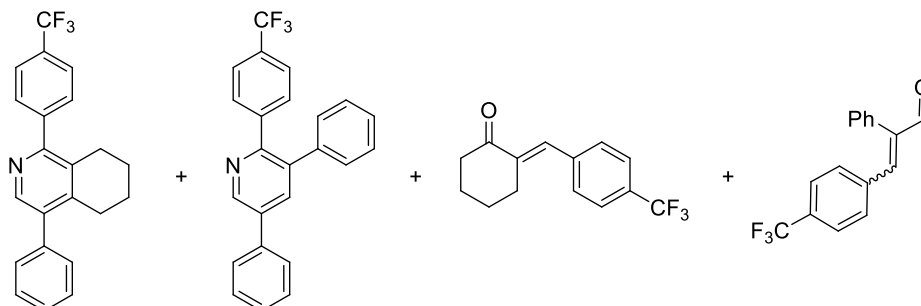
**4-Phenyl-1-(4-trifluoromethylphenyl)-5,6,7,8-tetrahydroisoquinoline 142,****3,5-Diphenyl-2-(4-trifluoromethylphenyl)pyridine 140,****(E)-2-(4-Trifluoromethyl)benzylidene)cyclohexanone 143,****2-Phenyl-3-(4-trifluoromethylphenyl)propenal 144.**

A solution of acyl azide (0.14 g, 0.81 mmol) in toluene (10 ml) was heated under reflux for 30 minutes until IR analysis showed the disappearance of the azide signal at  $2141\text{ cm}^{-1}$  and appearance of the isocyanate signal at  $2259\text{ cm}^{-1}$ . The isocyanate solution was cooled to room temperature then added dropwise over 5 hours to a stirred solution of 4-trifluoromethylbenzaldehyde (280  $\mu\text{l}$ , 2.0 mmol) and phospholene oxide (19 mg, 0.1 mmol) in toluene (1.0 ml) heated under reflux. After addition was complete the reaction mixture was stirred for a further 15 minutes until IR analysis showed that the isocyanate signal had disappeared, then cooled to room temperature and enamine (340  $\mu\text{l}$ , 2.0 mmol) added. The reaction mixture was heated under reflux overnight then cooled to room temperature and reduced *in vacuo* to give orange oil. The product was purified by column chromatography ( $\text{SiO}_2$ , 2:1 petrol- $\text{CH}_2\text{Cl}_2$ , then 20:1 petrol-EtOAc then 8:1 petrol-EtOAc) to give the pyridine **142** as colourless solid (0.018 g, 6%), pyridine **140** as a yellow solid (0.041 g, 22%), ketone **143** as yellow oil (0.123 g) and alkene **144** as colourless solid (0.020 g, 7%).

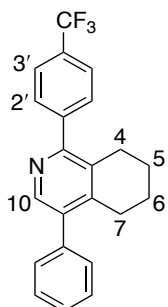
**4-Phenyl-1-(4-trifluoromethylphenyl)-5,6,7,8-tetrahydroisoquinoline 142**

M.p. =  $54\text{--}55\text{ }^\circ\text{C}$  ( $\text{CHCl}_3$ );  $\delta_{\text{H}}$  (300 MHz,  $\text{CDCl}_3$ ); 8.25 (1H, s, H10), 7.65 (2H, d,  $J$  8.1 Hz, H3'), 7.56 (2H, d,  $J$  8.1 Hz, H2'), 7.42-7.35 (3H, m, ArH), 7.30-7.24 (2H, m, ArH), 2.68-2.58 (4H, m, ArCH<sub>2</sub>), 1.71-1.63 (4H, m, CH<sub>2</sub>);  $\delta_{\text{C}}$  (125 MHz,  $\text{CDCl}_3$ ); 155.4 (quat.), 145.5 (C10), 143.9 (quat.), 143.4 (quat.), 136.9 (quat.), 135.8 (quat.), 129.6 (quat.), 128.8 (q,  $J$  33.1 Hz, CCF<sub>3</sub>), 128.7 (q,  $J$  274.0 Hz, CF<sub>3</sub>) 128.4 (ArCH), 128.3 (ArCH), 127.4 (ArCH), 126.6 (ArCH), 124.1 (q,  $J$  4.2 Hz, ArCH), 26.9 (CH<sub>2</sub>), 26.8 (CH<sub>2</sub>), 21.5 (CH<sub>2</sub>), 21.1 (CH<sub>2</sub>);  $\nu_{\text{max}}/\text{cm}^{-1}$  (thin film); 3058, 3029, 2962, 2938, 1618, 1542, 1453, 1406, 1324, 1261, 1165, 1124, 1067, 1019; HRMS ( $\text{ES}^+$ )  $m/z$  [ $\text{M}]^+$  requires 353.1391 for  $\text{C}_{22}\text{H}_{18}\text{F}_3\text{N}$ , found: 353.1398.

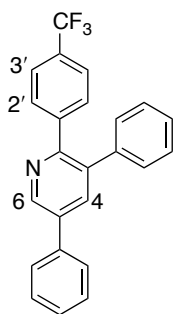
**3,5-Diphenyl-2-(4-trifluoromethylphenyl)pyridine 140**

Yellow needles (0.041 g, 22%).

M.p.= 163-166 °C (CHCl<sub>3</sub>);  $\delta_{\text{H}}$  (300 MHz, CDCl<sub>3</sub>); 8.94 (1H, d, *J* 2.4 Hz, H6), 7.96 (1H, d, *J* 2.4 Hz, H4), 7.68 (2H, d, *J* 6.7 Hz, H3'), 7.56-7.41 (7H, m, ArH + H2'), 7.37-7.30 (3H, m, ArH), 7.25-7.20 (2H, m, ArH);  $\delta_{\text{C}}$  (75 MHz, CDCl<sub>3</sub>) 154.2 (quat.), 146.9 (C6), 143.4 (q, *J* 1.1 Hz, quat.), 139.2 (quat.), 137.1 (C4), 136.2 (quat.), 135.7 (quat.), 130.2 (ArCH), 129.9 (quat.), 129.5 (ArCH), 129.2 (ArCH), 128.6 (ArCH), 128.4 (ArCH), 127.7 (ArCH), 127.2 (ArCH), 125.9 (quat.), 124.9 (q, *J* 4.4 Hz, C3'), 124.0 (q, *J* 270.2 Hz, CF<sub>3</sub>);  $\nu_{\text{max}}/\text{cm}^{-1}$  (solid, diamond); 3030, 2642, 1953, 1814, 1614, 1578, 1541, 1493, 1432, 1325, 1171, 1108, 1010; HRMS (ES<sup>+</sup>) *m/z* [M+H]<sup>+</sup> requires 376.1308 for C<sub>24</sub>H<sub>17</sub>F<sub>3</sub>N, found: 376.1310.

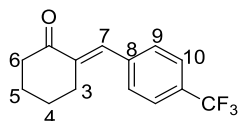
**(E)-2-(4-Trifluoromethyl)benzylidene)cyclohexanone 143**

Yellow oil (0.123 g).

$\delta_{\text{H}}$  (300 MHz, CDCl<sub>3</sub>); 7.64 (2H, d, *J* 8.5 Hz, H10), 7.48 (3H, m, H9 + H7), 2.86-2.78 (2H, m, H6), 2.57 (2H, t, *J* 6.7 Hz, H3), 2.01-1.90 (2H, m, CH<sub>2</sub>), 1.84-1.73 (2H, m, CH<sub>2</sub>);  $\delta_{\text{C}}$  (75 MHz, CDCl<sub>3</sub>); 201.6 (C=O), 139.1 (q, *J* 1.3 Hz, C8), 138.7 (quat.), 133.6 (C7), 130.2 (q, *J* 1.6 Hz, C9), 129.9 (q, *J* 32.4 Hz, CCF<sub>3</sub>), 125.0 (q, *J* 3.8 Hz, C10), 123.4 (q, *J* 272 Hz, CF<sub>3</sub>), 40.4 (C6), 28.9 (C3), 23.8 (CH<sub>2</sub>), 23.4 (CH<sub>2</sub>); *m/z* (ESI); 255 [M+H]<sup>+</sup>.

Spectroscopic data was consistent with literature values.<sup>205</sup>

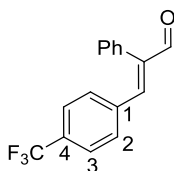
**2-Phenyl-3-(4-trifluoromethylphenyl)propenal 144**

Colourless solid (0.020 g, 7%)

M.p.= 116-118 °C (CHCl<sub>3</sub>);  $\delta_{\text{H}}$  (300 MHz, CDCl<sub>3</sub>); 9.75 (1H, s, CHO), 7.40 (2H, d, *J* 8.1 Hz, H3), 7.37-7.31 (4H, m, C=CH + ArH), 7.22 (2H, d, *J* 8.1 Hz, H2), 7.14-7.05 (2H, m, ArH);  $\delta_{\text{C}}$  (75 MHz, CDCl<sub>3</sub>) 11 signals of 12 observed; 193.4 (C=O), 147.4 (C=CH), 143.5 (quat.), 137.4 (q, *J* 12.4 Hz, CCF<sub>3</sub>), 132.7 (quat.), 131.3 (quat.), 130.7 (q, *J* 5.0 Hz, C2), 129.2 (ArCH), 129.0 (ArCH), 128.0 (ArCH), 125.4 (q, *J* 7.5 Hz, C3);  $\nu_{\text{max}}/\text{cm}^{-1}$  (solid, diamond); 3063, 2931, 2856, 1667, 1626, 1498, 1445, 1422, 1375, 1326, 1172, 1111, 1086, 1068, 1014; HRMS (ES<sup>+</sup>) *m/z*: [M+Na]<sup>+</sup> requires 299.0654 for C<sub>16</sub>H<sub>11</sub>F<sub>3</sub>NaO, found: 299.0641.

**General Procedure D for the preparation of enamines<sup>206</sup>**

Prepared by modified procedure of Pandit *et al.*<sup>206</sup> Pyrrolidine (0.42 ml, 5.0 mmol) was added dropwise to a solution of the alkyne (5.0 mmol) in acetonitrile (5.0 ml) with 4 Å molecular

sieves and the reaction mixture stirred at room temperature for 2 hours. The reaction mixture was filtered, washed with acetonitrile (20 ml) and evaporated *in vacuo* to give the enamine which required no further purification.

#### Ethyl (*E*)-3-(1-pyrrolidinyl)acrylate **9d**

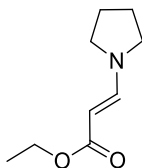

Prepared according to general procedure D from ethyl propiolate (0.58 ml, 5.0 mmol), to give enamine **9d** as orange plates (0.83 g, 99%).

M.p. = 39-41 °C (MeCN, Lit. 38-39 °C<sup>207</sup>);  $\delta_{\text{H}}$  (300 MHz, CDCl<sub>3</sub>) 7.65 (1H, d, *J* 12.8 Hz, NCH=CH), 4.47 (1H, d, *J* 12.8 Hz, C=OCH), 4.12 (2H, q, *J* 7.2 Hz, CH<sub>2</sub>), 3.36-3.17 (4H, br m, NCH<sub>2</sub>), 1.93 (4H, br s, NCH<sub>2</sub>CH<sub>2</sub>), 1.26 (3H, t, *J* 7.2 Hz, CH<sub>3</sub>);  $\delta_{\text{C}}$  (CDCl<sub>3</sub>, 75 MHz) 169.7 (C=O), 148.7 (C=OCH), 84.6 (NCH), 74.4 (CH<sub>2</sub>CH<sub>3</sub>), 58.8 (NCH<sub>2</sub>), 25.3 (NCH<sub>2</sub>CH<sub>2</sub>), 14.7 (CH<sub>3</sub>); *m/z* (ESI) 170.1 [M+H]<sup>+</sup>

Spectroscopic data was consistent with literature values.<sup>206</sup>

#### 1-(*E*)-2-[(4-methylphenyl)sulfonyl]ethenyl pyrrolidine **156a**

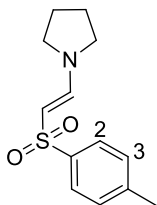

Prepared according to general procedure D from ethynyl *p*-tolyl sulfone (0.90 g, 5.0 mmol), to give enamine **156a** as brown plates (1.19 g, 88%).

M.p. = 126-127 °C (CHCl<sub>3</sub>, Lit.<sup>208</sup> 126-127 °C)  $\delta_{\text{H}}$  (300 MHz, CDCl<sub>3</sub>) 7.71 (2H, d, *J* 8.3 Hz, H<sub>2</sub>), 7.48 (1H, d, *J* 12.6 Hz, NCH=CH), 7.21 (2H, d, *J* 8.3 Hz, H<sub>3</sub>), 4.78 (1H, d, *J* 12.6 Hz, SCH=CH), 3.41 (2H, br s, NCH<sub>2</sub>), 2.98 (2H, br s, NCH<sub>2</sub>), 2.35 (3H, s, ArCH<sub>3</sub>), 1.87 (4H, br s, NCH<sub>2</sub>CH<sub>2</sub>);  $\delta_{\text{C}}$  (CDCl<sub>3</sub>, 75 MHz) 146.5 (NCH), 142.5 (quat.), 142.0 (quat.), 129.6 (ArCH), 126.1 (ArCH), 92.9 (SCH), 51.9 (NCH<sub>2</sub>), 46.8 (NCH<sub>2</sub>), 25.3 (NCH<sub>2</sub>CH<sub>2</sub>), 21.7 (CH<sub>3</sub>); *m/z* (ESI) 274.1 [M+H]<sup>+</sup>

<sup>1</sup>H NMR and mass spectra were consistent with literature values, however, additional signals at  $\delta_{\text{C}}$  51.9 and 46.8 were observed in <sup>13</sup>C NMR and HMQC that were not previously reported.<sup>208</sup>

#### 3-4-(1-Pyrrolidinyl)-(3*E*)-3-buten-2-one **156b**

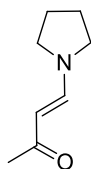

Prepared according to general procedure D from 3-butyne-2-one (0.34 ml, 5.0 mmol), to give enamine **156b** as a brown oil (0.65 g, 93%).

$\delta_{\text{H}}$  (300 MHz, CDCl<sub>3</sub>) 7.67 (1H, d, *J* 12.8 Hz, NCH=CH), 5.01 (1H, d, *J* 12.8 Hz, OCH=CH), 3.54-3.40 (2H, br m, NCH<sub>2</sub>), 3.21-3.08 (2H, br m, 2 NCH<sub>2</sub>), 2.10 (3H, s, CH<sub>3</sub>), 2.05-1.89 (4H, br m, NCH<sub>2</sub>CH<sub>2</sub>);  $\delta_{\text{C}}$  (CDCl<sub>3</sub>, 75 MHz) 195.1 (C=O), 148.4 (C=OCH), 97.2 (NCH), 52.1 (NCH<sub>2</sub>), 46.6 (NCH<sub>2</sub>), 25.2 (CH<sub>3</sub>), 23.9 (NCH<sub>2</sub>CH<sub>2</sub>); *m/z* (ESI) 140.1 [M+H]<sup>+</sup>

<sup>1</sup>H NMR and mass spectra were consistent with literature values, however, additional signal at  $\delta_{\text{C}}$  23.9 was observed in HMQC that was not previously reported.<sup>209</sup>

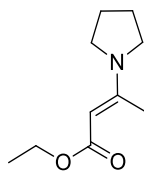
**Ethyl (E)-2-methyl-3-(1-pyrrolidinyl)acrylate **156c****

Prepared according to general procedure D from ethyl-2-butynoate (0.42 ml, 5.0 mmol), to give enamine **156c** as an orange oil (0.88 g, 97%).

$\delta_{\text{H}}$  (300 MHz,  $\text{CDCl}_3$ ) 4.46 (1H, s, C=CH), 4.09 (2H, q,  $J$  7.1 Hz,  $\text{OCH}_2$ ), 3.53-3.08 (4H, br s,  $\text{NCH}_2$ ), 2.46 (3H, s,  $\text{CH}_3$ ), 1.98-1.87 (4H, br s,

$\text{NCH}_2\text{CH}_2$ ), 1.25 (3H, t,  $J$  7.1 Hz,  $\text{OCH}_2\text{CH}_3$ );  $\delta_{\text{C}}$  ( $\text{CDCl}_3$ , 75 MHz) 169.3 (C=O), 159.6 (quat.), 83.2 (CH), 58.1 ( $\text{OCH}_2$ ), 47.9 ( $\text{NCH}_2$ ), 25.2 ( $\text{NCH}_2\text{CH}_2$ ), 16.7 ( $\text{CH}_3$ ), 14.7 ( $\text{CH}_3$ );  $m/z$  (ESI) 183.0  $[\text{M}+\text{H}]^+$

Spectroscopic data was consistent with literature values.<sup>210</sup>

**General Procedure E for the preparation of pyridines**

A solution of the cinnamic acid (1.0 mmol), diphenylphosphoryl azide (200  $\mu\text{l}$ , 0.9 mmol) and triethylamine (150  $\mu\text{l}$ , 1.0 mmol) in toluene (2.0 ml) was stirred at room temperature for 90 minutes then added to saturated  $\text{NaHCO}_3$  solution (20 ml). The organic phase was diluted with EtOAc (20 ml), the phases separated and the organic phase was washed with water ( $2 \times 20$  ml) then brine (20 ml), dried ( $\text{MgSO}_4$ ) and evaporated *in vacuo* at room temperature to give the acyl azide which was identified by crude  $^1\text{H}$  NMR and IR and used without purification (isolated yields calculated from cinnamic acid since acyl azides were not evaporated to dryness for safety). A solution of the acyl azide in toluene (5.0 ml) was heated under reflux. The reaction was monitored by IR for the disappearance of the azide signal ( $2142\text{ cm}^{-1}$ ) and appearance of the isocyanate signal at ( $2259\text{ cm}^{-1}$ ). Once formation of the isocyanate was complete ( $\sim 30$  min) the solution was cooled to room temperature and added dropwise over 2 hours to a stirred solution of the aldehyde (1.1 mmol) and 3-methyl-1-phenyl-2-phospholene-1-oxide (19 mg, 10 mol%) in toluene (1.0 ml) heated under reflux. The reaction mixture was cooled to room temperature and the enamine (2.0 mmol), magnesium bromide (0.18 g, 1.0 mmol) and 4 Å molecular sieves added and stirred at room temperature overnight then filtered through cotton wool and saturated  $\text{NaHCO}_3$  solution (20 ml) and EtOAc (20 ml) added. The phases were separated and aqueous phase extracted with EtOAc ( $2 \times 20$  ml). The combined organic extracts were washed with brine (40 ml), dried ( $\text{MgSO}_4$ ) and evaporated *in vacuo*. The residue was subsequently purified by flash silica column chromatography.

**General Procedure F for the preparation of pyridines**

A solution of the cinnamic acid (1.0 mmol), diphenylphosphoryl azide (200  $\mu\text{l}$ , 0.9 mmol) and triethylamine (150  $\mu\text{l}$ , 1.0 mmol) in toluene (2.0 ml) was stirred at room temperature for 90 minutes then added to saturated  $\text{NaHCO}_3$  solution (20 ml). The organic phase was diluted with EtOAc (20 ml), the phases separated and the organic phase was washed with water ( $2 \times 20$  ml)

then brine (20 ml), dried (MgSO<sub>4</sub>) and evaporated *in vacuo* at room temperature to give the acyl azide which was identified by crude <sup>1</sup>H NMR and IR and used without purification (isolated yields calculated from cinnamic acid since acyl azides were not evaporated to dryness). A solution of the acyl azide in toluene (5.0 ml) was heated under reflux. The reaction was monitored by IR for the disappearance of the azide signal (2142 cm<sup>-1</sup>) and appearance of the isocyanate signal at (2259 cm<sup>-1</sup>). Once formation of the isocyanate was complete (~30 min) the solution was cooled to room temperature and added dropwise over 2 hours to a stirred solution of the aldehyde (1.1 mmol) and 3-methyl-1-phenyl-2-phospholene-1-oxide (19 mg, 10 mol%) in toluene (1.0 ml) heated under reflux. The reaction mixture was cooled to room temperature and the enamine (2.0 mmol), magnesium bromide (0.18 g, 1.0 mmol) and 4 Å molecular sieves added and stirred at room temperature overnight then 5% Pd/C (50 mg) added and the reaction mixture heated under reflux for 6 hours then filtered through celite and washed with saturated NaHCO<sub>3</sub> solution (50 ml) and EtOAc (100 ml). The phases were separated and aqueous phase extracted with EtOAc (2 × 50 ml). The combined organic extracts were washed with brine (100 ml), dried (MgSO<sub>4</sub>) and evaporated *in vacuo*. The residue was subsequently purified by flash silica column chromatography.

#### 5-Phenyl-2-(4-trifluoromethylphenyl)nicotinic acid ethyl ester **146a**

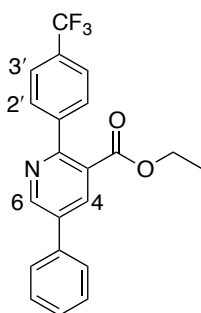

Prepared according to general procedure E using cinnamic acid (0.15 g, 1.0 mmol) and 4-trifluoromethylbenzaldehyde (0.15 ml, 1.1 mmol) and ethyl (*E*)-3-(pyrrolidin-1-yl)-2-propenoate (0.34 g, 2.0 mmol). Purification by column chromatography (SiO<sub>2</sub>, 0-10% EtOAc in hexane) gave the pyridine **146a** as yellow needles (0.12 g, 38%).

M.p.= 116-120 °C (CHCl<sub>3</sub>); δ<sub>H</sub> (300 MHz, CDCl<sub>3</sub>); 9.01 (1H, d, *J* 2.3 Hz, H6), 8.36 (1H, d, *J* 2.3 Hz, H4), 7.76-7.68 (4H, m, H2' + H3'), 7.68-7.64 (2H, m, *ArH*), 7.55-7.49 (2H, m, *ArH*), 7.48-7.43 (1H, m, *ArH*), 4.20 (2H, q, *J* 7.1 Hz, CH<sub>2</sub>), 1.09 (3H, t, *J* 7.1 Hz, CH<sub>3</sub>); δ<sub>C</sub> (75 MHz, CDCl<sub>3</sub>); 167.4 (C=O), 156.1 (C2), 149.6 (C6), 143.5 (quat.), 136.3 (C4), 136.2 (quat.), 135.4 (quat.), 130.6 (quat., q, *J* 32.2 Hz, ArCCF<sub>3</sub>), 129.3 (ArCH), 129.0 (ArCH), 128.7 (ArCH), 127.6 (quat., q, *J* 272.3 Hz, CF<sub>3</sub>), 127.1 (C2'), 125.0 (q, *J* 3.5 Hz, C3'), 122.8 (quat.), 61.7 (CH<sub>2</sub>), 13.6 (CH<sub>2</sub>CH<sub>3</sub>); ν<sub>max</sub>/cm<sup>-1</sup> (solid); 2986, 1722, 1618, 1581, 1549, 1450, 1406, 1368, 1323, 1246, 1160, 1096, 1065, 1033, 1014; HRMS (ES<sup>+</sup>) *m/z*; [M+H]<sup>+</sup> requires 372.1206 for C<sub>22</sub>H<sub>20</sub>NO<sub>3</sub>, found: 372.1212

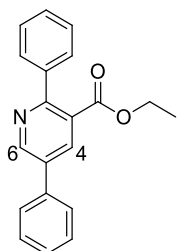
**2,5-Diphenylnicotinic acid ethyl ester 146b**

Prepared according to general procedure E using cinnamic acid (0.15 g, 1.0 mmol), benzaldehyde (0.12 ml, 1.1 mmol) and ethyl (*E*)-3-(pyrrolidin-1-yl)-2-propenoate (0.34 g, 2.0 mmol). Crude acyl azide (0.15 g, 0.84 mmol). Purification by column chromatography (SiO<sub>2</sub>, 0-40% EtOAc in hexane) gave the pyridine **146b** as pale yellow needles (0.034 g, 11%).

M.p. = 138-140 °C (EtOH, Lit.<sup>211</sup> 138-139 °C);  $\delta_{\text{H}}$  (300 MHz, CDCl<sub>3</sub>); 8.92 (1H, d, *J* 2.2 Hz, H6), 8.22 (1H, d, *J* 2.2 Hz, H4), 7.62-7.56 (2H, m, ArH), 7.56-7.54 (2H, m, ArH), 7.53-7.49 (2H, m, ArH), 7.40-7.33 (4H, m, ArH), 4.11 (2H, q, *J* 7.1 Hz, CH<sub>2</sub>), 0.99 (3H, t, *J* 7.1 Hz, CH<sub>3</sub>);  $\delta_{\text{C}}$  (75 MHz, CDCl<sub>3</sub>); 167.2 (C=O), 156.3 (C2), 148.4 (C6), 138.8 (quat.), 135.5 (quat.), 135.0 (C4), 133.6 (quat.), 128.2 (ArCH), 127.7 (ArCH), 127.6 (ArCH), 127.5 (ArCH), 127.1 (ArCH), 126.3 (quat.), 126.1 (ArCH), 60.6 (CH<sub>2</sub>), 12.6 (CH<sub>3</sub>);  $\nu_{\text{max}}/\text{cm}^{-1}$  (thin film); 3060, 2979, 2935, 1709, 1594, 1541, 1443, 1384, 1363, 1325, 1249, 1103, 1060, 1013; HRMS (ES<sup>+</sup>) *m/z*; [M+H]<sup>+</sup> requires 304.1332 for C<sub>20</sub>H<sub>18</sub>NO<sub>2</sub>, found: 304.1342. Spectroscopic data consistent with literature values.<sup>211</sup>

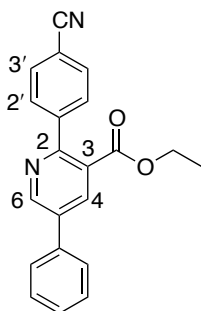
**2-(4-Cyanophenyl)-5-phenylnicotinic acid ethyl ester 146d**

Prepared according to general procedure E using cinnamic acid (0.15 g, 1.0 mmol) 4-cyanobenzaldehyde (0.14 g, 1.1 mmol) and ethyl (*E*)-3-(pyrrolidin-1-yl)-2-propenoate (0.34 g, 2.0 mmol). Crude acyl azide (0.18 g, 1.0 mmol). Purification by column chromatography (SiO<sub>2</sub>, 0-10% EtOAc in hexane) gave the pyridine **146d** as pale orange needles (0.066 g, 20%).

M.p.= 125-128 °C (EtOAc-petrol);  $\delta_{\text{H}}$  (300 MHz, CDCl<sub>3</sub>); 9.03 (1H, d, *J* 2.2 Hz, H6), 8.41 (1H, d, *J* 2.2 Hz, H4), 7.80-7.75 (2H, m, H3'), 7.72-7.66 (4H, m, ArH + H2'), 7.58-7.45 (3H, m, ArH), 4.24 (2H, q, *J* 7.1 Hz, CH<sub>2</sub>), 1.15 (3H, t, *J* 7.1 Hz, CH<sub>3</sub>);  $\delta_{\text{C}}$  (75 MHz, CDCl<sub>3</sub>); 167.1 (C=O), 155.6 (C2), 149.8 (C6), 144.5 (C3), 136.6 (C4), 136.0 (quat.), 135.8 (quat.) 131.9 (ArCH), 129.5 (ArCH), 129.4 (ArCH), 128.9 (ArCH), 127.2 (ArCH), 127.1 (quat.), 118.7 (C4'), 112.3 (CN), 61.9 (CH<sub>2</sub>), 13.8 (CH<sub>3</sub>);  $\nu_{\text{max}}/\text{cm}^{-1}$  (solid); 3004, 2222, 1725, 1449, 1360, 1247, 1095, 1023; HRMS (ES<sup>+</sup>) *m/z*; [M+H]<sup>+</sup> requires 329.1285 for C<sub>21</sub>H<sub>17</sub>N<sub>2</sub>O<sub>2</sub>, found: 329.1276.

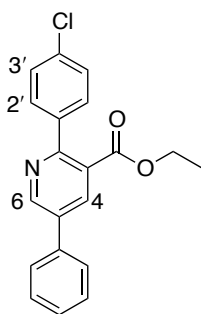

**2-(4-Chlorophenyl)-5-phenylnicotinic acid ethyl ester 146e**

Prepared according to general procedure E using cinnamic acid (0.15 g, 1.0 mmol), 4-chlorobenzaldehyde (0.15 g, 1.1 mmol) and ethyl (*E*)-3-(pyrrolidin-1-yl)-2-propenoate (0.34 g, 2.0 mmol). Crude acyl azide (0.17 g, 1.0 mmol). Purification by column chromatography (SiO<sub>2</sub>, 0-35% EtOAc in hexane) gave the pyridine **146e** as yellow plates (0.041 g, 12%). M.p.= 90-97 °C (EtOH);  $\delta_{\text{H}}$  (300 MHz, CDCl<sub>3</sub>); 9.01 (1H, d, *J* 2.2 Hz, H6), 8.33 (1H, d, *J* 2.2 Hz, H4), 7.70-7.64 (2H, d, *J* 7.4 Hz, H3'), 7.58-7.51 (4H, m, ArH), 7.50-7.42 (3H, m, ArH), 4.24 (2H, q, *J* 7.1 Hz, CH<sub>2</sub>), 1.16 (3H, t, *J* 7.1 Hz, CH<sub>3</sub>);  $\delta_{\text{C}}$  (75 MHz, CDCl<sub>3</sub>); 167.9 (C=O), 156.2 (quat.), 149.6 (C6), 138.3 (quat.), 136.4 (quat.), 136.3 (C4), 135.0 (quat.) 134.9 (quat.), 130.0 (ArCH), 129.3 (ArCH), 128.7 (ArCH), 128.4 (ArCH), 127.2 (C3'), 127.1 (quat.), 61.2 (CH<sub>2</sub>), 13.8 (CH<sub>3</sub>);  $\nu_{\text{max}}/\text{cm}^{-1}$  (solid); 3057, 2980, 2936, 1915, 1727, 1594, 1541, 1486, 1445, 1402, 1384, 1365, 1323, 1249, 1212, 1095, 1060, 1011; HRMS (ES<sup>+</sup>) *m/z*; [M+H]<sup>+</sup> requires 338.0942 for C<sub>20</sub>H<sub>17</sub><sup>35</sup>ClNO<sub>2</sub>, found: 338.0957.

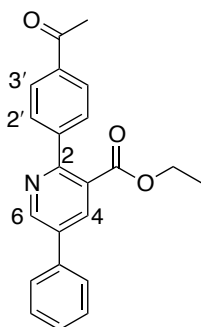
**2-(4-Acetylphenyl)-5-phenylnicotinic acid ethyl ester 146f**

Prepared according to general procedure E using cinnamic acid (0.15 g, 1.0 mmol) and 4-acetylbenzaldehyde (0.16 g, 1.1 mmol) and ethyl (*E*)-3-(pyrrolidin-1-yl)-2-propenoate (0.34 g, 2.0 mmol). Crude acyl azide (0.17 g, 1.0 mmol). Purification by column chromatography (SiO<sub>2</sub>, 0-35% EtOAc in hexane) gave the pyridine **146f** as yellow needles (0.042 g, 12%). M.p.= 109-112 °C (EtOH);  $\delta_{\text{H}}$  (300 MHz, CDCl<sub>3</sub>); 9.03 (1H, d, *J* 2.2 Hz, H6), 8.37 (1H, d, *J* 2.2 Hz, H4), 8.05 (2H, d, *J* 8.2 Hz, H3'), 7.72-7.64 (4H, m, H2' + ArH), 7.56-7.43 (3H, m, ArH), 4.22 (2H, q, *J* 7.1 Hz, CH<sub>2</sub>), 2.66 (3H, s, O=CCH<sub>3</sub>), 1.11 (3H, t, *J* 7.1 Hz, CH<sub>2</sub>CH<sub>3</sub>);  $\delta_{\text{C}}$  (75 MHz, CDCl<sub>3</sub>); 197.8 (O=CCH<sub>3</sub>), 167.4 (O=COCH<sub>2</sub>CH<sub>3</sub>), 156.2 (C2), 149.4 (C6), 144.2 (quat.), 136.9 (quat.), 136.5 (C4), 136.1 (quat.), 135.5 (quat.), 129.3 (ArCH), 129.0 (ArCH), 128.8 (ArCH), 128.2 (ArCH), 127.4 (quat.), 127.1 (ArCH), 61.8 (CH<sub>2</sub>), 26.8 (O=CCH<sub>3</sub>), 13.8 (CH<sub>2</sub>CH<sub>3</sub>);  $\nu_{\text{max}}/\text{cm}^{-1}$  (solid); 2980, 1714, 1682, 1607, 1541, 1510, 1454, 1407, 1365, 1325, 1298, 1247, 1209, 1103, 1058, 1012; HRMS (ES<sup>+</sup>) *m/z*; [M+H]<sup>+</sup> requires 346.1438 for C<sub>22</sub>H<sub>20</sub>NO<sub>3</sub>, found: 346.1441.

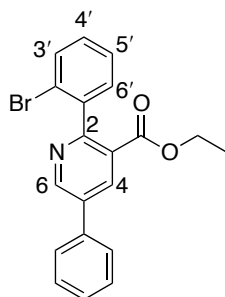
**2-(2-Bromophenyl)-5-phenylnicotinic acid ethyl ester 146g**

Prepared according to general procedure E using cinnamic acid (0.15 g, 1.0 mmol) 2-bromobenzaldehyde (0.13 ml, 1.1 mmol) and ethyl (*E*)-3-(pyrrolidin-1-yl)-2-propenoate (0.34 g, 2.0 mmol). Purification by column chromatography (SiO<sub>2</sub>, 0-50% EtOAc–petrol) gave the pyridine **146g** as yellow crystals (0.12 g, 33%).

M.p.= 99-100 °C (CHCl<sub>3</sub>); δ<sub>H</sub> (300 MHz, CDCl<sub>3</sub>); 8.97 (1H, d, *J* 2.5 Hz, H6), 8.46 (1H, d, *J* 2.5 Hz, H4), 7.63 (2H, m, ArH), 7.56 (1H, m, ArH), 7.49-7.33 (5H, m, C<sub>6</sub>H<sub>5</sub>), 7.24-7.21 (1H, m, ArH), 4.10 (2H, q, *J* 7.2 Hz, CH<sub>2</sub>), 0.97 (3H, t, *J* 7.2 Hz, CH<sub>3</sub>); δ<sub>C</sub> (75 MHz, CDCl<sub>3</sub>); 166.0 (C=O), 157.5 (quat.), 149.9 (C6), 141.8 (quat.), 136.5 (C4), 136.4 (quat.), 135.7 (quat.) 132.2 (ArCH), 130.1 (ArCH), 129.5 (ArCH), 129.3 (ArCH), 128.7 (ArCH), 127.3 (ArCH), 127.2 (ArCH), 127.0 (quat.), 122.3 (quat.), 61.6 (CH<sub>2</sub>), 13.6 (CH<sub>3</sub>); ν<sub>max</sub>/cm<sup>-1</sup> (solid); 2985, 2939, 1973, 1933, 1885, 1813, 1709, 1595, 1479, 1439, 1363, 1316, 1250, 1207, 1107, 1055, 1013; HRMS (ES<sup>+</sup>) *m/z*; [M+H]<sup>+</sup> requires 382.0437 for C<sub>20</sub>H<sub>17</sub><sup>79</sup>BrNO<sub>2</sub>, found: 382.0440.

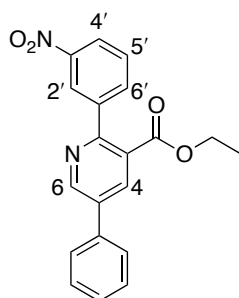
**2-(3-Nitrophenyl)-5-phenylnicotinic acid ethyl ester 146h**

Prepared according to general procedure E using cinnamic acid (0.15 g, 1.0 mmol), 3-nitrobenzaldehyde (0.17 g, 1.1 mmol) and ethyl (*E*)-3-(pyrrolidin-1-yl)-2-propenoate (0.34 g, 2.0 mmol). Crude acyl azide (0.14 g, 0.79 mmol). Purification by column chromatography (SiO<sub>2</sub>, 0-30% EtOAc in petrol) gave the pyridine **146h** as yellow needles (0.10 g, 26%).

M.p.= 74-78 °C (EtOAc–Petrol); δ<sub>H</sub> (300 MHz, CDCl<sub>3</sub>); 8.95 (1H, d, *J* 2.2 Hz, H6), 8.40 (1H, dd, *J* 2.2, 1.6 Hz, H2'), 8.34 (1H, d, *J* 2.2 Hz, H4), 8.23 (1H, ddd, *J* 8.2, 2.2, 1.1 Hz, H4'), 7.84 (1H, ddd, *J* 8.2, 1.6, 1.1 Hz, H6'), 7.63-7.52 (3H, m, H5' + ArH), 7.50-7.36 (3H, m, ArH), 4.18 (2H, q, *J* 7.1 Hz, CH<sub>2</sub>), 1.08 (3H, t, *J* 7.1 Hz, CH<sub>2</sub>CH<sub>3</sub>); δ<sub>C</sub> (75 MHz, CDCl<sub>3</sub>); 165.9 (C=O), 154.0 (C2), 148.8 (C6), 146.9 (quat.), 140.5 (quat.), 135.6 (C4), 135.0 (quat.), 134.8 (quat.), 133.8 (C6'), 128.3 (ArCH), 128.0 (ArCH), 127.8 (ArCH), 126.1 (ArCH), 125.8 (quat.), 122.9 (C3'), 122.3 (C4') 60.9 (CH<sub>2</sub>), 12.8 (CH<sub>3</sub>); ν<sub>max</sub>/cm<sup>-1</sup> (solid); 2990, 1729, 1583, 1526, 1448, 1352, 1241, 1079, 1040; HRMS (ES<sup>+</sup>) *m/z*; [M+H]<sup>+</sup> requires 349.1183 for C<sub>22</sub>H<sub>17</sub>N<sub>2</sub>O<sub>4</sub>, found: 349.1192.

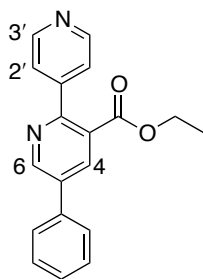
**5-Phenyl-[2,4']bipyridinyl-3-carboxylic acid ethyl ester 146i**

Prepared according to general procedure E using cinnamic acid (0.15 g, 1.0 mmol) and 4-pyridinecarboxaldehyde (0.10 ml, 1.1 mmol) and ethyl (*E*)-3-(pyrrolidin-1-yl)-2-propenoate (0.34 g, 2.0 mmol). Crude acyl azide (0.17 g, 0.96 mmol). Purification by column chromatography (SiO<sub>2</sub>, 0-80% EtOAc in petrol) gave the pyridine **146i** as colourless needles (0.10 g, 34%).

M.p.= 113-114 °C (CHCl<sub>3</sub>); δ<sub>H</sub> (300 MHz, CDCl<sub>3</sub>); 9.03 (1H, d, *J* 2.2 Hz, H6), 8.72 (2H, d, *J* 6.0 Hz, H3'), 8.39 (1H, d, *J* 2.2 Hz, H4), 7.70-7.65 (2H, d, *J* 6.0 Hz, H2'), 7.58-7.47 (5H, m, *ArH*), 4.23 (2H, q, *J* 7.1 Hz, CH<sub>2</sub>), 1.12 (3H, t, *J* 7.1 Hz, CH<sub>3</sub>); δ<sub>C</sub> (75 MHz, CDCl<sub>3</sub>); 167.1 (C=O), 149.9 (C6), 149.7 (C1'), 147.7 (C2), 136.5 (C4), 136.1 (quat.), 136.0 (quat.), 130.1 (quat.), 129.4 (C2'), 129.1 (quat.), 128.9 (*ArCH*), 127.2 (*ArCH*), 123.3 (*ArCH*), 61.9 (CH<sub>2</sub>), 13.6 (CH<sub>3</sub>); ν<sub>max</sub>/cm<sup>-1</sup> (solid); 2982, 1722, 1600, 1448, 1320, 1254, 1100, 1068, 1028; HRMS (ES<sup>+</sup>) *m/z*; [M+H]<sup>+</sup> requires 305.1285 for C<sub>19</sub>H<sub>17</sub>N<sub>2</sub>O<sub>2</sub>, found: 305.1270.

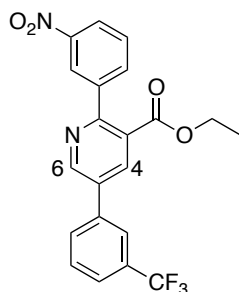
**5-(3-Trifluoromethylphenyl)-2-(3-nitrophenyl)nicotinic acid ethyl ester 146j**

Prepared according to general procedure F using 3-trifluoromethylcinnamic acid (0.21 g, 1.0 mmol), 3-nitrobenzaldehyde (0.17 g, 1.1 mmol) and ethyl (*E*)-3-(pyrrolidin-1-yl)-2-propenoate (0.34 g, 2.0 mmol). Crude acyl azide (0.21 g, 0.86 mmol). Purification by column chromatography (SiO<sub>2</sub>, 0-35% EtOAc in petrol) gave the pyridine **146j** as yellow needles (0.12 g, 28%).

M.p.= 127-129 °C (EtOAc–Petrol); δ<sub>H</sub> (300 MHz, CDCl<sub>3</sub>); 9.04 (1H, d, *J* 2.2 Hz, H6), 8.49 (1H, s, *ArH*), 8.43 (1H, d, *J* 2.2 Hz, H4), 8.33 (1H, dd, *J* 8.2, 1.6 Hz, *ArH*), 7.94-7.90 (2H, m, *ArH*), 7.88 (1H, d, *J* 8.2 Hz, *ArH*), 7.77-7.63 (3H, m, *ArH*), 4.28 (2H, q, *J* 7.1 Hz, CH<sub>2</sub>), 1.17 (3H, t, *J* 7.1 Hz, CH<sub>2</sub>CH<sub>3</sub>); δ<sub>C</sub> (75 MHz, CDCl<sub>3</sub>); 166.7 (C=O), 155.8 (quat.), 149.8 (C6), 148.0 (quat.), 141.3 (quat.), 137.0 (quat.), 136.9 (C4), 134.8 (*ArCH*), 134.5 (quat.), 132.1 (q, *J* 3.9 Hz, CCF<sub>3</sub>), 130.5 (*ArCH*), 129.9 (*ArCH*), 129.1 (*ArCH*), 127.1 (quat.), 125.6 (*ArCH*), 124.1 (*ArCH*), 124.0 (*ArCH*), 123.5 (*ArCH*), 122.1 (q, *J* 119.5, CF<sub>3</sub>), 62.1 (CH<sub>2</sub>CH<sub>3</sub>), 13.8 (CH<sub>2</sub>CH<sub>3</sub>); ν<sub>max</sub>/cm<sup>-1</sup> (solid); 3439, 3086, 2988, 1959, 1854, 1726, 1615, 1580, 1528, 1482, 1445, 1397, 1300, 1256, 1211, 1166, 1115, 1041; HRMS (ES<sup>+</sup>) *m/z*; [M+H]<sup>+</sup> requires 417.1057 for C<sub>21</sub>H<sub>16</sub>F<sub>3</sub>N<sub>2</sub>O<sub>4</sub>, found: 417.1055.

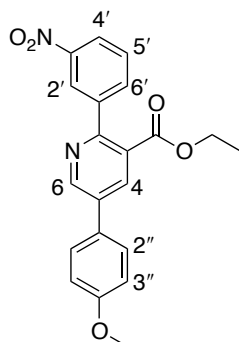
**5-(4-Methoxyphenyl)-2-(3-nitrophenyl)nicotinic acid ethyl ester 146k**

Prepared according to general procedure E using 4-methoxycinnamic acid (0.18 g, 1.0 mmol), 3-nitrobenzaldehyde (0.17 g, 1.1 mmol) and ethyl (*E*)-3-(pyrrolidin-1-yl)-2-propenoate (0.34 g, 2.0 mmol). Crude acyl azide (0.18 g, 0.89 mmol). Purification by column chromatography (SiO<sub>2</sub>, 0-35% EtOAc in petrol then 10-20% EtOAc in petrol) gave the pyridine **146k** as yellow needles (0.14 g, 38%).

M.p.= 45-46 °C (EtOAc–Petrol);  $\delta_{\text{H}}$  (300 MHz, CDCl<sub>3</sub>); 8.99 (1H, d, *J* 2.2 Hz, H6), 8.47-8.45 (1H, m, H2'), 8.36 (1H, d, *J* 2.2 Hz, H4), 8.29 (1H, ddd, *J* 8.2, 2.2, 1.1 Hz, H4'), 7.93-7.88 (1H, m, H6'), 7.66-7.59 (3H, m, H5' + H2''), 7.08-7.02 (2H, m, H3''), 4.25 (2H, q, *J* 7.1 Hz, CH<sub>2</sub>), 3.88 (3H, s, OCH<sub>3</sub>), 1.16 (3H, t, *J* 7.1 Hz, CH<sub>2</sub>CH<sub>3</sub>);  $\delta_{\text{C}}$  (75 MHz, CDCl<sub>3</sub>); 167.1 (C=O), 160.4 (quat.), 154.3 (quat.), 149.4 (C6), 147.9 (quat.), 141.6 (quat.), 136.0 (C4), 135.8 (quat.), 135.4 (C4'), 134.8 (C6'), 130.6 (C5' or C2''), 128.3 (C5' or C2''), 126.8 (quat.), 123.9 (C2'), 123.2 (C6'), 114.6 (C3''), 61.9 (CH<sub>2</sub>CH<sub>3</sub>), 55.4 (OCH<sub>3</sub>), 13.8 (CH<sub>2</sub>CH<sub>3</sub>);  $\nu_{\text{max}}/\text{cm}^{-1}$  (solid); 3419, 3092, 2984, 2939, 2908, 1715, 1634, 1538, 1446, 1348, 1286, 1184, 1101, 1029; HRMS (ES<sup>+</sup>) *m/z*; [M+H]<sup>+</sup> requires 379.1288 for C<sub>21</sub>H<sub>19</sub>N<sub>2</sub>O<sub>5</sub>, found: 379.1285.

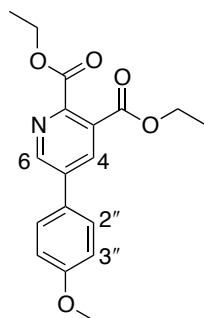
**5-(4-Methoxyphenyl)pyridine-2,3-diethyl carboxylate 146l**

Prepared according to general procedure E using 4-methoxycinnamic acid (0.18 g, 1.0 mmol), ethyl glyoxylate (0.15 ml, 1.5 mmol) and ethyl (*E*)-3-(pyrrolidin-1-yl)-2-propenoate (0.25 g, 1.5 mmol). Purification by column chromatography (SiO<sub>2</sub>, 0-80% EtOAc in petrol) gave the pyridine **146l** as orange oil (0.043 g, 13%).

$\delta_{\text{H}}$  (300 MHz, CDCl<sub>3</sub>); 8.94 (1H, d, *J* 2.2 Hz, H6), 8.25 (1H, d, *J* 2.2 Hz, H4), 7.58 (2H, d, *J* 9.0 Hz, H2'), 7.04 (2H, d, *J* 9.0 Hz, H3'), 4.48 (2H, q, *J* 7.1 Hz, CH<sub>2</sub>CH<sub>3</sub>), 4.42 (2H, q, *J* 7.1 Hz, CH<sub>2</sub>CH<sub>3</sub>), 3.88 (3H, s, OCH<sub>3</sub>), 1.44 (3H, t, *J* 7.1 Hz, CH<sub>2</sub>CH<sub>3</sub>), 1.40 (3H, t, *J* 7.1 Hz, CH<sub>2</sub>CH<sub>3</sub>);  $\delta_{\text{C}}$  (75 MHz, CDCl<sub>3</sub>); 166.1 (C=O), 165.9 (C=O), 160.5 (quat.), 149.3 (C6), 147.9 (quat.), 137.7 (quat.), 134.8 (C4), 128.5 (C2'), 128.1 (quat.), 127.4 (quat.), 114.8 (C3'), 62.3 (CH<sub>2</sub>), 62.2 (CH<sub>2</sub>), 55.5 (OCH<sub>3</sub>), 14.2 (CH<sub>2</sub>CH<sub>3</sub>), 14.1 (CH<sub>2</sub>CH<sub>3</sub>);  $\nu_{\text{max}}/\text{cm}^{-1}$  (solid); 2983, 2938, 1728, 1609, 1518, 1457, 1366, 1303, 1256, 1183, 1143, 1078, 1020; HRMS (ES<sup>+</sup>) *m/z*; [M+Na]<sup>+</sup> requires 330.1336 for C<sub>18</sub>H<sub>20</sub>NO<sub>5</sub>, found: 330.1328.

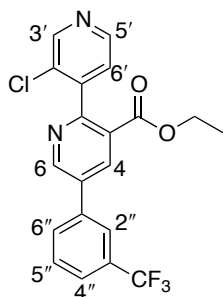
**Ethyl 2'-chloro-5-[3-(trifluoromethyl)phenyl]-2,4'-bipyridine-3-carboxylate 146m**

Prepared according to general procedure F using 3-trifluoromethylcinnamic acid (0.21 g, 1.0 mmol), 3-chloro-4-pyridinecarboxaldehyde (0.16 g, 1.1 mmol) and ethyl (*E*)-3-(pyrrolidin-1-yl)-2-propenoate (0.34 g, 2.0 mmol). Crude acyl azide (0.13 g, 0.56 mmol). Purification by column chromatography (SiO<sub>2</sub>, 0-50% EtOAc in petrol) gave the pyridine **146m** as yellow needles (0.12 g, 29%).

M.p.= 101-102 °C (EtOH);  $\delta_{\text{H}}$  (300 MHz, CDCl<sub>3</sub>); 8.98 (1H, d, *J* 2.5 Hz, H6), 8.59 (1H, s, H3'), 8.55 (1H, d, *J* 4.9 Hz, H5'), 8.51 (1H, d, *J* 2.5 Hz, H4), 7.85 (1H, s, H2''), 7.80 (1H, d, *J* 7.6 Hz, H4''), 7.69-7.58 (2H, m, H5'' + H6''), 7.33 (1H, d, *J* 4.9 Hz, H6'), 4.15 (2H, q, *J* 7.1 Hz, CH<sub>2</sub>), 1.02 (3H, t, *J* 7.1 Hz, CH<sub>3</sub>);  $\delta_{\text{C}}$  (75 MHz, CDCl<sub>3</sub>); 165.1 (C=O), 154.2 (quat.), 150.4 (C6), 149.0 (C3'), 147.9 (C5'), 147.2 (quat.), 136.9 (quat.), 136.8 (C4), 135.3 (quat.), 131.8 (q, *J* 33.2 Hz, CCF<sub>3</sub>), 130.6 (q, *J* 1.1 Hz, C5''), 130.3 (quat.), 129.9 (C6''), 127.2 (quat.), 125.7 (q, *J* 3.3 Hz, C4''), 124.3 (C6'), 124.1 (q, *J* 3.3 Hz, C2''), 120.2 (q, *J* 273.1 Hz, CF<sub>3</sub>), 62.1 (CH<sub>2</sub>), 13.5 (CH<sub>3</sub>);  $\nu_{\text{max}}/\text{cm}^{-1}$  (solid); 2970, 1738, 1590, 1554, 1365, 1217, 1116, 1025; HRMS (ES<sup>+</sup>) *m/z*: [M+H]<sup>+</sup> requires 407.0769 for C<sub>20</sub>H<sub>15</sub><sup>35</sup>ClF<sub>3</sub>N<sub>2</sub>O<sub>2</sub>, found: 407.0783.

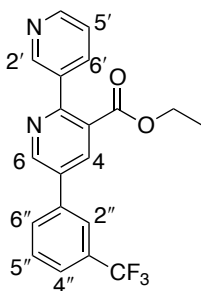
**5-(3-Trifluoromethylphenyl)-[2,4']bipyridinyl-3-carboxylic acid ethyl ester 146n**

Prepared according to general procedure F using 3-trifluoromethylcinnamic acid (0.21 g, 1.0 mmol), 3-pyridinecarboxaldehyde (0.1 ml, 1.1 mmol) and ethyl (*E*)-3-(pyrrolidin-1-yl)-2-propenoate (0.34 g, 2.0 mmol). Crude acyl azide (0.24 g, 0.98 mmol). Purification by column chromatography (SiO<sub>2</sub>, 20-100% EtOAc in petrol) gave the pyridine **146n** as yellow needles (0.081 g, 32%).

M.p.= 87-88 °C (EtOAc–Petrol);  $\delta_{\text{H}}$  (300 MHz, CDCl<sub>3</sub>); 9.04 (1H, d, *J* 2.7 Hz, H6), 8.79 (1H, d, *J* 1.6 Hz, H2'), 8.68 (1H, d, *J* 4.9, 1.6 Hz, H4'), 8.42 (1H, d, *J* 2.7 Hz, H4), 7.96 (1H, dt, *J* 8.0, 1.6 Hz, H6'), 7.91 (1H, s, H2''), 7.86 (1H, d, *J* 7.7 Hz, H4''), 7.74 (1H, d, *J* 7.7 Hz, H6''), 7.68 (1H, t, *J* 7.7 Hz, H5''), 7.43 (1H, ddd, *J* 7.7, 4.9, 1.6 Hz, H5'), 4.25 (2H, q, *J* 7.1 Hz, CH<sub>2</sub>), 1.14 (3H, t, *J* 7.1 Hz, CH<sub>2</sub>CH<sub>3</sub>);  $\delta_{\text{C}}$  (75 MHz, CDCl<sub>3</sub>); 167.0 (C=O), 155.4 (quat.), 149.8 (H2' or H4' or H6), 149.6 (H2' or H4' or H6), 149.5 (H2' or H4' or H6), 137.1 (quat.), 136.8 (ArCH), 136.1 (ArCH), 135.6 (quat.), 134.1 (quat.), 131.8 (q, *J* 32.6 Hz, CCF<sub>3</sub>), 130.5 (ArCH), 129.9 (ArCH), 127.4 (q, *J* 271.5 Hz, CF<sub>3</sub>), 127.2 (quat.), 125.5 (q, *J* 3.9 Hz, ArCH), 124.0 (q, *J* 3.9 Hz, ArCH), 123.0 (ArCH), 62.0 (CH<sub>2</sub>), 13.8 (CH<sub>3</sub>);  $\nu_{\text{max}}/\text{cm}^{-1}$  (solid); 2981, 1709, 1590, 1445, 1416, 1253, 1174, 1116, 1012; HRMS (ES<sup>+</sup>) *m/z*: [M+H]<sup>+</sup> requires 391.1064 for C<sub>20</sub>H<sub>15</sub>F<sub>4</sub>N<sub>2</sub>O<sub>2</sub>, found: 391.1079.

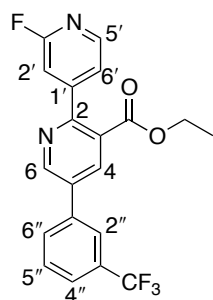
**2'-Fluoro-5-(3-trifluoromethylphenyl)-[2,4']bipyridinyl-3-carboxylic acid ethyl ester 146p**

Prepared according to general procedure F using 3-trifluoromethylcinnamic acid (0.21 g, 1.0 mmol), 3-fluoroisonicotinaldehyde (0.16 ml, 1.1 mmol) and ethyl (*E*)-3-(pyrrolidin-1-yl)-2-propenoate (0.34 g, 2.0 mmol). Crude acyl azide (0.24 g, 0.98 mmol). Purification by column chromatography (SiO<sub>2</sub>, 10-100% EtOAc in petrol) gave the pyridine **146p** as yellow oil (0.21 g, 53%).

$\delta_{\text{H}}$  (300 MHz, CDCl<sub>3</sub>); 9.08 (1H, d, *J* 2.2 Hz, H6), 8.59 (1H, br d, *J* 3.8 Hz, H2'), 8.56-8.50 (2H, m, H4 + H5'), 7.92 (1H, s, H2''), 7.88 (1H, d, *J* 7.7 Hz, H5''), 7.75 (1H, d, *J* 7.7 Hz, H4''), 7.69 (1H, d, *J* 7.7 Hz, H6''), 7.67-7.58 (1H, m, H6'), 4.30 (2H, q, *J* 7.1 Hz, CH<sub>2</sub>), 1.19 (3H, t, *J* 7.1 Hz, CH<sub>2</sub>CH<sub>3</sub>);  $\delta_{\text{C}}$  (75 MHz, CDCl<sub>3</sub>); 165.5 (C=O), 154.8 (d, *J* 257.6 Hz, CF, quat.), 150.6 (quat.), 150.3 (C6), 146.0 (d, *J* 146.0 Hz, C2'), 137.7 (d, *J* 24.9 Hz, C5'), 136.8 (quat.), 136.7 (C4), 135.6 (d, *J* 12.7 Hz, C1'), 135.2 (quat.), 131.8 (q, *J* 33.2 Hz, CCF<sub>3</sub>), 130.6 (d, *J* 1.1 Hz, ArCH), 129.9 (ArCH), 128.0 (d, *J* 1.1 Hz, C2), 125.7 (q, *J* 3.7 Hz, ArCH), 124.6 (ArCH), 124.1 (q, *J* 3.9 Hz, ArCH), 123.2 (q, *J* 273.7 Hz, CF<sub>3</sub>), 62.04 (CH<sub>2</sub>), 13.7 (CH<sub>3</sub>);  $\nu_{\text{max}}/\text{cm}^{-1}$  (solid); 3047, 2985, 1725, 1611, 1564, 1491, 1438, 1414, 1366, 1340, 1300, 1277, 1250, 1168, 1128, 1078, 1063, 1017; HRMS (ES<sup>+</sup>) *m/z*; [M+H]<sup>+</sup> requires 391.1064 for C<sub>20</sub>H<sub>15</sub>F<sub>4</sub>N<sub>2</sub>O<sub>2</sub>, found: 391.1079.

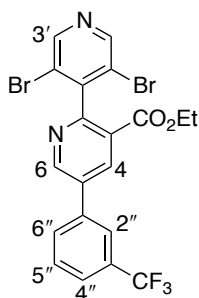
**Ethyl 3',5'-dibromo-5-[3-(trifluoromethyl)phenyl]-2,4'-bipyridine-3-carboxylate 146q**

Prepared according to general procedure F using 3-trifluoromethylcinnamic acid (0.21 g, 1.0 mmol), 3,5-dibromo-4-pyridinecarboxaldehyde (0.29 g, 1.1 mmol) and ethyl (*E*)-3-(pyrrolidin-1-yl)-2-propenoate (0.34 g, 2.0 mmol). Purification by column chromatography (SiO<sub>2</sub>, 0-30% EtOAc in petrol) gave the pyridine **146q** as yellow needles (0.17 g, 32%).

M.p.= 87-88°C (EtOH);  $\delta_{\text{H}}$  (300 MHz, CDCl<sub>3</sub>); 9.04 (1H, d, *J* 2.2 Hz, H6), 8.68 (2H, s, H3'), 8.61 (1H, d, *J* 2.2 Hz, H4), 7.89 (1H, s, H2''), 7.84 (1H, d, *J* 7.7 Hz, H4''), 7.70-7.59 (2H, m, H5''+H6''), 4.16 (2H, q, *J* 7.1 Hz, CH<sub>2</sub>), 1.03 (3H, t, *J* 7.1 Hz, CH<sub>3</sub>);  $\delta_{\text{C}}$  (75 MHz, CDCl<sub>3</sub>); 164.1 (C=O), 155.5 (quat.), 151.0 (C6), 150.0 (C3'), 149.7 (quat.), 137.3 (C4), 136.8 (quat.), 135.6 (quat.), 131.9 (q, *J* 33.7 Hz, CCF<sub>3</sub>), 130.6 (C4''), 129.9 (C5'' or C6''), 125.9 (quat.), 125.7 (C5'' or C6''), 124.2 (C2''), 122.0 (q, *J* 274.2 Hz, CF<sub>3</sub>), 120.8 (quat.), 62.1 (CH<sub>2</sub>), 13.6 (CH<sub>3</sub>);  $\nu_{\text{max}}/\text{cm}^{-1}$  (solid); 3005, 1716, 1425, 1365, 1225, 1093; HRMS (ES<sup>+</sup>) *m/z*; [M+H]<sup>+</sup> requires 528.9369 for C<sub>20</sub>H<sub>14</sub><sup>79</sup>Br<sub>2</sub>F<sub>3</sub>N<sub>2</sub>O<sub>2</sub>, found: 528.9360.

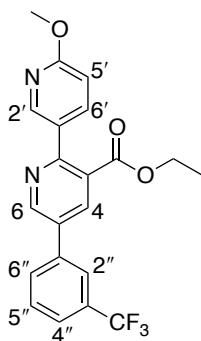
**Ethyl 6'-methoxy-5-[3-(trifluoromethyl)phenyl]-2,3'-bipyridine-3-carboxylate 146r**

Prepared according to general procedure F using 3-trifluoromethylcinnamic acid (0.21 g, 1.0 mmol), 6-methoxy-3-pyridinecarboxaldehyde (0.15 g, 1.1 mmol) and ethyl (*E*)-3-(pyrrolidin-1-yl)-2-propenoate (0.34 g, 2.0 mmol). Purification by column chromatography (SiO<sub>2</sub>, 0-100% EtOAc in petrol) gave the pyridine **146r** as yellow needles (0.045 g, 12%).

M.p.= 112-113°C (EtOH);  $\delta_{\text{H}}$  (300 MHz, CDCl<sub>3</sub>); 8.92 (1H, d, *J* 2.5 Hz, H6), 8.30 (1H, d, *J* 2.5 Hz, H2'), 8.26 (1H, d, *J* 2.5 Hz, H4), 7.82-7.75 (3H, m, H5' + ArH), 7.65-7.55 (2H, m, ArH), 6.77 (1H, d, *J* 8.8 Hz, H6'), 4.21 (2H, q, *J* 7.0 Hz, CH<sub>2</sub>), 3.93 (3H, s, OCH<sub>3</sub>), 1.13 (3H, t, *J* 7.0 Hz, CH<sub>3</sub>);  $\delta_{\text{C}}$  (75 MHz, CDCl<sub>3</sub>); 167.5 (C=O), 164.4 (quat.) 155.2 (quat.), 149.6 (C6), 147.1 (C2'), 139.1 (C5'), 137.3 (quat.), 136.7 (C4), 133.4 (quat.), 131.8 (q, *J* 32.1 Hz, CCF<sub>3</sub>), 130.4 (q, *J* 1.1 Hz, ArCH), 129.8 (ArCH), 128.6 (quat.), 126.9 (quat.), 125.3 (q, *J* 3.9 Hz, ArCH), 124.4 (q, *J* 272.6 Hz, CF<sub>3</sub>), 123.9 (q, *J* 3.9 Hz, ArCH), 110.4 (C6'), 61.9 (CH<sub>2</sub>), 53.8 (OCH<sub>3</sub>), 13.9 (CH<sub>3</sub>);  $\nu_{\text{max}}/\text{cm}^{-1}$  (solid); 3604, 3415, 2929, 2576, 2441, 2263, 2145, 2000, 1764, 1216, 1092; HRMS (ES<sup>+</sup>) *m/z*; [M+H]<sup>+</sup> requires 403.1264 for C<sub>21</sub>H<sub>18</sub>F<sub>3</sub>N<sub>2</sub>O<sub>3</sub>, found: 403.1260.

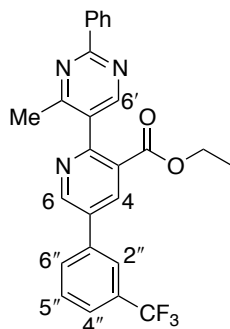
**2-(4-Methyl-2-phenylpyrimidin-5-yl)-5-(3-trifluoromethylphenyl)nicotinic acid ethyl ester 146s**

Prepared according to general procedure F using 3-trifluoromethylcinnamic acid (0.21 g, 1.0 mmol), 4-methyl-2-phenyl-5-pyrimidylcarboxaldehyde (0.22 g, 1.1 mmol) and ethyl (*E*)-3-(pyrrolidin-1-yl)-2-propenoate (0.34 g, 2.0 mmol). Purification by column chromatography (SiO<sub>2</sub>, 10-100% EtOAc in petrol) gave the pyridine **146s** as yellow needles (0.18 g, 39%).

M.p.= 99-100 °C (EtOH);  $\delta_{\text{H}}$  (300 MHz, CDCl<sub>3</sub>); 9.09 (1H, d, *J* 2.2 Hz, H6), 8.61 (1H, s, H6'), 8.59 (1H, d, *J* 2.2 Hz, H4), 8.54-8.49 (2H, m, ArH), 7.94 (1H, s, C2''), 7.88 (1H, d, *J* 7.7 Hz, C5''), 7.75 (1H, d, *J* 7.7 Hz, C4''), 7.69 (1H, t, *J* 7.7 Hz, C6''), 7.53-7.48 (3H, m, ArH), 4.21 (2H, q, *J* 7.1 Hz, CH<sub>2</sub>), 2.48 (3H, s, CH<sub>3</sub>), 1.16 (3H, t, *J* 7.1 Hz, CH<sub>2</sub>CH<sub>3</sub>);  $\delta_{\text{C}}$  (75 MHz, CDCl<sub>3</sub>); 165.6 (C=O or C2' or C4'), 164.7 (C=O or C2' or C4'), 163.7 (C=O or C2' or C4'), 155.8 (C6'), 155.0 (quat.), 150.4 (C6), 137.6 (quat.), 137.1 (C4), 137.0 (quat.), 134.7 (quat.), 131.8 (q, *J* 33.1 Hz, CCF<sub>3</sub>), 131.5 (quat.), 130.7 (C5'' or C6'' or ArCH), 130.6 (C5'' or C6'' or ArCH), 130.0 (C5'' or C6'' or ArCH), 128.6 (ArCH), 128.3 (ArCH), 127.4 (quat.), 125.6 (q, *J* 3.3 Hz, C4''), 124.5 (q, *J* 272.0 Hz, CF<sub>3</sub>), 124.1 (q, *J* 3.3 Hz, C2''), 62.1 (CH<sub>2</sub>CH<sub>3</sub>), 22.9 (CH<sub>3</sub>), 13.9 (CH<sub>2</sub>CH<sub>3</sub>);  $\nu_{\text{max}}/\text{cm}^{-1}$  (solid); 2965, 1723, 1572, 1532,

1422, 1338, 1252, 1168, 1120, 1019; HRMS ( $ES^+$ )  $m/z$ ;  $[M+H]^+$  requires 464.1580 for  $C_{26}H_{21}F_3N_3O_2$ , found: 464.1581.

#### Ethyl 2-(quinolin-4-yl)-5-[3-(trifluoromethyl)phenyl]pyridine-3-carboxylate **146t**

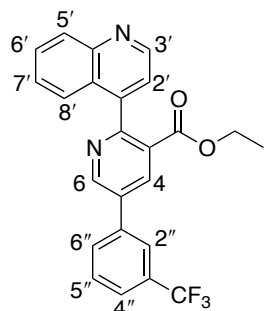

Prepared according to general procedure F using 3-trifluoromethylcinnamic acid (0.21 g, 1.0 mmol), 4-quinolinecarboxaldehyde (0.17 g, 1.1 mmol) and ethyl (*E*)-3-(pyrrolidin-1-yl)-2-propenoate (0.34 g, 2.0 mmol). Purification by column chromatography ( $SiO_2$ , 10-100% EtOAc in petrol) gave the pyridine **146t** as yellow needles (0.16 g, 38%).

M.p.= 127-128°C (EtOH);  $\delta_H$  (300 MHz,  $CDCl_3$ ); 9.14 (1H, d,  $J$  2.2 Hz, H6), 9.04 (1H, d,  $J$  4.4 Hz, H3'), 8.61 (1H, d,  $J$  2.2 Hz, H4), 8.21 (1H, d,  $J$  8.2 Hz, H4''), 7.98 (1H, s, H2''), 7.92 (1H, d,  $J$  7.7 Hz, ArH), 7.79-7.68 (3H, m, ArH), 7.57-7.47 (2H, m, ArH), 7.43 (1H, d,  $J$  4.4 Hz, H2'), 3.90 (2H, q,  $J$  7.1 Hz,  $CH_2$ ), 0.61 (3H, t,  $J$  7.1 Hz,  $CH_3$ );  $\delta_C$  (75 MHz,  $CDCl_3$ ); 165.7 (C=O), 155.7 (quat.) 150.3 (C6), 149.8 (C3'), 148.1 (quat.), 146.7 (quat.), 137.0 (quat.), 136.8 (C4), 134.9 (quat.), 131.9 (q,  $J$  33.2 Hz,  $CCF_3$ ), 130.6 (d,  $J$  1.7 Hz, ArCH), 130.1 (ArCH), 129.9 (ArCH), 129.4 (ArCH), 128.1 (quat.), 127.1 (ArCH), 126.6 (quat.), 125.5 (q,  $J$  3.9 Hz, ArCH), 124.8 (ArCH), 124.1 (q,  $J$  3.9 Hz, ArCH), 123.3 (q,  $J$  274.2 Hz,  $CF_3$ ), 120.6 (ArCH), 61.7 ( $CH_2$ ), 12.9 ( $CH_3$ );  $\nu_{max}/cm^{-1}$  (solid); 3063, 2984, 1715, 1591, 1509, 1385, 1123, 1018; HRMS ( $ES^+$ )  $m/z$ ;  $[M+H]^+$  requires 423.1315 for  $C_{24}H_{18}F_3N_2O_2$ , found: 423.1332.

#### Ethyl 2-(quinolin-3-yl)-5-[3-(trifluoromethyl)phenyl]pyridine-3-carboxylate **146u**

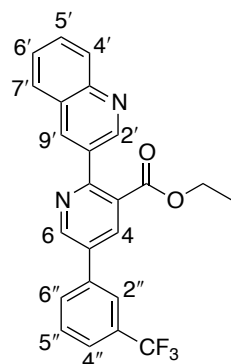

Prepared according to general procedure F using 3-trifluoromethylcinnamic acid (0.21 g, 1.0 mmol), 3-quinolinecarboxaldehyde (0.17 g, 1.1 mmol) and ethyl (*E*)-3-(pyrrolidin-1-yl)-2-propenoate (0.34 g, 2.0 mmol). Crude acyl azide (0.23 g, 0.93 mmol). Purification by column chromatography ( $SiO_2$ , 20-100% EtOAc in petrol) gave the pyridine **146u** as yellow needles (0.07 g, 16%).

M.p.= 120-121 °C (EtOH);  $\delta_H$  (300 MHz,  $CDCl_3$ ); 9.09 (2H, m, H6 + H2'), 8.47 (2H, m, H4 + H8'), 8.18 (1H, d,  $J$  8.5 Hz,  $HC_6H_3CF_3$ ), 7.94-7.87 (3H, m, ArH), 7.82-7.59 (4H, m, ArH), 4.25 (2H, q,  $J$  7.2 Hz,  $CH_2$ ), 1.07 (3H, t,  $J$  7.2 Hz,  $CH_3$ );  $\delta_C$  (75 MHz,  $CDCl_3$ ); 167.1 (C=O), 155.4 (quat.), 150.4 (C6 or C8'), 150.0 (C6 or C8'), 147.8 (quat.), 137.2 (quat.), 136.9 (C4 or C6'), 135.8 (C4 or C6'), 134.1 (quat.), 132.7 (quat.), 131.6 (q,  $J$  33.2 Hz,  $CCF_3$ ), 130.5 (q,  $J$  1.1 Hz, ArCH), 130.2 (ArCH), 129.9 (ArCH), 129.3 (ArCH), 128.4 (ArCH), 127.4 (quat.), 127.3 (quat.), 127.1 (ArCH), 125.5 (q,  $J$  3.9 Hz, ArCH), 125.4 (q,  $J$  272.6 Hz,  $CF_3$ ), 124.0 (q,  $J$  3.9 Hz, ArCH), 62.1 ( $CH_2$ ), 13.8 ( $CH_3$ );  $\nu_{max}/cm^{-1}$  (solid);



2990, 1730, 1569, 1549, 1438, 1341, 1298, 1276, 1235, 1209, 1087; HRMS (ES<sup>+</sup>) *m/z*; [M+H]<sup>+</sup> requires 423.1315 for C<sub>24</sub>H<sub>18</sub>F<sub>3</sub>N<sub>2</sub>O<sub>2</sub>, found: 423.1320.

### 5-(3-Trifluoromethylphenyl)-[2,4']bipyridinyl-3-carboxylic acid ethyl ester **150a**

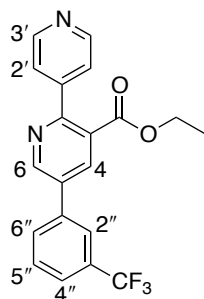

Prepared according to general procedure F using 3-trifluoromethylcinnamic acid (0.21 g, 1.0 mmol), 4-pyridinecarboxaldehyde (0.10 ml, 1.1 mmol) and ethyl (*E*)-3-(pyrrolidin-1-yl)-2-propenoate (0.34 g, 2.0 mmol). Crude acyl azide was a yellow solid (0.237 g, 0.98 mmol). Purification by column chromatography (SiO<sub>2</sub>, 30-100% EtOAc in petrol) gave the pyridine **150a** as yellow needles (0.16 g, 49%).

M.p. = 80-82 °C (EtOH); δ<sub>H</sub> (300 MHz, CDCl<sub>3</sub>); 8.96 (1H, d, *J* 2.2 Hz, H<sub>6</sub>), 8.66 (2H, dd, *J* 4.8, 1.6 Hz, H<sub>3'</sub>), 8.32 (1H, d, *J* 2.2 Hz, H<sub>4</sub>), 7.83 (1H, s, H<sub>2''</sub>), 7.78 (1H, d, *J* 7.7 Hz, H<sub>4''</sub>), 7.67 (1H, d, *J* 7.7 Hz, H<sub>6''</sub>), 7.60 (1H, t, *J* 7.7 Hz, H<sub>5''</sub>), 7.42 (2H, dd, *J* 4.4, 1.6 Hz, H<sub>2'</sub>), 4.16 (2H, q, *J* 7.1 Hz, CH<sub>2</sub>), 1.05 (3H, t, *J* 7.1 Hz, CH<sub>3</sub>); δ<sub>C</sub> (75 MHz, CDCl<sub>3</sub>); 167.8 (C=O), 154.7 (quat.), 148.7 (C<sub>6</sub> or C<sub>3'</sub>), 148.6 (C<sub>6</sub> or C<sub>3'</sub>), 146.3 (quat.), 135.8 (quat.), 135.6 (C<sub>4</sub>), 133.5 (quat.), 130.6 (quat., q, *J* 32.0 Hz, C<sub>3''</sub>), 129.4 (C<sub>4''</sub>), 128.9 (C<sub>5''</sub>), 126.4 (quat.), 124.6 (C<sub>6''</sub>), 123.1 (q, *J* 263.5 Hz, CF<sub>3</sub>), 123.0 (C<sub>2''</sub>), 122.9 (C<sub>2'</sub>), 61.1 (CH<sub>2</sub>), 12.6 (CH<sub>3</sub>); ν<sub>max</sub>/cm<sup>-1</sup> (solid); 3416, 3073, 3040, 2910, 2446, 1971, 1944, 1712, 1598, 1558, 1538, 1435, 1106, 1035, 1014; HRMS (ES<sup>+</sup>) *m/z*; [M+H]<sup>+</sup> requires 373.1158 for C<sub>20</sub>H<sub>16</sub>F<sub>3</sub>N<sub>2</sub>O<sub>2</sub>, found: 373.1157.

### 5-(4-Methoxyphenyl)-[2,4']bipyridinyl-3-carboxylic acid ethyl ester **150b**

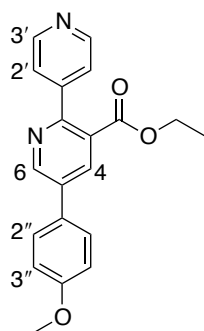

Prepared according to general procedure E using 4-methoxycinnamic acid (0.18 g, 1.0 mmol), 4-pyridinecarboxaldehyde (0.10 ml, 1.1 mmol) and ethyl (*E*)-3-(pyrrolidin-1-yl)-2-propenoate (0.34 g, 2.0 mmol). Crude acyl azide was a colourless solid (0.15 g, 0.71 mmol). Purification by column chromatography (SiO<sub>2</sub>, 30-100% EtOAc in petrol) gave the pyridine **150b** as yellow needles (0.16 g, 49%).

M.p. = 88-94 °C (EtOAc-petrol); δ<sub>H</sub> (300 MHz, CDCl<sub>3</sub>); 8.99 (1H, d, *J* 2.2 Hz, H<sub>6</sub>), 8.70 (2H, d, *J* 4.4 Hz, H<sub>3'</sub>), 8.34 (1H, d, *J* 2.2 Hz, H<sub>4</sub>), 7.64-7.58 (2H, m, H<sub>3''</sub>), 7.50 (2H, d, *J* 4.4 Hz, H<sub>2'</sub>), 7.08-7.02 (2H, m, H<sub>2''</sub>), 4.22 (2H, q, *J* 7.1 Hz, CH<sub>2</sub>), 3.88 (3H, s, OCH<sub>3</sub>), 1.12 (3H, t, *J* 7.1 Hz, CH<sub>3</sub>); δ<sub>C</sub> (75 MHz, CDCl<sub>3</sub>); 167.1 (C=O), 160.4 (quat.), 154.1 (quat.), 149.4 (C<sub>6</sub>), 149.3 (C<sub>1'</sub>), 147.9 (quat.), 135.8 (C<sub>4</sub>), 135.6 (quat.), 128.4 (ArCH), 128.3 (quat.), 127.1 (C<sub>2'</sub>), 123.4 (ArCH), 114.8 (ArCH), 61.9 (CH<sub>2</sub>), 55.4 (OCH<sub>3</sub>), 13.6 (CH<sub>3</sub>); ν<sub>max</sub>/cm<sup>-1</sup> (solid); 2978, 2836, 1714, 1597, 1519, 1441, 1406, 1365, 1322, 1295, 1249, 1184, 1120, 1107, 1061, 1017; HRMS (ES<sup>+</sup>) *m/z*; [M+H]<sup>+</sup> requires 335.1390 for C<sub>20</sub>H<sub>19</sub>N<sub>2</sub>O<sub>3</sub>, found: 335.1400.

### Ethyl 5,6-diphenyl-2,4'-bipyridine-3-carboxylate **150c**

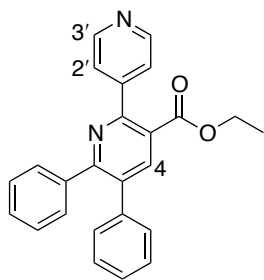

Prepared according to general procedure F using  $\alpha$ -phenylcinnamic acid (0.22 g, 1.0 mmol), 4-pyridinecarboxaldehyde (0.1 ml, 1.1 mmol) and ethyl (*E*)-3-(pyrrolidin-1-yl)-2-propenoate (0.34 g, 2.0 mmol). Crude acyl azide (0.25 g, 0.99 mmol). Purification by column chromatography (SiO<sub>2</sub>, 0-40% EtOAc in petrol) gave the pyridine **150c** as yellow needles (0.07 g, 18%).

M.p.= 174-175 °C (EtOH);  $\delta_{\text{H}}$  (300 MHz, CDCl<sub>3</sub>); 8.65 (2H, br s, H3'), 8.17 (1H, s, H4), 7.51 (2H, d, *J* 4.1 Hz, H2'), 7.38-7.35 (2H, m, ArH), 7.27-7.15 (8H, m, ArH), 4.16 (2H, q, *J* 7.1 Hz, CH<sub>2</sub>), 1.06 (3H, t, *J* 7.1 Hz, CH<sub>3</sub>);  $\delta_{\text{C}}$  (75 MHz, CDCl<sub>3</sub>); 166.9 (C=O), 158.8 (quat.), 154.7 (quat.), 149.2 (C3'), 148.1 (quat.), 140.9 (C4), 138.8 (quat.), 138.4 (quat.), 135.3 (quat.), 130.1 (ArCH), 129.4 (ArCH), 128.7 (ArCH), 128.6 (ArCH), 128.0 (ArCH), 127.9 (ArCH), 125.2 (quat.), 123.7 (C2'), 61.8 (CH<sub>2</sub>), 13.7 (CH<sub>3</sub>);  $\nu_{\text{max}}/\text{cm}^{-1}$  (solid); 3004, 2970, 1737, 1436, 1365, 1228, 1217; HRMS (ES<sup>+</sup>) *m/z*; [M+H]<sup>+</sup> requires 381.1598 for C<sub>25</sub>H<sub>21</sub>N<sub>2</sub>O<sub>2</sub>, found: 381.1594.

#### Ethyl 6-methyl-5-phenyl-2,4'-bipyridine-3-carboxylate **150d**

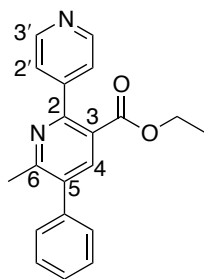

Prepared according to general procedure F using  $\alpha$ -methylcinnamic acid (0.16 g, 1.0 mmol), 4-pyridinecarboxaldehyde (0.1 ml, 1.1 mmol) and ethyl (*E*)-3-(pyrrolidin-1-yl)-2-propenoate (0.34 g, 2.0 mmol). Crude acyl azide (0.15 g, 0.82 mmol). Purification by column chromatography (SiO<sub>2</sub>, 50-100% EtOAc in hexane) gave the pyridine **150d** as yellow oil (0.088 g, 27%).

$\delta_{\text{H}}$  (300 MHz, CDCl<sub>3</sub>); 8.64 (2H, d, *J* 5.5 Hz, H3'), 8.01 (1H, s, H4), 7.46-7.37 (5H, m, ArH), 7.33-7.30 (2H, m, ArH), 4.11 (2H, q, *J* 7.1 Hz, CH<sub>2</sub>), 2.54 (3H, s, CH<sub>3</sub>) 1.01 (3H, t, *J* 7.1 Hz, CH<sub>2</sub>CH<sub>3</sub>);  $\delta_{\text{C}}$  (75 MHz, CDCl<sub>3</sub>); 166.9 (C=O), 159.0 (quat.), 154.7 (quat.), 149.3 (C2'), 148.2 (quat.), 139.4 (C4), 138.2 (quat.), 136.4 (quat.), 129.0 (ArCH), 128.7 (ArCH), 128.1 (ArCH), 124.4 (quat.), 123.5 (ArCH), 61.7 (CH<sub>2</sub>), 23.7 (CH<sub>3</sub>), 13.7 (CH<sub>2</sub>CH<sub>3</sub>);  $\nu_{\text{max}}/\text{cm}^{-1}$  (solid); 3032, 2982, 1722, 1599, 1537, 1427, 1388, 1254, 1113, 1057, 1015; HRMS (ES<sup>+</sup>) *m/z*; [M+H]<sup>+</sup> requires 319.1441 for C<sub>20</sub>H<sub>19</sub>N<sub>2</sub>O<sub>2</sub>, found: 319.1454.

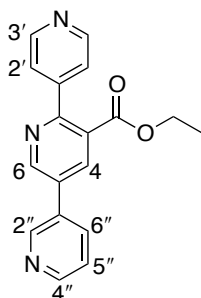
**Ethyl 2,1':5',1''-terpyridine-3-carboxylate 150e**

Prepared according to general procedure F using *trans*-3-(3-pyridyl)acrylic acid (0.30 g, 2.0 mmol), 4-pyridinecarboxaldehyde (0.2 ml, 2.0 mmol) and ethyl (*E*)-3-(pyrrolidin-1-yl)-2-propenoate (0.34 g, 2.0 mmol). Crude acyl azide (0.33 g, 1.87 mmol). Purification by column chromatography (SiO<sub>2</sub>, 20-75% EtOAc in petrol) gave the pyridine **150e** as orange needles (0.29 g, 46%).

M.p.= 119-120°C (EtOH);  $\delta_{\text{H}}$  (300 MHz, CDCl<sub>3</sub>); 8.97 (1H, d, *J* 2.5 Hz, H6), 8.88 (1H, br s, H2''), 8.68 (3H, br s, H3' + H4''), 8.34 (1H, d, *J* 2.5 Hz, H4), 7.92 (1H, m, H5''), 7.50-7.40 (3H, m, H2' + H6''), 4.16 (2H, q, *J* 7.1 Hz, CH<sub>2</sub>), 1.06 (3H, t, *J* 7.1 Hz, CH<sub>3</sub>);  $\delta_{\text{C}}$  (75 MHz, CDCl<sub>3</sub>); 166.7 (C=O), 155.7 (quat.), 150.1 (quat.), 149.7 (C6), 149.2 (C2''), 148.2 (ArCH), 147.8 (quat.), 136.6 (C2' + C6''), 134.5 (C4), 132.9 (quat.), 127.4 (quat.), 124.0 (ArCH), 123.4 (ArCH), 62.1 (CH<sub>2</sub>), 13.6 (CH<sub>3</sub>);  $\nu_{\text{max}}/\text{cm}^{-1}$  (solid); 2995, 1736, 1422, 1364, 1217, 1101, 1025; HRMS (ES<sup>+</sup>) *m/z*; [M+H]<sup>+</sup> requires 306.1237 for C<sub>18</sub>H<sub>16</sub>N<sub>3</sub>O<sub>2</sub>, found: 306.1249.

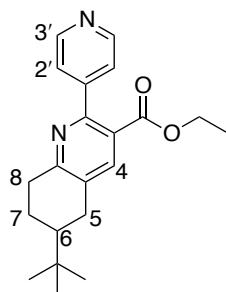
**Ethyl 6-(*tert*-butyl-2-pyridin-4-yl)-5,6,7,8-tetrahydroquinoline-3-carboxylate 150g**

Prepared according to general procedure E using 1-cyclohexenyl carboxylic acid (0.18 g, 1.0 mmol), 4-pyridinecarboxaldehyde (0.1 ml, 1.1 mmol) and ethyl (*E*)-3-(pyrrolidin-1-yl)-2-propenoate (0.34 g, 2.0 mmol). Purification by column chromatography (SiO<sub>2</sub>, 0-100% EtOAc in hexane) gave the pyridine **150g** as yellow plates (0.067 g, 10%).

M.p. = 89-90 °C (CHCl<sub>3</sub>);  $\delta_{\text{H}}$  (500 MHz, CDCl<sub>3</sub>); 8.58 (2H, d, *J* 4.1 Hz, H3'), 7.86 (1H, s, H4), 7.32 (2H, d, *J* 4.1 Hz, H2'), 4.07 (2H, q, *J* 7.4 Hz, CH<sub>2</sub>CH<sub>3</sub>), 3.08 (1H, ddd, *J* 17.6, 4.9, 1.6 Hz, H8<sub>eq</sub>), 2.86 (2H, m, H5<sub>eq</sub> + H8<sub>ax</sub>), 2.56 (1H, dd, *J* 16.6, 11.1 Hz, H5<sub>ax</sub>), 2.10-2.05 (1H, m, H7<sub>ax</sub> or H7<sub>eq</sub>), 1.52-1.37 (2H, m, H6 + H7<sub>ax</sub> or H7<sub>eq</sub>), 1.00 (3H, t, *J* 7.4 Hz, CH<sub>2</sub>CH<sub>3</sub>), 0.92 (9H, s, <sup>t</sup>Bu);  $\delta_{\text{C}}$  (125 MHz, CDCl<sub>3</sub>); 167.1 (C=O), 160.7 (quat.), 153.8 (quat.), 149.4 (C3'), 148.6 (quat.), 139.3 (C4), 132.3 (quat.), 138.4 (quat.), 124.0 (quat.), 123.4 (C2'), 61.4 (CH<sub>2</sub>CH<sub>3</sub>), 44.2 (C6), 33.7 (C8), 29.9 (C5), 27.6 (<sup>t</sup>Bu), 24.2 (C7), 13.6 (CH<sub>2</sub>CH<sub>3</sub>);  $\nu_{\text{max}}/\text{cm}^{-1}$  (solid); 2956, 2866, 1712, 1596, 1543, 1411, 1365, 1291, 1215, 1094, 1068, 1023; HRMS (ES<sup>+</sup>) *m/z*; [M+H]<sup>+</sup> requires 339.2067 for C<sub>21</sub>H<sub>27</sub>N<sub>2</sub>O<sub>2</sub>, found: 339.2080.

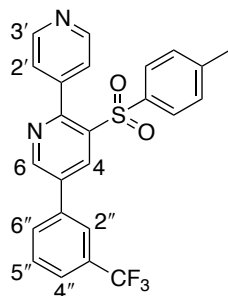
**3-Tosyl-5-(3-trifluoromethylphenyl)-2,4'-bipyridine 159a**

Prepared according to general procedure F using 3-trifluoromethylcinnamic acid (0.21 g, 1.0 mmol), 4-pyridinecarboxaldehyde (0.1 mL, 1.1 mmol) and 1-(*E*)-2-[(4-methylphenyl)sulfonyl]ethenyl pyrrolidine (0.50 g, 2.0 mmol). Purification by column chromatography (SiO<sub>2</sub>, 30-100% EtOAc in hexane then 0-100% EtOAc in CH<sub>2</sub>Cl<sub>2</sub>) gave the pyridine **159a** as brown plates (0.087 g, 19%).

M.p. = 145-146 °C (CHCl<sub>3</sub>); δ<sub>H</sub> (300 MHz, CDCl<sub>3</sub>); 8.98 (1H, d, *J* 2.2 Hz, H6), 8.84 (1H, d, *J* 2.2 Hz, H4), 8.52 (2H, br s, H3'), 7.88 (1H, s, H2''), 7.84 (1H, d, *J* 8.0 Hz, H6''), 7.73 (1H, d, *J* 8.0 Hz, H4''), 7.65 (1H, t, *J* 8.0 Hz, H5''), 7.17-7.14 (4H, m, SO<sub>2</sub>C<sub>6</sub>H<sub>4</sub>), 7.03 (2H, d, *J* 8.2 Hz, H2'), 2.30 (3H, s, CH<sub>3</sub>); δ<sub>C</sub> (75 MHz, CDCl<sub>3</sub>); 154.9 (quat.), 150.7 (C6), 148.7 (C3'), 145.9 (quat.), 145.1 (quat.), 138.0 (quat.), 136.2 (d, *J* 4.2 Hz, quat.), 135.4 (quat.), 135.2 (C4), 132.2 (q, *J* 33.2 Hz, CCF<sub>3</sub>), 130.7 (C6''), 130.1 (C5''), 129.6 (ArCH), 128.0 (C2'), 126.1 (q, *J* 4.2 Hz, C4''), 124.5 (ArCH), 124.2 (q, *J* 4.2 Hz, C2''), 124.0 (q, *J* 274.0 Hz, CF<sub>3</sub>), 122.8 (quat.), 21.6 (CH<sub>3</sub>); ν<sub>max</sub>/cm<sup>-1</sup> (solid); 3047, 1596, 1532, 1438, 1320, 1219, 1149, 1116, 1080, 1049; HRMS (ES<sup>+</sup>) *m/z*; [M+H]<sup>+</sup> requires 455.1040 for C<sub>24</sub>H<sub>18</sub>F<sub>3</sub>N<sub>2</sub>O<sub>2</sub>S, found: 455.1036.

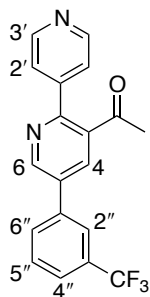
**1-(5-(3-Trifluoromethylphenyl)-[2,4'-bipyridin]-3-yl) ethanone 159b**

Prepared according to general procedure F using 3-trifluoromethylcinnamic acid (0.21 g, 1.0 mmol), 4-pyridinecarboxaldehyde (0.1 mL, 1.1 mmol) and ethyl (*E*)-3-(pyrrolidin-1-yl)-2-propenoate (0.34 g, 2.0 mmol). Purification by column chromatography (SiO<sub>2</sub>, 50-100% EtOAc-hexane) gave the pyridine **159b** as orange needles (0.14 g, 40%).

M.p.= 113-115°C (EtOH); δ<sub>H</sub> (300 MHz, CDCl<sub>3</sub>); 8.96 (1H, d, *J* 2.2 Hz, H6), 8.70 (2H, d, *J* 5.5 Hz, H3'), 8.02 (1H, d, *J* 2.2 Hz, H4), 7.82 (1H, s, H2''), 7.77 (1H, d, *J* 7.7 Hz, H6''), 7.67 (1H, d, *J* 7.7 Hz, H4''), 7.60 (1H, m, H5''), 7.48 (2H, d, *J* 5.5 Hz, H2'), 2.21 (3H, s, CH<sub>3</sub>); δ<sub>C</sub> (75 MHz, CDCl<sub>3</sub>); 201.2 (C=O), 152.7 (quat.), 149.7 (C3'), 148.3 (C6), 145.5 (quat.), 136.0 (quat.), 135.4 (quat.), 133.8 (quat.), 133.7 (C4), 131.1 (q, *J* 32.1 Hz, CCF<sub>3</sub>), 129.5 (ArCH), 128.9 (ArCH), 124.6 (q, *J* 3.9 Hz, C4''), 123.0 (q, *J* 3.9 Hz, C2''), 122.9 (q, *J* 243.3 Hz, CF<sub>3</sub>), 122.5 (C2'), 29.6 (CH<sub>3</sub>); ν<sub>max</sub>/cm<sup>-1</sup> (solid); 3054, 2961, 1692, 1596, 1533, 1433, 1342, 1296, 1161, 1099, 1076, 1052; HRMS (ES<sup>+</sup>) *m/z*; [M+H]<sup>+</sup> requires 343.1053 for C<sub>19</sub>H<sub>14</sub>F<sub>3</sub>N<sub>2</sub>O, found: 343.1056.

**Ethyl 4-methyl-5-(3-trifluoromethylphenyl)-[2,4'-bipyridine]3-carboxylate **159c** and 3,5-di(3-trifluoromethylphenyl)-2-(4-pyridyl)pyridine **159e****

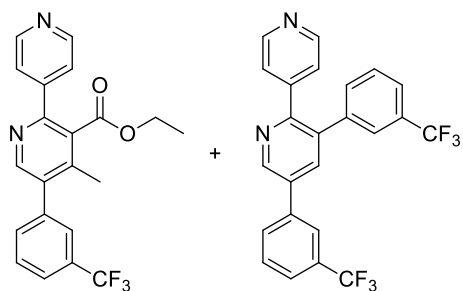

Prepared according to general procedure F using 3-trifluoromethylcinnamic acid (0.21 g, 1.0 mmol), 4-pyridinecarboxaldehyde (0.1 mL, 1.1 mmol) and ethyl trans-2-methyl-3-(1-pyrrolidiny)acrylate (0.37 g, 2.0 mmol). Purification by column chromatography (SiO<sub>2</sub>, 20-100% EtOAc in hexane then 0-100% EtOAc in CH<sub>2</sub>Cl<sub>2</sub>) gave a 5:1

inseparable mixture of pyridine **159c** (major) and pyridine **159e** (minor) as yellow oil (0.15 g, 30% yield **159c**).

$\nu_{\max}/\text{cm}^{-1}$  (solid); 3036, 2984, 1727, 1598, 1538, 1436, 1379, 1340, 1249, 1167, 1127, 1097, 1071, 1020.

**Ethyl 4-methyl-5-(3-trifluoromethylphenyl)-[2,4'-bipyridine]3-carboxylate **159c****

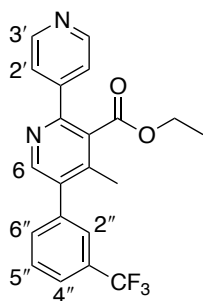

$\delta_{\text{H}}$  (300 MHz, CDCl<sub>3</sub>); 8.66 (2H, d, *J* 4.7 Hz, H3'), 8.53 (1H, s, H6), 7.66 (1H, d, *J* 7.7 Hz, ArH), 7.58-7.56 (2H, m, ArH), 7.52-7.50 (3H, m, H2' + ArH), 4.14 (2H, q, *J* 7.6 Hz, CH<sub>2</sub>CH<sub>3</sub>), 2.25 (3H, s, ArCH<sub>3</sub>), 1.03 (3H, t, *J* 7.6 Hz, CH<sub>2</sub>CH<sub>3</sub>);  $\delta_{\text{C}}$  (125 MHz, CDCl<sub>3</sub>) 18 of 19 signals observed; 168.0 (C=O), 153.1 (quat.), 150.4 (C6), 150.1 (C3'), 147.2 (quat.), 143.3 (quat.), 136.8 (quat.), 132.7 (q, *J* 1.7 Hz, quat.), 131.3 (q, *J* 33.5 Hz, CCF<sub>3</sub>), 130.4 (quat.), 129.7 (ArCH), 129.4 (ArCH), 126.1 (q, *J* 3.9 Hz, ArCH), 125.2 (q, *J* 3.9 Hz, ArCH), 122.8 (C2'), 62.1 (CH<sub>2</sub>CH<sub>3</sub>), 17.3 (ArCH<sub>3</sub>), 13.6 (CH<sub>2</sub>CH<sub>3</sub>); HRMS (ES<sup>+</sup>) *m/z*; [M+H]<sup>+</sup> requires 387.1315 for C<sub>21</sub>H<sub>18</sub>F<sub>3</sub>N<sub>2</sub>O<sub>2</sub>, found: 387.1320.

**3,5-Di(3-trifluoromethylphenyl)-2-(4-pyridyl)pyridine **159e****

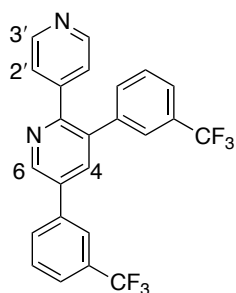

Characteristic signals:  $\delta_{\text{H}}$  (300 MHz, CDCl<sub>3</sub>); 8.93 (1H, d, *J* 2.2 Hz, H6), 8.49 (2H, d, *J* 5.7 Hz, H3'), 7.90 (1H, d, *J* 2.2 Hz, H4), 7.84 (1H, s, ArH), 7.81 (1H, d, *J* 7.2 Hz, ArH), 7.47 (2H, m, ArH), 7.40 (1H, t, *J* 8.5 Hz, ArH), 7.30 (1H, d, *J* 7.2 Hz, ArH), 7.24 (2H, d, *J* 5.7 Hz, H2');  $\delta_{\text{C}}$  (125 MHz, CDCl<sub>3</sub>); 153.7 (quat.), 149.5 (C3'), 147.9 (C6), 139.3 (quat.), 137.6 (quat.), 137.1 (C4), 135.2 (quat.), 133.2 (ArCH), 132.9 (q, *J* 1.7 Hz, ArCH), 131.5 (quat.), 131.0 (quat.), 130.6 (ArCH), 129.9 (ArCH), 129.3 (ArCH), 125.5 (q, *J* 3.1 Hz, ArCH), 124.7 (C2'), 124.1 (q, *J* 3.1 Hz, ArCH); HRMS (ES<sup>+</sup>) *m/z*; [M+H]<sup>+</sup> requires 445.1134 for C<sub>24</sub>H<sub>15</sub>F<sub>6</sub>N<sub>2</sub>, found: 445.1143.

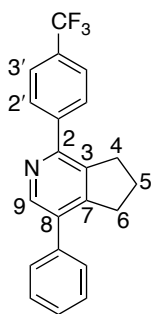
**4-Phenyl-1-(4-trifluoromethylphenyl)-6,7-dihydro-5H-[2]pyridine 159d**

Prepared according to general procedure E using cinnamic acid (0.74 g, 5.0 mmol), DPPA (1.0 mL, 4.5 mmol), triethylamine (0.75 mL, 5.0 mmol), 4-trifluoromethylbenzaldehyde (0.67 mL, 4.95 mmol) and 1-cyclopent-1-enylpyrrolidine (3.3 mL, 22.5 mmol). Crude acyl azide (0.78 g, 4.5 mmol). Purification by column chromatography (SiO<sub>2</sub>, 0-50% EtOAc in hexane then high grade SiO<sub>2</sub> with 0-20% EtOAc in hexane) gave the pyridine **159d** as yellow needles (0.013 g, 5%).

$\delta_{\text{H}}$  (500 MHz, CDCl<sub>3</sub>); 8.58 (1H, s, H<sub>9</sub>), 7.92 (2H, d, *J* 8.1 Hz, H<sub>3'</sub>), 7.73 (2H, d, *J* 8.1 Hz, H<sub>2'</sub>), 7.51-7.48 (4H, m, ArH), 7.43-7.40 (1H, m, ArH), 3.17 (2H, t, *J* 7.3 Hz, C<sub>4</sub>), 3.07 (2H, t, *J* 7.4 Hz, C<sub>6</sub>), 2.10 (2H, quin, *J* 7.3 Hz, C<sub>5</sub>);  $\delta_{\text{C}}$  (100 MHz, CDCl<sub>3</sub>); 152.8 (quat.), 151.3 (quat.), 147.3 (C<sub>9</sub>), 143.4 (quat.), 137.8 (quat.), 137.5 (quat.) 133.2 (quat.), 130.3 (q, *J* 34.9 Hz, CCF<sub>3</sub>), 128.7 (C<sub>2'</sub>), 128.6 (ArCH), 128.5 (ArCH), 127.8 (ArCH), 125.7 (q, *J* 271.4 Hz, CF<sub>3</sub>), 125.2 (q, *J* 4.6 Hz, C<sub>3'</sub>), 32.9 (C<sub>4</sub> or C<sub>6</sub>), 32.8 (C<sub>4</sub> or C<sub>6</sub>), 25.8 (C<sub>5</sub>);  $\nu_{\text{max}}/\text{cm}^{-1}$  (solid); 2950, 1615, 1579, 1497, 1447, 1411, 1373, 1325, 1209, 1165, 1114, 1065, 1014; HRMS (ES<sup>+</sup>) *m/z*; [M+H]<sup>+</sup> requires 340.1308 for C<sub>21</sub>H<sub>17</sub>F<sub>3</sub>N, found: 340.1315.

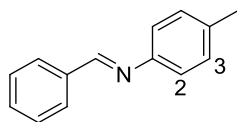
**(E)-N-Benzylidene-4-methylaniline 189**

A solution of ditolylcarbodiimide (0.22 g, 1.0 mmol), phospholene oxide (19 mg, 0.1 mmol) and benzaldehyde (0.2 mL, 2 mmol) in toluene was heated to 110 °C for 48 hours then cooled to room temperature and evaporated *in vacuo* to give the imine **189** as orange oil (2:1 imine:aldehyde ratio, conversion to imine 75%).

$\delta_{\text{H}}$  (300 MHz, CDCl<sub>3</sub>) of the crude reaction mixture; 8.44 (1H, s, N=CH), 7.89-7.83 (2H, m, ArH), 7.48-7.42 (3H, m, ArH), 7.18 (2H, d, *J* 9.1 Hz, H<sub>2</sub>), 7.12 (2H, d, *J* 9.1 Hz, H<sub>3</sub>), 2.36 (3H, s, CH<sub>3</sub>);  $\delta_{\text{C}}$  (75 MHz, CDCl<sub>3</sub>) of the crude reaction mixture; 159.7 (N=CH), 149.4 (quat.), 136.3 (quat.), 135.8 (quat.), 131.3 (ArCH), 129.8 (ArCH), 128.8 (ArCH), 128.7 (ArCH), 120.9 (ArCH), 21.2 (CH<sub>3</sub>);  $\nu_{\text{max}}/\text{cm}^{-1}$  (thin film) of crude reaction mixture; 3344, 3026, 2918, 2138 (N=C=N), 1703, 1627(C=N), 1596, 1495, 1449, 1310, 1191, 1073, 1028.

Spectroscopic data was consistent with literature values.<sup>212</sup>

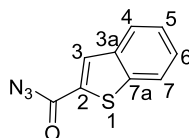
**Benzo[*b*]thiophene-2-carbonyl azide 191**

Prepared by general procedure B from benzo[*b*]thiophene-2-carboxylic acid (0.18 g, 1.00 mmol) to afford the acyl azide **191** as a colourless solid (0.13 g, 0.64 mmol, 64%) which was used without further purification.

$\delta_{\text{H}}$  (300 MHz,  $\text{CDCl}_3$ ); 8.11 (1H, s, H3), 7.93-7.86 (2H, m, ArH), 7.50 (1H, td,  $J$  7.7, 1.0 Hz, ArH), 7.43 (1H, td,  $J$  7.7, 1.0 Hz, ArH);  $\delta_{\text{C}}$  (100 MHz,  $\text{CDCl}_3$ ); 166.9 (C=O), 142.4 (C2), 138.0 (quat.), 133.8 (quat.), 131.0 (ArCH), 127.1 (ArCH), 125.3 (ArCH), 124.6 (ArCH), 122.2 (C3);  $\nu_{\text{max}}/\text{cm}^{-1}$  (thin film); 2156 ( $\text{N}_3$ ), 1677 (C=O), 1596, 1559, 1517, 1458, 1429, 1378, 1336, 1269, 1241, 1220, 1184, 1156.

Spectroscopic data was consistent with literature values.<sup>213</sup>

### Benzo[*b*]thiophene-3-carbonyl azide **198**

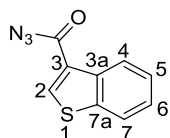

Prepared by general procedure B from benzo[*b*]thiophene-3-carboxylic acid (0.089 g, 0.50 mmol) to afford the acyl azide **198** as a colourless solid (0.092 g, 90%) which was used without further purification.

$\delta_{\text{H}}$  (300 MHz,  $\text{CDCl}_3$ ); 8.63 (1H, d,  $J$  8.2 Hz, H4), 8.40 (1H, s, H2), 7.84 (1H, d,  $J$  8.2 Hz, H7), 7.49 (1H, t,  $J$  8.2 Hz, ArH), 7.40 (1H, t,  $J$  8.2 Hz, ArH);  $\nu_{\text{max}}/\text{cm}^{-1}$  (thin film); 3109, 2148 ( $\text{N}_3$ ), 1680 (C=O), 1496, 1463, 1425, 1368, 1199, 1058.

Spectroscopic data was consistent with literature values.<sup>213</sup>

### Preparation of Imines

#### 2-[*N*-(Benzylideneamino)]benzo[*b*]thiophene **194a**

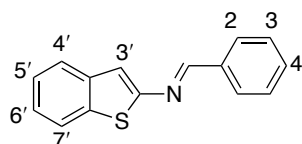

#### Method A

A solution of benzo[*b*]thiophene-2-carbonyl azide (0.15 g, 0.76 mmol), benzaldehyde (0.15 mL, 1.50 mmol) and phospholene oxide (15 mg, 0.076 mmol) in toluene (1.0 mL) was heated under reflux for 18 hours. The reaction mixture was cooled to room temperature and evaporated *in vacuo* to give the crude product (imine:aldehyde ratio 33:66, 2 equivalents aldehyde used, therefore 83% conversion to imine). Product was purified by column chromatography ( $\text{SiO}_2$ , 4:1 petrol–EtOAc) to give the imine **194a** as yellow oil, however, some decomposition occurred during purification.

$\delta_{\text{H}}$  (300 MHz,  $\text{CDCl}_3$ ) signals for imine only; 8.48 (1H, s, N=CH), 7.90 (2H, dd,  $J$  6.1, 2.0 Hz, H2), 7.76-7.68 (2H, m, ArCH), 7.48-7.45 (3H, m, H3, H4), 7.38 (1H, s, H3'), 7.34-7.29 (2H, m, ArCH);  $\nu_{\text{max}}/\text{cm}^{-1}$  (thin film); 3064, 2866, 1903, 1702, 1674, 1609, 1575, 1450, 1311, 1189, 1157, 1127, 1072;  $m/z$  (ESI) 238.1  $[\text{M}+\text{H}]^+$

Spectroscopic data was consistent with literature values.<sup>3</sup>

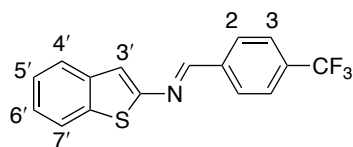
**2-[N-(4-Trifluoromethylbenzylideneamino)]benzo[*b*]thiophene 194b**

A solution of benzo[*b*]thiophene-2-carbonyl azide (0.11 g, 0.56 mmol) in toluene (1.0 mL) was heated under reflux. 4-Trifluoromethylbenzaldehyde (0.15 mL, 1.10 mmol) and phospholene oxide (10 mg, 0.06 mmol) were added and the reaction mixture heated under reflux for 105 minutes until IR analysis showed no azide or isocyanate signals remained (2153  $\text{cm}^{-1}$  and 2269  $\text{cm}^{-1}$  respectively). The reaction mixture was cooled to room temperature and evaporated *in vacuo* to give the crude product which was purified by column chromatography ( $\text{SiO}_2$ , 6:1 petrol–EtOAc) to give the imine **194b** as yellow plates (72 mg, 0.24 mmol, 42%).

M.p. = 198–200 °C ( $\text{CHCl}_3$ );  $\delta_{\text{H}}$  (300 MHz,  $\text{CDCl}_3$ ); 8.44 (1H, s, N=CH), 8.02 (2H, d,  $J$  8.2 Hz, H2), 7.79–7.69 (4H, m, H4', H5', H6', H7'), 7.45 (1H, s, H3'), 7.39–7.32 (2H, m, H3);  $\delta_{\text{C}}$  (100 MHz,  $\text{CDCl}_3$ ) observed 13 signals of 14; 157.2 (N=CH), 153.5 (quat.), 139.1 (quat.), 137.0 (quat.), 136.0 (quat.), 133.3 (q,  $J$  32.3 Hz, C4), 129.4 (C2), 126.2 (q,  $J$  3.2 Hz, C3), 126.1 (thioCH), 125.3 (thioCH), 124.7 (thioCH), 123.5 (thioCH), 123.2 (C3');  $\nu_{\text{max}}/\text{cm}^{-1}$  (solid, diamond); 3075, 2856, 2639, 2284, 2092, 1956, 1921, 1875, 1807, 1737, 1615, 1571, 1524, 1435, 1414, 1365, 1227, 1015; HRMS ( $\text{ES}^+$ )  $m/z$ ;  $[\text{M}+\text{H}]^+$  requires 306.0559 for  $\text{C}_{16}\text{H}_{11}\text{F}_3\text{NS}$ , found: 306.0552.

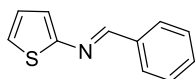
**Benzo[*b*]thiophen-2-ylbenzylidene amine 202**

To a stirred solution of benzaldehyde (0.10 mL, 1.00 mmol) and phospholene oxide (10 mg, 0.05 mmol) in toluene (4.2 mL) at 110 °C was added 2-thienyl isocyanate (0.11 mL, 1.10 mmol) over 5 hours. The reaction mixture was heated under reflux for 24 hours until IR showed the isocyanate signal had disappeared, then cooled to room temperature and solvents removed *in vacuo* to give the imine **202** as brown oil.  $^1\text{H}$  NMR showed conversion to imine was 80% (from imine to aldehyde ratio).

$\delta_{\text{H}}$  (300 MHz,  $\text{CDCl}_3$ ) of crude reaction mixture; 8.48 (1H, s, N=CH), 7.86–7.82 (2H, m, ArH), 7.48–7.42 (3H, m, ArH), 7.13 (1H, dd,  $J$  3.6, 1.0 Hz, ThioH), 7.08 (1H, dd,  $J$  5.6, 1.0 Hz, ThioH), 6.99 (1H, dd,  $J$  5.6, 3.6 Hz, ThioH);  $\nu_{\text{max}}/\text{cm}^{-1}$  (thin film); 3064, 2864, 2736, 1701, 1597, 1573, 1450, 1310, 1234, 1203, 1166, 1071, 1026.

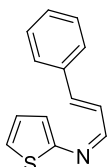
**Benzo[*b*]thiophen-2-yl(3-phenylallylidene) amine 203**

To a stirred solution of cinnamaldehyde (0.25 mL, 2.00 mmol) and phospholene oxide (10 mg, 0.05 mmol) in toluene (4.2 mL) at 110 °C was added 2-thienyl isocyanate (0.10 mL, 1.00 mmol) over 5 hours. The



reaction mixture was heated under reflux for 24 hours until IR showed the isocyanate signal had disappeared, then cooled to room temperature and reduced *in vacuo* to give the crude product which was purified by column chromatography (SiO<sub>2</sub>, 4:1 Petrol–EtOAc) to give the imine **203** as yellow needles (0.043 g, 20%).

$\delta_{\text{H}}$  (300 MHz, CDCl<sub>3</sub>); 8.26 (1H, d, *J* 7.7 Hz, N=CH), 7.55-7.48 (2H, m, ArH), 7.43-7.33 (3H, m, ArH), 7.12-7.03 (4H, m, ThioH + PhCH=C), 6.98-6.94 (1H, m, N=CCH);  $\nu_{\text{max}}$ /cm<sup>-1</sup> (thin film); 3019, 2927, 2854, 2400, 1674, 1626, 1579, 1523, 1496, 1450, 1216, 1162, 1126, 1072, 1007, 973; *m/z* (ESI) 214.1 [M+H]<sup>+</sup>

### Benzo[*b*]thiophen-2-yl-carbamic acid benzyl ester **193**

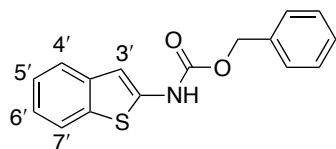

Benzyl alcohol (70  $\mu$ l, 0.68 mmol) and benzo[*b*]thiophene-2-carbonyl azide (0.14 g, 0.68 mmol) in toluene (1.0 mL) were heated under reflux for 1.5 hours until IR showed disappearance of azide signal (2153 cm<sup>-1</sup>). A colourless precipitate formed during the course of the reaction. The reaction mixture was cooled to room temperature and solvent removed *in vacuo* to give the carbamate **193** as a colourless solid which was recrystallised from petrol (0.13 g, 0.46 mmol, 67%).

M.p. = 188-192 °C (acetone);  $\delta_{\text{H}}$  (300 MHz, acetone-d<sub>6</sub>); 9.93 (1H, br s, NH), 7.70 (1H, d, *J* 7.9 Hz, H8), 7.52 (1H, d, *J* 7.9 Hz, H5), 7.41-7.25 (5H, m, ArH), 7.20 (1H, td, *J* 7.1, 1.3 Hz, H6 or H7), 7.11 (1H, td, *J* 7.9, 1.3 Hz, H6 or H7), 6.85 (1H, s, H3), 5.16 (2H, s, CH<sub>2</sub>);  $\delta_{\text{C}}$  (75 MHz, acetone-d<sub>6</sub>); 154.6 (C=O), 142.6 (C2), 139.6 (C9), 137.7 (quat.), 135.9 (C4), 129.7 (ArCH), 129.5 (ArCH), 129.4 (ArCH), 125.7 (C6 or C7), 123.8 (C6 or C7), 123.0 (C8), 122.9 (C5), 106.9 (C3), 68.2 (CH<sub>2</sub>);  $\nu_{\text{max}}$ /cm<sup>-1</sup> (solid, diamond); 3285, 2869, 2315, 1943, 1909, 1874, 1831, 1695, 1575, 1505, 1455, 1374, 1286, 1251, 1227, 1175, 1074, 1014, 938, 904, 855, 814; HRMS (ES<sup>+</sup>) *m/z*; [M+H]<sup>+</sup> requires 284.0740 for C<sub>16</sub>H<sub>14</sub>NO<sub>2</sub>S, found: 284.0736.

### 4-Phenylbenzo[*b*]thieno[2,3-*b*]pyridine **196**

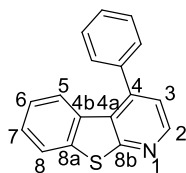

#### Method 1

Benzo[*b*]thiophene-2-carbonyl azide (0.274 g, 1.35 mmol), cinnamaldehyde (0.34 mL, 2.70 mmol) and phospholene oxide (0.026 g, 0.135 mmol) were heated under reflux in toluene (1.0 mL) for 48 hours then cooled to room temperature and evaporated *in vacuo* to give the crude product. Column chromatography (SiO<sub>2</sub>, 95:5 petrol–EtOAc) gave the pyridine **196** (11 mg, 8%) as a yellow solid.

M.p. = 161-163 °C (CHCl<sub>3</sub>);  $\delta_{\text{H}}$  (300 MHz, CDCl<sub>3</sub>); 8.41 (1H, d, *J* 8.2 Hz, H2), 8.14-8.11 (3H, m, ArH), 7.92-7.87 (1H, m, ArH), 7.83 (1H, d, *J* 8.2 Hz, H3), 7.56-7.40 (5H, m, C<sub>6</sub>H<sub>5</sub>);  $\delta_{\text{C}}$  (75 MHz, CDCl<sub>3</sub>); 158.0 (C8b), 156.9 (C8a), 139.3 (C4a), 138.7 (C4b), 133.3 (C4), 129.9 (C2),

129.6 (C4b), 129.3 (ArCH), 128.4 (quat.), 127.8 (ArCH), 127.7 (ArCH), 125.3 (C5 or C6 or C7), 123.6 (C5 or C6 or C7), 122.4 (C5 or C6 or C7), 117.1 (C3);  $m/z$  (ESI) 262.0  $[M+H]^+$   
Spectroscopic data was consistent with literature values.<sup>66</sup>

## Method 2

Benzo[*b*]thiophene-2-carbonyl azide (0.134 g, 0.66 mmol) was heated under reflux in toluene (5.0 mL) until IR showed the disappearance of the azide signal at 2153  $\text{cm}^{-1}$  and appearance of the isocyanate signal 2269  $\text{cm}^{-1}$ . The isocyanate solution was cooled to room temperature and added dropwise over 2 hours to a stirred solution of cinnamaldehyde (0.16 mL, 1.3 mmol) and phospholene oxide (13 mg, 0.07 mmol) in toluene (1.0 mL) and the reaction mixture stirred under reflux for 19 hours then cooled to room temperature, transferred to a microwave vial and heated at 160 °C in the microwave for 1 hour then evaporated *in vacuo* to give the crude product.  $^1\text{H}$  NMR showed that 12% pyridine had been prepared and 25% imine (from ratio of aldehyde:imine:pyridine).

Compound data as above.

## 4-Phenylbenzo[*b*]thieno[3,2-*b*]pyridine 200

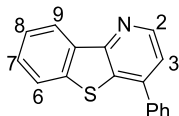

Benzo[*b*]thiophene-3-carbonyl azide (0.147 g, 0.70 mmol), cinnamaldehyde (0.18 mL, 1.40 mmol) and phospholene oxide (0.013 g, 0.07 mmol) were heated under reflux in toluene (2.0 mL) for 48 hours

then cooled to room temperature and evaporated *in vacuo* to give the crude product. Column chromatography ( $\text{SiO}_2$ , 95:5 petrol–EtOAc) gave the pyridine **200** (24 mg, 13%) as a yellow solid.

M.p. = 73-74 °C ( $\text{CHCl}_3$ , Lit. = 73-75 °C<sup>66</sup>);  $\delta_{\text{H}}$  (300 MHz,  $\text{CDCl}_3$ ); 8.84 (1H, d,  $J$  6.0 Hz, H2), 8.58-8.53 (1H, m, H9), 7.90-7.87 (1H, m, ArH), 7.83-7.79 (2H, m, ArH), 7.62-7.54 (5H, m, ArH), 7.45 (1H, d,  $J$  6.0 Hz, H3);  $\delta_{\text{C}}$  (75 MHz,  $\text{CDCl}_3$ ); 162.2 (C2), 147.1 (quat.), 144.1 (C3), 140.2 (quat.), 139.2 (quat.), 138.7 (C2), 137.0 (ArCH), 134.5 (quat.), 129.6 (ArCH), 128.5 (ArCH), 125.4 (ArCH), 125.2 (ArCH), 123.2 (ArCH), 122.5 (ArCH), 121.0 (ArCH);  $m/z$  (ESI) 262.0  $[M+H]^+$

Spectroscopic data was consistent with literature values.<sup>66</sup>

## 2-Cinnamyl aniline 274

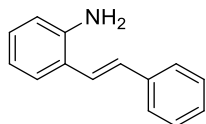

To a solution of 2-bromoaniline (0.17 g, 1.0 mmol) in triethylamine (1.0 mL) was added palladium acetate (2.2 mg, 0.01 mmol), tri-*o*-tolylphosphine (24 mg, 0.08 mmol) and styrene (0.14 mL, 1.25 mmol).

The reaction mixture was stirred at 100 °C for 20 hours then cooled to room temperature and poured into water and extracted with  $\text{CH}_2\text{Cl}_2$  (20 mL  $\times$  3). The combined organic extracts were

washed with brine (30 mL), dried (MgSO<sub>4</sub>) and evaporated *in vacuo* to give a brown solid which was purified by column chromatography (SiO<sub>2</sub>, eluting with 95:5 petrol–EtOAc) to give the aniline **274** as yellow needles (0.15 g, 75%).

M.p.= 100-101 °C (EtOH, Lit. 101-102 °C<sup>214</sup>);  $\delta_{\text{H}}$  (300 MHz, CDCl<sub>3</sub>); 7.57-7.55 (2H, m, ArH), 7.45 (1H, dd, *J* 7.7, 1.4 Hz, ArH), 7.41 (2H, m, ArH), 7.34-7.30 (1H, m, ArH), 7.24 (1H, d, *J* 16.2 Hz, PhCH=C), 7.12 (1H, td, *J* 7.7, 1.4 Hz, ArH), 7.04 (1H, d, *J* 16.2 Hz, ArCH=C), 6.89-6.84 (1H, m, ArH), 6.77 (1H, d, *J* 8.2 Hz, ArH), 3.86 (2H, br s, NH<sub>2</sub>);  $\delta_{\text{C}}$  (75 MHz, CDCl<sub>3</sub>); 143.8 (quat.), 137.6 (quat.), 130.4 (ArCH), 128.7 (ArCH), 128.7 (ArCH), 127.6 (ArCH), 127.2 (ArCH), 126.5 (ArCH), 124.3 (ArCH), 123.9 (quat.), 119.3 (C=CH), 116.4 (C=CH); *m/z* (ESI); 196.0 [M+H]<sup>+</sup>.

Spectroscopic data was consistent with literature values.<sup>215</sup>

### Butyl (2*E*)-3-(2-aminophenyl)prop-2-enoate **277**

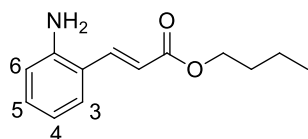

To a solution of 2-bromoaniline (0.56 mL, 5.0 mmol) in triethylamine (5.0 mL) was added palladium acetate (11 mg, 0.05 mmol), tri-*o*-tolylphosphine (120 mg, 0.40 mmol) and butyl acrylate (0.14 mL, 6.25 mmol). The reaction mixture was stirred at 100 °C for 20 hours then cooled to room temperature and poured into water and extracted with CH<sub>2</sub>Cl<sub>2</sub> (20 mL × 3). The combined organic extracts were washed with brine (30 mL), dried (MgSO<sub>4</sub>) and evaporated *in vacuo* to give a brown solid which was purified by column chromatography (SiO<sub>2</sub>, eluting with 95:5 petrol–EtOAc) to give the aniline **277** as yellow needles (0.80 g, 73%).

M.p.= 69-70 °C (EtOAc–petrol, lit. 70.9-71.7 °C<sup>216</sup>);  $\delta_{\text{H}}$  (300 MHz, CDCl<sub>3</sub>); 7.84 (1H, d, *J* 15.9 Hz, CHCO<sub>2</sub>Bu), 7.41 (1H, dd, *J* 7.7, 1.4 Hz, H3), 7.22-7.17 (1H, td, *J* 7.7, 1.4 Hz, H5), 6.79 (1H, t, *J* 7.7 Hz, H4), 6.72 (1H, d, *J* 7.7 Hz, H6), 6.38 (1H, d, *J* 15.9 Hz, CHAr), 4.23 (2H, t, *J* 7.0 Hz, OCH<sub>2</sub>), 3.99 (2H, br s, NH<sub>2</sub>), 1.76-1.66 (2H, m, OCH<sub>2</sub>CH<sub>2</sub>), 1.52-1.39 (2H, m, OCH<sub>2</sub>CH<sub>2</sub>CH<sub>2</sub>), 0.98 (3H, t, *J* 7.0 Hz, CH<sub>3</sub>);  $\delta_{\text{C}}$  (75 MHz, CDCl<sub>3</sub>); 167.4 (C=O), 145.5 (quat.), 140.0 (CHCO<sub>2</sub>Bu), 131.1 (C4), 128.1 (C3), 119.9 (quat.), 118.9 (C5 or CH), 118.2 (C5 or CH), 116.7 (C6), 64.4 (OCH<sub>2</sub>), 30.1 (CH<sub>2</sub>), 19.2 (CH<sub>2</sub>), 13.8 (CH<sub>3</sub>); *m/z*; 220.2 [M+H]<sup>+</sup>.

Spectroscopic data was consistent with literature values.<sup>216</sup>

### 3-(2-[(*E*)-2-Phenylethenyl]phenyl)-1,1-diisopropyl urea **275**

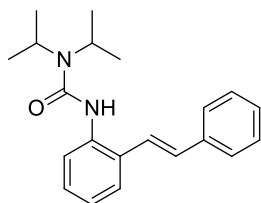

A solution of diisopropylcarbonyl chloride (0.18 g, 1.12 mmol) in CH<sub>2</sub>Cl<sub>2</sub> (1.0 mL) was added dropwise to a stirred solution of 2-cinnamylaniline (0.14 g, 0.75 mmol) and triethylamine (0.2 mL, 1.50 mmol) in CH<sub>2</sub>Cl<sub>2</sub> (4 mL). The reaction mixture was heated under

reflux for 48 hours then cooled to room temperature and washed with saturated  $\text{NaHCO}_3$  (aq.) (25 mL). The aqueous phase was extracted with  $\text{CH}_2\text{Cl}_2$  ( $3 \times 20$  mL) and the combined organic extracts washed with brine (40 mL), dried ( $\text{MgSO}_4$ ) and evaporated *in vacuo* to give an orange oil which was purified by column chromatography ( $\text{SiO}_2$ , eluting with 0-20% EtOAc in petrol) to give the alkene **275** as colourless needles (0.12 g, 50%).

M.p.= 104-105 °C (EtOAc–petrol);  $\delta_{\text{H}}$  (300 MHz,  $\text{CDCl}_3$ ); 7.68 (1H, dd,  $J$  7.8, 1.0 Hz, ArH), 7.41-7.39 (3H, m,  $\text{C}_6\text{H}_5$ ), 7.31-7.26 (2H, m,  $\text{C}_6\text{H}_5$ ), 7.23-7.16 (2H, m, ArH), 7.11 (1H, d,  $J$  16.1 Hz,  $\text{C}_6\text{H}_5\text{HC}=\text{C}$ ), 7.01 (1H, td,  $J$  7.8, 1.0 Hz, ArH), 6.89 (1H, d,  $J$  16.1 Hz,  $\text{C}_6\text{H}_5\text{HC}=\text{CH}$ ), 6.19 (1H, s, NH), 3.94 (2H, sept,  $J$  7.0 Hz, NCH), 1.25 (12H, d,  $J$  7.0 Hz,  $\text{CH}_3$ );  $\delta_{\text{C}}$  (75 MHz,  $\text{CDCl}_3$ ); 154.8 (C=O), 137.1 (quat.), 136.6 (quat.), 132.3 (C=CH $\text{C}_6\text{H}_5$ ), 129.5 (quat.), 128.8 (ArCH), 128.3 (ArCH), 127.9 (ArCH), 126.9 (ArCH), 126.7 (ArCH), 124.1 (ArCH), 123.7 (ArCH), 123.3 (ArCH), 45.5 (NCH), 21.5 ( $\text{CH}_3$ );  $\nu_{\text{max}}/\text{cm}^{-1}$  (solid, diamond); 3453, 3199, 2970, 1738, 1619, 1447, 1365, 1228, 1217, 1151, 1057; HRMS ( $\text{ES}^+$ )  $m/z$ ;  $[\text{M}+\text{Na}]^+$  requires 345.1937 for  $\text{C}_{21}\text{H}_{26}\text{N}_2\text{NaO}$ , found: 345.1948.

#### (*E*)-Butyl-3-(2-(*N,N*-diisopropylureido)phenyl acrylate **278**

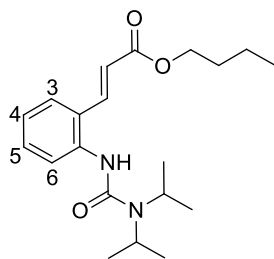

Prepared according to the procedure for **275** using diisopropylcarbamoyl chloride (0.67 g, 4.1 mmol), butyl (*E*)-3-(2-aminophenyl)prop-2-enoate (0.60 g, 2.7 mmol), and triethylamine (0.75 mL, 5.4 mmol) in  $\text{CH}_2\text{Cl}_2$  (15 mL). Purification by column chromatography ( $\text{SiO}_2$ , 8:1 petrol–EtOAc) to give the alkene **278** as yellow needles (0.20 g, 22%).

M.p.= 110-111 °C (EtOAc–Petrol);  $\delta_{\text{H}}$  (300 MHz,  $\text{CDCl}_3$ ); 7.82 (1H, d,  $J$  15.9 Hz, C=CHCO $_2$ Et), 7.67 (1H, dd,  $J$  8.2, 1.1 Hz, H3), 7.51 (1H, dd,  $J$  7.8, 1.5 Hz, H6), 7.36 (1H, td,  $J$  7.8, 1.5 Hz, H5), 7.14-7.08 (1H, m, H4), 6.38 (1H, d,  $J$  15.9 Hz, C=CHAr), 6.26 (1H, br s, NH), 4.20 (2H, t,  $J$  6.9 Hz, OCH $_2$ ), 4.03 (2H, spt,  $J$  6.9 Hz, NCH), 1.73-1.63 (2H, m, OCH $_2$ CH $_2$ ), 1.50-1.40 (2H, m, CH $_2$ CH $_3$ ), 1.36 (12H, d,  $J$  6.9 Hz, NCHCH $_3$ ), 0.97 (3H, t,  $J$  6.9 Hz, CH $_2$ CH $_3$ );  $\delta_{\text{C}}$  (75 MHz,  $\text{CDCl}_3$ ); 166.8 (OC=O), 154.7 (NHC=O), 140.0 (C=CHCO $_2$ Et), 137.8 (quat.), 130.6 (C5), 127.2 (quat.), 127.1 (C6), 124.4 (C3 or C4), 124.2 (C3 or C4), 120.2 (C=CHAr), 64.5 (OCH $_2$ ), 45.7 (NCH), 30.7 (OCH $_2$ CH $_2$ ), 21.4 (NCHCH $_3$ ), 19.2 (CH $_2$ CH $_3$ ), 13.7 (CH $_2$ CH $_3$ );  $\nu_{\text{max}}/\text{cm}^{-1}$  (solid, diamond); 3182, 2970, 1737, 1622, 1447, 1366, 1228, 1216, 1059; HRMS ( $\text{ES}^+$ )  $m/z$   $[\text{M}+\text{H}]^+$  requires 347.2329 for  $\text{C}_{20}\text{H}_{31}\text{N}_2\text{O}_3$ , found: 347.2321.

### 3-(2-Bromophenyl)-1,1-diisopropyl urea **293**

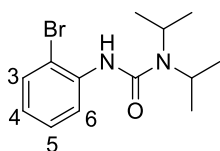

A solution of diisopropylcarbonyl chloride (1.23 g, 7.5 mmol) in  $\text{CH}_2\text{Cl}_2$  (7.5 mL) was added dropwise to a stirred solution of 2-bromoaniline (0.57 mL, 5.0 mmol) and triethylamine (1.4 mL, 10.0 mmol) in  $\text{CH}_2\text{Cl}_2$  (12.5 mL). The reaction mixture was heated under reflux for 48 hours then cooled to room temperature and washed with saturated  $\text{NaHCO}_3$  (aq.) (40 mL). The aqueous phase was extracted with  $\text{CH}_2\text{Cl}_2$  ( $3 \times 30$  mL) and the combined organic extracts washed with brine (60 mL), dried ( $\text{MgSO}_4$ ) and evaporated *in vacuo* to give an orange solid which was purified by column chromatography ( $\text{SiO}_2$ , eluting with 0-20% petrol–EtOAc) to give the urea **293** as colourless needles (0.68 g, 46%).

M.p.= 69-70 °C (MeCN);  $\delta_{\text{H}}$  (300 MHz,  $\text{CDCl}_3$ ); 8.15 (1H, dd,  $J$  8.2, 1.6 Hz, H6), 7.40 (1H, dd,  $J$  8.2, 1.6 Hz, H3), 7.18 (1H, td,  $J$  8.2, 1.6 Hz, H4), 6.82 (1H, br s, NH), 6.76 (1H, td,  $J$  8.2, 1.6 Hz, H5), 3.96 (2H, spt,  $J$  6.9 Hz, NCH), 1.27 (12H, d,  $J$  7.0 Hz,  $\text{CH}_3$ );  $\delta_{\text{C}}$  (75 MHz,  $\text{CDCl}_3$ ); 153.9 (C=O), 136.6 (quat.), 131.9 (C3), 128.2 (C4), 123.0 (C5), 121.1 (C6), 112.6 (quat.), 45.7 (NCH), 21.4 ( $\text{CH}_3$ );  $\nu_{\text{max}}/\text{cm}^{-1}$  (solid, diamond); 3182, 2960, 2765, 1621, 1471, 1337, 1149, 1047, 1028; HRMS ( $\text{ES}^+$ )  $m/z$ ;  $[\text{M}+\text{Na}]^+$  requires 321.0573 for  $\text{C}_{13}\text{H}_{19}^{79}\text{BrN}_2\text{NaO}$ , found: 321.0564.

### General Procedure G for the preparation of Ureas

The amine (1 equivalent) was added dropwise to a stirred solution of the isocyanate in  $\text{CH}_2\text{Cl}_2$  (1 mL/mmol). After 1 hour the reaction mixture was reduced under vacuum to give the product which was recrystallised in MeCN.

### *N,N*-Diisopropylphenyl urea **281**

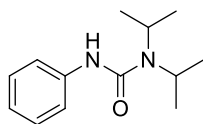

Prepared according to general procedure G using phenyl isocyanate (0.54 mL, 5.0 mmol) and diisopropylamine (0.70 mL, 5.0 mmol) to give the urea **281** as colourless needles (1.09 g, 99 %).

M.p.= 120-121 °C (EtOAc–petrol, lit. 123-124 °C<sup>129</sup>);  $\delta_{\text{H}}$  (300 MHz,  $\text{CDCl}_3$ ); 7.41-7.37 (2H, m, ArH), 7.32-7.27 (2H, m, ArH), 7.05-7.00 (1H, m, ArH), 6.21 (1H, br s, NH), 4.00 (2H, spt,  $J$  6.9 Hz, CH), 1.35 (12H, d,  $J$  6.9 Hz,  $\text{CH}_3$ );  $\delta_{\text{C}}$  (75 MHz,  $\text{CDCl}_3$ ); 154.6 (C=O), 139.3 (quat.), 128.8 (ArCH), 122.6 (ArCH), 119.6 (ArCH), 45.4 (CH), 21.6 ( $\text{CH}_3$ );  $\nu_{\text{max}}/\text{cm}^{-1}$  (solid, diamond); 3277, 2966, 1939, 1860, 1633, 1338, 1147, 1056;  $m/z$  (ESI); 221.1  $[\text{M}+\text{H}]^+$ .

Spectroscopic data was consistent with literature values.<sup>129</sup>

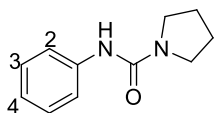
**N-Phenyl-1-pyrrolidine carboxamide 282a**

Prepared according to general procedure G using phenyl isocyanate (2.2 mL, 20 mmol) and pyrrolidine (2.0 mL, 20 mmol) to give the urea **282a** as colourless crystals (3.78 g, 99 %).

M.p.= 132-133 °C (MeCN, lit. 133-134 °C<sup>217</sup>);  $\delta_{\text{H}}$  (500 MHz, CDCl<sub>3</sub>); 7.44 (2H, d, *J* 7.8 Hz, H<sub>2</sub>), 7.30 (2H, t, *J* 7.8 Hz, H<sub>3</sub>), 7.01 (1H, t, *J* 7.8 Hz, H<sub>4</sub>), 6.17 (1H, br s, NH), 3.49 (4H, t, *J* 6.6 Hz, NCH<sub>2</sub>), 1.92-1.87 (4H, m, NCH<sub>2</sub>CH<sub>2</sub>);  $\delta_{\text{C}}$  (75 MHz, CDCl<sub>3</sub>); 153.9 (C=O), 139.2 (quat.), 128.8 (ArCH), 122.7 (ArCH), 119.5 (ArCH), 45.8 (CH<sub>2</sub>), 25.6 (NCH<sub>2</sub>CH<sub>2</sub>);  $\nu_{\text{max}}$ /cm<sup>-1</sup> (solid, diamond); 3298, 3052, 2875, 1641, 1536, 1441, 1378, 1239; *m/z* (ESI); 191.1 [M+H]<sup>+</sup>.

Spectroscopic data was consistent with literature values.<sup>217</sup>

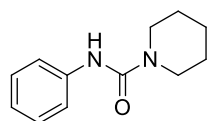
**N-Phenyl-1-piperidine carboxamide 284a**

Prepared according to general procedure G using phenyl isocyanate (0.54 mL, 5.0 mmol) and piperidine (0.49 mL, 5.0 mmol) to give the urea **284a** as colourless needles (0.98 g, 96 %).

M.p.= 170-172 °C (MeCN, lit. 169-171 °C<sup>218</sup>);  $\delta_{\text{H}}$  (300 MHz, CDCl<sub>3</sub>); 7.39-7.35 (2H, m, H<sub>2</sub>), 7.33-7.26 (2H, m, H<sub>3</sub>), 7.06-7.01 (1H, m, H<sub>4</sub>), 6.38 (1H, br s, NH), 3.49-3.45 (4H, m, NCH<sub>2</sub>), 1.71-1.60 (6H, m, CH<sub>2</sub>);  $\delta_{\text{C}}$  (75 MHz, CDCl<sub>3</sub>); 154.9 (C=O), 139.3 (quat.), 128.8 (ArCH), 122.8 (ArCH), 119.8 (ArCH), 45.3 (NCH<sub>2</sub>), 25.7 (CH<sub>2</sub>), 24.4 (CH<sub>2</sub>); *m/z* (ESI); 205.5 [M+H]<sup>+</sup>.

Spectroscopic data was consistent with literature values.<sup>219</sup>

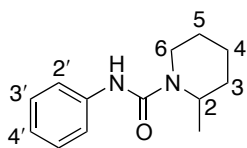
**N-Phenyl-1-(2-methylpiperidine) carboxamide 284b**

Prepared according to general procedure G using phenyl isocyanate (0.54 mL, 5 mmol) and 2-methylpiperidine (0.59 mL, 5 mmol) to give the urea **284b** as colourless needles (1.05 g, 96 %).

M.p.= 118-119 °C (MeCN, lit. 116°C<sup>220</sup>);  $\delta_{\text{H}}$  (300 MHz, CDCl<sub>3</sub>); 7.29 (2H, dd, *J* 7.7, 1.4 Hz, H<sub>2'</sub>), 7.19 (2H, td, *J* 7.7, 1.4 Hz, H<sub>3'</sub>), 6.94 (1H, tt, *J* 7.7, 1.4 Hz, H<sub>4'</sub>), 6.38 (1H, s, NH), 4.35-4.27 (1H, m, H<sub>2</sub>), 3.84-3.79 (1H, m, H<sub>6</sub>), 2.90 (1H, td, *J* 12.9, 2.7 Hz, H<sub>6</sub>), 1.72-1.63 (2H, m, H<sub>3</sub>), 1.56-1.35 (4H, m, H<sub>4</sub> + H<sub>5</sub>), 1.15 (3H, d, *J* 6.9 Hz, CH<sub>3</sub>);  $\delta_{\text{C}}$  (75 MHz, CDCl<sub>3</sub>); 155.0 (C=O), 139.4 (quat.), 128.8 (C<sub>3'</sub>), 122.7 (C<sub>4'</sub>), 119.9 (C<sub>2'</sub>), 46.7 (C<sub>2</sub>), 39.1 (C<sub>6</sub>), 30.2 (CH<sub>2</sub>), 25.6 (CH<sub>2</sub>), 18.6 (CH<sub>2</sub>), 15.7 (CH<sub>3</sub>);  $\nu_{\text{max}}$ /cm<sup>-1</sup> (solid, diamond); 3288, 2938, 1930, 1860, 1788, 1629, 1525, 1443, 1385, 1235, 1153, 1061, 1024; *m/z* (ESI); 219.1 [M+H]<sup>+</sup>.

Spectroscopic data was consistent with literature values.<sup>219</sup>

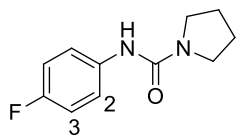
***N*-(4-Fluorophenyl)-1-pyrrolidinecarboxamide 282d**

Prepared according to general procedure G using 4-fluorophenyl isocyanate (0.22 mL, 2.0 mmol) and pyrrolidine (0.20 mL, 2.0 mmol) to give the urea **282d** as colourless plates (0.39 g, 93 %).

M.p.= 135-137 °C (MeCN);  $\delta_{\text{H}}$  (300 MHz,  $\text{CDCl}_3$ ); 7.37 (2H, dd,  $J$  9.1, 4.7 Hz, H2), 6.99 (2H, td,  $J$  8.9, 2.5 Hz, H3), 6.17 (1H, br s, NH), 3.49-3.44 (4H, m,  $\text{NCH}_2$ ), 2.01-1.96 (4H, m,  $\text{NCH}_2\text{CH}_2$ );  $\delta_{\text{C}}$  (75 MHz,  $\text{CDCl}_3$ ); 158.6 (d,  $J$  241.6 Hz, ArCF), 154.0 (C=O), 135.1 (quat.), 121.2 (d,  $J$  8.8 Hz, C2), 115.5 (d,  $J$  22.1 Hz, C3), 45.8 ( $\text{NCH}_2$ ), 25.6 ( $\text{CH}_2$ );  $m/z$  (ESI); 209.0  $[\text{M}+\text{H}]^+$ .

Spectroscopic data was consistent with literature values.<sup>221</sup>

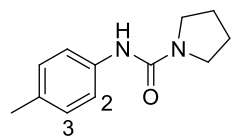
***N*-(4-Methylphenyl)-1-pyrrolidinecarboxamide 282e**

Prepared according to general procedure G using 4-tolyl isocyanate (0.25 mL, 2.0 mmol) and pyrrolidine (0.20 mL, 2.0 mmol) to give the urea **282e** as yellow needles (0.33 g, 80 %).

M.p.= 141-142 (MeCN, lit. 140-141 °C<sup>222</sup>);  $\delta_{\text{H}}$  (300 MHz,  $\text{CDCl}_3$ ); 7.31 (2H, d,  $J$  8.2 Hz, H3), 7.10 (2H, d,  $J$  8.2 Hz, H2), 6.15 (1H, br s, NH), 3.48-3.44 (4H, m,  $\text{NCH}_2$ ), 2.31 (3H, s,  $\text{CH}_3$ ), 1.99-1.95 (4H, m,  $\text{NCH}_2\text{CH}_2$ );  $\delta_{\text{C}}$  (75 MHz,  $\text{CDCl}_3$ ); 154.1 (C=O), 136.6 (quat.), 132.2 (quat.), 129.3 (C2), 119.7 (C3), 45.7 ( $\text{NCH}_2$ ), 25.6 ( $\text{CH}_2$ ), 20.7 ( $\text{CH}_3$ );  $\nu_{\text{max}}/\text{cm}^{-1}$  (solid, diamond); 3323, 2979, 188, 1739, 1435, 1365, 1216;  $m/z$  (ESI); 205.1  $[\text{M}+\text{H}]^+$ .

Spectroscopic data was consistent with literature values.<sup>222</sup>

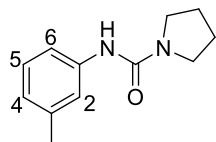
***N*-(3-Methylphenyl)-1-pyrrolidinecarboxamide 282f**

Prepared according to general procedure G using 3-tolyl isocyanate (0.64 mL, 5.0 mmol) and pyrrolidine (0.51 mL, 5.0 mmol) to give the urea **282f** as colourless crystals (0.92 g, 90 %).

M.p.= 122-123 °C (MeCN, lit. 124-125 °C<sup>223</sup>);  $\delta_{\text{H}}$  (300 MHz,  $\text{CDCl}_3$ ); 7.32 (1H, s, H2), 7.18-7.15 (2H, m, H5 + H6), 6.84 (1H, d,  $J$  7.4 Hz, H4), 6.27 (1H, br s, NH), 3.47-3.42 (4H, m,  $\text{NCH}_2$ ), 2.32 (3H, s,  $\text{OCH}_3$ ), 1.97-1.92 (4H, m,  $\text{NCH}_2\text{CH}_2$ );  $\delta_{\text{C}}$  (75 MHz,  $\text{CDCl}_3$ ); 154.1 (C=O), 139.2 (quat.), 138.6 (quat.), 128.9 (C5 or C6), 123.5 (C4), 120.2 (C2), 116.5 (C5 or C6), 45.7 ( $\text{NCH}_2$ ), 25.4 ( $\text{NCH}_2\text{CH}_2$ ), 21.4 ( $\text{CH}_3$ );  $\nu_{\text{max}}/\text{cm}^{-1}$  (solid, diamond); 3283, 2970, 1738, 1588, 1532, 1365, 1228, 1217; HRMS ( $\text{ES}^+$ )  $m/z$   $[\text{M}+\text{Na}]^+$  requires 227.1155 for  $\text{C}_{12}\text{H}_{16}\text{N}_2\text{NaO}$ , found: 227.1158.

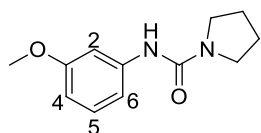
***N*-(3-Methoxyphenyl)-1-pyrrolidinecarboxamide 282i**

Prepared according to general procedure G using 3-methoxyphenyl isocyanate (0.26 mL, 2.0 mmol) and pyrrolidine (0.20 mL, 2.0 mmol) to give the urea **282i** as colourless needles (0.22 g, 50 %).

M.p.= 141-142 °C (MeCN);  $\delta_{\text{H}}$  (300 MHz,  $\text{CDCl}_3$ ); 7.27 (1H, t,  $J$  2.0 Hz, H2), 7.16 (1H, t,  $J$  8.1 Hz, H5), 6.84 (1H, ddd,  $J$  8.1, 2.0, 0.8 Hz, H6), 6.57 (1H, ddd,  $J$  8.1, 2.0, 0.8 Hz, H4), 6.22 (1H, br s, NH), 3.80 (3H, s,  $\text{OCH}_3$ ), 3.48-3.43 (4H, m,  $\text{NCH}_2$ ), 1.99-1.94 (4H, m,  $\text{NCH}_2\text{CH}_2$ );  $\delta_{\text{C}}$  (75 MHz,  $\text{CDCl}_3$ ); 160.2 (C=O), 153.8 (quat.), 140.6 (quat.), 129.4 (ArCH), 111.3 (ArCH), 108.8 (ArCH), 104.7 (ArCH), 55.2 ( $\text{OCH}_3$ ), 45.8 ( $\text{NCH}_2$ ), 25.46 ( $\text{NCH}_2\text{CH}_2$ );  $\nu_{\text{max}}/\text{cm}^{-1}$  (solid, diamond); 3511, 3316, 3004, 2970, 1738, 1655, 1606, 1541, 1448, 1428, 1365, 1228, 1217, 1092; HRMS ( $\text{ES}^+$ )  $m/z$   $[\text{M}+\text{H}]^+$  requires 221.1285 for  $\text{C}_{12}\text{H}_{17}\text{N}_2\text{O}_2$ , found: 221.1282.

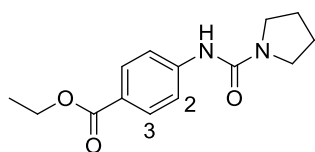
***N*-(4-Ethoxybenzoate)-1-pyrrolidinecarboxamide 282j**

Prepared according to general procedure G using 4-ethoxycarbonylphenyl isocyanate (0.38 g, 2.0 mmol) and pyrrolidine (0.20 mL, 2.0 mmol) to give the urea **282j** as colourless solid (0.42 g, 80 %).

M.p.= 175-176 °C (MeCN);  $\delta_{\text{H}}$  (300 MHz,  $\text{CDCl}_3$ ); 7.93 (2H, d,  $J$  8.6 Hz, H3), 7.54 (2H, d,  $J$  8.6 Hz, H2), 6.86 (1H, br s, NH), 4.33 (2H, q,  $J$  7.0 Hz,  $\text{CH}_2\text{CH}_3$ ), 3.47-3.43 (4H, m,  $\text{NCH}_2$ ), 1.94-1.90 (4H, m,  $\text{NCH}_2\text{CH}_2$ ), 1.37 (3H, t,  $J$  7.0 Hz,  $\text{CH}_2\text{CH}_3$ );  $\delta_{\text{C}}$  (75 MHz,  $\text{CDCl}_3$ ); 166.4 (OC=O), 153.7 (NHC=O), 143.8 (quat.), 130.7 (C3), 124.0 (quat.), 118.4 (C2), 60.5 ( $\text{CH}_2\text{CH}_3$ ), 45.9 ( $\text{NCH}_2$ ), 25.5 ( $\text{NCH}_2\text{CH}_2$ ), 14.4 ( $\text{CH}_2\text{CH}_3$ );  $\nu_{\text{max}}/\text{cm}^{-1}$  (solid); 3318, 2970, 1738, 1649, 1590, 1518, 1420, 1365, 1229, 1217, 1110; HRMS ( $\text{ES}^+$ )  $m/z$   $[\text{M}+\text{H}]^+$  requires 263.1390 for  $\text{C}_{14}\text{H}_{19}\text{N}_2\text{O}_3$ , found: 263.1392.

**Preparation of  $[\text{Pd}(\text{MeCN})_2(\text{OTs})_2]$ <sup>224</sup>**

Prepared according to the procedure of Drent *et al.*<sup>224</sup> A solution of *p*-toluenesulfonic acid monohydrate (1.49 g, 7.86 mmol) in acetonitrile (15 mL) was added dropwise to a stirred solution of palladium acetate (0.33 g, 1.47 mmol) in acetonitrile (20 mL). The reaction mixture was stirred at room temperature for 2 hours then  $\text{Et}_2\text{O}$  (30 mL) added and the reaction mixture left to stand for 20 hours. The resulting yellow precipitate was filtered and dried to give  $[\text{Pd}(\text{MeCN})_2(\text{OTs})_2]$  (0.60 g, 77%).

$\delta_{\text{H}}$  (300 MHz,  $\text{CDCl}_3$ ); 7.51 (2H, d,  $J$  6.9 Hz, ArH), 7.14 (2H, d,  $J$  6.9 Hz, ArH), 2.32 (3H, br s, ArCH<sub>3</sub>), 2.06 (3H, br s, NCCH<sub>3</sub>);  $\delta_{\text{C}}$  (75 MHz,  $\text{CDCl}_3$ ); 144.3 (quat.), 136.7 (quat.), 127.0 (ArCH), 124.3 (ArCH), 117.0 (CN), 19.6 (ArCH<sub>3</sub>), 0.75 (NCCH<sub>3</sub>). Anal. Calcd for



$C_{18}H_{20}N_2O_6PdS_2$ : C, 40.72; H, 3.80; N, 5.28; S, 12.08. Found: C, 40.65; H, 3.85; N, 5.15; S, 12.10.

Spectroscopic data was consistent with literature values.<sup>224</sup>

### General procedure H for the preparation of alkenes *via* oxidative Heck reaction

A solution of the urea (1.0 mmol), benzoquinone (0.13 g, 1.2 mmol) and  $[Pd(MeCN)_2(OTs)_2]$  (52 mg, 0.1 mmol) in acetonitrile (1.0 mL) was stirred at 60 °C for 15 minutes then the alkene (1.5 mmol) added. The reaction mixture was heated at 60 °C for 24 hours then cooled to room temperature, filtered through celite and washed with EtOAc (25 mL) and evaporated *in vacuo* to give the crude product which was purified by column chromatography.

#### (*E*)-Butyl-3-(2-(pyrrolidine-1-carboxamido)phenyl)acrylate **283a**

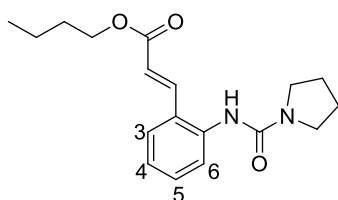

Prepared according to general procedure H using *N*-phenyl-1-pyrrolidine carboxamide (0.95 g, 5.0 mmol), benzoquinone (0.54 g, 5.0 mmol),  $[Pd(MeCN)_2(OTs)_2]$  (0.26 g, 0.5 mmol) and butyl acrylate (1.07 mL, 7.5 mmol). Purification by column chromatography ( $SiO_2$ , 0-50% EtOAc in petrol) gave the alkene

**283a** as yellow plates (1.47 g, 93%).

M.p.= 126-127 °C (MeCN);  $\delta_H$  (300 MHz,  $CDCl_3$ ); 7.86 (1H, d,  $J$  15.6 Hz,  $C=CHCO_2Bu$ ), 7.78 (1H, dd,  $J$  7.8, 0.8 Hz, H6), 7.53 (1H, dd,  $J$  7.8, 1.5 Hz, H3), 7.38 (1H, td,  $J$  7.8, 1.5 Hz, H5), 7.13 (1H, td,  $J$  7.8, 0.8 Hz, H4), 6.42 (1H, d,  $J$  15.6 Hz,  $C=CHAr$ ), 6.25 (1H, s, NH), 4.20 (2H, t,  $J$  6.8 Hz,  $OCH_2$ ), 3.52-3.48 (4H, m,  $NCH_2$ ), 2.02-1.98 (4H, m,  $NCH_2CH_2$ ), 1.74-1.65 (2H, m,  $OCH_2CH_2$ ), 1.51-1.38 (2H, m,  $OCH_2CH_2CH_2$ ), 0.98 (3H, t,  $J$  6.8 Hz,  $CH_2CH_3$ );  $\delta_C$  (75 MHz,  $CDCl_3$ ); 166.9 ( $^tBuOC=O$ ), 153.8 ( $NHC=O$ ), 139.7 ( $COC=C$ ), 137.4 (quat.), 130.8 (ArCH), 127.1 (ArCH), 126.6 (quat.), 124.3 (ArCH), 124.2 (ArCH), 120.2 ( $C=CHAr$ ), 64.5 ( $OCH_2$ ), 45.9 ( $NCH_2$ ), 30.7 ( $NCH_2CH_2$ ), 25.6 ( $CH_2$ ), 19.2 ( $CH_2$ ), 13.8 ( $CH_3$ );  $\nu_{max}/cm^{-1}$  (solid, diamond); 3285, 2951, 2870, 1703, 1642, 1573, 1517, 1385, 1300, 1267, 1193, 1123, 1102, 1066, 1026; HRMS ( $ES^+$ )  $m/z$   $[M+Na]^+$  requires 339.1679 for  $C_{18}H_{24}N_2NaO_3$ , found: 339.1672.

#### (*E*)-Butyl-3-(2-(piperidine-1-carboxamido)phenyl)acrylate **285a**

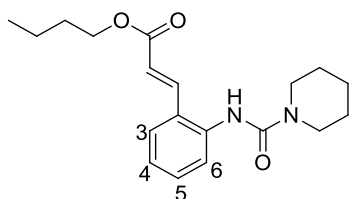

Prepared according to general procedure H using *N*-phenyl-1-piperidine carboxamide (0.20 g, 1.0 mmol), and butyl acrylate (0.17 mL, 1.2 mmol). Purification by column chromatography ( $SiO_2$ , 10-100% EtOAc in petrol) gave the alkene **285a** as a brown solid (0.092 g, 28%).

M.p.= 102-103 °C (EtOAc-petrol);  $\delta_H$  (500 MHz,  $CDCl_3$ ); 7.74 (1H, d,  $J$  16.0 Hz,  $HC=CHCO_2Bu$ ), 7.50 (1H, d,  $J$  7.3 Hz, H6), 7.45 (1H, d,  $J$  7.3, H3), 7.28 (1H, td,  $J$  7.3, 1.4 Hz

H5), 7.06 (1H, t,  $J$  7.3 Hz, H4), 6.32 (1H, d,  $J$  16.0 Hz, HC=CHAr), 6.28 (1H, br s, NH), 4.13 (2H, t,  $J$  7.2 Hz, OCH<sub>2</sub>), 3.41-3.39 (4H, m, NCH<sub>2</sub>), 1.64-1.55 (8H, m, NCH<sub>2</sub>CH<sub>2</sub> + NCH<sub>2</sub>CH<sub>2</sub>CH<sub>2</sub> + OCH<sub>2</sub>CH<sub>2</sub>) 1.36 (2H, sxt,  $J$  7.2 Hz, CH<sub>2</sub>CH<sub>3</sub>), 0.89 (3H, t,  $J$  7.2 Hz, CH<sub>3</sub>);  $\delta_C$  (75 MHz, CDCl<sub>3</sub>); 167.0 (BuOC=O), 154.3 (HNC=O), 139.8 (HC=CHCO<sub>2</sub>Bu), 137.7 (quat.), 130.7 (C5), 127.5 (quat.), 127.2 (C3), 124.9 (C4 or C6), 124.6 (C4 or C6), 119.8 (HC=CHAr), 64.5 (OCH<sub>2</sub>), 45.5 (NCH<sub>2</sub>), 30.7 (CH<sub>2</sub>), 25.7 (CH<sub>2</sub>), 24.4 (CH<sub>2</sub>), 19.2 (CH<sub>2</sub>), 13.8 (CH<sub>3</sub>);  $\nu_{\max}/\text{cm}^{-1}$  (solid, diamond); 3266, 2970, 1737, 1435, 1365, 1228, 1217; HRMS (ES<sup>+</sup>)  $m/z$  [M+Na]<sup>+</sup> requires 353.1836 for C<sub>19</sub>H<sub>26</sub>N<sub>2</sub>NaO<sub>3</sub>, found: 353.1832.

**(E)-Butyl-3-(2-(2-methylpiperidine-1-carboxamido)phenyl)acrylate 285b**

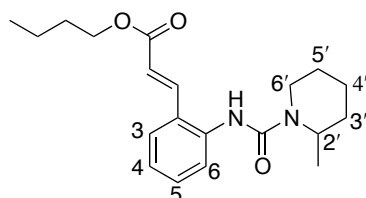

Prepared according to general procedure H using *N*-phenyl-1-(2-methylpiperidine) carboxamide (0.22 g, 1.0 mmol), and butyl acrylate (0.17 mL, 1.2 mmol). Purification by column chromatography (SiO<sub>2</sub>, 10-100% EtOAc in petrol) gave the alkene **285b** as brown oil (0.017 g, 5%).

$\delta_H$  (500 MHz, CDCl<sub>3</sub>); 7.73 (1H, d,  $J$  16.0 Hz, HC=CHCO<sub>2</sub>Bu), 7.51 (1H, dd,  $J$  8.2, 0.8 Hz, H6), 7.45 (1H, d,  $J$  8.2, 1.4 Hz, H3), 7.27 (1H, td,  $J$  8.2, 1.4 Hz, H5), 7.05 (1H, td,  $J$  8.2, 0.8 Hz, H4), 6.32 (1H, d,  $J$  16.0 Hz, HC=CHAr), 6.28 (1H, br s, NH), 4.30 (1H, m, H2'), 4.12 (2H, t,  $J$  6.4 Hz, OCH<sub>2</sub>), 3.84 (1H, dt,  $J$  13.3, 2.7 Hz, H6') 2.95 (1H, td,  $J$  13.3, 2.7 Hz, H6'), 1.74-1.29 (10H, m, H3', H4', H5', OCH<sub>2</sub>CH<sub>2</sub>, OCH<sub>2</sub>CH<sub>2</sub>CH<sub>2</sub>), 1.21 (3H, d,  $J$  2.7 Hz, CH<sub>3</sub>), 0.89 (3H, t,  $J$  7.3 Hz, CH<sub>2</sub>CH<sub>3</sub>);  $\delta_C$  (125 MHz, CDCl<sub>3</sub>); 167.0 (BuOC=O), 155.2 (HNC=O), 139.8 (HC=CHCO<sub>2</sub>Bu), 137.8 (quat.), 130.7 (C5), 127.6 (quat.), 127.1 (C3), 125.0 (C4 or C6), 124.6 (C4 or C6), 120.0 (HC=CHAr), 64.5 (OCH<sub>2</sub>), 47.1 (C2'), 39.3 (C6'), 30.7 (CH<sub>2</sub>), 30.2 (CH<sub>2</sub>), 25.6 (CH<sub>2</sub>), 19.2 (CH<sub>2</sub>), 18.6 (CH<sub>2</sub>), 15.8 (CH<sub>3</sub>), 13.8 (CH<sub>2</sub>CH<sub>3</sub>);  $\nu_{\max}/\text{cm}^{-1}$  (solid, diamond); 3455, 3288, 2970, 2939, 2869, 1737, 1715, 1633, 1513, 1480, 1443, 1365, 1275, 1218, 1180; HRMS (ES<sup>+</sup>)  $m/z$  [M+Na]<sup>+</sup> requires 367.1992 for C<sub>20</sub>H<sub>28</sub>N<sub>2</sub>NaO<sub>3</sub>, found: 367.1992.

**(E)-Butyl-3-(4-fluoro-1-(pyrrolidine-1-carboxamido)phenyl)acrylate 282d**

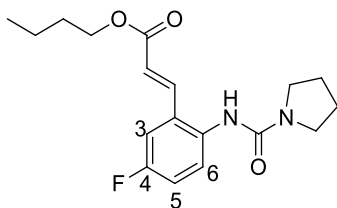

Prepared according to general procedure H using *N*-(4-fluorophenyl)-1-pyrrolidine carboxamide **282d** (0.18 g, 1.0 mmol), and butyl acrylate (0.22 mL, 1.5 mmol). Purification by column chromatography (SiO<sub>2</sub>, 0-50% EtOAc in petrol) gave an 3:2 inseparable mixture of urea **282d**:alkene **283d** as a

brown oil (0.10 g, 24%).

Values for the alkene were obtained after column chromatography of the subsequent electrocyclisation reaction.

$\delta_{\text{H}}$  (300 MHz,  $\text{CDCl}_3$ ); 7.72 (1H, dd,  $J$  15.8, 1.2 Hz,  $\text{C}=\text{CHCO}_2\text{Bu}$ ), 7.58 (1H, dd,  $J$  9.1, 5.2 Hz, H6), 7.15 (1H, dd,  $J$  9.1, 3.0 Hz, H3), 7.00 (1H, ddd,  $J$  9.1, 8.0, 3.0 Hz, H5), 6.31 (1H, d,  $J$  15.8 Hz,  $\text{HC}=\text{CHAr}$ ), 6.00 (1H, s, NH), 4.14 (2H, t,  $J$  6.7 Hz,  $\text{OCH}_2$ ), 3.44-3.36 (4H, m,  $\text{NCH}_2$ ), 1.95-1.90 (4H, m,  $\text{NCH}_2\text{CH}_2$ ), 1.62 (2H, tt,  $J$  8.2, 7.1 Hz,  $\text{OCH}_2\text{CH}_2$ ), 1.37 (2H, sxt,  $J$  7.1 Hz,  $\text{OCH}_2\text{CH}_2\text{CH}_2$ ), 0.88 (3H, t,  $J$  7.7 Hz,  $\text{CH}_2\text{CH}_3$ );  $\delta_{\text{C}}$  (75 MHz,  $\text{CDCl}_3$ ); 166.6 ( $^t\text{BuOC}=\text{O}$ ), 159.6 (d,  $J$  243.3 Hz, C4), 154.0 ( $\text{NHC}=\text{O}$ ), 138.6 (d,  $J$  2.2 Hz,  $\text{COHC}=\text{CH}$ ), 133.3 (d,  $J$  4.4 Hz, quat.), 129.1 (d,  $J$  8.8 Hz, quat.), 127.2 (d,  $J$  8.8 Hz, ArCH), 121.2 ( $\text{HC}=\text{CHAr}$ ), 117.6 (d,  $J$  22.7 Hz, ArCH), 113.0 (d,  $J$  24.9 Hz, ArCH), 64.7 ( $\text{OCH}_2$ ), 45.9 ( $\text{NCH}_2$ ), 30.7 ( $\text{OCH}_2\text{CH}_2$ ), 25.6 ( $\text{NCH}_2\text{CH}_2$ ), 19.2 ( $\text{CH}_2\text{CH}_3$ ), 13.8 ( $\text{CH}_3$ );  $\nu_{\text{max}}/\text{cm}^{-1}$  (solid, diamond); 3568, 3280, 3004, 2970, 1738, 1643, 1425, 1366, 1228, 1217, 1092; HRMS ( $\text{ES}^+$ )  $m/z$  [ $\text{M}+\text{Na}$ ] $^+$  requires 357.1585 for  $\text{C}_{18}\text{H}_{23}\text{FN}_2\text{NaO}_3$ , found: 357.1583.

**(E)-Butyl-3-(4-methyl-1-(pyrrolidine-1-carboxamido)phenyl)acrylate 283e**

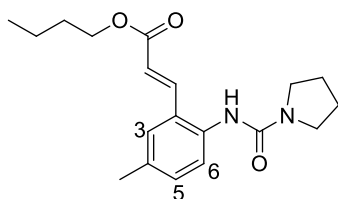

Prepared according to general procedure H using *N*-(4-methylphenyl)-1-pyrrolidine carboxamide (0.19 g, 0.93 mmol), and butyl acrylate (0.22 mL, 1.5 mmol). Purification by column chromatography ( $\text{SiO}_2$ , 0-50% EtOAc in petrol) gave the alkene **283e** as yellow oil (0.21 g, 70%).

$\delta_{\text{H}}$  (300 MHz,  $\text{CDCl}_3$ ); 7.84 (1H, d,  $J$  16.2 Hz,  $\text{HC}=\text{CHCO}_2\text{Bu}$ ), 7.59 (1H, d,  $J$  8.4 Hz, H6), 7.33 (1H, d,  $J$  1.6 Hz, H3), 7.14 (1H, dd,  $J$  8.3, 1.6 Hz, H5), 6.39 (1H, d,  $J$  16.2 Hz,  $\text{HC}=\text{CHCO}_2\text{Bu}$ ), 6.10 (1H, s, NH), 4.19 (2H, t,  $J$  6.6 Hz,  $\text{OCH}_2$ ), 3.50-3.46 (4H, m,  $\text{NCH}_2$ ), 2.32 (3H, s, Ar $\text{CH}_3$ ), 2.01-1.96 (4H, m,  $\text{NCH}_2\text{CH}_2$ ), 1.69 (2H, m,  $\text{OCH}_2\text{CH}_2$ ), 1.43 (2H, sxt,  $J$  7.4 Hz,  $\text{OCH}_2\text{CH}_2\text{CH}_2$ ), 0.96 (3H, t,  $J$  7.4 Hz,  $\text{CH}_2\text{CH}_3$ );  $\delta_{\text{C}}$  (75 MHz,  $\text{CDCl}_3$ ); 167.0 ( $^t\text{BuOC}=\text{O}$ ), 154.1 ( $\text{NHC}=\text{O}$ ), 139.8 ( $\text{COHC}=\text{CH}$ ), 134.9 (quat.), 134.1 (quat.), 131.6 (C5), 129.1 (C3), 127.0 (quat.), 124.8 (C6), 119.7 ( $\text{C}=\text{CHAr}$ ), 64.5 ( $\text{OCH}_2$ ), 45.9 ( $\text{NCH}_2$ ), 30.7 ( $\text{OCH}_2\text{CH}_2$ ), 25.6 ( $\text{NCH}_2\text{CH}_2$ ), 20.8 (Ar $\text{CH}_3$ ), 19.2 ( $\text{CH}_2\text{CH}_3$ ), 13.8 ( $\text{CH}_2\text{CH}_3$ );  $\nu_{\text{max}}/\text{cm}^{-1}$  (solid, diamond); 3283, 2970, 1736, 1365, 1228, 1216, 1066, 1026; HRMS ( $\text{ES}^+$ )  $m/z$  [ $\text{M}+\text{H}$ ] $^+$  requires 331.2016 for  $\text{C}_{19}\text{H}_{27}\text{N}_2\text{O}_3$ , found: 331.2013.

**(E)-Butyl-3-(5-methyl-1-(pyrrolidine-1-carboxamido)phenyl)acrylate 283f**

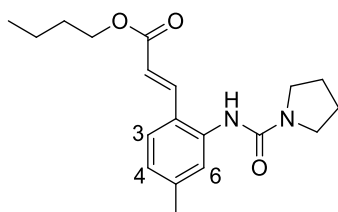

Prepared according to general procedure H using *N*-(3-methylphenyl)-1-pyrrolidine carboxamide (0.41 g, 2.0 mmol), benzoquinone (0.26 g, 2.4 mmol),  $[\text{Pd}(\text{MeCN})_2(\text{OTs})_2]$  (52 mg, 0.1 mmol) and butyl acrylate (0.43 mL, 3.0 mmol) in acetonitrile (2.0 mL). Purification by column chromatography

( $\text{SiO}_2$ , 0-50% EtOAc in petrol) gave the alkene **283f** as colourless needles (0.45 g, 68%).

M.p.= 125-126 °C (MeCN);  $\delta_{\text{H}}$  (300 MHz,  $\text{CDCl}_3$ ); 7.82 (1H, d,  $J$  15.9 Hz,  $\text{C}=\text{CHCO}_2\text{Bu}$ ), 7.63 (1H, d,  $J$  0.8 Hz, H6), 7.42 (1H, d,  $J$  8.0 Hz, H3), 6.93 (1H, dd,  $J$  8.0, 0.8 Hz, H4), 6.38 (1H, d,  $J$  15.9 Hz,  $\text{HC}=\text{CHAr}$ ), 6.18 (1H, s, NH), 4.20 (2H, t,  $J$  6.6 Hz,  $\text{OCH}_2$ ), 3.51-3.47 (4H, m,  $\text{NCH}_2$ ), 2.35 (3H, s,  $\text{ArCH}_3$ ), 2.02-1.97 (4H, m,  $\text{NCH}_2\text{CH}_2$ ), 1.73-1.63 (2H, m,  $\text{OCH}_2\text{CH}_2$ ), 1.43 (2H, sxt,  $J$  7.4 Hz,  $\text{OCH}_2\text{CH}_2\text{CH}_2$ ), 0.96 (3H, t,  $J$  7.4 Hz,  $\text{CH}_2\text{CH}_3$ );  $\delta_{\text{C}}$  (75 MHz,  $\text{CDCl}_3$ ); 167.2 ( $^t\text{BuOC}=\text{O}$ ), 154.2 ( $\text{NHC}=\text{O}$ ), 141.1 (quat.), 139.9 (quat.), 137.5 ( $\text{HC}=\text{CHAr}$ ), 126.6 ( $\text{ArCH}$ ), 125.5 ( $\text{ArCH}$ ), 125.4 ( $\text{ArCH}$ ), 124.5 (quat.), 118.2 ( $\text{HC}=\text{CHAr}$ ), 64.3 ( $\text{OCH}_2$ ), 45.8 ( $\text{NCH}_2$ ), 30.7 ( $\text{OCH}_2\text{CH}_2$ ), 25.6 ( $\text{NCH}_2\text{CH}_2$ ), 21.5 ( $\text{CH}_3$ ), 19.2 ( $\text{CH}_2\text{CH}_3$ ), 13.7 ( $\text{CH}_2\text{CH}_3$ );  $\nu_{\text{max}}/\text{cm}^{-1}$  (solid, diamond); 3455, 3288, 3005, 2900, 1738, 1564, 1435, 1365, 1228, 1217, 1092; HRMS ( $\text{ES}^+$ )  $m/z$  [ $\text{M}+\text{H}$ ] $^+$  requires 331.2016 for  $\text{C}_{19}\text{H}_{27}\text{N}_2\text{O}_3$ , found: 331.2007.

**(*E*)-*N*-(2-(3-Dimethylamino)-3-oxoprop-1-en-yl)phenylpyrrolidine-1-carboxamide 288a**

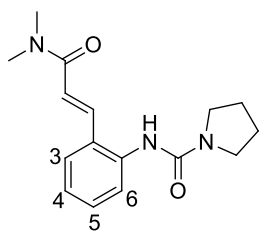

Prepared according to general procedure H using *N*-phenyl-1-pyrrolidine carboxamide (0.19 g, 1.0 mmol), and *N,N*-dimethylacrylamide (0.15 mL, 1.5 mmol). Purification by column chromatography ( $\text{SiO}_2$ , 50% EtOAc in petrol) gave the alkene **288a** as yellow plates (0.22 g, 76%).

M.p.= 74-75 °C (MeCN);  $\delta_{\text{H}}$  (300 MHz,  $\text{CDCl}_3$ ); 7.73 (1H, d,  $J$  15.1 Hz,  $\text{C}=\text{CHCONMe}_2$ ), 7.62 (1H, dd,  $J$  7.8, 1.1 Hz, H3), 7.38 (1H, dd,  $J$  7.8, 1.5 Hz, H6), 7.39 (1H, td,  $J$  7.8, 1.5 Hz, H4), 7.00-6.95 (1H, td,  $J$  7.8, 1.1 Hz, H5), 6.82 (1H, s, NH), 6.67 (1H, d,  $J$  15.1 Hz,  $\text{C}=\text{CHAr}$ ), 3.41-3.37 (4H, m,  $\text{NCH}_2$ ), 2.98 (3H, s,  $\text{NCH}_3$ ), 2.80 (3H, s,  $\text{NCH}_3$ ), 1.85-1.81 (4H, m,  $\text{NCH}_2\text{CH}_2$ );  $\delta_{\text{C}}$  (75 MHz,  $\text{CDCl}_3$ ); 166.4 ( $\text{Me}_2\text{NC}=\text{O}$ ), 153.8 ( $\text{NHC}=\text{O}$ ), 137.4 (quat.), 137.3 ( $\text{C}=\text{CHCONMe}_2$ ), 130.2 (C4), 126.8 (quat.), 126.7 (C6), 123.8 (C3 or C5), 123.7 (C3 or C5), 119.8 ( $\text{C}=\text{CHAr}$ ), 45.9 ( $\text{NCH}_2$ ), 37.4 ( $\text{NCH}_3$ ), 36.0 ( $\text{NCH}_3$ ), 25.6 ( $\text{NCH}_2\text{CH}_2$ );  $\nu_{\text{max}}/\text{cm}^{-1}$  (solid, diamond); 3289, 2970, 1736, 1365, 1228, 1217, 979; HRMS ( $\text{ES}^+$ )  $m/z$  [ $\text{M}+\text{Na}$ ] $^+$  requires 310.1526 for  $\text{C}_{16}\text{H}_{21}\text{N}_3\text{NaO}_2$ , found: 310.1522.

**(*E*)-*N*-(2-(3-Dimethylamino)-3-oxoprop-1-en-1-yl)-5-methoxyphenylpyrrolidine-1-carboxamide 288b**

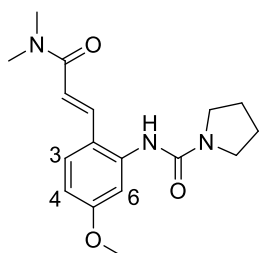

Prepared according to general procedure H using *N*-(3-methoxyphenyl)-1-pyrrolidine carboxamide (0.22 g, 1.0 mmol), and *N,N*-dimethylacrylamide (0.15 mL, 1.5 mmol). Purification by column chromatography ( $\text{SiO}_2$ , 50% EtOAc in petrol) gave the alkene **288b** as pale yellow crystals (0.22 g, 77%).

M.p.= 152-153 °C (MeCN);  $\delta_{\text{H}}$  (300 MHz,  $\text{CDCl}_3$ ); 7.77 (1H, d,  $J$  14.8 Hz,  $\text{HC}=\text{CHCONMe}_2$ ), 7.55 (1H, d,  $J$  2.8 Hz, H6), 7.45 (1H, dd,  $J$  8.9 Hz, H3), 6.69 (1H, d,  $J$  14.8 Hz,  $\text{ArCH}=\text{CH}$ ), 6.62 (1H, dd,  $J$  8.9, 2.8 Hz, H4), 3.81 (3H, s,  $\text{OCH}_3$ ), 3.52-3.47 (4H, m,

$\text{NCH}_2$ ), 3.13 (3H, s,  $\text{NCH}_3$ ), 3.01 (3H, s,  $\text{NCH}_3$ ), 1.97-1.93 (4H, m,  $\text{NCH}_2\text{CH}_2$ );  $\delta_{\text{C}}$  (75 MHz,  $\text{CDCl}_3$ ); 166.9 (C=O), 161.2 (quat.), 153.8 (C=O), 139.1 (quat.), 136.8 (ArHC=CH), 127.6 (C3), 118.8 (quat.), 116.7 (C=CHAr), 111.3 (C4), 107.2 (C6), 55.4 ( $\text{OCH}_3$ ), 45.9 ( $\text{NCH}_2$ ), 37.7 ( $\text{NCH}_3$ ), 35.9 ( $\text{NCH}_3$ ), 25.6 ( $\text{NCH}_2\text{CH}_2$ );  $\nu_{\text{max}}/\text{cm}^{-1}$  (solid, diamond); 3267, 3015, 1637, 1379, 1042, 980; HRMS ( $\text{ES}^+$ )  $m/z$   $[\text{M}+\text{H}]^+$  requires 318.1812 for  $\text{C}_{17}\text{H}_{24}\text{N}_3\text{O}_3$ , found: 318.1810.

**(E)-N-(2-(3-Dimethylamino)-3-oxoprop-1-en-1-yl)-4-methylphenylpyrrolidine-1-carboxamide 288c**

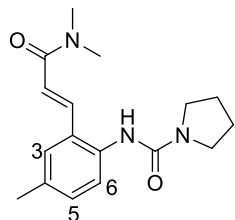

Prepared according to general procedure H using *N*-(4-methylphenyl)-1-pyrrolidine carboxamide (0.20 g, 1.0 mmol), and *N,N*-dimethylacrylamide (0.15 mL, 1.5 mmol). Purification by column chromatography ( $\text{SiO}_2$ , 50-100% EtOAc in petrol) gave the alkene **288c** as brown oil (0.22 g, 74%).

$\delta_{\text{H}}$  (300 MHz,  $\text{CDCl}_3$ ); 7.80 (1H, d,  $J$  15.2 Hz, HC=CHAr), 7.59 (1H, d,  $J$  8.2 Hz, H6), 7.29 (1H, d,  $J$  1.4 Hz, H3), 7.12 (1H, dd,  $J$  8.2, 1.4, H5), 6.78 (1H, d,  $J$  15.2 Hz, HC=CHAr), 6.51 (1H, s, NH), 3.49-3.45 (4H, m,  $\text{NCH}_2$ ), 3.14 (3H, s,  $\text{NCH}_3$ ), 2.99 (3H, s,  $\text{NCH}_3$ ), 2.31 (3H, s,  $\text{CH}_3$ ), 1.97-1.91 (4H, m,  $\text{NCH}_2\text{CH}_2$ );  $\delta_{\text{C}}$  (75 MHz,  $\text{CDCl}_3$ ); 166.6 ( $\text{Me}_2\text{NC}=\text{O}$ ), 154.4 ( $\text{HNC}=\text{O}$ ), 137.7 (HC=CHAr), 135.0 (quat.), 133.7 (quat.), 130.9 (C5), 127.8 (quat.), 126.7 (C3), 125.0 (C6), 118.7 (HC=CHAr), 45.9 ( $\text{NCH}_2$ ), 37.4 ( $\text{NCH}_3$ ), 35.8 ( $\text{NCH}_3$ ), 25.6 ( $\text{NCH}_2\text{CH}_2$ ), 20.9 ( $\text{CH}_3$ );  $\nu_{\text{max}}/\text{cm}^{-1}$  (solid, diamond); 3589, 3413, 3006, 2971, 1721, 1424, 1365, 1223, 1092; HRMS ( $\text{ES}^+$ )  $m/z$   $[\text{M}+\text{Na}]^+$  requires 324.1681 for  $\text{C}_{17}\text{H}_{23}\text{N}_3\text{NaO}_2$ , found: 324.1682.

**(E)-N-(2-(3-Dimethylamino)-3-oxoprop-1-en-yl)-5-methylphenylpyrrolidine-1-carboxamide 288d**

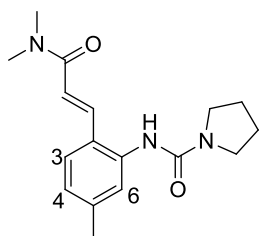

Prepared according to general procedure H using *N*-(3-methylphenyl)-1-pyrrolidine carboxamide (0.41 g, 2.0 mmol), and *N,N*-dimethylacrylamide (0.31 mL, 3.0 mmol). Purification by column chromatography ( $\text{SiO}_2$ , 50-100% EtOAc in petrol) gave the alkene **288d** as brown oil (0.17 g, 28%).

$\delta_{\text{H}}$  (300 MHz,  $\text{CDCl}_3$ ); 7.74 (1H, d,  $J$  15.1 Hz, C=CHCONMe<sub>2</sub>), 7.57 (1H, d,  $J$  1.1 Hz, H6), 7.33 (1H, d,  $J$  8.0 Hz, H3), 6.83 (1H, dd,  $J$  8.0, 1.1 Hz, H4), 6.71 (1H, d,  $J$  15.1 Hz, HC=CHAr), 6.33 (1H, s, NH), 3.40 (4H, t,  $J$  6.3 Hz,  $\text{NCH}_2$ ), 3.07 (3H, s,  $\text{NCH}_3$ ), 2.96 (3H, s,  $\text{NCH}_3$ ), 2.26 (3H, s, ArCH<sub>3</sub>), 1.88 (4H, t,  $J$  6.3 Hz,  $\text{NCH}_2\text{CH}_2$ );  $\delta_{\text{C}}$  (100 MHz,  $\text{CDCl}_3$ ); 166.6 ( $^t\text{BuOC}=\text{O}$ ), 153.9 ( $\text{NHC}=\text{O}$ ), 140.7 (quat.), 137.2 (quat.), 137.1 (HC=CHCONMe<sub>2</sub>), 126.5 (C3), 124.8 (C4), 124.2 (C6), 124.1 (quat.), 118.8 (HC=CHAr), 45.9 ( $\text{NCH}_2$ ), 37.5 ( $\text{NCH}_3$ ), 35.9 ( $\text{NCH}_3$ ), 25.6 ( $\text{NCH}_2\text{CH}_2$ ), 21.6 (ArCH<sub>3</sub>);  $\nu_{\text{max}}/\text{cm}^{-1}$  (solid,

diamond); 3455, 3016, 2970, 1738, 1645, 1435, 1365, 1228, 1217; HRMS (ES<sup>+</sup>)  $m/z$  [M+Na]<sup>+</sup> requires 324.1682 for C<sub>17</sub>H<sub>23</sub>N<sub>3</sub>NaO<sub>2</sub>, found: 324.1693.

**(E)-Ethyl 3-(3-dimethylamino)-3-oxoprop-1-en-1-yl)-4-(pyrrolidine-1-carboxamide) benzoate 288e**

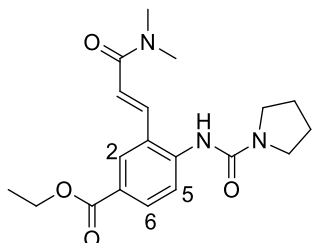

Prepared according to general procedure H using *N*-(4-ethoxycarbonylphenyl)-1-pyrrolidine carboxamide (0.26 g, 1.0 mmol), and *N,N*-dimethylacrylamide (0.15 mL, 1.5 mmol). Purification by column chromatography (SiO<sub>2</sub>, 10% MeOH in EtOAc) gave the alkene **288e** as brown oil (0.064 g, 18%).

$\delta_{\text{H}}$  (300 MHz, CDCl<sub>3</sub>); 8.13 (1H, d,  $J$  1.9 Hz, H3), 8.08 (1H, d,  $J$  8.6 Hz, H5), 7.96 (1H, d,  $J$  8.6, 1.9 Hz, H6), 7.80 (1H, d,  $J$  15.1 Hz, ArHC=CH), 6.90 (1H, d,  $J$  15.1 Hz, ArHC=CH), 6.85 (1H, s, NH), 4.36 (2H, q,  $J$  7.1 Hz, CH<sub>2</sub>CH<sub>3</sub>), 3.53-3.49 (4H, m, NCH<sub>2</sub>), 3.18 (3H, s, NCH<sub>3</sub>), 3.02 (3H, s, NCH<sub>3</sub>), 1.98-1.94 (4H, m, NCH<sub>2</sub>CH<sub>2</sub>), 1.40 (3H, t,  $J$  1.40 Hz, CH<sub>2</sub>CH<sub>3</sub>);  $\delta_{\text{C}}$  (75 MHz, CDCl<sub>3</sub>); 166.2 (C=O), 166.2 (C=O), 153.2 (NHC=O), 141.7 (quat.), 136.3 (ArCH=CH), 131.1 (C6), 128.4 (C2), 125.6 (quat.), 124.8 (quat.), 121.9 (C5), 120.7 (ArCH=CH), 60.9 (OCH<sub>2</sub>), 46.0 (NCH<sub>2</sub>), 37.4 (NCH<sub>3</sub>), 35.9 (NCH<sub>3</sub>), 25.5 (NCH<sub>2</sub>CH<sub>2</sub>), 14.3 (OCH<sub>2</sub>CH<sub>3</sub>);  $\nu_{\text{max}}$ /cm<sup>-1</sup> (solid, diamond); 3321, 2977, 2876, 1711, 1656, 1609, 1592, 1416, 1367, 1277, 1251, 1175, 1108, 1020; HRMS (ES<sup>+</sup>)  $m/z$  [M+Na]<sup>+</sup> requires 382.1737 for C<sub>19</sub>H<sub>25</sub>N<sub>3</sub>NaO<sub>4</sub>, found: 382.1742.

**General Procedure I for the preparation of hydroxamic acids**

Oxalyl chloride (0.51 mL, 6.0 mmol) was added to a stirred solution of the benzoic acid (5.0 mmol) in CH<sub>2</sub>Cl<sub>2</sub> (50 mL) and DMF (4 drops). The reaction mixture was stirred at room temperature for 3 hours then evaporated *in vacuo* to give the acid chloride as a yellow solid which was diluted in EtOAc (50 mL) and added dropwise to a stirred solution of hydroxylamine hydrochloride (0.38 g, 5.5 mmol) and K<sub>2</sub>CO<sub>3</sub> (1.38 g, 10.0 mmol) in water (25 mL). The biphasic mixture was stirred vigorously for 18 hours and a colourless precipitate crashed out of solution. The reaction mixture was diluted with EtOAc (30 mL) and the phases separated. The aqueous phase was extracted with EtOAc (2 × 20 mL) and the combined organic extracts washed with brine, dried (MgSO<sub>4</sub>) and evaporated *in vacuo* to give the hydroxamic acid.

***N*-Hydroxy-2-bromobenzamide 295a**

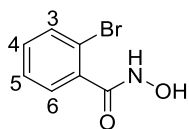

Prepared according to general procedure I using 2-bromobenzoic acid (1.0 g, 5.0 mmol) to give the hydroxamic acid **295a** as colourless needles (0.98 g, 91%) which required no further purification.

$\delta_{\text{H}}$  (300 MHz,  $\text{CDCl}_3$ ); 10.97 (1H, br s, *NH* or *OH*), 9.25 (1H, br s, *NH* or *OH*), 7.68-7.65 (1H, m, H6), 7.46-7.35 (3H, m, *ArH*);  $\delta_{\text{C}}$  (75 MHz,  $\text{CDCl}_3$ ); 164.1 ( $\text{C}=\text{O}$ ), 136.7 (quat.), 132.7 (C6), 131.2 (C4 or C5), 129.3 (C4 or C5), 127.5 (C3), 119.7 (quat.);  $\nu_{\text{max}}/\text{cm}^{-1}$  (solid, diamond); 3220, 2879, 1623, 1592, 1544, 1471, 1455, 1321, 1171, 1051, 1033;  $m/z$  (ESI) 218.0  $[\text{M}+\text{H}]^+$

### General Procedure J for the preparation of 2-bromophenyl ureas

A solution of the hydroxamic acid (4.5 mmol) and carbonyl diimidazole (0.87 g, 5.4 mmol) in acetonitrile was heated to 60 °C for 30 minutes. Pyrrolidine (1.40 mL, 13.5 mmol) was added and the reaction mixture was stirred at 60 °C for 1 hour then cooled to room temperature, diluted with EtOAc (30 mL) then washed with  $\text{NH}_4\text{Cl}$  ( $2 \times 20$  mL), water (20 mL) then brine (20 mL), dried ( $\text{MgSO}_4$ ) and evaporated *in vacuo* to give the urea.

### 3-(2-Bromophenyl)-1,1-pyrrolidine urea 294a

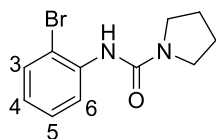

Prepared according to general procedure J using hydroxamic acid **295a** (0.98 g, 4.5 mmol) to give the urea **294a** as orange needles which were recrystallised from acetonitrile (1.09 g, 90%).

M.p.= 67-69 °C (MeCN);  $\delta_{\text{H}}$  (300 MHz,  $\text{CDCl}_3$ ); 8.34 (1H, dd,  $J$  8.5, 1.6 Hz, H3), 7.51 (1H, dd,  $J$  8.5, 1.4 Hz, H6), 7.31 (1H, td,  $J$  7.5, 1.4 Hz, H4), 6.89 (2H, m, H5 + *NH*), 3.54 (4H, m,  $\text{NCH}_2$ ), 2.03 (4H, m,  $\text{NCH}_2\text{CH}_2$ );  $\delta_{\text{C}}$  (75 MHz,  $\text{CDCl}_3$ ); 152.2 ( $\text{C}=\text{O}$ ), 136.0 (quat.), 132.2 (*ArCH*), 126.8 (*ArCH*), 122.2 (*ArCH*), 119.1 (*ArCH*), 111.7 (quat.), 44.7 ( $\text{NCH}_2$ ), 22.6 ( $\text{NCH}_2\text{CH}_2$ );  $\nu_{\text{max}}/\text{cm}^{-1}$  (solid, diamond); 3417, 3319, 2970, 1738, 1434, 1365, 1217; HRMS ( $\text{ES}^+$ )  $m/z$   $[\text{M}+\text{Na}]^+$  requires 291.0103 for  $\text{C}_{11}\text{H}_{13}^{79}\text{BrN}_2\text{NaO}$ , found: 291.0101.

### *N*-Hydroxy-2-bromo-5-methoxybenzamide 295b

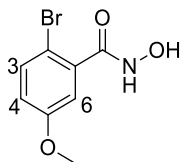

Prepared according to general procedure I from 2-bromo-5-methoxybenzoic acid (1.15 g, 5.0 mmol) in  $\text{CH}_2\text{Cl}_2$  (50 mL) and DMF (4 drops) to give the hydroxamic acid **295b** as colourless needles (0.886 g, 72%) which required no further purification.

M.p.= 182-183 °C (EtOAc);  $\delta_{\text{H}}$  (300 MHz,  $\text{CDCl}_3$ ); 10.95 (1H, br s, *NH* or *OH*), 9.23 (1H, br s, *NH* or *OH*), 7.53 (1H, d,  $J$  8.3 Hz, H3), 6.98 (1H, dd,  $J$  8.3, 3.1 Hz, H4), 6.91 (1H, d,  $J$  3.1 Hz, H6), 3.77 (3H, s,  $\text{CH}_3$ );  $\delta_{\text{C}}$  (75 MHz,  $\text{CDCl}_3$ ); 163.7 ( $\text{C}=\text{O}$ ), 158.2 (quat.), 137.3 (quat.), 133.6 (*ArCH*), 116.9 (*ArCH*), 114.8 (*ArCH*), 109.9 (quat.), 55.6 ( $\text{CH}_3$ );  $\nu_{\text{max}}/\text{cm}^{-1}$  (solid, diamond); 3454, 3225, 3016, 2970, 1738, 1365, 1217; HRMS ( $\text{ES}^+$ )  $m/z$   $[\text{M}+\text{H}]^+$  requires 251.9631 for  $\text{C}_8\text{H}_8^{79}\text{BrNNaO}_2$ , found: 251.9606.

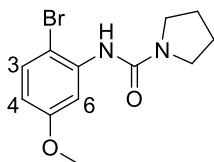
**3-(2-Bromo-5-methoxyphenyl)-1,1-pyrrolidine urea 294b**

Prepared according to general procedure J from 2-bromo-5-methoxyphenyl hydroxamic acid (1.05 g, 4.0 mmol) and carbonyl diimidazole (0.78 g, 4.8 mmol) and pyrrolidine (1.2 mL, 12.0 mmol) in acetonitrile to give the crude product which was purified by column chromatography (SiO<sub>2</sub>, 0-50% EtOAc in petrol) to give the urea **294b** as colourless plates (0.32 g, 27%).

M.p. = 184-185 °C (CHCl<sub>3</sub>); δ<sub>H</sub> (300 MHz, CDCl<sub>3</sub>); 8.00 (1H, d, *J* 3.0 Hz, H6), 7.26 (1H, d, *J* 8.8 Hz, H3), 6.81 (1H, br s, NH), 6.40 (1H, dd, *J* 8.8, 3.0 Hz, H4), 3.73 (3H, s, CH<sub>3</sub>), 3.46-3.42 (4H, m, NCH<sub>2</sub>), 1.95-1.91 (4H, m, NCH<sub>2</sub>CH<sub>2</sub>); δ<sub>C</sub> (75 MHz, CDCl<sub>3</sub>); 159.6 (quat.), 153.3 (C=O), 137.7 (quat.), 131.9 (C3), 110.5 (C4), 104.8 (C6), 102.7 (quat.), 55.5 (CH<sub>3</sub>), 45.7 (NCH<sub>2</sub>), 25.6 (NCH<sub>2</sub>CH<sub>2</sub>); ν<sub>max</sub>/cm<sup>-1</sup> (solid, diamond); 3421, 3003, 2970, 1738, 1435, 1365, 1228, 1217, 1091; HRMS (ES<sup>+</sup>) *m/z* [M+H]<sup>+</sup> requires 299.0390 for C<sub>12</sub>H<sub>16</sub><sup>79</sup>BrN<sub>2</sub>O<sub>2</sub>, found: 299.0394.

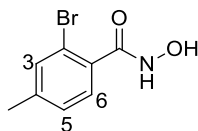
**N-Hydroxy-2-bromo-4-methylbenzamide 295c**

Prepared according to general procedure I from 2-bromo-4-methylbenzoic acid (0.53 g, 2.5 mmol) in CH<sub>2</sub>Cl<sub>2</sub> (20 mL) and DMF (4 drops) to give the hydroxamic acid **295c** as colourless needles (0.43 g, 74%) which required no further purification.

M.p. = 78-79 °C (EtOAc); δ<sub>H</sub> (300 MHz, CDCl<sub>3</sub>); 10.90 (1H, s, NH or OH), 9.20 (1H, s, NH or OH), 7.50 (1H, s, H3), 7.24 (2H, s, H5 + H6), 1.99 (3H, s, CH<sub>3</sub>); δ<sub>C</sub> (75 MHz, CDCl<sub>3</sub>); 164.1 (C=O), 141.3 (quat.), 133.7 (quat.), 133.0 (ArCH), 129.1 (ArCH), 128.0 (ArCH), 119.5 (quat.), 20.3 (CH<sub>3</sub>); *m/z* (ESI) 213.0 [M-OH]<sup>-</sup>

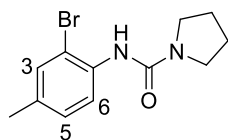
**3-(2-Bromo-4-methylphenyl)-1,1-pyrrolidine urea 294c**

Prepared according to general procedure J from 2-bromo-5-methylphenyl hydroxamic acid (1.05 g, 4.0 mmol) and carbonyl diimidazole (0.78 g, 4.8 mmol) and pyrrolidine (1.2 mL, 12.0 mmol) in acetonitrile to give the crude product which was purified by column chromatography (SiO<sub>2</sub>, 0-50% EtOAc in petrol) to give the urea **294c** as colourless plates (0.32 g, 28%).

M.p. = 158-159 °C (CHCl<sub>3</sub>); δ<sub>H</sub> (300 MHz, CDCl<sub>3</sub>); 8.04 (1H, d, *J* 8.3 Hz, H6), 7.21 (1H, d, *J* 1.7 Hz, H3), 6.98 (1H, dd, *J* 8.3, 1.7 Hz, H5), 6.67 (1H, br s, NH), 3.42-3.37 (4H, m, NCH<sub>2</sub>), 2.17 (3H, s, CH<sub>3</sub>), 1.90-1.86 (4H, m, NCH<sub>2</sub>CH<sub>2</sub>); δ<sub>C</sub> (75 MHz, CDCl<sub>3</sub>); 153.4 (C=O), 134.5 (quat.), 133.1 (quat.), 132.1 (C3), 129.0 (C5), 120.6 (C6), 112.5 (quat.), 45.7 (NCH<sub>2</sub>), 25.6 (NCH<sub>2</sub>CH<sub>2</sub>), 20.4 (CH<sub>3</sub>); ν<sub>max</sub>/cm<sup>-1</sup> (solid, diamond); 3211, 3016, 2970, 1738, 1630, 105, 1532, 1365, 1217; HRMS (ES<sup>+</sup>) *m/z* [M+H]<sup>+</sup> requires 283.0443 for C<sub>12</sub>H<sub>16</sub><sup>79</sup>BrN<sub>2</sub>O, found: 283.0443.

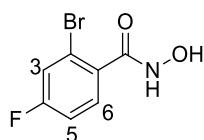

**N-Hydroxy-2-bromo-4-fluorobenzamide 295d**

Prepared according to general procedure I from 2-bromo-4-fluorobenzoic acid (0.98 g, 5.0 mmol) in  $\text{CH}_2\text{Cl}_2$  (50 mL) and DMF (4 drops) to give the hydroxamic acid **295d** as colourless needles (0.72 g, 62%) which required no further purification.

M.p.= 154-155°C (EtOAc);  $\delta_{\text{H}}$  (300 MHz,  $\text{CDCl}_3$ ); 11.14 (1H, br s, *NH* or *OH*), 9.38 (1H, br s, *NH* or *OH*), 7.70 (1H, m, H3), 7.38 (2H, m, H5 + H6);  $\delta_{\text{C}}$  (75 MHz,  $\text{CDCl}_3$ ); 168.1 (d, *J* 1.7 Hz, C=O), 166.0 (d, *J* 251.5 Hz, CF), 143.3 (d, *J* 6.6 Hz, quat.), 139.9 (d, *J* 7.2 Hz, C6), 123.6 (d, *J* 23.8 Hz, ArCH), 121.7 (d, *J* 23.8 Hz, ArCH), 119.7 (d, *J* 2.8 Hz, quat.);  $\nu_{\text{max}}/\text{cm}^{-1}$  (solid, diamond); 3455, 3016, 2970, 1738, 1435, 1365, 1217; HRMS ( $\text{ES}^+$ ) *m/z* [ $\text{M}+\text{Na}$ ] $^+$  requires 255.9380 for  $\text{C}_7\text{H}_5^{79}\text{BrFNNaO}_2$ , found: 255.9375.

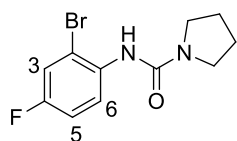
**3-(2-Bromo-4-fluorophenyl)-1,1-pyrrolidine urea 294d**

Prepared according to general procedure J from 2-bromo-4-fluorophenyl hydroxamic acid (0.46 g, 1.96 mmol) and carbonyl diimidazole (0.38 g, 2.30 mmol) and pyrrolidine (0.59 mL, 5.88 mmol) in acetonitrile to give the crude product which was purified by column chromatography ( $\text{SiO}_2$ ,

0-50% EtOAc in petrol) to give the urea **294d** as colourless plates (0.26 g, 46%).

M.p.= 91-92 °C ( $\text{CHCl}_3$ );  $\delta_{\text{H}}$  (300 MHz,  $\text{CDCl}_3$ ); 8.06 (1H, dd, *J* 11.5, 3.0 Hz, H3), 7.27 (1H, dd, *J* 8.9, 5.9 Hz, H6), 6.78 (1H, s, *NH*), 6.46 (1H, ddd, *J* 8.9, 7.7, 3.0 Hz, H5), 3.38-3.33 (4H, m,  $\text{NCH}_2$ ), 1.91-1.80 (4H, m,  $\text{NCH}_2\text{CH}_2$ );  $\delta_{\text{C}}$  (75 MHz,  $\text{CDCl}_3$ ); 162.1 (d, *J* 244.4 Hz, CF), 152.7 (C=O), 138.2 (d, *J* 14.9 Hz, CBr), 132.3 (d, *J* 9.4 Hz, C6), 109.8 (d, *J* 23.2 Hz, C5), 107.5 (d, *J* 23.2 Hz, C3), 106.3 (d, *J* 3.3 Hz, CNH), 45.7 ( $\text{NCH}_2$ ), 14.2 ( $\text{NCH}_2\text{CH}_2$ );  $\nu_{\text{max}}/\text{cm}^{-1}$  (solid, diamond); 3589, 3005, 2145, 1725, 1421, 1362, 1219, 1093; HRMS ( $\text{ES}^+$ ) *m/z* [ $\text{M}+\text{Na}$ ] $^+$  requires 309.0009 for  $\text{C}_{11}\text{H}_{12}^{79}\text{BrFNNaO}$ , found: 309.0004.

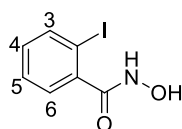
**N-Hydroxy-2-iodobenzamide 295e**

Prepared according to general procedure I from 2-iodobenzoic acid (1.24 g, 5.0 mmol) in  $\text{CH}_2\text{Cl}_2$  (50 mL) and DMF (4 drops) to give the crude product as an orange solid which was triturated with  $\text{CH}_2\text{Cl}_2$  to give the

hydroxamic acid **295e** as a colourless solid (1.05 g, 80%) which required no further purification. M.p.= 191-192°C (EtOAc);  $\delta_{\text{H}}$  (300 MHz,  $\text{CDCl}_3$ ); 10.92 (1H, br s, *NH* or *OH*), 9.23 (1H, br s, *NH* or *OH*), 7.88 (1H, dd, *J* 7.6, 1.1 Hz, H6), 7.45 (1H, td, *J* 7.6, 1.6 Hz, H5), 7.29 (1H, dd, *J* 7.6, 1.6 Hz, H3), 7.18 (1H, td, *J* 7.6, 1.1 Hz, H4);  $\delta_{\text{C}}$  (75 MHz,  $\text{CDCl}_3$ ); 165.7 (C=O), 140.5 (quat.), 139.2 (C6), 131.0 (C4), 128.6 (C3), 127.9 (C5), 94.4 (quat.);  $\nu_{\text{max}}/\text{cm}^{-1}$  (solid, diamond); 3455, 3208, 3026, 2970, 1738, 1613, 1540, 1365, 1228, 1217.

Spectroscopic data was consistent with literature values.<sup>225</sup>

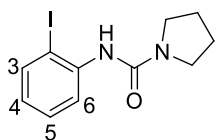
**3-(2-Iodophenyl)-1,1-pyrrolidine urea 297**

Prepared according to general procedure J from 2-iodophenyl hydroxamic acid (1.05 g, 4 mmol) and carbonyl diimidazole (0.78 g, 4.8 mmol) and pyrrolidine (1.2 mL, 12.0 mmol) in acetonitrile to give the crude product which was purified by column chromatography (SiO<sub>2</sub>, 0-

50% EtOAc in petrol) to give the urea **297** as colourless plates (0.75 g, 59%).

M.p. = 47-48 °C (MeCN);  $\delta_{\text{H}}$  (300 MHz, CDCl<sub>3</sub>); 8.12 (1H, dd,  $J$  8.0, 1.6 Hz, H3), 7.56 (1H, dd,  $J$  8.0, 1.4 Hz, H6), 7.24 (1H, ddd,  $J$  8.0, 7.4, 1.6 Hz, H4), 6.67 (2H, ddd,  $J$  8.0, 7.4, 1.6 Hz, H5), 6.63 (1H, br s, NH), 3.46 (4H, m, NCH<sub>2</sub>), 1.94 (4H, m, NCH<sub>2</sub>CH<sub>2</sub>);  $\delta_{\text{C}}$  (75 MHz, CDCl<sub>3</sub>); 153.4 (C=O), 139.6 (quat.), 138.4 (C6), 129.2 (C4), 124.1 (C5), 120.5 (C3), 89.3 (quat.), 45.9 (NCH<sub>2</sub>), 25.6 (NCH<sub>2</sub>CH<sub>2</sub>);  $\nu_{\text{max}}/\text{cm}^{-1}$  (solid, diamond); 3397, 2970, 1738, 1673, 1583, 1522, 1430, 1365, 1229, 1217, 1006; HRMS (ES<sup>+</sup>)  $m/z$  [M+H]<sup>+</sup> requires 317.0145 for C<sub>11</sub>H<sub>15</sub>IN<sub>2</sub>O, found: 317.0148.

**General Procedure K for the preparation of alkenes via Heck reaction**

A solution of Pd(OAc)<sub>2</sub> (2 mg, 0.01 mmol) and tri-*o*-tolylphosphine (12 mg, 0.08 mmol) in toluene (0.5 mL) was added to a solution of the urea (1.00 mmol) and triethylamine (1.4 mL, 1 M). The reaction mixture was heated to 110 °C and alkene added then stirred at 110 °C for 20 hours. The reaction mixture was cooled to room temperature, filtered through celite, washed with EtOAc (25 mL) and reduced *in vacuo* to give the crude product which was purified by column chromatography.

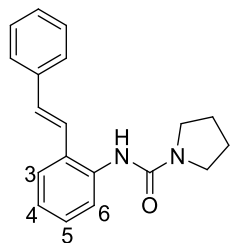
**(E)-N-(2-Styrylphenyl)pyrrolidine-1-carboxamide 296a**

Prepared according to general procedure K using *N*-(2-bromophenyl)-1-pyrrolidine carboxamide (0.27 g, 1.0 mmol), and styrene (0.14 mL, 1.25 mmol). Purification by column chromatography (SiO<sub>2</sub>, 0-50% EtOAc in petrol) gave the alkene **296a** as colourless oil (0.24 g, 84%).

$\delta_{\text{H}}$  (300 MHz, CDCl<sub>3</sub>); 7.88 (1H, dd,  $J$  8.0, 1.0 Hz, H6), 7.53-7.48 (3H, m, ArH), 7.43-7.37 (2H, m, ArH), 7.34-7.26 (2H, m, ArH), 7.20 (1H, d,  $J$  15.9 Hz, HC=CHC<sub>6</sub>H<sub>5</sub>), 7.11 (1H, td,  $J$  8.0, 1.0 Hz, H4 or H5), 7.02 (1H, d,  $J$  15.9 Hz, HC=CHC<sub>6</sub>H<sub>5</sub>), 6.26 (1H, br s, NH), 3.50-3.46 (4H, m, NCH<sub>2</sub>), 2.91-1.97 (4H, m, NCH<sub>2</sub>CH<sub>2</sub>);  $\delta_{\text{C}}$  (75 MHz, CDCl<sub>3</sub>); 154.1 (C=O), 137.2 (quat.), 136.3 (quat.), 132.3 (HC=CHC<sub>6</sub>H<sub>5</sub>), 129.2 (quat.), 128.8 (ArCH), 128.4 (ArCH), 127.9 (ArCH), 126.9 (ArCH), 126.5 (ArCH), 123.9 (ArCH), 123.8 (HC=CHC<sub>6</sub>H<sub>5</sub>), 123.1 (C6), 45.9 (NCH<sub>2</sub>), 25.6 (NCH<sub>2</sub>CH<sub>2</sub>);  $\nu_{\text{max}}/\text{cm}^{-1}$  (solid, diamond); 3609, 3282, 3004, 1725, 1574, 1369, 1214, 1093; HRMS (ES<sup>+</sup>)  $m/z$  [M+Na]<sup>+</sup> requires 315.1468 for C<sub>19</sub>H<sub>20</sub>N<sub>2</sub>NaO, found: 315.1471.

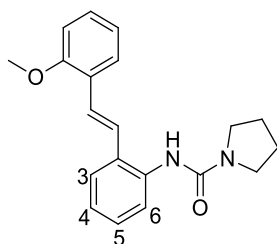
**(E)-N-(2-(2-Methoxystyryl)phenyl)pyrrolidine-1-carboxamide 296b**

Prepared according to general procedure K using *N*-(2-bromophenyl)-1-pyrrolidine carboxamide (0.13 g, 0.50 mmol), and 2-vinylanisole (80  $\mu$ L, 0.63 mmol). Purification by column chromatography (SiO<sub>2</sub>, 0-50% EtOAc in petrol) gave the alkene **296b** as colourless plates (0.10 g, 63%).

M.p.= 49-50 °C (EtOAc–petrol);  $\delta_{\text{H}}$  (300 MHz, CDCl<sub>3</sub>); 7.84 (1H, d, *J* 8.3 Hz, H<sub>6</sub>), 7.47 (1H, dd, *J* 7.5, 1.5 Hz, ArH), 7.40 (1H, dd, *J* 7.5, 1.5 Hz, ArH), 7.26 (1H, d, *J* 16.2 Hz, C=CH), 7.21-7.16 (2H, m, ArH), 7.11 (1H, d, *J* 16.2 Hz, C=CH), 7.01 (1H, td, *J* 7.5, 1.1 Hz, ArH), 6.92 (1H, t, *J* 7.5 Hz, ArH), 6.85 (1H, d, *J* 8.3 Hz, ArH), 6.25 (1H, br s, NH) 3.81 (3H, s, CH<sub>3</sub>), 3.42-3.38 (4H, m, NCH<sub>2</sub>), 1.92-1.87 (4H, m, NCH<sub>2</sub>CH<sub>2</sub>);  $\delta_{\text{C}}$  (75 MHz, CDCl<sub>3</sub>); 155.9 (C=O), 153.0 (quat.), 135.2 (quat.), 128.3 (quat.), 128.0 (C=CH), 127.1 (ArCH), 126.4 (ArCH), 126.1 (ArCH), 125.8 (C=CH), 125.2 (quat.), 123.5 (ArCH), 122.5 (ArCH), 121.5 (ArCH), 119.8 (ArCH), 109.9 (ArCH), 54.4 (OCH<sub>3</sub>), 44.8 (NCH<sub>2</sub>), 24.6 (NCH<sub>2</sub>CH<sub>2</sub>);  $\nu_{\text{max}}$ /cm<sup>-1</sup> (solid, diamond); 3455, 3282, 2970, 1738, 1436, 1365, 1228, 1217, 1092, 1020; HRMS (ES<sup>+</sup>) *m/z* [M+Na]<sup>+</sup> requires 345.1573 for C<sub>20</sub>H<sub>22</sub>N<sub>2</sub>NaO<sub>2</sub>, found: 345.1587.

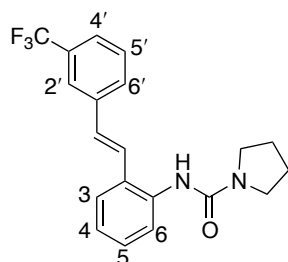
**(E)-N-(2-(3-Trifluoromethyl)styrylphenyl)pyrrolidine-1-carboxamide 296c**

Prepared according to general procedure K using *N*-(2-bromophenyl)-1-pyrrolidine carboxamide (0.13 g, 0.50 mmol), and 3-trifluoromethylstyrene (90  $\mu$ L, 0.63 mmol). Purification by column chromatography (SiO<sub>2</sub>, 0-50% EtOAc in petrol) gave the alkene **296c** as yellow plates (0.14 g, 80%).

M.p.= 135-136 °C (EtOAc–petrol);  $\delta_{\text{H}}$  (300 MHz, CDCl<sub>3</sub>); 7.80 (1H, d, *J* 8.0 Hz, H<sub>6</sub>), 7.72 (1H, s, H<sub>2'</sub>), 7.66 (1H, d, *J* 7.5, ArH), 7.53 (1H, d, *J* 7.5 Hz, H<sub>4'</sub>), 7.51-7.47 (2H, m, ArH), 7.31 (1H, t, *J* 8.0 Hz, H<sub>4</sub>), 7.29 (1H, d, *J* 16.0 Hz, HC=CH), 7.13 (1H, t, *J* 7.5 Hz, H<sub>5</sub>), 7.02 (1H, d, *J* 16.0 Hz, HC=CH), 6.15 (1H, br s, NH), 3.48 (4H, t, *J* 6.7 Hz, NCH<sub>2</sub>), 1.99 (4H, t, *J* 6.7 Hz, NCH<sub>2</sub>CH<sub>2</sub>);  $\delta_{\text{C}}$  (75 MHz, CDCl<sub>3</sub>); 154.1 (C=O), 138.1 (quat.), 136.5 (quat.), 131.2 (q, *J* 32.2 Hz, CCF<sub>3</sub>), 130.4 (HC=CH), 129.6 (ArCH), 129.3 (ArCH), 129.2 (quat.), 128.9 (ArCH), 126.9 (ArCH), 126.0 (HC=CH), 124.4 (q, *J* 4.2 Hz, C<sub>4'</sub>), 124.2 (C<sub>5</sub>), 124.1 (q, *J* 273.0 Hz, CF<sub>3</sub>), 123.8 (C<sub>6</sub>), 123.2 (q, *J* 4.2 Hz, C<sub>2'</sub>), 46.0 (NCH<sub>2</sub>), 25.6 (NCH<sub>2</sub>CH<sub>2</sub>);  $\nu_{\text{max}}$ /cm<sup>-1</sup> (solid, diamond); 3265, 2957, 2879, 1878, 1802, 1634, 1446, 1328, 1250, 1120; HRMS (ES<sup>+</sup>) *m/z* [M+H]<sup>+</sup> requires 361.1526 for C<sub>20</sub>H<sub>20</sub>F<sub>3</sub>N<sub>2</sub>O, found: 361.1522.

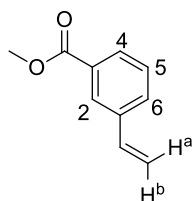
**Methyl-3-vinyl benzoate**

Sulfuric acid (0.5 mL) was added to a mixture of 3-vinylbenzoic acid (0.50 g, 3.4 mmol) and methanol (15 mL) and the reaction mixture heated under reflux for 20 hours. The reaction mixture was cooled to room temperature and evaporated *in vacuo* to give yellow oil which was diluted with EtOAc (20 mL) and organic phase washed with saturated NaHCO<sub>3</sub> solution (3 × 20 mL) followed by brine (20 mL), dried (Na<sub>2</sub>SO<sub>4</sub>) and evaporated *in vacuo* to give methyl-3-vinyl benzoate (0.46 g, 84%) as yellow oil which required no further purification.

$\delta_{\text{H}}$  (300 MHz, CDCl<sub>3</sub>); 8.08 (1H, t, *J* 1.4 Hz, H<sub>2</sub>), 7.92 (1H, dt, *J* 7.7, 1.4 Hz, H<sub>4</sub>), 7.59 (1H, dt, *J* 7.7, 1.4, H<sub>6</sub>), 7.40 (1H, t, *J* 7.7 Hz, H<sub>5</sub>), 6.75 (1H, dd, *J* 17.7, 11.0 Hz, ArHC=CH<sub>2</sub>), 5.83 (1H, dd, *J* 17.7, 0.5 Hz, H<sup>a</sup>), 5.32 (1H, dd, *J* 11.0, 0.5 Hz, H<sup>b</sup>), 3.92 (3H, s, CH<sub>3</sub>);  $\delta_{\text{C}}$  (75 MHz, CDCl<sub>3</sub>); 167.0 (C=O), 137.8 (quat.), 135.9 (CH), 130.5 (ArCH), 130.4 (quat.), 128.8 (ArCH), 128.6 (ArCH), 127.4 (ArCH), 115.1 (CH<sub>2</sub>), 52.2 (CH<sub>3</sub>); *m/z* (ESI) 162.1 [M+H]<sup>+</sup>.

Spectroscopic data was consistent with literature values.<sup>226</sup>

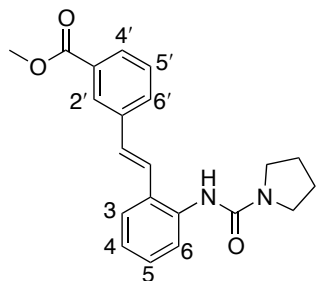
**(E)-Methyl 3-(*N*-(pyrrolidine-1-carboxamide)styryl)benzoate 296d**

Prepared according to general procedure K using *N*-(2-bromophenyl)-1-pyrrolidine carboxamide (0.27 g, 1.0 mmol), and methyl-3-vinyl benzoate (0.20 g, 1.5 mmol). Purification by column chromatography (SiO<sub>2</sub>, 30-100% EtOAc in petrol) gave alkene **296d** as yellow oil (0.19 g, 53%).

$\delta_{\text{H}}$  (300 MHz, CDCl<sub>3</sub>); 8.16 (1H, s, H<sub>2'</sub>), 7.95 (1H, td, *J* 8.0, 1.6 Hz, H<sub>4'</sub>), 7.81 (1H, dd, *J* 8.0, 0.8 Hz, H<sub>6'</sub>), 7.67 (1H, d, *J* 7.7 Hz, H<sub>3</sub>), 7.49 (1H, dd, *J* 7.7, 1.1 Hz, H<sub>4</sub>), 7.45 (1H, t, *J* 8.0 Hz, H<sub>5'</sub>), 7.31 (1H, dd, *J* 7.7, 1.1 Hz, H<sub>6</sub>), 7.26 (1H, d, *J* 16.5 Hz, MeO<sub>2</sub>CC<sub>6</sub>H<sub>4</sub>HC=CH), 7.11 (1H, t, *J* 7.7 Hz, H<sub>5</sub>), 7.02 (1H, d, *J* 16.5 Hz, MeO<sub>2</sub>CC<sub>6</sub>H<sub>4</sub>HC=CH), 6.21 (1H, br s, NH), 3.94 (3H, s, CH<sub>3</sub>), 3.50-3.45 (4H, m, NCH<sub>2</sub>), 2.00-1.96 (4H, m, NCH<sub>2</sub>CH<sub>2</sub>);  $\delta_{\text{C}}$  (75 MHz, CDCl<sub>3</sub>); 166.9 (C=O), 154.1 (C=O), 137.6 (quat.), 136.4 (quat.), 130.9 (MeO<sub>2</sub>CC<sub>6</sub>H<sub>4</sub>HC=CH), 130.8 (C<sub>3</sub>), 130.7 (quat.), 129.2 (quat.), 128.9 (C<sub>5'</sub>), 128.8 (C<sub>6</sub> or C<sub>4'</sub>), 128.7 (C<sub>6</sub> or C<sub>4'</sub>), 127.6 (C<sub>2'</sub>), 126.9 (C<sub>4</sub>), 125.3 (MeO<sub>2</sub>CC<sub>6</sub>H<sub>4</sub>HC=CH), 124.1 (C<sub>5</sub>), 123.6 (C<sub>6'</sub>), 52.3 (OCH<sub>3</sub>), 45.9 (NCH<sub>2</sub>), 25.6 (NCH<sub>2</sub>CH<sub>2</sub>);  $\nu_{\text{max}}$ /cm<sup>-1</sup> (solid, diamond); 3287, 3030, 2970, 2874, 1722, 1644, 1580, 1517, 1483, 1450, 1376, 1290, 1252, 1208, 1108, 1082; HRMS (ES<sup>+</sup>) *m/z* [M+H]<sup>+</sup> requires 351.1703 for C<sub>21</sub>H<sub>23</sub>N<sub>2</sub>O<sub>3</sub>, found: 351.1717.

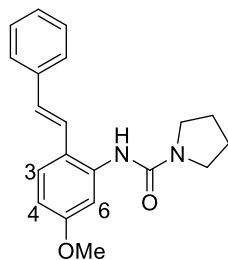
**(E)-N-(5-Methoxy-2-styrylphenyl)pyrrolidine-1-carboxamide 296e**

Prepared according to general procedure K using *N*-(2-bromo-3-methoxyphenyl)-1-pyrrolidine carboxamide (0.30 g, 1.00 mmol), and styrene (0.14 mL, 1.25 mmol). Purification by column chromatography (SiO<sub>2</sub>, 0-50% EtOAc in petrol) gave alkene **296e** as yellow oil (0.19 g, 63%).

$\delta_{\text{H}}$  (300 MHz, CDCl<sub>3</sub>); 7.60 (1H, d, *J* 8.3 Hz, H3), 7.44-7.40 (2H, m, ArH), 7.30 (2H, m, ArH), 7.24-7.20 (2H, m, ArH), 7.10 (1H, d, *J* 16.0 Hz, HC=CHC<sub>6</sub>H<sub>5</sub>), 7.01 (1H, dd, *J* 8.3, 2.0 Hz, H4), 6.91 (1H, d, *J* 16.0 Hz, HC=CHC<sub>6</sub>H<sub>5</sub>), 6.03 (1H, br s, NH), 3.41-3.37 (4H, m, NCH<sub>2</sub>), 2.27 (3H, s, CH<sub>3</sub>), 1.92-1.87 (4H, m, NCH<sub>2</sub>CH<sub>2</sub>);  $\delta_{\text{C}}$  (75 MHz, CDCl<sub>3</sub>); 154.3 (C=O), 137.3 (quat.), 133.7 (quat.), 133.5 (quat.), 131.7 (HC=CHC<sub>6</sub>H<sub>5</sub>), 129.5 (quat.), 129.1 (C4), 128.8 (ArCH), 127.8 (ArCH), 127.2 (ArCH), 126.5 (ArCH), 124.1 (ArCH), 123.6 (HC=CHC<sub>6</sub>H<sub>5</sub>), 45.9 (NCH<sub>2</sub>), 25.6 (NCH<sub>2</sub>CH<sub>2</sub>), 20.9 (CH<sub>3</sub>);  $\nu_{\text{max}}$ /cm<sup>-1</sup> (solid, diamond); 3266, 2969, 2870, 1638, 1506, 1375, 1252, 1123, 1074, 1028; HRMS (ES<sup>+</sup>) *m/z* [M+H]<sup>+</sup> requires 323.1754 for C<sub>20</sub>H<sub>23</sub>N<sub>2</sub>O<sub>2</sub>, found: 323.1744.

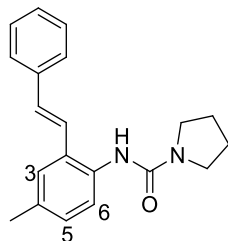
**(E)-N-(4-Methyl-2-styrylphenyl)pyrrolidine-1-carboxamide 296f**

Prepared according to general procedure K using *N*-(2-bromo-4-methylphenyl)-1-pyrrolidine carboxamide (0.26 g, 0.92 mmol), and styrene (0.14 mL, 1.25 mmol). Purification by column chromatography (SiO<sub>2</sub>, 0-50% EtOAc in petrol) gave alkene **296f** as colourless needles (0.083 g, 29%).

M.p.= 171-173 °C (EtOAc-petrol);  $\delta_{\text{H}}$  (300 MHz, CDCl<sub>3</sub>); 7.67 (1H, d, *J* 2.5 Hz, H3), 7.50 (2H, d, *J* 8.6 Hz, ArH), 7.41-7.36 (3H, m, ArH), 7.33-7.27 (1H, m, H6), 7.11 (1H, d, *J* 15.6 Hz, HC=CHC<sub>6</sub>H<sub>5</sub>), 6.91 (1H, d, *J* 15.6 Hz, HC=CHC<sub>6</sub>H<sub>5</sub>), 6.67 (1H, dd, *J* 8.6, 2.5 Hz, H5), 6.37 (1H, br s, NH), 3.85 (3H, s, CH<sub>3</sub>), 3.51-3.47 (4H, m, NCH<sub>2</sub>), 2.02-1.98 (4H, m, NCH<sub>2</sub>CH<sub>2</sub>);  $\delta_{\text{C}}$  (75 MHz, CDCl<sub>3</sub>); 159.9 (C4), 154.3 (C=O), 137.5 (quat.), 137.4 (quat.), 130.7 (HC=CHC<sub>6</sub>H<sub>5</sub>), 128.8 (ArCH), 128.0 (ArCH), 127.7 (ArCH), 126.3 (ArCH), 123.4 (HC=CHC<sub>6</sub>H<sub>5</sub>), 120.9 (quat.), 110.7 (C5), 106.4 (C3), 55.4 (CH<sub>3</sub>), 45.9 (NCH<sub>2</sub>), 25.6 (NCH<sub>2</sub>CH<sub>2</sub>);  $\nu_{\text{max}}$ /cm<sup>-1</sup> (solid, diamond); 3453, 2970, 1738, 1653, 1446, 1365, 1229, 1216, 1034; HRMS (ES<sup>+</sup>) *m/z* [M+H]<sup>+</sup> requires 323.1754 for C<sub>20</sub>H<sub>23</sub>N<sub>2</sub>O<sub>2</sub>, found: 323.1760.

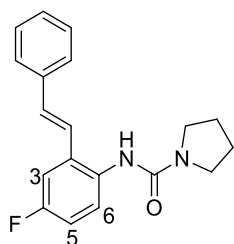
**(E)-N-(4-Fluoro-2-styrylphenyl)pyrrolidine-1-carboxamide 296g**

Prepared according to general procedure K using *N*-(2-bromo-4-fluorophenyl)-1-pyrrolidine carboxamide (0.20 g, 0.70 mmol), and styrene (0.10 mL, 0.87 mmol). Purification by column chromatography (SiO<sub>2</sub>, 0-50% EtOAc in petrol) gave alkene **296g** as yellow oil (0.17 g, 58%).

$\delta_{\text{H}}$  (300 MHz, CDCl<sub>3</sub>); 7.78 (1H, dd, *J* 11.3, 2.7 Hz, H3), 7.48 (2H, d, *J* 7.4 Hz, ArH), 7.40-7.27 (4H, m, ArH + H6), 7.05 (1H, d, *J* 16.2 Hz, HC=CHC<sub>6</sub>H<sub>5</sub>), 6.88 (1H, d, *J* 16.2 Hz, HC=CHC<sub>6</sub>H<sub>5</sub>), 6.75 (1H, td, *J* 8.3, 2.6 Hz, H5), 6.50 (1H, br s, NH), 3.44-3.40 (4H, m, NCH<sub>2</sub>), 1.96-1.91 (4H, m, NCH<sub>2</sub>CH<sub>2</sub>);  $\delta_{\text{C}}$  (75 MHz, CDCl<sub>3</sub>); 162.4 (d, *J* 244.9 Hz, C4), 153.5 (C=O), 137.8 (d, *J* 11.6 Hz, C1 or C2), 136.9 (ArC), 132.2 (d, *J* 1.7 Hz, HC=CHC<sub>6</sub>H<sub>5</sub>), 128.8 (ArCH), 128.1 (ArCH), 128.0 (d, *J* 9.4 Hz, C6) 126.5 (ArCH), 124.4 (d, *J* 3.3 Hz, C1 or C2), 122.8 (HC=CHC<sub>6</sub>H<sub>5</sub>), 110.4 (d, *J* 22.7 Hz, C5), 109.2 (d, *J* 26.4 Hz, C3), 45.8 (NCH<sub>2</sub>), 25.5 (NCH<sub>2</sub>CH<sub>2</sub>);  $\nu_{\text{max}}$ /cm<sup>-1</sup> (solid, diamond); 3424, 3286, 2970, 2876, 1737, 1714, 1663, 1592, 1524, 1433, 1365, 121, 1045; HRMS (ES<sup>+</sup>) *m/z* [M+H]<sup>+</sup> requires 311.1554 for C<sub>19</sub>H<sub>20</sub>FN<sub>2</sub>O, found: 311.1560.

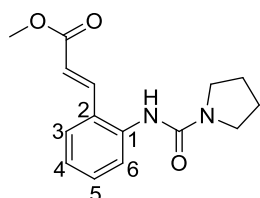
**(E)-Methyl 3-(N-pyrrolidine-1-carboxamido)phenyl acrylate 296i**

Prepared according to general procedure K using *N*-(2-iodophenyl)-1-pyrrolidine carboxamide (0.31 g, 1.00 mmol), and methyl *trans*-methoxyacrylate (0.13 mL, 1.25 mmol). Purification by column chromatography (SiO<sub>2</sub>, 0-100% EtOAc in petrol) gave alkene **296i** as yellow plates (0.03 g, 11%).

M.p.= 154-155 °C (EtOAc-petrol);  $\delta_{\text{H}}$  (300 MHz, CDCl<sub>3</sub>); 7.78 (1H, d, *J* 15.6 Hz, C=CHCO<sub>2</sub>Me), 7.69 (1H, dd, *J* 8.0, 0.8 Hz, H6), 7.43 (1H, dd, *J* 8.0, 1.5 Hz, H3), 7.28 (1H, td, *J* 8.0, 1.5 Hz, H5), 7.04 (1H, td, *J* 8.0, 0.8 Hz, H4), 6.33 (1H, d, *J* 15.6 Hz, C=CHAr), 6.15 (1H, s, NH), 3.72 (3H, s, OCH<sub>3</sub>), 3.43-3.39 (4H, m, NCH<sub>2</sub>), 1.94-1.89 (4H, m, NCH<sub>2</sub>CH<sub>2</sub>);  $\delta_{\text{C}}$  (75 MHz, CDCl<sub>3</sub>); 167.3 (<sup>t</sup>BuOC=O), 153.8 (NHC=O), 140.1 (COC=C), 137.5 (C2), 130.8 (C5), 127.1 (C3), 126.7 (C1), 124.4 (C4 or C6), 124.3 (C4 or C6), 119.7 (C=CHAr), 51.8 (OCH<sub>3</sub>), 45.9 (NCH<sub>2</sub>), 25.6 (NCH<sub>2</sub>CH<sub>2</sub>);  $\nu_{\text{max}}$ /cm<sup>-1</sup> (solid, diamond); 3259, 2970, 2875, 1715, 1635, 1517, 1480, 1450, 1380, 1321, 1197, 1171; HRMS (ES<sup>+</sup>) *m/z* [M+Na]<sup>+</sup> requires 297.1210 for C<sub>15</sub>H<sub>18</sub>N<sub>2</sub>NaO<sub>3</sub>, found: 297.1207.

**General Procedure L for the preparation of quinolones**

To a mixture of the alkene in dichlorobenzene (0.04 M) was added sulfonyl chloride polystyrene resin (2.4 Mmol/g or 3.8 mmol/g, 1 equivalent) and the reaction mixture heated to 150 °C for one hour in the microwave. The reaction mixture was cooled to room temperature,

filtered and reduced *in vacuo* to give the product which was purified by column chromatography.

#### Butyl-2-oxo-1,2-dihydroquinoline-3-carboxylate **279a**

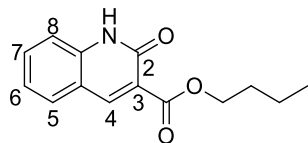

Prepared according to general procedure L using **283a** (0.12 g, 0.40 mmol) and the sulfonyl chloride resin (2.4 mmol/g, 0.17 g) in dichlorobenzene (10 mL). Purification by column chromatography (SiO<sub>2</sub>, 0-100% EtOAc in CH<sub>2</sub>Cl<sub>2</sub>) gave quinolone **279a** as colourless needles (57 mg, 57%).

M.p.= 145-146 °C (EtOAc–Petrol);  $\delta_{\text{H}}$  (300 MHz, CDCl<sub>3</sub>); 12.84 (1H, s, NH), 8.50 (1H, s, H4), 7.59 (1H, d, *J* 7.8 Hz, H5), 7.53 (1H, ddd, *J* 8.0, 7.8, 1.4 Hz, H7), 7.46 (1H, dd, *J* 7.8, 0.6 Hz, H8), 7.18 (1H, ddd, *J* 8.0, 7.8, 1.4 Hz, H6) 4.33 (2H, t, *J* 6.7 Hz, OCH<sub>2</sub>), 1.76 (2H, tt, *J* 7.9, 6.7 Hz, OCH<sub>2</sub>CH<sub>2</sub>), 1.49 (2H, sxt, *J* 7.9 Hz, CH<sub>2</sub>CH<sub>3</sub>), 0.95 (3H, t, *J* 7.9 Hz, CH<sub>2</sub>CH<sub>3</sub>);  $\delta_{\text{C}}$  (75 MHz, CDCl<sub>3</sub>); 164.7 (C=O), 161.6 (C=O), 145.8 (C4), 140.1 (quat.), 133.0 (C7), 129.2 (C5), 123.1 (C6), 122.2 (quat.), 118.5 (quat.), 116.3 (C8), 65.3 (OCH<sub>2</sub>), 30.8 (OCH<sub>2</sub>CH<sub>2</sub>), 19.3 (CH<sub>2</sub>CH<sub>3</sub>), 13.9 (CH<sub>3</sub>);  $\nu_{\text{max}}$ /cm<sup>-1</sup> (solid, diamond); 3163, 2958, 1682, 1625, 1566, 1496, 1387, 1315, 1297, 1214, 1134, 1086; HRMS (ES<sup>+</sup>) *m/z* [M+Na]<sup>+</sup> requires 268.0944 for C<sub>14</sub>H<sub>15</sub>NNaO<sub>3</sub>, found: 268.0956.

#### Butyl 6-fluoro-2-oxo-1,2-dihydroquinoline-3-carboxylate **279d**

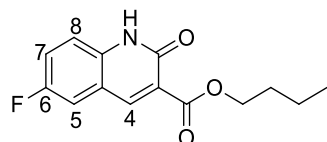

Prepared according to general procedure L using **283d** (0.10 g, 0.30 mmol) and the sulfonyl chloride resin (3.8 mmol/g, 0.079 g) in dichlorobenzene (7.5 mL). Purification by column chromatography (SiO<sub>2</sub>, 0-50% EtOAc in CH<sub>2</sub>Cl<sub>2</sub>) gave the quinolone **279d** as colourless solid (10 mg, 18%).

M.p.= 168-170 °C (EtOAc);  $\delta_{\text{H}}$  (300 MHz, CDCl<sub>3</sub>); 12.54 (1H, br s, NH), 8.42 (1H, s, H4), 7.41 (1H, dd, *J* 8.5, 4.4 Hz, H7), 7.33-7.27 (2H, m, H5 + H8), 4.33 (2H, t, *J* 6.6 Hz, OCH<sub>2</sub>), 1.72 (2H, tt, *J* 7.1, 6.6 Hz, OCH<sub>2</sub>CH<sub>2</sub>), 1.47 (2H, sxt, *J* 7.1 Hz, CH<sub>2</sub>CH<sub>3</sub>), 0.95 (3H, t, *J* 7.1 Hz, CH<sub>2</sub>CH<sub>3</sub>);  $\delta_{\text{C}}$  (75 MHz, CDCl<sub>3</sub>); 164.2 (C=O), 160.8 (C=O), 158.3 (d, *J* 243.9 Hz, C6), 144.4 (C4), 136.7 (quat.), 123.6 (quat.), 121.4 (d, *J* 24.9 Hz, C5), 119.1 (quat.), 117.9 (d, *J* 6.9 Hz, C8), 113.5 (d, *J* 24.9 Hz, C7), 65.5 (OCH<sub>2</sub>), 30.7 (OCH<sub>2</sub>CH<sub>2</sub>), 19.3 (CH<sub>2</sub>CH<sub>3</sub>), 13.8 (CH<sub>3</sub>);  $\nu_{\text{max}}$ /cm<sup>-1</sup> (solid, diamond); 2875, 1693, 1569, 1499, 1419, 1289, 1235, 1152, 1084; HRMS (ES<sup>+</sup>) *m/z* [M+H]<sup>+</sup> requires 286.0850 for C<sub>14</sub>H<sub>14</sub>FNNaO<sub>3</sub>, found: 286.0857.

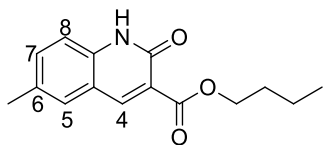
**Butyl 6-methyl-2-oxo-1,2-dihydroquinoline-3-carboxylate 279e**

Prepared according to general procedure L using **283e** (0.17 g, 0.5 mmol) and the sulfonyl chloride resin (3.8 mmol/g, 0.13 g) in dichlorobenzene (12.5 mL). Purification by column chromatography (SiO<sub>2</sub>, 0-50% EtOAc in CH<sub>2</sub>Cl<sub>2</sub>) gave the

quinolone **279e** as yellow needles (28 mg, 22%).

M.p.= 167-168°C (EtOAc);  $\delta_{\text{H}}$  (300 MHz, CDCl<sub>3</sub>); 12.74 (1H, br s, NH), 8.42 (1H, s, H4), 7.36 (3H, s, H5 + H7 + H8), 4.32 (2H, t, *J* 6.8 Hz, OCH<sub>2</sub>), 2.35 (3H, s, ArCH<sub>3</sub>), 1.74 (2H, quin, *J* 6.8 Hz, OCH<sub>2</sub>CH<sub>2</sub>), 1.49 (2H, sxt, *J* 7.6 Hz, CH<sub>2</sub>CH<sub>3</sub>), 0.95 (3H, t, *J* 7.6 Hz, CH<sub>2</sub>CH<sub>3</sub>);  $\delta_{\text{C}}$  (75 MHz, CDCl<sub>3</sub>); 164.8 (C=O), 161.4 (C=O), 145.5 (C4), 138.2 (quat.), 134.6 (C5 or C6 or C8), 132.7 (quat.), 128.5 (C5 or C6 or C8), 122.0 (quat.), 118.6 (quat.), 116.2 (C5 or C6 or C8), 65.2 (OCH<sub>2</sub>), 30.8 (OCH<sub>2</sub>CH<sub>2</sub>), 20.8 (CH<sub>3</sub>), 19.3 (CH<sub>2</sub>CH<sub>3</sub>), 13.8 (CH<sub>2</sub>CH<sub>3</sub>);  $\nu_{\text{max}}$ /cm<sup>-1</sup> (solid, diamond); 3589, 3005, 1738, 1424, 1365, 1218, 1092; HRMS (ES<sup>+</sup>) *m/z* [M+Na]<sup>+</sup> requires 282.1101 for C<sub>15</sub>H<sub>17</sub>NNaO<sub>3</sub>, found: 282.1102.

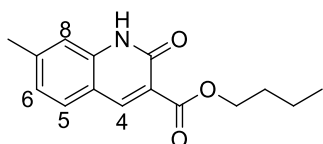
**Butyl 7-methyl-2-oxo-1,2-dihydroquinoline-3-carboxylate 279f**

Prepared according to general procedure L using **283f** (0.17 g, 0.5 mmol) and the sulfonyl chloride resin (3.8 mmol/g, 0.13 g) in dichlorobenzene (12.5 mL). Purification by column chromatography (SiO<sub>2</sub>, 0-100% EtOAc in CH<sub>2</sub>Cl<sub>2</sub>) gave the

quinolone **279f** as colourless needles (42 mg, 32%).

M.p.= 156-157°C (EtOAc);  $\delta_{\text{H}}$  (500 MHz, CDCl<sub>3</sub>); 12.82 (1H, br s, NH), 8.52 (1H, s, H4), 7.52 (1H, d, *J* 8.2 Hz, H5), 7.32 (1H, s, H8), 7.06 (1H, d, *J* 8.2 Hz, H6), 4.38 (2H, t, *J* 6.6 Hz, OCH<sub>2</sub>), 2.47 (3H, s, ArCH<sub>3</sub>), 1.81 (2H, quin, *J* 6.8 Hz, OCH<sub>2</sub>CH<sub>2</sub>), 1.54 (2H, sxt, *J* 7.6 Hz, CH<sub>2</sub>CH<sub>3</sub>), 0.99 (3H, t, *J* 7.6 Hz, CH<sub>2</sub>CH<sub>3</sub>);  $\delta_{\text{C}}$  (75 MHz, CDCl<sub>3</sub>); 164.9 (C=O), 161.8 (C=O), 145.7 (C4), 144.5 (quat.), 140.4 (quat.), 128.9 (C8), 124.8 (C7), 120.8 (quat.), 116.5 (quat.), 116.1 (C5), 65.1 (OCH<sub>2</sub>), 30.8 (OCH<sub>2</sub>CH<sub>2</sub>), 22.0 (ArCH<sub>3</sub>), 19.3 (CH<sub>2</sub>CH<sub>3</sub>), 13.8 (CH<sub>2</sub>CH<sub>3</sub>);  $\nu_{\text{max}}$ /cm<sup>-1</sup> (solid, diamond); 2957, 1655, 1640, 1564, 1504, 1309, 1291, 1257, 1204, 1154, 1089; HRMS (ES<sup>+</sup>) *m/z* [M+Na]<sup>+</sup> requires 282.1101 for C<sub>15</sub>H<sub>17</sub>NNaO<sub>3</sub>, found: 282.1103.

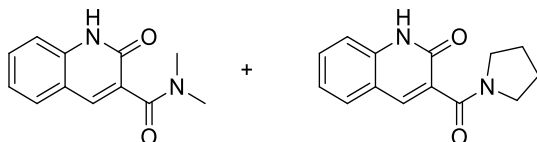
**1,2-Dihydro-*N,N*-dimethyl-2-oxo-3-quinolinecarboxamide 289a and 3-(pyrrolidin-1-ylcarbonyl)quinolin-2(1*H*)-one 290a**

Prepared according to general procedure L using **288a** (0.10 g, 0.35 mmol) and the sulfonyl chloride resin (3.8 mmol/g, 0.091 g) in dichlorobenzene (8.75 mL).



Recrystallisation in MeCN gave an inseparable 15:1 mixture of quinolones **289a** and **290a** as a colourless solid (49 mg, 60% and 4% respectively).

M.p.= 206-208°C (MeCN);  $\nu_{\max}/\text{cm}^{-1}$  (solid, diamond); 3429, 2963, 1666, 1626, 1567, 1505, 1429, 1400, 1286, 1261, 1225, 1183, 1063.

### 1,2-Dihydro-*N,N*-dimethyl-2-oxo-3-quinolinecarboxamide **289a**

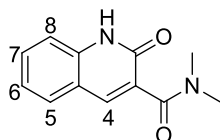

$\delta_{\text{H}}$  (300 MHz,  $\text{CDCl}_3$ ); 11.76 (1H, br s, NH), 7.98 (1H, s, H4), 7.60 (1H, dd,  $J$  7.9, 1.1 Hz, H5), 7.55 (1H, td,  $J$  7.9, 1.1 Hz, H7), 7.40 (1H, d,  $J$  7.9 Hz, H8), 7.25 (1H, m, H6), 3.18 (3H, s,  $\text{NCH}_3$ ), 3.05 (3H, s,  $\text{NCH}_3$ );  $\delta_{\text{C}}$  (75 MHz,  $\text{CDCl}_3$ ); 166.8 (C=O), 160.7 (C=O), 140.1 (C4), 138.6 (quat.), 131.5 (C7), 129.9 (quat.), 128.4 (C5), 123.2 (C6), 119.3 (quat.), 116.0 (C8), 38.7 ( $\text{NCH}_3$ ), 35.2 ( $\text{NCH}_3$ ); HRMS ( $\text{ES}^+$ )  $m/z$   $[\text{M}+\text{H}]^+$  requires 217.0972 for  $\text{C}_{12}\text{H}_{13}\text{N}_2\text{O}_2$ , found: 217.0975.

Spectroscopic data was consistent with literature values.<sup>227</sup>

### 3-(Pyrrolidin-1-ylcarbonyl)quinolin-2(1*H*)-one **290a**

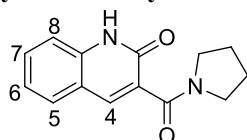

Characteristic signals:  $\delta_{\text{H}}$  (300 MHz,  $\text{CDCl}_3$ ); 8.01 (1H, s, H4), 3.72 (2H, br s,  $\text{NCH}_2$ ), 3.50 (2H, br s,  $\text{NCH}_2$ ), 1.99 (4H, m,  $\text{NCH}_2\text{CH}_2$ ).

### 7-Methoxy-*N,N*-dimethyl-2-oxo-1,2-dihydroquinoline-3-carboxamide **289b** and 7-methoxy-3-(pyrrolidin-1-ylcarbonyl)quinolin-2(1*H*)-one **290b**

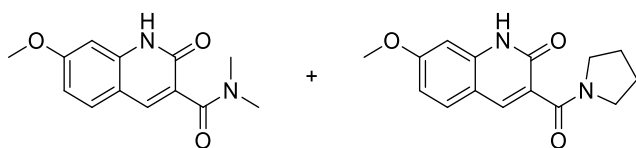

Prepared according to general procedure L using **288b** (0.14 g, 0.44 mmol) and the sulfonyl chloride resin (3.8 mmol/g, 0.13 g) in dichlorobenzene (12.5 mL). Purification by column chromatography ( $\text{SiO}_2$ , 0-10% MeOH in EtOAc) gave an inseparable 2.5:1 mixture of quinolones **289b** and **290b** as yellow solid (0.11 g, 70% and 28% respectively).

M.p.= 224-225 °C (EtOAc);  $\nu_{\max}/\text{cm}^{-1}$  (solid, diamond); 3456, 3208, 3004, 2970, 1738, 1661, 1605, 1510, 1448, 1365, 1229, 1217, 1030.

### 7-Methoxy-*N,N*-dimethyl-2-oxo-1,2-dihydroquinoline-3-carboxamide **289b**

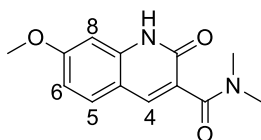

$\delta_{\text{H}}$  (300 MHz,  $\text{CDCl}_3$ ); 12.54 (1H, br s, NH), 7.93 (1H, s, H4), 7.47 (1H, d,  $J$  8.7 Hz, H5), 6.87 (1H, d,  $J$  2.1 Hz, H8), 6.82 (1H, dd,  $J$  8.7, 2.1 Hz, H6), 3.88 (3H, s,  $\text{OCH}_3$ ), 3.16 (3H, s,

$\text{NCH}_3$ ), 3.05 (3H, s,  $\text{NCH}_3$ );  $\delta_{\text{C}}$  (75 MHz,  $\text{CDCl}_3$ ); 167.5 (C=O), 162.5 (C=O), 161.4 (quat.), 140.8 (quat.), 140.2 (C4), 129.6 (C5), 126.2 (quat.), 113.5 (quat.), 112.9 (C6), 98.3 (C8), 55.7 (OCH<sub>3</sub>), 38.5 ( $\text{NCH}_3$ ), 35.2 ( $\text{NCH}_3$ ); HRMS ( $\text{ES}^+$ )  $m/z$   $[\text{M}+\text{H}]^+$  requires 247.1077 for  $\text{C}_{13}\text{H}_{15}\text{N}_2\text{O}_3$ , found: 247.1084.

#### 7-Methoxy-3-(pyrrolidin-1-ylcarbonyl)quinolin-2(1H)-one 290b

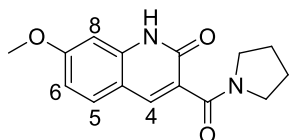

Characteristic signals:  $\delta_{\text{H}}$  (300 MHz,  $\text{CDCl}_3$ ); 7.98 (1H, s, H4), 3.69 (2H, t,  $J$  6.6 Hz,  $\text{NCH}_2$ ), 3.53 (2H, t,  $J$  6.6 Hz,  $\text{NCH}_2$ ), 1.91 (4H, m,  $\text{NCH}_2\text{CH}_2$ );  $\delta_{\text{C}}$  (75 MHz,  $\text{CDCl}_3$ ); 165.7 (C=O), 162.6 (C=O), 161.3 (quat.), 140.9 (quat.), 140.3 (C4), 129.7 (C5), 126.9 (quat.), 113.4 (quat.), 112.9 (C6), 98.2 (C8), 47.5 ( $\text{NCH}_2$ ), 46.1 ( $\text{NCH}_2$ ), 26.0 ( $\text{NCH}_2\text{NCH}_2$ ), 24.5 ( $\text{NCH}_2\text{CH}_2$ );  $m/z$  (ESI) 273.1  $[\text{M}+\text{H}]^+$ .

#### *N,N*,7-Trimethyl-2-oxo-1,2-dihydroquinoline-3-carboxamide 289c and 7-methyl-3-(pyrrolidin-1-ylcarbonyl)quinolin-2(1H)-one 290c

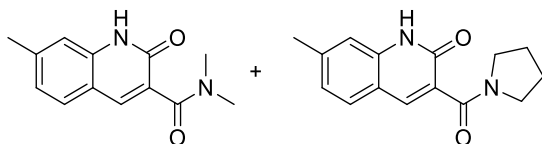

Prepared according to general procedure L using **288c** (0.162 g, 0.54 mmol) and the sulfonyl chloride resin (3.8 mmol/g, 0.142 g) in dichlorobenzene (12.5 mL). Purification by column chromatography ( $\text{SiO}_2$ , 0-100% EtOAc in  $\text{CH}_2\text{Cl}_2$ ) gave an inseparable 5.5:1 mixture of quinolones **289c** and **290c** as pale brown needles (63 mg, 42% and 8% respectively).

M.p. = 212-213 °C (EtOAc);  $\nu_{\text{max}}/\text{cm}^{-1}$  (solid, diamond); 2915, 1633, 1567, 1514, 1397, 1255, 1231, 1181, 1064.

#### *N,N*,7-Trimethyl-2-oxo-1,2-dihydroquinoline-3-carboxamide 289c

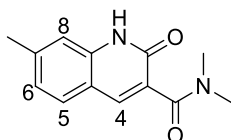

$\delta_{\text{H}}$  (300 MHz,  $\text{CDCl}_3$ ); 12.37 (1H, br s, NH), 7.94 (1H, s, H4), 7.47 (1H, d,  $J$  8.0 Hz, H5), 7.23 (1H, s, H8), 7.06 (1H, d,  $J$  8.0 Hz, H6), 3.15 (3H, s,  $\text{NCH}_3$ ), 3.08 (3H, s,  $\text{NCH}_3$ ), 2.46 (3H, s,  $\text{ArCH}_3$ );  $\delta_{\text{C}}$  (75 MHz,  $\text{CDCl}_3$ ); 167.2 (C=O), 161.2 (C=O), 142.6 (quat.), 139.9 (C4), 138.8 (quat.), 128.5 (quat.), 128.1 (C5), 124.8 (C6), 117.1 (quat.), 116.0 (C8), 38.5 ( $\text{NCH}_3$ ), 35.2 ( $\text{NCH}_3$ ), 21.9 ( $\text{ArCH}_3$ ); HRMS ( $\text{ES}^+$ )  $m/z$   $[\text{M}+\text{H}]^+$  requires 231.1128 for  $\text{C}_{13}\text{H}_{15}\text{N}_2\text{O}_2$ , found: 231.1132.

#### 7-Methyl-3-(pyrrolidin-1-ylcarbonyl)quinolin-2(1H)-one 290c

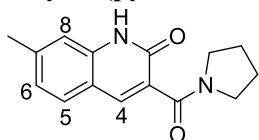

Characteristic signals:  $\delta_{\text{H}}$  (300 MHz,  $\text{CDCl}_3$ ); 7.93 (1H, s, H4), 3.71 (2H, t,  $J$  6.6 Hz,  $\text{NCH}_2$ ), 3.47 (2H, t,  $J$  6.6 Hz,  $\text{NCH}_2$ ), 1.95 (4H, m,  $\text{NCH}_2\text{CH}_2$ ).

***N,N*,6-Trimethyl-2-oxo-1,2-dihydroquinoline-3-carboxamide 289d and 6-methyl-3-(pyrrolidin-1-ylcarbonyl)quinolin-2(1*H*)-one 290d**

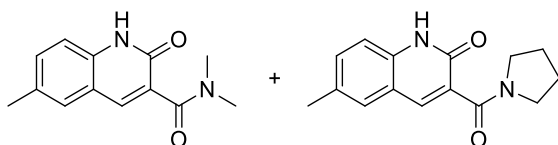

Prepared according to general procedure L using **288d** (0.15 g, 0.50 mmol) and the sulfonyl chloride resin (3.8 mmol/g, 0.13 g) in dichlorobenzene (12.5 mL). Purification

by column chromatography (SiO<sub>2</sub>, 0-100% EtOAc in CH<sub>2</sub>Cl<sub>2</sub>) gave an inseparable 8:1 mixture of quinolones **289d** and **290d** as colourless solid (46 mg, 35% and 4% respectively).

M.p.= 188-190 °C (EtOAc);  $\nu_{\max}/\text{cm}^{-1}$  (solid, diamond); 3456, 2970, 1738, 1662, 1436, 1365, 1228, 1217.

***N,N*,6-Trimethyl-2-oxo-1,2-dihydroquinoline-3-carboxamide 289d**

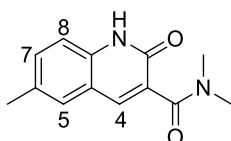

$\delta_{\text{H}}$  (300 MHz, CDCl<sub>3</sub>); 11.34 (1H, br s, NH), 7.89 (1H, s, H4), 7.39-7.36 (3H, m, H5 + H7 + H8), 3.18 (3H, s, NCH<sub>3</sub>), 3.03 (3H, s, NCH<sub>3</sub>), 2.42 (3H, s, CH<sub>3</sub>);  $\delta_{\text{C}}$  (75 MHz, CDCl<sub>3</sub>); 167.0 (C=O), 160.4 (C=O), 139.7 (C4), 136.5 (quat.), 133.0 (ArCH),

132.8 (quat.), 129.8 (quat.), 127.9 (ArCH), 119.2 (quat.), 115.7 (ArCH), 38.4 (NCH<sub>3</sub>), 35.2 (NCH<sub>3</sub>), 20.1 (OCH<sub>3</sub>); HRMS (ES<sup>+</sup>)  $m/z$  [M+Na]<sup>+</sup> requires 253.0947 for C<sub>13</sub>H<sub>14</sub>N<sub>2</sub>NaO<sub>2</sub>, found: 253.0948.

**6-Methyl-3-(pyrrolidin-1-ylcarbonyl)quinolin-2(1*H*)-one 290d**

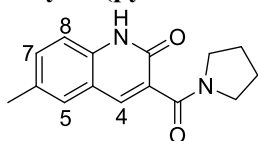

Characteristic signals:  $\delta_{\text{H}}$  (300 MHz, CDCl<sub>3</sub>); 7.99 (1H, s, H4), 3.72 (2H, t,  $J$  6.2 Hz, NCH<sub>2</sub>), 3.51 (2H, t,  $J$  6.2 Hz, NCH<sub>2</sub>), 2.00-1.90 (4H, m, NCH<sub>2</sub>CH<sub>2</sub>).

**Ethyl 3-(dimethylcarbamoyl)-2-oxo-1,2-dihydroquinoline-6-carboxylate 289e and ethyl 2-oxo-3-(pyrrolidin-1-ylcarbonyl)-1,2-dihydroquinoline-6-carboxylate 290e**

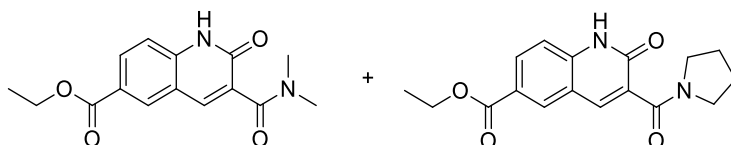

Prepared according to general procedure L using **288e** (0.064 g, 0.18 mmol) and the sulfonyl chloride resin (3.8

mmol/g, 0.047 g) in dichlorobenzene (4.5 mL). Purification by column chromatography (SiO<sub>2</sub>, 0-10% MeOH in CH<sub>2</sub>Cl<sub>2</sub>) gave an inseparable 2:1 mixture of quinolones **289e** and **290e** as pale orange solid (25 mg, 31% and 16% respectively).

M.p.= 193-194°C (EtOAc);  $\nu_{\max}/\text{cm}^{-1}$  (solid, diamond); 3456, 3003, 2971, 1737, 1722, 1670, 1622, 1575, 1446, 1365, 1306, 1262, 1209, 1100.

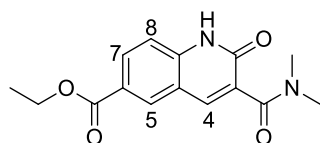
**Ethyl 3-(dimethylcarbamoyl)-2-oxo-1,2-dihydroquinoline-6-carboxylate 289e**

$\delta_{\text{H}}$  (300 MHz,  $\text{CDCl}_3$ ); 12.41 (1H, br s, *NH*), 8.33 (1H, d, *J* 1.4 Hz, H5), 8.20 (1H, dd, *J* 8.6, 1.4 Hz, H7), 8.06 (1H, s, H4), 7.47 (1H, d, *J* 8.6 Hz, H8) 4.44 (2H, q, *J* 7.3 Hz,  $\text{CH}_2\text{CH}_3$ ), 3.20 (3H, s,  $\text{NCH}_3$ ), 3.04 (3H, s,  $\text{NCH}_3$ ), 1.43 (3H, t, *J* 7.3 Hz,  $\text{CH}_2\text{CH}_3$ );  $\delta_{\text{C}}$  (75 MHz,  $\text{CDCl}_3$ ); 166.4 (C=O), 165.6 (C=O), 164.7 (C=O), 161.2 (quat.), 141.4 (quat.), 140.0 (C4), 132.0 (C7), 130.6 (C5), 125.4 (quat.), 118.6 (quat.), 116.2 (C8), 61.3 ( $\text{CH}_2$ ), 38.4 ( $\text{NCH}_3$ ), 35.2 ( $\text{NCH}_3$ ), 14.4 ( $\text{CH}_2\text{CH}_3$ ); HRMS ( $\text{ES}^+$ ) *m/z* [ $\text{M}+\text{H}$ ]<sup>+</sup> requires 289.1183 for  $\text{C}_{15}\text{H}_{17}\text{N}_2\text{O}_4$ , found: 289.1178.

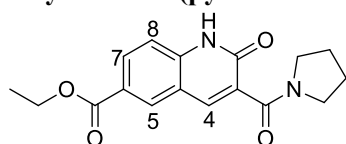
**Ethyl 2-oxo-3-(pyrrolidin-1-ylcarbonyl)-1,2-dihydroquinoline-6-carboxylate 290e**

Characteristic signals:  $\delta_{\text{H}}$  (300 MHz,  $\text{CDCl}_3$ ); 8.05 (1H, s, H4), 3.72 (2H, t, *J* 6.6 Hz,  $\text{NCH}_2$ ), 3.47 (2H, t, *J* 6.6 Hz,  $\text{NCH}_2$ ), 2.03-1.93 (4H, m,  $\text{NCH}_2\text{CH}_2$ ); HRMS ( $\text{ES}^+$ ) *m/z* [ $\text{M}+\text{H}$ ]<sup>+</sup> requires 315.1339 for  $\text{C}_{17}\text{H}_{19}\text{N}_2\text{O}_4$ , found: 315.1351.

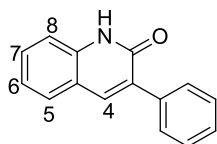
**3-Phenylquino-2(1*H*)-lone 276a**

Prepared according to general procedure L using **296a** (0.12 g, 0.40 mmol) and the sulfonyl chloride resin (2.4 mmol/g, 0.17 g) in dichlorobenzene (10 mL). Purification by column chromatography ( $\text{SiO}_2$ , 0-100% EtOAc in  $\text{CH}_2\text{Cl}_2$ ) gave the quinolone **276a** as colourless solid (57 mg, 57%).

M.p.= 232-233°C (EtOAc, lit. 230-231 °C<sup>228</sup>);  $\delta_{\text{H}}$  (300 MHz,  $\text{CDCl}_3$ ); 11.76 (1H, br s, *NH*), 7.95 (1H, s, H4), 7.83 (1H, dd, *J* 7.5, 1.4 Hz, H5), 7.64 (1H, dd, *J* 7.5, 1.4 Hz, H7), 7.55-7.44 (5H, m, ArH), 7.43-7.39 (1H, m, H8), 7.24 (1H, dt, *J* 7.8, 1.4 Hz, H6);  $\delta_{\text{C}}$  (75 MHz,  $d_6$ -DMSO); 161.0 (C=O), 138.4 (quat.), 137.6 (ArCH), 136.3 (quat.), 131.5 (quat.), 130.1 (ArCH), 128.6 (ArCH), 128.1 (ArCH), 127.9 (ArCH), 127.8 (ArCH), 121.8 (ArCH), 119.5 (quat.), 114.6 (ArCH);  $\nu_{\text{max}}/\text{cm}^{-1}$  (solid, diamond); 3025, 1653, 1566, 1496, 1428, 1227; *m/z* (ESI) 222.1 [ $\text{M}+\text{H}$ ]<sup>+</sup>.

Spectroscopic data was consistent with literature values.<sup>228</sup>

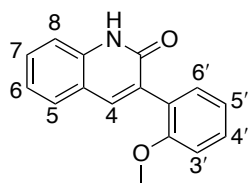
**3-(2-Methoxyphenyl)quino-2(1H)-lone 276b**

Prepared according to general procedure L using **296b** (0.05 g, 0.15 mmol) and the sulfonyl chloride resin (3.8 mmol/g, 0.039 g) in dichlorobenzene (3.75 mL). Purification by column chromatography (SiO<sub>2</sub>, 0-25% EtOAc in CH<sub>2</sub>Cl<sub>2</sub>) gave the quinolone **276b** as a yellow solid (20 mg, 53%).

M.p.= 248-250°C (EtOAc);  $\delta_{\text{H}}$  (300 MHz, d<sub>6</sub>-DMSO); 11.84 (1H, br s, NH), 7.88 (1H, s, H4), 7.71 (1H, dd, *J* 7.3, 1.6 Hz, H8), 7.54 (1H, td, *J* 7.3, 1.6 Hz, H6), 7.44-7.36 (2H, m, H5 + H6'), 7.33 (1H, dd, *J* 7.3, 1.1 Hz, H4'), 7.22 (1H, td, *J* 7.3, 1.6 Hz, H7), 7.13 (1H, dd, *J* 7.3, 1.1 Hz, H3'), 7.04 (1H, td, *J* 7.3, 1.1 Hz, H5'), 3.77 (3H, s, CH<sub>3</sub>);  $\delta_{\text{C}}$  (75 MHz, d<sub>6</sub>-DMSO) 15 signals of 16 observed; 160.8 (C=O), 157.0 (quat.), 138.7 (C4), 138.4 (quat.), 130.8 (ArCH), 129.9 (ArCH), 129.2 (ArCH), 127.8 (ArCH), 125.7 (quat.), 121.7 (ArCH), 119.9 (ArCH), 119.2 (quat.), 114.6 (ArCH), 111.2 (ArCH), 55.4 (CH<sub>3</sub>);  $\nu_{\text{max}}/\text{cm}^{-1}$  (solid, diamond); 3455, 3015, 2970, 1739, 1570, 1370, 1217, 1024; HRMS (ES<sup>+</sup>) *m/z* [M+Na]<sup>+</sup> requires 274.0838 for C<sub>16</sub>H<sub>13</sub>NNaO<sub>2</sub>, found: 274.0837.

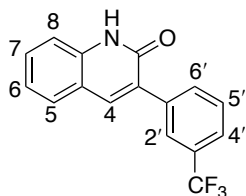
**3-(3-Trifluoromethylphenyl)quino-2(1H)-lone 276c**

Prepared according to general procedure L using **296c** (0.12 g, 0.33 mmol) and the sulfonyl chloride resin (2.4 mmol/g, 0.13 g) in dichlorobenzene (8 mL). Purification by column chromatography (SiO<sub>2</sub>, 0-100% EtOAc in CH<sub>2</sub>Cl<sub>2</sub>) gave the quinolone **276c** as colourless solid (56 mg, 59%).

M.p.= 211-212°C (EtOAc);  $\delta_{\text{H}}$  (300 MHz, CDCl<sub>3</sub>); 12.01 (1H, br s, NH), 8.04 (1H, s, H2'), 7.96 (1H, d, *J* 7.8 Hz, H6'), 7.92 (1H, s, H4), 7.57 (2H, m, H4' + H5'), 7.54 (1H, d, *J* 8.2 Hz, H5), 7.47 (1H, dd, *J* 8.2, 7.0 Hz, H7), 7.32 (1H, d, *J* 8.2 Hz, H8), 7.22-7.17 (1H, m, H6);  $\delta_{\text{C}}$  (100 MHz, d<sub>6</sub>-DMSO); 160.8 (C=O), 138.7 (C4), 138.6 (quat.), 137.2 (quat.), 132.6 (C5' or C6'), 130.6 (C7), 129.6 (quat.), 129.1 (C5), 128.8 (q, *J* 31.1 Hz, CCF<sub>3</sub>), 128.4 (C5' or C6'), 125.1 (q, *J* 5.2 Hz, C2'), 124.4 (q, *J* 4.2 Hz, C4'), 124.1 (quat., *J* 273.0 Hz, CF<sub>3</sub>), 122.0 (C6), 119.4 (quat.), 114.8 (C8);  $\nu_{\text{max}}/\text{cm}^{-1}$  (solid, diamond); 2961, 1665, 1570, 1443, 1336, 1099; HRMS (ES<sup>+</sup>) *m/z* [M+H]<sup>+</sup> requires 290.0787 for C<sub>16</sub>H<sub>11</sub>F<sub>3</sub>NO, found: 290.0777.

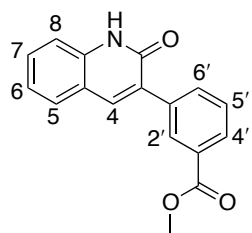
**Methyl 3-(2-oxo-1,2-dihydroquinolin-3-yl)benzoate 276d**

Prepared according to general procedure L using **296d** (0.14 g, 0.4 mmol) and the sulfonyl chloride resin (3.8 mmol/g, 0.10 g) in dichlorobenzene (10 mL). Purification by column chromatography (SiO<sub>2</sub>, 0-10% MeOH in CH<sub>2</sub>Cl<sub>2</sub>) gave the quinolone **276d** as a yellow solid (61 mg, 55%).

M.p.= 153-154°C (EtOAc);  $\delta_{\text{H}}$  (300 MHz, CDCl<sub>3</sub>); 11.85 (1H, br s, NH), 8.45 (1H, s, H2'), 8.10-8.06 (2H, m, H4' + H5'), 7.99 (1H, s, H4), 7.65 (1H, d, *J* 8.0 Hz, H8), 7.57-7.50 (2H, m, H6 + H6'), 7.40 (1H, d, *J* 8.0 Hz, H5), 7.27-7.20 (1H, m, H7), 3.96 (3H, s, CH<sub>3</sub>);  $\delta_{\text{C}}$  (75 MHz, CDCl<sub>3</sub>); 167.1 (C=O), 162.8 (C=O), 138.9 (C4), 138.1 (quat.), 136.4 (quat.), 133.5 (C4' or C5'), 131.5 (quat.), 130.7 (C6 or C6'), 130.2 (quat.), 129.9 (C2'), 129.3 (C4' or C5'), 128.4 (C6 or C6'), 128.0 (C8), 122.9 (C7), 120.2 (quat.), 115.6 (C5), 55.4 (CH<sub>3</sub>);  $\nu_{\text{max}}/\text{cm}^{-1}$  (solid, diamond); 3300, 2950, 1721, 1655, 1577, 1536, 1433, 1290, 1208, 1109, 1083; HRMS (ES<sup>+</sup>) *m/z* [M+H]<sup>+</sup> requires 280.0968 for C<sub>17</sub>H<sub>14</sub>NO<sub>3</sub>, found: 280.0956.

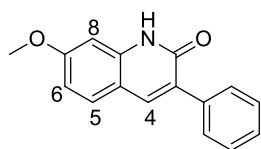
**7-Methoxy-3-phenylquino-2(1H)-lone 276e**

Prepared according to general procedure L using **296e** (0.15 g, 0.5 mmol) and the sulfonyl chloride resin (3.8 mmol/g, 0.13 g) in dichlorobenzene (12.5 mL). Purification by column chromatography (SiO<sub>2</sub>, 0-50% EtOAc in CH<sub>2</sub>Cl<sub>2</sub>) gave the quinolone **276e** as a yellow solid (46 mg, 37%).

M.p.= 225-226 °C (EtOAc);  $\delta_{\text{H}}$  (300 MHz, CDCl<sub>3</sub>); 11.73 (1H, br s, NH), 7.80 (1H, s, H4), 7.74 (2H, m, ArH), 7.44-7.39 (2H, m, ArH), 7.37-7.31 (2H, m, H5 + ArH), 7.26 (1H, dd, *J* 6.9, 1.6 Hz, H6), 7.23 (1H, s, H8), 2.36 (3H, s, CH<sub>3</sub>);  $\delta_{\text{C}}$  (75 MHz, CDCl<sub>3</sub>); 162.0 (C=O), 138.4 (C4), 136.3 (quat.), 135.9 (quat.), 132.3 (quat.), 132.2 (quat.), 131.8 (ArCH), 128.9 (ArCH), 128.3 (ArCH), 128.1 (ArCH), 127.4 (C6), 120.4 (quat.), 115.4 (C8), 21.0 (CH<sub>3</sub>);  $\nu_{\text{max}}/\text{cm}^{-1}$  (solid, diamond); 3021, 2921, 1650, 1570, 1479, 1447, 1409, 1364, 1317, 1250, 1237, 1185, 1150, 1077, 1035; HRMS (ES<sup>+</sup>) *m/z* [M+Na]<sup>+</sup> requires 274.0838 for C<sub>16</sub>H<sub>13</sub>NNaO<sub>2</sub>, found: 274.0839.

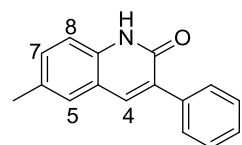
**6-Methyl-3-phenylquino-2(1H)-lone 276f**

Prepared according to general procedure L using **296f** (0.03 g, 0.11 mmol) and the sulfonyl chloride resin (3.8 mmol/g, 0.029 g) in dichlorobenzene (2.75 mL). Purification by column chromatography (SiO<sub>2</sub>, 0-100% EtOAc in CH<sub>2</sub>Cl<sub>2</sub>) gave the quinolone **276f** as a colourless solid (20 mg, 20%).

M.p.= >250 °C (EtOAc);  $\delta_{\text{H}}$  (300 MHz, CDCl<sub>3</sub>); 11.23 (1H, br s, NH), 7.84 (1H, s, H4), 7.71-7.68 (2H, m, ArH), 7.46 (1H, d, *J* 8.8 Hz, H8), 7.40-7.30 (3H, m, ArH), 6.79 (1H, dd, *J* 8.8, 2.5

Hz, H7), 6.73 (1H, d,  $J$  2.5 Hz, H5), 3.82 (3H, s, CH<sub>3</sub>);  $\delta_C$  (75 MHz, CDCl<sub>3</sub>); 161.9 (C=O), 139.4 (quat.), 138.9 (C4), 136.2 (quat.), 136.0 (quat.), 129.3 (ArCH), 128.8 (ArCH), 128.2 (ArCH), 128.1 (quat.), 127.9 (ArCH), 114.9 (quat.), 112.9 (C7), 97.8 (C5), 55.6 (CH<sub>3</sub>);  $\nu_{\max}/\text{cm}^{-1}$  (solid, diamond); 2838, 1645, 1622, 1566, 1506, 1443, 1405, 1383, 1291, 1258, 1177, 1124, 1076, 1030; HRMS (ES<sup>+</sup>)  $m/z$  [M+Na]<sup>+</sup> requires 258.0889 for C<sub>16</sub>H<sub>13</sub>NNaO, found: 258.0888.

### 6-Fluoro-3-phenylquino-2(1H)-lone **276g**

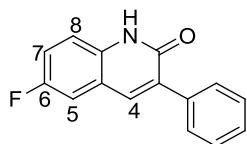

Prepared according to general procedure L using **296g** (0.14 g, 0.50 mmol) and sulfonyl chloride resin (3.8 mmol/g, 0.13 g) in dichlorobenzene (12.5 mL). Purification by column chromatography (SiO<sub>2</sub>, 0-25% EtOAc in CH<sub>2</sub>Cl<sub>2</sub>) gave the quinolone **276g** as yellow crystals (29 mg, 24%).

M.p. = 241-242°C (EtOAc);  $\delta_H$  (300 MHz, CDCl<sub>3</sub>); 11.82 (1H, br s, NH), 7.83 (1H, s, H4), 7.72 (2H, dd,  $J$  8.3, 1.3 Hz, ArH), 7.52 (1H, dd,  $J$  8.7, 5.9 Hz, H8), 7.45-7.32 (3H, m, ArH), 7.00 (1H, dd,  $J$  9.5, 2.3 Hz, H5), 6.90 (1H, td,  $J$  8.7, 2.3 Hz, H7);  $\delta_C$  (75 MHz, CDCl<sub>3</sub>); 163.5 (d,  $J$  25.9 Hz, ArCF), 163.2 (C=O), 139.7 (quat.), 139.2 (quat.), 138.1 (C4), 135.7 (quat.), 130.0 (d,  $J$  8.8 Hz, C8), 128.8 (ArCH), 128.4 (ArCH), 128.3 (ArCH), 117.1 (quat.), 111.4 (d,  $J$  25.4 Hz, C7), 101.8 (d,  $J$  25.4 Hz, C5);  $\nu_{\max}/\text{cm}^{-1}$  (solid, diamond); 2874, 1653, 1573, 1511, 1443, 1409, 1370, 1291, 1249, 1160, 1114, 1070; HRMS (ES<sup>+</sup>)  $m/z$  [M+Na]<sup>+</sup> requires 262.0639 for C<sub>15</sub>H<sub>10</sub>FNNaO, found: 262.0644.

### Methyl 2-oxo-1,2-dihydroquinoline-3-carboxylate **276i**

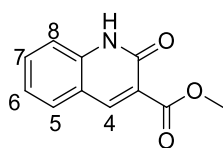

Prepared according to general procedure L using **296i** (0.015 g, 0.055 mmol) and sulfonyl chloride resin (2.4 mmol/g, 0.02 g) in dichlorobenzene (1.2 mL). Purification by column chromatography (SiO<sub>2</sub>, 0-100% EtOAc in CH<sub>2</sub>Cl<sub>2</sub>) gave the quinolone **276i** as colourless needles (7 mg, 63%).

$\delta_H$  (300 MHz, CDCl<sub>3</sub>); 12.11 (1H, br s, NH), 8.55 (1H, s, H4), 7.60 (1H, dd,  $J$  7.6, 1.1 Hz, H5), 7.55 (1H, dt,  $J$  7.2, 1.1 Hz, H7), 7.42 (1H, m, H8), 7.19 (1H, td,  $J$  7.6, 1.1 Hz, H6), 3.93 (3H, s, CH<sub>3</sub>);  $\delta_C$  (75 MHz, CDCl<sub>3</sub>); 165.1 (C=O), 161.1 (C=O), 146.3 (C4), 140.0 (quat.), 133.3 (C7), 129.3 (C5), 123.3 (C6), 121.7 (quat.), 118.5 (quat.), 116.2 (C8), 52.6 (CH<sub>3</sub>);  $m/z$  (ESI) 226.0 [M+H]<sup>+</sup>

Spectroscopic data was consistent with literature values.<sup>229</sup>

## 6.0 References

1. Bonini, C.; Funicello, M.; Spagnolo, P. *Synlett* **2006**, (10), 1574-1576.
2. Funicello, M.; Laboragine, V.; Pandolfo, R.; Spagnolo, P. *Synlett* **2010**, (1), 77-80.
3. Bonini, C.; D'Auria, M.; Funicello, M.; Romaniello, G. *Tetrahedron* **2002**, *58*, 3507-3512.
4. Robin, A.; Julienne, K.; Mesline, J. C.; Deniaud, D. E. *Eur. J. Org. Chem.* **2006**, 634-643.
5. Carey, J. S.; Laffan, D.; Thomson, C.; Williams, M. T. *Org. Biomol. Chem.* **2006**, *4*, 2337-2347.
6. Hantzsch, A. *Justus Liebig's Ann. Chem.* **1882**, *215*, 1-82.
7. Bohlmann, F.; Rahtz, D. *Chem. Ber.* **1957**, *90*, 2265-2272.
8. Nicolaou, K. C.; Nevalainen, M.; Safina, B. S.; Zak, M.; Bulat, S. *Angew. Chem. Int. Ed.* **2002**, *41*, 1941-1945.
9. Buonora, P.; Olsen, J. C.; Oh, T. *Tetrahedron* **2001**, *57*, 6099-6138.
10. Bachrach, S. M.; Liu, M. *J. Org. Chem.* **1992**, *57*, 6736-6744.
11. Catozzi, N.; Edwards, M. G.; Raw, S. A.; Wasnaire, P.; Taylor, R. J. K. *J. Org. Chem.* **2009**, *74*, 8343-8354.
12. Pinho e Melo, T. M. V. D.; Fausto, R.; d'A Rocha Gonsalves, A. M. *J. Org. Chem.* **1998**, *63*, 5350-5355.
13. González, J.; Houk, K. N. *J. Org. Chem.* **1992**, *57*, 3031-3037.
14. Barluenga, J.; Tomas, M.; Ballesteros, A.; Gotor, V. *J. Chem. Soc., Chem. Commun.* **1987**, 1195-1196.
15. Steinhagen, H.; Corey, E. J. *Angew. Chem. Int. Ed.* **1999**, *38*, 1928-1931.
16. Boger, D. L. *Tetrahedron* **1983**, *39*, 2869-2939.
17. Boger, D. L. *Chem. Rev.* **1986**, *86* (781-793).
18. Raw, S. A.; Taylor, R. J. K. *Adv. Heterocycl. Chem.* **2010**, *99*, 75-100.
19. Catozzi, N.; Wasnaire, P.; Taylor, R. J. K. *Tetrahedron Lett.* **2008**, *49*, 2865-2868.
20. Raw, S. A.; Taylor, R. J. K. *J. Am. Chem. Soc.* **2004**, *126*, 12260-12261.
21. Palacios, F.; Deheredia, I. P.; Rubiales, G. *J. Org. Chem.* **1995**, (60), 2384-2390.
22. Palacios, F.; Alonso, C.; Rubiales, G.; Ezpeleta, J. M. *Eur. J. Org. Chem.* **2001**, 2115-2122.
23. Boger, D. L.; Panek, J. S. *J. Org. Chem.* **1981**, *46*, 2179-2193.
24. Palacios, F.; Alonso, C.; Rubiales, G.; Villegas, M. *Tetrahedron Lett.* **2004**, *45*, 4031-4034.
25. Palacios, F.; Alonso, C.; Rubiales, G.; Villegas, M. *Tetrahedron* **2005**, *61*, 2779-2794.



26. Khlebnikov, A. F.; Novikov, M. S.; Amer, A. A. *Tetrahedron Lett.* **2004**, *43*, 6003-6006.
27. Barluenga, J.; Ferrero, M.; Palacios, F. *Tetrahedron Lett.* **1988**, *29*, 4863-4864.
28. Palacios, F.; Alonso, C.; Aparicio, D.; Rubiales, G.; de los Santos, J. M. *Tetrahedron* **2007**, *63*, 523-575.
29. Palacios, F.; Herran, E.; Rubiales, G. *J. Org. Chem.* **1999**, *64*, 6239-6242.
30. Palacios, F.; Herran, E.; Rubiales, G.; Ezpeleta, J. M. *J. Org. Chem.* **2002**, *67*, 2131-2135.
31. Kano, N.; Hua, X. J.; Kawa, S.; Kawashima, T. *Tetrahedron Lett.* **2000**, *41*, 5237-5241.
32. Wong, A. W.; Johnson, S. C. K. *Can. J. Chem.* **1966**, *44*, 2793-2803.
33. Cossio, F. P.; Alonso, C.; Lecea, B.; Ayerbe, M.; Rubiales, G.; Palacios, F. *J. Org. Chem.* **2006**, *71*, 2839-2847.
34. Koketsu, J.; Ninomiya, Y.; Suzuki, Y.; Koga, N. *Inorg. Chem.* **1997**, *36*, 694-702.
35. Lu, W. C.; Liu, C. B.; Sun, C. C. *J. Phys. Chem.* **1999**, *103*, 1078-1083.
36. Eguchi, S. *Arkivoc* **2005**, *ii*, 98-119.
37. Fresneda, P. M.; Molina, P. *Synlett* **2004**, 1-17.
38. Viliplana, M. J.; Molina, P. *Synthesis* **1994**, 1197-1218.
39. Molina, P.; Fresneda, P. M.; Delgado, S.; Bleda, J. A. *Tetrahedron Lett.* **2002**, *43*, 1005-1007.
40. Molina, P.; Garcia-Zafra, S.; Fresneda, P. M. *Synlett* **1995**, 43-45.
41. Marsden, S. P. *Nature Chem.* **2009**, *1*, 685-687.
42. Denton, R. M.; An, J.; Adeniran, B.; Blake, A. J.; Lewis, W.; Poulton, A. M. *J. Org. Chem.* **2011**, 6749-6767.
43. O'Brien, C. J.; Tellez, J. L.; Nixon, Z. S.; Kang, L. J.; Carter, A. L.; Kunkel, S. R.; Przeworski, K. C.; Chass, G. A. *Angew. Chem. Int. Ed.* **2009**, *48*, 6836-6839.
44. van Kalker, H. A.; Leenders, S. H. A. M.; Hommersom, C. R. A.; Rutjes, F. P. J. T.; van Delft, F. L. *Chem. Eur. J.* **2011**, *17*, 11290-11295.
45. van Kalker, H. A.; Bruins, J. J.; Rutjes, F. P. J. T.; van Delft, F. L. *Adv. Synth. Catal.* **2012**, 1417-1421.
46. Harris, J. R.; Haynes, M. T. I.; Thomas, A. M.; Woerpel, K. A. *J. Org. Chem.* **2010**, *75*, 5083-5091.
47. Cheng, C.; Brokhardt, M. *J. Am. Chem. Soc.* **2012**, *134*, 11304-11307.
48. Campbell, T. W.; Monagle, J. J.; Foldi, V. S. *J. Am. Chem. Soc.* **1962**, *84*, 3673-3677.
49. Marsden, S. P.; McGonagle, A. E.; McKeever-Abbas, B. *Org. Lett.* **2008**, *10*, 2589-2591.
50. Staudinger, H.; Meyer, J. *Helv. Chim. Acta* **1919**, *2*, 635-646.

51. Monagle, J. J.; Campbell, T. W.; McShane, H. F. *J. Am. Chem. Soc.* **1962**, *84*, 4288-4295.
52. Monagle, J. J.; Mengershauser, J. V. *J. Org. Chem.* **1966**, *31*, 2321-2324.
53. Monagle, J. J. *J. Am. Chem. Soc.* **1962**, *84*, 3851-3855.
54. Aksnes, G.; Frøyen, P. *Acta Chem. Scand.* **1969**, *23*, 2697-2703.
55. Dennis, E. A.; Westheimer, F. H. *J. Am. Chem. Soc.* **1966**, *88*, 3432-3433.
56. Marsi, K. L. *J. Am. Chem. Soc.* **1969**, *91*, 4724-4729.
57. Guberman, F. S.; Bakhitov, M. I.; Kuznetsov, E. V. *Zh. Obshch. Khim.* **1974**, *44*, 754-756.
58. McGonagle, A. E. *Ph.D. Thesis, University of Leeds* **2007**.
59. Ooi, T.; Wälchli, M. R.; Kakisawa, H. *J. Am. Chem. Soc.* **1998**, *110*, 2954.
60. Chaney, M. O.; Demarco, P. V.; Jones, N. D.; Occolowitz, J. L. *J. Am. Chem. Soc.* **1974**, *96*, 1932.
61. Yoshida, S.; Watanabe, T.; Sato, Y. *Bioorg. Med. Chem.* **2007**, *15*, 3515.
62. Byrne, L. *Ph.D. Thesis, University of Leeds* **2011**.
63. Rigby, J. H. *Synlett* **2000**, *1*, 1-12.
64. Rigby, J. H.; Balasubramanian, N. *J. Org. Chem.* **1989**, *54*, 224-228.
65. Rigby, J. H.; Lee, C. S. *Org. Lett.* **2003**, *5*, 1151-1153.
66. Bonini, C.; Chiummiento, L.; Funicello, M.; Spagnolo, P. *Tetrahedron* **2000**, *56*, 1517-1521.
67. Molina, P.; Aller, E.; Lorenzo, A. *Tetrahedron* **1991**, *47*, 6737-6746.
68. Spagnolo, P.; Zanirato, P. *J. Org. Chem.* **1978**, *43*, 3539-3541.
69. *Prudent Practices for Disposal of Chemicals From Laboratories*. 1991; p 87-88.
70. Jennings, W. J.; Lovely, C. J. *Tetrahedron* **1991**, *47*, 5561-5568.
71. Williams, D.; Fleming, I. *Spectroscopic methods in organic chemistry*. 6 ed.; McGraw-Hill Education: 2006.
72. Schoenecker, J. W.; Takemori, A. E.; Portoghese, P. S. *J. Med. Chem.* **1986**, *29*, 1868-1871.
73. Kricheldorf, H. R. *Angew. Chem. Int. Ed.* **1972**, *11*, 128-129.
74. Byerley, T. J.; Chappelow, C. C.; Eick, J. D. *US 5 346 044* **1994**.
75. Piers, E.; Yeung, B. W. A. *J. Org. Chem.* **1984**, *49*, 4569-4571.
76. Patai, S. *The chemistry of the azido group*. John Wiley and Sons: 1971; p 61-62.
77. Vitnik, V. D.; Ivanovic, M. D.; Vitnik, Z. J.; Dordevic, J. B.; Zizak, Z. S.; Juranic, Z. D.; Juranic, I. O. *Synth. Commun.* **2009**, *39*, 1457-1471.
78. Patai, S. *The chemistry of cyanates and their thio derivatives*. John Wiley and Sons: 1977; p 198.
79. Coffman, D. D. *US 2 334 476* **1943**.

80. Jones, G. D.; Zomlefer, J.; Hawkins, K. *J. Org. Chem.* **1944**, *9*, 500-512.
81. Fuks, R. *Tetrahedron* **1970**, *26*, 2161-2166.
82. Raw, S. A.; Taylor, R. J. K. *Chem. Commun.* **2004**, 508-509.
83. Palacios, F.; Alonso, C.; Tobillas, C.; Rubiales, G. *Heterocycles* **2004**, *64*, 229-240.
84. Branowska, D. *Synthesis* **2003**, *13*, 2096-2100.
85. Carreira, E. M.; Zhao, W. *Org. Lett.* **2011**, *13*, 5084-5087.
86. Hutchby, M.; Houlden, C. E.; Ford, J. G.; Tyler, S. N. G.; Gagné, M. R.; Lloyd-Jones, G. C.; Booker-Milburn, K. I. *Angew. Chem. Int. Ed.* **2009**, *48*, 8877-8800.
87. Dubé, P.; Fine Nathel, N. F.; Vetelino, M.; Couturier, M.; Larrivée Aboussafy, C.; Pichette, S.; Jorgensen, M. L.; Hardink, M. *Org. Lett.* **2009**, *11*, 5622-5625.
88. Delaney, P. M.; Huang, J.; MacDonald, S. J. F.; Harrity, J. P. A. *Org. Lett.* **2008**, *10*, 781-783.
89. Zifcsak, C. A.; Mulder, J. A.; Hsung, R. P.; Rameshkumar, C.; Wei, L. L. *Tetrahedron* **2001**, *57*, 7575-7606.
90. Vinogradova, E. V.; Fors, B. P.; Buchwald, S. L. *J. Am. Chem. Soc.* **2012**, *134*, 11132-11135.
91. Mason, B. P.; Steinbacher, J. L.; Bogdan, A. R.; McQuade, D. T. *Chem. Rev.* **2007**, *107*, 2300-2318.
92. Baumann, M.; Baxendale, I. R.; Ley, S. V.; Nikbin, N.; Smith, C. D. *Org. Biomol. Chem.* **2008**, *6*, 1587-1593.
93. Baumann, M.; Baxendale, I. R.; Ley, S. V.; Nikbin, N.; Smith, C. D.; Tierney, J. P. *Org. Biomol. Chem.* **2008**, *6*, 1577-1586.
94. Smith, C. J.; Smith, C. D.; Nikbin, N.; Ley, S. V.; Baxendale, I. R. *Org. Biomol. Chem.* **2011**, *9*, 1927-1937.
95. Palacios, F.; Herran, E.; Alonso, C.; Rubiales, G.; Lecea, B.; Ayerbe, M.; Cossio, F. P. *J. Org. Chem.* **2006**, *71*, 6020-6030.
96. Molina, P.; Almendros, P.; Fresneda, P. M. *Tetrahedron Lett.* **1993**, *34*, 4701-4704.
97. Molina, P.; Fresneda, P. M.; Canovas, M. *Tetrahedron Lett.* **1992**, *33*, 2891-2894.
98. Ciller, J. A.; Seoane, C.; Soto, J. L. *J. Heterocycl. Chem.* **1986**, *23*, 1583.
99. Lythgoe, D. L.; McClenagan, I.; Ramsden, C. A. *J. Heterocycl. Chem.* **1993**, *30*, 113.
100. Murai, M.; Miki, K.; Ohe, K. *Chem. Commun.* **2009**, *23*, 3466-3468.
101. Amati, M.; Bonini, C.; D'Auria, M.; Funicello, M.; Lelj, F.; Racioppi, R. *J. Org. Chem.* **2006**, *71*, 7165-7179.
102. Iaroshenko, V. O.; Wang, Y. F.; Zhang, B.; Volochnyuk, D.; Sosnovskikh, V. Y. *Synthesis* **2009**, *14*, 2393-2402.
103. Gupta, S.; Kumar, B.; Kundu, B. *J. Org. Chem.* **2011**, *76*, 10154-10162.
104. Benoit, R.; Dupas, G.; Bourguignon, J.; Quegunier, G. *Synthesis* **1987**, 1124.

105. Erba, E.; Gelmi, M. L.; Pocar, D. *Tetrahedron* **2000**, *56*, 9991.
106. Herz, W. *J. Am. Chem. Soc.* **1951**, *73*, 351.
107. Herz, W.; Tocker, S. *J. Am. Chem. Soc.* **1954**, *77*, 3554-3556.
108. Herz, W.; Tsai, L. *J. Am. Chem. Soc.* **1953**, *75*, 5122.
109. Levacher, V.; Boussad, N.; Dupas, G.; Bourguignon, J.; Quegunier, G. *Tetrahedron* **1992**, *48*, 831.
110. Rocca, P.; Marsais, F.; Godard, A.; Queguiner, G. *Tetrahedron* **1993**, *49*, 49-64.
111. Degl'Innocenti, A.; Funicello, M.; Scafato, P.; Spagnolo, P.; Zanirato, P. *J. Chem. Soc., Perkin Trans. 1* **1996**, 2561-2563.
112. Kurzer, F.; Douraghi-Zadeh, K. *Chem. Rev.* **1967**, *67*, 107-52.
113. Sebastian, H. M.; Simnick, J. J.; Lin, H. M.; Chao, K. C. *J. Chem. Eng. Data* **1980**, *25*, 246-248.
114. Yamamoto, I.; Gotoh, H.; Minami, T.; Ohshiro, Y.; Agawa, T. *J. Org. Chem.* **1974**, *39*, 3516-3519.
115. Fakhr, I. M. I.; Radwan, M. A. A.; El-Batran, S.; Abd El-Salam, O. M. E.; El-Shenawy, S. M. *Eur. J. Med. Chem.* **2009**, *44*, 1718-1725.
116. Chen, X.; Engle, K. M.; Wang, D. H.; Yu, J. Q. *Angew. Chem. Int. Ed.* **2009**, *48*, 5094-5115.
117. Moritani, I.; Fukjiwana, Y. *Tetrahedron Lett.* **1967**, *12*, 1119-1122.
118. Fujiwana, Y.; Moritani, I.; Danno, S.; Asano, R.; Teranishi, S. *J. Am. Chem. Soc.* **1969**, *91*, 7166-7169.
119. Jia, C.; Lu, W. C.; Kitamura, T.; Fujiwara, Y. *Org. Lett.* **1999**, *1*, 2097-2100.
120. Cho, S. H.; Kim, J. Y.; Kwak, J.; Chang, S. *Chem. Soc. Rev.* **2011**, *40*, 5068-5083.
121. Kuhl, N.; Hopkinson, M. N.; Wencel-Delord, J.; Glorius, F. *Angew. Chem. Int. Ed.* **2012**, *51*, 10236-10254.
122. Newhouse, T.; Baran, P. S. *Angew. Chem. Int. Ed.* **2011**, *50*, 3362-3374.
123. McMurray, L.; O'Hara, F.; Gaunt, M. J. *Chem. Soc. Rev.* **2011**, *40*, 1885-1895.
124. Colby, D. A.; Tsai, A. S.; Bergman, R. G.; Ellmann, J. A. *Acc. Chem. Res.* **2012**, *45*, 814-825.
125. Godula, K.; Sames, D. *Science* **2006**, *312*, 67-72.
126. Heck, R. F.; Nolley Jr., J. P. *J. Org. Chem.* **1972**, *37*, 2320-2323.
127. Beletskaya, I. P.; Cheprakov, A. V. *Chem. Rev.* **2000**, *100*, 3009-3066.
128. Houlden, C. E.; Bailey, C. D.; Ford, J. G.; Gagné, M. R.; Lloyd-Jones, G. C.; Booker-Milburn, K. I. *J. Am. Chem. Soc.* **2008**, *130*, 10066-10067.
129. Houlden, C. E.; Hutchby, M.; Bailey, C. D.; Ford, J. G.; Tyler, S. N. G.; Gagné, M. R.; Lloyd-Jones, G. C.; Booker-Milburn, K. I. *Angew. Chem. Int. Ed.* **2009**, *48*, 1830-1833.

130. Rauf, W.; Hazari, A.; Gouverneur, V.; Brown, J. M. *Pure. Appl. Chem.* **2010**, *82*, 1415-1428.
131. Michael, J. P. *Nat. Prod. Rep.* **2007**, *24*, 223-246.
132. Barraja, P.; Diana, P.; Montalbano, A.; Carbonea, A.; Violab, G.; Bassob, G.; Salvadorc, A.; Vedaldic, D.; Dall'Acquac, F.; Cirrincione, G. *Bioorg. Med. Chem.* **2011**, *19*, 2326-2341.
133. Abonia, R.; Insuastya, D.; Castilloa, J.; Insuastya, B.; Quiroga, J.; Noguerasb, M.; Cobob, J. E. *J. Med. Chem.* **2012**, *57*, 29-40.
134. Kraus, J. M.; Tatipaka, H. B.; McGuffin, S. A.; Chennamaneni, N. K.; Karimi, M.; Arif, J.; Verlinde, C. L. M. J.; Buckner, F. S.; Gelb, M. H. *J. Med. Chem.* **2010**, *53*, 3887-3898.
135. Pak, C. S.; Choi, E. B.; Yon, G. H.; Yang, H. C.; Lee, H. K.; Lee, G. H.; Lee, J. P. *WO 95/00488* **1995**.
136. Fischer, R.; Ullmann, A.; Erdelen, C.; Kuck, K. H.; Hillebrand, S.; Trautwein, A.; Konze, J.; Wachendorff-Neumann, U.; Maukler-Machnik, A. *WO 03/01045* **2003**.
137. Connel, R. D. *Expert Opin. Ther. Patents* **2002**, *12*, 1763-1782.
138. Bilodeau, M. T.; Fraley, M. E.; Hartman, G. D. *Expert Opin. Invest. Drugs* **2002**, *11*, 737-745.
139. Anzini, M.; Cappelli, A.; Vomero, S. *J. Heterocycl. Chem.* **1991**, *28*, 1809.
140. Godard, A.; Fourquez, J. M.; Tamion, R.; Marsais, F.; Quéguiner, G. *Synlett* **1994**, 235.
141. Marco-Contelles, J.; Pérez-Mayoral, E.; Samadi, A.; do Carmo Carreiras, M.; Soriano, E. *Chem. Rev.* **2009**, *109*, 2652-2671.
142. Cortese, N. A.; Zielger, J., C.B.; Hrnjez, B. J.; Heck, R. F. *J. Org. Chem.* **1978**, *43*, 2952-2958.
143. Liu, Z.; Shi, C.; Chen, Y. *Synlett* **2008**, *11*, 1734-1736.
144. Tadd, A. C.; Matsuno, A.; Fielding, M. R.; Willis, M. C. *Org. Lett.* **2009**, *11*, 583-586.
145. Kadnikov, D. V.; Larock, R. C. *J. Org. Chem.* **2004**, *69*, 6772-6780.
146. Inamoto, K.; Saito, T.; Hiroya, K.; Doi, T. *J. Org. Chem.* **2010**, *75*, 3900-3903.
147. Wasa, M.; Yu, J. Q. *J. Am. Chem. Soc.* **2008**, *130*, 14058-14059.
148. Inamoto, K.; Kawasaki, J.; Hiroya, K.; Kondo, Y.; Doi, T. *Chem. Commun.* **2012**, *48*, 4332-4334.
149. Berrino, R.; Cacchi, S.; Fabrizi, G.; Goggioamani, A. *J. Org. Chem.* **2012**, *77*, 2537-2542.
150. Arshad, N.; Hashim, J.; Kappe, C. O. *J. Org. Chem.* **2008**, *73*, 4755-4758.
151. Manley, P. J.; Bilodeau, M. T. *Org. Lett.* **2004**, *6*, 2433-2435.
152. Kobayashi, K.; Kitamura, T.; Yoneda, K.; Morikawa, O.; Konishi, H. *Chem. Lett.* **2000**, *29*, 798-799.
153. Fürstner, A.; Jumbam, D. N.; Shi, N. *Z. Naturforsch. B* **1995**, *50*, 326.

154. Merault, G.; Bougeois, P.; Duffant, N. *Bull. Soc. Chim. Fr.* **1974**, 1949.
155. Collet, F.; Dodd, R. H.; Dauban, P. *Chem. Commun.* **2009**, 5061-5074.
156. MacMillan, J. H.; Washburne, S. S. *J. Org. Chem.* **1973**, *38*, 2982-2984.
157. Luo, L.; Bartberger, M. D.; Dolbier, J. W. R. *J. Am. Chem. Soc.* **1997**, *119*, 12366-12367.
158. Chuang, T. H.; Yang, C. H.; Kao, P. C. *Inorg. Chim. Acta* **2009**, *362*, 5017-5022.
159. Fresneda, P. M.; Molina, P.; Delgado, S. *Tetrahedron* **2001**, *57*, 6197-6202.
160. Hazeldine, S. T.; Polin, L.; Kushner, J.; White, K.; Corbett, T. H.; Biehl, J.; Horwitz, J. P. *Bioorg. Med. Chem.* **2005**, *13*, 1069-1081.
161. Hayashi, K.; Choishi, T.; Chikaraishi, K.; Oda, A.; Yoshinaga, R.; Hatae, N.; Ishikura, M.; Hibino, S. *Tetrahedron* **2012**, *68*, 4274-4279.
162. Overman, L. E.; Tsuboi, S. *J. Am. Chem. Soc.* **1977**, *99*, 2813-2815.
163. Overman, L. E.; Tsuboi, S.; Roos, J. P.; Taylor, G. F. *J. Am. Chem. Soc.* **1980**, *102*, 747-754.
164. Birney, D. M.; Ham, S.; Unruh, G. R. *J. Am. Chem. Soc.* **1997**, *119*, 4509-4517.
165. Ross, J. A.; Seiders, R. P.; Lemal, D. M. *J. Am. Chem. Soc.* **1976**, *98*, 4325-4327.
166. Bushweller, C. H.; Ross, J. A.; Lemal, D. M. *J. Am. Chem. Soc.* **1977**, *99* (629-631).
167. Ozaki, S. *Chem. Rev.* **1972**, *72*, 457-496.
168. Caron, S.; Dugger, R. W.; Gut Ruggeri, S.; Ragan, J. A.; Brown Ripin, D. H. *Chem. Rev.* **2006**, *106*, 2943.
169. Yoshimura, A.; Luedtke, M. W.; Zhandkin, V. V. *J. Org. Chem.* **2012**, *77*, 2087-2091.
170. Liu, P.; Wang, Z.; Hu, X. *Eur. J. Org. Chem.* **2012**, 1994-2000.
171. Hutchby, M.; Houlden, C. E.; Ford, J. G.; Tyler, S. N.; Gagné, M. R.; Lloyd-Jones, G. C.; Booker-Milburn, K. I. *Angew. Chem. Int. Ed.* **2009**, *48*, 8721-8724.
172. O'Connor, C. J.; Barnett, J. W. *J. Chem. Soc. Perkin Trans 2* **1973**, 1457-1461.
173. Giffney, C. J.; O'Connor, C. J. *J. Chem. Soc. Perkin Trans 2* **1976**, 362-368.
174. Mollet, K. J.; O'Connor, C. J. *J. Chem. Soc. Perkin Trans 2* **1976**, 369-374.
175. Laudien, R.; Mitzner, R. *J. Chem. Soc. Perkin Trans 2* **2001**, 2226-2229.
176. Laudien, R. M., R. *J. Chem. Soc. Perkin Trans 2* **2001**, 2230-2232.
177. Salvestrini, S.; Di Cerbo, P.; Capasso, S. *J. Chem. Soc. Perkin Trans 2* **2002**, 1889-1893.
178. Williams, A.; Jencks, W. P. *J. Chem. Soc. Perkin Trans 2* **1974**, 1753-1759.
179. Alexandrova, A. N.; Jorgensen, W. L. *J. Phys. Chem. B* **2007**, *111*, 720-730.
180. Mucsi, Z.; Chass, G. A.; Csizmadia, I. G. *J. Phys. Chem.* **2008**, *112*, 7885-7893.
181. de Vries, J. G. *Dalton Trans.* **2006**, 421-429.
182. Zhao, M.; Crooks, R. M. *Angew. Chem. Int. Ed.* **1999**, *38*, 364-366.

183. Abass, M.; Mohamed, E. A.; Ismail, M. M.; Mayas, A. S. *Eur. J. Chem.* **2011**, *2*, 378-387.
184. Rivkin, A.; Kim, Y. R.; Goulet, M. T.; Bays, N.; Hill, A. D.; Kariv, I.; Krauss, S.; Ginanni, N.; Strack, P. R.; Kohl, N. E.; Chung, C. C.; Varenerin, J. P.; Goudreau, P. N.; Chang, A.; Tota, M. R.; Munoz, B. *Bioorg. Med. Chem. Lett.* **2006**, *16*, 4620-4623.
185. Detsi, A.; Bouloumbasi, D.; Prousis, K. C.; Koufaki, M.; Athanasellis, G.; Melagraki, G.; Agfantitis, A.; Igeelessi-Markopoulou, O.; Kontogiogis, C.; Hadjipaviou-Litina, D. *J. Med. Chem.* **2007**, *50*, 2450-2458.
186. Sakamoto, T.; Kondo, Y.; Kashiwagi, Y.; Yamanaka, H. *Heterocycles* **1988**, *27*, 257-260.
187. Fan, S.; Yang, J.; Zhang, X. *Org. Lett.* **2011**, *13*, 4374-4377.
188. Gøgsig, T. M.; Lindhart, A. T.; Dekhane, M.; Grouleff, J.; Skrydstrup, T. *Chem. Eur. J.* **2009**, *15*, 5950-5955.
189. Meseroll, L. M. N.; McKee, J. R.; Zanger, M. *Synth. Commun.* **2011**, *41*, 2557-2568.
190. Zhang, H. C.; Ye, H.; Moretto, A. F.; Brumfield, K. K.; Maryanoff, B. E. *Org. Lett.* **2000**, *2*, 89-92.
191. Littke, A. F.; Fu, G. C. *J. Am. Chem. Soc.* **2001**, *123*, 6989-7000.
192. Morschhäuser, R.; Krull, M.; Kayser, C.; Boberski, C.; Bierhaum, R.; Püschner, P. A.; Glasnov, T. N.; Kappe, C. O. *Green Process Synth.* **2012**, *1*, 281-290.
193. Razzaq, T.; Glasnov, T. N.; Kappe, C. O. *Eur. J. Org. Chem.* **2009**, 1321-1325.
194. Öhrngren, P.; Fardost, A.; Russo, F.; Schanche, J. S.; Fagrell, M.; Larhed, M. *Org. Process Res. Dev.* **2012**, *16*, 1053-1063.
195. Vyas, D. J.; Frohlich, R.; Oestreich, M. *Org. Lett.* **2011**, *13*, 2094-2097.
196. Kim, J. W.; He, J.; Yamaguchi, K.; Mizuno, N. *Chem. Lett.* **2009**, *38*, 920-921.
197. Bennett, J. S.; Charles, K. L.; MIner, M. R.; Heuberger, C. F.; Spina, E. J.; Bartels, M. F.; Foreman, T. *Green Chem.* **2009**, *11*, 166-168.
198. Duran-Galvan, M.; Connell, B. T. *Tetrahedron* **2011**, *67*, 7901-7908.
199. Torregrosa, R.; Pastor, I. M.; Yus, M. *Tetrahedron* **2005**, *61*, 11148-11155.
200. Zhu, S.; Dong, J.; Fu, S.; Jiang, H.; Zeng, W. *Org. Lett.* **2011**, *13*, 4914-4917.
201. Santos, L. L.; Serna, P.; Corma, A. *Chem. Eur. J.* **2009**, *15*, 8196-8203.
202. Katritzky, A. R.; Widyan, K.; Kirichenko, K. *J. Org. Chem.* **2007**, *72*, 5802-5804.
203. Willis, M. C.; Brace, G. N.; Holmes, I. P. *Synthesis* **2005**, *19*, 3229-3234.
204. Yang, H.; Li, H.; Wittenberg, R.; Egi, M.; Huang, W.; Liebeskind, L. S. *J. Am. Chem. Soc.* **2007**, *129*, 1132-1140.
205. Qiu, R.; Qiu, Y.; Yin, S.; Song, X.; Meng, Z.; Xu, X.; Zhang, X.; Luo, S.; Au, C. T.; Wong, W. Y. *Green Chem.* **2010**, *12*, 1767-1771.
206. Kanner, C. B.; Pandit, U. K. *Tetrahedron* **1982**, *38*, 3597-3604.

207. Clemo, N. G.; Pattenden, G. *J. Chem. Soc., Perkin Trans. 1* **1986**, 2133-2136.
208. Arjona, O.; Iradier, F.; Medel, R.; Plumet, J. *J. Org. Chem.* **1999**, *64*, 6090-6093.
209. Kozmin, S. A.; Janey, J. M.; Rawal, V. H. *J. Org. Chem.* **1999**, *64*, 3039-3052.
210. Felice, E.; Fioravanti, S.; Pellacani, L.; Tardella, P. A. *Tetrahedron Lett.* **1999**, *40*, 4413-4416.
211. Toh, K. K.; Wang, Y. F.; Jian Ng, E. P.; Chiba, S. *J. Am. Chem. Soc.* **2011**, *133*, 13942-13945.
212. Liu, L.; Zhang, S.; Fu, X.; Yan, C. H. *Chem. Commun.* **2011**, *47*, 10148-10150.
213. Galvez, C.; Garcia, F.; Veiga, M.; Viladoms, P. *Synthesis* **1983**, *11*, 932-933.
214. Detar, D. F.; Chu, Y. W. *J. Am. Chem. Soc.* **1954**, *76*, 1686.
215. Shen, M.; Leslie, B. E.; Driver, T. *Angew. Chem. Int. Ed.* **2008**, *47*, 5056-5059.
216. Chen, J.; Ding, J.; Liu, M.; Gao, W.; Wu, H. *Synthesis* **2011**, 213-216.
217. Doyle, M. P.; Pieters, R. J.; Taunton, J.; Pho, H. Q. *J. Org. Chem.* **1991**, *56*, 820-829.
218. Orito, K.; Miyazawa, M.; Nakamura, T.; Horibata, A.; Ushito, H.; Nagasaki, H.; Yuguchi, M.; Yamashita, S.; Yamazaki, T.; Tokuda, M. *J. Org. Chem.* **2006**, *71*, 5951-5958.
219. Wei, Y.; Liu, J.; Ding, H.; Liang, F.; Zhao, B. *Org. Lett.* **2010**, *12*, 4220-4223.
220. Cragg, R. H.; Miller, T. J. *J. Organomet. Chem.* **1983**, *255*, 143-152.
221. Foussard-Blanpin, O. *Ann. Pharm. Fr.* **1982**, *40*, 339.
222. Hera, M.; Font, D.; Linden, A.; Villalgorido, J. M. *Helv. Chim. Acta* **2003**, *86*, 3204-3214.
223. Adams, B. F.; Pyne, W. J.; Gullo, J. M. *US 3 639 608* **1972**.
224. Drent, E.; Van Broekhoven, J. A. M.; Doyle, M. J. *J. Organomet. Chem.* **1991**, *417*, 235-251.
225. Hoshino, S.; Okuno, M.; Kawamura, E.; Honda, K.; Inoue, S. *Chem. Commun.* **2009**, *17*, 2281-2283.
226. Erdélyi, M.; Varedian, M.; Sköld, C.; Niklasson, I. B.; Nurbo, J.; APersson, A.; Bergquist, J.; Gogoll, A. *Org. Biomol. Chem.* **2008**, *6*, 4356-4373.
227. Jacquelin, J. M.; Robin, Y.; Godard, A.; Queguiner, G. *Can. J. Chem.* **1988**, *66*, 1135-1140.
228. Li, H.; Yang, H.; Peterson, J. L.; Wang, K. K. *J. Org. Chem.* **2004**, *69*, 4500-4508.
229. Tedesco, R.; Shaw, A. N.; Bambal, R.; Chai, D.; Concha, N. O.; Darcy, M. G.; Dhanak, D.; Fitch, D. M.; Gates, A.; Gerhardt, W. G.; Halegoua, D. L.; Han, C.; Hofmann, G. L.; Johnston, V. K.; Kaura, A. C.; Liu, N.; Keenan, R. M.; Lin-Goerke, J.; Sarisky, R. T.; Wiggall, K. J.; Zimmerman, M. N.; Duffy, K. J. *J. Med. Chem.* **2006**, *49*, 971-983.