

**PULVERISED COAL COMBUSTION IN HIGH CO<sub>2</sub>, OXYGEN-  
RICH ENVIRONMENTS**

**RAMLAN ZAILANI**

Submitted in accordance with the requirements for the degree of

Doctor of Philosophy

The University of Leeds  
Energy and Resources Research Institute

September, 2007

The candidate confirms that the work submitted is his/her own and that appropriate credit has been given where reference has been made to the work of others.

*Also, for certain degrees:-*

This copy has been supplied on the understanding that it is copyright material and that no quotation from the thesis may be published without proper acknowledgement.

## Acknowledgements

I would like to express my sincere gratitude to Dr. B. M. Gibbs, my research supervisor, for his guidance and support throughout the course of the study.

This research has been carried out with major contributions from Dr. H. Liu (previously with Energy and Resources Research Institute, ERRI/SPEME, University of Leeds) on the design and modification of the combustion system for the operation with O<sub>2</sub>/CO<sub>2</sub> oxidant, and on the experimental runs and data acquisitions, without which this study would not have proceeded. I would also like to thank the technical staff of SPEME, in particular to Mr. R. Harris and Mr. S. Lyod for their assistance in the research.

I gratefully acknowledge the scholarship provided by the MARA University of Technology, Malaysia, which enabled me to carry out this study.

Special thanks to my colleagues in Room 4.33 ERRI/SPEME (2003-2007) for their warm and friendly companionship throughout my time at the University of Leeds.

My sincere gratitude to my dearest parent, my dearest wife, Nurul 'Ain and children: Nurul Fathin, Nurul 'Aqilah and Abdul Muhaimin for their endless love and patience, and the continuous physical and moral support.

Last but not least, my heartfelt appreciation to all my beloved brothers and sisters in the MSM-UK/Ireland, for their priceless, continuous support and prayers throughout my stay in the United Kingdom.

## ABSTRACT

Experiments on pulverised coal combustion in air and O<sub>2</sub>/CO<sub>2</sub> mixtures of various molar ratios, were conducted in a 20 kW-rated, down-fired furnace equipped with a single pulverised fuel (pf) burner, which was designed for the laboratory-scale experimental studies on coal combustion in air. In coal-O<sub>2</sub>/CO<sub>2</sub> combustion tests, all the oxidants and fuel were delivered into the furnace with the same configurations as those in the coal–air combustion firing tests. In each test, the coal firing rate was fixed, and the furnace stoichiometric ratio was fixed at SR=1.20. Seven bituminous coals with fuel ratio ranging from 1.50 to 2.33 were used in the study. The effectiveness of air/oxidant staging on reducing NO<sub>x</sub> emissions was investigated for combustion in air and O<sub>2</sub>/CO<sub>2</sub> mixtures. The fate of recycle NO in combustion with different oxidants and combustion conditions was also investigated.

Continuous furnace operations with stable flames and a comparable operating temperature to that in air were established for O<sub>2</sub>/CO<sub>2</sub> combustion, without major operational problems related to burner ignition, flame stability, coal firing and the effect of oxidants switching, both in unstaged and staged conditions. The results show that temperature and emission profiles are highly influenced by the oxidant compositions. A continuous flame could not be sustained by the direct replacement of combustion air with O<sub>2</sub>/CO<sub>2</sub> mixture with the same O<sub>2</sub> concentration as air (21:79-O<sub>2</sub>/CO<sub>2</sub>). In O<sub>2</sub>/CO<sub>2</sub> atmospheres, NO<sub>x</sub> Conversion Ratio (CR<sub>NO<sub>x</sub></sub>) decreased with the increasing concentration of the CO<sub>2</sub> in the oxidant and combustion with 21:79-O<sub>2</sub>/CO<sub>2</sub> produced NO<sub>x</sub> of about one-fourth to that in air.

With a same firing rate and combustion stoichiometry, coal combustion in 30:70-O<sub>2</sub>/CO<sub>2</sub> produced a similar flame temperature profile to that in air combustion.

while producing a significantly lower furnace  $\text{NO}_x$  emission and a higher char burnout. The  $\text{NO}_x$  Conversion ratio ( $\text{CR}_{\text{NO}_x}$ ) ranged from 27.7 - 39.7% in air and 18.4 - 35.5% in 30:70- $\text{O}_2$ : $\text{CO}_2$ . The Burnout Efficiency ( $\eta_{\text{BO}}$ ) in air and in 30:70- $\text{O}_2$ / $\text{CO}_2$  ranged from 92.5-98.5% and 95.0-99.3 % respectively. Compared to that in air combustion,  $\text{NO}_x$  conversion was more sensitive to coal properties in 30:70- $\text{O}_2$ / $\text{CO}_2$ .

The CO concentration in the combustion zone of the 30:70- $\text{O}_2$ / $\text{CO}_2$  mixture was more than 50% higher than that of air but the level decreased to an insignificant level at the exhaust. With the presence of air in the oxidant from atmospheric leakages, a high  $\text{CO}_2$  concentration of more than 80% of the flue gas was attained in 30:70- $\text{O}_2$ : $\text{CO}_2$  combustion, compared to around 15% in air firing. The  $\text{CO}_2$  concentration in the flue gas could be increased further to more than 90 % by reducing air infiltration into the combustor.

The staged combustion tests result show that oxidant staging is a very effective method in reducing  $\text{NO}_x$  emissions for coal combustion in 30:70- $\text{O}_2$ / $\text{CO}_2$ , and can be more effective than in staged air combustion. For coal combustion in air, staging with  $\text{SR}_1=0.80$  reduced  $\text{NO}_x$  emission by 54 - 65%, while combustion in 30:70- $\text{O}_2$ / $\text{CO}_2$ , reduced  $\text{NO}_x$  by 44 - 73 %. Compared to normal air combustion, staged combustion in 30:70- $\text{O}_2$ : $\text{CO}_2$  reduced the overall furnace  $\text{NO}_x$  by 67-77 %.

The recycled NO tests results show that the NO Reduction Efficiency ( $\eta_{\text{NO}}$ ) depends on the combustion media, combustion conditions and NO recycling injection locations, and is influenced by the coal properties but not by the recycled NO concentrations. Compared to that in air, NO Reduction Efficiency in 30:70- $\text{O}_2$ : $\text{CO}_2$  is more sensitive to coal properties, particularly coal Fuel Ratio (FR).

# CONTENTS

<b>Acknowledgements</b> .....	ii
<b>Abstract</b> .....	iii
<b>Contents</b> .....	v
<b>Figures</b> .....	x
<b>Tables</b> .....	xv
<b>Nomenclature</b> .....	xvii
<b>CHAPTER 1. Introduction</b> .....	1
1.1. Introduction .....	1
1.1.1. Greenhouse Gases and Global Temperature .....	1
1.2. Anthropogenic Carbon-dioxide.....	5
1.2.1. Main Sources of Anthropogenic Carbon-dioxide. ....	6
1.3. World Energy Scenario .....	9
1.3.1. World Energy Demand And Outlook.....	9
1.3.2. The Future of Coals.....	10
1.4. Global Carbon dioxide Emissions: Current Trends and Projection.....	12
1.5. Coal Combustion and Environments .....	16
1.5.1. Emissions Control in Coal-Based Power-Generation Plants. ....	17
1.5.1.1. SO <sub>x</sub> , NO <sub>x</sub> and Particulates.....	18
1.5.1.2. CO <sub>2</sub> .....	19
1.5.2. CO <sub>2</sub> Capture and Storage .....	21
1.6. Oxygen-enriched Coal Combustion Technologies Description.....	23
1.6.1. Benefits Associated with Combustion of Coal in Oxygen-enriched Environments Technology.....	24
1.6.2. Problems Associated with Combustion of Coal in Oxygen-enriched, High CO <sub>2</sub> Environments.....	27
1.7. Motivation and Objectives of this Research .....	28

<b>CHAPTER 2. Literature Review</b> .....	30
2.1. Introduction .....	30
2.2. Recent Investigations on O <sub>2</sub> /CO <sub>2</sub> Coal Combustion Technology .....	33
2.2.1. Techno-Economics Assessments.. .....	34
2.2.2. Combustion Characteristics in O <sub>2</sub> /CO <sub>2</sub> .....	35
2.2.2.1. Flame Temperature and Profiles .....	38
2.2.2.2. Ignition and Flame Stability.....	43
2.2.2.3. Heat Transfer Characteristics .....	46
2.2.2.4. Coal Particles Combustion.....	48
2.2.2.5. Coal Combustibility and Unburned Carbon in Ash .....	50
2.2.3. Combustion Emissions Characteristics.....	51
2.2.3.1. CO <sub>2</sub> , O <sub>2</sub> and CO .....	52
2.2.3.2. SO <sub>x</sub> .....	55
2.2.3.3. NO <sub>x</sub> .....	59
2.3. Outstanding Issues In Coal Combustion O <sub>2</sub> /CO <sub>2</sub> Technology.....	67
2.3.1. Combustion Principles... .....	68
2.3.2. Economics Considerations.....	70
2.3.3. Other Issues.....	71
2.4. NO <sub>x</sub> Emissions and Reduction Technologies in Coal Combustion .....	72
2.4.1. NO <sub>x</sub> Formation mechanisms.. .....	72
2.4.2. NO <sub>x</sub> Reduction Technology .....	79
2.4.2.1. Furnace Air Staggering (Overfire Air) .....	81
2.4.2.2. Furnace Fuel Staging (Reburning) .....	83
2.4.2.3. Low NO <sub>x</sub> Burner .....	84
2.4.2.4. Other Techniques .....	85
<b>CHAPTER 3. Experimental Programme</b> .....	87
3.1. Combustion System .....	87
3.1.1. Furnace.....	88
3.1.2. Burner.....	89
3.1.3. Air/Oxidant and Fuel Supply.. .....	89
3.1.4. Coal Feeder .....	93

3.1.5 Monitoring Systems .....	93
3.1.5.1. Gas sampling.....	93
3.1.5.2. Temperature measurements.....	94
3.1.5.3. Char/Ash Sampling .....	94
3.1.6 Gas Analyser .....	95
3.2. Experimental Approach. ....	96
3.2.1. Coal Sample.. .....	96
3.2.2. Experimental Procedure .....	96
3.2.3. Experimental Conditions.....	99
3.2.3.1. Theoretical Air / Oxidant Requirement.....	99
3.2.3.2. Air/Oxidant Flow Rates .....	100
3.2.4. Sources of Experimental Errors .....	101
<b>CHAPTER 4. Experimental Results .....</b>	<b>109</b>
4.1. General Furnace Operations.....	110
4.2. Variation of Gas Temperature with Oxidant Compositions. ....	114
4.3. Gas Emissions Compositions.....	126
4.3.1. Gas Emissions in the Furnace.. .....	126
4.3.2. Flue Gas Emissions.....	129
4.3.2.1. O <sub>2</sub> and CO <sub>2</sub> . .....	129
4.3.2.2. CO .....	131
4.3.2.3. SO <sub>x</sub> .....	131
4.3.2.3. NO <sub>x</sub> .....	132
4.4. Unburned Carbon in Ash and Burnout Efficiency. ....	144
4.5. Staged Combustion. ....	154
4.5.1. Effect of Oxidant Staging on Temperature.. .....	154
4.5.2. Effect of Oxidant Staging on Flue Gas Compositions... .....	159
4.5.3. Effect of Oxidant Staging on Burnout Efficiency... .....	159
4.5.4. NO <sub>x</sub> Reduction Through Staged Combustion.... .....	159
4.6. Recycled NO Test .....	175
4.6.1. Effect of Combustion Media.....	176

4.6.2. Effect of Combustion Conditions and NO Injection Locations .....	176
4.6.3. Effect of Levels of Recycled NO .....	178
4.6.4. Effect of Coal Properties.....	178
4.7. Summary of Results .....	189
<b>CHAPTER 5 Discussion of Results .....</b>	<b>195</b>
5.1. Effect of Oxidants Composition on Flame Characteristics and Gas Temperature .....	195
5.1.1. Replacing any parts of combustion air with O <sub>2</sub> /CO <sub>2</sub> .....	195
5.1.2. 30:70-O <sub>2</sub> /CO <sub>2</sub> Combustion.....	201
5.1.3. Flame Stability and Ignition.....	205
5.2. Effect of Combustion Oxidants on Combustion Emissions.....	206
5.2.1. Furnace gas compositions... ..	206
5.2.2. Flue gas .....	208
5.2.2.1. O <sub>2</sub> ,CO <sub>2</sub> and CO.....	208
5.2.2.2. SO <sub>x</sub> .....	211
5.2.3. Unburned Carbon in Ash and Char Burnout.....	205
5.3. NO <sub>x</sub> Emissions in O <sub>2</sub> /CO <sub>2</sub> combustion. ....	214
5.3.1. Variation of NO <sub>x</sub> emissions with oxidant compositions.....	214
5.3.2. Comparison with 30:70-O <sub>2</sub> /CO <sub>2</sub> . ....	215
5.4. Staged Combustion. ....	219
5.4.1. Effect of Oxidant Staging on Temperature and Emissions.....	219
5.4.2. Effect of Oxidant Staging on Burnout Efficiency.....	220
5.4.3. NO <sub>x</sub> Reduction Through Staged Combustion.....	221
5.5. Recycled NO .....	224
5.5.1. Effect of Combustion Media.....	224
5.5.2. Effect of Combustion Conditions.... ..	225
5.5.3. Effect of NO Injection Locations..... ..	225
5.5.4. Effect of Recycled NO Concentrations .....	226
5.5.5. Effect of Coal Properties .....	226
5.5.6. Summary on NO Recycle Tests .....	227



<b>CHAPTER 6 Conclusions</b> .....	230
6.1. Conclusions.....	223
6.2. Summary .....	236
6.2. Proposals for Further Research .....	237
<b>REFERENCES</b> .....	241
<b>APPENDIX A</b> .....	253
<b>APPENDIX B</b> .....	257
<b>APPENDIX C</b> .....	261

# LIST OF FIGURES

## CHAPTER 1

<b>Figure 1.1a.</b> The recorded global surface temperature since the mid 19 <sup>th</sup> Century, compared to the 1961-1990 average.....	3
<b>Figure 1.1b.</b> The measured and projected global concentrations of greenhouse gases, based on ranges of different scenario. ....	3
<b>Figure 1.2.</b> Global share of greenhouse gases emissions .....	8
<b>Figure 1.3.</b> Global CO <sub>2</sub> emissions by sector .....	8
<b>Figure 1.4a.</b> Fuel shares of World TPES at the turn of 21 <sup>st</sup> Century and for The Reference Scenario .....	12
<b>Figure 1.4b.</b> Fuel shares of electricity generation at the turn of 21 <sup>st</sup> Century and for the Reference Scenario .....	12
<b>Figure 1.5.</b> The projected potential of global saving in CO <sub>2</sub> emissions which could be generated under the <i>WEO-2006 Alternative Policy Scenario</i> .....	15
<b>Figure 1.6.</b> World energy-related CO <sub>2</sub> emissions by fuel at the turn of 21 <sup>st</sup> century and in the Reference Scenario .....	16
<b>Figure 1.7.</b> The potential of the various technological approaches on the global CO <sub>2</sub> emissions reduction from Coal-fired power plants .....	21
<b>Figure 1.8a.</b> Schematic diagram of the proposed coal-O <sub>2</sub> / CO <sub>2</sub> recycled flue gas, combustion process.....	26
<b>Figure 1.8b.</b> Schematic diagram of the coal-oxygen enriched-air, combustion process. ....	26

## CHAPTER 2

<b>Figure 2.1.</b> Comparison of ratio of different thermal and physical properties of CO <sub>2</sub> and N <sub>2</sub> at 1200k.....	37
<b>Figure 2.2.</b> Simplified concept of pulverized coal combustion.....	73
<b>Figure 2.3.</b> The simplified pathway of formation and destruction of nitrogen compounds originating from the combustible-N .....	77
<b>Figure 2.4.</b> The schematic of basic furnace Air Staging and Fuel Staging for NO <sub>x</sub> emission reduction .....	83

## CHAPTER 3

<b>Figure 3.1.</b> The main features of the experimental set-up.....	90
<b>Figure 3.2.</b> The main features and relative dimensions of the furnace. ....	91
<b>Figure 3.3a.</b> General view of the test facility .....	92
<b>Figure 3.3b.</b> General view of the test facility .....	92
<b>Figure 3.4.</b> The air/oxidant requirements for both unstaged and staged combustion tests. (Air and 30:70-O <sub>2</sub> /CO <sub>2</sub> ). ....	105

## CHAPTER 4

<b>Figure 4.1.</b> The effect of oxidant switching from Air to 30:70-O <sub>2</sub> /CO <sub>2</sub> on furnace gas temperature profiles. (Run #4, Coal B).....	111
<b>Figure 4.2a.</b> The effect of oxidant switching from Air to 30:70-O <sub>2</sub> /CO <sub>2</sub> on furnace gas temperature profiles. (Run #4, Coal B).....	112
<b>Figure 4.2b.</b> The effect of oxidant switching from Air to 30:70-O <sub>2</sub> /CO <sub>2</sub> on furnace gas temperature profiles. (Run #4, Coal B).....	112
<b>Figure 4.3.</b> The effect of 2 <sup>nd</sup> oxidant switching from air to O <sub>2</sub> /CO <sub>2</sub> mixture on gas temperature in the furnace .....	116
<b>Figure 4.4.</b> The effect of both 1 <sup>st</sup> and 2 <sup>nd</sup> oxidant switching from air to O <sub>2</sub> /CO <sub>2</sub> mixture on gas temperature in the furnace.....	117
<b>Figure 4.5.</b> The effect of direct oxidant replacement from air to 21:79-O <sub>2</sub> /CO <sub>2</sub> mixture on gas temperature in the furnace. (Coal A).....	118
<b>Figure 4.6a.</b> Gas temperature profiles in the furnace from combustion in air and 30:70-O <sub>2</sub> /CO <sub>2</sub> mixture. (Unstaged, SR=1.20, Coal B).....	123
<b>Figure 4.6b</b> Gas temperature profiles in the furnace from combustion in air and 30:70-O <sub>2</sub> /CO <sub>2</sub> mixture. (Unstaged, SR=1.20, Coal G). ....	124
<b>Figure 4.7a.</b> Gas temperature profiles in the furnace from combustion in air and 30:70-O <sub>2</sub> /CO <sub>2</sub> mixture. (Unstaged, SR=1.20, Coal E).....	122
<b>Figure 4.7b.</b> Gas temperature profiles in the furnace from combustion in air and 30:70-O <sub>2</sub> /CO <sub>2</sub> mixture. (Unstaged, SR=1.20, Coal F). ....	122
<b>Figure 4.8a.</b> O <sub>2</sub> concentration along the furnace axis in air and 30:70-O <sub>2</sub> /CO <sub>2</sub> . (Unstaged, SR=1.20, Coal A). ....	127
<b>Figure 4.8b.</b> CO <sub>2</sub> concentration along the furnace axis in air and 30:70-O <sub>2</sub> /CO <sub>2</sub> . (Unstaged, SR=1.20, Coal A). ....	127
<b>Figure 4.8c.</b> CO concentration along the furnace axis in air and 30:70-O <sub>2</sub> /CO <sub>2</sub> . (Unstaged, SR=1.20, Coal A). ....	128
<b>Figure 4.8d.</b> NO <sub>x</sub> concentration along the furnace axis in air and 30:70-O <sub>2</sub> /CO <sub>2</sub> . (Unstaged, SR=1.20, Coal A). ....	128

<b>Figure 4.9.</b> NO <sub>x</sub> Conversion Ratio (CR <sub>NO<sub>x</sub></sub> ) in various oxidants mixtures relative to that in air combustion. (Unstaged, SR=1.20, Coal A) .....	137
<b>Figure 4.10.</b> NO <sub>x</sub> Conversion Ratio (CR <sub>NO<sub>x</sub></sub> ) in 30:70-O <sub>2</sub> /CO <sub>2</sub> , relative to those in air combustion, for all coals. ....	138
<b>Figure 4.11a.</b> The dependence of NO <sub>x</sub> Conversion Ratio (CR <sub>NO<sub>x</sub></sub> ) in air and 30:70-O <sub>2</sub> /CO <sub>2</sub> with coal Fuel Ratio (FR).(Unstaged, SR=1.20).....	139
<b>Figure 4.11b.</b> The variation of the NO <sub>x</sub> Conversion Ratio in 30:70-O <sub>2</sub> /CO <sub>2</sub> mixture relative to those in air combustion, with coal fuel ratio. (Unstaged, SR=1.20).....	140
<b>Figure 4.12a.</b> The variation of NO <sub>x</sub> emission concentration (ppmv) in air and 30:70-O <sub>2</sub> /CO <sub>2</sub> with coal-N. (Unstaged, SR=1.20).. ....	141
<b>Figure 4.12b.</b> The variation of NO <sub>x</sub> Conversion Ratio (CR <sub>NO<sub>x</sub></sub> ) in air and 30:70-O <sub>2</sub> /CO <sub>2</sub> with coal-N. (Unstaged, SR=1.20).. ....	142
<b>Figure 4.12c.</b> The variation of NO <sub>x</sub> Conversion Ratio (CR <sub>NO<sub>x</sub></sub> ) in air and 30:70-O <sub>2</sub> /CO <sub>2</sub> with coal-volatile. (Unstaged, SR=1.20) .....	143
<b>Figure 4.13a.</b> Carbon concentrations in ash (C <sub>a</sub> ) in different combustion media and conditions (Coal A). ....	146
<b>Figure 4.13b.</b> Burnout Efficiency (η <sub>BO</sub> ) in different combustion media and conditions (Coal A). ....	146
<b>Figure 4.14a.</b> Carbon concentration in ash (C <sub>a</sub> ) from air and 30:70-O <sub>2</sub> /CO <sub>2</sub> combustion for all coals. (Unstaged, SR=1.20). ....	148
<b>Figure 4.14b.</b> Burnout Efficiency (η <sub>BO</sub> ) in air and 30:70-O <sub>2</sub> /CO <sub>2</sub> for all coals. (Unstaged, SR=1.20).....	149
<b>Figure 4.15a</b> The dependence of Burnout Efficiency (η <sub>BO</sub> ) in air combustion on coal Fuel Ratio (FR) for all coals. (Unstaged, SR=1.20).....	150
<b>Figure 4.15b.</b> The dependence of Burnout Efficiency (η <sub>BO</sub> ) in 30:70-O <sub>2</sub> /CO <sub>2</sub> combustion on coal Fuel Ratio (FR), for all coals.(Unstaged, SR=1.20)... ..	151
<b>Figure 4.16a.</b> The dependence of Relative NO <sub>x</sub> Conversion (CR <sub>NO<sub>x</sub></sub> ) <sub>r</sub> on combustion Burnout Efficiency (η <sub>BO</sub> ) in air, for all coals. (Unstaged, SR=1.20). ....	152
<b>Figure 4.16b.</b> The dependence of Relative NO <sub>x</sub> Conversion (CR <sub>NO<sub>x</sub></sub> ) <sub>r</sub> on combustion Burnout Efficiency (η <sub>BO</sub> ) in 30:70-O <sub>2</sub> /CO <sub>2</sub> , for all coals. (Unstaged, SR=1.20) .....	153
<b>Figure 4.17a.</b> The effect of air staging on temperature profile inside the furnace. (SR <sub>1</sub> =0.80, Coal A). ....	155
<b>Figure 4.17b.</b> The effect of oxidant staging in 30:70-O <sub>2</sub> /CO <sub>2</sub> , on temperature profiles inside the furnace. (SR <sub>1</sub> =0.80, Coal A).....	156

<b>Figure 4.18a.</b> Flue gas emissions from staged-air combustion. (Coal A).	157
<b>Figure 4.18b.</b> Flue gas emissions from staged-oxidant. 30:70-O <sub>2</sub> /CO <sub>2</sub> combustion. (Coal A).	158
<b>Figure 4.19a.</b> Carbon concentration in combustion (C <sub>a</sub> ) ash in different combustion media and conditions.	163
<b>Figure 4.19b.</b> Coal Burnout Efficiency ( $\eta_{BO}$ ) in different combustion media and conditions.	164
<b>Figure 4.20a.</b> The effect of air staging ratio (combustion zone stoichiometry, SR <sub>1</sub> ) in air combustion on flue gas NO <sub>x</sub> concentrations. (Coal A).	165
<b>Figure 4.20b.</b> The effect of oxidant staging ratio (combustion zone stoichiometry, SR <sub>1</sub> ) in 30:70-O <sub>2</sub> /CO <sub>2</sub> combustion on flue gas NO <sub>x</sub> concentration. (Coal A).	165
<b>Figure 4.21a.</b> The effect of air/oxidant staging ratio (combustion zone stoichiometry, SR <sub>1</sub> ) on flue gas NO <sub>x</sub> emission. Staging at L <sub>1</sub> (0.57 m, Coal A).	166
<b>Figure 4.21b.</b> The effect of air/oxidant staging ratio (combustion zone stoichiometry, SR <sub>1</sub> ) on flue gas NO <sub>x</sub> emission. Staging at L <sub>2</sub> (0.88 m, Coal A).	166
<b>Figure 4.22a.</b> The effect of air/oxidant staging ratio (combustion zone stoichiometry, SR <sub>1</sub> ) on flue gas NO <sub>x</sub> emission. Staging at L <sub>1</sub> (0.57 m, Coal E).	167
<b>Figure 4.22b.</b> The effect of air/oxidant staging ratio (combustion zone stoichiometry, SR <sub>1</sub> ) on flue gas NO <sub>x</sub> emission. Staging at L <sub>2</sub> (0.88 m, Coal E).	167
<b>Figure 4.23a.</b> The effect of air/oxidant staging ratio (combustion zone stoichiometry, SR <sub>1</sub> ) on flue gas NO <sub>x</sub> emission. Staging at L <sub>2</sub> (0.88 m, Coal B).	168
<b>Figure 4.23b.</b> The effect of air/oxidant staging ratio (combustion zone stoichiometry, SR <sub>1</sub> ) on flue gas NO <sub>x</sub> emission. Staging at L <sub>2</sub> (0.88 m, Coal F).	168
<b>Figure 4.24a.</b> The NO <sub>x</sub> conversion in staged air and staged 30:70-O <sub>2</sub> /CO <sub>2</sub> relative to normal unstaged combustion in the same combustion media. (SR <sub>1</sub> =0.80, Staging at L <sub>1</sub> (0.57m)).	169
<b>Figure 4.24b.</b> The NO <sub>x</sub> conversion in staged air and staged 30:70-O <sub>2</sub> /CO <sub>2</sub> relative to normal unstaged combustion in the same combustion media. (SR <sub>1</sub> =0.80, Staging at L <sub>2</sub> (0.88m)).	170
<b>Figure 4.25.</b> The dependence of relative NO <sub>x</sub> reduction. RNO <sub>x</sub> on coal Fuel Ratio (FR), for staged combustion in air and 30:70-O <sub>2</sub> /CO <sub>2</sub> (SR <sub>1</sub> = 0.80, staging at L <sub>2</sub> (0.88 m)).	171
<b>Figure 4.26a.</b> NO <sub>x</sub> Reduction efficiency – The effect of oxidant staging on NO <sub>x</sub> Conversion Ratio (CR <sub>NO<sub>x</sub></sub> ). (Coal B).	172

<b>Figure 4.26b.</b> NO <sub>x</sub> Reduction efficiency – The effect of oxidant staging on NO <sub>x</sub> Conversion Ratio (CR <sub>NO<sub>x</sub></sub> ). (Coal B).....	172
<b>Figure 4.27.</b> The NO <sub>x</sub> conversion in staged air and staged 30:70-O <sub>2</sub> /CO <sub>2</sub> relative to normal unstaged combustion in the same combustion media. (SR <sub>1</sub> =0.80, Staging at L <sub>2</sub> (0.58m)) .....	173
<b>Figure 4.28</b> The effect of the injection of NO to the streams of 1 <sup>st</sup> and 2 <sup>nd</sup> oxidant, on the flue gas compositions. (Unstaged air combustion, SR=1.20, Coal A).....	179
<b>Figure 4.29a.</b> Reduction efficiency of recycled NO ( $\eta_{NO}$ ) in air and 30:70-O <sub>2</sub> /CO <sub>2</sub> for all coals, recycled in 1 <sup>st</sup> oxidant. (Recycled NO concentrations: 500 – 700 ppmv).....	180
<b>Figure 4.29b.</b> Reduction efficiency of recycled NO ( $\eta_{NO}$ ) in air and 30:70-O <sub>2</sub> /CO <sub>2</sub> for all coals, recycled in 2 <sup>nd</sup> oxidant.(Recycled NO concentrations: 500 – 700 ppmv).....	181
<b>Figure 4.30.</b> The effect of air/oxidant staging and injection location of recycled NO on NO Reduction Efficiency ( $\eta_{NO}$ ). (Recycled NO concentrations: 500 – 700 ppmv, Coal A). .....	182
<b>Figure 4.31a.</b> The effect of oxidant staging and injection location of recycled NO on NO Reduction Efficiency ( $\eta_{NO}$ ). (Recycled NO concentrations: 500 – 700 ppmv, (Coal C).....	183
<b>Figure 4.31b.</b> The effect of oxidant staging and injection location of recycled NO on NO Reduction Efficiency ( $\eta_{NO}$ ). (Recycled NO concentrations: 500 – 700 ppmv, (Coal E).....	183
<b>Figure 4.32a.</b> The effect recycled NO concentrations on NO Reduction Efficiency ( $\eta_{NO}$ ). (Unstaged, SR=1.20, Coal A) .....	186
<b>Figure 4.32b.</b> The effect recycled NO concentrations on NO Reduction Efficiency ( $\eta_{NO}$ ). (Unstaged, SR=1.20, Coal C).. .....	187
<b>Figure 4.32c.</b> The effect recycled NO concentrations on NO Reduction Efficiency ( $\eta_{NO}$ ). (Unstaged, SR=1.20, Coal F).....	187
<b>Figure 4.33.</b> The dependence of recycled NO Reduction Efficiency ( $\eta_{NO}$ ) , on coal Fuel Ratio (FR).(Unstaged, SR=1.20, NO injection through 1 <sup>st</sup> oxidant).. .....	188

## LIST OF TABLES

### CHAPTER 3.

<b>Table 3.1.</b> The axial positions of the gas temperature probe in the furnace and gas sampling probe ports relative to the burner .....	103
<b>Table 3.2.</b> Ultimate and Proximate Analyses of the coal samples. ....	104
<b>Table 3.3.</b> The theoretical major combustion emission compositions for coal A in various combustion media.....	106
<b>Table 3.4.</b> The air/oxidants flow rates used in the combustion tests. (Unstaged combustion).....	107
<b>Table 3.5.</b> The air/oxidants flow rates used in the combustion tests. (Staged combustion).....	108

### CHAPTER 4.

<b>Table 4.1a.</b> Gas temperature variation in the furnace in different combustion media. Coal A, Unstaged SR = 1.20. ....	119
<b>Table 4.1b.</b> Oxidant flow rates and the molar ratio of the composition of the oxidant mixtures.....	120
<b>Table 4.2.</b> The comparison of the gas temperature in the furnace, in combustion with air and 30:70-O <sub>2</sub> /CO <sub>2</sub> for all coal. Unstaged, SR = 1.20 ...	125
<b>Table 4.3.</b> The O <sub>2</sub> and CO <sub>2</sub> concentration in the flue gas in various combustion media. (Unstaged, SR =1.20, Coal A). ....	130
<b>Table 4.4.</b> NO <sub>x</sub> emission levels and NO <sub>x</sub> Conversion Ratio (CR <sub>NO<sub>x</sub></sub> ) in various combustion media (Unstaged, SR = 1.20, Coal A). ....	135
<b>Table 4.5</b> NO <sub>x</sub> emission levels and NO <sub>x</sub> Conversion Ratio (CR <sub>NO<sub>x</sub></sub> ) in air and in 30:70-O <sub>2</sub> /CO <sub>2</sub> , for All Coals (Unstaged, SR = 1.20). ....	136
<b>Table 4.6.</b> The carbon concentrations in ash and char burnout efficiency in Air and 30:70-O <sub>2</sub> /CO <sub>2</sub> combustion, and the effect of air/oxidant staging on burnout efficiency .....	147
<b>Table 4.7.</b> The Relative NO <sub>x</sub> Conversion in staged combustion to those in unstaged combustion (CR <sub>NO<sub>x</sub></sub> ) <sub>r</sub> , and the NO <sub>x</sub> reduction R <sub>NO<sub>x</sub></sub> and (R <sub>NO<sub>x</sub></sub> ) <sub>air</sub> for all coals.....	174
<b>Table 4.8.</b> Recycled NO reduction efficiency in various combustion conditions, NO injection points and NO Concentrations. (All coals).....	184

## CHAPTER 5.

**Table 5.1.** The variation of oxidant molar specific heat capacity,  $c_p$  with oxidant compositions used in the combustion tests. .... 198

**Table 5.2.** The calculated adiabatic flame temperature ( $T_{ad}$ ) of Coal A in combustion in various oxidant mixtures (SR=1.20). .... 199



## NOMENCULATOR

$C_a$	Carbon fraction in ash. (%).
$CR_{NO_x}$	$NO_x$ Conversion Ratio (%).
$(CR_{NO_x})_r$	Relative $NO_x$ conversion.
$(CR_{NO_x})_o$	$NO_x$ Conversion Ratio of a particular coal in unstaged $O_2/CO_2$ combustion (%).
$(CR_{NO_x})_{air}$	$NO_x$ Conversion Ratio of a particular coal in unstaged air combustion (%).
$(CR_{NO_x})_{stg}$	$NO_x$ Conversion Ratio in staged combustion (%).
$(CR_{NO_x})_{unstg}$	$NO_x$ Conversion Ratio in unstaged combustion (%).
$CR_{SO_x}$	$SO_x$ Conversion Ratio (%).
FR	Coal Fuel Ratio, (Fixed Carbon/Volatile matter) <sub>daf</sub> .
$L_1$	Injection point for tertiary oxidant at Level 1 (0.57 m from the burner).
$L_2$	Injection point for tertiary oxidant at Level 2 (0.88 m from the burner).
$NO_e$	Flue gas NO concentration, at the furnace exit (ppmv).
$NO_{cal}$	Calculated NO emission, assuming that all of fuel Nitrogen is converted to NO (ppmv).
$NO_o$	NO concentration at the furnace exit without recycled NO (ppmv).

$NO_r$	Amount of NO injected into the furnace through the air/oxidant streams (ppmv).
$\eta_{BO}$	Char Burnout efficiency (%).
$\eta_{NO}$	Recycled NO reduction efficiency (%).
$P_i$	Axial positions of the furnace gas probe/flame observation ports.
$R_{NOx}$	Relative $NO_x$ Reduction, in staged combustion.
$SO_{2,e}$	Flue gas $SO_2$ concentration at the furnace exit (ppmv).
$SO_{2,cal}$	Calculated $SO_2$ emission, assuming that all fuel sulphur is converted to $SO_2$ (ppmv).
SR	Overall furnace stoichiometric ratio.
$SR_1$	Combustion zone stoichiometric ratio.
$T_i$	Temperature along the axis of the furnace / positions of temperature probes ( $^{\circ}C$ ).
$T_e$	Furnace exhaust temperature ( $^{\circ}C$ ).
$T_p$	Approximate peak temperature in the furnace ( $^{\circ}C$ ).
$T_{ad}$	Adiabatic flame temperature, constant pressure ( $^{\circ}C$ )
$V_{air}$	Volume flow rate of air as oxidant (l/min).
$V_O$	Volume flow rate of $O_2/CO_2$ oxidant (l/min).
$x_p$	Approximate axial distance of furnace peak temperature from the burner (m).

# CHAPTER 1

## INTRODUCTION

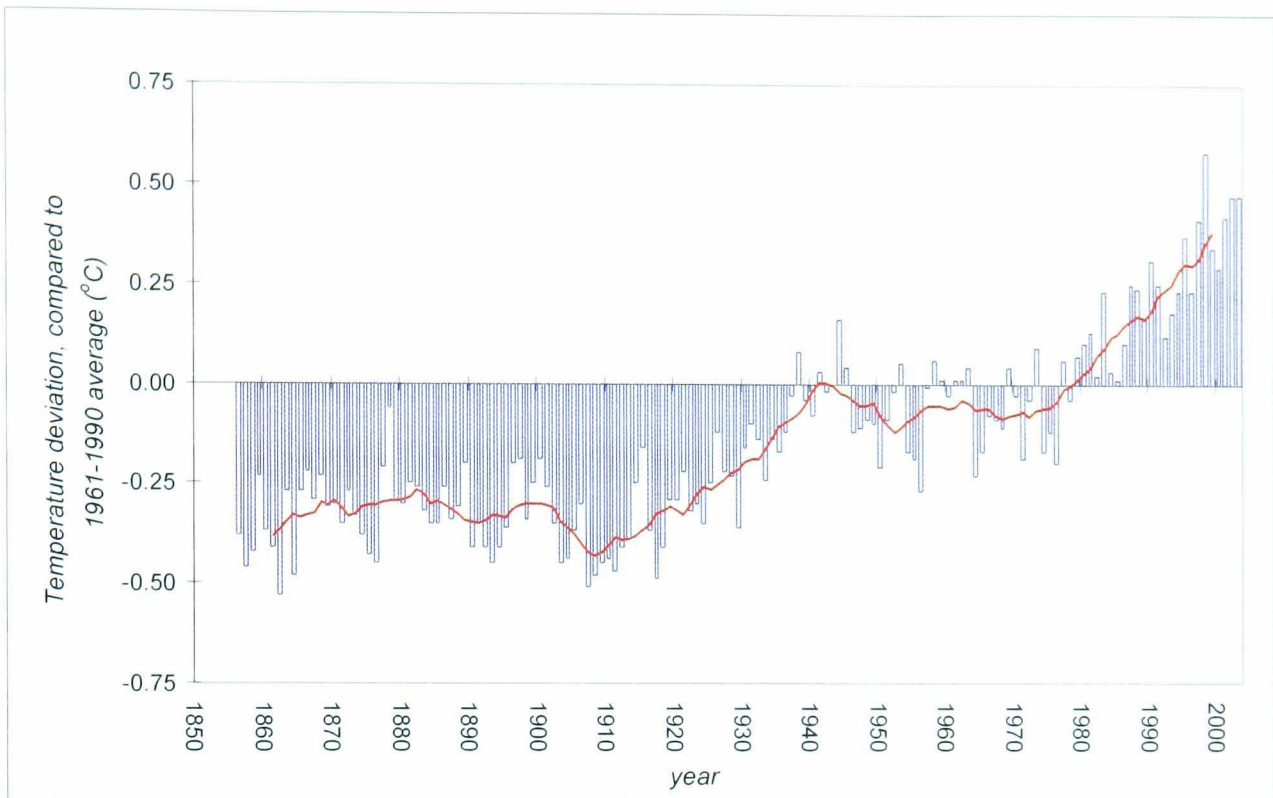
It is now globally accepted that the continuous increase of the concentrations of greenhouse gases in the atmosphere from anthropogenic sources is one the major contributors to the changes in the world's climate associated with the global warming effect. The impacts of climate changes are already visible globally and these are highly expected to become more pronounce in the very near future. *The Third Assessment Report on climate changes* by The Intergovernmental Panel on Climate Change (IPCC) revealed that new and stronger evidence emerged that most of the global warming phenomena observed over the past half-century were attributable to human activities and suggested that human influences will continue to change global atmospheric compositions throughout the 21<sup>st</sup> century (IPCC, 2001). These findings were further supported by more recent and comprehensive studies as compiled in The IPCC's *Fourth Assessment Report* which concludes that, it is at least 90% certain that human emissions of greenhouse gases, rather than their natural variations, are currently warming the earth's surface (IPCC, 2007a, 2007b).

### **1.1. Greenhouse Gases and Global Temperature.**

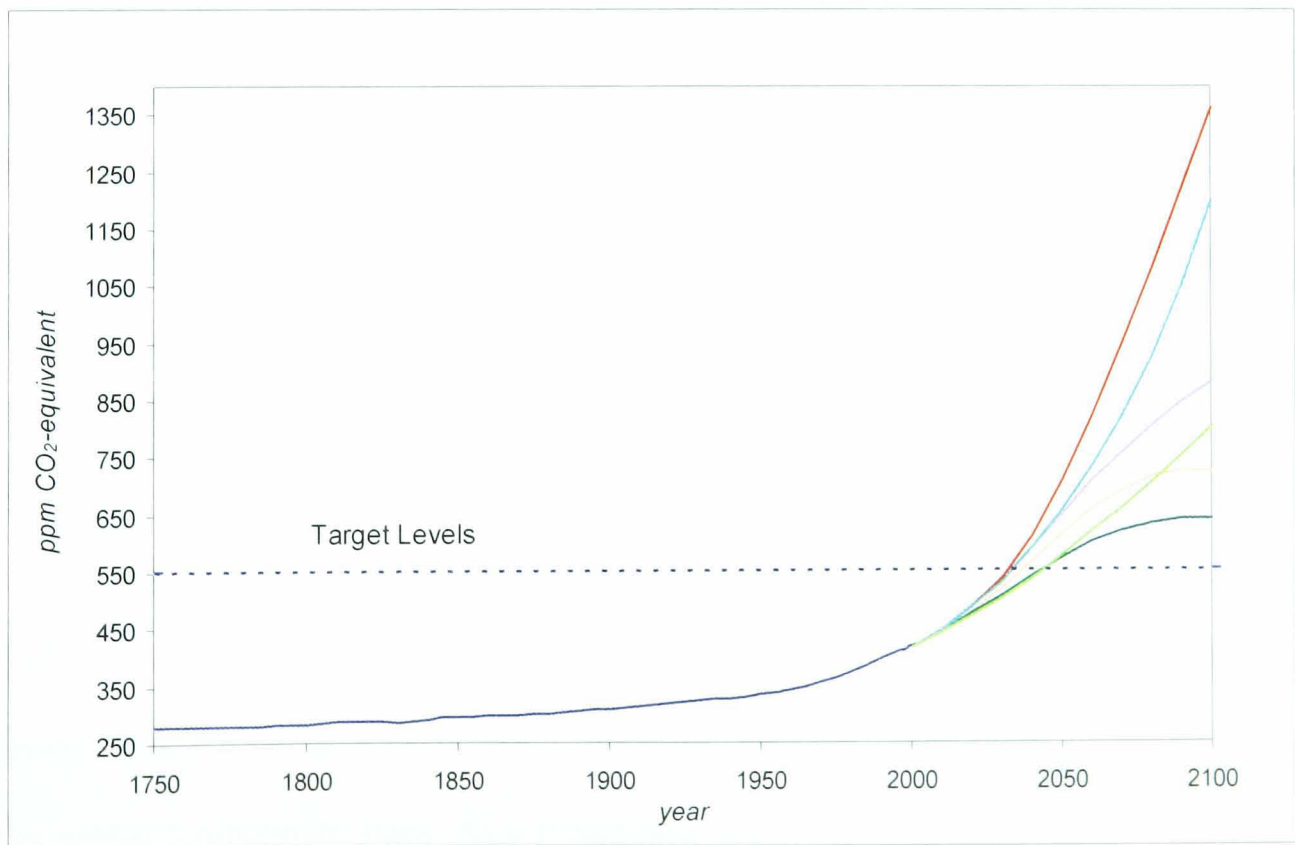
It has been recorded that, since the beginning of the industrial revolution in the mid 19<sup>th</sup> century, the global average atmospheric concentration of CO<sub>2</sub> has increased by almost 36 % from around 280 ppmv to the present level of 380 ppmv, with an

accelerated rise recorded in the second half of the 20<sup>th</sup> century and continue into the first decade this century (IEA, 2007a, 2006b). Similarly, in the same period, the concentrations of methane (CH<sub>4</sub>) and nitrous oxide (N<sub>2</sub>O) have increased by more than 150% and 18 %, respectively. Ice core studies reveals that the present atmospheric concentrations of CO<sub>2</sub> and CH<sub>4</sub> have not been exceeded during the past 650 000 years and the N<sub>2</sub>O concentration has not been exceeded during at least the past 1000 years (IPCC, 2007a). In recent years, between 1970 and 2004, the global anthropogenic CO<sub>2</sub> emission has increased by 87% and the annual CO<sub>2</sub> concentration growth-rate was also the largest during the last ten years with an average growth of almost 1.9 ppmv per year. Over the same period, CH<sub>4</sub> concentrations increased by almost 40%, N<sub>2</sub>O by 50% and flourinated industrial gases by almost 400 % (IEA, 2006b). The marked increases of the concentrations of these gases in recent years, have been very strongly attributed to human activities.

Coincidentally, over the past 100 years the global mean temperature has increased by  $0.7 \pm 0.2$  °C and the rate of warming in the last 50 years is almost that over past 100 years and the current global rate of change is about  $0.18 \pm 0.05$  °C per decade (IPCC, 2001, 2007c). It was also recorded that the 1990s was the warmest decade and eleven of the last twelve years (1995-2006) rank among the warmest years in the instrumental record global surface temperature, since 1850 (IPCC, 2007a). Figure 1.1a shows the global temperature deviation since the mid 19<sup>th</sup> century, compared to the average temperature of 1960 – 1990. These records and observations suggest that the global temperature changes are very unusual in terms of both magnitude and rate of changes, which are more than natural climate cycles would explain (IPCC, 2001).



**Figure 1.1a.** The recorded global surface temperature since the mid 19<sup>th</sup> Century, compared to the 1961-1990 average. (EEA, 2005).



**Figure 1.1b.** The measured and projected global concentrations of greenhouse gases, based on ranges of scenarios. (IPPC, 2001 & EEA, 2005).

The projection of the global greenhouse gas concentrations for the 21<sup>st</sup> century, based on a ranges of scenarios of socio-economic, technological and demographic developments and with various assumptions, have been studied by various groups and are presented in Figure 1.1b (IPCC, 2001). One of the most likely projected scenarios is that greenhouse gas concentrations will exceed 550 ppm CO<sub>2</sub>-equivalent before 2050, and to increase further to between 650-1350 ppm CO<sub>2</sub>-equivalent by 2100. It is anticipated that if these concentration levels are exceeded, there is little chance that global temperature rise will stay below the targeted levels set by various parties (EEA, 2005). Based on these projected scenarios, extensive modelling studies have revealed that the global mean surface temperatures are projected to further increase by between 1.4 °C and 5.8°C, at the end of this century. The latest and more comprehensive studies as reported in the IPCC's *Fourth Assessment Report*, projected that, without further action to reduce greenhouse gases emissions, the earth's surface temperature is likely to rise by between 1.8 °C and 4.0 °C, although depending on various difference scenarios, increases as small as 1.1°C or as large as 6.4 °C may also possible (IPCC, 2007a).

Therefore, the continuous increase of anthropogenic greenhouse gaseous emissions into the atmosphere is becoming a major concern world wide and is emerging as one of the main environmental issues to be addressed in this century. Consolidated and substantial global efforts to reduce the emissions of greenhouse gases through various possible measures are essential to meet the targeted limits of the global temperature rises. As a major step towards stabilising global greenhouse gases concentrations, at The *Third Conference of Parties to the The United Nations Framework Convention on Climate Change (UNFCCC)*, held in Kyoto in 1997,

several major industrialised nations have agreed to reduce their collective emissions of six greenhouse gases: carbon dioxide (CO<sub>2</sub>), methane (CH<sub>4</sub>), nitrous oxide (N<sub>2</sub>O), hydrofluorcarbons (HFCs), perfluorcarbons (PFCs) and sulphur hexafluoride (SF<sub>6</sub>) gases, by at least 5% in the period 2008–2012 compared to the 1990 levels (UNFCCC, 2007). The Accord, later known as *The Kyoto Protocol*, which has gone into force only in 2005, was the first legally binding plan to tackle climate changes. The main objective of The Accord is to collectively achieve stabilisation of global greenhouse gases, known as Kyoto Gases, concentrations in the atmosphere “at a level that would prevent dangerous anthropogenic interference with the climate systems”. As in 2007, The Accord binds 35 nations and has been ratified by more than 170 nations, although a few nations of major CO<sub>2</sub> emitters have not ratified it. (UNFCCC, 2007). Currently however, reports from various individual nations suggest that, although some degree of stabilisation in the emissions of these gases has been recorded in some regions, the overall global trend indicates that, driven by mainly the robust economic activities in the developing nations, the global greenhouse gases emissions, particularly CO<sub>2</sub>, is still rising at unsustainable rates. New global binding legislations on greenhouse gas emissions beyond The Kyoto Protocol time frame are therefore highly essential. In March 2007, The European Union member states have in principle, agreed to reduce carbon dioxide emissions by 20% from 1990 levels by the year 2020 (EC, 2007).

## **1.2. Anthropogenic Carbon-dioxide.**

Carbon dioxide has been singled out as the most significant contributor of anthropogenic greenhouse gases which is strongly believed to largely responsible for

the changes in the world's climate. Although methane and nitrous oxide are much stronger greenhouse gases than CO<sub>2</sub>, methane has over 20 times the effect of CO<sub>2</sub> while nitrous oxide is nearly 300 times stronger. Both gases have a much smaller presence in the atmosphere than CO<sub>2</sub>. The contribution index of CO<sub>2</sub> from anthropogenic sources to global greenhouse gases are presented in Figure 1.2 which shows that, expressed in CO<sub>2</sub>-equivalent units, CO<sub>2</sub> accounts about 75% of the total index, compare to 16% for CH<sub>4</sub>, 9 % for N<sub>2</sub>O and fluorinated gases are accounted for around 1% (IEA, 2006b). Therefore, to have a significant long term effect in global warming stabilisation, drastic reductions in global anthropogenic CO<sub>2</sub> emissions is crucial, as well as the reduction of the other greenhouse gases.

### **1.2.1. Main Sources of Anthropogenic Carbon-dioxide.**

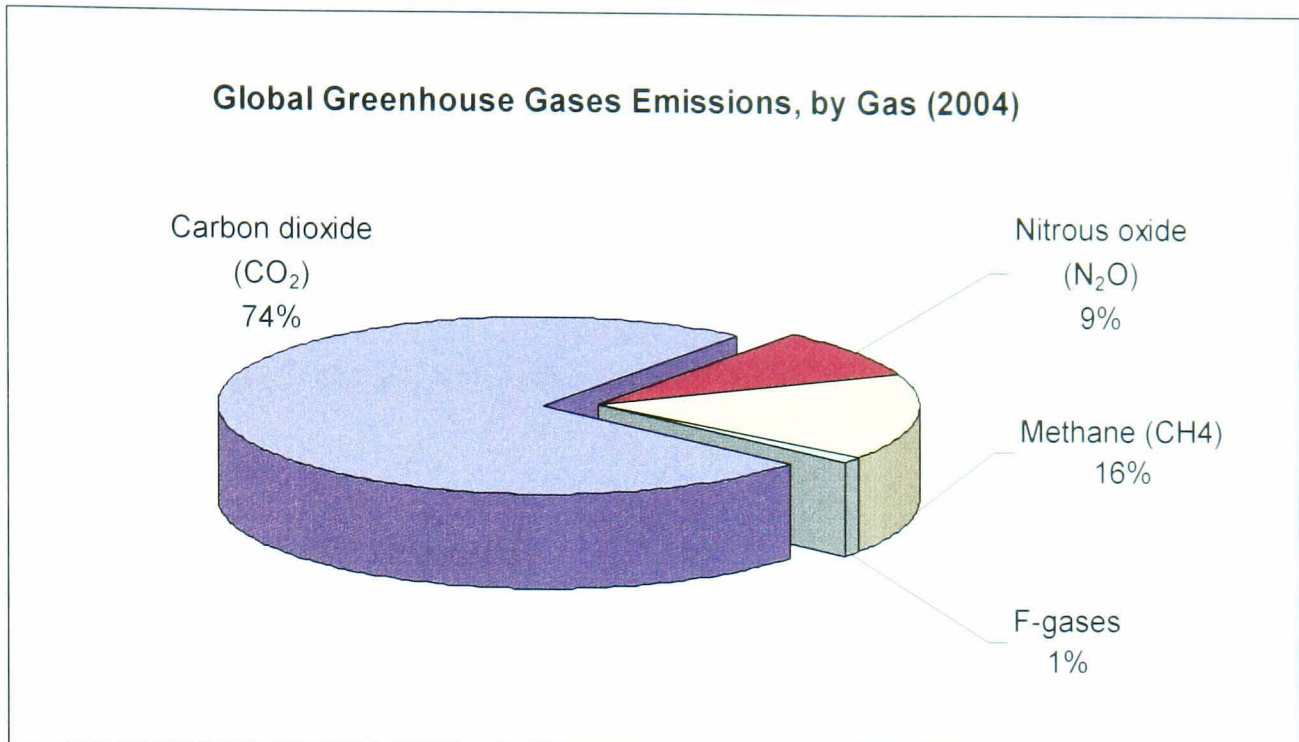
Anthropogenic carbon dioxide is released into the atmosphere by a number of sources, predominately from the combustion of fossil and renewable fuels, lands clearing through burning, industrial facilities, buildings, transportations and resource extraction activities. The uses of energy represent the largest source of anthropogenic greenhouse gas emissions which accounts around 80% of the global share, and about 95% of which is dominated by CO<sub>2</sub> (IEA, 2006b). The share of CO<sub>2</sub> emission in the energy sector is dominated by the combustion of fossil fuels, and the main sources of energy-related anthropogenic CO<sub>2</sub> are :

- a) **Electricity and heat generation plants.** Fossil fuels-based power generation plants are the largest source of stationary CO<sub>2</sub> emissions, and each plant is capable of emitting several million tonnes of CO<sub>2</sub> annually. The electricity and heat production sector is the largest contributor of CO<sub>2</sub> emissions, emitting as much CO<sub>2</sub> as the rest of the industrial sector combined, and is the

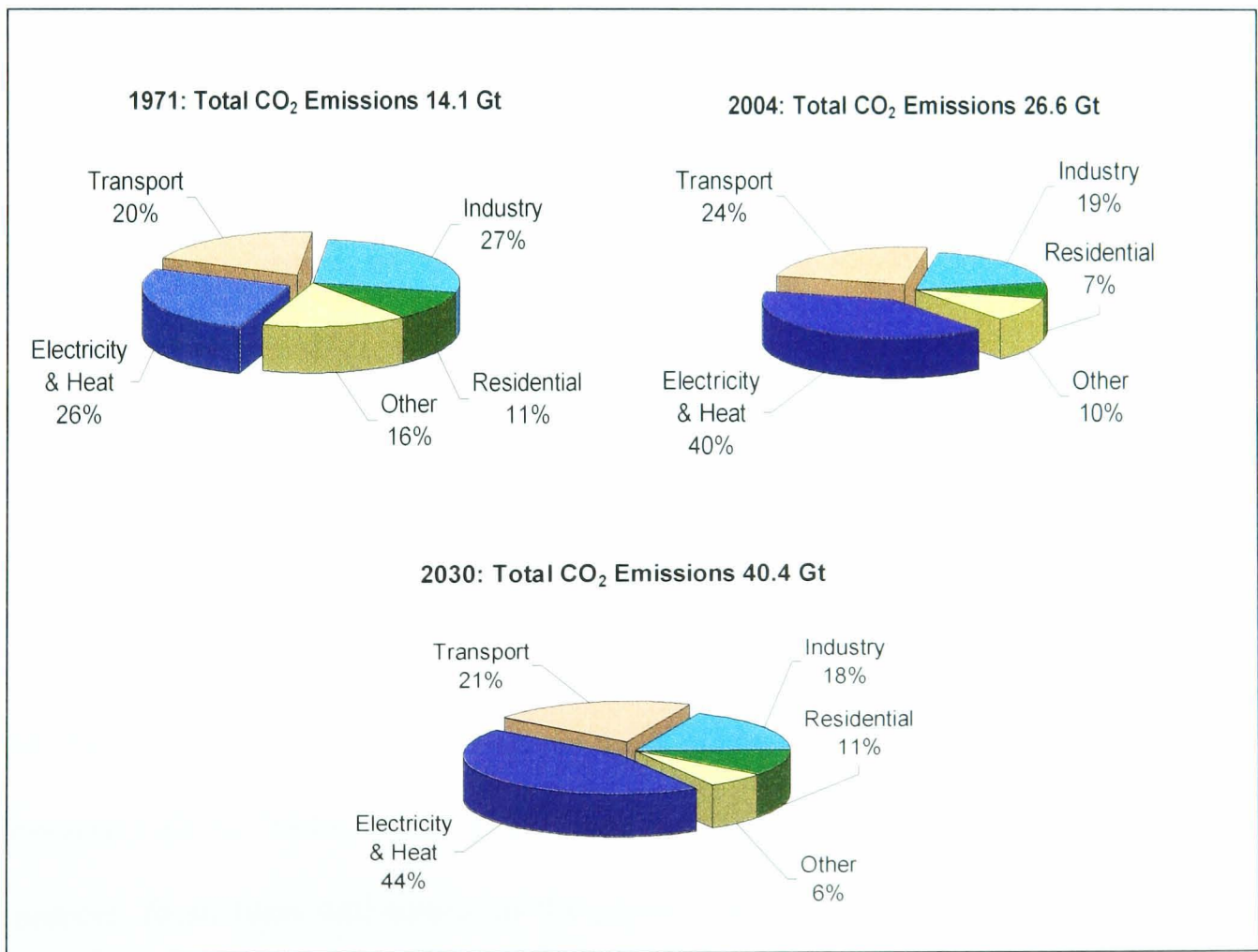


fastest-growing source of CO<sub>2</sub> emissions (IEA, 2005a). The share of this sector to the total global CO<sub>2</sub> emissions has increased significantly by 53% between 1990 and 2004, and the current share amounts to around 40% as compared to only 26 % in 1970 (IEA, 2006b).

- b) **Transportation.** The transport sector, which rely almost entirely on oil, is the second largest source of energy-related CO<sub>2</sub> with the current share of 24 %, which is also a fast-growing source, increasing by 37% since 1990 (IEA, 2006b) as a result of rising demand for land and air mobility.
- c) **Industrial.** A variety of other industrial activities also emit substantial amounts of CO<sub>2</sub> from each plant. The major energy-intensive industries include for examples, oil refineries, cement kilns and blast furnaces in iron and steel production. The sector is currently responsible for about 22% of worldwide CO<sub>2</sub> emissions, with 26% of which are from the iron and steel, 25% from non-metallic minerals and 18% from petrochemicals industries. (IEA, 2006c).
- d) **Domestics.** Significant amounts of CO<sub>2</sub> are also produced by dispersed sources such as domestic appliances and residential buildings.



**Figure 1.2.** Global share of greenhouse gases emissions (IEA, 2006*b*).



**Figure 1.3.** Global CO<sub>2</sub> emissions by sector (IEA, 2006*b*).

Figure 1.3 presents the share of world CO<sub>2</sub> emissions by sectors which shows that the electricity and heat generation and transportation sectors contribute nearly two-thirds of the global energy-related CO<sub>2</sub> emissions in 2004, a marked increase from less than one-half in 1971 (IEA, 2006b ). The share of emissions from these sectors are expected to consolidate further in the next few decades.

### **1.3. World Energy Scenario**

At the turn of the 21<sup>st</sup> century, fossil-fuels are still the most dominant source of the world's energy, which contribute to more than 80 % of the world's Total Primary Energy Supply (TPES). The current scenarios indicate that although renewable energy will grow in importance, their shares in the global energy supply in the next few decades will remain largely unchanged due to limited sources which can reliably produce significant amounts of energy. The share of nuclear power is also not expected to increase in the next few decades due to the limited new installation of nuclear-powered stations, world wide (IEA, 2006a).

#### **1.3.1. World Energy Demand And Outlook**

The International Energy Agency (IEA's) *Reference Scenario – World Energy Outlook (WEO) 2006* projected that the global primary energy demand will increase by 53 % by 2030, with more than 70 % of the increase coming from developing countries (IEA, 2006a). Due to the huge energy demand and lack of alternative sources, fossil fuels will remain as the primary sources of energy for a foreseeable future. It is forecasted that fossil-fuels will supply 83% of the energy demand of 2030, and will remain as the main energy source by the end of this century (IEA,

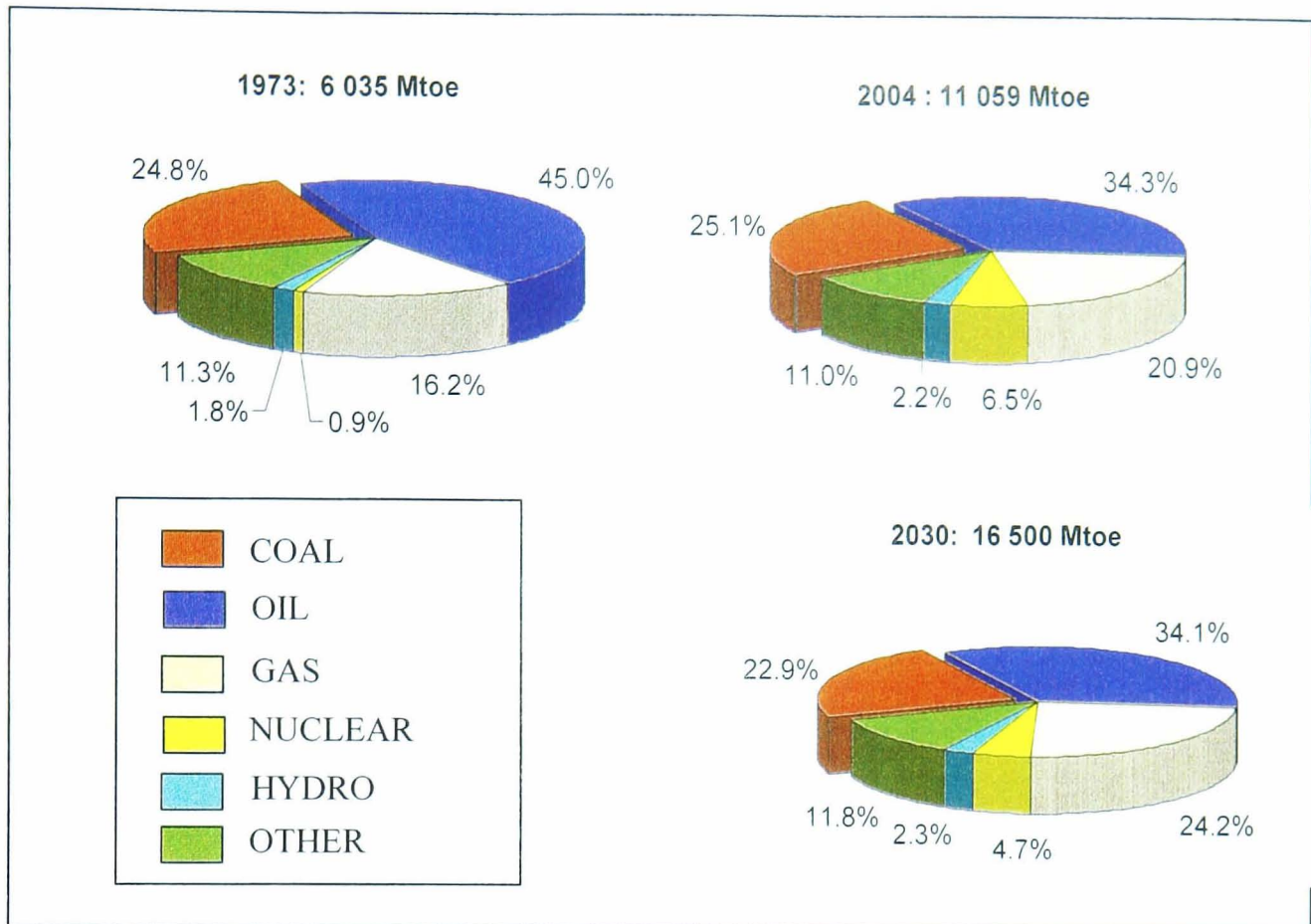
2006a, 2006b). Fuel shares of the world's TPES at the turn of 21<sup>st</sup> century and the projected scenario is presented in Figure 1.4a, which shows the dominance of fossil-fuels as the major energy source for the next few decades. Therefore, the current and immediate global challenge is still to respond effectively to the risks of global climate changes associated with fossil-fuel's energy utilisation, while continuing to meet the high energy demands in developing nations and the rapidly increasing energy demands of developing economies.

### **1.3.2. The Future of Coal.**

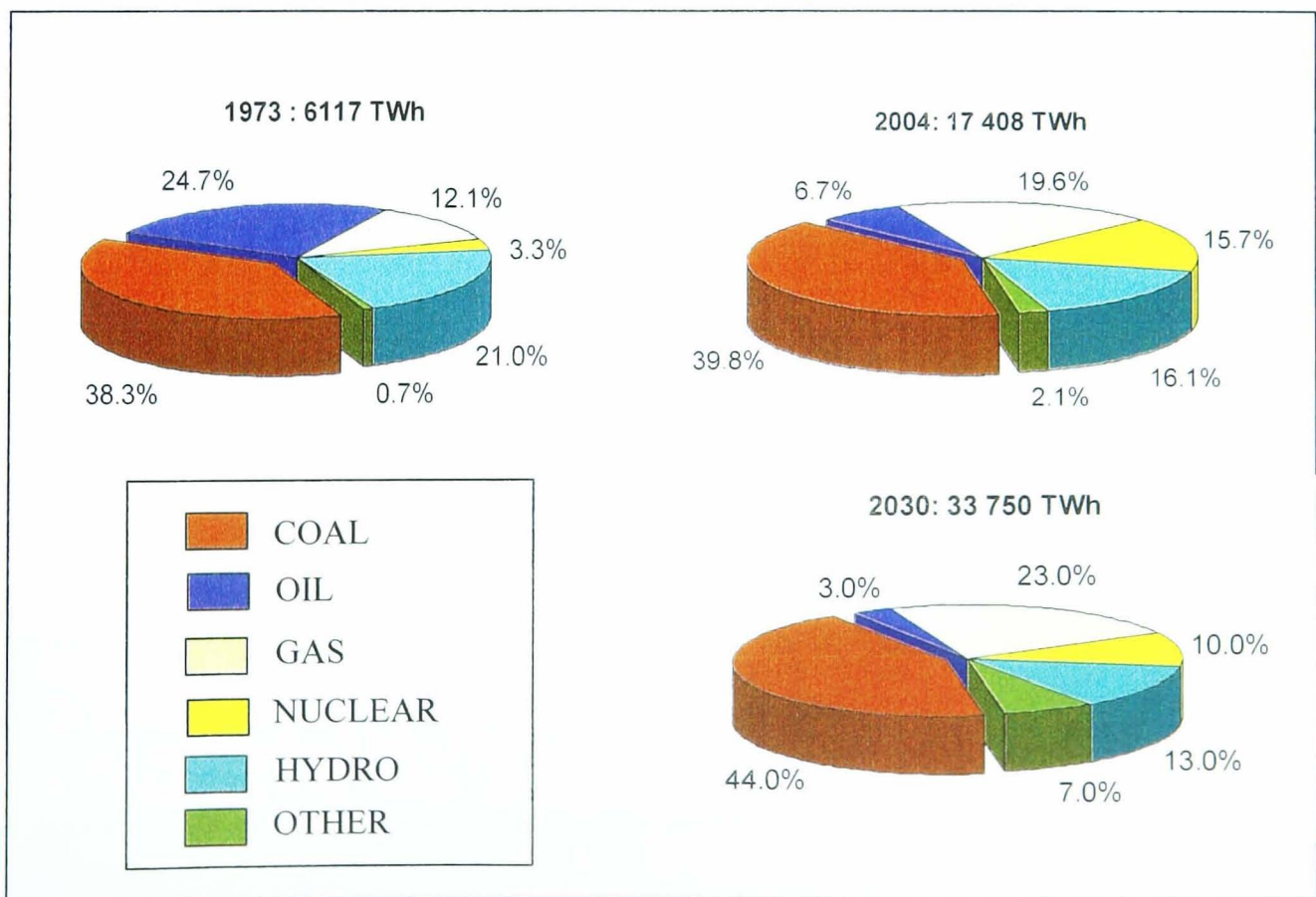
Coal is the most important energy resources since it exists in more abundant reserves than other fossil fuels and currently, coal accounts for around one-quarter of the World's TPES (IEA, 2006a). For the next several decades, coal will remain hugely important for the economies of both developed and developing countries, and towards the end of this century, coal is expected to continue to make an important contribution to the global energy security because of its widespread geographic distribution, and the extent of available resources relative to the anticipated energy needs (IEA, 2006d). The proven reserves of coal at the end of 2005 amounted to around 990 billion tonnes which is equivalent to almost 170 years of the current production rates, as compared to 64 and 42 years for gas and oil respectively. (IEA, 2006a, 2006d)

About two-third of the almost 6 billion tonnes of coal currently produced annually, is used for electricity generation and the combustion of pulverised coal in steam generating boilers is the most widely used process (IEA, 2006e ). In the early 1970s, coal contributed about 38% to total world electricity supply, and more than three decades later, coal-fired power plants are still providing almost 40% of global

electricity needs which is more than double the amount of electricity generated from other single energy sources. The share of coal in world's electricity generation will remain very significant and rising, and is expected to contribute to around 44% of the world's electricity generations in 2030, as projected in the IEA's *Reference Scenario - WEO 2006* (IEA, 2006a). In comparison, over the same period, the share of oil for electricity generation is expected to fall to only around 3% and nuclear power share is expected to experience the largest fall, from 16 % to around 10 %, while natural gas share increases from 20% to 23%. The share of renewable sources is expected to grow but remains limited. Currently, renewable energy sources account for only 2 % of total electricity production and is expected to increase to only about 7% by 2030, while the share of hydro-electricity decreases from 16% to around 13%. The current and projected distribution of world electricity generation by fuel sources is shown in Figure 1.4b. There are several alternative scenarios which project the coal demands for the next few decades, taking into account the various energy policies and measures which could be adopted globally, that could lead to a lower global reliance on coal. However, energy policies that were assumed to be enacted and adopted only recently as in the IEA's *Alternative Policy Scenario - WEO 2004* (IEA, 2004) have not been implemented in the developing countries whilst the major developing countries are following energy-intensive growth paths which lead to a much higher global consumption of coal (IEA, 2006e). The current annual global coal consumption has already exceeded the earlier forecasted figures with little signs that the growth trend will reverse in the immediate future. The annual growth of the global coal demand between 2000 and 2005 was recorded at



**Figure 1.4a.** Fuel shares of World TPES at the turn of 21<sup>st</sup> Century and for the *Reference Scenario* (IEA,2006b)



**Figure 1.4b.** Fuel shares of electricity generation at the Turn of 21<sup>st</sup> Century and for the *Reference Scenario* (IEA,2006b)

5.5 % with China, as a fast emerging industrial nation, recording the highest growth of 13.4 %, followed by other developing nations. (IEA, 2006e).

#### **1.4. Global Carbon-dioxide Emissions: Current Trends and Projections.**

The emission of carbon dioxide from fossil fuel combustion is almost certainly, the most dominant influence on the future trends in the global atmospheric CO<sub>2</sub> concentrations. The global annual CO<sub>2</sub> emissions generated from the combustion of fossil fuels have increased by over 87% between 1970 and 2004. In the last decade, they rose drastically from an average of 23.5 Gt per year in the 1990s to 26.4 Gt per year in 2000–2005 and between 2000 and 2003, the annual growth was 2.2 % (IPCC, 2007a). Currently, the combustion of fossil fuels accounts for about 75% of the global anthropogenic CO<sub>2</sub> emissions. Hence, as the global demand of energy, which is greatly dependent on fossil fuel is continuously increasing, CO<sub>2</sub> emissions from fuel combustion is expected to significantly increase. The current scenario also indicate that energy-related CO<sub>2</sub> emissions are increasing at a slightly higher rate than the global primary energy consumptions because the global fuel mix have shifted to more carbon-intensive (IEA, 2006b).

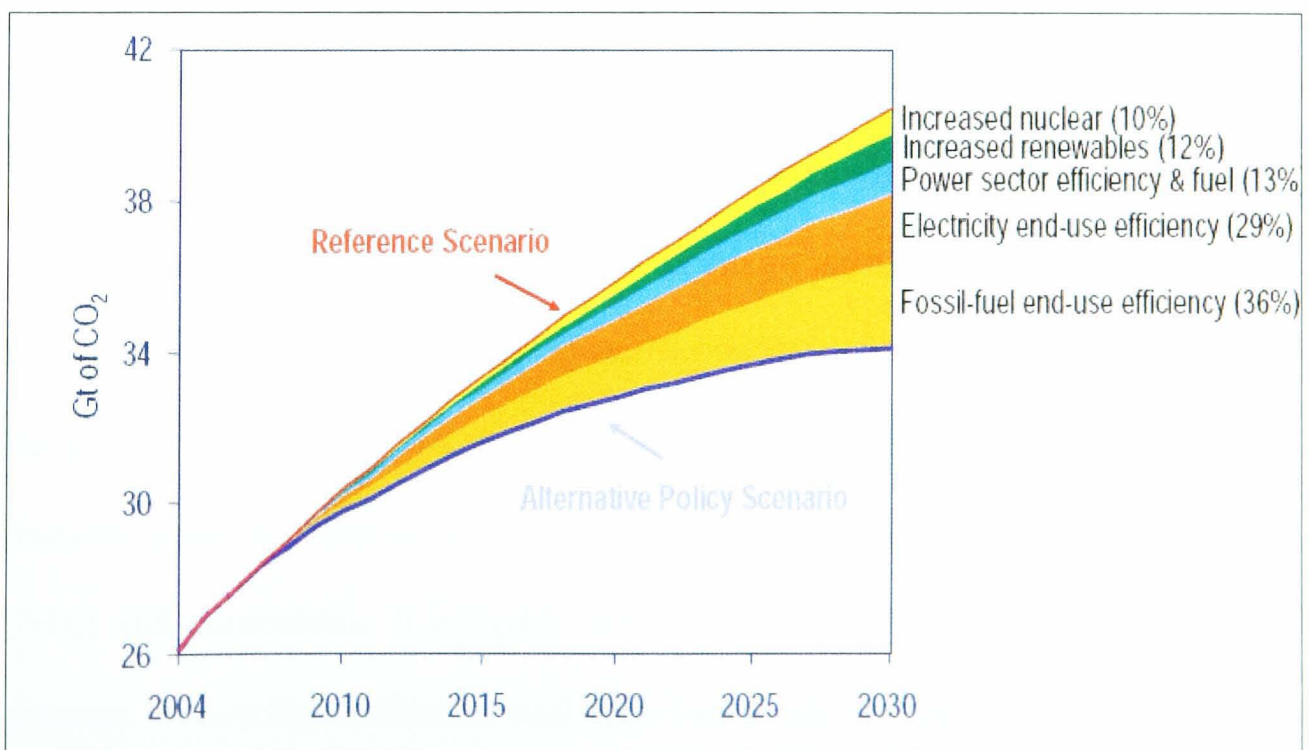
Electricity generation will be the most prominent and growing source of total CO<sub>2</sub> emissions, rising from around 41 % of total current CO<sub>2</sub> emissions to the forecasted level of around 44% in 2030 (IEA, 2006a). The world electricity generations have expanded at an average annual rate of 3.7% from 1971 to 2001 and the world electricity demand is expected to double between now and 2030, with most of the growth occurring in developing countries. This increase is largely due to

more usage of electrical appliances, development of electrical heating and rural electrification programmes in developing countries. On a longer time frame, IEA's *Energy Technology Perspectives Baseline Scenario* (IEA, 2006f) forecasts that electricity production will increase by almost three times between 2003 and 2050 and CO<sub>2</sub> emissions from the power generation sector will increase by more than 160%. Similarly, as more automobiles are expected on the roads and more air-travel hours are recorded, the global CO<sub>2</sub> emissions from the transportation sector are projected to rise by more than 85% from 2000 to 2030 (IEA, 2006a).

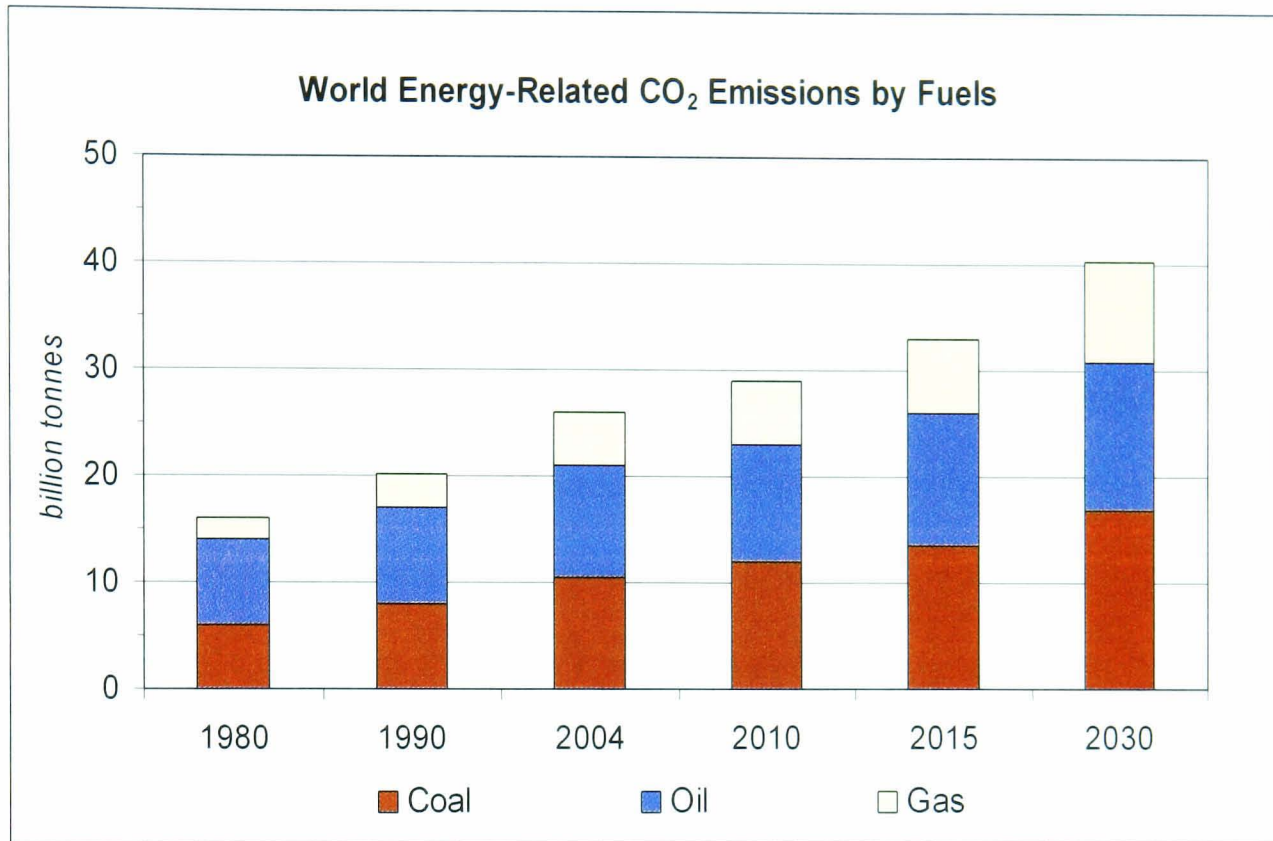
All these trends indicate a continuing sharp increase in the emissions of CO<sub>2</sub> in the next few decades if no new major policies and measures to curb CO<sub>2</sub> emissions are to be adopted globally. The IEA's *Reference Scenario – WEO 2004* initially projected that annual global CO<sub>2</sub> emissions, in 2030, will be around 90% higher than 20.4 Gt at 1990 level. However, due to the much higher energy demand which leads to higher global coal consumption than earlier forecasted, The IEA's *Reference Scenario - WEO 2006* have revised the projected energy-related CO<sub>2</sub> emissions to rise much higher to around 98% above the 1990 level over the same period, increasing at an average annual rate of 1.7 % (IEA, 2006a, 2006e). In the longer term, in the absence of new major policies, CO<sub>2</sub> emissions are projected to increase to an unsustainable amount of 58 Gt in 2050 (IEA, 2006f), with most of the growth in energy demand, and hence the emissions, coming from developing nations. Hence, if the recent and current trends in global CO<sub>2</sub> emissions continue, the world will not be on a path towards the stabilisation of greenhouse gas concentrations in the atmosphere, unless every possible route to curb the growth of the CO<sub>2</sub> emissions is explored and adopted soon.



In order to achieve the ultimate goal of reducing CO<sub>2</sub> concentration in atmosphere, both short and long terms policies and measures to stabilise the growth of the energy-related emissions are required. From the source of the emissions, the largest contribution to the global CO<sub>2</sub> emissions reduction could be achieved from the power generation sector. Several significant measures, to reduce the growth of CO<sub>2</sub> emissions, have been introduced in energy planning policies worldwide, which include improving energy conversion and utilisation efficiencies and by fuel switching to less carbon-fuels such as gas. The potential of global energy-related CO<sub>2</sub> emissions reduction through various policies and measures, under IEA's *WEO 2006 Alternative Scenario* policies, is presented in Figure 1.5 which shows that the improvement of end-use efficiencies of electricity and fossil fuels energy conversion processes could contribute up to two-thirds of the avoided CO<sub>2</sub> emissions by 2030. (IEA, 2006a, 2006e).



**Figure 1.5.** The projected potential of global saving in CO<sub>2</sub> emissions which could be generated under the *Alternative Policy Scenario - WEO 2006*. (IEA, 2006a).



**Figure 1.6.** World energy-related CO<sub>2</sub> emissions by fuel at the turn of 21<sup>st</sup> Century and in *The Reference Scenario - WEO 2006*. (IEA, 2006a).

### 1.5. Coal Combustion and Environments.

Although coal, as a prime energy source, provides an important contribution for the economic development worldwide, its environmental impact has always been a major challenge to the coal users. Coal is always considered as the dirtiest fossil fuel since it contains a significant amount of sulphur and nitrogen. Over the years, the major challenge for coal users is still how to reduce its environmental impact from the main combustion emissions such as sulphur oxides (SO<sub>x</sub>), nitrogen oxides (NO<sub>x</sub>) and particulates. It is highly anticipated that there will be growing global pressure for new legislations for coal users worldwide to reduce CO<sub>2</sub> emissions from coal-based power generation plants in the near future.

Coal users have a huge potential to contribute significantly to the global CO<sub>2</sub> emission reductions which are in-line with the global low emissions future since coal is not only the most abundant fossil source, but is also the fossil fuel with the highest carbon content per unit of energy i.e. compared to other fuels, coal produces the largest amount of carbon dioxide per unit of energy released. Although coal contributes to only around 25 % of the current world's TPES compared to 35 % and 21% for oil and gas respectively, it produces an equal share of CO<sub>2</sub> emission to that of oil which is twice as much as that of gas. In 2004, coal combustion is accounted for 40% of CO<sub>2</sub> emissions from fossil fuels, and the share is projected to consolidate further to around 43%, which will be the highest contributor to the global energy-related CO<sub>2</sub> emissions, by 2030 (IEA, 2006*b*, 2006*d*). The current and projected energy-related CO<sub>2</sub> emissions by fuel is shown in Figure 1.6 which shows the growing share of coal combustion as the major source of CO<sub>2</sub> emissions. Hence, as coal-fired power plants have a large impact on the global CO<sub>2</sub> emissions, there is a compelling need to develop cleaner combustion technologies for existing and new coal-fired plants.

### **1.5.1. Emissions Control in Coal Power-Generation Plants.**

In the last few decades, significant technological advancements on environmental performance of conventional coal-fired power stations have been developed. Effective and mature technologies are already in place for the control of major pollutants from coal-fired power stations and the cost of addressing environmental issues related to coal combustion has reduced over the years (WCI, 2005).

### 1.5.1.1. SO<sub>x</sub>, NO<sub>x</sub> and Particulates.

In coal combustion, oxides of sulphur (SO<sub>x</sub>), mainly in the forms of sulphur dioxide (SO<sub>2</sub>), are produced from the combustion of the sulphur in coals and its emissions can lead to the generation of acid rain and acidic aerosols. SO<sub>x</sub> emissions have been substantially reduced through the application of post-combustion flue gas de-sulphurisation techniques which include wet and dry scrubbers, sorbent injection and regenerable processes, some of which could reduce the emissions by over 95%. The pre-combustion coal treatment such as coal washing and drying, has also contributed to the reduction of SO<sub>x</sub> emissions by lowering the level of sulphur in coals (WCI, 2005).

Oxides of nitrogen, usually referred to collectively as NO<sub>x</sub>, are formed from the combustion process where air is used and from the nitrogen present in the fuel. In addition to its characteristics of nitrous oxide (N<sub>2</sub>O) as a greenhouse gas, NO<sub>x</sub> could contribute to other environmental concerns such as smog, ground level ozone and can also cause acid rain (WCI, 2005). NO<sub>x</sub> emissions has been significantly reduced through various advanced post combustion technologies such as the selective and non selective catalytic reduction (SCR and NSCR), which could reduce the emissions by up to 90%, as well as by the application of low NO<sub>x</sub> burners and other combustion modification techniques such as air staging (OFA) and fuel staging (reburning) methods, which capable of generating up to 70 – 80% of NO<sub>x</sub> reduction (WCI, 2005). More detail discussions on NO<sub>x</sub> emission reduction technology in coal combustion systems is discussed in Chapter Two. Particulates emissions, mainly from combustion ashes, can affect people's respiratory system and impact local visibility. Particulates emissions have been successfully tackled through

electrostatic precipitators and fabric filters technologies, which have removal efficiencies of over 99.5%. The application of pre-combustion coal treatment such as coal washing and drying, has also contributed to the reduction of particulate emissions, by reducing the ash content, by as much as 50%.

However, despite continuous and significant improvements made during the recent years, there remains increasing global pressure for coal users to further reduce the combustion emissions. New and more stringent legislations on coal combustion emissions are expected to be introduced and enforced by the authority of many countries in the coming years (WCI, 2006).

#### **1.5.1.2. CO<sub>2</sub>**

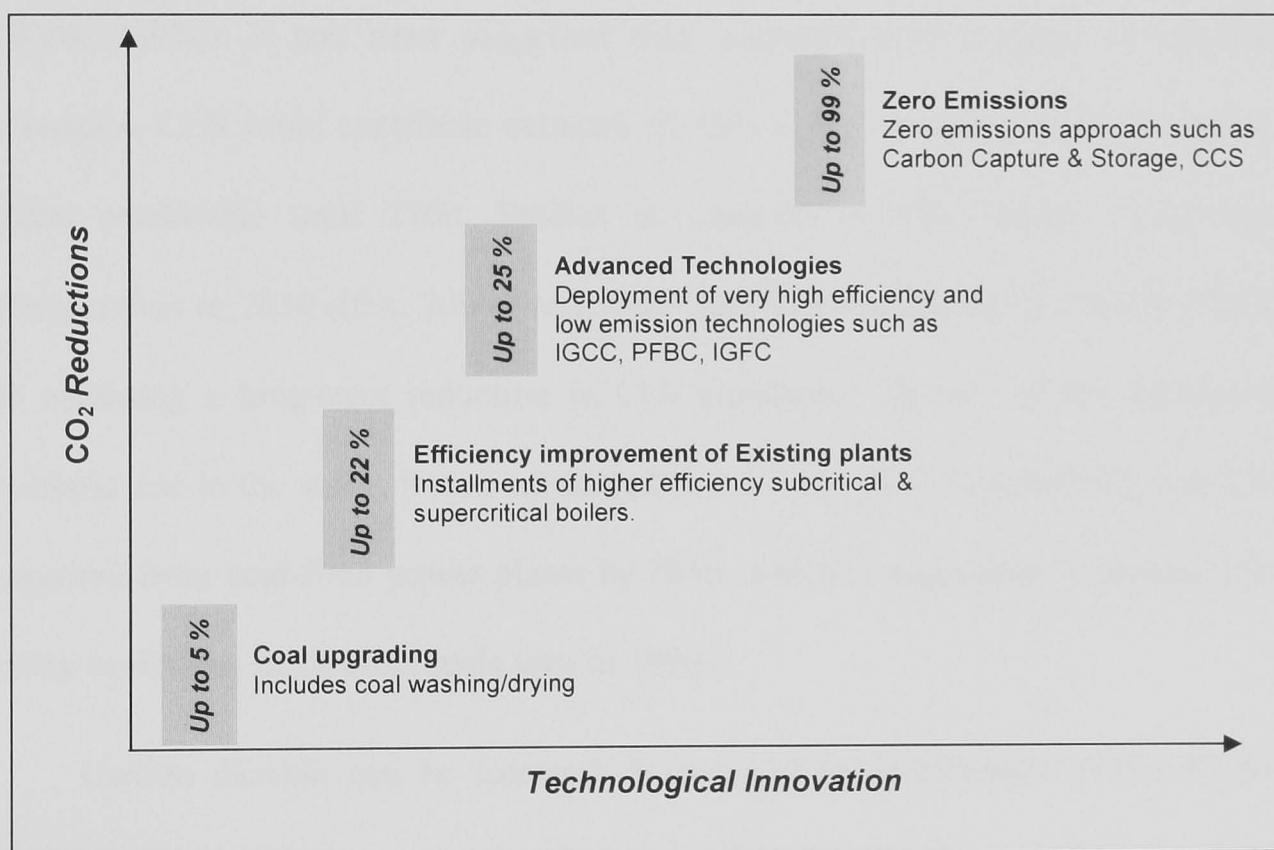
In coal-fired power generation plants, CO<sub>2</sub> emissions are being addressed through various options that lead to the adoption of latest technologies that would improve the efficiency of the energy conversion and hence progressively reduce the emissions per unit of electricity generated. It is well documented that improving the efficiency coal-fired power plants is one of the most a cost-effective measures to limit the growth of CO<sub>2</sub> emissions and it has been suggested that one percentage point increase in efficiency of coal power stations could reduce the plant CO<sub>2</sub> emissions by around two percent (IEA, 2006*e*). Upgrading the existing or replacing older plants with the new and more efficient operations could therefore, yield significant CO<sub>2</sub> emissions reduction. The efficiencies of coal-fired power plants have increased steadily in recent years, with conventional sub-critical boilers efficiency approaching 40% are already in operation. In 2003, the energy efficiencies for coal-fired power generation range from 30% for developing nations to 42% for Japan, with the average efficiency of the countries of around 35% (Graus et al.,

2007). It has been suggested that, with the further development and deployment of supercritical and ultra-supercritical processes with the current efficiency of up to 46% and continue its steady upward advances over the next few decades, the global coal plants efficiency improvements route could potentially reduce global CO<sub>2</sub> emissions from coal-fired plants by up to 22 % (WCI, 2006).

New technologies such as coal-fired Integrated Gasification Combined-Cycle (IGCC) are expected to become more competitive, in terms of energy conversion efficiency, with gas-fired plant in future and the average efficiency of IGCC technology is expected to reach around 53% in 2030 as compared to around 43% at present (IEA, 2006a). Other high-efficiency technologies such as Pressurized Fluidized Bed Combustion (PFBC) have also been in operation in new plant installations in developed nations. The worldwide deployment of these technologies potentially could raise the world's average efficiency of coal-fired power stations from 35% today to more than 50% by 2050 (IEA, 2006f). It has also been suggested that the widespread application of coal upgrading by washing and drying could potentially contribute to global CO<sub>2</sub> emissions reduction from coal-fired plants by up to 5 % (WCI, 2006). The adoption of these technologies worldwide, will not only reduce CO<sub>2</sub> emissions from coal power plants but will also contribute to preserve the fast depleting fossil fuels resources.

The potential of the various technological approaches on the global CO<sub>2</sub> emission reduction from coal-fired power plants is shown in Figure 1.7. However, although these technological advances are expected to be adopted globally to meet tighter environmental requirements, they will be incremental rather than revolutionary. Further more, the incremental reduction of CO<sub>2</sub> through the adoption

of these new technologies will always involve increasing costs. Therefore, for the next few decades, the expected increase of thermal efficiency in the coal-fired power generation plants may only moderate the growth in the global CO<sub>2</sub> emissions levels to certain levels, but will not be very decisive. Hence, to balance the cost of carbon emission penalty in coal-fired power generation in the near future, more drastic measures are also required.



**Figure 1.7.** The potential of the various technological approaches on the global CO<sub>2</sub> emissions reduction from Coal-fired power plants. (WCI, 2005).

### 1.5.2. CO<sub>2</sub> Capture and Storage.

The CO<sub>2</sub> concentration in the atmosphere can be stabilised either by reducing its emissions or by increasing the rate at which it is removed. It has been proposed in recent years that one of the most drastic and effective long term measure to reduce CO<sub>2</sub> emissions from coal-fired power plants is to capture the gas and store them in a

process known as carbon sequestration. There are many ways in which a large amount of CO<sub>2</sub> can be utilized or stored for the long term use, for example, in enhanced oil recovery (EOR) processes from oil fields. The technology for Carbon Capture and Storage (CCS) has been developed beyond the stage of technical feasibility and is already at the stage of options for policymakers as described extensively in several publications (IPCC, 2005 and IEA 2005a), these include a comprehensive review on the current technological development of the technology (Wall, 2007a). It has been suggested that, averaged over a range of baseline scenarios, CCS could contribute between 15-55% to the cumulative CO<sub>2</sub> mitigation effort worldwide until 2100. Studies as reported in *The Energy Technology Perspectives to 2050* (IEA, 2006f) concluded that CO<sub>2</sub> capture and storage is critical to obtaining a long-term reduction in CO<sub>2</sub> emissions. In one of the alternative scenario use in the study, it was calculated that 4 Gt/yr of CO<sub>2</sub> potentially could be captured from coal-fired power plants by 2050, which is equivalent to around 20% of the emissions from fossil fuels uses in 1990s.

Carbon dioxide can be captured from coal-fired combustion plants by the direct removal of nitrogen in the flue gas. Nitrogen may be removed by amine absorbers and cryogenic coolers to produce high CO<sub>2</sub> concentration flue gas. However, the CO<sub>2</sub> concentration in the exhaust gas discharged from the conventional coal-fired power plants is low, between 13 to 15 % of volume on a dry basis. This is due to the combustion air constitutes only about 21% of oxygen, and the remaining 79%, mostly in the form of inert nitrogen, is also discharged in the flue gas. Capturing CO<sub>2</sub> from the dilute concentration in flue gas is therefore, very expensive. The cost of CO<sub>2</sub> separation process from flue gas can be significantly



reduced by increasing the concentration of the gas which can be achieved through combustion of the fuel in an oxygen-enriched atmosphere. In this process, nitrogen and oxygen in the air is separated in advance, and only oxygen is fed into the combustion furnace. Coal is then burned in oxygen-rich environments, either with oxygen-enriched air or in the mixture of oxygen and CO<sub>2</sub>-rich recycled flue gas, instead of in normal air.

## **1.6. Oxygen-enriched Coal Combustion Technology.**

There are two distinct variations of the possible systems in which the oxygen-enriched combustion could be employed. In the first scheme, pulverized coal is fired in an oxygen-rich environment in which the secondary air is mixed with pure oxygen. Depending on the level of oxygen enrichment, the concentration of CO<sub>2</sub> in the flue gas can be increased by 30 to 60%. (Thambimuthu & Croiset, 1998). In the second configuration, cool flue gas, rich in CO<sub>2</sub>, is recycled back to the burner to dilute the oxygen intake and provide O<sub>2</sub>/CO<sub>2</sub> mixture environments. Flue gas recirculation was proposed for this process mainly to lower the flame temperature to within an acceptable temperature of the materials used in the furnaces and boilers and to compensate the volume of the missing nitrogen to ensure there is enough gas to carry the heat through the boiler (Wall et al., 2005). By adjusting the O<sub>2</sub> concentration in the feed gas and the fraction of the recycled flue gas, flame, heat transfer and emissions characteristics similar to those of combustion in air could be achieved. Since nitrogen is eliminated from the feed gas, the concentration of CO<sub>2</sub> in the exhaust gas of this process, could reach up to 95% volume on a dry basis (Abraham, 1982). Carbon dioxide could be easily separated from the flue gas which

is largely CO<sub>2</sub> and water. For some industrial applications, the direct use of CO<sub>2</sub>-rich flue gas without further separation processes is also possible. Both approaches, theoretically, can be retrofitted with minimum modifications to existing power plant installations. The schematic diagrams of the proposed processes are presented in Figures 1.8a and 1.8b

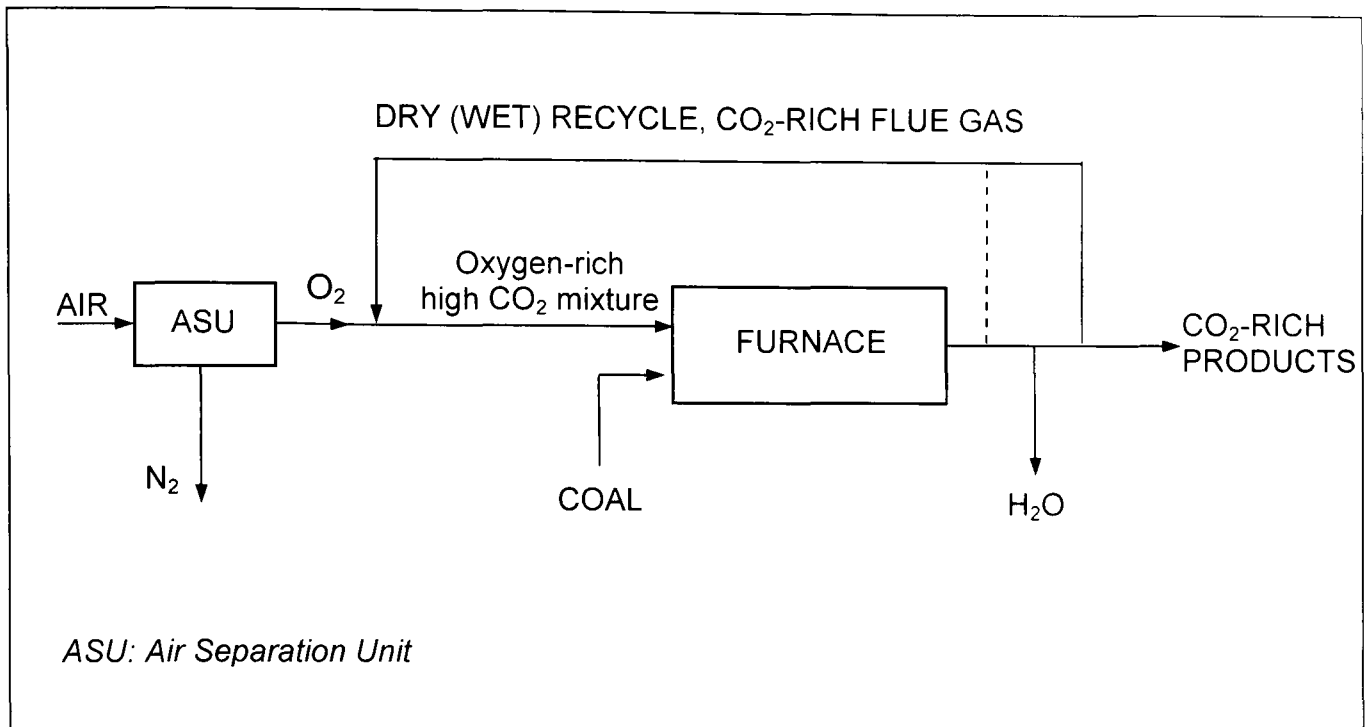
### **1.6.1. Benefits Associated with Combustion of Coal in Oxygen-enriched Environments Technology.**

Results from various studies have demonstrated the high potential of coal combustion in O<sub>2</sub>/CO<sub>2</sub> environments as an effective method to produce a CO<sub>2</sub>-rich flue gas that can be readily captured and sequestered. Although the emphasis of the earlier studies has been on the application of the technology to maximise CO<sub>2</sub> concentrations in the flue gas from coal combustion, the prospect of coal/O<sub>2</sub>-enriched combustion in increasing the overall plant efficiency and reducing the emissions of pollutants such as NO<sub>x</sub>, SO<sub>x</sub>, and unburned carbon from coal-fired power plants compared to those from conventional coal-air combustion have also attracted special attentions in recent years (Buhre et al., 2005). There are several important benefits which could be generated from the combustion of pulverized coal in oxygen-enriched environments in utility boiler plants, as suggested in various studies which includes :

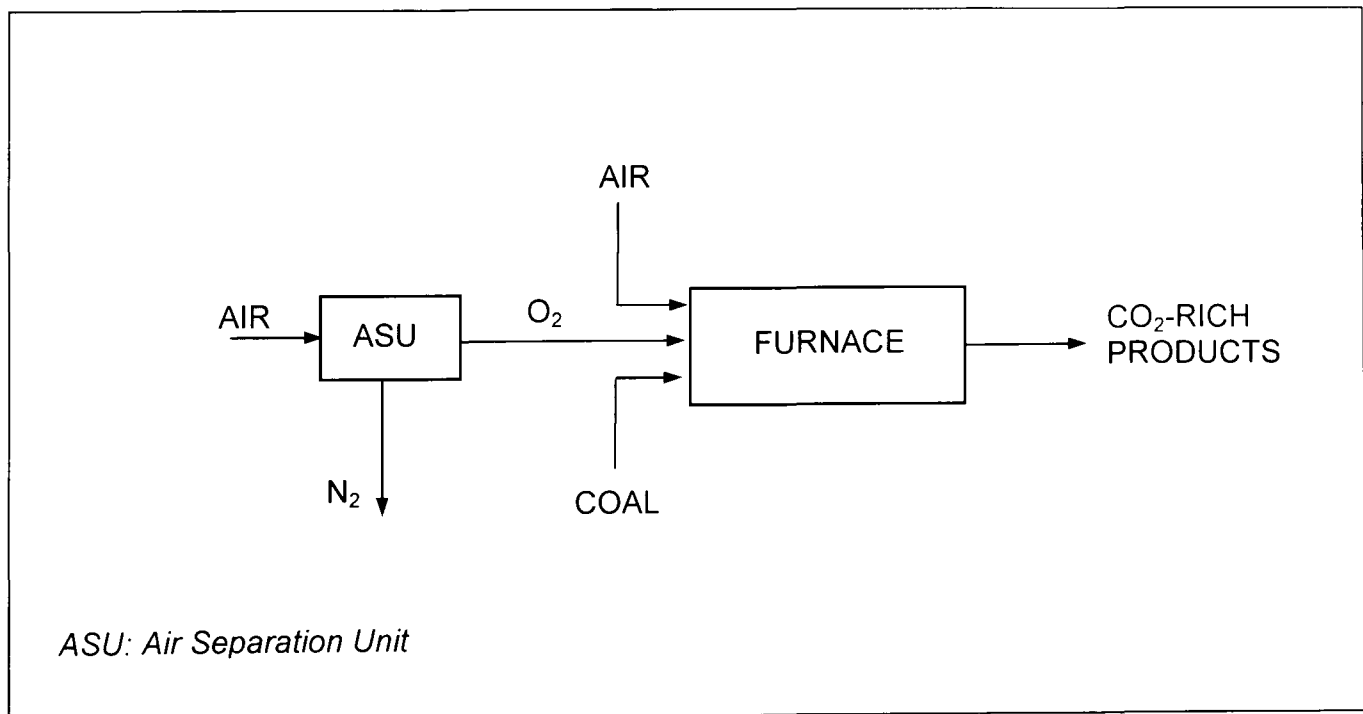
1. The recovery of CO<sub>2</sub> from exhaust gas will become less costly due to high concentration of CO<sub>2</sub> in dry flue gas, allowing CO<sub>2</sub> to be stored or reused with little or no further treatment.
2. In boiler plants, higher concentration of O<sub>2</sub> in combustion reduces the volume of inert nitrogen and the boiler efficiency will increase because the

amount of exhaust gas is greatly reduced and the lower flow rate of flue gas will reduce the dry gas energy loss and energy loss for gas cleaning and separation. The smaller volume of gas flow in the furnace may lead to a more compact boiler design.

3. The combustion efficiency could be enhanced by the release of heat combustion at a higher temperature, resulting in higher efficiency in a combined cycle power plant.
4. The combustion temperature can be controlled with the recirculation of part of the flue gas, mainly  $\text{CO}_2$ , making the process more flexible in operation and with coal ranks variations.
5. The overall  $\text{NO}_x$  emissions may be reduced due to the decrease of the conversion of fuel-N to  $\text{NO}_x$ . In combustion with flue gas recirculation, significant parts of the recycled  $\text{NO}_x$  may be reduced to molecular nitrogen in the coal flame. The amount of thermal  $\text{NO}_x$  generated in the combustion can also be reduced because of the elimination of atmospheric nitrogen fixation to NO.
6. The  $\text{SO}_x$  emission may be reduced due to high desulfurisation efficiency inherent of both the system and the process.
7. The unburned carbon concentration in ash can be minimised i.e. higher burnout efficiency can be achieved in combustion with higher  $\text{O}_2$  concentrations.



**Figure 1.8a.** Schematic diagram of the proposed Coal-O<sub>2</sub>/CO<sub>2</sub> recycled flue gas, combustion process. Adapted from Pyne et al. (1989).



**Figure 1.8b** Schematic diagram of the Coal-Oxygen enriched-air, combustion process. Adapted from Thambimuthu & Croiset (1998).

### **1.6.2. Problems Associated with Combustion of Coal in Oxygen-enriched High CO<sub>2</sub> Environments.**

The characteristics of coal combustion in high oxygen concentration atmospheres are considerably different from those in normal air combustion. Theoretically, the addition of small quantities of oxygen in the coal-air combustion zone would increase the combustion intensity and hence the flame temperature. The theoretical flame temperature in oxygen enriched combustion can be very high, which could lead to very high temperature conditions in the flue gas. The actual flame temperature may also well above the coal ash fusion temperature (Nikzat et al., 2004). The elevated flame temperature can also lead to higher thermal NO<sub>x</sub> formation.

The combustion temperature can be moderated to allow conventional combustion equipments to be used by recycling a proportion of the CO<sub>2</sub> rich-flue gas to the combustion zone. However, the combustion characteristics of coal combustion in O<sub>2</sub>/CO<sub>2</sub> environments can be very different from those in the conventional air-fired combustion. The specific heat of the main components of the recycled flue gas, mainly CO<sub>2</sub> and H<sub>2</sub>O are higher than that of N<sub>2</sub>, hence higher O<sub>2</sub> concentrations in the furnace inlet gas is needed to attain comparable flame temperatures to those in air combustion (Yamada et al., 2000, Croiset et al., 2000). Since CO<sub>2</sub> is a radiative gas, the high CO<sub>2</sub> concentration could also cause higher heat flux to the systems furnace walls and hence, high-temperature corrosion is therefore likely to occur more rapidly in an O<sub>2</sub>/CO<sub>2</sub> combustion boiler than in an air-fired boiler (Jordal et al., 2004). Recycling high concentration of CO<sub>2</sub> in flue gas to combustion zone may also cause the combustion intensity of coal combustion in O<sub>2</sub>/CO<sub>2</sub> to be significantly

lower than that in air combustion, and may caused unstable and less luminosity flames, which could results in higher unburned carbon concentrations in ash (Kiga et al., 1997). Lower flame luminosity may also affect heat absorption performances in the furnace. Therefore, controlling the coal combustion in O<sub>2</sub>-high CO<sub>2</sub> environments will not be as simple as in the conventional air combustion. Research on coal combustion in O<sub>2</sub>/CO<sub>2</sub> have attracted special attentions in recent years and discussions on the current status and the related issues on the technology are discussed further in Chapter Two.

### **1.7. Motivation and Objectives of this Research.**

The main objective of this study is to experimentally investigate pulverised coal combustion in various O<sub>2</sub>/CO<sub>2</sub> mixtures, with high CO<sub>2</sub> concentration to simulate the O<sub>2</sub>/CO<sub>2</sub>-recycled environments. Experiments were conducted on a 20-kW, down-fired pulverised coal combustor which was designed for normal air combustion, where the configuration is representative of commercial units in terms of residence times and temperature characteristics. The emphasis of the work was on the study of the influence of the oxidant mixtures on the combustion parameters such as flame characteristics and the formation of the major combustion products such as CO<sub>2</sub> and pollutant emissions such as NO<sub>x</sub>, SO<sub>x</sub> and the unburned carbon concentration in ash, in comparison to those in air combustion. The study was extended on the combustion in O<sub>2</sub>/CO<sub>2</sub> atmospheres in relation to the NO<sub>x</sub> reduction technology, under oxidant staging conditions. NO is also introduced in the oxidant to study the fate of recycled NO<sub>x</sub> in the combustion, both in air and in O<sub>2</sub>/CO<sub>2</sub> mixtures.

The principle experimental aims are :

- 1) To determine an O<sub>2</sub>/CO<sub>2</sub> mixture that could produce a sustainable and stable flame with combustion temperature and profiles comparable to that in air combustion.
- 2) To extract the main features of coal flame and emissions formation in both, combustion in air and O<sub>2</sub>/CO<sub>2</sub> mixtures.
- 3) To evaluate the effect of O<sub>2</sub>/CO<sub>2</sub> combustion in conditions associated with the reduction of the exhaust NO<sub>x</sub> by oxidant staging, in comparison to that in conventional air combustion.
- 4) To investigate the fate of recycle NO in combustion in different atmospheres, to relate it to the overall furnace NO<sub>x</sub> reduction of the combustion systems.

In Chapter Two, a literature survey is presented which includes recent findings in O<sub>2</sub>/CO<sub>2</sub> combustion technology and in the second part, on the NO<sub>x</sub> emissions formation and reductions technology that could be related to the coal-O<sub>2</sub>/CO<sub>2</sub> combustion technology. The description of the experimental approaches and equipment is given in Chapter Three. This is followed by a presentation of the experimental results and observations in Chapter Four. These results are then discussed in Chapter Five. Chapter Six includes the conclusions of this study and suggestions for further research in the area of O<sub>2</sub>/CO<sub>2</sub> combustion technology.

At the end of the study it is hoped that the findings would contribute to further supporting the potential of oxygen-enriched combustion as an effective combustion technology for reducing CO<sub>2</sub> emission and other pollutants from coal combustion systems.

## CHAPTER 2

### LITERATURE REVIEW

In this chapter, a literature survey is presented which includes recent findings related to coal-O<sub>2</sub>/CO<sub>2</sub> combustion technology and in the second part, discussions on the NO<sub>x</sub> emission formation and reduction mechanisms in coal-air combustion that could be significant to the O<sub>2</sub>/CO<sub>2</sub> combustion technology. The NO<sub>x</sub> reduction technological options in coal combustion, particularly through the combustion modification technique route which could be applicable to coal-O<sub>2</sub>/CO<sub>2</sub> combustion systems are also discussed.

#### 2.1. Introduction

Coal combustion in oxygen-rich environments with high CO<sub>2</sub> recycled has been identified and proposed to be the most feasible method for CO<sub>2</sub> recovery from coal-fired power plants directly from flue gas without the process of CO<sub>2</sub> concentration. The process is attractive since large proportions of CO<sub>2</sub> could be captured from the flue gas without significantly affecting the overall efficiency of the plants. The other prospects of the process in reducing the emission of pollutants such as NO<sub>x</sub>, SO<sub>x</sub> and unburned carbon in ash from coal-fired power plants, compared to those from conventional air combustions, have also attracted special attentions in recent years. The technology is expected to offer a possibility for close-to-zero-



emission coal power plants, which can be applied for retrofitting the existing power plants as well as for the designing of a new plant.

The earliest proposals for oxygen-enriched combustion process, specifically for CO<sub>2</sub> recovery was by Abraham et al. (1982) who have suggested that a high concentration of CO<sub>2</sub> of up to 95% by volume, can conceptually be produced in the flue gas, by recycling part of the flue gas to the combustion zone. Since then, theoretical, laboratory and pilot scale studies on the topic, particularly on coal combustion, have been carried out by various investigators. The results from both experimental and theoretical evaluations show that flue gas recycle is a viable mean of controlling coal combustion and heat transfer characteristics in the furnace. Several technical and feasibility studies have been conducted in various areas of the proposed combustion systems which include the evaluation of the air separation or oxygen generator units, flue gas treatment, firing and boiler operations, CO<sub>2</sub> separation processes and the evaluation of the overall performance of the plant. Techno-economic evaluations on the proposed system requirements for major new items of equipment and operating costs, and on the overall costs of electricity generation compared the those in conventional air combustion systems have also been conducted.

Although full-scale plants assessment studies have shown that coal combustion in O<sub>2</sub>/CO<sub>2</sub> is technically feasible and economically very promising, the successful implementation of this technology in conventional coal plants depends on several key factors, particularly the understanding in the differences in the combustion and emission characteristics resulting from the replacement of nitrogen in combustion air with CO<sub>2</sub> and the variation of oxygen concentrations in the

oxidiser, and also the operational issues related to the changes in physical properties of oxidiser such as gas density and flow rates. Currently, a full-scale plant employing the technology is yet to be in operation, although some fundamental theoretical studies and laboratory-scale and pilot-scale investigations have been carried out by various researchers. The findings from these fundamental studies are essential in the understanding of the relevant design parameters and the operational issues of the proposed O<sub>2</sub>/CO<sub>2</sub> combustion systems, both for retrofits of the existing coal plants or for new designed combustion systems. However, there are many issues still remain that must be subjected to further investigations (Buhre et al., 2005. Jordal et al., 2004). Fundamental studies on the combustion characteristics and pollutant emissions mechanism and reduction in O<sub>2</sub>/CO<sub>2</sub> mixture are relatively, still at early stages. Flame characteristics of pulverized coal combustion in O<sub>2</sub>/CO<sub>2</sub> atmosphere are also still not well understood. The results from various investigations have shown that the application of O<sub>2</sub>/CO<sub>2</sub> combustion could cause differences in furnace operation parameters such as burner stability, gas temperature profiles and heat transfer characteristics and the combustion emissions profiles including the combustion burnout, compared to those in normal coal-air combustion (Buhre et al., 2005). It has also been reported that the overall NO<sub>x</sub> formation in O<sub>2</sub>/CO<sub>2</sub> combustion system is lower compared to those in air firing, but it is still not yet clear how the NO<sub>x</sub> formation from fuel nitrogen and other sources are dependent on the combustion process. The potential of the effect of oxidant-staging, fuel-reburning and others technologies on the NO<sub>x</sub> reduction from coal combustion in O<sub>2</sub>/CO<sub>2</sub> atmospheres and have not been studied in detail.

## 2.2. Recent Investigations on Coal-O<sub>2</sub>/CO<sub>2</sub> Combustion

### Technology.

One of the earliest study on coal combustion in enriched oxygen in a pilot-scale furnace was carried out for Argonne National Laboratory, USA, in a 3 MW pilot facility as reported by Wang et al. (1988) and Payne et al. (1989). The main objective of the study was to establish operational conditions to provide a basis for scaling-up to full scale plants. It was reported that the measured and predicted data trends of distributions of temperature and species concentrations of the combustion system are generally predictable. The study also confirmed that the combustion of pulverized coal can be completed in a CO<sub>2</sub>/O<sub>2</sub> atmosphere over a range of CO<sub>2</sub>:O<sub>2</sub> mole ratios between 2.23 and 3.65. It was reported that with wet recycle flue gas, an oxygen concentration of around 24 % through the burners in CO<sub>2</sub>/O<sub>2</sub> combustion matched the overall heat transfer performance of the air firing case and with dry recycle, the oxygen concentration needed was 27% at which O<sub>2</sub>/CO<sub>2</sub> combustion had a similar in-furnace gas temperature profiles as in normal air-fired combustion. It was also reported, compared to air firing, combustion in O<sub>2</sub>/CO<sub>2</sub> reduce NO<sub>x</sub> by around 50% and a high carbon burnout was attained. The study concluded that the technology could be applied successfully as a retrofit to a wide range of coal combustion systems.

There are also several reports and reviews which presented research activities at a specific location and installation; these include the studies conducted by IHR-Heavy Industries, Japan, Kimura et al. (1995), Takano et al. (1995), Kiga et al. (1997) and Yamada et al. (2000 & 2006); CANMET, Canada (Thambimuthu et al., 1998, Croiset and et al., 2000, Croiset and Thambimuthu, 2001 and Tan et al.,

2006); Chalmers University of Technology and Vattenfall AB, Sweden. Andersson et al. (2006) and Stromberg (2007); and Air Liquide, USA (Châtel-Pélage et al., 2003, Farzan et al., 2005, 2007). An extensive and comprehensive review on coal-O<sub>2</sub>/CO<sub>2</sub> recycled combustion technology was presented very recently by Buhre et al. (2005) which provides a review of research that has been undertaken and also gives the status of the development of the coal-O<sub>2</sub>/CO<sub>2</sub> combustion technology. More recently, Sarofim (2007), Wall (2007a) and Gupta (2005) also presented progress, related issues and research needs of the technology.

### **2.2.1. Techno-Economics Assessments.**

The techno-economic assessments on coal O<sub>2</sub>/CO<sub>2</sub>-recycled combustion for CO<sub>2</sub> capture in coal power plants have been carried out by various investigators and one of the earliest evaluations was reported by Nakayama et al. (1992). Several other earlier works focus on an assessment on the capital cost of additional equipment required for the adoption of the technology in utility plants, among which Okawa et al. (1997) who evaluated the economic of the process in a trial design plant. Singh et al. (2003) studied the techno-economics of the CO<sub>2</sub> capture from a proposed O<sub>2</sub>/CO<sub>2</sub> coal fired plant and compared to that in conventional approach by amine scrubbing. This provides one of the most comprehensive studies on this topic by comparing the two technologies and concluded that the capital and operating cost of CO<sub>2</sub> capture are lower for O<sub>2</sub>/CO<sub>2</sub> combustion route. In recent years, there are many studies on a full economic assessments of the technology with reference to retrofitting the existing plants and also for the development of new plants (Andersson & Johnsson, 2006; Davison, 2007). In general, the techno-economic assessments of the O<sub>2</sub>/CO<sub>2</sub> pulverized coal combustion in power plants, conducted

by various investigators lead to the following broad conclusions, as summarised from the review on the application of the technology by Buhre et al.(2005).

1. Pulverized coal combustion in  $O_2/CO_2$  is technically and economically feasible for retrofitting existing power generation plants and  $O_2/CO_2$  combustion for  $CO_2$  recovery and sequestration is a competitive power generation technology.
2. The application of coal combustion in  $O_2/CO_2$  technology is always associated with extra costs and efficiency penalties, from the additional capital and the operational costs of new equipment. In addition,  $CO_2$  capture reduces the net electricity efficiency by about 10% compared to the conventional air firing power plants without  $CO_2$  capture. However, the efficiency and costs of are less or comparable if the  $CO_2$  capture is also included in the conventional power plants.
3. The most expensive component, both for the capital and operation of the  $O_2/CO_2$  proposed combustion system, is the air separation unit, in which a large amount of oxygen is produced. This cost could be balanced by eliminating the  $NO_x$  and  $SO_x$  removal equipment and decreasing the capital cost of post-combustion clean up due to the reduced flue gas volume, which is the main feature of the  $O_2/CO_2$  combustion technology.

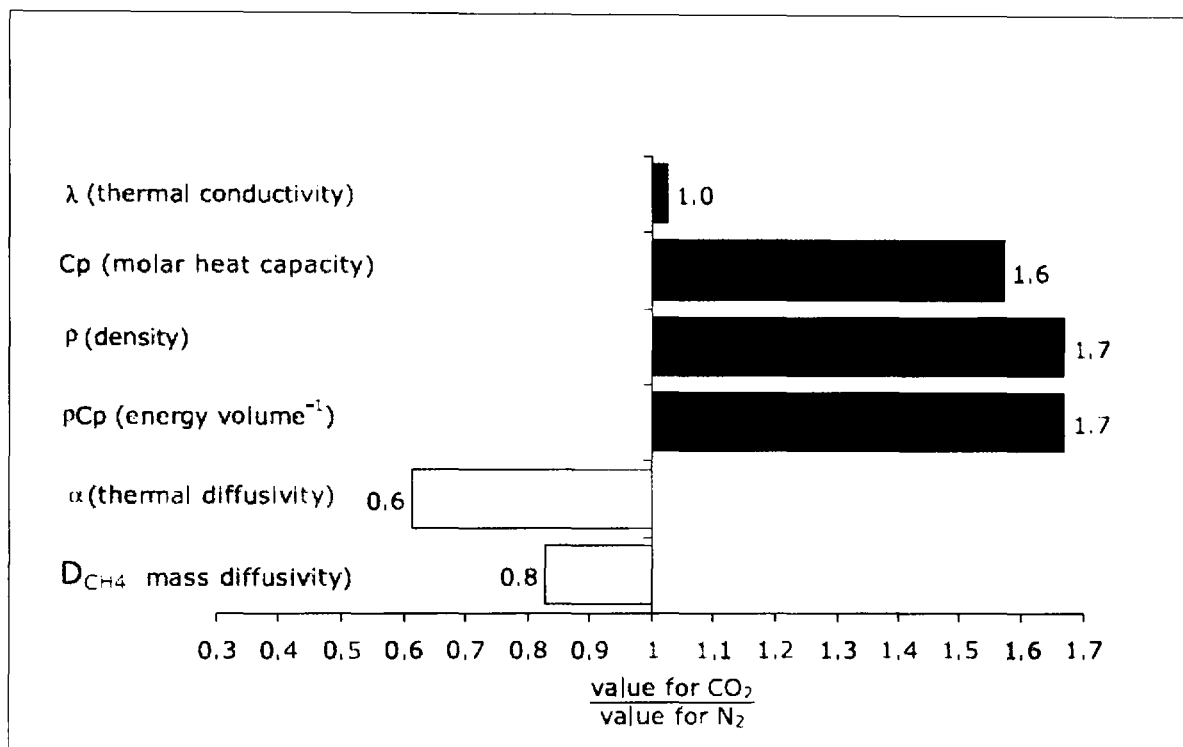
### **2.2.2. Combustion Characteristics in $O_2/CO_2$ .**

Nikzat et al. (2004) highlighted that the operation of a burner that uses high oxygen concentration instead of air to burn coal could be very difficult. The theoretical adiabatic flame temperature of combustion in high  $O_2$  concentrations

oxidant indicates a very high flue gas temperature conditions and the actual temperature is also expected to be well above the ash fusion temperature. Results from various experimental and theoretical evaluations have shown that flue gas recycled high in CO<sub>2</sub> is a viable means of controlling combustion and heat transfer characteristics in the furnace. A mixture of O<sub>2</sub>/CO<sub>2</sub> in different concentrations to stimulate CO<sub>2</sub>-rich recycled flue gas to control flame temperature has been used by several researchers in laboratory and in pilot test facilities. Theoretically, the characteristics of coal combustion in O<sub>2</sub>/CO<sub>2</sub> are different from those in air combustion in many aspects which could be related mainly to the properties of CO<sub>2</sub>. There are several affects on combustion characteristics that could be caused by the present of high CO<sub>2</sub> in the oxidant, which includes the effect on heat and mass transport from the increase of heat capacity of the oxidant, increase in absorption of radiation and decrease of the diffusion coefficient and to some extent, the effect on chemical reactions (Suda et al., 2007).

Figure 2.1 show the comparison of thermo-physical properties and non dimensional groups for CO<sub>2</sub> and N<sub>2</sub> at 1200 K (Molina and Shaddix, 2007). Compared to that of N<sub>2</sub>, the specific heats of CO<sub>2</sub> is higher and CO<sub>2</sub> gas is more radiative while thermal diffusivity is significantly less. The differences in these properties are more pronounced at a higher temperature of normal coal combustion in a boiler furnace (1600-1800K). Since the molar specific heat of CO<sub>2</sub> is significantly higher than that of N<sub>2</sub>, the adiabatic flame temperature of combustion in CO<sub>2</sub> environments with the same O<sub>2</sub> concentration is significantly lower than that in air. For example, the calculated adiabatic flame temperature  $T_{ad}$  of CH<sub>4</sub> flame in air is 2226 K compared to the calculated  $T_{ad} = 1783$  K for CH<sub>4</sub> in 21:79 O<sub>2</sub>-CO<sub>2</sub>. The

flame temperature could be increased to match that in air by increasing the  $O_2$  molar ratio in the oxidant mixture, and for  $CH_4$  flame, the calculated adiabatic flame temperature in 32:68- $O_2/CO_2$  matches that in air ( $T_{ad} = 2226$  K) (Shaddix, 2007). Similarly, coal flame temperature in  $O_2-CO_2$  environments are expected to be significantly differ to that in air combustion.



**Figure 2.1.** Comparison of ratio of different thermal and physical properties of  $CO_2$  and  $N_2$  at 1200k (Molina and Shaddix, 2007).

Due to high capability of  $CO_2$  to absorb radiation in flames, a much less luminous flame is also expected in coal combustion with high  $CO_2$ . In addition to the anticipated changes in the furnace's heat transfer characteristics in  $O_2/CO_2$ , the effect of changes in the combustibility of the coal which could lead to higher amount of carbon in ash in combustion with high  $CO_2$  is also a major concern. Higher oxygen-fuel stoichiometry to those in air combustion is therefore needed to obtain

comparable flame temperature and to produce stable flames. As the molecular weight of CO<sub>2</sub> is 44 compared to 28 for N<sub>2</sub>, the density of the O<sub>2</sub>/CO<sub>2</sub> oxidant mixture is also significantly higher than that of air, which would significantly affect the mass flow rates of the gas that pass through the furnace. Hence, replacing N<sub>2</sub> with CO<sub>2</sub> in the oxidiser would require various adjustments to the combustion systems operations that related to combustion and heat transfer characteristics. In addition to the lower combustion flame temperature, one of the anticipated problems with system operation on coal combustion in O<sub>2</sub>/CO<sub>2</sub> mixtures is the delay in flame ignition which is associated mainly with the presence of high CO<sub>2</sub> concentrations in the oxidants (Suda, 2007).

#### **2.2.2.1 Flame Temperature Profiles.**

There are several reports on pilot-scaled studies on combustion characteristics in O<sub>2</sub>/CO<sub>2</sub> environments on coal and other fuels for comparison. The results from these studies generally revealed that to attain a similar adiabatic flame temperature of coal combustion in O<sub>2</sub>/CO<sub>2</sub> environments as in air combustion, the O<sub>2</sub> proportion of the oxidiser passing through the burner should be significantly higher than 21% as in air combustion. Depending on the burner designs, furnace configurations and fuel and oxidant delivery in the combustion system, various O<sub>2</sub> concentrations in the oxidiser that could produce comparable temperature profiles to those in air combustion have been suggested.

In earlier work, Kimura et al. (1995) and later Kiga et al. (1997) investigated the characteristics of coal combustion with O<sub>2</sub>/recycled flue gas on an industrial-scale test facility, 1.2 MW horizontal tunnel (1.3 x 7.5 m) furnace with a coal feed rate of 100 kg/h. The combustion tests were conducted by maintaining the firing



rate, oxygen content in the exhaust gas, coal-transport gas volume, and excess oxygen ratio at the burner fixed. The main findings from their investigations were also presented by Yamada et al. (2000). Nozaki et al. (1997) conducted numerical simulations and combustion tests in the same test facility using low and medium volatile coals to study the flame characteristics of the combustion related to coal properties. Kimura et al. (1995) reported that, from their calculations based on the investigated coal-O<sub>2</sub>/CO<sub>2</sub> combustion system, to reach the same adiabatic flame temperature as in air, oxygen concentration in O<sub>2</sub>/CO<sub>2</sub> mixture should be as high as 42 %. It was also suggested that 30% O<sub>2</sub> concentrations in the furnace could ensure stable combustion in O<sub>2</sub>/CO<sub>2</sub> combustion. It was also reported that, compared to that in air combustion, the gas temperature at the burner outlet for O<sub>2</sub>/CO<sub>2</sub> combustion with 30% O<sub>2</sub> in the secondary gas was 200 °C lower, and the combustion temperature reaches its peak value further away from the burner. They also observed that the coal volatiles content, has a dominant effect on the temperature profiles in the furnace in which the gas temperatures on firing with high volatile coals are higher and increase more rapidly near the burner than those on firing lower volatile coals.

Croiset et al. (2000) compared coal combustion in O<sub>2</sub>/CO<sub>2</sub> mixtures to those in air, in a 0.3 MW cylindrical (0.6 m x 6.7 m) down-fired combustor. In the study, the inlet oxygen concentrations between 21 % to 42% were used and the flue gas excess oxygen concentration was fixed at 5 %. Experiments were conducted using sub bituminous and bituminous coals in various O<sub>2</sub>/CO<sub>2</sub> mixtures to simulate O<sub>2</sub>/CO<sub>2</sub>-recycle flue gas combustion. Later the study was extended by employing both dry and wet recycled flue gas. Based on the experimental results, CFD modelling was later used to evaluate the burner and combustor design concept (Chui et al., 2003 &

2004). Other related works were reported in various publications and some of the major findings obtained from these research activities were presented by Tan et al. (2006). Croiset et al. (2000) reported that for an equivalence  $O_2$  concentration, flame temperature is lower in  $O_2/CO_2$  combustion compared to that in air. It was found that combustion with only 21%  $O_2$  concentration produced a flame temperature close to the burner 300 °C lower than that in air, and the flame temperature matched that in air only when the  $O_2$  concentration was increased to about 35%. They attributed the differences in the temperature profiles, in part, to the higher specific heat of  $O_2/CO_2$  mixtures although other parameters may have also contributed. It was noted that the  $O_2$  concentration profiles in the furnace indicate that coal particles are burned further away from the burner in  $O_2/CO_2$  mixture, compare to those in air. They also reported that the presence of up to 5% nitrogen in the  $O_2/CO_2$  mixtures has no significant effect on the flame temperature compare to that in pure  $O_2/CO_2$  mixtures. Later, Tan et al. (2006) reported that coal flame in  $O_2/CO_2$  recycled flames are much less luminous due to high capability of  $CO_2$  to absorb radiation and flames are also more compact than the conventional coal-air flames. It was also reported that combustion with only 21%  $O_2$  result in flame temperature that significantly lower than combustion in air and, in certain cases, it was not even possible to maintain stable flames.

Andersson et al., (2006) and Maier et al. (2006) reported studies on combustion of two types of coal in  $O_2/CO_2$  mixtures in a specifically designed, electrically heated, 20 kW coal combustion test-unit without flue gas recycled. In their studies, the wall temperature was fixed at 1400 °C while the total volumetric flow of oxidants through the burner was kept constant and  $O_2/CO_2$  mixture with 21% and 27%  $O_2$  were use as oxidants. The stoichiometry was kept constant at  $\lambda =$

1.15 in all test set-ups by varying the coal feed rate to the combustor. For comparison, the combustion characteristics in  $O_2/CO_2$  was also studied in a 100 kW gas-fired test facility. Andersson et al. (2006) reported that compared to that in air, gas combustion in 21:79- $O_2/CO_2$  produced a significant drop in temperature that leads to a suppressed development of the flame which exhibits a poor burn-out rate of the fuel and combustion with 27:73- $O_2/CO_2$  produced temperature profile almost similar to that in air combustion. In combustion of one of the tested coals in the smaller furnace with 27:73- $O_2/CO_2$ , the measured axial temperatures along the furnace recorded a maximum of 1330°C for air and 1306°C for the 27:73 oxidizer, at 0.5 and 0.6 m distance from the burner, respectively. However tests on a different coal, with higher volatiles content, produced a slightly higher maximum temperature of 1326 °C at 0.7 m from the burner in the 27:73- $O_2/CO_2$  oxidizer, compared to 1287 °C at 0.9 m in the air case. It was suggested that for coal of lower volatile content, the combustion was dominated more by the char burnout which resulted in a less intense release of fuel-bound combustibles into the gas phase during the pyrolysis stage.

Châtel-Pélage et al. (2003) and Farzan et al. (2005) reported a study on coal combustion with  $O_2/CO_2$  recycled in a 1.5 MW boiler test unit, in which both the radiative and the convective sections of the furnace are representative in terms of geometry and heat exchangers of a utility boiler. The test runs employed similar overall mass flow rates of combustion gases through the boiler for the  $O_2/CO_2$  and air-blown conditions. A stable flame, attached at the burner's throat was obtained under the  $O_2/CO_2$  conditions. It was found that  $O_2/CO_2$  flame was more flared than the air-blown flame when both flames were under substoichiometric conditions and it was suggested that, this was due to lower burner velocities under the  $O_2/CO_2$

combustion case. From visual judgments, it was observed that the  $O_2/CO_2$  flame is colder than the air-fired flame under similar substoichiometric conditions, and this was explained due to the higher specific heat of  $CO_2$ . It was also reported that a less flared flame, similar to the air-blown combustion, was attained by increasing the mass flow rate of the recycled flue gas to the burner.

In other related studies, Lee et al. (2005) investigated experimentally the effect of the  $CO_2$  on thermal characteristics of an oxygen-enriched hydrogen flame, which was stabilized by a co-flow swirl burner mounted on the top of a vertical, 1m long cylindrical furnace. Various oxidiser compositions were used by replacing  $N_2$  with  $CO_2$  in  $O_2$ -enriched environments and the total and radiative heat flux from the flame to the wall of the furnace in different oxidants were measured and compared. When  $N_2$  was replaced by  $CO_2$ , the overall upstream temperature in the furnace decreased. For example, the peak temperature in (40:0:60- $O_2/N_2/CO_2$ ) was lower by 172 °C as compared to that in (40:60:0- $O_2/N_2/CO_2$ ) and 59 °C lower than in (40:30:30- $O_2/N_2/CO_2$  oxidizer mixtures. However, the positions of the maximum flame temperature along the axis of the furnace in different environments were similar. The differences in the maximum temperature were attributed mainly to the differences in molar specific heat of  $N_2$  and  $CO_2$  and also in the total heat loss to the wall. It was also suggested that the phenomenon is linked to the chemical effect incurred by  $CO_2$  addition in which the increase of initial  $CO_2$  concentration induces the increase of CO mole fraction and hence reduce the overall reaction rate of the fuel. Hence the increase of initial  $CO_2$  concentration produced lower maximum flame temperature. The results also showed that replacing  $N_2$  with  $CO_2$  in the oxidant with fixed  $O_2$  resulted in more visual radiation of the flame due to the fact

that CO<sub>2</sub> played an active role in emitting radiation, but as more CO<sub>2</sub> was added, no further changes were detected. Park et al. (2007) conducted a numerical investigation on the flame structure and NO emissions of CH<sub>4</sub> counter flow diffusion flame from combustion with a wide range of oxidiser compositions and various mole fractions of recirculated CO<sub>2</sub> in O<sub>2</sub>/N<sub>2</sub>/CO<sub>2</sub>. It was reported that oxygen displacement significantly modifies the diffusion flame structure obtained with air as the oxidiser. It was also found that chemical effects of the recirculated CO<sub>2</sub> not only reduce flame temperature but also increase CO production.

#### **2.2.2.2. Ignition and Flame Stability.**

Since CO<sub>2</sub> has an inhibitory effect on any flame stability, the potential changes in coal flame stability in coal-O<sub>2</sub>/CO<sub>2</sub> combustion which could affect the pollutants formation have also been investigated. The effect of high CO<sub>2</sub> in the oxidant on flame stability in coal-O<sub>2</sub>/CO<sub>2</sub> combustion was highlighted by Kimura et al. (1995) and Kiga et al. (1997) who reported that the high concentration of CO<sub>2</sub> in the combustion produced flames with vague ignition points and less luminosity and the flame was unstable and dark resulting in higher unburned carbon in ash. The flame stability was also attributed to the way oxidants were delivered to the combustion zone and it was found that flame stability was improved by the injection of pure O<sub>2</sub> directly at the centre of the burner. Croiset et al. (2000) also reported that the problems in flame ignition and stability in CO<sub>2</sub>/O<sub>2</sub> were also related to burner throughput which was resolved by the addition of an oxygen stream into the combustor. Tan et al. (2006) highlighted that higher concentrations of O<sub>2</sub> in the feed gas are required to raise the flame temperature and maintain stable flames since in

some of their coal combustion tests in  $O_2/CO_2$ , it was not possible to maintain stable flames with only 21%  $O_2$  in the oxidant.

The higher heat capacity of  $CO_2$  compared to that of  $N_2$ , has also been attributed to cause of the delay on flame ignition in  $O_2/CO_2$  combustion which was highly related to the flame propagation velocity. Kiga et al. (1997) studied the flame propagation speed of pulverized coal combustion in  $CO_2$ -rich atmospheres in a microgravity combustion chamber, which ensured a homogeneous distribution of coal particles and avoided mixing by natural convection, to determine the ignition characteristics of the flame in various oxidant mixtures of  $O_2$  with  $N_2$ ,  $CO_2$  and Ar. It was reported that the flame propagation speed in an  $O_2/CO_2$  atmosphere was markedly lower compared to that in  $O_2-N_2$  and  $O_2-Ar$  atmospheres, and that it was improved by increasing the  $O_2$  concentrations in the mixtures. The differences of ignition delay in different media were linked to the ratio of the heat capacity of coal particle and the thermal conductivity of dilution gas. It was found that when the thermal conductivity of atmospheric gas becomes low, ignition delay seems to increase. Since the thermal conductivity of  $CO_2$  is only fractionally higher than that of  $N_2$  the large ignition delay in  $CO_2$  dilution gas is attributed mainly due to differences in specific heat of  $CO_2$  gas. This finding was later supported by Suda et al. (2007) who investigated, both experimentally and numerically, the flame propagation speed of coal clouds in similar conditions. Numerical analysis was made by simple one-dimensional model concerning radiation heat transfer using Monte Carlo method. The  $O_2$  concentration in the tests was fixed to 40% because the flame propagation behavior was found to be unsteady at lower oxygen concentrations. It was reported that in 40:60- $O_2/CO_2$  mixture, flame propagation velocity of pulverized

coal cloud decreases to about  $1/3$ – $1/5$  compared of that in 40:60  $O_2/N_2$  (Oxidant of same  $O_2$  concentration). From a further comparison using  $Ar/O_2$ , it was revealed that, thermal diffusivity of the gas may also have a large effect on flame propagation velocity. From the numerical analyses, it was proven that the effect of absorption of radiation by  $CO_2$  gas on flame velocity was relatively small compared to that of thermodynamic properties especially the heat capacity of  $CO_2$ . Consequently, it was clarified that reduction of flame stability in  $CO_2/O_2$  combustion was mainly due to the larger heat capacity of  $CO_2$  gas. It was also reported that flames propagate more slowly for lower volatile coal than higher volatile coal and the brightness of the flame also decreases. From the measurement of particle temperature, it was found that the absolute temperature of the coal particle was lower in  $CO_2$  diluted gas compared to that in  $N_2$ , and the particles heating rate decreased.

Liu and Okazaki (2003) studied numerically the effect of heat recirculation on the systems combustion characteristics and emissions. In their studies, the theoretical flame temperatures in oxidant of different  $CO_2$  concentrations were obtained and the effect of  $CO_2$  concentration on reaction rate of coal combustion was investigated, based on the proposed mass and energy balance model. It was suggested that  $O_2/CO_2$  coal combustion with flue gas and heat recirculation could provide a more stable combustion conditions. From their calculation, it was suggested that about 30% of heat recirculation should be sufficient to compensate the decrease of coal combustion intensity caused by higher specific heat capacity of  $CO_2$ . It was also suggested that  $O_2/CO_2$  combustion with about 40% of heat recirculation, the same coal coal burning rate as that of coal combustion in air could be realised even at an  $O_2$  concentration of as low as 15%.

### 2.2.2.3. Heat Transfer Characteristics.

In comparison to combustion in air, changes in furnace heat transfer in O<sub>2</sub>/CO<sub>2</sub> combustion system are also related mainly to the differences in gas heat capacities and radiative properties of the oxidants. There were a few fundamental studies reported on the comparison of coal flame radiation and furnace heat transfer characteristics in combustion with O<sub>2</sub>/CO<sub>2</sub> and air. In an earlier evaluation study of boilers operating with O<sub>2</sub>/CO<sub>2</sub>-recycled flue gas, Pyne et al. (1989) suggested that both the measured heat flux distributions in pilot-scale test unit and the calculated heat flux distributions for full-scale boilers could be related as a function of the amount of recycled CO<sub>2</sub>. It was estimated that, wet recycle ratio of 0.76 and dry recycle ratio of 0.73, which correspond to ((CO<sub>2</sub> + H<sub>2</sub>O) /O<sub>2</sub>) ratio of 3.2 and (CO<sub>2</sub>/O<sub>2</sub>) of 2.7 respectively, could match the overall heat transfer performance of the scale-up boiler, as in normal air-fired combustion. However, it was also reported that a higher recycle ratio were required for a smaller furnaces. It was also highlighted that, to achieve the same overall furnace efficiencies as in air firing, moderate changes of relative heat flux distribution throughout the boiler must be taken into account and addressed accordingly.

Cha<sup>^</sup>tel-Pe<sup>^</sup>lag et al. (2003) suggested, based on the test results on a 1.5 MW pilot boiler, a smooth transition from air to oxygen combustion with favourable flame stability and heat transfer characteristics could be achieved in utility retrofit boiler. Later it was reported that, with similar gas mass flow rate in the boiler, similar convective pass heat absorption and flue gas exit temperature could be achieved with higher burner stoichiometry in O<sub>2</sub>/CO<sub>2</sub>, with SR<sub>1</sub>=1.05 compared to SR<sub>1</sub>= 0.88 in air (Farzan, 2007). From the pilot plant investigations, Tan et al. (2006)



also reported that with an O<sub>2</sub> concentration of 35% in the feed gas with the rest being mainly CO<sub>2</sub>, the combustion produced slightly higher heat flux and in-furnace temperatures compared to air firing at the same heat input and concluded that the enhancement of heat transfer resulted directly from higher O<sub>2</sub> concentration in the feed gas. In combustion with only 28% of O<sub>2</sub> in the feed gas, the measured heat flux and temperature profiles were slightly lower than air firing.

Wall (2007) highlighted that, compared to air combustion in retrofit boilers, higher thermal capacity of the oxidants in O<sub>2</sub>/CO<sub>2</sub> combustion would increase the heat transfer in the convective section of the boiler. However it is also noted that, in a O<sub>2</sub>/CO<sub>2</sub> combustion system, the amount of gas passing through the boiler is lower, and increased heat transfer in the radiative section of the boiler results in lower gas temperatures entering the convective pass. Hence, for the same adiabatic flame temperature to that in air, furnace heat transfer increases while convective pass transfer decreases. Therefore to ensure efficient operations in retrofit systems, the heat transfer in both the radiative and convective sections of the boiler need to be optimized. Similarly, Khare et al. (2005) highlighted that adjustments to the plant operations and to some extents plant designs, are required to maintain satisfactory balance for heat transfer in the different sections of the furnace. It was also suggested that the balancing of heat transfer depends on the moisture content of the recycle stream. It is also reported that if furnace heat transfer in O<sub>2</sub>/CO<sub>2</sub> combustion is matched to those in air combustion, at a given flue gas oxygen concentration, O<sub>2</sub>/CO<sub>2</sub> combustion will result in a lower furnace exit gas temperature.

In a related study, Anderson et al. (2006) reported the experimental results from a 100 kW gas-fired O<sub>2</sub>/CO<sub>2</sub> combustion, which showed that temperatures

decreased drastically for the 21:79- O<sub>2</sub>/CO<sub>2</sub> case compared to that in air-fired conditions, and this caused the suppressed development of the flame. In the 27:73- O<sub>2</sub>/CO<sub>2</sub> case, the temperatures of the combusting flow were slightly lower than in the air-fired case, however the flame radiation intensity increases by up to 25 to 30 %. It was also noted that although the temperatures were significantly lower in the 21:79-O<sub>2</sub>/CO<sub>2</sub> case compared to air-fired conditions, the radiation intensity levels approached those of the air combustion, which they explained was due to the fact that CO<sub>2</sub> partial pressure increased to about seven times the level of normal air-fired conditions, from which an increase in gas band radiation was anticipated. However, from the comparisons of the total mean emissivity and the gas emissivity for the 27:73-O<sub>2</sub>/CO<sub>2</sub> and the air cases, it was concluded that the change in emissivity was not only due to the increased in band radiation from the CO<sub>2</sub>, but may also be due to the increased in soot volume fraction. Lee et al. (2005) reported that for an oxygen-enhanced hydrogen flame in an oxidant mixture of O<sub>2</sub>/N<sub>2</sub> without CO<sub>2</sub>, radiation was the dominant heat transfer mode to the wall, but as the volumetric CO<sub>2</sub> proportion in the oxidizer increased, the convection became the main heat transfer mode to the wall due to 'heat blockage' effect in radiation, while the total heat flux increased. For example the total heat flux increased by 5.5% and 12 % respectively in the (40:30:30) and (40:0:60) compared to that in (40:60:0) of O<sub>2</sub>:N<sub>2</sub>:CO<sub>2</sub> oxidizer mixtures.

#### **2.2.2.4 Coal Particles Combustion.**

Fundamental studies on coal particles ignition in O<sub>2</sub>/CO<sub>2</sub> environments have also generated some interest. One of the most recent studies was reported by Molina and Shaddix (2007) who studied experimentally, the effect of enhanced O<sub>2</sub> levels

and CO<sub>2</sub> for their influences on ignition and devolatilisation characteristics of single-particle pulverized bituminous coal. The effect of CO<sub>2</sub> on coal ignition was evaluated by entraining coal particles into mixtures with N<sub>2</sub> or CO<sub>2</sub> as the balance gas at two different oxygen concentrations (21 and 30%), in a combustion-driven entrained flow reactor. It was reported that CO<sub>2</sub> in the oxidant retards coal particle ignition but has no measurable effect on the duration of volatile combustion while increasing O<sub>2</sub> concentration accelerates particle ignition for both O<sub>2</sub>/N<sub>2</sub> and O<sub>2</sub>/CO<sub>2</sub> atmospheres. The effect of CO<sub>2</sub> was explained due to its higher specific molar heat and lower diffusivity and the effect of O<sub>2</sub> was by its effect on mixture reactivity. Their results also suggested that an increased in O<sub>2</sub> concentration in CO<sub>2</sub>/O<sub>2</sub> combustion to 30 % should produce ignition times and volatile flames similar to those obtained in coal-air combustion. It was highlighted that these results have significance for coal combustion in utility boilers since they show that differences in coal ignition and in the time required for volatile oxidation during O<sub>2</sub>/CO<sub>2</sub> coal combustion are not only affected by the lower adiabatic flame temperature due to the presence of CO<sub>2</sub> the system, but also by the high specific heat and the lower mass diffusivities of the CO<sub>2</sub> mixtures.

Earlier, Murphy and Shaddix (2006) measured the combustion rates of a sub-bituminous and a high-volatile bituminous coal chars in both air and oxygen-enriched atmospheres, over oxygen concentrations ranging from 6 to 36 mol% and gas temperatures of 1320–1800 K. It was reported that, in elevated oxygen environments, despite higher burning rate, pulverized coal char particles burn under increasing kinetic control. Combustion in oxygen enriched environment significantly increases the char combustion temperature and reduces the char burnout time. It was also reported that the predicted char burnout rates and char particle temperatures

showed good agreement with measurement value and the predicted char particle temperatures tend to be lower for combustion in oxygen-depleted environments. It was also reported earlier by Shaddix and Murphy (2003) that gasification reactions of the char by  $\text{CO}_2$  become significant under oxygen-enriched char combustion at temperatures prevailing in practical processes.

#### **2.2.2.5. Coal Combustibility and Unburned Carbon in Ash.**

Theoretically, increasing the amount of  $\text{O}_2$  in coal combustion will enhance carbon burnout due to higher intensity of the combustion. From the bench-scale tests on coal- $\text{O}_2/\text{CO}_2$  with low recycling ratio, Nikzat et al. (2004) reported the results of stoichiometric oxygen-enriched combustion with 15 %  $\text{CO}_2$  dilution, more than 99.8% burnout and above 99.9 % for combustion with excess oxygen higher than 6.8 % was found. The unburned carbon concentration in the ash was expected to increase with the introduction of higher concentration of  $\text{CO}_2$  which was related to the combustion temperature and flame stability. In combustion with high  $\text{CO}_2$ , Kimura et al. (1997) observed that the flame in  $\text{O}_2/\text{CO}_2$  mixtures was generally unstable and dark and they reported that the amount of unburned carbon fraction was higher than that in air firing, when the amount of  $\text{O}_2$  was less than 30%. However, it was found that flame stability greatly improved and hence the amount of unburned carbon in ash significantly decreased by the introduction of pure Oxygen at the centre of the burner. Châtel-Pélage et al. (2003) reported an improvement in boiler efficiency and a large reduction (22%) in ash carbon content were achieved in pilot boiler  $\text{O}_2/\text{CO}_2$ -recycled combustion tests, which they suggested were due to the use of higher oxygen concentration in the combustion than that in air firing. Tan et al.

(2006) also reported that, in  $O_2/CO_2$ -recycled combustion, excellent combustion efficiency was achieved with over 99% carbon burnout.

Kumar et al. (2006) studied experimentally the effect of oxidant compositions in  $O_2/N_2$  and  $O_2/CO_2$ , on the coal char burnout. The experiment was conducted in a drop tube furnace at a fixed temperature of 1400 °C. The oxygen concentration was varied in the range of 3 to 21 % in  $O_2/N_2$  and between 5 to 30 % in  $O_2/CO_2$  mixtures. From their measurements, for the same concentration of  $O_2$ , higher char burnouts were observed in  $O_2/CO_2$ . It was suggested that the devolatilisation in  $O_2/CO_2$  was greater than in  $O_2/N_2$  due to char gasification by  $CO_2$ . It was also suggested that, for the same  $O_2$  in the flue gas for  $O_2/CO_2$  and air combustion, improvements in burnout are expected and proposed that compared to those in air combustion, lower flue  $O_2$  levels and therefore lower excess  $O_2$  levels, could be used in a  $O_2/CO_2$  combustion system. Wall (2007) suggested that even if the coal and char reactivities in the two environments ( $O_2/N_2$  and  $O_2/CO_2$ ) are similar, the overall improvement in coal burnout  $O_2/CO_2$  combustion system was anticipated due to the higher  $O_2$  partial pressures experienced by the burning particles, the possible gasification by  $CO_2$ , and longer residence times due to the smaller volume of gas flows. It was also suggested that, for the same  $O_2$  in the flue gas for  $O_2/CO_2$  and air combustion, improvement in burnout are expected and proposed that compared to those in air combustion, lower flue  $O_2$  levels and therefore lower excess  $O_2$  levels, could be used in  $O_2/CO_2$  combustion system.

### **2.2.3. Combustion Emissions.**

Since it was first proposed by Abraham (1982) that a high concentration of  $CO_2$  of up to 95% by volume can conceptually be produced in the flue gas by

recycling part of the flue gas to the combustion zone. the main emphasis of the study on coal-O<sub>2</sub>/CO<sub>2</sub> combustion has been to apply the technology to attain a high CO<sub>2</sub> concentration in the flue gas. In coal-air combustion system, excess air of around 20% are typically used to complete the combustion and to keep the emissions levels low (Mitchell, 1998). Similarly, combustion in a O<sub>2</sub>/CO<sub>2</sub> mixture would also require a percentage excess O<sub>2</sub> to achieve a similar O<sub>2</sub> fraction in the flue gas as those in air firing, which is normally in the range of 3–5% (Buhre et al., 2005). Tan et al. (2006) highlighted, depending on the way fuel and O<sub>2</sub> interact, the effect of increasing O<sub>2</sub> concentration in the feed gas to raise the flame temperature and to improve flame stability, can also have significant influences on various aspects of combustion, including the combustion emissions.

#### **2.2.3.1. CO<sub>2</sub>, O<sub>2</sub> and CO.**

In numerical studies conducted by Chui et al. (2003), it was suggested that a CO<sub>2</sub> concentration of 98 % theoretically could be produced from coal combustion in O<sub>2</sub>/CO<sub>2</sub> with recycle gas, with 2% excess oxygen. Several laboratory studies have reported that the CO<sub>2</sub> concentration in the flue gas from pulverised coal combustion in O<sub>2</sub>/CO<sub>2</sub> mixture could reach more than 95%. In a laboratory study employing a small electrically heated reactor Chen et al. (2006) reported that in the experimental runs with the same O<sub>2</sub> concentration in the feed gas, the concentration of CO<sub>2</sub> from O<sub>2</sub>/CO<sub>2</sub>-coal combustion was much higher than that from O<sub>2</sub>/N<sub>2</sub> combustion. With 21:79-O<sub>2</sub>/N<sub>2</sub> gas volume ratio only 13% CO<sub>2</sub> was produced in the coal combustion in O<sub>2</sub>/N<sub>2</sub>, compare to almost 98% in the O<sub>2</sub>/CO<sub>2</sub>. It was reported that the concentrations of CO<sub>2</sub> produced from O<sub>2</sub>/N<sub>2</sub> combustion increased with the concentration of O<sub>2</sub> in the feed gas and the highest CO<sub>2</sub> concentration produced was

34% at a feed gas composition of 50:50-O<sub>2</sub>/N<sub>2</sub>. The average concentration of CO<sub>2</sub> in the flue gas of O<sub>2</sub>/CO<sub>2</sub> coal combustion system was higher than 90% with the maximum concentration of 95% obtained from combustion with 30:70-O<sub>2</sub>/CO<sub>2</sub> feed gas. Hu et al. (2000) reported studies on combustion of a high-volatile coal with low flue gas recycling ratio (high O<sub>2</sub> concentration of 20 – 100%) in N<sub>2</sub> and CO<sub>2</sub> mixtures in an electrically heated, laboratory-scale 28 mm-diameter up-flow tube, with 180g/h coal feed, at gas temperatures of 1123–1573 K. It was reported that, CO<sub>2</sub> concentrations in flue gas was higher than 95% for the combustion with O<sub>2</sub>/CO<sub>2</sub> inlet gases, compared to 16% in air and in O<sub>2</sub>/N<sub>2</sub>. It was also reported that CO<sub>2</sub> concentration increased with the equivalence ratio in fuel-lean combustion but decreased in fuel-rich combustion. From tests in a large electrically heated furnace, Maier et al. (2006) reported that the volumetric fraction of CO<sub>2</sub> in the flue gas of O<sub>2</sub>/CO<sub>2</sub> combustion reached 95%, since the combustion system was operated at slightly positive pressure hence avoiding air infiltration.

However, the flue gas CO<sub>2</sub> concentrations reported in larger laboratory-scaled and pilot-scaled studies were generally lower than those obtained from laboratory-scale test units, mainly due to air infiltration into the furnace and also due to the excess air required to complete the combustion. In pilot plant studies reported by Croiset et al. (2000) and Croiset & Thambimuthu (2001), from combustion with the an inlet oxygen concentrations from 21 % to 42% and the flue gas excess oxygen concentration fixed at 5 %, the measured CO<sub>2</sub> concentrations in the flue gas agreed very closely (within 1%) with the theoretical values calculated for complete combustion. It was also reported that, the CO<sub>2</sub> concentration in the flue gas was affected by the purity of oxygen, and on average 92 % CO<sub>2</sub> concentration was

achieved in the flue gas. Later, from the same test facilities. Tan et al., (2006) reported that, with a well-sealed boiler system employing recycled flue gas. CO<sub>2</sub> concentration of up to 97 % could achieved in combustion with 2.1% of O<sub>2</sub> in the flue gas. From a study in a small boiler test facility, Farzan et al. (2005) reported that only a maximum of 80% CO<sub>2</sub> concentration was attained from coal combustion in O<sub>2</sub>/CO<sub>2</sub> recycle due to air infiltration in the boiler of approximately 5% of the overall stoichiometry, and suggested higher CO<sub>2</sub> concentration in flue gas could be achieved from boiler upgrades which reduce more air infiltration to the system. Croiset et al. (2000) and Croiset & Thambimuthu (2001) also reported that the oxygen concentration profiles in the furnace indicated that coal particles were burned further away from the burner in O<sub>2</sub>/CO<sub>2</sub> mixture compare to those in air and the O<sub>2</sub> concentration in the flue gas reach its final value faster in higher O<sub>2</sub> concentration mixtures. It was also reported that the CO emission decreased faster with higher O<sub>2</sub> concentration in the combustion chamber, which was linked to the temperature variation. However, the decrease of CO concentration along the flame is slower compared to air combustion because of high CO<sub>2</sub> gas concentration in O<sub>2</sub>/CO<sub>2</sub> mixtures which leads to the conclusion that high concentrations of CO<sub>2</sub> could also affect CO in the furnace. Tan et al. (2006) noted that in coal combustion in O<sub>2</sub>/CO<sub>2</sub>, CO concentration in the flue gas was higher than the air case and suggested that it was most likely due to the slower diffusion rate of volatiles under high CO<sub>2</sub> conditions. However, it was also reported, despite of the slightly higher CO concentration, excellent combustion efficiency was achieved with over 99% carbon burnout. In their study however, the CO concentration in the flue gas was always low and was not considered as a problem.



Andersson et al. (2006) reported that the suppressed development of the flame in 21:79-O<sub>2</sub>/CO<sub>2</sub> gas combustion could be observed from the CO profiles, which showed significantly lower CO concentration levels compared to those in air firing and 27:73-O<sub>2</sub>/CO<sub>2</sub> cases. From one of the coal combustion tests it was also observed that although the CO concentrations in the furnace in the 27:73-O<sub>2</sub>/CO<sub>2</sub> combustion peaked at 5.7% and was significantly higher than 1.6 % as in the air case, they decreased immediately to insignificant levels at the furnace exit. Maeir et al (2006) reported that the CO emission was higher in 27:73-O<sub>2</sub>/CO<sub>2</sub> than that in air combustion, and the CO emission rate (mg/MJ), especially in the region close to the burner, was also much higher and suggested this is due to the shift reaction of CO<sub>2</sub> towards CO when it reacts with carbon in the coal in the near burner region.

The trial results in bigger furnaces on coal combustion with low flue gas recycling ratio, as reported by Pak et al. (2004) and Nikzat et al. (2004) were in agreement with those from the earlier laboratory-scale tests by Hu et al. (2000). They reported that CO<sub>2</sub> concentration increased with the equivalence ratio in fuel-lean combustion but decreased in fuel-rich combustion. For the stoichiometric combustion, flue gas CO<sub>2</sub> concentration of around 90% was observed. They reported that in fuel-rich combustion, CO<sub>2</sub> increased with the O<sub>2</sub> concentration mainly due to the oxidation of CO to CO<sub>2</sub>. In the fuel-lean region, higher O<sub>2</sub> concentration reduced CO<sub>2</sub> concentration due to the diluting effect of O<sub>2</sub>. The highest CO<sub>2</sub> concentration of 92.5 % was observed at an equivalence ratio = 1.08.

#### **2.2.3.2. SO<sub>x</sub>**

The possibility of a reduction of SO<sub>x</sub> through O<sub>2</sub>/CO<sub>2</sub> combustion has also been studied by several investigators. Kiga et al. (1997) noticed a marked reduction

in SO<sub>2</sub> emission from the stack of O<sub>2</sub>/CO<sub>2</sub>-recycled coal combustion flue gas compared to air combustion and suggested that it was due to the condensation of sulphates in the furnace ducts and the absorption of sulphur in the ash. Croiset et al. (2000) reported that SO<sub>2</sub> emission, in term of mass per unit of energy released from the coal was not affected significantly by the variations of O<sub>2</sub> or CO<sub>2</sub> concentration in the feed mixtures. It was reported that SO<sub>2</sub> emissions appeared to be affected mainly by the sulphur content in the coal. However, it was later found that the type of combustion environments has some impact on the SO<sub>2</sub> conversion (Croiset & Thambimuthu, 2001). They reported that in O<sub>2</sub>/CO<sub>2</sub> once-through combustion tests, the SO<sub>2</sub> conversion averaged 75 % which were lower than the 91% averaged conversion in air firing tests. In O<sub>2</sub>/CO<sub>2</sub> recycle tests, the average conversion dropped further to 64 %. One possible explanation given, was that parts of the sulphur could be retained in the ash or part of the SO<sub>2</sub> was oxidised to SO<sub>3</sub>, although further tests on the ash revealed only about 3% of the initial sulphur was retained in the ash. It was also reported that the comparisons between dry and wet recycled tests did not show any significant differences in SO<sub>2</sub> emission rates. It was also observed that the SO<sub>2</sub> concentrations (in ppmv) differ greatly inside the furnace, where SO<sub>2</sub> concentration was almost doubled when part of the flue gas was recycled compare to a once-through O<sub>2</sub>/CO<sub>2</sub> system. They suggested that this phenomenon could have practical consequences related to the increased potential for material corrosion in the combustion system. Later, Tan et al. (2006) reported that when flue gas was recycled without SO<sub>2</sub> removal, there were significant increases of SO<sub>2</sub> concentrations in the furnace, which were about 3 to 4 times higher than in the corresponding air cases. due to the accumulated effects of flue gas recycled and reduced volume of flue gas. However it was also noted that even though the SO<sub>2</sub> volumetric concentrations were

higher. its mass emission rates was usually slightly lower than combustion in air, due to an increase in sulphur retention on ash deposits and on the cool surfaces of the gas cooler in flue gas recycled systems. Hence, it was highlighted that if the flue gas were recycled without the removal of  $\text{SO}_2$ , there would be significant accumulation of  $\text{SO}_2$  and consequently, increased  $\text{SO}_3$  in the recycled stream, with serious implications on the corrosion issues of the boiler systems. Hence it was proposed that, for a power plant design operating on  $\text{O}_2/\text{CO}_2$ -recycled without  $\text{SO}_2$  removal system, it is necessary to ensure that surfaces in contact with the flue gas to be maintained above the acid dew point to avoid material corrosion.

Andersson et al. (2006) reported that, from the the emission profiles in the furnace, the conversion of sulphur was completed at a short distance downstream of the burner, in both air and in 27:73- $\text{O}_2/\text{CO}_2$  combustion. The  $\text{SO}_2$  emissions appeared to be affected mainly by the sulphur content in the coal and not by the  $\text{O}_2$  or  $\text{CO}_2$  concentrations in the oxidiser. It was found that the conversion rate of fuel-S to  $\text{SO}_2$  in one of the coals was only slightly lower, at 89 % in 27:73- $\text{O}_2/\text{CO}_2$  compared to 94 % in air, and tests using coal with a much lower sulphur content in both environments resulted in slightly lower fuel-S conversion rate, which are 74% and 79 % respectively.

Liu et al. (2001) investigated in-furnace desulphurization in  $\text{O}_2/\text{CO}_2$  combustion in a laboratory-scaled fixed-bed reactor (0.02 m  $\phi$  x 0.65 m) and suggested that the system desulphurisation efficiency in  $\text{O}_2/\text{CO}_2$ -recycled pulverized coal combustion could be increased to about four to six times higher than that of conventional pulverized coal combustion. It was suggested that this high sulphation efficiency in  $\text{O}_2/\text{CO}_2$  combustion was mainly attributed to the system configuration

itself. The  $\text{SO}_x$  emission reduction was attributed to the extended practical residence time of  $\text{SO}_2$ , higher  $\text{SO}_2$  concentrations in the the furnace owing to the flue gas recirculation, and the inhibition of  $\text{CaSO}_4$  decomposition in the high  $\text{SO}_2$  concentrations. It was also reported that the system desulphurisation efficiency in  $\text{O}_2/\text{CO}_2$  pulverized coal combustion, maintained a high value over a wide range of temperature and particle residence time. In  $\text{O}_2/\text{CO}_2$  combustion with high concentration of  $\text{O}_2$ , Liu et al. (2000) observed that limestone, which was used for sulphur absorption in the study, exhibits more porous structure due to the presence of  $\text{CO}_2$  in  $\text{O}_2/\text{CO}_2$  combustion which could lead to direct sulfation of sulphur onto the limestone, enabling better sorbent utilization than in air combustion. From another laboratory-scaled study, Hu et al. (2000) reported that  $\text{SO}_2$  emission (ppmv) increases with the equivalence ratio in fuel-lean region and slightly decreases in fuel-rich region, when  $\Phi > 1.2$ . The effect of temperature on the  $\text{SO}_x$  emissions was reported as very small.

Although laboratory tests indicated that  $\text{SO}_2$  emissions in  $\text{O}_2/\text{CO}_2$  differ to those in air combustion, the thermodynamic modelling calculations by Zheng & Furimsky (2003) suggested that  $\text{SO}_x$  emissions from coal combustion, being governed only by oxygen concentrations, would be similar in  $\text{O}_2/\text{CO}_2$  at the same  $\text{O}_2$  concentration as that in air firing. Buhre et al. (2005) suggested that this contrary result to those from experimental data may due to the fact that the formation of  $\text{SO}_x$  in either  $\text{O}_2/\text{CO}_2$  or air combustion has not reached equilibrium and is governed by rate limitations, whereas the thermodynamic calculations assumed that equilibrium has been established.

### 2.2.3.3. NO<sub>x</sub>

A significant reduction of NO<sub>x</sub> emissions in coal-O<sub>2</sub>/CO<sub>2</sub>-recycled coal combustion, under both high recycling ratios (high CO<sub>2</sub> concentration in inlet gas) and under low recycling ratio (high O<sub>2</sub> concentration), compared to those in air firing has been reported by several researchers. Nakayama et al. (1992) in their economics evaluation of a proposed coal power plant earlier suggested that the NO<sub>x</sub> emissions from pulverized coal power plants that based on combustion in O<sub>2</sub>/CO<sub>2</sub> mixtures utilising recycled flue gas could be less than in conventional air-blown combustion. Takano et al. (1995) conducted tests with a high volatile bituminous coal and two medium volatile bituminous coals in a vertical electrically heated flow reactor (combustion rates of 1g/min). The oxygen concentration in the inlet gas was controlled at 21% and with oxygen ratio of 1.2, N<sub>2</sub> was gradually replaced by CO<sub>2</sub>. It was reported that the NO<sub>x</sub> conversion rate decreased as the CO<sub>2</sub> substitution proceeded, even though the combustion efficiencies almost unchanged. They suggested that the decrease in NO<sub>x</sub> conversion rate is caused by CO<sub>2</sub> which reacts with the char to become CO, and NO is reduced on the char surface through NO/CO/char reactions. The results also indicated that NO<sub>x</sub> conversion ratio is markedly higher in coal with lower fuel ratio. Takano et al. also studied the behaviour of NO<sub>x</sub> in recycled gas by adding NO to the recycled flue gas. They reported that the NO<sub>x</sub> reduction efficiency increases with the decrease in oxygen ratio. More than 90% of the recycled NO<sub>x</sub> was reduced at the oxygen ratio 0.8, and 50% at the oxygen ratio 1.2. The reduction of NO<sub>x</sub> in the recycled flue gas was attributed to the interaction with hydrocarbons produced in the devolatilisation process of the pulverised coal combustion. Nozaki et al. (1997) conducted

experiments on O<sub>2</sub>/CO<sub>2</sub> combustion with low volatile and medium volatile bituminous coals. They also reported that the NO<sub>x</sub> emission for O<sub>2</sub> CO<sub>2</sub> combustion was lower than that for air combustion although the recycled flue gas contained relatively large amounts of NO<sub>x</sub>. They concluded that the recycled NO<sub>x</sub> was rapidly reduced into HCN and NH<sub>3</sub> in the combustion zone. The result also indicated that NO<sub>x</sub> emission (ppmv) is markedly higher in coal with higher fuel ratio. It was also reported that, compared to air firing, the NO formation near the burner was delayed in O<sub>2</sub>/CO<sub>2</sub> combustion.

Okazaki and Ando (1997) studied the separate effects of CO<sub>2</sub> concentrations, reduction of recycled NO<sub>x</sub>, and interaction between fuel-N and recycled NO<sub>x</sub> on the reduction of the final overall NO<sub>x</sub> exhausted from coal-combustion systems with recycled CO<sub>2</sub>. The study was conducted using a flat CH<sub>4</sub> flame burner laden with anthracite coal particles in an electrically-heated furnace with a maximum controlled flame temperature of 1450 K and an initial O<sub>2</sub> concentration of 21 %. They reported that the amount of NO<sub>x</sub> exhausted from the O<sub>2</sub>/CO<sub>2</sub> combustion system was reduced to less than one third of that with combustion in air. This result was also attributed to the decreased conversion of fuel-N to NO<sub>x</sub> and the reduction of recycled NO<sub>x</sub> in the flame zone. They estimated that the contributions to total NO<sub>x</sub> decrease caused by recycled CO<sub>2</sub> are as follows:

1. The effect of an increase of CO<sub>2</sub> concentration in the furnace was not significant, below 10%
2. The effect of interaction between fuel-N and recycled NO was between 10 - 50%

3. The effect of reduction of recycled NO in the furnace was dominant, between 50 - 80%

They concluded that the drastic decrease of total exhausted NO in coal combustion with recycled CO<sub>2</sub> was due to the significant reduction of recycled NO to N<sub>2</sub> in the combustion zone by coal volatile matter. They also estimated that more than 50% of the recycled NO<sub>x</sub> was reduced when 80% of the flue is recycled.

From the pilot tests, Kimura et al. (1995) reported coal combustion in high recycle ratio of flue gas with oxygen concentration in the inlet gas of up to 30% produced a NO<sub>x</sub> conversion ratio (the ratio of conversion of fuel-N to NO<sub>x</sub>, assuming that fuel N causes overall NO<sub>x</sub>) of less than 10%, which was markedly lower than the 30% in air blown combustion. They concluded that the NO<sub>x</sub> emission was reduced mainly because the recycle NO<sub>x</sub> deoxidized in the furnace. Using the same test setup, Kiga et al.(1997) reported that in O<sub>2</sub>/CO<sub>2</sub> combustion, NO<sub>x</sub> emissions was not so significantly decreased by gas staging as that in air-blown combustion. They suggested, this was due to the NO<sub>x</sub> in the staging gas was not decomposed because of lack of reducing components like hydrocarbons.

Croiset and Thambimuthu (2001) noted that the expression of NO<sub>x</sub> emissions in terms of concentration (ppmv) would be inadequate for the purpose of comparing pollutant emissions between different combustion conditions. The emission concentrations of NO<sub>2</sub> (in ppmv) in O<sub>2</sub>/CO<sub>2</sub> could be higher than those to air combustion due the smaller amount of flue gas produced on O<sub>2</sub>/CO<sub>2</sub> combustion and the recycle of NO<sub>2</sub> in the recycled flue gas. Hence, the NO<sub>x</sub> emissions were expressed in terms of the emission rate, defined as the mass of NO<sub>x</sub> emitted per unit

heat produced by coal (ng/J). From the pilot plant tests, they observed that the  $\text{NO}_x$  emission rate was higher for combustion in air than that in  $\text{O}_2/\text{CO}_2$  mixtures with  $\text{O}_2$  concentration of less than 35 %. They linked this observation to the formation of thermal  $\text{NO}_x$  due to the presence of  $\text{N}_2$  in oxidant (air). However, it was suggested that the differences in  $\text{NO}_x$  emissions between the different environments could be decreased significantly, if as little as 3% of  $\text{N}_2$  was present in the  $\text{O}_2/\text{CO}_2$  mixtures. In  $\text{O}_2/\text{CO}_2$  combustion, higher  $\text{O}_2$  concentration in feed gas increased  $\text{NO}_x$  emission rates, which was attributed probably due to the increase in flame temperature at higher  $\text{O}_2$  concentration. Later, Croiset and Thambimuthu (2001) reported that combustion with recycled flue gas led to lower  $\text{NO}_x$  emission rates of between 40 – 50 % than for one-through combustion in  $\text{O}_2/\text{CO}_2$  mixtures. This was also explained to be due to further reduction of  $\text{NO}$  into  $\text{N}_2$  when  $\text{NO}$  was recycled back into the combustor. Higher  $\text{NO}_x$  concentration (ppmv) in the furnace was measured when the flue gas was recycled compared to those in once-through  $\text{O}_2/\text{CO}_2$  combustion. Similarly, it was reported that higher oxygen concentration in the feed stream led to higher  $\text{NO}_x$  concentration in the combustor.

Maier et al. (2006) studied the  $\text{NO}_x$  emission profiles of a medium and a high volatile coal, in  $\text{O}_2/\text{CO}_2$  in an electrically heated furnace with a fixed furnace wall temperature of 1300 °C and a fixed combustion stoichiometric ratio of 1.15, by employing a fixed oxidant flow rate. Since the coal feed rate was varied to maintain a fixed combustion stoichiometric, the  $\text{NO}_x$  emission was expressed in terms of emissions rate (mg/MJ). It was observed that the  $\text{NO}_x$  emission rate in 21:79- $\text{O}_2/\text{CO}_2$  is lower than that in air and suggested this phenomena to be due to the reduction of thermal  $\text{NO}_x$  from  $\text{N}_2$  in the oxidant. It was also reported that the  $\text{NO}_x$  emission rate is a



minimum at 27:73-O<sub>2</sub>/CO<sub>2</sub> but increases with O<sub>2</sub> concentrations when O<sub>2</sub> is higher than 27%. It was concluded that, the decrease in the NO<sub>x</sub> emission due to the absence of thermal NO<sub>x</sub> was outweighed by the increase in fuel NO<sub>x</sub>. It was also reported that the axial profile of NO<sub>x</sub> emission (ppmv) in the furnace was higher in 27:73-O<sub>2</sub>/CO<sub>2</sub> than those in air for both coals. However the NO<sub>x</sub> emission rate (mg/MJ) for the medium volatile coal was lower in 27:73-O<sub>2</sub>/CO<sub>2</sub> but higher for higher volatiles coals than those in the respective air combustion and concluded that the coal volatiles content has an impact on NO<sub>x</sub> emission rates. From the investigations using the same test facility and coals but without fixing the wall temperature as reported by Andersson (2006), it was revealed that the conversion of combustible nitrogen into NO<sub>x</sub> is completed about the same positions inside the furnace both for the air and the 27:73-O<sub>2</sub>/CO<sub>2</sub> and the NO<sub>x</sub> emissions at the outlet of the reactor are similar for the 27:73-O<sub>2</sub>/CO<sub>2</sub> and the air case. However in air combustion, an increase in NO<sub>x</sub> emissions was observed in the furnace which was suggested due to the formation of thermal NO<sub>x</sub> from the air-nitrogen. It was also reported that for the higher volatile coal, 23% of the fuel-N is converted to NO<sub>x</sub> in 27:73-O<sub>2</sub>/CO<sub>2</sub>, compared to 15 % for lower volatile coal. It was suggested that for lower volatile coal, a less intense release of fuel-bound combustibles into the gas phase during pyrolysis and hence NO<sub>x</sub> conversion is dominated more by the char burnout. However, the axial furnace's temperature profiles indicted that for higher volatile coal, the furnace's temperature for 27:73-O<sub>2</sub>/CO<sub>2</sub> is slightly higher than in air (with a maximum of 1326 °C compared to 1287 °C in the air case), whereas for the lower volatile coal the maximum temperature in 27:73-O<sub>2</sub>/CO<sub>2</sub> is lower (1306 °C vs. 1330 °C).

From the coal combustion in pilot boiler tests as described previously, Châtel-Pe'lage et al. (2003) reported that under  $O_2/CO_2$  conditions,  $NO_x$  emissions are influenced by the burner stoichiometry, oxygen flow rate into the primary air zone, and flue gas recirculation rate. It was reported that  $NO_x$  emission with  $O_2/CO_2$  combustion conditions that produced almost similar furnace temperature without flue gas recirculation, is 27% less than in air firing tests. The  $NO_x$  emission is reduced further to around one-third when parts of the flue gas were recirculated to the combustion zone. The  $NO_x$  emissions reduction were attributed to several factors which include the reburning process that promotes  $NO_x$  destruction and the fuel-N reduction process which limits the fuel- $NO_x$  formation, both of which are more effective in fuel rich conditions, and also the decrease in flame temperature resulting from the  $N_2-CO_2$  replacement, thereby limiting thermal- $NO_x$  formation. Later, Farzan et al. (2005) reported that the  $NO_x$  emissions from  $O_2/CO_2$  combustion, under substoichiometric conditions were significantly lower (65%) than the air-fired case that employed similar overall mass flow rates through the boiler. They suggested, this was due to higher flame temperature resulting from increased  $O_2$  content in the primary oxidiser zone of the boiler where higher temperature in the reducing zone promotes the conversion of re-circulated  $NO_x$  and devolatilised fuel nitrogen to molecular nitrogen. It was also suggested that  $NO_x$  can be reduced primarily by optimising the primary-zone oxygen level and burner stoichiometry so that flame shape could be maintained.

Hu et al. (2000, 2001) also studied the emissions of  $NO_x$  from the combustion of a high-volatile coal in  $O_2/CO_2$  with low flue gas recycling ratio or high  $O_2$  concentrations (20 – 100%) in  $N_2$  and  $CO_2$  mixtures, in an electrically heated, laboratory-scale (28 mm id, 180g/h coal) up-flow-tube at gas temperatures between

1123–1573 K. Later the study was extended to the parameters affecting the reduction of recycled-NO<sub>x</sub>. The recycled flue gas was simulated with a mixture of CO<sub>2</sub>, O<sub>2</sub> and NO<sub>x</sub>. Using the same experimental set-up, Hu et al. (2003) studied the effect of coal properties using three types of coal: high volatile bituminous, medium volatile bituminous and a semi-anthracite, on the emissions of NO<sub>x</sub> and the reduction of recycled-NO<sub>x</sub>. To extend the validity of laboratory-scaled test results, the study was later extended to a 145kW vertical down-fired experimental set-up as reported by Nikzat et al. (2004). Hu et al (2000, 2001) found that, under low flue gas recycling ratios of 0.0–0.4, the NO<sub>x</sub> concentration in the flue gas (ppmv) increased with fuel equivalence ratio  $\Phi$  ((Fuel/Oxidant)/(Fuel/Oxidant)<sub>S</sub>) in fuel-lean conditions, then declined dramatically as  $\Phi$  approached and exceeded the stoichiometric point, with the peak concentration being observed at  $\Phi= 0.8$ . It was observed that the peak value of NO<sub>x</sub> decreased as the O<sub>2</sub> concentration in inlet gas was lowered. Under the same O<sub>2</sub> concentration in the inlet gas, combustion with CO<sub>2</sub> based inlet gas emitted less NO<sub>x</sub> than N<sub>2</sub>-based processes. However, the NO<sub>x</sub> emission index (defined as mg-N/g-coal-fed) decreased monotonically with the increase of  $\Phi$  in both fuel-lean and fuel-rich combustion. The results also indicated a significant effect of temperature on the NO<sub>x</sub> emissions. In O<sub>2</sub>/CO<sub>2</sub> combustion, the NO<sub>x</sub> emission increased by 30–50% when the gas temperature was increased from 1123 to 1573 K, but the increase was much lower than in O<sub>2</sub>/N<sub>2</sub> combustion. It was reported that the reduction efficiency of the recycled-NO changed, both with equivalence ratio and recycling ratio. A higher reduction efficiency was obtained in fuel rich conditions than in lean and less recycled-NO was reduced under lower recycling ratio than that under higher recycling ratio. They also found that there was little influence of temperature on the

reduction of recycled NO. Later, Hu et al. (2003) concluded that the relative release rate of fuel-nitrogen to volatile matter and the partitioning of volatile-N and char-N are more critical than volatile matter content and nitrogen content in coal for NO<sub>x</sub> emissions in predicting the emissions of NO<sub>x</sub> especially in fuel lean conditions. The results also confirmed that the reduction efficiency of recycled-NO increases with fuel equivalence ratio and recycling ratio and the reduction efficiency reached 80% at a fuel equivalence ratio of 1.4. It was also suggested that there is a possibility that a large fraction of NO<sub>2</sub> produced in a furnace with coal combustion with high oxygen concentrations and it was found that the reduction of recycled-NO<sub>2</sub> follows the same trend as that of recycled-NO. From a larger bench-scale study, Nikzat et al. (2004) reported that the NO<sub>x</sub> concentrations in the flue gas increased with stoichiometric ratio in fuel-lean region, and declined dramatically as the stoichiometric ratio approached and exceeded the fuel-rich zone. This result is in agreement with those from the earlier laboratory-scale experiments, however, the maximum NO<sub>x</sub> concentration recorded is much lower than that found in the laboratory-scaled investigations. It was suggested that this variation could be due to the differences in coal temperature and gas residence time in the combustor. The reduction of NO<sub>x</sub> to N<sub>2</sub> under higher furnace temperature conditions than those in the laboratory scale was another suggested reason. It was also noted that, although considerable reduction in the thermal NO<sub>x</sub> emission in O<sub>2</sub>/CO<sub>2</sub> combustion were expected, due to the lower flue gas rate, the NO<sub>x</sub> concentration (ppmv) was observed to be higher compared to that in the combustion with air.

Liu and Okazaki (2003) suggested that a further reduction of NO<sub>x</sub> of up to one-seventh to that in air combustion could be realised by recirculating parts of the

heat in the flue gas. Heat recirculation could facilitate stable combustion at a lower  $O_2$  concentration in  $O_2/CO_2$  environments. They explained that, due to a much lower  $O_2$  concentration employed in the combustion gas mixtures, the conversion ratio from fuel-N to NO can be decreased and the reduction ratio from recycled NO to  $N_2$  can be increased. The higher temperature due to the heat recirculation could also lead to a higher NO reduction ratio. From the numerical investigation of  $CH_4-O_2/N_2/CO_2$  counter flow diffusion flame with various mole fractions of recirculated  $CO_2$ , Park et al. (2007) reported that the NO-Fenimore mechanism mainly contributes to NO formation for combustion of mole fractions of recirculated  $CO_2$  less than 0.3, while the NO formation through the thermal mechanism is dominant and that NO formation through the Fenimore mechanism mainly contributes to NO destruction. It was found that the recirculated  $CO_2$  and its chemical effects not only reduce the formation and destruction of NO through the Fenimore mechanism but also suppress the NO formation through the thermal mechanism.

### **2.3. Outstanding Issues In Coal Combustion $O_2/CO_2$ Technology.**

From the literature review, all laboratory and pilot scale studies have demonstrated the technical feasibility for coal- $O_2/CO_2$  combustion to be incorporated to the existing coal-air combustion systems for power generation or in the designing of a new combustion systems that adopts the technology. However there are several important issues related to the fundamental studies of combustion of coal in  $O_2/CO_2$  environment that need to be addressed further for the successful implementation of this technology in conventional coal-fired plants as highlighted by several researchers, including by Buhre et al. (2005) and Jordal et al. (2004) and

more recently by Sarofim (2007), Wall (2007) and Davison (2007). Other related issues on coal combustion in O<sub>2</sub>/CO<sub>2</sub> systems are also presented. as summarised in next section.

### **2.3.1. Combustion Principles.**

**Combustion characteristics.** Coal combustion characteristics in O<sub>2</sub>/CO<sub>2</sub> atmosphere including ignition, gas phase kinetics, flame and burn-out needs further clarification for a full understanding of the differences in these characteristics that arise from the replacement of N<sub>2</sub> in combustion air with CO<sub>2</sub>, the variation of O<sub>2</sub> concentrations in the oxidiser and also the compositions and the recycle ratio of the recycled flue gas. For a combustion system utilising recycled flue gas, the optimum ratio of the recycled flue gas was found to be dependent on the furnace size, hence the effect of the variation of this parameter on combustion characteristics in scaled-up units requires further investigations. More experimental studies on coal combustion in O<sub>2</sub>/CO<sub>2</sub> environments in various combustion conditions are also required to support the development of CFD modelling tools in this area.

**Heat transfer characteristics.** It was highlighted by Buhre et al. (2005) that the higher radiative absorption from the presence of high CO<sub>2</sub> in O<sub>2</sub>/CO<sub>2</sub> combustion will result in radiative heat transfer being transmitted over shorter distances in the furnace which may caused local variations in heat transfer, metal hot spots and higher gas temperature gradients that would affect gas temperature uniformity in the furnace and hence, requires various adjustments to the gas flow pattern. It has also been suggested that conditions may not be established for the same radiative transfer in the boiler and convective heat transfer in the convective sections, simultaneously and hence the requirement for modification in plant designs and operations when

retrofitting an existing plant need to be clarified. The detailed furnace heat transfer characteristics and performance analysis from the effect the variation of both O<sub>2</sub> and CO<sub>2</sub> feed concentrations, and flue gas recycle ratio particularly for retrofits system, are essential for the optimum output conditions in O<sub>2</sub>/CO<sub>2</sub> combustion system that would match those in air-fired system. There is also a need for verification and validation of reliable heat transfer models in O<sub>2</sub>/CO<sub>2</sub> combustion, both for new and retrofitted plants.

**Emission characteristics.** Generally, in coal-O<sub>2</sub>/CO<sub>2</sub> combustion with recycled flue gas, the furnace's NO<sub>x</sub> reduction has been attributed mostly by the reduction of recycled NO<sub>x</sub> in the volatile matter release region of the flame. Other routes, which include the decrease in thermal NO<sub>x</sub> due to lower concentrations of N<sub>2</sub> in the oxidants, the interactions between recycled NO<sub>x</sub> and fuel-N and hydrocarbons released from coal have also been attributed to the decrease in the overall NO<sub>x</sub> emissions. However, from the studies reported in literature, it is still not clear what mechanisms are responsible for the reduced NO<sub>x</sub> emissions in O<sub>2</sub>/CO<sub>2</sub> combustion from the effect of replacement of N<sub>2</sub> by CO<sub>2</sub> in the oxidant. The coal combustion emission characteristics in O<sub>2</sub>/CO<sub>2</sub> including the formation mechanisms of the major emission compositions, behaviour of sulphur and nitrogen in an O<sub>2</sub>/CO<sub>2</sub> atmosphere and the effect of the variation of the oxidant compositions and combustion conditions on the combustion emissions, ash-behaviour, slagging and fouling, and composition of deposits need further clarification. The flue gas emission levels including trace elements emissions and fly ash size distribution also need to be determined for environmental impact assessments (Buhre et al., 2005). The potentials of reducing pollutant emissions from O<sub>2</sub>/CO<sub>2</sub> combustion through the

existing available or new measures need to be explored for the extra cost benefits to the overall plants operations and to the environmental impacts of the technology.

### **2.3.2. Economics Considerations.**

Although the techno-economic studies on the proposed coal power generation plants have revealed that coal combustion in  $O_2/CO_2$  is one of the most cost-effective measure of  $CO_2$  capture from coal plants, the assessment of the proposed utility plants operating with  $O_2/CO_2$  have also revealed the generation of  $O_2$  for the combustion oxidants is a major additional cost, both in terms of capital and operational, which would severely penalised the plant net efficiency for electricity generation. At present, cryogenic air separation technique, which is an energy intensive process, is the only technology available for large scale oxygen production. The development of new and less expensive large-scale oxygen generation technology is therefore essential to reduce the energy penalty for the oxygen production in the application of the technology in utility plants. It has been proposed that development of other oxygen production techniques such as high temperature oxygen separation with ceramic materials (oxygen transfer membranes) which could be scaled up for utility plants requirement would reduce the cost of oxygen production considerably (Jordal et al, 2004). Recycling cool flue gas to the furnace would also increase the cooling load of the system and energy consumption for the gas cleaning. It was also highlighted by Buhre et al. (2005) that most of the techno-economic assessments studies conducted were for new plant designs and suggested that retrofits of existing air fired plants for  $O_2/CO_2$  combustion also need to be evaluated, based on the economic value assigned to the plant considered.



### 2.3.3. Other Issues.

**Designs and materials selection.** Since the heat flux to the furnace walls and heat exchangers are higher due to presence of high CO<sub>2</sub> in the flue gas, high-temperature corrosion is therefore likely to occur more rapidly in an O<sub>2</sub>/CO<sub>2</sub> combustion boiler than in an air-fired boiler (Jordal et al., 2004). The risk of corrosion is also compounded from the anticipated accumulation of SO<sub>3</sub> deposits in the flue gas recycled delivery systems. It has been suggested that if the flue gas were recycled without removal of SO<sub>2</sub>, there would be significant accumulation of SO<sub>2</sub> and consequently, increased SO<sub>3</sub> in the recycled stream, with serious implications on the corrosion issues of the boiler systems (Tan, 2006). Further investigations on these corrosion problems are essential for the requirements of boiler materials to be determined more accurately.

**Designs and operations.** For the application of recycled flue gas in the combustion, the point at which the flue gas recirculation should be extracted is also an important factor that may contribute to the additional equipments and operational costs that related to the recycled gas cooling, dehydration and cleaning (particularly for SO<sub>x</sub> removal), which also need to be addressed (Jordal et al., 2004). Gas purity in both oxidiser and flue gas is critical to both combustion and emission characteristics and the costs for CO<sub>2</sub> capture from the flue gas and air infiltration to a large combustion system operating with O<sub>2</sub>/CO<sub>2</sub> is highly anticipated. Problems related to the air leakages into the boiler which could lead to positive pressure boiler operations to minimize air leakage should be further investigated on the effect to the combustion characteristics.

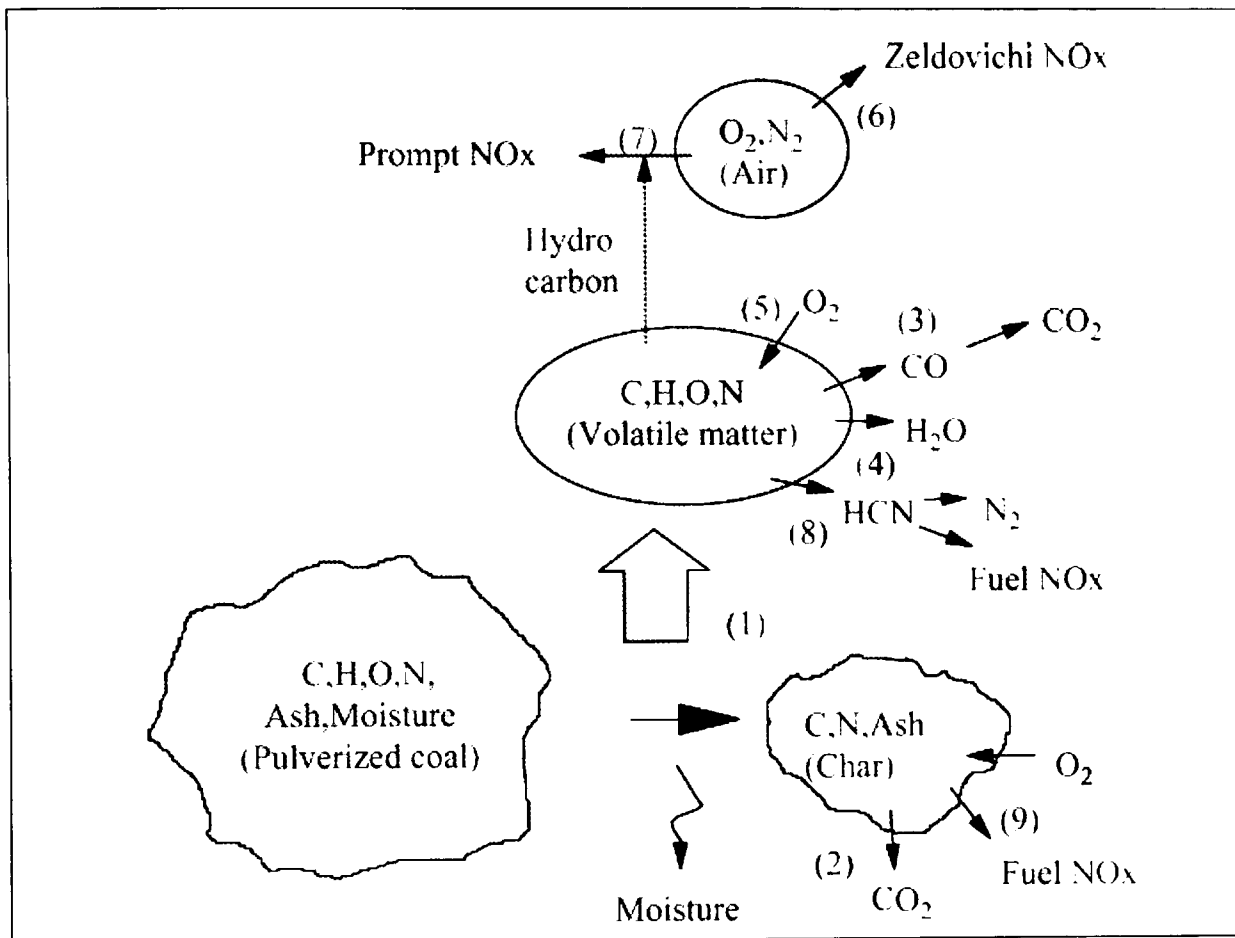
## **2.4. NO<sub>x</sub> Formations and NO<sub>x</sub> Reduction Technologies in Coal Combustion.**

In fuel combustion, oxides of nitrogen, referred to collectively as NO<sub>x</sub>, are formed from the combustion process where air is used and/or where nitrogen is present in the fuel. In pulverised coal-air combustion, NO<sub>x</sub> originate mainly from the coal-bound nitrogen and to a lesser extent from nitrogen in air used in the firing process (WCI, 2005). The majority of NO<sub>x</sub> emitted are in form of nitric oxide (NO), and only a small fraction (<5%) as nitrogen dioxide (NO<sub>2</sub>) and nitrous oxide (N<sub>2</sub>O). Hence, in many applications, only the emissions of NO is taken into account since the NO<sub>x</sub> emitted from the coal combustion consists of much lower concentrations of NO<sub>2</sub> and N<sub>2</sub>O compared to NO (Mitchell, 1998).

### **2.4.1. NO<sub>x</sub> Formation Mechanisms.**

It is known that the combustion of pulverised coal in air involve three overlapping but not entirely independent processes, started with the heating and the pyrolysis of the coal particles (devolatilisation stage), followed by volatile combustion (homogeneous gas phase) and char combustion (heterogeneous phase). NO<sub>x</sub> formation and destruction processes in coal combustion systems are very complex which involve various reactions. The fundamental and reactions chemistry of NO<sub>x</sub> formation and destruction mechanisms in pulverized coal-air combustion have been extensively studied and well understood. Detailed and comprehensive reviews on the study of NO<sub>x</sub> formation and destruction mechanisms in coal-air combustion have been provided in various publications, among which by Mitchell (1998), which described investigations in laboratory-scale, pilot-scale, and full-scale

furnaces and by Glarborg et al. (2003). Various computational modelling studies on coal-air combustion including those on the prediction of  $\text{NO}_x$  emissions have also been developed and continuously improved, and advanced coal combustion models are available (Williams et al., 2000 and Hill & Smoot, 2000).



**Figure 2.2.** Simplified concept of pulverized coal combustion (Kurose et al., 2004).

The concept of the pulverized coal-air combustion can be simplified as shown on the schematic diagram presented in Figure. 2.2. The amount of  $\text{NO}_x$  produced in coal-air combustion is attributed to a combination of three different mechanisms and the contributions of which are depending on the fuels compositions and/or combustion environments and conditions.  $\text{NO}_x$  is formed principally from the oxidation of the organic nitrogen content in the coal (fuel- $\text{NO}_x$ ) but some  $\text{NO}_x$  can be formed at high combustion temperature from the oxidation of  $\text{N}_2$  in the

combustion air (thermal NO<sub>x</sub> or Zeldovich NO<sub>x</sub>). Smaller amounts of 'Prompt NO<sub>x</sub>' may be formed by the interaction of CH<sub>i</sub> radicals with N<sub>2</sub>. Since NO<sub>2</sub> in atmosphere is formed from NO, in many applications, it is sufficient to study the mechanisms of formation of NO.

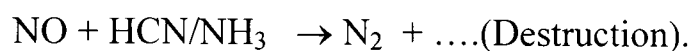
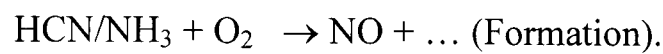
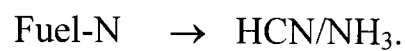
These three mechanisms of NO formation in coal combustion are summarised as follows:

**A). Fuel NO**

Fuel NO is formed from the liberation of coal-bound nitrogen which oxidised at temperature > 750<sup>o</sup>C. Nitrogen content in coals differs among coals and typically coals contain about 0.5-2.5% mass of nitrogen (van der Lans et al, 1997). Although the quantity of nitrogen present in coal (fuel-N) is small compared to nitrogen in the combustion air (molecular N<sub>2</sub>), the high conversion of fuel-N to NO, results in total NO produced in coal combustion being attributed mainly to the fuel NO mechanism. In pulverized coal combustion fuel-N conversion to NO accounts between 75 % - 95 % of the total NO generated in the combustion and hence it is the major source of NO in coal utility boilers (Mitchell, 1998).

Fuel NO is formed during both volatile combustion (homogeneous gas phase) and char combustion (heterogeneous) phase, with the majority of the fuel NO is formed via the release of nitrogen during the devolatilisation process. Coal particles combustion begins with fuel-N being distributed between the volatiles and the solid char matrix. The distribution of nitrogen between char and volatiles, as well as the volatile nitrogen composition, depends mainly on the fuel structure and the temperature (Glarborg et al., 2003). For bituminous coals the volatile-N consists mostly of tarry compounds that at high temperatures decay rapidly to hydrogen

cyanide (HCN) or soot-nitrogen. Fuel NO formation in gas phase combustion is very complex and involve several nitrogenous species mainly HCN, NH<sub>i</sub>, NO and N<sub>2</sub>. Nitrogen in coal is released during devolatilisation process in simple nitrogenous compounds such as HCN, NH<sub>3</sub> or HNCO which may react in the flame to form NO or N<sub>2</sub> in a proportion depending on the local stoichiometry, in which under fuel rich conditions, N<sub>2</sub> is favoured. The main reactions involves in the formation and destruction of NO can be simplified as :



For pulverized-coal flames with normal levels of excess air, approximately 20–40% of nitrogen devolatilised from the coal is converted to NO with the remainder are presumed to be converted to N<sub>2</sub> (Smoot et al., 1998). The NO formed can also be reduced by heterogeneous reactions with char particles (Molina et al., 2002, 2004). The conversion efficiency of fuel NO varies between 15% - 40%, which is determined by a variety of factors which include combustion conditions such as flame temperature and local combustion stoichiometry, particle size, and coal properties such as nitrogen content, coal rank (C/H ratio) and volatile content (Mitchell, 1998). The volatile NO conversion is strongly affected local stoichiometry where monotonic decrease of NO formation with decreasing fuel/O<sub>2</sub> ratio. This is due to delayed contact between volatile nitrogen and O<sub>2</sub> in lower air/fuel ratio atmospheres which reduce NO formation (Glarborg et al., 2003). In fuel rich conditions, the main product of reaction with hydrocarbon radical is HCN which is then readily converted to N<sub>2</sub> due to deficiency of oxygen. Higher proportion of

fuel increases the presence of  $\text{CH}_i$  radicals in the flame and these radicals react with NO to form the intermediate specie HCN, and the low proportion of  $\text{O}_2$  increases the proportion of intermediate species turning into  $\text{N}_2$  instead of NO (Glarborg et al. 2003).

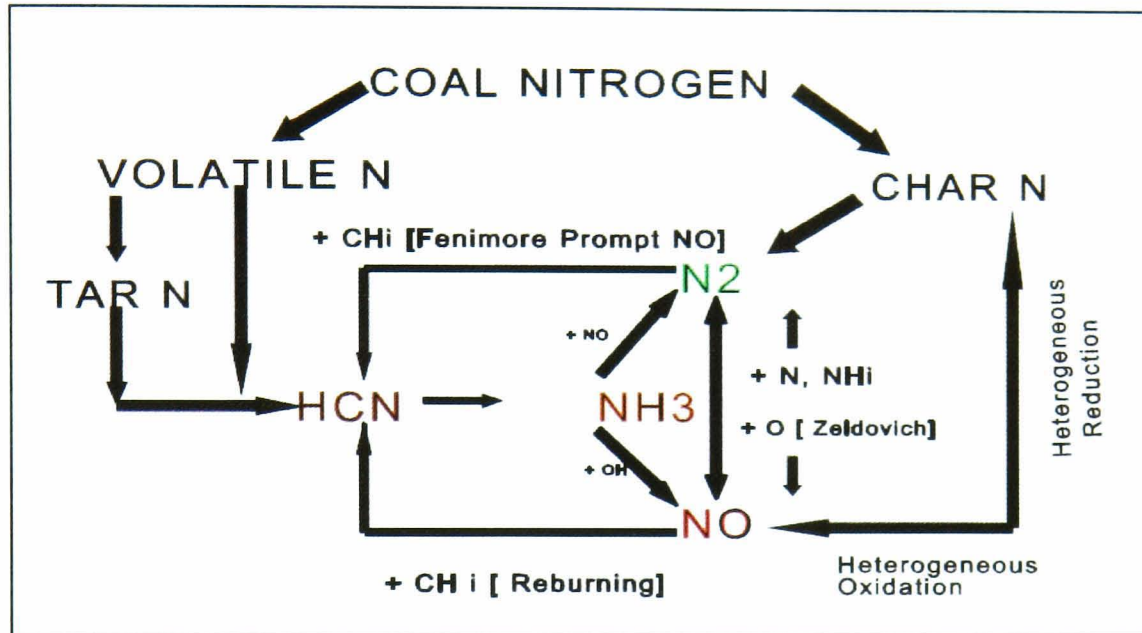
The conversion of fuel NO also depends weakly on temperature due to competing effects, increase of generation of NO (formation) and  $\text{N}_2$  (destruction) with temperature (Hill & Smoot, 2000). Fuel NO formation also depend on coal properties, especially volatile matter and coal-N. For example, higher rank coals release less volatile-N than lower rank coals due to the increased stability of nitrogen functionality (Mitchell, 1998). It has also been reported that NO emission increases with increasing coal-N although the fractional conversion of coal N to NO was found to decrease with the increasing Coal-N.

Char-N behaviour is more complex than volatile-N (Molina et al., 2000, 2004). In char phase combustion, fuel-N is believed to be converted to HCN before reacting to  $\text{N}_2$  or NO, or oxidised directly to NO as :



The net amount of NO formed by these heterogeneous reactions is strongly dependent on the intrinsic reactivity and internal surface area of the char (Hill & Smoot, 2000). Reactions on the char surface are also much slower than homogeneous reactions in gas phase. The overall contribution of NO from char combustion is less than that of volatiles, however, heterogeneous  $\text{NO}_x$  reactions are affected less by combustion modification than homogeneous  $\text{NO}_x$  reactions. hence  $\text{NO}_x$  form from these reactions are more difficult to control (Hill & Smoot, 2000).

Molina et al., 2000). The overall reactions pathway of fuel NO can be simplified as schematically illustrated in Figure 2.3.



**Figure 2.3** The simplified pathway of formation and destruction of nitrogen compounds originating from the combustible-N. (Wendt, 1995).

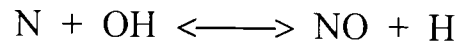
## B). Thermal NO

Thermal NO is the source of NO from the fixation of N<sub>2</sub> by the O<sub>2</sub> of air in high temperatures. The main reaction governing the formation of thermal NO is the reaction of atomic oxygen formed from dissociation of O<sub>2</sub> with nitrogen molecules or atoms, where conversion starts at temperature above 1300 °C and increases exponentially with temperature. This mechanism is well known and is called the extended Zeldovich mechanism with the following equations :

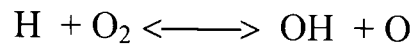
In fuel-lean conditions ( or close to stoichiometric conditions),



And in fuel rich conditions.



Where OH radicals coming from the reaction,

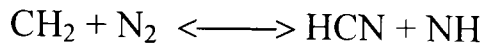
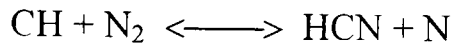


Thermal NO formation is highly dependent on temperature. linearly dependent on the oxygen atom concentration and associated with long residence time (Williams et al., 2000). Since the formation of thermal NO is sensitive to local stoichiometry and residence time and the formation is more significant in the post flame region than within the flame, hence, control of thermal NO can be achieved by lowering peak temperature in the furnace, minimising residence time in the highest temperature region and controlling the oxygen availability at various stage within the furnace including the amount of excess air levels. (Mitchell, 1998). Depending on furnace temperature, thermal NO accounts up to 20% of the total NO generated in coal combustion.

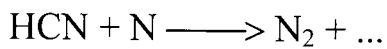
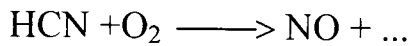
### c.) **Prompt NO**

Prompt NO is the NO generated in the flame front from the fixation of N<sub>2</sub> by the hydrocarbon radicals in reducing atmosphere. Prompt NO formation occurs in fuel rich, low temperature environments and is associated with short residence times (Williams et al, 2000). The main reaction product of CH<sub>i</sub> radicals with N<sub>2</sub> is HCN, which may then react further with oxygen to form NO or N<sub>2</sub>, and the amount of formation of NO is governed by the reactions of the nitrogen atom with the available CH<sub>i</sub> radicals species (Mitchell, 1998). The main equations involves in prompt NO formation are :





Then



The formation prompt NO is proportional to the concentration of N<sub>2</sub> and hydrocarbon radicals in the flame, and compared to thermal NO the amount formed is only a weaker function of temperature, and it shows a maximum at fuel-rich conditions (Van de Lans et al., 1997). The relative importance of prompt NO in coal combustion is uncertain but is believed to be very small (<5%) and can be almost always neglected (Mitchell, 1998).

#### **2.4.2. NO<sub>x</sub> Reduction Technology.**

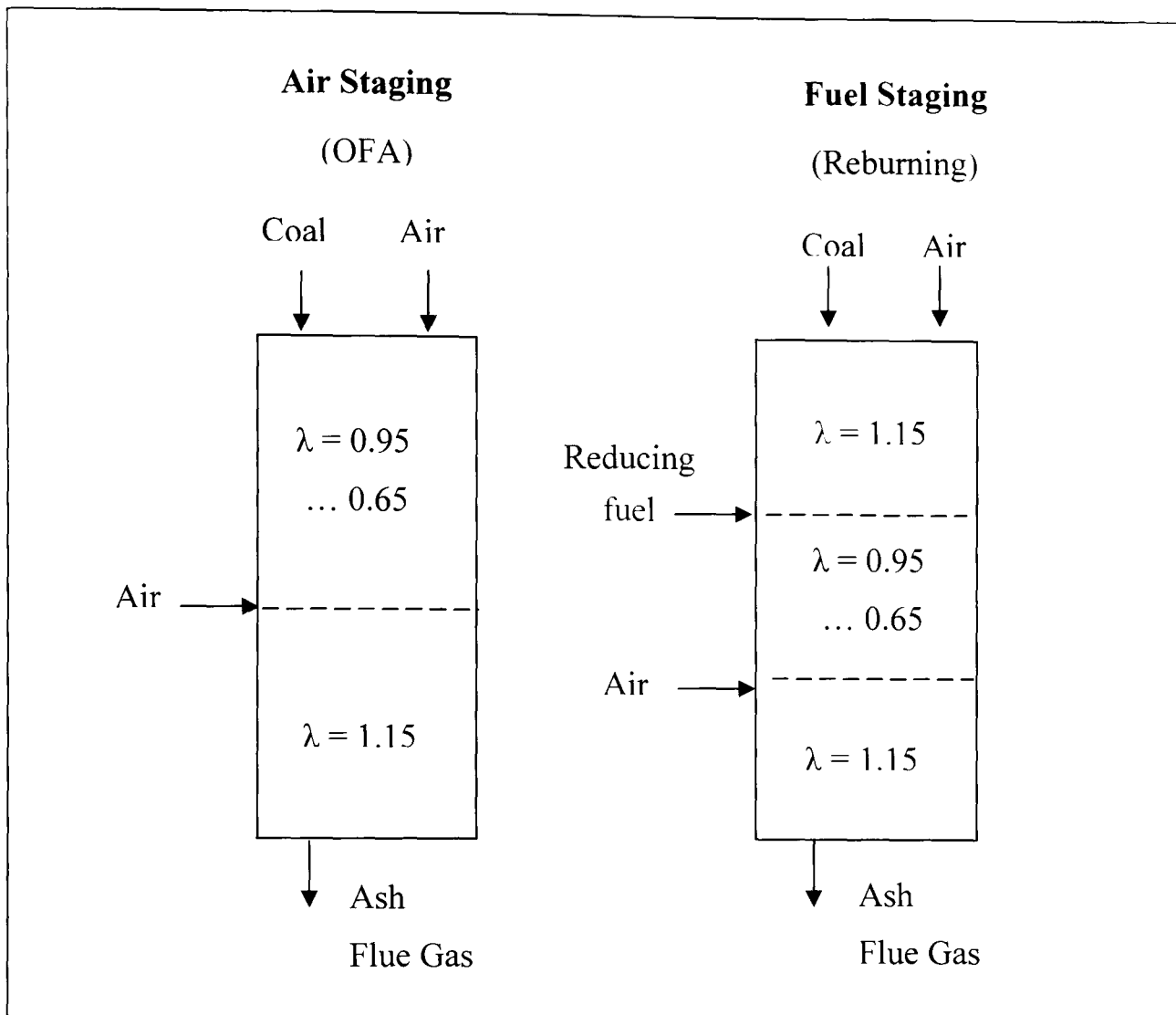
In the last few decades, NO<sub>x</sub> emissions in pulverized coal plants have been significantly reduced through various NO<sub>x</sub> reduction technological options. However, despite continuous and significant improvements on combustion emissions reduction, including NO<sub>x</sub>, achieved in recent years, there remains increasing global pressure for coal users to further reduce the combustion emissions. More stringent legislations on coal combustion emissions are expected to be introduced and enforced by the authority of many countries in the coming years (WCI, 2006). It was also highlighted by Glarborg et al. (2003) that even though NO<sub>x</sub> emission formation mechanisms has been the subject of extensive researches over the last few decades, there are still unresolved issues that may limit the potential of primary measures for NO<sub>x</sub> control.

The NO<sub>x</sub> reduction technology in pulverized coal plants can be classified into two broad approaches: Primary NO<sub>x</sub> reduction through combustion modification techniques and the secondary NO<sub>x</sub> reduction through flue gas treatment methods. Primary NO<sub>x</sub> control technology includes Low NO<sub>x</sub> Burners, Furnace Air Staging or Overfire Air (OFA) and Furnace Fuel Staging (Reburning). Other methods under this category are burner air/fuel staging and flue gas recirculating (FGR) techniques. Flue gas treatment methods are the removal of NO<sub>x</sub> in the post combustion, i.e. after NO<sub>x</sub> has been formed. The technology includes the Selective Noncatalytic Reduction (SNCR), Non Selective Catalytic Reduction (NSCR) and Selective Catalytic Reduction (SCR) which could reduce the emissions of NO<sub>x</sub> by up to 90% (Mitchell, 1998).

Combustion modification techniques can achieve up to 70% NO<sub>x</sub> reduction when applied individually or in combination and are relatively less expensive than flue gas treatment methods. In conventional coal fired installations, a combination of several methods are commonly practiced (Mitchell, 1998). The objective of most of these modification techniques is to minimize the reaction temperature and/or the contact of nitrogen from the fuel with oxygen in the combustion air, while creating a fuel-rich zone in which NO<sub>x</sub> can be reduced to N<sub>2</sub> (Hill & Smoot, 2000). This can be achieved by a combination of temperature reduction in all reaction zones, decreasing the residence time in all high temperature zone and decreasing the excess air and hence reducing the concentration of atomic oxygen in high temperature zone (in reburning however, most NO<sub>x</sub> reduction is achieved chemically by hydrocarbon radicals during combustion process). NO<sub>x</sub> reduction through combustion modification techniques are discussed in more details as follows:

#### 2.4.2.1. Furnace Air-staging (Overfire air).

The principle of furnace air staging method is to control the amount of combustion oxygen in zones where it is critical for  $\text{NO}_x$  formation. By staging the combustion air, two distinct regions are created in the furnace: a primary zone operating with a deficiency of air (sub-stoichiometric region) and a second burnout zone operating with excess air, hence, furnace air staging is also referred as Two Stage Combustion (TSC). The two-stage zones is achieved by diverting the combustion air so that the main combustion zone operates with an overall fuel rich stoichiometry in which  $\text{NO}_x$  is reduced to molecular nitrogen during coal devolatilisation and gas-phase combustion of volatiles and the remaining air required to complete the heterogeneous char combustion including the burnout of CO, soot and hydrocarbon, is then supplied in the burnout zone. The schematic diagram of the basic air staging is shown in figure 2.4. In industrial application, air staging can be applied to dry bottom boiler particularly in wall fired, tangentially fired burner furnaces. However, in modern dry-bottom firing with several burner levels, a combination of air staging with other  $\text{NO}_x$  emission reduction techniques is mostly used. (Spliethoff et al., 1996). The two stages combustion technique reduces both thermal and fuel  $\text{NO}_x$ . As the flame region is fuel rich, the conversion of fuel-N to molecular nitrogen is favoured due to lack of oxygen. This is because the higher proportion of fuel increases the presence of  $\text{CH}_i$  radicals in the flame and these radicals react with NO to form the intermediate specie HCN, and the low proportion of  $\text{O}_2$  increases the proportion of intermediate species turning into  $\text{N}_2$  instead of NO (Glarborg et al. 2003). Thermal  $\text{NO}_x$  is reduced as the peak temperature of the combustion occurs in an oxygen-deficient region.



**Figure 2.4.** The schematic of basic furnace Air Staging and Fuel Staging for  $\text{NO}_x$  emission reduction (Spliethoff et al., 1996).

The efficiency  $\text{NO}_x$  reduction by air staging depends on various parameters, mainly the stoichiometry and residence time in the main combustion zone and coal properties (Spliethoff et al., 1996). In substoichiometric conditions, more  $\text{NO}_x$  is reduced as the fuel ratio decreases up to an optimum value, beyond which less air produces more gaseous nitrogen species that are efficiently oxidised to  $\text{NO}$  in the burnout region. Generally, by prolonging the residence time in the fuel-rich primary zone,  $\text{NO}_x$  emission is reduced since longer residence time in the fuel-rich zone favours the decompositions of gaseous nitrogen species ( $\text{NO}$ ,  $\text{HCN}$ ,  $\text{NH}_3$ ), resulting

in reduction the conversion of coal-N to NO (Spliethoff et al., 1996). Studies have shown that the optimum residence time may depend on the coal types. It was reported that that under air-staged conditions, high volatiles bituminous coal produce less NO than low volatile bituminous coal, irrespective of nitrogen content of coal (Mitchell, 1998). Kurose et al. (2003) reported that the NO<sub>x</sub> reduction efficiency in staged-air combustion is affected by coal fuel ratio. It was revealed that as the fuel ratio increases, NO<sub>x</sub> reduction owing to the staged combustion decreases, and unburned carbon fraction increment becomes significant.

However, air staging in coal combustion usually have negative effect on char burnout efficiency due to changes in furnace conditions such as uniformity of fuel/air distribution, aerodynamic and mixing phenomena and longer residence time in oxygen deficient region, and also on CO emission due to incomplete combustion in the primary zone (Mitchell, 1998). Hence, in air-staged combustion, the location of the injection points and the mixing of the burnout in the combustor are also critical in achieving efficient combustion.

#### **2.4.2.1. Furnace fuel-staging (Reburning)**

Fuel staging or reburning technique involves staging both the supplementary fuel and combustion air, creating three distinct combustion regions in the furnace and hence, fuel staging is also referred to as three-stage combustion. The first region is the primary flames zone that operating in fuel-lean conditions, followed by the fuel-rich fuel reburning zone and the fuel-lean burnout zone (overfire). Coal is fired with some excess air in the flame zone in which NO<sub>x</sub> formation is maximised. The supplementary fuel in the reburning zone consumes the excess air for the combustion, creates a fuel-rich condition which provides CH<sub>i</sub> radicals, and

converts NO formed in the flame zone to molecular N<sub>2</sub> by reaction of NO with CH<sub>4</sub> from the fuel combustion. The remaining air required to complete the heterogeneous char combustion including the burnout of CO, soot and hydrocarbons leaving the reburn zone, is then supplied in the burnout zone. The reburn-zone is usually operated at lower temperatures and with higher hydrocarbon concentrations than with air-staging (Mereb & Wendt, 1994). Typically, 10-30% of the total heat input can be supplied as the reburn fuel. The schematic diagram of the basic fuel reburning is shown in Figure 2.4. However, in dry-bottom firing with several burner levels, the difference between air and fuel staging in the combustion chamber as illustrated is hardly apparent (Spliethoff, 1996). In industrial applications, oil, gas or coals are used as reburned fuel, and the application of coal fuel is becoming more attractive due to the economic advantages over other fuels as a reburning fuel (Naja, 1997).

The effectiveness of the reburning process on NO<sub>x</sub> reduction is dependent on numerous factors including the local mixing and stoichiometry in the reburning region (Hill & Smoot, 2000). The most critical factor affecting NO<sub>x</sub> emission is the reburn zone stoichiometry which value is determined by the amount of oxygen from the flame zone and the amount of the added reburning fuel. Other factors include fuel properties and primary zone residence time (Naja 1997).

#### **2.4.2.3. Low NO<sub>x</sub> Burner.**

Low NO<sub>x</sub> burners are designed to achieve the combustion fuel and air staging effect internally by partitioning and controlling the air and fuel flow. The principle of Low NO<sub>x</sub> Burner method in limiting NO<sub>x</sub> emission in coal-air combustion is by controlling the mixing of the coal particles and air during the combustion process, where combustion, reduction and burnout are achieved in three distinct zones.

Various designs of Low NO<sub>x</sub> burners are available commercially, with 30-60 % NO<sub>x</sub> reduction has been achieved (Mitchell, 1998). Advanced and Ultra-Low NO<sub>x</sub> burner designs which are being developed, in principle could achieved NO<sub>x</sub> reduction of up to 90% (Kurose, et al., 2004).

#### **2.4.2.4. Other Techniques**

Other NO<sub>x</sub> emissions reduction from coal combustion through combustion modification techniques include the optimisation of burner and furnace operating conditions by balancing both fuel and air flow in each individual burner (for multiple-burner furnace) and the level of excess air. Staging fuel and/or air in each burner creates fuels leans and fuel rich zones and lower temperature regions in the furnace that are critical to NO<sub>x</sub> formation. However, these operations may result in increased in CO emission and lower overall efficiency (Mitchell, 1998). Lowering excess air will limit both fuel and thermal NO<sub>x</sub> formation but excessive air reduction may caused unstable combustion that lead to burnout reduction and slagging and fouling that could lead to corrosion.

Flue gas recirculation (FGR) technique involves recycling parts of the flue gas and mix with the primary zone combustion air or with the staged air. The flue gas recirculation reduces thermal NO<sub>x</sub> from the both effects, the temperature reduction and dilution of oxygen in air, by the recirculated gas. The effectiveness of flue gas recirculation techniques depends on the amount of flue gas and the temperature of the recirculated gas. The fraction of the recirculated gas is usually only 10-20% of the exhaust gas at temperature around 300-400 °C. The reduction in NO<sub>x</sub> emission in coal-fired boiler by flue gas recirculation is usually less than 20% due to relatively low contribution of thermal NO<sub>x</sub> to the total NO<sub>x</sub> emissions.

However, there are several problems in the application of flue gas recirculation in the existing plants. It was reported that increasing the amount of recycling gas beyond the optimum value of around 20% could lead to flame instabilities and increased combustion and hydrocarbon emissions (Clarke & Williams, 1992). It was also reported that a reduction in radiant heat transfer due to lower temperature and increase in convective heat transfer as a result of the larger flow rate of flue gas. The high capital cost related to extra equipments and loads to recirculating flue gas at high temperature also make this technique economically less attractive.



## CHAPTER 3

### EXPERIMENTAL PROGRAMME

This chapter describes the experimental apparatus and procedure followed in conducting the tests. Test runs were conducted to investigate the suitability of the combustor for the O<sub>2</sub>/CO<sub>2</sub> combustion, and to extract the main features of combustion flames and emissions in air and O<sub>2</sub>/CO<sub>2</sub> mixtures with high CO<sub>2</sub> concentrations. The tests were extended to investigate the affect of oxidant staging on the reduction of NO<sub>x</sub> in air and O<sub>2</sub>/CO<sub>2</sub> environments and the fate of NO injected through various points in the air/oxidant lines to simulate the recycled NO.

#### **3.1. Combustion System Description.**

The experimental runs were conducted in a 20 kW (maximum thermal rating) down-fired combustor equipped with a pulverised fuel (pf) burner. The single burner of the combustor simulates typical power plant pf-burners in having a swirling secondary oxidant supply and a non-swirling coal-carrying primary oxidant supply and the furnace configuration is representative of commercial units in terms of residence times and temperature characteristics. Further down the combustor a tertiary oxidant can be added to simulate the air staging/OFA or low-NO<sub>x</sub> burner combustion. Coal combustion tests were conducted with air and O<sub>2</sub>/CO<sub>2</sub> mixtures and initially, various concentrations of O<sub>2</sub>/CO<sub>2</sub> mixture were used. It was later found that coal combustion using 30% O<sub>2</sub> and 70% CO<sub>2</sub> as the primary and

secondary oxidants produces similar temperature profiles to that in air combustion. All the proceeding tests on O<sub>2</sub>/CO<sub>2</sub> combustion including the staged combustion and NO recycled tests were conducted using 30:70-O<sub>2</sub>/CO<sub>2</sub> mixture. The main features of the experimental set-up are shown in Figure 3.1. The main components of the experimental set-up are:

### **3.1.1. Furnace.**

The furnace is a 20 kW-rated firing capacity, vertical down-fired, cylindrical combustor which employs a dual-fuel system which could be used for natural gas or coal firing. The internal diameter of the combustor is 190 mm and the wall is refractory lined with three-layer insulation materials to a thickness of 100 mm. The combustor is 3.0 m long and divided into nine bolted sections of varying length. Several circular ports are provided in each segment throughout the length of the furnace for the probing of gas species, temperature measurements and flames observation. The top section houses the burner quarl and transition section. The burner quarl section and the section connected to the quarl are lined with cast alumina and only the burner assembly being protected by cooling water. Further, down the combustor a tertiary oxidant can be added to simulate the air staging/OFA combustion. A pair of opposing ports, located at L<sub>1</sub> (0.57 m) and L<sub>2</sub> (0.88 m) from the burner were used for the injection of tertiary air/oxidant (over fire) in the staged combustion tests. A water-filled tray is located at the bottom to seal the furnace and is used as a vent in case of overpressure in the furnace. Bottom wet-ash can be collected in the tray while the ash sampling port from which fly ash is collected is located at the exit of the furnace. The flue gas is vented out through the exhaust gas pipe and the flue gas is diluted and the exit is aided by air entrainment from a 3 kW

fan. The main features and the relative dimensions of the furnace are shown in Figure 3.2 and the general view of the furnace is shown in Figures 3.3a and 3.3b.

### **3.1.2. Coal Burner.**

The single burner of the combustor simulates typical power plant p- burners and has been designed to simulate the approximate coal-air combustion temperature of a commercial burner. The non-swirling primary oxidant and coal particles are mixed with swirling secondary oxidant near the entrance to the burner quarl where the mixture of coal and primary air/oxidant are fed through the central pipe and the secondary gas feed through the side of the burner. The burner quarl is cone-shaped with diameter of 75 mm extended to 130 mm over a length of 200mm and has been designed for fuel delivery into to the furnace and to prevent pre-ignition of fuel before entering the furnace.

### **3.1.3. Air/Oxidant and Fuel Supply.**

The primary air was supplied by a compressor where air pressure was set at 20 psig to compensate for the drop in the coal feeding line while the secondary air is supplied by a 7.5 kW fan. CO<sub>2</sub> and O<sub>2</sub> were supplied through manifolds of gas cylinders and mixed according to the required molar ratio, prior to the deliver through the primary and secondary oxidant lines. The flow rates of air/gas were regulated and monitored by separate volume flow rate meters with corrections for pressure is applied where appropriate. N<sub>2</sub> and NO doping gas for recycled NO tests can be injected to the main gas lines through a separate gas supply line from gas cylinders. Natural gas for furnace ignition and heating up was supplied through the main gas pipeline, and the flow rate of gas was monitored by a rotameter.

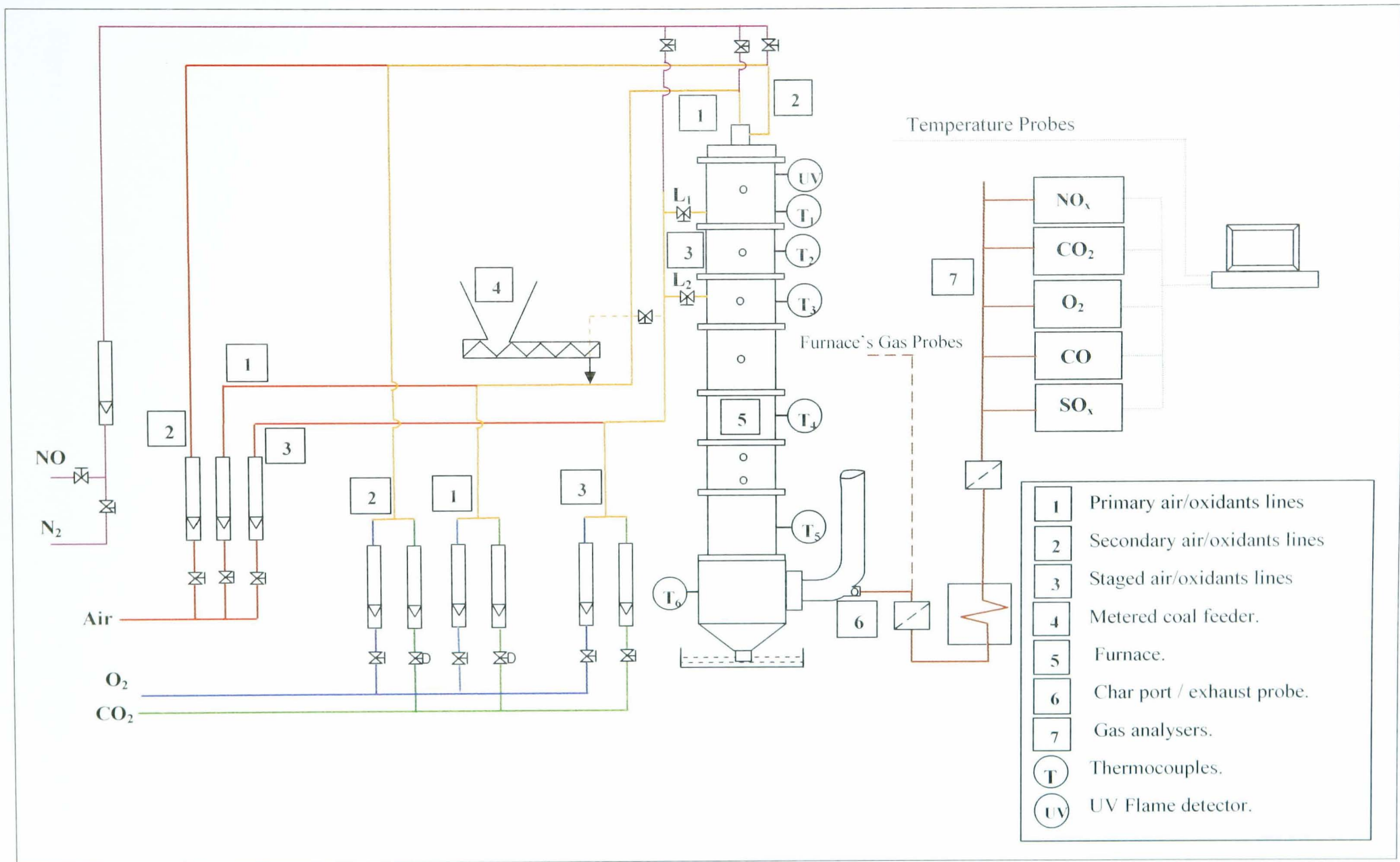
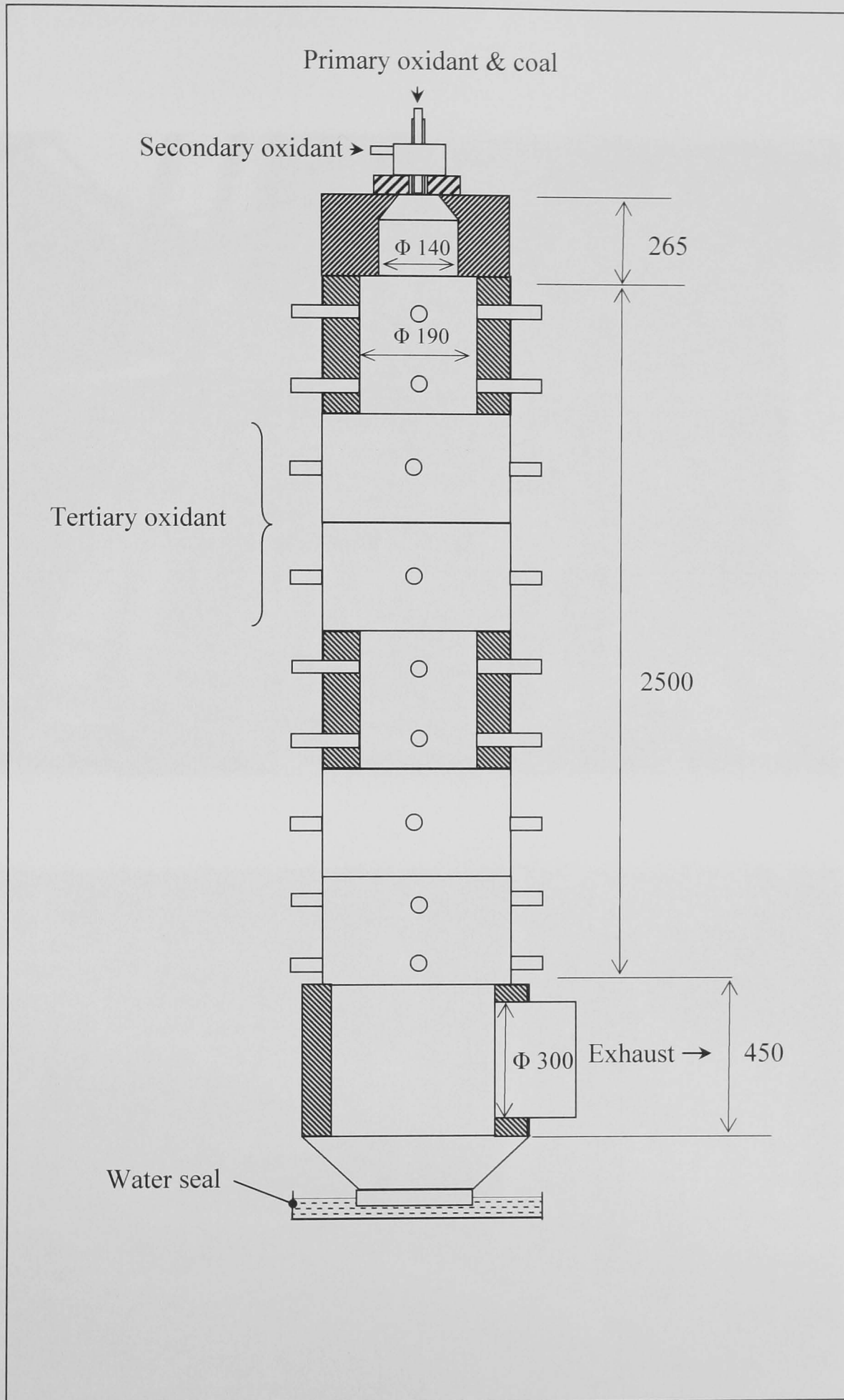


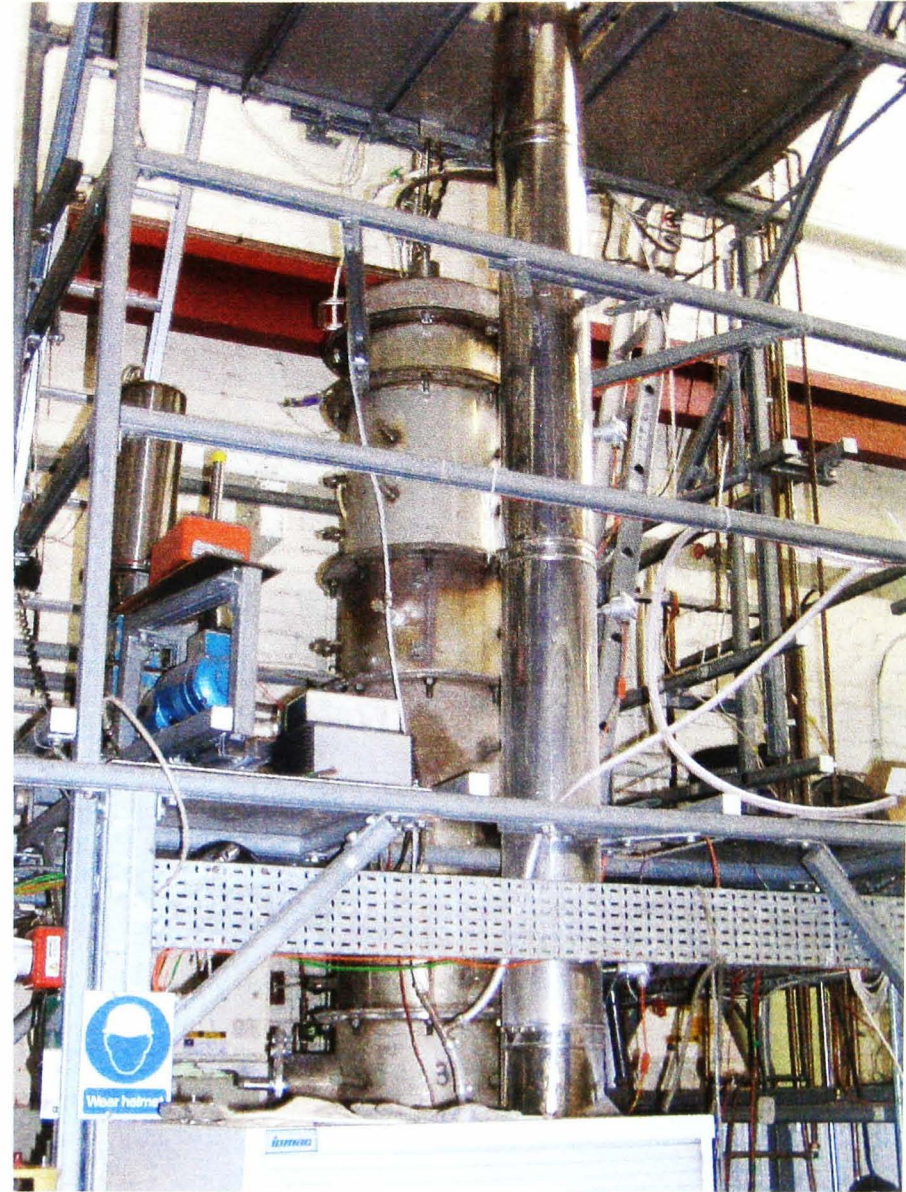
Figure 3.1. The Main Features of the Experimental Set-up.



**Figure 3.2.** The main features and relative dimensions of the furnace. (mm).



**Figure 3.3a.** General view of the test facility.



**Figure 3.3b.** General view of the test facility.

In O<sub>2</sub>/CO<sub>2</sub> combustion, a safety control measure is provided by solenoid switch relays connected to the flow meter, which will be activated in the event when CO<sub>2</sub> flow rates dropped to below a minimum set value, which will then stop the coal feeder. The natural gas combustion flame is lit using an electrical ignition rod and the fuel and air supplies to the burner are operated and control via independent rotameters.

Staging air/oxidant for the two-staged combustion tests were achieved by diverting the secondary gas to the tertiary gas line, while the primary gas is fixed. Two opposing stainless tubes were used as tertiary air/oxidant injectors and the injectors can be positioned in any of the two opposing sampling ports with their tips leveling with the furnace lining inner surface.

#### **3.1.4. Coal feeder.**

Pulverized coal was fed from a loss-in-weight metering twin-screw feeder and vibrating tray assembly (LBC 2000, Rospen Ltd) and delivered pneumatically to the burner by a fixed flow of primary air/oxidants to ensure uniformity in the coal delivery. In every test, the feed rate of each type of coal used was calibrated in advance and calculated to the nearest g/min (0.01 kg/hour). The feed rates of the coal feeder can be controlled to within 1 % of a set value by adjusting the rotational speed of the feeder.

#### **3.1.5. Monitoring Systems.**

##### **3.1.5.1. Gas Sampling.**

The major flue gas species CO<sub>2</sub>, O<sub>2</sub>, minor species NO<sub>x</sub> and SO<sub>x</sub> and CO were measured at the exit of the furnace. Gas samples were continuously drawn through a

hot stainless steel probe fixed with ceramic wool to prevent ash blockage to the gas sampling lines. The concentrations of combustion emission components inside the furnace were determined by drawing the gas using a water-cooled stainless steel probing device.

The extracted flue gas from the probes was transferred using *PTFE* tubing and cleaned and dried by passing it through a series of quartz and glass wool filters and a wet trap. The glass wool filters were replaced and the water trap was cleaned regularly throughout the test runs to prevent blockage to the gas sampling lines. The flue gas was then cooled and maintained at 2 °C by passing it through a chiller (refrigerator) and the remaining moisture was removed further by silica gels before they were pumped to the gas analysers through a series of mini-filters. The flue gas was passed through a manifold of individual valve that directed the sample gas to different gas analysers.

#### **3.1.4.2. Temperature Measurements**

The gas temperature inside the furnace was measured with sheathed R-type thermocouples. The thermocouples were fixed at six axial locations of the furnace. Table 3.1 shows the vertical positions of the thermocouples and the gas probing ports, relative to the burner. Each temperature probes was monitored by a data logging system connected to a personal computer.

#### **3.1.4.3. Char/Ash sampling.**

Dry ash was collected at the exhaust duct at the furnace exit for carbon-in-ash analysis, at the end of every test section on when required. The sample of wet ash at



the bottom furnace tray was also collected at the end of each test runs for comparison in ash analyses.

### **3.1.6. Gas Analysers.**

The NO<sub>x</sub>, O<sub>2</sub> and CO<sub>2</sub> concentrations were continuously monitored and recorded by on-line analysers, while SO<sub>2</sub> and CO concentrations were measured when they were required.

The gas analysers used for gas measurement:

1. NO<sub>x</sub> (NO and NO<sub>2</sub>) – Analysis Automation Ltd Series 440, chemiluminescent analyser
2. O<sub>2</sub> - Taylor-Servomax OA 570, Pragmagnetic O<sub>2</sub> Analyser.
3. CO<sub>2</sub>/CO/SO<sub>2</sub> – ADC-ABB Easyline, Non-Dispersive Infra red Gas Analyser.

The gas analysers were calibrated in every test run using standard calibration gases. Each gas analyser and temperature probes are monitored by a data logging system connected to a PC. Since nitric oxide was always the dominant part of NO<sub>x</sub> under conditions of this study, NO<sub>x</sub> analyser was set to measure NO<sub>x</sub> (NO and NO<sub>2</sub>). SO<sub>2</sub> measurement was used for SO<sub>x</sub> emissions. NO<sub>x</sub> and SO<sub>x</sub> emissions were expressed in ppmv (part-permillion by volume) but the comparisons of NO<sub>x</sub> and SO<sub>x</sub> emissions between coal–air combustion and coal–O<sub>2</sub>/CO<sub>2</sub> combustion were made on the amounts of NO<sub>x</sub> and SO<sub>x</sub> emitted with each combustion media (conversion ratio). CO<sub>2</sub> and O<sub>2</sub> concentrations were measured in % dry volume, while CO was expressed in both % of dry volume and ppmv.

## **3.2. Experimental Approach.**

### **3.2.1. Coal Samples**

Eight commercial bituminous coals samples were used in the tests, however seven were used in all tests. The properties of all coal samples, proximate and ultimate analyses, were determined in advanced and their properties are presented in Table 3.2. The fuel ratio of the coals varies from 1.59 – 2.33. (8.01)

### **3.2.2. Experimental Procedures.**

For each type of coal, the feed rate from the coal feeder was calibrated with the rotational speed (rpm) of the feeder in advance, by measuring the amount of coal discharge from the feeder for each setting, the coal was then conveyed pneumatically by the fixed primary air flow rate and collected in a dust bag. The feed rate from the coal feeder can be controlled to within 1 % of a set value by adjusting the rotational speed of the feeder. Generally, for each type of coal, tests were conducted by maintaining coal firing rate and primary air/oxidant flow rate. Since the amount of oxygen in the oxidant was fixed in combustion with air or O<sub>2</sub>/CO<sub>2</sub> oxidants mixtures, a fixed combustion stoichiometric ratio was maintained throughout the test run.

The preparation for each test run was conducted before the day of the test run by testing all the instrument and main components. The amount of coals used in each test run was also determined for comparison to the metered coal feed rates. Each test run started with normal coal air combustion and may be followed by NO<sub>x</sub> recycled tests and staged combustion tests where applicable, before the air supplies to the furnace were switched to O<sub>2</sub> and CO<sub>2</sub> with continuous coal feeding at the

same rate. The continuous coal feeding during changing over from air combustion to O<sub>2</sub>/CO<sub>2</sub> combustion minimizes any errors resulting from coal feeding rate variations between the two combustion environments.

The main experimental procedures are summarised as follow:

1. The furnace was first sufficiently heated to a temperature close to the normal coal-air firing around 1250 °C by natural gas firing and the heating-up period could be achieved within two hours. In each test, all gas sampling lines were thoroughly checked from leakages and all gas analysers were tested and calibrated during the natural gas combustion.
2. When the top gas temperature (T<sub>1</sub>) reach about 1200 °C, the flue gas sampling and temperature measurements were started. Once the flame was stabilized i.e. when the flue gas emission levels were uniform and constant, the methane supply to the burner was switched off and then the process was shifted to pulverised coal combustion by activating the coal feeder. Coal flames were continuously monitored by a UV flame detector which connects to an automatic start-up/purge in the flame failure detection control system.
3. The stoichiometric ratio of the primary and secondary air to pulverized coal (Air/Coal) was set at SR =1.20, with fixed primary air (coal carrier). The coal feeder was adjusted to the desired setting of this excess oxygen.
4. Coal-air combustion tests were started when the stability had been reached i.e. when the temperatures of the combustion air were constant and the concentration of the exhaust gas components were steady and uniform. If profiles of gas compositions were to be measured, a water-cooled probe was used to draw gas samples. To minimize the cooling effect of the probe on the

- coal flame. samplings started at the bottom of the furnace and gradually moved up to the top of combustor.
5. The gas sampling lines were regularly cleaned from the deposited ash and moisture. This was done when O<sub>2</sub> and CO<sub>2</sub> concentrations in the flue gas shifted from the desired levels.
  6. Ash tray was placed at the char ports at the furnace exit prior to each test. The fly ash at the end of each test component was collected and later analysed for the unburned carbon concentration using the standard procedures for ash in coal tests. The ash collected at the bottom ash collector was also analysed for comparison.
  7. In two-stage combustion tests, combustion zone stoichiometric ratio SR<sub>1</sub> was varied between 0.80 and 1.20, by diverting a proportion of secondary air to the tertiary air, with the primary air/oxidant was fixed. The furnace overall stoichiometric ratio SR is fixed at 1.20. The staged or tertiary air/oxidant was introduced at two different port positions, either at L<sub>1</sub> (0.57 m) or L<sub>2</sub> (0.88 m) downstream from the burner.
  8. For recycled NO<sub>x</sub> tests, 5 % of NO in N<sub>2</sub> was added and mixed to the different streams of oxidants to simulate the NO<sub>x</sub> recycle. The simulated recycled NO was in the range of 0–1500 ppmv. NO and N<sub>2</sub> were introduced alternately for about 6 – 9 minutes intervals throughout the test periods.
  9. Once coal-air combustion tests were completed, the operation was shifted to O<sub>2</sub>/CO<sub>2</sub> combustion. The required proportions of O<sub>2</sub> and CO<sub>2</sub> were set in each gas line by controlling the individual gas flow rate. As a safety measure.

the O<sub>2</sub> was always introduced after the CO<sub>2</sub> valve was opened. The oxidant requirements and required the gas flow rates for combustion in O<sub>2</sub>/CO<sub>2</sub> .both for unstaged and staged combustion is discussed in the next section.

10. At the end of each test session, the O<sub>2</sub>/CO<sub>2</sub> oxidants were switched back to air supplies for coal-air combustion to check the stability of the coal feed rates, gas sampling procedures and to rectify any error related to the oxidant switching before the furnace was finally shut down by the switching off the coal feeder followed by the furnace cooling down procedures.
11. At the end of each test runs, samples from the bottom ash were also collected and analysed for comparison. Ash samples from each test section were later analysed for the carbon content in ash using standard test procedures.
12. Depending on coal samples and the scope of the individual tests, each test run could be completed between seven to eleven hours of continuous firing of fuel including the furnace heat-up time. utilising 2.0 – 2.5 kg of coal per hour.

### **3.2.3. Experimental Conditions.**

#### **3.2.3.1. Theoretical Air / Oxidant Requirement**

The theoretical air/oxidant flow requirements for the combustion and the expected concentrations of the major combustion products in the flue gas can be determined for each type of coal using calculations for the stiochimetric combustion, as shown in Appendix A. The calculated expected concentrations of the major flue gas species in various oxidant mixtures for coal A and the expected concentrations

of the major flue gas components for other coals in air and are shown in are presented in Table 3.3.

### 3.2.3.2 Air/Oxidant Flow Rates

In all combustion tests, the flow rate to of the primary air/oxidant was fixed at 121 l/min ( $2.017 \times 10^{-3} \text{ m}^3/\text{s}$ . (at 15 °C, 1 atm) to prevent possible blockages with the coal particles' transportation and to maintain uniform delivery of coal particles to the burner. In air combustion tests, the total air was fixed at 330 l/min, which is the maximum flow rate that could be attained from the air supply system. Air entrained through the coal feeder entering the burner is calculated as the primary oxidant and the entrained air, is about 10% of the total combustion air. The amount of entrained air to the furnace was determined from the natural gas and coal-air combustion trial test runs.

In all tests, the overall furnace stoichiometric ratio was fixed at 1.20. Hence for a particular coal sample, the coal feed rate was adjusted according this fixed combustion stoichiometricity. For  $\text{O}_2/\text{CO}_2$  combustion, the flow rates to the secondary oxidant were adjusted accordingly to maintain the fixed stoichiometric ratio of the furnace at the fixed firing rate similar to those in air combustion. Any changes for oxygen requirements corresponding to a particular mixture of  $\text{O}_2/\text{CO}_2$  were implemented by changing volume flow rates of the secondary and tertiary oxidants. The air/oxidant flow rates used for the unstaged combustion tests are shown in Table 3.4

The two-staged combustion conditions were achieved by diverting a proportion of the secondary air/oxidant to the tertiary air/oxidant, while keeping the primary and the total air/oxidant flow rates fixed to change the burner stoichiometric ratio  $\text{SR}_1$ .

while maintaining the overall furnace stoichiometric ratio SR at 1.20. The staged combustion tests were conducted with  $SR_1$  between 0.80 and 1.20. The general air/oxidant requirements for the combustion are shown in Figure 3.3. The oxidant flow rates for staged combustion test conditions are as shown in Table 3.5. For recycled  $NO_x$  tests, 5 % of NO in  $N_2$  was added and mixed to the different streams of oxidants to simulate the recycled  $NO_x$ . The NO concentrations was in the range of 0–1500 ppmv.

### **3.2.4. Source of Experimental Errors.**

The feed rate from the coal feeder can be controlled to within  $\pm 1$  % of a set value by adjusting the rotational speed of the feeder and the feed rates has been approximated to the nearest 0.1 g/min. The amount of coals used in each test run was also determined for comparison to the metered coal feed rates. The  $CO_2$  and  $O_2$  measurements were corrected and reported to the nearest 0.1%. The  $NO_x$  reading was reported to the nearest 1 ppmv while CO and  $SO_x$  measurements, depending on the range of the scale used, were estimated to the nearest 0.01 – 0.1 %. The air flow measurements have a typical accuracy of  $\pm 2.5\%$  at the full scale. The flow rates of  $O_2$  and  $CO_2$  are corrected at 15 °C and effect of small variation in ambient temperature during experimental runs on oxidants mixture flow rates were considered as negligible. The flow rates of NO and nitrogen in the recycled NO tests were continuously monitored and kept constant at a set value. The combustion gas temperature measurements were reported based on the uncorrected, sheathed R-type thermocouples. The measurements of  $CO_2$ ,  $O_2$ ,  $NO_x$ , CO and  $SO_x$  were taken using standard gas analysers and recorded on data logger and hence the readings were averaged over a typical period where the levels were uniform.

In coal-O<sub>2</sub>/CO<sub>2</sub> combustion tests, all the oxidants and fuel were delivered into the furnace with the same configurations as those in the coal–air combustion firing tests. The continuous coal feeding during changing over from air combustion to O<sub>2</sub>/CO<sub>2</sub> combustion minimizes any errors resulting from coal feeding rate variations between the two combustion environments. The main features of flame temperature and emissions formation in both, combustion in air and O<sub>2</sub>/CO<sub>2</sub> mixtures, of each type of coals were measured from several test runs. For each type of coals, the Burnout Efficiency ( $\eta_{BO}$ ) in a particular combustion medium and condition was determined based on the average values of carbon-in-ash from several ash sampling procedures. In the recycled NO tests, the NO Reduction Efficiency ( $\eta_{NO}$ ) in each combustion medium and condition for each coal were averaged over two sets of readings.

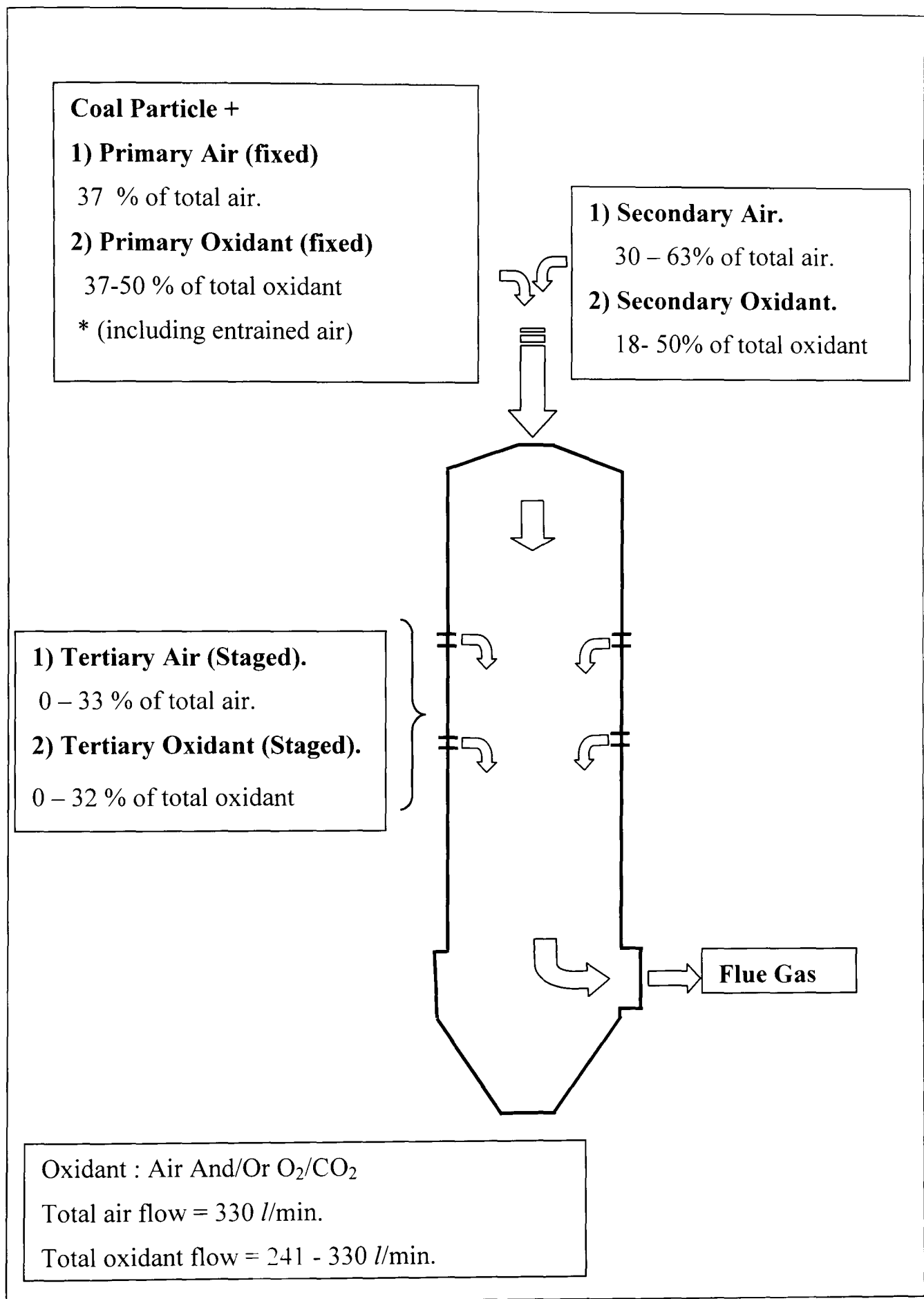


**Table 3.1** The axial positions of the gas temperature probe in the furnace, gas sampling probe ports and staged oxidant injection points relative to the burner.

Temperature Probes	Axial Position From the Burner (m)
T <sub>1</sub>	0.43
T <sub>2</sub>	0.88
T <sub>3</sub>	1.72
T <sub>4</sub>	2.24
T <sub>5</sub>	2.73
T <sub>e</sub>	2.93
Gas Probes	
probe 0	0.42
probe 1	0.57
probe 2	0.86
probe 3	1.50
probe 4	2.23
exhaust	2.93
Staged (Tertiary) Oxidants Injection Points	
L <sub>1</sub>	0.57
L <sub>2</sub>	0.88

**Table 3.2.** Ultimate and Proximate Analyses of the coal samples. All values presented are on samples as received basis.

<b>Coal</b>	<b>C</b> %	<b>H</b> %	<b>N</b> %	<b>(O+S)</b> %	<b>S</b> %	<b>Moisture</b> %	<b>Volatile</b> %	<b>Ash</b> %	<b>fixed C</b> %	<b>N<sub>daf</sub></b> %	<b>f-C<sub>daf</sub></b> %	<b>Vol<sub>daf</sub></b> %	<b>Fuel Ratio</b> (C/Vol) <sub>daf</sub>
UK Bit. (Coal A)	70.57	4.62	1.62	9.13	2.06	2.64	29.35	11.42	56.59	1.89	65.85	34.15	1.93
USA Bit (Coal B)	69.65	4.50	1.45	9.41	1.50	3.43	31.65	11.57	53.36	1.71	62.77	37.23	1.69
Prodeco-Colombian (Coal C)	72.88	5.1	1.6	10.87		3.54	33.12	6.01	57.33	1.77	63.38	36.62	1.73
Polish (Coal D)	72.05	4.58	1.30	9.33		1.62	30.56	11.12	56.70	1.49	64.98	35.02	1.86
Oakbridge -Australian (Coal E)	69.90	4.40	1.62	10.16		2.01	29.60	11.91	56.48	1.88	65.61	34.39	1.91
Rotterdam-S.African (Coal F)	69.35	4.15	1.75	10.26		3.59	25.67	10.90	59.84	2.05	69.98	30.02	2.33
Daw Mill – UK (Coal G)	64.20	4.55	1.15	2.50		5.31	28.44	22.29	43.96	1.59	60.72	39.28	1.55
Signal Fern-Wales (Coal H)	76.70	3.40	1.30	3.23		1.55	9.39	13.82	75.24	1.54	88.90	11.10	8.01
Blends - 50% A /50% H	73.64	4.01	1.46	6.18		2.10	19.37	12.62	65.91	1.71	77.29	22.71	3.40



**Figure 3.4.** The air/oxidant requirements for both unstaged and staged combustion tests.

**Table 3.3** The theoretical major combustion emission compositions for coal A in various combustion media. (Unstaged, SR =1.20)

Oxidants	Case 1		Case 2		Case 3		Case 4	
	1 <sup>st</sup> : Air, 2 <sup>nd</sup> : Air		1 <sup>st</sup> : Air, 2 <sup>nd</sup> : 21:79-O <sub>2</sub> /CO <sub>2</sub>		1 <sup>st</sup> : Air, 2 <sup>nd</sup> : 26:74-O <sub>2</sub> /CO <sub>2</sub>		1 <sup>st</sup> : Air , 2 <sup>nd</sup> : 30:70-O <sub>2</sub> /CO <sub>2</sub>	
	(pure)	(+ entrained air)	(pure)	(+ entrained air)	(pure)	(+ entrained air)	(pure)	(+ entrained air)
Species	% vol (dry)		% vol (dry)		% vol (dry)		% vol (dry)	
CO <sub>2</sub>	15.30		96.10	66.47	95.15	57.52	94.38	51.38
N <sub>2</sub>	80.95		0.15	29.78	0.19	38.25	0.22	44.11
O <sub>2</sub>	3.58		3.58	3.58	4.46	4.04	5.16	4.30
Max SO <sub>2</sub>	1674 (ppmv)		1674 (ppmv)	1674 (ppmv)	2084 (ppmv)	1891 (ppmv)	2416 (ppmv)	2013 (ppmv)
*Max Fuel NO	3010 (ppmv)		3010 (ppmv)	3010 (ppmv)	3747 (ppmv)	3400 (ppmv)	4343 (ppmv)	3619 (ppmv)

Oxidants	Case 5		Case 6		Case 7		Case 8	
	1 <sup>st</sup> : Air, 2 <sup>nd</sup> : 35:65-O <sub>2</sub> /CO <sub>2</sub>		1 <sup>st</sup> : 21:79, 2 <sup>nd</sup> : 21:79-O <sub>2</sub> /CO <sub>2</sub>		1 <sup>st</sup> 21:79, 2 <sup>nd</sup> : 30:70-O <sub>2</sub> /CO <sub>2</sub>		1 <sup>st</sup> : 30:70, 2 <sup>nd</sup> : 30:70-O <sub>2</sub> /CO <sub>2</sub>	
	(pure)	(+ entrained air)	(pure)	(+ entrained air)	(pure)	(+ entrained air)	(Pure)	(+ entrained air)
Species	% vol (dry)		% vol (dry)		% vol (dry)		% vol (dry)	
CO <sub>2</sub>	93.40	44.98	96.10	88.01	95.03	82.89	94.38	79.64
N <sub>2</sub>	0.25	50.29	0.15	8.23	0.19	12.49	0.22	15.26
O <sub>2</sub>	6.06	4.52	3.58	3.58	4.57	4.42	5.16	4.87
Max SO <sub>2</sub>	2834(ppmv)	2115 (ppmv)	1674 (ppmv)	1674 (ppmv)	2136 (ppmv)	2066 (ppmv)	2416 (ppmv)	2278 (ppmv)
*Max Fuel NO	5095 (ppmv)	3802 (ppmv)	3010 (ppmv)	3010(ppmv)	3840 (ppmv)	3714 (ppmv)	4343 (ppmv)	4095 (ppmv)

**Table 3.4.** The air/oxidants flow rates used in the combustion tests. (Unstaged combustion)

<b>Coal air:</b>	Entrained Air ( $\approx 33$ l/min)							
<b>Combustion Test</b>	<b>Case 1</b>	<b>Case 2</b>	<b>Case 3</b>	<b>Case 4</b>	<b>Case 5</b>	<b>Case 6</b>	<b>Case 7</b>	<b>Case 8</b>
<b>Oxidants:</b>								
1st	Air	Air	Air	Air	Air	21:79-O <sub>2</sub> /CO <sub>2</sub>	21:79-O <sub>2</sub> /CO <sub>2</sub>	30:70-O <sub>2</sub> /CO <sub>2</sub>
2nd	Air	21:79-O <sub>2</sub> /CO <sub>2</sub>	26:74-O <sub>2</sub> /CO <sub>2</sub>	30:70-O <sub>2</sub> /CO <sub>2</sub>	35:65-O <sub>2</sub> /CO <sub>2</sub>	21:79-O <sub>2</sub> /CO <sub>2</sub>	30:70-O <sub>2</sub> /CO <sub>2</sub>	30:70-O <sub>2</sub> /CO <sub>2</sub>
<b>Oxidant flow rate :</b> ( l/min)								
1 <sup>st</sup> *	121	121	121	121	121	121	121	121
2nd	209	209	169	146	126	209	146	120
Total *	330	330	290	267	247	330	267	241

\* Including entrained air

**Table 3.5.** The air/oxidants flow rates used in the combustion tests. (Staged combustion)

Air/Oxidants	Flow rate (l/min)					
	Air			30:70-O <sub>2</sub> /CO <sub>2</sub>		
	*Primary	Secondary	Tertiary	*Primary	Secondary	Tertiary
Combustion Zone Stoichiometry(SR <sub>1</sub> )						
1.20	121	209	0	121	120	0
1.00	121	154	55	121	82	38
0.90	121	127	82	121	62	58
0.80	121	99	110	121	43	77

\* Including entrained air.

## CHAPTER 4

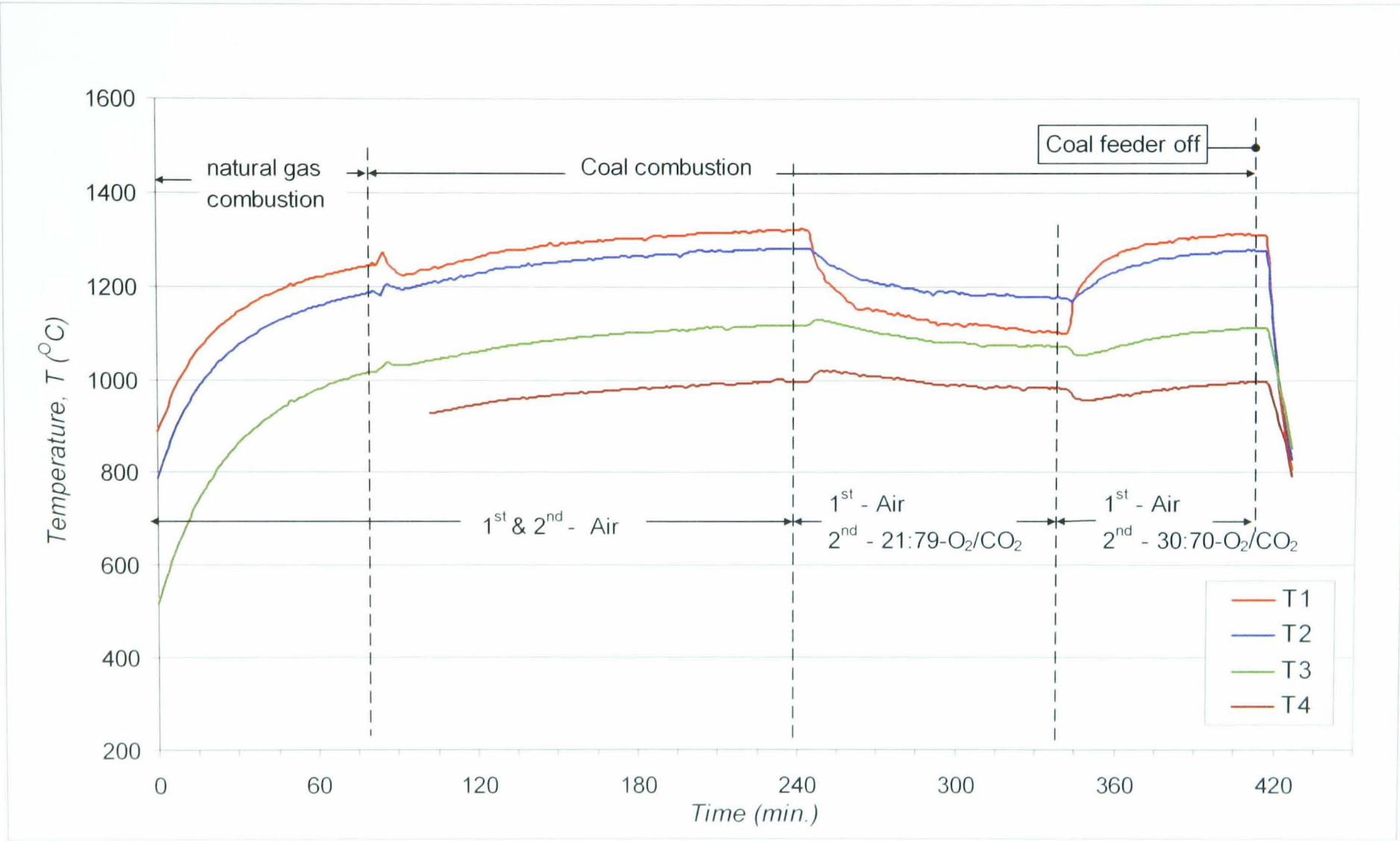
### EXPERIMENTAL RESULTS

In this chapter, the results of the experimental study on pulverised coal combustion in air and  $O_2/CO_2$  mixtures with various compositions are presented. The profiles of the gas temperature and the combustion species inside the furnace, the flue gas compositions and the burnout efficiency of combustion in both air and  $O_2/CO_2$  mixtures are presented in graphical forms and the details figures in tabular forms. The majority of the results presented are from the combustion of the UK Bituminous Coal (Coal A) as the main fuel, and the combustion tests were conducted with the main combustion zone stoichiometric ratio,  $SR = 1.20$ , unless stated otherwise. The effect of oxidant staging on  $NO_x$  emissions reduction in air and  $O_2/CO_2$  mixtures combustion are also compared. The fate of the simulated recycled NO in combustion with different oxidants and conditions are also presented. Initially, various compositions of  $O_2/CO_2$  mixtures were used as oxidant in the combustion. It was later found that, for all tested coals, combustion with mixture of 30%- $O_2$  and 70%- $CO_2$  in the primary and secondary oxidants produced similar temperature profiles to those in air combustion. Hence, unless stated otherwise, all the proceeding tests on  $O_2/CO_2$  combustion including the staged combustion and NO recycle tests were conducted with 30:70- $O_2/CO_2$  mixture as the primary, secondary and tertiary oxidants where applicable.

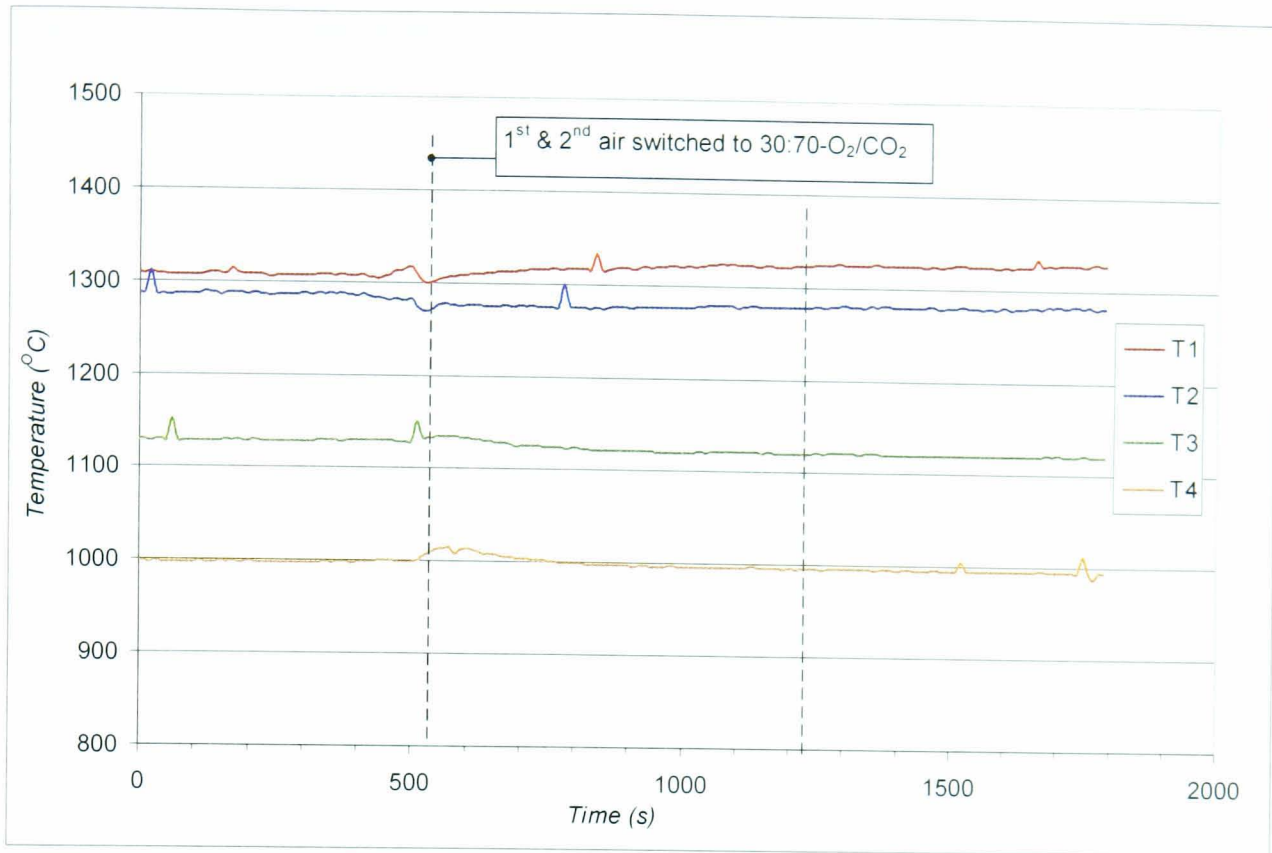
## 4.1. General Furnace Operations.

As described in the preceding chapter, the coal combustion tests were conducted in a 20-kW vertical down-fired combustor equipped with a pulverised coal burner that simulates typical power plant burners in having a swirling secondary oxidant supply and a non-swirling coal-carrying primary oxidant supply. Tertiary oxidant could be added further downstream from the burner to simulate the over-fire air/oxidant (staging) conditions. In coal-O<sub>2</sub>/CO<sub>2</sub> combustion tests, all the oxidants and coal particles are delivered to the burner and furnace with the same configuration as those in the coal–air combustion firing tests. Since the burner, furnace and the combustion system were designed and constructed for coal-air firing, safety issues in the operational procedure related to the application of O<sub>2</sub> in high temperature combustion conditions was always the paramount objective. Oxygen and CO<sub>2</sub> were mixed in advanced before the oxidant were delivered to the combustion zone. Tests on combustion system operations were first carried out to investigate any effect of the switching of oxidant from air to O<sub>2</sub>/CO<sub>2</sub> mixtures. Generally in all tests, smooth and continuous operations of the system were achieved. The data collection procedures through gas analysers were occasionally interrupted from the unscheduled cleaning of gas sampling lines from the accumulation of excessive ash and moisture in the gas delivery tubes and by the scheduled ash sampling procedures.

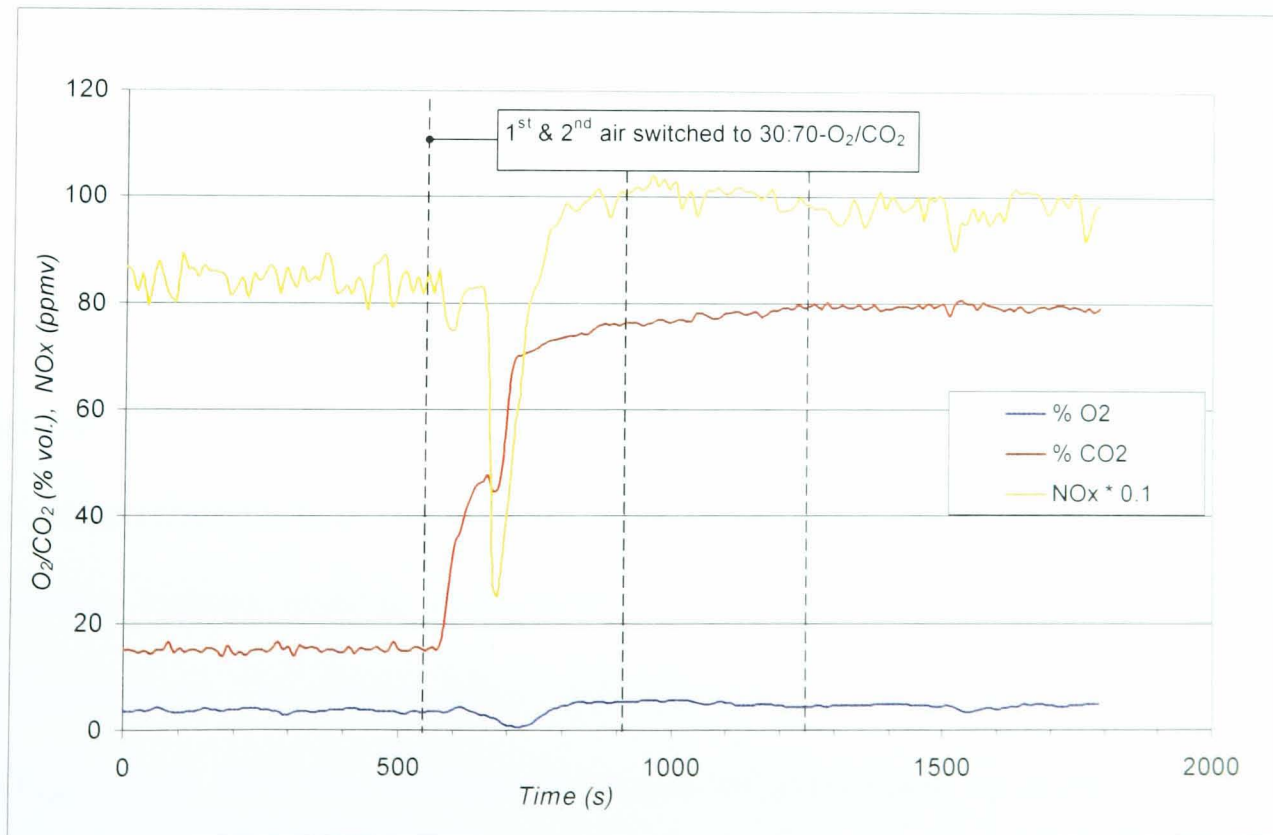




**Figure 4.1.** Temperature profiles in the furnace in one of the test runs (Run #4a , Unstaged, SR=1.20, Coal B).



**Figure 4.2a.** The effect of oxidant switching from air to 30:70- $O_2/CO_2$  on furnace gas temperature profiles. (Run #4a. Unstaged, SR=1.20, Coal B).



**Figure 4.2b.** The effect of oxidant switching from air to 30:70- $O_2/CO_2$  combustion on the flue gas emissions profiles. (Run #4a. Unstaged, SR=1.20, Coal B).

Figure 4.1 shows the temperature profiles in the furnace from the continuous firing of the fuel, started with natural gas combustion, followed by coal firing in air and the change-over of the oxidants from air to O<sub>2</sub>/CO<sub>2</sub>, in one of the test runs. The emission profiles show that steady and uniform combustion were achieved during the test runs. The stable and uniform delivery of fuel from the coal feeder are confirmed by the stable emissions of the CO<sub>2</sub> and O<sub>2</sub> in both coal-air firing and coal-O<sub>2</sub>/CO<sub>2</sub> combustion, both in normal and staged conditions. All gas temperature and emissions data were obtained from the period when the measured temperature and emissions were steady which indicate stable flames conditions has been achieved. It was also found that the gas temperature in the furnace was significantly influenced by the changes in combustion media and conditions. Whenever there was a change in the oxidant compositions or combustion conditions, changes in the furnace temperature were recorded almost immediately but a longer time frames were required for the temperatures to stabilise and the flame to reach steady state in the new combustion conditions and environments, especially in the high CO<sub>2</sub> oxidant mixtures. However, switching from air supply to 30:70-O<sub>2</sub>/CO<sub>2</sub> for coal combustion in which furnace temperature profiles were almost similar, produced smooth transition to both temperature and combustion emissions profiles without any significant effect from the oxidant 'change-over' procedures. Figure 4.2a shows the gas temperature profiles in the furnace during the switching of both primary and secondary oxidant from air to 30:70-O<sub>2</sub>/CO<sub>2</sub> for Coal B, presented over a thirty minute-interval. The corresponding combustion gas emission profiles are presented in Figure 4.2b. Over this transition this period, the temperature recorded by all four probes closest to the burner (T<sub>1</sub>-T<sub>4</sub>) in both air and 30:70-O<sub>2</sub>/CO<sub>2</sub> combustion are steady and uniform and the temperatures change smoothly and stabilise immediately.

However, the gas emissions, particularly the  $\text{CO}_2$  require more times to stabilise, which is achieved within five to ten minutes after the switching of the oxidant from air to 30:70- $\text{O}_2/\text{CO}_2$ .

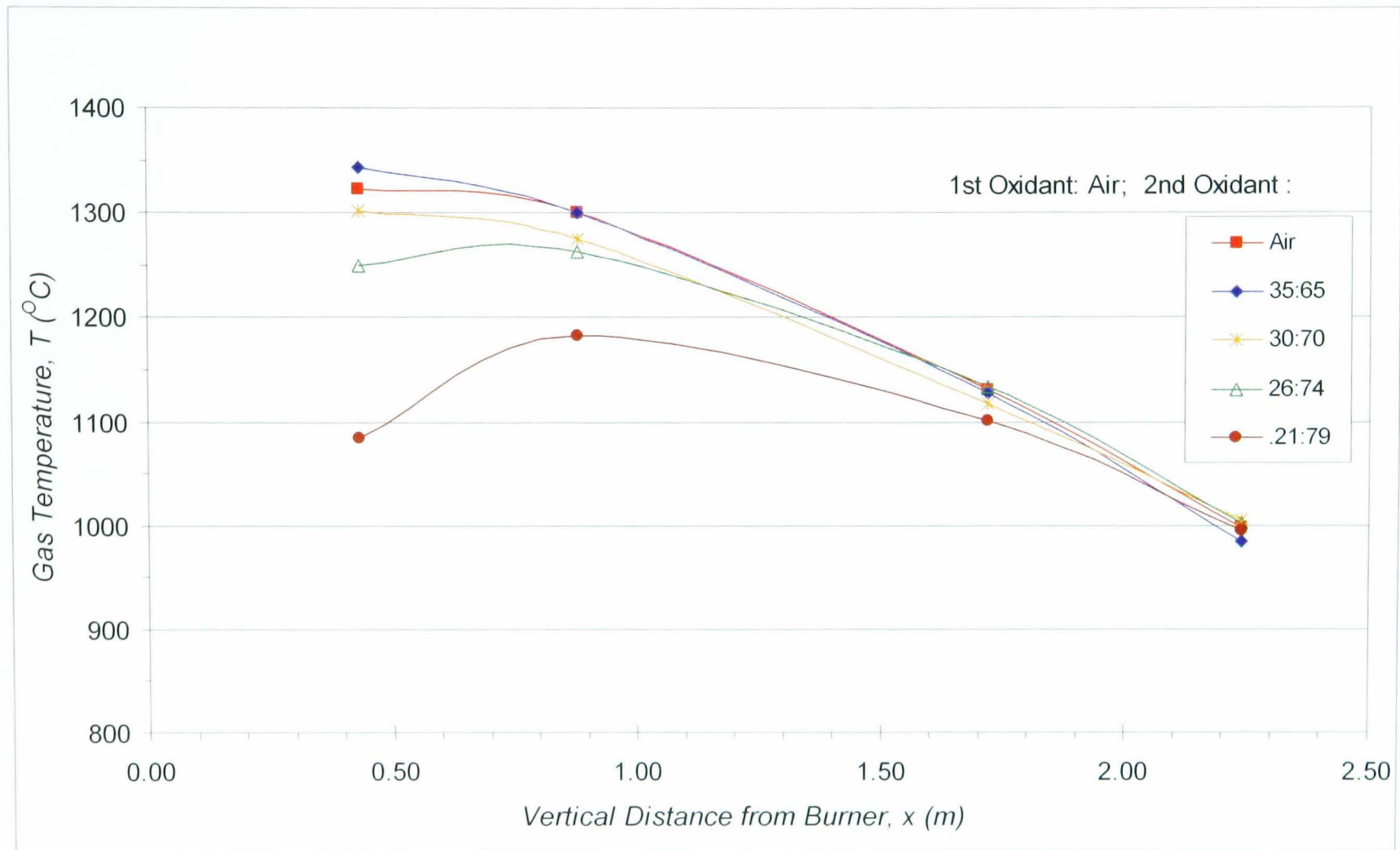
## **4.2. Variation of Gas Temperature with Oxidant Compositions.**

The effect of the variation in oxidant compositions on the combustion temperature profiles are presented in this section. Figure 4.3 shows the gas temperature profiles in the furnace of the combustion of Coal A in various combustion media obtained from the replacement of the secondary air with  $\text{O}_2/\text{CO}_2$  mixtures with  $\text{O}_2$  volume fraction ranging from 21 % to 35 %, while the primary oxidant was maintained with air (Case 1 - Case 5). The details of oxidant compositions and molar fraction in the oxidant, and the variation of temperature in the furnace are shown in Table 4.1a and 4.1b.

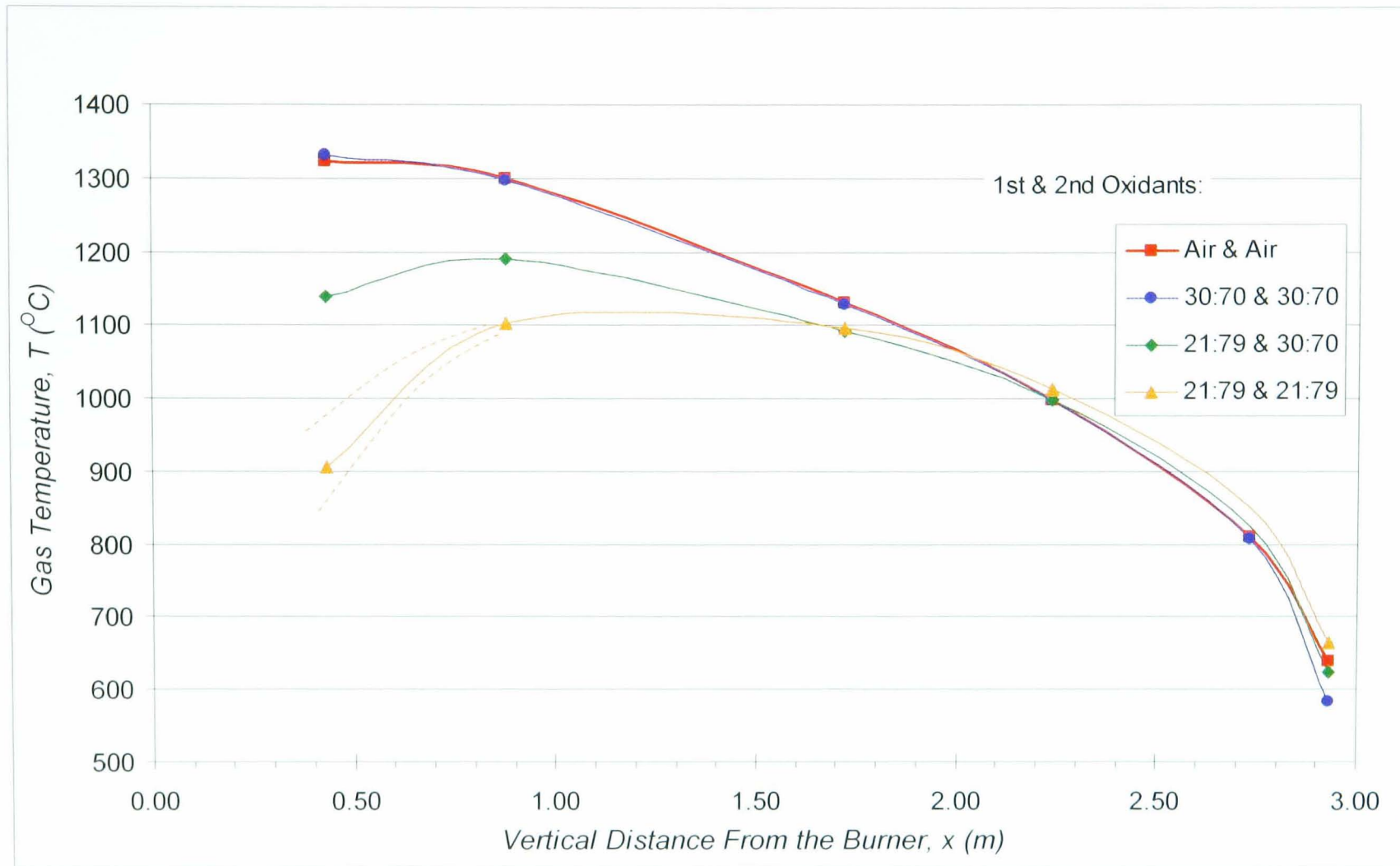
The temperature closest to the burner ( $T_1$ ) is markedly lowered when the secondary air was replaced by  $\text{O}_2/\text{CO}_2$ . In combustion with 21:79- $\text{O}_2/\text{CO}_2$  as the secondary oxidant (Case 2),  $T_1$  is only 1085 °C, which is significantly lower than 1322 °C as in the air combustion. The temperature profile curve is also flatter in which the position of the peak temperature is shifted away from the burner, to around 1.0 m downstream compared to around 0.43 m in air. The peak temperature is only about 1190 °C, which is also significantly lower than around 1325 °C as in air combustion. With 26:74- $\text{O}_2/\text{CO}_2$  in the secondary oxidant (case 3),  $T_1$  increases significantly to 1250 °C and the peak temperature increases to above 1263 °C at the position around 0.80 m from the burner. The overall gas temperature in combustion with 30:70- $\text{O}_2/\text{CO}_2$  in the secondary oxidant (Case 4) is still lower than those in air

combustion and temperature profiles matches that in air combustion only when the O<sub>2</sub> concentration in the secondary oxidant is increased to 35% (Case 5). However, the peak temperature in 35:65-O<sub>2</sub>/CO<sub>2</sub> was 1343 °C, which was slightly higher than that in air, but the temperature at T<sub>4</sub> is 985 °C was slightly lower than 998 °C as in the air combustion.

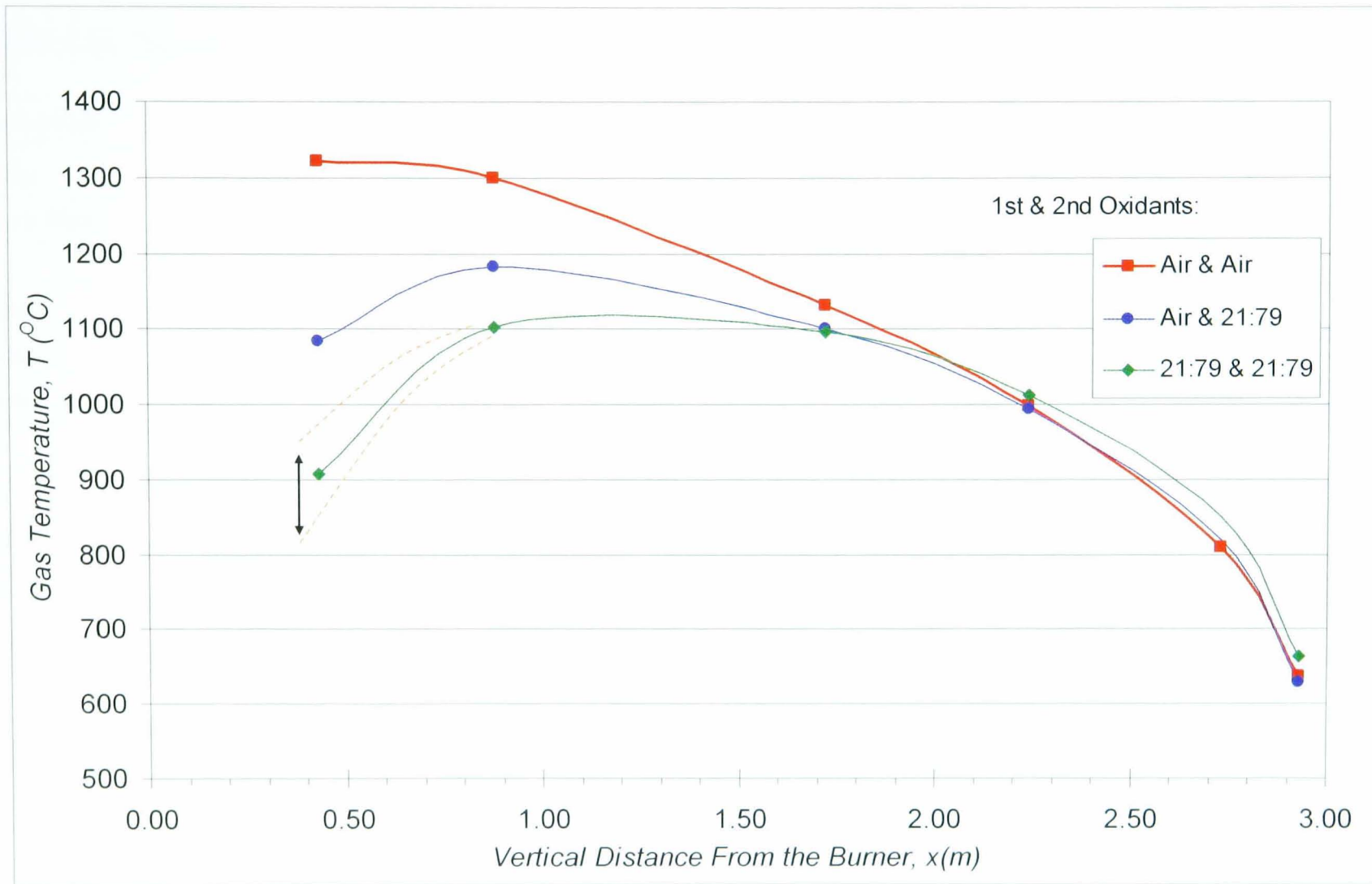
Figure 4.4 shows the temperature profiles in the furnace when both the primary and secondary air were replaced by O<sub>2</sub>/CO<sub>2</sub> mixtures. These temperature profiles confirm that high CO<sub>2</sub> concentrations in the oxidant mixtures caused coal particles to burn further away downstream as indicated by the positions of the peak temperature relative to the burner. When both primary and secondary air were replaced by 21:79-O<sub>2</sub>/CO<sub>2</sub> (Case 6) T<sub>1</sub> is only around 900 °C and in several other runs, the switching of oxidant to 21:79-O<sub>2</sub>/CO<sub>2</sub> in both oxidiser lines caused continuous drop in temperature at T<sub>1</sub> and T<sub>2</sub>, which indicate that stable flames could not be fully established in combustion with 21:79-O<sub>2</sub>/CO<sub>2</sub>. The peak temperature increases and moves closer to the burner as the O<sub>2</sub> concentration in the mixture increases (Case 7). The temperature profiles match that in air combustion when 30:70-O<sub>2</sub>/CO<sub>2</sub> mixtures were both used as the primary and secondary oxidant (Case 8). The temperature closest to the burner in 30:70-O<sub>2</sub>/CO<sub>2</sub> is only slightly higher than that in air (T<sub>1,O</sub>=1331 °C, T<sub>1,air</sub>=1322 °C) while the temperatures in the middle section of the furnace (T<sub>3</sub> – T<sub>4</sub>) in both media are almost identical. The peak temperature in 30:70-O<sub>2</sub>/CO<sub>2</sub> combustion (T<sub>p</sub> ≈1331 °C) is only slightly higher than that in air combustion (T<sub>p,air</sub> ≈1325 °C). However, the temperature at furnace exit is 30:70-O<sub>2</sub>/CO<sub>2</sub> (T<sub>6,O</sub> = 584 °C ) is markedly lower than that in air combustion (T<sub>6,air</sub> = 638 °C).



**Figure 4.3.** The effect of 2<sup>nd</sup> oxidant switching from air to O<sub>2</sub>/CO<sub>2</sub> mixtures on gas temperature in the furnace. (Unstaged, SR=1.20, Coal A).



**Figure 4.4.** The effect of both 1<sup>st</sup> and 2<sup>nd</sup> oxidant switching from air to O<sub>2</sub>/CO<sub>2</sub> mixtures on gas temperature in the furnace.  
(Unstaged, SR=1.20, Coal A).



**Figure 4.5.** The effect of a direct oxidant replacement from air to 21:79- $\text{O}_2/\text{CO}_2$  mixture on gas temperature in the furnace. (Unstaged,  $\text{SR}=1.20$ , Coal A).



**Table 4.1a.** Gas temperature variation in the furnace in different combustion media. (Coal A. Unstaged SR = 1.20).

<b>Coal-entrained air:</b>	Air ( $\approx 33$ l/min)							
<b>Coal fee rate :</b>	$\approx 2.12$ kg/h.							
<b>Combustion Test</b>	<b>Case 1</b>	<b>Case 2</b>	<b>Case 3</b>	<b>Case 4</b>	<b>Case 5</b>	<b>Case 6</b>	<b>Case 7</b>	<b>Case 8</b>
<b>Oxidants:</b>								
1st	Air	Air	Air	Air	Air	21:79-O <sub>2</sub> /CO <sub>2</sub>	21:79-O <sub>2</sub> /CO <sub>2</sub>	30:70-O <sub>2</sub> /CO <sub>2</sub>
2nd	Air	21:79-O <sub>2</sub> /CO <sub>2</sub>	26:74-O <sub>2</sub> /CO <sub>2</sub>	30:70-O <sub>2</sub> /CO <sub>2</sub>	35:65-O <sub>2</sub> /CO <sub>2</sub>	21:79-O <sub>2</sub> /CO <sub>2</sub>	30:70-O <sub>2</sub> /CO <sub>2</sub>	30:70-O <sub>2</sub> /CO <sub>2</sub>
<b>Temperature <math>T</math> °C</b>								
$T_1$	1322	1085	1250	1301	1343	907*	1139	1331
$T_2$	1300	1182	1263	1275	1300	1102*	1191	1298
$T_3$	1131	1101	1133	1117	1128	1097	1093	1129
$T_4$	998	995	1002	1006	985	1013	998	999
$T_5$	810	820				850	825	807
$T_6$	638	630				665	625	584
$\approx T_p$	1325	1190	1265	1303	1345	1110	1195	1331
$\approx$ axial distance $x_p$ (m)	0.43	1.00	0.80	0.50	<0.40	1.50	0.80	0.43

**Table 4.1b.** Oxidant flow rates and the molar ratio of the composition of the oxidant mixtures.

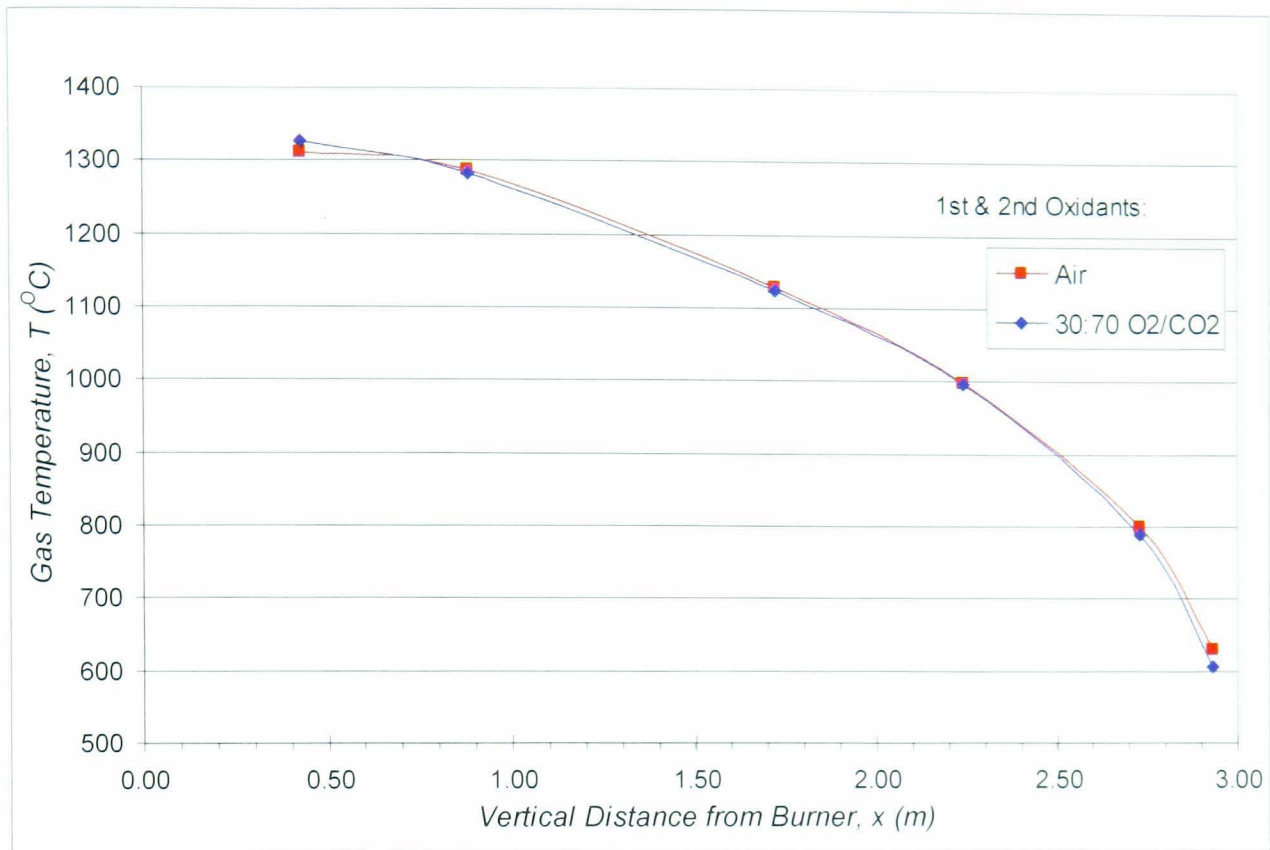
<b>Combustion Test</b>	<b>Case 1</b>	<b>Case 2</b>	<b>Case 3</b>	<b>Case 4</b>	<b>Case 5</b>	<b>Case 6</b>	<b>Case 7</b>	<b>Case 8</b>
<b>Oxidants:</b>								
1st	Air	Air	Air	Air	Air	21:79-O <sub>2</sub> /CO <sub>2</sub>	21:79-O <sub>2</sub> /CO <sub>2</sub>	30:70-O <sub>2</sub> /CO <sub>2</sub>
2nd	Air	21:79-O <sub>2</sub> /CO <sub>2</sub>	26:74-O <sub>2</sub> /CO <sub>2</sub>	30:70-O <sub>2</sub> /CO <sub>2</sub>	35:65-O <sub>2</sub> /CO <sub>2</sub>	21:79-O <sub>2</sub> /CO <sub>2</sub>	30:70-O <sub>2</sub> /CO <sub>2</sub>	30:70-O <sub>2</sub> /CO <sub>2</sub>
<b>Oxidant Flow Rates (l/min)</b>								
1 <sup>st</sup> *	121	121	121	121	121	121	121	121
2nd	209	209	169	146	126	209	146	120
Total *	330	330	290	267	247	330	267	241
<b>Molar Ratio O<sub>2</sub>:CO<sub>2</sub>:N<sub>2</sub></b>								
O <sub>2</sub>	0.210	0.210	0.239	0.259	0.281	0.210	0.259	0.288
CO <sub>2</sub>	0.000	0.500	0.431	0.383	0.331	0.711	0.643	0.604
N <sub>2</sub>	0.790	0.290	0.330	0.357	0.388	0.079	0.098	0.108
<b>Molar Ratio O<sub>2</sub>:CO<sub>2</sub></b>								
O <sub>2</sub>	1.0	0.296	0.357	0.403	0.459	0.228	0.287	0.323
CO <sub>2</sub>	0.0	0.704	0.643	0.597	0.541	0.772	0.713	0.677

\*including entrained air

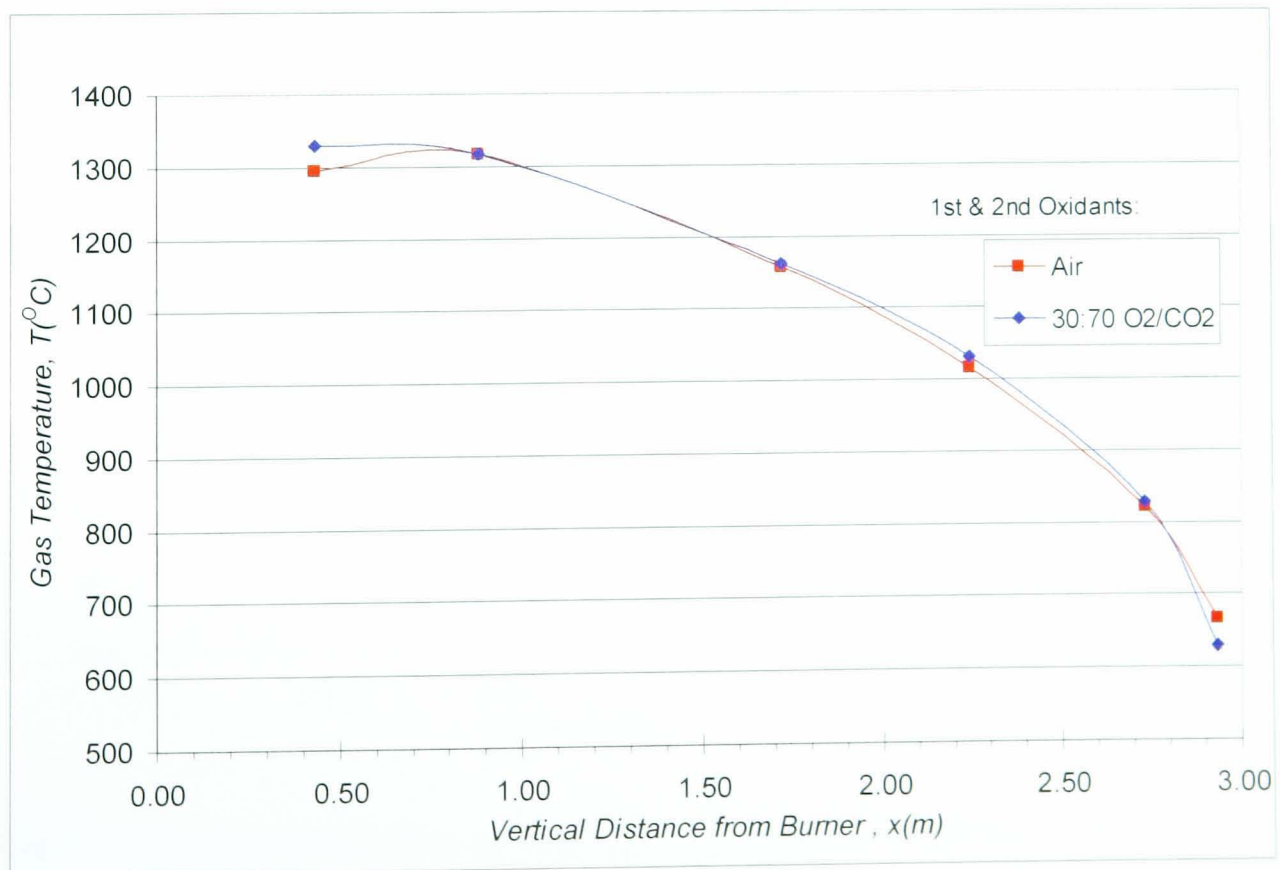
The comparison of temperature profiles from the direct replacement of air with 21:79-O<sub>2</sub>/CO<sub>2</sub> is summarised in Figure 4.5. Generally, replacing any part of the combustion air with 21:79-O<sub>2</sub>/CO<sub>2</sub> with the same volumetric flow rates causes significant drop to the peak gas temperature in the furnace, which is more pronounced when both the primary the secondary air are replaced with O<sub>2</sub>/CO<sub>2</sub>. With 21:79-O<sub>2</sub>/CO<sub>2</sub> as both primary and secondary oxidants, gas temperatures inside the furnace drop so drastically that a steady coal combustion flame can no longer be sustained within the furnace. The delay in combustion in oxidant with high CO<sub>2</sub> is indicated by the shifting of the peak temperature away from the burner and also by the higher gas temperature at the furnace exit (T<sub>6</sub>). The peak temperature in 21:79-O<sub>2</sub>/CO<sub>2</sub> combustion (Case 6) is around 1110 °C, at between 1.20 – 1.50 m from the burner, compared to 1325 °C at around 0.43 m in air firing (Case 1). The visual observation during the experimental runs also show that bright volatile combustion flame that could be seen in air combustion was not visible as in air combustion at the sampling ports close to the burner when both combustion air was replaced by O<sub>2</sub>/CO<sub>2</sub> with high CO<sub>2</sub> concentrations. In 21:79-O<sub>2</sub>/CO<sub>2</sub> combustion, flames was not visible at the first sampling port P<sub>1</sub> (0.43 m) but a dark volatile combustion flame with little char burning was observed at the second sampling port P<sub>2</sub> (0.57 m). However, bright volatile combustion flames with char burning was observed at the third sampling port P<sub>3</sub> (0.88 m) and a considerable coal-char burning between P<sub>3</sub> and the fourth sampling port P<sub>4</sub> (1.50 m) was observed.

The results of the combustion of other coals yield similar trends where the temperature profiles in the furnace with 30:70-O<sub>2</sub>/CO<sub>2</sub> in both primary and secondary generally are very similar in terms of the peak temperatures and their

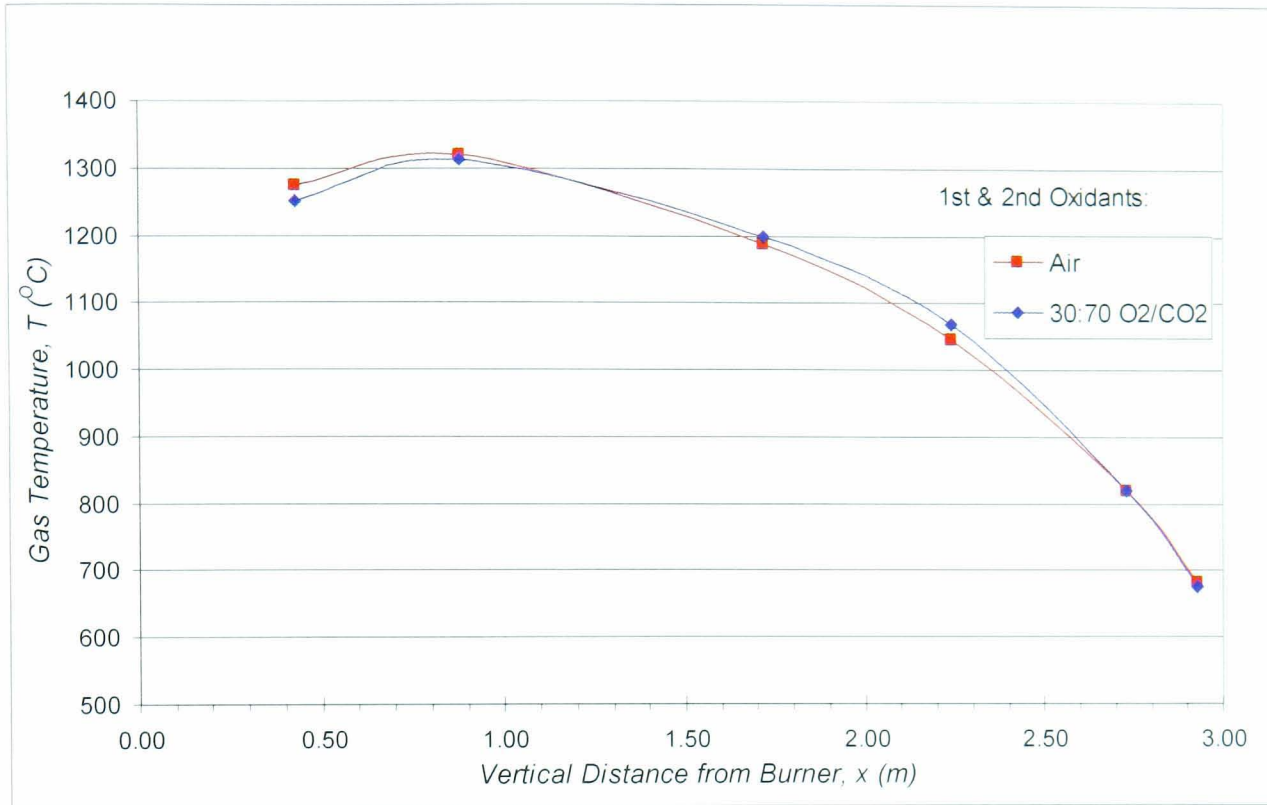
positions relative to the burner, to those in air combustion. However, the temperature at the furnace exit in the combustion with 30:70-O<sub>2</sub>/CO<sub>2</sub> are markedly lower than those in air. The temperature profiles of the combustion of reactive (high fuel ratio) coal (Coal B and Coal G) are presented by Figures 4.6a and 4.6b which show that furnace temperature profiles in 30:70-O<sub>2</sub>/CO<sub>2</sub> combustion are almost identical to those in the air combustion. A slightly higher combustion temperatures were measured in 30:70-O<sub>2</sub>/CO<sub>2</sub> combustion those in air and the temperature but the furnace exit are markedly lower. Figures 4.7a and 4.7b show temperature profiles from the combustion of less reactive coals (Coal E and Coal F). For less reactive coals, the positions of peaks temperature in both combustion media are slightly further downstream from the burner as compared to those for reactive coals. In addition, slightly lower combustion temperatures were measured in 30:70-O<sub>2</sub>/CO<sub>2</sub> combustion those in air. However the differences in the peak temperatures in 30:70-O<sub>2</sub>/CO<sub>2</sub> compared those in air firing for all coals are very small, which is less than 15 °C. Generally, for all coals, the temperatures at furnace exit in 30:70-O<sub>2</sub>/CO<sub>2</sub> are markedly lower than those in air combustion, but the differences are smaller in the combustion of less reactive coals. The details on temperature variation along the furnace axis from combustion of all coals in air and in 30:70-O<sub>2</sub>/CO<sub>2</sub> are presented in Table 4.2.



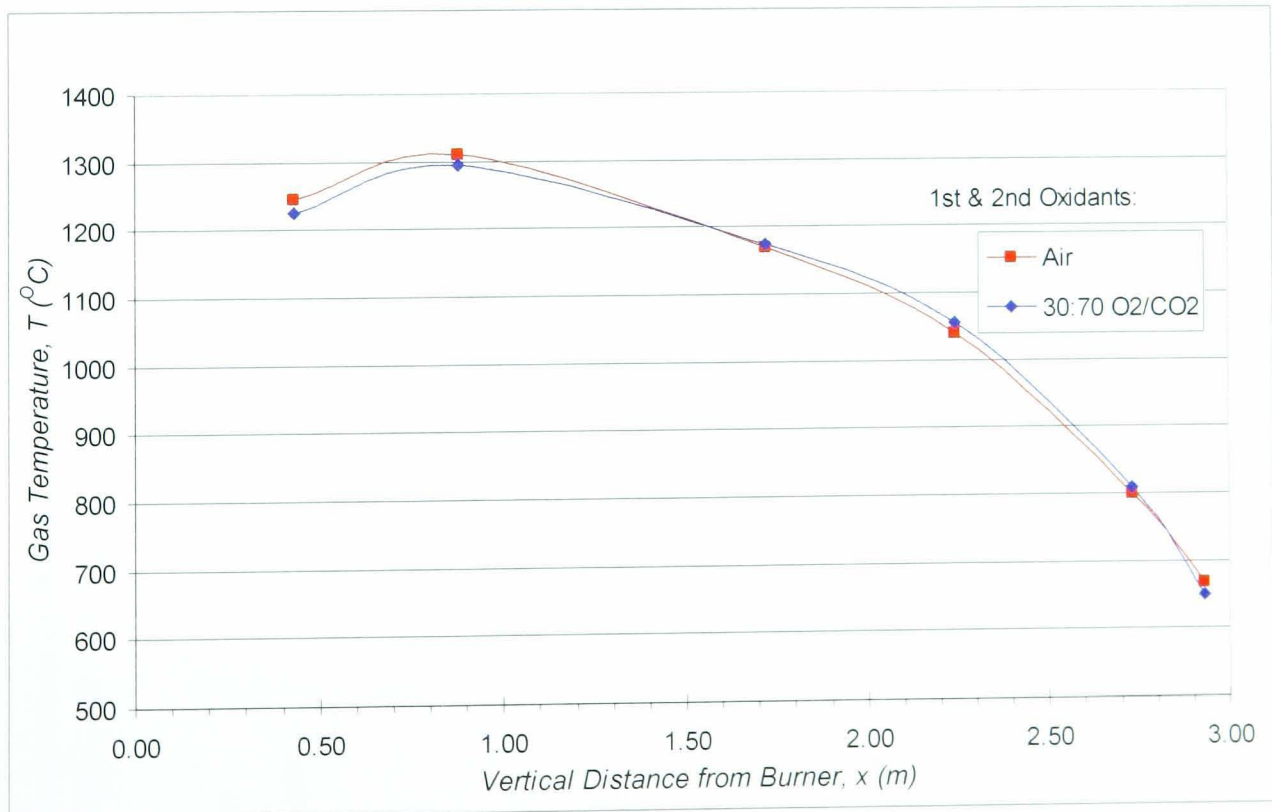
**Figure 4.6a.** Gas temperature profiles in the furnace from combustion in air and 30:70- $\text{O}_2/\text{CO}_2$  mixture. (Unstaged, SR=1.20, Coal B).



**Figure 4.6b.** Gas temperature profiles in the furnace from combustion in air and 30:70- $\text{O}_2/\text{CO}_2$  mixture. (Unstaged, SR=1.20, Coal G).



**Figure 4.7a.** Gas temperature profiles in the furnace from combustion in air and 30:70-O<sub>2</sub>/CO<sub>2</sub> mixture. (Unstaged, SR=1.20, Coal E).



**Figure 4.7b.** Gas temperature profiles in the furnace from combustion in air and 30:70-O<sub>2</sub>/CO<sub>2</sub> mixture. (Unstaged, SR=1.20, Coal F).

**Table 4.2.** The comparison of the gas temperature in the furnace, in combustion with air and 30:70-O<sub>2</sub>/CO<sub>2</sub> for all coals. (Unstaged, SR = 1.20).

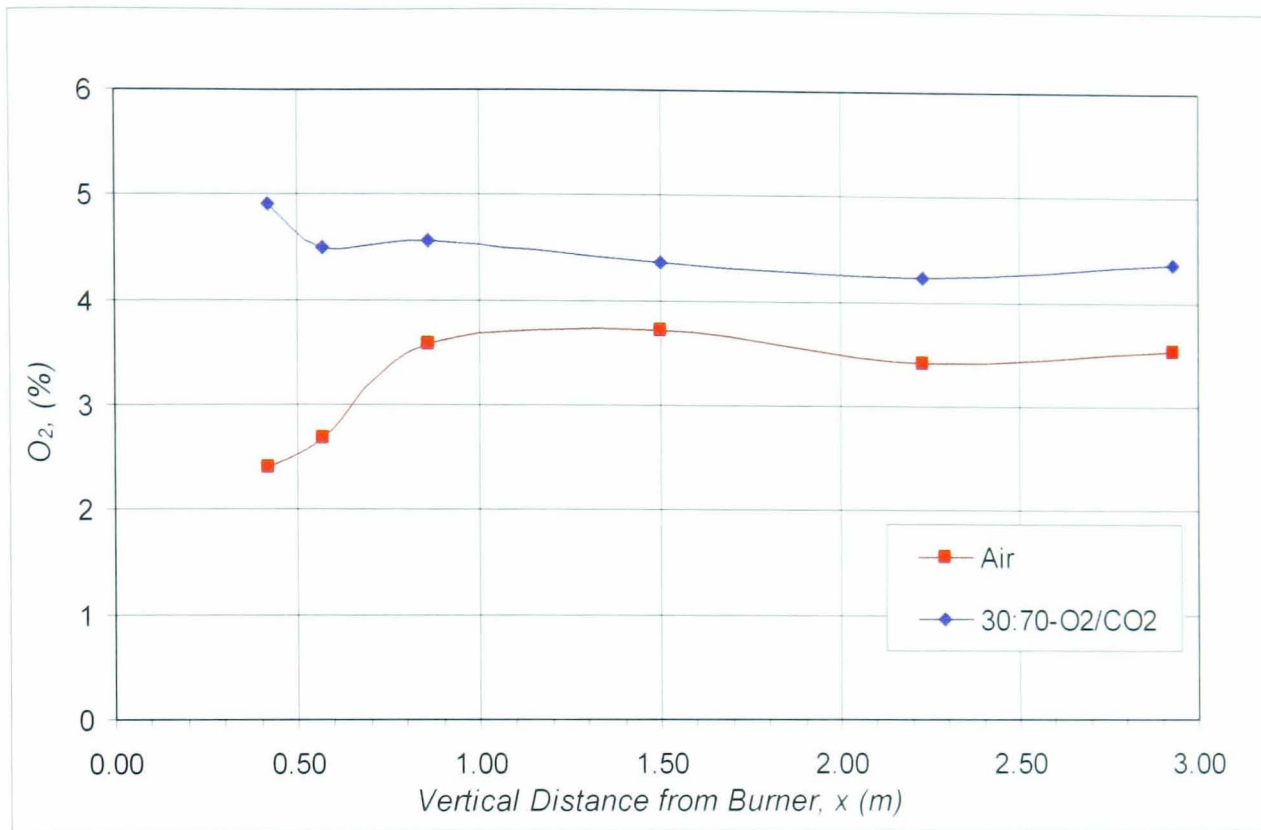
Oxidant flow rates	*1 <sup>st</sup> = 121 l/min, 2 <sup>nd</sup> = 209 l/min,													
Coal feed rate (kg/h):	≈ 2.12		≈ 2.18		≈ 2.08		≈ 2.12		≈ 2.19		≈ 2.25		≈ 2.28	
Coals :	<b>Coal A</b>		<b>Coal B</b>		<b>Coal C</b>		<b>Coal D</b>		<b>Coal E</b>		<b>Coal F</b>		<b>Coal G</b>	
Oxidants:														
1st	Air	30:70	Air	30:70	Air	30:70	Air	30:70	Air	30:70	Air	30:70	Air	30:70
2nd	Air	30:70	Air	30:70	Air	30:70	Air	30:70	Air	30:70	Air	30:70	Air	30:70
Temperature, T °C														
T <sub>1</sub>	1322	1331	1312	1327	1308	1335	1310	1280	1275	1251	1246	1226	1296	1330
T <sub>2</sub>	1300	1298	1288	1284	1312	1346	1329	1316	1319	1314	1310	1295	1316	1316
T <sub>3</sub>	1131	1129	1129	1125	1140	1173	1172	1188	1188	1198	1169	1175	1157	1161
T <sub>4</sub>	998	999	998	996	1001	1050	1040	1055	1047	1068	1039	1055	1016	1030
T <sub>5</sub>	810	807	801	790			797	810	820	820	800	810	822	828
T <sub>6</sub>	638	584	630	605	665		666	670	683	677	668	650	665	628
≈ T <sub>p</sub>	1325	1331	1315	1330			1330	1320	1320	1315	1310	1295	1318	1330

## 4.3 Gas Emission Compositions.

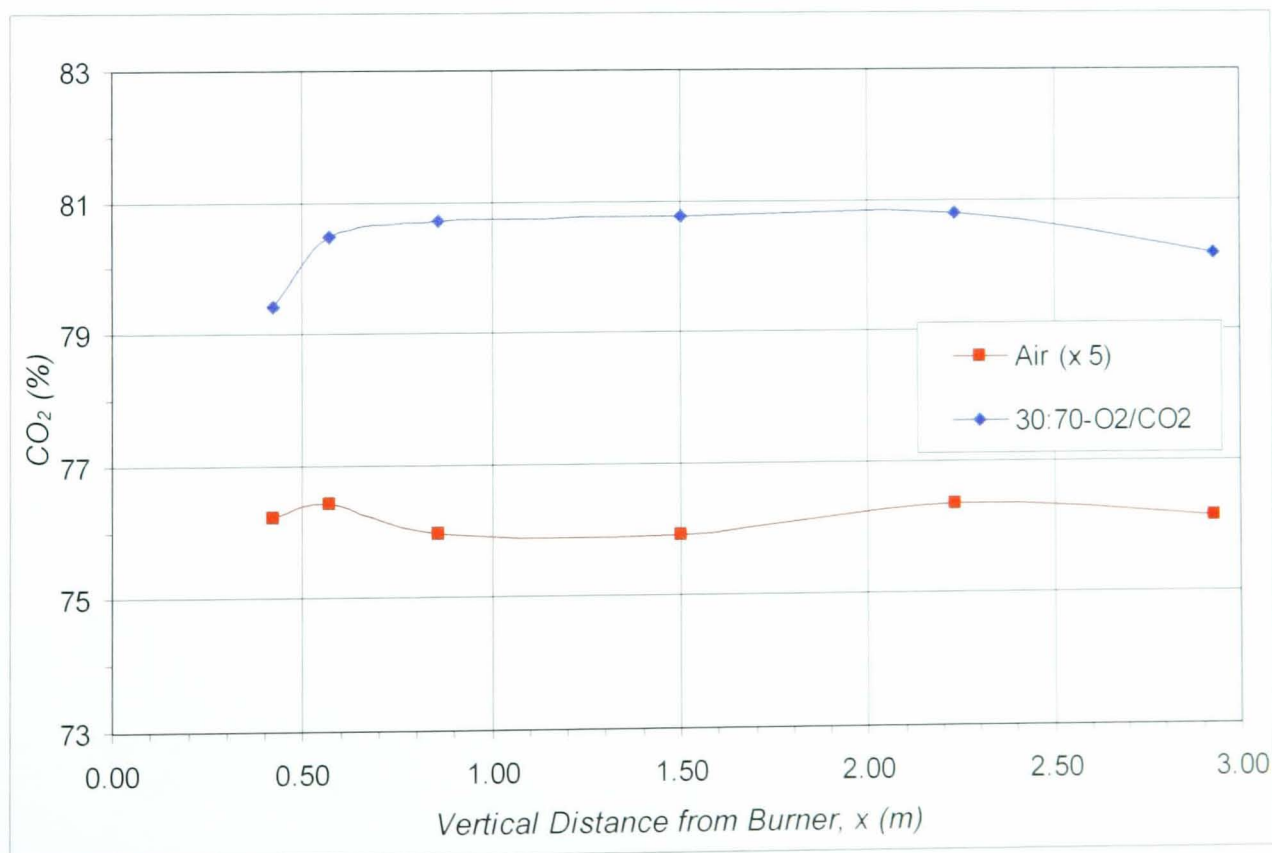
### 4.3.1. Gas Emissions in the furnace.

Figures 4.8a-4.8d show the CO<sub>2</sub>, O<sub>2</sub>, CO and NO<sub>x</sub> concentrations along the axis of the furnace, for combustion of Coal A in both air and in 30:70-O<sub>2</sub>/CO<sub>2</sub>. The emissions of CO and NO<sub>x</sub> are relatively very low and hence, expressed in ppmv. The emissions of CO<sub>2</sub> and O<sub>2</sub> approach the final values at around 1.0 m downstream from the burner, beyond which there is little change in gas compositions. The NO<sub>x</sub> emission profiles also indicate the emission levels almost reach the final values at about the same point, both for the air and 30:70-O<sub>2</sub>/CO<sub>2</sub> cases. Generally the gas composition profiles in both environments show similar characteristics although the O<sub>2</sub> and NO<sub>x</sub> concentrations appear to reach their final value a slightly further away from the burner in 30:70-O<sub>2</sub>/CO<sub>2</sub> combustion. In combustion with 30:70-O<sub>2</sub>/CO<sub>2</sub>, a significantly higher concentration of CO was measured in the main combustion zone compared to that in air, which was highly anticipated due to the lower flow rate of the combustion gas. The CO concentration in 30:70-O<sub>2</sub>/CO<sub>2</sub> at 0.42 m from the burner is almost 12000 ppmv, which is markedly higher than 7800 ppmv in the air combustion. However, the CO concentration drops rapidly to less than 290 ppmv at 1.50 m downstream from the burner, compare to 310 ppmv in air, and decreases further to less than 50 ppmv at the furnace exit.

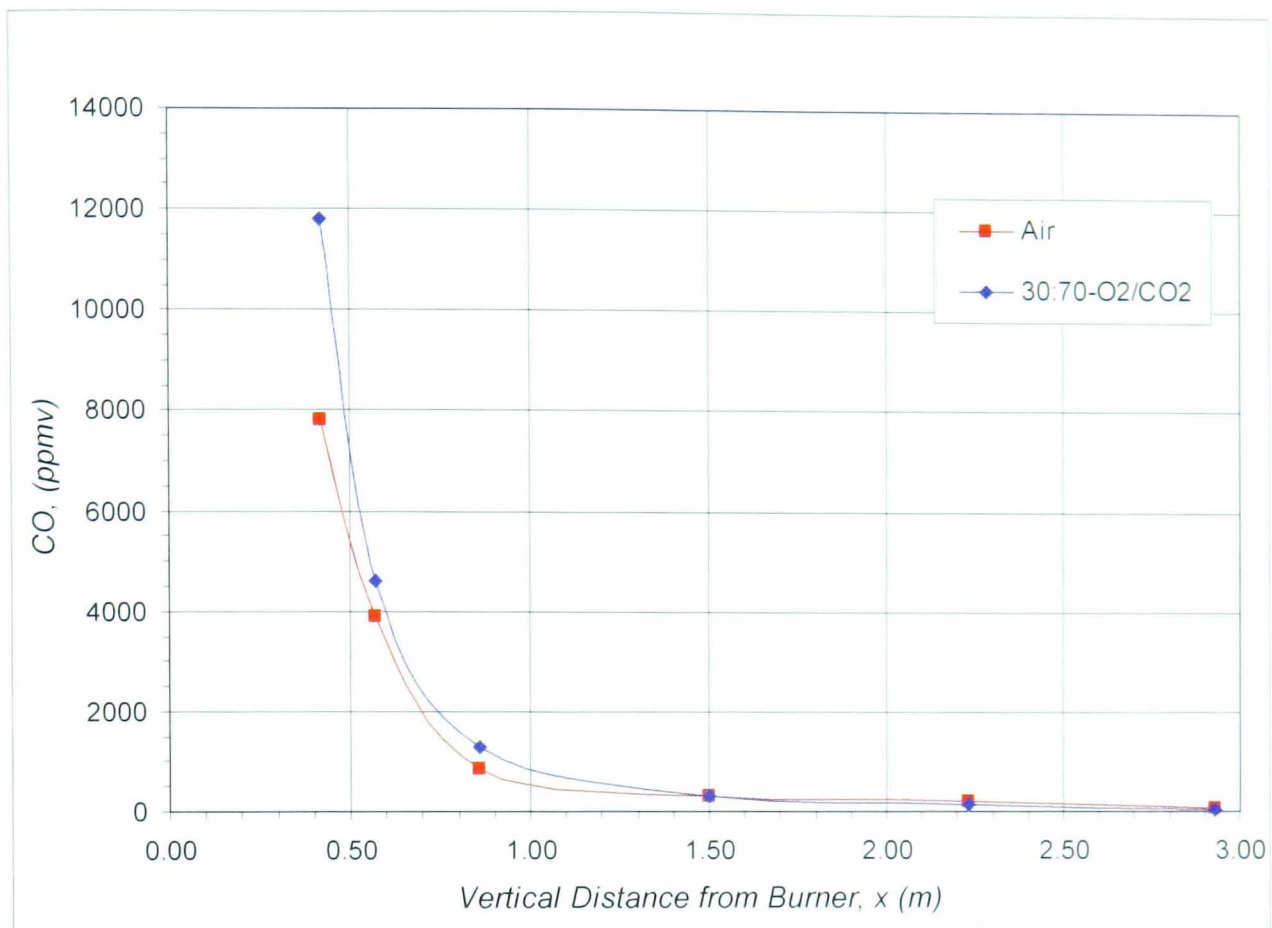




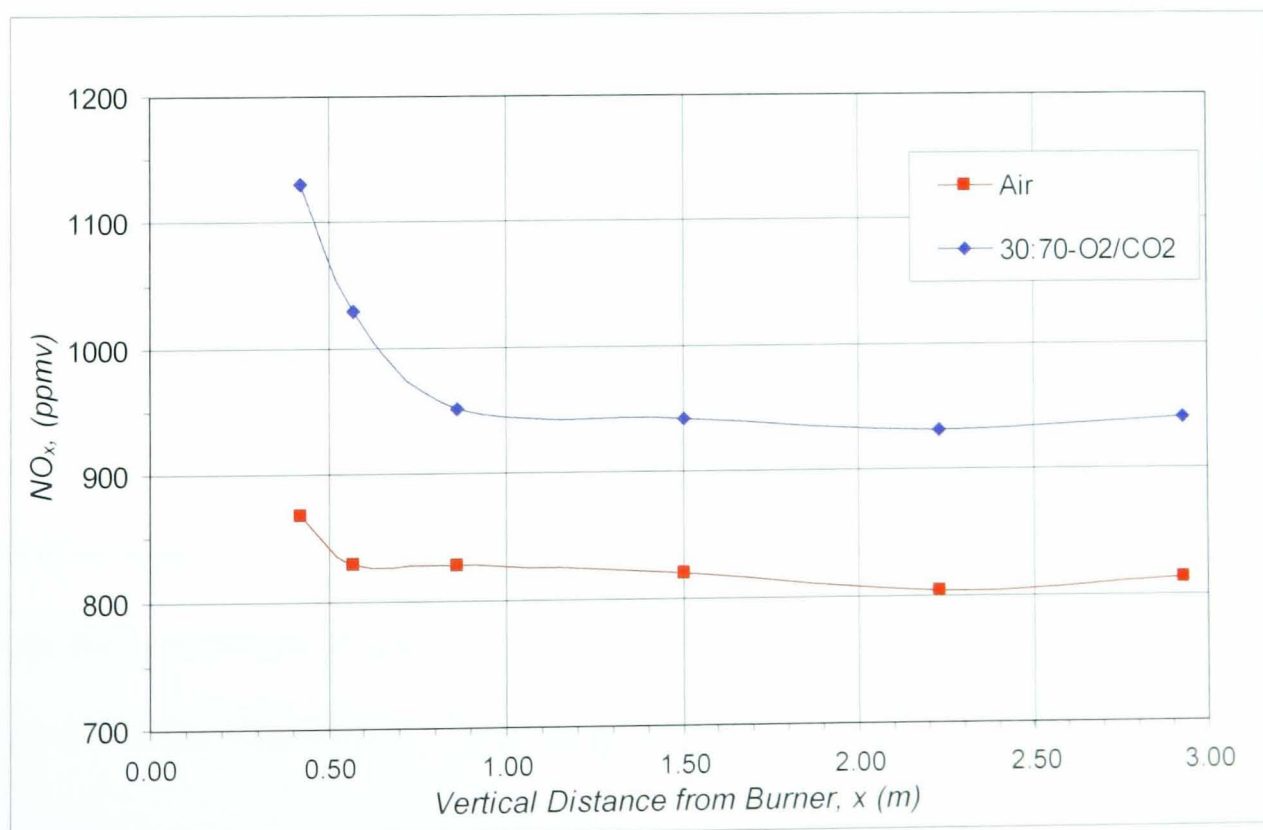
**Figure 4.8a.** O<sub>2</sub> concentration along the furnace axis in air and 30:70-O<sub>2</sub>/CO<sub>2</sub>. (Unstaged, SR=1.20, Coal A).



**Figure 4.8b.** CO<sub>2</sub> concentration along the furnace axis in air and 30:70-O<sub>2</sub>/CO<sub>2</sub>. (Unstaged, SR=1.20, Coal A).



**Figure 4.8c.** CO concentration along the furnace axis in air and 30:70-O<sub>2</sub>/CO<sub>2</sub>. (Unstaged, SR=1.20, Coal A).



**Figure 4.8d.** NO<sub>x</sub> concentration along the furnace axis in air and 30:70-O<sub>2</sub>/CO<sub>2</sub>. (Unstaged, SR=1.20, Coal A).

### 4.3.2. Flue Gas Emissions.

#### 4.3.2.1. O<sub>2</sub> and CO<sub>2</sub>.

In all coal-air combustion tests, the oxygen and CO<sub>2</sub> concentrations in the flue gas were uniform and always very close to the nominal value of the calculated excess oxygen with SR=1.20. In air combustion of Coal A with a firing rate of around 2.12 kg/h, the O<sub>2</sub> and CO<sub>2</sub> concentrations in the flue gas are stable, averaging at 3.6 % and 15.3 % respectively compared to the calculated concentrations of O<sub>2</sub> and CO<sub>2</sub> from the combustion of this coal in air with SR = 1.20 which are 3.58 % and 15.31 % dry volume respectively. In 30:70-O<sub>2</sub>/CO<sub>2</sub> combustion with the same coal firing rate, both O<sub>2</sub> and CO<sub>2</sub> concentrations were also steady which indicate that the combustion is always stable. For Coal A, the averaged measured CO<sub>2</sub> and O<sub>2</sub> in the flue gas with 30:70-O<sub>2</sub>/CO<sub>2</sub> (Case 8 ) in both primary and secondary are 80.0 % and 4.7 % respectively compared to the calculated value 79.64% and 4.87% respectively. The combustion of other coals also resulted in similar trend in which the measured concentration of flue gas emissions are generally in a close agreement with the theoretical calculations. In a few test runs with coal G, where entrained air in the feeder was purged by O<sub>2</sub>/CO<sub>2</sub>, a much higher CO<sub>2</sub> concentration in the flue gas of above 90 % was achieved. The maximum calculated CO<sub>2</sub> concentration that could be attained in 30:70-O<sub>2</sub>/CO<sub>2</sub> is 94.4 %. The CO<sub>2</sub> concentrations in the flue gas from the combustion in various mixture O<sub>2</sub>/CO<sub>2</sub> are presented in Table 4.3 which shows that the CO<sub>2</sub> emission level decreases with higher N<sub>2</sub> concentrations in the oxidant.

**Table 4.3** The O<sub>2</sub> and CO<sub>2</sub> concentration in the flue gas in various combustion media. (Unstaged, SR =1.20, Coal A).

Oxidants	Case 1 1 <sup>st</sup> : Air, 2 <sup>nd</sup> : Air		Case 2 1 <sup>st</sup> : Air, 2 <sup>nd</sup> : 21:79-O <sub>2</sub> /CO <sub>2</sub>		Case 3 1 <sup>st</sup> : Air, 2 <sup>nd</sup> : 26:74-O <sub>2</sub> /CO <sub>2</sub>		Case 4 1 <sup>st</sup> : Air , 2 <sup>nd</sup> : 30:70-O <sub>2</sub> /CO <sub>2</sub>	
	Measured	Calculated	Measured	Calculated	Measured	Calculated	Measured	Calculated
Species	% vol (dry)		% vol (dry)		% vol (dry)		% vol (dry)	
CO <sub>2</sub>	15.30	15.31	57.0	66.47	52.7	57.52	52.3	51.38
O <sub>2</sub>	3.6	3.58	4.1	3.58	4.2	4.04	4.3	4.30

Oxidants	Case 5 1 <sup>st</sup> : Air, 2 <sup>nd</sup> : 35:65-O <sub>2</sub> /CO <sub>2</sub>		Case 6 1 <sup>st</sup> : 21:79, 2 <sup>nd</sup> : 21:79-O <sub>2</sub> /CO <sub>2</sub>		Case 7 1 <sup>st</sup> 21:79, 2 <sup>nd</sup> : 30:70-O <sub>2</sub> /CO <sub>2</sub>		Case 8 1 <sup>st</sup> : 30:70, 2 <sup>nd</sup> : 30:70-O <sub>2</sub> /CO <sub>2</sub>	
	Measured	Calculated	Measured	Calculated	Measured	Calculated	Measured	Calculated
Species	% vol (dry)		% vol (dry)		% vol (dry)		% vol (dry)	
CO <sub>2</sub>	46.1	44.98	82.1	88.01	79.0	82.89	79.7	79.64
O <sub>2</sub>	4.9	4.52	3.5	3.58	4.0	4.42	4.7	4.87

#### 4.3.2.2. CO

Although a high concentration of CO was measured in the main combustion zone in both 30:70-O<sub>2</sub>/CO<sub>2</sub> and air firing, the CO in the flue gas was always very low. The average CO emissions in the flue gas from the combustion of Coal A is around 56 ppmv and 34 ppmv in air and 30:70-O<sub>2</sub>/CO<sub>2</sub> combustion respectively. Similar trend were observed with the combustion of other coals, where low CO levels in the flue gas of less than 50 ppmv were measured. It was also recorded that in combustion of Coal A in 21:79-O<sub>2</sub>/CO<sub>2</sub>, the CO concentration at the exhaust was markedly higher than that in air, at over 200 ppmv.

#### 4.3.2.3. SO<sub>x</sub>

Due to the variation in the gas flow rates in different combustion media, the comparison of SO<sub>x</sub> emission in different media is given by the SO<sub>x</sub> Conversion Ratio, (SR<sub>SO<sub>x</sub></sub>) which is defined as :

$$CR_{SO_x} = \left( \frac{SO_{2,e}}{SO_{2,cal}} \right) \times 100\% \dots\dots\dots 4.1$$

Where,

SO<sub>2,e</sub> (ppmv) is the measured flue gas NO concentration at the furnace exit.

SO<sub>2,cal</sub> (ppmv) is defined such that all of fuel sulphur is converted to SO<sub>2</sub>.

The conversion of sulphur in the coal to SO<sub>2</sub> for Coal A in all combustion media is very high. SO<sub>2</sub> concentration of 1500 ppmv was measured in the exhaust of air combustion, which corresponds to 89 % SO<sub>x</sub> conversion ratio. As expected, due to a lower flow rate of combustion gas, SO<sub>2</sub> concentration is significantly higher in

30:70-O<sub>2</sub>/CO<sub>2</sub>, at around 2050 ppmv. However the SO<sub>x</sub> conversion, CR<sub>SO<sub>x</sub></sub> in 30:70-O<sub>2</sub>/CO<sub>2</sub> (CR<sub>SO<sub>x</sub></sub> = 90.0) is very similar to that in air firing (CR<sub>SO<sub>x</sub></sub> = 89.6 %). The SO<sub>x</sub> conversion in 30:70-O<sub>2</sub>/CO<sub>2</sub> combustion is also only slightly higher than in 21:79-O<sub>2</sub>/CO<sub>2</sub> (CR<sub>SO<sub>x</sub></sub> = 86.0 %). Similar results were obtain from the combustion of other coals. For Coal B, in which sulphur content is slightly lower than Coal A, the SO<sub>2</sub> concentration in the flue gas in air combustion is 990 ppmv which corresponds to CR<sub>SO<sub>x</sub></sub> = 79.5 %, compared to 1340 ppmv in 30:70-O<sub>2</sub>/CO<sub>2</sub> combustion (CR<sub>SO<sub>x</sub></sub> = 79.1 %). For Coal F, the SO<sub>x</sub> conversion in 30:70-O<sub>2</sub>/CO<sub>2</sub> is 76.9%, which is slightly less than that in air (CR<sub>SO<sub>x</sub></sub> = 79.9%).

#### 4.3.2.4. NO<sub>x</sub>

The average NO<sub>x</sub> concentration in the exhaust gas in normal air combustion for coal A is 835 ppm which is 12 % lower than 930 ppmv as in 30:70-O<sub>2</sub>/CO<sub>2</sub>. This variation in NO<sub>x</sub> concentrations is partly due to the difference in the flue gas flow rate between the two combustion media. Therefore, NO<sub>x</sub> conversion ratio, CR<sub>NO<sub>x</sub></sub>(%) is used to compare the NO<sub>x</sub> emission, where,

$$CR_{NO_x} = \left( \frac{NO_e}{NO_{cal}} \right) \times 100\% \quad \dots\dots\dots 4.2a$$

Where,

NO<sub>e</sub> (ppmv) is the measured flue gas NO concentration at the furnace exit.

NO<sub>cal</sub> (ppmv) is defined such that all of fuel Nitrogen is converted to NO.

The Relative NO<sub>x</sub> Conversion Ratio, (CR<sub>NO<sub>x</sub></sub>)<sub>r</sub> is the ratio of NO<sub>x</sub> conversion in a combustion media relative to that in unstaged air combustion.

$$(CR_{NO_x})_r = \frac{(CR_{NO_x})_o}{(CR_{NO_x})_{air}} \dots\dots\dots 4.2b$$

Where,

$(CR_{NO_x})_o$  is the  $NO_x$  Conversion Ratio of a particular coal in unstaged  $O_2/CO_2$  combustion.

$(CR_{NO_x})_{air}$  is the  $NO_x$  Conversion Ratio of a particular coal in unstaged air combustion.

Figure 4.9 presents the relative  $NO_x$  Conversion Ratio,  $(CR_{NO_x})_r$  in various  $O_2/CO_2$  concentrations for Coal A, which show that the combustion media has a major influence on the  $NO_x$  formation in the furnace. Table 4.4 shows the  $NO_x$  concentrations in the flue gas and the corresponding  $NO_x$  conversion ratio, from combustion of Coal A in various media. The  $NO_x$  conversion is significantly lower in combustion with high  $CO_2$  concentrations and increases with higher  $O_2$  concentration in the oxidants mixture. The  $NO_x$  conversion in 30:70- $O_2/CO_2$  combustion is significantly lower at 22.7 % compared to 27.7 % in air, which corresponds to 18.1 % less in the total furnace  $NO_x$  emissions. The  $NO_x$  concentration in the flue gas is less than that of air firing when only the secondary air was replaced by the  $O_2/CO_2$  mixture, even in combustion with high  $O_2$  concentrations of above 30 % (Case 5). Replacing the secondary air with 21:79- $O_2/CO_2$  (Case 2) reduces  $CR_{NO_x}$  to 12.1%, which corresponds to 56.5 %  $NO_x$  reduction. In combustion with 21:79- $O_2/CO_2$  in both primary and secondary oxidiser,  $CR_{NO_x}$  is just below 7 % which is about one-fourth to that in air combustion.

Similar results were obtained from the combustion of the other coals. Figure 4.10 shows the the  $\text{NO}_x$  emission and conversion in 30:70- $\text{O}_2/\text{CO}_2$  compared to those in air combustion, and the detail figures are shown in Table 4.5 For all of the tested coals, combustion in 30:70- $\text{O}_2/\text{CO}_2$  produces lower  $\text{NO}_x$  than combustion in air, however, the conversion of  $\text{NO}_x$  varies between coals. The relative  $\text{NO}_x$  conversion in 30:70- $\text{O}_2/\text{CO}_2$  varies markedly from as low as 0.60 as in the case of Coal F, to around 0.90 for coal G, which indicate that the  $\text{NO}_x$  conversion seems to depend on the reactivity (coal fuel ratio) of the coals. It is also noted that, for less reactive coal (Coal D, E and F) the  $\text{NO}_x$  emissions (in ppmv) in 30:70- $\text{O}_2/\text{CO}_2$  was also lower than those in air combustion. Figure 4.11a and 4.11b show the variation of  $\text{CR}_{\text{NO}_x}$  and  $(\text{CR}_{\text{NO}_x})_{\text{rel}}$  with coal fuel ratio which show a high linear correlation between the two parameters. The  $\text{NO}_x$  conversion decreases with the increasing fuel ratio, and the variation with coal fuel ratio is more significant in 30:70- $\text{O}_2/\text{CO}_2$ . Figure 4.12a, 4.12b and 4.12c show the variation of  $\text{NO}_x$  Conversion Ratio with coal-volatile and coal-N respectively which indicate that for the seven tested coals,  $\text{CR}_{\text{NO}_x}$  is also influenced by these two coal properties particularly in 30:70- $\text{O}_2/\text{CO}_2$ . For unstaged air combustion, the  $\text{NO}_x$  concentration (ppmv) increases with the increasing coal-N whereas for 30:70- $\text{O}_2/\text{CO}_2$ ,  $\text{NO}_x$  emission seems to be decreasing. However, the  $\text{NO}_x$  conversion ratio decreases with the Coal-N in air combustion and this trend is more obvious in 30:70- $\text{O}_2/\text{CO}_2$ . The  $\text{NO}_x$  conversion ratio increases with the increasing coal-volatiles, and compared to that in air, the dependence seems to be more for 30:70- $\text{O}_2/\text{CO}_2$ . The  $\text{NO}_x$  conversion is also affected by the present of small amount of air in 30:70- $\text{O}_2/\text{CO}_2$ . when the coal entrainment air was purged by 30:70- $\text{O}_2/\text{CO}_2$  for combustion of Coal G,  $(\text{CR}_{\text{NO}_x})_{\text{r}}$  decreases slightly from 0.89 to 0.86.

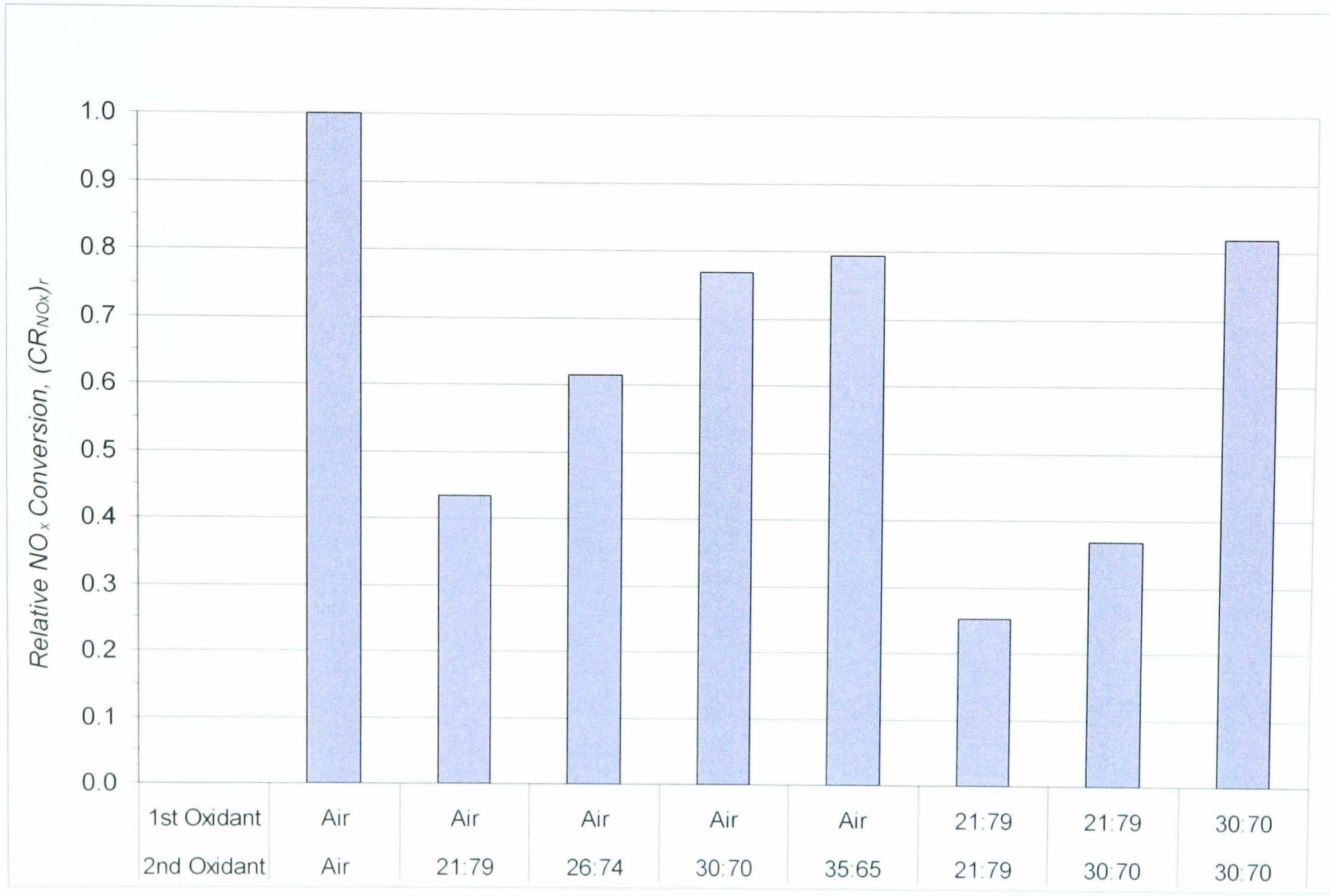


**Table 4.4.** NO<sub>x</sub> emission levels and NO<sub>x</sub> Conversion Ratio (CR<sub>NO<sub>x</sub></sub>) in various combustion media (Unstaged, SR = 1.20, Coal A).

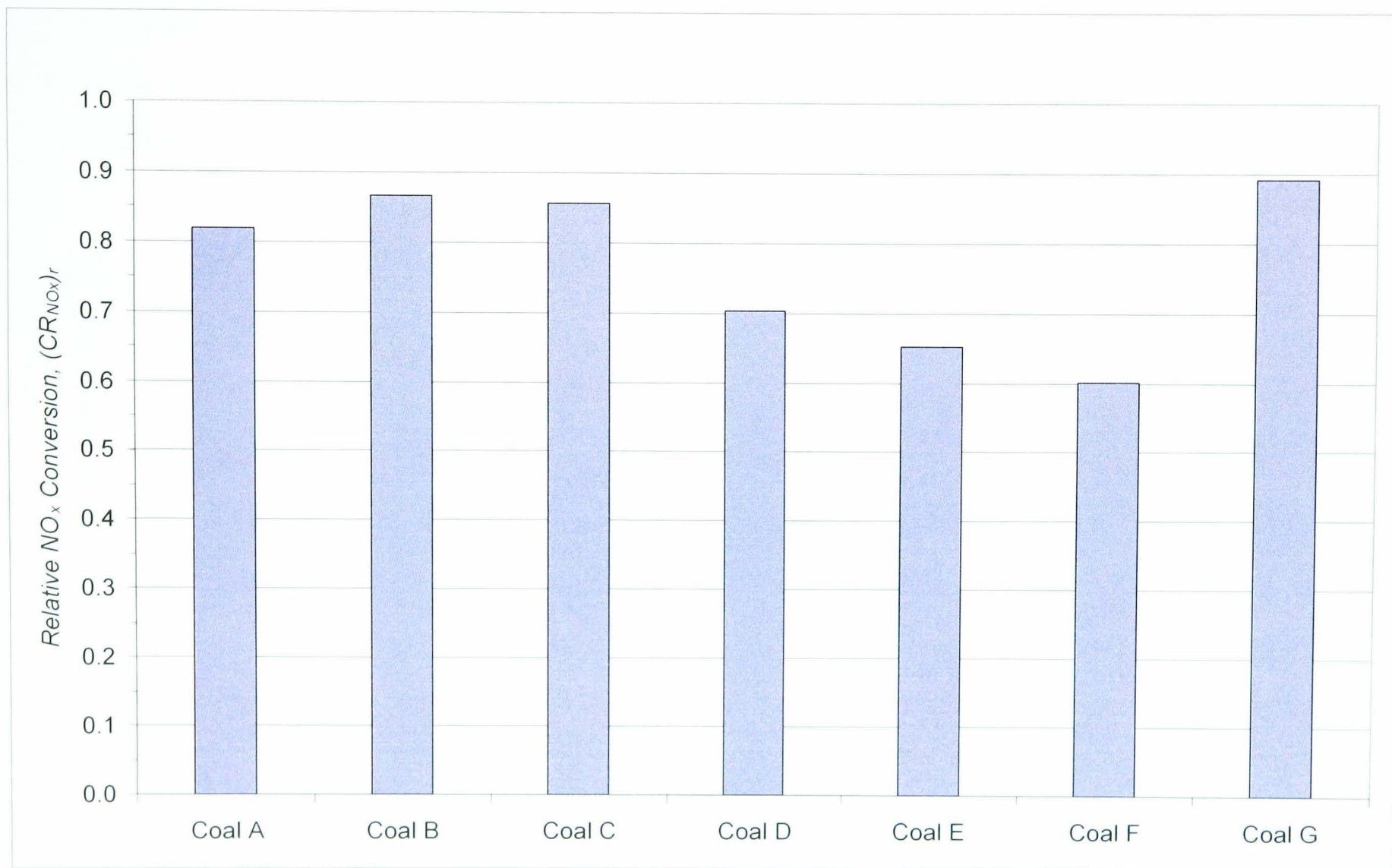
Fuel:	Coal A							
Combustion Test	Case 1	Case 2	Case 3	Case 4	Case 5	Case 6	Case 7	Case 8
Oxidants:								
1st	Air	Air	Air	Air	Air	21:79-O <sub>2</sub> /CO <sub>2</sub>	21:79-O <sub>2</sub> /CO <sub>2</sub>	30:70-O <sub>2</sub> /CO <sub>2</sub>
2nd	Air	21:79-O <sub>2</sub> /CO <sub>2</sub>	26:74-O <sub>2</sub> /CO <sub>2</sub>	30:70-O <sub>2</sub> /CO <sub>2</sub>	35:65-O <sub>2</sub> /CO <sub>2</sub>	21:79-O <sub>2</sub> /CO <sub>2</sub>	30:70-O <sub>2</sub> /CO <sub>2</sub>	30:70-O <sub>2</sub> /CO <sub>2</sub>
Max. NO <sub>cal</sub> (ppmv)	3011	3010	3400	3619	3803	3010	3714	4095
NO <sub>e</sub> (ppmv)	835	363	580	771	839	210	380	930
CR <sub>NO<sub>x</sub></sub> (%)	27.7	12.1	17.1	21.3	22.0	7.0	10.2	22.7
(CR <sub>NO<sub>x</sub></sub> ) <sub>r</sub> (-)	1.0	0.44	0.62	0.77	0.79	0.25	0.37	0.82

**Table 4.5.** NO<sub>x</sub> emission levels and NO<sub>x</sub> Conversion Ratio (CR<sub>NO<sub>x</sub></sub>) in air and in 30:70-O<sub>2</sub>/CO<sub>2</sub>, for All Coals (Unstaged, SR = 1.20).

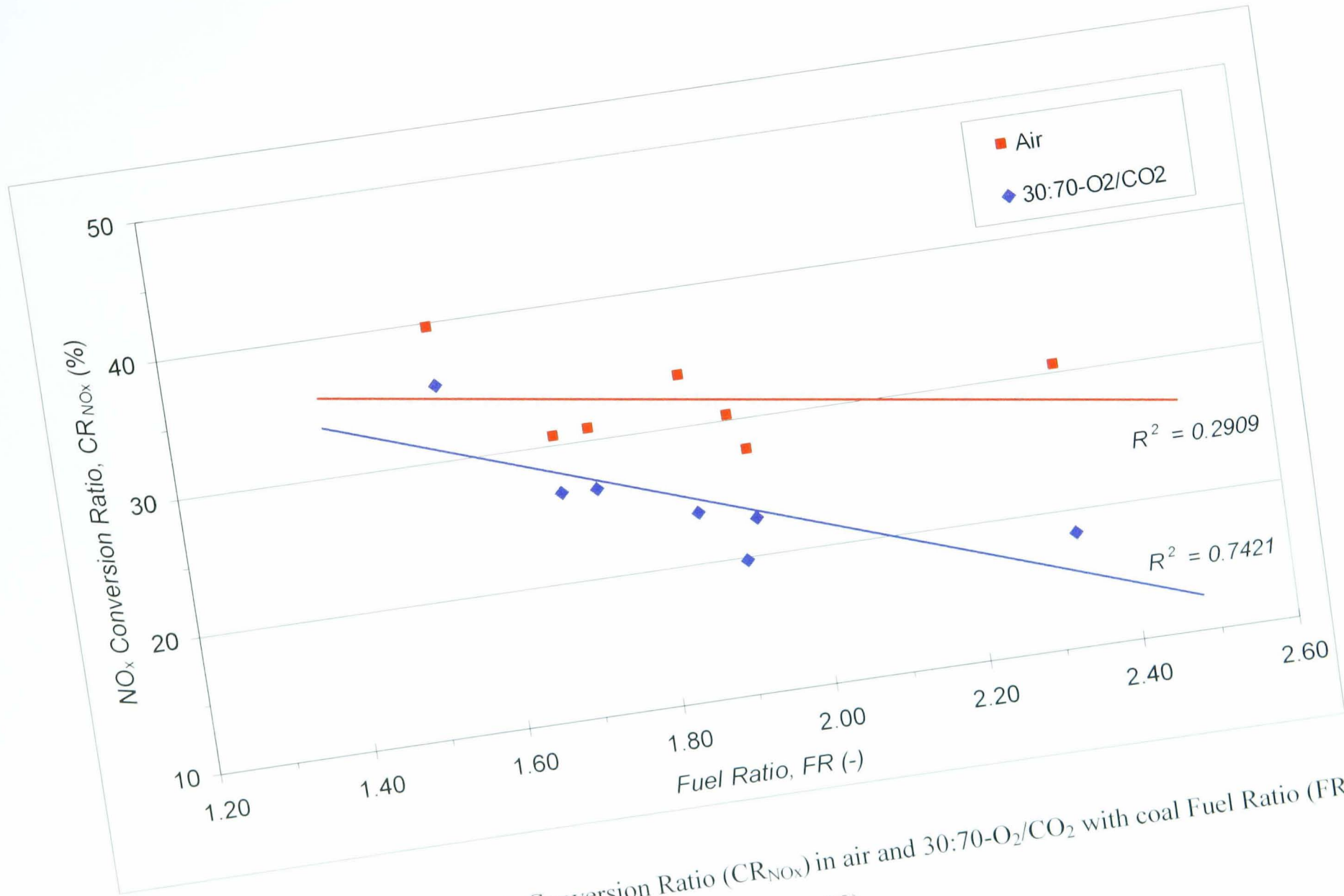
		<b>Coal A</b>	<b>Coal B</b>	<b>Coal C</b>	<b>Coal D</b>	<b>Coal E</b>	<b>Coal F</b>	<b>Coal G</b>
Coal fuel ratio, FR (-)		1.93	1.69	1.73	1.86	1.91	2.33	1.54
Coal-N, daf (%)		1.89	1.71	1.77	1.49	1.88	2.04	1.59
Coal-volatile, daf (%)		34.15	37.23	36.61	35.02	34.39	30.02	39.28
	Max. NO <sub>cal</sub> (ppmv)	3010	2753	2900	2390	3084	3410	2297
Air	NO <sub>e</sub> (ppmv)	835	845	895	807	937	1042	913
	CR <sub>NO<sub>x</sub></sub> (%)	27.7	30.7	30.9	33.7	30.4	30.6	39.8
	Max. NO <sub>cal</sub> (ppmv)	4095	3744	3944	3250	4191	4632	3131
30:70-O <sub>2</sub> /CO <sub>2</sub>	NO <sub>e</sub> (ppmv)	930	995	1043	772	832	850	1110
	CR <sub>NO<sub>x</sub></sub> (%)	22.7	26.7	26.4	23.8	19.9	18.4	35.5
(CR <sub>NO<sub>x</sub></sub> ) <sub>r</sub> (-)		0.82	0.87	0.86	0.70	0.65	0.60	0.89



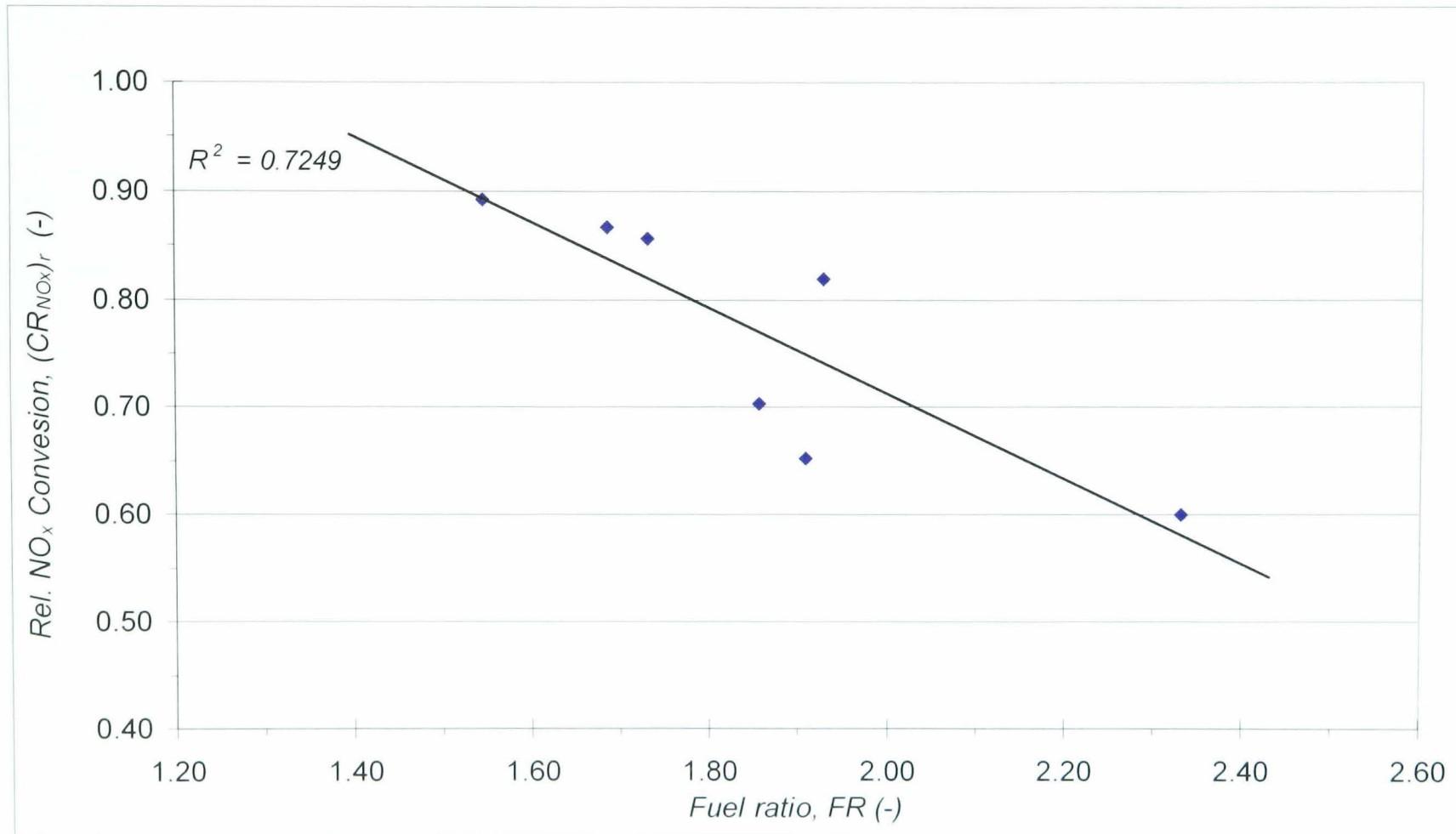
**Figure 4.9.**  $NO_x$  Conversion Ratio ( $CR_{NO_x}$ ) in various oxidants mixtures relative to that in air combustion. (Unstaged,  $SR=1.20$ , Coal A).



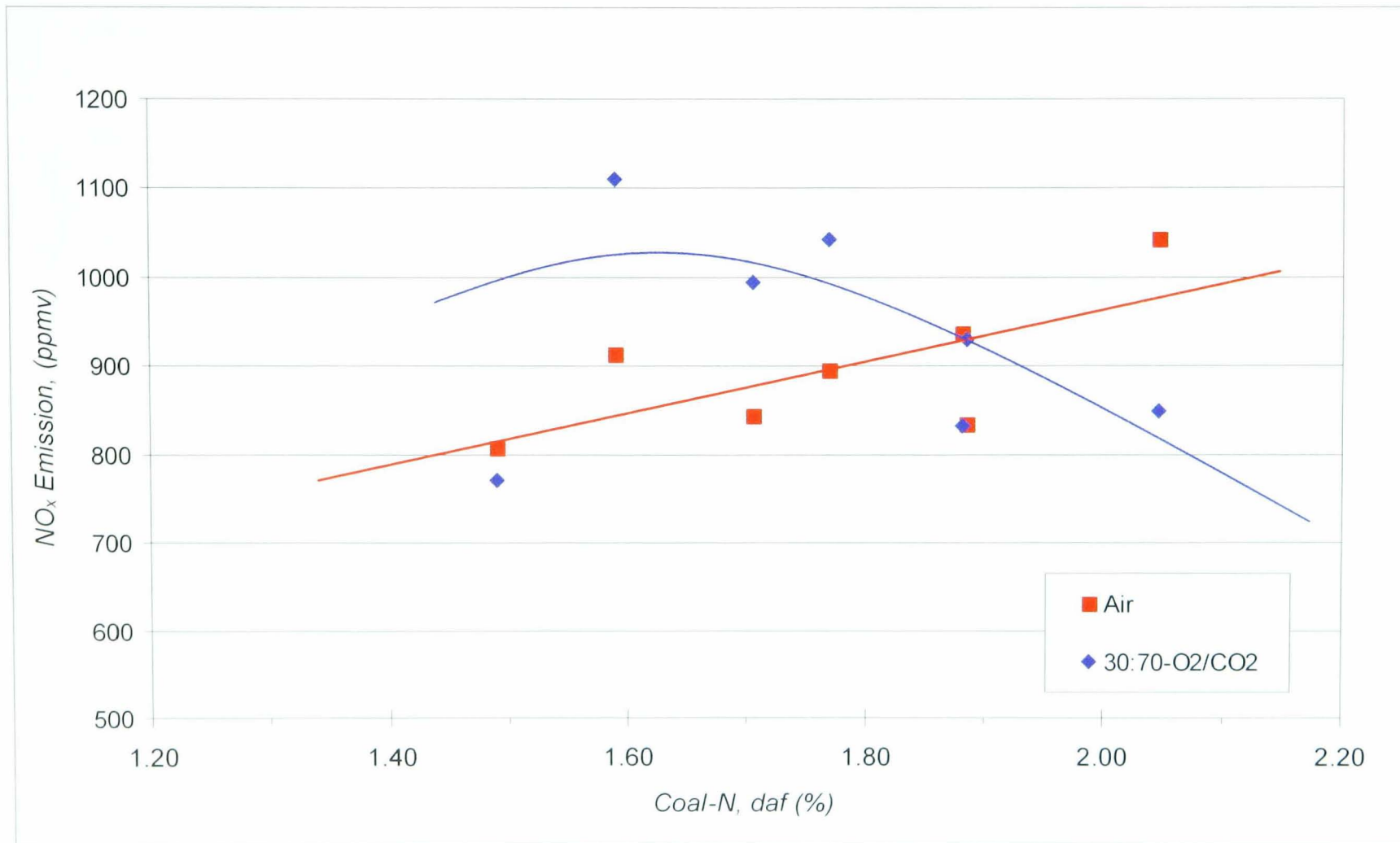
**Figure 4.10.** NO<sub>x</sub> Conversion Ratio (CR<sub>NO<sub>x</sub>) in 30:70-O<sub>2</sub>/CO<sub>2</sub>, relative to those in air combustion, for all coals. (Unstaged, SR=1.20).</sub>



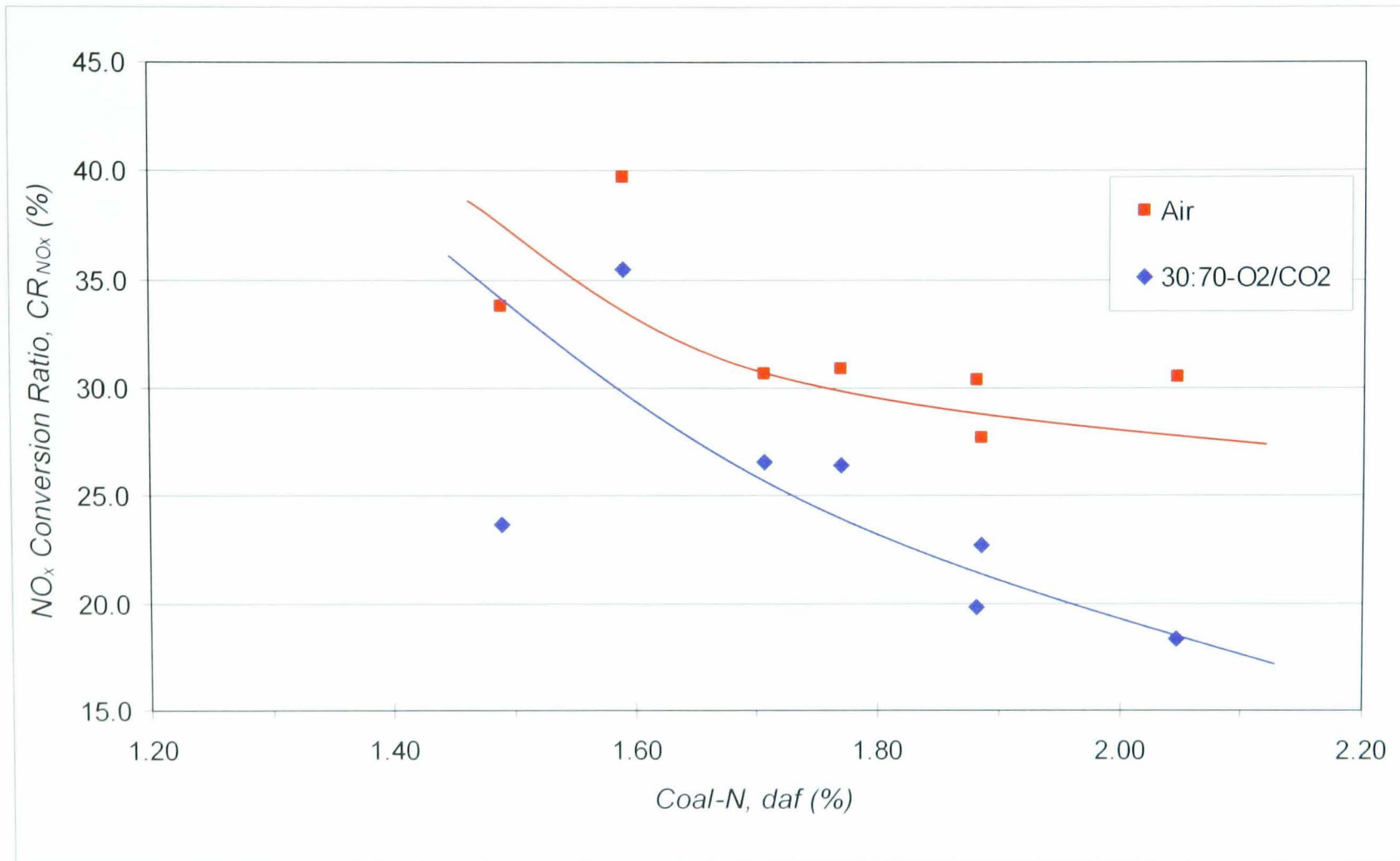
**Figure 11a.** The dependence of NO<sub>x</sub> Conversion Ratio (CR<sub>NO<sub>x</sub></sub>) in air and 30:70-O<sub>2</sub>/CO<sub>2</sub> with coal Fuel Ratio (FR). (Unstaged, SR=1.20).



**Figure 4.11b.** The variation of the NO<sub>x</sub> Conversion Ratio in 30:70-O<sub>2</sub>/CO<sub>2</sub> mixture relative to those in air combustion, with coal fuel ratio. (Unstaged, SR=1.20).

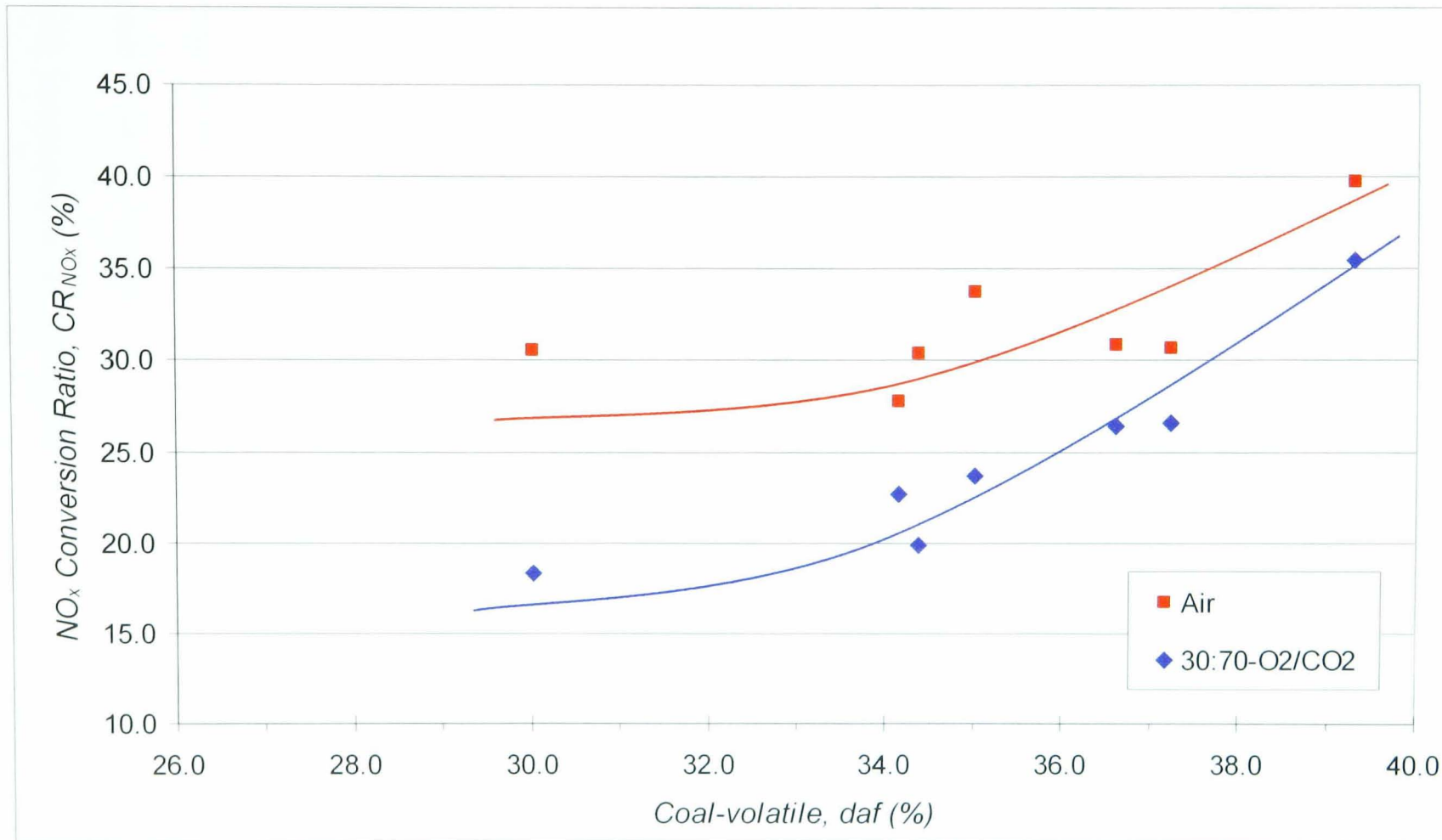


**Figure 12a.** The variation of NO<sub>x</sub> emission concentration (ppmv) in air and 30:70-O<sub>2</sub>/CO<sub>2</sub> with coal-N. (Unstaged, SR=1.20)



**Figure 12b.** The variation of NO<sub>x</sub> Conversion Ratio (CR<sub>NO<sub>x</sub></sub>) in air and 30:70-O<sub>2</sub>/CO<sub>2</sub> with coal-N. (Unstaged, SR=1.20).





**Figure 12c.** The variation of NO<sub>x</sub> Conversion Ratio (CR<sub>NO<sub>x</sub></sub>) in air and 30:70-O<sub>2</sub>/CO<sub>2</sub> with coal-volatile. (Unstaged, SR=1.20).

#### 4.4. Unburned Carbon in Ash and Char Burnout Efficiency.

It is known that the carbon concentration in ash from coal combustion depends on the ash content of the coal and hence the combustibility of coal is characterised by the burnout efficiency and not only by the carbon concentration in ash. The percentage of char burnout efficiency,  $\eta_{BO}$  is calculated by the following equation: (Ikeda et al.,2003) and (Costa et al., 2003).

$$\eta_{BO} = \frac{1 - (\omega_c / \omega_x)}{(1 - \omega_c)} \times 100\% \dots\dots\dots 4.3$$

where,

$\omega_c$  is ash weight fraction in coal.

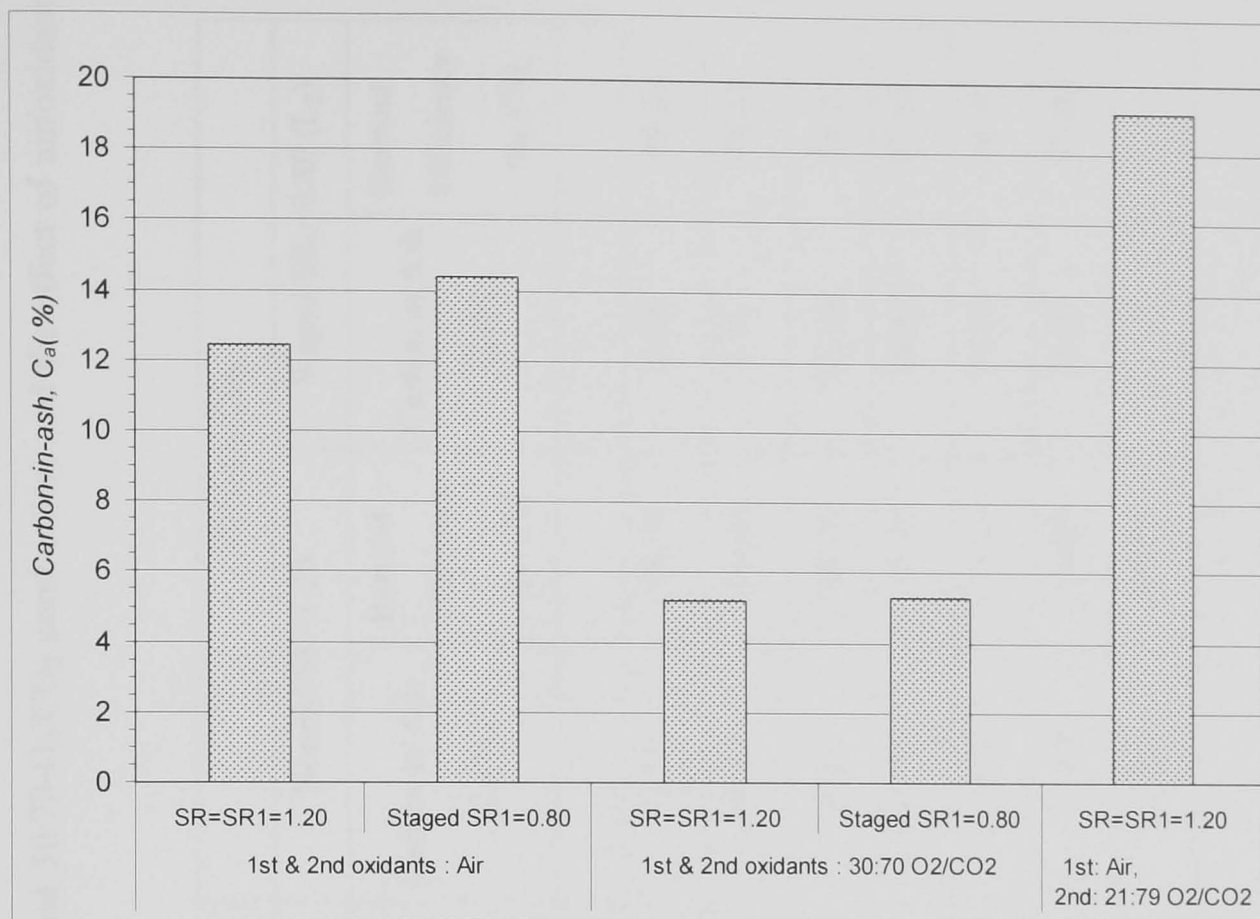
$\omega_x$  is ash weight fraction in char.

From all combustion tests, high burnout was achieved with coal combustion in air and the value varies between coals and combustion media. Figures 4.13a and 4.13b show the char carbon in ash from the combustion of Coal A and the corresponding burnout efficiency, in air and various combustion media, respectively. The average carbon concentration in the ash in air combustion is 12.4 % which corresponds to 98.2% burnout efficiency. The carbon content in ash increases with higher CO<sub>2</sub> concentration in the oxidant. Combustion in 21:79-O<sub>2</sub>/CO<sub>2</sub> produces 19.2% carbon in ash which corresponds to a burnout of only 96.8 %. The average

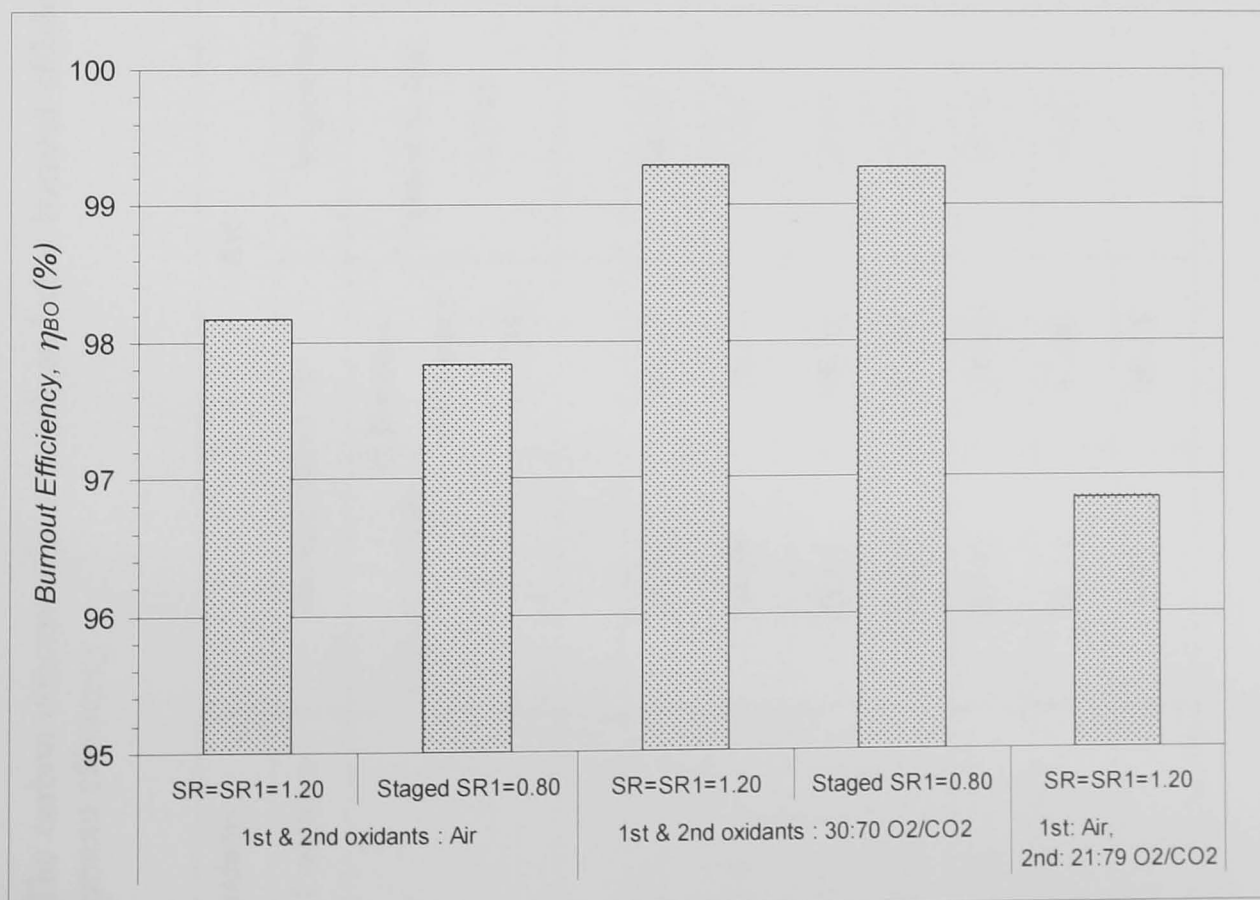
carbon concentration in the ash in 30:70-O<sub>2</sub>/CO<sub>2</sub> combustion is significantly lower at 5.2%, which corresponding to 99.3% in burnout efficiency.

Generally, compared to those in air combustion, the burnout efficiency of all coals is significantly higher in 30:70-O<sub>2</sub>/CO<sub>2</sub> combustion. Figure 4.14a presents a comparison of carbon concentrations in ash in 30:70-O<sub>2</sub>/CO<sub>2</sub> to those in air combustion for all coals and the corresponding burnout efficiency is shown in Figure 4.14b, which show that higher burnout efficiency is attained in 30:70-O<sub>2</sub> CO<sub>2</sub>. The combustion efficiency in air varies from 92.5% for Coal F to 98.5% for Coal B whereas in 30:70-O<sub>2</sub>/CO<sub>2</sub>, the values vary between 95.0% for Coal F and 99.3 % for Coal G. A few test runs on coal G with 50:50-O<sub>2</sub>/CO<sub>2</sub> in the secondary oxidant produced a higher burnout of more than 99.6 %.

The results also show that the burnout efficiency is influenced by the coal fuel ratio, both in air and 30:70-O<sub>2</sub>/CO<sub>2</sub>. Generally higher burnout efficiency is obtained from the combustion of coal with lower fuel ratio, as shown by Figures 4.15a and 4.15b. The detailed figures on ash and burnout efficiency for all coals are presented in Table 4.6. The burnout efficiency of the combustion for each coal could be linked to the NO<sub>x</sub> reduction efficiency in the combustion. The plot shown in Figure 4.16a indicates that NO<sub>x</sub> conversion ratio increases with the coal burnout efficiency for both air and 30:70-O<sub>2</sub>/CO<sub>2</sub> combustion, as shown in Figure 4.16b.



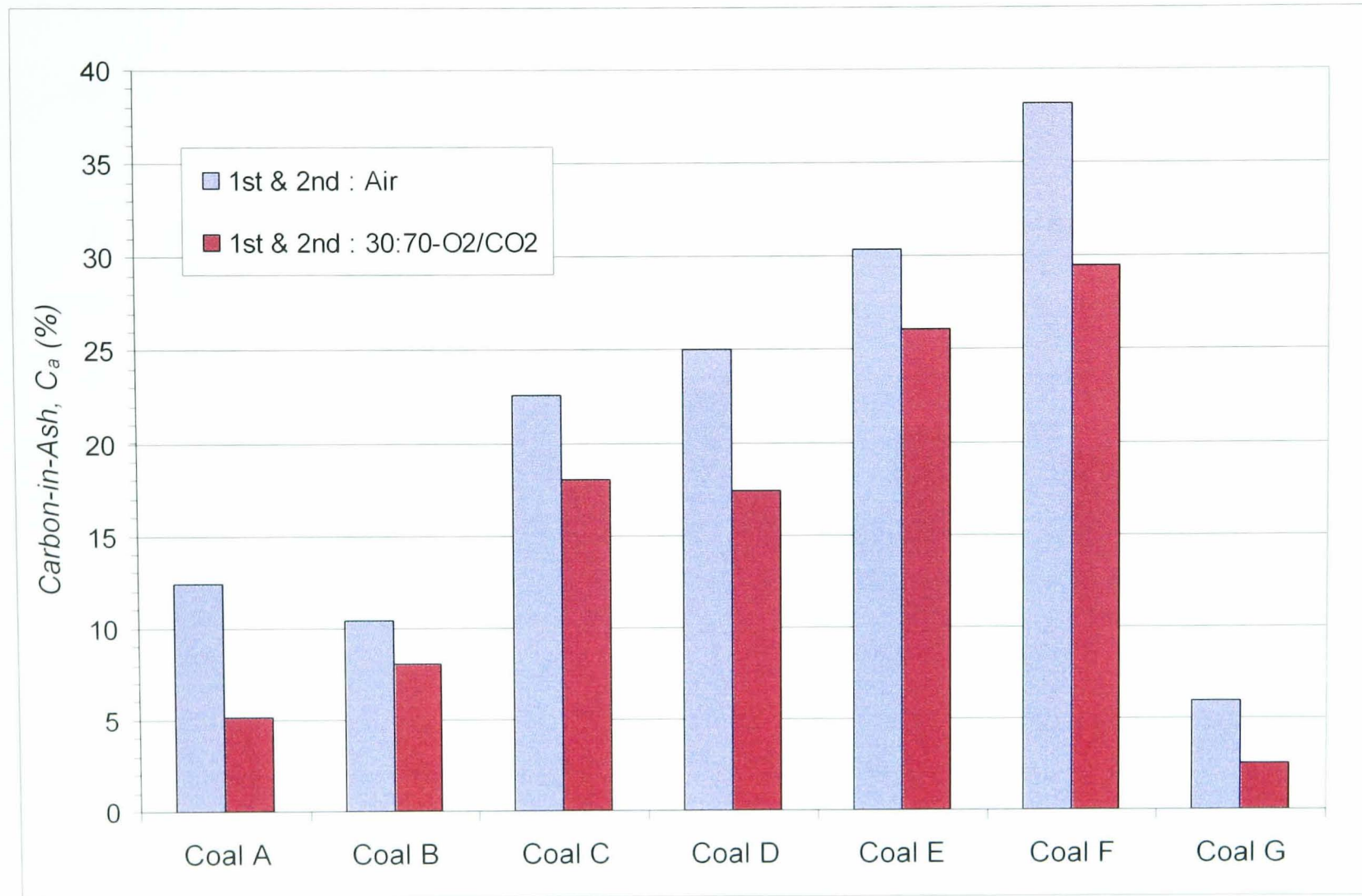
**Figure 4.13a.** Carbon concentrations in ash ( $C_a$ ) in different combustion media and conditions (Coal A).



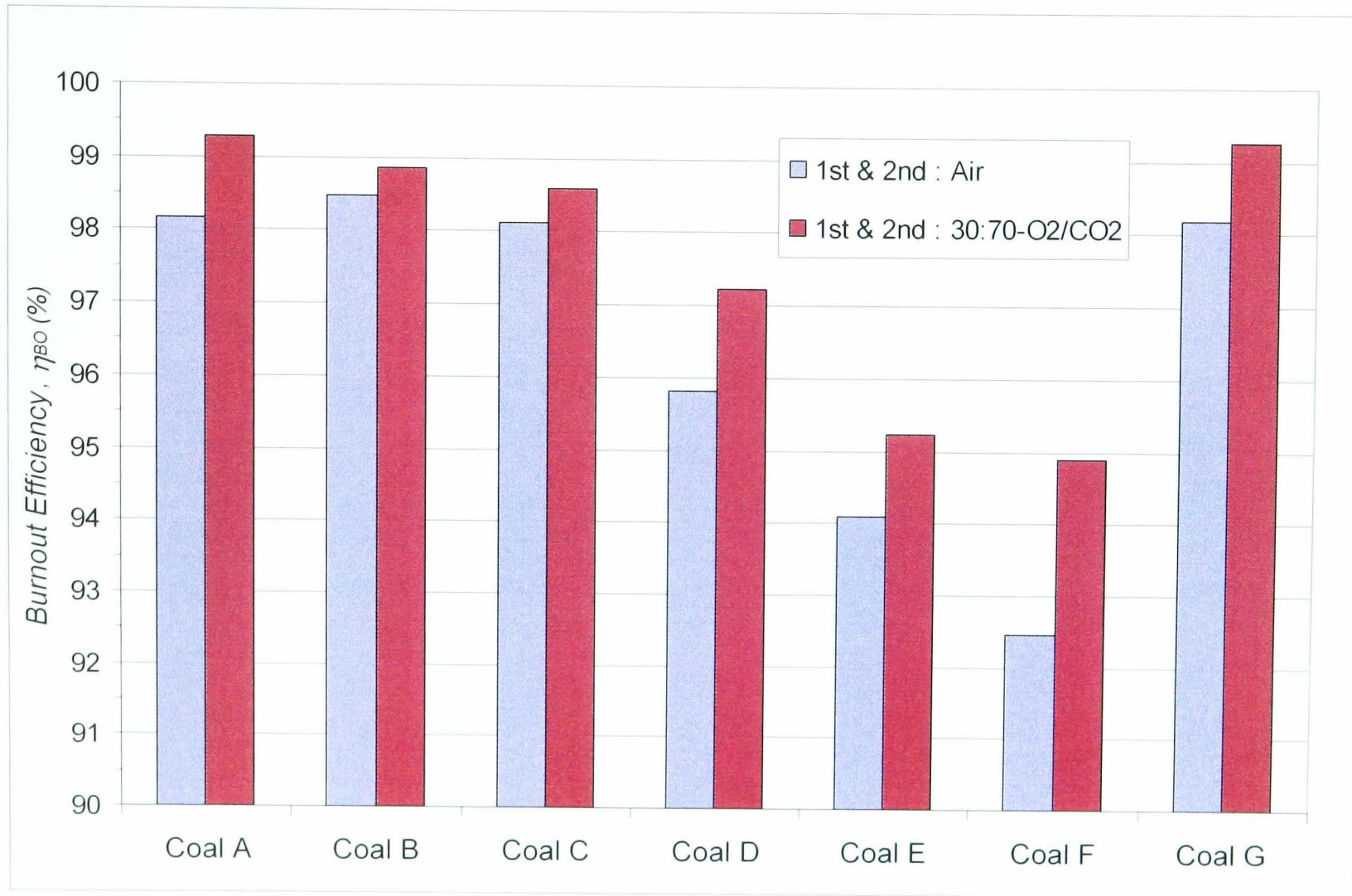
**Figure 4.13b.** Burnout Efficiency ( $\eta_{BO}$ ) in different combustion media and conditions (Coal A).

**Table 4.6.** The carbon concentrations in ash and char burnout efficiency in Air and 30:70-O<sub>2</sub>/CO<sub>2</sub> combustion, and the effect of air/oxidant staging on burnout efficiency.

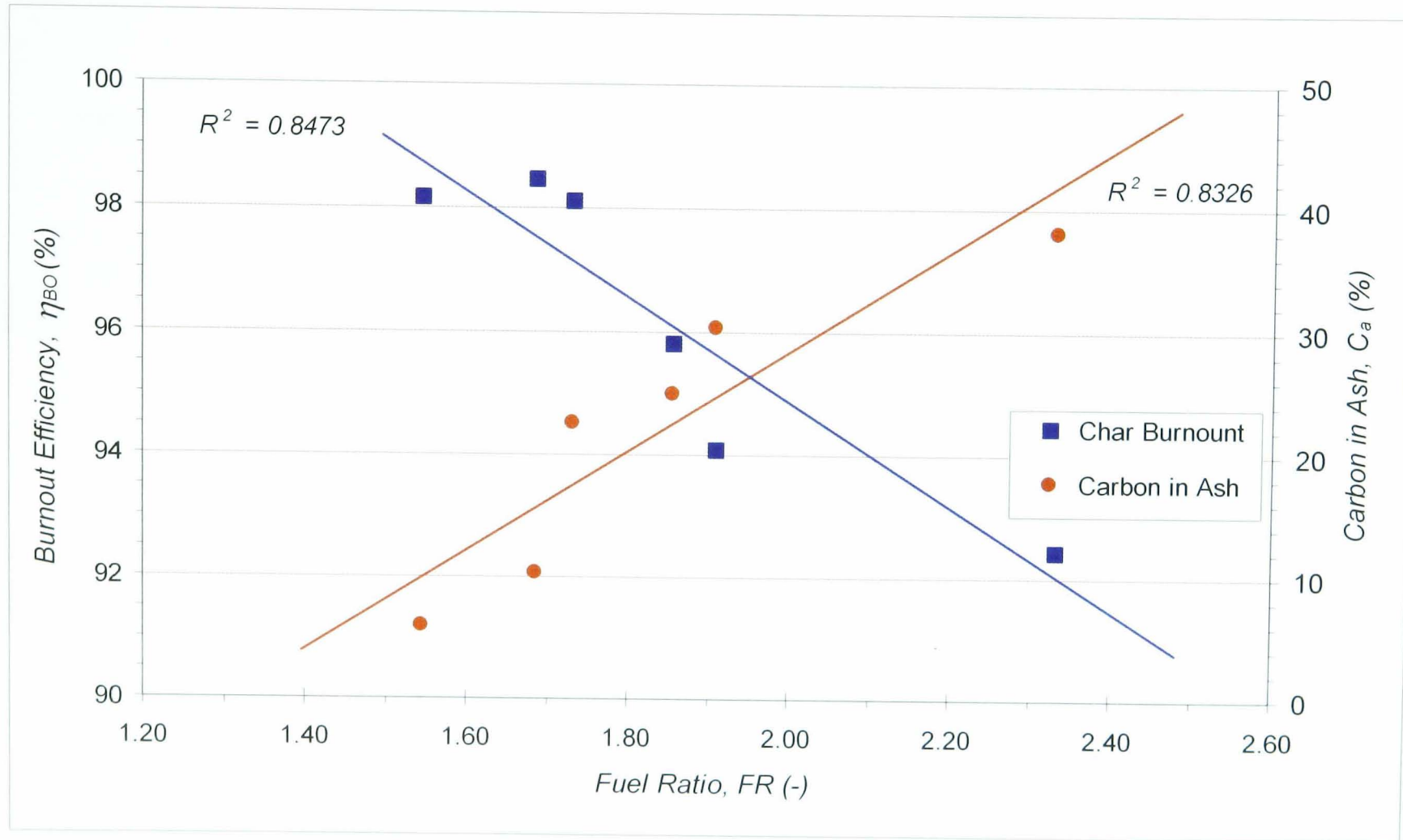
1st & 2nd Oxidants:	Air				30:70-O <sub>2</sub> /CO <sub>2</sub>			
Combustion Conditions	Normal SR=1.20		Staged SR <sub>1</sub> =0.80 (L <sub>2</sub> )		Normal SR=1.20		Staged SR <sub>1</sub> =0.80 (L <sub>2</sub> )	
	Carbon in Ash <i>C<sub>a</sub></i> (%)	Burnout Efficiency <i>η<sub>BO</sub></i> (%)	Carbon in Ash <i>C<sub>a</sub></i> (%)	Burnout Efficiency <i>η<sub>BO</sub></i> (%)	Carbon in Ash <i>C<sub>a</sub></i> (%)	Burnout Efficiency <i>η<sub>BO</sub></i> (%)	Carbon in Ash <i>C<sub>a</sub></i> (%)	Burnout Efficiency <i>η<sub>BO</sub></i> (%)
Coals:								
Coal A	12.43	98.17	14.38	97.83	5.21	99.29	5.28	99.28
Coal B	10.38	98.49	13.37	97.98	8.01	98.86	8.15	98.84
Coal C	22.61	98.13	26.93	97.64	18.03	98.59	21.96	98.20
Coal D	25.04	95.82	25.54	95.71	17.43	97.23	18.40	97.18
Coal E	30.39	94.10	31.95	93.65	26.06	95.23	27.20	94.95
Coal F	38.14	92.46	39.82	91.91	29.50	94.89	29.02	95.00
Coal G	5.97	98.18			2.50	99.26		



**Figure 4.14a.** Carbon concentration in ash ( $C_a$ ) from air and 30:70-O<sub>2</sub>/CO<sub>2</sub> combustion for all coals. (Unstaged, SR=1.20).

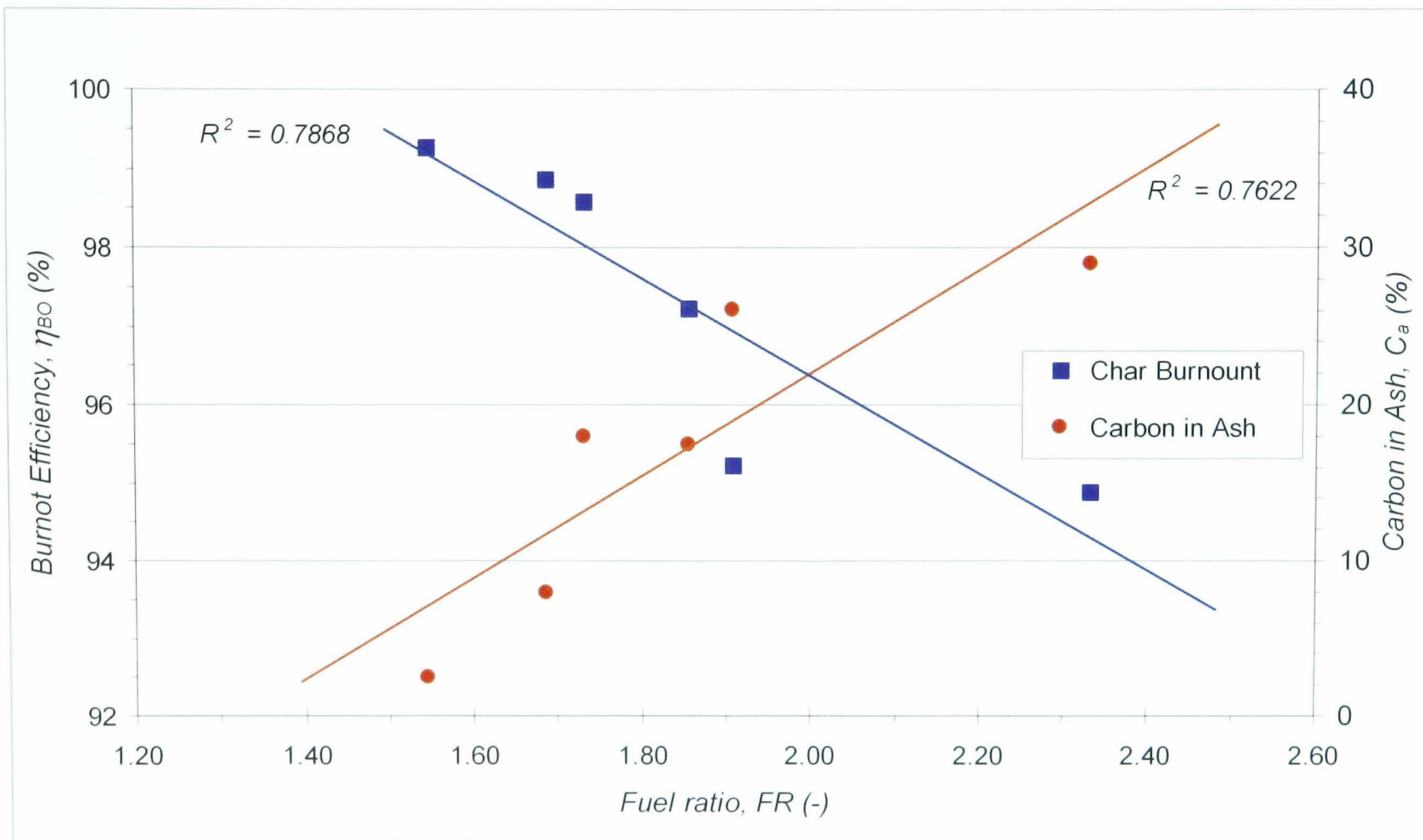


**Figure 4.14b.** Burnout Efficiency ( $\eta_{BO}$ ) in air and 30:70-O<sub>2</sub>/CO<sub>2</sub> for all coals. (Unstaged, SR=1.20)

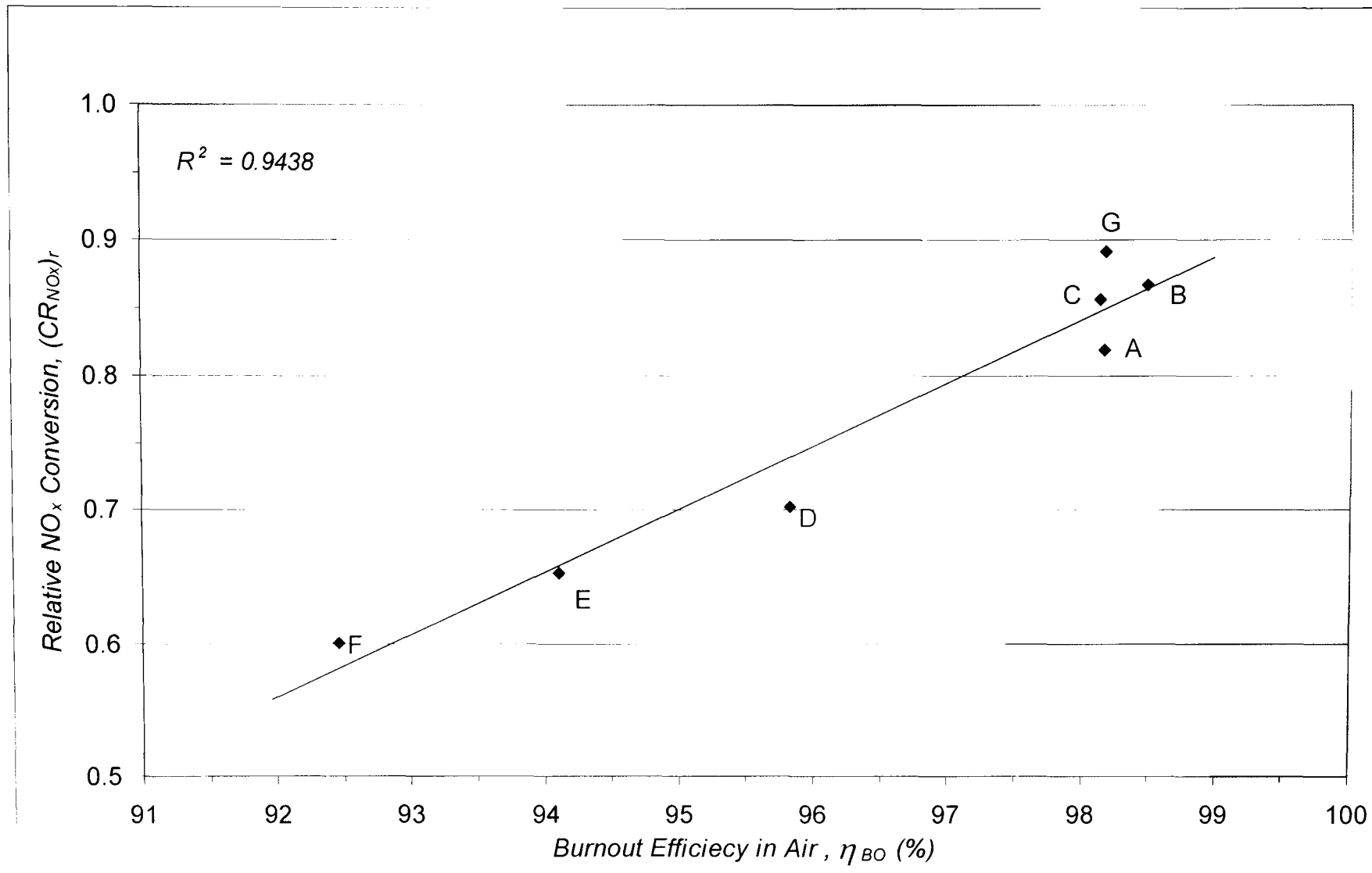


**Figure 4.15a.** The dependence of Burnout Efficiency ( $\eta_{BO}$ ) in air combustion on coal Fuel Ratio (FR) for all coals. (Unstaged, SR=1.20).

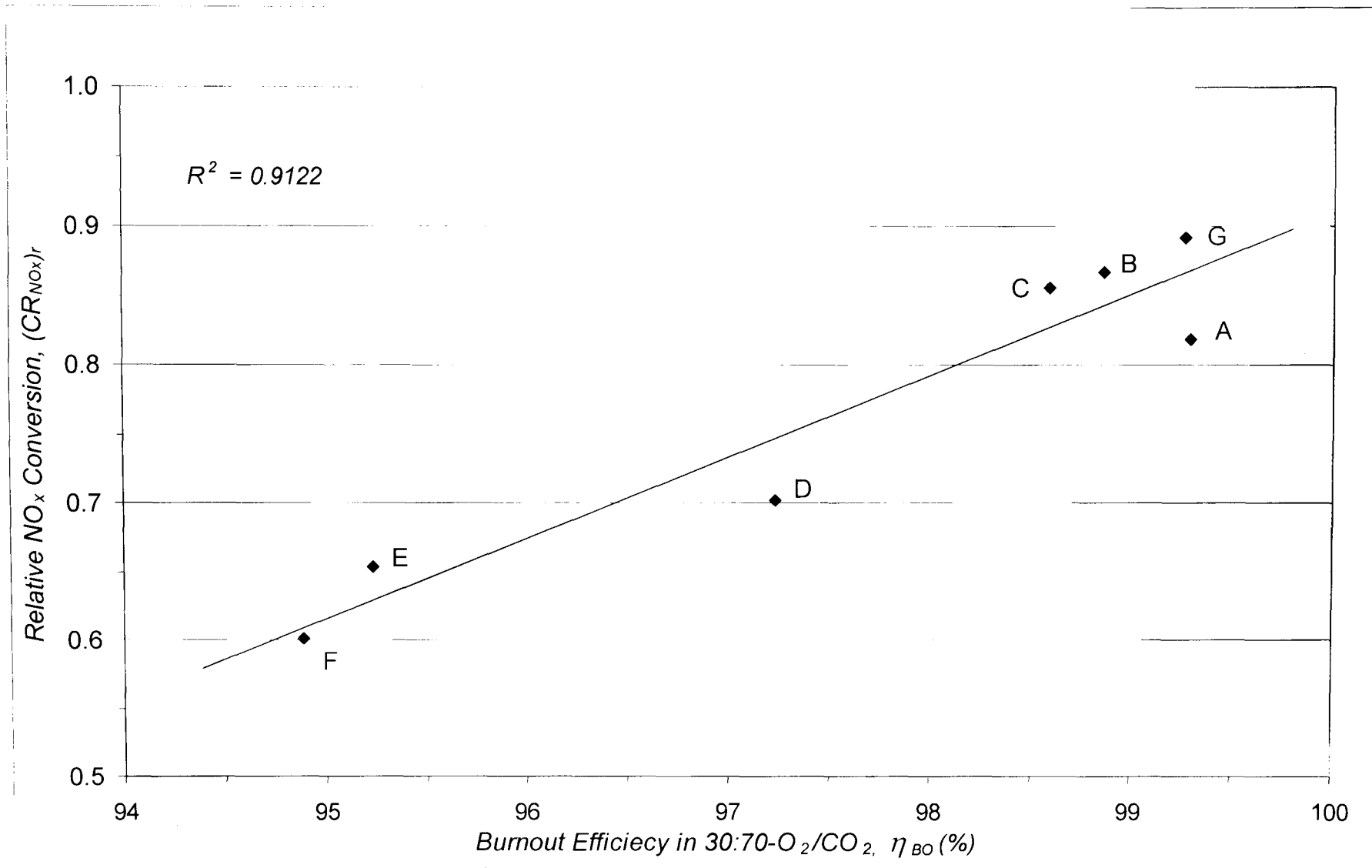




**Figure 4.15b.** The dependence of Burnout Efficiency ( $\eta_{BO}$ ) in 30:70-O<sub>2</sub>/CO<sub>2</sub> combustion on coal Fuel Ratio (FR), for all coals. (Unstaged, SR=1.20).



**Figure 4.16a.** The dependence of Relative  $NO_x$  Conversion  $(CR_{NO_x})_r$  on combustion Burnout Efficiency  $(\eta_{BO})$  in air, for all coals. (Unstaged, SR=1.20).



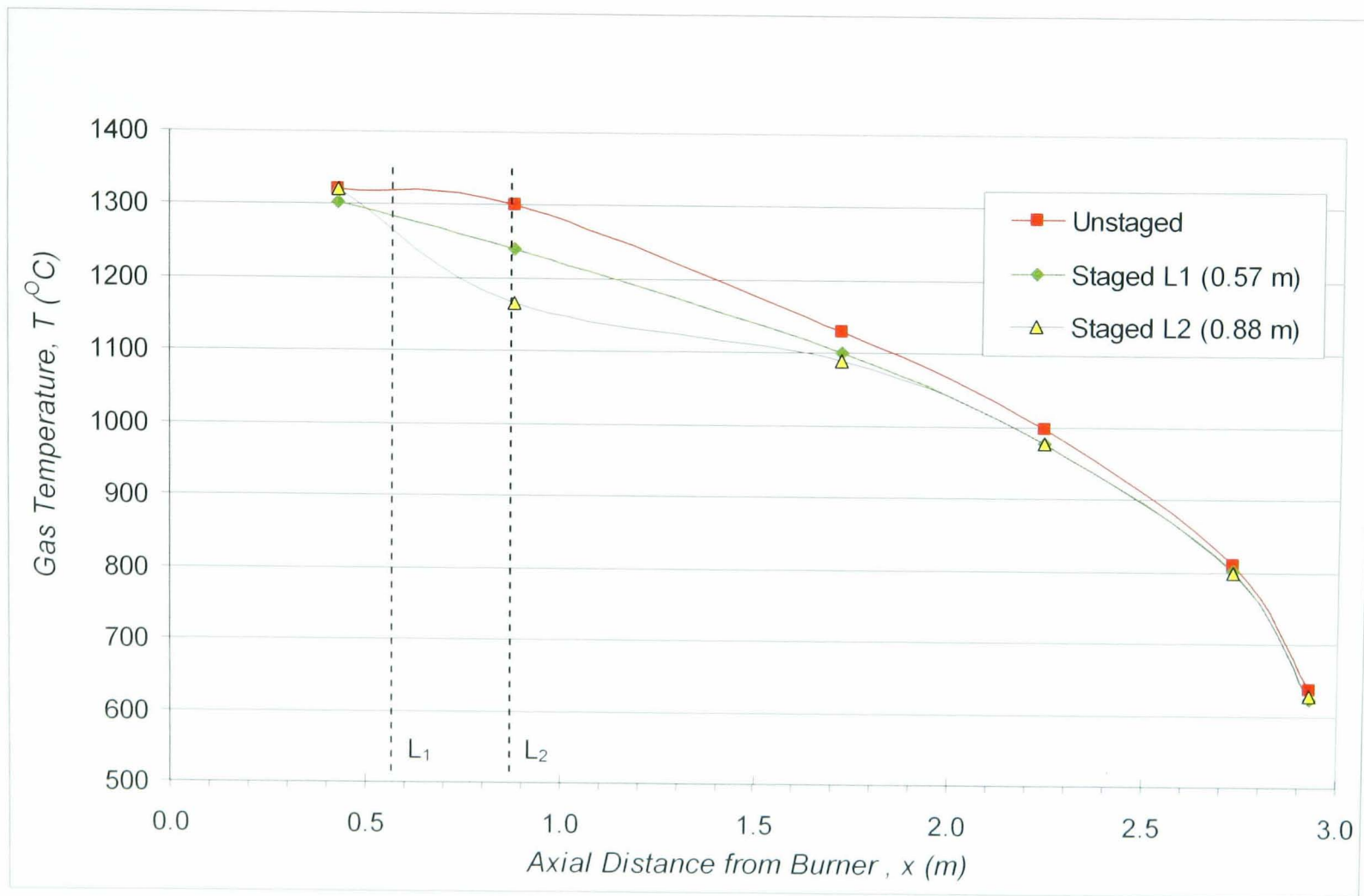
**Figure 4.16b.** The dependence of Relative NO<sub>x</sub> Conversion (CR<sub>NO<sub>x</sub>)<sub>r</sub> on combustion Burnout Efficiency (η<sub>BO</sub>) in 30:70-O<sub>2</sub>/CO<sub>2</sub>, for all coals. (Unstaged, SR=1.20).</sub>

## 4.5. Staged Combustion.

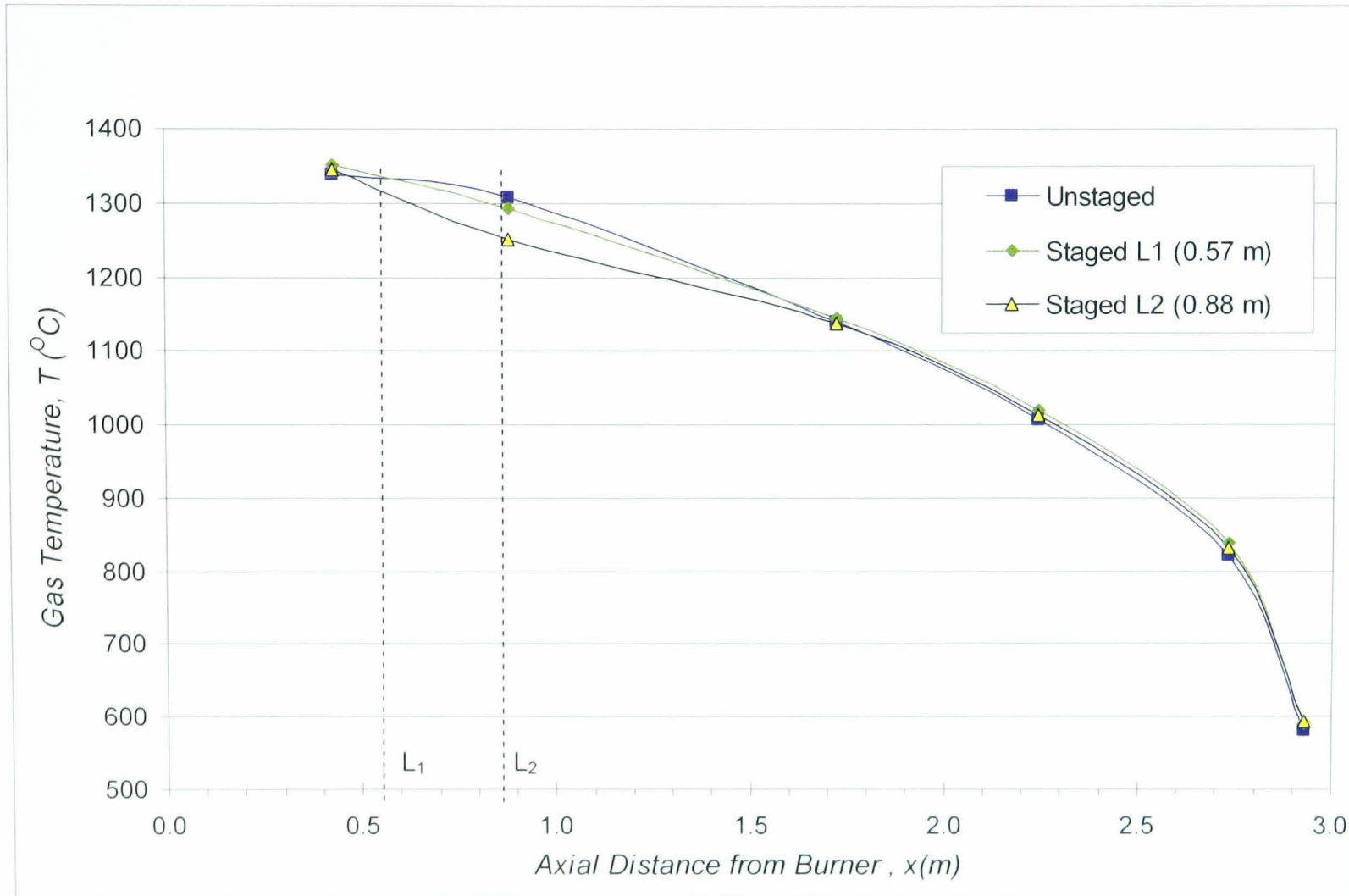
Two-staged combustion conditions were achieved by diverting a proportion of the secondary air/oxidant to the tertiary air/oxidant to change the burner stoichiometric ratio  $SR_1$ , while maintaining the overall furnace stoichiometric ratio  $SR$  at 1.20. The staged combustion tests were conducted with  $SR_1$  between 0.80 and 1.20. The staged or tertiary air/oxidant was introduced at two different port positions, either at  $L_1$  (0.57 m) or  $L_2$  (0.88 m) downstream from the burner.

### 4.5.1. Effect of Oxidant Staging on Temperature.

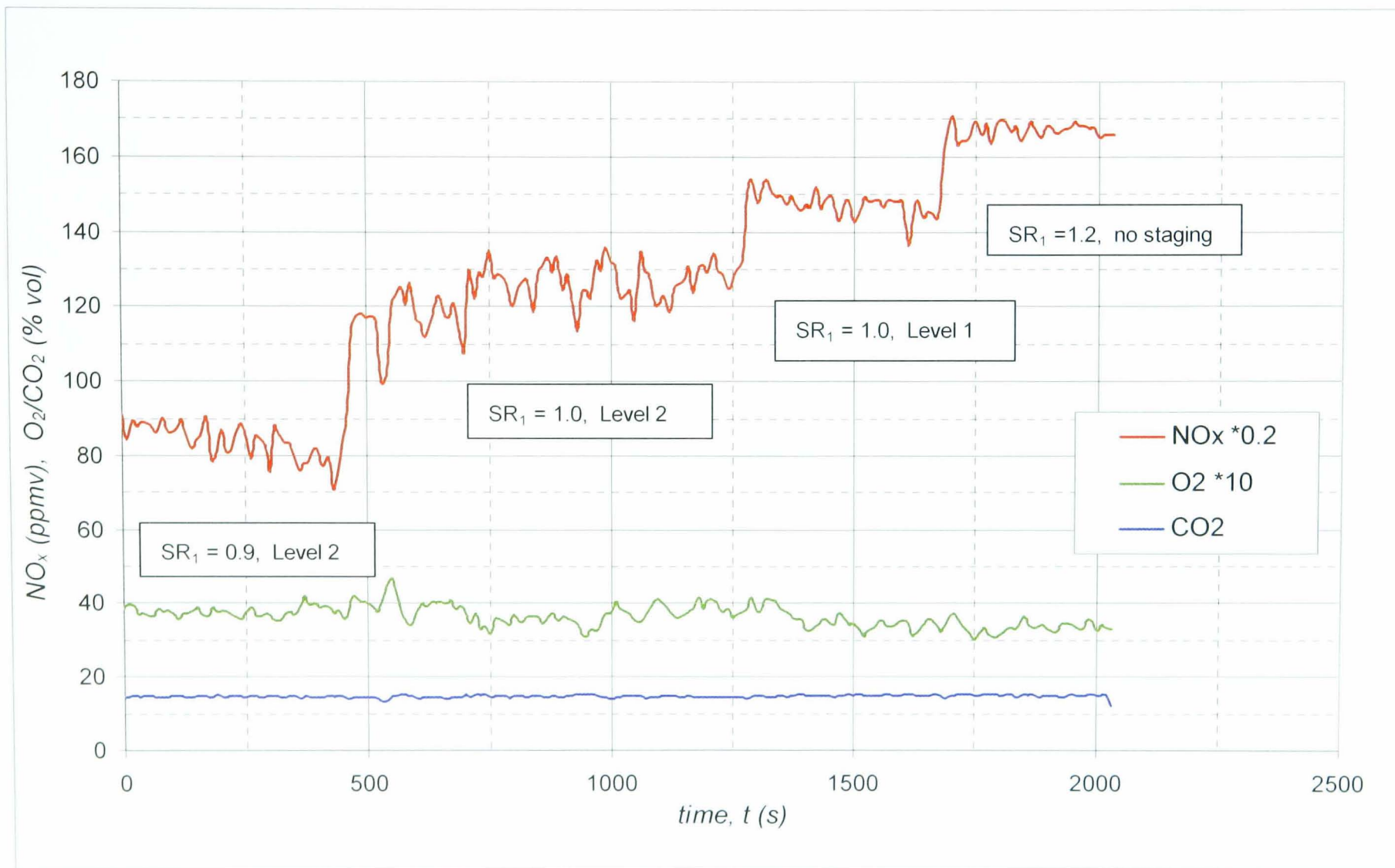
Generally gas temperature profiles in the furnace in the staged combustion are similar to those in normal air combustion. Figures 4.17a shows the effect of air staging on the furnace gas temperature of combustion of Coal A, with  $SR_1=0.80$ , where one-third of total combustion air (or 40 % of stoichiometric oxygen) is diverted as the tertiary air. Air staging reduces temperature in the regions close to the tertiary gas inlet port, but the peak and the furnace exit temperatures are almost unchanged. The reduction of temperature in the combustion zone were more pronounced in higher staging (lower  $SR_1$ ) conditions and from the introduction of staging air/oxidant further downstream at  $L_2$ . Figure 4.17b shows the effect of a similar oxidant staging on 30:70- $O_2/CO_2$  combustion, which show comparable overall temperature profiles to those in unstaged combustion. Compared to those in air firing, the combustion zone temperature reduction by oxidant staging is smaller in 30:70- $O_2/CO_2$  combustion. Similar variation in temperature profiles for staged combustion in both air and 30:70- $O_2/CO_2$  are also obtained from the combustion of the other six coals.



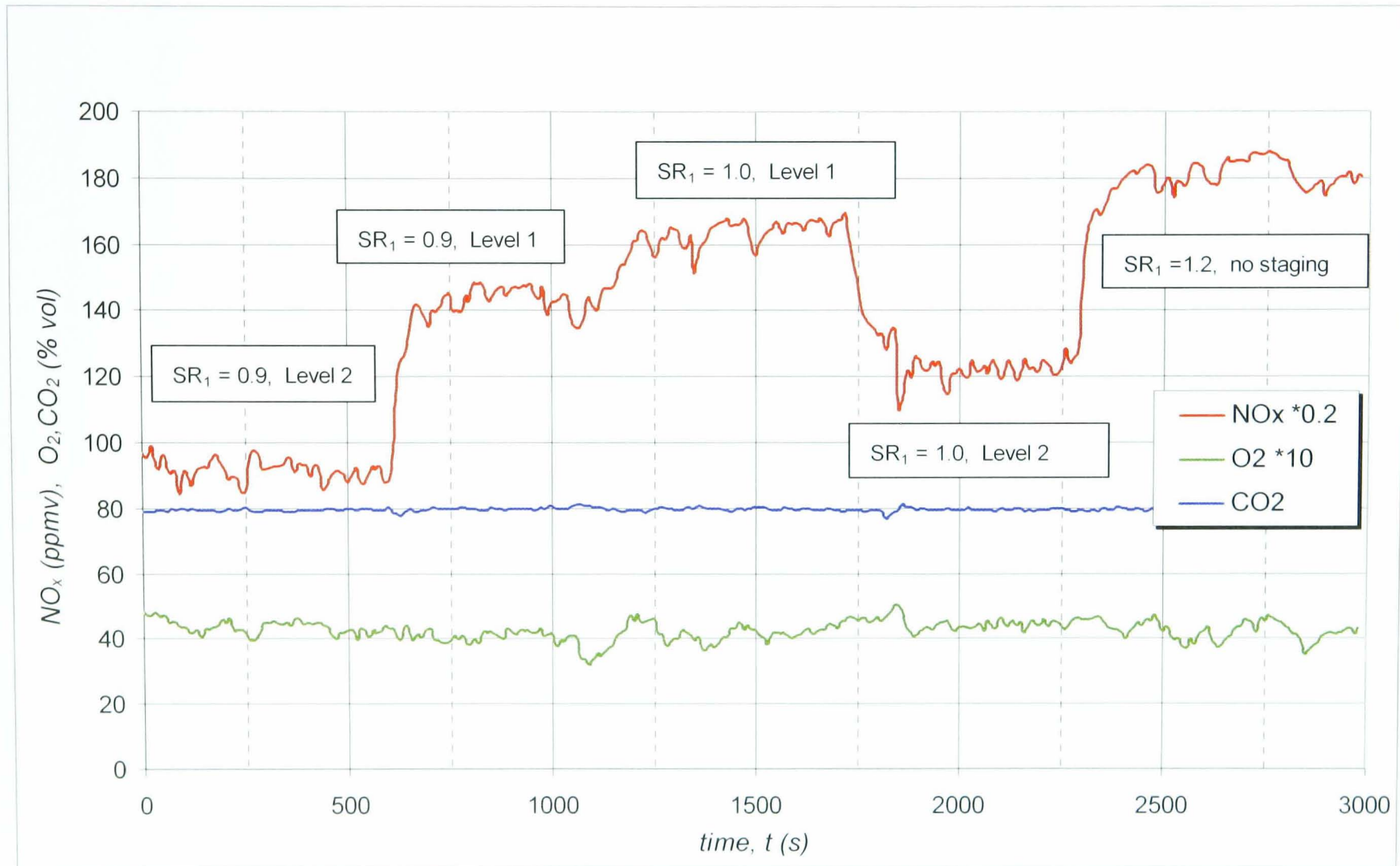
**Figure 4.17a.** The effect of air staging on temperature profiles inside the furnace. ( $SR_1=0.80$ , Coal A).



**Figure 4.17b.** The effect of oxidant staging in 30:70- $O_2/CO_2$ , on temperature profiles inside the furnace. ( $SR_1=0.80$ , Coal A).



**Figure 4.18a.** Flue gas emissions from staged-air combustion. (Coal A).



**Figure 4.18b.** Flue gas emissions from staged-oxidant, 30:70-O<sub>2</sub>/CO<sub>2</sub> combustion. (Coal A).



#### **4.5.2. Effect of Oxidant Staging on Flue Gas Compositions.**

Figures 4.18a and 4.18b show the flue gas emissions from the staged-air and staged-oxidant in 30:70-O<sub>2</sub>/CO<sub>2</sub> combustion for Coal A, respectively. Apart from the general reduction in the NO<sub>x</sub> emissions by air/oxidant staging, the flue gas emissions compositions in both media are similar to those in unstaged combustions. Similar results were obtained from the staged combustion of the other six coals.

#### **4.5.3. Effect of Oxidant Staging on Burnout Efficiency.**

As presented in Section 4.4, the burnout efficiency in unstaged combustion for all tested coals are significantly higher in 30:70-O<sub>2</sub>/CO<sub>2</sub> than those in air firing. The effect of air or oxidant staging on the unburned carbon concentrations in the ash and char burnout efficiency are illustrated in Figures 4.19a & 4.19b, and the details are presented in Table 4.6. For each coals, the carbon concentration in ash is slightly higher in staged air combustion compare to those in normal combustion and the corresponding burnout efficiency decreases between 0.11% to 0.55 %. However, compared to unstaged 30:70-O<sub>2</sub>/CO<sub>2</sub> combustion, oxidant staging only marginally reduces char burnout efficiency. For reactive coal such as Coal B, air staging reduce burnout efficiency by 0.34 % in air combustion but in 30:70-O<sub>2</sub>/CO<sub>2</sub>, the burnout efficiency is almost unchanged by oxidant staging.

#### **4.5.4. NO<sub>x</sub> Reduction Through Staged Combustion.**

Air staging is a combustion technique in which furnace emission of NO<sub>x</sub> is reduced by the combustion of coal particles in fuel-rich conditions. Figures 4.20a & 4.20b show NO<sub>x</sub> concentrations at the furnace exit in both air and 30:70-O<sub>2</sub>/CO<sub>2</sub> staged combustion of Coal A, with different staging ratios and staging oxidant

injection locations. Figure 4.21a & 4.21b show the corresponding  $\text{NO}_x$  conversion ratio from the combustion in both media. As expected, air staging significantly reduces  $\text{NO}_x$  concentration in air combustion. The  $\text{NO}_x$  reduction increases as the burner stoichiometric ratio,  $\text{SR}_1$ , decreases, and staging further away from the burner at  $L_2$  facilitates higher  $\text{NO}_x$  reduction. Air staging with  $\text{SR}_1 = 0.80$  at  $L_2$  reduces  $\text{NO}_x$  concentration from 835 to 296 ppmv. ( $\text{CR}_{\text{NO}_x}$  decreases from 27.7% to 9.9%) which corresponds to about 65 % reduction. Staging with  $\text{SR}_1 = 0.80$  at  $L_1$  reduces  $\text{NO}_x$  concentration to about 450 ppmv ( $\text{CR}_{\text{NO}_x} = 15.0\%$ ) which corresponds to only about 46 %  $\text{NO}_x$  reduction.

Similarly, in 30:70- $\text{O}_2/\text{CO}_2$  combustion, oxidant staging reduces  $\text{NO}_x$  concentration as effectively as in air combustion. The  $\text{NO}_x$  reduction efficiency by oxidant staging with  $\text{SR}_1 = 0.80$  at  $L_1$  in 30:70- $\text{O}_2/\text{CO}_2$  combustion is significantly lower at only 36 % compare to 46 % in air. However, there is only a small difference in the  $\text{NO}_x$  reduction effectiveness in the two media by staging at  $L_2$ . Staging with  $\text{SR}_1 = 0.80$  at  $L_2$  in 30:70- $\text{O}_2/\text{CO}_2$  combustion produced a slightly higher  $\text{NO}_x$  reduction, 68 % compared to 65 % as in air combustion. Similar results were obtained from the combustion of the other reactive coals such Coal B and coal C, in which the reduction in the  $\text{NO}_x$  conversion in both oxidants, particular staging at  $L_2$ , are similar. However the  $\text{NO}_x$  reduction efficiency is markedly lower in staged combustion in both air and 30:70- $\text{O}_2/\text{CO}_2$  for less reactive coals such as Coal E, as shown Figures 4.22a & 4.22b . The differences in  $\text{NO}_x$  reduction efficiency in staged air combustion compared to staged oxidant in 30:70- $\text{O}_2/\text{CO}_2$  of the different coals with the same staging condition are presented in figures 4.23a & 4.23b which show that for reactive coal (Coal B), staged combustion in 30:70- $\text{O}_2/\text{CO}_2$  is as

effective as in air combustion, whereas for less reactive coal (Coal F), the effectiveness of oxidant staging in 30:70-O<sub>2</sub>/CO<sub>2</sub> is less than in air case.

The Effectiveness of NO<sub>x</sub> reduction by air/oxidant staging is measured by the Relative NO<sub>x</sub> Reduction, R<sub>NO<sub>x</sub></sub>, which is defined as :

(Kurose et al. 2004)

$$R_{NO_x} = \left( \frac{(CR_{NO_x})_{unstg} - (CR_{NO_x})_{stg}}{(CR_{NO_x})_{unstg}} \right) \dots\dots\dots 4.4$$

Where,

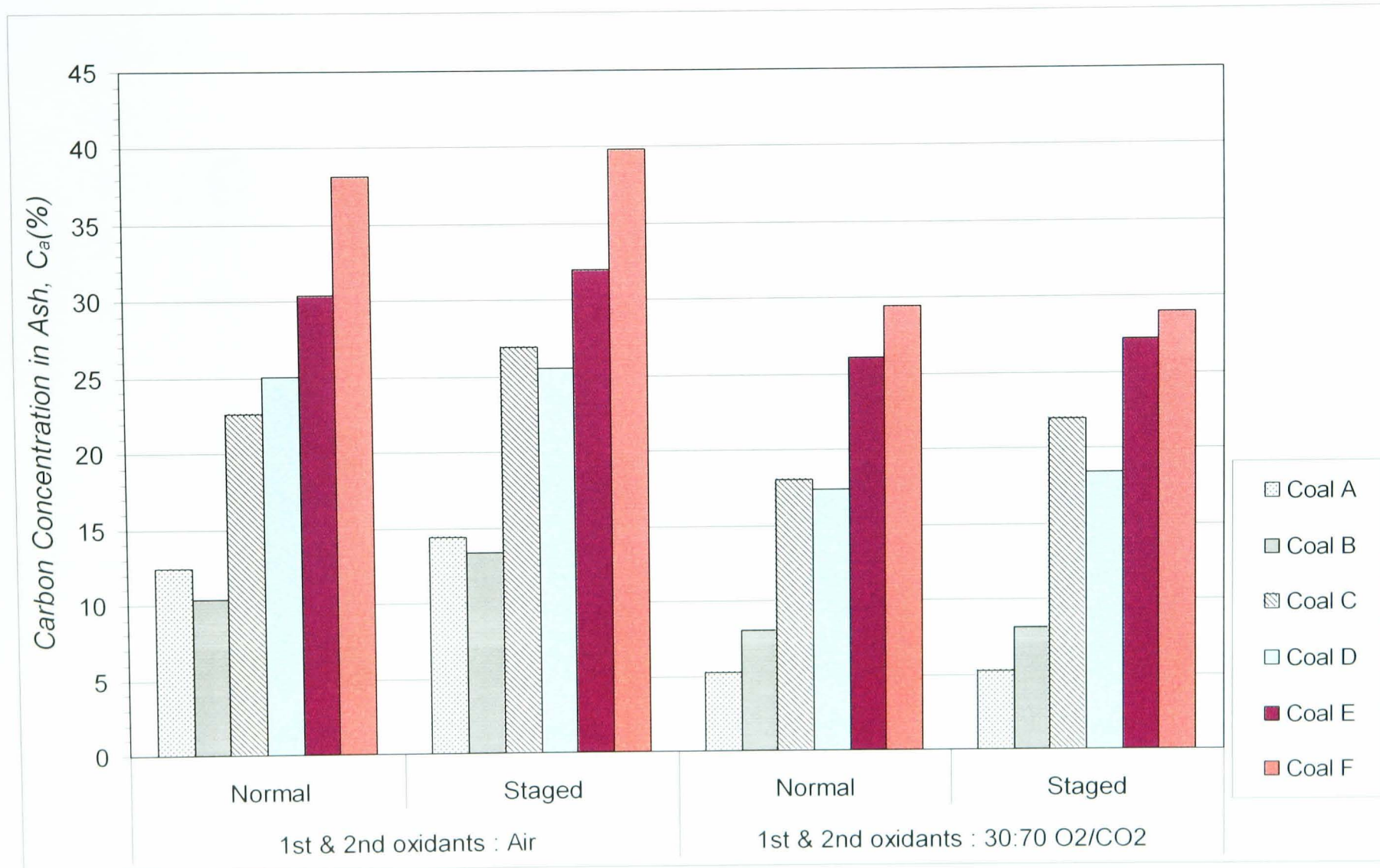
(CR<sub>NO<sub>x</sub></sub>)<sub>stg</sub> is the NO<sub>x</sub> Conversion Ratio in staged combustion.

(CR<sub>NO<sub>x</sub></sub>)<sub>unstg</sub> is the NO<sub>x</sub> Conversion Ratio in unstaged combustion.

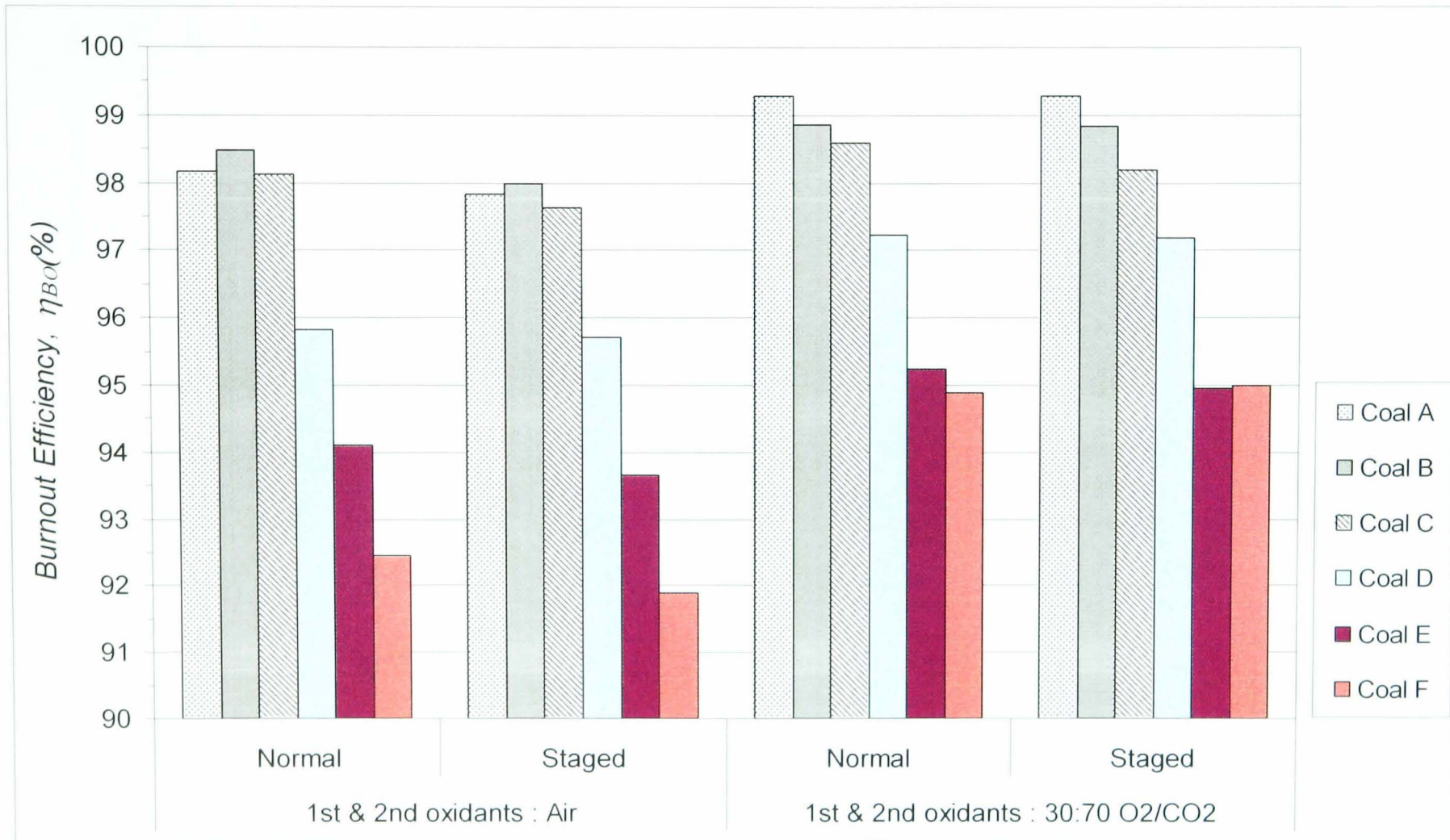
Figure 4.24a & 4.24b shows (CR<sub>NO<sub>x</sub></sub>)<sub>r</sub>, the ratio of CR<sub>NO<sub>x</sub></sub> in both, staged air and staged 30:70-O<sub>2</sub>/CO<sub>2</sub> with SR<sub>1</sub> = 0.80 at L<sub>1</sub> and L<sub>2</sub>, relative to those in unstaged combustion for each tested coal. The results show that the effectiveness of oxidant staging in reducing NO<sub>x</sub> in staged combustion in both air and 30:70-O<sub>2</sub>/CO<sub>2</sub> varies between coals. Figure 4.25 shows the variation of the NO<sub>x</sub> reduction efficiency (R<sub>NO<sub>x</sub></sub>) through air staging with SR<sub>1</sub>=0.80 at L<sub>2</sub> on the coal Fuel Ratio (FR) and the corresponding effect of oxidant staging in 30:70-O<sub>2</sub>/CO<sub>2</sub>. Air staging at this condition reduces NO<sub>x</sub> between 50% for less reactive Coal F, to around 65 % as in more reactive Coal B. The corresponding conditions of staged combustion in 30:70-O<sub>2</sub>/CO<sub>2</sub> reduce NO<sub>x</sub> between 44 % and 73%. The difference in NO<sub>x</sub> reduction efficiency by staged combustion between these two coals are illustrated in figure 4.26a and 4.26b. The result also show that for more reactive coals the effectiveness of staging on NO<sub>x</sub> reduction in 30:70-O<sub>2</sub>/CO<sub>2</sub> at L<sub>2</sub> are higher than those for staged

air combustion whereas for less reactive coals,  $\text{NO}_x$  reduction is smaller for staged-30:70- $\text{O}_2/\text{CO}_2$ . Oxidant staging closer to the burner at  $L_1$  generally results in less  $\text{NO}_x$  reduction in 30:70- $\text{O}_2/\text{CO}_2$  compared to those in air as indicated by the corresponding features shown in Figure 4.24a. However, compared to those in unstaged combustion in air, the  $\text{NO}_x$  emission in 30:70- $\text{O}_2/\text{CO}_2$  staged combustion for all coals are significantly less. These overall furnace  $\text{NO}_x$  emission reductions  $(R_{\text{NO}_x})_{\text{air}}$  vary between 60 % for less reactive coals to 77 % for the more reactive coals, as shown in Figure 4.27. The detailed figures of  $\text{NO}_x$  conversion and  $\text{NO}_x$  reduction in air/oxidant staged combustion of all coals are summarised in Table 4.7.

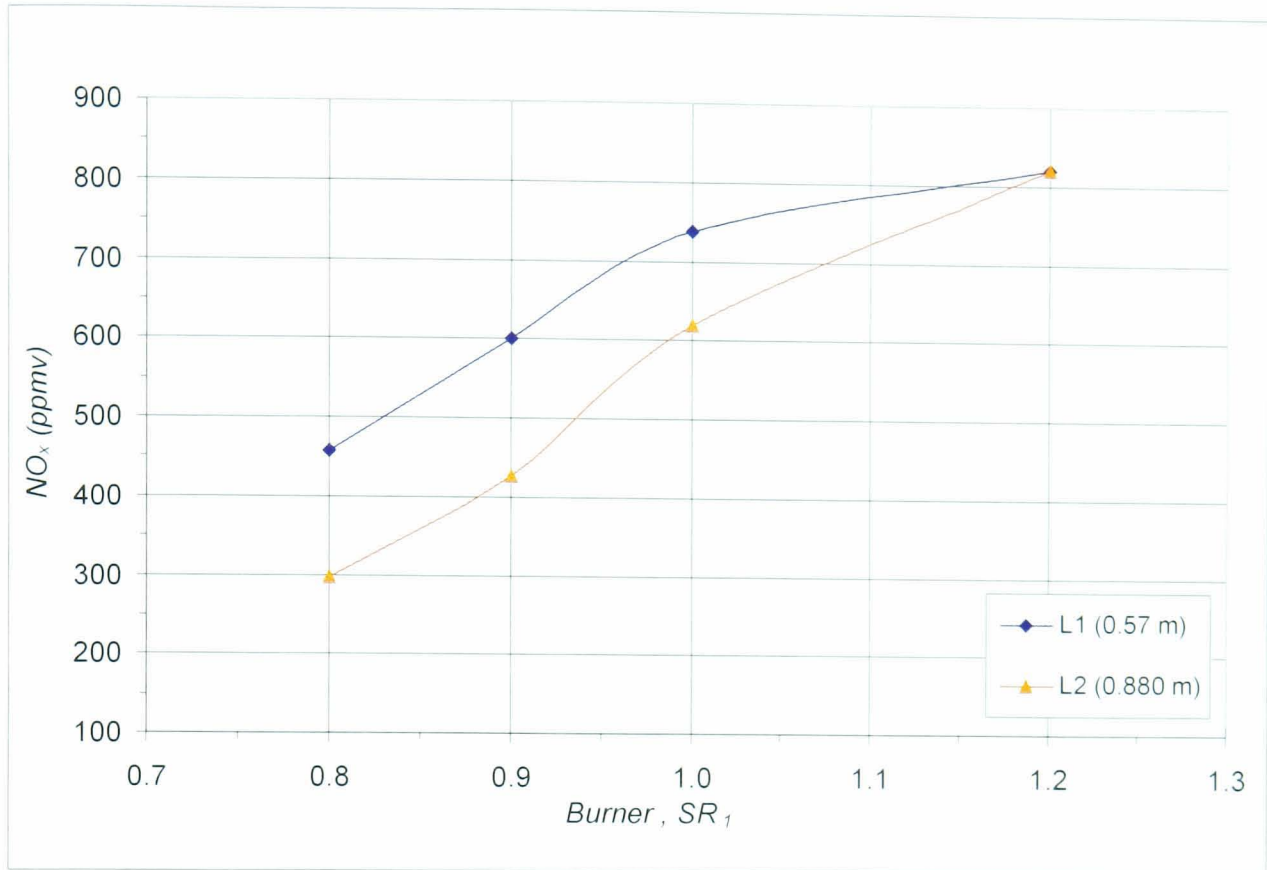
oxidant can be reduced.



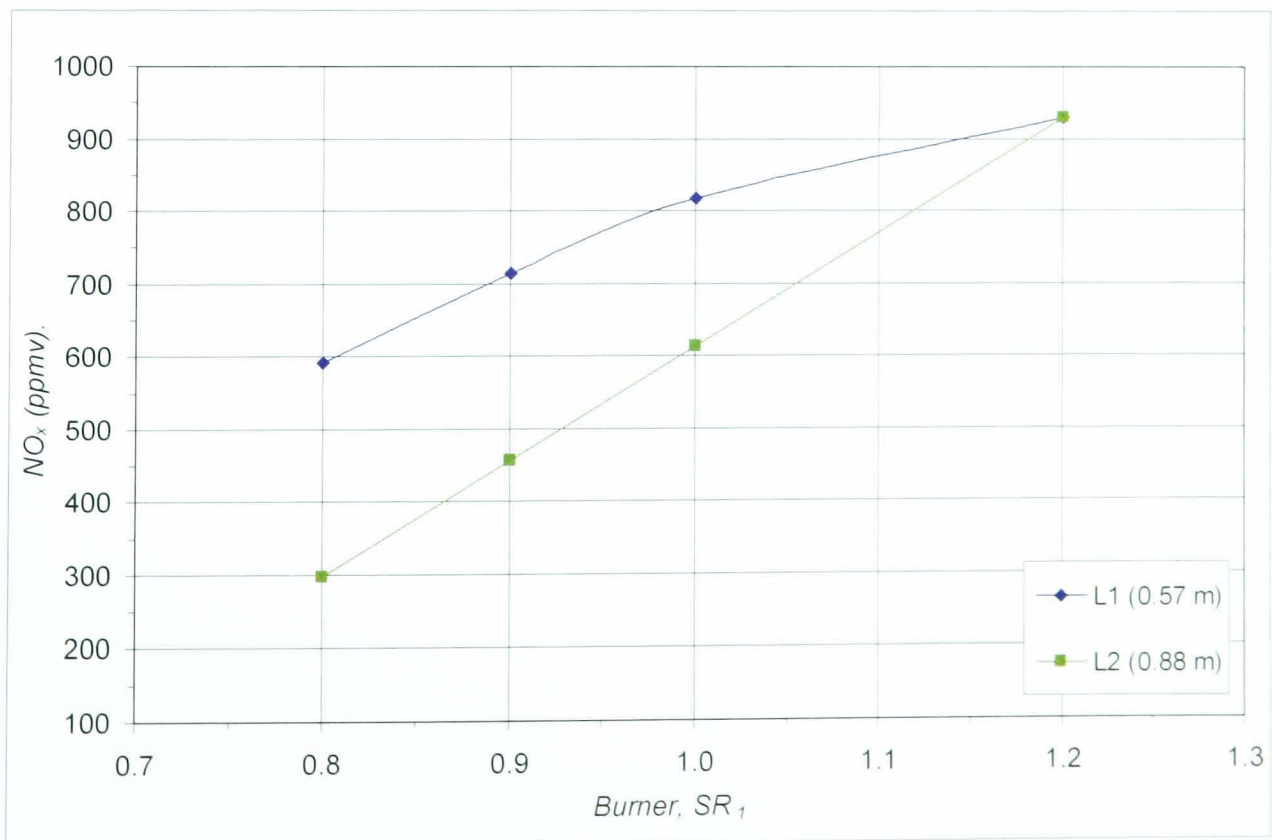
**Figure 4.19a.** Carbon concentration in combustion ( $C_a$ ) ash in different combustion media and conditions.



**Figure 4.19b.** Coal Burnout Efficiency ( $\eta_{BO}$ ) in different combustion media and conditions.

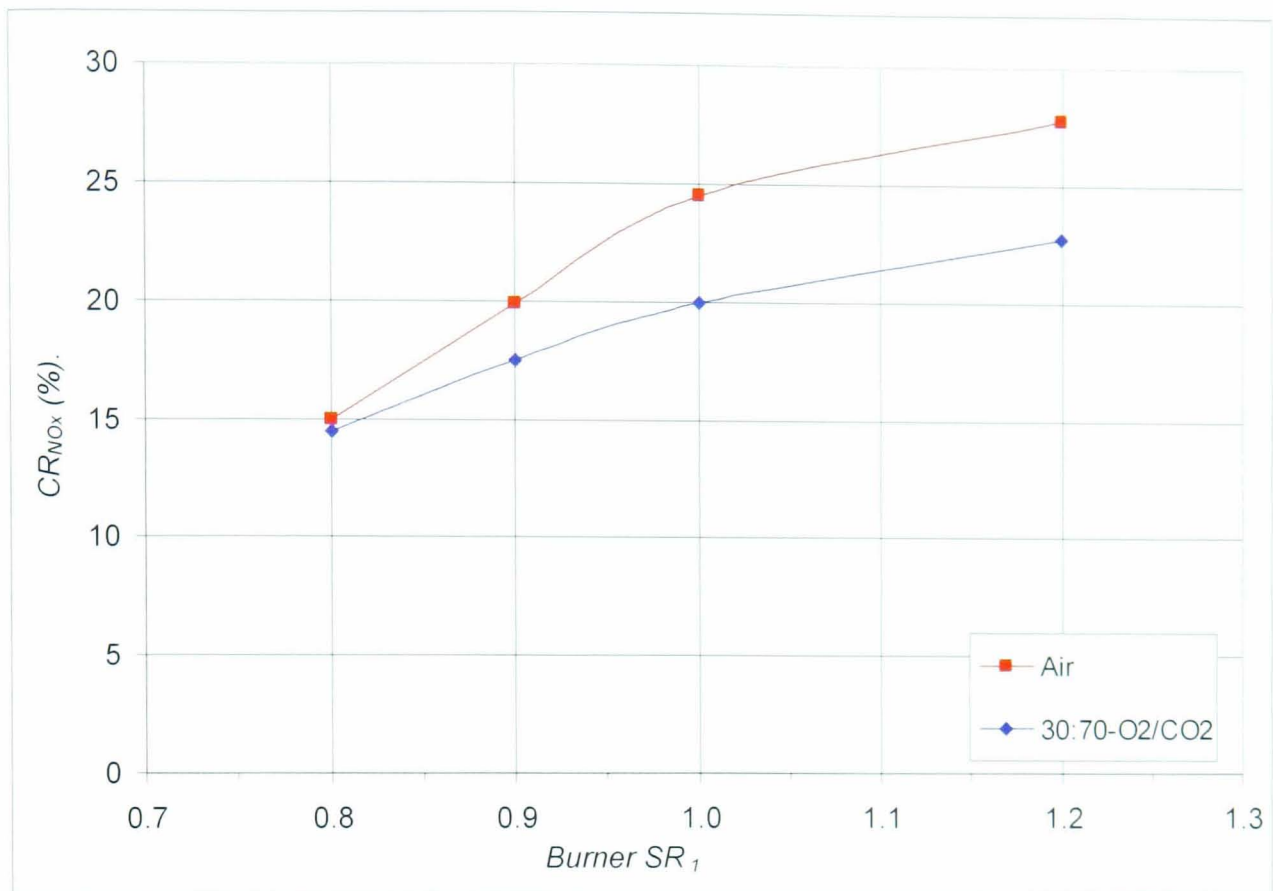


**Figure 4.20a.** The effect of air staging ratio (combustion zone stoichiometry, SR<sub>1</sub>) in air combustion on flue gas NO<sub>x</sub> concentrations. (Coal A).

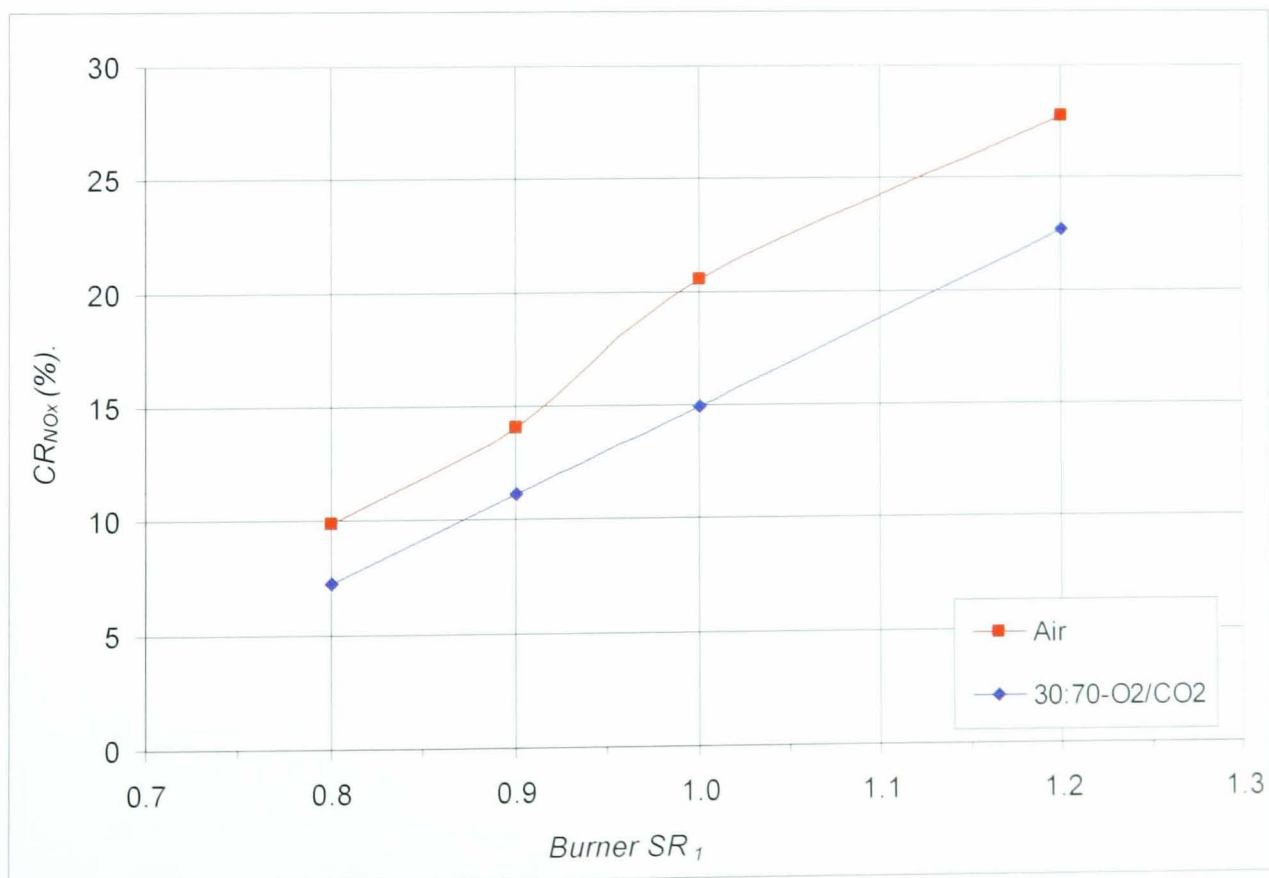


**Figure 4.20b.**

The effect of oxidant staging ratio (combustion zone stoichiometry, SR<sub>1</sub>) in 30:70-O<sub>2</sub>/CO<sub>2</sub> combustion on flue gas NO<sub>x</sub> concentration. (Coal A).

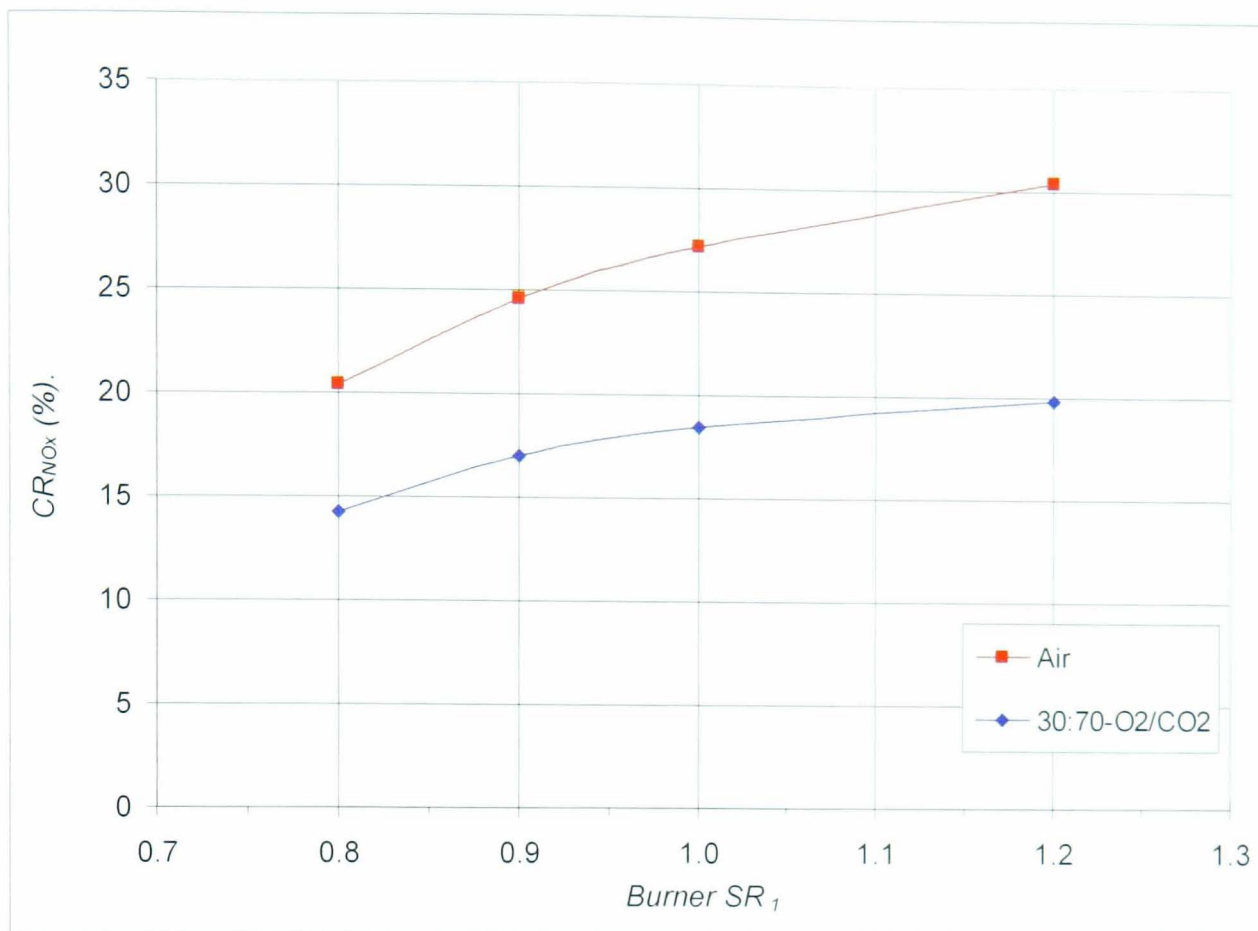


**Figure 4.21a.** The effect of air/oxidant staging ratio (combustion zone stoichiometry,  $SR_1$ ) on flue gas  $NO_x$  emission. Staging at  $L_1$  (0.57 m, Coal A).

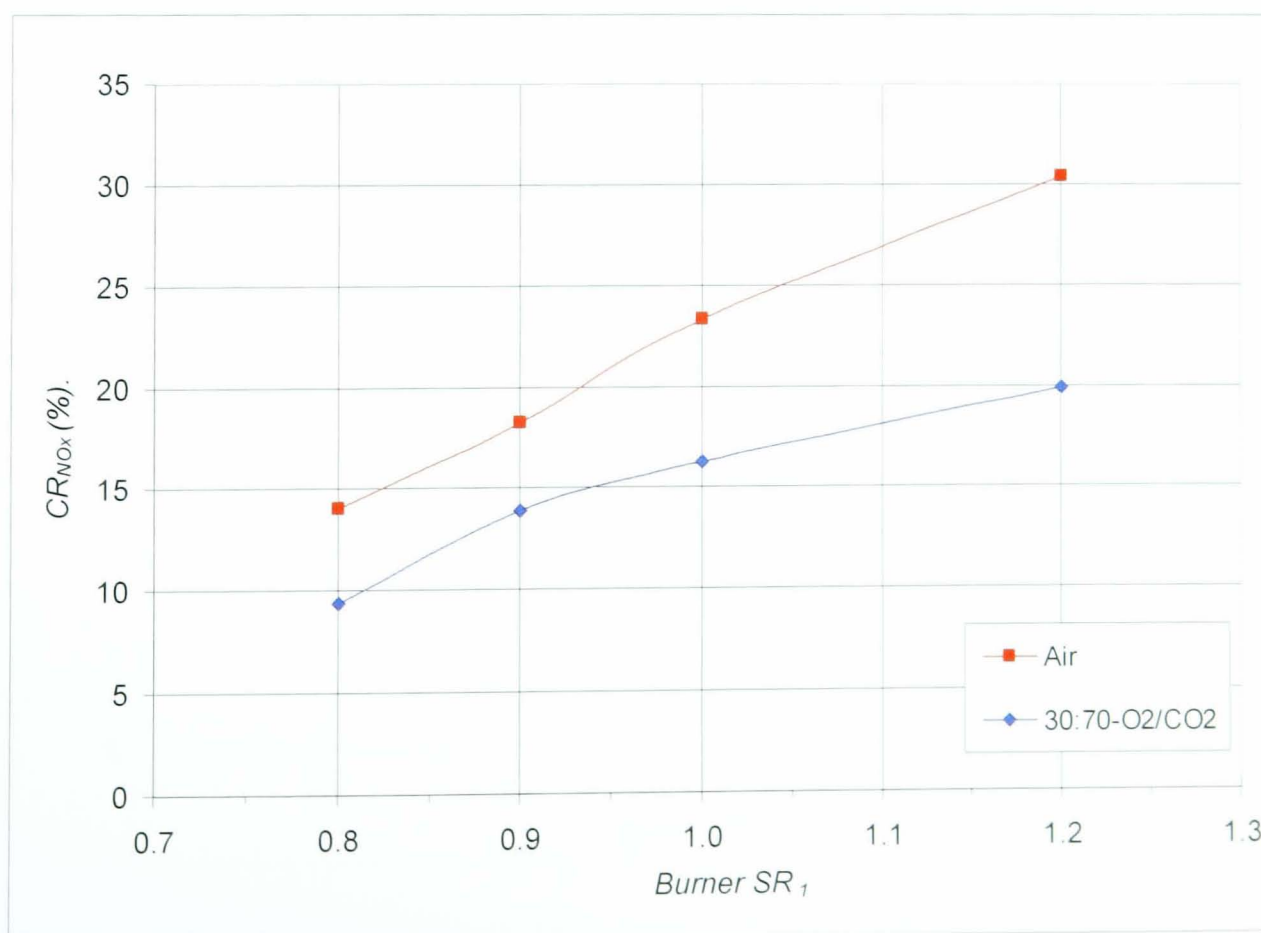


**Figure 4.21b.** The effect of air/oxidant staging ratio (combustion zone stoichiometry,  $SR_1$ ) on flue gas  $NO_x$  emission. Staging at  $L_2$  (0.88, Coal A).

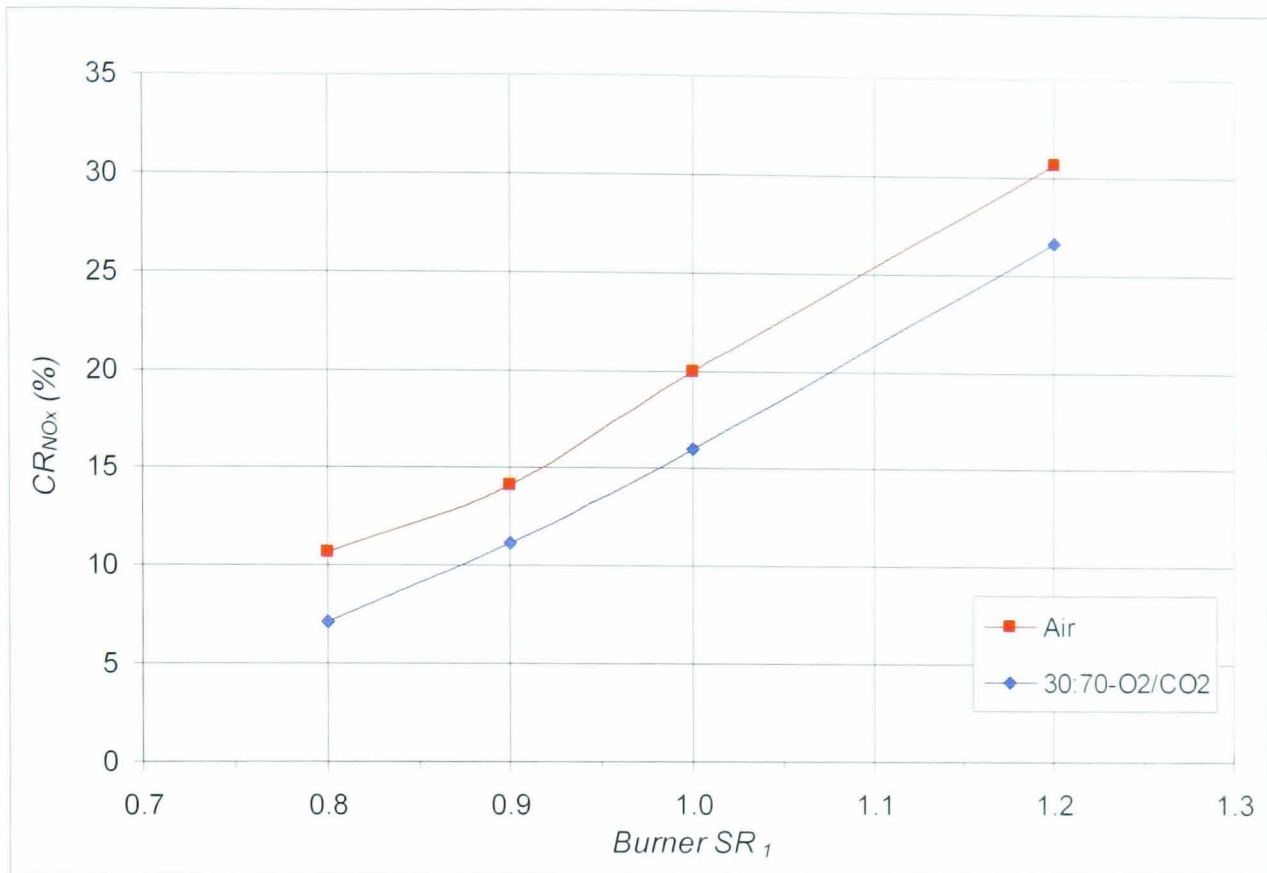




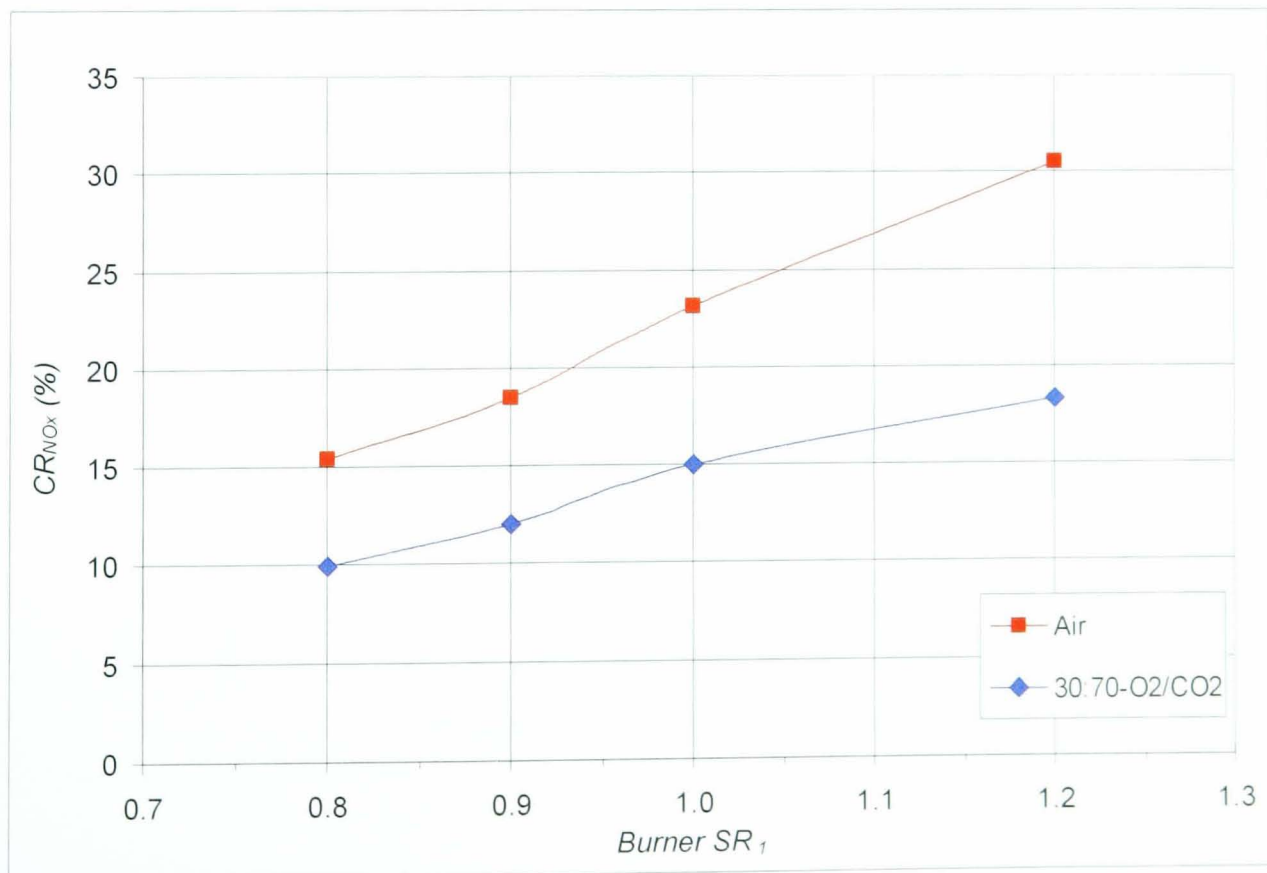
**Figure 4.22a.** The effect of air/oxidant staging ratio (combustion zone stoichiometry, SR<sub>1</sub>) on flue gas NO<sub>x</sub> emission. Staging at L<sub>1</sub> (0.57 m, Coal E).



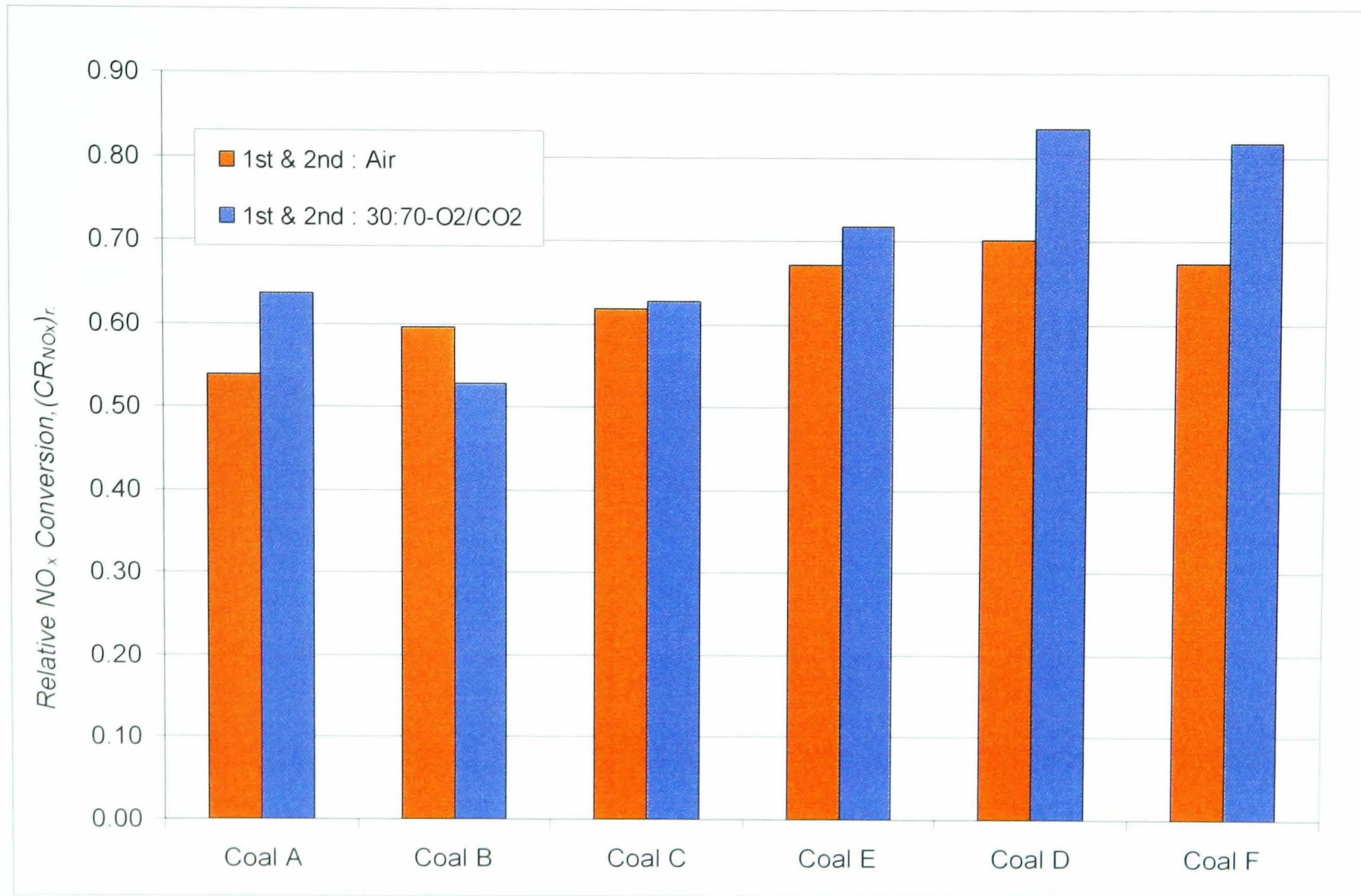
**Figure 4.22b.** The effect of air/oxidant staging ratio (combustion zone stoichiometry, SR<sub>1</sub>) on flue gas NO<sub>x</sub> emission. Staging at L<sub>2</sub> (0.88 m, Coal E).



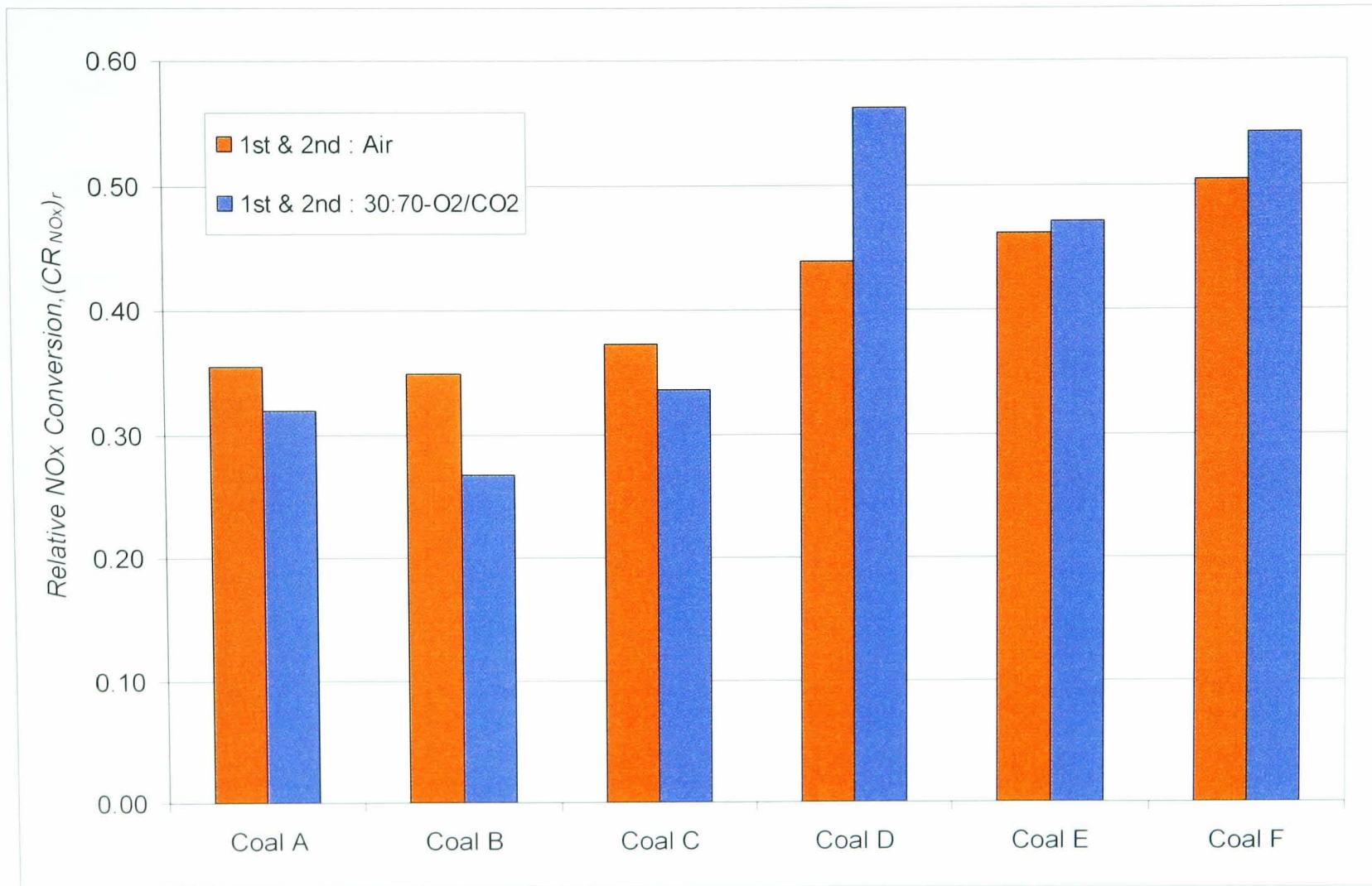
**Figure 4.23a.** The effect of air/oxidant staging ratio (combustion zone stoichiometry,  $SR_1$ ) on flue gas  $NO_x$  emission. Staging at  $L_2$  (0.88 m, Coal B).



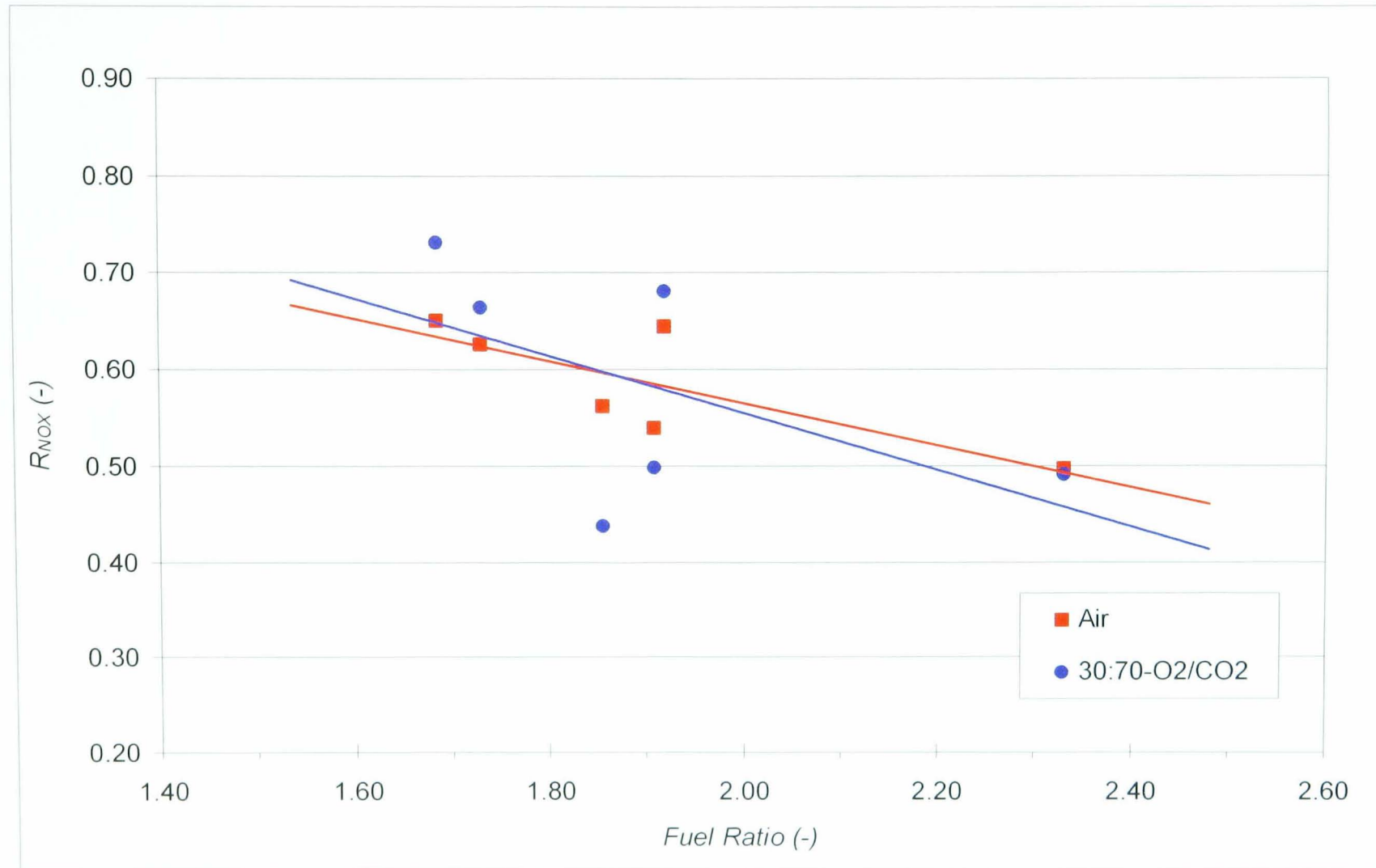
**Figure 4.23b.** The effect of air/oxidant staging ratio (combustion zone stoichiometry,  $SR_1$ ) on flue gas  $NO_x$  emission. Staging at  $L_2$  (0.88 m, Coal F).



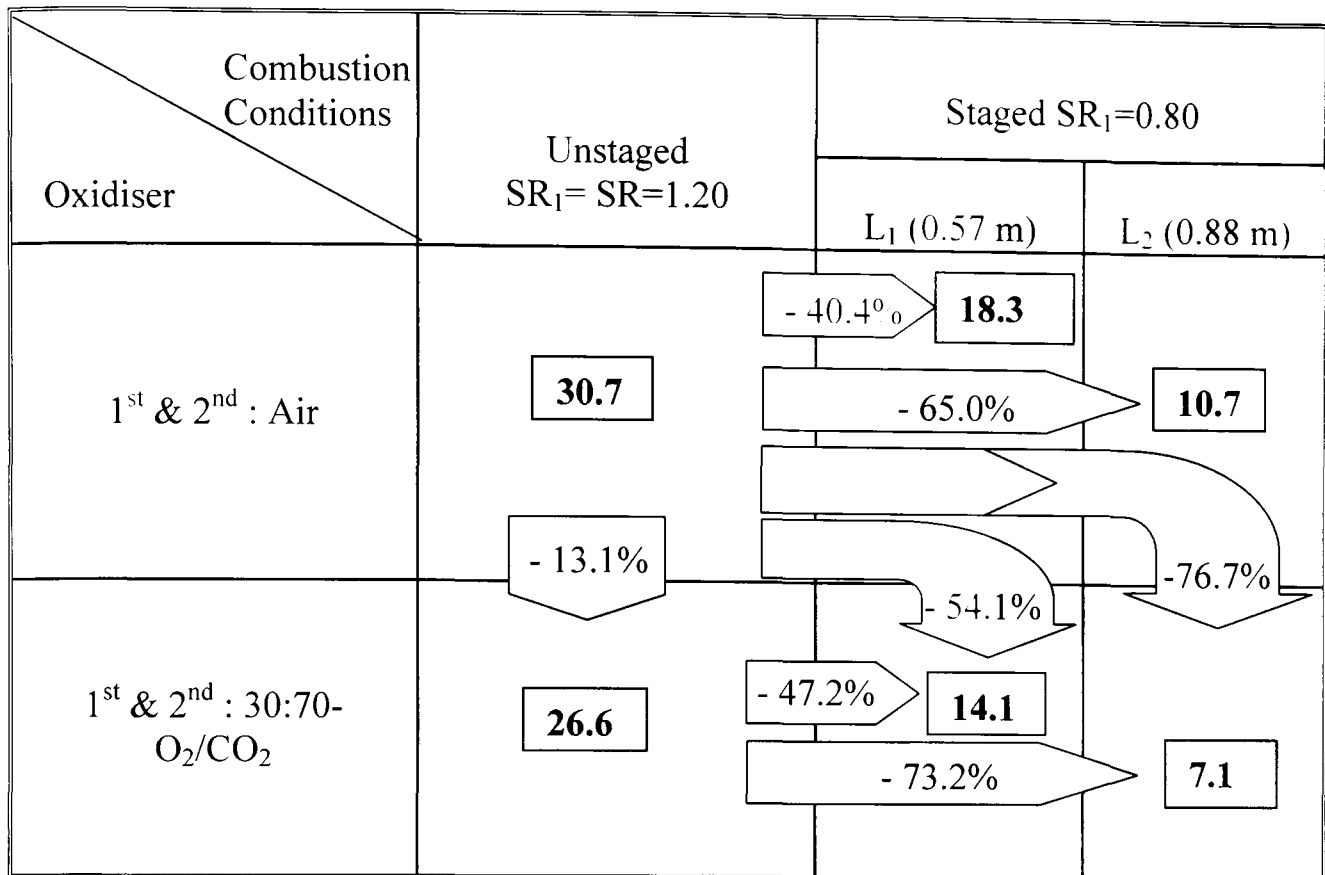
**Figure 4.24a.** The NO<sub>x</sub> conversion in staged air and staged 30:70-O<sub>2</sub>/CO<sub>2</sub> relative to unstaged combustion in the same combustion media. (SR<sub>1</sub>=0.80, Staging at L<sub>1</sub> (0.57 m)).



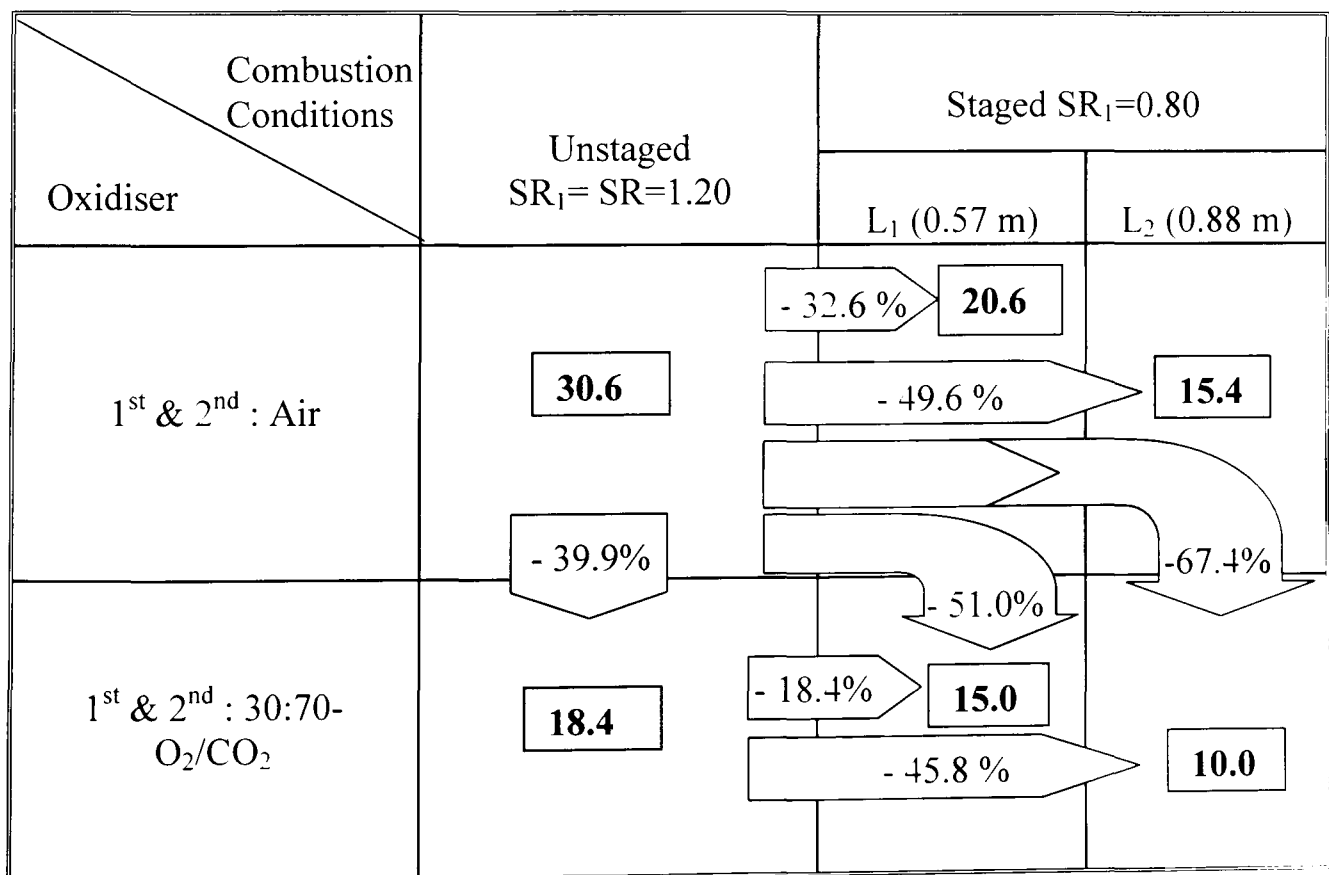
**Figure 4.24b.** The NO<sub>x</sub> conversion in staged air and staged 30:70-O<sub>2</sub>/CO<sub>2</sub> relative to unstaged combustion in the same combustion media. (SR<sub>1</sub>=0.80, Staging at L<sub>2</sub> (0.88 m)).



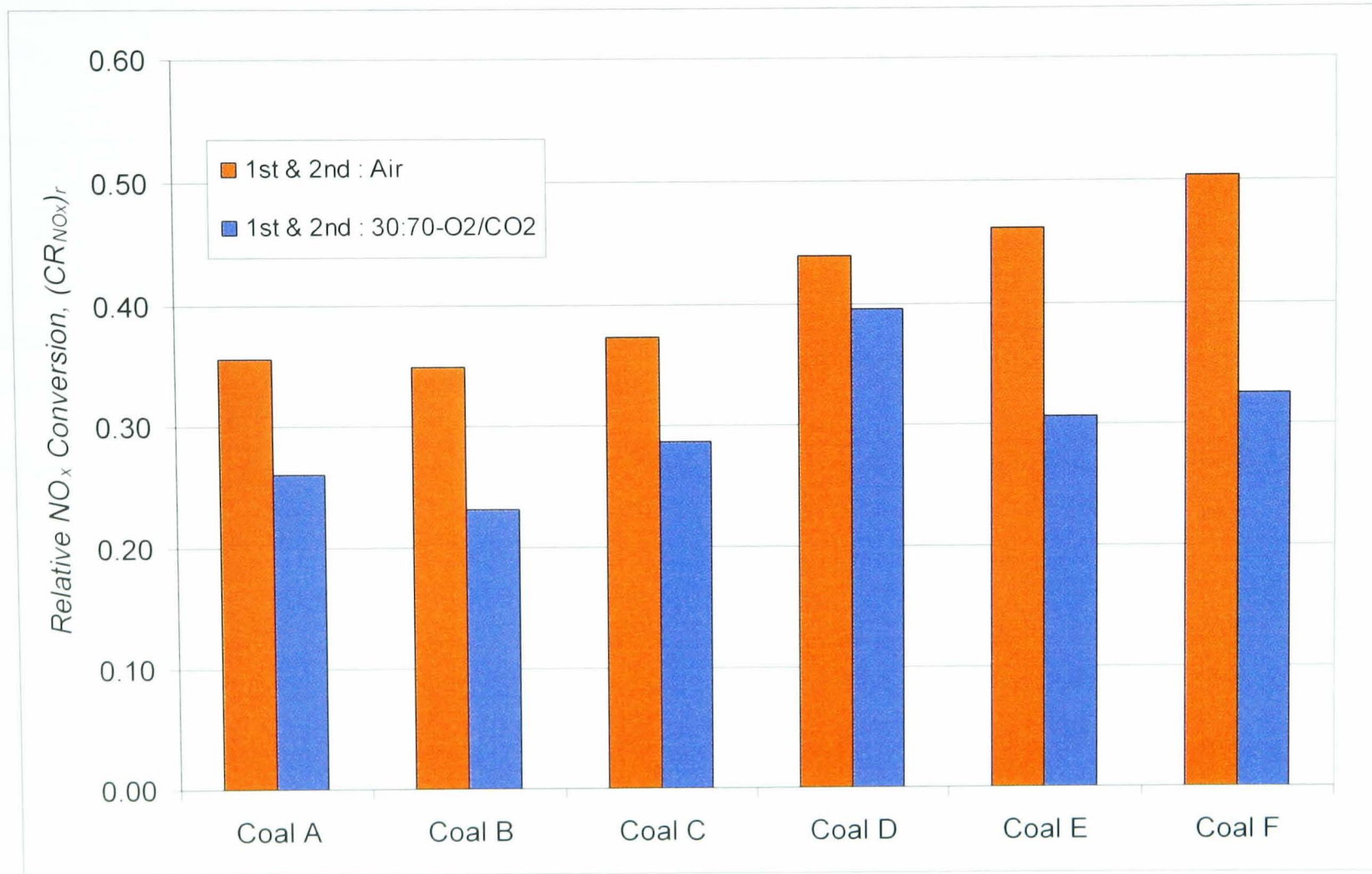
**Figure 4.25.** The dependence of the Relative NO<sub>x</sub> Reduction ( $R_{NO_x}$ ) on coal Fuel Ratio (FR), for staged combustion in air and staged 30:70-O<sub>2</sub>/CO<sub>2</sub>. ( $SR_1 = 0.80$ , staging at  $L_2$  (0.88 m)).



**Figure 4.26a.** NO<sub>x</sub> Reduction efficiency – The effect of oxidant staging on NO<sub>x</sub> Conversion Ratio (CR<sub>NO<sub>x</sub></sub>). (Coal B).



**Figure 4.26b.** NO<sub>x</sub> Reduction Efficiency – the effect of oxidant staging on NO<sub>x</sub> Conversion Ratio. (CR<sub>NO<sub>x</sub></sub>). (Coal F).



**Figure 4.27** The NO<sub>x</sub> conversion in staged air and staged 30:70-O<sub>2</sub>/CO<sub>2</sub> relative to normal air combustion. (SR<sub>1</sub>=0.80, Staging at L<sub>2</sub> (0.88 m)).

**Table 4.7** The Relative NO<sub>x</sub> Conversion in staged combustion to those in unstaged combustion, (CR<sub>NO<sub>x</sub></sub>)<sub>r</sub>, and the NO<sub>x</sub> reduction R<sub>NO<sub>x</sub></sub> and (R<sub>NO<sub>x</sub></sub>)<sub>air</sub> for all coals.

1st & 2nd Oxidants:	Air					30:70-O <sub>2</sub> /CO <sub>2</sub>								
	Unstaged SR=1.20	Staged SR <sub>1</sub> =0.80, L <sub>1</sub> (0.57 m)		Staged SR <sub>1</sub> =0.80, L <sub>2</sub> (0.88 m)		Unstaged SR=1.20	Staged SR <sub>1</sub> =0.80, L <sub>1</sub> (0.57 m)				Staged SR <sub>1</sub> =0.80, L <sub>2</sub> (0.88 m)			
NO <sub>x</sub> Conversion	CR <sub>NO<sub>x</sub></sub> (%)	(CR <sub>NO<sub>x</sub></sub> ) <sub>r</sub>	R <sub>NO<sub>x</sub></sub> (%)	(CR <sub>NO<sub>x</sub></sub> ) <sub>r</sub>	R <sub>NO<sub>x</sub></sub> (%)	CR <sub>NO<sub>x</sub></sub> (%)	(CR <sub>NO<sub>x</sub></sub> ) <sub>r</sub>	R <sub>NO<sub>x</sub></sub> (%)	(CR <sub>NO<sub>x</sub></sub> ) <sub>r</sub> (air)	(R <sub>NO<sub>x</sub></sub> ) <sub>air</sub> (%)	(CR <sub>NO<sub>x</sub></sub> ) <sub>r</sub> (air)	R <sub>NO<sub>x</sub></sub> (%)	(CR <sub>NO<sub>x</sub></sub> ) <sub>r</sub>	(R <sub>NO<sub>x</sub></sub> ) <sub>air</sub> (%)
Coals:														
Coal A	27.7	0.539	46.1	0.355	64.5	22.7	0.637	36.3	0.522	47.8	0.320	68.0	0.262	73.8
Coal B	30.7	0.596	40.4	0.350	65.0	26.6	0.528	47.2	0.459	54.1	0.268	73.2	0.233	76.7
Coal C	30.9	0.619	38.1	0.373	62.7	23.1	0.627	37.3	0.537	46.3	0.336	66.4	0.287	71.3
Coal D	33.8	0.703	29.7	0.439	56.0	26.4	0.835	16.5	0.588	41.2	0.562	43.8	0.396	60.4
Coal E	30.4	0.672	32.8	0.461	53.9	19.8	0.717	28.3	0.469	53.1	0.471	52.9	0.308	69.2
Coal F	30.6	0.674	32.6	0.504	49.6	18.4	0.816	18.4	0.490	51.0	0.542	45.8	0.326	67.4
Coal G	39.8					35.5								



#### 4.6. Recycled NO<sub>x</sub> Tests.

In coal combustion with recycled flue gas, the reduction in overall NO<sub>x</sub> emissions in the furnace exhaust has been attributed partly due to the decreased of the recycled NO<sub>x</sub> to molecular nitrogen in the combustion zone. In the recycled NO<sub>x</sub> tests, 5% of NO in N<sub>2</sub> was added and mixed with the different streams of oxidants to simulate recycled NO in air and O<sub>2</sub>/CO<sub>2</sub>, in both normal and staged combustion. The concentrations of the recycled NO is in the range of 500–1500 ppmv, which represents the amount of recycled NO expressed in the unit of NO concentration at the furnace exit in each combustion media. The NO was introduced at three different locations, through the burner (1<sup>st</sup> or 2<sup>nd</sup> oxidants) and through the staging air/oxidizer (3<sup>rd</sup> oxidant), in three different combustion conditions (unstaged, staged at L<sub>1</sub>, staged at L<sub>2</sub>) in combustion with either air or 30:70-O<sub>2</sub>/CO<sub>2</sub>.

The introduction of NO to the combustion zone immediately affected the NO concentrations in the flue gas, however NO emission levels quickly stabilised to the measured average values. Figure 4.28 shows the effect of the addition of NO to the 1<sup>st</sup> and 2<sup>nd</sup> oxidant stream for air combustion of Coal A, which indicates that the increment and reduction in the NO emissions are uniform and quickly stabilised accordingly. The NO reduction efficiency of the recycled NO,  $\eta_{NO}$  (%) is defined as:

$$\eta_{NO} = \frac{(NO_e - NO_o)}{NO_r} \times 100\% \dots\dots\dots(4.5)$$

Where,

NO<sub>e</sub> (ppmv) is the flue gas NO concentration at the furnace exit.

$\text{NO}_o$  (ppmv) is the flue gas NO concentration at the furnace exit without recycled NO,

$\text{NO}_r$  (ppmv) is the amount of NO injected to the furnace through oxidant lines.

The effects of the combustion media, combustion conditions, recycled NO concentrations and locations on the reduction of recycled NO are presented in the next section.

#### **4.6.1. Effect of Combustion Media.**

Figures 4.29a and 4.29b show a comparison of the fate of recycled NO in unstaged air and 30:70- $\text{O}_2/\text{CO}_2$  combustion when NO is added into the stream of the primary or secondary oxidant respectively, for all coals. The NO reduction efficiency,  $\eta_{\text{NO}}$  in air combustion when NO is introduced to the primary oxidant varies from 60 % to 72 % and the values are almost identical when NO is injected into the stream of the secondary oxidant, where the differences in  $\eta_{\text{NO}}$  between the two injection location are within 1%. The reduction efficiency of recycled NO is significantly higher in 30:70- $\text{O}_2/\text{CO}_2$  in all coals and the value varies from 67 % 88 %. More NO is also reduced in staged 30:70- $\text{O}_2/\text{CO}_2$  than in staged air combustion.

#### **4.6.2. Effect of Combustion Conditions and NO Injection Locations.**

Figure 4.30 shows the effect of oxidant staging and the NO recycling location on the reduction efficiency of the recycled NO in air and 30:70- $\text{O}_2/\text{CO}_2$  for Coal A. In air combustion, changing the combustor conditions from unstaged to staged combustion results in more reduction of the recycled NO when NO is recycled in either primary or secondary oxidant stream. Staging at  $L_2$  results in a higher

reduction efficiency than staging at  $L_1$ . The NO reduction efficiency,  $\eta_{NO}$  increases from 65 % in normal combustion to 84% in staged combustion with  $SR_1 = 0.80$  at  $L_1$  and increases further to 89 % in staged combustion at  $L_2$ . A Similar effect was observed in 30:70- $O_2/CO_2$  combustion in which the corresponding  $\eta_{NO}$  increases from 69 % to 87% and 93 % respectively. However, when NO is recycled back to the combustor through the tertiary oxidant in staged combustion, the reduction of the recycled NO is significantly lower. In air combustion,  $\eta_{NO}$  is only 34% with staging at  $L_1$  and decreases further to only 28% with staging at  $L_2$ . The corresponding values in 30:70- $O_2/CO_2$  combustion are markedly higher, at 43 % and 39 % respectively.

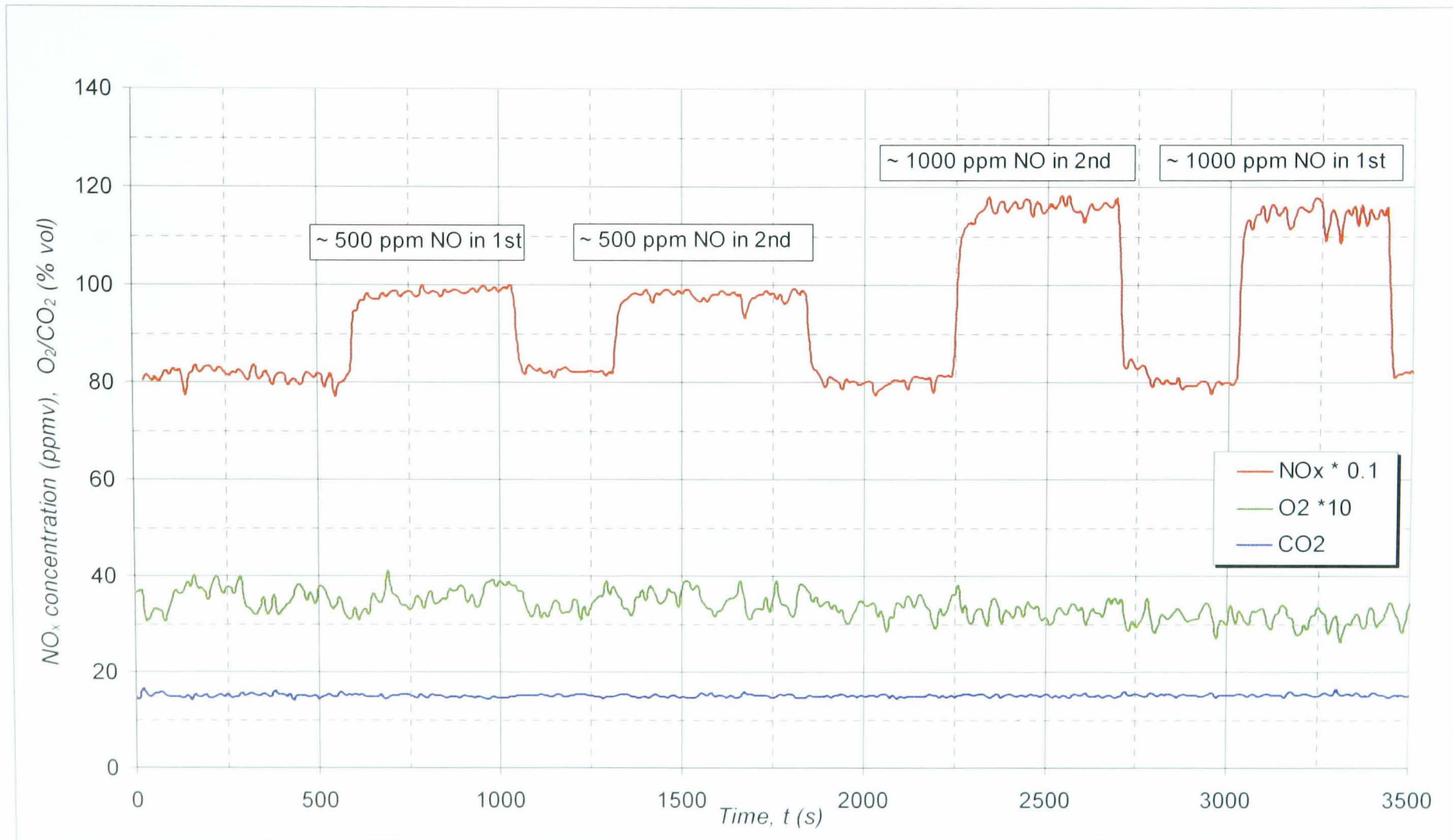
Similar results were obtained from the combustion of other coals. Figures 4.31a and 4.31b show the effect of oxidant staging and recycled NO injection points from the combustion of Coal C and Coal E respectively. The detailed figures of NO reduction efficiency in staged combustion for all coals are shown in Table 4.8. Generally with the same combustion media and the same NO recycling location and concentration, changing the combustor operation from the normal combustion to oxidant staging always results in higher reduction of the recycled NO, when NO is recycled either through primary or secondary oxidant streams. Recycling NO through the staging oxidants result in significantly less NO reduction and combustion of coal in staged 30:70- $O_2/CO_2$  produce significantly higher  $\eta_{NO}$  than those in staged air combustion.

### 4.6.3. The Effect of Levels of NO Recycled.

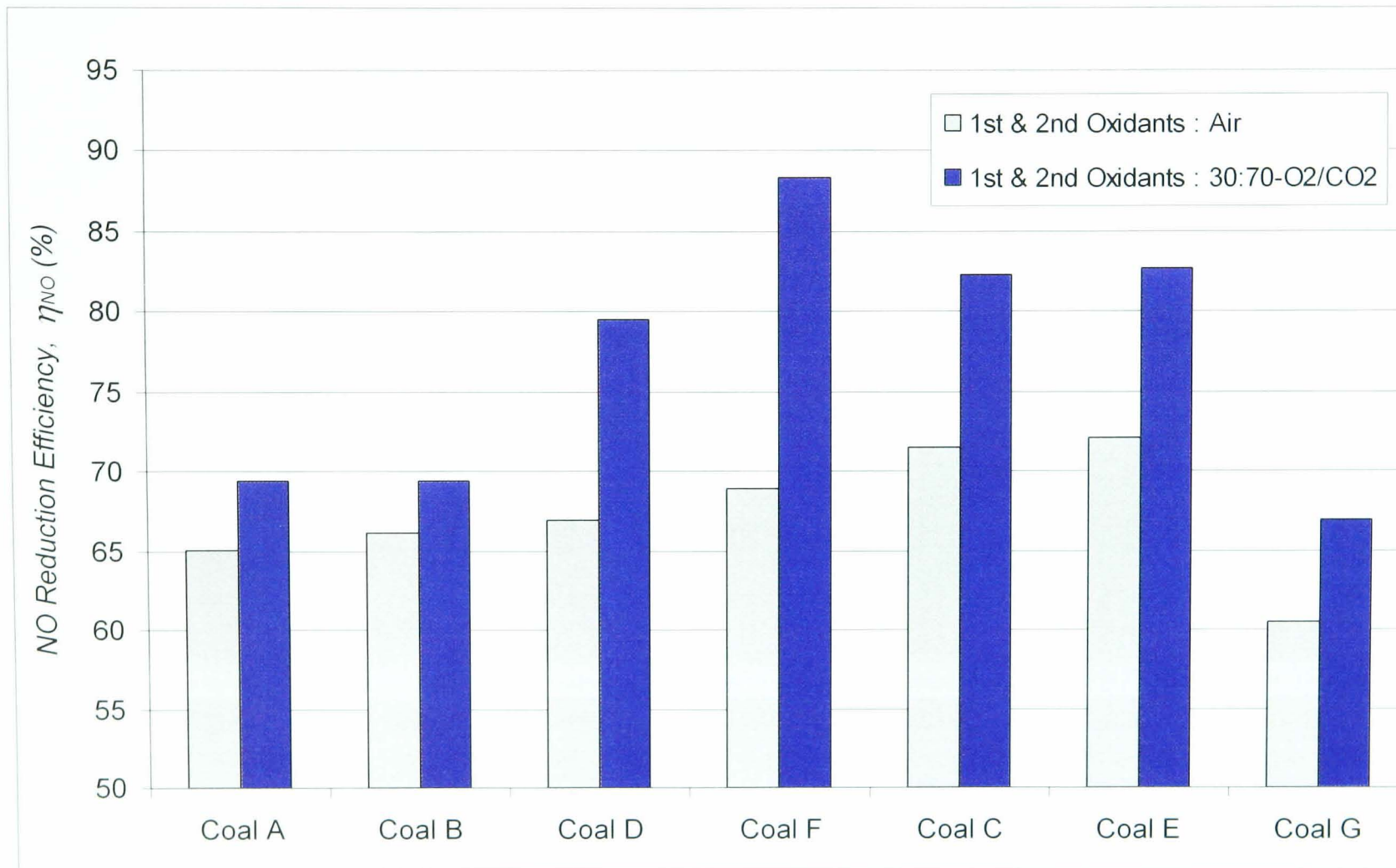
The effect of the concentration of the recycled NO on the NO reduction efficiency is shown in Figure 4.32 for Coal A. The differences in the reduction efficiency for recycled NO concentrations of between 500-700 ppmv and 1000-1400 ppmv concentration are also very small, less than ( $\pm 1\%$ ) for both combustion in air and in 30:70-O<sub>2</sub>/CO<sub>2</sub>. Similar results have also been obtained with combustion of the other coals. Figures 4.32b and 4.32c show the results of the NO recycling tests on Coal C and Coal F which indicate that changing the recycling NO concentration from 500-700 ppmv to 1000-1400 ppmv has little influences on the reduction efficiency of the recycled NO.

### 4.6.4 Effect of Coal Properties.

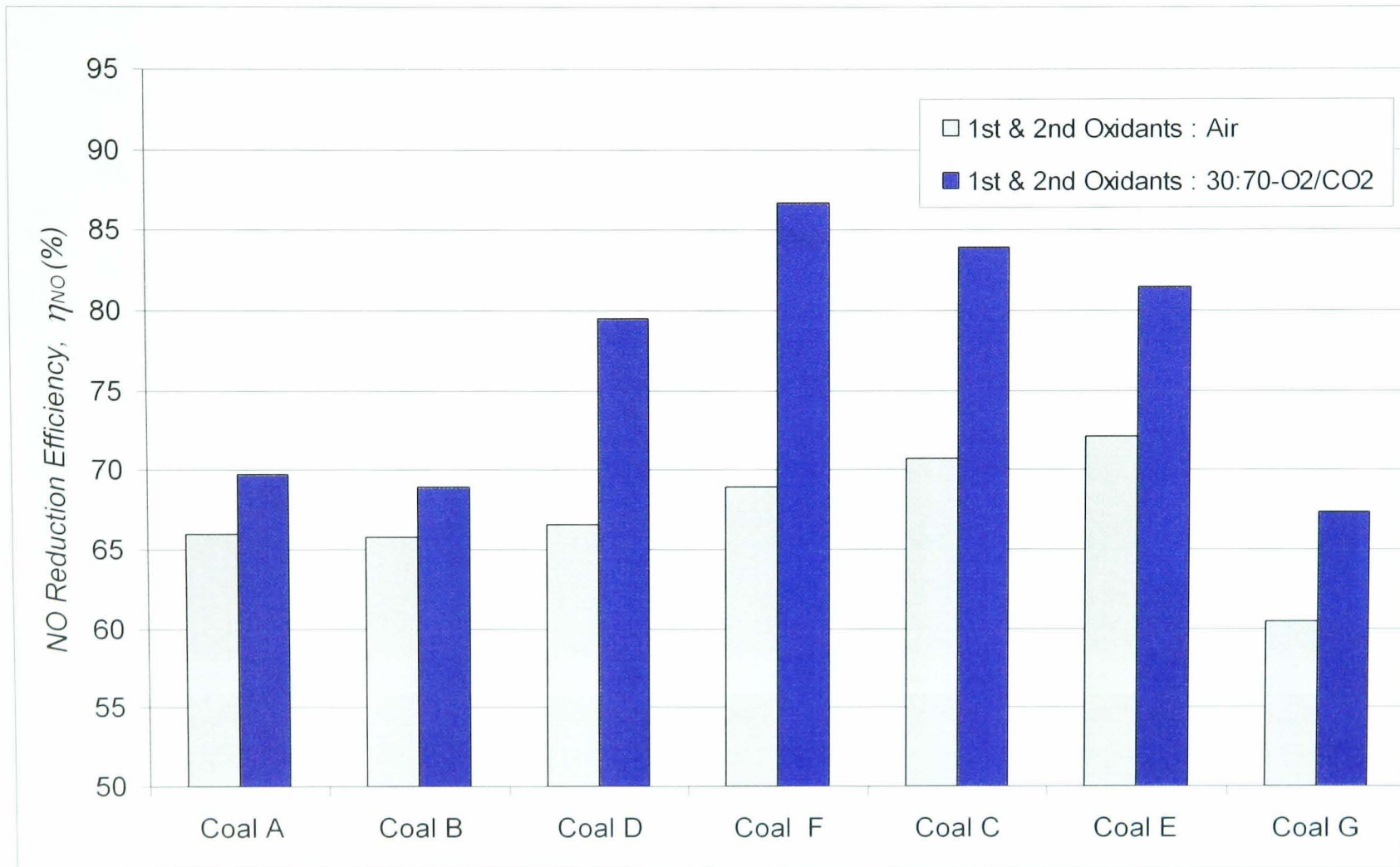
The NO reduction efficiency,  $\eta_{NO}$  in air combustion when NO is introduced to the primary or secondary oxidant varies from 60 % for the lowest fuel ratio Coal G to 72 % higher fuel ratio, Coal F. The reduction efficiency of recycled NO is significantly higher in 30:70-O<sub>2</sub>/CO<sub>2</sub> in all coals and the value varies from 67 % for Coal G to 88 % for Coal F. The dependence of NO reduction efficiency on coal fuel ratio is shown in figure 4.33, which indicates  $\eta_{NO}$  increases with coal fuel ratio and the dependence on coal fuel ratio is more significant in 30:70-O<sub>2</sub>/CO<sub>2</sub>.



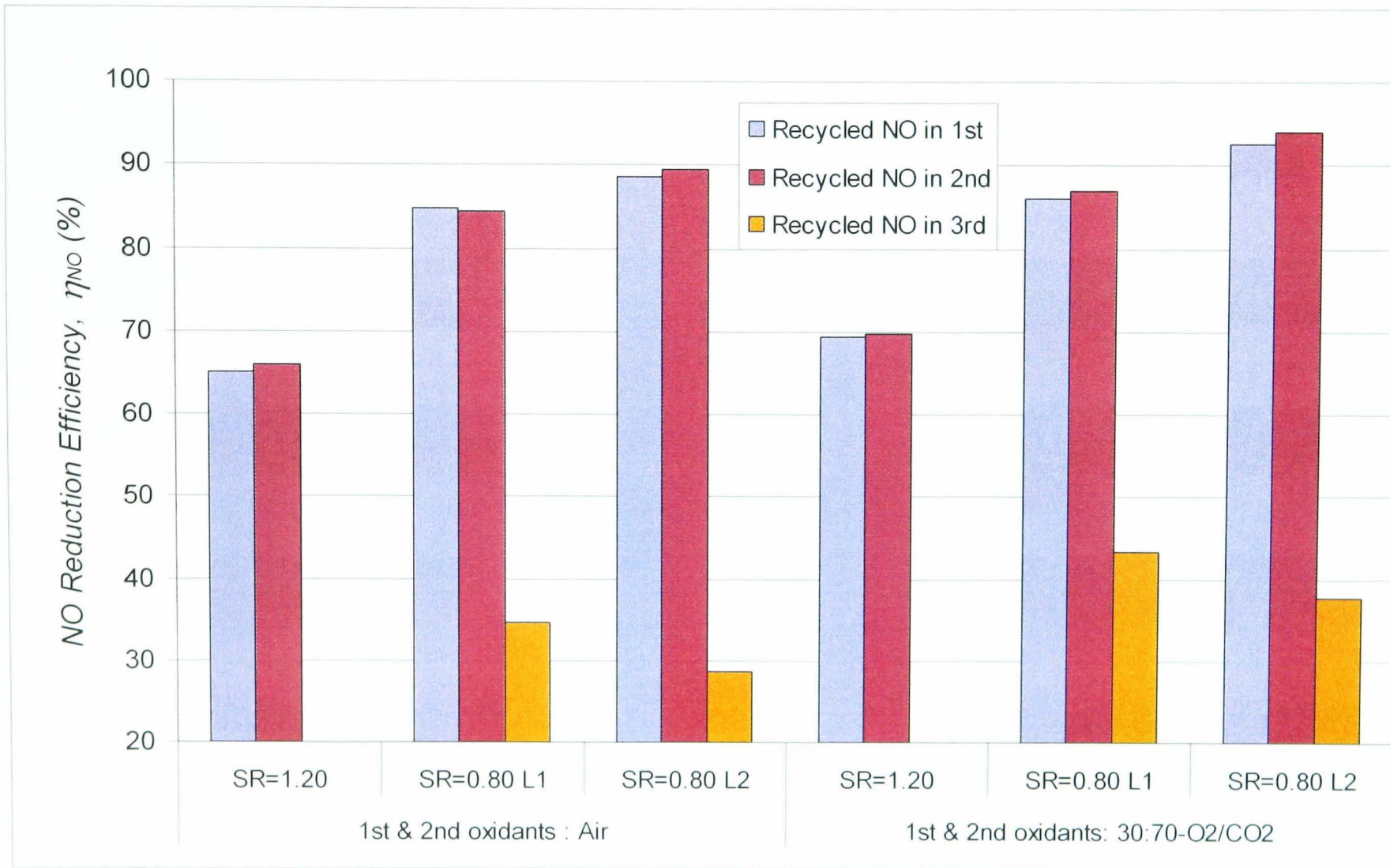
**Figure 4.28** The effect of the injection of NO to the streams of 1<sup>st</sup> and 2<sup>nd</sup> oxidant, on the flue gas compositions. (Unstaged air combustion, SR=1.20, Coal A).



**Figure 4.29a.** Reduction efficiency of recycled NO ( $\eta_{NO}$ ) in air and 30:70-O<sub>2</sub>/CO<sub>2</sub> for all coals, recycled in 1<sup>st</sup> oxidant. (Recycled NO concentrations: 500 – 700 ppmv)

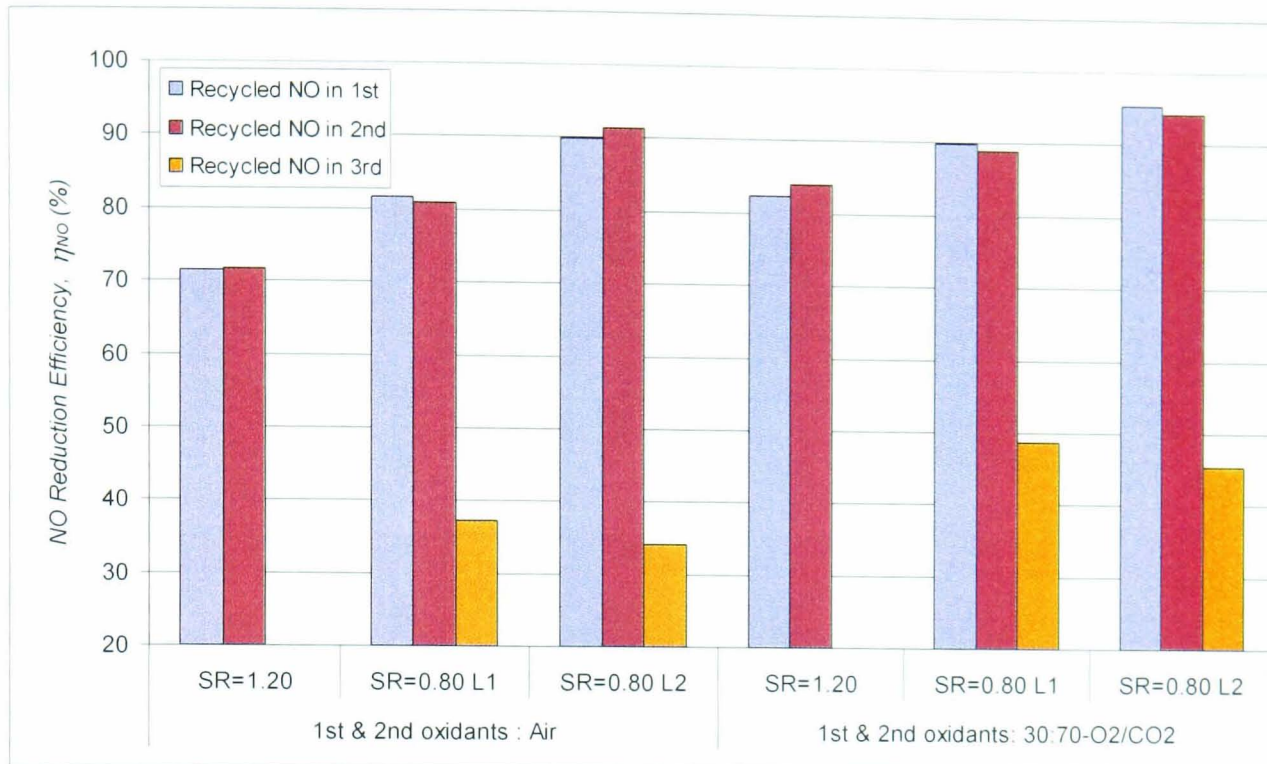


**Figure 4.29b.** Reduction efficiency of recycled NO ( $\eta_{NO}$ ) in air and 30:70-O<sub>2</sub>/CO<sub>2</sub> for all coals, recycled in 2<sup>nd</sup> oxidant. (Recycled NO concentrations: 500 – 700 ppmv)

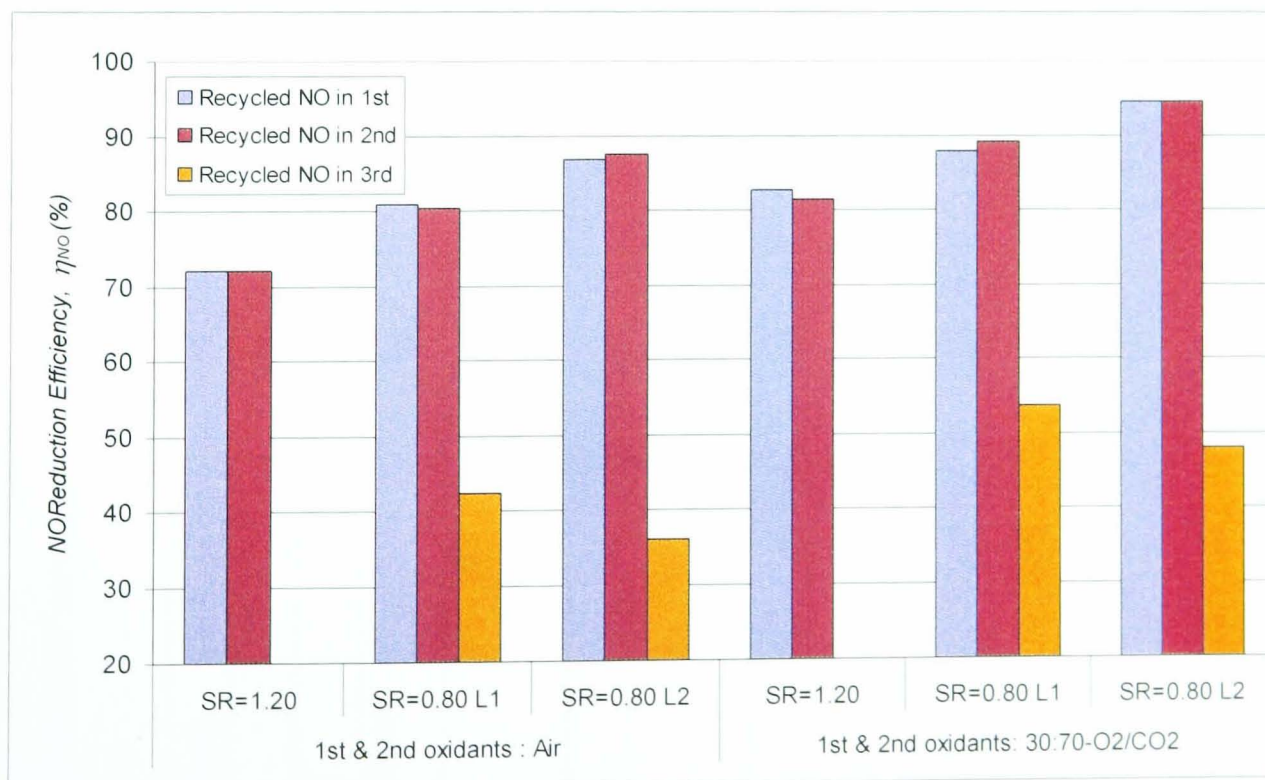


**Figure 4.30** The effect of air/oxidant staging and injection location of recycled NO on NO Reduction Efficiency ( $\eta_{NO}$ ) .  
 (Recycled NO concentrations: 500 – 700 ppmv, Coal A).





**Figure 4.31a.** The effect of oxidant staging and injection location of recycled NO on NO Reduction Efficiency ( $\eta_{NO}$ ). (Recycled NO concentrations: 500 – 700 ppmv, (Coal C).



**Figure 4.31b.** The effect of oxidant staging and injection location of recycled NO on NO Reduction Efficiency ( $\eta_{NO}$ ). (Recycled NO concentrations: 500 – 700 ppmv, (Coal E).

**Table 4.8.** Recycled NO reduction efficiency in various combustion conditions, NO injection points and NO Concentrations. (All coals).

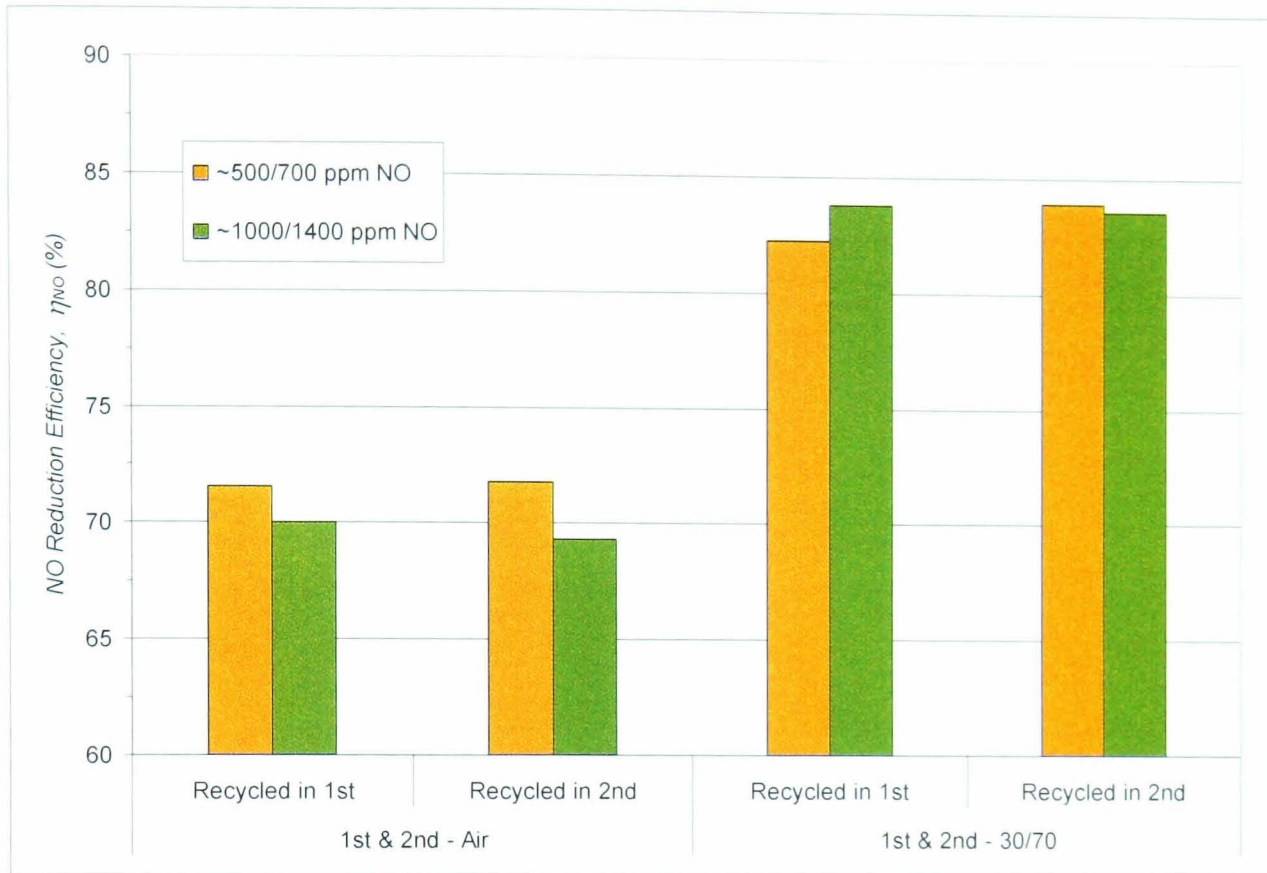
1st & 2nd oxidants		Air				30:70-O <sub>2</sub> /CO <sub>2</sub>			
		Unstaged, SR = 1.20		Staged, SR <sub>1</sub> = 0.80		Unstaged, SR = 1.20		Staged, SR <sub>1</sub> = 0.80	
Staging Levels				L <sub>1</sub> (0.57 m)	L <sub>2</sub> (0.88 m)			L <sub>1</sub> (0.57 m)	L <sub>2</sub> (0.88 m)
NO Concentrations (ppmv)		≈500	≈1000	≈500	≈500	≈700	≈1400	≈700	≈700
Coals:	NO Injection points	η <sub>NOx</sub> (%)	η <sub>NOx</sub> (%)	η <sub>NOx</sub> (%)	η <sub>NOx</sub> (%)	η <sub>NOx</sub> (%)	η <sub>NOx</sub> (%)	η <sub>NOx</sub> (%)	η <sub>NOx</sub> (%)
<b>Coal A</b>	1st	65.0	66.1	84.8	88.5	69.4	69.8	86.2	92.6
	2nd	66.0	64.9	84.4	89.5	69.7	68.6	87.0	93.9
	3rd			34.6	28.7			43.4	37.7
<b>Coal B</b>	1st	66.2	63.2	79.8	92.7	69.4		90.0	93.8
	2nd	65.8	63.8	80.2	93.3	69.7		91.0	94.5
	3rd			37.8	30.4			43.2	39.7
<b>Coal C</b>	1st	71.5	70.0	81.6	89.9	82.3	83.8	89.9	95.4
	2nd	71.7	69.3	80.8	91.3	83.9	83.6	89.0	94.4
	3rd			37.3	34.2			48.8	45.3

Cont....**Table 4.8.** Recycled NO reduction efficiency in various combustion conditions, NO injection points and NO Concentrations.

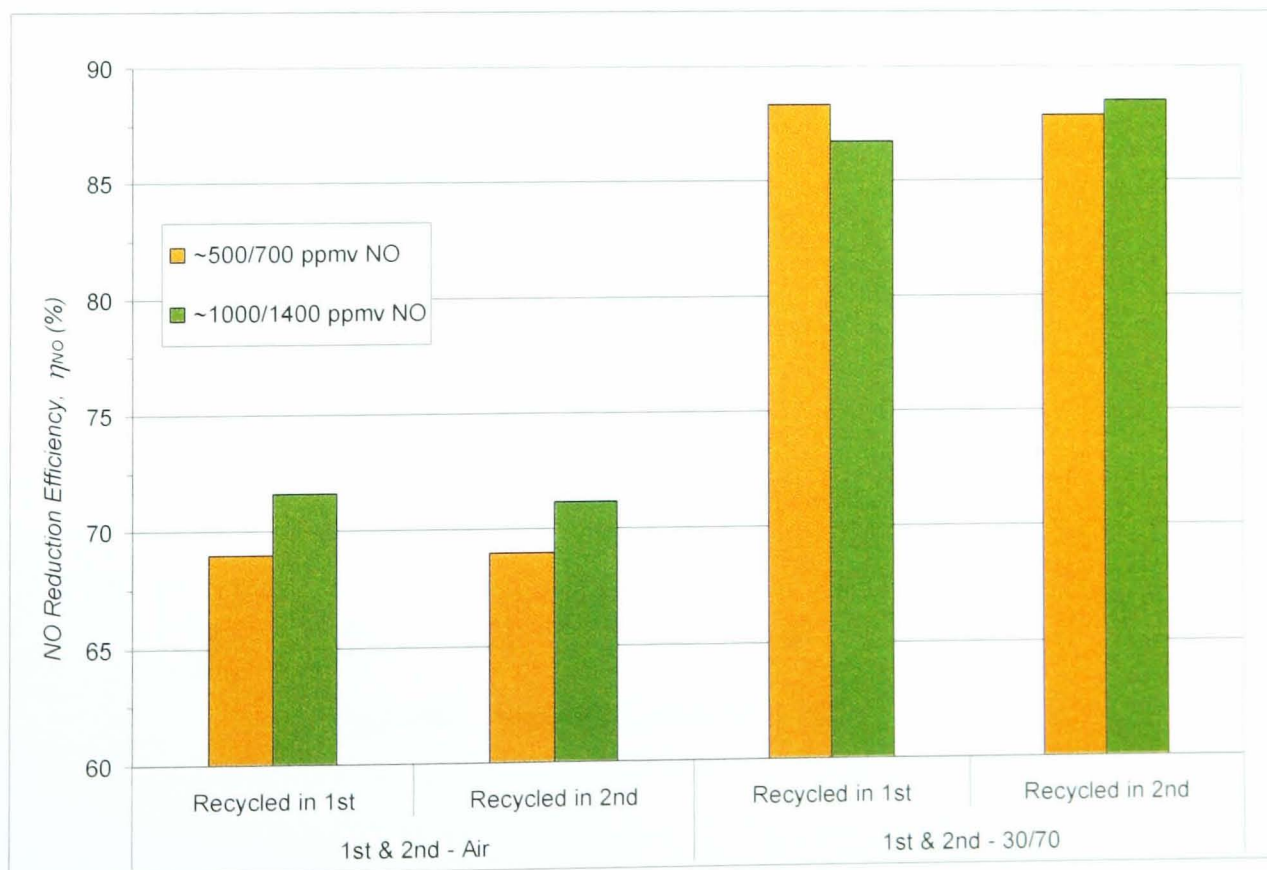
1st & 2nd oxidants		Air				30:70-O <sub>2</sub> /CO <sub>2</sub>			
		Unstaged, SR = 1.20		Staged, SR <sub>1</sub> = 0.80		Unstaged, SR = 1.20		Staged, SR <sub>1</sub> = 0.80	
Staging Levels				L <sub>1</sub> (0.57 m)	L <sub>2</sub> (0.88 m)			L <sub>1</sub> (0.57 m)	L <sub>2</sub> (0.88 m)
NO Concentrations (ppmv)		≈ 500	≈ 1000	≈ 500	≈ 500	≈ 700	≈ 1400	≈ 700	≈ 700
Coals:	NO injection points	η <sub>NO</sub> (%)	η <sub>NO</sub> (%)	η <sub>NO</sub> (%)	η <sub>NO</sub> (%)	η <sub>NO</sub> (%)	η <sub>NO</sub> (%)	η <sub>NO</sub> (%)	η <sub>NO</sub> (%)
<b>Coal D</b>	1st	67.0	64.3	81.8	86.6	79.5		84.3	90.6
	2nd	66.6	65.8	80.4	86.4	79.5		84.0	90.2
	3rd			38.1	33.4			53.7	43.2
<b>Coal E</b>	1st	72.1	71.3	80.8	86.8	82.7		87.9	94.5
	2nd	72.1	70.7	80.4	87.6	81.5		89.2	94.7
	3rd			42.3	36.0			53.7	47.9
<b>Coal F</b>	1st	69.0	71.6	84.8	87.8	88.3	87.9		
	2nd	70.0	71.2	84.0	87.0	86.7	88.5		
	3rd			41.1	34.4				
<b>Coal G</b>	1st	60.5				67.0			
	2nd	60.4				67.4			
	3rd								



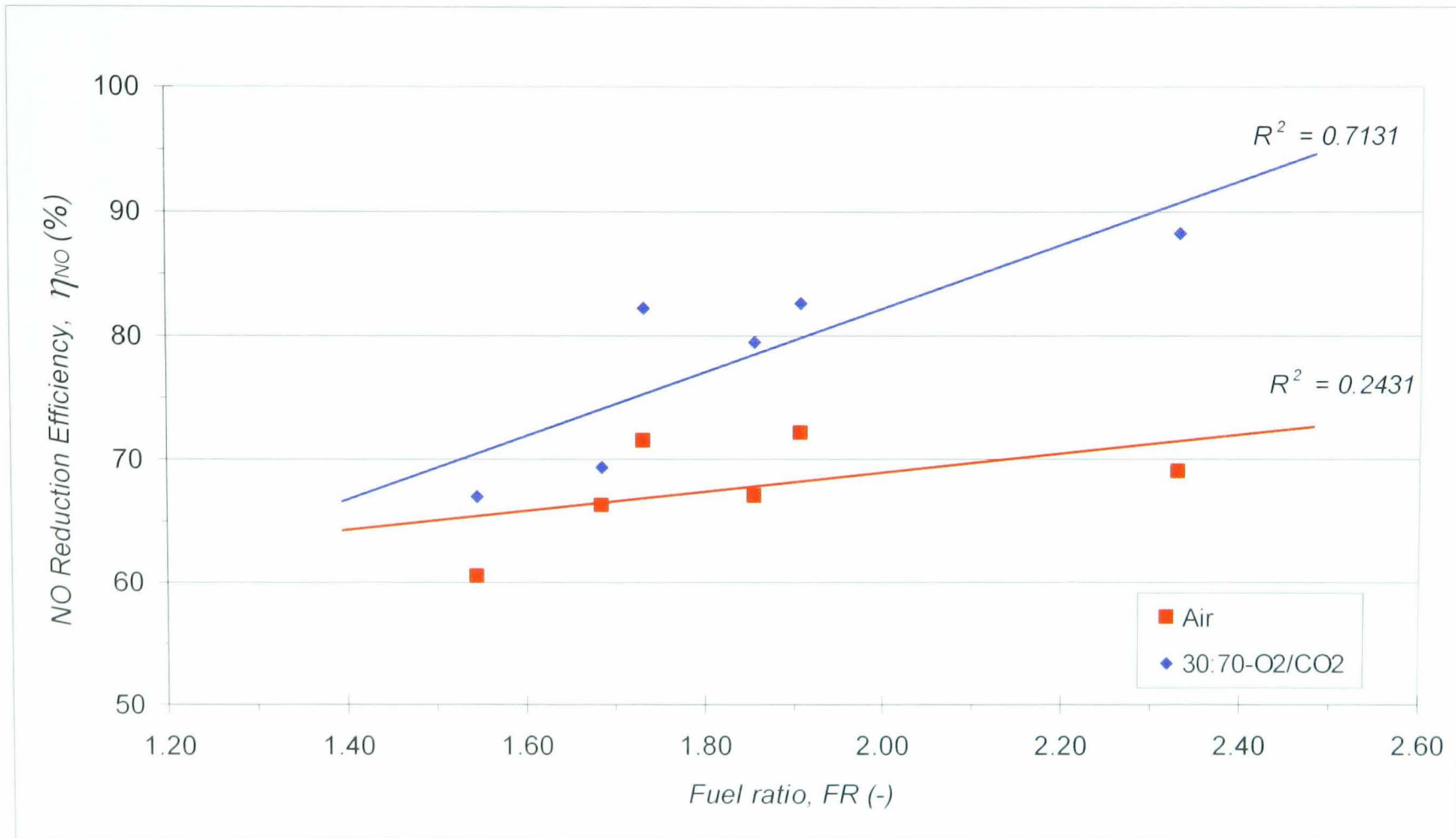
**Figure 4.32a.** The effect recycled NO concentrations on NO Reduction Efficiency ( $\eta_{NO}$ ). (Unstaged, SR=1.20, Coal A).



**Figure 4.32b.** The effect recycled NO concentrations on NO Reduction Efficiency,  $\eta_{NO}$ . (Unstaged, SR=1.20, Coal C).



**Figure 4.32c.** The effect recycled NO concentrations on NO Reduction Efficiency,  $\eta_{NO}$ . (Unstaged, SR=1.20, Coal F)



**Figure 4.33.** The dependence of recycled NO Reduction Efficiency ( $\eta_{NO}$ ), on coal Fuel Ratio (FR).  
(Unstaged, SR=1.20, NO injection through 1<sup>st</sup> oxidant).

## 4.7 Summary of Results.

The experimental results of coal combustion tests show that a pf-burner in a furnace of a combustion system which was designed for coal-air firing could be operated with coal combustion in  $O_2/CO_2$  with high  $CO_2$  concentration without major operational problems related to burner ignition, flame stability, coal firing and the effect oxidants switching, both in unstaged and staged conditions.

The results show that the temperature profile in the combustor is highly influenced by the combustion media. The temperature profiles are significantly altered by the replacement of any parts of the combustion air with  $O_2/CO_2$ , even when only the secondary air was replaced with  $O_2/CO_2$  while maintaining the primary oxidant with air. The main differences of the temperature profiles of combustion in different oxidant composition are that the peak temperature and the temperature closest to the burner significantly decrease and the position of the peak temperature shift downstream as the concentration of  $CO_2$  in the oxidant increases. These temperature profiles indicate that in a high  $CO_2$  environment, coal particles ignition and flame development is significantly delayed, which caused the coal combustion to start and completed further down stream from the burner. This observation was more pronounced when combustion air streams were replaced by 21:79- $O_2/CO_2$ . The visual observations of the flame also show that the bright coal volatile combustion flame which was visible in combustion with air and  $O_2/CO_2$  with high  $O_2$  concentration was not visible at the sampling ports close to the burner when both combustion air was replaced by  $O_2/CO_2$  mixtures with high  $CO_2$ . The results also show that coal combustion cannot be sustained by directly replacing

combustion air with O<sub>2</sub>/CO<sub>2</sub> mixture with the same O<sub>2</sub> concentration (21:79-O<sub>2</sub>/CO<sub>2</sub>). The temperature in the furnace increases and the positions of peaks temperature moves closer to the burner as O<sub>2</sub> concentration in the oxidant increases.

The results of the combustion of all coal samples show that combustion in 30:70-O<sub>2</sub>/CO<sub>2</sub> produced temperature profiles similar to those in air combustion. The visual observation also indicates that the flame brightness are similar. The combustion temperature profiles in the furnace also depend on the reactivity (fuel ratio) of the coal. Although the temperature profiles in both media matched each other, slightly higher combustion temperatures were measured with the combustion of reactive coals in 30:70-O<sub>2</sub>/CO<sub>2</sub> than in air whereas for less reactive coals, slightly lower combustion temperatures were attained. However the differences in the peak temperatures in these two combustion media are very small, which are between 10-15 °C. The exhaust temperatures at the furnace exit in 30:70-O<sub>2</sub>/CO<sub>2</sub> combustion are less than those in air firing which indicate that a slightly more compact flame than those in air were produced. The differences in exhaust temperature between the two media are smaller in less reactive coals.

Since temperature profiles in 30:70-O<sub>2</sub>/CO<sub>2</sub> combustion similar are to those in air combustion, the comparison of combustion emissions profiles, effect of oxidant staging, recycled NO and other combustion tests in O<sub>2</sub>/CO<sub>2</sub> to those in air combustion are based on the combustion in oxidant mixture with 30:70-O<sub>2</sub>/CO<sub>2</sub>. The gas composition profiles along the furnace axis show that coal combustion in 30:70-O<sub>2</sub>/CO<sub>2</sub> have similar characteristics as in coal-air combustion where CO<sub>2</sub> and O<sub>2</sub> profiles show that coal combustion are mostly completed at about the same distance downstream from the burner in both combustion environments. Although NO<sub>x</sub>



concentrations in the main combustion zone in 30:70-O<sub>2</sub>/CO<sub>2</sub> is markedly higher than those in air combustion, the levels decrease quickly to the final values. The measured NO<sub>x</sub> (ppmv) in 30:70-O<sub>2</sub>/CO<sub>2</sub> in the furnace are higher than those in air. Similarly, CO in the combustion zone is significantly higher than those in air combustion but the concentration quickly dropped to the exhaust emissions levels and the reduction rate of CO is much higher in 30:70-O<sub>2</sub>/CO<sub>2</sub>.

The measured CO<sub>2</sub> and O<sub>2</sub> concentration in the flue gas are always in the close agreement with the calculated values for complete combustion. For all coals, high CO<sub>2</sub> concentration of around 80% are measured in 30:70-O<sub>2</sub>/CO<sub>2</sub> combustion employing coal-air entrainment feeder, compared to around 15% in air combustion. The CO<sub>2</sub> concentration in the flue gas could be increased to around 92% by purging entrained air with 30:70-O<sub>2</sub>/CO<sub>2</sub>. With the same coal firing rate, the CO<sub>2</sub> composition in the flue gas decreases as the fraction of N<sub>2</sub> in the combustion increases while the O<sub>2</sub> concentration are not affected. Due to the lower flow rates of the combustion gas in 30:70-O<sub>2</sub>/CO<sub>2</sub>, the SO<sub>2</sub> emissions in the flue gas is significantly higher than those in air combustion. However, the SO<sub>x</sub> conversion ratio (CR<sub>SO<sub>x</sub></sub>) in 30:70-O<sub>2</sub>/CO<sub>2</sub> combustion are almost similar to those in air firing. The SO<sub>x</sub> emissions is only slightly lower in 21:75-O<sub>2</sub>/CO<sub>2</sub> than in 30:70-O<sub>2</sub>/CO<sub>2</sub> and in air.

Similarly, the NO<sub>x</sub> concentrations in the flue gas of 30:70-O<sub>2</sub>/CO<sub>2</sub> combustion are higher than those in air combustion, particularly in high fuel-ratio coals. However, the NO<sub>x</sub> conversion ratio (CR<sub>NO<sub>x</sub></sub>) in 30:70-O<sub>2</sub>/CO<sub>2</sub> combustion for all coal are markedly less than those in air firing, which lead to lower overall furnace NO<sub>x</sub> emissions. NO<sub>x</sub> conversion is greatly influenced by the variation of oxidant

compositions where lower conversion of  $\text{NO}_x$  are attained in combustion in oxidant with higher  $\text{CO}_2$  concentration and  $\text{CR}_{\text{NO}_x}$  increases with higher  $\text{O}_2$  concentration in the oxidants mixture.  $\text{NO}_x$  conversion is markedly reduced even when only the secondary air was replaced by the  $\text{O}_2/\text{CO}_2$  mixture with in a high  $\text{O}_2$  concentration. In combustion with 21:79- $\text{O}_2/\text{CO}_2$  (Case 6),  $\text{CR}_{\text{NO}_x}$  is only about one-fourth to that in air combustion.

The  $\text{NO}_x$  conversion varies with coal properties especially the fuel ratio where lower  $\text{NO}_x$  conversion ratio is produced with coals of high fuel ratio, in both air and 30:70- $\text{O}_2/\text{CO}_2$ . The relative  $\text{NO}_x$  conversion in 30:70- $\text{O}_2/\text{CO}_2$  to those in air markedly varies from 0.60 in coal of high fuel ratio, to around 0.90 for coal of lower fuel ratio. The  $\text{NO}_x$  conversion are not greatly affected by coal volatile content and coal-N, however, the effect of these properties on  $\text{NO}_x$  emissions are more significant in 30:70- $\text{O}_2/\text{CO}_2$  than in air. In all coal combustion tests in air, high burnout efficiency was achieved, and combustion in 30:70- $\text{O}_2/\text{CO}_2$  result in higher burnout efficiency than those in air firing. The experimental results also show that the burnout efficiency of combustion is closely related to the reactivity of coals. The combustion efficiency in air varies from 92.5% in less reactive coals to 98.5% most reactive coal, whereas the corresponding values in 30:70- $\text{O}_2/\text{CO}_2$  are between 94.8 % to 99.3 %.

The temperature profiles in the furnace in staged combustion are similar to those in normal combustion in both air and 30:70- $\text{O}_2/\text{CO}_2$ . Air/oxidant staging reduces temperature in the regions close to the tertiary oxidant inlet ports without significantly changes the peak temperature in the furnace and the furnace exit temperature. The temperature reduction in the combustion zone is more pronounced

in higher staging (lower burner  $SR_1$ ). However, the temperature decreased by staging is smaller in 30:70- $O_2/CO_2$  combustion than those in air. Apart from the general reduction in the  $NO_x$  emissions due to air/oxidant staging, the flue gas compositions are also similar to those in unstaged conditions, in both combustion media. Air staging generally increase carbon-in-ash level in all coals, however, the results show that there is no significant reduction (less than 0.5 %) in the char burnout efficiency due to air staging. Similarly, oxidant staging in 30:70- $O_2/CO_2$  only marginally reduced char burnout efficiency and compared to air combustion, the burnout efficiency is less affected by oxidant staging in 30:70- $O_2/CO_2$ .

Air staging significantly reduces  $NO_x$  concentrations in the flue gas of coal-air combustion. The  $NO_x$  reduction decreases as the burner stoichiometric ratio,  $SR_1$ , increases and introducing tertiary staging air further downstream at  $L_2$  (0.88 m) results in higher  $NO_x$  reduction compared to those at  $L_1$  (0.57 m). The results show that although the  $NO_x$  reduction in 30:70- $O_2:CO_2$  staged combustion from the introduction of tertiary oxidant at  $L_1$  is markedly lower than those in staged air cases, deeper oxidant staging conditions (staging at  $L_2$ ) in 30:70- $O_2/CO_2$  combustion reduces  $NO_x$  as effectively as in air combustion. The results also show that the effectiveness of air staging on  $NO_x$  reduction varies between coals where  $NO_x$  reduction efficiency is markedly lower for less reactive coals. i.e with increasing fuel ratio, the  $NO_x$  reduction effect due to the staged combustion weakens. Air staging with  $SR=0.80$  at  $L_2$  reduces  $NO_x$  between 50%, in less reactive coals to around 65 % in more reactive coals. Similarly, in 30:70- $O_2/CO_2$  combustion, the effectiveness of  $NO_x$  reduction through oxidant staging varies between coals, with the corresponding conditions of staged combustion in 30:70- $O_2/CO_2$  reduces  $NO_x$  between 44% to

73%. In addition, for reactive coals, the effectiveness of staging on  $\text{NO}_x$  reduction in 30:70- $\text{O}_2/\text{CO}_2$  are also marginally higher than those in air whereas in less reactive coals however,  $\text{NO}_x$  reduction is less in staged 30:70- $\text{O}_2/\text{CO}_2$  compared to that in air. However, in comparison to normal combustion in air, the  $\text{NO}_x$  emission in 30:70- $\text{O}_2/\text{CO}_2$  staged combustion for all coal are significantly less which vary from 60 % for less reactive coals to 77 % in more reactive coals.

The results of NO recycled tests show that for combustion of each coal, the reduction of the recycled NO in combustion with both air and 30:70- $\text{O}_2/\text{CO}_2$  is affected by all of three factors: the combustion oxidant composition, the NO recycling injection location and the combustion conditions (staged or unstaged, and burner stoichiometric ratio ( $\text{SR}_1$ ) and injection location of staged oxidant) but is not influenced by the concentration of the NO recycled. The reduction efficiency of recycled NO increases with the increasing coal fuel ratio, and compared to that in air combustion, the reduction efficiency is more sensitive to the coal properties (fuel ratio, coal-N and coal-volatiles) in 30:70- $\text{O}_2/\text{CO}_2$  case. For coal combustion with staged 30:70- $\text{O}_2/\text{CO}_2$ , most of the recycled NO in the oxidants (between 69-95%) passing through main combustion zones is reduced, however, only 37–54% of the recycled NO contained in the staging oxidant can be reduced.

## CHAPTER 5

### DISCUSSION OF RESULTS

The experimental results of the pulverised coal combustion in air and O<sub>2</sub>/CO<sub>2</sub> mixtures presented in Chapter Four are discussed in this Chapter. Combustion temperature profiles, gas emission profiles and burnout efficiency in both atmospheres are compared. The effect of the oxidant compositions on NO<sub>x</sub> conversion, is also elaborated. The comparisons are also made on the reduction of NO<sub>x</sub> emissions through staged combustion and the fate of recycled NO in combustion in air and O<sub>2</sub>/CO<sub>2</sub>, in both unstaged and staged combustion conditions.

#### **5.1. Effect of Oxidants Composition on Flame Characteristics and Gas Temperature.**

##### **5.1.1. Replacing any parts of combustion air with O<sub>2</sub>/CO<sub>2</sub>.**

The combustion temperature profiles change drastically when any part of the combustion air is replaced by O<sub>2</sub>/CO<sub>2</sub> mixtures which are characterised by significant drop of the temperature in the main combustion zone and the shift in the position of the peak temperature further downstream as the concentration of CO<sub>2</sub> in the oxidant increases. The visual observations during the experimental runs show that the bright coal volatile combustion flame which is visible in combustion with air, is not visible at the sampling ports close to the burner when both combustion air is replaced by O<sub>2</sub>/CO<sub>2</sub> mixtures with high CO<sub>2</sub>. The peak temperature increases and

its position moves closer to the burner as the  $O_2$  in the oxidant increases, as shown by the eight different test cases (Case 1– 8). These features indicate that in high  $CO_2$  environments, coal particles ignition and flame formation is significantly delayed, which leads to coal combustion to start and be completed further down stream from the burner, even though the stoichiometry  $O_2$  of the combustion was unchanged.

It is known that the thermal properties of  $CO_2$  and  $N_2$  differ greatly, particularly the heat capacity and the emissivity. The molar specific heat capacity,  $c_p$  of the oxidant, at temperature approximate to the combustion temperature in the tests (1600 K), based on the individual  $c_p$  of the main oxidant components ( $O_2$ ,  $CO_2$ ,  $N_2$ ), in eight different combustion cases are shown in Table 5.1. Replacing any part of combustion air with  $O_2/CO_2$  would significantly increase the heat capacity of the oxidant. The direct replacement of combustion air, (Case 1) with 21:79- $O_2/CO_2$  mixtures (Case 2 and case 6) significantly change the combustion temperature profiles. Although the oxidant flow rates in these three cases are similar, the differences in the heat capacity of the oxidant are significant, in which  $c_p$  in Case 6 and Case 2 are 1.47 and 1.33 higher than that of air, respectively. Hence, when  $N_2$  is directly replaced by  $CO_2$  with the same volumetric flow rates, the rate of increase in combustion gas temperature is greatly reduced which results in low combustion temperature. In most cases, the temperature in the main combustion zone dropped continuously when both oxidants were replaced by 21:79- $O_2/CO_2$ , which indicate that stable flames could not be established in 21:79- $O_2/CO_2$ . Hence, the variation in temperature profiles in different combustion media can be closely related to the significant differences in the thermal properties, particularly the heat capacity, between  $N_2$  and  $CO_2$ . The lower combustion temperature in high  $CO_2$  atmosphere

have also been linked to the highly radiative property of CO<sub>2</sub>, where high CO<sub>2</sub> concentration cause higher heat flux to the furnace wall and hence reduce the flame temperature (Lee et al, 2005). Other factors that may caused variation to combustion temperature with the oxidants composition in O<sub>2</sub>/CO<sub>2</sub> has also been proposed. From the study on hydrogen flame in O<sub>2</sub>/CO<sub>2</sub>, Lee at al. (2005) suggested that this phenomenon could also be linked to the chemical effect incurred by CO<sub>2</sub> addition in which the increase of initial CO<sub>2</sub> concentration induces the increase of CO mole fraction and hence reduces the overall reaction rate of the fuel resulting in lower maximum flame temperature. The delay on coal flame ignition in O<sub>2</sub>/CO<sub>2</sub> with high CO<sub>2</sub> has been attributed to lower flame propagation velocity due to the higher heat capacity of CO<sub>2</sub> (Kiga et al.,1997, Suda et al., 2007).

In O<sub>2</sub>/CO<sub>2</sub> combustion, the temperature increases as the oxygen molar ratio in the oxidant increases. Since the furnace stoichiometric ratio was fixed at SR=1.20, a higher O<sub>2</sub> fraction in the oxidant was obtained from the reduction of the CO<sub>2</sub> fraction while the amount of combustion oxygen unchanged. This results in lower heat capacity of the oxidant which leads to higher rate of increase in combustion temperature. This observation could also be explained by the individual coal particle ignition as reported by Molina and Shaddix (2007), that CO<sub>2</sub> in the oxidant retards coal particle ignition while increasing O<sub>2</sub> concentration accelerates particle ignition in both O<sub>2</sub>/N<sub>2</sub> and O<sub>2</sub>/CO<sub>2</sub> atmospheres. The effect of CO<sub>2</sub> was also explained by its higher specific molar heat compared to N<sub>2</sub> and the effect of O<sub>2</sub> on the reactivity of the mixture.

**Table 5.1.** The variation of oxidant molar specific heat capacity,  $c_p$  with oxidant compositions used in the combustion tests.

	1 <sup>st</sup> oxidant	2 <sup>nd</sup> oxidant	O <sub>2</sub> %	CO <sub>2</sub> %	N <sub>2</sub> %	$c_p$ @ 1600 K (kJ/kmol K)	T <sub>1</sub> (°C)	≈T <sub>p</sub> (°C)	≈x <sub>p</sub> (m)
Case 1	air	air	0.210	0.000	0.790	<b>35.63</b>	1322	1325	0.40
Case 2	air	21:79	0.210	0.500	0.290	<b>47.45</b>	1085	1190	1.00
Case 3	air	26:74	0.239	0.431	0.330	<b>45.86</b>	1250	1270	0.80
Case 4	air	30:70	0.259	0.383	0.357	<b>44.76</b>	1301	1303	0.50
Case 5	air	35:65	0.281	0.331	0.388	<b>43.56</b>	1343	1345	< 0.40
Case 6	21:79	21:79	0.210	0.711	0.079	<b>52.42</b>	907	1110	1.50
Case 7	21:79	30:70	0.259	0.643	0.098	<b>50.89</b>	1139	1195	0.80
Case 8	30:70	30:70	0.288	0.604	0.108	<b>50.02</b>	1331	1131	0.40



**Table 5.2.** The calculated adiabatic flame temperature ( $T_{ad}$ ) of Coal A in combustion in various oxidant mixtures (SR=1.20).

Oxidant Mixtures	$T_{ad}$ (K) ( <i>FLAME</i> ® output)		$T_{ad}$ (K) (Calculations)	
	Simple products	Normal products	Without dissociation	With dissociation
Air (21%O <sub>2</sub> -79% N <sub>2</sub> )	<b>2195</b>	<b>2174</b>	<b>1997</b>	<b>1987</b>
21:79- O <sub>2</sub> /CO <sub>2</sub>	1695	1694	1533	1532
24:76- O <sub>2</sub> /CO <sub>2</sub>	1863	1861	1686	1684
27:73- O <sub>2</sub> /CO <sub>2</sub>	2104	2010	1836	1827
30:70- O <sub>2</sub> /CO <sub>2</sub>	2143	2136	1984	1955
31.4:68.6- O <sub>2</sub> /CO <sub>2</sub>	<b>2195</b>	2187	-	-
31.1 :68.9-O <sub>2</sub> /CO <sub>2</sub>	-	-		<b>1997</b>
30.3 :69.7-O <sub>2</sub> /CO <sub>2</sub>			<b>1997</b>	

The variation of the temperature profile in various oxidant mixtures from the tests are consistent with the findings of coal combustion tests in both laboratory-scaled and pilot facilities by others. In all previous studies, the differences in furnace temperature in  $O_2/CO_2$  compared to those in air combustion were attributed, mainly as a result of the higher specific heat of  $O_2/CO_2$  mixtures although other factors also may have contributed. Nozaki et al. (1997) reported that, compared to air combustion, the gas temperature at the burner outlet for  $O_2/CO_2$  combustion with only 30%  $O_2$  in the secondary gas was lower by 200 °C, and the combustion temperature reached the peak value further away from the burner. Croiset et al. (2000) reported combustion with only 21%  $O_2$  in  $O_2/CO_2$  produced flame temperature close to the burner which was 300 °C lower than that in air. Tan et al. (2006) also reported that the flame temperature in combustion with only 21% of  $O_2$  in  $O_2/CO_2$ -recycled was significantly lower than combustion in air, and in certain cases, it was not even possible to maintain stable flames. It was also reported that a coal flame in  $O_2/CO_2$  is much less luminous due to higher absorption radiation by  $CO_2$ .

The results are also in close agreement with other related works of combustion in  $O_2/CO_2$  environments. Andersson et al. (2006) reported that compared to that in air, gas combustion in 21:79- $O_2/CO_2$  causes significant drop in temperature that led to the suppressed development of the flame which exhibits poor burn-out rates of the fuel. The studies on a hydrogen flame in  $O_2/CO_2$  by Lee et al. (2005) showed the peak temperature in combustion with 40:0:60- $O_2/N_2/CO_2$  is lower by 172 °C than that in 40:60:0- $O_2/N_2/CO_2$  and 59 °C lower than in 40:30:30- $O_2/N_2/CO_2$  mixtures and when  $N_2$  was replaced by  $CO_2$ , the overall upstream temperature in the furnace markedly decreases.

### 5.1.2. 30:70-O<sub>2</sub>/CO<sub>2</sub> Combustion.

Since the specific heat of CO<sub>2</sub> higher than that of N<sub>2</sub>, higher O<sub>2</sub> concentrations in the oxidant is needed to attain comparable flame temperatures to those in air combustion. As discussed previously in Section 2.2.3 the calculated theoretical adiabatic flame temperature of combustion of CH<sub>4</sub> in O<sub>2</sub>/CO<sub>2</sub> is significantly lower than that in air, and the theoretical flame temperature matches that of air combustion when the O<sub>2</sub> concentration is increased to 32%. The theoretical constant pressure adiabatic flame temperature ( $T_{ad}$ ) of coal combustion can be determined from the fundamental equations by equating the enthalpy ( $H$ ) of combustion reactants to enthalpy of the combustion products:

$$H_{react}(T_i, P) = H_{prod}(T_{ad}, P).$$

Since coals constitute of complex compounds, the approximate calculated adiabatic flame temperature can be based on the major compositions of both reactants and combustion products. Table 5.2 show the calculated adiabatic flame temperature of Coal A with SR= 1.20, obtained from the calculation based on both, with and without dissociated combustion products. Theoretically, combustion in O<sub>2</sub>/CO<sub>2</sub> with molar ratio of around 31:79-O<sub>2</sub>/CO<sub>2</sub> would produce a same peak temperature as that in air combustion with similar stoichiometric ratio. In the combustions tests of Coal A, with the present of air in the primary oxidant from the entrained air in the coal feeder, the flame temperature profiles in combustion with 30:70-O<sub>2</sub>/CO<sub>2</sub> mixture in both primary and secondary oxidant (Case 8) are comparable to that in air combustion in terms of the peak temperature and the

position of the peak temperature along the furnace axis. (30:70-O<sub>2</sub> CO<sub>2</sub> as 1<sup>st</sup> and 2<sup>nd</sup> oxidiser, approximate molar ratio O<sub>2</sub>:CO<sub>2</sub>:N<sub>2</sub> = 29:60:11; O<sub>2</sub>:CO<sub>2</sub> = 32:68). The combustion results of other seven coals confirm that coal combustion in 30:70-O<sub>2</sub>/CO<sub>2</sub> produce temperature profiles similar to those in air combustion. In addition, the visual observations during the experimental runs show the bright volatile combustion flames with some char burning at the sampling ports closest to the burner in combustion with both media, air or 30:70-O<sub>2</sub>/CO<sub>2</sub> which indicates that the flame characteristics in both media match each other. These observations are parallel with the results of studies on coal particles combustion in O<sub>2</sub>/CO<sub>2</sub> environments by Molina and Shaddix (2007) who suggested that an increase in oxygen concentration in CO<sub>2</sub>/O<sub>2</sub> combustion to around 30 % should produce ignition time and volatile flame similar to those obtained under air combustion. Therefore, it can be proposed that for a similar type of coals (bituminous coals), combustion with the same coal firing rate and furnace stoichiometric ratio in 30:70-O<sub>2</sub>/CO<sub>2</sub> mixture would produce almost identical furnace temperature profiles as those in the air combustion. Results from several other investigations have also suggested that to attain a similar adiabatic flame temperature in O<sub>2</sub>/CO<sub>2</sub> as that in coal-air combustion, the O<sub>2</sub> proportion of the gases passing through the burner should be increased, typically to around 30% (Buhre et al., 2005). Kimura et al. (1995) suggested that, to reach the same adiabatic flame temperature as in air, the calculated oxygen concentration in O<sub>2</sub>/CO<sub>2</sub> mixture based on their furnace configuration should be as high as 42 % and 30% O<sub>2</sub> concentration in the oxidant could produce stable combustion in O<sub>2</sub> CO<sub>2</sub> combustion. Croiset et al. (2000) reported the flame temperature in 28% or less O<sub>2</sub> in O<sub>2</sub>/CO<sub>2</sub> mixtures are lower than that in coal combustion, and the temperature only matched to that in air combustion when the O<sub>2</sub> concentration is increased to 35 %.

Andersson et al. (2006) and Maier et al. (2006) reported that combustion of coal in 27:73-O<sub>2</sub>/CO<sub>2</sub> produces temperature profiles that closely match those in air combustion. However, in their work, the oxidant flow rate was kept constant and the stoichiometric ratio of the combustion was fixed by varying the coal feed rates. In this study, the presence of entrained air from the coal feeder slightly lowers the required oxygen concentration in the mixture of O<sub>2</sub>/CO<sub>2</sub> to match the temperature profiles of coal–air combustion, from the theoretical value. However, in several runs in which the coal-entrainment air was purged with 30:70-O<sub>2</sub>/CO<sub>2</sub>, it was noted that the temperature profiles were not significantly different. Croiset et al. (2000) also reported that the presence of up to 5% nitrogen in the O<sub>2</sub>/CO<sub>2</sub> mixtures has no significant effect on the flame temperature compared to that in pure O<sub>2</sub>/CO<sub>2</sub> mixtures.

It can be deduced that the slight variation in the combustion temperature profiles of different coals between the two combustion media is due to the variation of the coal properties, particularly the fuel ratio. In both air and 30:70-CO<sub>2</sub>/O<sub>2</sub> combustion, the peak combustion temperature of higher fuel ratio coals (less reactive coals) are slightly further downstream compared to those of coals of lower fuel ratio (more reactive coals). Compared to those in air combustion, slightly higher peak temperatures were measured in 30:70-O<sub>2</sub>/CO<sub>2</sub> combustion of more reactive coals whereas for less reactive coals slightly lower combustion temperatures were measured. Andersson et al. (2006) reported that temperature profiles for coal combustion in air and O<sub>2</sub>/CO<sub>2</sub> combustion are influenced by coal volatile matter. Combustion of a medium-volatile coal produced temperature profiles where the maximum temperatures in air (1330 °C) is slightly higher than 1306 °C for the 27:73-O<sub>2</sub>/CO<sub>2</sub>, at 0.5 and 0.6 m distance from the burner respectively, while tests on another coal sample with higher volatile content produced higher maximum

temperature in the 27:73-O<sub>2</sub>/CO<sub>2</sub>, 1326 °C at 0.7 m from the burner compared to 1287 °C at 0.9 m in the air combustion. It was suggested for coal of lower volatile content, the combustion is dominated more by the char burnout which resulted in a less intense release of fuel-bound combustibles into the gas phase during the coal pyrolysis stages. Earlier, Nozaki et al. (1997) also reported that coal properties, mainly the volatile content, have a dominant effect on the temperature profiles in the furnace in which the gas temperatures of combustion of more volatile coals are higher and increase more rapidly near the burner than those from firing with lower volatile coals.

The temperature profiles also show that temperatures at the furnace exit from 30:70-O<sub>2</sub>/CO<sub>2</sub> combustion are markedly lower than those in air combustion which indicate that the flame is slightly shorter and more compact than that in air firing. The lower temperature closer to the furnace exit in 30:70-O<sub>2</sub>/CO<sub>2</sub> combustion could also be related to the lower flow rate of oxidant, since the oxidant flow rate in 30:70-O<sub>2</sub>/CO<sub>2</sub> combustion is less than in air combustion ( $V_o = 241$  l/min,  $V_{air} = 330$  l/min). The lower temperature closer to the furnace exit in 30:70-O<sub>2</sub>/CO<sub>2</sub> could also be related to the higher radiative properties of the oxidants from the presence of high CO<sub>2</sub> concentration, as suggested by Lee et al. (2005). These profiles are also in close agreement with the observations of others. Tan et al. (2006) reported that the coal flames in O<sub>2</sub>/CO<sub>2</sub> are more compact than conventional coal-air flames. Khare et al. (2006) reported that if furnace heat transfer in O<sub>2</sub>/CO<sub>2</sub> combustion matched those in air combustion at given flue gas oxygen concentration, O<sub>2</sub>/CO<sub>2</sub> combustion will result in a lower furnace exit gas temperature.

Therefore, from the comparison of results with those reported by others, it can be postulated that, the slight differences in the required amount of O<sub>2</sub> concentration in O<sub>2</sub>/CO<sub>2</sub> mixtures to match the combustion temperature as in coal-air combustion, reported in various investigations are due to variation in combustor configurations used in the investigations, the coal properties used in the tests and the purity of O<sub>2</sub> and CO<sub>2</sub> in the oxidant mixtures.

### **5.1.3. Flame Stability and Ignition.**

It is known that mixing of cold coal particles and air/gas mixtures prior to ignition can extinguish the flame and lead to unstable operation of the pulverised coal combustion in a furnace. Replacing combustion air with O<sub>2</sub>/CO<sub>2</sub> with high CO<sub>2</sub> concentration may further contribute to the problems related to the ignition and flame stability since higher heat capacity of CO<sub>2</sub> compared to that of N<sub>2</sub> has been attributed to cause delay on flame ignition in O<sub>2</sub>/CO<sub>2</sub> combustion, which was linked to the flame propagation velocity. Flame propagation velocity is significantly lower in O<sub>2</sub>/CO<sub>2</sub> mixtures compared to that in O<sub>2</sub>/N<sub>2</sub>, and the flame velocity could be improved by increasing the O<sub>2</sub> concentration in the mixture. (Suda et al., 2007).

In previous studies, problems of flame ignition and stability in O<sub>2</sub>/CO<sub>2</sub> combustion were also attributed to the burner throughput and furnace designs. Kimura et al (1995) reported that the high concentration of CO<sub>2</sub> in O<sub>2</sub>/CO<sub>2</sub> combustion produced a flame with a vague ignition point and less luminosity which were improved by injecting pure O<sub>2</sub> at the centre of the burner. Croiset et al. (2000) also reported that problems on flame ignition and stability in O<sub>2</sub>/CO<sub>2</sub> combustion furnace was resolved by the addition of an oxygen stream into the combustor in a concentric flow around the coal feed injector. In this O<sub>2</sub>/CO<sub>2</sub> combustion test, all

oxidants were introduced to the burner and furnace at the same configuration as in the coal–air combustion test to minimise any effect on the burner fluid dynamics that may influence combustion temperature profiles from the changes in oxidant flow rates with different oxidant compositions. Test results show that coal combustion could not be sustained only when all combustion air was replaced by O<sub>2</sub>/CO<sub>2</sub> mixture with the same O<sub>2</sub> concentration (21:79-O<sub>2</sub>/CO<sub>2</sub>). Hence, from the results, it can be deduced that flame ignition and stability were not greatly influenced by the burner design in the combustor, but mainly by the molar fraction of O<sub>2</sub> and CO<sub>2</sub> in the oxidants.

## **5.2. Effect of Oxidants compositions on Combustion Emissions.**

The comparison of the gas compositions profiles in the furnace and flue gas, in air and O<sub>2</sub>/CO<sub>2</sub> was presented in Section 4.3. The combustion test of all coals show that the temperature profiles in 30:70-O<sub>2</sub>/CO<sub>2</sub> closely match those in air combustion, hence the comparison of combustion emissions profiles, the effect of oxidant staging, the fate recycled NO<sub>x</sub> and other combustion tests in O<sub>2</sub>/CO<sub>2</sub> to those in air combustion are mostly based on the combustion in oxidant mixture with 30:70-O<sub>2</sub>/CO<sub>2</sub>.

### **5.2.1. Furnace gas compositions.**

The gas composition profiles along the furnace axis confirm that coal combustion in 30:70-O<sub>2</sub>/CO<sub>2</sub> has similar characteristics to those in coal–air combustion. The small change of CO<sub>2</sub> and O<sub>2</sub> concentrations beyond about 1.0 m downstream from the burner indicates that near complete combustion of coal



particles has been achieved in combustion with both media. Although a much higher concentration of  $\text{NO}_x$  was measured in the main combustion zone in 30:70- $\text{O}_2/\text{CO}_2$ , the conversion of combustible nitrogen into  $\text{NO}_x$  is completed in the main combustion zone, both for the air and 30:70- $\text{O}_2/\text{CO}_2$  cases. However,  $\text{O}_2$  and  $\text{NO}_x$  concentrations appear to reach their final value a slightly further away from the burner in 30:70- $\text{O}_2/\text{CO}_2$  combustion.

In 30:70- $\text{O}_2/\text{CO}_2$  combustion, the CO concentration in the furnace close to the burner is more than 50% higher than in the air case. The high concentrations of CO in the main combustion zone of  $\text{O}_2/\text{CO}_2$  indicate possibility of high temperature corrosion in practical applications of  $\text{O}_2/\text{CO}_2$  systems. However, CO in the furnace decreases rapidly, most likely oxidised into  $\text{CO}_2$ , and the CO concentration in the furnace decreases faster in 30:70- $\text{O}_2/\text{CO}_2$ . It can be deduced that, since the combustion temperature in both media are similar and the gas flow rate in 30:70- $\text{O}_2/\text{CO}_2$  is only around 36 % less than that in air combustion, the significantly higher CO concentration in the main combustion zone of 30:70- $\text{O}_2/\text{CO}_2$  is not only due to the lower flow rate of the combustion gas. It can be postulated that the high  $\text{CO}_2$  concentration in the oxidants also influences the emission of CO. Tan et al. (2006) has suggested that a higher CO emission in  $\text{O}_2/\text{CO}_2$  combustion of the same temperature as in air firing is most likely due to the slower diffusion rate of volatiles under high  $\text{CO}_2$  conditions. Similar finding was reported by Andersson et al. (2006) who observed that although the furnace's CO concentrations in 27:73- $\text{O}_2/\text{CO}_2$  coal combustion, which produce comparable temperature profiles to that in air combustion is significantly higher than in air case, the level decreases immediately to an insignificant value at the furnace exit. In the work by Croiset et al. (2000), it

was reported that, although the combustion temperature are similar, the furnace's O<sub>2</sub> concentrations in the O<sub>2</sub>/CO<sub>2</sub> combustion with oxygen concentration of less than 35 %, increases along the furnaces axis. whereas the O<sub>2</sub> concentration is almost constant in air combustion. These profiles indicate that coal particles are burned further away from the burner in O<sub>2</sub>/CO<sub>2</sub> mixture with O<sub>2</sub> concentration less than 35% and the O<sub>2</sub> concentration in the flue gas reach its final value faster in higher O<sub>2</sub> concentration mixtures. Croiset et al. (2000) also reported that the CO emission rate decrease faster with higher O<sub>2</sub> concentration in the combustion chamber, which was linked to the temperature variation. It was observed that the decrease of CO concentration along the flame is slower compared to air combustion because of the high CO<sub>2</sub> gas concentration in O<sub>2</sub>/CO<sub>2</sub> mixture which leads to the conclusion that the presencet of high concentrations of CO<sub>2</sub> could also affect CO formation in the furnace.

## **5.2.2. Flue gas.**

### **5.2.2.1. O<sub>2</sub>, CO<sub>2</sub> and CO.**

Although a high concentration of CO was measured in the main combustion zone in both 30:70-O<sub>2</sub>/CO<sub>2</sub> and air firing, the CO level in the flue gas was always very low, which suggest that CO is mostly oxidised in the furnace. The average CO emissions in the flue gas from the combustion of Coal A is around 56 ppmv and 34 ppmv in air and 30:70-O<sub>2</sub>/CO<sub>2</sub> respectively. In 21:79-O<sub>2</sub>/CO<sub>2</sub>, the CO concentration at the exhaust is markedly higher, at around 200 ppmv and is believed due to flame instability and lower flame temperature.

In all coal-air combustion tests, the measured  $O_2$  and  $CO_2$  concentrations in the flue gas are always very close to the calculated values. In air combustion of Coal A with  $SR=1.20$  at firing rate of around 2.12 kg/h, the measured  $O_2$  and  $CO_2$  concentrations in the flue gas are 3.6 % and 15.3 % compared to the calculated concentrations of  $O_2$  and  $CO_2$  of 3.58 % and 15.31 % dry volume respectively. Based on the pure 30:70- $O_2/CO_2$  combustion, the  $CO_2$  concentration in the flue gas theoretically should reach 94.4 %. The presence of inert nitrogen from the flow of air used in the coal entrainment and atmospheric leakages to the system contributed to the lower  $CO_2$  concentrations in the flue gas. However, based on the amount of excess oxygen and the infiltration of air to the system, the measured concentration of  $CO_2$  and  $O_2$  are very close to the calculated values. With the same firing rate and stoichiometric oxygen, the averaged measured  $CO_2$  and  $O_2$  in the flue gas with 30:70- $O_2/CO_2$  (Case 8) are 80.0 % and 4.7 % respectively compared to the calculated value 79.64% and 4.87% respectively. When entrained air from the feeder was purged by  $O_2/CO_2$ ,  $CO_2$  in flue gas increased to around 90-92%, which indicates total  $N_2$  isolation could not be achieved in the combustor system. The results also reveal that, with combustion at the same coal firing rate, the  $CO_2$  composition in the flue gas decreases as the fraction of  $N_2$  in the combustion increases while the  $O_2$  concentration is not affected. The purity of oxidants in coal- $O_2/CO_2$  environments and the amount of excess oxygen are the main parameters which determine the concentration of  $CO_2$  in the flue gas. Although lower amount of excess  $O_2$  in the oxidant theoretically could be employed to maximise the  $CO_2$  in the flue gas as suggested from laboratory-scale works and numerical calculations. coal- $O_2/CO_2$

combustion in a furnace requires a percent excess  $O_2$  to achieve a similar  $O_2$  fraction in the flue gas as air firing, typically in the range of 3–5%. (Khare et al., 2005).

#### 5.2.2.2. $SO_x$

The experimental results show that  $SO_2$  emissions are not significantly affected by the oxidant compositions. For Coal A, the sulphur conversion is only slightly lower in 21:79- $O_2/CO_2$  ( $CR_{SO_x} = 85.8\%$ ) than in 30:70- $O_2/CO_2$  ( $CR_{SO_x} = 90.0\%$ ) and in air ( $CR_{SO_x} = 89.0\%$ ). One possible reason of this small variation is the differences in the char burnout efficiency between the combustion media in which parts of the sulphur may be retained in the ash. Results from combustion of other coals also show that the conversion of  $SO_x$  are almost similar in both air and 30:70- $O_2/CO_2$  which suggested that the  $SO_x$  conversion is not greatly influenced by the oxidant compositions. This result is in a close agreement with the thermodynamic modelling equilibrium calculations by Zheng and Furimsky (2003) who proposed that,  $SO_x$  emissions being governed only by  $O_2$  concentration in the oxidant, would not be affected by the variation of oxidant mixtures. This result is also consistent with experimental results reported by Croiset and Thambimuthu (2001), Tan et al. (2006) and Andersson et al. (2006). Croiset & Thambimuthu (2001) also reported that  $SO_2$  emission was not affected significantly by the variations of  $O_2$  or  $CO_2$  concentration in the oxidant but appeared to be affected mainly by the sulphur content in the coal. The slight variation in  $SO_x$  conversion in different combustion media in their work was suggested due to parts of the sulphur may be retained in the ash or part of the  $SO_2$  is oxidised to  $SO_3$ , although tests on the ash revealed only about 3% of the initial sulphur is retained in the ash. Andersson et al. (2006) reported that the conversion of sulphur is completed at a short distance downstream of the burner, in

both air and in 27:73-O<sub>2</sub>/CO<sub>2</sub> combustion and SO<sub>2</sub> emissions appear to be affected mainly by the sulphur content in the coal and not by the O<sub>2</sub> or CO<sub>2</sub> concentrations in the oxidiser. Tan et al. (2006) also highlighted that the possible increase of sulphur retention on ash deposits and on the cool surfaces of the flue gas cooler in flue gas recycle line may lead to corrosion problems to the combustion system employing recycled gas.

### **5.2.3. Unburned Carbon in Ash and Char Burnout.**

It is known that the carbon concentrations in ash from coal combustion depend on the ash content of the coal and hence the combustibility of coal is not only characterised by the amount of carbon in ash, but characterised by the char burnout. (Ikeda et al., 2004). The comparison of carbon concentrations in ash and burnout efficiency between coal combustion in air and O<sub>2</sub>/CO<sub>2</sub> for all coals was presented in Section 4.4, which show that the amount of carbon in ash significantly increases with the CO<sub>2</sub> ratio in the oxidant. The introduction of CO<sub>2</sub> to the combustion zone reduces the burnout efficiency, which can be attributed mainly to the lower flame temperature and flame stability with the increasing CO<sub>2</sub> ratio. Increasing the amount of O<sub>2</sub> in coal combustion enhanced the burnout efficiency, which can be related to higher intensity of the combustion as shown in the temperature profiles.

For all tested coals, the amount of carbon in combustion ash is markedly lower in 30:70-O<sub>2</sub>/CO<sub>2</sub> than those in air. Generally, higher O<sub>2</sub> concentration in 30:70-O<sub>2</sub>/CO<sub>2</sub> combustion zone combined with similar combustion profiles to that in air firing result in higher burnout efficiency. This can be related, partly due to a slightly higher temperature in the combustion zone in 30:70-O<sub>2</sub>/CO<sub>2</sub> combustion. However, the results also show that the char burnout efficiency of less reactive coals in 30:70-

$O_2/CO_2$  are markedly higher than those in air, even though the peak temperatures are slightly lower than those in air combustion. It can be suggested that the gasification of carbon with  $CO_2$  inside the combustor and a longer residence time coal particles combustion in the furnace due to lower combustion gas flow rate may also contribute to the higher burn out efficiency in 30:70- $O_2/CO_2$  combustion as proposed by Kumar et al. (2006) who suggested that devolatilisation of coal particles in  $O_2/CO_2$  is greater than in  $O_2/N_2$  due to char gasification by  $CO_2$ . It was also reported that for the same concentration of  $O_2$ , the coal and char reactivities in  $O_2/N_2$  and  $O_2/CO_2$  environments are different and devolatilisation in  $O_2/CO_2$  is greater than in  $O_2/N_2$  due to char gasification by  $CO_2$ . It was also suggested that, since improvement in burnout are expected for the same flue  $O_2$  for  $O_2/CO_2$  and air combustion, lower excess  $O_2$  levels could be used in  $O_2/CO_2$  combustion systems. Wall et al. (2007) highlighted that even if the char reactivities in the air and  $O_2/CO_2$  are similar, the overall improvement in coal burnout in  $O_2/CO_2$  combustion system is expected, due to the higher  $O_2$  partial pressures experienced by the burning particles, the possible gasification by  $CO_2$ , and longer residence times from to the smaller volume of gas flows. It was also suggested that, since the improvement in burnout is expected or a given flue  $O_2$  for  $O_2/CO_2$  and air combustion, lower excess  $O_2$  could be used in  $O_2/CO_2$  combustion system.

It is well known that the amount of unburned carbon fraction in ash from pulverised coal combustion depends on various parameters such as furnace conditions and coal properties such as the ash content of the coal (Mitchell, 1998). The experimental results show that the fraction of carbon in ash depends highly on the fuel ratio of the coal in which higher unburned carbon fractions are generated

from the combustion of coal with higher fuel ratio, in both combustion media. The variation of carbon burnout efficiency in different combustion media could be linked to variation in the  $\text{NO}_x$  reduction efficiency which will be discussed in the next section. This result is in agreement with the experimental results of a study on the influence of coal properties in coal-air combustion by Kurose et al. (2004), who reported that the unburned carbon fraction in coal ash combustion increases with the increasing coal fuel ratio.

Several pilot-scaled studies by other investigators, as discussed in Chapter Two, also reported similar findings. Kimura et al. (1995) in their earlier investigation on coal combustion in  $\text{O}_2/\text{CO}_2$  reported that the combustion flame in  $\text{O}_2/\text{CO}_2$  are usually unstable and dark resulting in higher carbon in ash content and the amount of unburned carbon was reported higher in  $\text{O}_2/\text{CO}_2$  than that in air-blow when the amount of  $\text{O}_2$  was less than 30%. Châtel-Pélage et al. (2003) reported large reduction in fly ash carbon content resulting in improvement in boiler efficiency operating with  $\text{O}_2/\text{CO}_2$  which was suggested to be due to the application of higher oxygen concentration in the combustion. Tan et al. (2006) reported that despite the slightly higher CO concentration in the flue gas of  $\text{O}_2/\text{CO}_2$  combustion that matched air combustion temperature, excellent combustion efficiency was achieved with over 99% carbon burnout efficiency.

### **5.3. NO<sub>x</sub> Emissions in O<sub>2</sub>/CO<sub>2</sub> combustion.**

#### **5.3.1. Variation of NO<sub>x</sub> emissions with oxidant compositions.**

The experimental results presented in section 4.3.2 show that the NO<sub>x</sub> conversion is greatly affected by the variation of oxidant compositions where lower conversion of NO<sub>x</sub> are attained in combustion with higher CO<sub>2</sub> concentration. In combustion with 21:79-O<sub>2</sub>/CO<sub>2</sub> (Case 6), CR<sub>NO<sub>x</sub></sub> is only about one-fourth to that in air combustion. It can be deduced that, since the combustion in air utilised similar gas flow rate as in 21:79-O<sub>2</sub>/CO<sub>2</sub> (Case 1, 2 and 6), therefore the variation of the NO<sub>x</sub> conversion can be closely linked to the large differences in flame temperature of the combustion in these media and also to the differences in the amount of N<sub>2</sub> in combustion. With a fixed amount of stoichiometric O<sub>2</sub>, NO<sub>x</sub> conversion increases with higher O<sub>2</sub> concentration in the oxidant. Hence, the variation of NO<sub>x</sub> conversion in different O<sub>2</sub>/CO<sub>2</sub> compositions can also be closely related to the variation of combustion temperature since higher O<sub>2</sub> concentrations in O<sub>2</sub>/CO<sub>2</sub> mixtures result in higher combustion gas temperatures. It is known that both homogeneous and heterogeneous NO<sub>x</sub> formations in coal combustion are temperature dependent and a higher temperature in high O<sub>2</sub> concentrations leads to higher NO<sub>x</sub> conversion. The variation of the NO<sub>x</sub> conversion in different O<sub>2</sub>/CO<sub>2</sub> concentrations could also be related to the variation of the amount of unburned carbon in ash. Experimental results show that higher O<sub>2</sub> concentrations in the combustion zone reduce carbon concentrations in ash and carbon content in ash in 21:79-O<sub>2</sub>/CO<sub>2</sub> combustion is significantly higher than those in air firing. The higher carbon in ash in high CO<sub>2</sub>



combustion indicates lower char phase  $\text{NO}_x$  formation in the combustion. (Liu et al., 2005).

The experimental results also show that  $\text{NO}_x$  conversion is markedly lower even when air was replaced by an  $\text{O}_2/\text{CO}_2$  mixture with a high  $\text{O}_2$  concentration that produces a combustion temperature higher than that of air, as shown by the comparison between Case 5 and Case 1:

Case 5, ( $\text{O}_2:\text{CO}_2:\text{N}_2=28:33:39$ ;  $T_o = 1343$  °C.  $\text{CR}_{\text{NO}_x} = 22.03$ ).

Case 1, ( $\text{O}_2:\text{CO}_2:\text{N}_2=21:0:79$ ;  $T_o = 1322$  °C.  $\text{CR}_{\text{NO}_x} = 27.73$ ).

This indicates that the compositions of combustion media also have some influence on the  $\text{NO}_x$  formation in the furnace. The lower overall  $\text{NO}_x$  conversion in Case 5 than that in air may be due to less nitrogen in the oxidant which leads to lower thermal  $\text{NO}_x$  even at a higher temperature than that in air combustion.

### **5.3.2. Comparison with 30:70- $\text{O}_2/\text{CO}_2$ .**

Coal combustion in 30:70- $\text{O}_2/\text{CO}_2$  produce similar gas temperature profiles to those in air combustion. However, due to the lower flow rate of the combustion gas in 30:70- $\text{O}_2/\text{CO}_2$ , the  $\text{NO}_x$  concentration in the flue gas of combustion is always higher than that in air combustion, particularly for the reactive coals. For reactive coals, apart from the effect of less dilution of the flue gas, the higher concentrations of flue  $\text{NO}_x$  may also be linked to a slightly higher peak temperature in 30:70- $\text{O}_2/\text{CO}_2$  combustion. With combustion under fuel-lean conditions at  $\text{SR}=1.20$ , slightly higher temperatures in the combustion zone in 30:70- $\text{O}_2/\text{CO}_2$  may promote higher  $\text{NO}_x$  formation than in air. However, the  $\text{NO}_x$  Conversion Ratio,  $\text{CR}_{\text{NO}_x}$  in 30:70- $\text{O}_2/\text{CO}_2$  combustion is always markedly less than in air firing, which lead to

lower overall furnace  $\text{NO}_x$  emissions. This confirms that in addition to the temperature variation in different combustion media, the composition of the oxidants has some influence on the  $\text{NO}_x$  formation in the furnace. Compared to those in air combustion, higher concentrations of CO and NO were measured in the main combustion zone of coal combustion in 30:70- $\text{O}_2/\text{CO}_2$ . The higher CO concentrations inside the combustion zone and within the surrounding of burning coal particles could result in more NO to be oxidised (Liu et al., 2005a). The higher NO concentration in the combustion zone may also contribute to lower NO conversion (Spinti & Pershing, 2003). Molina et al. (2004) also observed a steep reduction in the conversion of fuel-N to NO as the background NO concentration was increased, which was explained due to an increase in the heterogeneous destruction of NO as the concentration gradient between char surface and gas concentration increases. The lower formation of thermal  $\text{NO}_x$  due the absence of  $\text{N}_2$  in the oxidant may also compensate the expected higher  $\text{NO}_x$  emission at the slightly higher temperature in 30:70- $\text{O}_2/\text{CO}_2$ .

Although  $\text{NO}_x$  conversions in 30:70- $\text{O}_2/\text{CO}_2$  combustion are already markedly lower than those in air, the presence of small amount of  $\text{N}_2$  in the oxidant from the coal entrainment air may have reduced the overall  $\text{NO}_x$  reduction in 30:70- $\text{O}_2/\text{CO}_2$ . When the coal entrainment air was purged by 30:70- $\text{O}_2/\text{CO}_2$  for combustion of Coal G,  $(\text{CR}_{\text{NO}_x})_r$  decreases from 0.89 to 0.86. Croiset & Thambimuthu (2001) suggested that the difference in  $\text{NO}_x$  emissions in air and  $\text{O}_2/\text{CO}_2$  combustion could decrease significantly, if as little as 3% of  $\text{N}_2$  was present in the  $\text{O}_2/\text{CO}_2$  mixtures.

It is also known that the release of Coal-N in coal-air combustion depend on various parameters which includes volatile matter content, nitrogen content and

nitrogen functionality (Mitchell, 1998). Although  $\text{NO}_x$  conversion could be related to these coal properties, in this test however, the dependence of  $\text{NO}_x$  conversion on the coal volatile content and coal-N could not be clearly established between coal-30:70- $\text{O}_2/\text{CO}_2$  and coal-air combustion, due to a comparatively small range of variation of the coal properties of the seven tested bituminous coals. However, the results suggest that  $\text{NO}_x$  formation in 30:70- $\text{O}_2/\text{CO}_2$  is more influenced by coal properties, especially coal fuel ratio and coal-N, than in air combustion. From the results it can be deduced that the  $\text{NO}_x$  conversion can be closely linked to fuel ratio since the relative  $\text{NO}_x$  conversion of the coals ( $\text{CR}_{\text{NO}_x}$ )<sub>rel</sub> increases almost linearly with the coal burnout efficiency in both 30:70- $\text{O}_2/\text{CO}_2$  and in air combustion, and the burnout efficiency is highly dependence on coal fuel ratio.

As discussed previously in Section 5.2.3, the higher  $\text{O}_2$  concentrations in combustion zone in 30:70- $\text{O}_2/\text{CO}_2$ , results in higher burnout efficiency than those in air. Although the temperature profiles in 30:70- $\text{O}_2/\text{CO}_2$  and air match each other, a slightly higher combustion temperature was measured with the combustion of reactive coals (low fuel ratio) in 30:70- $\text{O}_2/\text{CO}_2$  than in air whereas for less reactive coals (high fuel ratio), a slightly lower combustion temperature was measured. The slightly lower temperature in the combustion zone of less reactive coals in 30:70- $\text{O}_2/\text{CO}_2$  reduces  $\text{NO}_x$  formation further. It can also be suggested the lower  $\text{NO}_x$  conversion in less reactive coals may also be related to unburned char particles which the fraction is markedly higher in the less reactive coals than for the reactive coals. A study on coal-air combustion in an electrically heated furnace, as reported by Kurose et al. (2004), also revealed that both the conversion ratio of coal nitrogen

to  $\text{NO}_x$  and unburned carbon fraction in ash increases with increasing the fuel ratio of the coals.

The results from this study are also in agreement with the earlier finding by others. Takano et al. (1995) reported that the  $\text{NO}_x$  conversion rate decreases as the  $\text{CO}_2$  substitution to  $\text{N}_2$  increases and believed that the decrease in  $\text{NO}_x$  conversion rate is caused by  $\text{CO}_2$  reaction with the char to become  $\text{CO}$ , and  $\text{NO}$  is reduced on the char surface through  $\text{NO}/\text{CO}/\text{char}$  reactions. Their results also indicated that  $\text{NO}_x$  conversion ratio is markedly higher in coal with lower fuel ratio. Okazaki and Ando (1997) reported that the amount of  $\text{NO}_x$  exhausted from a laboratory scale  $\text{O}_2/\text{CO}_2$  combustion system with a controlled fixed flame temperature (1450 K) was reduced to less than one third of that with combustion in air. Their finding was attributed to some extent, to the decrease in conversion of fuel-N to  $\text{NO}_x$  as the  $\text{CO}_2$  concentration in the furnace increased. However, they reported that the contribution to total  $\text{NO}_x$  decrease caused by the increase of  $\text{CO}_2$  concentrations in the furnace is not as significant as compared to the contribution of the reduction of the recycled  $\text{NO}_x$ . Croiset & Thambimuthu (2001) observed that the  $\text{NO}_x$  emissions were higher for combustion in air than that in pure  $\text{O}_2/\text{CO}_2$  mixtures with  $\text{O}_2$  concentration of less than 35%. They linked this observation with the formation of thermal  $\text{NO}_x$  due to the presence of  $\text{N}_2$  in air. In  $\text{O}_2/\text{CO}_2$  combustion, a higher  $\text{O}_2$  concentration in the feed gas increases  $\text{NO}_x$  emissions, which they attributed probably due to the increase in the flame temperature at higher oxygen concentrations.

## 5.4. Staged Combustion

In two-staged air combustion, the location of the injection and the mixing of the over-fire air to the coal combustion zone are critical for maintaining efficient combustion as in normal combustion (Spliethoff et al., 1996). The injection points of the tertiary air (OFA) should be chosen in such a way as to minimise any effect of the combustion characteristics of the coal particles. In this staged combustion tests, the air/oxidant staging was achieved by diverting parts of the secondary air/oxidant to the tertiary oxidant to change the burner stoichiometric ratio,  $SR_1$  between 0.80 and 1.20, while maintaining the overall furnace stoichiometric ratio, SR at 1.20. Due to the lower gas flow rate, the furnace residence time in 30:70-O<sub>2</sub>/CO<sub>2</sub> is slightly longer than in air combustion.

### 5.4.1. Effect of Staging on Temperature and Gas Emissions.

The gas temperature profiles in the furnace in staged combustion are similar to those in normal combustion in both air and 30:70-O<sub>2</sub>/CO<sub>2</sub>. Air/oxidant staging only reduced temperature in the combustion regions close to the tertiary oxidant inlet ports without significantly changing the peak temperature and overall temperature profiles in the furnace. The temperature reduction in the combustion zone is more pronounced for a higher staging ratio (lower burner  $SR_1$ ) due to the higher flow rate of the tertiary air/oxidant. Compared to air combustion, the temperature reduction by staging is smaller in 30:70-O<sub>2</sub>/CO<sub>2</sub> partly due to the lower tertiary oxidant flow rate in 30:70-O<sub>2</sub>/CO<sub>2</sub>. For air or oxidant staging at  $SR_1 = 0.80$ , one-third of the total combustion oxygen was diverted to the tertiary oxidant which were achieved with

much lower flow rate of 30:70-O<sub>2</sub>/CO<sub>2</sub> oxidiser than that of air ( $V_a = 110$  l/min.  $V_o =$  or 73 l/min).

Since the temperature profiles in both media are similar to those in unstaged combustions, apart from the general reduction in the NO<sub>x</sub> emissions due to staging, as expected, the flue gas compositions are also similar to those in unstaged conditions which indicate that high combustion efficiency as in normal combustion is also achieved in staged combustion.

#### **5.4.2. Effect of Oxidant Staging on Burnout Efficiency.**

For each of the coals tested, the carbon concentrations in the ash is slightly higher in staged air combustion than to those in normal combustion. This was expected since air staging in coal combustion, which serves to reduced NO<sub>x</sub> emissions, usually has a negative effect on char burnout efficiency due to changes in furnace conditions such as uniformity of fuel/air distribution, aerodynamic and mixing phenomena and residence time (Mitchell, 1998). Air staging generally reduce burnout efficiency due to longer residence time of coal particles in the fuel-rich (oxygen starved) zone and excessively longer residence times would cause the char burnout efficiency to decrease considerably. However, in this study, there is no significant reduction (less than 0.5 %) in the char burnout efficiency due to air/oxidant staging. Compared to air combustion, the burnout efficiency is less affected by oxidant staging in 30:70-O<sub>2</sub>/CO<sub>2</sub>. This may be due to the slight variation in temperature profiles in the furnace between combustion in the two combustion media as discussed in previously in Section 5.4.1 and also due to the increase of residence time due to the changes in oxidant flow rates.

### 5.4.3. NO<sub>x</sub> Reduction Through Staged Combustion.

Air staging is a combustion technique where the combustion process is divided into fuel rich, oxygen-deficient stage and the burnout stage by the diversion of the combustion air. The emission of NO<sub>x</sub> is reduced through coal particle combustion in fuel-rich conditions in the main combustion zone which enhance the formation molecular N<sub>2</sub> rather than NO by limiting the supply of oxygen to the burning coal particles as long as possible. NO is also reduced by the reaction on char in the reducing region. The experimental results show that, as expected, air staging significantly reduces flue gas NO<sub>x</sub> concentrations in coal-air combustion. The NO<sub>x</sub> reduction decreases as the burner stoichiometric ratio (SR<sub>1</sub>) increases and introducing tertiary staging air further downstream at L<sub>2</sub> (0.88 m) results in higher NO<sub>x</sub> reduction compared to those at L<sub>1</sub> (0.55 m). Staging further downstream at L<sub>2</sub> provides longer residence time for combusting coal particles in the fuel-rich zone and a longer residence time in the fuel-rich zone favours the decompositions of gaseous nitrogen species (NO, HCN, NH<sub>3</sub>), resulting in reduction the conversion of coal-N to NO (Spliethoff et al., 1996).

The results show that oxidant staging in 30:70-O<sub>2</sub>/CO<sub>2</sub> combustion reduces NO<sub>x</sub> concentration as effectively as in air combustion, particularly with staging at L<sub>2</sub>. The results also show that the effectiveness of air staging on NO<sub>x</sub> reduction varies between coals where NO<sub>x</sub> reduction efficiency is markedly lower for less reactive coals. i.e with increasing fuel ratio, the NO<sub>x</sub> reduction effect due to the staged combustion weakens. Air staging reduces NO<sub>x</sub> between 50%, in less reactive coals to around 65 % as in more reactive coals. These results are comparable with the laboratory-scale investigation by Kurose et al. (2004) who reported that for staged-

air combustion of various coal samples, the  $\text{NO}_x$  reduction due to staged combustion decreases, and unburned carbon fraction becomes larger, as the fuel ratio increases. It was suggested that the most likely reason is that the char reaction rate significantly decreases owing to the  $\text{O}_2$  deficiency in the primary combustion region for the staged combustion, which increases the unburned carbon fraction. In 30:70- $\text{O}_2/\text{CO}_2$  combustion, the effectiveness of  $\text{NO}_x$  reduction through oxidant staging varies between coals, for the corresponding conditions of staged combustion in 30:70- $\text{O}_2/\text{CO}_2$   $\text{NO}_x$  reduction is between 45% - 73%. In addition, for reactive coals, the effectiveness of staging on  $\text{NO}_x$  reduction in 30:70- $\text{O}_2/\text{CO}_2$  is also marginally higher than those in air whereas for less reactive coals however,  $\text{NO}_x$  is less reduced in staged 30:70- $\text{O}_2/\text{CO}_2$  reduction compared to that in staged air combustion. However, compared to the normal combustion in air, the  $\text{NO}_x$  emission in 30:70- $\text{O}_2/\text{CO}_2$  staged combustion for all coals are significantly less. As discussed in Section 5.3.2, the  $\text{NO}_x$  conversion in combustion without staging in 30:70- $\text{O}_2/\text{CO}_2$  is already considerably less than that air combustion. By staging with  $\text{SR}_1 = 0.80$  at  $L_2$ , the  $\text{CR}_{\text{NO}_x}$  in 30:70- $\text{O}_2/\text{CO}_2$  combustion is reduced further. These overall furnace  $\text{NO}_x$  emission reductions vary from 67 % for less reactive coals to 77 % in more reactive coals. Higher  $\text{NO}_x$  reduction is anticipated at a lower combustion zone stoichiometric ratio, since the optimum  $\text{SR}_1$  has not been reached with  $\text{SR}_1=0.80$ . The staged combustion results confirm that oxidant staging is also a very efficient method to control  $\text{NO}_x$  emissions for coal combustion in  $\text{O}_2/\text{CO}_2$  environment as in the case of conventional air combustion but the effectiveness of the  $\text{NO}_x$  reduction vary and is more sensitive to both the reactivity of the coal(fuel ratio) and the burner stoichiometric ratio, compared to air staging. As in air combustion, the position at which the staging oxidant is introduced to the combustion zone, which determine the



substoichiometric residence time of coal particles in combustion gas and the post flame  $\text{NO}_x$  reduction, is also critical to the  $\text{NO}_x$  reduction efficiency, and the optimum position may vary in combustion with different oxidant compositions and coals. However, it can also be suggested that, a similar furnace configuration for air staged combustion could be employed for staged combustion in  $\text{O}_2/\text{CO}_2$  environments which produced similar flame profiles in the furnace to those in staged air combustion, to produced a comparable  $\text{NO}_x$  reduction efficiency, to that in air combustion.

There are a very limited number of studies reported on the staged combustion in  $\text{O}_2/\text{CO}_2$  environments. Kiga et al.(1997) reported that in  $\text{O}_2/\text{CO}_2$ -recycled combustion, the  $\text{NO}_x$  emission was not reduced by oxidant staging as effective in air-blown combustion. This was explained by the fact that,  $\text{NO}_x$ , under staged condition, was not decomposed because of lack of reducing components like hydrocarbons in the combustion zone. Recently, Maier et al. (2006) reported that oxidant staging for one type of coal (medium volatile) in 27:73- $\text{O}_2/\text{CO}_2$ , in an electrically heated test facility in which furnace wall temperature could be controlled, demonstrates higher effectiveness in terms of  $\text{NO}_x$  emission reduction than in air-staged combustion, for the same residence time in the combustion zone. However in their tests, the furnace residence time was fixed by employing the same gas flow rate, and the overall stoichiometric ratio was kept constant by varying the fuel feed rates. It was also reported that there is a possibility of reducing the stoichiometry further in 27:73- $\text{O}_2/\text{CO}_2$  to attained higher  $\text{NO}_x$  reduction, compared to that in air in which  $\text{NO}_x$  reduction is to closed to the optimum value at  $\text{SR}=0.75$ .

## 5.5. Recycled NO Tests.

In coal-air combustion systems, the overall NO<sub>x</sub> emissions in the furnace exhaust could be reduced by recycling a proportion of the flue gas to the combustion zone. Similarly, for coal combustion in O<sub>2</sub>/CO<sub>2</sub>-recycled, the reduction in the furnace NO<sub>x</sub> emission has been attributed mainly due to the destruction of the recycled NO<sub>x</sub> to molecular nitrogen in the combustion zone. The results of the recycled NO tests show that the recycle NO reduction is influenced by several parameters.

### 5.5.1. Effect of Combustion Media.

The experimental results show that with the same NO injection location and concentration for unstaged combustion, a larger amount of recycled NO is reduced in 30:70-O<sub>2</sub>/CO<sub>2</sub> combustion compared with that in air. Up to 72 % and 88% reductions of the recycled NO is achieved with unstaged coal combustion in air and in 30:70-O<sub>2</sub>/CO<sub>2</sub> respectively. Similarly, NO reduction efficiency for each coal is also significantly higher in staged 30:70-O<sub>2</sub>/CO<sub>2</sub> than that for the same staging conditions (SR<sub>1</sub> and injection point of the staged-oxidant) for air combustion. This additional reduction can be related to the higher CO concentrations inside the main combustion zone in 30:70-O<sub>2</sub>/CO<sub>2</sub>, as discussed in Section 5.2. It is well known that CO is a NO reducing gas. The CO concentrations inside pores of coal particles for combustion in 30:70-O<sub>2</sub>/CO<sub>2</sub> is also expected to be higher. Hence, the high concentrations of CO in the main combustion zone and inside pores of burning coal particles will reduce more of the recycled NO that is introduced through the main combustion zone (Liu et al. 2005b). In addition, the increase in residence time due to

the lower oxidant flow rate in 30:70-O<sub>2</sub>/CO<sub>2</sub> will contribute to more recycled NO being reduced in the combustion zone.

### **5.5.2. Effect of Combustion Conditions.**

The results also show that, for all coals, with the combustion oxidant and the same NO injection location and concentration, a higher reduction of the NO is attained when NO is introduced through the burner (NO injected into either the 1<sup>st</sup> or 2<sup>nd</sup> oxidant stream) in staged combustion than that in unstaged combustion. This is mainly because air/oxidant staging creates fuel-rich zones inside the combustor, in which more recycled NO could be reduced by NO reducing gases such as hydrocarbons and CO whose concentrations are known to increase as the combustion zone becomes more sub-stoichiometric. Higher NO reduction efficiency is also attained from deeper staging i.e. when tertiary oxidant is introduced further away from the burner. This is mainly because deeper staging provides longer residence time for recycled NO in the fuel-rich zone, and hence more NO introduced through the burner is reduced through deeper staging.

### **5.5.3. Effect of NO Injection Locations.**

The results also show that with the same combustion media and the same furnace conditions, the location of the injection of recycled NO has a significant influence on NO reduction efficiency in staged combustion. When NO is introduced into the furnace through the burner (either through the primary or secondary air/oxidant) for both staged and unstaged combustion, the NO reduction efficiencies are similar. Up to 88 % and 95 % NO is reduced in staged combustion with  $SR_1=0.80$  when the NO is recycled through the burner, in air and 30:70-O<sub>2</sub>/CO<sub>2</sub>

respectively. However, when NO is introduced into the furnace in tertiary air/oxidant stream, the reduction of the recycled NO is significantly less, and deeper staging reduces NO reduction efficiency even further. NO reduction efficiency is reduced to 37-54% in 30:70-O<sub>2</sub>/CO<sub>2</sub> and 28–42% in air when NO is recycled through the tertiary staged oxidant. Hence, the overall efficiency of recycled NO reduction is highly dependence on its proportion and residence time in the main combustion zone.

#### **5.5.4. The Effect of Recycled NO Concentrations.**

Within the range of NO recycled concentration employed in the tests, the recycling NO concentration has little influence on the reduction efficiency of the recycled NO. The differences in the reduction efficiency of the recycled NO from the variation of the recycled NO concentration are very small, less than ( $\pm 1\%$ ) for both combustion in air and in 30:70-O<sub>2</sub>/CO<sub>2</sub>, in normal and staged combustion.

#### **5.5.5 Effect of Coal Properties.**

The reduction efficiency of the recycled NO appears to be affected by the coal reactivity and the efficiency decreases as the coal fuel ratio decreases, which is more pronounced for combustion with 30:70-O<sub>2</sub>/CO<sub>2</sub>. However, due to the relatively narrow range of coals tested (FR = 1.54 – 2.33 ) this dependence should be subjected to further investigations.

### 5.5.6 Summary on NO Recycle Tests.

The results show that the reduction of the recycled NO is affected by the combustion oxidant, the NO recycling injection location and the combustion conditions (staged or unstaged and level of staging) and to some extent the coal properties, especially the fuel ratio, but not by the NO recycled concentrations. The recycled NO results suggest that in order to maximise NO<sub>x</sub> reduction when flue gas recirculation is used for NO<sub>x</sub> reduction, the recycled flue gas injection should be through or close to the burners so that the recycled NO<sub>x</sub> could pass through fuel-rich zones where NO<sub>x</sub> can be reduced. If the flue gas is recycled through the over-fire ports, most of the recycled NO<sub>x</sub> will bypass the reducing region and be in the exhaust. Similarly, for an O<sub>2</sub>/CO<sub>2</sub> combustion system that utilises recycled flue gas, the injection location points of recycled flue gas is one of the most important parameters that influences the overall furnace NO<sub>x</sub> emissions. Although oxidant staging can greatly reduce NO<sub>x</sub> emissions in O<sub>2</sub>/CO<sub>2</sub> combustion system, high proportions of NO<sub>x</sub> in the recycled flue gas will not be reduced to any extent, which could lead to lower overall furnace NO<sub>x</sub> reduction efficiency in O<sub>2</sub>/CO<sub>2</sub> combustion systems.

These results generally agree with other related works on NO<sub>x</sub> reductions in coal-air combustion with recycled flue gas. Zhou et al. (1996) reported that the highest reduction efficiency of the recycled NO<sub>x</sub> in air combustion could be achieved when NO<sub>x</sub> is recycled through the main air stream of the combustor. Kiga et al. (1997) reported that, in their study with coal-recycled O<sub>2</sub>/CO<sub>2</sub> combustion, the NO<sub>x</sub> emission was not as significantly decreased by gas staging as that in air-blown combustion because the recycled NO<sub>x</sub> in the staging gas was not decomposed due to

a lack of reducing components like hydrocarbons in the post flame regions. Takano et al. reported that the  $\text{NO}_x$  reduction efficiency increased with a decrease in oxygen ratio. More than 90% of the recycled  $\text{NO}_x$  was reduced at the oxygen ratio 0.8 but only 50% at an oxygen ratio 1.2. The reduction of  $\text{NO}_x$  in the recycled flue gas was attributed to the hydrocarbons produced by the devolatilisation process of the pulverized coal combustion. Nozaki et al. (1997) reported that the  $\text{NO}_x$  emission for  $\text{O}_2/\text{CO}_2$  combustion was lower than that for air combustion although the recycled flue gas contained relatively large amounts of  $\text{NO}_x$  and believed that the recycled  $\text{NO}_x$  was rapidly reduced into HCN and  $\text{NH}_3$  in the combustion zone. Okazaki and Ando (1997) suggested that the effect of reduction of recycled NO in the furnace to the overall furnace  $\text{NO}_x$  reduction, between 50—80%, is the most dominant factors. The drastic decrease of total exhausted NO in coal combustion with recycled  $\text{CO}_2$  was suggested to be due to the significant reduction of recycled NO to  $\text{N}_2$  in the combustion zone by coal volatile matter. They also estimated that more than 50% of the recycled  $\text{NO}_x$  is reduced when 80% of the flue is recycled. Croiset and Thambimuthu (2001) reported that combustion with recycled flue gas led to lower  $\text{NO}_x$  emission rates of between 40 – 50 % than for one-through combustion in  $\text{O}_2/\text{CO}_2$  mixtures. This was also explained by further reduction of NO into  $\text{N}_2$  when NO is recycled back into the combustor.

As a comparison, from the investigations on coal- $\text{O}_2/\text{CO}_2$  combustion with low recycling ratio, Hu et al. (2000, 2001 and 2003) reported that, the reduction efficiency of the recycled-NO changed, both with equivalence ratio and recycling ratio. A higher reduction efficiency was obtained under fuel rich conditions than in lean and less recycled-NO was reduced under lower recycling ratio than that under

higher recycling ratio. The study concluded that the relative release rate of fuel-nitrogen to volatile matter and the partitioning of volatile-N and char-N are more critical than volatile matter content and nitrogen content in coal for  $\text{NO}_x$  emissions in predicting the emissions of  $\text{NO}_x$  especially in fuel lean conditions.

## CHAPTER 6

### CONCLUSIONS

Pulverised coal combustion in  $O_2/CO_2$  environments, with high  $CO_2$  concentrations, has been studied in a combustor with a single pf-burner that was designed for the laboratory-scale experimental studies on coal combustion in air. In coal- $O_2/CO_2$  combustion tests, all the oxidants and fuel were delivered to the burner and furnace with the same configurations as those in the coal–air combustion firing tests and for a particular coal, the overall furnace stoichiometry and coal firing rate were maintained throughout the test runs. Seven bituminous coals were used in the study for comparison and verification of the results. The combustion temperature profiles, attained when air or 30:70- $O_2:CO_2$  was used as the primary and secondary oxidiser, match each other, hence the comparison of emissions, particularly  $NO_x$  emission reduction through air/oxidant staging, and the fate of recycled NO in the combustion are based on these two combustion environments. From the experimental results, the following conclusions have been deduced.

#### **6.1. Conclusions.**

1. A combustion system which was designed for pulverised coal combustion in air could be safely operated with combustion in  $O_2/CO_2$  mixtures, without major modifications and adjustments other than the installation of equipment for oxidant requirements. Continuous furnace operations with stable flames



and comparable operating temperature to that in air can be established for  $O_2/CO_2$  combustion, without major operational problems related to burner ignition, flame stability, coal firing and the effect oxidants switching, both in unstaged and staged conditions. Oxidant staging for  $NO_x$  reduction in  $O_2/CO_2$  combustion can be studied in a similar way to that for staged air combustion.

2. The combustion temperature profile in the furnace is influenced by the oxidant compositions. In  $O_2/CO_2$  mixture, with high  $CO_2$  concentrations, coal combustion started and completed further down stream from the burner. The peak combustion temperature decreases and the position of the peak temperature shifts further away from the burner as the  $CO_2$  concentration in the furnace increases. This phenomenon is related mainly to the increase in the heat capacity of the oxidant mixtures.
3. In  $O_2/CO_2$  combustion, coal firing with  $O_2$  concentration in the oxidant mixture of less than 30% results in lower combustion temperature than that in air combustion. Combustion with only 21%  $O_2$  concentration produces dark and unstable flames and a continuous flame could not be sustained by direct replacement of combustion air with  $O_2/CO_2$  mixture with the same  $O_2$  concentration (21:79- $O_2/CO_2$ ).
4. Stable flames and comparable operating temperature to that in air combustion can be established in combustion with 30:70- $O_2/CO_2$ , with the same oxygen stoichiometry and coal firing rate in which the furnace's temperature profiles and flame brightness are similar. However, slightly more compact flames than those in air are produced in 30:70- $O_2/CO_2$  as

indicated by the lower exhaust temperature at the furnace exit. The oxidant ratio requirements for  $O_2/CO_2$  combustion, that match peak temperature in air firing are, in close agreement with those obtained from the theoretical adiabatic flame temperature calculations.

5. The reactivity of the coal (fuel ratio) influences the combustion temperature profiles where a slightly higher combustion temperature is attained with the combustion of reactive coals in 30:70- $O_2/CO_2$  compared to combustion in air whereas less reactive coals produce slightly lower combustion temperature. The exhaust temperature from 30:70- $O_2/CO_2$  combustion is always less than that in air firing and this can be attributed partly due to lower oxidant flow rate.
6. A large amount of carbon in ash is attained for combustion with  $O_2/CO_2$  with higher  $CO_2$  ratio, which can be closely related to the reduction in the furnace gas temperature and flame stability. The carbon burnout efficiency in 30:70- $O_2/CO_2$  is markedly higher than that in air firing, even for combustion of coals that produce a slightly lower combustion temperature than that in air. This is strongly related to the longer residence time in the combustion zone resulting from the lower gas flow rates for 30:70- $O_2/CO_2$  combustion, although other parameters may have influences.
7. The burnout efficiency depends highly on the fuel ratio of the coal in which higher unburned carbon fractions are generated from the combustion of coal with lower fuel ratio, both in air and 30:70- $O_2/CO_2$ . The burnout efficiency in air and in 30:70- $O_2/CO_2$  vary from 92.5-98.5% and 95.0-99.3 % respectively.

8. CO<sub>2</sub> and O<sub>2</sub> emissions profiles in the furnace for combustion in air and 30:70-O<sub>2</sub>/CO<sub>2</sub> are similar and reached steady values at about the same axial distance from the burner which indicates near complete combustion is achieved in both combustion media.
9. In 30:70-O<sub>2</sub>/CO<sub>2</sub>, NO<sub>x</sub> concentration (ppmv) in the furnace is higher than that in air due to a lower gas flow rate. Although NO<sub>x</sub> concentration in the main combustion zone in 30:70-O<sub>2</sub>/CO<sub>2</sub> is markedly higher than those in air combustion, the level decreases quickly to the steady final value.
10. In 30:70-O<sub>2</sub>/CO<sub>2</sub>, CO in the combustion zone is significantly higher than that in air combustion but the concentration quickly drops to the exhaust emissions levels and that rate reduction of CO is much higher in 30:70-O<sub>2</sub>/CO<sub>2</sub>. The CO concentration in the flue gas of 30:70-O<sub>2</sub>/CO<sub>2</sub> combustion is very low, less than 40 ppmv, and is slightly less than that in air combustion. The high concentrations of CO in the main combustion zone indicate the possibility of high temperature corrosion in practical applications. In O<sub>2</sub>/CO<sub>2</sub>, higher CO emission is produced in combustion with higher CO<sub>2</sub> concentrations, which could be linked partly to the lower combustion temperature.
11. The concentrations of the major species in flue gas and the carbon burnout from the combustion in air and O<sub>2</sub>/CO<sub>2</sub> are within the predicted theoretical values. CO<sub>2</sub> concentrations in the flue gas increases with less air (N<sub>2</sub>) fraction in the oxidant. With the presence of air in the O<sub>2</sub> CO<sub>2</sub> combustion from atmospheric leakages, high CO<sub>2</sub> concentration of more than 80% of the flue gas is achieved in 30:70-O<sub>2</sub>:CO<sub>2</sub> combustion compared to about 15% in

air combustion. The CO<sub>2</sub> concentration can be increased further to more than 90 % if air infiltration to the combustor is reduced or eliminated.

12. When comparing emissions in different combustion media, there is a need to express the emissions in different forms (other than ppmv). With a fixed coal firing rate, the conversion ratio of NO<sub>x</sub> and SO<sub>x</sub> can be used to compare the emissions in different oxidant mixtures since the values are independent of the combustion gas flow rates.
13. NO<sub>x</sub> conversion is reduced when any part of air is replaced by O<sub>2</sub>/CO<sub>2</sub>, even at peak combustion temperature higher than that of air. In O<sub>2</sub>/CO<sub>2</sub> atmospheres, coal-N conversion (CR<sub>NO<sub>x</sub></sub>) decreases with a higher concentration of the CO<sub>2</sub> in the oxidants, which can be closely related to the reduction of combustion temperature and the burnout efficiency.
14. The NO<sub>x</sub> conversion ratio of coal combustion in 30:70-O<sub>2</sub>:CO<sub>2</sub> is significantly lower than that in air combustion, although the combustion temperature profiles are similar, which is due to more NO<sub>x</sub> reduction by CO in the combustion zone and the longer residence time in the combustion zone.
15. The NO<sub>x</sub> conversion is highly influenced by coal properties, particularly fuel ratio, where CR<sub>NO<sub>x</sub></sub> is lower in coals with high fuel ratio, and the value ranges from 27.7 - 39.7% in air and 18.4 - 35.5% 30:70-O<sub>2</sub>:CO<sub>2</sub>. The relative ratio of coal-N conversion to NO<sub>x</sub>, (CR<sub>NO<sub>x</sub></sub>)<sub>r</sub> increases linearly with the burnout efficiency both in air and 30:70-O<sub>2</sub>:CO<sub>2</sub>, and the value ranges from 0.60 to 0.90. The NO<sub>x</sub> conversion in 30:70-O<sub>2</sub>:CO<sub>2</sub> is also more sensitive to coal-N content than in air combustion.

16.  $\text{SO}_x$  conversion in both air and 30:70- $\text{O}_2$ : $\text{CO}_2$  is very high, greater than 90% for some coals, and is influenced mostly by the Coal-S.  $\text{SO}_2$  emission is almost independent of the combustion media, where  $\text{SO}_2$  conversion in 21:79- $\text{O}_2$ : $\text{CO}_2$  combustion is only fractionally lower than that in 30:70- $\text{O}_2$ : $\text{CO}_2$  and air.
17. Oxidant staging is a very effective method in reducing  $\text{NO}_x$  emissions for coal combustion in 30:70- $\text{O}_2$ / $\text{CO}_2$ , and can be more effective than in staged air combustion. For coal combustion in air, staging with  $\text{SR}_1=0.80$  reduces  $\text{NO}_x$  emissions by 54 - 65% while combustion in 30:70- $\text{O}_2$ / $\text{CO}_2$ , reduces  $\text{NO}_x$  by 44 - 73 % through oxidant staging.
18. The effectiveness of oxidant staging on  $\text{NO}_x$  reduction in 30:70- $\text{O}_2$ / $\text{CO}_2$  compared to that air, depends on both staging ratio and injection location of the staging oxidant and is affected by the coal reactivity (fuel ratio).  $\text{NO}_x$  reduction efficiency during staged combustion decreases as the coal fuel ratio increases and this effect is more significant in 30:70- $\text{O}_2$ / $\text{CO}_2$ .
19. Compared to normal air combustion, staged combustion in 30:70- $\text{O}_2$ : $\text{CO}_2$  could achieved 67-77 % overall furnace  $\text{NO}_x$  reduction. Higher  $\text{NO}_x$  reduction is expected at lower combustion zone stoichiometry, since the  $\text{NO}_x$  reduction has not reach the optimum level with  $\text{SR}_1 =0.80$ , particular in combustion with lower fuel ratio coals.
20.  $\text{CO}_2$  and  $\text{O}_2$  concentrations in the flue gas are not affected by staging in both, 30:70- $\text{O}_2$ : $\text{CO}_2$  and air. The amount of carbon in ash increases with air/oxidant staging, however, the burnout efficiency is only slightly reduced (<0.5%) by the air/oxidant staging and this effect is less in 30:70- $\text{O}_2$ : $\text{CO}_2$  combustion.

21. The reduction efficiency of the recycled NO depends on the combustion media, combustion conditions and NO recycling injection locations, and is influenced by coal properties but not by the recycled NO concentrations, in particular :
- i. A larger amount of NO is reduced with coal combustion in 30:70-O<sub>2</sub>/CO<sub>2</sub> than with coal combustion in air, both in unstaged and staged combustion.
  - ii. More NO is reduced with oxidant staging than without oxidant staging, in both air and 30:70-O<sub>2</sub>/CO<sub>2</sub> when NO is recycled through the burner. However, much less NO is reduced when NO is recycled through the tertiary staging oxidant ports, and the reduction efficiency depends on the staging ratio and the locations of the injection of the staged oxidant.
  - iii. The concentration of the recycled NO, within the range of 0–1000 ppmv in air and up to 1400 ppmv in 30:70-O<sub>2</sub>/CO<sub>2</sub>, has little influence on the reduction efficiency of the recycled NO in both media.
  - iv. Generally, a larger amount of recycled NO is reduced in combustion of coals of higher fuel ratio, particularly in 30:70-O<sub>2</sub>/CO<sub>2</sub>.

## **6.2. Summary.**

Coal combustion in 30:70-O<sub>2</sub>/CO<sub>2</sub> produces a similar flame temperature profiles to that in air combustion, while producing lower furnace NO<sub>x</sub> emission and higher char burnout. Oxidant staging could reduce NO<sub>x</sub> emissions as effectively or

better, than in air combustion. Previously, the effects of oxidant staging in coal- $O_2/CO_2$  combustion have not been studied in details. From this study, the staged combustion results suggest that over-fire air ports of a conventional coal-fired power plant, designed for  $NO_x$  controls, can also be used to stage the oxidant to achieve low  $NO_x$  emissions when the boiler is retrofitted for coal- $O_2/CO_2$  combustion. The recycled  $NO$  results suggest that in order to maximise  $NO_x$  reduction the recycled flue gas injection should be through or close to the burners so that the recycled  $NO_x$  could pass through fuel-rich zones where  $NO_x$  can be reduced. If the flue gas is recycled through the over-fire ports, most of the recycled  $NO_x$  will appear in the exhaust. Although oxidant staging can greatly reduce  $NO_x$  emissions in  $O_2/CO_2$  combustion system, the  $NO_x$  in the recycled flue gas for the staged oxidants may not be reduced to any significant extent which could lead to lower overall furnace  $NO_x$  reduction efficiency in  $O_2/CO_2$  combustion systems that employed recycled flue gas.

### **6.3. Proposals For Further Research.**

One of the most attractive outcomes from the study of coal combustion in  $O_2/CO_2$  is that higher overall  $NO_x$  furnace reduction that could be achieved compared to those in normal air firing. In coal- $O_2/CO_2$  combustion with recycled flue gas, most of the  $NO_x$  reductions have been attributed mostly by the oxidation of recycled  $NO_x$  in the coal flame. However, it is still not clear what mechanisms are responsible for the reduced  $NO_x$  emissions in  $O_2/CO_2$  combustion from the effect of replacement of  $N_2$  by  $CO_2$  in the oxidant. The full understanding of how  $NO_x$  emission is reduced in coal combustion with  $O_2/CO_2$  could lead to the possibility for

the optimisation of  $\text{NO}_x$  reduction for coal- $\text{O}_2/\text{CO}_2$  combustion systems. The following recommendations are made for future works :

1. In combustion with high  $\text{CO}_2$  ratio in which the combustion temperatures are significantly lower than those in air combustion, the reduction in  $\text{NO}_x$  emissions can be highly related to the lower reaction temperature and the reduction of  $\text{N}_2$  which suppressed the formation of thermal  $\text{NO}_x$ . However, it is well known that the majority of  $\text{NO}_x$  emissions from coal combustion originate from fuel-bound nitrogen and not atmospheric nitrogen. Hence other factors may also have significant influences which require further investigations. Details measurements of  $\text{NO}_x$  precursors like  $\text{HCN}$  and  $\text{NH}_3$  in the  $\text{O}_2/\text{CO}_2$  combustion zone both in unstaged and staged combustion could lead to further understanding in the  $\text{NO}_x$  reduction mechanisms in  $\text{O}_2/\text{CO}_2$  environments.
2. In this study, the total oxygen flow rate similar for air combustion was held constant and air was replaced with a mixture of  $\text{CO}_2$  and  $\text{O}_2$  in order to simulate  $\text{O}_2/\text{CO}_2$  combustion at the same stoichiometric ratio, which was achieved by fixing the coal feed rates. However, this affects the residence times due to changes in the flow rate of the oxidants. The changes in flow rates of oxidant through the burner may also affect the behaviour of coal particle mixing in the combustion zone in both staged and unstaged combustion and hence  $\text{NO}_x$  emissions, which may need to be clarified by further investigations.
3. From the tests using a small range of variation of coal properties,  $\text{NO}_x$  emission in  $\text{O}_2/\text{CO}_2$  appear to be more sensitive to fuel properties than in



air firing, both in unstaged and staged conditions. Comparisons using a wider range of coals properties could lead to a more conclusive results.

4. It is also anticipated that  $\text{NO}_x$  reduction by oxidant staging could be further reduced since the optimum stoichiometry ratio for  $\text{NO}_x$  reduction has not been reached. The optimum stoichiometric ratio of the main combustion zone ( $\text{SR}_1$ ) and the optimum residence time for  $\text{NO}_x$  reduction in staged  $\text{O}_2/\text{CO}_2$  may be more dependent on coal properties, than those in air firing, which need further investigations.
5. Staged oxidant tests for  $\text{O}_2/\text{CO}_2$  were based on once-through combustion (without recycled flue gas). The effectiveness of oxidant staging in  $\text{O}_2/\text{CO}_2$  could be different when recycled flue gas are employed which could be included in future studies.
6. A full isolation of  $\text{N}_2$  in the  $\text{O}_2/\text{CO}_2$  combustion from air infiltration could not be fully achieved in the study with the available coal feeder. It is anticipated that higher  $\text{NO}_x$  reduction could be achieved with the total elimination of the air in  $\text{O}_2/\text{CO}_2$  combustion, both in staged oxidants and unstaged combustion.
7. The potential of fuel- $\text{NO}_x$  reduction in  $\text{O}_2/\text{CO}_2$  combustion with the application of oxidant-staging have been established and the results indicate that fuel- $\text{NO}_x$  formation mechanism in fuel rich condition in  $\text{O}_2/\text{CO}_2$  combustion is similar to air combustion. In principle, other  $\text{NO}_x$  emission reduction methods through combustion modification techniques could be applied to coal combustion in  $\text{O}_2/\text{CO}_2$ . The effect of fuel staging

(reburning) on  $\text{NO}_x$  emission reduction in  $\text{O}_2/\text{CO}_2$  could be investigated using a similar test set-up.

8. In this study, the temperature and emission profiles in the furnace were based on the axial measurements along the axis of the furnace. Due to a small diameter of the furnace, the radial variation of temperature and gas composition were found to be relatively small. However, to obtain sufficient data for a more detail comparison of combustion profiles in different combustion media and conditions, and for comparison of experimental results to kinetic modelling analysis, the tests could be extended to the radial measurements along the furnace at a smaller vertical interval than those in this study.
9. Kinetic modelling studies of coal-air combustion for  $\text{NO}_x$  emission predictions could be extended to combustion of coal in  $\text{O}_2/\text{CO}_2$  atmosphere to study the interaction of fuel-N in  $\text{O}_2/\text{CO}_2$  atmosphere and the effect on the overall furnace  $\text{NO}_x$  emissions.
10. There is a need to assess the effect of scale on the comparison of the combustion and emission profiles in air and  $\text{O}_2/\text{CO}_2$ . However, a large amount of  $\text{CO}_2$  was utilised in an experimental run, in this study. Hence, the use of  $\text{CO}_2$  as the main composition of the combustion oxidant from an independent  $\text{CO}_2$  source would be very costly in a scale-up test unit. Therefore, it would be more desirable to use flue gas recirculation for  $\text{CO}_2$  oxidant requirements, and the study to the effect of gas recirculation should also be carried out.

## REFERENCES

- Abraham, M.,** Asbury, J. G., Lynch, E. P. and Teotia, A. P. S. (1982). "Coal-Oxygen Process Provides CO<sub>2</sub> For Enhanced Recovery." *Oil and Gas Journal*, **80**(11): 68 -75.
- Andersson, K. and P. Maksinen** (2002). "Process Evaluation of CO<sub>2</sub> Freecombustion in an O<sub>2</sub>/CO<sub>2</sub> Power Plant". *MSc Thesis, Department of Energy Conversion, Chalmers University of Technology, Sweden* .
- Andersson, K.,** Mönckert, P., Maier, J., Scheffknecht, G. and Johnsson, F. (2006). "Combustion and Flame Characteristics of Oxy-fuel Combustion Experimental Activities Within the ENCAP Project". *IGHGT-8, Trondheim, Norway*.
- Andersson, K. and F. Johnsson** (2006a). "Radiative Properties of 100 kW Oxy-fuel Flame - Experimental and Modelling of The Chalmer Test Facilities". *31st International Conference on Coal Utilization & Fuel Systems, Clearwater Fl. USA., Coal. Tech. Assoc.* 107 - 118.
- Andersson, K. and F. Johnsson** (2006b). "Process Evaluation of an 865 MW Lignite Fired O<sub>2</sub>/CO<sub>2</sub> Power Plant". *Energy Conversion and Management*, **47**(18-19): 3487 - 3498.
- Buhre, B. J. P.,** Elliott, L. K., Sheng, C. D., Gupta, R. P. and Wall, T. F. (2005). "Oxy-Fuel Combustion Technology For Coal-Fired Power Generation." *Progress in Energy and Combustion Science*, **31**: 283 - 307.
- Châtel-Pélage, F.,** Marin, O., Perrin, N., Farzan, H. and Vecci, S. J. (2003). "A Pilot-Scale Demonstration Of Oxy-Combustion With Flue Gas Recirculation

In a Pulverized Coal-Fired Boiler". *28th International Technical Conference on Coal Utilization & Fuel Systems*. Clearwater, FL., USA.

**Chen, J. C.,** Liu, Z. S. and Huang, J. S. (2007). "Emission Characteristics of Coal Combustion in Different O<sub>2</sub>/N<sub>2</sub>, O<sub>2</sub>/CO<sub>2</sub> and O<sub>2</sub>/RFG Atmosphere." *Journal of Hazardous Materials*, **142**(1-2): 266 - 271.

**Chui, E. H.,** Majeski, A. J., Douglas, M. A., Tan, Y. and Thambimuthu, K. V. (2004). "Numerical Investigation Of Oxy-Coal Combustion To Evaluate Burner And Combustor Design Concepts." *Energy*, **29**(9-10): 1285 – 1296.

**Chui, E. H.,** Douglas, M. A. and Tan, Y. (2003). "Modeling of Oxy-fuel Combustion for a Western Canadian Sub-bituminous Coal." *Fuel*, **82**(10): 1201 - 1210.

**Clarke, A.G. and Williams, A.** (1992). "The principle behind Controlling NO<sub>x</sub> Emissions". *Energy And Environment*, **3**(3): 280 – 295.

**Costa, M.** et al. (2003). "Measurement of Gas Species, Temperature and Char Burnout in a Low NO<sub>x</sub> Pulverised-Coal-Fired Utility Boiler". *Combustion Science and Technology*, **175**:179-189

**Croiset, E.,** Thambimuthu, K. V. and Palmer, A. (2000). "Coal Combustion in CO<sub>2</sub>/O<sub>2</sub> Mixtures Compared With Air." *The Canadian Journal of Chemical Engineering*, **78** (April): 402 - 407.

**Croiset, E. & Thambimuthu, K. V.** (2001). "NO<sub>x</sub> and SO<sub>x</sub> Emissions from O<sub>2</sub>/CO<sub>2</sub> Recycle Coal Combustion." *Fuel*, **80**: 2117 - 2121.

**Davison, J.** (2007). "Performance and Costs Of Power Plants With Capture And Storage Of CO<sub>2</sub>". *Energy*, **32**(7): 1163-1176.

**EC** (2007). *European Commission*, <<http://ec.europa.eu/>> (Access date : April 21<sup>st</sup> 2007).

**EEA** (2005). *European Environment Agency*. <<http://www.eea.europa.eu/>> (Access date : January 31<sup>st</sup> 2006).

**Farzan, H.**, Pranda, P., Châtel-Pélage, F. and Vecci, S. J. (2005). "Pilot-Scale Evaluation of Coal Combustion in an Oxygen-Enriched Recycled Flue Gas". *30th International Conference on Coal Utilization and Fuel Systems*, Clearwater, Fl, U.S.A.

**Farzan, H.** (2007). "Development of Cost Effective Oxy-combustion for Coal-fired Boiler". 2<sup>nd</sup> *IEA-GHG International Oxy-Combustion Workshop*, CT, USA.

**Glarborg, P.**, Jensen, A.D. and Johnsson, J.E. (2003). "Fuel Nitrogen Conversion in Solid Fuel Fired Systems." *Progress in Energy and Combustion Science*, **29**: 89 - 113.

**Graus, W.H.J.** and Worrell, E. (2007). "International Comparison of Energy Efficiency of Fossil Power Generation". *Energy Policy*, **35**(7): 3898-3908.

**Gupta, R.** (2005). "Oxy-fuel combustion in GHG Context –Status of Research. Technology and Assessment". *Advanced Coal Workshop*. 15-16 Mar., Brigham Young University, Provo,Ut., USA.

**Hill, S. C. and Smoot, D. L.** (2000). "Modeling of Nitrogen Oxides Formation and Destruction in Combustion Systems." *Progress in Energy and Combustion Science*, **26**: 417–458.

**Hu, Y. Q.**, Naito, S., Kobayashi, N. and Hasatani, M. (2000). "CO<sub>2</sub>, NO<sub>x</sub>, and SO<sub>x</sub> Emissions from the Combustion of Coal with High Oxygen Concentration Gases." *Fuel*, **79**: 1925 - 1932.

**Hu, Y. Q.,** Kobayashi, N. and Hasatani, M. (2001). "The Reduction of Recycled-NO<sub>x</sub> in coal combustion with O<sub>2</sub>-recycled flue gas under low recycling ratio." *Fuel*, **80**: 1851 - 1855.

**Hu, Y. Q.,** H. Nikzat, H.. Nawata, M.. Kobayashi, N. and M. Hasatani, M. (2001). "The characteristics of coal-char oxidation under high partial pressure of oxygen." *Fuel*, **80** (14): 2111 - 2116.

**Hu, Y. Q.,** Kobayashi, N. and Hasatani, M. (2003). "Effect of Coal Properties on Recycled-NO<sub>x</sub> Reduction in Coal Combustion with O<sub>2</sub>/Recycled Flue Gas." *Energy Conversion and Management*, **44** (14): 2331 - 2340.

**IEA** (2006a). *World Energy Outlook 2006*. International Energy Agency, Paris.

**IEA** (2006b). *CO<sub>2</sub> Emissions from Fuel Combustion 1974-2004* . International Energy Agency, Paris

**IEA** (2006c). *IEA Fact Sheets*. International Energy Agency, Paris.

**IEA** (2006d). *Coal Information 2006*. International Energy Agency, Paris

**IEA** (2006e). *Focus On Coal*. International Energy Agency, Paris.

**IEA** (2006f). *Energy Technology Perspectives: Scenarios & Strategies to 2050*. International Energy Agency, Paris.

**IEA** (2005a). *CO<sub>2</sub> Capture at Power Stations and Other Major Point Sources: Zero Emissions Technologies for Fossil Fuels*. International Energy Agency, Paris.

**IEA** (2005c). *Roadmapping Coal's Future*. International Energy Agency, Paris.

**Ikeda, M.,** Makino, H., Morinaga, H., Higashiyama, K. and Y. Kozai, Y. (2003). "Emission Characteristics of NO<sub>x</sub> and Unburned Carbon in Fly Ash during Combustion of Blends of Bituminous/sub-bituminous Coals." *Fuel*. **82**: 1851–1857.

**IPCC** (2001). *Climate Change 2001, Third Assessment Report of the Intergovernmental Panel on Climate Change*. Cambridge, UK. Cambridge University Press.

**IPCC** (2007a). Intergovernmental Panel on Climate Change: *WGI Fourth Assessment Report*. <<http://www.ipcc.ch/>> (Access date: April 1, 2007).

**IPCC** (2007b). Intergovernmental Panel on Climate Change: *WGI Fourth Assessment Report*. <<http://www.ipcc.ch/>> (Access date: April 1, 2007).

**IPCC** (2005). *Special Report on Carbon Dioxide Capture and Storage*. IPCC-UNFCCC.

**Jordal, K.,** Anheden, M., Yan, J. and Strömberg, L. (2004). "Oxyfuel Combustion For Coal-Fired Power Generation With CO<sub>2</sub> Capture - Opportunities And Challenges". *7th International Conference on Greenhouse Gas Control Technologies*, Vancouver, Can.

**Kiga, T.,** Takano, S., Kimura, N., Omata, K., Okawa, M. (1997). "Characteristics of Pulverized Coal combustion in the System of Oxygen/Recycled Flue gas Combustion." *Energy Conversion and Management*, **38** (Suppl): S129 - S123.

**Kimura, N.,** Omata, K., Kiga, T., Takano, S. and Shikisima, S. (1995). "The Characteristics of Pulverized Coal Combustion in O<sub>2</sub>/CO<sub>2</sub> Mixtures for CO<sub>2</sub> Recovery." *Energy Conversion and Management*, **36** (6-9): 805 - 808.

- Khare, S.P.**, Wall, T.F., Gupta, R.P. Elliott, L.K. and Buhre, B.J.P. (2005). "Oxy-fuel (O<sub>2</sub>/CO<sub>2</sub>, O<sub>2</sub>/RFG) Technology for Sequestration-ready CO<sub>2</sub> and Emission Compliance. 30<sup>th</sup> International Technical Conference on Coal Utilisation & Fuel Systems. Clearwater, FL, USA. CTA.
- Krishnamoorthy, G. and Veranth, J. M.** (2003). "Computational Modelling of CO/CO<sub>2</sub> Ratio Inside Single Char Particles During Pulverized Coal Combustion." *Energy & Fuel*, **17**: 1367 - 1371.
- Kumar, R. R.**, Elliott, L. K., Moghtaderi, B., Gupta, R. P. and Wall, T. F. (2006). "Differences in Coal Reactivity in Air and Oxy-fuel Conditions and Implication for Coal Burnout". 31<sup>st</sup> International Technical Conference on Coal Utilization & Fuel Systems. Clearwater FL., USA., CTA. 77-88.
- Kurose, R.**, Ikeda, M. and Makino, H. (2001). "Combustion Characteristics of High Ash Coal in a Pulverized Coal Combustion." *Fuel*, **80**: 1447 - 1455.
- Makino, H., Morinaga, H., Higashiyama, K. and Y. Kozai, Y.
- Kurose, R.**, Makino, H. and Suzuki, A. (2004). "Numerical Analysis of Pulverized Coal Combustion Characteristics Using Advanced Low-NO<sub>x</sub> Burner". *Fuel*, **83**: 693–703.
- Kurose, R.**, Ikeda, M., Makino, H., Kimoto, M. and Miyazaki, T. (2004). "Pulverized Coal Combustion Characteristics of High-fuel-ratio Coals." *Fuel*, **83**: 1777–1785.
- Le Bris, T.**, Cadavid, F. Sebastien, C., Pietrzyk, S., Blondin, J. and Baudoin, B. (2007). "Coal Combustion Modelling of Large Power Plant, for NO<sub>x</sub> Abatement." *Fuel*, **86**: 2213–2220.
- Lee, C. Y.**, Baek, S. W. and Choi, J. W. (2005). "Effect of Addition of Carbon Dioxide on Thermal Characteristics in Oxygen-enriched Hydrogen Flame." *JSAE International Journal*, **48**(2): 273 - 278.



**Liu, H.,** Katagiri, S. and Okazaki, K. (2001). "Drastic SO<sub>x</sub> Removal and Influence of Various Factors in O<sub>2</sub>/CO<sub>2</sub> Pulverized Coal Combustion System." *Energy & Fuel*, **15**: 403-412.

**Liu, H.,** Katagiri, S., Kaneko, U. and Okazaki, K. (2000). "Sulfation Behaviour of limestone under High CO<sub>2</sub> Concentration in O<sub>2</sub>/CO<sub>2</sub> Coal Combustion." *Fuel*, **79**: 945 - 953.

**Liu, H. and Okazaki, K.** (2003). "Simultaneous easy CO<sub>2</sub> recovery and drastic reduction of SO<sub>x</sub> and NO<sub>x</sub> in O<sub>2</sub>/CO<sub>2</sub> Coal Combustion with heat recirculation." *Fuel*, **82**: 1427 - 1436.

**Liu, H.,** Zailani, R. and Gibbs, B. M. (2005a). "Comparisons of Pulverized Coal Combustion in Air and in Mixtures of O<sub>2</sub>/CO<sub>2</sub>." *Fuel*, **84**(7-8): 833 - 840.

**Liu, H.,** Zailani, R. and Gibbs, B. M. (2005b). "Pulverized Coal Combustion in Air and in O<sub>2</sub>/CO<sub>2</sub> Mixtures with NO<sub>x</sub> Recycle." *Fuel*, **84**(16): 2019 - 2115.

**Maier, J.,** Dhungel, B. and Monckert, P. (2006). "Coal Combustion and Emission Behaviour Under Oxy-fuel Conditions." *31st International Conference on Coal Utilization & Fuel Systems*. Clearwater Fl. USA., Coal. Tech. Assoc.

**Mereb, J.B and Wendt, J.O.L.** (1994). "Air Staging and Reburning Mechanism for NO<sub>x</sub> Abatement in a Laboratory Coal Combustor". *Fuel*, **73**(7):1020-1026.

**Mitchell, S. C.** (1998). *NO<sub>x</sub> in Pulverised Coal Combustion*. IEA Coal Research. London.

**Molina, A.,** Eddings, E., Pershing, D. W. and Sarofim, A. F. (2002). "Reduction Of Nitric Oxide On The Char Surface at Pulverized Combustion Conditions". *Proceedings of the Combustion Institute*, **29**: 2275–2281.

**Molina, A.,** Eddings, E., Pershing, D. W. and Sarofim, A. F. (2004). "Nitric Oxide Destruction During Coal and Char Oxidation Under Pulverized-coal Combustion Conditions." *Combustion and Flame*, **136**: 303–312.

**Molina, A. and Shaddix, C. R.** (2007). "Ignition and Devolatilization of Pulverized Bituminous Coal particles During Oxygen/Carbon Dioxide Coal Combustion." *Proceedings of the Combustion Institute*, **31**: 1905 – 1912.

**Murphy, J. J. and Shaddix, C. R.** (2006). "Combustion Kinetics Of Coal Chars In Oxygen-Enriched Environments." *Combustion and Flame*, **144**: 71-70 - 729.

**Naja, T. A.** (1997). "Coal as a Reburn Fuel for NO<sub>x</sub> Control". *PhD Thesis*, Department of Fuel & Energy, University of Leeds, U.K.

**Nakayama, S.,** Noguchi, Y., Kiga, T., Miyamae, S., Maeda, U., *et al.* (1992). "Pulverized Coal Combustion in O<sub>2</sub>/CO<sub>2</sub> Mixtures on a Power Plant for CO<sub>2</sub> Recovery." *Energy Conversion and Management*, **33**(5 - 8): 379 - 386.

**Nikzat, H.,** Pak, H., Fuse, T., Hu, Y., Ogyu, K. (2004). "Characteristics of Pulverized Coal Burner Using a High-Oxygen Partial Pressure." *Chemical Engineering Research and Design*, **82**(1): 99 - 104.

**Nozaki, T.,** Takano, S. and Kiga, T. (1997). "Analysis of Flame Formed During Oxidation of Pulverized Coal by an O<sub>2</sub>/CO<sub>2</sub> Mixture." *Energy*, **22**(2/3): 199 - 205.

**Okawa, M.,** Kimura, N., Kiga, T., Takano, S. and Kato, M. (1997). "Trial Design For A CO<sub>2</sub> Recovery Power Plant by Burning Pulverized Coal in O<sub>2</sub>/CO<sub>2</sub>." *Energy Conversion and Management*, **38** (suppl): S123 - S127.

**Okazaki, K. and Ando, T.** (1997). "NO<sub>x</sub> Reduction Mechanism in Coal Combustion with recycled CO<sub>2</sub>." *Energy*, **22**(2/3): 207 - 215.

**Pak, H.Y.,** Kobayashi, N. and Hasatani, M. (2004). "Characteristics of Pulverized Coal and Oxygen Combustion in Bench Scale Trials". *10<sup>th</sup> Asian Pacific Confederation of Chemical Engineering congress (APCChE 2004)*. Fukuoka, Japan: 584.

**Park, D.C.,** Day, S. J. and Nelson, P.F. (2005). "Nitrogen Release During Reaction Of Coal Char with O<sub>2</sub>, CO<sub>2</sub>, and H<sub>2</sub>O". *Proceedings of the Combustion Institute*, **30**: 2169–2175.

**Park, J.,** Park, J. S., Kim, H. P., Kim, J. S. *et al.* (2007). "NO Emission Behavior in Oxy-fuel Combustion Recirculated with Carbon Dioxide." *Energy & Fuels*, **21**: 121-129.

**Payne, R.,** Chen, S. L., Wolsky, A. M. and Ritcher, W. F. (1989). "CO<sub>2</sub> Recovery via Coal Combustion in Mixtures of Oxygen and Recycled Flue Gas." *Combustion Science Technology*, **67**: 1 - 16.

**Shaddix, C. R. and Molina, A.** (2006). "Coal Particle Ignition and Devolatilization During Oxy-Fuel Combustion". *31st International Conference on Coal Utilization & Fuel Systems*, Clearwater, Fl., USA, CTA.169-180.

**Sarofim, A.** (2007). "Oxy-fuel Combustion: Progress and Remaining Issues". *2<sup>nd</sup> IEA-GHG International Oxy-Combustion Workshop*, 25-26<sup>th</sup> Jan, CT, USA.

**Singh, D.,** Croiset, E., Douglas, P. L. and Douglas, M. A. (2003). "Techno-economic Study of CO<sub>2</sub> Capture from an Existing Coal-fired Power Plant: MEA scrubbing vs. O<sub>2</sub>/CO<sub>2</sub> Recycle Combustion." *Energy Conversion and Management*, **44**: 3073 - 3091.

**Smoot, D. L.** (1998). "International Research Centers. Activities in Coal Combustion." *Progress in Energy and Combustion Science*, **24**: 409 - 501.

**Spinti, J.P and Pershing, D. W.** (2003). "The Fate of Char-N at Pulverized Coal Conditions". *Combustion and Flame*, **135** : 299–313.

**Spliethoff, H.,** Greul, U., Rodiger, H. and Hein, K. R. G. (1996). "Basic Effects on NO<sub>x</sub> Emissions in Air Staging and Reburning at a Bench-scale Test Facility." *Fuel*, **75**(5): 560-564.

**Stromberg, L.** (2007). "CO<sub>2</sub> Free Power Plant Project: Status Oxy-fuel Pilot Plant". 2<sup>nd</sup> Workshop, International Oxy-Combustion Research Network, Jan. 25-26, Windsor, CT, USA.

**Suda, T.,** Masuko, K., Sato, J., Yamamoto, A. and Okazaki . K. (2007). "Effect of Carbon Dioxide on Flame Propagation Of Pulverized Coal Clouds In CO<sub>2</sub>/O<sub>2</sub> Combustion." *Fuel*, **86**(12-13): 2008 - 2015.

**Takano, S.,** Kiga, T., Endo, Y., Miyamae, S. and Suzuki, K. (1995). "CO<sub>2</sub> Recovery from PCF Power Plant with O<sub>2</sub>/CO<sub>2</sub> Combustion Process." *IHI Engineering Review*, **28**(4): 160 – 168.

**Thambimuthu, K.V. and Croiset, E.** (1998). "Enriched Oxygen Coal-Fired Combustion". *Advanced Coal-Based Power and Environmental Systems '98*. July 21-23, Morgantown, WV., USA.

**Tan, Y.,** Croiset, E., Douglas, M.A. and Thambimuthu, K.V. (2006). "Combustion Characteristics of Coal in a Mixture of Oxygen and Recycled Flue Gas." *Fuel*, **85**: 507 - 512.

**UNFCCC,** *United Nations Framework Convention on Climate Change* <<http://unfccc.int/>> (Access date: April 1, 2007)

**Van der Lans, R. P.,** Glarborg, P. and Dam-Johansen, K. (1997). "Influence of Process parameters on Nitrogen Oxide Formation in Pulverized Coal Burners." *Progress in Energy and Combustion Science*, **23**: 349 - 377.

**Wall, T. F.** (2007a). "Combustion Processes for Carbon Capture." *Proceedings of the Combustion Institute*, **31**: 31-47.

**Wall, T.F.** (2007b). "Ignition of Oxy-fuel Flames." *2<sup>nd</sup> Workshop, International Oxy-Combustion Research Network*. Jan. 25-26. Windsor, CT, USA.

**Wang, C. S.,** Berry, G.F, Chang, K.C. and Wolsky, A.M. (1988). "Combustion of Pulverized Coal Using Waste Carbon Dioxide and Oxygen." *Combustion and Flame*, **72**(3): 301-310.

**WCI** (2005). *Clean Coal: Building a Future Through Technology*. World Coal Institute, London.

**Wendt, J.O.L.** (1995). "Mechanism Governing the Formation and Destruction of NO<sub>x</sub> and other Nitrogenous Species in Low NO<sub>x</sub> Combustion System". *Combustion Science and Technology*: 108:

**Wendt, J.O.L.** (2005). "Large Scale Oxy-fuel systems: The Role of Laboratory Combustor Research". *Advanced Coal Workshop*, Stanford University/Brigham Young University, Provo, UT., USA.

**Yamada, T.,** Kiga, T., Miyamae, S., Suzuki, K. and Okawa, M. (2000). "Experimental Studies On The Capture Of CO<sub>2</sub>, NO<sub>x</sub> And SO<sub>2</sub> in the Oxygen/Recycled Flue Gas Coal Combustion System. *Environmental Reaction Engineering And Catalysis: Reaction Engineering For Pollution Prevention*. **M. A. Abraham and R. P. Hesketh**. Elsevier, Amsterdam. 31 - 40.

**Yamada, T.,** Tamura, M. and Fujimori, T. (2006). "Comparison of Combustion Characteristics of Between Oxyfuel and Air Combustion". *31st International Conference on Coal Utilization & Fuel Systems*, Clearwater Fl, USA., Coal. Tech. Assoc. 159 – 168.

**Yang, Y.B. et al.** (1997). "Optimisation of Operating Parameters for NO<sub>x</sub> Reduction by Coal Reburning in a 0.2 MWt Furnace". *Journal of Institute of Energy*, **70**:9-16.

**Zheng, L. and Furimsky, E.** (2003). "Assesment of Coal Combustion in O<sub>2</sub>+CO<sub>2</sub> by Equilibrium Calculations." *Fuel Processing Technology*. **81**: 23 - 34.

**Zhou, C.Q., Neal, L. G., Bolli, R., Haslbeck, J. and Chang, A.** (1996). "Control of NO<sub>x</sub> Emissions by NO<sub>x</sub> Recycle Approach". *Proc. Combust Institute*. **26**(2): 2091-2097.

**Williams, A., Pourkashanian, Jones, J.M.** (2000). "Combustion and Gassification of Coal". Taylor & Francis. New York.

## APPENDIX A

Example of calculations on combustion oxidant requirement and main combustion product compositions.

**Table A1.** The oxidant requirement for combustion of Coal A.

<i>Ultimate Analysis (% mass as received)</i>	<b>% mass</b>	<b>kmol/kg O<sub>2</sub> required</b>	
C	70.57	0.05881	
H	4.62	0.01155	
O	7.07	-0.00221	
H <sub>2</sub> O	2.64	0.00000	
S	2.06	0.00064	
N	1.62	0.00058	
Ash	11.42		
	100		
At 273 K, 1atm.	Theoretical O <sub>2</sub>	0.06879	kmol/kg
		1541	litre/kg (coal)
		25.7	litre/min
At 273 K, 1atm.	Theoretical Air	0.32758	kmol/kg
		7337.9	litre/kg (coal)
		122.3	litre/min.

**Table A2.** The main compositions of combustion product. (SR = 1.20. Coal A).

	N (kgmol)		Species Concentrations	
	(wet)	(dry)		
AIR				
CO <sub>2</sub>	0.0588	0.0588	15.30	% dry
N <sub>2</sub>	0.3111	0.3111	80.95	% dry
O <sub>2</sub>	0.0138	0.0137	3.58	% dry
H <sub>2</sub> O	0.0246	0.0000	6.01	% wet
SO <sub>2</sub>	0.0006	0.0006	1675	^ppmv
NO	0.0012	0.0012	3011	^ppmv
	<i>0.4089</i>	<i>0.3843</i>		
Pure 30:70-O <sub>2</sub> /CO <sub>2</sub>				
CO <sub>2</sub>	0.2514	0.2514	94.38	% dry
N <sub>2</sub>	0.0006	0.0006	0.22	% dry
O <sub>2</sub>	0.0138	0.0137	5.16	% dry
H <sub>2</sub> O	0.0246	0.0000	8.44	% wet
SO <sub>2</sub>	0.0006	0.0006	2416	^ppmv
NO	0.0013	0.0012	4344	^ppmv
	<i>0.2910</i>	<i>0.2664</i>		
*1 <sup>st</sup> : 30:70-O <sub>2</sub> /CO <sub>2</sub> 2 <sup>nd</sup> : 30:70-O <sub>2</sub> /CO <sub>2</sub>				
CO <sub>2</sub>	0.2250	0.2250	79.64	% dry
N <sub>2</sub>	0.0431	0.0431	15.26	% dry
O <sub>2</sub>	0.0138	0.0138	4.87	% dry
H <sub>2</sub> O	0.0246	0.0000	8.00	% wet
SO <sub>2</sub>	0.0006	0.0006	2278	^ppmv
NO	0.0012	0.0012	4095	^ppmv
	<i>0.3071</i>	<i>0.2826</i>		



	N (kgmol)		Species Concentrations	
	(wet)	(dry)		
*1 <sup>st</sup> : 21:79-O <sub>2</sub> /CO <sub>2</sub> 2 <sup>nd</sup> : 30:70-O <sub>2</sub> /CO <sub>2</sub>				
CO <sub>2</sub>	0.2582	0.2582	82.88	% dry
N <sub>2</sub>	0.0389	0.0389	12.49	% dry
O <sub>2</sub>	0.0138	0.0138	4.42	% dry
H <sub>2</sub> O	0.0246	0.0000	7.31	% wet
SO <sub>2</sub>	0.0006	0.0006	2066	^ppmv
NO	0.0012	0.0012	3714	^ppmv
	0.3361	0.3115		
1 <sup>st</sup> : Air 2 <sup>nd</sup> : 30:70-O <sub>2</sub> /CO <sub>2</sub>				
CO <sub>2</sub>	0.1643	0.1643	51.38	% dry
N <sub>2</sub>	0.1410	0.1410	44.11	% dry
O <sub>2</sub>	0.0138	0.0138	4.30	% dry
H <sub>2</sub> O	0.0246	0.0000	7.14	% wet
SO <sub>2</sub>	0.0006	0.0006	2013	^ppmv
NO	0.0012	0.0012	3619	^ppmv
	0.3443	0.3197		
1 <sup>st</sup> : Air 2 <sup>nd</sup> : 26:74-O <sub>2</sub> /CO <sub>2</sub>				
CO <sub>2</sub>	0.1957	0.1957	57.52	% dry
N <sub>2</sub>	0.1302	0.1302	38.25	% dry
O <sub>2</sub>	0.0138	0.0138	4.04	% dry
H <sub>2</sub> O	0.0246	0.0000	6.73	% wet
SO <sub>2</sub>	0.0006	0.0006	1892	^ppmv
NO	0.0012	0.0012	3400	^ppmv
	0.3649	0.3403		
1 <sup>st</sup> : Air 2 <sup>nd</sup> : 35:65-O <sub>2</sub> /CO <sub>2</sub>				
CO <sub>2</sub>	0.1369	0.1369	44.98	% dry
N <sub>2</sub>	0.1530	0.1530	50.29	% dry
O <sub>2</sub>	0.0138	0.0138	4.52	% dry
H <sub>2</sub> O	0.0246	0.0000	7.47	% wet
SO <sub>2</sub>	0.0006	0.0006	2115	^ppmv
NO	0.0012	0.0012	3803	^ppmv
	0.3289	0.3043		

	N (kgmol)		Species Concentrations	
	(wet)	(dry)		
*1 <sup>st</sup> : 21:79-O <sub>2</sub> /CO <sub>2</sub> 2 <sup>nd</sup> : 21:79-O <sub>2</sub> /CO <sub>2</sub>				
CO <sub>2</sub>	0.3384	0.3384	88.01	% dry
N <sub>2</sub>	0.0317	0.0317	8.23	% dry
O <sub>2</sub>	0.0138	0.0138	3.58	% dry
H <sub>2</sub> O	0.0246	0.0000	6.01	% wet
SO <sub>2</sub>	0.0006	0.0006	1675	^ppmv
NO	0.0012	0.0012	3010	^ppmv
	<i>0.4090</i>	<i>0.3844</i>		
Pure 21:79-O <sub>2</sub> /CO <sub>2</sub>				
CO <sub>2</sub>	0.3694	0.3694	96.10	% dry
N <sub>2</sub>	0.0006	0.0006	0.15	% dry
O <sub>2</sub>	0.0138	0.0138	3.58	% dry
H <sub>2</sub> O	0.0246	0.0000	6.01	% wet
SO	0.0006	0.0006	1675	^ppmv
NO	0.0012	0.0012	3010	^ppmv
	<i>0.4090</i>	<i>0.3844</i>		
1 <sup>st</sup> : Air 2 <sup>nd</sup> : 21:79-O <sub>2</sub> /CO <sub>2</sub>				
CO <sub>2</sub>	0.2555	0.2555	66.47	% dry
N <sub>2</sub>	0.1144	0.1144	29.78	% dry
O <sub>2</sub>	0.0138	0.0138	3.58	% dry
H <sub>2</sub> O	0.0246	0.0000	6.01	% wet
SO <sub>2</sub>	0.0006	0.0006	1675	^ppmv
NO	0.0012	0.0012	3011	^ppmv
	<i>0.4089</i>	<i>0.3843</i>		

^ max. value.

\* include entrained air.

## APPENDIX B

Example of data from the main Air and O<sub>2</sub>/CO<sub>2</sub> combustion tests.

**Table B1.** Unstaged air combustion (Coal A).

AIR COMBUSTION - Unstaged						
Run NO.	16a					Sheet No. 20
Fuel	Coal A					
Coal Firing Rate (kg/h)	2.12					
Overall Stoichiometry (SR)	1.20					
Burner Stoichiometry (SR <sub>1</sub> )	1.20					
Volume Ratio of O <sub>2</sub> /CO <sub>2</sub> Mixture	Entrainment	Primary	Secondary	Tertiary		
O <sub>2</sub>	0.0	0.0	0	0		
CO <sub>2</sub>	0	0	0	0		
Corrected Oxidant Flow rate (l/min)	Entrainment	Primary	Secondary	Tertiary	Total	
Air	33	88	209	0	330	
O <sub>2</sub> /CO <sub>2</sub> mixture	0	0	0	0	0	
Total	33	88	209	0	330	
Corrected O <sub>2</sub> Flow rate (l/min)	Entrainment	Primary	Secondary	Tertiary	Total	
	6.93	18.48	43.89	0	69.3	
Combustion Media	% Air	% O <sub>2</sub> /CO <sub>2</sub>				
	100	0.00				
Molar Ratio of O <sub>2</sub> /CO <sub>2</sub> in Mixture *	O <sub>2</sub>	CO <sub>2</sub>				
	NA	NA				
Molar Ratio of O <sub>2</sub> /CO <sub>2</sub> in Oxidant	O <sub>2</sub>	CO <sub>2</sub>				
	1.00	0				
Molar Ratio of O <sub>2</sub> /CO <sub>2</sub> /N <sub>2</sub> in Oxidant	O <sub>2</sub>	CO <sub>2</sub>	N <sub>2</sub>			
	0.210	0	0.790			
Theoretical Products Compositions	Air	Pure O <sub>2</sub> /CO <sub>2</sub> *	Air/O <sub>2</sub> /CO <sub>2</sub>			
CO <sub>2</sub> (% dry vol)	15.3	NA	NA			
N <sub>2</sub> (% dry vol)	81.0	NA	NA			
O <sub>2</sub> (% dry vol)	3.6	NA	NA			
H <sub>2</sub> O % wet vol	6.0	NA	NA			
Max SO <sub>2</sub> (ppmv)	1674	NA	NA			
Max NO (ppmv)	3011	NA	NA			
Measured Products Compositions						
CO <sub>2</sub> (% dry vol)	15.1					
O <sub>2</sub> (% dry vol)	3.4					
NO <sub>x</sub> (ppmv)	835	CR <sub>NOx</sub> :	0.2771			
CO (ppmv)	55					
SO <sub>x</sub> (ppmv)	1500	CR <sub>SOx</sub> :	0.8956			
Temperature (°C)						
T <sub>1</sub>	1322	T <sub>4</sub>	998			
T <sub>2</sub>	1300	T <sub>5</sub>	810			
T <sub>3</sub>	1131	T <sub>6</sub>	638			
Burnout						
Carbon in Ash (%)	12.43					
Burnout Efficiency (η <sub>BO</sub> )	98.17					

**Table B2.** Unstaged 30:70-O<sub>2</sub>/CO<sub>2</sub> combustion (Coal A).

O <sub>2</sub> /CO <sub>2</sub> COMBUSTION - UNSTAGED						
Run NO.	16c					Sheet No. 22
Fuel	Coal A					
Coal Firing Rate (kg/h)	2.12					
Overall Stoichiometry (SR)	1.20					
Burner Stoichiometry (SR <sub>1</sub> )	1.20					
Volume Ratio of O <sub>2</sub> /CO <sub>2</sub> Mixture	Entrainment	Primary	Secondary	Tertiary		
O <sub>2</sub>	0.00	0.30	0.30	0.00		
CO <sub>2</sub>	0.00	0.70	0.70	0.00		
Corrected Oxidant Flow rate (l/min)	Entrainment	Primary	Secondary	Tertiary	Total	
Air	33	0	0	0	33	
O <sub>2</sub> /CO <sub>2</sub> mixture	0	88	120	0	208	
Total	33	88	120	0	241	
Corrected O <sub>2</sub> Flow rate (l/min)	Entrainment	Primary	Secondary	Tertiary	Total	
	6.9	26.4	36.0	0.0	69.3	
Combustion Media	% Air	% O <sub>2</sub> /CO <sub>2</sub>				
	13.7	86.3				
Molar Ratio of O <sub>2</sub> /CO <sub>2</sub> in Mixture *	O <sub>2</sub>	CO <sub>2</sub>				
	0.300	0.700				
Molar Ratio of O <sub>2</sub> /CO <sub>2</sub> in Oxidant	O <sub>2</sub>	CO <sub>2</sub>				
	0.323	0.677				
Molar Ratio of O <sub>2</sub> /CO <sub>2</sub> /N <sub>2</sub> in Oxidant	O <sub>2</sub>	CO <sub>2</sub>	N <sub>2</sub>			
	0.288	0.604	0.108			
Theoretical Products Compositions	Air	Pure O <sub>2</sub> /CO <sub>2</sub> *	Air/O <sub>2</sub> /CO <sub>2</sub>			
CO <sub>2</sub> (% dry vol)	15.3	94.4	79.6			
N <sub>2</sub> (% dry vol)	81.0	0.2	15.3			
O <sub>2</sub> (% dry vol)	3.6	5.2	4.9			
H <sub>2</sub> O % wet vol	6.0	8.4	8.0			
Max SO <sub>2</sub> (ppmv)	1675	2416	2278			
Max NO (ppmv)	3011	4344	4095			
Measured Products Compositions						
CO <sub>2</sub> (% dry vol)	79.8					
O <sub>2</sub> (% dry vol)	4.5					
NO <sub>x</sub> (ppmv)	930	CR <sub>NO<sub>x</sub></sub> :	0.2271			
CO (ppmv)	34					
SO <sub>x</sub> (ppmv)	2050	CR <sub>SO<sub>x</sub></sub> :	0.8998			
Temperature (°C)						
T <sub>1</sub>	1333	T <sub>4</sub>	1006			
T <sub>2</sub>	1308	T <sub>5</sub>	822			
T <sub>3</sub>	1140	T <sub>6</sub>	580			
Burnout						
Carbon in Ash (%)	5.21					
Burnout Efficiency (η <sub>BO</sub> )	99.29					

**Table B3.** Staged air combustion ( $SR_1=0.80$ ,  $L_2$ , Coal A).

AIR COMBUSTION -STAGED L2 (880 mm)						
Run NO.	16b					Sheet No. 21
Fuel	Coal A					
Coal Firing Rate (kg/h)	2.12					
Overall Stoichiometry (SR)	1.20					
Burner Stoichiometry ( $SR_1$ )	0.80					
Volume Ratio of $O_2/CO_2$ Mixture	Entrainment	Primary	Secondary	Tertiary		
O <sub>2</sub>	0.00	0.00	0.00	0.00		
CO <sub>2</sub>	0.00	0.00	0.00	0.00		
Corrected Oxidant Flow rate (l/min)	Entrainment	Primary	Secondary	Tertiary	Total	
Air	33	88	99	110	330	
$O_2/CO_2$ mixture	0	0	0	0	0	
Total	33	88	99	110	330	
Corrected O <sub>2</sub> Flow rate (l/min)	Entrainment	Primary	Secondary	Tertiary	Total	
	6.9	18.5	20.8	23.1	69.3	
Combustion Media	% Air	% $O_2/CO_2$				
	100.0	0.0				
Molar Ratio of $O_2/CO_2$ in Mixture *	O <sub>2</sub>	CO <sub>2</sub>				
	NA	NA				
Molar Ratio of $O_2/CO_2$ in Oxidant	O <sub>2</sub>	CO <sub>2</sub>				
	1.000	0.000				
Molar Ratio of $O_2/CO_2/N_2$ in Oxidant	O <sub>2</sub>	CO <sub>2</sub>	N <sub>2</sub>			
	0.2100	0.0000	0.7900			
Theoretical Products Compositions	Air	Pure $O_2/CO_2^*$	Air/ $O_2/CO_2$			
CO <sub>2</sub> (% dry vol)	15.3	NA	NA			
N <sub>2</sub> (% dry vol)	81.0	NA	NA			
O <sub>2</sub> (% dry vol)	3.6	NA	NA			
H <sub>2</sub> O % wet vol	6.0	NA	NA			
Max SO <sub>2</sub> (ppmv)	1675	NA	NA			
Max NO (ppmv)	3011	NA	NA			
Measured Products Compositions						
CO <sub>2</sub> (% dry vol)	14.7					
O <sub>2</sub> (% dry vol)	3.9					
NO <sub>x</sub> (ppmv)	297		CR <sub>NOx</sub> : 0.0986			
CO (ppmv)						
SO <sub>x</sub> (ppmv)	1480		CR <sub>SOx</sub> : 0.8836			
Temperature (OC)						
T <sub>1</sub>	1321		T <sub>4</sub>	976		
T <sub>2</sub>	1166		T <sub>5</sub>	801		
T <sub>3</sub>	1090		T <sub>6</sub>	628		
Burnout						
Carbon in Ash (%)	14.38					
Burnout Efficiency ( $\eta_{BO}$ )	97.83					

**Table B4.** Staged 30:70-O<sub>2</sub>/CO<sub>2</sub> combustion (SR<sub>1</sub>=0.80, L<sub>2</sub>, Coal A).

O <sub>2</sub> /CO <sub>2</sub> COMBUSTION - STAGED L2 (880 mm)						
Run NO.	16d					Sheet No. 24
Fuel	Coal A					
Coal Firing Rate (kg/h)	2.12					
Overall Stoichiometry (SR)	1.20					
Burner Stoichiometry (SR <sub>1</sub> )	0.80					
Volume Ratio of O <sub>2</sub> /CO <sub>2</sub> Mixture	Entrainment	Primary	Secondary	Tertiary		
O <sub>2</sub>	0.00	0.30	0.30	0.30		
CO <sub>2</sub>	0.00	0.70	0.70	0.70		
Corrected Oxidant Flow rate (l/min)	Entrainment	Primary	Secondary	Tertiary	Total	
Air	33	0	0	0	33	
O <sub>2</sub> /CO <sub>2</sub> mixture	0	88	43	77	208	
Total	33	88	43	77	241	
Corrected O <sub>2</sub> Flow rate (l/min)	Entrainment	Primary	Secondary	Tertiary	Total	
	6.9	26.4	12.9	23.1	69.3	
Combustion Media	% Air	% O <sub>2</sub> /CO <sub>2</sub>				
	13.7	86.3				
Molar Ratio of O <sub>2</sub> /CO <sub>2</sub> in Mixture *	O <sub>2</sub>	CO <sub>2</sub>				
	0.300	0.700				
Molar Ratio of O <sub>2</sub> /CO <sub>2</sub> in Oxidant	O <sub>2</sub>	CO <sub>2</sub>				
	0.323	0.677				
Molar Ratio of O <sub>2</sub> /CO <sub>2</sub> /N <sub>2</sub> in Oxidant	O <sub>2</sub>	CO <sub>2</sub>	N <sub>2</sub>			
	0.288	0.604	0.108			
Theoretical Products Compositions	Air	Pure O <sub>2</sub> /CO <sub>2</sub> *	Air/O <sub>2</sub> /CO <sub>2</sub>			
CO <sub>2</sub> (% dry vol)	15.3	94.4	79.6			
N <sub>2</sub> (% dry vol)	81.0	0.2	15.3			
O <sub>2</sub> (% dry vol)	3.6	5.2	4.9			
H <sub>2</sub> O % wet vol	6.0	8.4	8.0			
Max SO <sub>2</sub> (ppmv)	1675	2416	2278			
Max NO (ppmv)	3011	4344	4095			
Measured Products Compositions						
CO <sub>2</sub> (% dry vol)	79.6					
O <sub>2</sub> (% dry vol)	4.4					
NO <sub>x</sub> (ppmv)	297		CR <sub>NOx</sub> :	0.0725		
CO (ppmv)						
SO <sub>x</sub> (ppmv)			CR <sub>SOx</sub> :			
Temperature (°C)						
T <sub>1</sub>	1345		T <sub>4</sub>	1013		
T <sub>2</sub>	1251		T <sub>5</sub>	832		
T <sub>3</sub>	1137		T <sub>6</sub>	595		
Burnout						
Carbon in Ash (%)	5.28					
Burnout Efficiency (η <sub>BO</sub> )	99.28					

## APPENDIX C

### List of Publication from this study

1. **Liu, H., Zailani, R, and Gibbs, B.M.** (2005). "Comparisons of pulverized coal combustion in air and in mixtures of O<sub>2</sub>/CO<sub>2</sub>." *Fuel*. **84**(7-8): 833 - 840.
2. **Liu, H., Zailani, R. and Gibbs, B.M.** (2005). "Pulverized coal combustion in air and in O<sub>2</sub>/CO<sub>2</sub> mixtures with NO<sub>x</sub> recycle." *Fuel*, **84**(16): 2019 - 2115.