

**Appendix 1**  
**Funerary/Ritual Sites Examined in the Text**

**CORNWALL:**

Caerloggas I  
Caerloggas II  
Caerloggas III  
Carvinak  
Cataclews  
Chysauster  
Cocksbarrow  
Colliford Reservoir II  
Colliford Reservoir IVA  
Colliford Reservoir IVC  
Crig-a-Mennis  
Davidstow Moor XXVI  
Davidstow Moor XXV  
Davidstow Moor XXIV  
Davidstow Moor I  
Davidstow Moor II, IIA  
Davidstow Moor III  
Davidstow Moor IX  
Davidstow Moor IV, IVa, VI  
Davidstow Moor VII  
Davidstow Moor XIX  
Davidstow Moor V  
Gwithian Site GM-V  
Gwithian Ring Ditch  
Gwithian Layer 3 Cairns  
Longstone  
Lousey Barrow  
Nancekuke  
Poldowrian 1  
Stannon Downs 1  
Stannon Downs 2  
Stannon Downs 3  
Tregulland  
Trelen 2, Site 41  
Treligga 1  
Treligga 2  
Treligga 5  
Treligga 7  
Trenance Downs  
Try  
Watch Hill

**DEVON:**

Burnt Common Ring  
Daggers Piece Cairn  
East Putford I



East Putford II  
 Farway Hill Cairn  
 Farway Ring 1  
 Markham Lane  
 Rose Ash  
 Shaugh Moor Cairn 1  
 Shaugh Moor Cairn 126  
 Shaugh Moor Cairn 2  
 Shaugh Moor Cairn 70  
 Shaugh Moor Cairn 71  
 Shaugh Moor Cairn 4  
 Upton Pyne 248b  
 White Cross Ring  
 White Cross Cairn

**SOMERSET:**

Court Hill Cairn  
 Charmy Down 1  
 Charmy Down 2  
 Charmy Down 3  
 Charmy Down 4  
 Charmy Down 5  
 Charmy Down 6  
 Chewton Plain 1  
 Chewton Plain 2  
 Chewton Plain 3  
 Chewton Plain 4  
 Chewton Plain 5  
 Chewton Plain 6  
 Lansdown 6A

Charcoal with bark  
 Charcoal from old land surface  
 Charcoal from Urn P1  
 Charcoal from Urn P2  
 Charcoal from Urn P3  
 Charcoal from Urn P5  
 Charcoal from Urn P6  
 Charcoal from two wheel cremation  
 Charcoal from Urn P7  
 Charcoal from large oak timbers in ground  
 Charcoal from woodcrests outer pit  
 Charcoal from woodcrests outer pit  
 Charcoal scattered on old land surface  
 Charcoal with central cremation  
 Skeletal  
 Charcoal from cremation  
 Charcoal from old land surface under this heap  
 Pit 1  
 Charcoal from old land surface  
 Charcoal under low urn F2  
 Charcoal spread on old land surface  
 Charcoal from pit/ring 6B



## Appendix 2

### Radiocarbon Dates for Funerary/Ritual and Settlement Sites Examined in the Text

#### FUNERARY/RITUAL SITES:

##### Cataclews

HAR8099 3510±70BP

Charcoal with burial

##### Chysauster

HAR6548 3740±80

Charcoal from old land surface

OXA822 3430±80BP

Charcoal from Urn P1

HAR6652 3740±90BP

Charcoal from Urn P2

HAR6549 3790±120BP

Charcoal from Urn P3

OXA821 3330±80BP

Charcoal from Urn P5

HAR6654 3110±90BP

Charcoal from Urn P6

HAR6926 3150±90BP

Charcoal from unenclosed cremation

HAR6927 3280±120BP

Charcoal from Urn P7

##### Colliford Reservoir II

HAR2624 3610±70BP

Charcoal from large oak timbers in mound

HAR2617 3500±80BP

Charcoal from northern outer pit

HAR2622 3490±90BP

Charcoal from southern outer pit

##### Colliford Reservoir IVA

HAR2994 3510±80BP

Charcoal scattered on old land surface

##### Colliford Reservoir IVC

HAR2991 3580±80BP

Charcoal with central cremation

##### Court Hill Cairn

I5735 3325±100BP

Skeleton

I5734 2665±130BP

Charcoal accompanying cremation

##### Crig-a-Mennis

NPL193 3515±90BP

Fire on old land surface under slate heap

##### Davidstow I

HAR6634 3520±70BP

Fire 1

##### Davidstow III

HAR6640 3740±90BP

Charcoal from old land surface

##### Davidstow V

HAR6635 3580±70BP

Charcoal under low cairn F2

##### Davidstow XXIV

HAR8090 3440±100BP

Charcoal spread on old land surface

##### Gwithian Layer 5

NPL21 3170±103BP

Cremation pit/ring ditch



Nancekuke HAR8097 3550±80BP	Fire on old land surface
Poldowrain 1 HAR2829 3490±90BP HAR3107 3360±70BP HAR3108 4000±150BP	Mound Layer 8 Mound Layer 8 Charcoal from pit with bowl under mound
Rose Ash HAR2992 2980±70BP	Charcoal with cremation
Shaugh Moor 1 HAR2216 3520±70BP	Charcoal from central pit
Shaugh Moor 2 HAR2214 3240±80BP HAR2220 3430±90BP	Charcoal in pit under ring cairn Charcoal in central pit with pot and beads
Shaugh Moor 70 HAR2219 3430±80BP	Charcoal from south-east pit
Shaugh Moor 71 HAR2213 3430±80BP	Charcoal from pit next to boulder
Shaugh Moor 126 HAR2285 3400±90BP HAR2221 3350±70BP	Charcoal from first pit under cairn Charcoal from scoop into cairn
Stannon Downs 2 HAR5130 3440±70BP	Charcoal from small pit under cairn
Treligga 2 HAR8100 3380±80BP	Charcoal from cremation in kerb wall
Trelen 2 HAR4540 3740±110BP HAR5510 3530±80BP HAR4538 3040±90BP	Charcoal from secondary ditch 1 silt Charcoal from secondary ditch 1 silt Charcoal from upper ditch 2 silt
Watch Hill HAR654 3470±70BP HAR655 3420±80BP	Charcoal from pit in ditch Charcoal from pit in ditch
Upton Pyne BM402 3336±53BP	Charcoal from Urn T2

#### SETTLEMENT SITES:

Brean Down (selected assays) HAR7023 4720±140BP HAR8993 3390±90BP HAR8547 3460±80BP	Charcoal in Unit 8a Beaker/Neolithic paleosol Charcoal in Unit 8a Beaker/Neolithic paleosol Charcoal in Unit 8a/7 with "Maritime" Beaker
--	--



HAR8991 3120±90BP	Charcoal in Unit 6a Biconical Urn occupation
HAR7020 3310±80BP	Charcoal from Structure 57 Unit 6
HAR7018 2870±80BP	Charcoal from Structure 95 Unit 5b Trevisker occupation
HAR9151 2730±70BP	Animal bone from Unit 4 Plainware horizon
Charterhouse Warren Farm Swallet	
OXA1559 3790±60BP	Human Scapula, Horizon 2, upper shaft fill
OXA1561 3870±60BP	Auroch skull, Debris Cone 1, upper shaft fill
BM731 3250±37BP	Horizon 1
Gorse Bigbury (selected range)	
BM1088 3800±80BP	Charcoal in henge ditch
BM1087 3600±70BP	Charcoal in henge ditch
Saddlesborough Reave	
HAR4103 3540±80BP	Charcoal in refurbished Phase I ditch
HAR4003 3340±90BP	Charcoal in ditch just prior to Phase II construction
Shaugh Moor	
HAR2989 3280±90BP	Charcoal from Pre-enclosure soil
HAR2474 3430±90BP	Charcoal from House 15
HAR3419 2930±90BP	Charcoal from House 15
HAR2979 3220±80BP	Charcoal from House 67
HAR3358 3320±80BP	Charcoal from House 67
HAR2475 3160±70BP	Charcoal from enclosure wall debris
HAR2983 3260±80BP	Charcoal from House 66
HAR2960 3060±80BP	Charcoal from House 66
HAR2987 3260±120BP	Charcoal from House 18
HAR2472 3020±70BP	Charcoal from House 18
HAR2978 2640±70BP	Charcoal from House 19
HAR2473 2880±70BP	Charcoal from House 19
Trethellan (selected assays)	
UB3109 3088±40BP	Charcoal in pit on levelled platform 2503
UB3110 3070±40BP	Charcoal in burn spread in ritual hollow 136/2021
UB3111 3034±20BP	Ritual hollow 2765
UB3112 3216±16BP	Charcoal from smoking hollow prior to Later House 1034
UB3113 3023±100BP	Charcoal from House 1034
UB3114 3091±20BP	Charcoal from House 2222
UB3115 3110±40BP	Charcoal from House 3022
UB3116 3211±70BP	Charcoal from House 3022
UB3118 2981±40BP	Charcoal from House 2010
UB3119 3014±75BP	Charcoal from House 2001
UB3120 3093±50BP	Charcoal from House 2001
Trevisker	
NPL134 3060±95	Charcoal from House A
Venford Reave	
BM1609 3270±60BP	Charcoal in Phase 1 bank



## **Appendix 3**

### **Histories of Funerary/Ritual Sites**

#### **CORNWALL**

##### **Penwith**

##### **Try, Gulval (SW460350)**

The site is situated on a ridge just above 500 feet O.D. above and east of the Try Valley just north of New Mill on the granite. Activity on the site began with the erection of a roughly triangular 3.8 m granite menhir in a pit with an eastern orientation, which was closely followed by the excavation of a large pit just to its east. Mourners built a rectangular cist of granite stone slabs oriented north-south within this pit which they covered with a large granite capstone. The cist extended 1.58 m into the subsoil and its floor was paved with flat stones. Into the cist they placed a complete Lanting/Van Der Waals Style 7 handled reddish brown Beaker decorated with comb decoration and some other small possibly chaff impressions. The Beaker was found on its side in the south-west corner of the cist. Fragments of unburnt longbone (possibly tibia) were also found in the cist, perhaps representing an inhumation. At some point soon after this burial, the mourners filled the cist (and the Beaker) with a dark soil mixed with some subsoil which contained, oak, birch, ivy, and willow charcoal, 5 sherds from a reddish brown nail impressed and comb stamped beaker, one sherd of another beaker, the skull, long bone, vertebra and carpal fragments of at least one adult cremated individual, a number of water-worn pebbles, and scraps of hematite. One Beaker sherd, several fragments of calcined bone, and some of the oak and birch charcoal only were found in the complete Beaker. The pit around the cist was filled with a leached gritty stony soil. Into this fill just to the south-west of the cist, mourners dug a second smaller oval pit 0.22 m deep which they filled with a soft dark soil, and two probable fragments of the nail/comb impressed beaker from the cist. They



covered this pit with a granite slab. They then covered both pits with a low, slightly oval cairn of rough unshaped granite stones, which partially encompassed the menhir and measured roughly 4 m in diameter. Within these stones in the vicinity of the second pit, though above it, they incorporated a broken fine grained granite saddle quern. On the top of the cairn to the south of both pits was a patch of soil containing much charcoal, 5 sherds of a cord impressed Trevisker Style 1 vessel, and a hollow within this packed with a large number of water-worn pebbles. To the east of the cairn, within a Medieval ploughing horizon was a concentration of pottery representing 2 partial Style 1 Trevisker Urns with either shoulder cordons and/or lug handles and several fragments of possibly two additional vessels, four flint flakes, and fragments of cremated human longbone shafts, skull, and pelvis, all thought to represent a disturbed secondary burial which had been placed into the cairn at a later date (Russell and Pool 1964).

#### Chysauster (SW4736)

The site was built on the granite of West Penwith near Penzance in an area of open oak/hazel woodland after a period of possibly Neolithic clearance and hoe cultivation. The site, which consisted of a kerbed cairn with an outer cobbling lay at the junction of a later Bronze Age field boundary associated with a field system incorporating scattered round houses. Activity began at the site with the probable construction of a granite block enclosure with a 2 m wide entrance to the south. The ring had an external diameter of about 6.25 m and a regular outer sloping face. At locations just under 1 m east and west from the centre of the enclosure, funerary participants excavated two roughly circular pits (549 and 551 respectively) between 0.30 and 0.40 m in depth. Into Pit 549 they placed an inverted medium sized plain gabbroic Trevisker Urn. The urn contained oak charcoal, a clinker, and a small amount of cremated bone from an older child/adolescent. Charcoal from the pit returned the radiocarbon date of 1950-1530 BC (OXA822). Pit 551 contained an upright tall cord-decorated Trevisker urn with two tongue lugs, containing oak charcoal and a small amount of cremated bone from an adolescent/young adult. Charcoal from the pit returned a date of 2460-1910 BC (HAR6652). Both pits were surrounded by upright granite slabs which appeared as circular features surrounded and partially overlain by a low flat topped granite



cairn which filled the interior of the ring and probably quickly followed the creation of the two central features. One of the uppermost stones on the cairn contained a cupmark. At some point before they infilled the ring mourners deposited three quartz crystals, some red ochre, a pebble tool, a potsherd and several flints in the interior of the ring, three of these in the entrance. Three additional quartz crystals, two transverse arrowheads and a number of flints were found in the buried soil under the surface rubble on the site. Against the outer edge of the ring the mourners had created a zone of granite cobbling, which was contemporary with or immediately postdated the excavation and filling of 9 small roughly circular pits which lay next to the outer edge of the cairn. Two additional pits (542 and 544) lay some 3 meters to the east. Pit 544 was 0.10 m deep and contained fragments of a possibly inverted early cordmarked biconical gabbroic small Trevisker vessel. Pit 542 had been excavated to a depth of just over 0.20 m and contained no finds and no cremated bone. One small circular pit (554) predated the creation of the granite ring. Pit 548 lay in a line with the central pits to the west just outside the cairn, and was marked by two upright granite slabs. The pit had been excavated to a depth of roughly 0.45 m. It contained an upright quadruple lugged gabbroic Trevisker Urn (no basal sherds recovered) with comb point decoration, and contained oak, hazel charcoal, a quartz crystal, a piece of burnt clay, and a small amount of cremated bone from a juvenile. Charcoal from the pit returned a date of 2580-1890 BC (HAR6549). Pit 536 lay at the southwestern edge of the cairn and was roughly 0.40 m deep. Into it mourners had placed an inverted medium sized biconical gabbroic Trevisker vessel decorated with tubular tool impressions and having two tongue lugs, which contained a small amount of charcoal, and a small amount of cremated bone from a juvenile. Mourners covered the pit with two granite capstones. A radiocarbon assay for the charcoal was 1520-1220 BC (HAR6654). Pit 502 lay just over one metre to the south of Pit 536, and was just over 0.30 m in depth. Mourners placed a small amount of cremated bone from an older adult male into the pit which they then covered with soil containing one piece of flint debitage. After the pit was filled mourners covered it with a flat granite capstone. Two pits (546 and 531) were excavated just outside the entrance to the circle. They contained no finds and no cremations. Pit 529 lay just east of the ring entrance. Into it, the funerary participants had placed an inverted Style 1 gabbroic Trevisker vessel containing oak charcoal, a clinker, and



a small amount of cremated bone from an older juvenile/adult. Charcoal from the pit returned a radiocarbon determination of 2320-1880 BC (HAR6651). A small pit containing soil lay just at the edge of the ring in the south east. Into Pit 540 which lay at the eastern edge of the ring and measured just under 0.20 m deep, mourners placed an upright small quadruple lugged cord impressed Trevisker vessel containing oak charcoal. Charcoal from this pit returned an assay of 1880-1440 BC (OXA821). Mourners also excavated a large pit (538) 0.50 m deep at the north-eastern ring edge. All the vessels recovered from the site were of similar fabric, indicating a local potting tradition. At some point after the interior of the cairn had been infilled mourners tossed a number of items onto it, mainly concentrating on the eastern side of the cairn. These included three pebbles, an amber bead (entrance area), a quartz crystal, a slate disc (near over kerb) and a number of struck flints. A small cluster of flints overlay the Pit 548 area (Smith 1996).

## **The Lizard**

### **Poldowrian 1 (SW74901707)**

The site is situated on the gabbro area of the Lizard at 200 feet O.D., 300 metres from the cliff edge and roughly 200 metres northeast of the Poldowrain 3 Middle Bronze Age settlement (Harris 1979; Smith and Harris 1982). The site is best described as a series of accumulated deposits of stones and earth forming an oval mound oriented south-west/north-east with dimensions of c. 10 m by 6 m. Two features preceded the activity at Poldowrain I. They were both pits, the first of which was located 1 m to the south-east of the mound. It contained a broken pot or high sided plain coarse lugged bowl. Charcoal near this pot gave a radiocarbon date of 2910-2140 BC (HAR3108). Another pit (7) lay under the west edge of the mound in a gully. Its fill was predominantly composed of a large stone, some clay, and part of the dark fill (13) of the mound. The first mound deposit, Layer 8, was a platform composed of tightly packed black and white 5 centimetre pieces of gabbro interspersed with burnt decayed serpentine. Charcoal from



this layer yielded dates of 2038-1603 (HAR 2829) and 1782-1497 (HAR3107). This layer, the most expansive of the 6 encountered, was covered by a layer of medium loose brown earth, followed by 3 alternate deposits of stone and loose brown soil, Layers 10, 11, and 12 respectively, which tended to mound up towards the centre. Towards the central/northern end of the mound, a deposit of fine black soil (Layer 13) separated Layer 8 from the rest and continued uninterrupted throughout the profile of the mound. It also occurred in the brown earth of Layers 9 and 11 between the stony layers, and over top of layer 12, giving the impression of a gradual accumulation of both portions of the mound (Layer 8 and the others). Approximately 100 pot sherds with comb stamping or incised lines representing 5 different Beaker vessels with high waists and out turned rims, closely matched by Clarke's All Over Cord or Wessex Middle Rhine types were scattered throughout the mound, apart from the central/north black earth Layer 13. This was matched by a corresponding scatter of both worked and unworked beach pebble flints, smooth beach pebbles, and a possible greenstone tool in similar portions of the mound. Several proposed but subsequently rejected interpretations (due to lack of certain structural features) of this site considered by the excavator were a pottery production site, and a burnt mound (Harris 1979).

#### Trelen 2, Site 41 (SW73411928)

This barrow is located on the serpentine of the Goonhilly Downs just above 300 feet O.D., and is part of a large dispersed group of barrows, being the southern-most of a north-east/south-west linear group of four. The earliest activity on the site involved the erection of an irregularly spaced fence line running north-west/south-east, along the midpoint of the later mound. Charcoal from one of the posts produced a date of 2700-2190 BC (HAR5280). At some later time these posts were removed, though two of them were either replaced or reset at the edge of the later mound. Pollen from a trimmed or slightly disturbed old ground surface on which this mound was built indicated an immediate environment of pastoral grassland with nearby hazel and alder scrub woodland. This surface was exposed long enough before the construction of the mound for it to become slightly eroded. A deposit of oak and hawthorne charcoal on this surface just outside a later post-circle on the north-east could be related to earlier activity on the site. Following



the preparation of the surface mourners dug a small circular pit which they backfilled with turves. The pit was disturbed and the contents are unknown. They excavated the pit centrally to a 9.5 m wide circle of stakes, probably with hurdling between them. This circle/fence provided the revetment for a circular conical mound formed of inverted turves. Directly against the mound was a yellow subsoil clay ring bank which surrounded the site, and was turf covered. This ring bank was revetted by an outer bank of inverted turves which extended the diameter of the site by at least 4 m. The material for the ring bank and possibly the mound and turf revetment came from a V shaped, flat bottomed ditch with steep sloping sides (which had an internal diameter c. 17 m) which was separated from the turf bank revetment by a 1 m berm. The clay bank and ditch could have preceded the mound and hurdling. Following the construction of at least the ditch and circular bank no activity occurred at the site, during which time the ditch became almost entirely silted up. During the latter part of this process, mourners deposited a granite hammerstone and some local thermally altered local rock fragments into the ditch. This was followed by the excavation of a second shallower flat bottomed ditch into the outer edge of the first, and a new cap for the barrow of yellow subsoil. Two charcoal samples from the primary ditch silts of the first ditch which slumped into this new ditch dated to 2470-1880 BC (HAR4540) and 2130-1680 (HAR5510). This ditch then silted up and during the latter part of this process a gabbroic Style 6 Trevisker Urn with a charcoal residue on the inner side was placed into the ditch on its north/north-east side. Charcoal from this upper layer of ditch silt yielded a radiocarbon date of 1520-1010BC (HAR 4538) (Smith 1988). A number of residual lithics was recovered from the mound and old ground surface. Based upon the location of the unstratified finds, some flint working took place on the later mound which resulted in the production of a number of convex scrapers and debitage (Smith 1984).

### **Southern Devonian North Coastal Area**

Gwithian Sites (SW591423)



Four burial sites were examined during the course of excavations at the Gwithian site during the 1950s and 1960s: Site GM/V (a mound overlying two pits below the base of Level 5 at the southern end of the Gwithian complex), the ring ditch and four cremation pits in Level 5 at the central part of the complex, and two small cairns near the domestic structures in Level 3, at Site GM-X, just north-east of the ring ditch. All the sites lay over 50 m to the south-west of the Layer 7/8 Early Bronze Age hut and squatters camp (Callow, Baker and Pritchard 1963, Nowakowski 1989; Megaw, Thomas and Wailes 1960-61; Thomas 1961).

Site GM-V is the southernmost of the sites, and lay some 125 m south-west of the Early Bronze Age hut/squatters complex. The site was stratified below traces of criss-cross ploughing at the base of Layer 5, which was dated after 1530-1010 BC (NPL21). It consisted of an oval burial pit oriented north north-east to south south-west which measured some 1.5 by 0.6-0.9 m. A small cairn of stones lay at the south end of the pit, which may have held an upright cairn of stones. Some 3 m to the north of this pit lay a second circular pit with an organic fill. Both pits were overlain by a low flat circular sand mound some 12.1 m in diameter and at least 1.2 m tall. The origin of the sand was both local and beach derived. At some point in antiquity before the Layer 5 occupation/activity, a trench was excavated into the mound which encompassed both pits. No traces of an inhumation remained, and no grave goods or other artifacts were reported.

The ring ditch and cremation pits lay some 60 m to the north-east of Site GM-V, immediately below the plough marks at the base of Layer 5, and thus are possibly contemporary with Site GM-V. The site consists of a fragment of a ring ditch and 4 cremation pits which lay in a north-south orientation to its north-east. A radiocarbon date from one of the pits produced the aforementioned *terminus post quem* date for the Layer 5 occupation.

The last two sites lay immediately to the east of the rectilinear house (House 1) and stone bank in the upper levels of the later Bronze Age 12th century Layer 3 occupation horizon on site GM-X. They consist of two small slightly oval mounds of stone and soil lying 5 m apart, and having diameters between 7 and 10 metres. The mounds incorporated scattered cremations.



**Penhale Barrow, Nancekuke (SW67654627)**

Excavated by C. K. Croft Andrew in 1940 in advance of airfield construction, and published by Christie (1985), this isolated barrow was situated on the plateau of Nancekuke Common, some 600 metres from the sea south-west of Porthtowan, on Devonian slate at 285 feet O.D. and 500 metres from the coast. It had suffered some extensive plough disturbance, and the central pit was disturbed in 1931, yielding a layer of black matter and a white layer which could have been a cremation. Activity began on the site with the excavation of a rectilinear grave pit on a north-east/south-west orientation dug into a turf surface, and a presumed burial deposit. To the north-east of this pit mourners lit a fire. Charcoal from this fire yielded a radiocarbon determination of 2045-1641 BC (NPL134). They then built a turf mound measuring some 13.4 m in diameter over these features. The mound turves were inverted, inclined towards the centre of the barrow and thickly cut with a significant amount of attached yellow subsoil, giving the mound a yellow and black striped appearance. The mound material was presumably obtained from a ditch which funerary participants had excavated with V shaped profile which extended some 0.91 m into the subsoil. This ditch extended the diameter of the site to just over 18 m. The ditch was separated from the mound by a slight berm (less than 0.6 m) which increased in size to the north corresponding to a flat edge on the mound. After the site was completed the mourners threw a charred oak shovel-like object into the ditch on the west side. As the ditch silted, mourners threw a number of items into it including four quartz crystals, a cupped slate stone, a large quantity of rounded pebbles, and 26 pieces of worked and unworked flint. Some of the flint may be residual from the mound silting. When the ditch had nearly silted up, ?mourners lit a small fire, or deposited some oak and hazel charcoal and burnt vegetation on its inner south-east side, which they covered with a layer of clay either burnt or originally red in color. There is some indication from the photographs of the 1940 excavations that a stone revetment may have existed for the mound, though this was not mentioned in the site archive.

**Crig-A-Mennis (SW757528)**

This mound was originally one of a group of single or paired barrows scattered among the low



ridges south of Perranporth. Crig-A-Mennis itself lay on a ridge between the Penwortha and Perrancombe valleys, one mile south-east of Perranporth, between 200 and 300 feet O.D., on a border between Devonian soft pink sandstone and harder greenish gray slate (Christie 1960). Activity began on a turf surface in a clearing with grasses and heather with some small evidence of cultivation either nearby or at some previous time. Activity began with a series of activities roughly central to the site, possibly within a circular ditch, described below. Mourners deposited a large amount of charcoal on the old ground surface. To the north of the main charcoal heap they dug an oval pit which they filled with oak charcoal and organic matter. They covered the main charcoal heap with a low spaced out heap of slate blocks 3.4 m in diameter. A spur of stones from this slate heap covered the pit. Charcoal and a small quantity of cremated bone were placed over the stones covering the pit, blackening them (or this spur was part of an original cremation). Charcoal from the large central deposit yielded a radiocarbon date between 2042-1680 BC (NPL193). To the north of the stone heap they erected an arc of nine large stones (possibly part of a circle?) on the old ground surface. A patch of charcoal was found on this surface roughly 2.5 metres from the edge of the central stone heap. They then covered these features with a three phase turf stack, which was derived from stripping the berm of the site between the turf mound and ditch. The first mound was conical and covered the stone heap. They enlarged this to form a low oval mound between 8.5 and 9.1 m in diameter comprised of pinkish sandy loam, derived from the north-western portion of the site (overlying the sandstone). Two shallow pits were dug into the subsoil at the edge of this mound. The first, on the east, contained a heap of ash and charcoal and was covered by an inverted Style 1 Trevisker vessel packed around with horizontally laid slate slabs. Its inner surface was blackened by contact with hot ash and it contained soil and charcoal and some fragments of unidentified carbonized organic material. The second pit resembled the first, though it was located at the northern periphery of the pink turf stack. It too, was overlain by an inverted Style 1 Trevisker vessel. The soil fill of the pit contained three and one half biconical terra-cotta beads, a small clay cone, two calcined flakes, a discoidal quartz pebble, and traces of calcined bone. As with Urn 1, this urn also had a burned interior, and mourners had covered its base with a slate slab. The funerary participants covered these deposits and enlarged the mound with a 10.6 m in



diameter flattened orange and gray turf stack, derived from stripping the southern sector of the site over the shale bedrock. On the surface of this flattened mound in the north they built a fire with oak wood which left a deposit roughly one metre square containing substantial pieces of charcoal. They then covered the flattened turf stack with a pinkish-brown sandy subsoil, derived from the ditch, and possibly later capped this with some shaley rubble, which was discovered as primary fill within the ditch. The remains of a gray slate boulder and primarily small quartz stony revetment wall for the barrow were found on the north and west areas of the mound. Some large orthostats in this wall lay across from the causeway in the ditch. Mourners had lit a fire or made a deposit of charcoal in the north before this was added. At some point after the completion of the revetment an oval pit 0.45 m oriented north/south was cut into it. The pit had been filled with shale. The mound and revetment were separated from a ditch by a berm between 1.2 and 1.7 m width. It was partly stripped of turf, presumably for the mound. The ditch surrounding the mound was irregular in shape and flat bottomed in section (though somewhat mainly V shaped on the northeast), and contained a causeway to the west. During the construction of the ditch mourners cut through an earlier feature in the form of a trench/ramp oriented east/west on the eastern side of the site opposing the causeway of the ditch, and after its construction leading both into and out of the ditch. The excavator reasonably suggested that the ditch and ramp were early features perhaps contemporary with the central activities at the site, since the mounds and revetment blocked this east/west line. At the base of the ditch on the north-west mourners had deposited a oak scythe-like object, possibly a branch. The ditch fill consisted of a primary mound slip of slate, separated by a layer of dark soil (turf regrowth?) from a secondary slip of mainly quartz, suggesting that at some time well after the initial mound was completed a quartz cairn/cap was added to the site, turning it into a creamy white mound. As the mound began to initially slump into the ditch, mourners deposited two greenstone rubbers or pounders and part of a granite rotary quern into its west side, as well as a fragment of a granite quern or rubber onto the berm. At an unknown depth in the ditch north of the causeway was a slate comb, possibly used for ceramic decoration.

A number of other features occurred on the east side of the barrow, in the vicinity of the trench ramp on the east. It is not entirely clear from the report what their sequential position is in relation to the



rest of the mound features, though their general contemporaneity with the Trevisker Urn pits, or the construction and activity on the flat topped orange turf mound seems likely. On the edge of the revetment slip in the east, just north of the trench ramp, was a crushed undecorated miniature cup set in stones on the old land surface. Its fabric was similar to the two urns, and was flat rimmed with a concave base and contained charcoal and burned organic matter. To the south of the trench ramp a stone heap covered an area of charcoal and two flascular pits dug into the pink sandstone to depths of 0.15 to 0.19 m containing a black greasy substance and fragments of oak charcoal. A shallow pit lay to the south of the trench ramp near its head, and two circular pits lay to the south of the stone heap noted above. All three contained charcoal and organic matter but the fill of the pit nearest the trench-ramp closely resembled that of the miniature cup. A small pit also lay in the causeway of the ditch on the west side of the site. The determination of primary or secondary features is difficult to established for this barrow due to the lack of good contextual relationships between the pits, the pots, and the ditch and mound phases. The excavator postulates a primary phase involving the trench-ramp and the stone arc (?ring) and central features.

#### Carvinak (SW774483)

This monument lies at an elevation of 356 feet O.D., on the north-east/south-west plateau of mid-Cornwall, some 4.5 miles north-west of Truro among a group of sites. The plateau is drained by streams running to the north and south Cornish coasts, on alternating beds of Middle Devonian sandstone and shale. The site consists of a number of pits and cairns within a fence or stake ring surrounded by a quartz ring and overlain by a mound. The central features presumably took place within the space defined by the stake or cairn circle, though the north-eastern hollow preceded the cairn circle at the very least. The site profile appears to indicate that mourners stripped the original turf surface in a ring around a central area at some point in the history of the site before the ring and quartz cairn were built. On the central turf surface mourners excavated four circular hollows or shallow pits. Three of the hollows were 0.20 m deep. Near all the hollows apart from the north-westernmost, mourners had laid possibly burnt branches. They filled the hollows with soil containing fine charcoal. The most south-easterly pit contained a utility stone on its



floor, a large quartz block on its south side, and was ringed by small quartz stones and covered by a large flat piece of slate. The north-western pit contained more charcoal than the rest and some burnt stones. These hollows were then covered with large pieces of the natural soft pinkish purple shale, which when excavated by Dudley, appeared as a circular pink clay floor with a diameter of 13.7 m. On this surface the funerary participants built a small round platform c.1.2 m wide of milky white quartz blocks in the north-west quadrant of the floor. They took care to ensure the upper surface of the platform was flat. A poorly made plano-convex knife, fractured by fire was found near this platform. They also built one very large and two smaller white vein-quartz cairns on the pink floor over three additional, more substantial pits which were filled before the laying of the pink floor. The largest (Cairn 1) was oval in shape with a maximum diameter of 6.4 m. It occupied the centre and south-east areas of the platform and stood 1.2 m in height. It covered both a small deposit of calcined bone charcoal fragments lying on the pink platform, and, in the north-west, an oval pit (3.6 by 2.1 m) oriented north-east/south-west which was cut into the shale bedrock. At the base of this pit, a smaller 0.38 m square pit had been excavated. This lower pit and the lower portion of the larger pit were backfilled with purple-red shillet. The mourners had lined the upper portion of the large pit with quartz. No burial was recovered from the pit, and its upper fill consisted of turves with attached pink/purple clay and quartz fragments. Cairn 2 was built in the north-east quadrant of the platform. Mourners had first excavated a circular pit 0.55 m deep which they lined with yellow-white clay towards the bottom. They then placed a cremation surrounded by turves under a large stone into the pit which they then carefully filled with red sandy soil and quartz stones. Over the pit they built the white quartz oval cairn 0.60 m tall, which they capped with pink clay. Near the cairn they laid a branch on the pink floor. Cairn 3 was built just to the east of Cairn 1. Mourners first dug a pit 0.6 m through the subsoil into the bedrock which they lined, as in the pit under Cairn 1, with quartz. At the based of the pit they placed two cremations, one to the south and one to the north. The cremation to the south lay on a deposit of soil with much charcoal and was surrounded with a matt of roots. The northern cremation was contained in an inverted Case's Late Style Beaker with an inbent rim with shillet temper and fingernail decoration arranged in panels around the body. The mouth of the pot may have been covered



with a piece of cloth. The cremations were surrounded with a ring of white quartz at the base of the pit. Overlying them, mourners placed a fill of quartz and pink sand followed by pink sand and turves. The overlying cairn was of quartz. Roughly one metre south-west of Cairn 1 and near the south-western hollow mourners had deliberately smashed a Form Three notched Food Vessel Urn. It had an internally bevelled rim which was decorated with rows of vertical stabs. They also deposited a "cupped" sandstone pebble with opposed hollows and a flat face. As noted above, encircling these features mourners had built a low loose quartz wall (circular to oval in shape) roughly 1.5-1.8 m wide and 19.2 m in diameter, which was held in position on the interior by a ring of small stakeholes, irregularly but closely placed, presumably supporting a woven fence. This wall continued around the central area, except in the north-west, where the stake holes were more erratic. A coarse granite grain rubber had been deposited near the quartz ring in the south-west quadrant. Following the completion of the cairns over the pink surface, mourners built a steep sided oval turf mound over all of the above features (beginning with the three cairns). Some leaching of the soil had taken place prior to the construction of the barrow, hence its colours alternated between gray, cream and brown. The mound extended over the cairn ring (the stakes of the fence presumably withdrawn before the mound was built). The mound originally stood over 2.5 m tall and had a diameter of at least 19.8 m. During the construction of the mound, the funerary participants placed a cremation, possibly contained in some sort of bag in its north-east quadrant. They then covered the mound with a thin cap of light gray leached soil into which they imbedded a crust of white vein quartz. Remains of at least four separate ceramic vessels in two groups lay near the surface of the barrow (one associated with two small slate discs), close to the top in the south-east quadrant. It is not entirely clear whether these sherds were deposited on, or concurrent with the white quartz and gray soil cap, though the excavator considers the former to have been the likely case. They consisted of a barrel shaped Trevisker Style 1 or 2 vessel, a Collared vessel decorated with bird bone impressions, a handled vessel, and several sherds of a fourth vessel (Parker Pearson pers. comm.). No information is available for the cremations from the site (Dudley 1964).



## Cataclews (SW86947605)

Cataclews is the most westerly (SMR25) of a original linear group of 6 barrows (Cataclews SMR20-25) situated along the cliff edge between Cataclews Point and Mother Ivey's Bay just north-west of Harlyn Bay where they form a skyline feature. The sites lie on Lower Devonian Slate at 82 feet O.D.. All the sites were examined at various times during the 19th and early 20th centuries, producing a number of Bronze Age artifacts. Adjacent Site 24 or 23 to the east of Cataclews produced a small gabbroic biconical Food Vessel and possibly a perforated axe hammer. Further east, Site 22 was ploughed out around AD 1900 and contained an area of stone paving below an earthen mound. Site 21, east of this produced a ribbon handled Early or Middle Style Collard Urn plugged with clay and granite pieces which was situated in a square cist on the Bronze Age surface. The Cataclews cemetery lies some 300 m north of the 1865 double gold lunulae and Migdale axe stone cist find, which were possibly below a barrow at the cliff above Harlyn Bay. Some 400 m to the south-east of the lunulae find is another small group of at least three barrows above Bloodhound Cove overlooking Harlyn Bay, which produced 2 gabbroic Trevisker Style 1 vessels (one accompanied by a pygmy cup, bronze pin, slate hone, a Camerton-Snowhill type dagger (Pearce 1983), and possibly a spindle-whorl), and a Trevisker Style 5 Urn in a rectangular north/south rock cut pit under a capstone. This cist was covered by a small slate and sandy clay mound. Oak charcoal below the T5 Urn in the cist fill was dated to 3460+/-70 BP (BM2474) (Christie 1985; Crawford 1921; Preston-Jones and Rose 1987).

The site detailed here was excavated by C. K. Croft Andrew in 1944 in advance of quarry expansion and later published by P. Christie (1985). Activity began at Cataclews (25) when mourners stripped the turf and topsoil from the immediate area of the site, exposing the natural slate in places. Alternatively, the site may have been situated on a natural outcrop, with little original soil. On this surface they built a small cist into which they deposited the fairly complete cremated remains of one individual older than 15 years of age along with a quantity of oak charcoal. Although no duplicate bones were recovered, the deposit might have included the bones of a second individual. They covered the cist with a slate slab. To the south-east of the cist, mourners erected two small flat slate stones which screened the



deposit. Just over two meters to the north-east of the cist they built a large fire on the surface with oak wood. Charcoal from the fire yielded a date of 2109-1643 BC (HAR8099). A few fragments of cremated bone were recovered from the charcoal. A number of large slate stones were also identified in the vicinity of these deposits on the old surface. The fire and the burial were encircled or followed the construction of two low kerbs of slate, mainly laid flat. The inner kerb was 6.2-7.4 m in diameter, while the outer kerb formed a perfect circle with a diameter of 9.1 m and was probably built after the inner one. Mourners had deposited three white quartz pebbles among the kerbstones and some charcoal at the eastern side of the site. At some point, a number of loose stones may have filled the space between the kerbs. Following the construction of the kerbs mourners built a low cairn of small stones and earth with a yellow sandy soil cap over the site, its limit coinciding with outer kerb ring. Either during the construction of the yellow cap, or more likely afterward, mourners deposited a number of ceramic fragments into the yellow cap at the top of the barrow. These included sherds from Trevisker Styles 1, 2, 6 (most complete) vessels, and fragments of two others, one possibly a Food Vessel (Parker Pearson pers. comm.). A number of other small pebbles were recovered at the site from unknown contexts.

### **St. Austell granite**

The 7 sites described below formed part of a sparsely scattered group of at least 50 sites in small groups of one to three across the major hills of the St. Austell Granite at elevations roughly between 400 and 1024 feet O.D.. The area has not produced any traces of hut circles or field systems, though a number of Mesolithic and Neolithic flint projectiles and flakes have been recovered and numerous residual flint debitage and tools found on the sites attest to continuity of activity from the Mesolithic (Miles 1975; Miles and Miles 1971).

### **Cocksbarrow (SW98505630)**

This barrow is situated at 990 feet O.D. at the highest point on the Longstone Downs, and the



second highest eminence of the St. Austell granite (Miles and Miles 1971; Miles 1975). Activity at the site began in a grass heath clearing, with some evidence of the nearby presence of hazel, and to a lesser degree, oak, alder, and bracken. There was no indication of arable cultivation in the pollen profile of the buried soil, and the area was well on the way to a heath or moorland environment when the site was constructed (Dimbleby 1971). Mourners set up a double ring of post circles with an entrance to the south-east. One of the posts in the north-west quadrant near Pit Z contained a plano-convex knife, and another contained a broken unused blade. A third contained some polished white quartz pebbles. The mourners also built a granite cairn ring with a carefully constructed inner face around the posts with a diameter of 19.8 m and a height of no more than 1 m. The south terminal of its south-east entrance coincided with the post circle's while it extended past the northern terminus of the post circle, narrowing the south-east entrance considerably. They built the cairn mainly on the turf surface but underlying it in some places were patches of yellow clay. At the entrance to the ring cairn the mourners had deposited a patch of yellow clay, then built a fire upon it. There is some evidence to suggest that a number of the posts were free standing and withdrawn when the cairn ring and yellow clay patches were laid in place, pointing to a ritual involving all or some of the posts prior to the construction of the cairn. Two of these posts were on either side of the post circle entrance to the south-east and five others lay in an arc opposite the wide entrance in the north-west. A small pit (Z) stood within this arc and probably also preceded the circle since one of the posts had been dug out of line to avoid it. It was dug to a depth of 0.54 m and filled with fine black soil and broken pieces of quartzite. It lay in a direct line with the central burial deposit and the centre entrance of the later ring. Two additional oval/irregular pits were dug just inside the entrance of the post-circle. Pit X was roughly central to the entrance and had been filled with a fine black soil and a granite moorstone. It was dug to a depth of 0.6 m. Pit Y was dug to a depth of 0.20 m, lay just to the south-east of Pit X and contained a similar soil fill. Three additional pits (A,B,C) lying within the cairn ring had similar fills to the stakeholes of the ring. One was near the entrance, one in the south-west and a third was in the north, covered by the stones of the cairn. There was also a stake hole in the south. At some point mourners had constructed an inner granite ring composed of single stones sloping inward and partially supported by a turf



layer inside the post circle and cairn. Its chronological relationship to the other features of the mound is unknown. This ring had an entrance to the north-west, flanked by its two largest stones which was opposite the larger ring's entrance. It had a diameter of 7.3 m. Several granite stone heaps and lines lay on the old ground surface between the two rings, in the east and in the north, perhaps encouraging movement clockwise from the southeast entrance of the large circle to the centre of the inner. A burnt scraper was found in one of these heaps in the northwest quadrant. This inner ring encircled a circular pit which mourners had dug centrally to the post-circle and cairn rings. Its upcast lay to the south-east. They excavated this pit into the subsoil and lined it with granite moorstones. Into the pit they placed the cremated skull, longbone, metapodial and phalange fragments of an adult individual, probably in a bag. Next to the cremation lying on a turf they laid a ladle constructed from the horn of a probable Bronze Age domestic ox. They filled the remainder of the pit with black soil and slabs of granite. The sealing of the pit was immediately followed by the construction of a flat topped turf mound of inverted turves. Costal pebble flint scrapers, blades, a plano-convex knife and utilized flakes were found among the turves, all considered residual. The removal of the post-circle preceded the construction of this mound, as well as the blocking of the outer cairn circle. The mound extended to a diameter of 21.3 m, partially covering the outer cairn. The mound contained an annular depression in its surface which the builders filled with yellow clay, similar to that used elsewhere on the site. They also covered the cairn ring and just beyond with the clay. The excavator suggested that the mourners may have filled the space between the rings before the construction of the main stack, thus forming a ring cairn while the central activities were taking place, though no stratigraphic evidence existed to confirm this.

#### Longstone (SW98385614)

This multi-phase menhir and associated pits lay roughly 180 m south-west of Cocksbarrow, on kaolinised granite, though no relationship in terms of finds or astronomical sighting appeared to exist between them (Barnatt 1982; Miles 1971). It is one of at least two other standing stones in the St. Austell area, both on and off the granite. Four phases of activity took place on the site, and the whole sequence



may have been spread over at least one hundred years, having possible Late Neolithic features. Activity began with the erection of a probable wooden post with an associated pit which may have held a burial. This was followed the digging of a oblong grave-like pit which was partially lined with granite slabs. It contained 9 white quartzite pebbles. The post was then replaced by a menhir held upright by granite stones in a shallow pit, and surrounded by a granite paving. A possible period of inactivity followed in which some turf formation took place, after which the menhir was replaced by a dressed granite slab roughly 3 m high with its broad side facing north-east/south-west. All the pits were excavated on the eastern side of the posts/stones.

#### Watch Hill (SW97275424)

This monument is located roughly 2.5 km south east of Cocksbarrow at 870 feet O.D.. It lay some 200 meters south-west of two other barrows with diameters of 60 and 70 m, on a hilltop. All the sites are now buried by china clay waste. Activity at the Watch Hill site began in a probable clearing. The pollen diagram from the buried soil under the mound indicated a mixture of open land, forest, and forest margin species in decreasing order. Higher percentages of hazel existed compared to Cocksbarrow, and bracken was also visible, suggesting a slightly later date for this site. Work began at the site with the excavation of a flat bottomed steep sided ditch 2.2 to 2.8 m wide and 27 to 28 m in diameter. A stone was removed from the base of the ditch in the north-east and its hole packed with non-kaolinized head subsoil mixed with wood charcoal from 7 trees (Hawthorn, Blackthorn, Rowan, Oak, Alder, Hazel, and Elder). Two radiocarbon dates from the charcoal, HAR654 and HAR655, yielded date ranges of 1973-1678 BC and 1925-1522 BC respectively. The builders had created two ledges in the ditch sides on the north-east and south-west. They laid a sandstone rubbingstone on the north-east ledge at some point. They also constructed a cairn ring of granite and quartz blocks and turves (derived from the ditch) with a diameter of 15.2-16.2 m within the ditch and eccentric to it. An unused entrance which was later blocked lay in the north. A second much narrower arc of an outer ring similarly constructed lay between the inner cairn ring and the ditch on the north/northeast where it terminated in a standing stone. Another shorter similar ring



lay between the cairn ring and the ditch on the south/south-west. The space between the outer ring and the inner ring on the north was blocked by a short row of jumbled stones. A broken flint blade was found in one of the rings in the south-east, and a blade and two cores were found on the old ground surface in the north-west quadrant. The site appears to have been left alone for some time during which both rings weathered, and the ditch silted to a thickness of 0.3 - 0.6 m. This break in activity at the site ended when mourners excavated an oblong pit in the centre of the inner cairn ring oriented west-east which they excavated to a depth of 0.5 m. Into the pit they placed some brownish silt followed by an organic deposit which appeared as a fibrous material when reexcavated. They then placed some large stones followed by some clay lower subsoil and small granite blocks into the pit. Over this they laid a lidded monoxylous coffin containing an inhumation packed around with selected granite lumps, quartz, and some fine grained bluish granite which occurs in small quantities throughout the kaolinized head of the granite. Over this burial they placed another unlidded log coffin (burial unknown) which they packed around with grey leached less clayey upper subsoil which filled the remainder of the pit and covered the surface around it. Over this they built a small central cairn of turf and granite 3.6 m in diameter with a partial granite kerb. They then immediately built a low flat topped grey gritty inverted turf stack over the central cairn which also covered the main cairn ring. It measured some 16 m in diameter, and was covered was covered by a level of slightly compacted peaty soil, suggesting a period of inactivity. Before the burials and the construction of the mound, a rapid silt formed in the ditch bottom from its sides which was covered by a compact surface. On this surface, possibly concurrent with the burials and mound construction, mourners deposited three main groups of sherds from three quarters of a single freshly broken locally produced Enlarged Food Vessel in the south-east, south, and north-west of the ditch. One sherd lay over the pit location. They also scattered charcoal from Oak, Hazel and Alder trees on this surface. A hiatus in activity occurred at the site during which a soil developed on the stabilized ditch surface. A second flat topped brown inverted turf stack (from a different origin and containing 27 residual flints was then built over the first, heightening the barrow to 1 m. The building of this second stack was closely followed by the construction of a two level clay ring, which surrounded the barrow (and partially covered it, and



extended the mound some 2.5 m. The lower portion of the clay ring consisted of grey to brown to orange and yellow iron stained subsoil which lies over the kaolinized granite. The upper portion of the ring was yellow kaolinized granite. This ring was kerbed with granite lumps and brownish soil. A small berm still existed. The mound was left for a time in this state and then trampled upon. Five features were also cut into this barrow surface but may also have cut through the black gritty layer overlying it described below. Two in the south were probably postholes (a,b). The three others were larger pits on the top and the south-west of the barrow (c-e) and were filled with black gritty soil and granite lumps. They contained no finds. Probably around the time the second turf stack was constructed or concurrent with the activity on its surface, the ritual participants deliberately infilled the ditch with stones and a few turves, followed by gritty black soil and yellow kaolinized granite as on the mound, followed in turn by large stones and more black gritty soil. One large stone directly overlay the pit at the base of the ditch in the north-east and appeared to have originally come from it. During the infilling, they made several discrete deposits of fruit and some wood from sessile oak, sloe, crab-apple, hazel, oak and hawthorn plants/trees in the south, south-west and north, and to a lesser extent in the south-east. This distribution coincided slightly with discrete deposits of utilized flakes and broken blades in the south/south-west, north and east. In the north and north-west they also deposited a worn granite pebble, and a broken and worn sandstone pebble. Finally the builders deposited a 0.30 m thick "masking" layer/cap of black gritty soil over the mound, berm and ditch, which mingled with its upper fill, ending activities at the site.

#### Trenance Downs (SW99985461)

This infilled ring cairn was one of two barrows located on Trenance Downs ridge at the south of the granite, at an elevation of 793 feet O.D., some 3 km south-east of Cocksbarrow and 3 km east of Watch Hill. The other site, now buried under china clay waste lay to its south (Miles 1975). When the site was constructed, the surrounding area was relatively open, with comparatively little Hazel, Alder and Oak nearby. Activity at the site began when builders cleared a number of moorstones from the site area and filled their sockets with black gritty soil. They also deposited several patches of white kaolinised



granite (clay) on the ground surface in the south-east and south-west. They also dug a small oval pit 0.06 m deep to the north-east of these deposits, which they filled with brown soil and stones. Over the pit and surrounding a cleared area they then built a thick oval ring of gritty brown black soil and weathered granite which incorporated a number of white quartz line or piles. The cairn was approximately 0.60 m high and 20 m in diameter and enclosed an area 7 by 4 m. They capped and "finished" the inner edge of the ring with white to gray kaolinised granite (clay) in the north-east and south-west. An entrance to the ring lay on the north-east. Along part of the northern entrance wall they incorporated a very small cavity which at some point they filled with black gritty soil and covered by a granite slab. A post may have been supported in a small cairn of stones next to it in the ring. At the northern end of the enclosed area the builders set up a 0.40 m stone with a cluster of smaller stones, and excavated a small oval pit 0.20 m deep south of it at the opposite end of the enclosure which they filled with black gritty soil. After activities in the ring centre were complete, the builders filled the ring cairn interior and covered the entire monument with black gritty soil, stopping after 0.10 m to lay a small line of stones on the new interior surface. During the course of this process, they deposited 14 white quartz pebbles, a whetstone, and 4 pieces of trimmed slate in the central area and near the entrance and entrance cavity of the site. Two white quartz pebbles were found in the cairn and one on the old land surface. A number of lithics (some Mesolithic and residual) were also found in the infill, in the cairn, and across the site generally, including end scrapers, a plano-convex knife, blades and a number of utilized and retouched flints, as well as an adze. The majority of this material did not come from the central area or near the entrance (Miles 1975).

#### Caerloggas I (SX01705659)

This ring banked enclosure is situated on the highest point of the Caerloggas Downs at 886 feet O.D.. It is one of a group of three monuments (Caerloggas I, II and III), which in their southeast/northwest alignment, point to the Gribbon Head promontory at the east edge of St. Austell Bay (Miles 1975). Activity began at the site in an open environment, with some Oak and Alder present, in an area which had at one time been under cultivation. All activities revolved around a flat topped moorstone



some 0.5 m tall, which formed the top of a small remnant tor. Initially, the builders removed some moorstones around this central point and excavated two arcs of shallow ditch with an entrance 4.8 m wide to the south-west on a granite outcrop. The ditches were somewhat irregular and nowhere more than 0.6 m deep. The entrance or ditch causeway was worn and trampled at the time of modern excavation, indicating passage and just inside it, blocking it, were a number of either naturally rooted or supported upright moorstones (a-e). Two white quartz pebbles had been deposited in this entrance way. To the north-east and partially under the central moorstone noted above they excavated an oblong pit .45 m deep with a slightly deeper southern end. The pit contained a high phosphate content and had been backfilled initially with redeposited head from its fill, mixed with black soil. This had been tamped down and covered with granite lumps and black soil. The fill contained 18 flints including a burnt scraper fragment, three utilized flakes and a modified flake. They deposited a number of other items into the fill such as a burnt and broken slate pebble with a wear facet, one tourmaline pebble, fourteen polished white quartz pebbles, one worn white quartz crystal, three killas pebbles, one local slate pebble, two fragments of heavily burnt longbone fragments and a fragment of incised slate. Before the upper fill of the pit was deposited, they extended this pit to the south (j) and excavated two other small pits just south of it (k, l) which they filled with a similar fill to the upper portion of the first pit. Only Pit k contained a white quartz pebble. The builders then covered the pit complex and the area surrounding it with several layers of turves, vegetation side upwards, to level the site. While these turves were being laid the ritual participants deposited a number of items (concentrating on the central moorstone and pit area) including a Camerton-Snowhill dagger mid-section, a broken piece of tin slag, a serpentine spindle whorl, one incised slate piece, one cassiterite pebble, one gritstone pebble, one tourmaline pebble, 42 white quartz pebbles, 2 quartz crystals, and 52 flint tools and debitage, among them a barbed and tanged arrowhead, a heavily burnt broken plano-convex knife, a broken retouched flake and some utilized flakes. Some of the flints may have been residual. Upon these turves they spread patches of yellow kaolinized granite in a rough ring above which they built a ring bank composed of granite blocks covered by inverted turves which survived to a maximum height of 0.8 m. and which had a diameter of roughly 21 m. This bank blocked the causewayed ditch



entrance and had its own 3 m wide entrance 20 degrees south of it, flanked by enlarged terminals. They deposited an amount of black gritty soil in this entrance over the yellow clay which they trampled upon on their way in and out of the enclosure. The builders also erected posts in the bank on the inner and outer sides and at some point blocked the entrance to the enclosure with a chord of 7 posts. Several lay within the entrance, one directly in the centre. The ring bank was left unaltered for a time during which the posts rotted in situ and a soil developed on its surface. The ring bank was then heightened with a combination of bright yellow kaolinized granite (clay) and bands of smooth dark soil, lighter brown gritty soil and stones to a maximum height of 1.1 m. They also deposited a patch of yellow clay in the entrance which extended towards the interior. This entrance had been trampled upon by passage into and out of the enclosure. They erected at least twenty posts more central to the ring into the clay. The posts were later withdrawn and backfilled with black gritty soil but only after the ring bank was enlarged and heightened by a layer of this soil and covered by a rough cairn ring, ending construction on the site. The interior of the ring bank above the basal levelling turves at the time of modern excavation was filled with disturbed turves and erosion from the bank. A large number of flakes, a scrap of amber with three surface facets, a worn quartzite pebble and a slate pebble with two worn facets were recovered from this soil, primarily concentrated in the south-east portion of the enclosed area with a cluster in the north-west, perhaps indicating continued deposition of items throughout the sites history, or at least during its enlargement phase. The ditch silt contained comparatively few finds and included a "quern rider" granite pebble, 2 cassiterite pebbles, and 1 white quartz pebble.

#### Caerloggas II (SX01725657)

This small barrow lay central of the three and was badly damaged by a pipe trench at the time of excavation. Only the surviving western half of the monument was excavated. A turf stack with a kerb of granite blocks overlay at least one oval pit 0.2m deep in the north-east which was filled with hard black soil and lumps of granite. No attempt had been made to remove the moorstones from the old land surface. The barrow, which extended to a diameter of 1 m was overlain by a yellow kaolinized granite (clay) capping.



The site was then at least partially overlain by turves. A slate pebble was recovered from the kerb, and two flints were recovered from the old land surface.

### Caerloggas III (SX01755655)

This barrow was similar in construction to II, and was built on a surface from which moorstones had been removed to create a cleared area. It was constructed in a similar environment to Site I. Activity began at with the laying of two branches on the old ground surface in the south-east and the setting up of an granite orthostat 0.4 m tall some 9 m to the north-west of the branch which was supported with turves. The mourners then soon after constructed a low flat-topped turf stack (upright turves) over these features, working from the centre outward. A pause in construction of the stack took place when the mound was 6 m in diameter and 0.3 m tall (three quarters of its size) evidenced by a compacted surface. They did not obtain the turves from the immediate area of the site but from an are with similar vegetation, perhaps nearby. An intermittent kerb was constructed concurrent with the turf stack. The site measured 21 m in diameter and stood at least 1 m tall. A broken quartz rubbing stone had been placed among the kerbstones. The stack was built with a circular hollow in its surface just within the kerb which had a gap or a bridge 0.7 m across it to the south/south-east, matching a gap and a slight length of wall extending from the kerb at this point also. This may have allowed access to the mound surface. The builders had filled the circular depression with yellow kaolinized granite (clay) containing concentrations of bright red ferric oxides mainly on the south and west sides of the monument. A number of stones natural to the clay were concealed under its surface mainly on the on the south-west side of the site. The surface of the mound received little intensive further activity in the way of compaction or features on its surface. At some point afterwards, this gap was closed by the addition of a deposit of black slightly gritty soil around the edge of the mound which covered the kerb and extended the barrow 1-2 m in diameter. A large quantity of flints (including broken blades and utilized flakes) were recovered from the barrow from all contexts (mainly from the old land surface). The majority from the old land surface were Mesolithic and residual, while others came mainly from the turf stack.



## **Northern North Cornish Coast**

### **Treligga Cemetery**

The four barrow sites described below are part of an open roughly linear cemetery of 6 sites (Sites 1, 2, 5, 7, 8 and 9) which lay on Treligga Common between the village of Treligga and Start Point near the cliffs between 200 and 300 feet O.D. on Upper Devonian Slate. The sites were originally excavated by C. K. Croft Andrew in 1941 in advance of Wartime impact and published by P. Christie (1985). The surviving record of the 1941 excavations was partially incomplete and linked with several other North Cornish Coast barrow excavations, hence the omission of certain details of barrow construction burials or features in both the published account and this account (Christie 1985).

#### **Treligga 1 (SX04438573)**

This site is the northernmost of the group of Sites 1, 2 and 5, and lies just above 250 feet O.D. The site consists of at least four cremations which were covered by a slate cairn kerbed with a ring of white quartz, which was interspersed in the east and north-east with slate. At the geometric centre of the later cairn funerary participants may have removed a stone, or dug a small pit. Slightly northwest of this hole they dug a pit which they filled with the cremated bones of a young adult (Burial 1), possibly female, which they covered with a layer of shillet and turf. Most parts of the body were represented. Slightly north-east of the central hole they excavated another pit into the shillet into which they deposited the cremated remains of an adult (Burial 3). This cremation included the bones of the skull, longbones, vertebrae and other unidentified body parts. Mourners also deposited another cremation (Burial 4) in the south-east of the barrow in a rock cut pit accompanied by reddish burnt earth, and charcoal. This was an adult individual between the ages of 17 and 24. All parts of the body were represented except the feet. In an alcove within the northeast of the cairn near or partly under the kerb the mourners also deposited two hot cremations (Burials 2 and 2a - one perhaps lying just north of the other) and a considerable quantity of



charcoal and burnt stone. Some rocks surrounding the burials were also reddened. One individual was an almost complete, possibly female adult between the ages of 17 and 25. A second adult individual was represented by mainly skull and long bone cremated fragments, though the entire body was cremated. The burials were accompanied by a bronze awl or pin with broken distal end. Fragments of a small undecorated vessel in gabbroic fabric were possibly recovered from this site, and a holed stone and some flint were recovered from the south-west quadrant. The mixed slate and quartz kerb on the east points to possible prehistoric intrusions into the barrow, perhaps related to the eastern double cremation deposits.

#### Treligga 2 (SX04508559)

This site lay some 200-300 m south-east of Site 1 at a slightly higher elevation. Activity began at the site with the creation of a rock cut pit roughly central to the overlying monument into which mourners placed the cremated skull, long bones, hands, vertebrae and torso bones of 1 or 2 adult individuals, one male, and some oak charcoal within a matrix of soil. They placed a cup marked stone at the western edge of the pit. To the east of the pit they lit a fire, possibly the pyre. They scattered a great deal of charcoal all around the pit. They covered these burials with a small mound of clay and shillet some 1.8 m in diameter. They also laid an upright incomplete Style 2 Trevisker vessel (F4) with gabbroic fabric at the north-east edge of this mound. A slate slab was erected between it and the mound. Three large stones (l,m,n) lay in an arc to the south-east of the inner mound. They covered this mound with a mound of primarily slate, and quartz with a corbelled roof containing a large slate capstone. They enclosed and covered this structure with a cairn of inclined slate slabs and some quartz stones, and revetted it with horizontally laid slate slabs. A stone marked with 4 cup marks formed part of the kerb on the north side, and on the south-east a blue slate slab forming part of the kerb was associated with an oak peg or twig. On the east, a large stone in the kerb wall was underlain by a pocket of peat which in turn was overlay a cupmarked stone underlain by charcoal. Two small stones on the south-west just inside the kerb were cup marked. Just west of the cairn was a stone marked with three cup marks, and another cup marked stone lay just to the south of the cairn. Three charcoal patches were found just outside the cairn on the south-east,



north and north-east. Under the kerb wall in the south-east mourners had deposited the cremated skull and longbone fragments of an adult, possibly male in a pit, which was accompanied by black peaty soil (F3). One side of the pit was covered by a black and red deposit, and the surface next to the pit had been thermally altered. A radiocarbon date, from a secondary context of the site yielded a date range of 1887-1495 BC (HAR8100). A possible slate spindle whorl was recovered from the site near and east of the Trevisker urn as well as two unstratified flints.

#### Treligga 5 (SX10538552) and Treligga 7 (SX04318515)

Treligga 5 was badly recorded, but seems to have consisted of a slate covered pit (F1) 0.53 m in depth and 0.53-0.36 m wide containing a Style (5) Trevisker vessel lying on its side (containing a fatty deposit), as well as charcoal, earth and some cremated bone fragments, which may have been interred when hot, and covered with a slate capstone and possibly packed around with slate fragments. To the north of this pit mourners had deposited small cremated skull and longbone fragments of one individual in a rock cut pit 0.3 m in depth and 0.50 m wide. These deposits were then covered by a tall oval stone and earth cairn which may have had a revetment wall. A low wall surrounded the crest of the mound.

Treligga 7 was the southernmost site of the group when encountered, and lay some 450 m to the south of the other sites. Its mound structure bears more resemblance to the other north Cornish coast sites detailed above. Unfortunately, the site was damaged by heavy machinery before excavation and moreover, was not completely examined. Based upon this limited record, the earlier activities at the site involved the possible removal of A-horizon from the site area followed by the creation of a number of features on this surface over which a mound and associated ditch were constructed. Roughly central to the site mourners erected two possibly quartz orthostats. Roughly 1.2 m to the west of the orthostats, mourners constructed a rectangular cist into which they placed a grog tempered inverted undecorated tripartite food vessel which had a fatty deposit on its interior. These features were enclosed in a wall which may have encircled the deposits. The wall was constructed of a base of quartz boulders ( and one large cupmarked stone) and upper slate slabs. The wall, if complete would have measured some 4.8 m in diameter. Under the north-



western line of the wall mourners had also built a small cist. Within and over the stone wall they possibly erected a small mound of pink clay and shillet which contained some charcoal. Over this they built a mottled yellow subsoil mound some 16 m in diameter, which was surrounded by a narrow ditch, which possibly provided the material for the mound. An earth and shillet cap overlay the mound. A small blade and a broken flake were found inside the wall.

#### Lousey Barrow (SX13149321)

Lousey Barrow lies roughly central to a large open cemetery of at least 12 barrows on Tresparrett Down which lie in groups of threes arranged along a sandstone ridge at 861 feet O.D. perpendicular to the coast between Fire Beacon Point and Cambeak. The ridge lies generally within the Upper Carboniferous shales of the Culm Measures (Christie 1985). Due to its large size and wartime use by the Home Guard, the site was not fully excavated, leaving unanswered the question of whether or not the upper barrow caps were related to the original deposit or subsequent, unrecovered burials. Activity began at the site when mourners deposited some cremated bones on a turf surface accompanied by two white pebbles. This deposit accompanied an extended skeleton (F2) which they laid just to its east or west. They then scattered (or smashed) sherds from two Beaker vessels (at least one incomplete) and possibly some wood around these burials on the turf. One vessel was a zoned comb impressed pot matched by vessels in Case's Middle Style/Lanting Van der Waals' Steps 2-4 groups. The other vessel with a incised zoned decoration and slack profile, appeared as a Case's Late Style/Lanting Van der Waal's Step 6/Clarke's S3 or S4 Beaker. Both vessels contained grog temper and additional (though distinct) local inclusions. At some point mourners had erected a stake to the east (F6) of the burials and deposited a small amount of charcoal (F4) to the south. To the north-west of the burials mourners had erected an arc of three contiguous slate stones, and an inclined slab lay to the south of the burials. These may have been the remains of 5 cists containing food offerings and white pebbles reported by Croft-Andrew. The funerary participants then built a cairn of slate slabs which measured 13.4 m in diameter and stood 1.5 m tall over the deposits. A large white quartz block was incorporated into the cairn over the cremation. This cairn was revetted or edged with a ring of



upright slate slabs or orthostats. They slowly capped this cairn with a layered and trampled mound of turf with adhering subsoil, stopping during the first layer to light a large fire just above the western edge of the cairn. This cap heightened the mound to 2.2 m and extended its diameter to roughly 22 m. This phase of the barrow may have been revetted by a drystone slate wall, which also retained the upper cairn to a height of 0.39 m. They then capped this mound with an upper cairn of yellow clay and stone which heightened the barrow to at least 3 m. At some point they erected a post in this cap along the south slope of the barrow. The material for this outer cap and probably the turf underlying it came from a 1.5-2.7 m ditch surrounding the mound and separated from it by a berm of 1.5-2.1 m. The ditch had a narrow flat bottom, sloping sides and had been dug to a depth of 1.5 m. At some point mourners erected a posthole 3.6 m south of the ditch which lay in a direct nearly north/south line with the primary posthole and the one erected in the final cap. Before the ditch began to silt a cupped sandstone pebble with a utilized edge was thrown into it.

#### Tregulland (SX220867)

This isolated site was located at 895 ft. O.D. just below a ridge top on a south-east spur of Davidstow Moor drained by the River Inny to the west and tributaries of the Tamar to the east (Ashbee 1958). The site lay some 1200 m south-east of a barrow group on the ridgetop of Wisley Down on Devonian Slate. Activity at the site began in a rough hazel woodland near some agricultural activity. Two stake circles were erected on the site. The larger of the two measured 7-8 m in diameter. Within it lay a smaller 4 m post circle. Within the central circle but central to the larger circle mourners dug a rectangular grave pit (possibly slate or quartz lined, or covered) with a rough east/west axis. This had been disturbed historically during wartime and possibly earlier. Its fill yielded some cup marked slate stones, a plano-convex knife, and two undecorated pot sherds. A cairn ring constructed of slate blocks, and banked by smaller slate and quartz stones was probably built with, or just after the two rings. Its outer edge coincided exactly with the outer circle, while its inner edge corresponded roughly to the inner circle, though in places it failed to reach, or overran it, suggesting that the inner circle at least was withdrawn



before the cairn was built. The construction of the cairn was far more substantial and careful on the northern side, gradually thinning towards the south-east where there was a slight gap. One of the large slate boulders to the north of the cairn ring had cupmarks on its interior face and was inclined towards the centre of the enclosure. Numerous cupmarked slate slabs were embodied in the outer smaller banking stones of the ring and a large non-local cupmarked sandstone slab surmounted the cairn at its highest point. One undecorated potsherd was found in the inner wall face. An inverted, shattered but complete Form 3 undecorated Food Urn containing local tempering materials was found against the inner cairn wall in the south-east on the old ground surface. An unidentified deposit of cremated bone lay nearby. An irregularly shaped shallow pit was dug through the old ground surface on the berm in the north-east just outside the cairn, in which a fire was lit. The pit was then quickly backfilled with soil which had been burnt a vivid orange/brown along with some organic matter which appeared black when excavated, as well as large amounts of splintered vein quartz and one slate slab. After this filling took place mourners carefully covered the pit with turves, rendering it almost invisible to the modern excavators. In the south-east quadrant just outside the ring cairn funerary participants also excavated an oval pit 0.38 m into the subsoil oriented roughly east/west, which they also covered with carefully replaced turves. On a brown soil at the base of the pit they deposited the roughly complete cremated remains of an adult between 20 and 30 years old accompanied by the cremated tooth and metapodial bone of a Bronze Age ox. Somewhere in the grave pit they also deposited one barbed and tanged arrowhead, and one hollow based arrowhead. They then tamped down a clay layer which filled the remainder of the pit (though separate from the cremation by an air space). The cairn ring was built concurrently and supported by an outer buttress roughly 5 m wide which consisted of a combination of compact ochreous clay, dark loam, and clay and slate fragments (four cupmarked) and two slate discs. While this was taking place, the funerary participants also built an upper turf buttress for the cairn ring, which extended to its outer edge in the south-east, compensating for the small size of the ring cairn in this area. These buttresses covered the ritual pit and the cremation pits and extended to the edge of a ditch, from which their material was derived. The ditch was 2 m wide and 1.2 m deep and had a diameter of 16.5 m. This ditch possibly cut an earlier outer stake circle, evidenced by six



postholes on the south-east of the site. The funerary participants then constructed a final mound of clay and small slate fragments (probably derived from the lower ditch) which covered all the above features apart from the ditch. The outer mound contained two slate slabs, one elaborately cupmarked and channelled lying above the cremation pit. A kerb of slate slabs lay around the final mound, just at the inner edge of the ditch. The ditch fill, which accumulated after the completion of the structure contained a sandstone rock with an hourglass perforation, a slate disc and three cupmarked slabs or stones, one quartz.

## **Bodmin Moor**

### **Davidstow Moor Cemetery (SX124850)**

The sites examined below belong to a large barrow cemetery which lies on a northern ridge of Davidstow Moor between the Crowdy Reservoir and the River Inny at 900 feet O.D.. The cemetery lies on the Upper Devonian Slate at the northern edge of the Bodmin Moor granite mass. The cemetery forms a rough north-west/south-east open roughly linear arrangement along the prevailing landform, with five sites lying somewhat separated from the main group to the north and south-west. Fourteen sites were excavated by C.K. Croft-Andrew from 1941-1942, and subsequently published by P. Christie in 1988. The sites were all quite low when originally examined due to a long period of agricultural disturbance. Because of this disturbance, and problems with the recordation and archival of the sites and their contents during the original excavations, some uncertainties and omissions may occur with respect to the details, context, location, and relationship of certain barrow features, finds, and associated material in the following account (Christie 1988).

### **Site XXVI**

This barrow lies just over 1200 m north of the northeast terminus of the main barrow group. It was badly mutilated by ploughing and some looting, rendering the timing and location of certain of the



features in the earlier phase somewhat unclear. This site was the most structurally complex of the group, and may have been in use for at least 500 years, based upon the radiocarbon dates and ceramic evidence. Activity probably began on the site with the digging of several pits and the deposition of a small number of Durrington Walls Type Grooved Ware sherds, all of which were possibly overlain either by an old land surface or A-horizon through which later features were created. Earliest among the activities on the site, a large pit (P6) was dug, and lined with oak, hazel, willow/popular, heather, and Leguminosae charcoal. A radiocarbon determination from this charcoal yielded a date range of 2896-2570 BC (HAR 6624). Roughly 2 m to the south-east of this pit another pit (F8) was dug and lined with charcoal. It was overlain by a cairn of slate and quartz which may or may not have laid above the old ground surface. A third trench-like pit lay to its north-east and may have intersected it. This pit contained discoloured soil and oak bark charcoal. A fourth feature, which may have belonged to the subsequent phase of activity on the site was a fire which had been lit upon the shillet roughly 1.5 m to the south-east of Pit F5. It was associated with a group of unburnt stones which lay above it, and one grog tempered and three stone tempered plain body sherds which lay next to it. A layer of grey clay interpreted as an old land surface lay over these features and was probably stripped of turf. Into this surface at least two pits were dug, and encircled by a ring of stone, posts or pits which formed an internal revetment to a ring cairn. A historically disturbed pit (Pit 2) was dug north-west of the earlier pits and through the old land surface. It was partially covered by a stone and yellow subsoil backfill from an adjacent pit (Pit 1). Parts of a possible slate cist were found in the upper part of the pit and at its base were fragments of cremated bone (now lost) and charcoal mixed with subsoil and shillet. Other finds from the pit were 2 flints, two holed stones, and a notched stone. Pit 1 to its south-east had a historically disturbed upper fill. At some point a small Beaker with an unzoned incised lozenge decoration belonging to Clarke's Final Southern Group had been placed upright at its base, surrounded in some sort of organic matter, and filled or associated with fragments of cremated bone and charcoal. The disturbed upper portion of this pit contained yellow subsoil. A low cairn may have covered Pits 1 and 2. Pit 2 was central to a circle of 36 stoneholes, or postholes, some of which had packing. The ring measured 11 m in diameter. The contents of these pits (stones or posts) had been removed in



antiquity. A possible entrance to this circle lay towards the south-west. Opposing this possible entrance were two extra post- or stone holes (F11, F12) which lay just outside the main circle. A slight gap between two holes also lay on the south-east, near the fire and another outer pit (F6) which lay below the old land surface. All the features described above apart from F13 lined up along this gap along a north-west/south-east line orientation. A rough irregular ring cairn of small stones roughly 2 m in width and 11 m in diameter lay around the central feature area. Its inner limit coincided with the circle of pits/post sockets, and its outer diameter was 12.5 m. A deliberate wall face occurred between stone/post holes 19 and 20 along the south-east/north-west axis. There was a gap in the cairn roughly corresponding to the gap in the stone holes to the south-west. Under the cairn, on the ground surface near the stone/post holes and within the cairn itself, mourners had deposited between 30 and 40 pitted perforated or notched stones. A slate disc with a possible anthropomorphic representation also came from the cairn. A fragment of a slate vessel with a blackened interior deposit was found outside the ring cairn to the south-east. An incised pebble and a possible hammer stone were also found, unstratified. It is unclear how long the site appeared in this form, but at some later date, a turf and clay platform mound 13.5-14 m in diameter probably covered all the features within the cairn ring. A continuous shallow ditch which possibly provided the construction material for the mound closely surrounded the entire monument. A number of other trimmed holed stones were found throughout the monument. Most were slate, one was greenstone. A large amount of flint consisting of tools and waste flakes was recovered from the site in all quadrants and at all levels.

#### Sites XXV and XXIV

These two sites lay roughly 610 m south of Site XXVI and some 600 m north-west of the main group of barrows. Site XXV lay just over 6 m to the north of Site XXIV (though is pictured to its west on the main cemetery plan). Activity at the site began when mourners may have stripped a portion of the turf from the south-east portion of the site area. They then excavated a pit (central to the later mound) into the subsoil which they may have covered with a quartz cairn. It had been historically disturbed but contained charcoal and a turf fill. They also excavated a small round pit 0.30 m in depth 2 m to the east of this pit,



which they filled with shillet accompanied by an organic substance which stained it. The funerary participants then constructed a circular turf mound which also incorporated some yellow subsoil over the pits which had a diameter of 10-11 m. Two flint blades and one core were recovered from the mound.

Site XXIV had been severely damaged by agricultural activity, scattering the burial deposit, and some doubt exists as to the exact position of the charcoal deposit and the stones (Christie 1988: 99,100). The old ground surface which the barrow stood on may have been cleared in antiquity. Into this surface mourners dug a large oval bowl-shaped pit into the subsoil which they lined with shilley clay at the bottom and filled with a yellow stained subsoil and shillet mix. The original contents of the pit are unknown. The pit lay roughly central to the later barrow. Partially overlying this pit and extending to the south was a spread of charcoal, possibly from a fire, which was partially overlain by some burnt quartz stones. Charcoal from this feature yielded a date range of 1980-1520 BC (HAR8098). A large number of quartz stones lay on the old ground surface, especially on the south-east and north-east. These stones may represent a destroyed ring cairn or platform, which stood no more than 0.3 m in height. Under these stones on the northeast a holed slate stone was found. Roughly 6 m to the south-east of the large pit was an elongated grave-like pit oriented north-east/south-west. It contained loose darkened yellow shilley soil and quartz lumps. Two dark streaks of ?silt, on the base and halfway up in the fill were observed by Croft-Andrew. Just north of this pit was a small depression (possibly a posthole), containing soil and charcoal. Another possible post may have stood just south-west of the charcoal spread. An elliptical turf and clay subsoil mound (possibly flat and at least 14 m in diameter) overlay all these deposits. Either at some point after or during its construction, mourners built a cist of stone and turf, roughly central to this mound (which was disturbed historically) which contained fragments of cremated scapula, skull, longbone and a number of unidentified adult bone fragments. Two Trevisker Style 1 gabbroic vessels may have accompanied this burial, one possibly complete, and the other represented by only one sherd. Nine additional holed slate stones were recovered from the barrow, as well as a large quantity of flint flakes and a few tools, second only to the number recovered from Site XXVI.



## Site I

This barrow lay approximately 472 m south-east of Site XXIV, and some 152 m north-west of Site II. Three main "phases" of activity can be postulated for the site, the first involving a number of activities involving fires/charcoal deposition and pits taking place on a turf surface in a ritually defined space, followed by the mounding over of that space and some activities on the mound, terminating with a final mounding over of the site. It is difficult to be sure what activities taking place on the turf surface were subsequently covered by the initial turf mound and therefore relatively contemporary, due to some question about the size of the initial turf mound. Activity may have begun on the site when funerary participants demarcated a circular area some 26-28 m in diameter with a shallow trench. The excavation of this trench could have also taken place at any point during the history of the site. They possibly then removed and retained a circular ring of turf within this area, leaving a central circular platform of turf. The exact dimensions of this platform are unknown but probably extended some 9-12 m from the site's centre. They then built a stake ring or fence with a diameter of 21 m. The south-eastern quarter of the ring was left open, though a small line of stakes in the south-east on the original line and just outside it indicate some additional component to the structure in this area. The ring had a number of extra posts in the north-west and south-west. At the centre of the ring mourners excavated a hollow into the turf and backfilled it with turf, accompanied by three pieces of quartz and some oak charcoal. This hollow was capped with white clay, then the mourners built a small mound of turf, followed by white clay followed by turf over this. This mound was 1.4 m wide and 0.30 m in height. Some 4 metres to the north of this mound they deposited a steep sided small mound of charcoal (Fire 1) which contained 5 fragments of cremated human bone (two of which were teeth fragments). The charcoal came from hazel, heather, oak, hornbeam and leguminosae woods. A radiocarbon date from this deposit had a range of 2112-1645 BC (HAR6634). Just to the south-east of this they deposited a smaller spread of charcoal along with some red and white unburnt clay on the turf (Fire 2). Six other fires or spreads of charcoal lay within the stake ring. Fire 3 lay to the north of 1 and 2, and consisted of a mass of charcoal and ash which had thermally altered the mound soil above it, but like Fires 1 and 2, did not burn the underlying turf, suggesting a deposit of charcoal rather



than a fire. Fire 4 overlay a patch of yellow subsoil and consisted of red clay and leguminosae charcoal associated with three pits filled with oak charcoal and a small complex of irregular depressions and small pits which extended into the subsoil which may represent a burnt tree. Fire 5 was a burnt patch of turf and oak charcoal which lay above the surface. Fire 6, to the north-west consisted of a patch of oak and leguminosae charcoal on the old surface. Fire 7 lay just to the north-east of Fire 3 near the stake circle/fence and was probably a small fire which burnt hazel wood. Fire 8 lay 15 m to the south-east of the central deposit near the isolated arrangement of stakes and consisted of an area of charcoal associated with a large posthole which possibly burnt. To the west of the small central mound mourners also excavated a small pit 0.15 m in depth which was filled with turf and white clay and charcoal. This lay within a number of small stakeholes (IVC) and near three oak objects (IIIA-C) which had been thrust through the old land surface into the subsoil. One appeared to be a post, one looked like a club or ard, and the third was a small triangle. An associated patch of oak charcoal lay nearby. Two additional wooden objects (IIID,E), one resembling the club noted above, lay on the old ground surface to the north-east and north of the mound centre. Two small pits lay along the line of the stake circle in the north-east and south. Pit IVA was circular and 0.94 m deep. The funerary participants had filled it first with black soil, followed by turf, followed by subsoil. The southern pit was a shallow depression some 0.15 m in depth. These features, apart from the possibly the charcoal patch near the entrance and Pits IVa and b were covered when mourners built a flat topped turf stack which, in places lay well within the ring of stakes. As noted above, there is some confusion in the published report as to how wide this turf stack is, since the quoted diameter does not match the section drawings which are consulted here. After the completion of this mound (which stood at least 0.75 m tall), mourners burned of 6 fires on the east side of the mound, and participated in activities resulting in the deposition of a large number of quartz stones, a scatter of gabbroic sherds from an incomplete probably Trevisker Style 1 vessel (Parker Pearson, pers. comm.), two plain body sherds from a grog tempered vessel, as well as a flint blade and some flakes. On the south-west side of the mound some evidence of the consumption of cooked or at least burnt crab, lobster and crayfish remained. After these activities had been completed, mourners added a flat topped layer of homogeneous earth over the turf stack



and the outer features which extended the diameter of the site by 3-3.6 m. There is some uncertainty, based on the report text and section drawings as to whether this final cap to the barrow, or the earlier turf mound was edged or revetted by a double ring of stakes, or a fence.

Two irregular low mounds of black peaty soil some 0.8 m to the east of the barrow overlay one, possibly two graves associated with Medieval pottery. The graves contained charcoal, some timber, stratified fills and organic stains. One was overlain by a pile of stones.

Unstratified and residual artifacts found during excavation consisted of some flint tools and flakes, a cupped stone, a slate disc and 2 hones.

#### Sites II and IIA

These sites lay approximately 152 m southeast of Site I, and very close to one another. Due to extensive plough damage, a sketchy original site record, and an absence of radiocarbon dates, little can be said with certainty concerning the sequence of activities and forms of these sites.

Site II consisted of a continuous flat bottomed (V-shaped on the north and east) ditch which extended to a depth of 0.60-0.90 m which was possibly laid out from a central stake hole. On the inside and outside of the ditch were interior and exterior low banks, which mourners had constructed of yellow gritty subsoil, presumably from the ditch. The inner bank may have had a turf core or, a layer of turves predating the inner bank may have covered the internal area. Overall the site had a diameter of 20 m. The contemporaneousness of the banks and ditch with the following is unclear. In the centre of the ditch/banks enclosure a small quartz cairn 2.4 m in diameter had been built on the old ground surface which overlay some charcoal which was found within the subsoil. Twelve additional quartz stones within the central area lay to the north and south of the cairn. In places the cairn was so low it appeared more like paving. A turf mound had been built over the cairn. A trimmed slate disc and a granite pebble were found in the northwest quadrant of the site and several chert and flint flakes and tools were also recovered from the site. No mention is made of items "pot 2" or "pebble 3", marked on the map at the ditch edge in the west. After the primary silting of the ditch (which consisted of slip from the banks) mourners deposited some



carbonized wooden objects and a large number of quartz stones and a few slate stones into it on the eastern side of the site. The primary fill of the ditch was separated from a secondary gravel fill by a band of peaty soil, perhaps representing a period of inactivity at the site followed by further construction or deliberate infilling of the ditch.

Site IIA lay immediately south-east of Site 2. It consisted only of a circular hollow approximately 5.2 m in diameter which extended to a depth of 0.03 m below the modern ground surface. No finds were associated with the site, and it was thought by Croft-Andrew to represent a "pond barrow".

### Site III

This site lay 258 m south-east of Site I, and 122 m east/north-east of Site II, which it most resembled. Activity probably began at the site with the excavation of a narrow shallow circular ditch which provided the material for a low internal yellow subsoil bank with a turf core. The ditch was shallowest and widest in the south-east, coinciding with a 5 m gap in the bank to the east/south-east. The site at this point had a diameter of just over 9 m. At some point after its construction, slightly to the south-east of its centre mourners built a very low cairn or platform of quartz stones on the old land surface. On the top and partially within this cairn they laid some cremated bones of an adult between 25 and 35 years in age which consisted of tooth, longbone and tarsal fragments accompanied by the burnt fragments of an immature pit and other, non-human unidentified bone fragments. The cremated remains were possibly enclosed in a bag and surrounded by roots. Under the deposit mourners had placed two fine grained granite hones, or utility stones. Charcoal from the old land surface at the centre of the site yielded a date of 2409-1940 BC (HAR6640). Soon after its creation, mourners covered the cairn platform and cremation deposit with a circular turf mound 4 m in diameter, leaving a berm between it and the bank/ditch. On either side of the mound to the north-west and south-east were two hollows under the old ground surface.

Following the construction of the ditch, a period of inactivity occurred at the site during which the ditch silted up, and some turf regrowth took place within it. Activity then resumed at the site with the construction of a large wide bank of yellow clay subsoil, burnt red clay and white/buff unburnt clay across



the gap in the bank, partially covering the northern portion of the ditch, enabling access to the enclosure only at the southern end of the gap in the bank. The old ground surface within the enclosure near this entrance in the south-east had been heavily trampled. Directly before or as an earlier part of the construction of this outer bank, the ditch across the gap had been spread with red and white burnt and unburnt white and yellow clay (like the mound). This surface was walked across many times. In addition to activities within the enclosure at this time, a number of activities also took place on the surface of the blocking bank, evidenced by a considerable amount of charcoal at its south end, and patches of burnt clay and two flint scrapers on its surface to the north. One could interpret the sequence of activity in two ways at the site, seeing the ditch and bank as primary features, followed by the silting of the ditch, the central deposit and mound, which were contemporary with the outer bank and associated activities. Alternately, the central deposit, mound and ditch/inner bank could have been roughly contemporary.

#### Site IX

This mound lay just over 914 m southeast of Site II. Unlike the sites just described, Site IX consisted only of a patch of burnt clay on the old ground surface, possibly from a fire in place which was overlain by a small elliptical turf or soil mound oriented south-east/north-west. The deposit lay just east of the mound centre. The mound dimensions may have been roughly 5 m by 6 m.

#### Sites IV, IVa, VI

This group of sites lay in a north north-east to south south-west line, roughly central to the barrow complex. Site IV which lay in the centre of the three was situated roughly 487m southeast of Site IX. It consisted of a low turf platform surrounded by, and joined to a low circular bank constructed of turf clods and yellow subsoil. The bank, which had a diameter of 23 m may have appeared predominately yellow in places and may have had a turf core. A serrated blade was recovered from the south-east quadrant on the site.

Site IVa consisted of a small pit roughly 30 m south-west of Site IV with a flint flake at its base, which had naturally infilled with an accumulation of silt and peat.

Site VI lay roughly 45.7 m to the north-northeast of Site IV, and like Site IIA, consisted of an oval excavated depression 9.1 m in diameter and 0.6m in depth when excavated. This contained a thick even layer of quartz gravel at its base (naturally or artificially placed) which underlay a layer of brown clay with gravel. A hollow way which linked this site to Site IV, also contained this brown gravel fill. Christie (1988:74) suggested that this site may represent a ritual quarrying area for the adjacent turf platforms at Site IV.

#### Site VII

Site VII lay 119 m south-east of Site IV. Activity began with the stripping of the turf and topsoil from a circular area, exposing a gravelly yellow subsoil. This was used to build a low continuous bank with a diameter of 7.62 m and a width of 1.2-1.5 m. In the centre of the depression the builders excavated an oval pit 0.38 m in depth which had been filled a black clayey fill into which were placed two large quartz stones. On the rim of the pit to the south-west were a flint borer and three slate fragments. A fragment of burnt mollusc shell was also recovered from the site.

#### Site V

This barrow lay alone c. 365 m to the southeast of Site VII. It differed sharply from the central barrows of the cemetery, being comprised of a number of features overlain by a composite barrow. There is some confusion in the published report as to the placement of the stone revetment in the mound, and the size of the mound when complete. Although Christie (1988:83) ignores Croft-Andrew's assertion that the total site diameter measured 24.4 m based upon her interpretation of the plans, it is clear from the section drawings that his figure refers to the edge of the 2-3 m wide yellow revetment/bank, and that the turf stack is revetted by a slate and quartz kerb. My description of the features is based upon this interpretation of



the material.

Before any other activity began on the site, mourners stripped the old ground surface in a number of places in the area under the later turf mound. In the east of this stripped area they dug a shallow depression, filled it with charcoal and white clay, and covered it with a small cairn of quartz (F1). They covered this feature with a large platform turf (with adhering subsoil) mound with sloping sides and a diameter of 18 m, into which they erected 7 stones set in an arc at its north-west edge. Opposing these stones just outside the mound edge on the old land surface a number of activities took place, either before or after the construction of the mound. A deposit of charcoal (oak, hazel and leguminosae) and clay was placed on the old ground surface just at the edge of the mound and covered by a very low cairn of quartz and some slate. This charcoal was radiocarbon dated to 2140-1739 BC (HAR 6635). A large quartz stone in the cairn covered a small pit 0.10 m in depth which had been filled with charcoal and then sprinkled with some yellow material (?subsoil) around its upper edge. Against the south-east edge of the cairn the funerary/ritual participants had erected some timber posts, one of oak. A large oak post with packing stones which had been erected south-east of these (F3) had burnt in place and was then removed. Five metres north-east of the cairn participants excavated a small circular pit 0.10 m deep in which they placed an upright miniature plain grog and local tempered Early or Middle Style Collared vessel. A scatter of charcoal surrounded the pot rim and the edge of the pit. It contained stiff clay, and at some point, wood resin and fatty substance. At some point after its construction, the turf mound was revetted or kerbed with slate and quartz. In the north-west a large long stone of elvan or granite may have stood upright as part of this kerb. It is not clear to what degree this revetment/kerb was present on the south-east in the vicinity of the features. The site at this point measured around 18 m in diameter. Near the kerb in the south-east quadrant several trimmed slates, (one holed) were found above the ground surface. At some point after this kerb was constructed and the activities to the south-east completed, mourners built a revetment or bank around the mound comprised of turves and yellow subsoil which covered the features. The bank was 7.2 m wide and increased the site diameter to 25.2 m.

## Site XIX

This barrow lay roughly 488 m southwest of Site IV, and south of the main cemetery group. It was badly truncated by plough and heavy machinery, disturbing and almost obliterating both the south and the north parts of the site to a depth below the old ground surface. Thus, any further features than those described which the site may have contained were destroyed. Activity began on a turf surface when mourners excavated a slightly oval pit with sloping sides 0.30 m deep into the subsoil which they first lined with elvan slabs. They then filled the base of the pit with two layers of slate and elvan separated by an unknown deposit which appeared as a layer of greasy silt. They then placed a cremation (possibly in some sort of container), possibly representing a young adult consisting of skull, longbone and carpal fragments into the pit, which they covered with a black clayey fill and a group of small flat stones. The top of the stone cover of the pit was corbelled and then covered by a very small cairn. A large, low oval mound oriented north/south covered the deposit which measured roughly 11 by 13 m when excavated.

## Stannon Downs Cemetery

The three Stannon Downs cairns examined here form part of a group of 13 cairns in small clusters of one to four sites on a northwest facing granite ridge spur just over 1 km west/northwest of Rough Tor at 875 feet O.D. (Harris, Hooper and Trudgian 1984). Approximately 1 km to the south-west is the Stannon Downs Bronze Age settlement. Cairns 1 and 2 lay together, and Cairn 3 lay some 70 m to the south-west.

### Stannon Downs Cairn I (SX13448101)

Activity began on the site with the clearing of large moorstones from the immediate area. Then, mourners dug a large circular central pit with sloping sides 1 m into the subsoil which they lined with small stones. They then enacted three consecutive burnings of large chunks of wood in the pit, which they separated by deposits of turf and burnt earth. Smaller pieces of charcoal covered this fill and then the pit was sealed by some yellow/orange gritty subsoil. They then smeared this with soil from the original land



surface and laid a flat granite stone over all. The feature was then covered by a low spiral cairn of granite stones begun from the centre, which alternated in places with smaller chocking stones, ending in larger stones. The cairn was roughly 4 m in diameter and not more than 0.50 m in height. A rectangular lava whetstone and a rounded oval pebble were found among the lower cairn stones. A wall of granite stones joined the cairn at the south-east and north-west, and may have circled around the barrow to the north.

#### **Stannon Downs Cairn 2 (SX13448102)**

This cairn lay roughly ten metres to the north-west of Cairn 1. It had been disturbed by heavy machinery, but a plausible sequence of events was reconstructed by the excavator. Mourners began by removing the turf in the area of the later cairn, exposing the yellow/orange gritty subsoil. They then dug two pits. The first was an elongated grave like pit oriented north north-east/south south-west, which extended to a depth of 0.30 in the south and 0.40 in the north. It may have contained a burial, removed or rotted in antiquity. They filled the pit with dark brown or black soil. The second pit was small and round and lay just to the west of the first. It had been filled with black soft soil with charcoal fragments. A radiocarbon date for the charcoal fell between 1926-1601 BC (HAR5130). A small fragment of red ceramic was found on the stripped surface between the two pits. The funerary participants then constructed a cairn of granite stones over the pits. Details of its form are unknown.

#### **Stannon Downs Cairn 3 (SX13408095)**

This cairn lay roughly seventy metres south-west of the first two, and was attached to a stone walled enclosure to its south-west, into which it may opened. This irregular oval enclosure had an entrance just south-east of the cairn and a further wall curving to the south. Activity may have begun on the site with the erection of two stone rings or the excavation of a large round pit central to them. The pit was excavated through the old ground surface to a depth of 0.56 m into which mourners placed an inverted granite, quartz and mica tempered Style 1 Trevisker urn with a crack and repair holes. It was covered with yellow/orange subsoil upcast from the pit. Mourners had filled the urn with the incomplete cremation of an

adult, followed by a layer of bone-free soil, on top of which lay the incomplete cremated remains of two adults (one certainly male) and a fragment of a small ring-headed bone pin (from a small animal longbone) similar to those found in association with Wessex II burials elsewhere. Covering this was a further layer of stony soil and fragments of cremated bone. The pit was covered with a granite capstone. Near the pit on the old ground surface a thick flint blade with secondary working was found. Two concentric granite slightly oval low stone rings surrounded the pit. The inner had a maximum diameter of 4 m and the outer circle had a maximum diameter of just over 5 m. Both rings were constructed of large granite stones, had regular outer faces, outer revetments in places, and gaps to the south-west. Some quartzite stones were also incorporated into the outer kerb. To the north-west an area of paving was set against the stones of the outer ring. It also had a stone sill across its entrance. A fine grained rubbing stone was found at the edge of the outer ring in the north-east quadrant. On the old ground surface in the southwest quadrant between the two rings was a flat non-local sandstone rubbing stone. When completing the monument, mourners first threw medium sized stones between the two rings. Then they covered the area within the inner circle with a low cairn of medium granite stones, beginning with the pit and working outward. The inner entrance gap was also closed at this time by a rough line of large stones. Finally, further smaller stones were piled all over the cairn and the outer paving, raising the height of the cairn to just under 1 m. The enclosure walls which were connected to the cairn were of similar size to these cairn stones and were probably contemporary with this final phase of cairn construction. At the edge of the cairn under the outer wall in the north-west was a worn and used fragment of a plano-convex knife.

#### Colliford Reservoir Cemetery (SX176714)

The four Colliford monuments now lie under the south end of the Colliford Reservoir, near the southern edge of Bodmin Moor, and were excavated during the 1970s in advance of the reservoir construction. The sites form a small cemetery which originally occupied the eastern and western slopes above the St. Neot River near the southern end of the Bodmin Moor granite below Bron Gelly between 800



and 898 feet O.D.. The sites lay just to the north of a series of prehistoric lynched fields, hut circles, and clearance cairns which lay along the valley. An additional barrow lay on somewhat higher ground between the Colliford cemetery and Dozmary Pool, to the north-east (Griffith 1984).

## Colliford Reservoir II

CR II lay in a steep mid-slope position of the eastern side of the river at an elevation of 817 feet O.D., some 100 m south of two small clearance cairns. Activity began on the site with the erection of a large granite boulder on the old ground surface. Mourners then stripped the site area of its turf, revealing an orange/yellow subsoil before any other activity took place. The little turf which remained as a pile off to the side of the cairn indicated that the site was built in a cleared area of grasses and heather, near to a scrubby wood of primarily hazel and oak, with some alder and birch present. This stripped surface was then the recipient of some activities, the traces of which remained as trampled ground, some scattered charcoal and a flint core. Less than one half metre to the south/south-east of the boulder, mourners excavated a large irregular pit 0.60 m deep into the subsoil which they filled with a homogeneous gray clay loam. To the north of this feature and the boulder was a long irregular curved feature which contained subsoil fill below a gritty soil layer which produced flakes and a barbed and tanged arrowhead. The excavator suggested this feature may be the source for some redeposited material from later layers of the cairn. Overlying the first pit was a discontinuous layer of clay loam subsoil which provided a footing for the inner of two cairn rings. The first of these was 3.8 m in diameter and encircled the first pit and the orthostat. It was constructed of moorstones at least four courses high and packed around with clay. A second less well-constructed ring surrounded the first and was also set into the clay base. It measured roughly 5 m in diameter and partly overlay the elongated feature. Both rings had slight bulges in their western sides.

Soon after its construction, mourners filled the central ring with 5 layers of distinct material, the three lowest perhaps representing the continuation of the central feature. The first was a brown loam containing charcoal and small granite stones on its surface. This was followed by the deliberate deposit of

charcoal from large oak timbers. This yielded a date range of 2144-1809 BC (HAR2624). They followed this by the deposition of a layer of stone with charcoal sheathing and light brown clay with patches of yellow clay. These layers were then covered by a brown and a black layer of stony loam. This infilling may or may not have occurred before both the construction of the outer ring and/or the excavation of the elongated pit.

Just to the south-east of the outer ring were three small near-circular pits in a triangle formation. The northernmost pit was 0.28 m deep and had been filled with a great deal of charcoal in a black soil matrix containing small quartzite water-worn pebbles. It had a clay and gritty subsoil lining and was covered by a granite capstone. Charcoal from this pit yielded a date between 2036-1681 BC (HAR2617). The southern pit was 0.35 m deep, and contained a similar fill but was lined at the top with grayish and yellow clay and covered with three flat stones. A date for the charcoal from this pit fell between 2038-1603 BC (HAR2622). The eastern pit contained a similar fill to the others, but was very shallow and had no cover. Covering all of the above, and infilling the space between the two rings was a loose stone cairn, carefully built only in the south-east quadrant. Due to extensive robbing it is not possible to determine how far it extended beyond the outer ring, but it may have covered the pits.

#### Colliford Reservoir IVA

This barrow lay at an elevation of 837 feet O.D. at the point of a low spur on the slope to the west of the river. It lay 200 m downstream from CR11, and was the most northerly of a generally north-south linear group of three sites. Mourners began by stripping a small part of the activity area of the site of turf in the north-east, and scattering mature oak charcoal (including part of one branch) over the general ground surface. They also scattered another burned substance (possibly peat) which appeared as red and brown streaks across the area. The charcoal was dated to 2038-1684 BC (HAR2884). Pollen from the old ground surface suggested a site environment dominated by grasses, heather and bracken near scrubby woodland, probably in the valley bottom. This contrasts with the picture from the opposite slope. Mourners then built a small cairn 5 m in diameter and 1 m in height, consisting of a random mixture of granite moorstones



and the stripped turf with a outer moorstone shell and a well-made outer granite wall. A small layer of orange clay lay against the cairn on the north-east. This cairn had a possible brown soil cap. Roughly five metres to the north-west of the cairn mourners had erected several orthostats in a line (two forming a wide gateway), set in foundation pits. The yellow subsoil spoil from some of their pits underlay the cairn ring. These may or may not have preceded the inner cairn. A number of postholes lay further to the north-west of these orthostats. Their stratigraphic relationship to the cairn and final site structure is unknown. Soon after the erection of the orthostats and the inner cairn, mourners laid the bottom course of a narrow cairn ring between the inner cairn and the orthostats. It was 13.5 m in diameter and 0.7 m in height and displayed a poor construction in the south-east, and was perhaps begun from the south and constructed clockwise. This ring was immediately heightened and a barrow formed when mourners simultaneously constructed an inverted turf stack possibly over and around the inner cairn and added an upper ring wall with a carefully constructed impressive outer granite stone face everywhere except in the south-east quadrant. Shortly after turf stack was constructed funerary participants mounded up its north-western edge with brown loam, possibly to compensate for an irregular shape caused by the off-central position of the inner cairn below the turf stack. The site was left in this position.

#### Colliford Reservoir IVB, IVC

Site IVB lay between A and C and was quite disturbed. It consisted of several large moorstones which mourners had laid upon the old ground surface. To the east of these they built an above-ground cist-like enclosure with an open top. They enclosed and covered this with a turf flat topped mound surrounded and partially revetted by a ring of fairly massive granite boulders. The mound was roughly 6.5 m in diameter and stood no more than 0.75 m tall. The cist may have protruded through the top of the turf stack. No finds were recovered from the site.

Site IVC was the most southerly of the group and the least well constructed, though some care had been taken during its laying out. Funerary activities began at the site on a turf surface in a similar environment to Site IVA. Mourners began by driving a stake through the old ground surface just north-

west of the centre of the later barrow. Two metres south-east of the stake, and just east of the later barrow centre, they excavated a pit through the old ground surface into the yellow subsoil. The interior of the pit had been burnt to an orange color either by a fire, a re-cremation in the pit itself or perhaps by a deposit of still burning pyre material. The contents of the pit consisted of a rich charcoal deposit surrounding a lump of cremated human bones held together by a matt of roots. After this deposit was made they filled the remainder of the pit with several moorstones and a layer of gray-brown clay topped with a sprinkle of charcoal. Charcoal from the pit (which consisted of charred mature oak timbers) yielded a date range of 2142-1734 BC (HAR2991). Charcoal was scattered in several places around the pit on the old ground surface. A small layer or cap of yellow clay was then placed over the pit which extended towards the east onto the old ground surface. Mourners then built a flat topped turf stack over these features which was surrounded by a granite kerb which may or may not have been freestanding. The barrow measured some 7.5 m in diameter and was at least 0.75 m in height. During the construction of the mound, within the north-east quadrant of the turf stack, mourners deposited a small inverted biconical pygmy cup and packed it around with turves. The vessels fabric contained grog and an unknown temper and was decorated with Collared Urn style twisted cord impressed horseshoe motifs. The cup resembles some Aldbourne cups found with rivetted daggers and Trevisker Style 1 vessels. Above but separate from the pot were some haphazardly placed stones, also within the turf stack. Mourners then built a stone capping to the barrow which was imbedded in the turf stack everywhere except in the south-east quadrant, where a soil formed during a period of inactivity at the site. After this, the barrow was further altered by the addition of a loose capping of small stones, some of which tumbled soon after their deposition.



## DEVON

### Dartmoor

#### Shaugh Moor Cemetery (SX553635)

This group of six sites lay at the edge of a bench on the gentle north facing slope between Saddlesborough Tor and the River Plym at approximately 820 feet O.D. on the granite. The sites lay just north of the Saddlesborough Reave and the Shaugh Moor parallel reave system, and west and below Saddlesborough Tor which lay some 650 m to the south-east. North of the Tor and east of the cairn group lay a stone row circle, a small cairn and a number of hut circles and enclosures which also lie outside the reave system. A second isolated cairn occupies Saddlesborough Tor. The nearest cairn (unexcavated) to the group lay some 150 m upslope to the south-east. It appeared as a flat topped cairn with a kerb of spaced orthostats measuring 9 m in diameter. The Shaugh Moor settlement enclosure (Wainwright and Smith 1980) lay just over 1000 m to the east (Wainwright, Fleming and Smith 1979). Oak charcoal comprised 98% of all the charcoal examined from the cemetery. Small amounts of gorse, heather, mature hazel, hawthorne, and willow were also identified among the charcoal fragments.

#### Shaugh Moor Site 1

Approximately 1 metre to the south-east of a large earthfast granite boulder, mourners dug a conical wide-mouthed circular pit 0.27 m deep into the natural surface and filled it with a small amount of oak charcoal, followed by some charcoal flecked sandy loam. Charcoal from this pit yielded a date range of 2112-1645 BC (HAR2216). A 6-7 m low cairn of granite stones and gravel was then erected over the boulder and pit. Approximately 4 m to the south-east of the first pit, a slightly smaller pit was excavated into the natural surface, and charcoal was spread over a one-metre area nearby. This second pit contained a sandy loam. The chronological relationship between the cairn and the two features to the south-east cannot

be strictly determined from the site stratigraphy. At some later date, a low ring cairn 12 m in diameter was built around all of the above features which also incorporated a smaller cairn (Site 126) into its southern edge.

#### Shaugh Moor Site 126

Activity began at site 126 when mourners dug a moderately sized circular pit 0.30 m deep into the natural surface which they backfilled with fine black loam containing lumps of principally oak and hazel charcoal followed by a gray fibrous soil. Charcoal from this pit returned a date of 1925-1494 BC (HAR2285). Over this pit they constructed a 4 m low topsoil and turf mound with a kerb of large stones. At some point soon after the construction of this cairn, mourners dug a 0.20 m deep scoop into the cairn directly over, but not intrusive to, the first pit. They filled the scoop with orange subsoil and peaty loam containing oak charcoal and capped it with orange subsoil. Charcoal from this scoop yielded a date of 1781-1493 BC (HAR2221). The position of the cairn relative to the ring cairn at Site 1 and evidence for Medieval destruction indicate that the Site 126 cairn was incorporated into the ring cairn, which was constructed subsequent to the cairns on both sites. (Wainwright, Fleming and Smith 1979).

#### Shaugh Moor Site 2

Site 2 lay roughly 15 metres to the south west of Site 1. The site consists of three components, only two of which, the ring cairn and its underlying pit existed in some definable stratigraphic relationship. Mourners dug a medium sized circular 0.27 m deep pit through the old land surface just south of a number of large and medium earthfast boulders, which they backfilled with primarily oak charcoal, and then covered with a capstone. The charcoal could have been contained within a pot, based upon its shape within the pit. Charcoal from this pit yielded a date range of 1695-1367 BC (HAR2214). At some point after its infilling, the pit was covered by a 12 m in diameter low primarily granite and elvan ring cairn, which also surrounded the earthfast boulders and a second feature complex. This complex resulted from a number of activities. First, a fire was lit on the old ground surface central to the earthfast boulders. Through the



burnt surface a circular medium sized pit was dug. Into this pit participants placed a small grog tempered pot base, and seven segmented blue-green faience beads, likely made of local china clay. The pit was filled first with loam, which contained large oak charcoal pieces and second, with a yellowish brown backfill, and then was partially covered with a granite capstone. A date range of 1925-1528 BC (HAR2220) was obtained from the charcoal. A single layer small dark gray turf or topsoil loam mound roughly 2 m in diameter containing the burnt soil and some charcoal was built over the pit. No stratigraphic relationship existed between the loam mound and the ring cairn.

#### Shaugh Moor Site 70

Roughly 15 metres to the south-east of Site 1, two small cairns were constructed. At Site 70, the north-westernmost, activity began on an undisturbed surface when mourners dug two medium sized pits. One (Pit 79) they filled with primarily oak charcoal fragments in a powdery oak and hazel charcoal matrix and then covered it with a capstone. A date range of 1926-1528 BC (HAR2219) was returned for this pit. A metre to the north-west, against the south-east side of a large earthfast boulder they dug a second circular .12 m deep pit through the old land surface which they backfilled first with a gritty loam E horizon followed by a silt loam topsoil. Over these pits they constructed a low stone granite kerbed mound beginning with granite stones, followed by turf, followed by a mixture of both. The monument measured 4.6 m in diameter.

#### Shaugh Moor Site 71

This site lay roughly 5 metres to the south-east of Site 70 on a turf or topsoil surface and was considerably robbed and damaged before excavation. Activity on the site began when mourners excavated a shallow depression which they filled with charcoal. Also included in the fill was a mainly grog tempered plain biconical vessel, which was nearly complete when recovered. More charcoal was also scattered around the depression on the old land surface. This depression lay adjacent to a large earthfast boulder which provided a focus for the site. Against the south-east side of the boulder they also dug a small pit

which was then backfilled with charcoal. This yielded a date range of 1926-1528 BC (HAR2213).

Activities were brought to a close at the site with the erection of a small, low pile of granite, 3.5 meters in diameter which overlay the scoop and pit and incorporated the boulder. It is not known, due to the disturbance, whether the site originally had a turf component similar to nearby Site 70.

#### **Shaugh Moor Site 4**

Roughly 15 metres to the south-east of Sites 70 and 71 lay another site which had been considerably disturbed before excavation. Site 4 consists of a small 3 m stone and turf cairn, which had been built directly upon the old land surface. Surrounding this cairn was a badly robbed thick ring cairn of granite and elvan.

#### **North Devon**

##### **East Putford Sites**

These two sites are located within a partly linear group of eight barrows at Wrangworthy Cross just north of East Putford. This group is part of larger scattered number of single and clustered sites located on the extensive wet plateau between the upper and lower Torridge River at roughly 800 feet O.D., on the Culm Measures. None of the other sites in the group has been excavated, though one barrow to the north-west had a surrounding ditch, and the site immediately to the north-east of East Putford I may have incorporated a cairn structure (Grinsell 1970; Raleigh Radford and Rogers 1947).

##### **East Putford I (SS38391745)**

At East Putford I, mourners laid the body of their kinsman/woman on an undisturbed turf surface, with the head towards the south. Alongside the body, they laid what may have been a long wooden spear or pole. Also accompanying the corpse was a small bronze knife-dagger (measuring 0.10 by 0.5 m and



badly decomposed upon discovery) and a flint blade constructed of local material. They then constructed a log gabled structure over the body which was supported by four large stone packed corner posts. The structure was 2.4 m long, 1.5 m wide, stood approximately 1 m in height and was oriented roughly north/south. Directly after the completion of this log structure they encompassed it within a low turf and soil mound roughly 19.8 m in diameter. Some time then elapsed at the site, during which the log structure collapsed under the weight of the soil around and over it. After this hiatus, the mourners erected a tall pile of red burnt shillet and clay over the collapsed centre of the mound. This was immediately followed by the addition of a gray clay subsoil cap to the barrow which encompassed the burnt pile and enlarged the mound to a diameter of 21.3 m and a height of 1.37 m. No further additions were made to the barrow. The clay was obtained from a 1.5 m wide/deep circular ditch surrounding the mound (which was not completely excavated), and separated from it by a berm of similar size.

#### East Putford II (SS38361738)

This second mound which lay excavated by Raleigh Radford and Rogers lay south-west of the first. According to their interpretation, on an undisturbed turf surface a low platform of turves was erected on which eight inhumations in log coffins were placed in north-south alignments. Over the bodies a low log lean-to was constructed which was open and supported on the south by three large logs. The shelter was approximately 4.87 m in length and 1.8 m wide. A low turf mound capped with topsoil was then constructed over and around the log structure. It was approximately 12.2 m wide.

#### Rose Ash (SS798200)

This pit burial was located on a ridge between the upper tributaries of the Mole and Little Dart Rivers, on Lower Ashmore Farm at approximately 780 feet OD. The pit was discovered by modern ploughing, and no barrow would appear to have been present on the site. The sequence of activities at the site began with the digging of a circular tapering pit 0.55 m in diameter and 0.65 m in depth through a reddish yellow subsoil. Into this pit mourners placed an upright orange vessel containing the complete

cremated skeletal remains of one adult individual. The vessel was similar in size and form to Parker-Pearson's Style T3/4 and Patchett's Class F vessels (though undecorated) and contained grit and sand temper. Surrounding the vessel was a dark gray ashy soil containing large pieces of oak charcoal. The vessel was held upright by a upper cap of yellow clay over which had been placed a single capstone of local marl. Charcoal from the pit filling returned a radiocarbon determination of 1410-1047 BC (HAR2992) (Wainwright 1980).

### **South-east Devon**

#### **Exe Watershed**

##### **Markham Lane (SX91408925)**

This plowed-out site lay just south-west of Exeter near the Exe river, north-east of Shillingford near the eastern end of a ridge on New Red Sandstone bedrock at 55 ft O.D. No other barrows are known in the immediate vicinity, though a low density of funerary sites lies in this area some 5.5 miles south of the Upton Pyne barrow group. All that remained of the site at the time of excavation was a continuous U-shaped ring ditch which measured 1 m wide and .50 m deep. No features were observed in the centre of the ring, though its size and sharp inner edge suggested to the excavator that a 1.6 m high barrow could have been constructed within it. After the ditch had silted up to over half its depth (0.35 m) with a dark brown sandy clay loam (without developing a turf line) mourners scattered the well cremated longbone fragments of possibly one individual (older than an infant or young child) into the ditch, concentrating their efforts less in the north. Fragments of a small plain ceramic vessel with non-gabbroic inclusions and charcoal were also included in the scatter. They also dug two pits into the ditch fill. The first, in the south/south-east portion of the ditch was circular with a depth of 0.21 m and partially cut through a section of scattered bone and charcoal. It contained charcoal and a small amount of cremated bone. The excavator



thought it may have held a marker post. The second pit which lay immediately to the north-east of the first was slightly smaller and only 0.05 m deep, and contained cremated skull and longbone fragments of possibly the same individual, as well as additional sherds of the vessel, both of which spread from the pit into the surrounding ditch. The ditch was left to silt up naturally after these actions (Jarvis 1976). The published reconstruction of the small ceramic vessel, though of Trevisker Style 6 size and character, is somewhat dubious and not likely a Trevisker vessel as depicted (Parker Pearson pers. com.).

#### Upton Pyne 248b (SX914989)

Upton Pyne 248b lay somewhat apart within a clustered cemetery of nineteen barrows which generally were built in east/west linear arrangements of two to four barrows with adjacent outliers. The cemetery lies on a rise in otherwise low lying ground between the rivers Creedy and Exe. Two other smaller barrow clusters lie on rises one mile to the north, and just over one mile to the east across the Exe River, and three additional sites were recorded one half mile west of the Upton Pyne cemetery west of Jackmoor Brook. All the sites lie on a syncline of New Red Sandstone within the surrounding Culm bedrock. Sites 6, 7 and 8 (the Stevenstone Farm "Three Barrows"), part of a linear group of four barrows with an additional outlier which lie roughly one quarter of a mile to the north-west of Upton Pyne 248b, were excavated in the latter half of the last century. Sites 6 and 8 were earthen barrows and contained a layer of burnt material. Site 6 contained a charcoal heap. Site 7, which lay between them contained an assumed central cremation burial on the old ground surface accompanied by a grooved Wessex I/II knife dagger (Pearce 1983:367), a pygmy cup, a lignite, clay and fossil encrinite necklace, and a headed bronze pin which may have held together a bag containing the deposit. The cremation appeared to represent the skull and longbone fragments of a single possibly female or youth over 12 years of age. This burial was overlain by a hot heap of burnt clay and ashes which measured 1.2 m in diameter and stood roughly 1 m high and contained a carbonized grain of what may have been wheat. A mound of sand and clay which measured 18.2 m upon excavation, and may have stood up to 2 m in height overlay the burnt heap.

Upton Pyne 248b was built on a gentle south facing slope on the New Red Sandstone at 125 feet

O.D. near a small tributary stream to the Exe River, about half a mile away. Activity began in a cleared area which had been undisturbed for a long while, allowing podsolisation to occur. Mourners began by levelling a large area into the slope and removing turves, topsoil and some orange sandy subsoil, all of which were reserved for mound construction. The white leached A2 or E -horizon was also retained separately. Then, on the exposed subsoil surface a number of funerary acts took place in no discernable order. Mourners placed a grog tempered Biconical Urn in an inverted position directly on the ground. The urn was blackened on the inside and contained dark soil, some charcoal and a very small amount of cremated bones from a very young infant. Present were fragments of phalanges, skull, rib and vertebrae. The contents were not hot when they entered the vessel. This urn was then covered by a small sand pile roughly 1.2 m in diameter and similar in texture, though somewhat browner in colour than the reddish sandy subsoil mound overlying it. It may have been trampled. Two and one half metres to the west of this pile a small cist lined with sandstone was built into the subsoil surface. Into the cist mourners placed an inverted Collared Urn (Burgess' Middle Style) containing dark soil, a small amount of oak charcoal and some burnt vegetable matter which included some form of grass. The cist was then covered by 5-6 shaley slabs. On the subsoil surface next to the cist to the east two urns were placed in inverted positions. The urn touching the cist was a small Trevisker Style T5 vessel which had been manufactured from gabbroic Lizard clay. It contained dark soil, a small amount of oak charcoal, and a small amount of unidentified calcined bone. Next to this urn was a Trevisker Style T2 urn with grog and quartz temper. Into it had been placed some oak charcoal and a similar unidentified burned material to that placed in the Collard Urn. Charcoal from the T2 urn returned a date range of 1749-1495 BC (BM402; Pollard and Russell 1976). Nearly one metre to the southeast of this urn mourners dug a small oval depression into the subsoil surface. The fill was stratified and consisted of a lower fill of large oak charcoal pieces, and an upper one consisting of black earth and many tiny pieces of infant bone. The fabrics of all the above funerary urns were different, and there is a possibility the Biconical Urn and T2 urn were constructed of locally available clay sources. After the above deposits were emplaced, mourners covered the deposits with a low irregular mound constructed from the retained reddish sandy subsoil. The mound was approximately 7.31 m in



diameter. Evidence suggests that although the mound was built directly after the emplacement of the western features, some time (probably less than one year) took place before this subsoil mound was built over the sand pile covering the Biconical Urn. Incorporated into the sand mound were three concentrations of material. The first consisted of a few tiny calcined bone fragments, oak charcoal lumps and some dark earth which were placed into a shallow scooped out area just above the unurned cremation. The other three features appear to represent the scattering of handfuls of oak charcoal as the sand mound was being constructed. Further, at some point after the original surface was leveled, the mourners deposited three small spreads of purple-red clay upon it, though the timing of these actions in relation to the cremation deposits is unknown.

Following the completion of the subsoil mound, the mourners enlarged the barrow to a diameter of 10.7 m by the addition of a turf and sandy soil mound constructed of the turves and soil removed during the stripping of the site. They then heightened and capped this turf mound with the leached sandy A2 horizon. The barrow was left in this state for some time, during which the leached sandy cap hardened and weathered. Following this period, the barrow was gradually encased in a varying orange to red clay envelope by the addition of basketfuls of clay. The source for the orange-red clay of this outer covering appears to have been naturally occurring east-west subsoil clay bands which are present further uphill from the site. This enlargement increased the diameter of the barrow to 18 m and was the final act of construction at the site (Pollard and Russell 1969).

#### Farway/East Hill Area

The sites in this region of Devon lie in three main groups on a series of connected narrow upland watershed ridges between the Rivers Otter and Axe, which are drained by the Rivers Sid, Otter, Coly and Yarty. Additional small groups of barrows lie on isolated ridges nearer to the coast. The sites lay on Greensand which is capped by intermittent deposits of clay with flints and lie between 700 and 800 feet O.D.. Over 70 Late Neolithic or Bronze Age monuments of various sizes, profiles and heights have been recorded on the ridges including earthen barrows, flint cairns, flint cairn rings and two ring ditches. In

addition to the seven sites described below, which lie on the northern edge of Farway Hill and East Hill, at least 15 other sites on Broad Down and Gittisham Hill were excavated in the 19th Century. Of these, thirteen were either reported by the excavators in the Transactions of the Devon Association, and/or were later reviewed by Fox (1948; Pollard 1967; Grinsell 1983).

The Reverend R. Kirwan excavated six sites on Broad Down (Kirwen 1868; Fox 1948) which produced documented structural or funerary evidence and artifactual material (Kirwen A-E, and 50 or Kirwen 36, 51, 52, 46, 47, and 50, of which three barrows 47, 46 and 50 formed part of a north/south linear arrangement of seven sites). Site C lay slightly to the west of this line, and Sites A and B formed part of a cluster just under one quarter mile to the west. Kirwan A was a turf mound which overlay a small pavement of flints over which had been deposited a thick scatter of hot ashes and charcoal, and then a cremation. An incised and handled Kimmeridge shale cup of probable Wessex II affiliation lay with the cremation. Kirwen B consisted of a small mound of clay and earth or turves capped with chert boulders which overlay a deposit of charcoal on the old ground surface covered with cremated bones. A small incised pygmy cup with two perforation containing the bones of an infant was found on the spoil heap. At Kirwan C, an inverted bipartite Food Vessel containing a cremation lay on the old ground surface and was covered with a flint cairn 6 m in diameter which incorporated some charcoal just above the urn, and a Late Style Beaker accompanied by a cremation near its edge. The cairn may have been preceded by a flint boulder ring. A burnt earth mound overlay the cairn. At Kirwen D, a cist built into the old ground surface containing the cremated remains of an adult and a child and a segmented bone (or shell) bead was overlain by a small cairn and an overlying earth mound. The mound was directly surrounded by a ditch at whose outer edge 15 chert boulders had been set. In Kirwen E, a Camerton-Snowhill Style bronze dagger (Pearce 1983:386) accompanied a cremation which was placed in a wooden box cist and covered by a small cairn of flints which included a small shale cup of similar shape and design to that found in Kirwen A, though less fine. These were overlain by an earthen mound with surrounding ditch at whose outer edge (suspiciously) 14 chert boulders were set. At Site 50, Kirwen discovered a cremation accompanied by a "decayed bronze implement" below a flint cairn (Fox 1948:10).



### Farway Hill Cairn (SY165975)

This site and Farway Hill Rings I and II lay in a small possibly separate monument cluster on the northern end of Farway Hill some two and one half miles north of the sites just described. The cairn lay 90 m north/north-east of the rings. Farway Hill Cairn was partially disturbed by modern plowing and had been partially robbed of its cairn material. At the site, mourners created a number of pits, possible postholes and a central feature in no discernable order which they covered with a flint cairn measuring 5.5 m in diameter. Just outside the cairn at its north-west edge they lit a fire on the old ground surface. The features under the cairn are as follows: central to the cairn, mourners excavated a very shallow oval hollow oriented north-east/south-west into the old ground surface in which they built a platform of flat flints. They surrounded this with a setting of further flints. Among the flints of the platform they had scattered some charcoal. The excavator suggested the platform would have been large enough to contain a crouched inhumation. A possible large flat flint capstone to this sunken platform lay among the cairn stones nearby. The mourners also excavated five oval to slightly irregularly shaped pits between 2-2.5 m out from the edges of the platform to its south, south-west, north, north-east and east. The pits exhibited sloping sides and measured between .10 and .20 m deep. In Pit 2 they deposited a small amount of wood carbon, then filled the remainder of the pit with a dark stained fill of clay and flint. They filled Pit 1 with a mixture of oak charcoal fragments and backfilled dark stained clay and flint. Pits 3-5 contained a mixture of clay and flint mixed with varying amounts of wood carbon. Possible capstones to Pits 1 and 2 lay near these features. Funerary participants also created a partial circle of seven posts centred on the sunken platform with a gap to the west. It is not known whether they supported some sort of structure. One post at the south-western edge of the arc may have been replaced. An eighth post was erected just west of the sunken central platform. The fill of the postholes consisted of a mixture of dark soil and clay and flints (Pollard 1967).

### Farway Rings (SY164974)

These two circular flint rings lay 3.6 m apart. Ring II, the smaller of the two, lay north-west of

Ring I. The chronological relationships between the rings and between the rings and some of their internal and external features (pits) could not be precisely determined from the site stratigraphy, though a number of pits (termed below Class B pits based upon their fills) at the site predated the construction of the rings and therefore by association, similar pits within the rings were thought by the excavator to do also. Certain other pits (termed below Class A pits) were distinguished by the nature of their fills, occurred only within the rings, and were thought by the excavator to post-date them. Activity began at the sites when the ritual participants stripped off topsoil and the underlying leached clay with flints, exposing a yellow clay subsoil. Into this surface they excavated 101 pits (numbers 41-141 in the site illustration ) of varying sizes and configurations, many having smaller pits dug into their floors, or sloping downwards towards a vertical face, while others formed pit complexes, with pits independently excavated into one another. Several of these pit groups were oriented towards the north-east within Ring I. In general the pits were dug and backfilled all across the excavated portion of the site, possibly clustering together more in the vicinity of the rings. It was not determined how far their distribution extended in all directions. The Bronze Age excavators filled these pits with up to three different fills (dark loam, flints mixed with pale clay or stained clay, and a flint-free pale gray clay) which, when combined, were always clearly stratified according to two principals. First, if two or more fills were combined, the clay with flints always lay above the gray clay or the loam, and likely formed a cap over all the pits. Second, when the flint free clay occurred with other fills, it always occupied the lowest position. Pit 66, in the south-western quarter of Ring I contained a fossil sea urchin within the dark loam in a small pit at the base of a larger pit containing a clay and flint upper fill and capping. The origin of these fills is unclear but some may have come from the original strip of topsoil and gray clay with flints. None of these pits contained charcoal or cremated bone. Thirty one flint artifacts were also recovered from the pits, whose inclusion appeared to be incidental. It is likely that the participants then constructed the two flint rings which originally measured around 1.2-1.5 m wide and stood 0.60-1 m tall. Although the rings are drawn unbroken in plan, the plough damage to the site made it difficult for the excavator to determine if any entrances had ever existed. Ring I measured 14 m in diameter, while Ring II measured 9.4 m in diameter. Eight large flint slabs were observed on the west side



of Ring II which may have been the remains of one or more flint cists within the ring cairn. Forty one small, oval to circular relatively shallow, carefully and regularly shaped pits (Class A pits) were possibly then created within Ring I, concentrating towards the centre. All of these pits contained charcoal fragments or pieces, either scattered throughout a yellow clay subsoil backfill or at the base of a pit which was then backfilled with yellow clay subsoil or (in the case of the 10 Class A pits excavated into earlier Class B pits) backfilled with clay with flints. Pit 1 was dug approximately central to the ring and was shaped and refilled in a fashion unique to the other pits. This circular pit tapered to a depth of 0.76 m, was lined with flint free yellow clay, and had one vertical side. The base of the pit was then filled with pale gray clay, similar to the material at the base of some of the Class B pits. At the top of this deposit they incorporated 20 charcoal fragments. This was overlain by a gravelly/flinty dark loam, which was in turn underlain by a yellow clay backfill which also formed a small cap over and around the pit. Pit 39, a round shallow pit less than 0.10 m deep in the south-western quadrant of the site contained "many small pieces" (Pollard 1971:168) of calcined bone and 53 pieces of heat shattered flint below a yellow or gray subsoil backfill/cap. According to the published text, Pits 39 and 40 were covered by cappings of gray clay with flint, but this appears to disagree both with the illustrated pit profiles and the report Appendix (Pollard 1971:169,177), which indicate that they had yellow clay caps similar to Pit 1. Pits 38 and 40, located towards the periphery of the ring on the south-west and south-east sides respectively, contained a number of charcoal fragments below a yellow clay backfill cap. The excavator suggested that these pits may also have contained cremations due to their similarity to Pit 39 (Pollard 1971).

#### Burnt Common Ring (SY128950)

This heavily ploughed site lay just below the 800 ft contour at the northern end of East Hill, on Burnt Common, and just over one quarter mile north of Dagger's Piece Cairn, described below. Activity began at the site when the mourners removed the topsoil from the area, exposing the gray flinty clay below. They constructed a low circular cairn comprised of small and large flints with occasional pieces of sandstone and hematite which measured 10.9 m in diameter and 1.5 m wide, which stood 0.9-1.2 m high.

Under the cairn in the south-west quadrant a fossil sea urchin was also found. Before this cairn was constructed however, they built a fire with oak wood on the old ground surface which was left to cool before the construction of the ring. The large burned area from this fire lay partially under the flint ring in the west/south-west. Mourners likely then excavated a large D-shaped hollow in the centre of the ring, oriented north-east/south-west and 0.20 m in depth to the yellow subsoil, which was heavily stained when encountered. They lined the edges of the hollow with flints. This grave had been disturbed historically but may have contained either a cremation or a crouched inhumation which was accompanied, at the very least, by two fossil sea urchins and a beaker, of which 70 sherds were recovered in the gray clay with flints backfill that presumably covered the burial. The beaker was of Case's Late, or Lanting Van Der Waal's Style 7, roughly incised with chevrons and of an orange red color, containing no grog temper. The excavator suspected it was produced from the local red clay which underlies the Greensand which outcrops in the nearby Sid valley. This burial may then have been covered by a flint cairn, based upon the large number of flints found in the grave. The funerary participants also dug two pits to the north-west and south-west of this grave near the ring cairn. Pit 1 to the north-west was roughly circular and originally 0.30 m deep with sloping sides. Mourners had deposited several pieces of oak charcoal and then backfilled the pit. Pit 2 was oval in shape but otherwise similar to Pit 1, though charcoal had been scattered throughout the backfill. No evidence for a covering mound was found on the site. One costal flint core and five local flint flakes with some retouch were recovered from the old surface below the monument. A fourth fossil sea urchin was recovered from the plowzone in the centre of the ring. An alternative interpretation sees the ring cairn postdating the central cairn. (Pollard 1967).

#### Daggers Piece Cairn (SY125944)

This small heavily ploughed cairn lay south of Burnt Common Ring, as described above. Activity began at the site when the ritual participants stripped the original topsoil, exposing the gray flinty clay. They then excavated two circular/oval pits through to the yellow clay subsoil. Pit 1 lay under the south-eastern quadrant of the cairn. It was 0.35 m deep and contained a mix of soft dark soil and oak



charcoal fragments. The pit had been covered by a flint capstone. Pit 2, which lay under the north-eastern quadrant of the cairn was 0.25 m deep and was filled with soft black soil containing oak and primarily birch charcoal, three struck and one utilized natural flake of local flint, of which two were broken. This fill had been covered by a large piece of carbonized wood and additional charcoal had been spilled out over the edges of the pit. The pit and spread were covered by three flint cover stones. A small amount of unidentified wood carbon had also been deposited in a small hollow south-east of Pit 1 before the cairn was built. The cairn was built in an oval shape and measured 4.5 by 3.6 m wide, and 0.45 m in height when excavated (Pollard 1967).

#### White Cross Ring (SY115921)

This plowed site lay roughly one and one half miles south of Dagger's Piece Cairn on East Hill. Activities began on the site with the stripping of the topsoil to expose the gray flint clay below. As at the Farway Rings, into this surface at least thirteen pits were dug which were circular or oval in shape and which extended to depths of between 0.20 and 0.43 m into the underlying yellow clay subsoil. The pits were filled with a foreign sticky light gray clay containing small flints, sometimes over a gray clay base as observed in the Farway Ring Class B pits, and contained no backfill. Three of these pits were then overlain and the others enclosed by an low elliptical ring cairn of small and large flints (also containing pieces of hematite) which measured 10.6 by 12.8 m. The cairn had been robbed and plow disturbed obliterating any possible entrances. It may have stood 0.9-1.2 m tall and measured roughly the same width.

Just to the north of the centre of the ring mourners dug a large oval grave pit oriented north-east/south-west with a sloping base which extended a maximum of 1.1 m into the yellow subsoil. No burial was recovered from the pit which is not surprising given the acid soil conditions on the site. If there was a burial in the grave, the mourners accompanied it by a fossil sea urchin, which lay on the pit floor. They then backfilled the pit with yellow clay subsoil which contained six local utilized flakes. They capped this grave pit with a low cap of red clay, possibly obtained from the Sid or Otter valleys near the site where it outcrops. Over and extending beyond this red clay cap by a maximum of 0.60 m, the funerary

participants then built a low elliptical cairn of small flints which originally measured 3.6 by 2.7 m. A number of local utilized and non-utilized flint flakes, three cores, a hammer stone, and a scraper/borer were recovered from the original surface below and within the ring cairn. Three cores, two borers and 7 local flint flakes were recovered from the ploughsoil on the site. No covering mound appears to have been built over these features. An alternative interpretation sees the ring postdating the central cairn, whose outline it appeared to reproduce (Pollard 1971).

#### White Cross Cairn (SY116923)

This small flint cairn site lay towards the southern end of East Hill roughly one and one half miles south of Dagger's Piece Cairn. It was heavily disturbed by the plough and all that remained was a 5.7 m scatter of flints including one large possible flint capstone. No features were located under the cairn, though two costal flint tools and four struck flakes and four local flakes were recovered near the centre of the spread (Pollard 1967).



## SOMERSET

### Clevedon Hills

#### Court Hill Cairn (ST43687219)

This site is located on Court Hill, on the narrowest part of the Failand Ridge near Tickenham at an elevation of 246 feet O.D.. It lies on a fissure in the Carboniferous limestone. No other barrow sites are known from this landform. Funerary activity began with the probable stripping of the vegetated surface in an immediate environment consisting of shady, brushy woodland. Following this, mourners either began by digging a grave pit, or first constructed a low nearly circular drystone wall two courses in height with a diameter just over 7 m. A possible 2 m wide entrance in this wall lay to the north. While the published text indicates that the wall lay on the old land surface, the profile drawing appears to indicate it was laid upon the subsoil. The grave pit, which was boat shaped and 0.40 m deep, was oriented towards the opening in the wall. Initially, the mourners placed a 20-30 year old male facing south in a contracted position in the grave pit on some sort of rug or mat. His right humerus, and possibly his skull contained abnormalities concurrent with a wasting disease. His left arm, though severed just above the elbow immediately before or just after death, was found complete by the excavators. His body was then covered with turves removed earlier from the site. A sample of skeletal material returned a radiocarbon date of 1830-1430 BC (I5735). At some point afterwards, mourners reopened the grave and disturbed the body, possibly removing a number of bones. Because the skeleton was in a "disintegrating" condition (Westly 1973:37), the precise details of this removal are unclear. However, the bones of the facial region, almost the entire pelvis and the majority of the digits of the hands were conspicuously absent. The mourners then scattered the fragmentary cremated partial remains of a young person (possibly a teenage child) into the grave pit before and while backfilling it. Nineteen large and small stones were placed into the grave at this time as an edging to the corpse. Though fragmentary and incomplete, the cremation included skull, long-

bone, and tooth fragments. Also included among the human remains were the calcined fragments of several animals, including sheep metapodial fragments, a pig canine tooth and five bird bone fragments, possibly from a domestic fowl. Radiocarbon assay of the cremated human remains returned a date of 1110-480 BC (I5734). The funerary participants then constructed a low circular cairn 6 m in diameter over the grave, comprised of large and small freshly quarried and weathered limestone blocks. The cairn also incorporated a number of large Old Red Sandstone conglomerate blocks, which, like the limestone, outcrop near the site. A small ring of blocks (not free standing) demarcated the cairn edge. The space between the outer ring and the cairn was then filled with small stones, ending funerary activity on the site. Although no grave goods were found with either of the two burials, a post-Wilberton Late Bronze Age chisel was recovered from the base of the turf on the cairn. Two scrapers, two flake tools, and four waste flakes of non-local flint were also recovered from the surface/upper portion of the cairn, mainly in the south-east quadrant (Evans and Jones 1973; Green 1973; Westley 1973).

## **Cotswolds**

### **Charmy Down Sites**

This group of 7 sites, now destroyed, lay on the Ridgetop plateau of Charmy Down at just over 600 feet O. D., at the southern edge of the Cotswolds some 3 miles north of Bath. All the sites lay on oolitic limestone bedrock. Charmy Down 1 and 2 (CD1 and CD2) lay at the western end of the plateau, roughly one half mile from the linear group of Charmy Down 3-7 (CD3-7), known as the Tumpy Field Barrows (Williams 1950). The sites lie within the remains of large single "Celtic" or Bronze Age coaxial field system containing at least two possible settlement enclosures, which was documented by Grimes (1960). The exact relationship between the funerary sites and the field system is unknown based upon the fragmentary nature of the latter in the vicinity of the former, though the possible settlements lie near the barrow groups. Grimes also recorded a number of Neolithic and Bronze Age surface flint finds and



polished axes across the plateau, which included fragmentary polished axes, leaf shaped arrowheads, barbed and tanged arrowheads, waste flakes, and a number of Bronze Age tools.

It is unclear from the published record (Grimes 1960), and from the paucity of finds, whether or not the eastern group of sites is contemporary with CD1 and CD2. Both groups share identical structural elements, though their use, when clear, in the overall construction series of the sites varies slightly. The turf stripping or deliberate "landscaping" observed at CD1 and CD2 also appears to have been present at this group, though the exact details of its nature are unclear from the report. Within this eastern group, considerable structural similarities exist between adjoining sites CD4 and CD5, and on the whole, the presence and character if not the sequence, of alternating mounds, rings and cairns argues for near contemporaneity of these sites, or a strong local funerary tradition affecting both groups. The excavator, based upon the structural relationship between CD4 and CD5, CD5 and CD3, and the position of the ditch surrounding CD 6, suggested two alternative construction sequences for CD3-6. Charny Down 7 was heavily disturbed before its excavation, and no data concerning its construction or possible burials remained. The order of construction was suggested to be 3, 4, 5 and 6, though just as easily could have been 4, 3, 5, and 6, as CD3 and CD4 preceded CD5, and CD6 (based upon the north-western extension of the ditch, was thought to have been built subsequently to the group. The centre of CD6 was twice disturbed and the complex as a whole had been damaged by stone robbing and plowing. Finally, exact details concerning the nature of the cremations and specific barrow components are unavailable, and the eastern group as a whole is perhaps more useful for illustrating site constructional conformity/variability in the absence of firm dates and burial details.

#### Charny Down 1 (ST75547034)

This small, heavily robbed site lies just over 1 m to the north of CD2. Activities on both sites began with the preparation of the old ground surface. The topsoil (a yellowish brown loam containing small pebbles) was retained in the area later occupied by the sites' central cairns, but was stripped to the east and west to provide a raised platform for funerary activities. At CD1, after this platform was defined,

mourners deposited two burials. Nearly central to the site they laid an upright Form 3 Food Vessel Urn (Tomalin 1983:42) on the old ground surface. Handfulls of charcoal and fragments of cremated bone were placed within and around the urn which was covered with an oolite slab. Some 5 m to the north east of this urn they dug a shallow oval pit, oriented north/south, in which they placed the crouched body of a young person less than 25 years old. This burial, though undisturbed, was found in a somewhat jumbled and fragmented condition due to bioturbation. The body was facing south and lay on its left side.

Fragments of an incomplete Case's Late Style/Lanting Van Der Waals Style S6 Beaker (possibly complete when interred) were placed near its legs. A bronze knife dagger with a rounded butt and two rivet holes, as well as one Kimmeridge grooved shale bead (possibly the remains of a necklace) were laid on the ground near the body. A pitched up cairn of oolite stones with a revetment wall (which may have been free standing) was constructed over the burials. This cairn measured 5.7 by 5.4 m and was edged intermittently with upright slabs, a feature also present at CD2 and Lansdown 6a (described below). An extra revetment wall which may have also formed a cap to the cairn lay around the edges of the cairn and increased its diameter to 9.7 m (Williams 1950).

#### Charmy Down 2 (ST75547034)

The larger of the two sites, CD2 lay immediately to the south. The central portion of the site had been robbed at some point prior to excavations, disturbing a cremation burial. Activity began on the prepared platform with the deposit of a cremation which included charcoal and a convex flint scraper in a prepared hollow in the old soil. It is not known whether this cremation was originally complete or was associated with any other artifacts. To the north-east, mourners also deposited some unburned pig bones, some immature, on the old ground surface. They then built a small low walled slightly oval cairn edged with (or preceded by) a low wall faced with intermittent oolite slabs. The nature of the disturbance makes it unclear whether the gap in the wall to the east pictured on the plan was ever an entrance. The cairn material consisted of very small pebbles, obtained from the originally stripped topsoil. The cairn measured 8.2 by 7 m. A short time after the completion of the cairn, the mourners set a fire on the platform against



the south-west edge of the cairn. After the fire had cooled they then constructed an earth mound from the stoneless stripped topsoil. As in the earlier cairn, the mound was defined with a low oolite block wall, intermittently edged with upright slabs. The original height of this circular mound is likely to have been no more than one metre. Mourners then built an oolite slab revetment to the mound which also acted as a cap to the barrow, enlarging the site to a diameter of 21.6 m. At some time before this was built however, they deposited additional pig bones on the platform north-east of the barrow. No evidence of a final structural connection between CD1 and CD2 was observed, though their near contemporaneity is demonstrated by the initial design of the soil platform (Williams 1950).

#### Charmy Down 3 (ST76327028)

After some undefined turf removal or area "landscaping" around this site, mourners dug a small circular pit .40 m in depth. Into this they placed a small quantity of cremated bones of one individual which was accompanied by charcoal, one unidentified "Bronze Age" (Grimes 1960:218) sherd, one biconical shale bead, a small shale pulley ring, and a few snail shells. The pit was then filled with small stones and a little soil. They then placed a small heap of earth and rubble over this pit, which was then covered with a small cairn of large oolite slabs revetted by an incomplete ring of oolite boulders with a diameter of 6.1 m. It is unlikely that the site, or adjacent sites CD4 and CD5 stood very tall (Grimes 1960).

#### Charmy Down 4 (ST76287026)

Following, at some point, the turf stripping described earlier mourners dug an oval burial pit 0.45 m deep along the same axis as the mound group. The pit was backfilled first with an earthy deposit containing a cremation of a small adult, and then overlain by a number of medium sized upright stones. The pit lay inside a small circle of large oolite boulders. After the burial, the circle was filled with earthy rubble. Mourners then built a cairn of smaller oolite boulders against the ring, enlarging the diameter of the site to 7.3 m. It is not known whether the boulders originally covered the mound (Grimes 1960).

### Charmy Down 5 (ST76257027)

Mourners began by digging an oval pit on a perpendicular orientation to the barrow complex roughly 1 metre from the edge of CD 4. The pit was similar in size to the pit in CD4 but was 0.25 m deep. They filled the pit with small stones and a small amount of cremated bone, some of which might have belonged to an immature individual. The pit lay within a low wall of oolite boulders, the east side of which was openly built up against CD4. They then filled the space inside the wall with earthy rubble, covering the pit. The mourners then built an overlying cairn of small oolite slaps over this, which were pitched in towards the ring, and exactly abutted the edge of CD 3, giving CD5 a diameter of 6.25 m (Grimes 1960).

### Charmy Down 6 (ST76287026)

At this site, like the others, the turf was stripped from around the main part of the site, and the underlying "bresh" or C-horizon was cut down away from the site to make it appear higher than the surrounding area. This was most obvious on the berm between the mound and its surrounding ditch. The nature of the C-horizon suggested that at some point before the sites were constructed, the ground cover of the area had consisted of small trees and shrubs. The central area of CD6 was disturbed during the late Roman, or post-Roman Iron Age period, during which it was used as a burial place for a number of individuals. The central portion of the mound was again disturbed at a later period. These intrusions totally disturbed the original grave. After the presumed Bronze Age burial(s), the grave was covered with a nearly stoneless steep soil mound some 3.5 m in diameter. This was then capped with a single layer of large oolite boulders by a crew who worked from the outside inward. An outer cap of stoneless soil was then placed over the mound, which was in turn capped by a oolite slab cap built from the inside out, which was edged with a low, faced, oolite ring. When excavated, the mound stood 2 m high and 15 m in diameter, the highest of the Charmy Down Group. The barrow was partially surrounded with a 3 m wide ditch, which had been dug to a depth of 1.2 m, and which extended to the west/north-west to enclose CD 4 and part of CD 5. The ditch was only minimally sampled and appeared to contain oolite rubble. Apart



from the presence of the rubble, no stratigraphic/temporal relationship was apparent between the mound and the ditch (Grimes 1960).

#### Lansdown 6A (ST71506864)

This site was one of a linear group of three barrows scattered in groups of two or three across the western lobe of Lansdown Ridge at just over 700 feet O.D.. This group of 12 sites, now destroyed lay some 3 miles west of the Charney Down group just described, on the southern edge of the Cotswolds. All of the sites apart from 6A were excavated between 1904 and 1911. Sites 1 and 2 yielded no finds and may both have been double mounds. A disturbed cremation accompanied by several sherds in a stone cist were observed in Site 3. A cremation accompanied by two urns and fragments of a gold plated circular bronze "sun disc", and some fused fragments of copper were recovered from a small shallow circular cist below the old turf line in Site 4. Site 5 was mainly a soil mound and contained two cists and some bones of *Bos Longifrons*. Site 6, immediately to the north of Lansdown 6a contained a central cremation in a cist accompanied by a few flints and sherds. Three meters to the south was another cremation accompanied by finger-tipped decorated sherds. Site 7 contained a cremation with "pre-Roman sherds" and flints. Site 9 was a double site. One mound contained a near central cremation with charcoal and an urn with an incense cup in small shallow circular rock lined cist. No Bronze Age interment was recovered from the other mound. Site 10 contained a central primary skeleton in a rock cut grave, covered by a cairn with a retaining wall, into which had been inserted two inurned cremations. Site 11 contained at least 28 cremations which were buried in the east, south-east and south sectors of the mound. Not all were excavated but some were contained in inverted urns with fingertipping decoration, others were placed in shallow slab covered hollows. (Grinsell 1971; Williams 1950).

Activity on site 6A began in a similar fashion to that at CD 1 and 2, as mourners stripped the existing topsoil from the peripheral area of the site, leaving a platform upon which they later built the first cairn. On this platform they dug an oval pit .23 m deep into the subsoil in which they deposited a cremation with charcoal, possibly in a fill of black soil. The exact nature of this burial is unclear due to its

disturbance historically, but it was accompanied at least by two flint scrapers and a possibly complete Food Vessel of coarse red buff fabric, of which four sherds were recovered. The burial lay just north-east of the centre of an overlying circular cairn which was constructed of oolite slabs and edged with a low, intermittently faced wall. The cairn slabs were pitched up towards the centre, in a fashion similar to that observed at CD1. The site at this point measured 9.1 m. in diameter. At some later point before the development of a new surface surrounding the cairn, it was revetted and enlarged by a wall edged oolite revetment comprised of small stones. It is not known whether this stone revetment originally covered the inner cairn. By this action the site was enlarged to a diameter of 12.8 m.

## **Mendip Region**

### **Chewton Plain Sites**

This group of six sites, excavated in advance of Ministry of Defence operations, were part of an open cluster of 11 barrows which lay on the Chewton Plain plateau, a north-east extension of the Mendip Hills between Chewton Mendip and Ston Easton. At the time of excavation, all the sites were partially disturbed and reduced in height from agricultural activities. Two of the original sites on Chew Down to the south-east of the group were disturbed and no record exists of their contents. A third (an earthen barrow), near Chewton Plain 1 was opened in 1821 and produced charcoal, presumed to represent the remains of a cremation. Two other unexamined sites lie north and south of Stone Easton to the east of the group described here. (Grinsell 1971; Williams 1947). The sites lay on a bedrock of Lower Lias at elevations surrounding 500 ft. O.D..

#### **Chewton Plain 1 (ST60655380)**

Activity began at this site when mourners dug a small oval pit 0.15 m deep and oriented north/south into an undisturbed surface. They back-filled the pit with soft black soil, at least four



fragments of calcined bone, and oak and ash charcoal. Near the edge of the pit they laid two scrapers on the ground surface. They then constructed a mound of yellowish brown loam topsoil containing small lumps of carbonaceous shale (obtained away from the immediate site area) over the pit. The mound was 11.6 m wide and was centred to the east/north-east of the pit. Within the mound some 0.30 m above the pit and extending to the north they deposited a band of pale friable calcareous tufaceous material, then continued with the construction of the barrow. A number of flints and blades were recovered from the body of the mound.

#### **Chewton Plain 2 (ST61665460)**

This site lay roughly 1.2 km north-east of Chewton Plain 1 (CP1), and was built on a slight outcrop of lias. On an undisturbed surface, mourners dug a small shallow slightly oval pit oriented north-west which they filled with dark soil containing charcoal, a few scraps of calcined bone, a *petit tranchet* arrowhead, a damaged barb and tanged arrowhead, and a worked flake. Over the pit they built a mound of yellowish brown loam topsoil (obtained away from the site area) which measured 14 m in diameter. The mound was centered slightly to the north-east of the pit. A number of utilized blades and debitage were recovered from the body of the mound.

#### **Chewton Plain 3 (ST61405442)**

This site lay 366 m south-east of CP2, and was built upon an outcrop of lias, though some topsoil lay below the northern side of the mound. The funerary participants began by laying a Middle Style Collard Urn which contained the fragmentary cremation of an 18-25 year old man and the carbonized remains of a partial oak log on the outcrop. They covered the urn with one large and several small lias slabs. Some 9 m to the east/north/east of the urn burial, they deposited some cremated fragments of a young person. Over both burials, the mourners then constructed a yellowish brown loam mound (its origin unknown but similar to the old topsoil) 18.6 m in diameter. They capped this mound with slabs of lias, extending its height to 0.70 m. Both the stone and the earth for the mound were collected away from the

site. A number of utilized and worked flints were recovered from the old surface or the mound. The latter included 5 scrapers and one scraper/borer.

#### **Chewton Plain 4 (ST61765397)**

Chewton Plain 4 lay roughly .5 km south-east of CP3 on an undisturbed old reddish brown loam topsoil. Mourners began activity at the sites with either the construction of a stone ring or the excavation of a burial pit, which lay central to it. The ring, which had a diameter of 21 m, was nowhere more than 0.5 m in height. It varied in form, with mourners taking great care to face it internally and externally in the south-west, and stripping the ground surface to bedrock outside the wall before the revetment was laid in this area. They also masked the outer edges of the entire wall with a number of small pitched stones. The burial pit lay central to this wall and was dug in a conical fashion 0.83 m deep to a bedrock floor. The participants lined the pit with vertical slabs of lias. Unfortunately the cist was disturbed by the insertion of two Roman burials, during the course of which the original adult skeleton was moved to the edge of the cist. Any grave goods accompanying the interment were presumably removed at that time. The mourners then used the topsoil and turves they removed from the excavation of the grave pit to construct a mound 5 m in diameter with a height of 0.45 m. over the pit. They then constructed a cairn over the mound into which they possibly incorporated a cremation burial just to the south-east of its centre, which was disturbed historically. All that remained of this burial were several fragments of a coarse reddish brown Collared Urn of Early or Middle Style. The cairn was constructed of flat lias slabs and revetted with a wall five courses high. It measured 8.5-8.8 m in diameter and was slightly inclined towards the centre. At some time after the completion of the outer wall and the cairn, mourners constructed an earth mound of reddish brown loam (origin unknown) over the earlier features, which enlarged the barrow to a diameter of 22.9 m. A number of utilized flakes and blades were recovered from the old ground surface and the body of the mound. These included two scrapers and a fabricator.

#### **Chewton Plain 5 (ST61875418)**



This small site lay 1.2 m south of Chewton Plain 6 on the northern edge of an upper tributary to the Avon. Both CP5 and CP6 lay some 273 m north-east of CP4. Activity likely began at the site with a burial, which was disturbed historically. All that remained of this burial were a number of sherds of a rusticated beaker, which had been deposited on its side in antiquity at the north-west corner of the burial area. It does not appear from the published text or plan that the mourners had ever dug a burial pit. At the time of the burial, the metatarsal bones of an ox (*Bos longifrons*) had been laid immediately to its west on the old ground surface. Over the burial and the bones, the funerary participants built a simple, unrevetted cairn of lias slabs which measured 7.3 m in diameter. The burial, if there was one, would have been nearly central to this cairn. Two scrapers and an oval flake with evidence of two separate side workings were observed on the old ground surface under the cairn.

#### Chewton Plain 6 (ST61875420)

This site lay 1.2 m to the north of CP5 and was of similar construction, though larger. There is no evidence that the two cairns were ever joined. The central area of Chewton Plain 6 was disturbed in the Fourth Century AD, and all that remained of any possible burial or other deposit were a few flecks of charcoal. These lay on the old ground surface. Over this central deposit, the mourners constructed a simple cairn of lias slabs which measured 11.2 m in diameter. Within the cairn and on the old ground surface excavators found two scrapers and a *petit tranchet* arrowhead.

## Bibliography

- Allison, J. (1996) Ciscos Koan: educating archaeologists about indigenous people's self determination in the land use planning process for cultural resources. *Society for American Archaeology Bulletin* 14.1, 14-15, 26.
- ApSimon, A. M. (1961) Kynance Gate and Cornish prehistory. *The Lizard* 11.1, 13-15.
- ApSimon, A. M. (1973) The excavation of the Bronze Age barrow and a menhir at Ystrad-Hynod, Llanidloes (Mont.). *Archaeologia Cambrensis* 122, 1965-66.
- ApSimon, A. M. and Greenfield, E. (1972) The excavation of Bronze and Iron Age Settlements at Trevisker, St. Ewal, Cornwall. *Proceedings of the Prehistoric Society* 38, 302-381.
- ApSimon, A., Musgrave, J. H., Sheldon, J., Tratmen, E. K., and Van Wijngaarden-Bakker, L. H. (1976) Gorsey Bibgruy, Cheddar, Somerset: radiocarbon dating, human and bones, charcoals, archaeological reassessment. *Proceedings of the University of Bristol Spealeological Society* 14.2, 155-183.
- Ashbee, P. (1958) The excavation of Tregulland Barrow, Treneglos Parish, Cornwall. *The Antiquaries Journal* 38, 174-193.
- Ashbee, P. (1960) *The Bronze Age Round Barrow in Britain*. London: Phoenix House Ltd.
- Ashbee, P. (1978) *The Ancient British*. Norwich: Geo Abstracts Ltd.
- Aston, M. and Burrow, I. eds. (1982) *The Archaeology of Somerset*. Somerset County Council.
- Balaam, N. D. (1984) Trelen 1 and 2, Sites 40 and 41. The pollen analysis of the buried soils. In Excavations on the Goonhilly Downs, The Lizard by G. Smith, 27-33. *Cornish Archaeology* 23, 3-42.
- Balaam, N. D., Smith, K., and Wainwright, G. J. (1982) The Shaugh Moor project: fourth report – environment, context, and conclusion. *Proceedings of the Prehistoric Society* 48, 203-278.
- Barley, N. (1994) *Smashing Pots: Feats of Clay from Africa*. London: British Museum Press.
- Barnatt, J. (1982) *Prehistoric Cornwall: The Ceremonial Monuments*. Wellingborough: Turnstone Press Ltd.
- Barnatt, J. (1989) *Stone Circles of Britain*. B.A.R. 215(i).
- Barnes, B. (1974) *Scientific Knowledge and Sociological Theory*. London: Routledge.
- Barnes, B. and Bloor, D. (1982) Relativism, Rationalism and the Sociology of Knowledge. In *Rationality and Relativism* eds. M. Hollis and S. Lukes, 21-47. Oxford: Basil Blackwell.
- Barnes, B., Bloor, D., and Henry, J. (1996) *Scientific Knowledge: a Sociological Analysis*. Chicago: University of Chicago Press.
- Barrett, J. (1987a) Contextual Archaeology. *Antiquity* 61, 468-473.
- Barrett, J. (1987b) Fields of discourse: reconstituting a social archaeology. *Critique of Anthropology* 7.3, 5-19.
- Barrett, J. (1988) The living, the dead and the ancestors: Neolithic and Early Bronze Age mortuary practices. In *The Archaeology of Context in the Neolithic and Bronze Age: Recent Trends* ed. J.C. Barrett and I. Kinnes, 30-41. Sheffield: Collis Publications.



- Barrett, J. (1989) Time and tradition: the rituals of everyday life. In *Bronze Age Studies* by H.A. Nordstrom and A. Knapc, 113-126. *The Museum of National Antiquities, Stockholm Studies* 6.
- Barrett, J. (1990a) Archaeology in the age of uncertainty. *Scottish Archaeology Review* 7, 31-36.
- Barrett, J. (1990b) The monumentality of death: the character of Early Bronze Age mortuary mounds in southern Britain. *World Archaeology* 22.2, 179-189.
- Barrett, J. (1994) *Fragments from Antiquity: An Archaeology of Social Life in Britain, 2900-1200BC*. Oxford: Blackwell.
- Barrett, J. and Bradley, R. (1980) *The British Later Bronze Age*. B.A.R. 83.
- Barrett, J., Bradley, R., and Green, M. eds. (1991) *Landscape, Monuments and Society: The Prehistory of Cranbourne Chase*. Cambridge: Cambridge University Press.
- Barrett, J. and Kinnes, I. A. (1988) *The Archaeology of context in the Neolithic and Bronze Age: Recent Trends*. Sheffield: Collis Publications.
- Barth, F. (1975) *Ritual and Knowledge Among the Baktaman of New Guinea*. New Haven: Yale University Press.
- Barth, F. (1987) *Cosmologies in the Making*. Cambridge: Cambridge University Press.
- Barthes, R. (1984) *Image, Music, Text*. London: Fontana.
- Bauman, Z. (1978) *Hermeneutics and the Social Sciences*. London: Hutchinson.
- Bauman, Z. (1992) *Intimations of Postmodernity*. London: Routledge.
- Bayley, J. (1975) Pollen. In arrows on the St. Austell granite by H. Miles, 60-66. *Cornish Archaeology* 14, 5-81.
- Bell, C. (1987) *Ritual: Perspectives and Dimensions*. New York: Oxford University Press.
- Bell, M. (1990) Brean Down Excavations 1983-1987. *Historic Buildings and Monuments Commission Archaeological Report* 15.
- Bhaskar, R. (1979) *The Possibility of Naturalism*. New Jersey: Humanities Press.
- Binford, L. (1971) Mortuary practices: their study and their potential. *Antiquity* 36.3, 6-29.
- Binford, L. (1972) *An Archaeological Perspective*. New York: Seminar Press.
- Bloch, M. (1977) The past and the present in the present. *Man* 12, 278-292.
- Bloch, M. and Parry, J. (1982) *Death and the Regeneration of Life*. Cambridge: Cambridge University Press.
- Bloor, D. (1991) *Knowledge and Social Imagery*. Chicago: University of Chicago Press.
- Bourdieu, P. (1973) The Berber house. In *Rules and Meanings* ed. M. Douglas, 98-110. Hammondsouth: Penguin.
- Bourdieu, P. (1977) *Outline of a Theory of Practice*. Trans. R. Nice. Cambridge: Cambridge University Press.
- Bradley, R. (1984) *The Social Foundations of Prehistoric Britain*. New York: Longman.

- Bradley, R. (1986) Modernist Fantasies in Prehistory. *Man* 21, 747-748.
- Bradley, R. (1987) Time regained: the creation of continuity. *Journal of the British Archaeological Association* 140, 1-17.
- Bradley, R. (1988) Status, wealth, and the chronological ordering of cemeteries. *Proceedings of the Prehistoric Society* 54, 327-329.
- Bradley, R. (1991) Monuments and places. In *Sacred and Profane* eds. P. Garwood et al., 135-140. Oxford University Committee for Archaeology Monograph 32.
- Bradley, R. (1993) *Altering the Earth. Society of Antiquaries of Scotland Monograph Series 8.*
- Bradley, R. (1997) *Rock Art and the Prehistory of Atlantic Europe: Signing the land.* London: Routledge.
- Bradley, R. (1998) *The Significance of Monuments.* London: Routledge.
- Bradley, R. and Hodder, I. (1979) British prehistory: an integrated view. *Man* 14, 93-104.
- Braithwaite, M. (1984) Ritual and prestige in the prehistory of Wessex c. 2200-1400 BC: a new dimension to the archaeological evidence. In *Ideology, Power and Prehistory* eds. D. Miller and C. Tilley, 93-110.
- Braudel, F. (1980) *On History.* Trans. S. Matthews. London: Weidenfield and Nicholson.
- Brisbane, M. and Clews, S. (1979) The East Moor systems, Altarnum and North Hill, Bodmin Moor. *Cornish Archaeology* 18, 33-60.
- Brück, J. (1999) What's in a settlement? Domestic practice and residential mobility in Early Bronze Age southern England. In *Making Places in the Prehistoric World: Themes in Settlement Archaeology* eds. J. Brück and M. Goodman, 52-75. London: University College London Press.
- Brumfiel, E. M. (1987) Comments. In *Processual archaeology and the radical critique* by T. K. Earle and R. W. Preucel, 513. *Current Anthropology* 28.4, 501-534.
- Brumfiel, E. M. and Earle, T. K. eds. (1987) *Specialization, Exchange and Complex Societies.* Cambridge: Cambridge University Press.
- Budd, P., Gale, D., Pollard, A. M., Thomas, R. G., and Williams, P. A. (1992) The early development of metallurgy in the British Isles. *Antiquity* 66, 677-686.
- Burgess, C. (1974) The Bronze Age. In *British Prehistory: A New Outline* ed. C. Renfrew, 165-223. London: Duckworth.
- Burgess, C. (1980) *The Age of Stonehenge.* London: Dent.
- Burgess, C. (1982) "Urns of no small variety": Collared Urns reviewed. *Proceedings of the Prehistoric Society* 56, 339-351.
- Burl, H. A. W. (1969) Henges: internal features and regional groups. *The Archaeological Journal* 126, 1-28.
- Burl, A. (1983) *Prehistoric Astronomy and Ritual.* Aylesbury: Shire Publications.
- Callow, W. J., Barker, M. J., and Pritchard, D. H. (1963) National physical laboratory radiocarbon measurements I, *Radiocarbon* 5, 34-38.



- Cartwright, C. (1988) Charcoal from Davidstow Moor. In *A Barrow Cemetery on Davidstow Moor* by P. Christie, 163-164. *Cornish Archaeology* 27, 27-169.
- Caseldine, C. J. (1980) Environmental change in Cornwall during the last 13000 years. *Cornish Archaeology* 19, 3-16.
- Champion, T. (1989) *Centre and Periphery: Comparative Studies in Archaeology*. London: Unwin Hyman.
- Champion, T. (1990) Theoretical Archaeology in Britain. In *Archaeological Theory in Europe* ed. I. Hodder, 129-160. London: Routledge
- Chapman, T. (1987) The European Iron Age: assessing the state of the art. *Scottish Archaeological Review* 4, 98-107.
- Chapman, R., Kinnes, I., and Randsbourg, K. (1981) *The Archaeology of Death*. Cambridge: Cambridge University Press.
- Childe, V. G. (1930) *The Bronze Age*. Cambridge: Cambridge University Press.
- Childe, V. G. (1940) *Prehistoric Communities of the British Isles*. London: W. and R. Chambers, Ltd..
- Childe, V. G. (1951) *Social Evolution*. London: Watts and Co..
- Christie, P. (1960) Crig-a-Mennis; a Bronze Age barrow at Liskey, Perranzabuloe, Cornwall. *Proceedings of the Prehistoric Society* 26, 76-97.
- Christie, P. (1967) A barrow cemetery of the second millennium BC in Wiltshire, England. *Proceedings of the Prehistoric Society* 33, 336-366.
- Christie, P. (1985) Barrows on the North Cornish coast: wartime excavations by C. K. Croft-Andrew 1939-1944. *Cornish Archaeology* 24, 23-121.
- Christie, P. (1986) Cornwall in the Bronze Age. *Cornish Archaeology* 25, 81-110.
- Christie, P. (1988) A barrow cemetery on Davidstow Moor, Cornwall: wartime excavations by C. K. Croft-Andrew. *Cornish Archaeology* 27, 27-169.
- Clare, T. (1987) Towards a reappraisal of henge monuments: origins, evolution and hierarchies. *Proceedings of the Prehistoric Society* 53, 457-477.
- Clarke, D. L. (1970) *Beaker Pottery of Great Britain and Ireland. Volumes I, II*. Cambridge: Cambridge University Press.
- Clark, S. (1985) The *Annales* historians. In *The Return of the Grand Theory in the Human Sciences* ed. Q. Skinner, 177-198. Cambridge: Cambridge University Press.
- Clifford, J. (1986) On ethnographic allegory. In *Writing Culture: The Poetics and the Politics of Ethnography* eds. J. Clifford and C. Marcus, 98-121. Berkley: University of California Press.
- Cohen, J. and Swidler, N. (1997) Painting a "new" face on CRM: integrating traditional culture and archaeology. *SAA Bulletin* 15.1, 24-25.
- Coles, J. M. (1978) Man and landscape in the Somerset Levels. In *The Effect of Man on the Landscape: The Lowland Zone* eds. S. Limbrey and J. G. Evans, 86-89. *Council for British Archaeology Research Report* 21.

- Coles, J. M. and Orme, B. J. (1980) *Prehistory of the Somerset Levels*. Somerset Levels Project.
- Comaroff, J. (1985) *Body of Power, Spirit of Resistance*. Chicago: University of Chicago Press.
- Crabtree, K. and Maltby, E. (1974) Soil and land use change on Exmoor: significance of a buried profile on Exmoor. *Proceedings of the Somerset Archaeology and Natural History Society* 119, 38-43.
- Crawford, O. G. S. (1921) The ancient settlement at Harlyn Bay. *The Antiquaries Journal* 1, 283-299.
- Criado, P. (1985) Processualism, postprocessualism, and the politics of academia. In *Interpreting Archaeology* eds. I. Hodder et al., 227. London: Routledge.
- Criado, P. (1995) Appendix: further comment on interpretive archaeologies. In *Interpreting Archaeology*, eds. I. Hodder et al., 227. London: Routledge.
- Cunliffe, B. (1987) *Origins: the Roots of European Civilization*. London.
- Cummins, W. A. (1979) Neolithic stone axes: distribution and trade in England and Wales. In *Stone Axe Studies* eds. T. H. McClough and W. A. Cummins, 5-22. *Council for British Archaeology Research Report* 23.
- Cunliff, B. (1993) *Wessex to A.D. 1000*. London: Longman.
- Darvill, T. (1996) Neolithic buildings in England, Wales and the Isle of Man. In *Neolithic Houses in Northwest Europe and Beyond*, eds. T. Darvill and J. Thomas, 77-111. Oxford: Oxbow Press.
- Dimbleby, G. W. (1958) Appendix II: Pollen. In *The excavation of Tregulland Barrow, Treneglos parish, Cornwall* by P. Ashbee, 194-195. *The Antiquaries Journal* 38, 174-195.
- Dimbleby, G. W. (1960) Appendix III: Pollen Analysis. In *Crig-A-Mennis: a Bronze Age barrow in Leskey, Perranzabuloe, Cornwall* by P. Christie, 94-95. *Proceedings of the Prehistoric Society* 26, 76-97.
- Dimbleby, G. W. (1971) Appendix II: Pollen analysis. In *Excavations on Longstone Downs, St. Stephen-in-Brannel and St. Meway* by H. Miles and T. Miles, 26-27. *Cornish Archaeology* 10, 5-28.
- Douch, H. L. (1964) Tredarvah, Penzance. *Cornish Archaeology* 3, 85.
- Douglas, M. (1966) *Purity and Danger: An Analysis of the Concepts of Pollution and Taboo*. London: Routledge and Kegan Paul.
- Drewett, P. (1982) Later Bronze Age downland settlement and excavation at Black Patch, East Sussex. *Proceedings of the Prehistoric Society* 48, 321-400.
- Drewal, M. T. (1992) *Yoruba Ritual: Performance, Play, Agency*. Bloomington: Indiana University Press.
- Dreyfus, H. L. and Rabinow, P. (1982) *Michel Foucault: Beyond Structuralism and Hermeneutics*. Brighton: Harvester Press.
- Dudley, D. (1961) The excavation of the Otterham barrow, Cornwall. *Journal of the Royal Institute of Cornwall* 4.1, 62-80.
- Dudley, D. (1964) The excavation of the Carvinak barrow, Tregavethan, near Truro, Cornwall. *Journal of the Royal Institute of Cornwall* 2.44, 414-451.
- Eliade, M. (1952) *The Sacred and the Profane*. New York: Harcourt Publishing.



- Ellison, A. (1980) Settlements and regional exchange: a case study. In *The British Later Bronze Age* eds. J. Barrett and R. Bradley, 127-140. B.A.R. 83.
- Ellison, A. (1981) Towards a socioeconomic model for the Middle Bronze Age in southern England. In *Patterns of the Past* eds. I. Hodder, G. Issac, and N. Hammond, 413-38. Cambridge: Cambridge University Press.
- Ellison, A. (1984) The pygmy vessel. In *Archaeological Investigations at Colliford Reservoir, Bodmin Moor 1977-78* by F. M. Griffith, 78-81. *Cornish Archaeology* 23, 49-139.
- Emmerling, G. (1997) Ethnicity in complex societies: archaeological perspectives. *Journal of Archaeological Research* 5.4, 295-344.
- Emmet, D. D. (1979) Stone rows: the traditional view reconsidered. *Proceedings of the Devon Archaeological Society* 37, 94-114.
- Eogan, G. (1964) The excavation of a stone alignment and circle at Cholwichtown, Lee Moor, Devonshire, England. *Proceedings of the Prehistoric Society* 30, 25-38.
- Ereira, A. (1990) *The Heart of the World*. London: Jonathan Cape Ltd.
- Evans, J. G. and Jones, H. (1973) Court Hill cairn: land snails. In the excavation of a road cairn on Court Hill, Tickenham, North Somerset, 1969 by H. S. Green, 38-41. *Proceedings of the Somerset Archaeology and Natural History Society* 117, 33-45.
- Evans, E. D., Smith, I. F., and Wallis, F. S. (1972) The petrological identification of stone implements from south-western England. *Proceedings of the Prehistoric Society* 38, 235-275.
- Feyerabend, P. (1987) *Farewell to Reason*. London: Verso.
- Fine, A. (1996) Science made up: constructivist sociology of scientific knowledge. In *The Disunity of Science* eds. P. Galiston and D. J. Stump. Stanford: Stanford University Press.
- Fleming, A. (1971) Territorial patterns in Bronze Age Wessex. *Proceedings of the Prehistoric Society* 37, 138-166.
- Fleming, A. (1973 unpublished) Complex barrows, cemeteries and the problem of continuity.
- Fleming, A. (1973) Tombs for the living. *Man* 8.2, 172-193.
- Fleming, A. (1979) The Dartmoor Reaves: boundary patterns and behavior patterns in the second millennium BC. *Proceedings of the Devon Archaeological Society* 37, 115-131.
- Fleming, A. (1980) the cairnfields of north-west Dartmoor. *Proceedings of the Devon Archaeological Society* 38, 9-12.
- Fleming, A. (1983) The prehistoric landscape of Dartmoor Part 2: North and East Dartmoor. *Proceedings of the Prehistoric Society* 49, 195-241.
- Fleming, A. (1987) Bronze Age settlement in the south-western moors. In *The South-West to AD 1000* by M. Todd, 111-133. London: Batsford.
- Fleming, A. (1988) *The Dartmoor Reaves*. London: Batsford.
- Ford, S. (1991) An Early Bronze Age pit circle from Charnham Lane, Hungerford, Berkshire. *Proceedings of the Prehistoric Society* 57, 179-181.

- Fordham, S. and Mould, Q. (1982) The South Hams survey. In *The Shaugh Moor project: fourth report – environment, context and conclusion* by N. D. Balaam, K. Smith, and G. J. Wainwright, 261-274. *Proceedings of the Prehistoric Society* 48, 203-278.
- Fotiadis, M. (1994) What is archaeology's "mitigated objectivism" mitigated by? Comments on Whyllie. *American Antiquity* 59, 545-555.
- Foucault, M. (1984) *The Foucault Reader*. New York: Pantheon.
- Fowler, P. J. and Thomas, C. (1979) Lyonesse Revisited. *Antiquity* 53, 175-189.
- Fox, A. (1948) The Broad Down (Farway) necropolis and the Wessex Culture in Devon. *Proceedings of the Devon Archaeological and Exploration Society* IV.I, 1-19.
- Fox, A. (1957) Excavations on Dean Moor, in the Avon Valley, 1954-1956, the Late Bronze Age settlement. *Transactions of the Devonshire Association* 89, 18-77.
- Fox, A. (1969) Appendix: the Upton Pyne cemetery. In *Excavation of round barrow 248b, Upton Pyne, Exeter* by H. M. Pollard and P. M. G. Russel, 75-78. *Proceedings of the Devon Archaeological Society* 27, 49-78.
- Fraser, N. and Nicholson, L. (1993) Social criticism without philosophy: an encounter between feminism and postmodernism. In *Postmodernism: A Reader* ed. T. Docherty, 415-432. New York: Columbia University.
- Fried, M. H. (1967) *The Evolution of Political Society: an Essay in Political Economy*. New York: Random House.
- Friedman, J. (1973) Tribes, states and transformations. In *Marxist Analysis and Social Anthropology* ed. M. Bloch, 161-202. London: Malaby Press.
- Friedman, J. and Rowlands, M. J. (1977) Notes towards and epigenetic model of the evolution of civilization. In *The Evolution of Social Systems* eds. J. Friedman and M. J. Rowlands, 210-272. London: Duckworth.
- Gadamer, H. G. (1975) *Truth and Method*. Trans. W. Glen-Doepel. London: Sheen and Ward.
- Garwood, P. (1991) Ritual traditions and the reconstruction of society. In *Sacred and Profane* eds. P. Garwood et al., 10-32. Oxford: Oxford University for Archaeology Monograph 32.
- Geertz, C. (1973) *The Interpretation of Cultures*. New York: Basic Books.
- Geertz, C. (1989) Anti Anti-Relativism. In *Relativism: Interpretation and Confrontation* ed. M. Krausz, 12-35. Notre Dame: University of Notre Dame Press.
- Gero, J. M. (1989) Producing prehistory, controlling the past: the case of New England beehives. In *Critical Traditions in Contemporary Archaeology* eds. V. Pinsky and A. Whyllie, 96-103. Cambridge: Cambridge University Press.
- Gero, J. M. (1991) Genderlithics: women's roles in stone tool production. In *Engendering Archaeology* eds. J. M. Gero and M. W. Conkey, 163-193. Oxford: Basil Blackwell.
- Gero, J. and Conkey, M. eds. (1991) *Engendering Archaeology*. Oxford: Basil Blackwell.
- Gibbon, G. (1989) *Explanation in Archaeology*. Oxford: Basil Blackwell.



- Gibson, A. M. (1982) *Beaker Domestic Sites*. B.A.R. 107.
- Gibson, A. (1986) *Neolithic and Early Bronze Age Pottery*. Aylesbury: Shire Publications.
- Giddens, A. (1979) *Central Problems In Social Theory*. London: Macmillan.
- Giddens, A. (1981) *A Contemporary Critique of Historical Materialism Volume 1. Power, Property and the State*. London: Macmillan.
- Giddens, A. (1982) *Profiles and Critiques in Social Theory*. London: Macmillan.
- Giddens, A. (1984) *The Constitution of Society*. Cambridge: Cambridge University Press.
- Green, H. S. (1973) The excavation of a round cairn on Court Hill, Tickenham, North Somerset, 1969. *Proceedings of the Somerset Archaeology and Natural History Society* 117, 33-45.
- Griffith, F. M. (1984) Archaeological Investigations at Colliford Reservoir, Bodmin Moor, 1977-78. *Cornish Archaeology* 23, 49-139.
- Grimes, W. F. (1938) The excavation of Gorsey Bigbury. *Proceedings of the University of Bristol Spealeological Society* 5.1, 3-56.
- Grimes, W. F. (1960) Excavations on defense sites, 1939-1945. *Ministry of World Archaeological Reports* 5.
- Grinsell, L. V. (1953) *The Ancient Burial Mounds of England*. London: Methuen and Co. Ltd.
- Grinsell, L. V. (1960) Somerset barrows Part I: west and south. *Proceedings of the Somerset Archaeology and Natural History Society* 113, 1-43.
- Grinsell, L. V. (1970) The barrows of north Devon. *Proceedings of the Devon Archaeological Society* 28, 95-129.
- Grinsell, L. V. (1971) Somerset barrows Part II: north and east. *Proceedings of the Somerset Archaeology and Natural History Society* 115, 44-125, 132-134.
- Grinsell, L. V. (1974) Disc-barrows. *Proceedings of the Prehistoric Society* 40, 79-112.
- Grinsell, L. V. (1978) Dartmoor barrows. *Proceedings of the Devon Archaeological Society* 36, 85-180.
- Grinsell, L. V. (1983) The barrows of the south and east Devon. *Proceedings of the Devon Archaeological Society* 41, 5-46.
- Grinsell, L. V. (1987) Somerset barrows: revisions 1971-1987. *Proceedings of the Somerset Archaeology and Natural History Society* 131, 13-26.
- Harris, D. (1979) Poldowrain, St. Keverne: A Beaker mound on the gabbro of the Lizard peninsula. *Cornish Archaeology* 18, 13-31.
- Harris, D., Hooper, S., and Trudgian, P. (1984) Excavation of three cairns on Stannon Downs, St. Breward. *Cornish Archaeology* 23, 141-155.
- Harrison, R. (1990) Bell Beaker pottery. In Brean Down Excavations 1983-1987 by M. Bell, 117-120. *Historic Buildings and Monuments Commission Archaeological Research Report* 15.
- Harvey, D. (1990) *The Condition of Postmodernity*. Oxford: Basil Blackwell.

- Healey, C. J. (1988) Culture as transformed disorder: cosmological evocations amongst the Maring. *Oceania* 59, 106-122.
- Healey, F. (1985) The small finds. In Barrows on the north Cornish coast: wartime excavations by C. K. Croft-Andrew 1939-44 by P. Christie 68, 109. *Cornish Archaeology* 24, 23-121.
- Hedges, R. E. M. et al. (1989) Radiocarbon dates from the Oxford AMS System: *Archaeometry* datelist 9. *Archaeometry* 31.2, 207-234.
- Heidegger, M. (1962) *Being and Time*. Trans. J. MacQuarrie and E. Robinson. London: Basil Blackwell.
- Hertz, R. (1960) *Death and the Right Hand*. Trans. R. and C. Needham. New York: Free Press.
- Hibbert, F. A. (1978) The vegetational history of the Somerset Levels. In *The Effect of Man on the Landscape: The Lowland Zone* by S. Limbrey and J. G. Evans, 90-95. *Council for British Archaeology Research Report* 21.
- Hill, J. D. (1989) Rethinking the Iron Age. *Scottish Archaeology Review* 6, 16-24.
- Hodder, I. (1982a) Theoretical archaeology: a reactionary view. In *Symbolic and Structural Archaeology* ed. I. Hodder, 1-16. Cambridge: Cambridge University Press.
- Hodder, I. (1982b) The identification and interpretation of ranking in prehistory: a contextual perspective. In *Ranking Recourse and Exchange* eds. C. Renfrew and S. Shennan, 150-154. Cambridge: Cambridge University Press.
- Hodder, I. (1982c) *Symbols in Action*. Cambridge: Cambridge University Press.
- Hodder, I. (1982d) *The Present Past*. Cambridge: Cambridge University Press.
- Hodder, I. (1984) Burial, houses, women and men in the European Neolithic. In *Ideology, Power, and Prehistory* eds. D. Miller and C. Tilley, 1-15. Cambridge: Cambridge University Press.
- Hodder, I. (1986) *Reading the Past*. Cambridge: Cambridge University Press.
- Hodder, I. (1987) The contribution of the long term. In *Archaeology as Long Term History* ed. I. Hodder, 1-8. Cambridge: Cambridge University Press.
- Hodder, I. (1989) Post-modernism, post-structuralism and post-processual archaeology. In *The Meanings of Things: Material Culture and Symbolic Expression* ed. I. Hodder, 64-78. London: Unwin Hyman.
- Hodder, I. (1990) *The Domestication of Europe*. Oxford: Basil Blackwell.
- Hollis, M. and Lukes, S. (1982) *Rationality and Relativism*. Oxford: Basil Blackwell.
- Hudson, A. B. (1966) Death ceremonies of the Padju Epat Ma'anyan Dayaks. *Sarawak Museum Journal* 13.27, 341-416.
- Hugh-Jones, C. (1979) *From the Milk River: Spatial and Temporal Processes in Northwest Amazonia*. Cambridge: Cambridge University Press.
- Huntington, R. and Metcalf, P. (1979) *Celebrations of Death*. Cambridge: Cambridge University Press.
- Jameson, I. (1988) Postmodernism and consumer society. In *Postmodernism and Its Discontents* ed. E. A. Kaplan, 13-29. London: Verso.



- Jarvis, K. (1976) The excavation of a ring ditch, Markham Lane, Exminster. *Proceedings of the Devon Archaeological Society* 34, 62-67.
- Johns, C. (1993) Recent work. *Cornish Archaeology* 32, 167-177.
- Johnson, M. (1989) Conceptions of agency in archaeological interpretation. *Journal of Anthropological Archaeology* 8, 189-211.
- Johnson, N. (1980) Later Bronze Age settlement in the South-west. In *The British Later Bronze Age* eds. J. Barrett and R. Bradley, 141-80. B.A.R. 83.
- Kaplan, E. A. (1988) *Postmodernism and Its Discontents*. London: Verso.
- Keates (in press) The flashing blade: copper, colour and luminosity in North Italian Copper Age society. In G. MacGregor and A. Jones eds. *Colouring the Past: The Significance of Colour in Archaeological Research*. Oxford: Berg.
- Keeley, H. M. C. (1984) Environmental Archaeology: A regional Review. *Directorate of Ancient Monuments and Historical Buildings Occasional Paper* 6.
- Keesing, R. M. (1975) *Kin Groups and Social Structure*. Fort Worth: Holt, Rinehart and Winston, Inc..
- Kinnes, I. (1991) Radiocarbon dating and British Beakers: The British Museum programme. *Scottish Archaeological Review* 8, 35-68.
- Kirwan, R. (1868) Three barrows in Broad Down, Farway. *Transaction of the Devon Association* 2, 619-649.
- Kosso, P. (1991) Method in archaeology: middle-range theory as hermeneutics. *American Antiquity* 56.4, 621-627.
- Krausz, M. (1989) Introduction. In *Relativism: Interpretation and Confrontation* ed. M. Krausz, 1-11. Notre Dame: University of Notre Dame Press.
- Kristiansen, K. (1982) The formation of tribal systems in later European prehistory: Northern Europe, 4000-500 BC. In *Theory and Explanation in Archaeology* eds. C. Renfrew, M. Rowlands, and B. Seagraves, 241-280. New York: Academic Press.
- Kristiansen, K. (1984) Ideology and material culture. In *Marxist Perspectives in Archaeology* eds. M. Spriggs, 72-100. Cambridge: Cambridge University Press.
- Kristiansen, K. (1987) Centre and periphery in Bronze Age Scandinavia. In *Centre and Periphery in the Ancient World* eds. M. Rowlands, M. Larsen and K. Kristiansen, 74-86. Cambridge: Cambridge University Press.
- Kristiansen, K. (1989) Value, ranking, and consumption in the European Bronze Age. In *Domination and Resistance* eds. D. Miller, M. Rowlands and C. Tilley, 211-214. London: Unwin Hyman Ltd.
- Lakoff, G. (1987) *Women, Fire and Dangerous Things: What Categories Reveal about the Mind*. Chicago: University of Chicago Press.
- Lambrick, G. (1990) Ritual and burial in the Thames Valley. *Current Archaeology* 21.1, 6-13.
- Leach, E. (1966) *Re-thinking Anthropology*. London: Althone Press.

- Leach, E. (1977) A view from the bridge. In *Archaeology and Anthropology* ed. M. Spriggs, 161-175. B.A.R. S19.
- Leonard, S. T. (1990) *Critical Theory in Political Practice*. Princeton: Princeton University Press.
- Leone, M. P., Potter, P. B., and Shackel, P. A. (1987) Toward a critical archaeology. *Current Anthropology* 28.3, 238-302.
- Levitan, B. M. (1988) Site environment. In Charterhouse Warren Farm Swallet, Mendip, Somerset: exploration, geomorphology, taphonomy and archaeology by C. Levitan et al., 227-229. *Proceedings of the University of Bristol Spealeological Society* 18.2, 171-239.
- Levitan, B. M. (1990) The vertebrate remains. In Brean Down Excavations 1983-1987 by M. Bell, 220-241. *Historic Buildings and Monuments Commission Archaeological Report* 15.
- Levitan, B. M., et al. (1988) Charterhouse Warren Farm Swallet, Mendip, Somerset: exploration, geomorphology, taphonomy, and archaeology. *Proceedings of the University of Bristol Spealeological Society* 18.2, 171-239.
- Levy, J. (1977) *Social and Religious Change in Bronze Age Denmark*. Washington: Ph.D. Thesis. (unpublished).
- Lewis, J. M. (1965) The excavation of four standing stones in south Wales. *Bulletin of the Board of Celtic Studies* 21, 250-264.
- Lewis, J. M. (1974) Excavations at Rhos-Y-Clegyrn prehistoric site, St. Nicholas, Pembs. *Archaeologia Cambrensis* 123, 13-43.
- Lewis, J. M. (1976) A modern radiocarbon date from Rhos-Y-Clegyrn. *Archaeologia Cambrensis* 125, 162.
- Longworth, I. H. (1984) *Collard Urns of the Bronze Age in Great Britain and Ireland*. Cambridge: Cambridge University Press.
- Lucas, C. (1985) Introduction. In *Constructing the Past* eds. J. LeGoff and P. Nora, 1-11. Cambridge: Cambridge University Press.
- Lucas, G. (1995) Interpretation in contemporary archaeology: some philosophical issues. In *Interpreting Archaeology* eds. I. Hodder et al., 37-44. London: Routledge.
- Lynch, F. (1970) Ring-cairns and related monuments in Wales. *Scottish Archaeological Forum* 4, 61-80.
- Lynch, F. (1971) Report of the Re-excavation of Two Bronze Age Cairns in Anglesey: Bedd Branwen and Treiorwerth. *Archaeologia Cambrensis* 120, 11-83.
- Lynch, F. (1975) The impact on landscape of prehistoric man. In *The effect of man on the landscape: the highland zone* eds. J. G. Evans, S. Limbrey, and H. Cleere, 124-126. *Council for British Archaeology Research Report* 11.
- Lynch, F. (1980) Bronze Age monuments in Wales. In *Culture and environment in Prehistoric Wales* ed. J. A. Taylor, 233-242. B.A.R. 76.
- Lyotard, F. (1984) *The Postmodern Condition*. Manchester: Manchester University Press.
- Mack, J. (1986) *Madagascar: Island of the Ancestors*. London: British Museum Publications Ltd.



- Maltby, E. and Caseldine, C. J. (1984) Environment reconstruction at Colliford. In *Archaeological investigations at Colliford Reservoir, Bodmin Moor, 1977-78* by F. M. Griffith, 92-116. *Cornish Archaeology* 23, 49-139.
- Maguire, D., Ralph, N., and Fleming, A. (1983) Early land use on Dartmoor - palaeobotanical and pedological investigations on Holne Moor. In *Investigating the Subsistence Economy* ed. M. Jones. B.A.R. s181, 57-105.
- Mandelbaum, M. (1959) Social uses of funeral rites. In *The Meaning of Death* ed. H. Feifel, 189-217. New York: McGraw Hill.
- Marsden, B. (1974) *The Early Barrow Diggers*. Tring: Shire.
- Marsden, B. (1983) *Pioneers of Prehistory*. Ormskirk: G., W., and A. Hesketh.
- Metcalf, P. (1981) Meaning and materialism: the ritual economy of death. *Man* 16, 563-578.
- McAvoy, F. (1980) The excavation of a multi-period site at Carnoon bank, Lizard, Cornwall, 1979. *Cornish Archaeology* 19, 31-62.
- McGuire, R. H. (1995) Working together on the border. *Society for American Archaeology Bulletin* 13.5, 8-9.
- Megaw, J. V. S. (1976) Gwithian, Cornwall: some notes on the evidence for Neolithic and Bronze Age settlement. In *Settlement and Economy in the Third and Second Millennia BC* eds. C. Burgess and E. Micket, 51-66. B.A.R. S33.
- Megaw, J. V. S., Thomas, A. C., and Wailes, B. (1960-61) The Bronze Age settlement at Gwithian, Cornwall. *Proceedings of the West Cornwall Field Club* 2.5, 200-215.
- Meiland, J. M. and Krause, M. eds. (1982) *Relativism: Cognitive and Moral*. Notre Dame: University of Notre Dame Press.
- Mercer, R. (1968) The excavation of a Bronze Age hut circle settlement, Stannon Down, St. Brevard, Cornwall, 1969. *Cornish Archaeology* 9, 17-46.
- Mercer, R. (1986) The Neolithic in Cornwall. *Cornish Archaeology* 25, 35-80.
- Mercer, R. and Dimbleby, G. W. (1978) Pollen analysis and the hut circle settlement at Stannon Down, St. Brevard. *Cornish Archaeology* 17, 25-28.
- Merrifield, D. L. and Moore, P. D. (1974) Prehistoric human activity and blanket peat initiation on Exmoor. *Nature* 250, 439-441.
- Merriman, N. (1987) Value and motivation in prehistory: the evidence for Celtic spirit. In *The Archaeology of Contextual Meaning* ed. I. Hodder, 111-116. Cambridge: Cambridge University Press.
- Miles, H. (1975) Barrows on the St. Austell granite. *Cornish Archaeology* 14, 5-81.
- Miles, H. and Miles, T. J. (1971) Excavations on Longstone Downs, St. Stephen in Brannel and St. Mewan. *Cornish Archaeology* 10, 5-28.
- Miller, D. (1985) *Artifacts as Categories*. Cambridge: Cambridge University Press.
- Miller, D. (1987) *Material Culture and Mass Consumption*. Oxford: Basil Blackwell.
- Miller, D., Rolands, M. and Tilley, C. (1989) *Domination and Resistance*. London: Unwin Hyman.

- Millet, M. (1990) *The Romanization of Britain*. Cambridge: Cambridge University Press.
- Mizoguchi, K. (1992) A historiography of a linear barrow cemetery: a structurationist's point of view. *Archaeological Review from Cambridge* 11.1, 39-49.
- Mizoguchi, K. (1994) Time in the reproduction of mortuary practices. *World Archaeology* 25.2, 223-235.
- Moore, H. (1982) The interpretation of spatial patterning in settlement residues. In *Symbolic and Structural Archaeology* ed. I. Hodder, 74-79.
- Moore, H. (1986) *Space, Text and Gender*. Cambridge: Cambridge University Press.
- Morris, M. (1988) Changing perceptions of the past. In *Extracting Meaning from the Past* ed. J. Bintliff, 69-85. Oxford: Oxbow.
- Needham, S. (1978) The extent of foreign influence on Early Bronze Age axe development in southern Britain. In *The Origins of Metallurgy in Atlantic Europe* ed. M. Ryan, 265-291. Dublin: The Stationary Office.
- Needham, S. (1988) Selective deposition in the British Early Bronze Age. *World Archaeology* 20.2, 229-248.
- Nietzsche, F. (1983) *Untimely Meditations*. Trans. R. J. Hollingdale. Cambridge: Cambridge University Press.
- Nordstrom, H. A., Knape, A. eds. (1989) *Bronze Age Studies*. Stockholm: Statens Historiska Museum.
- Noujain, E. G. (1987) History as genealogy: an exploration of Foucault's approach to history. In *Contemporary French Philosophy* ed. E. P. Griffiths, 157-174. Cambridge: Cambridge University Press.
- Nowakowski, J. (1989) *Gwithian: An Assessment of the Bronze Age Excavations 1954-1961*. Truro: Cornwall County Council.
- Nowakowski, J. (1991) Trehallen Farm, Newquay: the excavation of a lowland Bronze Age settlement and Iron Age cemetery. *Cornish Archaeology* 30, 5-242.
- Nowakowski, J. (1993) Archaeology along the hard shoulder - the Indian Queens Project. *Cornish Archaeology* 32, 146-152.
- O'Neil, B. H. St. J. (1952) The excavation of Knackyboy cairn, St. Martins, Isles of Scilly, 1948. *The Antiquaries Journal* 32, 21-34.
- O'Shea, J. (1984) *Mortuary Variability, An Archaeological Investigation*. Orlando: Academic Press.
- Parker Pearson, M. (1982) Mortuary practices, society and ideology: an ethnological study. In *Symbolic and Structural Archaeology* ed. I. Hodder, 99-113. Cambridge: Cambridge University Press.
- Parker Pearson, M. (1990) The production and distribution of Bronze Age pottery in south-western Britain. *Cornish Archaeology* 29, 5-32.
- Parker Pearson, M. (1992) Tombs and monumentality in southern Madagascar: preliminary results of the central Androy survey. *Antiquity* 66, 941-948.
- Parker Pearson, M. (1995) South-Western Bronze Age pottery. In *Unbaked Urns of Rudely Shape* eds. I. Kinnes and Varndell, G., 89-100. Oxford: Oxbow Monograph 55.
- Parker Pearson and Richards, C. (1997) *Architecture and Order: Approaches to Social Space*. London: Routledge.



- Parker Pearson, M. and Ramilisonina (1998a) Stonehenge for the ancestors: the stones pass on the message. *Antiquity* 72, 308-326.
- Parker Pearson, M. and Ramilisonina (1998b) Stonehenge for the ancestors: part two. *Antiquity* 72, 855-856.
- Pearson, G. W. and Stuiver, M. (1986) High precision calibration of the radiocarbon time scale, 500-2500 BC. *Radiocarbon* 28.2B, 838-862.
- Peebles, C. and Kus, S. M. Some archaeological correlates of ranked societies. *American Antiquity* 42, 421-428.
- Peacock, D. P. S. (1969) Neolithic pottery production in Cornwall. *Antiquity* 43, 145-149.
- Pearce, S. (1983) *The Bronze Age Metalwork of South-Western Britain*. B.A.R. 120.
- Pearce, S. and Padley, T. (1977) The Bronze Age finds from Tredarvah, Penzance. *Cornish Archaeology* 16, 25-41.
- Peterson, F. F. (1972) Traditions of multiple burial in Later Neolithic and Early Bronze Age England. *Archaeological Journal* 129, 22-43.
- Peterson, F. F. (1977) *Bronze Age Funerary Monuments in England and Wales*. Edinburgh: Ph. D. Thesis (unpublished).
- Piggot, S. (1938) The early Bronze Age in Wessex. *Proceedings of the Prehistoric Society* 4, 52-106.
- Pollard, S. H. M. (1967) Seven prehistoric sites near Honiton, Devon, Part I, a Beaker flint ring and three flint cairns. *Proceedings of the Devon Archaeological Society* 25, 19-39.
- Pollard, S. H. M. (1971) Seven prehistoric sites near Honiton, Devon, Part II, three flint rings. *Proceedings of the Devon Archaeological Society* 29, 162-180.
- Pollard, S. H. M. and Russell, P. M. G. (1969) Radiocarbon dating. Excavation of round barrow 248b, Upton Pyne, Exeter. *Proceedings of the Devon Archaeological Society* 34, 95.
- Pollard, S. H. M. and Russell, P. M. G. (1969) Excavation of round barrow 248b, Upton Pyne, Exeter. *Proceedings of the Devon Archaeological Society* 27, 49-78.
- Pred, A. (1990) *Making Histories and Constructing Human Geographies: The Local Transformation of Practice, Power Relations and Consciousness*. Boulder: Westview Press.
- Preston-Jones, A. and Rose, P. (1987) Mrs. Hum's Urn. *Cornish Archaeology* 26, 85-95.
- Quinnell, H. (1987) Cornish gabbroic pottery: the development of a hypothesis. *Cornish Archaeology* 26, 7-12.
- Quinnell, H. (1988) The local character of the Devon Bronze Age and its interpretation in the 1980's. *Proceedings of the Devon Archaeological Society* 46, 1-12.
- Rabinow, P. (1986) *The Foucault Reader*. Middlesex: Penguin.
- Raleigh Radford, C. A. (1958) The chambered tomb at Broadsands, Paignton. *Proceedings of the Devon Archaeological Exploration Society* 5, 147-168.
- Raleigh Radford, C. A. and Rodgers, E. H. (1947) The excavation of two barrows at East Putford. *Proceedings of the Devon Archaeological Exploration Society* 3, 156-163.

- Randsbourg, K. (1973) Wealth and social structure as reflected in Bronze Age Burials - a quantitative approach. In *The Explanation of Culture Change: Models in Prehistory* ed. C. Renfrew. London: Duckworth.
- Randsbourg, K. (1974) Social stratification in early Bronze Age Denmark: a study in the regulation of cultural systems. *Præhistorische Zeitschrift* 49, 38-61.
- Ratcliffe-Densham, H. B. A. and M. M. (1960) an anomalous earthwork of the Late Bronze Age, on Cock Hill, Sussex. *Sussex Archaeological Collections* 99, 78-101.
- Rees, A. D. (1935) Notes on the significance of white stones in Celtic archaeology and folklore with reference to recent excavations at Ffynnon Degla, Denbighshire. *Bulletin of the Board of Celtic Studies* 6, 87-90.
- Renfrew, C. (1973) Monuments, mobilization and social organization in Neolithic Wessex. In *The explanation of Culture Change: Models in Prehistory* ed. C. Renfrew, 539-558. London: Duckworth.
- Renfrew, C., Rowlands, M. J., and Seagraves, B. A. (1982) *Theory and Explanation in Archaeology, the Southampton Conference*. New York: Academic Press.
- Rescher, N. (1993) *Pluralism: Against the Demand for Consensus*. Oxford: Clarendon Press.
- Richards, C. (1990) The Late Neolithic house in Orkney. In *The Social Archaeology of Houses* ed. R. Samson, 112-124. Edinburgh: Edinburgh University Press.
- Richards, C. (1996) Monuments as landscape: creating the centre of the world in Orkney. *World Archaeology* 28.2, 190-208.
- Ricoeur, P. (1971) The model of the text: meaningful action considered as a text. *Social Research* 38, 529-562.
- Ricoeur, P. (1974) *The Conflict of Interpretations: Essays in Hermeneutics* ed. D. Ihde. Evanston: Northwestern University Press.
- Ricoeur, P. (1976) *Interpretation Theory: Discourse and the Surplus of Meaning*. Fort Worth: Texas Christian University Press.
- Ricoeur, P. (1981) *Hermeneutics and the Human Sciences*. Trans. J. B. Thompson. Cambridge: Cambridge University Press.
- Ricoeur, P. (1984) *The Reality of the Historical Past*. Milwaukee: Marquette University Press.
- Roberston-Mackay, M. E. (1980) A 'head and hoofs' burial beneath a round barrow, with other Neolithic and Bronze Age sites, on Hemp Knoll, near Avebury, Wiltshire. *Proceedings of the Prehistoric Society* 46, 123-176.
- Roese, H. E. (1980a) Some aspects of topographical locations of Neolithic and Bronze Age monuments in Wales I. Menhirs. *Bulletin of the Board of Celtic Studies* 28, 645-655.
- Roese, H. E. (1980b) Some aspects of topographical locations of Neolithic and Bronze Age monuments in Wales II. Henges and Circles. *Bulletin of the Board of Celtic Studies* 29, 164-170.
- Ross, A. (1974) *Pagan Celtic Britain: Studies in Iconography and Tradition*. London: Cardinal Books.
- Rowlands, M. (1976) *The Organization of Middle Bronze Age Metalworking*. B.A.R. 31.



- Rowlands, M. (1984) Conceptualizing the European Bronze and Early Iron Ages. In *European Social Evolution* ed. J. Bintliff, 147-155. Bradford: Bradford University Press.
- Rowlands, M. (1987) Centre and Periphery: a review of a concept. In *Centre and Periphery in the Ancient World* eds. M. Rowlands, M. Larsen, and K. Kristiansen, 1-11. Cambridge: Cambridge University Press.
- Rowlands, M., Larsen, M., and Kristiansen, K. (1987) *Centre and Periphery in the Ancient World*. Cambridge: Cambridge University Press.
- Russel, V. and Poll, P. A. S. (1964) Excavation of a Menhir at Try, Gulval. *Cornish Archaeology* 3, 15-27.
- Sahlins, M. (1985) *Islands of History*. Chicago: University of Chicago Press.
- Saitta, D. J. (1989) Dialectics, critical inquiry, and archaeology. In *Critical Traditions in Contemporary Archaeology* eds. V. Pinsky and A. Whyllie, 38-43. Cambridge: Cambridge University Press.
- Sarup, M. (1988) *An Introductory Guide to Post-structuralism and Post-modernism*. New York: Harvester and Wheatsheaf.
- Shweder, R. A. (1989) Post-Nietzschean anthropology: the idea of multiple objective worlds. In *Relativism: Interpretation and Confrontation* ed. M. Krausz, 99-139. Notre Dame: University of Notre Dame Press.
- Shanks, M. and Tilley, C. (1987a) *Social Theory and Archaeology*. Cambridge: Polity Press.
- Shanks, M. and Tilley, C. (1987b) *Re-constructing Archaeology*. Cambridge: Cambridge University Press.
- Shanks, M. and Tilley, C. (1989) Archaeology into the 1990's. *Norwegian Archaeological Review*. 22.1, 1-54.
- Shell, C. A. (1978) The early exploitation of tin deposits in south-west England. In *The Origins of Metallurgy in Atlantic Europe* ed. M. Ryan, 251-263. Dublin: The Dublin Stationary Office.
- Shennan, S. (1982a) Exchange and ranking: the role of amber in the earlier Bronze Age in Europe. In *Ranking, Recourse and Exchange* eds. C. Renfrew and S. Shennan, 33-45. Cambridge: Cambridge University Press.
- Shennan, S. (1982b) Ideology, change, and the European Early Bronze Age. In *Symbolic and Structural Archaeology* ed. I. Hodder, 155-161. Cambridge: Cambridge University Press.
- Shennan, S. (1986) Interaction and change in third millennium BC Western and Central Europe. In *Peer Polity Interaction and Socio-Political Change* eds. C. Renfrew, and J. F. Cherry, 137-148. Cambridge: Cambridge University Press.
- Shennan, S. (1989) Cultural transmission and cultural change. In *What's New* eds. S. Van der Leeuw and R. Torrence, 330-346. London: Unwin Hyman.
- Simmons, I. G. (1964) Appendix: soil pollen analysis. In The excavation of a stone allignment and circle at Cholwichtown, Lee moor, Devonshire, England by G. Eogan, 34-38. *Proceedings of the Prehistoric Society* 30, 25-38.
- Simpson, D. D. A. (1968) Food vessels: association and chronology. In *Studies in Ancient Europe* eds. J. M. Coles and D. D. A. Simpson, 196-211. Leicester: Leicester University Press.
- Smith, G. (1984) Excavations on Goonhilly Downs, the Lizard, 1981. *Cornish Archaeology* 23, 3-42.



- Smith, G. (1987) The Lizard Project: landscape survey, 1978-83. *Cornish Archaeology* 26, 13-68.
- Smith, G. (1988) New radiocarbon dates from Medieval and Bronze Age monuments on Goonhilly Downs, The Lizard. *Cornish Archaeology* 27, 213-214.
- Smith, G. (1996) Archaeology and environment of a Bronze Age cairn and prehistoric field system at Chysauster, Gulval, Cornwall. *Proceedings of the Prehistoric Society* 67, 219.
- Smith, G. and Harris, D. (1982) The excavation of Mesolithic, Neolithic, and Bronze Age settlements at Poldowrain, S. Keverne, 1980. *Cornish Archaeology* 21, 23-66.
- Smith, K. (1979) The investigation of a cairn group. In The Shaugh Moor project: first reported by G. J. Wainwright, A. Fleming, and K. Smith, 10-33. *Proceedings of the Prehistoric Society* 45, 1-33.
- Smith, K. (1982) The Plym Valley Survey. In The Shaugh Moor project: fourth report - environment, context, and conclusion by N. D. Balaam, K. Smith and G. J. Wainwright, 240-261. *Proceedings of the Prehistoric Society* 48, 203-278.
- Smith, K. et al. (1981) The Shaugh Moor project: third report - settlement and environmental investigations. *Proceedings of the Prehistoric Society* 47, 205-273.
- Sperber, D. (1979) Claude Levi-Strauss. In *Structuralism and Since* ed. J. Sturrock, 19-51. Oxford: Oxford University Press.
- Spriggs, M. (1984) *Marxist Perspectives in Archaeology*. Cambridge: Cambridge University Press.
- Stuiver, M. and Reimer, P. (1987) *User's Guide to the Programs CALIB and DISPLAY*. Seattle: University of Washington.
- Tainter, J. A. (1978) Mortuary practices and the study of prehistoric social systems. In *Advances in Archaeological Method and Theory* 1, 105-141.
- Taylor, J. (1978) The relationship of British Early Bronze Age goldwork to Atlantic Europe. In *The Origins of Metallurgy in Atlantic Europe* ed. M. Ryan, 229-263. Dublin: The Stationary Office.
- Thomas, A. C. et al. (1961) The Bronze Age settlement at Gwithian, Cornwall. *Proceedings of the West Cornwall Field Club* 2.5, 200-215.
- Thomas, C. (1958) *Gwithian: Ten Years' Work (1949-1958)*. Camborne: Gwithian Excavation Staff.
- Thomas, C. (1985) *Explorations of a Drowned Landscape*. London: Batsford.
- Thomas, I. (1960) The excavations at Kynance 1953-60. *The Lizard* 1.4, 5-16.
- Thomas, I. (1980) Petrological examination of ceramic samples. In The Shaugh Moor project: second report by G. J. Wainwright et al., 95-99. *Proceedings of the Prehistoric Society* 46, 65-122.
- Thomas, J. (1988) The Neolithic/Early Bronze Age material. In Charterhouse Warren Farm Swallet, Mendip, Somerset: exploration, geomorphology, taphonomy and archaeology by B. M. Levitan et al., 201-209. *Proceedings of the University of Bristol Speleological Society* 18.2, 171-239.
- Thomas, J. (1900) Same, other, analogue: writing the past. In *Writing the Past in the Present* eds. F. Baker and J. Thomas, 18-23. Lampeter: St. David's University College.
- Thomas, J. (1991a) *Rethinking the Neolithic*. Cambridge: Cambridge University Press.



- Thomas, J. (1991b) Reading the body: Beaker funerary practice in Britain. In *Sacred and Profane* by P. Garwood et al., 33-42. *Oxford University Committee for Archaeology Monograph* 32.
- Tilley, C. (1989a) Archaeology as socio-political action in the present. In *Critical Traditions in Contemporary Archaeology* eds. V. Pinsky and A. Wylie, 104-116. Cambridge: Cambridge University Press.
- Tilley, C. (1989b) Interpreting material culture. In *The Meaning of Things* ed. I. Hodder, 185-194. London: Unwin Hymen Ltd.
- Tilley, C. (1990) On modernity and archaeological discourse. In *Archaeology after Structuralism* eds. I. Bapty and T. Yates, 128-152. London: Routledge.
- Tilley, C. (1991) *Material Culture and Text*. London: Routledge.
- Tilley, C. (1995) Rocks as resources: landscapes and power. *Cornish Archaeology* 34, 5-57.
- Tilley, C. (1996) The power of rocks: topography and monument construction in Bodmin Moor. *World Archaeology* 28.2, 161-176.
- Timberlake, S. (1992) Prehistoric copper mining in Britain. *Cornish Archaeology* 31, 15-34.
- Tinsley, H. and Grigson, C. (1981) The Bronze Age. In *The Environment in British Prehistory* eds. I. G. Simmons and M. J. Tooley, 210-249. London: Duckworth.
- Todd, M. (1987) *The South-West to AD 1000*. London: Longman.
- Tomalin, D. J. (1982) The formal and textural characteristics of the Biconical Urn assemblage from Shaugh Moor Enclosure 15 and their implications. In *The Shaugh Moor Project: fourth report – environment, context and conclusion* by N. D. Ballam, K. Smith, and G. J. Wainwright, 228-237. *Proceedings of the Prehistoric Society* 48, 203-278.
- Tomalin, D. J. (1983) *British Biconical Urns; Their Character and Chronology and Their Relationship with Indigenous Early Bronze Age Ceramics*. Southampton: Ph. D. dissertation (unpublished).
- Tomalin, D. J. (1988) Armorican vases a Anses and their occurrence in southern Britain. *Proceedings of the Prehistoric Society* 54, 203-221.
- Tomalin, D. J. (1996) The character and the inferred intra-site chronology of the Early Bronze Age pottery from Chysauster ring Cairn. The Archaeology and Environment of a Bronze Age cairn and prehistoric and Ramano-British field system at Chysauster, Gulval, Cornwall by G. Smith. *Proceedings of the Prehistoric Society* 62, 189-194.
- Trahair, J. E. R. (1978) A survey of cairns on Bodmin Moor. *Cornish Archaeology* 17, 3-24.
- Tratman, E. K. (1967) the Priddy Circles, Mendip, Somerset – henge monuments. *Proceedings of the University of Bristol Spealeological Society* 11.1, 97-125.
- Turner, J. R. (1990) Ring cairns, stone circles and related monuments on Dartmoor. *Proceedings of the Devon Archaeology Society* 48, 27-86.
- Turner, J. W. (1992) Ritual, habitus and hierarchy in Figi. *Ethnology* 31.4, 291-302.
- Turner, V. (1967) *The Forest of Symbols*. Ithaca: Cornell University Press.
- Turner, V. (1960) *The Ritual Process: Structure and Anti-Structure*. Ithaca: Cornell University Press.

- Turner, V. (1975) Symbolic Studies. *Annual Review of Anthropology* 4, 145-161.
- Ucko, P. (1969) Ethnography and archaeological interpretation of funerary remains. *World Archaeology* 1, 262-280.
- Van Gennep, A. (1960) *The Rites of Passage*. London: Routledge and Kegan Paul.
- Vyner, B. (1977) The excavation of a standing stone at Minskin, Llantrisant, Glamorgan. *Archaeologia Cambrensis* 126, 17-23.
- Wainwright, G. J. (1965) The excavation of a cairn at St. Neot, Bodmin Moor. *Cornish Archaeology* 4, 4-9.
- Wainwright, G. J. (1980) A pit burial at Lower Ashmore Farm, Rose Ash, Devon. *Proceedings of the Devon Archaeological Society* 38, 13-14.
- Wainwright, G. J., Fleming, A. and Smith, K. (1979) The Shaugh Moor project: first report. *Proceedings of the Prehistoric Society* 45, 1-33.
- Wainwright, G. J. and Smith, K. (1980) The Shaugh Moor project: second report – the enclosure. *Proceedings of the Prehistoric Society* 46, 65-122.
- Ward, A. H. (1978) The excavation of a Bronze Age composite mound and other features on Pentre Farm, Pontardulais, West Glamorgan. *Archaeologia Cambrensis* 127, 40-74.
- Ward, A. H. (1983) Excavation around two standing stones on Mynydd Llangyndeyrn, Dyfed. *Archaeologia Cambrensis* 132, 30-45.
- Westley, B. (1973) The human skeleton and the cremation. In the excavation of a round cairn on Court Hill, Tickenham, 1969 by H. Green, 37-38. *Proceedings of the Somerset Archaeology and Natural History Society* 117, 33-45.
- White, D. A. (1982) The Bronze Age Cremation Cemeteries at Simon's Ground, Dorset. *Dorset Natural History and Archaeological Society Monograph Series* 3.
- Whyllie, A. (1995) Putting Shakertown back together: critical theory in archaeology. *Journal of Anthropological Archaeology* 4, 133-147.
- Whyllie, A. (1992) The interplay of evidential constraints and political interests: recent archaeological research on gender. *American Antiquity* 57.1, 15-35.
- Williams, A. (1947) Bronze Age barrows near Chewton Mendip, Somerset. *Proceedings of the Somerset Archaeology and Natural History Society* 93, 36-67.
- Williams, A. (1950) Bronze Age barrows on Charmy Down, Lansdown, Somerset. *The Antiquaries Journal* 30, 34-46.
- Williams, D. F. (1988) Appendix 1: petrological examination of Bronze Age pottery from the Croft Andrew barrows. In A barrow cemetery on Davidstow Moor, Cornwall. Wartime Excavations by C. K. Croft-Andrew by P. Christie, 161-163. *Cornish Archaeology* 27, 27-169.
- Williams, G. (1988) *The Standing Stones of South-West England*. B.A.R. 197.
- Williams, G. (1989) Excavations in Longstone Field, St. Ishmaels, Pembrokeshire. *Archaeologia Cambrensis* 138, 20-45.



- Wilson, J. C. (1983) The standing stones of Anglesey: a discussion. *Bulletin of the Board of Celtic Studies* 30, 363-389.
- Wilson, M. C. (1995) The household as a portable mnemonic landscape: archaeological implications for Plains stone circle sites. In *Beyond Subsistence: Plains Archaeology and the Postprocessual Critique* eds. P. Duke and M. C. Wilson, 169-192. Tuscaloosa: University of Alabama Press.
- Woodward, A. (1990) The Bronze Age pottery. In *Brean Down Excavations 1983-1987* by M. Bell, 121-145. *Historic Buildings and Monuments Commission Archaeological Report* 15.
- Woodward, A. and Cane, C. (1991) The Bronze Age pottery. In *Trethellan Farm, Newquay: the excavation of a lowland Bronze Age settlement and Iron Age cemetery* by J. A. Nowakowski, 103-133. *Cornish Archaeology* 30, 5-242.

	CORNWALL, DEVON, WEST SOMERSET	CENTRAL SOMERSET	NORTH-EAST SOMERSET
<b>SETTLEMENTS 150 BC</b>	Strongly defended homesteads		Hillforts dominant
<b>CERAMICS 100 BC</b>	Glastonbury ware	Glastonbury ware	Glastonbury ware and saucepan pot continuum
<b>NUMISMATIC EVIDENCE</b>		South-western coin zone	Western coin zone
<b>SETTLEMENTS AD 0-50</b>	Hillforts present	Hillforts dominant	Oppida present
<b>CIVITATES</b>	<i>Dumnoni</i>	<i>Durotriges</i>	<i>Belgae</i>

Table 4.1 Regional settlement characteristics, artifact patterning and tribal affiliation in Late Iron Age and Roman south-west Britain (after Millet 1990).



Sites	Dates	Provenience	Sites	Dates	Provenience
Chysauster OXA822	1926-1528BC 1832-1687BC	Charcoal from urn P1	Treligga 2 HAR8100	1887-1495BC 1755-1600BC	Secondary
OXA821	1778-1448BC 1694-1524BC	Charcoal from urn P5	Stannon Downs 2 HAR5130	1926-1601BC 1831-1690BC	Charcoal from central pit
HAR 6654	1604-1208BC 1495-1293BC	Unenclosed cremation	Davidstow I HAR6634	2112-1645BC 1925-1746BC	Charcoal mound (fire 1)
HAR6927	1880-1310BC 1690-1440BC	Urn P7 north of cairn	Davidstow III HAR6640	2409-2008BC 2295-2032BC	Charcoal on OGS at centre
Poldowrain 1 HAR2829	2038-1603BC 1925-1720BC	Charcoal from basal layer 8	Davidstow V HAR6635	2140-1739BC 2036-1877BC	Charcoal from clay layer in cairn F2
HAR3107	1782-1497BC 1741-1600BC	As above	Davidstow XXIV HAR6090	1980-1520BC 1890-1680BC	Charcoal from central spread on OGS
HAR3108	2910-2140BC 2670- 2340BC	Pit 5 below mound	Davidstow XXVI HAR6643	2896-2570BC 2778-2715(.30) 2706-2652(.25)BC	Charcoal from pit 6 on south-west edge of stone ring
Trelen 2 HAR4540	2470-1880BC 2310-2030BC	Charcoal in primary fill of phase 2 ditch	Colliford CR2 HAR2624	2142-1807BC 2037-1883BC	Charcoal infill in ring centre
HAR5510	2135-1643BC 1960-1768BC	As above	HAR2617	2036-1681BC 1925-1732BC	Charcoal from pit 86
HAR4538	1496-1049BC 1415-1212BC	Charcoal from backfill layer of phase 2 ditch	HAR2622	2038-1603BC 1925-1720BC	Charcoal from pit 85
Mancekuke HAR8097	2045-1691BC 1975-1852(.56)BC	Charcoal from pre-barrow fire on OGS	Colliford IVA HAR2994	2038-1684BC 1926-1738BC	Charcoal scatter on OGS below central cairn
Crig-A-Mennis NPL193	2042-1680BC 1962-1738BC	Charcoal from fire on OGS under central slate cairn	Colliford IVC HAR2991	2142-1734BC 2037-1875BC	Charcoal with cremation in central pit
Cataclews HAR8099	2109-1643BC 1924-1741BC	Charcoal from fire on OGS associated with central cremation			
Watch Hill HAR654	1973-1678BC 1886-1724BC	Charcoal from pit in ditch bottom			
HAR655	1925-1522BC 1784-1683(.52)BC	As above			

**Notes:**

Two-sigma error dates appear above one-sigma error dates.  
Probability results less than (.70) are shown in parentheses.

Table 5.1 Radiocarbon dates and proveniences for Cornish sites.

Sites	Dates	Provenience	Sites	Dates	Provenience
Shaugh Moor 1 HAR2216	2112-1645 1925-1746	Charcoal in central pit	Shaugh Moor Enclosure 15 (cont.): Enclosure Wall HAR2475	1607-1291 1522-1376	Soil associated with wall
Shaugh Moor 2 HAR2220	1925-1528 1832-1686	Charcoal in central pit	House 15 HAR2474	1966-1522 1834-1683(.66) 1882-1839(.18) 1673-1627(.17)	Charcoal from Phase 1 posthole
HAR2214	1695-1376 1606-1409	Charcoal in Pit 146	HAR2968	1500-1208 1439-1289	Charcoal from fill of Phase 1 drain
Shaugh Moor 70 HAR2219	1926-1528 1832-1686	Charcoal in Pit 79	HAR3419	1394-968 1264-1047	Charcoal from Phase 2 drain
Shaugh Moor 71 HAR2213	1926-1528 1832-1686	Charcoal in Pit 104	House 67 HAR2979	1693-1307 1603-1432	Charcoal from drain below Phase 1 house wall
Shaugh Moor 126 HAR2285	1925-1494 1780-1604	Charcoal in central pit	HAR3358	1775-1435 1693-1519	Charcoal between cobbles outside Phase 2 house
HAR2221	1781-1493 1697-1598(.61) 1572-1532(.20) 1736-1698(.19)	Charcoal in scoop into cairn	House 18 HAR2987	1830-1290 1670-1430	Charcoal from Phase 1 drain
Upton Pyne BM402	1749-1495 1692-1599	Charcoal from Urn 4	HAR2472	1437-1074 1393-1213	Charcoal between Phase 2 flagstones
Rose Ash HAR2992	1410-1047 1320-1208(.53) 1181-1148(.14)	Charcoal from pit fill	House 66 HAR2960	1501-1187 1433-1257	Charcoal from hollow below Phase 1 wall
			HAR2983	1740-1406 1626-1488	Charcoal from gully on east side house
Venford Reave BM1609	1665-1434 1624-1493	Charcoal from Phase 1 bank	House 19 HAR2473	1266-897 1115-999(.53) 1192-1142(.21)	Charcoal from soil around cobbled entryway
Saddlesborough Reave HAR4103	2043-1690 1969-1808	Charcoal from turf regrowth above Phase 1 animal tracks	HAR2978	945-754 901-769	Charcoal from interior house drain
HAR4003	1832-1448 1737-1524	Wood from initial bank cut down for construction of Phase 2 stone reave			
Shaugh Moor Enclosure 15: Pre-enclosure HAR2986	1746-1407 1638-1491	Charcoal from old ground surface below wall			
HAR2989	1643-1491	Pit 633 and vessels P12-14			

Notes:

Two sigma error dates appear above one sigma error dates.  
Probability results less than (.70) are shown in parentheses.

Table 5.2 Radiocarbon dates and proveniences for Devon sites.



Sites	Dates	Provenience
Court Hill		
I5735	1830-1430	Skeleton
	1700-1500	
I5734	1110-480	Cremated bone
	1010-760	
Charterhouse Warren Farm Swallet		
OXA1559	2415-2129	Human scapula in
	2345-2190	Horizon 2
OXA1561	2472-2266	Auroch skull,
	2467-2309	Debris Cone 1
BM731	1624-1445	Horizon 1
	1601-1551(.49)	
	1543-1493(.51)	
Gorseby Bigbury*		
BM1088	2470-2030	Charcoal in henge
	2360-2140	ditch
BM1087	2145-1760	Charcoal in henge
	2040-1885	ditch
Brean Down*		
HAR8547	2020-1540	Unit 8a charcoal with
	1890-1685	Maritime Beaker
HAR7023	3790-3045	Charcoal from 8a
	3680-3350	palaeosol
HAR8993	1930-1510	Unit 8a charcoal
	1870-1545	
HAR8991	1610-1135	Unit 6a charcoal
	1510-1310	
HAR7020	1870-1430	Charcoal from
	1730-1515	Structure 57, Unit 6a
HAR7018	1310-840	Charcoal from
	1210-925	Structure 95, Unit 5b
HAR9151	1040-800	Animal bone from
	975-820	Unit 4

**Notes:**

2-sigma probability ranges appear above 1-sigma probability ranges. Probability results less than (.80) are shown in parentheses.

\* representative assays only

Table 5.3 Radiocarbon dates and proveniences for Somerset sites.

PRE-MOUND ALIGNMENTS, RINGS, "MOUND PITS"		SKLETAL SELECTION, GRAVE REOPENING	HOT OR IN-SITU CREMATIONS, MULTIPLE FIRES, CHARCOAL DEPOSITS/PITS, RECREMATIONS	TIMED MOUND ENLARGEMENTS, POST-MOUND RITUAL ACTIVITIES/FEATURES
BEAKER/ 3RD MILL.	Trelen 2, Carvinak, Cocksbarrow, Davidstow III Davidstow XVI, Farway Sites, White Cross Ring	Try, ?Longstone, Cocksbarrow, Tregulland, ?Davidstow XII, Davidstow III, Davidstow XVI, Cheyton Plain 5	-	Lousey, Charry Down 2
BEAKER/ FOOD VESSEL	Tregulland	-	-	-
FOOD VESSEL	Watch Hill	?Gwithian CH-V	-	Watch Hill
URN/NON- BEAKER EBA	Crig-a-Mennis, Davidstow I	Trelliga 1, ?Court Hill	Davidstow Moor V, Crig- a-Mennis, Davidstow Moor I, Cataclews, Colliford CRIVC, Colliford CRII, Treligga 1,2, 5, Stannon Downs 1, Sbaugh Moor Cairns, Opton Pyne, Chysauster	Davidstow Moor V, Crig-a-Mennis, Davidstow I, Mancekuke, Caerloggas Downs I, III, Colliford CRII, CRIVC East Putford I, Charry Down 6, Opton Pyne

Table 5.4 Summary of information presented in Section 5.5.



Alignment ID#	Azimuth	Alignment ID#	Azimuth
1a	130°	25ee	228°
1b	306°	25f	190°
1c	94-134°	25ff	185°
1d	278-317	25g	345°
2a	250°	25h	5°
2b	230°	26	50/230°
3a	115°	27	49/229°
3b	308°	28 a, b	10°
4a	50°	29	360/180°
4b	320°	30	228°
4c	50°	10b	115°
4d	100/280°		
5a	50°		
5b	360°		
6	360/180°		
7a	185°		
7b	100/280°		
8a	126-306°		
8b	240-265°		
8c	82°		
9	139°		
10	314°		
10a	95°		
11a	129°		
11b	293-310°		
13	90/270°		
14	360/180°		
15	14/194°		
16	50/230°		
17a	129°		
17b	270°		
17c	100°		
17d	110°		
18	129/310°		
19	73/253°		
20	24/204°		
21a	93°		
21b	272/273°		
22	15/195°		
23	360/180°		
24	90/270°		
25a	45, 43°		
25b	85°		
25bb	90°		
25c	325°		
25d	130°		
25e	228°		

Table 6.1 Azimuths for all alignments in Figure 6.1.

CATEGORIES	OBESERVED	EXPECTED	COMPARISON(O-E) <sup>2</sup> /E
1	8.5	5.2	2.1
2	2.5	5.2	1.4
3	7	5.2	0.6
4	3	5.2	0.93
5	10.5	5.2	5.4
6	8	5.2	1.5
7	1.5	5.2	2.6
8	4	5.2	.28
9	5	5.2	.008
10	6	5.2	0.012
11	5	5.2	0.008
12	5.5	5.2	0.02
13	3.5	5.2	0.6
14	7	5.2	0.62
15	1	5.2	3.4

TOTAL

$X^2 = 19.58$

$$\sum_{i=1}^k \frac{(O_i - E_i)^2}{E_i}$$

**$H_0$ : Alignments are evenly distributed between 1-360 degrees**

Selected significance level:  $\alpha = 0.05$  (95% confidence)

Tabulated chi-square value at 15-1 degrees of freedom = 6.571

$X^2 \text{ calc} \geq X^2 \alpha$

**$H_0$  rejected**

Table 6.2 One-sample Chi-Squared Test results assessing the distribution of selected alignments in the study.



	MSSR &/or MWSS ±2°	MSSR &/or MWSS ±2-5°	Equinox ±2°	Equinox ±2-5°	MWSR &/or MSSS ±2°	MWSR &/or MSSS ±2-5°	N/S ±2°	N/S ±2- 5°	All ± 5-10°	Other
Entranc.	2	-	1	3	1	2	-	1	*9 28b	8b 2a
Graves	4	1	1	-	-	-	2		28a 4d	15, 20 19, 22
Pits/ Posts/ Stones	3	2	2	1	3	-	2	2	17c 25f	3a, 4b 17d 25g 25c
Feature Cluster/ Align.	-	-	1	-	4	1	3		7b10b 8c 1d <sup>2</sup>	

\* Refer to Figure/Table 6.1 for details of alignments occurring over 5 degrees from significant azimuths.

Table 6.3 Deviation from significant azimuths for all entrance, grave, post/stone, and feature solar alignments.

**\* DEVIATION IN DEGREES FROM SIGNIFICANT AZIMUTHS**

	$\pm 2^\circ$	$\pm 2-5^\circ$	$\pm 5-10^\circ$
MSSR &/or MWSS	9 (75%)	3 (25%)	-
EQUINOX	5 (33%)	5 (33%)	5 (33%)
MWSR &/or MSSS	8 (67%)	3 (25%)	2 (15%)
NORTH &/or SOUTH	7 (54%)	3 (23%)	3 (23%)

-Numerals in fields indicate the combined number of entrances, graves, pits/ posts/stones, and feature clusters/alignments observed to occur on, or deviate as indicated, from the 8 alignments in the study. Percentages in fields were obtained using the total number of alignments within 10 degrees of "error" only.

\*Eleven alignments were observed which occurred over 10 degrees from a significant azimuth (listed and shown in Figure 6.1 and Table 6.1,3). Of these, 7 are within or at 15 degrees from a significant azimuth.

**Table 6.4 Percentages for deviation in degrees from most common solar alignments.**



SOLSTIAL ALIGNMENTS

a

INDIVIDUAL ALIGNMENT AZIMUTHS

	S/N	C1	E/W	C2	MSSR/MWSS	C3	MWSR/MSSS	C4
1		185		82		45		126
2		190		85		43		129
3		194		90		49		129
4		185		90		50		129
5		190		90		50		130
6		185		93		50		130
7		195		95		50		134
8		180		94		50		139
9		180		100		50		
10		180		100		48		
11		180		100		48		
12		180		98		48		
13				93				
14				90				

b

Confidence Intervals

Variable C1      N 12      Mean 185.33      StDev 5.68      ( 95.0 % CI ( 181.73, 188.94)      C1: S/N = 180°

Confidence Intervals

Variable C2      N 14      Mean 92.86      StDev 5.53      ( 95.0 % CI ( 89.66, 96.05)      C2: E/W = 90°

Confidence Intervals

Variable C3      N 12      Mean 48.417      StDev 2.275      ( 95.0 % CI ( 46.971, 49.862)      C3: MSSR/MWSS = 50.5°

Confidence Intervals

Variable C4      N 8      Mean 130.75      StDev 3.99      ( 95.0 % CI ( 127.41, 134.09)      C4: MWSR/MSSS = 129°

Table 6.5 Spread of average direction of alignments at 95% confidence interval.

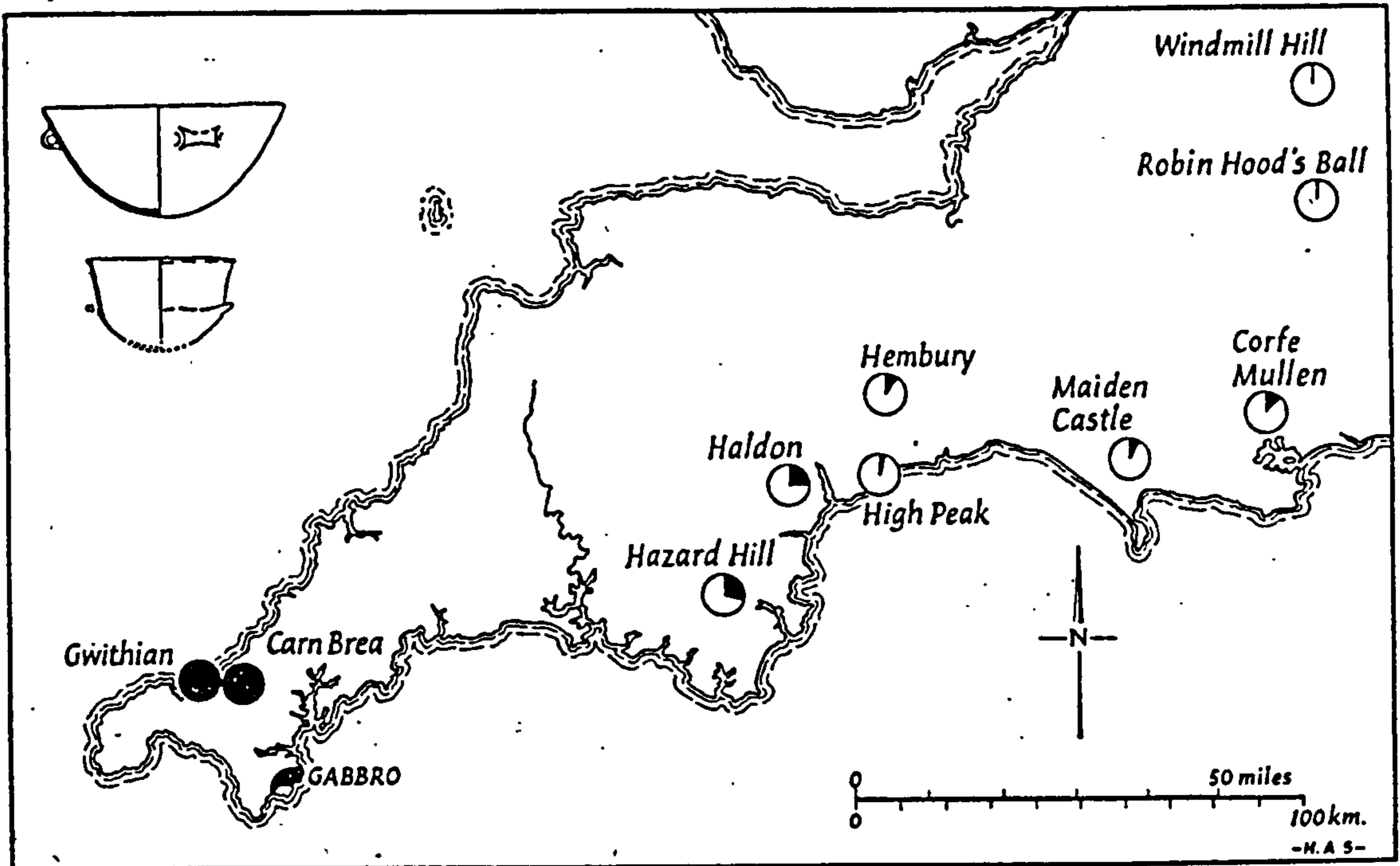


Figure 4.1 Source and distribution of Early Neolithic pottery produced from the gabbroic clay of the Lizard (after Peacock 1969).



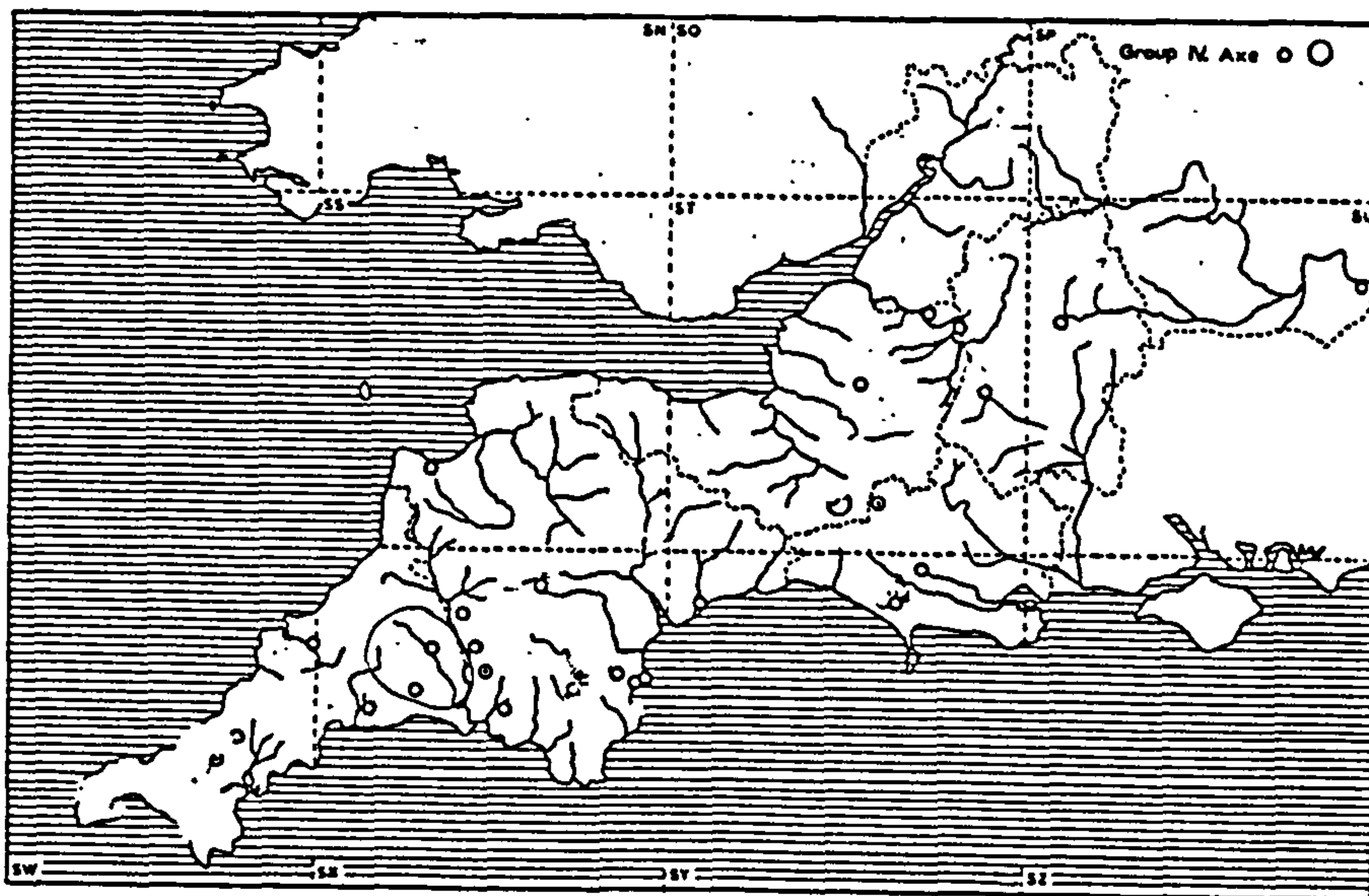
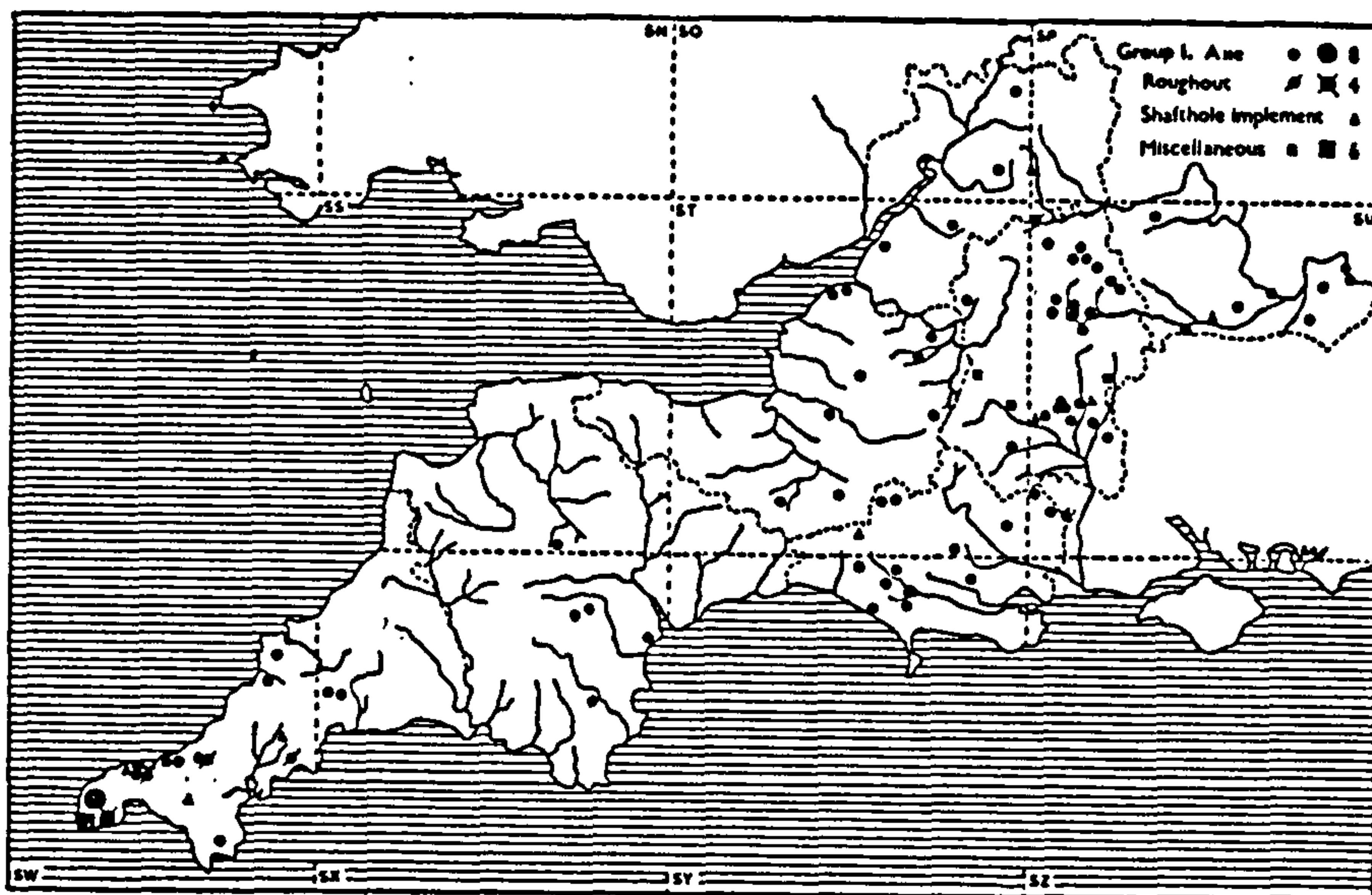


Figure 4.2 Distribution of Groups I and IV later Neolithic stone axes and shaft-hole implements (after Evans, Smith and Wallis 1972).

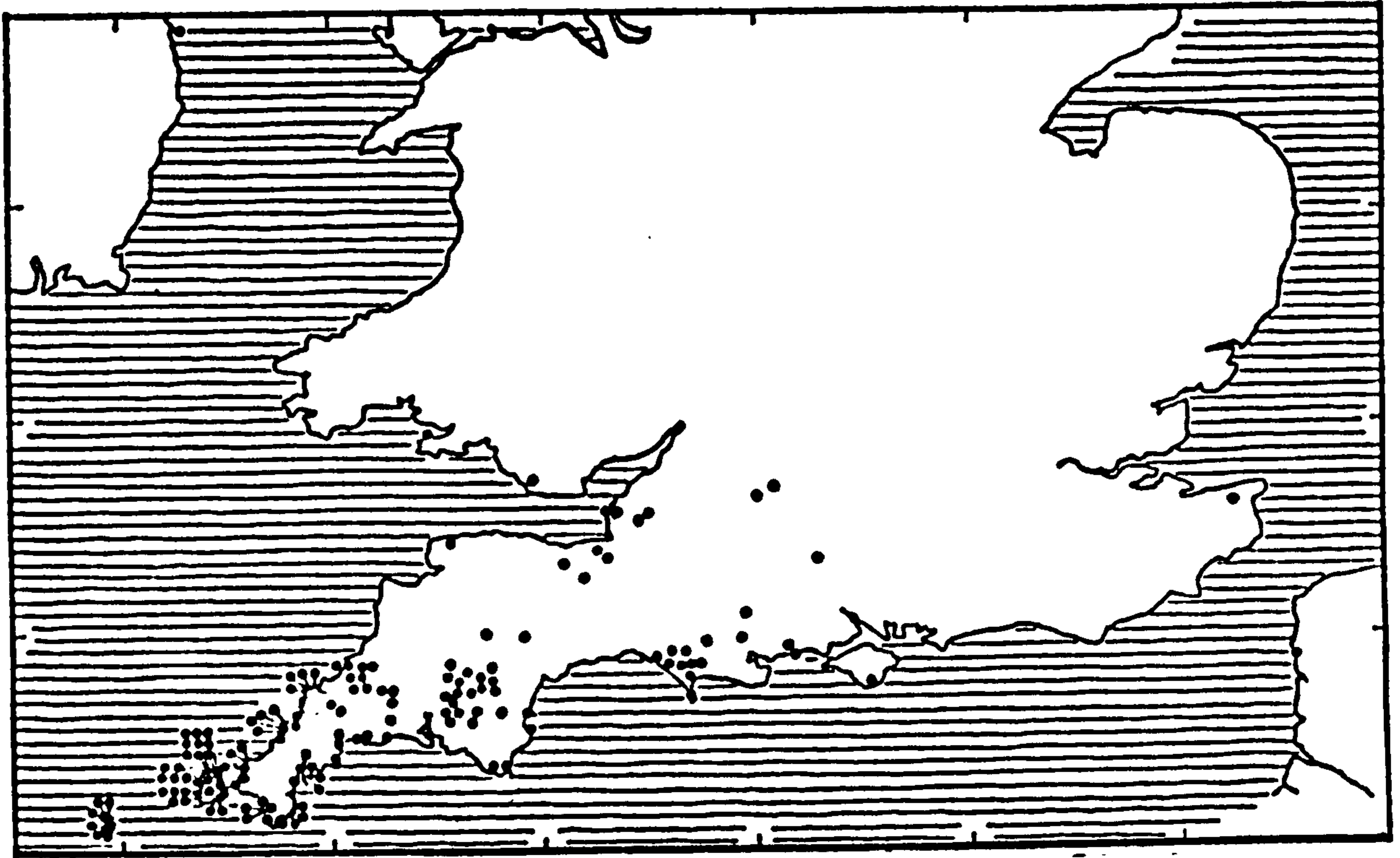


Figure 4.3 Distribution of Trevisker ceramics in southern Britain (after ApSimon and Greenfield 1972; Gibson, MacPherson-Grant and Stewart 1997; Woodward 1990).



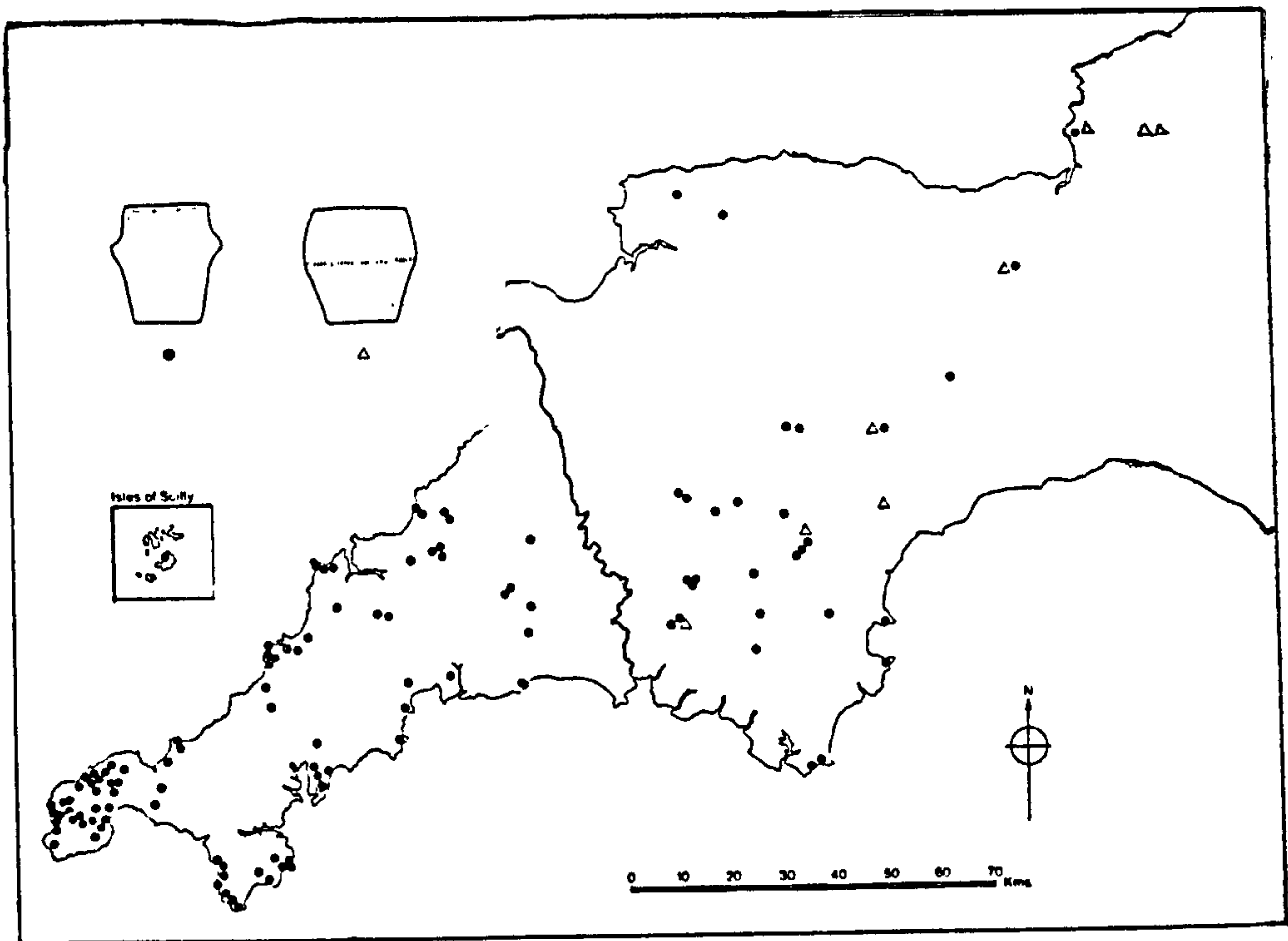


Figure 4.4 Distribution of Trevisker pottery (filled circles) and Wessex Biconical forms (open triangles) in the South-West (after Parker Pearson 1990 ; Woodward 1990).

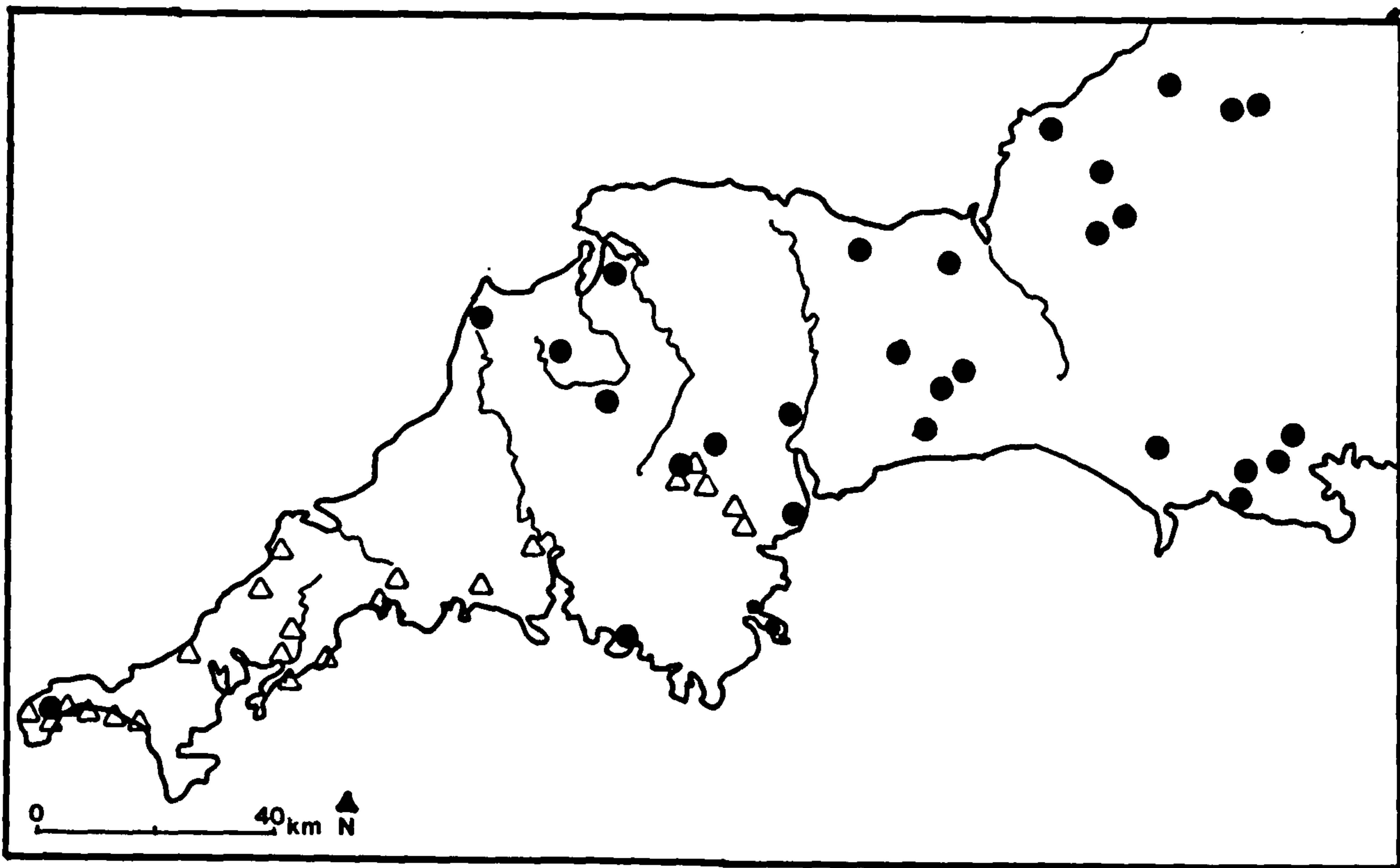


Figure 4.5 Distribution of Early Type Palstaves (●) and Crediton Palstaves (▲) (after Pearce 1983).



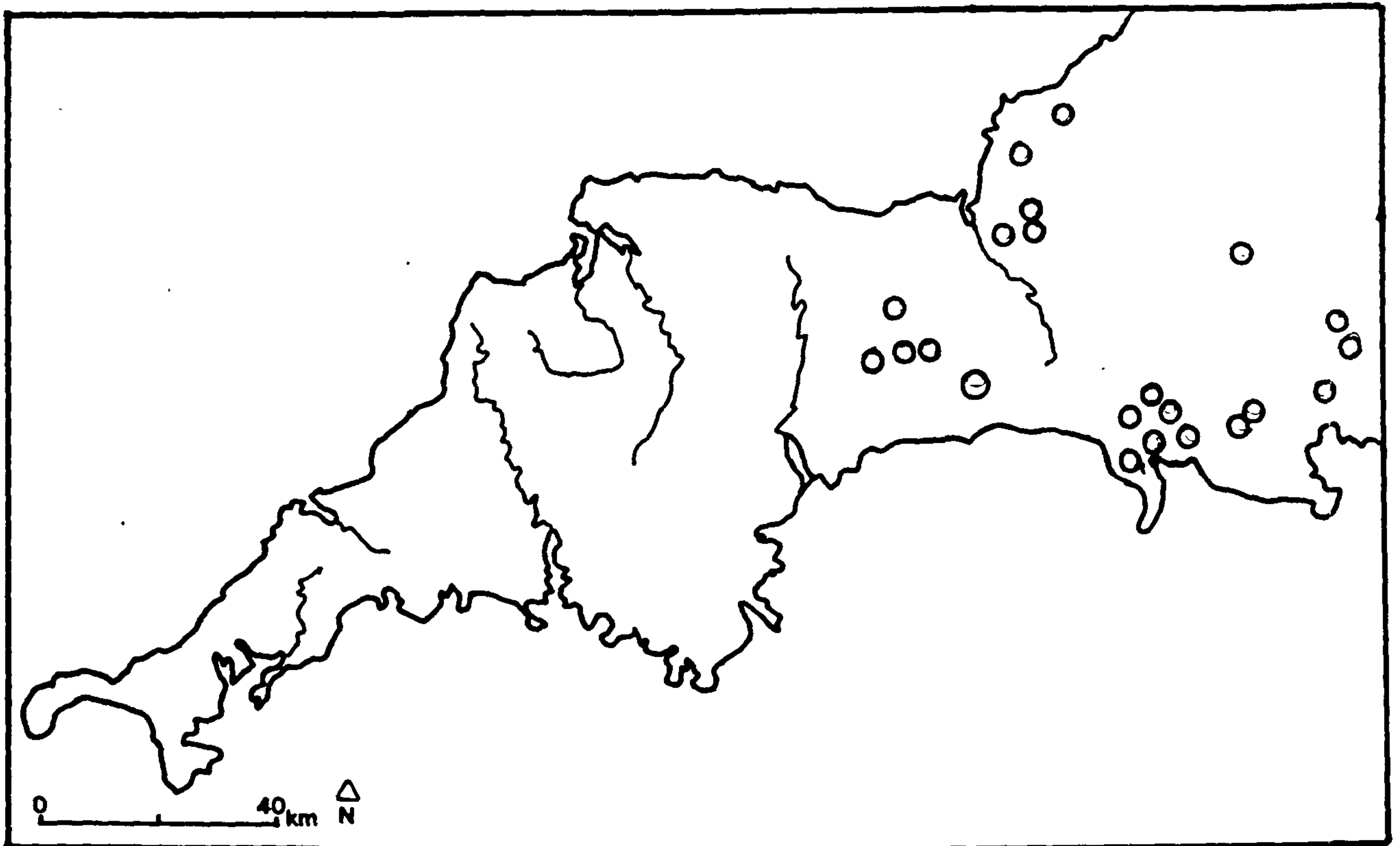


Figure 4.6 Distribution of Middle Bronze Age spiral twisted torcs and penannular armrings (after Rowlands 1976).

2500 2300 2100 1900 1700 1500 1300 1100 900 BC

**Funerary/Ritual Sites:**

**Cornwall:**

- Davidstow III
- Trelen 2
- Davidstow V
- Nancekuke
- Colliford Reservoir 2 (1)
- Colliford Reservoir IVC
- Crig-A-Mennis
- Cataclews
- Davidstow I
- Colliford Reservoir IVA
- Colliford Reservoir 2 (2)
- Poldowrain
- Chysauster
- Watch Hill
- Davidstow XXIV
- Stannon Down 2
- Treligga 2

**Devon:**

- Shaugh Moor 1
- Shaugh Moor 2
- Shaugh Moor 70
- Shaugh Moor 71
- Shaugh Moor 126
- Upton Pyne
- Rose Ash

**Somerset:**

- Court Hill Cairn

**Settlement Sites:**

**Cornwall:**

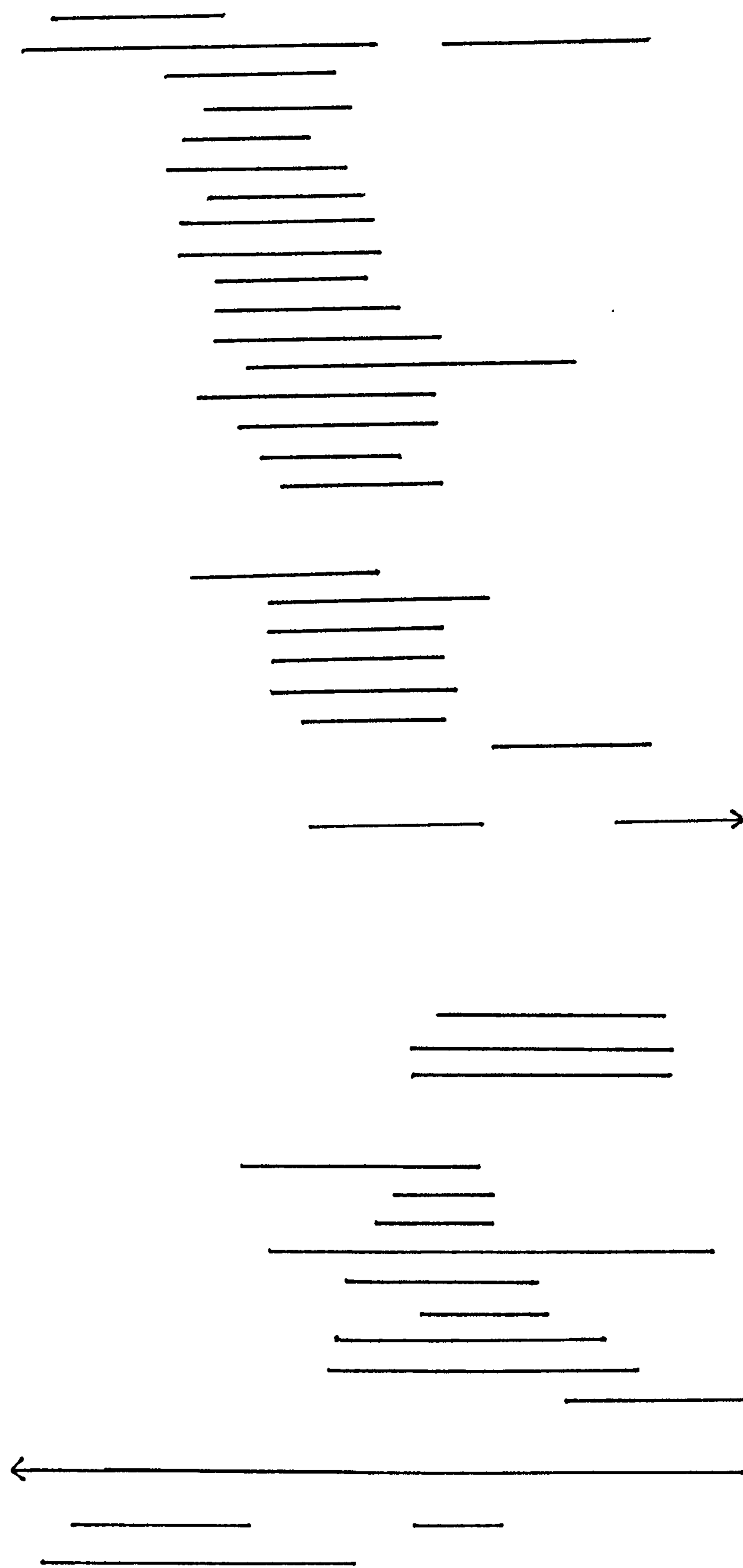
- Trevisker
- Gwithian Level 5
- Trethellan

**Devon:**

- Saddlesborough Reave
- Venford Reave
- Shaugh Moor Pre-enclosure
- Shaugh Moor House 15
- Shaugh Moor House 67
- Shaugh Moor Enclosure Wall
- Shaugh Moor House 66
- Shaugh Moor House 18
- Shaugh Moor House 19

**Somerset:**

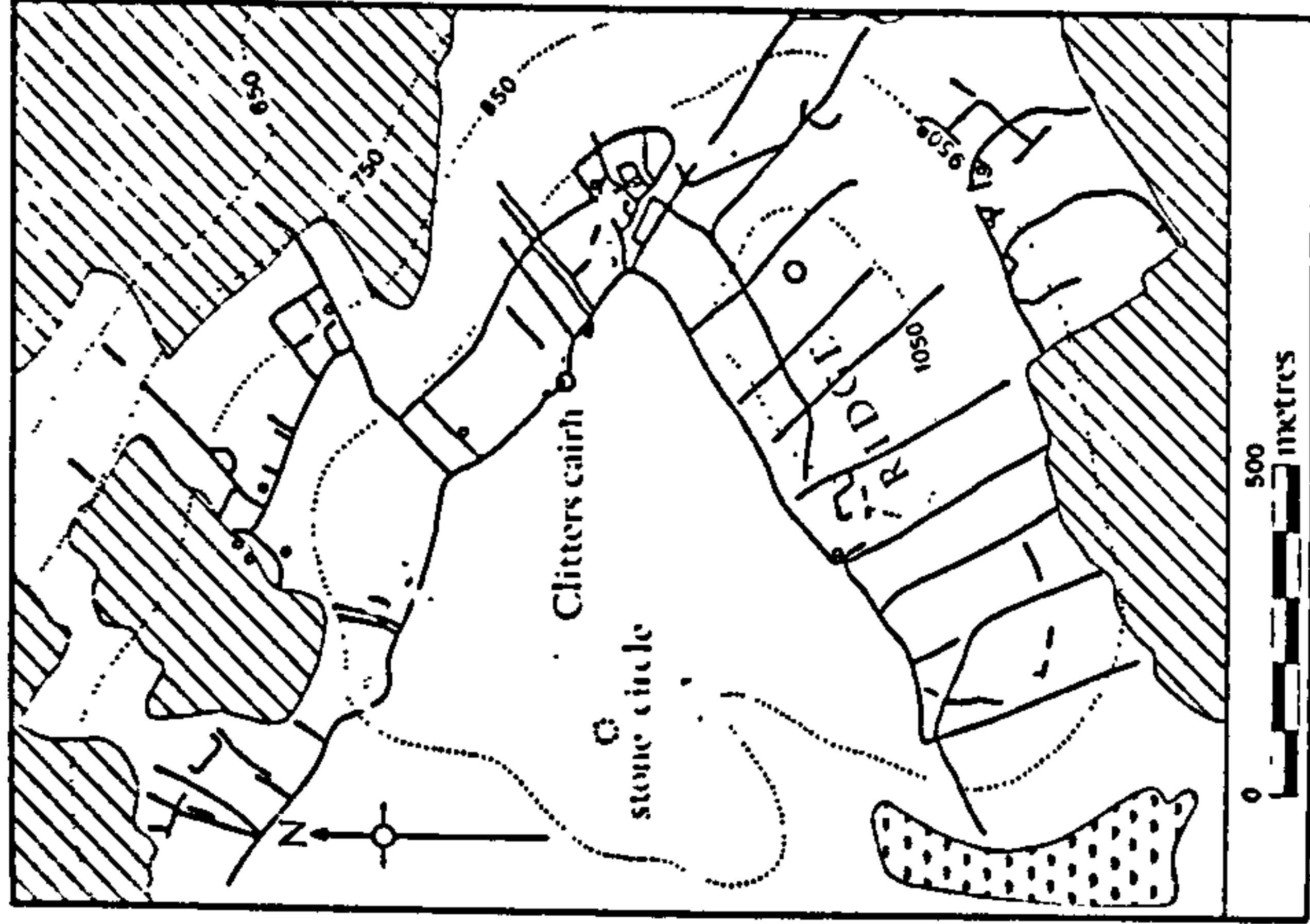
- Brean Down
- Charterhouse Warren Farm
- Swallet
- Gorsey Bigbury



**Figure 4.7 Chronology of Bronze Age settlement and funerary sites in study area.**

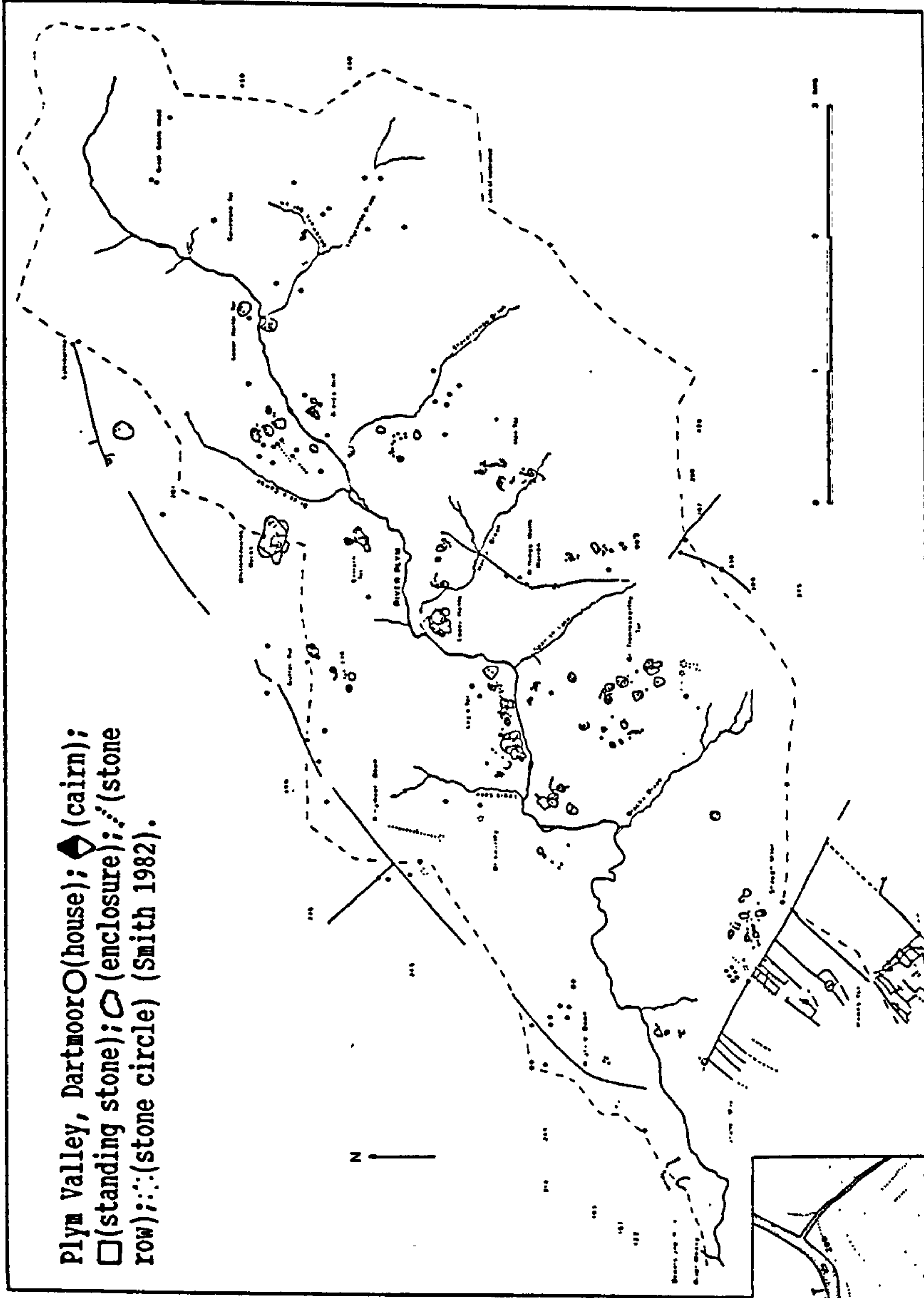


The East Moor field system, Bodmin Moor (Brisbane and Clews 1978).

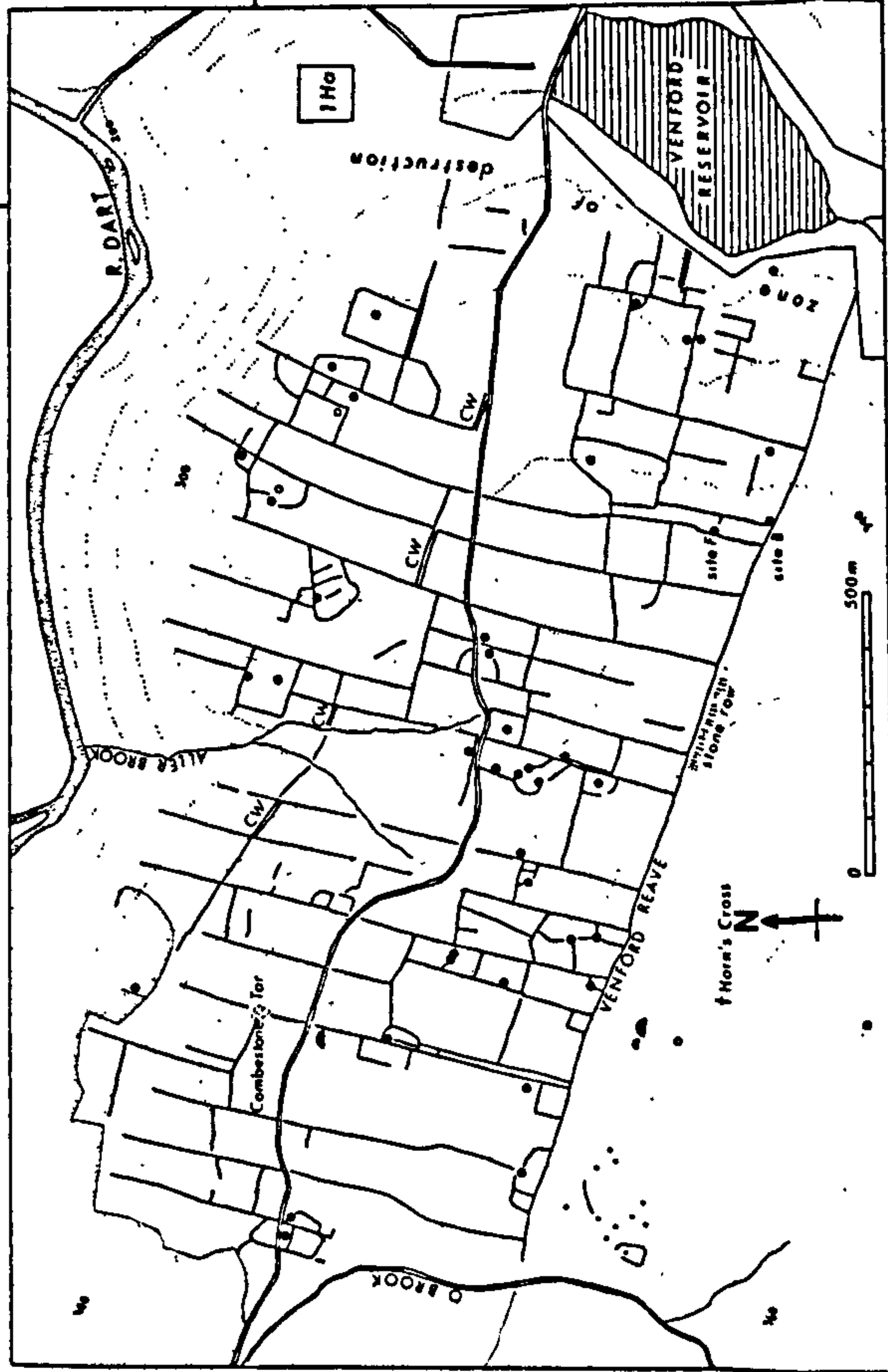


a

377



c



b

The Dartmoor field system, Holne Moor, Dartmoor (houses); (ring-cairns); (large cairns) (Fleming 1988).

Figure 4.8 Spatial relationships between earlier funerary/ritual sites and later settlement and field systems.

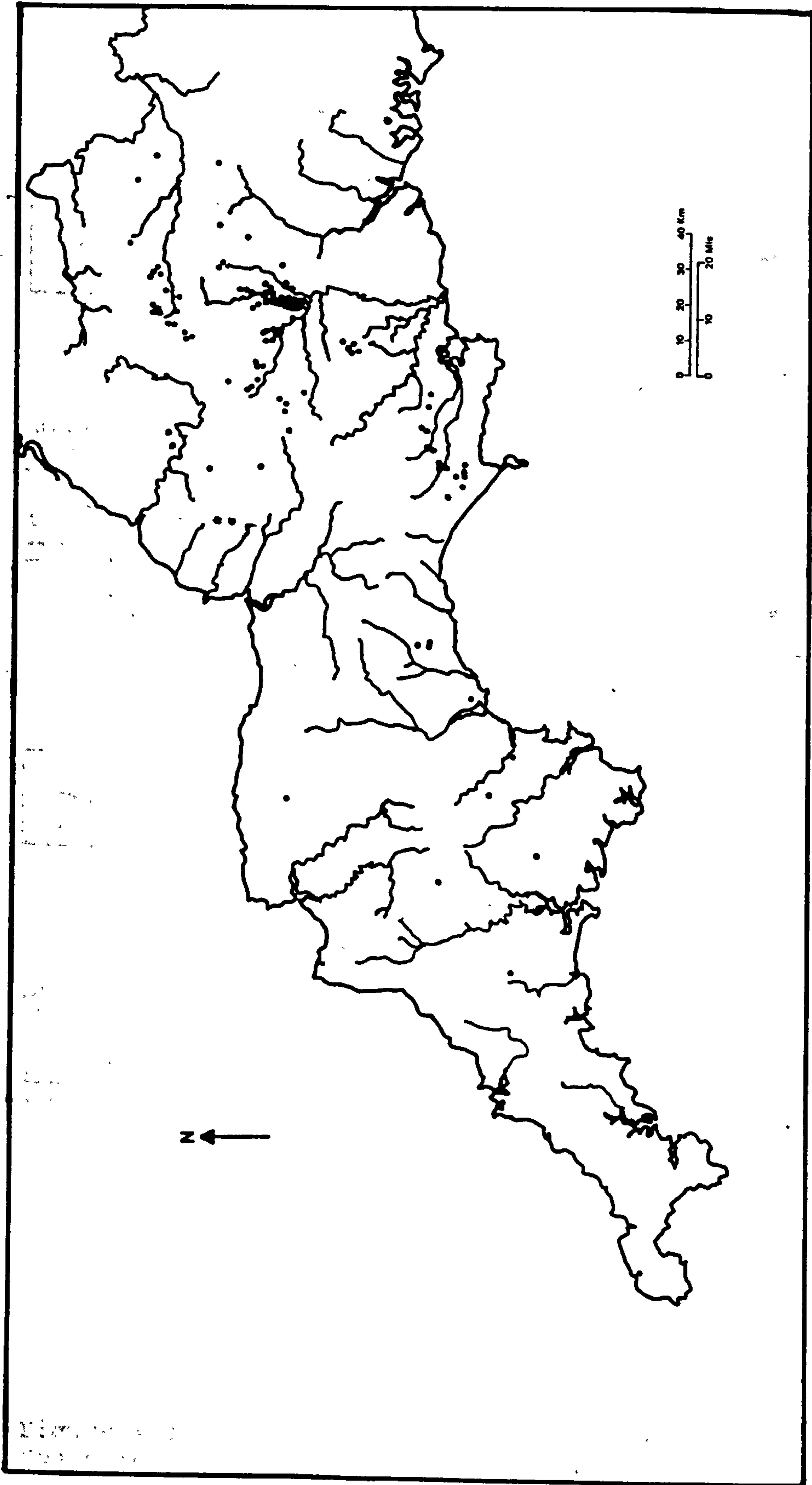


Figure 4.9 Funerary wealth in Early and Middle Bronze Age graves in the South-West and Wessex (after Cunliff 1993; Fox 1941; Grinsell 1969; 1971; Johnson 1980; Williams 1950).



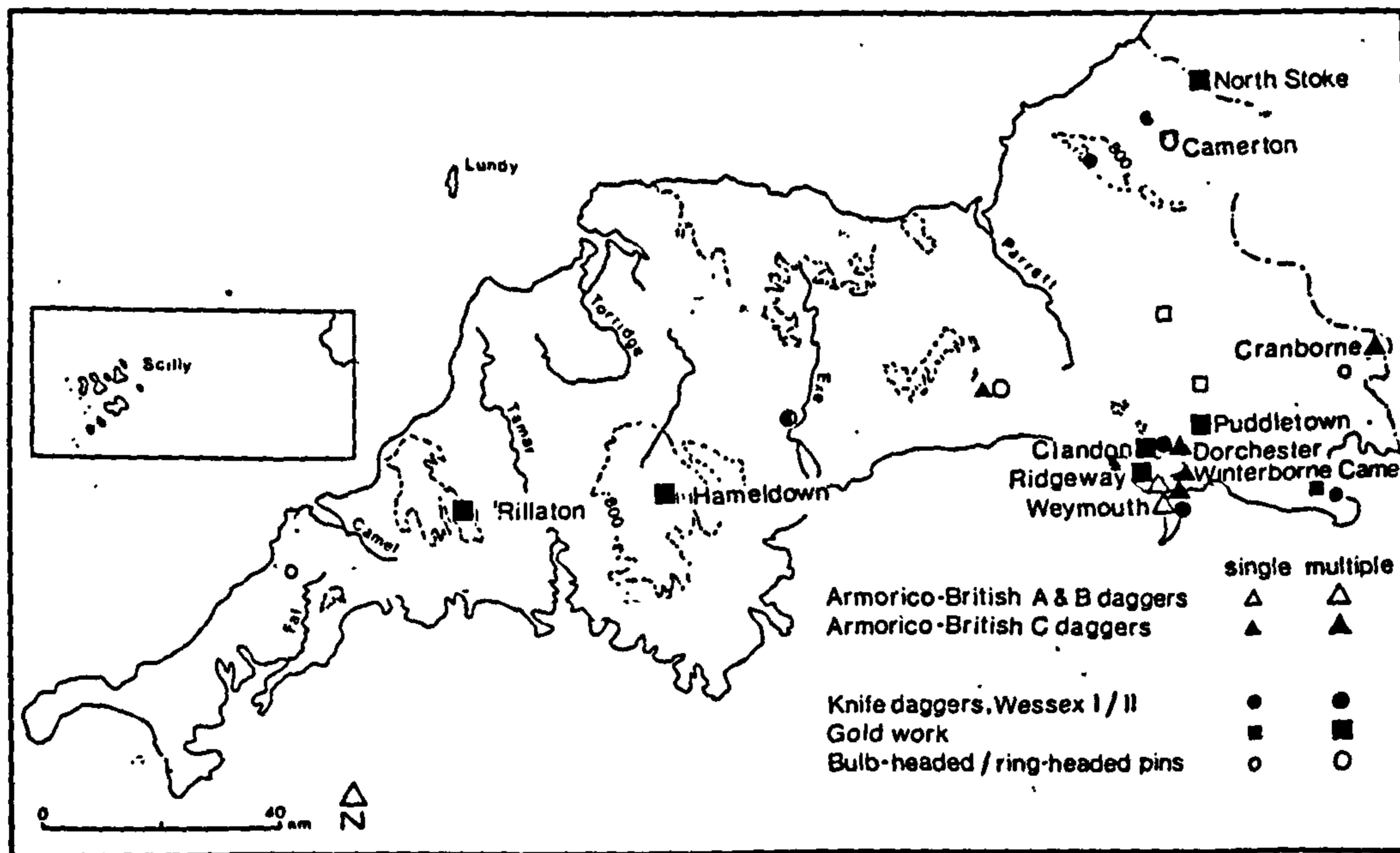
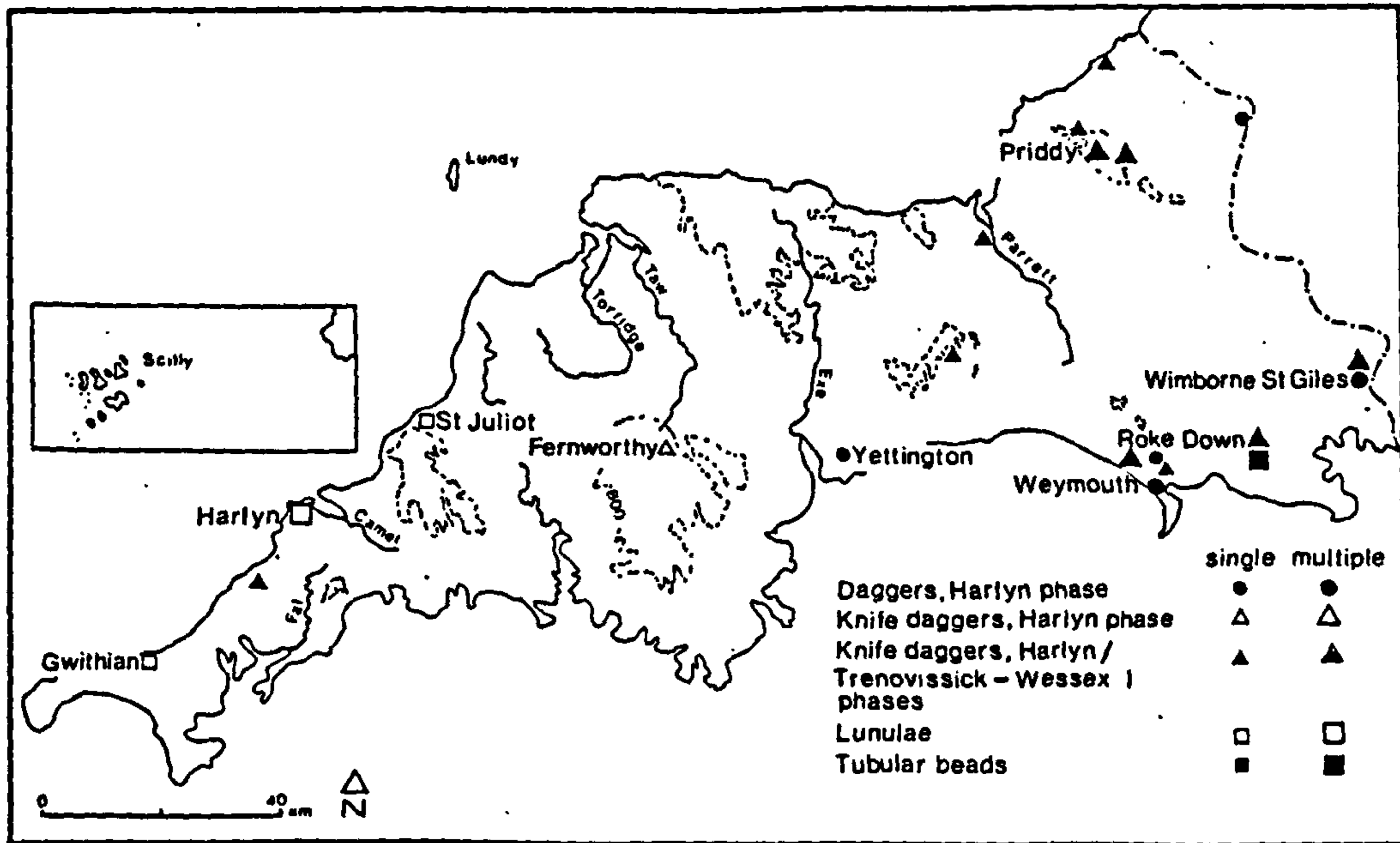
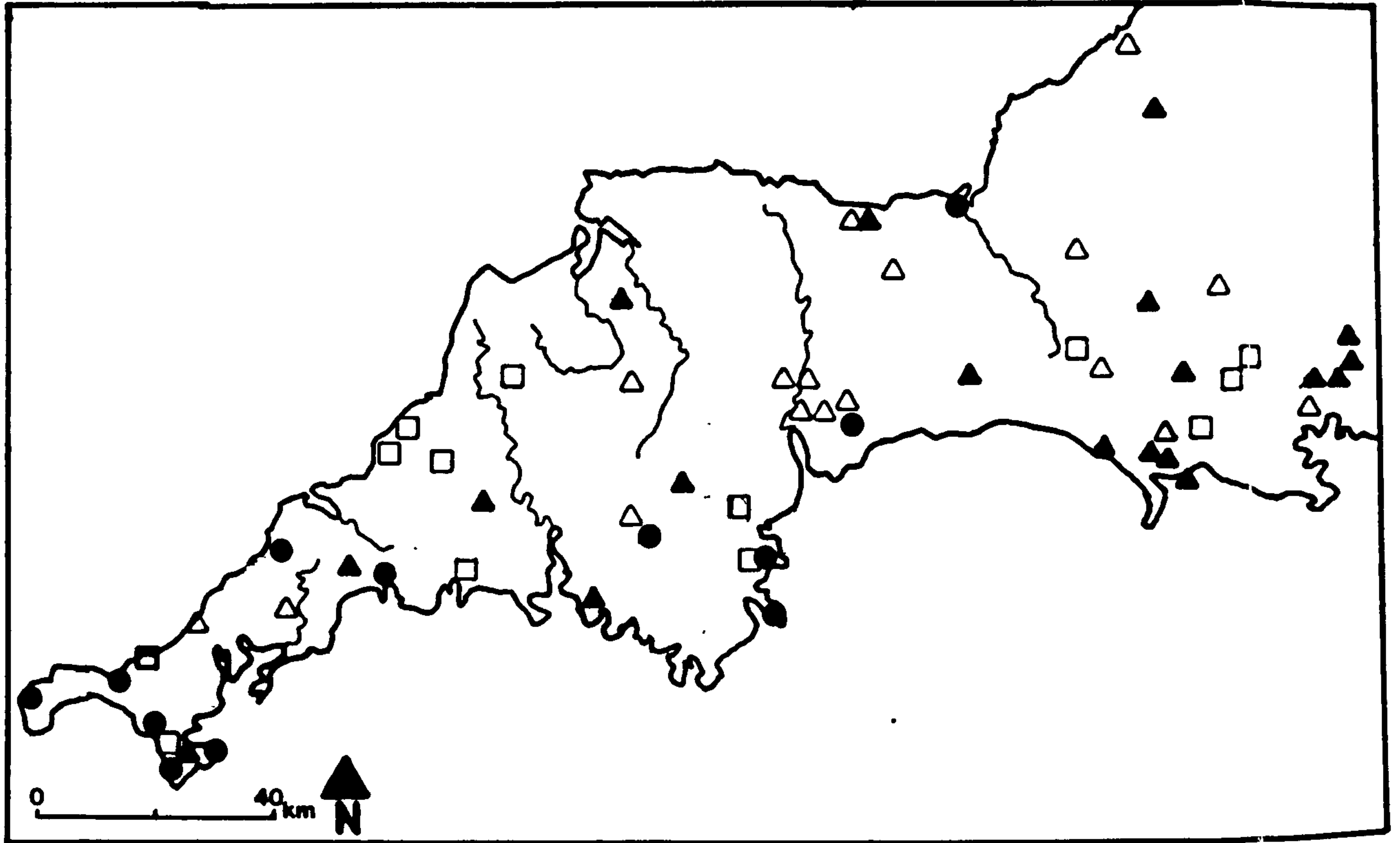


Figure 4.10 Distribution of Early Bronze Age metalwork in the South-West (after Pearce 1983).



● bronze ingots or tin; □ moulds; △ dirks/rapiers; ▲ middle bronze age daggers

Figure 4.11 *Distribution of Middle Bronze Age metal artifacts, moulds and metalworking materials (after Pearce 1983).*



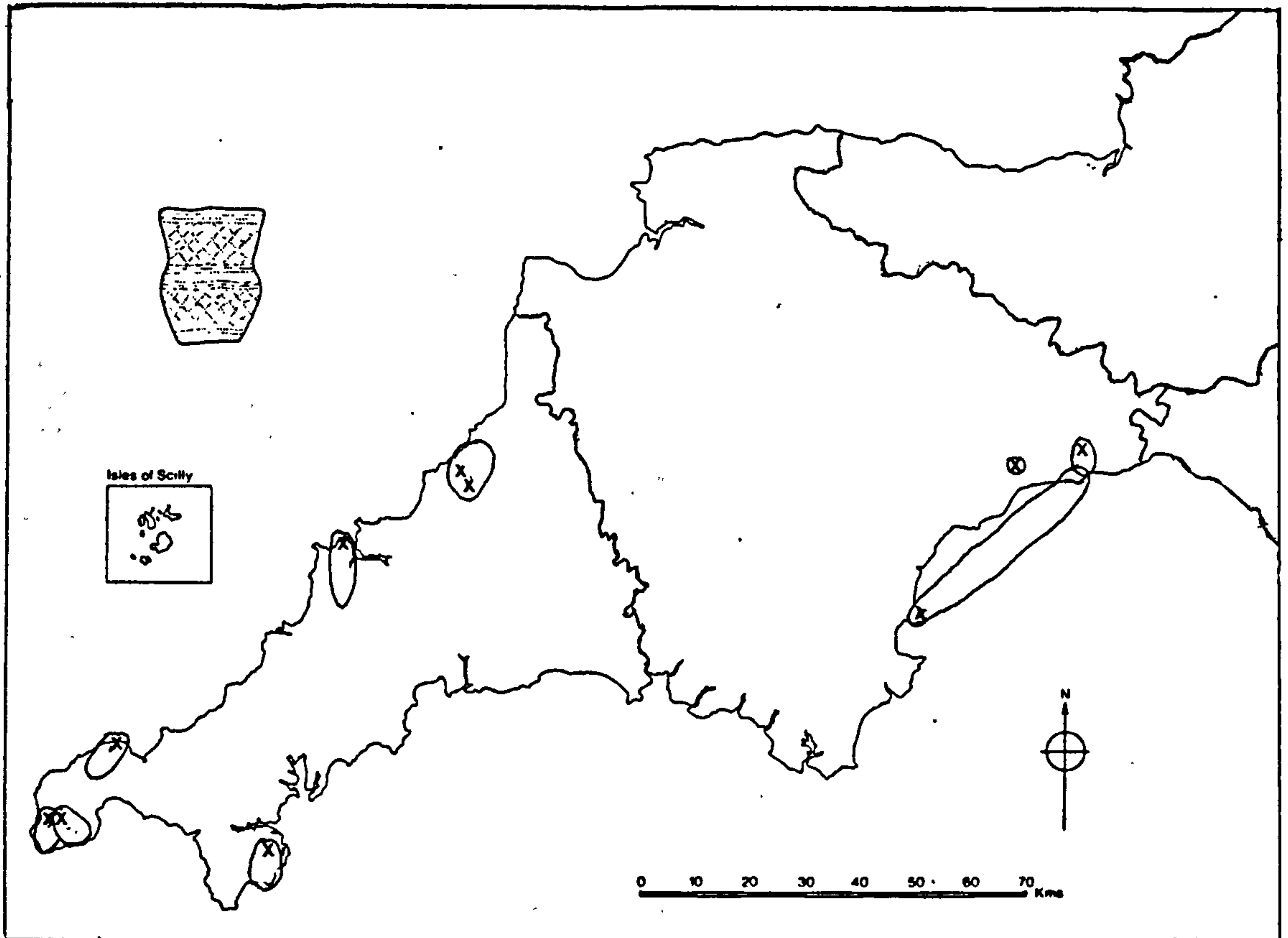


Figure 4.12 Probable Beaker production (X) sites and distributions in the South-West after (Parker Pearson 1990; Williams 1988).

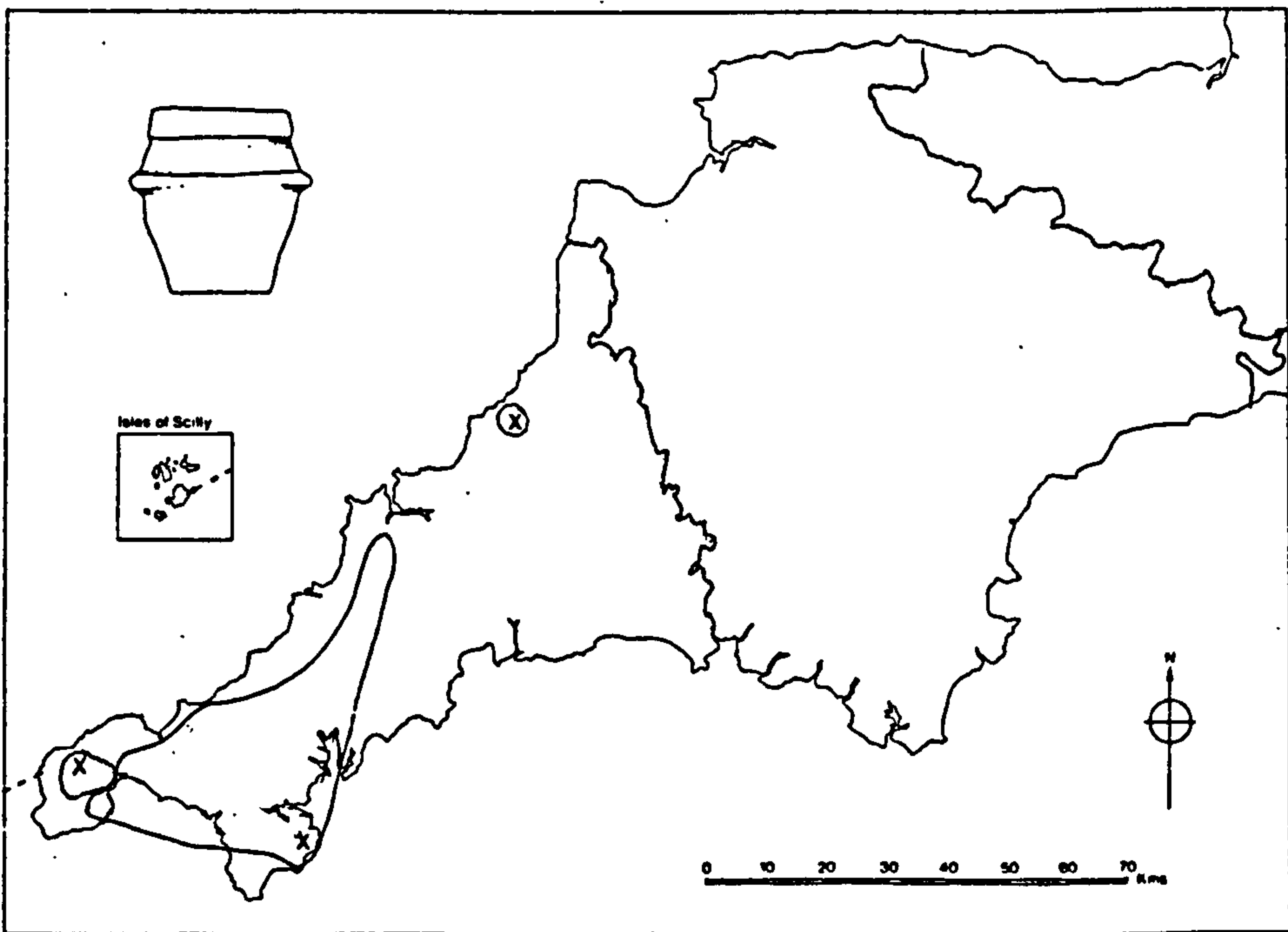
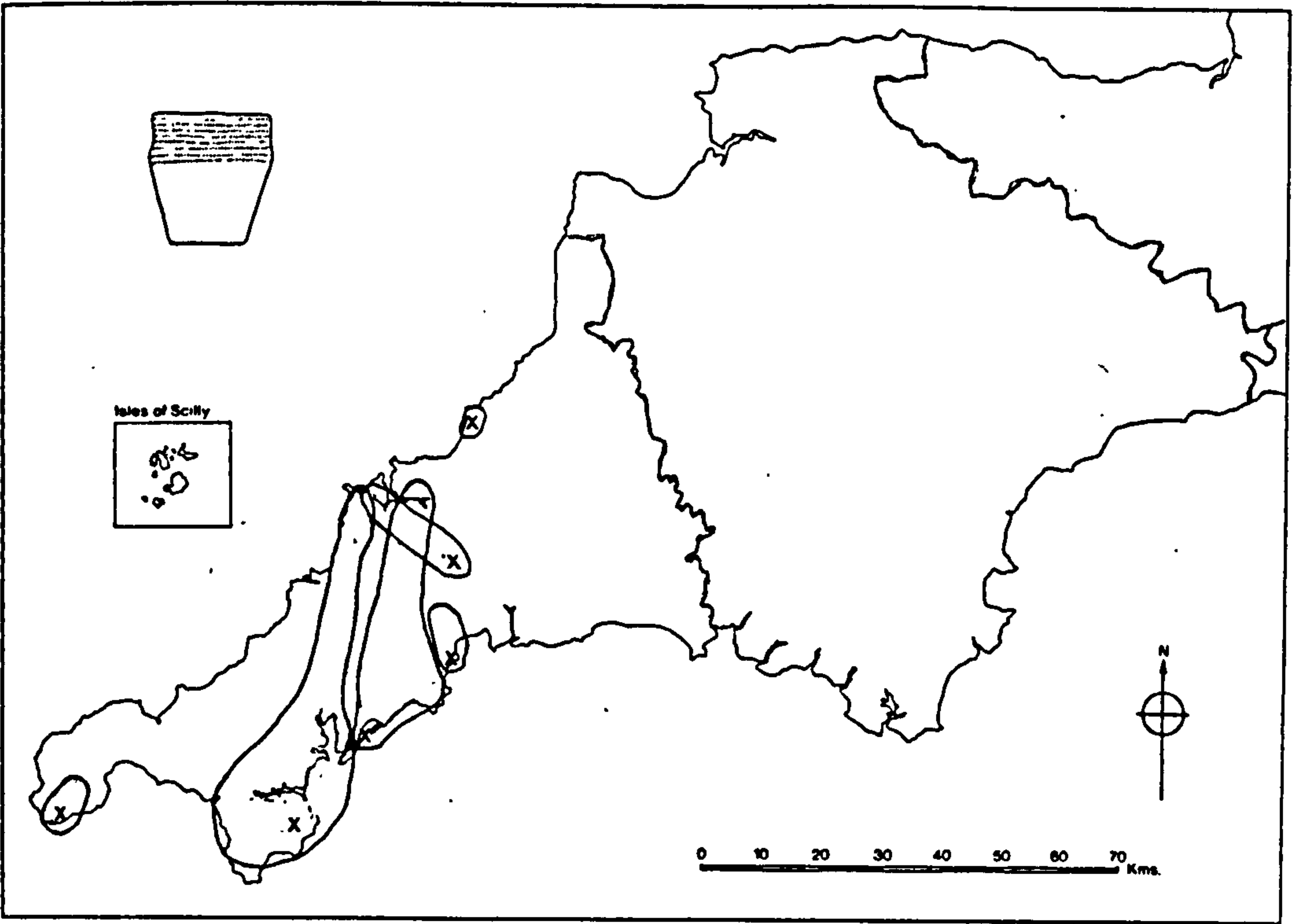


Figure 4.13 Probable Food Vessel and Collard Urn production (X) areas and distributions in Cornwall (after Parker Pearson; Williams 1988; Healey 1985).



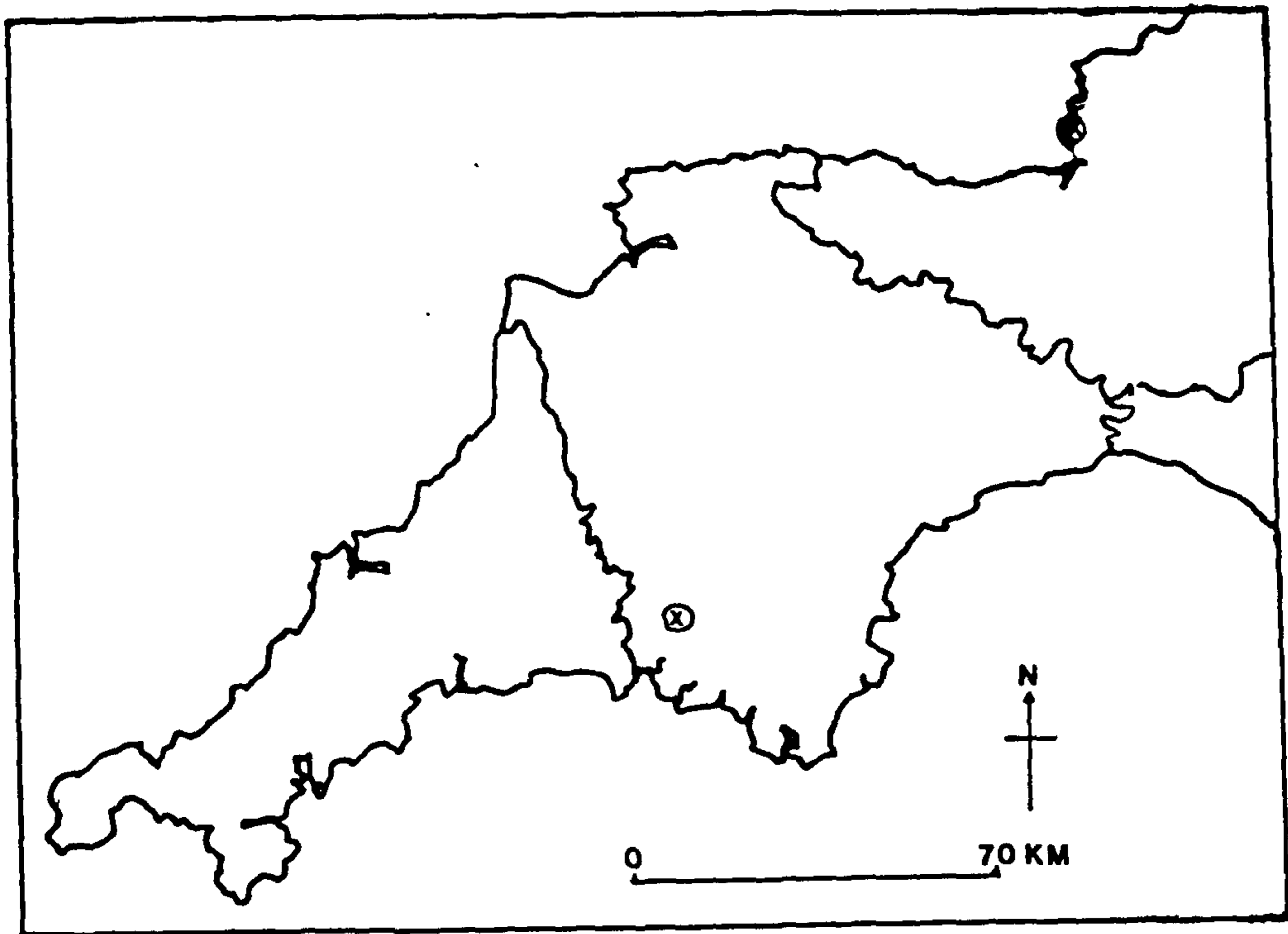


Figure 4.14 Probable Biconical Urn production (X) areas and distributions in Devon and Somerset (after Parker Pearson 1995).

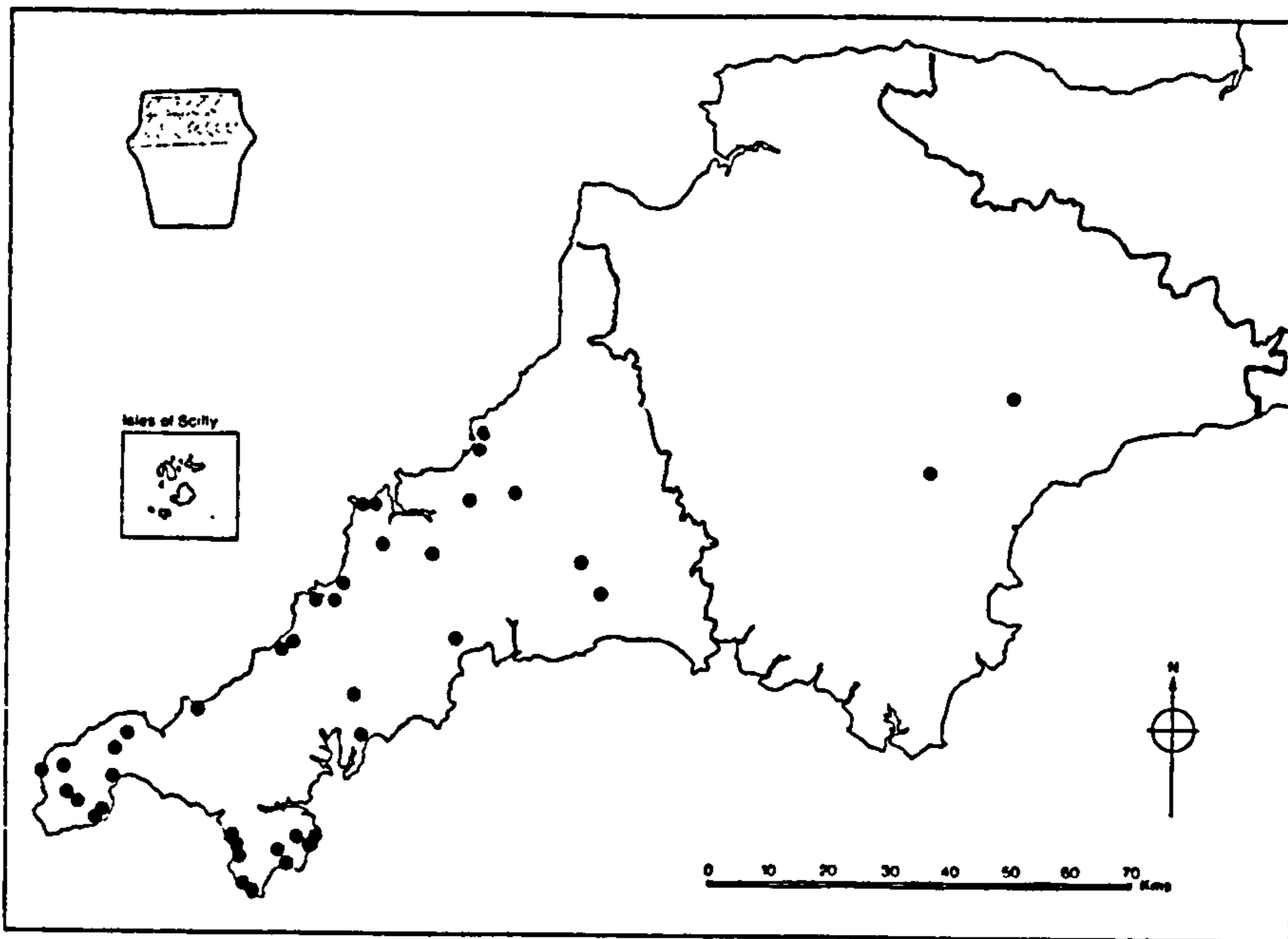
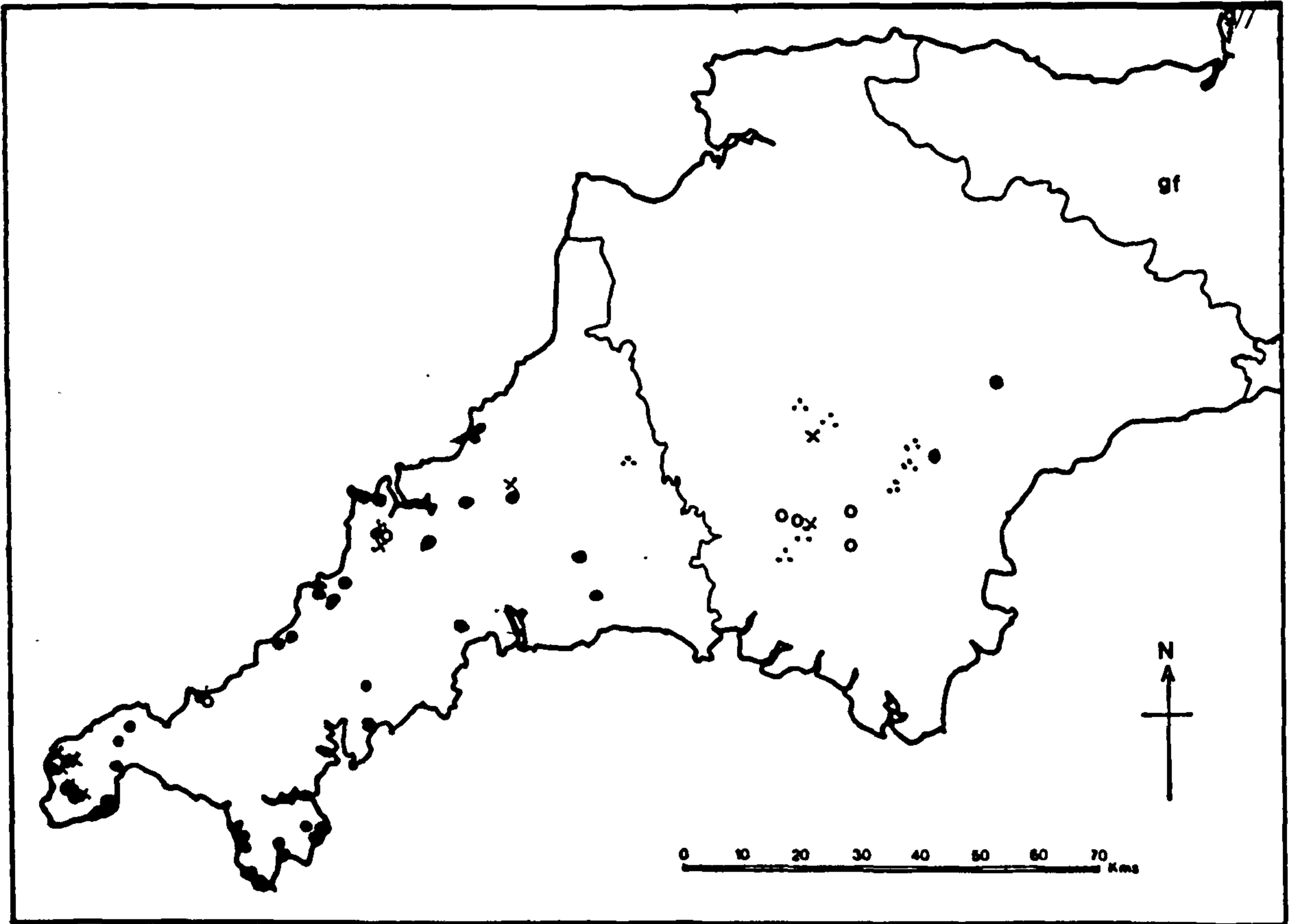


Figure 4.15 Distribution of Trevisker pottery produced from the gabbroic clay of the Lizard in the South-West (after Parker Pearson 1990; 1995).

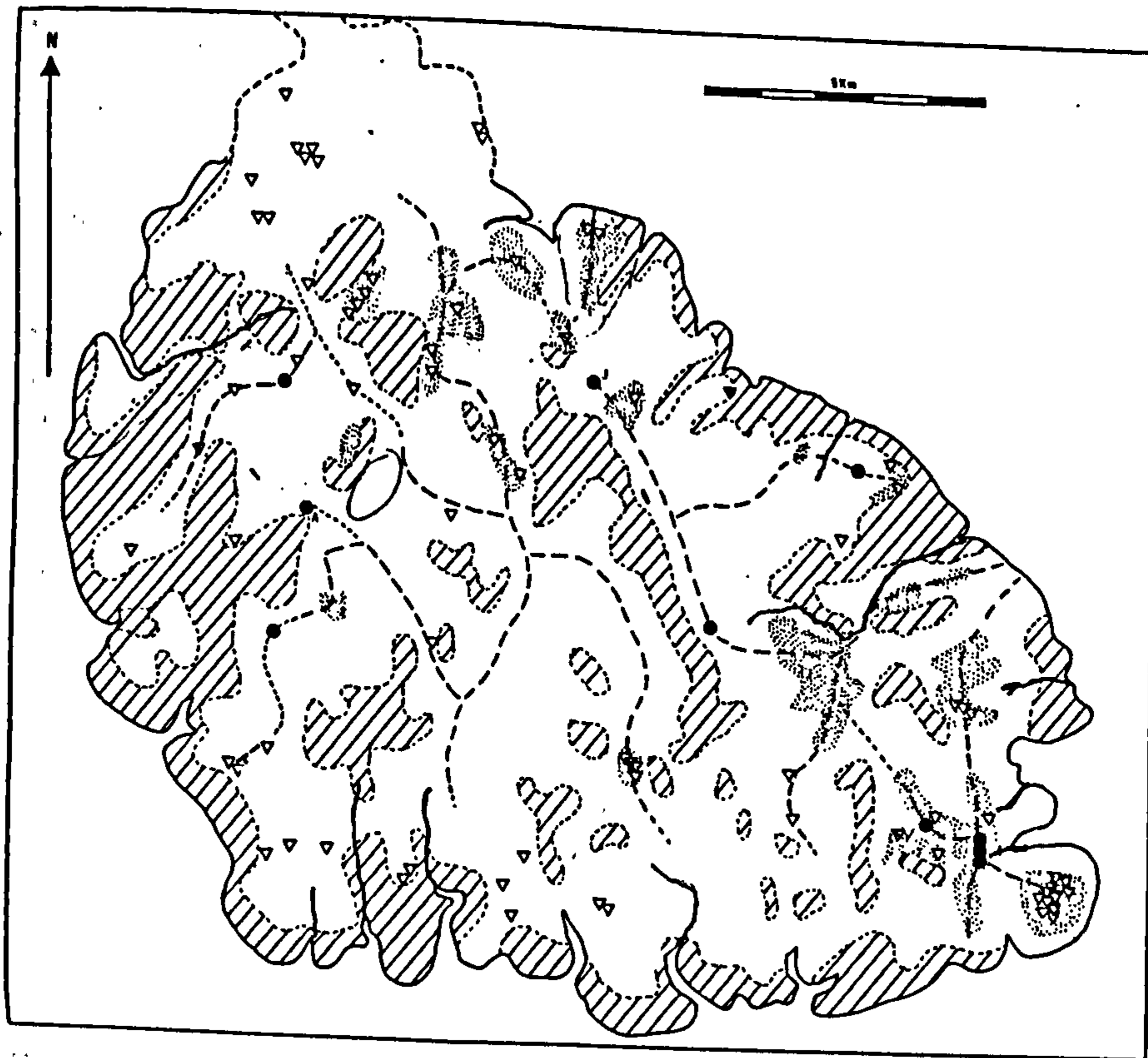




● (gabbroic clay), ○ (greenstone inclusions), · (greenstone and rounded quartz inclusions), x (granitic inclusions), g (grog), f (felspathic tuff inclusions), // (limestone and sand inclusions).

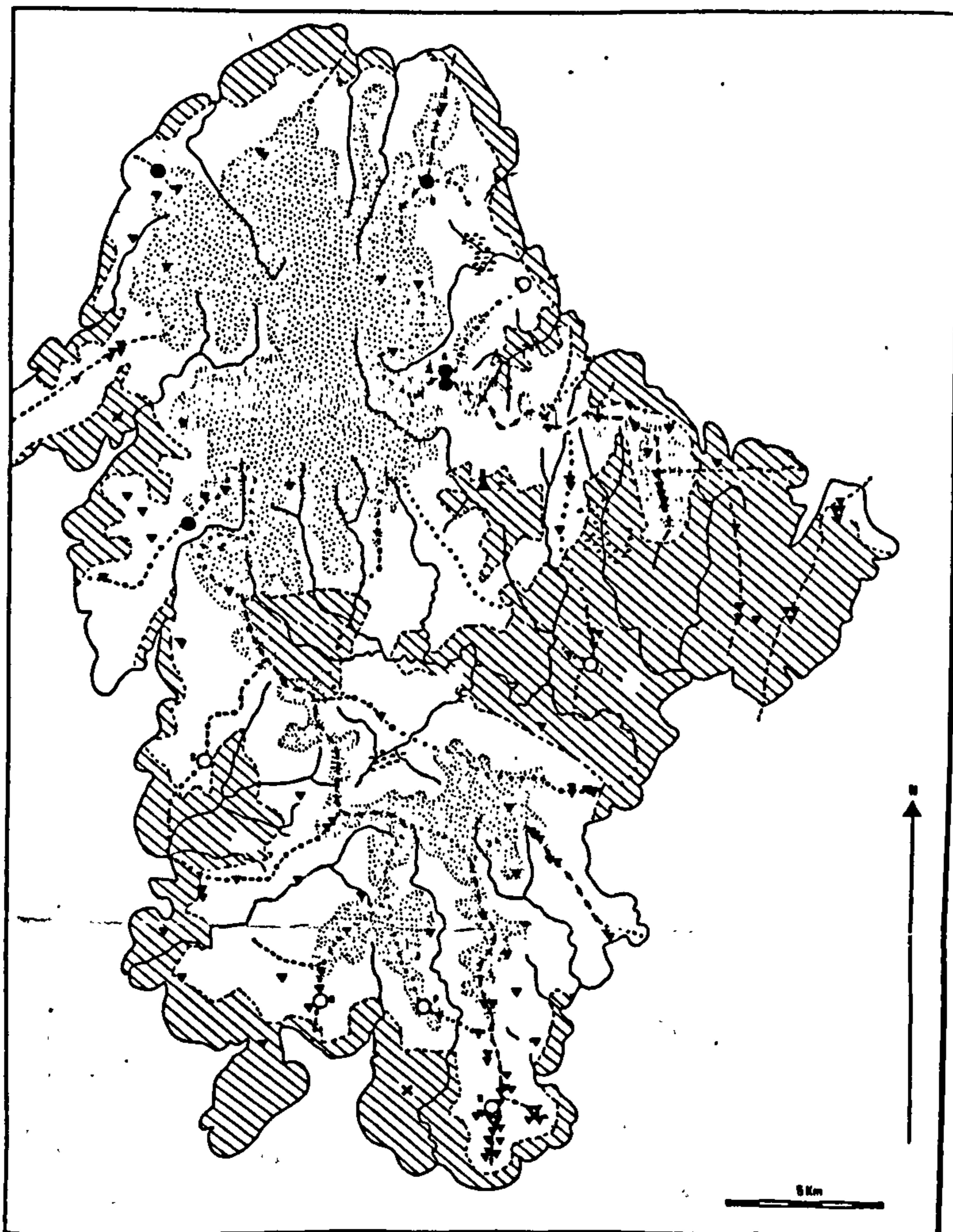
Figure 4.16 Distribution of various Trevisker ware fabrics in the South-West (after Parker Pearson 1990).

### BODMIN MOOR



(▽) barrows, (●) symmetrical circles

### DARTMOOR



(▽) barrows, (●) symmetrical circles,  
(○) atypical stone row complexes

Figure 4.17 Positions of Bronze Age barrows relative to landforms, symmetrical stone circles and atypical stone row complexes on Dartmoor and Bodmin Moor (after Barnatt 1989).



**Funerary/Ritual Sites:**

1. Try
2. Chysauster
3. Trelen 2
4. Poldowrain 1
5. Nancekuke
6. Crig-A-Mennis
7. Carvinak
8. St. Austell Granite Sites
9. Cataclews/Harlyn Bay
10. Treligga Cemetery
11. Lousey Barrow
12. Tregulland
13. Davidstow Moor Cemetery
14. Stannon Down Cemetery
15. St. Neot
16. Colliford Reservoir Sites
17. Shaugh Moor Cairns
18. East Putford Sites
19. Rose Ash
20. Upton Pyne Cemetery
21. Farway Hill/East Hill Sites
22. Court Hill Cairn
23. Chewton Plain Cemetery
24. Charmy Down Cemetery
25. Lansdown Area

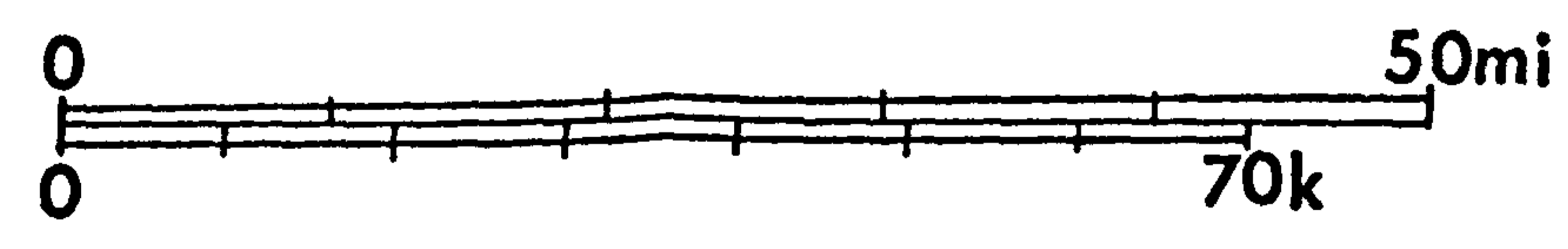
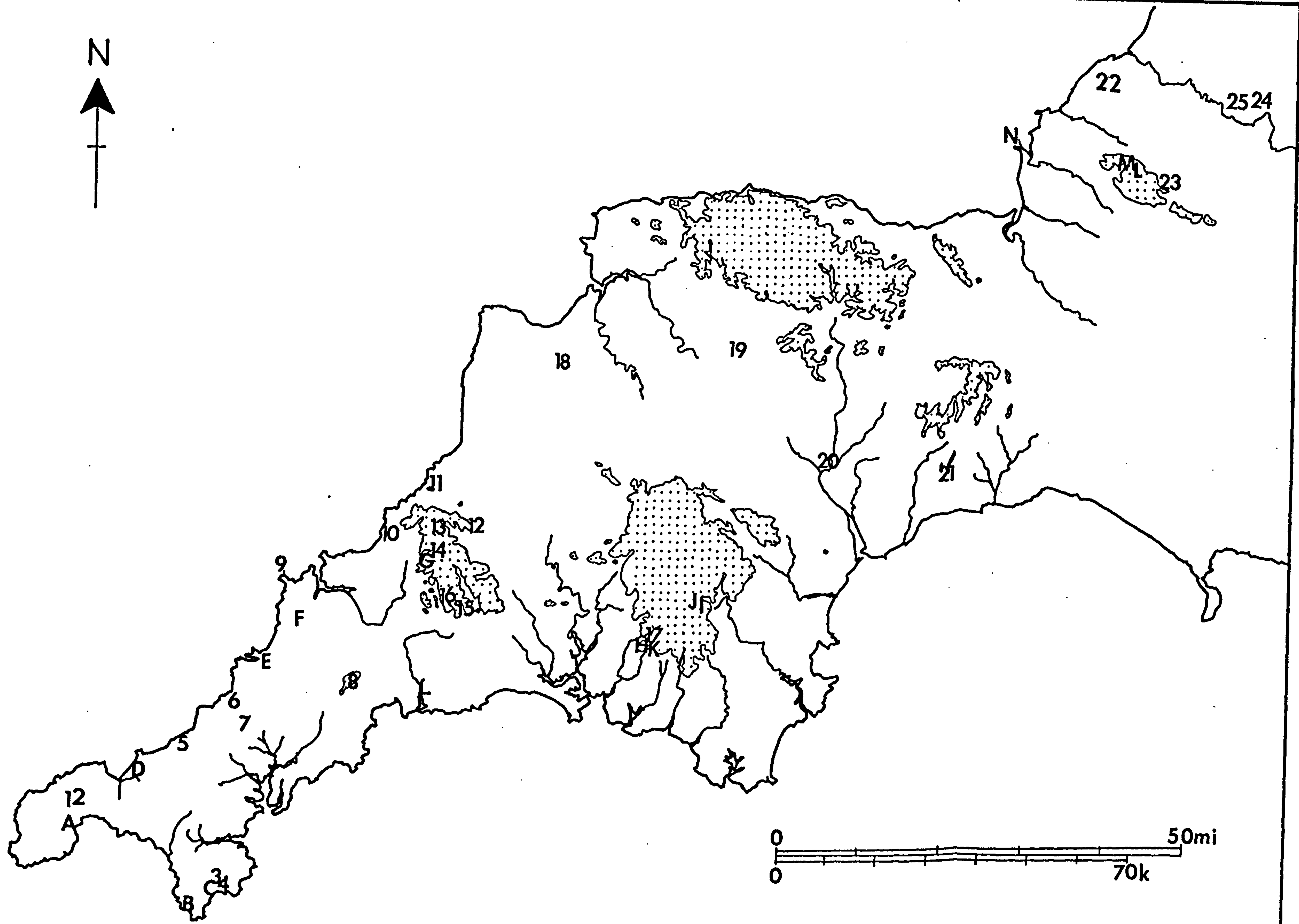
**Settlement Sites:**

- A. Tredarvah
- B. Kynance Gate
- C. Poldowrain 2
- D. Gwitihiian
- E. Trethellan
- F. Trevisker
- G. Stannon Down
- H. Shaugh Moor 15
- I. Holne Moor
- J. Venford Reave
- K. Saddlesborough Reave
- L. Charterhouse Warren  
Farm Swallet
- M. Gorsey Bigbury
- N. Brean Down

LAND ABOVE  
800 ft O.D.

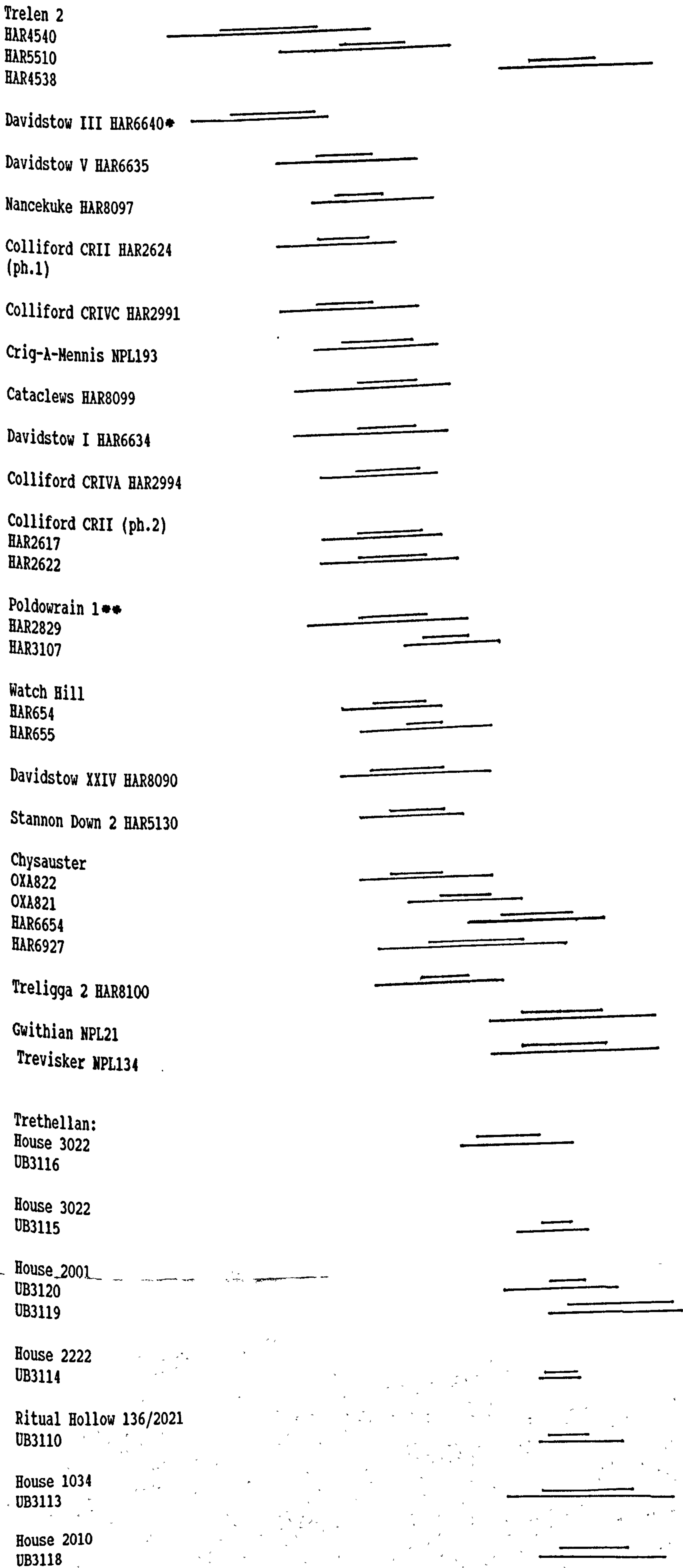


**Figure 5.1** *Distribution of sites referred to in the text.*





2500 2300 2100 1900 1700 1500 1300 1100 900 BC



\* Davidstow XXVI (HAR6634): 2896-2570 BC (2-sigma); 2778-2652 BC (1-sigma)  
 \*\* Poldowrain 1 (HAR3108): 2910-2140 BC (2-sigma); 2670-2340 BC (1-sigma)

Figure 5.3 Radiocarbon dates from Cornish sites (1-sigma probability above 2-sigma probabilities).

2200 2100 2000 1900 1800 1700 1600 1500 1400 1300 1200 1100 1000 900 BC

Shaugh Moor:

Site 1 HAR2216

Site 2 HAR2220

HAR2214

Site 70 HAR2219

Site 71 HAR2213

Site 126 HAR2285

HAR2221

Upton Pyne BM402

Rose Ash HAR2992

Venford Reave BM1609

Saddlesborough Reave HAR4103

HAR4003

Shaugh Moor

Enclosure 15:

Pre-Enclosure HAR2986

HAR2989

House 15 HAR2474

HAR2968

HAR3419

House 67 HAR2979

HAR3358

House 18 HAR2987

HAR2472

House 66 HAR2960

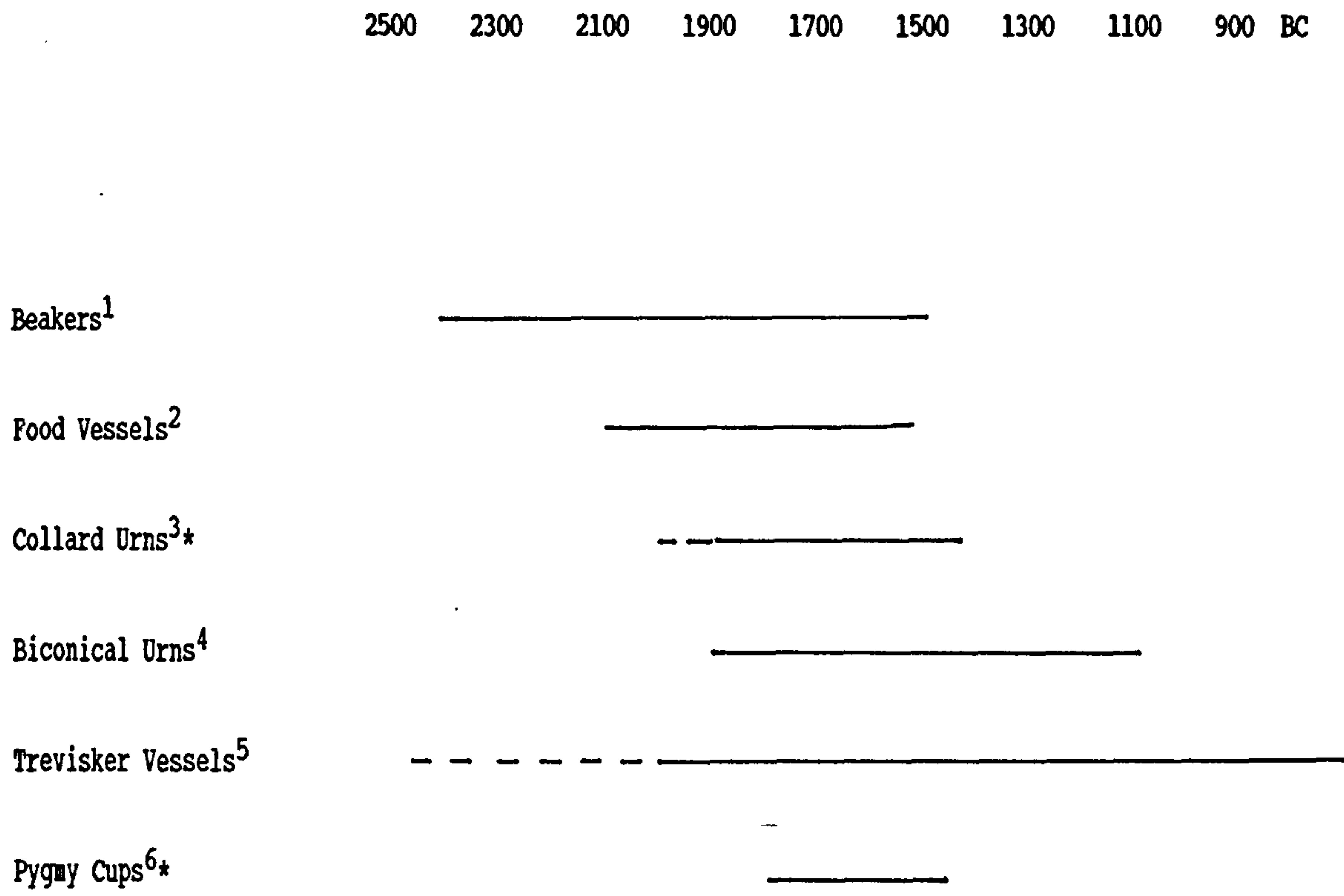
HAR2983

House 19 HAR2473

HAR2978

Figure 5.4 Radiocarbon dates from Devon sites (1-sigma probability represented above 2-sigma probability).





<sup>1</sup>(Bell 1990; Kinnes et. al. 1991; Harris 1979; Hedges et. al. 1989)  
<sup>2</sup>(Miles 1971; Christie 1985; Tomalin 1988)  
<sup>3</sup>(Burgess 1986; Tomalin 1988; Christie 1967)  
<sup>4</sup>(Bell 1990; Smith 1979; Tomalin 1982; 1988; Williams 1980)  
<sup>5</sup>(Bell 1990; Parker Pearson 1991; Smith 1996; Tomalin 1988)  
<sup>6</sup>(Burgess 1982; Ford 1991; Ellison 1984)  
 \*includes Wessex dates

Figure 5.5 Chronology of Bronze Age ceramics in south-west Britain.

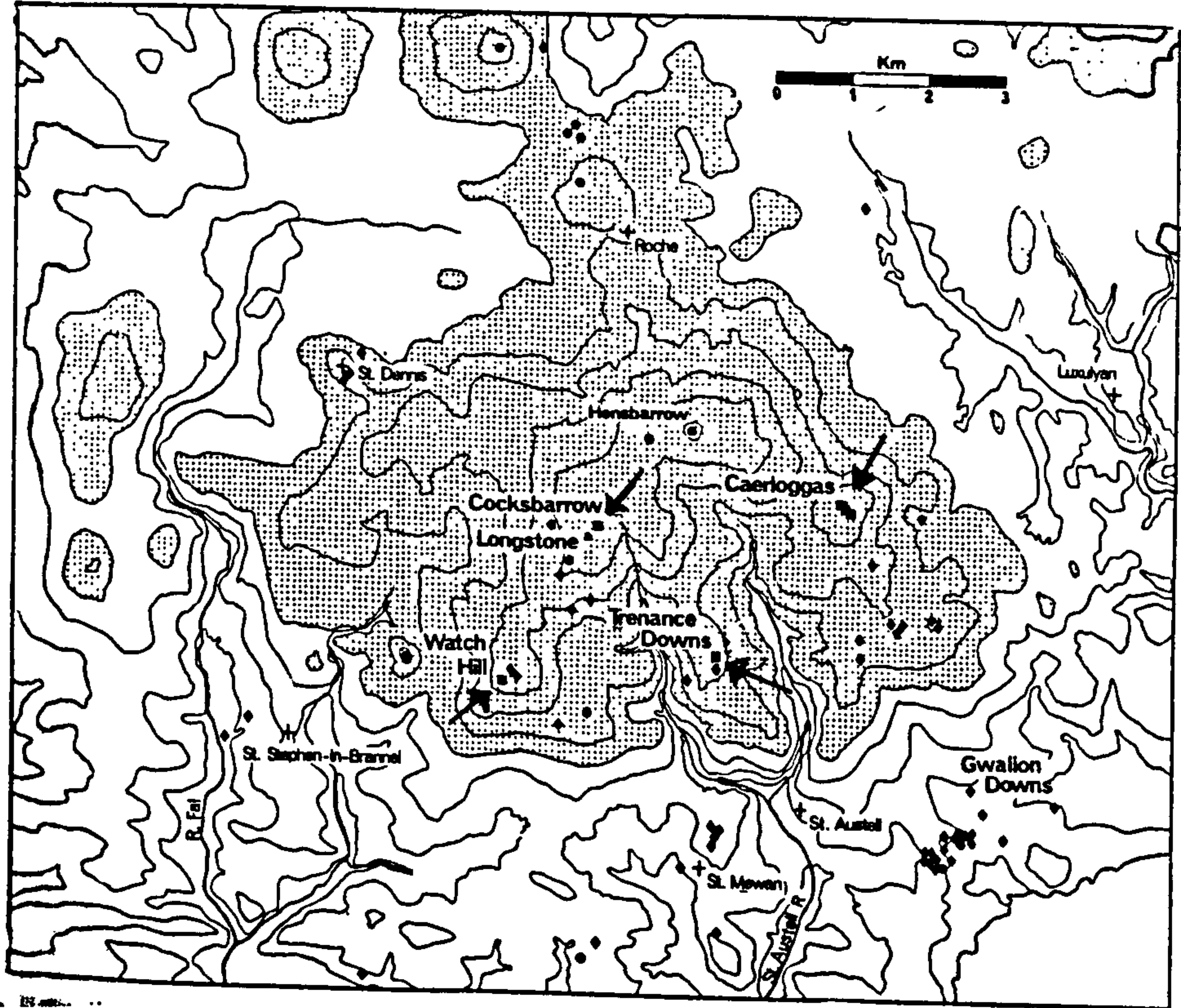


Figure 5.6 *The St Austell granite sites (after Miles 1975).*



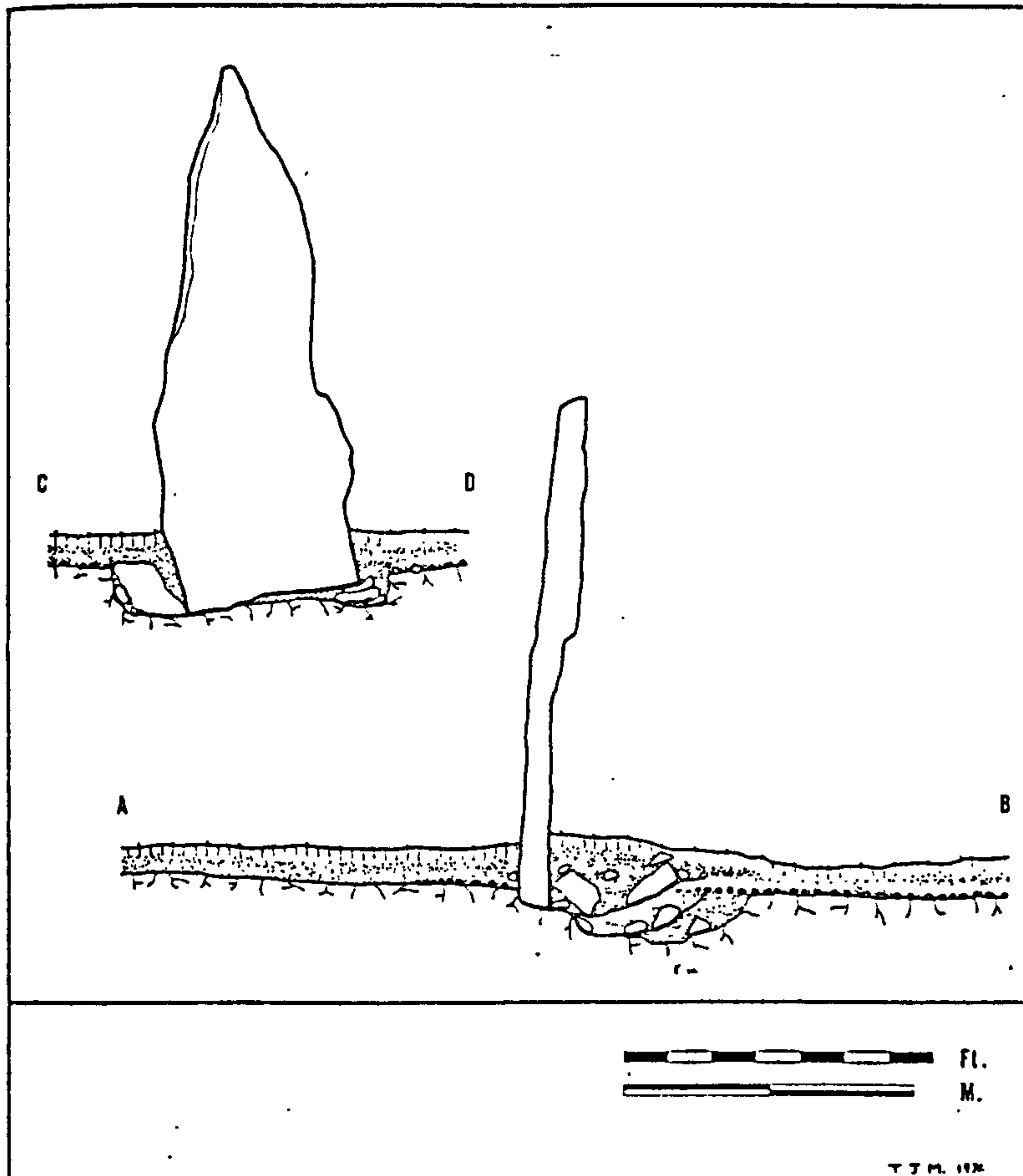


Figure 5.7 The Longstone (after Miles and Miles 1971).

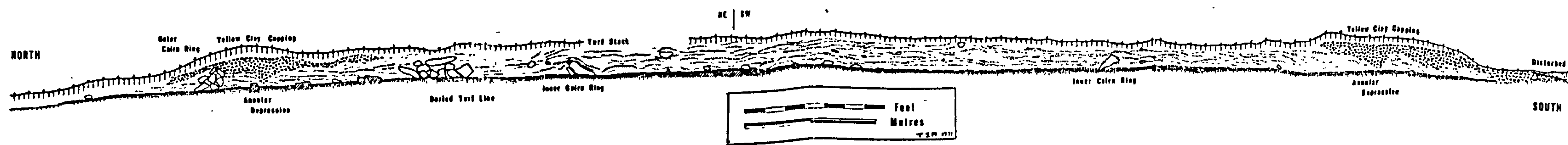
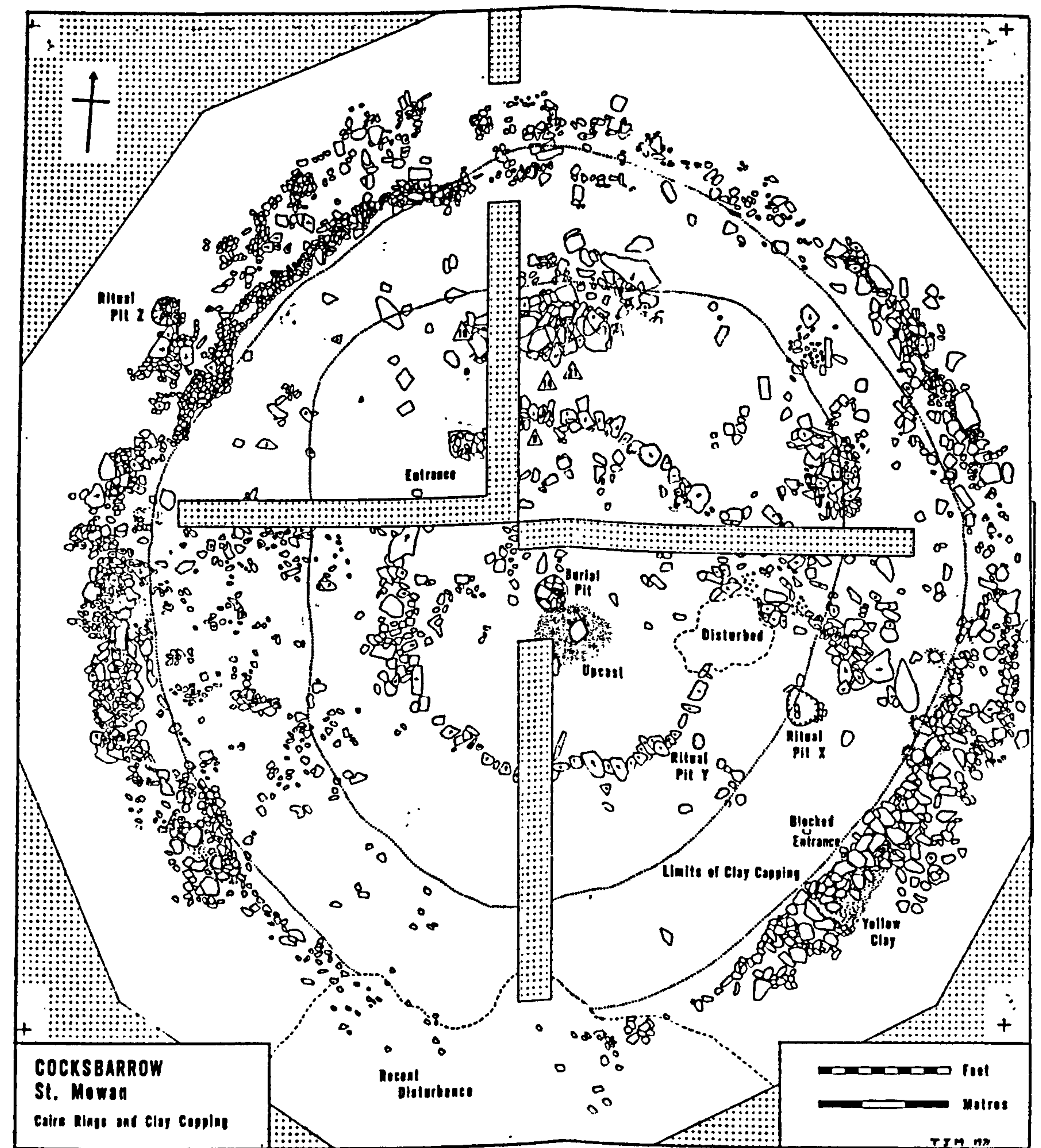
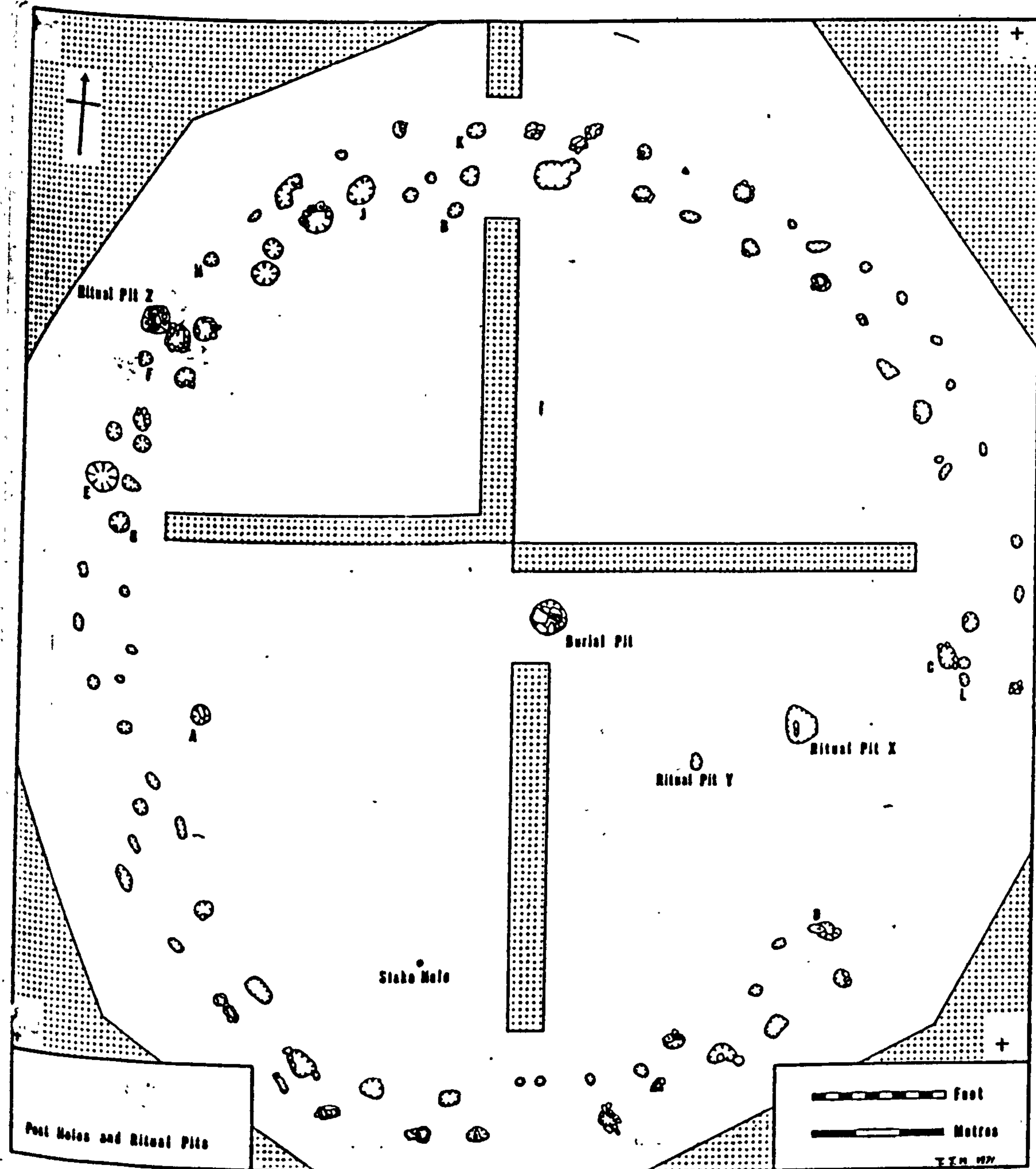


Figure 5.8 Cocksbarrow, earlier and later phases (after Miles and Miles 1971).






Figure 5.8.1 Cocksbarrow sequence of activities (after Miles 1975).



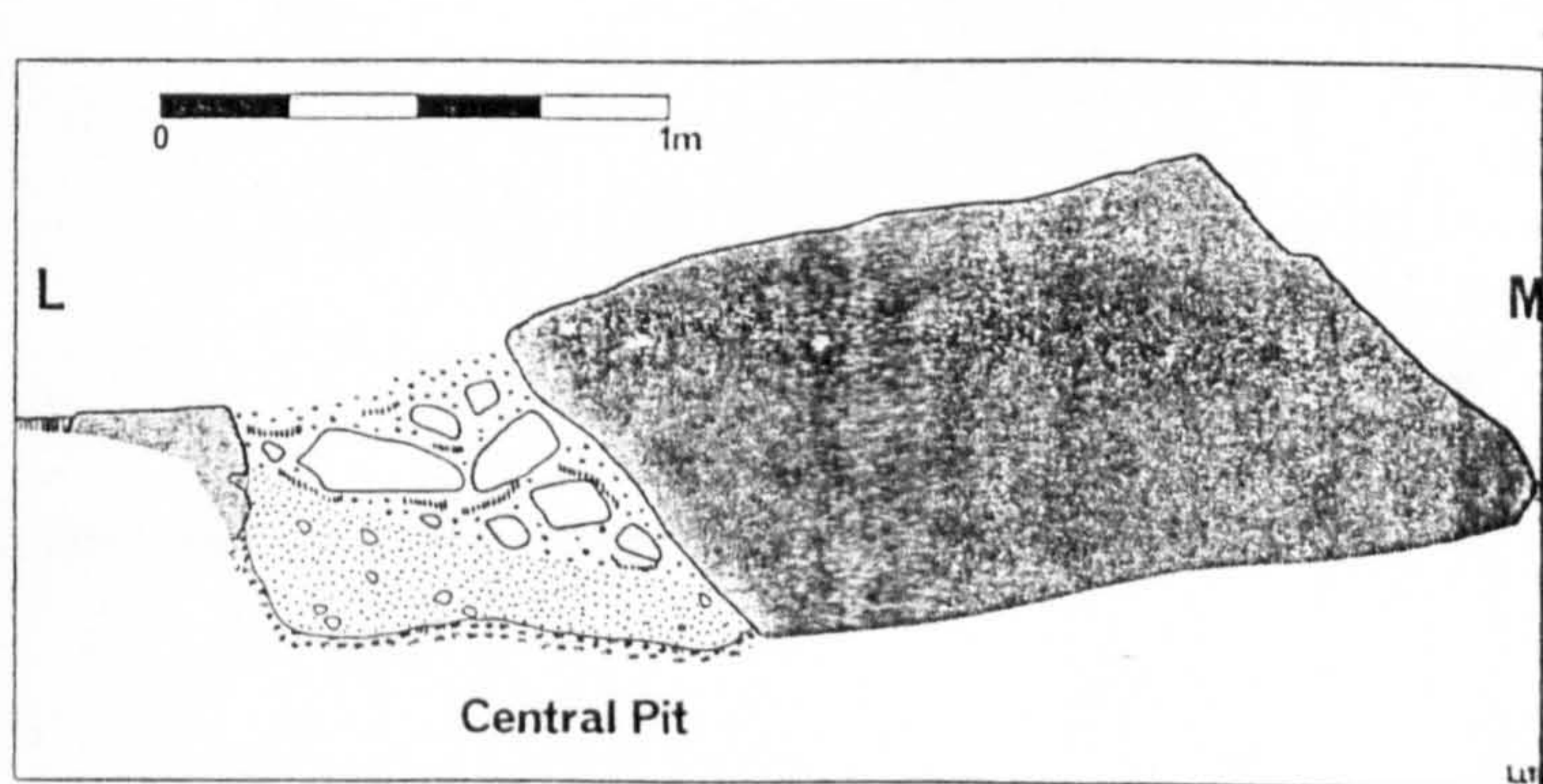


Figure 5.9 Caerloggas Downs I, initial phases and central pit (after Miles 1975).



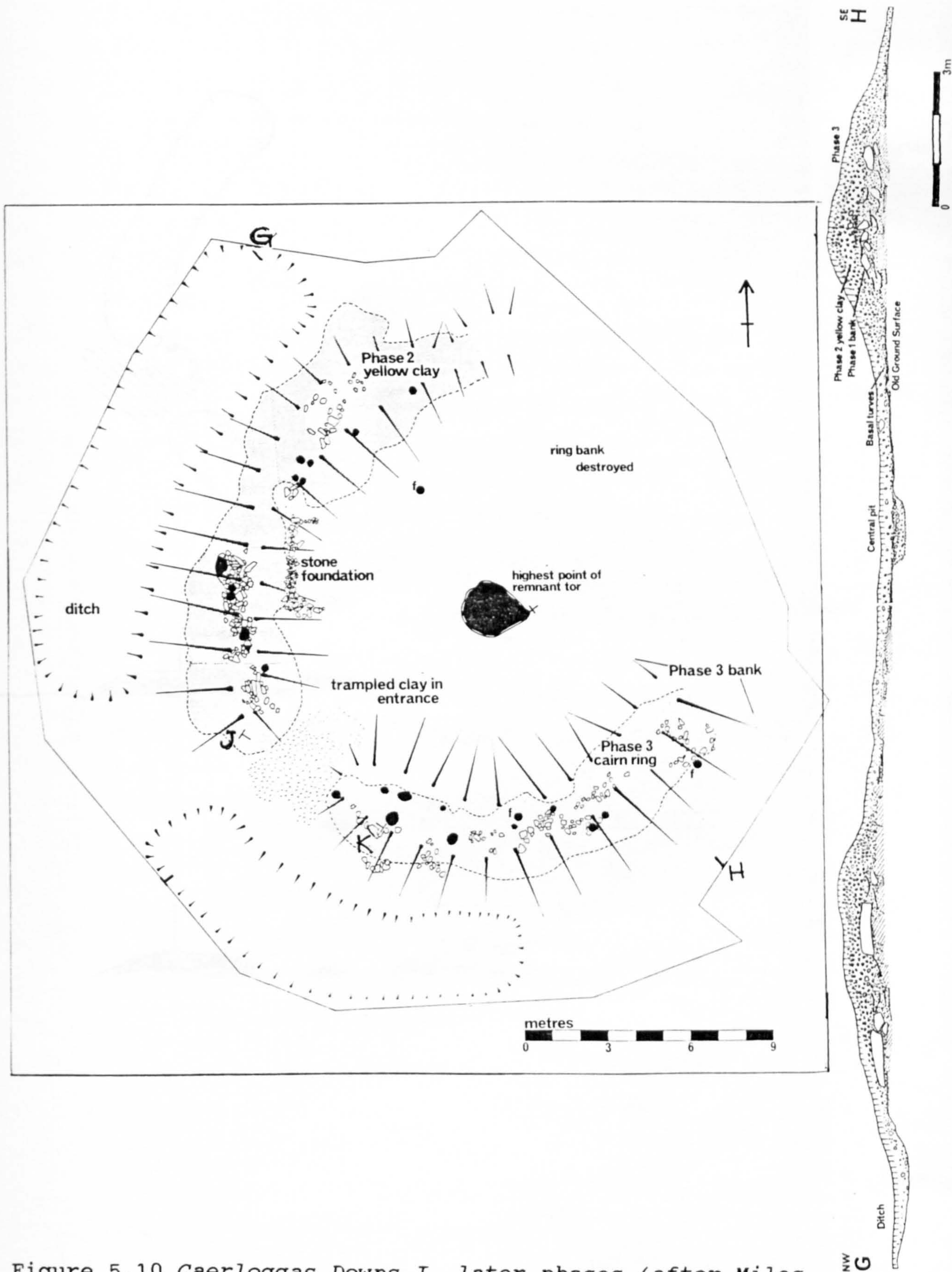


Figure 5.10 Caerloggas Downs I, later phases (after Miles 1975).



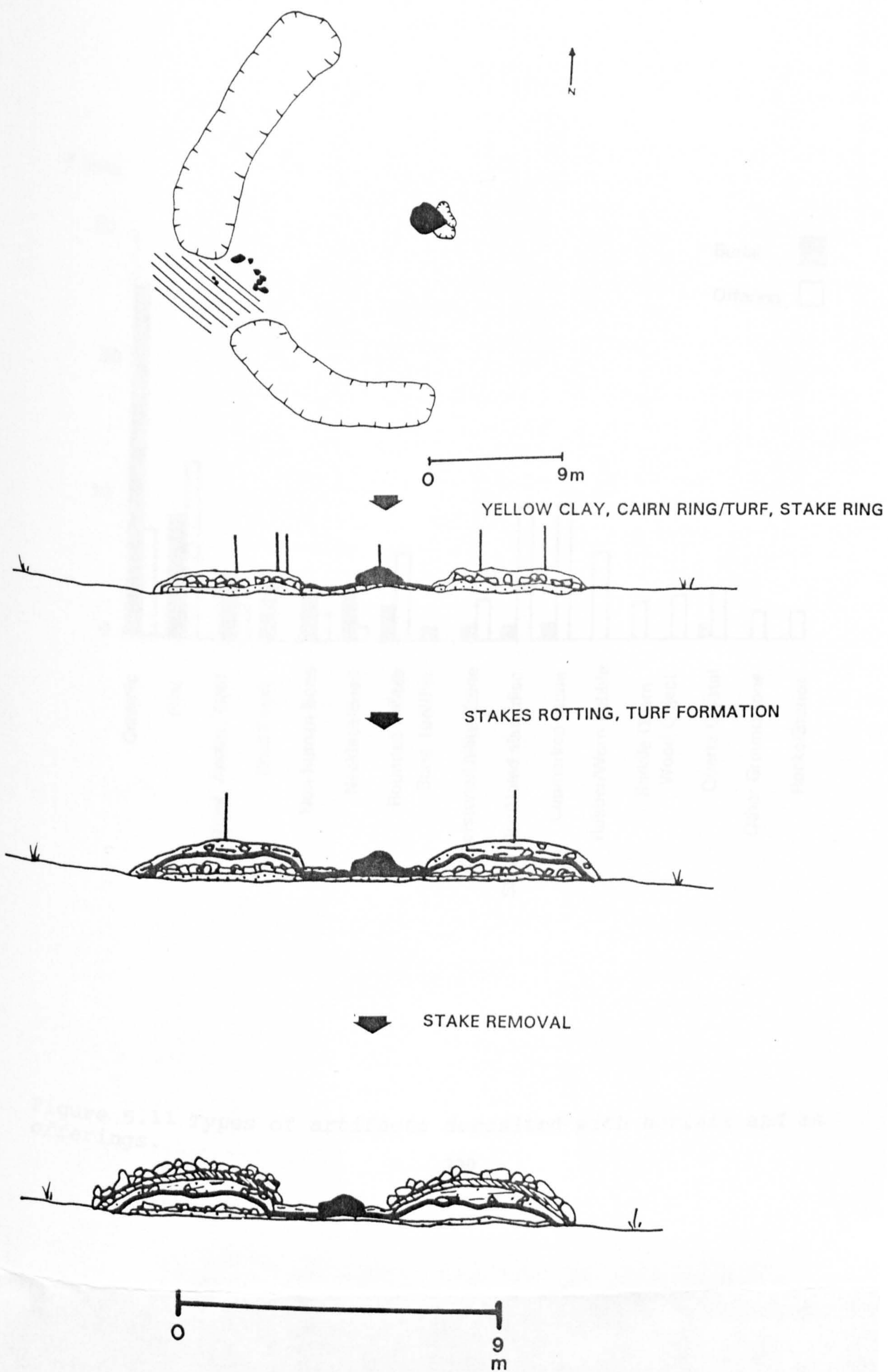


Figure 5.10.1 Caerloggas Downs I enclosure construction (after Miles 1975).



# Sites

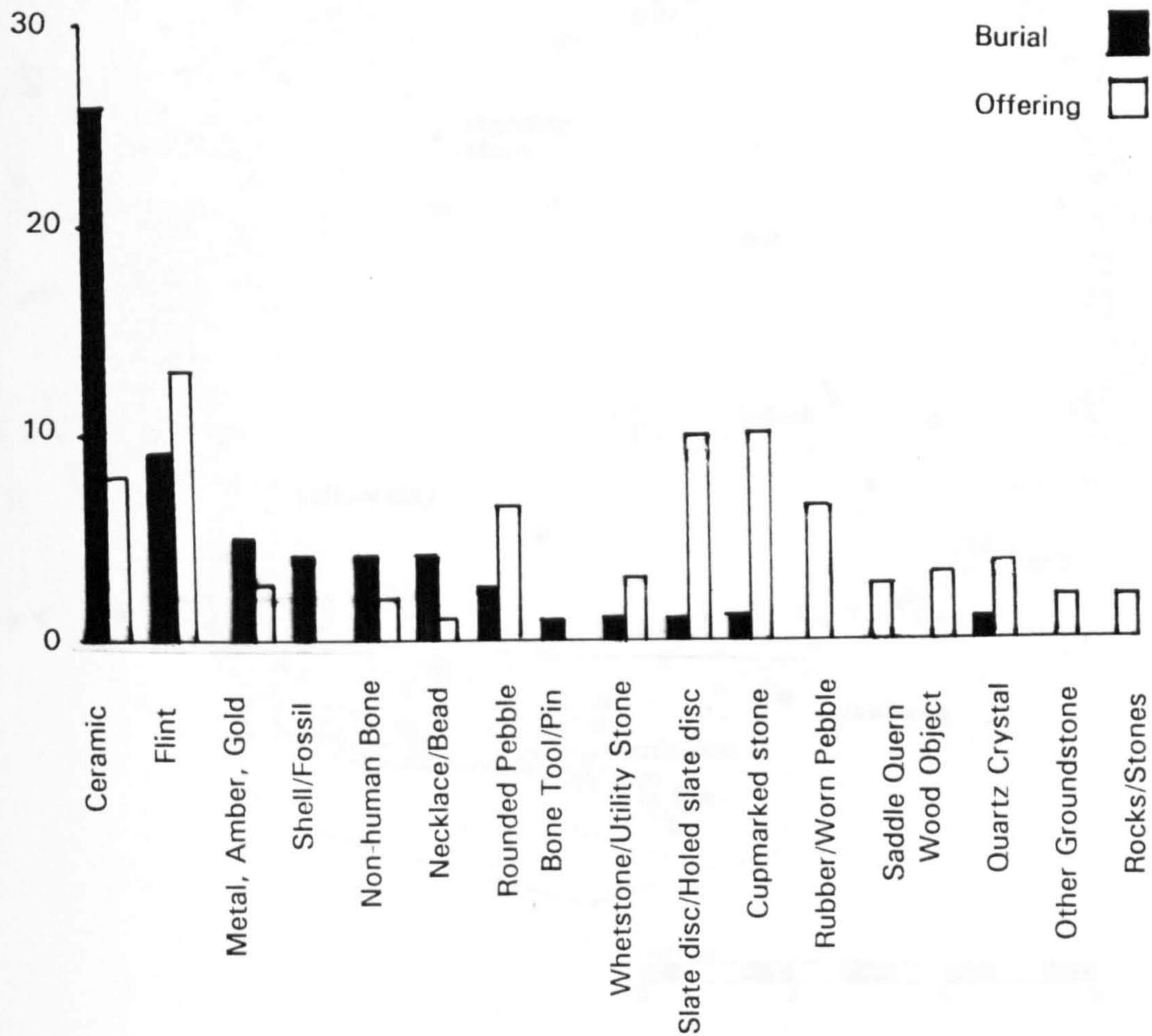


Figure 5.11 Types of artifacts deposited with burials and as offerings.



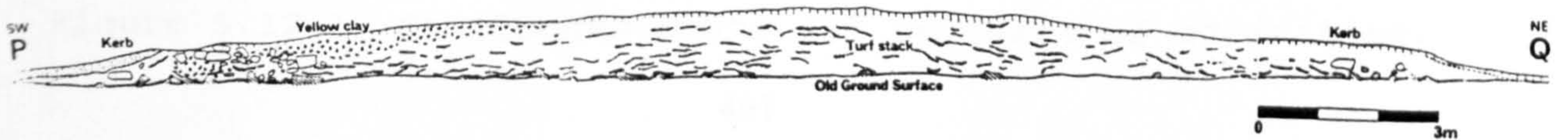
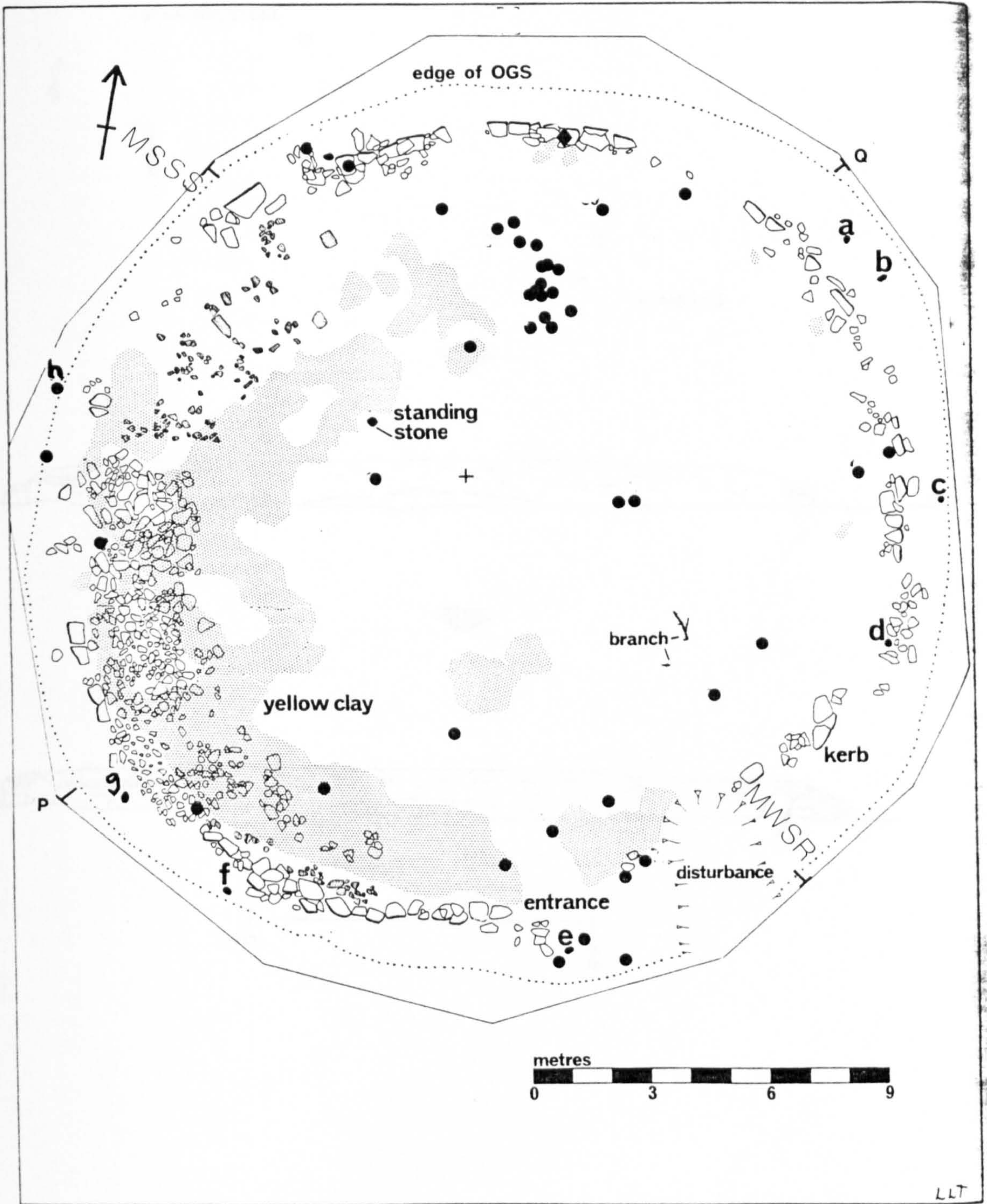


Figure 5.12 Caerloggas Down III (after Miles 1975).



STANDING STONE



BRANCHES

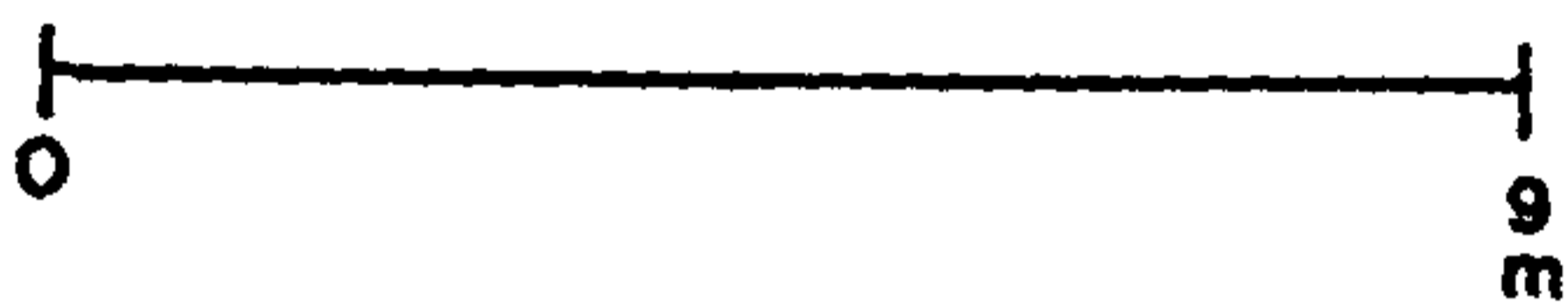
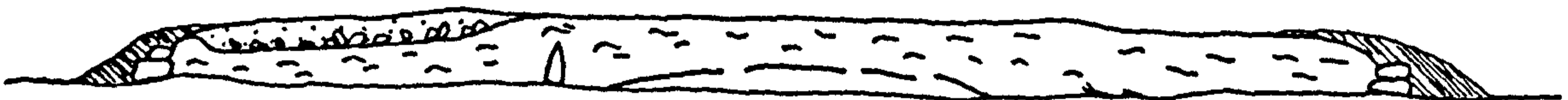


Figure 5.12.1 *Caerloggas Downs III* sequence of activities.


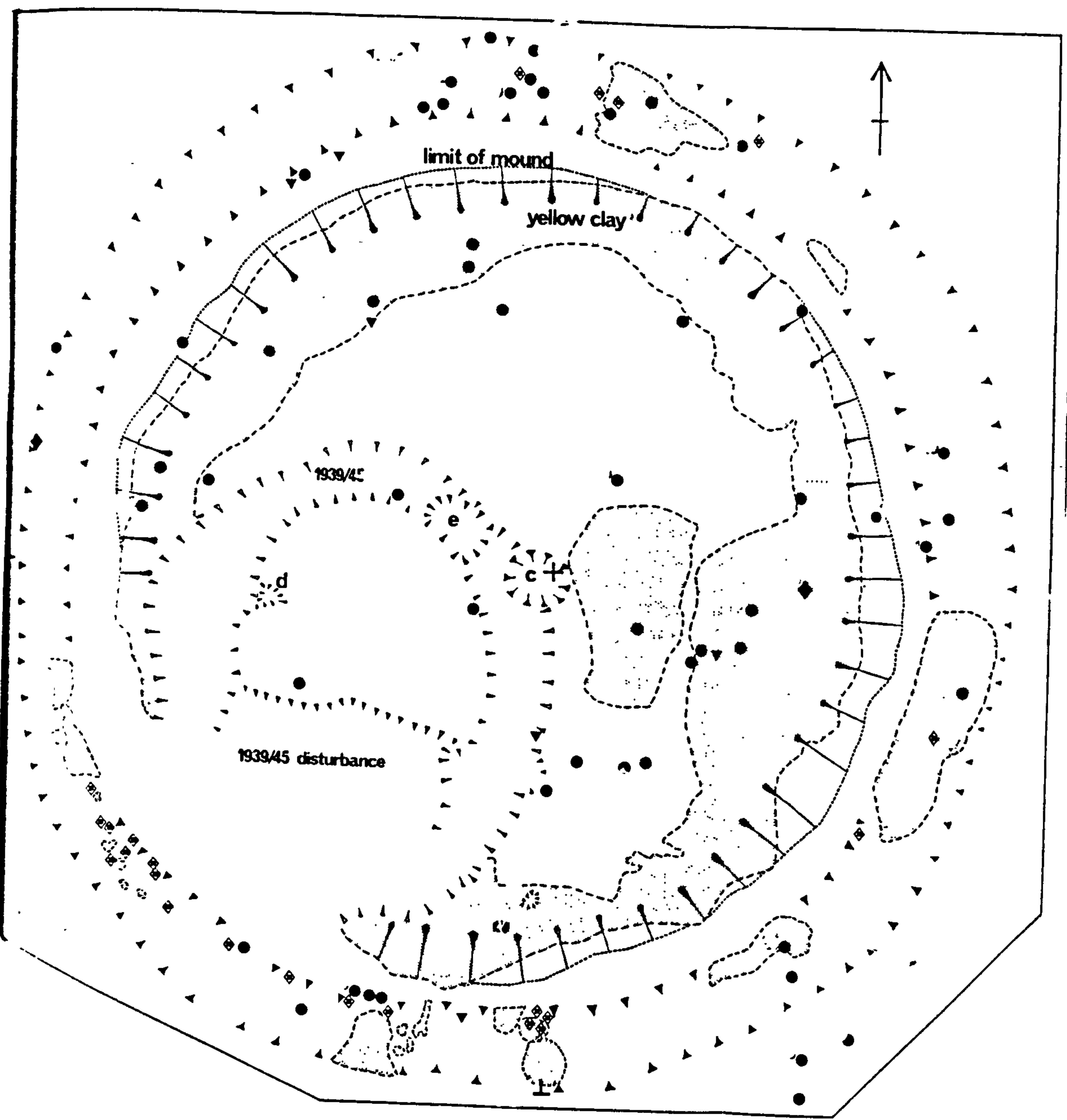
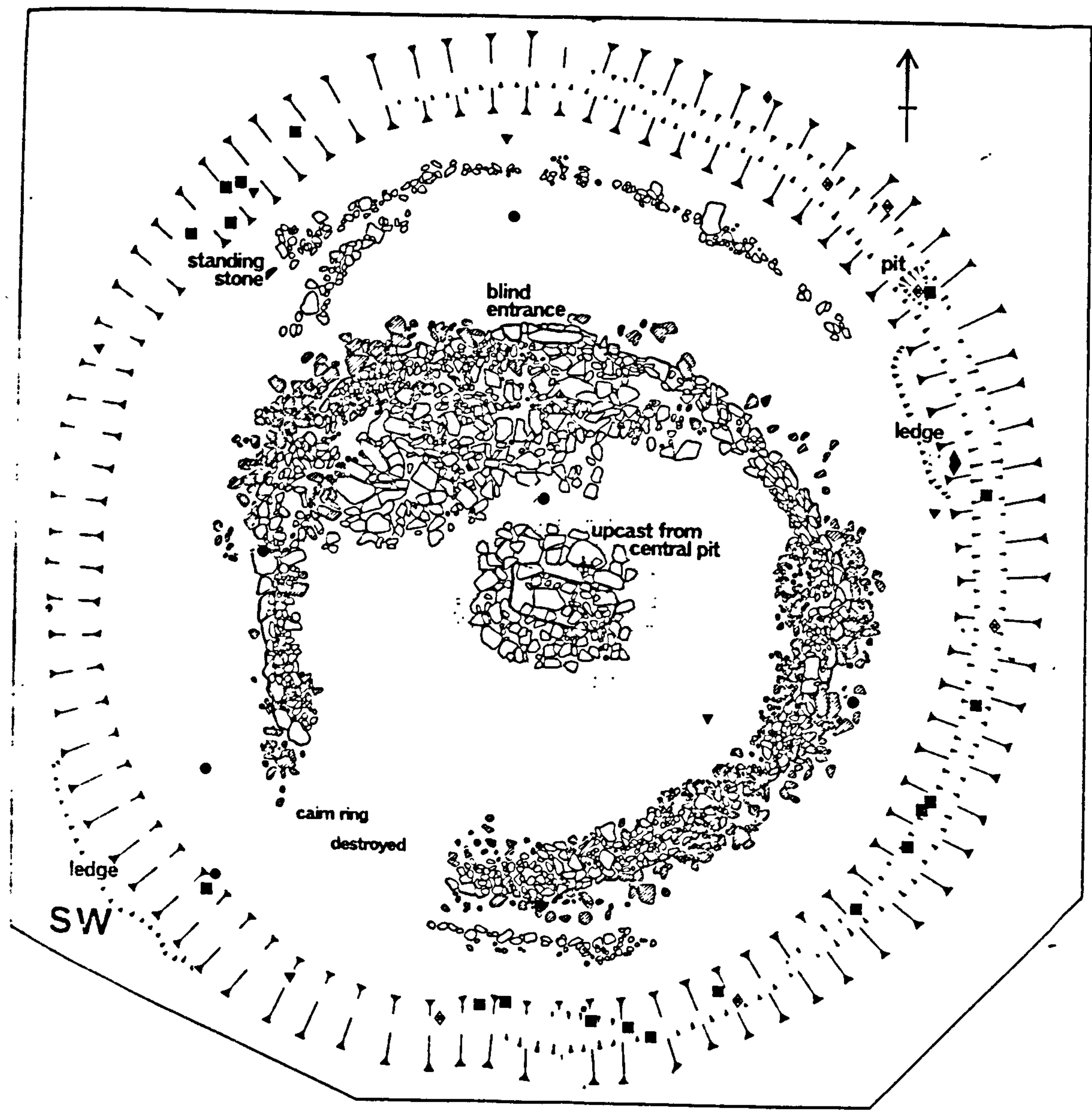


Figure 5.13 Watch Hill (after Miles 1975).






Figure 5.13.1 Watch Hill sequence of activities (after Miles 1975).

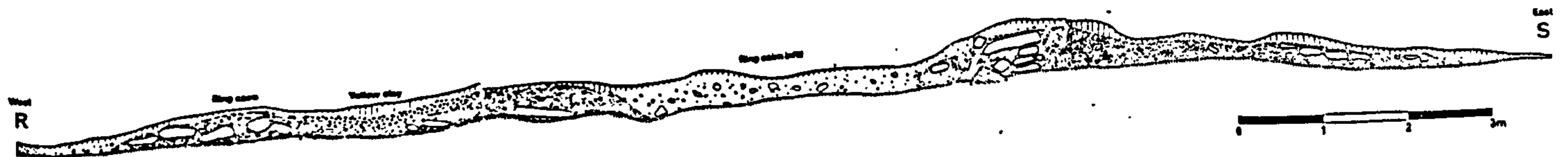
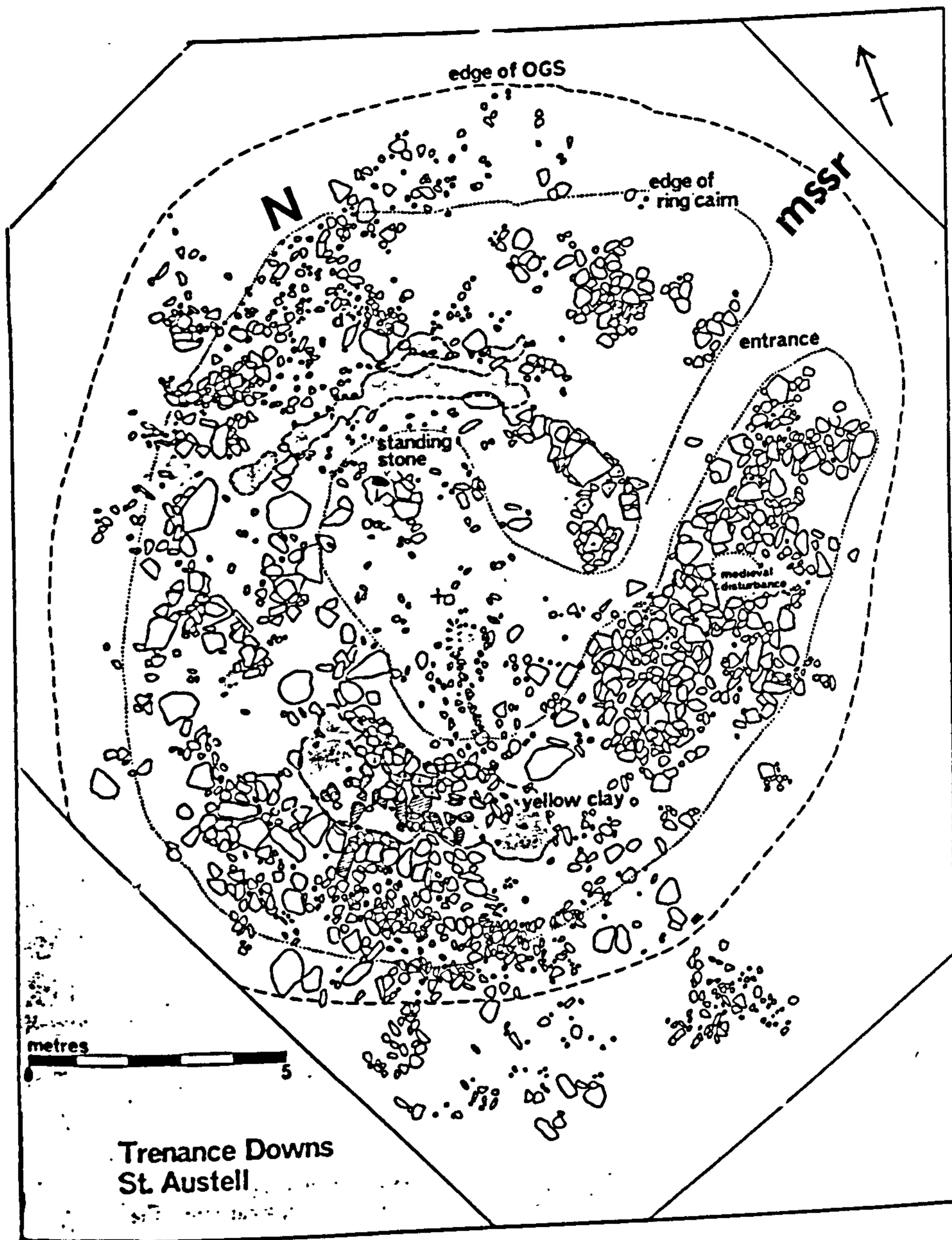
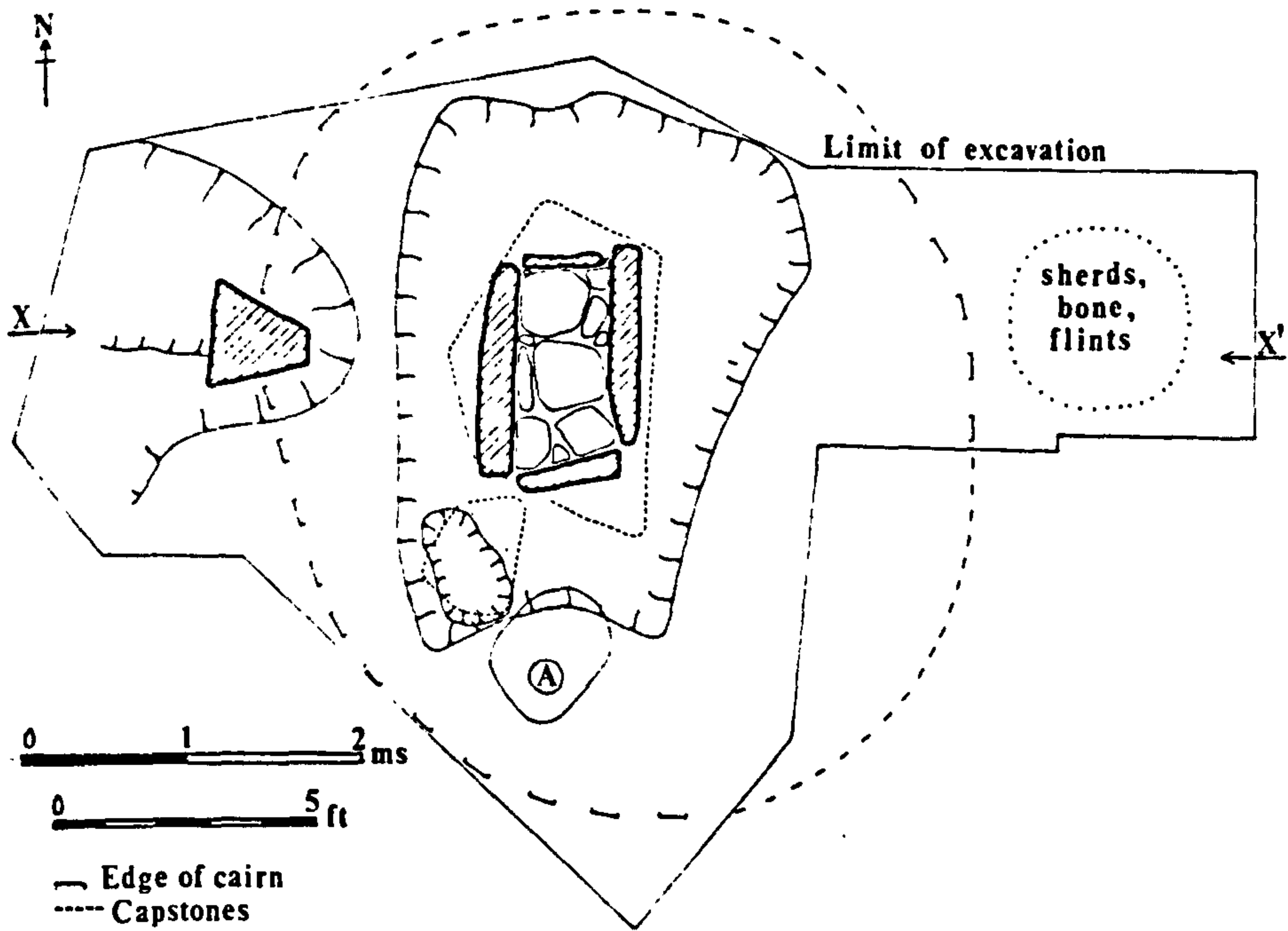
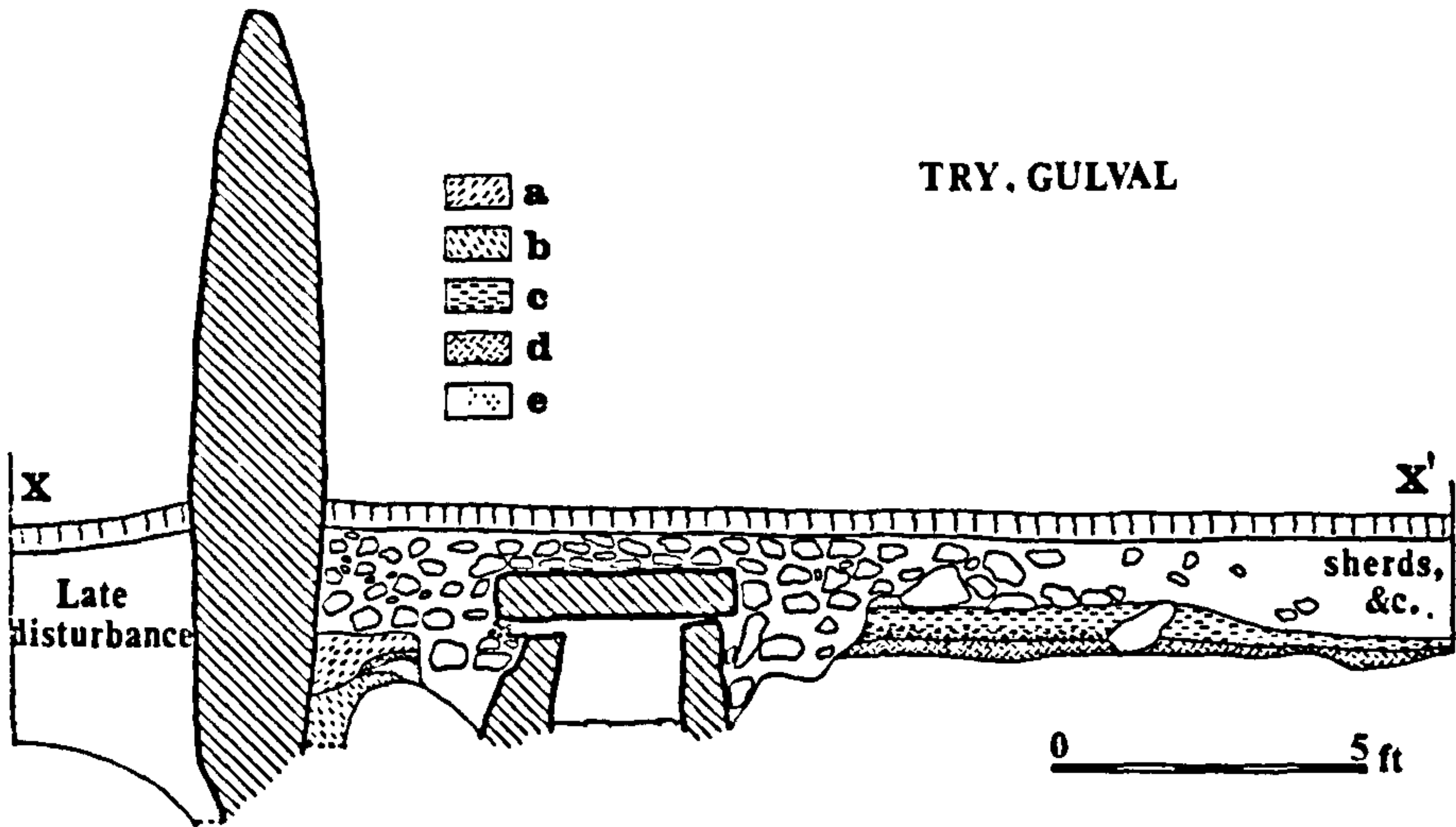


Figure 5.14 Trenance Downs (after Miles 1975).





— Edge of cairn  
 ---- Capstones



TRY. GULVAL

Figure 5.15 Try (after Russel and Pool 1964).

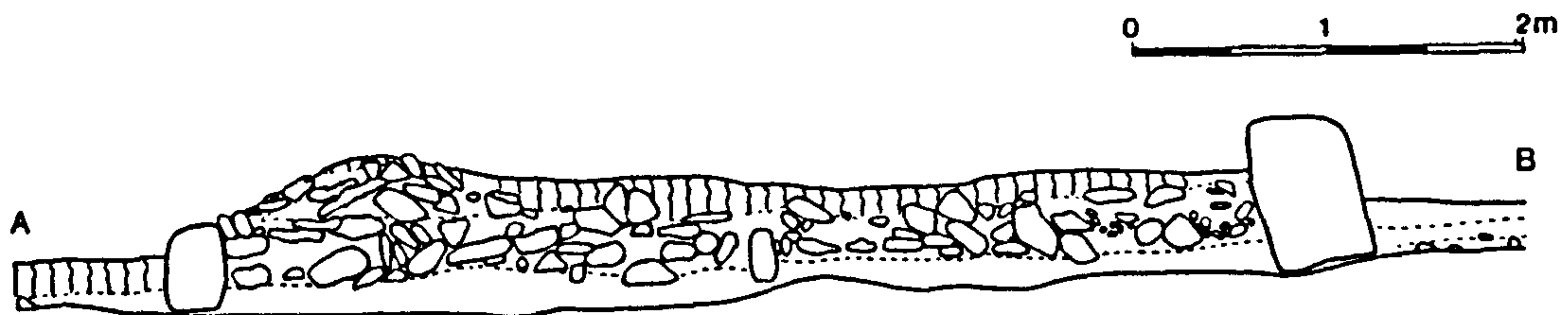
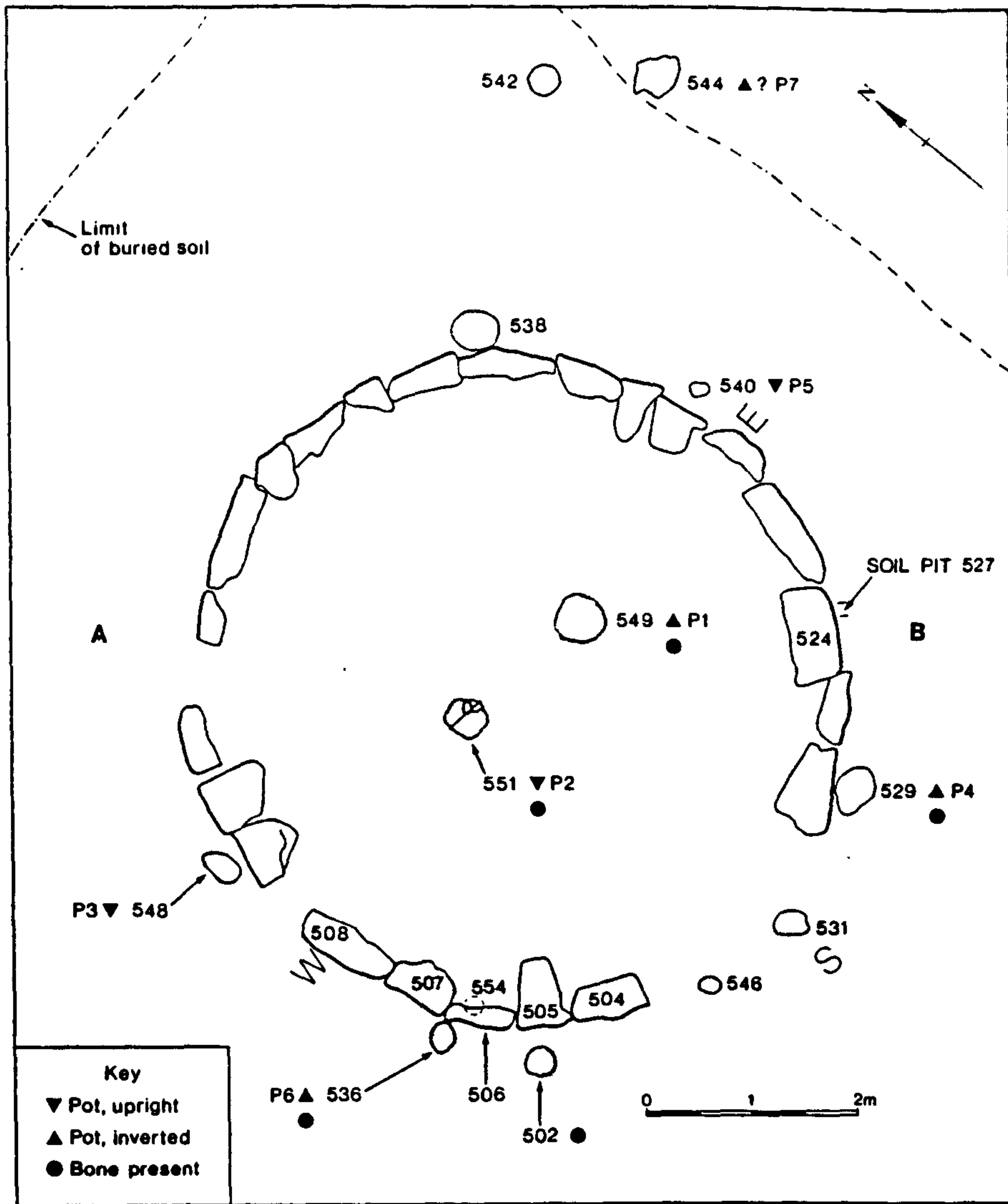


Figure 5.16 *Chysauster* (after Smith 1996).



KEY	
◆	Flint/Chert
★	Quartz Crystal
□	Pot Sherd
○	Pebble
△	Other

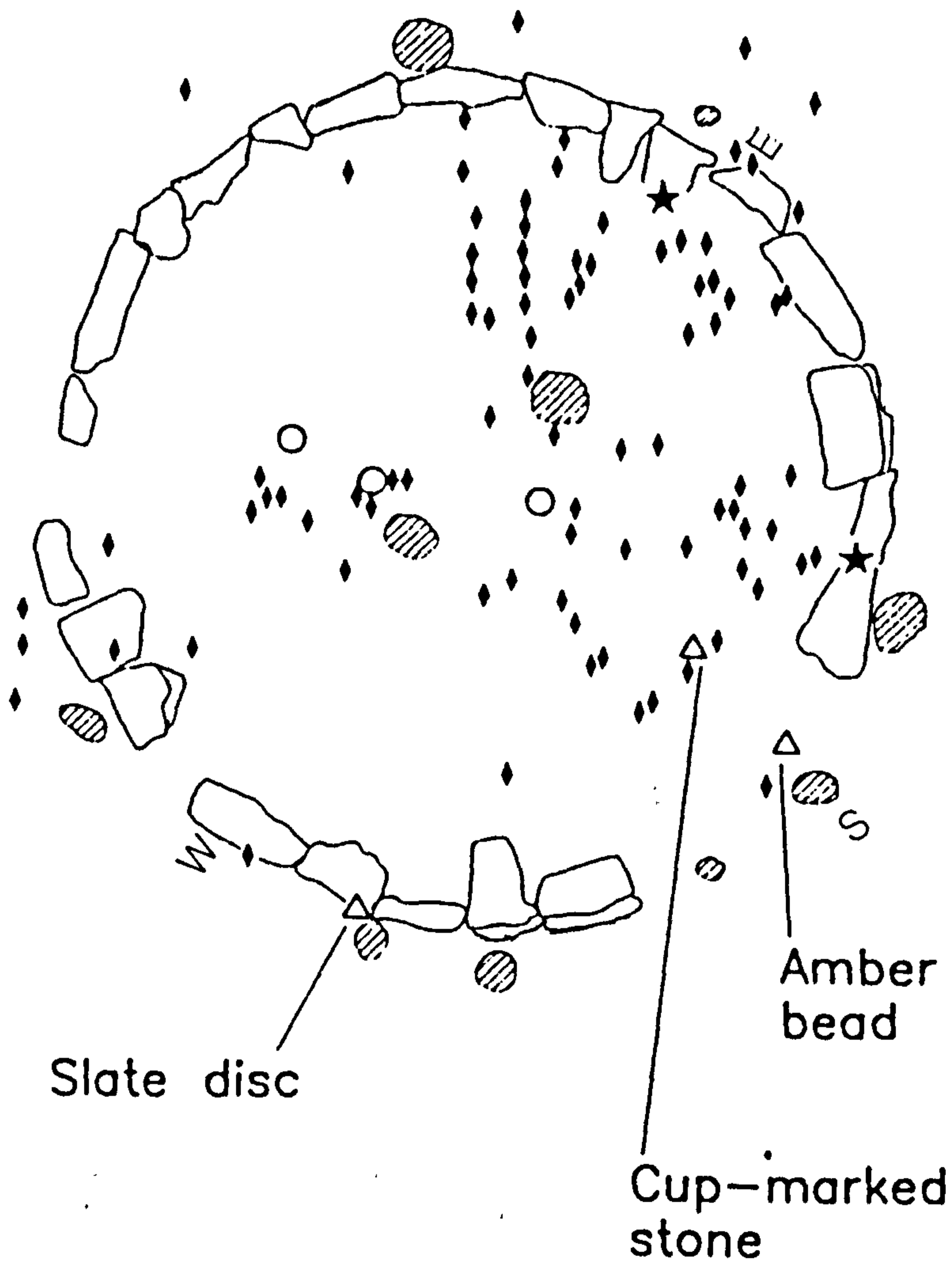


Figure 5.16.1 Chysauster offerings (after Smith 1996).

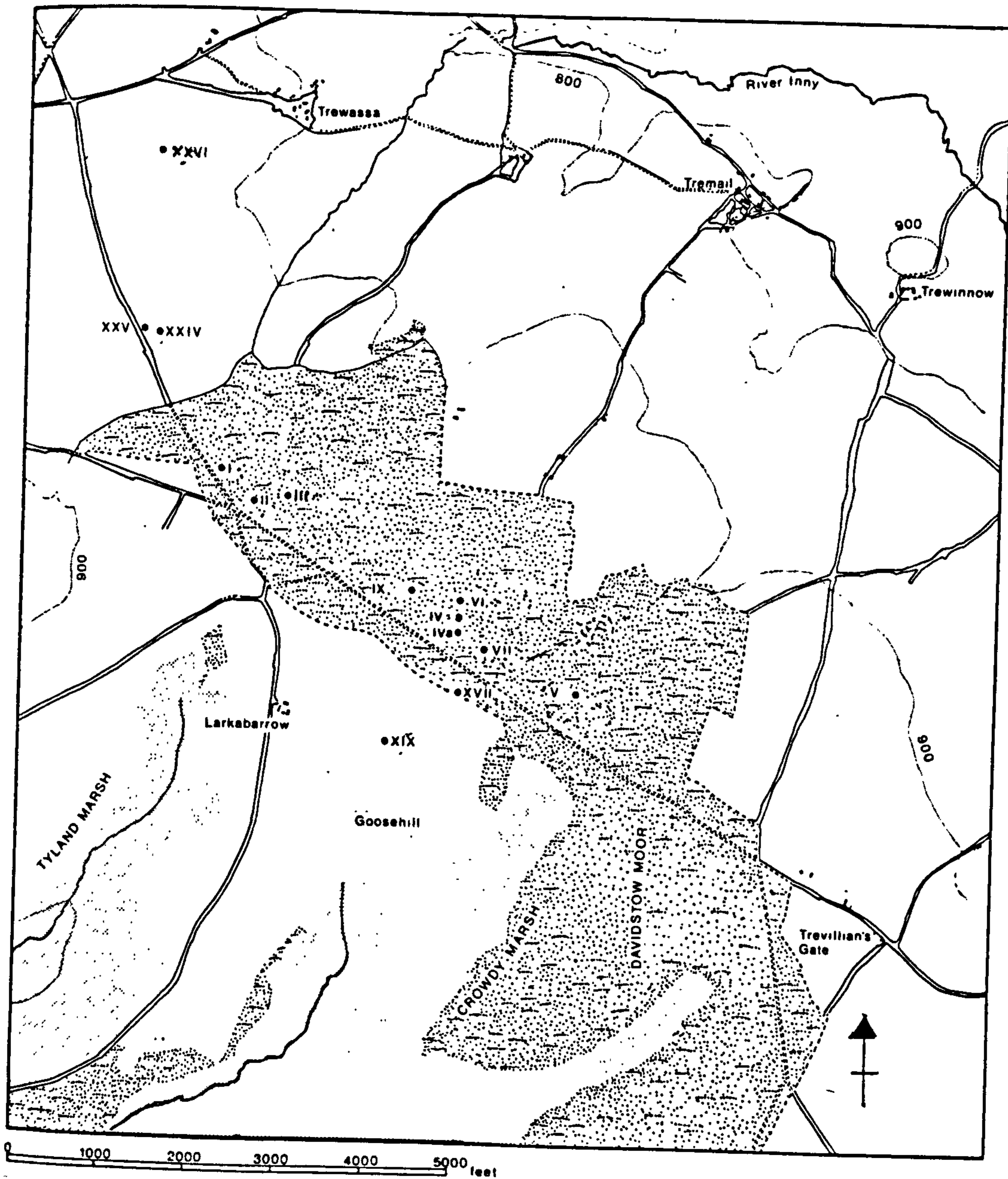


Figure 5.17 Davidstow Cemetery, Bodmin Moor (after Christie 1988).



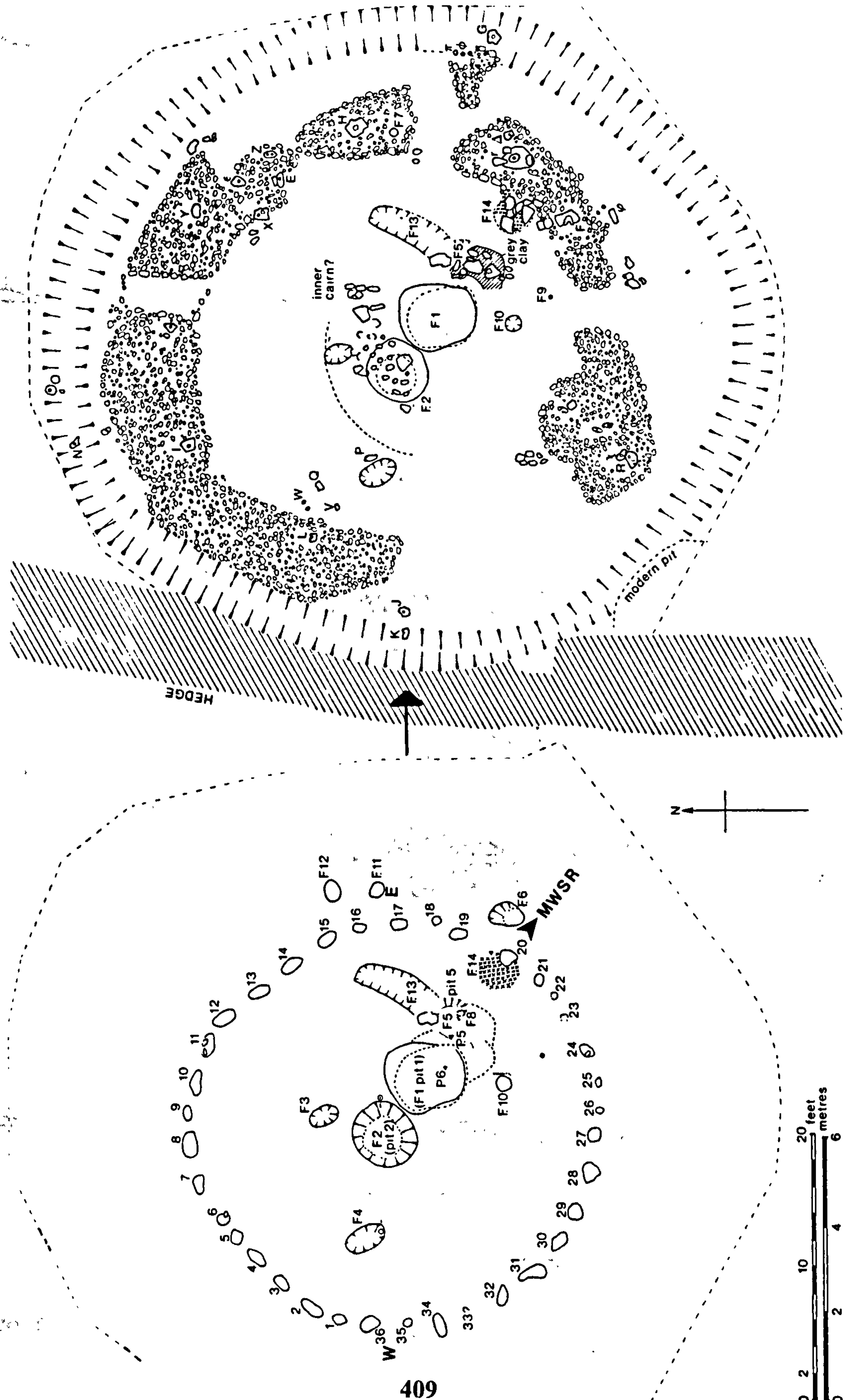


Figure 5.18 Davidstow Moor Site XXVI (after Christie 1988).

GROOVED WARE SHERDS/PITS

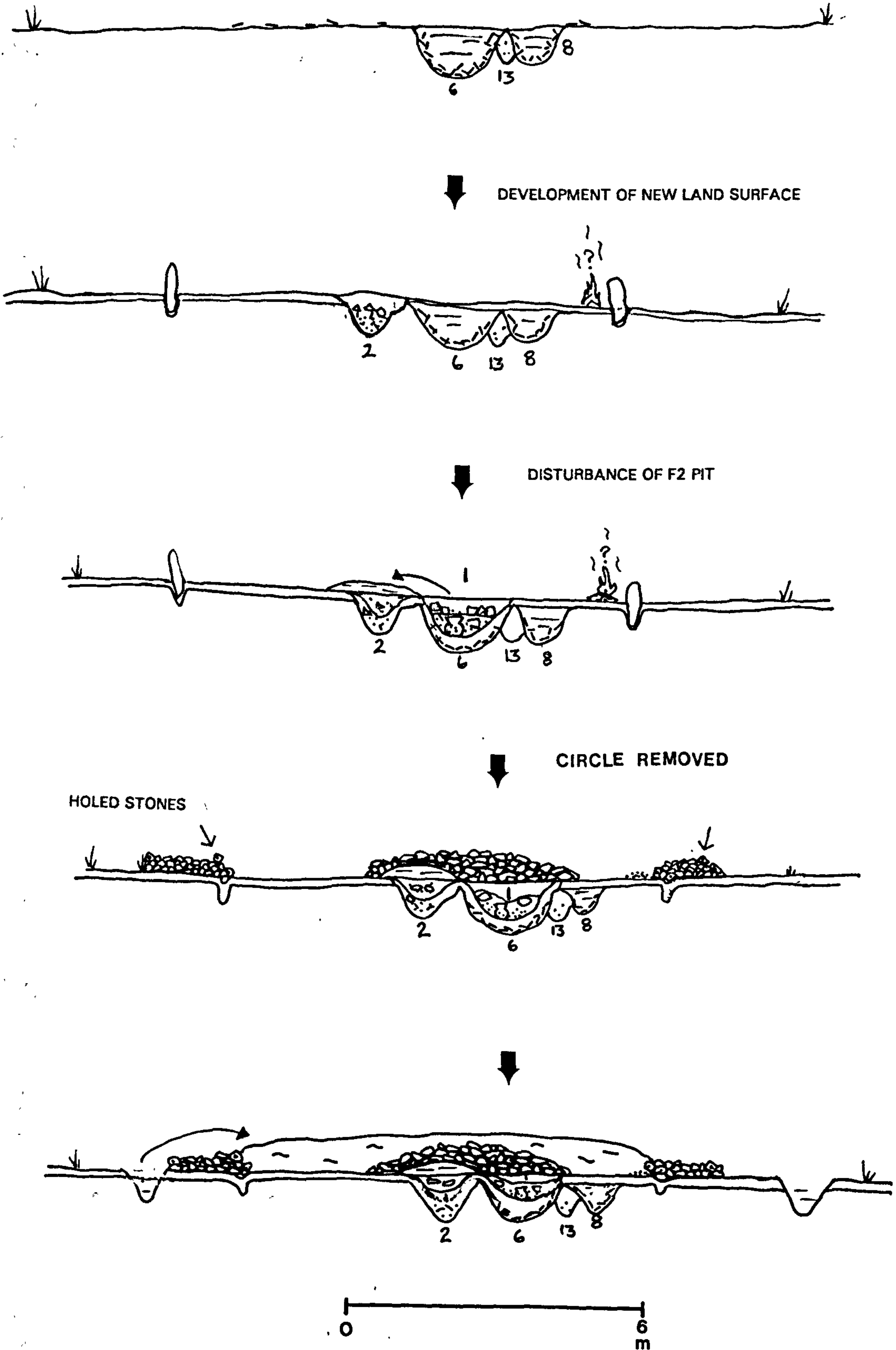


Figure 5.18.1 Davidstow Moor XXVI sequence of activities.



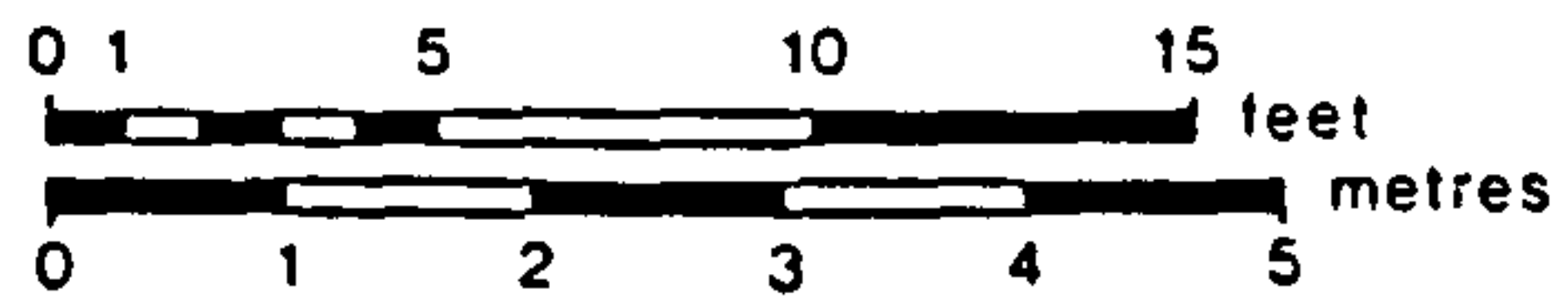
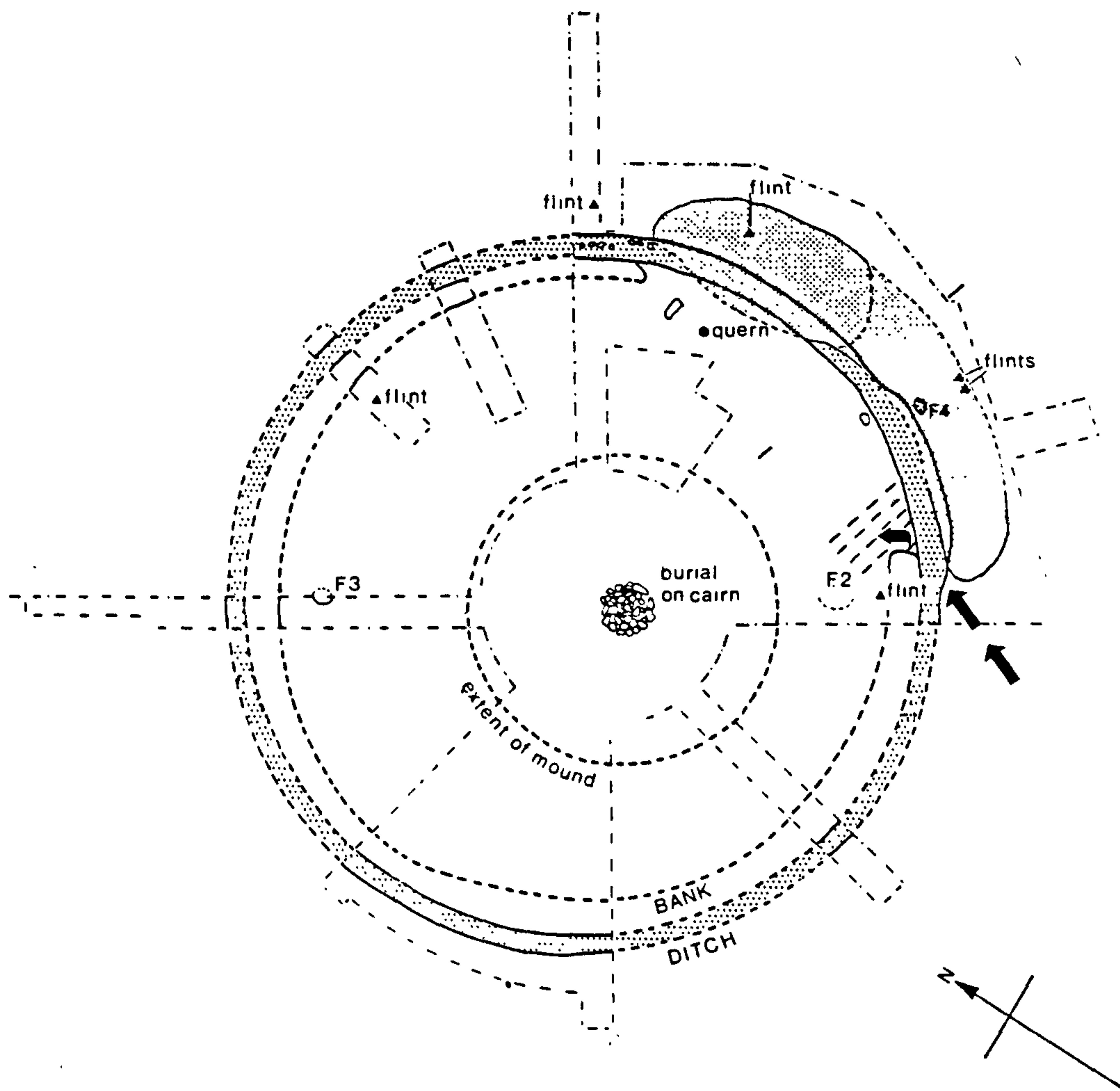


Figure 5.19 Davidstow Moor Site III (after Christie 1988).

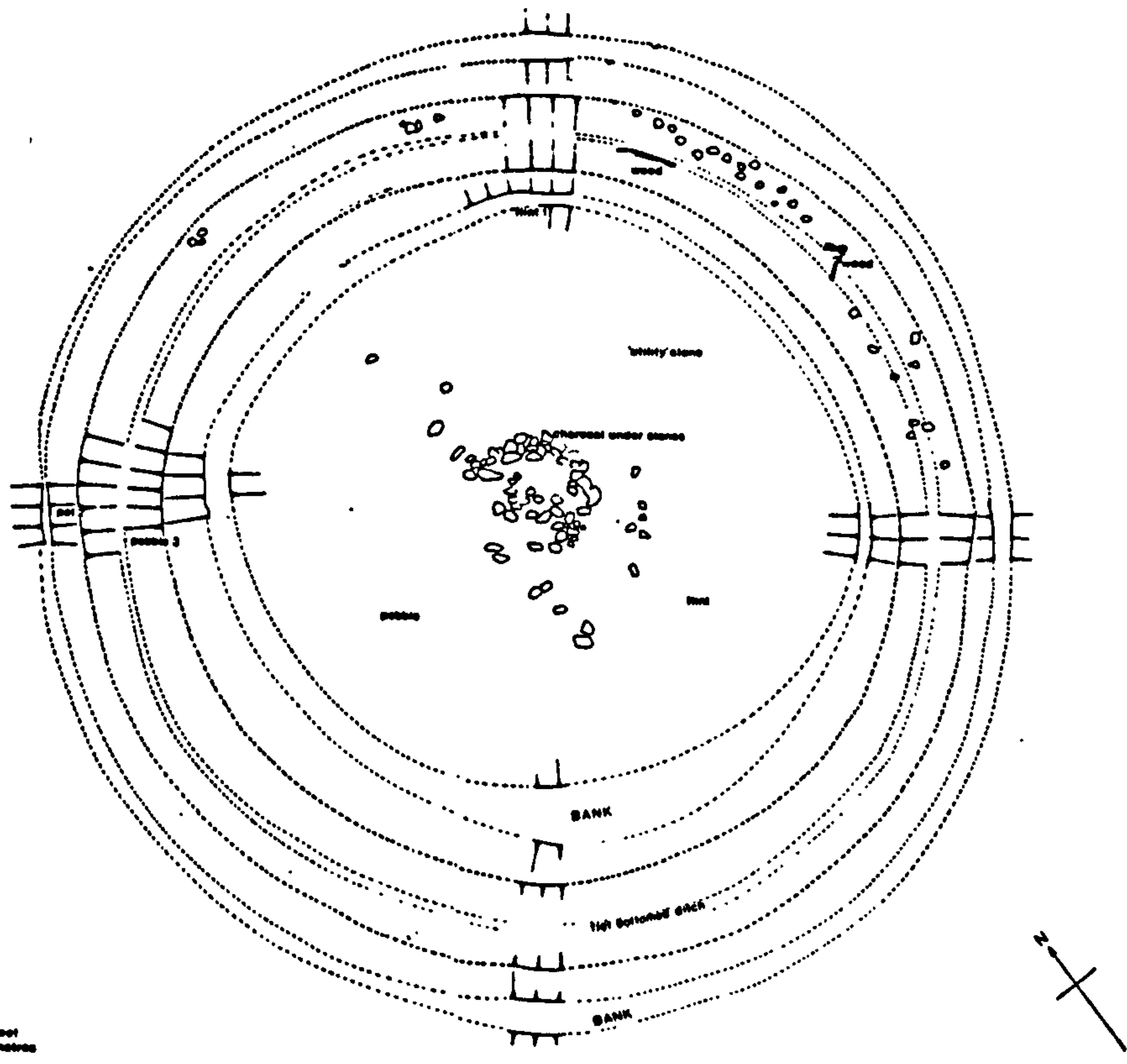


Figure 5.20 Davidstow Moor Site II (after Christie 1988).



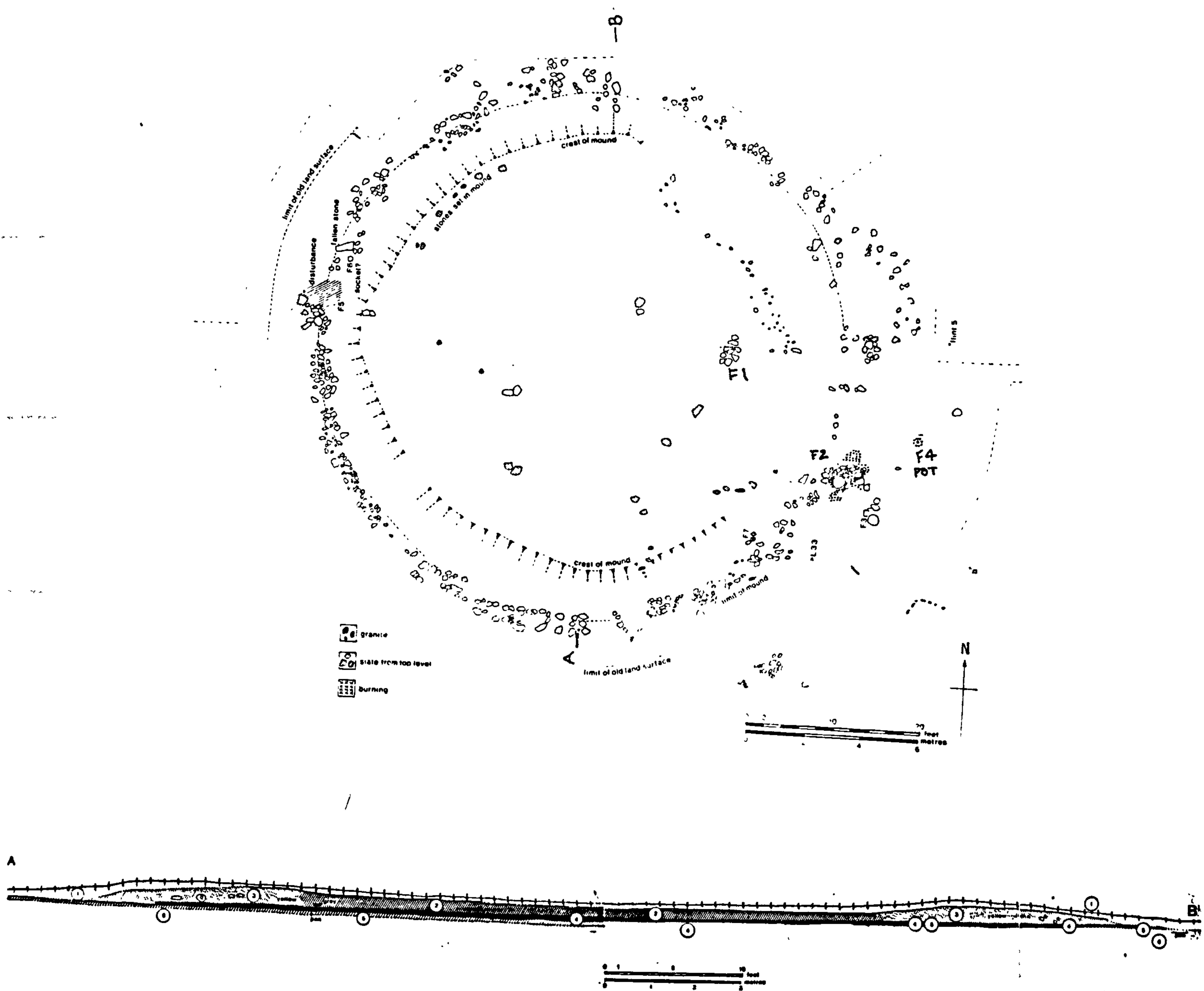


Fig 43  
 Site V(2) Section A-B: (1) turf; (2) black/grey clay (mound of turves); (2a) gritty lower mound material; (3) stones and yellow material; (4) black 'old turf'; (5) grey/yellow clay; (6) orange/yellow clay and pan

Figure 5.21 Davidstow Moor Site V (after Christie 1988).

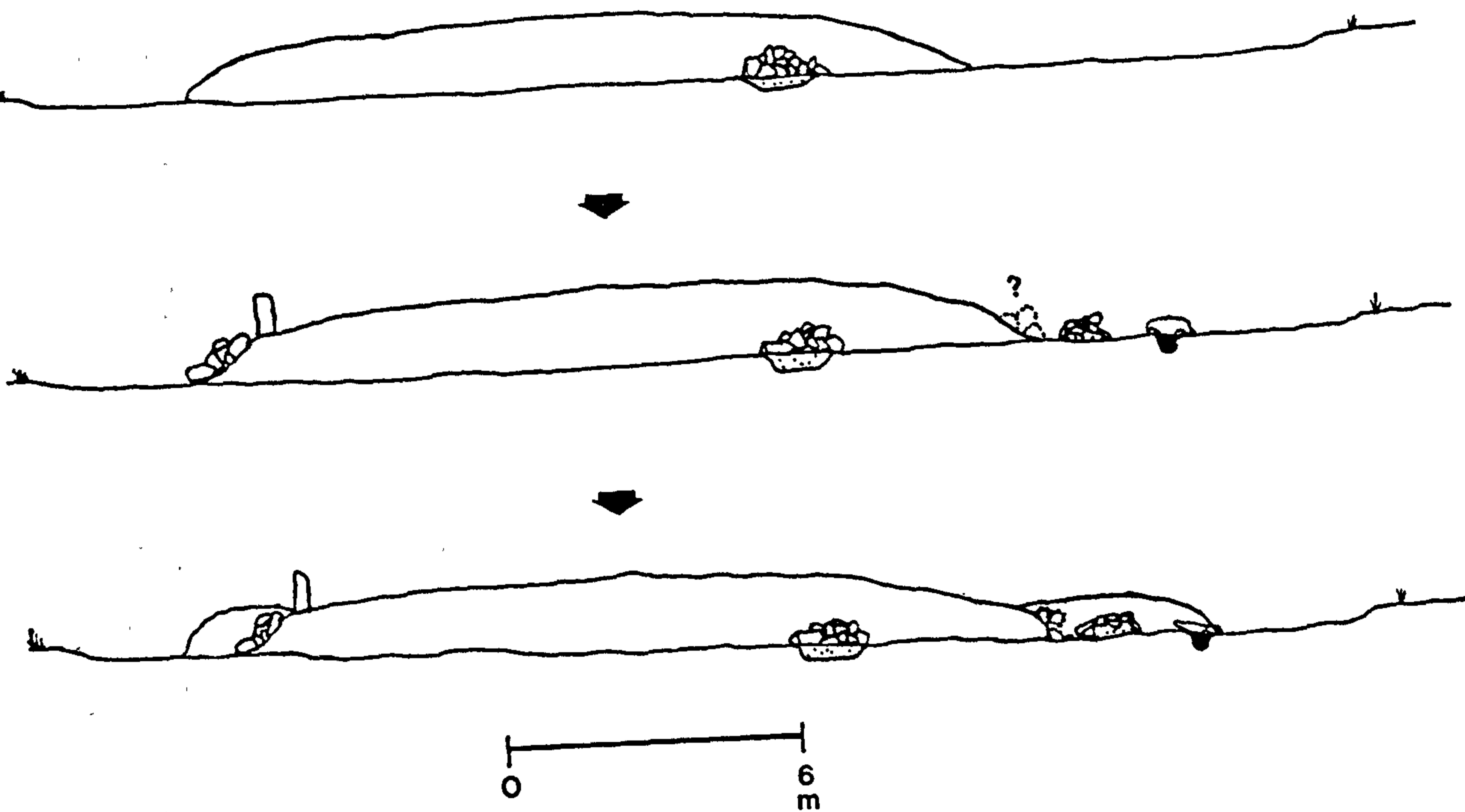


Figure 5.21.1 Davidstow Moor V sequence of activities.



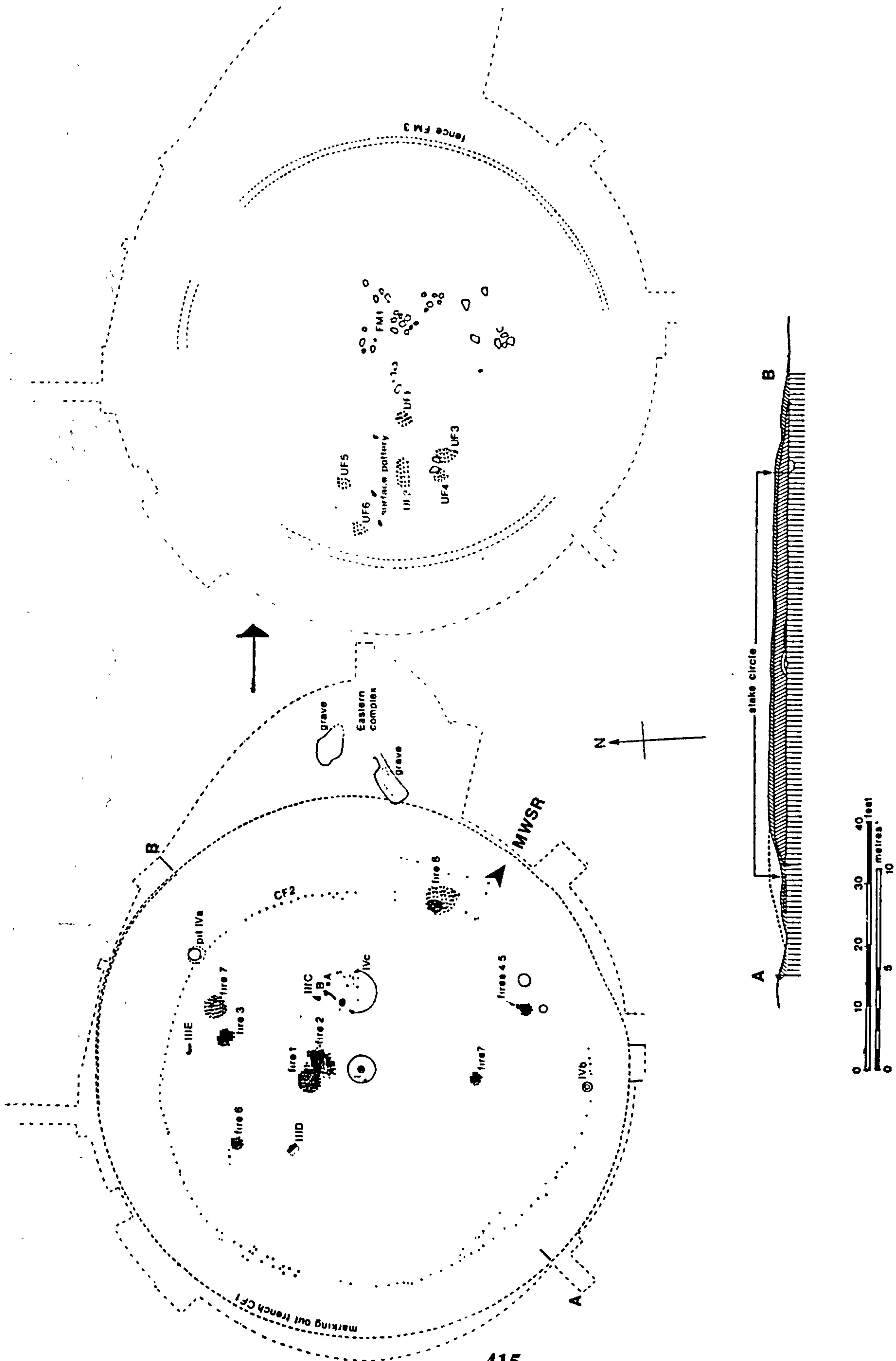
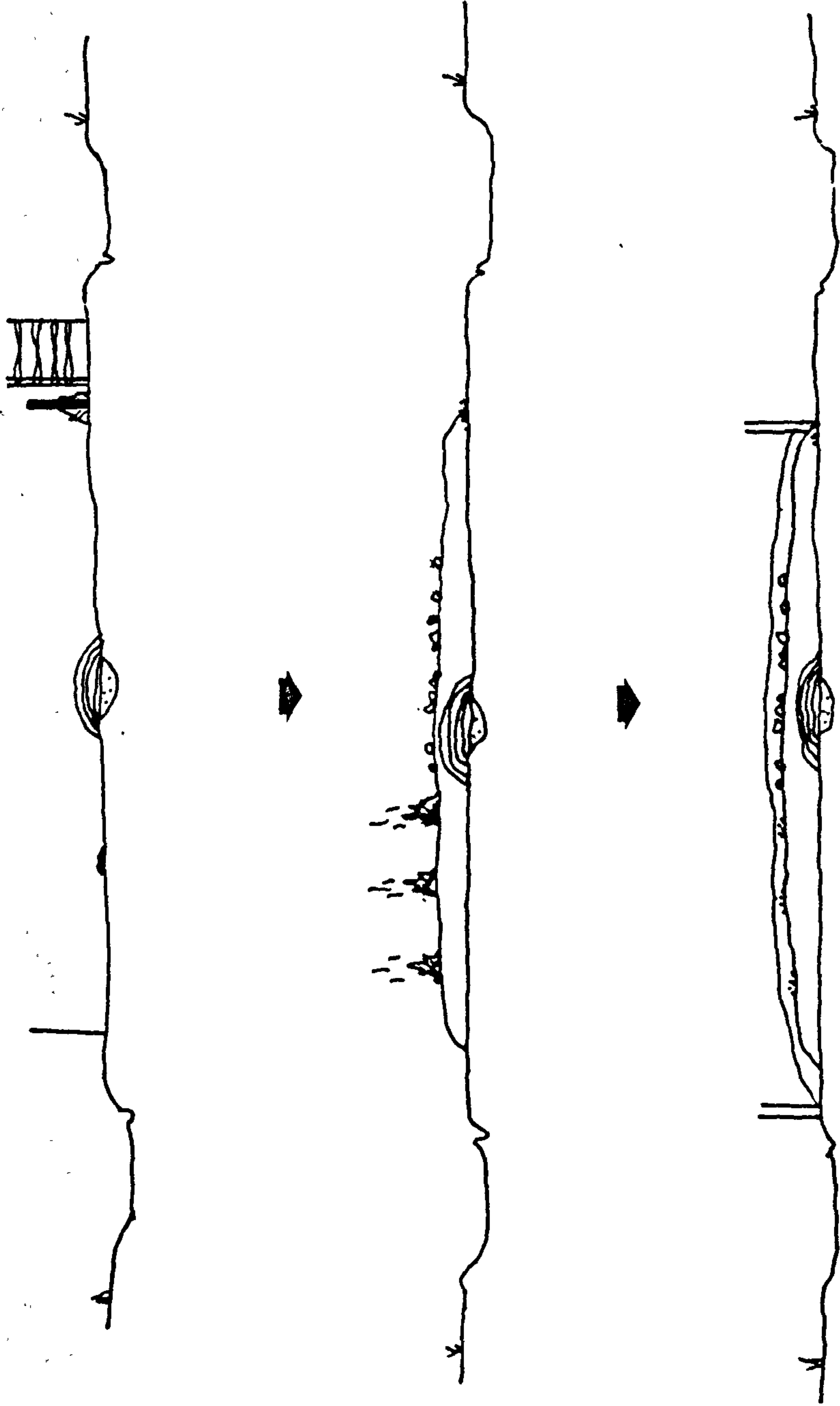


Figure 5.22 Davidstow Cemetery Site I (after Christie 1988).

MWSR "ENCLOSURE"



0 10 m

Figure 5.22.1 Davidstow Moor I sequence of activities.



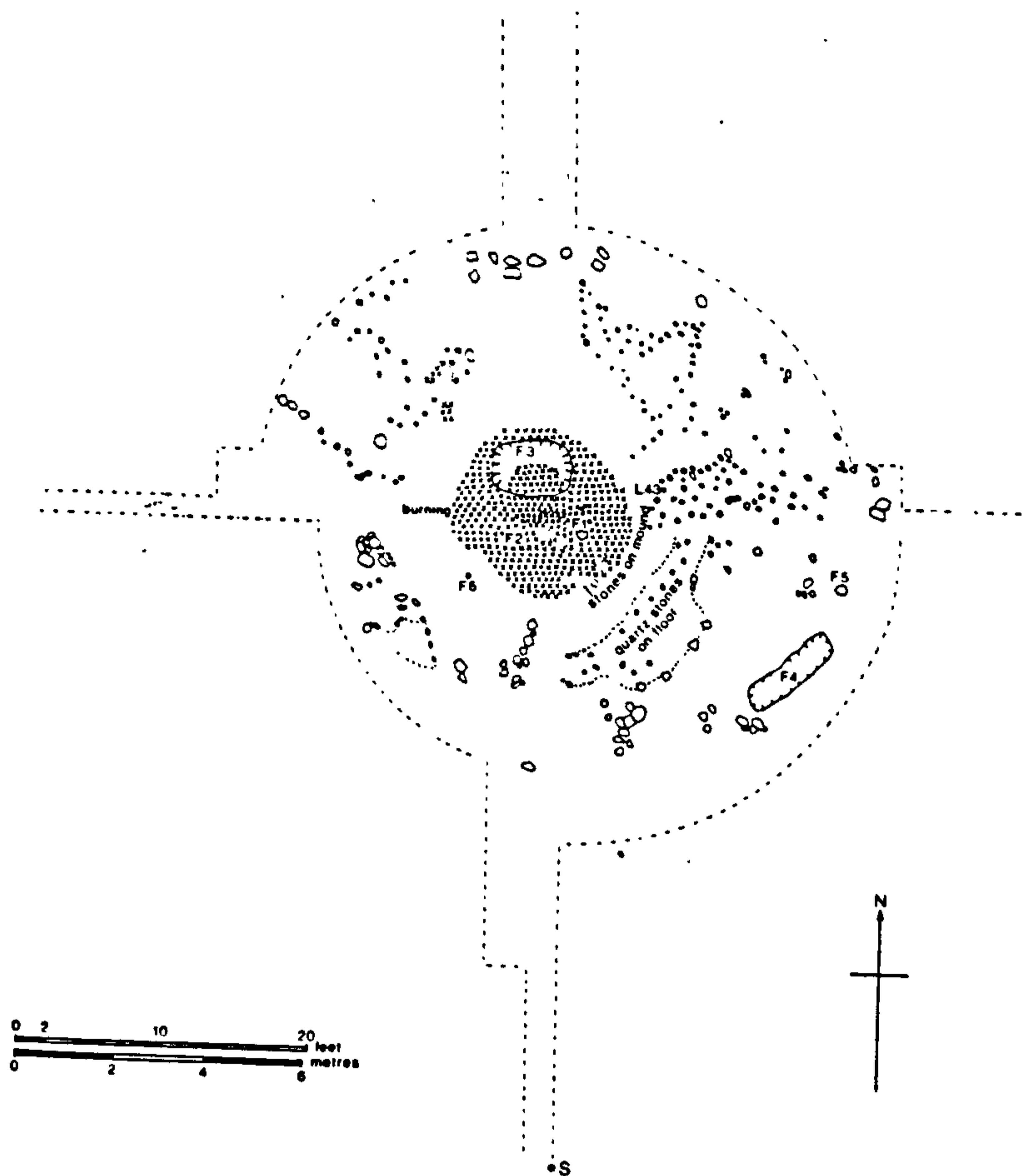


Figure 5.23 Davidstow Cemetery Site XXIV (after Chrisite 1988).


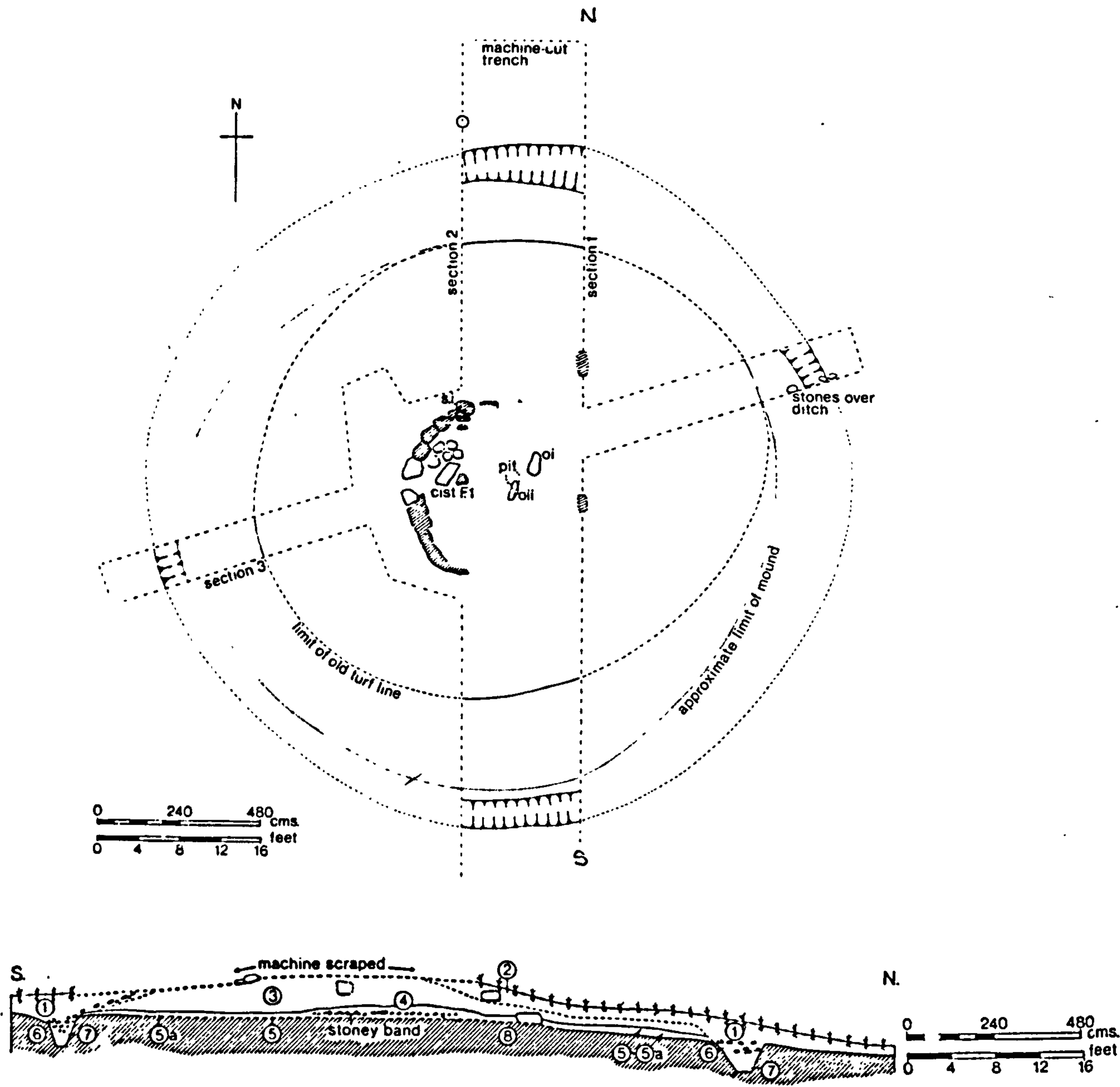


Figure 5.24 Tregulland, earlier and later phases (after Ashbee 1958).





Treligga 7: sections 1, 2 and 3: (1) turf and topsoil (2) disturbed earth over mound (3) mottled yellow clay (4) pink clay and shillet and charcoal (5) red/black layer (?old turf) (5a) brown stony layer (rotted shillet) (6) stony ditch fill (7) brown earth and shillet (primary ditch fill) (8) shillet bedrock.

Figure 5.25 Treligga 7 (after Christie 1985).

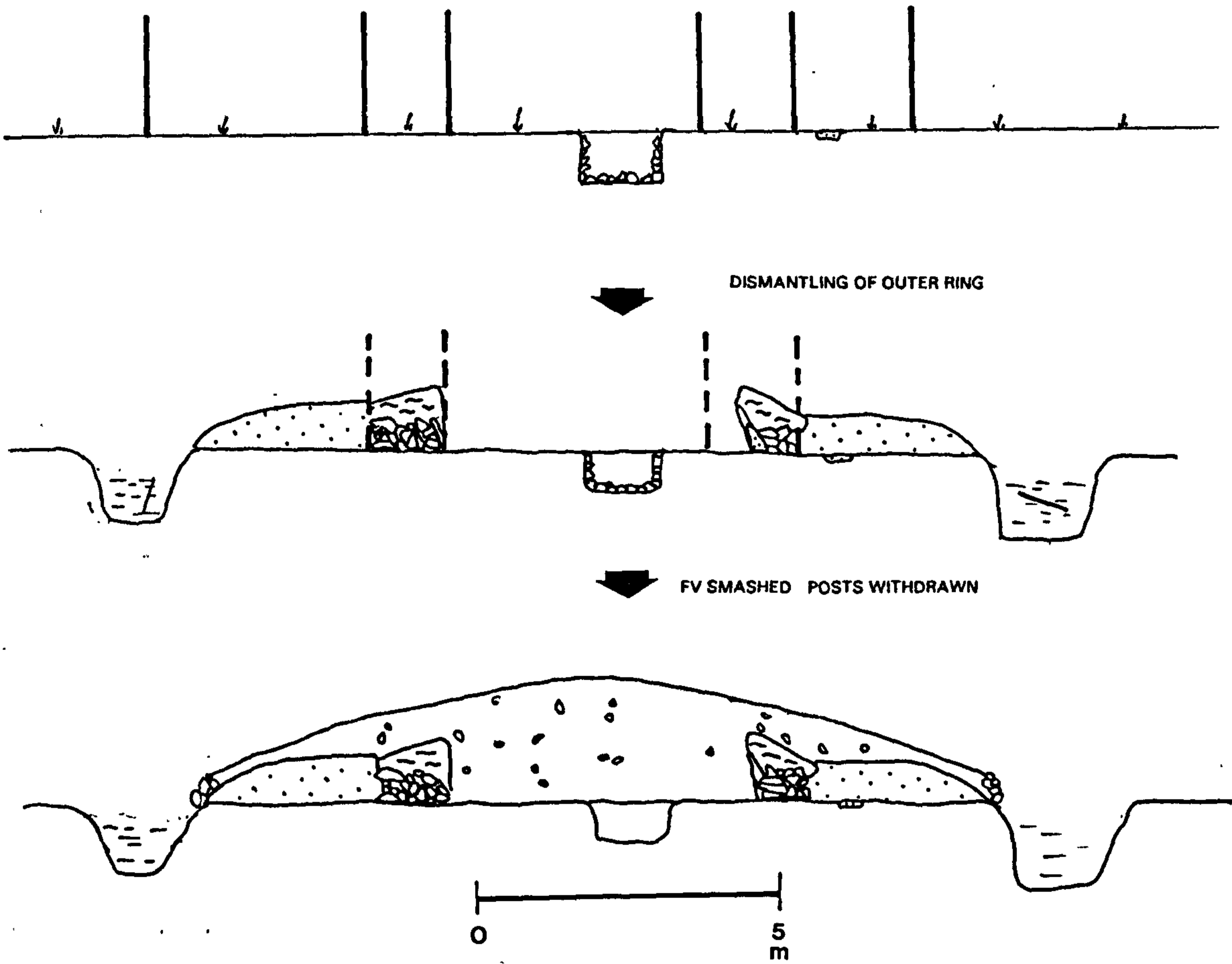


Figure 5.24.1 *Tregulland enclosure and mound structure.*



QUARTZ/SLATE ENCLOSURE WALL

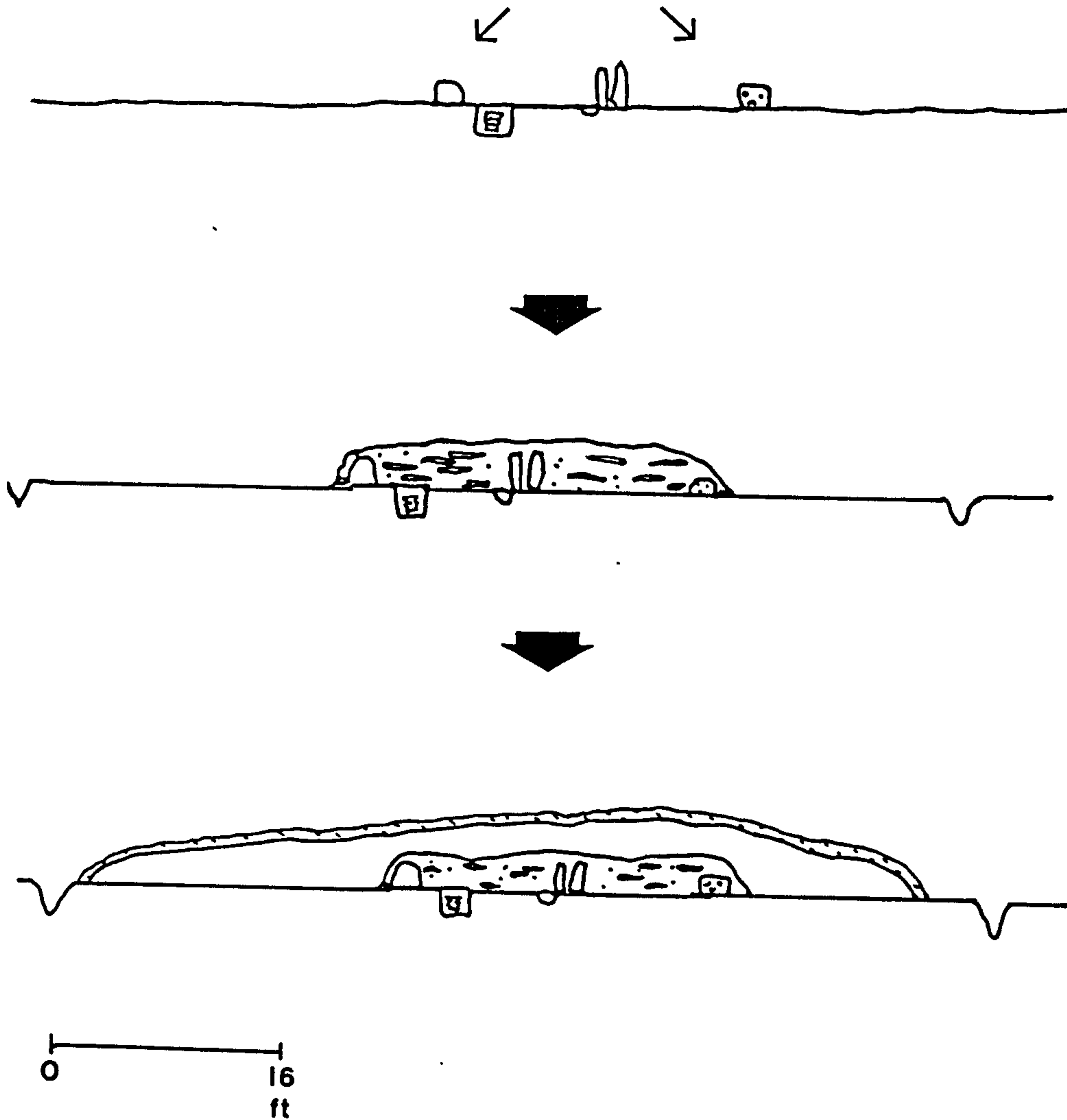
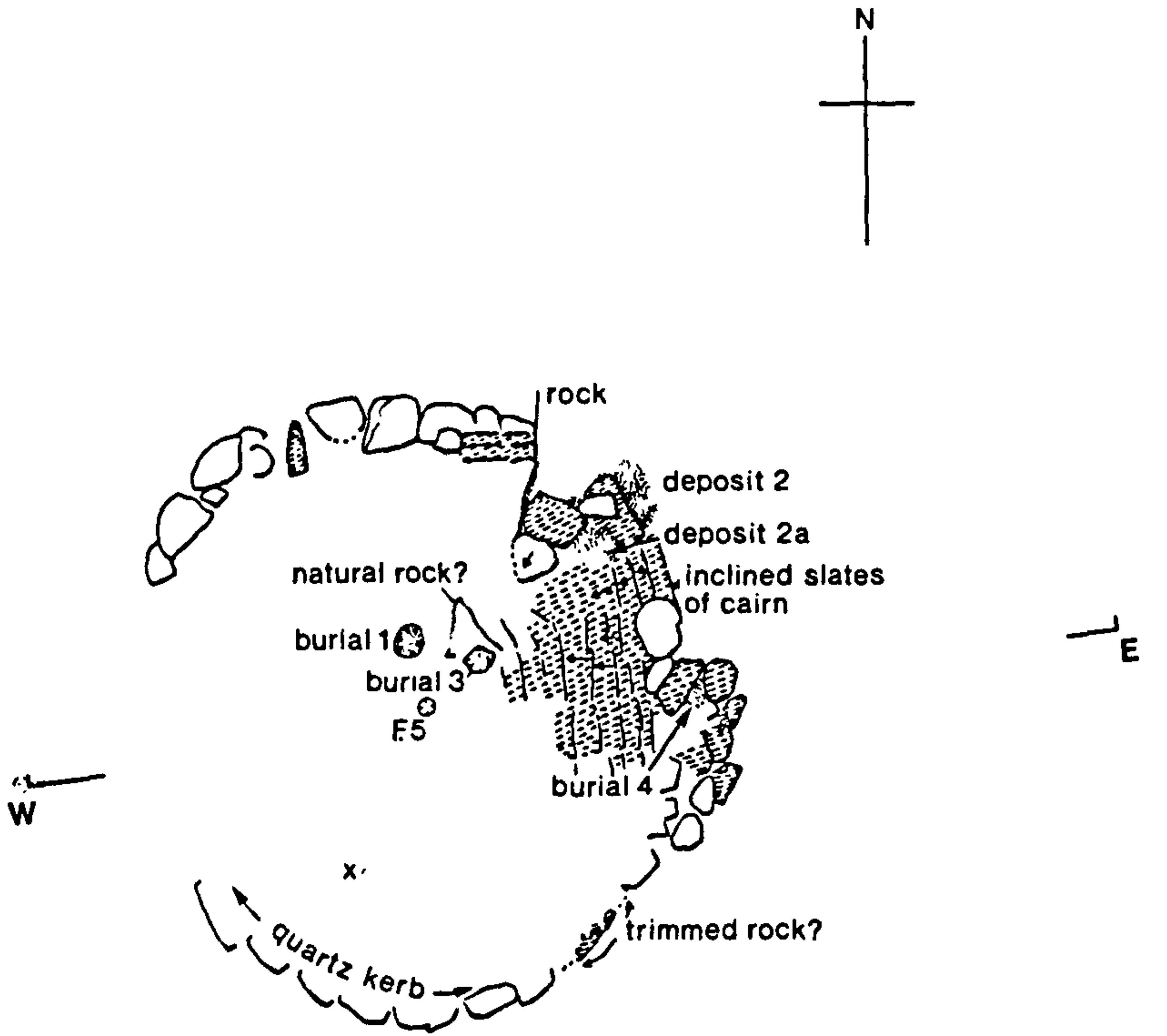
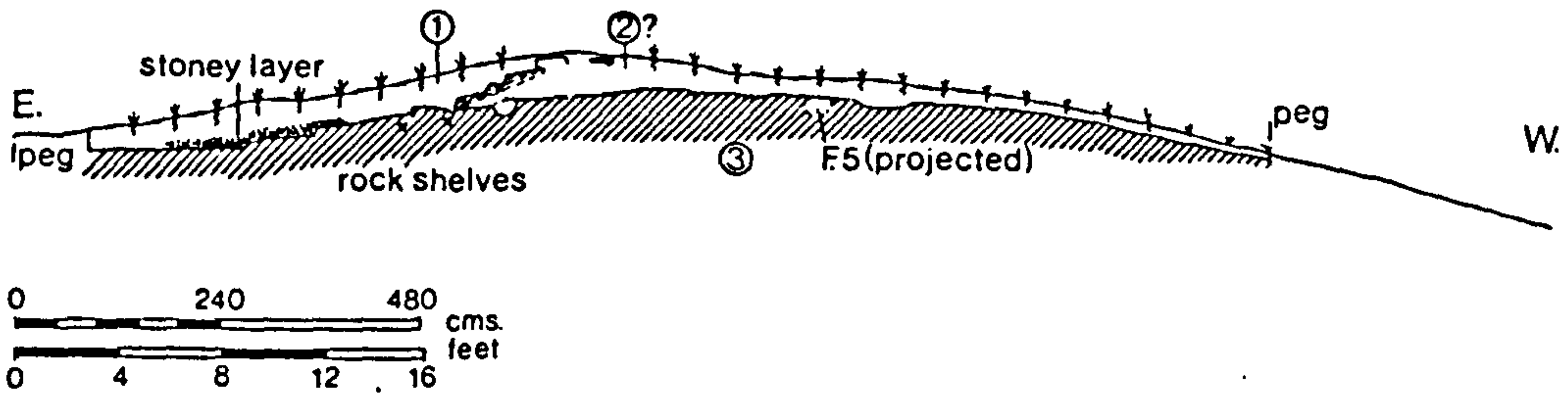
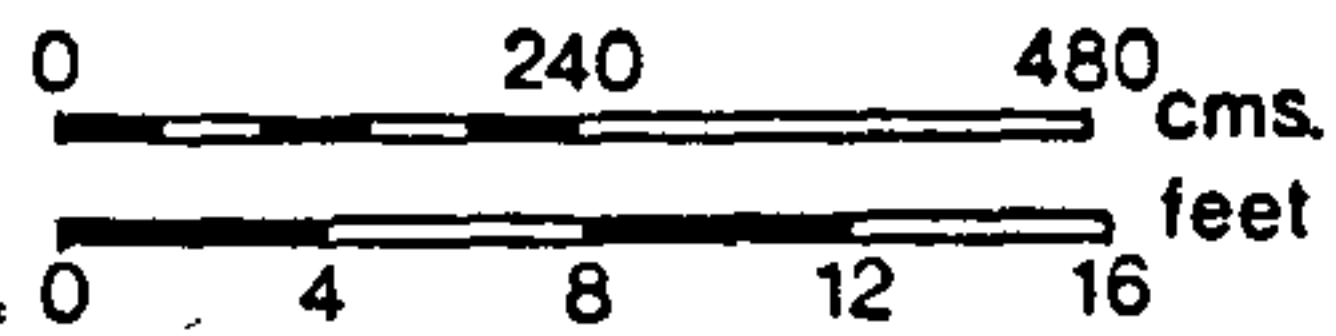


Figure 5.25.1 Treligga 7 mound construction.



-  slate
-  quartz
-  burning

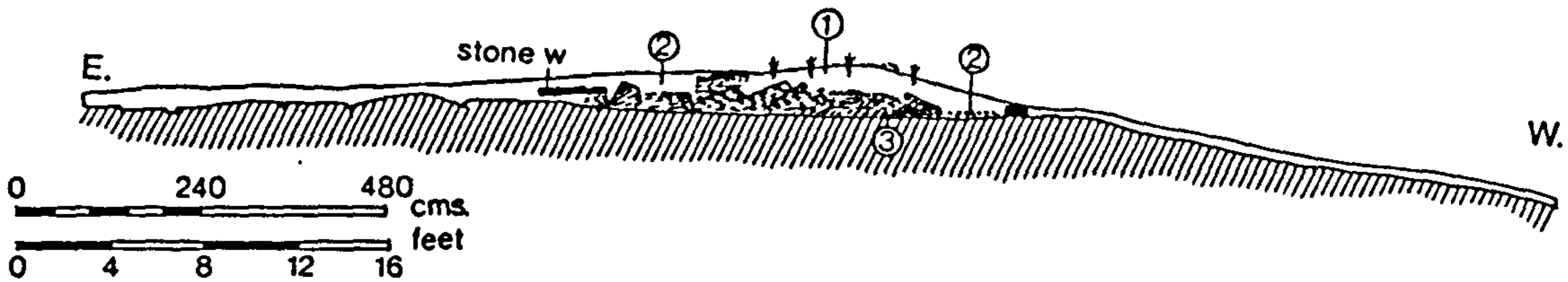
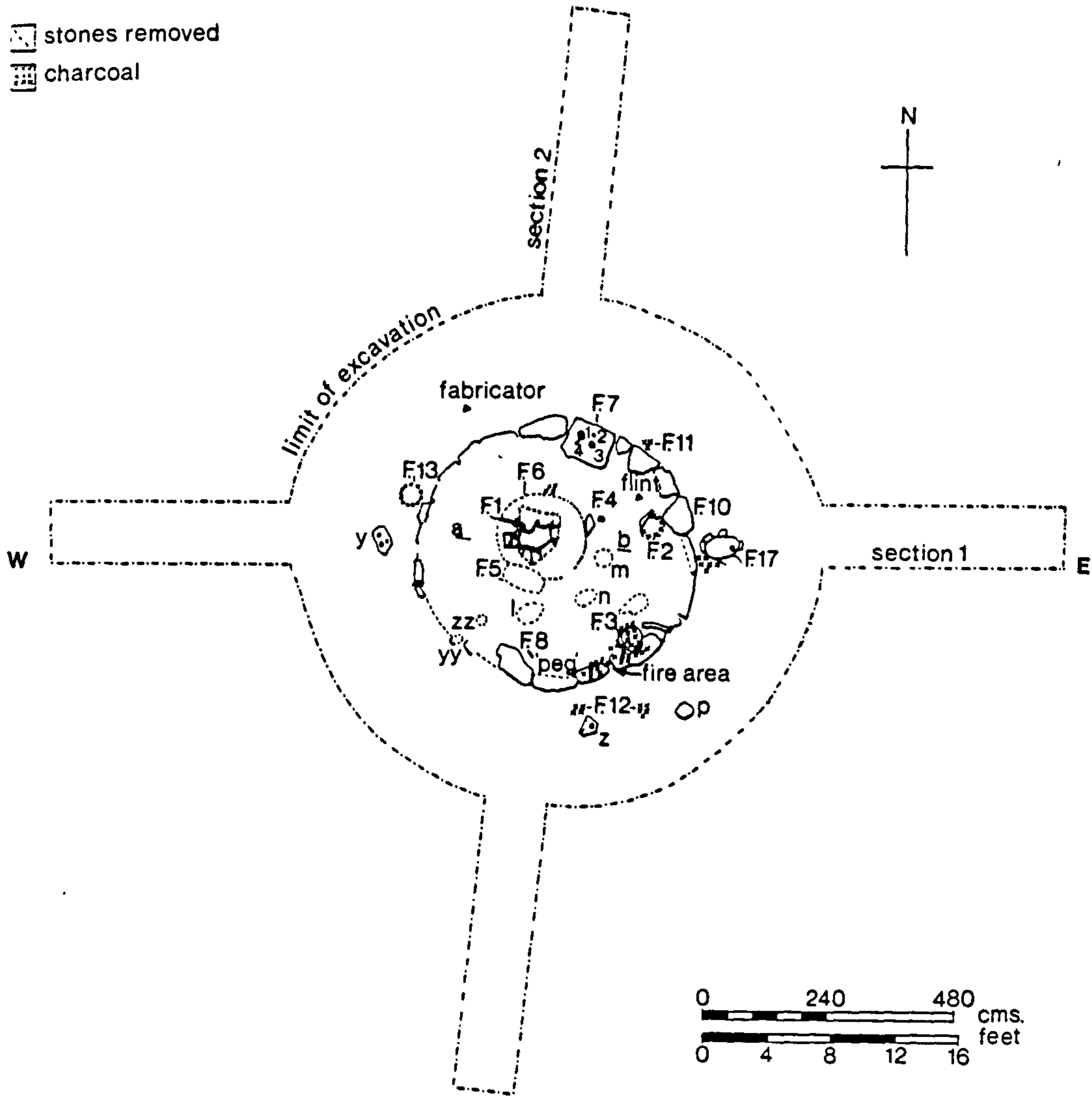


(1) turf and topsoil (2) brown earth and stones (cairn material)  
(3) natural rock.

Figure 5.26 Treligga 1 (after Christie 1985).

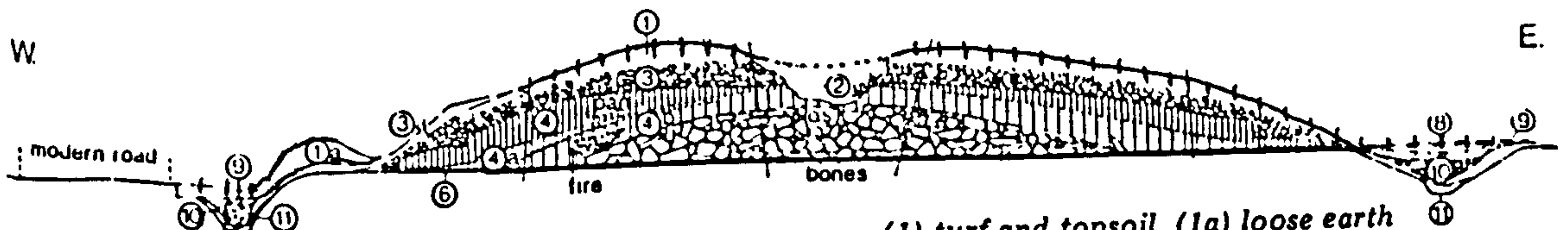
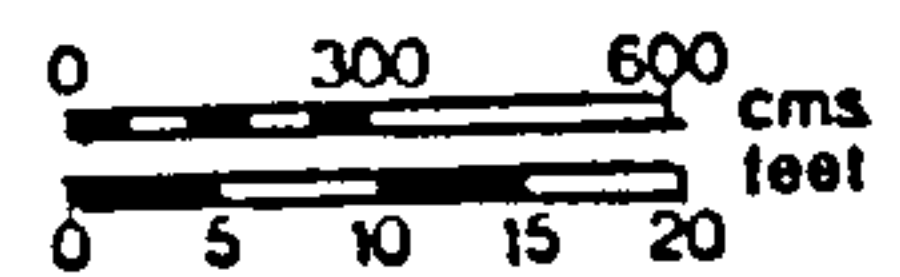
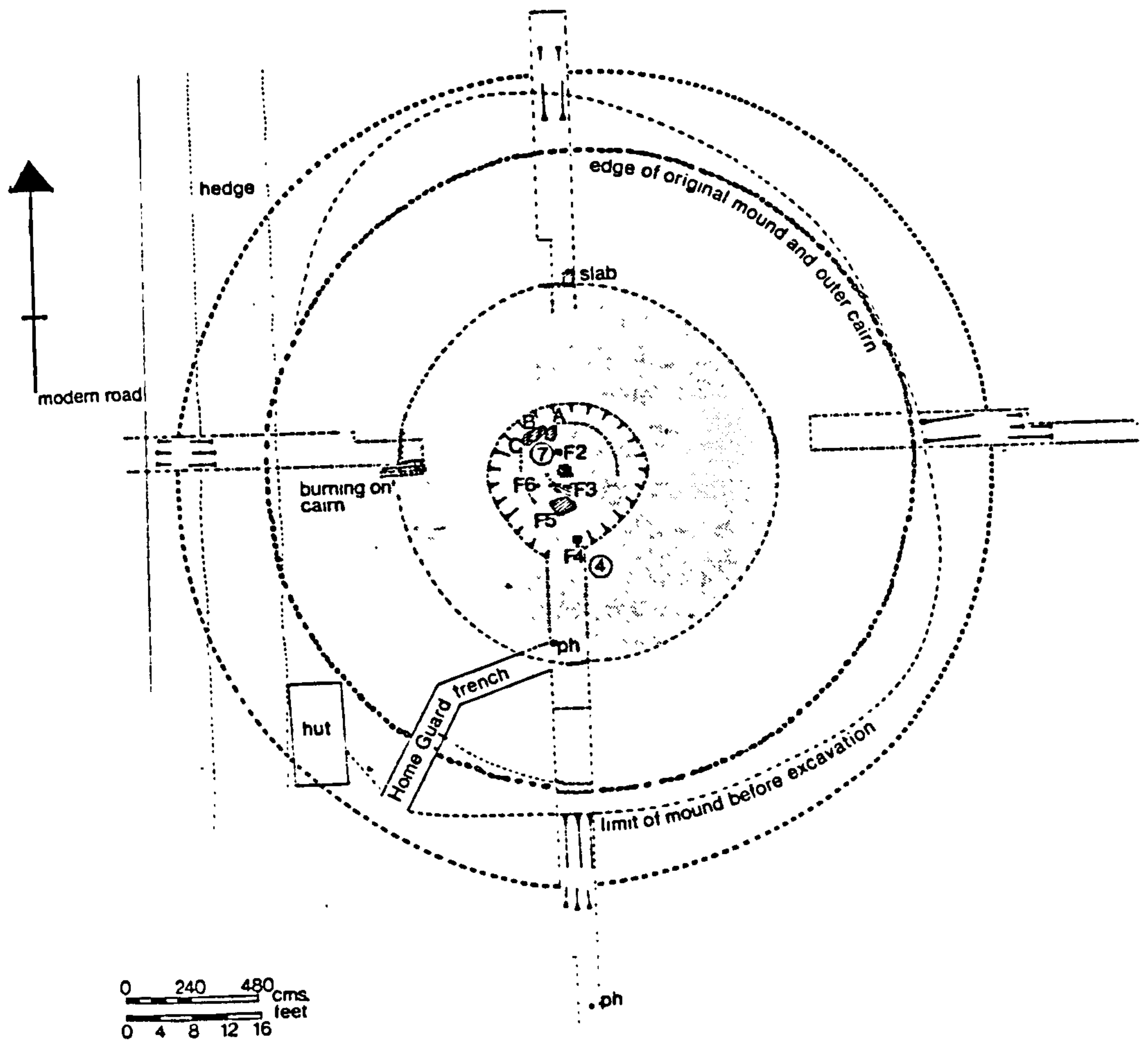


stones removed  
 charcoal



(1) turf and topsoil (1a) loose blue shillet (decayed 'natural') (2) small shillet fragments (3) inclined slates of cairn (4) dark brown earth and charcoal over OLS around pit (5) black earth and bone in pit (6) shillet bedrock.

Figure 5.27 Treligga 2 (after Christie 1985).



(1) turf and topsoil (1a) loose earth of road hedge (2) disturbed earth (3) upper cairn (3a) yellow clay with stones (? remains of cairn) (4) dark clay and 'black and white peaty layers' on north (4a) multicoloured clay with pan (4b) brown/white clay over OLS (5) inner cairn (6) black 'old turf' (7) yellow/white clay (8) turf over ditch (9) black peaty fill (10) stones and yellow (11) 'quick silt'.

Figure 5.28 Lousey Barrow (after Christie 1985).



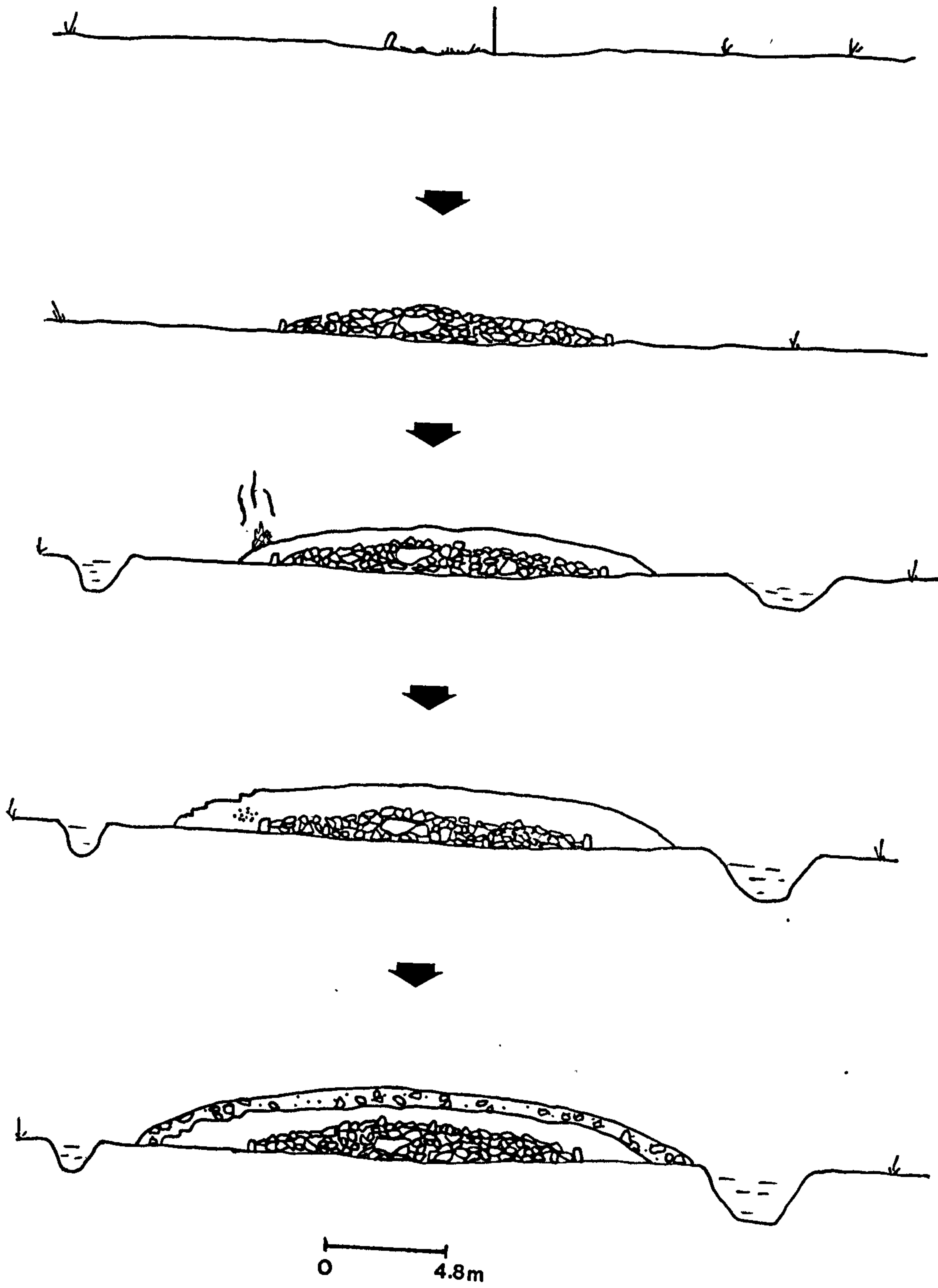


Figure 5.28.1 Lousey Barrow sequence of activities.

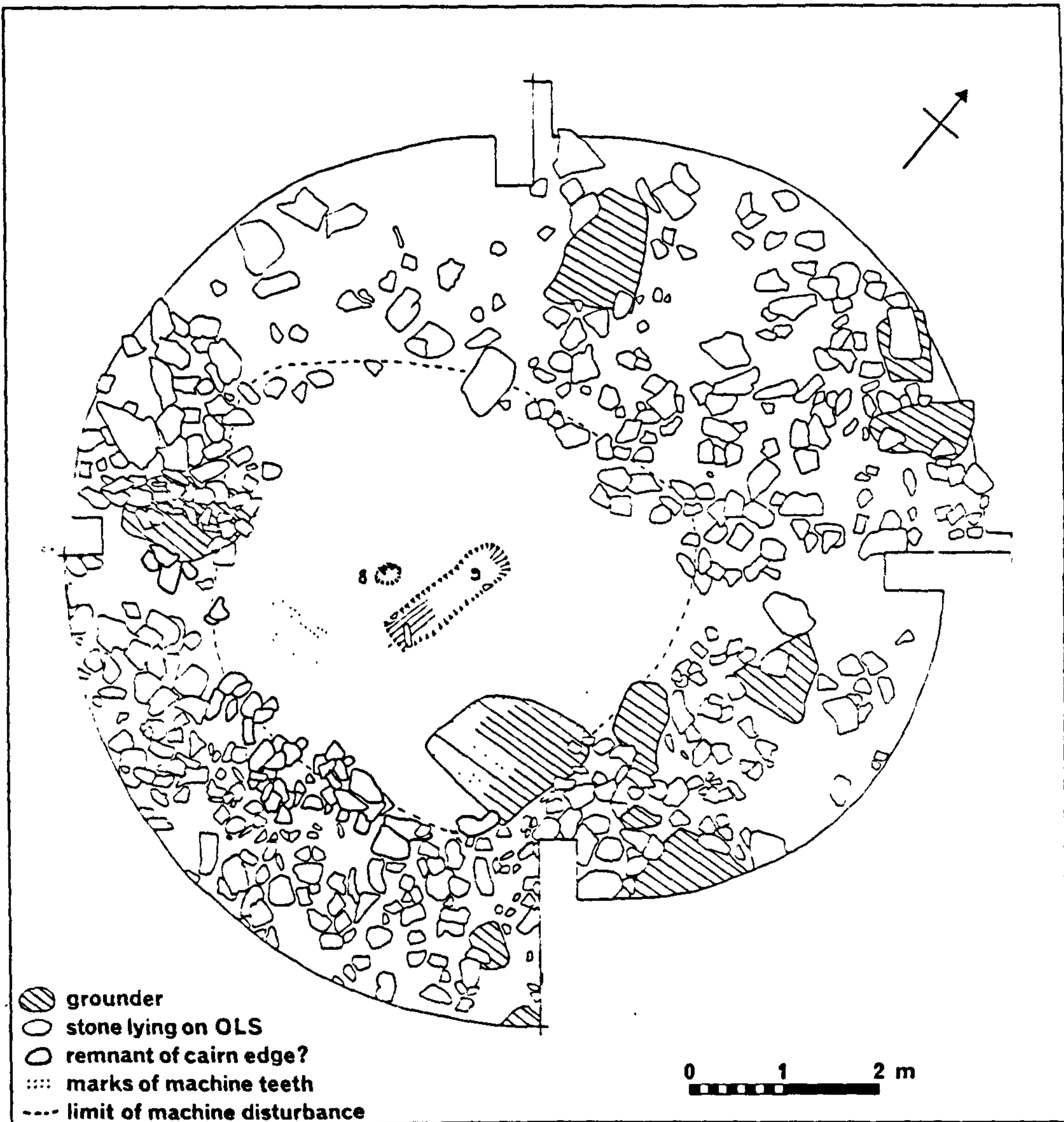


Figure 5.29 Stannon Downs2 (after Harris, Hooper and Trudgian 1984).



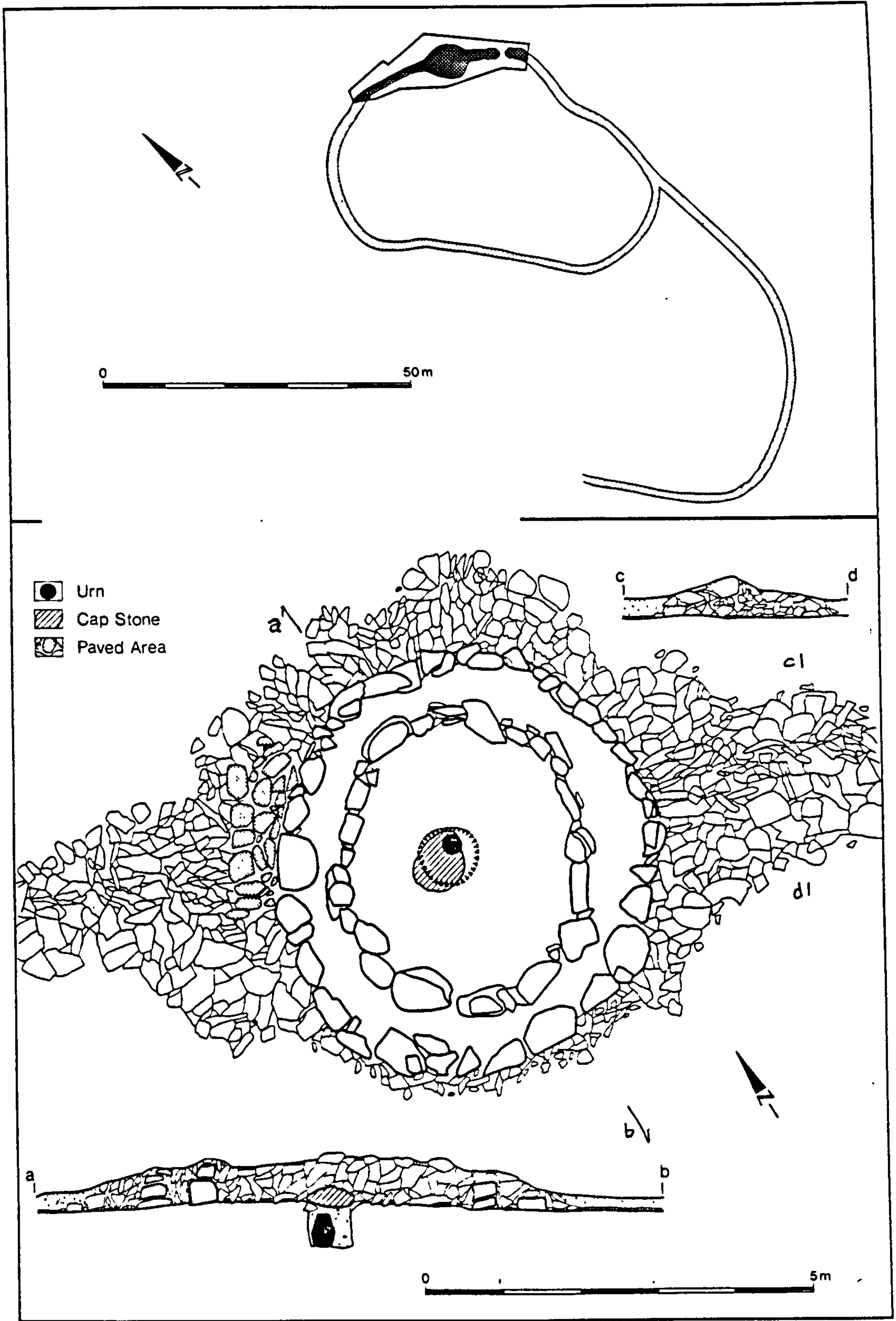


Figure 5.30 Stannon Downs3 (after Harris, Hooper and Trudgian 1984).

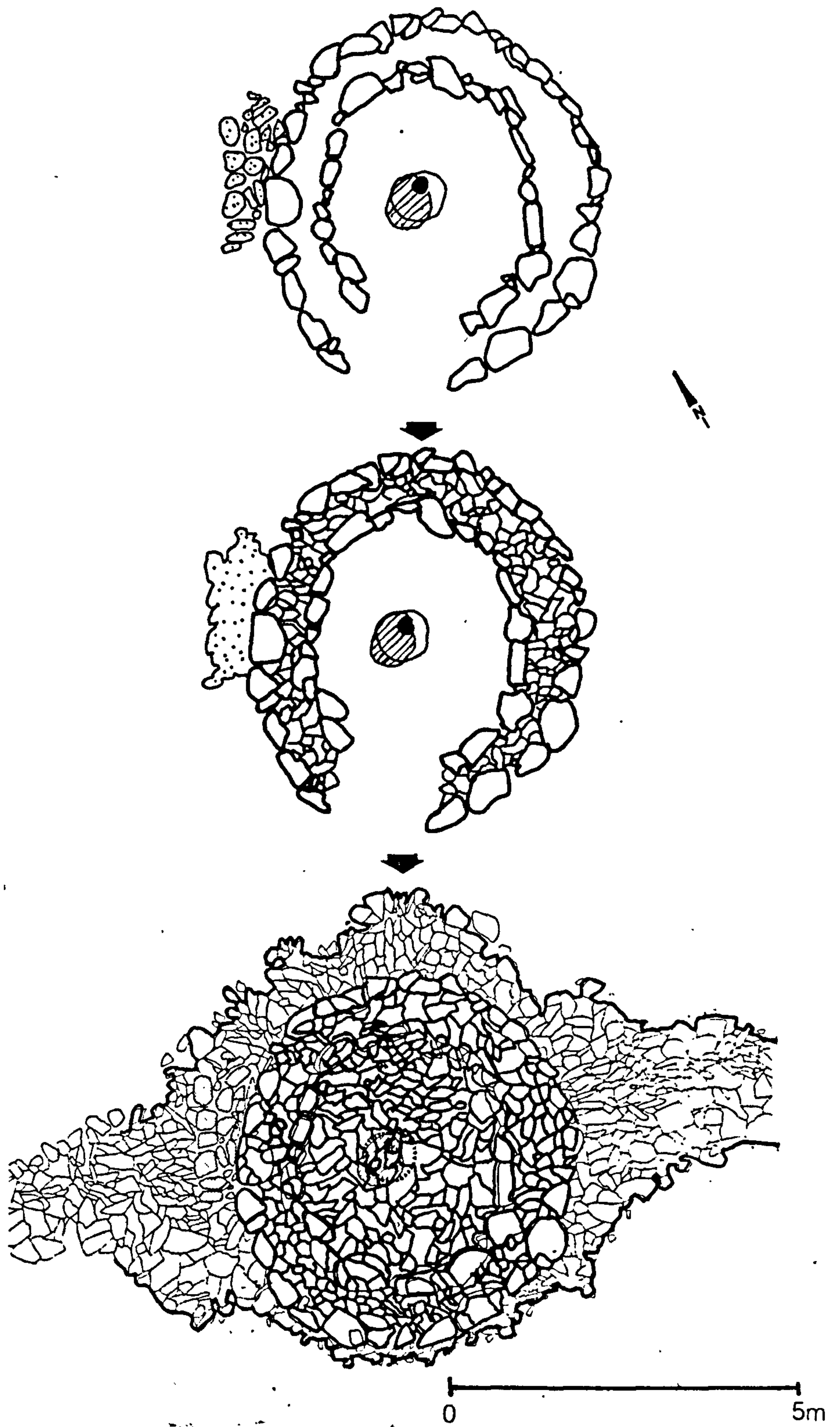


Figure 5.30.1 *Stannon Downs III* sequence of construction (after Harris, Hooper, and Trudgian 1984).



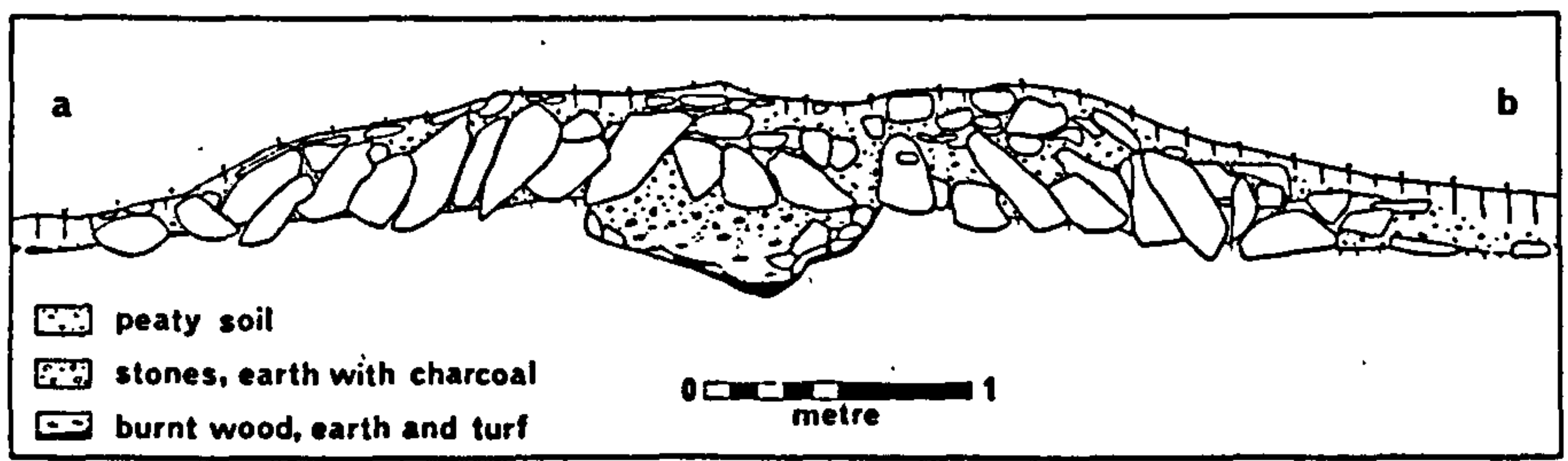
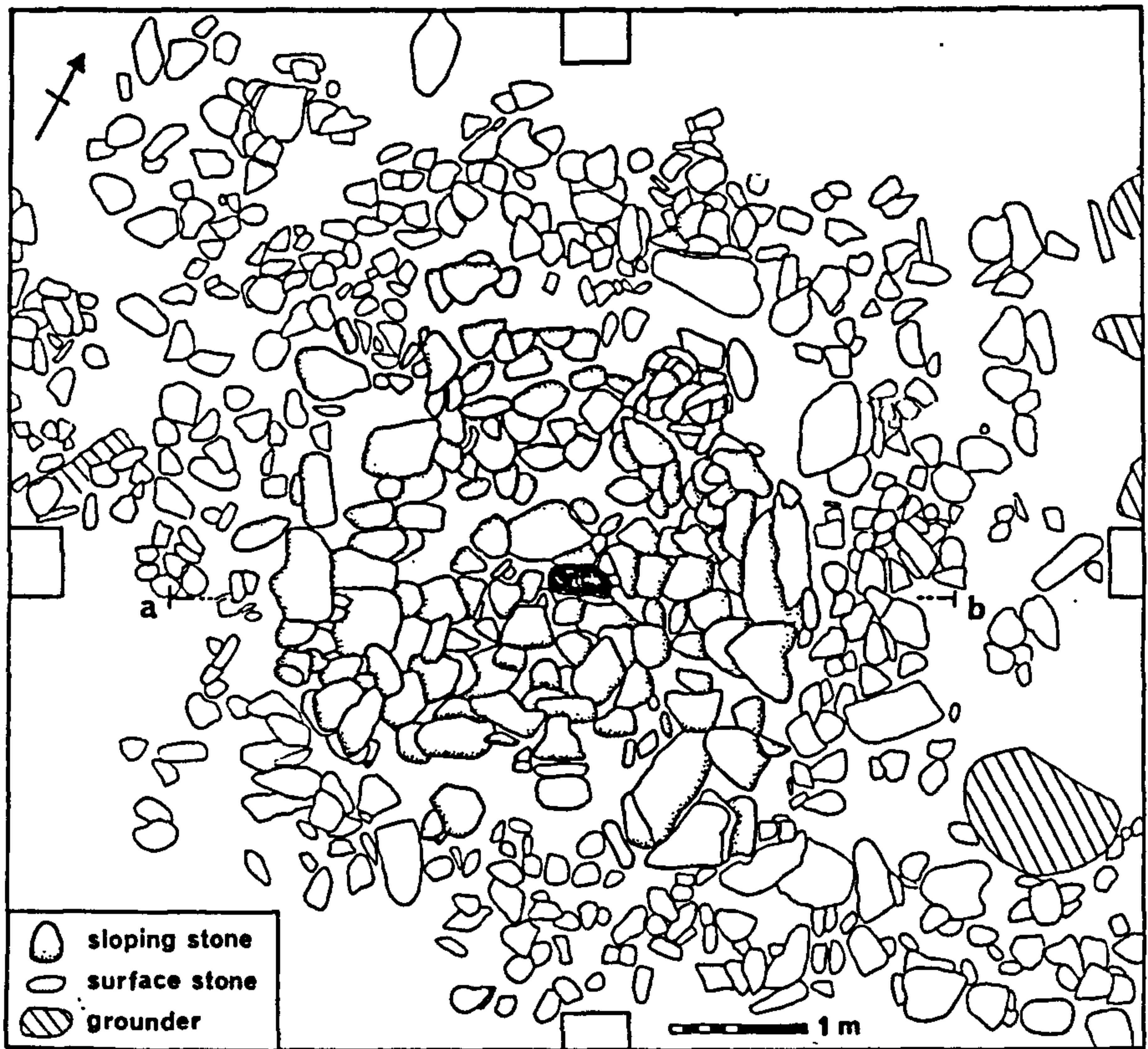


Figure 5.31 Stannon Downs1 (after Harris, Hooper and Trudian 1984).

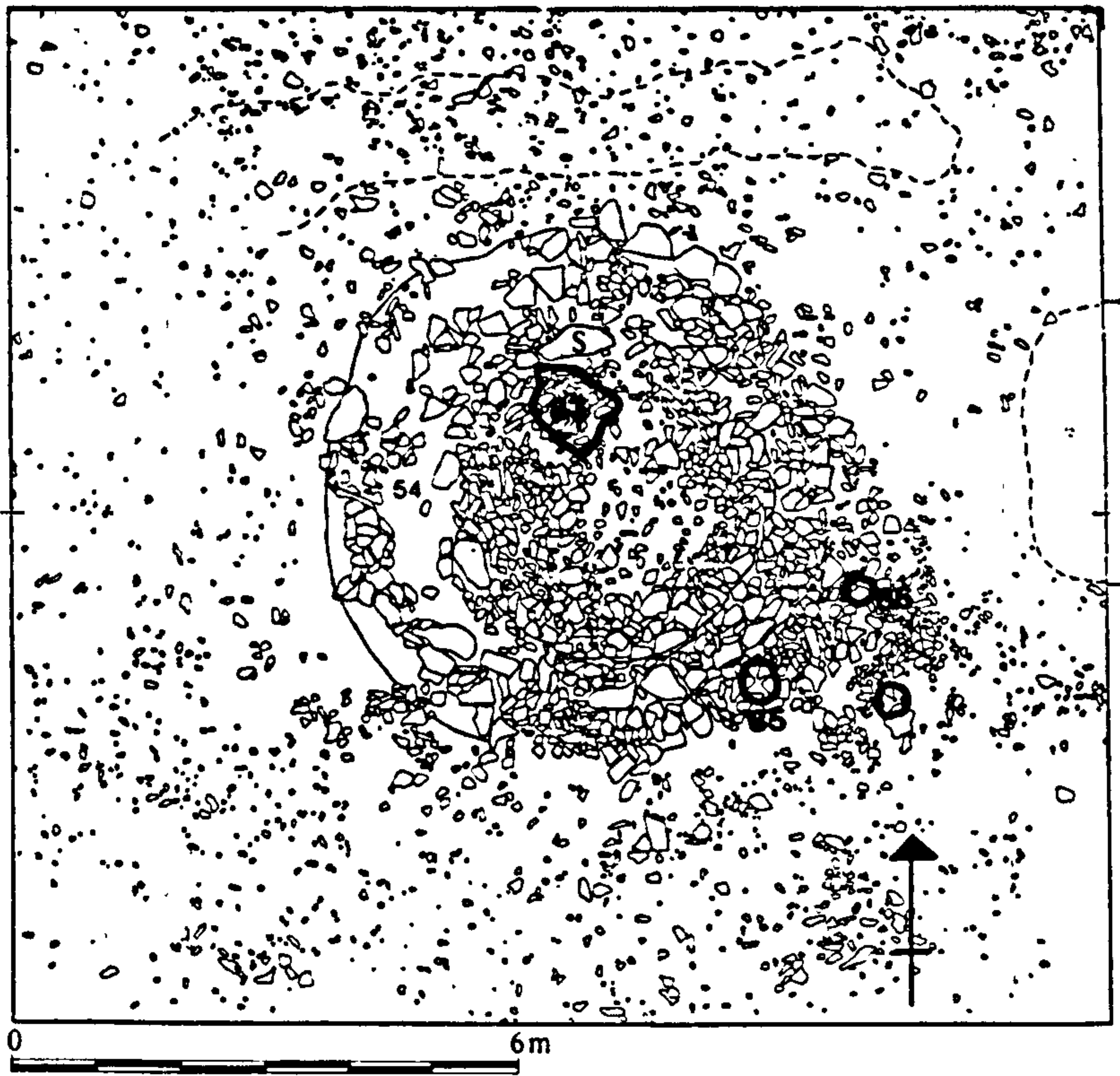


Figure 5.32 Colliford Reservoir Site CRII (after Griffith et.al. 1984).



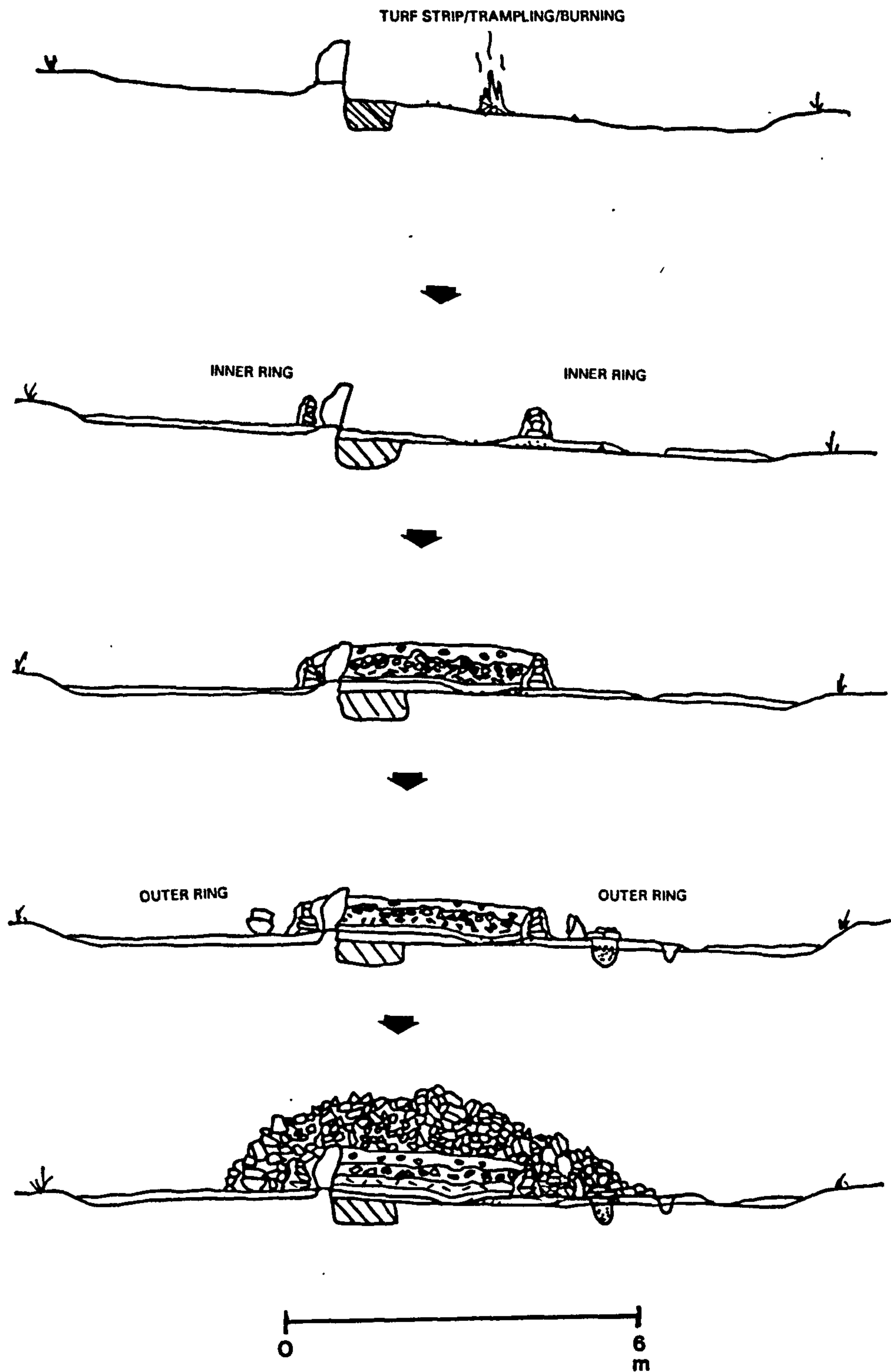


Figure 5.32.1 Colliford Reservoir II sequence of activities.

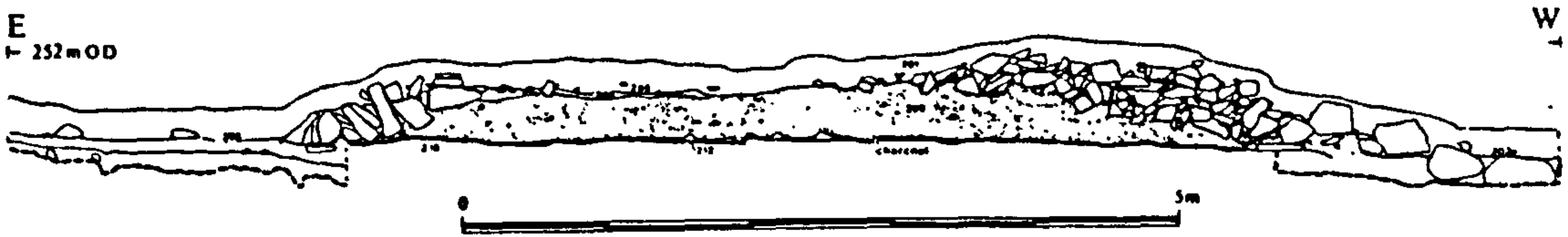
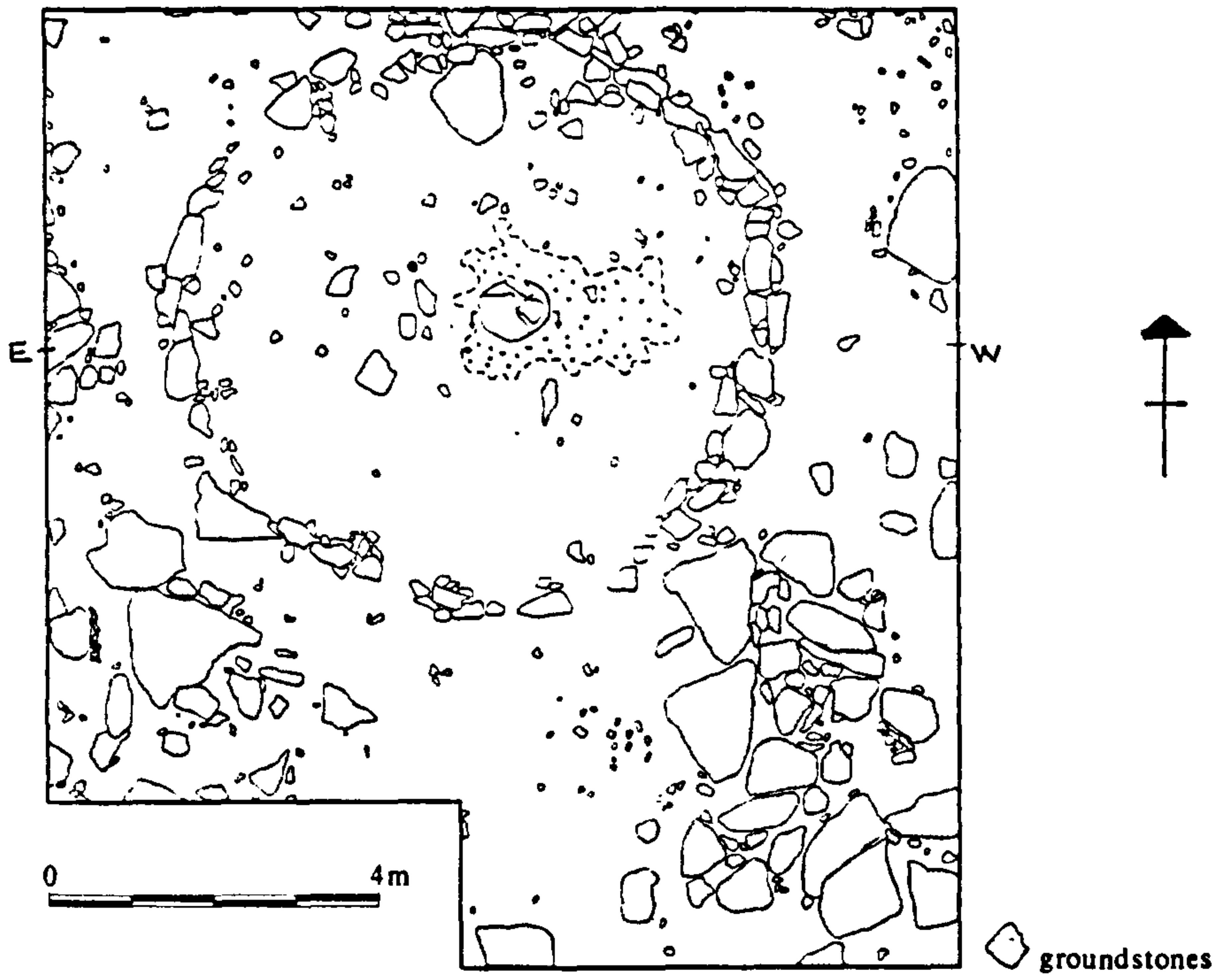


Figure 5.33 Colliford Reservoir CRIVC (after Griffith et.al.1984).



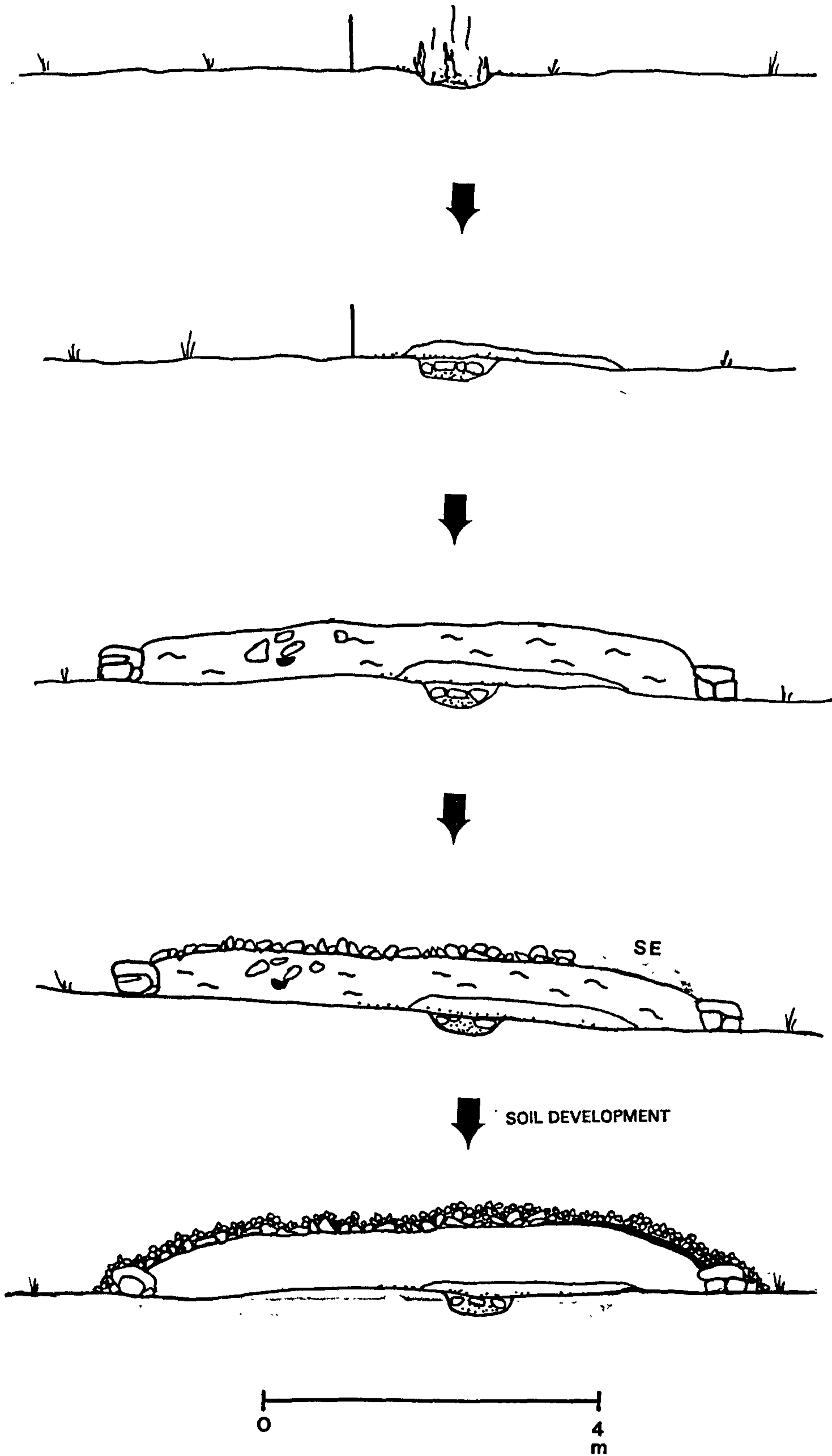


Figure 5.33.1 Colliford Reservoir IVC mound construction.

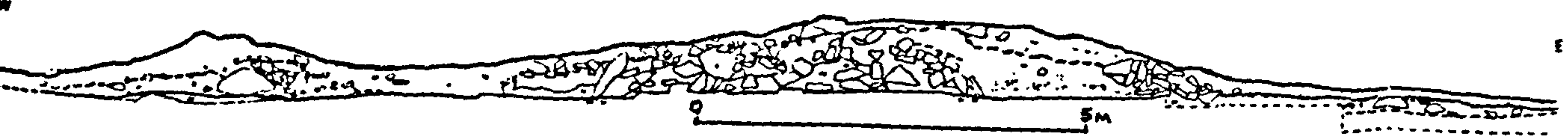
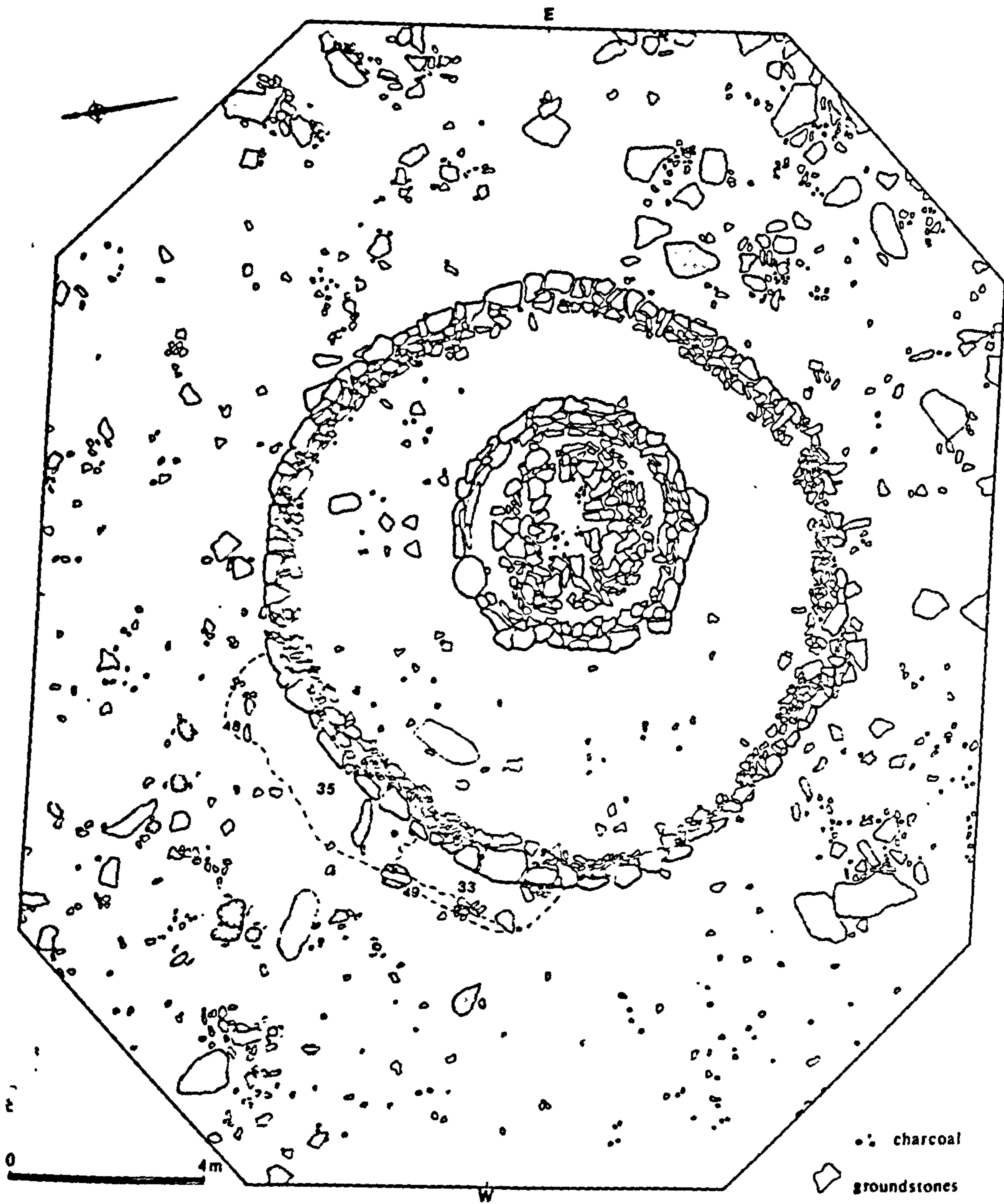


Figure 5.34 Colliford Reservoir Site CRIVA (after Griffith et. al. 1984).



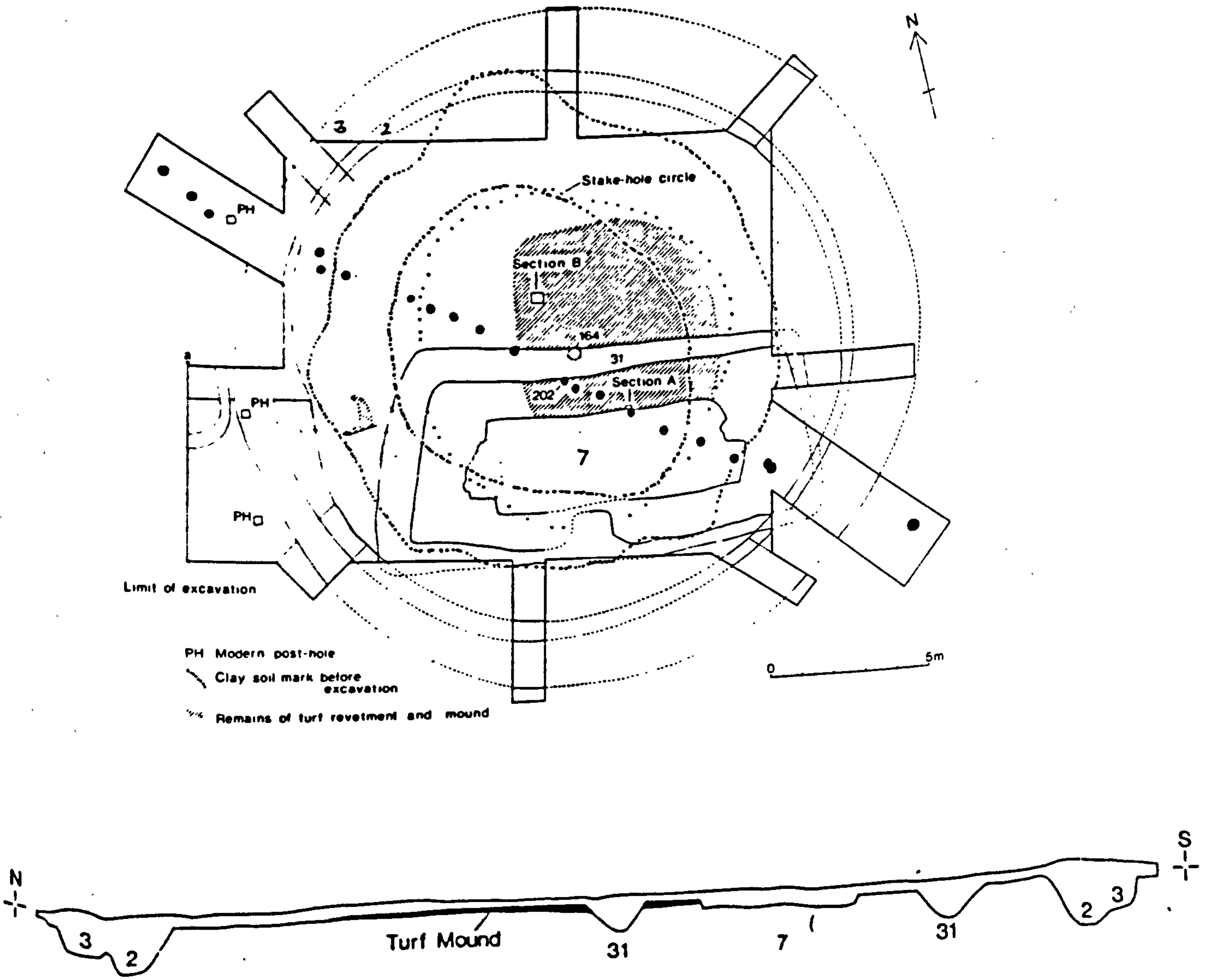


Figure 5.35 Trelen 2 (after Smith 1984).

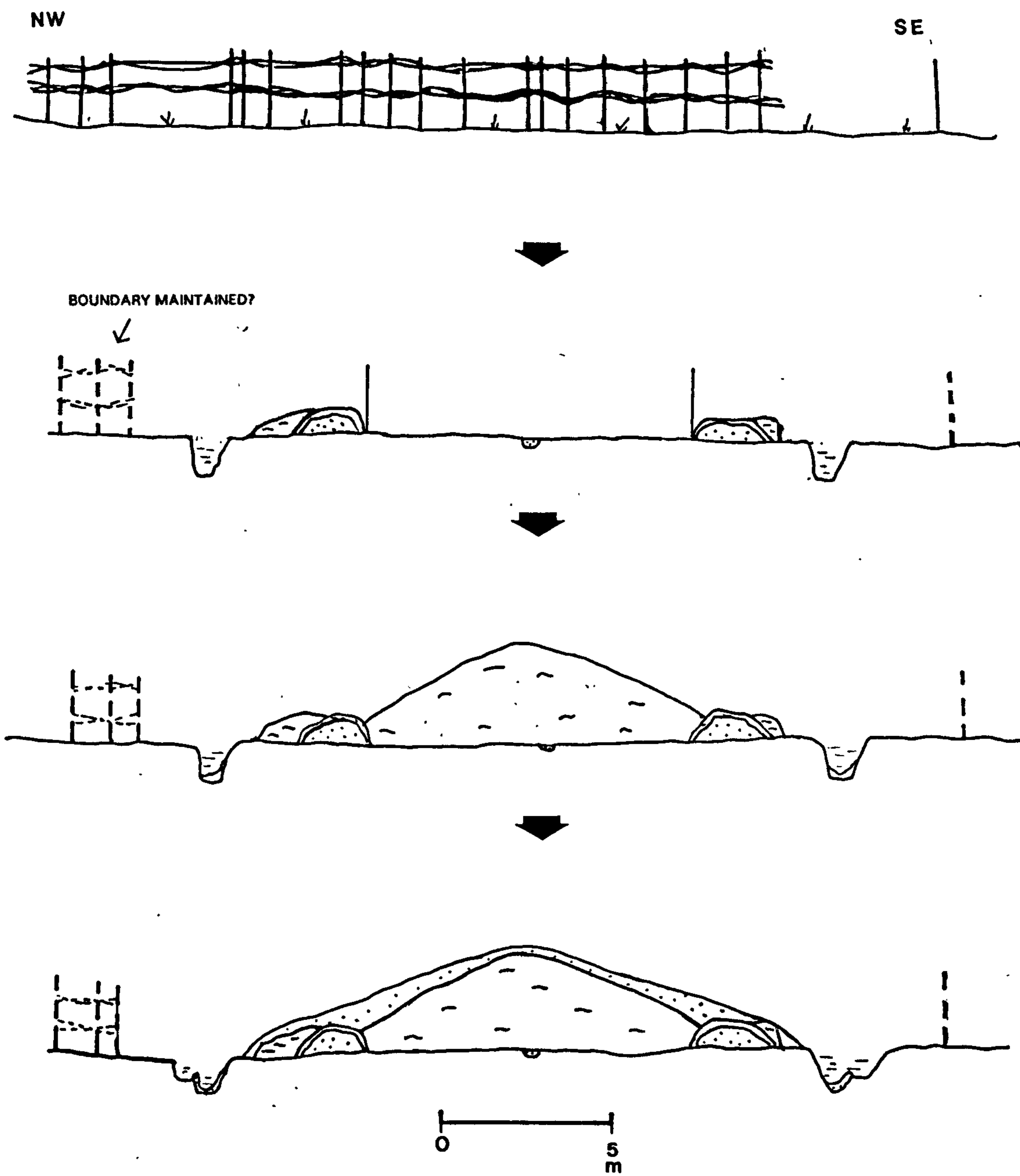


Figure 5.35.1 Trelen 2 sequence of activities.



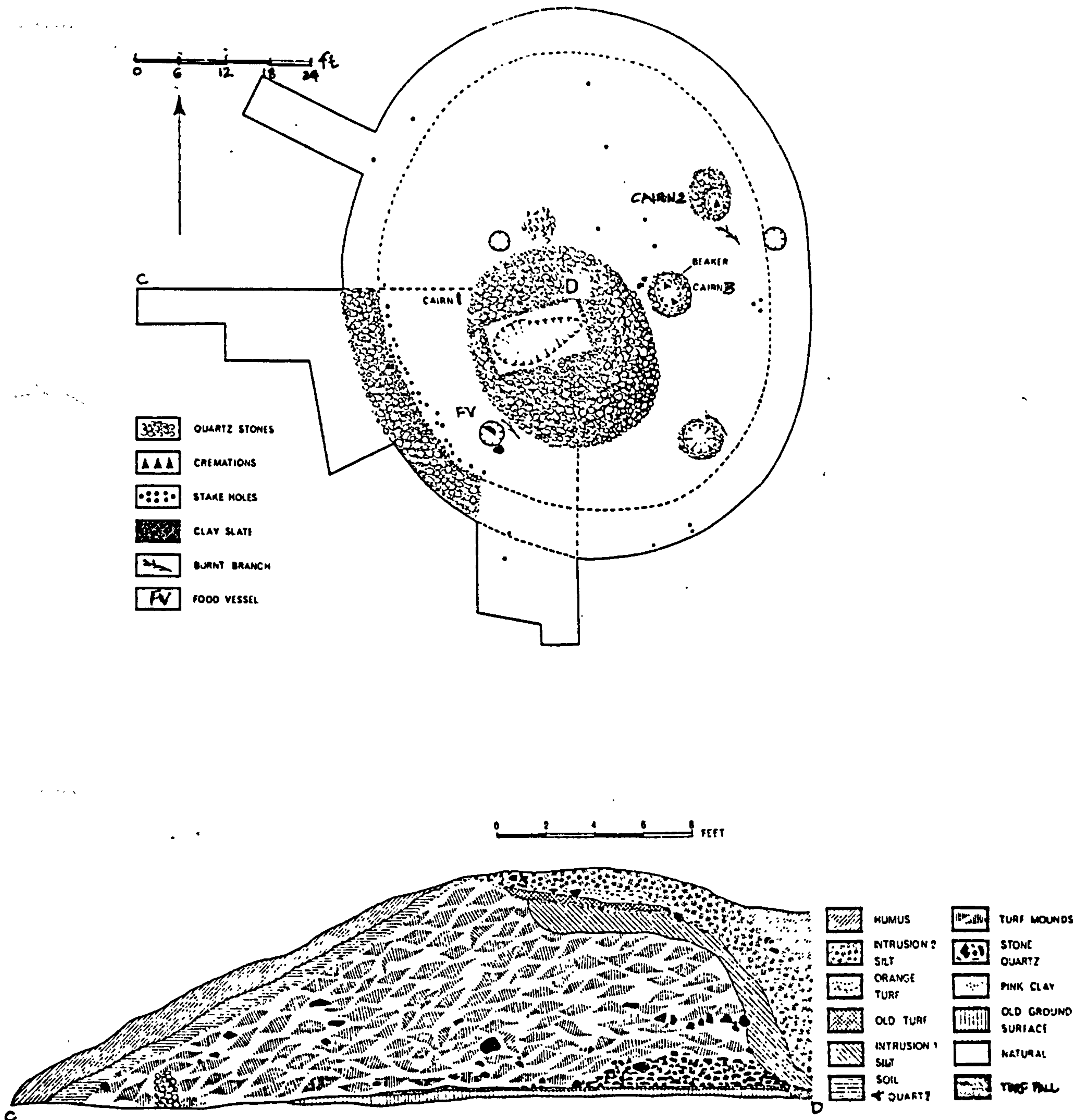


Figure 5.36 Carvinack (after Dudley 1964).

BURIALS, SHILLET LAYER, CAIRNS

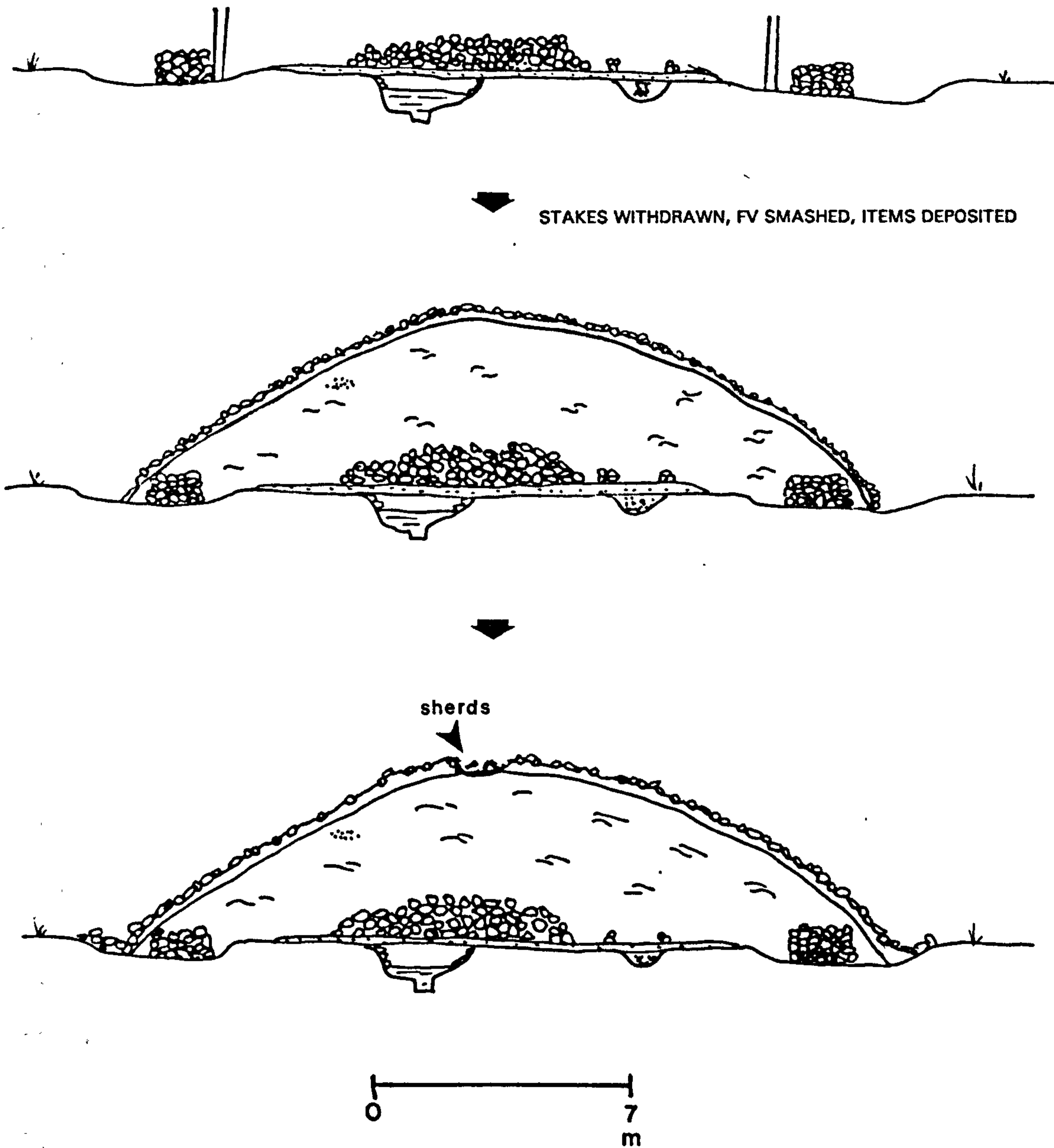
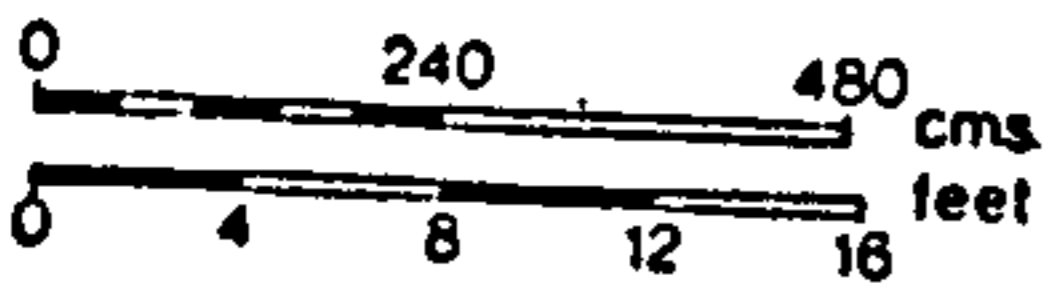
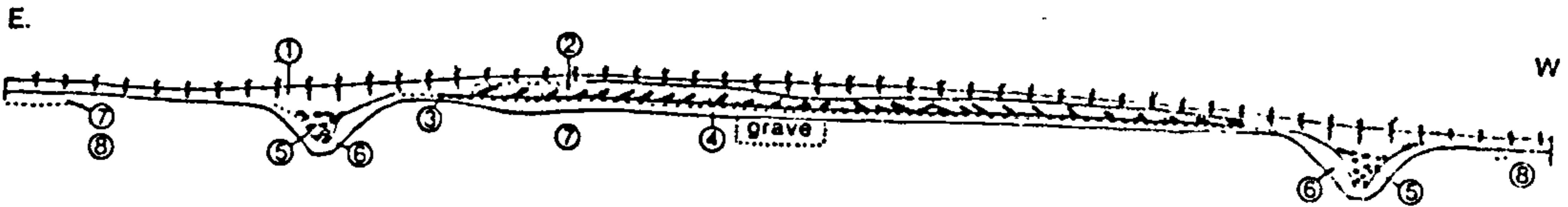
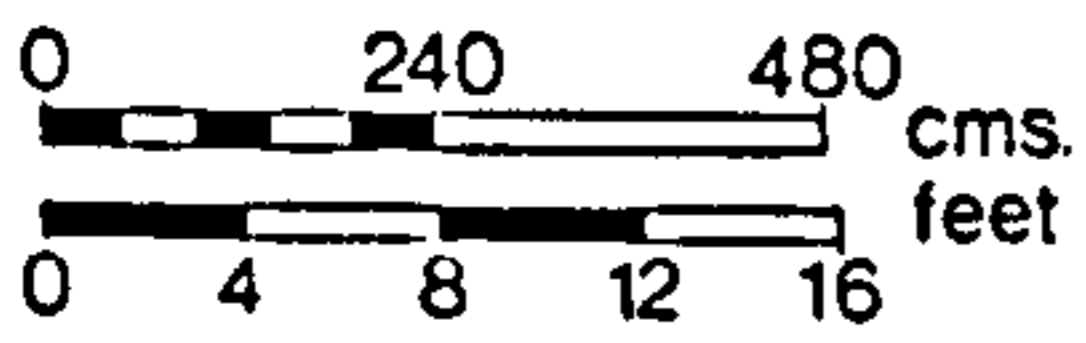
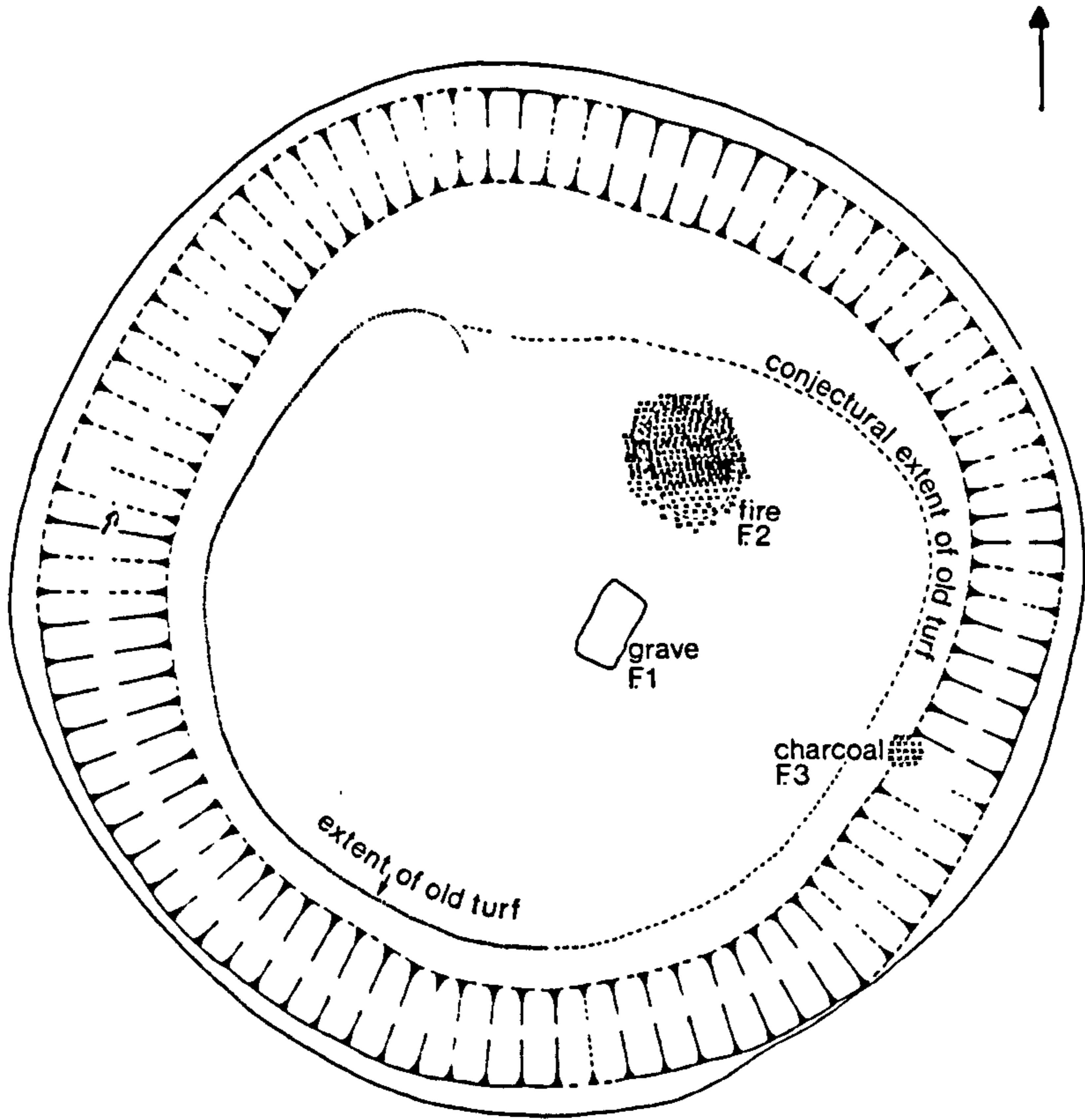


Figure 5.36.1 Carvinak sequence of activities.





(1) plough soil (2) turf stack (3) buried turf (4) yellow clay over killas  
 (5) stone silt (6) primary silt and 'pink slide' (7) pink (weathered) killas (8) pink rock (un-  
 weathered killas).

Figure 5.37 Nancekuke (after Christie 1985).

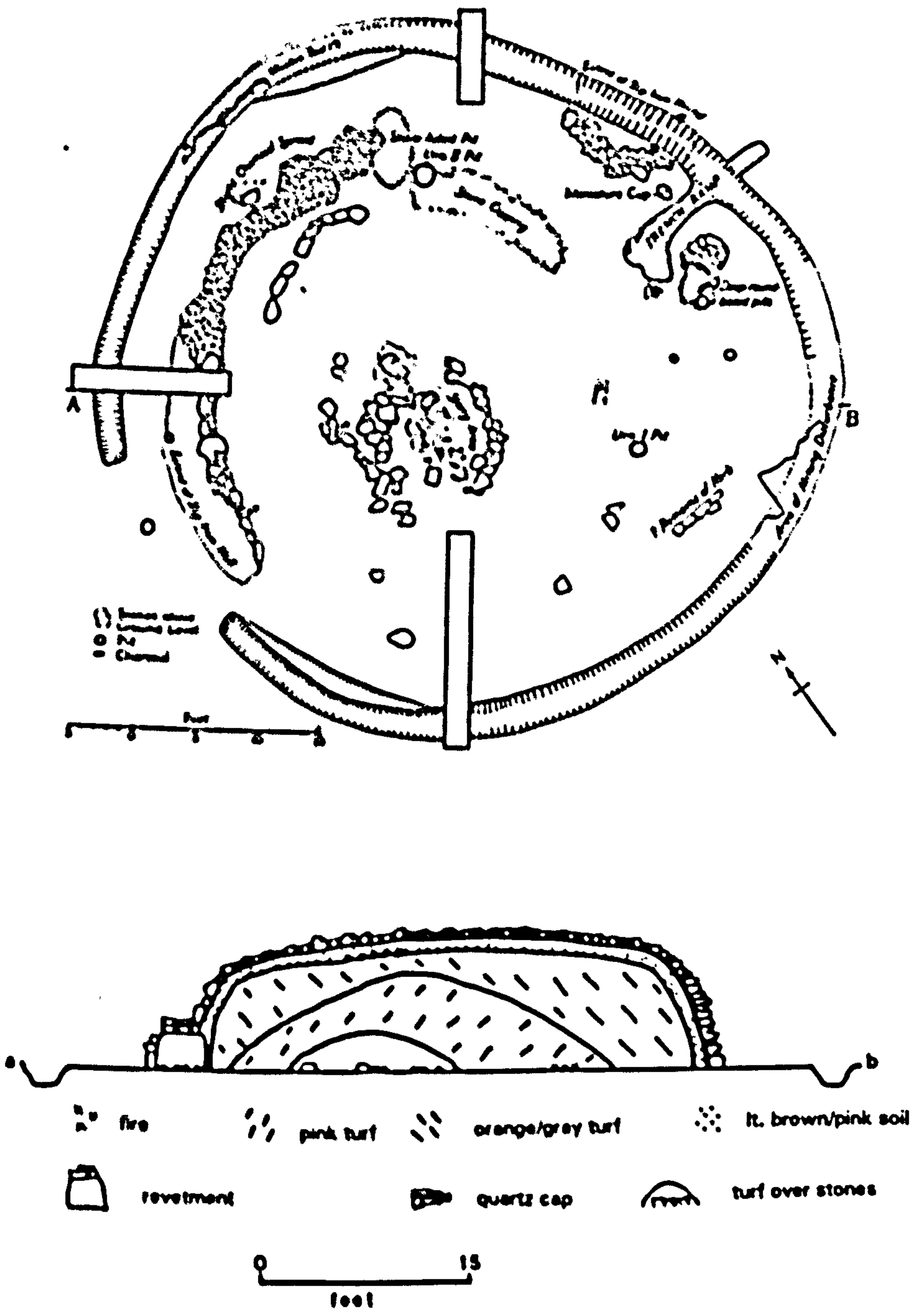
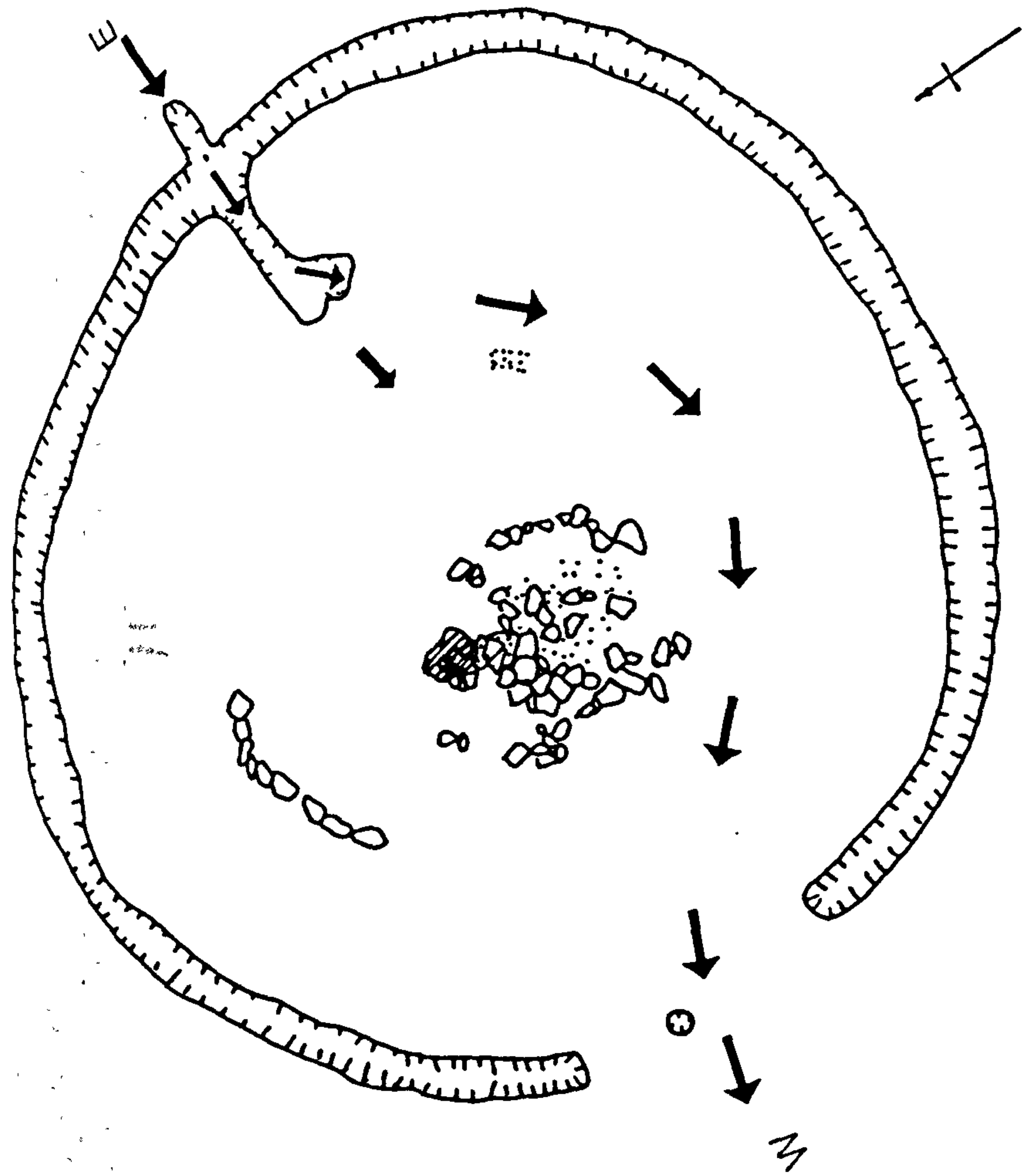


Figure 5.38 Crig-a-Mennis (after Christie 1960).





441

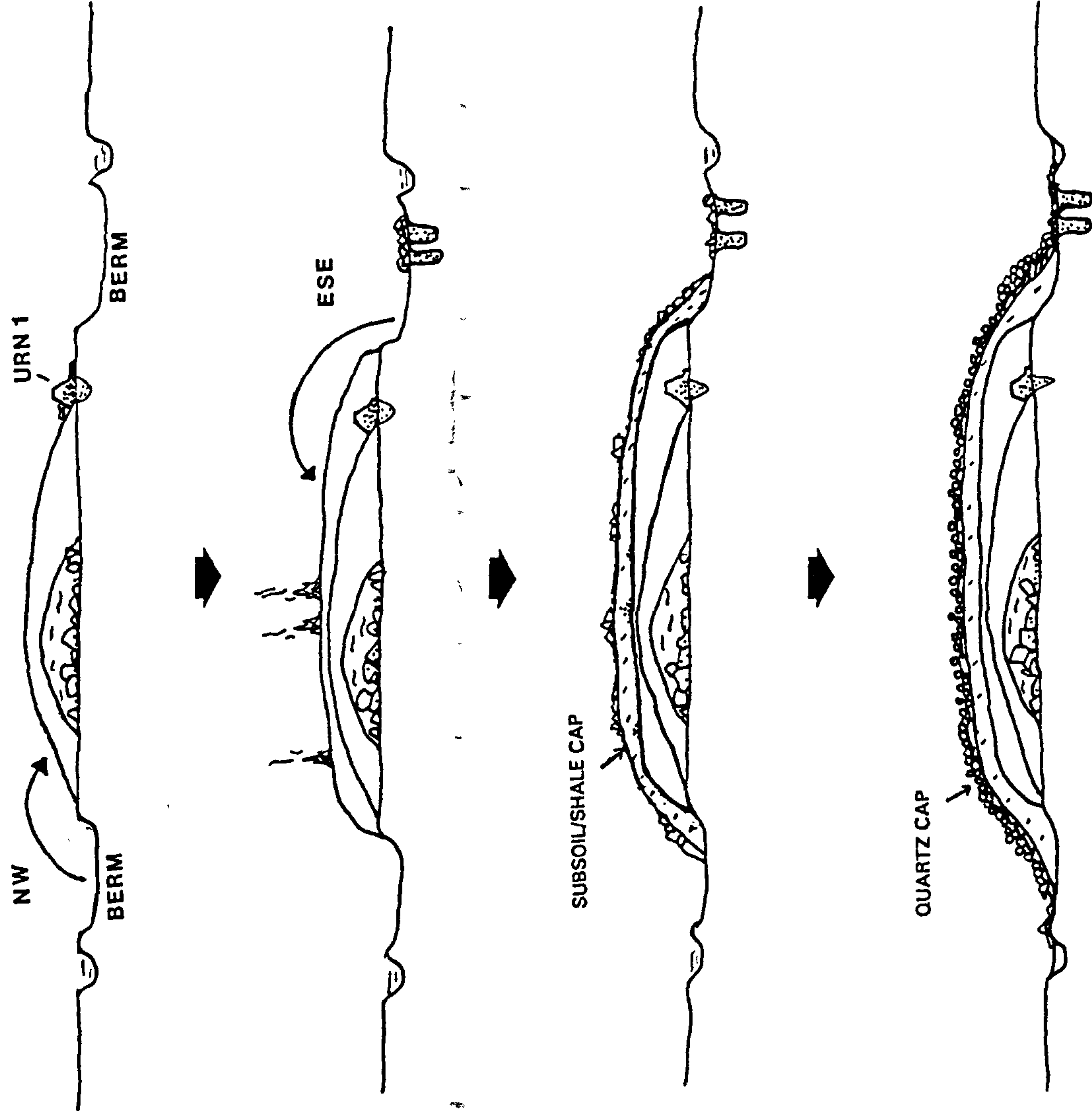


Figure 5.38.1 Crig-A-Mennis sequence of activities (after Christie 1960).

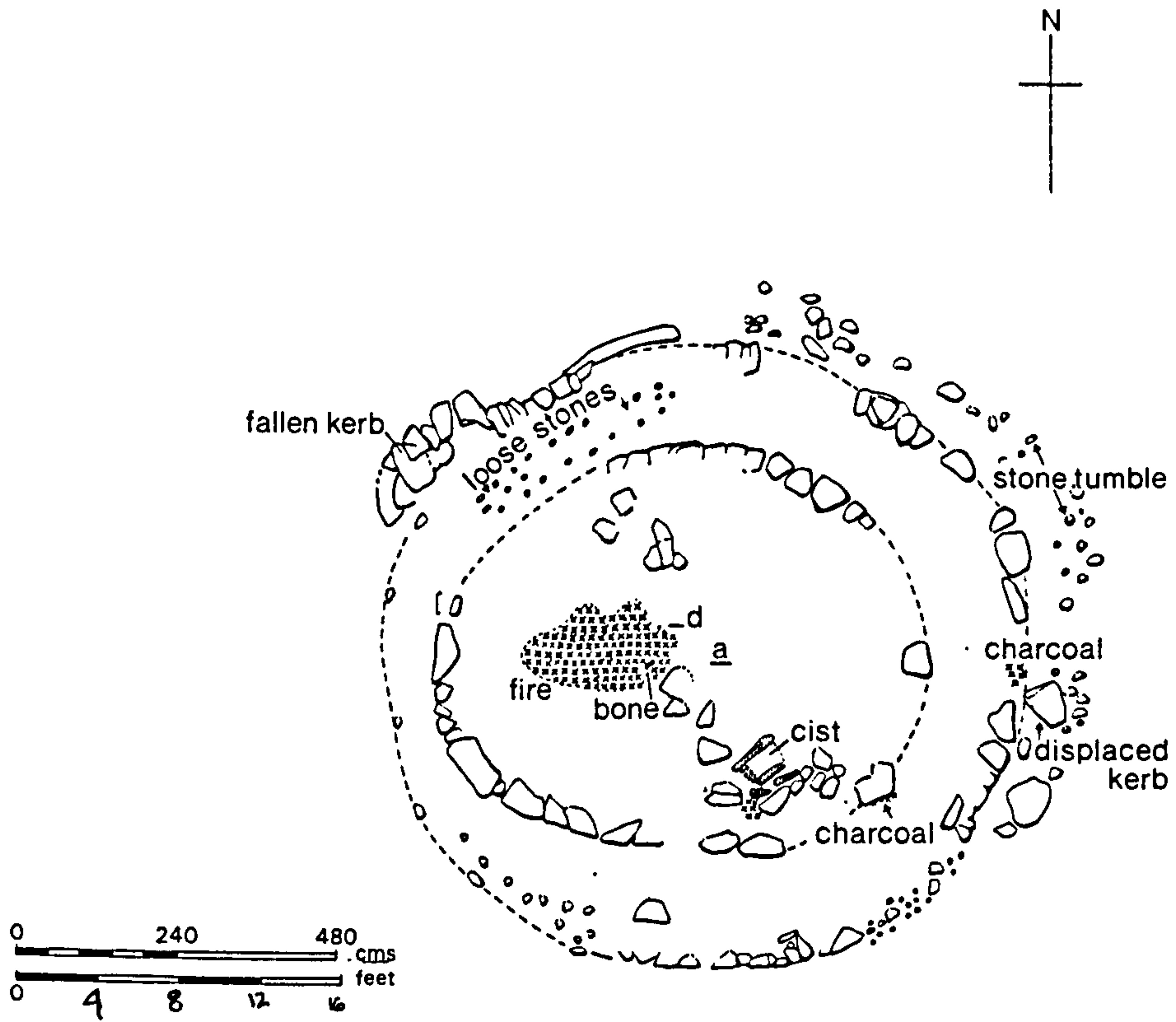


Figure 5.39 Cataclews (after Christie 1985).



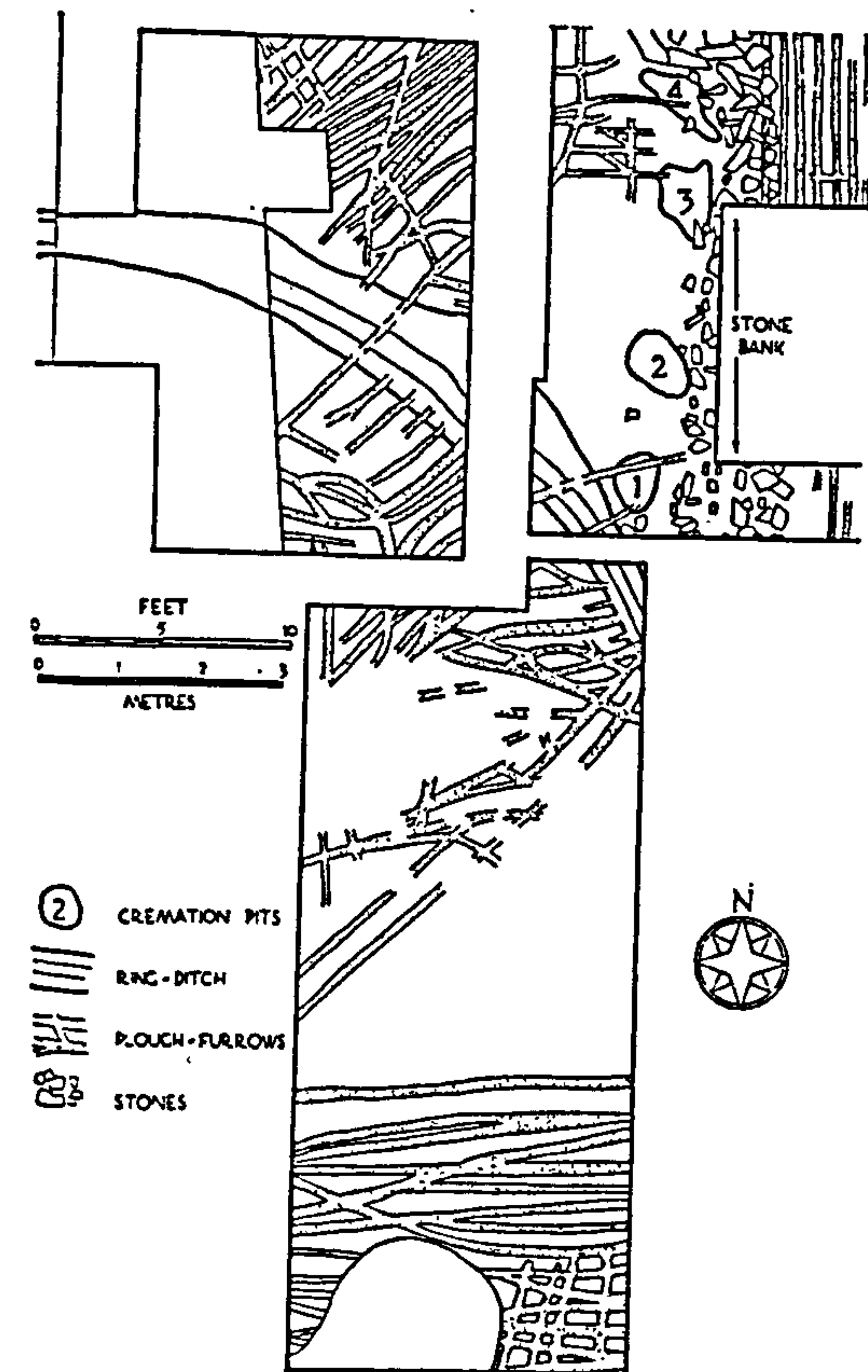
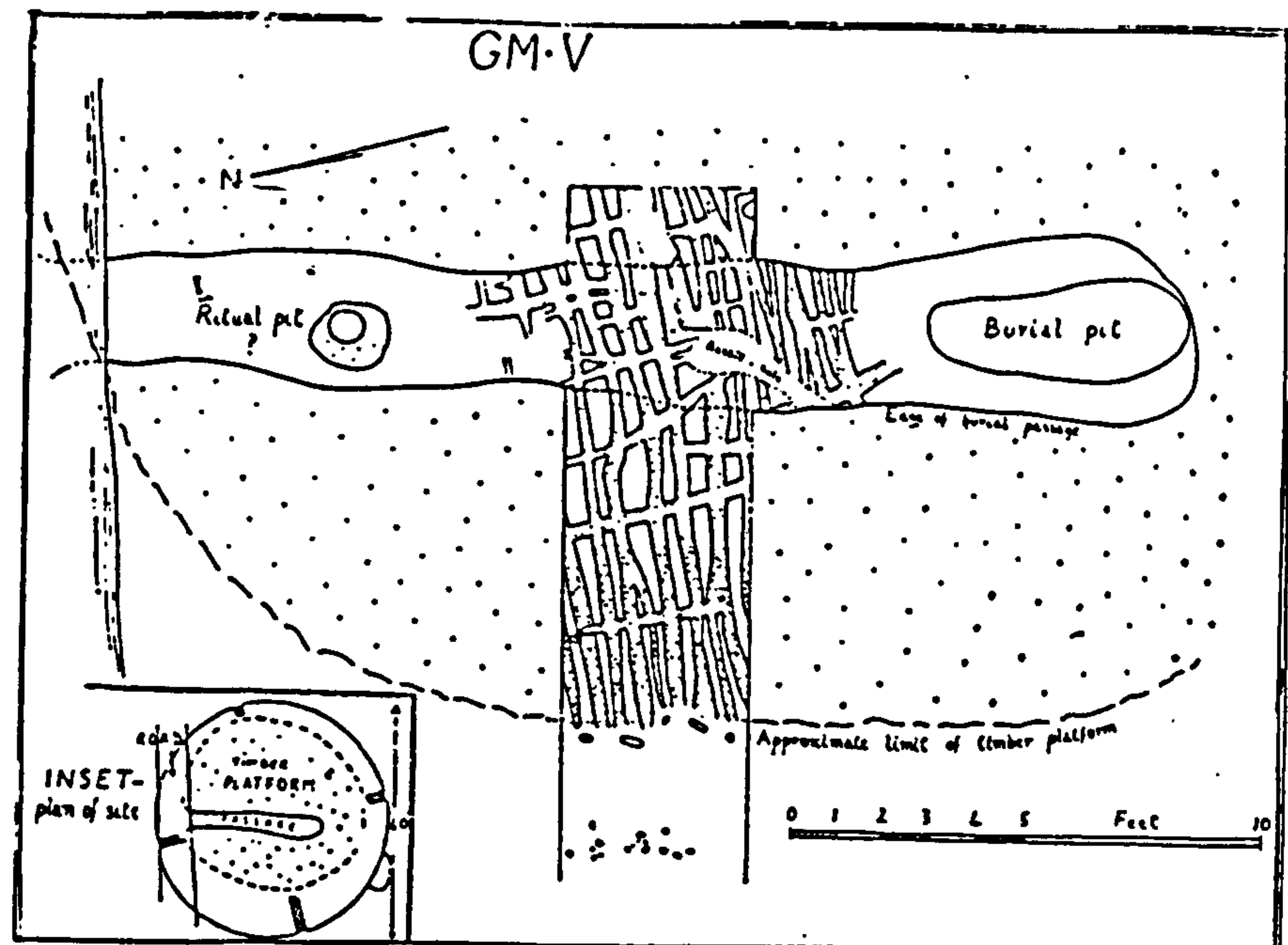
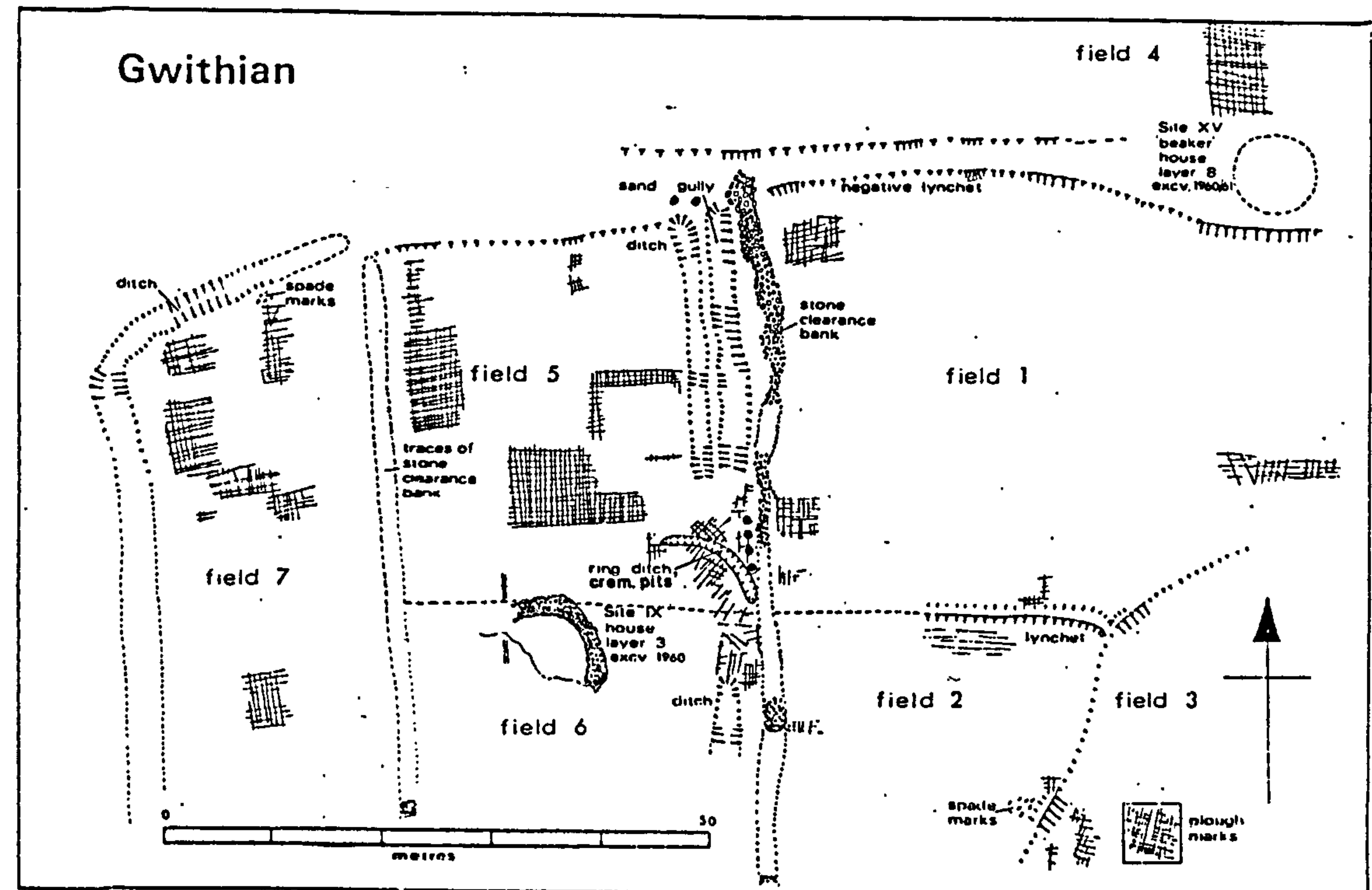
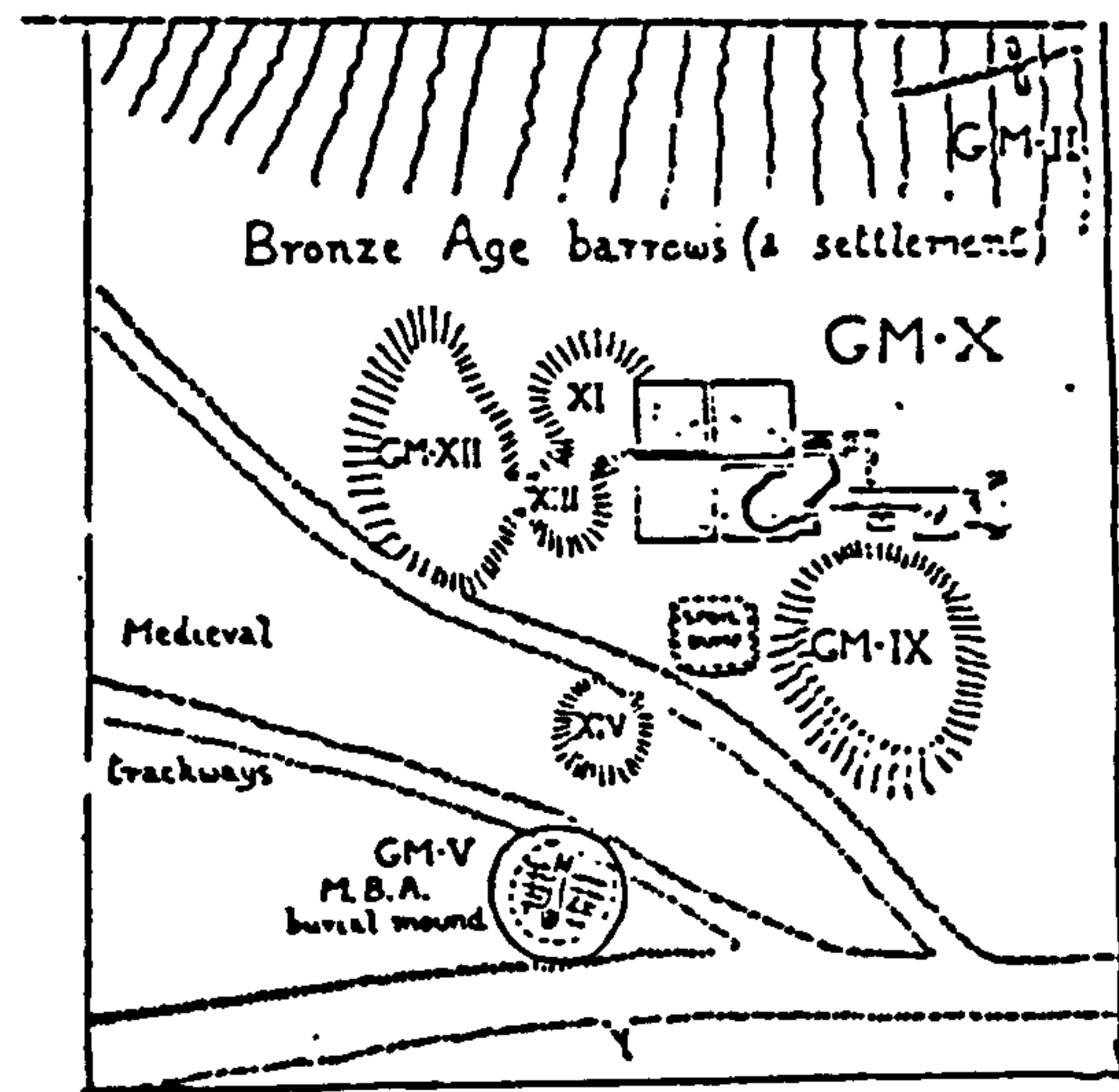


Figure 5.40 Gwithian Plan, Layer 5 Site V, Ring Ditch and Cremation Pits (after Megaw, Thomas and Wailes 1960-61; Nowakowski 1989; Thomas 1958).

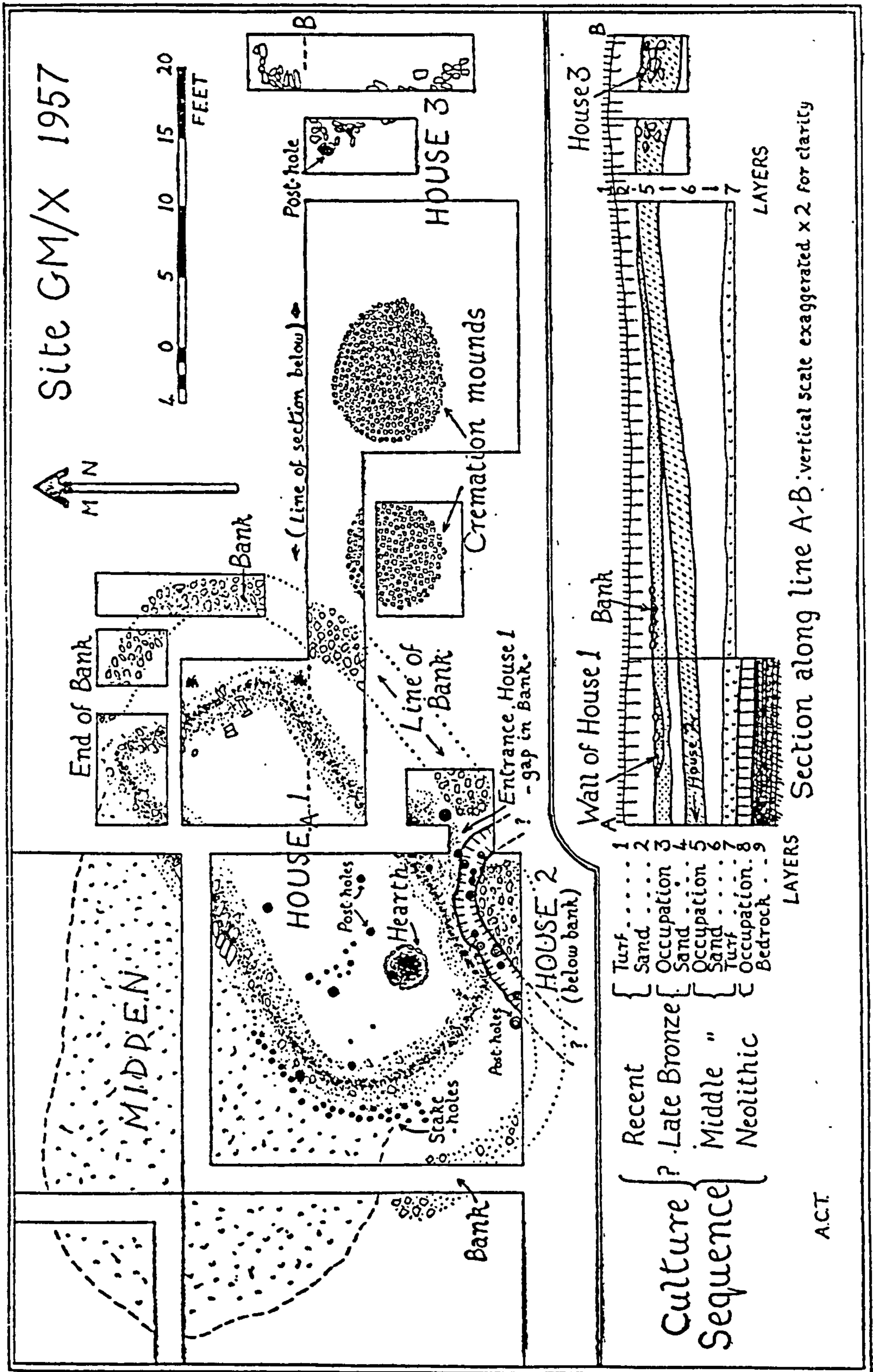
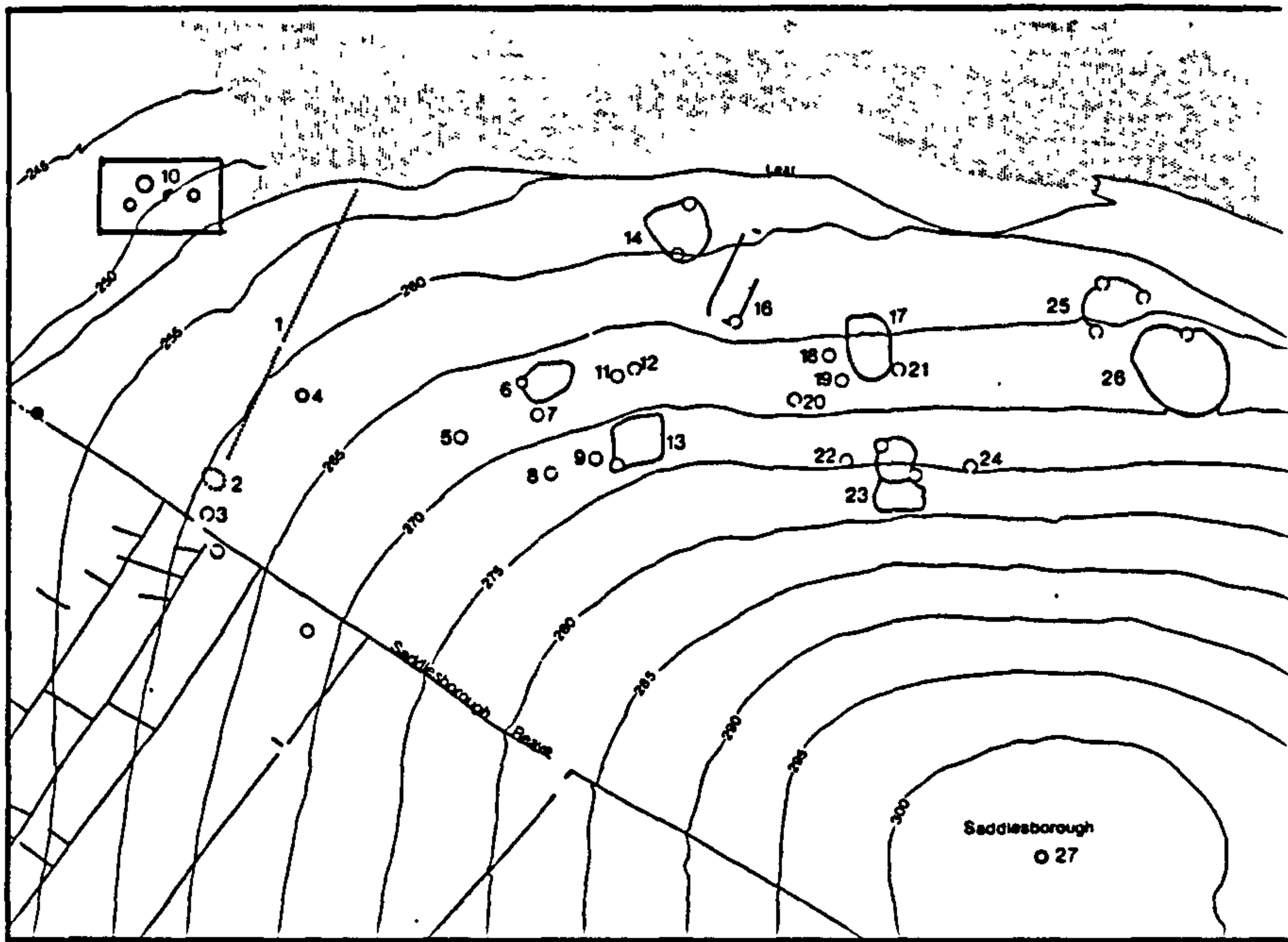


Figure 5.41 Gwithian Level 3 Cairns (after Thomas 1958).





- ◻ Reave
- ◻ Stone Row
- Cairn
- Barrow
- Hut Circle
- ◻ Spill Tips & Ponds

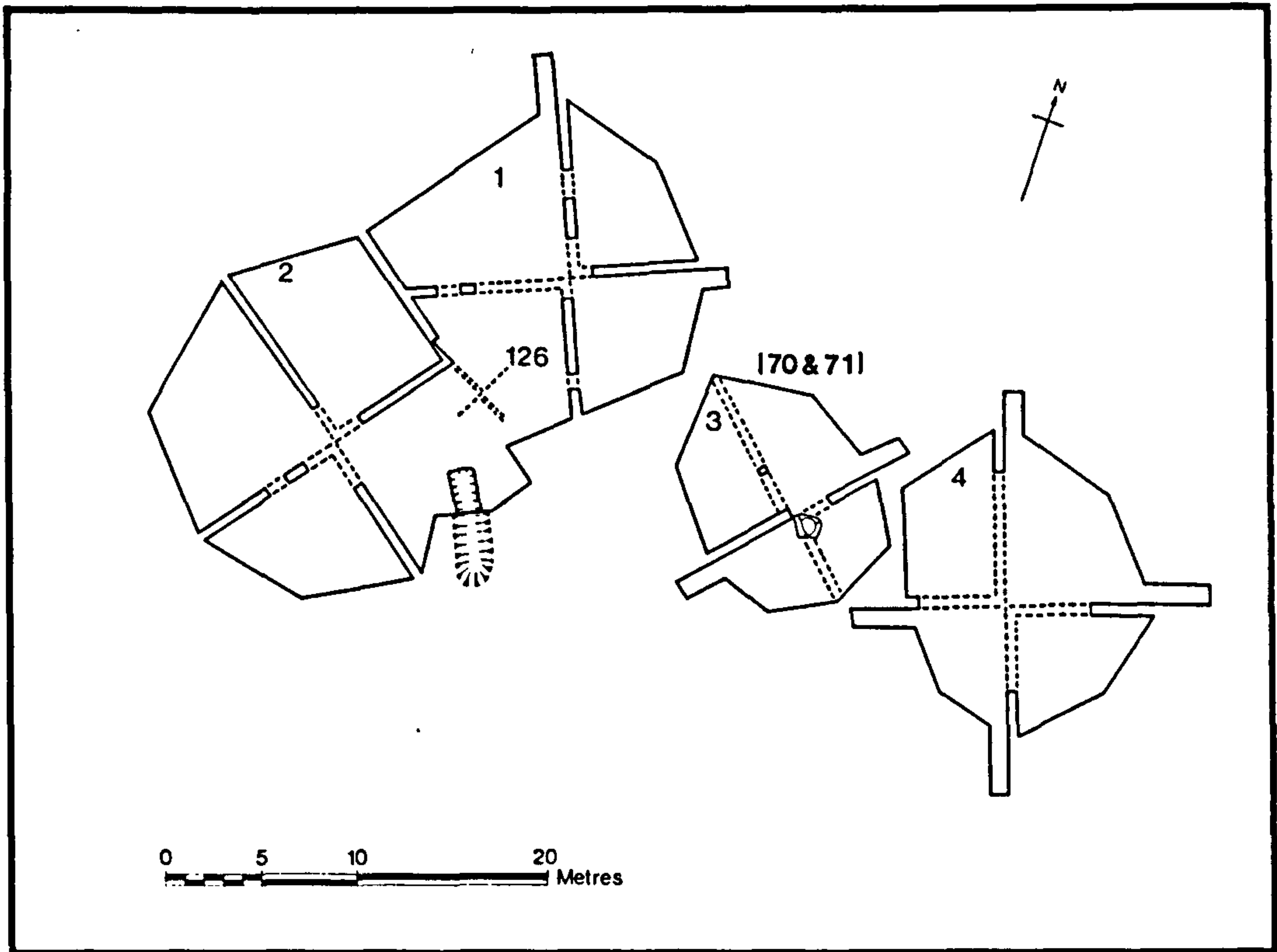
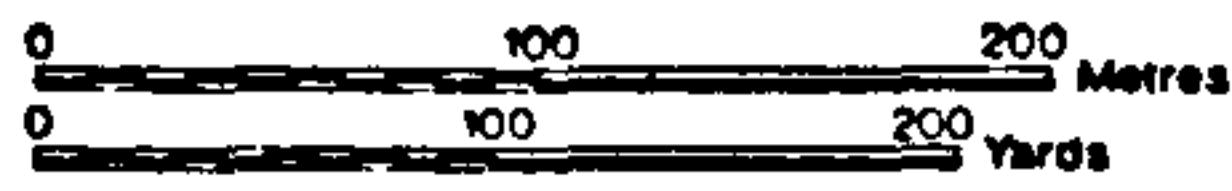


Figure 5.42 Shaugh Moor Cairns (after Wainwright, Fleming and Smith 1979).

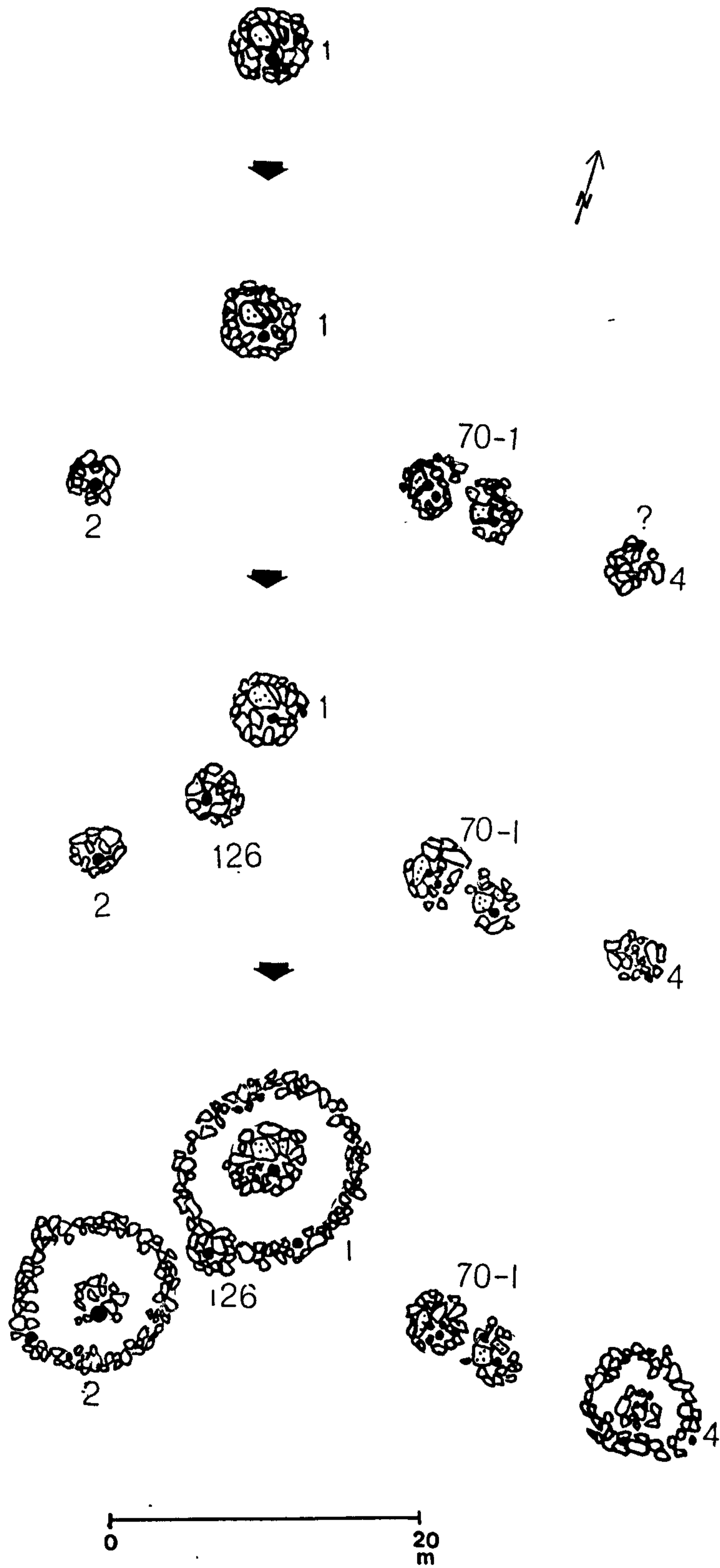


Figure 5.42.1 Shaugh Moor Cemetery developmental history.



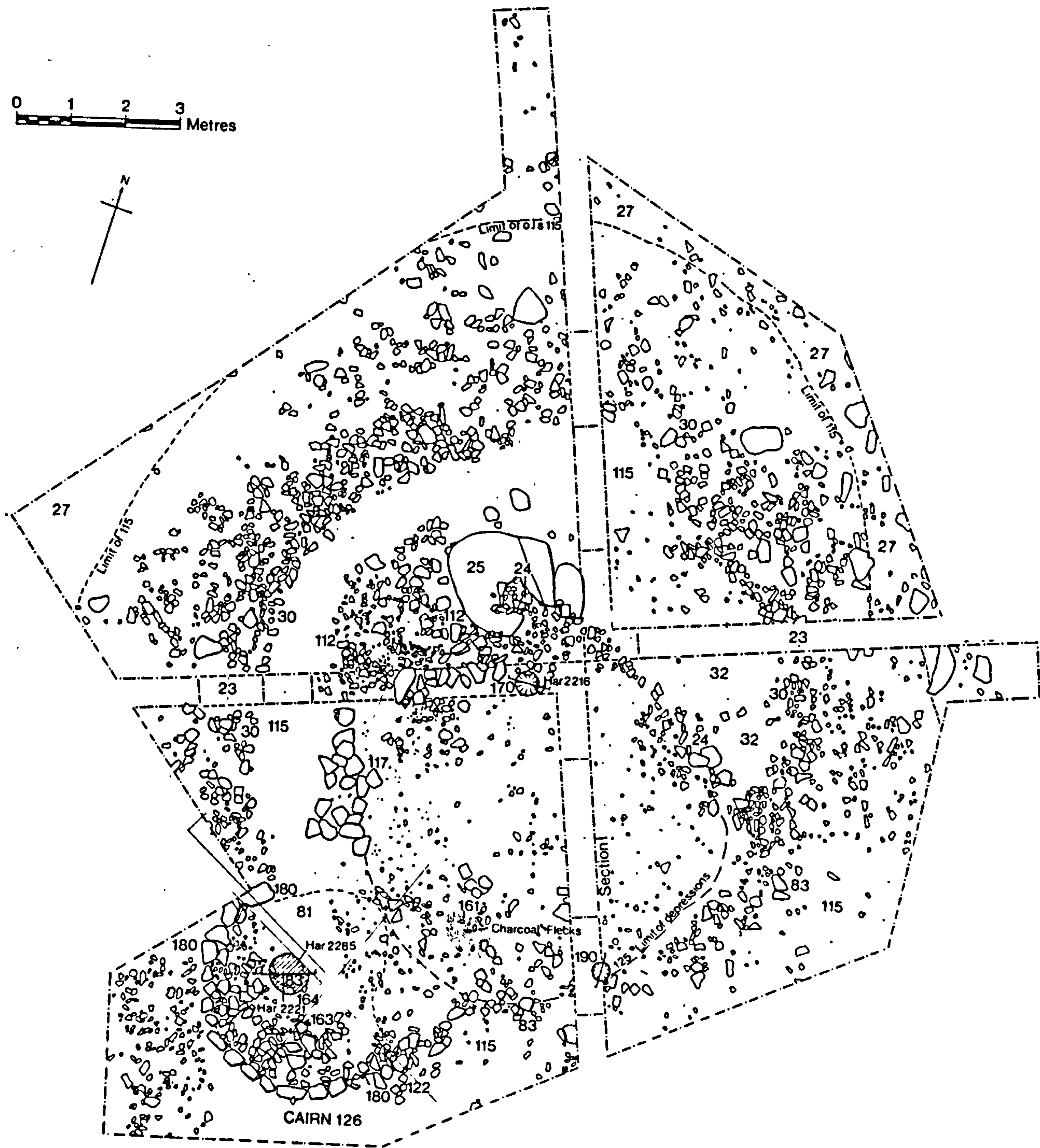


Figure 5.43 Shaugh Moor Sites 1 and 126 (after Wainwright, Fleming and Smith 1979).



Figure 5.44 Shaugh Moor Site 2 (after Wainwright, Fleming and Smith 1979).



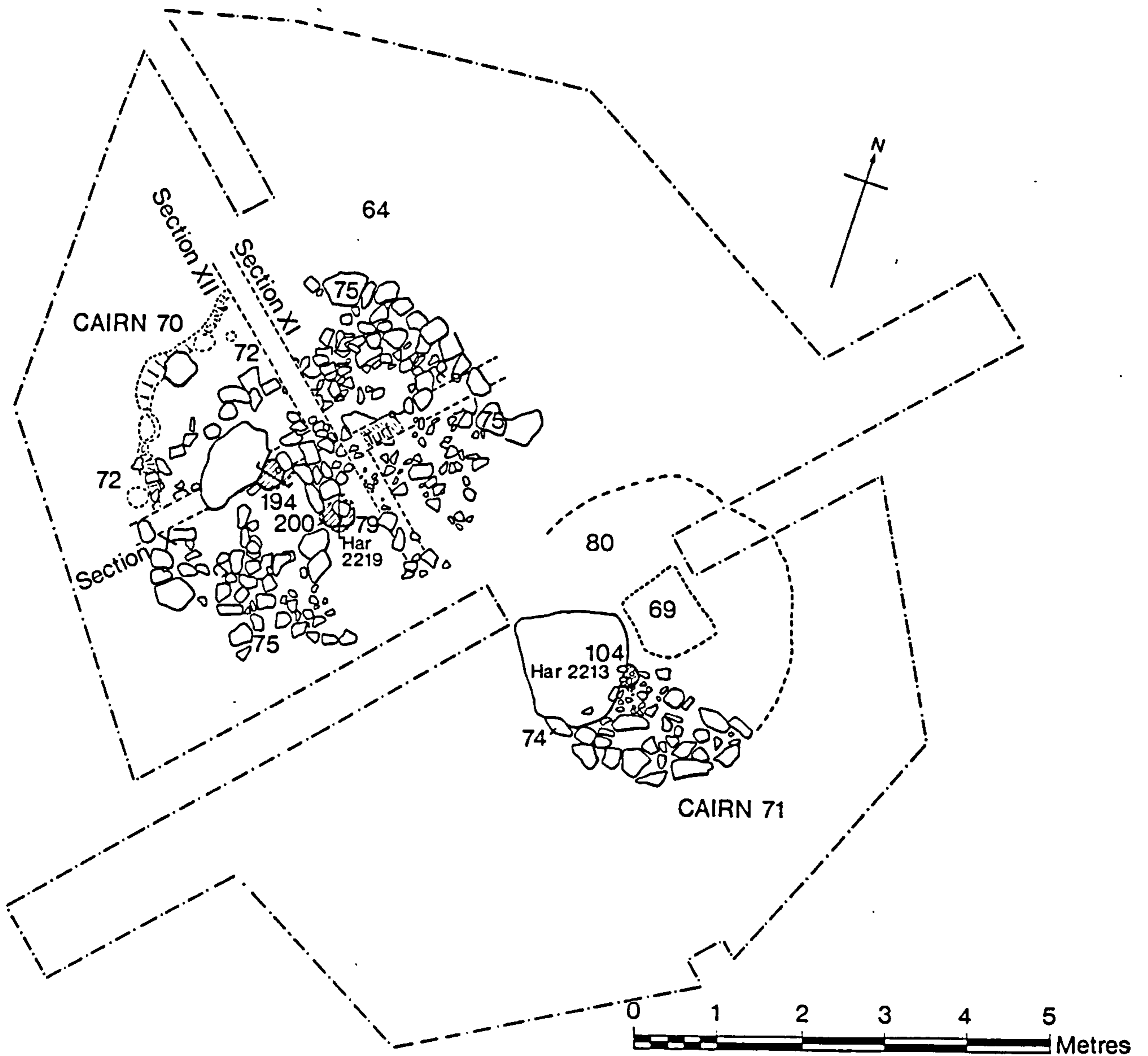


Figure 5.45 Shaugh Moor Sites 70 and 71 (after Wainwright, Fleming and Smith 1979).

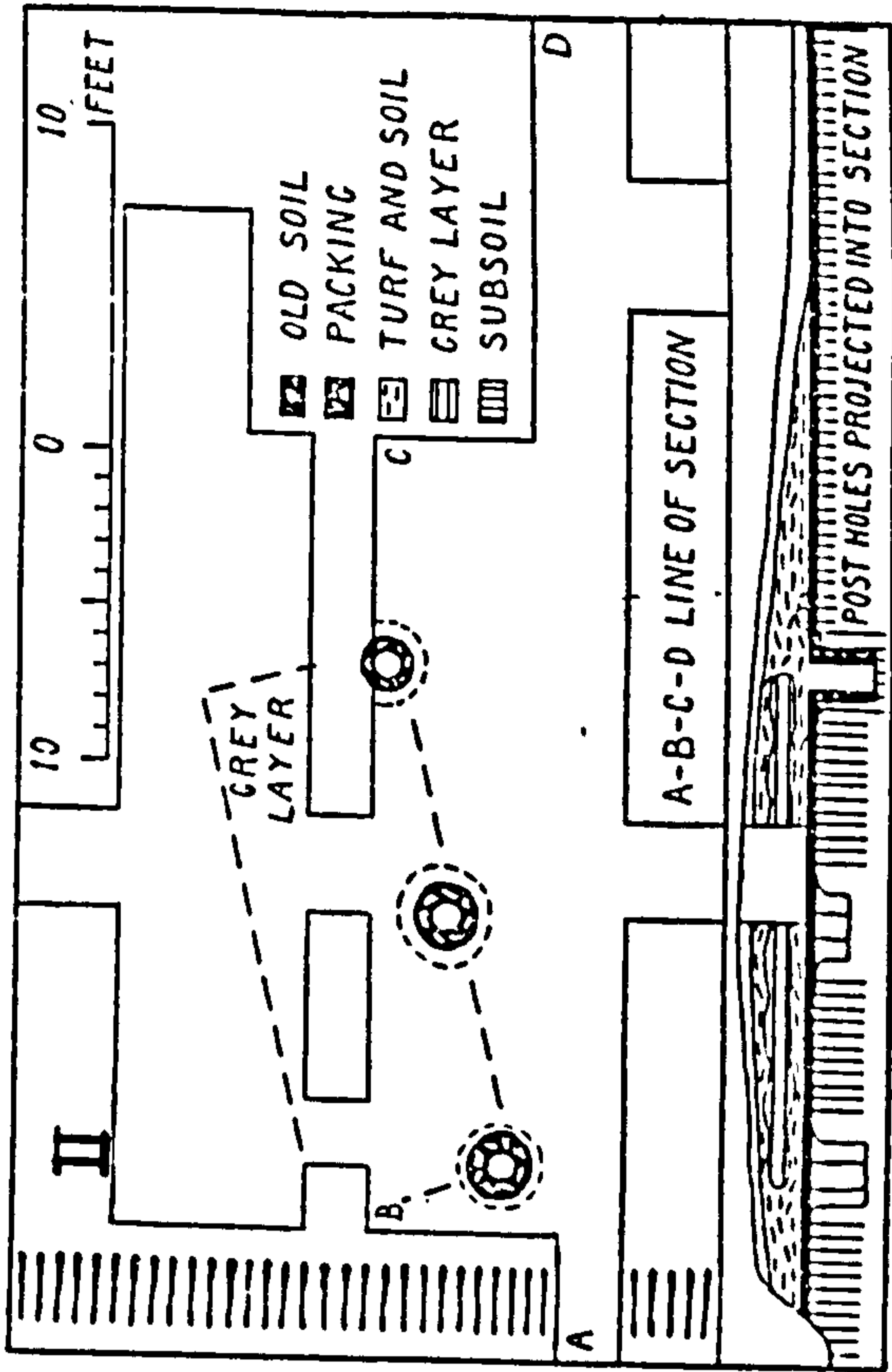
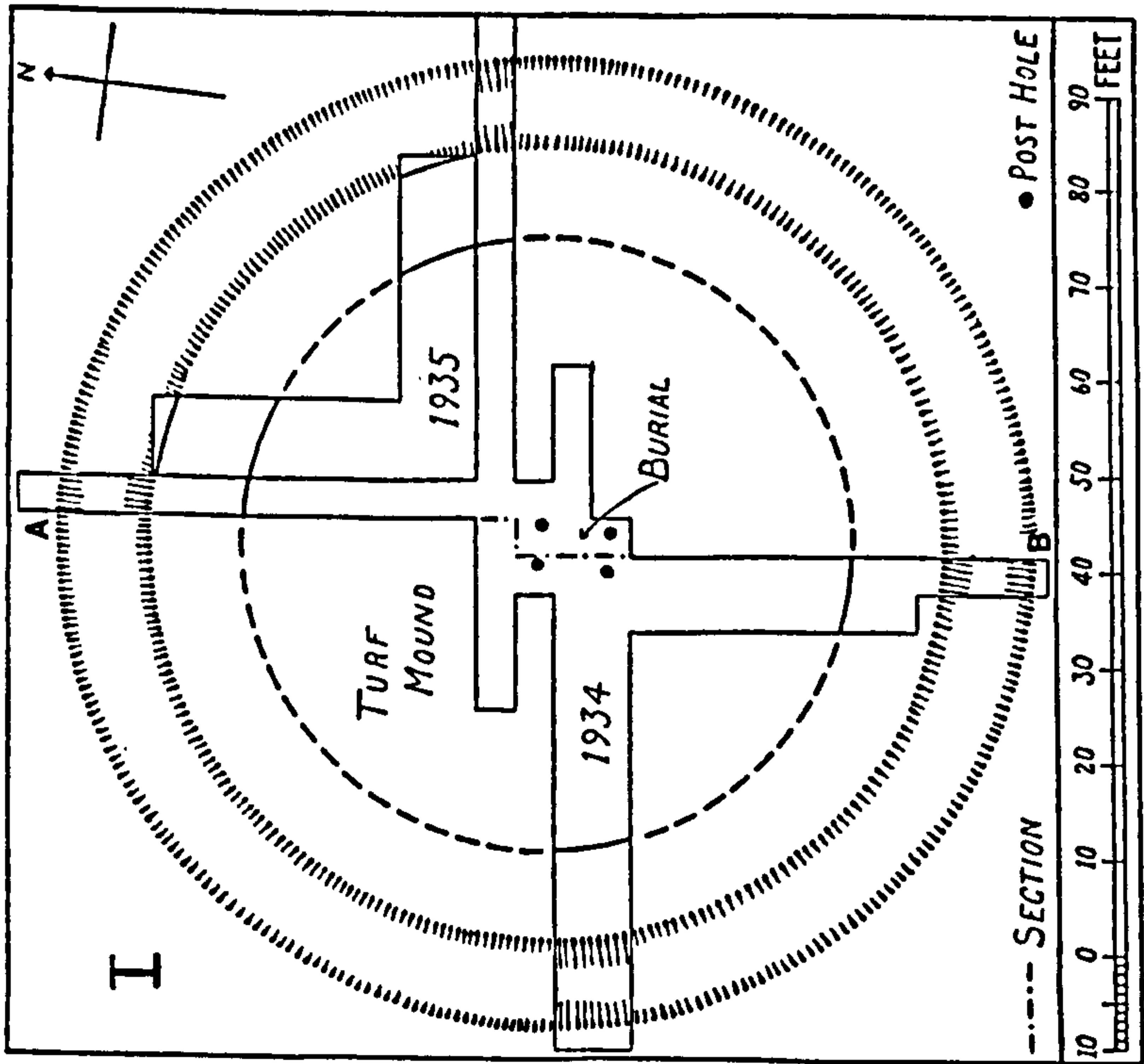


Fig. 1. East Putford: Barrow I. Plan.

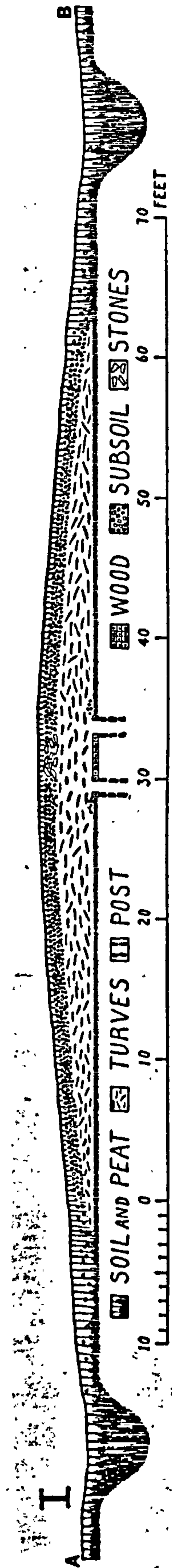


Figure 5.46 East Putford Sites I and II (after Raleigh Radford and Rodgers 1947).



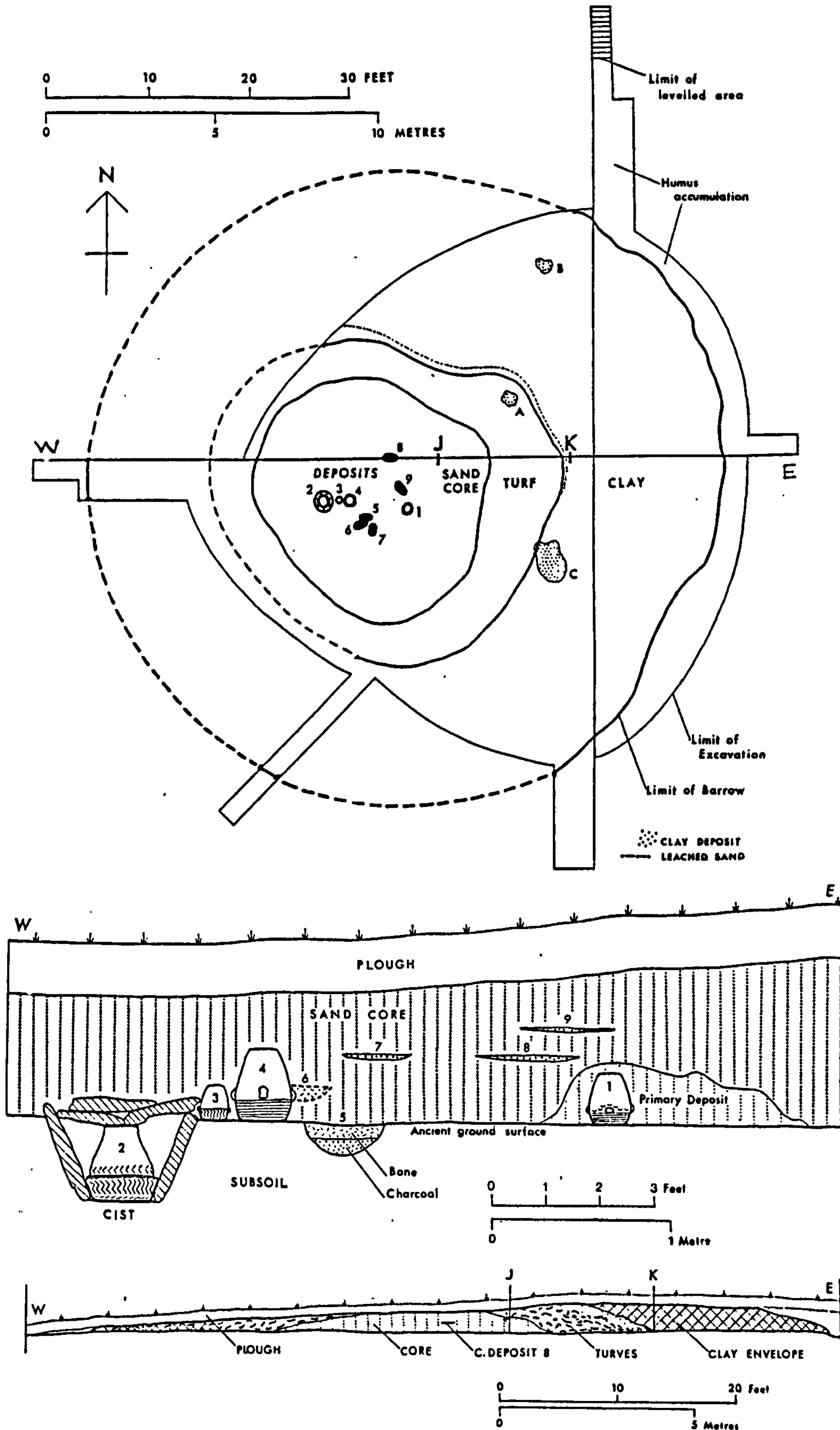


Figure 5.47 Upton Pyne (after Pollard and Russell 1969).

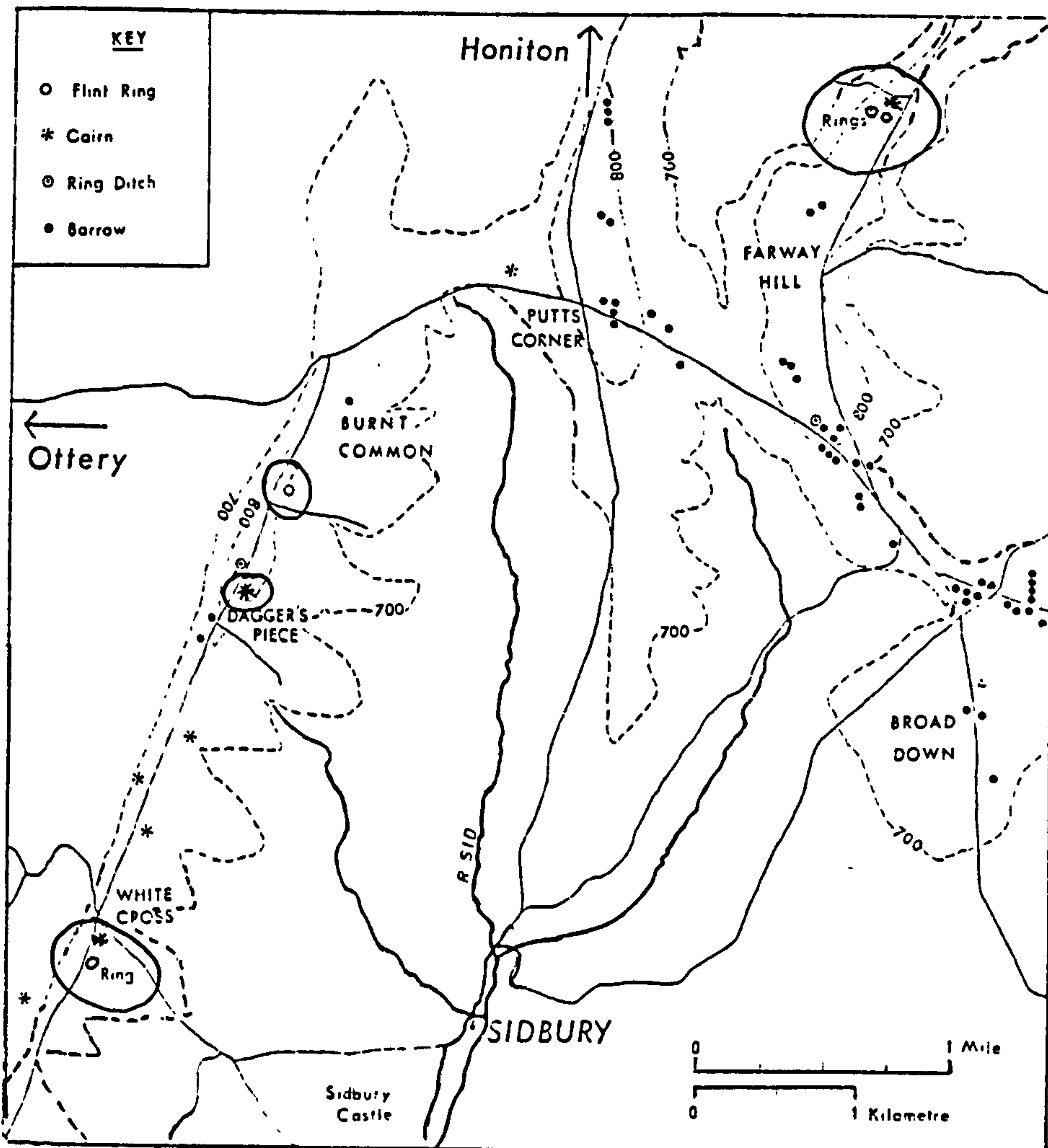


Figure 5.48 Honiton sites (After Pollard 1967; 1971).



**FARWAY CAIRN**

--- Displaced flints

● Post hole

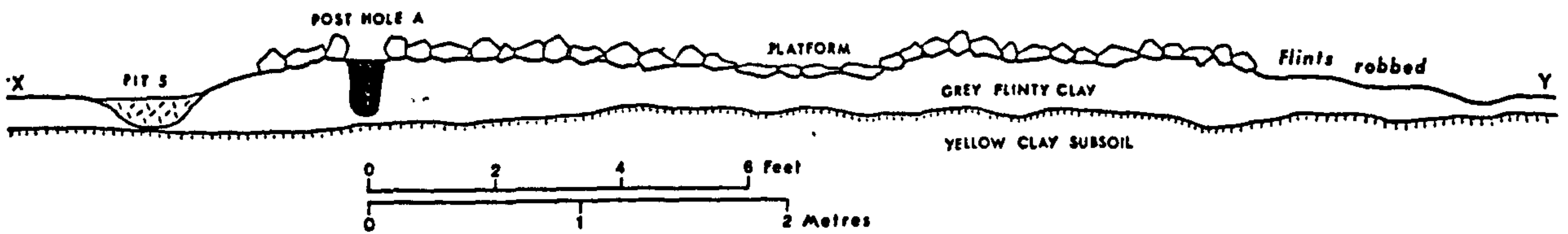
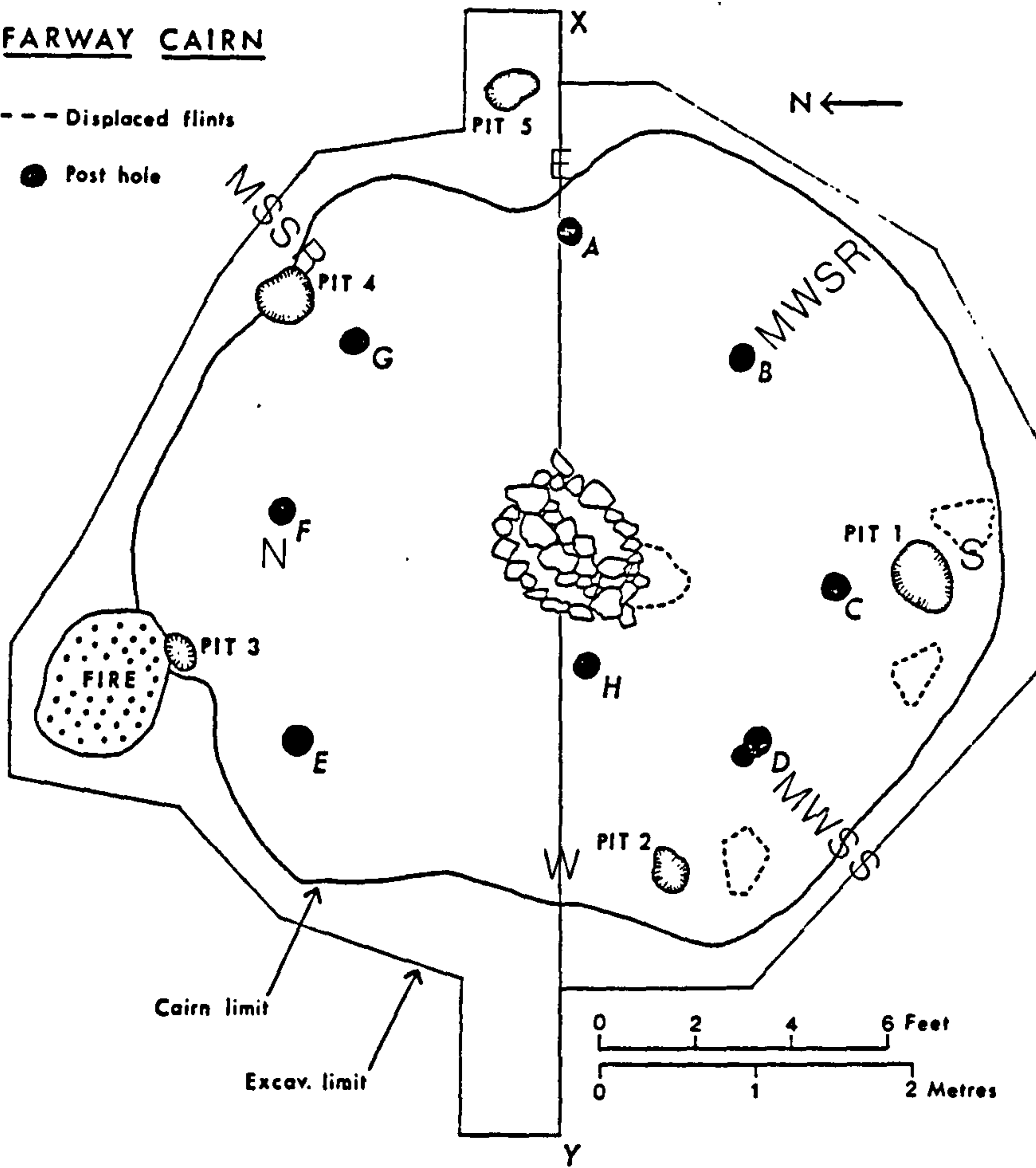


Figure 5.49 Farway Cairn (after Pollard 1971).

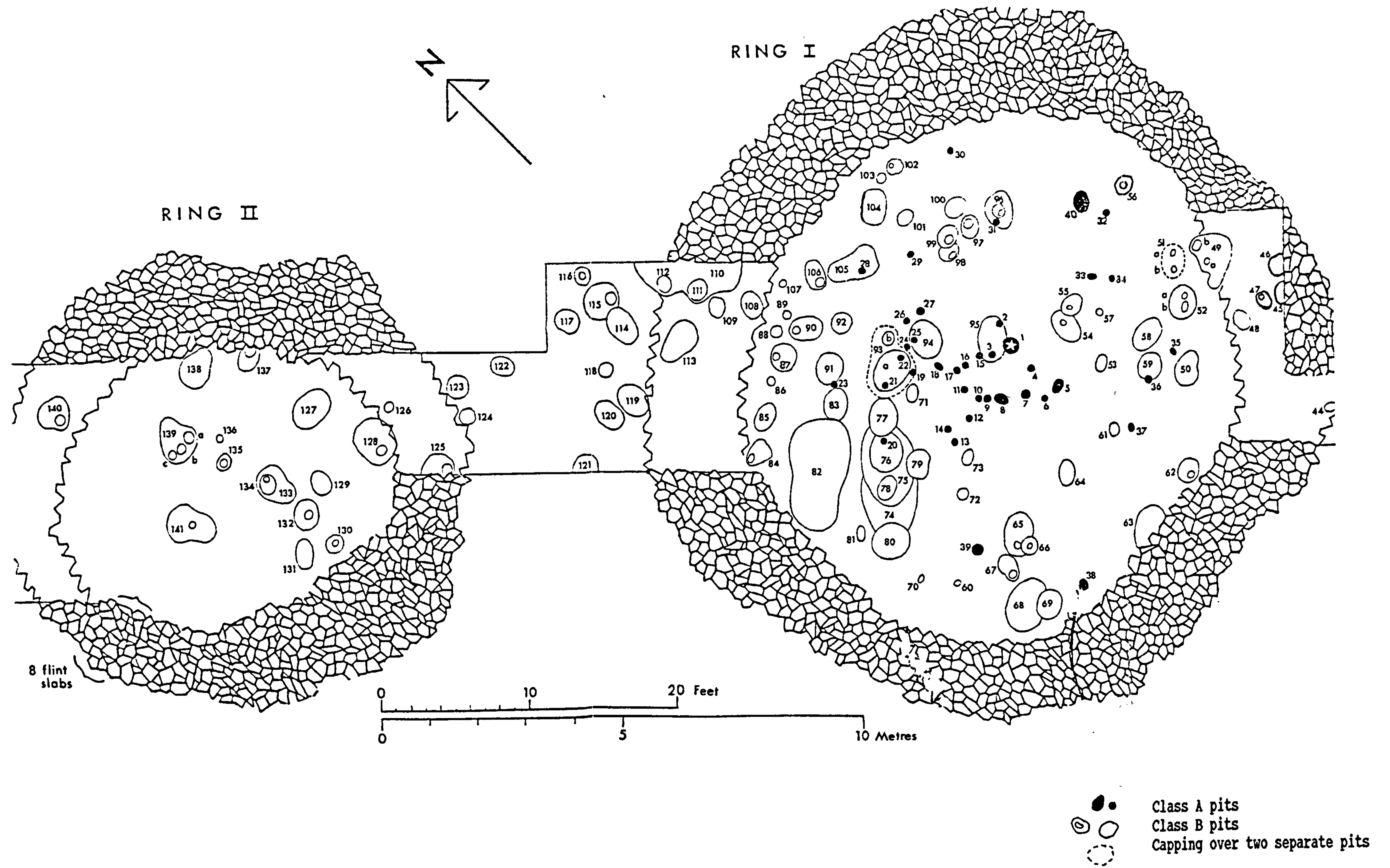


Figure 5.50 Farway Hill Rings (after Pollard 1971).



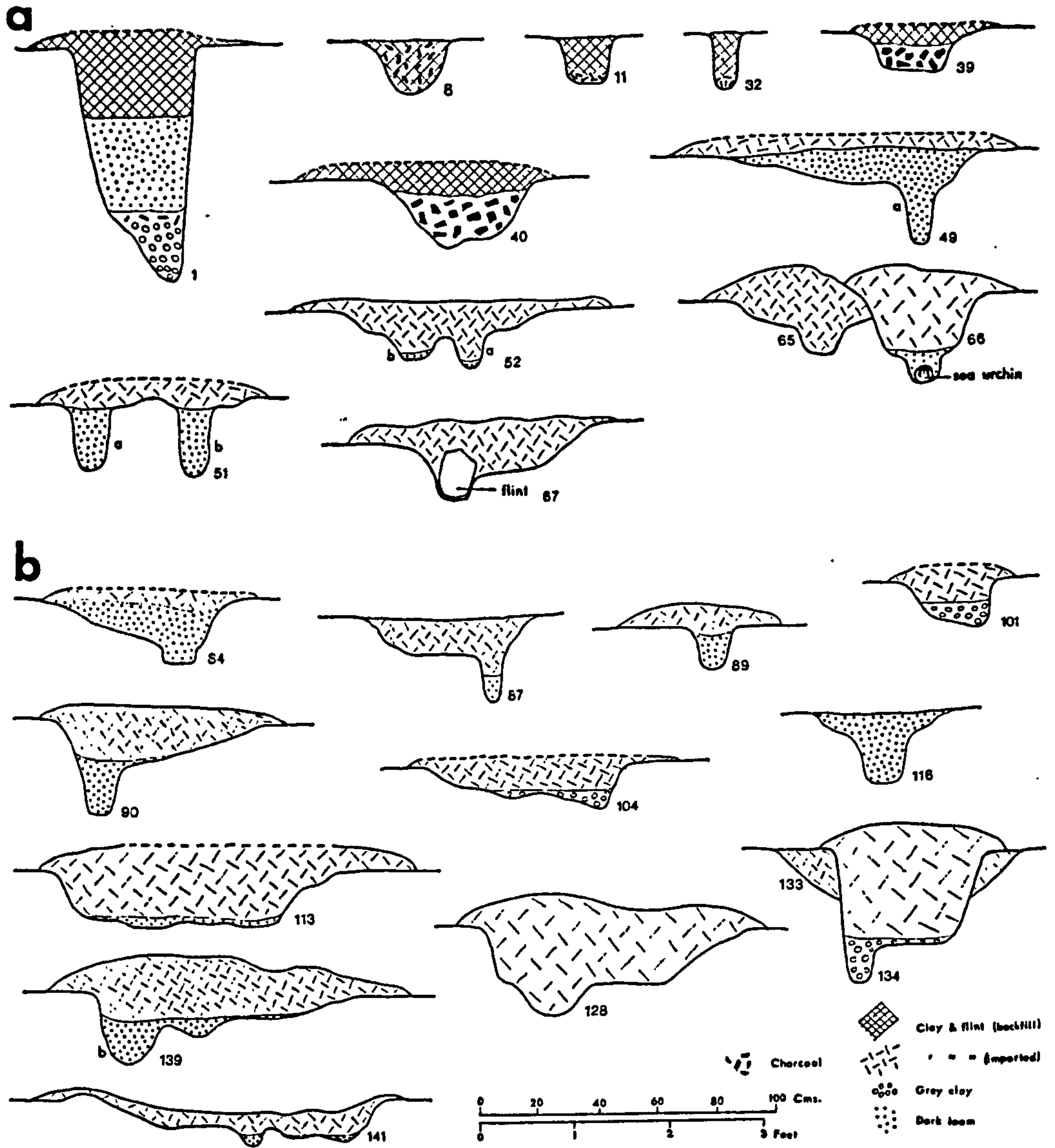


Figure 5.51 Stratigraphy of the pits at Farway and Burnt Common Rings (after Pollard 1967 1971).

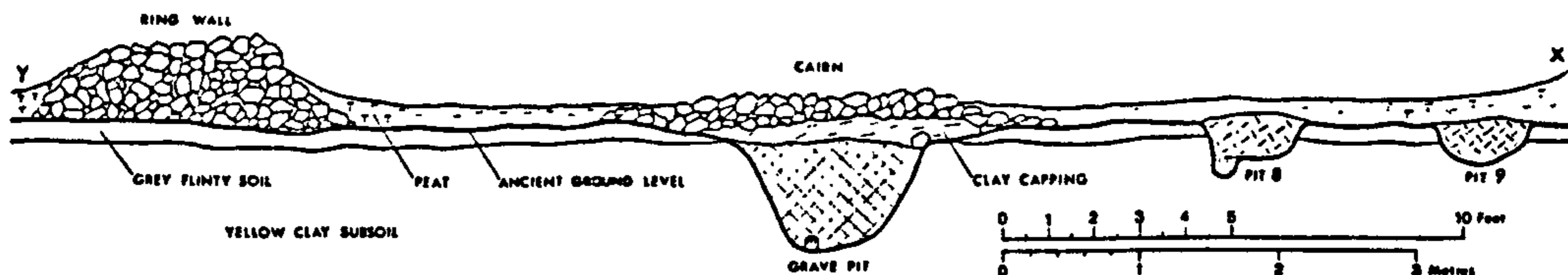
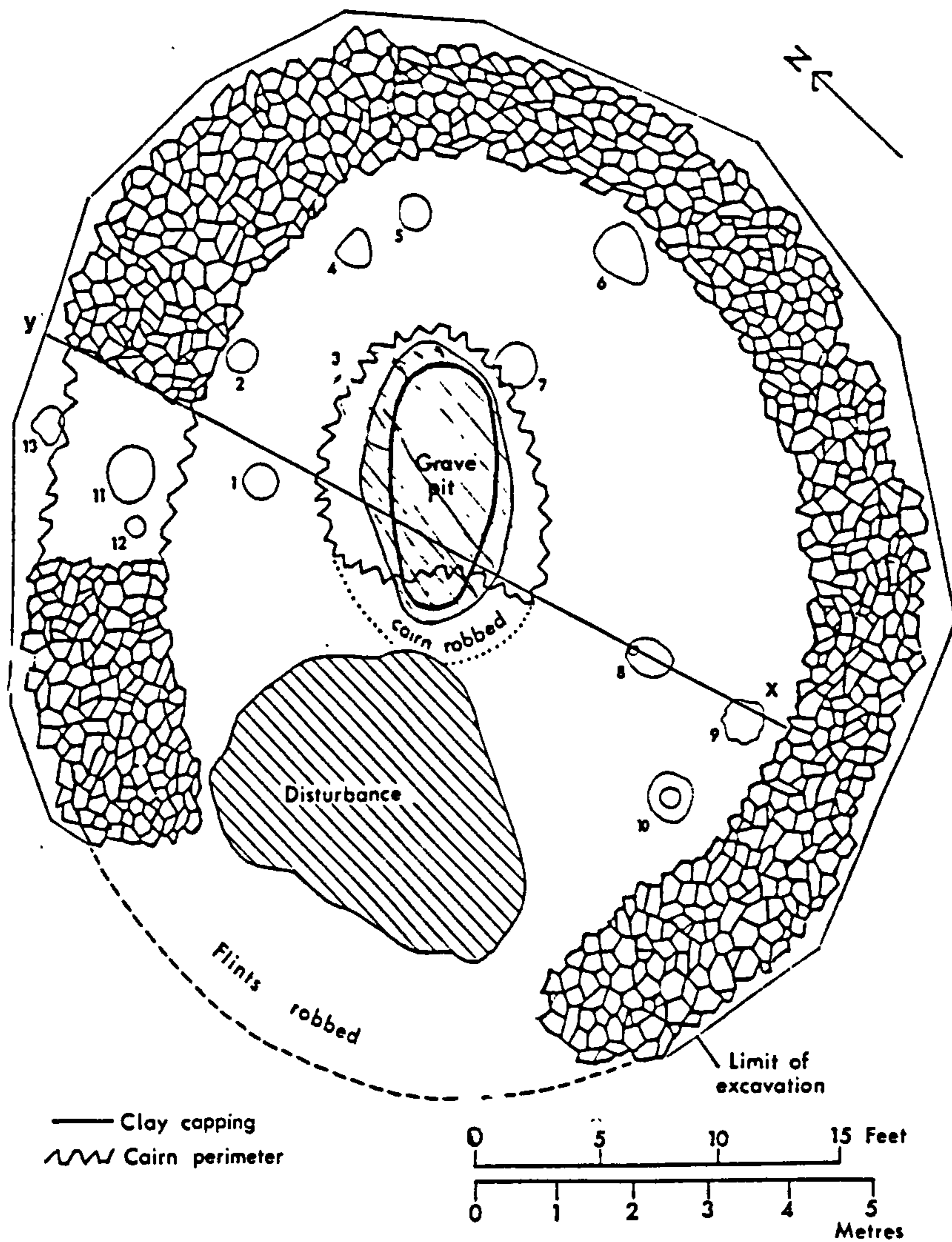


Figure 5.52 White Cross Ring (after Pollard 1971).



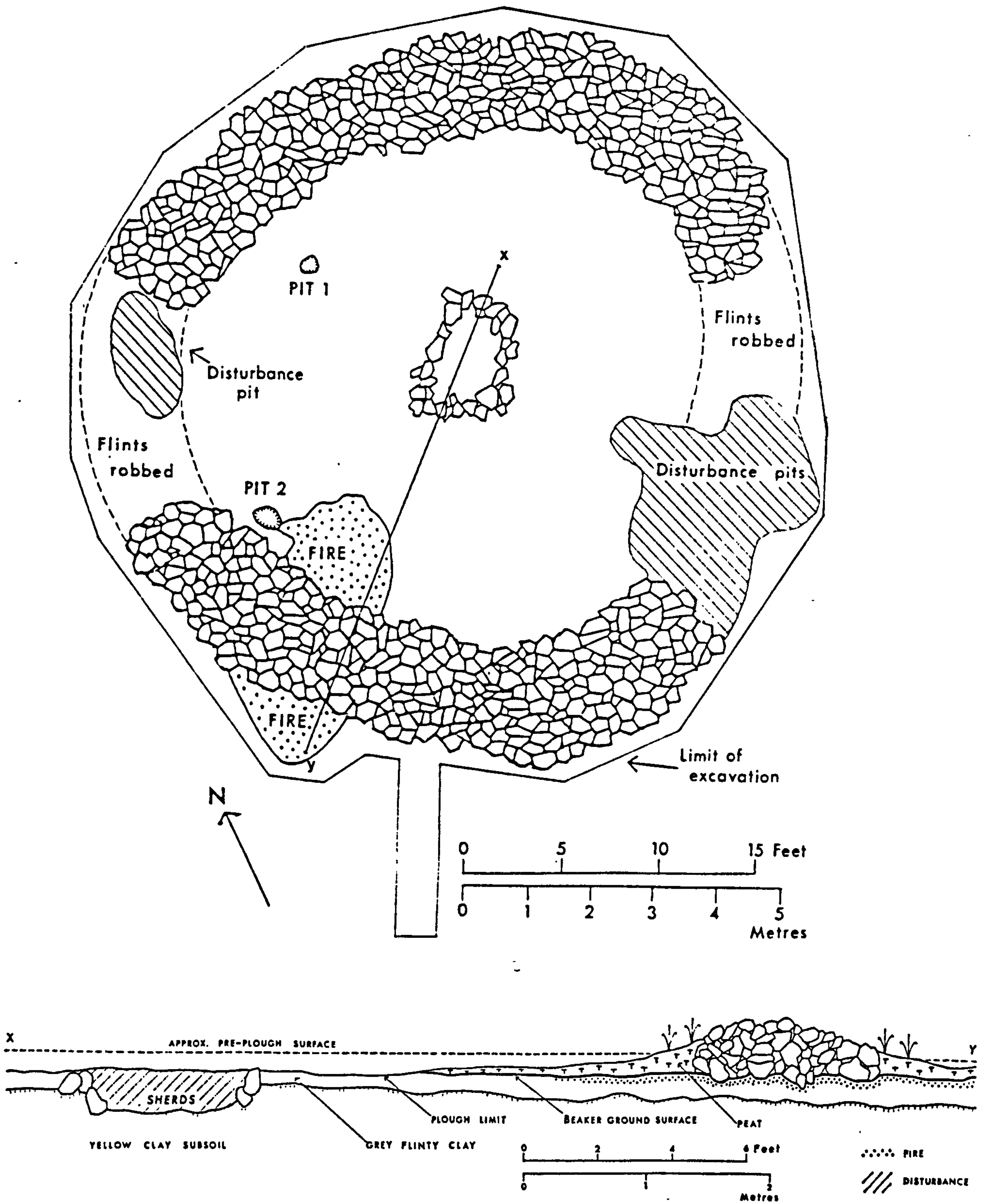
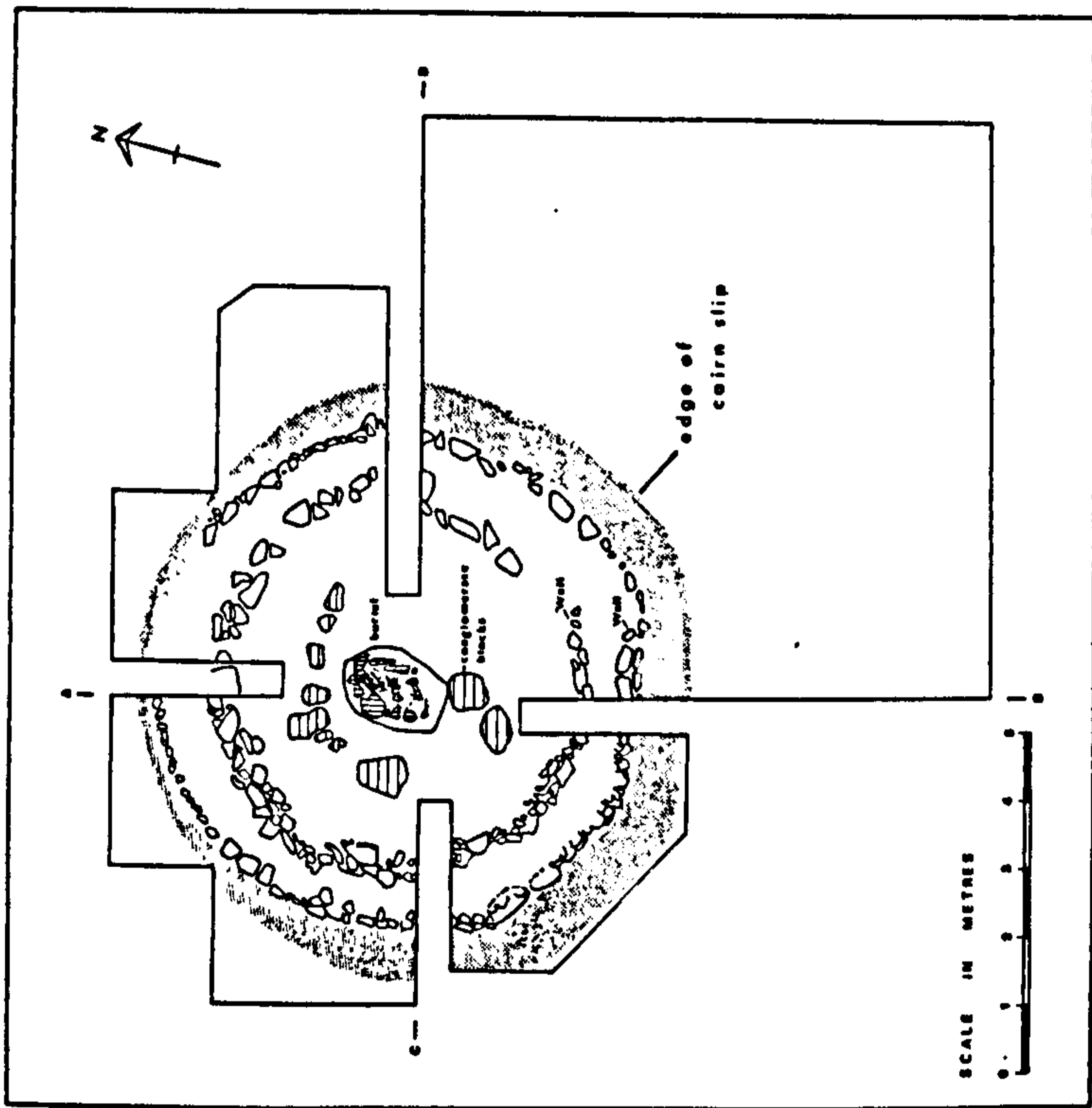


Figure 5.53 Burnt Common Ring (after Pollard 1967).



..... EARTH ADMIXED WITH CAIRN MATERIAL  
 ..... SAND ON FLOOR OF SERIAL PIT  
 ..... EARTH FILL OF SERIAL PIT  
 ..... SERIAL PIT

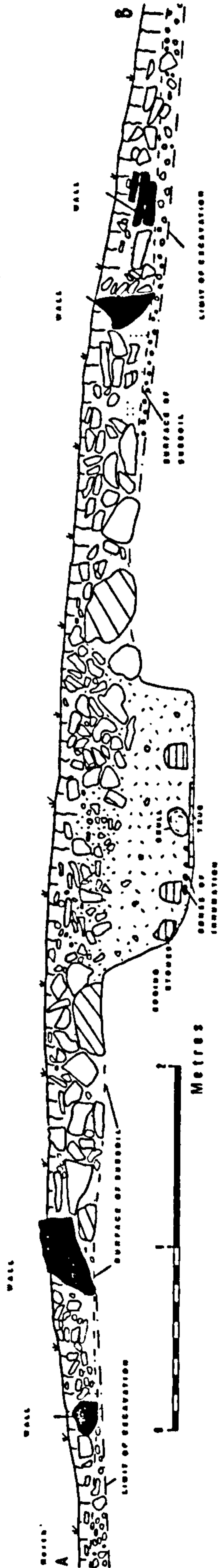


Figure 5.54 Court Hill Cairn (after Green 1973).



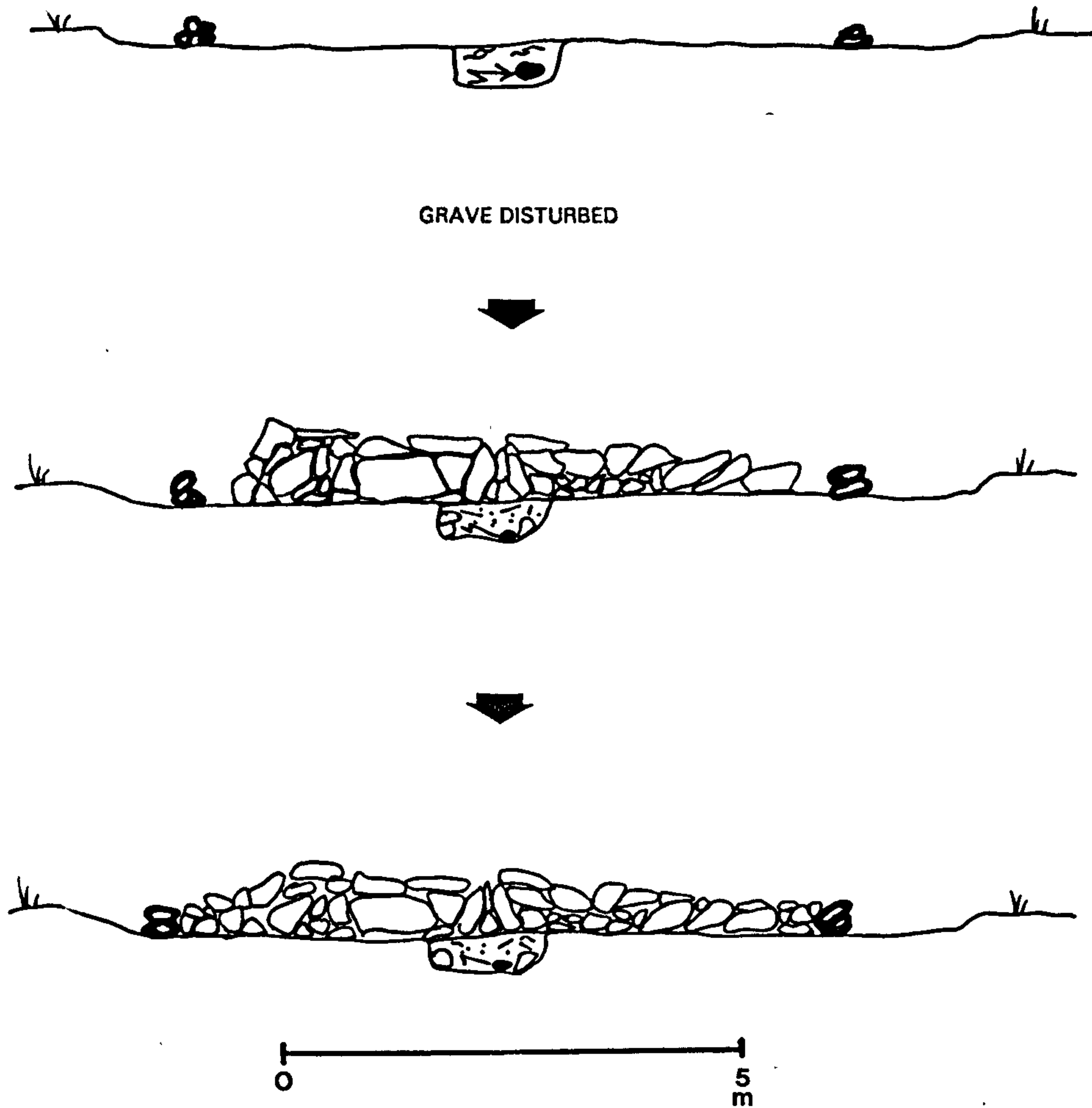


Figure 5.54.1 Court Hill Cairn sequence of activities.

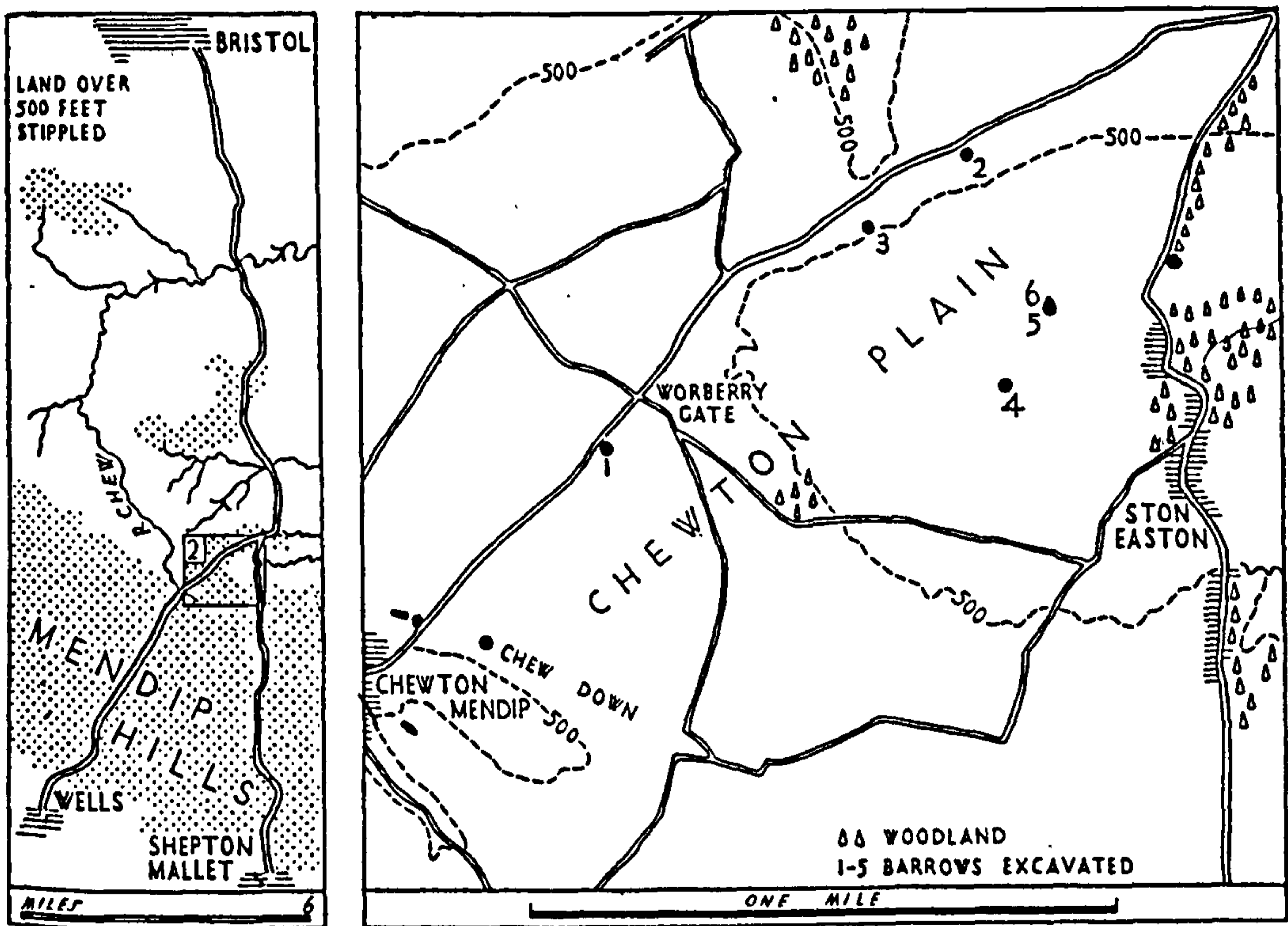


Figure 5.55 Chewton Plain Sites (after Williams 1947).



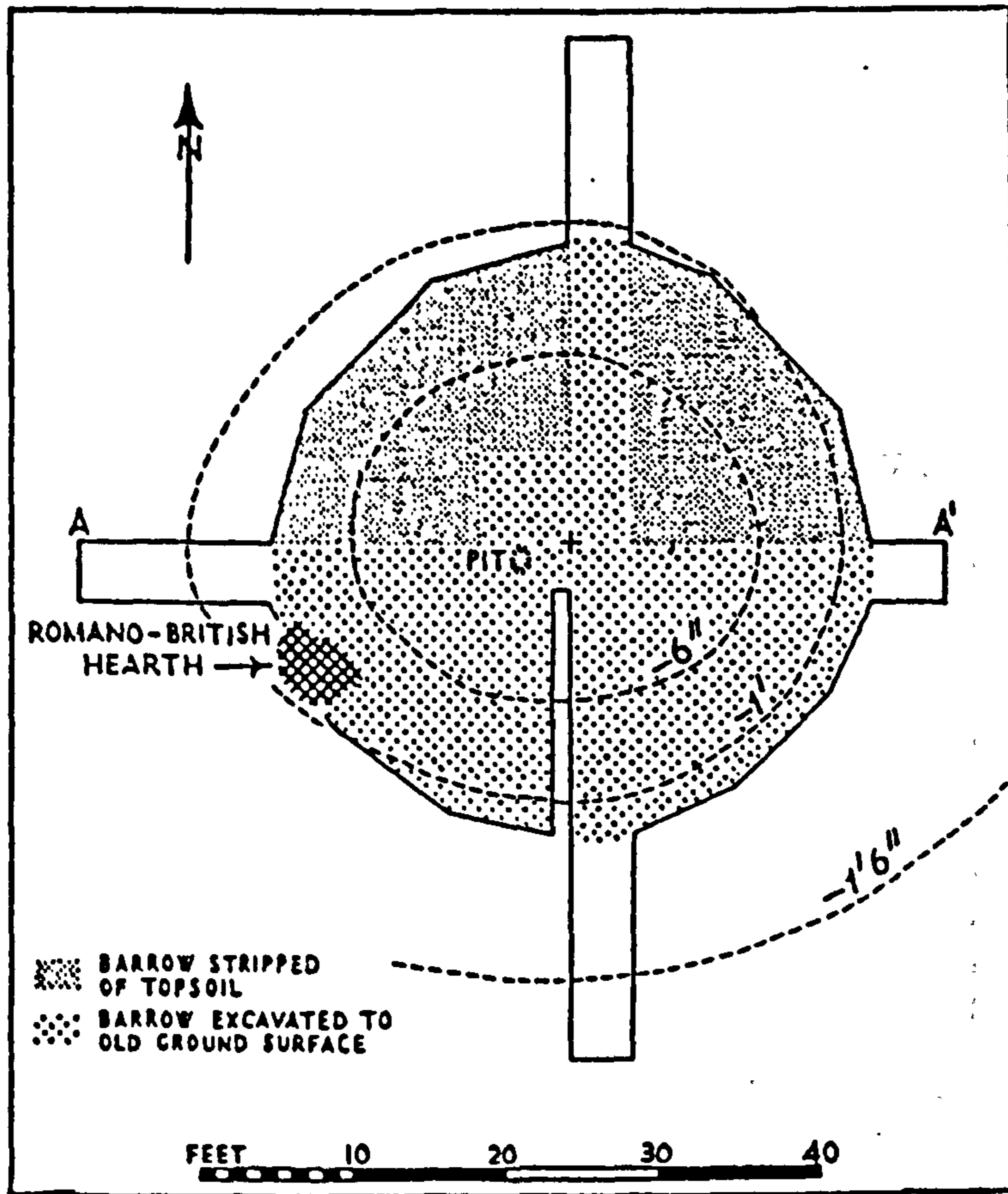


Figure 5.56 Chewton Plain 1 (after Williams 1947).

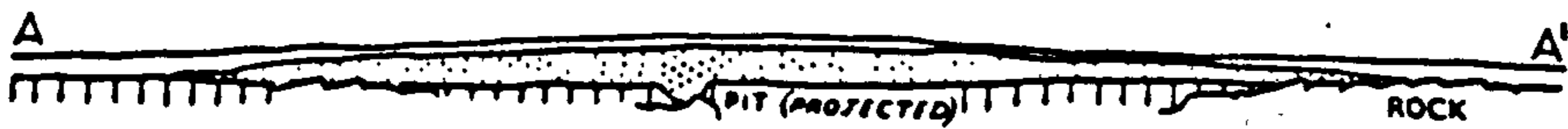
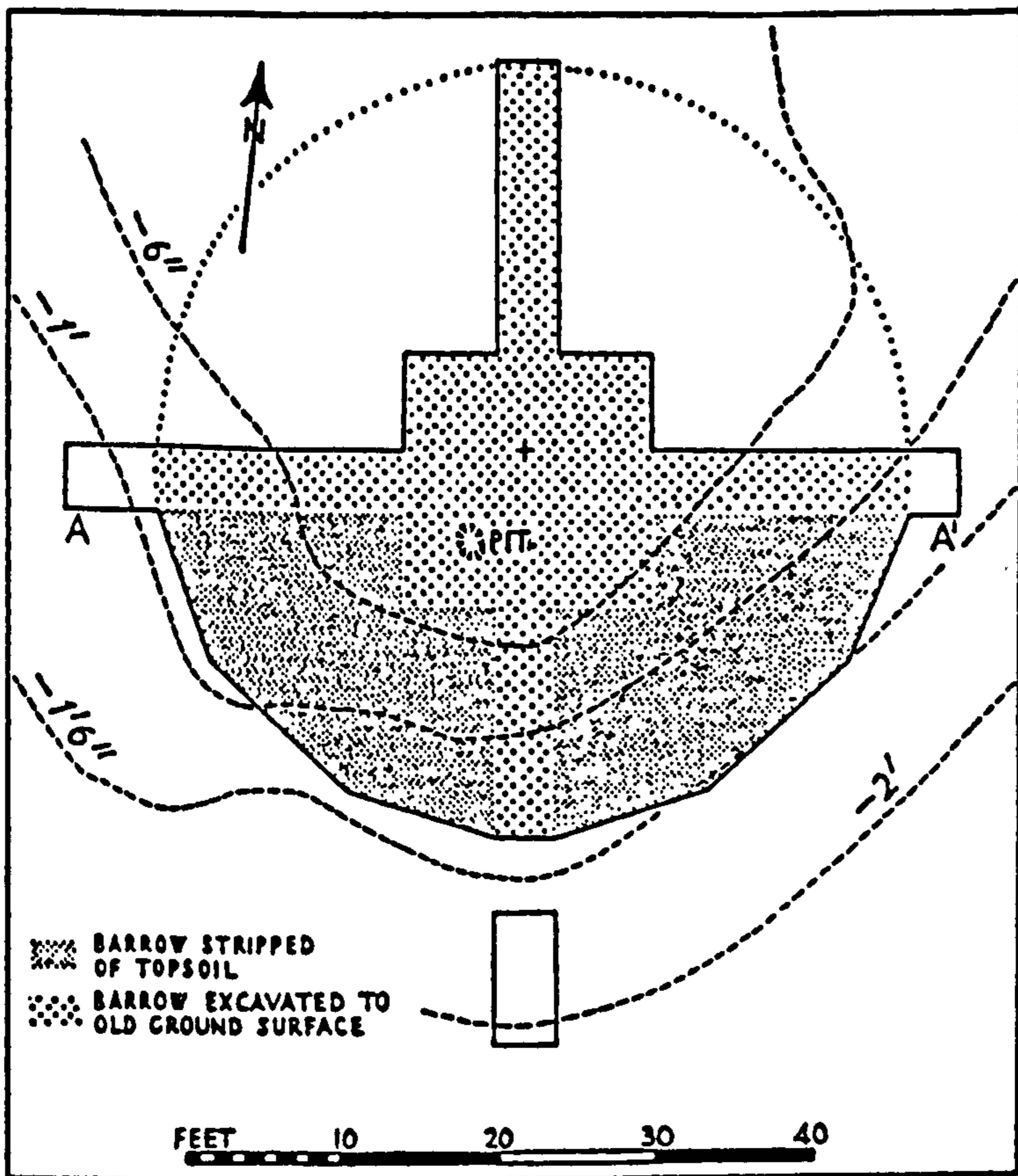


Figure 5.57 Chewton Plain 2 (after Williams 1947).



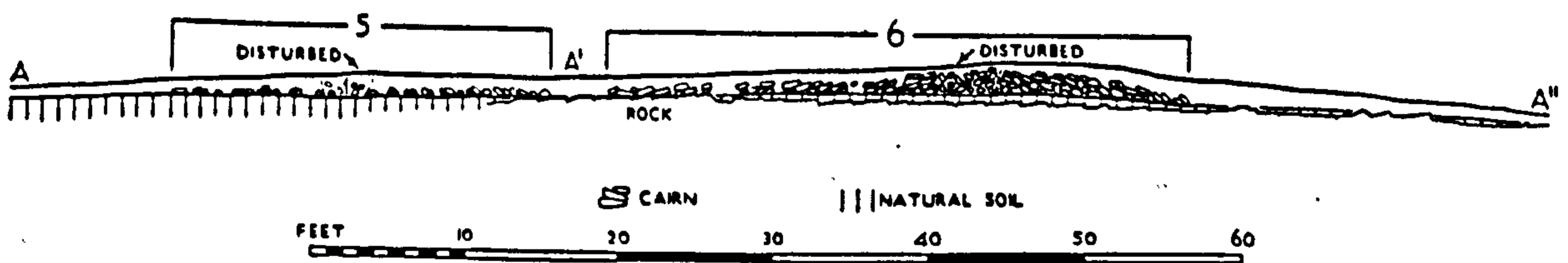
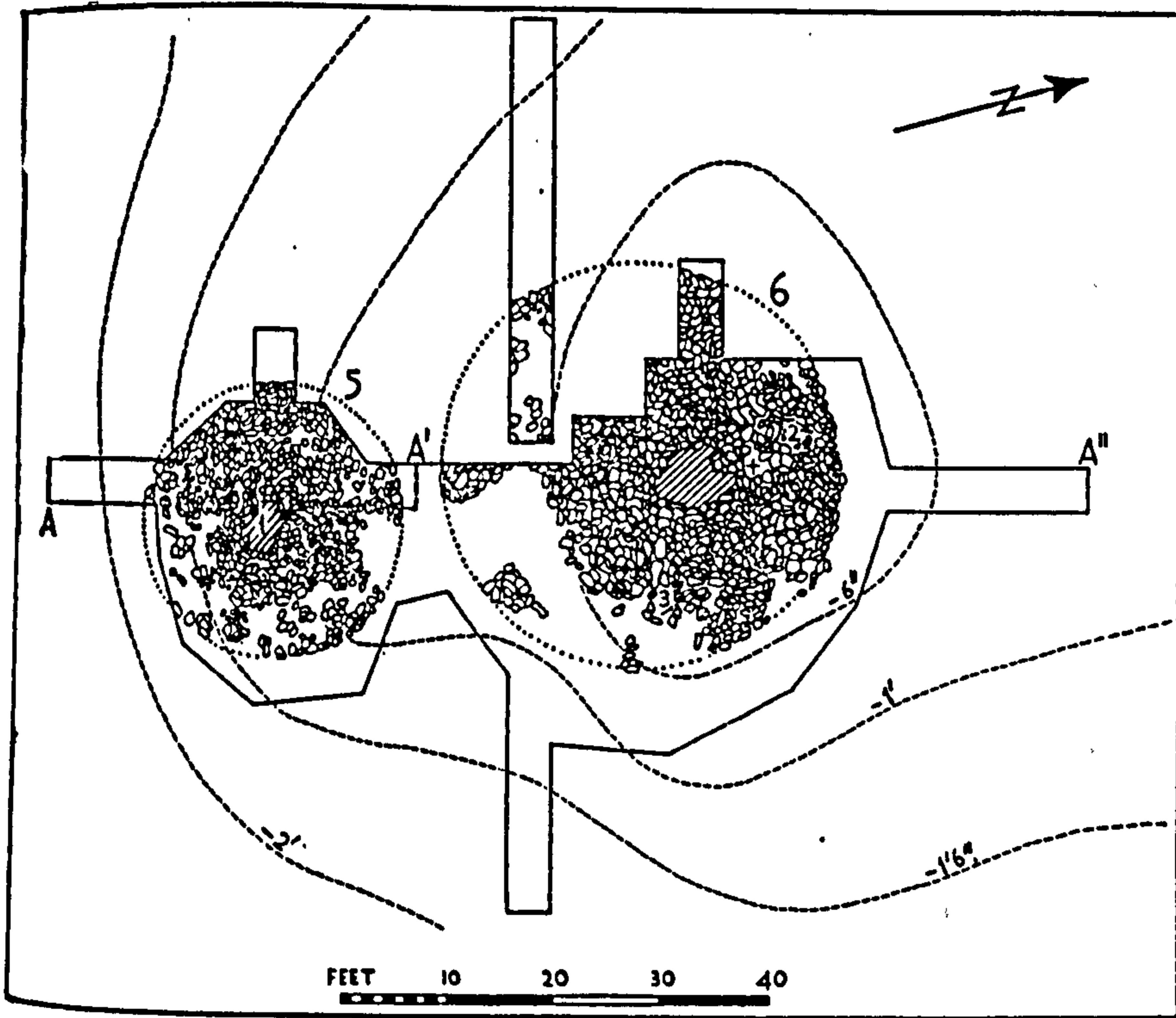


Figure 5.58 Chewton Plain 5 and 6 (after Williams 1947).

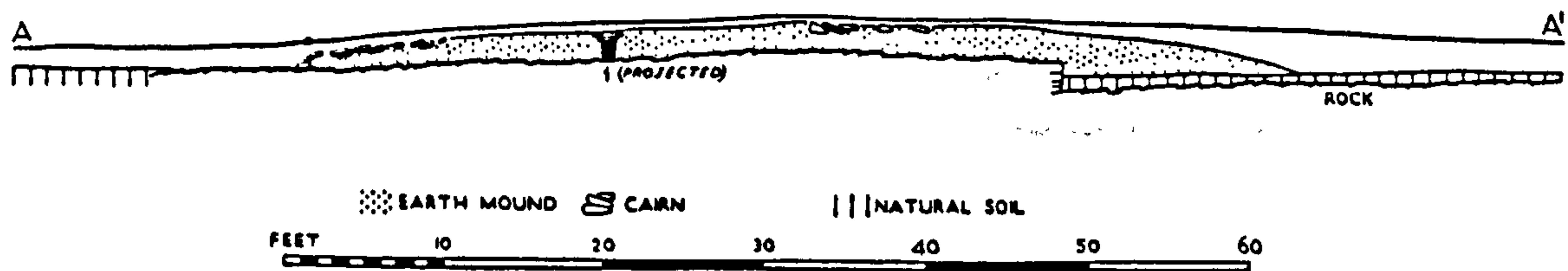
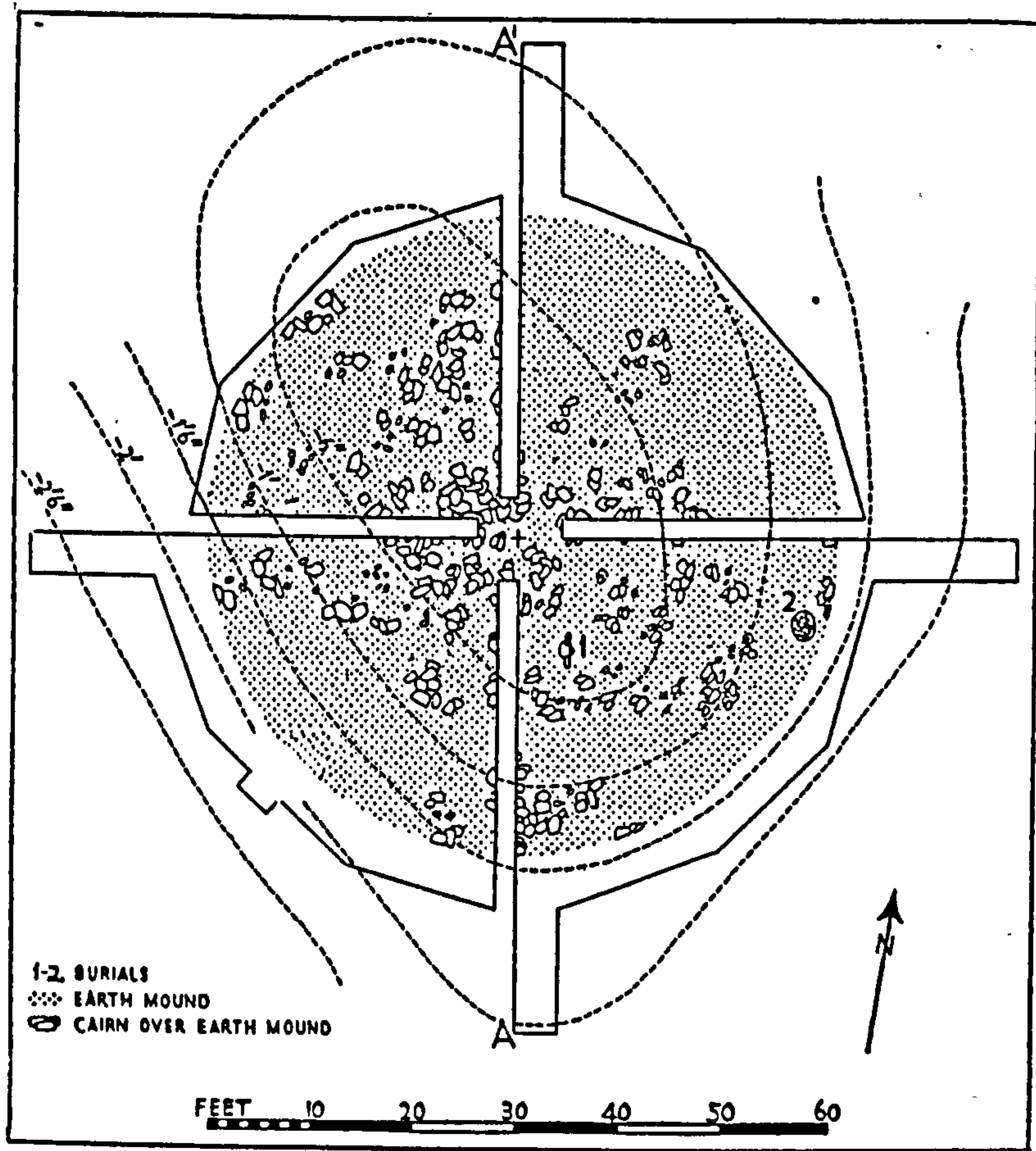


Figure 5.59 Chewton Plain 3 (after Williams 1947).



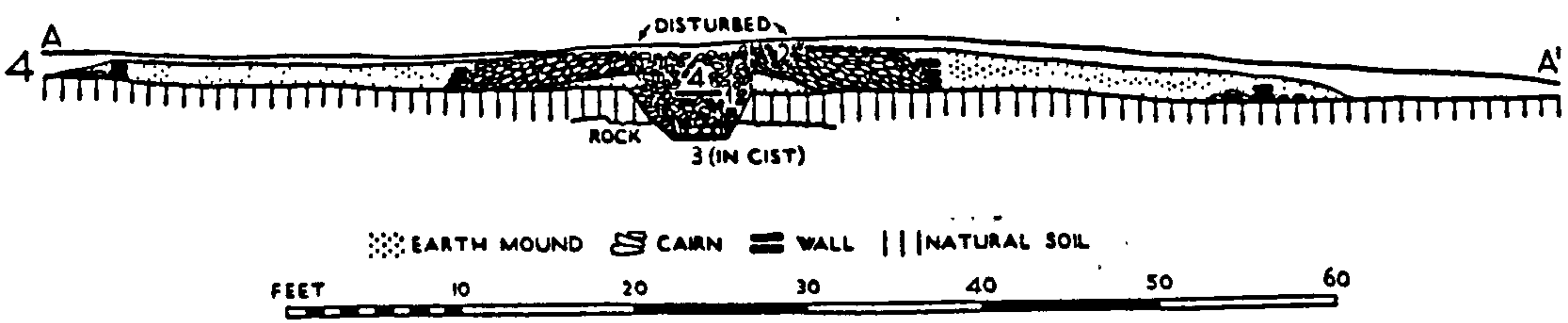
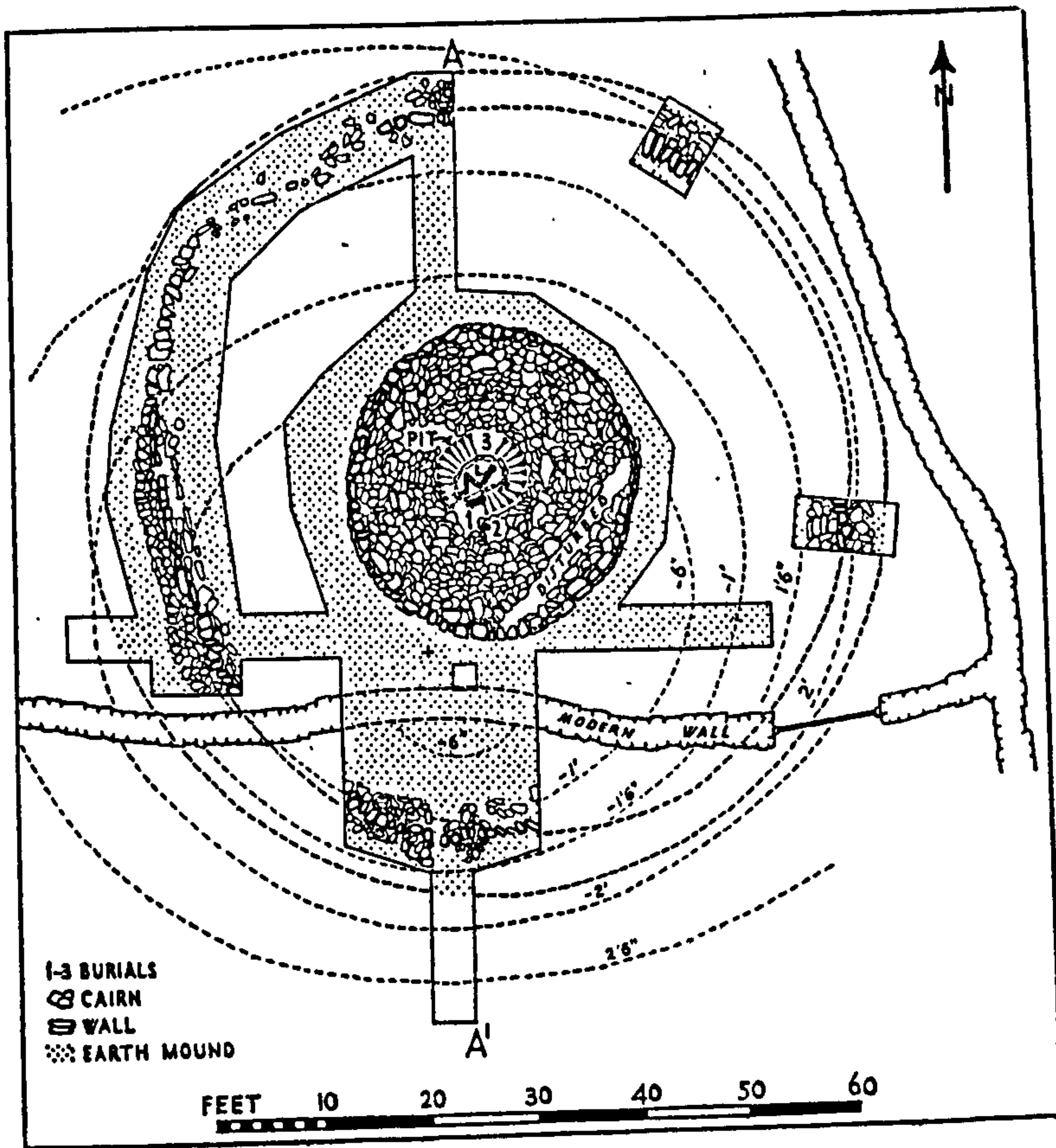


Figure 5.60 Chewton Plain 4 (after Williams 1947).

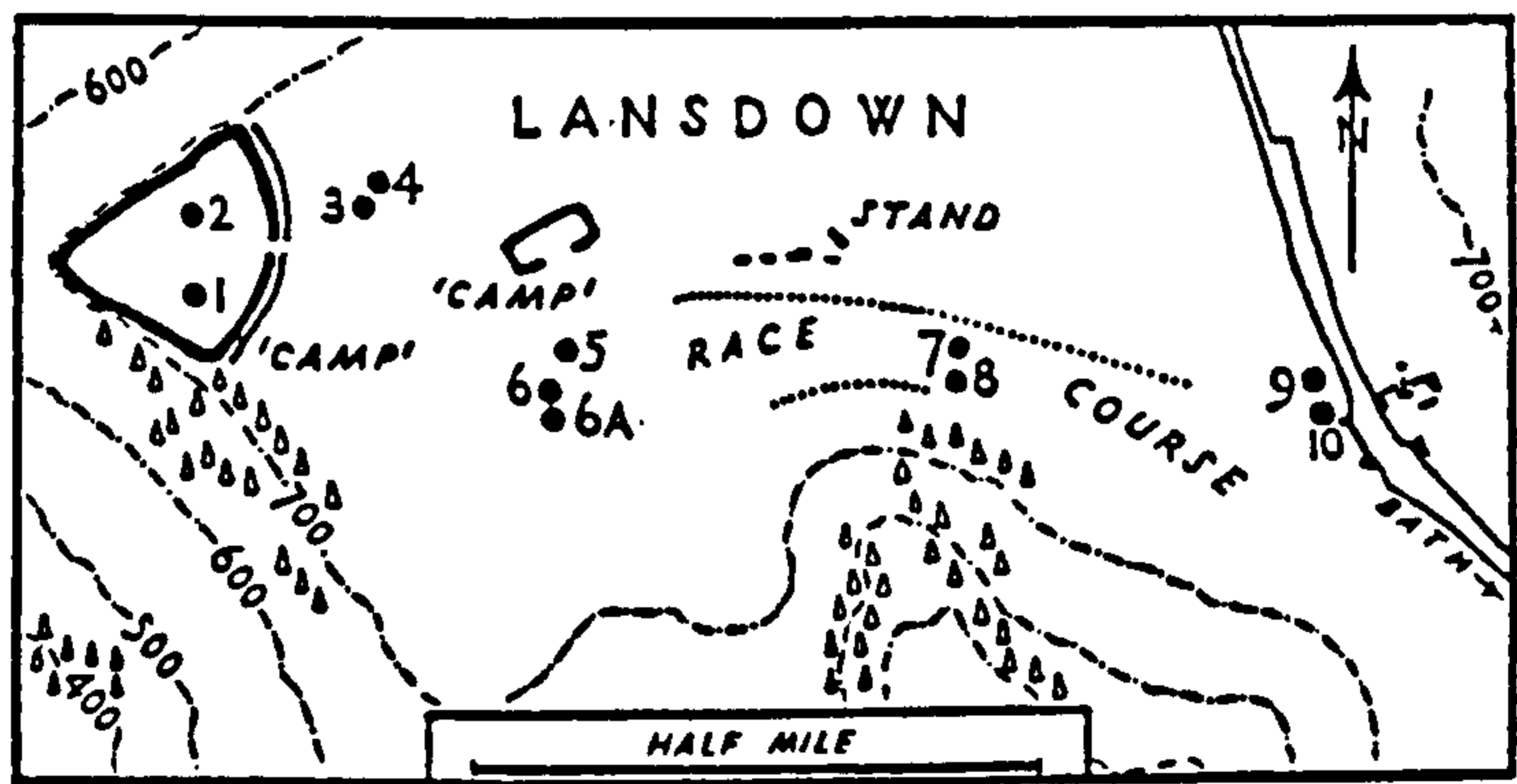
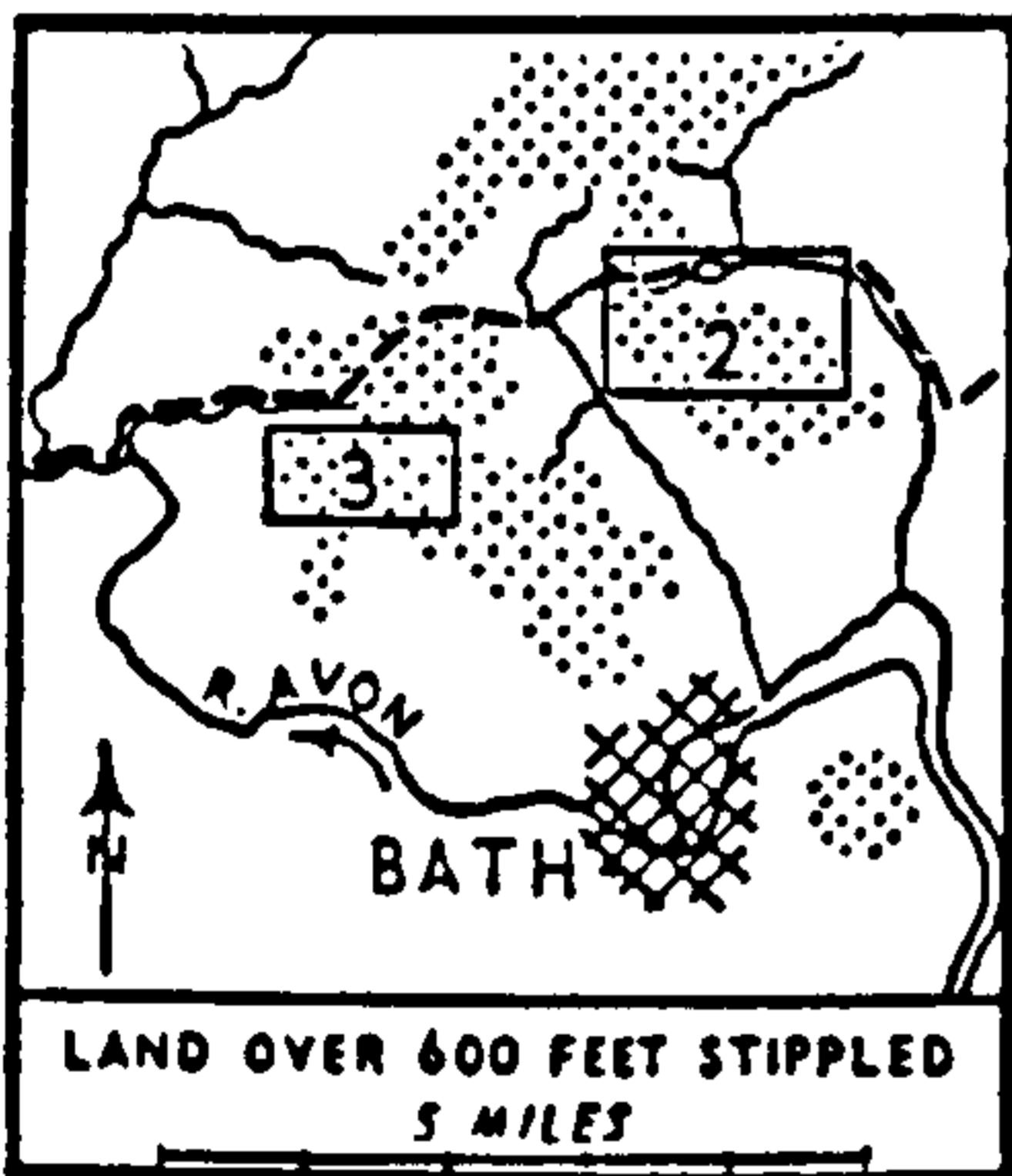
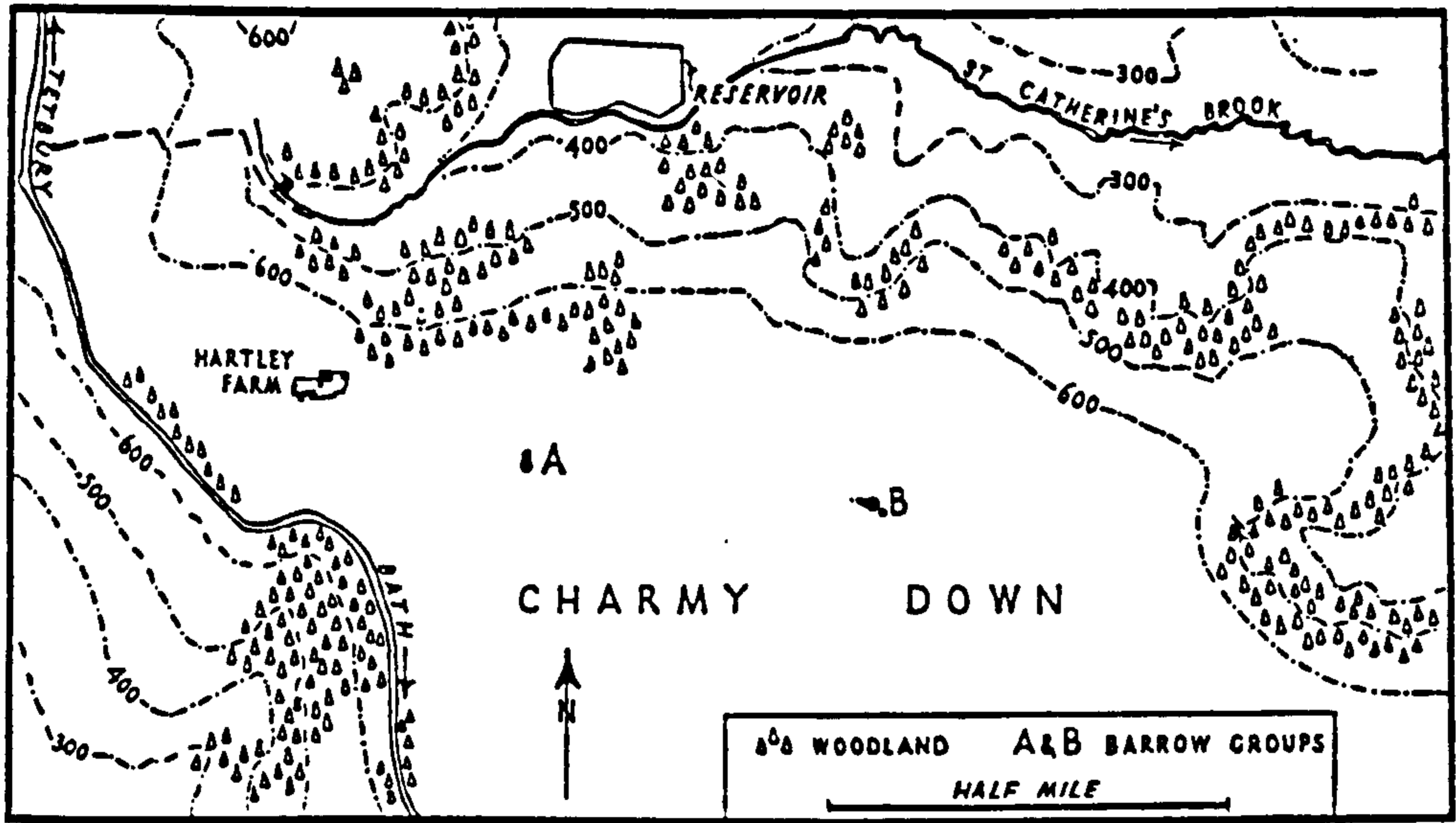


Figure 5.61 Charmy Down and Lansdown cemeteries (after Williams 1950).



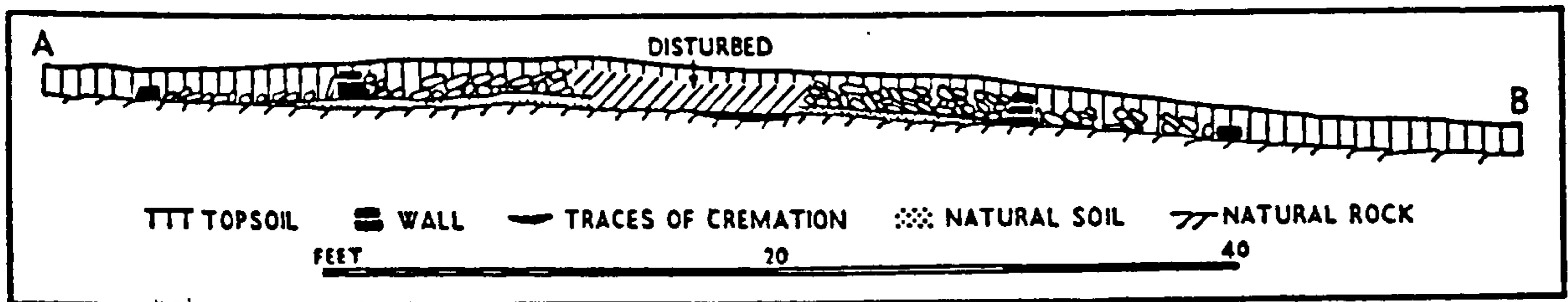
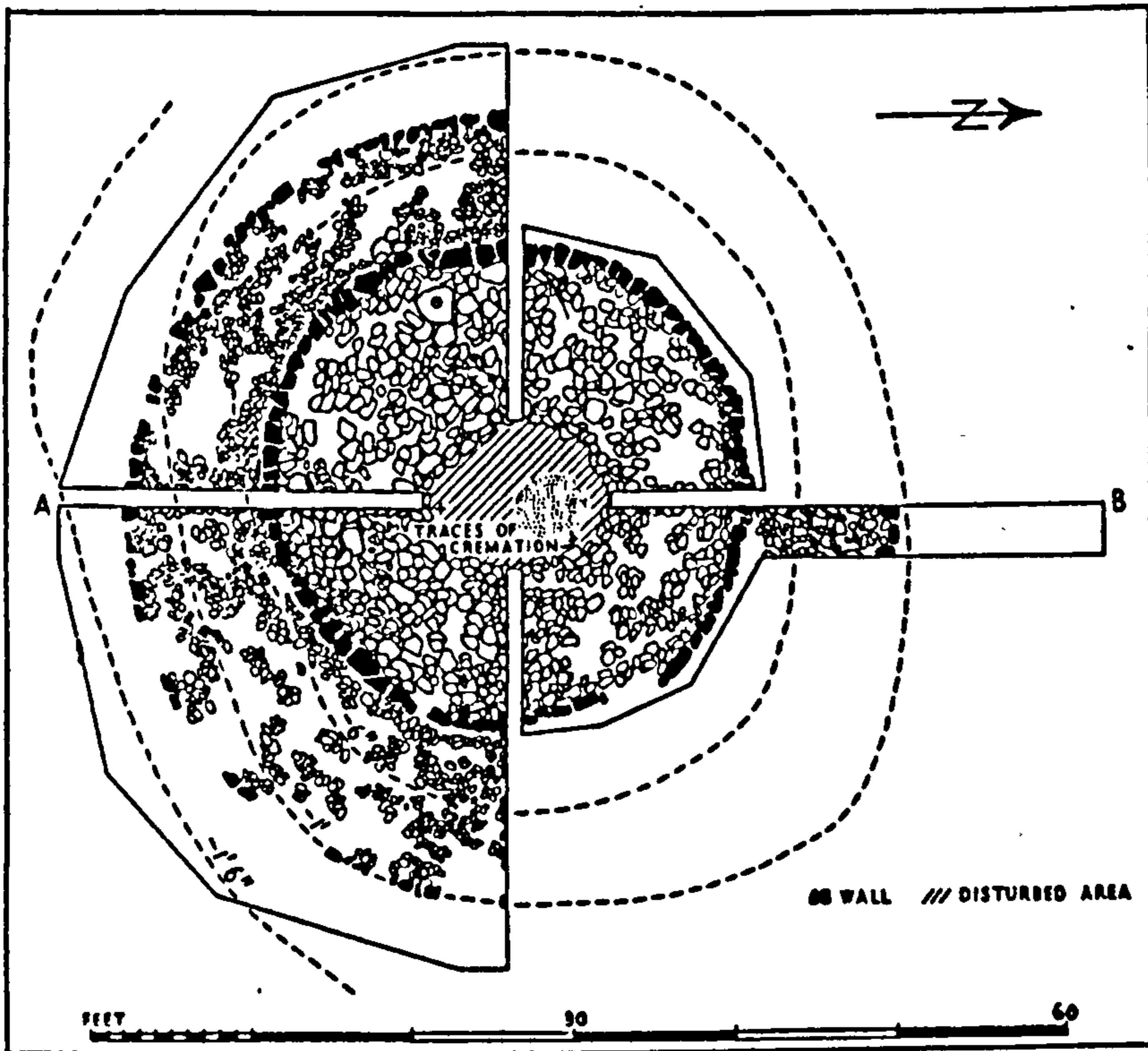


Figure 5.62 Lansdown 6a (after Williams 1950).

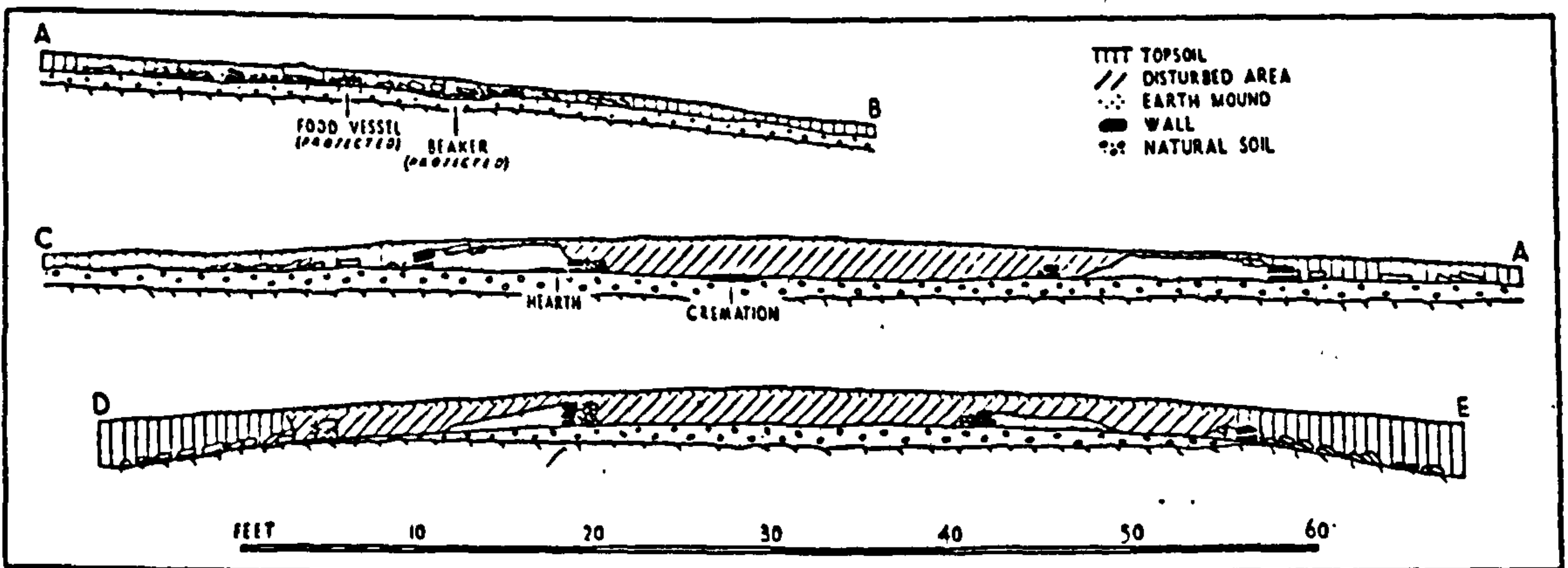
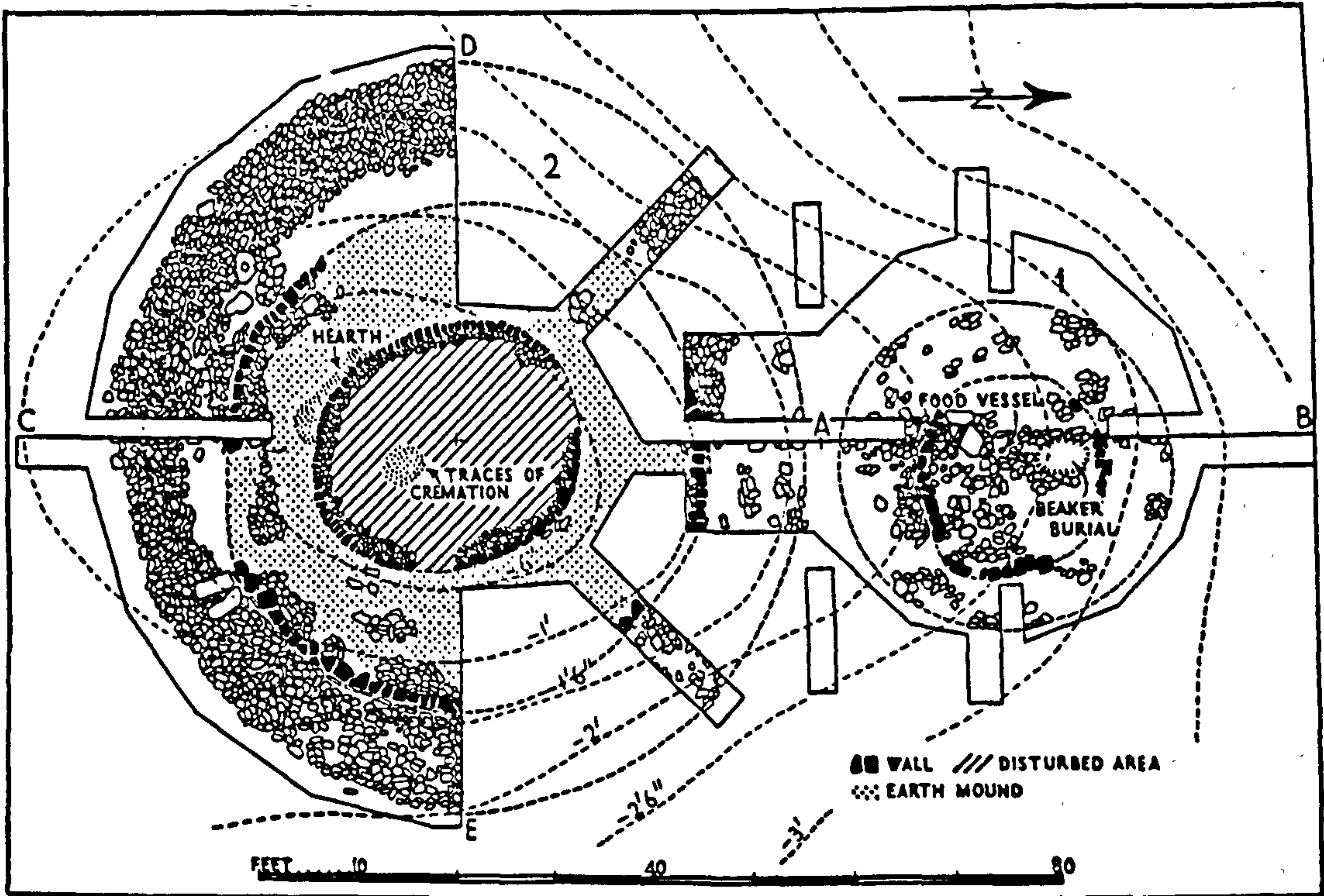


Figure 5.63 Charmy Down 1 and 2 (after Williams 1950).



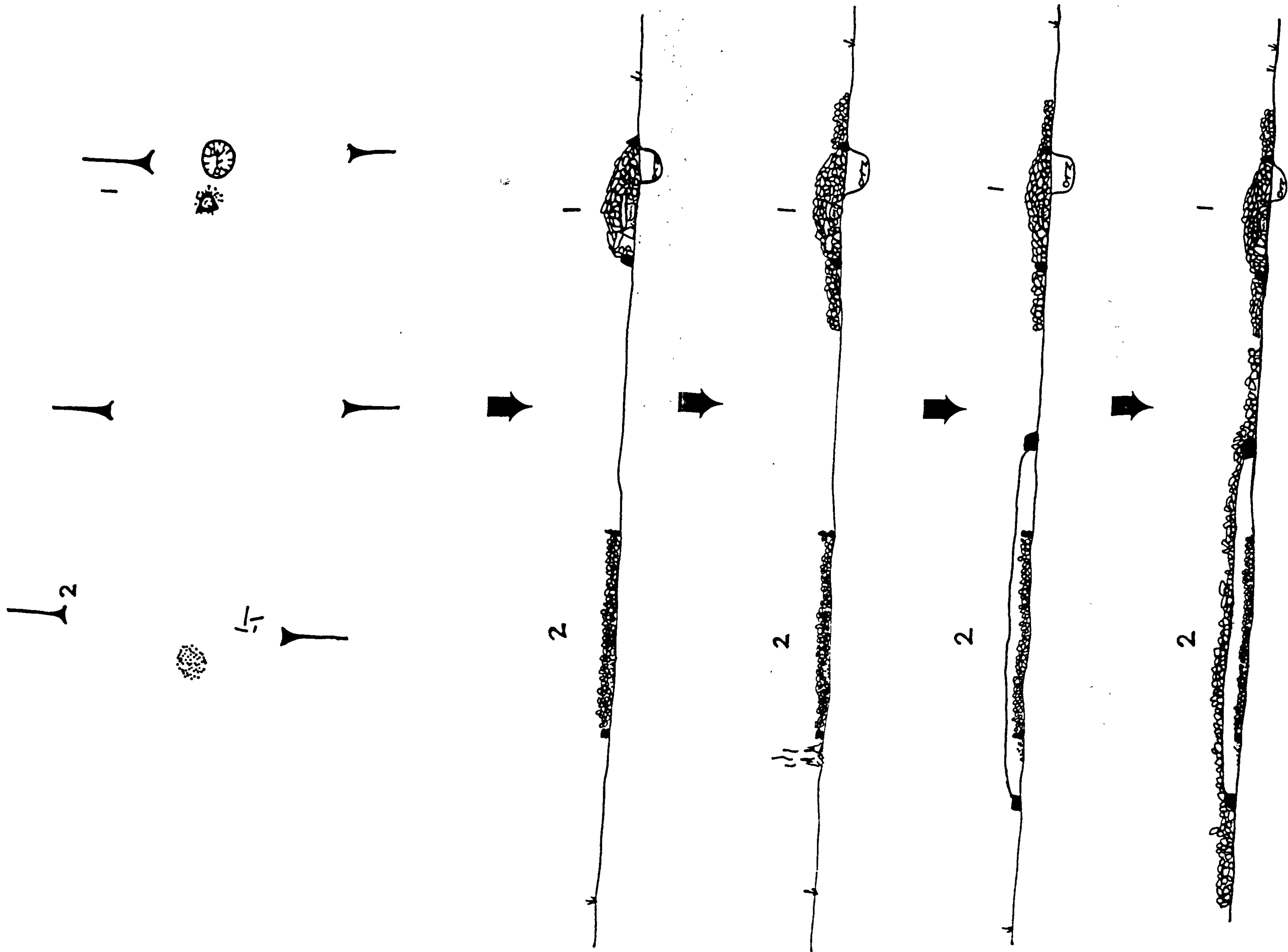


Figure 5.63.1 Charmy Down 1 and 2 possible construction sequence (after Williams 1950).

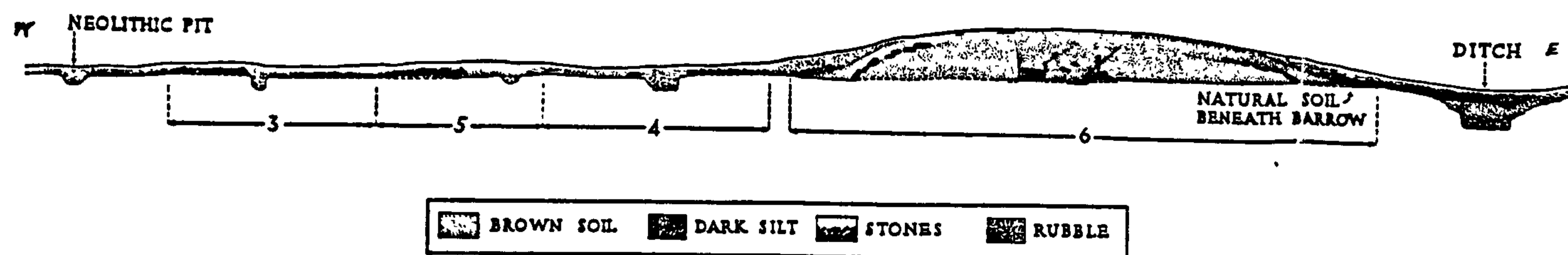
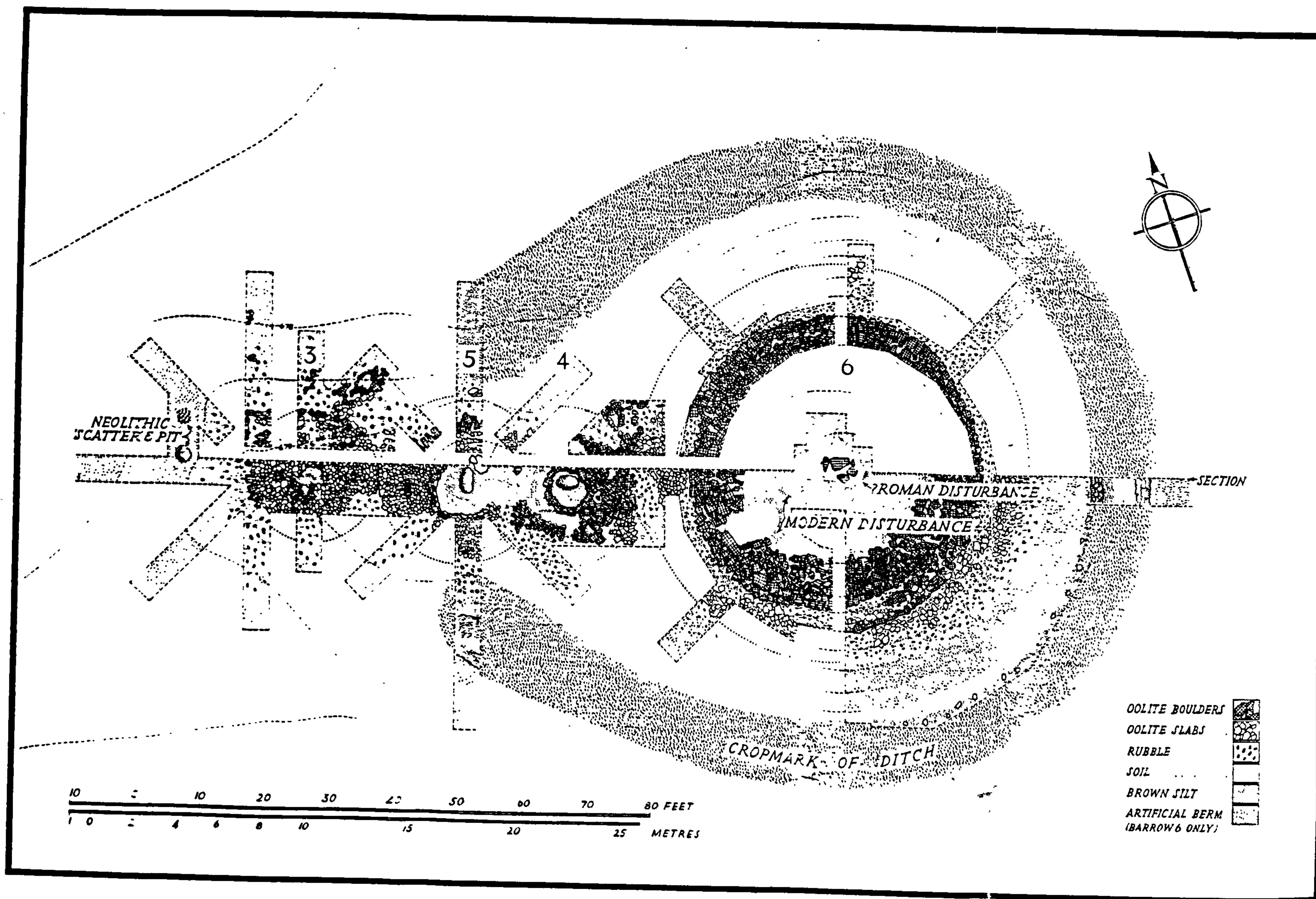
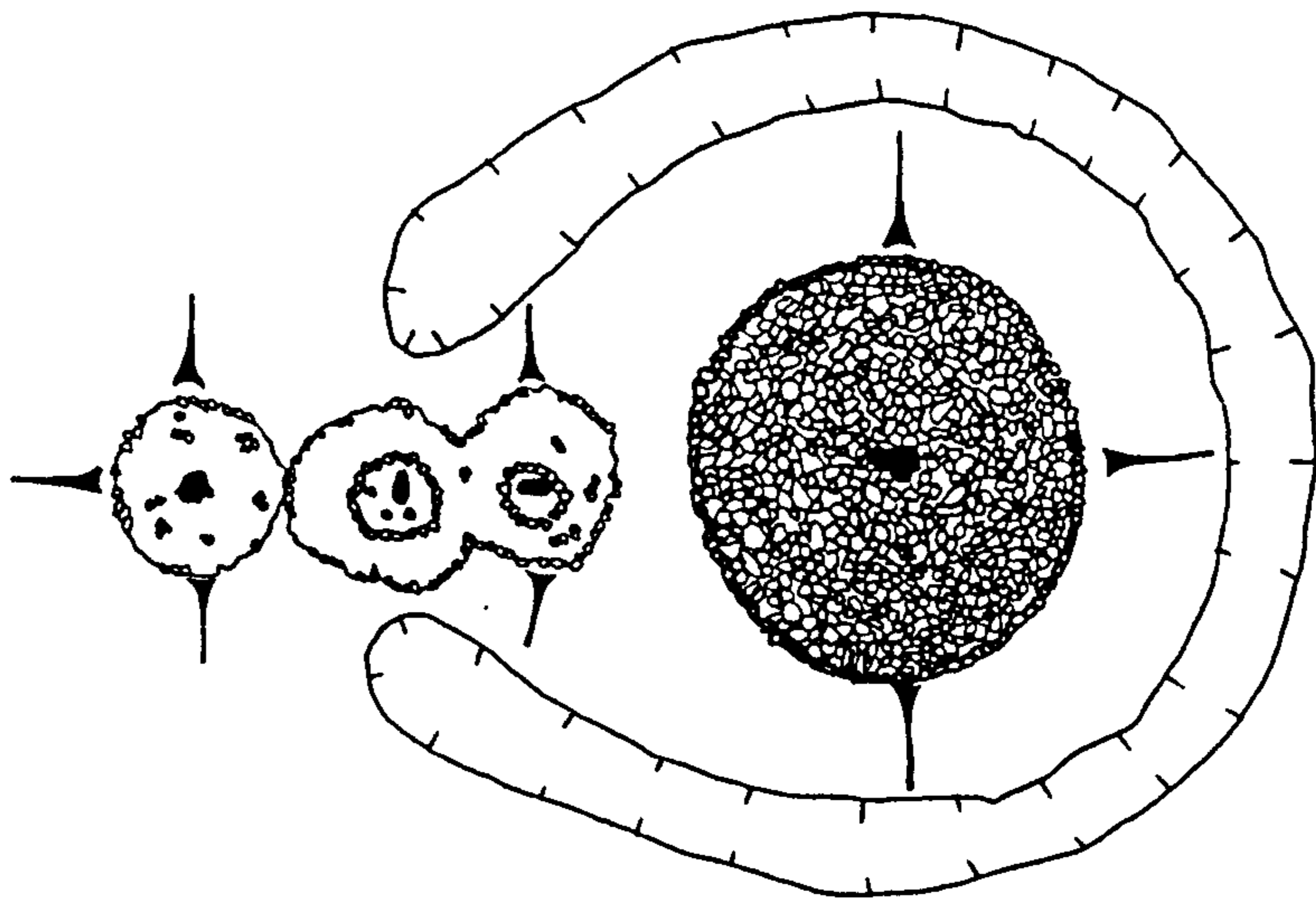
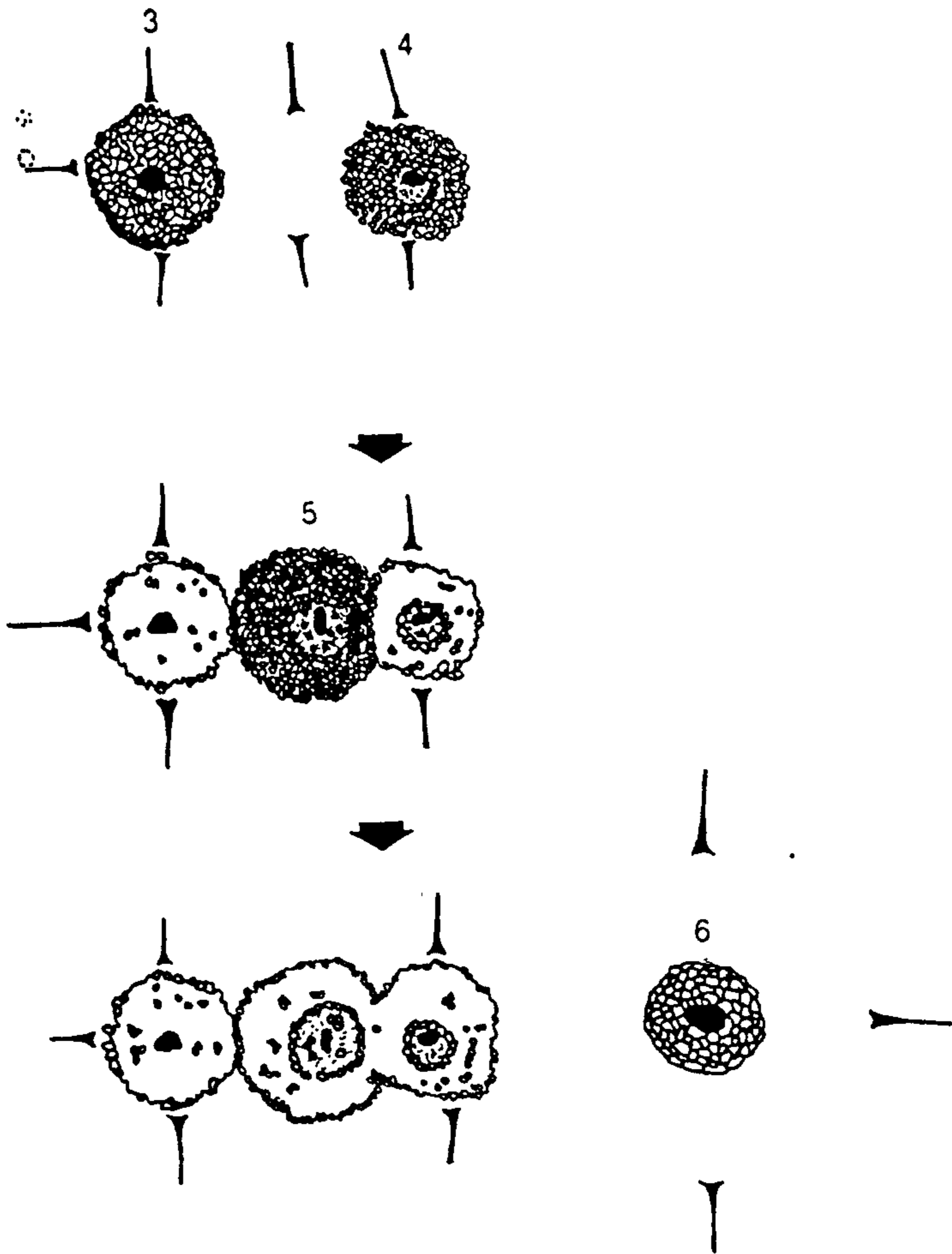


Figure 5.64 Chazy Down 3, 4, 5 and 6 (after Grimes 1960).





0 10  
m

Figure 5.64.1 Charmy Down Sites 3-6 developmental sequence (after Grimes 1960).

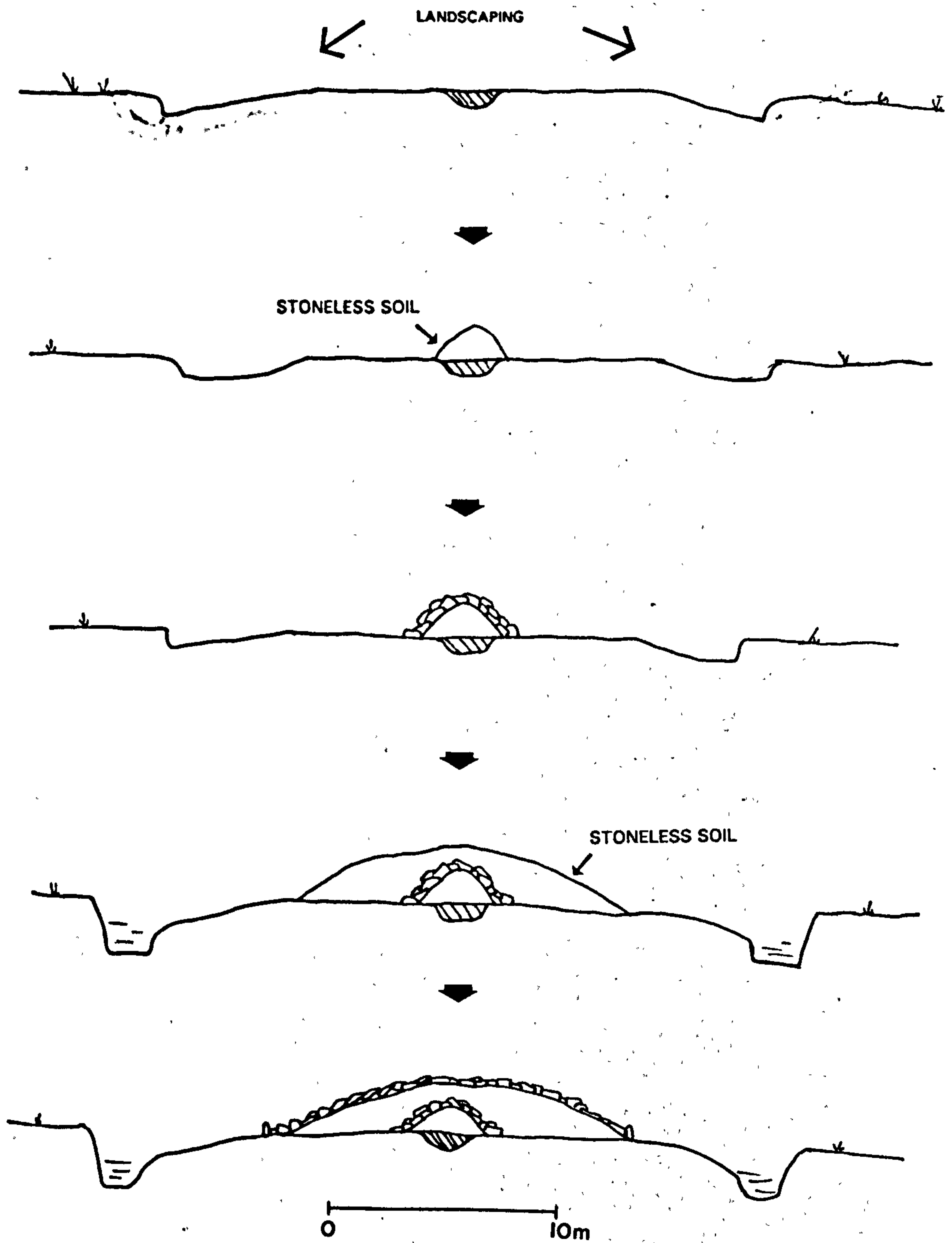


Figure 5.64.2 Charmy Down 6 construction sequence.



---

2400      2200      2000      1800      1600      1400      1200    BC

---

*Pre-mound allignments, circles*

*Bone selection, grave reopening*

*Multiple fires, charcoal  
deposits/pits, re-  
cremations*

*Timed mound enlargement,  
post-barrow rituals*

*Urn burials,            →  
domestic burials*

---

B    E    A    K    E    R  
          F    O    O    D            V    E    S    S    E    L  
                  U                    R                    N                    S

---

Figure 5.65 *Development of south-western Beaker/Bronze Age funerary practice.*

<b>Symbols</b>	<b>Alignments</b>	<b>Symbol</b>	<b>Alignment</b>
1a	Cocksbarrow entrance to outer ring	30	St. Neot grave orientation
1b	" entrance to inner ring and Pit Z	4c	Watch Hill pit in ditch
1c	" eastern post entrance ends	4d	Watch Hill graves' orientation
1d	" western post entrance ends		
2a	Caerloggas Downs I ditch entrance		
2b	" cairn entrance		
3a	Caerloggas Downs III branch		
3b	" standing stone		
4a	Watch Hill east end north wall		
4b	" west end north wall		
5a	Trenance Downs entrance		
5b	" standing stone		
6	Try grave		
7a	Chysauster southern entrance, centre		
7b	" central cremations alignment		
8a	Davidstow Moor XXVI orientation of central features		
8b	" western ring entrance ends		
8c	" eastern pits' centre opposing 8b		
9	Davidstow Moor III later small gap between banks		
10a	Davidstow Moor V stone arc midpoint		
10b	" centre of south-east features		
11a	Davidstow Moor I south edge of eastern post enclosure		
11b	" centre of extra north-west stake arc		
13	Tregulland central grave		
14	Lousey Barrow post alignment		
15	Stannon Downs 2 grave		
16	Davidstow XXIV grave		
17a	Colliford Reservoir II Pit 85		
17b	" Pit 83 orientation		
17c	" Pit 86		
17d	" Pit 90 (not numbered)		
18	Trelen 2 post alignment		
19	Carvinak grave pit under Cairn 1		
20	Nancekuke grave		
21a	Crig-a-Mennis eastern trench ramp		
21b	" centre of western ditch causeway		
22	Gwithian GM-V grave		
23	East Putford I mortuary structure orientation		
24	Upton Pyne cremation vessels 2-4		
25a	Farway Cairn posthole G and Pit 4		
25b	" Pit 5; 25bb:posthole A		
25c	" posthole E		
25d	" posthole B		
25e	" orientation of central grave; 25ee:posthole DD		
25f	" Pit C; 25ff:Pit 1		
25g	" Pit 3		
25h	" posthole F		
26	White Cross Ring grave		
27	Burnt Common Ring grave		
28	Court Hill cairn grave orientation and wall exit gap		
29	Charmy Down Sites 1 and 2 orientation		





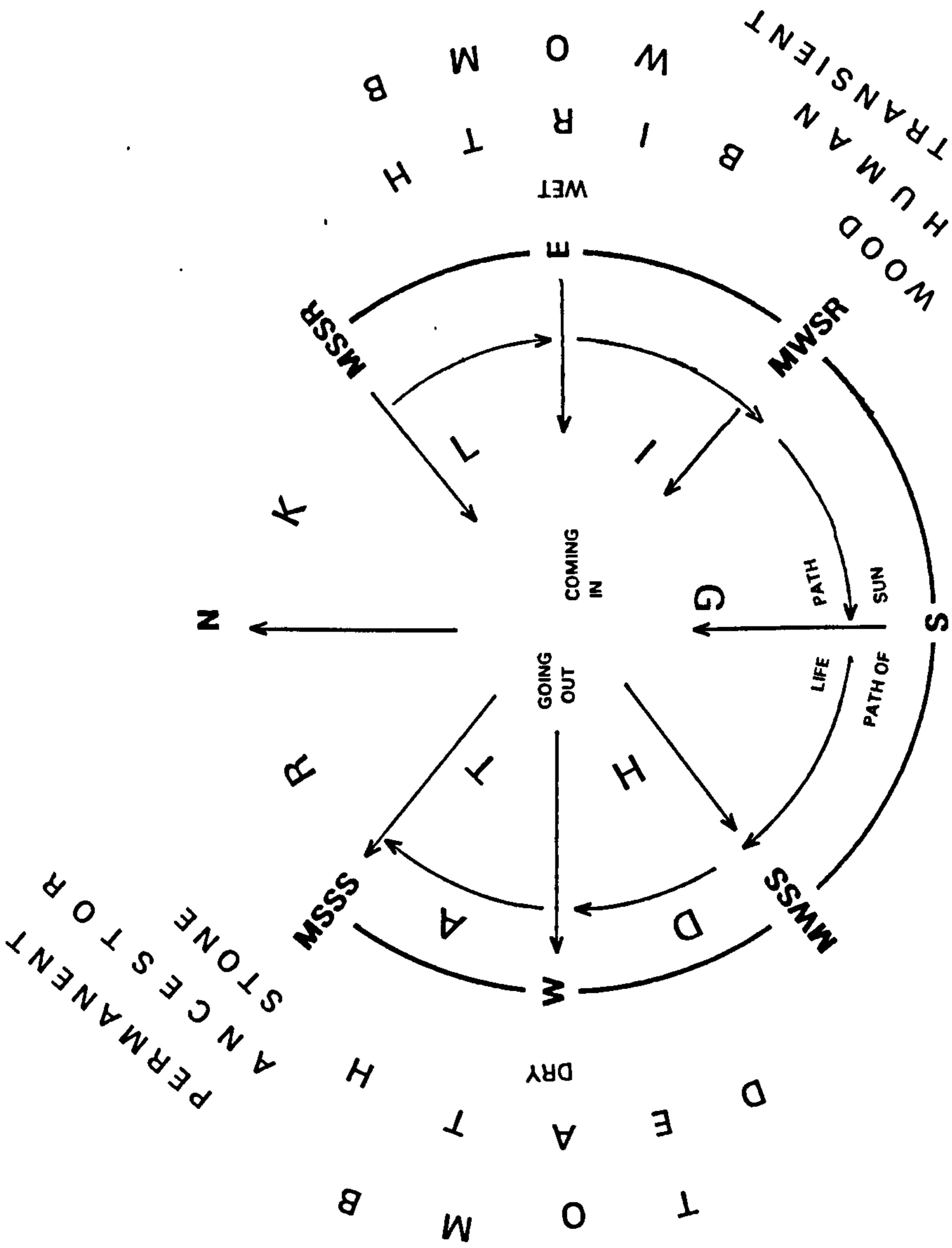


Figure 6.2 Synoptic diagram of pertinent oppositions in a cosmic circular conception of time-space.



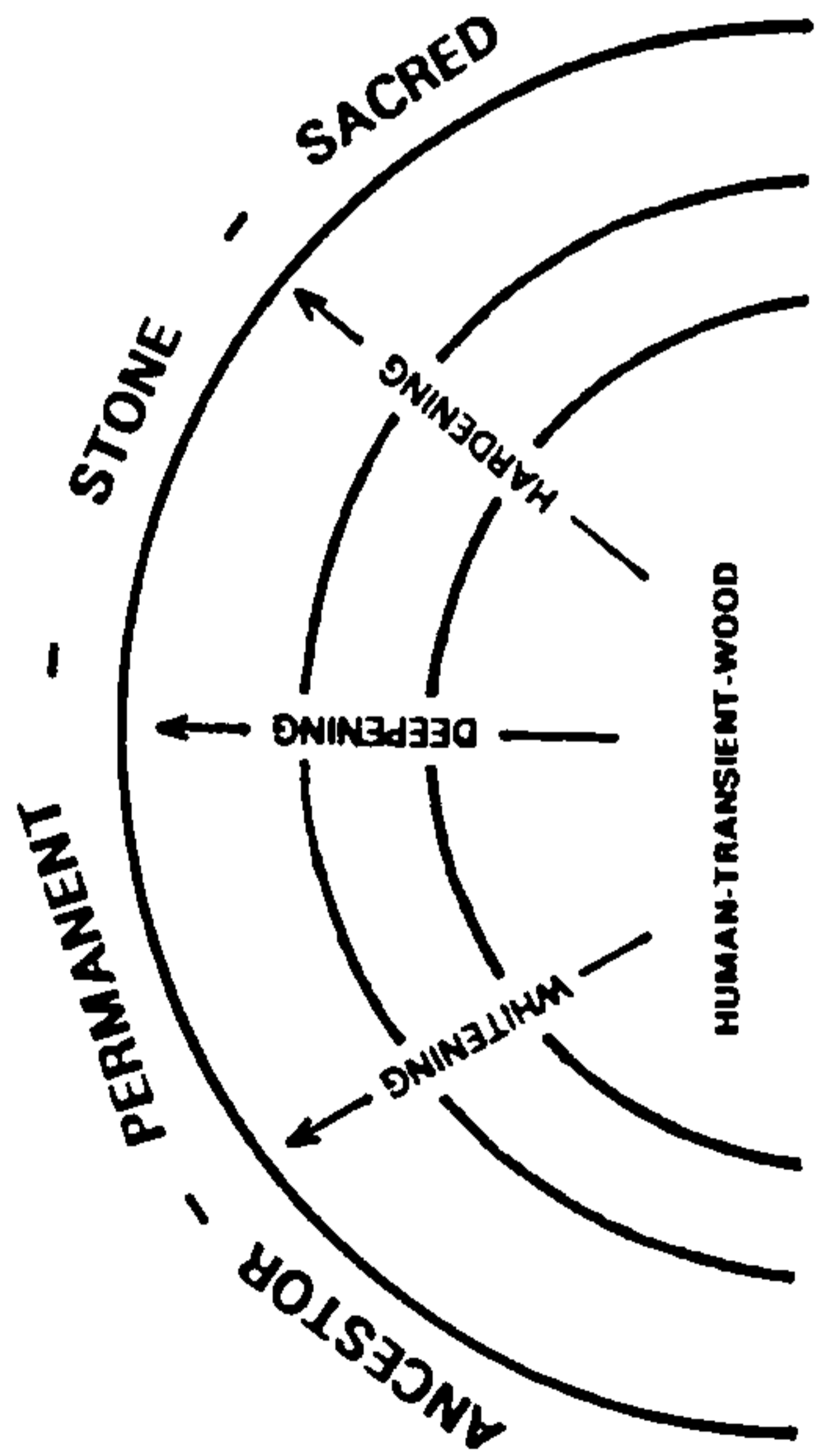
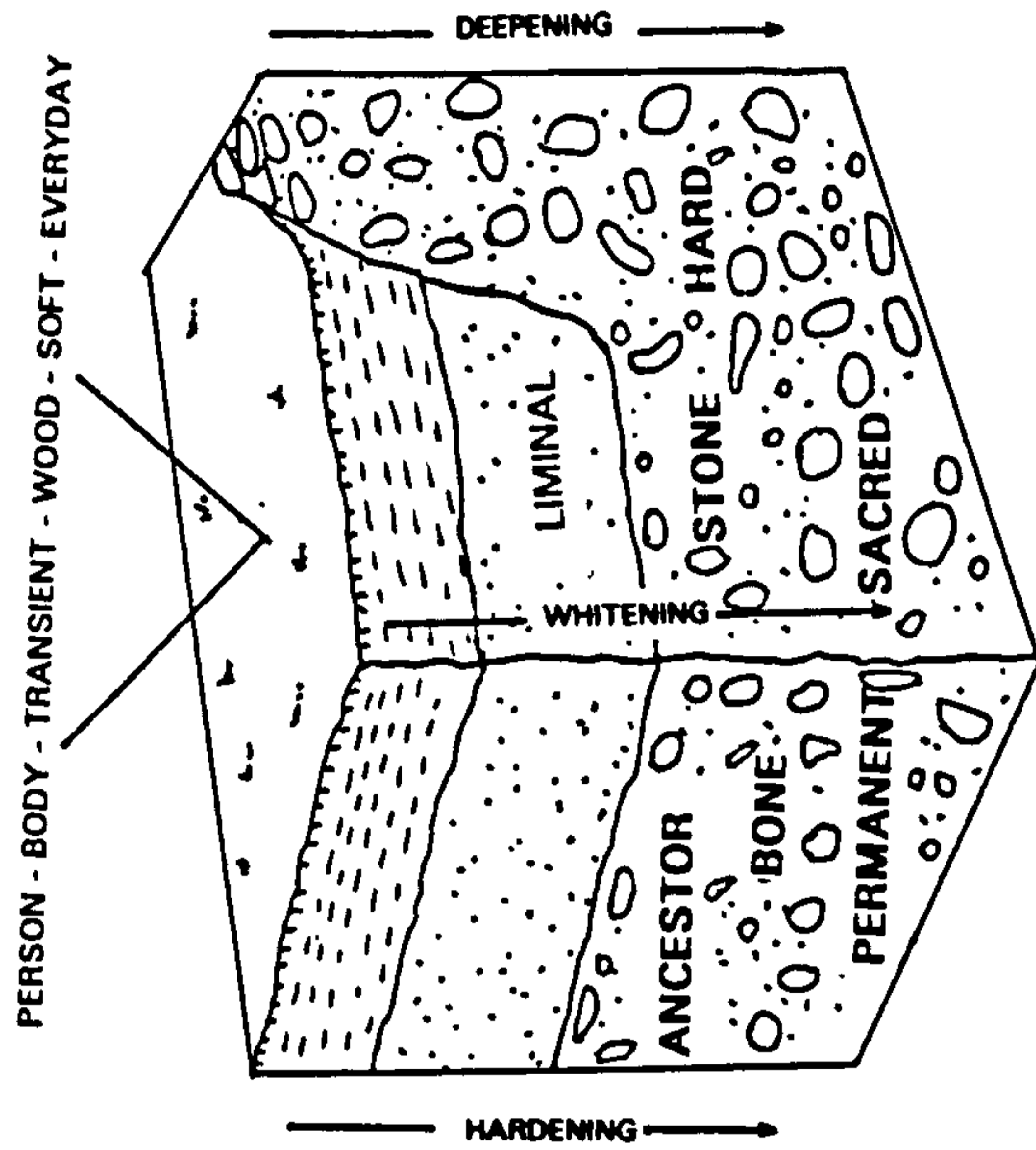


Figure 6.3 The vertical conception of space as objectified in tomb and landscape.

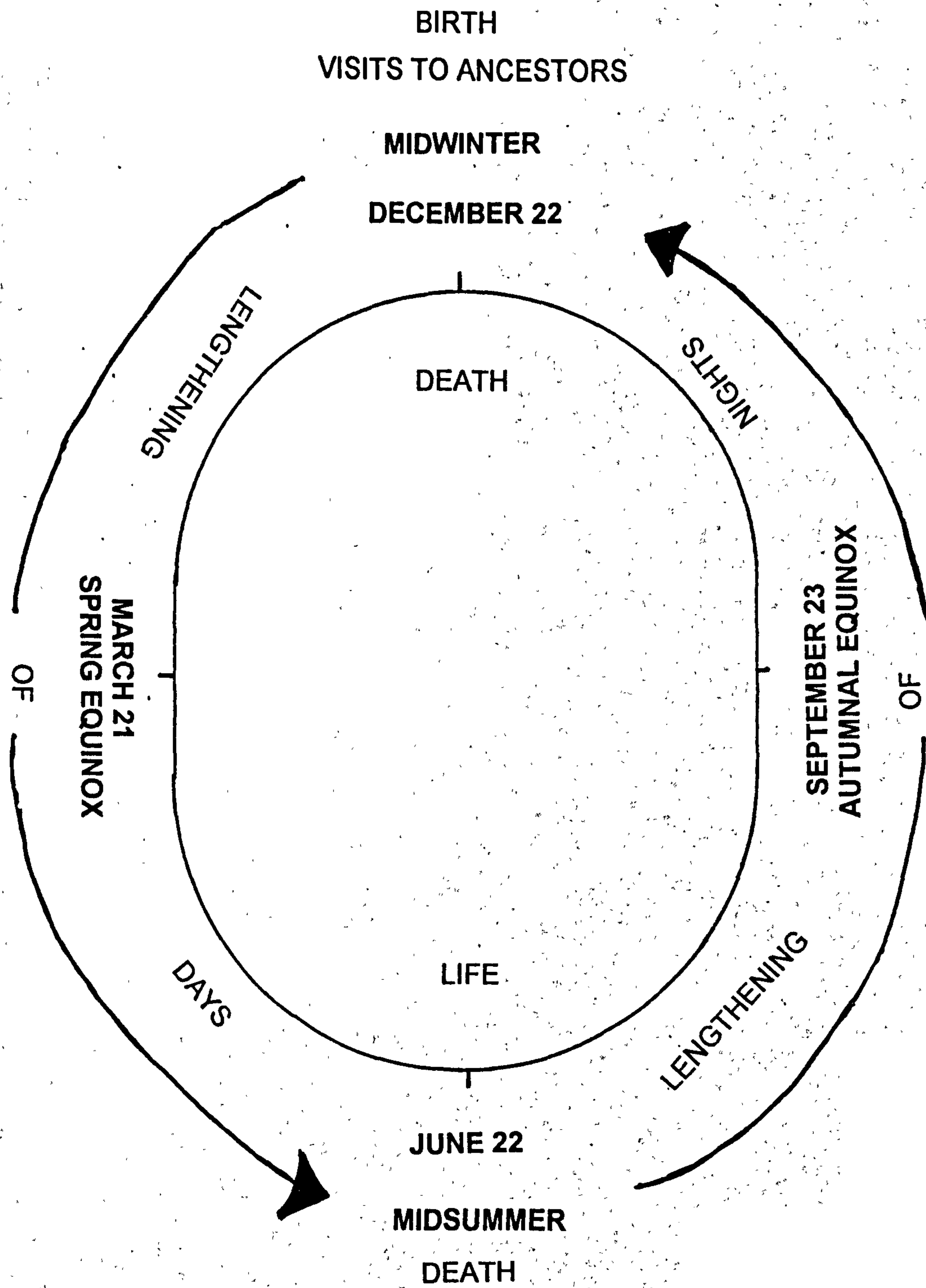


Figure 6.4 Bronze Age solar calendar.