

the enigma machine 2a: properties and essence  
lauren redhead

## Performance Notes

This piece consists of 92 chords which should be played one after the other.

In addition to this, four other configurations are suggested (for which the composer will be happy to make a score if requested). These are detailed below. Any other configuration may be put together by the performers, so long as it consists of 11 sets of related material. These relations need not be disclosed at the time of the performance. No repetition is permitted, unless of the whole piece.

### Configuration 2.a.i

3 58 48 27 43 20 41 64  
8 59 62 91 29 79 35 51 67  
9 2 65 19 36 73 42 60 92  
24 39 82 21 44 77 54 76 22  
25 49 83 31 57 79 63 16 68  
5 30 38 45 71 72 89  
50 75 32 46 66 81 78 17  
52 86 37 74 80 90 1 26  
53 6 47 87 4 10 7 28  
55 18 69 88 11 12 23 40  
56 33 84 13 15 14 34 61

Configuration 2.a.ii

3 8 9 24 25 50 52 53 55 56 58 59  
2 39 49 75 86  
6 18 33 48 62 65 68 82 83  
32 37 47 69 84 85 91  
19 21 31 46 74 87 88  
5 30 38 45 71 72 89  
13 27 29 36 44 57 66 80  
4 11 15 43 70 73 77 79 81 90  
10 12 14 20 35 42 54 63 78  
1 7 21 23 34 41 51 60 76  
16 17 26 28 40 61 64 67 92

Configuration 2.a.iii

28 29 48 49 63 78 87 91 92  
19 27 47 57 58 59 77 86  
9 26 46 54 56 76 85  
25 35 39 45 53 55 75 84 90  
1 10 20 30 40 50 60 70 80  
22 11 21 31 41 51 61 71 81  
8 18 24 44 65 67 74 83 89  
3 12 22 32 42 52 62 72 82  
7 23 37 43 64 66 73 79 88  
5 7 15 16 34 36 38 69

4 6 13 14 17 33 35 68

Configuration 2.a.iv

17 19 21 23 48 61 78

25 28 31 34 49 63 76

10 12 14 16 51 65 74 86 88

9 11 13 15 50 67 72 85 87

18 20 22 24 47 59 80

27 30 33 36 52 66 70 79 89 91 92

37 39 41 43 54 64 77 81 90

26 29 32 35 53 62 68 75 82 83 84

38 40 42 44 55 56 57 73

2 4 6 8 46 60 71

1 3 5 7 45 58 65 69

For Piccolo and Alto Flute

The following microtonal scheme is used:  
Precise microtones:

↓ ¼ flat

↓↓ ¾ flat

↑ ¼ sharp

↑↑ ¾ sharp

Inflectional microtones, each 8 < • < 14 c sharp or flat:



Accidentals apply only to the note they precede.

Duration:

○ Long (not necessarily equal) durations

● Short (not necessarily equal) durations

Directions apply only to the chord over which they are indicated.

Time:

↑ ↓ Cue the other performer

↕ Begin at the same time

↙ ↘ Begin after the previous action

All other chords concurrently, without synchronising with each other

Where no line joins the two staves, play without any recourse to each other.  
Where a tempo is indicated, this should be strict.

Other peculiarities of notation are explained in the score.  
Except where indicated, please play at all times without vibrato.  
Please play from the full score.

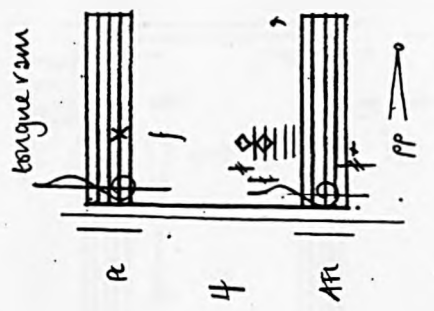
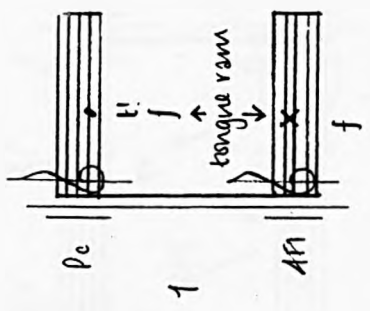
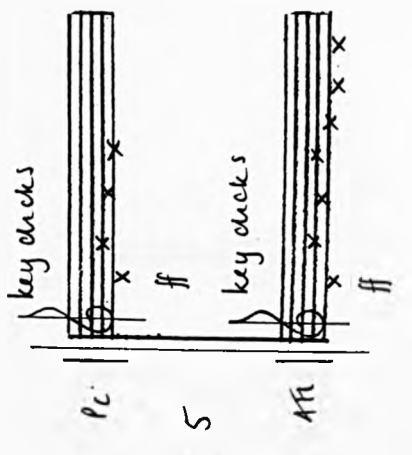
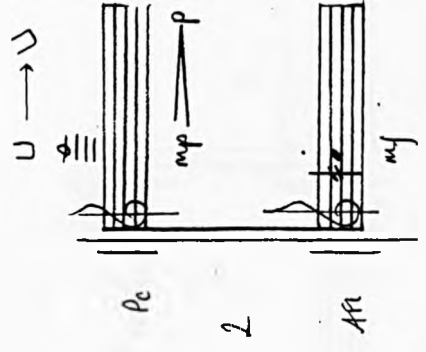
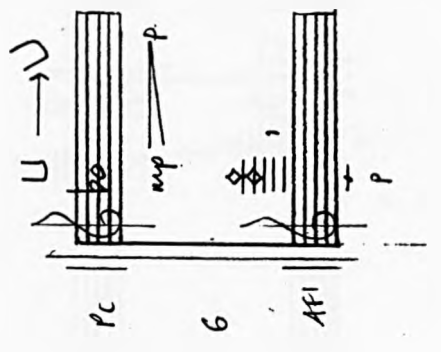
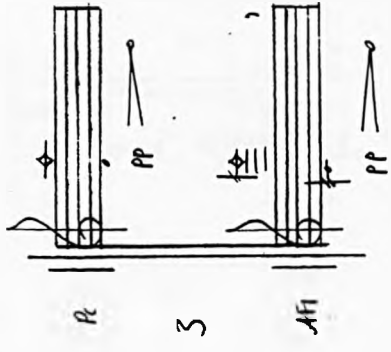



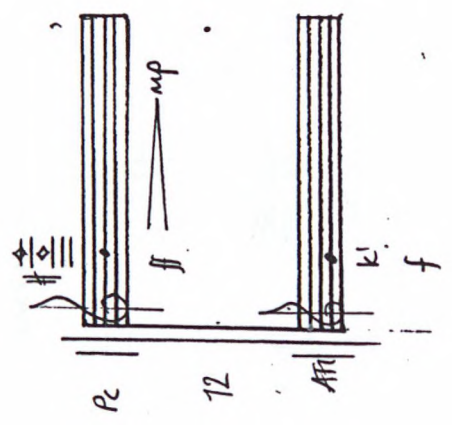
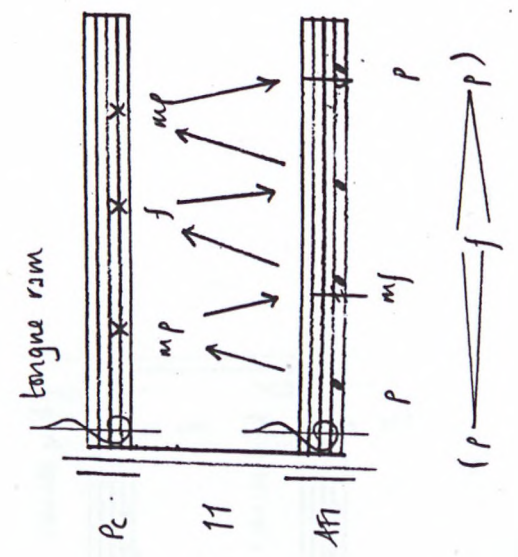
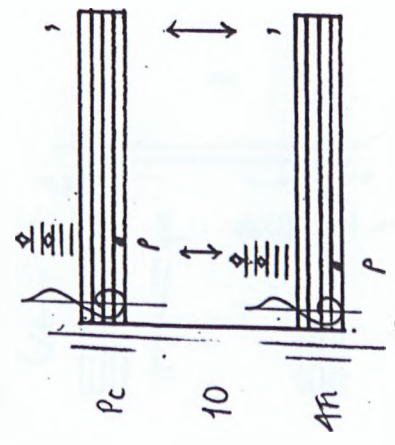
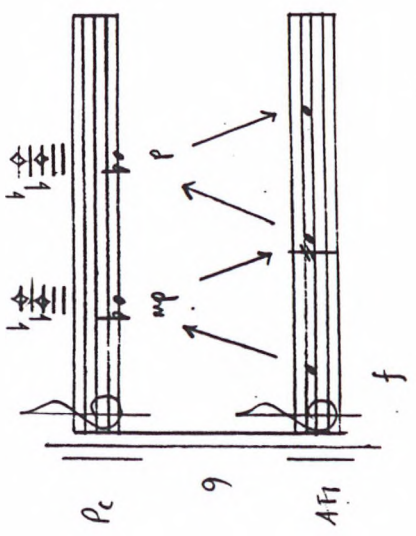
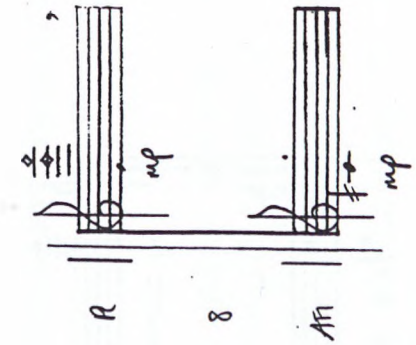
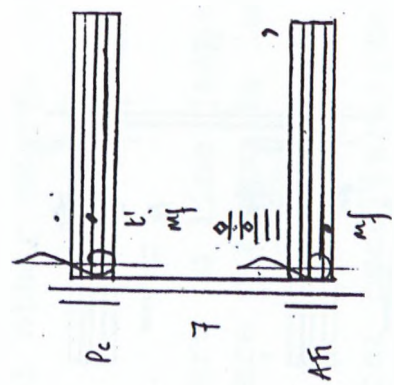

13

Pc

pp

playing and singing

ffzg

pp

ATr

pp

14

Pc

mp

playing and singing

p

mp

ATr

p

mp

15

Pc

f

playing and singing

f

f

ff

f

ATr

f

ff

f

tongue roll

16

Pc

p

playing and singing

pp

ff

ATr

pp

ff

17

Pc

mp

playing and singing

mp

ff

ATr

mp

ff

nb (breath)

18

Pc

p

ATr

p

♩ = 120

19

Pc

2iv

ff

vib (brema)

AFI

pp

20

Pc

$\text{♩} = 100$

mf

f

mp

(d)

(d)

AFI

mf

f

mf

(d)

(d)

21

Pc

2iv

ff

AFI

mf

22

Pc

$\text{♩} = 112$

ff

AFI

ff

23

Pc

k!

k!

k!

k!

↓

↓

↓

↓

AFI

t!

t!

t!

t!

ff

24

Pc

$\text{♩} = 120$

f

AFI

f

25

Pc

ff

↑ air

26

Pc

mf

playing and singing

AFl

tongue ram

ff

27

Pc

fleg

p

f

AFl

mp

gloss

28

Pc

playing and singing

mp

AFl

f

29

Pc

fleg

mp

p

AFl

mp

30

Pc

f

ff

AFl

f

Pc  
 31  
 AFI

'f' > 'p' 'f' > 'p'  
 'f' > 'p' 'f' > 'p'

Pc  
 - 32  
 AFI

pp ppp  
 p pp  
 fleg

Pc  
 S3  
 AFI

mf  
 playing and singing  
 mf  
 mf p  
 guss guss

Pc  
 S4  
 AFI

d1  
 f  
 playing and singing  
 mp

Pc  
 S5  
 AFI

pp  
 pp

Pc  
 S6  
 AFI

fleg  
 f > p  
 molto vibrato (instrument)  
 mf

37

Pc

vib (breath)

pp — p — pp

AFl

longue rsm

sfz p —

38

Pc

key clicks

lv

ff

AFl

key clicks

lv

ff

39

Pc

ff

AFl

ff

40

Pc

playing and singing

f > mp

AFl

gliss

k!

f — mp

41

Pc

d!

f

AFl

pp

42

Pc

mp

AFl

vib (breath)

mp

43

Pc

ff

tr

mf

tongue rsm

44

Pc

mp

mf

mp

tr

f

mp

vib (instrument)

45

Pc

ff

tr

ff

key clicks

46

Pc

ff

tr

pp

stg

air sound

47

Pc

ff

tr

f

mf

ff

mp

f

(d)

(d)

(d)

3

♩ = 100

48

Pc

sfz

tr

f

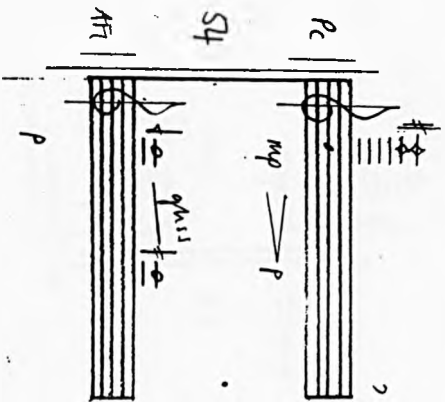
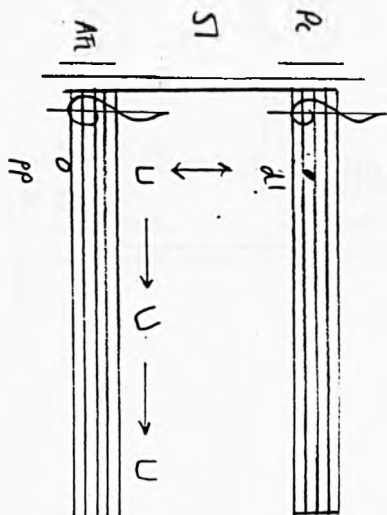
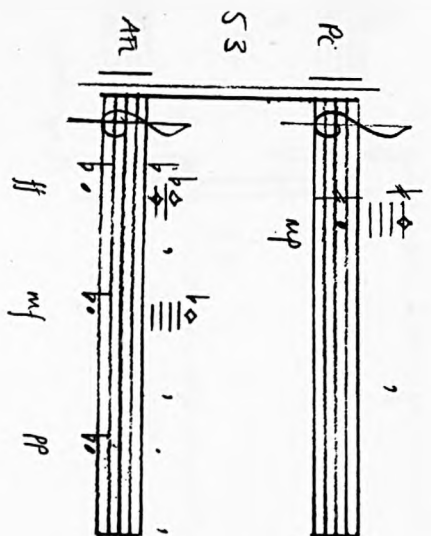
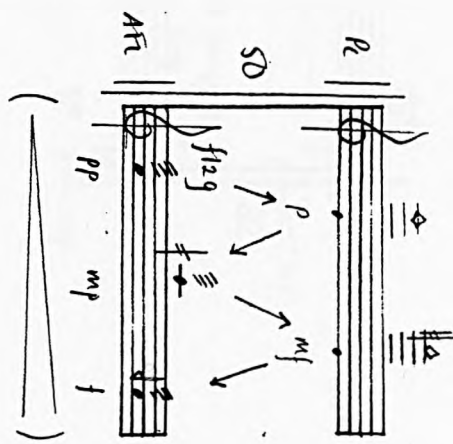
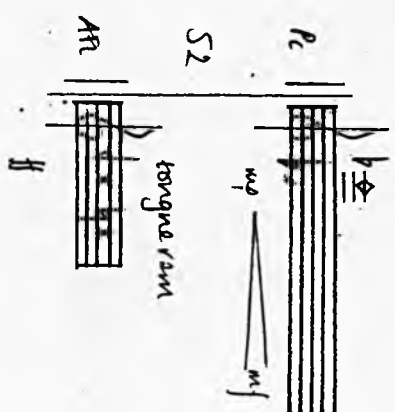
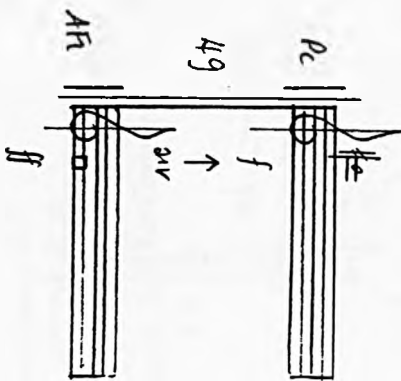



Handwritten musical notation for rehearsal mark 55. It consists of two staves: *Pc* (Piano) and *AFI* (Acoustic Fiddle). The *Pc* staff has a treble clef and a key signature of one flat. The *AFI* staff has a treble clef. The *Pc* part starts with a whole note chord, marked *pp*. The *AFI* part starts with a whole note chord, marked *f*. There is a handwritten *di* above the *AFI* staff.

Handwritten musical notation for rehearsal mark 56. It consists of two staves: *Pc* (Piano) and *AFI* (Acoustic Fiddle). The *Pc* staff has a treble clef and a key signature of one flat. The *AFI* staff has a treble clef. The *Pc* part starts with a whole note chord, marked *pp*. The *AFI* part starts with a whole note chord, marked *mp*. The text "playing and singing" is written above the *AFI* staff, and "ghis" is written below it.

Handwritten musical notation for rehearsal mark 57. It consists of two staves: *Pc* (Piano) and *AFI* (Acoustic Fiddle). The *Pc* staff has a treble clef and a key signature of one flat. The *AFI* staff has a treble clef. The *Pc* part starts with a whole note chord, marked *mf*. The *AFI* part starts with a whole note chord, marked *f*. The text "sing" is written above the *Pc* staff, and "air sound" is written above the *AFI* staff. An arrow labeled "U" points to the right above the *Pc* staff.

Handwritten musical notation for rehearsal mark 58. It consists of two staves: *Pc* (Piano) and *AFI* (Acoustic Fiddle). The *Pc* staff has a treble clef and a key signature of one flat. The *AFI* staff has a treble clef. The *Pc* part starts with a whole note chord, marked *mp*. The *AFI* part starts with a whole note chord, marked *p*.

Handwritten musical notation for rehearsal mark 59. It consists of two staves: *Pc* (Piano) and *AFI* (Acoustic Fiddle). The *Pc* staff has a treble clef and a key signature of one flat. The *AFI* staff has a treble clef. The *Pc* part starts with a whole note chord, marked *p*. The *AFI* part starts with a whole note chord, marked *p*. A tempo marking  $\text{♩} = 100$  is written to the left of the staves. The text "playing and singing" is written above the *AFI* staff.

Handwritten musical notation for rehearsal mark 60. It consists of two staves: *Pc* (Piano) and *AFI* (Acoustic Fiddle). The *Pc* staff has a treble clef and a key signature of one flat. The *AFI* staff has a treble clef. The *Pc* part starts with a whole note chord, marked *p*. The *AFI* part starts with a whole note chord, marked *pp*.

playing and singing

Pc

vib.

mf

61

playing and singing

ATI

mp

mf

mp

Pc

62

p

mp

ATI

p

mp

Pc

63

mf

ATI

ff

mp

playing and singing

Pc

mf

64

ATI

f

mf

molto vibrato (microgussandos)

Pc

65

p

ATI

molto vibrato (microgussandos)

p

fl2 g

Pc

p

mp

p

66

ATI

fl2 g

p

mp

playing and singing

Pc

67

ATI

f ff

Pc

68

ATI

mp mf

mf f

air sound

Pc

69

ATI

f

vib (instrument)

u

f mp

tongue ram.

Pc

70

ATI

f

glass

p mp p

key clicks

Pc

71

ATI

br

key clicks

ff

open

Pc

72

ATI

ff

73

pc

mf

ff

mf

ATr

longue rsm

74

pc

ff

f

ATr

longue rsm

75

pc

mf

ff

mp

mf

ATr

77

pc

ff

pp

ATr

longue rsm

78

pc

f

ff

pp

ATr

79

Pc

4Fl

tongue rsm

ff

air

f  $\rightarrow$  mp

80

Pc

80

4Fl

ff

tongue rsm

f ff f

$\text{♩} = 132$

flzg

81

Pc

81

4Fl

tongue rsm

ff

flzg

f  $\rightarrow$

82

Pc

82

4Fl

vib (instrument)

mf  $\rightarrow$

f

83

Pc

83

4Fl

molto vibrato (microglissandos)

mp

air

f f

84

Pc

84

4Fl

mf  $\rightarrow$  p

playing and singing

mp mf

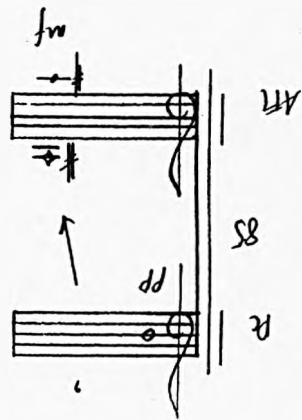
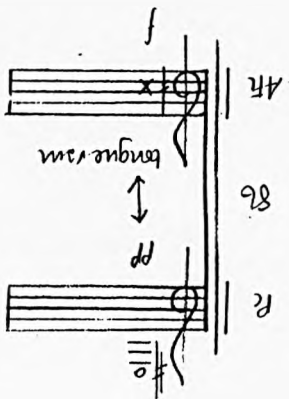
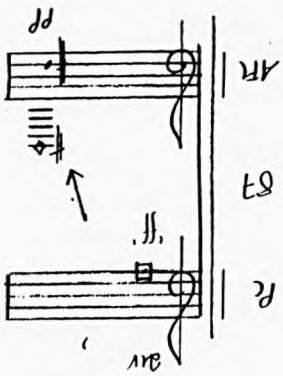
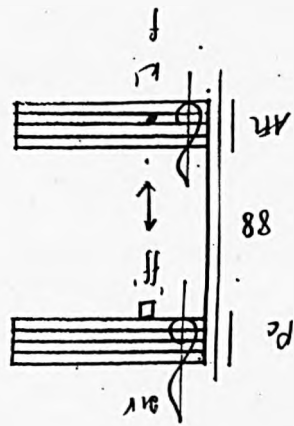
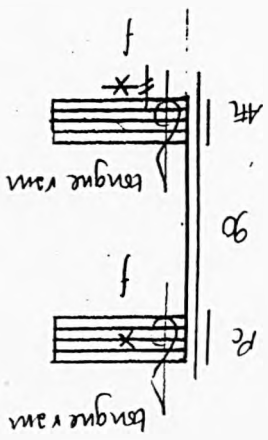

musical score for measures 91-92. The score is written for two staves: Pe (Piano) and AF1 (Acoustic Fiddle).  
Measure 91: Pe part starts with a note on the first line (G4), followed by a slur over a glissando (microglissandos) to a note on the second line (A4). The instruction "molto vibrato (instrument)" and "[microglissandos]" are written above the staff. The dynamic is "p".  
Measure 92: AF1 part has a single note on the first line (G4) with a vibrato line above it. The instruction "molto vibrato (instrument)" and "[microglissandos]" are written above the staff. The dynamic is "p".

musical score for measures 91-92. The score is written for two staves: Pe (Piano) and AF1 (Acoustic Fiddle).  
Measure 91: Pe part starts with a note on the first line (G4), followed by a slur over a glissando (microglissandos) to a note on the second line (A4). The instruction "playing and singing" is written above the staff. The dynamic is "mp".  
Measure 92: AF1 part has a single note on the first line (G4) with a vibrato line above it. The instruction "molto vibrato (instrument)" and "[microglissandos]" are written above the staff. The dynamic is "mp".