

The typology of industrial buildings
with reference to the steel trades in
Sheffield, 1750-1900

by
Williams, Alan Owen

University of Sheffield
PhD 2003

**The typology of industrial buildings
with reference to the steel trades in Sheffield, 1750-1900**

Volume 2: Illustrative material and appendices

submitted by

Alan Owen Williams, BA, Dip Arch, MA (Sheffield)

for the degree of Doctor of Philosophy

Faculty of Architectural Studies, The University of Sheffield

2003



IMAGING SERVICES NORTH

Boston Spa, Wetherby
West Yorkshire, LS23 7BQ
www.bl.uk

CONTAINS
PULLOUTS



Fig. 1.1 Damascus steel blades displaying the characteristic water pattern.

GEORGII AGRICOLAE

DE RE METALLICA LIBRI XII ▷ QVI
 bus Officia, Instrumenta, Machinae, ac omnia denique ad Metallie-
 ram spectantia, non modo luculentissime describuntur, sed & per
 effigies, suis locis insertas, adiunctis Latinis, Germanicisque appella-
 tionibus ita ob oculos ponuntur, ut clarius tradi non possint.

E I V S D E M

DE ANIMANTIBUS SVBERRANEIS Liber, ab Autore reco-
 gnitus: cum Indicibus diuersis, quicquid in opere tractatum est,
 pulchre demonstrantibus.



BASILEAE M ▷ D ▷ LVI ▷

Cum Priuilegio Imperatoris in annos v.
 & Galliarum Regis ad Sexennium.

Fig. 1.2 Frontispiece to Agricola's *De Re Metallica*.

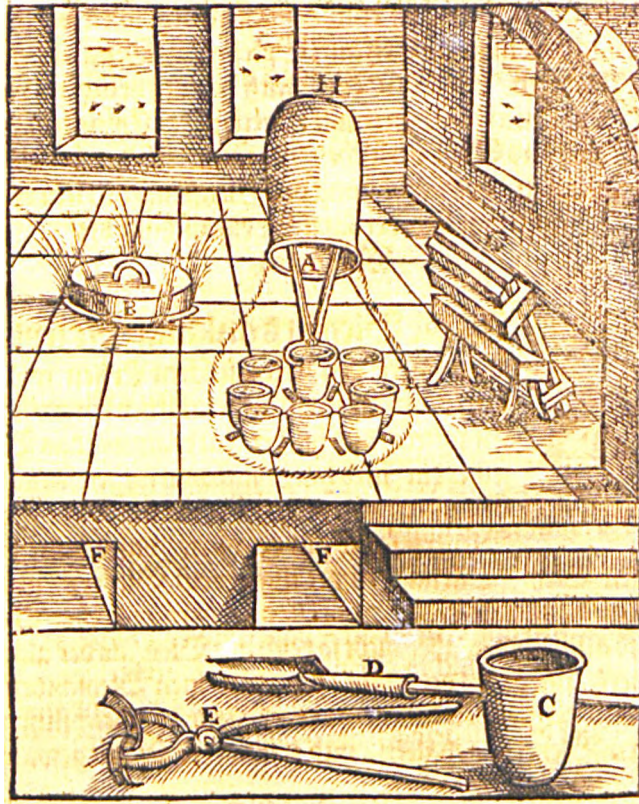

Fig. 1.3 Illustration of a brass furnace from Lazarus Ercker's treatise of 1598.

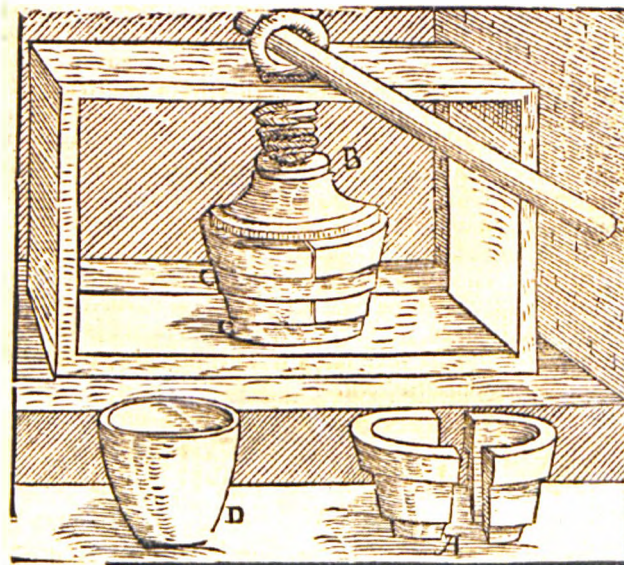

Fig. 1.4 Crucible manufacture from Ercker (1598).

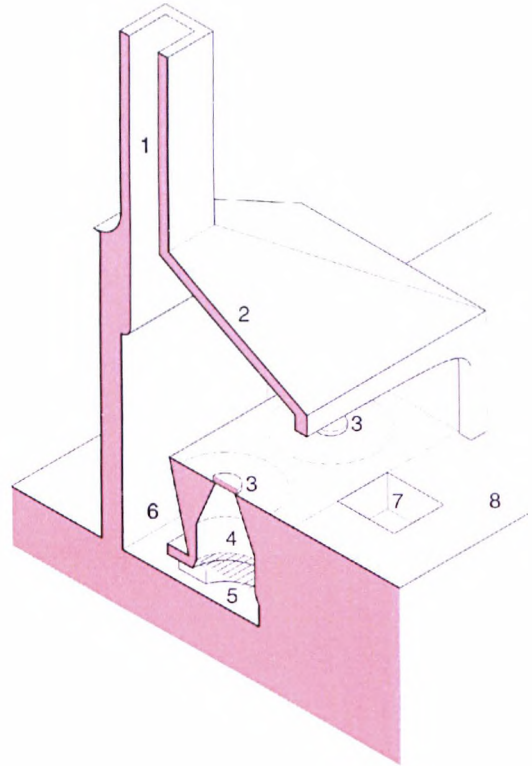
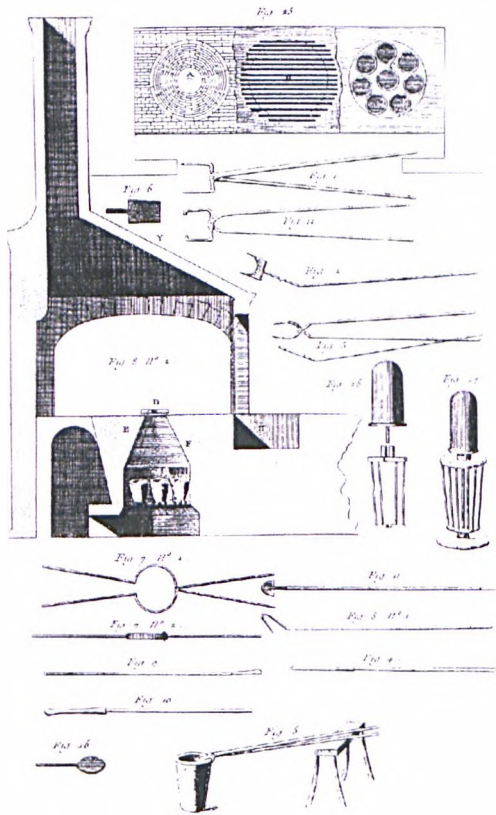
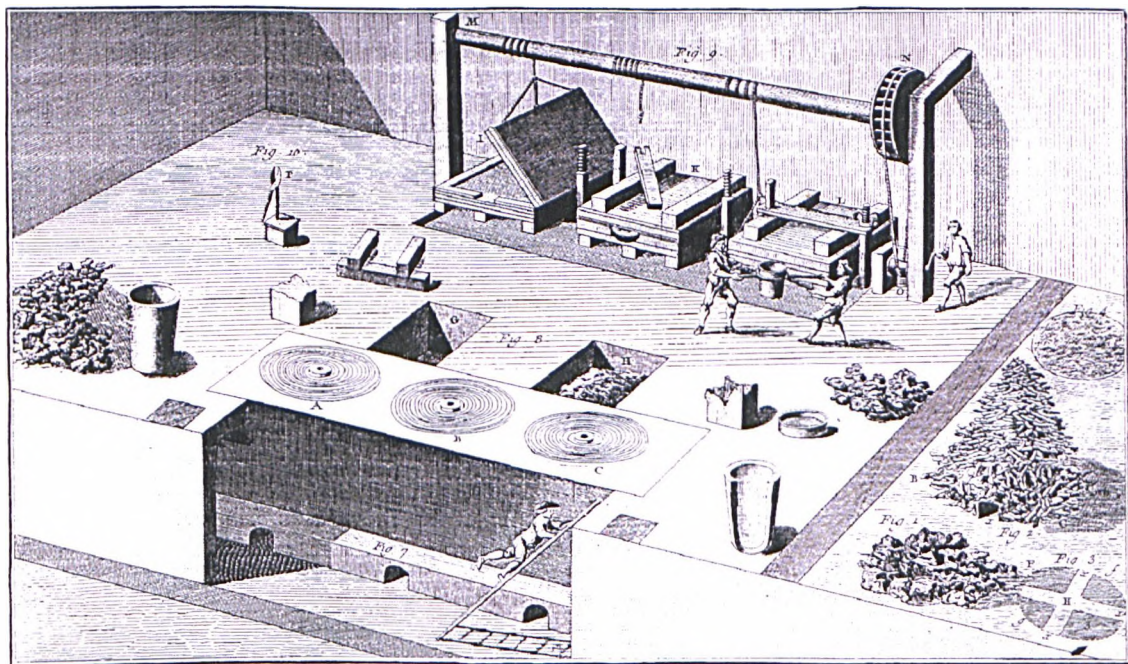

Fig. 1.5 (left) Calamine or brass furnace from the *Encyclopédie*.

Fig. 1.6. (right) Isometric reconstruction of the calamine furnace (author).



Métallurgie, calamine, conder du Cuivre en Table, Venue ou l'on travaille le cuivre coulé et Tréfilerie.

Fig. 1.7 Interior of an eighteenth century brass manufactory from the *Encyclopédie*.

Calamine or brass furnace from the *Encyclopédie*

Reconstructed sectional isometric

key:

- 1 Ventilation chimney
- 2 Masonry hood over melting holes
- 3 Furnace lids
- 4 Furnace above grate (space for 8 crucibles)
- 5 Ash pit below grate
- 6 Access to ash pits (reached by ladder from shop floor)
- 7 Pit for calamine
- 8 Shop floor

Source:

Encyclopédie, plates vol. 6, 'Histoire naturelle', 'Métallurgie: Calamine' plates 1, 2.

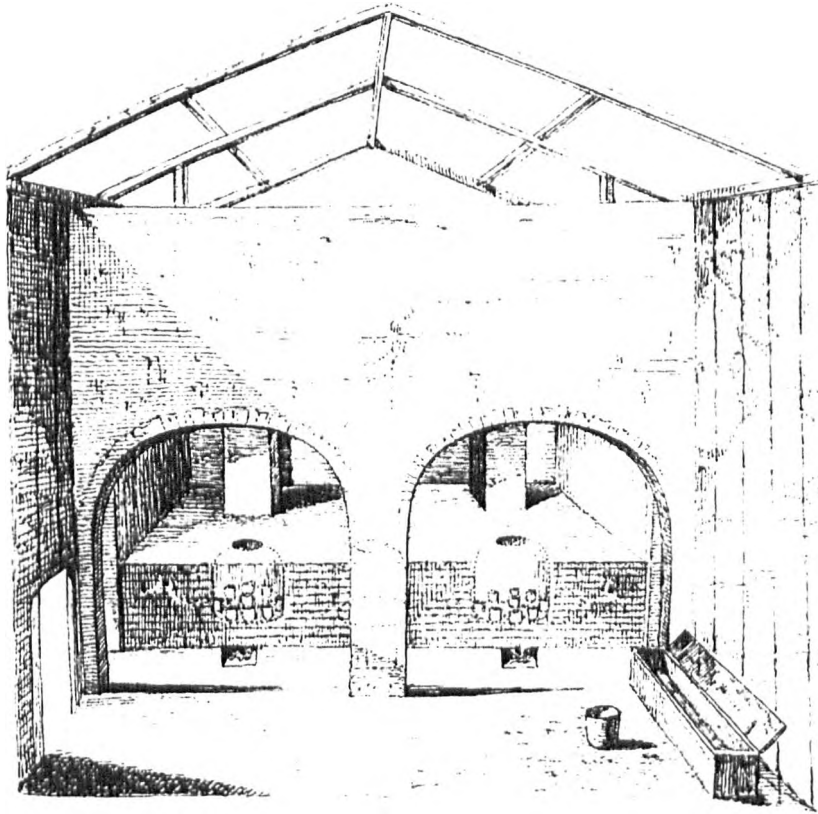

Fig. 1.8 Angerstein's rendering of a brass furnace seen at Birmingham in 1754.

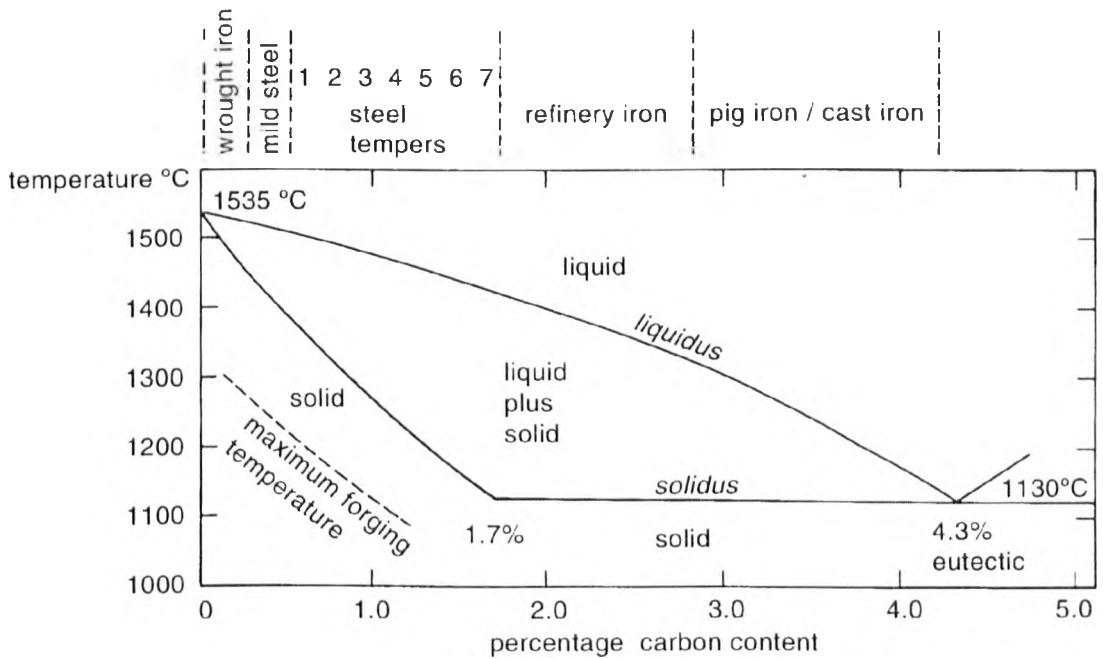

Fig. 1.9 The changing melting point of steel based on its carbon content (adapted from Barraclough 1984).



Fig. 1.10 Photograph of Huntsman's cottage and outbuildings at Handsworth (SCL).

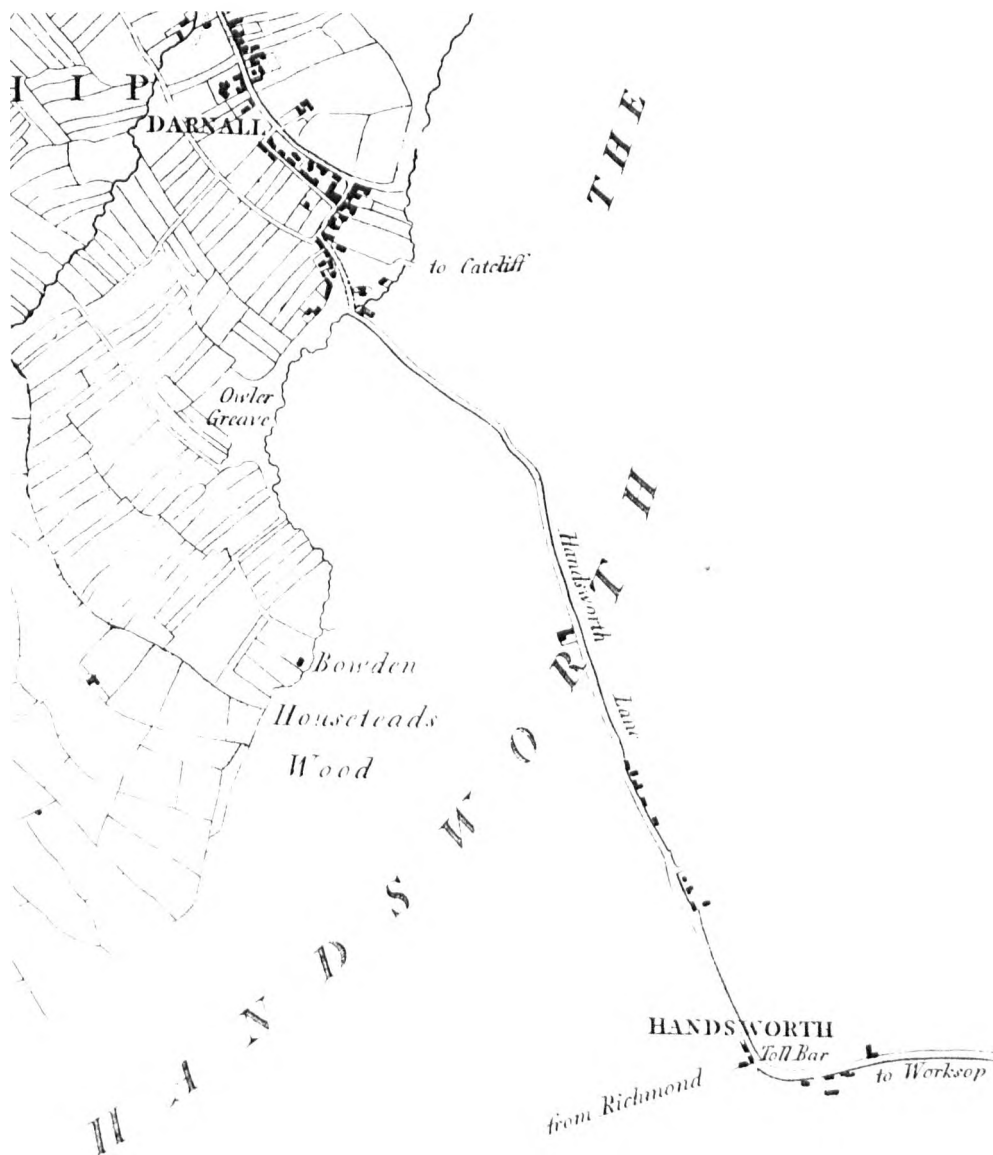

Fig. 1.11 Handsworth from Fairbank's 1795 Map of the Parish of Sheffield.

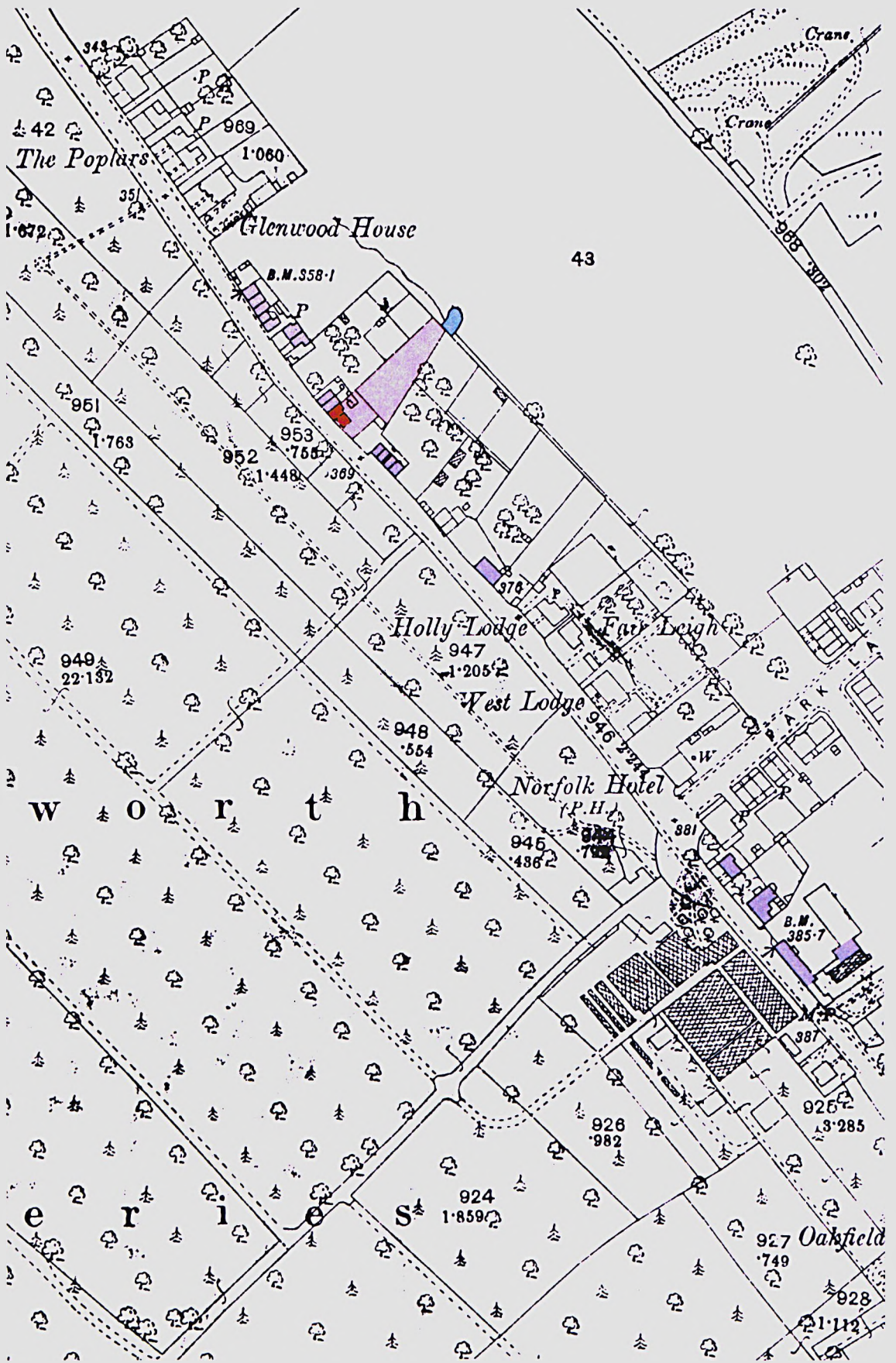

Fig. 1.12 1850 OS plan showing the Handsworth cottage and land formerly occupied by Huntsman coloured red, with pond at the rear and other 18th century structures in grey (author's colours). Scale six inches to the mile (1:10560).



Fig. 1.13 (inset) Huntsman's steel furnaces recorded in Fairbank survey notes of 1763.
 Fig. 1.14 (main picture) The same survey redrawn to scale, 1:1000 (author).

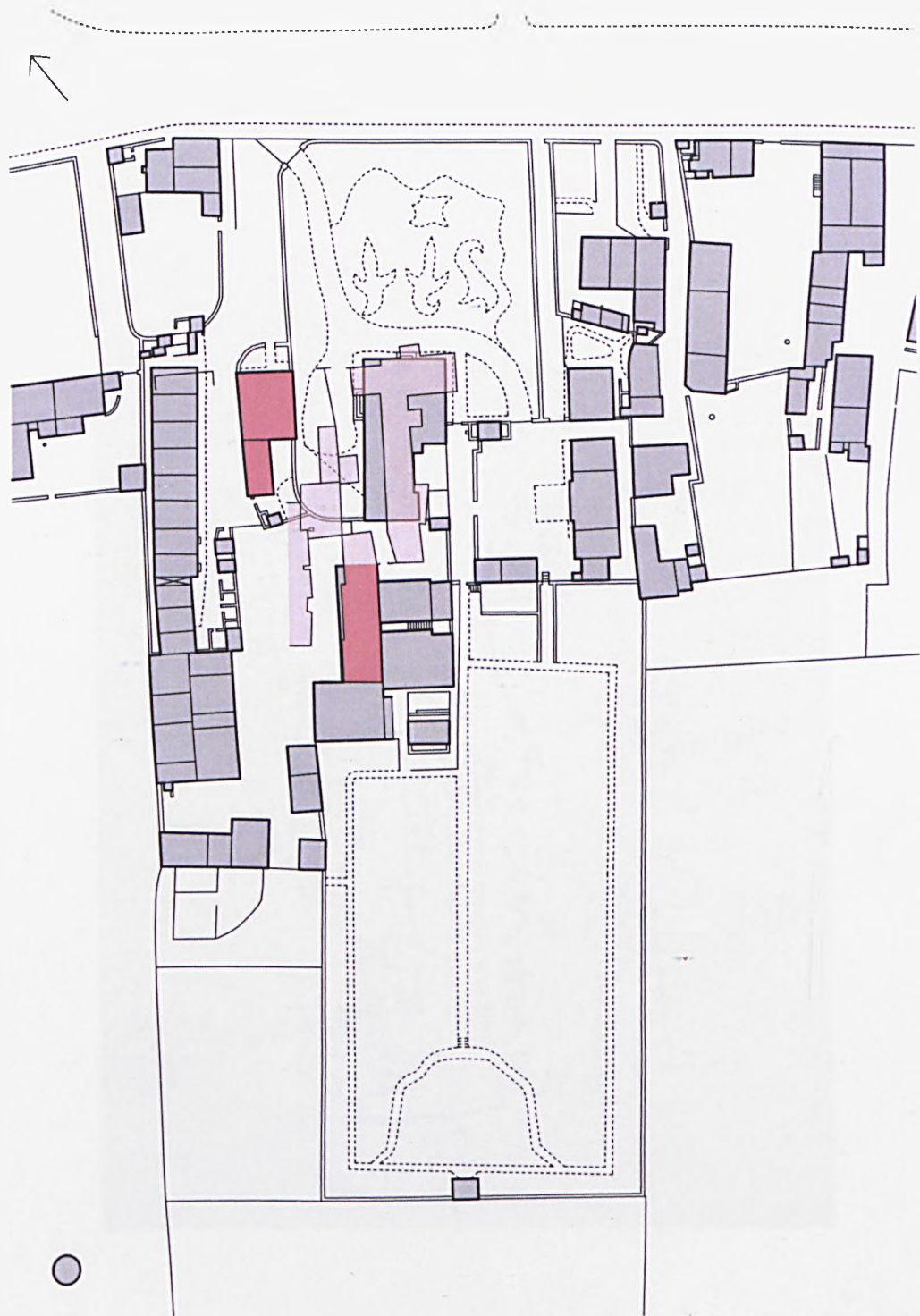

Fig. 1.15 Huntsman's 1781 site layout (pink) superimposed on the 1850 plan (grey) with coincident structures shown in red. Scale 1:1000 (author).

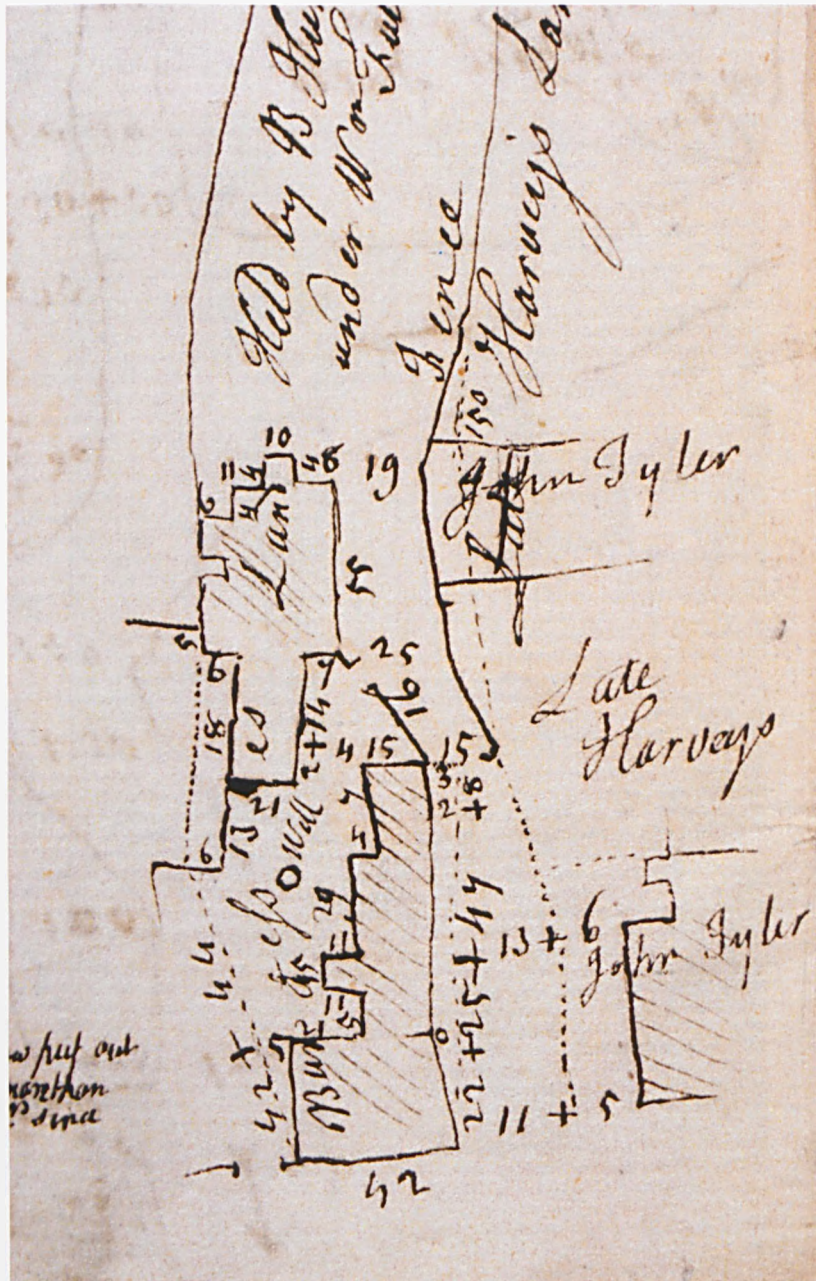

Fig. 1.16 Fairbank survey of Huntsman's steelworks in 1767 (detail), indicating the well in the back yard. North is at bottom right (SCL).

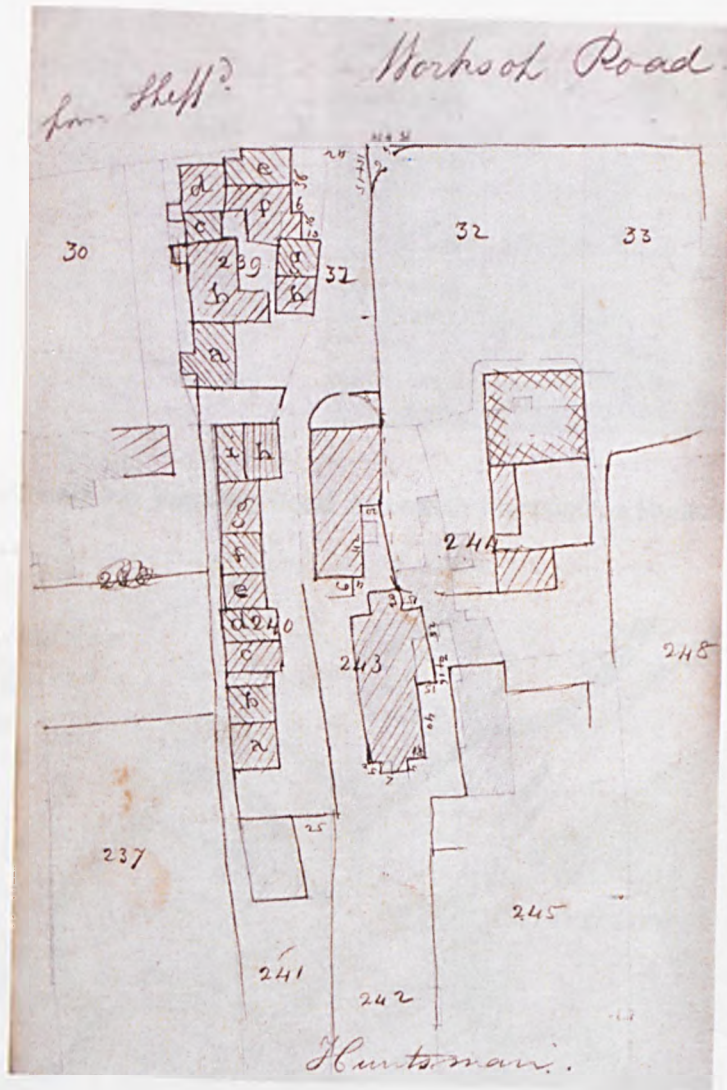

Fig. 1.17 1819 rate assessment survey of Huntsman's works. The 1781 plan can be seen as a faint pencil drawing behind, with new measurements in pen. North is at top left (SCA).



Fig. 1.18 The Britannia Inn, Worksop Road, incorrectly identified as Huntsman's house.

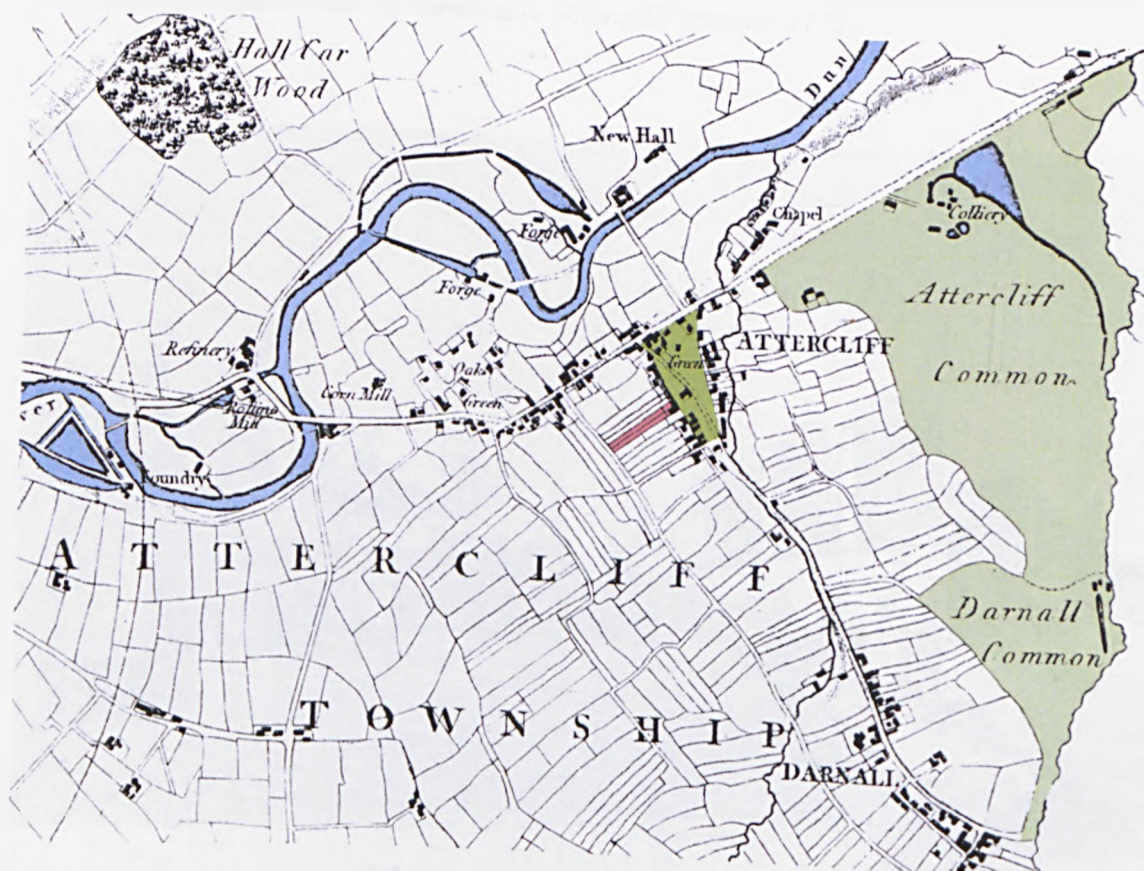

Fig. 1.19 Attercliffe Green (dark green) and Attercliffe Common (pale green) in 1795. Huntsman's land is highlighted in red (author's colours).

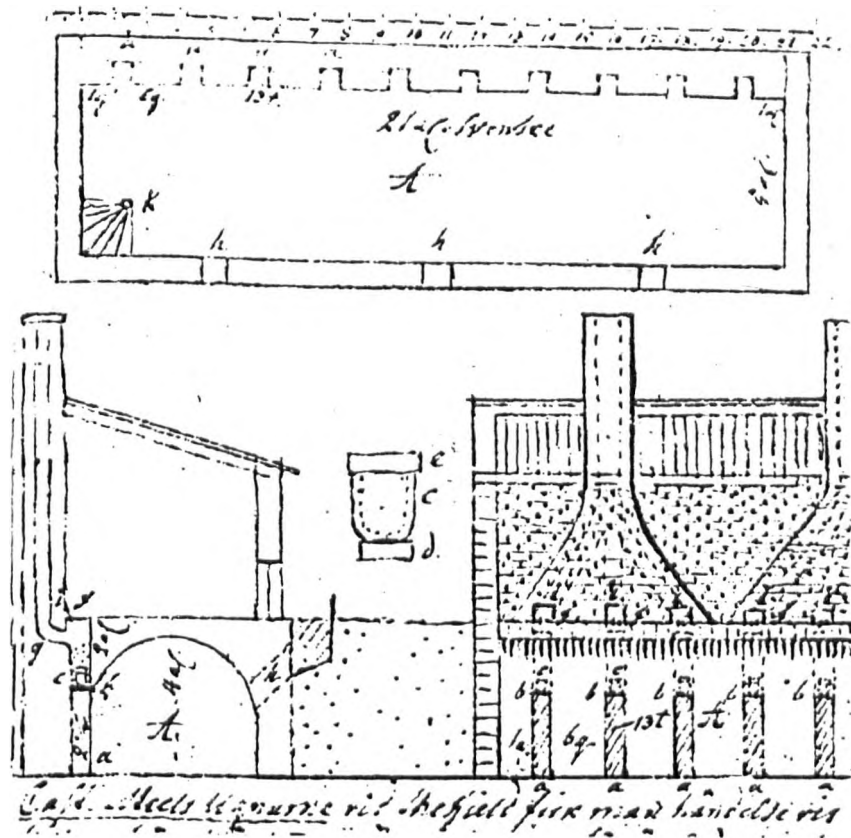

Fig. 1.20 Erik Geisler's three-view drawing of a Sheffield crucible furnace, almost certainly made during or after a visit to Huntsman's Attercliffe works in 1772.



Fig. 1.21 Sketch of Huntsman's steelworks by local artist William Topham made between 1850 and 1889, probably closer to the later date (SCL).

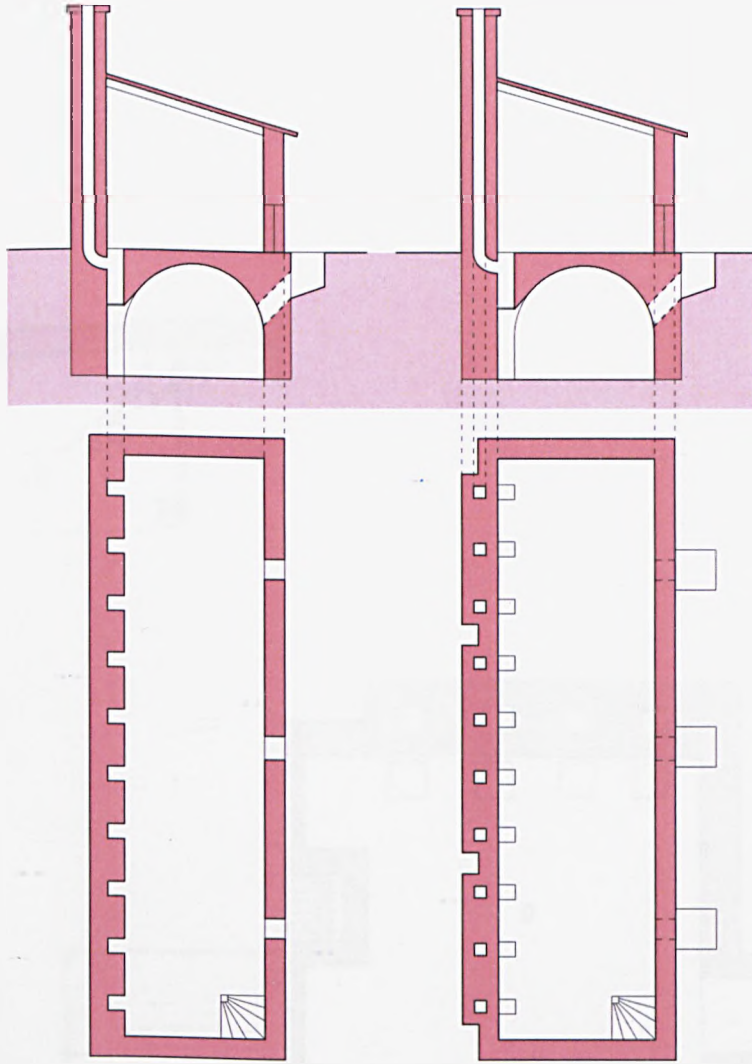

Fig. 1.22 Reconstruction of Huntsman's ground floor plan (right) from information contained in the section (above) and basement plan (left). Scale 1:200 (author).

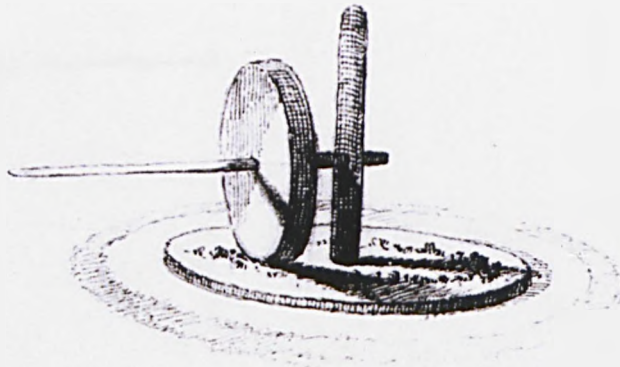

Fig. 1.23 Horse-powered edge roller mill for crushing bricks as seen by Angerstein at Bristol in 1754.

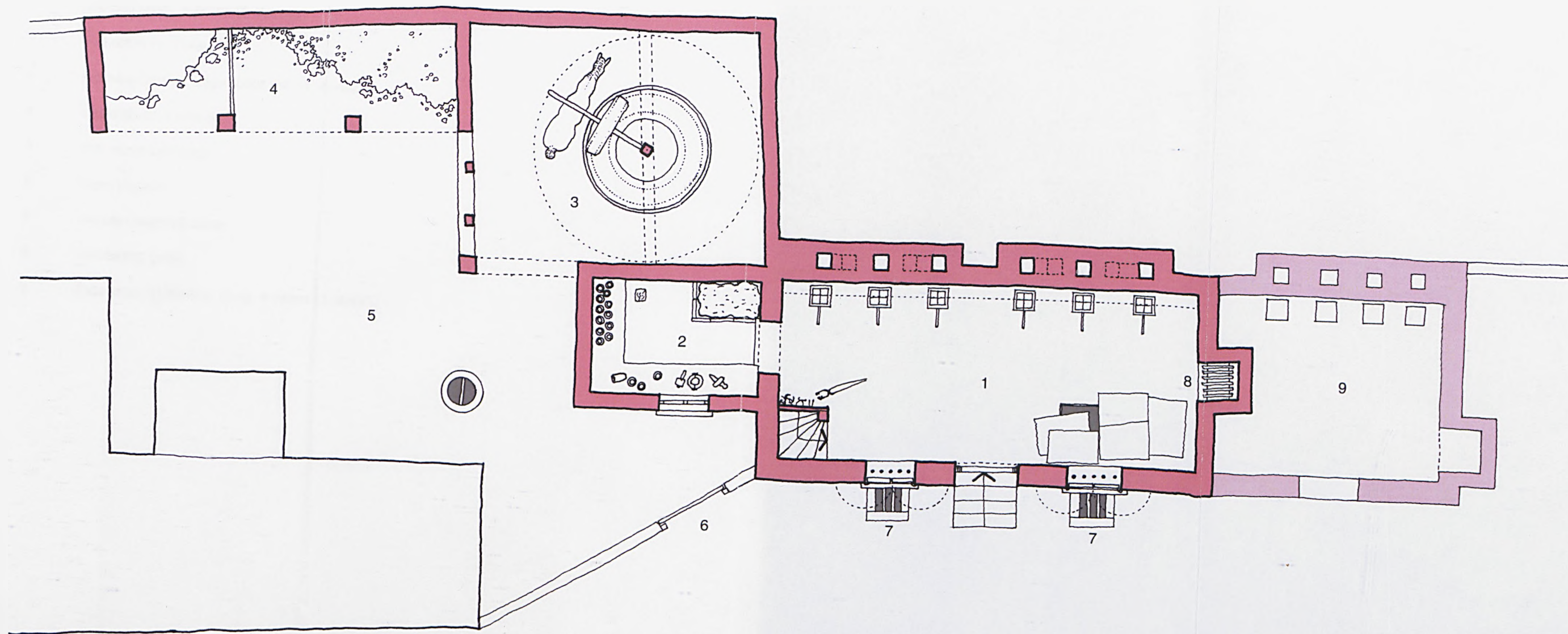

Fig. 1.24 Reconstructed plan of Huntsman's original 1750 steel furnaces, situated immediately behind his cottage. Scale 1:100 (author).

B Huntsman Ltd.

Attercliffe steelworks, reconstructed ground plan (1751-1781)

scale 1:100

key:

- 1 Melting shop, 6 holes (1 storey)
- 2 Pot room (1 storey)
- 3 Horse-powered edge roller mill (1 storey)
- 4 Coke shed (1 storey)
- 5 Backyard with well
- 6 Gate to yard
- 7 Air passages to cellar
- 8 Annealing grate
- 9 Extension to melting shop, 4 holes (1 storey)

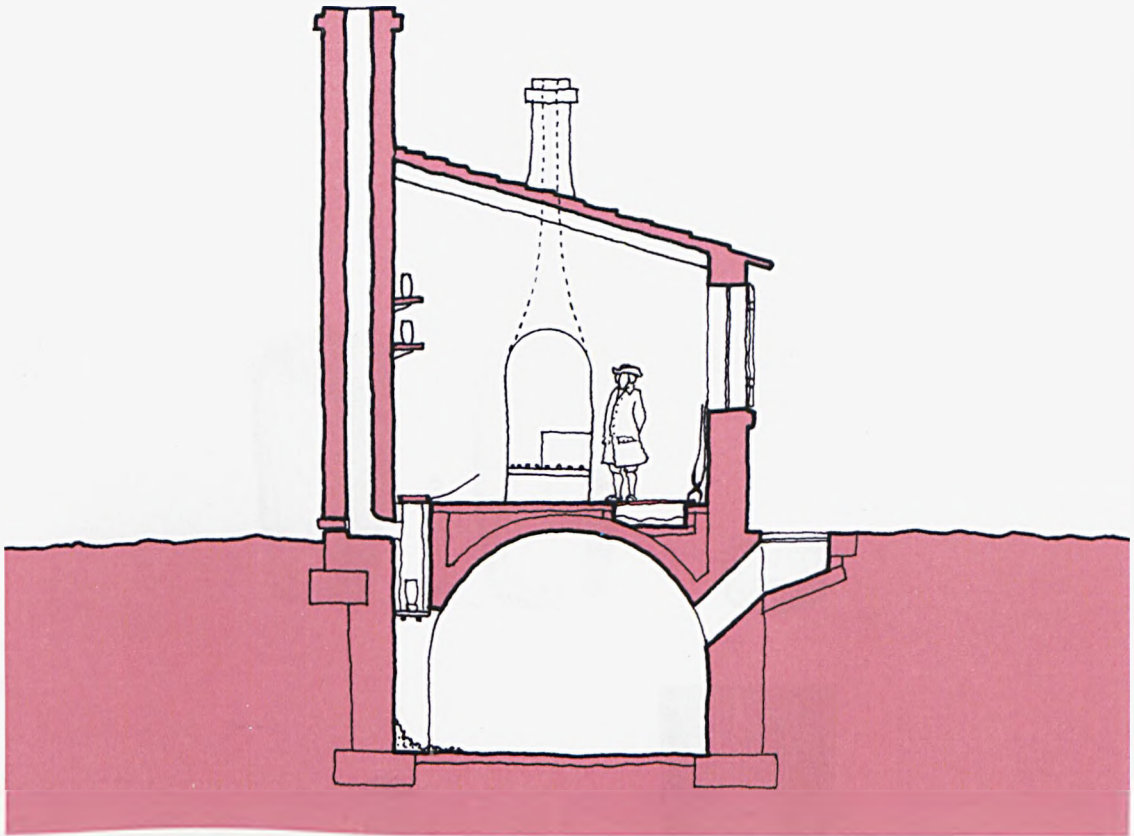

Fig. 1.25 Section of Huntsman's steel melting shop of 1751, with the crucible holes at the left of the vaulted cellar and annealing stove on the back wall. Scale 1:100 (author).

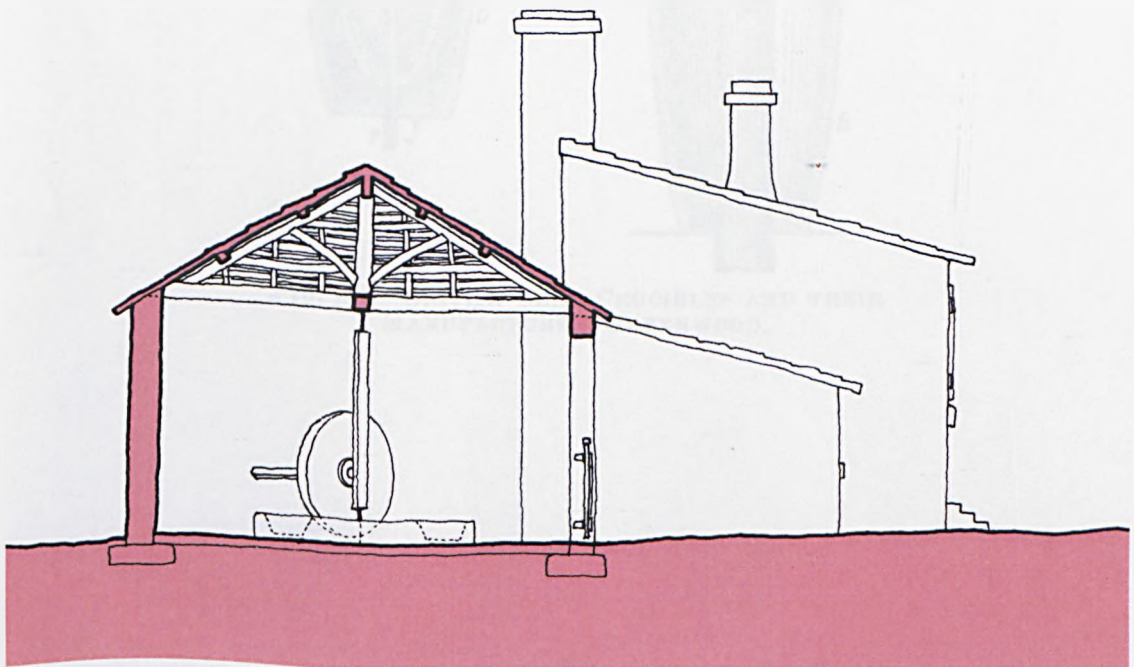

Fig. 1.26 Section through the horse-powered edge roller mill with melting shop in the background, c.1763. Scale 1:100 (author).

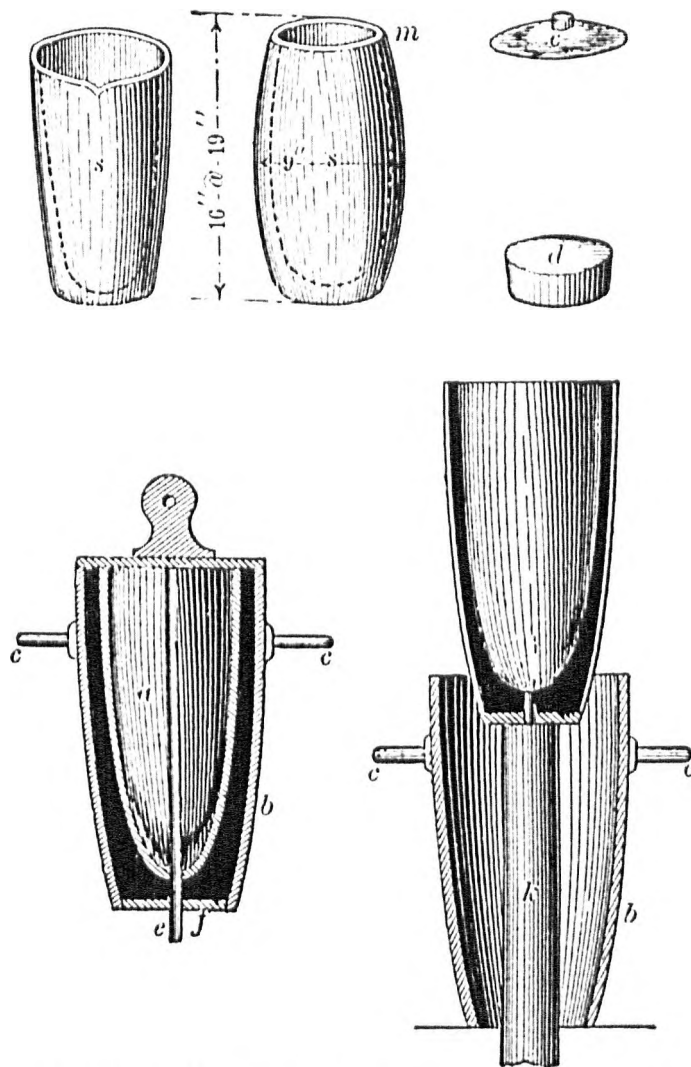

Fig. 151. BRITISH CLAY CRUCIBLES AND THEIR MANUFACTURE. GREENWOOD.

Fig. 1.27 The stages of crucible manufacture from a nineteenth century textbook. The parts include plug (a), flask (b), handles (c), and tree (k).

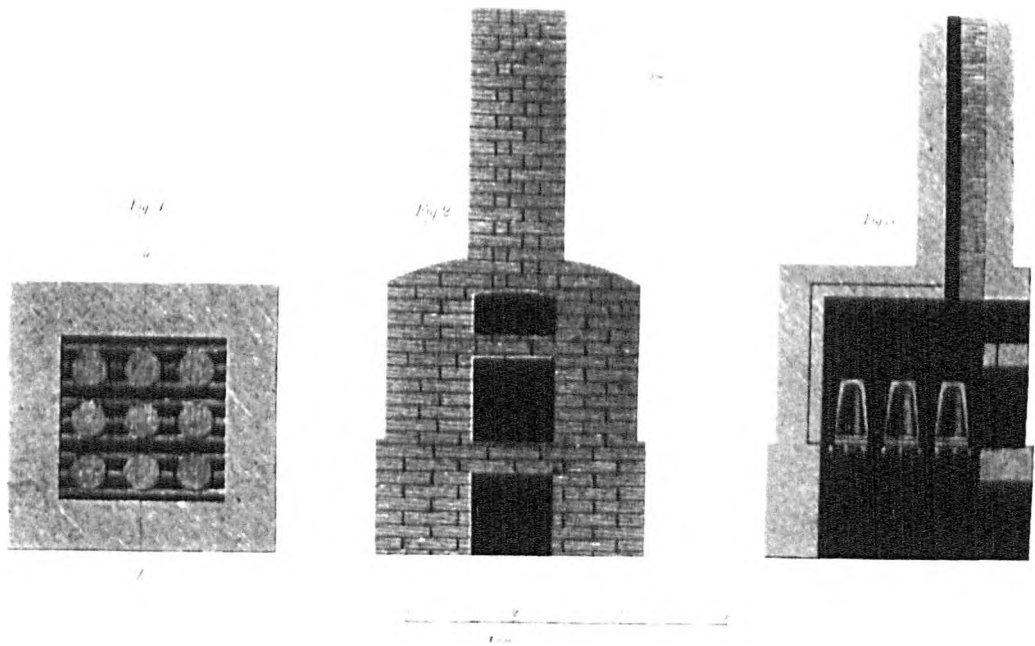

Fig. 1.28 Three-view drawing of an annealing stove, from Gustav Broling's report on the crucible process.

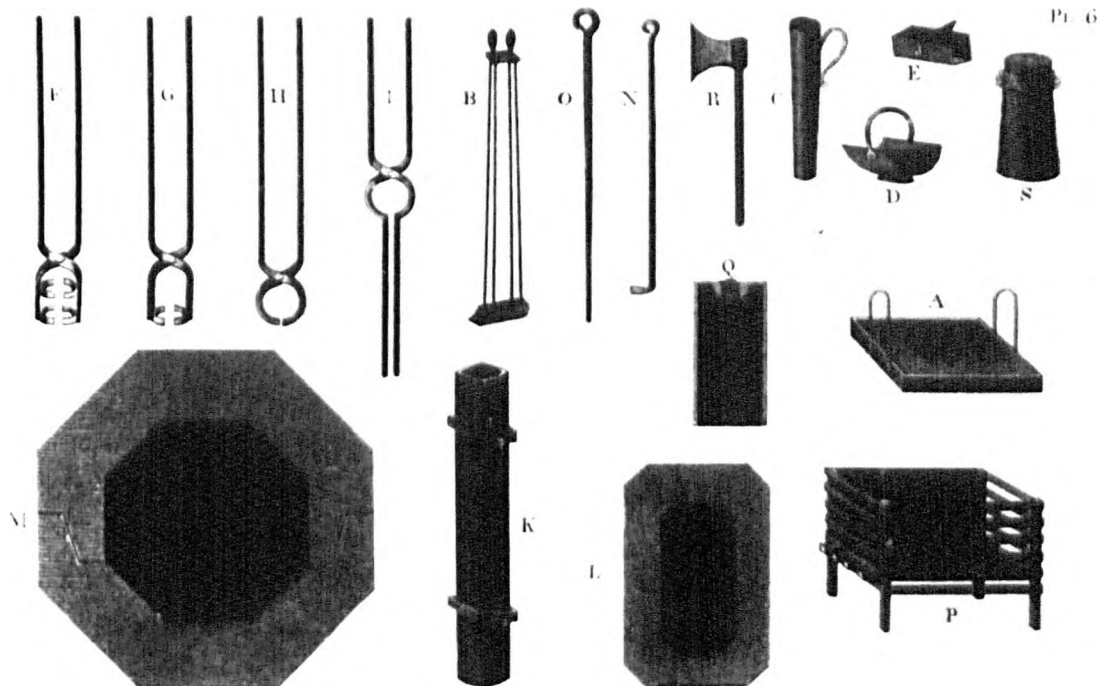

Fig. 1.29 Broling's illustration of the equipment used in Sheffield crucible furnaces.



Fig. 1.30 Teeming molten steel into the preheated ingot moulds, twentieth century. The assistant left foreground is removing surface slag with a slag-tipped rod (SCL).



Fig. 1.31 Proximity of water-powered forges (circled red) to Huntsman's Attercliffe steelworks, from the 1795 plan (author's colours).



Fig. 1.32 Detail of William Fairbank's 1781 additions to the earlier survey of the Attercliffe works, probably as a consequence of Huntsman's bankruptcy in the same year (SCA).

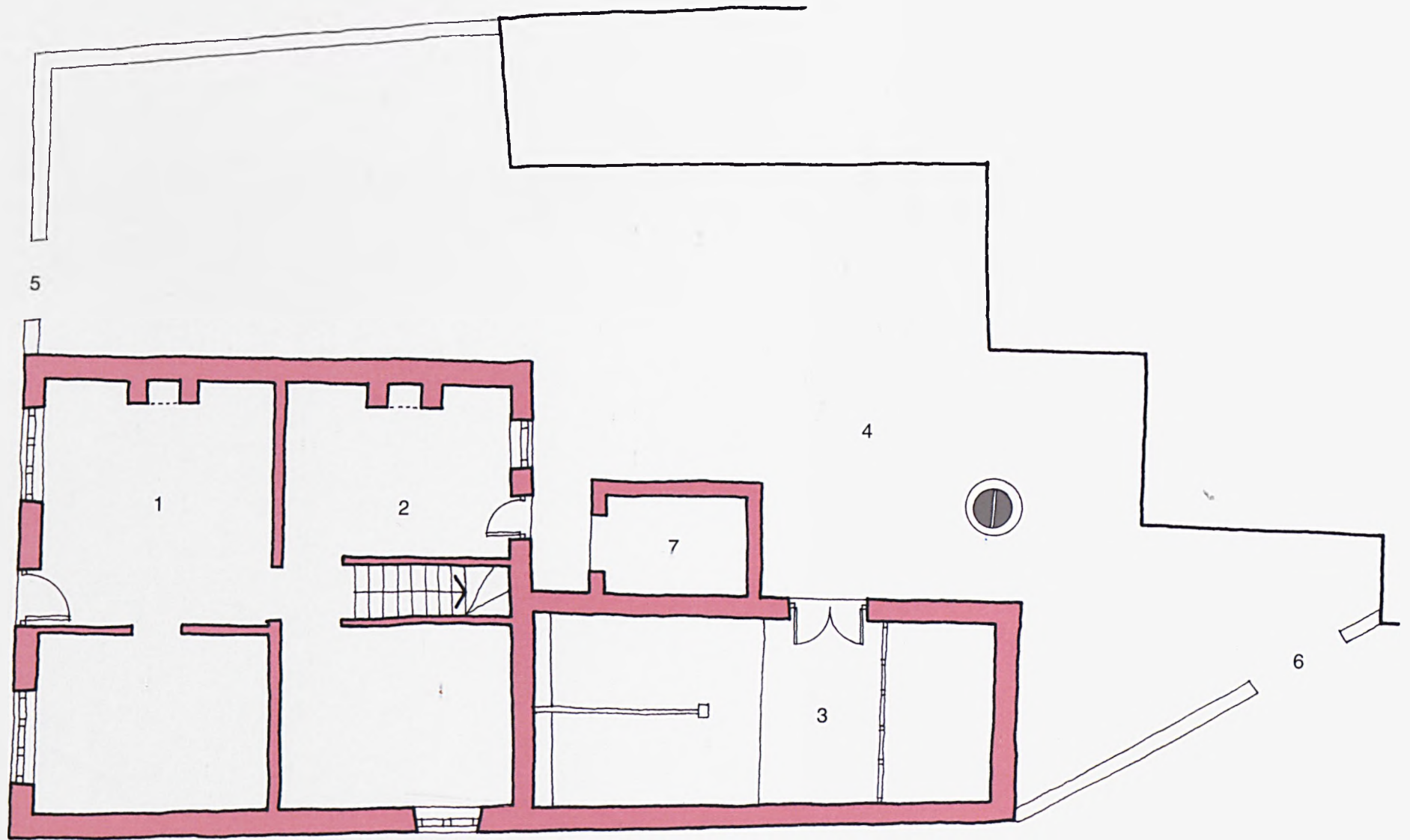

Fig. 1.33 Hypothetical plan of Huntsman's cottage, based on survey measurements and common local plan types. Scale 1:100 (author).

B Huntsman Ltd.

Huntsman's cottage on Attercliffe Green, reconstructed ground plan (c.1751)

scale 1:100

key:

- 1 Front room / parlour
- 2 Back room / kitchen
- 3 Stables
- 4 Backyard with well
- 5 Front gates
- 6 Back gates to furnace
- 7 Privy?



Fig. 1.34 The workers' cottages at Huntsman's Yard on the 1850 OS plan. Scale 1:1056 (OS, author's colours).



Fig. 1.35 Terraced cottages at Abbeydale Works, built to a similar plan as Huntsman's Row.



Fig. 1.36 Portrait of William Huntsman (SCL).



Fig. 1.37 The 'cartwheel' penny produced at Matthew Boulton's Soho Works using dies of Huntsman's cast steel. Actual size.

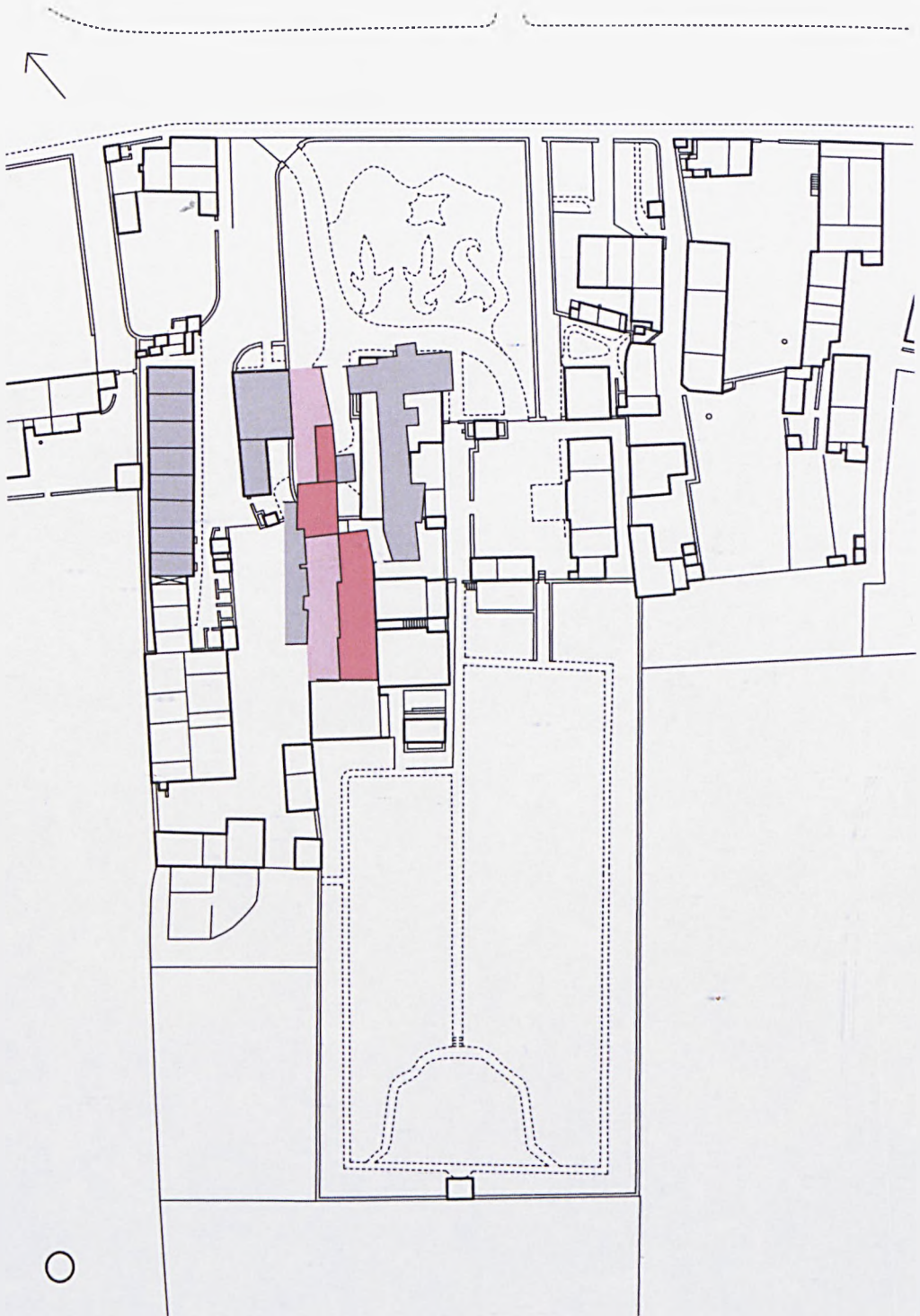

Fig. 1.38 Plan of Attercliffe works c.1850 with Gunning's ownership of 1781 highlighted. Note that he was not in possession of the cast steel furnaces (author).

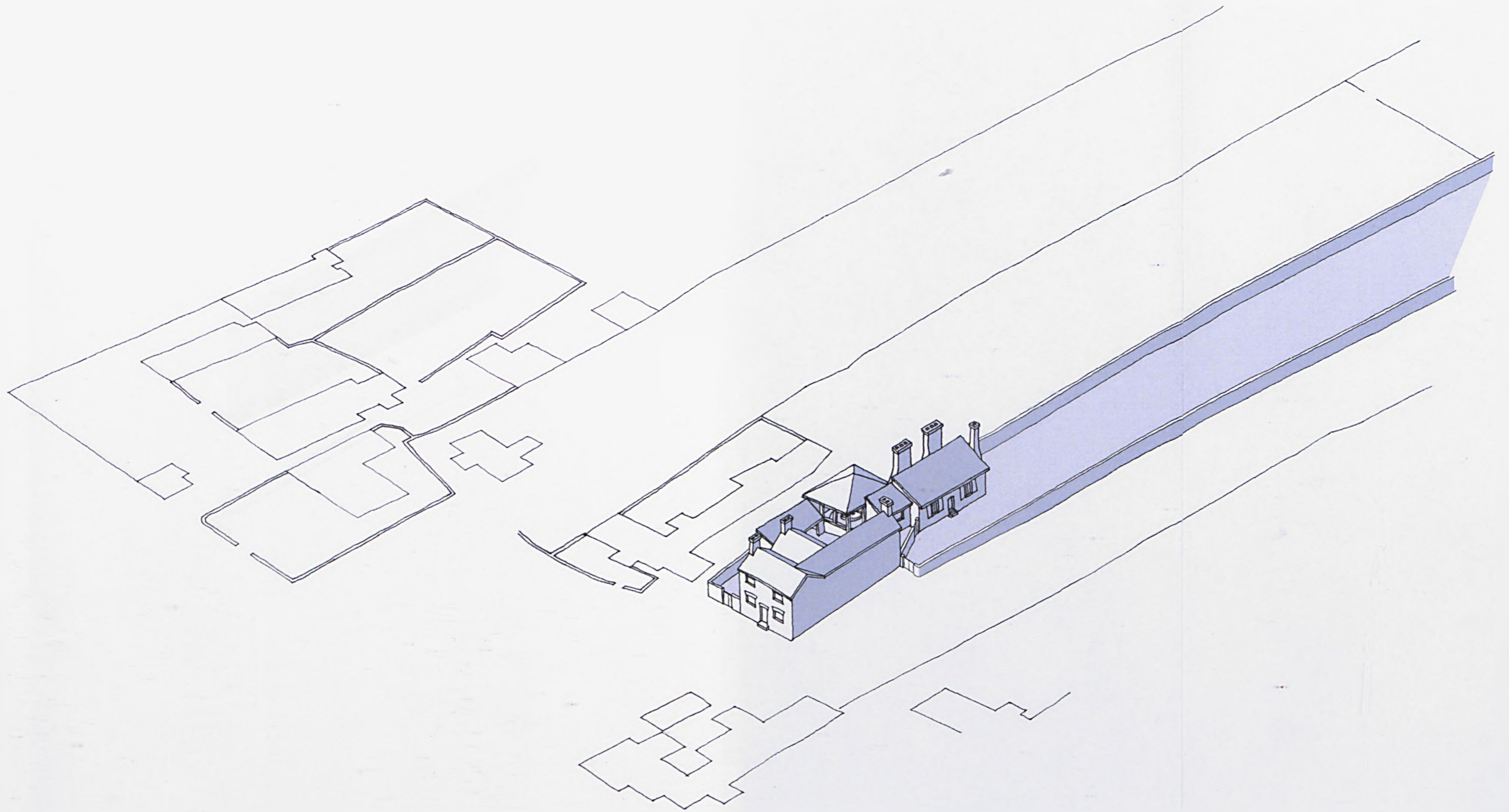

Fig. 1.39 Isometric reconstruction of Huntsman's house and steel furnaces in 1763. Scale 1:500 (author).

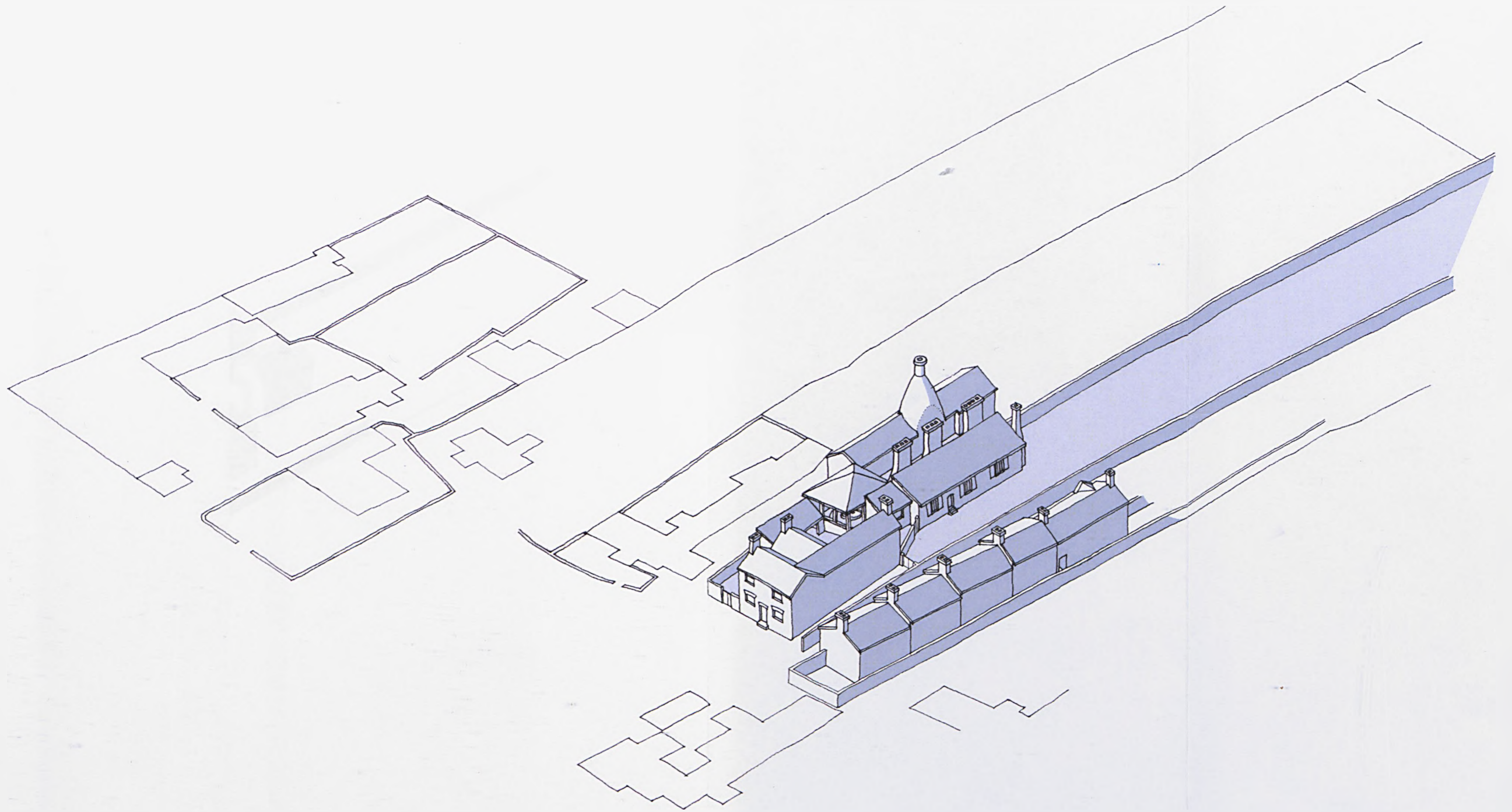

Fig. 1.40 Isometric reconstruction of Huntsman's extended steelworks in 1781. Scale 1:500 (author).

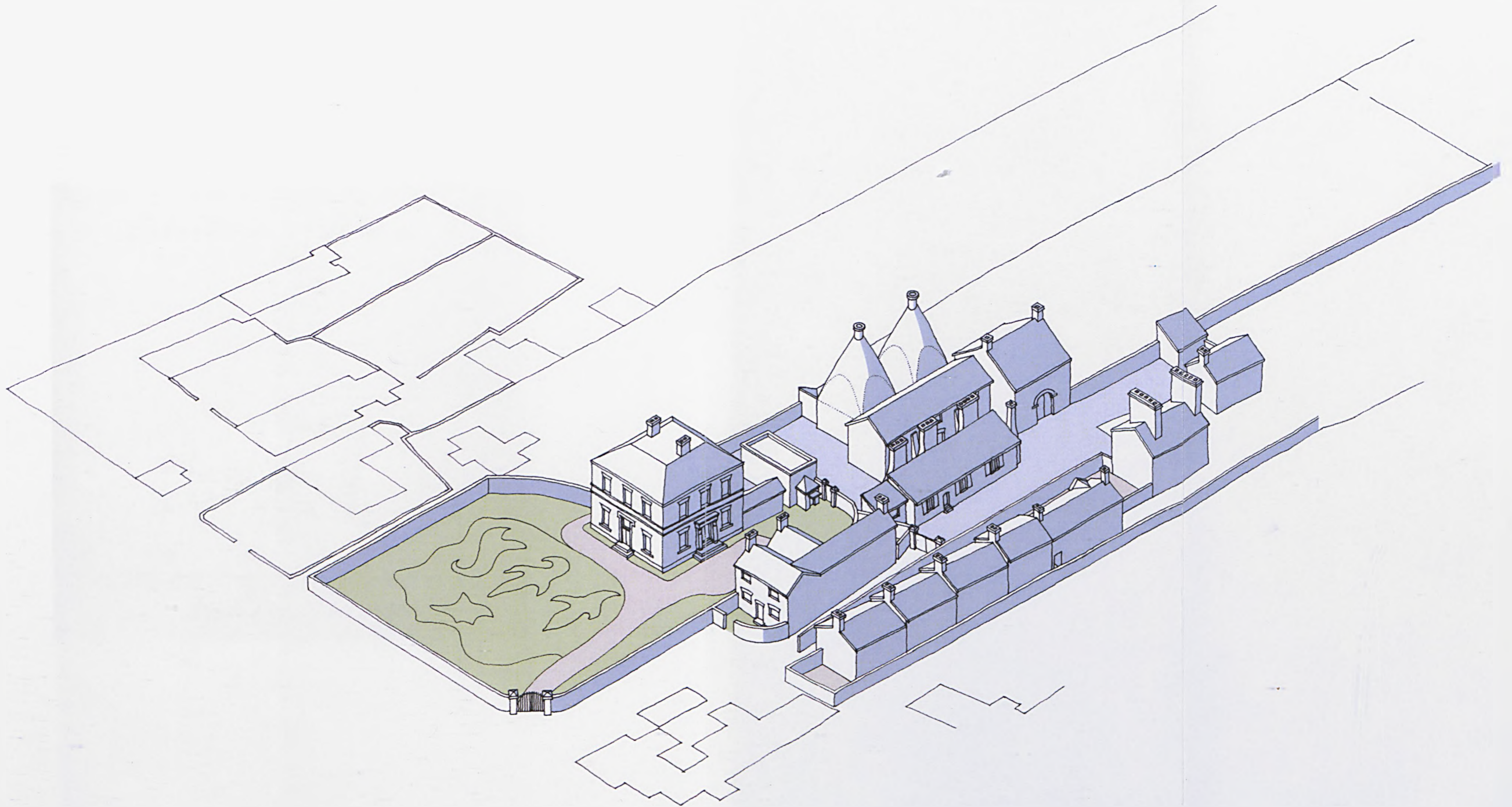

Fig. 1.41 Isometric reconstruction of the Attercliffe steelworks at the beginning of Francis Huntsman's management in 1818. Scale 1:500 (author).

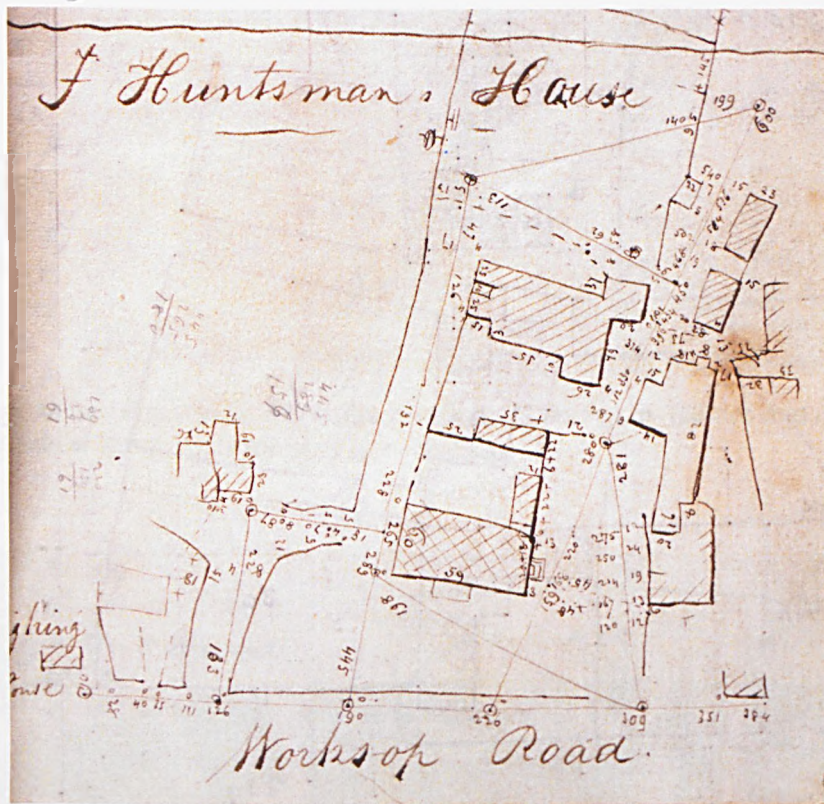

Fig. 1.42 Revised survey of Huntsman's works undertaken in 1819 by the Fairbanks (SCA).

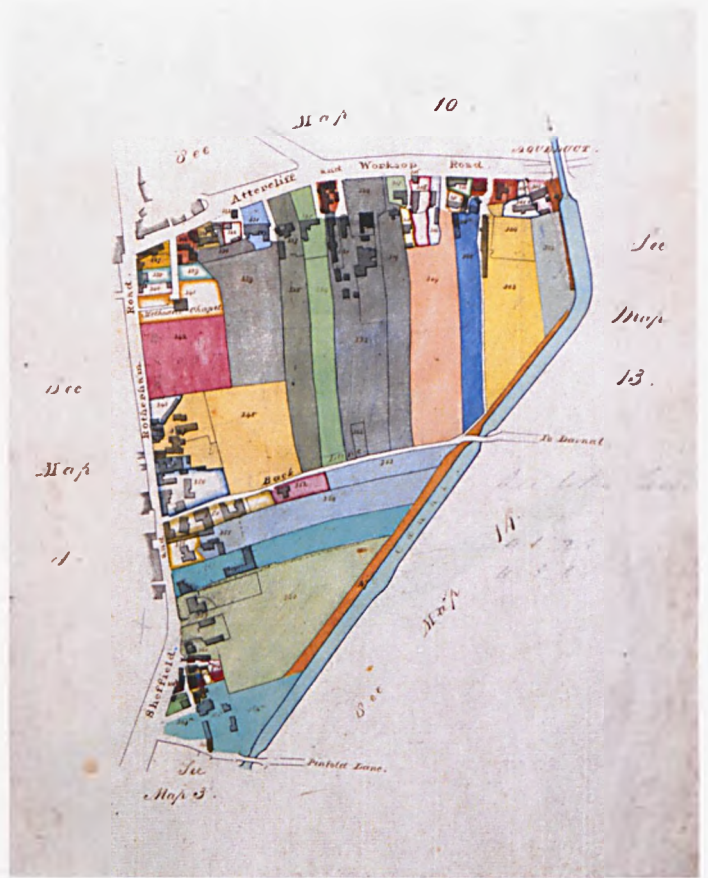

Fig. 1.43 Plan to accompany the 1819 rate assessment survey by William and Josiah Fairbank, Attercliffe sheet 12. North is at top left (SCA).

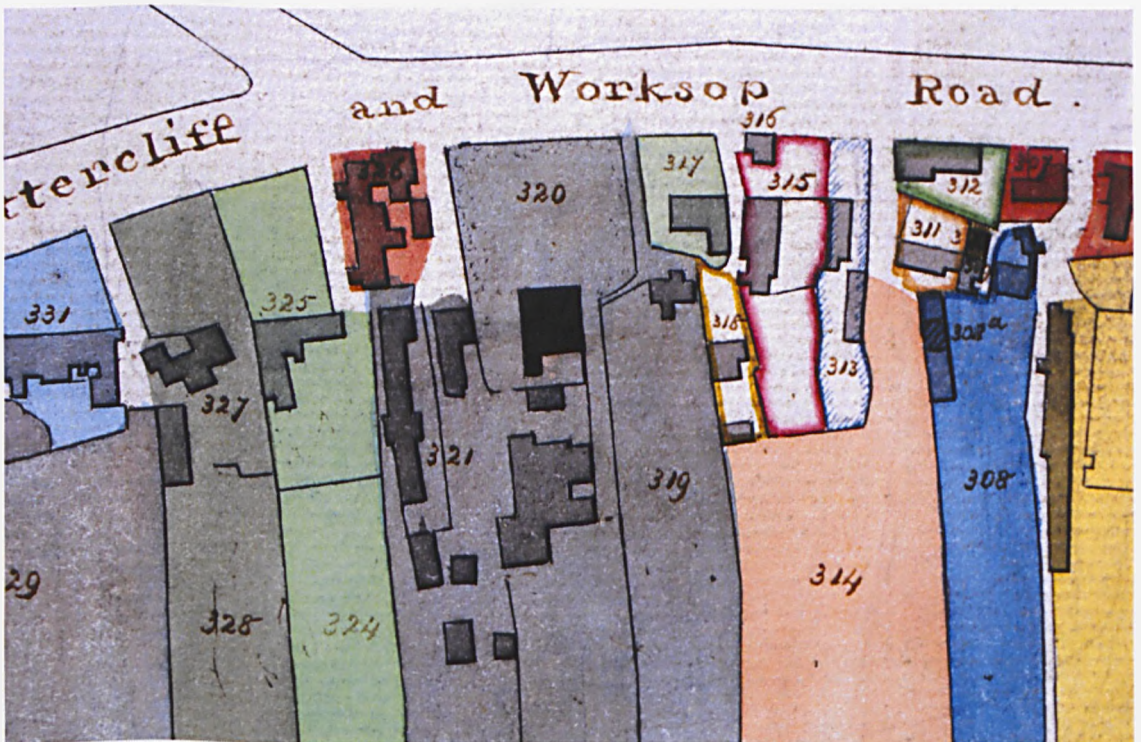

Fig. 1.44 Detail of the above plan. Huntsman's property is numbered 319 to 321 and includes the recent enclosure additions to the front.

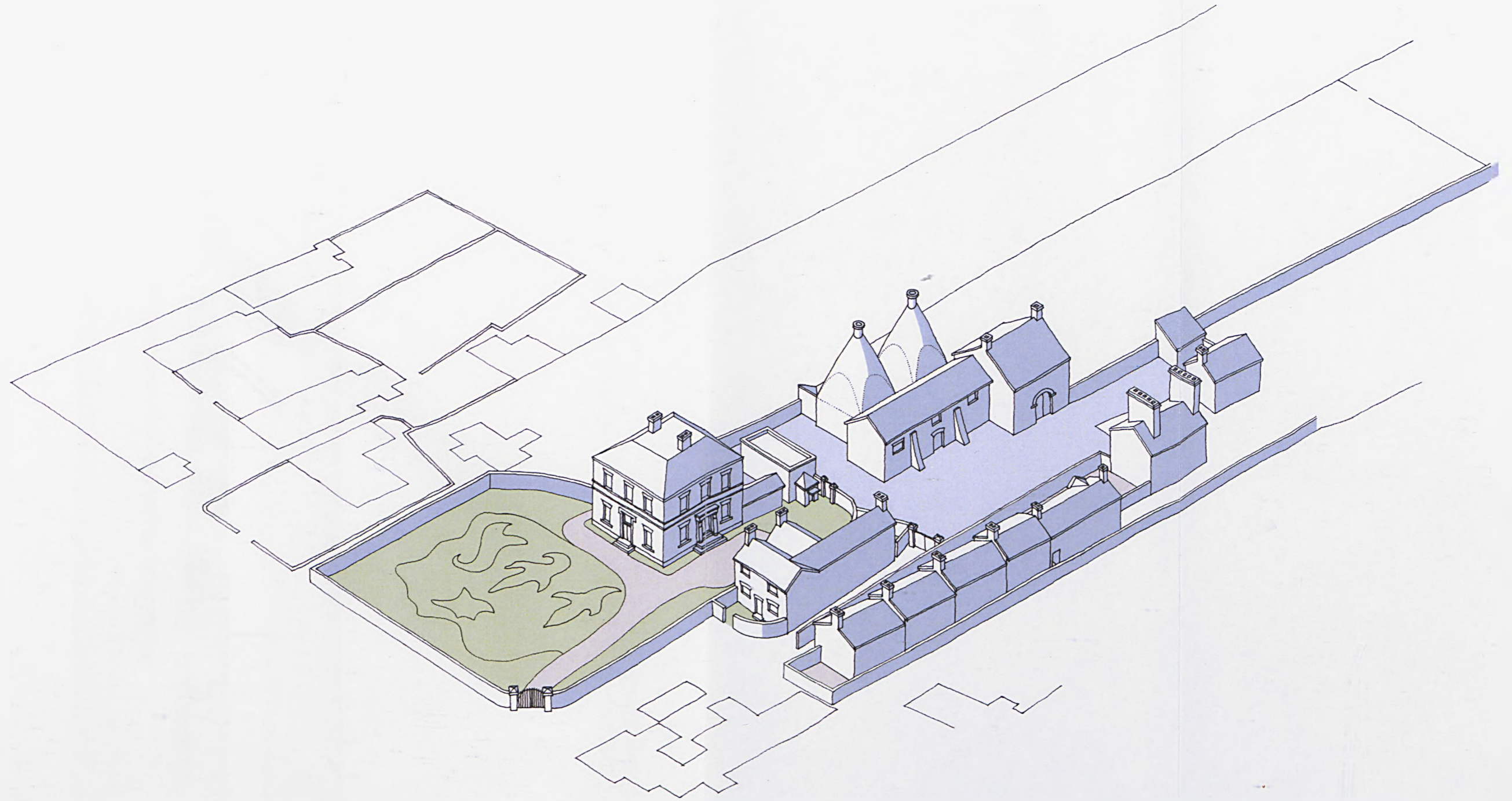

Fig. 1.45 Isometric reconstruction of the Attercliffe steelworks following the demolition of Benjamin Huntsman's original steel furnaces in 1819. Scale 1:500 (author).



Fig. 1.46 Plan of the south side of Attercliffe Green, with the pre-enclosure line of the Green dashed red. New roads created through Huntsman's enclosure gains are coloured brown. Scale 1:1000 (author).



Fig. 1.47 Isometric reconstruction of the Attercliffe steelworks including the Weigh House Furnace site acquired and developed by Francis Huntsman in 1826. Scale 1:500 (author).



Fig. 1.48 Huntsman's original steelworks and the adjacent Weigh House Furnace seen on the 1850 OS plan, scale 1:1056. North is at top (OS).

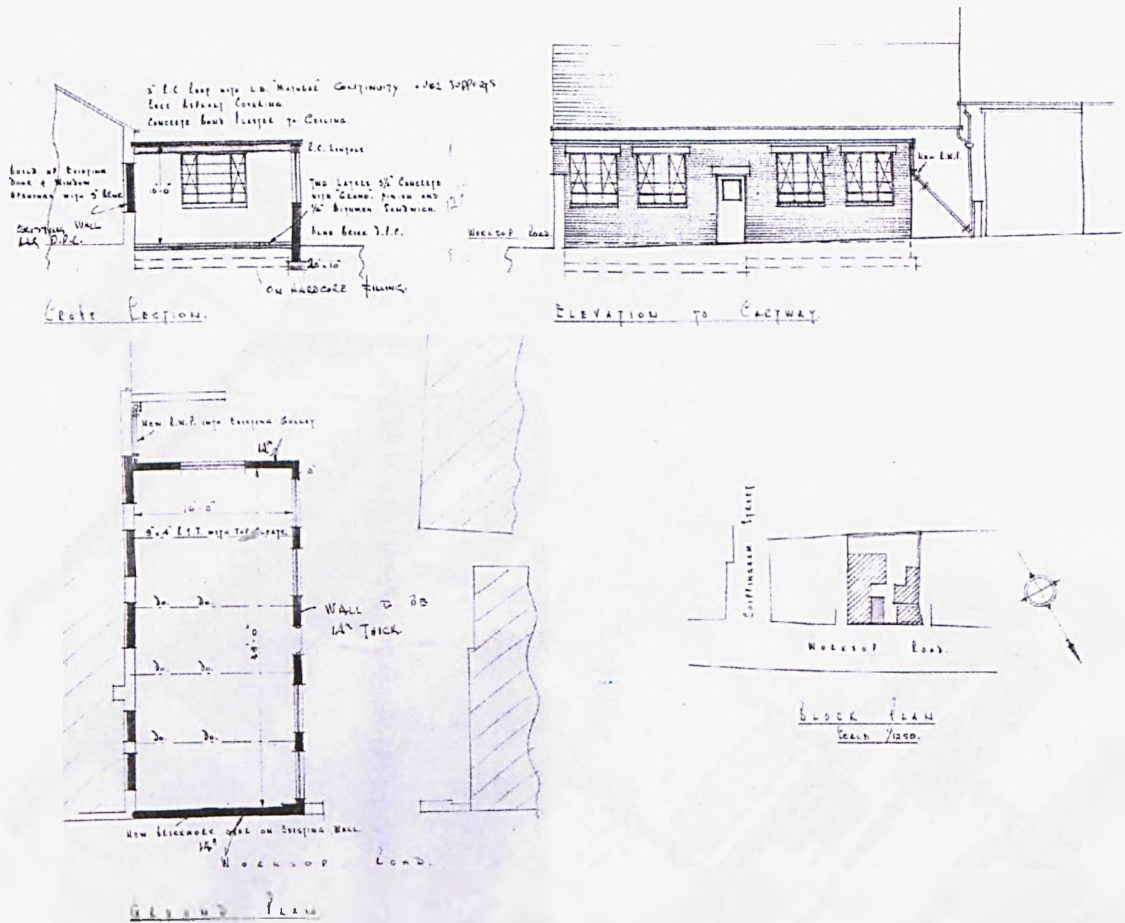

Fig. 1.49 Planning drawings for an extension to the former Weigh House cast steel furnace, with information on construction and window layout (SCA).



Fig. 1.50 Survivals at the Weigh House site, including the cast steel furnace building (left ground storey), porter's lodge (right) and cementation furnace shed in the yard (author).

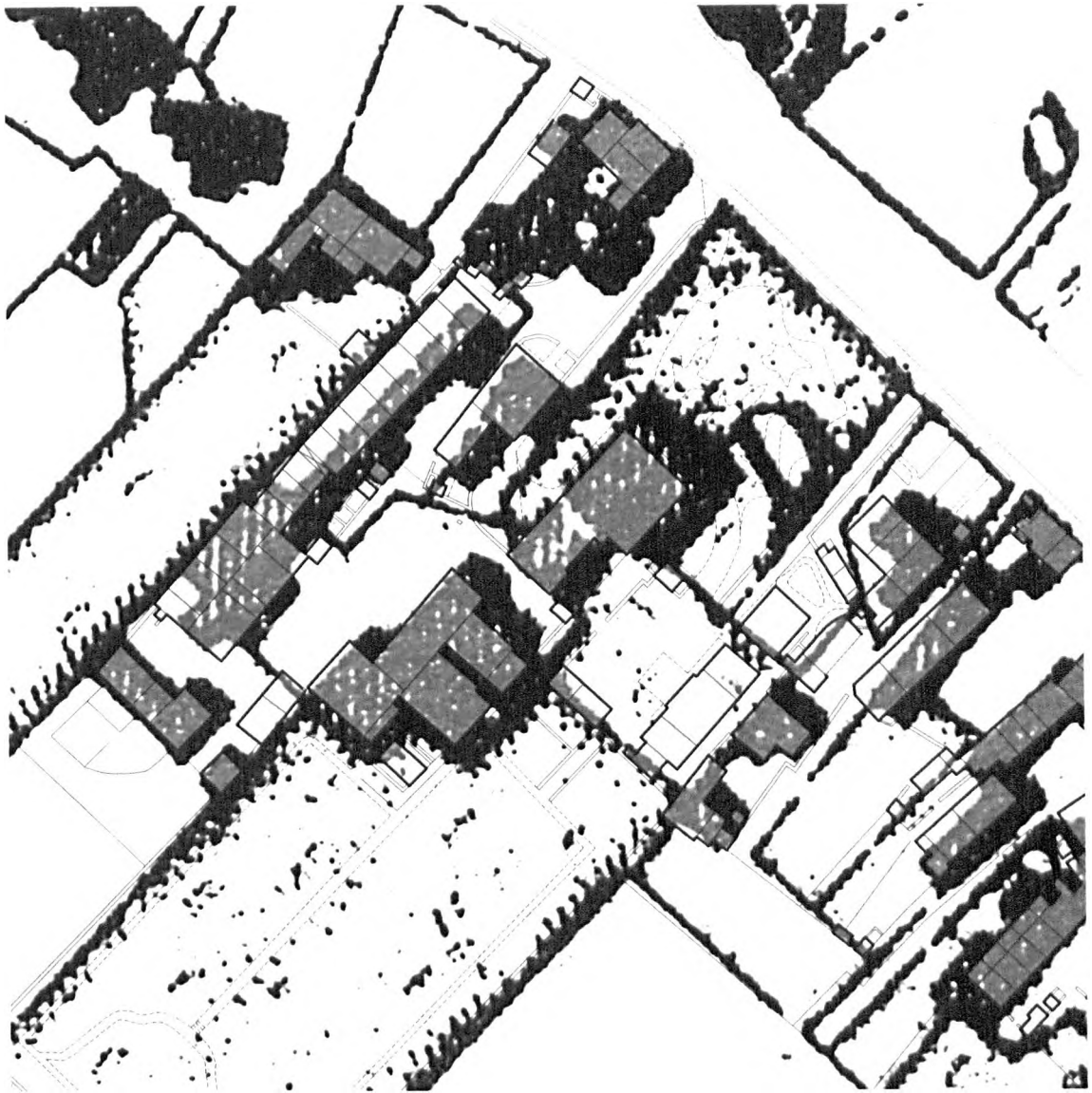

Fig. 1.51 Comparison of the 1850 OS plan (semi-transparent) and 1832 town plan, both at a scale of 1:1000. North is at top (author).

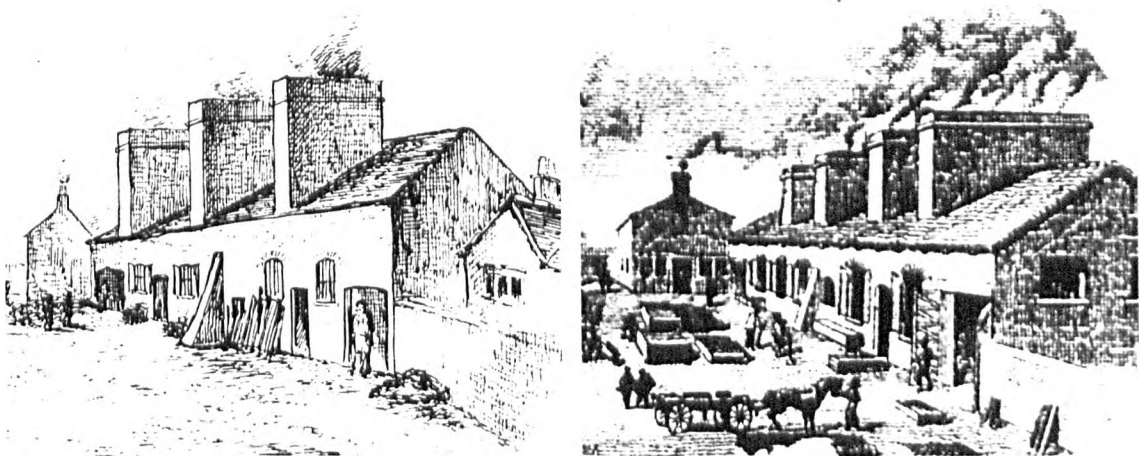

Fig. 1.52 Details of the cast steel furnaces from Topham's sketch (left) and a late nineteenth century advertisement for the firm (right). Note the addition of a fourth stack in the latter.

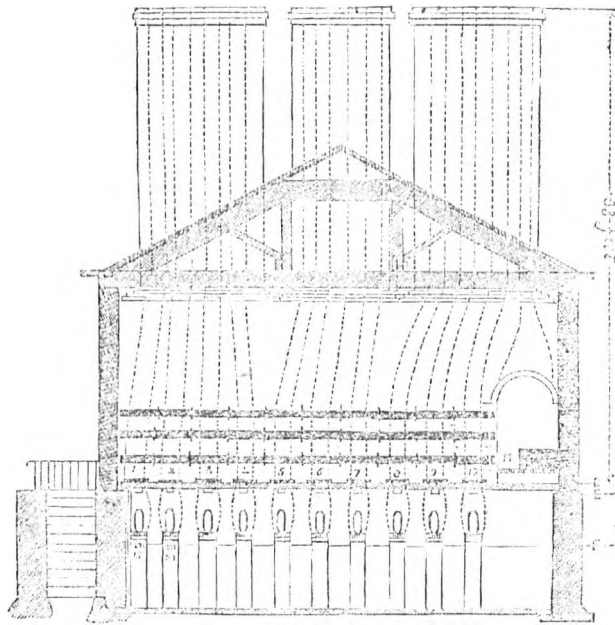

Fig. 4.

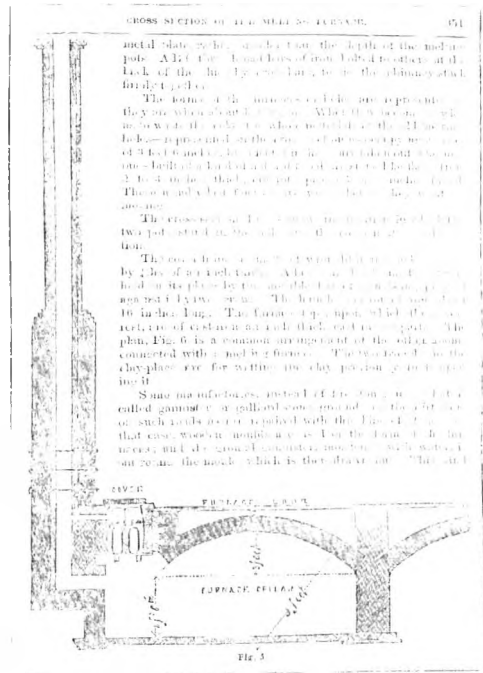

Fig. 5.

Figs. 1.53 and 1.54 Long and short sections of a cast steel furnace based on Francis Huntsman's 1842 building from *The Useful Metals and their Alloys* (Scoffern 1857).

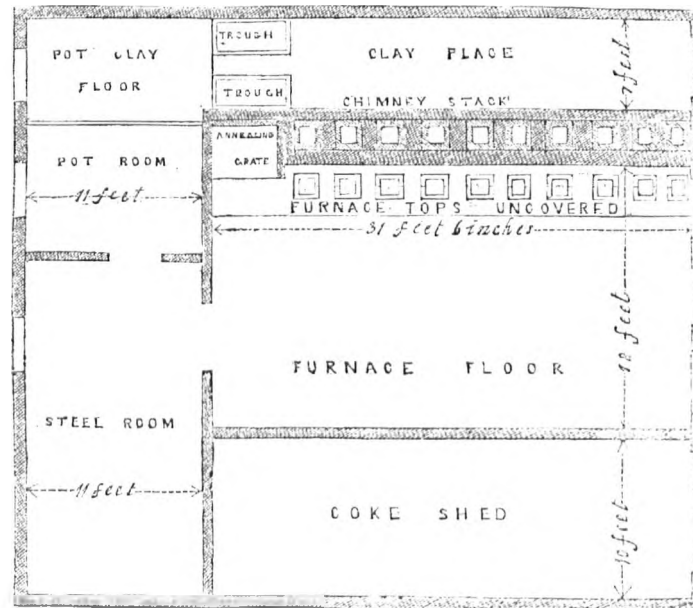

Fig. 1.55 Plan of a cast steel furnace from *The Useful Metals and their Alloys* (Scoffern 1857).

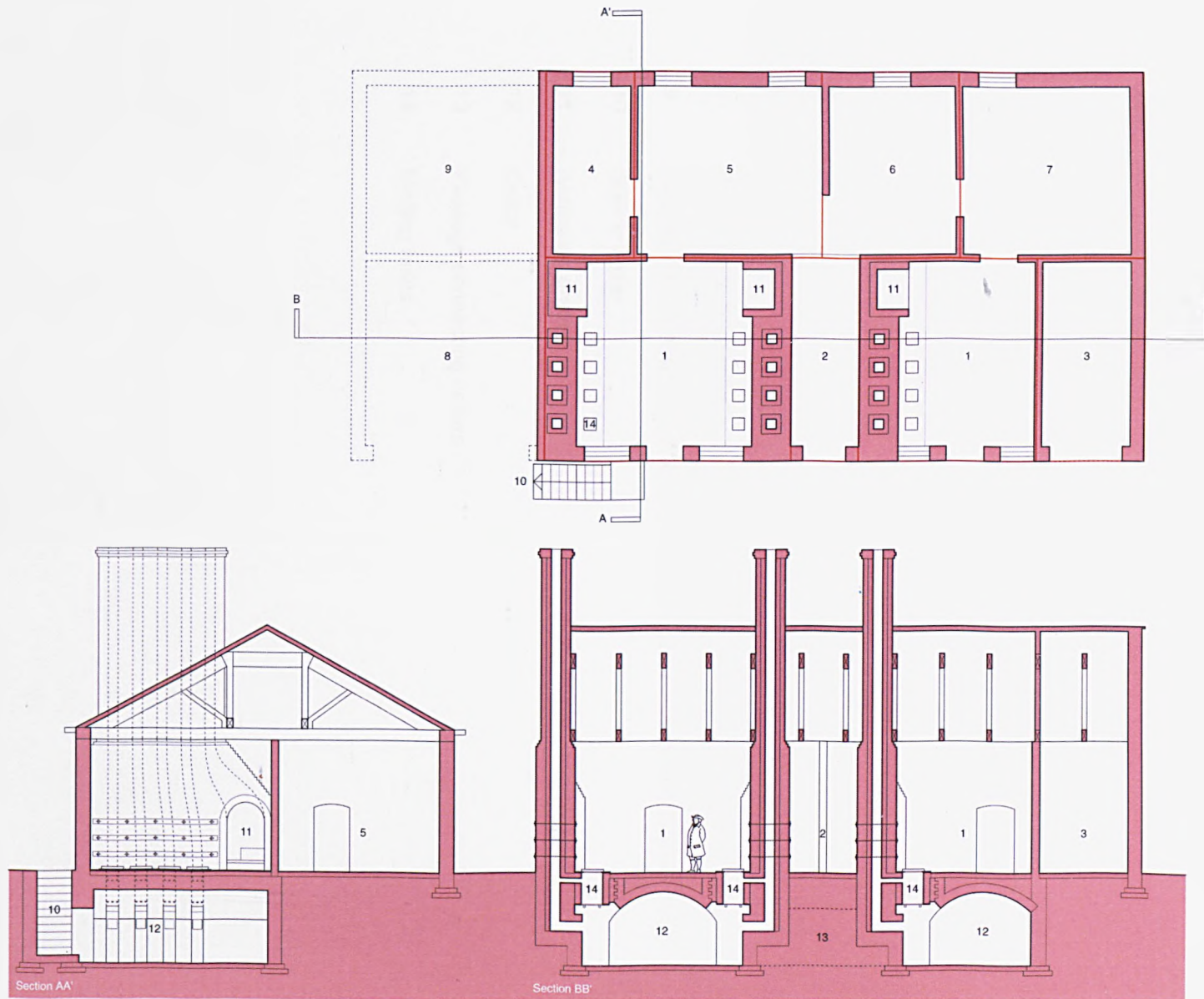

Fig. 1.56 Reconstruction of the Huntsman's Yard melting shop of 1842, combining information from OS plans, rate valuations and the idealised *Useful Metals* drawings. Scale 1:200 (author).

B Huntsman Ltd.

Attercliffe steelworks, crucible furnaces, reconstructed plan and sections (1842)

scale 1:200

key:

- 1 Melting shop (total 12 holes)
- 2 Clay place
- 3 Coke shed
- 4 Store room
- 5 Pot room
- 6 Pot clay floor
- 7 Steel room
- 8 Extension to coke shed
- 9 Extension to store room
- 10 Stair to cellar
- 11 Annealing grate
- 12 Cellar
- 13 Passage connecting cellars
- 14 Melting holes

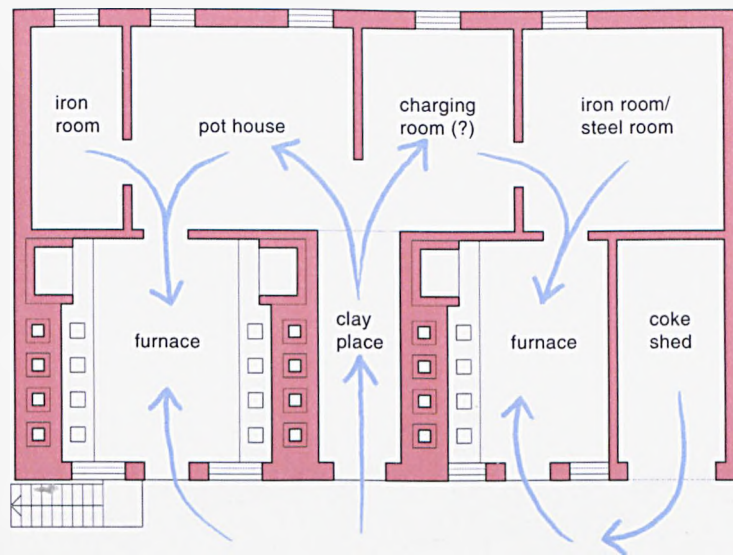

Fig. 1.57 Routes most commonly followed in the working of Huntsman's 1842 melting shop, demonstrating the importance of the plan arrangement. Scale 1:200 (author).



Fig. 1.58 The location of 'Narrow Field' alongside the Sheffield Canal, and site of Huntsman's wharf and warehouse. Based on 1850 OS plan, scale 1:2000 (author).



Fig. 1.59 Plan of Attercliffe with Francis Huntsman's property c.1860 indicated in pink. Scale 1:1000 (author).

B Huntsman Ltd.

Attercliffe steelworks, reconstructed general site plan (1850)

scale 1:1000

key:

- 1 Cottage (formerly Benjamin Huntsman's home)
- 2 House and outbuildings
- 3 Cottage
- 4 Stables and gig house
- 5 Ornamental front garden
- 6 Kitchen garden
- 7 Pleasure gardens
- 8 Garden house
- 9 'Huntsman's Row' terraced cottages
- 10 Cast steel furnace (12 holes)
- 11 Iron house
- 12 Cementation steel furnaces
- 13 Storage and mill
- 14 Counting house
- 15 Cowhouse
- 16 Works' yard
- 17 Animal enclosure
- 18 Porter's cottage (formerly Turnpike weighing house)
- 19 Cast steel furnace
- 20 Workshops
- 21 Cementation steel furnace
- 22 'Weigh House Furnace' yard
- 23 'Swallow Row'
- 24 Wharf and field
- 25 Warehouse

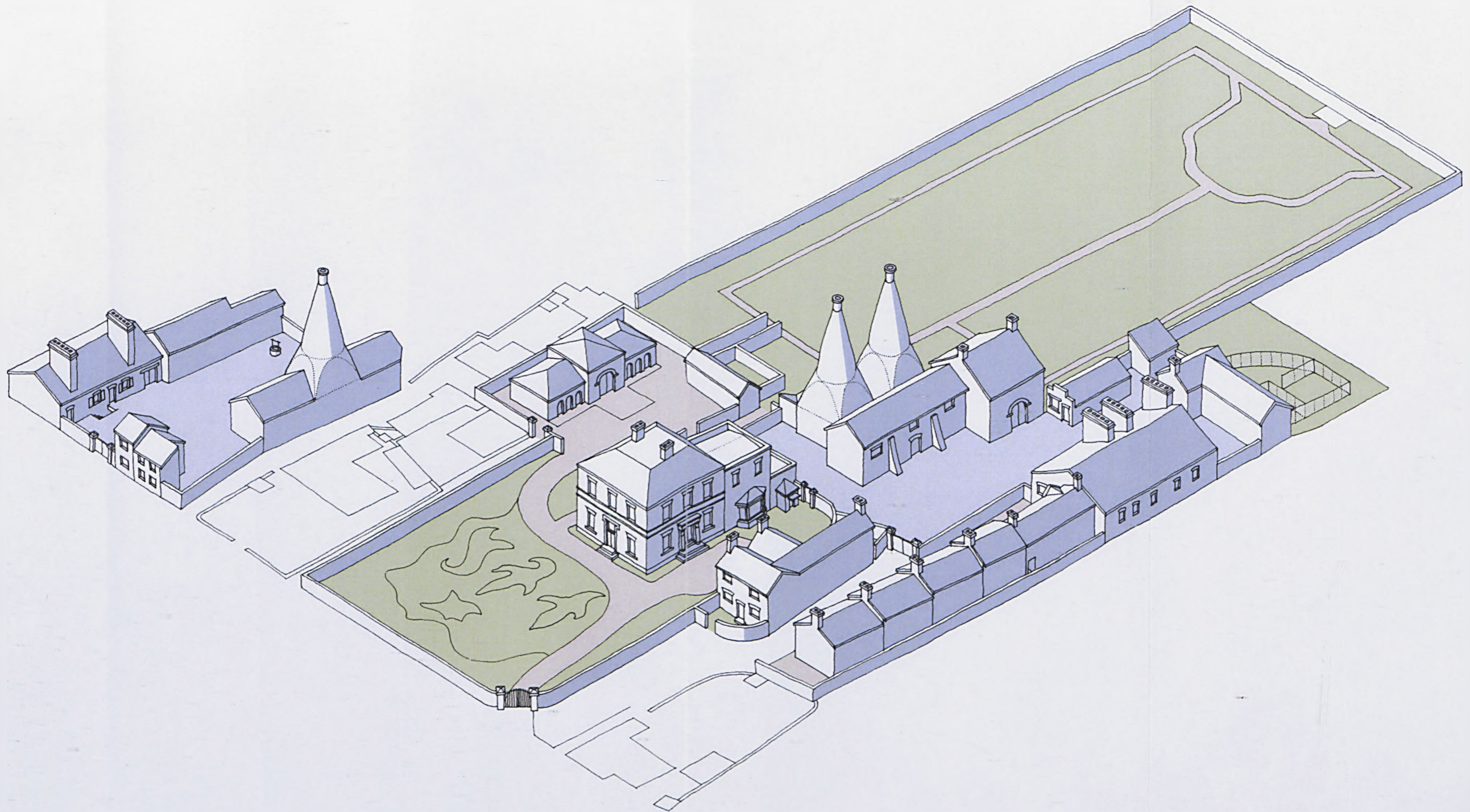

Fig. 1.60 Isometric reconstruction of the Huntsman's Yard and Weigh House steelworks, Francis Huntsman's house, gardens and stable as existing in 1850, not including the wharf. Scale 1:500 (author).

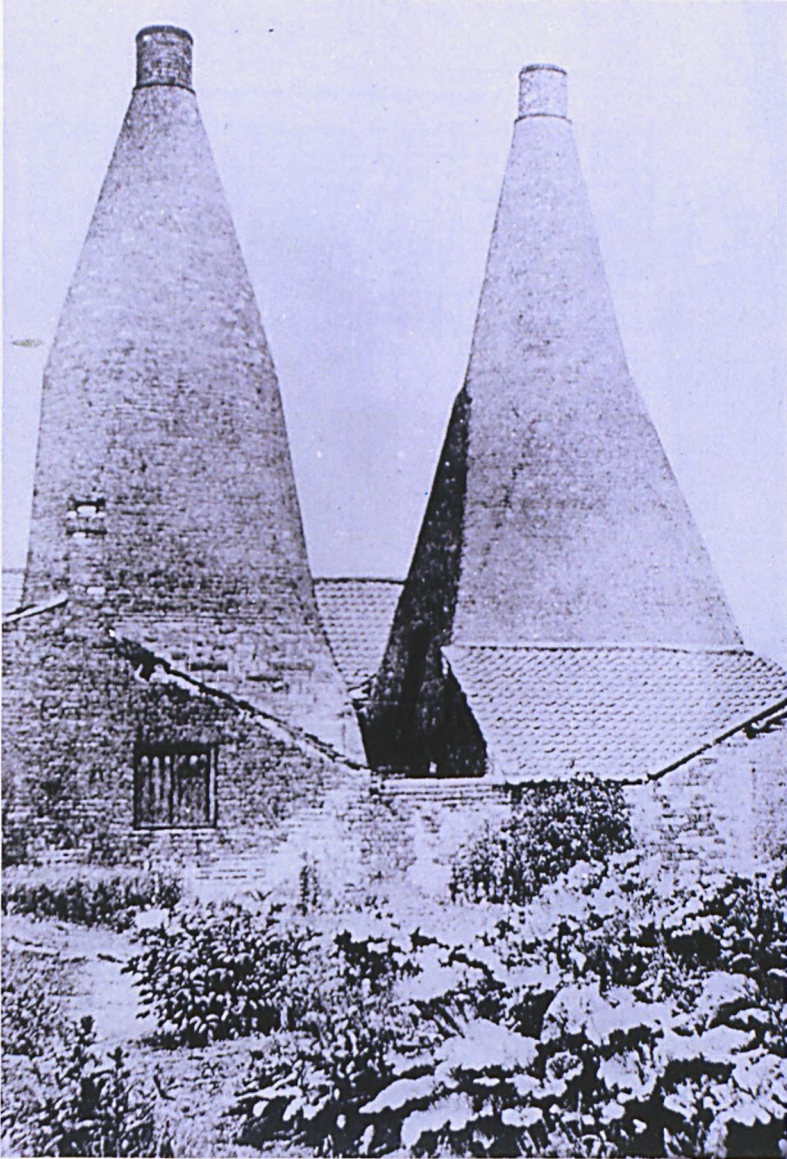

Fig. 1.61 Cementation furnace cones seen from the kitchen garden at the Attercliffe works of B. Huntsman Ltd. Photograph taken before 1890.



Fig. 1.62 The extent of property in Francis Huntsman's occupancy (green) in 1860, comprising about half of the south side of Attercliffe Green. Scale 1:2000 (author).



B. HUNTSMAN, STEEL FURNACES & OFFICES, ATTERCLIFFE.

Fig. 1.63 Advertising view depicting Huntsman's Attercliffe steelworks in its heyday. Note the steam engine stack (behind the large house, left) and extra cementation furnace (SCL).

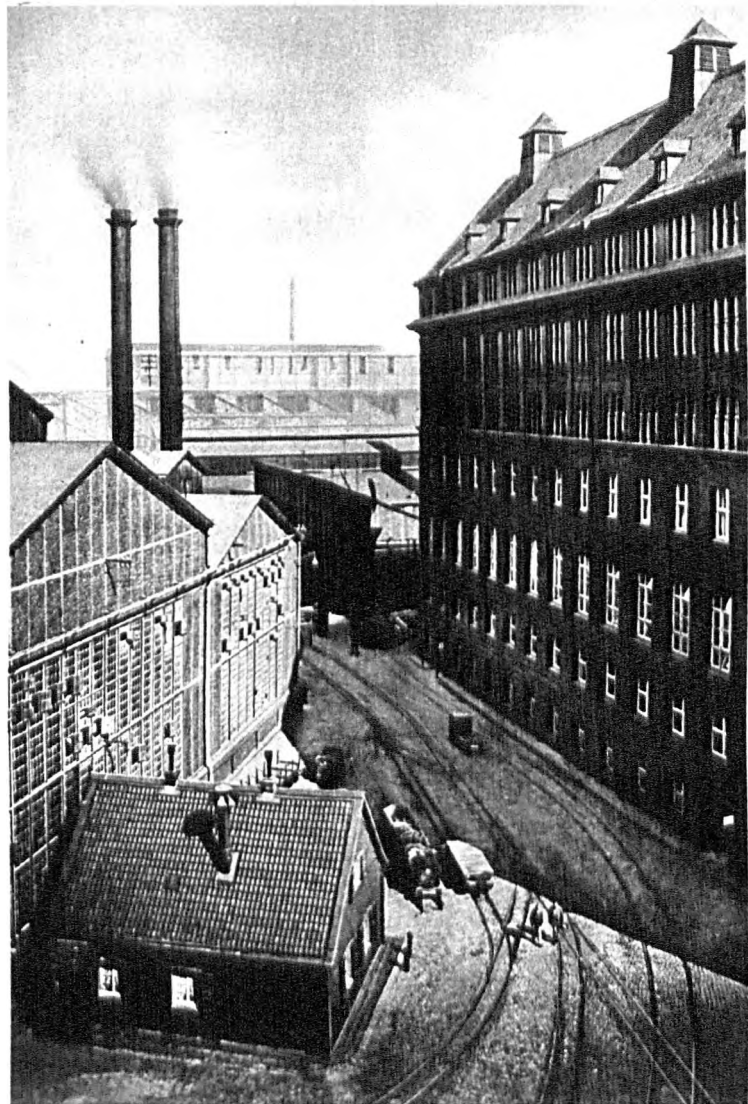
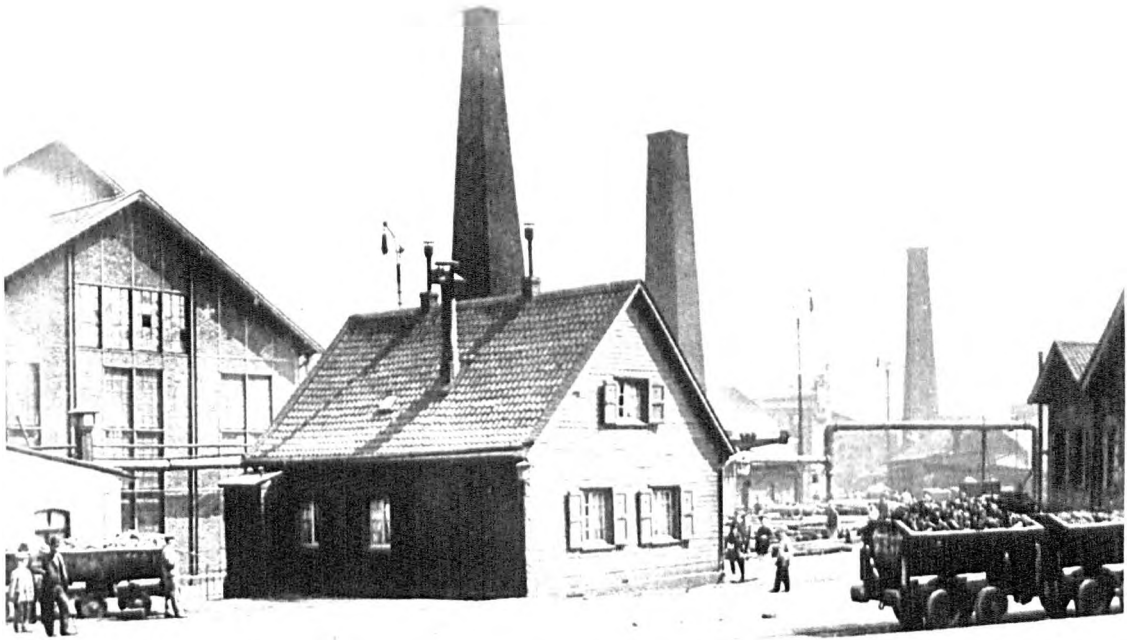

Fig. 1.64 Two early twentieth century views of the Krupp *Stammhaus* or ancestral home, preserved at the heart of the greatly enlarged steelworks.

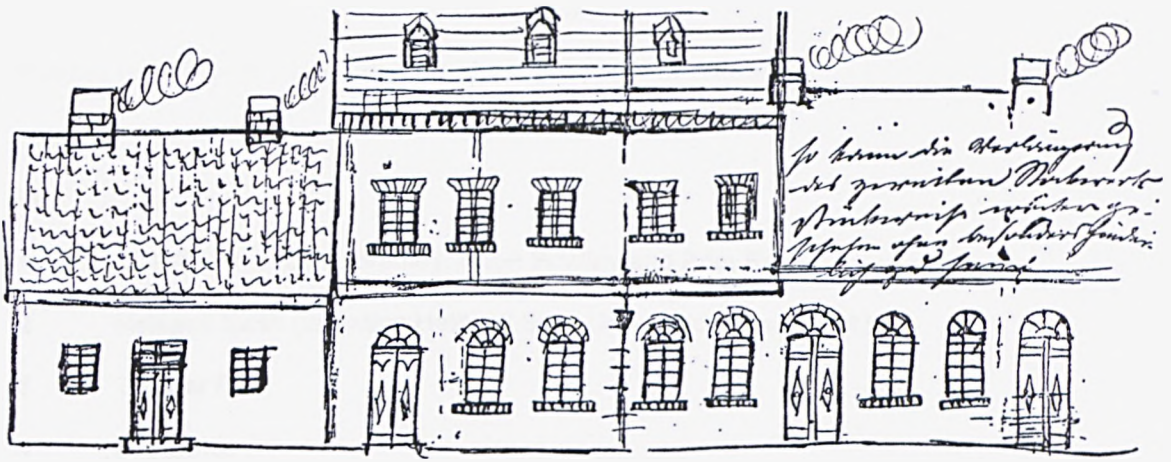

Fig. 1.65 Sketch of Krupp's new two-storey house situated between the original cottage (left) and the steelworks buildings (right).

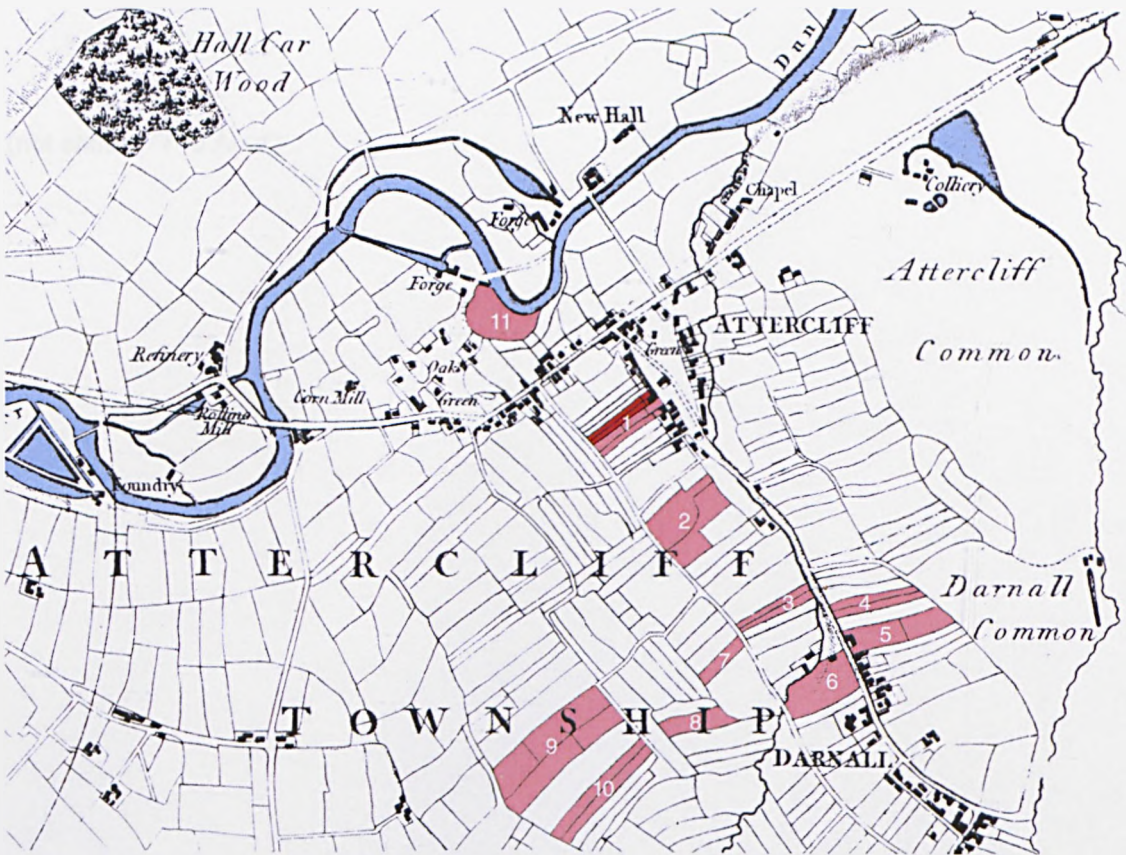

Fig. 1.66 Francis Huntsman's property in and around Attercliffe by the 1860s, plotted on the 1795 plan to demonstrate the relationship to the field boundaries (author's colours).

Huntsman's land from SCA CB1579 (up to 1855)

Plotted on the 1796 Fairbank plan of the parish of Sheffield

key:

- 1 Site of works (Long Bradley, Short Bradley and Prior Row)
- 2 Helliwell Sicks (including Helliwell Sick, Upper Sick, Lower Sick)
- 3 Toll Bar Field
- 4 Ley Lands
- 5 Barber Field
- 6 Wheel Croft
- 7 Unger Hills
- 8 The Two Acres
- 9 Ashforth Hill, Dean Field
- 10 Acre Hill
- 11 Kay Meadows

(not shown: 'The Acre')

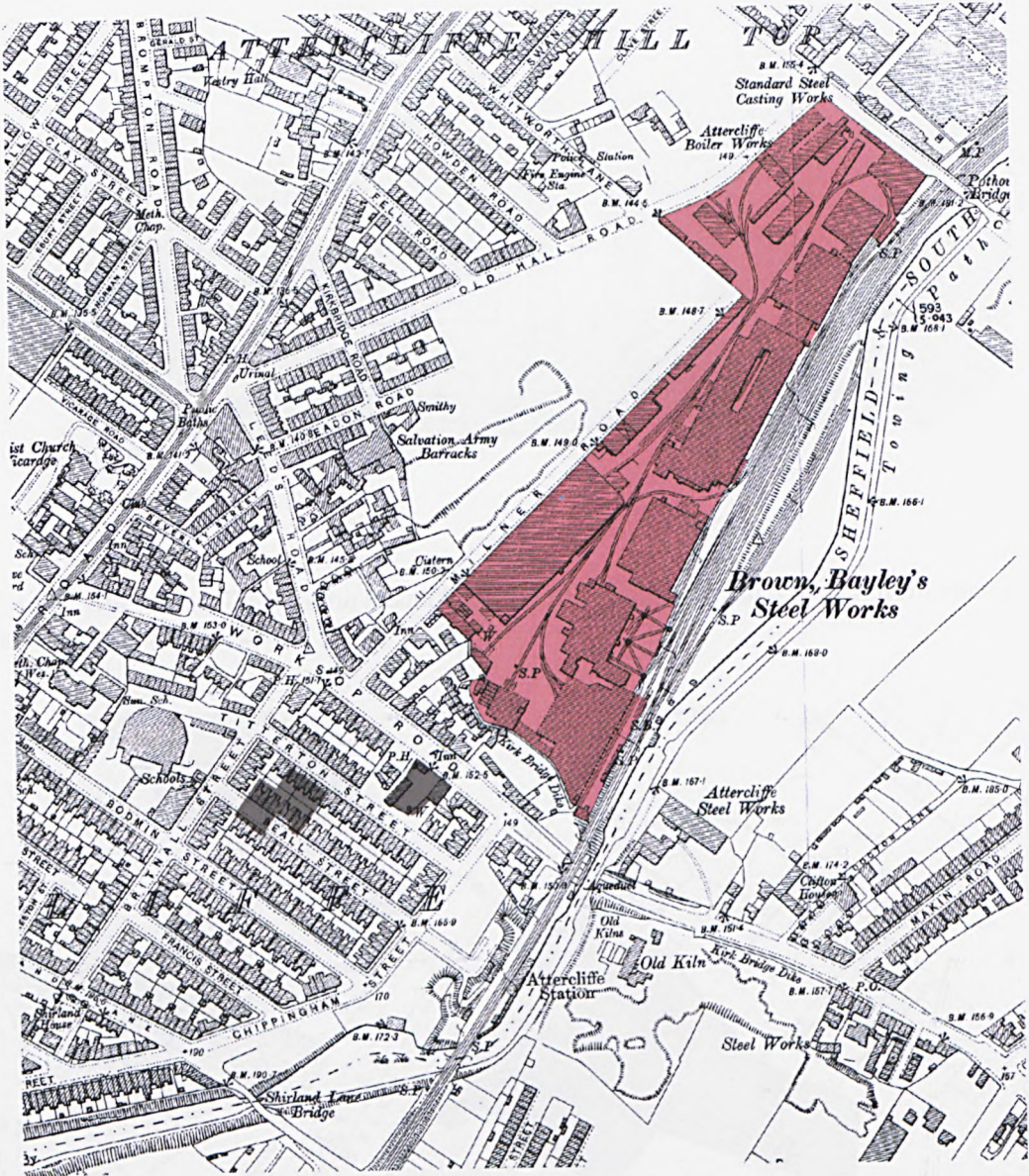

Fig. 1.67 Comparative areas of the steelworks of Brown Bayley (pink) and Huntsman (grey) plotted on the 1903 OS plan. North is at top, scale 1:5000 (OS, author's colours).

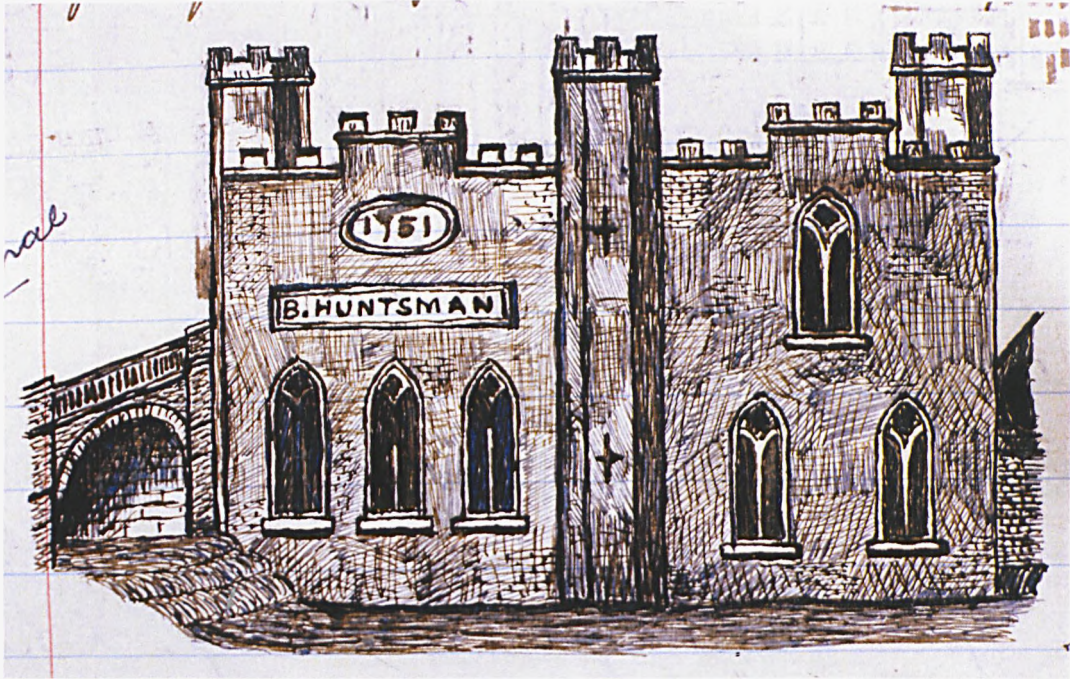

Fig. 1.68 The Wicker Tilt with the inscription '1751 B. Huntsman', in a sketch from Henry Tatton's scrapbook (SCL).

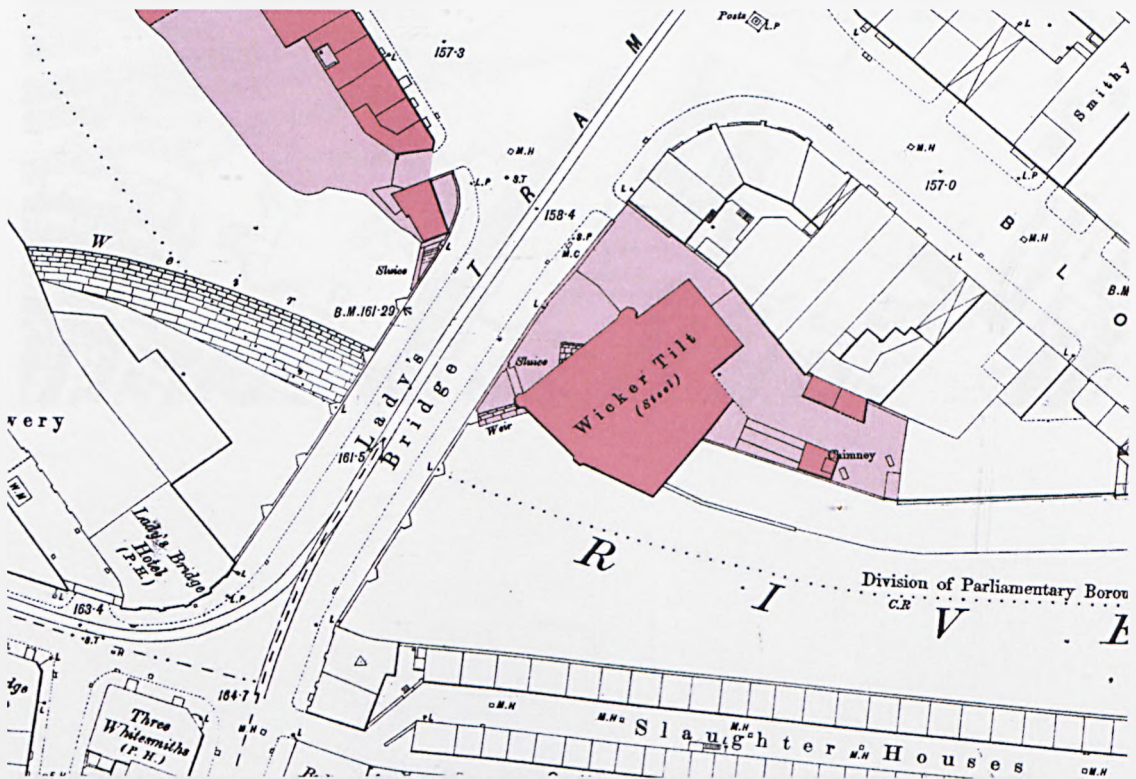

Fig. 1.69 Site of Huntsman's Wicker Tilt (centre) and goods yard (top left) at Lady's Bridge in Sheffield, from the 1889 OS plan. North is at top, scale 1:1000 (OS, author's colours).

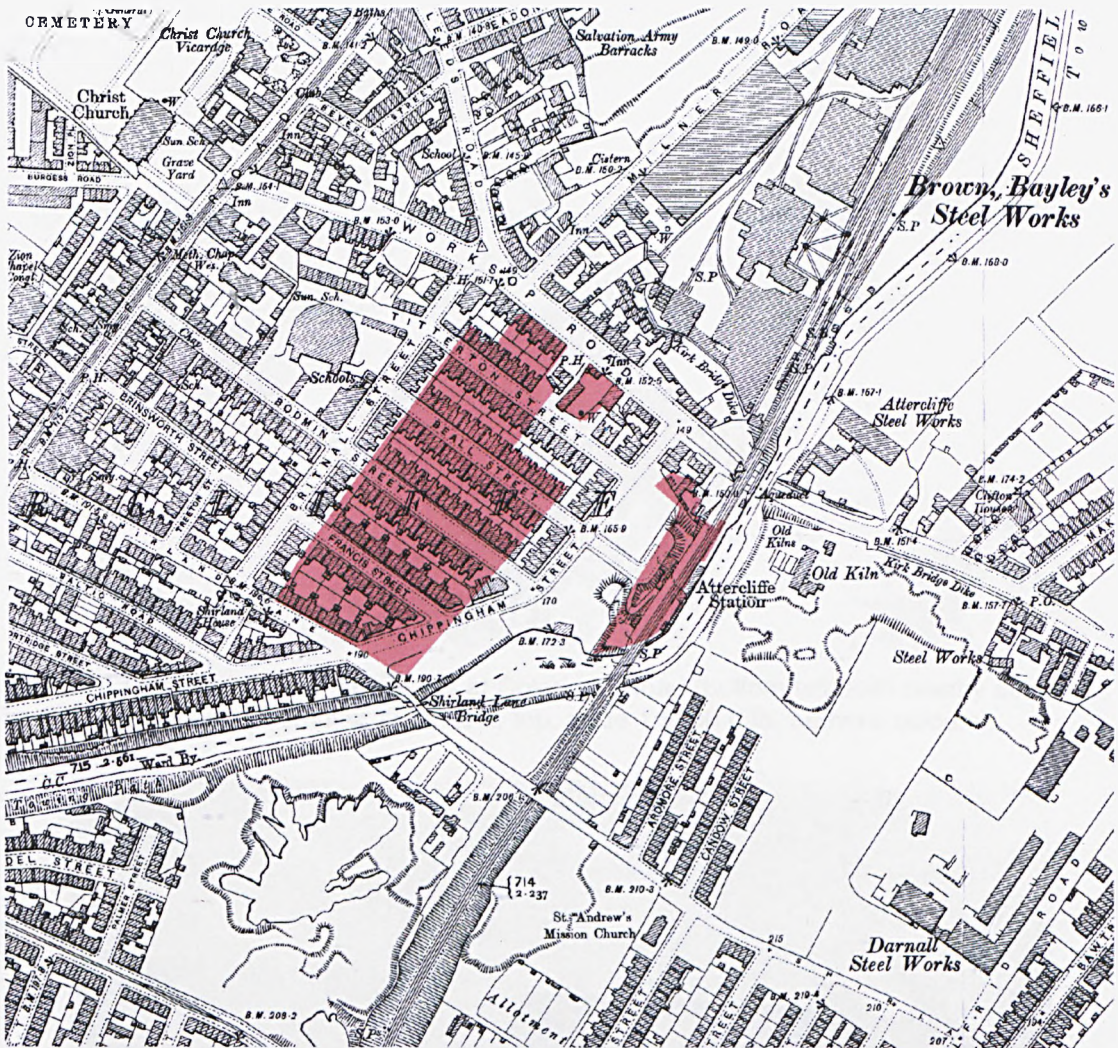

Fig. 1.70 Huntsman's Attercliffe works site area in relationship to the later residential development of the site, based on the 1903 OS plan. North is at top, scale 1:5000 (OS, author's colours).

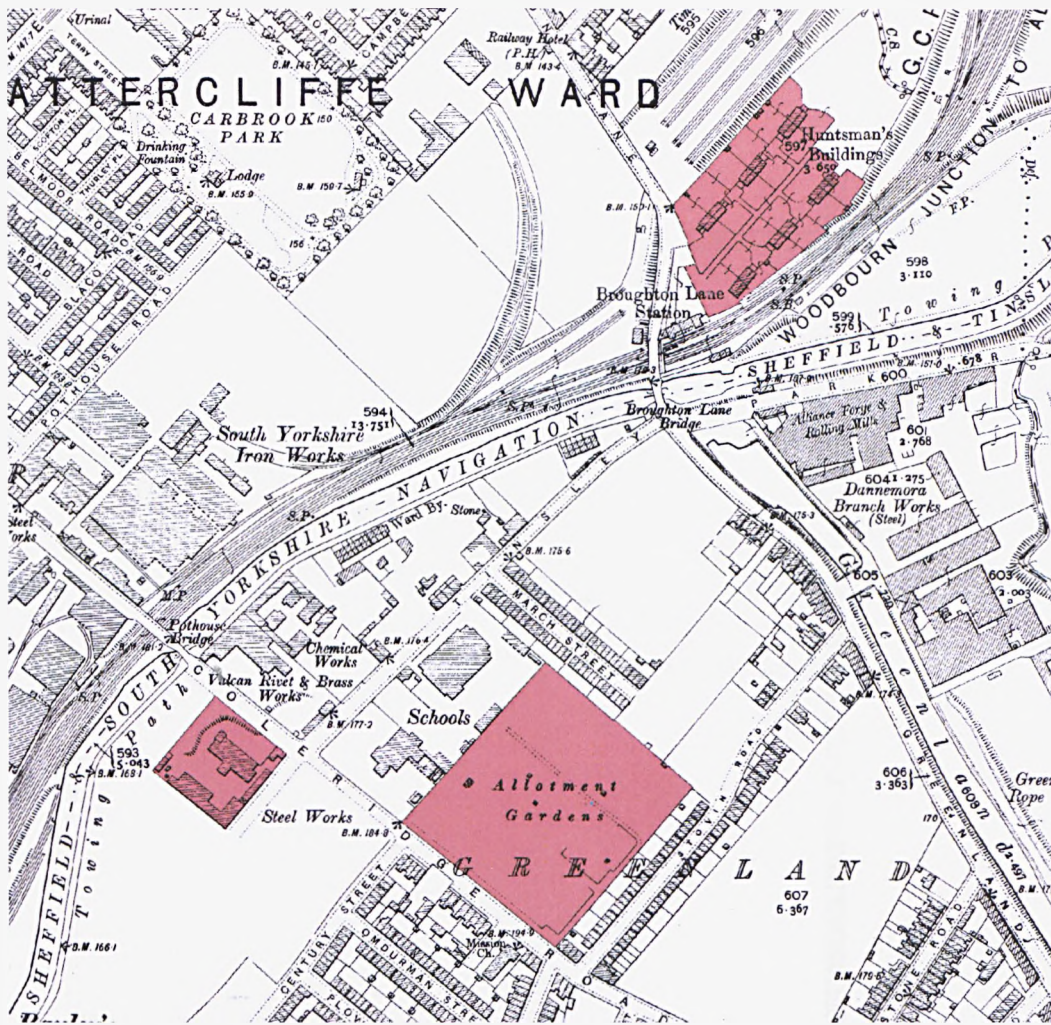

Fig. 1.71 Huntsman's new steelworks at Coleridge Road (bottom left) with nearby allotment and workers' housing complex. North is at top, scale 1:5000 (OS, author's colours).



Fig. 1.72 Coleridge Road looking southeast from Pot House Bridge with Huntsman's steelworks on the right, 2001 (author).



Fig. 1.73 Ground plan of the Huntsman Coleridge Road steelworks, redrawn from the architect's planning drawings of 1898. Scale 1:200 (author).

B Huntsman Ltd.

Coleridge Road steelworks, proposed ground plan (1898)

scale 1:200

key:

- 1 Melting shop (18 holes)
- 2 Coke shed
- 3 Ingot shed
- 4 Steel house
- 5 Pot house
- 6 Store room
- 7 WCs
- 8 Yard with ashes place
- 9 Kitchen
- 10 Living room
- 11 Parlour
- 12 General office
- 13 Entrance passageway
- 14 Weigh office
- 15 Warehouse
- 16 Chipping house
- 17 Blacksmith's shop
- 18 Pickling trough
- 19 Hammer shop
- 20 Boiler
- 21 Coal and coke shed
- 22 Steam engine chimney stack
- 23 Yard
- 24 Vacant ground

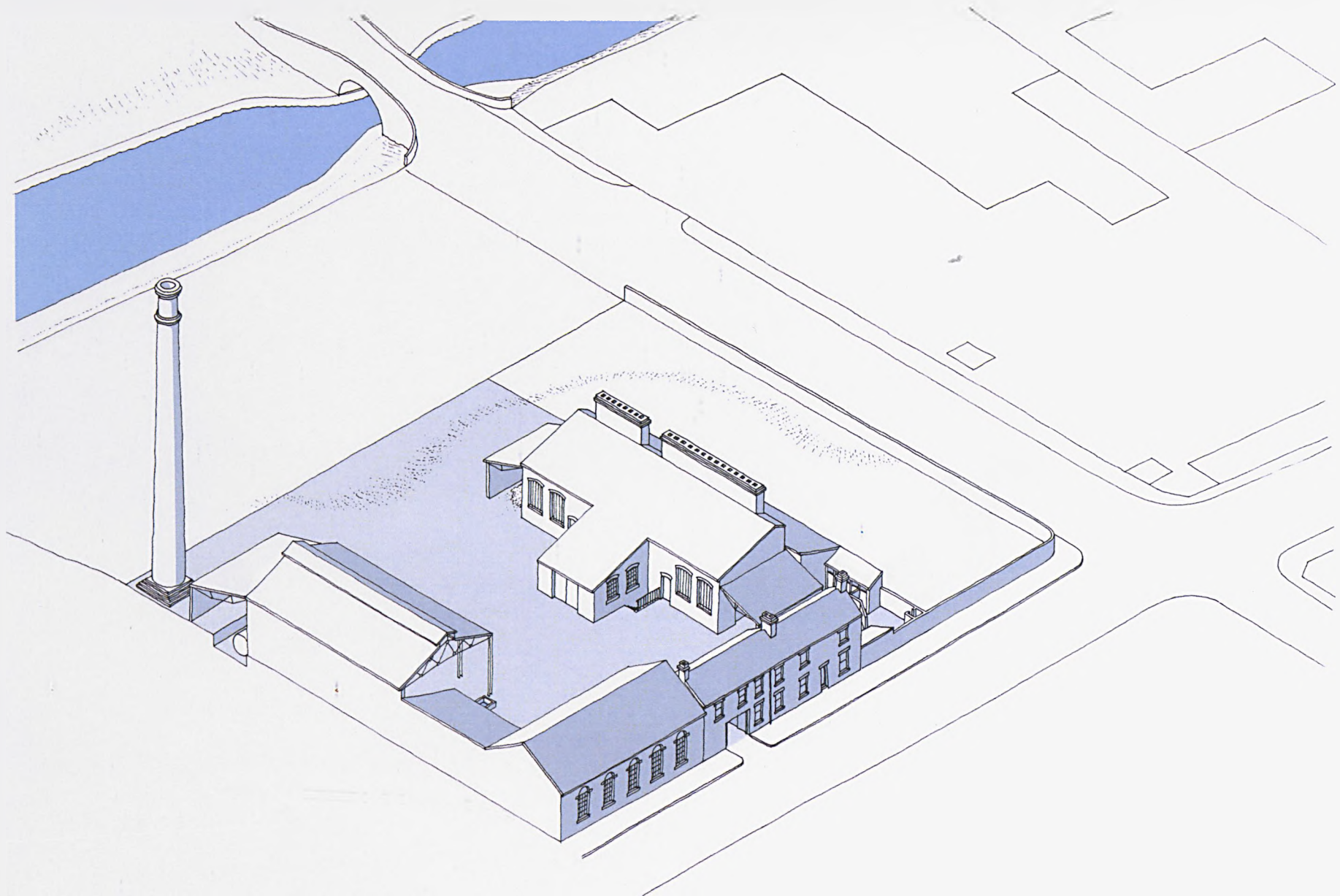

Fig. 1.74 Isometric reconstruction of the Coleridge Road steelworks as proposed in 1898, scale 1:500 (author).

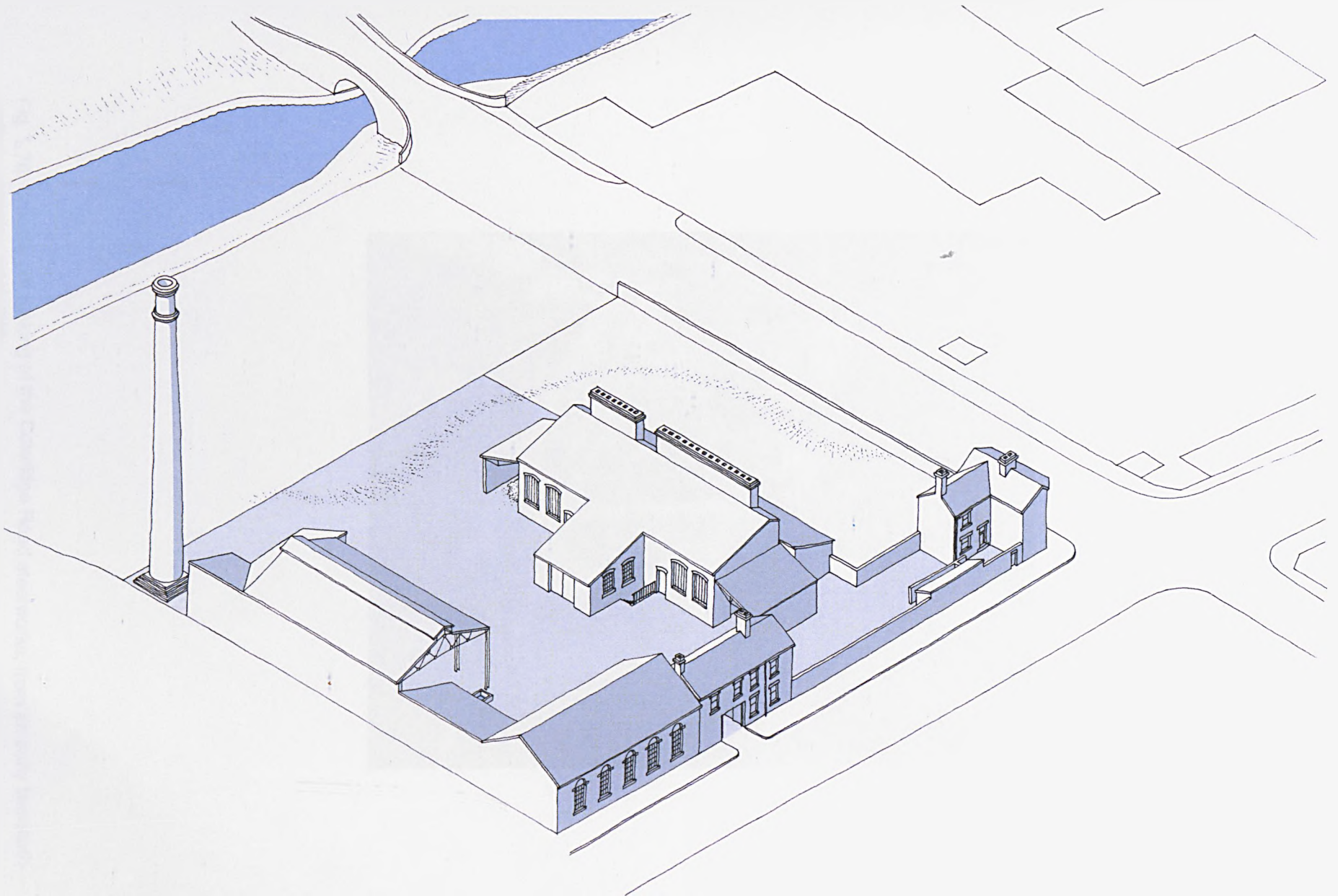

Fig. 1.75 Isometric reconstruction of the Coleridge Road steelworks as built, with the relocated porter's house. Scale 1:500 (author).

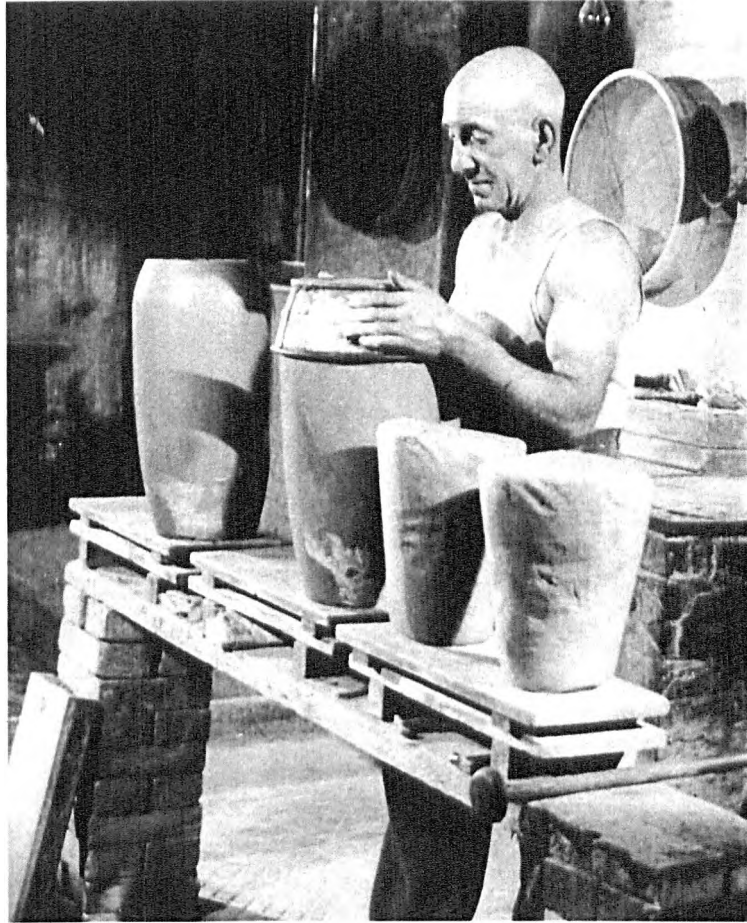

Fig. 1.76 Crucible pot making at the Coleridge Road steelworks, from an early twentieth century company catalogue.

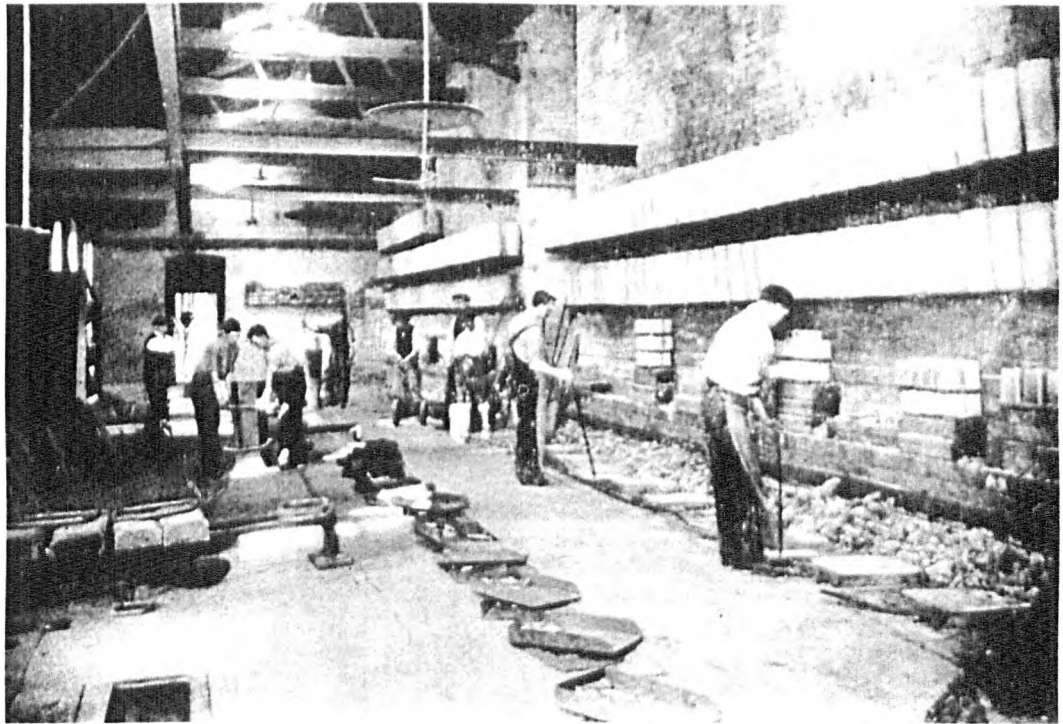

Fig. 1.77 Tending the crucible holes in the Coleridge Road melting shop. The weighed charges for the next round of melts are laid out in the centre foreground.



Fig. 1.78 Casting steel at Coleridge Road. Wheeled tongs (left) were used to transport the crucible from its melting hole to the teeming box. The door at the end led to the coke shed.



Figs 1.79 (top) and 1.80 Surviving steelworks buildings at Coleridge Road, including the porter's house, offices and warehouse and the melting shop behind (author).



THE PRE-1974 COUNTIES OF ENGLAND, WALES AND SOUTHERN SCOTLAND

Fig. 1.81 Plan of England and Wales with circles of 15, 25 and 30km radius within which the proportion of English Huntsmans was 17.2%, 21.8% and 29.2% respectively (author).



Fig. 1.82 Huntsman's land ownership in 1819, including the steelworks, house, enclosure additions and 'Bradley Nook' fields at the rear. Scale 1:2000 (author).



Fig. 1.83 The area of 'Pitt Lane' plotted onto Huntsman's site excluding the 'Bradley' fields, to demonstrate the derivation of the plan from earlier field boundaries. Scale 1:2000 (author).

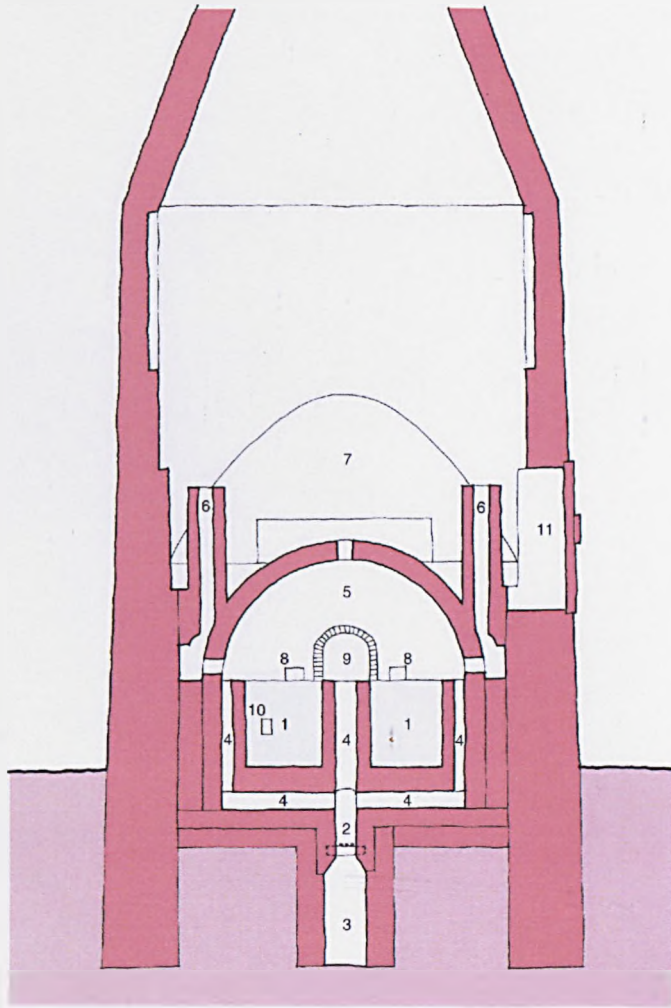

Fig. 2.1 Section of a cementation furnace based on the Holmes Furnaces (see fig. 2.39). Scale 1:100 (author).

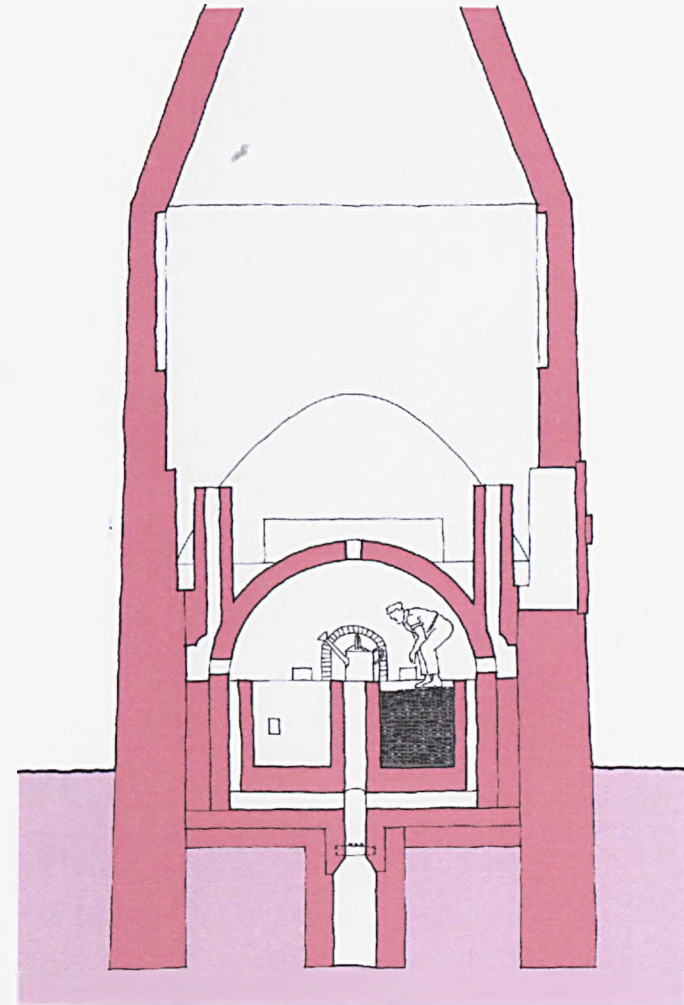

Fig. 2.2 Loading: the chests are stacked with alternate layers of steel and charcoal, passed through the arch in the background (author).

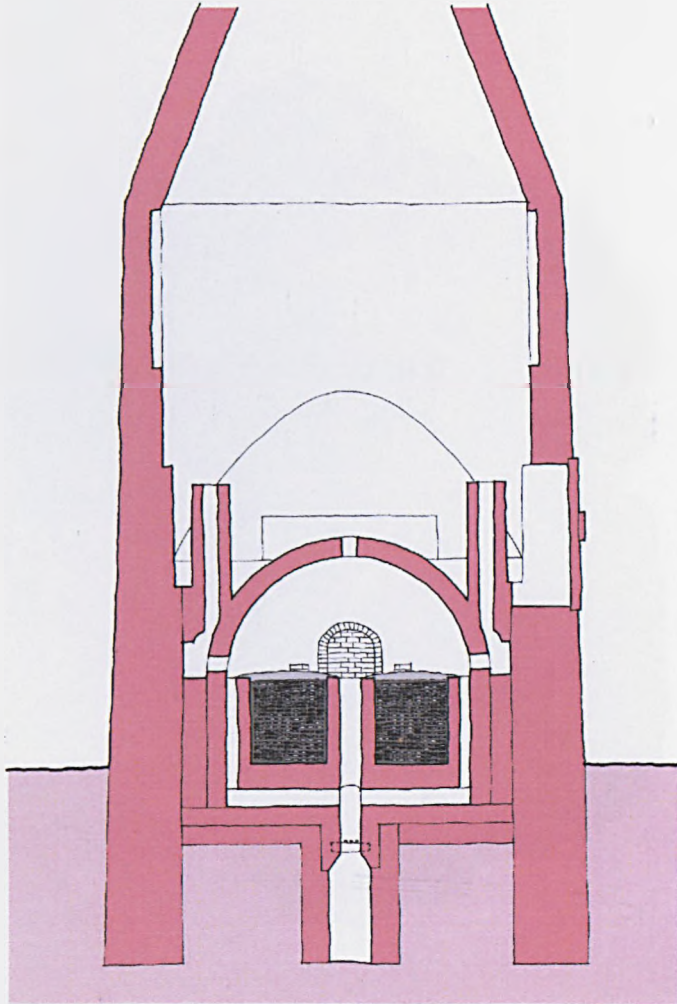

Fig. 2.3 Ready for firing: the fully loaded chests are topped with 'wheelswarf' and all openings bricked up and sealed (author).

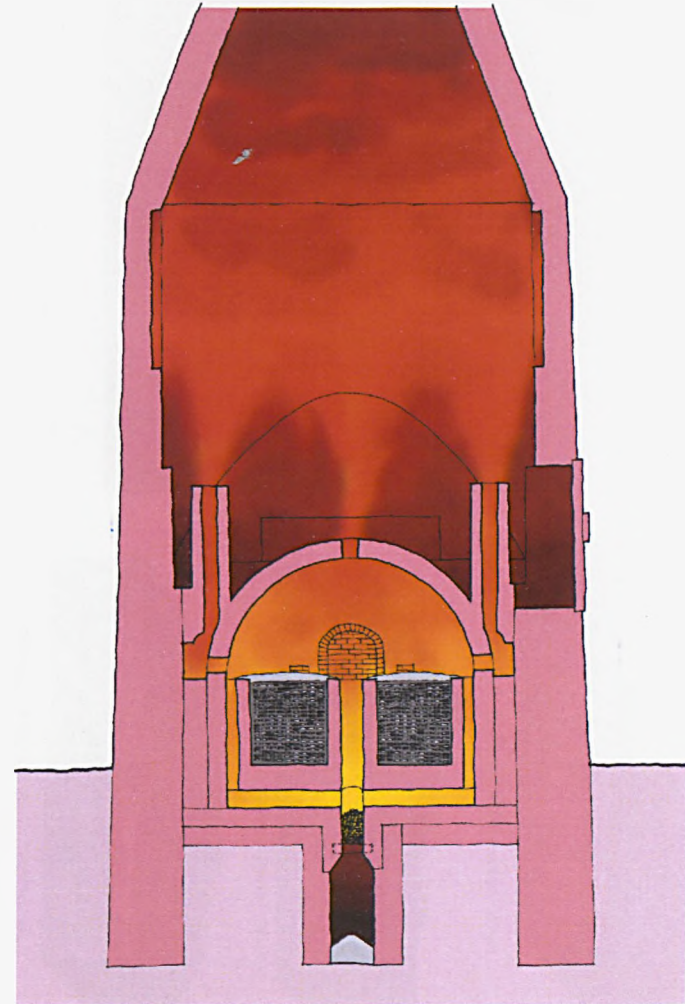
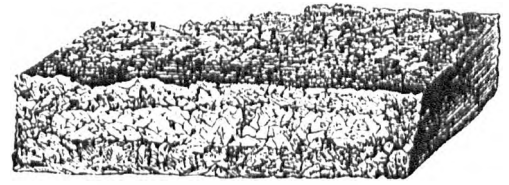

Fig. 2.4 Firing: coal is burnt at grate level, circulating heat around the chests aided by the draught generated by the outer cone (author).



Fig. 2.5 View inside a cementation furnace during loading (SCL).



Fracture of Blister Steel.—Shear Heat.

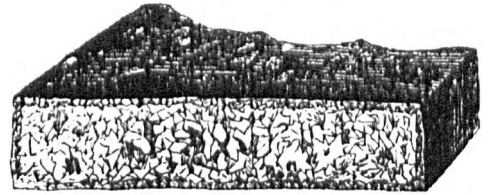

Fracture of Blister Steel.—Spring Heat.

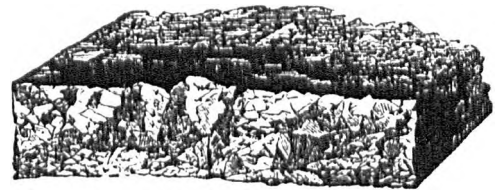

Fracture of Blister Steel.—Melting Heat

Fig. 2.6 Identification of different blister steel grades by fracture (Sexton).



Fig. 2.7 A specimen of 'crozle', the vitrified crust removed from the top of cementation furnace chests and used locally for building purposes (author).

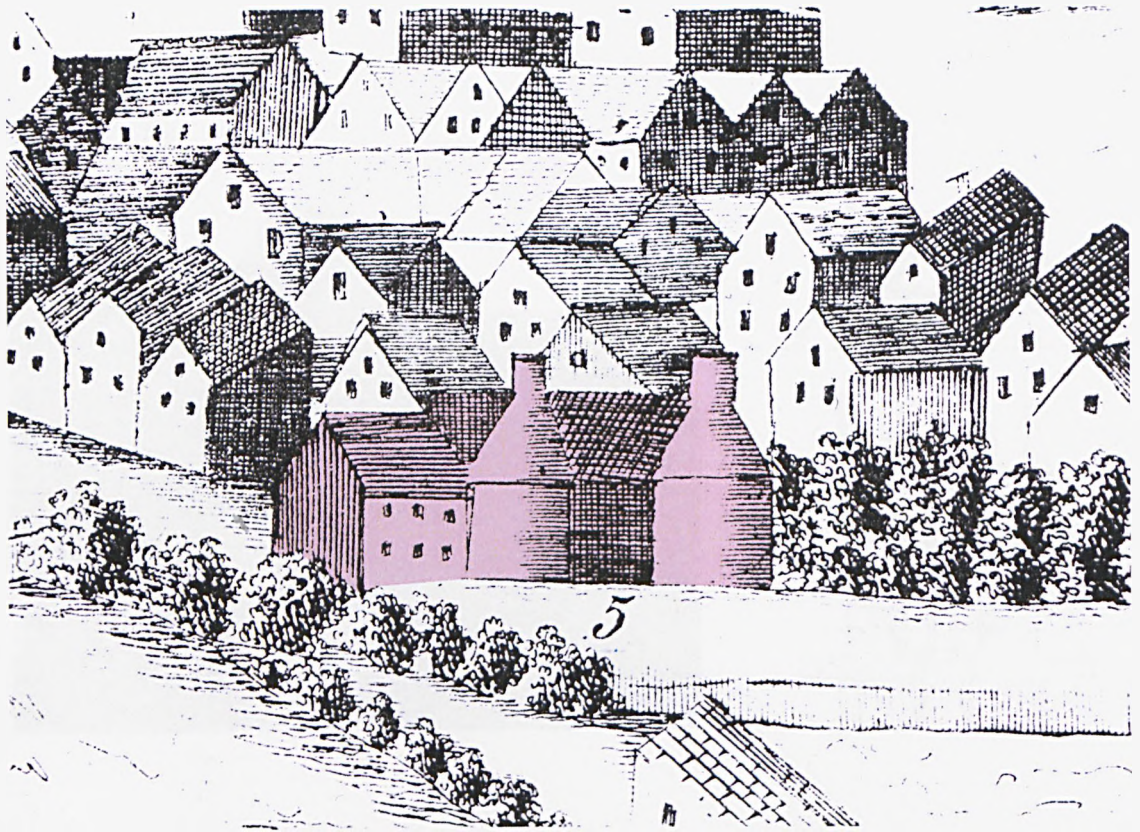

Fig. 2.8 Samuel Shore's two conical cementation furnaces on the northern outskirts of Sheffield, from a view of 1737 (Oughtibridge 1737).

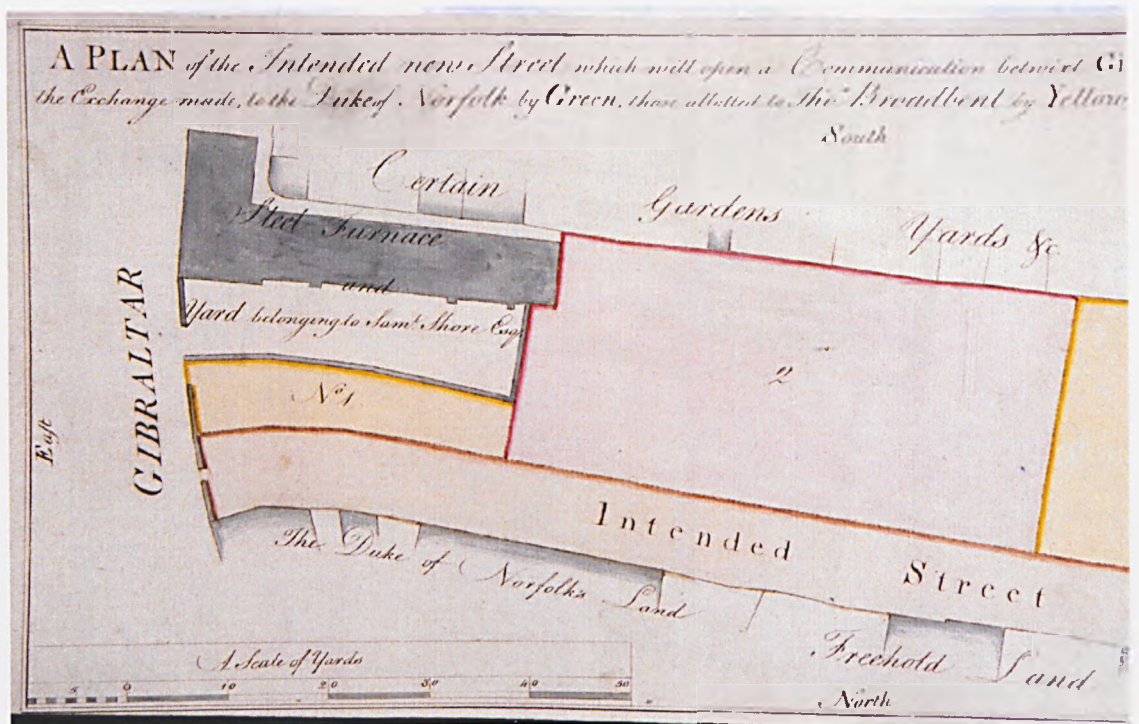
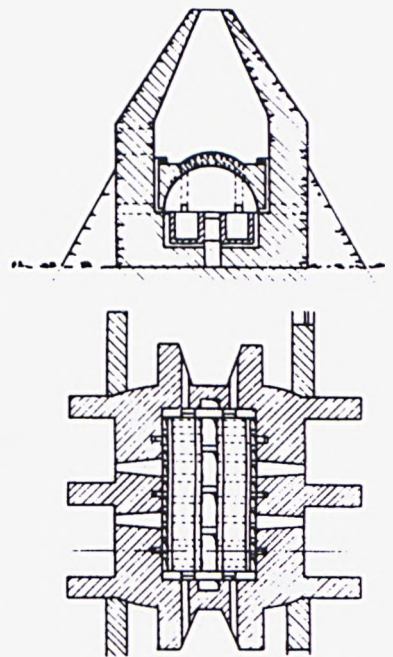

Fig. 2.9 Plan of Shore's furnaces (coloured grey) and yard, drawn for the setting-out of Furnace Hill in 1775. Scale c.1:750 (SCA).



Figs. 2.10 and 2.11 Photograph, section (top right) and plan (bottom right) of Derwentcote cementation furnace before its restoration, the oldest surviving structure of its kind.

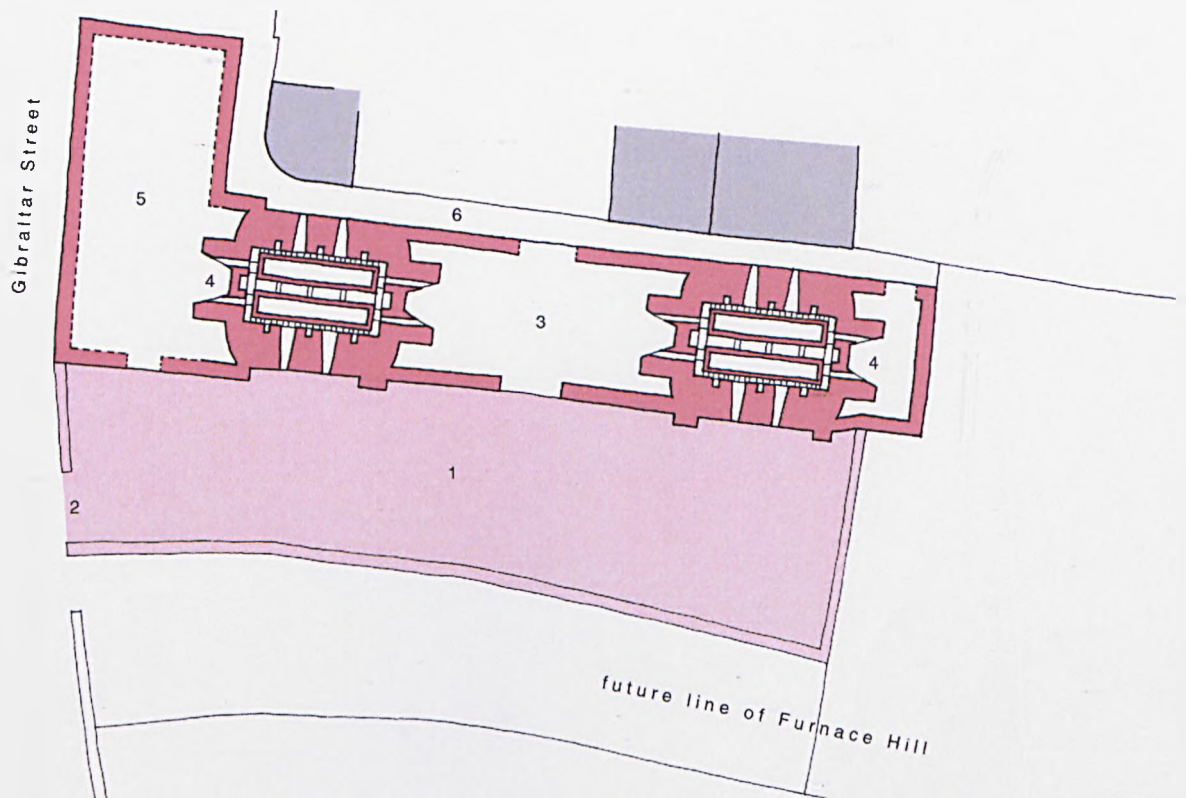

Fig. 2.12 Hypothetical plan of Shore's furnace building, based on fig. 2.9 with furnace dimensions taken from Derwentcote, above. Scale 1:300 (author).

Samuel Shore

Cementation furnaces, Furnace Hill, hypothetical ground plan (c.1770)

scale 1:200

key:

- 1 Furnace yard
- 2 Main gates to Gibraltar Street
- 3 Steel house
- 4 Cementation furnaces (derived from Derwentcote plan)
- 5 Front building (function not known)
- 6 Back access lane

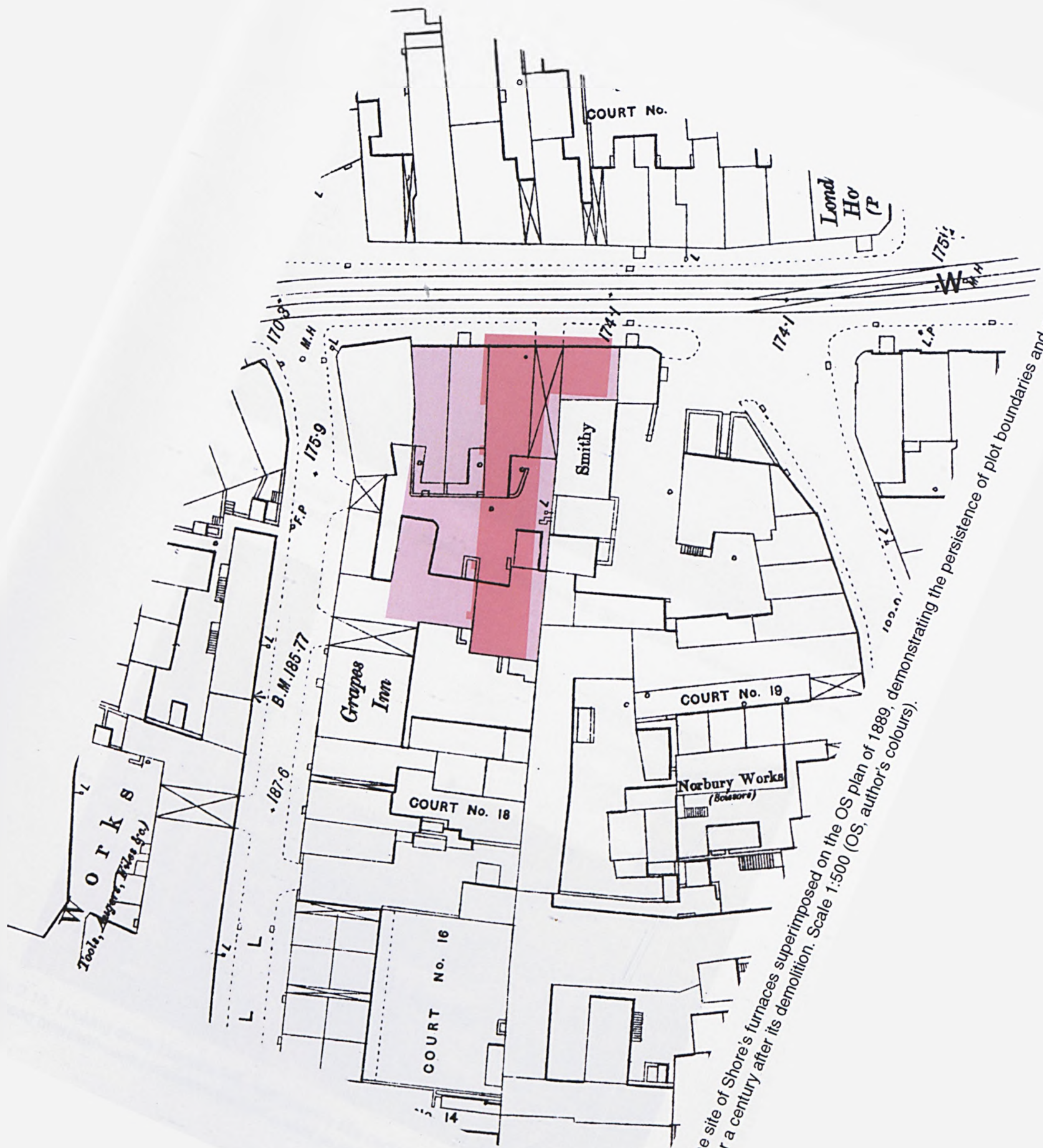

Fig. 2.13 The site of Shore's furnaces superimposed on the OS plan of 1889, demonstrating the persistence of plot boundaries and possibly built form over a century after its demolition. Scale 1:500 (OS, author's colours).



Fig. 2.14 View up the severe gradient of Furnace Hill in 2003. Shore's furnaces occupied the site to the left (author).



Fig. 2.15 Looking down Furnace Hill, with Shore's site centre right, now occupied by disused twentieth-century workshops and a yard (author).

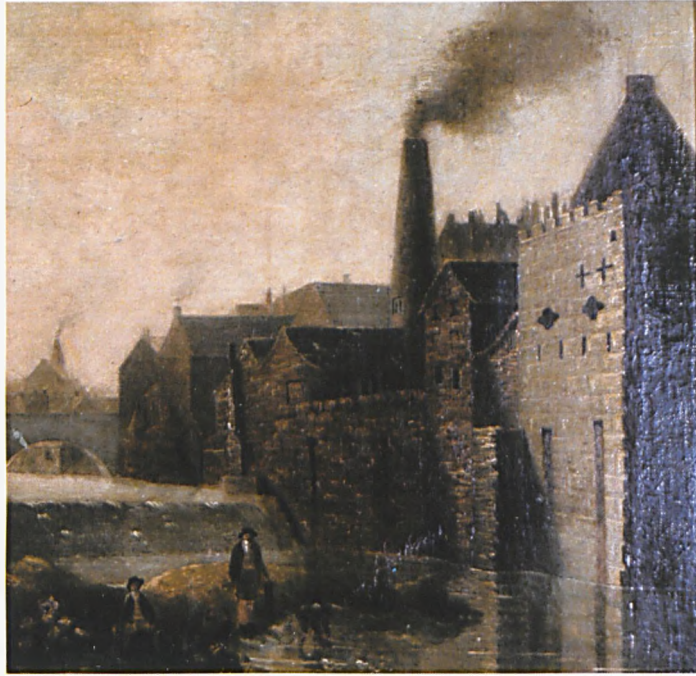

Fig. 2.16 Detail of a late eighteenth century painting of the river Sheaf, depicting Castle Hill with the Castle Green cementation furnace silhouetted on the right (Kelham Island Museum).

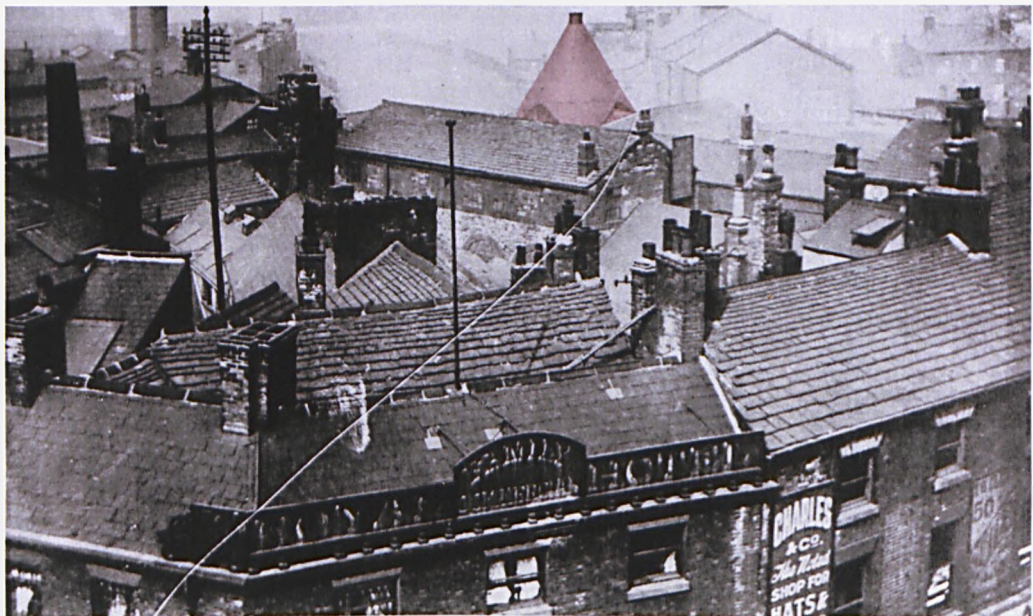

Fig. 2.17 Nineteenth century rooftop photograph of the Castle Green furnace (highlighted) from the opposite direction, showing the dense development of the castle site.



Fig. 2.18 Newspaper photograph of the Castle Green furnace during demolition. Note its heavy stone construction reinforced by iron tie-plates above each opening (SCL).

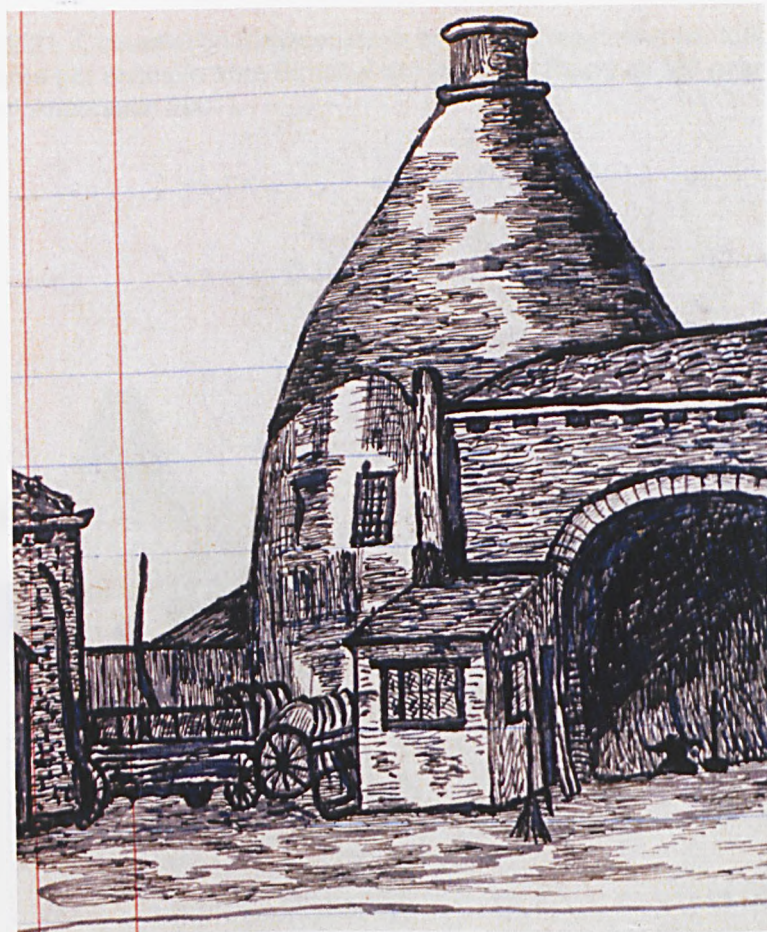
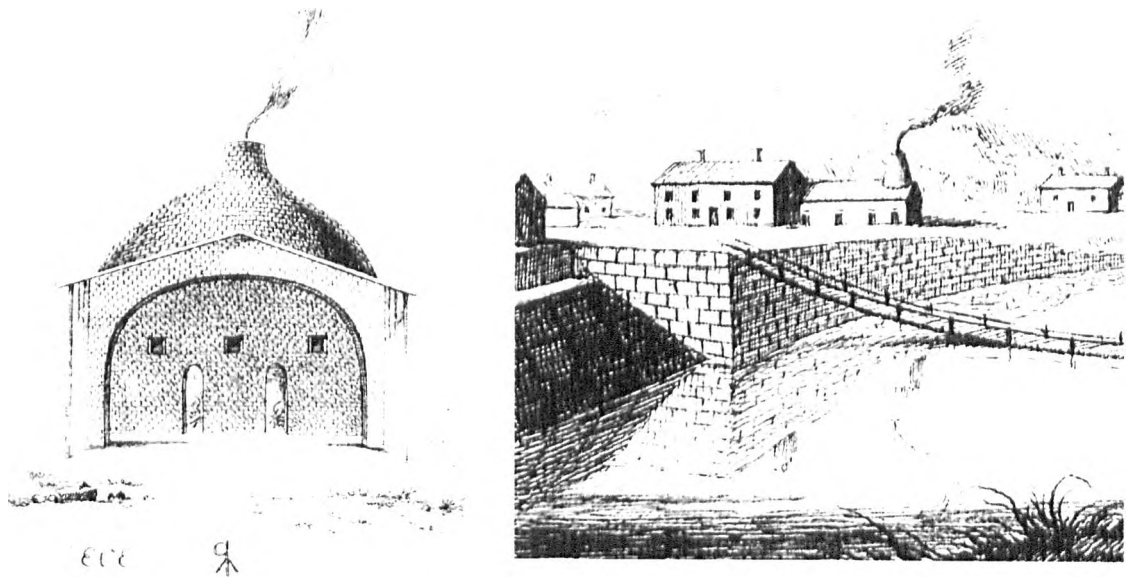

Fig. 2.19 Henry Tatton's early twentieth century sketch of the Castle Green furnace reused as a storage shed. Note the added window on its vertical hyperbolic face (SCL).



Figs. 2.20 and 2.21 Cementation furnaces seen by Angerstein during his tour of England (1753-55). A three-pot example from Birmingham (left) and Blackhall Mill near Newcastle (right, both from Angerstein 2001).

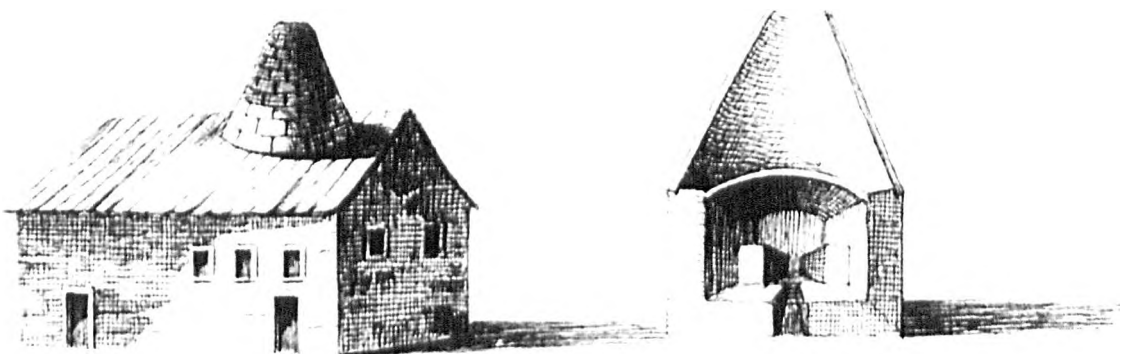

Fig. 2.22 Angerstein's more detailed study of the two-chest Blackhall Mill furnaces, showing their rough stone construction and enclosing iron house (Angerstein 2001).

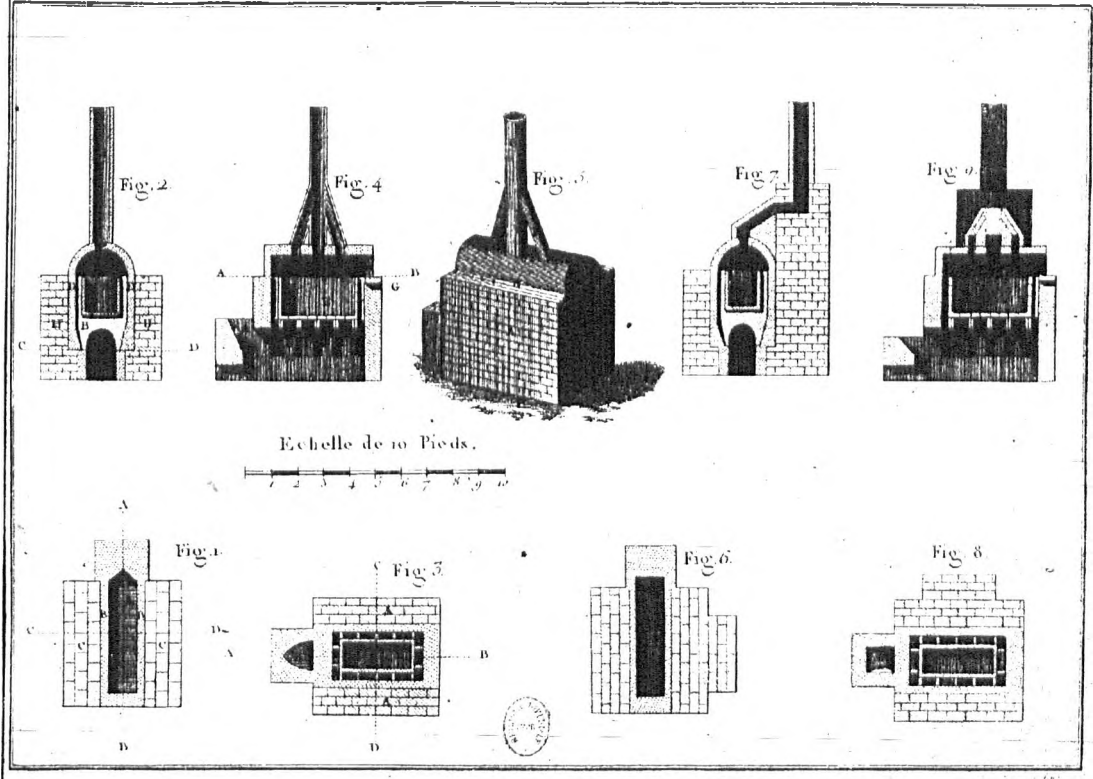

Fig. 2.23 Single-chest trial furnace based on Gabriel Jars' 1774 drawings. Jars based his design on larger commercial furnaces he had seen at Sheffield in 1765, below.

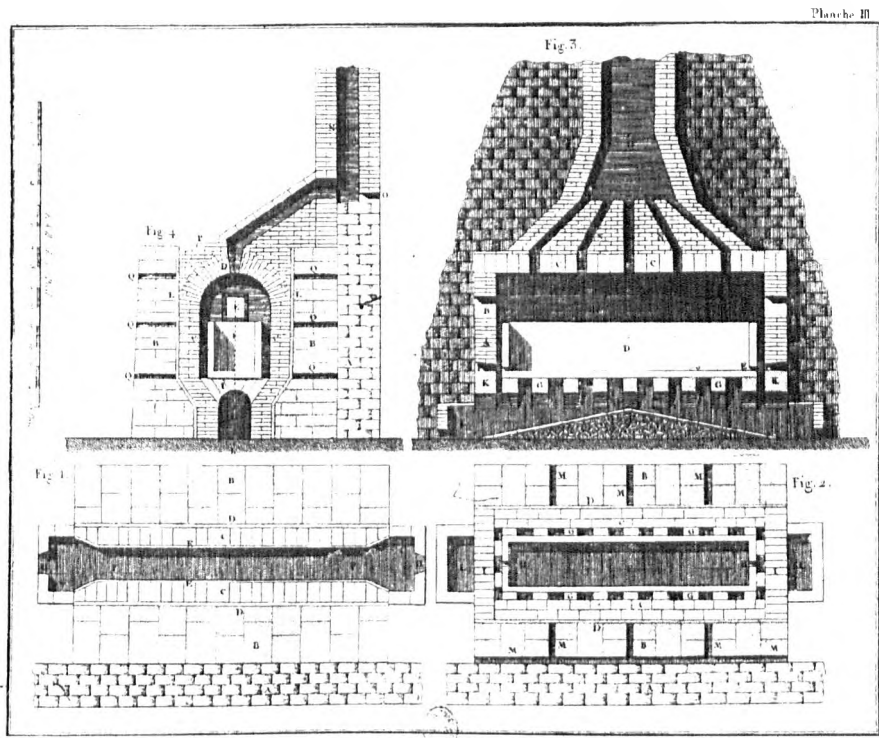

Fig. 2.24 The smaller type of cementation furnace as used in Sheffield during the eighteenth century, with a chimney in place of the more usual cone (Vandermonde *et al.* 1793?).

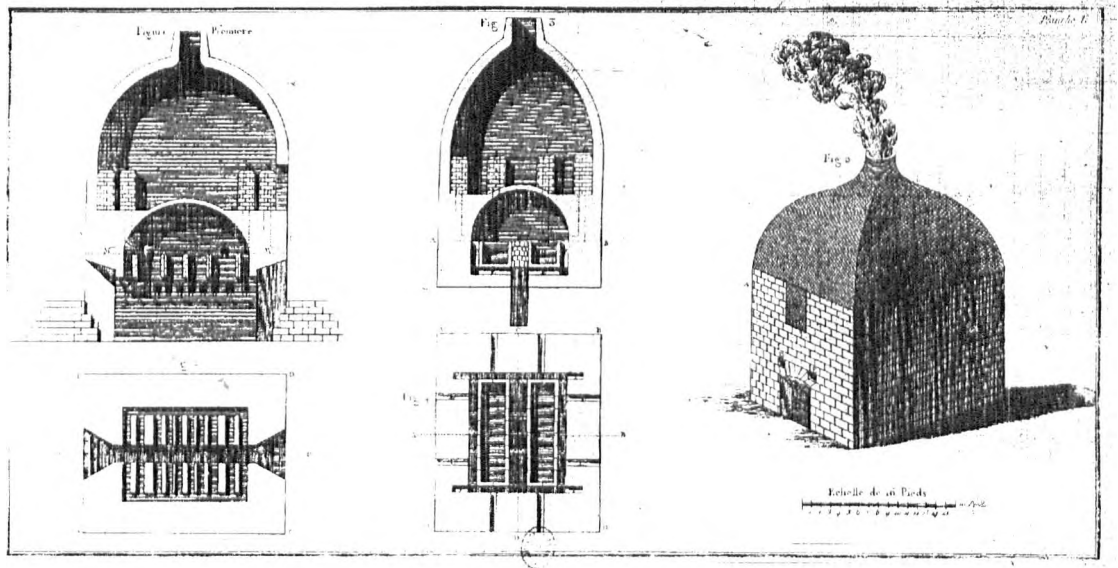
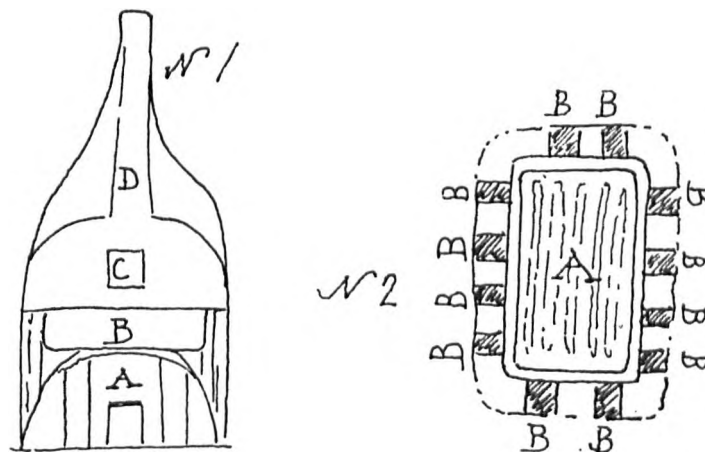

Fig. 2.25 Twin chest furnace with superimposed 'cone', as seen by Jars at Newcastle. The design changed little over the next century (Vandermonde *et al.* 1793?).



Key to no. 1:
 A The Fire Place
 B The Stone Chest in which the Iron Bars are placed
 C The Vaulted Roof
 D The chimney

Key to no. 2:
 A The Chest with the [iron] Bars
 BB etc. Flues by which the flame passes up so as to be reverberated on the top of this chest by means of the Vaulted Roof, C in No. 1.

Fig. 2.26 Sketch plan ('No. 1') and section ('No. 2') of the single-chest furnace at John Marshall's Millsands steelworks, Sheffield, made by Charles Hatchett on a visit of 1796 (Raistrick 1967).

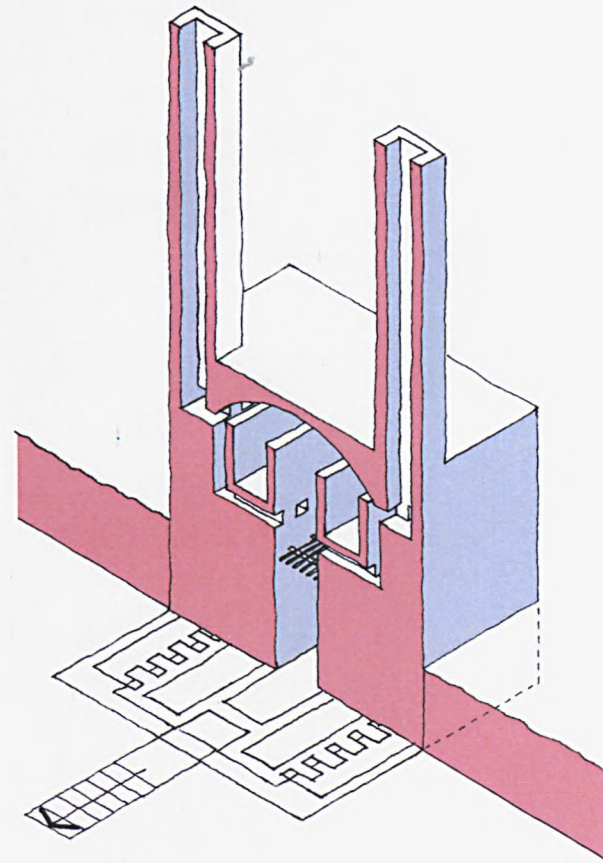
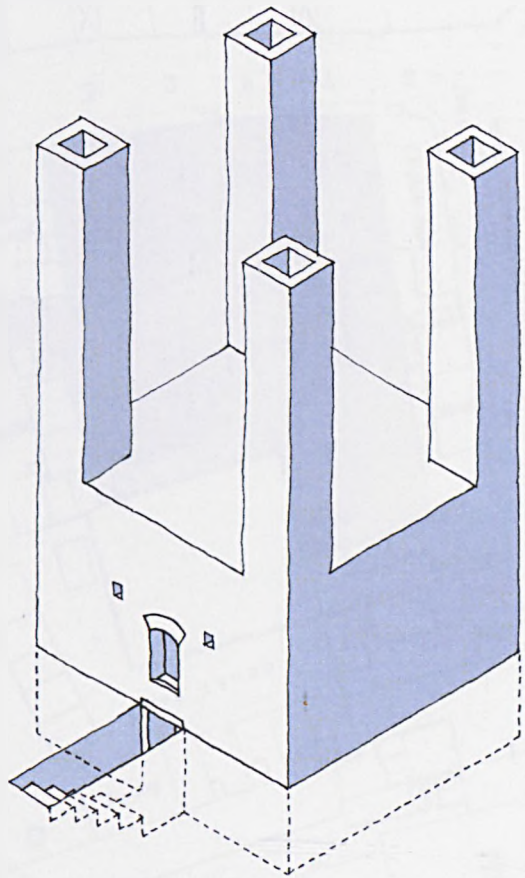

Fig. 2.27 Reconstructed isometric views of a Sheffield cementation furnace (left) described by Broling, based on drawings of a similar example he had seen at London (right, reconstructed isometric section) but with four corner chimneys instead of two (author).



Fig. 2.28 Holly Street cementation furnaces (the top of the second can be seen above the ridge) and iron warehouse operated by Simon Younge in the late eighteenth century (SCL).

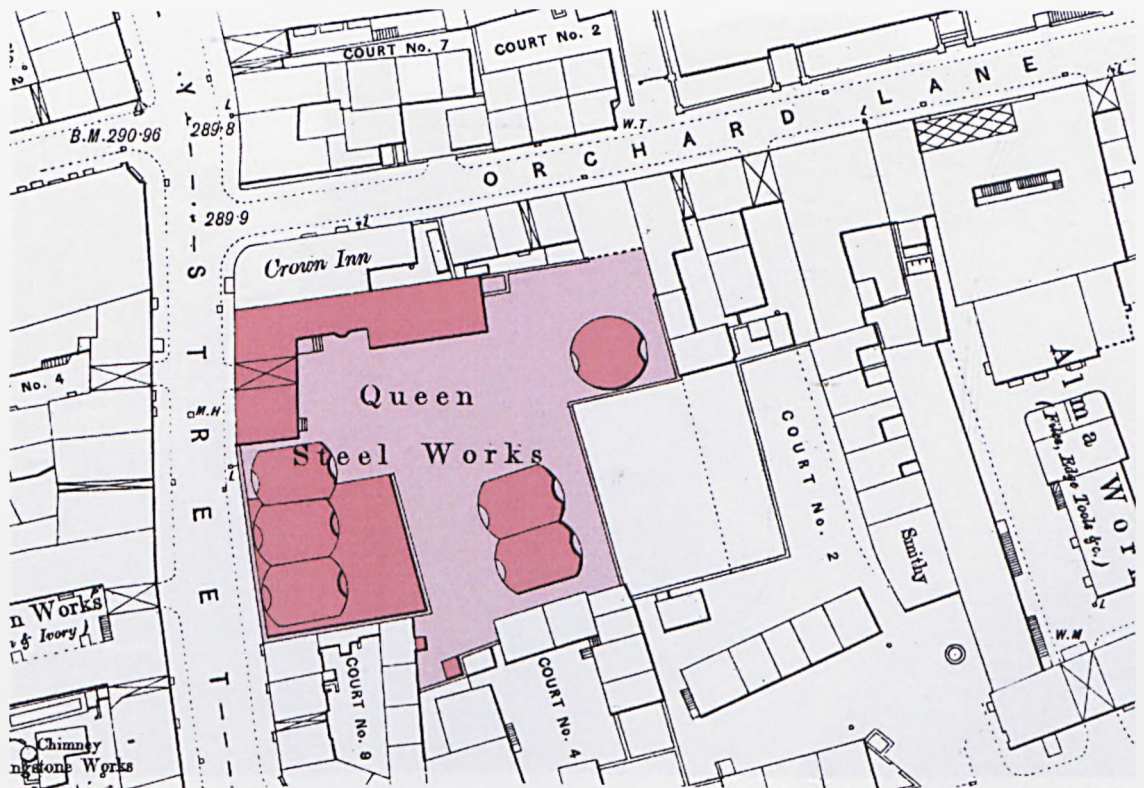

Fig. 2.29 Queen Steel Works with six cementation furnaces in 1889, near to or on the site of Younge's premises, above. Scale 1:1000 (OS, author's colours).



Fig. 2.30 Two large cementation furnaces that belonged to Cocker's Nursery Street Wire Mills. Unusually, the iron house had a lantern ridge ventilator (Pawson & Brailsford 1862).



Fig. 2.31 Traces of the left hand cone from the view above, describing a hyperbolic section against the adjacent party wall. Photographed in 2000 (author).



Fig. 2.32 Partial furnace remains at Bower Spring, including the heat-attacked internal brickwork of the chests and vault (centre foreground) and sections of the cone (author).

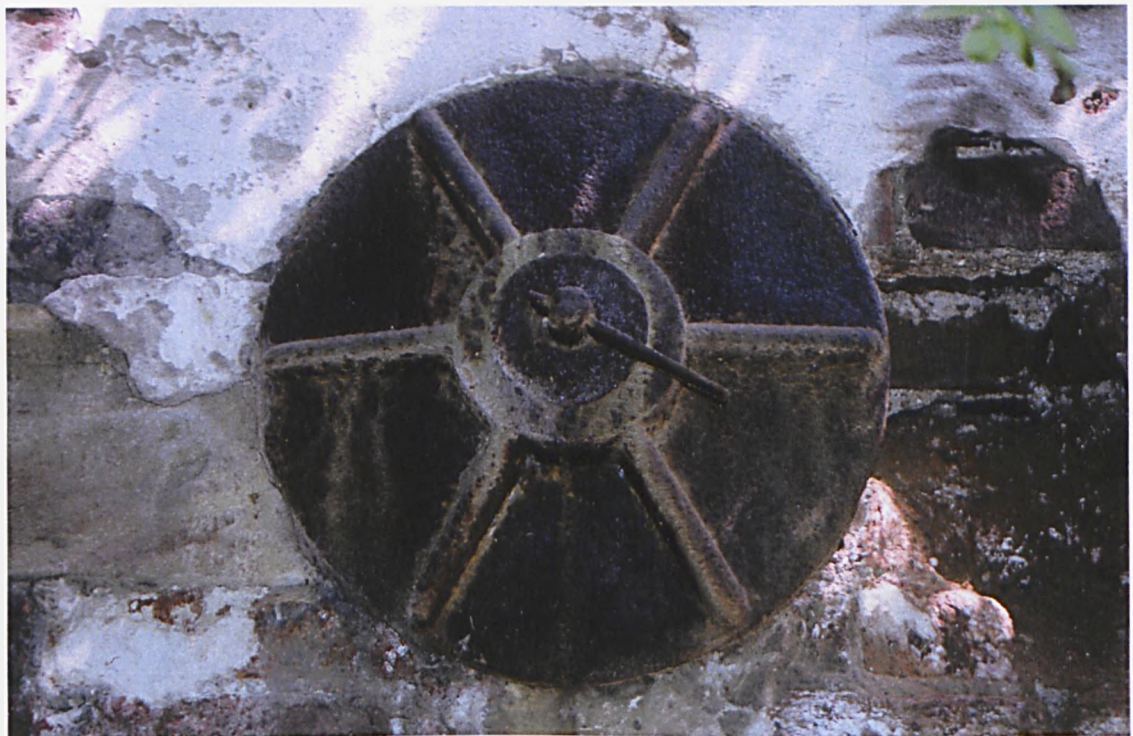

Fig. 2.33 Cast iron tie-plate from the rear wall of the Bower Spring furnaces, above. Iron rods passed through the space of the cone to provide extra lateral support (author).

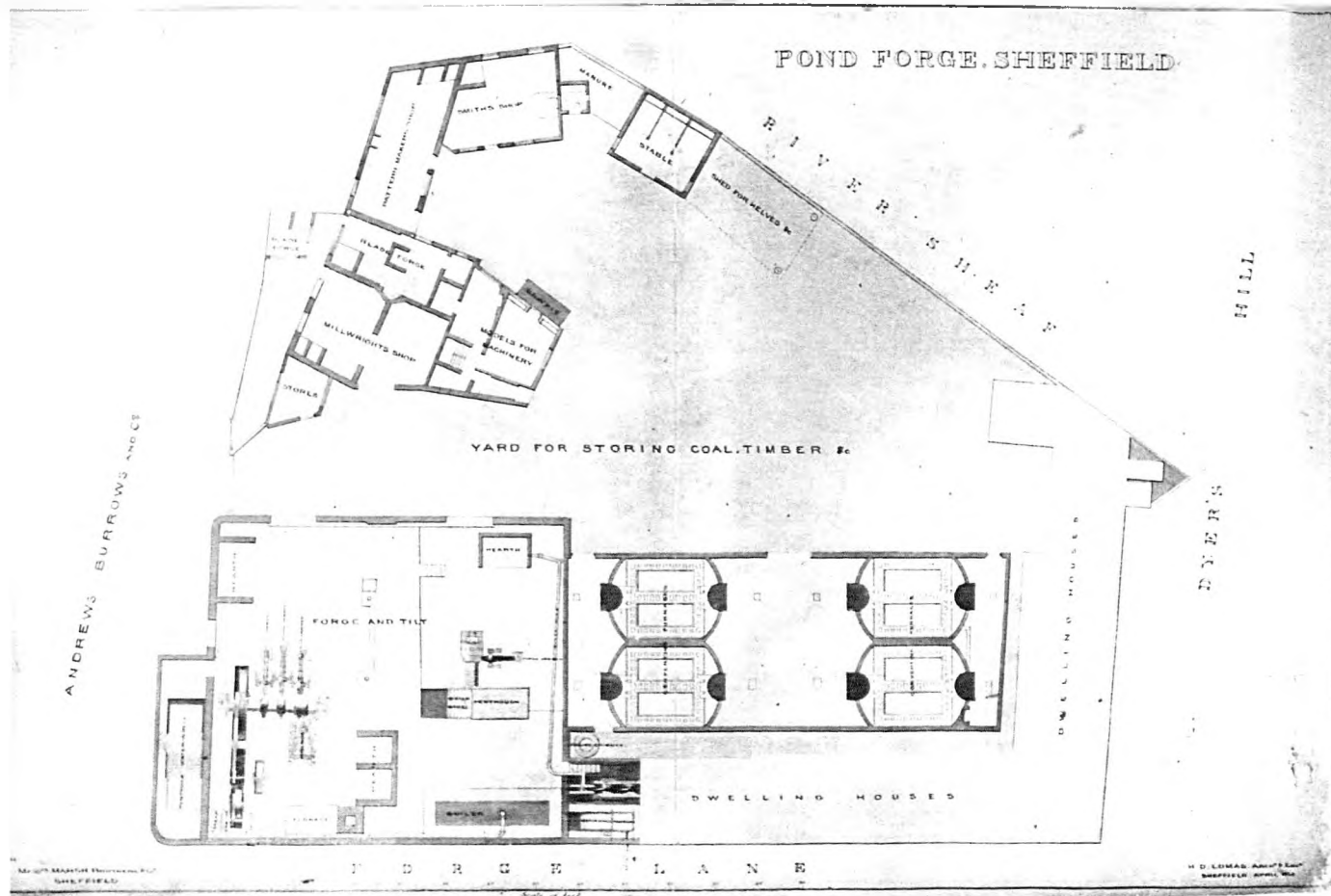
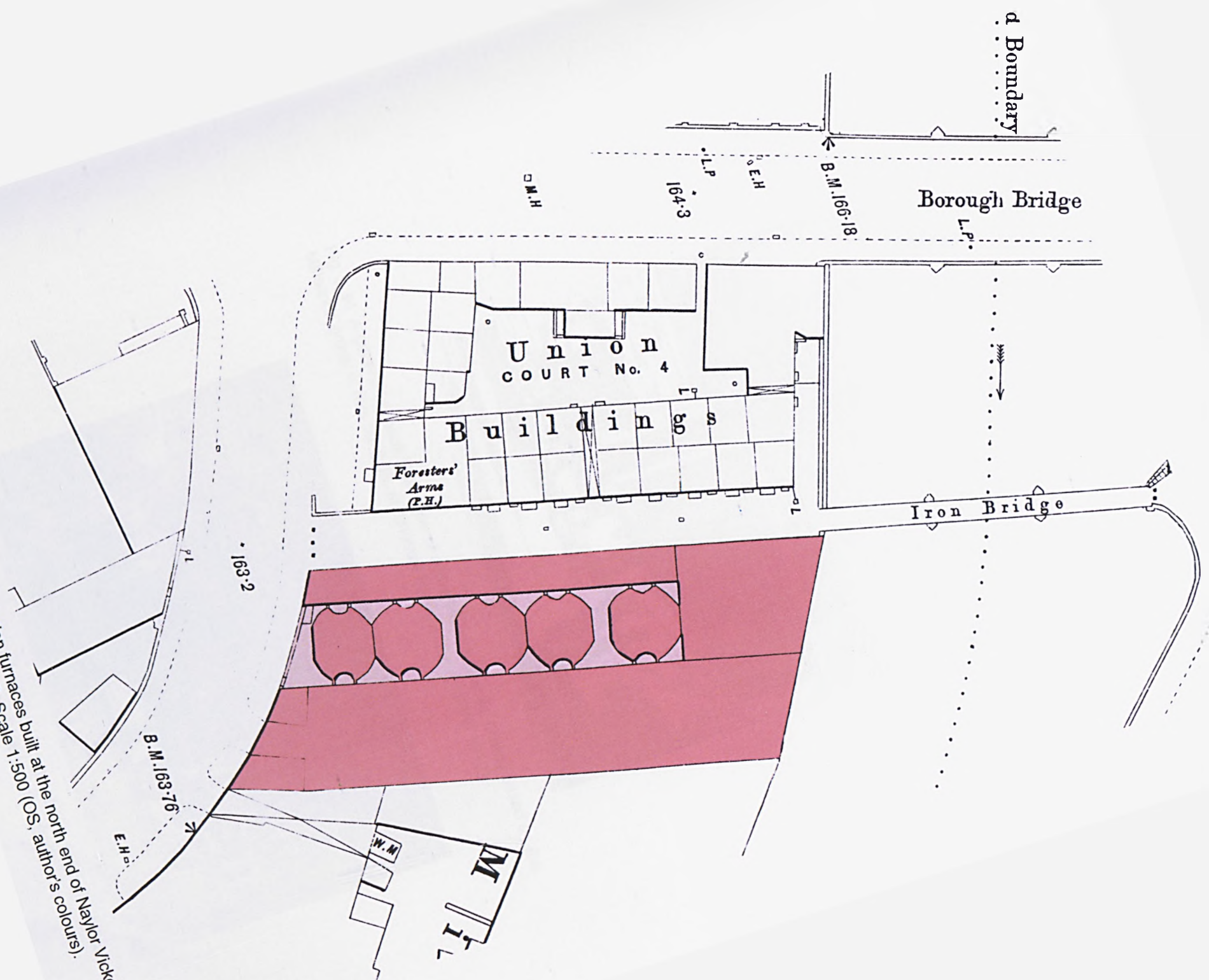

Fig. 2.34 Extensions to the Pond Forge Works of Marsh & Shepherd, in an architect's plan of 1864. Four cementation furnaces shared a single iron house, a relatively common pattern in Sheffield. Note the uncomfortable proximity to the adjacent dwellings on Forge Lane (Pollard 1954).

Fig. 2.35 A bank of five cementation furnaces built at the north end of Naylor Vickers' Millisande Steelworks, from a map of 1889. Scale 1:500 (OS, author's colours).



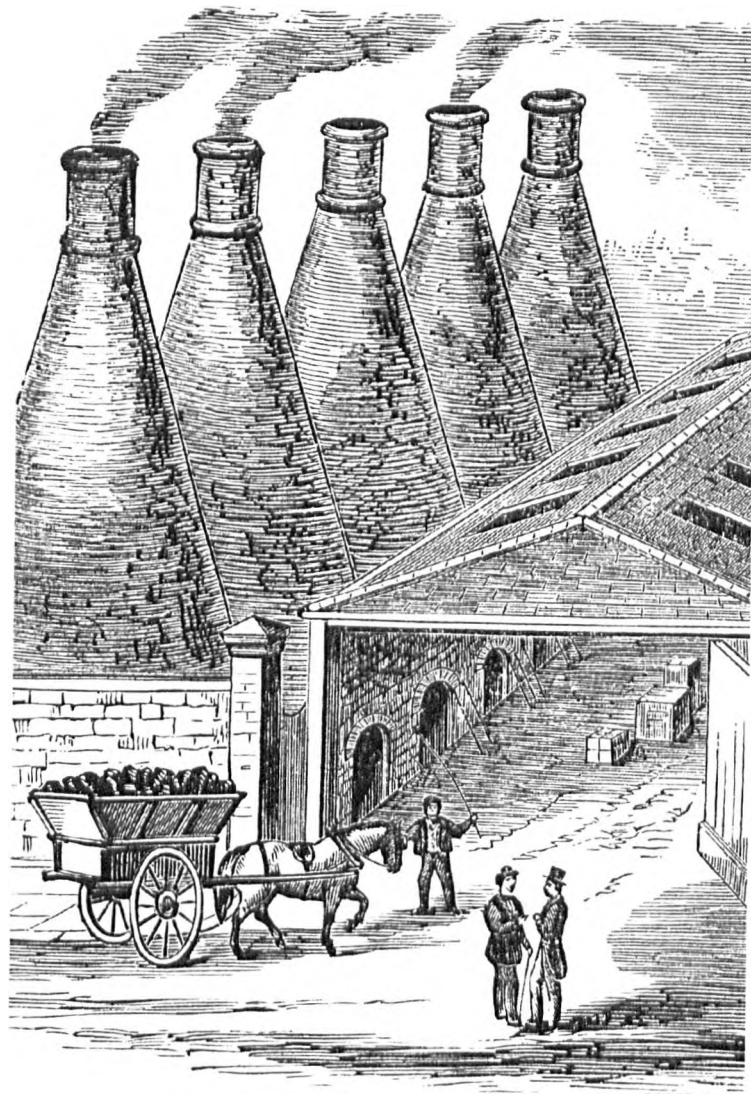

Fig. 2.36 A generic textbook illustration of cementation furnaces, clearly based on the Millsands group of five, fig. 2.35, an unusual configuration (Sexton 1912).

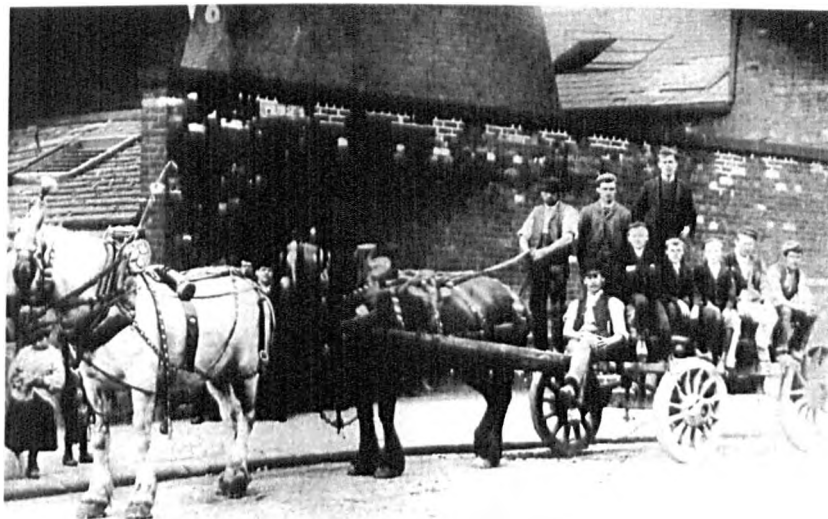

Fig. 2.37 The Millsands furnaces as a backdrop to a posed photograph, indicative of the landmark status acquired by such characteristic structures (SCL).

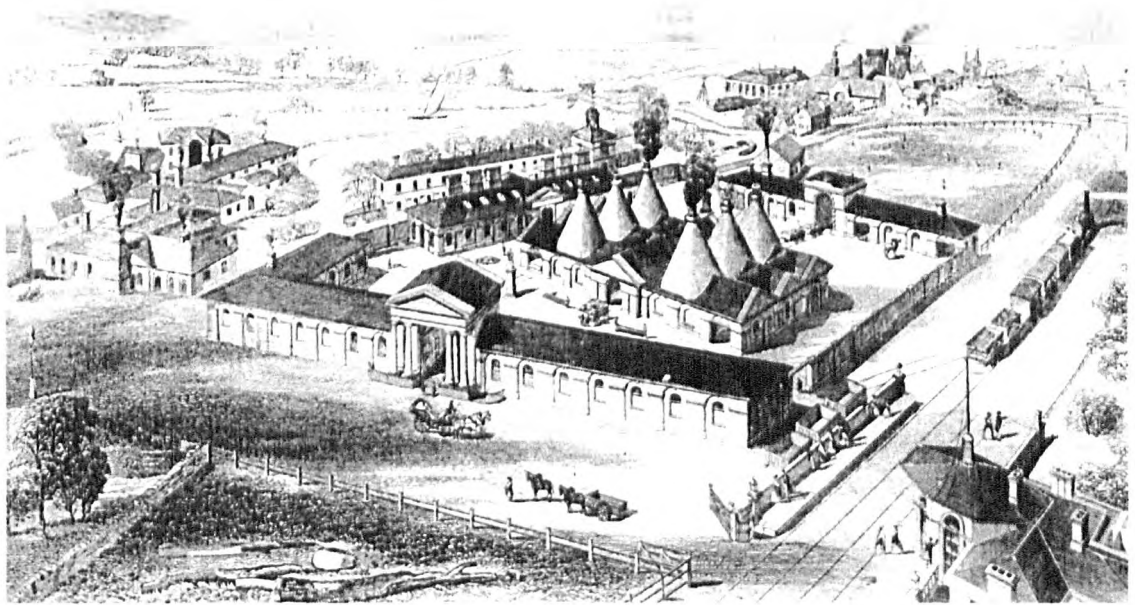
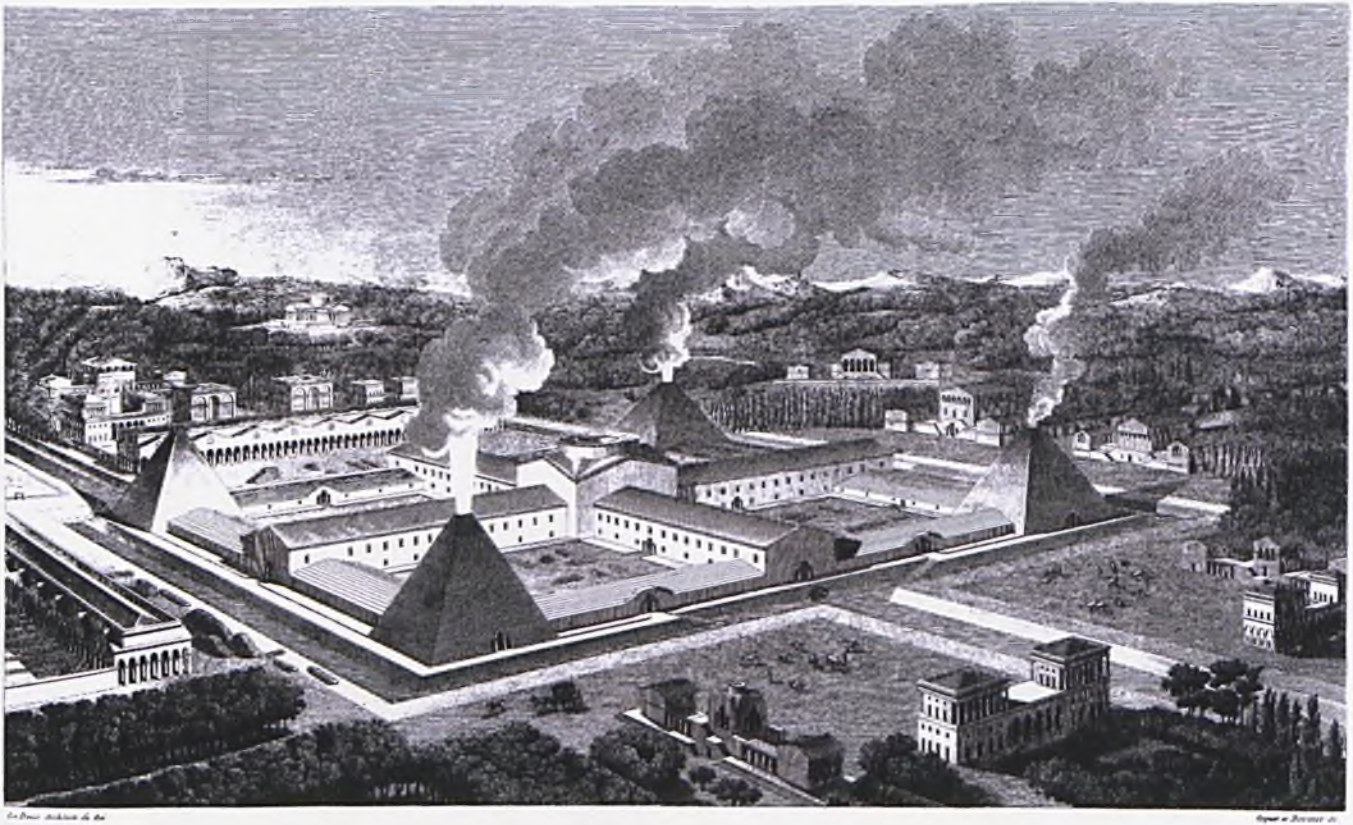

Fig. 2.38 Holmes Steel Works, one of the most sophisticated architectural expressions of the type. Behind the block of six cementation cones can be seen the cast steel furnaces.



Fig. 2.39 Photograph of the Holmes group, showing the stripped classical detail and rigorous composition that set them aside from more utilitarian examples (Allison 1936).



VUE PERSPECTIVE DE LA FORGE

Fig. 2.40 Unrealised scheme for a cannon foundry by Ledoux, in which the pyramidal furnace structures are used to dramatic effect (Ledoux 1804).

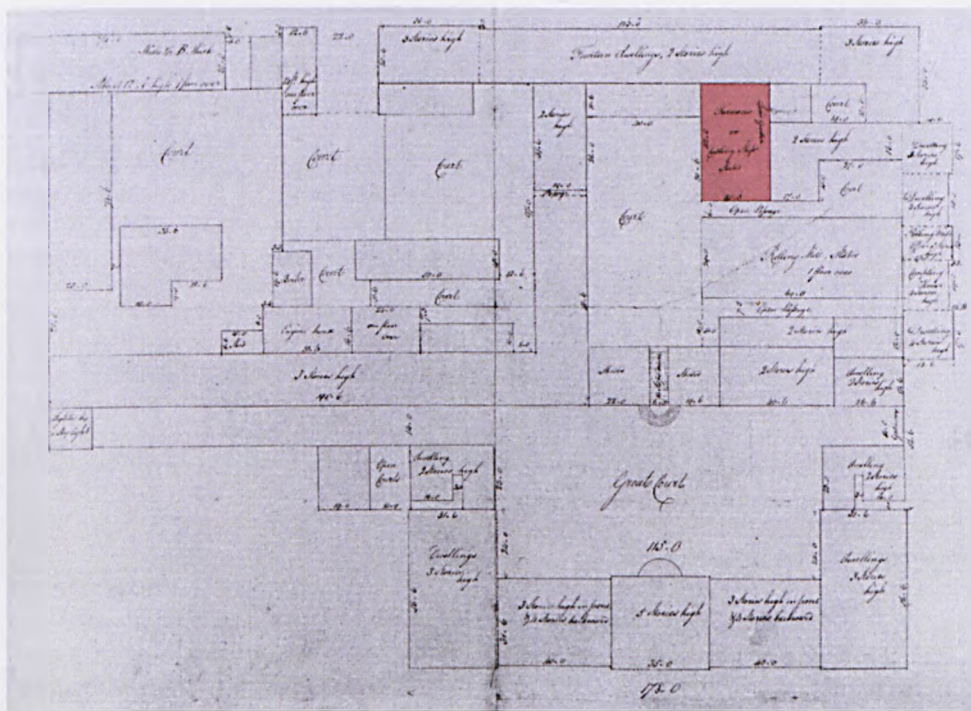

Fig. 2.41 Small steel melting furnace at Matthew Boulton's Soho Works. Although a customer of Huntsman, Boulton also prepared his own cast steel from scraps (BCL).

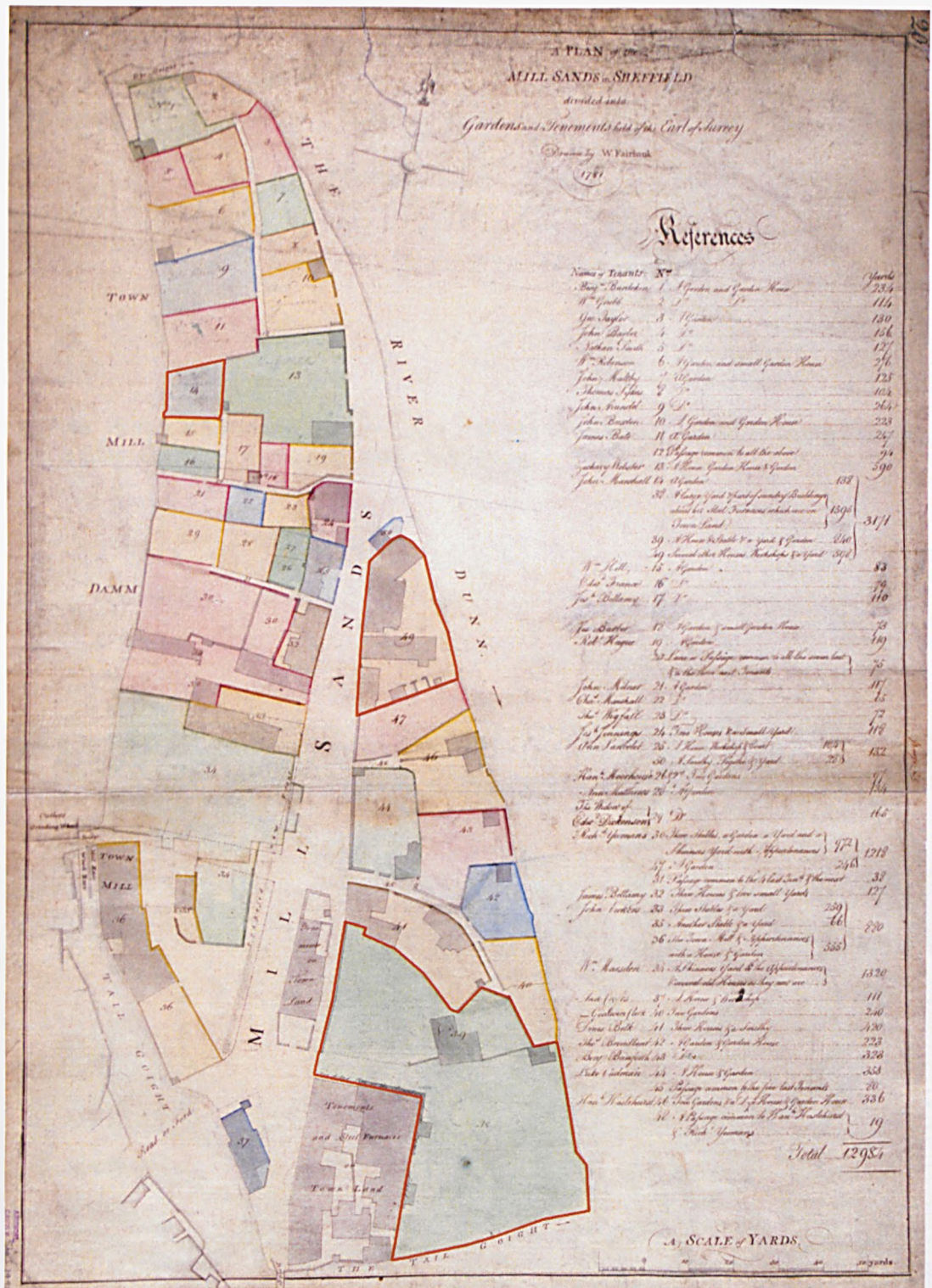
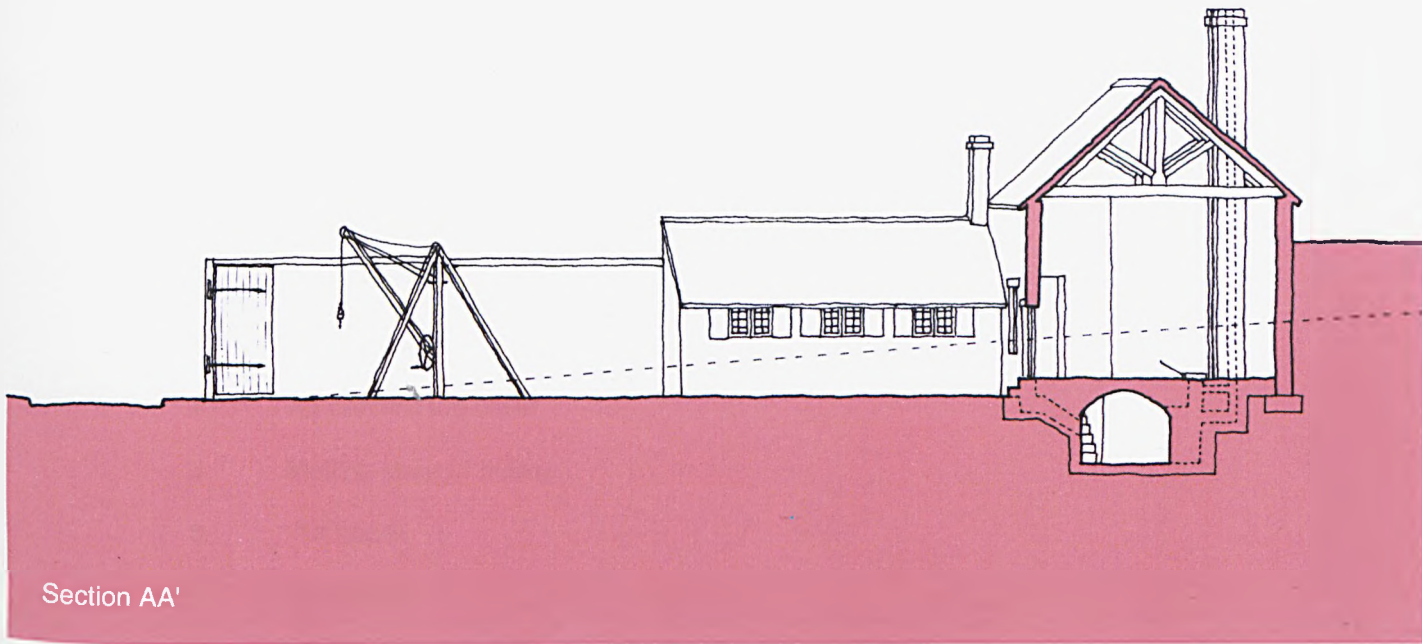

Fig. 2.42 John Marshall's land at Millsands in 1781. His steel furnaces (coloured grey, bottom) were built on ground leased from the Town Trustees (SCA, author's highlights).



Section AA'

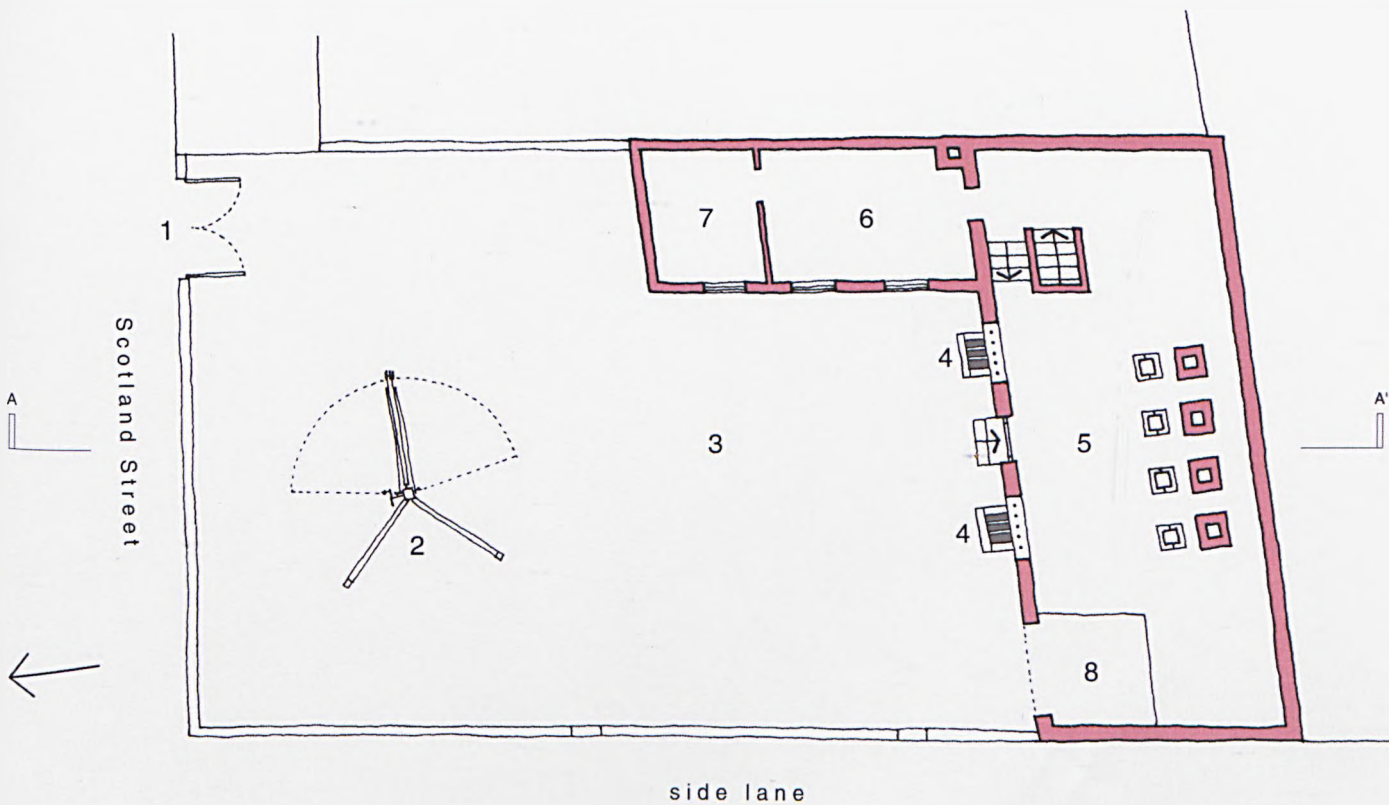

Fig. 2.45 Reconstruction of the Cutlers' cast steel furnaces, derived from Fairbank's survey (fig. 2.43) and written bills of quantities made during construction. Scale 1:200 (author).

Cutlers' Company

Scotland Street cast steel furnace, reconstructed ground plan and section (1764)

scale 1:200

key:

- 1 Great gates
- 2 Derrick crane
- 3 Steel yard
- 4 Air openings to cellar
- 5 Melting shop (4 holes)
- 6 Pot house
- 7 Clay room
- 8 Coke shed (hypothetical location)

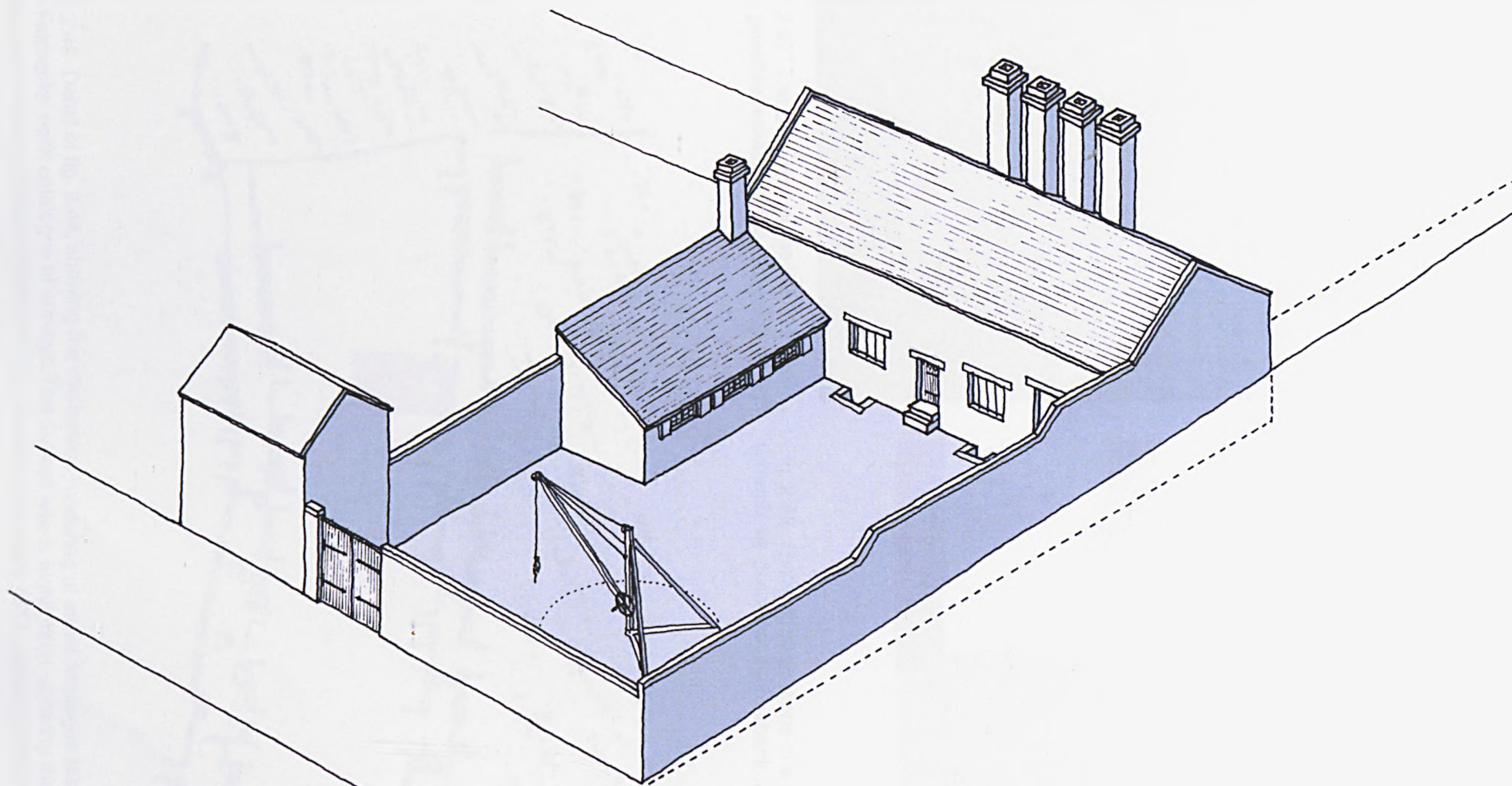

Fig. 2.46 Isometric reconstruction of the Cutlers' furnace, fronting Scotland Street. The ramped wall to the right indicates the steep gradient of the site, excavated within the boundary to form a level yard. The monopitched structure on the right was the pot room and clay house. Scale 1:200 (author).



Fig. 2.47 The back wall of the site in 2001, with possible remains of the furnace (author).

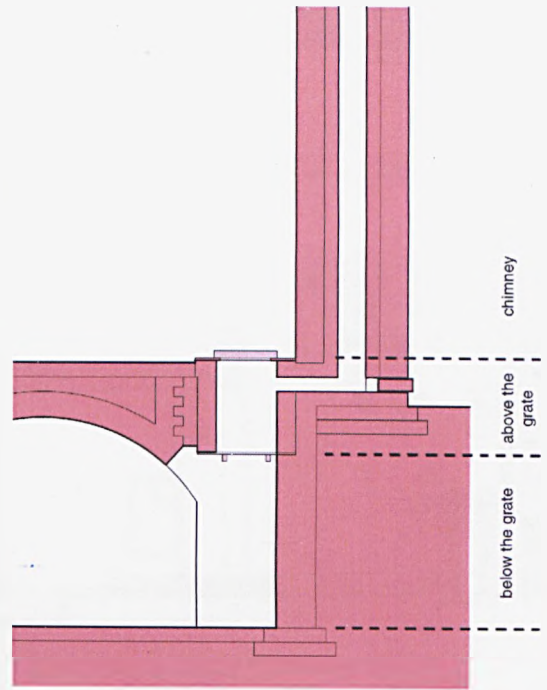

Fig. 2.48 The vertical portions of a melting furnace, as described by Fairbank (author).



Fig. 2.49 Detail of fig. 2.44, showing the meticulous rendering of street frontages taken from the Fairbanks' back catalogue of surveys. The Cutlers' site is highlighted, showing the absence of street frontage building and the side lane (Fairbank 1771, author's colours).

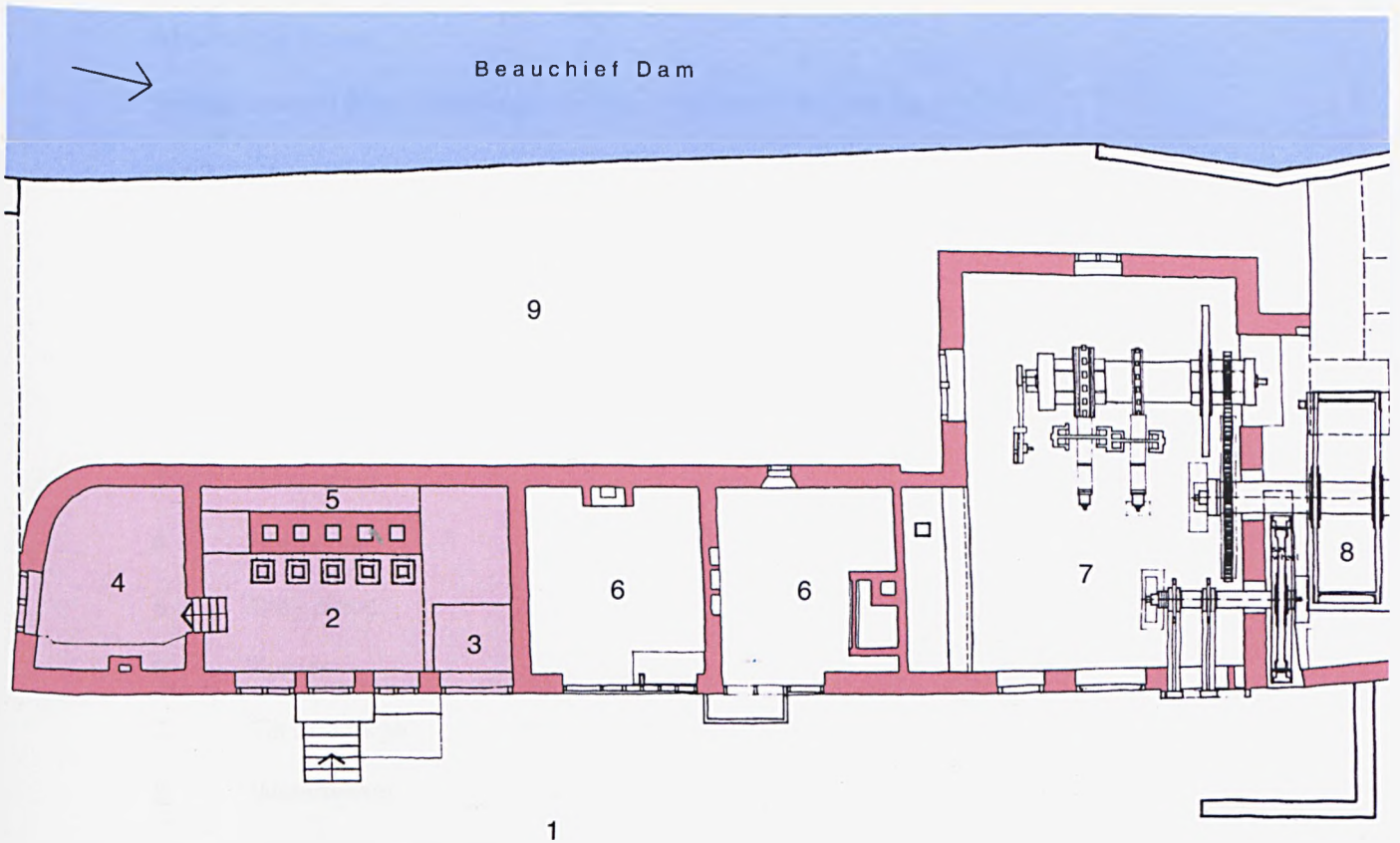

Fig. 2.50 Five-hole cast steel furnace at Abbeydale Works, a rare survival of its type with many features in common with that of the Cutlers' Company (adapted from Bestall 1967).



Fig. 2.51 Abbeydale Works (now an industrial museum) with the cast steel furnace at far left, its stack clearly visible against the dam behind (SMT).

Abbeydale Works

Partial ground plan (including cast steel furnace) as existing

scale 1:200

key:

- 1 Yard
- 2 Melting shop (5 holes)
- 3 Coke shed
- 4 Pot house
- 5 Clay place
- 6 Forges
- 7 Tilt and forge
- 8 Waterwheel
- 9 Embankment to dam

Source: adapted from Bestall (1967)



Fig. 2.52 View down Scotland Street towards the Cutlers' Company site on the left, showing the unfavourable terrain partly responsible for its fringe location even today (author).



Fig. 2.53 Courtyard housing replaced the Scotland Street furnace at the beginning of the nineteenth century, although the plot was still evident in 1889 (OS, author's colours).

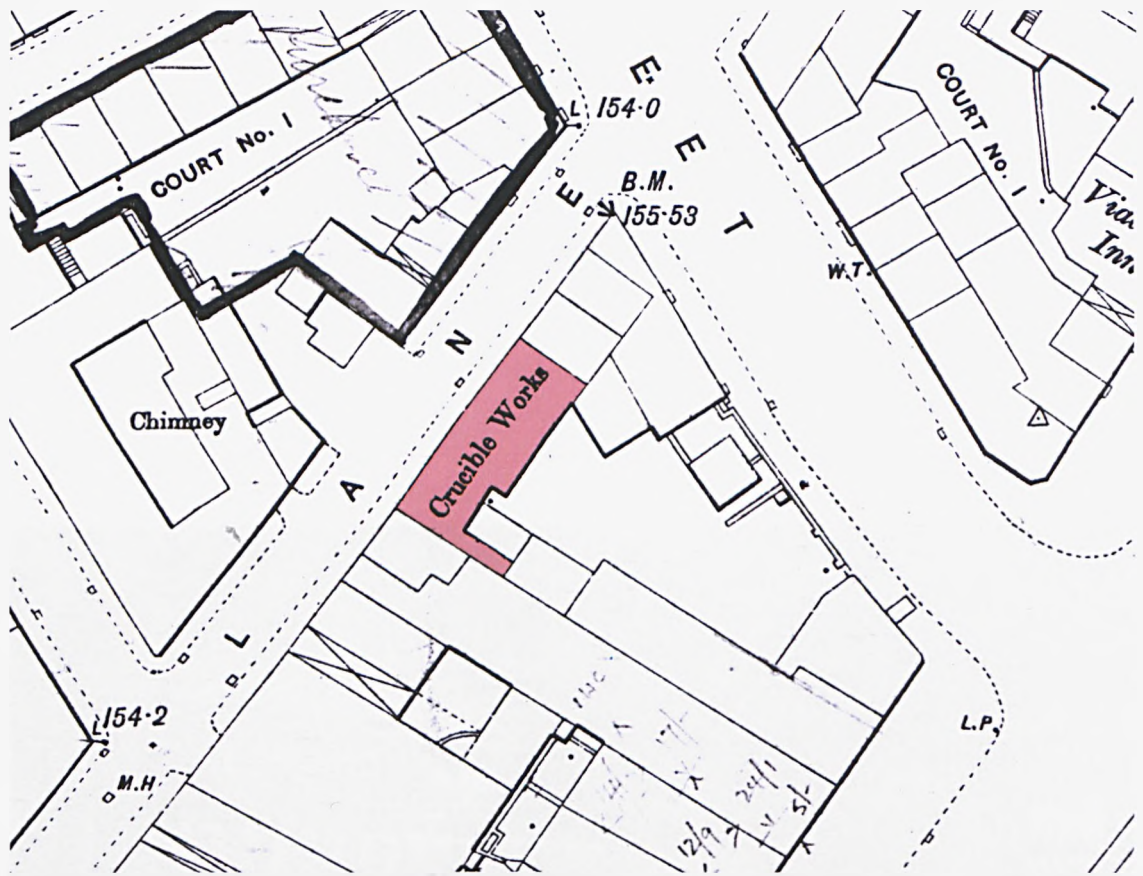

Fig. 2.54 'Crucible Works' in the Nursery Estate, probably one of the few facilities dedicated to the production of metallurgical clay crucibles in Sheffield (OS, author's colours).



Fig. 2.55 Photograph of the buildings remaining on the site in 2002 (author).

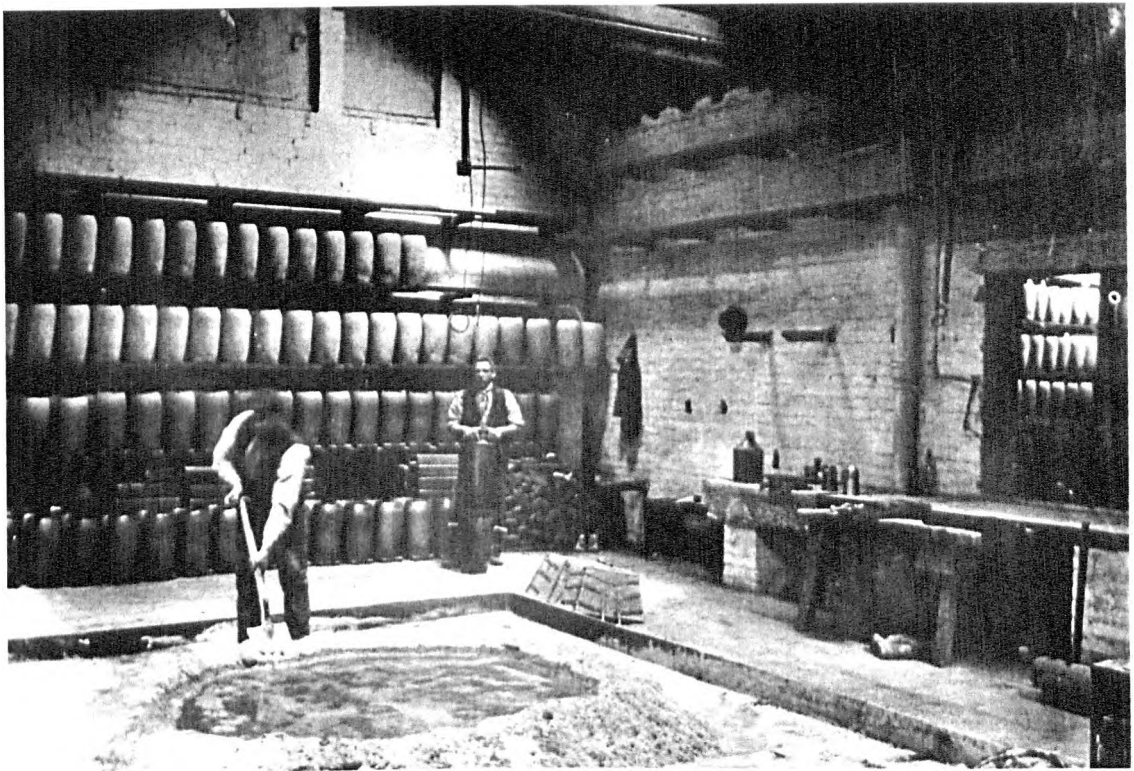

Fig. 2.56 Mixing finely sieved clay and water on the treading floor of a large pot house connected to melting furnaces at Jessop's Brightside steelworks.

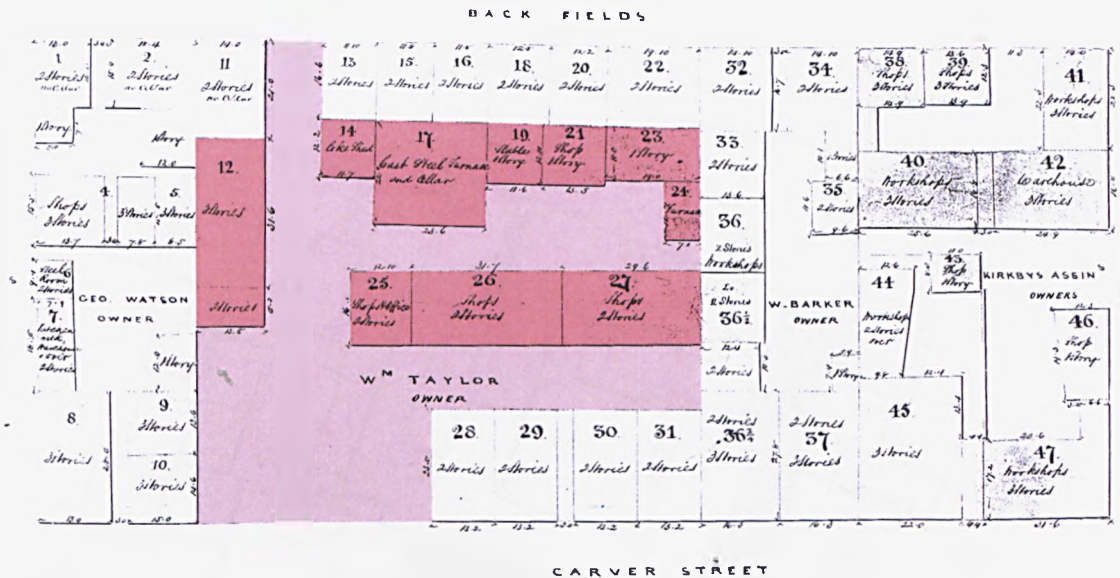

Fig. 2.57 An example of the small urban steelworks, closely integrated with housing and light industrial workshops, from a survey of 1842. North is to left (SCA, author's colours).

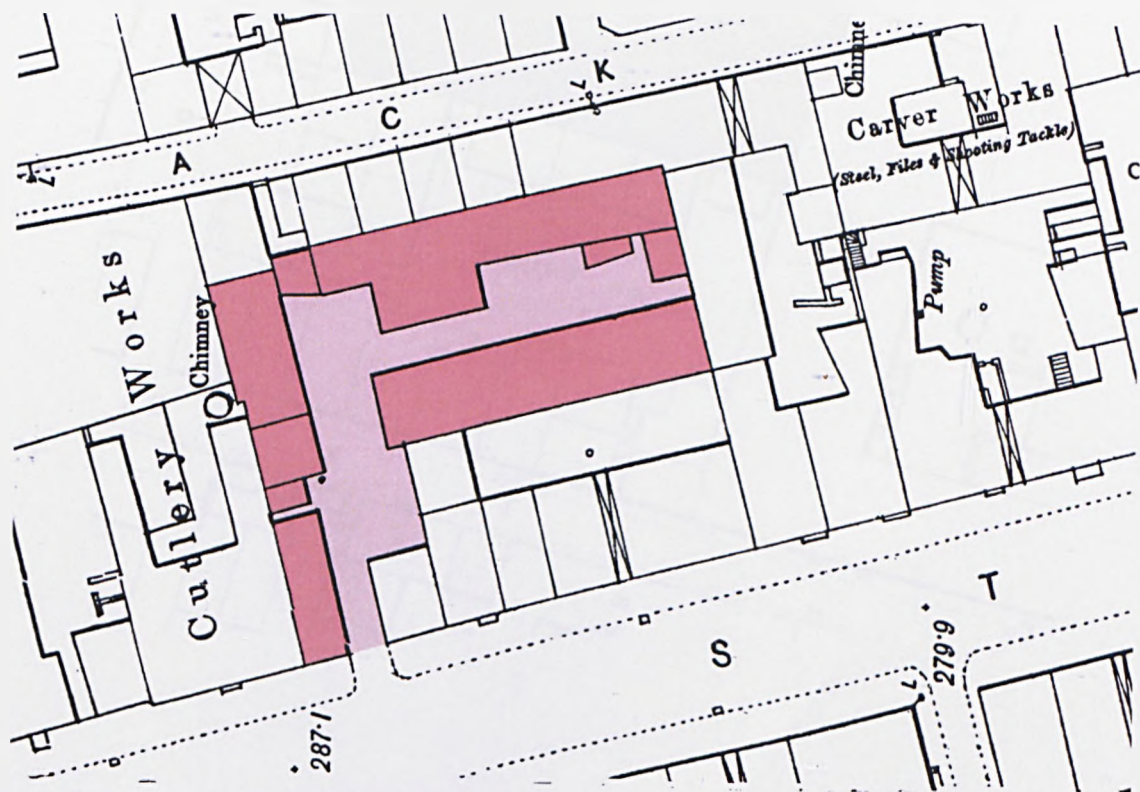
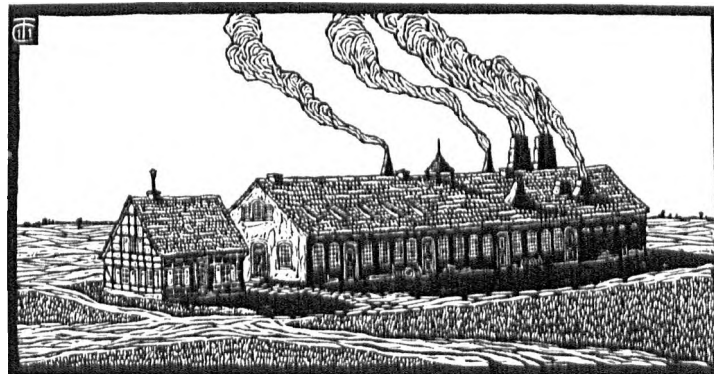
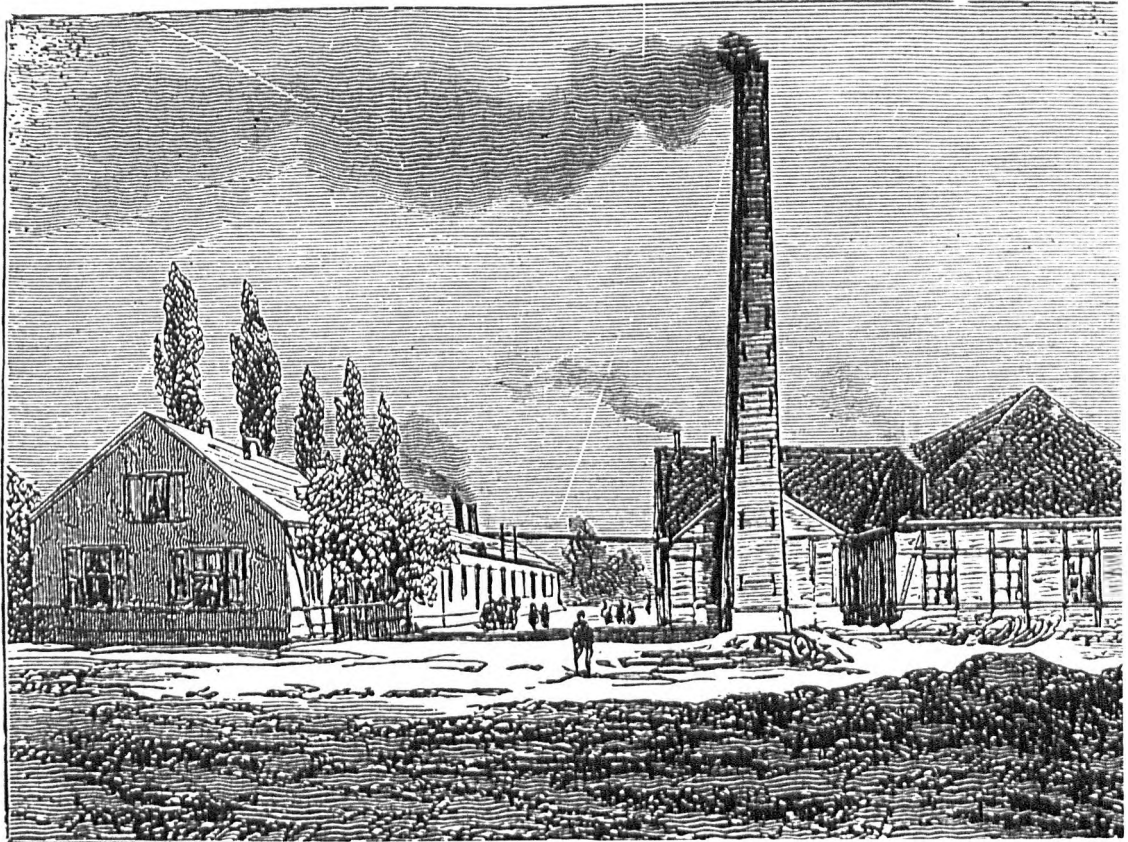

Fig. 2.58 The same Carver Street site as above, from the OS plan of 1889. The plan has changed to a courtyard format by building over the cross lane (OS, author's colours).

Fig. 2.59 Cementation and cast-steelworks embedded in the depths of the Crofts and still in use by 1889. North is at top, scale 1:500 (OS, author's colours).





Der neue Schmelzbau im Jahre 1835



Die Gußfabrik im Jahre 1835

Figs. 2.60, 2.61 and 2.62 The early development of Krupp's crucible steelworks at Essen, showing a very different approach to planning than was found at Sheffield (Menne 1937).

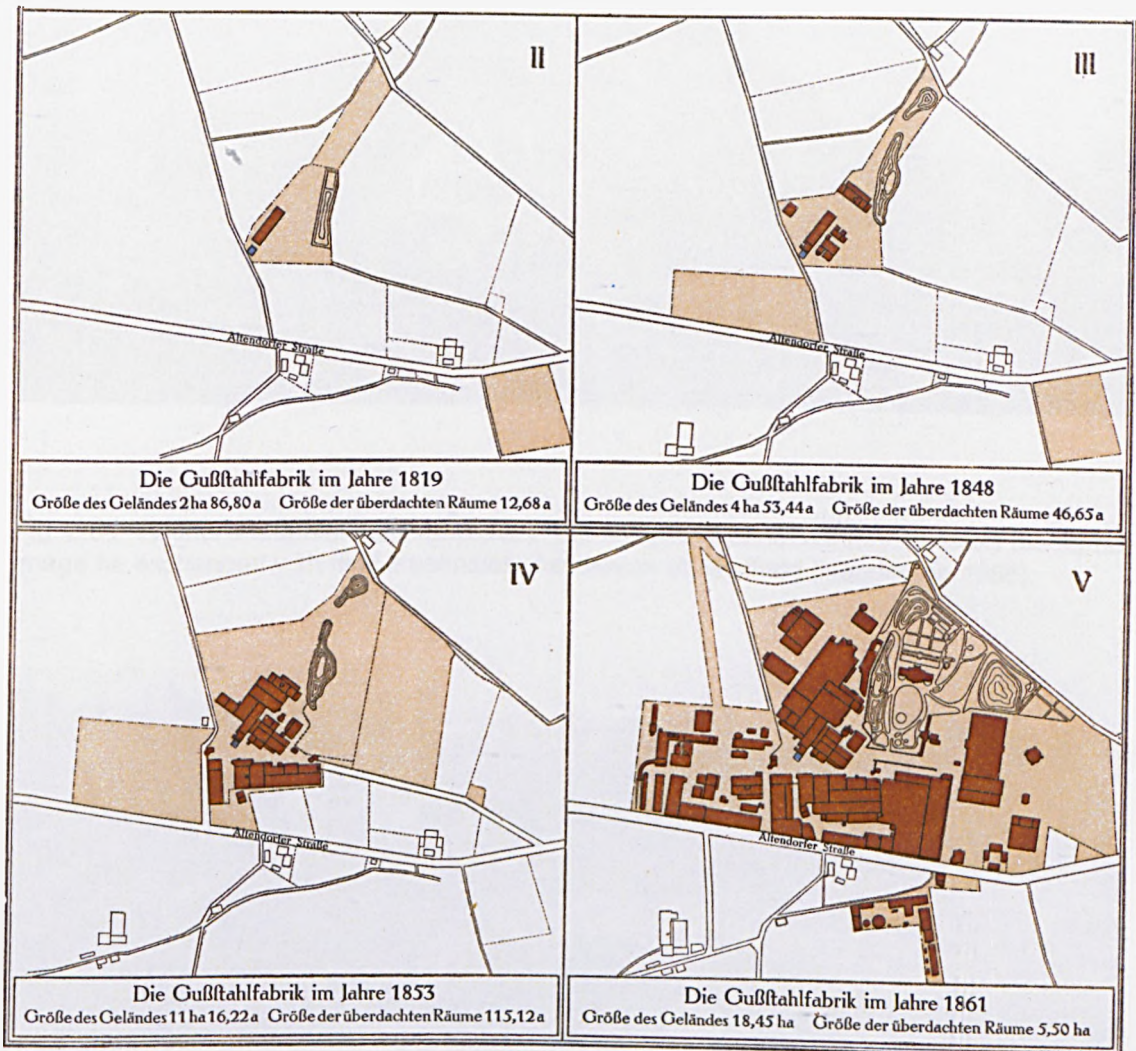

Fig. 2.63 Development of Krupp's steelworks from 1819 to 1861. This outward accretion of stand-alone buildings was in contrast to Sheffield's inward-looking courtyards (Conz 1912?).

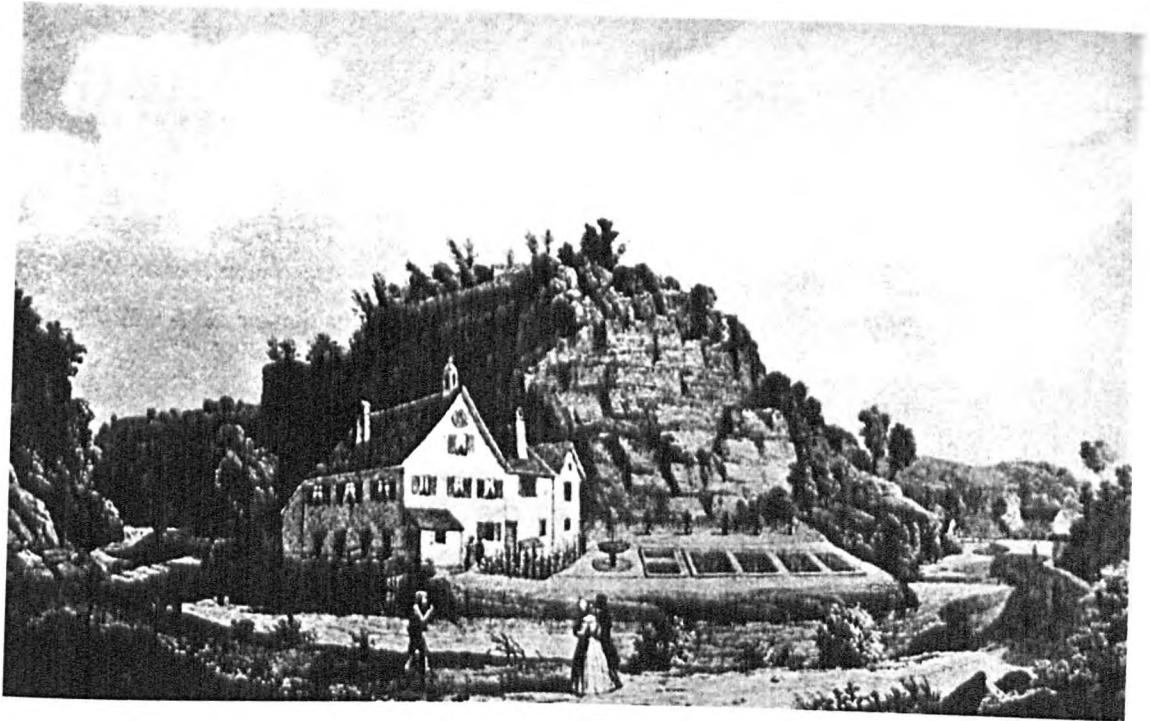

Fig. 2.64 Fischer's Muehlental steelworks in the early nineteenth century, possibly the same image he exchanged with rival steelmaker Sanderson of Sheffield (Henderson 1966).



Fig. 2.65 Spent crucible pots used as a construction material for walls (bottom right) in a nineteenth century photograph of allotments to the west of Sheffield (SCL).

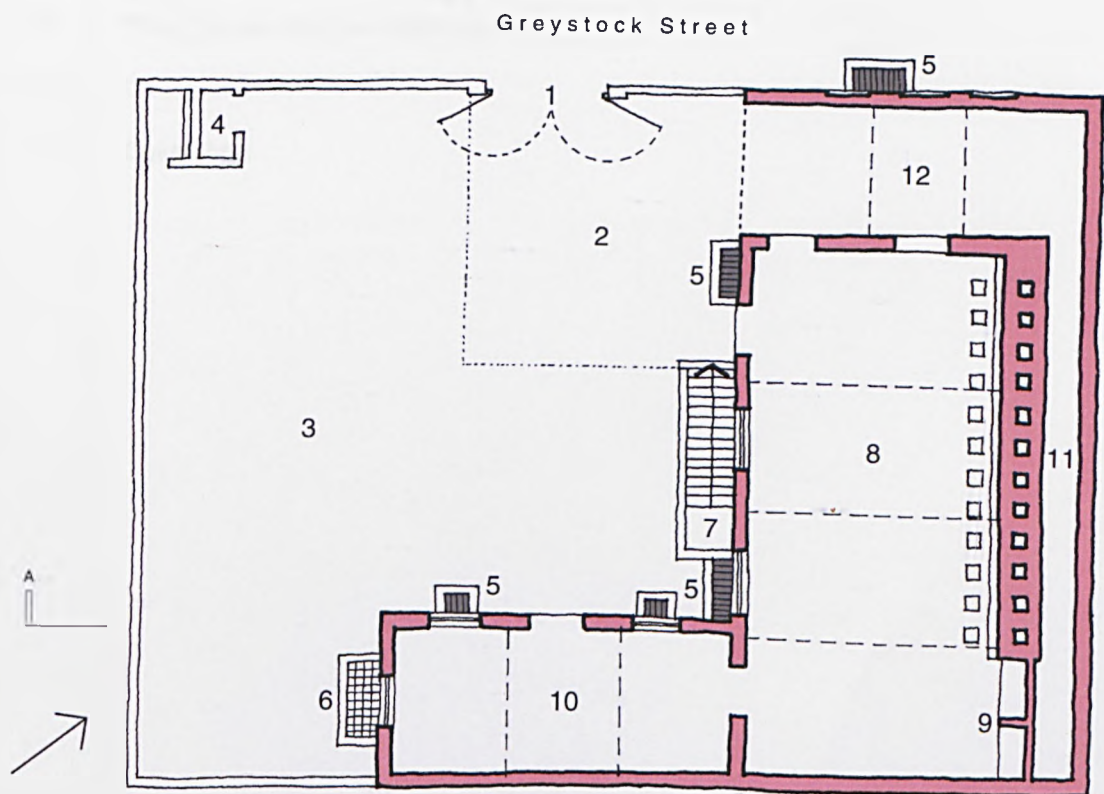
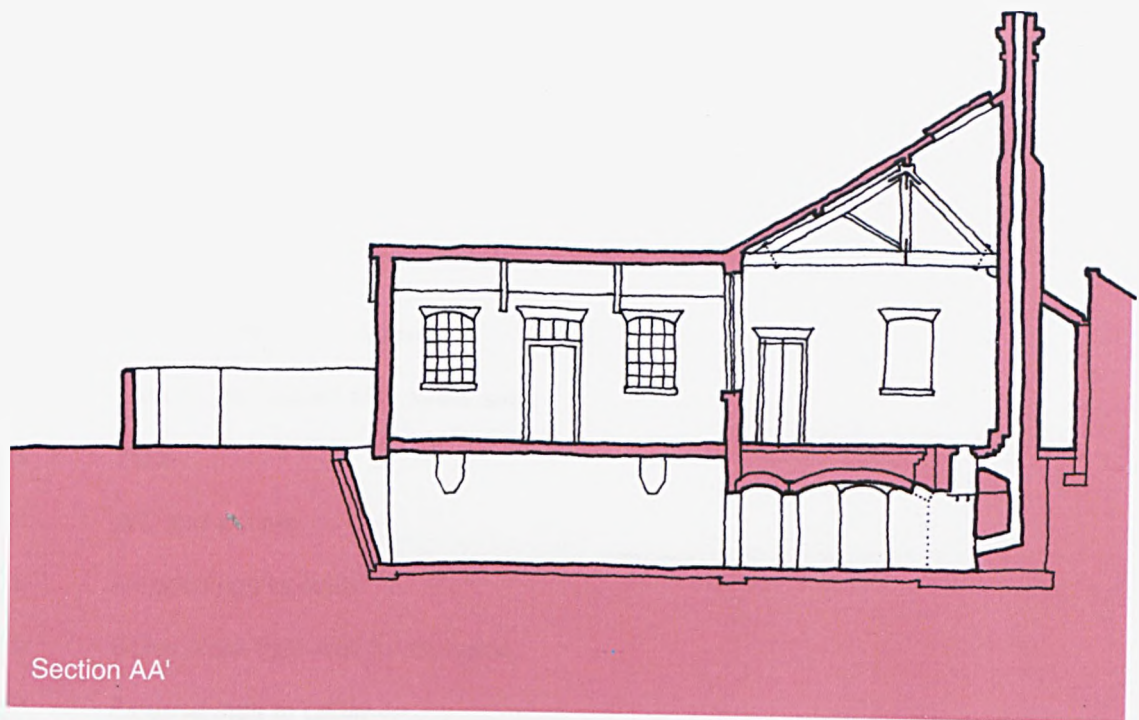

Fig. 2.66 Twelve-hole cast steel furnace built for Spear and Jackson in 1899. The long persistence of this building type's basic features may be seen by comparison to the Cutlers' Company furnace fig. 2.45. Scale 1:200 (author).

Spear & Jackson

Greystock Street cast steel furnace, ground plan and section (1899)

scale 1:200

key:

- 1 Gates to Greystock Street
- 2 Area of yard paved with stone setts
- 3 Yard
- 4 WC and urinals
- 5 Air openings to cellar
- 6 Glass block light-well to pot cellar
- 7 External stair to cellar
- 8 Melting shop with drying cellar beneath
- 9 Annealing grate
- 10 Steel house with pot cellar beneath
- 11 Clay place
- 12 Coke shed

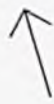

Hollis Croft

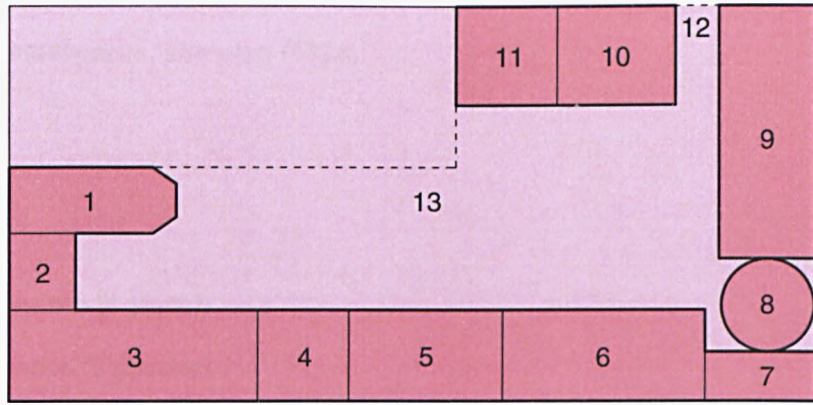

Figs. 2.67 (top) and 2.68 Kenyon's Hollis Croft steelworks, surveyed by the Fairbanks in 1834 and seen in a roughly contemporary advertising view (author).

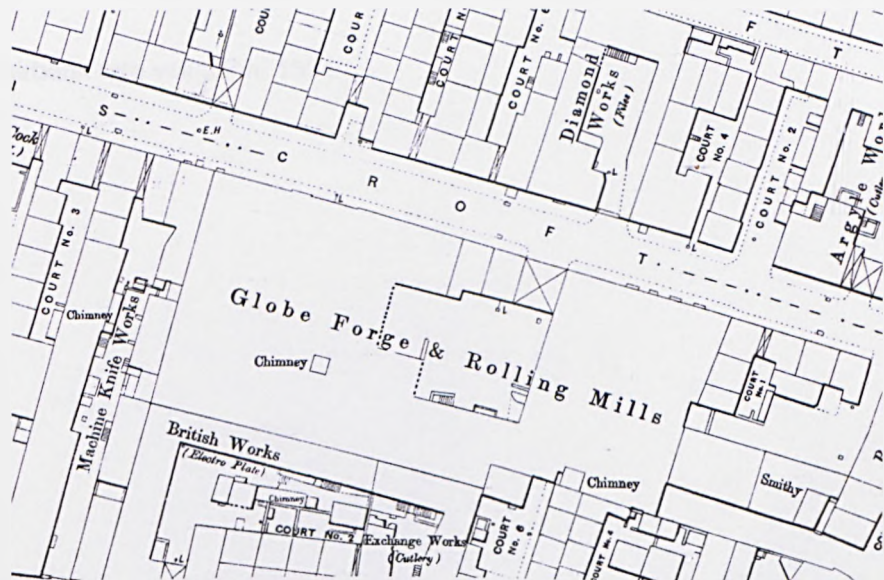

Fig. 2.69 The redeveloped Hollis Croft site in 1889, out of scale with its surroundings in Sheffield's highly fragmented Crofts district. Scale 1:1000 (OS).

Kenyon & Co.

Hollis Croft steelworks, site plan (1834)

scale 1:500

key:

- 1 Warehouse (1 storey)
- 2 File shops (2 storeys)
- 3 File workshops (2 storeys)
- 4 Lumber warehouse (3 storeys)
- 5 Warehouse and counting house (4 storeys)
- 6 New cast steel furnace (8 holes; 1 storey)
- 7 Softening furnace (1 storey)
- 8 Converting furnace, 20ft diameter
- 9 Iron warehouse (1 storey)
- 10 Coke shed (1 storey)
- 11 Stable, 3 stalls (2 storeys)
- 12 Entrance from Hollis Croft
- 13 Yard

Source: Fairbank rate valuation, 1834



Fig. 2.70 Three contiguous steelworks sites on Rockingham Street, part of an estate development of the 1830s (SCA, author's colours).



Fig. 2.71 The same premises in 1850 with the cast steel furnaces highlighted. Key: 1 William Tyzack; 2 Earle & Co.; 3 Maw & Stayley (OS, author's colours).



Figs. 2.72 and 2.73 Early nineteenth century workshops on Backfields, showing the characteristic lack of ground floor windows. Those at Leah's Yard (left) are later insertions (author).

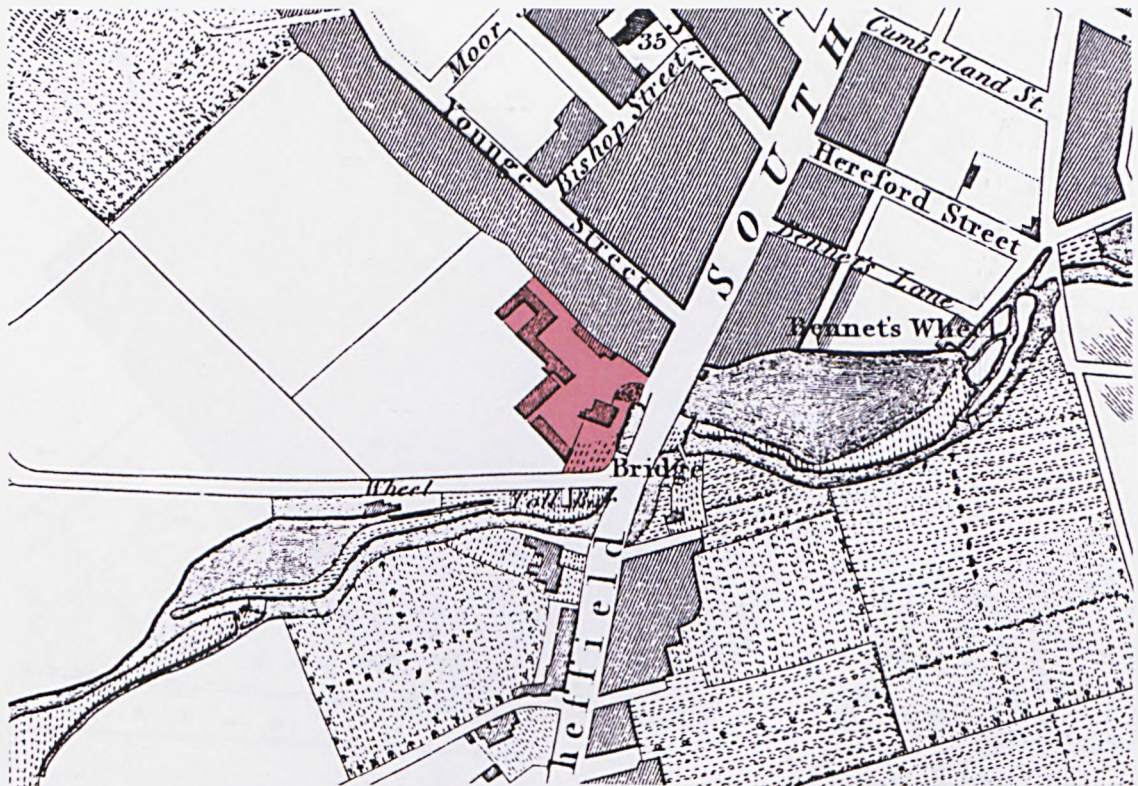

Fig. 2.74 Newbould's Bridgefield Works from the 1808 town plan, an edge of town location that allowed a looser form of planning (Fairbank 1808, author's colours).

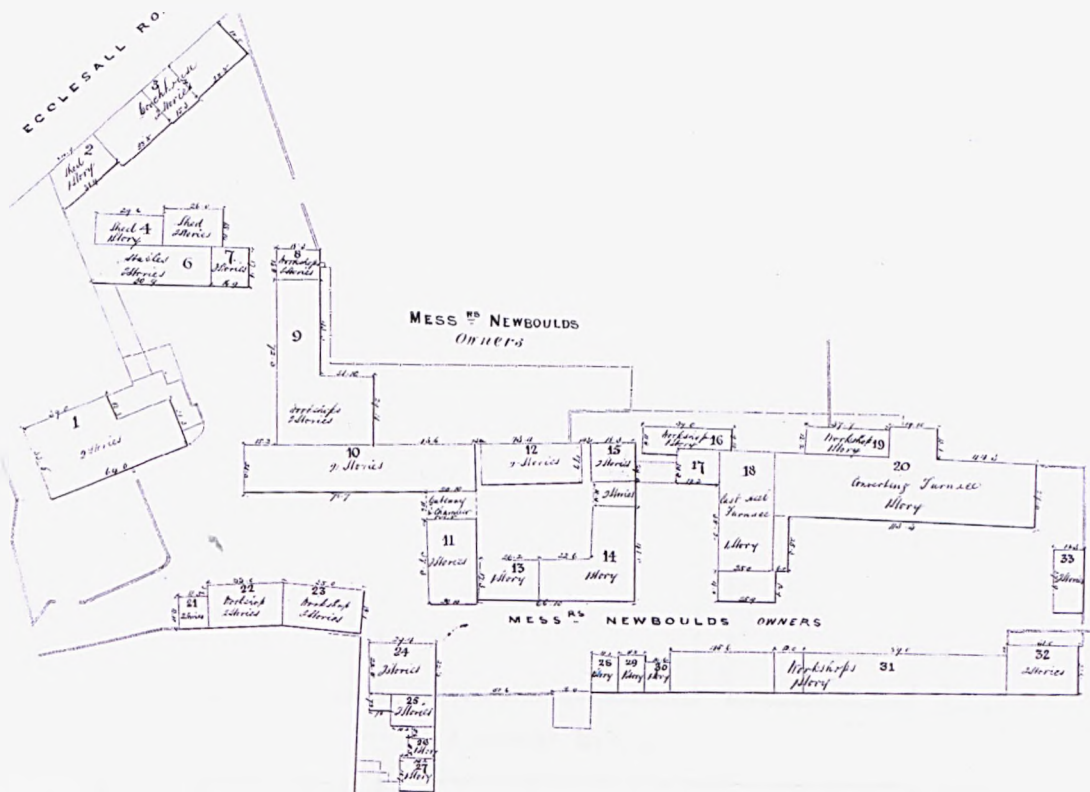

Fig. 2.75 Survey of Bridgefield Works made in 1842. The premises have been augmented by a steel melting shop and converting furnace (SCA).

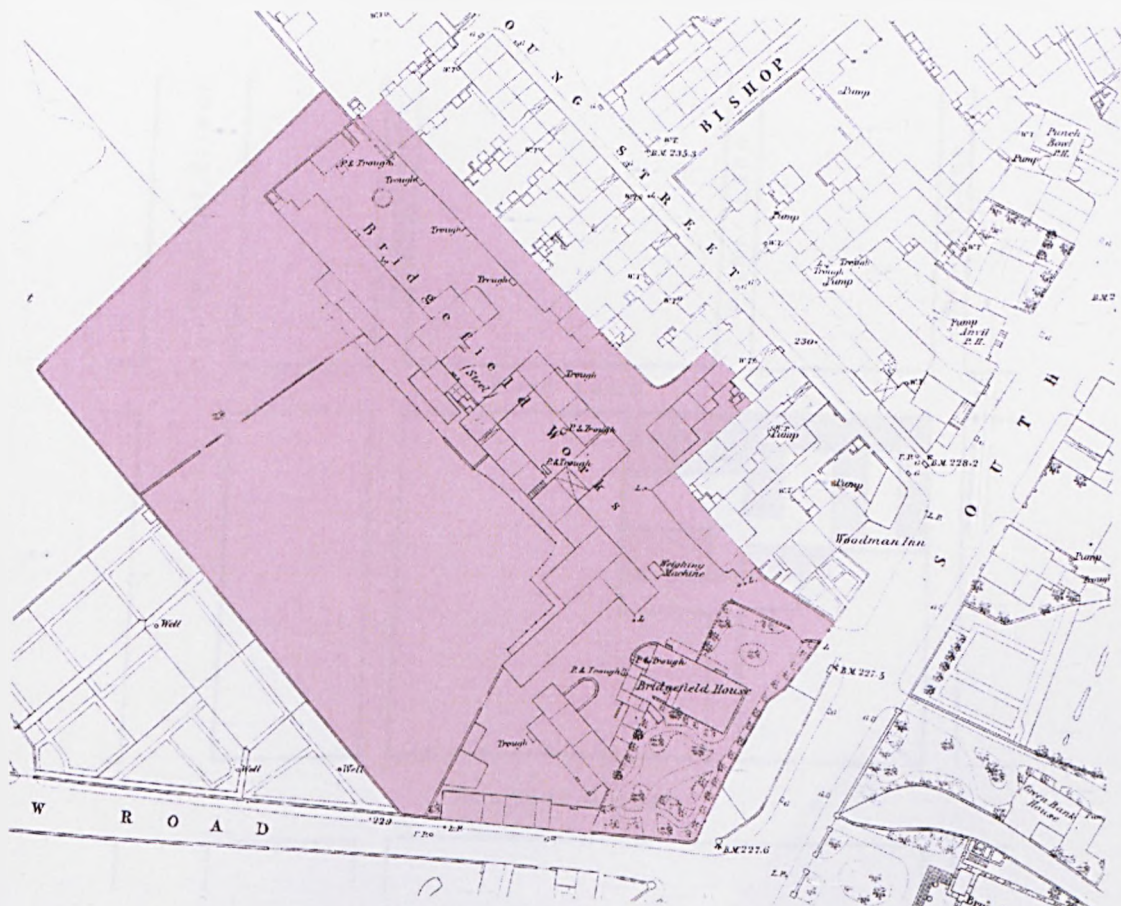

Fig. 2.76 The same premises eight years later, showing the extent of the site and its piecemeal absorption of land to the northeast. North is at top, 1:1500 (OS, author's colours).

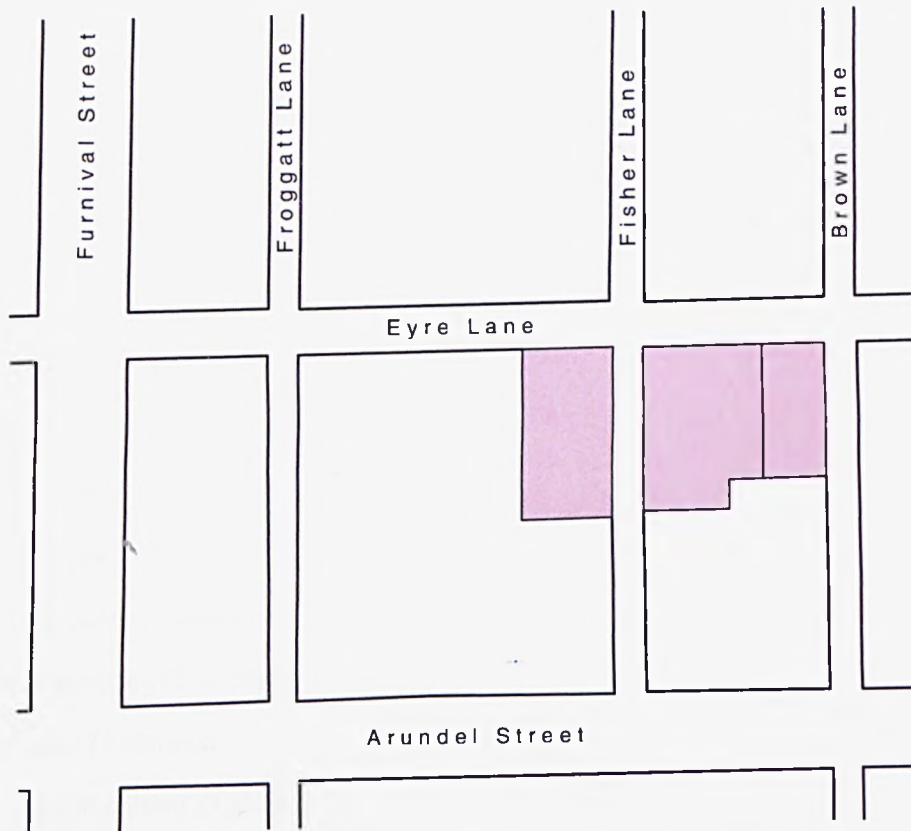

Fig. 2.77 The three plots upon which W & S Butcher built their Eyre Lane steelworks and edge tool manufactory Scale 1:1000 (author).

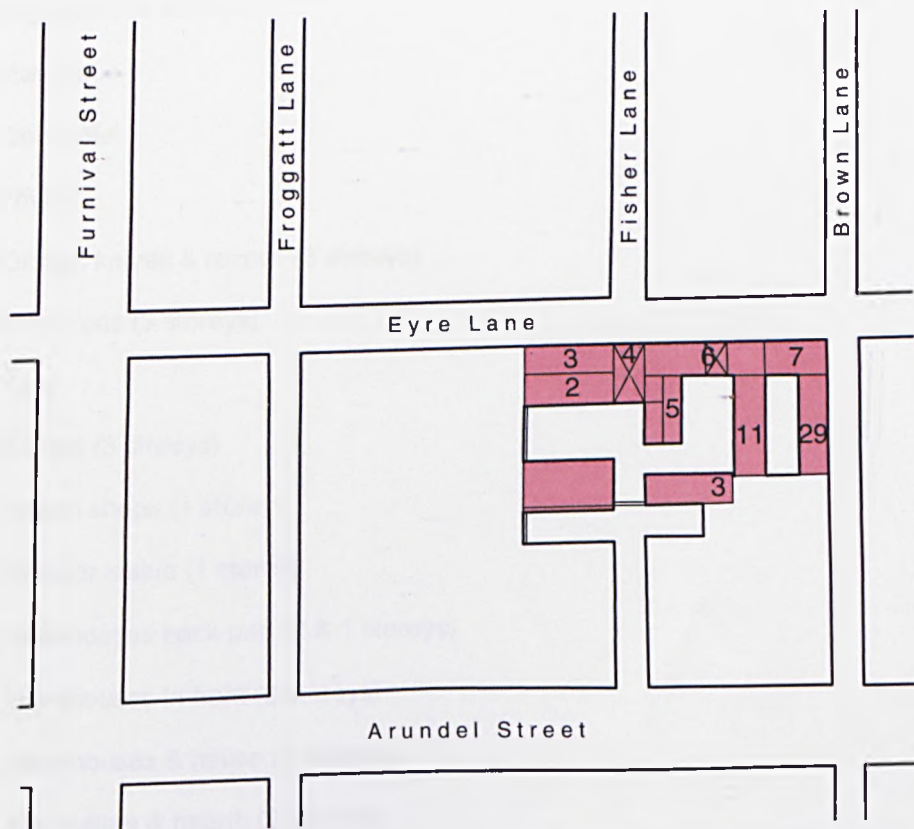

Fig. 2.78 W & S Butcher's Eyre Lane Works in 1822, following the construction of their first cast steel furnaces. Scale 1:1000 (author).

W & S Butcher

Eyre Street and Furnival Street works, reconstructed site plans (1836-1850)

scale 1:1000

key:

- 1 'Furnish 7 fires' (1 storey)
- 2 Razors (3 storeys)
- 3 Edge tools (3 storeys)
- 4 Gateway
- 5 Edge tools (3 storeys)
- 6 Warehouses (3 storeys)
- 7 House (3 storeys)
- 8 'Tournir chishill' (1 storey)
- 9 'Hevey tools' (3 storeys)
- 10 'Drawg knives' (3 storeys)
- 11 Edge tools (4 storeys)
- 12 Clay place
- 13 'Cole hole'
- 14 Privies
- 15 'Drawg. knives & razors' (3 storeys)
- 16 Plain irons (3 storeys)
- 17 Yard
- 18 Razors (3 storeys)
- 19 Hearth shops (1 storey)
- 20 Shed or stable (1 storey)
- 21 Warehouses back part (2 & 1 storeys)
- 22 Warehouses in front (2 storeys)
- 23 Warehouses & house (2 storeys)
- 24 File cutters & hearth (2 storeys)
- 25 File cutters & hearths (2 storeys)

- 26 Melting furnace 19 holes (1 storey)
- 27 2 converting furnaces (1 storey)
- 28 File forgers (1 storey)
- 29 Workshops (1 storey)
- 30 Stable (2 storeys)
- 31 Six cottages (3 storeys)
- 32 Workshops (3 storeys)
- 33 Shed or stable (1 storey)
- 34 Turning shops (3 storeys)
- 35 Grindg. penknife (3 storeys)
- 36 Engine (3 storeys)
- 37 Axle tree makers
- 38 Axle tree shops
- 39 House
- 40 Edge tools (2 storeys)
- 41 Axle tree shop
- 42 Blacksmith shop
- 43 House
- 44 Castg. room
- 45 Furnace
- 46 Tailor Butt (?)

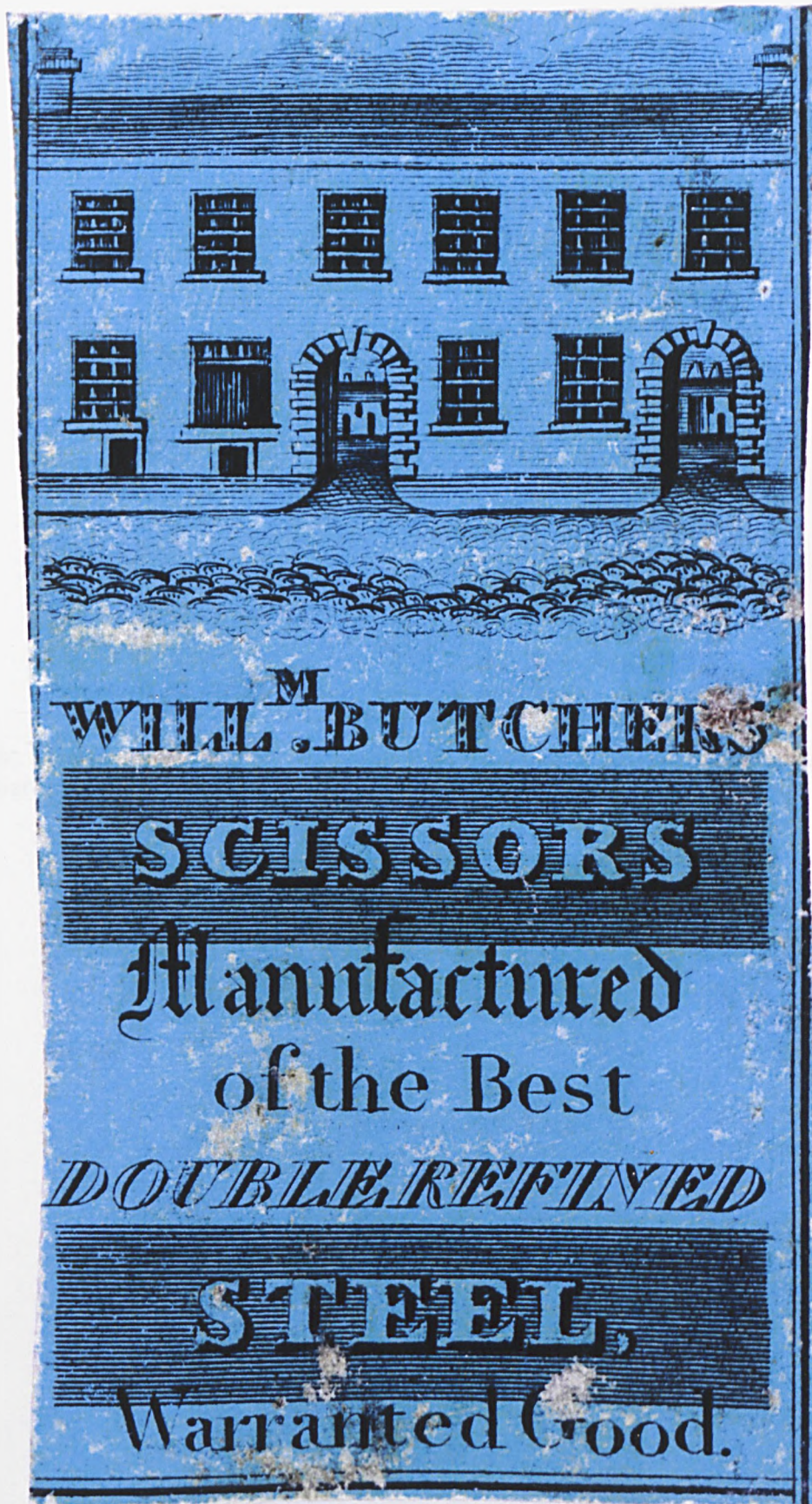

Fig. 2.79 Early label for W & S Butcher's scissors, with an elevation of their Eyre lane works. An impression of the melting shop can be seen through the right hand arch (SCL).



Fig. 2.80 Oblique view of Butcher's surviving Eyre Lane facade with later additions, including the upper storey. The pair of arches are painted white (author).



Fig. 2.81 View down the small lane leading directly to Butcher's main entrance, possibly at first intended as a continuation of the street. The brick infill is a later alteration (author).

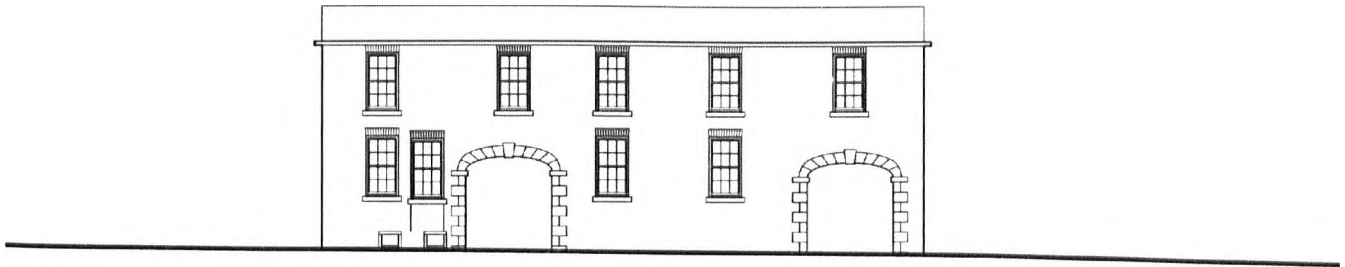

Eyre Lane elevation in 1822

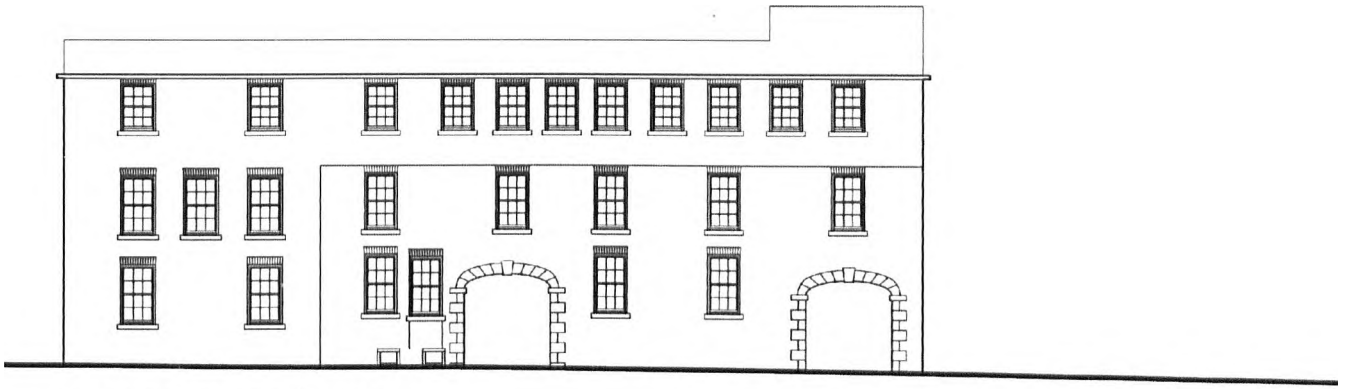

Eyre Lane elevation in 1836

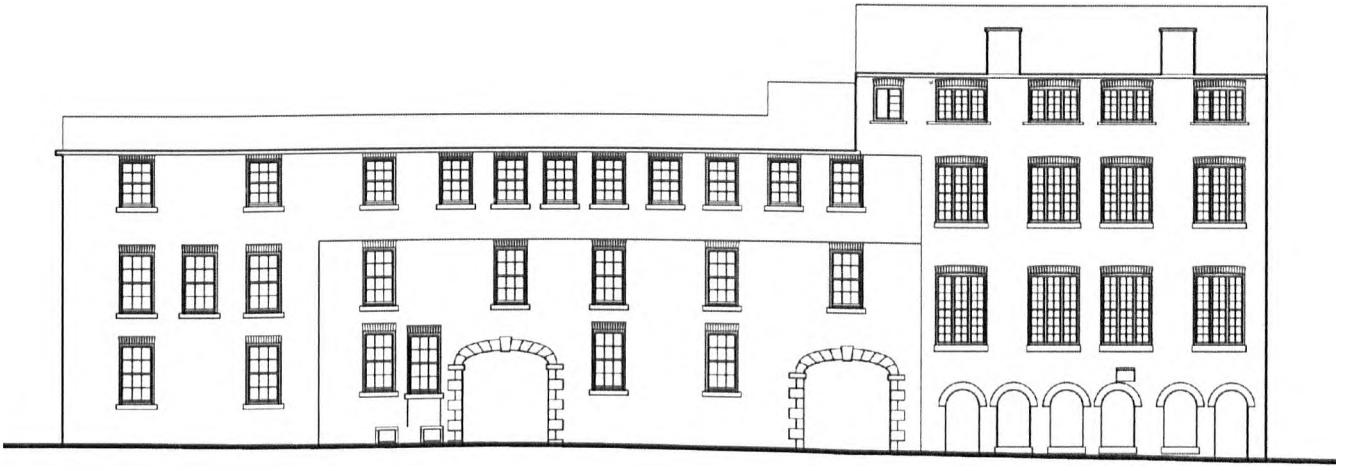

Eyre Lane elevation as existing

Fig. 2.82 Three major development phases of the Eyre lane elevation, derived from field evidence and measurements (author).

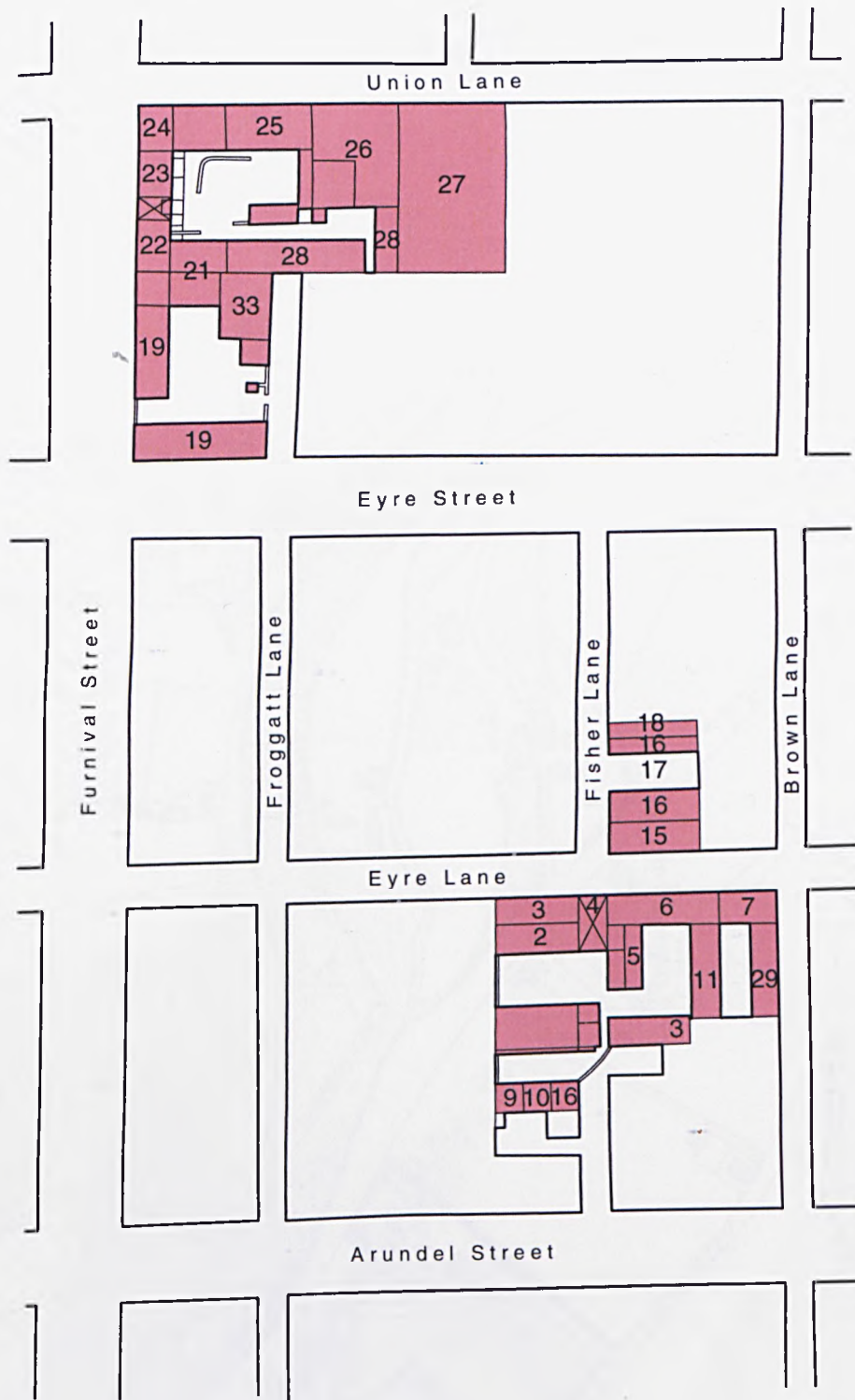

Fig. 2.84 Expansion of W & S Butcher's Alsop Fields Estate premises by the acquisition of the nearby Furnival Street steelworks of Mitchell Bros. in 1836. Scale 1:1000 (author).

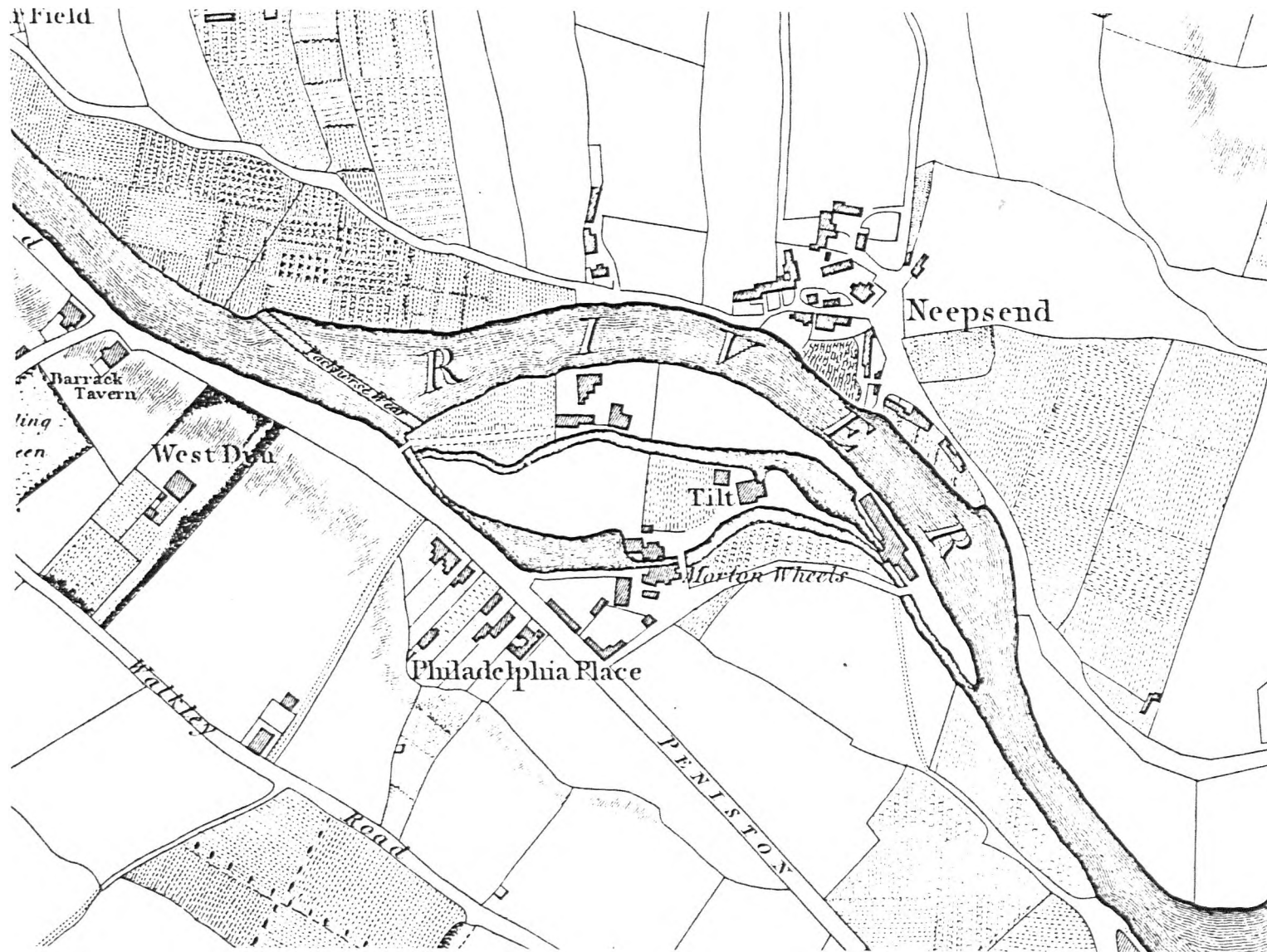

Fig. 2.85 Philadelphia and the Morton Wheels. taken by W & S Butcher to extend their steelmaking capacity with tilting and rolling. The plan predates the Butchers occupancy, but shows the works much as they existed when taken over (Fairbank 1808).

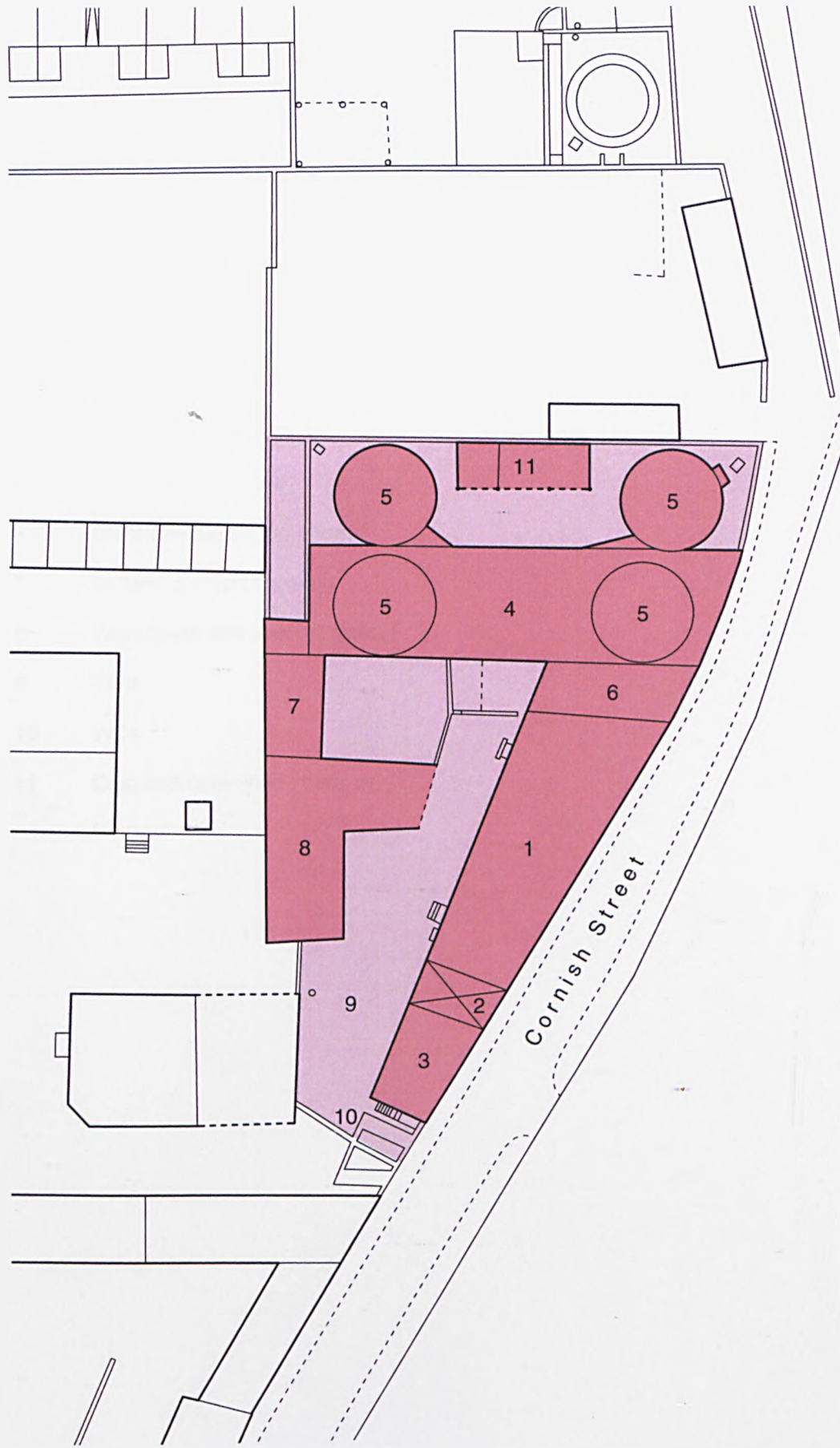

Fig. 2.86 Steelworks at the rear of Globe Works, as subdivided and taken by W & S Butcher in the 1850s. Scale 1:500 (author).

W & S Butcher

Globe Works (part), Cornish Street, reconstructed site plan (1852)

scale 1:500

key:

- 1 Cast steel furnace (22 holes, 1 storey)
- 2 Entrance archway from Cornish Street with warehouse above
- 3 House and warehouse (2 storeys)
- 4 Iron house (1 storey)
- 5 Converting furnaces
- 6 Steel warehouse, pot room
- 7 Softening shop (1 storey)
- 8 Warehouse and shed (1 storey)
- 9 Yard
- 10 WCs
- 11 Coal and coke shed (1 storey)

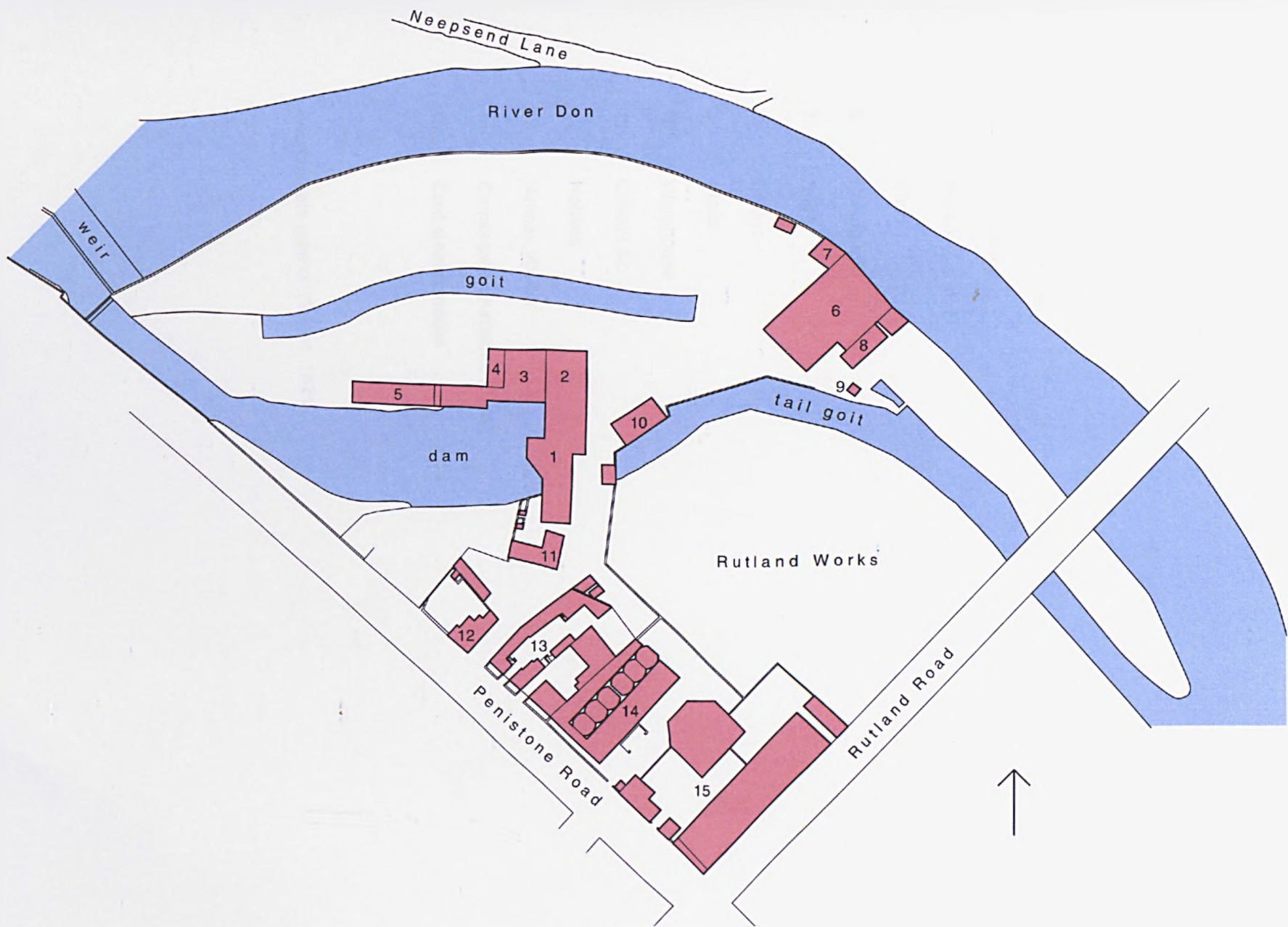

Fig. 2.87 Philadelphia Works at the time of their sale in 1871, showing the additions made by the Butchers. The southern corner of the site was developed as steelworks from 1854. Scale 1:2500 (author's redrawing of SCL sale plan).

W & S Butcher

Philadelphia Works, site plan (1871)

scale 1:2000

key:

- 1 Water hammer
- 2 Steam hammer
- 3 Workshops
- 4 Boilers and stack
- 5 Shed
- 6 Rolling mill
- 7 Shed
- 8 Boilers
- 9 Stack
- 10 Warehouse
- 11 Offices &c.
- 12 Houses
- 13 'Artisan Works'
- 14 Cementation furnaces (6 no.)
- 15 Cast steel furnaces

Source: sale plan of 19 Dec. 1871

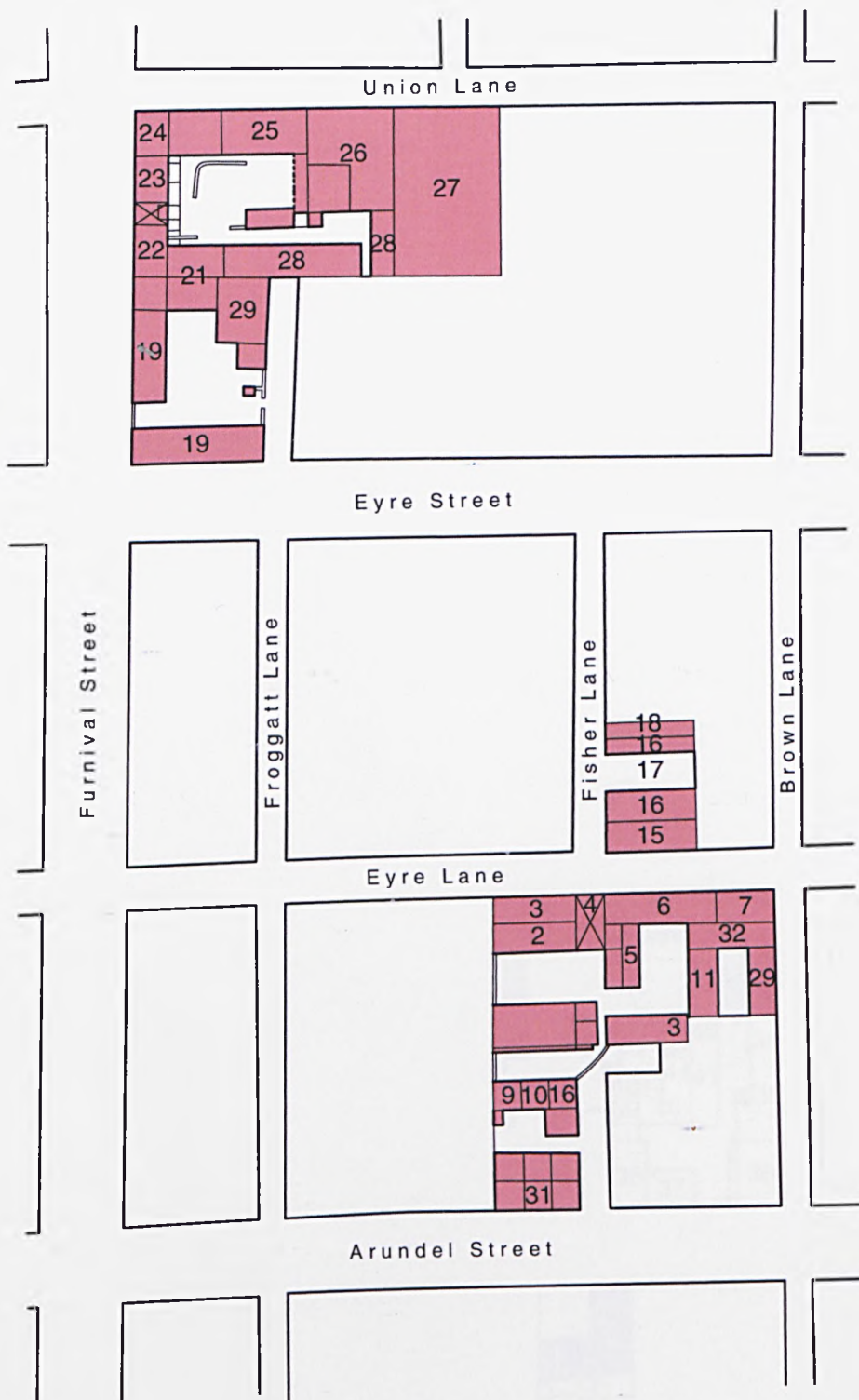

Fig. 2.88 Further consolidation at Alsop Fields with the purchase of cottages and stables adjoining the Eyre Lane Works, 1844. Scale 1:1000 (author).

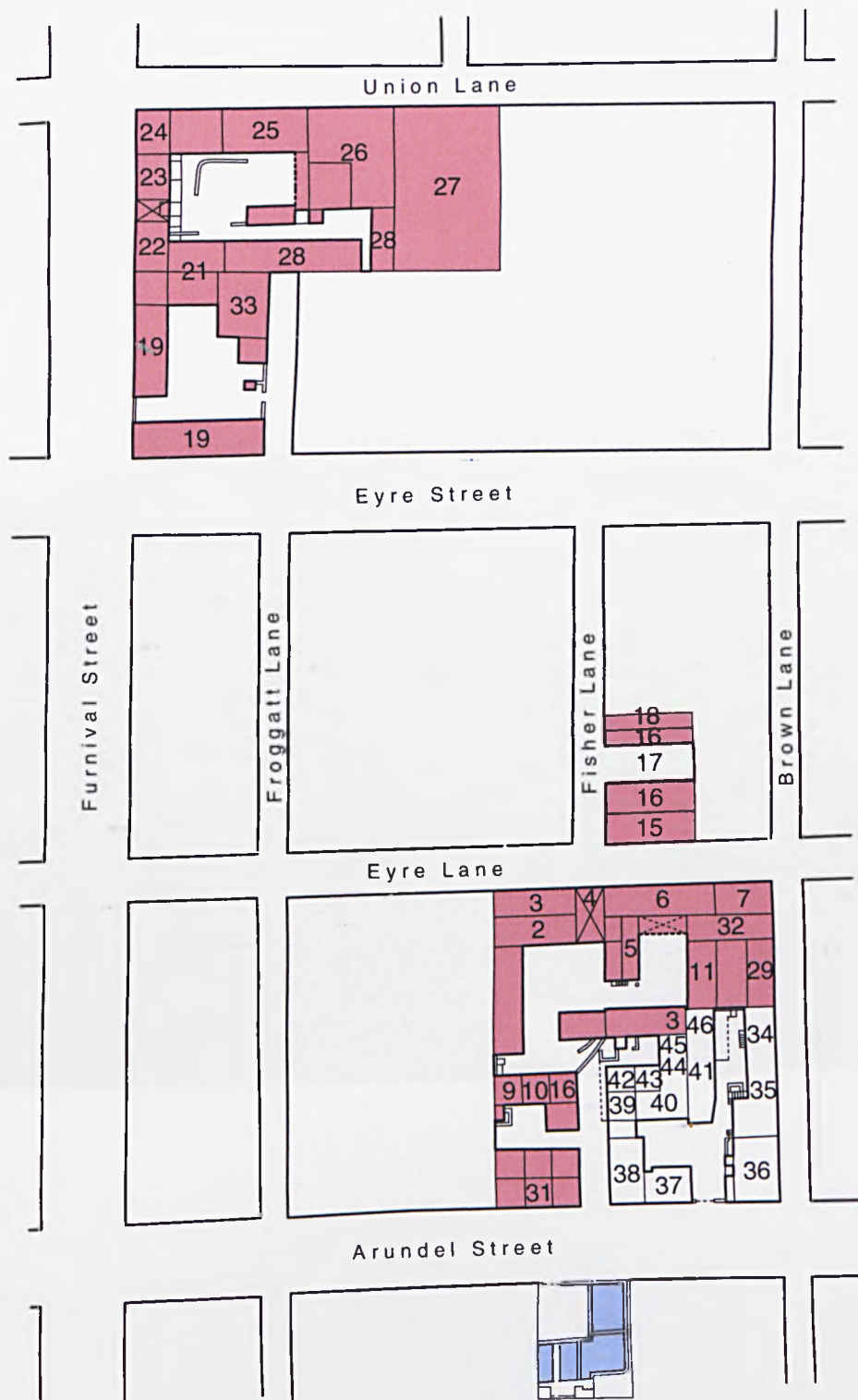

Fig. 2.89 The Eyre Lane premises upon the purchase of Raworth's steam grinding wheel and workshops, but before redevelopment as Butcher Works, c.1850. Scale 1:1000 (author).



Fig. 2.90 The fabric of an earlier steam grinding wheel embedded in the courtyard of Butcher Works. The flue positions are known from mismatches in the brickwork (author).



Fig. 2.91 Side elevation of Butcher Works, with the first three storeys to the right of centre belonging to the earlier grinding wheel. Arundel Street is at the left (author).



Fig. 2.92 Detail of the side elevation, above, with an original ventilation grille from the back wall of the grinding hulls. Note the later window to the right (author).



Fig. 2.93 Arundel Street frontage of Butcher Works (author).



Fig. 2.94 Archway to courtyard at the centre of the frontage above, with porter's accommodation to the right. This led the premises to be known as the 'safe wheel' (author).

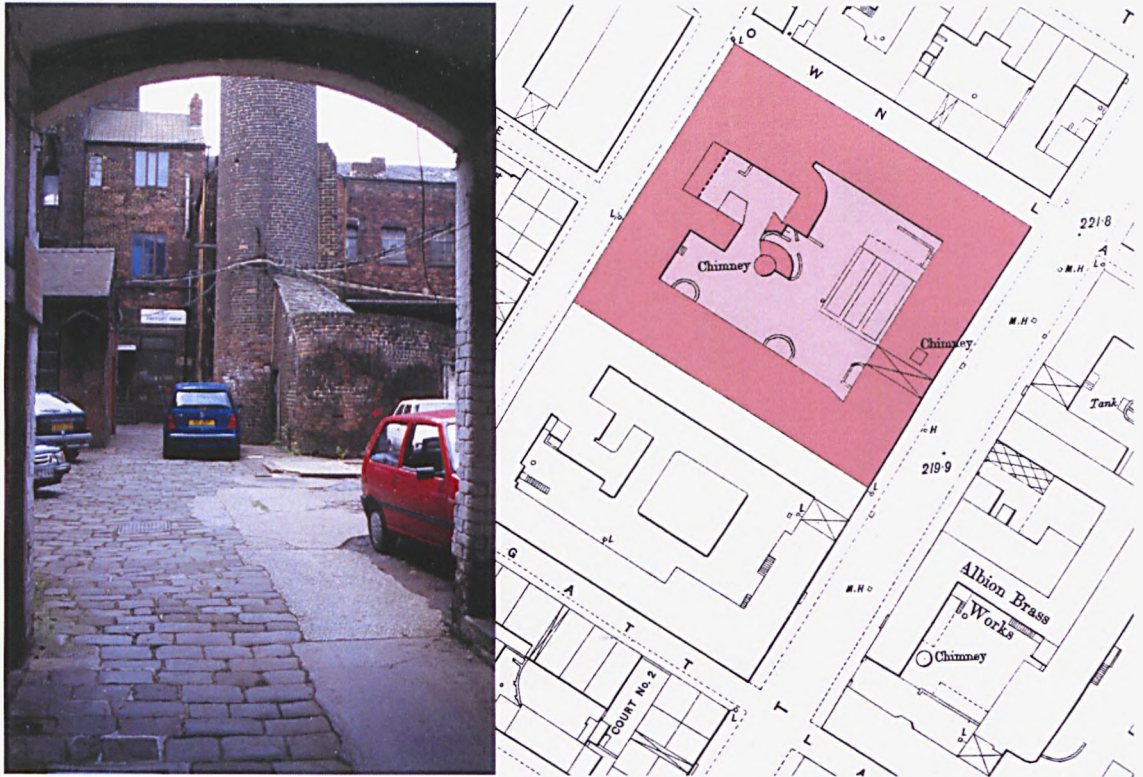

Fig. 2.95 (left) View through the arch in fig. 2.94, with steam engine stack at centre (author).
Fig. 2.96 (right) Plan of Butcher Works in 1889. Scale 1:1000 (OS, author's colours).



Fig. 2.97 The accretion of buildings that constitute Butcher Works, an example of the difficult design decisions faced by expanding businesses on restricted urban sites (author).

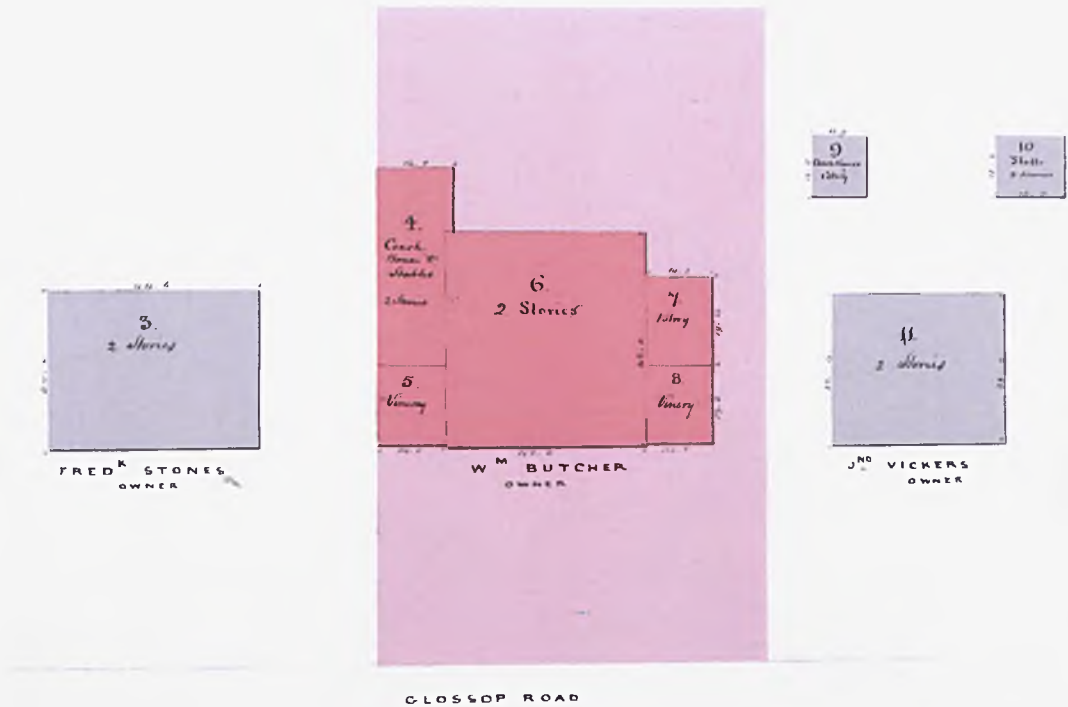
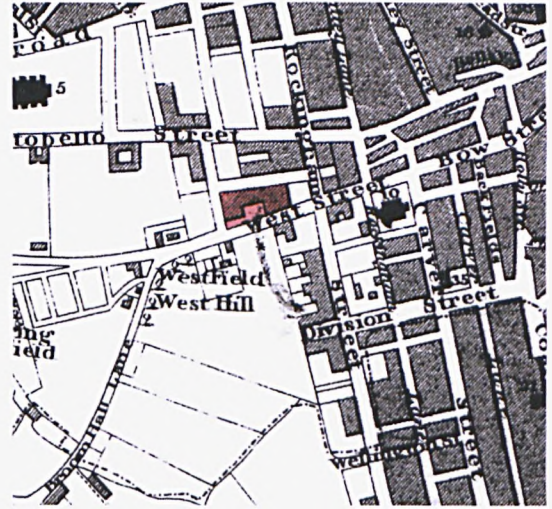

Fig. 2.98 William Butcher's mansion and grounds at Broomhill, an early western suburb of Sheffield. Not to scale (SCA, author's colours).



Fig. 2.99 Aerial view of Butcher Works with its landmark chimney, a rare survival of a courtyard form found especially in the gridded estates of the town.



Figs. 3.2 and 3.3 The location of West Field (the name of a large house in the area) on town plans of 1795 (left) and 1823 (right), close to which Naylor & Sanderson chose to build their steelworks (author's highlighting).

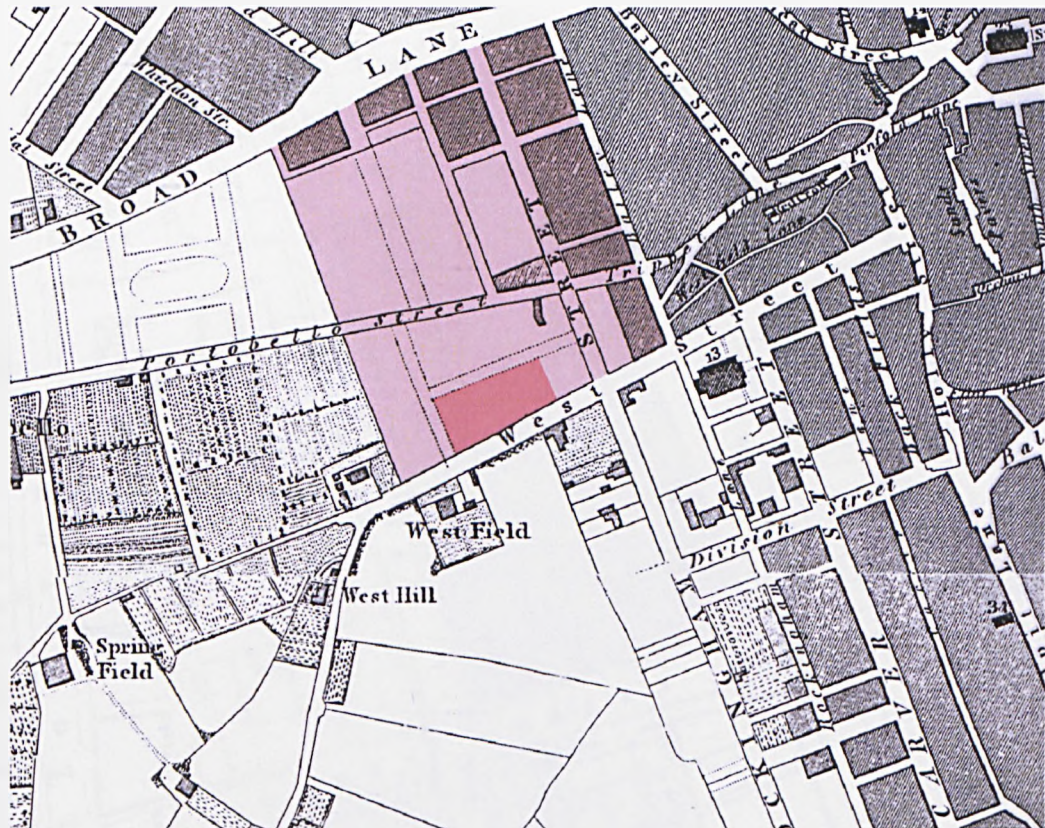

Fig. 3.4 Emerging estate structure on the western edge of Sheffield (pale pink), indicating the future site of Naylor Sanderson's steelworks (dark pink). Scale 1:5000 (Fairbank 1808, author's colours).



Fig. 3.5 The West Street steelworks in 1850, by this time in the sole occupation of Sanderson Brothers. The truncation of north-south streets above and below the site is apparent (OS, author's colours).

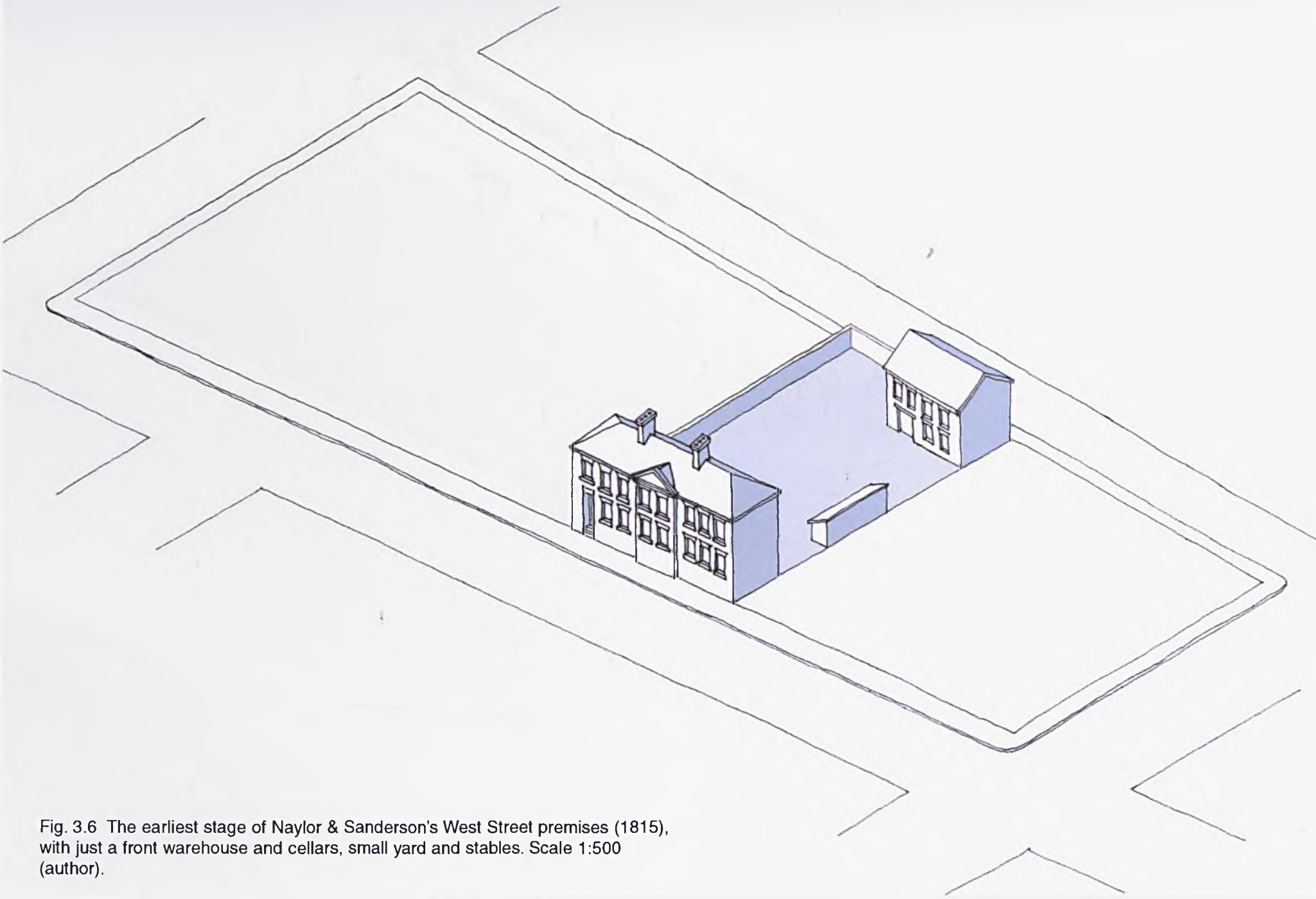

Fig. 3.6 The earliest stage of Naylor & Sanderson's West Street premises (1815), with just a front warehouse and cellars, small yard and stables. Scale 1:500 (author).

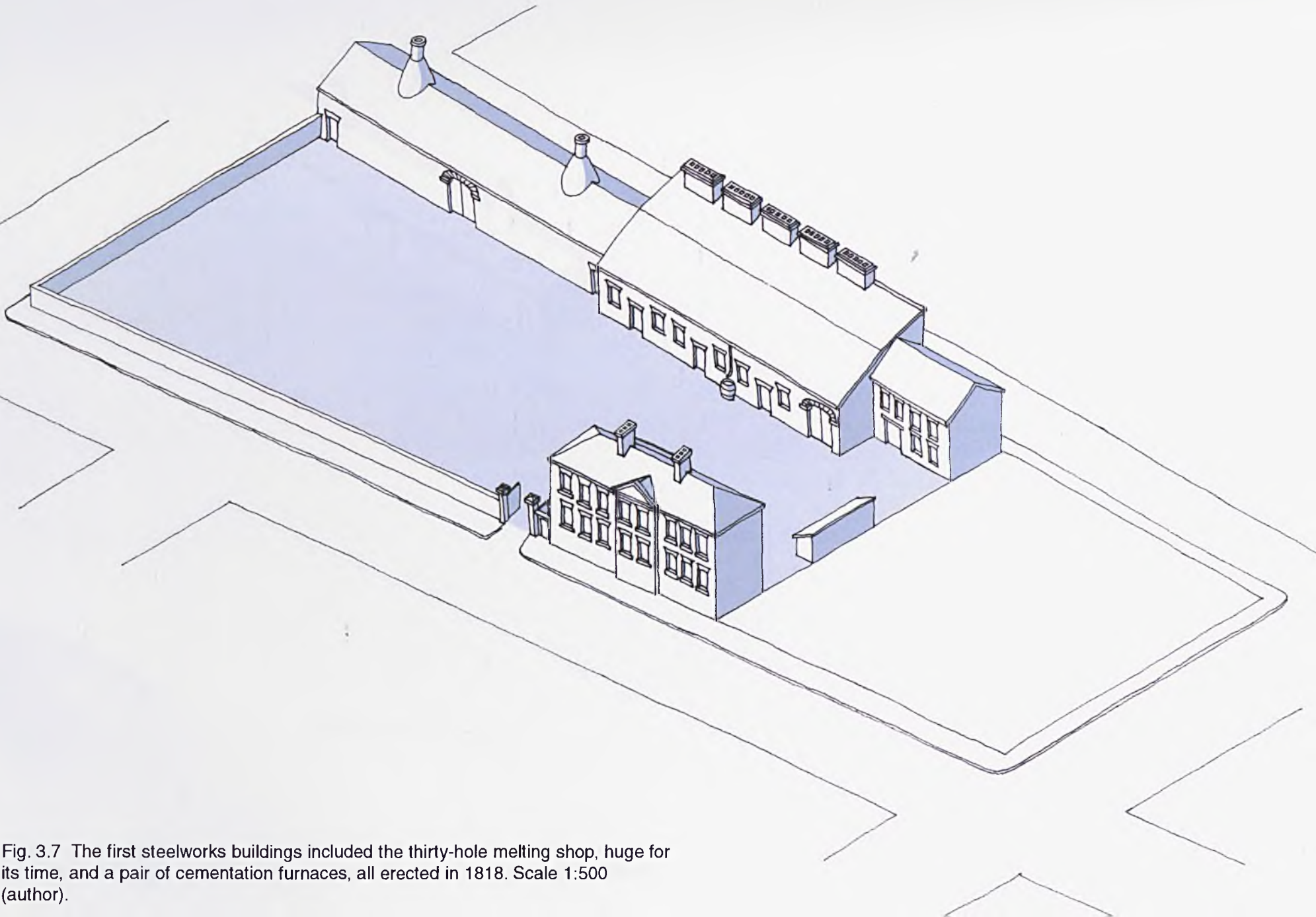

Fig. 3.7 The first steelworks buildings included the thirty-hole melting shop, huge for its time, and a pair of cementation furnaces, all erected in 1818. Scale 1:500 (author).



Fig. 3.8 Another pair of cementation furnaces with their own iron house were added to the front of the first in 1822, a common expansion strategy. Scale 1:500 (author).

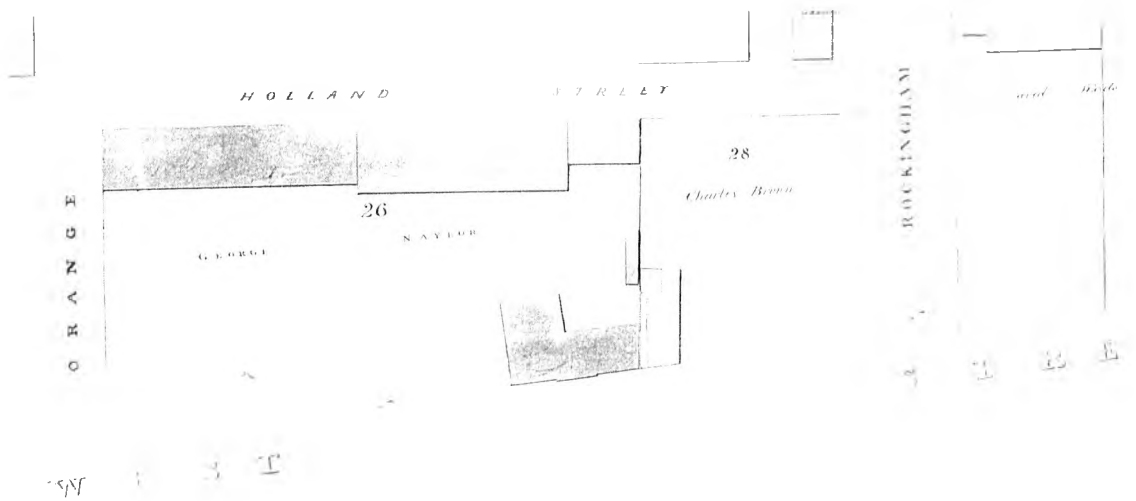

Fig. 3.9 The earliest surviving plan of Naylor Sanderson's steelworks, made between 1818 and 1822. Earlier field boundaries appear faintly in the background (SCA).

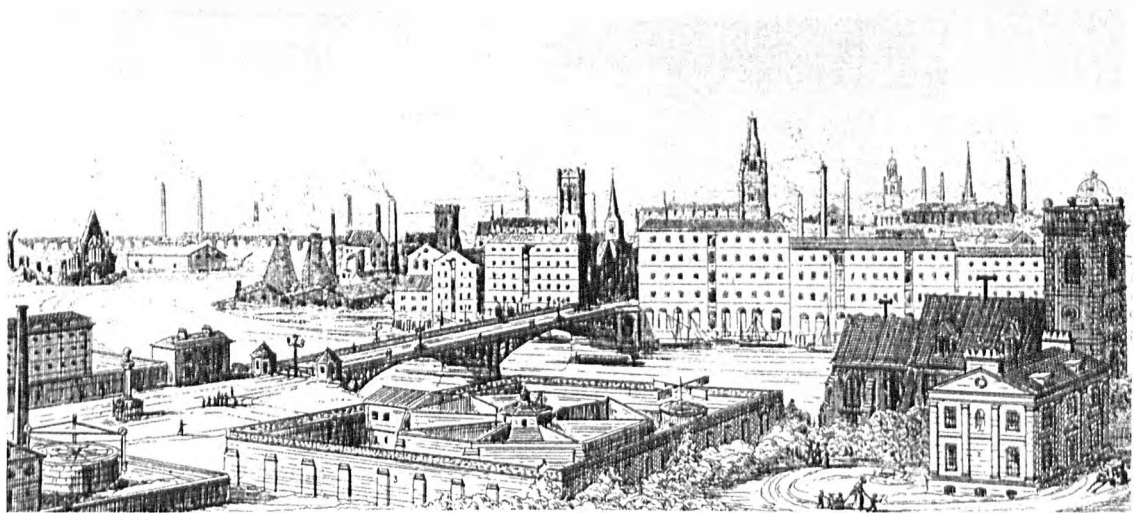

Fig. 3.10 Pugin's satirical impression of the nineteenth century English town, blighted by chimneys, furnaces and mills. The design of public buildings was a particular target.

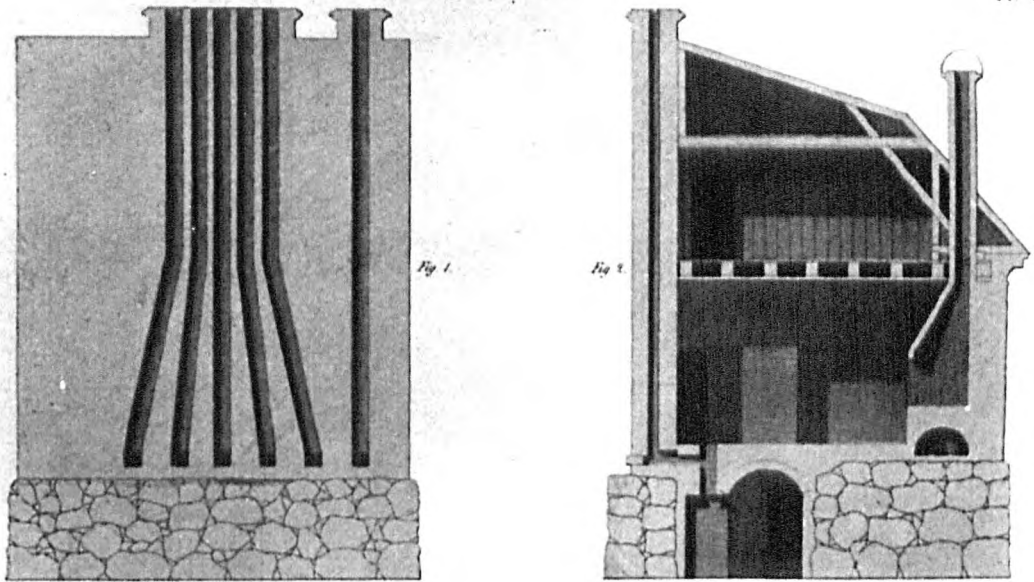

Fig. 3.11 Broling's crucible shop built on his return to Sweden from a visit to Huntsman's steelworks, and therefore representative of early Sheffield practice (Broling 1812).

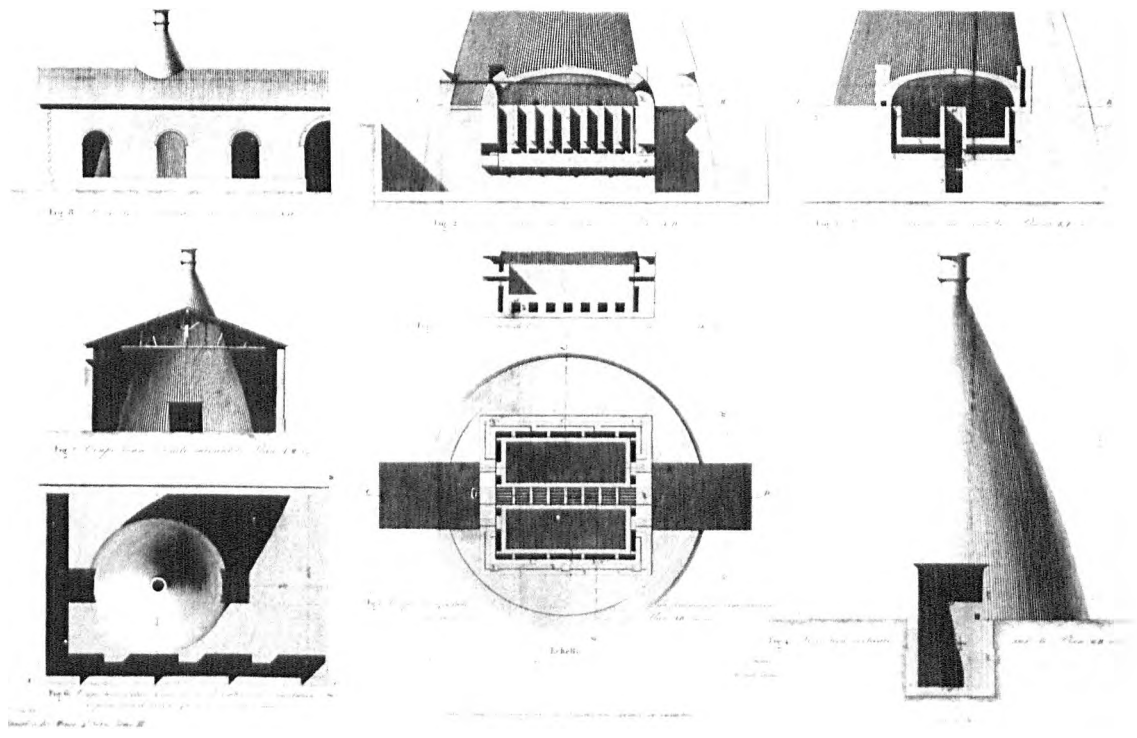

Fig. 3.12 Le Play's detailed study of a Sheffield cementation furnace, probably based on those at West Street (Le Play 1843).

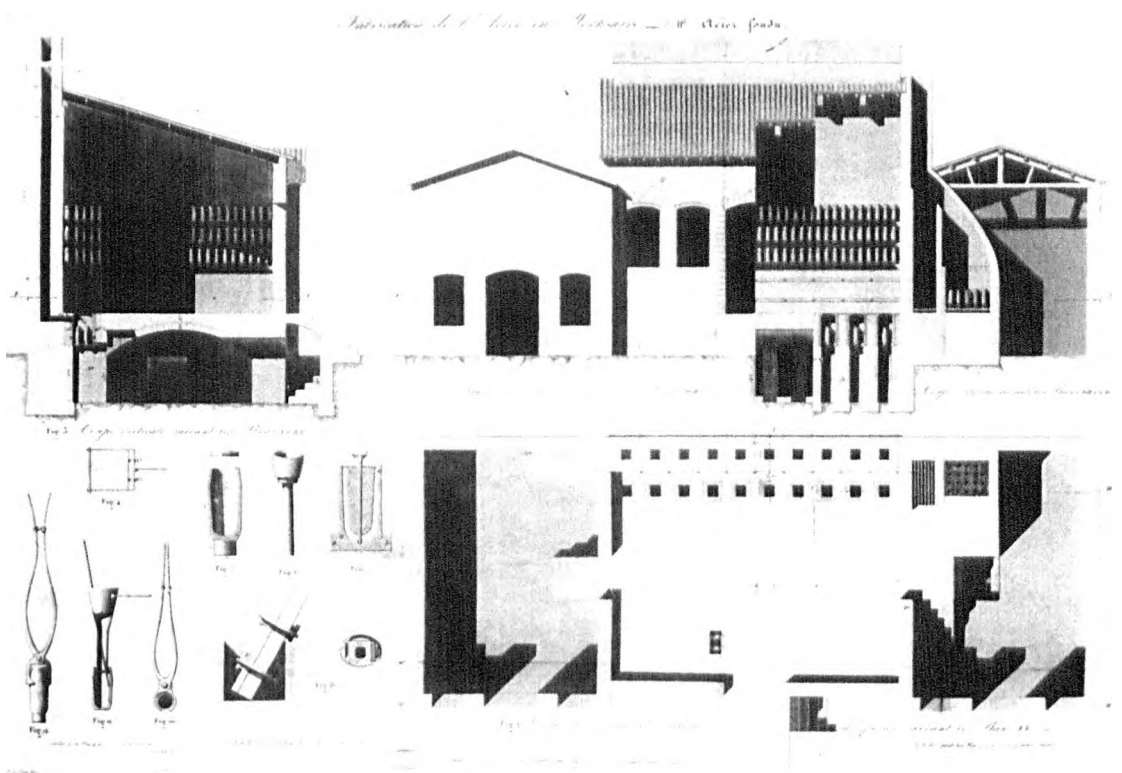

Fig. 3.13 A Sheffield melting shop and its equipment, from the same source. The ten-hole shop was a common unit, Sanderson having two such examples at the time of Le Play's visit. Elements of the drawing including the side 'pavilions' are clearly idealised.

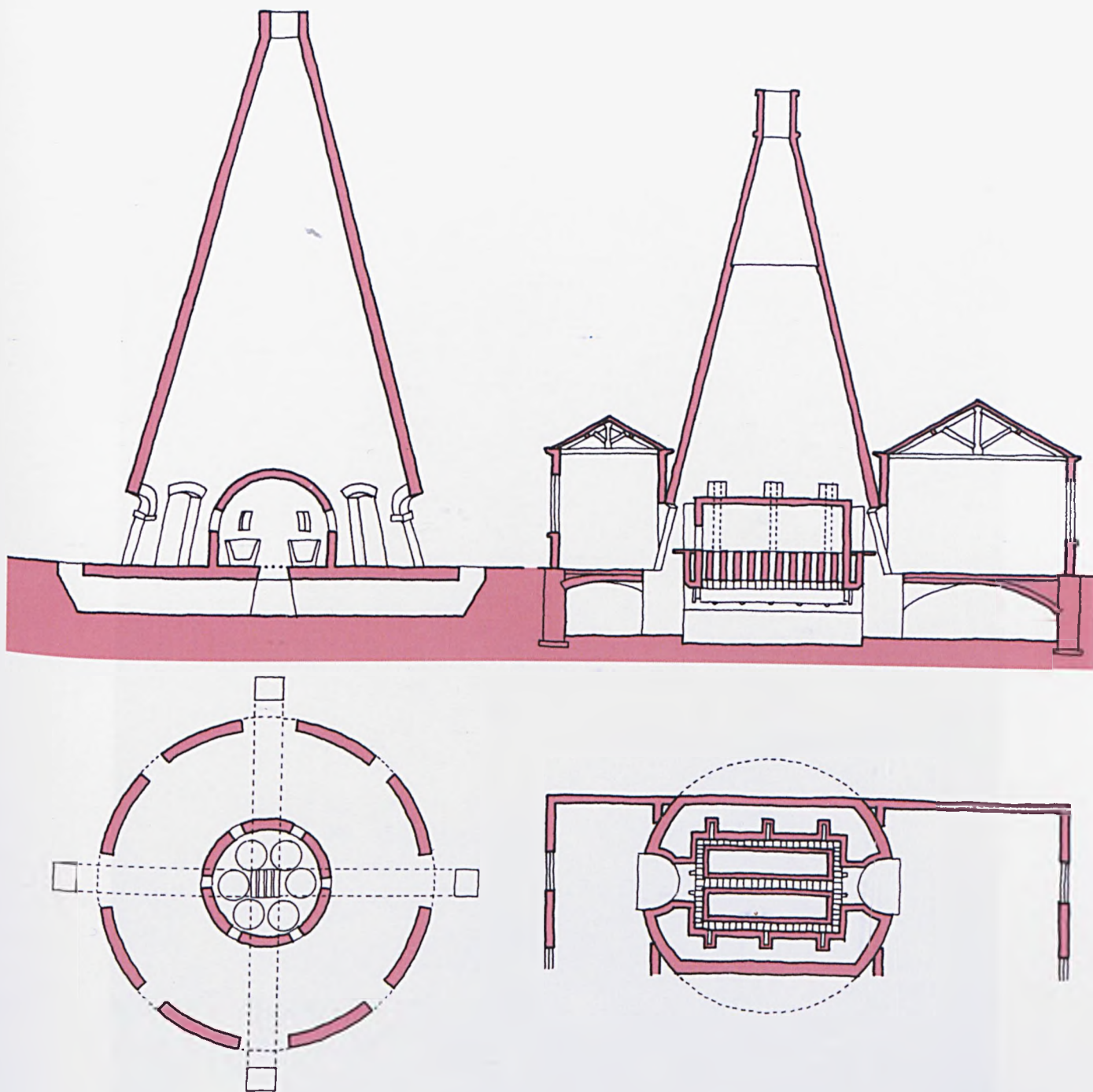

Fig. 3.14 Comparative plan and section of a glass furnace (left) and steel cementation furnace (right) to demonstrate the relative ease with which Sanderson Brothers could have converted the former to the latter. Scale 1:200 (author).



Fig. 3.15 Catcliffe glass cone, near Sheffield, a survival of the once thriving South Yorkshire glass industry that may have drawn Huntsman to the area (author).

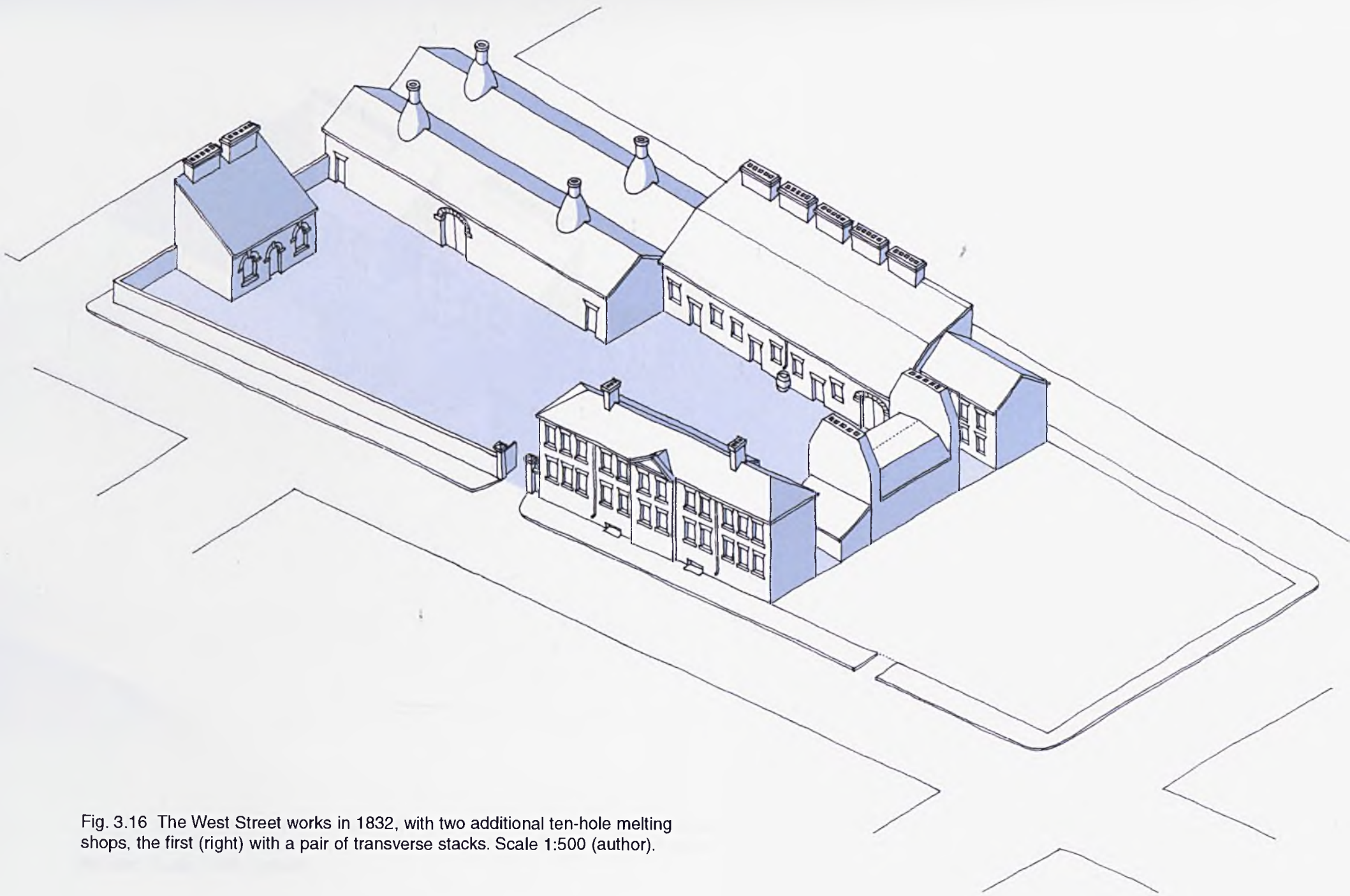

Fig. 3.16 The West Street works in 1832, with two additional ten-hole melting shops, the first (right) with a pair of transverse stacks. Scale 1:500 (author).



Fig. 3.17 Sanderson Brothers works at full capacity, with further cast steel furnaces built in front of the cementation furnace sheds, and utility buildings scattered about the yard. Scale 1:500 (author).

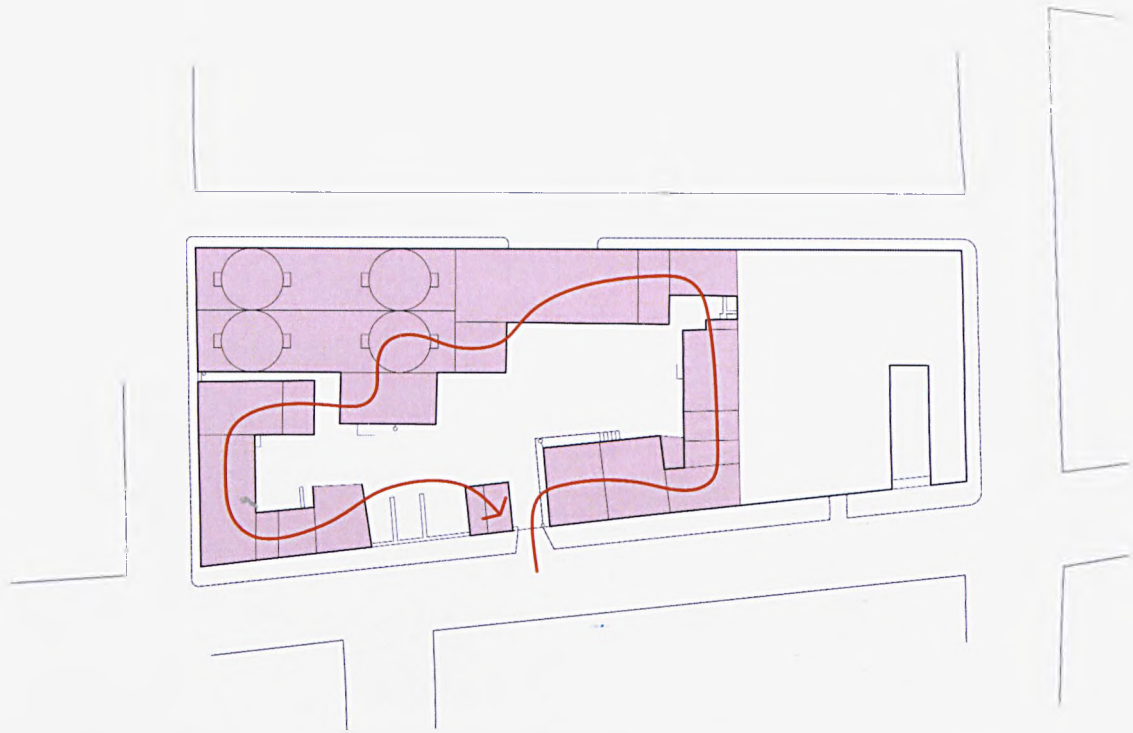

Fig. 3.18 Path taken by the rate collectors anticlockwise around the yard, of assistance in reconstructing the location of building uses. Scale 1:1000 (author).



Fig. 3.19 Sanderson Brothers' Darnall Road steelworks including the converted glassworks premises (top left) and new steelworks below. North is at top, scale 1:2000 (OS, author's colours).

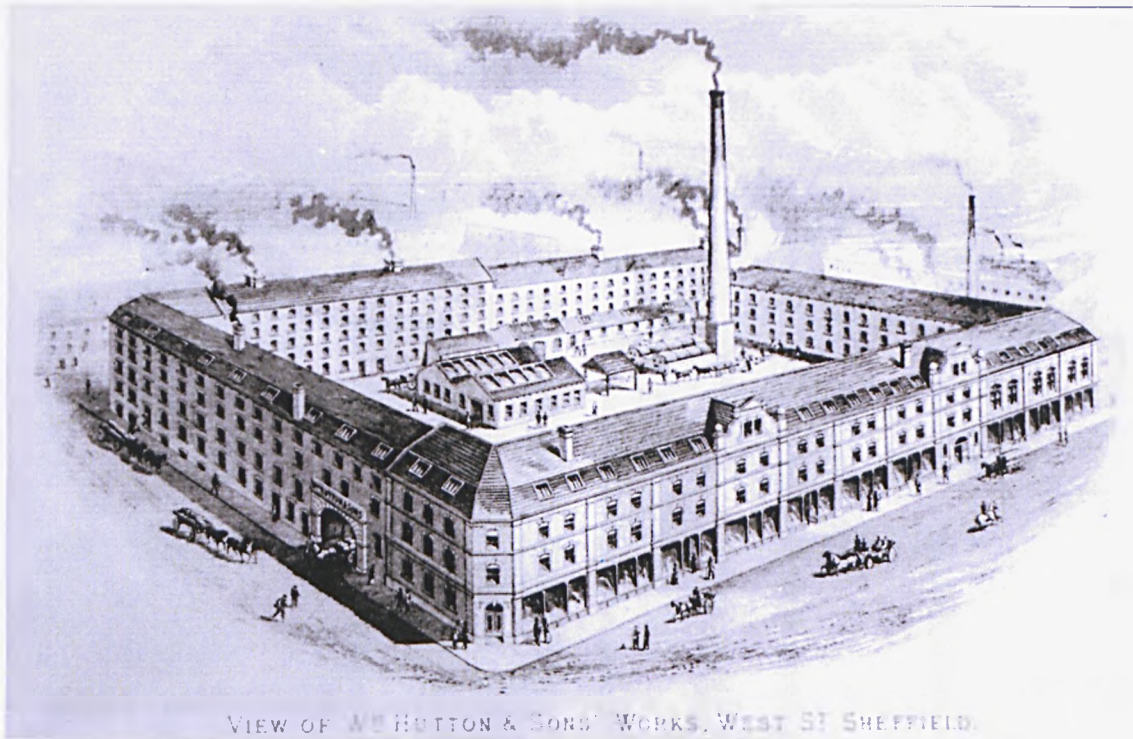

Fig. 3.20 William Hutton's premises that replaced the outgrown steelworks of Sanderson Brothers with more elegant buildings.

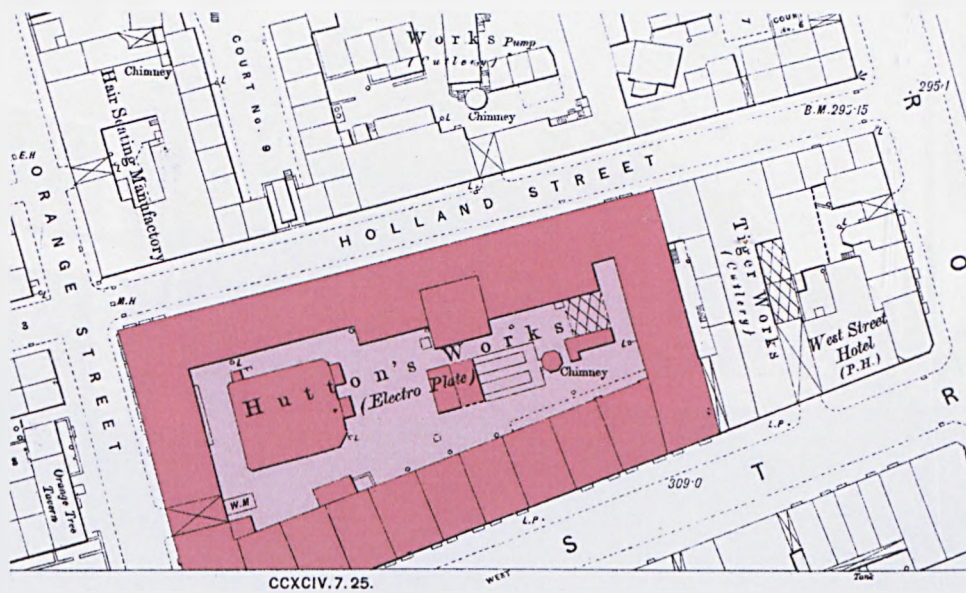

Fig. 3.21 Plan of Hutton's Works from the 1889 OS sheet, scale 1:1000 (OS, author's colours).



Figs. 3.22 and 3.23 Details of Hutton's buildings, with their late Victorian detail and solid construction (author).



Fig. 3.24 Hutton's redevelopment achieved a much higher density than the old steelworks, making use of the street frontage for shops with manufacturing premises concentrated around the concealed yard behind (author).

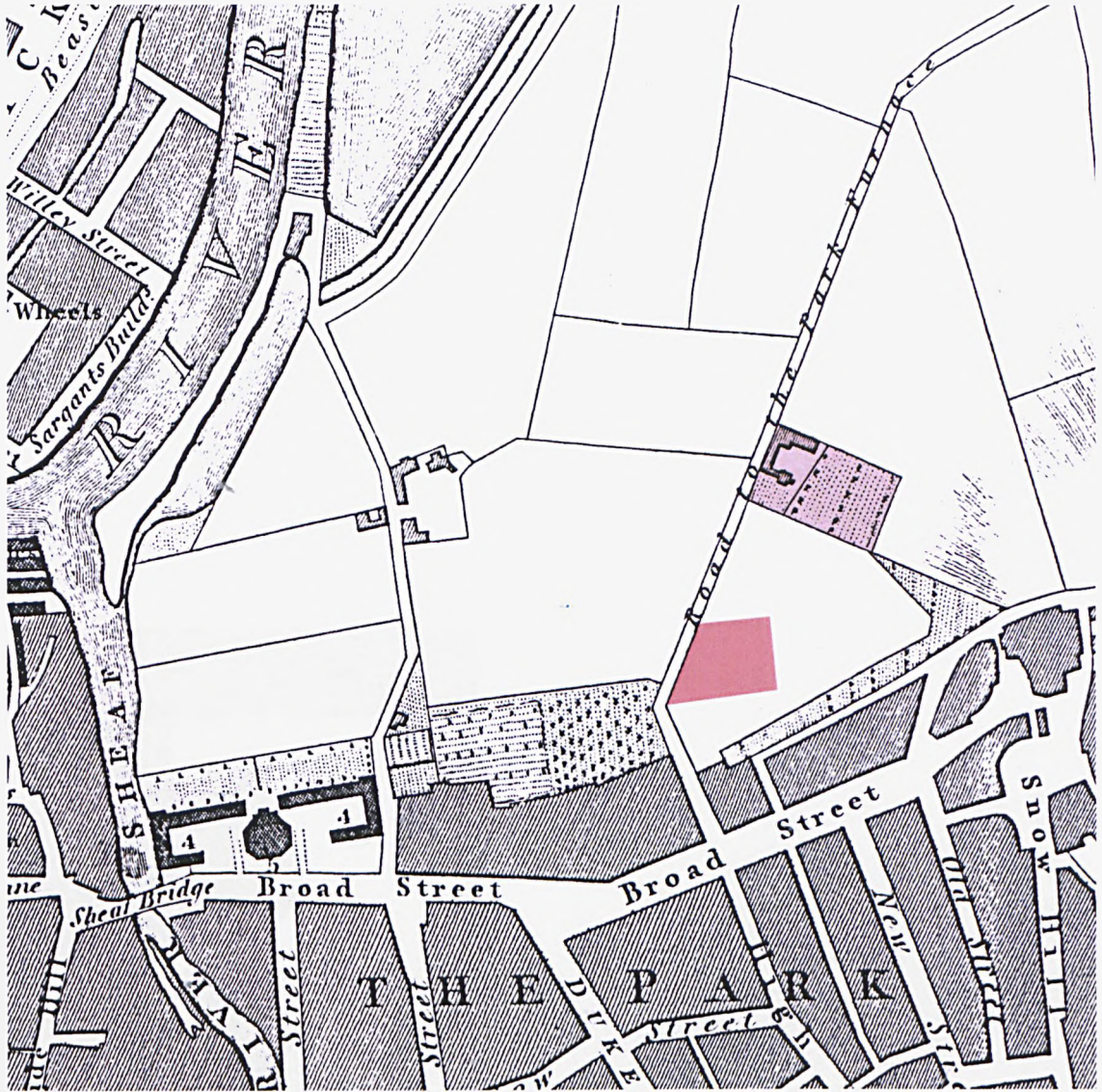
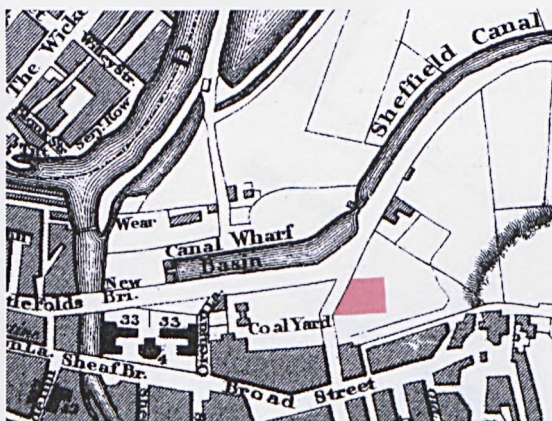

Fig. 3.25 The future site of Jessop's Park Works identified on the 1808 town plan (pink) with what was possibly William Jessop's Blast Lane house above. Scale 1:3600 (Fairbank 1808, author's colours).



Figs. 3.26 and 3.27 Park Works on the town plans of 1823 (prior to construction) and 1832, not to scale (Leather 1823, Tayler 1832, author's colours).



Fig. 3.28 Reconstructed plan of Jessop's Park Works in 1834, scale 1:500 (author).

William Jessop and Sons

Park Works, reconstructed site plans (1834-1850)

scale 1:500

key:

- 1 House (2 storeys)
- 2 Gateway
- 3 Warehouses, counting house and cellars (2 storeys)
- 4 Kitchen (1 storey)
- 5 Iron warehouse (1 storey)
- 6 Cementation furnace, 2 pots
- 7 Cast steel furnace, 16 holes (1 storey)
- 8 Clay room (1 storey)
- 9 Lightening house (1 storey)
- 10 Scrap room (1 storey)
- 11 Coke house (1 storey)
- 12 Stable and gig house (1 storey)
- 13 Yard
- 14 Duke of Norfolk's coal yard
- 15 Melting furnace, 12 holes (1 storey)
- 16 Annealing room (1 storey)
- 17 Coke shed
- 18 Steel house
- 19 Gig house
- 20 Stable
- 21 Cast steel furnace (1 storey)
- 22 Cast steel furnace (1 storey)
- 23 Weighing machine

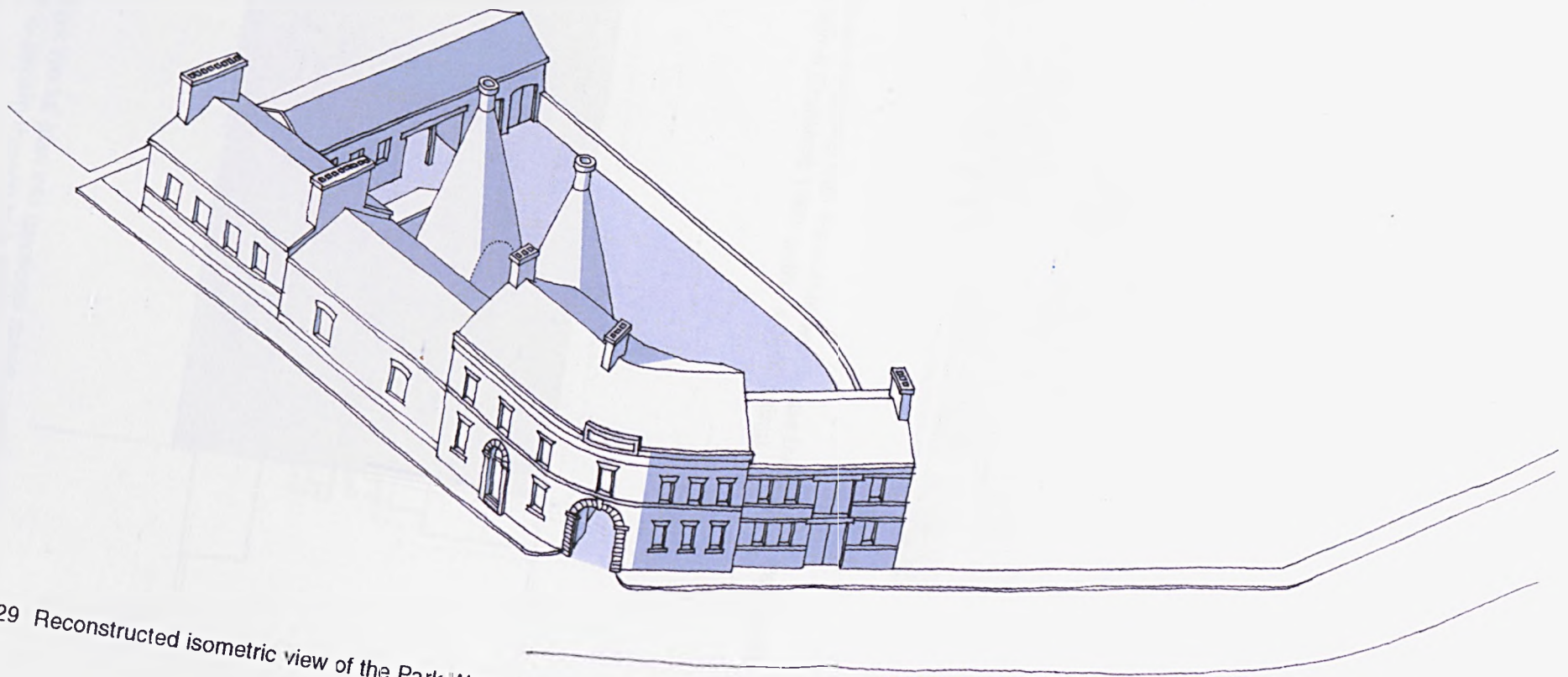

Fig. 3.29 Reconstructed isometric view of the Park Works in 1834, scale 1:500 (author).

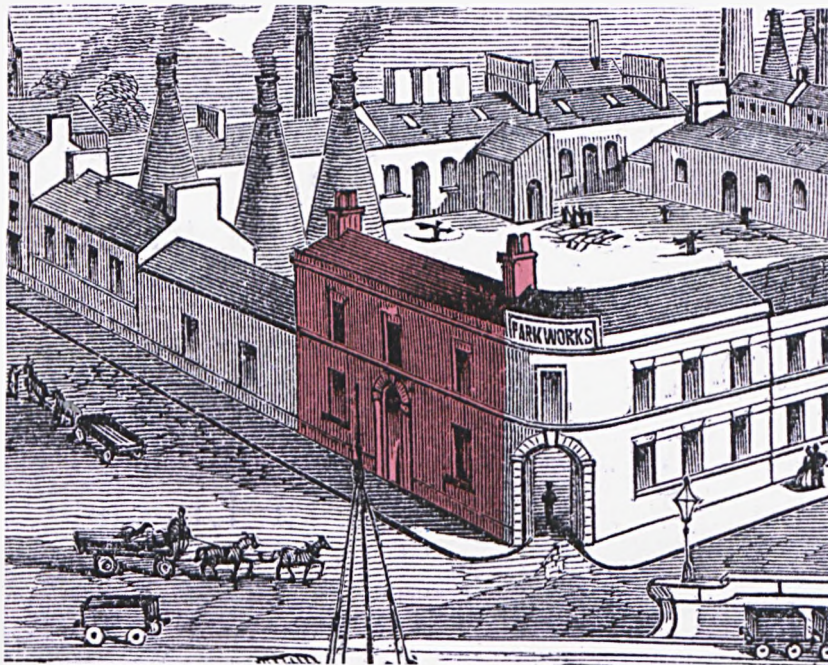

Fig. 3.30 The dwelling house integrated with the corner warehouse buildings at Park Works, detail of works' view (Pawson & Brailsford 1862, author's highlighting).

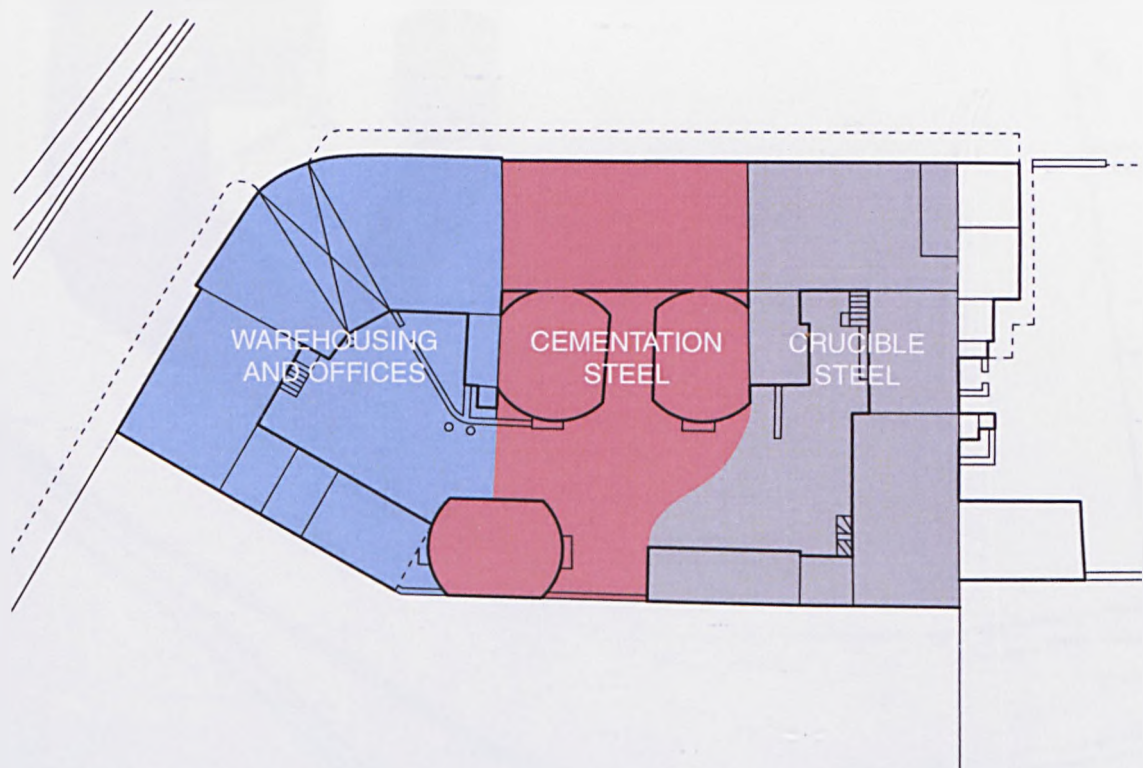

Fig. 3.31 Schematic division of the Park Works' plan into functional zones, recognised spatially and operationally but difficult to discern through built form. Scale 1:500 (author).

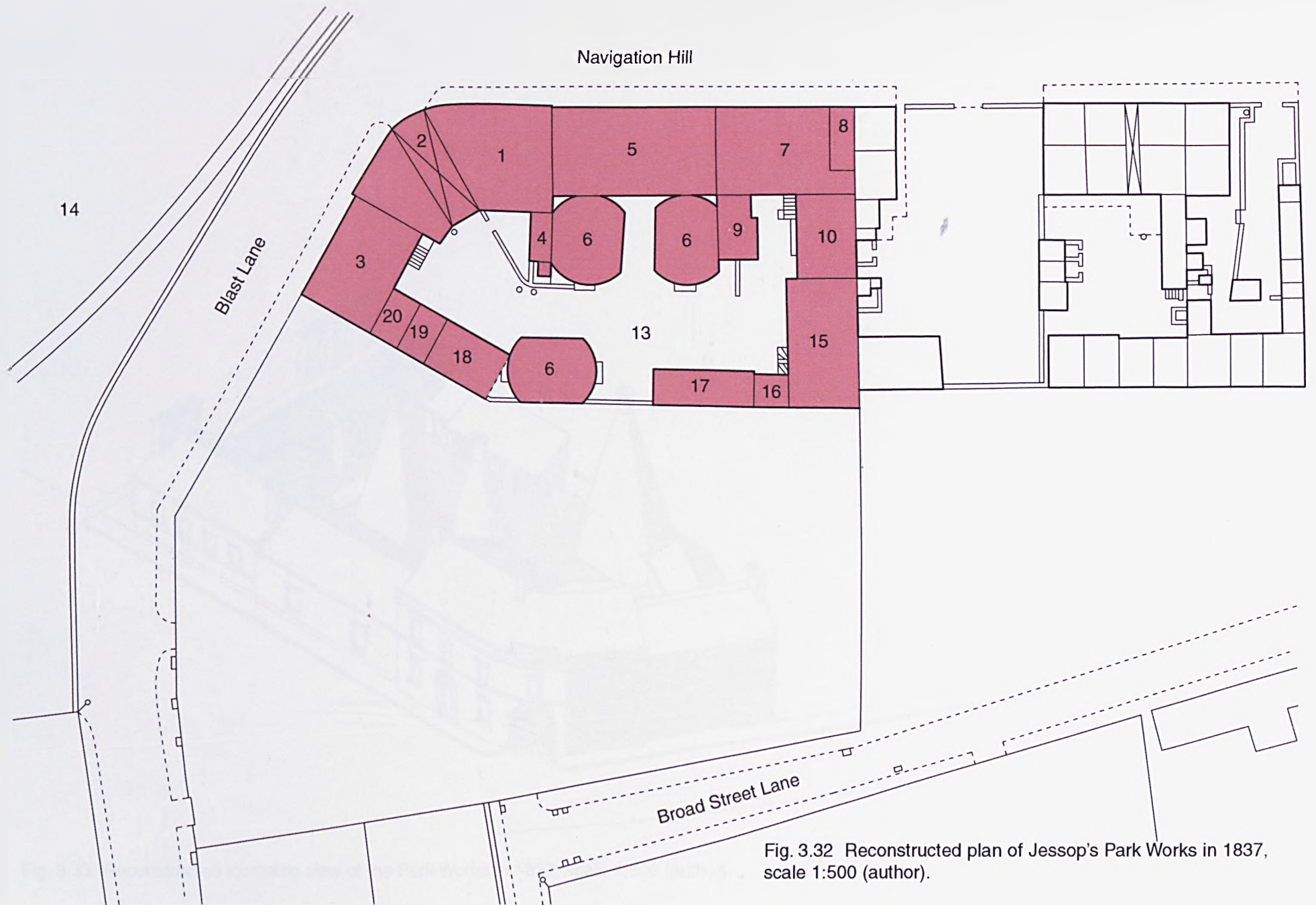

Fig. 3.32 Reconstructed plan of Jessop's Park Works in 1837, scale 1:500 (author).

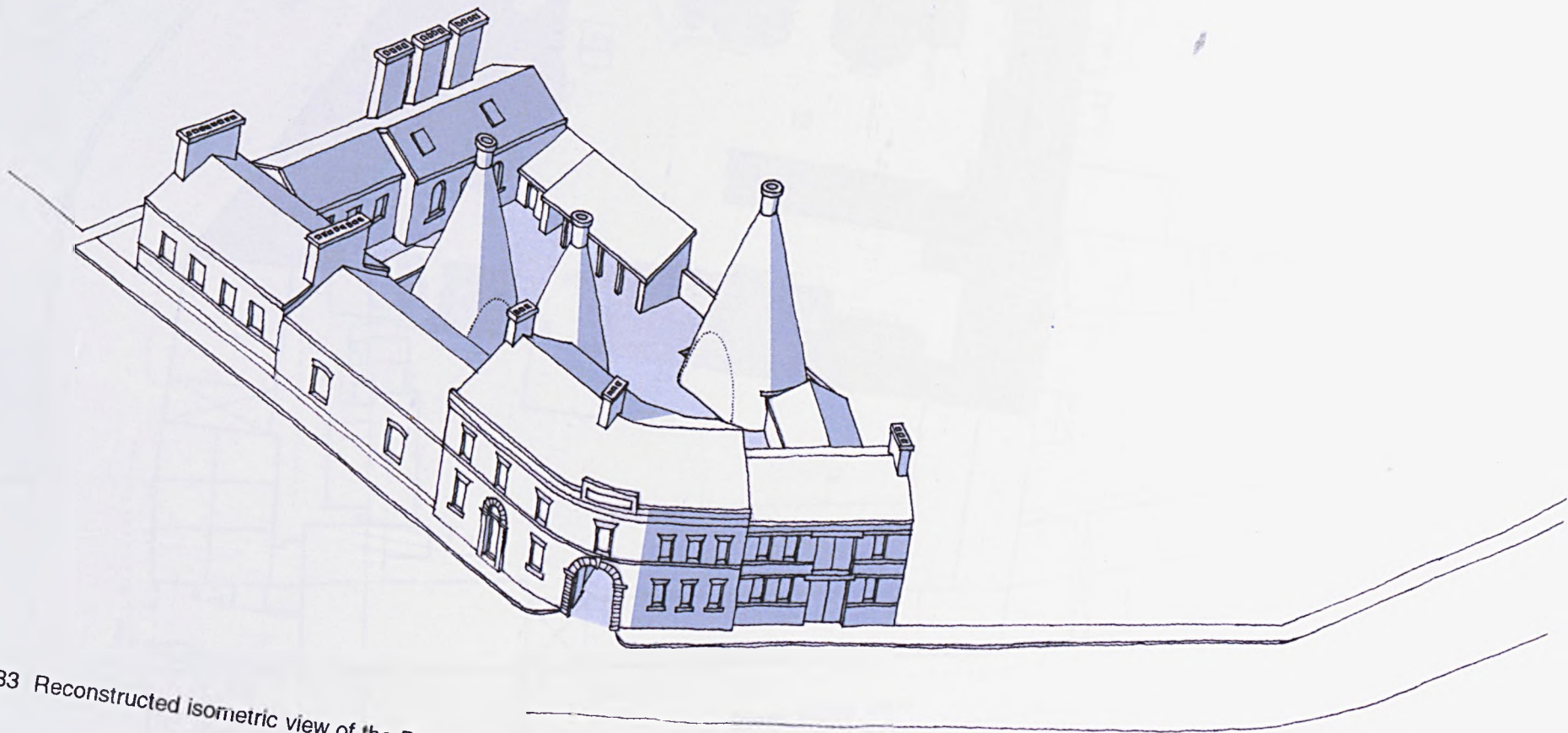

Fig. 3.33 Reconstructed isometric view of the Park Works in 1837, scale 1:500 (author).

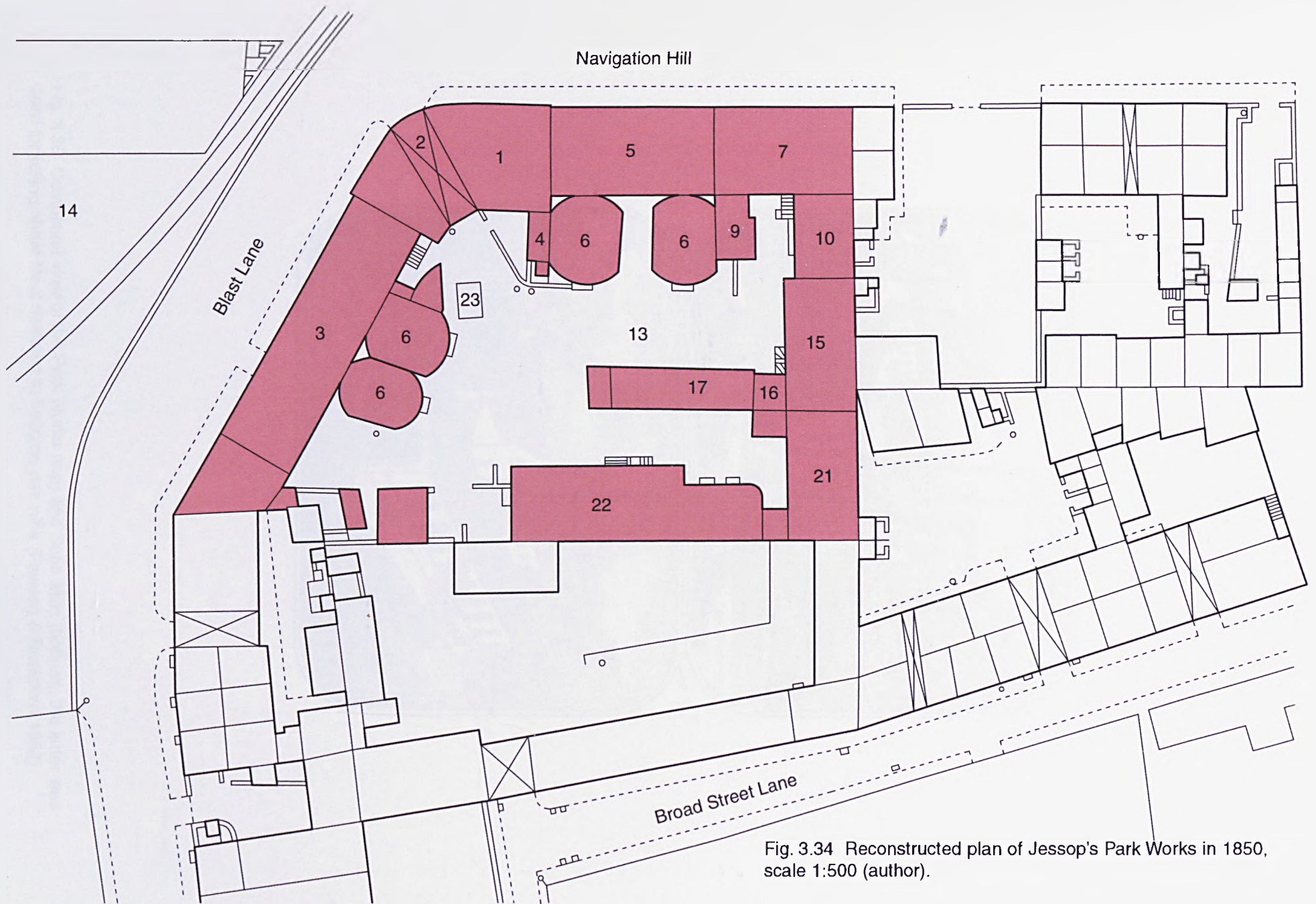

Fig. 3.34 Reconstructed plan of Jessop's Park Works in 1850, scale 1:500 (author).

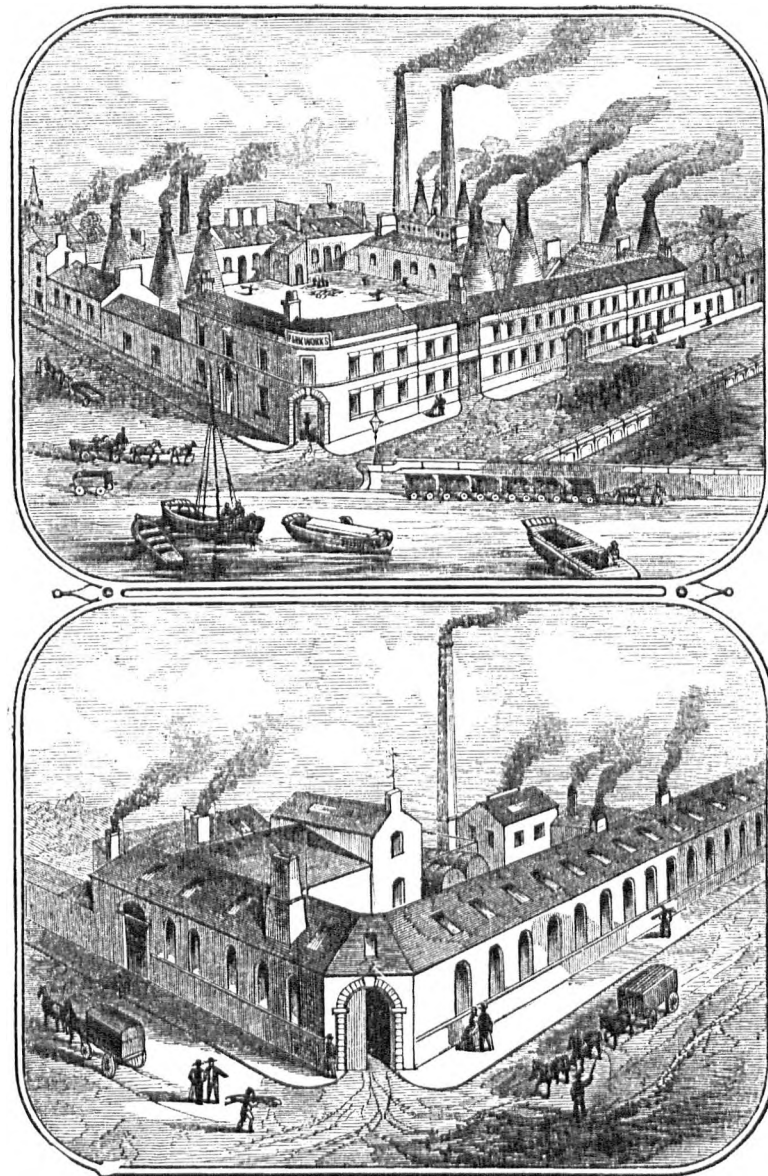

Fig. 3.35 Compound view of the Park Works (top) and Soho Mills (bottom); the latter was used for rolling sheet steel destined to become pen nibs (Pawson & Brailsford 1862).

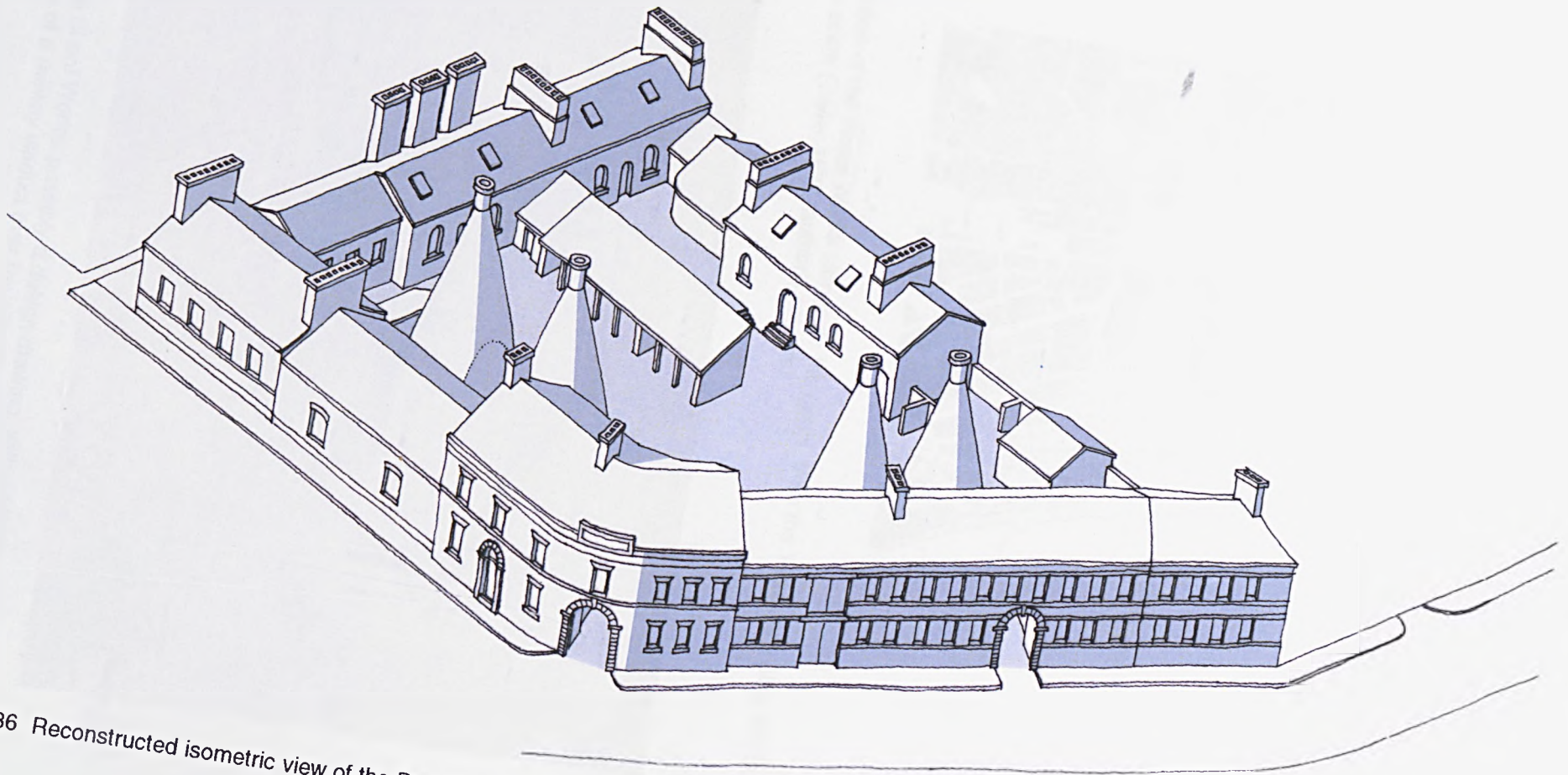

Fig. 3.36 Reconstructed isometric view of the Park Works in 1850, scale 1:500 (author).

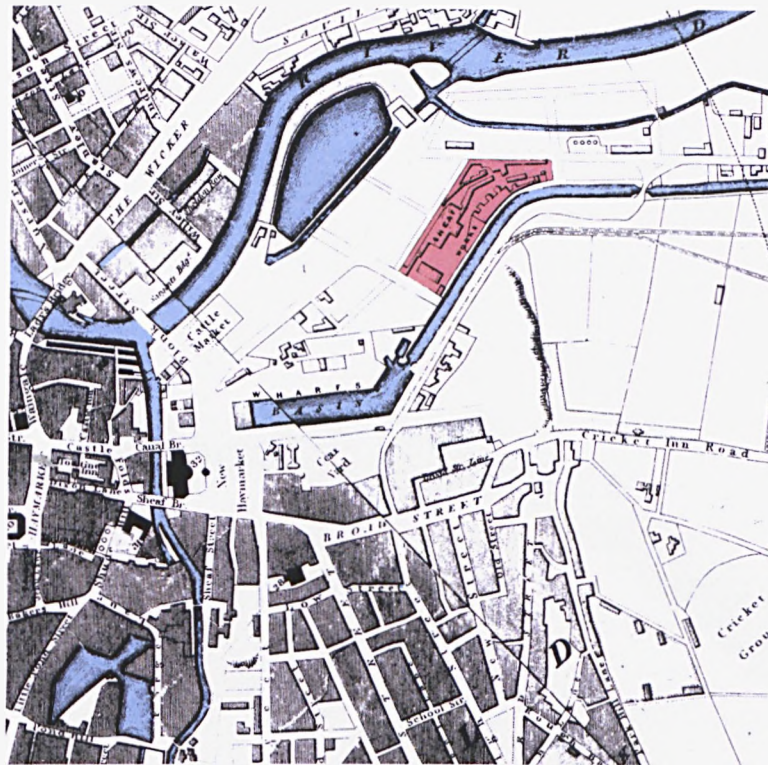

Fig. 3.37 Location of the Sheaf Works alongside the canal, from the 1832 town plan. North is at top, not to scale (Tayler 1832, author's colours).

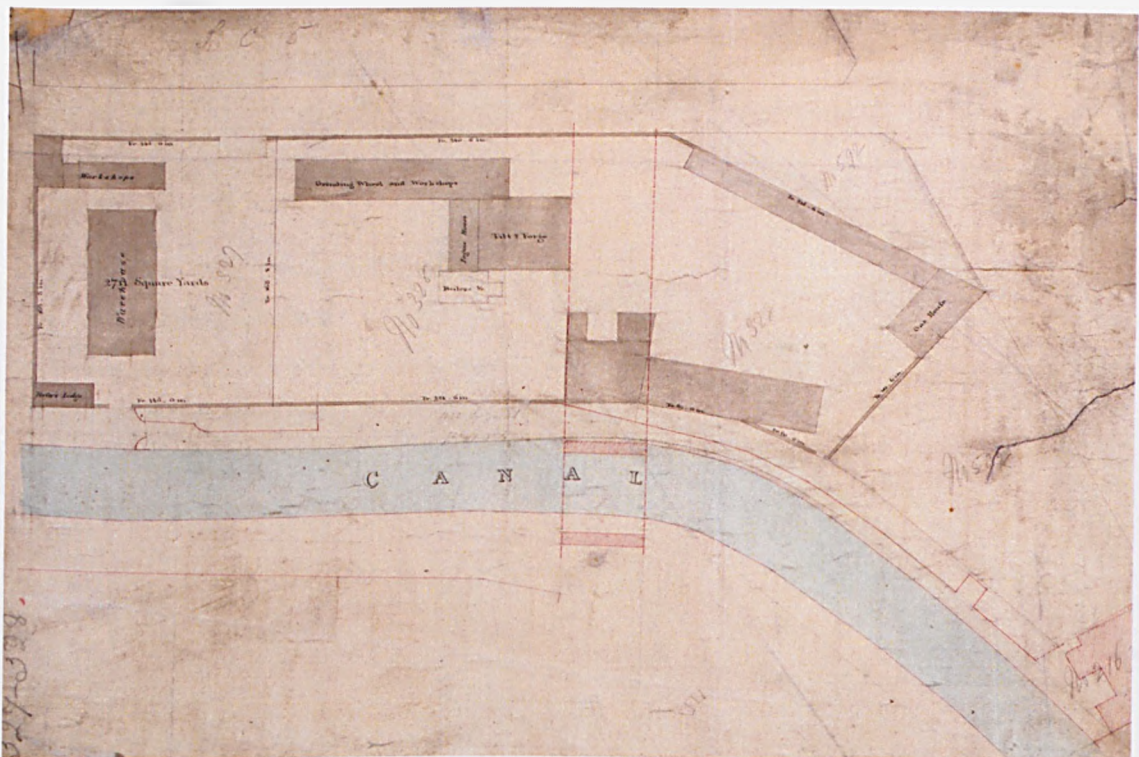

Fig. 3.38 Early plan of the Sheaf Works, possibly a design drawing, with additions in red pen relating to the construction of a railway viaduct over the site. Scale c.1:1500 (SCA).

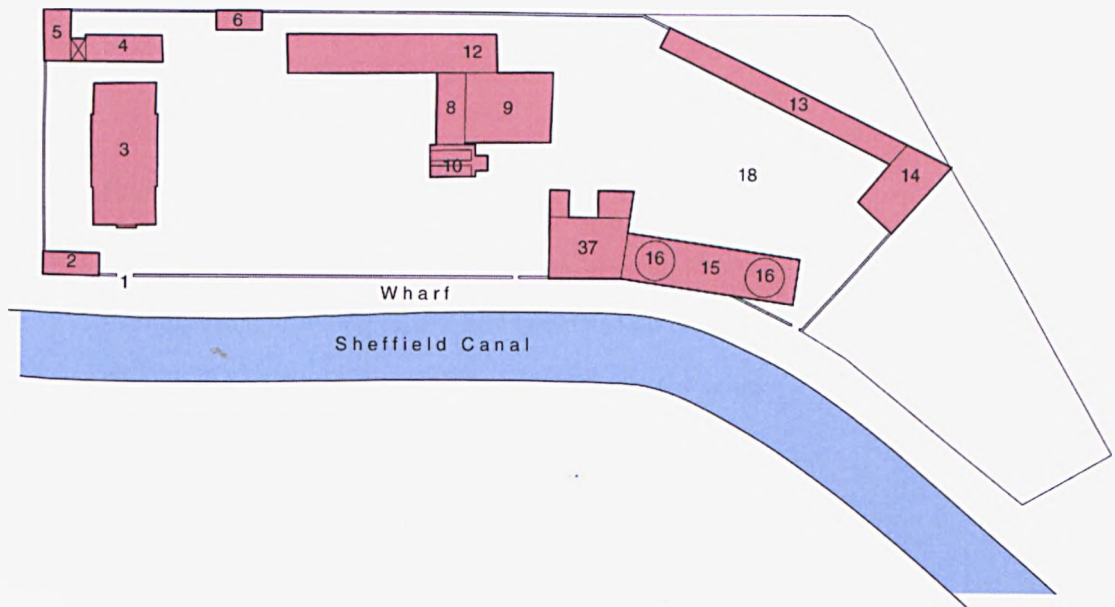

Fig. 3.39 Redrawing of fig. 3.38 with building uses, 1825. Scale 1:1500, north is at top right (author).

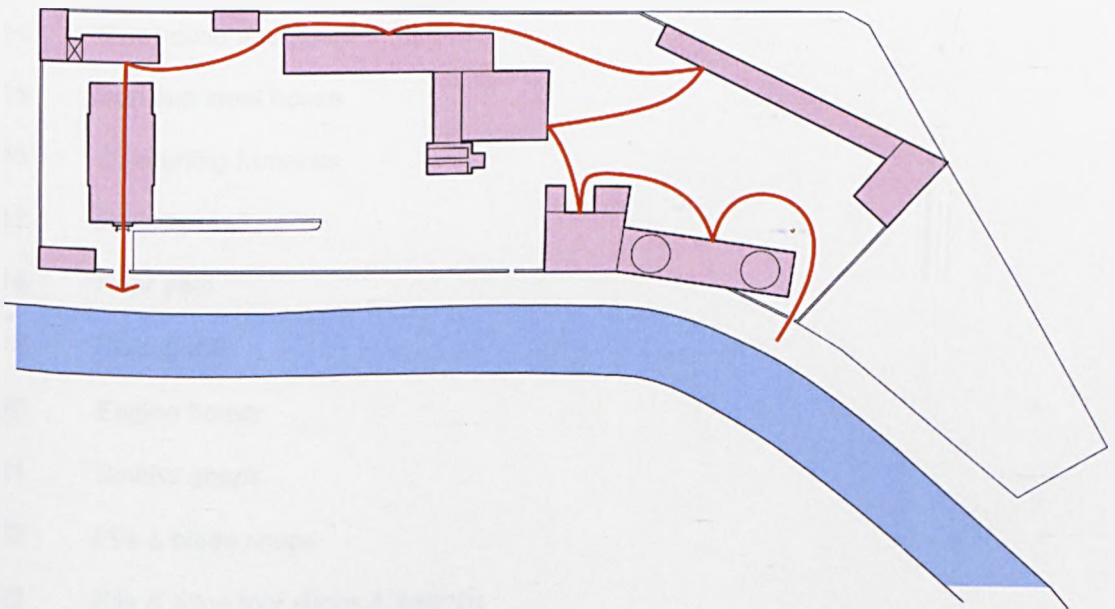

Fig. 3.40 Sequential progress of materials through the works, beginning at right with imported bar iron and ending at the warehouse, left, with the finished product ready for dispatch. Scale 1:1500 (author).

William Greaves

Sheaf Works, Maltravers Street, reconstructed site plans (1823-1850)

scale 1:1500

key:

- 1 Front entrance to works
- 2 Time keeper's house (1 storey)
- 3 Warehouses, counting house and cellars (3 storeys)
- 4 Edge tool and file shops, warehouses & pressers' shop
- 5 Tenement
- 6 Stables
- 7 Hardening & lightening shops & office
- 8 Engine house, wheel house
- 9 Tilt and forge (1 storey)
- 10 Boiler seats & stack
- 11 Front yard
- 12 Grinding wheels and bone mill
- 13 File cutters', blade and file shops
- 14 Gas house and tank
- 15 Iron and steel house
- 16 Converting furnaces
- 17 Railway viaduct
- 18 Rear yard
- 19 Rolling mill
- 20 Engine house
- 21 Smiths' shops
- 22 File & blade shops
- 23 File & edge tool shops & hearths
- 24 Tank
- 25 Bone shed & smiths' shop

- 26 Cask sheds
- 27 Joiners' shop & shed
- 28 Stable & gig house
- 29 Stable
- 30 File shops
- 31 Coke furnace
- 32 Coke shed
- 33 Melting furnace
- 34 Steel house & pot house
- 35 Melting furnaces, steel & pot house & clay room
- 36 Weigh machine frame
- 37 WCs

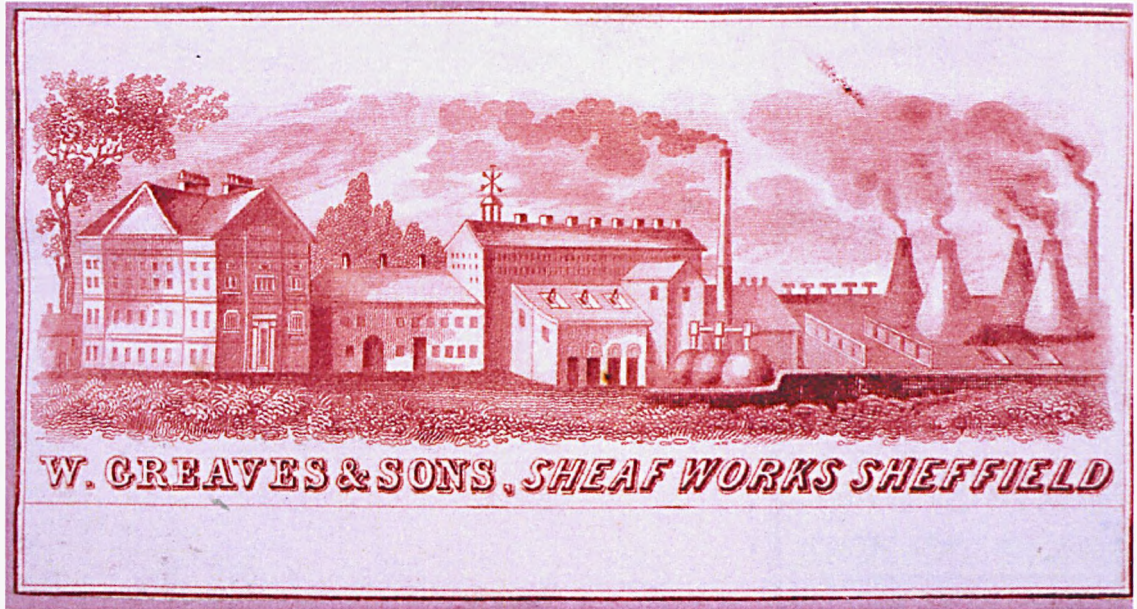

Fig. 3.41 Early label depicting the Sheaf Works in a semi-rural setting (SCL).

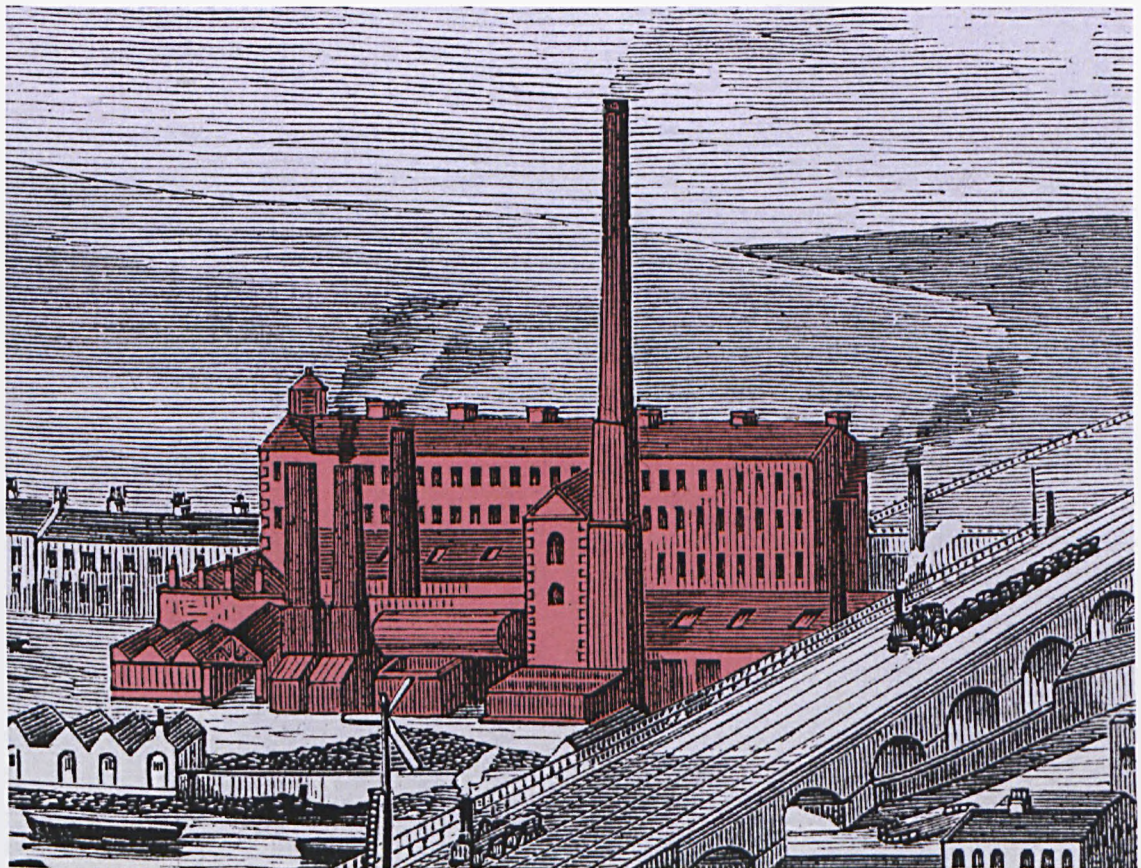

Fig. 3.42 Detail of works view showing the steam-powered grinding wheel and forge, with classical engine house and adjacent stack (Pawson & Brailsford 1862, author's colours).



Fig. 3.43 (right) Label for Greaves' cast steel with generic view of cementation furnaces (SCL).



Fig. 3.44 The main warehouse at Sheaf Works with porter's lodge and gateposts alongside (left). In 2001 the building was in use as a pub, since closed down (author).

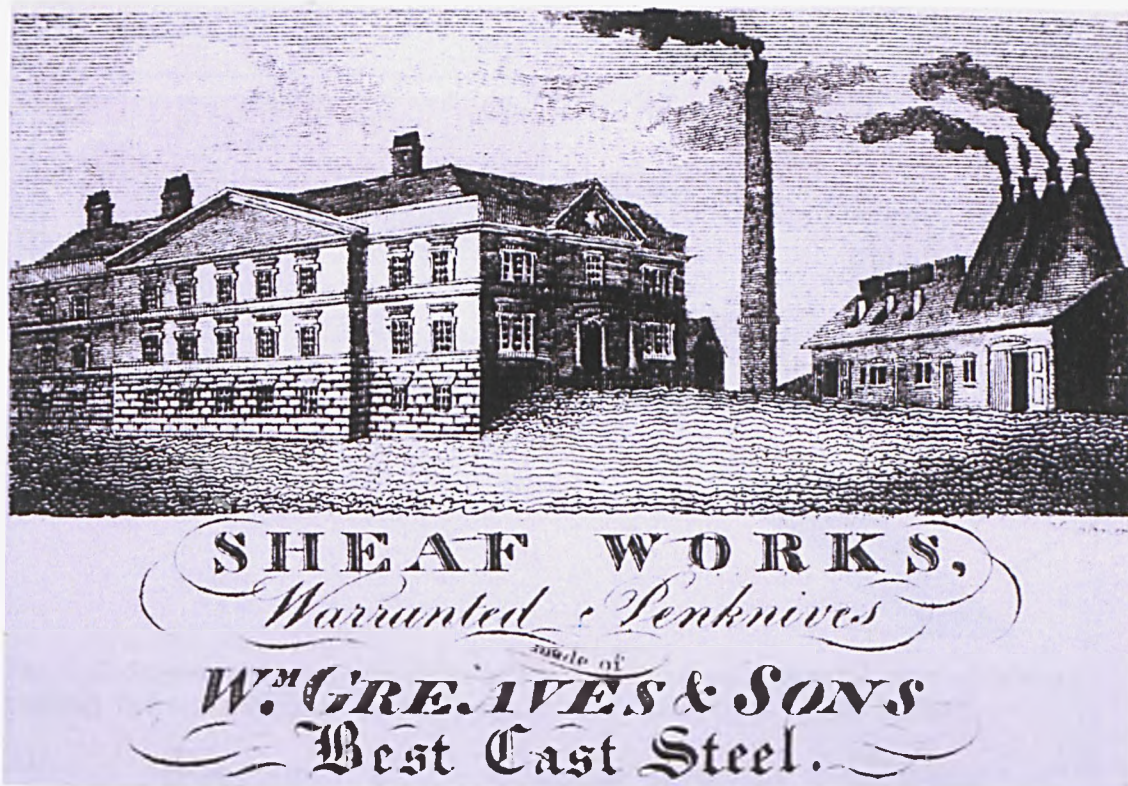

Fig. 3.45 Loosely-interpreted view of the Sheaf Works, in which the plant is reduced to its symbolic content, reading left to right: warehouse, steam engine stack, melting shop and cementation furnaces (SCL).



Fig. 3.46 Edge tool label emphasising the canalside aspect of the works, with unrealistically prominent warehouse and grinding wheel buildings (SCL).

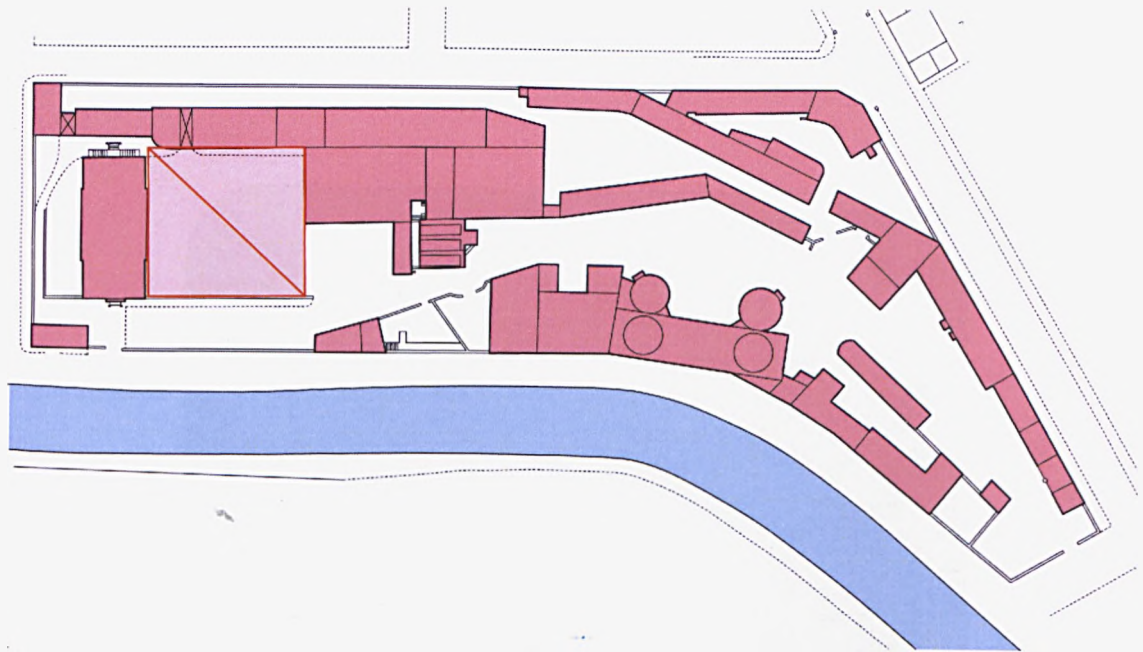

Fig. 3.47 Square courtyard area described at the lower level behind the main warehouse building. The rear portion of the works was the 'dirty' side. Scale 1:1500 (author).

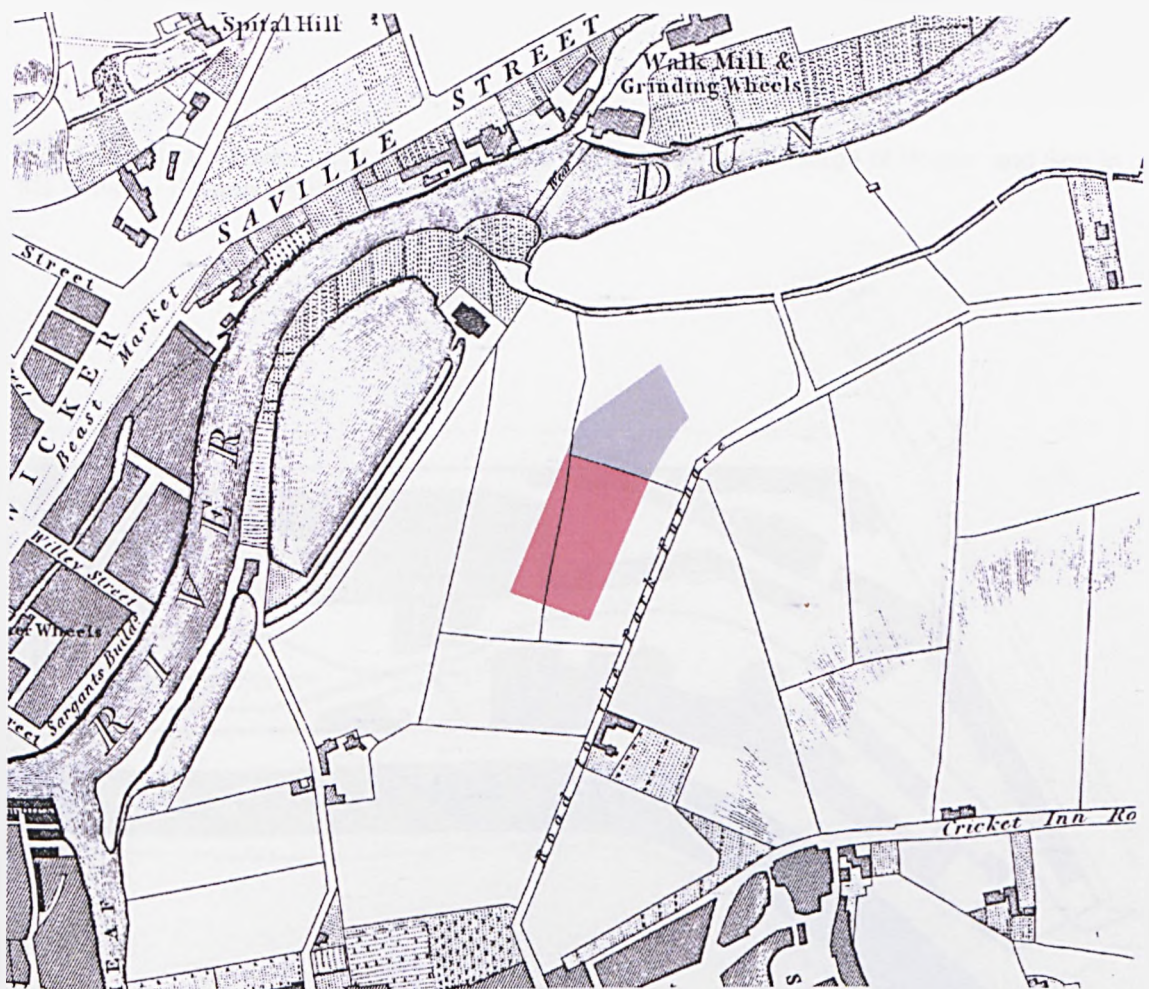

Fig. 3.48 Planning of the Sheaf Works was influenced by earlier field boundaries, seen on the 1808 town plan. The two areas lie to either side of the straight line between the cast steel furnaces and forge, dividing the works into front and back. Scale 1:5000 (Fairbank 1808, author's colours).

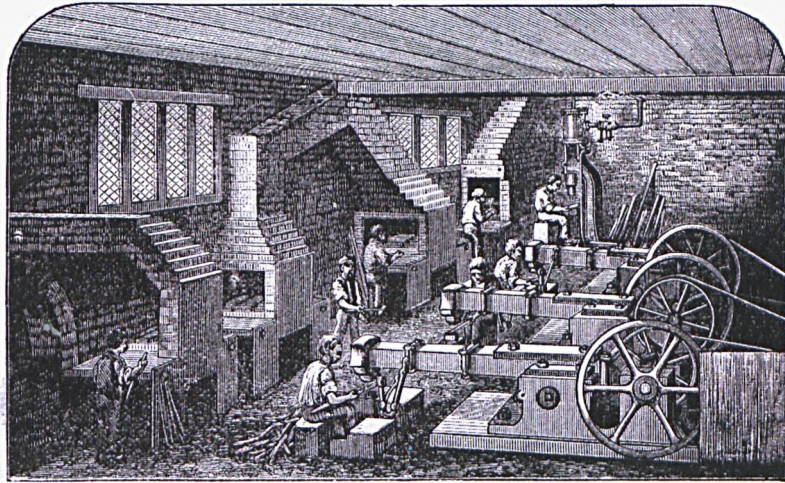

TABLE BLADE FORGING—MESSRS. M. HUNTER AND SON.

Fig. 3.49 Steam power used with traditional tilt hammers, at the forge of Hunter and Son in the Nursery (Pawson & Brailsford 1862).

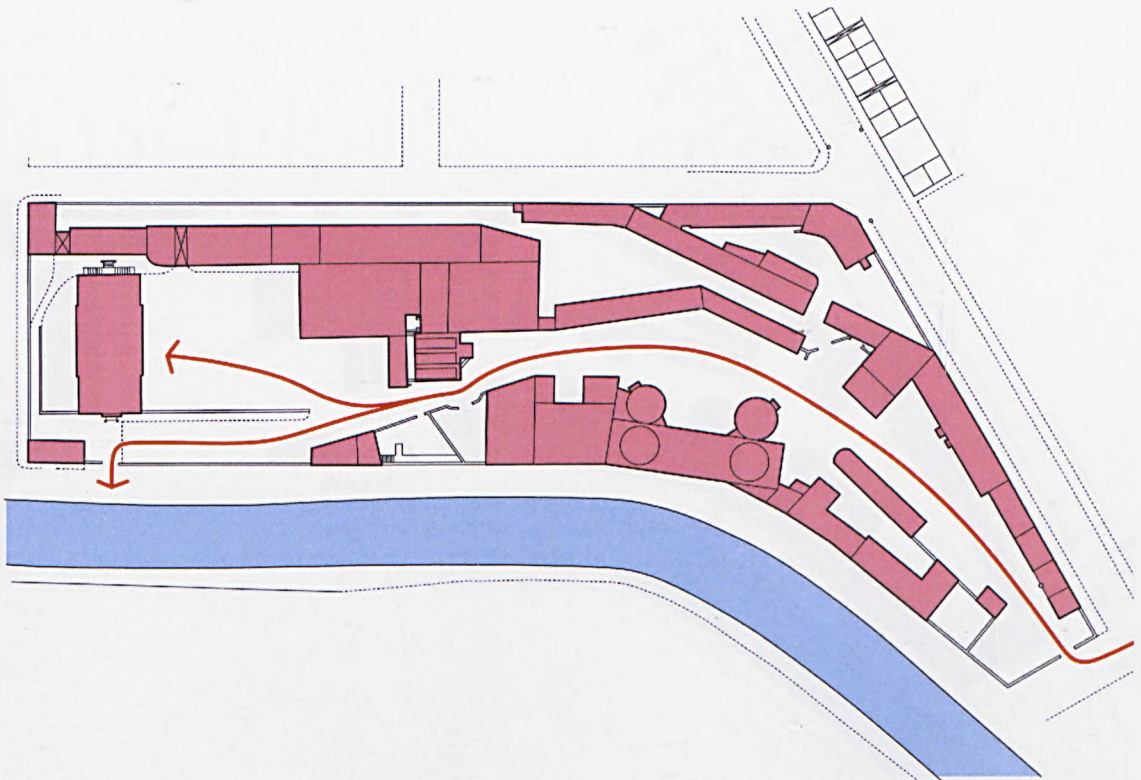

Fig. 3.50 Modified route through the works in 1832, preserving the directional flow of materials through the different production stages. Scale 1:1500 (author).

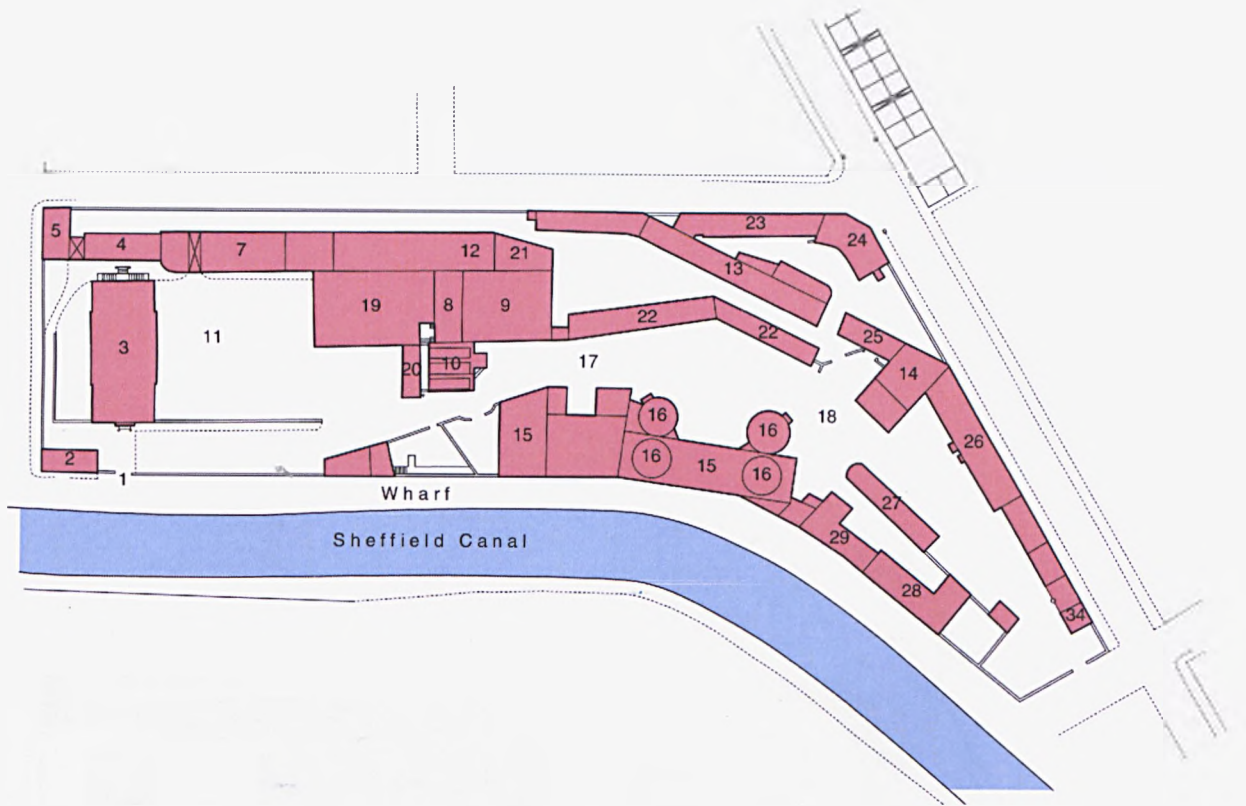

Fig. 3.51 The Sheaf Works in 1832, scale 1:1500 (author).

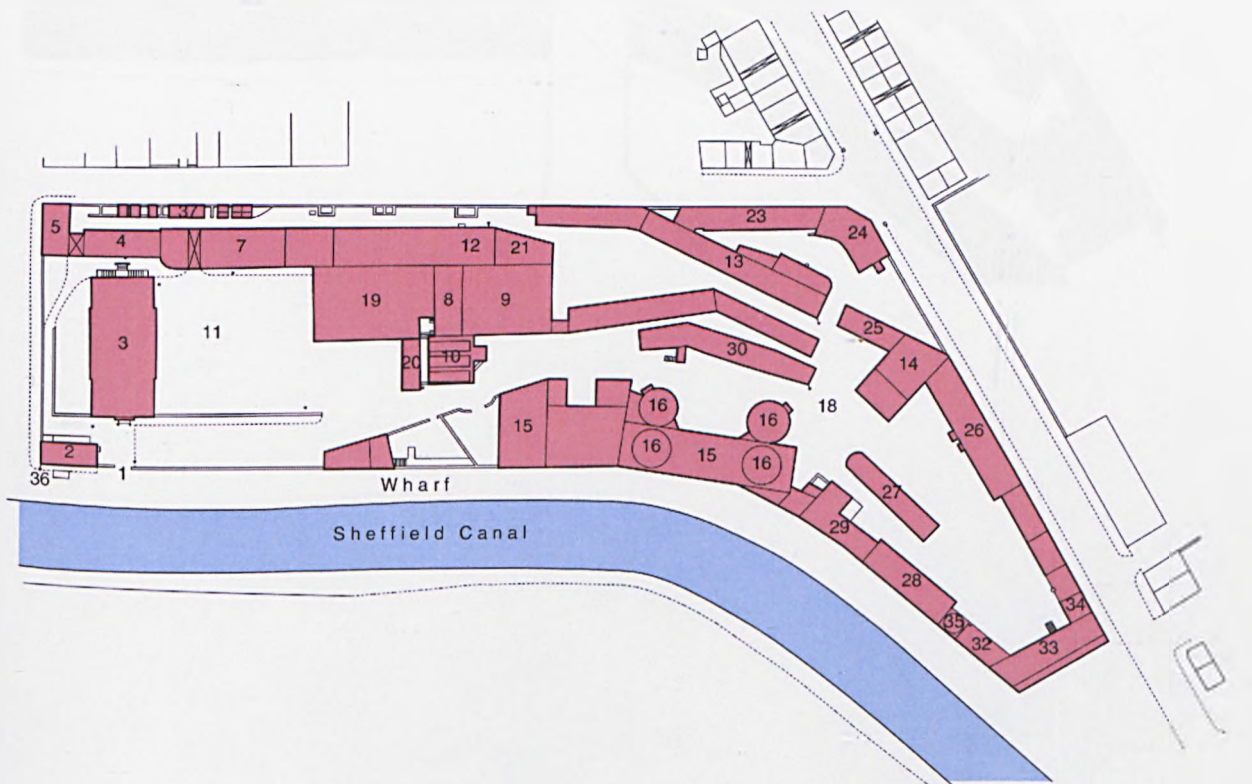

Fig. 3.52 The Sheaf Works in 1836, with the closure of the rear courtyard by new cast steel furnaces, scale 1:1500 (author).

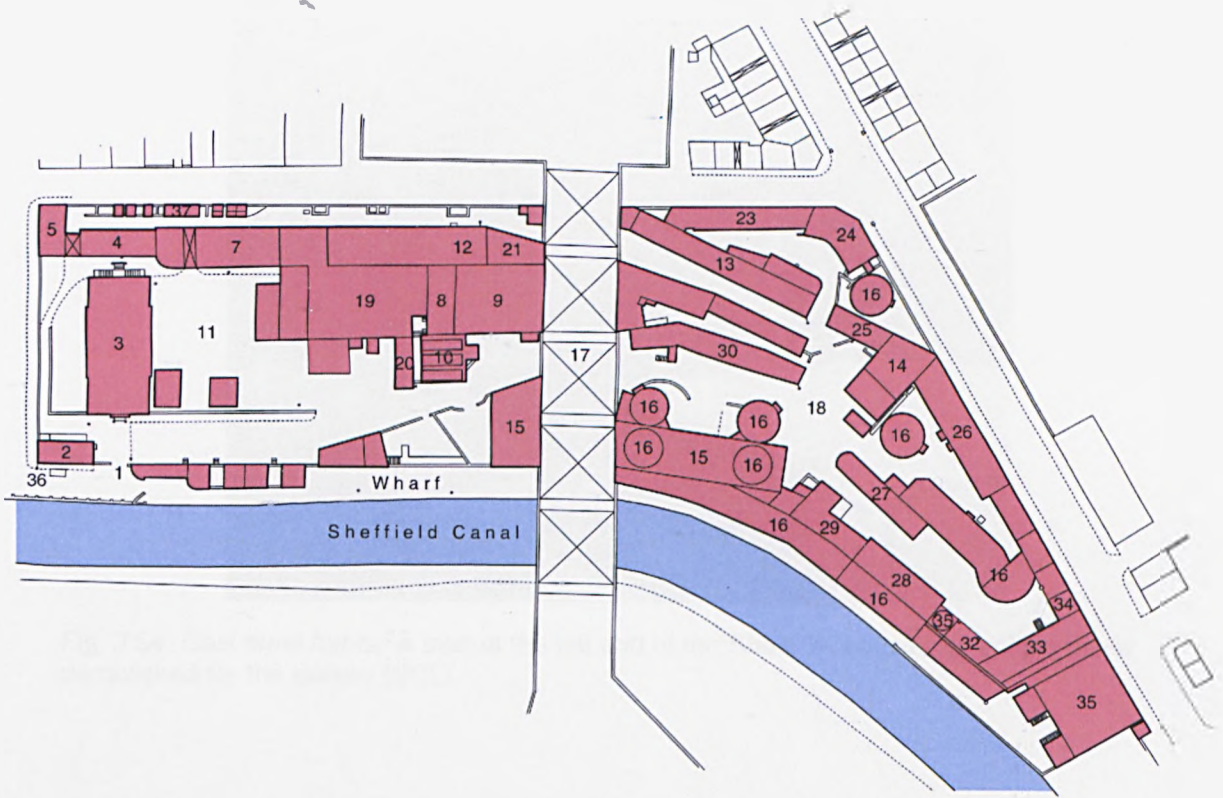

Fig. 3.53 The Sheaf Works at the end of Greaves' occupancy in 1850, scale 1:1500 (author).

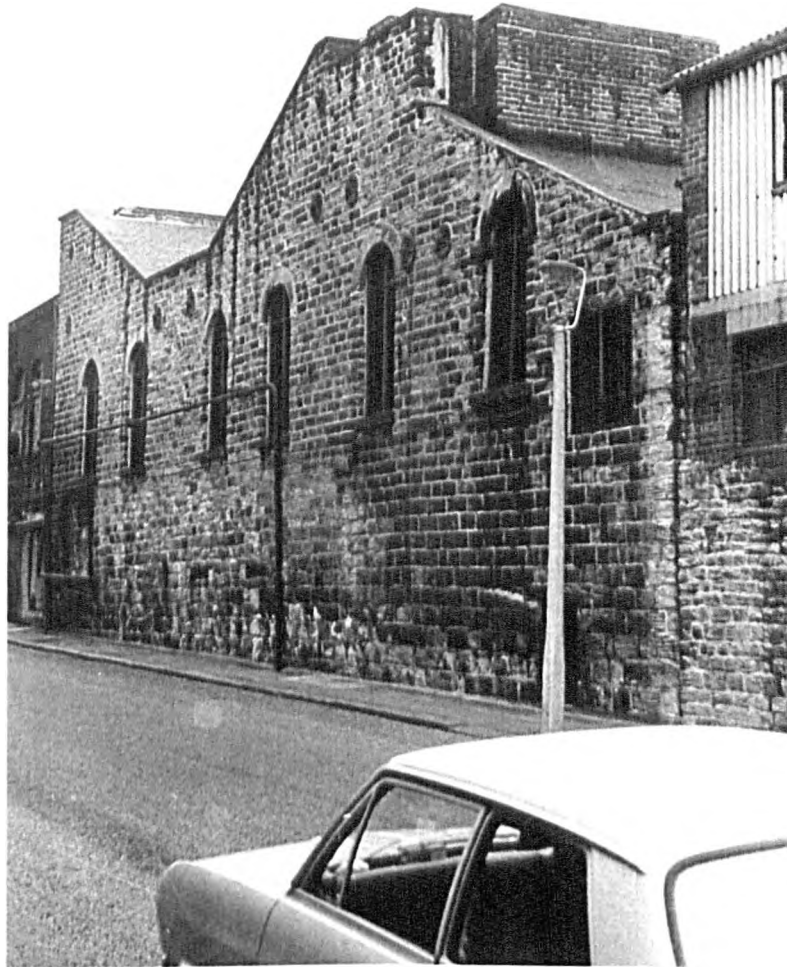

Fig. 3.54 Cast steel furnaces built at the tail end of the Sheaf Works site to replace those demolished for the railway (SCL).

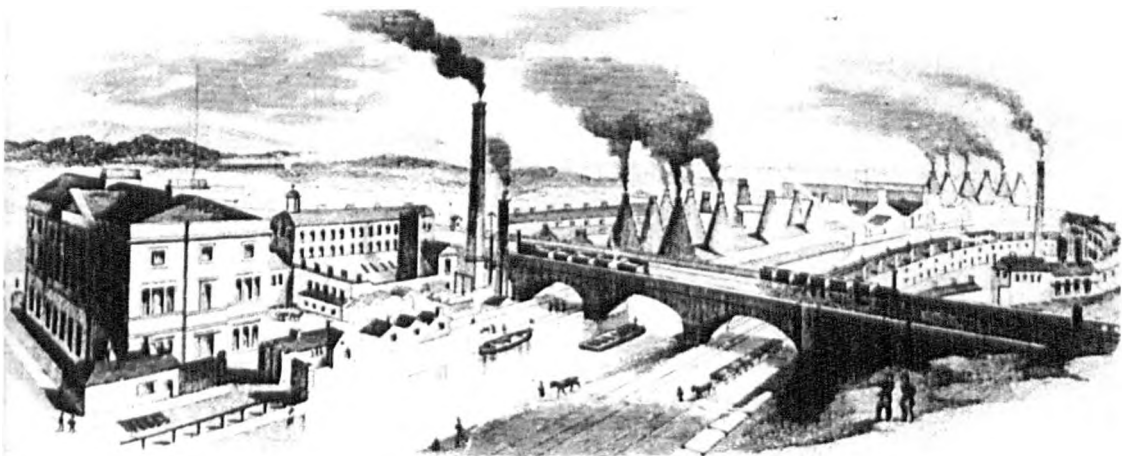

Fig. 3.55 Panoramic view of the Sheaf Works in Turton's occupancy, with the new spring works to the far right (SCL).

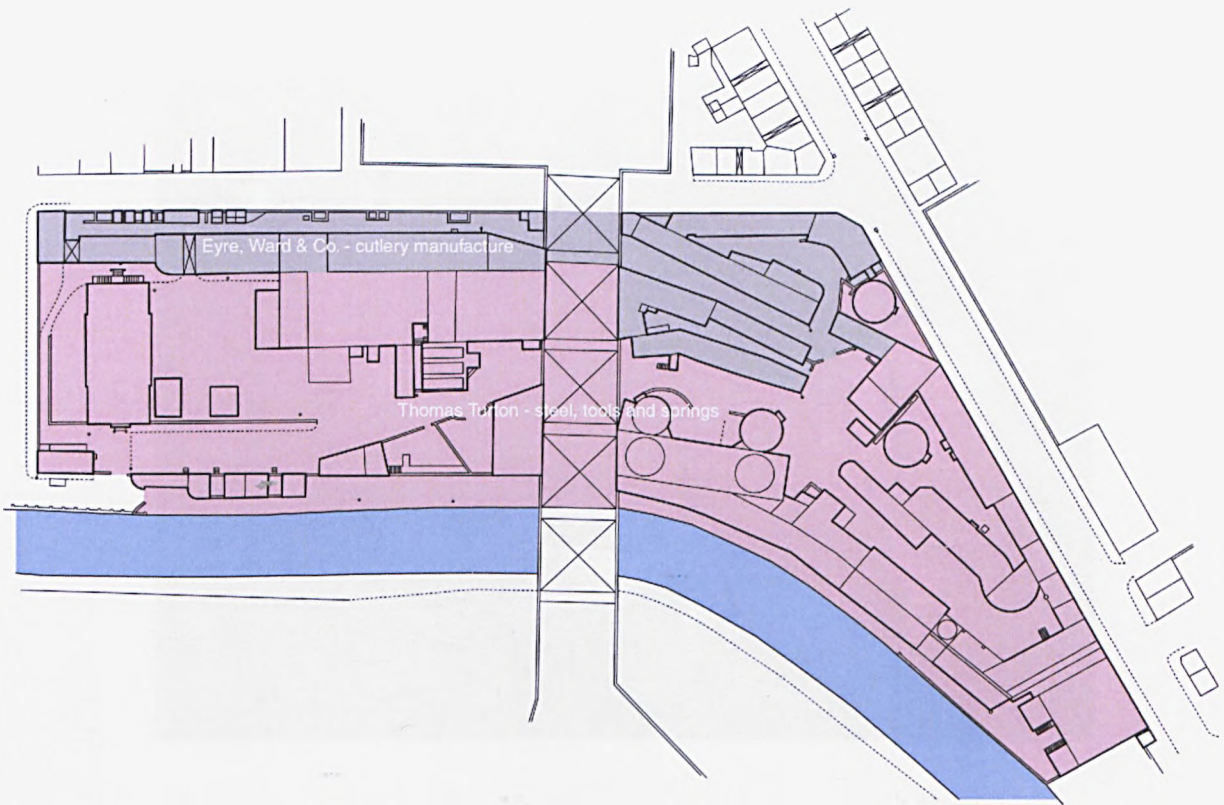

Fig. 3.56 Turton's subletting of the Sheaf Works' cutlery department to Eyre, Ward & Co., achieved with the minimum of structural intervention. Scale 1:1500 (author).



Fig. 3.57 Lavish advertising image for Thomas Turton, showing the enlarged Sheaf Works bisected by the railway. Note the attempt to regularise the site's geometry (SCL).

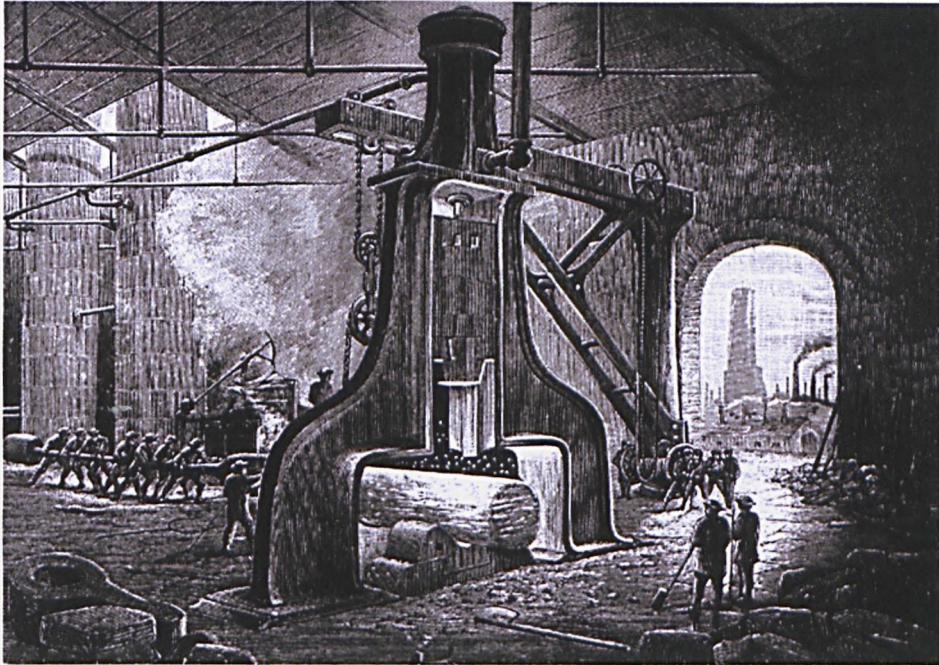

Fig. 3.58 Nasmyth's steam hammer, from a drawing by its inventor. Sheaf Works was purportedly the first Sheffield premises to acquire the technology (Nasmyth 1883).

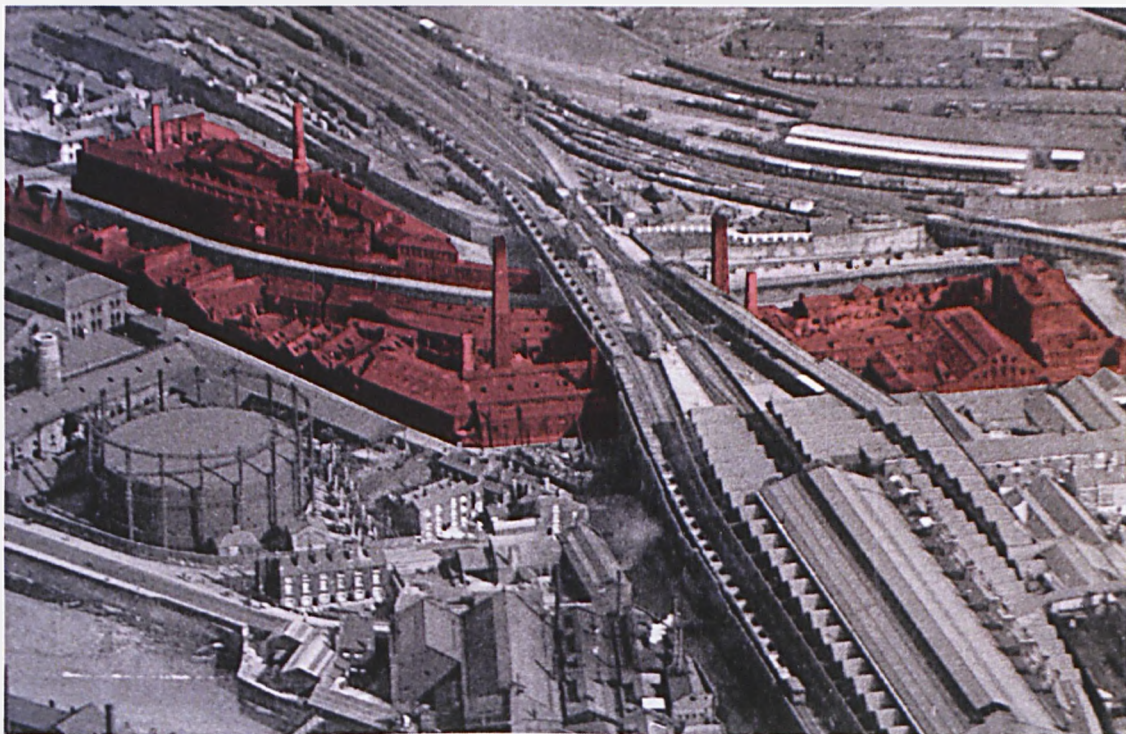

Fig. 3.59 Early twentieth century aerial view of Sheaf Works and Spring Works,



Fig. 3.60 Photograph of the warehouse at the Sheaf Works, looking towards Sheffield centre. Lightweight sheds had come to occupy most of the site (SCL).



Fig. 3.61 The main entrance to the Sheaf Works warehouse, relegated to the back door of a multi-level public house (author).



Fig. 3.62 The inner ring road passing through what was originally the front yard of the Sheaf Works, leaving the warehouse isolated at a lower level (author).



Figs. 3.63 and 3.64 Original 1820s engine house remains (note stone quoins) and later stack both on the main Sheaf Works site, photographed in 2001 (author).



Fig. 3.65 Globe Works warehouse: one of Sheffield's finest surviving examples of industrial architecture (author).



Fig. 3.66 Fairbank plan for setting out the Duke of Norfolk's Coulson Crofts estate, with the site reserved for Ibbotson's steelworks outlined in red (SCA, author's colours).

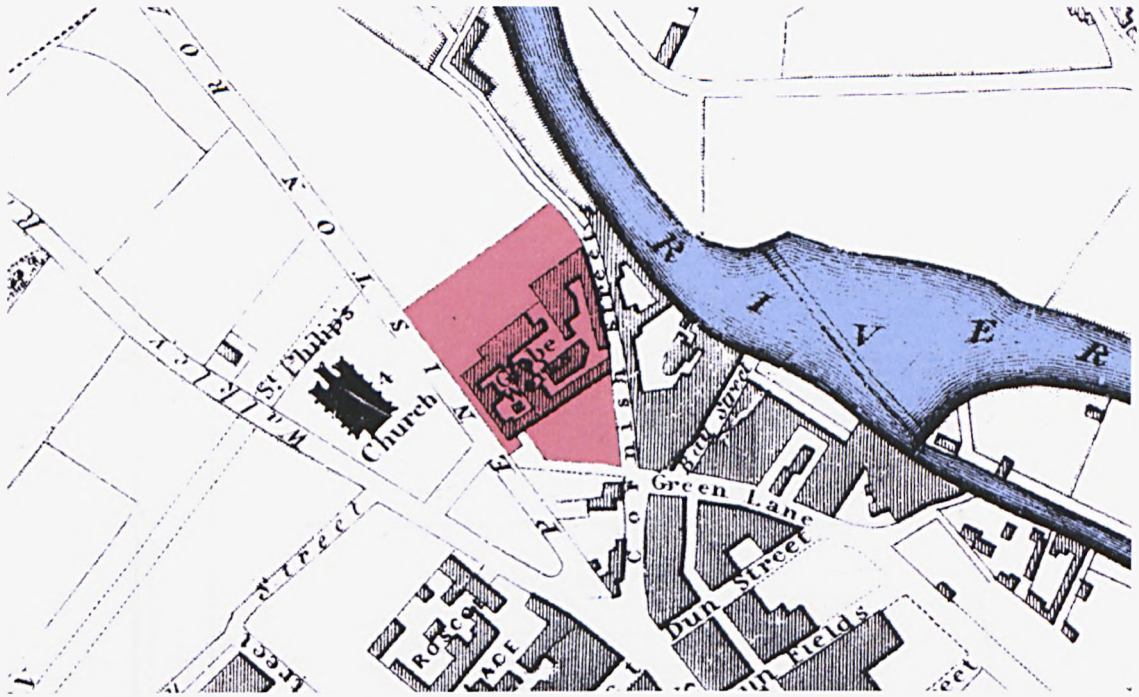

Fig. 3.67 Globe Works on the 1832 town plan, with additional land as yet unoccupied by building save for the first pair of cementation furnaces. North is at top, not to scale (Tayler 1832, author's colours).

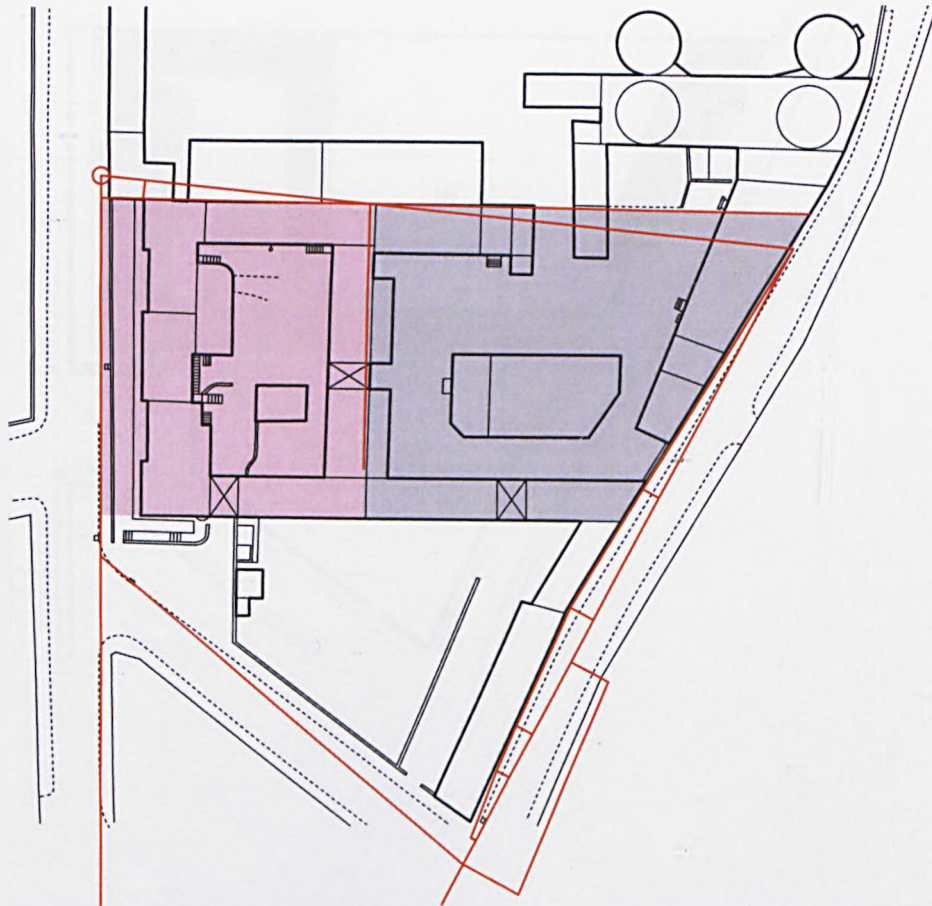

Fig. 3.68 Fairbank setting-out survey of the Globe Works plot made prior to construction (red lines) redrawn and superimposed on the 1836 plan, describing the front and back courtyard areas of the proposed works. Scale 1:1000 (author).

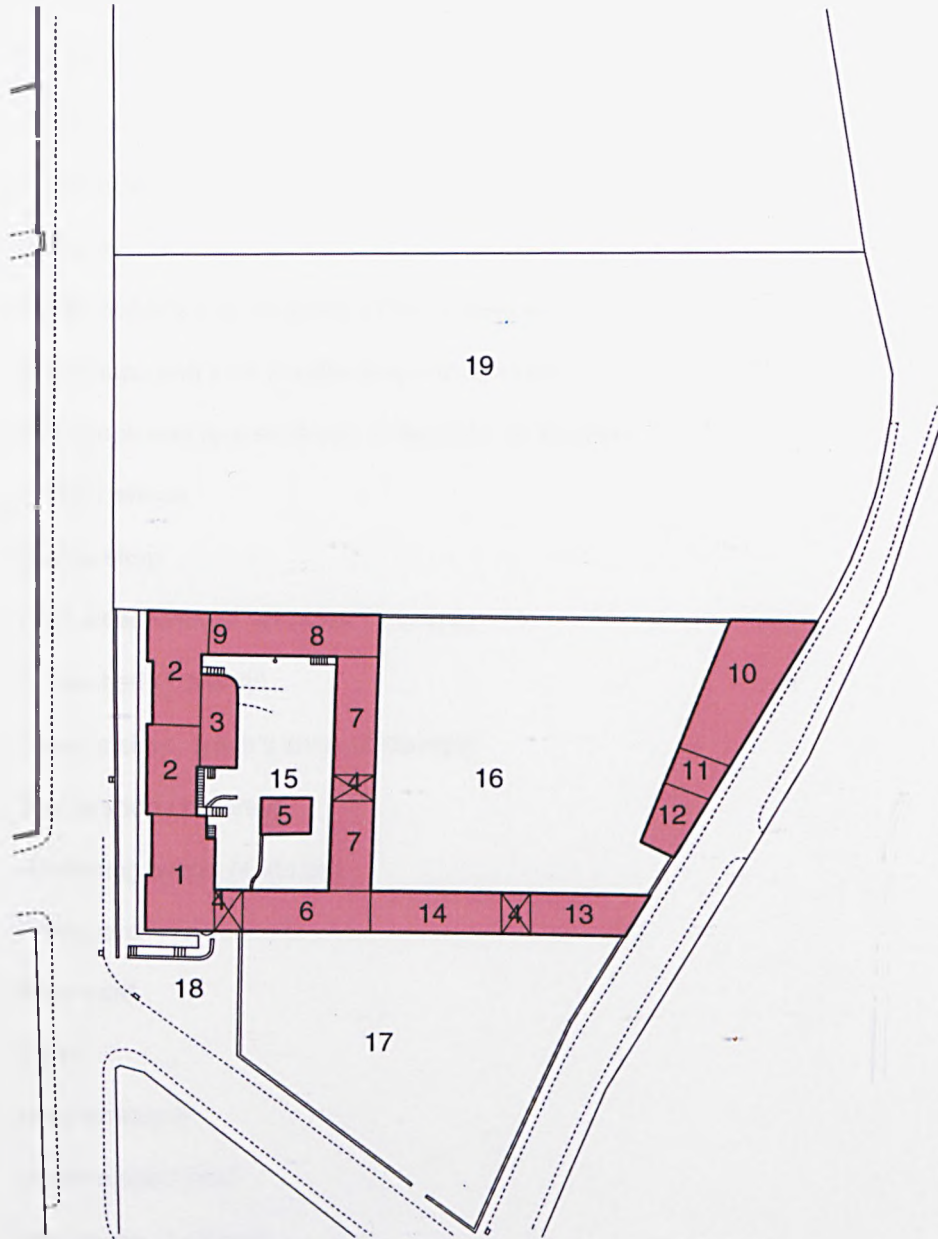

Fig. 3.69 Hypothetical plan of the original Globe works layout c.1825. Scale 1:1000 (author).

William Ibbottson

Globe Works, Penistone Lane, reconstructed site plans (1825-1850)

scale 1:1000

key:

- 1 House (2 storeys)
- 2 Warehouses and cellars (2-3 storeys)
- 3 Warehouses (3 storeys)
- 4 Gateway
- 5 Time keeper's and weighing office (1 storey)
- 6 Saw shops and saw handle shops (3 storeys)
- 7 File shops and fender shops, chambers (2 storeys)
- 8 Cutlers' shops
- 9 Stamp shop
- 10 Cast steel furnace, 22 holes (1 storey)
- 11 Coke shed (1 storey)
- 12 Joiner's shop, smith's shop (2 storeys)
- 13 Stable shop (1 storey)
- 14 Hardening shops (1 storey)
- 15 Front yard
- 16 Rear yard
- 17 Yard
- 18 Main entrance
- 19 Undeveloped land
- 20 Iron house (1 storey)
- 21 Converting furnace
- 22 Steel warehouse, pot room
- 23 Softening shop (1 storey)
- 24 Horse shed (1 storey)
- 25 Boiler

- 26 Stack
- 27 Engine house, 20 hp
- 28 Grinding wheels (3 storeys)
- 29 Grinding rooms on ground floor,
scythe and grinders' shops above (3 storeys)
- 30 File cutters (1 storey)
- 31 Holing sawshops (1 storey)
- 32 Bone shop (1 storey)
- 33 Scythe backs (1 storey)
- 34 File shop (1 storey)
- 35 Smithy hearths (1 storey)
- 36 Grinding wheels and workshops (3 storeys)
- 37 Scissors shop (1 storey)
- 38 File hardening shop (1 storey)
- 39 Screw shop (1 storey)
- 40 Blade maker's shop
- 41 Privies
- 42 Cowhouse and pigsty
- 43 Sheds (?)
- 44 Smithy hearths (1 storey)
- 45 File cutter's shop (1 storey)
- 46 Charcoal shed (1 storey)
- 47 Warehouse and shed (1 storey)
- 48 House and warehouse (2 storeys)
- 49 Privies and ashes place
- 50 Scythe backs
- 51 Workshops (1 storey)



Fig. 3.70 Matthew Boulton's Soho Works at Birmingham. The front range, designed to appear as a Palladian country house, proved highly influential (Gale 1946).



Fig. 3.71 Based on the Soho Works, Ibbotson's premises were built on the northeast fringe of Sheffield, an area rapidly transformed in the 1820s (author).



Fig. 3.72 The back of Globe Works where the steel furnaces were located was built to much lower standards than the Penistone Road side (author).



Fig. 3.73 The minimal facade of the cast steel furnaces to Cornish Street (author).

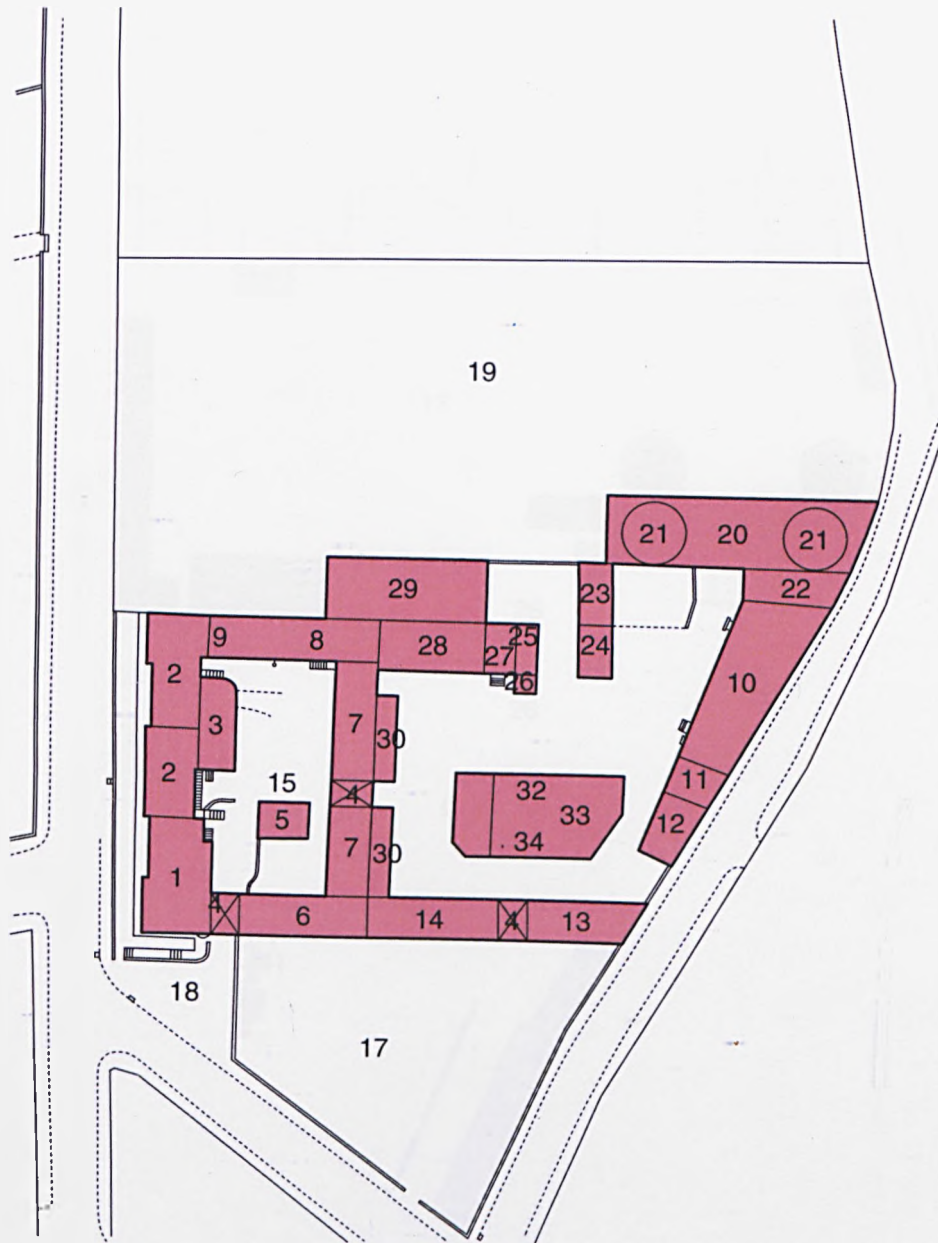

Fig. 3.74 Globe Works in 1832. Scale 1:1000 (author).

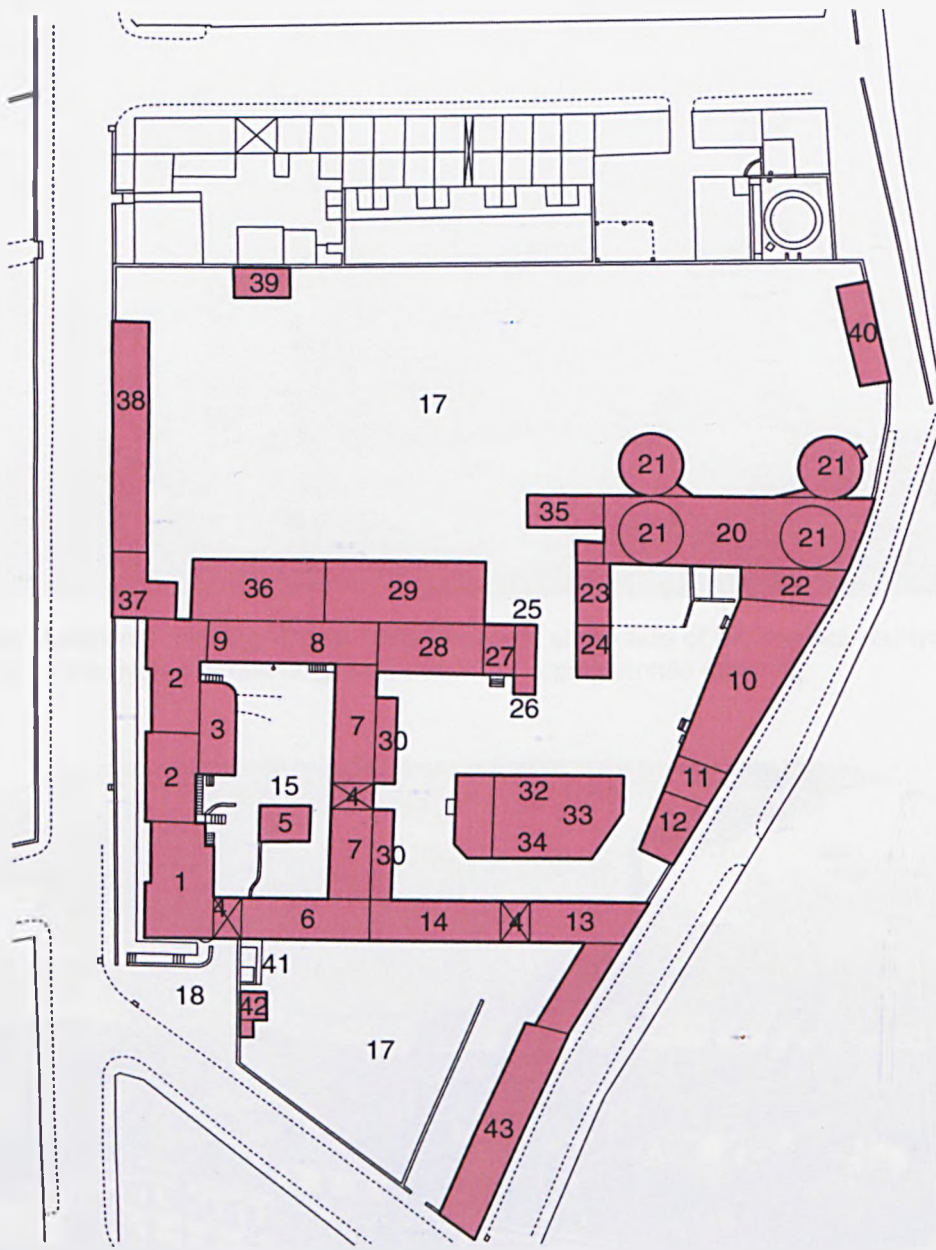

Fig. 3.75 Globe Works in 1835. Scale 1:1000 (author).



Fig. 3.76 Additional grinding wheels (left) were built at the side of the original courtyard in the early 1830s. Note the use of 'grindle cokes' as coping stones (author).

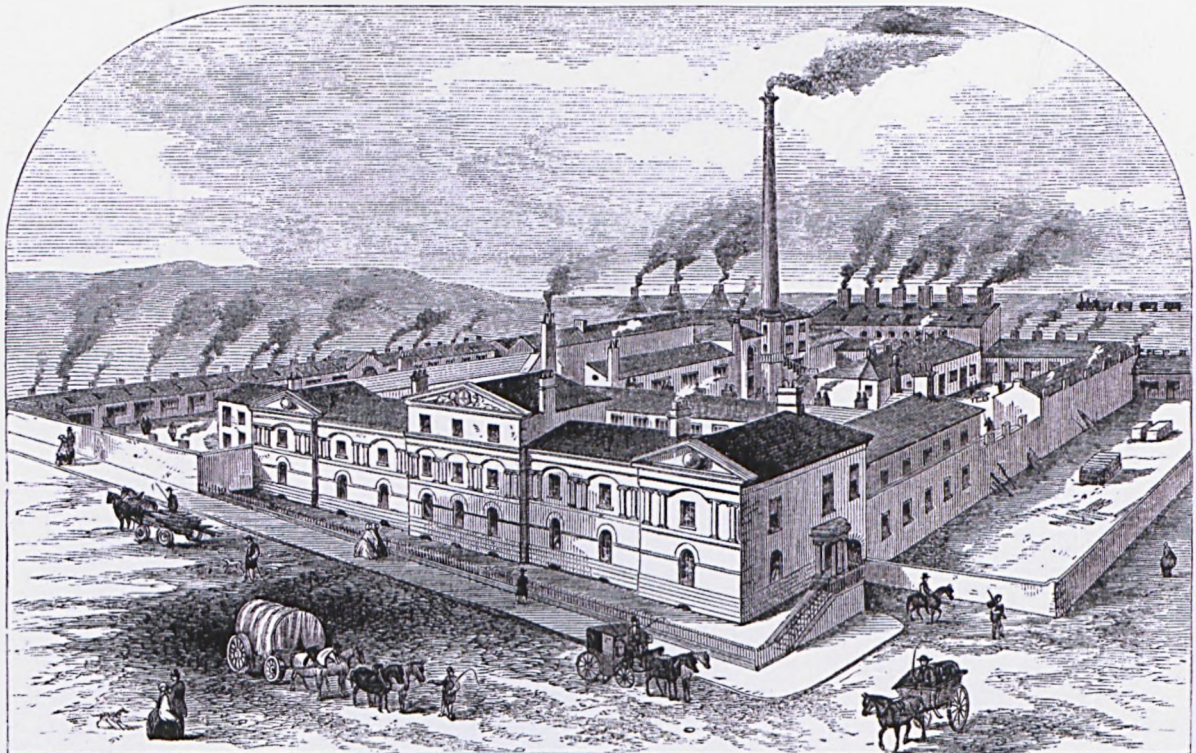

Fig. 3.77 Globe Works following Ibbotson's departure, with secondary courtyard spaces to the left and right (Pawson & Brailsford 1862).

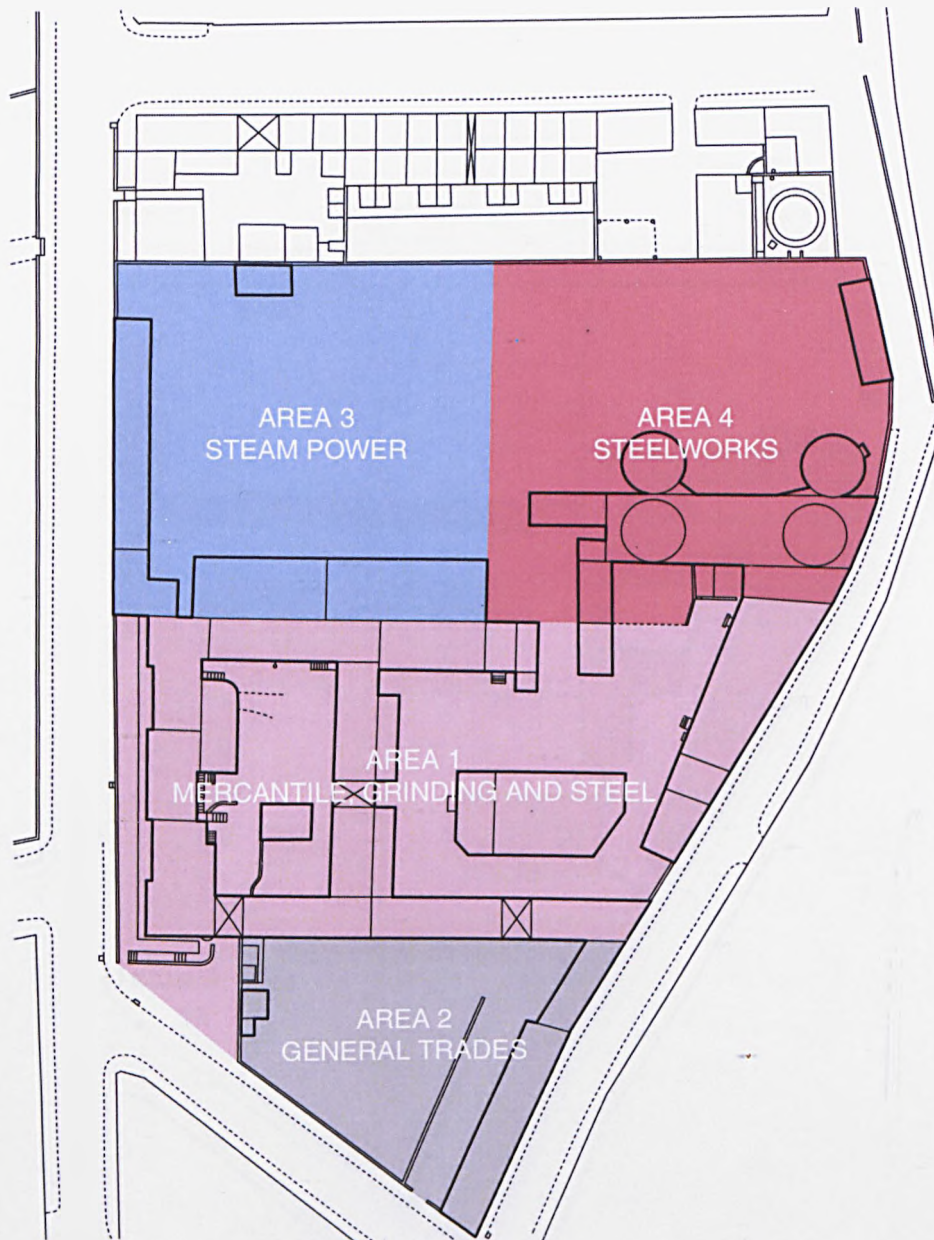

Fig. 3.78 Subdivision of Globe Works after Ibbotson's departure as proposed by William Flockton (a local surveyor and architect) for its resale in the depressed economic climate of the 1840s. Scale 1:1000 (areas as reconstructed by the author).

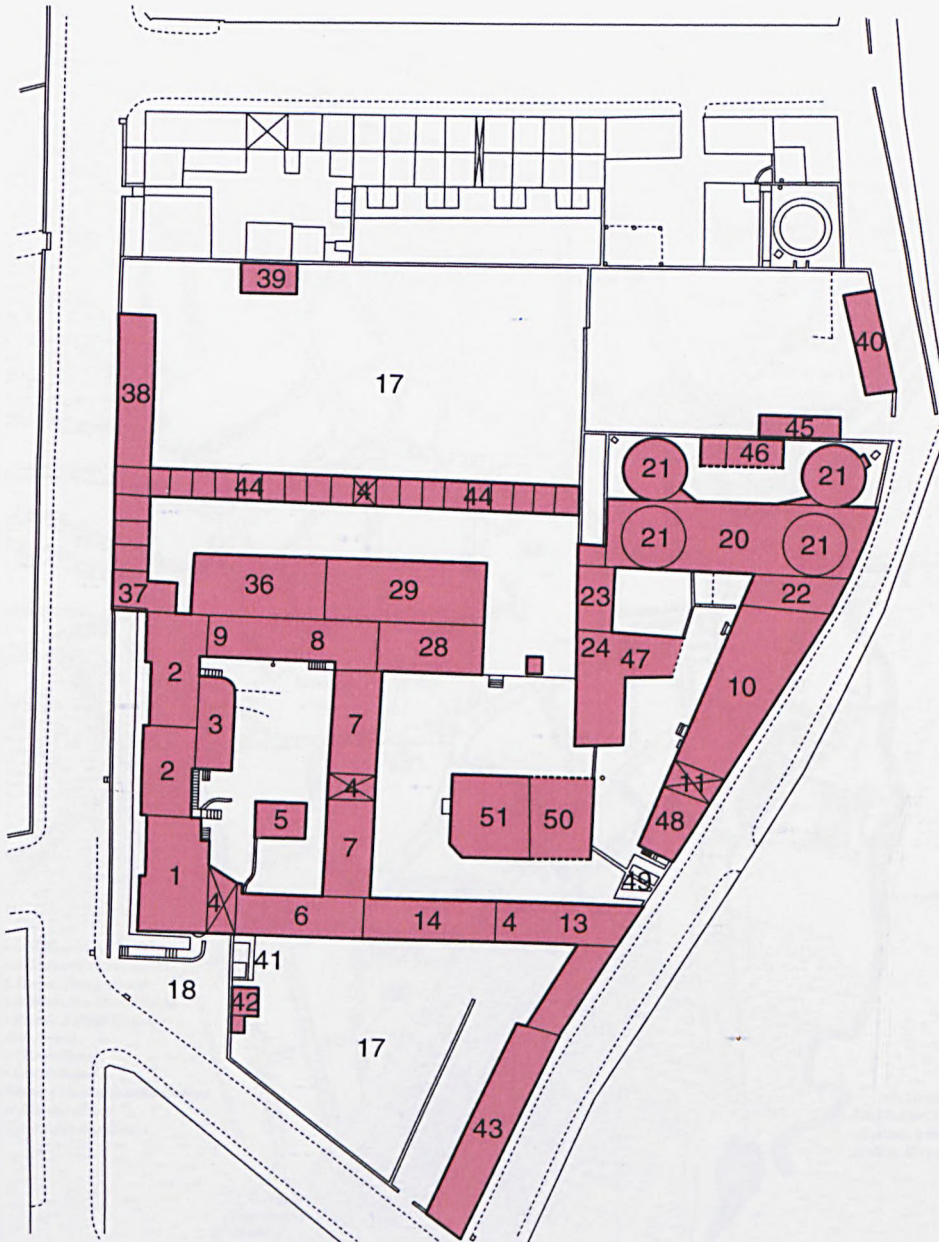

Fig. 3.79 Globe Works as subdivided by 1850. Scale 1:1000 (author).

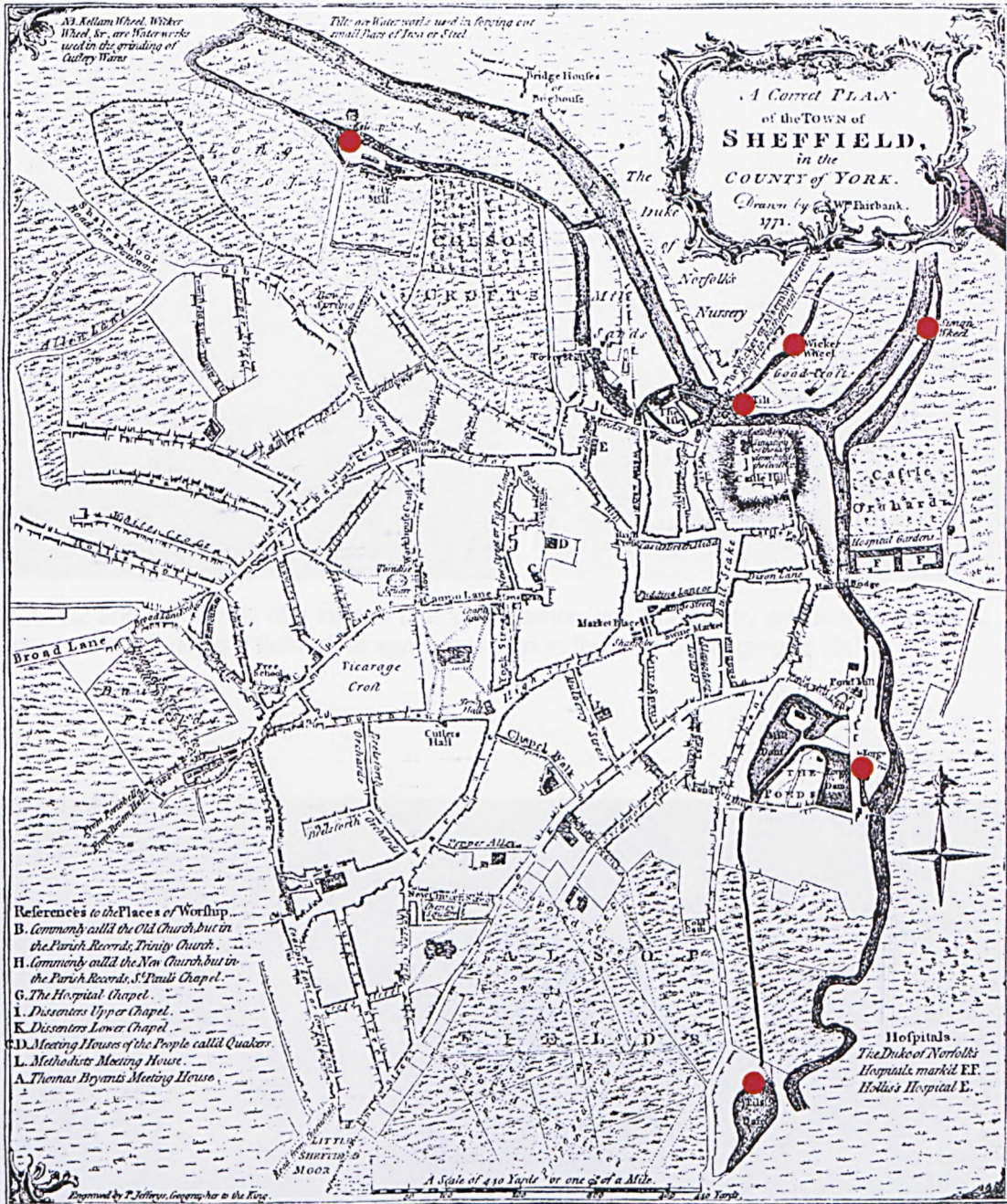
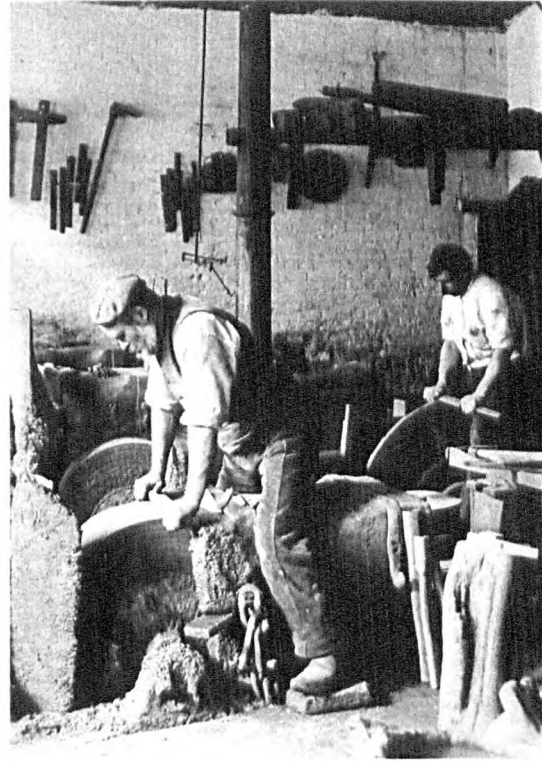
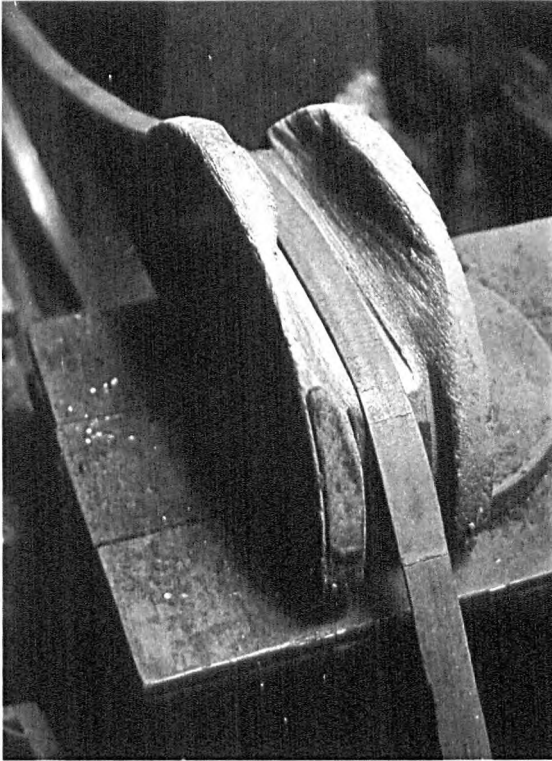

Fig. 4.1 Plan of Sheffield in 1771 with the sites of water-powered grinding wheels and tilt hammers located in red. Scale c.1:8600 (Fairbank 1771, amended by author).



Figs. 4.2 and 4.3 Detail of a leather belt and retainer (left) and heavy grinders at work, the man on the left using a flatstick to apply pressure to the item being ground (SCL).

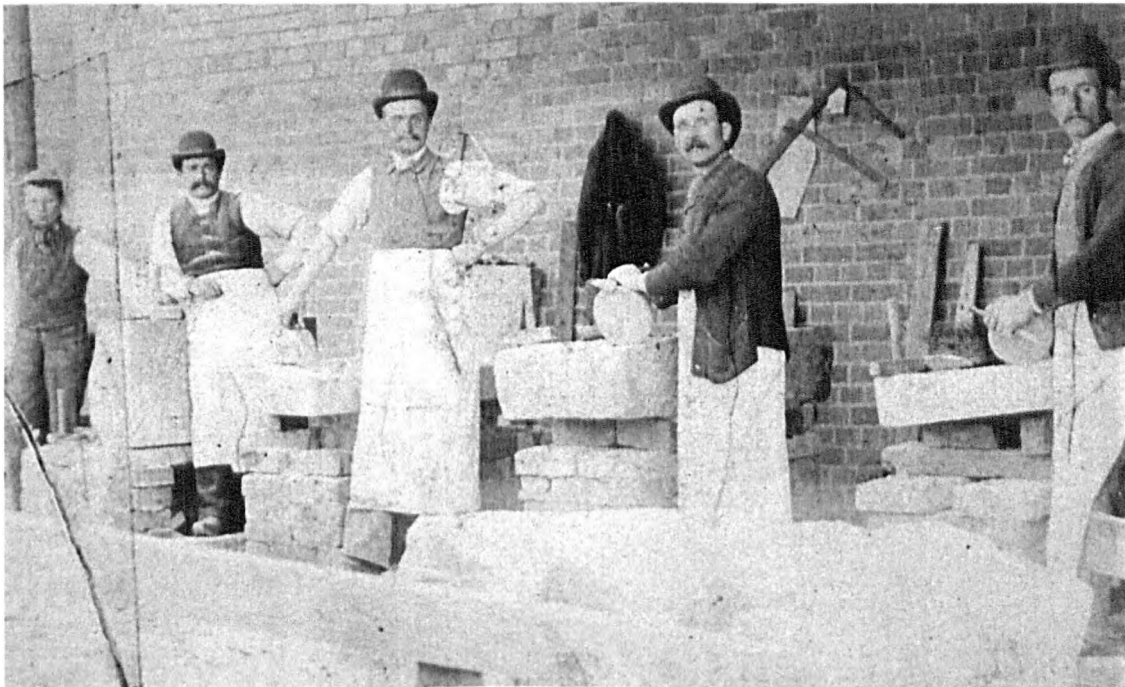

Fig. 4.4 Posed photograph of masons at work. Grinders usually finished their own stones in the wheel yard and required some of the skills of the stonemason (SCL).



SAW GRINDING.

Fig. 4.5 The unusual posture adopted by the saw grinder. Note the metal rods and ropes that support the ends of the work piece from the ceiling (Pawson & Brailsford 1862).

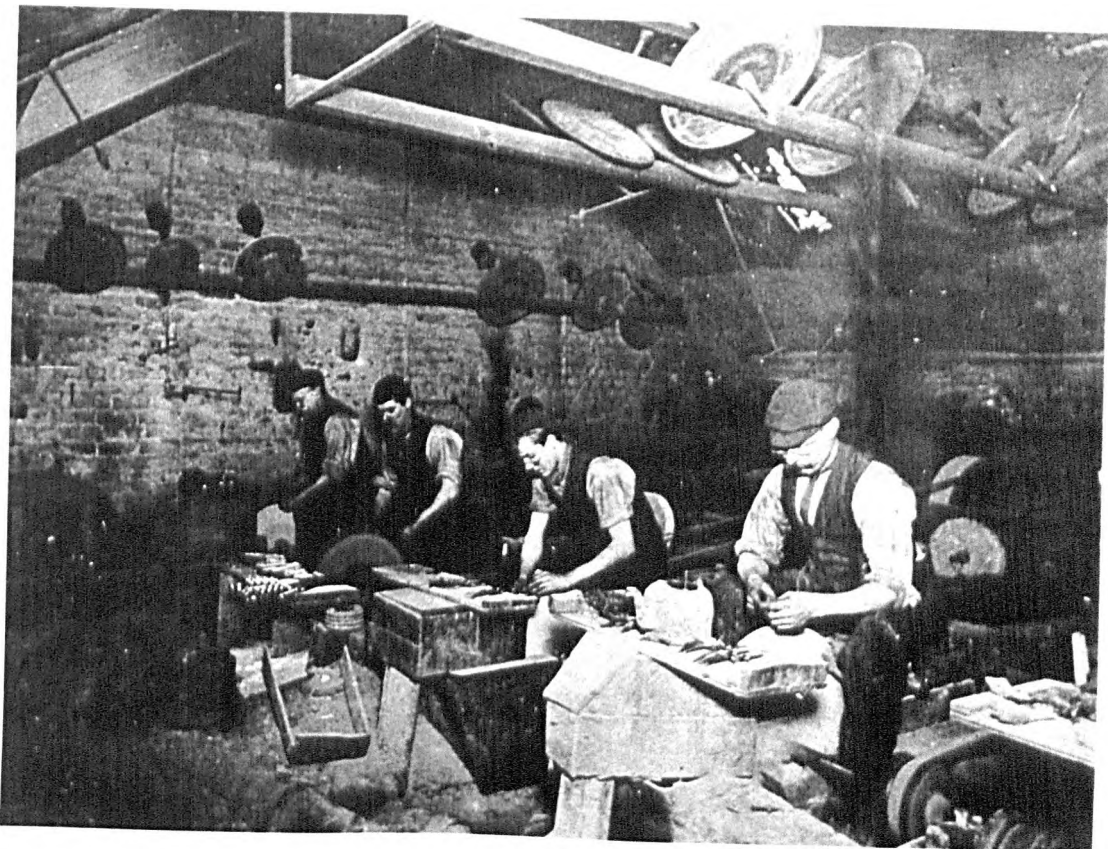

Fig. 4.6 Lighter grinding operations were often housed in the roofspace or garret of the grinding wheel, with simple boarded floors (SCL).

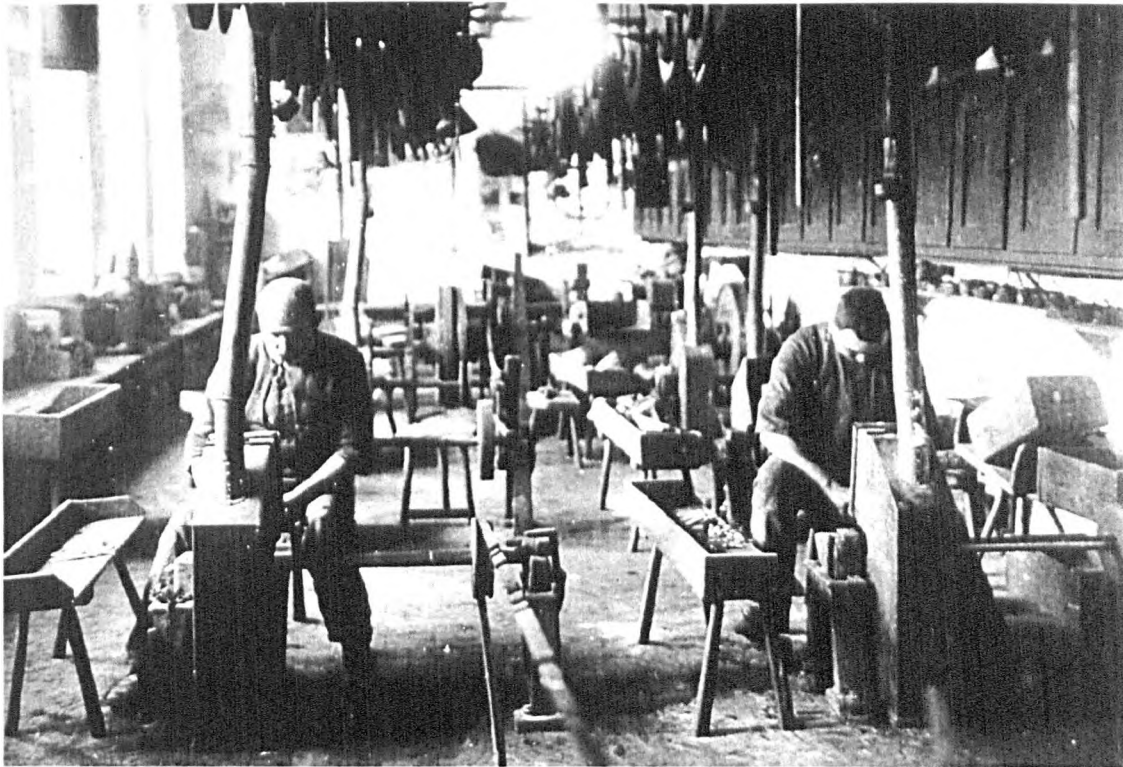

Fig. 4.7 Scissor grinders at work on dry stones with fans to reduce exposure to deadly metal dust. The fan was invented in the early nineteenth century, but was adopted slowly (SCL).



Fig. 4.8 A scissor grinder with his work laid out alongside the 'trough'. The simple timber box structure of the fan is clearly visible (SCL).

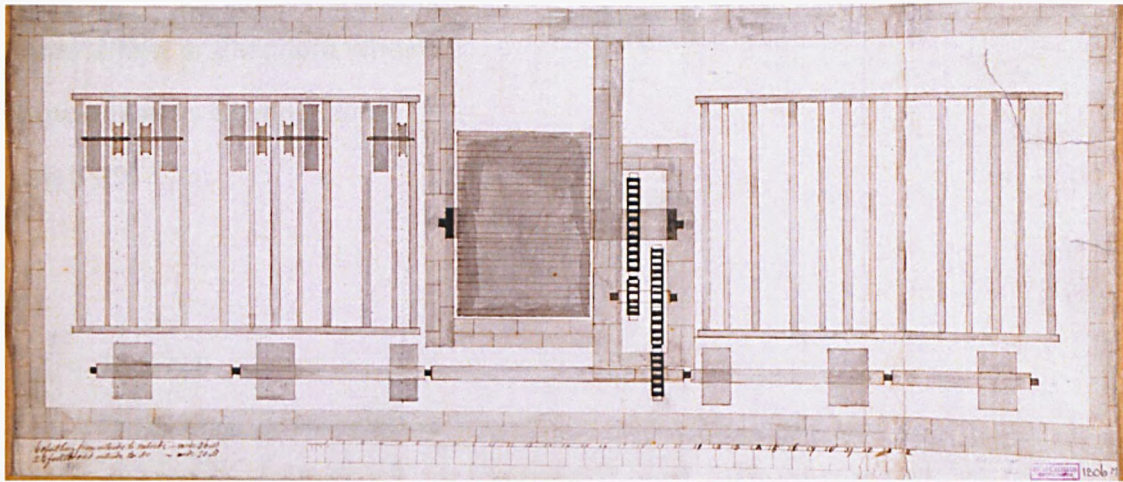

Fig. 4.9 Proposed water-powered grinding wheel for Wadsley Forge (1812), with ten stones or 'troughs' arranged in two hulls or 'ends' (SCA).

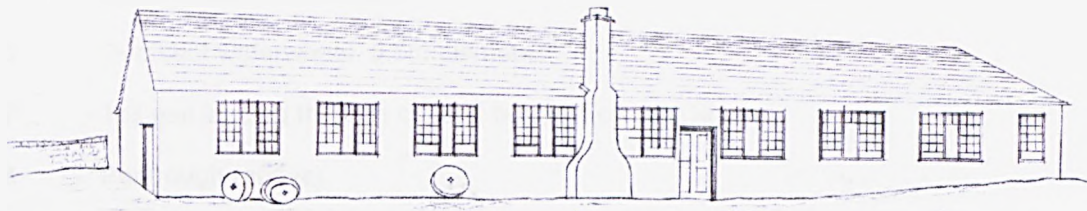

Fig. 4.10 Nether Spurgear wheel from a drawing in the Fairbank collection. It is probable that the Fairbanks designed this and other wheels (SCA, author's tracing).

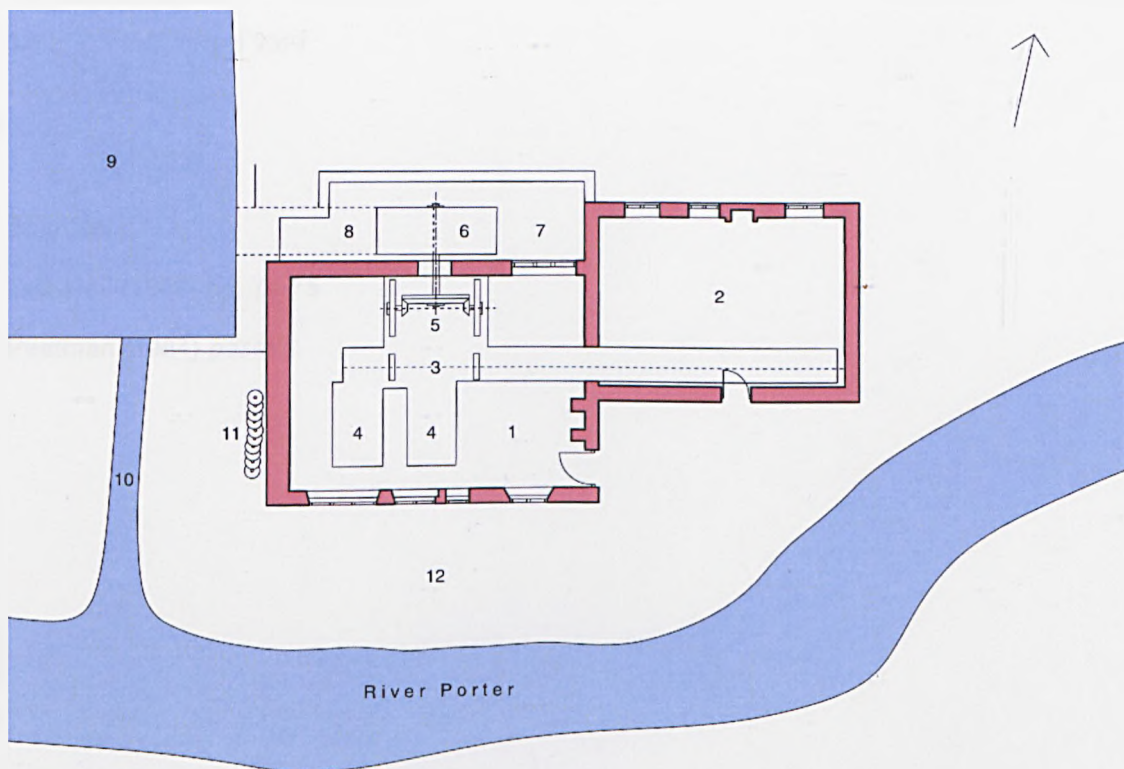

Fig. 4.11 Shepherd Wheel, a surviving water-powered grinding wheel on the Porter Brook near Sheffield. Scale 1:300 (author).

Porter Wheel or Shepherd Wheel

Ground plan as existing (2002)

scale 1:200

key:

- 1 Main hull
- 2 Smaller hull, or 'Hinde's End'
- 3 Drums and shafting
- 4 Recessed floor for troughs
- 5 Crown wheel and pinions
- 6 Overshot waterwheel, 5.5m diameter
- 7 Tail goit leading through conduit beneath smaller hull
- 8 Pentrough (above)
- 9 Dam / reservoir
- 10 Overspill channel
- 11 'Grindlecoke' steps to dam
- 12 Front wheel yard

Sources:

Crossley (1989) pp. 74-75

Peatman (1984) *passim*.



Fig. 4.12 (left) A typical grinding hull hearth (this example at Butcher Wheel; SCL).
 Fig. 4.13 (right) Remains of steam engine seating at Kelham Wheel (author).

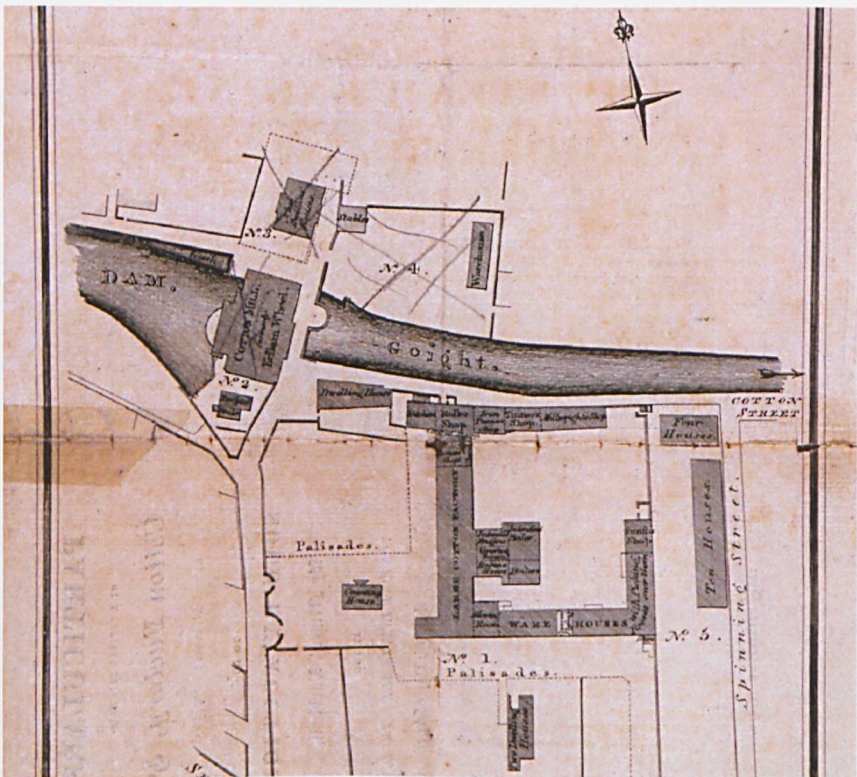

Fig. 4.14 Cotton Mill sale plan of 1815, showing the early courtyard layout of the site. Kelham wheel is at top left, now powered by a Boulton & Watt steam engine (SCL).

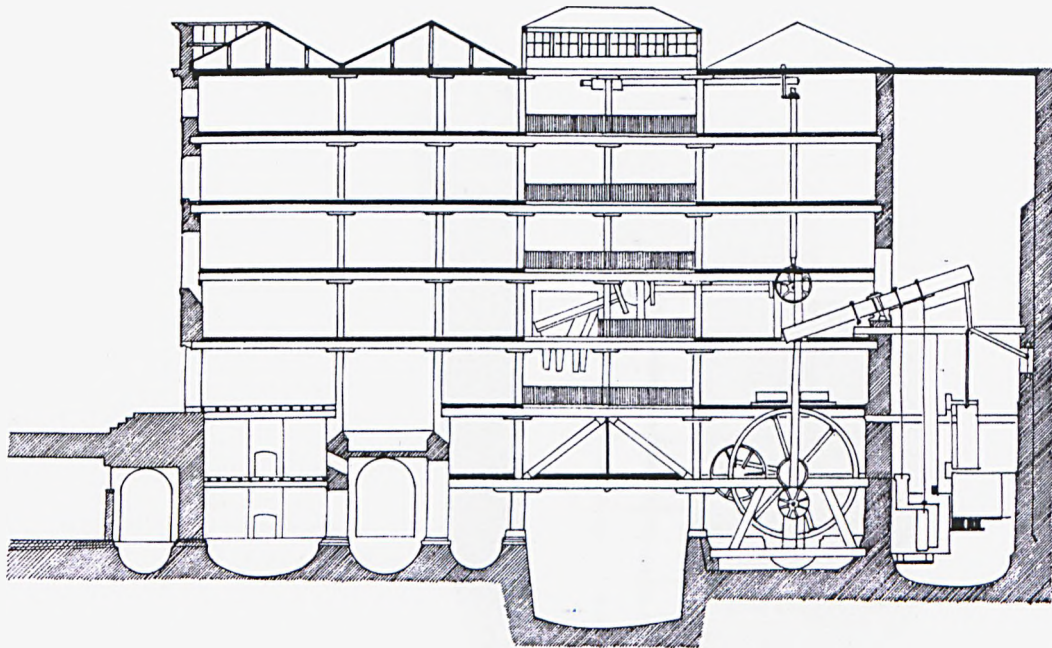

Fig. 4.15 Albion Mills, London (1786), used as a shop window for Boulton & Watt's new rotative steam engine. The mill was destroyed by fire in 1791.



Fig. 4.16 'Plan of the Steam Engine Grinding Wheel' as built on the east bank of the Sheaf in 1786. The regular plot seems to have been part of a wider estate plan (SCA).

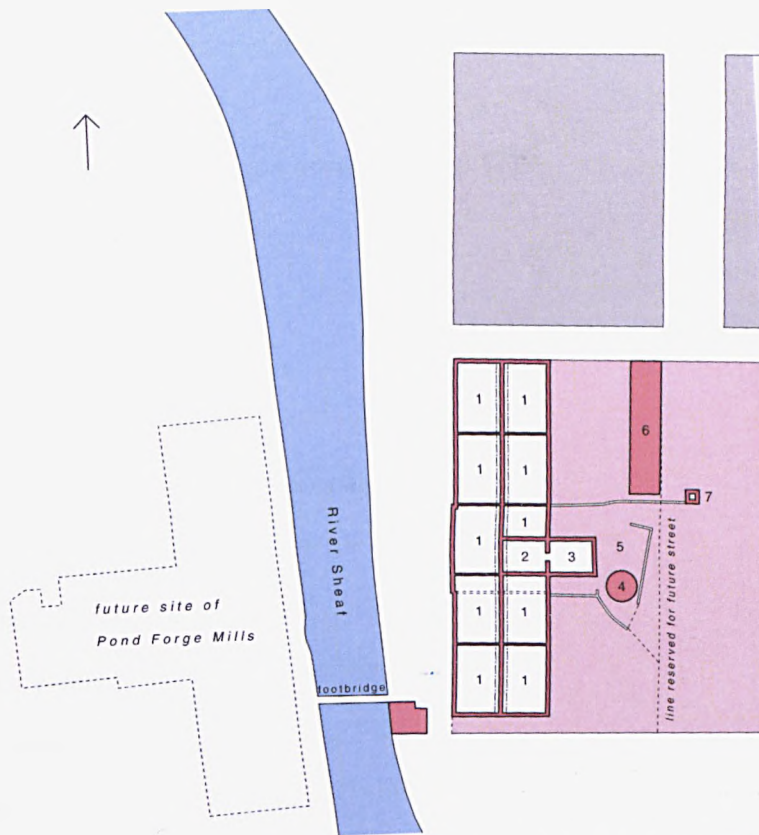

Fig. 4.17 Ground plan of the Park Wheel as first built, with the location of its house-built engine and boiler indicated. Proposed estate blocks in grey. Scale 1:1000 (author).

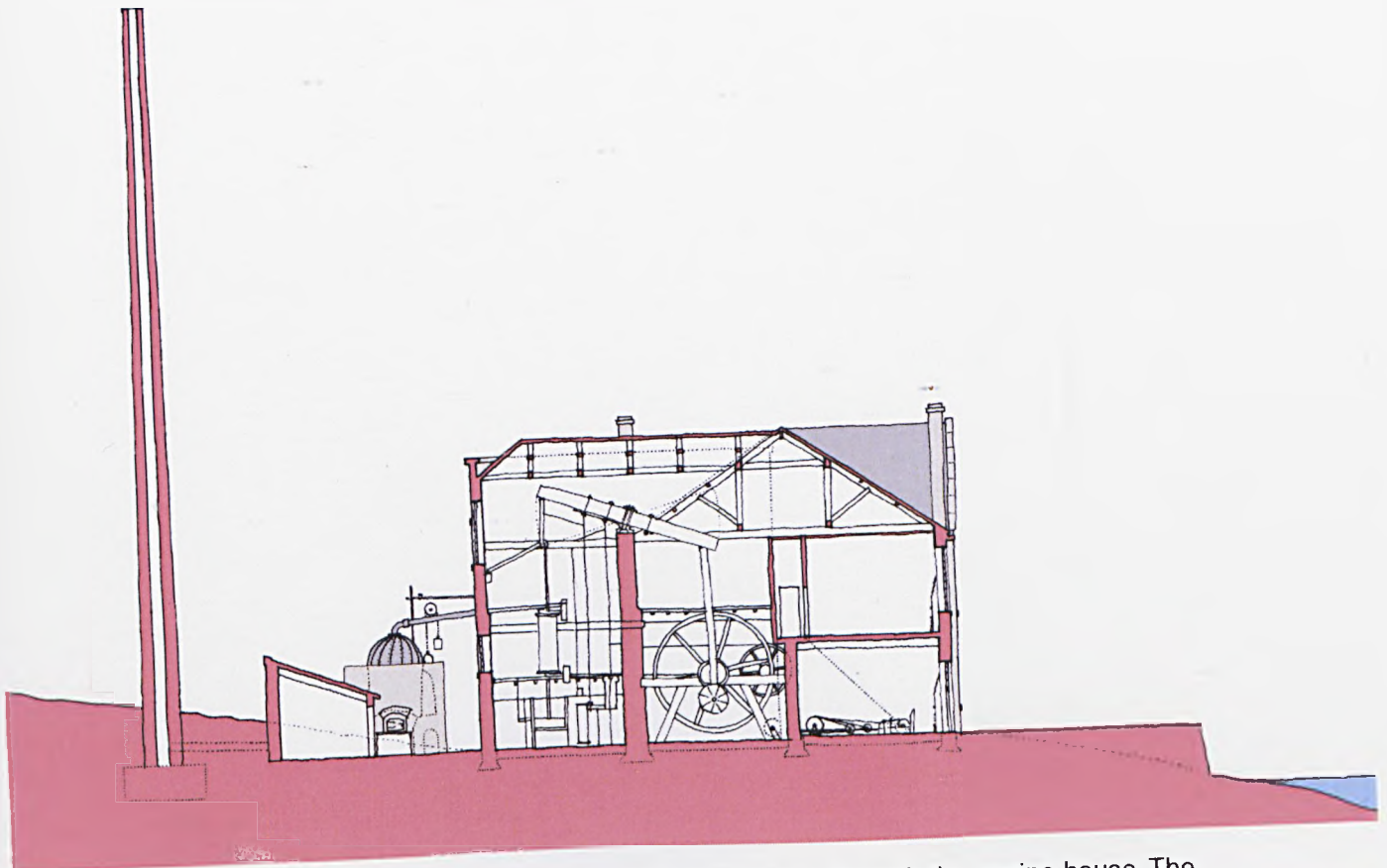

Fig. 4.18 Short section of the Park grinding wheel taken through the engine house. The dimensions of the engine are taken from Farey's treatise. Scale 1:300 (author).

Proctor & Beilby

Park Grinding Wheel, reconstructed ground plan c.1786

scale 1:1000

key:

- 1 Heavy grinding hulls
- 2 Engine house (gearing and flywheel)
- 3 Engine house (cylinder)
- 4 Haystack boiler
- 5 Engine yard
- 6 Coal shed?
- 7 Stack

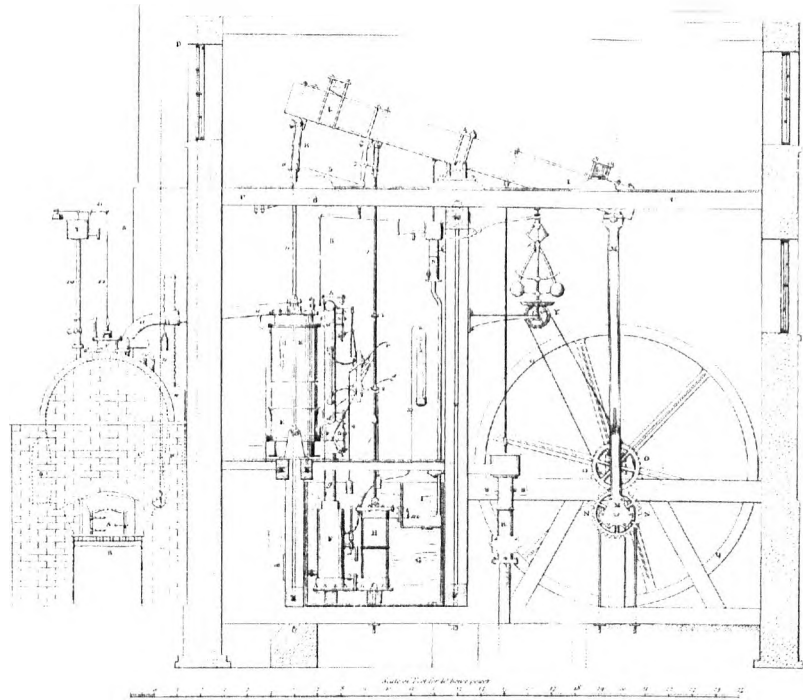

Fig. 4.19 Ten horsepower Boulton & Watt engine as used in smaller wheels. Most early Sheffield engines were twenty horsepower or greater. Scale 1:100 (Farey 1827).

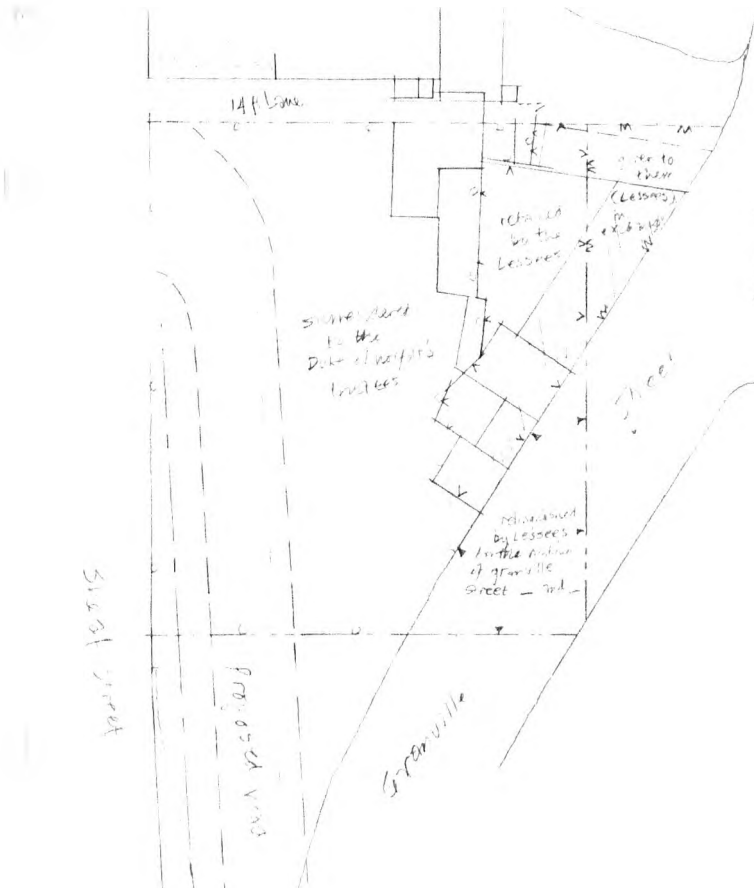

Fig. 4.20 The Park wheel was finally lost to street improvements in the 1870s, shown on a contemporary plan of land ownership (SCA, author's tracing).

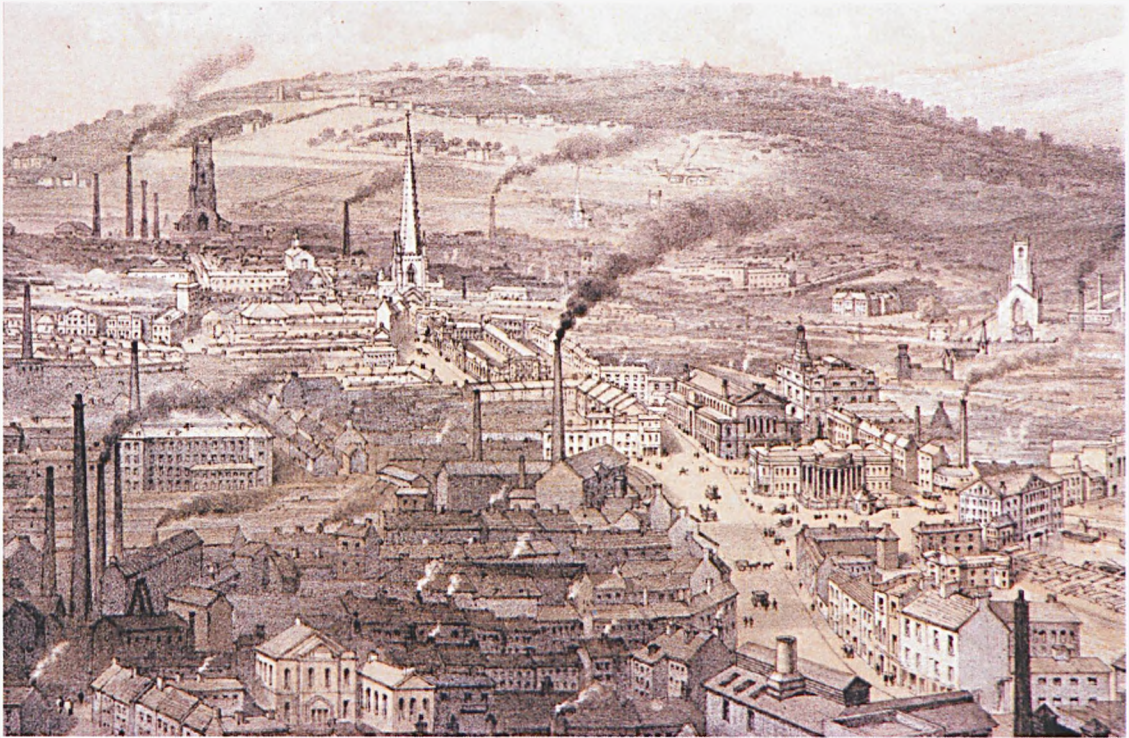

Fig. 4.21 Detail of William Ibbitt's 'South East view of Sheffield' (1854) showing the chimneys of steam engines congregating on the low ground of the Ponds (Kelham Island Museum).



Fig. 4.22 Earlier view down the river Sheaf, with what may be the only image of the Park Wheel seen over the top of the Shrewsbury Hospital (Kelham Island Museum).

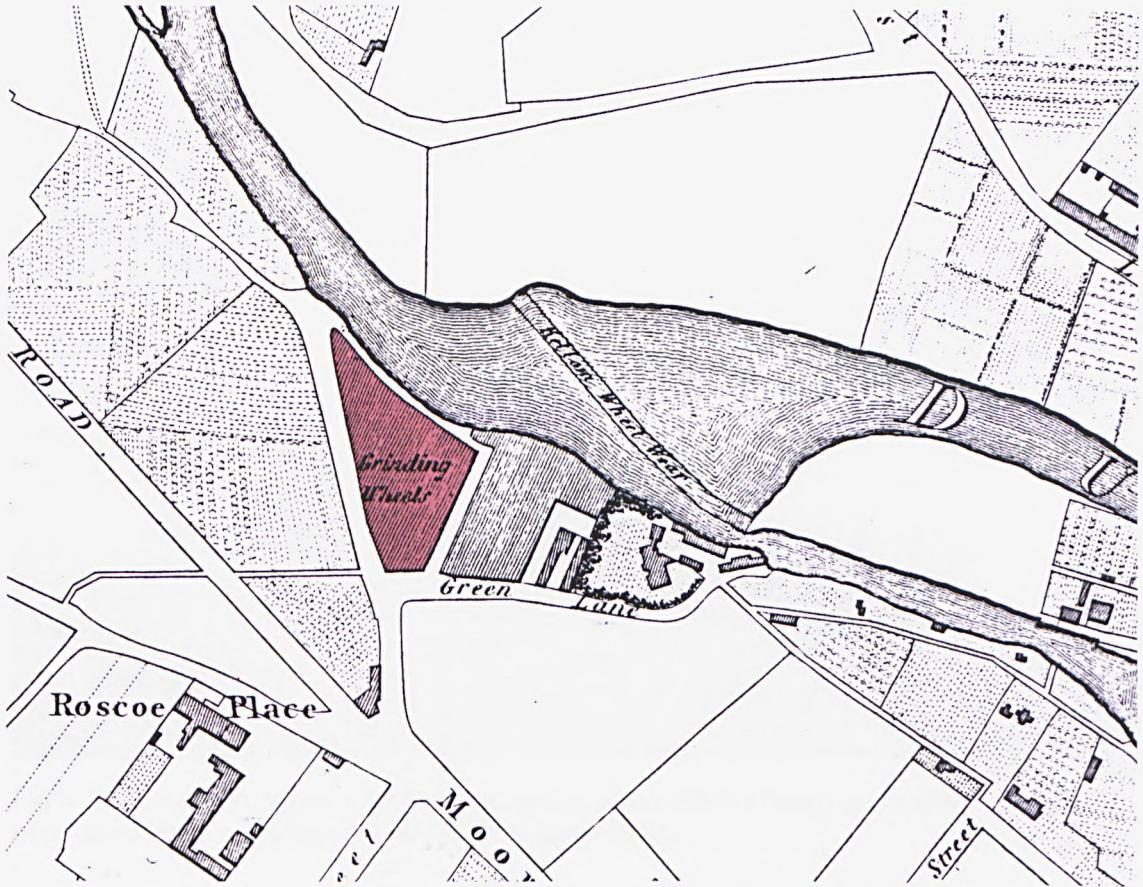

Fig. 4.23 Site of Cleakham grinding wheels and rolling mill to the northwest of Sheffield. North is at top, scale 1:3600 (Fairbank 1808, author's colours).

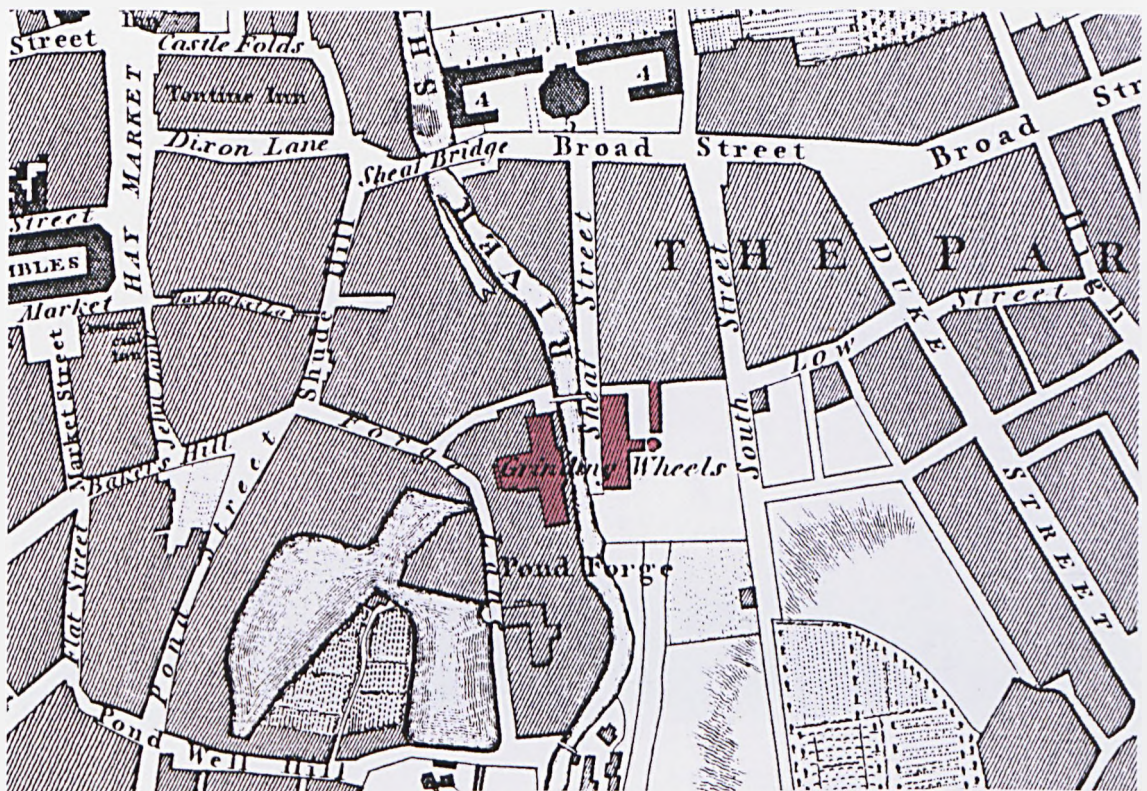

Fig. 4.24 Pond Forge Mills and Park Wheel faced each other across the constricted channel of the Sheaf. North is at top, scale 1:3600 (Fairbank 1808, author's colours).

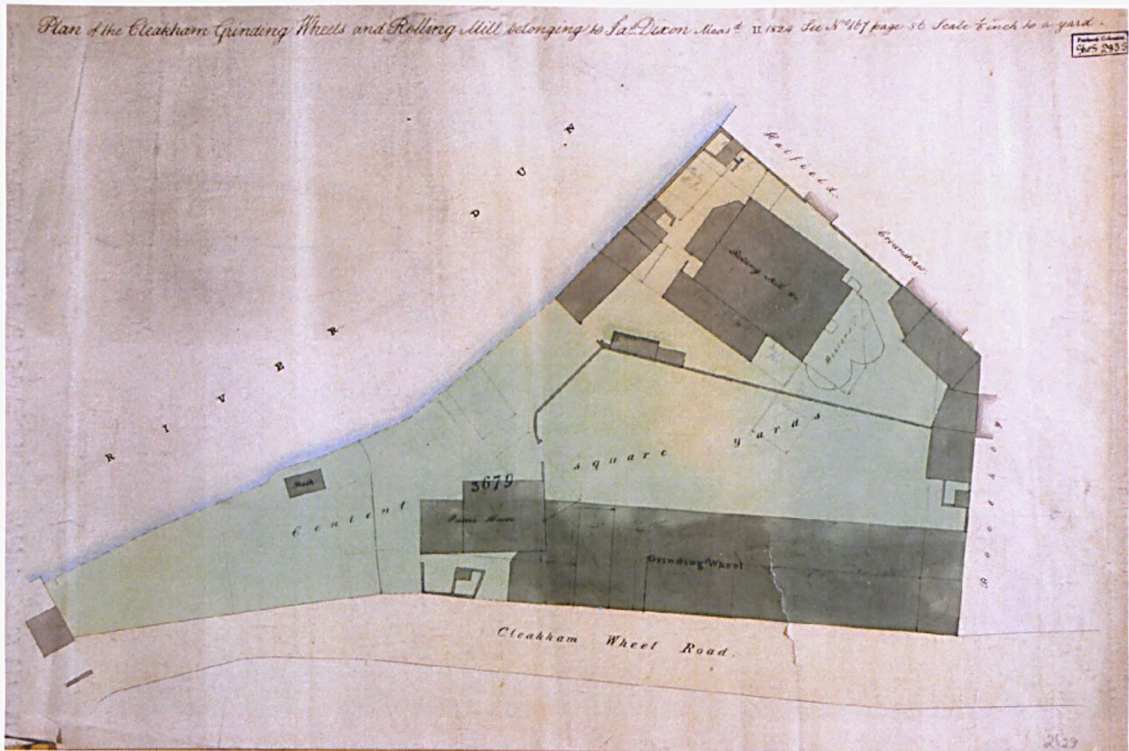

Fig. 4.25 Cleakham Wheels (bottom, along Cleakham Wheel Road) and rolling mill (top) as purchased by James Dixon in 1819. Not to scale (SCA).

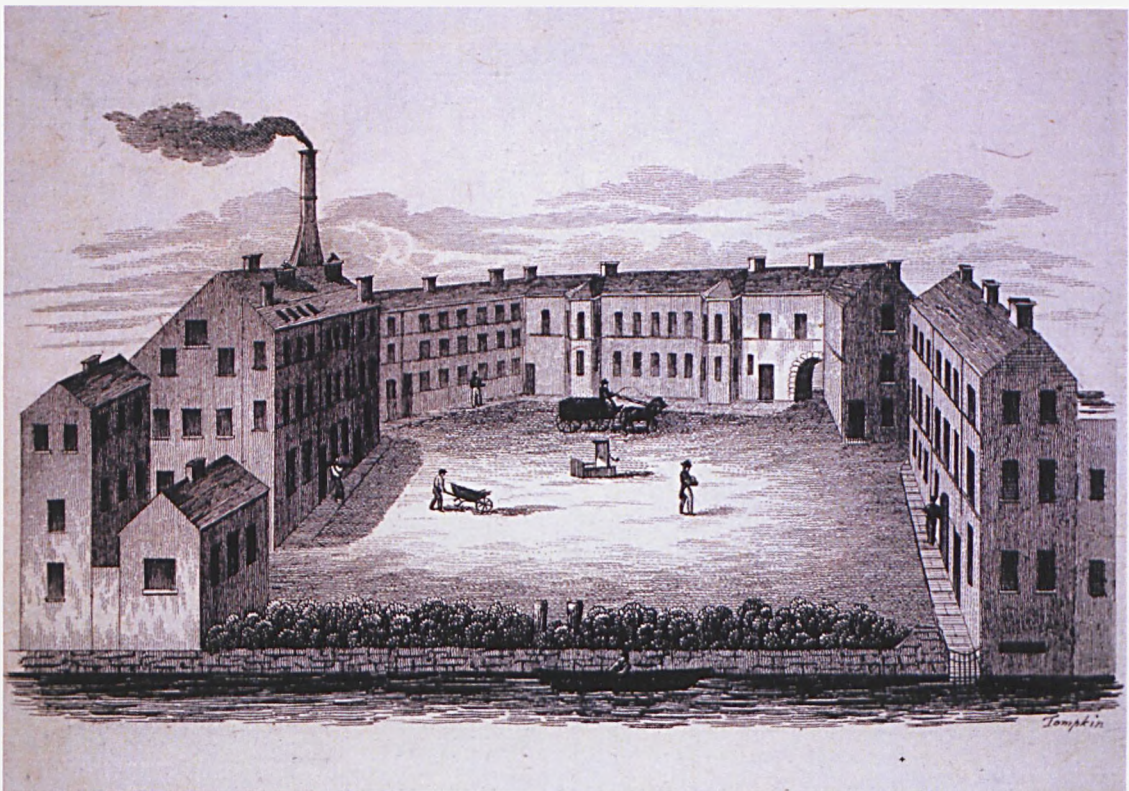

Fig. 4.26 Dixon's Cornish Place silverware manufactory, built on the foundations of Cleakham Wheel and retaining the rolling mill and steam engine, left (author).

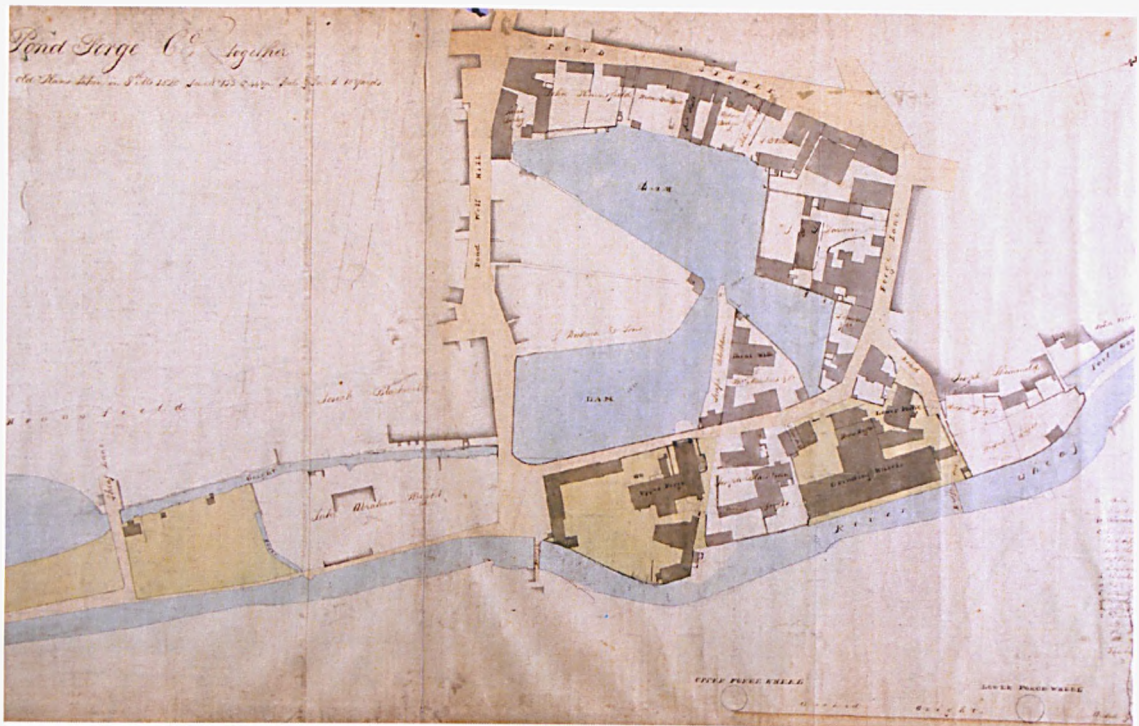

Fig. 4.27 Pond Forge grinding wheel built alongside the Sheaf in the waterlogged district of the Ponds. Not to scale, north indicated (SCA).

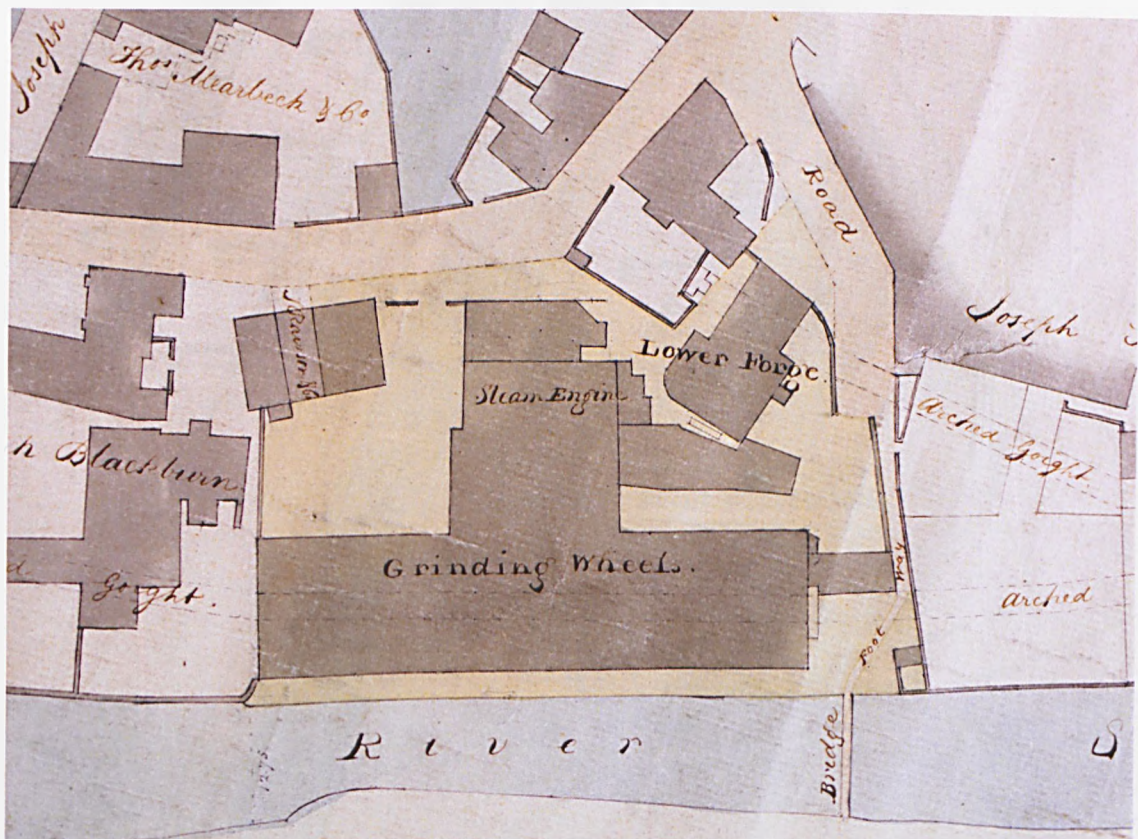

Fig. 4.28 Detail of the above plan, with the early layout of engine, wheel building and the adjacent water-powered 'Lower Forge'. The footbridge was rebuilt to accommodate the new grinding wheel, see fig. 4.17. Not to scale (SCA).

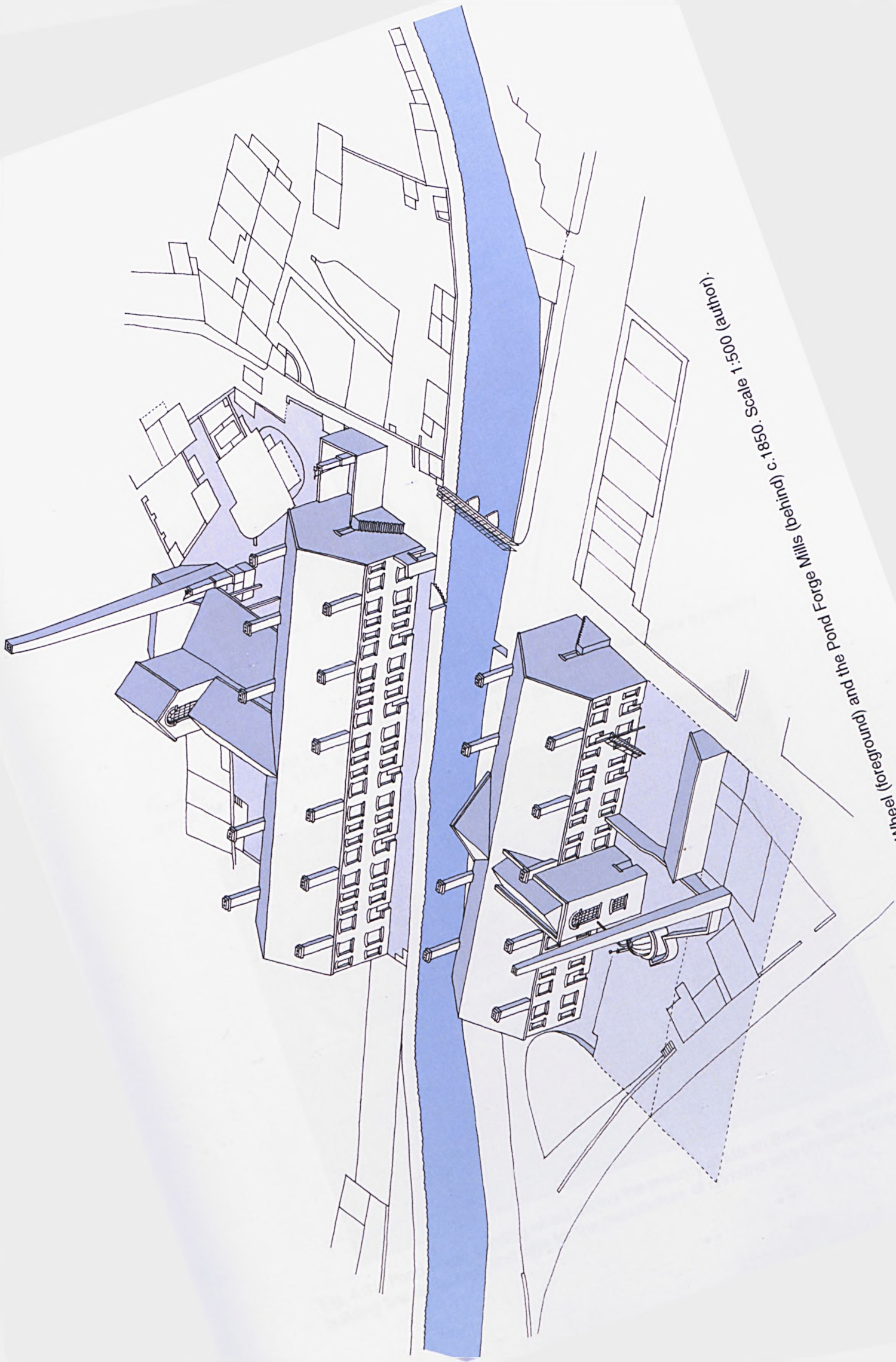

Fig. 4.29 Reconstruction of the Park Wheel (foreground) and the Pond Forge Mills (background) c. 1850. Scale 1:500 (author).



Fig. 4.30 Site location plan of the Pond and Park wheels, with their near mirror symmetry across the Sheaf, c. 1850. North is at top, scale 1:1000 (author).

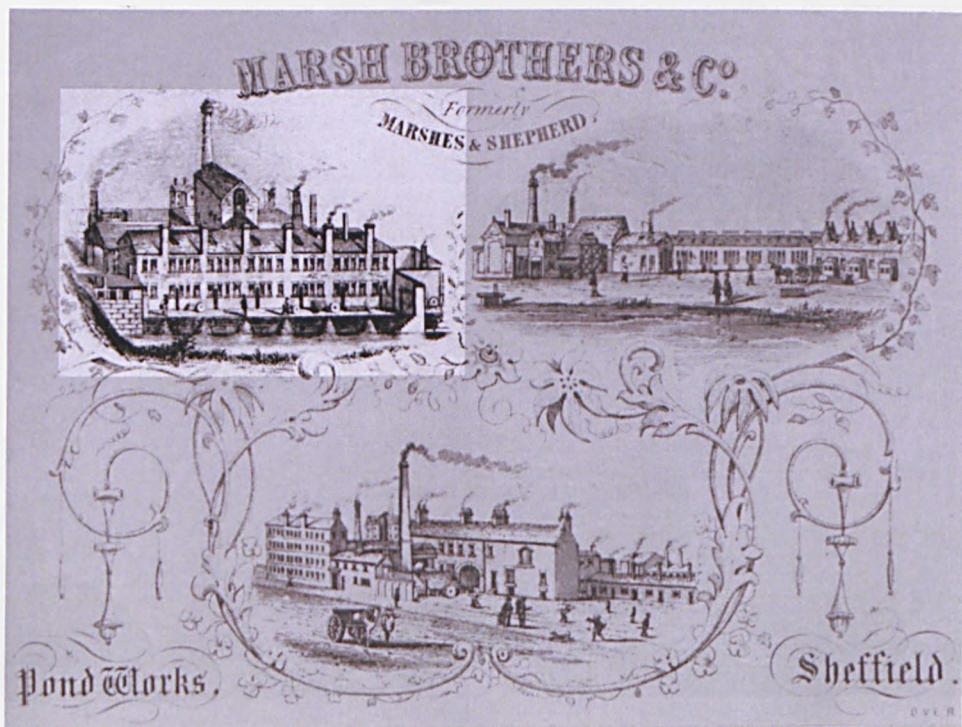

Fig. 4.31 Pond Forge grinding wheel during the tenancy of Marsh Bros., who used the building first for storage and later for the manufacture of crinoline wire (Pollard 1954).

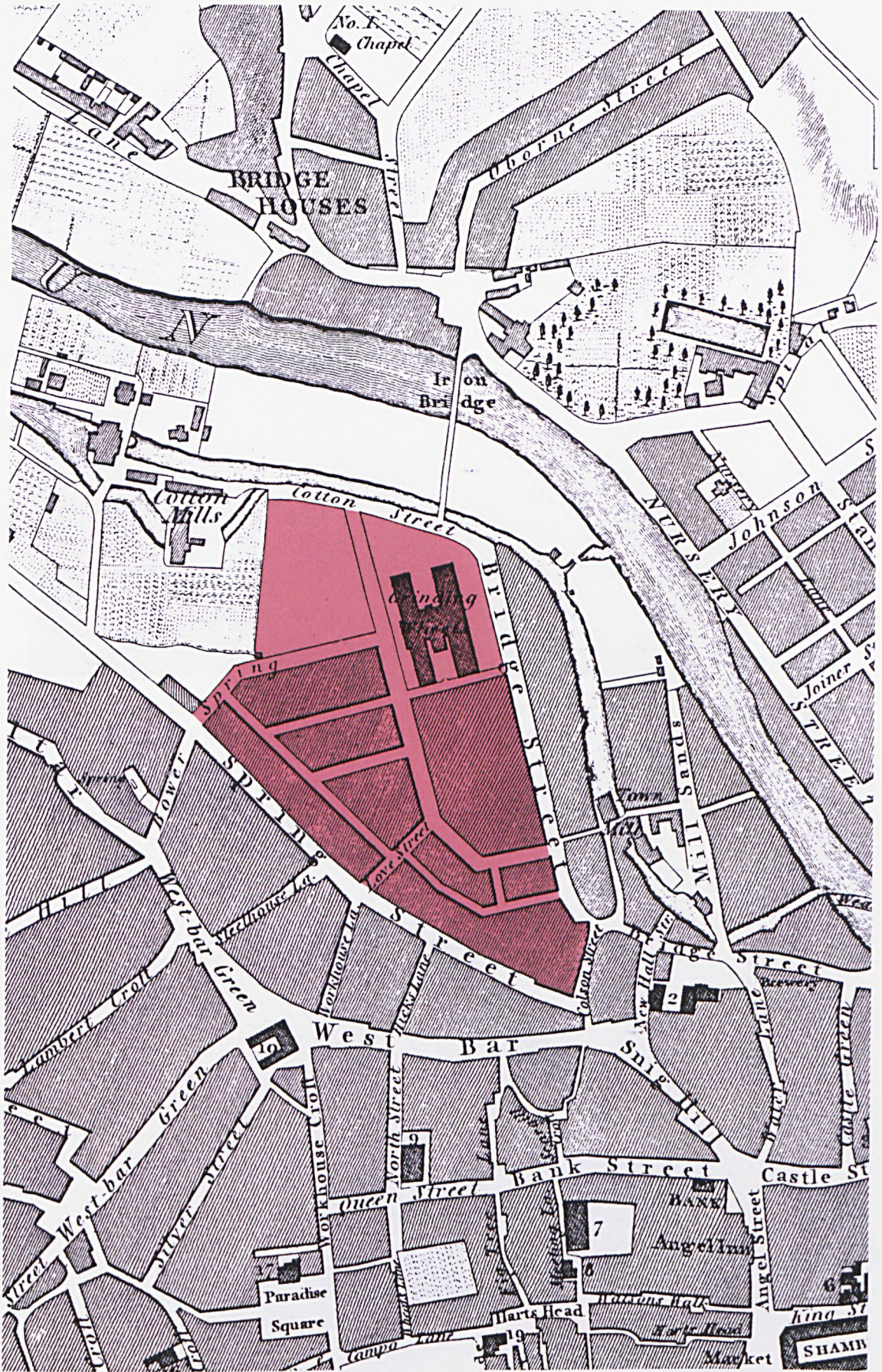

Fig. 4.32 Coulson Crofts estate, developed on the Duke of Norfolk's land from the 1790s, with the characteristic 'H' plan of the Soho Wheel, finished 1805, clearly visible. North is at top, scale 1:3600 (Fairbank 1808, author's colours).



Fig. 4.33 Fairbank plan of the estate c.1790, reusing an earlier scheme for the same area based on a radically different concept. Not to scale (SCA).

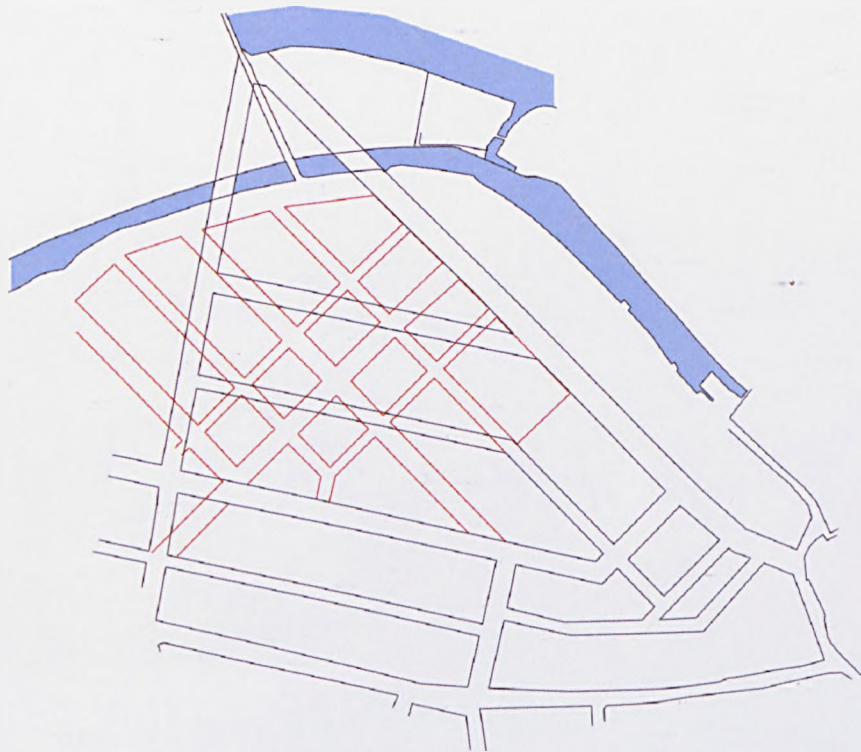

Fig. 4.34 Redrawing of fig. 4.33, with original street layout shown in black and revised geometry in red. Ultimately, a hybrid of the two variants was adopted (author).

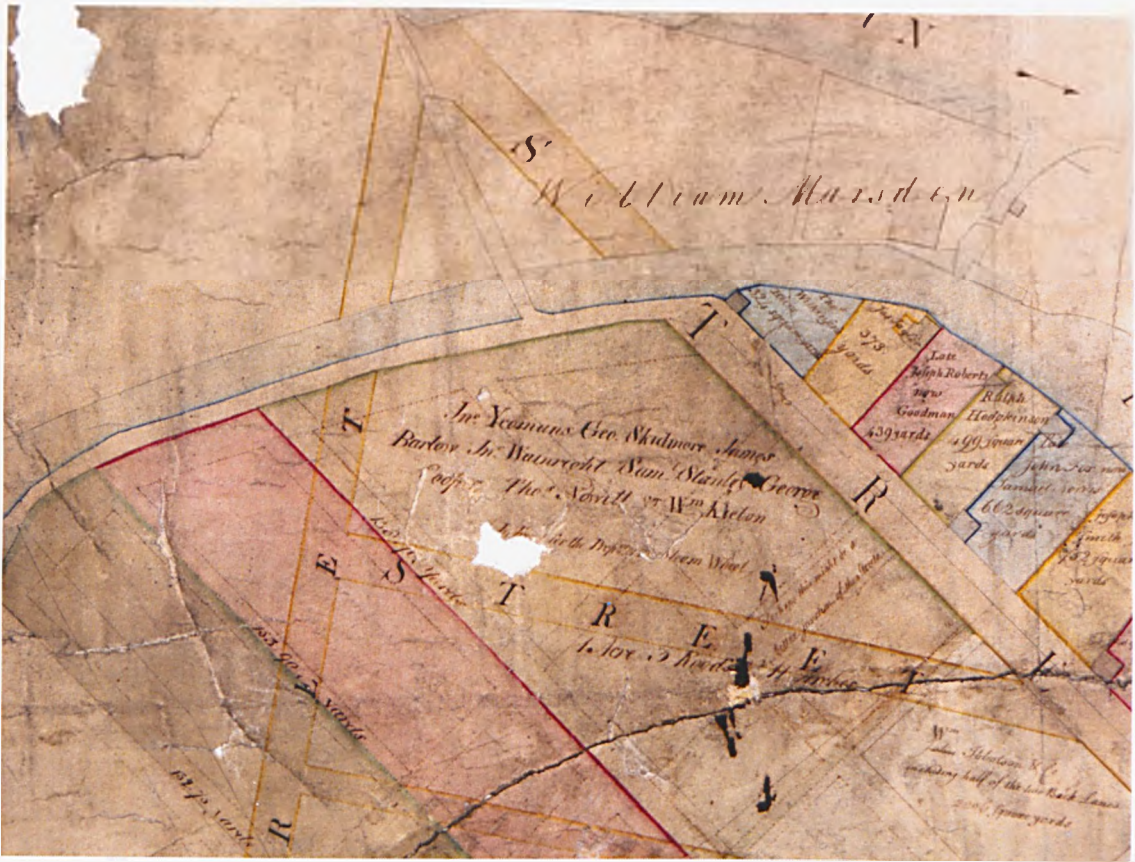

Fig. 4.35 Detail of fig. 4.33, with the site of the Soho Wheel shaded green and labelled 'In Trust for the Prop^{rs}. of a Steam Wheel' (SCA).

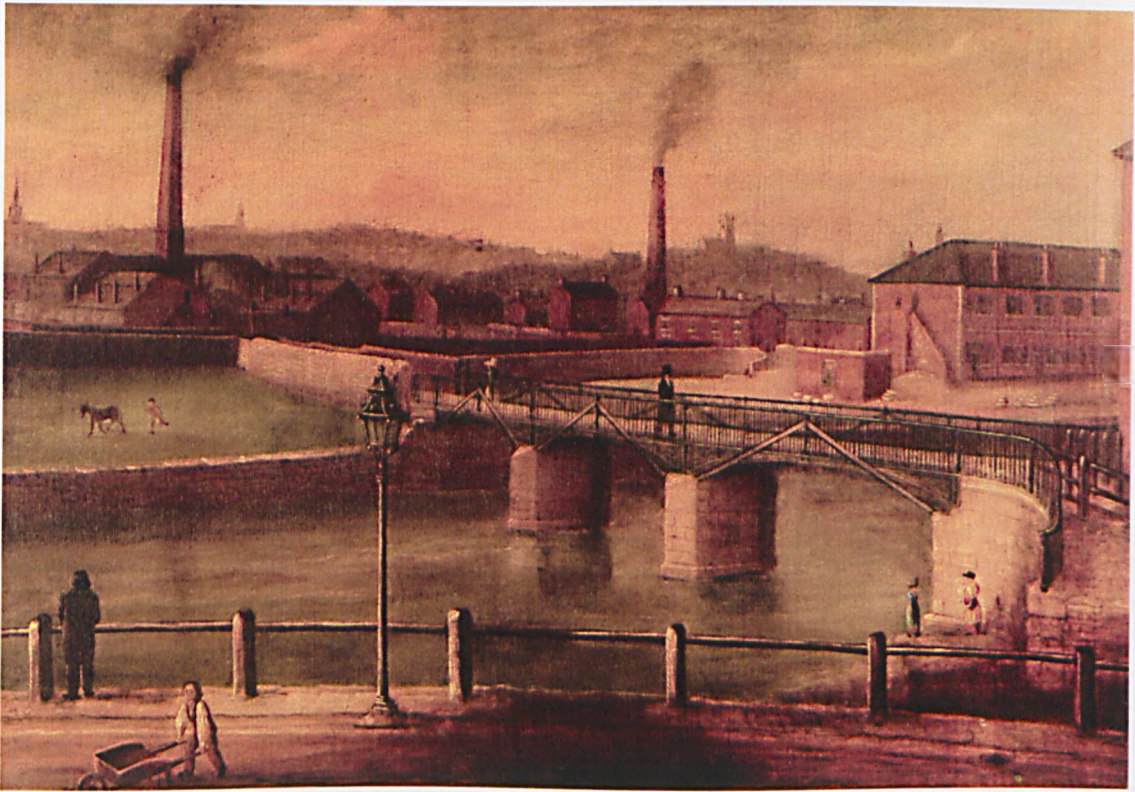

Fig. 4.36 Anonymous painting of Bridgehouses. The Soho Wheel can be seen on the left, and the newly constructed Union Wheel (1819) on the right (Kelham Island Museum).

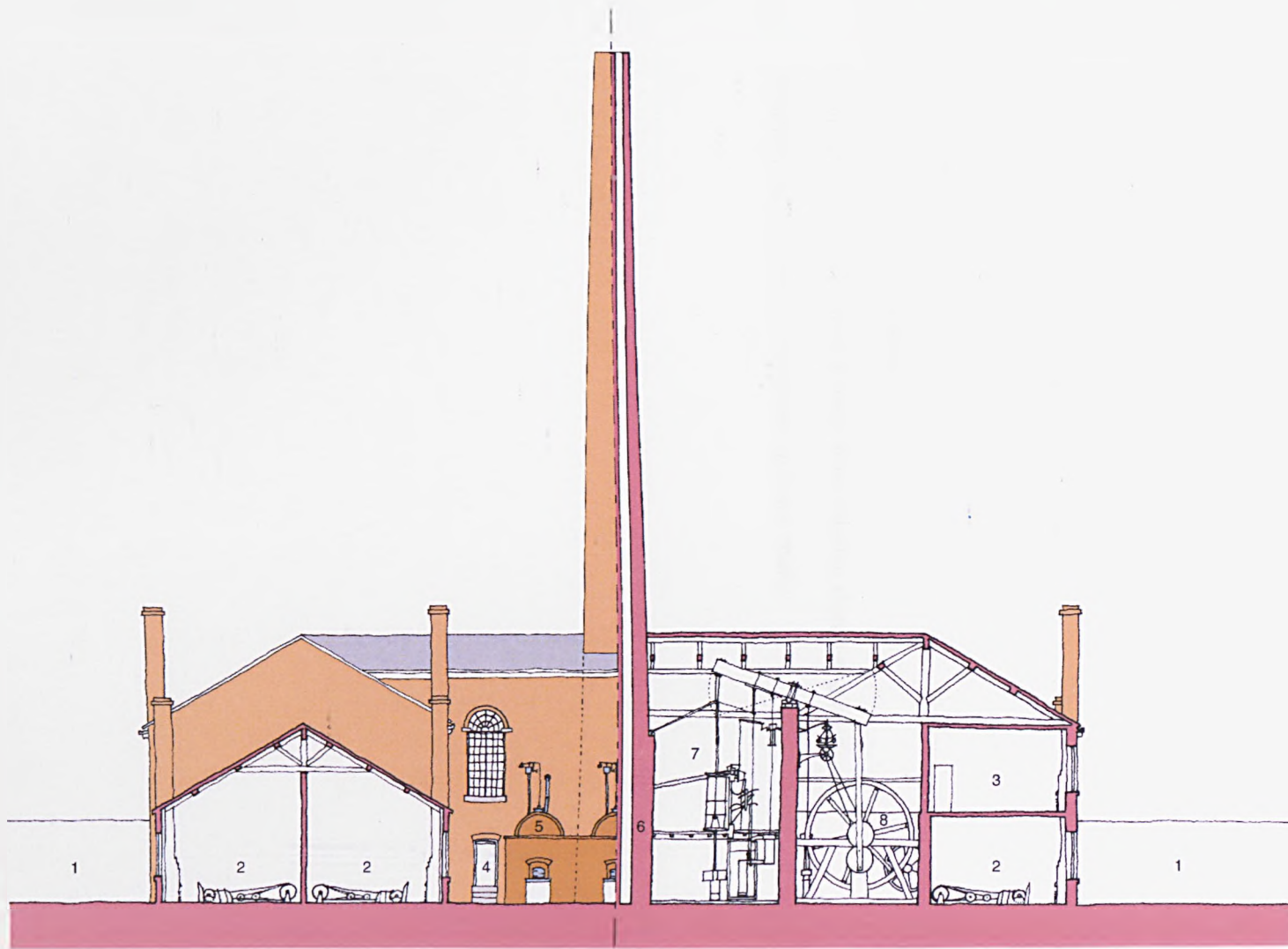

Fig. 4.37 Short section of the Soho Grinding Wheel, the left half taken through a single storey hull and the right half through the central engine house to show one of the two 40hp Boulton & Watt patent engines. The upper chamber floors were used for lighter grinding and other trades. Scale 1:300 (author).

The Proprietors of the Soho Steam Grinding Wheel

Soho Steam Grinding Wheel, reconstructed section (c.1830)

scale 1:200

key:

- 1 Wheel yard
- 2 Heavy grinding hulls (6 troughs each)
- 3 Chamber rooms (light grinding and workshops)
- 4 Door to engine house
- 5 Wagon boilers (3 no.)
- 6 Four-flue steam engine stack
- 7 Engine house with Boulton & Watt 40hp rotative steam engine
- 8 Flywheel and gearing transmission to main shafts

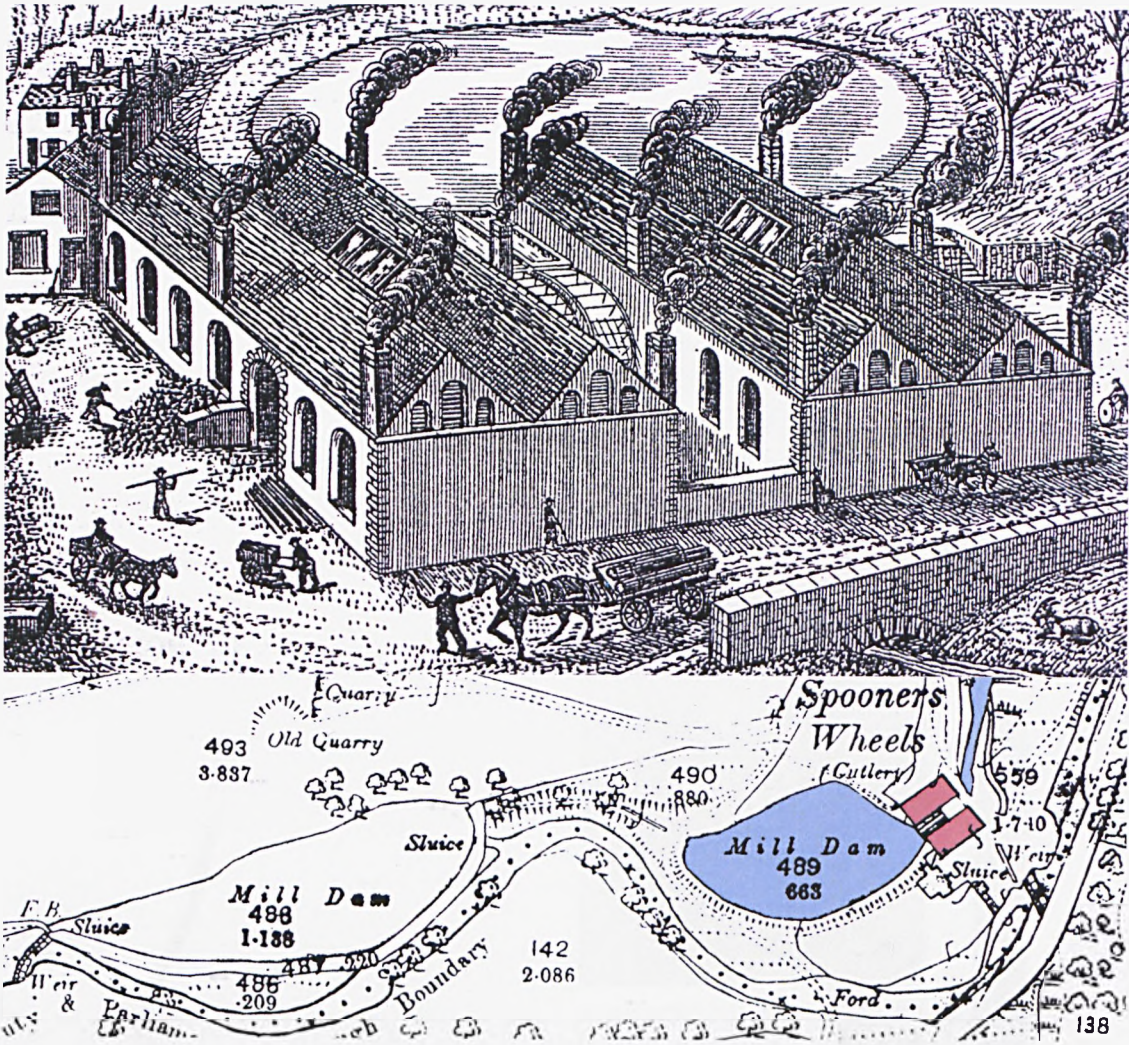

Figs. 4.38 and 4.39 Engraved view and OS plan of Spooner's Wheels or the Rivelin Valley Wheel, an example of the double water-powered grinding wheel (OS, author's colours).

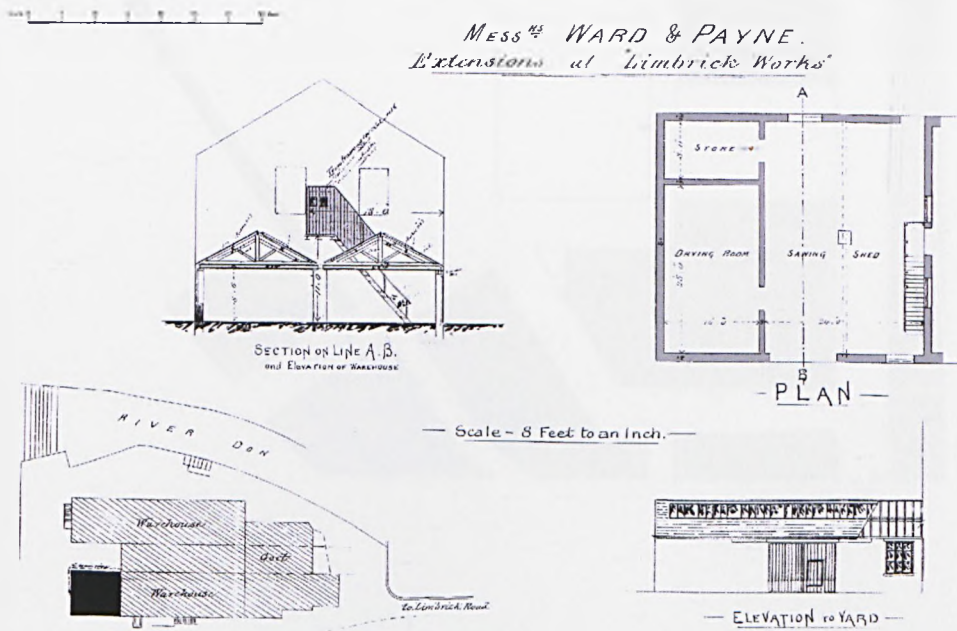

Fig. 4.40 Limbrick Works grinding wheels on the river Loxley near Sheffield, a larger example of the double-wing wheel type on which the Soho was based. Scale 1:350 (SCA).

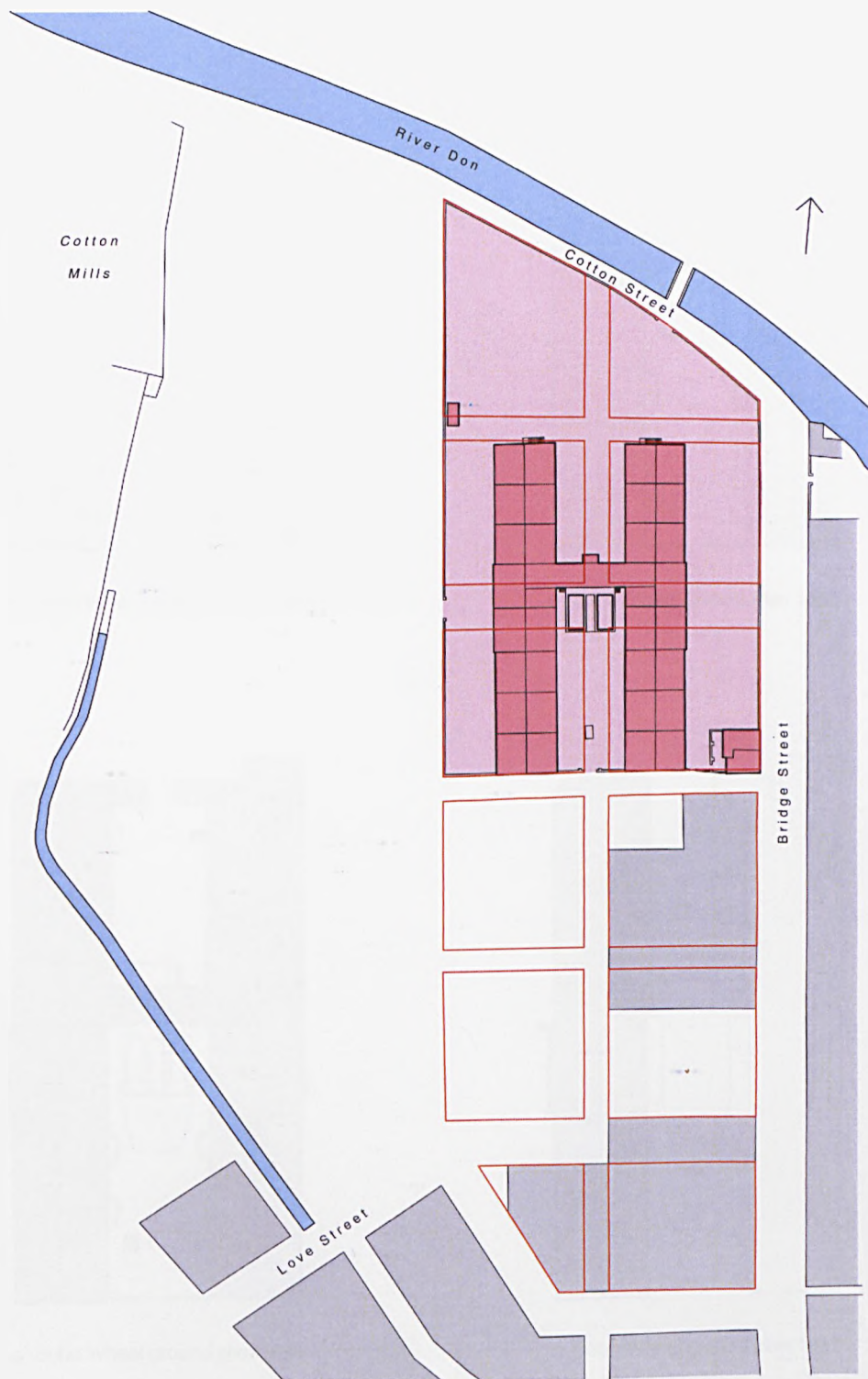
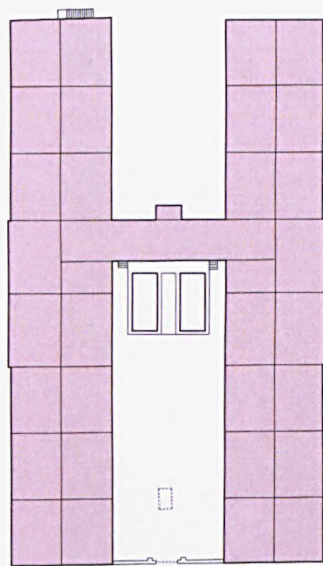
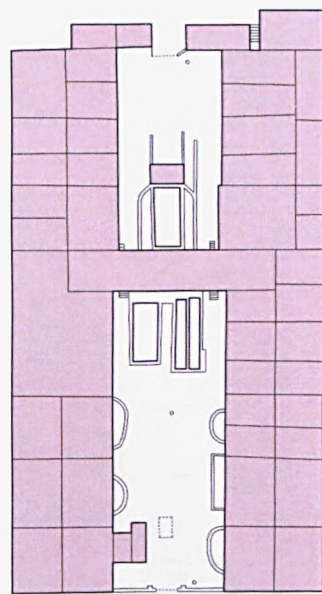

Fig. 4.41 Soho Wheel site plan c.1805, with the short lived water channel to the west. The red blocks show its relationship to the unrealised estate plan. Scale 1:1500 (author).



a Soho Wheel ground plan c.1805



b Soho Wheel ground plan 1850

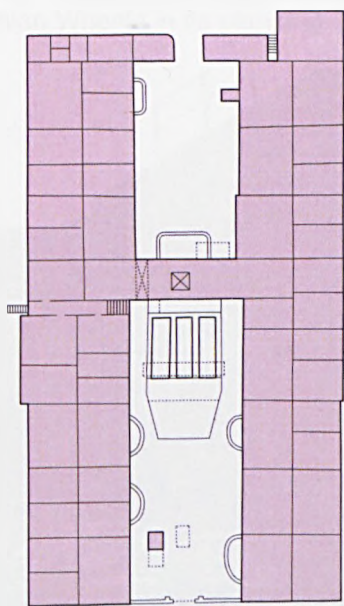

c Soho Wheel ground plan 1889

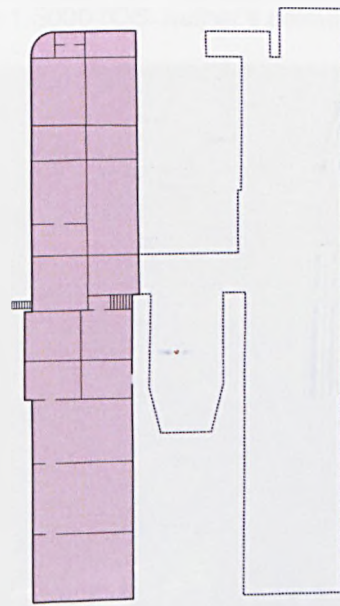

d Soho Wheel ground plan 1937

Fig. 4.42a-d Development of the Soho Wheel plan, 1805-1937. Scale 1:1000 (author).

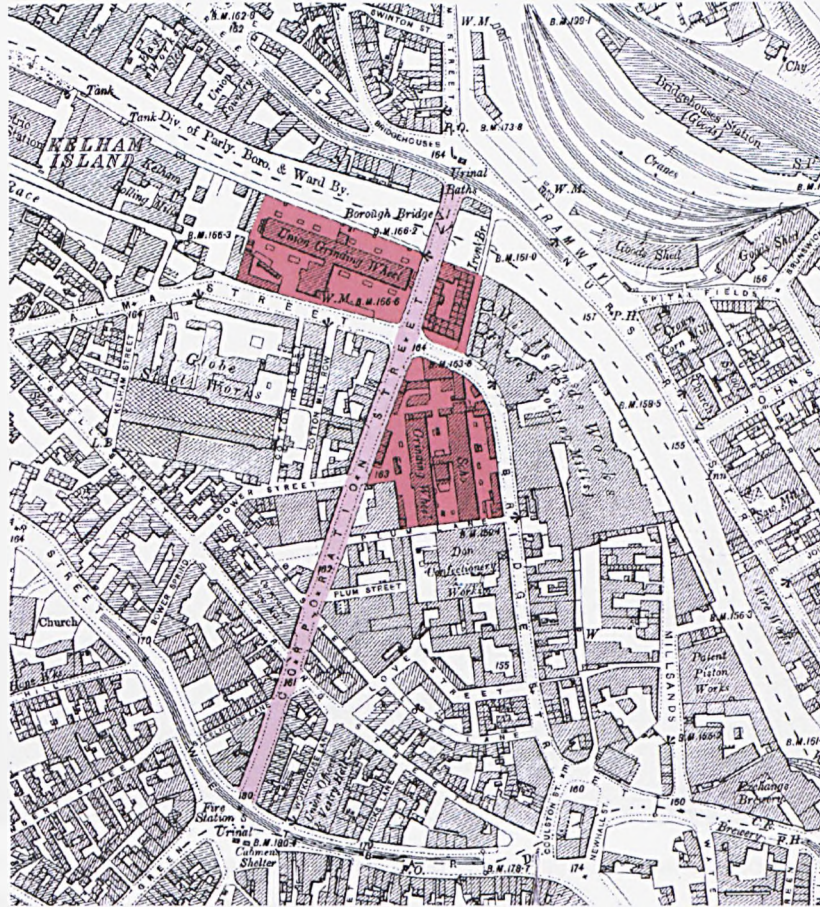

Fig. 4.43 Corporation Street on the 1903 OS plan, that somehow avoided both the Soho and Union Wheels in its planning. North is at top, scale 1:5000 (OS, author's colours).



Fig. 4.44 Embedded remains of the Soho Wheel west wing, now used as a car park for the Sheffield Star newspaper depot (author).



Fig. 4.45 The other internal elevation of the west wing, with the interface to the two storey central portion evident on the left (author).



Figs. 4.46 and 4.47 Two storey chamber walls, with embedded tiles from the lower wings at bottom (left) and detail of an iron column, probably salvaged from the interior (author).

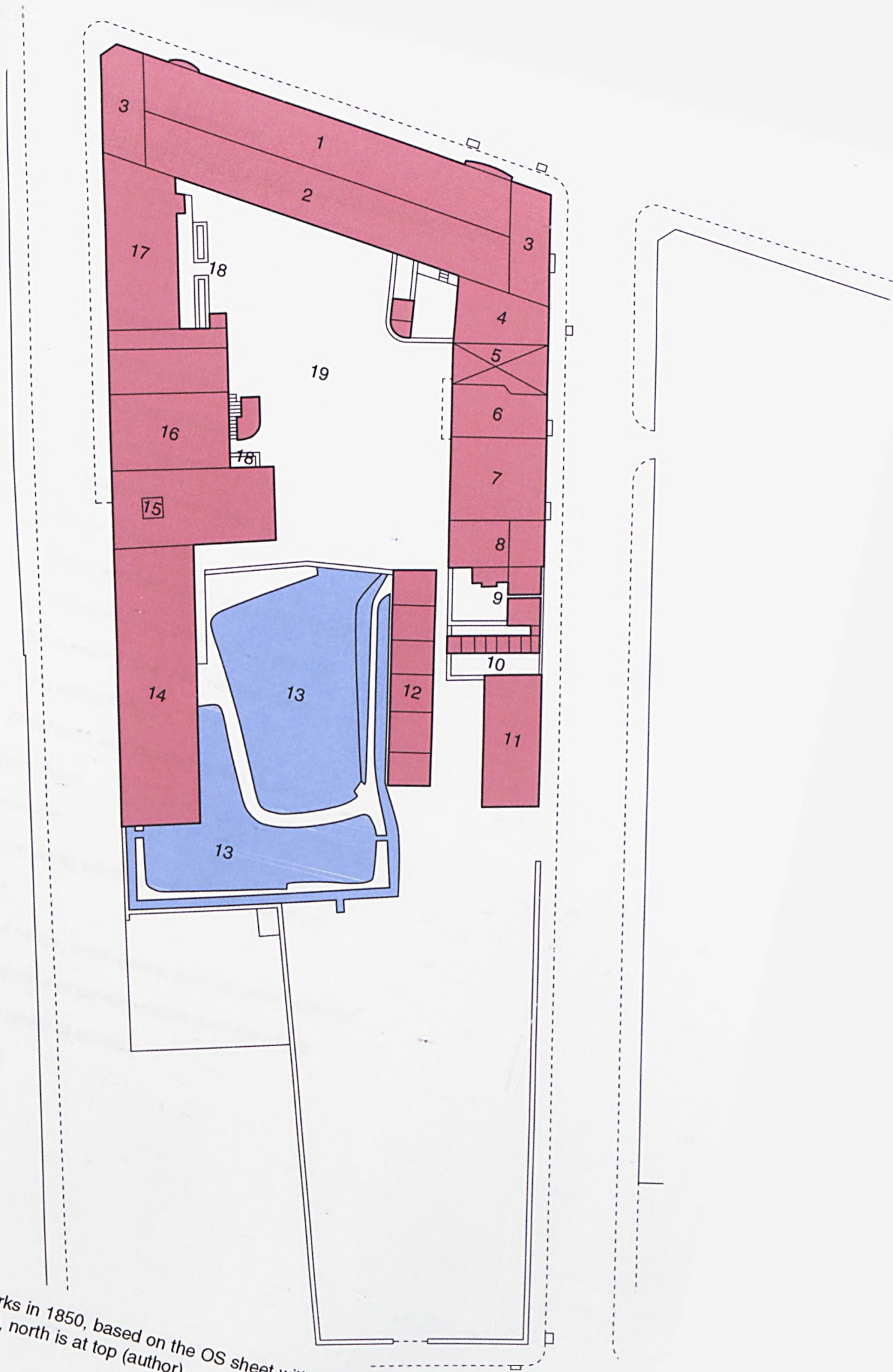

Fig. 4.48 Washington Works in 1850, based on the OS sheet with reconstructed uses from valuation lists. Scale 1:500, north is at top (author).

George Wostenholm

Washington Place, reconstructed site plan (c.1850)

scale 1:1000

key:

- 1 Warehouse (3 storeys)
- 2 Hearths, warehouse and workshops (5 storeys)
- 3 Office and staircase
- 4 Best dwelling house (3 storeys)
- 5 Gateway and workshops over
- 6 House (2 storeys)
- 7 Coach and cart house and chambers (2 storeys)
- 8 Stabling and hay chambers (2 storeys)
- 9 Blacksmith's shop and manure place
- 10 Yard and privies
- 11 Warehouse and packing rooms (3 storeys)
- 12 Workshops
- 13 Reservoir
- 14 New grinding wheel (4 storeys) [March 1837]
- 15 Stack
- 16 Engine house, boiler house, gearing room, staircase,
with 2 storeys of grinding rooms over the whole
- 17 Grinding wheel (4 storeys)
- 18 Swarf bins
- 19 Yard

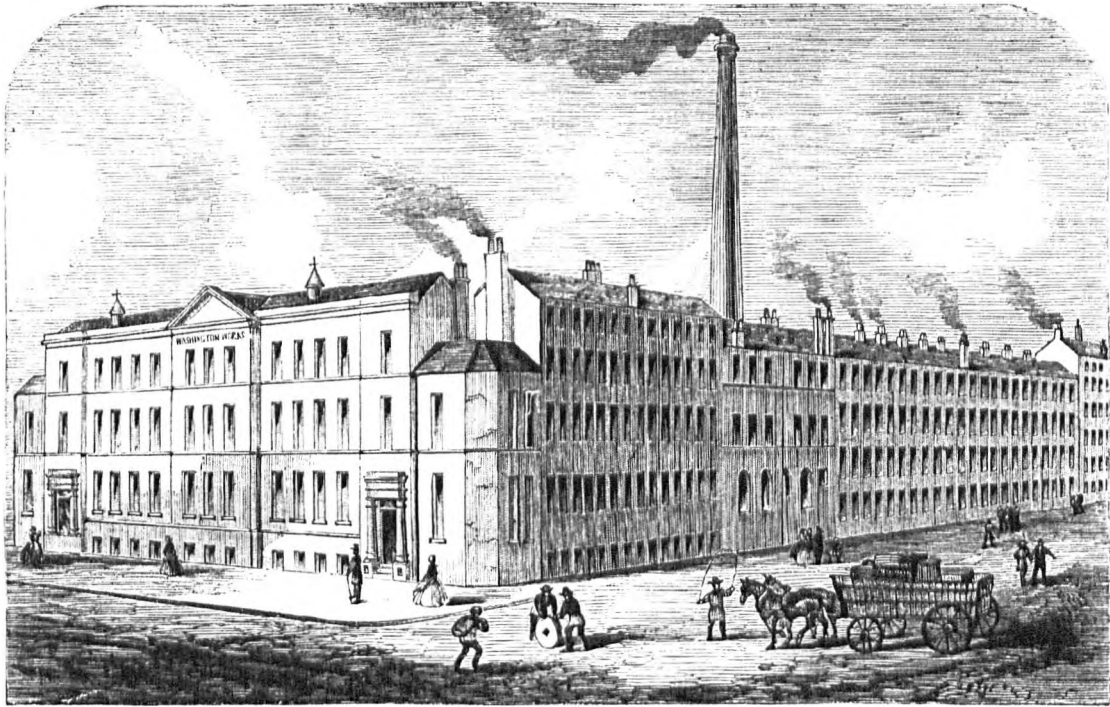

WASHINGTON WORKS.—MESSRS. GEORGE WOSTENHOLM AND SON LIMITED.

Fig. 4.49 Street elevations of the Washington Works, a public grinding wheel that passed into private hands in 1848 (Pawson & Brailsford 1862).

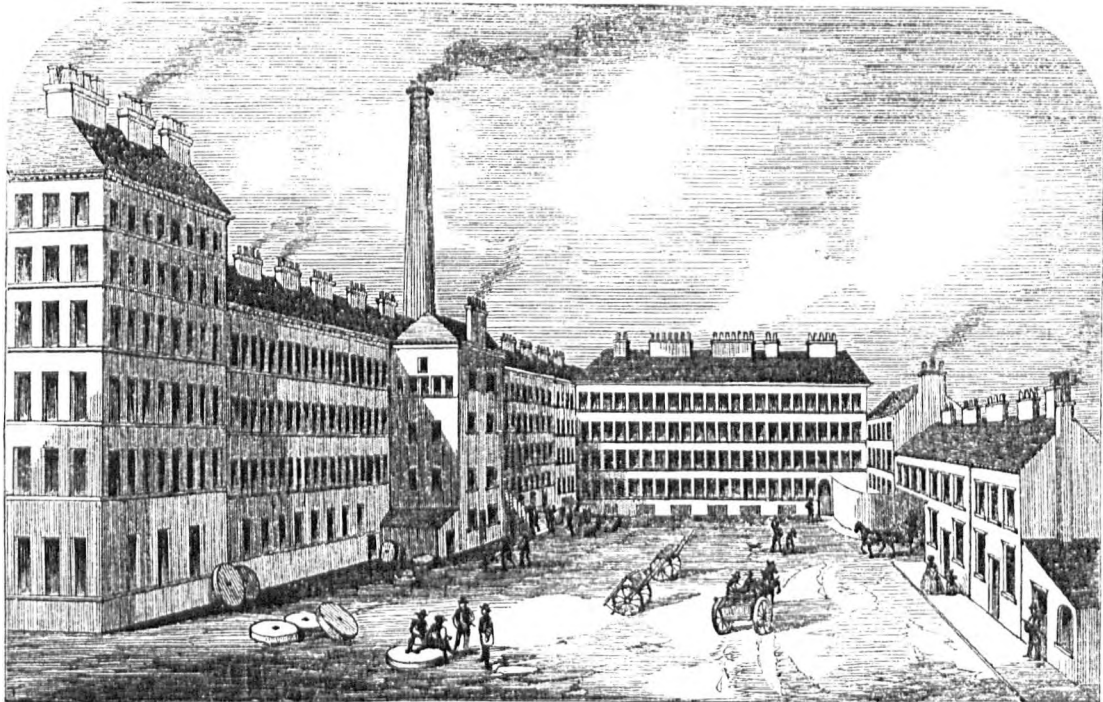

BACK VIEW OF WASHINGTON WORKS.—MESSRS. G. WOSTENHOLM AND SON, CUTLERY MANUFACTURERS.

Fig. 4.50 Internal courtyard of the Washington Works, occupied by the well-known cutlery manufacturer George Wostenholm (Pawson & Brailsford 1862).

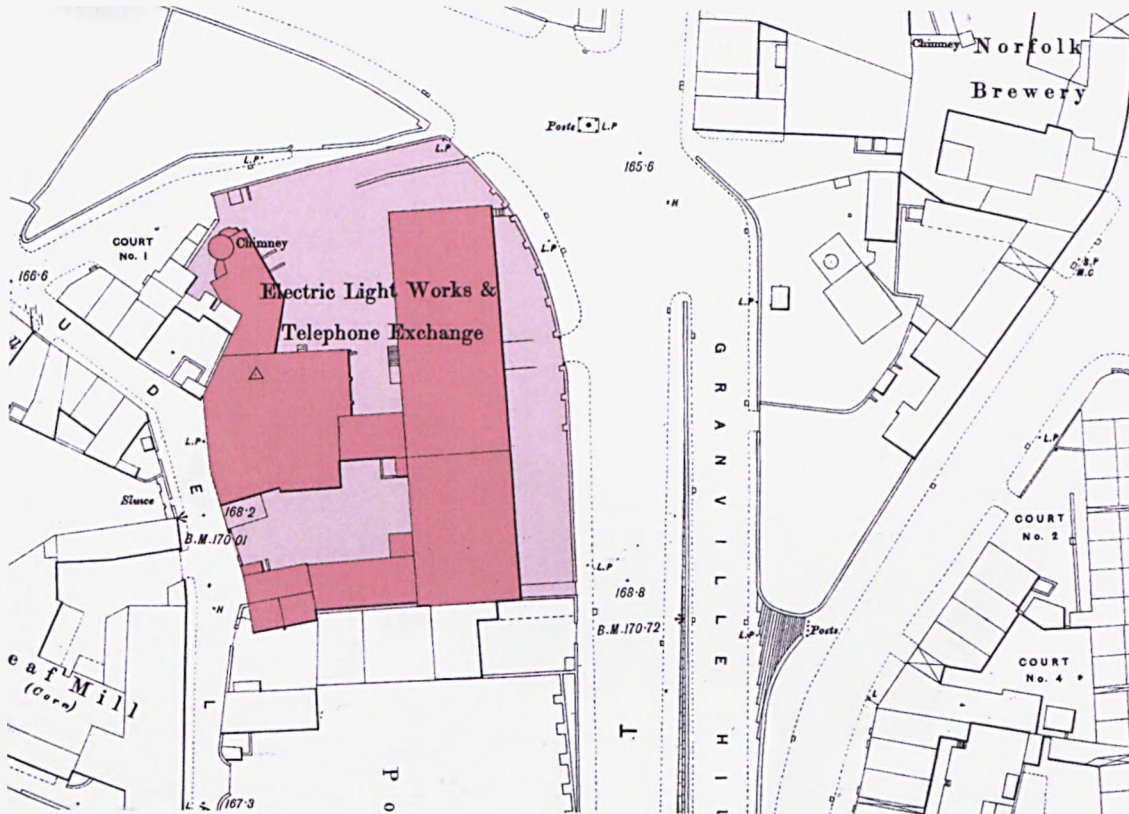

Fig. 4.51 Pond Forge grinding wheel in its final use as Sheffield's first electricity generating station and telephone exchange. North is at top, scale 1:1000 (1889 OS, author's colours).

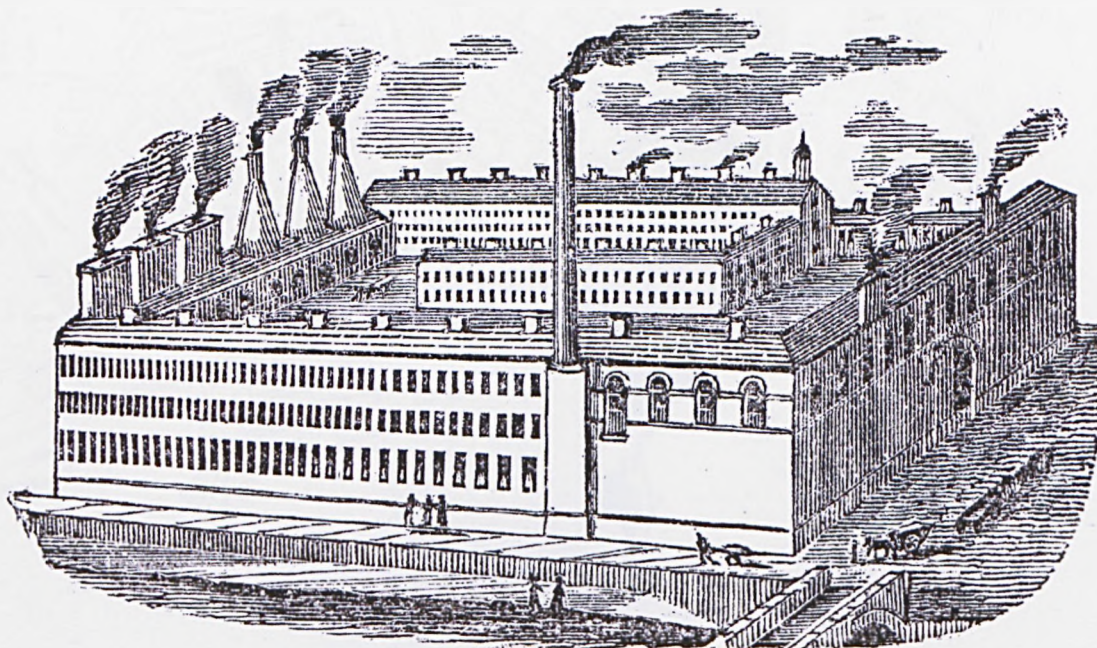

Fig. 4.52 Sheaf Island Works, built around the nucleus of a public grinding wheel that occupied the entire river frontage (foreground, with stack).



Fig. 4.53 Land in Sheffield historically subject to flooding and standing water, collated from textual sources and local topology. The locations of pre-1850 grinding wheels are plotted in black for comparison. North is at top, scale 1:15,000 (author).

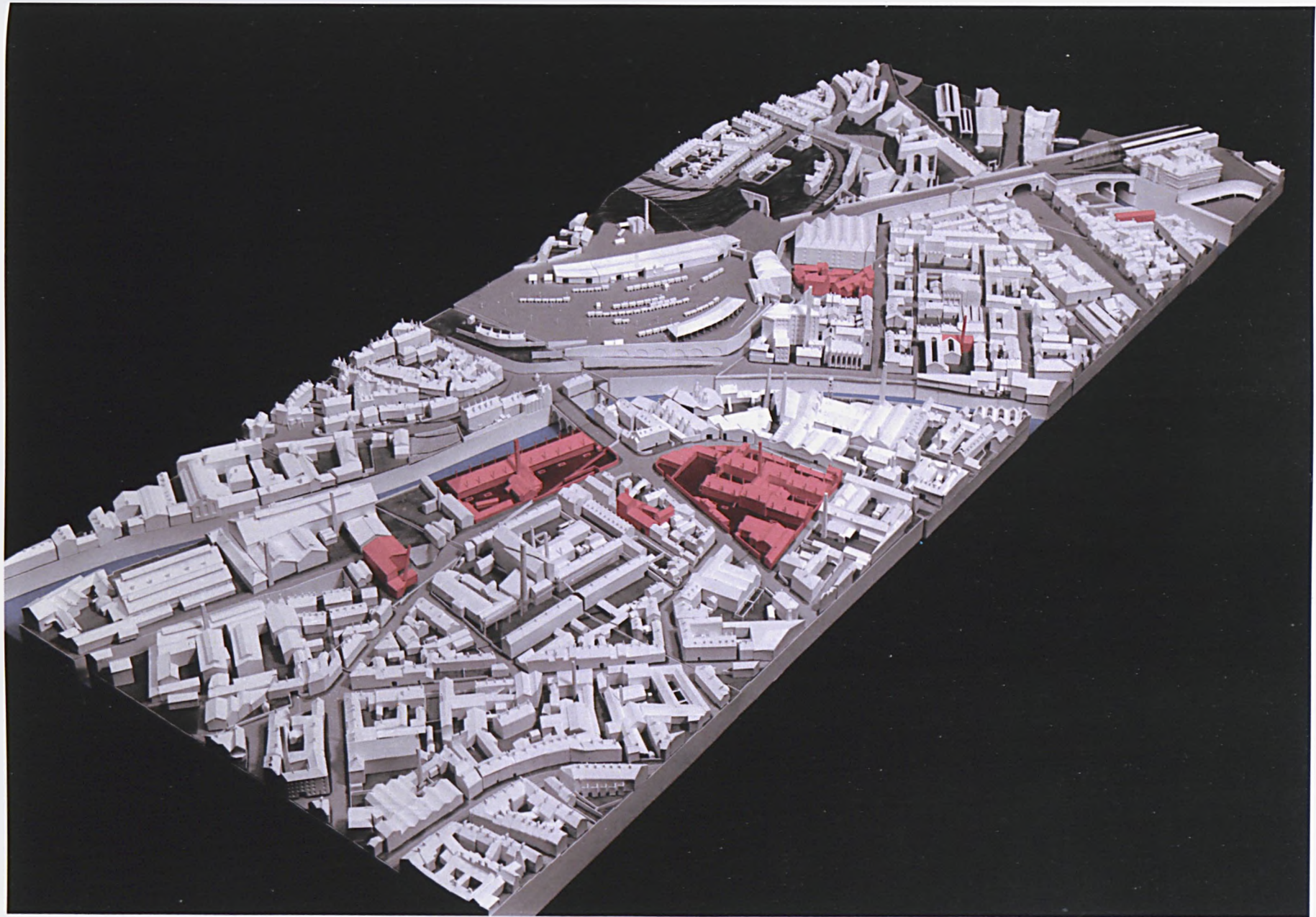

Fig. 4.54 Locations of steam-powered grinding wheels in the Kelham Island / Coulson Crofts / Wicker districts of Sheffield in 1900. The model was researched and built by diploma students at the University of Sheffield in collaboration with the author (photograph P. Lathey, author's colours).

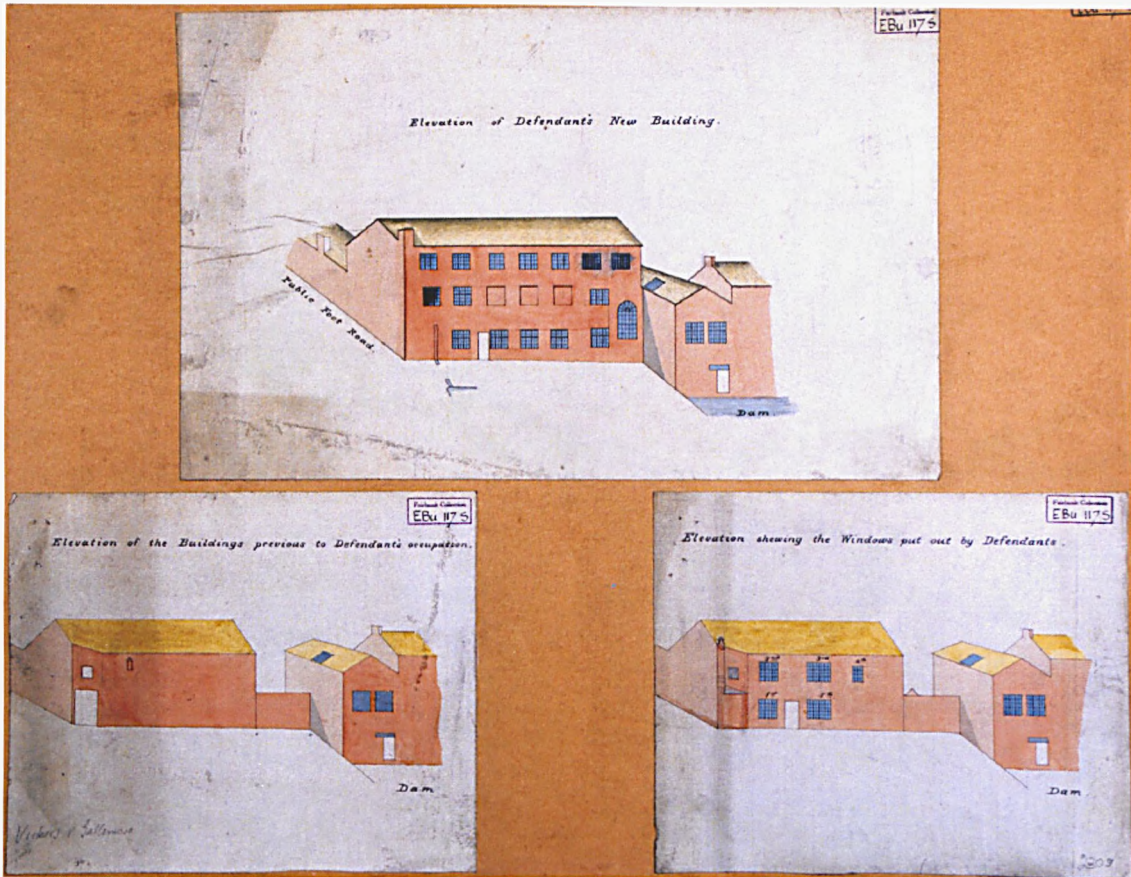

Fig. 4.55 Elevations of Gallimore's Bridge Street grinding wheel in 'cavalier' projection, made by Josiah Fairbank for a right of light dispute. Note the arched engine house window (SCA).



Fig. 4.56 Small steam-powered tenement works at Leah's Yard with truncated stack (left) and external water tank (centre). The engine was housed in a room beneath the stair and the boiler at basement level beneath the yard (author).



Fig. 4.57 The police district defined by the 1818 'Police Act' in relation to the locations of pre-1850 steam-powered grinding wheels. Scale 1:15,000 (author).



Fig. 4.58 Castle Mills, popularly known as the Tower Wheel, drawn and almost certainly designed by local architect William Flockton (SCA).



Fig. 4.59 Temporary arch erected for a royal visit alongside the Tower Wheel (right), echoing its castle-like aesthetic, itself a reference to the nearby Sheffield castle site (SCL).

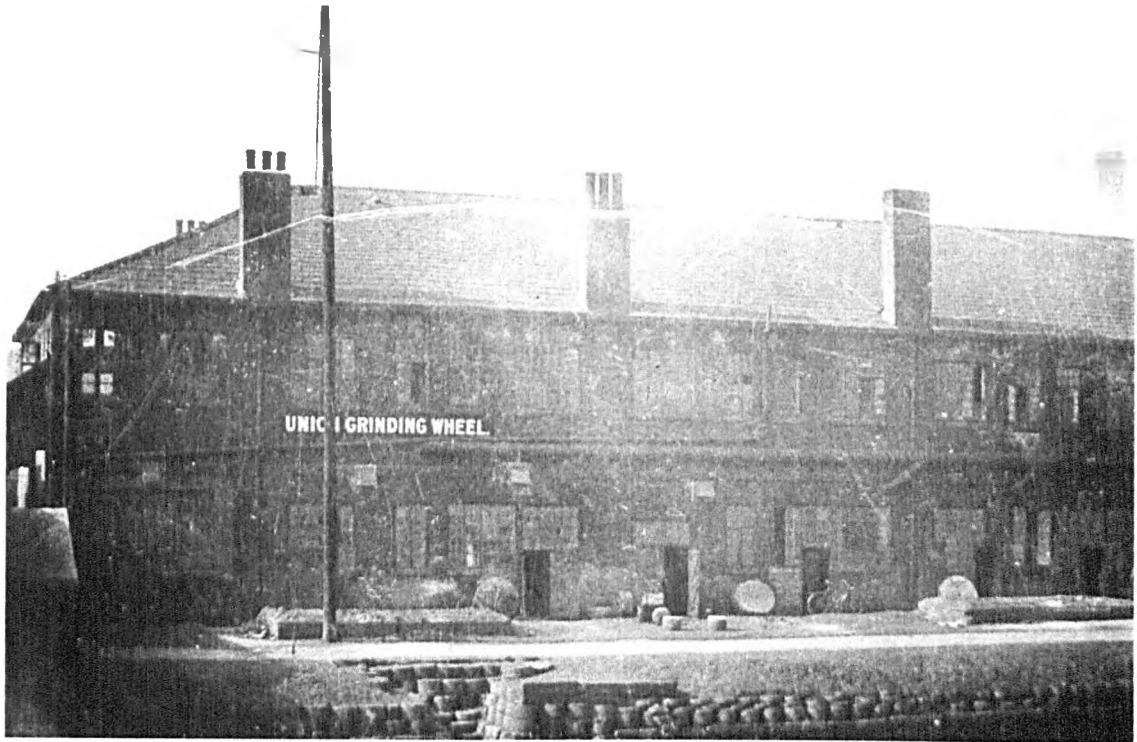

Fig. 4.60 Union Grinding Wheel seen from the river Don, the embankment built up with used grindstones. Note the low 'swarf bins' for disposal of the waste residue of wet grinding (SCL).



Fig. 4.61 Another view of the Union Grinding Wheel, showing the regular rhythm of hearth stacks and windows. The projecting shed was a later addition (Johnson 1959).

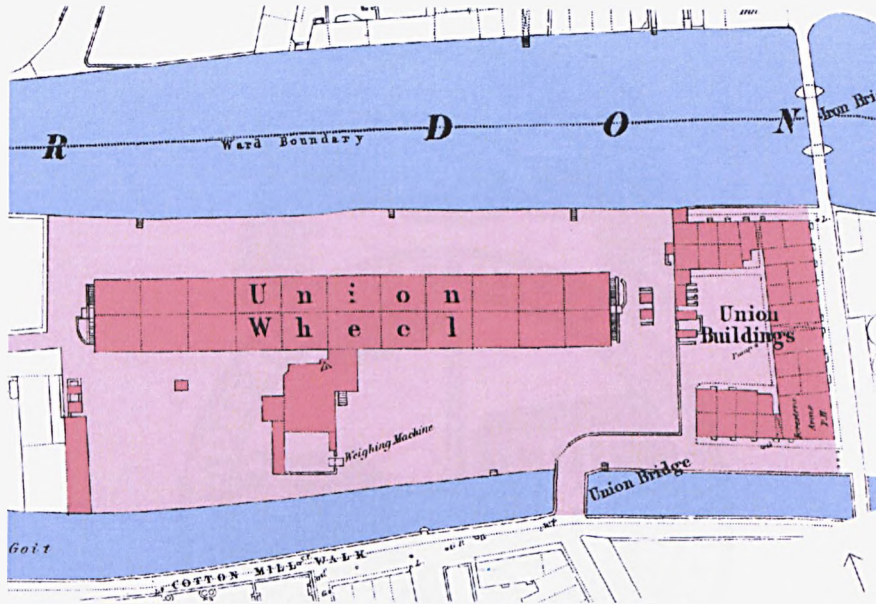
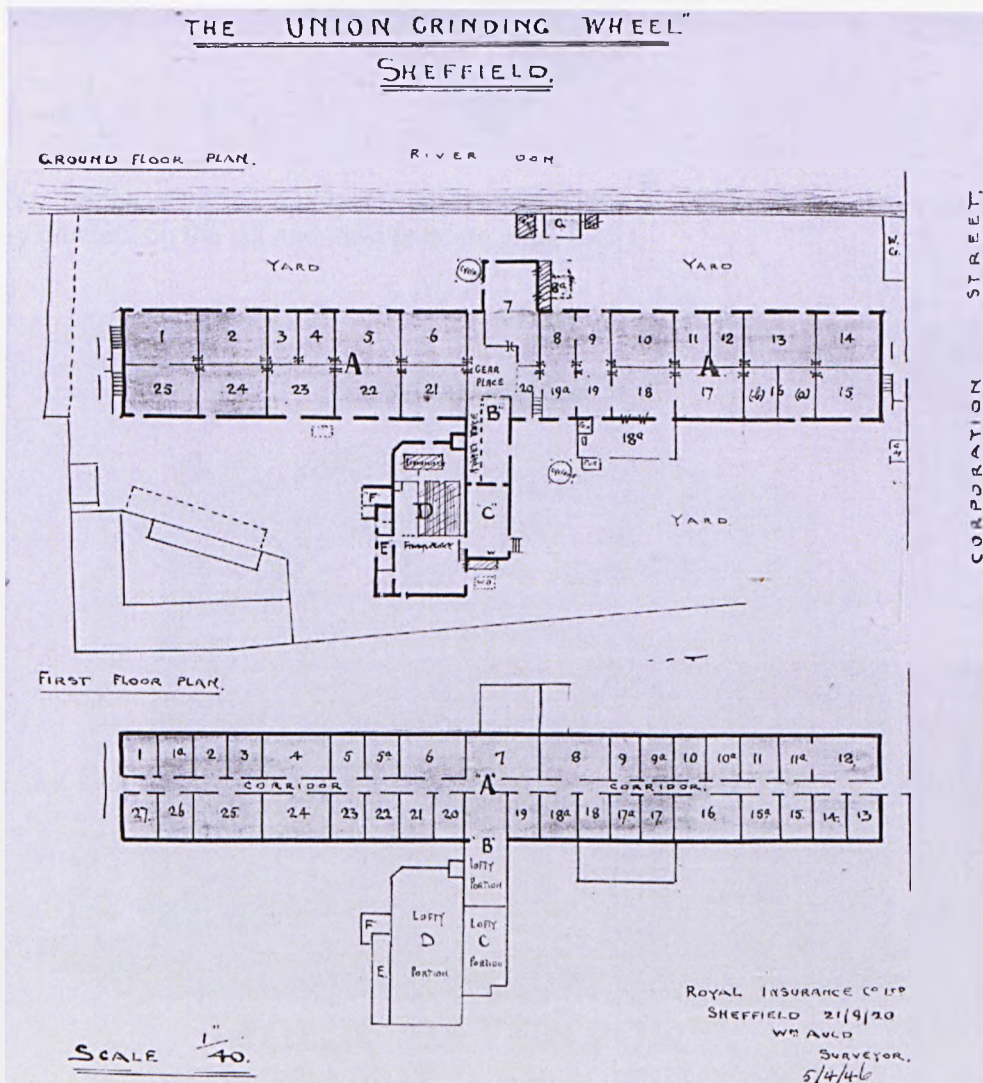

Fig. 4.62 Defensive site planning of the Union Wheel and Union Buildings, isolated by the river and goit and accessed by a private bridge. Scale 1:1500 (OS, author's colours).



Figs. 4.63 and 4.64 Twentieth century insurance plans of the Union Grinding Wheel, ground floor (top) and first floor (beneath) with details of the internal layout. Scale 1:1000 (SCA).

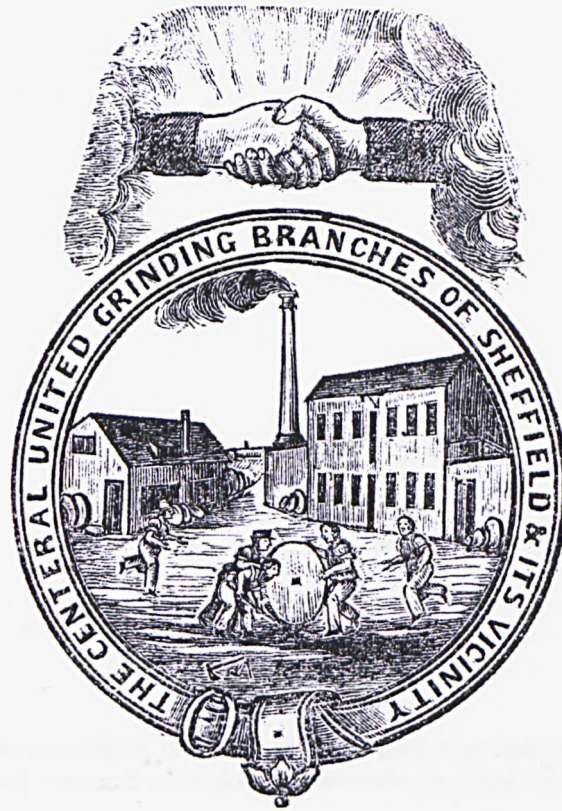

Fig. 4.65 Badge of the 'Central and United Grinding Branches' symbolising unity between country grinders on the left and town grinders, right (SCL).

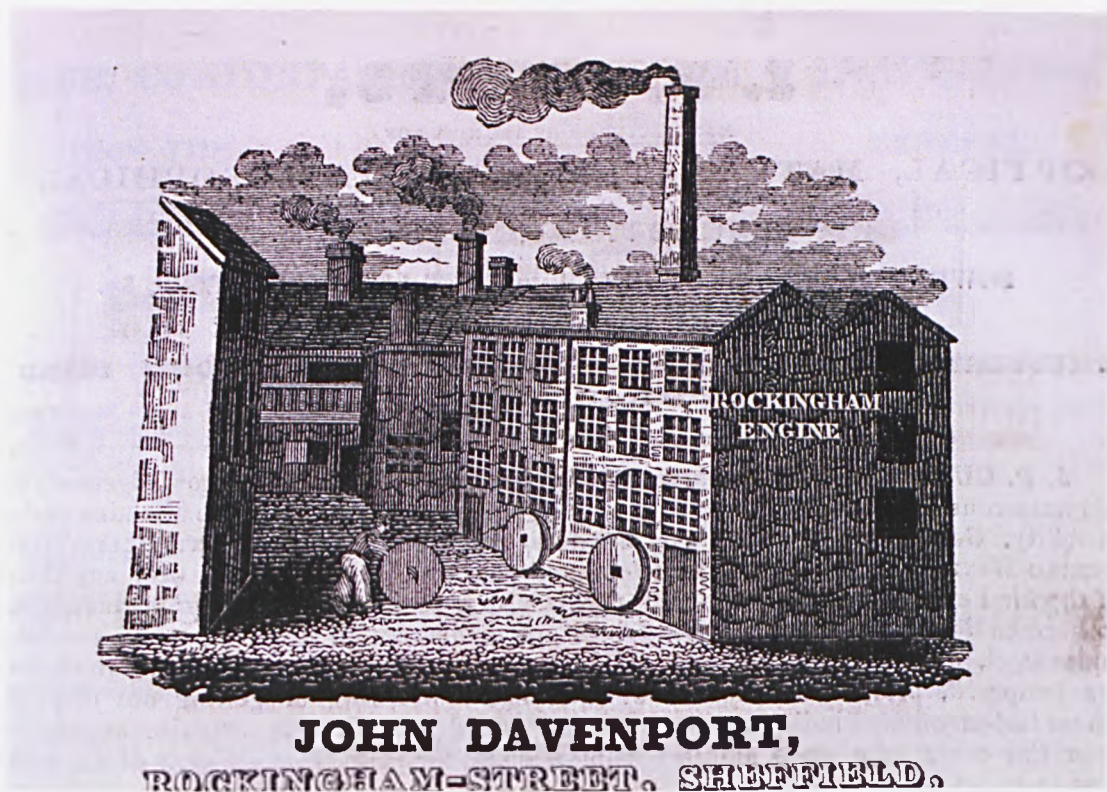

Fig. 4.66 Davenport's Rockingham Engine, an early example of the smaller public and semi-public wheels made possible by the greater availability of small steam engines.

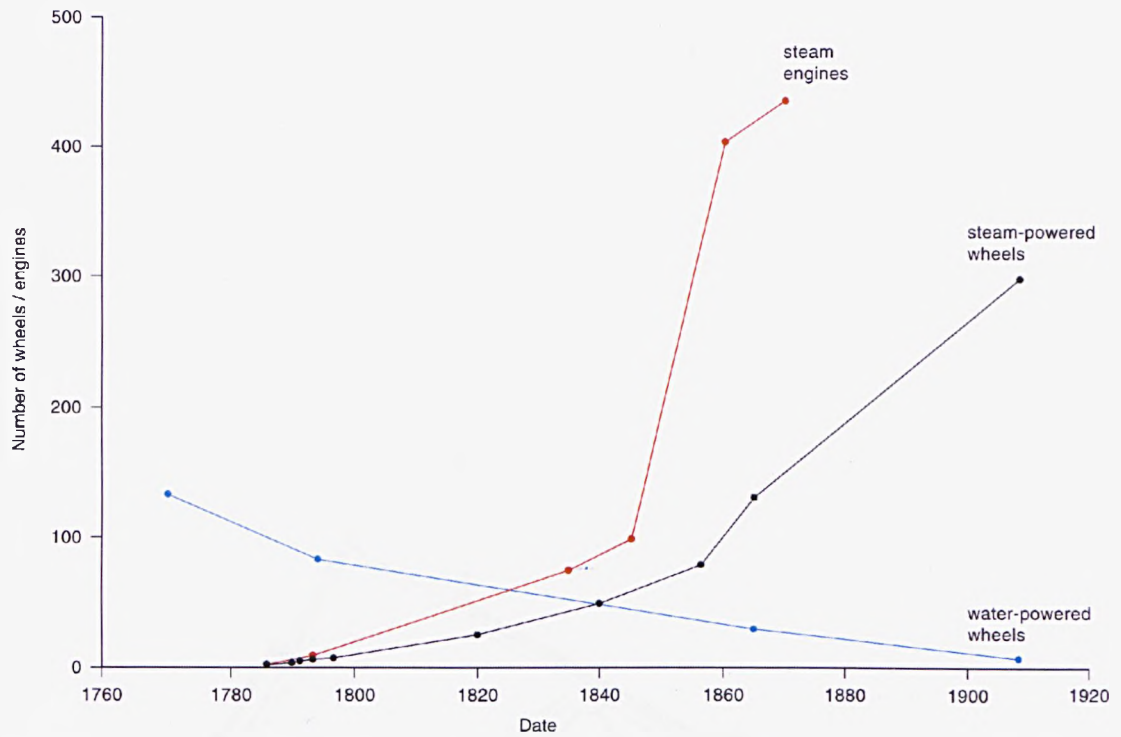

Fig. 4.67 Graphical representation of the increase in steam-powered grinding wheels (black) and steam engines (red) versus the decline of waterwheels (blue) in Sheffield (author).

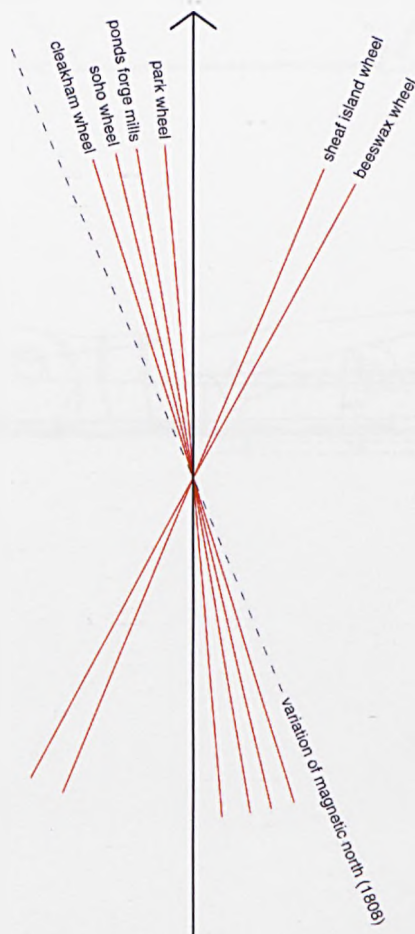

Fig. 4.68 Orientation of the principal axes of major public grinding wheels prior to 1820 with respect to magnetic north, indicating the variation measured in 1808 (author).

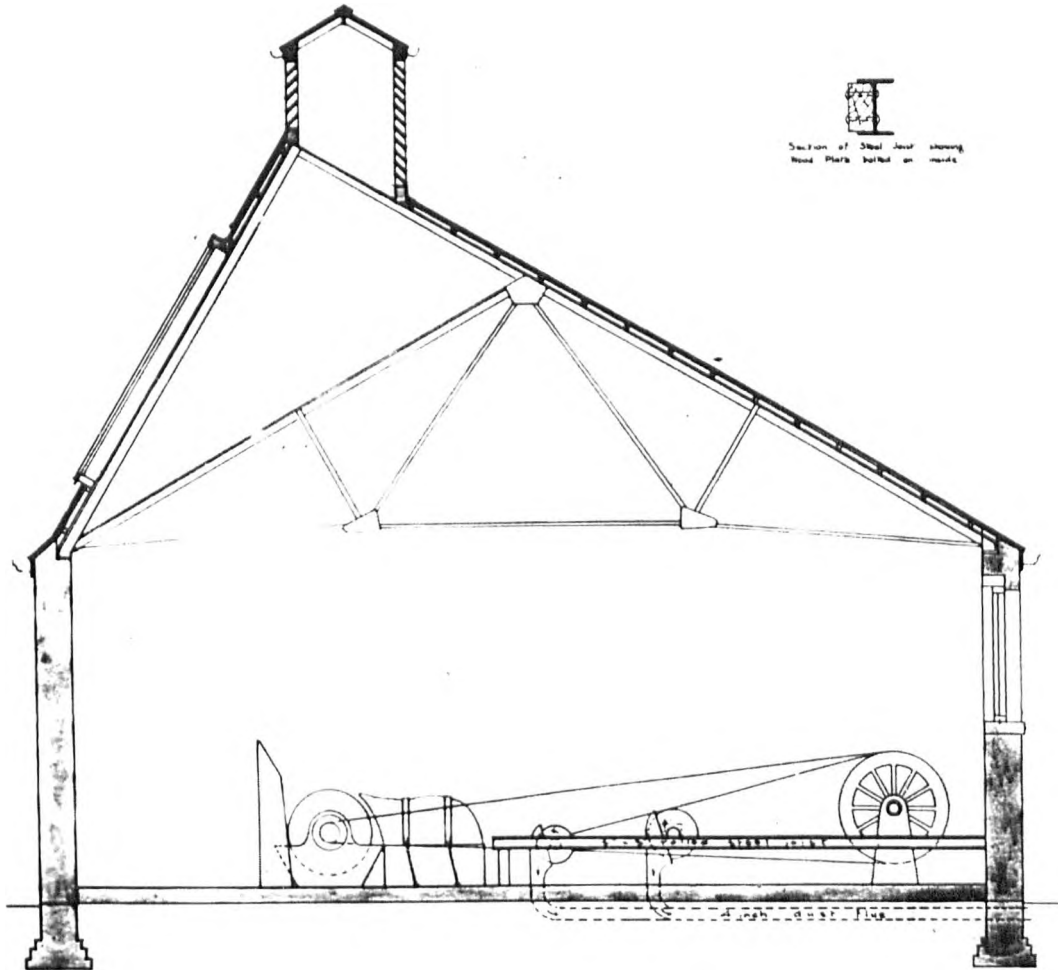

Fig. 4.69 An early twentieth century grinding hull with lightweight north-lit roof structure, but otherwise similar in layout to its early steam-powered antecedents (SCL).

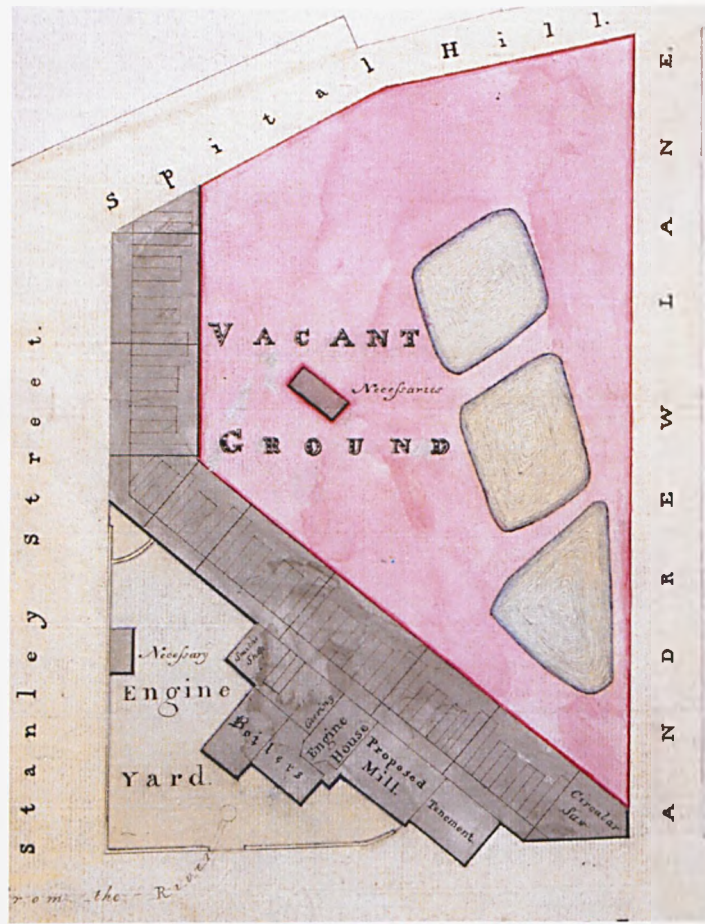
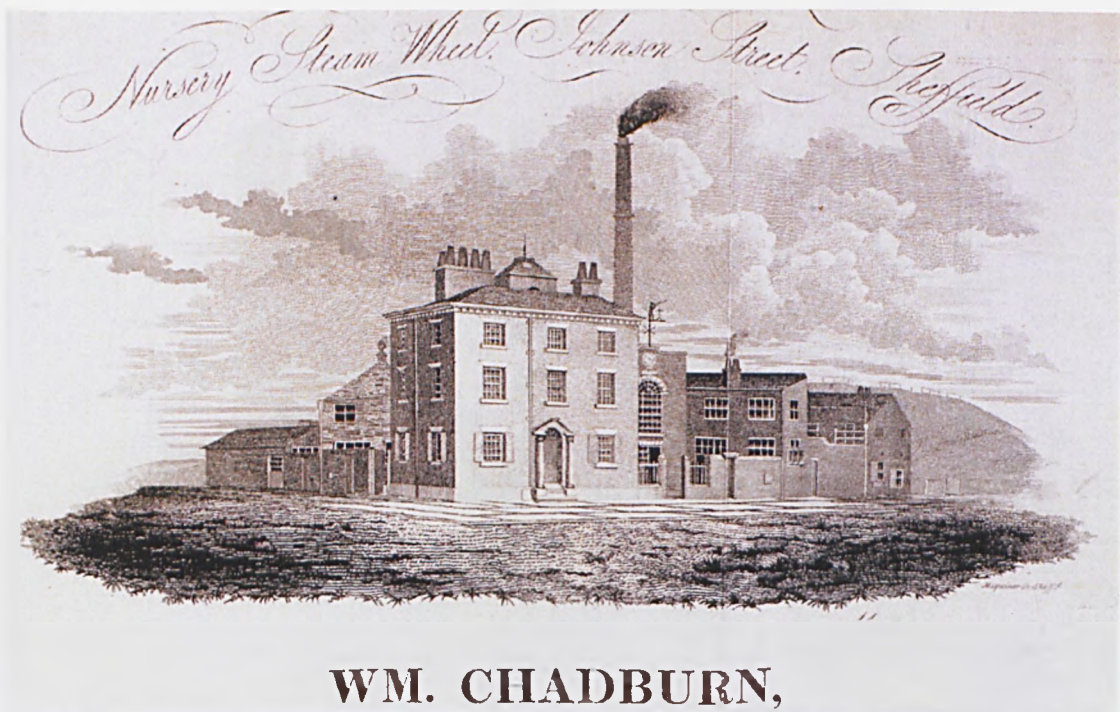

Fig. 4.70 The Nursery Steam Wheel, drawn in 1822 by John Leather (who was also probably its owner) to show alterations and proposed additions to its structure (SCA).



WM. CHADBURN,

Fig. 4.71 Nursery Wheel after its purchase by William Chadburn, manufacturer of scientific instruments, who built the large house on the corner of Johnson and Stanley Streets.

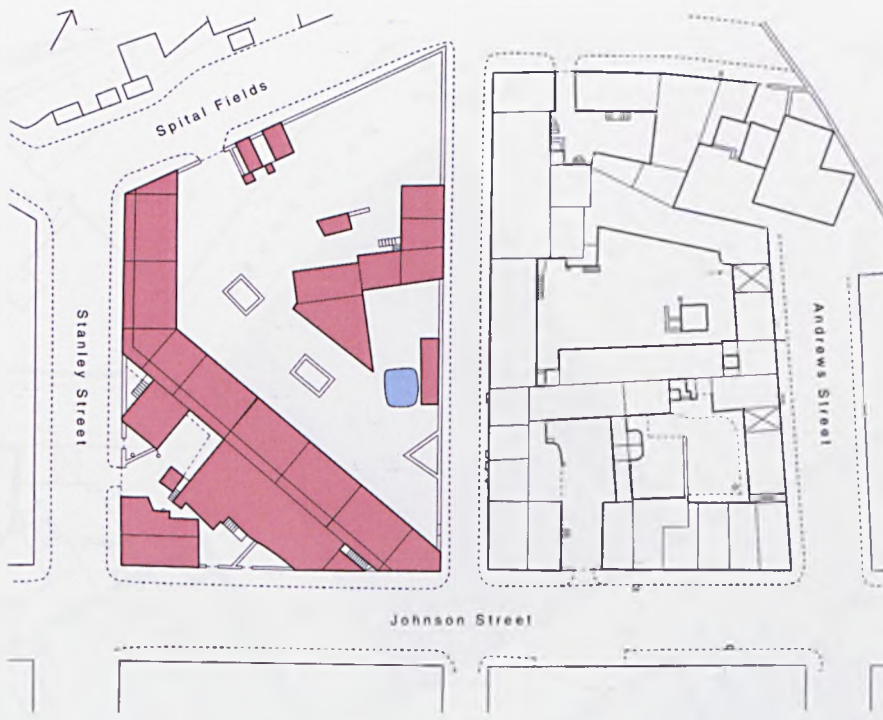
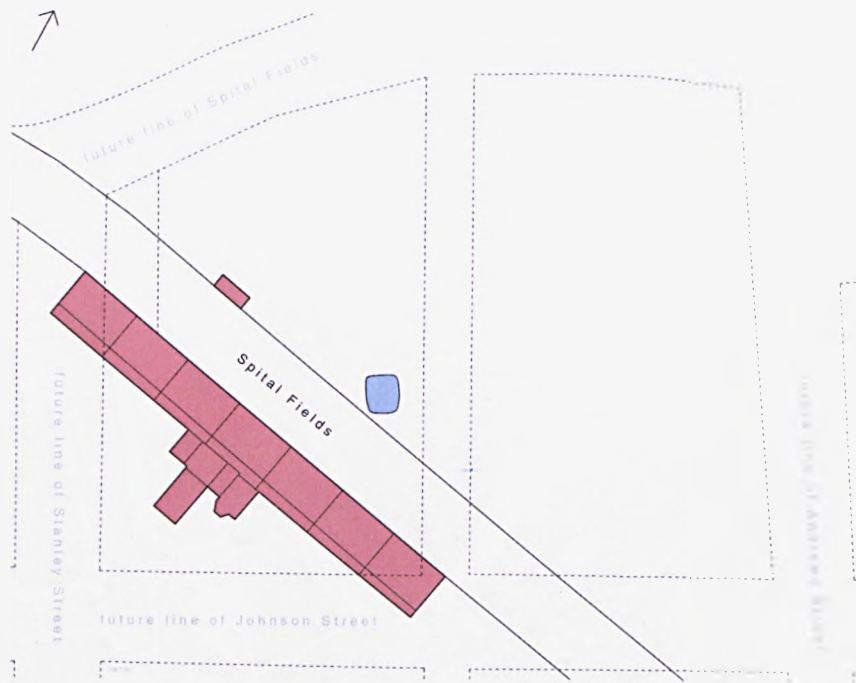

Fig. 4.72 Hypothetical reconstruction of the original Nursery Wheel plan, top, based on the old line of Spital Fields and modifications to the geometry of the later wheel, bottom (from the 1850 OS plan). Scale 1:1000 (author).

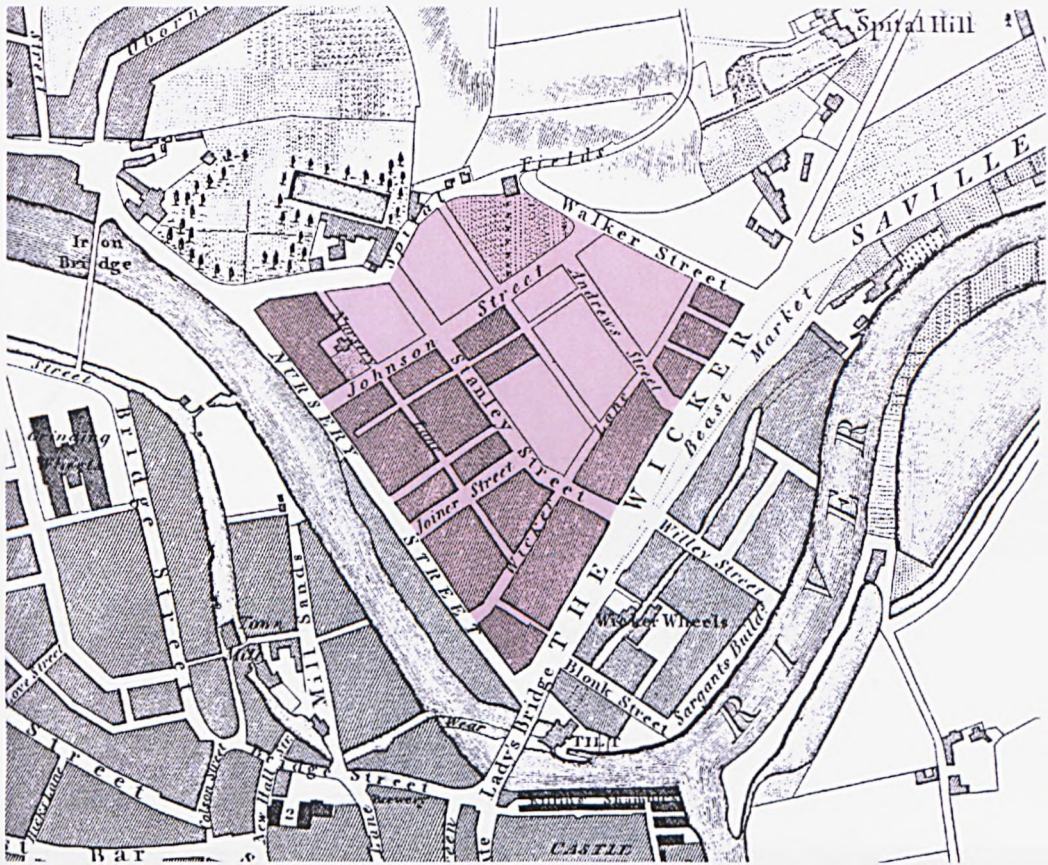

Fig. 4.73 The Duke of Norfolk's Nursery Estate, once again planned and set out by the Fairbank firm of surveyors. North is at top, scale 1:5000 (Fairbank 1808, author's colours).

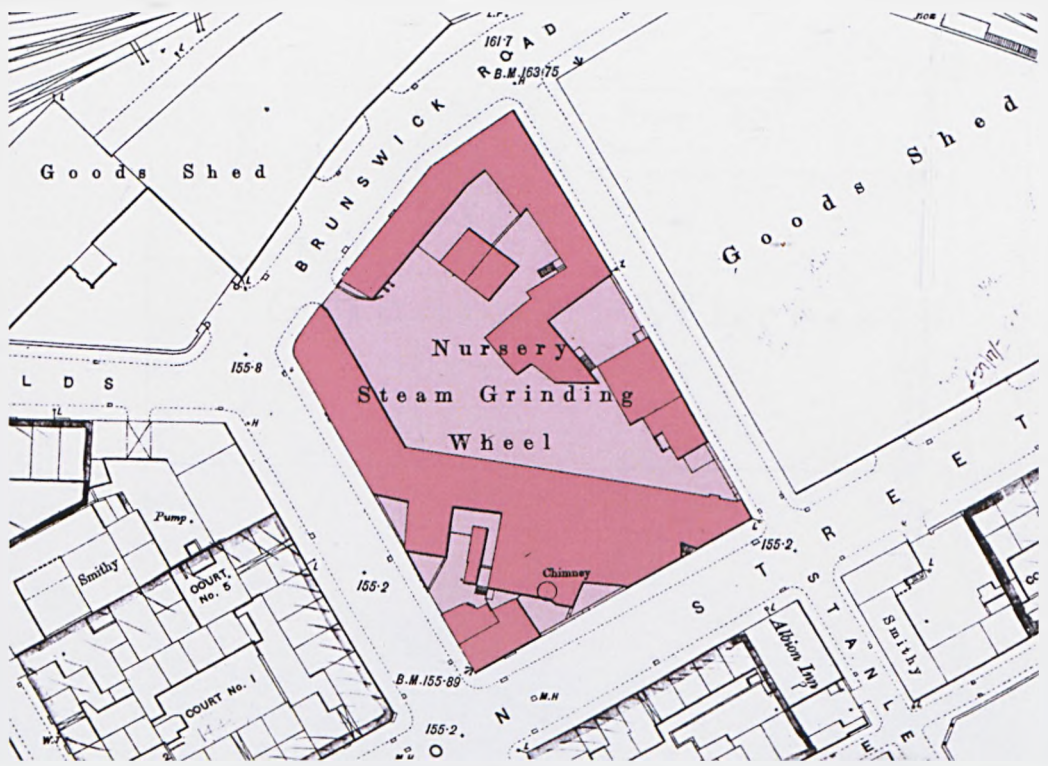

Fig. 4.74 Additions to the Nursery Steam Wheel site by 1889. North is at top, scale 1:1000 (OS, author's colours).

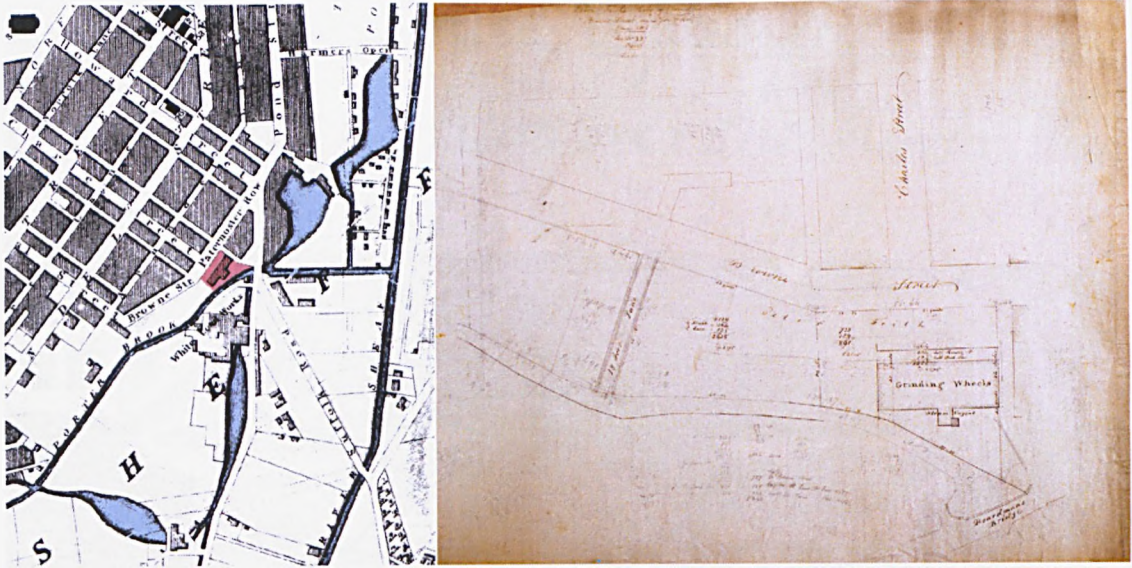

Fig. 4.75 Site location of the Bees' Wax Wheel (Tayler 1832, author's colours).
 Fig. 4.76 Fairbank survey of Peter Frith's Bees' Wax site, 1816 (SCA).



Fig. 4.77 Detail of fig. 4.76 above, with the plan of the Bees' Wax Grinding Wheel. Calculations relate to the site area, including half of all the adjacent roads (SCA).

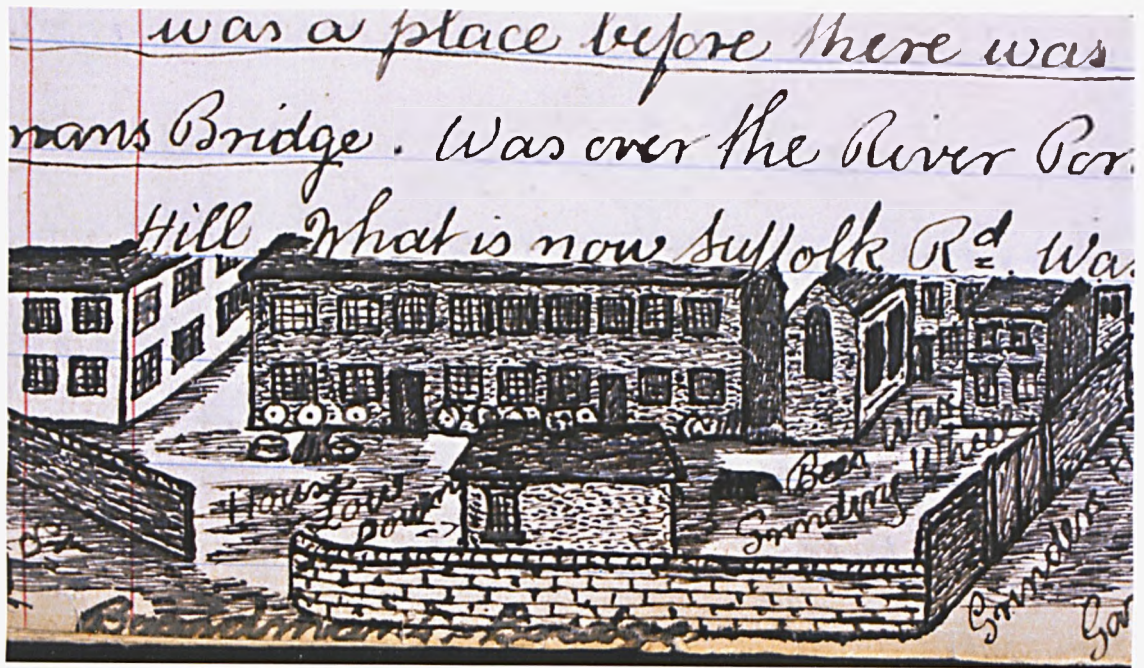

Fig. 4.78 Henry Tatton's thumbnail sketch of the Bees' Wax wheel, which despite its inaccuracy manages to capture the essence of the form (SCL).

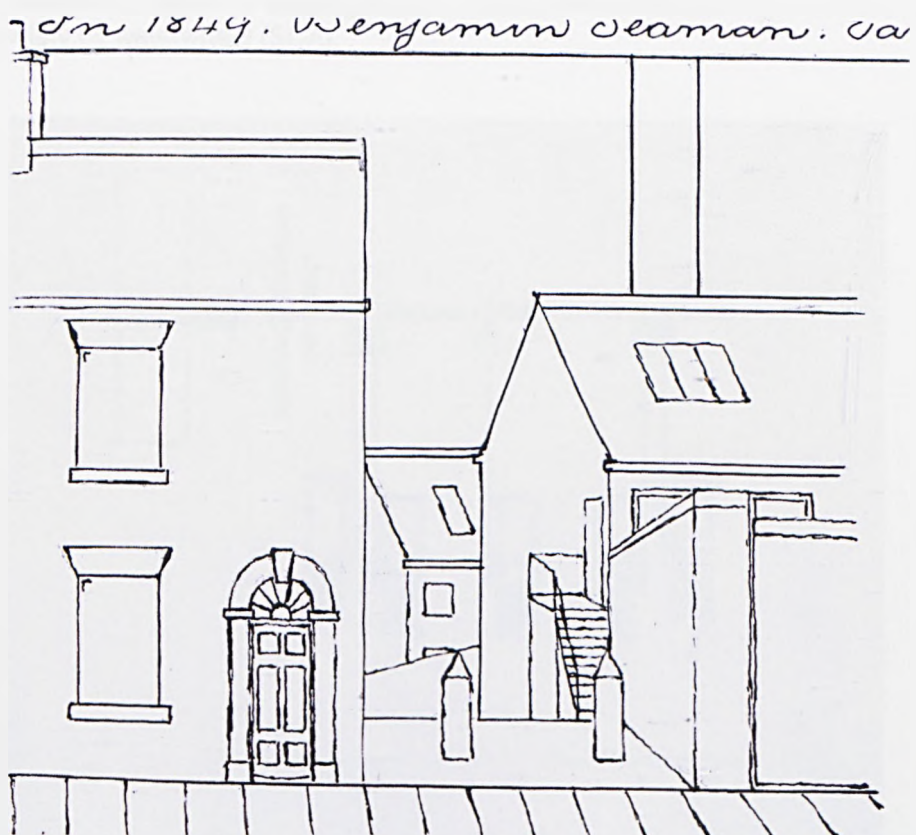

Fig. 4.79 Tatton's view down Grinder's Hill, with the Bees' Wax Wheel on the right, its stack visible behind. Note the stair to the upper chambers and rooflight to the garret level (SCL).

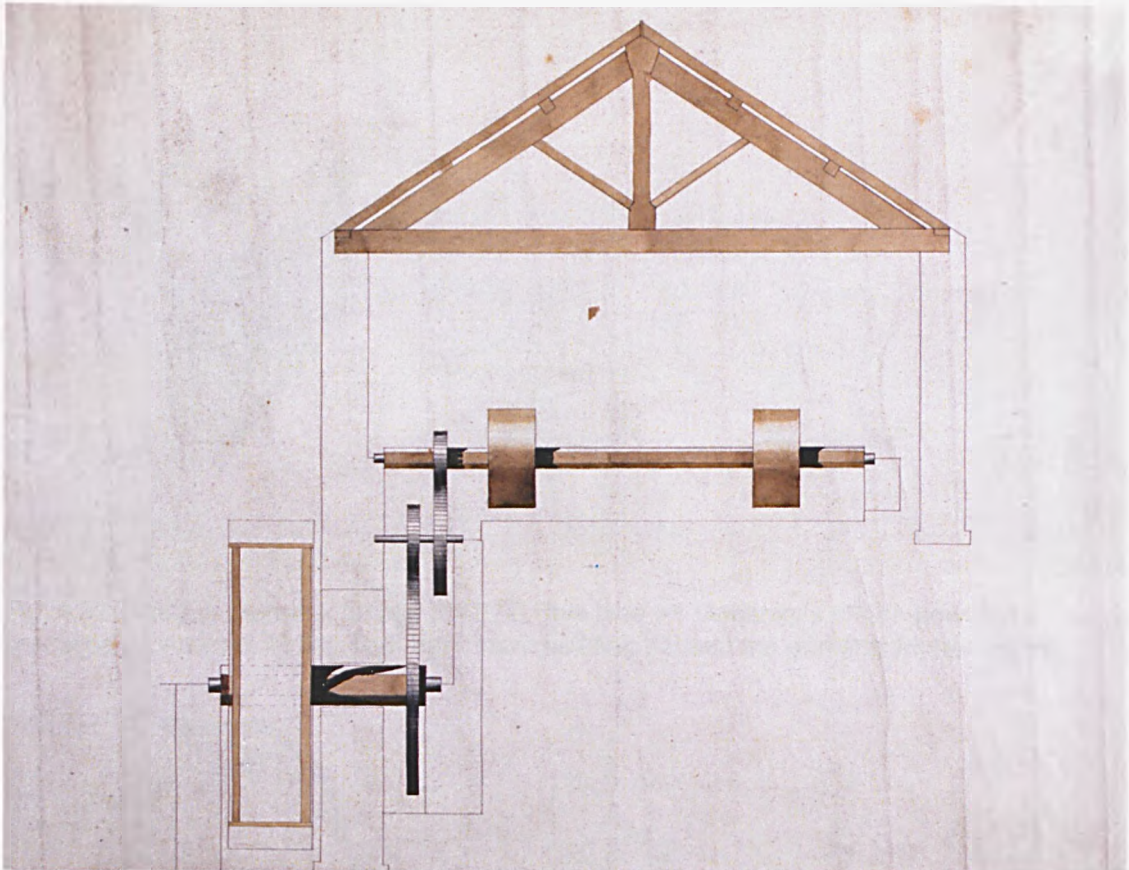

Fig. 4.80 Fairbank scheme for building work at Moscar Wheel on the Sheaf in 1833-34, still powered solely by waterwheel (SCA).

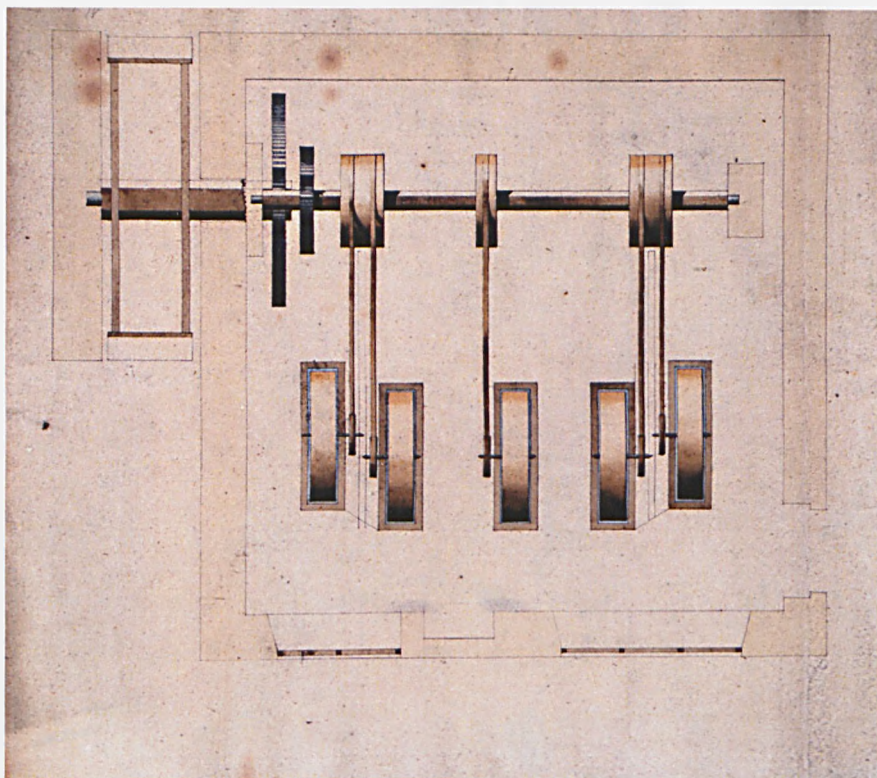

Fig. 4.81 Plan of the same scheme, with arrangement of five heavy troughs facing the large windows at the front, door on the right and ubiquitous hearth in the centre (SCA).

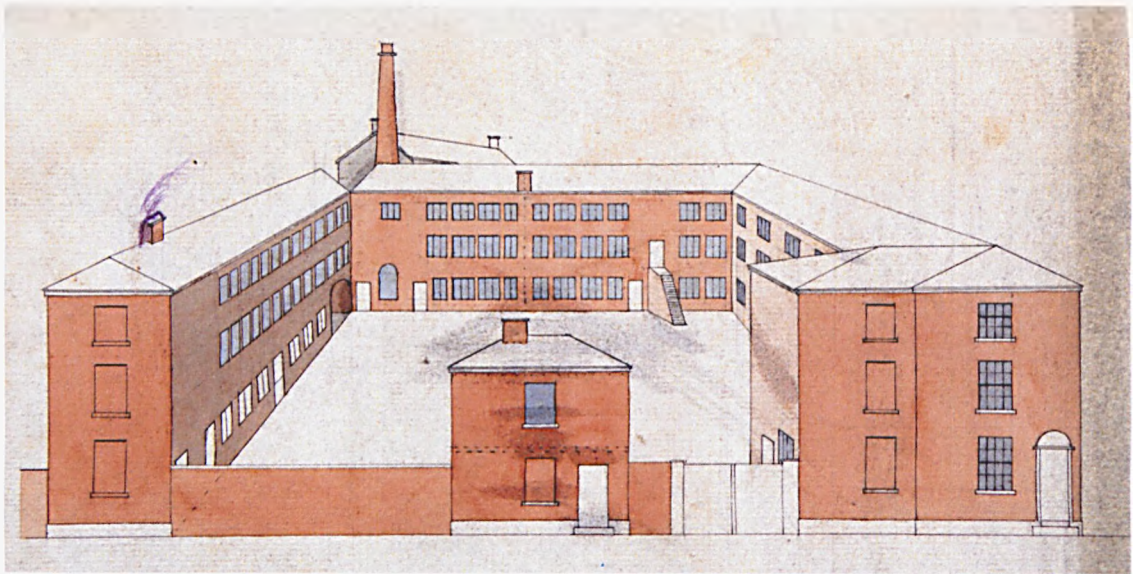

Fig. 4.82 Another Fairbank design (c.1827), this time for Dewsnap's steam-powered premises on Arundel Street. The rear centre building housed the grinding wheels (SCA).



Fig. 4.83 Location of Fairbank's proposed Thomas Street public wheel (red, bottom), outside the police district and some distance from other steam wheels. Scale 1:20,000 (author).

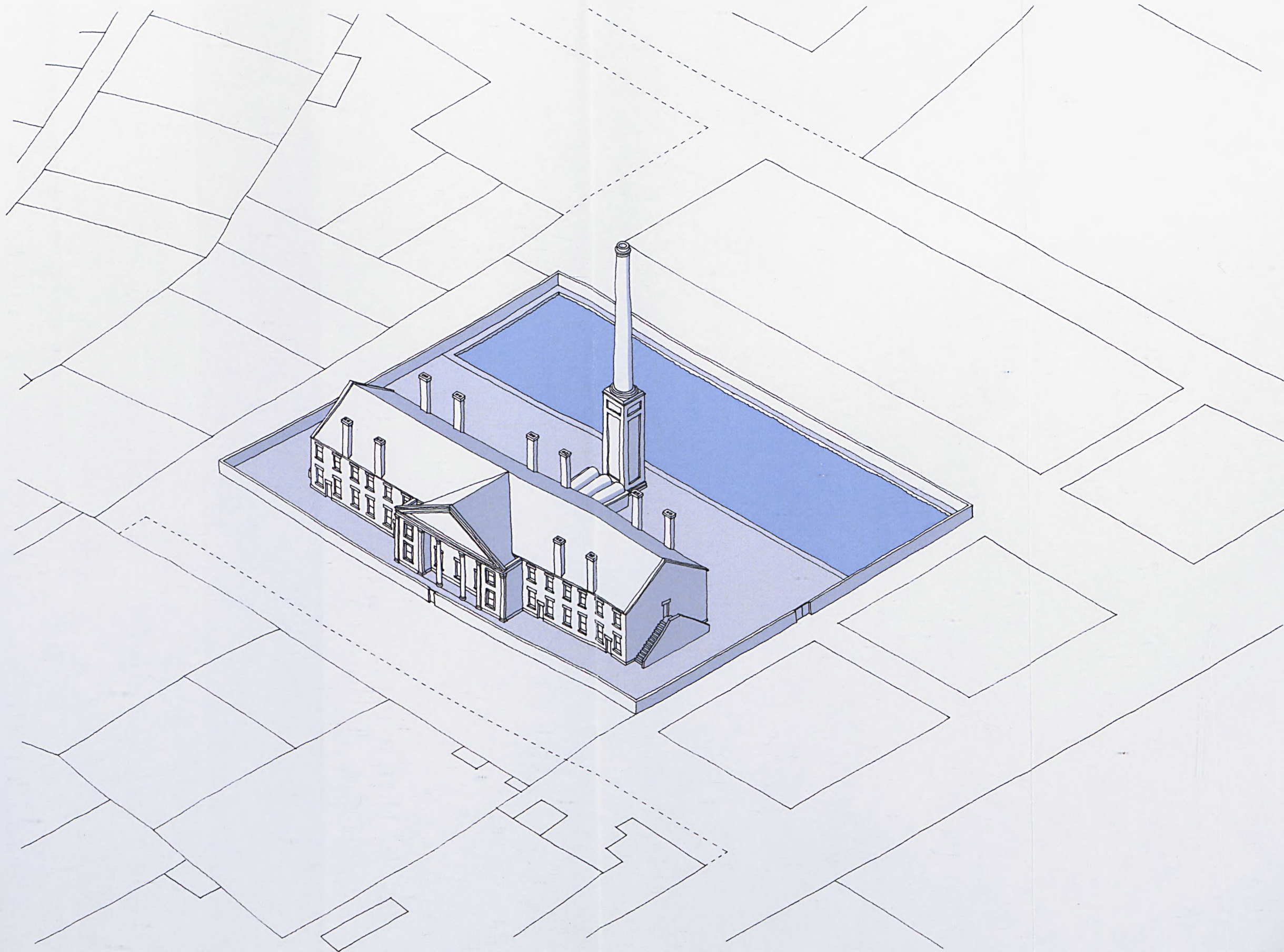

Fig. 4.84 Josiah Fairbank's proposal for a steam-powered public grinding wheel to the south of Sheffield, reconstructed from bills of quantities and rough sketch drawings. Scale 1:500 (author).

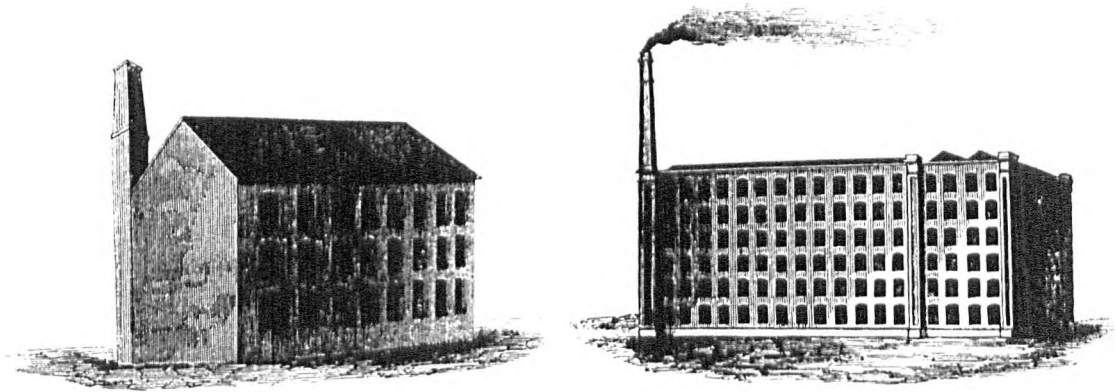

Fig. 4.85 Fairbairn's 'uncouth' (left) and 'improved' textile mill designs, that helped to establish the popularity of limited classical detailing in industrial buildings (Fairbairn).

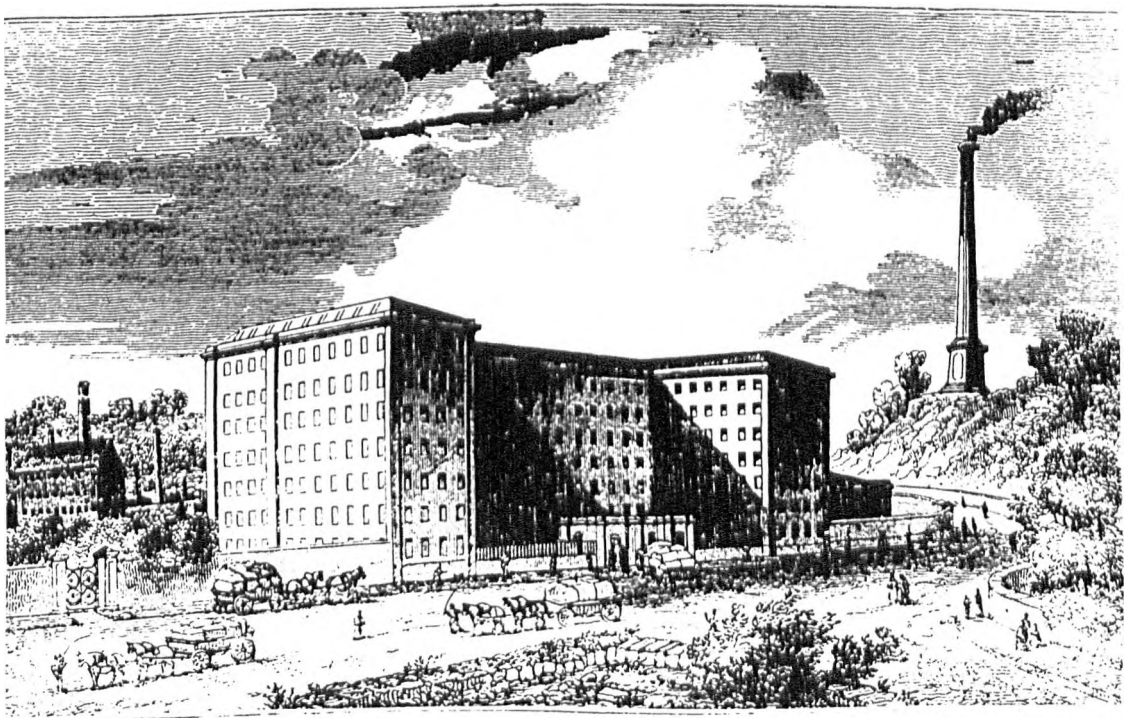

Fig. 4.86 Orrell's Mill at Stockport, where the steam engine stack was elevated to the rank of an architectural symbol in the guise of a classical column on a square base.

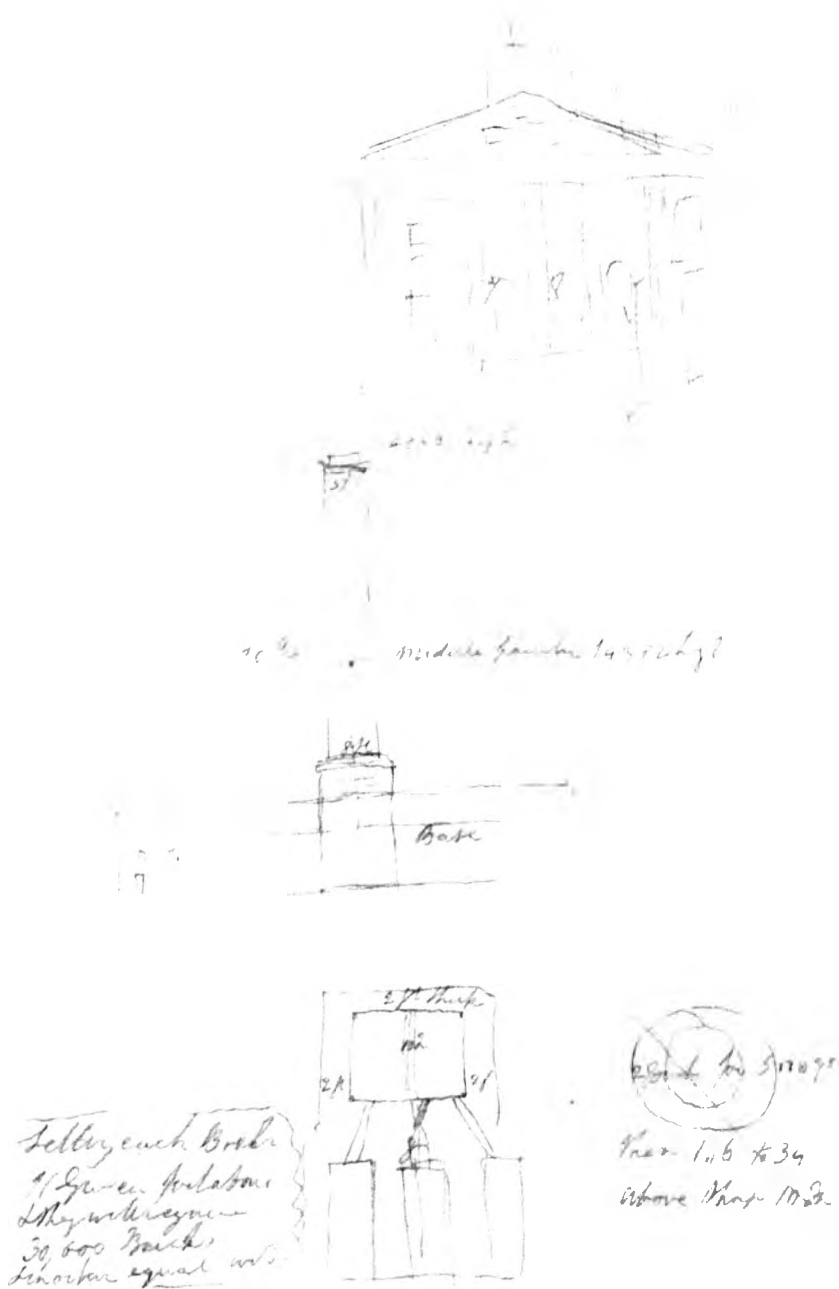

Fig. 4.87 The only known sketches relating to the Thomas Street wheel proposal, showing portico (top), chimney (centre) and boiler layout (bottom; SCA, author's tracing).

20 Iron Beams  on wall !!
 120 Droughs complete at £9

Fig. 4.88 Small in-line sketch of the iron inverted 'T' beam for the Thomas Street wheel, designed to carry the jack-arched first floor (SCA).

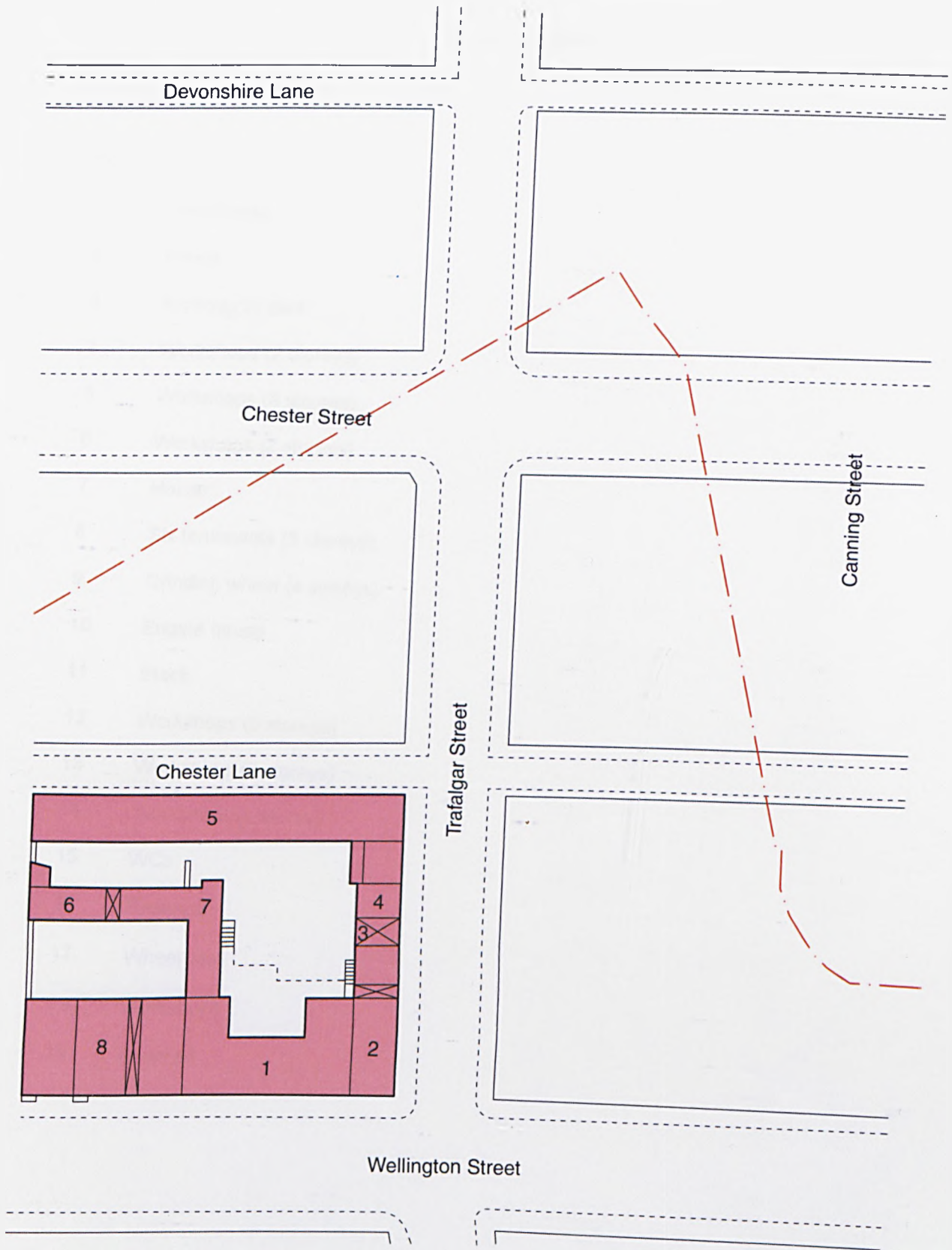

Fig. 4.89 The premises of Sarah Wells & Sons in 1833, before the construction of Wells' Wheel opposite. Scale 1:500 (author).

Sarah Wells & Sons

Wells' Wheel, reconstructed site plans (1833-1850)

scale 1:500

key:

- 1 Warehouse
- 2 House
- 3 Archway to yard
- 4 Workshops (2 storeys)
- 5 Workshops (3 storeys)
- 6 Workshops (2 storeys)
- 7 House
- 8 Six tenements (3 storeys)
- 9 Grinding wheel (4 storeys)
- 10 Engine house
- 11 Stack
- 12 Workshops (3 storeys)
- 13 Workshops (2 storeys)
- 14 Workshops (1 storey)
- 15 WCs
- 16 Reservoir
- 17 Wheel yard
- 18 Workshops
- 19 Swarf pit

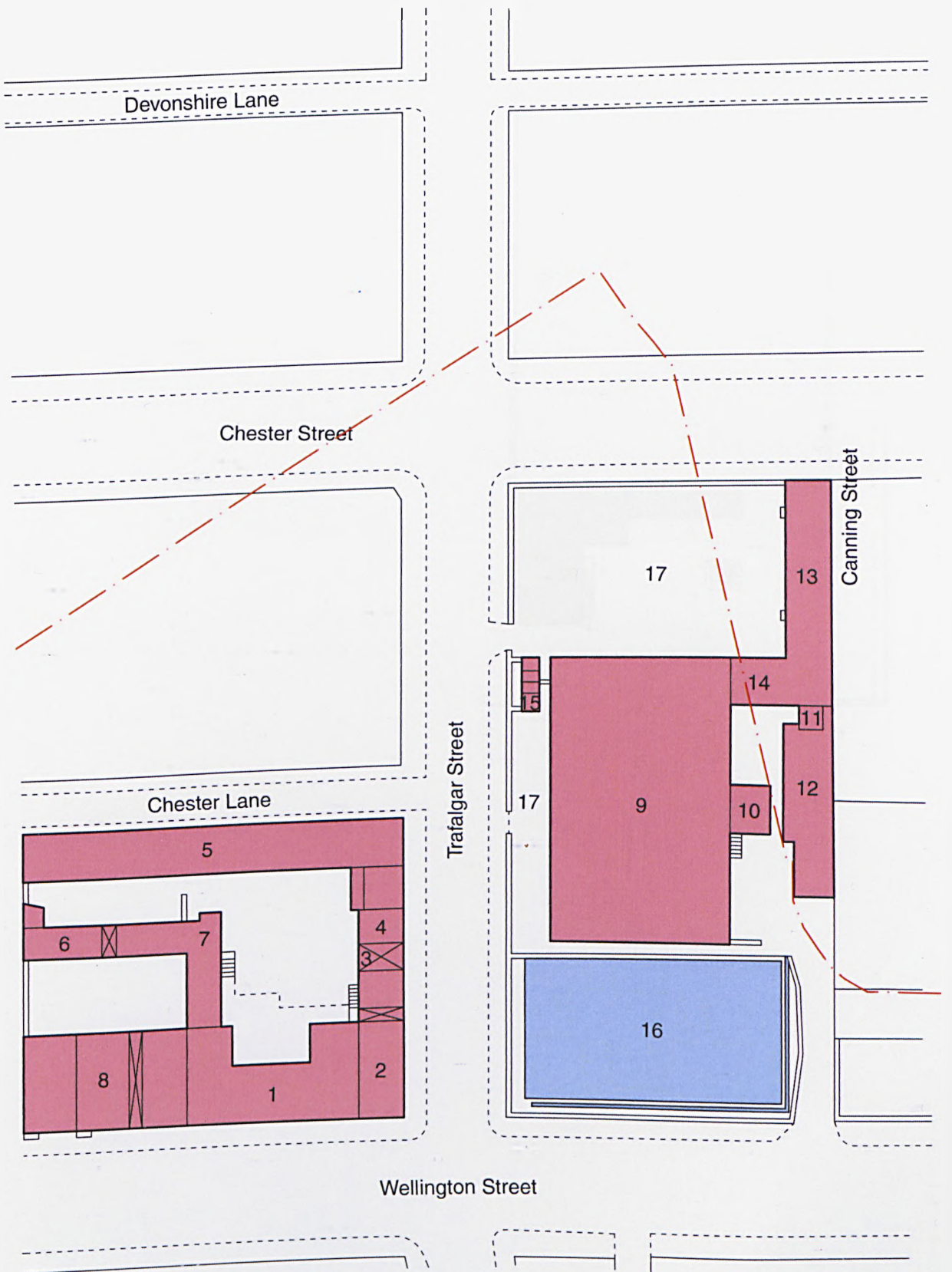

Fig. 4.90 Wells' Wheel in 1842 based on William Flockton's valuation of the same date. Scale 1:500 (author).

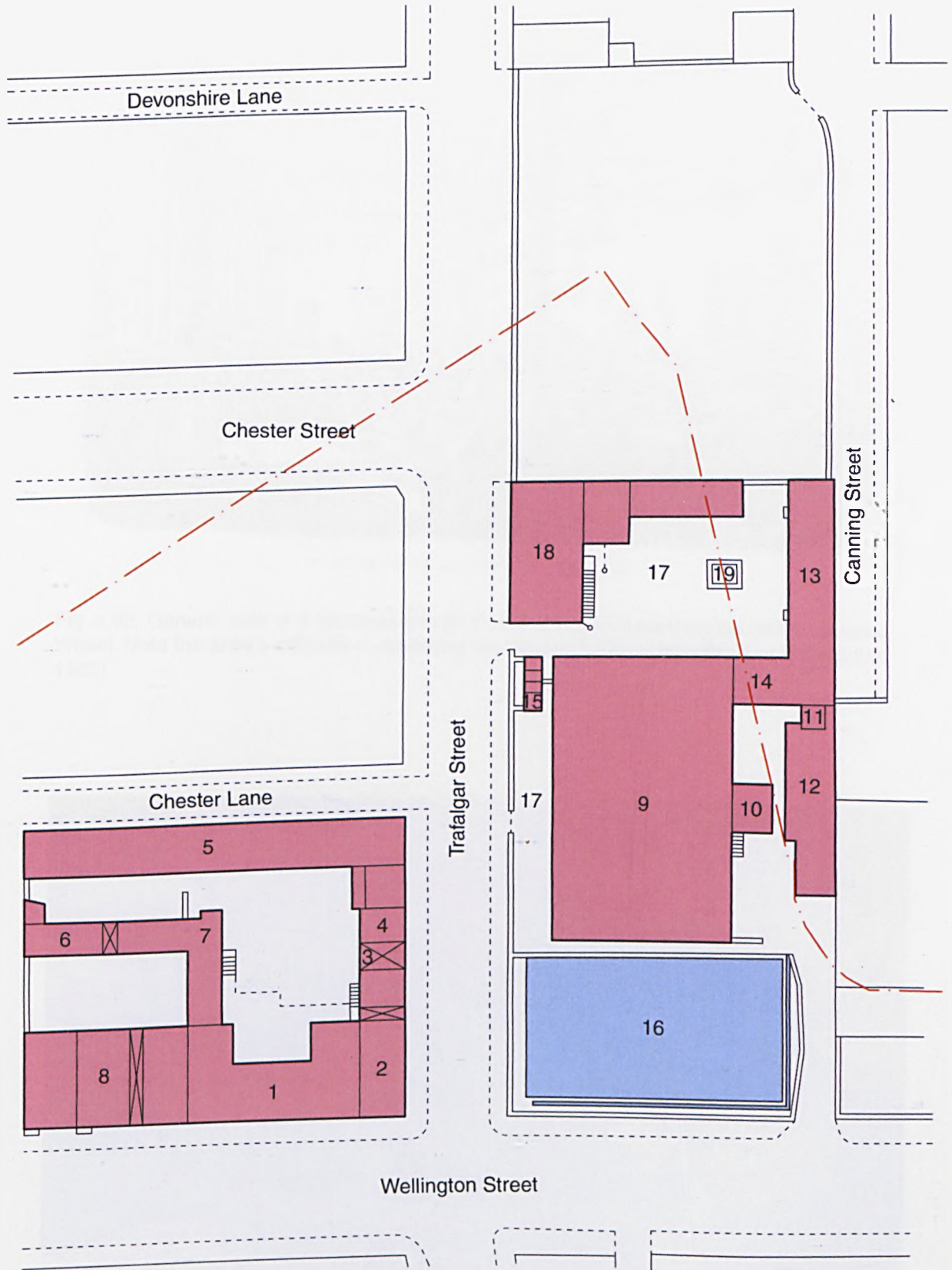
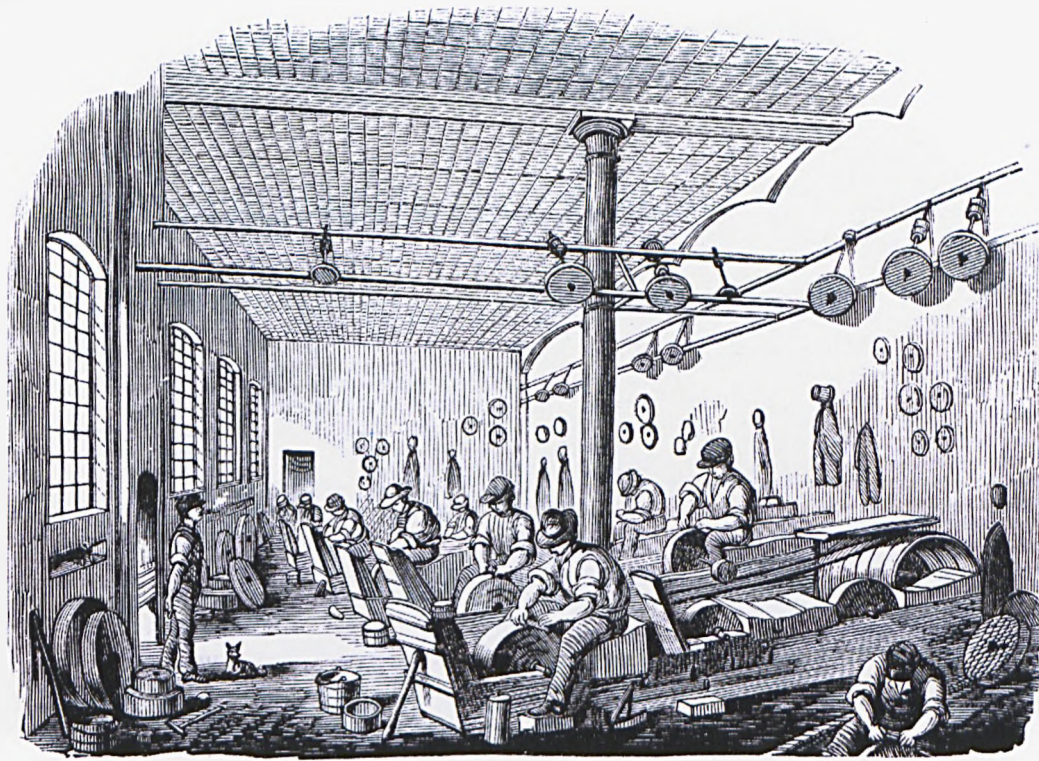

Fig. 4.91 Wells' Wheel in 1850, derived from the OS sheet and valuation records. Scale 1:500 (author).



A SHEFFIELD GRINDERS' "HULL."

Fig. 4.92 Generic view of a Sheffield grinder's 'Hull', possibly based on the Union Grinding Wheel. Note the artist's difficulty in rendering the vaulted brick ceiling (Pawson & Brailsford 1862).



Fig. 4.93 Kangaroo Works front workshop range, built over the reservoir of what was previously Wells' Wheel (remains of which survive in the yard behind; author).



Fig. 4.94 Back of Kangaroo Works with the set-back portion of Wells' Wheel, centre (author).



Fig. 4.95 Detail of partly demolished facade of Wells' Wheel, with partial survival of two window openings and lintels. The springing of the vaults is visible behind (author).



Fig. 4.96 Projecting tie rod that connected lateral iron beams and counteracted the outward thrust of the vaults, with the flange of an embedded 'T' beam visible beneath (author).



Fig. 4.97 Looking up to the first and second floor springing structures. The third floor would have been constructed of timber boarding (author).

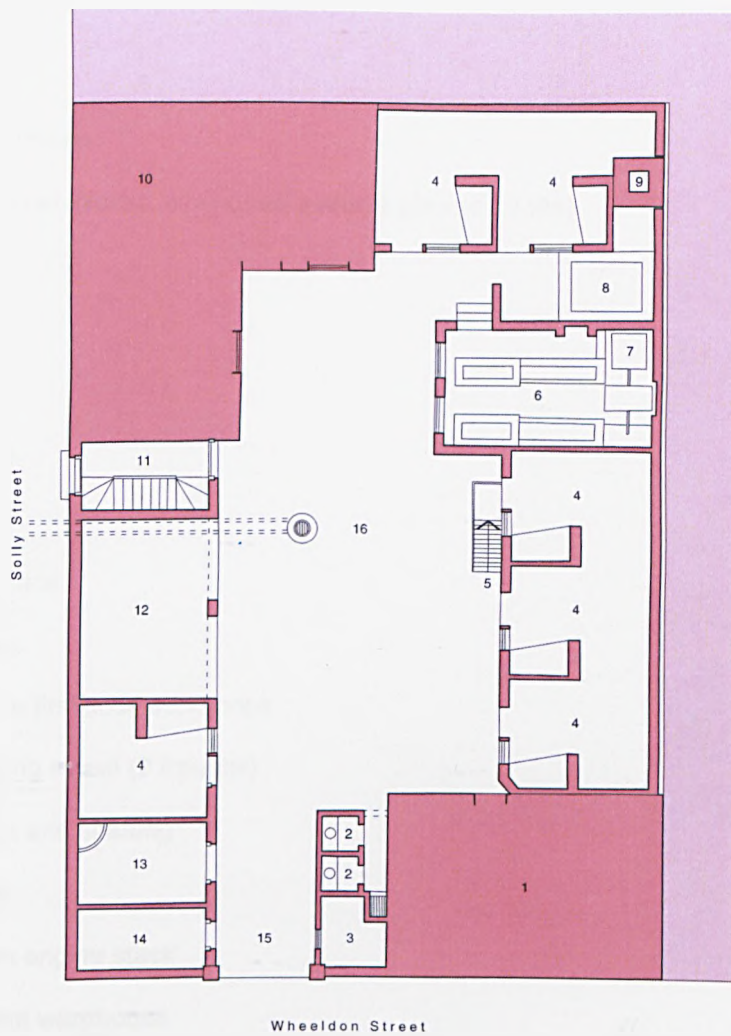

Fig. 4.98 One of the smallest steam-powered grinding wheels proposed (just two troughs), from a plan for the Wheeldon Street works of Wilson & Southern. Scale 1:200 (author).

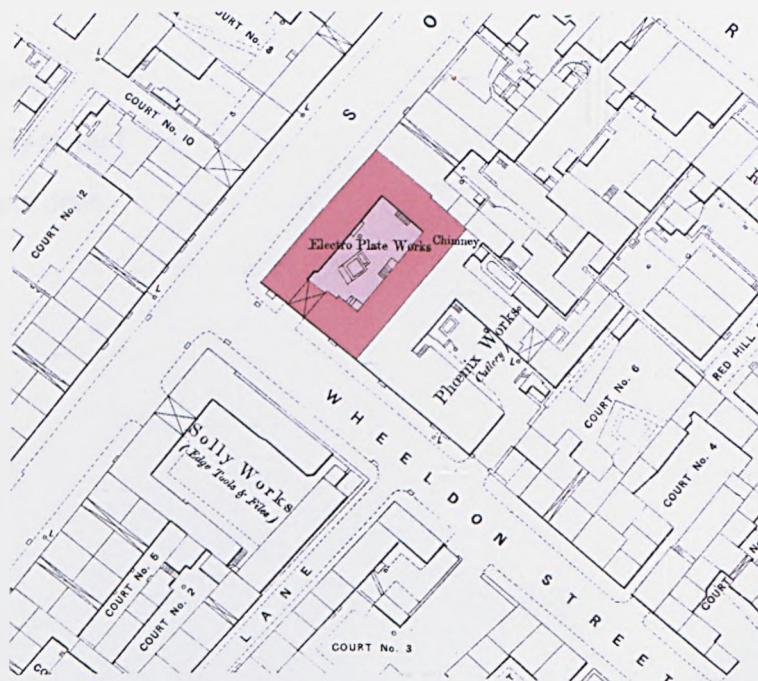

Fig. 4.99 Wheeldon Works on the 1889 OS plan. The layout suggests that the proposed scheme may have been abandoned or later demolished. North is at top, scale 1:1000 (OS, author's colours).

Wilson & Southern

Wheeldon Street Works, proposed ground plan (c.1830s)

scale 1:100

key:

- 1 House
- 2 Privy
- 3 Ash place
- 4 Hearth
- 5 Stair to first floor workshops
- 6 Grinding wheel (2 troughs)
- 7 Drums and shafting
- 8 Boiler
- 9 Steam engine stack
- 10 Present warehouse
- 11 Stair to first floor
- 12 Coke shed
- 13 Stable
- 14 Hay place
- 15 Gateway to yard
- 16 Yard and drain

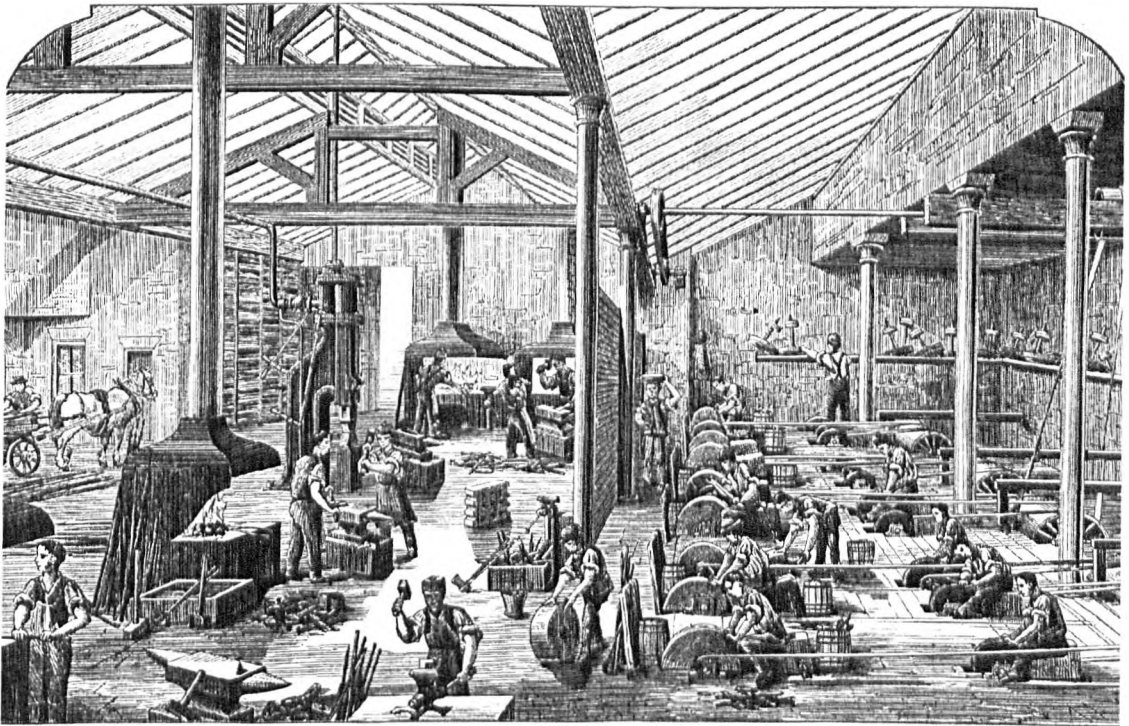

Fig. 4.100 Open plan grinding troughs in a large, glass-roofed shed with steam hammers and hand forges, belonging to James Howarth & Sons (Pawson & Brailsford 1862).



Fig. 4.101 Scythe grinders at work in unappealing conditions; scythes were generally manufactured out of town in water-powered works such as at Abbeydale.

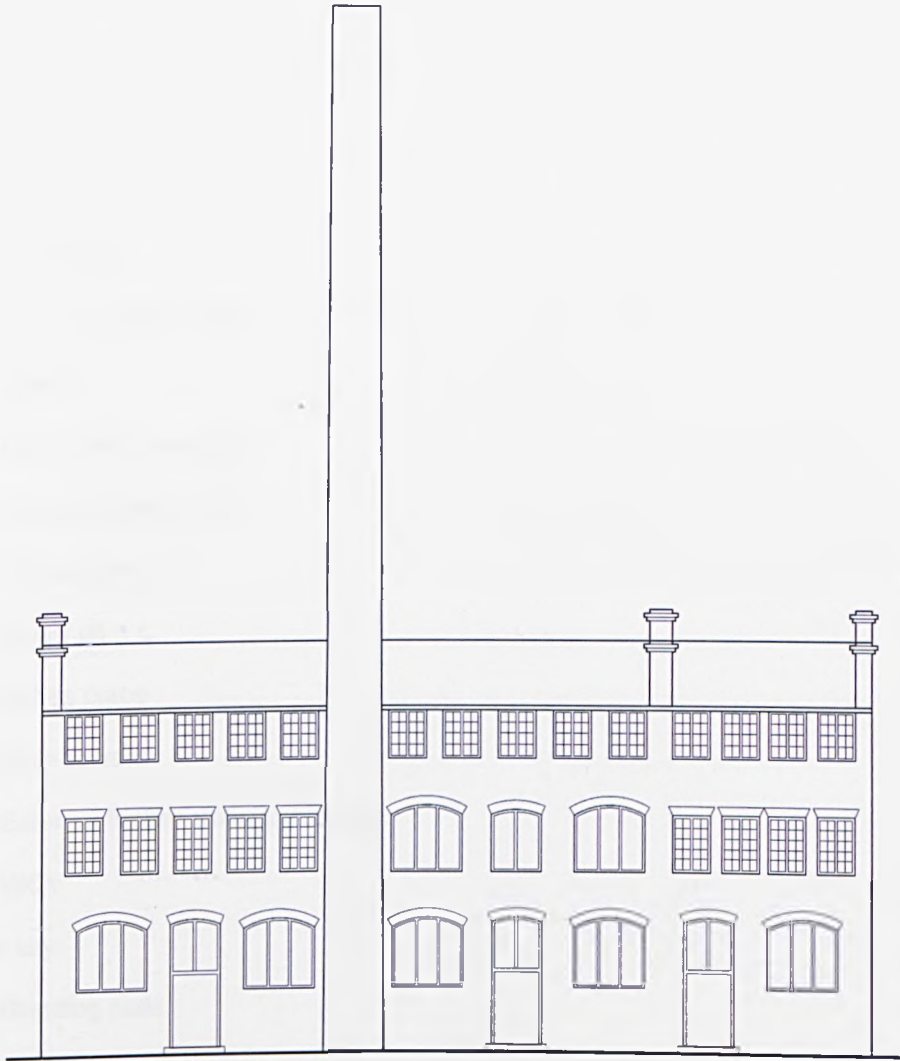

Fig. 4.102 Gaunt's Cambridge Street grinding wheel and cutlers' shops, south elevation to yard. Scale 1:200 (author).

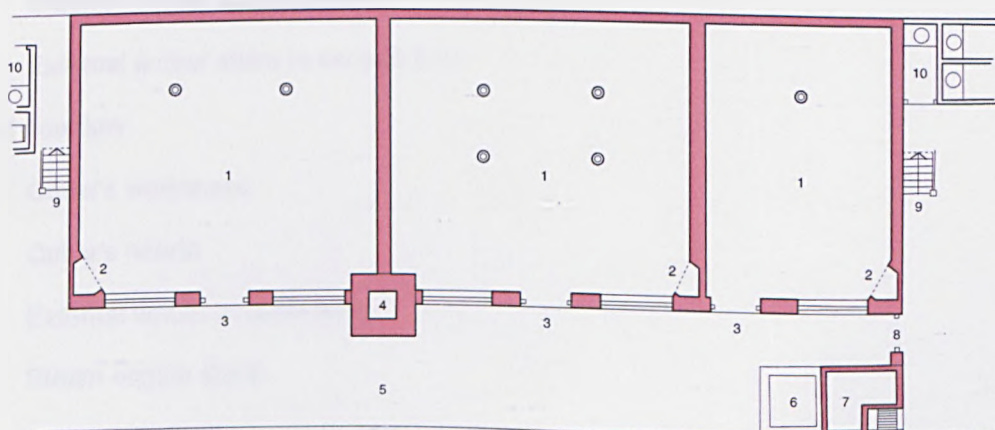

Fig. 4.103 Ground floor plan of Gaunt's wheel, scale 1:200 (author).

Gaunt's Grinding Wheel

Cambridge Street, floor plans (c.1890)

scale 1:200

ground floor key:

- 1 Heavy grinding hulls
- 2 Hearth
- 3 Door from wheel yard
- 4 Steam engine stack
- 5 Wheel yard
- 6 Swarf pit
- 7 Ashes place
- 8 Gate to yard
- 9 External timber stairs to first floor
- 10 WCs

first floor key:

- 1 Grinding hulls
- 2 Hearth
- 3 Cutler's hearth
- 4 Steam engine stack
- 5 Cutler's workshops
- 6 External timber access decks
- 7 External timber stairs to second floor

second floor key:

- 1 Cutler's workshops
- 2 Cutler's hearth
- 3 External timber access decks
- 4 Steam engine stack

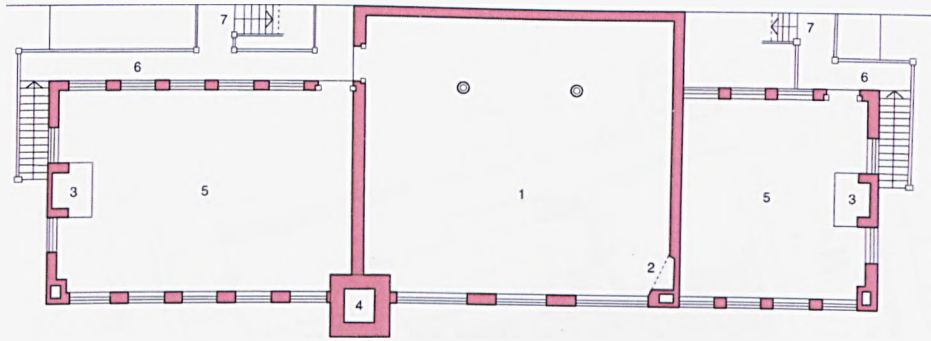

Fig. 4.104 First floor plan of Gaunt's wheel, scale 1:200 (author).

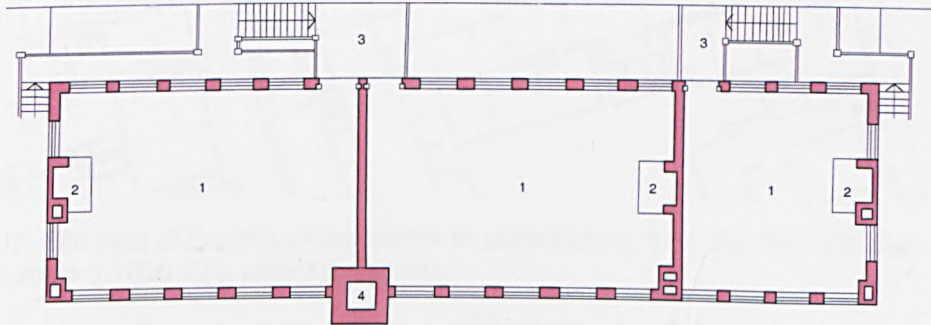

Fig. 4.105 Second floor plan of Gaunt's wheel, scale 1:200 (author).



Fig. 4.106 Linear plots of land on Coalpit Lane in 1736, a pattern that has survived in plan to the present day (Gosling 1736, author's colours).

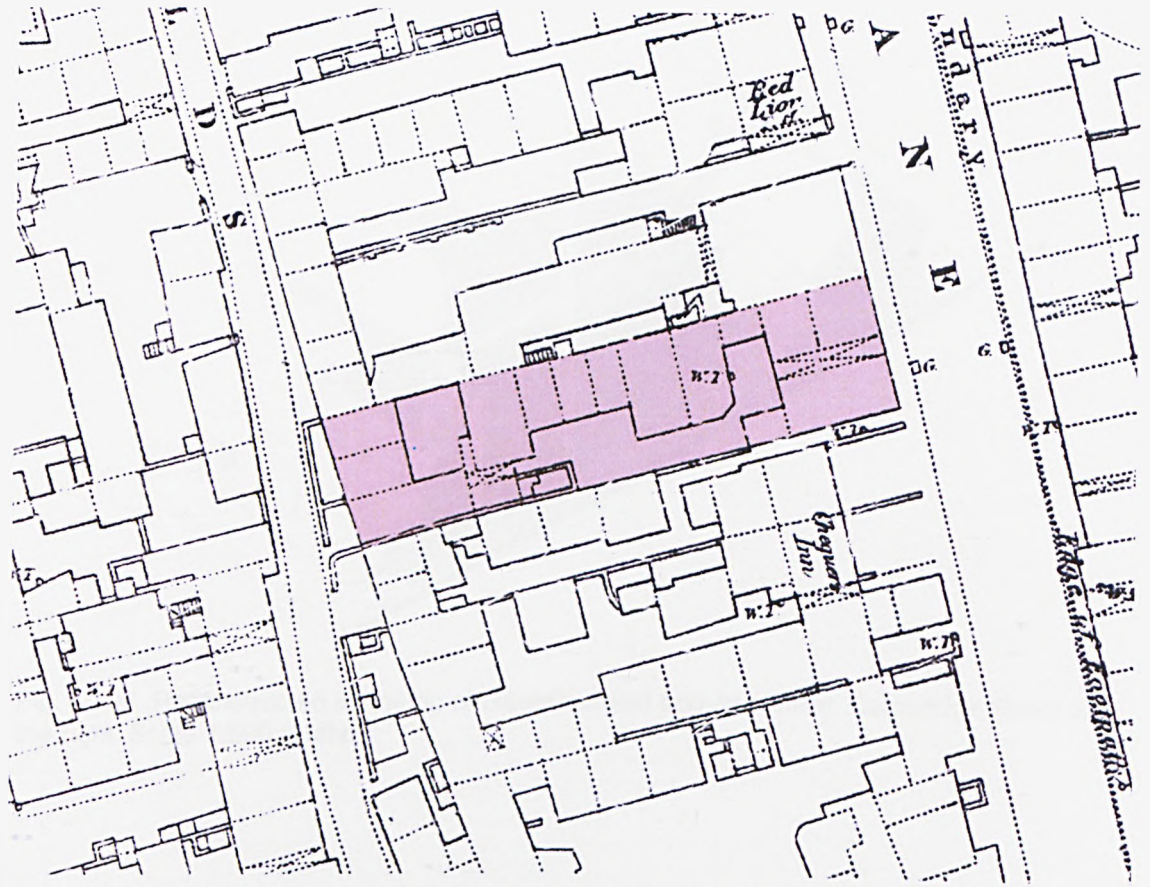

Fig. 4.107 Site plan of Gaunt's wheel before its construction, from the 1850 OS plan. North is at top, scale 1:1000 (OS, author's colours).

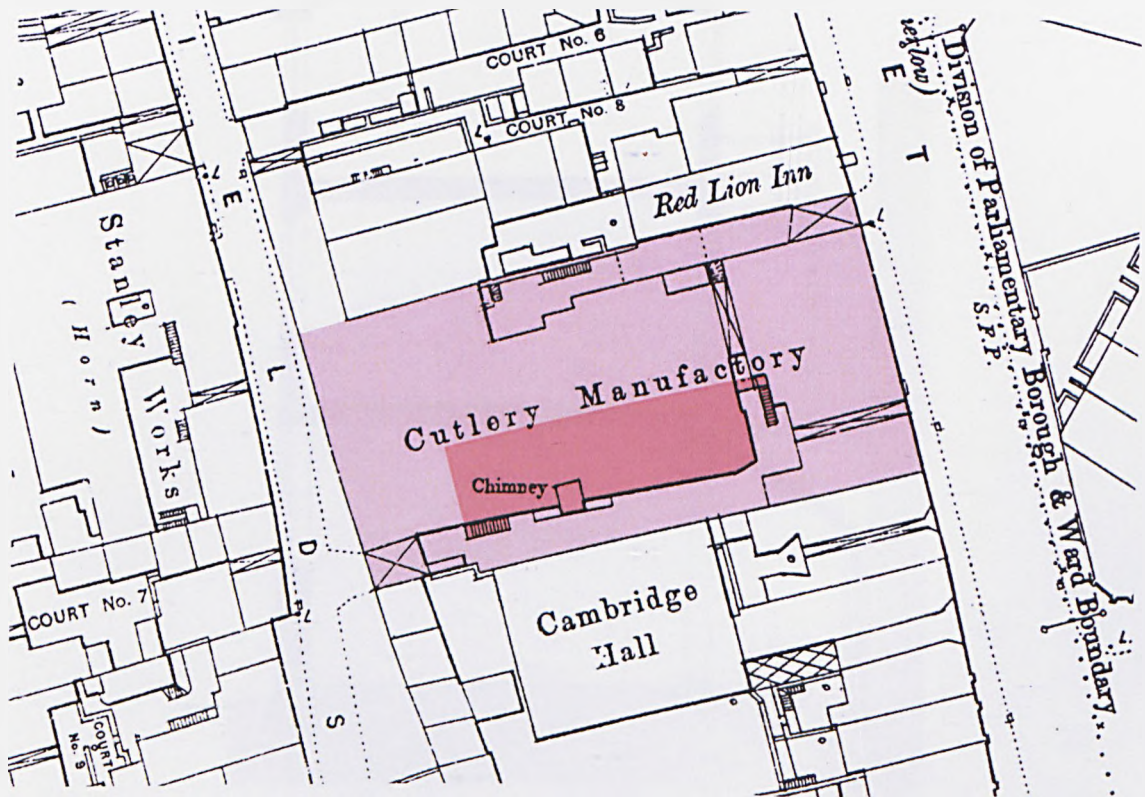

Fig. 4.108 Site plan of Gaunt's works (pale pink) and grinding wheel (pink) in 1889, with minimal alterations to the proposed plans. Scale 1:1000 (OS, author's colours).

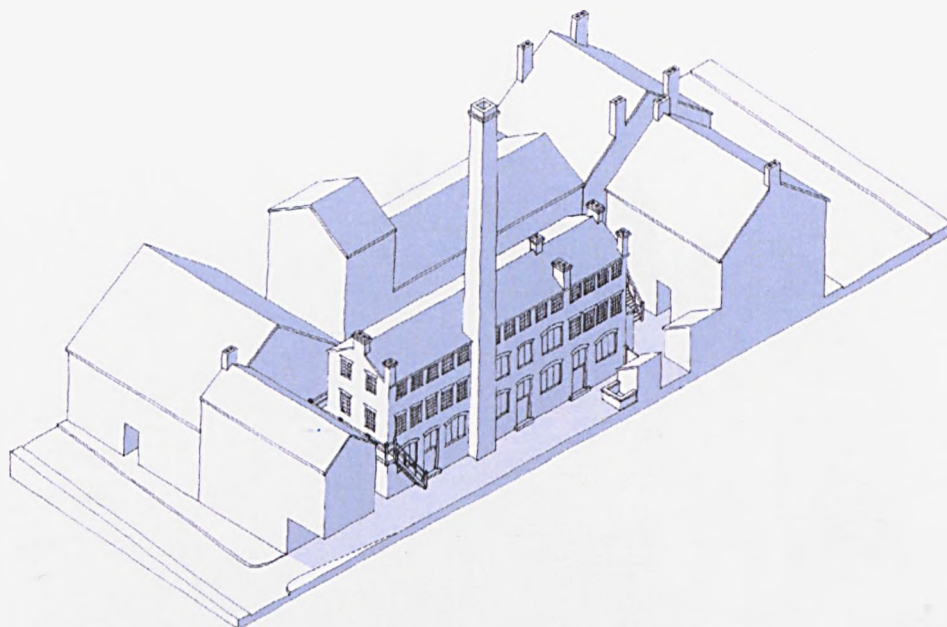

Fig. 4.109 Reconstructed isometric of Gaunt's wheel and its context. Cambridge Street is to the right. Scale 1:500 (author).

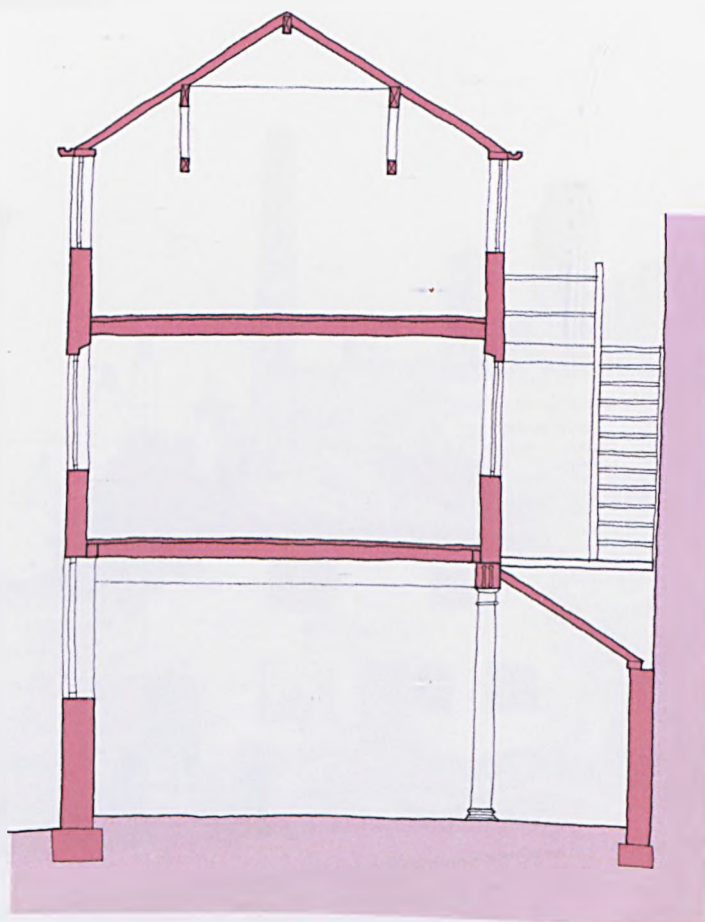

Fig. 4.110 Short section of Gaunt's wheel, showing the lean-to rear projection housing the extra machinery required in the grinding hulls. Scale 1:100 (author's redrawing).



Fig. 4.111 Late nineteenth century view of Cambridge Street, with the stack of Gaunt's wheel in the background.



Fig. 4.112 Another view of Cambridge Street with Gaunt's wheel visible over the rooftops (SCL, author's highlighting).

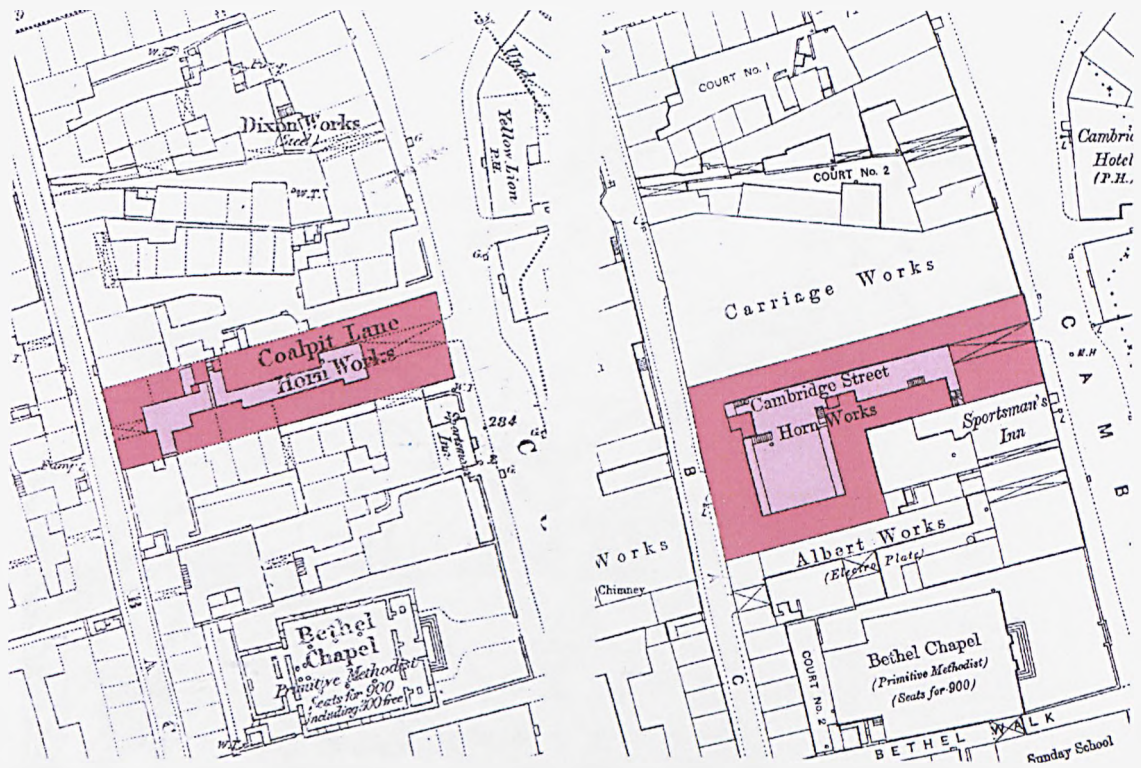

Figs. 4.113 and 4.114, Coalpit Lane Horn Works (later Leah's Yard) on the OS plans of 1850 (left) and 1889 (right). North is at top, scale 1:1000 (OS, author's colours).

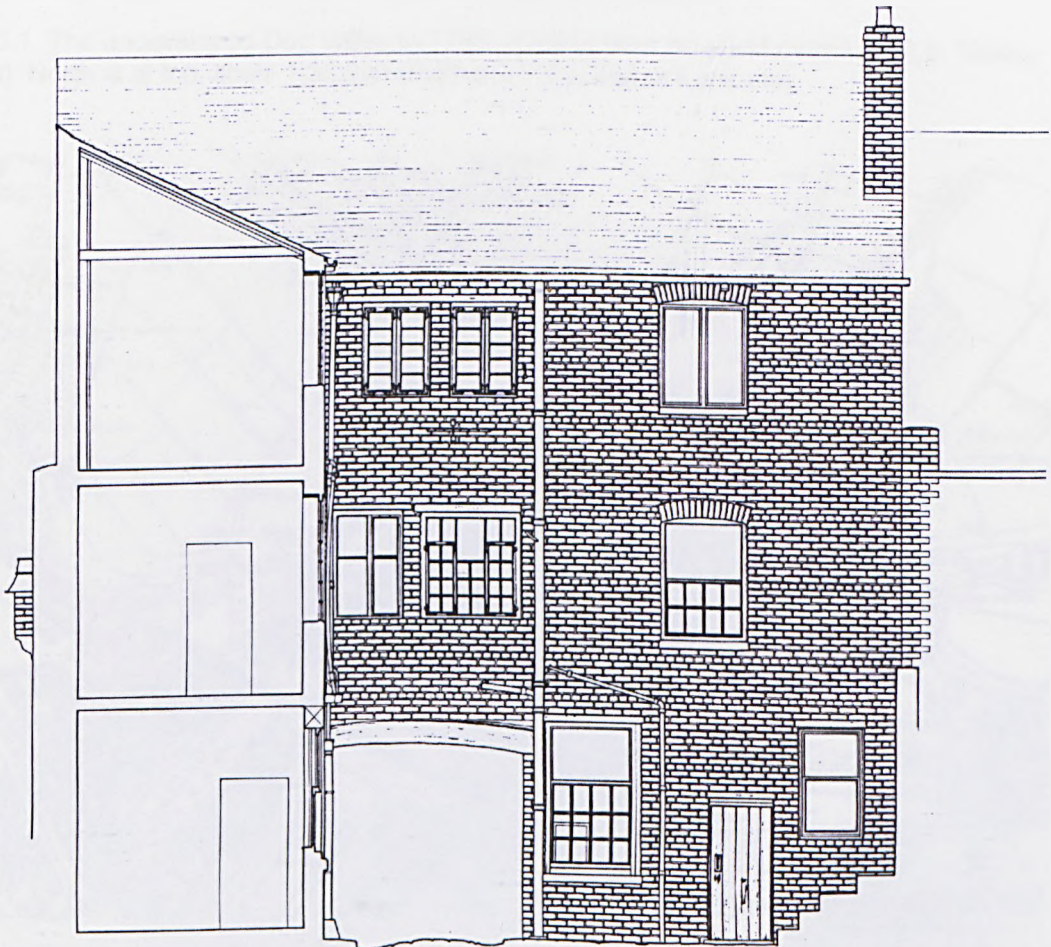

Fig. 4.115 Section through long workshop range at Leah's Yard. Scale 1:200 (author).

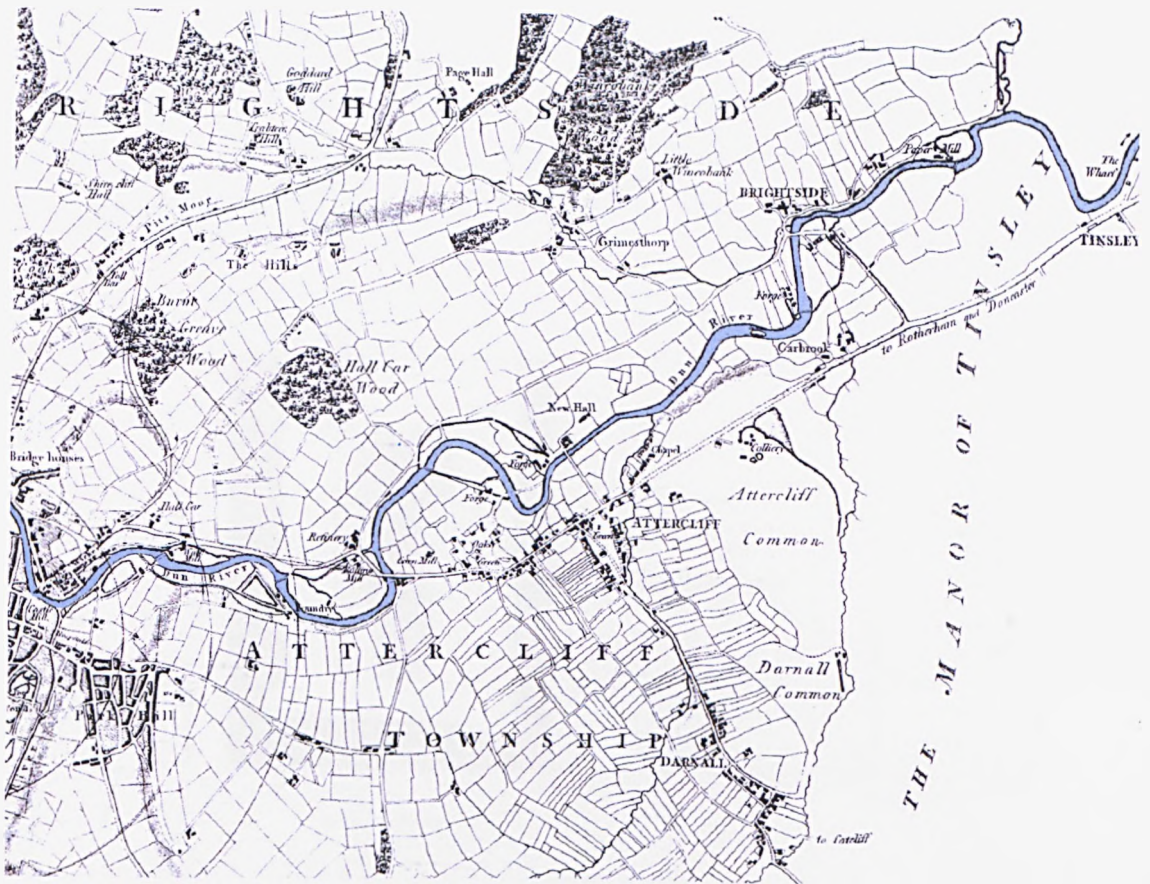

Fig. 5.1 The undeveloped Don Valley in 1795, winding from Sheffield centre (left) to Tinsley (right). North is at top, scale 1:35,000 (Fairbank 1795, author's colours).

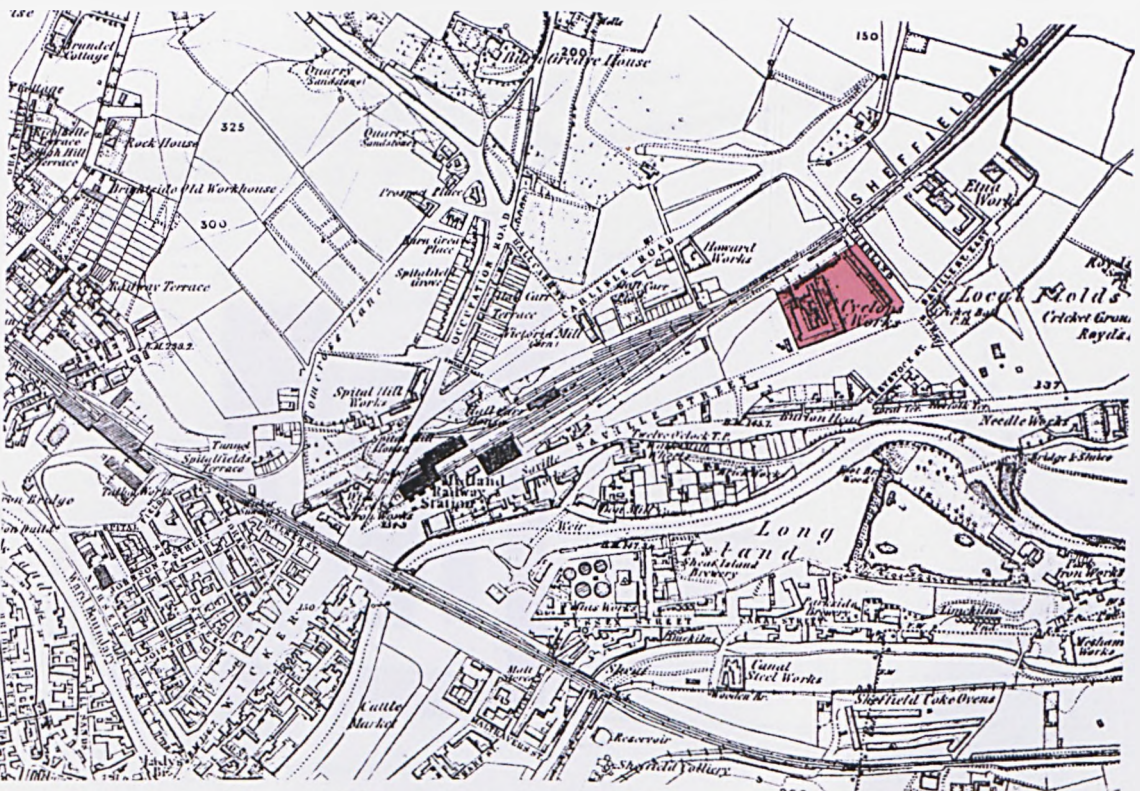

Fig. 5.2 Site of Johnson & Cammell's Cyclops Works in 1850, the first steelmakers to relocate alongside the railway. North is at top, scale 1:10,000 (OS, author's colours).

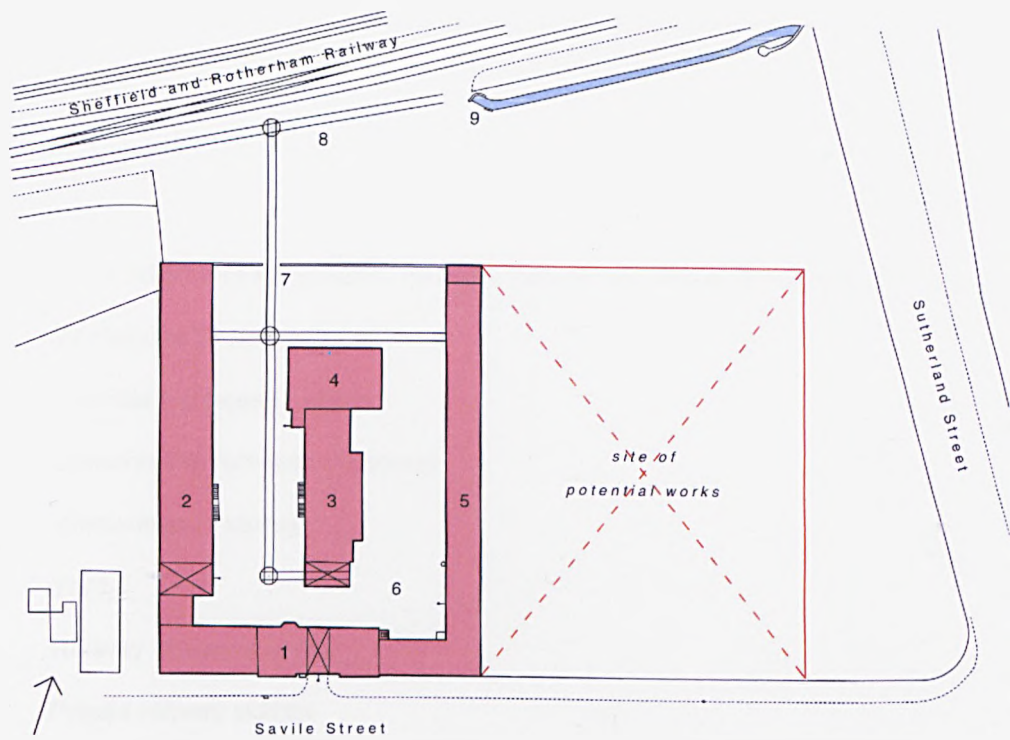

Fig. 5.3 Reconstructed first phase of the Cyclops Works, 1845. Scale 1:1500 (author).

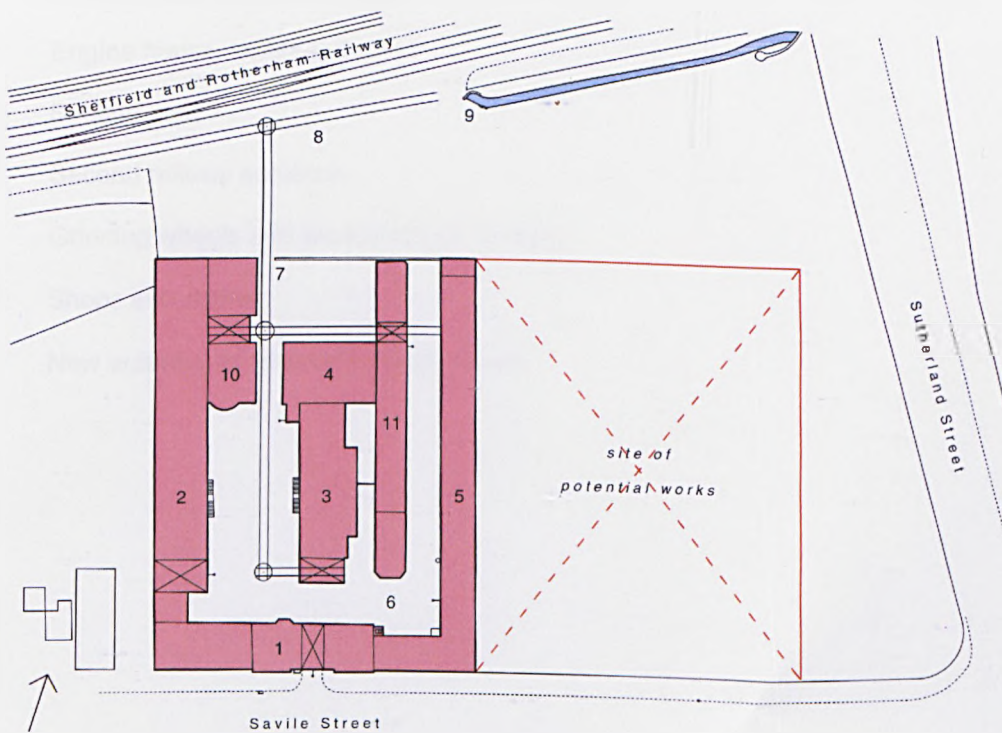

Fig. 5.4 Reconstructed second phase of the Cyclops Works, 1846. Scale 1:1500 (author).

Johnson Cammell & Co.

Cyclops Works, Savile Street, reconstructed site plans (1845-1850)

scale 1:1500

key:

- 1 Front office and warehouse, entrance from Savile Street (2 storeys)
- 2 Workshops (2 storeys)
- 3 Crucible furnaces (1 storey)
- 4 Cementation furnaces (1 storey)
- 5 Workshops (1 storey)
- 6 Yard
- 7 Railway entrance at rear
- 8 Private railway sidings
- 9 Conduit for water supply
- 10 Cementation furnaces (1 storey)
- 11 Workshops (1 storey)
- 12 Spring shops and hand forges
- 13 Engine house, boiler and stack
- 14 Second yard
- 15 Second railway entrance
- 16 Grinding wheels and workshops (2 storeys)
- 17 Shops and stores
- 18 New entrance to yard from Savile Street

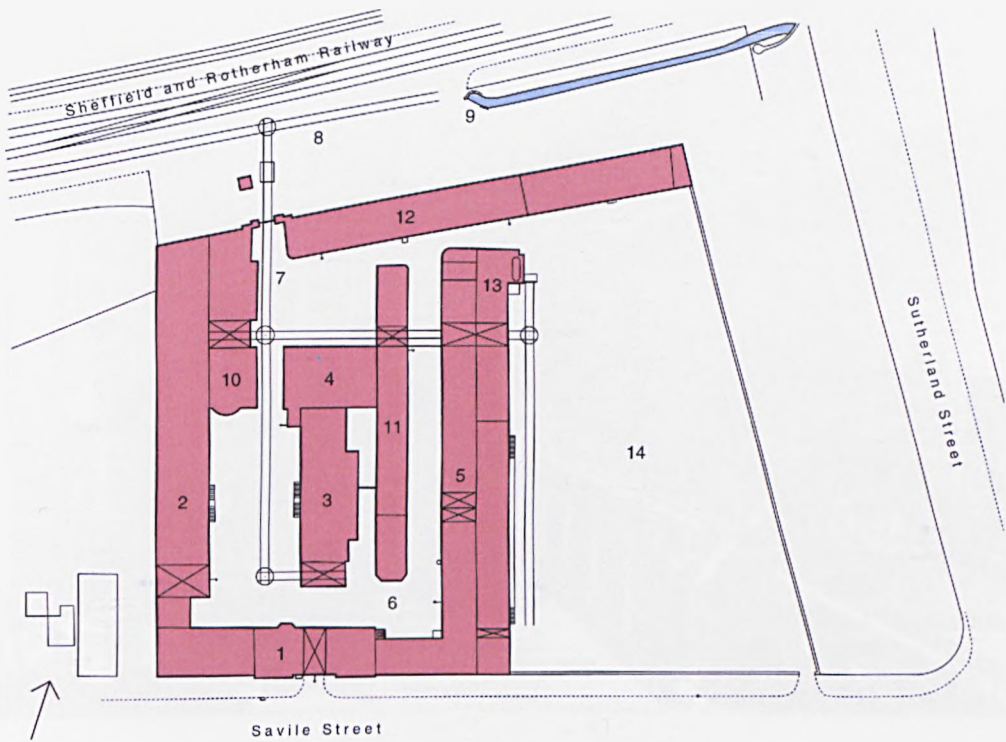

Fig. 5.5 Reconstructed third phase of the Cyclops Works, 1847. Scale 1:1500 (author).

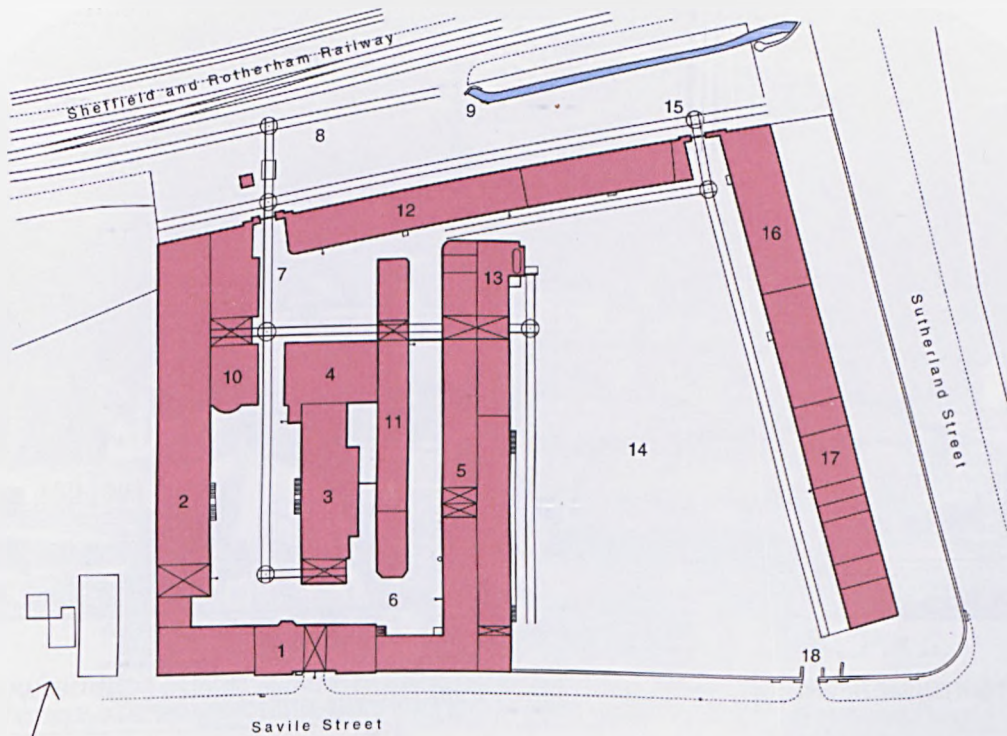

Fig. 5.6 Arrangement of the Cyclops Works in 1850. Scale 1:1500 (author).

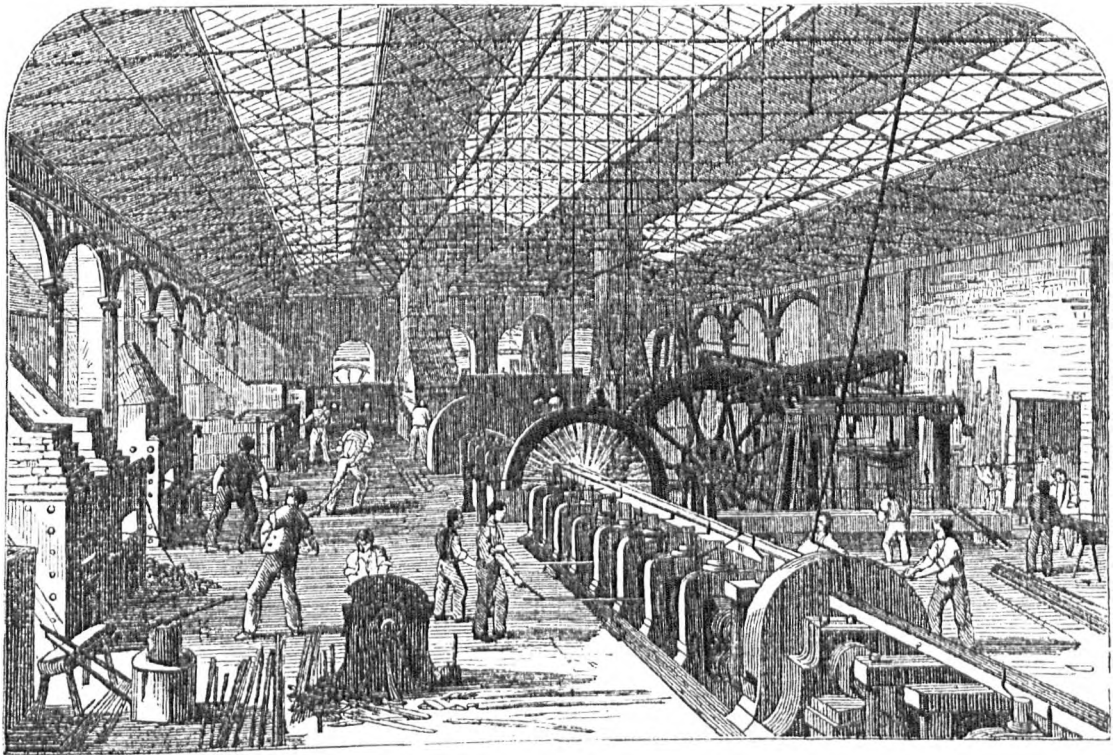

Fig. 5.7 Bar mills at the Cyclops Steel Works, powered by a large steam engine and housed in a long iron-roofed shed open at the sides (Pawson & Brailsford 1862).

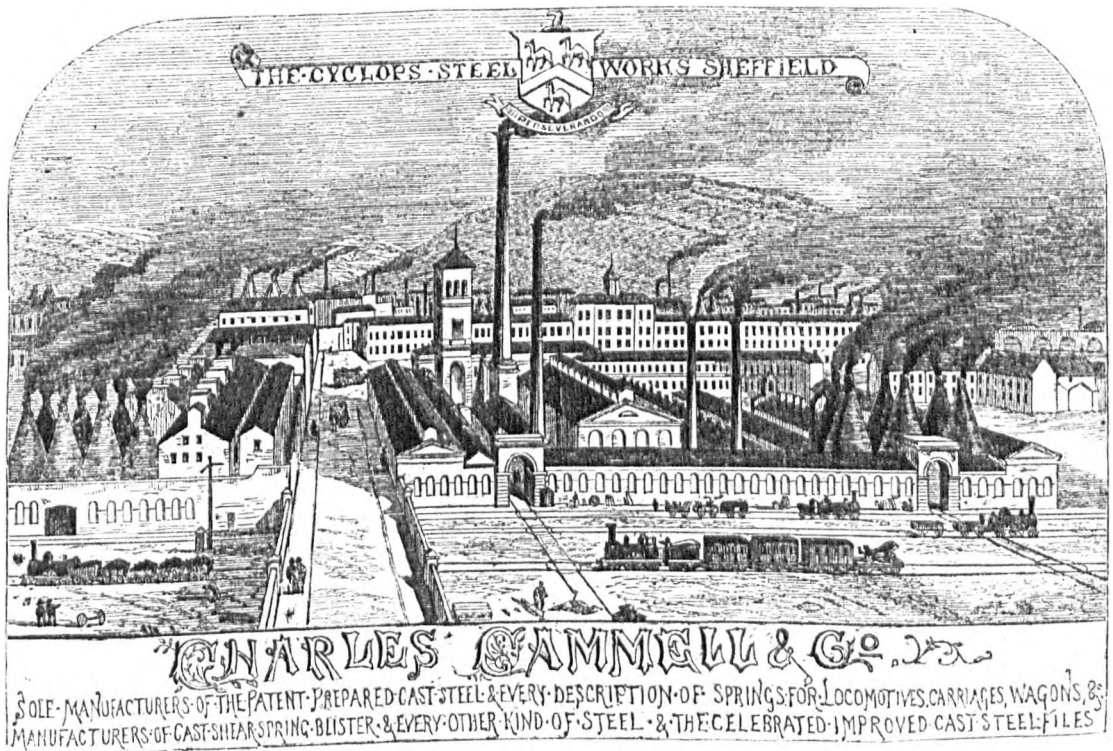

Fig. 5.8 General view of the Cyclops Steel Works overlooking the railway, with recent extensions on the left of the road crossing the tracks (Pawson & Brailsford 1862).

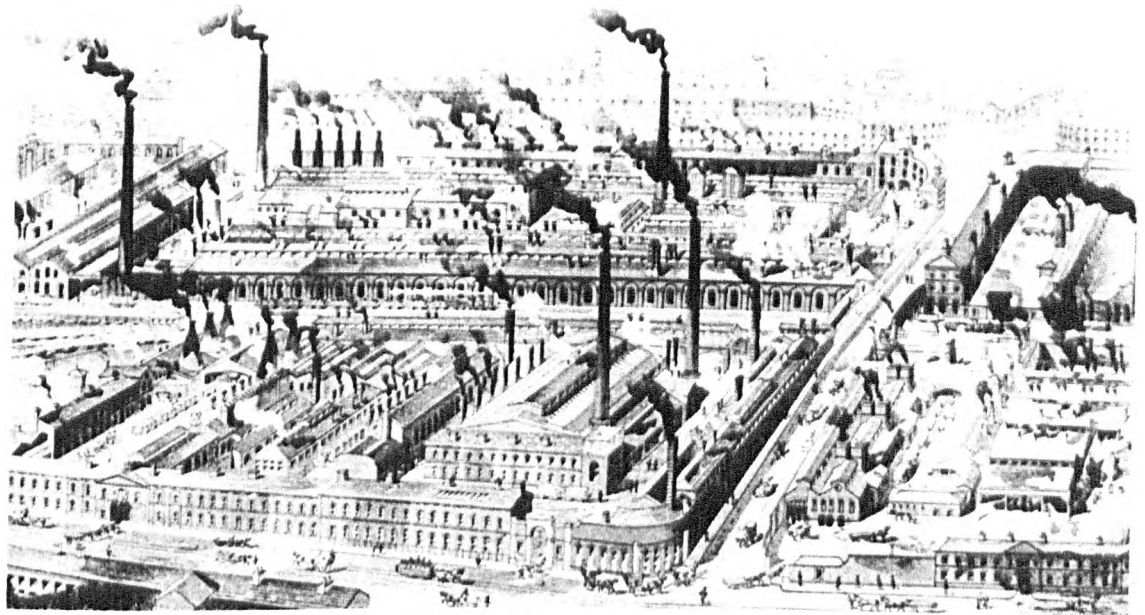

Fig. 5.9 The Cyclops Works in the 1860s, having extended across the railway tracks.

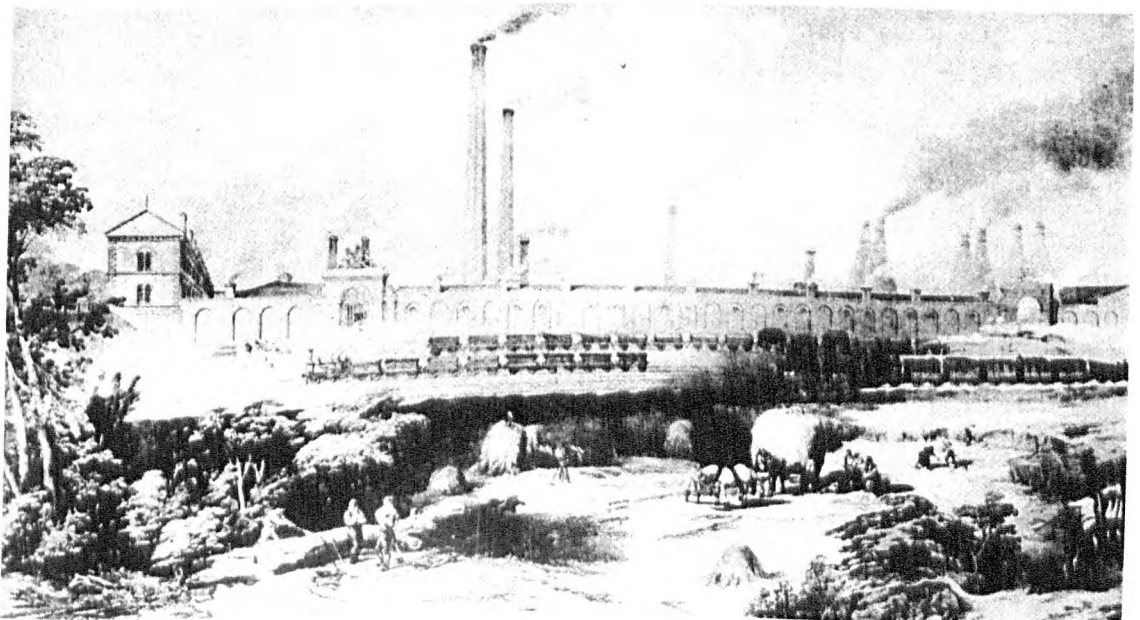

Fig. 5.10 Railway view of the Cyclops Works, evoking the contrast between the pastoral landscape and the invading steelworks.

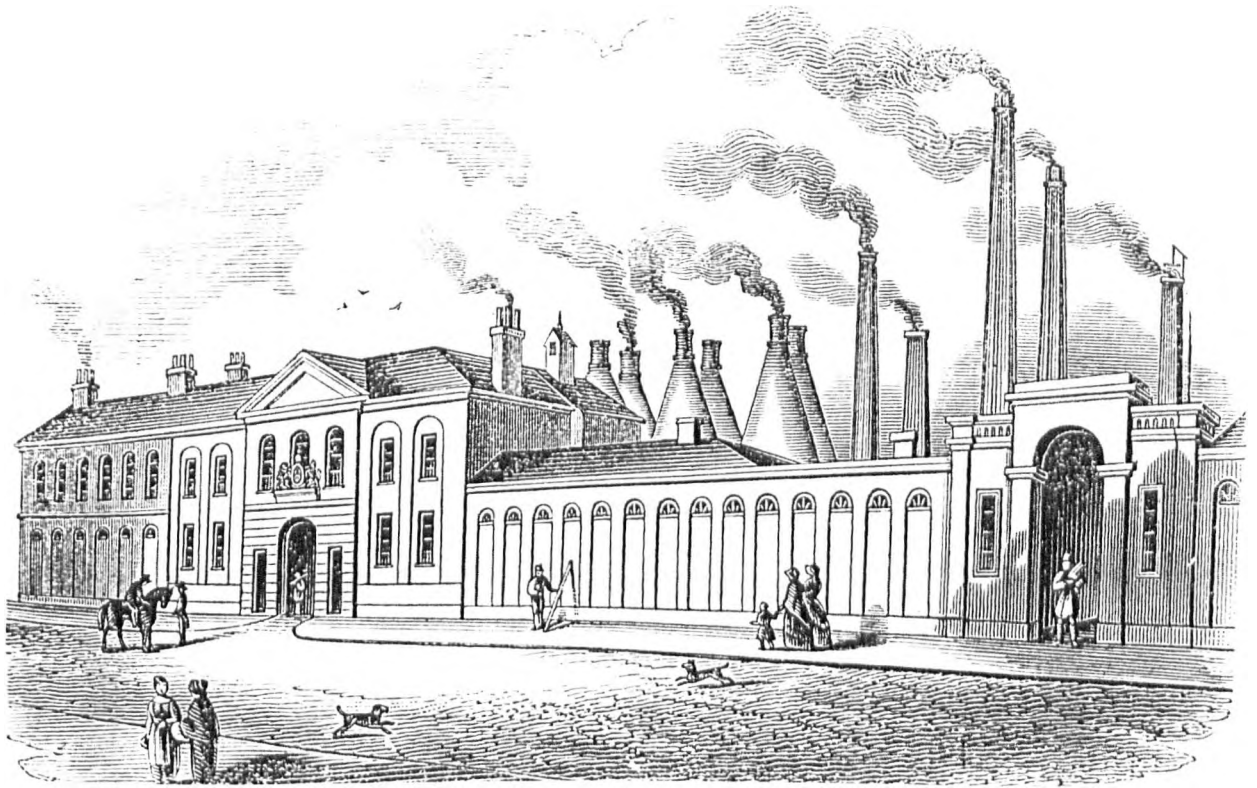

Fig. 5.11 Savile Street elevation of the Cyclops Works in 1856 to accompany the railway view, fig. 5.12 below (White 1856).

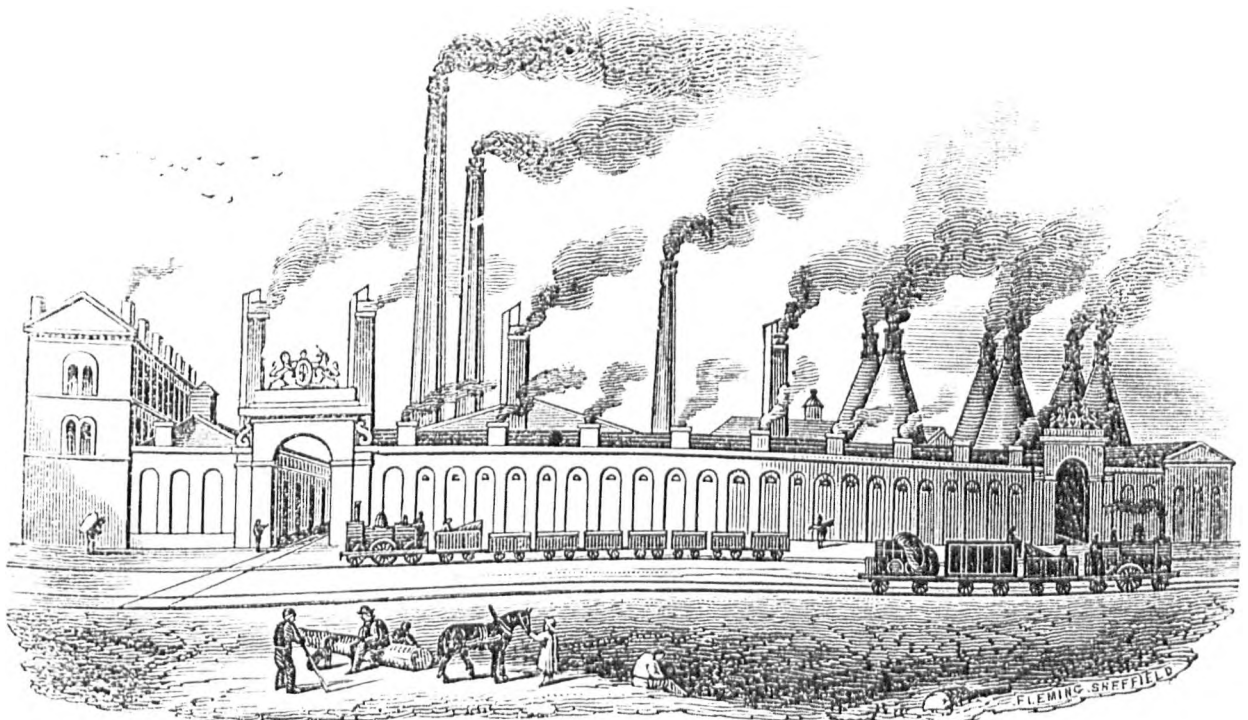

Fig. 5.12 Railway elevation of the Cyclops Works based on the earlier engraving (fig. 5.10), with relevant additions to the plant (White 1856).

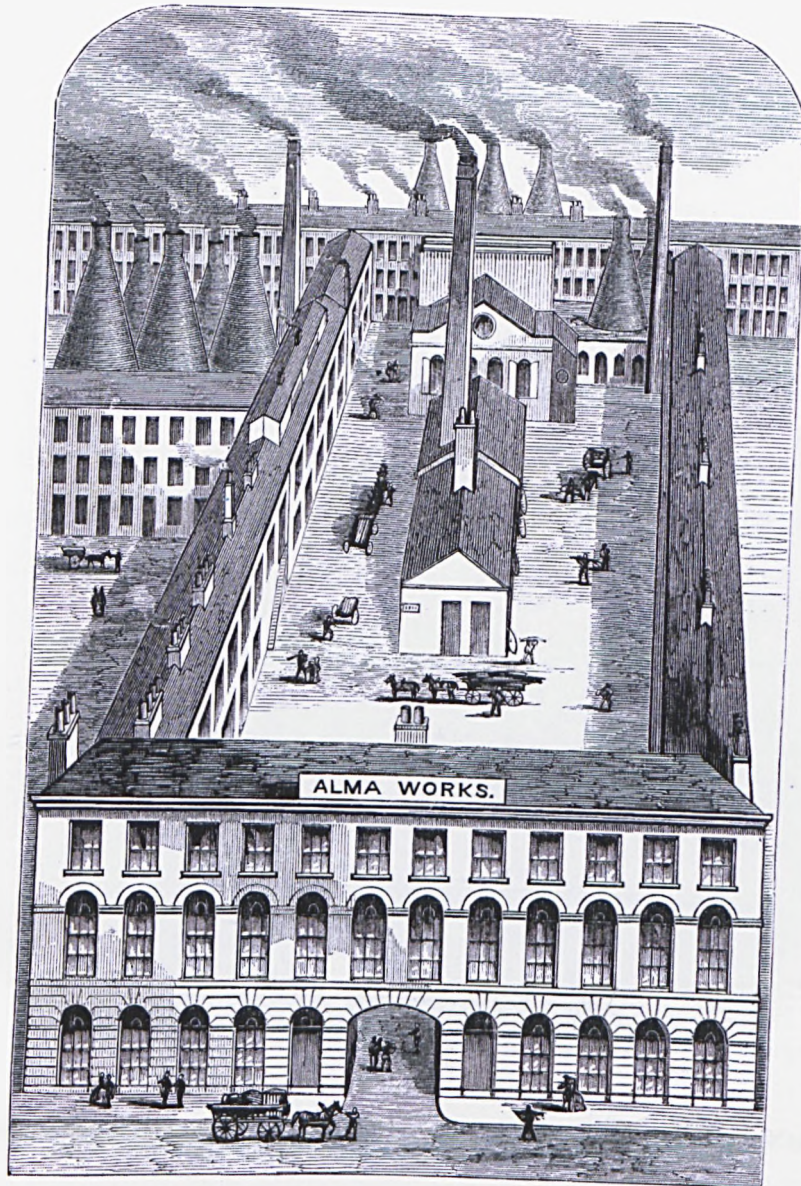

Fig. 5.13 View of Alma Works, a town centre premises aspiring to the Don Valley model (Pawson & Brailsford 1862).

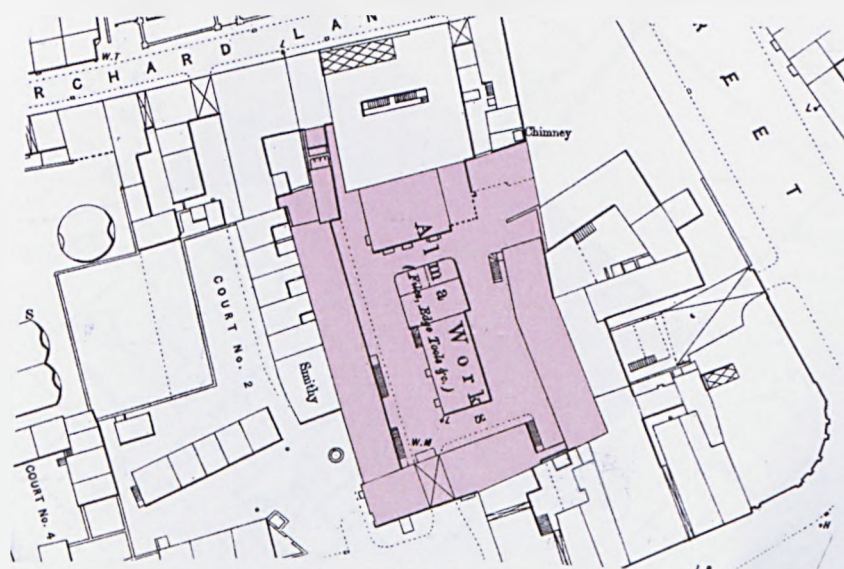

Fig. 5.14 Reality of the Alma Works plan, showing the irregularities ironed out by the artist. Scale 1:1000 (OS, author's colours).

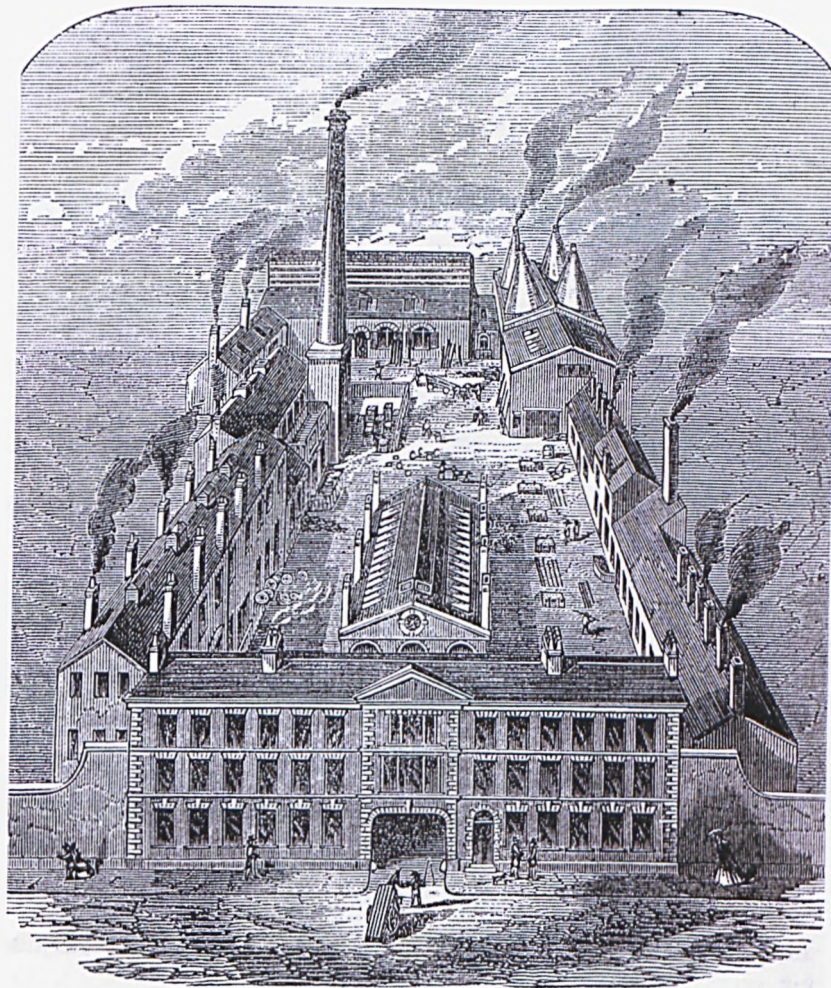

Fig. 5.15 George Fisher's Hoyle Street Works, another Don Valley pretender (Kelly 1865).

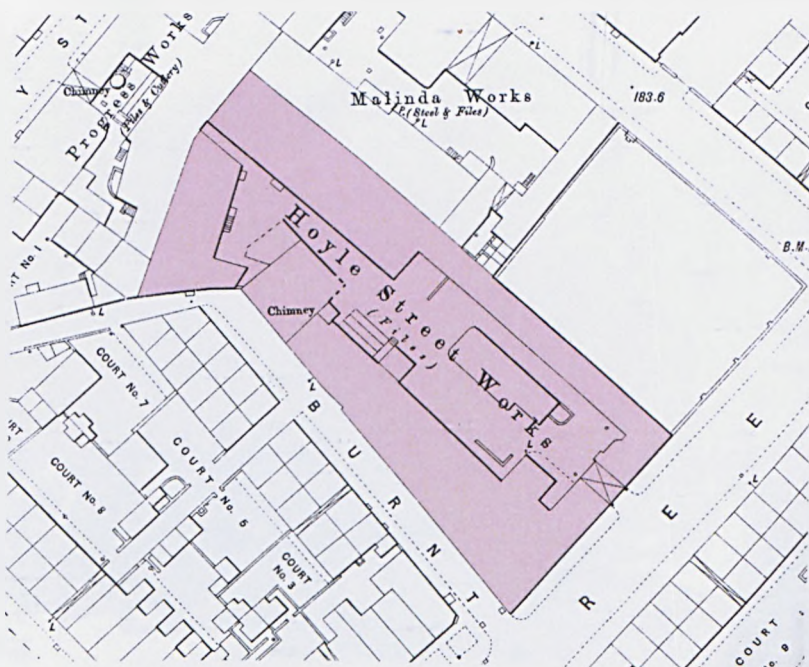

Fig. 5.16 Fisher's irregular premises at Hoyle Street in Sheffield, not the open country as suggested by the engraving above. Scale 1:1000 (OS, author's colours).

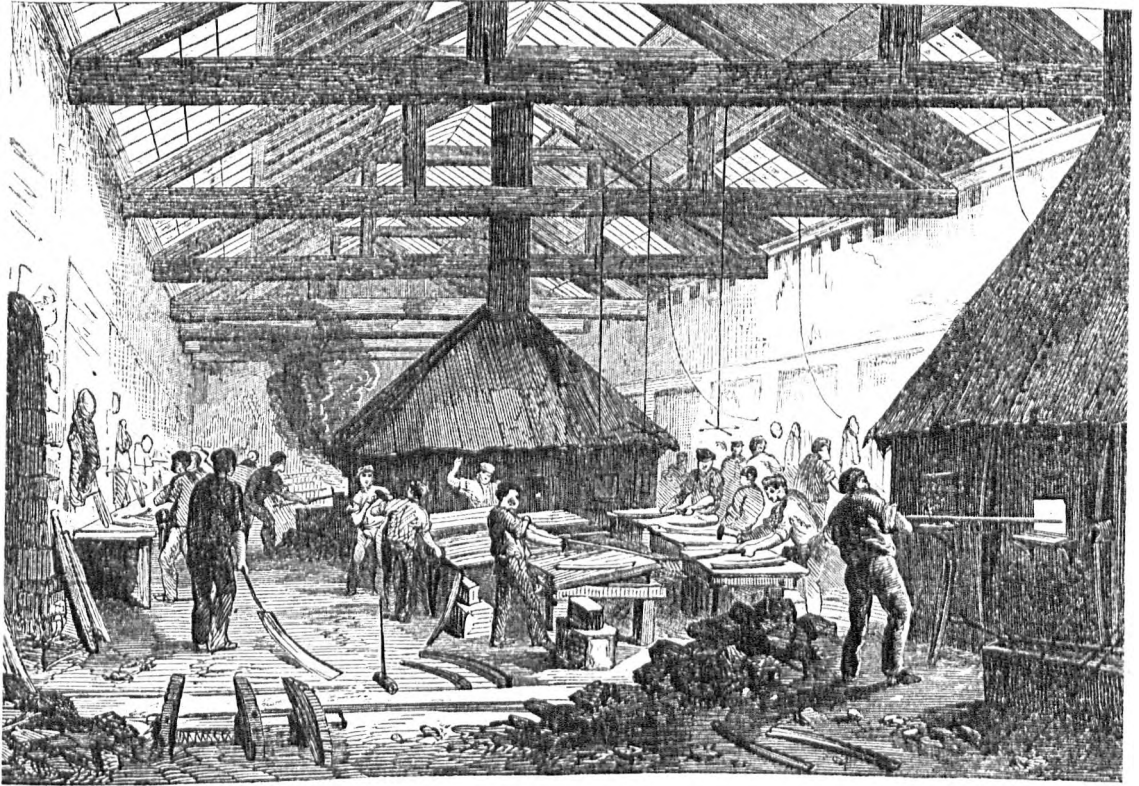

Fig. 5.17 Spring shop at Cammell's Cyclops Works (Pawson & Brailsford 1862).

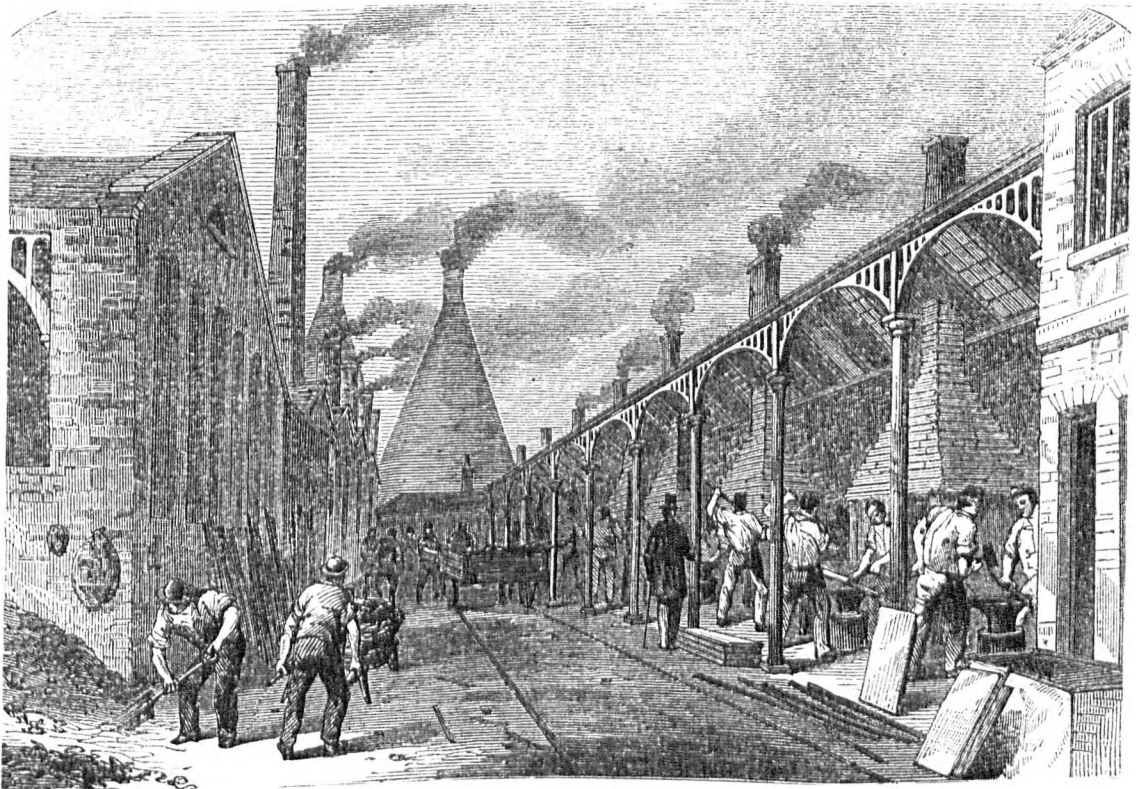

Fig. 5.18 Forge shops at Cammell's Cyclops Works (along the right) presided over by the cementation furnaces (Pawson & Brailsford 1862).



Fig. 5.19 Stuart & Parkin's Savile Works fender manufactory (c.1823) before its lease to Spear & Jackson in around 1833. Scale 1:1000 (author).

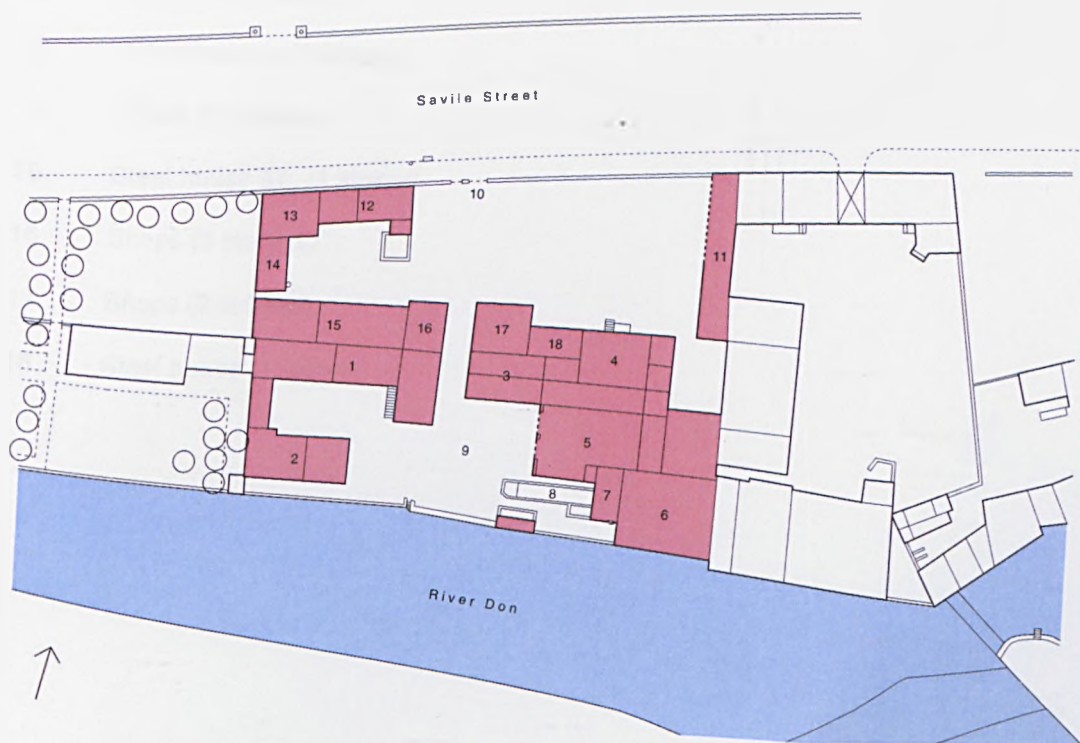

Fig. 5.20 Savile Works as occupied and modified by Spear & Jackson around the time of their departure to the newly built Etna Works also on Savile Street. Scale 1:1000 (author).

Stuart & Co. (later Spear & Jackson)

Savile Works, Savile Street, reconstructed site plans (1823-1846)

scale 1:1000

key:

- 1 Shops (3 storeys)
- 2 Shops (1 storey)
- 3 Shops (2 storeys)
- 4 Cast steel furnace (1 storey, 10 holes)
- 5 Open saw mill
- 6 Grinding wheel (2 storeys)
- 7 Engine house and stack (2 storeys)
- 8 *Boiler*
- 9 Inner yard
- 10 Main entrance from Savile Street
- 11 Shed (1 storey)
- 12 File shop (1 storey)
- 13 Joiner's shop (2 storeys)
- 14 House (2 storeys)
- 15 Steel house &c. (1 storey)
- 16 Shops (3 storeys)
- 17 Shops (2 storeys)
- 18 Steel house (1 storey)

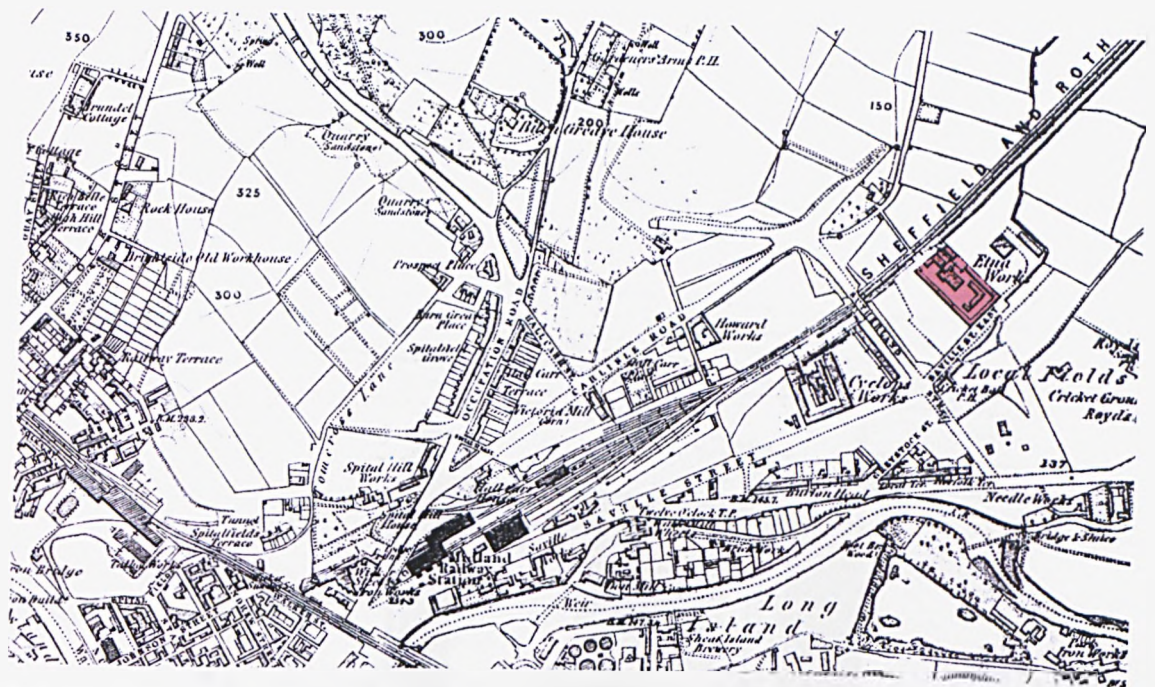

Fig. 5.21 Site plan of Etna Works in 1850, at the end of Savile Street East. North is at top, scale 1:10,000 (OS, author's colours).

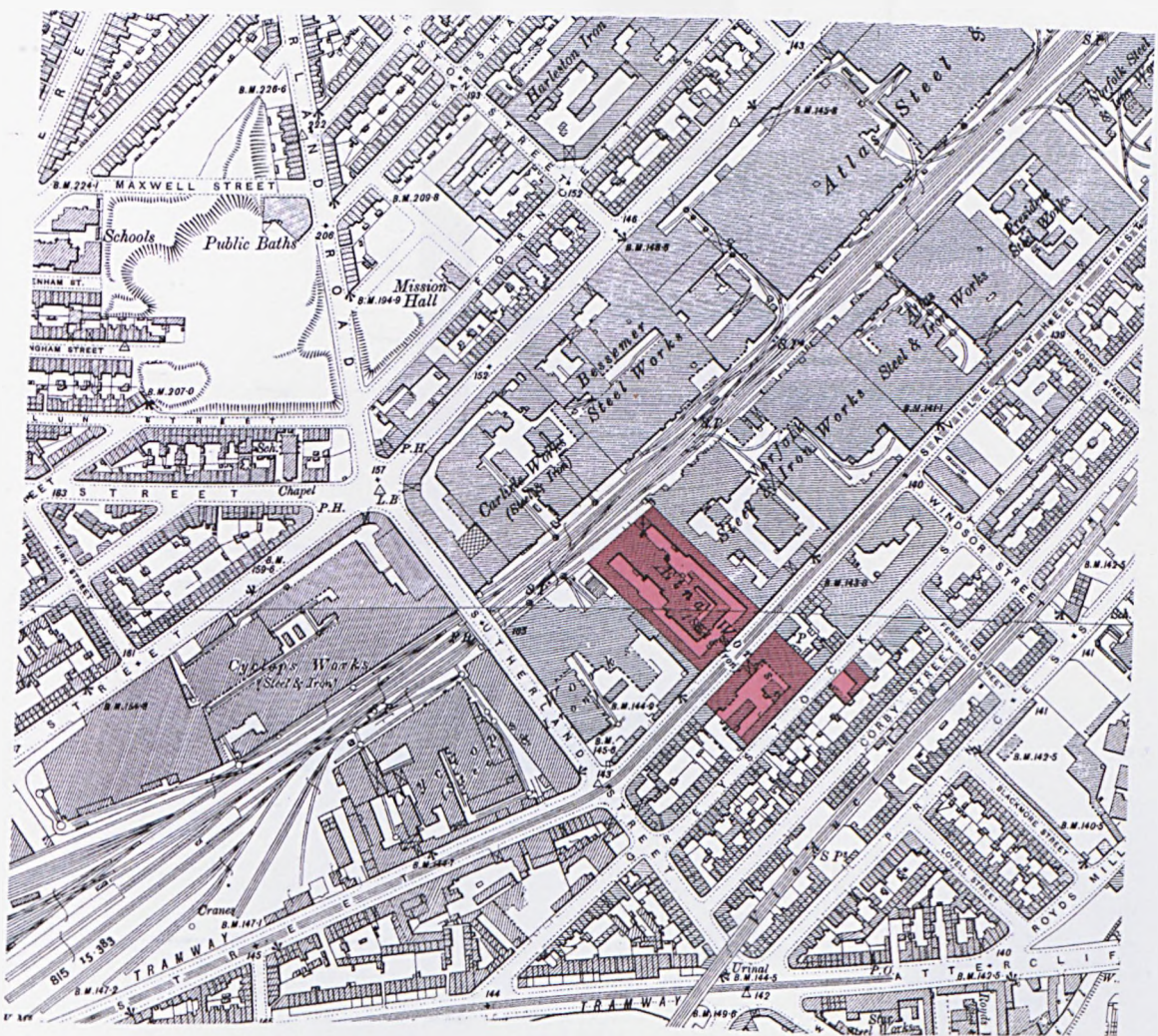

Fig. 5.22 Etna Works by 1903, in much its original form with minor additions across the road (see fig. 2.66). North is at top, scale 1:5000 (OS, author's colours).

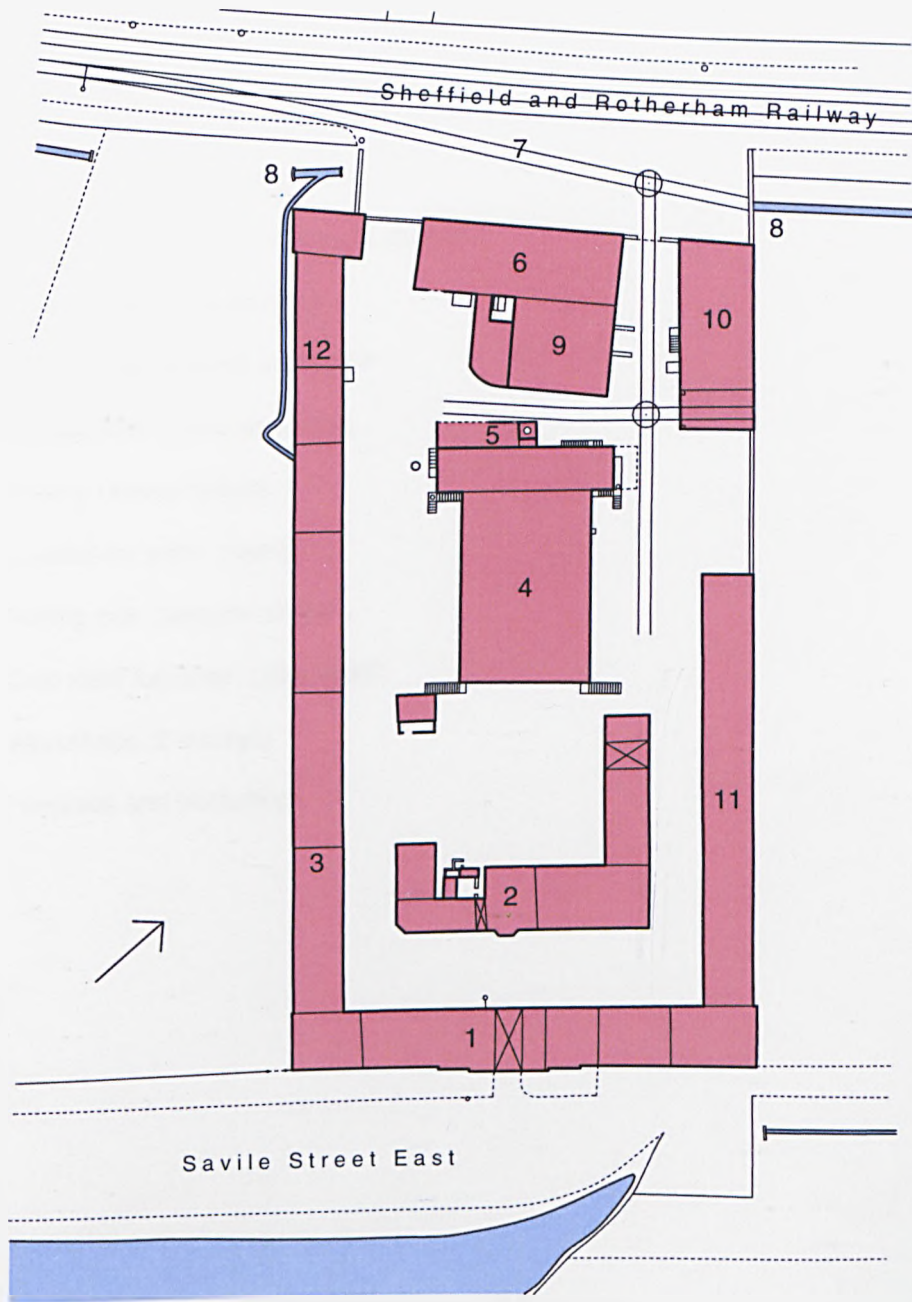

Fig. 5.23 Etna Works general arrangement plan c.1850, based on the 1850 OS sheet. Scale 1:1000 (author).

Spear & Jackson

Etna Works, Savile Street East, reconstructed site plan (c.1850)

scale 1:1000

key:

- 1 Front office and warehouse with entranceway (2 storeys)
- 2 Timekeeper's office with clock
- 3 Workshops and hand forges (2 storeys)
- 4 Grinding wheel (2 storeys)
- 5 Steam engine, stack and boiler
- 6 Cementation furnaces (4 no.)
- 7 Private railway sidings
- 8 Conduit for water supply
- 9 Rolling mill / hammer shop?
- 10 Cast steel furnaces, coke shed?
- 11 Workshops (2 storeys)
- 12 Furnaces and workshops

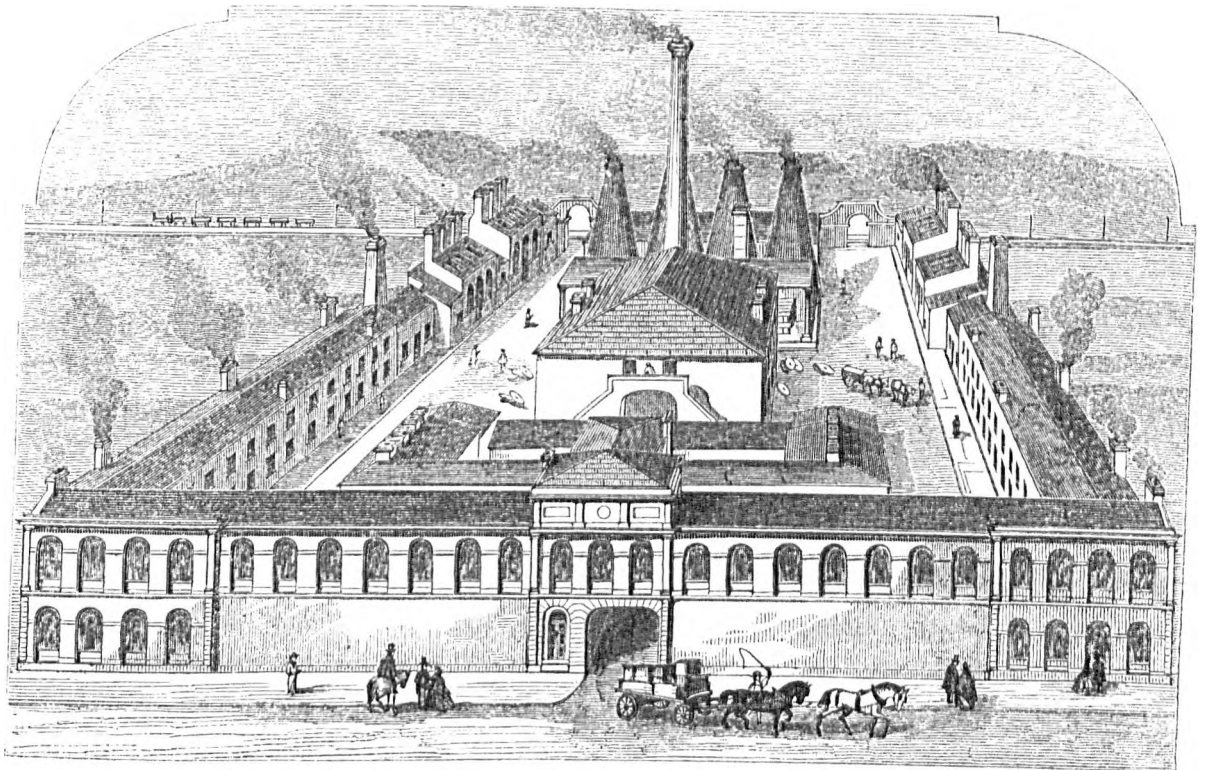

PRESIDENT WORKS.—MESSES. MOSES EADON AND SONS, MANUFACTURERS OF SAWS, FILES, STEEL, ETC.

Fig. 5.24 Advertising view of the President Steelworks, built to the pattern of the Etna Works further along Savile Street East (Pawson & Brailsford 1862).

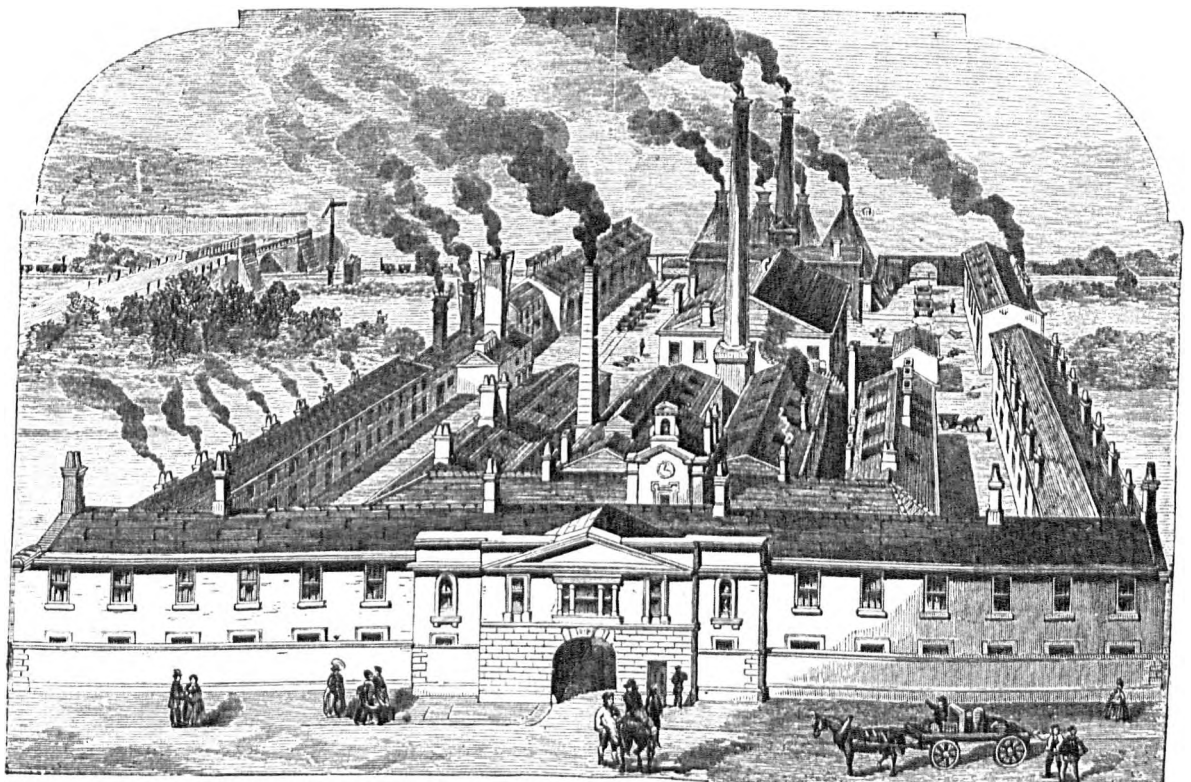
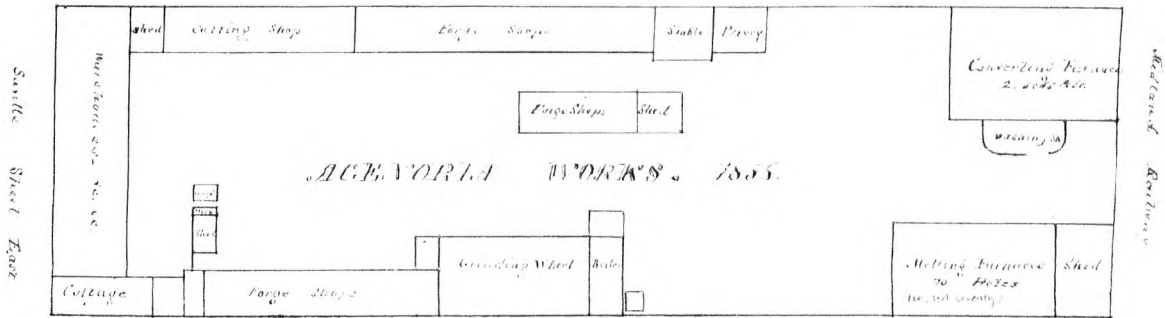

Fig. 5.25 Bird's eye view of Etna Works in its original semi-rural setting, making dramatic use of symmetry and functional forms (Pawson & Brailsford 1862).

The Plan is drawn to be the Basis of a Partnership between the undersigned Parties dated the 2nd day of July 1855.

Property held on Lease by Cammell & Johnson under the Duke of Norfolk.



Property held on Lease by Spence Jackson under the Duke of Norfolk.

The said Thomas
in favor of the said
Bech and Benjamin
the amount in
sum of
Mrs. Smith
has Marched down

Y^{rs} Obedt
W J Bech

Henry Price
Benjamin Schofield - Jr.

Fig. 5.26 Agenoria Works surveyed in 1855 for a partnership agreement, based on half the plot size of the neighbouring Etna Works. Scale c. 1:800 (SCA).

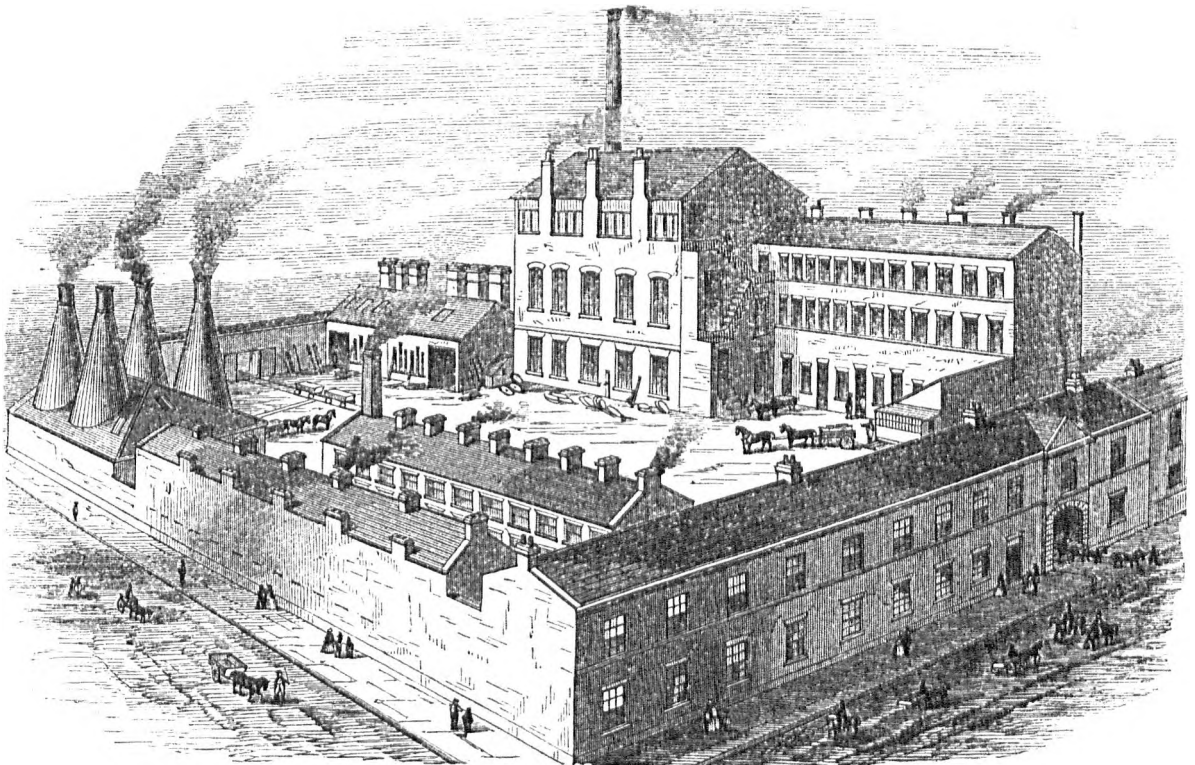

Fig. 5.27 Engraved view of the Agenoria Works that unusually attempts to conceal its true scale and proportions (Pawson & Brailsford 1862).

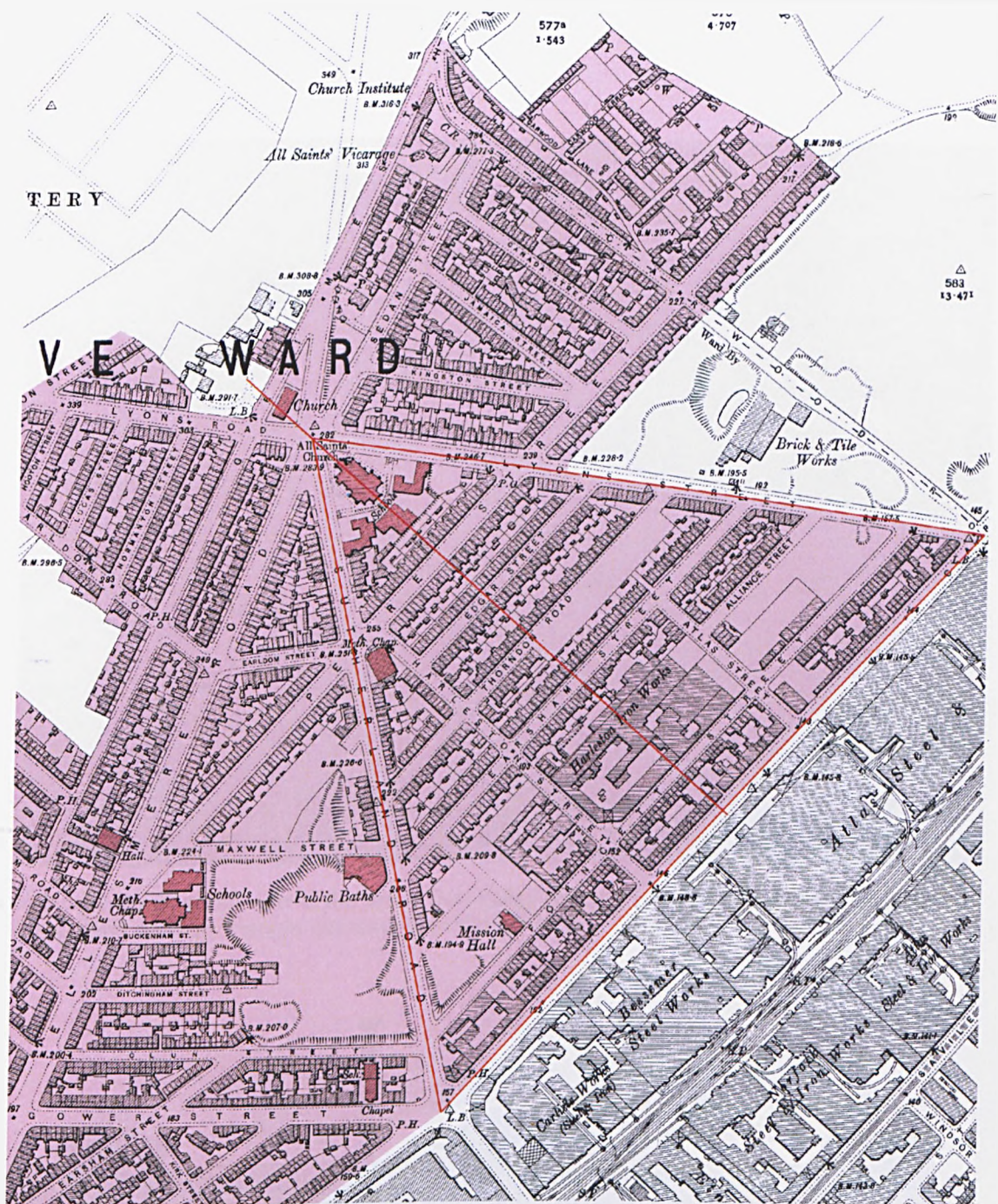

Fig. 5.28 The generative triangle of the apparently uncompleted residential estate to the northwest of Carlisle Street. North is at top, scale 1:5000 (OS, author's colours).



Fig. 5.29 'The Triangle' at Pentrebach near Merthyr Tydfil, Wales, built as workers' housing (c.1814) for the Plymouth Iron Works, but to a much smaller scale than at Brightside.



Fig. 5.30 Early aerial view of the lower Don Valley with the Cyclops Works occupying the foreground and the 'triangle' discernible to the left (SCL).



FIG. 27

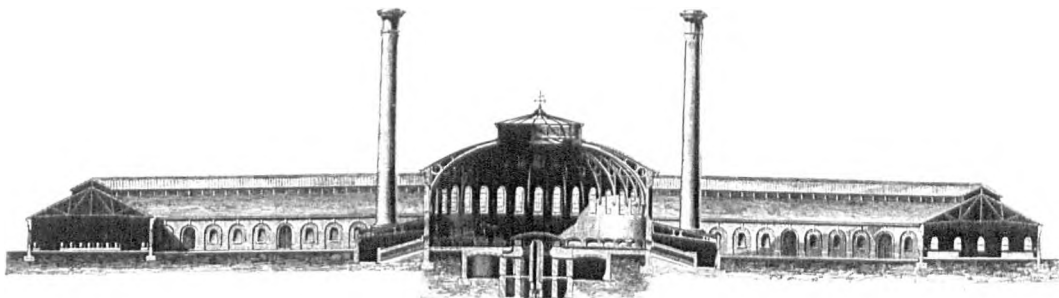

FIG. 28.

DESIGN FOR BESSEMER PLATE GLASS WORKS

Fig. 5.31 Henry Bessemer's design for a plate glass works, predating the converter for which he is best known (Bessemer 1905).

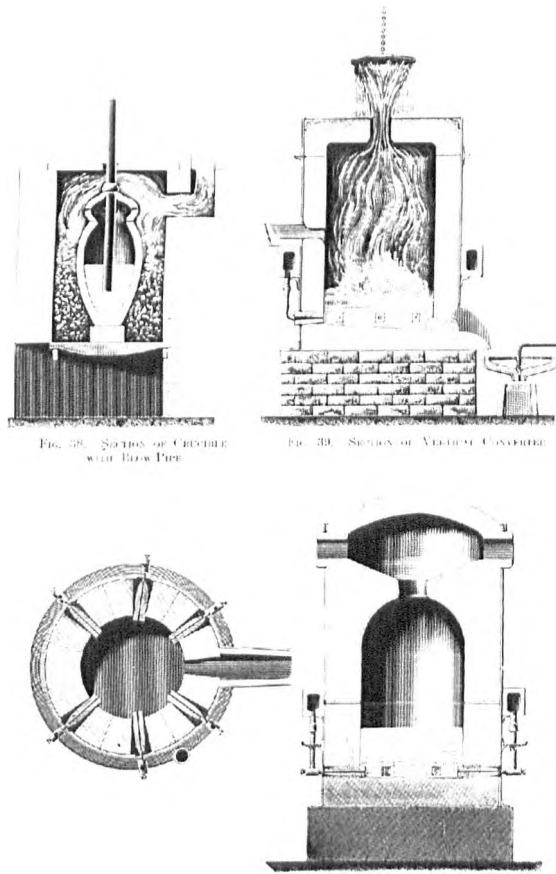

Fig. 5.32 Early forms of the Bessemer converter, evolving from the simple crucible apparatus (top left) to fixed converters without tilting mechanism (Bessemer 1905).

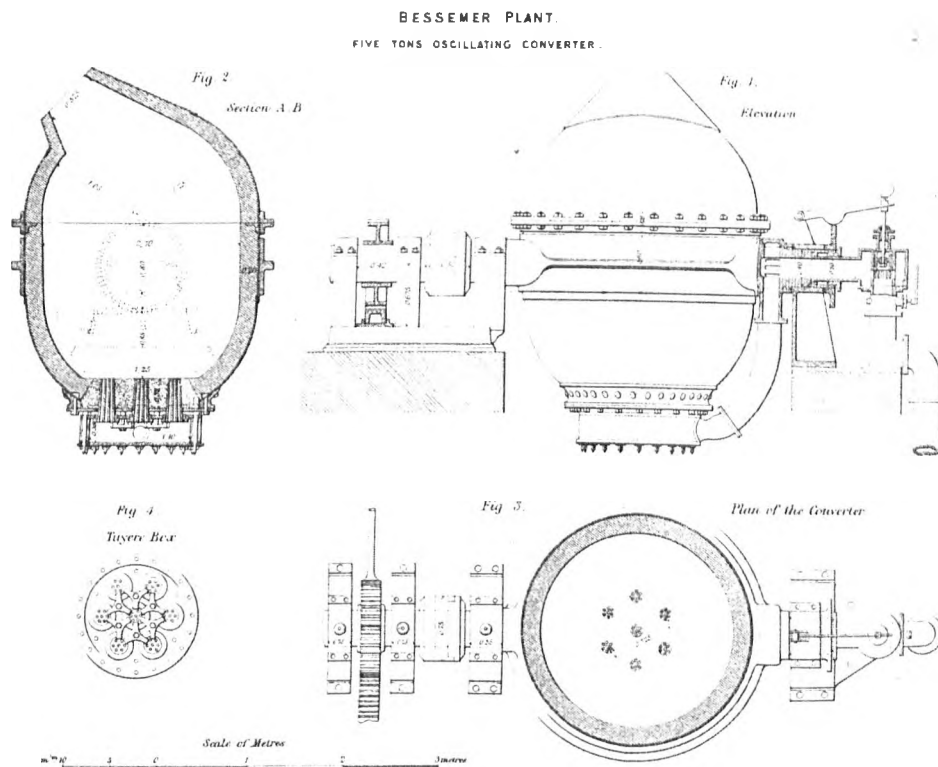

Fig. 5.33 The oscillating or tilting converter as it was finally developed by Bessemer, lined with incombustible gannister sand. Scale c.1:80 (Jeans 1880).

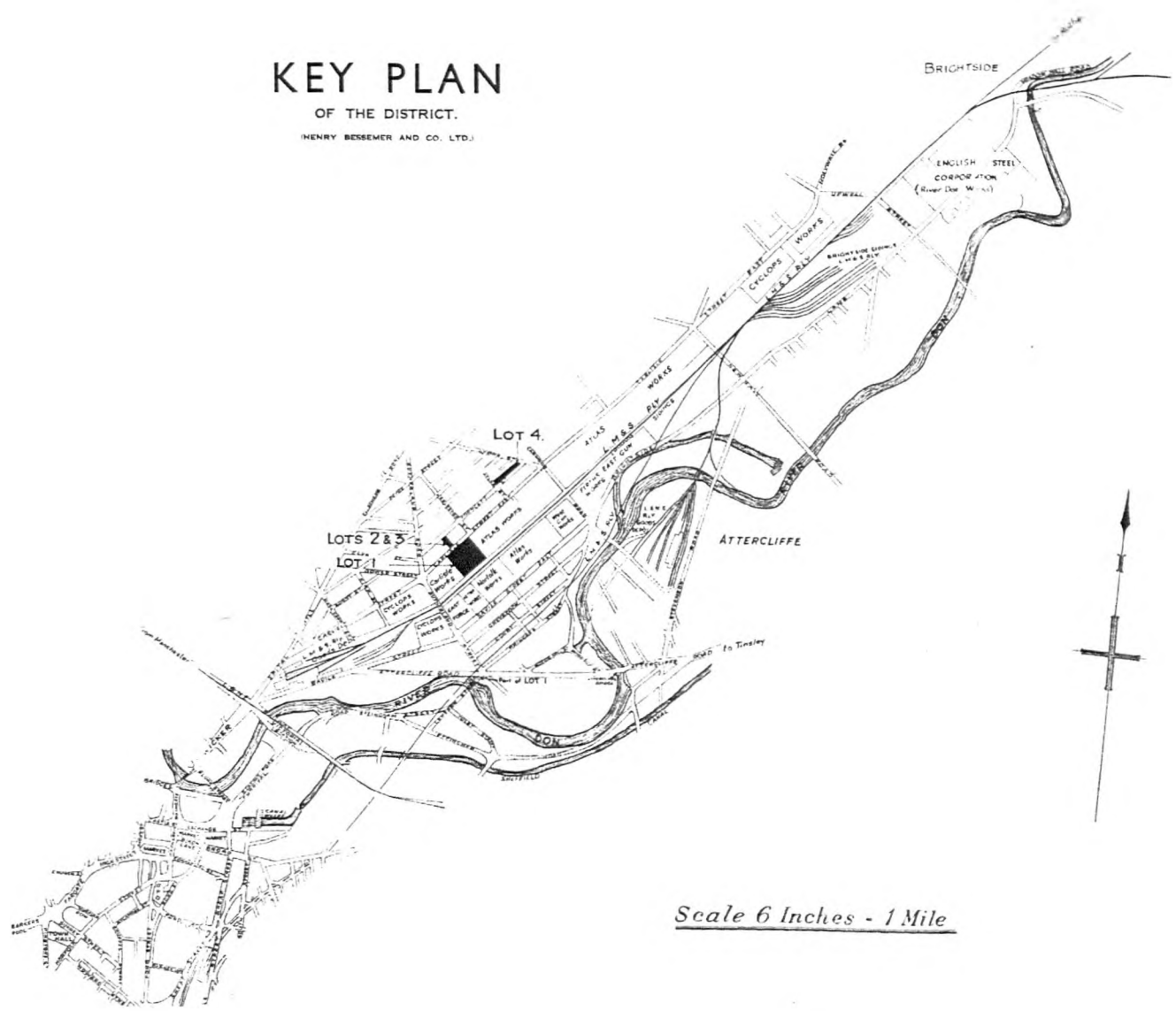

Fig. 5.34 Site location plan of Henry Bessemer's Don Valley steelworks, built at the heart of the evolving heavy steel industrial district. Others were soon to see the potential for profit in Bessemer's system, beginning with his neighbour John Brown. Not to scale (SCA).

PLAN OF MESSRS. HENRY BESSEMER AND CO'S WORKS & OFFICES
IN CARLISLE STREET, EAST, SHEFFIELD.
TO BE SOLD BY AUCTION BY MESSRS. EADON & LOCKWOOD, F.A.I.
DECEMBER 10TH, 1929.

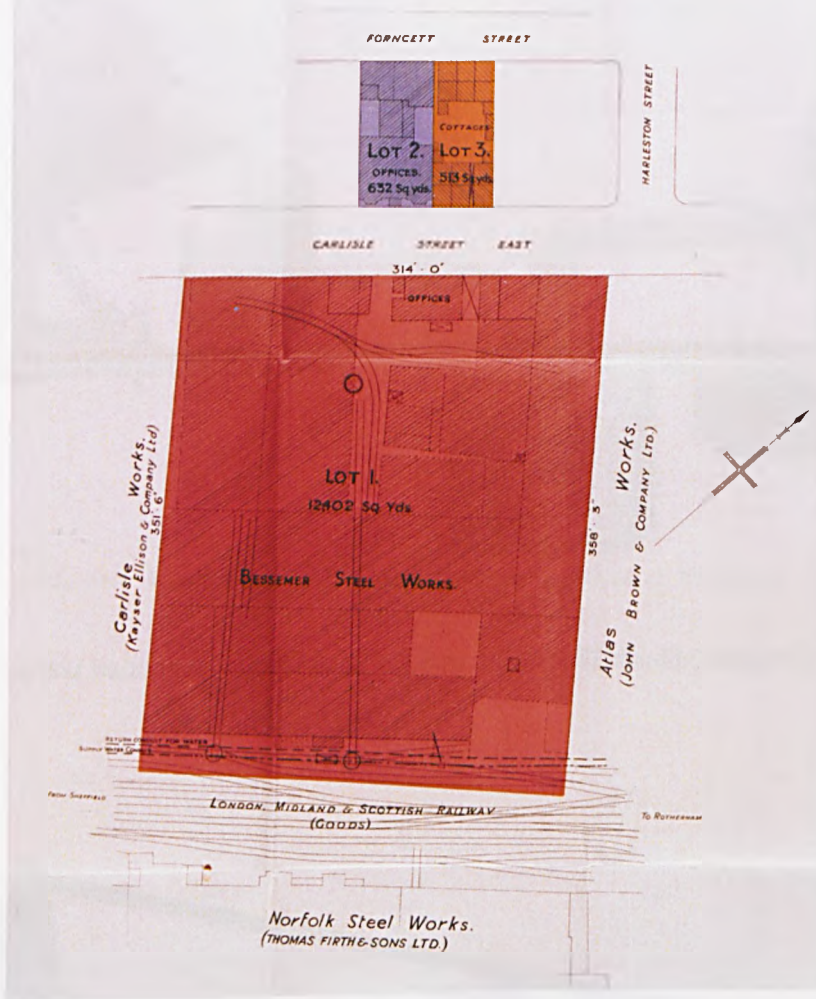

Fig. 5.35 Sale plan of the Bessemer Steel Works, Sheffield. Not to scale (SCA).

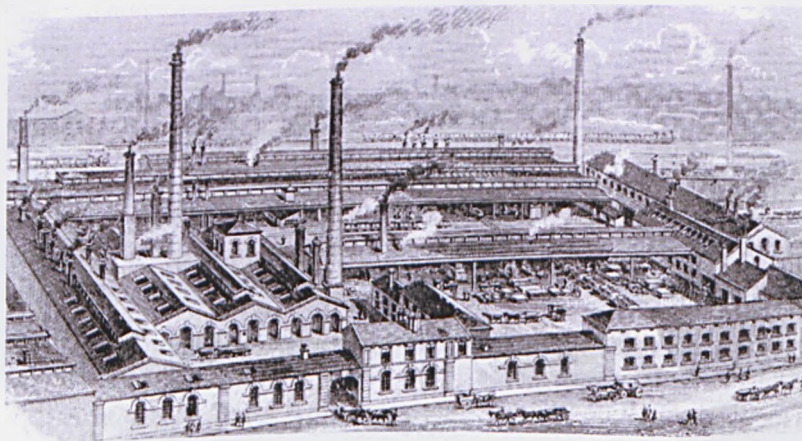

Fig. 5.36 Engraving of the Bessemer Steel Works. Unlike the traditional Sheffield steelworks, functions are not readily deduced from their external manifestations.

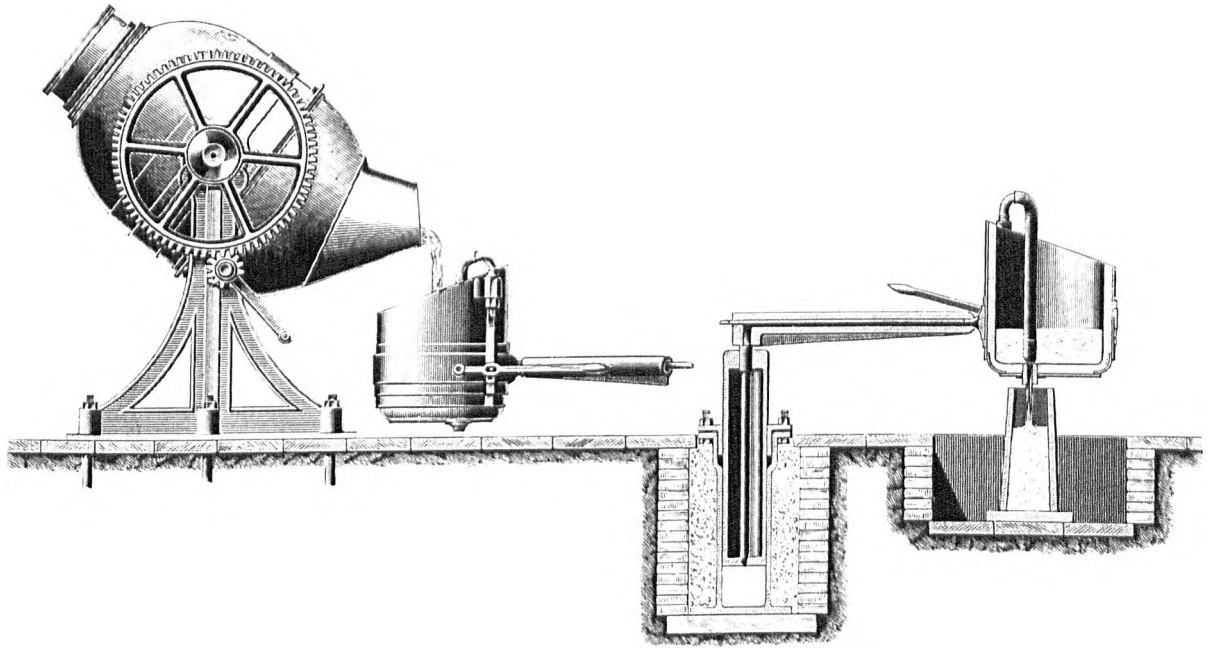

FIG. 44. EARLY FORM OF BESSEMER CONVERTING PLANT AT SHEFFIELD

Fig. 5.37 The first hand-tilted converter of 1858 as used at Sheffield (Bessemer 1905).

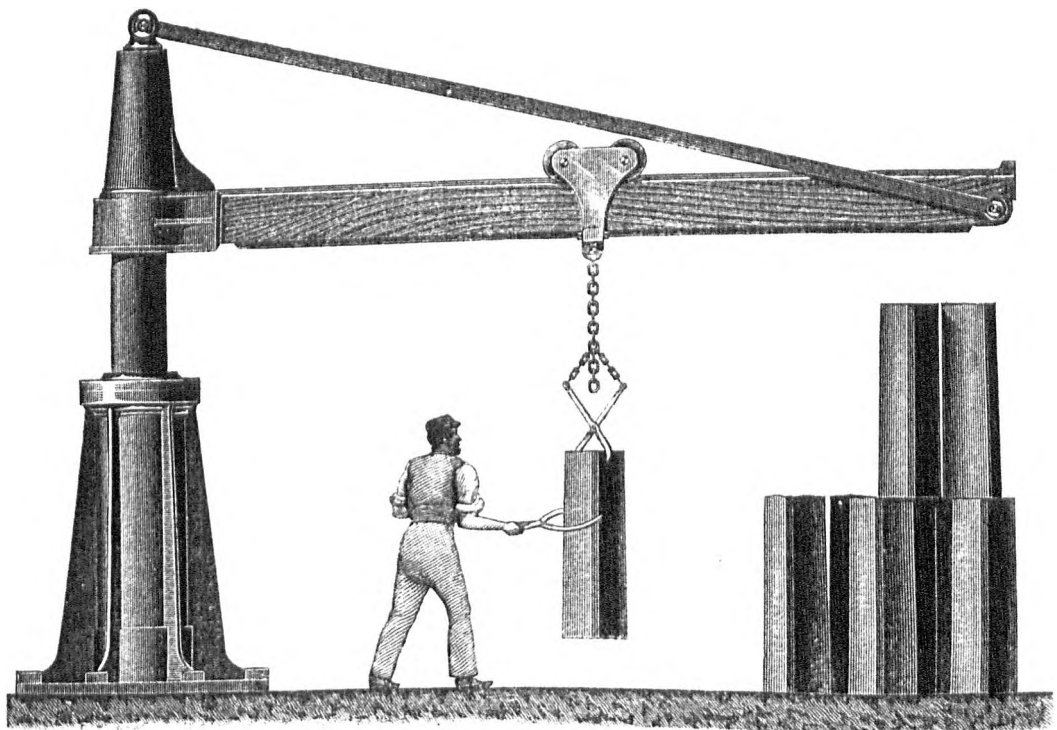

FIG. 47 INGOT CRANE; BESSEMER PLANT AT SHEFFIELD

Fig. 5.38 Powerful hydraulic ingot cranes were an indispensable element in the landscape of the Bessemer shop (Bessemer 1905).

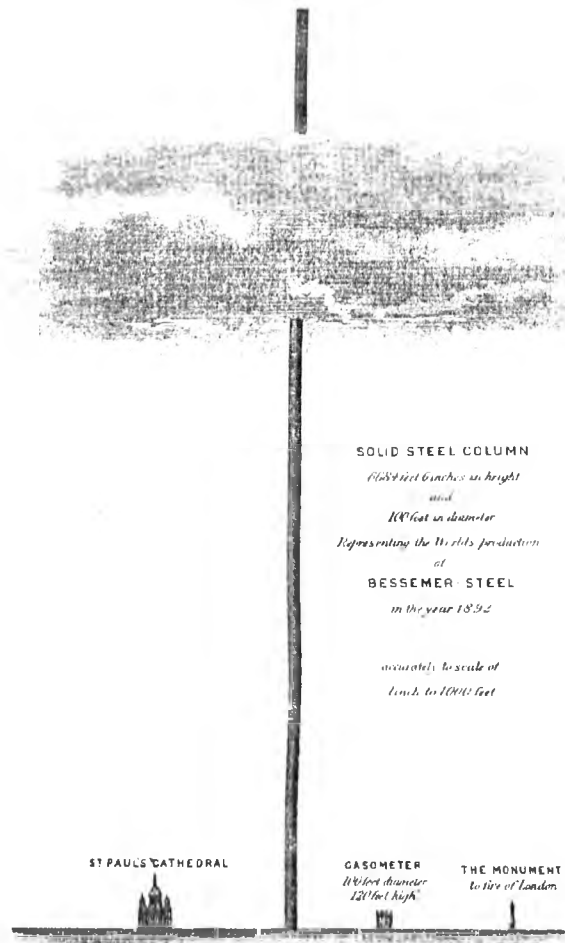

Fig. 5.39 Bessemer's unconventional sense of architectural form is evident in this publicity drawing of a solid column of Bessemer steel that would dwarf St. Paul's (Bessemer 1905).

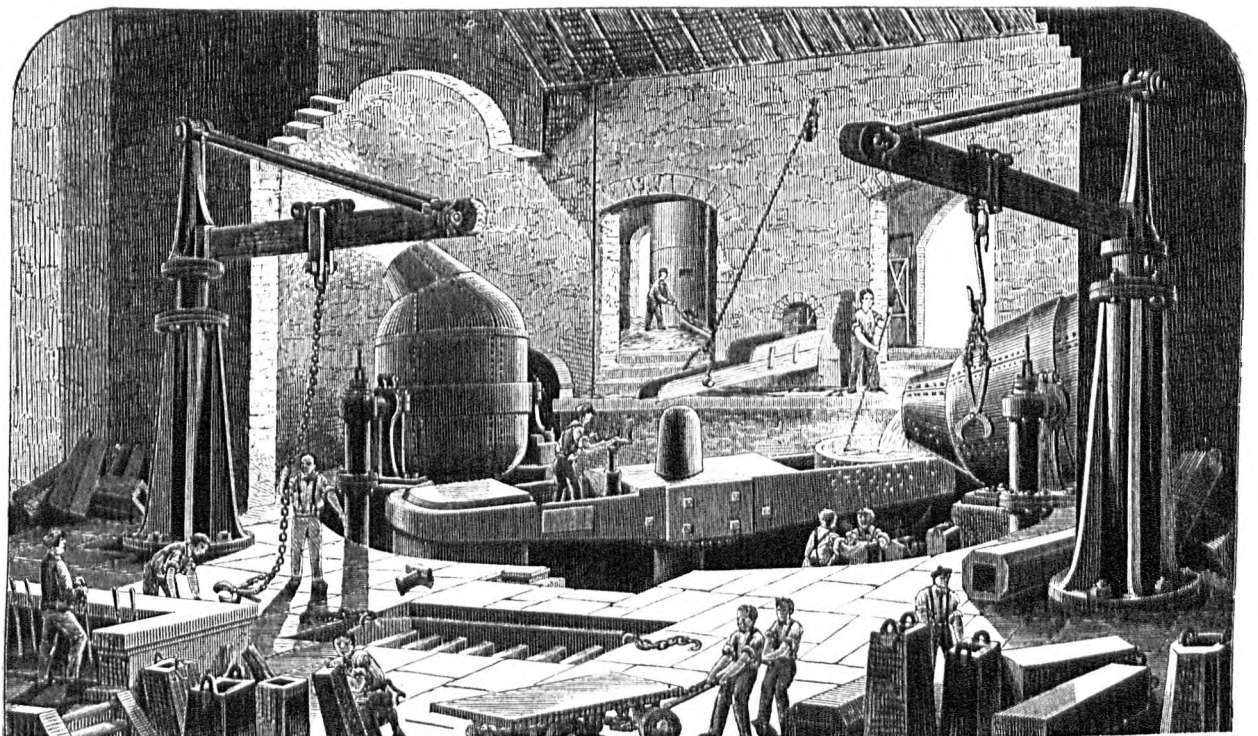

Fig. 5.40 The tableau of Bessemer's own converter house at Carlisle Street. Cupola furnaces to melt the iron are visible through the proscenium arches (Taylor 1879).

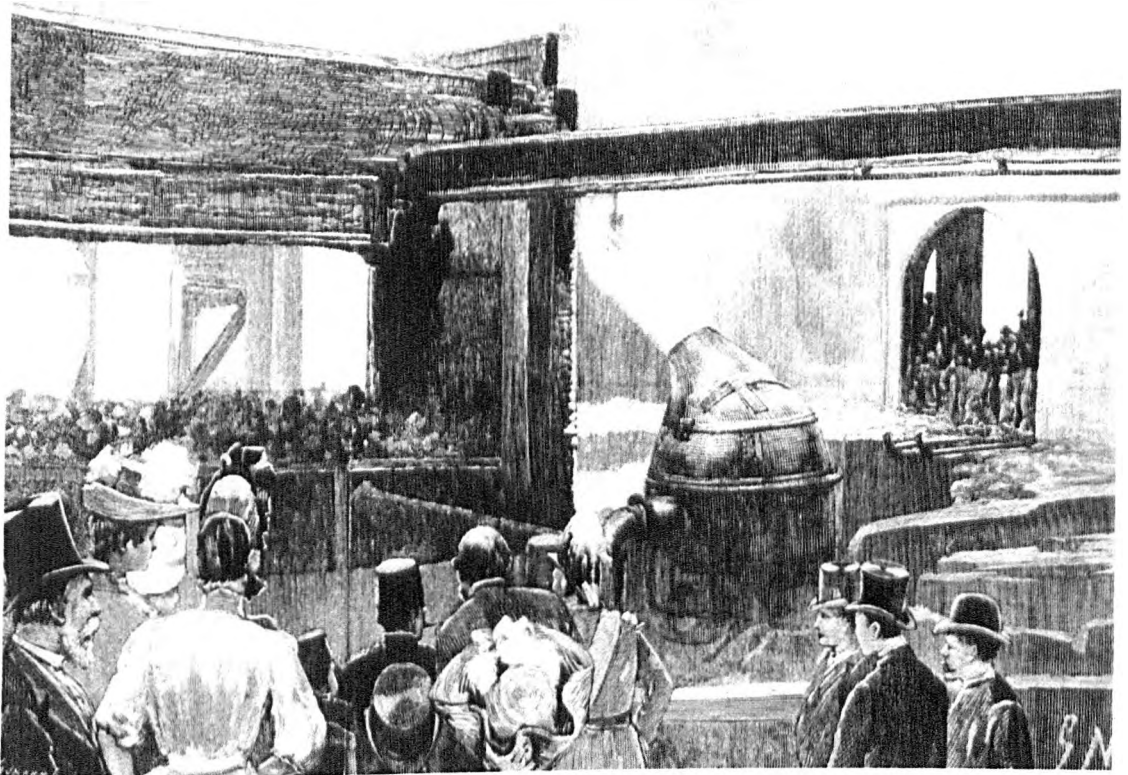

Fig. 5.41 The ferocity and visual drama of a Bessemer converter 'blow' proved a popular spectacle with upper-class visitors to steelworks

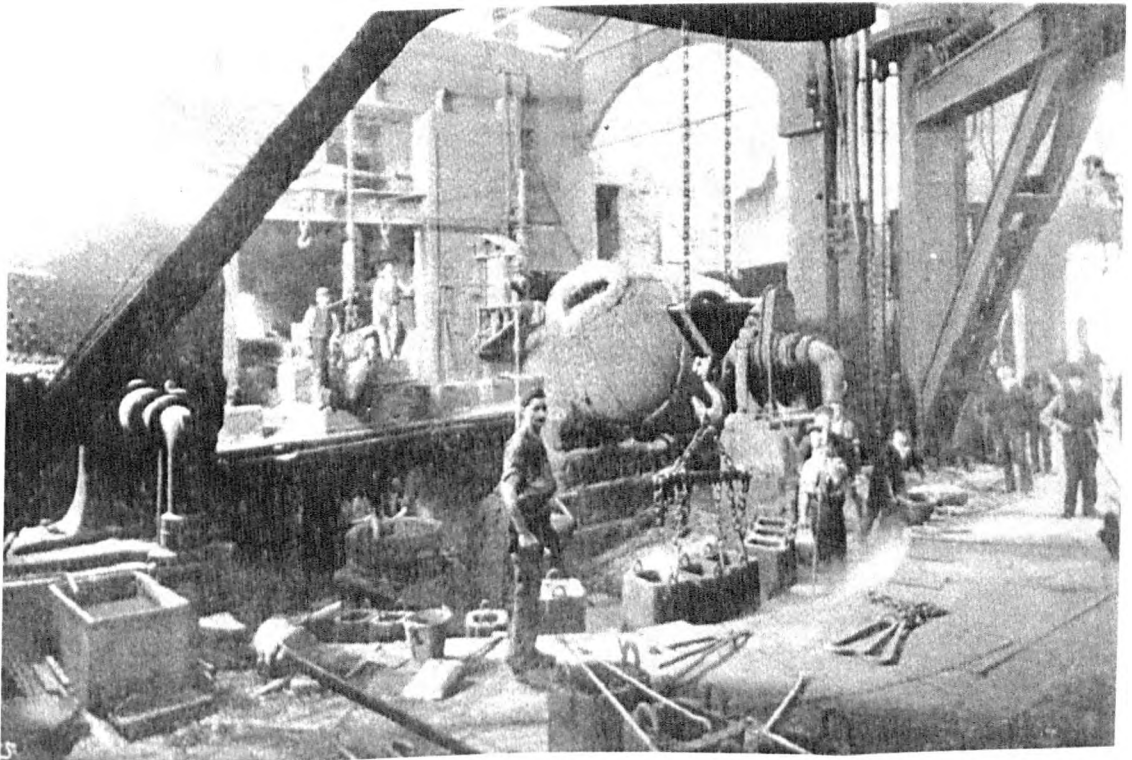
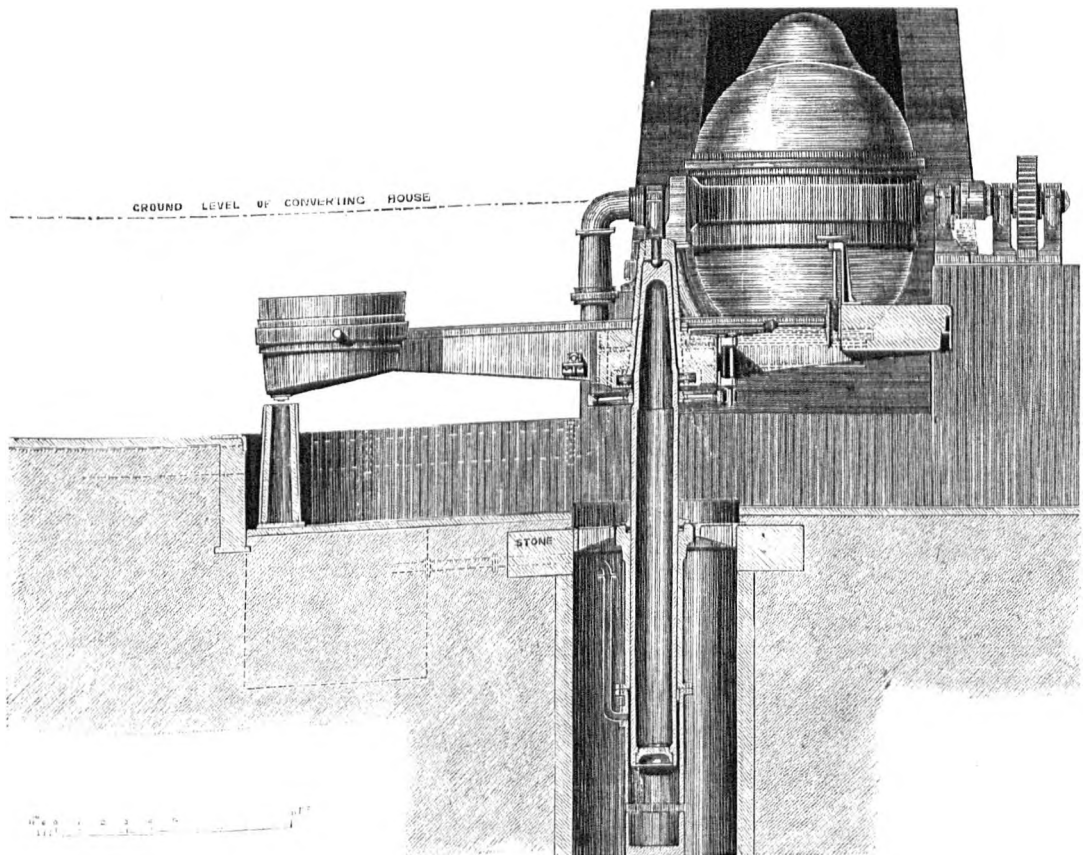
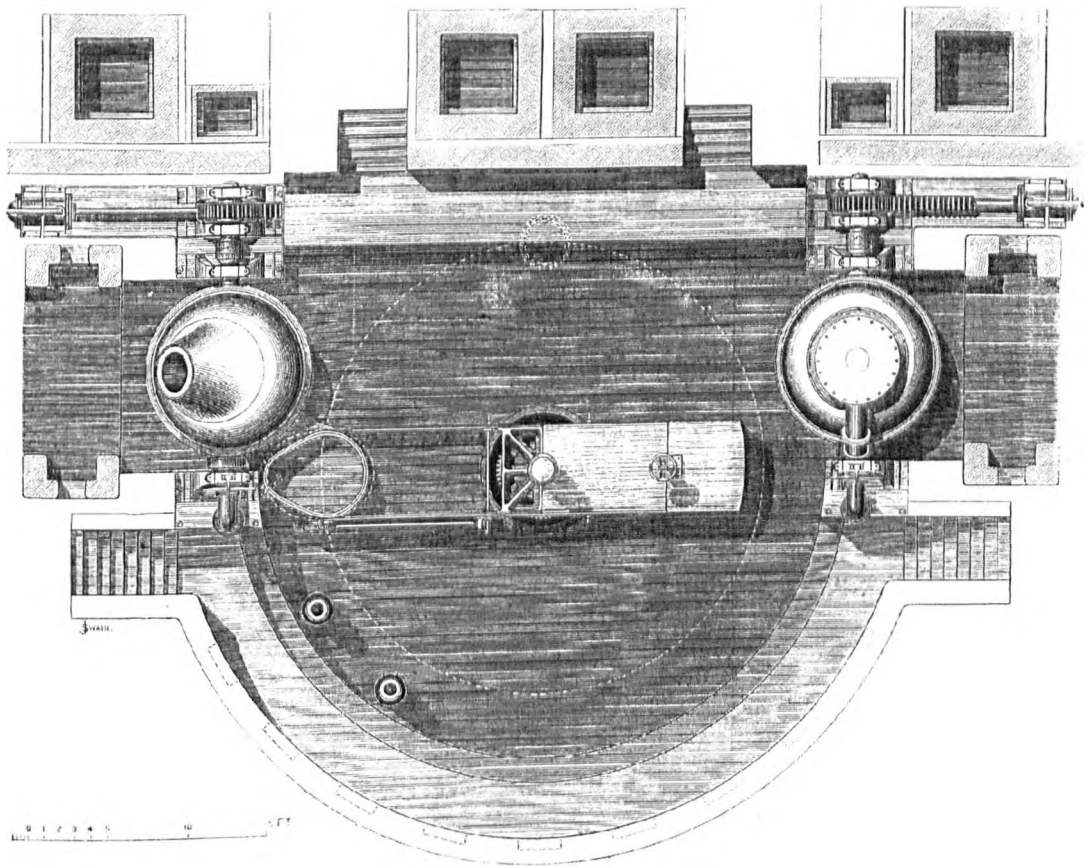

Fig. 5.42 The dirtier everyday reality of the Bessemer Shop, this example being Charles Cammell's dedicated premises at Penistone, built after 1865.



Figs. 5.43 and 5.44 Plan and elevation of John Brown's Bessemer arrangement at the Atlas Works. Drawings published to different scales, indicated (*The Engineer* 1867).

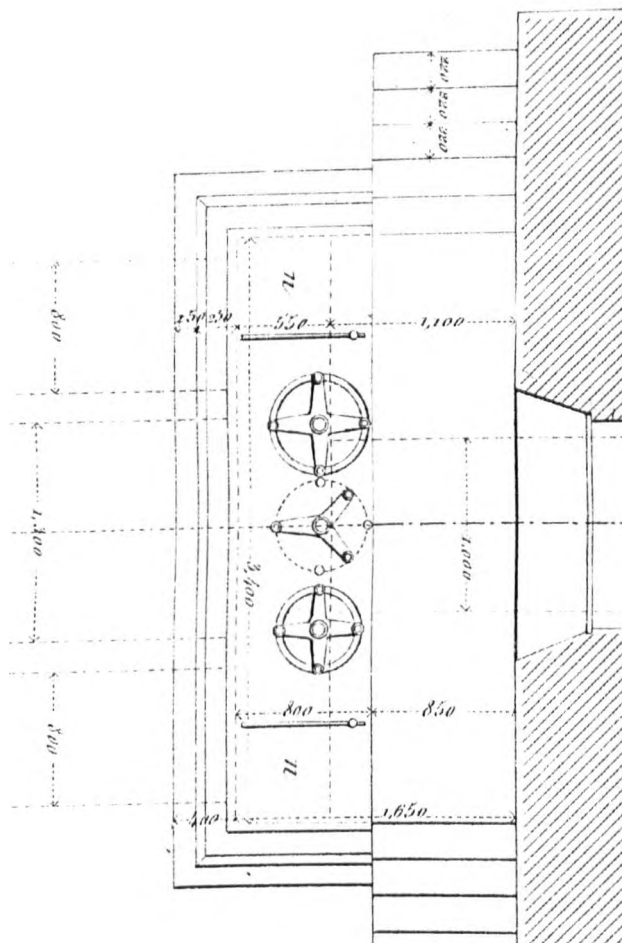
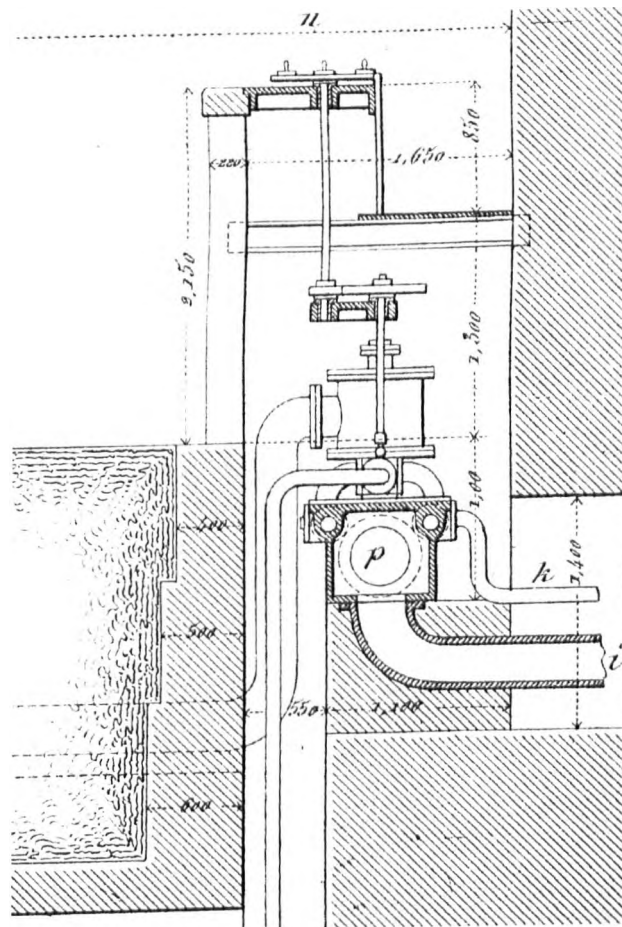

Fig. 5.45 The 'pulpit' from which all of the hydraulics in the converter house were operated by multi-way valves. Scale 1:50 (Jordan 1878, based on Bessemer's patent).

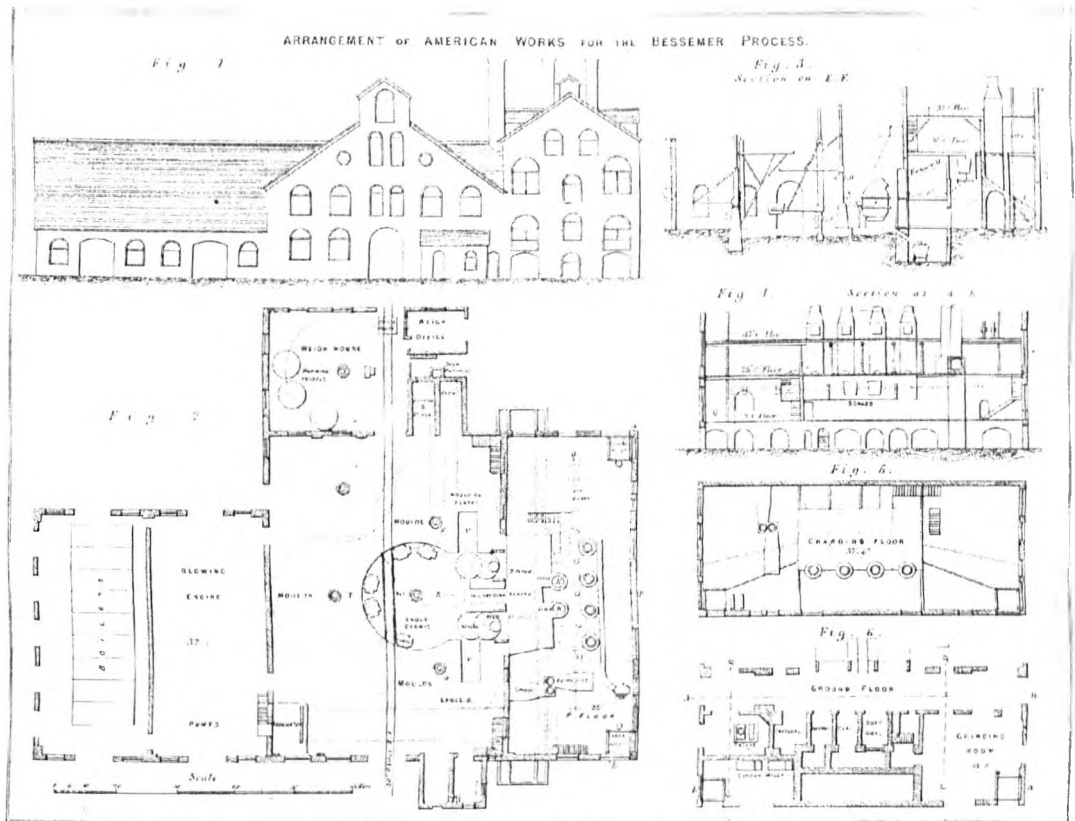

Fig. 5.46 The characteristic American form of Bessemer plant, indebted to local vernacular modes of building (Jeans 1880).

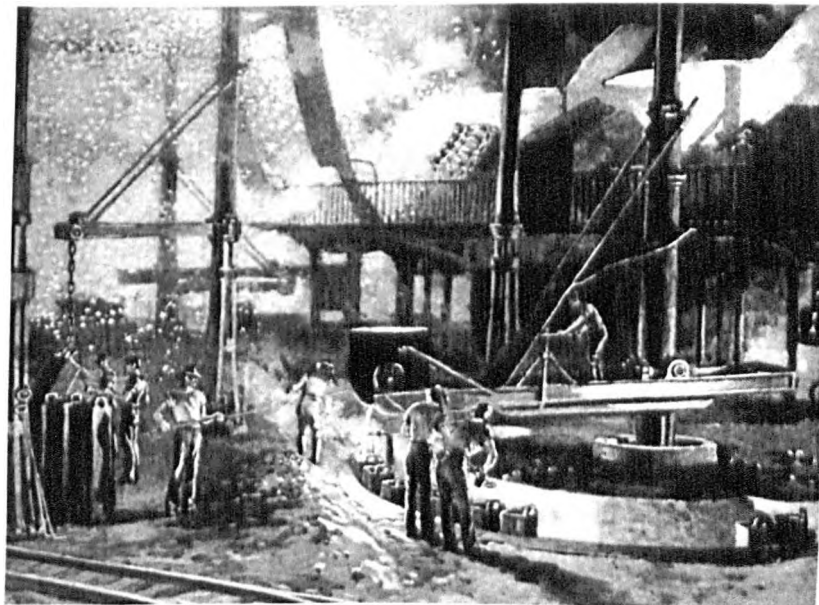
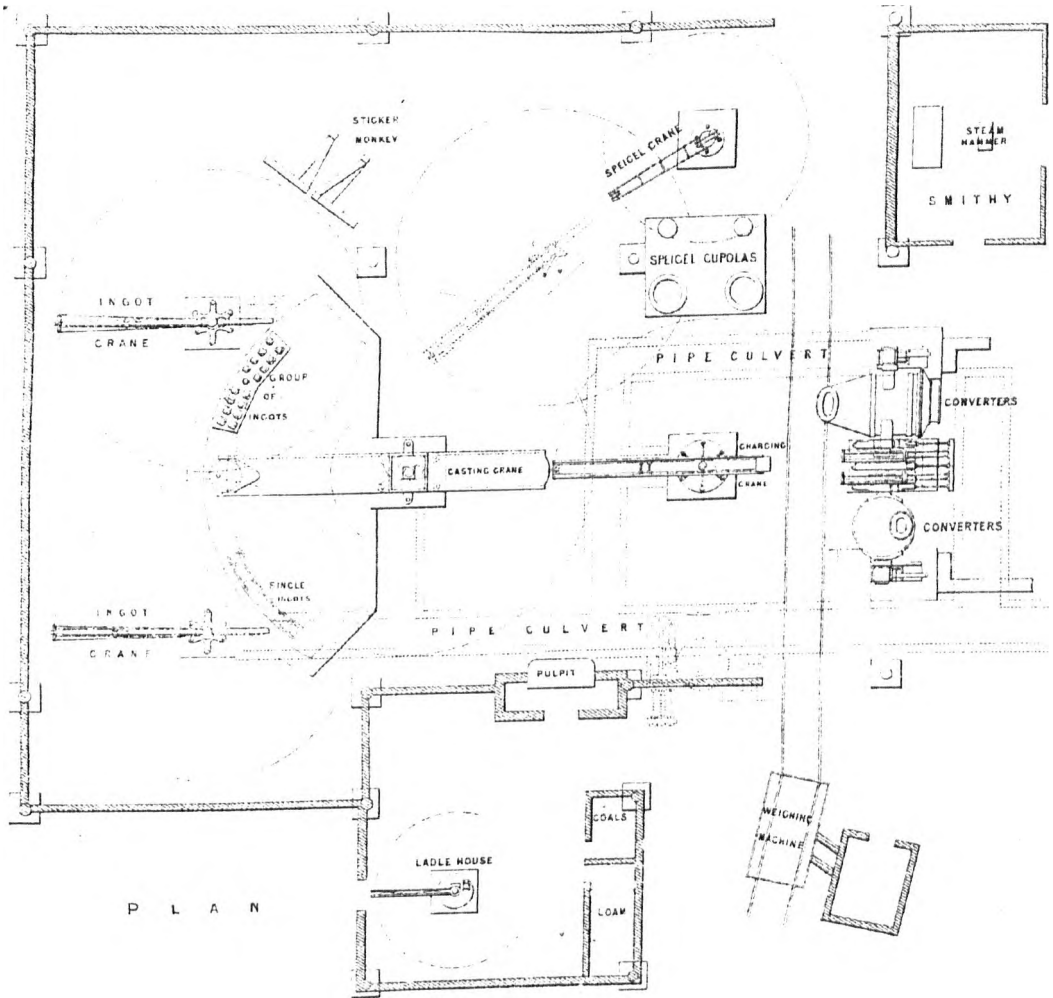
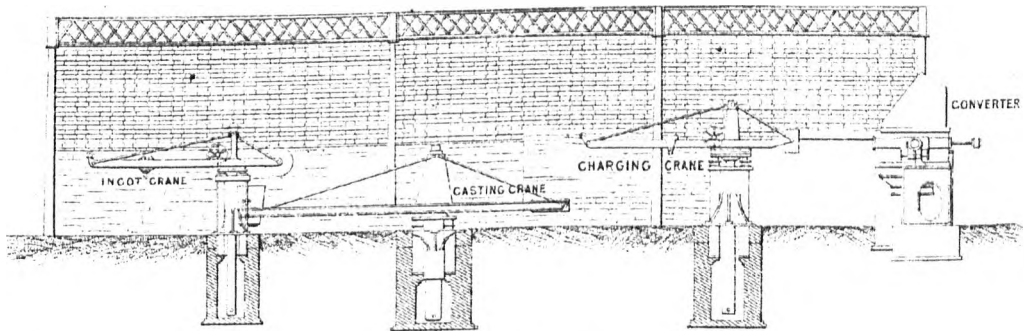

Fig. 5.47 Activity in the Bessemer shop at Bethlehem Steel Works, Pittsburgh, more heavily mechanised than its British counterparts.

BESSEMER PLANT ERECTED AT RHYMNEY.
STEEL CONVERTER HOUSE.



SECTIONAL ELEVATION.



Scale, $\frac{1}{4}$ of an Inch = 1 Foot.

Fig. 5.48 The development of Bessemer plant at Rhydney, Wales. Here the steelworks buildings have become simple trussed sheds with optional cladding where needed, leaving the ground plan clear for crane swings and railway lines (Jeans 1880).

LADLE CRANE FOR STEEL WORKS.
CONSTRUCTED BY THE ATELIERS DE LA MEUSE, LIEGE.

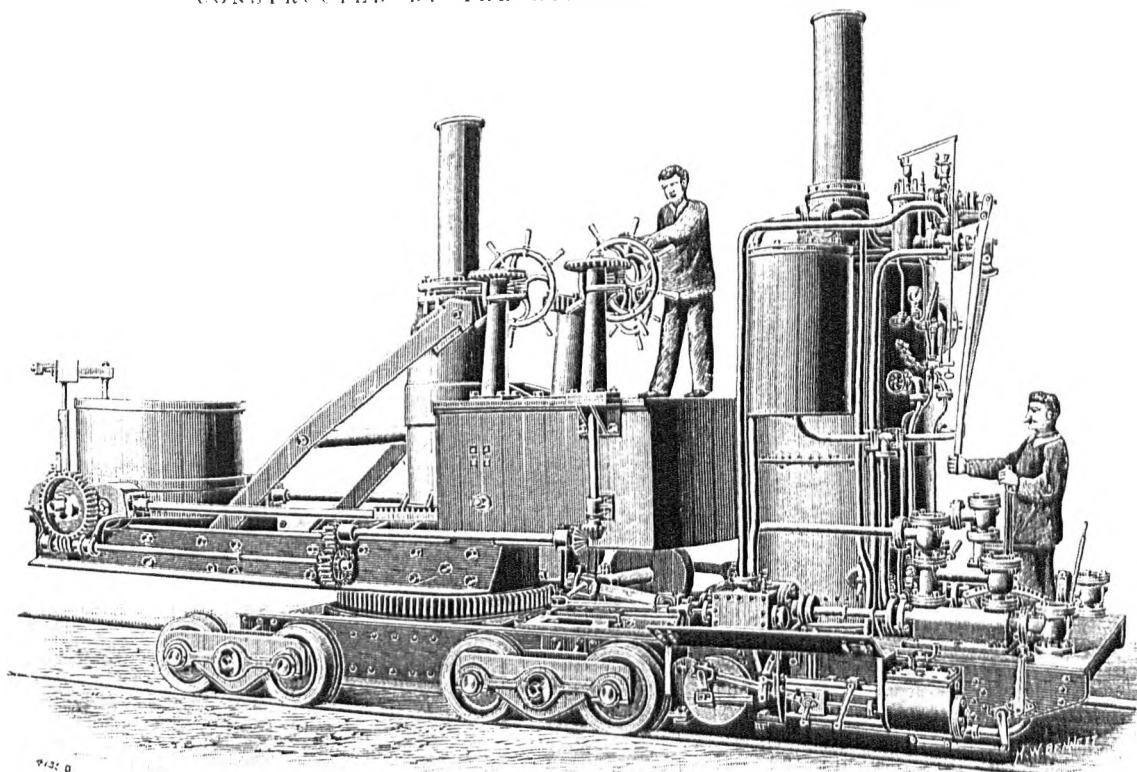

Fig. 5.49 Increasingly elaborate solutions were devised for the more efficient management of Bessemer plant, as traditionally high profit margins began to fall (*Engineering* 1897).

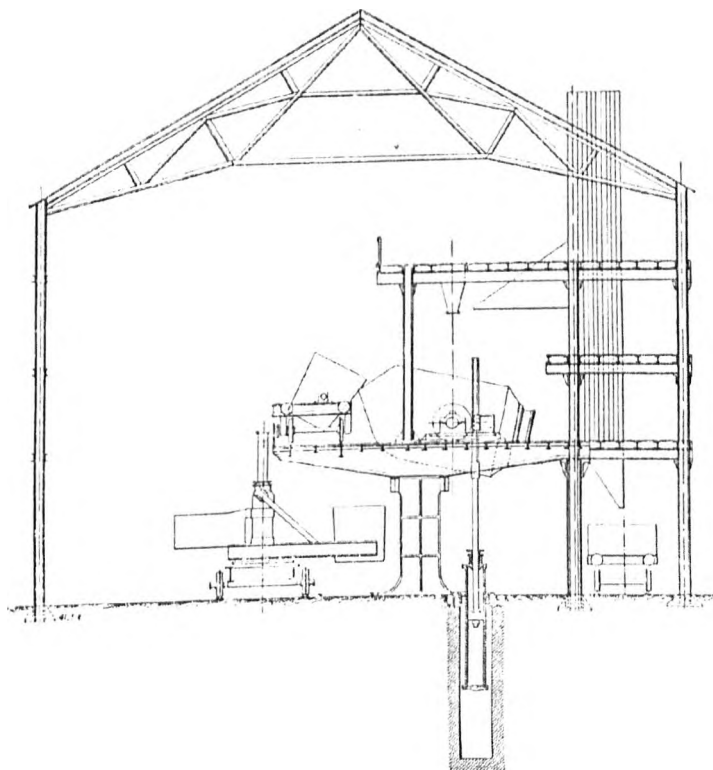

Fig. 5.50 Section of a Bessemer shed, demonstrating the use of the ladle-crane above, which ran under its own steam on tracks alongside ranks of converters (*Engineering* 1897).

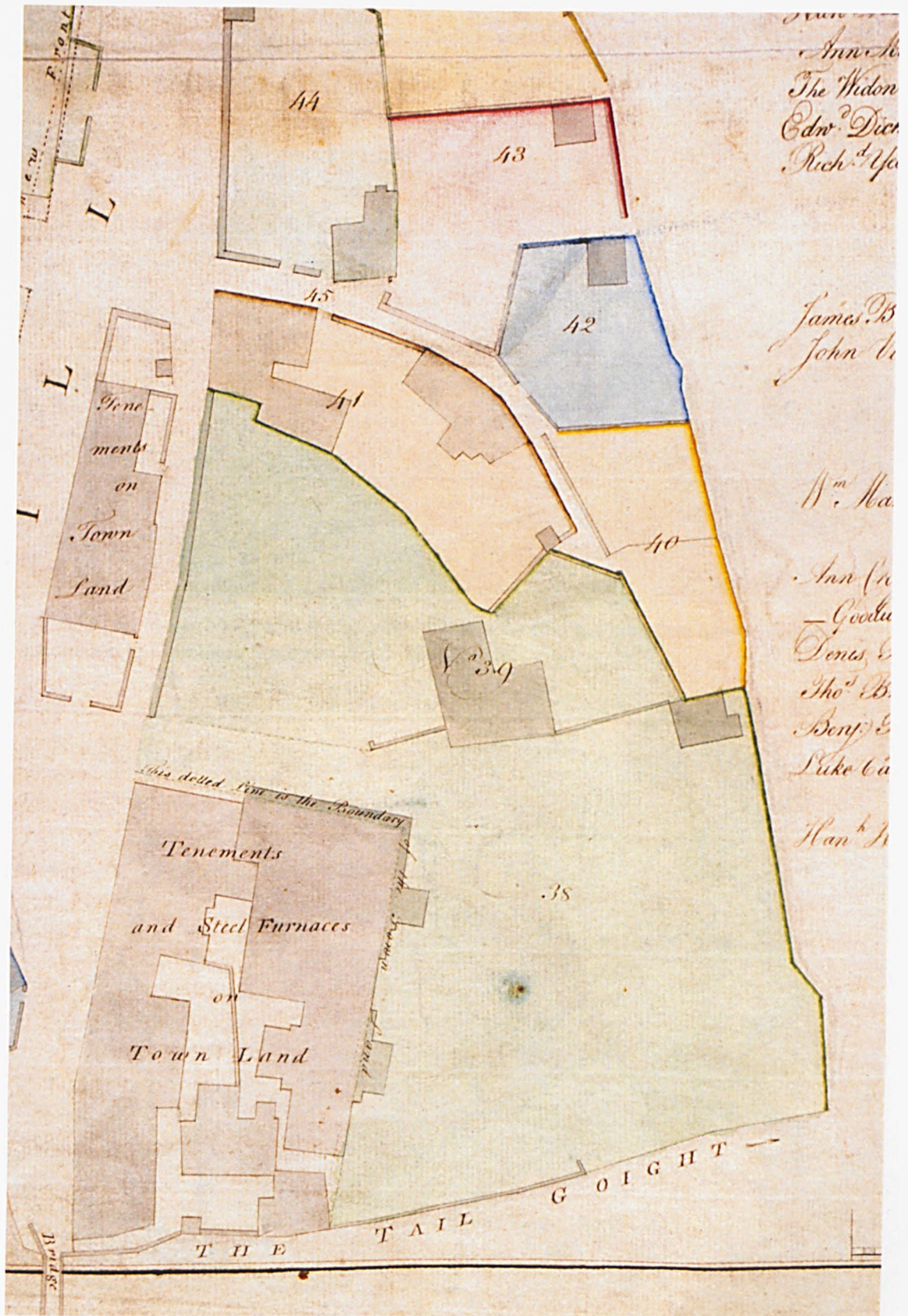

Fig. 5.51 Detail of fig. 2.42, with John Marshall's 'Tenements and Steel Furnaces' that comprised the groundbreaking Millsands steelworks (SCA).

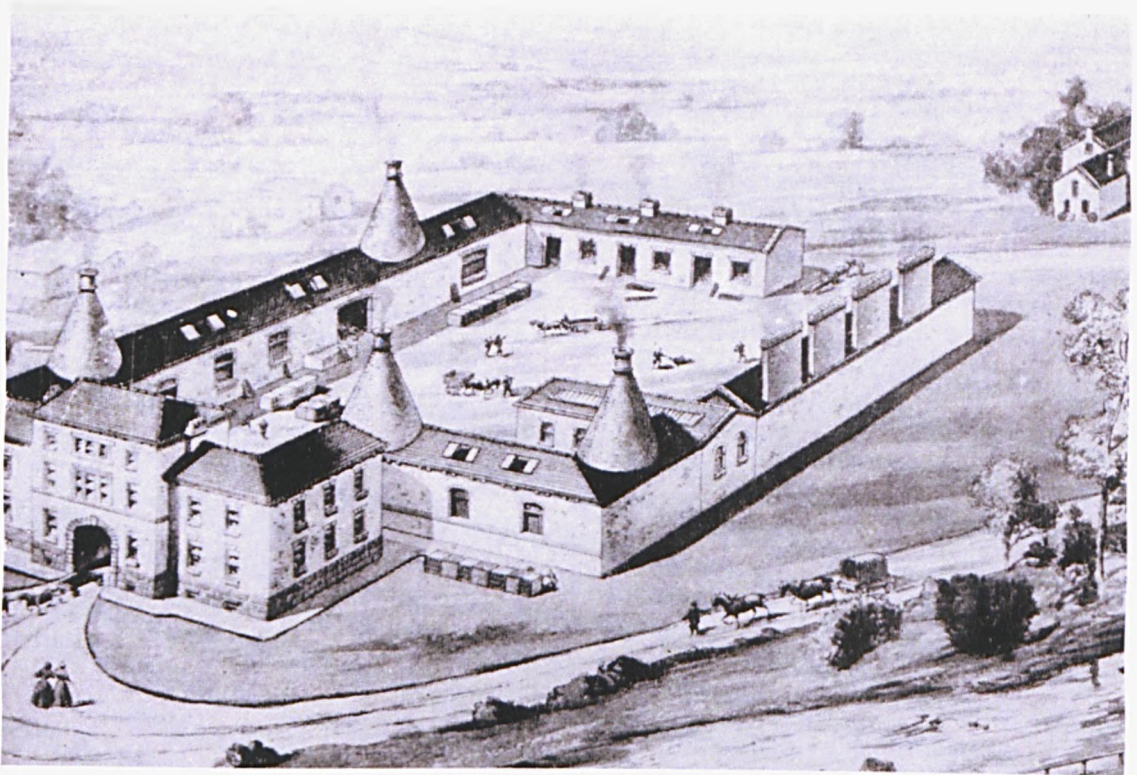

Fig. 5.52 An idealised view of the Millsands Works around the time that Naylor Vickers succeeded to Marshall's business (Scott 1962).

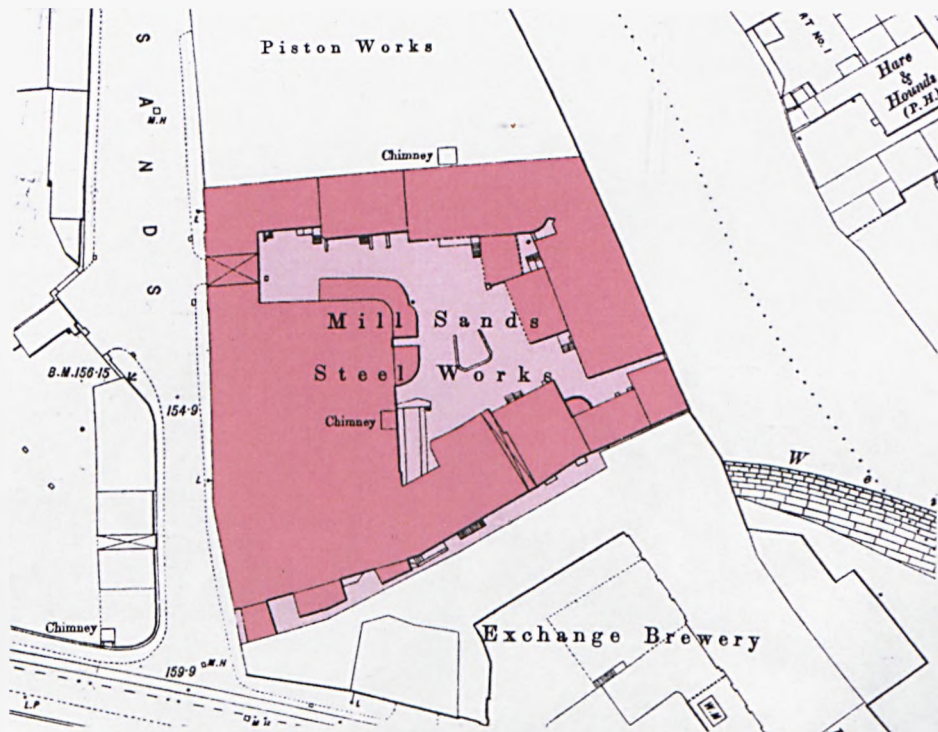

Fig. 5.53 The nucleus of the Millsands Steel Works in 1889, still retaining some of Marshall's original structures. North is at top, scale 1:1000 (OS, author's colours).

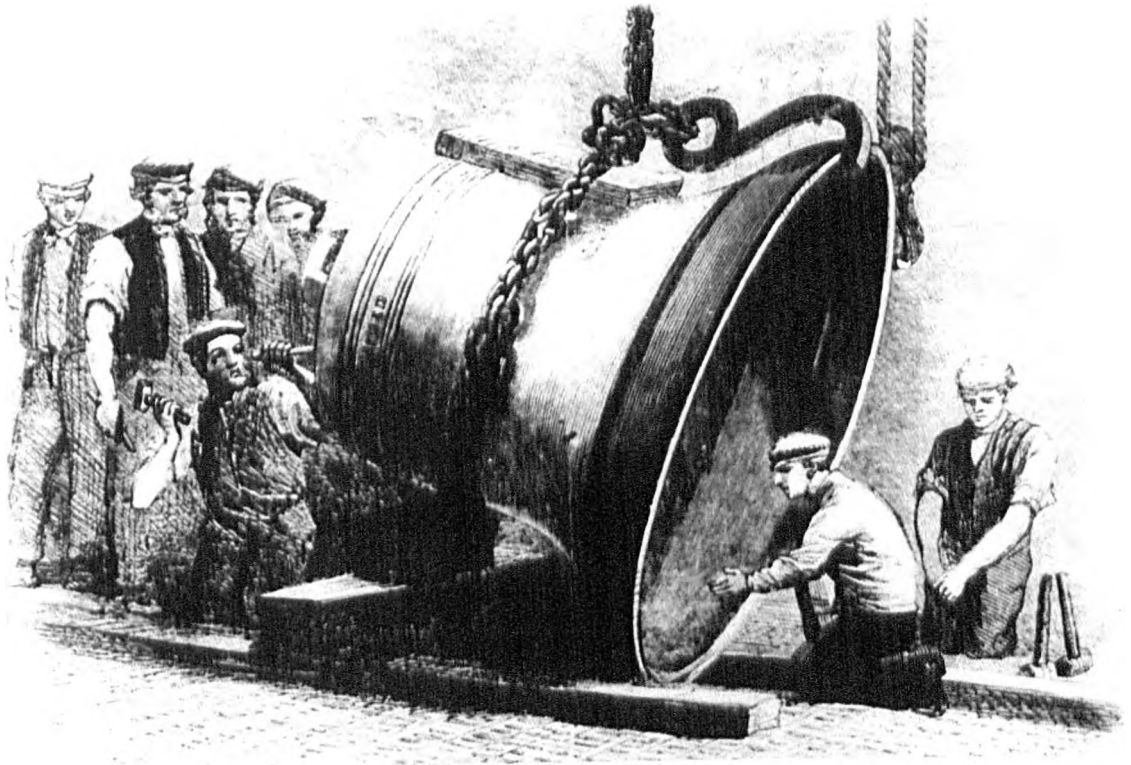

Fig. 5.54 Cast steel bell for the San Francisco fire station, manufactured by Naylor Vickers.

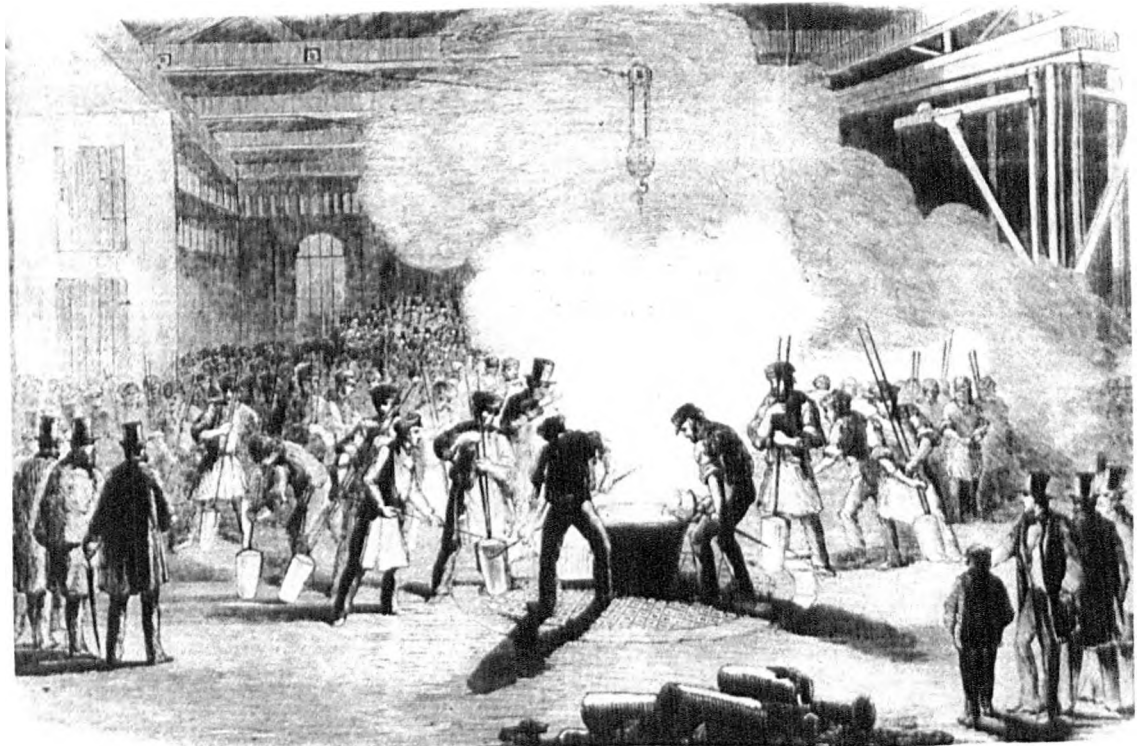

Fig. 5.55 Steel bell casting in the main melting shop at Millsands. The exercise required the co-ordination of scores of men handling white-hot crucibles of steel.



Fig. 5.56 Another view of the bell-casting process, with important visitors watching from an theatre-type box at top left.



STEEL BELL CASTING--RIVER DON WORKS.

Fig. 5.57 The main bell foundry at Millsands with its heavy timber roof construction from which hung shelves of drying crucibles (Pawson & Brailsford 1862).

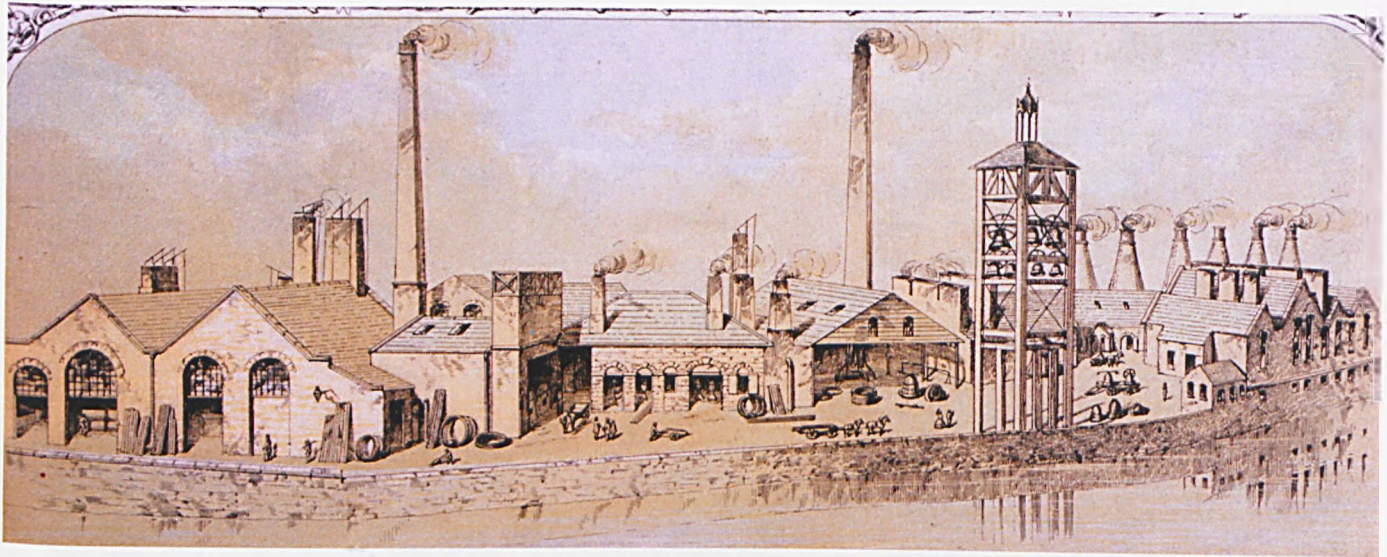

Fig. 5.58 Panorama of Vickers' River Don Works seen from over the river with production moving from right to left. (SCL, detail of fig. 5.59 below).

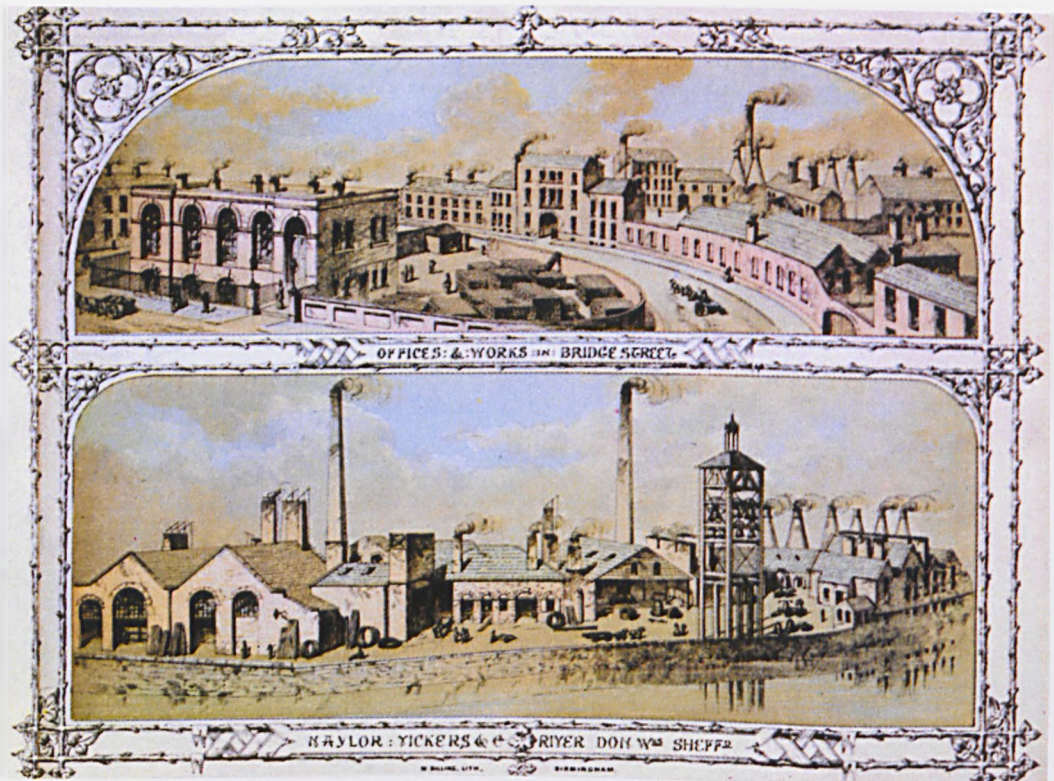

Fig. 5.59 Multi-view advertisement for Naylor Vickers at the River Don Works, Millsands and Bridge Street (SCL).

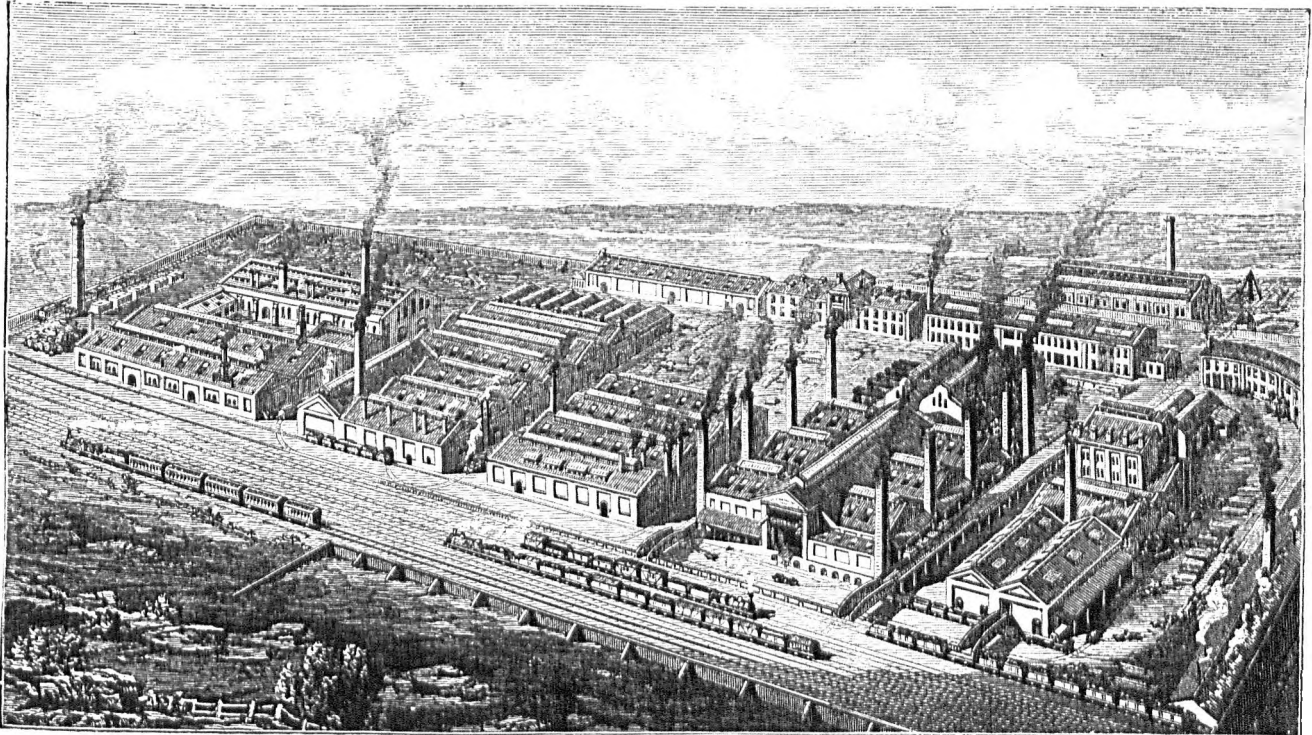

Fig. 5.60 The new River Don Works at Brightside, with the 'five masses of building' that housed the different processes (Pawson & Brailsford 1862).

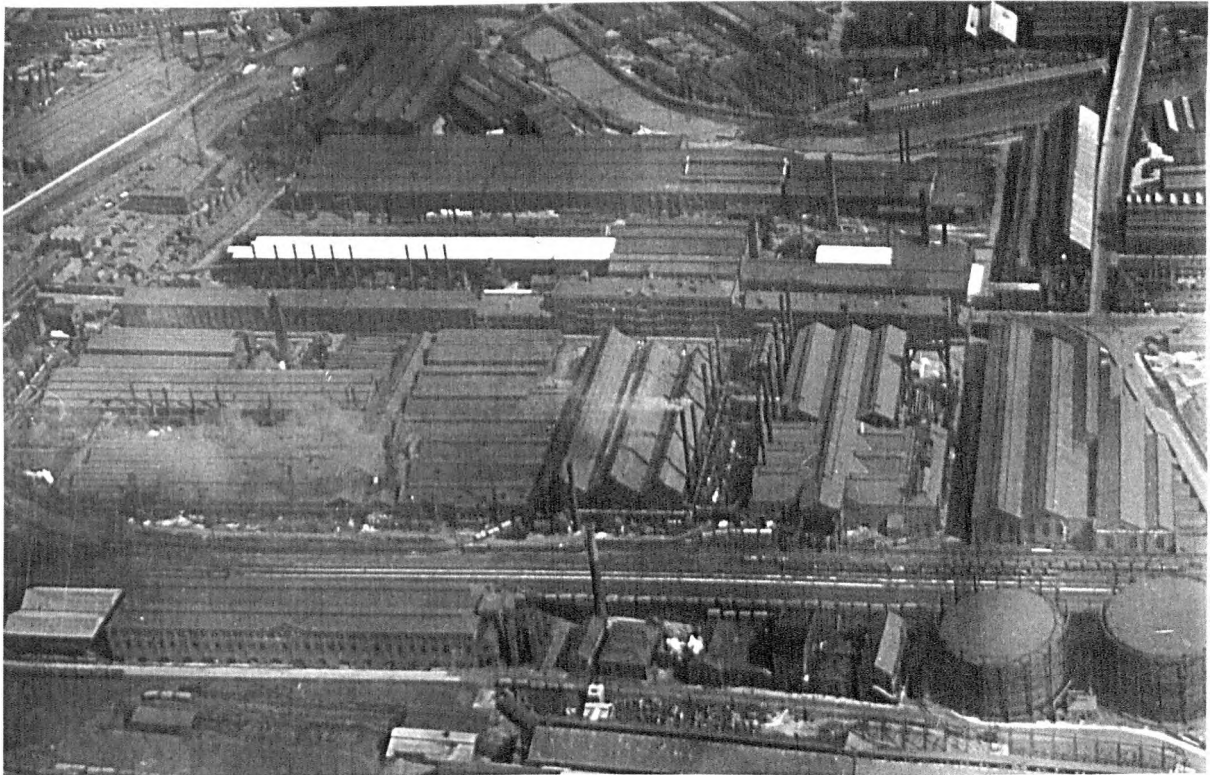

Fig. 5.61 Early aerial view of the River Don Works, of interest in comparison to fig. 5.60 above (SCL).

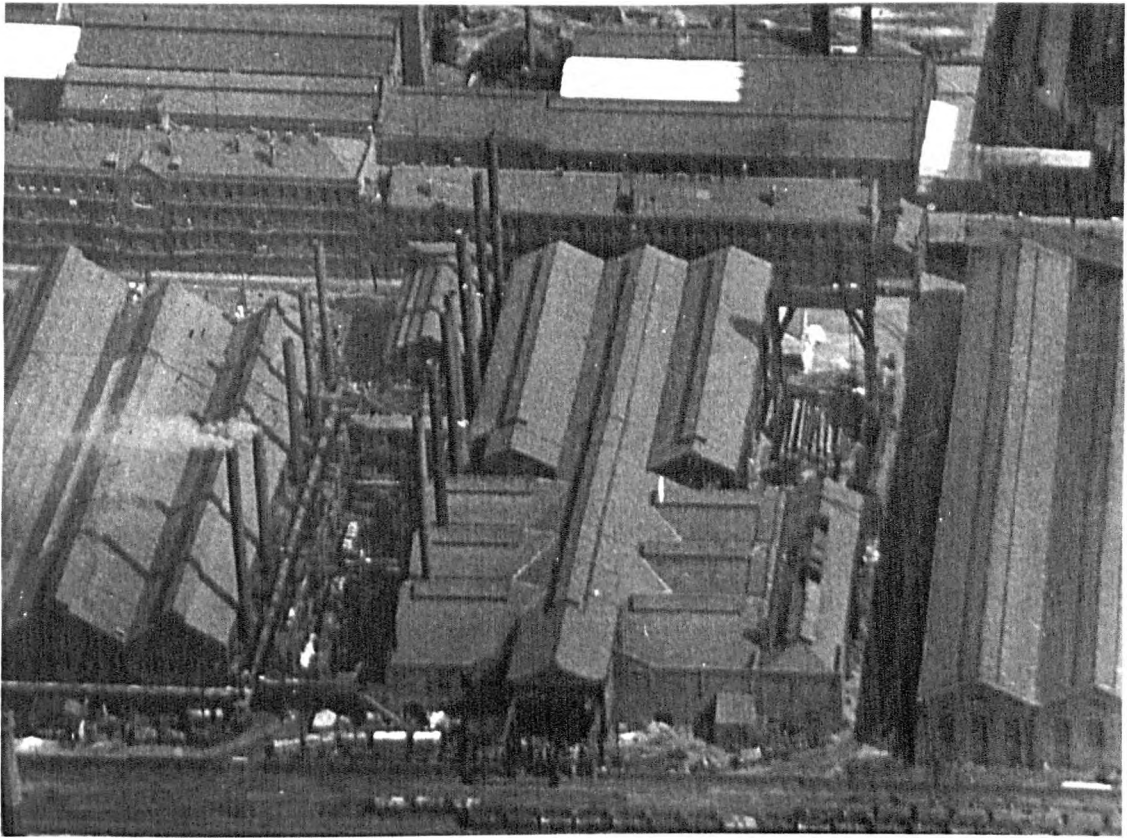

Fig. 5.62 Detail of the steel melting building. The crucible furnaces and their tall corner stacks have been replaced by larger gas-fired open hearth furnaces (SCL).

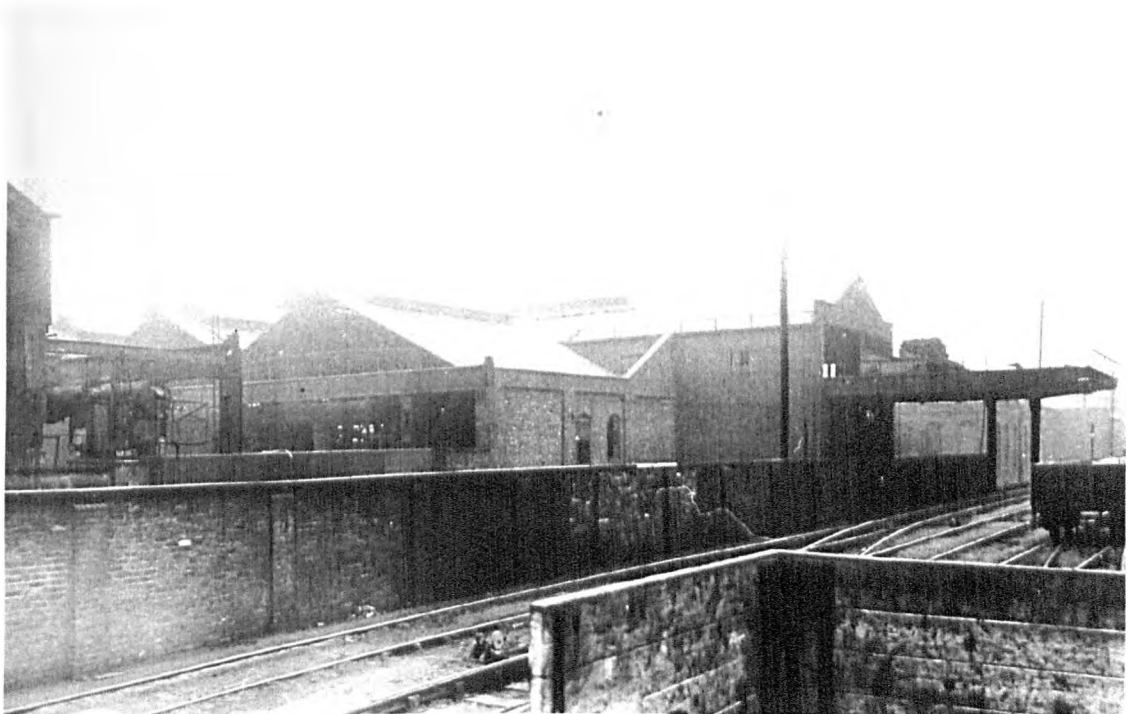

Fig. 5.63 The melting shop seen from the railway, with its great travelling crane straddling the tracks (SCL).

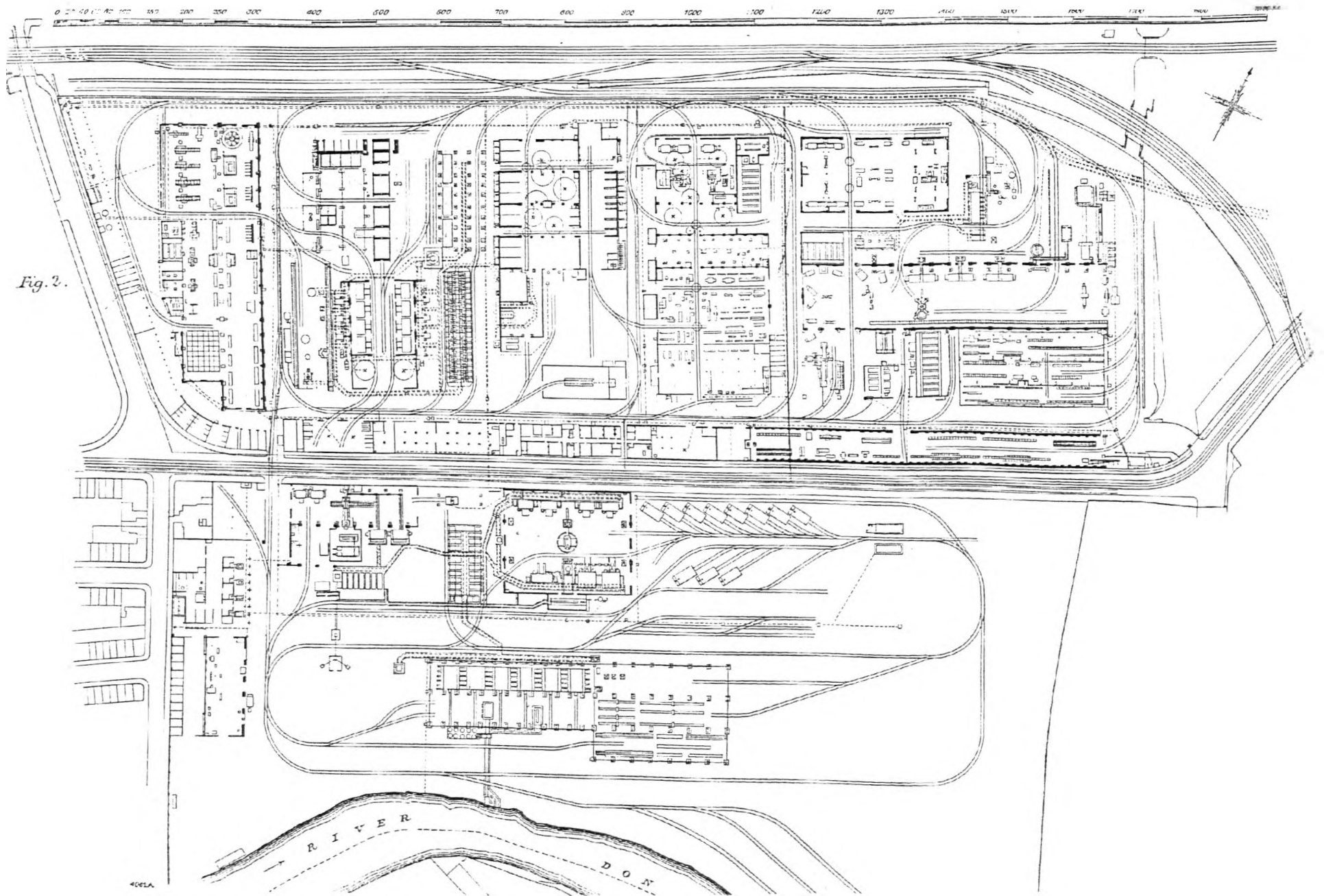

Fig. 5.64 General arrangement plan of the River Don Works. Brightside. Scale 1:2500 (*Engineering* 1897).

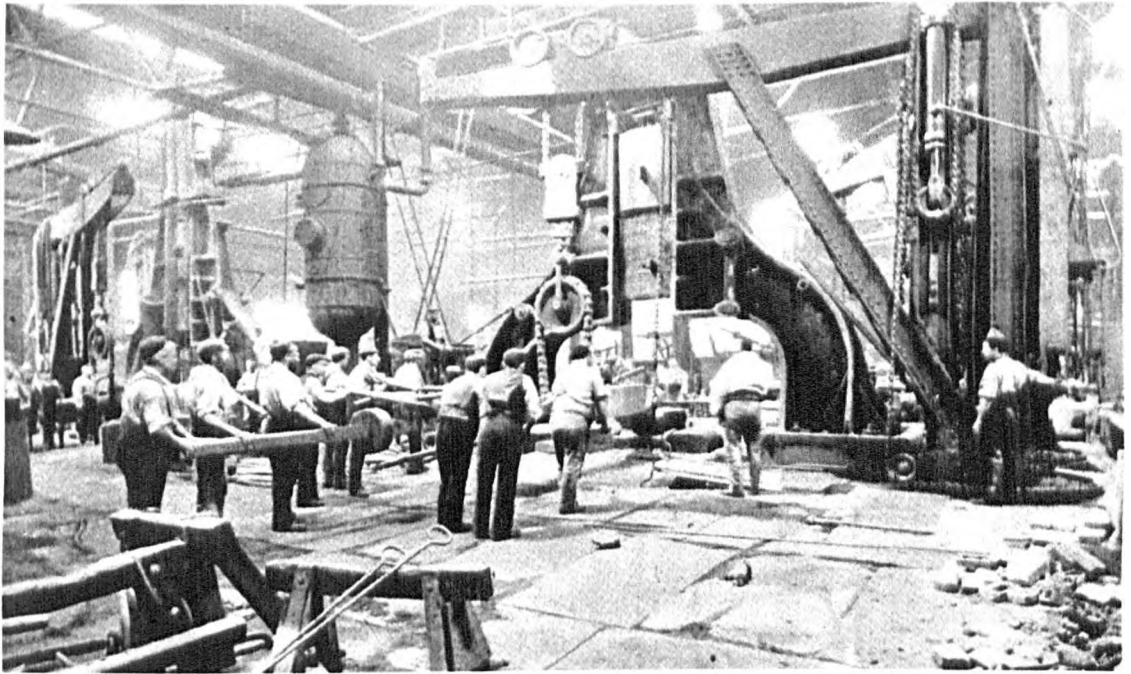

Fig. 5.65 Vickers' hammer shop, one of the original buildings at the River Don Works.

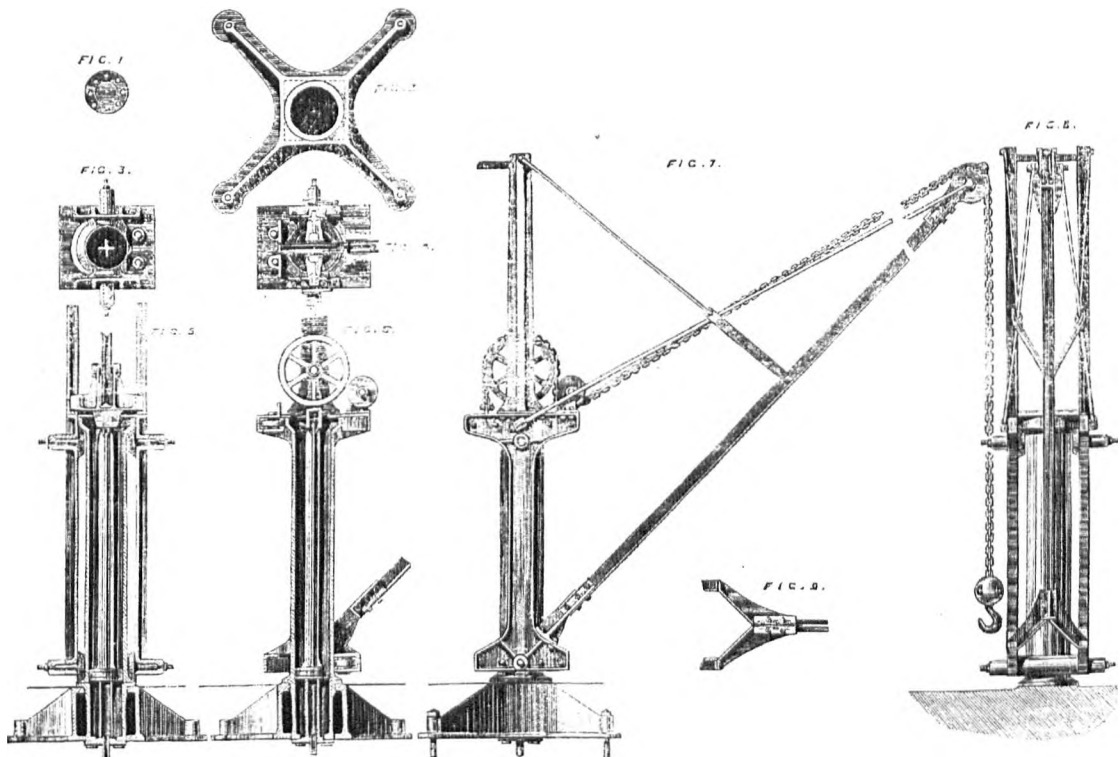

Fig. 5.66 Edward Reynolds' innovative design for a hydraulic crane, used throughout the River Don Works and moved by natural waterpower (*Engineering* 1867).

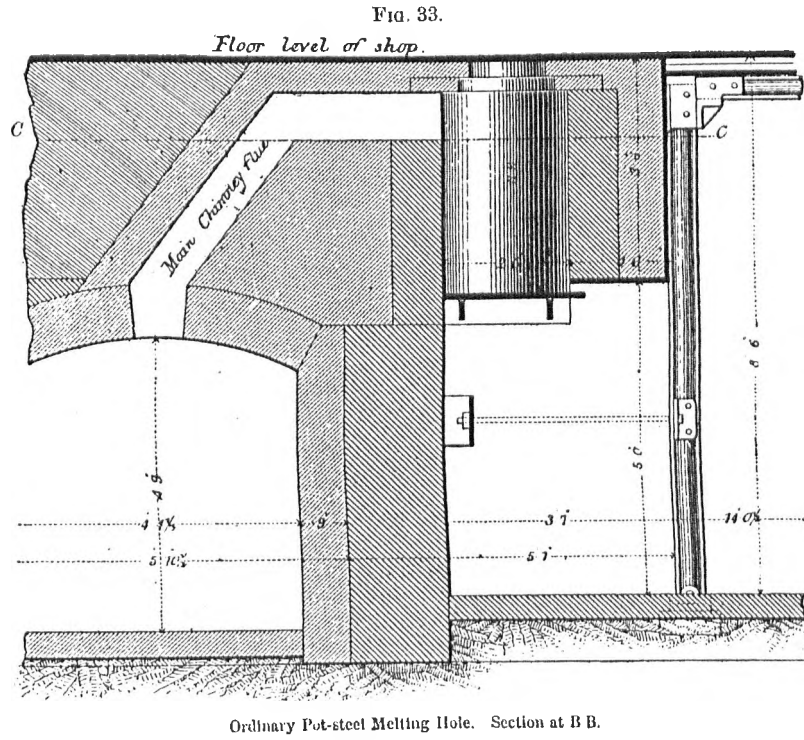

Fig. 5.67 Section of Vickers' crucible steel furnaces at the River Don Works (Jeans 1880).

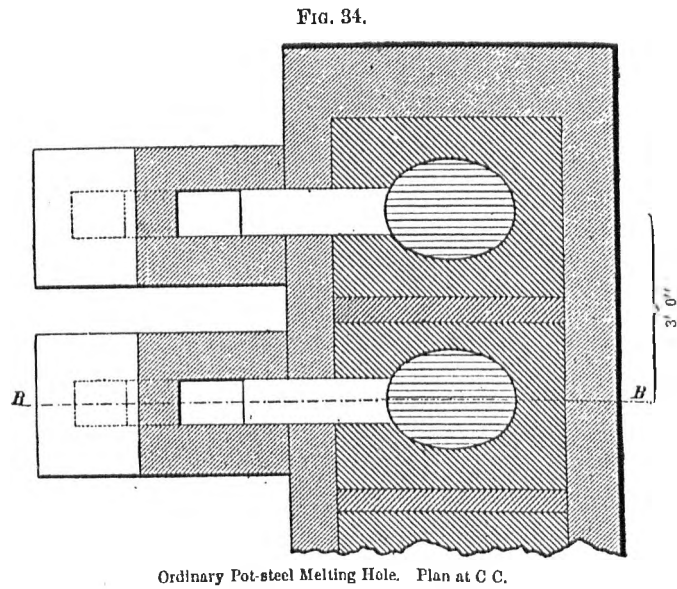

Fig. 5.68 Plan of the melting holes as above (Jeans 1880).

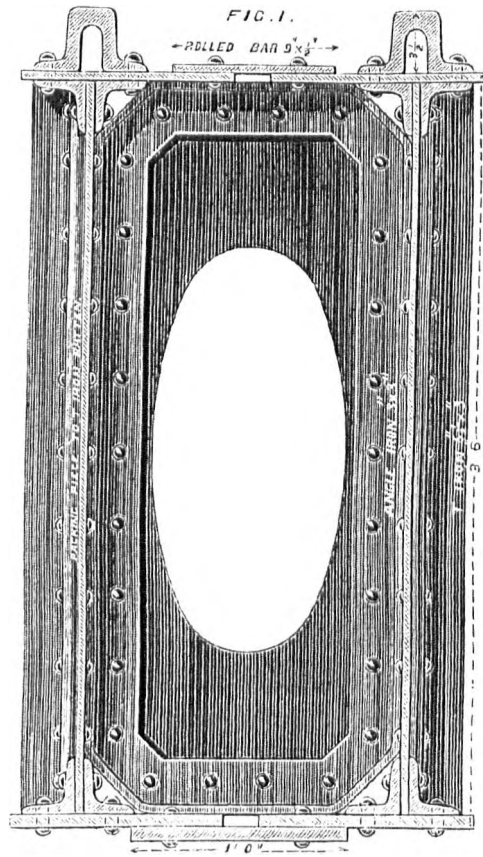
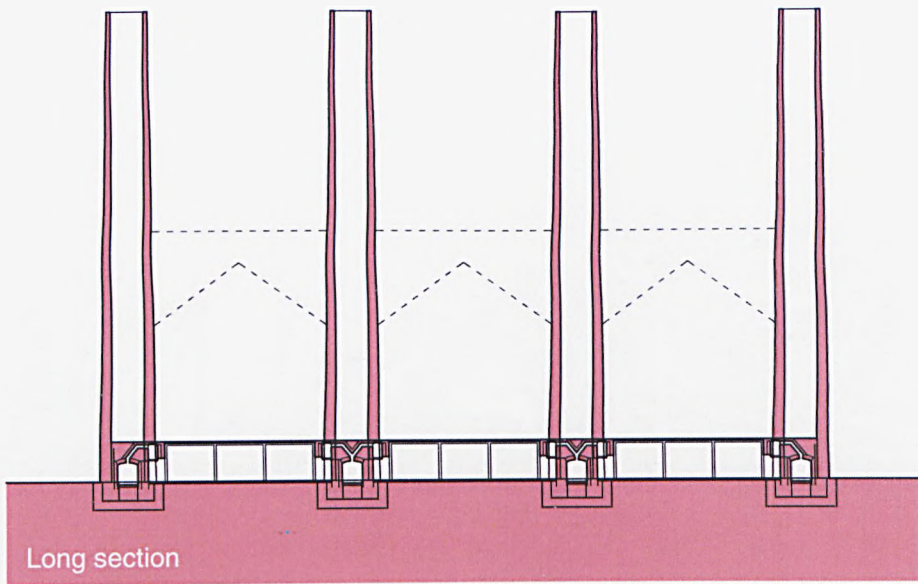

Fig. 5.69 Section of the fifty-foot box girders that supported the roof of the steel melting shop (*Engineering* 1867).



Fig. 5.70 Photograph inside the steel melting shop during alterations. The heavy masonry structures at basement level may be the remains of the original crucible furnaces (SCL).



Plan at basement level

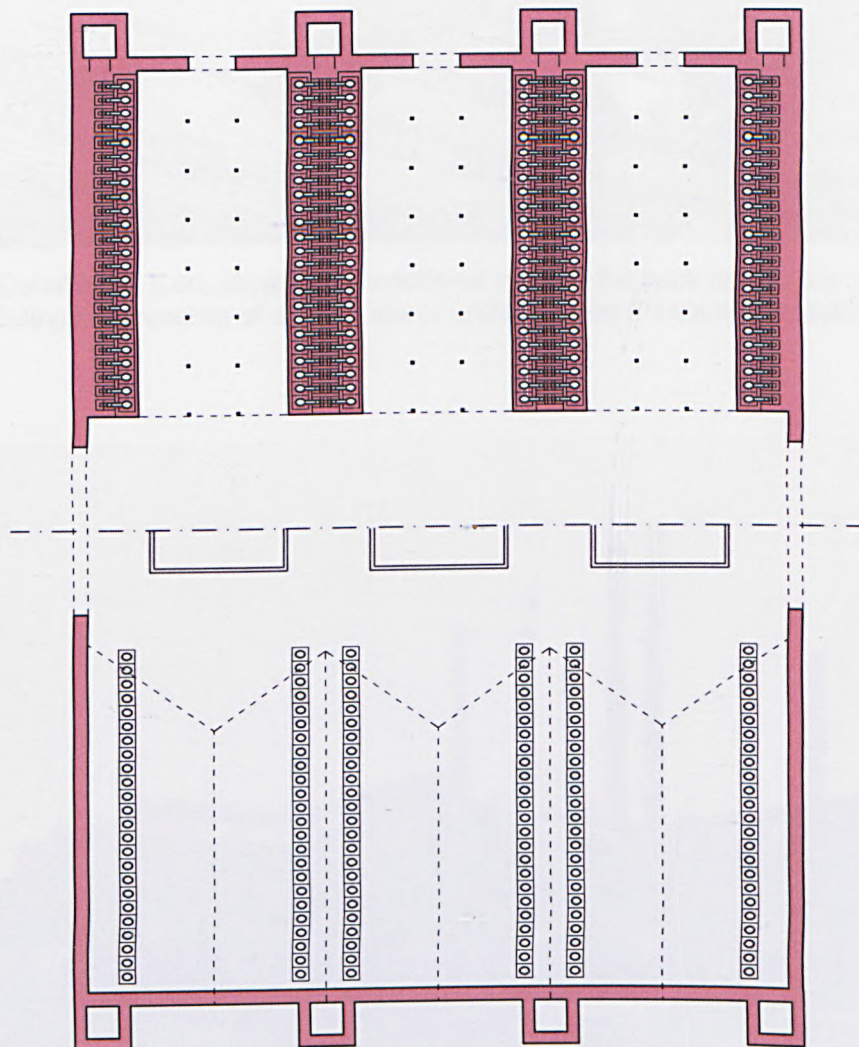

Plan at melting shop floor level

Figs. 5.71 (top) and 5.72 (below) Reconstructed section and split plan of the River Don Works melting shop, based on the description from *Engineering* in 1867, augmented by dimensions from figs. 5.87 and 5.88 above. Scale 1:500 (author)

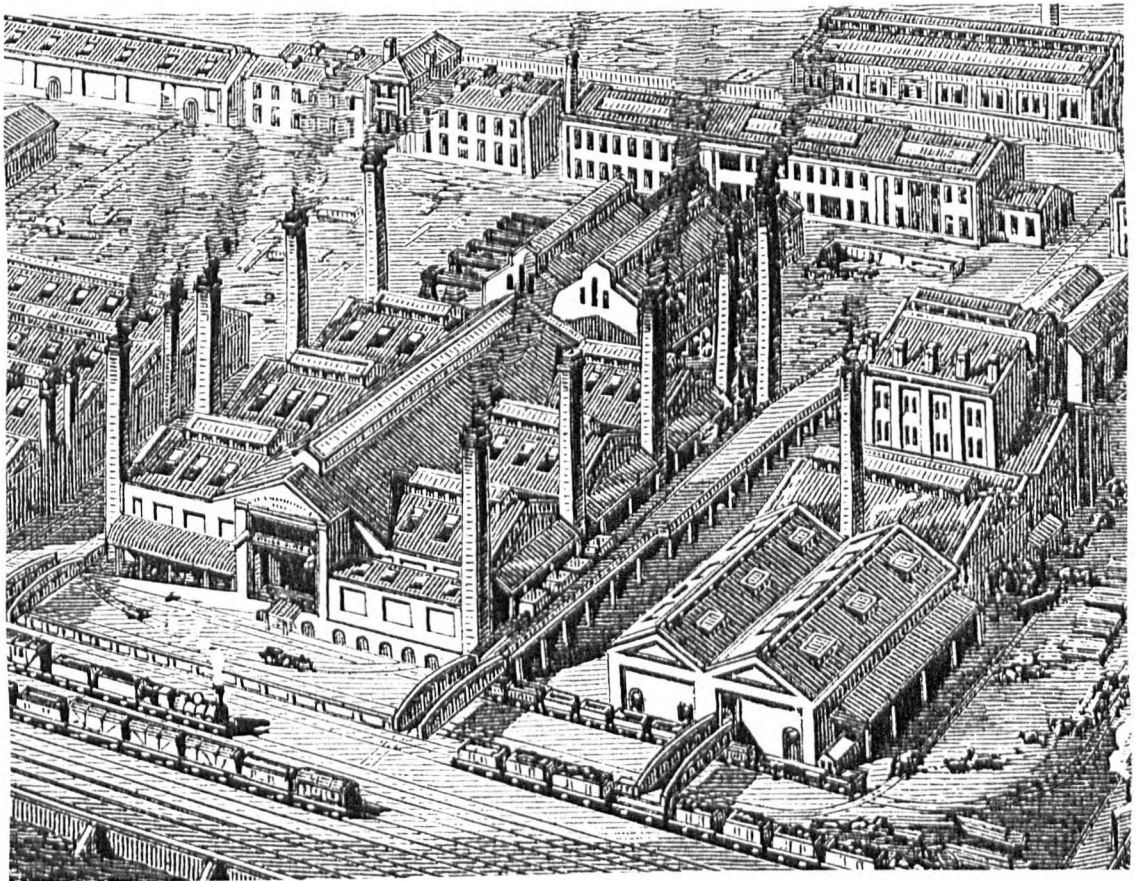

Fig. 5.73 Detail of fig. 5.60, showing the additional stack at the back right of the melting shop, indicating the presence of another row of crucible holes (Pawson & Brailsford 1862).

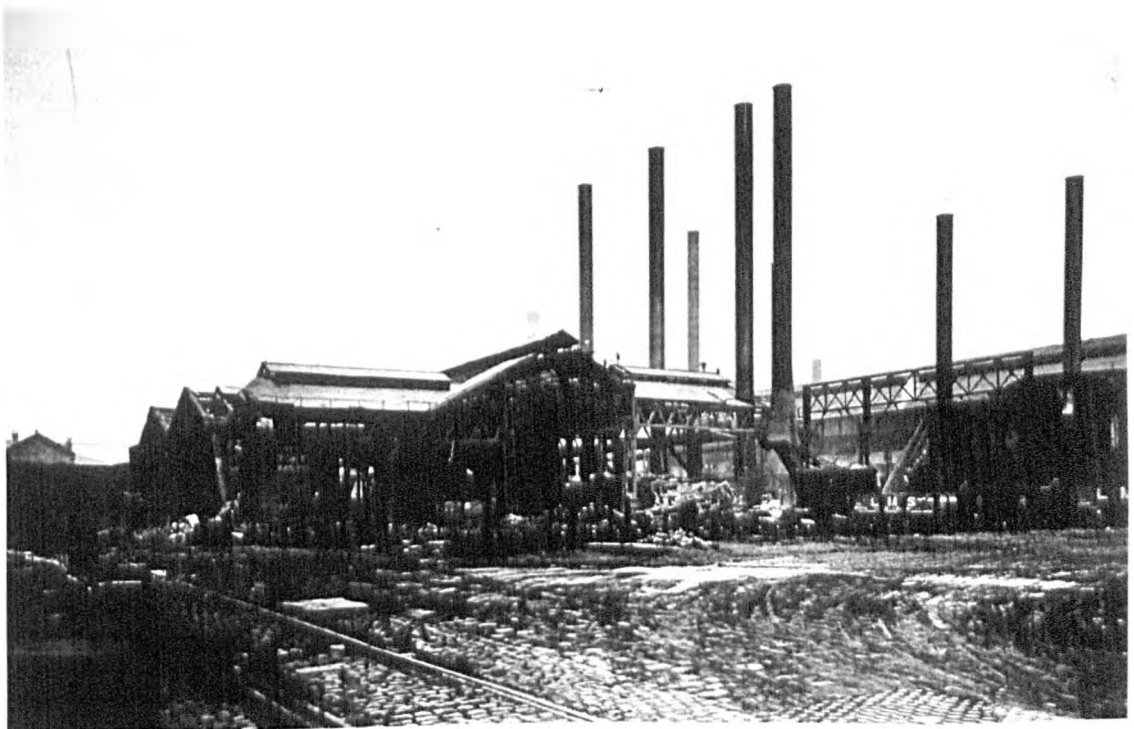

Fig. 5.74 (SCL). The melting shop during demolition, seen from across the yard (SCL).

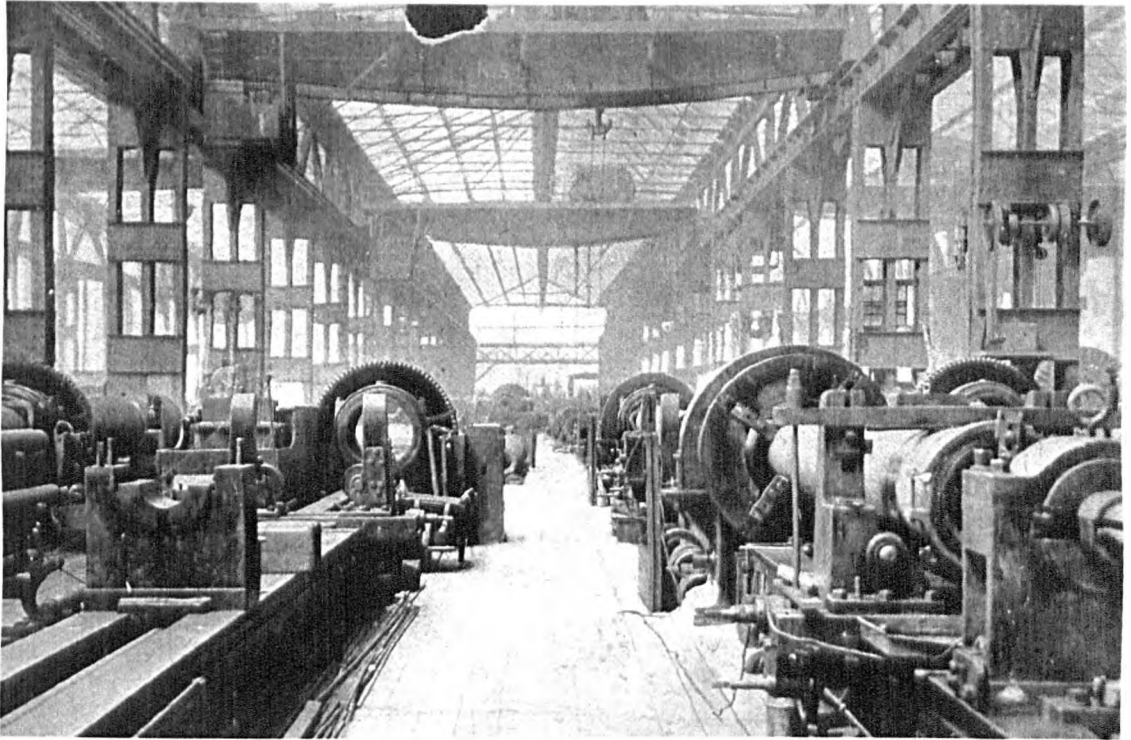

Fig. 5.75 Lathes for turning steel gun barrels inside one of the lightweight gun shops constructed on the other side of the road (*Engineering* 1897).

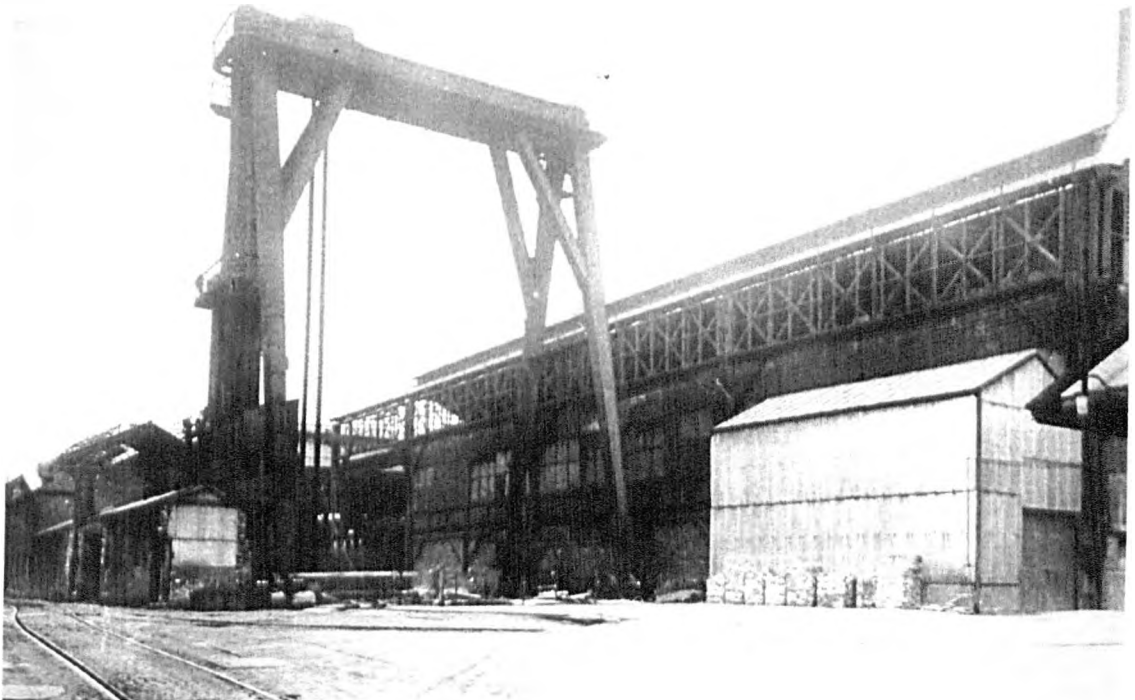
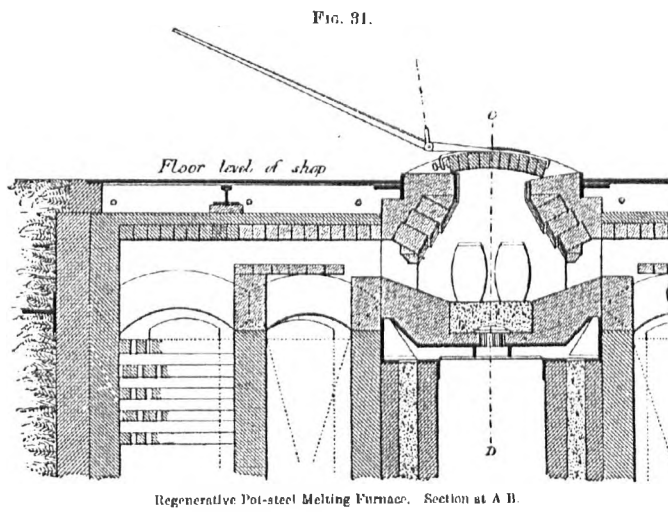
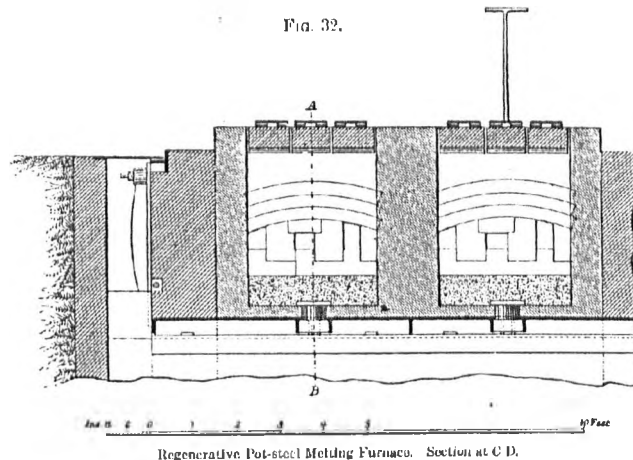

Fig. 5.76 The 'goliath' crane dedicated to gun assembly alongside the old steel melting shop at the main River Don Works site (SCL).



Regenerative Pot-steel Melting Furnace. Section at A B.



Regenerative Pot-steel Melting Furnace. Section at C D.

Fig. 5.77 Siemens' gas-fired regenerative crucible holes, each capable of holding several pots, as replaced the 'traditional' coke-fired holes at the River Don Works (Jeans 1880).

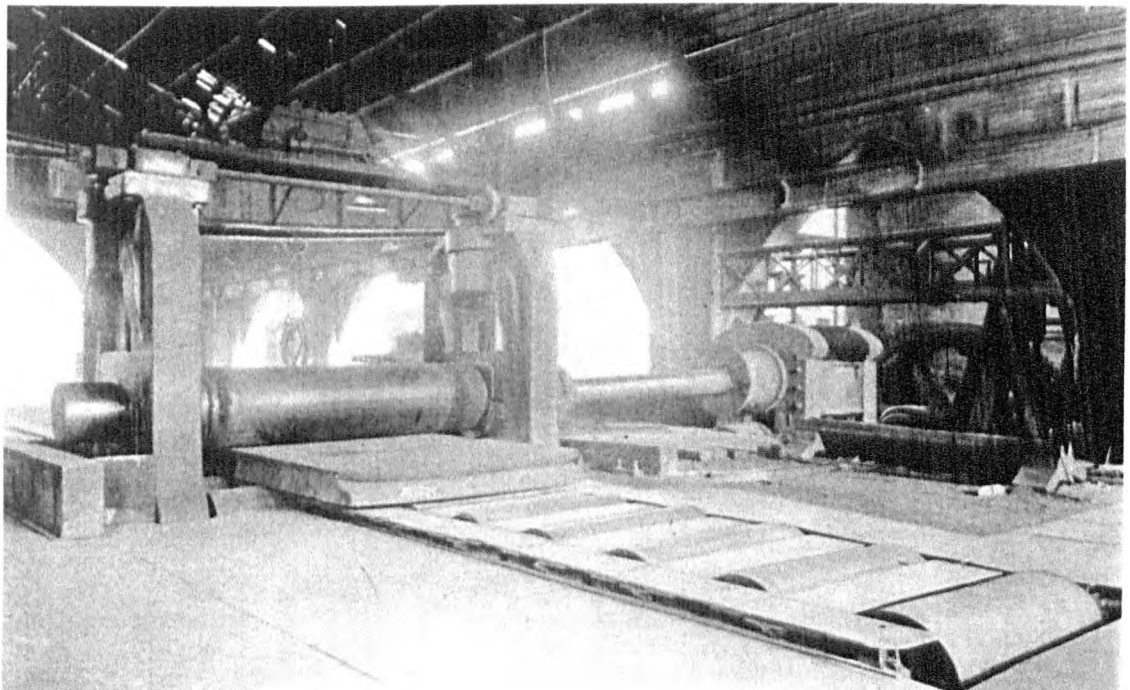

Fig. 5.78 Armour plate rolling mill at the River Don Works (SCL).

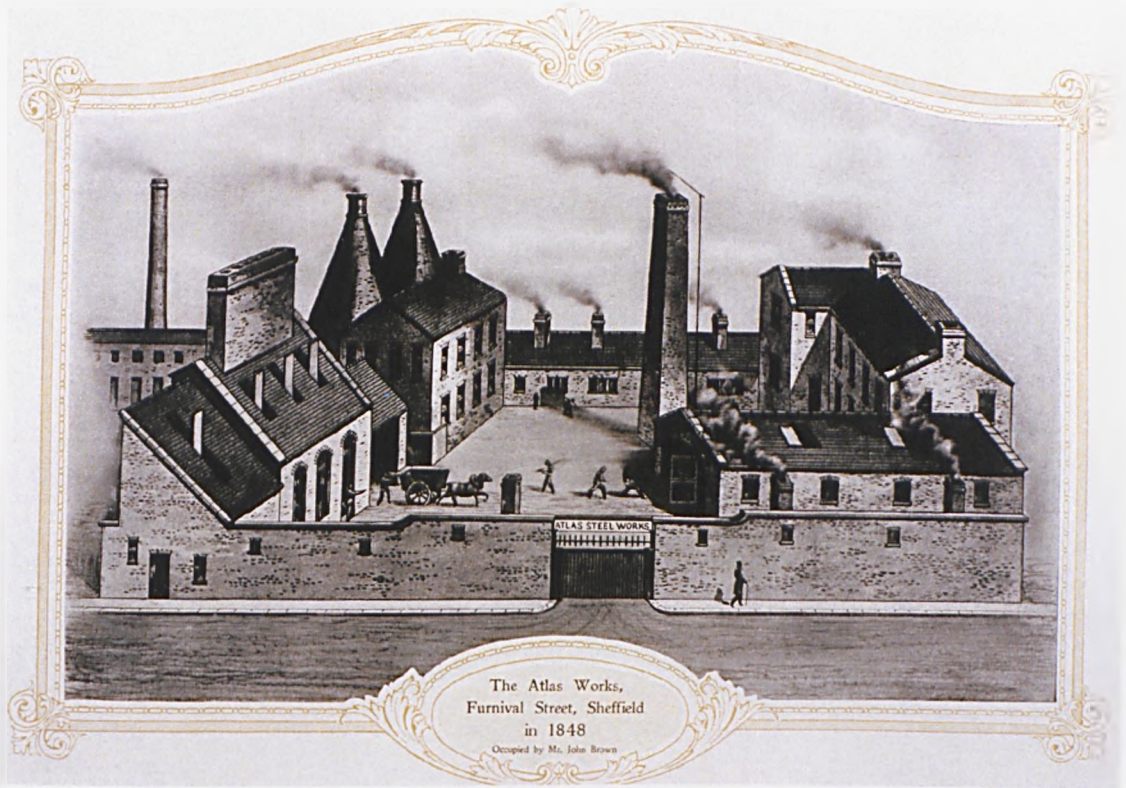

Fig. 5.79 John Brown's original Atlas Works on Furnival Street in Sheffield town centre ('John Brown and Company' 1924).

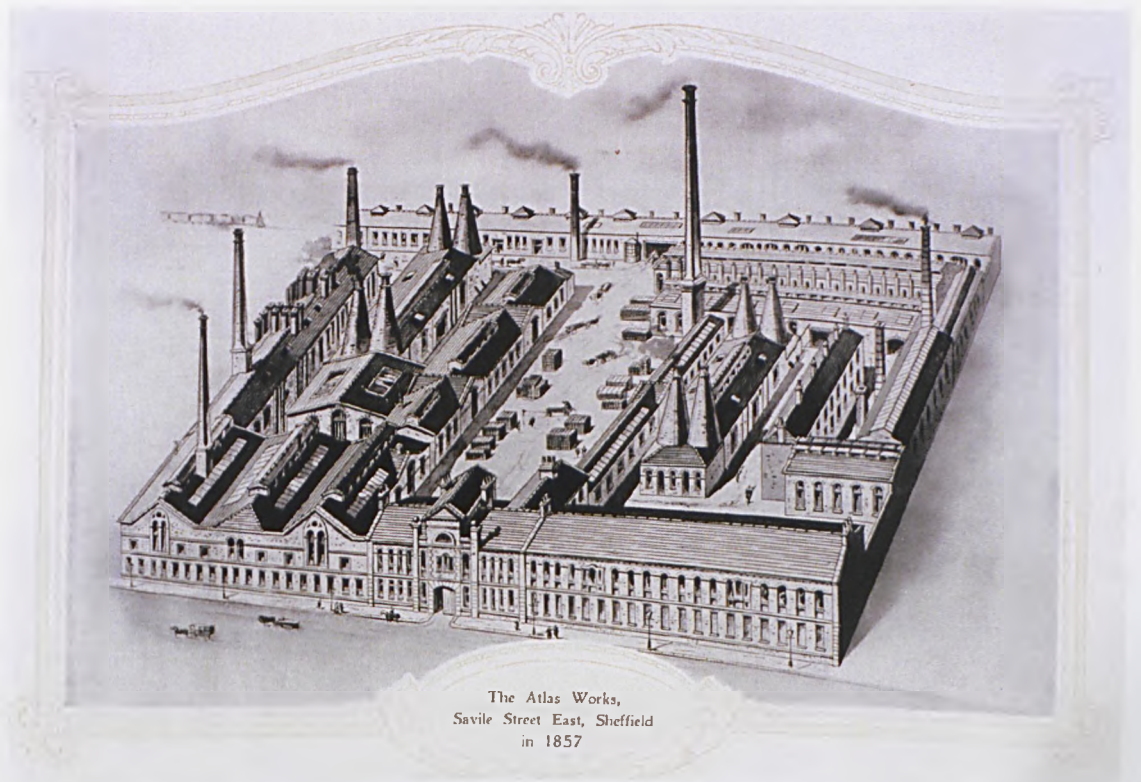
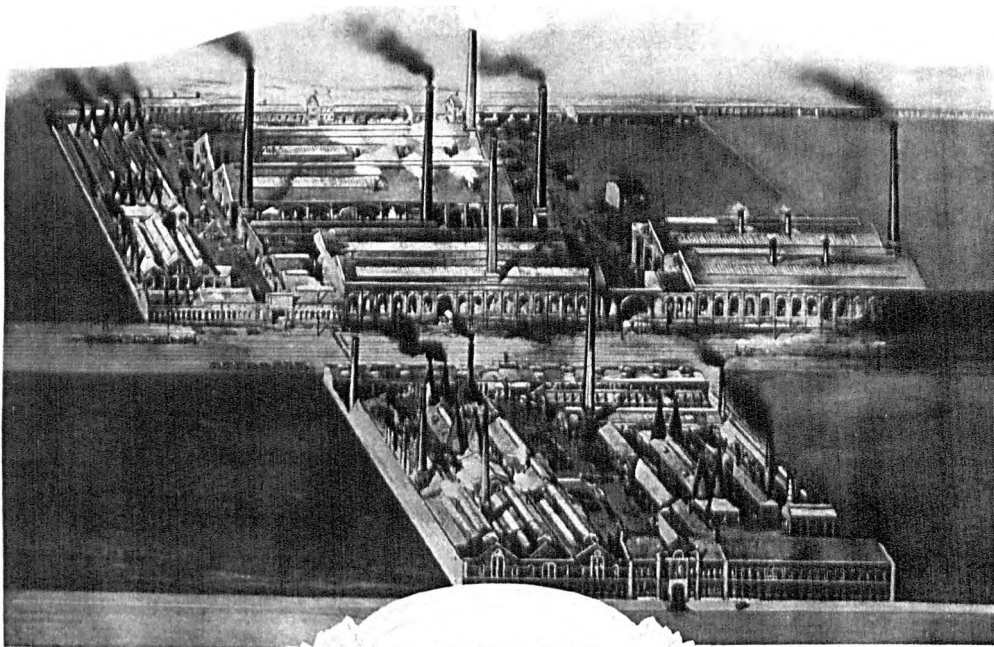
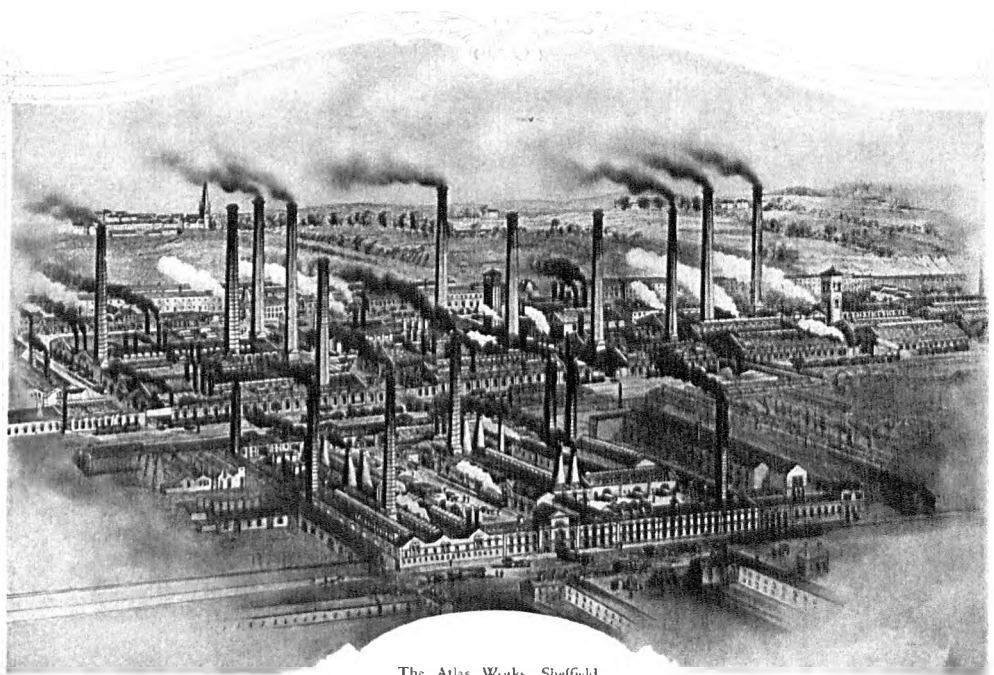

Fig. 5.80 The first phase of Brown's Don Valley Atlas Works, previously the Queen's Works of Armitage, Frankish & Barber ('John Brown and Company' 1924).



The Atlas Works, Sheffield
in 1862

Fig. 5.81 Enlargement of the original Atlas Works (foreground) with premises across the railway, c.1862 ('John Brown and Company' 1924).



The Atlas Works, Sheffield
in 1869

Fig. 5.82 Further expansion of the Don Valley premises up to 1869, fuelled by the railway business and investment in Bessemer plant ('John Brown and Company' 1924).

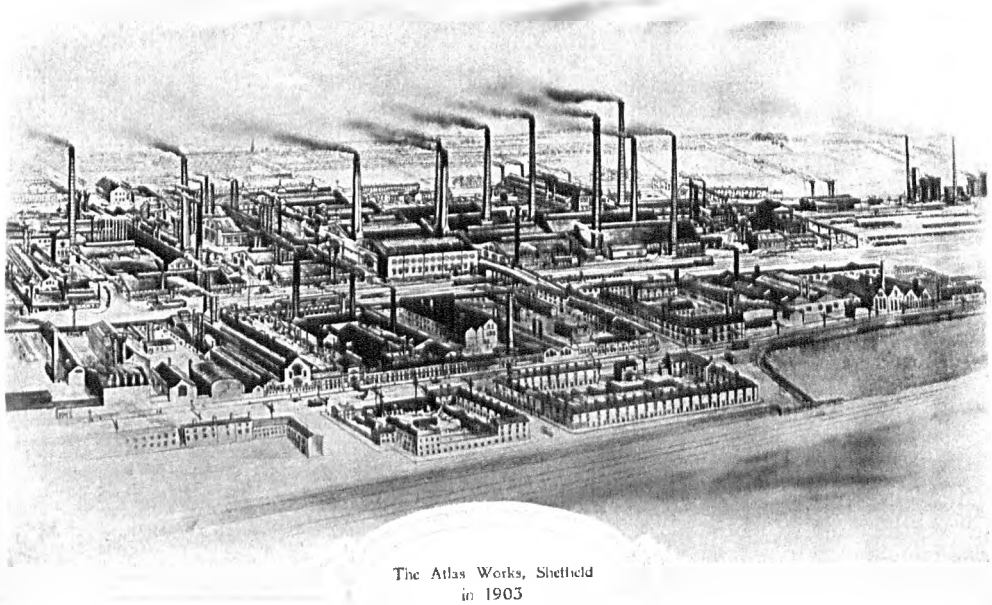

Fig. 5.83 The extent of the various branches of the Atlas Works at the outset of the twentieth century ('John Brown and Company' 1924).

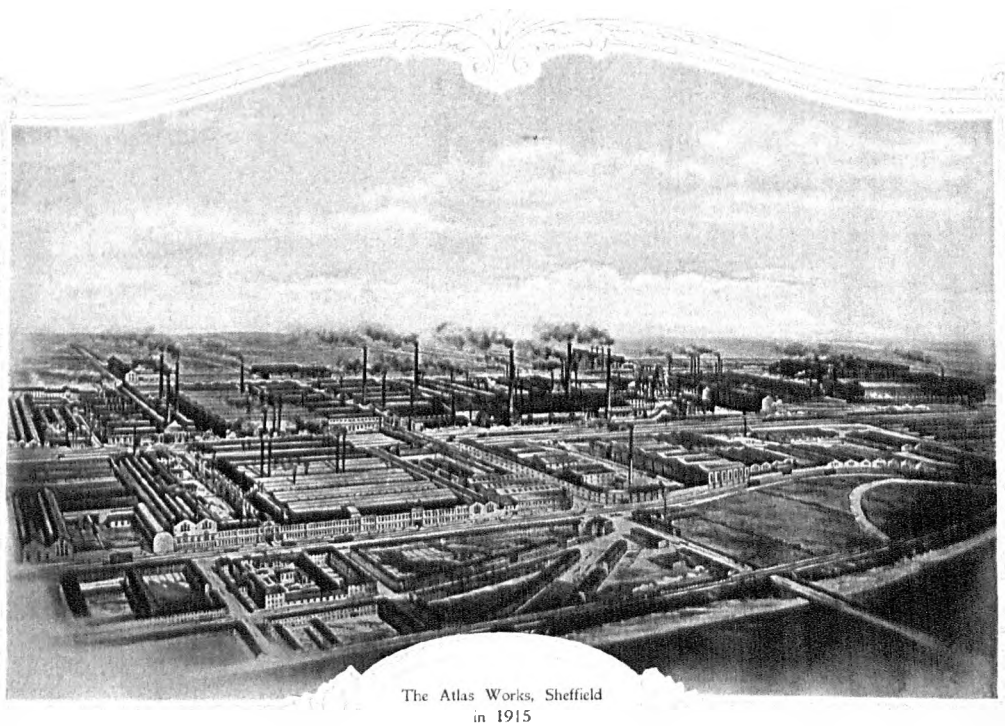

Fig. 5.84 The 'Atlas' district of the Don Valley, a result of the lucrative arms and armour plate business ('John Brown and Company' 1924).

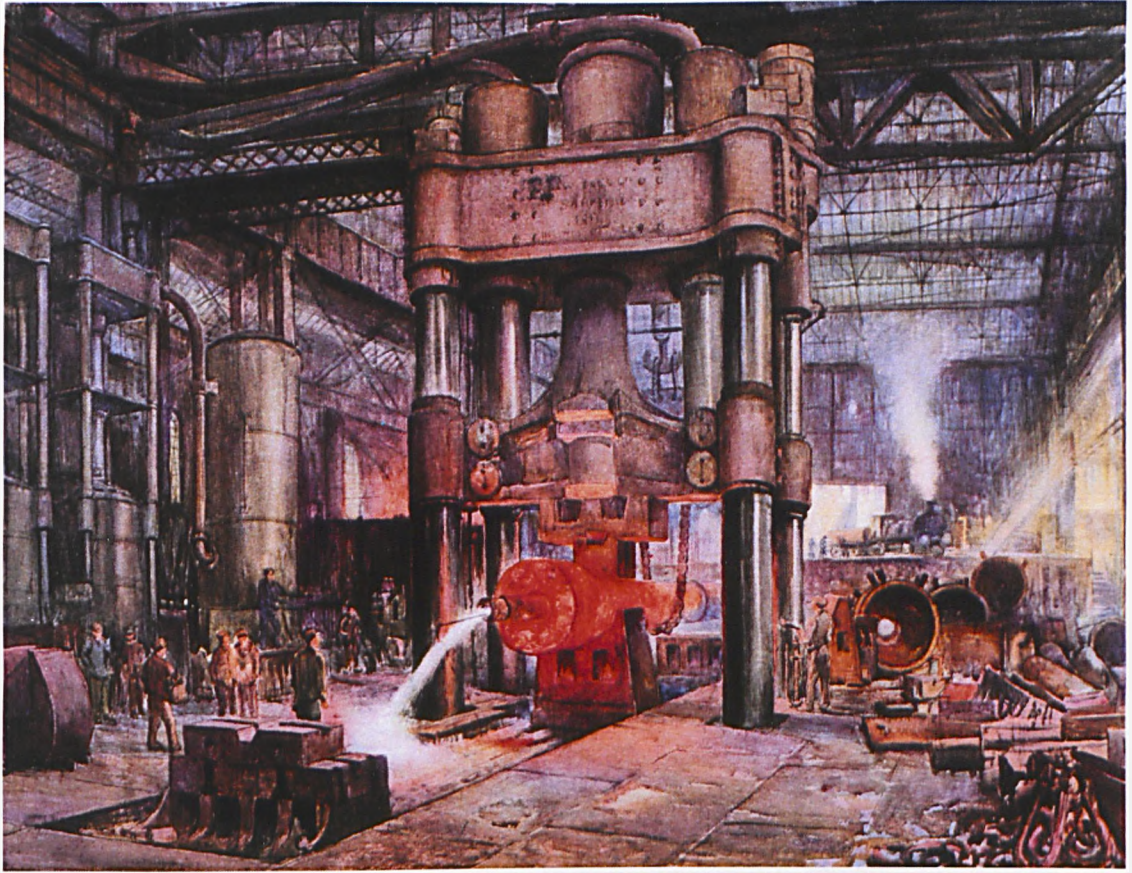

Fig. 5.85 Painting of heavy forging at the Atlas Works ('John Brown and Company' 1924).

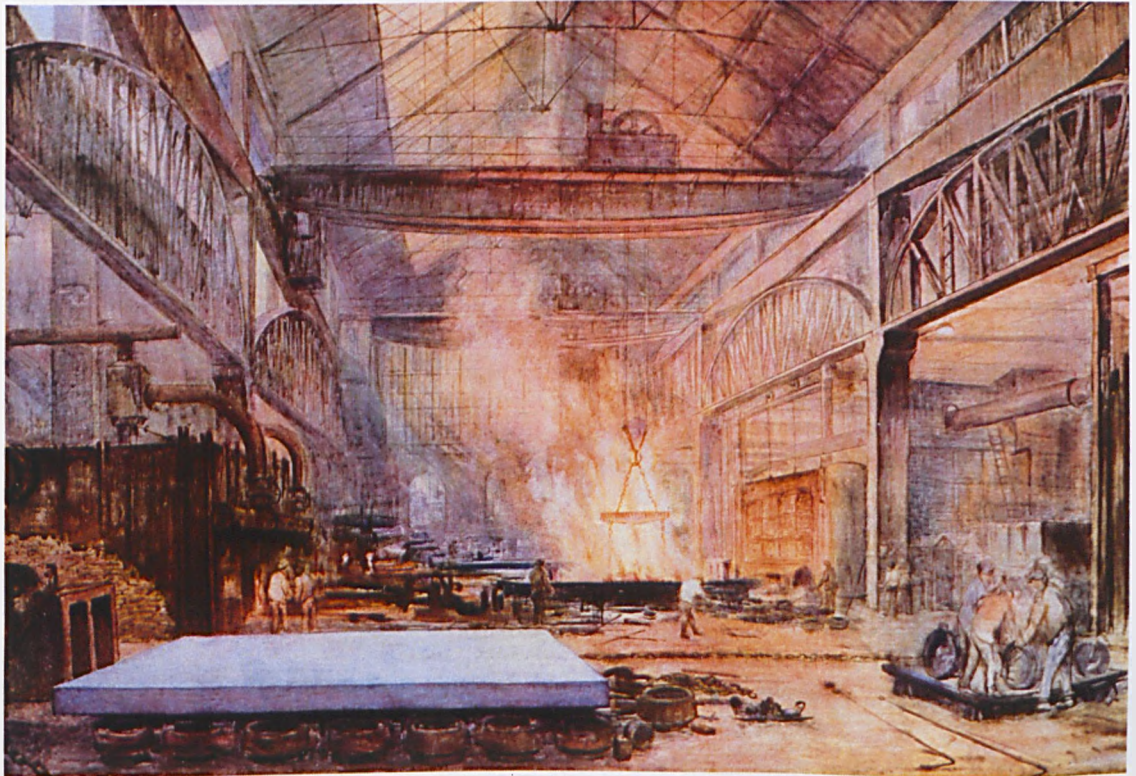

Fig. 5.86 Inside the plate mill of the Atlas Works ('John Brown and Company' 1924).

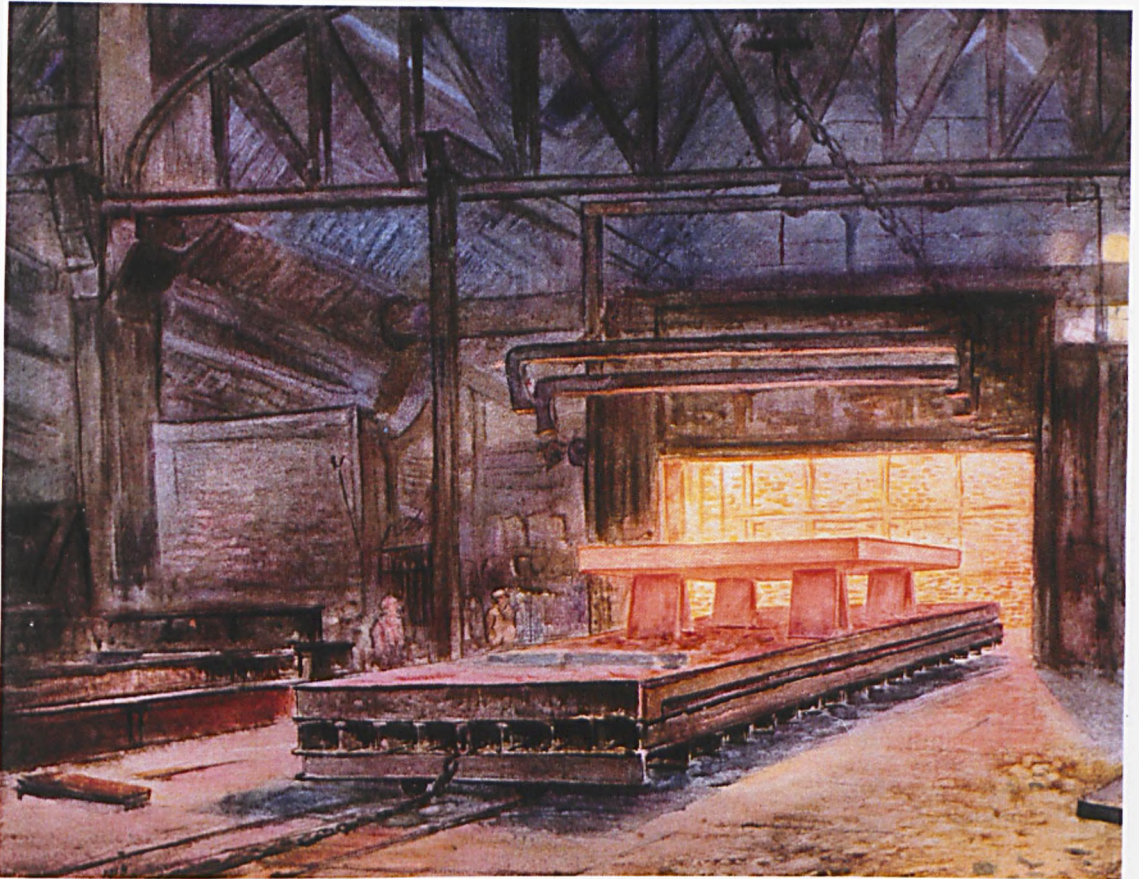

Fig. 5.87 Steel armour plate emerging from a reheating furnace in the Atlas Works plate mill ('John Brown and Company' 1924).

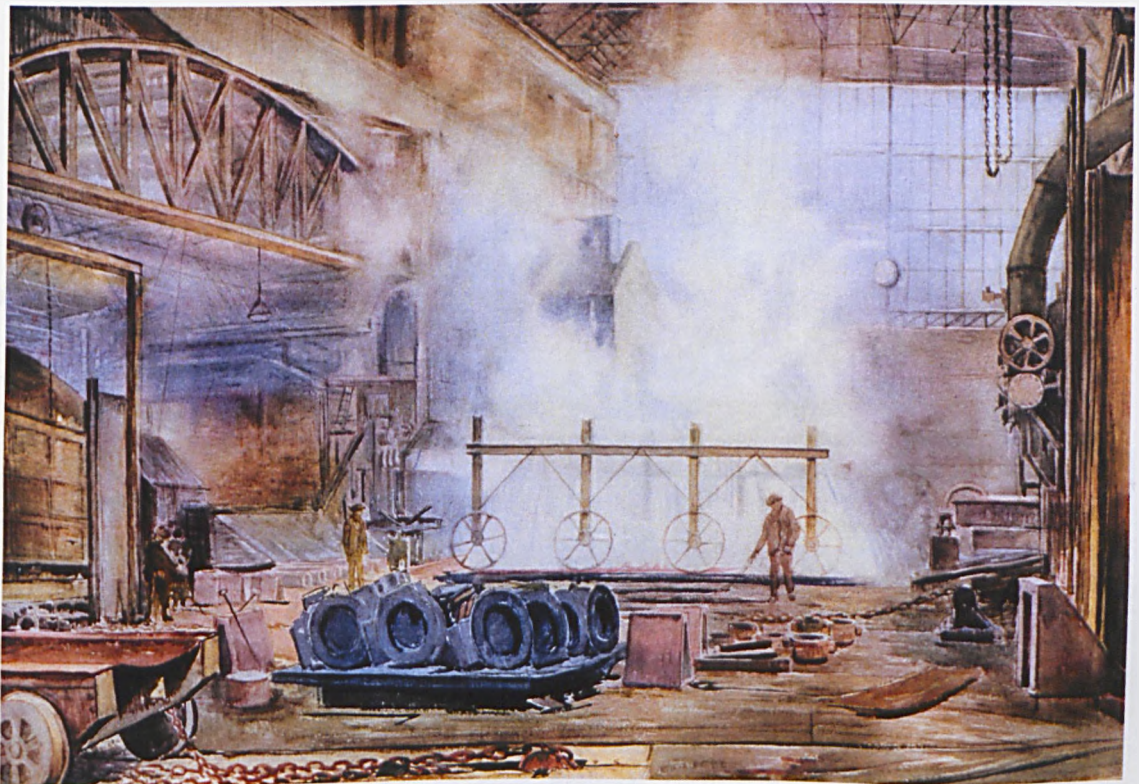

Fig. 5.88 Sprinkling armour plates using the 'Harveyising' process of tempering ('John Brown and Company' 1924).

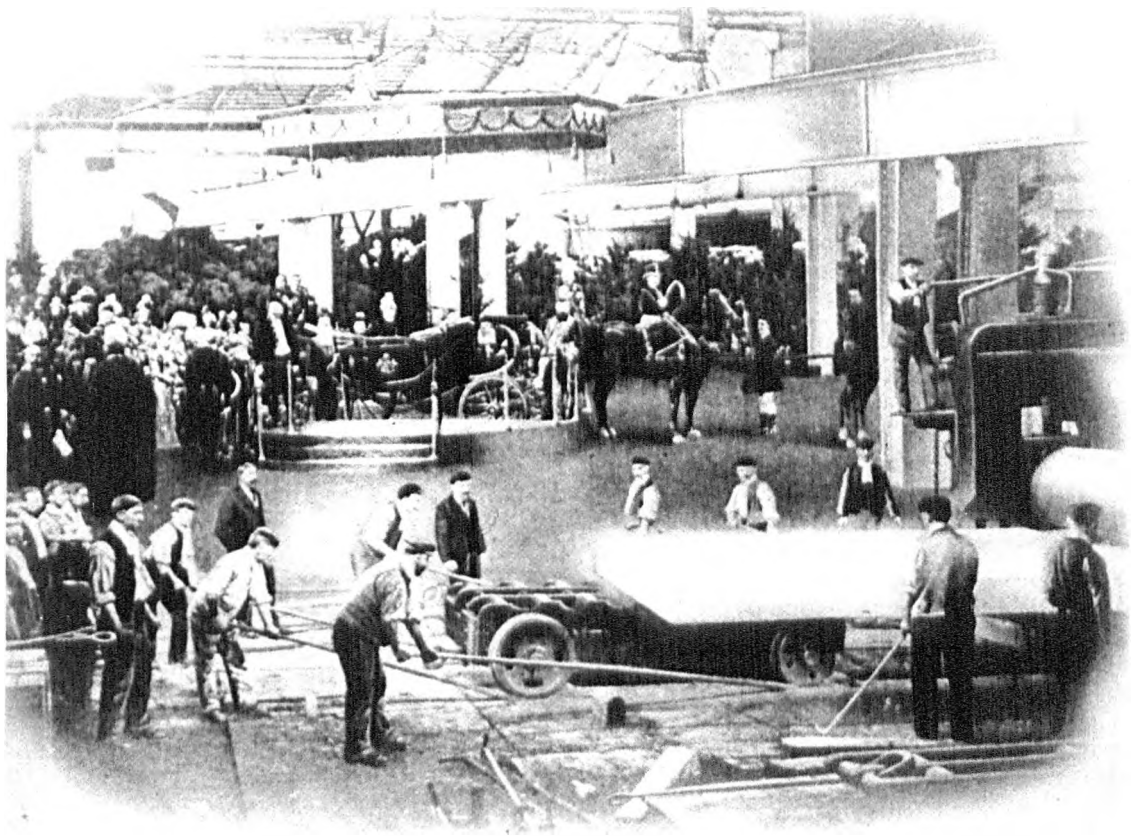

Fig. 5.89 Queen Victoria watches the manufacture of armour plate at Cammell's Cyclops Works during a royal visit of 1897.

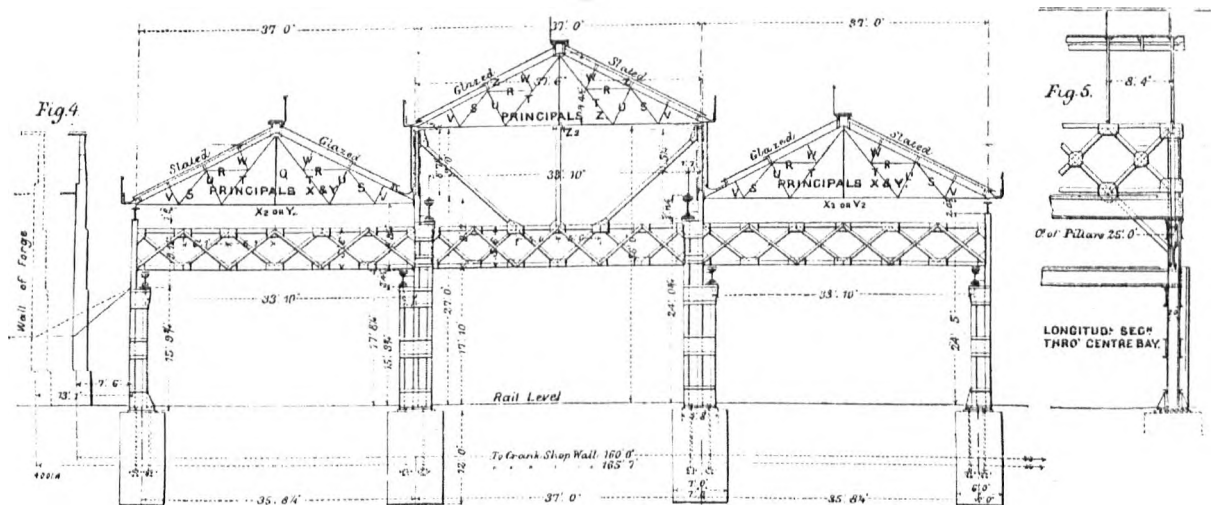

Fig. 5.90 Structure of the gun shop at Vickers' River Don Works, constructed mainly of rivetted iron sections (*Engineering* 1897).

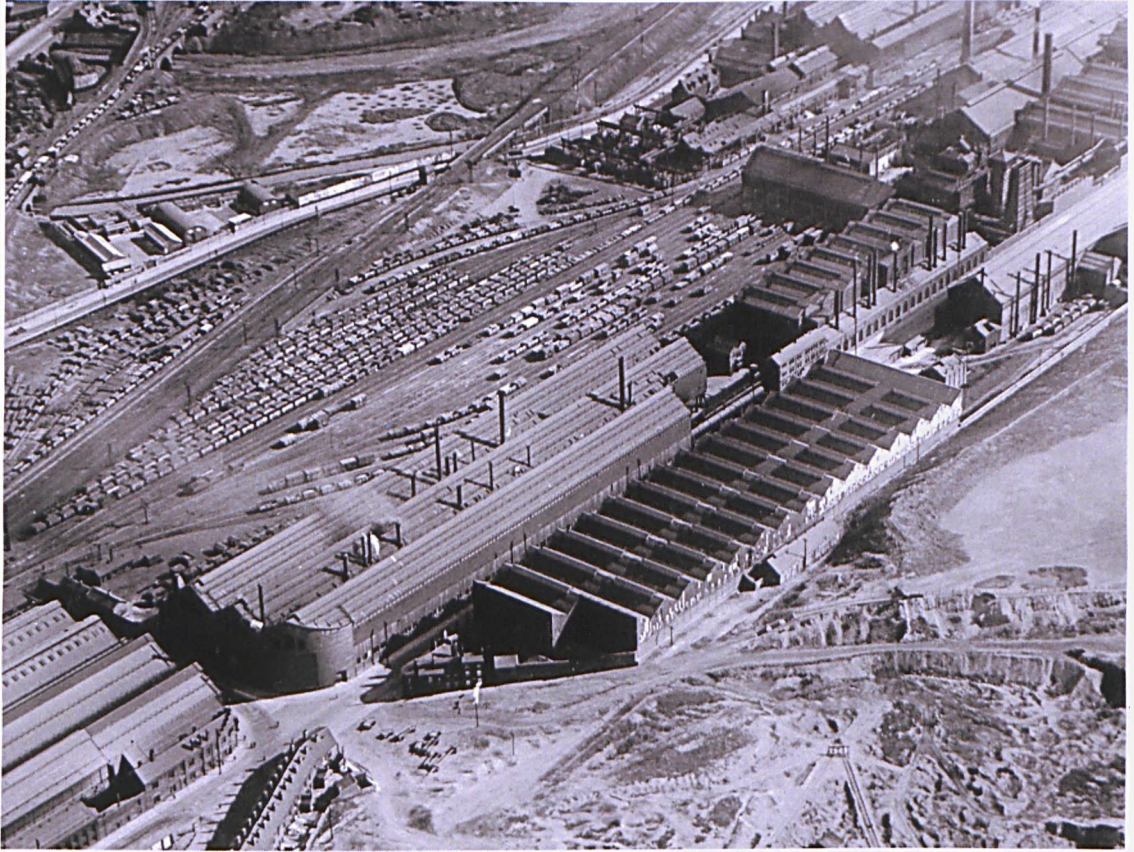

Fig. 6.1 Elements of the works of Cammell and Brown at Grimesthorpe. Following Vickers' lead, large sheds provide shelter and light to dislocated plant within (author).



Fig. 6.2 Large sheds in the Don Valley. This new landscape of inert objects and open spaces has largely replaced that of fig. 6.1 above (author).



Fig. 6.3 The steel 'drums' of the National Centre for Popular Music during construction. The resemblance to industrial forms, particularly Bessemer's converter, is clear (author).



Fig. 6.4 The systematic erasure of Sheffield's disused industrial buildings still provokes strong feelings in local residents, as evidenced by this defaced site board (author).