

**A Conversation Analysis of Facebook
Confessions Pages: Identity and
Identification**

Nurul Firdauz Binti Abd Rahman

PhD

The University of York

Sociology

September 2018

Abstract

How individuals identify each other through digital media and display their claims of knowledge is at the core of this study. This work contributes new insights into how participants accomplished identity work by looking at the conversational resources they use in addressing matters of identity in their interaction. The study draws on Conversation Analysis (CA), particularly conceptual work on membership categorization analysis (MCA) and epistemics for analysis. The findings based on two interrelated aspects of the data taken from Facebook Confession Pages interaction. The first concerns the features of the initial (confessional) message, and the second relates to subsequent responses on the initial message. Close examination of the initial message shows ways that identity work is initiated as it would implicate in that subsequent response messages. Two primary forms of messages were then identified on the basis of person reference: those that inform and those that inquire. In each category, the analysis demonstrates that person reference is used as interactional resource in making an epistemic claim of the referent. The person reference is contextual in that they are locally based and understood within the specific contexts of the message. Thus, it is shown that the employment of person reference in the initial message illustrates the epistemic level that author has with the referent. Accordingly, analysis of the subsequent response messages demonstrated ways in which the identity, as presented in the initial message, is identified. The analysis of the subsequent response messages offers insight into how identity works is accomplished through a collaborative commenter's epistemic stance. Additionally, the study also examines the technological element of FCPs that assist participants in their identity work that is Facebook name. It indicates that this Facebook functionality performed various interactional works including identification work as it provides a link to the right identified referent. Overall, the finding shows that as the identity work is performed, epistemic stance is a requisite component of the interactions. It then may challenge the notions of the invisibility of identity in digital contexts.

Table of Contents

Abstract	2
List of Tables.....	8
Acknowledgements	10
Author’s Declaration.....	11
Chapter 1: An Introduction to the Study.....	12
Research Focus	12
(Defining) Identity and Identification.....	13
Facebook Confession Pages.....	14
Research Methodology	16
Overview of Chapters	19
Chapter 2: Literature Review	22
Introduction.....	22
Studies of Computer- Mediated- Communication.....	24
Studies of Social Identity in Computer- Mediated- Communication	31
Considering Social Identity Studies in This Study.....	35
Conversation Analysis of Computer- Mediated- Communication	38
Conversation Analytic Studies of Facebook	42
Facebook Confession Pages (FCPs).....	46
Conversation Analysis	48
Sequential Organisation.....	50
Membership Categorization Analysis.....	53

Person Reference in Practice	57
Epistemics	61
Conclusion	64
Chapter 3: Methodology	66
Introduction.....	66
Facebook.....	66
User Profile and Timeline	67
Friends and Followers	68
Tagging and Notification.....	69
The Corpus.....	70
The Material	70
How the FCPs Work.....	71
The Language	73
Data Collection and Organization.....	74
Collecting the Data	75
Managing the Data	76
Data Analysis	82
Ethical Considerations	83
Conclusion	85
Chapter 4: Analysis of the Initial Messages in FCPs.....	86
Introduction.....	86
Some Practices for Referring to Persons in Talk- in- Interaction.....	88

Informing Messages.....	94
Non- Recognitional References.....	94
Recognitional Descriptions	100
Inquiring Messages	107
Description	108
Recognitional Reference	113
Epistemic Relationship of the Author and the Referent	115
Discussion.....	117
Chapter 5: Identification Work on Response Messages	119
Introduction.....	119
Identity and Identification Work on FCPs.....	121
Epistemic stance: Networks.....	123
The Recipient	123
The Author	132
Epistemic Stance: Localness.....	139
Epistemic Stance: Situational	142
Discussion.....	152
Chapter 6 – The Role of Facebook Naming.....	155
Introduction.....	155
Name Reference.....	156
Typical Practice of Referring on Facebook	160
Facebook- Name- Reference	165

Multiple Facebook- name- reference	171
Third Person Reference	177
Non- Friend Person Reference	182
Discussion.....	187
Chapter 7: Discussion and Conclusion	190
The Findings	190
Implications of the Study.....	195
Implications to the Methodological Approaches.....	195
Disrupted Turn Adjacency	197
Implications to the Identity Study	198
Limitations and Future Direction.....	199
Appendices.....	203
Appendix A: Ethics Application.....	203
Appendix B: Facebook Confession Page #794.....	219
Appendix C: Facebook Confession Page #860.....	222
Appendix D: Facebook Confession Page #868	223
Appendix E: Facebook Confession Page #879.....	225
Appendix F: Facebook Confession Page #956.....	228
Appendix G: Facebook Confession Page #996	229
Appendix H: Facebook Confession Page #1072	230
Appendix I: Facebook Confession Page #1086.....	231
Appendix J: Facebook Confession Page #1098.....	235

Appendix K: Facebook Confession Page #1103	237
Appendix L: Facebook Confession Page #1106.....	239
Appendix M: Facebook Confession Page #1128.....	241
Appendix N: Facebook Confession Page #1187	242
Appendix O: Facebook Confession Page #1191	245
Appendix P: Facebook Confession Page #1633	246
Appendix Q: Facebook Confession Page #1686	248
Appendix R: Facebook Confession Page #1707.....	250
Appendix S: Facebook Confession Page #1773	251
Appendix T: Facebook Confession Page #5242.....	253
Bibliography.....	255

List of Tables

Figure 3.1	Facebook Page Timeline	68
Figure 3.2	The tagging process	70
Figure 3.3	Conversation on Facebook	79
Figure 3.4	A diagram representing the relationship between message turns	81
Figure 4.1	FCPs Initial Message	87
Figure 4.2	Initial message 1086	95
Figure 4.3	Initial message 879	97
Figure 4.4	Initial message 1707	99
Figure 4.5	Initial message 1191	101
Figure 4.6	Initial message 1106	102
Figure 4.7	The inquiring message	105
Figure 4.8	Initial message 868	107
Figure 4.9	Initial message 1072	108
Figure 4.10	Initial message 794	110
Figure 4.11	Initial message 6056	112
Figure 4.12	Initial message 1098	114
Figure 4.13	Epistemic relationship between the author and the referent	116
Figure 5.1	Identity suggestion (FCP #879)	124
Figure 5.2	Listing the recipient's recognitional descriptions (FCP #1103)	128
Figure 5.3:	Recognitional description (FCP #1103)	131
Figure 5.4:	Searching for the author (FCP #1103)	133

Figure 5.5:	Identification of the author (FCP #1103)	135
Figure 5.6:	Knowledge of a location (FCP #5242)	140
Figure 5.7	iweek event (FCP #1686)	144
Figure 5.8:	Recipient identification (FCP #1128)	148
Figure 5.9:	Lady in red (FCP #1128)	150
Figure 6.1	A typical IRC interaction	158
Figure 6.2	Facebook Confession Pages #1187	158
Figure 6.3	Facebook Tagging Tool	161
Figure 6.4	Facebook- name- referring on Facebook (FCP #1191)	163
Figure 6.5	Name Reference through Facebook Software (FCP #794)	164
Figure 6.6	Addressivity in Facebook (FCP #956)	167
Figure 6.7	Facebook Cross- turn (FCP #1187)	170
Figure 6.8	Calling a person (FCP #860)	171
Figure 6.9	Questioning more than one person on Facebook (FCP #1103)	172
Figure 6.10	Responding to more than one person on Facebook (FCP #996)	174
Figure 6.11	Conversation dissemination (FCP #1098)	176
Figure 6.12	Facebook Third Person Reference (FCP #879)	178
Figure 6.13	Unresponsive Third Person Reference (FCP #1103)	181
Figure 6.14	Prior Facebook - name- reference (FCP #1773)	183
Figure 6.15	Nickname (FCP #1633)	184
Figure 6.16	Direct reply interaction (FCP #1086)	186

Acknowledgements

First and foremost, I would like to express my gratitude to my supervisors Dr. Darren Reed and Dr. Clare Jackson. Their utmost patience, generosity, guidance, encouragement, enthusiasm, support and trust in my ability throughout my research efforts have motivated me to keep continue this study. Their thoughtful criticism, invaluable ideas, insightful feedback and detailed comments as well as their contributions from the beginning to the final stages enabled me not only to enhance and develop my understanding but also to gain a wider perspective on my study area. Thank you for understanding my position and the challenges I faced as an international student during my academic journey. Again, thank you for being so supportive and ‘cool’ when I was in difficult time. It gave me the strength to move on and complete my studies. It has been a great honour and privilege for me to have been guided by such excellent supervisors.

A special thank you is further expressed to the Ministry of Higher Education (MOHE), Malaysia, for sponsoring this study, as well as to my employer, Sultan Idris University of Education for providing me with study leave and allowing me to pursue my PhD abroad. This study was made possible through their support, especially in finance, and I am indebted to them for this opportunity.

I extend my gratitude to all my friends at the Department of Sociology, and the Malaysian York community for their support and relationships during my journey here. You all have been a great source of comfort, support and laughter for me here.

Last, but not least, this thesis is dedicated to all my loved ones, especially to my parents and family. To my late Mother, it is so sad that you are not here with me anymore. For the first time, I have to stand by my own. You are always in my thoughts and prayers. And to my father, thank you abah for everything. You are my hero and will always be. To all my brothers, thanks for being my brothers. Thanks for not spoiling me and always being supportive to me. Also to my sister- in- laws, nieces and nephews, thanks for your love, support, understanding. I am incredibly grateful to have you all in my life.

Author's Declaration

I, Nurul Firdauz Binti Abd Rahman, declare that this thesis, submitted in partial fulfilment of the requirement for the award of Doctor of Philosophy, in the Department of Sociology, is carried out in line with the regulations of the University of York. All the materials provided in this thesis are based on an original research and I am the sole author except where indicated and explained by special reference in the text. This thesis has never been submitted for qualifications at any other academic institution.

Chapter 1: An Introduction to the Study

Having been introduced to Facebook Confession Page a few years ago by my college friends, I was thankful at first because it provides a place for me and my friends to reminisce about our college life after leaving the college and live separately. The initial message on Facebook Confession Page which appears anonymous often provides scenarios of our college environment and lifestyle which makes our conversation fun and interesting. It was until I was directed to a particular message and asked whether I can recognize the author of the message based on its content that I realize Facebook Confession Page is not just about confessing, sharing a story or, like me and my friends, reminiscing our memories. People do a lot more there, and trying to identify the ‘unidentified’ author or referents are a part of it. This phenomenon eventually caught my interest.

Overtime, I become intrigued by how people display and share their ideas regarding one’s identity and negotiate them through the interaction. Though at times, the ideas may seem trivial or downright silly, they are doing identification. It is interesting to see how the locally contextual information is transformed into a resource of information and used to display claim of knowledge over someone or something. Accordingly, my interest in identity and identification developed.

Research Focus

The topic of empirical and conceptual inquiry of this study is the online interactional practices through which individuals assemble and display their knowledge concerning identity. That is how locally contextual information is utilized in the interaction with regard to identity. In particular, this study investigates how identity is presented and achieved through online interactional practices and what role the interactional context plays in the identity and identification work.

People may not always make explicit reference to referents in their talk, but they perform

various interactional work. This interactional work linguistically identifies themselves and others. Prior research has established that certain reference terms used by speakers display their level of knowledge regarding the identity of the referents (in talk) in relation to the recipients (of talk) (Enfield & Stivers, 2007; Schegloff, 1996; Stivers, 2007). Recognitional reference terms convey an understanding that the ‘referred-to’ person is known by the recipient. Alternatively, a non-recognitional reference (non-recognitional reference term) conveys that the referred-to persons are unknown. These actions of conveying known and unknown referents can be done through a range of interactional resources including referencing and describing, as well as categorization and affiliation devices. For example, an individual can be referred to not by her name but by a description such as ‘that woman who looks like a girl’. In this case, such categories like ‘gender’ (woman and girl) and ‘age’ (woman vs. girl) become relevant resources in the interaction in identifying the individual.

Accordingly, this study focuses on these interactional resources that online participants used in displaying their level of knowledge concerning the identity of other persons. With the help of Conversation Analysis (CA), and particularly conceptual work on membership categorization analysis (MCA) and epistemics, it explores how participants in Facebook Confession Pages claim access to particular kinds of knowledge to accomplish identity work. This would make this study the first to use these methods on Facebook Confession Pages to study the issues of identity. Therefore, it can be argued that the outcomes will be valuable in adding knowledge to the study of online interactions.

(Defining) Identity and Identification

In this study, identity is viewed as something that emerges from interactions and not a static feature of an individual. This means identity is recognized through an individual’s actions and interactions with others in a given context (Benwell & Stokoe, 2006). It is something that participants enact at a ‘micro’ level as they engage in positioning themselves and others. So, it involves “active processes of identification and self-understanding, seeking or eschewing commonality, connectedness and groupness” (Leppänen, Kytölä, Jousmäki, Peuronen, & Westinen, 2014, p. 112). As such, one’s identity depends on how he/ she

defines him/ herself as well as how other people recognize him/ her in such situations. It is only because of this recognition as a certain kind of person, in a given context, that one's particular traits, such as being a student, are recognized and identified.

Identity then is referring to specific identifications of persons in a particular context in the interaction. Accordingly, identification refers to the practices of identifying the relevant aspect of persons in that particular context in the interaction. As such, the practices of identification are always context- dependent. People identify other persons in a variety of ways (through name or descriptions), on different occasions (i.e., among friends, with stranger), and with different purposes at hand (i.e., to inform, to request). In other words, identity is not merely an 'individual attribute or role but an "emergent feature" of social interactions' (Benwell & Stokoe, 2006, p. 50). Identity and identification then constituted the practical actions of everyday life which are produced in relation to what is known and understood within the interactional context. For that reason, this study is oriented to the practical actions of everyday lives in which identity and identification are seen as something that participants enact at a micro level as they interact with each other. This may involve, for example, making relevant something that can be weakly linked, rather than bound, to a particular category such as membership of certain category (e.g. the faculty of language) being 'good in writing'. The concept of identity and identification is given detailed consideration in identity work in Chapters 4 and 5.

Facebook Confession Pages

The popular online 'confessions' sites on Facebook are the subject of the present study. Facebook Confession Pages (FCPs) are Facebook community pages, often unofficially linked to certain colleges and universities. A distinctive feature of these confession pages is that students openly confess about anything or reveal secrets to their respective communities in a sort of 'de-identified' manner. FCPs present a unique configuration in which they are managed by an administrator who sets up an external web form (e.g., SurveyMonkey and Google form) via which anybody may submit content without providing any personal information such as a name. The administrator then decides which confessions to post on the page where others in the community can view them and respond.

The responses are via identifiable Facebook comments and likes – messages that include the writer’s name - thus it makes FCPs semi-anonymous Facebook pages. Additionally, Facebook functions such as name-tagging and notification play a significant role in FCPs as they require user’s online usernames. It is through these functions that messages on FCPs are spread and gain attention from other Facebook users¹, so that they can respond to the messages. Consequently, these identifying functions of Facebook are significant for further interaction on FCPs², even though the earlier (initial) messages on FCPs are anonymous. This is what sets FCPs apart from other Facebook pages.

It should be remembered, however, that although most FCPs are linked to a particular college or university, they are not officially associated with their respective colleges or universities. A page can be started by anyone as long as they are willing to act as a page administrator. While there are assumptions that the administrator comes from the respective college’s community, for most FCPs this has never been confirmed. The administrator remains anonymous. In some FCPs, administrators even ‘playfully’ dissociate themselves from the college or university while using the respective college or university logo or acronym. For instance, an FCP is known as ‘UKM confession’ is associated with the Malaysia National University (in Malay called Universiti Kebangsaan Malaysia) due to the acronym that is used as well as its community members. However, instead of directly identify itself with the university, the administrator defines it as U-Know- Me which can be translated as ‘you know me’ ([https:// www.facebook.com/ pg/ ukmconfess/about/?ref=page_internal](https://www.facebook.com/pg/ukmconfess/about/?ref=page_internal)).

As FCPs often target a local community, such as a university, this makes it more personal. As Morris et al. (2010) claim, people, even in anonymous situations, are likely to express their feeling to their social networks, instead of the wider public because they believe their network is reputable and more accepting of their expressions. At the same time, they seek personalized or contextualized knowledge, which their networks are likely to provide due to the common background they share. A similar situation has been observed in the data set of this current study. Participant’s actions (confessing, responding, identifying etc.) are concerned with, and bound to, their offline social networks. FCPs become a ‘local’ place to

¹ This matter on dissemination and separation of information are discusses in Chapter Six along with the function of tagging and notification on Facebook.

² Detail explanation on Facebook and FCPs will be highlighted in Chapter three.

vocalize certain opinions or topics. Consequently, FCPs are used not only to confess but also for other actions such as complaining, ranting, informing, recruiting help to locate someone or something, and many more. The actions are targeted to the local audiences who share common background knowledge. Additionally, due to the ‘anonymous’ nature of the message, FCPs can be a perfect place to express all of the opinions that users otherwise might not share.

Accordingly, sometimes, the messages on FCPs could cause quite a stir due to the raunchy nature of the ‘confessions’ (Houlihan & Houlihan, 2014). For instance, a message by HELP University student saying that he had ‘contaminated’ the sauce at *Chee Cheong fun* stall and this had an unexpected outcome (Leong, 2013). As outlandish as the claim was, the after effect caused the *Chee Cheong fun* stall near the college to be empty for a couple of months. Although the message did not mention the name of the stall or explain how the person contaminated the sauce, the readers made their own deductions based on the bits of information available in the message. Clearly, FCPs is a place where the students are likely to turn to express their feelings, share their experiences or just gossip. Therefore, it would be advantageous to this study to use Facebook Confession Pages as a starting point to think about the details of identity and identification in online interaction. Furthermore, there is no other study that has used FCPs to study identity work. As we will see later on in the literature review in chapter two, few studies have used FCPs and they were more concerned with opinion mining and sentiment analysis (Barari, 2015; Birnholtz, Merola, & Paul, 2015; Yeo & Chu, 2017b). They examine the patterns of language use in the pages to determine the users’ opinions and feelings. This study then will be the first one that uses FCPs to study identity and identification in online interaction. Therefore, it would be expected that the outcomes will bring more knowledge on a range of issues in the study of online interaction particularly in relation to online identity work.

Research Methodology

The research methodology for this study draws on Conversation Analysis (CA), and the related methodological approaches of membership categorization analysis (MCA) and epistemics (Heritage, 2011; Heritage, 2012b; Heritage, 2012c). The rationale to use these

approaches is because their utility for studying the process of interaction have been well demonstrated (Garcia & Jacobs, 1999). While both CA and MCA derive from the lectures of Harvey Sacks (1992) and can thus be seen as part of the same analytical enterprise, the two approaches are concerned with different phenomena (Stokoe, 2012). MCA's primary interest is in how participants orient to identity in a talk (Stokoe, 2012), while the primary analytic focus of CA is on sequentiality (Schegloff, 2007c). CA was originally developed to study talk- in-interaction, but it has been profitably applied to various aspects of computer-mediated communication (CMC) (Antaki, Ardevol, Nunez, & Vayreda, 2006; Garcia & Jacobs, 1999; Herring, 1999; Meredith & Stokoe, 2013; Reed, 2001). These studies provide perspectives on people's use of the basic interactional tools such as turn-taking, and the sequential placement of messages in CMC as people construct their activities. As the goal of CA is to discover the common-sense understandings and procedures people use to shape their conduct in particular interactional settings (Garcia & Jacobs, 1999), it is relevant for this study to utilize it to examine the sequential unfolding of Facebook Confession Pages interaction.

Also, CA is utilized because it supports the analysis of data collected from naturally-occurring situations such as everyday conversations or telephone calls, rather than experiments or surveys (ten Have, 2007b). In this study, the data are naturally-generated data collected from Facebook Confession Pages. FCPs do not require 'login in' in order to view the interactions, instead the pages are open to anyone whether they have a Facebook account or not. However, they need a Facebook account to be a follower of the page and to respond to the messages. Since I am already a Facebook user, I became a follower of the FCPs chosen for the study. This gave me more benefits such as receiving notifications when there was a new message in the pages, though, it was not necessary for me to receive notifications because I searched for the 'complete' interactions where the identity work had been completed. The interactions were 'screen-shot' (visually recorded), which includes every element of the interaction without any changes.

The CA approach is beneficial to this study as it is concerned with the sequential organization of interaction, which details how interactions on FCPs can be understood. Often online conversations are categorised into either asynchronous or synchronous (Garcia & Jacobs, 1999); (Gibson, 2009). In asynchronous conversations, interaction takes place at different times. For instance, email messages are an asynchronous conversation

that is, there is a delay between sending the message and receiving a response. Synchronous conversations, on the other hand, take place in real time. In online chatting, for example, users join the chat room and participate in an ongoing interaction. However, there are claims that synchronous conversation cannot really take place in online interaction because the process of message transmission is not synchronous with message production (Garcia & Jacobs, 1999). This happens as, during the online interactions, the actual message production process is available only to the person composing the message. It is only the posted (completed) messages that are available synchronously to all online participants. So rather than synchronous, some scholars considered these interactions 'quasi-synchronous' conversations (Castro, 2007; Garcia & Jacobs, 1999; Giles, Stommel, Paulus, Lester, & Reed, 2015; Reed & Ashmore, 2000). It is also due to this that the sequencing of utterances in online conversation differs from typical interactions (face-to-face interactions), hence the online interactions may appear disorganized (disrupted turn adjacency) due to the technical arrangements of the messages (Herring, 1999). Yet, interaction in social networking such as FCPs could be the combination of synchronous (or quasi-synchronous) and asynchronous conversation. The initial message (anonymous) may be asynchronous, in the sense that it was composed earlier before posted on FCPs by the administrator. As for the response messages, they could be (quasi-) synchronous if users interact in a real-time, and they can also be asynchronous if they occurred in delayed-time, especially if the user used the Facebook name-tagging function to notify another user. The tagged person may take some time to respond to the message. As the synchronous interaction continues, the participant's choice about when and where to take turns affects the placement of messages and hence their sequential position and context. However, in certain situations, Facebook software allows users to decide where to take a turn which then makes the interaction appear synchronous even though in reality, it is asynchronous. This sequential context is critical for the interpretation of messages in FCPs. Fortunately, in CA, sentences and utterances are viewed not merely as social interactions between people. They are understood as actions situated in a specific context and designed with specific attention to the context. This, in turn, provides insight for this study in understanding the interactions in FCPs and from here, to analyse the interactions.

Related to this, MCA and epistemics allowed this study to approach what people understand. While MCA centre on how people orient to identity, epistemics refer to a

stance that people display in relation to other concerning some particular information such as the identity, and where they stand in relation to the right to the information. Together, they help to explain how the interactional practices performed by participants carry out certain actions such as identification (through guessing for example). Given that CA's "analytic purpose is not to explain why people act as they do, but rather to explicate how they do it" (ten Have, 2007a, p. 9), it is well suited for the purpose of this study that is to see how identity work is accomplished in online interaction and specifically in FCPs.

Further, it is important to note that in studying the issue of identity, this study focuses on the interaction itself, rather than giving the most attention to the medium. It would be controversial however for this study to claim that the medium of interaction did not impact the action produced. As a medium of interaction, Facebook Confession Pages allow such interactions like an online confession to take place and help disseminate it to a wider audience. So, the medium is indirectly influencing the interaction. But, the analysis of this study focuses on the way participants' interaction works towards identification, that is how they make claims and display knowledge concerning identity information. This knowledge access, in a way, is not influenced or determined by the medium of interaction. The analysis of the various conversational devices (membership category, person reference) that participants used in this study demonstrate their local knowledge based on their personal relationship with each other. So, although the medium provides an 'overt' identity (e.g., in a form of name profile, pictures, etc.), that is not the concern of this study. Though in certain situations, participants' interaction is assisted by the medium in performing certain actions such as the use of Facebook usernames. As in later analysis in Chapters five and six, the use of the Facebook username is prominent, however, the focus of the analyses is on the detailed description of the actual procedures that participants use in their talk rather than on the affordance of the medium. This lends the analysis relevance far beyond the online context.

Overview of Chapters

The structure of the thesis is as follows. This first chapter introduces the study. This includes the research focus and the rationale for the research methodology. This chapter

also introduces Facebook Confession Pages and their related information.

Chapter 2 consists of two parts. In the first, it provides a review of existing literature regarding computer-mediated communication and indicates the area of enquiry that has received considerable attention in the study that is identity. It discusses studies where the focus has been on online interaction. A special section discusses studies of Facebook using Conversation Analysis. This is to show how this study differs from earlier work in the way that it focuses on the participants' actions in the interactions themselves. Then, another section discusses studies that have already been done on Facebook Confession Pages which not necessarily used Conversation Analysis. This is to show the gap in the literature which this study intends to fill. To understand the way that this study adapted conversation analysis and the related approaches to the study of Facebook Confessions pages, it is necessary to provide methodological literature. This is included in the literature review, and then the specifics of its adaptation – premised upon the technical features of FCPs – given in the methodological chapter.

Chapter 3 offers a more detailed description of the methodological considerations of the thesis. It introduces Facebook and Facebook Confession Pages so that to understand the differences between these two as Facebook Confession Pages is data set used in this study. The chapter describes specific details of the technical features of Facebook. Also, it explains how data were collected and managed, and how ethical issues were managed.

Chapter 4 is the first of three data analysis chapters that use CA and MCA to analyse Facebook Confession Pages interaction, with each chapter addressing a different element of the interaction. The analysis in Chapter 4 specifically looks at the initial messages without the response messages which are later analysed in Chapter 5. The reason for this chapter to focus only on the initial messages is to provide an understanding of how the initial message frames the topic of subsequent interactions should they occur later. So, this chapter demonstrates how writers of the initial (anonymous) messages strategically display their knowledge in relation to the identity of the referent(s) of their messages. Analysis of selected initial messages shows how interactional devices such as person reference reflect participants' levels of knowledge in relation to the referent(s). Essentially, this chapter looks at the coherence of the initial messages and how they were constructed. This analysis helps situate the later analysis of the response messages in Chapter 5.

Continuing from the analysis in Chapter 4, Chapter 5 explores another element of the Facebook Confession Pages interaction that is the response messages. This chapter will show how the audience took up the identity work set off in the initial messages. Accordingly, the analysis in this chapter demonstrates ways in which the referent, as presented in the initial message, is 'identified'. It also shows how identity work is accomplished through a collaborative commenter's epistemic work.

The final data analysis chapter, Chapter 6, looks at a particular element in the Facebook Confession Pages interaction which is the 'Facebook name'. It explores the use of this element in the interaction and how participants exploit it in their identity work.

The final chapter summarizes the findings from the previous chapters. This chapter also discusses the findings in relation to their implications for the methodologies of conversation analysis, membership categorization analysis and epistemics.

Chapter 2: Literature Review

Introduction

This chapter reviews the literature that sets the context for and has informed this study. It begins with a brief exploration of the relationship between the Computer-mediated Communication and language, focusing particularly on the kinds of language use in online interactional practices. As a means of managing and forming impressions online, studies of CMC language lay the groundwork for this later study on identity and identification.

In face-to-face communication, people read visual as well as audible cues about one another, and based on these they form judgments about the social identity of their interlocutor. Communication and interaction nowadays, however, have gone beyond the usual face-to-face communication. Social media is a relatively new way of communicating. Since the first development of a social media site (SixDegrees.com) 20 years ago, various social media platforms have emerged, and they have quickly come to be central to our culture. People meet and get to know each other online without necessarily meeting and knowing each other offline. But without the cues on which we always used to rely - body language, the tone of voice, eye contact etc, how can one be identified through this sort of interaction? Specifically, how does social identity emerge in an interaction between people in one particular form of CMC such as Facebook?

Many studies on CMC have explored this issue and often language becomes the main focus to analyse identity online. It is through language, or specifically conversation, that people reveal who they are; through their style of communication, they make claims to a certain identity, etc. I will look at some of these studies later in understanding this general issue. Some of these studies on online identity have also used the Conversation Analysis (CA), an approach to studying the social organization of everyday conduct (ten Have, 2007b). CA is concerned with how individuals engage through speech and language to make sense of their surroundings. In that sense, language is a tool of interaction to be used to engage in social action (Stivers, Enfield, & Levinson, 2007), hence CA's suitability for

this study of online identity. Therefore, I propose to study how identity emerges in non-subject specific interaction on CMC, particularly on Facebook, using CA. The remainder of this chapter will be arranged as stated below.

The chapter has two main sections. In the first, I will review the literature on computer-mediated- communication and related topics, such as social identity. This will include studies that have used CA in their approach. The second section will focus on CA as a methodological approach, exploring several CA- related approaches necessary for this study.

The first section, then, begins with a brief review of the literature on Computer- Mediated Communication (CMC) studies in general, with particular attention given to studies of language and the internet, exploring various trajectories and showing how these studies have attempted to address and manipulate some of the limitations claimed to exist in CMC. After this, the issue of identity on the internet is examined. This has a direct relationship with the objectives of this thesis since it looks at how identity and identification occur in online interactions. Reviewing selected literature on this issue will help to highlight what is and what is not known about the issue, in relation to this study. The chapter also looks at a CA approach to identity, and selected literature on social identity categories will be reviewed and discussed, prior to an overview of CA studies of CMC in general, which will give a better idea of how CA (which originally developed as the study of face- to- face interaction) is used in studies of other communication media, and particularly online interaction. Finally, this section briefly reviews studies of Facebook that have used CA, which establishes the legitimacy of Facebook as a conversational medium, like other Computer- mediated- communication (CMC) and justifies this study's focus on Facebook.

The second part of the chapter reviews the methodological literatures used by this study. Although, as mentioned above, CA is the primary method used here, there are several other approaches that originated in CA, such as Membership Categorization Analysis (MCA), person reference and epistemics, and these provide a more comprehensive and powerful analytic toolkit with which relationships between people can be understood (Antaki & Widdicombe, 1998b; Hester & Eglin, 1997; Sacks, 1992; Schegloff, 2007a). Together, they will be utilized in this study along with CA per se. Consequently, they merit further

discussion here, with particular reference to how they may inform and address the objective of this study.

Studies of Computer- Mediated- Communication

This section provides a general overview of studies of Computer- Mediated-communication (CMC), a general term used to describe any form of communication via the medium of a computer. So for example, Thurlow et al. (2004, p. 83) define it as “communication that takes place between human beings via the instrumentality of computers”. A comprehensive definition was given by December (1996, p. 1),

“Internet- based, computer- mediated communication involves information exchange that takes place on the global, cooperative collection of networks using the TCP/ IP protocol suite and the client- server model for data communication. Messages may undergo a range of time and distribution manipulations and encode a variety of media types. The resulting information content exchanged can involve a wide range of symbols people use for communication.”

Important aspects of this more technical description include the idea that CMC involves ‘time and distribution manipulations’. It is also important to note that such communication involves various media types, from sound to video, to text. Finally, the ‘range of symbols’ include forms of symbolic language not seen in more mundane forms of communication. This includes pseudo- identity conventions, such as usernames, which are different from the ‘given names’ of the people undertaking the communication.

CMC refers to communication produced and displayed through networked computer. Other terms used to describe communication via computer include ‘Computer- mediated discourse’ (Herring & Androustopoulos, 2015, p.127) and ‘electronic discourse’ (Meredith & Potter, 2014). The nature of CMC varies depending on the technical properties of the CMC system used. Originally, most CMC are text- based (Thurlow et al., 2004) such as e- mail, chat/ instant messaging, text messaging. However, with the development of more advanced CMC technology, textual CMC has been supplemented by

graphical, audio and video communication (Haimson & Tang, 2017). Therefore, the variety of terms used to refer to this similar type of communication is to show a concern with understanding 'communication' as 'discourse'. They also distinguish 'the language and language use' in conversation in computer networked environment (Herring 2015 p.127). The claim that text- based CMC could be viewed analytically as a conversation was controversial since it is not produced orally or received auditorily like speech (Herring, 2011). However, as the uses and study of CMC have grown, this view has become more accepted.

A dominant theme within this range of concerns is the manner in which we might talk about 'conversation' on CMC. Researchers have explored whether, and in what ways, CMC interaction differs from face- to- face interaction (Baron, 2004; Garcia & Jacobs, 1999; Walther, 2012). For example, spoken discourse is considered synchronous in the sense in which the communication occurs in real time. The process of communication begins with a speaker composing a message and a recipient hearing the message at the same time. However, in CMC, communication can occur synchronously or asynchronously (Greenfield & Subrahmanyam, 2003), in the sense that this 'real time' reciprocity is lost. Chatroom conversations, for example, have been considered a synchronous form of communication because participants communicate with others by writing and reading their own and others' messages in real time. In this way text 'chat' seems similar to spoken discourse, since the communication potentially happens in real time (Giles et al., 2015). But other scholars (Garcia & Jacobs, 1999; Greenfield & Subrahmanyam, 2003) suggest that although chatroom conversations occur in real time, they are less synchronous compared to spoken discourse. This is because the message takes time to be composed before it can be sent. A message is posted sequentially along with other messages sent by other participants in the chatroom. The order in which the messages are posted is governed by hardware constraints and server speed, although participants might type and send them at the same time. Consequently, there is a short delay between composition, input, and appearance on the screen (Garcia & Jacobs, 1999; Greenfield & Subrahmanyam, 2003). For that reason, analysts of CMC have recently begun to refer to this communication condition as 'quasi- synchronous' (Garcia & Jacobs, 1999; Gibson, 2013; Meredith, 2017; Meredith & Potter, 2014; Vandergriff, 2013) because the nature of CMC communication is different from spoken discourse in that construction and transmission are done separately,

and cannot be monitored, nor can there be immediate synchronous feedback as in spoken interaction (Meredith, 2017).

Conversely, asynchronous communication refers to conversations that take place across time delays, such as e-mail and bulletin boards (Crystal, 2006). Unlike synchronous communication, this type of communication does not require a recipient to be present during message sending by the sender. Thus, messages are sent sequentially and may remain unread for hours, days, or months. This is similar to a conventional 'letter' sent through the post where there is a delay between sending the message and receiving a response.

Another element of conversation on CMC that concern analysts are in terms of language use. They explain the nature of language use in CMC, as either more like spoken or written discourse. Early studies on this matter considered the language used in CMC is unsuitable for interactional studies because the combination of written and oral styles of communication make it appear to be complex and distant from conventional spoken or written discourse (Herring, 1999). This assumption, however, is rejected as there are many studies showing that CMC interaction is productive despite its complexity (Baym, 1996; Greenfield & Subrahmanyam, 2003). Some researchers treat it as a new form of language which is unique, rather than comparing it with spoken or written discourse. Crystal (2006, p. 238), for example, characterizes CMC as neither spoken-writing nor written-speech. Unlike traditional writing, he argues, CMC has certain distinguishing characteristics, like emoticons and abbreviations. He claims that the main ways it is different from face-to-face interaction are the lack of such features as simultaneous feedback and overlaps, and the lack of prosodic, paralinguistic and kinetic features. Some researchers even coined a new term such as 'netspeak' (Crystal, 2006), 'text-speak' (Carrington, 2004) and 'digitalk' (Turner, 2010) to distinguish CMC language from spoken and written discourse. Netspeak and textspeak refer to a combination and manipulation of written and conversational languages produce in different digital technology settings. Netspeak refers to the use of language in the internet communication such as Internet Relay Chat (IRC) or blogs, and textspeak refers text-language use in the cell phone for Short Messaging Services (SMS) for instance. What the terms netspeak and textspeak share conceptually is an attention to the written nature of the language used in these settings. Whereas digitalk views 'talking' as the driving force behind the communication and it encompasses the wide

variety of digital technologies (phone, Internet, computer, PDA) that allow for this exchange. Regardless of the variety in the terminology, however, all these terms pointed to ‘the language and language use’ in talking or interaction via CMC. Accordingly, it shows that such language is the best form of communication for communicating via CMC in the sense in which the language is produced on CMC, although it may not in accordance to conventional spoken or written discourse.

This tendency to treat CMC as distinct from spoken and written discourse, however, has been condemned by some other researchers (Androutsopoulos, 2006; Benwell & Stokoe, 2010). Studies suggest that the formation of new words, structures, and styles of expression on CMC is to overcome the communicative limitations of CMC (Hassan, Hashim, & Phillip, 2012; Rafi, 2014; Riva & Galimberti, 1998). In referring to this type of language, some authors have described how interactional moves such as ‘emoticons’ or smileys (e.g., ☺, ^_^) are used to convey an emotional state and attitudinal intention of the writer to compensate for the lack of expressive features like those used in face- to- face interaction, in CMC (Crystal, 2006; Markman & Oshima, 2007; Tan, 2009; Werry, 1996). Additionally, Markman and Oshima’s (2007) examination of cultural variation in the use of a smiley emoticon, found that the Japanese form, Kaomoji, had a much wider range of uses than smiley. These findings suggest that rather than creating ‘a new language’, CMC users have found ways of adapting to its lack of physical and contextual cues.

Closely related, researchers have been concerned with how the technological features or affordances of CMC may shape discourse and interaction (Herring, 2007; Herring, 2011; Hutchby, 2001b; Meredith, 2017; Meredith & Potter, 2014). The concept of affordances suggests that the way a person interacts with an object is not only related to its physical properties but also to social norms and rules. Affordance, therefore, basically refers to properties or relationships that emerge through the interaction between people and a particular object (Meredith, 2017; Meredith & Potter, 2014). Indeed, CMC is not the first technological medium of interaction that has been studied. Earlier research (Schegloff, 1979) has looked at communication through the telephone and how the device affects the interaction. For example, Schegloff’s (1979) description of the telephone ring as the first pair part of a summons- answer adjacency pair offers a crucial insight that demonstrates how the communication device is incorporated into the interactional work. In a more recent study of mobile phone users, Arminen and Leinonen (2006) observed that the availability

of caller ID allows recipients to tailor their answers accordingly, depending on whether or how well they know the caller and whether the caller ID is blocked. These studies are of course not directly related to CMC, but they do offer an indication of the adaptability of discourse and interaction into different technological formats and devices.

According to Walther (2012), the main concern in studies of CMC is how communicators adapt language to electronic text, how the reintroduction of certain visual cues in mediated communication helps ground collaborations and alters the language. Researchers want to see how CMC users are able to adapt everyday conversational rules as needed and apply new ones that better fit the medium (Anderson, Beard, & Walther, 2010). For instance, based on dyadic conversations typed into Instant Messenger (IM), Baron (2004) explores users' conversation management strategies and how these become conventions among users. Her analysis shows that IM users incorporate the typical features of spoken conversation such as turn-taking, without nonverbal accompaniments or simultaneous interactions by breaking up a turn into segments. These segments are sent in temporal proximity but not simultaneously, so that receivers recognize that the turn has not yet ended. An example from (Baron, 2004, pp. 410–411) is as below:

1. Gale: hey I gotta run
2. Sally: Okay.
3. Sally: I'll ttyl?
4. Gale: gotta do errands.
5. Gale: yep!!
6. Sally: Okay.

In this conversational closing, instead of composing one longer turn, both interlocutors breaks their turn into segments. Note that Gale does not respond to Sally's question in line 3 until after she has finished constructing another turn which is related to her previous turn in line 4. This, however, does not affect Sally's understanding as we can see she responds appropriately to Gale in line 6 after gale gave her answer.

A relevant thing to note in this example is the use of some sort of shorthand 'ttyl' (talk to you later) by Sally (line 3). This type of 'language' is another common feature adapt by communicators to electronic text. This language is not discussed specifically by Baron in

her study, but a number of studies have explored its emergence in the text- communication (Carrington, 2004; Nishimura, 2003; Turner, 2010). This type of language involves a manipulation of standard spellings, shortens text to the minimum syllable length, usually with the removal of vowels (for example, 'thanks' becomes THX). Articles and conjunctions such as 'the' and 'and' are often dropped and common phrases become acronyms (ROFL is 'rolling on the floor laughing'). Other features include the substitution of numbers for graphemic units such as '4' substitutes for 'for'. According to Carrington (2004), it is inappropriate to dismiss this 'language' as simply a shorthand and inferior form of 'real' text in the sense that it reflects quite different functions and conditions of use than those involved in interactions around real textual forms. Originally, this language emerges to accommodate the character limitation set by the technological devices such as Short Messaging Service (SMS) that leads to brevity. In order to convey meaning, brevity requires some degree of directness, hence the shortened text and the use of emoticons is a way to extend meaning in a constrained context. Therefore, this economy of language usage is not random instead it a language format with a strong social function. As such, users introduce yet more conventions, abbreviations, and phrases which are rather necessary adaptations (Rafi, 2014).

A main interest of CMC is when people interact through online multi- party contexts, such as in chat rooms or forums (Herring, 1999; van Gass, 2008). In these multi- party interaction environments, participants may not know each other in the offline world prior to joining the interaction (Hutchby, 2001b), and researchers are interested in how people manage this sort of interaction, often focussing on how speech- exchange systems in such interactions differ from spoken conversation (Garcia & Jacobs, 1999); how people have adapted face- to- face conversation practices to interact effectively online (Greenfield & Subrahmanyam, 2003; Rintel, Mulholland, & Pittam, 2001); and how sequential and interactional coherence is maintained across multiparty interactions (Greenfield & Subrahmanyam, 2003; Herring, 1999). Terms like addressivity have been introduced by Werry (1996) to denote the act of addressing employed by Internet Relay Chat (IRC) users to catch an addressee's attention when new utterances are initiated. Rutter and Smith (1998) highlight a similar action in newsgroup interactions. They found that not only were those who posted and read the messages highly aware of the implications of addressing persons within a posting, but they also employed a range of addressivity techniques to

make their messages inferentially rich. Another study noted that not only does addressivity ease interactional coherence, but also that in a multiparty interaction where visual cues are absent, its usage becomes more prominent (Halbe, (2012).

Recently, there is an upsurge of a new type of CMC known as live streaming which combined a live video and audiences' participation. Essentially, live streaming is an upgrade version of the older CMC such as IRC and video sharing. Many social networking sites upgrade their platform to allow live streaming and participation such as Facebook Live, Snapchat, Periscope, Youtube and Twitch. There are at least four reasons why this latest CMC is gaining popularity that is engagement, immediacy, interactive, and sociality (Haimson & Tang, 2017; Hamilton, Garretson, & Kerne, 2014; Lu, Xia, Heo, & Wigdor, 2018). According to Haimson and Tang (2017), these four elements of live streaming make interaction in CMC more engaging. The ability to respond to the video, get an immediate response from the streamer and interact with other audiences give users full experience of the ongoing an event. One thing worth to be highlighted is that interaction in CMC goes beyond language. It can be an action such as 'like' (Haimson & Tang, 2017; Kashian, Jang, Shin, Dai, & Walther, 2017), 'heart' (Aisyah & Yun Jin, 2017; Haimson & Tang, 2017) or 'gift' (Lu et al., 2018). These actions which are done through specific features provided by the mediated-platform claimed to be useful in filling the social gap caused by the language barrier (Aisyah & Yun Jin, 2017). In a study of Korea artist live streaming, Aisyah and Yun Jin (2017) find such actions like 'heart' and 'like' counting could give the fans from the various background a better viewing experience. Particularly among international fans who do not understand the language used by the streamer, the 'actions' compensated the language barrier and allow them to participate in the live streaming.

So far, then, I have shown the concern towards CMC conversation, whether it can be considered as discourse or not. CMC scholars have shown the adaptability of language and social action to accommodate the lack of physical and contextual cues of CMC mediums. Instead of emphasizing too much on technology, they acknowledge the social factors which might impact people's use of language. Studies have also shown that CMC users are able to adapt everyday interactionl rules as needed and apply new ones that better fit the medium. As such, research on CMC has explored online discourse as designedly interactional, which has resulted in a number of studies which examine the outcomes of online interactional practices.

Studies of Social Identity in Computer- Mediated- Communication

Identity is another key area in CMC research. Earlier internet scholars tended to highlight instances in which online spaces provided unique opportunities for identity exploration through the representation of multiple identities (Boyd & Heer, 2006; Turkle, 1996; Turkle, 1999). This sort of research shows how both anonymous and less anonymous environments, such as Multi- User Dungeons (MUDs), Chat Rooms, Bulletin Boards, and Internet dating sites allow individuals to create and play with identities (Ellison, Heino, & Gibbs, 2006; Gibbs, Ellison, & Heino, 2006; Yurchisin, Watchravesringkan, & McCabe, 2005). Often, people used a nickname to represent their identity, reinventing themselves by selectively hiding their real identities while revealing the desired personal identity cues (Danet, Ruedenberg-Wright, & Rosenbaum-Tamari, 1997). ten Have (2000) examined the significance of nicknames in finding a chat partner online, explaining that nicknames could give identity information to a potential chat partner in initiating a conversation. This is because, often, nicknames illustrate one's background such as gender and ethnic group.

Studies of online identities in CMC have had mixed results. A study by Collins-Jarvis (1997) suggested that users are not necessarily interested in exploiting or creating a new identity online as they believe that using their real name lends more accountability, meaning that their message will be taken more seriously. However, another study suggested that although they are not necessarily disconnected from people's offline lives and contexts, new identities are created online (Baym, 2005). It happens as online selves are constructed depending on the norms and contexts within which they are constructed. So that though the online identities are real, they are not fully represented users' offline selves. Compared to face- to- face communication, text- only CMC reveals less personal information, and this gives an opportunity to some people for identity play, deception and other behaviours divorced from social context. The removal of physical and social cues giving an opportunity for some people to construct their desired identities (Bargh, McKenna, & Fitzsimons, 2002).

Relatedly, the absence of physical cues in CMC would make us simply assume that the medium is gender- neutral since social traits such as gender, race, ethnicity, age, or other features such as height or tone of voice, are invisible. But research on online interaction shows differently as many studies have shown that there are differences between men and

women online (Herring, 2000). Research on identity and gender communication on CMC for example, suggests that there are differences in participation patterns and discourse styles of males and females online (Dresner & Herring, 2010; Herring, 2000; Herring & Martinson, 2004; Herring & Stoerger, 2014; Kapidzic & Herring, 2011; Panyametheekul & Herring, 2003; Supun, Ciampaglia, Su, & Ahn, 2017). The linguistic features that signal gender in CMC interaction are found to be more or less similar to those used in face to face interaction, in which some behaviours correlate more with female users and others with males. Herring (2000) and Smith et al. (1997) found that politeness is one common means through which gender can be seen in CMC. Compared to men, women are more likely to thank, appreciate and apologize, and to be upset by violations of politeness. In term of discourse style, female users are found to be more expressive and supportive than male users (Fox, Bukatko, Hallahan, & Crawford, 2007; Herring, 2000; Kapidzic & Herring, 2011).

A number of studies have also found that male and female users use language differently online. Abusive language and sarcasm among male users occur frequently, while female users tend to be more affectionate, especially with the use of first- person pronouns and showing personal feelings during interaction (Herring & Martinson, 2004; Herring & Stoerger, 2014; Savicki, Kelley, & Lingenfelter, 1996). Baron (2010) also found that the way a single turn in a message was broken up into small segments is different between male and female users of Instant Messenger (IM). Grammatically, male users' patterns resemble breaks in spoken language with a tendency to begin the next subsequent turn with a conjunction, and female break patterns were more similar to breaks in written language in which the next subsequent turn begins with the independent clause.

Another study by Herring and Martinson (2004) looked at how users perform a different gender online. Using synchronous text chat logs for public identity- games, they examined the language that participants invoke to display gender online, and the behavioural cues to which co- participants attend in assessing others' real- life gender. Given that participants cannot see or hear each other in the game, participants have to portray their 'assigned' gender textually. In turn, co- participants make gender identity assumptions based on the how someone's gender is portrayed. The results showed some interesting findings concerning gender- linked language where contestants produce stereotypical content when attempting to pass as the opposite gender, as well as persisting in giving off stylistic cues

to their real- life gender at the level of words and sentences. The study revealed that men did slightly better at reflecting female microlinguistics in their portrayal of women by using as many female language forms as they did male language. Women, on the other hand, were found to have slight difficulty pretending to be males, even though they discussed male- stereotypical topics.

This finding was duplicated in Palomares and Lee (2010) study of individuals' gendered chat avatars. The study concerned whether men and women would linguistically assimilate a virtual gender identity that was randomly assigned to them. Similar to the Herring and Martinson study, this study found that women have slight difficulty in using male- typical language and also showed that gender- matched avatars increase the likelihood of the use of gender- typical language. This shows that although it is possible to construct a different gender identity online, the unconscious use of gendered discourse styles can reveal someone's actual gender even when they are performing a different gender and trying not to give off any gender cues.

Recently, another study is conducted on how gender is associated with the nature of conversation in CMC. Using a social game-streaming platform, Supun et al. (2017) analyze the live chat messages log quantitatively using language exploratory analysis. They find female streamers receive significantly more objectifying comments such as their physicality, while male streamers receive more game- related comments. Further, they also show that the audiences' choice of channels is also strongly gendered that is they choose to watch and comment on the channels based on their gender. Overall, the study suggests that gendered conversation and objectification is prevalent in social game-streaming platform, and most users produce strongly gendered messages.

A related area in the study of identity has been that of shifting and multiple identities that are indexed in the act of speaking different linguistic varieties (Hassan & Hashim, 2009), whether they are code- switching languages or style- shifting language. In the area of code-switching, Myers-Scotton (1993) states that a change in code might signal a different identity in which the switch indexes a different set of social rights and obligations that the speaker proposes to apply in that particular interaction. Studies of code- switching in CMC support this claim. For instance, Hassan and Hashim (2009) found a variety of code-switching occurred among Malaysian internet users, as they moved between English and

Malay, Chinese, Tamil and the indigenous languages of Malaysia in interaction. This switching not only overcomes contextual constraints such as lack of words or expressions but also affirms their membership of a particular group, shows their allegiances and conveys a common identity. Similarly, Tsiplakou (2009) argued that language switching in online interaction forms part of participants' performativity, allowing individuals to generate group solidarity.

In another study, Montes-Alcalá (2007) claimed that code-switching is often performed by those who are bilingual. Her exploration of this phenomena on Spanish-English weblogs found that despite the social stigma of mixing both languages in oral production, such stigma does not seem to obtain in informal written interaction such as weblogs (Tsiplakou, 2009). In fact, Montes-Alcalá found that code-switching is perceived as a valid strategy for bloggers to show off their superior expressiveness with languages. At the same time, this indicates sufficient cultural knowledge in each language for them to be able to manipulate both stylistic and communicative effect. Halim and Maros (2014) concur with this finding through their examination of status updates posted by bilingual users on Facebook. They argue that for users to be able to switch languages, they need to be fully competent not only in the languages they use but also in their cultural context. Only then can users manipulate the language to serve both their communicative and stylistic objectives. These studies, therefore, claim to show that code-switching is a way to show cultural identity as much as language.

Additionally, code-switching and style-shifting languages play a part in enabling a multiplicity of representations of identity online. A number of studies find that the ability to switch and shift languages whenever necessary allows online users to create different identities based on the language they use. For instance, Themistocleous' (2013) investigation of digital code-switching between Cypriot and Standard Greek among Greek IRC chatters reveals that code-switching provides chatters with an opportunity to play with their identity, even performing imaginary roles. This is due to the fact that linguistic patterns usually reflect a particular community or a group of people. So, switches not only enable the chatters to change their roles and identities in the conversation but also transfer these linguistic patterns into their online interactions. This study, then, highlights the possibility of identity play in an online environment.

Considering Social Identity Studies in This Study

Research into identity in CMC have shown that language often becomes the primary means of managing and forming impression online, whether our own or others' selves. This section continues looking at the language use but in different ways in which the concept of identity has been defined. Benwell and Stokoe's (2006) definition of identity resonates Gee, who writes identity means 'being recognized as a certain "kind of person", in a given context' (Gee, 2000, p. 99), while Bucholtz and Hall (2005, p. 586) define identity as "the social positioning of self and other". These definitions maintain that identity does not exist in a vacuum, but is interactionally emergent. It is as 'other people treat, talk about, and interact' with a particular individual that his/ her particular traits (such as being a good leader, for example) are recognized (Gee, 2000, p. 103). In other words, social identity is discursively constructed. It is not a pre- given characteristic that inherently exists within individuals, but rather emerges through interaction (Benwell & Stokoe, 2006). This is the relevant and important feature of identity that this study wants to highlight, that is identity emerges from the specific conditions of linguistic interaction. Having said this, this study particularly agrees with Bucholtz and Hall (2005) that 'identity is best viewed as the emergent product rather than the pre- existing source of linguistic and other semiotic practices and therefore as fundamentally a social and cultural phenomenon' (P.588). This perspective has also become a base for many approaches to social identity including a Conversation Analytic (CA) approach.

Antaki and Widdicombe (1998a; 1998b) explain that the analysis of social identity has been central to research in the CA tradition since Sacks' early lectures in the mid- 1960s and early 1970s. In his work on a group of 1960's teenagers, Sacks (1992) was concerned with how social identity categories are used in a conversation. He noted how speakers use particular descriptive categories as a way of defining group identity, that is who is included and who is not included in the group. This study became the main reference for later CA approaches on social identity categories (Antaki & Widdicombe, 1998b; Cashman, 2005; Edwards, 1998; Jacknick & Avni, 2017). Fitzgerald et al. (2009) argue that people attend to 'who- we- are- and- what- we- are- doing' (Fitzgerald et al., 2009, p. 46) in the course of a particular interaction through displays of knowledge and understandings relevant to their identities. Thus, identities, which are interactional in nature, are invoked, deployed, negotiated and made relevant by speakers during a conversation.

Along similar lines, Rafi (2014) claims that Internet users are habitually and increasingly customizing language to capture their experiences and to express their e-identity through various linguistic strategies. A number of studies have explored this online interactional practice using CA and discursive psychology (DP). DP treats all language as action, which is designed for a particular recipient (Potter & Hepburn, 2008), and this applies to both online written language and spoken talk. The studies identified several identities made relevant by the participants of the conversations such as ‘vegan’ (Sneijder & te Molder, 2009) and ‘ana’ (Stommel & Koole, 2010). These social identities, however, are rarely explicitly stated in the discourse, but they are encoded in participants’ use of various linguistic strategies, such as making a claim to knowledge (Jacknick & Avni, 2017) or employing specialist vocabularies (Kitzinger & Mandelbaum, 2013). Jacknick and Avni (2017), whose study was of how participants identify themselves and others in an anonymous asynchronous discussion forum, found that identities are relative and categorical. Approaching the study through membership categorization analysis (MCA) and Epistemics, they demonstrated that identities are constructed in part through participants’ claims to knowledge associated with a particular topic. These identities can be challenged by co-participants claiming greater knowledge and legitimacy, which may lead to participants defending themselves against such challenges with claims or displays of understanding. Jacknick and Avni (2017) argue that it is through this interactional process that various identity categories are invoked, suggesting that both self- and other-identities are relational, which means that they are relative to the position one has in relation to other participants, which in turn is brought out during an interaction.

A couple of studies by Sneijder and te Molder (2006; 2009) explore the topic of identity in consumers’ everyday lives. With a particular focus on social identity issues relating to food choice lifestyles, they show how identities develop through the discursive construction of independent access to, knowledge of, and experience with food items. In their 2006 study of members of an online forum on food pleasure, Sneijder and te Molder looked at how the participants work up and establish their identities as ‘gourmets’. They demonstrated how participants entitle themselves to know what good food is all about, by actively negotiating their relative socio-epistemic rights to assess taste. Consequently, participants claim expertise or membership of the ‘gourmet’ category by portraying better knowledge, rather than by merely displaying subjective taste preferences. Their 2009 study explored the

relation between ideologically based food choice and identity in an online forum on veganism. They found that while participants do not deny their vegan identity, they draw on the alternative identity of an ordinary person to counter negative implications and inferences, such as extremist, that are imposed on them. In orienting to and constructing their identity, participants position themselves and their food-related choice as accountable. In this sense, their claimed ordinariness underlines the relevance and importance of their vegan-ness. Both studies illustrate how identities always carry with them inferences and implications, and are thus an achievement in interaction rather than fixed categories.

Additionally, social identity could also refer to identification with certain social groups. For example, Stommel and Koole (2010) used a case study approach to analyse interaction with a new member of an online support group for those suffering from eating disorders. Using MCA, they noted that becoming a member involved subscribing to the normative requirements of the forum, including not displaying a pro-anorexia stance or that an eating disorder is an illness that needs to be cured, not celebrated. The new member was confronted with this demand by the established members via various strategies, and thus was not granted full acceptance as long as the group's normative requirements in relation to the illness were not lived up to. Stommel and Koole (2010) argued that in this interaction, orientation to the online support group was as a community of practice to which membership is granted on the condition that newcomers align to the norms and practices that are constitutive of that community. Similarly, Lamerichs and te Molder (2003) studied how the users of a forum for people suffering depression discursively manage their identities. They noted that participants were challenged to present themselves appropriately and accountably as 'depressed' through their posts. Their deployment of descriptions of emotions in their messages invoked various categories related to depression. These emotion descriptions and categories played a significant role in the interaction in identifying a rightful member.

Other studies have also explored the development of a community around video game streaming and viewing (Hamilton et al., 2014; Tang, Venolia, & Inkpen, 2016). While they found that the main motivation for starting to view the streams was to learn more about a specific game, it usually developed into an interest in social interaction and forming community (Tang et al., 2016). Hamilton et al. (2014) claimed such streaming platform

could act as a virtual third place that is an informal public space where people engage in sociability to form and maintain communities. Over time, stream communities form around shared identities drawn from streams' contents and participants' shared experiences. Often, the shared identity reflects the streamer's attitude and values such as friendly, silly or aggressive.

To sum, the studies suggest that identity is not just pre-determined characteristics but it is emerged from the specific conditions such as linguistic interaction. Language has been used strategically to convey one's identity so that the desired identity can be achieved. Therefore, these studies of the way that social identity is achieved through interaction are an important consideration for this study. Additionally, these studies suggest that it is possible to use CA to analyse online interaction though it may not exactly utilize as it was developed for face-to-face interaction. The next section reviews the literature on the adaptation of a conversational Analytic methodological approach as it has been adapted to technology-mediated communication or CMC.

Conversation Analysis of Computer-Mediated-Communication

There is an increasing interest in the use of conversation analysis (CA) in the study of online interaction in recent years (Paulus, Warren, & Lester, 2016). This is not limited to widening the range of online interaction topics studied, but also covers the potential of methodological approaches to explore online talk (Baym, 1996; Bou-Franch, Lorenzo-Dus, & Blitvich, 2012; Lipinski-Harten & Tafarodi, 2012; Shokouhi, H., & Hamidi, N., 2010). Often, these studies use CA features as the foundation for information. For example, Lipinski-Harten and Tafarodi (2012) used CA features such as topic, reference, and turn-taking in their coding scheme; and Shokouhi, H., & Hamidi, N. (2010) listed the features of opening speech functions and continuing speech functions to be used in quantitative analysis of online chat among Iranian youth. These studies, while they can be considered to use a conversation analytic method, are primarily quantitative in nature. Their results are restricted to the categorization of CA features that occurs in interaction with limited explanation of the nature of the interaction.

A notable trend in research in the field of online interaction which uses CA is to make a

comparison between face- to- face interaction and online talk. This is not surprising considering that CA was originally used to analyse spoken interaction. Features of CA, like turn- taking and sequential coherence, are examined in order to establish how action is organized through the conversation (Schegloff, 2007c). Accordingly, they become the standard guidelines for researchers who wish to study and explain online interaction. Garcia and Jacobs (1999), for instance, used the turn- taking system of spoken conversation to explain and understand the turn- taking system of chat interaction. They noted that adjacency pairs are organized differently in chat interaction compared to spoken conversation. Question–answer pairs that appear in the chat window, for example, are not necessarily adjacency pairs. This may be a coincidental by- product of the chat technology that makes the posting turns to look like adjacency pairs when they are not. A similar observation was also recorded by Negretti in her 1999 study of the English chat sessions of non- native speakers. According to her, although the same basic structure of interaction and sequence organization are present in the chat session, they are handled quite differently from the oral or face- to- face interaction. For instance, a response in a chat session could be delayed, and an opening could be explicit as participants visibly introduce themselves to others. Consequently, online participants often experience difficulties in interpreting the relationship between utterances, and thus their meaning and interactional status.

Conversely, Greenfield and Subrahmanyam’s (2003) study of an online chat room found that conversational coherence was unproblematic. Chat users were found to adapt well to the chat environment despite the unconventional nature of the conversation. In achieving conversational coherence in the chat room, users use available cues which are similar to those of face- to- face conversation, such as repetition and addressing, as well as creating new strategies specific to the chat room, such as chat codes and nicknames. This study also highlighted the significance of the visual nature of the online interactional medium in facilitating the coherence of the conversation, in the sense that it helps users to identify the relevant conversation to respond to.

Later studies are in agreement with Greenfield and Subrahmanyam’s study (Berglund, 2009; Bou-Franch et al., 2012; Garcia & Jacobs, 1999; Gibson, 2009; Reed, 2001). While there might be difficulties in establishing coherence, online users did not orient to it as problematic. Meredith (2017) finds that while the inability to mutually co- ordinate turns in quasi- synchronous interaction does impact upon turn adjacency, it does not disturb

participants' understanding. A feasibly one longer message could even 'break up' into a number of shorter turns, leading to disrupted turn adjacency. She contributes this affordance to the persistence of text on- screen that allows participants to deduce which turns 'fit' together by examining the interaction as it appears on screen. Nilsen and Makitalo (2010) also found, in their work on online training courses, that participants seemed to know which postings were meant for whom, and to what threads they were related, although, in the earlier stage, they seemed to have minor difficulties in coordinating their interaction online. These difficulties were overcome by developing specific strategies such as using names to address postings to a specific participant, and reformulating and recycling parts of others' postings. Nilsen and Makitalo (2010) argue that in online interaction, these strategies could function as instructions for how postings were to be read. These findings update earlier findings that claimed that disrupted adjacency, as well as overlapping exchanges, could frustrate users. For example, Herring (1999) claimed that although CMC is enjoyed and accepted by many people, it is naturally incoherent in various ways and the inaccurate position of turns often led to misunderstandings. Likewise, (Marcoccia, 2004) claimed that the sequential organization of asynchronous interactions cannot be adequately modelled (Marcoccia, 2004).

However, CMC, as its name suggests, is a technologically mediated communication. Therefore its study is closely related to the affordance of the medium of interaction. Often, CA studies of online interaction have examined the way that participants orient to its technological and interactional features. For example, Gibson's (2013) observation of the nature of sequential ordering in online educational environments that utilize audio and text-based communications found that one of the key differences between written and spoken discourse exchanges is that talk turns unfold in real time whereas written turns are made available as completed turns. Because of this, there is comparative disorder in the sequential organization of this mixed discourse because written turns are not visible until they are produced, and in the meantime, other spoken and written interaction is occurring. Despite this disorderly sequential organization, the study reveals participants do not have a problem establishing sequential relevance across the discourse modes. One way they achieve this is by closely tying and latching their talk to speech and completed text turns. The technological affordances of the medium that can indicate the point at which various forms of action, like typing or using the microphone, assist participants in planning the

production of their feedback. A similar finding was also reported by Anderson et al. (2010) in their experiment with online groups undertaking a problem-solving task. Using a particular system of CMC that allowed every interactional element, such as who was typing, who was not, and how long a participant spent typing a particular utterance to be detected and recorded, they found that participants routinely constructed message units from complete sentences, rather than from phrases or fragments. Although this led to overlapping turns, the ability to monitor each other's utterances- in- progress minimized the interrupted overlapping utterances. Interestingly, these findings support Garcia and Jacobs (1999) assumption that although online sequential organization continues to be disorganized, confusion is decreased as users become more familiar with the system. Eventually, the disorganization of the system will become part of the background knowledge of conversing by CMC.

CA has also been used to look at the phenomenon of 'repair' in online interaction. Here, research suggests that that repairs in written interaction are oriented to the same basic repair mechanisms that are available in spoken interaction but shaped by the medium of interaction. For example, a work by Meredith and Stokoe (2013) identified two types of repair, visible repairs and message construction repair, designed to accomplish repair online. Of these types, message construction repair is particular to online interaction due to the technological affordance of the medium which allows the repair to occur before the turn is posted. This type of repair was also reported by Garcia and Jacobs (1999) in their exploration of CMC turn construction components. They found that in addition to the three locations for self- repair in oral conversation described by Sacks et al. (1978), self- repair in CMC, although occurring within the turn of the current speaker, could happen without the knowledge of co- participants. This happens because participants can edit and revise a message- in- progress to response to messages that may be posted while they are constructing their turn (Schönfeldt & Golato, 2003).

Even though many studies of online interaction tend to focus on the structure of the interaction such as its coherence by comparison with face- to- face interaction, there are also a number of studies that use CA to understand how participants accomplish social actions in asynchronous environments (Stommel & Koole, 2010). Paulus et al. (2016) note that some of these use discursive psychology, but also draw upon CA in order to understand broader social practices in online interaction. Stommel and Koole (2010), for

instance, took a case study approach to analysing the interaction between the established members and a new member of an online support group on eating disorders. They showed how categorization is used in negotiating and confronting the normative requirements of the forum to which the newcomer should be oriented. Stommel and Koole's study utilized both frameworks of CA, sequence analysis and Membership Categorization Analysis (MCA), to understand the underlying social practices, and how identity categories work in online discourse. It suggested that messages or posts can be analysed as sequentially related since participants treat their contributions as such. The finding shows a similarity with previous studies to the extent that becoming a member involved subscribing to the normative requirement of the forum, such as displaying themselves as having a certain condition (Antaki et al., 2006; Vayreda & Antaki, 2009). CA helps in these studies by explaining the action that each message enacts through their sequential placement in the interaction.

Analysts of digital CA have reminded us that in applying CA to online interaction, it is important to not assume that findings will be similar to those obtained from the study of spoken interaction (Giles et al., 2015; Meredith & Potter, 2014). Due to the differences between these media of interaction, particularly in their affordances, certain features of spoken interaction are not present in a similar way in online interactions, such as pauses and turn-taking (Greenfield & Subrahmanyam, 2003; Guise, Widdicombe, & McKinlay, 2007). Therefore, it is not necessary for digital CA to exactly follow CA approaches to spoken discourse (Simpson, 2005) which has led some researchers (Giles et al., 2015; Meredith, 2017) to suggest that rather than comparing online talk to spoken interaction, a researcher should use CA to study online interaction on its own.

Conversation Analytic Studies of Facebook

A number of studies have utilized Conversation Analysis (CA) to study Facebook. These few that used CA extend the issue that has been studied in another medium of online interaction, on Facebook. The prominent issue of study includes Facebook's affordance (Meredith, 2017; Meredith & Potter, 2014; Meredith & Stokoe, 2013), and the interactional features of Facebook (Ab Rashid, 2016; Farina, 2015; Meredith & Stokoe, 2013).

Much of Meredith's work focuses on Facebook's instant messaging service (Facebook chat). There, interaction is characterized by real-time one-to-one quasi-synchronous interactions, where both participants have to be online at the same time in order to interact. She finds that the separation of message construction and sending which allows participants to write messages at the same time impacts upon turn adjacency, which can lead to disrupted turn adjacency (Meredith, 2017). Interestingly, she finds that this situation does not seem to bother the participants. Often, they create further disrupted turn adjacency through the production of multiple turns in the form of short messages. She also finds that identification and recognition sequences rarely occur in Facebook chat as they deem to be unnecessary because the names of the participants are visible in the chat window. This affords the possibility of knowing the identity of both interlocutors. This finding differentiates Facebook chat specifically, and other similar Facebook-like chats such as Twitter from Schegloff's earlier study of identification and recognition in a telephone conversation (Schegloff, 1979), where he noted that since recognition cannot be accomplished visually, identification and recognition sequences usually take place earlier in the first utterances and turns at talk before proceeding to the real conversation.

Meredith (2017) notes that Facebook chat requires that a summons is produced through constructing and sending a message, which not only functions as the first turn of the interaction but also leads to the recipient receiving a notification. In a way, it is quite different to other online chat such as IRC where there is an automatic notification which informs already-present users that someone else is joining the chatroom (Rintel et al., 2001). Meredith's (2017) study also finds a lack of availability check that is the ability to check if the recipient is available and ready to start the interaction. The study argues that this could imply that although the medium affords the possibility of instant interaction, participants do not necessarily treat a summons as requiring an instant response. Because of this Meredith suggests that the idea of synchronicity as a fixed state may need to be rethought, and instead, it should be considered as a participation concern. This is because although an interactional medium such as Facebook chat can be defined as quasi-synchronous, its synchronicity is not a fixed feature but is something that participants negotiate through the course of the interaction.

In another work using a similar corpus of quasi-synchronous instant messaging chats, Meredith and Stokoe (2013) explored the phenomenon of repair and how it might function

in these new contexts. By repair, they understood the processes by which speakers dealt with troubles in speaking, hearing or understanding which arose during the interaction. In doing this, they considered the similarities and differences between the forms and types of repair (Schegloff, 2007c) found in spoken and online conversation. The study shows that, as in spoken interaction, repair happens in Facebook text- based interaction. The study further clarifies two types of repair that occur in Facebook interaction (Meredith & Stokoe, 2013). One is ‘visible repair’ (p.181) which can be seen and oriented to by both participants in the interaction. This type of repair occurs in the same sequential position as in spoken conversation and is most commonly targeted at a trouble- source such as a spelling or typing error particular to written online interaction. Another type of repair is ‘message construction’ (p.181) repairs which are available only to the message’s writer and occurs during message construction. This type of repair is not visible to the recipient as the trouble- source is corrected before the writer sends out the message to the recipient. According to Meredith and Stokoe (2013), this type of repair is unique to text- based interaction due to the technological affordances of online interaction where there is a separation of message production and transmission. This affordance allows the chat’s authors not only to repair their messages but also to repair the action or sequential implications of their turn. Consequently, they argue that in online interactions, the development of action in a turn could happen unaccountably or might be unavailable to recipients, as they state (p. 202):

The separation of message production and ‘transmission’ meant that, for example, the development of action in a turn, and the way action may be restarted, reformulated, and so on, was unavailable to recipients. This is a key affordance because it means that, unlike in spoken interaction, online interlocutors are unaccountable for some interactional matters.

Meredith’s later work (Meredith, 2017; Meredith & Potter, 2014) demonstrates how Conversation Analysis (CA) can be used to analyse electronic interactions. Using CA and the concept of affordances, Meredith (2017) argues that analysis should not only focus on online interactions, but also on the technological contexts of that interaction. Meredith and Potter (2014) propose to fully utilize the technological elements of the conversational medium in collecting and analysing the data. For instance, screen shot tools can capture not only the conversation logs but also show how users actually conduct online interactions. However, they noted the difficulties in analysing such rich and complicated data.

Therefore, they suggest first analysing the data using standard CA (Meredith & Potter, 2014), and noted any interesting interactional features of the participants' conduct. Then, it follows to see if this interactional conduct is oriented to any particular affordance. By following these steps of analysis, analysts can avoid overwhelmingly focussing only on one aspect of analysis, such as the presumption that technology plays a particular role or that findings from spoken interaction will be relevant.

Other studies that use CA on Facebook focus on initial Facebook posts, or status updates (Ab Rashid, 2016; Farina, 2015). These studies argue that Facebook status updates are not merely interactions, but that they are “telling”: making announcements and narrating stories. Ab Rashid (2016) for example, in exploring how teachers construct their identity, finds that status updates written by teachers show characteristics of storytelling (Schegloff, 2007c) although they may not fully fit into the storytelling genre. Certain styles of communication used by teachers in presenting and justifying their views and opinions, such as exaggeration and constructed dialog do fit the criteria of storytelling. This finding is consistent with Farina’s (2015) study, which found that Facebook status updates normally consist of “telling”. Evidence for this is seen when responders' respond to status updates which include second tellings, evaluations, and requests for clarification. This orientation suggests the way they interpret the updates as “telling”. Initially, status updates share features of both spoken announcements and storytellings. They consist of multiple units that resemble telling within a short or single post which may also appear like an announcement. Therefore, a status update is also a narration of an individual’s story.

Ab Rashid (2016) took the study of Facebook status updates further by explaining how a topic introduced in a status update is negotiated with/ by respondents through the comment function. Using 20 Facebook chat interactions of Malaysian secondary school English language teachers, he showed how a particular topic is negotiated through conversation. Often, respondents would employ certain strategies such as repetition and ask a question whenever a response from the topic introducer is delayed. Through these strategies, respondents attempted to continue the topic.

While these few studies show that Facebook has been studied using CA, it must be noted that there are many aspects need to be considered as CA was developed for spoken interaction or face- to- face interaction. Although some researchers (Meredith, 2017;

Meredith & Stokoe, 2013) suggest that digital CA should be studied on its own rather than continuously comparing it with CA approaches to spoken discourse, it is undeniable that digital CA is still considered new. As such, it required guidance and assistance from the ‘conventional’ CA. The following section will provide a brief discussion on Conversational Analytic and its related approaches as necessary for this study. Before that, I will highlight several studies on Facebook Confession Pages. These studies are not necessarily used CA but it would be significant to see the studies that have been done on the sites since they will give better understanding of the sites.

Facebook Confession Pages (FCPs)

Facebook Confession Pages (FCPs) are not a new phenomenon. The sites are well known, especially among college students, since almost every college has its own FCPs. Nonetheless, little research has been done on them. This section will look at existing studies and how they were conducted. This will give a better understanding of FCP sites and help this study fill the gap in the literature.

To date, researchers have used FCPs mainly for opinion mining and sentiment analysis (Barari, 2015; Paul, Ankit, Liao, & Choudhary, 2013). They have tried to capture and understand quantitatively users’ emotions as well as their positive and negative feelings. For example, Paul et al. (2013) identify taboo and stigmatising topics by comparing the text from FCPs with the crowd-sourced Urban Dictionary. According to them, understanding this text helps us to understand the classification of self-disclosure texts. Since FCPs are often limited to a particular college community, this finding can assist college services in a comprehensive monitoring of students’ mental health, and can be extended to other psychological facilities. Similarly, Barari (2015) has analysed the natural language characteristics of a college community on an FCP using a natural language processing tool. He looked for topic patterns, pointwise mutual information and sentiment analysis. His study identified the topics latent across the entire corpus, and found that loneliness is a dominant topic of confessions. These findings to some extent support previous sociological research, contextualising student loneliness in the age of social networks (Ellison, Gray, Vitak, Lampe, & Fiore, 2013)

FCPs are often utilised in exploring the usefulness of SNS in facilitating supportive communication among young people (Birnholtz et al., 2015; Hayman, Smith, & Storrs, 2018; Yeo & Chu, 2017a; Yeo & Chu, 2017b). For instance, a study by Birnholtz et al. (2015) examined how FCPs provided a medium of interaction for users to explore identity and taboo topics within their local community. Using computer analytical processing, they coded the collected data into three categories: question type, taboo, and stigmatized identity. The results showed evidence of users asking questions and engaging with taboo topics such as sex, prejudice and drug use, and revealing potentially stigmatised identities with others locally. There was little evidence of negativity in people's responses, however; the researchers found that most were potentially useful or relevant to the questions asked. The study attributed these phenomena to the nature of FCPs that allow users to ask questions anonymously in their local community, in circumstances where the responder can be identified. The combination of anonymity and identifiability allows discussion of taboo topics to reach the known audience while avoiding negative disinhibition. Similar findings have been revealed in other studies on the use of FCPs for peer advice and social support among young people on sexual health and intimate relations (Yeo & Chu, 2017a; 2017b). The findings provide evidence to demonstrate that Facebook Confession Pages may facilitate youth participation and dialogue about sensitive personal concerns in a constructive manner. They further suggest that social media channels that facilitate de-identified sharing of experiences within a network of peers may accommodate both young people's desire for peer opinion and validation regarding intimate concerns and their fear of social repercussions from self-disclosure. Additionally, Hayman et al. (2018) reported a similar positive finding in their study concerning the usefulness of FCPs among undergraduate students. Their study demonstrates that students use FCPs to inform their undergraduate learning legitimately and support their academic experience.

However, a different situation is demonstrated by Rachoene and Oyedemi's (2015) study. Using five Facebook sites popular among youth in South Africa, including FCPs, they reveal a culture of cyberbullying that exists on these online sites. The study showed that attacks on intelligence and physical appearance, sexting and outing, insults and threats are common bullying types found on the sites. A key observation of the study highlighted the fact that victims of cyberbullying attacks did not usually respond or defend themselves and remained silent when being bullied in the presence of a mass audience. The study

considered certain types of bullying, like sexting and outing with the use of sexually explicit pictures, to be common practice within the population.

This describes the little research that has been done on FCPs. Almost all the studies have focused on young people, particularly undergraduate students. It is therefore logical for them to be using FCPs, since these are college-affiliated sites. All the studies were quantitative. While there are studies that look at the issue of identity, they explore an explicit identity characteristic such as gender. All this suggests the need for more studies of FCPs. In particular they suggest the need for a qualitative study of identity construction. By adapting the qualitative approach to Conversation Analysis, therefore this study will be able to fill the gap in the literature on FCP as well as on identity and CA.

Conversation Analysis

To ground the study, it is important to look in more detail at the development of Conversation Analysis (CA) and its primary focus – sequential organisation. In addition this section will detail the related approach of memberships categorisation analysis. The connecting issue of person reference will be detailed. Finally, the area of epistemics will be discussed.

Conversation analysis (CA) developed as a field of study most notably through the ethnomethodology of Harvey Sacks, Emanuel Schegloff and Gail Jefferson (ten Have, 2007a). Ethnomethodology is a method that focuses primarily on talk-in-interaction, and was developed precisely to explicate how people bring off social actions through their talk (Hutchby & Wooffitt, 2008; ten Have, 1999). Using naturally occurring interaction for its data, CA is interested in uncovering and describing the ways that actions, events and the like are locally produced and recognized by interactants. As Sacks (1984) states, “it is possible that detailed study of small phenomena may give an enormous understanding of the way humans do things and the kinds of objects they use to construct and order their affairs” (Sacks, 1984, p. 25). In doing this, CA looks at the ways in which people organise their talk and analyse each other’s conversations in the construction and negotiation of social actions including the interactional elements such as sequencing, which is the structured order of interaction parts, turn-taking, turn design and construction, to provide

useful insights into a person's relationship to society (ten Have, 2007a).

Basically, the proponents of CA undertook a shift in the perspective of social scientific inquiry, where instead of treating social interaction as a social product, they were more interested in studying the very structures of interaction itself (Gibson, 2009). CA thus seeks to describe, analyse, and understand interaction as a basic and a constitutive feature of human social life. As Psathas (1995, p. 1) says, CA represents a "methodological approach to the study of mundane social action" due to its preference for naturally occurring data and its approach to the data for what it actually contains, rather than predetermined data that corresponds to existing theoretical categories or concepts. So, instead of viewing talk as a mere social interaction between people, CA understands sentences and utterances as forms of action situated in specific contexts and designed with specific attention according to the contexts. Therefore, authentic conversation and its organization are crucial in CA since they are the starting point for further investigation.

This study draws its analytic framework from CA, and its parallel methodological approaches: membership categorization analysis (MCA), person references and epistemics. Whilst all of these approaches come under the same banner as CA, due to their historical and analytical enterprise, they are concerned with different phenomena. CA and MCA are both rooted in Sacks's (1992) *Lectures on Conversation* but develop differently, with CA being concerned mainly with sequentiality (that is, 'the normative structuring and particular courses of social action and their organization into systems through which participants manage turn-taking, repair, and other systemic dimensions of interaction's organization (Heritage, 2005, p. 104)), while MCA focuses on 'members' methodical practices in describing the world, and displaying their understanding of the world and of the common-sense routine workings of society' (Fitzgerald et al., 2009, p. 47). Meanwhile, person reference refers to a practice for referring to another person (Schegloff, 2007b). This interactional practice is mostly associated with membership categorization devices (MCD) though there is a claim that they should be differentiated and dealt with accordingly (Lerner & Kitzinger, 2007; Schegloff, 2007a). As for epistemics, though it has diverse lineage across a range of disciplines, it has generated a lively and productive engagement within CA, particularly through a series of works by Heritage (1984; 1998; 2011; 2012b; 2012c; 2013; Raymond & Heritage, 2006). These works deal in a systematic way with the construction and transformation of meaning over the course of interaction

mostly through sequential analysis. All these approaches are primarily concerned with the basic feature of social life, talk- in- interaction. This study draws on these analytic frameworks to examine the sequential unfolding of online interaction, looking at how participants identify themselves and others as they display their epistemic stance.

Sequential Organisation

A key concern of CA has been that the conversational process is organized through sequences of turn- utterances in which the participants in a conversation take turns at speaking (Gibson, 2009). There is a question, however, about how participants *know* when to take a turn and how they manage the exchange of turns. In his lectures, Sacks (cited in (Silverman, 1998) proposed a number of maxims that can be seen to operate as general procedures for talk. Three of the most basic of these are: (1) that one person speaks at a time; (2) that conversational turns do not overlap; (3) that people take turns at producing turns (Silverman, 1998, p. 101). Sacks points out that in almost all conversational settings there is a preference that only one speaker talks at any given time, and it is an alteration of turns. He further emphasized that the enactment of such alteration requires considerable skill and negotiation over aspects such as the start and end points of utterances, the length of the utterances, the appropriate content of turns or the relation between utterances (Sacks, 1992).

The alteration of turns is also one among various interaction organizational phenomena that are the focus of the sequential organization. Alteration of turns or turn- taking refers to the way in which speakers alternate in conversation in an orderly, recognizable fashion. For instance, if only one person ever talks, it may not be considered a conversation. But it may appear like a monologue or lecture of some kind. So an interest in turn- taking involves examining the sequentially organized way of ordering conversation through changes of speaker. There are basic rules for turn- taking, in which the current speaker selects the next speaker, and only if this is not done is it open to any speaker to self- select (Schegloff, 2007c). There are also other element to take into consideration in turn- taking such as an imbalance of knowledge between interlocutors (Lerner, 2003), but this element is the interest of another branch of CA (epistemics). The focus of turn- taking, therefore, is

on the organized way of ordering conversation which in turn shows that conversation does not happen at random, but follows a certain system (Sacks et al., 1978).

Closely related with turn- taking is the notion of adjacency pairs, which is another key concern in CA. Technically, an adjacency pair is a sequence of conversational turns that are tied to each other in which the former calls forth the latter (Hutchby & Wooffitt, 2008, p. 42). In CA, adjacency pairs involve an examination of how turns in conversations can be hearable, linked as two- part sequences such as question- answer, and greeting- greeting. The main rule implies that a current action or a 'first pair part' such as a greeting or a question, requires the production of a reciprocal action or 'second pair part' at the first possible opportunity after the completion of the first (Goodwin & Heritage, 1990). Schegloff and Sacks in (Stivers, 2013, p. 192) list the features of adjacency pairs as:

- Composed of two turns
- Produced by different speakers
- Adjacently placed (one after the other)
- Relatively ordered such as first- pair parts precede second- pair parts
- Pair- type related such that particular first- pair part are paired with particular second- pair parts.

This is the basis of conversation, in which, most of all, for a talk to be considered a conversation, it must have at least two speakers, who produce at least a turn each. For instance, when a first person produces a 'question', a second person would respond with an 'answer'. It is unreasonable for the first person to make a response to the 'question', or the second person to provide an answer before the first person's 'question'. Similarly, a pair of speech utterances will not be considered an adjacency pair if the interlocutor responds differently from the appropriate pair- type part (for example by answering a 'greeting' with a 'question'). Therefore, the adjacency pair is a basic sequence of conversation which may be expanded in various ways (Stivers, 2013). For example an adjacency pair can also be an analytic device for researchers to investigate the ordering of a conversation. Particularly in a situation in which a subsequent pair part does not follow the first pair part, it may seem as if some form of repair work is needed. Thus, repair initiation (which is the way in which speakers react to instances of 'trouble' - and whether to try to repair the situation in a

sequentially organized way), may be considered. Likewise, adjacency pairs can also indicate how the next speaker is selected, which is a key interest of turn construction and turn design (Schegloff, 2007c).

In CA, these interactional phenomena like turn-taking, adjacency pairs and repair, including mundane and minute occurrences such as how much gap or silence is present in the conversation, are looked at with a view to explicating how such interactional elements open up particular ways for others to continue the interaction, as well as to perform particular types of interactional work (Hutchby & Wooffitt, 2008; ten Have, 1999). What an utterance accomplishes in a series of talks, is dependent upon its sequential position within the interaction. As ten Have (1999) states: “what a doing, such as an utterance, means practically, the action it actually performs, depends on its sequential position” (ten Have, 1999, p. 6). So, in order to see what action is produced in the interaction, it needs to be analysed sequentially.

In a context in which conversational participants do not ‘speak’ such as in online chatting, one might wonder about the relevance of this sequential organization. Online conversations are normally asynchronous, distributed across time, and do not occur at a given temporal point. Messages could be sent successively but can also remain unread for a long period of time (Meredith, 2017). So, aspects such as gaps and silences may be analytically useless. In a multiple-party online discourse such as in forum or blog, the sequential turns may appear disorganized in the sense that there could be more than one person speaking at a time which consequently violates a basic rule of turn-taking. Also, it is difficult to determine which turn is the next turn (Herring, 1999; Herring, 2011). So, the basic maxims of offline conversation seem odd and inappropriate for characterizing online discourse. However, as shown in the earlier discussion, CA has been used to study CMC and other online interaction (Baym, 1996; Benwell & Stokoe, 2010; Bou-Franch et al., 2012; Gibson, 2009; 2013). This suggests that online interactions including CMC, qualify as ‘conversation’ and that CA may still be an appropriate method for analysing them.

One challenge with online asynchronous conversation, however, is to uncover the logical sequence of the posts (Gibson, 2009). Participants do not always take turns at the relevant time and place, but whenever they can, such as when they log on to the computer. Consequently, the sequential turn has often appeared haphazard in comparison to the order

of turns in face- to- face conversation (Herring, 1999). However, Gibson (2009) claims that participants nonetheless do display their accountability and demonstrate through the organization of their posts how they relate functionally to other contributions. This means that despite the appearance of disorganized turns, there is still a systematic way of organizing the sequence. As Benwell and Stokoe (2010) have noted, participants in online conversation do not create entirely new ways of communicating, but rather recreate and adapt features of face- to- face communication.

Membership Categorization Analysis

Membership categorization analysis (MCA), developed initially in the work of Harvey Sacks in the 1960s (1992). Basically, it is concerned with the practical oriented, common-sensical, and cultural reasoning of people as they go about their social lives and make sense of their activities (Hutchby & Wooffitt, 2008; Schegloff, 2007a). It focuses on the recognizability of people as certain sorts of people or, more specifically, people as certain sorts of members of society, and how this recognizability is a resource for members in their dealings with each other. For Sacks (1992), categories and the process of categorization are a key feature of conversation because they are inference- rich, and can invoke a cultural understanding of expected characteristics, and thus bring organization to an interaction (Housley & Fitzgerald, 2016; Silverman, 1998). A famous example to illustrate this principle can be seen in Sacks's analysis of a story told by a child, "The baby cried. The mommy picked it up" (1992). Someone who is reading it will perceive that the activity of crying is natural to the baby, the mommy is the mother of that baby, and that the mommy is tied to the baby as a caregiver. Yet, through these two sentences, Sacks illustrates how complex layers of social knowledge and social action are built into common sense knowledge of who was involved, what happened, and why.

An important aspect of MCA, however, is that the categories must be generated by members and demonstrate locally by the participants in talk- in- interaction (Hester & Eglin, 1997; Housley & Fitzgerald, 2016; Sacks, 1992) rather than pre- imposed categories. This is because the categories constitute common sense knowledge to people in society (Schegloff, 2007b). So, if one wants to make a claim about a certain category such

as gender or kid, it must be shown to be relevant to the members. In other words, the category is defined by examining its surrounding network, which gives insight into how the members define the category. Thus, analytically, all MCA is doing is simply bringing to light members' own analyses. This also means that MCA, unlike sequential organization analysis, takes cultural resources into consideration, including the language usage that is brought into play in the conversation (Bilmes, 2011). In a way, MCA is useful for analysing the cultural elements in a talk, which are an undeniably major factor in communication. However, MCA should not be thought of as a theory of social categorization that is applied to some empirical materials to test its predictability, but rather as an approach to explicating social categorization as a display of, and the accomplishment of people's (or 'members') local reasoning practices, or what might be called 'culture- in- action' (Fitzgerald, 2015, p. 1).

The focus then is on how participants 'do' category and how they go about making the word choices they do (Schegloff, 2007a). Fitzgerald (2015) states that this can be understood through the basic concepts of MCA, including 'membership categorization devices,' 'membership categories,' 'category- bound activities,' 'rules of economy and consistency,' and 'viewers and hearers maxims'. Previously, in a *Discourse Studies Special Issue on Categories and Social Interaction*, Stokoe (2012) lists ten key concepts of membership categorization derived from both Sacks and later MCA work on how to approach MCA (Stokoe, 2012, p. 281):

1. "Membership categorization device (MCD): This refers to the apparatus through which categories are understood to 'belong' to a collective category (e.g. the categories 'mommy' and 'baby' are heard to belong to the MCD 'family').
2. Category- bound activities: Activities that are, in situ, linked to categories, such as 'Why are men (category) so reluctant to go to the doctors (activity)?'.
3. Category- tied predicates: A category's characteristics, such as 'this mother (category) cares (predicate) tremendously for her baby'.
4. Standardized relational pairs: Pairs of categories that carry duties and moral obligations in relation to the other, such as 'parent- child'.

5. Duplicative organization: Categories that work as a unit or in a 'teamlike' way, having specific obligations to each other, such as 'centre- forward', 'goalkeeper' and 'defender' in a 'football team'.
6. Positioned categories: Some collections of categories occupy a hierarchical relationship, such that an 'adult' can be accused of behaving like a 'teenager', and so on.
7. Category- activity 'puzzles': People do particular actions by putting together (un)expected combinations such as 'Killer Nuns!'; jokes are often built this way (e.g. 'women drivers').
8. The economy rule: A single category may be sufficient to describe a person.
9. The consistency rule: If two or more categories are used next to each other, like 'father' and 'daughter' in 'Father and Daughter in Snow Ordeal', and both belong to a standard collection or MCD (e.g. family), then people hear those referred to as members of the same family.
10. Categorization 'maxims': Sacks (1992: 221, 259) derived the hearer's maxim for duplicatively organized categories ('if two or more categories are used to categorize two or more members of some population, and those categories can be heard as categories from the same collection, then: hear them that way') and the viewer's maxim for category- bound activities ('if a Member sees a category- bound activity being done, then, if one sees it being done by a member of a category to which the activity is bound, see it that way')."

In the process of categorization in talk, membership categories are the 'classifications or social types that might be used to describe persons' (Hester & Eglin, 1997, p. 3). They can be grouped together into collections of related categories, such as the categories of 'mommy' and 'baby' comprising the collection or Membership Categorization Device (MCD) of 'family'. However, which MCD that categories comprise of, must be explicitly stated in the talk, or inferred from the context because certain categories could belong to more than one device such as 'baby' can belong also to the MCDs 'stage of life'. Category- bound activities and predicates, then, are resources for actions which tell the kinds of

things that members of a certain membership category do. Thus, categories, activities, and predicates must 'go together' in a contextualized way in any given stretch of discourse. That means the way the categories are selected, used, and configured by members are in orientation to the topic at hand, and that their use in any particular situation is purposeful or practical for that topic, as Fitzgerald (2015, p. 4) explains:

“The associated actions of social categories comprise a kind of stock of knowledge- in- action or culture- in- action, which involves common-sense knowledge about the world and how social categories are expected or assumed to act in general and in particular situations. That is, while there is any number of ways in which categories, devices, and their associated actions can be configured prior to their use it is only through their use in any particular situation that they become operative for the participants.”

Further, Sacks (cited in (Silverman, 1998) observes that there are a couple of rules that provide further insights into how these social categorization practices are used. The first rule is known as the economy rule (Silverman, 1998, p. 77), that is it is sufficient to describe people using one membership category at a time, without further need of elaboration such as 'mommy' and 'baby'. This does not mean that more than one category cannot be used but there is often a category that is the most relevant to be used to describe a person under a certain circumstance. Another rule is the 'consistency rule' (Silverman, 1998, p. 77) that is if a member has been categorized as within a particular device then other members of that population can be categorized in terms of the same collection. So, if one were to see a baby being held by a female, in categorizing the 'baby' as belonging to the collection 'family', the woman holding the baby can be categorized from categories available within that device, such as mother, grandmother, or sister. Sacks then derived a corollary known as the 'hearer's maxim,' which posits "if there are two categories which can be heard as from the same collection, hear them as from the same collection" (Silverman, 1998, p. 78). This means that particular categories can be seen as belonging to a collection by applying the hearer's maxim. For instance, categories mommy and baby can be heard as belonging to the collection of 'family' because they are seen as related to one another, also known as standardized relational pairings. As Sacks (1992, p. 327) suggests, the use of this 'pairing' device can also help to identify a person:

“Take the person you have to categorize; treat them as the second person of a pair for which the first is known; find a first. If you can find a first—and in principle, you can find a first—you've got a solution”.

These rules of application and corollary, therefore, reinforce the observed or described actions that draw upon common- sense understandings for their practical sense making within occasioned organizational devices.

According to Fitzgerald (2015), it is through understanding these basic concepts of MCA that a common- sense understanding of the story can be made analytically interesting. Again, referring to the example that Sacks gave in his early lectures ‘The baby cried, the mommy picked it up’, we can hear that ‘baby’ and ‘mommy’ as belonging to the same collection or device of ‘family’ since they are common standardized relational pairings. Then, ‘the baby cried’ and ‘the mommy picked it up’ shows the common and expected actions attributed to both categories: mothers pick their babies up when they are crying to comfort them. These ‘category- bound activities’ constitute the actions that are expected from each category.

Since this study focuses on identity, approaching the research from an MCA perspective serves to address the primary interest in participants’ use of membership categories and how such use serves to maintain and negotiate their social identity. Although this study may use a different platform (that is, online interaction), yet the principle approach of MCA as listed by Stokoe (2012) is still relevant in text- based conversations. This is because the assumptions that underpin MCA are closely aligned with those informing the research undertaken here, such as that the categories are not predetermined but emerge through interaction; the use of categories in participant identification; and the locally produced and situated nature of the interaction. Additionally, MCA is closely related to the practice of person reference, which is discussed below.

Person Reference in Practice

Person reference is an action that is grounded in a speech situation between the speaker, the recipient, and the referent. In this situation, at least three social relationships should be

taken into account in relation to person reference: the relationship between speaker and recipient, recipient and referent, and speaker and referent (Stivers et al., 2007). We should bear in mind, however, each of the interlocutors may understand themselves to have a different position in the relationship. For example, a speaker may understand that the recipient has a casual relationship with the referent, whereas the recipient may understand the relationship differently. Therefore, it is crucial to set parameters for the appropriate use of person reference.

Sacks and Schegloff (2007) suggest that there are two preferences to persons that are used in a conversation, which are the preference for 'minimization' (p. 24) and the preference for 'recipient design' (p. 24). They frame minimization as follows: "On occasions when reference is to be done, it should preferably be done with a single reference form" (p. 24). By this, they mean that the practice of referring to a person in conversation is usually accomplished by the use of a single reference form as in the use of the name or pronoun. Even if a person may possess a name with two or more components, it is unlikely that the entire name will actually be used other than for occasional official documents or ceremonies. It is not necessary, however, to use an additional referential information because it may not bring any new referential information (Hacohen & Schegloff, 2006) especially if the referent is recognized by the recipient. In a situation where the referent is not recognized by the recipient then the speaker can produce further elaborate descriptions (Sacks & Schegloff, 2007).

However, there are many available forms that can be used in making a reference to persons such as names, title, or kinship. The most preferred form, then, is the most recognizable, that is, the form of reference which the speaker thinks that the recipient would easily recognize (Hacohen & Schegloff, 2006). This preference for using a recognizable form in making a reference to a person is what Sacks and Schegloff (2007) specify as recipient design. The purpose of recipient design is to achieve recognition, in which a speaker makes use of referential forms that enable the addressee to link the referring expressions with the referent (Stivers et al., 2007). In doing so, a speaker should consider who the recipient is, and what kind of relationship he/ she has with the referent. Thus, recipient design, in this respect, is irredeemably tied to understandings of, and past experiences between, speaker and recipient (Schegloff, 2007b).

In relation to this, Schegloff (1996) also introduced two types of reference forms that can be used to analyse references to a non- present person: recognitional and non-recognitional. Each of these helps a speaker find an appropriate referring expression, whether or not a recipient can identify to whom a speaker is referring. Recognitional reference forms are those that the recipient can easily recognize, such as a name. Using this type of form indicates the speaker's expectation that the recipient knows a particular referent to be able to identify him/ her through the name or description used (Schegloff, 1996). Non- recognitional reference forms refer to those referring expressions which not clearly recognizable and most of the time, do nothing except refer (Schegloff, 1996) such as a generic term 'a teacher'.

Two common recognitional reference forms are names and descriptions (Schegloff, 1996). A name, as in a personal name, is considered as the clearest and most direct recognitional reference in a conversation that can be easily recognised as the referent. Also, a name holds a special position in the practice of person reference. It can concurrently satisfy both the preferences, minimization and recipient design, highlighted by Sacks and Schegloff (2007). Given that the name is a single reference form and therefore it is minimized, its use as a recognitional reference could also satisfy the preference for recipient design. In many societies, a person's name could also indicate family or clan membership (Griffin, 2010). Therefore, the name identifies the person as a member of a particular family while separating him or her from another family.

However, according to Brennan (2000), the individuality of names may cease to be processed after persons and names become familiar. Especially in a society where a common name is used, it may end up that many people share similar names, making it difficult to recognize the referent. For instance, in Malay society, it is common for women to have their first name 'Nurul', although it is not common as a surname. Therefore, to make a reference to 'Nurul' in that society may require some additional referential information (Sacks & Schegloff, 2007). Nickname is another recognitional reference that is commonly used (Griffin, 2010). Across cultures, nicknames tend to be based on the individual's personality, physical characteristics, behaviours, or experiences which can easily identify the person (Aceto, 2002). However, drawing attention to personal information is either associated with acceptance and intimacy, as when nicknames are used among friends, or aggression and hostility, as when they are part of name- calling and

bullying. Therefore, although nickname is a recognitional reference, it should be used carefully.

Alternatively, in the situation where a personal name is unidentifiable, recognitional description is commonly used (Schegloff, 1996). A recognitional description such as 'the women who sits next to you' or 'the person who created Facebook', has the capacity to pick out the individual in mind, as in the example below (Schegloff, 1996, p. 461).

- (17) SN- 4, 16:2- 20
02 Mark: So ('r) you da:ting Keith?
03 (1.0)
04 Karen: 'Sa frie:nd.
05 (0.5)
06 b→ Mark: What about that girl 'e use tuh go with fer so long.
07 c→ Karen: A:lice? I [don't-] they gave up.
08 Mark: [(mm)]

Note how Karen managed to figure out the referent (arrow 'c') through the recognitional description provided by Mark (arrow 'b') by upgrading it into a name. Although the name given is in a question- intonation, which could indicate uncertainty, it still shows that the referring expression used by Mark is recognizable. The example also shows that there appears to be a preference for the use of the name over a recognitional description (Schegloff, 1996).

In addition to recognitional and non- recognitional reference forms, there are other alternatives for analysing reference to a non- present person. In fact, forms of reference may vary even within a single conversation. It is common to use names the first time one mentions a referent and use a pronoun in subsequent references. Schegloff (1996) referred to this as 'locally initial and locally subsequent reference' (p. 450) in which, in the spate of talk, there is a common form of reference used the first time to refer to a person, and other forms of reference for subsequent mentions. For example, a full noun phrase could be used as an initial reference form, which subsequently becomes a pronoun. The following conversation taken from an online interaction between several people illustrates this situation. The conversation begins following a girl's announcement concerning her

'unnamed' secret admirer, whose identity is under discussion.

1. Chloe: My first thought is...Kin Chun..
2. Janice: Obviously, a little dark skin.....
3. Chloe: Guess he is going to be so famous starting from tonight

The referent, Kin Chun, is mentioned for the first time by Chloe in line 1 using the initial noun phrase that is his name. Chloe mentioned Kin Chun again in line 3 but this time through the appropriate locally subsequent form 'he', which is warranted by Janice's recognition of the referent in her response, acknowledging and confirming Chloe's opinion. This practice of using a pronoun for a locally subsequent reference form is prevalent in the English-speaking society, where pronouns take a clear form (Schegloff, 1996). In some other societies, however, this practice is less apparent. For instance, Oh (2007) states that in the Korean language, there is no clear distinction between full noun phrases and pronouns. The so-called third-person pronouns are a composite of both, pronoun and noun. Hence, the locally subsequent reference is done with zero anaphora. As this example shows, the practice of referring is highly influenced by the language and the culture of a society.

Epistemics

Epistemics is the study of the social organization of knowledge in interaction (Drew, 2018a; Heritage, 2013). In CA, epistemics focuses on the attribution of knowledge and the representation and use of knowledge claims by interactants in sequences of interaction (Heritage, 2013). It is concerned with how speakers display their knowledge to one another rather than with examining whether speakers may or may not actually know. Epistemics are manifested through interaction.

According to Heritage (2013), the role of epistemics in interaction can be analysed by making a distinction between epistemic status and epistemic stance. Epistemic status concerns the relative position of interactants in relation to knowledge distribution and access. This means that the territory of knowledge of each interactant regarding certain

knowledge could be on a different level, positioned along a continuum from relatively knowing (K+) to relatively unknowing (K-) (Heritage, 2012b). Using an example from Terasaki (2004: 176) the statement "I forgot to tell you the two best things that happened to me today" displays that the speaker has a different level of knowledge in relation to the hearer, where the speaker is projecting possession of knowledge about something, and the hearer is projected as not knowing. The level of knowledge among interactants can also be equal, and in such circumstances the speaker may invoke equality of access to the recipient's situation (Heritage, 2013). As to how individuals come into possession of particular knowledge, this can be obtained through their own experience regarding the matter (Heritage, 2011; Kamio, 1994). This is because aspects like thoughts, feelings, experiences, and expectations are generally treated as personal information, to which the experiencing person has the right of knowing and describing (Raymond & Heritage, 2006). Consequently, particular information can be within a person's territory of knowledge. In sum, epistemic status is not just about the actual possession of information but also concerns the rights to possess particular knowledge and to articulate it (Raymond & Heritage, 2006).

Meanwhile, the idea of epistemic stance concerns the moment- by- moment expression of the K+ and K- relationship, as managed through the design of turn- at- talk (Heritage, 2013). It refers to the expression adopted by the interlocutors in displaying their knowledge. For instance, a speaker can present a question by saying either "you are married?" or "you're are married, aren't you?" (Heritage, 2013). Both questions display a similar purpose (that is, to inquire about the recipient's marital status (K-)), in which the recipient is the one with the knowledge, since it is within the recipient's domain of knowledge (K+). However epistemically, the formulation of each question illustrates the speaker's different level of knowledge regarding the matter. In the first question "you are married?", the speaker is shown to have no knowledge regarding the recipient's status, while in the second question "you're are married, aren't you?" it is obvious that the speaker already has some information and is seeking confirmation (Heritage, 2012b; Heritage, 2013). In this situation, according to Heritage (Heritage, 2012b), the relationship between K+ and K- can be represented by epistemic gradients; that is, for the first question, the relationship is indexed by a sloping epistemic gradient where at one point the speaker has no knowledge and at the other point the recipient has the knowledge. In the second

question, the relationship between K+ and K- could be indexed by a shallow epistemic gradient due to the increase in information possessed by the speaker. The subsequent conversation develops depending on which stance a speaker takes. An unknowing stance (as in the first question), may invite further elaboration, and a more knowing stance like the second question, may invite confirmation (Heritage, 2012b). Therefore, while epistemic status is concerned with knowledge territory such as who knows who and what, the epistemic stance is concern with the flow of interaction; that is, how the knowledge displayed may bolster or terminate the conversation. As such, epistemics in interaction can be observed and analysed sequentially.

In his paper ‘Epistemic Engine’, Heritage (2012c) claims that knowledge displayed or expressions of epistemic imbalance could be one of the principles that informs sequence organization. This happens as the imbalance of information between speaker and hearer will often be pursued until the imbalance is acknowledged. This is sufficient to warrant a development of a sequence of interaction. The following sequence, in which Lesley asks her mother about a herbal medication that she has apparently recommended, illustrates this situation (Heritage, 2012c, p. 34).

(3) [Field 1:1:89–94]

- 1 Les: Uh didyuh get yer garlic tablets.
 2 Mum: Yes I’ve got them,
 3 Les: Have yuh t- started tak[ing th’*m*
 4 Mum: [I started taking th’*m* t’*da*:y
 5 Les: - > Oh well do:n[e
 6 Mum: [Garlic’n parsley.
 7 Les: ↑THAT’S RI:ght. [BY hhoh- u- Whole Food?
 8 Mum: [()
 9 (0.3)
 10 Mum: Whole Foo:ds ye[s,
 11 Les: [YES well done,

Lesley’s questions in line 1 and 3 are responded to appropriately by her mother in line 2 and 4, with confirmations. Lesley then closes the sequence at line 5 with an ‘oh’ that registers the information and ‘well do:ne’ that treats the information as sufficiently complete. In this sequence, we can see that a request for information positions Lesley as

occupying an unknowing (K-) epistemic status and her mother as occupying a knowing (K+) one. The use of 'oh' indexes a change- of- state (Heritage, 1984) in Lesley's epistemic status, which shifts from unknowing to knowing. This in turn indexes not only that the question was asked in search of information, but also that the information sought is in fact provided. Ultimately, this notion of epistemic imbalance adds to the understanding of sequence organization other than those sequences centred on the notion of adjacency pairs (Heritage, 2012c), particularly in tracing through post- expansions to adjacency pairs in sequential terms. For this, the attribution of epistemic imbalances becomes a resource that underlies the progression of sequences and makes such progression accountable (Drew, 2018b).

This has been contradicted by the claim that epistemics does not attend to the details of sequential organization and thus epistemic analyses cannot be considered as true conversation analysis (CA) (Lindwall, Lymer, & Ivarsson, 2016). However, as proven by a group of epistemic analysts in a series of papers (Drew, 2018b; Heritage, 2018; Raymond, 2018), epistemic considerations play a crucial role in sequence organization as well as in understanding the actions that participants implement within sequences. Moreover, there are certain actions that can only be understood through sequential analysis like 'oh- preface' to indicate new observations or a change of state following information provided. Such observation can only happen in relation to what occurred before (in the previous sequence). Therefore, the relevance of epistemic stance in interactions operates in parallel with sequence organization. On the one hand, the interaction proceeds through the sequential system such as turn- taking and adjacency pairs, and on the other, the interaction also develops through the imbalance of knowledge between interactants.

Conclusion

This chapter reviews related literature on CMC and CA. It had shown how CMC is a broad and varied discipline. There has been a gradual move towards viewing online language as designedly interactional, and CA studies of online interaction are becoming more common. It has revealed that there are differences in turn- taking and sequential organizational practices in online interaction and face- to- face interaction. However, people have found ways to compensate for the lack of interactional features of online interaction. Similarly,

research on social identity has developed further with more researchers adopt CA related approach of MCA in their studies of discursive identity. Yet, there are still less conversation analytic studies on identity particularly in social media such as Facebook. Much of the studies concerns on asynchronous online interaction such as blog and forum. Thus, the present study works to fill this gap as it considers not only the categorizations used by participants to make identification possible but also the way in which participants work with language to construct particular identities and categories relating to the identification work.

Also reviewed in this chapter is the methodological literatures used in this thesis. There are four distinct yet related approaches originated from Conversational Analytic highlighted in this chapter. These approaches are considered relevant in this study in informing how the data can be approached and analysed. Further elaboration on their application in this study will be discussed in the Methodological chapter.

Chapter 3: Methodology

Introduction

This chapter provides the detail of the method for the present study. Because every research environment is different and every project has specific requirements, what follows is a tailored account of how this study is conducted. This chapter will begin with discussing the medium of interaction that this study utilises that is Facebook. This is to provide general information regarding the background and structure of the medium, as well as how the interactions occur on the medium. This information is important to be explained earlier before focusing on the specific Facebook page that is Facebook Confession Pages (FCPs). Details of the corpus then will be discussed in the following section. This chapter will also discuss ethical issues around data collection. Further, it explains the data collection procedures as well as its organisation before describing the analytic process.

Facebook

Facebook is a popular social networking site with over 1.4 billion daily active users on average (Facebook). Launched in 2004, it started as space for university students to gather on the web before expanding it to general public users. In describing Facebook's purpose, values and social mission, its creator, Zuckerberg (2012, p. 1) outlines some important core business of Facebook, which includes 'giving people the power to share' and 'to strengthen how people relate to each other'.

Technically, Facebook is similar to Internet Relay Chat (IRC) in a way that users communicate through texts in a specific channel, and more than IRC in a way that the communication is not necessarily happening in real-time. It is also like a blog and broadcast where users can write whatever they want on their personal web space and disperse it to a broader audience if they want. It is a free site, and anyone over the age of 13 with a valid email address can register to be a user (Facebook). Facebook is a social

networking website and service where users can do many activities including post comments, share photographs and news, play games, chat live, and even stream live video. All these are done through Facebook's particular structures and elements that differentiate it from other social networks. Subsequent section will briefly elaborate the structures and elements of the Facebook site and their functions.

User Profile and Timeline

Each registered user of Facebook has a 'page' that consists of a personal profile that shows their posts and content on a 'Timeline'. The Timeline will display user's name together with the profile picture which represents user identity on Facebook. Facebook requires and encourages users to use real names on Facebook (Facebook), but practically, not all users use their real name on Facebook (Boyd & Heer, 2006).

The Timeline also displays a feed of a user's stories, including status updates, photos and videos, and events which ordered according to the time in which they were uploaded or created (Facebook). To add the stories, users write or upload photo or video on an empty status box available at the top of the timeline. Additionally, there are interactive features on Timeline such as 'Like' button on all status update, option for comment and read, location tag, etc. Another interesting element on Timeline is the ability to incorporate third-party applications which consequently expand the affordance of Facebook. It is through this affordance that Facebook Confession Pages manage their posts. In FCPs, the message post on the Timeline was written in other third-party application incorporated to the FCPs in order to avoid using a real Facebook username.

There is also a brief background summary of a user on Timeline, such as gender, birthday, hometown, etc. Users can manage this information and select which information they want to display on their Timeline. Facebook profiles also have advanced their privacy features to restrict content to specific users, such as non-friends or persons on a specific list. To do this, users can change the default privacy setting according to their preference. Other Facebook interactive applications such as notification, friend request, like and follow, photo album, etc. are also available on the profile page. Technically, the Timeline is a centre, where user manages his/ her Facebook identity. Figure 3.1 below shows an example

of Facebook Timeline.

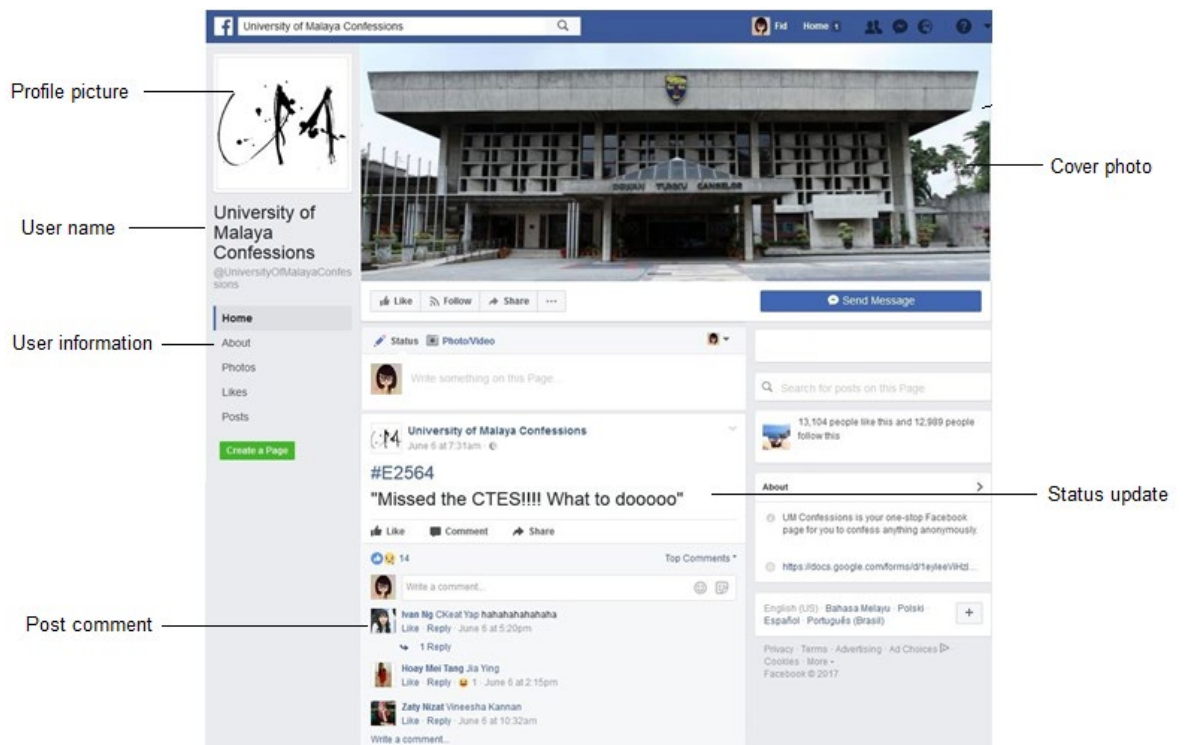

3.1: Facebook Page Timeline

Friends and Followers

Contacts on Facebook are called 'Friends'. A 'friending' request must be sent and accepted before users become friends on Facebook. Users can find potential friends by searching for them using 'search bar' at the top of the page, or using the 'People' option where Facebook will provide a list of recommended friends. Once they become a friend on Facebook, they may see each other's profile and received news feed. In case the friending request is declined by the other user, the two users will not consider a friend on Facebook which may then affect their activities on the network such as they may not be able to see each other activities on Facebook, or receive each other news feed.

Facebook also allows users to 'Follow' others without Friend them. To merely 'follow' others, it does not need an invitation and approval. Users can choose to follow a person,

and they will receive that person's status updates automatically through their news feed. Originally, the following function is devised for public figures like celebrities, journalists, politicians, etc. where they can broadcast their news to broad audiences. Facebook public pages also utilise the function; hence FCPs can also be followed for users to get updates on the pages.

Tagging and Notification

The concept of tagging on Facebook refers to the action of putting the name of a user, a brand, an event or a group in such a way that linked to the wall of the Facebook page being tagged, and made the post appear in news feeds for that page, as well as those of selected friends. It is done by typing a part of the user's name and selecting the name from the drop-down menu. The tagged name then will appear in blue- coloured word indicating that the name was tagged and the tagged person notified. Figure 3.2 below shows an example of the process. As we can see, the drop- down menu lists a friends' name according to the name written, and users can select the name without necessarily written the whole name. Once the name selected, it will appear light- blue like Bryan Chai Kang Weng's name.



3.2: The tagging process

The tagging feature is not limited to friends' name but can be used in everywhere in Facebook, photo, status update, post- comment, etc. However, it restricted among friends

which means that if a user tags a non- friend's name, it will not generate an active link to that non- friend's Facebook page. Later in chapter 5, I will show how friends' name play a crucial role not only as an identity but also in locating the person as well as 'gathering' people for interactional purposes.

Consequently, the tag will generate a notification. Facebook notification is a kind like an alert system where it will tell users whenever something occurred that relates to their profile. So, in case their name was tagged, Facebook will notify the users and provide a link to the 'tagged' event. These Facebook features are also the focus of analysis in Chapter 6 where it explores the roles of these functions in Facebook turn-taking interaction. Indeed, Facebook tagging system and notification are significant in preserving the coherence of the interaction. In fact, Facebook notification occurs to every event that involved the user's profile; a message shared on the user's wall, or a comment on a status update or on another post that the user has previously commented on, someone has 'liked' user's Status Update, etc. The notification is a personal update system that Facebook provides so that users will not miss updates from their networks.

The Corpus

This section will outline the basic demographics of the corpus of online interactions that this study used. The data collected from several Facebook Confession Pages (FCPs). So, the following discussion will highlight the significance of the data collected from these FCPs to this study as compared to other typical Facebook data. It will also discuss the characteristic of these FCPs so that the data can be understood better.

The Material

The data collected for this study come from the Status updates on the Facebook confession pages (FCPs) Timelines. FCPs are Facebook- based page associated with a specific organisation, where users who are usually related to the institution, have the option of "confessing" their secrets or any information that they would like to share with others. The trend of confessions pages on Facebook started with college students (Bounds, 2013) who

use these pages to “confess” about a variety of issues, including their secret crushes, their past relationships and experience, their schools, their daily occurrence, to even the frivolous things such as the food in their dining courts or a picture in their school’s hallway.

The potential effect of the FCPs heightened by the fact that they are public Facebook Page and accessible to all Facebook users. Anyone who knows the FCPs, either from the affiliated community or not, or whether they are Facebook users or not, can read the page without necessarily join the community. Facebook users can also “like” it and become the Page “fan”, so they can stay in the loop by receiving its updates in their News Feed. At this point, they can participate as a voyeur, or more actively by liking, commenting on, or sharing specific confessions.

It should be remembered, however, that although most FCPs are linked to a particular institution, they are not officially associated with their respective institutions. The page could have been started by anyone as long as they are willing to act as the page administrator. While there are many assumptions that the administrator must come from the respective institution (Bounds, 2013), for most FCPs, this has never confirmed. The administrator remains anonymous. In some FCPs, they even ‘playfully’ dissociate themselves from the institution while using the respective institution's logo or acronym. For instance, a Facebook confessions page known as ‘UKM confession’ is associated with the Malaysia National University (in Malay called Universiti Kebangsaan Malaysia or known through its acronym UKM). However, the page defines the acronym (UKM) as U-Know- Me while maintaining the university’s logo as its profile picture (<https://www.facebook.com/ukmconfess>)

How the FCPs Work

FCPs can be considered ‘semi- anonymous’ pages although in general Facebook is not an anonymous website. The semi- anonymous natures of FCPs occur due to the ‘de-identify’ nature of the initial message posts on the page. Technically, all Facebook initial messages including the FCPs display a similar interface with similar features including a profile picture and a name to represent users’ identity. All these identity features are machine

generated in the sense that Facebook automatically produces them. The only content composed by the user is the message itself. The message can still be attributed to the identity features of the Facebook page because the author of the message is also the owner of the Facebook page.

It is different, however, to the Facebook Confession Pages (FCPs). The FCPs created via Facebook community page platform which does not require individual's recognition to set up a page. Hence, the identity of the FCPs owner is concealed by being the page administrator/ s. As for the initial message, it can be from anybody whether the readers, the followers or even the administrators. Often, the FCPs integrate a third- party application such as GoogleDocs or crush- ninja where the users could write their messages without including any identifiable information about them. These anonymous messages will be received by the administrator who, then, will post them onto the FCPs without any need for the identity verification. As the message post mostly unaltered by the administrator/ s, the authors always have an option if they want to make themselves known in which they can introduce themselves in the (content) message, or not. Consequently, in the FCPs, the owner of the FCPs account and the author of the message are two different entities. The author cannot be identified through the identity features of FCPs which belong to the owner of the FCP account so that FCPs are not representing the identity of the author. In a way, FCPs disentangle the default 'inbuilt' identity recognition that connected the message and its author in a typical Facebook page. This distinct feature sets FCPs initial message aside from other typical Facebook initial messages.

However, the responses to the initial message are identifiable. Since the responses such as commenting and liking come in through users' Facebook accounts, the responders are identified. This combination of identifiable and de- identifiable makes FCPs distinct, hence significant in this study. As this study is about identity and identification, it will be interesting to explore the issues in this semi- anonymous environment, particularly between the author who want to be anonymous and the readers or the responders who want to identify the author.

The Language

It is important to mention here that although this study utilises a global- oriented online site Facebook, its focus is more locally oriented that is in the Malaysian context. Consequently, the FCPs that this study looks into is Malaysia- based FCPs. Further elaboration on how the FCPs are selected will be discussed in the subsequent section below. In this section, it will discuss the language of the corpus taken from the selected FCPs.

The primary language used in the corpus is in English. However, rather than a standard English, the English used in the interactions in the corpus is better known as Manglish or colloquial Malaysia English. This type of variety English is mostly a combination of several languages of Malaysia ethnic groups with English as a primary language. Its grammar does not necessarily follow a Standard English but more likely from local ethnic groups' dialect (Hashim & Tan, 2012). Historically, Manglish developed following the arrival of British to Malaya who brought in Chinese and Indian into the country to work for them. British then established the English- medium school for economic development especially to provide civil servants (Tan, 2009). Consequently, English becomes a medium of interaction especially for inter- group interaction at school. After independent, there are several educational policies changed which resulted in the Malay language becomes the national language while other ethnic groups' language is respectably used at schools³ and daily life, together with English (Omar, 2001). With multi- languages exist and use together in the country, it becomes norms to use them interchangeably (Hashim & Tan, 2012).

As for what constitutes Manglish, (Kuang, 2017) describes it as a form of spoken English that is distinguished by its linguistic features of ungrammatical structures and nativisation which include various features of and borrowed words and expressions from other local languages and dialects. Previously concentrated on spoken interaction (Hashim & Tan, 2012), now Manglish has been practised on online interactions, hence, the corpus of this study. As Manglish is slowly infused with items of the local languages, utterance likes '*lazylah to edit*' can also be observed in the corpus which is a direct or literal translation of Malay's "*malaslah nak edit*". The intended meaning of such utterance could be 'I do not

³ Malaysia allows the establishment of school based on ethnic groups. Often, this school uses its language as a primary medium of interaction while Malay language and English become compulsory subjects.

want to do the editing on such...' which is an obvious syntax deviation. The particle 'lah' in this utterance does not bring any particular meaning but it is a distinct feature of Manglish which can be traced in almost every spoken interaction, not restricted to Manglish but also in other ethnic languages like Malay and Chinese (Kuang, 2017). Eventually, the corpus of this study characterised with such added particle as well as many other features that are distinct to Manglish or colloquial Malaysia- English. In the future analysis, these features will be explained and discussed further whenever additional explanation is required.

Data Collection and Organization

While there are a number of articles which address collecting internet data, yet, there are no standardised procedures for doing so (Meredith, 2017). Researchers approach the data as they deem fit to their study including interviews, focus groups or surveys for data collection methods. Other studies use a mixture of approaches, including participant observation, interviews, surveys and textual analysis in order to provide a complete account of online activities (Baym, 2009; Fielding, Lee, & Blank, 2008). These methods aimed to understand the people 'behind the screen', rather than their online activities (Meredith, 2017). Meredith (2017) argues that if we want to understand how social interaction is organised online, then we need to examine the interaction in its actual occurring setting.

As discussed in the previous chapter, conversation analysis (CA) typically focuses on naturally occurring interactions. This way provides a better understanding of the way people do things and the kinds of objects they use to construct and order their daily affairs. This also applies to online interaction; to understand what people actually do online, and how they construct and order their daily affairs, we should examine the data as natural as possible. In other words, the data should not be 'shaped' or 'generated' by the researchers. Accordingly, this focus on natural online interactions carries implications for data collection, organisation and usage. In addressing these implications, this section discusses the techniques and methods that this study uses for data collection in line with the conversation analysis approach.

Collecting the Data

As mentioned previously, this study uses a corpus of online interactions from the Facebook Confession Pages (FCPs). The data consisted of FCPs initial messages and responses are gathered using Facebook's Graph API, which gives developers access to publicly visible Facebook content. Through this process, a range of FCPs regardless of their geographical locations or language usage can be acquired, as long as they use a keyword 'confession'. However, as this study intended to focus on Malaysia context, it restricted the search process to the Malaysia higher institutions only. Therefore, before the collection of data from the FCPs, the study, first, checked with the Malaysian Qualification Register website (<http://www.mqa.gov.my/mqr/english/eakrbyipta.cfm>) to get a full list of Malaysia Universities. Specifically, the study only acquired the list of Malaysia universities, public and private, excluded other higher educational institutions such as polytechnic or community college. The acquired list, then, is used as a guide during the search process in which a keywords 'confession' is used together with the name of the universities provided by the list.

Based on the Malaysian Qualification Register's list, the study found 65 Malaysia universities' FCPs from 44 universities. Further, those FCPs that were empty or inactive for at least a year were eliminated. This left 45 active FCPs from 36 universities. The reason for the higher number of FCPs compared to the number of universities is because some universities have more than one FCPs. For these FCPs, the sizes are ranging from 360 to 23777 followers.

Since the FCPs consist of huge interactions database, it is impossible for this study to analyse them all. Therefore, before selecting the sample messages, the study first identified the FCPs with the most interactions out of the 45 active Malaysia universities' FCPs by utilising the Facebook's engagement- metric- function of 'People Talking About This' (PTAT). The reason for this is because the number of PTAT informs the level of engagement that the page had. The Facebook PTAT refers to the number of people who have created a story or had established a connection to a particular Facebook page within a seven- day range. The story includes when someone likes or/ and recommends the page, or likes, shares, comments and tags the page. All these actions resulted in a news feed story generated, hence increased the PTAT's number of the page. Directly, it also informs the

amount of interaction that the page had and notifies the study of which FCPs had garnered users' attention the most. Accordingly, the study decided to focus on six most active Malaysia universities' FCPs at the time. After identifying the FCPs, the study proceeds with selecting the sample messages.

Compared to identifying the FCPs, the process of selecting sample messages is more straightforward. Since the PTAT has established the level of engagement that the FCPs had, the study conveniently selects the message posts from the identified FCPs regardless of the number of 'likes' or date of the post. There are a couple of characteristics, however, specified for selecting the message post: the interaction stemmed from the initial message must be more than 20 responses (response messages), and display identifying actions. Identifying actions refer to the responders' actions in identifying the person of interest of the initial messages, whether this is the writer of the initial message or the referent(s) of the initial message. The identifying actions could tell whether the initial message encompasses significant elements of identity work that is worth studying. It happened that certain initial messages appeared to contain identity elements but they were not given any attention by the participants. That is, there were no responses. Such initial messages were useless for this study since they do not provide any subsequent identifying action (work) from the audience members (readers or responders). So, at this point, the study defines 'identity' as any elements in the initial message that responders used for their identifying actions. They can be as simple as 'a guy', or as complicated as 'description of a situation' in which responders would later use in the interactions.

Additionally, for each Status Update, the study collected every detail including the content, date, and the numbers of 'likes' and comments, as well as the responses along with the name of the responders. In the end, there are 30 series of interactions (post) consisting of FCPs initial messages and their responses collected for this study.

Managing the Data

This study deals with data of online interactions. Researchers who used this kind of data have developed a variety of methods on how to use and present the data in their study since there is no standard transcription for it (Meredith & Potter, 2014). Some of the researchers

based their transcript on chat logs, and they included information such as the timing as it appears on screen (Rellstab, 2007). Others did not include such information (Berglund, 2009) and added their initiatives such as inserting a gap between turns (Raclaw, 2008). There are also researchers who use picture and screenshot to present the data (Greiffenhagen & Watson, 2009; Meredith, 2017). All these methods are useful in informing this study on how to present the data in the best possible ways that suit this study.

An advantage of dealing with digital data is its ability to be preserved. The online server that hosts the interaction where the data is taken will keep the interactional data in its archive. So, technically, the data can be accessed anytime. However, this type of data is also prone to change. For example, the system may be upgraded, or the user may change his/ her username which then may impact the understanding of the data and later the analysis process. For this reason, this study believes that by capturing the data in the form of an image, it may 'freeze' not only the content of the data but also its context. Hence, the 'authentic' and the originality of the interaction can be preserved. For that, this study uses a screen- shot image in presenting the data.

Additionally, the screen- shot image of the interaction provides this study with rich and comprehensive data. The image is provided not only textual data but also the relevant visual cues relating to action or sound (e.g., use of capital letter). This technique then is consistent with 'traditional' CA transcription that requires reporting every aspect of interaction including sound and visual cues. The figure below shows one of the initial messages and its responses that had been converted into an image. Noticeably, the image had captured every detail of the interaction, such as the date, the structure of the interaction, the use of the icons and the number of 'likes'. Besides, it also maintained the illustration of the technological elements, particularly the role of name- tag. As we can see in the figure below, names such as Bibie Yani, Chun Kin, Kelxin Lim and many others which appear in the text- conversation are written in light- blue, while profile names are in a darker shade of blue. The colour difference is an indication of the technological element that is integrated into the interaction. The role of this technological element is significant in the analysis process in which it will guide and assist the understanding of the whole interaction. It also assists in determining which message turns are related to which message. If this study resorts to a normal transcription, this technological element may be

left- out or need a special approach to record it (e.g., special symbol). However, through screen shotd image, all of this element of the interaction can be preserved in its original form, including its context and technical affordance which are important for the analysis. Essentially, this screen- shot image data is a ‘digital’ transcription in which instead of translating the data into written- language, the data is translated into a comprehensive visual image.



University of Malaya Confessions

May 31, 2015 · 🌐

👍 Like Page

#1103

"I fall in love with a FBA 2nd year guy, he is a little dark skin, skinny, wear spec and he is the BODs of UMAC. I am very into him and I am very lucky to be join his team in a mega event of UMAC. Under his leadership, I totally in love with him, I always imagine holding his hand while he is very near to me during departmental workshop. But then rumours around the faculty begins to spread, people are saying we are in love, especially my matric friends, and I started to worry that this will scare him away and we can't even be friend, and so, I become low-profile and not dare to near him as much as when we were working in the same event. I also heard that some people are saying he and another senior are in relationship. I sometimes wonder he really likes her or not, if it is true, I might be a little heart broken. Anyway, I still hope that someday we can have a chance to hang out, only two of us.

Sincerely,
Just a shy little 1st year girl"

👍 Like 💬 Comment ➦ Share

👍 55

Most Recent ▾



Daniel Tay Chun Kin 春天来了

Like · Reply · 👍 4 · May 31, 2015 at 5:33pm



Bibie Yani LiHong Boo and Thanesh Kumar. Please alert with the situation now 😬😬😬😬

Like · Reply · 👍 1 · May 31, 2015 at 5:26pm



Teh Wei Ting Bibie Yani should we jz dun show up tomorrow? Kelxin Lim jz wan 2 of them 😬😬😬

Like · Reply · 👍 5 · May 31, 2015 at 5:24pm



Choon Kwan Pua Kah Yong -Xin Yan Kho- Xian Yui Gan Wei Teng Zhilin Chong your fren?==

Like · Reply · 👍 2 · May 31, 2015 at 4:58pm



Zhilin Chong Kelxin Lim!!!!!! 😬😬

Like · Reply · 👍 1 · May 31, 2015 at 5:14pm



Kelxin Lim U all know right walaooooo not me 🙄🙄🙄

Like · Reply · May 31, 2015 at 5:15pm



Gan Wei Teng Kolian Kelxin Lim, be strong, haha

Like · Reply · 👍 1 · May 31, 2015 at 5:22pm



Bibie Yani Oh My Gosh!!! Kelxin Lim !!!!!!!!!!!

Like · Reply · May 31, 2015 at 5:06pm



Kelxin Lim NO!!! Walaooooo not me

Somebody save me pleaseeee 🙄🙄🙄

Like · Reply · 👍 1 · May 31, 2015 at 5:14pm



Bibie Yani Wei Ting see ur member. She cannot tahan ady 😬😬😬 btw Kelxin Lim #yolo

Like · Reply · 👍 1 · May 31, 2015 at 5:16pm



Jh Chen Kelxin Lim, is that u? U serious? 😬😬😬

Like · Reply · 👍 11 · May 31, 2015 at 5:04pm



Kelxin Lim Seriously not me okay walao 🙄🙄

Like · Reply · May 31, 2015 at 5:11pm



Sinpei Lim Bibie Yani 😬

Like · Reply · 👍 3 · May 31, 2015 at 5:04pm

Figure 3.3: Conversation on Facebook

Once the image has captured, the main task is to make the data understandable, especially in the analysis process. This is important as the interactions are disorganised in the sense that the message turns are not necessarily adjacent to each other, unlike synchronous spoken interaction. In FCPs interactions, adjacency pair can be far separated and sometimes are hard to recognise. Therefore, it would be better to establish and recognise the relationship earlier before starting the analysis process.

Consequently, I developed a diagram for each interaction to illustrate the relationship between the turns. The figure 3.4 below is an example of a diagram generated by one of the interactions. The diagram illustrates the exact structure of the interaction but only includes the details of the message turns excluding the text- interaction. The message at the top of the diagram refers to the initial message and the numbers below it refer to the chronological order of the response within the thread. The arrangement of the response is inverted since it was arranged based on the 'most recent' view where the newest response appears at the top. However, the responses that branched out from the main response such as 20.1, 14.1, etc., are chronologically sorted that is the most recent reply appears at the bottom (e.g., 20.5, 14.10 etc.). On the right side of the diagram, the dotted lines indicate the connection or relationship between responses. This is the crucial information that this diagram is all about. This relationship is determined through certain criteria such as address term in the form of name- tagged. As shown in figure 3.3, name- tagged in the interaction has technological properties. The name can point to the right addressee, and so it is helpful to locate the right pair of the message turn. Additionally, time can also give way to sequence. The date and time in each box in figure 3.4 refer to the date and time that each response posted. So, observing the time stamp of each response help the understanding of the temporal relationships between message turns. This diagram gives me a broader and better view of the relationship between messages turns. So, though the message turns are far apart from each other like message turn 3 and 19, the diagram helps to indicate the relationship. Accordingly, I tend to re- refer to this diagram during the analysis.

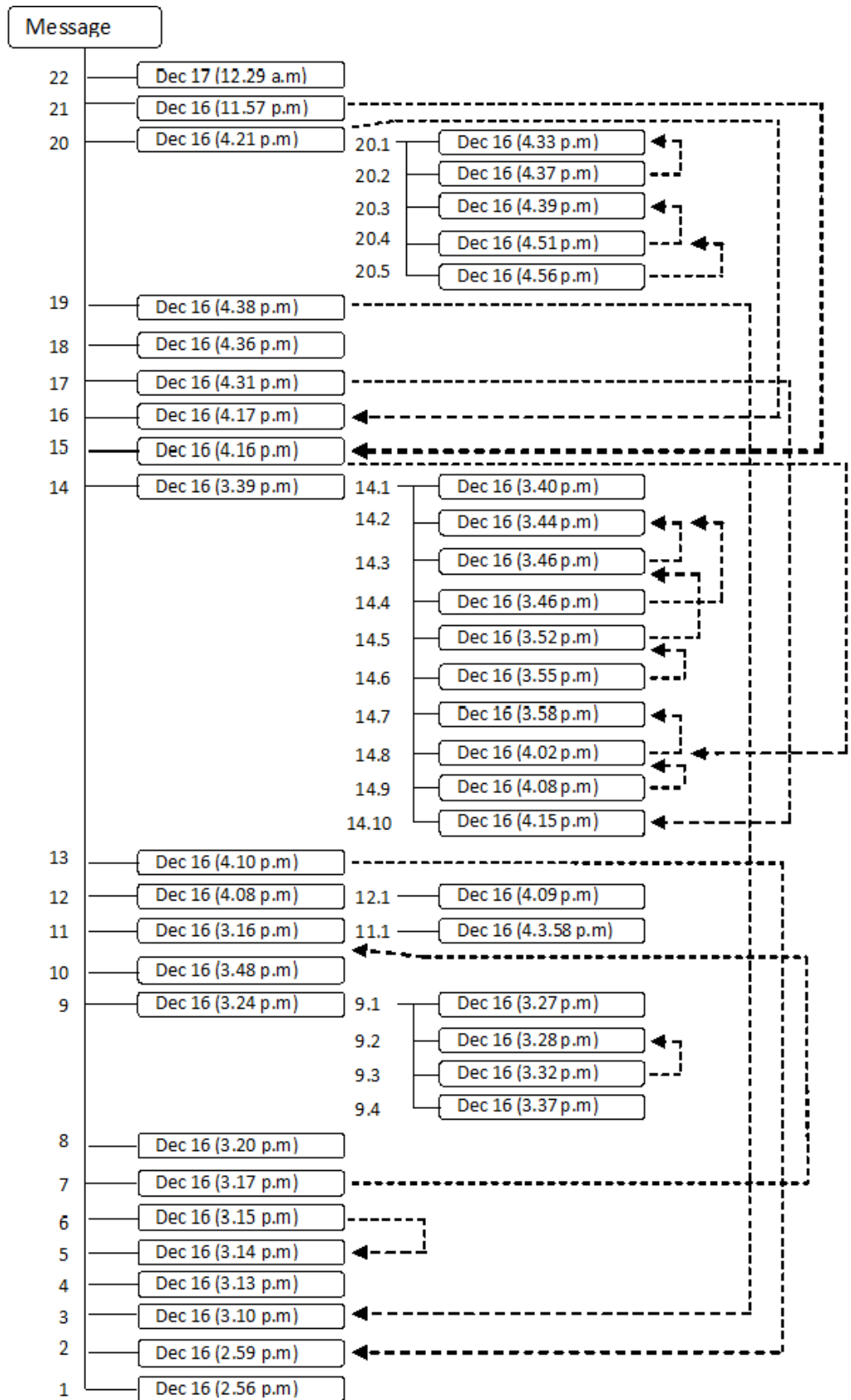

Figure 3.4: A diagram representing the relationship between message turns

Another aspect of the data that need to focus earlier is the nature of the language used in the interactions. As explained earlier, the language is in English, but the usage is from Malaysia context. This means the language does not follow English grammar or understanding but rather the Malaysia spoken language. Therefore, though it is easy to read it may require further explanation in term of meaning and context of the language usage. For example, as can be seen in figure 3.3, there are mixed of several languages in the interaction with English as the main language. These languages need to be translated and interpreted based on the context of the interaction. For this task, I seek help from fellow Malaysian students for the interpretation. This is because although I am a Malaysian, there are styles of language/ speech that I may not familiar. For instance, the conversation written mixed with Chinese letters such as illustrated in figure 3.3. For such conversation, although I can find its translation in order to understand its meaning within its context, I would refer to Malaysian- Chinese for a correct interpretation. So, in practice, both tasks, interpreting the data and recognising the relationship, are done together to make the data understandable. Afterwards, the data is analysed using CA.

Data Analysis

Conversation analysis provides a way of looking at the data, without requiring strict adherence to a singular way of doing the analysis (Hutchby & Wooffitt, 2008). Once data have been gathered and transcribed, the first step in developing an analysis is to identify the phenomenon that is worthy of study through ‘unmotivated looking’ that is “we sit down with a piece of data, make a bunch of observations, and see where they will go” (Sacks, 1984, p. 27). Then, a formal description of a particular instance in the talk should be highlighted, concentrating on the sequential organisation of the interaction. As a pattern begins to emerge, the collected data should be referred to determine if other instances exhibit similar patterns. This technique addresses the two core questions of CA: "What interactional business is being mediated or accomplished through the use of a sequential pattern or device; how do participants demonstrate their active orientation to this business" (Hutchby & Wooffitt, 2008, p. 98). So, researchers should look closely at the conversational strategies and devices used in its production.

In this study, I approach the data with a particular intention, to explore the elements of identity in online interaction. However, I do not have any particular theoretical constructs or research questions in mind. Thus, rather than entirely followed the approach of "unmotivated looking", I observed the data with a particular motivation that is how identity is made relevant in the FCPs interactions. Once I noticed a possible phenomenon in my data, I made a collection of instances. I then analysed how participants built this action, and how it was accomplished in the interaction.

Throughout the research, the concern is how participants invoke the element of identity in the interactions. Thus, categories that highlight particularly associated roles, actions and relationships are an essential consideration. As this study also uses other analytical approaches including membership categorisation analysis (MCA), epistemics and person references which are inherently linked to conversation analysis, it is appropriate to consider these approaches within a conversation analytic framework. The consideration of roles and categories, for example, speaks to the membership categorisation interest of the study as it informs how someone is understood and how they are treated in the setting. They also illustrate participants' epistemic levels. So, the selection of certain categories within a similar device by participants in the interactions must carefully consider as they inform how the categories become relevantly oriented to the interactions.

Once I had identified specific practices, I refer to previous findings from spoken interaction, as well as online and offline written interaction, where relevant. This is not however to make a comparison to another context of interaction, but it is to get a better understanding of how participants organised their interaction online.

Ethical Considerations

The issue of ethics has always debated within the field of social sciences, particularly in online research (Flicker, Haans, & Skinner, 2004). The primary concern usually is regarding the status of the data, whether it is public or private. Subsequently, do researchers need informed consent to obtain this type of data (Bassett & O'Riordan, 2002). Regarding these issues, there at least two things become the main concern of this study, which is the use of participants' name or Facebook users' name, and another one is the

status of the Facebook Confession Pages that is being utilised in this study.

Online names may seem to be a minor aspect of communicating in the CMC environment. However, upon closer examination, it is the user's name that gives other users their first impression of the person behind the screen such as their gender and ethnic group. User's name becomes a part of individual identity online and often, they are incorporated aspects of an individual's real self. ten Have (2000) even illustrates a vital role that a username plays online in determining how online users find each other and establish a connection. So, names become a particularly important means of identification online. Consequently, the name becomes the main consideration in much research.

Regarding this issue, the role of name is exceptionally significant in this study. As per Facebook requirement, users have to use a real name or seem to appear as a real name in Facebook. Additionally, most interactions on Facebook based on profile name or username. Since this study involves a broad and complex interaction between participants' account and FCPs, therefore, it would be difficult to change or anonymise all names. The interaction occurs on FCPs which is not a personal Facebook page, and so participants relied on Facebook- name- tagged to establish a link to make a reference to persons and distribute the news. Further, it appears that not all participants involve in the same interaction knew each other, with a few cases, happened that the participants have a similar name, Facebook- name- tagged assisted in identifying which participant as which and whom. Most importantly, this study, in particular, involves the examination of person references in which in this data were partly done through Facebook username. Due to these situations, this study decides not to anonymise the participants' name. Moreover, based on the analyst observation, participants tend to change their profile name after sometime. Since the time the data was collected (in 2015), many of the participants had changed their username and their profile.

Researcher realises that since name and nickname have essential implication in CMC, collecting data without removing identifiers has ethical implications. Although participants may be chatting in a 'public' website/ space that is open to anyone such as the Facebook Confession Pages, they may feel that their conversation is private. Furthermore, such Facebook Page like FCPs are usually 'unofficial' institution related Facebook Pages where the 'Fans' are usually members of the institution. However, based on the British

Sociological Association's Ethics Guidelines and Collated Resources for Digital Research (2016), observation of public behaviour can be conducted in a place where people would expect to be observed by strangers. In this case, the use of Facebook confession pages (FCPs) is acceptable because it is a community-based Facebook page where everybody can access it.

Also, as explained before, FCPs present a unique configuration in which the status updates or the initial messages posted on the page are 'de-identified'. Therefore, there is no unintended identification attached to the status updates. The only visible identification occurs on FCPs is through the responses to the initial message since these responses are done via regular, identifiable Facebook comments and likes. For this, if we refer to Facebook's terms of agreement regarding the publish content or information using the public settings, it states that everyone, including people off of Facebook, can access and use that information because it is considered as public (<https://www.facebook.com/about/privacy>). Additionally, this study also seeks permission from the University's Ethic Committee (see appendix A for the application) and has been given permission to do the research. Still, according to Zimmer (2010), it is critical for researchers to consider user privacy and the possibility of inadvertent identification out of context even when data are publicly visible. For that, this study will take extra caution in dealing with participants' identity and will only display and discuss their identity-related matter whenever necessary.

Conclusion

This chapter has outlined the methodology that guided this study. It provided an overview of how the Facebook Confession Pages operated as different from other typical Facebook pages. It also discussed how the data from FCPs are collected and organised, so that the 'authentic' and the originality of the interaction that took place in the FCPs could be preserved for a longer time. It also described the technique to make the data understandable so that the analysis can be done correctly. It has also briefly described CA and considered the issues which might be relevant when applying CA to online interaction. Finally, it considers the ethical implications of using the FCPs in this study.

Chapter 4: Analysis of the Initial Messages in FCPs

Introduction

This thesis is concerned with identity work in Facebook Confessions Pages. As we have seen in the literature review ‘identity’ is constructed through ‘identity work’, and this work can take many forms. The process of identifying a person is better seen as a sequence of actions, normally carried out by a series of actors rather than a ‘state of knowledge’ (knowing or not knowing a person). This is best seen in the canonical opening of a (landline) telephone call. Recognition and identification in face- to- face situations are often immediate, precisely because the actors can see one- another. In Facebook pages, such visual information is missing (as it is on the telephone) and hence identification and recognition become an important aspect of FCPs.

Due to the particular features of these message boards, identity – and practices of identifying - becomes a key issue. Identity refers primarily to the author of the first or initial messages in the conversation thread. However, given that each message is normally about a person or persons, identity work is also implicated in terms of the referents of the message that is who they are about. When the referent (object) of the message is also the person being communicated with, we can say that the referent is also the intended recipient. However, it should always be remembered that Facebook messages are public documents, and hence the ‘recipients’ of the message are the general audience of the page. Consequently, formulating the right ‘recipient(s)’ in the messages is essential in FCPs. Depending on the purpose of the message, it must be constructed or designed in ways which could display the author’s orientation to the particular other(s) whether to be identified or not, and at the same time be vigilant to the general audience of FCPs. As in typical interaction, recipient design can be manifested in many ways, for instance through salutations, grammar and lexical choice, or in address forms. Figure 4.1 below shows an example of the initial message collected in this study.

Dear beautiful
You gracious. World just stops to admire your beauty. Your eyes shine like
the moon on cool night..your are the definition of perfection.
P/s: Happy Birthday Y_ _ _ _ A
From your secret admirer

Figure 4.1: FCPs Initial Message

It is obvious from the message that it was constructed for a particular recipient since it is a birthday wish from the author to someone that he/she admires. The author used a salutation and an address form to display his orientation to the recipient. However, the author also uses a common identifier as their identity (from your secret admirer) and incomplete spelling of the recipient's name (Y_ _ _ _ A) so as to not give out his real identity as well as the recipient to the general audience of FCPs. This action reflects the importance of recipient design in constructing the initial message. This study then explores the ways in which message design with recipients in mind can have an effect on the dynamic of the whole interaction. Put simply, it looks at how the initial messages could frame the topic for the subsequent responses. In this sense, identity work can be viewed as emergent practices in the given settings.

In this chapter, however we are concerned only with analysing the initial messages of FCP posts. This is because often the initial messages are written precisely to engage the general audience in identity work, in that they omit not only the author's name, but also specific information about the referent and the recipient. As such, the initial message was placed earlier to set up a discussion and also to invites participants. This setting though relatively new in Facebook is not really new in other types of interaction. In the study of the sequential organisation of calls on talk radio, Hutchby (1996) has demonstrated the different roles between the 'first' and 'second' position in a sequence of interaction. He states that the caller's opening turn not only sets out the agenda for a discussion, but is also a possible first action in a potential action-opposition sequence, so that the second position (radio host) able to challenge the agenda set out by the caller's remarks. Although Hutchby's (1996) study is concerned more with the power relationship between the participants, it highlights the significance of the first position in the sequence of interaction in attracting other participants (the audiences) for further discussion. The study argues that since introducing an agenda is the caller's prerogative, so the argumentative initiative can

rest with other participants. As such, in FCPs, the initial messages can be considered as acquiring the 'first position' to set up an agenda and initiating the first action, so that other participants (general audience) may continue the discussion in the subsequent response messages. However, considering that the initial messages are mostly unidentified, it is interesting to see how they would begin the 'agenda'. Also, taking into account the two different natures of the initial message and response messages as the initial postings are anonymous while the subsequent responses are identifiable, this study decides to separate the analysis with this chapter analyses the initial messages. So, by focusing first on the initial messages, it set the foundation for the identity work in subsequent 'response' messages in the next analytic chapter.

In the following analysis then, we want to see the ways in which messages were constructed with recipient/s as well as audiences in mind. To do this we focus on 'person reference' and the manner in which it allows for different epistemic claims. Person reference is a term used in Conversation Analysis which rests on the primary function of conversation to 'reference' people and things in the world. Hence the chapter begins by summarising the person reference literature outlined in the literature review, so as to provide a foundation and guide for the analysis. The subsequent analysis rests on a basic distinction between message types (identified in the observation of different FCPs). There are two primary forms of messages, those that inform and those that inquire. We will use this basic distinction to set out an account of the different uses of person references, based upon the literature in CA. The objective is to show how identity work is implicated in subsequent response messages, through the selective use of person reference forms.

Some Practices for Referring to Persons in Talk- in- Interaction

Conversation rests on 'referencing' in a general sense. Referencing enables a speaker to establish or maintain a 'communicative focus on some entity, usually in order to say something about it' (Enfield, 2013:433)

“In perhaps its barest form, referring consists of literally pointing to something in order for two people to share attention on that thing, for some interactional purpose” (Enfield, 2013:433).

While referencing can be accomplished through gestures and other embodied behaviours, face to face social interaction is premised primarily on spoken language, and hence it here that we find the majority of referencing. Also, given that spoken language is structured through turns at talk, it is through sequences of conversational turns that we see the establishing of common referents. The means, according to Enfield, that referencing is ‘a general problem of recipient design’ (ibid) in that successful referencing is an interactional matter and an initial speaker must design their talk to be understood by another other, being sensitive to both what the other knows as well as the social context.

One type of referencing occurs when the ‘communicative focus’ is a person, whether that be the speaker, a person in the immediate environment or a person not present. There are various ways of referring to persons. Speakers may refer to themselves, co- participants, and a third party using a specific term. Each language has its own term for this purpose. For example English may use a simple ‘I’ for self- reference, while Malay has more forms of self- reference, ‘aku’ and ‘saya’ depending on the situation and context of the interaction. References to persons can also be done using kinship or relational terms such as ‘mom’ and ‘my wife’, or categorical terms such as ‘teacher’ or ‘doctor’, particularly to third party references (Schegloff, 1996). The ways of referring to persons convey something of the relationship between the speaker, recipient, and referent. So, precise formulations of references are significant for the interaction. These references are systematically organised over sequences of behaviour and interaction. That is, they are not simply about lexical ‘selection’ (Enfield, 2013) but also are a matter of recipient design.

Generally, recipient design refers to how speakers devise their talk in ways which display orientation and sensitivity to the particular other(s) who are the co-participants in the interaction (Sacks et al., 1978). Recipient design is considered crucial elements in any conversation as it is fundamental in making and sustaining a relationship with other people. Therefore, failure to do it may render the speaker as an inadequate conversationalist which may cause social implications such as being accused impolite or disrespect (Stommel, 2012). Recipient design can be manifested in many ways, such as in the topic selection, or in question design, but it can obviously observe through the selection of reference term.

Schegloff (1996) outlines a systematic framework for understanding the organization of person- reference in conversation through his paper “Some practice in referring to person”.

In organizing his ideas, Schegloff (1996, p. 439) poses the following question:

“How do speakers do reference to persons so as to accomplish, on the one hand, that nothing but referring is being done, and/ or on the other hand that something else in addition to referring is being done by the talk practice which has been employed?”

The answer to this question builds upon his earlier work with Sacks on the ‘preferences in the organization of reference to persons in conversation’ (Sacks & Schegloff, 2007). In that paper, they propose the operation of two general preference structures: the preference for minimization and the preference for recognitional reference. Schegloff’s (1996) later work expands understanding of the organization of practices for referring to persons. The paper shows that there are defaults or systematic ways of how person references are organized in conversation. For example, there is a proper way to address third person referent in conversation that is to use recognitional full noun phrase for the first- time mention and subsequently to use pronoun. Deviation from the default practices then could signify something else other than merely referring is being performed.

In his analysis, Schegloff (1996) first discusses the organization of practices for referring to speaker and recipient. For him, this practice of referring to speaker and recipient is the most common form of person reference and such references are provided for by the provision of the terms ‘I’ and ‘you’ in English. He notes that these terms particularly the term ‘you’ can be used to refer to people other than the recipient. The term depends on the context of interaction, and can also refer to everyone. Referring to Sacks’s work from a call to a suicide prevention centre, Schegloff (1996) shows part of a more general usage of “you” for “everyone”:

A: Why do you want to kill yourself?

B: For the same reason everybody does.

A: What is that?

B: Well, **you** just want to know if someone cares.

Here, the term ‘you’ used by ‘B’ (bold in the last line) is not specific to the recipient but

refers more generally to “everyone”. This is one of the examples of various dedicated terms that can be used to refer to people other than the speaker and recipient.

With regard to non- present persons, Schegloff (1996) makes a distinction between ‘locally initial’ and ‘locally subsequent’ reference (p. 450). The first time a referent is used in a conversation, it tends to be in a full noun phrase such as name or description. Subsequently, pronouns are used in what is called the ‘locally subsequent reference position’ (p. 450) to index a referent that has already been used in the conversation. This distinction shows a systematic sequential way of doing reference to persons in conversation. Another way of doing this is understood as to achieve distinctive outcomes. For example, Kitzinger et al. (2012) illustrate how pronoun is used in a locally subsequent reference position to mute the relevance of referent in favour of the action performed.

Eventually, the choice of reference terms implicates considerations of ‘recipient design’(Schegloff, 1996). How the talk is designed usually depends on the recipients’ features and the level of relationship between the interactants. As such, a speaker style of talk including his selection of reference terms can inform his relationship with the recipient. There are two types of reference forms discriminated by their relationship to the recipient; ‘recognitional’ reference forms and ‘non- recognitional’ reference forms (Schegloff, 1996; Schegloff, 1996, p. 450).

Recognitional forms convey to the recipients that the one being referred to is someone that they know about, hence the recipient able to figure out who the referent is through the use of the reference form. The most common recognitional reference forms are names and descriptions such as “the woman who sits next to you” (Schegloff, 1996).

In contrast, non- recognitional reference forms display that the identity of the referent is unknown or unavailable to speakers or recipients, or to both of them such as the use of a term ‘someone’ or ‘this guy’ when referring to persons. The preferred practice, however, as stated by Sacks and Schegloff (2007) “if it is possible, use a recognitional.” The conditional "If it is possible" refers to the following contingencies: a) If the speaker may (or ought to) suppose the recipient to know the referent; b) if the speaker may be supposed by recipient to have so supposed; and c) if the speaker may suppose the recipient to have so supposed (Schegloff, 1996, p. 459). If all these conditions are met, then recognitional reference forms are the preferred ways of referring to persons.

However, in some situations speakers may choose to depart from this principle (Pomerantz & Heritage, 2013). For example, a speaker may use a non-recognitional reference to a known referent that is also known-to-be known to the recipient in order to keep the referent's identity from the recipient. According to Pomerantz and Heritage (2013), this act may be seen as withholding information from the recipient.

This circumstance is similar to the data studied in this chapter. As I will show later, authors withhold referent information using non-recognitional reference forms. Unfortunately, Pomerantz and Heritage (2013) do not provide further explanation or real examples of this instance other than stating that speakers and recipients are both able to *exploit* the preferred practice of person reference in conveying the action they are performing in relation to the referent. Additionally, there are situations where non-recognitional reference forms are used when recognitional reference forms could be used. Stivers's (2007) 'alternative recognitional reference' is one of the reference practices that departs from the preferred practice of person reference where speakers use other than default recognitional reference forms, yet a particular referent can still recognize by the recipient.

Stivers (2007) shows how this alternative recognitional reference is done in a conversation between a mother and a daughter when the daughter uses a referring term 'your sister' instead of preferred recognitional term 'aunt Alene'.

(Stivers, 2007, p. 78)

Mom: so- what are you grinnin' (cuz you picked)

Nic: [Cuz yer sister been on the phone all mo:rnin' an' I told' er-

Mom: which o:ne

Nic: Aunt Ale:ne? [I got a cramp in my=

Mom: [hehhehhehhehhehheh

Nic: =ne: (h)ck 'n I gotta g(h)o.

Whenever speakers depart from the use of default referring practices, it indicates that they are doing more than just referring (Schegloff, 1996; Stivers, 2007). Here, Stivers (2007) argues the term 'your sister' by the daughter is not only used to refer to 'aunt Alene' but

also to highlight the relationship between the aunt and the mom. By doing so, the daughter emphasizes the nature of the relationship between the referent and the recipient while distancing herself from the referent. It is argued then that alternative recognitional reference can shift the ‘domain of responsibility’ (Stivers, 2007, p. 94) among the speakers, recipients, and referents.

Additionally, the use of recognitional or non-recognitional, speaks to the relationship and/or shared understandings of the interaction participants. In a way, the reference terms formulated by the speakers reflect their knowledge concerning the recipients and the referents. As references to persons are constructed by reference to what speakers take the recipient to know (Sacks & Schegloff, 2007), they also illustrate the relevance of speaker's relationship to the recipient and his/ her domain of knowledge regarding the referent information (Heritage, 2018). The choices between recognitional and non-recognitional references will depend in substantial part on who is being spoken to and the knowledge that is attributed to them, which in turn reflect the recipient design in interaction.

Stivers's (2007) alternative recognitional reference, for instance, requires several elements, including that the speaker knows the referent and the hearer knows the referent, and the form used (‘your sister’) is recognised by the hearer. This requirement reflects the epistemic status (Heritage, 2013) of the speaker, and hence the use of an alternative recognitional reference shows up the design of the talk as sensitive to what each of the interacting parties knows. An alternative recognitional reference is irrelevant to a speaker who has no knowledge of the relationship between the recipient and the referent. The use of such references in a situation in which such knowledge is lacking would fail the recognitional preferences and cause disruption. Whether speakers have knowledge regarding the referent or not are displayed through their formulations of references in the interaction. Taken together the understanding of the practice of person reference used to perform a range of social action, that particular way that references are formulated bear examining for their function beyond just achieving reference.

For the sake of analysis, I categorize the actions displayed in the initial messages into two general categories, informings and inquiries. These two categories represent the general action of the initial message towards the general audience. An informing message includes various ‘telling’ actions such as confessing, ranting, and other related actions. This

category of message is doing a 'telling' about someone or something. The inquiry message is doing 'asking', hence it includes actions such as seeking information, requesting something, and other inquiry actions. With each category of message, I look at how the authors design their message with reference to persons, in order to convey the individual (referent) to the recipients of the message (audiences).

Informing Messages

The act of telling usually displays a speaker's epistemic status as a knowing person. When speakers tell something to another, they are conveying what they know. The normative principle that underpins the interaction is "that one should not tell one's co-participants what one takes it they already know" (Sacks, 1992, p. 100). Sacks may not explicitly talk about information giving in terms of epistemics, but epistemics scholars such as Heritage and Goodwin make it clear that an utterance which conveys information or news is premised upon matters of epistemics (Heritage, 2013). In FCPs, the act of telling is done discreetly, in the sense that identities which play a crucial role in the practice of references are either tends to be hidden, or unknown, by authors. Based on the data, non-recognitional references and descriptions are used by authors to accomplish person reference, in the act of informing.

Non- Recognitional References

As discussed before, non-recognitional references display that the identity of the referent is unavailable to the author or recipient. So, usually, by using non-recognitional reference, it is to indicate that nothing but referring is being done. The current study, however, shows the use of non-recognitional reference form to a *known* referent. This is done so as to omit the referent or the recipient identity deliberately. Pomerantz and Heritage (2013) considered such act as withholding information from the recipient in favour of the action performed. Here, the data shows that such instances occur in FCP initial messages. This could be due to the nature of FCPs wherein the 'real' identity of the author and/ or the referent can be omitted. The author deliberately uses the non-recognitional references

term, so as to hide the identity of the recipient, the referent or him/ herself.

Initial message #1086 in Figure 4.2 shows how the author intentionally uses a non-recognitional term 'roommate' to the 'intended recipient'⁴ who is the author's roommate. In this initial message, the author confesses to having deleted the recipient's porn collection and seeks his/ her forgiveness. The description of deleting recipient's porn collection indicates that it is a real event that took place in the real world. This also indicates that author and recipient know each other.

```
#1086
1 "I have a confession to make.
2 Dear roommate,
3 Sorry I *accidentally* deleted your porn collection. But really, that time I
4 urgently needed a hard disc big enough to transfer the project file.... and
5 the only *redundant* thing I found in your hard disc was..... the collection.
6 Aiyoh don't angry la. I belanja you maggi goreng at Food Central la okay?
7 Roommate-ship forever~
8 Your roommate at 5th college."
```

Figure 4.2: Initial message 1086

From the use of pronouns 'I' and 'you' in the message, it is understood that the message is directed to the 'roommate' (line 2) although the author does address a general audience earlier through his/ her statement "I have a confession to make" (line 1). The dedicated terms 'I' and 'you' are the simple reference for speaker and recipient, at least in English (Schegloff, 1996). Other than referring, these two terms have no other indication unlike other pronouns in English such as 'he' or 'she' which indicate gender. So, the uses of these reference terms in the initial message 1086 are considered non-recognitional since they do not convey the identity of the referents. The author, however, addresses the recipient earlier through a simple non-recognitional 'roommate' (line 2). So we know that the recipient of the initial message is a 'roommate'. Yet, such non-recognitional term appears virtually nothing other than as a generic address term, 'roommate'. However, the event description that the author provides shows that they are close to each other to the extent

⁴ Here the intended recipient refers to the person whom this initial message is directed. This is to differentiate it with the general recipient (will only refer as recipient) that is anyone who reads the initial message. These terms will be used to the rest of this analysis chapter.

that the author is allowed to use the recipient's computer (that time I urgently needed a hard disc big enough to transfer the project file... [line 4 and 5]). The term 'roommate' in the greeting, then, could be understood as the author's roommate which is later confirmed through the author's sign off at the end of the message 'your roommate at 5th college' (line 8).

What is interesting, then, is the choice that the author makes to use a non-recognitional form to someone that he or she knows. As mentioned before, in a conversation, there is a preference for a recognitional over non-recognitional term in referring to others (Sacks & Schegloff, 2007) because the objective is to achieve recognition. Therefore, when speakers use a non-default term when a default term is usable, it indicates that they are doing more than simply referring (Schegloff, 1996), they are *obscuring* the identity of the person. Although this argument was made concerning the practice of person-reference, a similar understanding could be applied here in understanding the generic address term used by the author and subsequently the dedicated terms 'I' and 'you' for self-referent and recipient. In this initial message, the author is telling that he/she deleted the roommate's porn collection in his/her computer. Having said that the porn collection is in the roommate's computer, it tells that the roommate is a porn watcher which morally perceived as unethical and unacceptable. Therefore, the non-recognitional term is deliberately used by the author to conceal the identity of the recipient, which in turn will conceal his/her identity from the general audience. It happens as the identity of the author is very much related to the recipient. As we can see in the initial message, at the end of the message, the author's sign-off 'your roommate at 5th college' (line 8), deftly positions the author in relation to the recipient. As Stivers (2007) explains, this kind of 'addressee –associates' reference (Stivers, 2007, p. 94) works by placing the referent within the domain of responsibility of the recipient. In this situation, however, the referent is the author him/herself. So through the sign-off, it explicitly emphasized their relationship. Additionally, the content of the initial message illustrates an event that happened between the author and the recipient, thus portrays that the recipient knows the author. Hence the non-recognitional term can actually be a recognitional reference to the recipient. Still, by omitting the identity of the recipient name, and instead presenting the ambiguous (and widely relevant) term 'roommate', the author is protecting his or her identity, and the roommate, from being known to the public audience.

Initial message 879 in the figure 4.3 shows another instance where the terms ‘I’ and ‘you’ are used to refer to the recipient after a non- recognitional term (course mate) is used to address a recipient. In this initial message, the author makes a confession to his/ her course mate. Consistently using first and second pronouns for self- references and referring to the recipient throughout the message, it gives impression as though the author is confessing directly to the recipient. Again, however, we see small identifying bits of information that give clues to the identity of the recipient.

#879

1 "To my gorgeous Materials Engineering's coursemate, my heart was
2 broken when I found out that you were going to change course. You can't
3 imagine my excitement when you decided to stay. I think this is the second
4 chance given to me but I still don't have the courage to confess my love to
5 you. My feeling gets even stronger in this rainy season. Whenever I see
6 you walking alone in the rain, I really hope that I am an umbrella to be hold
7 by you, accompanying you every moment, providing you with shelter from
8 the scorching sun and windy rain. What's more, at night, I hope to
9 transform to a blanket, providing you with warmth in the freezing nights.
10 Most importantly, I hope to be your shoes, dancing along with you silently
11 as if I am dancing with you on the stage. I do not wish to steal your
12 limelight, all I want is to support you on the path of pursuing your dream."

Figure 4.3: Initial message 879

The author begins the confession by addressing the recipient using the non- recognitional term ‘my gorgeous Materials Engineering’s course mate’ (line 1). This act simultaneously introduces the recipient of the message and expresses an opinion about the recipient. Arguably ‘gorgeous’ is a gendered assessment, typically directed to a female recipient. The author then subsequently uses the pronoun ‘you’ to re- refer to the recipient. Technically, if we refer to Schegloff’s (1996) ‘locally initial and locally subsequent reference’ Schegloff, 1996, p. 450), it tells that the referent is introduced in the locally initial reference position, so the referent can be identified and minimal subsequent reference forms can be formulated to refer back to the referent. What is interesting in this initial message 879, is that this default reference practice helps in shedding the identity of the recipient, despite the non- recognitional term used to address her. The dedicated terms ‘you’ tied the identity descriptions in the message to the recipient. The most identifiable description is the ‘news’ that she was about to leave the course (line 2 “... I found out that you were going to change

course”). This description positioned the recipient in a special category among the students of materials engineering course which in turn may assist the general audience to identify the recipient. Later in the next analytical chapter on response message, we will see how commenters (the general audience) pick- up this identity description in displaying their epistemic claim of identity of the recipient.

The address term ‘my gorgeous Materials Engineering’s coursemate’ (line 1) reflect the author identity. As in the previous example (initial message 1086 in Figure 4.2), the use of such possessive pronoun like ‘my’ can explicitly associates the recipient to the author, thus, placed the recipient within the author domain of responsibility (knowledge). This further emphasizes the kind of relationship that the author has with the recipient. The whole address term, then, implies that the author and the recipient belong to a similar social category that is in the Materials Engineering course. The author also describes some event description such as ‘I see you walking alone in the rain’ (line 6) which indicates the author’s first- hand access to the event (Raymond & Heritage, 2006). This implies that the author used to be in the same location with the recipient, hence he could actually are known to the recipient, though the identity hint is too broad. Still, as with the previous message, we see the use of non- recognitional referents combined with indicative detailing that hints at the identity of the recipient and the author. This additional information implicates a sequence of recognition and identification in later response messages.

Another way that non- recognitional reference term is used in the informing messages is through the use of locally initial indexicals that is to use pronoun in locally initial reference position. According to Schegloff (1996), whenever the default way of referring to references are not follow (for example, locally subsequent reference form in a locally initial reference position), it invites immediate attention. The question becomes why the speaker has done this and what outcome the speaker seeks by doing so.

The initial message 1707 (Figure 4.4) shows an example of how locally initial indexicals is used as a non- recognitional reference. In the initial message, the author confesses his or her feeling towards an unidentified man. This man is introduced through a third person male pronoun ‘him’ and subsequently uses the male pronoun variants (he, him) to rerefer to him. The use of these third person pronouns indicates that the author is not directing his/ her message directly to the recipient, but is instead informing a general audience. In this

sense, the author is performing an act of telling about his/ her feeling towards the man. Only in the last two sentences does the author change the footing of the message content towards the man when he or she shifts the use of a pronoun to 'we' that understood to include both the author and the man.

```
#1707
1  "I met him about a month ago and he melt my heart all the time. The way
2  he smile,dance, laugh. He seems like a very good person with good
3  friends. Whenever I saw him I automatically got excited and smile like
4  crazy. Its too bad that we are from different religion and he seems not so
5  close with people with other religion. But I hope that we can get to know
6  each other soon ^^
7  DTKH"
```

Figure 4.4: Initial message 1707

In the initial message 1707, the indexical 'him' (line 1) is clearly a locally initial reference term used by the author as there is no prior noun phrase reference has been used before. With only a third person indexical references form 'him', it may leave the general audience wondering to whom the pronoun is referring to since pronouns are mostly used as a locally subsequent reference form to referring back the relationship it has with its antecedent reference. Given that each initial message in FCPs is a stand- alone message, it is doubtful that the referent has been mentioned previously. Therefore, in this situation, indexical 'him' could be understood as a non- recognitional reference form. According to Kitzinger et al. (2012), locally initial indexicals can mute the relevance of the referent in favour of the action being conveyed. In this message, the author's is confessing to the referent which normally would require a specific referent. However, given that FCPs is a public online website, it may inflict undesirable consequences if the referent's name is mentioned. Also, as describes by the author, the referent is from 'different religion' (line 4) and seems 'not so close' (line 5) with people from other religion. So, it is reasonable for the author to put less emphasis on the referent's identity, because it could cause uncomfortable to the referent if his name is mention in a public. So, by using a locally initial indexicals, the author may deliberately want to conceal the identity of the referent in favour of his/ her action to confess to the referent. Additionally, the third person pronouns in English index gender. So, by using the pronoun 'him' (line 1) in the locally initial position, this replaces the requirement to say, 'a man'. Therefore, although the noun phrase is absent in the

locally initial position, the locally initial indexical serves the role of a non-recognitional reference, so that the referent can be identified through his gender and introduced in the message.

As we see in this section, despite the use of non-recognitional term to address the recipient and the referent, there are still indicative detailing that hints at their identity, and sometimes even reflect the author's identity. This additional information implicates a sequence of recognition and identification in later response messages. As we will see later in the next analytical chapter, these hints of identity become resources for identification works.

Recognitional Descriptions

A recognitional reference term is the preferred practice for referring to persons. Within the category of recognitional reference, however, the preference is to use a name over a recognitional description (Schegloff, 1996). For example, if both the speaker and the recipient know the referent by name, then name is the preferred reference term. In a situation where the name of referents is unknown, then description is used to achieve recognitional. So, we can see that recognitional descriptors often upgrade to name in a typical verbal conversation. In FCPs initial message, however, the knowledge display is restricted only to the author. It means that the reference term used reflects the epistemic level of the author with regard to the referent. Therefore, in a situation where the author used description to referent, it portrays the author distant relationship to the referent or the referent is not within the author domain of knowledge. Consequently, audiences may recognize the description and upgrade it to name in the subsequent response messages.

The initial message 1191 in the figure 4.5 shows an instance where a recognitional description is used to the referent. In this message, the author introduces the referent early in a locally initial reference position with a list of descriptions concerning the referent, before stating her attention (confessing his or her feelings to the referent) at the end of the message.

#1191

1 "So there is this one guy from Faculty of Med. Tall, good
2 looking(seriouslyyyy good looking) , with a charming smile and ummm what
3 else? I dont know if he is an indian or chinese who looks like an indian. But
4 trust me, you can melt my heart ❤️❤️"

Figure 4.5: Initial message 1191

In line 1, the author introduces the referent through a description, ‘this one guy from faculty of Med’. This description can be categorized as a non- recognitional reference in the sense that it is too general and can refer to any guy from the ‘Faculty of Med’. The author then provides additional descriptions such as ‘tall’ (line 2), and ‘who looks like an Indian’ (line 3). All these descriptions narrow down the potential referents, and hence assist the recipients to identify the referent. In this sense, it shows the author is orienting his or her reference form to suit the recipients.

Note, however, the author's statement in line 2 and 3, “ umm what else? I don't know if he is an indian or chinese who looks like an indian”. This statement displays the author’s epistemic status regarding the referent appearance. It indicates that the author may know the referent but his/ her knowledge about the referent is incomplete. Therefore, when he/ she says “umm what else?”, it appears like the author is thinking on what other thing that could be describe about the referent so that he can be recognized. Subsequently, when he/ she says ‘I don’t know if he is an Indian or Chinese who look like an Indian”, it provides an explicit category on a basis of ethnic group. This can be significant information of the referent’s identity, given that in Malaysia there are three major ethnic groups, Malay, Chinese and India. By this description, the author excludes Malay category from the referent, thus further narrow down the referent identity to two ethnic groups. Additionally, considered that Chinese and Indian have quite significant differences in term of their appearance, the description “I don’t know if he is an Indian or Chinese who look like an Indian” can also refers to a particular group of people in Malaysia informally known as ‘Chindian’. They are of mixed Chinese and Indian ancestry but often they tend to adopt either one of the ethnic group (Chinese or Indian) as their official identity. So, through the description, the author is trying to limit the potential candidate of the referent by categorizing him based on ethnic group.

This action, at the same time, portrays the author's epistemic levels with regard to the referent. It indicates that he/ she may not know the referent personally. The selection of a description as a reference then is a way to make the referent recognizable. As we see later towards the end of the message, the author is expressing his/ her feeling to the referent ("trust me, you can melt my heart [line 4]). So it is important to establish the referent identity so that he can be identified. This will also implicate the subsequent response from the audience regarding the identity of the referent.

In the next initial message 1106 (Figure 4.6), the author uses description to identify an unknown recipient. In this message, the author is ranting to an unknown driver that he/ she encountered while driving within the university compound. The unknown driver made him/ her uncomfortable by 'tailgating' him/ her. Hence, the author composes the message and addresses it specifically to the unknown driver using descriptions.

```
#1106
1 "Dearest red saga driver,
2 you're the stupidest driver i've ever encountered with in UM. Thank you for
3 tailgating me like hell just now all the way from the main KL Gate to KPS.
4 You were lucky i didnt brake and make you pay for any damages.
5 Annoying much! You're driving on campus for heaven's sake! You wanna
6 race, you go outside UM! I think the UM authorities should install speed
7 traps. Ugh -.-"
```

Figure 4.6: Initial message 1106

Note that the author uses non- recognitional description to address the recipient (line 1), 'Dearest red saga driver'. The address formulation is interesting because, as a non-recognitional term, it could have been 'dear driver' but that would not have done the additional work in providing additional information about the car of the recipient. Especially in this situation where the message is made public on social networks, every driver could be the recipient. So, the additional referential information 'red saga' is important in determining whom the author is addressing. In doing so, it shows the author's awareness about the existence of the general audience that may read the message, and provides information that might form a foundation for an identification and recognition sequence in subsequent responses. Further, the selection of the word 'dearest' appears contradictory to the use of a non- recognitional description because the word is usually

used as an affectionate form of address. However, the non-recognitional description 'red saga driver' does not show a close relationship, being a non-specific identifier based on what the writer sees. The line 'Dearest red saga driver' parodies a salutation in a personal letter but lacks its specificity. So, rather than show affection, the word 'dearest' has a different meaning that is the author's frustration toward the recipient. This is confirmed when the author expresses his/ her anger in the message (line 5 'annoying much!'). So, the whole description 'dearest red saga driver' then is devised specifically by the author with a particular recipient in mind, while withholding identification and recognition of the actual person.

Technically, addressing someone at the beginning of the message can be useful since it provides a grounding for the recognition of the referent of the message. In the initial message 1106, the author makes a reference to the referent using a dedicated term 'you' after addressing the recipient. By this, the author indicates that the message is meant for the recipient, and excludes the general audience. As such, addressing the referent earlier is meant to determine who the right recipient is. If the author omits the addressing part, such as in message 1707, the author may face difficulties in indicating the right referent.

Additionally, the author conveys his/ her dissatisfaction towards the driver by describing him as the 'stupidest driver' he/ she ever encountered in 'UM' (line 2). The author then states a reason for describing the driver as such because he/ she had "tailgated" the author "all the way from KL gate to KPS" (line 3). These descriptions also serve as identifiers of the recipient in the sense that they specify which 'red saga driver' that the author is referring to. In a way, the author is designing his/ her message to a more specific recipient. As such, the author is conveying relevant information about the recipient that is within his/ her domain of knowledge by specifying a place and local knowledge. This information (presented as acronyms) also limits the potential audience because it requires that they understand what the 'KL gate' is and what 'KPS' refers to.

Here, then, we see various forms of epistemics. The writer expresses a certain amount of known information about the recipient based upon the visual information available to them. They also construct the text to include abbreviated location information, so as to limit the potential respondents, who by definition must have the necessary epistemic access and knowledge to understand them. While referent/ intended recipient and general

recipient (audience) are presented with descriptive non-recognitional, they are formulated with enough information to indicate who should guess (those who know the campus).

A similar situation is illustrated in the initial message 868 in the figure 4.7. In this ranting message, the author expresses his/ her annoyance due to the noise from unknown persons. What is interesting about the message is in its original version (in the Malay language), there is a very limited person reference term is being used. Even a pronoun, which could indicate to whom the writer is talking to, like in the previous examples (messages 1707, 879, 1191), is absent. The author composes the message through descriptions, which are typical in a spoken Malay language. Technically, making a reference to a person in the Malay language is not much different from English. Noun phrases and pronouns are used for references and there is a selection of Malay pronouns used depending on the context of the interaction. Due to the social norms, however, Malay speakers tend to skip the reference or adopt reference terms from another language, especially in an event where they are not sure how to refer to a person⁵ (Jamil, Yusof, & Harun, 2016). As in the initial message 868 in the figure 4.7, we see that it was composed with mainly descriptions which appears common and understandable to a Malay speaker.

⁵ In Malay, addressee can be referred with 'engkau' in a casual daily basis interaction but the term may appear impolite to use to someone older or younger. So it is common to drop the reference term, particularly in a situation where gesture can be used.

#868

- 1 Omg! Agak2 la tinggal dalam asrama. Bayar yuran sama kot. Tolong jgn
Omg! Consider la live in hostel. pay fee same kot. please don't
Omg! Mind you that we're living in a residential hall. Everybody pay the same fee. Please don't
- 2 karok guna speaker, guna MICROFON! Please! Cc blok k*4. Kalau nak
*Karaoke use speaker, use Microphone! please! cc block k*4. if want*
*use a speaker when you're karaoke-ing, use MICROPHONES! Please! CC block k*4. If you*
- 3 karok, p karok kat kbox. Tolong sgt2. Dah la sesak nafas dgr suara.
Karaoke, go karaoke at kbox. please much. enough la suffocate hear voice
wanna karaoke, go do it at KBox. I beg you. Your voice is suffocating.
- 4 Lepastu, jgn jerit2 kalau bercakap tu. Pempuan kot, tak elok syg.
after that, don't shout if talk that. girl kot. not nice dear
And please, don't scream like that when you're talking. You're a girl, it's not nice dearie.

Figure 4.7: Initial message 868⁶

The author's complaint starts with him/ her begging for a consideration, from a person who can be assumed a fellow residential hall. This is indicated through descriptions "*tinggal dalam asrama. Bayar yuran sama kot*" (living in a residential hall. Everybody pays the same fee) in line 1. Thus conveying that the author and the recipient stay in the same residential hall. The author then lists the recipient's actions that caused his/ her frustration; '*karok guna speaker*' (use a speaker when karaoke), '*guna microphone*' (use microphones), '*jerit kalau bercakap*' (screaming while talking). Here, in addition to descriptions of the complaint, the author lists the recipient's action so that he/ she can be identified. These descriptions are a recognitional description of the recipient, and provide valuable information for the audience recipients.

Other identification of the recipient made in the initial message 868, is when the author categorizes the recipient based on her gender in line 4, "*perempuan kot*" (you're a girl). And another one is when the author writes "cc blok k*4" (line 2) which is a name of a building. These two descriptions convey that the recipient is a girl who is staying in blok k*4, and hence narrows down – quite considerably – the potential referents. It also sets up

⁶ The first line is the original message in Malay spoken language. Below it is a direct translation of each word in English, and the third line is the translation of the message in English.

a category of potential audience recipients who live in or near the block. Other than these two identification, there is no reference made to the recipient (that is using pronoun to refer to the recipient). The author's action to leave out the reference terms for person references may be seen as him/ her being cautious on how to make a reference to the recipient so that he/ she is not violating the social rule of person reference. Moreover, in Malay, the act of referring to persons is social and context- bound, which may lead to an awkward situation if it is performed inappropriately (Jamil et al., 2016). But that cannot be the reason since the author has provided a list of complaints towards the referent, hence being awkward can no longer be a concern to the author. Rationally, the reason for the author to drop the reference terms in the message could be because he/ she does not have definite knowledge of the referent. Perhaps he or she does not know precisely who made the noise. Other than knowing what the person is doing, the author may not know who the real person is. So, rather than making a reference to the unknown person, the author describes the action that the person is doing as an inference to the person, and hope to recruit the other participants to the task of identifying precisely who the referent is. In this initial message, the author shows that it is possible to make a reference to a person with minimal reference forms, at least in Malay. Using a list of descriptions, the recipient can be referred in the interaction without necessarily named the recipient. Epistemically, this action of providing a list of descriptions displays the author's domain of knowledge regarding the recipient. The author may have a collection of information regarding recipient behaviour but he/ she may not have definite information of the recipient.

In the examples of 'informing messages' then, we have a series of instances in which identity work is based upon different epistemic levels. The writer includes non-recognitional terms, and descriptive recognitional terms to narrow down the identity of the referent, but does not name them. At times the omission of direct references work to emphasise the primary action of the message (such as complaining) but also provides a space for further identity work in subsequent response messages. A key aspect of this ongoing identity work is to limit the potential respondents by including information that implicates a certain level of knowledge and membership. Relevant audience recipients must be able to use the information provided and – crucially – understand it. Membership includes being present at a concert, knowing the university campus layout (and abbreviations for different point places on the campus), living near a particular university

block, and the like. Each bit of information restricts the membership of those who might do recognitional work, based upon their knowledge. By writing the messages this way, the writer is making assumptions and assertions about epistemic access and status. And by calling on those who are ‘in the know’, the writer potentially recruits interested parties who may be able to ‘fill in’ the crucial, and determinative, identity information – the person’s name.

Inquiring Messages

The category of inquiry includes all actions of requesting information such as asking a question, requesting persons to do something and other related actions. It is differ from informing message where its main objective is to give information to the recipient (also referent and the audience). Generally, the act of inquiring conveys a lack of knowledge and seeks more information. In the epistemic field, often it is categorized under less knowing (k-) and one of the reasons for sequence continuation. In FCPs, inquiring usually is done by the author who is requesting something from the general audience recipients. The request is often about something that the author has less knowledge about, so it is directed to the audiences for information. Figure 4.8 Show an example of a requesting message.

```
1  confession #22547
2  8/17/2015 15:20:45 "Salam abg n akak semua
    " Hello brothers and sisters
3  Adik rasa nk fly time orientasi nnti... Heheheh ade tips tak??"
    I plan to skip the orientation... Heheheh do you have any tips?
```

Figure 4.8: Inquiring message

In this initial message, the author is asking for a tip to skip an orientation programme in a university for new students. Through the reference terms “abg n akak semua” ([older] brothers and sisters [line 1]), this message is particularly directed to the senior in the college. Moreover, the author called him/ herself “adik” (younger brother/ sister [line 2]) which would categorized him/ her as a new student who is suppose to attend the orientation programme. So the whole message is understood as the author, as a new student, is seeking advice from the senior students, who are supposed to have experience,

on how to miss the orientation programme. As in informing message, most of the time, authors use descriptions for references in the act of inquiring. But there is an instance where recognitional reference (name) is used for inquiring.

Description

In inquiring, a description is often used to describe the referent of the message. It is done earlier before the act of inquiry is performed. So that, the general audience or recipient can identify the referent and understood the inquiry better.

Returning to an example we have already looked at, message 1072 in figure 4.9 illustrates this situation. In the message, the author is looking for a person from a different community. He/ she saw the person through a musical event at UPSI and found out that the person is from UM. So, the author posted the initial message on FCPs of UM with a description of the person and asks the community of FCPs of UM help him/ her locate the person.

#1072
1 "Hi.. a few days ago a team of musician from UM came to UPSI, Tanjung
2 Malim for a competition called Rentak Bitara 2015. There was this
3 Sarawakian guy who played sape for the band and boy I fell in love with
4 you. Please someone tag that guy. I want to befriend him and get to know
5 him and..you know what.. #sapeman you are so talented and you breathe
6 music. Please help me find this guy. Oh and congratulations on getting
7 second place. UPSI got third..

Figure 4.9: Initial message 1072

As understood from the message, the author is looking for a ‘Sarawakian guy who played sape’ (line 3) in a ‘competition called Rentak Bitara 2015’ (line 2). Also, the author states that the guy was in a team of the musician from UM who went to UPSI for the competition (line 1). The reason for all these recognitional descriptions used by the author could possibly because the author does not know the referent’s name. Therefore, the author used the recognitional description as a referring expression to point the very individual in his/ her mind. This action is in accordance with the underlying principle of recipient design that

is to use the most appropriate expression in order to achieve recognition (Sacks & Schegloff, 1979). There is an interesting point to note here that is how the author formulates the reference expressions to convey the particular referent. In line 3, the author describes the referent as a 'Sarawakian guy who played sape' in which the word 'Sarawakian' is understood as referring to the origin of the guy, that is from Sarawak, one of the states in Malaysia. On how the author knows that the guy is from Sarawak probably due to the fact that the guy played 'sape', a musical instrument traditionally belongs to a Malaysian native group from Sarawak. All this shows how the author formulates a recognitional description using available social cues of the very person in mind that he/ she want to identify. Epistemically, this description displays the author's epistemic status regarding the relevant referent. Yet, the epistemic status displayed appears lacking or under K- category. Hence the author seeks audiences' assistant in locating him.

Consequently, one thing that can point in this initial message 1072 is that the author may not know the referent on a personal level. As such, the author makes a description of the referent prior to stating his/ her inquiry. Indeed, it is common for a speaker to introduce a piece of information about the referent that is unknown to the recipient. It happens as the referent may not within the shared territory of knowledge between the speaker and the recipient (Heritage, 2012a; Raymond & Heritage, 2006). Therefore, by giving information about the referent prior to conversing about the referent, it helps the recipient to locate the right referent in the speaker's mind.

In relation to this, another interesting point that can be noted in the initial message 1072 is the author's orientation in conveying his/ her message. The author first greets the general audience with 'Hi..' (line 1) at the beginning of the message. After introducing the referent, He/ she changes the direction to the referent to express his/ her feeling to the referent, "boy I fell in love with you" (line 3). Afterward, the author shifts back to the general audience to request their assistance in locating the referent, "please someone tag that guy" (line 4). Again, the author changes the referent to praise him, "you are so talented and you breathe music" (line 5). Lastly, the author re- direct the general audience to once again request their assistance in finding the referent and congratulating them on getting the second place in the musical event 'Rentak Bitara'. Here, there are a couple of things that can be observed. First, the author displays a different level of commutation to the referent and to the audiences. Whenever the author addresses the audiences, it is done in a general manner

with no specific reference to the audience and using a non-recognitional term such as 'someone'. While the referent is addressed in a more personal manner like "you know what...sapeman.." (line 5). Rationally, this is because the author does not know exactly who his / her audience is, but he/ she knows who the referent is.

The next initial message shows another instance where a description is used for the referent. In the initial message 794 (Figure 4.10), the author is looking for a man whom he/ she met during a visit to the dentistry faculty. The man helped the author around the faculty during the visit. Unfortunately, the author does not know the name of the man. Hence, he/ she composes the initial message asking the audiences if they can identify the man.

```
#794
1 "I dunno where to start but i hope this works.
2 I went to dentistry faculty last monday to have an extraction.but i was lost
3 there.then suddenly got one man with red helmet approached me and
4 asked.i was mesmerized by his perfume actually but i got covered
5 up.hahaha.i wanted to go for registration counter and he without being
6 asked to help me,took my file and walked along with me.omaigod.i was
7 moved by his gentlemanity meh.even it was a short meet up but i think i
8 like this man and i want to get close with him.problem is i dunno his name!
9 He is a malay guy n has white chubby face.really cute.the hair is so eyes
10 attracted cause its wavy and high up at front.he wears red bag.that is what
11 i can remember.so please,anyone know this i just want to say i like u n this
12 earth need people like u.i hope my gratutude is taken aware by u,mr
13 gentleman."
```

Figure 4.10: Initial message 794

Clearly, from the initial message 794, the referent is 'one man with red helmet' in which the author introduces for the first time in line 3. This initial reference is aimed to be a recognitional description of the man she/ he met at the dentistry faculty (line 2). Later in line 9 and 10, the author offers more elaborate descriptions based on ethnicity and physical appearance such 'a Malay guy n has white chubby face' and 'the hair is so eyes attracted cause its wavy and high up at front'. Interestingly, in introducing the referent, the author also engages in a storytelling about her/ his encounter with the referent (line 2 to 8). This storytelling is significant for the author's introduction of the referent in the sense that it makes the descriptions about the referent fuller. Instead of knowing the referent as just 'one man with red helmet' who is a 'Malay' with 'white chubby face' and having 'wavy and

high up at front' hair, the story gives additional information such as the time and place that the author encountered the referent. These descriptions could make the referent more 'recognitional' to the audiences. It happens as they can point out which person among the general population of 'malay man' with 'white chubby face' and 'wavy hair' is the potential referent. Somehow, this act of introducing the referent fits the preference for recipient design (Sacks & Schegloff, 2007), that is to use appropriate referring expressions so that the recipients could link them to the referent. In the initial message 794 (Figure 4.10), even though the referent is yet to be identified, the audiences might be able to specify which person that the referent could be, based on the descriptions provided.

It is towards the end of the message that the author states her/ his agenda to look after the referent before confessing that she/ he likes the referent (line 11) and conveys his/ her appreciation towards the referent (line 12). The author's request, however, is done tactfully. Note at line 11, the author states "please, anyone know this..." which could indicate the author's request to the audiences but he/ she does not clearly state so. Instead, the author continues the sentence by changing the footing to the referent "I just want to say I like u...". By doing this, it seems like the author is talking directly to the referent, but the non-recognitional term 'anyone' at the beginning of the sentence seems to general to refer to the referent. It could mean then the non-recognitional 'anyone' is a way for the author to say that 'if any of the audience is the referent'. So, by changing the footing to the referent afterward, the author is excluding the general audience and talk specifically to the referent among the audiences. In such a situation, the author may not explicitly make a request to the audience to find the referent, but he/ she asks each audience if they could be the person.

Figure 4.11 below shows another instance where recognitional descriptions are used for a person unknown to the writer. In the message, the author is looking for her unrecognized saviour to show her gratitude. As the writer does not recognize the referent, recognitional descriptions are used to help identify the referent.

#6056

1 Admin tlg post. Tkasih
2 I had an accident few weeks ago and in ICU for 5 days. I am a malay girl
3 and the girl saved is an indian. I just know that she doing her degree in
4 engineering. If im not mistaken she is a 3rd year student in aerospace
5 engineering. Hospital staff got the information from her id card. If anyone
6 know her please tag her name here. I am still alive because of her courage
7 to save me. She is the wonderful person ever I have met before. We never
8 meet before but she treated me like her own sibling at the accident spot.
9 Her friends must be lucky to have her as their friend. I would like to thank
10 her for her kindness. My English is not that good. Sorry

Figure 4.11: Initial message 6056

There are a number of interesting observations can be made about this message. However, the focus is on the author's attempt to introduce the referent that she does not know (recognize). It is clear from the message that the author was involved in an accident and was hospitalized for five days (line 2), and she does not recognize the referent who helped her during the accident (line 3). Therefore, she writes the message to look for her (line 6). The writer provides what she hopes will be recognitional descriptions of the referent prior to stating her agenda. Rather than just defining 'the girl is an Indian' (line 3), the writer makes the reference more specific by adding descriptions such as 'degree in engineering', and a '3rd year student in aerospace'. This act is not only informs the general readers, of whom she is looking for but also separated the referent from the general population. It filtered through the general population of 'Indian girl' to those who study engineering and is in her 3rd year. In some way, this recognitional description could lead to the identification of the referent.

Interestingly, the author also made an explicit introduction of herself in the message (I am a malay girl [line 2]). Though this introduction could be ambiguous (she can be any Malay girl who had accident few weeks ago and been save by an Indian girl), it is recognitional at least to the referent. This happened as the referent is the one who may recognize the author better (in the sense that she helps the author at the accident area and brought her to the hospital) compared to the author (she asked about the referent's information from the hospital staff [line 5]). Epistemically, it positions the referent as the one with the knowledge while the author in a less knowledge category. Hence the author seeks audiences' assistant in locating the referent.

Another noticeable thing in this message is the author request to the general audience in line 6 “ If anyone know her please tag her name here”. Compare to the previous inquiring messages, the author of this message request specific action from the audience, not only to find the referent but also to ‘tag’ her. By tag, it means to include the referent’s name in the response message through Facebook functionality. This action will directly link the tag-name to the Facebook account of the person which subsequently may identify the referent. Indeed, this is the most efficient practice to identify someone in Facebook. Later in Chapter 6, we will examine further this Facebook functionality and its role in the practice of person reference in Facebook interaction. In fact, we will also see in the next chapter that this tag function is a common way to indicate and identify the person of interest in relation to the initial messages used in the response messages. As mentioned before, FCPs is a place for many purpose, and exploiting its larger local audience is one of its advantage. This happens as FCPs could reach a larger local audience than a personal Facebook page might ordinarily can. Hence, in the occasion where a person is looking for someone from the local network like the author in this message, FCPs might be helpful in increasing the possibility of the sought referent to be identified by the audiences.

Recognitional Reference

It has already been established that the preferred practice of referring to persons is through recognitional reference forms, and a name is the most preferred form. However, in FCPs, the use of a name in the initial message may appear unusual in the sense that real identities are often concealed or unstated in favour of the action that the message is conveyed. The intricate relationship between the author, the referent and recipient is also among the reasons why real names are not use in the initial message since the exposure of one’s identity (e.g., the referent) could lead to the revelation of the other identity (e.g., the author). Therefore whenever a name is used in FCPs initial message, it invites an attention as to why the author is using a name and what the author is trying to get through the name. There is only one instance found in the data of this study that use a full name in the initial message. Hence, it becomes a deviant case and immediately gets my attention. I present the initial message below (Figure 4.12).

What is interesting about this message is that the author is looking for someone that he/ she

already knew in a real world. So, the author addresses the referent from the very beginning using his name.

#1098

```
1 "To Kuan Ming from chemical engineering,  
2 I wanted to tell you that wherever I am, whatever happens, I will always  
3 think about you,and the time I saw you for the first time was my happiest  
4 time in my university life. I love your smile,your skin colour You may not  
5 know who amand your handsome face.You may not know who am I but I  
6 know you well.  
7 Anyone can help me tag him after reading this ?  
8 ~someone special~"
```

Figure 4.12: Initial message 1098

In the message 1098, there is an instance of recognitional reference used by the author. It is interesting to note that the author uses a name as well as descriptions in referring to the referent (line 1). A name usually is considered as a full noun phrase and it is recognitional. However, the author adds more elaborate descriptions to the name. According to the preference for recognition (Sacks & Schegloff, 2007), additional referential information is not necessary for a recognitional reference. In this case, the author treats the referent's name as less recognitional. It is possible in the sense that there could be more than one person named 'Kuan Ming'. This is a common practice in a conversation where a speaker uses the name and descriptions when they introduce a referent unknown to the recipient. Although in this case, the author recognizes the referent, he/ she may consider the domain of knowledge of the general audience who might not know the referent. Moreover, the message can be accessed by the public which would increase the number of the potential referent. So, by adding a description to the name, the author specifies which 'Kuan Ming' that he/ she is addressing.

Later, in line 7, the author asks, 'anyone can help me tag him after reading this?'. This request may appear puzzling since the author has already said that he/ she knew the referent (line 6 'I know you well'). The request then could mean for something else. If we look at the word 'tag' that the author used, it is actually a technical term on Facebook. It refers to the act of tagging a person's Facebook profile to create a link directly to his/ her Facebook account. This action can be done by writing the person's name using Facebook's

software assistant. This technical action, however, is restricted among Facebook friends. So by requesting the audiences to tag the referent, the author is asking for someone who is 'friend' with the referent on Facebook to tag him. Understandably, it is by writing 'Kuan Ming' Facebook profile name in the comment section (further elaboration on this action will be discussed in the next chapter). This also indicates that although the author knew the referent in the real world, he/ she is not 'friend' with the referent in the Facebook. Therefore, in this message, the author is actually looking for Kuan Ming's Facebook profile rather than the person Kuan Ming. Indirectly, it shows a dual life that a person could live that is in the real world as well as in the digital world.

Epistemic Relationship of the Author and the Referent

The basic distinction between information and inquiring messages is the primary action of giving information and seeking information. In FCPs, these two types of action involve an intricate relationship between the author, the recipient and the referent. As demonstrated through the instances, person reference forms are use not only about achieving recognition. For example, the authors use non-recognitional reference forms to a known referent in the informing messages to obscure their identity because they are closely related to the referent. The reference forms are designed specifically for the action that the authors want to convey. In that sense, with each form of person reference that the author utilized, they also reflect the author epistemic levels in relation to the referent. Based on the data discussed in this chapter, I try to summarize the relationship between the author and the referent on the basis of their epistemic levels for both types of messages (informing and inquiring) as illustrated in Figure 4.13. The linear line represents the kind of relationship that the author has with the referent. As the line goes to the right (to the referent), it illustrates the distances the author has to the referent/s.

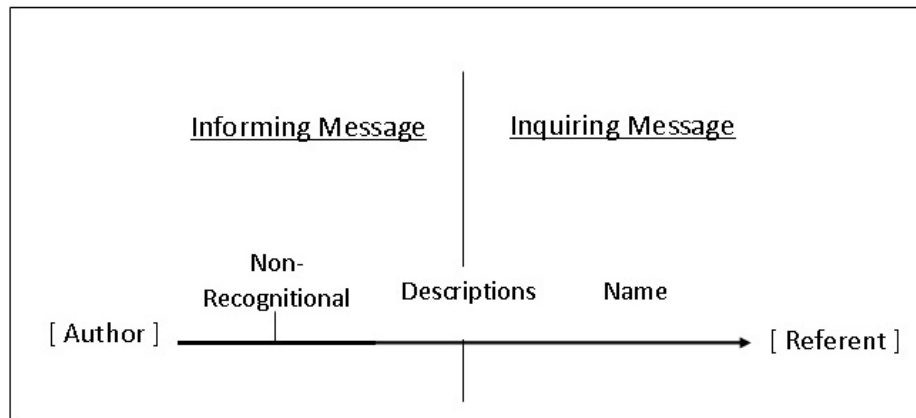

Figure 4.13: Epistemic relationship between the author and the referent

In informing messages category, it shows that non-recognitional terms are used for a known referent. It is due to the author close relationship with the referent that the terms are exploited to obscure the real identity of the referent. Warrant saying that the author knows the referent is based on the possessive pronouns that usually associate with the non-recognitional terms (e.g., your roommate, my class mate). The pronouns illustrate the close relationship between the author and the referent.

Descriptive terms often display the author's 'incomplete' information with regard to the referent. Based on the data presented in this chapter, we see that the authors use description to the referent when they do not know the referent on personal level. It could be that the author saw the referent but does not have full information about the referent (e.g., guy from Faculty of Med, sape man), or the author may have indirectly encountered with the referent yet never meet the referent (e.g., red saga driver, K*4 complaint). So, description is use to achieve recognition of the referent. In this manner, it portrays the author somehow distant relationship to the referent, or the referent is not within the author domain of knowledge, as portray in the figure 4.13. This practice is found in both categories of message, informing and inquiring. Consequently, audiences may recognize the description and upgrade it to name in the subsequent response messages.

With regard to the use of 'name' in FCPs initial message, it is quite similar with the use of the 'description' in term of relationship between the author and the referent. It happened as the author, most probably, does not know the referent on personal basis. Based on the instance presented in the inquiring message, the author portrays the referent as someone she encounters in real life. So, the author might get the referent's name but the initial

message is requesting for the referent's Facebook identity. In so doing, it portrays that the author does not have a close relationship with the referent though she knows his name. Therefore, in Figure 4.13, it illustrates the author as distant from the referent.

The use of these three type reference terms in the initial message are eventually lead to identity and identification work in the subsequent response messages. It may assume that the inquiring message may get more response due to its nature that explicitly orienting to generated information. However, as we have seen the informational messages are structured so as to leave out the specific details of the referent (their name), and hence implicated further identification and recognitional work on the part of audience recipients

Discussion

The aim of this chapter is to describe some of the interactional organization on Facebook. In this chapter, it illustrates how interaction could be designed, not only for the specific recipient but also the general audience. By focusing mainly on the use of person reference form, this chapter shows how the initial message of FCPs could direct the audience and frame the topic for subsequent interactions should they occur later. The findings show some similarities, as well as differences in the practices of spoken interaction, derive from how authors manage and exploit the context of the interaction.

As in talk- in- interaction, the analysis of this study also revealed the preferences to follow the sequence of locally initial and locally sequence references regarding third person referent. Non- recognitional reference forms and descriptions are found to be the preferred forms in a locally initial reference position. The reason for this is due to the nature of the FCPs that separated the identity of the author and the page's account, hence provide the opportunity to the authors to exploit their real identity. Still, the action conveys the need for referent's identification in order for the later action to be performed.

Eventually, it has become the style of writing among the authors of the FCPs initial message to introduce the referents using descriptions and 'storytelling' style before conveying the action of the message. Particularly for the 'inquiry' action, a description is found to be crucial for person reference. The rationale for this is due to the unknown

referent as illustrated in figure 4.12. Meanwhile, non-recognitional references tend to be exploited by the author to refer to a known recipient/referent, particularly in asserting or telling something. The reason to use a non-recognitional reference instead of a recognitional reference to known referent is to conceal the referent's identity as well as him/ her self. This is because the FCP is a public online site with mostly local audiences. So, there is a possibility that the audience may recognize the referent if the author uses a recognitional reference. In the sense, this reflects the 'recipient design' of the message construction.

One interesting observation from the analysis is how the authors exploit the general audience. For example, the FCPs initial message occasionally used to locate a particular individual for whatever reason (e.g., initial message 1098, 6056). In these cases, the messages present a description of a particular individual's and requested the general audience to help identify the referent. While this may not be the objective for the creation of FCPs, it is understandable given the geographic targeting of FCPs. It illustrates the locality of FCPs within a wider Facebook platform as the readers of particular FCPs usually come from a similar local network. One clear example of this is as illustrated by the initial message 1072 where the author is looking for a person from a different community. So the author posts the message on the FCPs belongs to the community that he/ she thought the referent may belong to.

Additionally, analysis in this chapter shows that interactions in Facebook do not differ much from other typical interactions such as face-to-face interaction or phone call interaction. As in other interactions, the initial messages in FCPs performed the first action to set an agenda for a discussion by the general audiences. Through the specific construction of the message and the use of person reference term, the initial message may raise the curiosity of the audiences, hence provides a floor for subsequent discussion. The following chapter then will examine the subsequent response messages.

Chapter 5: Identification Work on Response Messages

Introduction

Previous chapters have examined the basic organization of Facebook Confession Pages initial message. Focussing on the way the messages were constructed particularly on the practice of person reference, the analysis looks at how the authors of the message strategically formulate reference to the referent and recipient (including the audience). Using non-recognitional terms and descriptive terms to narrow down the identity of the referent, they indirectly portray the epistemic level that the author has with the referent and provide a space for further identity works. In this chapter, we will see how these reference terms become resources for further identity works in the subsequent 'response' messages. The main focus will be on how the commenters unfold the identity information and display their stance. As response messages are identifiable, the identity work is accomplished collaboratively as they interactionally work up their claim to bolster their epistemic stance.

Identification is a common and relevant act in interactions (Marx, 1999; Schegloff, 1979) including online interaction (Donath, 1996). People identify each other, so that they can behave accordingly to each other. In a situation where identification cannot be performed, it may leave certain impression especially to the receivers of the communication (message) as they are left with the information that someone is attempting to communicate with them but, for whatever reason, does not want to or cannot reveal his or her identity. According to Rains and Scott (2007), upon encounter such situation, receivers of the message often react in a couple of ways: they may try to identify the source of the message, and/ or they may formulate their perception about the source as well as the message (what is the message is about and who might be created it). As in FCPs, the initial message may raise the curiosity among the readers as to why the authors want to post such message without revealing their real identity (i.e., name). Since FCPs is a local community- based Facebook page where the possibility that the community members may know or have a connection with each other is high, the curiosity may eventually lead to the act of identification. As Anonymous

(1998) assert that, “If the [communication] channel can provide clues (e.g., handwriting analysis, electronic mail records, phone traces) to the source’s identity, then that will increase the likelihood that a receiver will engage in identification efforts” (p. 396). So, it seems likely that, upon reading the initial message on FCPs, readers may want to know who the author of the initial message is as well as its related matters such as the recipient and/ or the referent of the message. Subsequently, they may ‘ask around’ searching for the identity of the persons related to the initial message.

Additionally, the desire to identify the source of the initial message could depend on the relationship that readers have with the initial message itself. According to Rains and Scott (2007), receivers’ level of perception towards the initial message may influence their subsequent identification effort. Those receivers who have a weaker relationship typically viewed anonymity as appropriate since they usually do not have a personal connection or interest to the initial message. So, they are less likely to want to know the identity of the anonymous source. Meanwhile, those receivers with a good relationship are likely to want to identify the source of the initial message due to their personal interest or connection to the initial message. Accordingly, those readers who engage in a ‘guessing game’ looking for the identity of the person of interest of the initial message in FCPs may have a special connection to the initial message. That is they may have ideas or information concerning the initial message that lead them to change their status from mere readers to more active by commenting on the initial message. This happens as only those readers with information or personal connection to the initial message would want to attempt to identify the initial message. Those readers who have no personal connection to the initial message may less likely want to engage in this ‘guessing game’, mainly because they may have no information to even make a guess at a first place. As Sack (1992) observed that in everyday conversation, having witnessed a tellable event entitle a speaker to have an experience associated with the event (e.g emotional). This gives the witness not only a particular right to tell others about the event, but also to tell how it emotionally affected him (Hutchby, 2001a).

Eventually, this ‘guessing game’ or identification act in FCPs illustrates epistemic status of the readers. It is because upon identifying the initial message, readers need to convey their opinion, making claims and negotiating the matter of identity through the interactions in the comment section. In doing this, as in typical interaction, involves categorical

referencing as well as knowledge claims. In Conversation Analysis, these two actions are the interest of Membership Categorization Analysis (MCA) and the study of Epistemics. Therefore, this study incorporates Membership Categorization Analysis and Epistemics to show how identity and identification work is accomplished interactionally on FCPs.

Identity and Identification Work on FCPs

As shown in the previous chapter, the identity work on FCPs begins with its initial social act found in the status updates, that is the initial message. This message, as explained in the previous chapter may implicate subsequent responses. From this message, subsequent acts on FCPs are generated that is readers' comments. It is in these subsequent acts following the initial act of the status update that readers' actions can be observed, of which for this study it is the act of identifying the person of interest of the initial message particularly the author and the recipient of the initial message.

The act of identifying the person of interest in the initial message in FCPs is normative, particularly because FCPs is a local community- based Facebook page which also means that the readers usually belong to the same community. As evidence in many study of computer- mediated community, group members tend to make attribution about the identity of the message sender during the interaction (Donath, 1996; Hayne, Pollard, & Rice, 2003; Rains & Scott, 2007). Moreover, individuals from a similar group may get familiar with one another from their face- to face encounter, which then may reduce their anonymity perception if they reencountered in computer- mediated environment (Rains, 2016; Rains & Scott, 2007). Such things like style of writing, use of particular jargon and background story are just some of the cues that may provide information about a member's identity. Similarly, in FCPs, readers may be compelled to comment on the particular initial message to make a guess concerning the identity of the person of interest of the initial message based on the information they may have.

Based on the observation of the FCPs data, the 'guessing game' that is the act of identifying the person of interest of the initial message is usually concentrated on

identifying the identity of the author and/ or the recipient of the initial message⁷. Therefore, particular attention will be given to what can be broadly described as identity proffers, that is the initiations of identity suggestion (by a commenter⁸) as these are identified to be significant in the identity and identification works across the dataset as other commenters pick- up the identity suggestion and negotiated them through their interactions. Consequently, identity and identification works are interactional in nature, as commenters position themselves and others to bolster their own claims to knowledge in relation to the identity information and the initial message, or to weaken the claims of others. This action of knowledge claim is generally known as ‘epistemic stance’ that is “moment- by- moment expression” (Heritage, 2012b, p. 6) of commenters as they portray their differential access to knowledge within certain domains. Given the nature of the Facebook Confession Pages (FCPs) in the current study, epistemic status (Heritage, 2012b), a more stable phenomenon related to commenters access to knowledge, is essentially unknowable especially to the analysts. Although commenters do make claims to epistemic access, they are, in effect, their epistemic stance. And so, this study will refer to commenters’ claim to knowledge access as ‘epistemic stance’.

Additionally, in analysing the identity works by the commenters, the current study reveals many different categories of identity made relevant in the interaction including gender, age, race, religion etc. For the analysis of this study, however, it focuses on several broad main areas of epistemic stance that relate to identity; networks, localness and situational. These areas of epistemic stance include not only explicit categories of identity (such as gender, religion and race), but also commenter’s claim to knowledge about certain thing such as geographic location, associated- occasions, person’s traits and characteristic, etc index multi- layered identities. So, through these areas of epistemic stance, we identify and explicate categories and devices that were used to build and warrant various identity and identification works. The remaining sections then will look at identity and identification works arranged based on these main areas of epistemic stance.

⁷ This includes the referents of the initial message too as the referents are often referred as the recipients at the end of the initial message.

⁸ This term will be used in this study to refer to participants in the response messages. This is to differentiate it from the author of the initial message and to the general recipient or readers.

Epistemic stance: Networks

Identity and identification works are performed through displaying an epistemic stance regarding what commenters know about their networks. Here, the networks refer to a claim of knowledge relating to particular information that is usually known among members of a group or community. It is a kind like members' social stock of knowledge that includes local and background knowledge about the group and its members. Networks is the most common ways of displaying epistemic stance identified to be used by commenters in this study when they make identification in relation to the initial message. The knowledge displays usually based on the local knowledge in which 'outsiders' or persons who are not from the community or group may not know. Often, the commenters negotiate the identities based on their personal knowledge that they gained as they encountered with each other offline and/ or on their daily basis.

The Recipient

Figure 5.1 below shows an instance of this situation. The excerpt is taken from a series of interaction from FCPs initial message #879⁹. The initial message is about the author's love confession to his/ her course mate. The author describes the course mate as someone from the Material Engineering course who once planned to change to another course. Therefore, the author feels grateful when he/ she decides to cancel the plan and stay in the course. What is noticeable about the initial message is how it was written poetically using metaphor such as dance and weather, in expressing the writer's declaration of love to the course mate. This noticeable element of the initial message then was picked up by commenters in discussing the identity of the author and the recipient of the initial message.

⁹ The full interactions are included in the appendixes

#879

"To my gorgeous Materials Engineering's coursemate, my heart was broken when I found out that you were going to change course. You can't imagine my excitement when you decided to stay. I think this is the second chance given to me but I still don't have the courage to confess my love to you. My feeling gets even stronger in this rainy season. Whenever I see you walking alone in the rain, I really hope that I am an umbrella to be hold by you, accompanying you every moment, providing you with shelter from the scorching sun and windy rain. What's more, at night, I hope to transform to a blanket, providing you with warmth in the freezing nights. Most importantly, I hope to be your shoes, dancing along with you silently as if I am dancing with you on the stage. I do not wish to steal your limelight, all I want is to support you on the path of pursuing your dream."

((lines omitted))

- 54  **Elvis Ng** Pei Qi u wan change course a? haha.. 👍
Like · Reply · December 16, 2013 at 3:16pm
- 55  **Hoay May** yo, peiqi last time said wan change course de leh 👍 👍
Like · Reply · December 16, 2013 at 3:58pm

((lines omitted))

- 68  **Pei Qi** Elvis Ng this is no more latest news lo~~~
Like · Reply · 1 · December 16, 2013 at 3:17pm
- 69  **Pei Qi** wahhh~~ anyway thx to the admirer~~ bt i tink mostprobably is prank lo~description is jz so obvious~
70 Like · Reply · December 16, 2013 at 3:15pm
- 71  **Chin Joo Tan** Pei Qi, Someone is confessing to you? 😊!
Like · Reply · 5 · December 16, 2013 at 3:14pm

Figure 5.1: Identity suggestion ¹⁰ (FCP #879)

In the excerpt above, Chin Joo Tan initiates the identity proffer for the recipient of the initial message. He asks in line 71 "Pei Qi, someone is confessing to you?". While this question is in interrogative format, a common way for information request, it is also directly position Pei Qi as a recipient of the initial message. This is due to the fact that he specifically addresses Pei Qi which suggests that he may have knowledge about Pei Qi in relation to the initial message. So, although he is taking less knowing (K-) position through the question to Pei Qi, he is not in a position of zero knowledge. In Heritage (2012b) epistemic gradients, this question by Chin Joo Tan could be index by increasingly

¹⁰ The interaction is arranged in reverse order that is the latest response appears at the top and the earliest at the bottom, however for response to response such as in line 55, the arrangement is in order that is the response to response (line 55) is arrange below the main response (line 54).

knowledge relationship (K- to K+) due to some knowledge he possessed, while Pei Qi is expected to have the primary knowledge. consequently, the question is not only for information request but could also be to seek a confirmation, and/ or just to make a guess (Heritage, 2012b). Inverse

Pei Qi response in line 69- 70 saying “wahh~~anyway thx to the admirer~~bt I tink mostprobably is prank lo~description is jz so obvious~”. This response by Pei Qi answers Chin Joo Tan question, although she does not directly say ‘yes’ as expected from the way Chin Joo Tan formulated his question. Raymond (2003) called this type of answer as ‘nonconforming response’ (Raymond, 2003, p. 946) where a preferred response relative to the question is provided in a dispreferred grammatical form where it does not use preferred answer such as ‘yes’ or ‘no’. It shows the stance that the speaker is taking in relation to the question. In Pei Qi situation, using confirming response may not be a good choice since it may imply her being immodest. It is interesting to note that among Malaysian culture, being too direct in certain situation such as accepting compliment right away can be seen as immodest (Gibson, 2009; Gupta, 2006; Jaafar, 1999; Omar, 2001). Therefore, by directly say ‘yes’ may bring negative impression to herself. However, through her gratitude to the author of the initial message (anyway thx to the admirer) as well as her last part in the statement which saying, “description is jz so obvious”, Pei Qi implies that Chin Joo Tan is right in guessing that she could be the person that the author is talked about since the description on the initial message could fit her.

Pei Qi’s identity as the recipient of the initial message as suggested by Chin Joo Tan is further emphasize through Elvis Ng question in line 54 saying “Pei Qi, u wan change course a?”. This question appears more specific in a sense that it states the relevant aspect that may tie Pei Qi with the initial message. This question could be oriented from Pei Qi previous response in line 69- 70 where she admits the possibility that she may be the recipient of the initial message because the “description is jz so obvious” (line 70). Yet, she does not clarify about the ‘description’ that may consider her as the recipient. So, by posing such question in line 54, Elvis Ng seeks for clarification as well as confirmation concerning the relation between Pei Qi and the initial message. Subsequently, Pei Qi

response in line 68¹¹ saying “Elvis Ng this is no more latest news lo” not only informed Elvis Ng that she wanted to change a course previously, but also emphasize her position as a possible recipient of the initial message.

Note however the word ‘lo’ at the end of Pei Qi’s response in line 68. This word is actually is a variety spelling of discourse particle ‘lor’, a common discourse particle use among Malaysian which can loosely translated as ‘I think’¹². With the addition of this particle, it changes slightly Pei Qi’s epistemic stance towards her previous statement ‘this is no more latest news’. It shows some level of uncertainty in Pei Qi’s response which in turn could also portray her decrease level of epistemic knowledge regarding the matter. Her whole statement then can be understood as she is telling Elvis Ng that since her plan to change course happened quite some time, most probably everybody in her course knew it. Hence, when Chin Joo Tan previously identifies her as recipient of the initial message, it could be

¹¹ This interaction was positioned below its first pair part due to a new response to Elvis Ng’s question in line 55 which automatically rearrange Elvis Ng’s response at the top.

¹² It is important to note that the inclusion of discourse particle in the interaction could also change the meaning of the statement. An instance to show this situation is illustrated by Miel’s Miel, 2015 cartoon. In his cartoon illustration, he shows how people response using an English word ‘can’ which a common English word used among Malaysian for short response, with an addition of discourse particles. Table 1 below summarize the responses.

With the addition of discourse particles	Its meaning
Can ah	Can you or can’t you? yes or no
Can lah	Yes
Can leh	Of course
Can lor	I think so
Can hah	Are you sure?
Can hor	You are sure then?
Can meh	Are you certain?

Table 1: The incorporation of discourse particles to an English word ‘can’ and its meaning in informal conversation. Miel, 2015, p. 54

As seen, with the addition of different discourse particles, the meaning of the word ‘can’ or the response is changed. But, the meaning of discourse particle as illustrated in Table 1 is not constant because the meaning can also change with the change of their position in the utterance. For instance, the discourse particle ‘lah’ can also be used to show ‘politeness’ such as when someone says ‘you book lah the ticket’. The discourse particle ‘lah’ then function as a ‘polite’ stressor of the action ‘book’ and does not bring any meaning.

due to this information which common- information known among Pei Qi's course mates. Consequently, it divides Pei Qi's networks into two categories in relation to the information (she wanted to change course), 'those who know' (Chin Joo Tan) and 'those who do know' (Elvis Ng).

This is later confirmed by Hoay May in line 55 "yo, peiqi last time said wan change course de leh". The uses of discourse particle 'leh' at the end of her turn which can be understood as 'of course', together with the token of agreement 'yo' (yes) in the beginning of her turn, give confirmation to Elvis Ng question, and indirectly to Pei Qi's assumption that everybody knew about her previous plan to change course. In this sense, Hoay May position herself within the category of 'those who know' together with Chin Joo Tan. So, her claim, indirectly, acts to strengthen Pei Qi's identity as the recipient of the message.

Figure 5.2 below shows another instance of identification works relate to networks. For this instance, the interactions stemmed from a FCPs initial message #1103 written by a person introduced herself as 'Just a shy little 1st year girl'. In the initial message, she expresses her admiration to a '2nd year guy' who was her team leader during a university event. She provides descriptions of the '2nd year guy' as someone with dark skin, skinny, wearing glasses and one of the directors of UMAC (students club). She also narrates some events concerning her relationship with the person such as rumours about them among their cliques and also his relationship with a female senior. Following the initial message, commenters begin to search for the author's identity and the recipient by calling their friends into the initial message. Figure 5.2 below shows an excerpt from the interaction where the commenters are looking for the recipient of the initial message. In the excerpt, the identity is suggested by Chloe Zhaoyi in line 20.

#1103

"I fall in love with a FBA 2nd year guy, he is a little dark skin, skinny, wear spec and he is the BODs of UMAC. I am very into him and I am very lucky to be join his team in a mega event of UMAC. Under his leadership, I totally in love with him, I always imagine holding his hand while he is very near to me during departmental workshop. But then rumours around the faculty begins to spread, people are saying we are in love, especially my matric friends, and I started to worry that this will scare him away and we can't even be friend, and so, I become low-profile and not dare to near him as much as when we were working in the same event. I also heard that some people are saying he and another senior are in relationship. I sometimes wonder he really likes her or not, if it is true, I might be a little heart broken. Anyway, I still hope that someday we can have a chance to hang out, only two of us.

Sincerely,
Just a shy little 1st year girl"

((lines omitted))

20  **Chloe Zhaoyi** My first thought is...Kin Chun LOLLOL
Like · Reply ·  9 · May 31, 2015 at 5:11pm

21  **Janice Wong** Obviously...a little dark skin ahahaha..member的春天
22 到了吗?    Kin Chun
Like · Reply ·  2 · May 31, 2015 at 5:15pm

*Obviously... a little dark skin ahahaha..member
springtime?    Kin Chun*

23  **Chloe Zhaoyi** Woohoo!!! Guess he is going to be SO famous starting
24 from tonight. ACCOUNT 001   
Like · Reply ·  1 · May 31, 2015 at 5:19pm

25  **Janice Wong** The scope is sooo limited, "join his team in one mega
26 project".. ITAC only rite?
Like · Reply ·  1 · May 31, 2015 at 5:23pm

27  **Chloe Zhaoyi** Hahahahahaha ONLY ITAC 😏😏😏😏
Like · Reply ·  1 · May 31, 2015 at 5:24pm

28  **Yen Zi Joyce** Ya...obviously is Chun Kin ge liao hahaha
Like · Reply ·  1 · May 31, 2015 at 5:27pm

29  **Yee Han Khoo** Kin Chun ge...u win lioorr..hahaha
Like · Reply · May 31, 2015 at 6:12pm

30  **BRi Eun Cher Shong Teoh** more leng zai from medic fac
Like · Reply ·  4 · May 31, 2015 at 5:37pm

31  **Daniel Tay** Chun Kin 春天来了
Chun Kin Spring is here
Automatically Translated
Like · Reply ·  4 · May 31, 2015 at 5:33pm

((lines omitted))

Figure 5.2: Listing the recipient's recognitional descriptions (FCP #1103)

This response is more like a monologue in a sense that she is stating her opinion based on her knowledge “My first thought is...Kin Chun LOLLOL”. Though this claim of identity knowledge does not provide a clarification on which identity she is referring to (whether the author or the recipient), it can be expected as the recipient of the initial message due to the gender category that Kin Chun belongs to which is similar to the ‘2nd year guy’ that the author of the initial message is referred. Additionally, by saying “My first thought is...” implies that Chloe Zhaoyi does have candidates for the category of recipient as described in the initial message. and so, the triple dots that she uses afterward could mean to add an element of surprise before she announces the name. Consequently, Chloe Zhaoyi positioned herself as someone with knowledge about Kin Chun in relation to the initial message though she does not state the kind of relationship they may have.

Chloe Zhaoyi’s identity claim of Kin Chun as the recipient of the initial message is supported later by Janice Wong. In lines 21- 22, she states her agreement saying “Obviously...a little dark skin ahahah...member (Chinese characters means springtime)? (clapping icon, speak- no- evil monkey icon) Kin Chun”. By stating ‘a little dark skin’, she is referring to one of the criteria of the recipient as described in the initial message. So by ascribing the criteria to Kin Chun, she technically puts him under the category as someone with ‘a little dark skin’ which then fits the category of the recipient of the initial message. This act of categorization, in turn, portrays Janice Wong as someone who knows Kin Chun and has knowledge about him personally. Additionally, her inquiry ‘member (Chinese characters means springtime)?’ could be to further clarify Kin Chun identity, although there is nowhere in the initial message mention about it. This additional criterion (Chinese characters means springtime) has also been mentioned by another user, Daniel Tay in line 31. The reason to add this new criterion then could be to specifically indicate which Kin Chun that they are referring to. Rationale for this act could be that there is more than one Kin Chun among their friend, so by ascribing relevant criteria to the very person in mind, they could specifically point which Kin Chun they are referring to.

Chloe Zhaoyi acknowledges Janice Wong identification of Kin Chun by teasingly says ‘he is going to be so famous starting from tonight’ in lines 23- 24. In return, Janice Wong again makes a reference to the initial message by saying “The scope is sooo limited, “join his team in one mega project”.. ITAC only rite?”. By saying this, Janice Wong is not only trying to emphasize Kin Chun’s identity as the recipient of the initial message by adding

another relevant category to him, but she is also looking for confirmation. That is she might be knew that Kin Chun involved in ITAC but she may not sure if ITAC could be the mega project. Subsequently, Chloe Zhaoyi gives a confirmation that ITAC is the mega project (in line 27). Kin Chun identity as the recipient of the initial message is further emphasized by Yen Zi Joyce (line 28) and Yee Han Khoo (line 29). Interesting, both of them adds a title 'ge' mean brother in Chinese to Kin Chun's name. Often this title is use for someone who is older and has a close relationship with each other. Therefore, by calling Kin Chun 'ge', it shows that both Yen Zi Joyce and Yee Han Khoo could have a close relationship with Kin Chun, thus makes the descriptions presented in the initial message as recognitional to them.

Chloe Zhaoyi however is not the only person that identifies Kin Chun as the potential recipient. prior to her response, Fazreena Islam had mention his name in line 49 in respond to Choon Kwan Pua who tagged her with several of her friends (Figure 5.3).

#1103

"I fall in love with a FBA 2nd year guy, he is a little dark skin, skinny, wear spec and he is the BODs of UMAC. I am very into him and I am very lucky to be join his team in a mega event of UMAC. Under his leadership, I totally in love with him, I always imagine holding his hand while he is very near to me during departmental workshop. But then rumours around the faculty begins to spread, people are saying we are in love, especially my matric friends, and I started to worry that this will scare him away and we can't even be friend, and so, I become low-profile and not dare to near him as much as when we were working in the same event. I also heard that some people are saying he and another senior are in relationship. I sometimes wonder he really likes her or not, if it is true, I might be a little heart broken. Anyway, I still hope that someday we can have a chance to hang out, only two of us.

Sincerely,
Just a shy little 1st year girl"

((lines omitted))

46  Choon Kwan Pua Ashlee Jae Amirul Asyraaf Carey HY Shu Fern Racheal
47 Ong Cow Cow Fazreena Islam Lynn Goh Saeda Iman Kushairi :OOOOOO
Like · Reply ·  4 · May 31, 2015 at 4:58pm

48  Fazreena Islam There are like 4 guys in our team, unfortunately the
49 first criteria answered it all! Kin Chun , how's my smart guess?
Like · Reply ·  4 · May 31, 2015 at 5:01pm

((lines omitted))

Figure 5.3¹³: Recognitional description (FCP #1103)

Fazreena Islam responds in line 48- 49, saying “There are like 4 guys in our team, unfortunately the first criteria answered it all! Kin Chun, how’s my smart guess?” can be understood as her attempts to identify the recipient of the initial message. Warrant for this is showed mainly through the term ‘guys’ she used in her deduction as it can be a membership category device to the ‘2nd year guy’ described for the recipient of the initial message. Additionally, the tagged name ‘Kin Chun’ that she referred to as the result of her deduction is a male thus fit the gender description of the recipient of initial message. Consequently, it excludes the author of the initial message who can be defined as a female through her self- identification as ‘Just a shy little 1st year girl’ in the initial message.

Eventually, Fazreena Islam’s response could also indicate the type of social networks that she and Choon Kwan Pua belong to; That is as for a group of friends Choon Kwan Pua

¹³ This excerpt is from the same FCP #1103 as in Figure 5.2

tagged in line 46- 47 (Ashlee Jae Amirul Asyraaf Carey HY Shu Fern Racheal Ong Cow Cow Fazreena Islam Lynn Goh Saeda Iman Kushairi), they might have knowledge concerning the recipient of the initial message. While Choon Kwan Pua may not explicitly categorize this group of friends as such, Fazreena Islam uses of pronoun ‘our’ in her response (There are like 4 guys in our team) could indicates that they, she and Choon Kwan Pua (and most probably the tagged friends), are in the same team. In other words, the pronoun ‘our’ can be a membership category device to show how certain people associate themselves with others to indicate that they belong together. Consequently, Fazreena Islam’s response gives the impression that they all, including Kin Chun the potential recipient of the initial message, belong in a same ‘team’, hence make it possible for her to identify him as the recipient of the initial message.

Retrospectively, Choon Kwan Pua’s turn in lines 46- 47 can be understood as informing her tagged friends about the initial message. The “:OOOOOO” at the end could be her ‘creative’ spelling of ‘oh’ as her change of state token (Heritage, 1984) to show her recognition regarding the initial message’s content. It could also be a short- hand for ‘shock’ emoticon as ‘:- O’ of which Facebook usually will automatically change it to an emoticon, but with a missing ‘- ’ and multiple ‘O’s, the Facebook system may not recognize it, and hence doesn’t change it. However, whether “:OOOOOO” is referring to a change of state token or an expression of shock, it shows that Choon Kwan Pua has some information concerning the initial message. So, her act of tagging several of her friends is not only to inform them about the initial message but also to indicate that this circle of friends may also have a connection to, or have information concerning the recipient of the initial message.

The Author

Interestingly, within the same interactional thread (Initial message # 1103), Choon Kwan Pua also tagged several other friends in line 36- 37 (Figure 5.4) asks “your fren?”. Given that this group of friends are different from the group of friends she tagged in line 46- 47, it indicates that Choon Kwan Pua may categorized this group friends in a different category than the group of friends she tagged in lines 46- 47. Therefore, when she tagged this group of friends, it means that she intended to project different action than to those other group of



friends. So the question “your fren?” can be understood as she is asking this group of friends if they know and/ or have connection to the person in relation to the initial message. It is ambiguous however on which identity she is referring to, the author or the recipient. The question becomes clearer through the subsequent responses.



#1103

"I fall in love with a FBA 2nd year guy, he is a little dark skin, skinny, wear spec and he is the BODs of UMAC. I am very into him and I am very lucky to be join his team in a mega event of UMAC. Under his leadership, I totally in love with him, I always imagine holding his hand while he is very near to me during departmental workshop. But then rumours around the faculty begins to spread, people are saying we are in love, especially my matric friends, and I started to worry that this will scare him away and we can't even be friend, and so, I become low-profile and not dare to near him as much as when we were working in the same event. I also heard that some people are saying he and another senior are in relationship. I sometimes wonder he really likes her or not, if it is true, I might be a little heart broken. Anyway, I still hope that someday we can have a chance to hang out, only two of us.

Sincerely,
Just a shy little 1st year girl"

((lines omitted))

36  **Choon Kwan Pua** Kah Yong -Xin Yan Kho- Xian Yuin Gan Wei Teng Zhilin
37 Chong your fren?==
Like · Reply ·  2 · May 31, 2015 at 4:58pm

38  **Zhilin Chong** Kelxin Lim!!!!!! 😊 😊
Like · Reply ·  1 · May 31, 2015 at 5:14pm

39  **Kelxin Lim** U all know right walaooooo not me 🙄 🙄 🙄
Like · Reply · May 31, 2015 at 5:15pm

((lines omitted))

Figure 5.4: Searching for the author (FCP #1103)

Tagged by Choon Kwan Pua in line 36, Zhilin Chong responds by giving out a name, Kelxin Lim (line 38). This simple response can be interpreted in many ways. It could be that Zhilin Chong is alerting Kelxin Lim about the initial message by directing it through Choon Kwan Pua’s question because Choon Kwan Pua did not includes Kelxin Lim’s name in her turn. It could also mean that Zhilin Chong is giving out the identity of the author of the initial message because Kelxin Lim is a female (it can be determined through Kelxin Lim’s Facebook profile), and the author identify herself as “Just a shy little 1st year girl”, hence it fits Kelxin Lim’s gender category. Subsequently, Kelxin Lim responds to

Zhilin Chong in line 38 saying “U all know right walao not me” which seems like a rejection. By responding as such, it seems like Kelxin Lim interpreted Zhilin Chong response in line 37 as giving out her name as the author of the initial message. It leads to the understanding that Zhilin Chong interprets Choon Kwan Pua question “your fren?” in line 36 as ‘is the writer of the initial message is your friend?’ in which she response by giving out Kelxin Lim’s name.

While this rejection is responding directly to Zhilin Chong in the sense that it was position right below Zhilin Chong’s response, the intended recipient may not specifically for Zhilin Chong. It is due to the pronoun term ‘U all’ used by Kelxin Lim in her rejection which could extend to those who had identified her as the author of the initial message which could include Choon Kwan Pua and her tagged friends. Moreover, Kelxin Lim’s identity as a potential candidate of the author of the initial message is not simply came up with Zhilin Chong’s identification in line 38. In fact, Kelxin Lim’s denial in line 39 is actually her third and last response in this series of interaction. Excerpt below (Figure 5.5) shows other sequences of claim that positions Kelxin Lim as the author of the initial message.

#1103

"I fall in love with a FBA 2nd year guy, he is a little dark skin, skinny, wear spec and he is the BODs of UMAC. I am very into him and I am very lucky to be join his team in a mega event of UMAC. Under his leadership, I totally in love with him, I always imagine holding his hand while he is very near to me during departmental workshop. But then rumours around the faculty begins to spread, people are saying we are in love, especially my matric friends, and I started to worry that this will scare him away and we can't even be friend, and so, I become low-profile and not dare to near him as much as when we were working in the same event. I also heard that some people are saying he and another senior are in relationship. I sometimes wonder he really likes her or not, if it is true, I might be a little heart broken. Anyway, I still hope that someday we can have a chance to hang out, only two of us.

Sincerely,
Just a shy little 1st year girl"

((lines omitted))

41  Bibie Yani Oh My Gosh!!! Kelxin Lim !!!!!!!!!!!
Like · Reply · May 31, 2015 at 5:06pm

42  Kelxin Lim NO!!! Walaooooo not me
43 Somebody save me pleaseeee 🙏🙏🙏
Like · Reply · 1 · May 31, 2015 at 5:14pm

((lines omitted))

51  Jh Chen Kelxin Lim, is that u? U serious? 😱😱😱
Like · Reply · 11 · May 31, 2015 at 5:04pm

52  Kelxin Lim Seriously not me okay walao 🙏🙏
Like · Reply · May 31, 2015 at 5:11pm

53  Sinpei Lim Bibie Yani 😊
Like · Reply · 3 · May 31, 2015 at 5:04pm

((lines omitted))

Figure 5.5¹⁴: Identification of the author (FCP #1103)

As seen in Figure 5.5, Senpei Lim and Jh Chen made a response at a same time, 5.04 p.m (line 51 and 53). Practically, both of their responses are about the same topic that is the identity of the author of the initial message, but they display different approach towards the topic. In line51, Jh Chen’s question “Kelxin Lim, is that u? U serious? (shock emoticons)” seems like he is seeking a confirmation about something from Kelxin Lim. While it might not explicitly indicate that Jh Chen is saying Kelxin Lim is the author of the initial

¹⁴ This excerpt is from a similar interaction as in Figure 5.4

message, the context and content of the questions might say so. The use of a determiner 'that' (is that u?) means that Jh Chen is referring to something that had previously mentioned, and since his turn is responding to the initial message, he might be referring to it. Additionally, the author of the initial message is a female, so Kelxin Lim could fit the gender category of the author. The question then, shows that Jh Chen may have knowledge about Kelxin Lim in relation to the initial message. Therefore, by asking "U serious? (shock emoticons)" he is looking for further confirmation from Kelxin Lim regarding her connection with the initial message. This statement could be his expression of disbelief where he may try to say like 'are you seriously confessing here?'. So the use of three shock emoticons at the end of the turn may represent Jh Chen's expression of surprise that he tries to project in his question. As many study in emoticon suggested, the use of emoticon in computer- mediated- communication could provide additional social cues as well as to intensify the meaning expression of the text- utterance (Derks, Bos, & Grumbkow, 2007; Garrison, Remley, Thomas, & Wierszewski, 2011; Jibril & Abdullah, 2013). Therefore, the shock emoticons could be a way for Jh Chen to show his surprise towards Kelxin Lim in relation to the initial message.

While Jh Chen makes a direct question to Kelxin Lim, Senpei Lim can be said to take a discreet approach in identifying the author of the initial message. In line 53, she makes a simple response by tagging Bibie Yani and adds a 'smirking face' emoticon afterwards. It is difficult to comprehend her response without any statement. However, according to Garrison et al. (2011), in the situation where the emoticon appears alone in the conversation, it should be understood on the basis of its nature. The use of emoticon in written- communication is not limited to expressing one's emotion but could also indicate other things, such as attitudes or intentions which are different from what is constituted emotion or feeling (Dresner & Herring, 2010; Wolf, 2000). Therefore, certain emoticon should be treated as an utterance on its own which conveys similar understanding as a written language (Jibril & Abdullah, 2013). With regards to Senpei Lim's 'smirking face', it could mean that she is suggesting something since 'smirking face' emoticon usually is associated with an act of suggestion in an insinuating way. In Snapchat, this emoticon is use as an indicator of imbalance 'mutual action' that is once this emoticon appears next to a particular contact, it suggests that that person is frequently 'snaps' you, but you are rarely return his/ her 'snaps'. In a way, smirking face emoticon represents a sneaky or

mischievous feeling in a playful manner. So on its own, the ‘smirking face’ emoticon could portray an epistemic stance without necessarily use a written language. However, in order to make a suggestion, Senpei Lim must have something that worth to be suggested first. By making a response direct to the initial message, it could suggest that she has knowledge concerning the initial message, and her act of addressing Bibie Yani shows that Bibie Yani could be a part of that particular knowledge. Therefore, Senpei Lim’s response in line 53 could mean that she is suggesting that Bibie Yani is the author of the initial message (because Bibie Yani is a female), and so through the ‘smirking face’ she is portraying her knowledge. It could also mean that she called out to Bibie Yani to insinuate that they are sharing a particular knowledge concerning the initial message.

Then, as we can see in line 41, Bibie Yani makes a response, two minutes after. Her response, “Oh My Gosh!!! Kelxin Lim !!!!!!!!!!!!!” shows her surprise. The reaction illustrates through the use of multiple exclamation marks and capital letters to portray the depth of her feeling. According to many study on textual paralanguage, grammatical markers like capitalization, question mark, period, and exclamation marks can be manipulated in writing to add stress on the text- utterances because they have auditory properties to tell how the utterance should be spoken (Luangrath, Peck, & Barger, 2017). So, by writing “Oh My Gosh!!!”, Bibie Yani is not only expresses her surprise but she also shows how she may produce the speech by emphasizing each word using capital letter at the beginning, rather than merely saying ‘oh my gosh’ which is more straight and flat tone. In a way, the response shows that there is something about Kelxin Lim that may cause Bibie Yani to produce such reaction. Given that the response is following Senpei Lim’s earlier response¹⁵, it can be considered as her acknowledgement to Senpei Lim’s cryptic ‘smirking face’ message in line 53, and the call out of Kelxin Lim’s name to indicate that she knows what/ who Senpei Lim is talking about that is ‘Kelxin Lim (a person that both of them know) is or could be the anonymous author’. In a way, this interaction between Senpei Lim and Bibie Yani shows how information is shared among immediate networks.

Having been referred by Jh Chen and Bibie Yani, Kelxin Lim makes two quite similar responses to each of them. As can be seen in excerpt above (Figure 5.5), in line 52, Kelxin

¹⁵ Senpei Lim tagged Bibie Yani in her earlier response in line 53, and so Bibie Yani earliest response afterward in line 41 is expected to be the second pair part to Senpei Lim.

Lim writes “Seriously not me okay walao (two crying face emoticons)” in response to Jh Chen’s question. She makes another response three minutes after to Bibie Yani in lines 42-43 saying “NO!!! Walaoooo not me Somebody save me pleaseeee (three crying face emoticons)”. These two responses show Kelxin Lim’s denial or rejection towards the previous accusation or claim that she is the author of the initial message.

However, in showing her rejection, Kelxin Lim seems to put more emphasize on her response to Bibie Yani. It can be seen through the usage of multiple paralanguage cues like capitalization for ‘NO’, multiple exclamation marks, extended spelling for emphasize word (discourse particle) ‘walaoooo’ and more crying face emoticons (line 61- 62 Figure 1). All these paralanguage cues often being used in written- language to strengthen the message content (Derks et al., 2007; Postmes, Spears, & Lea, 2000). So, compared to her earlier response to Jh Chen (line 77 in Figure 1) which has less paralanguage cues, Kelxin Lim’s response to Bibie Yani appears more intense. It could be because Jh Chen is the first one who associates her with the initial message, so she straight forwardly denies it. However, with another accusation from Bibie Yani, she may feel the need to put emphasize on her word. With more people thought that she is the author of the initial message, she may feel the burden to clarify herself, so she says “Somebody save me pleaseeee” in addition to her denial in her response to Bibie Yani (line 43)

Interestingly, all Kelxin Lim’s responses to reject the claim that she is the author of the initial message (line 52 to Jh Chen, line 42 to Bibie Yani and line 39 to Zhilin Chong), the variety spelling of emphasize word (discourse maker) ‘walao’ has been used. This word is an additional term used mostly in spoken Malaysian interaction, and it does not bring any specific meaning on its own. Its usage within an utterance would give an impression that the speaker is casually emphasizing the subject that is being talked. The term often employed during spoken interaction among those who have close relationship such as friends and family as a softening strategy that is to show a sense of politeness and respect (Hashim & Tan, 2012). In Kelxin Lim situation for example, the absent of ‘walao’ in her utterance as in her response to Jh Chen “Seriously not me okay” (line 52 Figure 5.5) can be interpreted as her strong denial. But the incorporation of the term ‘walao’ in her utterances would give the impression of ‘soft’ in her rejection. To make a comparison with English, it is like the addition of ‘please’ in the sentence which would give the impression of being polite. However, in contrast with ‘please’, the term ‘walao’ is informal speech and does not

bring any specific meaning. The use of such term in spoken interaction among Malaysian is significant since it meant to avoid conflicting situation and preserve the relationship that the interlocutors have (Kuang, 2017; Omar, 2001). This happen as spoken interaction often occurs in face- to- face interaction and being too direct may, culturally, considered impolite and could affect one's social relationship. So, in case of Kelxin Lim, the use of term 'walao' is not only to soften her rejection, but it can also be a device which helps maintain her social relationship with others. Consequently, it shows a kind of relationship that Kelxin Lim may have with others (Jh Chen, Bibie Yani and Zhilin Chong) that is they all could belong to a similar cycle of friends.

Illustrated in this section are instances where identification works are done through social networks. This is the most common way of identification that found in this study. People tend to identify those in their circle of networks although their real names are concealed. It can be argued that this is due to the nature of FCPs which are community- based Facebook pages, and so community members may know and recognized each other.

Epistemic Stance: Localness

Localness refers to a claim of knowledge relating to a particular place. This includes knowledge about the place and also its related matters such as the criteria of the people/ residents of the place. Localness is one of the ways of displaying of epistemic stance that found to be used by commenters in this study when they make identification in relation to the initial message. The knowledge displays usually based on local knowledge in which outsiders may not know.

Figure 5.6 shows an excerpt from FCPs conversation #5242. In the excerpt, two commenters engage in a discussion concerning the identity of the author of the initial message. The initial message is about a condition of student's accommodation known as 'K11' which from the author's perspective is unsatisfactory due to the attitudes of its residents. However, it is the writing style of the initial message which consists of an obscene word that make the initial message appears like the author is ranting towards a particular group of 'K11' residents. Consequently, the conversations following the initial message revolve around the identity of the author and his/ her choice of word. Excerpt

below shows one of a series of interaction that discuss about the identity of the author. The commenters use their local information about the place as a basis for their knowledge claim.

#5242
Dear k11 girls,
Firstly, why do you fucking throw food in the sink? Everytime i brush my teeth it makes me wanna gag. I don't want to see what u fucking eat yesterday. Throw it in the fucking dustbin.
Secondly, u girls don't fucking know how to close the fucking tap water properly or what? Putting the fucking tap water on is your hobby? U just like the sound flowing in the toilet is it?
Thirdly, u girls don't know how to fucking knock the door before u enter ha? What if i am naked and i punch u in the face for not knocking. U want that to happen?
Macam buat rumah sendiri je pegimateyyy
Sincerely,
♥ k11ers

16  **Mohd Sani** I count 7 f*cking. And here are the details;
17 1st F*cking was question i.e "why do you fucking throw food in the sink?"
18 2nd F*cking was Adjective i.e "...to see what u fucking eat yesterday"
19 3rd F*cking was Command i.e "Throw it in the fucking dustbin"
20 4th F*cking was statement i.e "u girls don't fucking know"
21 5th & 6th F*cking was rhetorical question i.e "Putting the fucking tap water on
22 is your hobby?"
23 7th F*cking was Observation i.e "u girls don't know how to fucking knock the
24 door before u enter ha?"
25 Good essay though, same word, different context. The confessor must be frm
26 FBMK. Hahah
Like · Reply ·  22 · October 19, 2015 at 11:15am

27  **Nurul Ezaty** As i know only engineering and architecture student lives
28 in k11.
Like · Reply ·  2 · October 19, 2015 at 11:27am

29  **Mohd Sani** Good point. Perhaps the confessor is engineering or
30 architecture student. Lol
Like · Reply · October 19, 2015 at 11:30am

31  **Nurul Ezaty** For sure yeah. She's not only good in calculating or
32 drawings, she's also good in writing essay. 😊
Like · Reply · October 19, 2015 at 11:36am

33  **Mohd Sani** Exactly! hahaha 😊
Like · Reply · October 19, 2015 at 11:38am

Figure 5.6¹⁶: Knowledge of a location (FCP #5242)

¹⁶ This extract is 'responds to response', so the interactions were arranged chronologically (in order).

The conversational excerpt above shows claim to knowledge related to location and local information. In line 16 to 24, Mohd Sani initiates an identity proffer of the author by listing the grammatical usage of a word 'f*cking' that the author used in the initial message, before give out his remark "Good essay though, same word, different context. The confessor must be from FBMK" (line 25- 26).

This remark is claim of the author's identity that Mohd Sani made by associating the author to 'FBMK' which is the acronym for 'Fakulti Bahasa Modern dan Komunikasi' (Faculty of Modern Language and Communication). Through the claim, Mohd Sani is actually making an inference about the membership category of the author of the initial message, as he is ascribing relevant characteristic which typically associate with linguistic students to the author, as can be seen in his saying "Good essay though, same word, different context" (line 25). This action of making inference based on certain characteristic typically known to a particular membership category is a common way of identification. This is because certain activity or characteristic can illustrates a relevance tie to a certain category which in turn a person who is doing that activity, or having that characteristic, can also be identified with that category (Drew, 1978; ten Have, 2007b). So, as we can see in line 16- 26, after making some evaluation of a particular word (f*cking) used in the initial message, Mohd Sani projected his common- sense knowledge regarding the identity of the author based on the content of the initial message.

Mohd Sani identity suggestion then is challenged by Nurul Ezaty in line 27. She presents new information, saying "as I know only engineering and architecture student lives in k11" which not only display her knowledge concerning the characteristic of k11 residents but also indicates a possible membership category of the author of the initial message. The rationale for Nurul Ezaty to present this information could be because the author of the initial message is one of the K11 residents since she identified herself as 'K11ers' in the initial message. Therefore by stating that 'only engineering and architecture student lives in k11' Nurul Ezaty implies that the author of the initial message could be either engineer or architecture student. Indirectly, it shows her disagreement with Mohd Sani earlier suggestion that the author of the initial message must be from FBMK. This disapproval, eventually, leads to epistemic incongruence with Mohd Sani's earlier identity suggestion. What is interesting however, while Mohd Sani make a reference based on the relevant characteristic that he deciphered from the initial message, Nurul Ezaty's reference is based

on the location of the author. In both of these identification acts, they portray their local knowledge regarding their surrounding social structure. This act is similar to Drew (1978) 'reflexive property of common sense knowledge' (Drew, 1978, p. 10) where location descriptions are employed to identify a person. This is possible because knowledge about particular category could common- sensically inform about its relevant activities or characteristics (Housley & Fitzgerald, 2016). So, when Mohd Sani evaluates the writing style of the initial message, he common- sensically tied it with a category of people who are typically known to be good with writing or language. Hence, as FBMK is a well-known faculty that deal with language and writing, it is only common for him to associate the author with the faculty and identify someone from it as the author. Similarly, Nurul Ezaty identifies the author by presenting her already constitute knowledge regarding the location of the author.

In response to Nurul Ezaty's claim in line 27, Mohd Sani says "Good point" in line 29 which could indicate his acknowledgement towards Nurul Ezaty valid argument regarding the identity of the author of the initial message. This acknowledgement however does not necessarily indicate an increase epistemic status for Mohd Sani because the acknowledgement could be for the evidence that Nurul Ezaty presented. Hence, his subsequent statement "Perhaps the confessor is engineering or architecture student. Lol" (line 28- 29) shows his epistemic congruence towards Nurul Ezaty. Subsequently, Nurul Ezaty responses "For sure yeah. She's not only good in calculating or drawings, she's also good in writing essay" in line 30. This utterance shows how Nurul Ezaty emphasizes the relevant characteristics of the categories identity that she and Mohd Sani have ascribed to the author previously. This series of interaction between Mohd Sani and Nurul Ezaty illustrates how claim of localness that is knowledge about a particular place and its related matters could be used in identifying someone.

Epistemic Stance: Situational

Situation is another common display of epistemic stance in identification works. Situational refers here to a claim of a particular knowledge that can be attached to one's identity depending on a particular social situation in a particular context of interaction. The

identification then is performed through a claim of knowledge in relation to the particular social situation.

Excerpt in Figure 5.7 below shows an instance where commenters are searching for the identity of the recipient of the initial message through an event. The interaction is stemmed from FCPs initial message #1686. In the initial message, the recipient is introduced as a 'guy who danced on stage' during a university event known as 'iweek'. In the initial message, the author briefly states that the guy looks 'much more better' with a cap on due to his 'thick hair'. Other than these limited clues, users do not have clear identity of who is the recipient. Yet, the commenters took these limited cues looking for the identity of the recipient of the initial message. Figure 5.7 below presents a series of related interaction between several commenters who used the 'iweek' event as basis for knowledge claim concerning the identity of the recipient of the initial message.

#1686

"Dear the guy who danced on stage during iweek, you look much more better with cap on bcause your hair is wayyy toooo thicckkk. Pls do something about it 😊
From ur secret admirer"

((lines omitted))

17  Ayieda Ahmad Which IWeek?? Who dance?? Hilal Halmi ke?
Like · Reply · 👍 2 · September 25, 2015 at 2:37pm

18  Hilal Halmi Semestinya bukan saya. Saya mana menari
Like · Reply · September 25, 2015 at 3:34pm

Obviously it is not me, I'm not dancing

((lines omitted))

23  Laura Lian Anyang Foo Chuan Liang u wore cap on the stage during i week
24 right?
Like · Reply · 👍 1 · September 25, 2015 at 2:51pm

25  Foo Chuan Liang Not me. Confirm.
Like · Reply · 👍 1 · September 25, 2015 at 3:00pm

26  Laura Lian Anyang Ok...
Like · Reply · September 25, 2015 at 3:01pm

((one line omitted))

28  Laura Lian Anyang N pls which i week?
Like · Reply · 👍 1 · September 25, 2015 at 2:32pm

29  Aruna Suframanyam haha i assumed it was our iweek..no idea
30 which other faculty call it as iweek..
Like · Reply · 👍 1 · September 25, 2015 at 2:36pm

((lines omitted))

33  Laura Lian Anyang Few guy danced. Can u b more specific on which
34 dance?
Like · Reply · September 25, 2015 at 2:32pm

35  Aruna Suframanyam Ayieda Ahmad Laura Lian Anyang who is tat guy???
Like · Reply · 👍 1 · September 25, 2015 at 2:31pm

Figure 5.7¹⁷: iweek event (FCP #1686)

The identity searching was started by Aruna Suframanyam when she asks, “who is tat guy???” in line 35 to two of her friends Ayieda Ahmad and Laura Lian Anyang. The term ‘tat guy’ tied her question back to the initial message in which the author is directed the

¹⁷ This extract consists of several arrangements. The interactions arranged at the left are responding to the initial message, so they were arranged in reverse order. While the interactions which were indented to the right (like in line 18, 25, 26, 29) are responding to the responses, so they were arranged chronologically.

message to ‘a guy who danced on stage during iweek’. Given that Aruna Suframanyam specifically addresses Ayieda Ahmad and Laura Lian Anyang, it could suggest that Aruna Suframanyam is expecting that both of them may have information regarding the ‘guy’. By doing so, she is portraying that she has less knowledge about the guy while displaying some knowledge about her friends’ epistemic status in relation to the ‘guy’. This could be because Aruna Suframanyam knew that Ayieda Ahmad and Laura Lian Anyang attended the ‘iweek’ event where the author stated that ‘the guy’ had danced on stage. Hence, they may have the knowledge regarding the ‘guy’. This is later confirmed through Laura Lian Anyang response in line 33- 34¹⁸ when she says “few guy danced. can u b more specific on which dance?” which indicates that she attended the event and knew that there are few guys who danced during the event. However, the second part of her response (can u b more specific on which dance?) could implies that she may not have knowledge about the guy. In fact the question itself is quite ambiguous in the sense that it implies that Aruna Suframanyam could be the author of the initial message through the pronoun ‘u’ (you) that she uses in the question. It could also be that the question is meant for the author of the initial message instead of Aruna Suframanyam although she is responding to Aruna Suframanyam’s question. Either way, Laura Lian Anyang is portraying her epistemic status in relation to the content of the initial message through this turn.

Then in line 28, Laura Lian Anyang posted another question “and please which iweek?”. Looking at the way she constructs the question, begins with ‘and’, it seems like it is a continuation of her previous statement. Commonly, discourse marker ‘and’ function as a linker or extension of a topic between utterances (Fung & Carter, 2007). Speaker strategically uses it in order to show a relationship between the existing utterances with the preceding one while maintaining listener attention to the topic of conversation. Because of that, it commonly used by speaker to indicate the desire to hold the floor of the conversation (Fung & Carter, 2007; Mohd. Nor, 2017). Similarly, Laura Lian Anyang may use a similar technique to connect her two turns. Further, if we look at the timestamp of her turn in line 28, it was posted at the same time as her previous turn in line 33- 34. This suggests that both turns are related and her question in line 28 could be a continuation of her question in line 33- 34. Both are seeking further clarification on the information

¹⁸ Noted that the interactions are arranged in inverse order where the latest interaction appears at the top while the earliest interaction at the bottom.

concerning the initial message content. As these turns are considered as second pair part following first pair part from Aruna Suframanyam in line 35, the questions are expected to be directed back to Aruna Suframanyam. Hence, it implies that Aruna Suframanyam may also have knowledge about the 'iweek' event mentioned in the initial message. This, then, may put both of them on equal level of knowledge regarding the identity of the 'guy' that the author is talking about, as well as the iweek event.

Evident to suggest that Aruna Suframanyam may have knowledge about the 'iweek' event can be seen through her turn in line 29- 30. By saying "haha I assumed it was our iweek.. no idea which other faculty call it as iweek", Aruna Suframanyam displays her knowledge about the event. further, the pronoun 'our' that she uses could indirectly put her and Laura Lian Anyang (and possibly Ayieda Ahmad) into a similar category that is a category of persons belong to a faculty that organized an event called iweek. Therefore, when she tagged and asked Laura Lian Anyang and Ayieda Ahmad in line 35, it could be because she knew these two friends have knowledge about the event since they belong to the same category, hence may know the 'guy who danced' mentioned by the author in the initial message.

Another person tagged by Aruna Suframanyam in line 35, Ayieda Ahmad, responds at line 17 asks "which IWeek?? Who dance?? Hilal Halmi ke?"¹⁹. This response seems similar to Laura Lian Anyang's questions in line 33 and 28, that is seeking for further clarification. However, Ayieda Ahmad also provides a name 'Hilal Halmi' which can be a potential candidate of 'the guy who danced' that the author of the initial message is talking about. Warrant for this lies in a particle 'ke' that Ayieda Ahmad used at the end of her question. This particle is a common addition in Malaysian conversation to makes any statement or word appears as a question (Kuang, 2017). So, by saying "Hilal Halmi ke?", Ayieda Ahmad is asking 'could the guy be Hilal Halmi?'. Such question construction means that

¹⁹ In this response, although she was tagged by Aruna Suframanyam previously, it does not appear like she is answering to Aruna Suframanyam's question. However, due to the addressivity that Aruna Suframanyam used in line35, this turn may appear like it is a second pair part to Aruna Suframanyam. This situation has been recorded by many studies on online interaction Werry, 1996; Reed, 2001; Greenfield & Subrahmanyam, 2003; Meredith & Stokoe, 2013. Disrupted turn adjacency occurs when first pair part and second pair part are not adjacent due to unrelated turn exist between them. This unrelated turn emerged as it was sent before second pair part can be sent, or due to the automatic arrangement of the interaction set by the medium of the interaction, in this case, Facebook.

the question is not necessarily meant to be directed to Hilal Halmi, although the tag name could inform Hilal Halmi that Ayieda Ahmad is suggesting that he could be the ‘guy who danced’ mentioned in the initial message²⁰. Consequently, Ayieda Ahmad’s act of mentioning Hilal Halmi’s name in line 17 is for identity ‘fishing’. As discussed before, the reason for Aruna Suframanyam tagging Ayieda Ahmad and Laura Lian Anyang in line 35 is because they all belong in a same membership category that is persons from a faculty that organized the iweek event and attended the event. So, when Ayieda Ahmad suggests Hilal Halmi’s name, it could be because she knew Hilal Halmi is also connected to the ‘iweek’ event, hence a possibility for him to be ‘the guy who danced’. So, Ayieda Ahmad act in line 17 can be considered as an attempt for possible eliciting information from Hilal Halmi.

Her suggestion is rejected by Hilal Halmi himself when he states “Semestinye bukan saya. Saya mana menari (Obviously it is not me, I’m not dancing)” in line 18. While this response rejects Ayieda Ahmad suggestion that he could be ‘the guy who danced’, it does not deny that Hilal Halmi could attend the iweek event. Warrant for this can be seen through his saying ‘Saya mana menari (I’m not dancing)’ in which it can be interpreted as ‘I am not dancing although I have been there’. So, by disassociating the important criteria of the category ‘the guy who danced’, Hilal Halmi is excluding himself from being a potential candidate of the ‘the guy who danced’ that Ayieda Ahmad, Aruna Suframanyam and Laura Lian Anyang is looking for.

A similar act of searching for recipient’s identity is performed by Laura Lian Anyang in line 23. Addressing Foo Chuan Liang, she then says “u wore cap on the stage during iweek right?”. This turn puts Laura Lian Anyang in a witness position where she might see Foo Chuan Liang on the stage of the ‘iweek’ event wearing a cap. Because of that she might think that he could fits the characteristic of ‘the guy who danced’ mentioned in the initial message. However, the knowing that Laura Lian Anyang projected in her claim concerning Foo Chuan Liang is by virtue of the occasion. And all she did in line 23 is presenting evidence suggesting that Foo Chuan Liang could be ‘the guy who danced’. Eventually, in

²⁰ In Facebook, the tagged username will generate a notification to notify the owner that his/ her username has been mentioned ‘somewhere’. In turn, he/ she can follow the notification link to see where his/ her name has been used. Chapter 6 will discussed this matter further.

line 25, Foo Chuan Liang straight forwardly deny it by saying “Not me. Confirm”. His rejection, then, illustrates his epistemic status as the one who own the knowledge. Subsequently, Laura Lian Anyang states her verification with “ok” in line 26. This simple verification could signal her acknowledgement to Foo Chuan Liang’s response.

Another example where an event is used as a significant identifier is illustrated in the excerpt below (Figure 5.8). The excerpt is taken from FCPs initial message #1128 where the author expresses his admiration towards one of the students’ club president whom he met during a dinner organized by HEPA (Student affairs department). He describes the person as a ‘charming, elegant and gorgeous (lady) in red gown’. He also praises her achievement to ‘run 13 projects within a session’ successfully before stating his frustration to find out that she has a boyfriend. Based on the descriptions provided in the initial message, many commenters presume that the club president is Sookmun Liew and start a conversation revolving her identity.

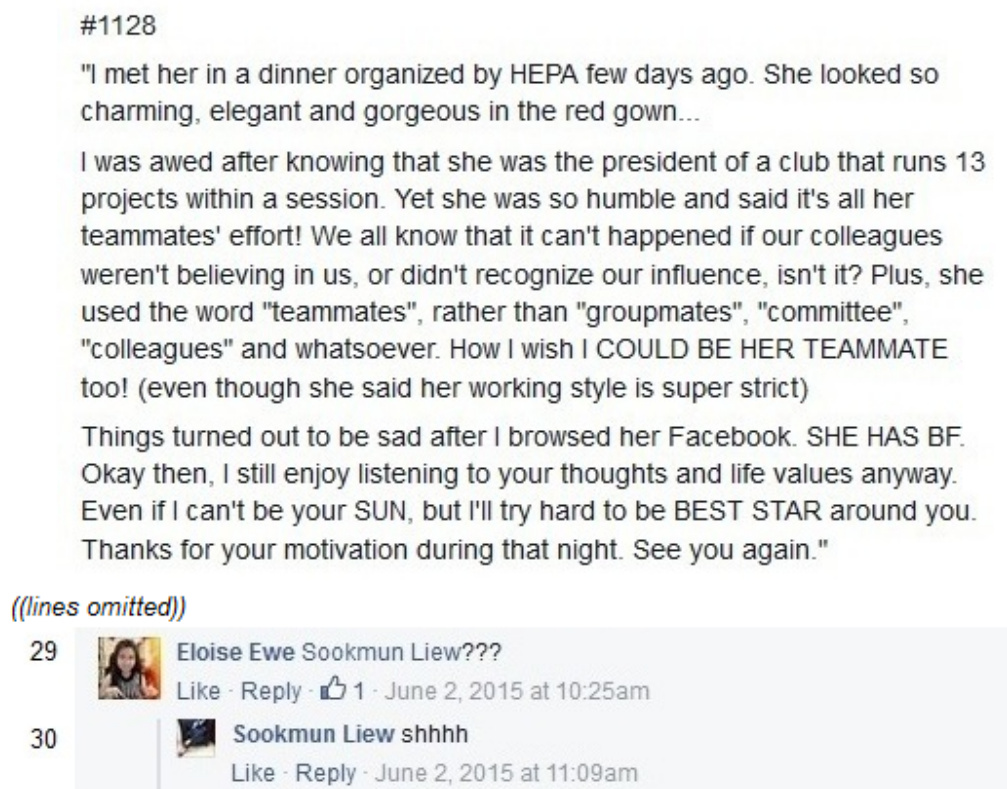

Figure 5.8: recipient identification (FCP #1128)

The name of Sookmun Liew was first mentioned by Eloise Ewe in line 29, right after the initial message. She tagged Sookmun Liew’s name and added triple question marks after

the name. As minimal as this turn is, it could be read in several ways. The fact that Sookmun Liew's name was tagged rather than just plainly written shows that Eloise Ewe wants to notify Sookmun Liew and brings her attention to the initial message. Meanwhile, the triple question marks after the tagged name could easily make this turn as an enquiry. It could be a question for Sookmun Liew whether she knows anything concerning the initial message, or it could be that Eloise Ewe is throwing out Sookmun Liew's name in making a guess regarding the identity of the persons in relation to the initial message. Either way, Eloise Ewe's act of specifically tags Sookmun Liew's name in line 29 portrays her epistemic stance concerning the relationship that Sookmun Liew has to the initial message. Yet, it can argue that her information regarding the matter is insufficient. Evident for this is illustrates through her minimal construction of the enquiry. Often, individuals who have higher degree or more knowledge about the matter at talk tend to express their knowledge confidently although they are taking K- position. Eloise Ewe, on the other hand, only tagged Sookmun Liew's name with triple question marks. While it shows her confident that Sookmun Liew may have some connection to the initial message, it also shows that she may not possess much information about the relationship.

Sookmun Liew's response in line 30 is not only update Eloise Ewe but also unpack the meaning of her enquiry. Response with "shhh", it is an expression used to call for silence or be quiet. In this context, it could be translated as Sookmun Liew's action to tell Eloise Ewe to be quiet or keep it as a secret, which indirectly tells Eloise Ewe that she is related to the initial message. Given that Sookmun Liew is a female, she can be the recipient of the initial message (as the author of the message is believed to be a male since he wish to be her boyfriend). Looking back at Eloise Ewe response in line 29, it is best seen as an action of guessing where she tries to unpack the content presented in the initial message by throwing out a name that may fit the description provided for the recipient of the initial message.

#1128

"I met her in a dinner organized by HEPA few days ago. She looked so charming, elegant and gorgeous in the red gown...

I was awed after knowing that she was the president of a club that runs 13 projects within a session. Yet she was so humble and said it's all her teammates' effort! We all know that it can't happened if our colleagues weren't believing in us, or didn't recognize our influence, isn't it? Plus, she used the word "teammates", rather than "groupmates", "committee", "colleagues" and whatsoever. How I wish I COULD BE HER TEAMMATE too! (even though she said her working style is super strict)

Things turned out to be sad after I browsed her Facebook. SHE HAS BF. Okay then, I still enjoy listening to your thoughts and life values anyway. Even if I can't be your SUN, but I'll try hard to be BEST STAR around you. Thanks for your motivation during that night. See you again."

((lines omitted))



Figure 5.9²¹: Lady in red (FCP #1128)

Extract above shows another instance from the similar interaction of FCPs initial message #1128 where Sookmun Liew is identified as the recipient of the initial message. In this interaction, the commenter presents evident to support their claim. As we can see in line 15, Khai Wern make a claim to Sookmun Liew by accusing her as the recipient of the initial message when she says “Sookmun Liew you have admirer !!!”. In response, Sookmun Liew says “that night many ladies were in red too, I think...” in line 16 that can be understood as Sookmun Liew rejection. This response also positions her as someone with insider knowledge that is someone who has attended the event where the author met the recipient. So when she says “many ladies were in red too”, she is presenting evident for

²¹ This Excerpt is ‘responds to response’ so it is arranged chronologically with the earliest at the top and the latest in the bottom

her rejection that she could be the recipient since they were other females who wore red dress like what is described by the author about the recipient besides her. This is a claim to direct access to knowledge of the event, and so her rejection appears to have superior epistemic status to dismiss Khai Wern's claim. Technically, her denial towards Khai Wern's accusation could result in epistemic incongruence (Heritage, 2013) where she downgraded Khai Wern's claim by presenting her own evidence. According to (Heritage, 2013) in a situation where there is a rejection towards the epistemic status projected, the speaker may attempt to produce a subsequent version to deal with the rejection.

Accordingly, KeSin Lim presents another evident to claim Sookmun Liew as a recipient in line 17 by saying "Sookmun Liew, but not every girl is the president of a club?". With the use of addressivity at the beginning, it is clear that this response is meant for Sookmun Liew. The use of a word 'but' after the addressivity could also indicate that this statement is a continuation of a previous statement. It happens as the word 'but' usually use to introduce a statement that adds something to a previous statement in a contrasting way. So, when KeSin Lim says 'the president of a club' (line 17) which is one of the characteristics of the recipient of the initial message, she is presenting an evident to reject Sookmun Liew stance in line 17. While KeSin Lim is not the person who present earlier claim of Sookmun Liew as the recipient of the initial message (that is Khai Wern in line 15), the content of her response shows a continuation which deals with Sookmun Liew's denial. Therefore, her response can be considered as a defending attempt, a continuation of Khai Wern's claim in line 15 that reached epistemic incongruence through Sookmun Liew's denial in line 16. Most importantly, through her claim, KeSin Lim further emphasizes Sookmun Liew identity as the recipient of the initial message.

In response, Sookmun Liew replies in line 19 says "KeSin Lim banyak kacau huh you (KeSin Lim you are so annoying)". This could read as her attempt to dodge KeSin Lim's claim that emphasizes her identity as the recipient of the initial message. However, what is interesting in this turn is the way Sookmun Liew constructs her response. Technically, the appropriate way to construct such utterance would be 'KeSin Lim you banyak kacau huh', with discourse particle 'huh' gives the impression of tag question such as 'right?' or 'isn't it?'. But by positioning 'huh' before 'you', it appears like Sookmun Liew is re-emphasize her statement against KeSin Lim. Sookmun Liew also switched to Malay words 'banyak kacau' while maintaining using English second person reference 'you' in the utterance.

Such code-switching practice is considered common particularly among bilingual or multilingual individuals as a conversational strategy to express certain meaning (Montes-Alcalá, 2007; Wei, 2005). Often the code-switching occurs due to difficulty in finding an accurate word or expression in the current spoken language (Halim & Maros, 2014; Halim & Maros, 2014). Similarly, Sookmun Liew might use Malay words 'banyak kacau' instead of English word 'so annoying' because it could express her feeling and intention better. Indeed, the words 'banyak kacau' give the impression that someone is interrupting your current action or situation in a non-serious way. So by saying 'banyak kacau', Sookmun Liew is playfully telling KeSin Lim that she is being such a disturbance. This assertion could be directed back to KeSin Lim's response as it happens that KeSin Lim self-selected herself in defending Khai Wern's assessment in saying Sookmun Liew could be the recipient of the initial message. On a whole, Sookmun Liew response in line 19 could be understood as she is being discreet from directly accepting or rejecting the accusation throwing on her. However, by doing so, it seems like Sookmun Liew is accepting KeSin Lim's claim that she could be the recipient of the initial message. Eventually, with epistemic stance projected by KeSin Lim in line 17 received by Sookmun Liew in line 19, their interaction reached epistemic congruence (Heritage, 2013).

This section has shown the identification work done by commenters through their knowledge about a particular event in relation the identified person. It illustrates how descriptions which comprise an occasion as well as characteristic of a person could be used to identify the person. So, identification works, in this sense, to be practices by specifying what aspects of a person or people are relevant in a particular situation.

Discussion

This chapter aims to provide an account of how identities are negotiated and identified in the FCPs interactions. It shows that as the identity work is performed, epistemic stance is a requisite component of the interactions. Commenters display their knowledge access to bolster their claims to knowledge in relation to the identity, or to weaken the claims of others. Though these claims to knowledge may sometimes seem trivial or inconsequential, they are in fact what allow the commenters to engage in the identity works further. This

finding shows a similarity with Hutchby's (2001a) Talk Radio study where it finds callers seek to strengthen their claim through legitimation and authentication. Although Hutchby's study does not claim to use epistemic approach, it illustrated how the callers' present first-hand knowledge to support their standpoint which is similar with the way the commenters display their knowledge (K+) to make a claim. Additionally, this study also finds that many of the identity proffers were done from a less knowing (K-) position, such as identity solicitation. It suggested that this may be because of the commenters' uncertainty since the identities provided in the initial messages are in descriptions. So, though they may have knowledge about the person, they need confirmation, or sometimes supports their claims.

Accordingly, this chapter considered three main areas of epistemic stance in relation to identity as commonly found in the data set that are networks, localness and situational. With regards to networks, it shows how members' of a group or community have a stock of knowledge about each other. In a situation where explicit identity is not use, this knowledge comes to display to make a claim to one's identity. Often, it is something that is known within the group. It found that the identity proffers for networks are straight forward but can be ambiguous. This happened as commenters can identify the person of interest easily but may not directly identify him/ her as such. The identity can be delineated, then, based the action projected and the epistemic stance displayed. It suggested however, that this situation is more evident within certain limitation such as a close group or a small community. Other consideration is localness where it has shown how information about a particular place can lead to identification works. In turn, this finding show how identity is connected to one's surrounding and not just something relates to one's personal. Another area of epistemic stance considered in this chapter is situational which shows, like localness, identity is relative to a particular situation. As find in this chapter, identification works are accomplished through association in which one identity is associated with knowledge about a particular situation such as event. As such, this chapter challenges notions of the invisibility of identity in digital contexts by showing ways in which individuals get around the non- visual and non- aural properties of the online medium to accomplish identity work.

Additionally, the analysis in this chapter is a continuation of the analysis in the previous chapter. On the whole, we can see that FCPs bring into play the potential for a new kind of interaction between 'news bearer' and the audiences. In this chapter, it shows how

audiences are invited to discuss and respond to the 'issue' brought in the initial message, but not necessarily concerning the issue but in whichever manner that they prefer. In this sense, the initial message, as discussed in the previous chapter, provides a context in which the audiences can determine which issues are worth to be responded and discuss. In a way, this is similar to the previous study on talk radio that examines how laypersons call in to give their idea concerning the item in the news provided (Hutchby, 2001). As the initial message set up an environment by framing the topic (referent/s), it also prepared the audiences with respect to the topic (referent/s). If we follow Hutchby terms of going 'first' and 'second' (Hutchby, 1996, p. 486; Hutchby, 2001a), the initial message would be the 'going first' that is to provide an agenda for discussion as well to prepare the audience who will be the 'second'. Going second then gives more freedom to the audiences to present their opinion in the sense that they can challenge, argue or reject the topic. In FCPs, however, the initial message is considered one-way interaction in the sense that the authors do not have the opportunity to counter-argue responders' claim without revealing their identity.

This chapter has also shown the benefits of technological resources in assisting the interaction, particularly in adjacency pairs. The most prevalent practice of adjacency pairs is through the use of Facebook's tag function which has heavily used on the username. Such technology makes it possible not only to identify the right person, but also to notify its owner given that Facebook interactions occur 'everywhere' within the Facebook realm. It also assists the disrupted turn adjacency due to the arrangement of the turns by Facebook. The following chapter will further show the wide possibilities of this digital feature in assisting interaction on Facebook. In Chapter 6, it will focus on Facebook username, that is the tagged username incorporated in the interaction, whether as a referent or addressor.

Chapter 6 – The Role of Facebook Naming

Introduction

Previous chapters 4 and 5 have investigated how identity work is accomplished in Facebook Confession Pages. They illustrated how the practice is intricately linked to participants' (the authors and the commenters) display of epistemic stance. This happened as participants display their orientation to certain identity, they invoked a relevant category of the identity. In doing so, participants draw upon various interactional resources in their negotiation and construction of identity, particularly the person reference (recognitional and descriptive term). Hence, it shows that while identity may not be explicitly referred to in the interaction, there will always be a meaningful identification that could represent it.

The analysis in Chapter 6 will shift it focused slightly away from this identity work. Still related to identity, it will explore participants' 'explicit' identity in Facebook that is Facebook username. As we see in the data presented, particularly in Chapter 5, commenters used username rather than 'normal' name when referencing to another participant. This practice partly can be contributed to the availability of the username to be utilized in the interaction. In Facebook, username is not just a text- of- name but it is an object of technology which can be manipulated in many ways, including summon and reference. In fact, it is the most efficient conversational device for person reference, as far as Facebook is concern. It can directly show who the person is and at the same time inform the person that he/ she was referred. This aspect of Facebook that set it far apart from just a merely text- of- name is the concern of this chapter.

Accordingly, the focus of this chapter is on the role of Facebook username. For the purpose of this analysis, it will be called with just 'Facebook name'. The chapter begins by briefly outlines the property of name for reference as it is used in different medium of interactions. This is not to make a comparison on how it is used in each medium, but to provide a foundation and guide for the analysis. The subsequent analysis will explore the property of Facebook name as it is used and utilized in the interaction. The objective is to

show that while Facebook name serves as reference in interaction, it also has different properties that can give advantage (or disadvantage) to participants.

Name Reference

Name is the most explicit identity knowledge that can inform who we are (Marx, 1999). It is commonly used for referring in interactions (Enfield & Stivers, 2007; Kushida, 2015). Other methods of person referring in face- to- face interaction include identity descriptions (e.g. “the girl who wears a flowery scarf”), pronouns (“he”, “she”, “them”), and the use of head movement, eye contact, and turning to someone physically without saying their name (Stivers et al., 2007). In a typical spoken interaction, initial naming tends to be dropped once the referred to person has been recognized by both the recipient (Crystal, 2006), such that in a normal face- to- face interaction, it would be unusual to hear:

Mary: John, are you going to rehearsal tonight?

John: Mary, yes, I am.

Mary: John, what time?

John: Mary, about six.

(Crystal, 2001, p. 162)

This style, however, is acceptable or normal in communication channels such as internet relay chat (IRC) and social media. For instance, in IRC, the practice of including the name of an intended recipient in a turn is widely practiced (Werry, 1996). The reason for this conversational strategy, is explained by Werry (1996) as a conventional form of addressivity,

“it has become entirely conventional for speakers to indicate the intended addressee by putting that person’s name at the start of an utterance, followed by a colon:

<boot> franck: there’s a girl

<Franck> boot: where? where?

Such a high degree of addressivity is an imperative on IRC, since the addressee's attention must be recaptured anew with each utterance. A contributing factor to the emergence of this convention may be that the role of the "listener" becomes more passive on IRC than in spoken dialogue".

(Werry, 1996, p. 52)

In computer- mediated- communication, the receiver is usually unable to supply the appropriate response such as nodding or giggles, etc., which in face- to- face interaction is used to signal active attention and maybe used to indicate understanding (Greenfield & Subrahmanyam, 2003; Werry, 1996). Often participants in computer- mediated- communication clarify whom they are addressing, with whom they are initiating a conversation, or to whom they are responding, by starting their contribution with the name of the addressee (Ahti & Lahtevanoja, 2004; Graham, 2007; Greenfield & Subrahmanyam, 2003; Rintel et al., 2001; Werry, 1996). Therefore, using names in Computer- mediated- Communication is not unusual phenomenon owing to the fact that participants cannot see one another while delivering the message. The absence of audio and visual cues significantly impacts and alters the standard method of face- to- face addressing. In other words, person reference, as in direct address by name, has become a typical phenomenon in computer- mediated- communication such as IRC.

Another reason why person name reference plays an important role in computer- mediated- communication is that the name, either real name or nickname, is one of the few mutually known features participants of the chat can rely on and draw on when chatting (Greenfield & Subrahmanyam, 2003). The importance of the name in online interaction is illustrated in the following examples from IRC and Facebook.

[339] <ashna> hi jatt
 [340] *** Signoff: puja (EOF From client)
 [341] <Dave-G> kally i was only joking around
 [342] <Jatt> ashna: hello?
 [343] <kally> dave-g it was funny
 [344] <ashna> how are u jatt
 [345] <LUCKMAN> ssa all
 [346] <Dave-G> kally you da woman!
 [347] <Jatt> ashna: do we know eachother?. I'm ok how are you

Figure 6.1: A typical IRC interaction (Paolillo, 2011)



Figure 6.2: Facebook Confession Pages #1187

Figure 6.1 illustrates an excerpt of a typical log of an interaction on IRC taken from a public IRC channel called #punjab (taken from Paolillo, 2011). In this example, as in a typical log of IRC interaction, there is a list of names in the left side before each utterance, indicating the name of the current participants of the chat. The line numbers, however, have been added by the data owner (Paolillo, 2011) to the log file for reference. In this example, there are a couple of conversational exchanges interleaved, one between Ashna and Jatt, and the second between Dave- G and Kally. Notice how the chat participants are addressing each other by name in each conversation. In line 339, ashna addresses jatt who responds in line 342. In between of ashna and jatt interaction, Dave- G is addressing Kally in line 341, and Kally responds in line 343. Given that the participants have no way of seeing who is online in this real- time synchronous communication, name is one feature that the chat participant can rely on when interacting with each other. Name facilitates the interaction by determining the recipient of the conversation, as illustrated in the example, the exchanges between ashna and jatt (line 339 and 342), and Dave- G and Kally (line 341

and 343). It could be that without name addressing, the position of the greeting by jatt (line 342) could be confusing to Kally (line 343) given the proximity and positioning of the greeting. Hence, names ensure the coherence (Greenfield & Subrahmanyam, 2003; Werry, 1996) of the interaction in this real- time synchronous communication environment.

The conversation in Figure 6.2 is taken from the data of this study. It shows slightly different from Figure 6.1. The interface is more attractive with an incorporated profile picture, and the users' names are written in bold blue. The conversation still involves name addressing or referring but notice that the name referring is in blue. The Facebook technology changes the colour of the text when a Facebook username is typed into the text input box. The technology also sends a 'notification' directly to this user (further explanation of this will be given in the following section). So, even without reading the whole interaction, the user can easily detect which conversation is meant for him/ her due to the notification system that links back to the original name reference in the conversation.

Interaction on Facebook is also different in many other ways than IRC, although both are known as Computer- Mediated- Communication (CMC). For instance, IRC is a real- time communication in the sense that turns are taken more immediately and frequently, although the message production and transmission are separate (Garcia & Jacobs, 1999). Due to this, some scholars prefer IRC as "quasi- synchronous" communication format rather than synchronous communication (Garcia & Jacobs, 1999; Meredith & Stokoe, 2014). Meanwhile, this is not necessarily the case for Facebook. The conversation on Facebook can happen in real- time as well as delayed- time, where the users join or continue the conversation whenever they log into the Facebook site. As a social network, Facebook allows connectivity and has a wide global reach which means that the interaction on Facebook is not static or closed but it could be shared and joined by many people. Facebook facilitates information sharing by allowing the users to create connections via web contents such as sharing photos through Instagram or news from the news website. Thereby, Facebook creates opportunities for a wider interaction among its users. Arguably, Facebook needs a better system to organize interactions, especially in referring to each other. Otherwise, the interaction may be ignored.

Meanwhile, although IRC can be very active, no one outside the channel will notice. For instance, in the example presented in Figure 6.1, the interaction on the #punjab channel

could be active in the sense that there are always new topics to be discussed among the participants, but participation in the channel is restricted to those who registered with the channel and those who are not a member of the channel will not have access to the channel. In other words, although both IRC and Facebook are considered text- in- interaction, the nature and features of the medium of communication would differentiate the way their users communicate. Therefore the role of a name also functions differently in each medium. IRC could only use it locally, among the members who are chatting at the same time. While on Facebook, a name might be used widely, extending the function of reference in interaction. This will be examined in the subsequent section.

Typical Practice of Referring on Facebook

Based on the close observation of the Facebook interaction data set gathered for this study, there are certain particularities in a conversational technique related to person reference and addressing or summoning others. As Chapter 4 and 5 demonstrated, the practices of person reference are influenced by their epistemic level in relation to the referent. In the initial messages, non- recognitional and descriptive terms are used. While in the response messages, Facebook name is used not necessarily for identification actions but also for summon and information distribution (will later explain in this analysis).

Owing to the fact that Facebook users cannot see one another, and the conversation happens through texts, and the message has to reach the right person, Facebook has introduced a tagging tool and a notification system to assist the interactions. Through these software applications, Facebook users can create a link to another Facebook user if they are ‘friends’ on Facebook. That is the users have added each other to their Facebook friends list. The practice of referring or summoning others in Facebook, then, can be performed via these two software elements.

In practice, however, it is not necessary that Facebook users have to use these Facebook functionalities every time they refer to others on Facebook. They can still use a conventional method that is directly type a name without using the applications, in which case, the referring will not technologically link to the friend. For the purpose of this current study, this act of referring which does not use Facebook applications will be called a ‘non-

friend- name- reference' (NFNR), to differentiate it from the one that use Facebook applications when referring to others.

However, a typical practice of person reference on Facebook usually involves a Facebook user types and tags another Facebook user in his or her friends' list. The tagging tool works by transforming the text (profile name) into a technical object, which sends a notification to the named person. For instance, when one's Facebook name is typed into the Facebook interface, Facebook auto- fills with the friend's names suggestion as illustrated in Figure 6.3 below.



Figure 6.3: Facebook Tagging Tool

The names of suggested friends will be available in a drop- down box below the message writing space. It is not necessary, however, to type a complete name because users can just select the name that they wanted. Once the right name has been selected or tagged, the name will turned blue (like the name of Bryan Chai Kang Weng in Figure 6.3) to indicate that a link has been created between the conversation and the name's Facebook account, and notification has been sent to that person. Subsequently, the notified person will receive a message or a 'notification' in his or her Facebook account.

This whole process of tagging and notify other, interestingly, show similarity with the telephone's ring and summons (Schegloff, 1979). To start a call, a caller makes a conscious action as whom he wants to call before then dialling the person's number. Or in a mobile phone, a caller may select the name of the person from the contact list. The notification sent resembles the phone's ring to draw the recipient's attention and eventually

answer the summons. However, Facebook notification is more like the mobile phone that is the summons conveys information about the caller (Arminen & Leinonen, 2006). So, a Facebook name is also functioning as a summons to get the attention of the notified person.

Additionally, referring to others in Facebook is not much different from typical spoken interaction. The Facebook applications that emphasize on the use of a name is actually satisfied both preferences in the organization of reference to persons that are recognitional reference and minimization (Sacks & Schegloff, 1979). As it happens, in recognitional reference, although description can be used, there is a strong preference for a name. A name also is considered a single reference which is a minimal form of referring. What makes Facebook- name- referring different from the typical name referring is that its practice is restricted to the name used on the Facebook profile that is the name registered with Facebook. Therefore, if a person's real name is Barbara Fox, but she registered herself as 'Miss BF' on Facebook, then 'Miss BF' will be her name on Facebook. And she will be referred to using this name on Facebook, although in the real world she may be referred to as 'Barbara' by her colleagues. She can still be referred to as Barbara on Facebook but the name will not instigate a Facebook- name- referring which means that she will not receive a notification whenever her name been mentioned.

Normally, the practice of person reference on Facebook happens as a user types and tags a Facebook profile name to determine that that user is the one who is being referred to, as a Figure 6.4 shows below. This figure is an extract of a conversation stem from an anonymous confession message which gave descriptions about the person whom he/ she is confessed to²². In this extract, Francesca Chen responds to the initial message, while Bri Eun makes a response to Francesca Chen's response in line 2.

²² For a full conversation, refer to Facebook Confession Pages #1191 in the appendix



Figure 6.4²³: Facebook- name- referring on Facebook (FCP #1191)

In line 1, Francesca Chen makes a reference to Cher Shong Teoh. Notice that Cher Shong Teoh's name is in blue colour which indicates that Francesca Chen used the tagging tool in referencing him. Similarly, in line 2, Bri Eun makes another reference to Cher Shong Teoh in his response to Francesca Chen. This suggests that Bri Eun knows who and which Cher Shong Teoh is being referred to by Francesca Chen. This is later confirmed by Francesca Chen in line 4 when she says 'I guess he's related to everything on this page' in which the use of the pronoun 'he' in the sentence is to refer to Cher Shong Teoh that they both referred in the line 1 and 2.

One interesting aspect that worth to mention from the conversation above is the mismatch between a locally- initial form and a locally- subsequent position. According to Schegloff (1996), there is a standard way to make a reference to a third party that is to use locally- initial form such as a name in a locally- initial position that is when the referent is mentioned for the first time. Then in a locally- subsequent position (subsequent occasions when the same person has referred again), locally subsequent reference forms such as a pronoun will be used. In the conversation above, in line 2, we see that Bri Eun uses a repeated locally- initial form (name Cher Shong Teoh) in a locally- subsequent position. In a normal situation, Bri Eun can replace Cher Shong Teoh name with a simple pronoun 'he' since Francesca Chen had mentioned the name earlier in line 1. So, there is no need for Bri Eun to use the name to refer to a similar referent. The mismatch between locally initial form and locally subsequent position like this, according to Schegloff (1996) may invite attention from the hearer as why the speaker uses that referring expression. Here, Bri Eun's action could be due to the accessibility of Facebook applications in making person

²³ The extract is 'responds to response' so the interactions were arranged chronologically (in order).

reference.

Facebook's tagging tool helps to simplify the intended referent as well as the recipient, by turning the name of the person into a technical object which links directly to the person. This act of tagging is really helpful, especially in a situation where there is a huge user database, like Facebook, as it is difficult to even use a name, such as 'Nurul', as it might not apply uniquely to one user (Lerner, 2003), as many users might share similar names. In a way, tagging a person's name in Facebook is similar to telephone ring or IRC automated joining event (Rintel et al., 2001; Schegloff, 1979) in which the producer (callers, IRC and Facebook users) produced the actions to attempt a connection with the person. For example, as illustrated in Figure 6.5 below.

52  **Hisyam Zainal** Ey bkn aku la,aku x pkai beg merah,aku pkai plastic bag je n
53 aku x pkai helmet jln2 kt fac
Like · Reply ·  2 · October 25, 2013 at 2:01am
it's not me, I didn't use red bag, I only have plastic bag n I didn't wear helmet while walking around fac

54  **Nurul Ain Fawzi** Hisyam Zainal fuyyooo..haha
Like · Reply ·  3 · October 25, 2013 at 1:27am · Edited
Hisyam Zainal fuyyooo..haha

55  **Aiman Najhan** Kalau bukan wan dgn hisyam mmg tak syak lagi Hafizul Hafiz
56 lah orgnya hihi
Like · Reply ·  6 · October 24, 2013 at 6:17pm
If it is not wan or hisyam, then the person must be Hafizul Hafiz

57  **Khairuldin Majid** Kalau bukan hisyam myb Muhammad Syazwan Salahudin
58 kot
Like · Reply · October 24, 2013 at 5:52pm
if it is not hisyam maybe it is Muhammad Syazwan Salahudin

59  **Aiman Najhan** Malangnya dia sudah mempunya haha
Like · Reply ·  1 · October 24, 2013 at 5:11pm
Unfortunately he's taken haha

60  **Amirul Azzat** kudin, aku bace nie pon trus terpikir kt hisyam.. hahaha
Like · Reply · October 24, 2013 at 4:32pm
kudin, I also thought it was hisyam when I read it...hahaha

61  **Khairuldin Majid** Hahaha hisyam....red helmet wavy n jambul hair perfume
62 harum semerbak
Like · Reply ·  10 · October 24, 2013 at 4:27pm
Hahaha hisyam....red helmet wavy n spike hair sweet-smell perfume

Figure 6.5: Name Reference through Facebook Software (FCP #794)

As seen, the name Hisyam has been mentioned repeatedly in lines 61, 60, 57 and 55, but since it did not make it through the Facebook's tagging tool, as the Facebook- name-referring, the name hisyam still appears in black- coloured text which indicates that other than referring, the name does not signify anything else. Also, the name could be referring to multiple Facebook users who share the similar name Hisyam. Only after several turns does Nurul Ain Fawzi make an effort to use the Facebook application (in line 54) and the name Hisyam Zainal turns blue to show that it has made a link to a particular individual. By specifically linking the conversation to the intended person through Facebook tagging tool, Nurul Ain Fawzi has retrospectively made the name Hisyam as recognitional reference form. Consequently, it eliminates other Facebook users with the name of Hisyam.

It is notable that Hisyam only produces a message once notification has been generated through this Facebook functionality. This implies that he is responding to the notification, or at least is drawn into the conversation because of the notification. Perhaps in Facebook interaction, in which messages are not continuously read, the (technical) notification system has foundational (social) interactional consequences. As in telephone conversation, where the ring becomes a crucial opening element as it acts as a summon and set up a sequence of interaction (Schegloff, 1979), in Facebook, the notification could similarly act as a summon, thus implies that the producer of the notification has a reason to notify the person. It is this implication that choosing the next speaker when they are not 'present' (currently reading and participating) rest on and requires such technical functionality.

This instance where the name Hisyam is typed without the use of the Facebook tagging tool (line 61, 60, 57 and 55) illustrates the so- called non- friend- name- reference (NFNR) mentioned earlier in this section. This type of name reference does not generate an automatic link to the person's Facebook account, hence there is no notification sent to the person. This term will be discussed further in the non- friend- name- reference section.

Facebook- Name- Reference

A name holds a special status within the realm of Facebook since it serves as the user's main identification. In fact, Facebook's rules officially require the use of real names, or

authentic names, on the site ([https:// www.facebook.com/ legal/ terms](https://www.facebook.com/legal/terms)), which allows the person to be recognised by other Facebook users. There are of course people with the same name across the world, and hence this doesn't completely specify an individual. Essentially, it is the Facebook- name that assists Facebook users to connect and interact with each other, as the name is turned into a technological object (explained in the section above).

Observation of the Facebook interaction corpora gathered in this study finds that the Facebook- name- reference is used for various purposes. It is used for summoning and notifying others about the certain message posted, to invite others to a conversation and to select the next turn speaker, to name a few. All these functions are performed by Facebook- name- reference through two conversational practices that are the person reference and addressing. Summoning other/ s by addressing them via Facebook- name- reference is the most common practice among Facebook users. The reason is to draw their attention to the ongoing conversation. This is because interaction on Facebook can take place on any page in the Facebook realm, in a friend's Facebook page²⁴, in the page of a friend of a friend, in a group or community page, or in the user's own page. In the absence of audio- visual cues, Facebook users could easily overlook the ongoing interactions which relate to them. In this situation, other means to alert, connect and invite users or friends to the interaction are needed. Hence, Facebook- name- reference helps to alert and connect Facebook users to the ongoing interactions. The following example illustrates the practice of Facebook- name- reference. This example is an extract from a Facebook conversation stemming from an initial message that thanked a foreign worker at a restaurant who treated the author of the message to a free lunch due to a certain situation happening in the restaurant. In the anonymous message, the author described the person and encouraged the readers to be kind to others regardless of their background.

²⁴ Facebook user interface is commonly called a page. It is believed the term is stemmed from the 'face book', a directory of American universities consisting of individuals' photographs and names, since Facebook was created by its founder out of his frustration with his university's official facebook. Hence, the term 'page' used for Facebook user interface is to emulate the page of the face book of the American Universities ([http:// www.thecrimson.com/ article/ 2004/ 2/ 9/ hundreds- register- for- new- facebook- website/](http://www.thecrimson.com/article/2004/2/9/hundreds-register-for-new-facebook-website/)).



Figure 6.6: Addressivity in Facebook²⁵ (FCP #956)

Figure 6.6 illustrates how a Facebook- name- reference is used in the interaction, both in the speaker's turn (line 1), as well as in the recipient's turn (line 2). In line 1, a Facebook user Minnie Zatie addresses Sau Fei at the beginning of her turn, and continues with 'macam pernah baca je' ("it seems familiar") in reference to the anonymous message. The address can be considered as a common feature of interaction, that is to seek the attention of a recipient before the substantive content of an utterance or message (Sacks, 1992, p. 685). However, Minnie Zatie not only addresses Sau Fei but also tagging him. Consequently, a link to Sau Fei's Facebook account has been established from this interaction. The Facebook notification system, then, will alert Sau Fei and draw his attention to the conversation.

In a way, the notification initiated by Minnie Zatie through Facebook- name- reference has several similarities to the telephone ring. Both are produced as a result of a conscious action of one interactant, and their structure and content are dictated and produced by the medium. Also, both illustrate the attempted connection to a particular person. However, while both automated events function as notification devices about potential interaction, there are also some differences. Facebook notification is text, while the telephone rings are mechanized alarms. Therefore, the name of a notifier is known, while the name of a phone caller is not necessarily known. This difference then affects the initiation and direction of each interaction.

As summons, both have the ability to set up the interaction sequence (Schegloff, 1979).

²⁵ The interaction in this extract has been rearranged from the original appearance in Facebook. The original arrangement is in reverse order and can be referred in the appendix in FCP #956

For the telephone ring, it acts as an initiatory cue which requires a response since the ring itself is not communicative beyond its summoning power, and it does not provide identity or information about the caller for the receiver. So, the ring requires an opening response and thereafter requires that the caller carry on producing turns related to the reason for calling and that the receiver responds. However, Facebook notification set up the interaction sequence slightly different from the phone ring. As Facebook notification contains information about who is notifying, it invites tailored responses directly to the notifier. As in Figure 6.6, Minnie Zatie notification-summon to Sau Fei does not wait for an opening response before she continues with the reason for summoning.

Further, the Facebook notification is commonly used to coordinate the ongoing activity in the Facebook interaction. It may demonstrate the interactants' orientation to the ongoing activity and may be shaped accordingly just like the interaction shown in Figure 6.6 above. As we can see, the notifications produce by both users, Minnie Zatie and Sau Fei, seem to be embedded in the interactional activity itself. Their interaction shows that it is a means of achieving something else, which is Minnie Zatie informing Sau Fei that she knows Sau Fei is the author of the initial message. Therefore, unlike phone rings, the responses to Facebook notification could be diversified, as they are no longer answers to a neutral summons.

Accordingly, as we can see in line 2 in Figure 6.6, Sau Fei responds by making a similar Facebook- name- reference to Minnie Zatie which can be understood as his response to Minnie Zatie's summons. This is interesting since, in this situation where the talk has been established (Minnie Zatie specifically summons Sau Fei, hence it is expected that Sau Fei's response is for her), another summon may not be necessary (Crystal, 2001). However, studies in IRC consider this act as a conversational strategy normally adopted by users to ensure the coherence in the chat room (Greenfield & Subrahmanyam, 2003; Werry, 1996; Rintel et al., 2001) since the interaction takes place at a distance or in the non- present to each other (the speaker and the recipient), so enacting a notification tells the notifier that an answer sequence has been created. In a way, it is a technique that participants used in managing the disrupted turn adjacency often occurred in CMC interaction. As it happened, adjacency pairs which are among the basic tenets of sequence organization (Schegloff, 2007c), often difficult to be maintained exactly like in spoken interactions. Turn of the second pair part which is supposed to be adjacent to the first pair part may not appear as

such in CMC, rather they may be far separated. Accordingly, on Facebook, users use Facebook names to summon each other and maintained the sequence organization.

Another reason for issuing a Facebook- name- reference in the second pair part could be because the recipient (in this case Sau Fei) does not know whether the summoner (Minnie Zatie) is still present or not. Moreover, the turns between Minnie Zatie (line 1) and Sau Fei (line 2) is almost an hour different, in which it could be that Minnie Zatie has left the conversation. Therefore, by issuing Facebook- name- reference, Sau Fei is also sending a notification to Minnie Zatie. In this case, the use of a Facebook- name- reference in the second pair part could be for a practical reason that is to bring back the first person's attention to the conversation. This situation somehow shows similarity with phone ring summons which has the condition of non-terminality (Rintel et al., 2001; Schegloff, 1979). That is a summons' producer has a reason for summoning the respondent. So, the summons requires a response. As a summons, therefore, the ring sets up a condition of non-terminality at least until the reason for the call has been dealt with in some way. However, as phone call occurs in real-time, the response is immediate. But on Facebook, the interaction can be in delay-time, so the condition of non-terminality could take a longer time.

As mention before, summons has the ability to set up an interaction in which it acts as an initiatory cue which requires a response. A similar situation also found in Facebook interaction where Facebook- name- reference is used to initiate interaction and construct adjacency pairs in the conversation. Figure 6.7 illustrates how a Facebook- name- reference is used to construct adjacency pair and bring coherence to the conversation. The example is an excerpt of Facebook conversation coming from an anonymous message where the writer describes his physical features using several celebrities as a reference.



Figure 6.7: Facebook Cross- turn²⁶ (FCP #1187)

In line 1, a Facebook user Sylvester Keith Liaw makes a Facebook- name- reference to Jun Yen at the beginning of his turn, and follows with ‘please dont confess here I know u are handsome’ (“Please don’t confess here, I know you are handsome”). This Facebook- name- reference could be understood as Sylvester Keith Liaw attempting to attract Jun Yen’s attention and draw him into the conversation. Eventually, Jun Yen responds in line 5, and also makes a Facebook- name- reference to Sylvester Keith Liaw which indicates that it is his response to Sylvester Keith Liaw’s turn in line 1. This situation highlights the significance of Facebook- name- reference in facilitating the coherence of the interaction in Facebook as it tends to be easily disrupted. There might also be a delay in the recipient’s response that will separate the speaker and the recipient’s turns, as seen in Figure 6.7, where there are two utterances (line 3 and 4) separating the conversation between Sylvester Keith Liaw and Jun Yen. Therefore, Facebook- name- reference is one of the techniques that users can use to construct the adjacency pair in the Facebook conversation.

However, it is not necessary for the second pair part to make a Facebook- name- reference in the Facebook interaction. Figure 6.8 shows a situation where the second pair part does not use a Facebook- name- reference. The instance is an excerpt from one of the Facebook interactions that revolves around an anonymous complaint message where the writer is frustrated with his/ her laboratory group member who is always going missing and has not complete his/ her task.

²⁶ The interaction in this extract has been rearranged from the original appearance in Facebook. The original arrangement is in reverse order and can be referred in the appendix in FCP #1187

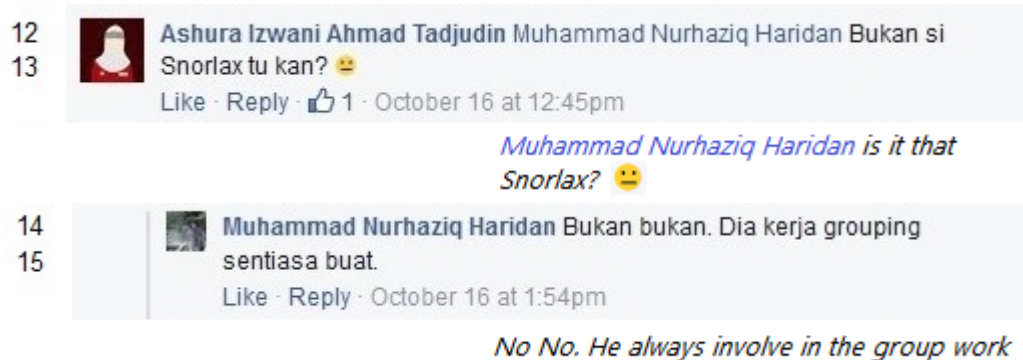

Figure 6.8: Calling a person²⁷ (FCP #860)

In line 12, the Facebook user Ashura Izwani Ahmad Tadjudin summons ‘Muhammad Nurhaziq Haridan’ at the beginning, before continuing with a question ‘Bukan si Snorlax tu kan?’ (“is it that Snorlax?”). As seen, Muhammad Nurhaziq Haridan’s name has turned blue, which indicates that the Facebook recognised the name as Ashura Izwani Ahmad Tadjudin’s friend and transformed the text into a technical object. It then notified Muhammad Nurhaziq Haridan. Consequently, Muhammad Nurhaziq Haridan responds in line 14 with ‘Bukan bukan. Dia kerja grouping sentiasa buat’ (“No no. He always involve in the group assignment”). This response represents quite a remarkable understanding of Muhammad Nurhaziq Haridan as a recipient as it is not only indicating that he understands what Ashura Izwani Ahmad Tadjudin was asking about (whether the Snorlax is the group member who is always going missing mentioned in the anonymous message), but he also acknowledges that he is the person who has been addressed in the line 12. This example shows the significance of Facebook- name- references in the Facebook in maintaining the sequence of interaction. It also ensures a successful transfer of the message from the speaker to the recipient in the absence of visual and audio means in the Facebook realm.

Multiple Facebook- name- reference

The practice of referring and addressing in the Facebook is not restricted to one person. Facebook users can include as many Facebook- name- references as they want in a single

²⁷ This message sequentially ordered because Muhammad Nurhaziq Haridan respond directly to Ashura Izwani. For responses message like this, Facebook will arrange it sequentially.

turn, provided that those friends are in their Facebook friends list. For example, in Figure 6.9, the excerpt is from a Facebook conversation that stemmed from an anonymous love confession message directed to one of a male senior student at the Faculty. The conversation then revolves around identifying the writer of the confession.

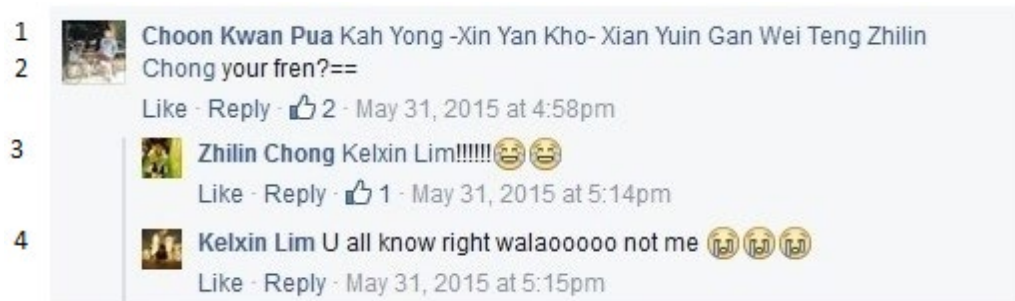

Figure 6.9: Questioning more than one person on Facebook (FCP #1103)

As seen on line 1, Choon Kwan Pua makes several Facebook- name- references at the beginning of her turn, and follows them with a simple question ‘your fren?’ (Understood as ‘your friend?’). Notice that all the names have turned blue, which indicates that those persons are Choon Kwan Pua’s friends on Facebook. This act of addressing several persons at the same time is peculiar to the Facebook interaction. It could be because the addressed persons are invisible and separated from one another; hence Choon Kwan Pua feels the need to address each one of them. Alternatively, in a normal face- to- face interaction, Choon Kwan Pua can simply say ‘your fren?’ to address everyone in the vicinity simultaneously. This act of addressing multiple friends in the same utterance could be seen as Choon Kwan Pua’s strategy in pursuing a response to her question. By integrating several Facebook- name- references in the same turn, Choon Kwan Pua lures them to the anonymous initial message, and especially to her turn. This action could increase the probability for her question to be responded to by any one of them and indeed one of them does come back with a suggestion of Kelxin Lim. This situation reflects Herring’s (1999) findings regarding multiple initiations in IRC interaction in which users tend to increase their initiations (address/ post) in order to get a response. Additionally, Choon Kwan Pua’s action in Figure 6.9 above could also indicate her ‘fishing’ for a person to ‘self- select’ themselves as relevant next speaker. In turn-taking, generally, the current speaker would select the next speaker, usually using an addressed question towards the selected person (Sidnell, 2010). Such a question will initiate a sequence of actions for the

next speaker to so. In a situation where there is more than one person becomes a candidate for the next speaker, the earliest one to respond will be the next speaker. Similarly here, in line 3, we see one of the addressed friends in line 1, Zhilin Chong, responds by making a Facebook- name- reference to another Facebook user, Kelxin Lim. This could be understood as her response to Choon Kwan Pua question in line 1. Essentially, this situation reflects the affordances of Facebook to make certain actions possible despite the limitation for interaction such as visual and audio. Facebook offers a variety of features that allow users to manipulate for better interaction experience.

Another instance that shows how multiple Facebook- name- references are used in a same turn is illustrated in Figure 6.10. This excerpt is from a Facebook interaction stemmed from an anonymous love message to a person named Chai Chuan Wei. In the interactions, Facebook users identify Chai Chuan Wei as a person with a name Nicholas Chai Chuan Wei in the Facebook and make a Facebook- name- reference to him.

- 13  **Nicholas Chai Chuan Wei** Kevin Chee Theresa Chu Alex Fang Lim Siew
 14 Ying Gary Lee Kah Meng Karen Yky Shu Ying Terry Hoong Shiong Lam
 15 Adrian Zheyu Samuel Yeoh Zheng Yi I aint sure whether this is a juz a prank
 16 or a true confession. Thanks fr d tagging n congratulation. so chill guys! Life
 17 goes on as usual! Enjoy ur holiday while it last. ^^
 Like · Reply ·  2 · August 28, 2014 at 11:44am
- 18  **Zen Ljw** Lollllll
 Like · Reply · August 28, 2014 at 11:44am
- 19  **Ming Shyang Loi** U attract me too Nicholas Chai Chuan Wei
 Like · Reply · August 28, 2014 at 10:27am
- 20  **Kevin Chee** HAHHAHA! Congrats, Nicholas Chai Chuan Wei~ 😊
 Like · Reply · August 28, 2014 at 7:50am
- 21  **Theresa Chu** Miri is proud of you XD Nicholas Chai Chuan Wei
 Like · Reply · August 28, 2014 at 6:06am
- 22  **Alex Fang** Nicholas Chai Chuan Wei I m proud of u, buddy!!!
 Like · Reply ·  4 · August 28, 2014 at 4:52am
- 23  **Lim Siew Ying** wow Nicholas Chai Chuan Wei NOT BAD WOR x)
 Like · Reply ·  2 · August 28, 2014 at 4:14am
- 24  **Gary Lee Kah Meng** Congrat! Nicholas Chai Chuan Wei
 Like · Reply ·  3 · August 28, 2014 at 4:08am
- 25  **Karen Yong Kai Yuan** Wow wow wow! Nicholas Chai Chuan Wei bebai ahh..
 Like · Reply ·  2 · August 28, 2014 at 3:43am
- 26  **Shu Ying** omo, Nicholas Chai Chuan Wei, u gt new wife liao lol!
 Like · Reply ·  3 · August 28, 2014 at 3:32am
- 27  **Terry Hoong** Nicholas Chai Chuan Wei win liao lo!!!! xDDDD
 Like · Reply ·  1 · August 28, 2014 at 3:19am
- 28  **Adrian Zheyu** Nicholas Chai Chuan Wei u hurt the girl this way. Not prank lol
 Like · Reply ·  2 · August 28, 2014 at 3:11am
- 29  **Samuel Yeoh Zheng Yi** Nicholas Chai Chuan Wei!!! 😊
 See Translation
 Like · Reply ·  6 · August 28, 2014 at 2:37am
- 30  **Adrian Zheyu** Nicholas Chai Chuan Wei
 See Translation
 Like · Reply ·  4 · August 28, 2014 at 2:32am

Figure 6.10: Responding to more than one person on Facebook (FCP #996)

As seen in the interaction, several Facebook users identify the ‘Chai Chuan Wei’ mentioned in the message as Nicholas Chai Chuan Wei and make a Facebook- name-reference to congratulate him (line 30 to 199). Then, in line 13, Nicholas Chai Chuan Wei responds by including Facebook- name- references to each of those who had addressed and congratulated him. He manages to recognize and address each addressee due to the

Facebook features such tagging and notification, as well as Facebook affordances in preserving textual record of the interaction. With each tagging, Nicholas Chai Chuan Wei will receive a notification from the notifier which includes the name. The notifications also preserve in his Facebook account, so that he can always check who has notified him. Furthermore, Facebook text- in- interaction features allows persistent textual record of the interaction. Hence, users are able to participate in simultaneous multiple interactions without getting lost or confused, because there is a written record to which they can refer to keep track of what is going on. Accordingly, as shown in Figure 6.10, Nicholas Chai Chuan Wei manages to keep track of who have notified him as well as the preceding interactions despite the time- gap between interactions. This then allows him to acknowledge each friend who had notified him previously and response to them all at once.

Another example of the usage of multiple Facebook- name- references in a single turn is illustrated in Figure 6.11 below. This instance shows an excerpt from a Facebook interaction stemming from an anonymous initial message where the writer revealed that he/ she love to watch a person named Kuan Ming from Chemical Engineering. The writer then asked the readers to ‘tag’ his name in the comment section if they know the ‘Kuan Ming’ that he/ she is referring to. In the preceding conversation before this excerpt in Figure 6.11, several Facebook users tagged a Facebook profile name ‘Lim Kuan Ming’ and identifies him as the ‘Kuan Ming from Chemical Engineering’.



Figure 6.11: Conversation dissemination (FCP #1098)

In line 1, Lim Chun Jiann makes several friend- name- references in his turn. There is no other utterance accompanying these multiple Facebook- name- references. Therefore, it is difficult to understand the reason for his action, nor what the action aims to accomplish. It could be that Lim Chun Jiann is fishing for a response from any of them as Choon Kwan Pua did in figure 6.9 line 1. If this is Lim Chun Jiann’s motive, then he succeeds in increasing the response rate of his turn because a number of persons whom he has summoned through Facebook- name- reference in line 1 have responded; Mei Yi in line 5, Sylvester Keith Liaw in line 8, and Mei Qi in line 9. However, in line 17, Lim Chun Jiann says ‘I simply tag haha’ in response to Mei Qi utterance in line 15 ‘Chunjian tagged me lol dk he got tag wrong ppl or not’ (translated as Chunjian tagged me [laugh out laugh] don’t

know he tag wrong people or not). This shows Lim Chun Jiann's attention when he summoned several of his Facebook friends (in line 1) is to draw their attention to the conversation. This act of summons multiple Facebook friends at the same time, then, could be understood as a method to disseminate the information on the Facebook and generate potential participation to the ongoing interaction. Indeed, similar action has been found in many other social networking sites such as Twitter where users utilised such conversational tagging as a tool for prompting individuals to join in a conversation and build a community around a given topic (Bruns & Burgess, 2011; Oeldorf-Hirsch & Sundar, 2015). Tagging friends push the information specifically to them and thereby draws their attention to the interaction and increases the likelihood that they will read the post to see why they have been tagged. As for the taggers, the feature affords the opportunity to determine the audience of the post and encourage them to participate. In sum, the social function serves by the features of social networking sites such as the tagging and notification functions in Facebook ensure the smoothness of the interaction.

Third Person Reference

Facebook- name- reference is also used by Facebook users for third person references. Basically, the third- person reference is a practice of referring to others, present or non-present, other than the speaker and the recipient using an appropriate reference form (Enfield, 2013; Schegloff, 1996). Although in the previous chapter, I have shown the used of recognitional descriptors for the referents in the anonymous initial message, in a normal conversation that use real Facebook identity, the practice of referring to a third person is similar with a typical talk- in- interaction, especially in English, where there is a preference for the use of a name over recognitional description (Schegloff, 1996; Stivers, 2007).

In Figure 6.10 above, it shows one instance where a Facebook- name- reference is used as a third person reference in an interaction initiated by an anonymous love confession message. In a longer conversation of this excerpt, users are curious to find out who is the writer as well as his/ her love interest. Several names have been mentioned and discussed based on the descriptions and other social cues extracted from the message concerning the identity of the writer as well as the referent of the message. In the excerpt in figure 6.12, the interaction is between Muhammad Nor Shafiq Guaperas and Chin Joo Tan who are

also making a guess about the identity of the writer and his/ her love interest.

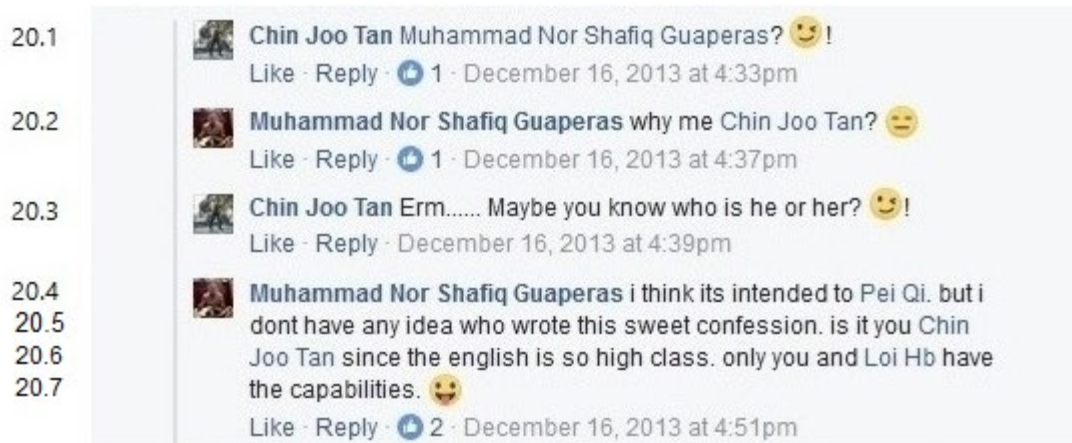

Figure 6.12: Facebook Third Person Reference²⁸ (FCP #879)

As seen in line 20.4, Muhammad Nor Shafiq Guaperas makes a third person reference to Pei Qi, and again on line 20.6 to Loi Hb. Notice how the third person name references have turned blue, both Pei Qi (line 20.4) and Loi Hb (line 20.6). It indicates that Muhammad Nor Shafiq Guaperas is not only making a third person reference, but he made it through Facebook- name- reference which involved the use of the Facebook's tagging tool and the notification system. Consequently, both Pei Qi and Loi Hb will receive a notification through their Facebook account. This situation differentiates Facebook- name- reference with a normal practice of person reference, in which most of the time the non- present third person referent in talk- in- interaction are not aware their name has been mentioned. To illustrate the difference, I borrow a conversational data from (Schegloff, 1996, p. 439).

- 01 Mark: Where were we
 02 (0.5)
 03 Sheri: I dunno.=’ve you been studying lately?
 04 Mark: No. °not et aw- ° not et a:ll:. I hafta study this whole
 05 week.<every ni:ght, {(·hhh)/ (0.8)} en then I got s’mthing
 06 planned on Sunday with Lau:ra,

²⁸ This interaction occurs under someone else main response, so Facebook rearrange this interaction sequentially that is the earlier message at the top and the latest message at the bottom. However, this arrangement only takes place below the main response, while in the main response is still arranged in reverse order. Please refer to appendix FCP #879 for a full interaction.

07 (0.5)
 08 Mark: She- she wen- she 'n I are gonna go out 'n get drunk at four
 09 o'clock in the afternoon.

In this interaction between Mark and Sheri, the use of a simple name reference to refer to a non- present person Laura in line 06, suggests that the referent is someone that both of them know. However, this interaction happened without Laura (the referent) knowing, since she was not present during the interaction, and there is no means for her to know that her name has been mentioned in the conversation unless Mark or/ and Sheri inform her afterwards. Conversely, Pei Qei (Figure 12 line 4) and Loi Hb (Figure 12 line 6) alert that their names have been mentioned in the interaction between Muhammad Nor Shafiq Guaperas and Chin Joo Tan due to the fact that they received a Facebook notification once their names have been used as a Facebook- name- reference.

In this situation, although in typical talk- in- interaction, they do not have the right or obligation to respond since they are not selected as the next turn speaker, Pei Qi and Loi Hb may join the interaction because they are aware about the ongoing interaction. Moreover, by notifying them, it seems like an invitation to both of them to the interaction. Hence, they might feel the obligation to respond. This situation has been illustrated by the interaction in Figure 6.9. In that interaction Kelxin Lim's name was used as a third person reference by Zhilin Chong (Figure 6.9 line 3) in responding to Choon Kwan Pua's question in line 2. Since Zhilin Chong uses Facebook- name- reference in referring to Kelxin Lim, the ongoing interaction comes to the knowledge of Kelxin Lim. Therefore, she makes a turn in line 4 (Figure 6.9) to deny that she is the person who writes the confession letter by saying 'U all know right walaooooo not me' (Walao is an expressive word which can loosely translate as 'of my god'). This whole interaction shows how a Facebook- name- reference at times simplifies the preferences for recipient design in interaction. It solves the speaker's problem in finding a referring expression that will identify and contact the very individual that the speaker has in mind, to the recipient. Facebook helps to identify the very individual by linking the name with the person through its technology. As shown on Figure 6.9 line 3, Zhilin Chong makes a simple Facebook- name- reference without any additional identifying description, in responding to the question by Choon Kwan Pua on line 1. Subsequently, on line 4 (Figure 6.9), a response from Kelxin Lim, the referred

person on line 3 (Figure 6.9), confirmed that she is the person that Zhilin Chong was referring to. In this case, Choon Kwan Pua might know or might not know Kelxin Lim (since she did not include Kelxin Lim's name in her turn in line 1), but the Facebook-name- reference made by Zhilin Chong on line 3 (Figure 6.9) has directly indicated which Kelxin Lim that Zhilin Chong is referring to, hence make it clear to Choon Kwan Pua the identity of Kelxin Lim.

Additionally, the Facebook- name- reference, Kelxin Lim, which was used by Zhilin Chong in Figure 6.9 line 3, could be considered as a third person reference as well as a summon. This happens as the Facebook- name- reference of Kelxin Lim serves as a third person reference in Zhilin Chong's answer to Choon Kwan Pua question (figure 6.9 line 2), where Zhilin Chong makes a reference to someone. At the same time it also acts as a second name reference or address (figure 6.9 line 3) because Zhilin Chong uses Facebook-name- reference on Kelxin Lim's name which automatically notifies Kelxin Lim about the conversation. In conversation between Zhilin Chong and Kelxin Lim (figure 6.9 line 3 and 4), the Facebook- name- reference to Kelxin Lim could be understood as a summon from Zhilin Chong. So, it may be argued that Facebook- name- reference, unlike the person name reference in typical talk- in- interaction, could perform two or more actions in a single turn.

Having said that a single Facebook- name- reference in Facebook conversation could denote both, a second person reference and a third person reference, it would be appropriate to make a distinction between the two to facilitate a better understanding of the role of Facebook- name- reference. For that, this study will define a second person reference as a direct address from a speaker to the recipient, while third person reference is a reference to refer to someone other than the speaker or the person to whom he or she is talking.

A response from a person who has been referred as a third person reference in a Facebook interaction, however, is not necessarily occurring all the times. As mentioned before, a person who has been referred through a third person reference may not feel obliged to make a next turn in the interaction. It could be because in a typical talk- in- interaction, the person who has been referred as the third person reference did not realize his/ her name was mentioned in the interaction, hence there is no opportunity for him/ her to join in the

interaction. Yet, in the Facebook interaction, we can consider it as the persons' choice whether they want to join in the interaction or not whenever their name is used as a third person reference using the Facebook- name- reference. Figure 6.13 reflects a situation where the referred Facebook- name- reference does not make a turn in the interaction. This example is an excerpt from a Facebook conversation stemming from an anonymous message from a girl who has a crush to his team leader. In the message, she used recognitional descriptors instead of name in referring to the referent. So, in the following conversation from the message, the Facebook users are trying to figure out the identity of the referent using the descriptions provided in the message.



Figure 6.13: Unresponsive Third Person Reference (FCP #1103)

As seen in Figure 6.13, a Facebook user Kin Chun's name has been mentioned a few times through Facebook- name- reference (in line 1, 3 and 9). In line 1, Chloe Zhaoyi writes 'My first thought is...Kin Chun LOLLOL'. This utterance is more like a general statement in the sense that it is stating what Chloe Zhaoyi feel or think, and the Facebook- name- reference of Kin Chun could be understood as a third person reference. Similarly, in line 2 Janice Wong says 'Obviously...a little dark skin ahahaha...member of springtime? Kin Chun' (Translated) which could be understood as her agreement with Chloe Zhaoyi's statement in line 1, and the Facebook- name- reference of Kin Chun (in line 3) is used after

repeating the recognitional descriptors provided in the message, as an identity indication of the message's referent. Kin Chun's name is once again mentioned in line 9 by Yen Zi Joyce in stating her agreement that the referent of the anonymous message is Kin Chun. In these three utterances, Kin Chun's name was mentioned through Facebook- name-reference as we can see that Kin Chun's name has turned blue (line 1, 3 and 9) to indicate that Facebook had created a link to Kin Chun's Facebook account. Consequently, Kin Chun was notified that his name has been mentioned in the interaction, unless if he does not log in to his Facebook account. However, despite has been mentioned several times, Kin Chun did not make any response or join in the interaction. From CA perspective, this is similar to alternative types of response (Schegloff, 2010, p. 48), where it is not all the time that the recipient may accept the invitation to talk. In this situation, Kin Chun might decide not to join in the interaction as he feels no obligation to respond as his name was used as the third person referent. Another similar situation is when joining announcement is made on IRC to introduce a new person who has joined the forum interaction. Though there is an announcement, production of response is a matter of choice. The joining announcement is, then, initiatory in the sense of a basic signal of presence, but it does not ratify the beginning of dyadic interaction (Rintel et al., 2001). Likewise, a third person reference in Facebook may signal the person's virtual presence in the interaction but it does not necessarily require a response from the person.

Non- Friend Person Reference

Although there is an option to use Facebook- name- reference, this current study finds that Facebook users still use a conventional method in making a person reference occasionally, depending on the context of the conversation. By conventional method, it refers to the common practice of person reference such as using name and nickname without using Facebook applications. To differentiate it with the Facebook- name- reference, this conventional practice of person reference on Facebook will be called non- friend- name-reference (NFNR) in this study.

There are many occasions where Facebook users tend to use NFNR. One reason would due to the Facebook friend status. As explained earlier, in order to make Facebook- name-reference, the users must be a 'friend' in Facebook, which means they have each other

name in their Facebook friend list. In a situation where the users are not friends in Facebook, they cannot perform a Facebook- name- reference, although they type a correct name according to the profile name of the person in Facebook. In this situation, the supposedly Facebook- name- reference becomes a normal name reference or NFNR in Facebook. Another situation where NFNR is used is after the referred person has been identified or has been addressed through Facebook- name- reference preceding the interaction, as illustrated in Figure 6.14. This extract is from a Facebook conversation stemming from an anonymous initial message from a girl who is looking for a potential vegetarian boyfriend. In a conversation following the message, Facebook users have brought up several names who could be the potential person, and in this particular excerpt of the conversation in figure 6.14, another name, Karan Bavisi is mentioned.



Figure 6.14: Prior Facebook- name- reference (FCP #1773)²⁹

In this example, Kishan Naidu makes a Facebook- name- reference to Karan Bavisi in line 1. One minute after, he makes another turn saying ‘looks like karan gonna get a gf’ followed with several Facebook- name- references (line 2). Interestingly, although he uses Facebook- name- reference to several of his Facebook friends at the end of his turn, Kishan Naidu did not use Facebook- name- reference on Karan’s name in his turn in line 2. The reason for this could be because Kishan Naidu has notified Karan Bavisi in his previous turn (line 1) through Facebook- name- reference. And the NFNR ‘karan’ in line 2 is expected to be a similar person as the Facebook- name- reference in line 1. Therefore,

²⁹ The interactions in this excerpt were arranged chronologically.

there is no need for Kishan Naidu to re-notify him. Meanwhile, the reason Kishan Naidu uses several Facebook- name- references at the end of his turn, as explained in the previous section on multiple friend name reference, to disseminate the conversation to other Facebook friends as well as to lure their response towards his conversation. Eventually, Deva Kumar, one of the addressed friends (line 3), responds in line 4. Similar with Kishan Naidu, Deva Kumar also uses NFNR Karen ji³⁰ in his turn, which indicate that Deva Kumar also makes a reference to a similar person that is to Karan Bavisi. Later, in line 5, Karan Bavisi responds by saying ‘it’s look like a prank played’. Through this response, Karan Bavisi indirectly acknowledged that he is the person that Kishan Naidu and Deva Kumar referred to using NFNR in line 2 and 4. In this case, we can say that Karan Bavisi alerts about the conversation through the Facebook- name- reference made by Kishan Naidu in line 1. Furthermore, there is a short time gap between the turn where Kishan Naidu summons Karan Bavisi (line 1) using Facebook- name- reference, and the subsequent turn when he use NFNR to Karan (line 2). Therefore, even Kishan Naidu uses NFNR in line 2, it can be assumed that he is referring to Karan Bavisi. This example shows that a conventional person reference is still relevant and acknowledge in Facebook conversation.

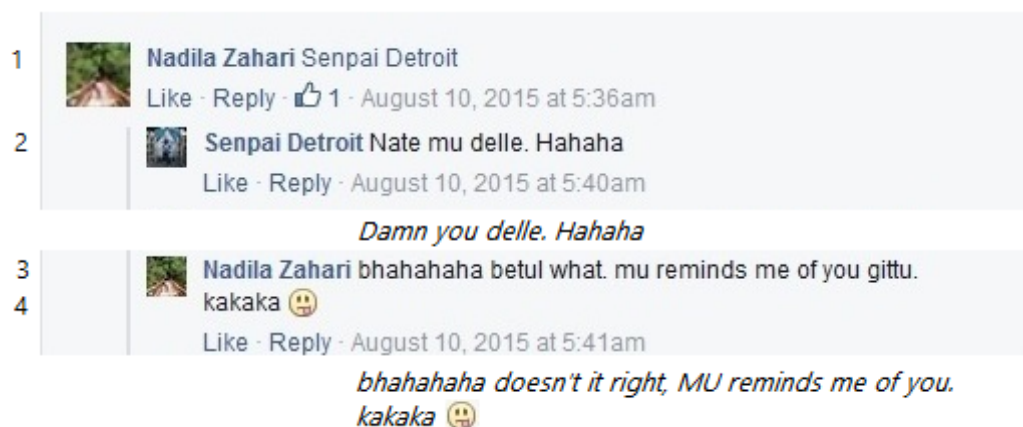

Figure 6.15: Nickname (FCP #1633)

Figure 6.15 illustrates another example on how NFNR is used in the Facebook interaction. In this excerpt of a Facebook interaction, the users talk about an anonymous initial message where its writer is looking for a female Manchester United fan to be his girlfriend.

³⁰ *Ji* is a term used together with one's name to show respect to older brother in Indian culture. It is a formal term which rarely use in casual conversation, but sometime it is use as an inside joke within a group of friends.

In line 1, Nadila Zahari summons Senpai Detroit through a Facebook- name- reference. Then in line 2, Senpai Detroit replies to Nadila Zahari by saying ‘Nate mu delle. Hahaha’ (Damn you delle. Hahaha). Notice how Senpai Detroit’s turn in line 2 has been pushed to the right. This happened as Senpai Detroit intentionally replies to Nadila Zahari by clicking the word ‘reply’ below Nadila Zahari’s name in line 1. In Facebook comment section, this action would create a new space for direct reply below Nadila Zahari’s turn in line 1. Consequently, Senpai Detroit’s response will be arranged directly below Nadila Zahari’s turn (line 1), rather than follow the default arrangement by Facebook (such as the most recent conversation appear at the top, or chronologically order, etc.) in which Senpai Detroit’s response could be far separated from Nadila Zahari’s turn. As seen in line 2, Senpai Detroit did not use Facebook- name- reference in her response; instead she uses NFNR delle to address Nadila Zahari. The word delle could be understood as Nadila Zahari’s nickname since it is used after a pronoun ‘you’, to indicate the recipient of the conversation. Later in line 3, Nadila Zahari responds by saying ‘betul what. mu reminds me of you gittu’ (doesn’t it right, mu (Manchester United) reminds me of you). This shows that Nadila Zahari understood Senpai Detroit’s turn in line 2, including the NFNR that she used for her. This whole conversation also shows that Nadila Zahari and Senpai Detroit could be a close friend (maybe in offline realm as well) in the sense that Nadila Zahari knows Senpai Detroit’s favourite team, and Senpai Detroit is comfortable in using a nickname to Nabila Zahari in their conversation. This example illustrates how NFNR is used in Facebook conversation, especially among close friends.

The above examples, however, illustrate the practice of NFNR done by a person who has been referred through Facebook- name- reference previously. In practice, once a user used a Facebook- name- reference in making a reference to another, he/ she is not only sending a notification to the referred person, but also create a Facebook’s alert system for him/ herself on the conversation, that is when the referred person responds to the conversation, he/ she will be notified by Facebook. Hence, even if the referred friend does not use Facebook- name- reference in the subsequent turn, the person who had used a Facebook- name- reference previously would still receive a notification from Facebook updating the conversation status. For instance, Nadila Zahari would get a notification when Senpai Detroit replies to her conversation (Figure 6.15).

There is also an instance where NFNR is used without a prior friend- name- reference. This

instance usually happens in a small interaction within a main Facebook conversation. Figure 16 below will illustrate the structure of the interaction. Notice in line 2, the turn is indented to the right. This is to indicate that this turn is a direct reply to the earlier turn in line 1. It happened as word ‘reply’ in line 1 is clicked to create new space for direct reply. This action will automatically notify the user of the earlier turn (where the reply is clicked) that his/ her turn has been responded by someone.



Figure 6.16: Direct reply interaction (FCP #1086)

In figure 6.16, the excerpt is from a Facebook conversation that revolves around an anonymous initial confession message from a person who introduced him/ herself as ‘your roommate at 5th college’. The anonymous confessor asks for forgiveness from his/ her roommate for ‘accidentally’ deleting his/ her roommate porn collection. As seen in line 87, Faiz Zeo uses a NFNR when he says ‘Lco u delete t ah fatt punya collection ke? (Lco did u delete ah fatt’s collection?)’. In this turn, the NFNR Lco, could be understood as an acronym for Leong Chen Onn, the person whom Faiz Zeo replied to in line 86. This NFNR acronym could act as a summons in this turn as Faiz Zeo ‘replies’ directly to Leong Chen Onn. Further, Faiz Zeo also uses a NFNR ah fatt as a third person reference in the same turn in which it could be assumed that Faiz Zeo is referring ah fatt as Leong Chen Onn’s roommate. As explained before, the creation of a new space for a direct reply in a Facebook conversation would notify the very person whom his/ her turn has been clicked ‘reply’. In this instance, Leong Chen Onn would get the notification once Faiz Zeo replies to him. Subsequently, Leong Chen Onn responds in line 88 by saying ‘ah fatt not my roommate pun.haha’ (“ah fatt is not even my roommate”). This response by Leong Chen Onn illustrates that he understood as well as acknowledged the NFNR that Faiz Zeo used

in line 87 is referring to him as well as ah fatt.

However, it should be noted here that the reason Leong Chen Onn received the notification is because Faiz Zeo created a direct reply below Leong Chen Onn conversation. Both NFNRs that Faiz Zeo used in the conversation (line 87) did not generate any link extension to Leong Chen Onn or ah fatt's Facebook account. It also means that, ah fatt as a third person reference, may not realize that his name has been mentioned in the conversation between Leong Chen Onn and Faiz Zeo. In this instance, the conversation is similar with other text- in- interactions in the sense that the conversation is technology- mediated but it does not have the ability to connect the referred person as a Facebook- name- reference able to do. In this conversation, ah fatt situation is similar to Laura (the third person reference taken from Schegloff, 1996, used in the discussion on the third person reference section) since there is no means for him to know that his name has been mentioned in the conversation, unless he has been told by Leong Chen Onn and/ or Faiz Zeo in person, or he personally comes to the conversation and read the conversation between them.

Discussion

This analysis investigates the practice of name reference use in Facebook interaction and argues that referring to others is a fundamental interactional action on Facebook. It was performed mainly through what this study has called a 'Facebook-name-reference', which is the name registered and used by Facebook users. Facebook-name-references are performed when a user tags a Facebook friend's name which then generates a notification on the friend's Facebook account. Additionally, through this Facebook function, a range of actions are performed such as selecting the next speaker and coordinating one action.

Previous studies on openings on mediated-communication have emphasized the importance of summons abilities in initiating a conversation (Arminen & Leinonen, 2006; Rintel et al., 2001; Schegloff, 1979). Unlike a telephone ring or machine announcement in IRC, the analysis in this study shows that a Facebook notification acts as a 'comprehensive' summons in the sense that it includes identification and recognition in the form of a user's Facebook name. Hence, the identification and recognition sequences that often follow phone summons are not necessary on Facebook. Following the received

notification, users can immediately join the ongoing interaction since Facebook-name-references are embedded in and used to draw attention to the ongoing interaction. In a way, a Facebook notification opening is similar to a mobile phone opening which allows the interactants to jump straight to the ongoing event because they involve explicit identification (Arminen & Leinonen, 2006). The identity information provided by the machine allows the medium of interaction to be embedded in the ongoing event.

Additionally, the analysis shows that the significance of the Facebook-name-reference lies in how it has been exploited in/for the interaction. The ability to turn the user's names into a technological object improves the users' connectivity with each other. As illustrated in the analysis above, a simple name on Facebook can do more than just referring. It increases the identifiability of the referent by linking the name to the person. Hence, as discussed in the previous two chapters, the use of the Facebook-name-reference is also a form of recipient design, in the sense that it solves the problem of the participant finding the right expression that will identify a specific individual. Consequently, it also illustrates the affordances of Facebook in assisting and supporting interactional social actions.

Discovered in the above analysis is the capability of a Facebook-name-reference to disseminate information to a wider set of Facebook users. Additionally, by using a multiple friend-name-reference, a participant attracts and draws in a larger audience to the conversation, although it is not necessary for them to join the interaction. Previous research on SNS has also highlighted the significant role of tagging features in disseminating information news to other users (Boyd, Golder, & Lotan, 2010; Lomicka & Lord, 2012; Oeldorf-Hirsch & Sundar, 2015). Essentially, tagging someone will push the information directly to the person and thereby draw their attention and increase the likelihood that they will read the post to see why they have been tagged. As for the tagger, the action of tagging may not only to notify and attract others to the interaction but may also give them a new role, as a moderator that is to disseminate information to others. As such, we can see in the analysis in this chapter, there a few situations where the users illustrate the role of a moderator (such as in figure 6.9 and 6.11) where they summons several of their friends to the interaction for a particular set of reasons.

There are also limitations discovered in the practice of person reference in Facebook. While Facebook- name- reference could perform several functions through simple

recognitional name, it is restricted in term of reference forms. As discussed in non- friend- name- reference section, Facebook software only associated with the registered Facebook name. In the occasion where the Facebook users did not use the Facebook registered name in referring to another, the referred person will not be notified by the Facebook, even if the person is the referrer's friend. Eventually, this would lead to a missing conversation in the sense that the referred person did not realize that he or she has been addressed in the interaction.

Chapter 7: Discussion and Conclusion

In this concluding chapter, it will present first the summary of the main findings, before discussing of the implications of the study for both Conversation Analysis and broader sociological understanding of identity on online interactions. It ends with an assessment of the limitations of study and recommendations for future research.

The Findings

The first analytical chapter (Chapter 4) focused on the initial element of interactions in the FCPs which is the initial message. The findings of this chapter provided an overview of the basic organization of FCPs initial message which is the foundation for the identity works in the subsequent chapter. In this chapter, it identified two primary forms of messages, (1) those that inform and (2) those that inquire. The informing messages are doing a ‘telling’ whether it is about someone or something. This includes various ‘telling’ actions such as confessing, ranting, and other related actions. The inquiry message is doing ‘asking’, hence it includes actions such as seeking information, requesting something, and other inquiry actions. With each category of message, the analysis looks further at how authors of the initial message strategically design the message to suit their intended recipient/s and audiences. In particular, the analysis looks at the formulation of reference to other, including the referent, the recipient/ s and the author him/ herself, in order to convey the individual (referent) to the recipients (including the audiences) of the message.

As it found, the reference terms reflect the different epistemic levels that the authors have with the referent. Non- recognitional reference terms are used to a known referent particularly for the informing messages. In line with Schegloff (1996), this practice suggests that there are other actions that the authors want to achieve other than just referring. Given that FCPs allows the authors to strip away the name and send the message ‘anonymously’, the use of recognitional reference form could self- identify the authors due

to the relationship they have with the referent or recipient. Therefore, non-recognitional reference terms become a device for the authors to conceal their 'real' identity. In contrast, recognitional descriptions are found to be used to an unknown referent or recipient in both categories of messages. Recognitional descriptions narrow down the identity of the referent by including information that implicates a certain level of knowledge and membership. This information is particularly 'useful' for further identity and identification works as demonstrated in Chapter 5. Further, there is one initial message found that uses a name as reference term in the inquiring category. This particular message, however, was directed more to the audience in the sense that the author is searching for that particular referent in order to become a 'friend' with him on Facebook. So, it is only possible for the author to use the name to the referent. Overall, Chapter 4 showed how the initial message was 'anonymously' designed for a particular recipient/s and audiences, so that it provides the opportunity for identity and identification works in the subsequent response messages. The fact that the initial message provided identity information means that they are calling for recognitional works from those who have the knowledge.

Following the initial message, the subsequent response messages are analysed in Chapter 5. In this chapter, the aim is to see how the identity information provided in the initial message will be unpacked by the commenters. The focus then is on the interactions among the commenters. The finding reveals how commenters strategically draw upon identity information in the initial message to identify the person of interest in relation to the initial message. Using Membership Categorization Analysis (MCA) and epistemics, identity and identification works were shown to be locally constructed via categories invokes by commenters based on the information provided in the initial message. These categories include knowing the demography of a particular area, being present at an event, known to be a friend of someone, etc. These categories were then used in the identity works as commenters display their knowledge concerning the person of interest of the initial message that is the referent, the recipient or the author.

The analysis of this chapter also finds that certain interactional elements such as particles and formal- informal term which previously deem insignificant in written- interaction are highly relevant in FCPs interactions. For example, the study finds that particles used in Malaysia spoken language such as 'la' and 'lor' could changes the meaning of the statement. This, in turn, can affect the epistemic level of the speaker (commenter). Overall,

the findings challenge the notions of the invisibility of identity in digital contexts as they demonstrate the ways in which individuals manage and overcome the non-visual and non-aural properties of the medium to accomplish the identity work. Additionally, the finding from these two chapters demonstrates the advantage of using semi-anonymous CMC such as FCPs in understanding the identity constructions and identification in interaction. This is because FCPs provides both perspectives, from the anonymous author and identifiable responders, in understanding the issues of identity.

In Chapter 6, the study explores another element of interaction in FCPs particularly in relation to name reference. The study revealed that a particular functionality of Facebook which this study called 'Facebook-name-reference' was evident in the interaction in a number of ways. Commenters designed their actions using this functionality and demonstrate the impact it has in assisting the coherent of the interaction on Facebook. Its ability to be exploited in the interaction increases the identifiability of the referent by linking the username directly to the person which ultimately solves the speaker's problem in finding a right expression to identify the right referent. Further, the way 'Facebook-name-reference' was integrated and embedded into the interaction shown to be useful in disseminating information to a wider Facebook user. Eventually, it illustrates the phenomena of 'viral' in the online environment. There were also situations where commenters did not use Facebook-name-reference which then resembles the conventional spoken and written interaction, but was perceived differently in the respective context. Non-Facebook-name-reference (NFNR) found to be used mostly under response-to-response message within a longer interaction. In this situation, although the name reference appeared normal which is not a Facebook-name-reference, the action of reference lies on the 'creation of a new interaction' within the larger interaction. The one who initiated the 'new' interaction, as well as those, joined the interaction will be informed whenever there is change or addition in that particular interaction. This, in turn, assists the act of referencing without the use of Facebook-name-reference. In a way, it also reflects the sequence of interaction in Facebook interaction.

Overall the findings of this study show that online identity, especially in social networking sites such as Facebook, is beyond one's online profile. Despite the interaction is took place online, without audio-visual cues available, identification could still occur in interaction just like a typical offline interaction. Shown in this study, one's identity persists through

the interaction even when no clear identification is attached to the person. Such identity was invoked and attached to the person through continuous interpretations and evaluations against the background of normative expectations and social practices by participants in the course of interaction. Therefore, identity is seen as a relational work and the product of interactions, rather than as something that is already established for an individual. This study is not the first attempt that the issue of identity is explored, especially on CMC but it is the first attempt on FCPs using Conversation analysis. Therefore, the findings of this study could add up, complement and extend the available literature on the issue of identity, especially in CMC, by showing how identity is constructed and locally accomplished through interactional and relational work. Particularly for FCPs, the findings would be valuable since they will add to the few literatures available.

Generally, the findings of this study concur with Lamerichs and te Molder's (2003) earlier work on identities in web-based interactions on depression. They state that categorical identities are only relevant when they are oriented to by the participants. Identity construction then is taking place through the social norms of behaviour that are relevant in particular social practices and events as perceived by others. As in this study, commenters do the identification work by displaying their knowledge based on the identity information cues provided in the initial message. The use of particular terms to referent/s, somehow, initiated the casting of the person into a category with associated characteristics or features that fits the descriptions (Antaki & Widdicombe, 1998a; Schegloff, 2007b). In other words, commenters are actively searching for relevant identity against their relationship with larger social constructs. The identity itself can be broadly divided into categorical and situational identities. For instance, in the analysis of this study, the use of particular English phrases and words by responders illustrate that they are categorically Malaysian, hence differentiated them from other English-speaking people. Similarly, particular criteria attached to others for identification such as 'the lady in red dress' or 'the user of north gate' illustrates situational identities which come into play in a particular social situation (Stommel, 2008). Eventually, this study suggests that, identity is situated and emerges in-situ in the course of interaction. As such, it agrees with Locher (2008) when he claims that identity is closely related to relational work that is "the ways in which the construction of identity is achieved in interaction, while identity refers to the 'product' of these linguistic and non-linguistic processes" (Locher, 2008, p. 511).

Further, this study identified several descriptive devices, which could be argued, worked to conceal the identity of the person of interest in the initial message, thus making the message itself appeared anonymous. This includes using non- recognitional terms, descriptions, and indexical term to address and refer to other persons in the initial message. These devices mainly used by the authors of the initial message to a known referent, so that they do not have to use explicit identity such as name, which in turn could hide their identity. These devices, however, can be put into categorical identity in the sense that they can be ascribed to a certain property such as gender. As a result, they can be identified. As observed in this study, commenters display their epistemic stance in relation to the descriptive category to accomplish the identity work. The descriptive identity prompt further interactional action in the subsequent response messages as commenters search for the potential candidate of the person of interest in relation to the initial message. Still, FCPs initial message is not all about concealing identity. As found in Chapter 4, especially in inquiring messages, descriptions are used instead of a name is because the authors do not know is the referent or the recipient. Therefore, descriptions are used to achieve recognition. In fact, in one inquiring message, the author used name to refer to the referent that she know offline but is not within her Facebook friend list. This reflects that FCPs is not necessarily about hiding one's identity, but it provides an option for those who wanted to.

From the observation, this study finds that there is a preference for person name reference occurs during identification work. This could be contributed to the affordance of Facebook which allows name reference to act as a 'call-out' or summons, hence manage to draw more audiences and responders to the conversation. Eventually, this also means that more knowledge concerning the identification cues was shared and negotiated in the course of interaction. As Greenfield and Subrahmanyam (2003) suggest, online participants are adapting to the online chat environment by using available cues and creating new strategies to recognize others and to continue the conversation. In fact, referring to other by name is a typical strategy to attract one's attention to someone or something (Stivers et al., 2007; Werry, 1996) even in face- to- face conversation. In FCPs, the username was incorporated into the written- text to which links directly to the owner. Ultimately, it increases the identifiability of the referent.

This study also finds that there are systematic differences between face- to- face and online

interaction. Although this issue is not the main interest of this study, it is still relevant since it is part and parcel of the analytical method that this study adopts. From the observation on this study, it shows the interactional practices on FCPs oriented to the technological affordances. This is in accordance to many studies on CMC that claim the medium of interaction and its affordances do impact the interaction in certain particular ways (Greenfield & Subrahmanyam, 2003; Meredith, 2017; Panyametheekul & Herring, 2003). For example, the gap between turns and the possibilities for overlap could disrupt turn adjacency, yet it did not cause difficulty to commenters. The persistence of written-text assists commenters to monitor previous turns including those that they might miss. As found in this study, the gap between the first pair part and the second pair part could be a day long or more. Additionally, the tag function on the Facebook name could inform Facebook users whenever their name is referred or summoned. This functionality helps users to find the right conversation that involves their name. In turn, it could minimize the possibility for the first pair part being ignored, especially if the conversation involves a long series of interaction or gap. Therefore, in Facebook, interactional differences such as the disrupt turn adjacency, mutual addressing or summoning are not perceived as problematic, rather they are tolerable since the differences somehow are expected, especially among expert users. It is relevant to claim that the differences are conventional for interaction in Facebook, and generally in CMC, since everyone is doing as such. These differences, however, do not entirely separate the interactional practices of Facebook from the spoken face-to-face interaction. On the basis of interaction, it still displays similarities with spoken interaction, albeit the interaction may be heavily influenced by the medium of interaction and its affordances.

Implications of the Study

Implications to the Methodological Approaches

At a general level, the contribution of this study has been the collection of a new data set of online interaction. Conversation Analysis is not new to online interaction for sure. It has been applied to many studies, particularly in Computer-Mediated-Communication (CMC). Even, Facebook has been subject to the study many times. However, as far as I know, it

has not been used on Facebook Confession Pages (FCPs) –like data which is semi-anonymous. In many studies that use anonymous online data, it was taken from forum or blog. Facebook, after all, is not an anonymous online platform. But FCPs is exceptional in a sense that it allows ‘unidentified’ message to be posted on its timeline and identified users to respond. In that sense, it provides sources for analysing social interaction from two perspectives: from the ‘un- identified’ author, and from the identified Facebook users. This is important because as in this study, it demonstrates ways that identity is performed and accomplished in everyday lives of persons. In a way, it differs from other ‘anonymous’ data where often all participants are anonymous. This does not mean that they no longer work on identity as identity is always present. But having two perspectives on something may provide a better understanding on the subject study.

Other implication of this study to the methodology lies on the consideration of several related conversation analysis approaches Conversation analysis (CA), Membership Categorical Analysis (MCA), epistemics, and person reference. Though CA and MCA derive from a similar source, the lectures of Harvey Sacks (1992), and thus can be seen as part of the same analytical enterprise, there has been a trend to isolating sequential and categorical phenomena from each other, focusing on each as a separate aspect. Epistemics study is helpful in understanding the relationship between speaker, referent and recipient. In many studies, epistemics has been incorporated with person reference and membership categorization. This study made an attempt to draw all these approaches to analysing the data. This is important because each approach provides insight on how the element being discussed works within the interaction. In the data of this study, for example, we see that non- recognitional terms used by the authors indicate that the intended social action is not just referring (or addressing). In such a case, they want to obscure the identity of the referent in order to tell their story. It is important that had they use real identity to the referent, their identity may also be known to other people due to the relationship they have with the referent. For example, when the author makes an address ‘my course mate’, the generic non-recognitional term together with the use of a pronoun index oneself, indicates that the author knows the referent (recipient), yet he formulated the address as such so that his course mate’s real identity which linked to his identity is not exposed to the general audiences. This led us to consider the intersection between membership categorization, person reference and epistemics.

Overall, this work supports previous studies that illustrated the possibility of combining several approaches of CA. This research reiterates the ability of CA and MCA to examine how members attend to categorical and sequential phenomena as conversational resources, also to emphasize the crucial relationship between epistemics and person reference in social action. Additionally, this study supports CA and its related methodological approaches as useful approaches to the study of social interaction in text-based conversational interaction.

Disrupted Turn Adjacency

Although I have discussed the implication of Conversation analysis above, I think it still relevant to discuss it further here, especially concerning the disrupted turn adjacency which is unique to CMC interaction. Conversation in quasi-synchronous CMC is quite different from spoken conversation. It follows that applying approaches to spoken discourse analysis directly to quasi-synchronous CMC discourse is not profitable. One significant difference between traditional CA data and quasi-synchronous CMC that has been pointed out by many studies deals with the sequencing of turns. In CA, researchers examine features of the interaction, including how turns are managed and allocated, in order to explain how such interactional elements and patterns open up particular ways for others to continue the interaction, as well as perform particular types of interactional work (Hutchby & Wooffitt, 2008; ten Have, 2007a). However, in quasi-synchronous CMC interaction, the interactional patterns such as turn-taking may appear different than in the typical face-to-face interaction. For example, the turn adjacency pair that is the first pair part of interaction followed by the second pair part may not appear adjacent to one another. This is not to say that they are not existing or irrelevant to quasi-synchronous CMC interaction, rather they appear differently due to the affordances of the medium. For that, researchers on CMC tend to use a term such as ‘disrupted turn adjacency’ to illustrate and differentiate the turn taking features in CMC interaction. Consequently, the formulation of this term is not only to differentiate the interactional patterns of CMC interactions, but also indicates the relevance of such interactional features in online interaction just like in face-to-face interactions.

Earlier research on CMC has suggested that disrupted turn adjacency may result in miscommunication between parties (Garcia & Jacobs, 1999). However, it may well be that, in this earlier study, CMC is not as advanced as today or the participants may not be familiar with the medium. In such a situation, it is expected for any miscommunication occurred due to the incompetent rather than the interactional context itself. With the advancement in CMC that spread out to almost every aspect of human relationships, interacting via CMC has become a common practice. As illustrated in many recent studies as well as in this study, disrupted turn adjacency is no longer present difficulties to participants in understanding the relationship between turns. They manage to overcome the situation as a result of their familiarity with the medium of interactions. The understanding is also extended to the readers or the audiences of the interaction as demonstrated in this study.

Therefore, disrupted turn adjacency should not be seen or treated as problematic in online interaction. Considering how people can understand and embraced it in the interaction, we should acknowledge it as a part of CMC turn taking features, rather than make a constant comparison to spoken turn taking features. Yet, the term ‘disrupted turn adjacency’ may want to be maintained so that to differentiate the different settings that the practice takes place. It does not, in any way, to reflect the difficulties of the participant in understanding the relationship between turns. As such, this observation on disrupted turn adjacency tends to support the view that applying models of turn-taking in spoken conversation directly to CMC discourse is not profitable (Meredith & Potter, 2014; Simpson, 2005). Having said this does not mean that the model of spoken turn-taking is not relevant to quasi-synchronous CMC. Each setting has its own condition that may influence the conversation, yet the conversation is still occurring on the same principles. Therefore, spoken discourse is useful in providing guidance to a newly emerging practice on quasi-synchronous CMC conversation. Yet, it is also important to be aware of the different features that both conversational settings have such as the disrupted turn adjacency, so that they both can be understood and study appropriately.

Implications to the Identity Study

Research on identities now tends to view social identity as discursively constructed (e.g.

(Bucholtz & Hall, 2005; Giles, 2006; Raymond & Heritage, 2006; Sierra & Botti, 2014; Young, 2017). It is not a merely pre-given characteristic that inherently exists within individuals, but rather it emerges through interaction. Recently, the role of epistemics and epistemic rights that is what we know and how we establish our rights to that knowledge, have been highlighted in the study of interactional identity construction (e.g. Raymond & Heritage, 2006). This study adds up to this growing body of work on identity and epistemics, particularly in the social positioning of self and others. In this study, it looks at how participants make a reference to persons in relation to the context and the referent, and how it depends on the participants' negotiation of epistemic rights. In so doing, it also shows how the broad sociological categories most commonly associated with the concept (such as race and gender) are put to use in the interaction. For example, in this study, race is used as a social category to narrow down the identity of the potential person of interest in relation to the initial message. The race, however, is defined not necessarily through its explicit category, but through exclusive term belong to the particular race such title 'ge' (means older brother in Chinese) or 'adik' (means younger relative in Malay). So the identity is achieved through the epistemic access of the race's social and cultural conduct. In this case, then, participants' race only becomes relevant when it is invoked during the interaction in relation to the context of the interaction. Consequently, in this study, identity is seen as the product of interaction rather than as a static characteristic of an individual.

Limitations and Future Direction

Analysing the data and writing this thesis have highlighted the fact that things can change quickly particularly on the internet. In the time it has taken to finish writing this, a lot of things have taken place in Facebook Confession Pages. The data that I gathered earlier may appear differently now with all the update in the user interfaces done by Facebook. It could then easily be argued the validity of this study, and its applicability in today's situation. The response to this is that though Facebook updated regularly, it does not change its main features or even changed the interaction. With each new update, users basically keep doing relatively similar actions on Facebook while integrating the updates in their interaction for a better experience. Additionally, for Facebook Confession Pages, changes could also occur in term of the community. As FCPs is college affiliated site, it

expected that the community is the students, so their commitment and involvement with the page are depending on the time period they spent in the college. However, that will also ensure the continuity of FCPs as new community members will keep working on the page. In fact, based on my own observation, few FCPs have been upgraded and received recognition and assistance from the university authority as a place for students to express their opinion and issues in relation to the university.

There are also possible limitations regarding data collection. As explained in Chapter 3, this study collecting the data retrospectively means the interactions had completed when they were collected. For this study, this would mean two things, the study could not see how participants managed their interactions at the time, and there might be changes since the data was created. The data were collected through a screen-shot technique which displays the participants' interactions as they unfolded. However, they do not provide participants' embodied conduct, so could not see how they managed their interaction. Possibly, if the study follows and collects current interactions, it can get more involvement from participants in the sense that participants can be approached personally. The information from participants can be integrated into the interaction which then would improve the data collection. But that might also change the methodological approach of this study.

Further, the screen capture data displays interactions which could have been completed a year before the data is collected. This indirectly affects the data in the sense that they might have changed from the time the data was created. For instance, username might have been changed or the participant might have been quit Facebook. Moreover, the internet and more specifically social networking sites are updated regularly. So, it would be expected that at the time the data was collected, there were changes in the networking sites which could also cause the changes in the older interaction. However, that is not an issue for this study since the main focus is on the interaction rather than the affordances of the site. Although it could be argued that online interactions are closely dependent on the affordances of the medium. Still, the basic functionalities for the interaction often will be remained the same. The changes will not make internet sites obsolete or totally altered the interaction. In fact, often, the update includes the previous events, for example, the tagging function still involves the user's Facebook profile even though the user might change the username. Conversation on the phone relatively remained the same although there are a lot

of development and changes with the telephone device. Similarly, the retrospective data was sufficient to provide understanding on the account of the online interactional practices. In fact, particularly for this study, the retrospective data is really useful because it provides a comprehensive process and progress of the topic of the study. Although having updated interactions as data may allow for further analysis on a wider issue related to online interaction.

Another possible limitation of this study is related to the source of reference particularly in the local context. While there are many studies use Conversation analysis, there are concentrated mostly on the Western countries. Though we can say that there are no differences since all interactions, in principle, involve a basic interaction like turn-taking, action formation and sequential organization, there is still a certain thing that requires local- context understanding, i.e. norm and culture. While doing this study, I found very few published works on the use of Conversation analysis in Malaysia. The few published works mainly concentrated on the field of education and linguistic, and almost none found in the sociological field (except few papers published in Singapore that includes Malaysian society such as Gupta, 1992; Gupta, 2006). In fact, I myself was introduced to the Conversation analysis at the beginning of this study. As I continue to examine the data for this study, I find that these methodological approaches (CA, MCA, epistemics, and person reference) allowed me to look at my own so-called culture in a new perspective. Particularly with Person Reference and Epistemic, their approaches explain social and moral conducts that we practice in daily life. For example, in this study, there are many instances shows that participants' actions are influenced by cultural norms although the interaction is taken place in an online environment. The use of the pronoun, for instance, illustrates participants' consideration of each other. In Malaysian society, there are several selections of pronouns can be used; each constitutes power relation between the interlocutors. Technically, the selection of a pronounce reflects the epistemic levels of the interlocutors. This element, however, is not presented much in this study mainly due to my own limitation in analyzing it from the CA perspective. It will be interesting then to return to this issue later in the future.

Additionally, with social networking tools such as Twitter, Instagram and Facebook, as well as cross-platform messaging applications like WhatsApp and Line, increasing the possibilities for connection with others, a growing body of research has begun to explore

the ways in which people utilized and exploit the online environments in their daily life. Despite the growing interest in online communities and internet communication research, the means by which online users orient to issues of identity still need further study, particularly among non- western society. The study presented here has begun to address this gap, and will add and serve for future research in the field.

Appendices

Appendix A: Ethics Application

THE UNIVERSITY *of York*

ELMPS Ethics Committee

SUBMISSION FORM

(Version of 30 May 2015)

This form is intended to enable you and the Committee to ensure that your proposed research is compliant with the relevant codes of practice and ethical guidelines. The University recognises its obligation to the wider research community and to society as a whole to uphold the integrity of academic research. The University also has a responsibility to ensure that the funds it receives are spent in accordance with the legitimate expectations of the funding providers and the law and in the public interest. The University formally endorses the [UUK Concordat to Support Research Integrity \(2012\)](#).

Please ensure that you are familiar with the University's Code of Practice on Research Integrity and the University Data Management Policy as well as any relevant professional guidelines for your discipline (e.g. the Statement of Ethical Practice for the British Sociological Association) or funding organisation (e.g. ESRC Framework for Research Ethics). Useful links include:

<https://www.york.ac.uk/staff/research/governance/policies/ethics-code/>

<https://www.york.ac.uk/staff/research/governance/policies/research-code/>

<http://www.esrc.ac.uk/about-esrc/information/framework-for-research-ethics/>

<http://www.britsoc.co.uk/about/equality/statement-of-ethical-practice.aspx>

<http://www.york.ac.uk/recordsmanagement/dpa/>

<http://www.york.ac.uk/about/departments/support-and-admin/information-directorate/information-policy/index/research-data-management-policy/>

Internet research may involve new and unfamiliar ethics questions and dilemmas. A good place to start is with the Association of Internet Researchers 2002 Guidelines and the BPS 'Conducting Research on the Internet: Guidelines for ethics practice in psychological research online (2007)'.

Note: If you are collecting data from NHS patients or staff, or Social Service users or staff, you will need to apply for approval through the Integrated Research Application System (IRAS) at <https://www.myresearchproject.org.uk/Signin.aspx> If you are a staff member please fill in the IRAS form NOT this one and send your completed IRAS form to ELMPS. Student applications for approval through IRAS should normally be pre-reviewed by department ethics committees or ELMPS.

Completed forms should be submitted by the advertised deadline as follows:

one signed hard copy (to Debbie Haverstock, Research Centre for the Social Sciences, University of York, 6 Innovation Close, York YO10 5ZF), and

one electronic copy (including attachments) combined into ONE pdf file (email to: elmps-ethics-group@york.ac.uk).

Initial decisions will normally be made and communicated within two weeks of the Committee meeting.

SECTION 1 ABOUT YOU

1a. Please provide the following details about the principal investigator at YORK

Name of Applicant:	Nurul Firdauz Abd Rahman
e-mail address:	Nfaf501@york.ac.uk
Telephone:	07478464568
Staff/Student Status:	PhD Student
Dept/Centre or Unit:	Sociology
Head of Department:	Ellen Annandale
HoD e-mail address:	ellen.annandale@york.ac.uk
Head of Research: (If applicable)	
HoR e-mail address: (If applicable)	
If you are a student, please provide details about your supervisor(s)	Supervisor(s) Name: Dr Darren Reed e-mail address(es): darren.reed@york.ac.uk

1b. Any other applicants (for collaborative research projects) Expand as necessary

Name of Applicant:	
e-mail address:	
Telephone:	
Staff/Student Status:	
Dept/Centre or Unit:	
Head of Department:	
HoD e-mail address:	
Head of Research: (if applicable)	
HoR e-mail address: (if applicable)	

SECTION 2 ABOUT THE PROJECT

2.1 Details of Project

Title of Project:	Conversation Analysis on Facebook Confession Pages
Date of Submission to ELMPS:	July 2016
Project Start Date:	October 2014
Duration:	3 years
Funded Yes/No:	No
Funding Source:	
External Ethics Board Jurisdictions (if any):	

2.2 Aims and objectives of the research

Please outline the aims of your project and key research questions. Show briefly how existing research has informed the research proposal and explain what your research adds and how it addresses an area of importance.

The main objective of the research is to deal with the phenomenon of so-called anonymous online confessions and from that point explore the notion of identity around the anonymous confessions. The research is included in the discussion about the reality of identity and the ways in which identity is ubiquitous which does not confine to certain elements such as name or gender. Also, in this context, the research tries to detail the ways that the elements of identity may be identified and recognized in the online anonymous confessions, centred in the subsequent interactions following the online anonymous confessions. Hence, the objective is set to explore the elements of identity as they are discussed in the online interactions with regards to the online anonymous confessions.

By looking at the online interactions and the way they discuss and view the elements of identity in the anonymous confessions, it could be possible to develop a better understanding about the concept of privacy, especially in the online environment.

As such, this study seeks to ask questions like;

How the readers of the anonymous confessions view the anonymous confessions.

How the readers respond towards the identity information revealed in the anonymous confessions.

How readers use the identity cues in identifying a person

How the element of identity is disclosed or revealed in the interactions.

2.3 Methods of Data Collection

Provide a brief summary of the method(s) of the research making clear what it will involve for participants (e.g. interviews, observation, questionnaires). If you (or your research assistants) are meeting face-to-face with research participants, specify *where* you will be meeting them (and you will need to address how any risks associated with this will be managed in Section 2.10)

The main method will be online observation. The observation is conducted by keeping track of the online behaviours and activities without interacting with the participants (i.e. Lurking). This method is preferred so as not alter the online community under study. Therefore, the interactions will remain genuine without any outside force that may alter the direction of the interactions.

The observation will be used to investigate the online interactions, familiarized with the context, and gain knowledge of the nature of anonymous confessions and interactions in the Facebook Confession Pages (FCPs). These online pages are Facebook community-based pages, and they are public which means that everybody could access them. In line with the research objective, the research will also explore the elements of identity that are attached to the anonymous confession posts in the FCPs, in which latter, they are utilized and revealed in the subsequent interactions.

In addition to the observation, the research will also downloading relevant messages and images posted in FCPs. This practice comes to action in order to keep the data for analysis process. As the contents of social media tend to continuously change from time to time, it is necessary for the data to be maintained in its original state as the time the data was accessed. Hence, the research will take an initiative to screen- shot the interactions. Through this process, the genuine of the interactions can be maintained since the whole interactions together with their context are captured in an image-form.

2.4 Sampling and Recruitment of participants

How many participants will take part in the research? How will they be identified – describe your *sampling* method. How will they be invited to take part in the study – describe your *recruitment* method. If research participants are to receive any payments, reimbursement of expenses or any other incentives or benefits for taking part in the research please give details, indicating what and how much they will receive and the basis on which this was decided.

Data will be collected from Facebook community pages known as Facebook Confession Pages (FCPs). The data which consisted of FCPs messages and interactions are gathered using Facebook's Graph API, which gives developers access to publicly visible Facebook content. Through this process, a range of FCPs regardless of their geographical locations or language uses, can be acquired, as

long as they use a keyword 'confession'. However, as this research intended to focus on Malaysia context, it restricts the search process to the Malaysia higher institution only. Therefore, prior to the collection of data from the FCPs, a list of Malaysia universities will be acquired from the Malaysian Qualification Register website (<http://www.mqa.gov.my/mqr/english/eakrbyipta.cfm>). Specifically, the research only acquired the list of Malaysia public universities, excluded other higher educational institutions like private, polytechnic or community college. The acquired list, then, is used as a guide during the search process in which a keywords 'confession' is used together with the name of the universities provided by the list. Further, the research will be limited to the Facebook page with the most active and the most followers.

After identifying the FCPs, the research will proceed with selecting the sample interactions. Only those 'confession message posts' that had garnered more than 15 subsequent interactions will be selected. These selected messages will then be scrutinized whether they fit the objective of the research or not; whether the elements of identity exist in the interactions. Those messages that do not fit the objective of the research will be eliminated.

2.5 'Vulnerable' Participants

Please indicate whether any research participants will be from the following groups; if so, please explain the justification for their inclusion. In most cases, researchers working with vulnerable people will need to be registered with ISA (www.isa.homeoffice.gov.uk) which has links with the CRB. The CRB offers organisations a means to check the background of researchers to ensure that they do not have a history that would make them unsuitable for work involving children and vulnerable adults.

NB: If you are collecting data from NHS patients or staff, or Social Service users or staff, you will need to apply for approval through the Integrated Research Application System (IRAS).

Children under 18	No
Those with learning disability	No
Those who are severely ill or have a terminal illness	No

Those in emergency situations	No
Those with mental illness (particularly if detained under Mental Health Legislation)	No
People with dementia	No
Prisoners	No
Young offenders	No
Adults who are unable to consent for themselves	No
Those who could be considered to have a particularly dependent relationship with the investigator or gatekeeper, e.g. those in care homes	No
Other vulnerable groups (please specify) – discuss the issues this raises	No

If yes to any of the above, do you have Criminal Records Bureau Clearance?

Yes/No

Describe the procedures you are using to gain (a) consent and/or (b) proxy consent if applicable

2.6. 'Sensitive' topics

During your study, will anyone discuss sensitive, embarrassing or upsetting topics (e.g. sexual activity, drug use) or issues likely to disclose information requiring further action (e.g. criminal activity)? If so, please give details of the procedures in place to deal with these issues, including any support/advice (e.g. helpline numbers) to be offered to participants. Consider, too, the risks this may pose to the researcher. Note that where applicable, consent procedures should make it clear that if something potentially or

actually illegal is discovered in the course of a project, it may need to be disclosed to the proper authorities.

The research deal with online anonymous confessions in the Facebook confession pages (FCPs). Some of the confessions could be considered as a sensitive issue. However, the FCPs are usually linked to a particular community such as a university, although they are not officially associated with their respective community. Due to that, FCPs are usually monitored by the respective community, and whenever there is a need for further action to be taken, the respective community will immediately know. Additionally, the confessions are anonymous with no clear personal identification of the writers. Hence, as far as the writers' concern, there is no harm that could inflict them.

However, if the research encounters such a situation where it needs further action to be taken, the respective community will be informed.

2.7 Covert research

If the research involves covert data gathering or deception of any kind, please explain and justify the deception. Specify what procedures (if any) will be used to debrief participants after the data have been collected.

There is no covert research involved in this research.

2.8 Informed Consent

Please attach (1) the project information sheet to be given to all participants and (2) the informed consent form. (It is recognised that in some cases these may be combined into a single document). (It is recognised that in some cases these may be combined into a single document). In line with the University's Code of Practice on Research Integrity, participants and/or their representatives should be provided with details of a first point of contact through which any concerns can be raised: this should be your Head of Department (or if you *are* a Head then the Pro-Vice-Chancellor for Research).

i. If you are not seeking informed consent...

If you do NOT intend to seek informed consent, please explain carefully why you believe this is not necessary for your project. You should explain this with reference to the research ethics guidelines for your discipline and cite other recent published research using your methodological approach or ethics discussions about this to support your case.

The research does not intend to seek informed consent because it involves observation of public behaviours in a public space. Based on the British Psychological Society's Code of Ethics and Conduct (2006), observation of public behaviour can be conducted in a place where people would expect to be observed by strangers. In this case, the research will use Facebook confession pages (FCPs) which are a community-based Facebook pages. Like any other community-based Facebook pages, FCPs are public where it can be accessed by everybody. Moreover, FCPs present a unique configuration in which the user can post messages anonymously. It happens by integrating a third-party application into the pages that allows people to post anonymously. Hence, there is no clear identification attached to the message posts. However, response to these posts is via ordinary, identifiable Facebook comments and likes. On this matter, the research will refer to Facebook's terms of agreement regarding the publish content or information using the Public setting in which it considers the situation as public where everyone, including people off of Facebook, can access and use that information.

Based on the above, it's not necessary for the research to seek informed consent. However, even when data are publicly visible, according to Zimmer, M. (2010), it is critical for researchers to consider user privacy and the possibility of inadvertent identification out of context. For this reason, the research will not include any personal identifiable details such as individual or university identifiers which are not relevant in the research outcome.

ii. Please confirm you have included the project information sheet to be given to all participants with your submission to ELMPS. If these have not been attached, please explain why this is the case.

iii. Please confirm you have included all the relevant, informed consent forms. If these have not been attached, please explain why this is the case.

iv. Are the results to be given as feedback or disseminated to your participants (if yes, please specify when, in what form, and by what means). If no, why not?

The result of this research will not be disseminated to the participants since the research are not engaging with them during the research process. Moreover, the research result will not contain their personal data information.

2.9 Anonymity

In most instances the Committee expects that anonymity will be offered to research participants. Please set out how you intend to ensure anonymity. If anonymity is not being offered, please explain why this is the case. Note that if anonymity is not offered (or cannot be guaranteed) this has implications you must address in relation to the Data Protection Act (see Section 3 below). Note: if you are using a transcriber or translator you must have a signed confidentiality agreement with them.

The research already deals mainly with anonymous data. As for the data with identifiable information, the research will ensure their anonymity mainly by dissociating any personal identifiable information that could lead to their identification in the outcome, such as individual or university identifiers.

The offline data will be kept in the researcher's personal computer and cloud with a password protected known only to the researcher.

2.10 Anticipated Risks or Ethical Problems

Please outline any anticipated risks or ethical problems that may adversely affect any of the participants, the researchers and/or the university, and the steps that will be taken to address them. (Note: all research involving human participants

<p>can have adverse effects.) Please also refer to the University's <u>Health, Safety and Welfare Policy Statement and associated Management Procedures</u>, as well as to any ethical guidelines you have consulted. Where relevant, <u>risk assessments</u> should be carried out not only in relation to the researchers themselves, but also for those participating in the project or affected by its conduct, and in relation to any impact on the environment. Researchers should ensure that appropriate <u>insurance</u> is in place, liaising with the University's Insurance Officer as necessary (via standard departmental procedures where these exist).</p>
<p>Risks to participants (e.g. emotional distress, financial disclosure, physical harm, transfer of personal data, sensitive organisational information...)</p>
<p>The research does not involve direct human participants.</p>
<p>Risks to researchers (e.g. personal safety, physical harm, emotional distress, risk of accusation of harm/impropriety, conflict of interest...)</p>
<p>Any risk to the researcher is expected, but it is expected to be minimized since the research does not require the researcher to be in a dangerous place or meet a stranger face-to-face. The research will be conducted mainly in front of the computer equipped with internet access.</p>
<p>University/institutional risks (e.g. adverse publicity, financial loss, data protection...)</p>
<p>The research does not foresee any risk to the university.</p>
<p>Financial conflicts of interest (e.g. perceived or actual with respect to direct payments, research funding, indirect sponsorship, board or organisational memberships, past associations, future potential benefits, other...)</p>
<p>The research does not foresee any financial conflicts of interest.</p>

2.11 Research outside the UK

If you are planning research overseas, you should also take account of the ethical standards and processes of the country/countries in question as well as those of the University. If the research is being conducted outside the UK please specify any local guidelines (e.g. from local professional associations/learned societies/universities) that exist and whether these involve any ethical stipulations beyond those usual in the UK. Also specify whether there are any specific ethical issues raised by the local context in which you are conducting research, for example, particular cultural sensitivities or vulnerabilities of participants.

The research uses mainly the data extracted from the Facebook. Therefore, most of the time, the research will be conducted in front of the computer equipped with internet access, and the researcher will be in the university during the research process. However, geographically, the data collected are originated from Malaysia. On this matter, the research may be subject to the country's rules and regulations regarding the use of personal data. In Malaysia, such matter usually comes under The Personal Data Protection Act 2010 (PDPA). However, in that document it states that the law only applies to the processing of personal data by persons established in Malaysia. With regards to the universal digital data, such as the data uses in this research, the applicability of PDPA is blurred.

Alternatively, the research could refer to the Facebook's terms of agreement regarding the users' publish contents. It states that when the users publish content or information using the Public setting, it means that they are allowing everyone, including people off of Facebook, to access and use that information. However, the research will be secured by fulfilling all the requirement of the university's Code of Practice on Research Integrity and the University Data Management Policy.

SECTION 3: DATA PROTECTION

Please ensure you have read the information on data protection at:

<http://www.york.ac.uk/recordsmanagement/dpa/> before you complete this section

3.1 Does your project involve personal data (as defined by the Data Protection Act): Yes/No. If yes, please provide a description of the data and explain why you need to collect this data.

Yes. The research involves personal data in a form of users' profile on Facebook such as name and profile pictures. Such data are collected as they are the interactions' identifier, and the research needs them to identify and organize the flow of interactions. However, this personal data tend to be temporary in which they will be changed from time to time. It expected that at the time the research completed, these personal identifiers are no longer used. However, if the study find the need to change them, they will be omitted in the research outcome and will replace with a pseudonym whenever necessary.

3.2 Does it involve sensitive personal data (as defined by the Data Protection Act) :

Yes/No. If yes, please provide a description of the data:

No

3.3. If the research will involve any of the following activities, please indicate so and provide further details. Explain how this will be conducted in accordance with the Data Protection Act (and/or any international equivalent)

Electronic transfer of data in any form	The data will be kept mainly in the researcher's computer. However, the data will also be kept in the researcher's personal digital cloud for back-up purposes. These two devices will be password protected known only to the researcher.
Sharing of data with others at University of York	The researcher is the only person who has the access to the data.
Sharing of data with other organisations	No
Export of data outside the European Union or importing of data from outside the UK	N/A
Use of personal addresses, postcodes, faxes, emails or telephone numbers	No
Publication of data that might allow identification of individuals	No

Use of audio/visual recording devices	The data gathered will be in a form of images. The research will use screen-shot, and the data will be kept in the same computer.
Use of data management system (e.g. nvivo, ATLAS.ti)	No
Data archiving	The data will be kept on the researcher's personal computer with password protected known only to the researcher.

3.4. If the research will involve storing personal data on any one of the following, please indicate so and provide further details.

Manual files (i.e. in paper form)	No	
University computers	The researcher uses mainly her personal computer. However, from time to time, the researcher may use the university's computer.	Password protected - Yes Encrypted - Yes
Private company computers	N/A	Password protected Y/N Encrypted Y/N
Home or other personal computers	The information will be stored and managed in the researcher's personal computer.	Password protected - Yes Encrypted - Yes
Laptop computers/ CDs/ Portable disk-drives/ memory sticks	N/A	Password protected Y/N Encrypted Y/N
Websites	N/A	Password

		protected Y/N Encrypted Y/N
Other	For backup purposes, the researcher will use her personal digital cloud with password protected known only to the researcher to store the data.	Password protected - Yes Encrypted - Yes

3.5 Please explain the measures in place to ensure data confidentiality, including details of encryption and anonymisation.

The data collected may include personal data such as users' profile name and pictures. However, these personal data will be omitted in the research outcome and whenever necessary, pseudonym will be used.

3.6 Please detail all who will have access to the data generated by the study.

The researcher is the only person who has access to the data collected.

3.7 Please detail who will have control of, and act as custodian(s) for, data generated by the study.

The data will be kept in the researcher's personal computer.

3.8 Please give details of data storage arrangements, including where data will be stored, how long for, and in what form. Will data be archived – if so how and if not why not. Note the university policy that "Where possible, relevant elements of research data must be deposited in an appropriate national or international subject-based repository, according to their policies. Data should be kept by the researcher in an appropriate manner when suitable subject repositories are not available."

<http://www.york.ac.uk/about/departments/support-and-admin/information-directorate/information-policy/index/research-data-management-policy/#tab-1>

The data will be stored on the researcher’s personal computer with password protected. This personal computer is used solely by the researcher and the password is known only to the researcher. For backup purposes, the data will also be kept on the researcher’s personal cloud with password protected known only to the researcher. The raw data will be in a form of an image and the analysis data will be in a form of document. The data will be kept until the end of the research, and they will be deleted once the research is completed.

SECTION 4 SIGNED UNDERTAKING

In submitting this application I hereby confirm that I undertake to ensure that the above named research project will meet the University’s Code of Practice on Research Integrity <https://www.york.ac.uk/staff/research/governance/policies/research-code/>.

..... (Signed Lead Researcher/Principal Investigator)

..... (Date)

..... (Signed Supervisor (where relevant))

..... (Date)

Submission Checklist for Applicants

Send one **signed hard copy** to Debbie Haverstock, Research Centre for the Social Sciences, University of York, 6 Innovation Close, York YO10 5ZF), and **one electronic copy** (including attachments) in **one pdf** file to: elmeps-ethics-group@york.ac.uk

- ELMPS Application form
- Consent form for participants
- Information Sheet for participants
- ELMPS Compliance form

Appendix B: Facebook Confession Page #794

1 #794
2 "I dunno where to start but i hope this works.
3 I went to dentistry faculty last monday to have an extraction.but i was lost
4 there.then suddenly got one man with red helmet approached me and
5 asked.i was mesmerized by his perfume actually but i got covered
6 up.hahaha.i wanted to go for registration counter and he without being
7 asked to help me,took my file and walked along with me.omaigod.i was
8 moved by his gentlemenity meh.even it was a short meet up but i think i
9 like this man and i want to get close with him.problem is i dunno his name!
10 He is a malay guy n has white chubby face.really cute.the hair is so eyes
11 attracted cause its wavy and high up at front.he wears red bag.that is what
12 i can remember.so please,anyone know this i just want to say i like u n this
13 earth need people like u.i hope my gratutude is taken aware by u,mr
14 gentleman."

 Like  Comment  Share

 82

Most Recent ▾

- 15  **Ali Gorimi** maybe u saw Angle 😊
Like · Reply · October 25, 2013 at 7:52pm
- 16  **Sofya Zulkiffli** Omg nad! It is definitely u la! Sbb ur perfume....mmg sedap
17 bau die. I rmmber telling u tht. Amboiiii....ada peminat..
Like · Reply ·  3 · October 25, 2013 at 6:28pm
- 18  **Nazrin Sarajuddin** Haha.bangang jeksyen.
Like · Reply · October 25, 2013 at 4:37pm
- 19  **Haziq Ismail** pe lg ohmynazrin. jodoh kau lelaki nih
Like · Reply ·  1 · October 25, 2013 at 4:22pm
- 20  **Nurul Asyikin Che Hassan** haha Nurul Ain Fawzi,tu la kan..keke 😊
21 so,sapekah gerangan si jejaka ni??untungla dpt confession kt sini,1 UM tau
22 kot hahaha
Like · Reply ·  1 · October 25, 2013 at 1:48pm
- 23  **Nadhirah Ghazali** Kenapa aku br tau nih?! Aish melepas nk join komen teka
24 sape kah gerangan si jejaka dental yg pakai perfume dgn beg dan helmet
25 merah yg gentleman..
Like · Reply ·  2 · October 25, 2013 at 1:37pm
- 26  **Khairuldin Majid** I was mesmeriaed by his perfume...ohh my
27 bicepppp...hahha
Like · Reply ·  2 · October 25, 2013 at 12:32pm

- 28  **Nurul Ain Fawzi** Gaaayyyy
Like · Reply ·  2 · October 25, 2013 at 12:30pm
- 29  **Khairuldin Majid** Aku syak yg confess nie lelaki..omygod nazrinnnn
30 hahahah
Like · Reply ·  1 · October 25, 2013 at 12:30pm
- 31  **Ikhwan Khu Sairi** yg konfess ni laki ke pompuan sebenarnya? hahahaha
Like · Reply · October 25, 2013 at 12:29pm
- 32  **Nurul Ain Fawzi** Thank uuuu OhMy Nazrin
Like · Reply · October 25, 2013 at 12:25pm
- 33  **Haziq Ismail** ini lawak
Like · Reply · October 25, 2013 at 12:25pm
- 34  **Nurul Ain Fawzi** Aku manada chubby.aku kurus slim jelita hahahaha
Like · Reply ·  1 · October 25, 2013 at 12:25pm
- 35  **Nazrin Sarajuddin** Ok dh unlike. 😊
Like · Reply ·  1 · October 25, 2013 at 12:24pm
- 36  **Haziq Ismail** ad org like. hewhewhewhew
Like · Reply · October 25, 2013 at 12:23pm
- 37  **Nurul Ain Fawzi** Haaaaa lawaknyewww
Like · Reply · October 25, 2013 at 12:22pm
- 38  **Haziq Ismail** chubby chubby ni ain. eh jap. salah jantina
Like · Reply ·  1 · October 25, 2013 at 12:11pm
- 39  **Nurul Ain Fawzi** Chubby2 ni maybe Mahathir Abdul Ghani.lol hehehe
Like · Reply ·  1 · October 25, 2013 at 11:56am · Edited
- 40  **Nabila Ilani Wan** pkai bag ape smlm? Hahaha. Muhammad Syazwan
41 Salahudin
Like · Reply · October 25, 2013 at 11:25am
- 42  **M Shaifunizam B Alias** hahaha..hisyam malu2 plak dahh...jeles si dia
43 nnti.haha
Like · Reply · October 25, 2013 at 10:52am
- 44  **Ikhwan Khu Sairi** bukan beg la isyan. helmet. lol. kau sorang je pakai helmet
45 merah dalam fac kite. hahaha
Like · Reply · October 25, 2013 at 10:51am
- 46  **Haziq Ismail** epu r nih
Like · Reply ·  2 · October 25, 2013 at 9:42am
- 47  **M Shaifunizam B Alias** i'm not WHITE ok..hahaha
Like · Reply ·  4 · October 25, 2013 at 10:49am
- 48  **Nazrin Sarajuddin** Bahahahahaha.chubby kut.bukan ak lah.mana ak
49 chubby.jeksyen nie.haha
Like · Reply ·  1 · October 25, 2013 at 10:47am
- 50  **Ikhwan Khu Sairi** hahaha. chubby tu sapa lagi. nazrin ada peminat. fuh fuh.
Like · Reply ·  1 · October 25, 2013 at 10:45am

- 51  **M Shaifunizam B Alias** mmg OhMy Nazrin nih..haahaha.
Like · Reply ·  2 · October 25, 2013 at 10:33am
- 52  **Hafizul Hafiz** fuhhhh...naseb baek helmet silver
Like · Reply ·  5 · October 25, 2013 at 8:55am
- 53  **Khairuldin Majid Nazrin** kot..hahahahah
Like · Reply · October 25, 2013 at 6:47am
- 54  **Hyzan Dz** Confirm Hisyam Zainal!
Like · Reply · October 25, 2013 at 6:32am
- 55  **Nurul Ain Fawzi** Kak syikin kluar awal sikit.kalau tak ada org confess ckp
56 nampak kat dental ada mek klate tinggi kurus cantik lalu dia tergoda.hihihi
Like · Reply ·  4 · October 25, 2013 at 4:37am · Edited
- 57  **Nurul Asyikin Che Hassan** perghh
Like · Reply ·  3 · October 25, 2013 at 3:42am
- 58  **Nurul Ain Fawzi** Hahaha tu lah.aku tak rasa pulak kau rajin nak bawakkan
59 fail org.
Like · Reply ·  1 · October 25, 2013 at 2:08am
- 60  **Hisyam Zainal** Ohmynazrin ni
Like · Reply ·  3 · October 25, 2013 at 2:03am
- 61  **Hisyam Zainal** Ey bkn aku la,aku x pkai beg merah,aku pkai plastic bag je n
62 aku x pkai helmet jln2 kt fac
Like · Reply ·  2 · October 25, 2013 at 2:01am
- 63  **Nurul Ain Fawzi** Hisyam Zainal fuyyooo..haha
Like · Reply ·  3 · October 25, 2013 at 1:27am · Edited
- 64  **Azrul Hizam** ensem r dak dak dental ni suma ... Khairuldin Majid Aiman
65 Najhan
Like · Reply ·  1 · October 24, 2013 at 7:47pm
- 66  **Aiman Najhan** Kalau bukan wan dgn hisyam mmg tak syak lagi Hafizul Hafiz
67 lah orgnya hihi
Like · Reply ·  6 · October 24, 2013 at 6:17pm
- 68  **Khairuldin Majid** Kalau bukan hisyam myb Muhammad Syazwan Salahudin
69 kot
Like · Reply · October 24, 2013 at 5:52pm
- 70  **Aiman Najhan** Malangnya dia sudah mempunya haha
Like · Reply ·  1 · October 24, 2013 at 5:11pm
- 71  **Amirul Azzat** kudin, aku bace nie pon trus terpikir kt hisyam.. hahaha
Like · Reply · October 24, 2013 at 4:32pm
- 72  **Khairuldin Majid** Hahaha hisyam....red helmet wavy n jambul hair perfume
73 harum semerbak
Like · Reply ·  10 · October 24, 2013 at 4:27pm
- 74  **Shah Rizan Abd Rahman** 
Like · Reply · October 24, 2013 at 4:09pm

Appendix C: Facebook Confession Page #860

1 #860
2 16/10/2015
3 Ini cara terakhir untuk menegur wahai sahabatku setelah telinga kau
4 sudah lali dengan teguran kami. Bermain dota tu boleh, tpi jangan sampai
5 abaikan perbincangan kumpulan untuk laporan makmal, kami tengok kau
6 main dota dari malam ke siang. Waktu pagi tidur, lepastu merungut x
7 cukup tidur. aku buang katil ko nnti. --

 Like  Comment  Share

253 people like this.

Most Recent ▾

- 8  **Tzuji Ryuu** rasanya pemain dota tegar baca ke mesej kat ni? haha.. better
9 pm je dia personally senang
Like · Reply · October 17 at 8:21am
- 10  **Aizat Hafiz** Salman Escee kau ke yg confess ni .
Like · Reply · October 17 at 3:31am
- 11  **leMs EbRahim** Bagi penampar sulung sedas~
Like · Reply · October 17 at 12:16am
- 12  **Ashura Izwani Ahmad Tadjudin** Muhammad Nurhaziq Haridan Bukan si
13 Snorlax tu kan? 😊
Like · Reply ·  1 · October 16 at 12:45pm
- 14  **Muhammad Nurhaziq Haridan** Bukan bukan. Dia kerja grouping
15 sentiasa buat.
Like · Reply · October 16 at 1:54pm
- 16  **Ashura Izwani Ahmad Tadjudin** Good good. Or might be you. Kah!
Like · Reply · October 16 at 2:37pm
- 17  **Muhammad Nurhaziq Haridan** Yeah it might be me too.
Like · Reply · October 16 at 4:46pm
- 18  **Muhammad Farhan Azmi** Mesti kau Burhanuddin Abd Ghani
Like · Reply ·  1 · October 16 at 2:07pm
- 19  **Burhanuddin Abd Ghani** Saya tak mcm ni, saya yg selalu buat lab
20 report hahaha
Like · Reply · October 16 at 3:08pm
- 21  **Izzuan Ishar** buat2lah air tumpah kat laptop dia....
Like · Reply ·  1 · October 16 at 3:06pm
- 22  **Faiq Amin** pm klw nk player.. haha
Like · Reply ·  1 · October 16 at 2:24pm
- 23  **Salman Khai** Ideal Mirak
Like · Reply ·  2 · October 16 at 2:14pm
- 24  **Ideal Mirak** Kah3 ..
Like · Reply · October 16 at 2:23pm

Appendix D: Facebook Confession Page #868

1 #868
2 24/10/2015
3 Omg! Agak2 la tinggal dalam asrama. Bayar yuran sama kot. Tolong jgn
4 karok guna speaker, guna MICROFON! Please! Cc blok k*4. Kalau nak
6 karok, p karok kat kbox. Tolong sgt2. Dah la sesak nafas dgr suara.
7 Lepastu, jgn jerit2 kalau bercakap tu. Pempuan kot, tak elok syg.

 115  10 Comments  1 Share

 Like  Comment  Share

Most Relevant ▾

8  **Safi Solehin** aku dulu pasang lagu clubbing pastu ade brader
9 masuk bilik.. der slow sikit...dengan rasa rendah diri aku slowkan..
10 tapi lupa korang perempuan.. tegur la kalau nak bermusuh setahun.
11 hahahah  31
Like · Reply · 2y

12  **Love Zaireen** Hahaha....kelakar2....ada erk gitu....asal x g sound
13 je depan2....nk tau gak ...spa gerangan.....  3
Like · Reply · 2y

14  **Fudael Rosli** Ek eleh...confessor jeles la tu suara dye x
15 best...mcm katak...suara org nyanyi tu sedap mcm Elizabeth
16 Tan...biasa la manusia...jeles...cemburu...hahahahaha  6
Like · Reply · 2y

17  **Mohd Azwan Haiyub** Ko ni stiap confessor confess, ade
18 je ko. Ahahaha  2
Like · Reply · 2y

19  **インラン ハスナン** Mohd Azwan Haiyub Jeles ke bro?
hahaha  1
Like · Reply · 2y

20  **Mohd Azwan Haiyub** Jeles sangat 😄  1
Like · Reply · 2y

- 20  **Mohd Azwan Haiyub** Jeles sangat 😄👍 1
Like · Reply · 2y
- 21  **Mohd Azwan Haiyub** Weh Fudael Firmino mne skrg?
Like · Reply · 2y
- 22  **Love Zaireen** Bro..sokong bro....nk tau nie...spa ala
23 elizabeth tan nie.....hahahahah....
Like · Reply · 2y
- 24  **Afzal Asyraaf** Knape perempuan suke panggil fake syg kt blkg ayat
25 ye...hrmm everybody knows kot
Like · Reply · 2y 15
- 26  **Khairul Hafiz Khai** Alah block k14, kolej tun razak. Macamlah aku
27 xtahu prempuan tu... perempuan yg sama....
Like · Reply · 2y
- 28  **Zul Hilmi Abdullah** Mst yg konfess ni pmpuan jgk....
Like · Reply · 2y 3
- 29  **Muhammad Syafiq Abdul Rashid** Meh karok kat stage fesko.
30 Duet ngn hazama mlm ni
Like · Reply · 2y 3
- 31  **Syazwan Ishak** Aku taw ni kerja spa.. hahahhahaa.. kn Nur Ain
32 Syainaleila??
Like · Reply · 2y 1
- 33  **Shazrul Ibnu Azami** btw kolej bkn asrama...weeewee
Like · Reply · 2y 5
- 34  **Nurul Syifa Nasir** Klo kolej ni ,ase nya mcm jiran aku..
Like · Reply · 2y

Appendix E: Facebook Confession Page #879

1 #879

2 "To my gorgeous Materials Engineering's coursemate, my heart was broken
3 when I found out that you were going to change course. You can't imagine
4 my excitement when you decided to stay. I think this is the second chance
5 given to me but I still don't have the courage to confess my love to you. My
6 feeling gets even stronger in this rainy season. Whenever I see you walking
7 alone in the rain, I really hope that I am an umbrella to be hold by you,
8 accompanying you every moment, providing you with shelter from the
9 scorching sun and windy rain. What's more, at night, I hope to transform to
10 a blanket, providing you with warmth in the freezing nights. Most
11 importantly, I hope to be your shoes, dancing along with you silently as if I
12 am dancing with you on the stage. I do not wish to steal your limelight, all I
13 want is to support you on the path of pursuing your dream."

 Like  Comment  Share

 99

Most Recent ▾

14  **Nurul Shahidah** that disappointment and abrupt change of mood when I
15 found out that this may be just a prank.. *sigh* to be frank, it's damn too sweet
16 to be true. haha

Like · Reply · December 17, 2013 at 12:29am

17  **Ong Ji Yan** Carlie Tan but my heart is faithful to materials, takda tukar course
18 pun

Like · Reply · December 16, 2013 at 11:57pm

19  **Dini Dayana** Syafeeka Tajuddin i wish...hahah. Sweet sesangatnyaaa oii

Like · Reply ·  1 · December 16, 2013 at 4:21pm

20  **Chin Joo Tan** Muhammad Nor Shafiq Guaperas? 😊!

Like · Reply ·  1 · December 16, 2013 at 4:33pm

21  **Muhammad Nor Shafiq Guaperas** why me Chin Joo Tan? 😞

Like · Reply ·  1 · December 16, 2013 at 4:37pm

22  **Chin Joo Tan** Erm..... Maybe you know who is he or her? 😊!

Like · Reply · December 16, 2013 at 4:39pm

23  **Muhammad Nor Shafiq Guaperas** i think its intended to Pei Qi. but i
24 dont have any idea who wrote this sweet confession. is it you Chin
25 Joo Tan since the english is so high class. only you and Loi Hb have
26 the capabilities. 😊

Like · Reply ·  2 · December 16, 2013 at 4:51pm

27  **Chin Joo Tan** I am not that kind of poetic person. I think Loi Hb is
28 more likely. 😊!

Like · Reply · December 16, 2013 at 4:56pm

- 29  **Kew Zi Ting** wow~~~
Like · Reply ·  1 · December 16, 2013 at 4:38pm
- 30  **Nurmaziah Zainuddin** Kau pernah nak tukar course ke Dini Dayana? Hahaha
Like · Reply · December 16, 2013 at 4:36pm
- 31  **Jing Zheng Poon** Ermm ... ur batch no fr boys. Is it ur batch Chin Joo Tan?
Like · Reply ·  1 · December 16, 2013 at 4:31pm
- 32  **Syafeeka Tajuddin** Dini Dayana!!!! haha
Like · Reply ·  1 · December 16, 2013 at 4:17pm
- 33  **Carlie Tan** 2nd year know how to dance de only Ong Ji Yan and Kim Fong
34 Chan!!!hahaha
Like · Reply ·  3 · December 16, 2013 at 4:16pm
- 35  **Kim Ming** wow~ Jia Herng!
Like · Reply ·  4 · December 16, 2013 at 3:39pm
- 36  **Chin Joo Tan** Huh? Jia Herng is the last person I think of. Really is
37 you? 😊!
Like · Reply · December 16, 2013 at 3:40pm
- 38  **Jia Herng** i dun hv such sophisticated english level 😊
Like · Reply ·  1 · December 16, 2013 at 3:44pm
- 39  **Kim Ming** don't know why, the first person came in my mind who
40 confessed is you leh~hahaha~ but is it possible to be juniors???
Like · Reply ·  1 · December 16, 2013 at 3:46pm
- 41  **Chin Joo Tan** Jia Herng, The "sophisticated" you used show your
42 proficient english skill already. 😊!
Like · Reply · December 16, 2013 at 3:46pm · Edited
- 43  **Chin Joo Tan** Juniors? Who else can dance? 😊!
Like · Reply · December 16, 2013 at 3:52pm
- 44  **Kim Ming** How could I know since I'm not there? lol
Like · Reply ·  1 · December 16, 2013 at 3:55pm
- 45  **Chin Joo Tan** Still got second year juniors. Not necessarily first year
46 juniors. 😊!
Like · Reply · December 16, 2013 at 3:58pm
- 47  **Kim Ming** I dunno there're 2nd year juniors who can dance, Joo Joo
48 please tell me who're they 😊
Like · Reply ·  1 · December 16, 2013 at 4:02pm
- 49  **Chin Joo Tan** I also don't know. Later, I ask Lah Bebe. 😊!
Like · Reply ·  1 · December 16, 2013 at 4:08pm
- 50  **Chin Joo Tan** Jing Zheng Poon, Who can dance in your batch? 😊!
Like · Reply · December 16, 2013 at 4:15pm
- 51  **Jeremy Ooi Set Wai Hong** !!!!!
Like · Reply ·  5 · December 16, 2013 at 4:10pm
- 52  **Wei Qian Pei Qi** on liao la, wait what? ❤️
Like · Reply ·  2 · December 16, 2013 at 4:08pm

- 53  **Pei Qi** wei qian~ u work till sot le?
Like · Reply · December 16, 2013 at 4:09pm
- 54  **Elvis Ng** Pei Qi u wan change course a? haha.. 👍
Like · Reply · December 16, 2013 at 3:16pm
- 55  **Hoay May** yo, peiqi last time said wan change course de leh 👍 👍
Like · Reply · December 16, 2013 at 3:58pm
- 56  **Ibrahim D. Fatih K**
Like · Reply · December 16, 2013 at 3:48pm
- 57  **Loi Hb** Chin Joo Tan, you think we dont know this is written by your admirer?!
58 You were trying to change to FSKTM, I saw your cover photos ! The post just
59 say gorgeous, it didnt say he or she. xD
Like · Reply · 9 · December 16, 2013 at 3:24pm
- 60  **JenYang Chong** Buddy i dun think he can dance 😊
Like · Reply · 2 · December 16, 2013 at 3:27pm
- 61  **Chin Joo Tan** JenYang Chong has a point. I can't dance. 😊!
Like · Reply · December 16, 2013 at 3:28pm
- 62  **Loi Hb** Chin Joo Tan, you have shown the best 洗刷刷 dance during
63 our orientation week. ^^
See Translation
Like · Reply · 5 · December 16, 2013 at 3:32pm
- 64  **Chin Joo Tan** Set Wai Hong, Please be brave. Admit that you confess
65 to Pei Qi. I am really innocent. Loi Hb is trying to frame me. 😊!
Like · Reply · December 16, 2013 at 3:37pm
- 66  **Pravin Vejan** Ah! Spell-bounded by love.You dwarf the likes of bruno mars and
67 chase coy. 😊
Like · Reply · December 16, 2013 at 3:20pm
- 68  **Pei Qi** Elvis Ng this is no more latest news lo~~~
Like · Reply · 1 · December 16, 2013 at 3:17pm
- 69  **Pei Qi** wahhh~~ anyway thx to the admirer~~ bt i tink mostprobably is prank
70 lo~description is jz so obvious~
Like · Reply · December 16, 2013 at 3:15pm
- 71  **Chin Joo Tan** Pei Qi, Someone is confessing to you? 😊!
Like · Reply · 5 · December 16, 2013 at 3:14pm
- 72  **Arif Syazwan** If u want to be supportive, then be a bra.
Like · Reply · 3 · December 16, 2013 at 3:13pm
- 73  **Jaymint J-Min** T Kew Zi Ting??
Like · Reply · 1 · December 16, 2013 at 3:10pm
- 74  **Elvis Ng** Jeremy Ooi u? XD
See Translation
Like · Reply · 4 · December 16, 2013 at 2:59pm
- 75  **Aslam Amran** University of Malaya "Deep-Heartbroken-DownToEarth-
76 Confessions"
Like · Reply · 3 · December 16, 2013 at 2:56pm

Appendix F: Facebook Confession Page #956

1 #956
2 "To the Pakistani worker in the Ayam A1 store in UM, you, sir truly have a
3 heart of gold. I was ordering my regular dose of chicken rice as usual, and
4 you, being the nice guy who always accommodate my picky wishes (no
5 chili, extra rice), serve the the regular dish to me. When I grab hold of the
6 rice and tried to put it down on the table to start eating, a clumsy slip of
7 hand caused the entire dish to fall down to the floor, scattering the rice
8 and chicken everywhere, and ruining the otherwise perfect lunch. Most
9 people who watched this incident unfold, would probably just sympathize
10 and walk away, but no, you, sir, being the saint you truly are, without an
11 ounce of hesitation, simply scooped together another perfect dish of
12 chicken rice and hand it to me.
13 Flashing your pleasant smile again, you uttered " It's alright. Here, my
14 treat". When I tried to pay for that, you simply shake your head and said
15 "It's alright, accidents do happen". You have no idea how much that meant
16 to me. Thank you for your kind treat,sir. There may be a lot of scandals,
17 social issues and other problems caused by a lot of foreign workers. But
18 incidents like these reminds me that those bad news are likely caused by
19 just a few bad apples that exists in every society, regardless of their race,
20 creed or nationality. Most of our foreign friends are generally hardworking,
21 kind souls that simply wanted to earn a good living for themselves in this
22 country. And more people should be aware of this fact. Let's treat our
23 foreign brothers and sisters here in Malaysia with more respect and love,
24 so that they too can feel, they are completely welcomed here 😊"

👍 Like 💬 Comment ➦ Share

793 Most Recent ▾

25  **Robert Teng** Well said. ^^
Like · Reply · May 5, 2014 at 12:09pm

26  **Caroline Joy** a touch of kindness moves many hearts .
Like · Reply · May 3, 2014 at 2:18pm

27  **Sau Fei Minnie Zatie** memang aku punya confession lol. Confess sini bagi
28 ramai orang sedar saja 😊 haha
Like · Reply · 👍 20 · May 3, 2014 at 8:00am

29  **Minnie Zatie** Sau Fei macam pernah baca je ~
Like · Reply · 👍 4 · May 3, 2014 at 7:05am

30  **Hazim Hanif** love, respect, god bless.
Like · Reply · 👍 5 · May 3, 2014 at 6:42am

31  **Nabilah Husna** *touching
Like · Reply · 👍 1 · May 3, 2014 at 6:35am

32  **Hazmi Ramli** Dislike.
33 Eh, hold on, I meant "dis I like". Hahaha 👍
Like · Reply · 👍 10 · May 3, 2014 at 6:34am

34  **Neesa Annisa Keegan** God bless him 😊
Like · Reply · 👍 2 · May 3, 2014 at 6:34am

35  **Muhd Nor Afdzal Idris** ni pekerja tadi lah kan
Like · Reply · 👍 3 · May 3, 2014 at 6:33am

36  **Yap Yee King** what a kind soul
Like · Reply · 👍 5 · May 3, 2014 at 6:28am

Appendix G: Facebook Confession Page #996

1 #996
 2 "There's one hot guy call Nicholas Chuan Wei from chemical engineering.
 3 Almost every weekend saw him badminton with his friends. The way you
 4 talk and the funny pose when you walking really attracts. I'm waiting you 😊
 5 Cheers,
 6 Your crush"

👍 Like 💬 Comment ➦ Share

👍 87 Most Recent ▾

7  **Xiang Kai Ngu** wuiyoooo Nicholas Chai Chuan Wei we r proud of u gogogo
 8 hahaha
 Like · Reply · August 28, 2014 at 5:04pm

9  **Nicholas Chai Chuan Wei** Ming Shyang Loi u r too late!! U shud have be the
 10 #995 confession baru gt chance ><
 Like · Reply · August 28, 2014 at 11:48am

11  **Nicholas Chai Chuan Wei** Go How Kean congratz to u more ahh!! U baru
 12 really partner liao d! haha although i not sure is wat partner. 😊
 Like · Reply · August 28, 2014 at 11:45am

13  **Nicholas Chai Chuan Wei** Kevin Chee Theresa Chu Alex Fang Lim Siew
 14 Ying Gary Lee Kah Meng Karen Yky Shu Ying Terry Hoong Shiong Lam
 15 Adrian Zheyu Samuel Yeoh Zheng Yi I aint sure whether this is a juz a prank
 16 or a true confession. Thanks fr d tagging n congratulation. so chill guys! Life
 17 goes on as usual! Enjoy ur holiday while it last. ^^
 Like · Reply · 👍 2 · August 28, 2014 at 11:44am

18  **Zen Ljw** Lolllll
 Like · Reply · August 28, 2014 at 11:44am

19  **Ming Shyang Loi** U attract me too Nicholas Chai Chuan Wei
 Like · Reply · August 28, 2014 at 10:27am

20  **Kevin Chee** HAAAAHA! Congrats, Nicholas Chai Chuan Wei~ 😊
 Like · Reply · August 28, 2014 at 7:50am

21  **Theresa Chu** Miri is proud of you XD Nicholas Chai Chuan Wei
 Like · Reply · August 28, 2014 at 6:06am

22  **Alex Fang** Nicholas Chai Chuan Wei I m proud of u, buddy!!!
 Like · Reply · 👍 4 · August 28, 2014 at 4:52am

23  **Lim Siew Ying** wow Nicholas Chai Chuan Wei NOT BAD WOR x)
 Like · Reply · 👍 2 · August 28, 2014 at 4:14am

24  **Gary Lee Kah Meng** Congrat! Nicholas Chai Chuan Wei
 Like · Reply · 👍 3 · August 28, 2014 at 4:08am

25  **Karen Yong Kai Yuan** Wow wow wow! Nicholas Chai Chuan Wei bebai ahh..
 Like · Reply · 👍 2 · August 28, 2014 at 3:43am

26  **Shu Ying** omo, Nicholas Chai Chuan Wei, u gt new wife liao lo!
 Like · Reply · 👍 3 · August 28, 2014 at 3:32am

27  **Terry Hoong** Nicholas Chai Chuan Wei win liao lo!!!! xDDDD
 Like · Reply · 👍 1 · August 28, 2014 at 3:19am

28  **Adrian Zheyu** Nicholas Chai Chuan Wei u hurt the girl this way. Not prank lol
 Like · Reply · 👍 2 · August 28, 2014 at 3:11am

29  **Samuel Yeoh Zheng Yi** Nicholas Chai Chuan Wei!!!! 😊
 See Translation
 Like · Reply · 👍 6 · August 28, 2014 at 2:37am

30  **Adrian Zheyu** Nicholas Chai Chuan Wei
 See Translation
 Like · Reply · 👍 4 · August 28, 2014 at 2:32am

Appendix H: Facebook Confession Page #1072

1 #1072
2 "Hi.. a few days ago a team of musician from UM came to UPSI, Tanjung
3 Malim for a competition called Rentak Bitara 2015. There was this
4 Sarawakian guy who played sape for the band and boy I fell in love with
5 you. Please someone tag that guy. I want to befriend him and get to know
6 him and..you know what.. #sapeman you are so talented and you breathe
7 music. Please help me find this guy. Oh and congratulations on getting
8 second place. UPSI got third..
9 #missanonymous
10 #sapeman"

 Like  Comment  Share

 12

Most Recent ▾

- 11  **Oscar Jefferson Chew** Wow Eli Lee
Like · Reply ·  3 · May 29, 2015 at 2:02pm
- 12  **Matthew John Mah** Uuuuu Eli Lee , love is in the air. Dah kalah aku
Like · Reply ·  1 · May 28, 2015 at 9:00pm
- 13  **Aldrich Pinso** Eli Lee omgggg your fan!!!
Like · Reply ·  8 · May 28, 2015 at 6:05am
- 14  **Elishama Zicri Abit** What the heck?!!! Haha! Didn't see that coming.
Like · Reply · May 28, 2015 at 6:25am
- 15  **Aldrich Pinso** Eli you're mine! Lol
Like · Reply · May 28, 2015 at 6:38am
- 16  **Elishama Zicri Abit** 😞😞😞
Like · Reply ·  2 · May 28, 2015 at 6:53am

Appendix I: Facebook Confession Page #1086

1 #1086
2 "I have a confession to make.
3 Dear roommate,
4 Sorry I *accidentally* deleted your porn collection. But really, that time I
5 urgently needed a hard disc big enough to transfer the project file.... and
6 the only *redundant* thing I found in your hard disc was..... the collection.
7 Aiyoh don't angry la. I belanja you maggi goreng at Food Central la okay?
8 Roommate-ship forever~
9 Your roommate at 5th college."

 Like  Comment  Share

 240

Most Recent ▾

- 10  **Syed Ahmad Nazrullah** Zulkhalid Afandi aloi aku rasa kau pernah buat ni
11 dekat Shahrir 'Popo' Roseley kan??
Like · Reply · January 4, 2015 at 10:39pm
- 12  **Milad Moazzam** Did he not set your home town on fire for that ?
Like · Reply · January 3, 2015 at 6:12pm
- 11  **Tan Yi Huan** Where is my hardisc? Hahaha. Yong Pak Nian you stole it is
12 it??? Hahaha
Like · Reply ·  1 · January 2, 2015 at 9:09am
- 13  **Samuel Leong** Laugh die me wei. Yi Hong Tan, Is this ur msg to Tan
14 Yi Huan
Like · Reply · January 3, 2015 at 8:11am
- 15  **Nazmus Sakib** balls were ripped that night
Like · Reply ·  2 · January 2, 2015 at 11:07pm
- 16  **Hfz Sni** Not cool bro
Like · Reply · January 2, 2015 at 9:37pm
- 17  **Song Wei Jian** Sorry Kien Yeap...
Like · Reply ·  1 · January 2, 2015 at 5:53pm
- 18  **Kien Yeap** Bitch please. I'm staying second college.
Like · Reply · January 2, 2015 at 5:54pm
- 19  **Joanne Lim** Omg! Nevermind that maggi goreng in a lousy cafeteria is
20 INCOMPARABLE replacement to secretive hours, days and years of
21 incognito Google search for the perfect personal collection, but deleting the
22 whole folder? He would have already know it before this confession, so it
23 was ALREADY embarrassing between you two #thefeels. Well at least now he
24 got closure lol.
Like · Reply ·  1 · January 2, 2015 at 3:17pm

- 25  **Zachary Lau** Marxwel Marcus Lundang I'll do that to yr hard disk if u lend me.
See Translation
Like · Reply · January 2, 2015 at 2:43pm
- 26  **Goh Gavin** SORRY.. ZhiDa Eng..
Like · Reply ·  3 · January 2, 2015 at 12:20pm
- 27  **ZhiDa Eng** Fuck oh so funny
Like · Reply ·  1 · January 2, 2015 at 1:16pm
- 28  **Abu Raihan Khalizan** Kevin Gan Wai Ming dont be angry at your roommate
29 k?
Like · Reply ·  9 · January 2, 2015 at 7:54am
- 30  **Kevin Gan Wai Ming** -- not cool at all! Haha
Like · Reply · January 2, 2015 at 9:13am
- 31  **Idzwan Fariz Tan** noob
Like · Reply · January 2, 2015 at 9:34am
- 32  **Abu Raihan Khalizan** disgrace
Like · Reply · January 2, 2015 at 9:37am
- 33  **Syafikah Kunhamoo** Ish ish ish.
See Translation
Like · Reply · January 2, 2015 at 12:37pm
- 34  **Kevin Gan Wai Ming** Syafikah Kunhamoo, jangan gatal! 😊
Like · Reply · January 2, 2015 at 1:01pm
- 35  **Cynthia Lee Ong** Jiunchong Tan Jia Quan
Like · Reply ·  3 · January 2, 2015 at 10:27am
- 36  **Tan Jia Quan** Hahaha
Like · Reply · January 2, 2015 at 11:53am
- 37  **JC Ong** I checked mine haddisk, my collection still there hahaha
Like · Reply ·  2 · January 2, 2015 at 12:01pm
- 38  **JC Ong** Go How Kean you last week borrow haddisk from Jing Xiong right?
Like · Reply ·  5 · January 2, 2015 at 12:01pm
- 38  **Kok Wai Yi Yao** Jun Jie
Like · Reply · January 2, 2015 at 11:57am
- 39  **Shamsudin Isman** Megat Mohd Adli Guaperas redz punye confession
40 ni...haha
Like · Reply ·  2 · January 2, 2015 at 11:37am · Edited
- 41  **Megat Mohd Adli Guaperas** Haihhh patut laaaa
Like · Reply · January 2, 2015 at 11:38am
- 42  **Yong Xiang** Eryc Eu yours hard disc gt a lot.
Like · Reply ·  1 · January 2, 2015 at 10:04am
- 43  **Eryc Eu** Xiang, wahh.. Dont reveal my secret bahh.. If you knew this
44 person, ask him to pass me the hardisk. I can help him recover xD
Like · Reply · January 2, 2015 at 10:33am
- 45  **Ifan Andria** Marxwel Marcus Lundang this is u right? No wonder la Samios
46 Erron said that vid deleted ady.. hahaha
Like · Reply ·  2 · January 2, 2015 at 10:31am
- 47  **KC Nyau** Chuah Min Yi u?
Like · Reply ·  2 · January 2, 2015 at 9:59am
- 48  **Vivinesh Menon** hahahxx... new year joke ever! 😊
Like · Reply ·  2 · January 2, 2015 at 9:59am

- 49  **KC Nyau** Ng Hao Yi I have plenty of pen drive 😞 and BTW, no one dare to touch my disk without my consent.
Like · Reply · 👍 1 · January 2, 2015 at 9:58am
- 59
- 60  **Jo Ray Yeo** Best of 2015 initiating
Like · Reply · 👍 2 · January 2, 2015 at 9:57am
- 61  **Marxwel Marcus Lundang** Zachary Lau Is it u??
Like · Reply · 👍 2 · January 2, 2015 at 9:53am
- 62  **Rik Kie Chong** Dont make this another TARC confession page ==
Like · Reply · January 2, 2015 at 9:43am
- 63  **Tara Tan Tze Linn** OP's brave. very brave. Later at night roommate CHOPCHOP as revenge.
64 Like · Reply · January 2, 2015 at 9:41am
- 65  **Koay Hean Ghee** Sci Wong 是你吗?
Sci Wong is that you?
Automatically Translated
Like · Reply · 👍 6 · January 2, 2015 at 9:03am
- 66  **Chia Chong** #ops
Like · Reply · 👍 1 · January 2, 2015 at 9:37am
- 67  **Ng Hao Yi** KC Nyau you?
Like · Reply · 👍 10 · January 2, 2015 at 9:34am
- 68  **Dolce Heng** This guy shall burn in bro's hell for violating the bro's code!!!
Like · Reply · 👍 1 · January 2, 2015 at 9:26am
- 69  **Yong Pak Nian** Tan Yi Huan must be you
Like · Reply · 👍 1 · January 2, 2015 at 9:01am
- 70  **Datok Kame** dayyumm
Like · Reply · January 2, 2015 at 8:56am
- 71  **Faiz Zeo** Oh u mean cut and paste? Nur Fazlan
Like · Reply · 👍 4 · January 2, 2015 at 7:03am
- 72  **Nur Fazlan** yeah, sure..haha..
Like · Reply · January 2, 2015 at 8:20am
- 73  **Tengku Fauzan** Topkek
See Translation
Like · Reply · January 2, 2015 at 8:16am
- 74  **Jeyganesh Palanisamy** Eashwar Shanmugam Vivinesh Menon
Like · Reply · January 2, 2015 at 8:14am
- 75  **Cancan Raw** Bro Rule Number 1
76 A bro never judge another bro for his porn collection, no matter how weird it is.
77 Number 2
78 A bro NEVER deletes another Bro's porn. you just basically deleted his favorite preference that he has been saving for years
79
80 Like · Reply · 👍 39 · January 2, 2015 at 7:56am

- 81  **Henry Loh Yung Hao** Epic confession !
Like · Reply · January 2, 2015 at 7:36am
- 82  **Norman Zakaria** Unforgivable!!
Like · Reply ·  1 · January 2, 2015 at 7:24am
- 83  **Hazmi Ramli** Not cool, OP. I'm pretty sure that broke the Bro Code in one way
84 or another.
85 And do be grateful that your roommate doesn't whoop yo' ass for doing that.
Like · Reply ·  12 · January 2, 2015 at 7:08am
- 86  **Leong Chen Onn** best confession ever.... haha
Like · Reply ·  16 · January 2, 2015 at 6:58am
- 87  **Faiz Zeo** Lco u delete t ah fatt punya collection ke?
Like · Reply · January 2, 2015 at 7:01am
- 88  **Leong Chen Onn** ah fatt not my roommate pun.haha.
Like · Reply · January 2, 2015 at 7:02am
- 89  **Faiz Zeo** Haha. I think this guy cut and paste then delete. Lol.
Like · Reply · January 2, 2015 at 7:02am
- 90  **Mas Haikal Faiz** Ok. Ini confession paling epic...
Like · Reply ·  7 · January 2, 2015 at 7:00am

Appendix J: Facebook Confession Page #1098







1 #1098
2 "To Kuan Ming from chemical engineering,
3 I wanted to tell you that wherever I am, whatever happens, I will always
4 think about you, and the time I saw you for the first time was my happiest
5 time in my university life. I love your smile, your skin colour. You may not
6 know who am and your handsome face. You may not know who am I but I
7 know you well.
8 Anyone can help me tag him after reading this ?
9 ~someone special~"

 Like  Comment  Share

 60

Most Recent ▾

- 10  **Aik Yin Chien** This sounds like a prank love letter.
Like · Reply · June 1, 2015 at 6:57am
- 11  **Meng Fang** Is your parents know you are a gay??Hahaha XP
Like · Reply · June 1, 2015 at 5:12am
- 12  **Alex Roldan** inb4 "btw, I'm a guy"
Like · Reply · June 1, 2015 at 3:36am
- 13  **Mei Qi** WAHHHHHHHHHHHHHHH Lim Kuan Ming SO POPULAR OOO
14 HAHAAHAHAHAHAHAHAHAHAHAHA
Like · Reply ·  3 · May 31, 2015 at 5:51pm
- 15  **Lim Kuan Ming** lols..even u come comment..haha
Like · Reply · May 31, 2015 at 5:52pm
- 16  **Mei Qi** U so popular of course need give face abit mah woots
17 hahahahahaha 😊😊😊😊
Like · Reply ·  1 · May 31, 2015 at 5:53pm
- 18  **Lim Kuan Ming** Mei Qi why you found this de?lols
Like · Reply · May 31, 2015 at 5:57pm
- 19  **Mei Qi** Chunjian tagged me lol dk he got tag wrong ppl or not
20 hahahahahaha
Like · Reply · May 31, 2015 at 5:58pm
- 21  **Lim Chun Jiann** I simply tag haha
Like · Reply · June 1, 2015 at 2:29am

- 22  **Lim Chun Jiann** Saw Cy Chosing Tan Gan Yi Huang Meng Fang Mei Yi Shin
 23 Ying Weiyao Yeoh Tan ChunRen Vivace Min Sylvester Keith Liaw Rongteng
 24 Ho Qing Ning Mei Qi
 Like · Reply ·  7 · May 31, 2015 at 5:50pm · Edited
- 25  **Lim Kuan Ming** WALAO!!!
 Like · Reply ·  1 · May 31, 2015 at 5:46pm
- 26  **Mei Yi** woahhhhhhhhhhhhhhhhhhhhh kuan ming i doubt did u write
 27 this yourself? XD
 Like · Reply ·  2 · May 31, 2015 at 5:48pm
- 28  **Lim Kuan Ming** WALAO eh.....
 Like · Reply · May 31, 2015 at 5:49pm
- 29  **Sylvester Keith Liaw** mei yi ppl confess to kuan ming u jealous?
 Like · Reply · June 1, 2015 at 2:24am
- 30  **Saw Cy** hahahahhahahababababaha
 See Translation
 Like · Reply · May 31, 2015 at 5:57pm
- 31  **Alan Tiow** Roommate!!! I m proud of u!!! haha
 Like · Reply · May 31, 2015 at 5:47pm
- 32  **Lim Kuan Ming** roommate..haha..i dunno what should i say
 Like · Reply · May 31, 2015 at 5:48pm
- 33  **Chosing Tan** Omg Lim Kuan Ming HAHAHAHA is boy or girl?
 Like · Reply ·  2 · May 31, 2015 at 5:47pm
- 34  **Lim Chun Jiann** Good question!!! XD
 Like · Reply · May 31, 2015 at 5:48pm
- 35  **Weiyao Yeoh** Waseh! Vivace kah?!
 Like · Reply ·  1 · May 31, 2015 at 5:47pm
- 36  **Lim Kuan Ming** Thank you.. ="
 Like · Reply ·  6 · May 31, 2015 at 5:43pm
- 37  **Lim Chun Jiann** So sweet!!!!  
 Like · Reply ·  2 · May 31, 2015 at 5:36pm
- 38  **Siok Zhen** Omg Lim Kuan Ming
 Like · Reply ·  4 · May 31, 2015 at 5:32pm
- 39  **Su Ann Tan** Lim Lim Kuan Ming woahhhhhhh!!!!   
 Like · Reply ·  1 · May 31, 2015 at 5:21pm
- 40  **Kerryann Chin** Lim Kuan Ming hahahahahahahaha
 Like · Reply ·  2 · May 31, 2015 at 5:20pm
- 41  **Beng Ern Low** Lim Kuan Ming wah!!!!!!
 Like · Reply ·  1 · May 31, 2015 at 4:57pm
- 42  **Lee Yan Han** Lim Kuan Ming
 Like · Reply ·  7 · May 31, 2015 at 4:24pm

Appendix K: Facebook Confession Page #1103

1 #1103
2 "I fall in love with a FBA 2nd year guy, he is a little dark skin, skinny, wear
3 spec and he is the BODs of UMAC. I am very into him and I am very lucky
4 to be join his team in a mega event of UMAC. Under his leadership, I totally
5 in love with him, I always imagine holding his hand while he is very near to
6 me during departmental workshop. But then rumours around the faculty
7 begins to spread, people are saying we are in love, especially my matric
8 friends, and I started to worry that this will scare him away and we can't
9 even be friend, and so, I become low-profile and not dare to near him as
10 much as when we were working in the same event. I also heard that some
11 people are saying he and another senior are in relationship. I sometimes
12 wonder he really likes her or not, if it is true, I might be a little heart broken.
13 Anyway, I still hope that someday we can have a chance to hang out, only
14 two of us.
15 Sincerely,
16 Just a shy little 1st year girl"

Like Comment Share

55

Most Recent

- 17  **Jun Mao** Actually is Kin Chun write for himself one lol 😏😏
Like · Reply · 2 · June 1, 2015 at 3:37pm
- 18  **Lo Sin Kuang** Kin Chun ❤️
Like · Reply · 1 · June 1, 2015 at 3:25am
- 19  **Terry Hoong** Awww Bibie Yani since when were u so shy huh????
Like · Reply · May 31, 2015 at 6:43pm
- 20  **Chloe Zhaoyi** My first thought is...Kin Chun LOLOLOL
Like · Reply · 9 · May 31, 2015 at 5:11pm
- 21  **Janice Wong** Obviously...a little dark skin ahahaha..member的春天
22 到了吗? 🙄🙄🙄 Kin Chun
Like · Reply · 2 · May 31, 2015 at 5:15pm
- 23  **Chloe Zhaoyi** Woohoo!!! Guess he is going to be SO famous starting
24 from tonight. ACCOUNT 001 🙄🙄🙄
Like · Reply · 1 · May 31, 2015 at 5:19pm
- 25  **Janice Wong** The scope is sooo limited, "join his team in one mega
26 project".. ITAC only rite?
Like · Reply · 1 · May 31, 2015 at 5:23pm
- 27  **Chloe Zhaoyi** Hahahahaha ONLY ITAC 😏😏😏😏
Like · Reply · 1 · May 31, 2015 at 5:24pm
- 28  **Yen Zi Joyce** Ya...obviously is Chun Kin ge liao hahaha
Like · Reply · 1 · May 31, 2015 at 5:27pm
- 29  **Yee Han Khoo** Kin Chun ge...u win liao lorr..hahaha
Like · Reply · May 31, 2015 at 6:12pm

- 30  **BRi Eun Cher Shong Teoh** more leng zai from medic fac
Like · Reply · 👍 4 · May 31, 2015 at 5:37pm
- 31  **Daniel Tay Chun Kin** 春天来了
Chun Kin Spring is here
Automatically Translated
Like · Reply · 👍 4 · May 31, 2015 at 5:33pm
- 32  **Bibie Yani LiHong Boo** and Thanesh Kumar. Please alert with the situation
33 now 😄😄😄😄
Like · Reply · 👍 1 · May 31, 2015 at 5:26pm
- 34  **Teh Wei Ting** Bibie Yani should we jz dun show up tomorrow? **Kelxin Lim** jz
35 wan 2 of them 😄😄😄
Like · Reply · 👍 5 · May 31, 2015 at 5:24pm
- 36  **Choon Kwan Pua** Kah Yong -Xin Yan Kho- Xian Yui Gan Wei Teng Zhilin
37 Chong your fren?==
Like · Reply · 👍 2 · May 31, 2015 at 4:58pm
- 38  **Zhilin Chong** Kelxin Lim!!!!!! 😄😄
Like · Reply · 👍 1 · May 31, 2015 at 5:14pm
- 39  **Kelxin Lim** U all know right walaooooo not me 🙄🙄🙄
Like · Reply · May 31, 2015 at 5:15pm
- 40  **Gan Wei Teng** Kolian Kelxin Lim, be strong, haha
Like · Reply · 👍 1 · May 31, 2015 at 5:22pm
- 41  **Bibie Yani** Oh My Gosh!!! Kelxin Lim !!!!!!!!!!!!!
Like · Reply · May 31, 2015 at 5:06pm
- 42  **Kelxin Lim** NO!!! Walaoooo not me
43 Somebody save me pleaseeee 🙄🙄🙄
Like · Reply · 👍 1 · May 31, 2015 at 5:14pm
- 44  **Bibie Yani** Wei Ting see ur member. She cannot tahan ady 😄😄😄
45 btw Kelxin Lim #yolo
Like · Reply · 👍 1 · May 31, 2015 at 5:16pm
- 46  **Choon Kwan Pua** Ashlee Jae Amirul Asyraaf Carey HY Shu Fern Racheal
47 Ong Cow Cow Fazreena Islam Lynn Goh Saeda Iman Kushairi :OOOOOO
Like · Reply · 👍 4 · May 31, 2015 at 4:58pm
- 48  **Fazreena Islam** There are like 4 guys in our team, unfortunately the
49 first criteria answered it all! Kin Chun , how's my smart guess?
Like · Reply · 👍 4 · May 31, 2015 at 5:01pm
- 50  **Chloe Zhaoyi** Omg!!! Hahahhahahahhahaa
Like · Reply · May 31, 2015 at 5:12pm
- 51  **Jh Chen** Kelxin Lim, is that u? U serious? 😞😞😞
Like · Reply · 👍 11 · May 31, 2015 at 5:04pm
- 52  **Kelxin Lim** Seriously not me okay walao 🙄🙄
Like · Reply · May 31, 2015 at 5:11pm
- 53  **Sinpei Lim** Bibie Yani 😄
Like · Reply · 👍 3 · May 31, 2015 at 5:04pm
- 54  **Melissa Duchess** Afizan AmirBi Zurin Azie Bahrin Nor Aliaa Fatini Mokhtar
55 Izzana Satar
Like · Reply · 👍 4 · May 31, 2015 at 4:54pm

Appendix L: Facebook Confession Page #1106

1 #1106
2 "Dearest red saga driver,
3 you're the stupidest driver i've ever encountered with in UM. Thank you for
4 tailgating me like hell just now all the way from the main KL Gate to KPS.
5 You were lucky i didnt brake and make you pay for any damages.
6 Annoying much! You're driving on campus for heaven's sake! You wanna
7 race, you go outside UM! I think the UM authorities should install speed
8 traps. Ugh -.-"

 Like  Comment  Share



26 people like this.

Most Recent ▾

9  **Clarence Wong Qun Fei** Just switch on n switch off your headlights. The
10 brakelight will light up. But be prepared to fight la if the dude is a hot head.
Like · Reply · June 5, 2015 at 5:46pm

11  **Ko Hsiao Ping Sue Fyenn**
Like · Reply ·  1 · June 1, 2015 at 7:07am

12  **Sue Fyenn** Hahahaha. I don't use the KL gate much. Only PJ gate 😊
Like · Reply ·  1 · June 1, 2015 at 7:25am

13  **Aik Yin Chien** I drove behind a car that ran at 10km/h before, almost drove
14 me nuts. Yes, this is a campus and it's not okay to drive too fast, but if
15 someone drives at the tortoise speed of 10km/h I think they should go back
16 to driving school. Note that I'm not encouraging you guys to race in campus.
17 If you wanna speed you can do it at F1.
Like · Reply ·  2 · June 1, 2015 at 6:55am · Edited

18  **Jun Lin** Yeah it's me. I think is not my problem. Anything wanna to add?
19 Haha.. Jh Chen replied like this ok mah?
Like · Reply ·  3 · June 1, 2015 at 5:49am

20  **Jh Chen** Jun Lin, lol...
Like · Reply · June 1, 2015 at 5:30am

21  **Max 彭欣阳** I was shocked when I saw red saga! Then I saw KL gate... Ahh...
22 What a relief. It's not me~
Like · Reply · June 1, 2015 at 3:26am

- 23  **Darren Tay** Hy Wong don't race inside the campus
Like · Reply · 👍 1 · June 1, 2015 at 2:55am
- 24  **Hy Wong** "Red Saga" . sounds like your car
Like · Reply · June 1, 2015 at 3:05am
- 25  **Darren Tay** Mine is red Ferrari bro
Like · Reply · 👍 2 · June 1, 2015 at 3:19am
- 26  **Ng Eng Leng** Joseph Lee ChinYung,you??
Like · Reply · 👍 1 · May 31, 2015 at 6:49pm
- 27  **ChinYung Lee** I haven't been driving for the past 2 days lol
Like · Reply · 👍 1 · May 31, 2015 at 6:56pm
- 28  **Carlson Stark** Yin Meng hahaha
Like · Reply · 👍 4 · May 31, 2015 at 4:59pm
- 29  **Yin Meng** 😊
Like · Reply · May 31, 2015 at 5:20pm
- 30  **Carlson Stark** Red Saga
Like · Reply · May 31, 2015 at 6:27pm
- 31  **Jack Holtby** I feel your pain. But they just don't seem to realise what they're
32 doing. Stupid licensing system.
Like · Reply · 👍 4 · May 31, 2015 at 4:59pm
- 33  **Titus Ong** and then there are those who drive 10km/h haha
Like · Reply · 👍 1 · May 31, 2015 at 5:55pm
- 34  **BRi Eun** Leong Yu Kai I think this post is for you although your saga Isn't red
35 in color 😊😊
Like · Reply · May 31, 2015 at 5:43pm

Appendix M: Facebook Confession Page #1128

1 #1128

2 "I met her in a dinner organized by HEPA few days ago. She looked so
3 charming, elegant and gorgeous in the red gown...

4 I was awed after knowing that she was the president of a club that runs 13
5 projects within a session. Yet she was so humble and said it's all her
6 teammates' effort! We all know that it can't happened if our colleagues
7 weren't believing in us, or didn't recognize our influence, isn't it? Plus, she
8 used the word "teammates", rather than "groupmates", "committee",
9 "colleagues" and whatsoever. How I wish I COULD BE HER TEAMMATE
10 too! (even though she said her working style is super strict)

11 Things turned out to be sad after I browsed her Facebook. SHE HAS BF.
12 Okay then, I still enjoy listening to your thoughts and life values anyway.
13 Even if I can't be your SUN, but I'll try hard to be BEST STAR around you.
14 Thanks for your motivation during that night. See you again."

 Like  Comment  Share

 21

Most Recent ▾

15  **Khai Wern Sookmun Liew** you have admirer !!! Hahaha

Like · Reply ·  9 · June 2, 2015 at 10:45am

16  **Sookmun Liew** That night many ladies were in red too, I think...

Like · Reply · June 2, 2015 at 11:09am

17  **KeSin Lim** Sookmun Liew but not every girl is the president of a club
18 ? xD

Like · Reply ·  1 · June 2, 2015 at 11:25am

19  **Sookmun Liew** KeSin Lim banyak kacau huh you.

Like · Reply ·  1 · June 3, 2015 at 1:40pm

20  **Jun Yung** Sookmun Liew haha. so many admirer~~ XD

Like · Reply · June 4, 2015 at 2:44pm

21  **Shelly Phang** Sookmun Liew jeng jeng jeng!

Like · Reply · June 3, 2015 at 1:04pm

22  **Sookmun Liew** UM has 80 over clubs larh.. Coincidence coincidence

Like · Reply · June 3, 2015 at 1:41pm

23  **Shelly Phang** Not so much of coincidence as being a president and
24 wore red dress 😊

Like · Reply · June 3, 2015 at 1:43pm · Edited

25  **Jiun Khan** Sookmun Liew keep this away from your bf hahahah

Like · Reply ·  1 · June 2, 2015 at 12:26pm

26  **Sookmun Liew** too bad he saw that. 😊

Like · Reply · June 3, 2015 at 1:39pm

27  **Henry Loh Yung Hao** a charming lady is similar to a diamond stone. Enjoy
28 seeing it but no need to own it.

Like · Reply ·  2 · June 2, 2015 at 11:15am

29  **Eloise Ewe** Sookmun Liew???

Like · Reply ·  1 · June 2, 2015 at 10:25am

30  **Sookmun Liew** shhhh

Like · Reply · June 2, 2015 at 11:09am

Appendix N: Facebook Confession Page #1187

#1187

"I feel weird.

I'm so handsome yet no girls like me.

I look at my eyes, so attractive like robert downey jr.

my nose like chris evans.

I have mouth like orlando bloom.

My skin quite dark also, a little bit like johnny depp.

six pack i don't have, but i'm quite tall. Imagine a hulk protecting you.

I have all the characteristics of a lengchai. But no girls ever think i'm

lengchai.

zzzzzzz"

Like Comment Share

40 Most Recent

Write a comment...

Ben Adam Keenakan buah kurma dr timur tengah (yusuf taiyoob) kelazatan buah kurma yg tiada tandinganya (yusuf taiyoob) buah kurma safia, wasem, safina dan byk lg, pastinya menjadi pilihan anda setiap masa, pilihan eksklusif (yusuf taiyoob)
Like · Reply · June 11, 2015 at 12:42pm

Jon Black Two words: Face Problem
Like · Reply · June 11, 2015 at 7:16am

Wani Wani Hahahahahah hahahahahah omgggg!!!!!! Never met anyone like tht!!! Too much is everything is too overwhelmed 😞😞😞😞 Amos Aw
Like · Reply · 1 · June 11, 2015 at 2:20am

Amos Aw k stick to me then.Lol
Like · Reply · June 11, 2015 at 7:04am

Yap Boon Nie Sorry but no sorry, i prefer Jude Law 😞
Like · Reply · 1 · June 10, 2015 at 5:15pm

Carlson Stark Colin Farrell yo
Like · Reply · June 10, 2015 at 7:15pm

Jxuan Teh Wilson Chuah is that you?hahah
Like · Reply · June 9, 2015 at 9:45am

Wilson Chuah Lol..haha..off course no la.
Like · Reply · June 9, 2015 at 9:52am

 **Wilson Chuah** Lol..haha..off course no la.

Like · Reply · June 9, 2015 at 9:52am



Dylan Hii Yong Jie Feel like want to use photoshop to figure out your face base on what you said in your statement.

Like · Reply ·  13 · June 5, 2015 at 3:34pm



Aik Yin Chien Dear Dylan Hii Yong Jie, please do! I'm curious to see what the end product looks like!

Like · Reply · June 7, 2015 at 2:36pm



Dylan Hii Yong Jie Aik Yin Chien, yes I did. It was on my FB's wall now. I want post it here but too bad there's no way for me to do it. hahaha ! Kinda handsome tho... Aik Yin Chien

Like · Reply · June 7, 2015 at 4:12pm · Edited



Faith Olubunmi Oluwaseyi Sodiya Are you waiting for a girl to approach you ? Be yourself mate .. move out of your shell and socialize . Definitely there is a girl out there that is waiting for you to ask her out ..

Like · Reply · June 6, 2015 at 4:56pm



Milad Moazzam Faith Olubunmi Oluwaseyi Sodiya man are u talking to me ?

Like · Reply ·  1 · June 6, 2015 at 5:51pm



Faith Olubunmi Oluwaseyi Sodiya LOL! So that was your confession Milad Moazzam

Like · Reply ·  1 · June 6, 2015 at 6:06pm · Edited



Ivan Marland Bulang I learned one of the shittiest way to use the word "handsome". Have you ever heard of the word "threesome"? Now replace the word "three" with "hand".

Looks like you've been doing yourself a little bit too much lately.

Like · Reply · June 6, 2015 at 6:08pm



Tham Hui Ling Well if u really have such features..I am for sure that u would have been noticed...coz I'm sure UM girls are not blind..if this is not happening means u have to look in the mirror N reevaluate..hahahaha..happy saturday 😊

Like · Reply ·  1 · June 6, 2015 at 11:39am



Amos Aw Wani Wani, closest you can get to Chris Evans? Lol

Like · Reply ·  1 · June 6, 2015 at 9:15am



BRi Eun This guy has all the leng zai characteristics.. Cher Shong Teoh

Like · Reply ·  2 · June 6, 2015 at 3:00am



Cheryl Chia BRi Eun how much did he pay you

Like · Reply ·  1 · June 6, 2015 at 6:19am



Ooi Wei Zhen Sure, these people look good. But if you combine all these features into one single face, you'd look pretty hideous isn't it? 😞

Like · Reply ·  2 · June 6, 2015 at 6:19am



D Reza Sabri Huikang Ck the description mcm you la~~ 😊

Like · Reply · June 6, 2015 at 4:41am



Obada Baghdadi Johnny depp ma ass 😊😊

Like · Reply · June 5, 2015 at 8:55pm



Kok Siang Koay Yong Sheng, did u write this for Yap Chee Aik ? Fit all his characteristics leh

Like · Reply ·  1 · June 5, 2015 at 2:07pm

 **Koay Yong Sheng** Yap Chee Aik
Like · Reply · June 5, 2015 at 7:07pm

 **Kok Siang** He really looks like a hulk
Like · Reply · June 5, 2015 at 7:08pm

 **Clarence Wong** Qun Fei Maybe its the personality bro. No disrespect but u sound like an over over confident guy
Like · Reply · June 5, 2015 at 4:57pm

 **Pang Wen Shean** Wa Koh Chuan Pey not bad ah confess here
Like · Reply ·  1 · June 5, 2015 at 2:22pm

 **Koh Chuan Pey** "My skin quite dark also, a little bit like johnny depp." im as pale as ghost not johnny Herp Derp
Like · Reply · June 5, 2015 at 4:29pm

 **Wei Sern** Well written Hao Wei.
Like · Reply ·  1 · June 5, 2015 at 2:43pm

 **Wei Hao** Can you stop defame me ?
Like · Reply · June 5, 2015 at 3:50pm



 **Wong Lee Mei** Attention seeker. Nailed it. Congrats.
Like · Reply · June 5, 2015 at 3:36pm

 **Jun Yen** Sylvester Keith Liaw I want face won't do such things de... Haha
Like · Reply ·  3 · June 5, 2015 at 3:16pm

 **Vig Chan** Yea you're freak
Like · Reply · June 5, 2015 at 3:07pm

 **Jun Hong** Jason Seong Jiann Koay
Like · Reply ·  7 · June 5, 2015 at 2:53pm



 **Sylvester Keith Liaw** Jun Yen please dont confess here i know u are handsome
Like · Reply ·  6 · June 5, 2015 at 2:52pm

 **Samantha Soon** You sure you're looking at a mirror instead of a poster? 😏
Like · Reply ·  4 · June 5, 2015 at 2:12pm



 **Shelly Phang** RDJ's eyes huh? 😏
Like · Reply · June 5, 2015 at 2:09pm

 **Ariff Hamdi** Kau buat confession ke Nasruddin
Like · Reply ·  4 · June 5, 2015 at 2:00pm

 **Nasruddin Nasehir** Ariff Hamdi.. mamat ni syok sendiri...poyo la..
Like · Reply ·  2 · June 5, 2015 at 2:09pm

 **Manson Lim** Conclusion = Monster 🐉
Like · Reply ·  1 · June 5, 2015 at 1:55pm

 **Kenny Liaw** tall, but no six pack, yet still call urself a Hulk?
this bloke is a joke 😏 😏 😏
Like · Reply ·  4 · June 5, 2015 at 1:55pm

 **Ponnurajah Panjavarnam** All of these are physical characteristics, none which last forever. Only your inner character will last forever
Like · Reply ·  2 · June 5, 2015 at 1:53pm

Appendix O: Facebook Confession Page #1191

1 #1191
2 "So there is this one guy from Faculty of Med. Tall, good
3 looking(seriouslyyyy good looking) , with a charming smile and ummm what
4 else? I dont know if he is an indian or chinese who looks like an indian. But
5 trust me, you can melt my heart ❤️❤️"

👍 Like 💬 Comment ➦ Share

👍 18 Most Recent ▾

1 share 8 comments

- 6  **Kevin Loh** It only counts if he melts your panties, girl.
Like · Reply · June 9, 2015 at 9:02am
- 7  **Francesca Chen** Aww Cher Shong Teoh +1 admirer 😊😊
Like · Reply · 👍 8 · June 6, 2015 at 10:14am
- 8  **BRi Eun** Haha.. I didn't know that Cher Shong Teoh is mixed blood 😊
9 😊
Like · Reply · 👍 1 · June 6, 2015 at 3:51pm
- 10  **Francesca Chen** I guess he's related to everything in this page 😊
Like · Reply · 👍 1 · June 6, 2015 at 3:57pm
- 11  **BRi Eun** Lets make him famous then 😊
Like · Reply · 👍 1 · June 7, 2015 at 3:06pm · Edited
- 12  **Cher Shong Teoh** BRi Eun no pls...i belanja u keropak ok?
Like · Reply · 👍 1 · June 7, 2015 at 3:06pm
- 13  **Bin Ting Ang** wait wait... Cher Shong Teoh tall???
Like · Reply · June 7, 2015 at 3:56pm
- 14  **Sumitra Ropini Karuthan** Untungla Lughen Harikrishnan, charming smile
15 that melts hearts. 😊
Like · Reply · 👍 3 · June 6, 2015 at 5:56pm
- 16  **Lughen Harikrishnan** Not specifically stated like yours 😊
Like · Reply · June 6, 2015 at 6:18pm
- 17  **Sumitra Ropini Karuthan** No idea what you're talking about.. But I
18 like how you 'liked' the status.. 😊
Like · Reply · 👍 1 · June 7, 2015 at 1:16pm
- 19  **Ariff Hamdi** Hensemnya Lughen Harikrishnan
Like · Reply · 👍 2 · June 7, 2015 at 11:07am
- 20  **Lughen Harikrishnan** Tak sehandsome you bro 😊
Like · Reply · June 7, 2015 at 11:09am
- 21  **Suhanya Aries** Lughen? Snr Kuganathan?annaiya Rathakrishnan? Not sure
22 whc one of u 😊
Like · Reply · June 6, 2015 at 5:33pm
- 23  **Arullthevan Rajendram** Lughen Harikrishnan-No doubt. It is you bro.
Like · Reply · 👍 1 · June 6, 2015 at 4:09pm
- 24  **Lughen Harikrishnan** Hahaha. Ille bro. Junior la bro 😊
Like · Reply · 👍 1 · June 6, 2015 at 4:12pm
- 25  **Lughen Harikrishnan** Kushla: No Bro. Your buddy Kot 😊
Like · Reply · June 6, 2015 at 1:18pm
- 26  **Kushla Renganadan** Sri Kabelen, you are being mentioned here. 😊
Like · Reply · 👍 1 · June 6, 2015 at 1:18pm
- 27  **Kushla Renganadan** Lughen, mcm you je, bro.
Like · Reply · 👍 1 · June 6, 2015 at 1:17pm

Appendix P: Facebook Confession Page #1633

#1633

"I am one of the Manchester United fans. I hope my future GF will be wearing the same jersey together with me, singing club song together! Any other MU fans here in UM?"

Like Comment Share

76 Most Recent ▾

 **Coffeandsweets FluffyWhinnie** Sometimes I wish I can wear the same couple jersey too but too bad, I am not supporting any team. 😞
Like · Reply · August 11, 2015 at 11:10am

 **Haroon Wardak Me...**
First barca fan #Cules
Second man utd fan #RedDevils
Like · Reply · August 10, 2015 at 3:49pm

 **Jia Ying Foo Chong Tsen nah MU fans**
Like · Reply · 1 · August 10, 2015 at 2:31pm

 **Chong Tsen GGMU hahaha**
Like · Reply · August 10, 2015 at 2:42pm

 **Jia Ying Foo #coyg**
Like · Reply · August 10, 2015 at 2:42pm

 **Chong Tsen great debut from Cech, oh I mean in the community shield 😞**
Like · Reply · 3 · August 10, 2015 at 2:44pm

 **Ashley Tay Nick Teh for a moment i tot this was you HAHAHAHA**
Like · Reply · 1 · August 10, 2015 at 7:53am

 **Nick Teh HAHAHA I shared the same thought as this guy hehe ❤️❤️**
Like · Reply · August 10, 2015 at 8:13am · Edited

 **Ashley Tay 'Glory glory man united! Glory glory man united!' I know how to sing also okay 😞 or are you waiting for your FUTURE gf like that guy 😞**
Like · Reply · 1 · August 10, 2015 at 8:22am

 **Ashley Tay Nick Teh**
Like · Reply · 1 · August 10, 2015 at 8:23am

 **Nick Teh HAHA Wow u know how to sing!! Great!!
OMG NONO!! I shared the same thought as him but with the current gf hehehe
Ashley Tay**
Like · Reply · 1 · August 10, 2015 at 8:25am

 **Nadila Zahari Senpai Detroit**
Like · Reply · 1 · August 10, 2015 at 5:36am

 **Senpai Detroit Nate mu delle. Hahaha**
Like · Reply · August 10, 2015 at 5:40am

 **Nadila Zahari bhahahaha betul what. mu reminds me of you gittu. kakaka 😞**
Like · Reply · August 10, 2015 at 5:41am

-  **Kafhsi Labqi** I am barca fan but , I would love to have gf supports real Madrid. So that I can play EL classiso every time. .. 🙄🙄🙄🙄🙄🙄
Like · Reply · August 10, 2015 at 4:24am
-  **Khalil Gibran Von Najib** also a fan, go call him up.
Like · Reply · August 10, 2015 at 2:25am
-  **Milad Moazzam** Real Madrid for life!
Like · Reply · 👍 1 · August 9, 2015 at 10:59pm
-  **Umai Jamal** GGMU
Like · Reply · 👍 1 · August 9, 2015 at 6:16pm
-  **Aun Yi Yang** Hands up.
Like · Reply · 👍 1 · August 9, 2015 at 4:40pm
-  **Kymi Tan** Michael Cheow ?
Like · Reply · 👍 4 · August 9, 2015 at 11:05am
-  **Michael Cheow** Manu fans, how u know de haha
Like · Reply · August 9, 2015 at 11:20am
-  **Huimin Teoh** First thought of michael also hahaha
Like · Reply · 👍 1 · August 9, 2015 at 1:00pm
-  **Kymi Tan** Ur laptop de background lar. Lol During meeting got saw before lar
Like · Reply · August 9, 2015 at 3:21pm
-  **Michael Cheow** dun stalk me plz
Like · Reply · August 9, 2015 at 3:21pm
-  **Kymi Tan** I just Accidentally know this.hahaha
Like · Reply · August 9, 2015 at 3:26pm
-  **Arnee Farzana Mohd Nurdin** Hazreena Aida nah MU fan
Like · Reply · August 9, 2015 at 2:45pm
-  **Thiru Chelvi Thirumurugu Arivanandan** Shoba Govin 😊😊
Like · Reply · 👍 1 · August 9, 2015 at 11:35am
-  **Shoba Govin** Hahax... Yea glory glory MU!!! 😊
Like · Reply · 👍 1 · August 9, 2015 at 1:18pm
-  **Darren Tay** Janna Sugiharto
Like · Reply · 👍 1 · August 9, 2015 at 11:56am
-  **Janna Sugiharto** I predict my future boyfriend will do the same HAHA
Vinodhan Kuppz is a fan too xD
Like · Reply · 👍 1 · August 9, 2015 at 12:21pm
-  **Hazmi Ramli** Walker best striker.
Like · Reply · 👍 2 · August 9, 2015 at 12:06pm
-  **Faiz Zeo** I am not and I hope my future GF wont supporting MU.
Like · Reply · 👍 6 · August 9, 2015 at 11:57am
-  **Sky Heart** Hahahaha. Don't worry. I love MU too. So it's not impossible wish. Hahahaa
Like · Reply · August 9, 2015 at 11:51am
-  **Munawwar Ar Ko** eh Bala Murugan Chandiran?
Like · Reply · 👍 1 · August 9, 2015 at 11:32am
-  **Bala Murugan Chandiran** Ak ingat ko yg confess
Like · Reply · 👍 1 · August 9, 2015 at 11:50am

Appendix Q: Facebook Confession Page #1686

1 #1686
2 "Dear the guy who danced on stage during iweek, you look much more
3 better with cap on bcause your hair is wayyy toooo thickkkk. Pls do
4 something about it 😊
5 From ur secret admirer"

👍 Like 💬 Comment ➦ Share

👍 28

Most Recent ▾

- 6  **Karsin Lew** The 1st one i think off is u Buddy Ong Yern Yee wahaha
Like · Reply · September 26, 2015 at 6:15am
- 7  **Ong Yern Yee** Ma de.. haha. Don't like that say me. If i got dance jiu
8 will wear hat de.
Like · Reply · September 26, 2015 at 11:28am
- 9  **Redbean Koi** Ck Chen go cut ur hair pls
10 **Kien Wui Teoh Wei Jin Yun De Tan Calvin Wong**
Like · Reply · 👍 2 · September 25, 2015 at 3:27pm
- 11  **Ck Chen** No nid tag me..sure not me
Like · Reply · September 25, 2015 at 3:43pm
- 12  **Yun De Tan** Lol sure is you!!
Like · Reply · September 25, 2015 at 3:46pm
- 13  **Kien Wui** hahaha really got the feeling is you Ck Chen no nid deny
14 ald xD 151
Like · Reply · September 25, 2015 at 4:00pm · Edited
- 15  **MingJing Yeoh** I also feel is u
Like · Reply · 👍 1 · September 25, 2015 at 4:05pm
- 16  **Redbean Koi** Mingjing 亂入
Mingjing mess into
Automatically Translated
Like · Reply · 👍 1 · September 25, 2015 at 4:14pm
- 17  **Ayieda Ahmad** Which IWeek?? Who dance?? Hilal Halmi ke?
Like · Reply · 👍 2 · September 25, 2015 at 2:37pm
- 18  **Hilal Halmi** Semestinya bukan saya. Saya mana menari
Like · Reply · September 25, 2015 at 3:34pm

- 19  **Shafikha Azreen** Diyana Junaidi did u do this?
Like · Reply ·  3 · September 25, 2015 at 2:43pm
- 20  **Diyana Junaidi** No i did not! 😞😞😞 aina kot hahahha tak pun you
21 kan? You were there kan that night? 😞
Like · Reply · September 25, 2015 at 3:28pm
- 22  **Jun Lin** i thought Low Bigshian is the most handsome and sexy guy? haha
Like · Reply · September 25, 2015 at 3:13pm
- 23  **Laura Lian Anyang** Foo Chuan Liang u wore cap on the stage during i week
24 right?
Like · Reply ·  1 · September 25, 2015 at 2:51pm
- 25  **Foo Chuan Liang** Not me. Confirm.
Like · Reply ·  1 · September 25, 2015 at 3:00pm
- 26  **Laura Lian Anyang** Ok...
27 Then who? XD
Like · Reply · September 25, 2015 at 3:01pm
- 28  **Laura Lian Anyang** N pls which i week?
Like · Reply ·  1 · September 25, 2015 at 2:32pm
- 29  **Aruna Suframanyam** haha i assumed it was our iweek..no idea
30 which other faculty call it as iweek..
Like · Reply ·  1 · September 25, 2015 at 2:36pm
- 31  **Laura Lian Anyang** Econs? Sains
Like · Reply · September 25, 2015 at 2:50pm
- 32  **Sylvester Keith Liaw** Rongteng Ho opps
Like · Reply ·  1 · September 25, 2015 at 2:32pm
- 33  **Laura Lian Anyang** Few guy danced. Can u b more specific on which
34 dance?
Like · Reply · September 25, 2015 at 2:32pm
- 35  **Aruna Suframanyam** Ayieda Ahmad Laura Lian Anyang who is tat guy???
Like · Reply ·  1 · September 25, 2015 at 2:31pm

Appendix R: Facebook Confession Page #1707

1 #1707
2 "I met him about a month ago and he melt my heart all the time. The way
3 he smile,dance, laugh. He seems like a very good person with good
4 friends. Whenever I saw him I automatically got excited and smile like
5 crazy. Its too bad that we are from different religion and he seems not so
6 close with people with other religion. But I hope that we can get to know
7 each other soon ^^
8 DTKH"

 Like  Comment  Share

 10 Most Recent ▾

- 9  **Carlson Stark** Darren Tan Kwi Hiong
10 hahahahahahahahaahahahahahahahahaha
Like · Reply · October 31, 2015 at 9:54am
- 11  **Darren Tan Kwi Hiong** not me la 😊 so many DTKH in UM
Like · Reply · October 31, 2015 at 9:55am
- 12  **Carlson Stark** Nope, one and only
13 Other religion tak nak wor
Like · Reply ·  1 · October 31, 2015 at 9:56am
- 14  **Darren Tan Kwi Hiong** if yesh i think most probably kena prank
15 gua
Like · Reply ·  1 · October 31, 2015 at 11:33am
- 16  **Carlson Stark** Believe in yourself Darren Tan Kwi Hiong
Like · Reply · October 31, 2015 at 11:48am
- 17  **Darren Tan Kwi Hiong** this is obviously not me because im very friend with
18 people from other religion. #aintracist #1malaysia Gabriel H'ng Pei Ying
Like · Reply ·  1 · October 31, 2015 at 9:54am
- 19  **Gabriel H'ng** who else DTKH?
Like · Reply · October 31, 2015 at 10:01am
- 20  **Darren Tan Kwi Hiong** UM so big, sure got other DTKH ba
Like · Reply · October 31, 2015 at 10:03am
- 21  **Pei Ying** Darren Tan Kwi Hiong wo fan dui. hahaha
Like · Reply · October 31, 2015 at 10:04am
- 22  **Darren Tan Kwi Hiong** ni fan dui what Pei Ying
Like · Reply · October 31, 2015 at 10:28am
- 23  **Gabriel H'ng** OMG Darren Tan Kwi Hiong
Like · Reply · October 31, 2015 at 9:37am
- 24  **Pei Ying** Darren Tan Kwi Hiong hahaha
Like · Reply · October 31, 2015 at 9:24am

Appendix S: Facebook Confession Page #1773

#1773

"I am very dry, but I am a vegetarian. Nobody wants me. I am a girl. Please comment if you know any vegetarian guy. "

Like Comment Share

42 Most Recent

 **Raveenaa Lingwei Mogan** JeyRomeo MustDie
Like · Reply · March 18 at 3:40pm

 **Chia Wei Chin** Shy Chien
Like · Reply · March 15 at 11:38pm

 **Ron Gui** Shy Chien
Like · Reply · 1 · March 15 at 4:30pm

 **Yik Ken Melvin** Tong Hung Jun go back uni eat some fresh grass.
Like · Reply · 2 · March 15 at 1:04pm

 **David Wen Melvin** Tong Hung Jun go intern as lai vege d deliveryman. Sure win
Like · Reply · 2 · March 15 at 3:00pm

 **Yuh Shen Lye** Tay Zhan Yang is time to become vegetarian
Like · Reply · March 14 at 9:46am

 **Tay Zhan Yang**



Like · Reply · March 14 at 12:03pm

 **Bryan Puan** Amanda Khoo
Like · Reply · March 14 at 9:11am

 **Helen Heng** lol..dun think too much ya
Like · Reply · March 14 at 7:05am

 **Pistaqiu Lee** Helen Heng is this you?
Like · Reply · March 14 at 6:12am

 **Joe Gan Wen** Shuoh Isaac Yue Yuan
Like · Reply · 2 · March 14 at 3:45am

 **Isaac Yue Yuan** Lol...
Like · Reply · March 14 at 5:34am



Ong Xin Kai Hand Shake but u don't eat meat n vege Oso wo...

Like · Reply · 2 · March 13 at 5:56am



Kelvin Siew Har? Then what he eat?!

Like · Reply · March 13 at 7:13am



Hand Shake lol i just dont eat meat haha, tak suit dia punya requirements

Kelvin Siew i eat mushroom... n taufu... n taueh,,, n many fuchok... n many more haha

Like · Reply · 1 · March 13 at 7:35am · Edited



Ong Xin Kai And fried vege dumplings

Like · Reply · 1 · March 13 at 11:47am



Kishan Naidu looks like karan gonna get a gf Sathiyanda Rao Superamani Inthiran Jazz Deva Kumar

Like · Reply · 5 · March 13 at 7:58am



Deva Kumar Congrats karen ji...so happy for u

Like · Reply · 1 · March 13 at 8:29am



Karan Bavisi It's look like a prank played

Like · Reply · 1 · March 13 at 11:21am



Kishan Naidu Karan Bavisi

Like · Reply · 1 · March 13 at 7:57am



Soh Wai Ching Sinyee Elvix jia you !

Like · Reply · 1 · March 13 at 7:55am



Soh Wai Ching Kar Seng Sinyee Elvix

Like · Reply · 2 · March 13 at 7:08am



Cheryl Chia Chong Jia Jie

Like · Reply · 3 · March 13 at 5:47am



Chong Jia Jie ==

Like · Reply · March 13 at 5:54am





Appendix T: Facebook Confession Page #5242

1 #5242
2 Dear k11 girls,
3 Firstly, why do you fucking throw food in the sink? Everytime i brush my
4 teeth it makes me wanna gag. I don't want to see what u fucking eat
5 yesterday. Throw it in the fucking dustbin.
6 Secondly, u girls don't fucking know how to close the fucking tap water
7 properly or what? Putting the fucking tap water on is your hobby? U just like
8 the sound flowing in the toilet is it?
9 Thirdly, u girls don't know how to fucking knock the door before u enter ha?
10 What if i am naked and i punch u in the face for not knocking. U want that to
11 happen?
12 Macam buat rumah sendiri je pegimateyyy
13 Sincerely,
14  k11ers

 Like  Comment  Share

 45

Top Comments ▾

- 15  **Emma Coelho** Omgggggg the 1st and last I couldn't agree more!!!
Like · Reply · October 22, 2015 at 12:05pm
- 16  **Mohd Sani** I count 7 f*cking. And here are the details;
17 1st F*cking was question i.e "why do you fucking throw food in the sink?"
18 2nd F*cking was Adjective i.e " ..to see what u fucking eat yesterday"
19 3rd F*cking was Command i.e "Throw it in the fucking dustbin"
20 4th F*cking was statement i.e "u girls don't fucking know"
21 5th & 6th F*cking was rhetorical question i.e "Putting the fucking tap water on
22 is your hobby?"
23 7th F*cking was Observation i.e " u girls don't know how to fucking knock the
24 door before u enter ha?"
25 Good essay though, same word, different context. The confessor must be frm
26 FBMK. Hahah
Like · Reply ·  22 · October 19, 2015 at 11:15am
- 27  **Nurul Ezaty** As i know only engineering and architecture student lives
28 in k11.
Like · Reply ·  2 · October 19, 2015 at 11:27am
- 29  **Mohd Sani** Good point. Perhaps the confessor is engineering or
30 architecture student. Lol
Like · Reply · October 19, 2015 at 11:30am

- 31  **Nurul Ezaty** For sure yeah. She's not only good in calculating or
32 drawings, she's also good in writing essay. 😊
Like · Reply · October 19, 2015 at 11:36am
- 33  **Mohd Sani** Exactly! hahaha 😊
Like · Reply · October 19, 2015 at 11:38am
- 34  **Suffian Osman** Wout No. She's only good in fking. Eh! joke2 😏😏😏
Like · Reply · October 20, 2015 at 10:32am · Edited
- 35  **Nuraini Za'abar** That's f-ing happen in every other block at any other colleges
36 too. *i know what you feel*
Like · Reply · 4 · October 20, 2015 at 7:45am
- 37  **Diyana Abdullah** Ni mesti peminat cte crank high voltage ni. Bunyik da cm
38 jason statham da.
See Translation
Like · Reply · October 20, 2015 at 5:20am
- 39  **Yusairina Mohd Yusof** Marahnya 😏
Like · Reply · October 19, 2015 at 7:37pm
- 40  **Zila Ila** U only learn FUCKING in degree? Lol
Like · Reply · 1 · October 19, 2015 at 2:06pm
- 41  **David Joel** Etiqatakaful Omg... too much fucking... married already i guess...
Like · Reply · October 19, 2015 at 12:09pm
- 42  **Annuar Espresso** Hahahaha. Siapa la yg duk kolej 11 tu? Kikiki
See Translation
Like · Reply · October 19, 2015 at 11:53am
- 43  **Jea Joey** Bahasa jiwa bangsa...shame on you
See Translation
Like · Reply · 3 · October 19, 2015 at 11:46am
- 44  **Nur Afifah** Same with k12 problems about the food leftover in the sink 😏
Like · Reply · 1 · October 19, 2015 at 6:10am
- 45  **رايزا رحمن** Fucking everywhere. Lol 😏
Like · Reply · 1 · October 19, 2015 at 6:03am
- 46  **Nurul Ezaty** The percentage of 'fucking' words is too high. Ini perempuan k11
47 ke abg technician k11 ni buat confession ni? Haha 😏
Like · Reply · 40 · October 19, 2015 at 5:09am
- 48  **Suffian Osman** Wout So much fking here.
Like · Reply · 1 · October 19, 2015 at 4:39am
- 49  **Alif Allaudin** So much rage here
Like · Reply · 1 · October 19, 2015 at 4:26am
- 50  **Nadiatul Amirah Ibrahim** I do experienced those things. I don't know where
51 they put their brain. Really pity to watch makcik cleaner had to clean up the
52 mess that they created.
Like · Reply · 10 · October 19, 2015 at 4:05am

Bibliography

- Ab Rashid, R. (2016). Topic Continuation Strategies Employed by Teachers in Managing Supportive Conversations on Facebook Timeline. *Discourse Studies*, 18(2), 188–203.
- Aceto, M. (2002). Ethnic personal names and multiple identities in Anglophone Caribbean speech communities in Latin America. *Language in Society*, 31(04).
- Ahti, J., & Lahtevanoja, H. (2004). Showing Politeness in Opening Sequences in Finnish and Finland-Swedish Chat Conversations. In *Proceedings of International Conference on Language, Politeness and Gender. The pragmatic roots* (pp. 41–52). University of Helsinki.
- Aisyah, A., & Yun Jin, N. (2017). K-Pop V Fansubs, V LIVE and NAVER Dictionary: Fansubbers' Synergy in Minimising Language Barriers. *3L The Southeast Asian Journal of English Language Studies*, 23(4), 112–127.
- Anderson, J. F., Beard, F. K., & Walther, J. B. (2010). Turn-Taking and the Local Management of Conversation in a Highly Simultaneous Computer-Mediated Communication System. *Language@Internet*, 7.
- Androutsopoulos, J. (2006). Introduction: Sociolinguistics and Computer-Mediated Communication. *Journal of Sociolinguistics*, 10(4), 419–438.
- Anonymous (1998). To Reveal or Not to Reveal: A Theoretical Model of Anonymous Communication. *Communication Theory*, 8(4), 381–407.
- Antaki, C., Ardevol, E., Nunez, F., & Vayreda, A. (2006). "For She Who Knows Who She is": Managing Accountability in Online Forum Messages. *Journal of Computer-Mediated Communication*, 11, 114–132.
- Antaki, C., & Widdicombe, S. (Eds.) (1998a). *Identities in Talk*. London: SAGE.
- Antaki, C., & Widdicombe, S. (1998b). Identity as an Achievement and as a Tool. In C. Antaki & S. Widdicombe (Eds.), *Identities in Talk* (pp. 1–14). London: SAGE.

- Arminen, I., & Leinonen, M. (2006). Mobile Phone Call Openings: Tailoring Answers to Personalized Summonses. *Discourse Studies*, 8(3), 339–368.
- Barari, S. (2015). Analyzing Latent Topics in Student Confessions Communities on Facebook, from <http://arxiv.org/pdf/1506.05193v4>.
- Bargh, J. A., McKenna, K. Y., & Fitzsimons, G. M. (2002). Can you see the real me?: Activation and Expression of the “true self” on the Internet. *Journal of social issues*, 58(1), 33–48.
- Baron, N. S. (2004). See you Online: Gender Issues in College Student Use of Instant Messaging. *Journal of Language and Social Psychology*, 23(4), 397–423.
- Baron, N. S. (2010). Discourse Structures in Instant Messaging: The Case of Utterance Breaks. *Language@Internet*, 7(Article 4).
- Bassett, E. H., & O’Riordan, K. (2002). Ethics of Internet Research: Contesting the Human Subjects Research Model. *Ethics and Information Technology*, 4(3), 233–247.
- Baym, N. K. (1996). Agreements and Disagreements in a Computer-Mediated Discussion. *Research on Language & Social Interaction*, 29(4), 315–345.
- Baym, N. K. (2005). Interpersonal Life Online. In L. A. Lievrouw & S. M. Livingstone (Eds.), *Handbook of new media. Social shaping and social consequences of ICTs* (pp. 35–54). London, Thousand Oaks, CA: SAGE Publications.
- Baym, N. K. (2009). The Emergence of On-line Community. In S. G. Jones (Ed.), *Cybersociety 2.0. Revisiting Computer-Mediated Communication and Community* (pp. 35–68). London: SAGE.
- Benwell, B., & Stokoe, E. (2010). Analysing Identity in Interaction: Contrasting Discourse, Genealogical, Narrative and Conversation Analysis. In M. Wetherell & C. T. Mohanty (Eds.), *The SAGE Handbook of Identities* (pp. 83–103). London: SAGE Publications Ltd.
- Benwell, B., & Stokoe, E. (2006). *Discourse and identity*. Edinburgh: Edinburgh University Press.

- Berglund, T. Ö. (2009). Disrupted Turn Adjacency and Coherence Maintenance in Instant Messaging Conversations. *Language@Internet*, 6(Article 2).
- Bilmes, J. (2011). Occasioned Semantics: A Systematic Approach to Meaning in Talk. *Human Studies*, 34(2), 129–153.
- Birnholtz, J., Merola, N. A. R., & Paul, A. (2015). "Is it Weird to Still Be a Virgin". In B. Begole, J. Kim, K. Inkpen, & W. Woo (Eds.), *CHI 2015. Proceedings of the 33rd Annual CHI Conference on Human Factors in Computing Systems / sponsored by ACM SIGCHI* (pp. 2613–2622). New York, New York: The Association for Computing Machinery.
- Bolden, G. B. (2018). Speaking 'out of turn': Epistemics in action in other-initiated repair. *Discourse Studies*, 20(1), 142–162.
- Bou-Franch, P., Lorenzo-Dus, N., & Blitvich, P. G.-C. (2012). Social Interaction in YouTube Text-Based Polylogues: A Study of Coherence. *Journal of Computer-Mediated Communication*, 17(4), 501–521.
- Bounds, A. (2013). 'Confessions': Anonymous Facebook Pages Gain Popularity Among Boulder High School, College Students. Retrieved April 25, 2016, from https://www.huffingtonpost.com/2013/03/27/confessions-facebook-page-cu-boulder-students_n_2962252.html.
- Boyd, D., Golder, S., & Lotan, G. (2010). Tweet, Tweet, Retweet: Conversational Aspects of Retweeting on Twitter. In *2010 43rd Hawaii international conference on system sciences. (HICSS 2010) : 5-8 January 2010* (pp. 1–10). New York: Curran.
- Boyd, D., & Heer, J. (2006). Profiles as Conversation: Networked Identity Performance on Friendster. In R. H. Sprague (Ed.), *Proceedings of the 39th Annual Hawaii International Conference on System Sciences. Abstracts and CD-ROM of full papers : 4-7 January, 2006, Kauai, Hawaii / edited by Ralph H. Sprague, Jr (59c-59c)*. Los Alamitos, Calif.: IEEE Computer Society.
- Brennan, S. E. (2000). Processes that shape conversation and their implications for computational linguistics. In H. Iida (Ed.), *Proceedings of the 38th Annual Meeting*

on Association for Computational Linguistics - ACL '00 (pp. 1–11). Morristown, NJ, USA: Association for Computational Linguistics.

British Sociological Association (2016). *Ethics Guidelines and Collated Resources for Digital Research: Statement of Ethical Practice Annexe*.

Bruns, A., & Burgess, J. E. (2011). The Use of Twitter Hashtags in the Formation of Ad Hoc Publics. In *Proceedings of the 6th European Consortium for Political Research (ECPR) General Conference 2011*. Reykjavik: University of Iceland.

Bucholtz, M., & Hall, K. (2005). Identity and Interaction: A Sociocultural Linguistic Approach. *Discourse Studies*, 7(4-5), 585–614.

Carrington, V. (2004). Texts and Literacies of the Shi Jinrui. *British Journal of Sociology of Education*, 25(2), 215–228.

Cashman, H. R. (2005). Identities at play: Language preference and group membership in bilingual talk in interaction. *Journal of Pragmatics*, 37(3), 301–315.

Castro, M. C. (2007). Let's Chat: An Analysis of Some Discourse Features of Synchronous Chat. *Journal of English studies and comparative literature*, 9(1).

Collins-Jarvis, L. (1997). Participation and consensus in collective action organizations: The influence of interpersonal versus mass-mediated channels. *Journal of Applied Communication Research*, 25(1), 1–16.

Collister, L. B. (2011). *-repair in Online Discourse. *Journal of Pragmatics*, 43(3), 918–921.

Crystal, D. (2006). *Language and the Internet* (2nd ed.). Cambridge: Cambridge University Press.

Danet, B., Ruedenberg-Wright, L., & Rosenbaum-Tamari, Y. (1997). Hmmm... Where's That Smoke Coming From? *Journal of Computer-Mediated Communication*, 2(4), 0.

December, J. (1996). Units of Analysis for Internet Communication. *Journal of Computer-Mediated Communication*, 1(4), 0.

- Derks, D., Bos, A. E.R., & Grumbkow, J. v. (2007). Emoticons and social interaction on the Internet: The importance of social context. *Computers in Human Behavior*, 23(1), 842–849.
- Donath, J. S. (1996). Identity and Deception in the Virtual Community. *Communities in cyberspace*, 29–59.
- Downing, P. A. (1996). Proper Names as a Referential Option in English Conversation. In B. A. Fox (Ed.), *Studies in Anaphora* (pp. 95–143). Amsterdam: John Benjamins Publishing Company.
- Dresner, E., & Herring, S. C. (2010). Functions of the Nonverbal in CMC: Emoticons and Illocutionary Force. *Communication Theory*, 20(3), 249–268.
- Drew, P. (1978). Accusations: The Occasioned Use of Members' Knowledge of 'Religious Geography' in Describing Events. *Sociology*, 12(1), 1–22.
- Drew, P. (2018a). Epistemics – The Rebuttal Special Issue: An introduction. *Discourse Studies*, 20(1), 3–13.
- Drew, P. (2018b). Epistemics in social interaction. *Discourse Studies*, 20(1), 163–187.
- Edwards, D. (1998). The Relevant Thing About Her: Social Identity Categories in Use. In C. Antaki & S. Widdicombe (Eds.), *Identities in Talk* (pp. 15–33). London: SAGE.
- Eisenlauer, V. (2014). Facebook as a third author—(Semi-)automated participation framework in Social Network Sites. *Journal of Pragmatics*, 72, 73–85.
- Ellison, N. B., Gray, R., Vitak, J., Lampe, C., & Fiore, A. T. (2013). Calling All Facebook Friends: Exploring Requests for Help on Facebook. In *Proceedings of the International Conference on Weblogs and Social Media (ICWSM)*.
- Ellison, N., Heino, R., & Gibbs, J. (2006). Managing Impressions Online: Self-Presentation Processes in the Online Dating Environment. *Journal of Computer-Mediated Communication*, 11(2), 415–441.
- Enfield, N. J. (2013). Reference in Conversation. In *The Handbook of Conversation*

Analysis (pp. 433–454). Wiley-Blackwell.

Enfield, N. J., & Stivers, T. (Eds.) (2007). *Language, culture, and cognition: Vol. 7. Person Reference in Interaction: Linguistic, Cultural, and Social Perspectives*. Cambridge: Cambridge University Press.

Facebook. *Facebook Newsroom*. Retrieved November 25, 2017, from <https://newsroom.fb.com/company-info/>.

Farina, M. (2015). Facebook first post telling. *Journal of Pragmatics*, *90*, 1–11.

Fielding, N., Lee, R. M., & Blank, G. (Eds.) (2008). *The SAGE Handbook of Online Research Methods*. London: SAGE.

Fitzgerald, R. (2015). Membership Categorization Analysis. In K. Tracy, C. Ilie, & T. Sandel (Eds.), *The International Encyclopedia of Language and Social Interaction* (pp. 1–11). Chichester, West Sussex: Wiley Blackwell.

Fitzgerald, R., Housley, W., & Butler, C. W. (2009). Omnirelevance and Interactional Context. *Australian Journal of Communication*, *36*(3), 45–64.

Flicker, S., Haans, D., & Skinner, H. (2004). Ethical Dilemmas in Research on Internet Communities. *Qualitative health research*, *14*(1), 124–134.

Fox, A. B., Bukatko, D., Hallahan, M., & Crawford, M. (2007). The Medium Makes a Difference: Gender Similarities and Differences in Instant Messaging. *Journal of Language and Social Psychology*, *26*(4), 389–397.

Fung, L., & Carter, R. (2007). Discourse Markers and Spoken English: Native and Learner Use in Pedagogic Settings. *Applied Linguistics*, *28*(3), 410–439.

Garcia, A. C., & Jacobs, J. B. (1999). The Eyes of the Beholder: Understanding the Turn-Taking System in Quasi-Synchronous Computer-Mediated Communication. *Research on Language and Social Interaction*, *32*(4), 337–367.

Garrison, A., Remley, D., Thomas, P., & Wierszewski, E. (2011). Conventional Faces: Emoticons in Instant Messaging Discourse. *Computers and Composition*, *28*(2),

112–125.

- Gee, J. P. (2000). Chapter 3: Identity as an Analytic Lens for Research in Education. *Review of Research in Education*, 25(1), 99–125.
- Gibbs, J. L., Ellison, N. B., & Heino, R. D. (2006). Self-Presentation in Online Personals: The Role of Anticipated Future Interaction, Self-Disclosure, and Perceived Success in Internet Dating. *Communication Research*, 33(2), 152–177.
- Gibson, W. (2009). Negotiating Textual Talk: Conversation Analysis, Pedagogy and the Organisation of Online Asynchronous Discourse. *British Educational Research Journal*, 35(5), 705–721.
- Gibson, W. J. (2013). Sequential order in multimodal discourse: Talk and text in online educational interaction. *Discourse & Communication*, 8(1), 63–83.
- Giles, D. (2006). Constructing Identities in Cyberspace: The Case of Eating Disorders. *The British journal of social psychology*, 45(Pt 3), 463–477.
- Giles, D., Stommel, W., Paulus, T., Lester, J., & Reed, D. (2015). Microanalysis Of Online Data: The methodological development of “digital CA”. *Discourse, Context & Media*, 7, 45–51.
- Goodwin, C., & Heritage, J. (1990). Conversation Analysis. *Annual Review of Anthropology*, 19, 283–307.
- Graham, S. L. (2007). Disagreeing to agree: Conglict, (im)politeness and identity in a computer-mediated community. *Journal of Pragmatics*, 39, 742-759.
- Greenfield, P. M., & Subrahmanyam, K. (2003). Online discourse in a teen chatroom: New codes and new modes of coherence in a visual medium. *Journal of Applied Developmental Psychology*, 24(6), 713–738.
- Greiffenhagen, C., & Watson, R. (2009). Visual Repairables: Analysing the Work of Repair in Human–Computer Interaction. *Visual Communication*, 8(1), 65–90.
- Griffin, Z. M. (2010). Retrieving Personal Names, Referring Expressions, and Terms of

Address. *Psychology of Learning and Motivation*, 53, 345–387.

- Guise, J., Widdicombe, S., & McKinlay, A. (2007). 'What is it like to have ME?': The discursive construction of ME in computer-mediated communication and face-to-face interaction. *Health (London, England : 1997)*, 11(1), 87–108.
- Gupta, A. F. (2006). Epistemic Modalities and the Discourse Particles of Singapore. In K. Fischer (Ed.), *Studies in pragmatics: Vol. 1. Approaches to Discourse Particles* (pp. 244–263). Amsterdam, London: Elsevier.
- Gupta, A. F. (1992). The Pragmatic Particles of Singapore Colloquial English. *Journal of Pragmatics*, 18(1), 31–57.
- Hacohen, G., & Schegloff, E. A. (2006). On the Preference for Minimization in Referring to Persons: Evidence from Hebrew Conversation. *Journal of Pragmatics*, 38(8), 1305–1312.
- Haimson, O. L., & Tang, J. C. (2017). What Makes Live Events Engaging on Facebook Live, Periscope, and Snapchat. In G. Mark, S. Fussell, C. Lampe, m.c. schraefel, J. P. Hourcade, C. Appert, et al. (Eds.), *CHI '17. Proceedings of the 2017 ACM SIGCHI Conference on Human Factors in Computing Systems : May 6-11 2017, Denver, CO, USA / sponsored by ACM SIGCHI* (pp. 48–60). New York, NY: The Association for Computing Machinery.
- Halbe, D. (2012). "Who's there?": Differences in the Features of Telephone and Face-to-Face Conferences. *Journal of Business Communication*, 49(1), 48–73.
- Halim, N. S., & Maros, M. (2014). The Functions of Code-switching in Facebook Interactions. *Procedia - Social and Behavioral Sciences*, 118, 126–133.
- Hamilton, W. A., Garretson, O., & Kerne, A. (2014). Streaming on twitch. In M. Jones, P. Palanque, A. Schmidt, & T. Grossman (Eds.), *Proceedings of the SIGCHI Conference on Human Factors in Computing Systems* (pp. 1315–1324). New York, NY: ACM.
- Hashim, A., & Tan, R. (2012). Malaysian English. In E. L. Low & A. Hashim (Eds.), *Varieties of English around the world: v. G42. English in Southeast Asia. Features*, 262

- Policy and Language in Use* (pp. 55–74). Amsterdam, Philadelphia: John Benjamins Pub. Co.
- Hassan, N., & Hashim, A. (2009). Electronic English in Malaysia: Features and Language in Use. *English Today*, 25(04), 39.
- Hassan, N., Hashim, A., & Phillip, A. S. (2012). Language Use in the Construction of Interpersonal Relationships: Electronic English in Malaysia. In E. L. Low & A. Hashim (Eds.), *Varieties of English around the world: v. G42. English in Southeast Asia. Features, Policy and Language in Use* (pp. 325–341). Amsterdam, Philadelphia: John Benjamins Pub. Co.
- Hayman, R., Smith, E., & Storrs, H. (2018). Undergraduate Students' Academic Information and Help-Seeking Behaviours using an Anonymous Facebook Confessions Page. *Proceedings of the Annual Conference of CAIS / Actes du congrès annuel de l'ACSI*.
- Hayne, S. C., Pollard, C. E., & Rice, R. E. (2003). Identification of Comment Authorship in Anonymous Group Support Systems. *Journal of Management Information Systems*, 20(1), 301–329.
- Heritage, J. (1984). A Change-of-State Token and Aspects of Its Sequential Placement. In J. M. Atkinson & J. Heritage (Eds.), *Studies in emotion and social interaction. Structures of social action. Studies in conversation analysis* (pp. 299–345). Cambridge: Cambridge University Press.
- Heritage, J. (1998). Oh-Prefaced Responses to Inquiry. *Language in Society*, 27(03), 291–334.
- Heritage, J. (2005). Conversation Analysis and Institutional Talk. In K. L. Fitch & R. E. Sanders (Eds.), *LEA's communication series. Handbook of Language and Social Interaction* (pp. 103–147). Mahwah, N.J., London: Lawrence Erlbaum.
- Heritage, J. (2011). Territories of Knowledge, Territories of Experience: Empathic Moments in Interaction. In T. Stivers, L. Mondada, & J. Steensig (Eds.), *The Morality of Knowledge in Conversation*. Cambridge: Cambridge University Press.

- Heritage, J. (2012a). Beyond and Behind the Words: Some Reactions to My Commentators. *Research on Language & Social Interaction*, 45(1), 76–81.
- Heritage, J. (2012b). Epistemics in Action: Action Formation and Territories of Knowledge. *Research on Language & Social Interaction*, 45(1), 1–29.
- Heritage, J. (2012c). The Epistemic Engine: Sequence Organization and Territories of Knowledge. *Research on Language & Social Interaction*, 45(1), 30–52.
- Heritage, J. (2013). Epistemic in Conversation. In J. Sidnell & T. Stivers (Eds.), *The handbook of conversation analysis* (pp. 370–394). Chichester, West Sussex, UK: Wiley-Blackwell.
- Heritage, J. (2018). The ubiquity of Epistemics: A Rebuttal to the ‘Epistemics of Epistemics’ Group. *Discourse Studies*, 20(1), 14–56.
- Herring, S. C., & Stoerger, S. (2014). Gender and (a)nonymity in Computer-Mediated Communication. In S. Ehrlich, M. Meyerhoff, & J. Holmes (Eds.), *The Handbook of Language, Gender, and Sexuality* (2nd ed., pp. 567–586). Chichester, UK.: John Wiley & Sons, Ltd.
- Herring, S. C. (2007). A Faceted Classification Scheme for Computer-Mediated Discourse. *Language@Internet*, 4.
- Herring, S. C. (2011). Computer-Mediated Conversation.: Introduction and Overview. *Language@Internet*, 8.
- Herring, S. (1999). Interactional Coherence in CMC. *Journal of Computer-Mediated Communication*, 4(4), 0.
- Herring, S. C. (2000). Gender differences in CMC: Findings and implications. *Computer Professionals for Social Responsibility Journal*, 18(1), from <http://cpsr.org/issues/womenintech/herring/>.
- Herring, S. C., & Androutsopoulos, J. (2015). Computer-Mediated Discourse 2.0. In D. Tannen, H. E. Hamilton, & D. Schiffrin (Eds.), *The Handbook of Discourse Analysis* (2nd ed., pp. 127–151).

- Herring, S. C., & Martinson, A. (2004). Assessing Gender Authenticity in Computer-Mediated Language Use: Evidence From an Identity Game. *Journal of Language and Social Psychology, 23*(4), 424–446.
- Hester, S., & Eglin, P. (1997). Membership Categorization Analysis: An Introduction. In S. Hester & P. Eglin (Eds.), *Studies in ethnomethodology and conversation analysis: no. 4. Culture in action. Studies in membership categorization analysis* (pp. 1–24). Washington D.C.: International Institute for Ethnomethodology and Conversation Analysis & University Press of America.
- Houlihan, D., & Houlihan, M. (2014). Adolescents and the Social Media: The Coming Storm. *Journal of Child and Adolescent Behaviour, 02*(02).
- Housley, W., & Fitzgerald, R. (2016). The Reconsidered Model of Membership Categorization Analysis. *Qualitative Research, 2*(1), 59–83.
- Hutchby, I. (1996). Power in Discourse: The Case of Arguments on a British Talk Radio Show. *Discourse & Society, 7*(4), 481–497.
- Hutchby, I. (2001a). 'Witnessing': The Use of First-Hand Knowledge in Legitimizing Lay Opinions on Talk Radio. *Discourse Studies, 3*(4), 481–497.
- Hutchby, I. (2001b). Technologies, Texts and Affordances. *Sociology, 35*(2), 441–456.
- Hutchby, I., & Wooffitt, R. (2008). *Conversation Analysis*. Cambridge, England: Polity.
- Jaafar, M. (1999). Emblematic Codeswitching Represented in Fiction: The Case of the Malay Discourse Markers lah, what, ah. *Journal Of Modern Languages,, 12*(1), 41–58.
- Jacknick, C. M., & Avni, S. (2017). Shalom, bitches: Epistemic stance and identity work in an anonymous online forum. *Discourse, Context & Media, 15*, 54–64.
- Jamil, N. S., Yusof, M., & Harun, K. (2016). Dieksis Sosial Dalam Interaksi Masyarakat Melayu Kedah. *Geografia-Malaysian Journal of Society and Space, 12*(11).
- Jibril, T. A., & Abdullah, M. H. (2013). Relevance of Emoticons in Computer-Mediated

Communication Contexts: An Overview. *Asian Social Science*, 9(4).

- Kamio, A. (1994). The theory of territory of information: The case of Japanese. *Journal of Pragmatics*, 21(1), 67–100.
- Kapidzic, S., & Herring, S. C. (2011). Gender, Communication, and Self-Presentation in Teen Chatrooms Revisited: Have Patterns Changed? *Journal of Computer-Mediated Communication*, 17(1), 39–59.
- Kashian, N., Jang, J.-w., Shin, S. Y., Dai, Y., & Walther, J. B. (2017). Self-disclosure and liking in computer-mediated communication. *Computers in Human Behavior*, 71, 275–283.
- Kitzinger, C., & Mandelbaum, J. (2013). Word Selection and Social Identities in Talk-in-Interaction. *Communication Monographs*, 80(2), 176–198.
- Kitzinger, C., Shaw, R., & Toerien, M. (2012). Referring to Persons Without Using a Full-Form Reference: Locally Initial Indexicals in Action. *Research on Language & Social Interaction*, 45(2), 116–136.
- Kuang, C. (2017). The Implications of lah, ah, and hah as Used By Some Speakers in Malaysia. *Journal Of Modern Languages*, 14(1), 133–153.
- Kushida, S. (2015). Using Names for Referring without Claiming Shared Knowledge: Name-Quoting Descriptors in Japanese. *Research on Language and Social Interaction*, 48(2), 230–251.
- Lamerichs, J., & te Molder, H. (2003). Computer-Mediated Communication:: From a Cognitive to a Discursive Model. *New Media & Society*, 5(4), 451–473.
- Leppänen, S., Kytölä, S., Jousmäki, H., Peuronen, S., & Westinen, E. (2014). Entextualization and Resemiotization as Resources for Identification in Social Media. In P. Seargeant & C. Tagg (Eds.), *The Language of Social Media* (pp. 112–136). London: Palgrave Macmillan UK.
- Lerner, G. H. (2003). Selecting Next Speaker:: The Context-Sensitive Operation of a Context-Free Organization. *Language inn Society*, 32, 177–201.

- Lerner, G. H., & Kitzinger, C. (2007). Introduction: Person-reference in conversation analytic research. *Discourse Studies*, 9(4), 427–432.
- Lester, J. N., & Paulus, T. M. (2011). Accountability and Public Displays of Knowing in an Undergraduate Computer-Mediated Communication context. *Discourse Studies*, 13(6), 671–686.
- Lindwall, O., Lymer, G., & Ivarsson, J. (2016). Epistemic status and the recognizability of social actions. *Discourse Studies*, 18(5), 500–525.
- Lipinski-Harten, M., & Tafarodi, R. W. (2012). A Comparison of Conversational Quality in Online and Face-to-Face First Encounters. *Journal of Language and Social Psychology*, 31(3), 331–341.
- Locher, M. A. (2008). Relational work, politeness, and identity construction. In G. Antos & E. Ventola (Eds.), *Handbooks of Applied Linguistics. Handbook of Interpersonal Communication*. Berlin: Walter de Gruyter.
- Lomicka, L., & Lord, G. (2012). A tale of tweets: Analyzing microblogging among language learners. *System*, 40(1), 48–63.
- Lu, Z., Xia, H., Heo, S., & Wigdor, D. (2018). You Watch, You Give, and You Engage. In R. Mandryk, M. Hancock, M. Perry, & A. Cox (Eds.), *CHI 2018. Proceedings of the 2018 CHI Conference on Human Factors in Computing Systems : April 21-26, 2018, Montréal, QC, Canada / sponsored by ACM SIGCHI* (pp. 1–13). New York, New York: The Association for Computing Machinery.
- Luangrath, A. W., Peck, J., & Barger, V. A. (2017). Textual Paralanguage and Its Implications for marketing Communications. *Journal of Consumer Psychology*, 27(1), 98–107.
- Marcoccia, M. (2004). On-line polylogues: Conversation structure and participation framework in internet newsgroups. *Journal of Pragmatics*, 36(1), 115–145.
- Markman, K. M., & Oshima, S. (2007). Pragmatic play? Some Possible Functions of English Emoticons and Japanese Kaomoji in Computer-Mediated Discourse. *In Association of Internet Researchers Annual Conference*, 8.

- Marx, G. T. (1999). What's in a Name?: Some Reflections on the Sociology of Anonymity. *The Information Society*, 15(2), 99–112.
- Meredith, J. (2017). Analysing technological affordances of online interactions using conversation analysis. *Journal of Pragmatics*, 115, 42–55.
- Meredith, J., & Potter, J. (2014). Conversation Analysis and Electronic Interactions: Methodological, Analytic and Technical Considerations. In H. L. Lim & F. Sudweeks (Eds.), *Advances in human and social aspects of technology book series (AHSAT). Innovative methods and technologies for electronic discourse analysis* (pp. 370–393). Hershey PA: Information Science Reference.
- Meredith, J., & Stokoe, E. (2013). Repair: Comparing Facebook ‘chat’ with spoken interaction. *Discourse & Communication*, 8(2), 181–207.
- Miel (2015). *An Essential Guide to Singlish* (New expanded edition). Singapore: Gartbooks.
- Mohd. Nor, S. N. (2017). The Discourse Function of "well", "and" and "now" in Turn-Initial Positions in Interruptive Speech. *Journal Of Modern Languages*, 18(1), 42–53.
- Montes-Alcalá, C. (2007). Blogging in Two Languages: Code-Switching in Bilingual Blogs. In J. Holmquist, A. Lorenzino, & L. Sayahi (Eds.), *Selected Proceedings of the Third Workshop on Spanish Sociolinguistics* (pp. 162–170). Somerville, MA: Cascadilla Proceeding Project.
- Morris, M. R., Teevan, J., & Panovich, K. (2010). What do people ask their social networks, and why? In E. Mynatt, D. Schoner, G. Fitzpatrick, S. Hudson, K. Edwards, & T. Rodden (Eds.), *CHI 2010 - we are HCI. Conference proceedings : the 28th annual CHI conference on Human Factors in Computing Systems* (p. 1739). New York: Association for Computing Machinery.
- Myers-Scotton, C. (1993). Common and uncommon ground: Social and structural factors in codeswitching. *Language in Society*, 22(4), 475–503.
- Nilsen, M., & Makitalo, A. (2010). Towards a Conversational Culture?: How Participants

- Establish Strategies for Co-ordinating Chat Postings in the Context of In-service training. *Discourse Studies*, 12(1), 90–105.
- Nishimura, Y. (2003). Linguistic Innovations and Interactional Features of Casual Online Communication in Japanese. *Journal of Computer-Mediated Communication*, 9(1), 0.
- Oeldorf-Hirsch, A., & Sundar, S. S. (2015). Posting, commenting, and tagging: Effects of sharing news stories on Facebook. *Computers in Human Behavior*, 44, 240–249.
- Oh, S.-Y. (2007). The Interactional Meanings of Quasi-Pronouns in Korean Conversation. In N. J. Enfield & T. Stivers (Eds.), *Language, culture, and cognition: Vol. 7. Person Reference in Interaction. Linguistic, Cultural, and Social Perspectives* (pp. 203–225). Cambridge: Cambridge University Press.
- Omar, A. H. (2001). Language Management and Language Problems: A Special Reference to the Implementation of the Policy on Malay and English in Malaysia. *Journal of Asian Pacific Communication*, 10(2), 239–253.
- Palomares, N. A., & Lee, E.-J. (2010). Virtual Gender Identity: The Linguistic Assimilation to Gendered Avatars in Computer-Mediated Communication. *Journal of Language and Social Psychology*, 29(1), 5–23.
- Panyametheekul, S., & Herring, S. C. (2003). Gender and Turn Allocation in a Thai Chat Room. *Journal of Computer-Mediated Communication*, 9(1), 0.
- Paolillo, J. C. (2011). Conversational” codeswitching on Usenet and Internet relay chat. *Language@Internet*, 8(3).
- Paul, A., Ankit, A., Liao, W.-k., & Choudhary, A. (2013). AnonyMine: Mining anonymous social media posts using psycho-lingual and crowd-sourced dictionaries. In P. Forbrig (Ed.), *Proceedings of the 5th ACM SIGCHI symposium on Engineering interactive computing systems*. New York, NY: ACM.
- Paulus, T., Warren, A., & Lester, J. N. (2016). Applying conversation analysis methods to online talk: A literature review. *Discourse, Context & Media*, 12, 1–10.

- Pomerantz, A., & Heritage, J. (2013). Preference. In J. Sidnell & T. Stivers (Eds.), *The handbook of conversation analysis* (pp. 210–228). Chichester, West Sussex, UK: Wiley-Blackwell.
- Postmes, T., Spears, R., & Lea, M. (2000). The Formation of Group Norms in Computer-Mediated Communication. *Human Communication Research*, 26(3), 341–371.
- Potter, J., & Hepburn, A. (2008). Discursive Constructionism. In J. A. Holstein & J. F. Gubrium (Eds.), *Handbook of Constructionist Research* (pp. 275–293). New York: Guildford.
- Psathas, G. (1995). *Conversation Analysis: The Study of Talk-in-Interaction*. Thousand Oaks, Calif., London: SAGE.
- Rachoene, M., & Oyedemi, T. (2015). From self-expression to social aggression: Cyberbullying culture among South African youth on Facebook. *Communicatio*, 41(3), 302–319.
- Raclaw, J. (2008). Two Patterns for Conversational Closings in Instant Message Discourse. *Colorado Research in Linguistics*, 21(1), 34–54.
- Rafi, M. S. (2014). Meaning Making Through Minimal Linguistic Forms in Computer-Mediated Communication. *SAGE Open*, 4(2), 215824401453593.
- Rains, S. A., & Scott, C. R. (2007). To Identify or Not to Identify:: A Theoretical Model of Receiver Responses to Anonymous Communication. *Communication Theory*, 17, 61–91.
- Rains, S. A. (2016). The Impact of Anonymity on Perceptions of Source Credibility and Influence in Computer-Mediated Group Communication: A Test of Two Competing Hypotheses. *Communication Research*, 34(1), 100–125.
- Raymond, G. (2003). Grammar and Social Organization: Yes/No Interrogatives and the Structure of Responding. *American Sociological Review*, 68(6), 939–967.
- Raymond, G. (2018). Which epistemics?: Whose conversation analysis? *Discourse Studies*, 20(1), 57–89.

- Raymond, G., & Heritage, J. (2006). The Epistemics of Social Relations: Owning Grandchildren. *Language in Society*, 35(05), 677–705.
- Reed, D. (2001). Making conversation: Sequential integrity and the local management of interaction on Internet newsgroups. In *Proceedings of the 34th Annual Hawaii International Conference on System Sciences. Abstracts and CD-ROM of full papers : January 3-6, 2001, Maui, Hawaii*. Los Alamitos, Calif: IEEE Computer Society Press.
- Reed, D., & Ashmore, M. (2000). The Naturally-Occurring Chat Machine. *A Journal of Media and Culture*, 3(4). Retrieved October 31, 2016, from <http://journal.media-culture.org.au/0008/machine.php>.
- Rellstab, D. H. (2007). Staging gender online: Gender plays in Swiss internet relay chats. *Discourse & Society*, 18(6), 765–787.
- Rintel, E. S., Mulholland, J., & Pittam, J. (2001). First Things First: Internet Relay Chat Openings. *Journal of Computer-Mediated Communication*, 6(3), 0.
- Riva, G., & Galimberti, C. (1998). Computer-mediated Communication: Identity and Social Interaction in an Electronic Environment. *Genetic, Social, and General Psychology Monographs*, 124(4), 434–464.
- Rutter, J., & Smith, G. (1998). Addressivity and Sociability in “Celtic Men”. In C. Ess & F. Sudweeks (Eds.), *Proceedings Cultural Attitudes Towards Communication and Technology '98* (pp. 196–201).
- Sacks, H. (1984). Notes on methodology. In J. M. Atkinson & J. Heritage (Eds.), *Studies in emotion and social interaction. Structures of social action. Studies in conversation analysis* (pp. 21–27). Cambridge: Cambridge University Press.
- Sacks, H. (1992). *Lectures on conversation (Vol. 1)*. Oxford, UK: Blackwell.
- Sacks, H., & Schegloff, E. A. (2007). Two Preferences in the Organization of Reference to Persons in Conversation and Their Interaction. In N. J. Enfield & T. Stivers (Eds.), *Language, culture, and cognition: Vol. 7. Person Reference in Interaction. Linguistic, Cultural, and Social Perspectives* (pp. 23–28). Cambridge: Cambridge

University Press.

- Sacks, H., Schegloff, E. A., & Jefferson, G. (1978). A Simplest Systematics for the Organization of Turn Taking for Conversation. In J. Schenkein (Ed.), *Language, thought and culture. Studies in the Organization of Conversational Interaction* (pp. 7–55). New York, London: Academic Press.
- Savicki, V., Kelley, M., & Lingenfelter, D. (1996). Gender, group composition, and task type in small task groups using computer-mediated communication. *Computers in Human Behavior, 12*(4), 549–565.
- Schegloff, E. A. (1979). Identification and Recognition in Telephone Conversation Openings. In G. e. Psathas (Ed.), *Everyday Language. Studies in Ethnomethodology*. New York: Irvington.
- Schegloff, E. A. (1996). Some Practices for Referring to Persons in Talk-in-Interaction: A Partial Sketch of a Systematics. In B. A. Fox (Ed.), *Studies in Anaphora* (pp. 437–485). Amsterdam: John Benjamins Publishing Company.
- Schegloff, E. A. (2007a). Categories in action: Person-reference and membership categorization. *Discourse Studies, 9*(4), 433–461.
- Schegloff, E. A. (2007b). A Tutorial on Membership Categorization. *Journal of Pragmatics, 39*(3), 462–482.
- Schegloff, E. A. (2007c). *Sequence organization in interaction. A primer in conversation analysis : v. I*. Cambridge: Cambridge University Press.
- Schegloff, E. A. (2010). Commentary on Stivers and Rossano: “Mobilizing Response”. *Research on Language & Social Interaction, 43*(1), 38–48.
- Schönfeldt, J., & Golato, A. (2003). Repair in Chats: A Conversation Analytic Approach. *Research on Language & Social Interaction, 36*(3), 241–284.
- Shokouhi, H., & Hamidi, N. (2010). A Conversation Analysis of the Iranian Youths’ Written Chats of English. *Iranian journal of applied linguistics, 13*(1), 149–177.

- Sidnell, J. (2010). *Conversation analysis: An introduction. Language in society: Vol. 37.* Chichester, U.K., Malden, MA: Wiley-Blackwell.
- Sierra, S. A., & Botti, A. (2014). "You haven't been to Queens": The Epistemics of Identity and Place. *LSA Annual Meeting Extended Abstracts.*
- Silverman, D. (1998). *Harvey Sacks: Social science and conversation analysis / David Silverman. Key contemporary thinkers.* Cambridge: polity Press.
- Simpson, J. (2005). Conversational floors in synchronous text-based CMC discourse. *Discourse Studies, 7*(3), 337–361.
- Smith, C. B., McLaughlin, M. L., & Osborne, K. K. (1997). Conduct Control on Usenet. *Journal of Computer-Mediated Communication, 2*(4), 0.
- Sneijder, P., & te Molder, H. F.M. (2006). Disputing taste: Food Pleasure as an Achievement in Interaction. *Appetite, 46*(1), 107–116.
- Sneijder, P., & te Molder, H. (2009). Normalizing Ideological Food Choice and Eating practices. Identity work in online discussions on veganism. *Appetite, 52*(3), 621–630.
- Stivers, T. (2007). Alternative Recognitionals in Person reference. In N. J. Enfield & T. Stivers (Eds.), *Language, culture, and cognition: Vol. 7. Person Reference in Interaction. Linguistic, Cultural, and Social Perspectives* (pp. 73–98). Cambridge: Cambridge University Press.
- Stivers, T. (2013). Sequence Organization. In J. Sidnell & T. Stivers (Eds.), *The handbook of conversation analysis.* Chichester, West Sussex, UK: Wiley-Blackwell.
- Stivers, T., Enfield, N. J., & Levinson, S. C. (2007). Person Reference in Interaction. In N. J. Enfield & T. Stivers (Eds.), *Language, culture, and cognition: Vol. 7. Person Reference in Interaction. Linguistic, Cultural, and Social Perspectives.* Cambridge: Cambridge University Press.
- Stokoe, E. (2012). Moving Forward with Membership Categorization Analysis: Methods for Systematic Analysis. *Discourse Studies, 14*(3), 277–303.

- Stommel, W. (2008). Conversation Analysis and Community of Practice as Approaches to Studying Online Community. *Language@Internet*, 5(Article 5).
- Stommel, W. (2012). Salutations, Closings and Pronouns: Some Aspects of Recipient Design in Online Counselling. *Communication & Medicine*, 9(2), 91.
- Stommel, W., & Koole, T. (2010). The online support group as a community: A micro-analysis of the interaction with a new member. *Discourse Studies*, 12(3), 357–378.
- Supun, N., Ciampaglia, G. L., Su, N. M., & Ahn, Y.-Y. (2017). Gendered Conversation in a Social Game-Streaming Platform. In *the Eleventh International AAAI Conference on Web and Social Media*. Quebec, Canada,.
- Tan, S. I. (2009). Lexical borrowing from Chinese languages in Malaysian English. *World Englishes*, 28(4), 451–484.
- Tang, J. C., Venolia, G., & Inkpen, K. M. (2016). Meerkat and Periscope. In J. Kaye, A. Druin, C. Lampe, D. Morris, & J. P. Hourcade (Eds.), *CHI 2016. Proceedings, the 34th Annual CHI Conference on Human Factors in Computing Systems, San Jose Convention Center : San Jose, CA, USA, May 7-12* (pp. 4770–4780). New York, New York: The Association for Computing Machinery.
- ten Have, P. (2000). Computer-Mediated Chat: Ways of Finding Chat Partners. *A Journal of Media and Culture*, 3(4). Retrieved October 31, 2016, from <http://journal.media-culture.org.au/0008/partners.php>.
- ten Have, P. (2007a). *Doing Conversation Analysis: A Practical Guide*. London: SAGE Publications Ltd.
- ten Have, P. (1999). *Doing conversation analysis: A practical guide. Introducing qualitative methods*. London: SAGE.
- ten Have, P. (2007b). *Doing Conversation Analysis (Second Edition). Introducing Qualitative Methods series*. London: SAGE Publications Ltd.
- Themistocleous, C. (2013). Digital code-switching between Cypriot and Standard Greek: Performance and identity play online. *International Journal of Bilingualism*, 19(3),

282–297.

- Thurlow, C., Lengel, L. B., & Tomic, A. (2004). *Computer mediated communication: Social interaction and the Internet*. London: SAGE.
- Tsiplakou, S. (2009). Doing (Bi)Lingualism: Language Alternation as Performative Construction of Online Identities. *Pragmatics*, 19(3), 361–391.
- Turkle, S. (1999). Cyberspace and Identity. *Contemporary sociology*, 28(6), 643–648.
- Turkle, S. (1996). *Life on the screen: Identity in the age of the Internet / Sherry Turkle*. London: Weidenfeld & Nicolson.
- Turner, K. H. (2010). Digitalk: A New Literacy for a Digital Generation. *Phi Delta Kappan*, 92(1), 41–46. Retrieved February 05, 2018, from <http://journals.sagepub.com/doi/10.1177/003172171009200106#articleCitationDownloadContainer>.
- van Gass, K. M. (2008). Language contact in computer-mediated communication: Afrikaans-English code switching on internet relay chat (IRC). *Southern African Linguistics and Applied Language Studies*, 26(4), 429–444.
- Vandergriff, I. (2013). Emotive communication online: A contextual analysis of computer-mediated communication (CMC) cues. *Journal of Pragmatics*, 51, 1–12.
- Vayreda, A., & Antaki, C. (2009). Social support and unsolicited advice in a bipolar disorder online forum. *Qualitative health research*, 19(7), 931–942.
- Walther, J. B. (2012). Interaction Through Technological Lenses. *Journal of Language and Social Psychology*, 31(4), 397–414.
- Wei, L. (2005). “How can you tell?” Towards a Common Sense Explanation of Conversational Code-Switching. *Journal of Pragmatics*, 37(3), 375–389.
- Werry, C. C. (1996). Linguistic and Interactional Features of Internet Relay Chat. In *Computer-Mediated Communication. Linguistic, social, and cross-cultural perspectives* (pp. 47–63). John Benjamins Publishing Company.

- Wolf, A. (2000). Emotional Expression Online: Gender Differences in Emoticon Use. *Cyberpsychology & behavior : the impact of the Internet, multimedia and virtual reality on behavior and society*, 3(5), 827–833.
- Yeo, T. E. D., & Chu, T. H. (2017a). Promoting Hook-Ups or Filling Sexual Health Information Gaps? Exploring Young People's Sex Talk on Facebook. In A. A. Gruzd (Ed.), *ICPS. 8th International Conference on Social Media & Society. Social Media for Good or Evil : Toronto, Canada, July 28-30, 2017*. New York, New York: The Association for Computing Machinery.
- Yeo, T. E. D., & Chu, T. H. (2017b). Sharing "Sex Secrets" on Facebook: A Content Analysis of Youth Peer Communication and Advice Exchange on Social Media about Sexual Health and Intimate Relations. *Journal of health communication*, 22(9), 753–762.
- You, H.-J. (2015). Reference to Shared Past Events and Memories. *Journal of Pragmatics*, 87, 238–250.
- Young, R. F. (2017). World Languages, World Englishes and Local Identities. *World Englishes*, 61(4-5), 1039.
- Yurchisin, J., Watchravesringkan, K., & McCabe, D. B. (2005). An Exploration of Identity Re-Creation in The Context of Internet Dating. *Social Behavior and Personality: an international journal*, 33(8), 735–750.
- Zimmer, M. (2010). "But the Data is Already Public": On the Ethics of Research in Facebook. *Ethics and Information Technology*, 12(4), 313–325.
- Zuckerberg, M. (2012). *Letter from Mark Zuckerberg. Form S-1: Registration Statement*. Washington, DC: United States Securities and Exchange Commission.