

**Molecular identification and characterisation of  
*Meloidogyne* and *Pratylenchus* species**

Christopher Andrew Bell

Submitted in accordance with the requirements for the degree of Doctor of  
Philosophy

The University of Leeds  
School of Biology  
Faculty of Biological Sciences

September 2018

The candidate confirms that the work submitted is their own, except where work which has formed part of jointly authored publications has been included. The contribution of the candidate and the other authors to this work has been explicitly indicated below. The candidate confirms that appropriate credit has been given within the thesis where reference has been made to the work of others.

The work in Chapter Three of the thesis has appeared in publication as follows:

**BELL, C. A.**, ATKINSON, H. J., ANDRADE, A. C., NGUYEN, H. X., SWIBAWA, I. G., LILLEY, C. J., MCCARTHY, J. & URWIN, P. E. 2018. A High-Throughput Molecular Pipeline Reveals the Diversity in Prevalence and Abundance of *Pratylenchus* and *Meloidogyne* Species in Coffee Plantations. *Phytopathology*, 108, 641-650.

The work in Chapters Four and Five have been formed into an article that has been accepted for publication in *Plos Pathogens*:

**BELL, C. A.**, LILLEY, C. J., MCCARTHY, J., ATKINSON, H. J. & URWIN, P. E. 2018. Plant-parasitic nematodes respond to root exudate signals with host-specific gene expression patterns.

This copy has been supplied on the understanding that it is copyright material and that no quotation from the thesis may be published without proper acknowledgment.

© 2018 The University of Leeds, Christopher Andrew Bell

## Acknowledgements

---

I would like to thank both Prof Peter Urwin and Prof Howard Atkinson for their help over the last four years; each have offered unique guidance and knowledge in all aspects of my work.

I would also like to thank Dr Catherine Lilley for all of the time and effort she has invested in my project, without which it would have had a fraction of the output.

In addition, thanks go to Dr James McCarthy and Nestlé for assistance in organising sampling trips and providing funding.

Finally, thanks go to my fellow lab members in Leeds for their constant support and to those who assisted in sampling for coffee-nematodes in the locations I had the fortune to visit.

This project was also funded by the Biotechnology and Biological Sciences Research Council (BBSRC).

## Abstract

---

Plant-parasitic nematodes devastate a wide range of plant species across the world including many economically important crops such as coffee. Determining the mechanisms that underpin nematode entry and parasitism of the root is of great interest for the design of control strategies.

The first aspect of crop protection is to accurately and reliably diagnose the nematode species of concern. A molecular pipeline is described in this thesis that utilises PCR to rapidly detect and quantify the major *Meloidogyne* and *Pratylenchus* nematode species that are capable of parasitising coffee. This methodology assessed the prevalence of these species across the major coffee growing regions in Brazil, Vietnam and Indonesia. Distinct profiles of *Meloidogyne* species were detected across the regions whereas congruent *Pratylenchus* species were associated with coffee in all three countries. Furthermore, the pathogens were more numerous around intercropped plants such as banana and black pepper compared to coffee, suggesting that these crops may aggravate the issue. There was a high abundance of *Meloidogyne* in soil in which *Pratylenchus* was low, suggesting that the success of one genus may deter another. There is a clear widespread, yet differential nematode problem within coffee plantations that is likely to be effecting production and the issue is compounded by local practices and choices of intercrops. The global scale of the problem and the cost to coffee production could be elucidated with wider application of the approach.

Plant-nematode interactions must be defined in order to act upon diagnoses from the field. As obligate plant parasites, *Meloidogyne* and *Pratylenchus* nematodes must be able to locate and feed from their host in order to survive. The plant cell wall provides protection and support to plant cells and is a major barrier that the nematode must overcome to initiate feeding. This projects shows that *Pratylenchus coffeae*, a key species detected in the field, regulates the expression of selected cell-wall degrading enzyme genes relative to the abundance of substrate in root exudates, thereby tailoring gene expression to maximise the chances of successful parasitism. Treatment with the substrates directly or with root exudates deficient in the substrates conferred a specific gene expression response with no effect on expression of another cell wall degrading enzyme gene. This indicates that host-specific gene expression in this plant-parasitic nematode is influenced by cell wall components that derive from plant secretion or degradation of root tissue. The illustrated transcriptional plasticity may have evolved as an adaptation for recognition and increased root invasion of a wider range of host species.

# Contents

---

Chapter 1.	Introduction .....	1
1.1.	Coffee consumption.....	1
1.2.	Coffee biology and production .....	1
1.2.1.	The coffee plant.....	1
1.2.2.	Coffee production .....	2
1.2.3.	Coffee berry harvesting and processing .....	2
1.3.	Pests and pathogens of coffee .....	4
1.3.1.	Coffee leaf rust .....	4
1.3.2.	Coffee berry borer .....	5
1.3.3.	Plant-parasitistic nematodes.....	5
1.4.	Project aims.....	17
Chapter 2.	General Materials and Methods.....	18
2.1.	Biological material .....	18
2.1.1.	Plants .....	18
2.1.2.	Nematodes .....	18
2.1.3.	Plant maintenance and nematode infection .....	19
2.1.4.	Molecular protocols .....	22
Chapter 3.	A high throughput molecular pipeline reveals the diversity in prevalence and abundance of <i>Pratylenchus</i> and <i>Meloidogyne</i> species in coffee plantations.....	25
3.1.	Introduction.....	25
3.1.1.	Identification of <i>Meloidogyne</i> and <i>Pratylenchus</i> parasites of coffee through morphological and biochemical methods.....	25
3.1.2.	Nematode identification through molecular methods .....	26
3.2.	Aims .....	28
3.3.	Methods.....	29
3.3.1.	Testing the species-specificity of PCR primers .....	29
3.3.2.	Field sampling .....	29
3.3.3.	Application of diagnostic PCR primer sets to field sample nematode DNA.....	30
3.3.4.	Data analysis.....	30
3.4.	Results .....	36
3.4.1.	Testing the specificity of species-specific primers.....	36

3.4.2.	Nematode detection in field samples .....	36
3.4.3.	Evaluation of primers for quantification .....	37
3.4.4.	Quantification of plant-parasitic nematode species in field samples.....	37
3.5.	Discussion .....	52
3.6.	Summary .....	56
Chapter 4.	Identification and characterisation of genes encoding cell wall degrading enzymes in <i>Pratylenchus coffeae</i> .....	57
4.1.	Introduction.....	57
4.1.1.	The plant cell wall .....	57
4.1.2.	Pathogen attack on the plant cell wall .....	57
4.1.3.	Invasion of roots by plant-parasitic nematodes .....	59
4.2.	Aims .....	61
4.3.	Methods.....	62
4.3.1.	Identification of cell wall degrading enzyme genes in <i>P. coffeae</i> .....	62
4.3.2.	Producing alignments .....	62
4.3.3.	Signal peptide prediction .....	62
4.3.4.	Phylogenetic trees .....	62
4.3.5.	<i>In situ</i> hybridisation.....	62
4.3.6.	Gene expression analysis throughout nematode development .....	63
4.3.7.	Confirming cellulase activity of identified beta-1,4-endoglucanase genes.....	63
4.3.8.	Gene expression analysis in the nematode post-removal from the host.....	64
4.4.	Results .....	67
4.4.1.	Identification of cell wall degrading enzymes in <i>P. coffeae</i> .....	67
4.4.2.	Enzyme activity of beta-1,4-endoglucanase genes from <i>P. coffeae</i> .....	70
4.4.3.	Relationship between beta-1,4-endoglucanase genes from <i>P. coffeae</i> and different plant-parasitic nematode species .....	70
4.4.4.	Relationship between the beta-1,4-endoxylanase gene from <i>P. coffeae</i> and different plant-parasitic nematode species .....	70
4.4.5.	Relationship between the alpha-1,4-galacturonan lyase genes from <i>P. coffeae</i> and different plant-parasitic nematode species.....	70
4.4.6.	Spatial expression of cell wall degrading enzyme genes from <i>P. coffeae</i> .....	76
4.4.7.	Temporal expression of cell wall degrading enzyme genes from <i>P. coffeae</i> .....	76

4.4.8. Expression of beta-1,4-endoglucanase genes from <i>P. coffeae</i> post-removal from host tissue .....	76
4.5. Discussion .....	83
4.6. Summary .....	87
Chapter 5. <i>Pratylenchus coffeae</i> respond to root exudate signals with host-specific gene expression patterns.....	88
5.1. Introduction.....	88
5.2. Aims .....	91
5.3. Materials and Methods .....	92
5.3.1. Stylet thrusting assay.....	92
5.3.2. Gene expression analysis.....	92
5.3.3. Quantification of cellulose and xylan in root exudates.....	93
5.3.4. RNA interference of <i>Pc-eng-1</i> and <i>Pc-xyl</i> .....	93
5.4. Results .....	96
5.4.1. Host root exudates stimulate a stylet thrusting response .....	96
5.4.2. Expression of <i>Pc-eng</i> , <i>Pc-xyl</i> and <i>Pc-pel-1</i> is influenced by the host plant.....	96
5.4.3. <i>Pc-eng-1</i> and <i>Pc-xyl</i> expression correlates with cellulose and xylan quantities exuded by plant roots.....	101
5.4.4. Cellulose and xylan specifically up-regulate expression of <i>Pc-eng-1</i> and <i>Pc-xyl</i> , respectively. ....	105
5.4.5. RNA interference of <i>Pc-eng-1</i> and <i>Pc-xyl</i> reduces infection of <i>P. coffeae</i> .....	105
5.5. Discussion .....	109
5.6. Summary .....	114
Chapter 6. Neuronal inhibition of <i>P. coffeae</i> responses to host root exudates.....	115
6.1. Introduction.....	115
6.1.1. Host perception .....	115
6.2. Aims .....	118
6.3. Methods.....	119
6.3.1. Determining the EC <sub>50</sub> for paralysis with levamisole .....	119
6.3.2. Elucidating the effect of compounds that disrupt neuronal signalling in nematodes .....	119
6.4. Results .....	120
6.4.1. EC <sub>50</sub> for paralysis for <i>P. coffeae</i> .....	120

6.4.2.	Levamisole inhibits stylet thrusting in <i>P. coffeae</i> .....	120
6.4.3.	Nicotinic acetylcholine receptor agonists inhibit the upregulation of <i>Pc-eng</i> in response to root exudates in <i>P. coffeae</i> .....	120
6.4.4.	Atropine inhibits nematode responses to root exudates.....	120
6.4.5.	Serotonin signalling is involved in the stylet thrusting and gene induction response to root exudates.....	121
6.5.	Discussion .....	127
6.5.1.	Plant-parasitic nematodes are more resistant to levamisole than <i>C. elegans</i> .....	127
6.5.2.	Cholinergic signalling is involved in mediating <i>P. coffeae</i> responses to host root exudates .....	127
6.5.3.	Serotonin induces responses in <i>P. coffeae</i> .....	128
6.6.	Summary .....	131
Chapter 7.	General Discussion.....	132
7.1.	Improving field-based identification methods .....	132
7.2.	Predicting shifts in nematode distribution.....	133
7.3.	Nematodes adapting to host exudates.....	135
7.4.	Transcription alteration in insects towards different plants .....	137
7.5.	Nematode perception of host roots involves complex mechanisms .....	138
Chapter 8.	References .....	141



## Table of Figures

---

<b>Figure 1-1:</b> Largest producers of coffee as percentage of world production .....	3
<b>Figure 1-2:</b> Life cycle of a <i>Pratylenchus</i> nematode.....	7
<b>Figure 1-3:</b> Life cycle of a <i>Meloidogyne</i> nematode.....	12
<b>Figure 3-1:</b> Workflow to obtain the identification and quantification of coffee-parasitising nematodes present within soil samples from coffee plantations. ....	31
<b>Figure 3-2:</b> Field locations (▲) in (A) Minas Gerais, south-eastern Brazil, (B) Buon Ma Thuot, central-highlands Vietnam and (C) Lampung, southern Sumatra island, Indonesia.....	32
<b>Figure 3-3:</b> Representative images of sampling locations in Brazil (A), Vietnam (B) and Indonesia (C). ....	33
<b>Figure 3-4:</b> Testing of primers that amplify nematode 18S sequence.....	39
<b>Figure 3-5:</b> Testing of primers specific to <i>Pratylenchus</i> spp. ....	40
<b>Figure 3-6:</b> Testing of primers specific to <i>Meloidogyne</i> species. ....	41
<b>Figure 3-7:</b> Testing of primers specific to <i>Pratylenchus coffeae</i> .. ....	42
<b>Figure 3-8:</b> Identification of plant-parasitic nematodes in field samples.....	43
<b>Figure 3-9:</b> Testing of qPCR primers specific to <i>Pratylenchus</i> .....	46
<b>Figure 3-10:</b> Testing of qPCR primers specific to <i>Meloidogyne</i> . ....	47
<b>Figure 3-11:</b> Calibration curve of $C_t$ values vs $\log_2$ number of nematodes for quantification of <i>P. brachyurus</i> , <i>P. coffeae</i> , <i>M. exigua</i> , <i>M. paranaensis</i> , <i>M. hapla</i> and <i>M. incognita</i> .....	48
<b>Figure 3-12:</b> Percentage of samples and the range of densities per 100 g soil sample. ....	49
<b>Figure 3-13:</b> Mean species abundance per 100 g soil obtained from each crop.....	50

<b>Figure 3-14:</b> Correspondence analysis showing association between <i>Pratylenchus</i> and <i>Meloidogyne</i> abundance.....	51
<b>Figure 4-1:</b> Schematic diagram to show the cell wall structure containing cellulose, hemicellulose, pectin and soluble proteins .....	58
<b>Figure 4-2:</b> Enzyme activity of <i>P. coffeae</i> homogenate (A), <i>P. coffeae</i> secretion (B), <i>Pc-ENG-1</i> (C), <i>Pc-ENG-2</i> (D), <i>Pc-ENG-3</i> (E) and <i>Pc-ENG-4</i> (F) on 0.5 % carboxymethyl cellulose agar.....	72
<b>Figure 4-3:</b> Phylogenetic tree of the relationship between beta-1,4-endoglucanase genes from different plant-parasitic nematode species. ....	73
<b>Figure 4-4:</b> Phylogenetic tree of the relationship between beta-1,4-endoxylanase genes from different plant-parasitic nematode species.....	74
<b>Figure 4-5:</b> Phylogenetic tree of the relationship between alpha-1,4-galacturonan lyase genes from different plant-parasitic nematode species .....	75
<b>Figure 4-6:</b> Expression of beta-1,4-endoglucanase genes from <i>P. coffeae</i> post-removal from host roots. ....	77
<b>Figure 4-7:</b> <i>In situ</i> hybridisation of <i>Pc-eng-1</i> , <i>Pc-eng-2</i> , <i>Pc-eng-3</i> and <i>Pc-eng-4</i> .....	78
<b>Figure 4-8:</b> <i>In situ</i> hybridisation of <i>Pc-xyl</i> .....	79
<b>Figure 4-9:</b> <i>In situ</i> hybridisation of <i>Pc-pel-1</i> .....	80
<b>Figure 4-10:</b> Expression of <i>Pc-eng-1</i> , <i>Pc-eng-2</i> , <i>Pc-eng-3</i> and <i>Pc-eng-4</i> for selected life stages of <i>P. coffeae</i> ). ....	81
<b>Figure 4-11:</b> Expression of <i>Pc-xyl</i> (A) and <i>Pc-pel-1</i> (B) for selected life stages of <i>P. coffeae</i> . ....	82
<b>Figure 5-1.</b> Effect of host root exudates on the stylet activity of <i>P. coffeae</i> .....	98
<b>Figure 5-2.</b> Relative expression of <i>Pc-eng</i> genes (A), <i>Pc-xyl</i> (B) and <i>Pc-pel-1</i> (C) in <i>P. coffeae</i> recovered from host roots of potato, banana, carrot, coffee or maize.....	99
<b>Figure 5-3.</b> Expression of <i>Pc-eng</i> , <i>Pc-xyl</i> and <i>Pc-pel-1</i> in <i>P. coffeae</i> after exposure to host root exudates of banana, carrot, coffee, maize or potato for 4 hours.....	100

<b>Figure 5-4.</b> Relationship between exudate induced <i>Pc-eng-1</i> (A) and <i>Pc-xyl</i> (B) expression with exudate cellulose and xylan content, respectively. ....	102
<b>Figure 5-5.</b> Quantification of cellulose (A) and xylan (B) in <i>Arabidopsis thaliana</i> mutants.....	103
<b>Figure 5-6.</b> Expression of <i>Pc-eng-1</i> , <i>Pc-xyl</i> and <i>Pc-pel-1</i> in <i>P. coffeae</i> after 4 hours exposure to root exudates of mutant lines of <i>A. thaliana</i> that are deficient in cell wall cellulose ( <i>rsw1</i> ), xylan ( <i>glz1</i> ) or xyloglucan ( <i>mur3</i> ).....	104
<b>Figure 5-7.</b> Effect of incubation in cellulose (A) and xylan (B) solutions for 4 hours on expression of <i>Pc-eng-1</i> (●), <i>Pc-xyl</i> (■) and <i>Pc-pel-1</i> (△) by <i>P. coffeae</i> . ....	106
<b>Figure 5-8.</b> Infection of potato and maize roots by <i>P. coffeae</i> after treatment in solutions designed to induce RNAi. ....	107
<b>Figure 5-9.</b> Expression of <i>Pc-eng-1</i> (A) and <i>Pc-xyl</i> (B) in <i>P. coffeae</i> treated with solutions designed to induce RNAi .....	108
<b>Figure 6-1.</b> Effect of levamisole on <i>Pratylenchus coffeae</i> individuals.....	122
<b>Figure 6-2.</b> Effect of host root exudates on the stylet activity of <i>P. coffeae</i> .....	123
<b>Figure 6-3.</b> Expression of <i>Pc-eng</i> in <i>P. coffeae</i> after pre-treatment with acetylcholine receptor agonists and subsequent exposure to host root exudates of potato, banana, carrot, coffee or maize for 4 hours .....	124
<b>Figure 6-4.</b> Effect of 10 mM atropine on the root exudate induced stylet thrusting (A) and <i>Pc-eng-1</i> upregulation (B).....	125
<b>Figure 6-5.</b> Evaluating the influence of the 5-hydroxytryptamine (5-HT) signalling pathway on stylet thrusting and expression of <i>Pc-eng-1</i> in <i>P. coffeae</i> .....	126

## List of Tables

---

<b>Table 1:</b> Coffee-parasitising <i>Pratylenchus</i> spp.....	9
<b>Table 2:</b> Coffee-parasitising <i>Meloidogyne</i> spp.....	14
<b>Table 3-1:</b> Primer sequences used for the identification of <i>Pratylenchus</i> and <i>Meloidogyne</i> species, alongside the annealing temperatures, product sizes and sources.....	32
<b>Table 3-2:</b> Primer sequences used for the quantification of <i>Pratylenchus</i> and <i>Meloidogyne</i> species, alongside the annealing temperatures and product sizes.....	33
<b>Table 3-3:</b> The <i>Pratylenchus</i> and <i>Meloidogyne</i> species detected in coffee plantations.....	41
<b>Table 3-4:</b> The <i>Pratylenchus</i> and <i>Meloidogyne</i> species detected in total samples...	42
<b>Table 4-1:</b> Primer sequences used for the temporal and spatial analysis of selected <i>P. coffeae</i> sequences.....	62
<b>Table 4-2:</b> Primer sequences for the cloning of <i>P. coffeae</i> beta-1,4-endoglucanase sequences for expression in <i>E. coli</i> for subsequent assay to determine cellulase activity.....	63
<b>Table 4-3:</b> Transcriptome and genome assembly comparisons between published data and this study.....	65
<b>Table 4-4:</b> CAZy search output identifying cellulase, xylanase and pectate lyase genes in the genome of <i>Pratylenchus coffeae</i> .....	66
<b>Table 5-1:</b> Primer sequences used for dsRNA construct cloning.....	92

# Chapter 1. Introduction

---

## 1.1. Coffee consumption

Approximately two billion cups of coffee are consumed worldwide every day (The British Coffee Association, 2018). The United Kingdom consumes the 45<sup>th</sup> highest amount of coffee (2.8 kg/capita/year), far lower than the top consumers; Finland (12 kg/capita/year), Norway (9.9 kg/capita/year) and Iceland (9 kg/capita/year) (International Coffee Organisation, 2018a). The majority of consumers in the UK (77 %) buy instant coffee, rather than speciality coffee, to drink at home. This is notably higher than the proportion of instant coffee consumed in other countries such as Finland (4 %), Italy (6 %) and France (4 %), reflecting the varying coffee cultures (International Coffee Organisation, 2016). Consumption of coffee increased by approximately 1 % from 2016-2017 and is approximately equivalent with coffee production (International Coffee Organisation, 2018b). Instability between harvests could severely impact global availability, especially if consumption continues to increase (International Coffee Organisation, 2018b). The worldwide availability of the beverage is due to the widespread and established production pipeline, described below.

## 1.2. Coffee biology and production

### 1.2.1. The coffee plant

*Coffea* is a genus within the family *Rubiaceae* and includes 103 species of which only *Coffea arabica* and *C. canephora* are economically important (Davis et al., 2006). *Coffea* species are perennial plants that occur in tropical and subtropical regions at altitudes up to 2500 m. Higher altitudes of 1000 - 2500 m favour *C. arabica* growth due to the cooler climate of 15 - 24 °C. In comparison, *C. canephora* grows optimally in altitudes < 600 m, at temperatures of 24 - 30 °C (Willson, 1985). *Coffea arabica* and *C. canephora* can grow to approximately 10 m but they are often pruned to assist harvesting. Both species fruit berries, each containing two seeds, for approximately 50 years. Plant yield is based upon total bean weight and can vary between cropping systems, with *C. arabica* production ranging between 300 - 4500 kg beans/ha compared to 600 - 6000 kg beans/ha from *C. canephora* (Jurgen and Janssens, 2010). These beans are then used to produce the beverage (Ponte, 2002).

Other coffee species such as *C. liberica* and *C. dewevrei* are grown on subsistence farms but are not favourable for commercial development due to their lower yield and height of over 10 m, which extends harvesting time in larger plantations.

### 1.2.2. Coffee production

*Coffea arabica* and *C. canephora* constitute approximately 74 % and 24 %, respectively, of total coffee production worldwide (Hobhouse et al., 2004). The preference to cultivate *C. arabica* over *C. canephora* results from its commercially popular taste deriving from the balance of several compounds within the bean. *C. arabica*, compared to *C. canephora*, has a higher abundance of acetaldehyde, pyrazines and sucrose and a lower concentration of chlorogenic acids, caffeine and sulphur-containing compounds, resulting in a commercially preferred aroma and taste (Sanz et al., 2002, Farah, 2012). Subsequently, *C. arabica* is sold for a higher price and is often used in blends that contain different compositions of both beans.

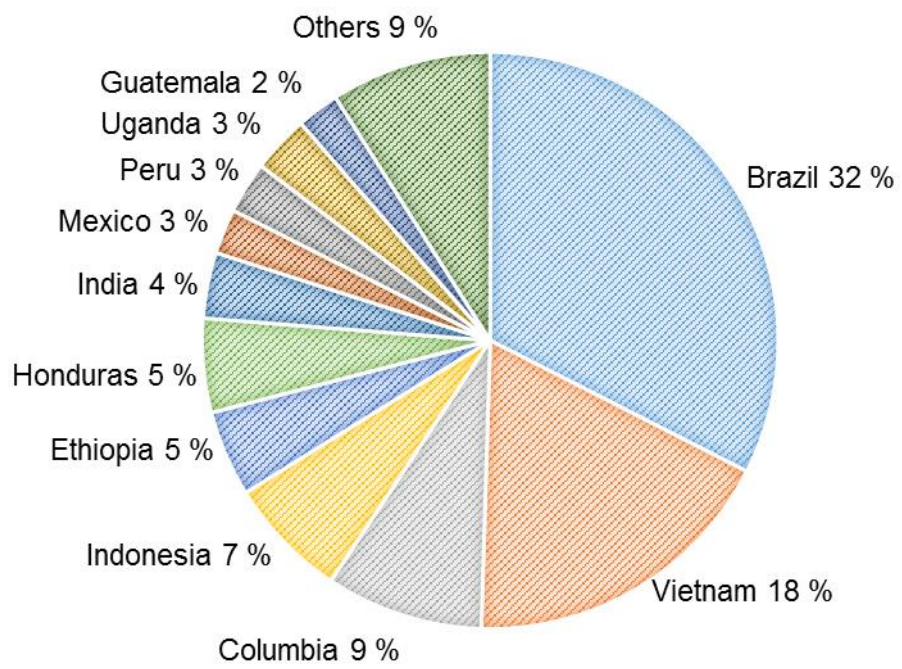
Sixty countries produce coffee with approximately 60 % of global production deriving from Central/South America, 25 % from Asia, 14 % from Africa and 1 % from the Pacific Islands (Villain, 2008). Approximately a third of total global coffee comes from Brazil, the world's largest coffee producer (Figure 1-1) (Council and Hanrahan, 2006). *Coffea arabica* represents 74 % of Brazilian coffee production and the majority is cultivated in the south-eastern states, in particular Minas Gerais, Rio de Janeiro, Sao Paulo, Parana and Bahia, due to the cooler climate. *C. canephora* represents 26 % of Brazilian coffee production and is cultivated in the states of Espirito Santo and Rondônia.

Vietnam supplies only 18 % of the world's total coffee production but accounts for 42 % of the global output of *C. canephora* (Wiriyadiputra, 2008). The Central and Western Highland regions account for 85 % of the country's total coffee production. *Coffea arabica* is less common due to its increased susceptibility to *Hemileia vastatrix*, coffee leaf rust, which causes mass defoliation, reduced berry production and even plant death (Silva et al., 2006, Avelino et al., 2004). However, some growers prefer to cultivate *C. arabica* due to its higher retail value. The geography of Vietnam promotes cultivation of both species as the Central and Southern provinces have a tropical, warm and humid climate compared to the milder northern regions.

*Coffea arabica* and *C. canephora* are often referred to as arabica and robusta coffee, respectively. These terms will be used throughout the rest of this thesis.

### 1.2.3. Coffee berry harvesting and processing

Harvesting seasons vary with the variety and the regional climate. This task employs approximately 50 % of the man-hours required by the crop, making it the most time consuming part of production (Vieira, 2008).



**Figure 1-1: Largest producers of coffee as percentage of world production, 2007-2011.** (Data source: International Coffee Organisation, 2018)

The berries are sent through washing channels where any debris or unripe berries will float and are subsequently removed. The outer layers of the ripe berries are then removed by machine to release the beans inside (National Coffee Association, 2015). The mechanical input into these processes is largely influenced by the value of the coffee market (Coffee Research Institute, 2006).

At this point the beans are sold by the growers and industrial companies roast and grind the beans. Roasting is a process of slowly heating the beans to approximately 230 °C so that the compounds responsible for the commercially preferred aromas and flavours are formed, such as the caramelisation of sucrose and breakdown of chlorogenic acids (Moon et al., 2009). As the final composition is unique to each roaster there are many different roasting protocols. A higher sucrose content generally results in greater caramelisation and therefore results in a 'darker roast' (Farah et al., 2005).

Coffee production, research and markets have widespread effects upon each other worldwide. In 2001 there was a 30 year price low which resulted in the application of intensive farming methods and a decrease in farm maintenance, affecting future disease and pest control (International Trade Centre, 2011). In 2011, coffee prices reached a 34 year high due to unfavourable weather conditions pressuring the market. This promoted expansion of the industry in several countries, such as Vietnam, and incentives for new cultivation methods that provide stability to the market (Wiryadiputra, 2008, International Trade Centre, 2011).

### **1.3. Pests and pathogens of coffee**

There are several major pests and pathogens which have an impact on coffee production. Coffee leaf rust, coffee berry borer and plant-parasitic nematodes are amongst the most widely known and well-documented. These pathogens have been detected in key coffee growing regions and control is attempted through agricultural and chemical applications.

#### **1.3.1. Coffee leaf rust**

*Hemileia vastatrix*, commonly referred to as coffee leaf rust, is a fungal pathogen that is estimated to be responsible for in excess of US\$1 billion in coffee losses, annually (McCook, 2006). The fungus is found in all coffee producing areas as a result of wind dispersion and transportation of infected material (Talhinhas et al., 2017). Spores land on the underside of the leaf, colonise the leaf through stomata and result in symptomatic yellow-orange spots. Infection reduces the nutrients within the leaf whilst also preventing photosynthesis, resulting in an overall reduction in plant vigour (Zambolim, 2016). The



pathogen is capable of infecting vast areas due to the high level of genetic variability, resulting in over 50 races. Additionally, the limited genetic variation of coffee reduces the possibility of natural resistance (Zambolim, 2016). Temperature, humidity, rainfall and field arrangements can all impact the success and speed of infection (Zambolim, 2016, Talhinhos et al., 2017). This has led to varying virulence of *H. vastatrix* between regions, with the fungus eradicating coffee production in Sri Lanka and Vietnam but producing yield losses of 30 - 90 % in Brazil and Central America (Capucho et al., 2013, Vandermeer et al., 2010, Zambolim, 2016). The damage potential may increase in the coming years due to predicted climate change potentially shortening the life cycle and increasing infection.

### **1.3.2. Coffee berry borer**

*Hypothenemus hampei*, commonly referred to as the coffee berry borer, is a significant pest of coffee and causes worldwide annual losses of over US\$500 million (Oliveira et al., 2013). The insect enters the coffee berry where it feeds on tissue and lays eggs. The eggs then hatch, mating occurs and the females fly to neighbouring berries to continue the cycle. This pathogen is difficult to eradicate from plantations as it spends most of its life within the berry and protected from control methods (Damon, 2000). The independent mode of dispersal and poor quarantine has resulted in the introduction of *H. hampei* to all coffee-producing countries (CABI, 2018). A variety of control methods can succeed in reducing populations, such as increasing shade trees to promote natural predators and application of insecticides/parasitic wasps (Aristizabal et al., 2012, Aristizabal et al., 2016).

### **1.3.3. Plant-parasitistic nematodes**

Nematodes are very abundant in soils and many are pathogens of below-ground plant tissue (Groombridge, 1992, Hunt et al., 2005). Plant-parasitic nematodes (PPN) are obligate parasites that are capable of parasitising a vast range of plants, including many important crops (Trudgill and Blok, 2001). Their pathogenicity affects many physiological processes of plants and has led to reported global agricultural losses of an estimated US\$157 billion per annum (Abad et al., 2008). PPN survive by feeding on the cytoplasm of plant cells and can be broadly classified as migratory ectoparasites, migratory endoparasites or sedentary endoparasites. Ectoparasites remain on the outside of the root and ingest cytosolic material from the host via a stylet. Migratory endoparasites penetrate the root and feed destructively during migration. Sedentary endoparasites enter the root as a juvenile and establish a feeding site where they remain and from which they acquire nutrients for the rest of their life cycle (Palomares-Rius et al., 2017).

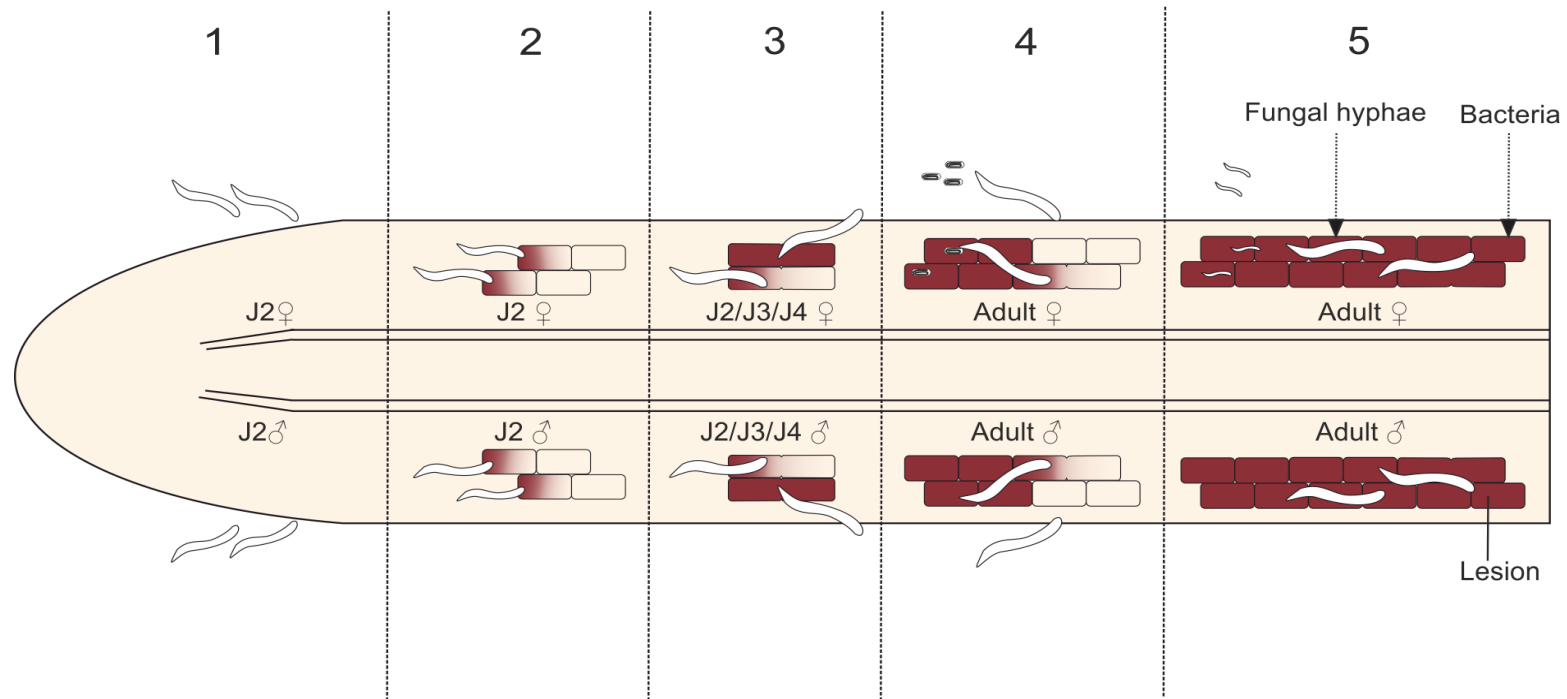
Coffee is a known host of both the migratory *Pratylenchus* and sedentary *Meloidogyne* endoparasites that are responsible for up to 15 % of coffee losses worldwide (Carneiro et al., 2004, Gaitan, 2008, Trinh et al., 2009, Villain et al., 2013, Wiryadiputra, 2008, Campos, 2005).

#### 1.3.3.1. *Pratylenchus*: Root-Lesion Nematodes

##### *Life cycle*

Root-lesion nematodes (RLN) are of the genus *Pratylenchus* and are the third most economically important PPN of global agriculture (Jones et al., 2013). The genus *Pratylenchus* includes over 70 species that are capable of infecting a vast range of plants (Jones and Fosu-Nyarko, 2014, Jones et al., 2013).

As a migratory endoparasite, all juvenile and adult *Pratylenchus* life stages can enter and leave roots (Figure 1-2). The egg hatches to release a second-stage juvenile that locates the roots by detecting gradients of ions, CO<sub>2</sub> and pH within the rhizosphere of growing plants (Jones and Fosu-Nyarko, 2014). When the host is identified, root invasion can occur along the entire root surface. Root invasion is achieved by thrusting the stylet, a hollow protrusion from the mouth, to mechanically disrupt epidermal and sub-epidermal cells and gain entry into the root (Quist et al., 2015). Root entry is aided by secretion of several gene products, such as effectors, from the pharyngeal gland cells through the stylet and into the host (Jones et al., 2013). Effectors are defined as molecules or proteins that alter host cell structure or function (Haegeman et al., 2012). Cell wall degrading enzymes, generally classed as effectors, are a feature of PPNs that break down the plant cell wall to enable nematode migration through host tissue (Fosu-Nyarko and Jones, 2016b). A range of these enzymes have been identified in *Pratylenchus* species and show a high similarity to bacterial enzymes, suggesting that they were acquired by horizontal gene transfer (Nicol et al., 2012, Dorris et al., 1999, Jones and Fosu-Nyarko, 2014). The nematode migrates intracellularly along the root whilst feeding from root cells. This disruptive movement/feeding results in necrotic lesions and often leads to the development of disease complexes such as secondary infection with *Fusarium* and *Verticillium* species (Fosu-Nyarko and Jones, 2016b, Saeed et al., 1998). The nematode moults during migration and matures into an adult. Adult females lay eggs singly, lacking an enclosing matrix, either in the root or in the nearby soil (Jones et al., 2013). Males are often not produced as many *Pratylenchus* species are parthenogenetic (Moens and Perry, 2009).



**Figure 1-2: Life cycle of a *Pratylenchus* nematode.** The second-stage juvenile enters the root by breaking down the epidermal cells via mechanical disruption and secretion of proteins (1). The nematode ingests cytoplasmic material as it migrates intracellularly. This leads to necrotic lesions visible from the exterior of the root (2). During migration and feeding, the nematode moults and matures into an adult. All vermiform stages of development can leave and re-enter the root (3). Adult females lay eggs, lacking an enclosing matrix, either within the root or in the nearby soil (4). The eggs then hatch to release second-stage juveniles that repeat the cycle (5). The migration pattern within the root leads to extensive necrotic areas that can result in disease complexes and death of the host (5). Males are often not produced as many *Pratylenchus* species are parthenogenetic.

### *Coffee and Root-Lesion Nematodes*

*Pratylenchus* species are highly destructive towards coffee, however their economic importance is probably underestimated due to the non-specific symptoms (Herve et al., 2005, Villain, 2008). There are eight known species that parasitise both commercial coffee species, with *P. brachyurus* and *P. coffeae* the most frequently reported (Table 1-1) (Campos and Silva, 2008, Villain et al., 2002, Villain, 2008, Campos, 2005). These two species are widely distributed and extremely damaging to coffee in Brazil (Villain, 2008, Tomazini et al., 2009, Inomoto et al., 2007). In Vietnam, *Pratylenchus* spp are the main plant-parasitic nematode threat to coffee and are found across the North-western and Central Highland regions where coffee production is concentrated (Trinh et al., 2009).

### *Management of Pratylenchus species in coffee plantations*

The correct diagnosis of root-lesion nematode infection is important in order to apply appropriate management practices. These practices vary greatly according to the host crop but are focused on either eradication, protection or resistance. The rudimentary control method is to rotate the field each year between host and non-host crops. Non-host crops reduce the field nematode population before the host crop is planted again. This method minimizes the detrimental effect of the nematodes on overall field yield, however for coffee, the perennial and slow-growing nature of the crop makes this method impractical.

Up until the late 20th century, fumigant and non-fumigant nematicides were used worldwide in to attempts to suppress nematode populations (Nyczepir and Thomas, 2009). These chemicals, in particular fumigants, were successful in reducing nematode populations and reducing yield losses; however after prolonged use their effectiveness diminished (Nyczepir and Thomas, 2009).

Nematicides have been applied to coffee nurseries and are capable of reducing nematode populations, however they do not assure nematode-free plantlets and the spread of nematodes from nurseries to plantations represents a significant issue for the industry (Abrego, 1974). Application of nematicides throughout plantations could potentially limit nematode infection, however these products need to be regularly applied to be efficient on coffee, and thereby significantly increase expenditure (Castillo and Vovlas, 2007, Villain, 2008). Application of nematicides in coffee plantations in Guatemala was shown to suppress RLN populations only until the second year after planting, therefore becoming ineffective before first harvest (Villain, 2000).

**Table 1-1: Coffee-parasitising *Pratylenchus* spp.** *Pratylenchus* species that have been reported to parasitise coffee and their described locations.

Coffee-parasitising <i>Pratylenchus</i> spp.	Reported countries
<i>P. brachyurus</i>	Australia, Brazil, Japan, Peru, South Africa, Turkey, West Africa, USA, Vietnam
<i>P. coffeae</i>	Brazil, Costa Rica, Dominican Republic, El Salvador, Guatemala, India, Indonesia, Madagascar, Tanzania, Venezuela, Vietnam
<i>P. goodeyi</i>	Tanzania
<i>P. loosi</i>	Sri Lanka
<i>P. panamaensis</i>	Costa Rica, Guatemala, Oman, Panama
<i>P. pratensis</i>	India
<i>P. vulnus</i>	Brazil
<i>P. zaeae</i>	Brazil, Columbia

However, in field trials in Brazilian coffee plantations nematicide treatments can be efficient at increasing coffee yields by 28 % through reducing *P. coffeae* populations (Villain, 2008, Figueroa, 1978). The factor determining efficacy is unclear and could be the nematode population in each country or the application methodology. Although some nematicides can be effective in coffee plantations, many are a concern to both environmental and human health and have therefore been removed from the market (Nyczepir and Thomas, 2009).

Biological methods for nematode control have been trialled, however the low efficacy and cost effectiveness have resulted in minimal applications in coffee plantations (Castillo and Vovlas, 2007, Timper, 2014). Fungal controls can successfully reduce *P. coffeae* levels after the first year of use, however, after the second year infection returns to the initial rate (Villain et al., 2000). Regular treatments make the control too expensive for smallholders and consequently the majority of coffee plantations (Fairtrade Foundation, 2018). The species-specificity of each method reduces its applications as several nematode species are usually present (Timper, 2014). Many of these controls also increase the infection of other *Pratylenchus* species, reducing overall effectiveness of the application (Villain, 2008).

The aforementioned control methods aim to reduce the field nematode populations in order to reduce the economic impact. However, the development of resistant plants that suppress nematode growth would be the most cost-effective and environmentally sustainable strategy. No naturally resistant arabica cultivars have been found, however resistant robusta trees have been identified and their rootstocks grafted with arabica to successfully reduce plant mortality rates from nematodes from 25 – 56 % to 6 % in Guatemala (Villain et al., 2001, Villain et al., 2000). There has been mixed success with grafting for resistance in other countries, showing the diversity of different RLN populations and the need for a worldwide control method (Villain, 2008). The genetic basis of resistance has not yet been described. Overall, coffee resistance provides the best hope for *Pratylenchus* species control and must be better characterised (Villain, 2008). Once the mechanisms behind natural resistance are understood they can be identified and introduced into other cultivars. No work has been carried out to produce transgenic coffee resistant to RLNs even though the introduction of such cultivars would have widespread effects.

Currently the only effective control is to exclude all infected coffee seedlings from *Pratylenchus*-free fields and properly enforce all regulatory restrictions (Campos and

Silva, 2008). This emphasises the urgency for development of effective control methods, in particular RLN-resistant cultivars.

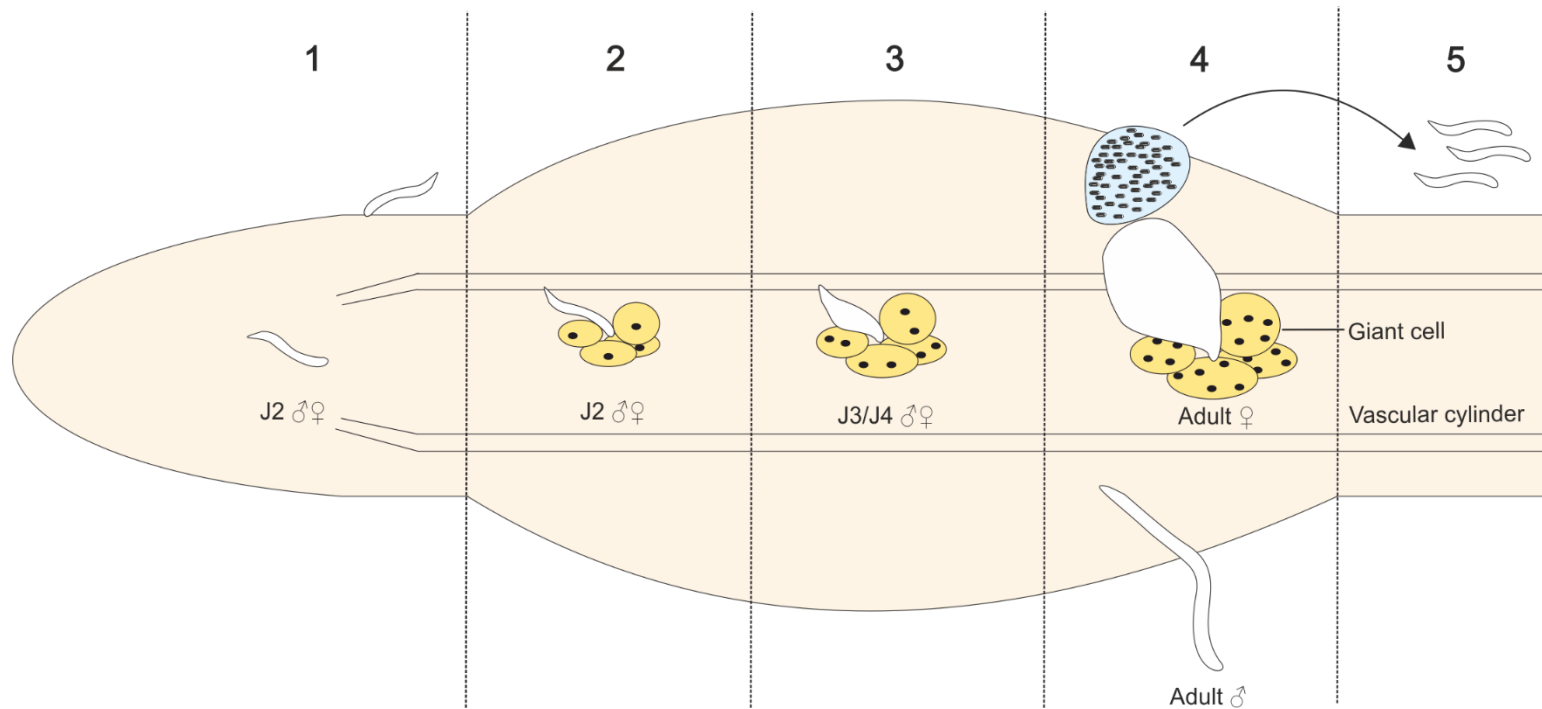
#### 1.3.3.2. *Meloidogyne*: Root-Knot Nematode

Root-knot nematodes (RKN) are of the genus *Meloidogyne* and are regarded as the most economically important PPN (Jones et al., 2013). The genus includes 97 species that are distributed across tropical and subtropical countries, parasitising many species of higher plants (Moens et al., 2009, Castagnone-Sereno et al., 2013, Trudgill and Blok, 2001).

##### *Life cycle*

The root-knot nematode life cycle is summarised in Figure 1-3. The second-stage juvenile (J2) emerges from the egg into the soil and finds the host by detecting gradients of ions, CO<sub>2</sub> and pH within the rhizosphere of growing plants (Wyss et al., 1992). When the host is identified, root invasion occurs primarily behind the root tip at the zone of elongation (Wyss and Grundler, 1992). The nematode uses its stylet, a hollow protrusion from the mouth, to mechanically disrupt epidermal and sub-epidermal cells and gain entry into the root (Wyss and Grundler, 1992, Jones et al., 2013). Like *Pratylenchus*, several RKN species secrete a range of cell wall degrading enzymes that are understood to be acquired via horizontal gene transfer due to their high similarity with bacterial orthologues (Paganini et al., 2012). The unprecedented number of these genes compared to other nematodes could explain the wide host range of the genus (Opperman et al., 2008). In contrast to *Pratylenchus* nematodes, RKN J2s move intercellularly, without damaging the root cells, towards the vascular cylinder (Wyss et al., 1992). Here, the nematode establishes a sophisticated nutritional interaction with the host by inducing unique feeding structures. The nematode stimulates the differentiation of protophloem and protoxylem cells into 'giant cells' through oesophageal gland secretions injected via the stylet (Berg et al., 2009).

Giant cells are multinucleate with volumes approximately 100-fold greater than unparasitised protophloem/xylem root cells (Moens et al., 2009). These are created by the induction of multiple rounds of mitosis whilst preventing cytokinesis by arresting cell division at the formation of the cell plate. In the regular cell cycle, cell plate precursor vesicles align at the midpoint between the two groups of chromosomes. However, in giant cells the vesicles are dispersed before they can form a cell wall; therefore preventing cell division and producing a multinucleate cell after several repetitions (Jones and Payne, 1978, Abad et al., 2009). Each nematode induces 4-7 giant cells which remain metabolically active throughout infection (Moens et al., 2009). These metabolites



**Figure 1-3: Life cycle of a *Meloidogyne* nematode.** The infective second-stage juvenile hatches from the egg and identifies the host by detecting signals from the plant. The nematode uses the stylet to disrupt the epidermis and enter the root where it then migrates intercellularly to the vascular cylinder (1). The nematode establishes a feeding site by inducing the formation of multinucleate cells, termed giant cells (2). The sedentary juvenile now remains in the feeding site as it matures into an adult, obtaining nutrients from the giant cells (3). Adult females lay eggs within an enclosing matrix on the exterior of the root (4). The eggs then hatch to release infective second stage juveniles (5).



are withdrawn from the cells via the nematode stylet, to sustain growth and reproduction (Williamson and Gleason, 2003). Feeding occurs sequentially across each giant cell and is observed by head movement and stylet insertion (Wyss and Grundler, 1992). Upon giant cell formation, proliferation of surrounding cortical and vascular tissue results in the symptomatic large galls (Castagnone-Sereno et al., 2013). These large galls result in the common name for the genus, 'root-knot nematode'.

The J2 moults three times to reach the adult stage. Adult males regain motility and leave the root whilst adult females remain and lay 30 - 40 eggs per day into a gelatinous matrix that is deposited on to the surface of the galled root (Williamson and Gleason, 2003). This protects the eggs from environmental extremes and soil pathogens (Moens et al., 2009). The J1 inside the egg will develop and moult to a J2 and remain at that stage until stimulated to hatch. Hatching of the egg is dependent upon temperature, soil moisture and root diffusates. The life cycle normally takes 20 - 45 days depending on conditions and is then repeated.

#### *Effects of root-knot nematodes upon coffee*

RKN are estimated to account for the majority of coffee losses through PPN as they are widespread across the main coffee producing countries in Central/Southern America (Herve et al., 2005, Campos, 2005). The nematode-plant interaction damages the roots and disrupts water and nutrient uptake. This retards growth and splits the roots which can lead to root rot. Subsequently, this promotes secondary infection by other pathogens, resulting in a wider range of symptoms (Bertrand et al., 2000). Parasitism causes non-specific symptoms in the host such as chlorosis, leaf loss and stunting which reduces plant yield (Barbosa et al., 2004). Virulence of *Meloidogyne* species to coffee plants varies and thereby modulates the extent of yield loss and can sometimes result in plant death (Bertrand and Anthony, 2008). Perennials, such as coffee, are exposed to soil parasites for a longer period of time than annuals, increasing the chances of infection and severity of symptoms.

There are 18 *Meloidogyne* species that have been found to parasitise coffee plants (Table 1-2) (Carneiro and Cofcewicz, 2008). In Brazil, *Meloidogyne coffeicola*, *M. exigua*, *M. hapla*, *M. incognita*, *M. javanica* and *M. paranaensis* have been detected on both arabica and robusta plants (Ferraz, 2008, Barros et al., 2014). *Meloidogyne exigua*, *M. incognita* and *M. paranaensis* have been identified as key species of concern as they greatly reduce yields across a wide geographical area (Campos, 2005). In Vietnam, the second largest producer of coffee, *M. incognita* has been detected in several plantations in both arabica and robusta plants (Trinh et al., 2009, Wiryadiputra, 2008).

**Table 1-2: Coffee-parasitising *Meloidogyne* spp.** *Meloidogyne* species that have been reported to parasitise coffee plants and their described locations.

Coffee-parasitising <i>Meloidogyne</i> spp.	Reported countries
<i>M. africana</i>	Kenya, Zaire
<i>M. arabicida</i>	Costa Rica
<i>M. arenaria</i>	Cuba, El Salvador, Jamaica
<i>M. coffeicola</i>	Brazil
<i>M. decalineata</i>	Tanzania, Sao Tome and Principe
<i>M. exigua</i>	Bolivia, Brazil, Colombia, Costa Rica, Dominican Republic, El Salvador, French Guiana, French West Indies, Guatemala, Honduras, India, Nicaragua, Panama, Peru, Suriname, Trinidad and Tobago, Venezuela.
<i>M. goldi</i>	Tanzania, Zaire, India, Kenya, Congo, Guatemala, El Salvador
<i>M. hapla</i>	Brazil, Congo, Guatemala, El Salvador, India, Kenya, Tanzania, Zaire.
<i>M. incognita</i>	Brazil, Costa Rica, Cote d'Ivoire, Cuba, El Salvador, India, Guatemala, Jamaica, Nicaragua, Tanzania, USA (Hawaii), Venezuela
<i>M. inornata</i>	Guatemala
<i>M. javanica</i>	Brazil, Cuba, El Salvador, India, Sao Tome and Principe, Tanzania, Zaire
<i>M. kikuyensis</i>	Kenya
<i>M. konaensis</i>	USA (Hawaii)
<i>M. mayaguensis</i>	Costa Rica, Cuba, Guatemala
<i>M. megadora</i>	Angola, Uganda, Sao Tome and Principe
<i>M. oteifae</i>	Zaire
<i>M. paranaensis</i>	Brazil, Guatemala, USA (Hawaii)

The wide distribution of the genus alongside the prominence of Brazil and Vietnam in coffee production increases the impact of *Meloidogyne* on coffee production.

### *Management of Meloidogyne species in coffee plantations*

Control methods for RKN are very similar to those discussed previously for RLN. Crop rotation is impractical and nematicides are being restricted due to environmental concerns (Nyczepir and Thomas, 2009). Restrictions and lack of novel products have resulted in a diminishing role for nematicides in crop protection (Starr et al., 2002). The prohibition of many chemical controls has led to the use of biological control methods in coffee plantations. Several bacterial and fungal pathogens and antagonists of RKN have been described that affect specific stages of the nematode life cycle. These are known to parasitise on the nematode, degrade root exudates, release toxins or produce enzymes that interfere with plant-nematode recognition. *Pasteuria penetrans* has been noted to be effective against *M. exigua*; infecting 21 – 65 % of *M. exigua* J2s in a Brazilian coffee plantation and reducing infection of the crop (Maximiniano et al., 2011).

Also, arbuscular mycorrhizal fungi have been shown to decrease nematode parasitism on coffee plants (Alban et al., 2013). Mycorrhizal treatment increased available phosphorus and nitrogen within the soil which can be taken into the roots and used to lignify the cell walls, thereby strengthening the roots. This strengthened barrier reduced *M. exigua* root invasion and stabilised plant growth, even when the fungi were added post-infection (Alban et al., 2013). Although biological controls have potential, many control organisms are extremely difficult to culture, have limited host ranges and require large quantities for an effect. As a result of this, the very few commercial biological products that exist are very expensive (Hallman et al., 2009).

Natural resistance to *Meloidogyne* is of great interest for crop protection and its application has been largely focussed in Brazil. Although few rootstocks are available, grafting these can yield over three times as much as non-grafted plants and provide resistance to a wide range of nematode species (Campos and Silva, 2008). However, reports from growers have raised concerns about the efficacy of these rootstocks once applied in the field (personal communication with growers).

The development of resistant plants that suppress nematode growth is the most promising aspect for controlling *Meloidogyne*, as discussed for *Pratylenchus* previously. Robusta coffee has increased resistance to certain *Meloidogyne* species in comparison to arabica cultivars, however so far only one resistance gene has been identified, *Mex-1*, which confers resistance to *M. exigua* by inducing a hypersensitive response (Noir et

al., 2003). Breeding the resistance into arabica cultivars has been achieved in the past but no stable lines have been generated (Bertrand et al., 2001, Bertrand and Anthony, 2008). Resistance genes for other *Meloidogyne* species have not been found in any *Coffea* species.

Currently the only effective control, as stated previously for *Pratylenchus*, is to exclude all infected coffee seedlings from *Meloidogyne*-free fields and properly enforce all regulatory restrictions.

#### 1.4. Project aims

Plant-parasitic nematodes are a major concern for the coffee growing industry, therefore additional insights into their distributions and interactions with the host are desirable. This will direct further research into control strategies towards the species of concern and assist the characterisation of the plant-nematode interactions that occur during parasitism.

The aims of this project were to:

1. Design a nematode diagnostic tool that offers rapid and reliable identification and quantification of nematode species from coffee plantations.
2. Apply the diagnostic method to a range of coffee plantations in locations that are economically important to the coffee industry.
3. Investigate the responses of *Pratylenchus coffeae* towards root exudates from different plants.
4. Determine how the nematode may perceive and respond to root exudate signals.

## Chapter 2. General Materials and Methods

---

### 2.1. Biological material

#### 2.1.1. Plants

- *Arabidopsis thaliana*
  - Col-0
  - *glz1* (NASC ID: N16279)
  - *mur3* (NASC ID: N8566)
  - *rsw1-1* (NASC ID: N6554)
- Banana – *Musa acuminata* ‘Cavendish’
- Coffee – *Coffea arabica*
- Carrot - *Daucus carota* ‘Kelly’
- Maize - *Zea mays* ‘Earlibird’
- Potato - *Solanum tuberosum* ‘Désirée’
- Tomato – *Solanum lycopersicum* ‘Ailsa craig’

#### 2.1.2. Nematodes

##### *Root-knot nematodes*

- *Meloidogyne exigua*
- *Meloidogyne hapla*
- *Meloidogyne incognita* (populations: VW6, Africa and Brazil)
- *Meloidogyne javanica*
- *Meloidogyne paranaensis*

##### *Root-lesion nematodes*

- *Pratylenchus brachyurus*
- *Pratylenchus coffeae* (populations: Ghana, Guatemala, Japan and Uganda)
- *Pratylenchus loosi*
- *Pratylenchus thornei*
- *Pratylenchus zaeae*

##### *Burrowing nematode*

- *Radopholus similis*

### 2.1.3. Plant maintenance and nematode infection

#### 2.1.3.1. Growth of plants in soil

Banana (*Musa acuminata*), coffee (*Coffea arabica*), tomato (*Solanum lycopersicum* var. Ailsa craig) and maize (*Zea mays*) plants were grown in 50:50 sand/loam mix in a glasshouse at 23 – 25 °C with supplementary lighting to provide 16:8 hr light:dark conditions. Carrot (*Daucus carota*) and potato (*Solanum tuberosum* var. Désirée) were grown similarly at 19 – 22 °C. All plants were watered as necessary.

*Arabidopsis thaliana* seeds (*Col-0*, *rsw1-1* (NASC ID: N6554), *glz1* (NASC ID: N16279) and *mur3* (NASC ID: N8566) were surface sterilised by soaking in 20% v/v household bleach for 20 min at room temperature on a rotational mixer. All work following bleach treatment was carried out in a laminar flow hood to prevent re-contamination. The seeds were then washed 5-7 times in sterile H<sub>2</sub>O by centrifugation at 3000 g for 30 s to remove all traces of bleach. Sterile seeds were then incubated for growth at 22 °C on ½ strength sterile Murashige and Skoog medium containing 1 % sucrose and 1 % plant agar. When required, maize and potato plants were also grown in CYG growth pouches (Mega International, USA) at 22 °C.

#### 2.1.3.2. Preparation of plant root exudate

For exudate collection, roots were washed, separated intact from above ground tissue and soaked in water (80 g/L) in darkness for 24 h at 4 °C. Root exudates were then filter sterilised (0.22 µm) and stored at 4 °C. The above method was used to prepare root exudate from all plants.

#### 2.1.3.3. Maintenance of nematode populations

Stocks of *Meloidogyne hapla*, *M. incognita*, *M. javanica* and *M. paranaensis* species were maintained on tomato plants. Four week-old tomato plants were potted into 18 cm pots containing compost and an even spread of chopped roots from previously infected tomato plants. The roots contained mature *M. incognita* females carrying egg masses. The newly-infected plants were then grown for a period of eight weeks before being used to infect new tomato plants. During this time roots were checked for galls to ensure infection had taken place.

Stocks of *Pratylenchus brachyurus*, *P. coffeae*, *P. loosi*, *P. thornei*, *P. zae* and *Radopholus similis* were maintained on carrot discs. Fresh carrots were washed, peeled and sterilised with a 10 % bleach solution for 30 min. Carrots were washed five times with sterile water and then cut into disks approximately 1 cm deep. Three disks were placed, root end down, onto a 1 % water agarose (Sigma, US) plate. Nematodes were

collected from previously infected carrot disks and sterilised with 0.1 % kanamycin (30 min), 0.1 % streptomycin (30 min), 50 µg/ml amphotericin B (30 min) and 0.1 % Cetrimonium bromide (5 min). These nematodes were washed five times with sterile tap water and then 30 individuals were placed at the base of each carrot disc. Plates were sealed with Parafilm, wrapped in foil and incubated at 26 °C. Nematodes were placed onto fresh plates every eight weeks.

#### 2.1.3.4. Extraction of nematodes

Mobile nematodes of *Meloidogyne* and *Pratylenchus* were extracted from roots eight weeks post-infection. Plant roots were removed from the bottom of the stem, washed to remove excess soil and chopped into small pieces. Roots were laid on sections of nylon mesh held over funnels and placed in a misting chamber. A warm mist of tap water encouraged egg hatching and the movement of second stage juveniles out of the root, through the mesh and into 50 ml collection tubes. The collection tubes were changed every day for three days and the roots were then removed and autoclaved as waste. Collected nematodes were stored at 10 °C in tap water and washed before use if required.

Nematodes were extracted from 100 g of the soil sample using the tray method (Whitehead and Hemming, 1965a). Soil was spread across a single layer of paper tissue that was supported in a wire basket. This was placed inside a plastic tray and water was added until the soil was damp but not waterlogged. Water containing nematodes was collected from the tray after 24 hours. Nematodes were recovered using a 25 µm sieve and concentrated by centrifugation at 3000 g for 3 min, or by leaving to settle overnight.

#### 2.1.3.5. Infection of plants

Four 1 ml pipette tips were inserted into the soil around the stems of banana, carrot, coffee, maize and potato plants to a depth of approximately 3 cm. A total of 1000 J2 *Meloidogyne* or 500 *Pratylenchus/Radopholus* of mixed life stages were applied to the roots through the pipette tips and washed through with 1 ml water. Plants were kept in the same conditions as stated previously and successful infection was confirmed by acid fuchsin staining.

#### 2.1.3.6. Staining of nematodes in root with acid fuchsin

Acid fuchsin was used to visualise nematodes in root tissue. Roots were removed from soil and soaked in sodium hypochlorite with 1 % available chlorine for three minutes. The roots were then washed in tap water and transferred to boiling acid fuchsin (0.035 % (w/v) acid fuchsin, 2.5 % (v/v) glacial acetic acid) for three minutes. After further washes



in tap water, the roots were placed in acidified glycerol (1 drop glacial acetic acid per 100 ml glycerol) to de-stain. Nematodes could then be visualised under a microscope.

## 2.1.4. Molecular protocols

### 2.1.4.1. DNA extraction from nematodes

Nematodes were suspended in 100 µl of lysis buffer (100 mM NaCl, 10 mM Tris pH8, 10 mM EDTA, 1 % SDS, 1 % β-mercaptoethanol, 100 µgml<sup>-1</sup> proteinase K (Adam et al., 2007)) for DNA extraction. Nematodes were then incubated at -20 °C for at least 30 min, 60 °C for one hour and 90 °C for 10 min to lyse cells and release DNA.

### 2.1.4.2. PCR

Template DNA was extracted as above from a range of reference nematode populations throughout the project: *Pratylenchus coffeae*, *P. brachyurus*, *P. zaeae*, *P. vulnus*, *P. loosi*, *P. thornei*, *Meloidogyne exigua*, *M. paranaensis*, *M. incognita*, *M. hapla*, *M. javanica* and *Radopholus similis*. PCR was carried out with MyTaq™ polymerase (Bioline, UK) with 0.5 µl DNA in a 20 µl reaction according to the manufacturer's requirements under the following conditions: 94 °C 60 s, x40 cycles of 94 °C 10 s, X °C\* 30 s, 72 °C 30 s and 72 °C 5 min (X °C\* specific annealing temperature for each primer pair is given in appropriate chapters).

Approximately 10 % of the reaction was visualised by agarose gel electrophoresis. The gel was formed from 1 % w/v agarose (Sigma) added to TAE buffer (40 mM Tris, 20 mM acetic acid, 1 mM EDTA) and dissolved by microwaving on full power for 2 minutes. DNA was visualised by addition of GelRed (Cambridge Bioscience, Cambridge, UK) to the agarose, before it set, at a concentration of 1:20,000. The gel was electrophoresed at 100 volts for sufficient time to resolve the relevant bands.

### 2.1.4.3. Total RNA extraction from nematodes

Total RNA was prepared from nematode samples using an RNeasy® Plant Mini Kit according to the manufacturer's protocol including DNase treatment (Qiagen, UK). Samples were frozen and 100 µl RLT extraction buffer was added. Samples were then ground using a sterile, RNase-treated pestle in 1.5 ml micro-centrifuge tubes. Total ground-nematode suspension was then used for RNA extraction. RLT extraction buffer (300 µl) with 10 µl/ml β-mercaptoethanol was added to the ground suspension and then centrifuged through a QIAshredder spin column. Ethanol was added to the supernatant and then this solution was applied to an RNeasy Spin Column. DNase I digestion was performed to remove DNA before elution. The column was washed in buffers RW1 and RPE to remove contaminants and RNA was then eluted in 30 µl RNase-free water. RNA was stored at -80 °C.

#### 2.1.4.4. Reverse transcription

A Nanodrop ND-1000 spectrophotometer (Nanodrop Technologies) was used to estimate the concentration of RNA from a 1.5 µl sample at a wavelength of 260 nm and purity at 230 and 280 nm. RNA (750 ng) was then used in a reverse transcription reaction to create cDNA using iScript™ cDNA Synthesis Kit (Biorad, UK) according to the manufacturer's instructions. iScript reaction mix (4 µl), containing oligo(dT) primers and dNTPs, and iScript Reverse Transcriptase was added to the RNA in a volume of 20 µl. The RNA was incubated at 25 °C for 5 min (priming), 42 °C for 20 min (reverse transcription) and 95 °C for 1 min (Reverse transcriptase inactivation). This protocol produces single stranded cDNA that is complementary to the mRNA within the sample.

#### 2.1.4.5. Quantitative -PCR

Analysis of gene expression by qPCR was carried out using a CFX Connect Real-Time PCR detection System (Biorad, UK) and Brilliant III Ultra-Fast SYBR® Green Master Mix containing buffer, MgCl<sub>2</sub>, dNTPs, polymerase and SYBR Green I. Each well of a 96-well polypropylene plate contained 12.5 µl Brilliant III Ultra-Fast SYBR® Green Master Mix, 1 µl combined primer set (7.5 µM each), 5 µl cDNA and 6.5 µl deionised water. Plates were sealed with optical quality sealing film and centrifuged briefly before starting the reaction. A two-step amplification profile was used for all reactions: initial denaturation of 95 °C for 10 min followed by 40 cycles of 95 °C for 30 sec and 60 °C for 10 sec. At each 60 °C stage fluorescence was recorded. Dissociation curves were constructed for each reaction by measuring fluorescence of each well throughout a temperature increase of 60 °C to 95 °C. Each sample was run in technical triplicate and negative controls, containing no cDNA, were included to test for contamination.

All primer sets were tested for their amplification efficiency prior to running experimental samples. This was conducted by generating a standard curve with five 10-fold dilution standards of cDNA. The number of peaks on the primer dissociation curve was used to determine the number of PCR products and therefore the primer specificity. Expression levels of target genes were calculated by normalising samples to the housekeeping gene *Elongation Factor 1* and calibrating against control samples.

CFX Manager™ Software (Biorad, UK) was used to determine the cycle number at which threshold fluorescence is reached ( $C_t$  number). An increase in  $C_t$  value of 1 indicates two times as much transcript abundance. These values were then used to calculate fold change by the  $2^{-\Delta\Delta C_t}$  method:  $2^{-(\text{Experimental sample: Target gene } C_t - \text{Elongation Factor 1 } C_t) - (\text{Control sample: Target gene } C_t - \text{Elongation Factor 1 } C_t)}$ . One-way ANOVA

with a Student-Newman-Keuls post hoc test was used to determine significant differences between groups unless otherwise stated.

## Chapter 3. A high throughput molecular pipeline reveals the diversity in prevalence and abundance of *Pratylenchus* and *Meloidogyne* species in coffee plantations

---

### 3.1. Introduction

#### 3.1.1. Identification of *Meloidogyne* and *Pratylenchus* parasites of coffee through morphological and biochemical methods

Reliable and accurate identification of nematodes in the field supports targeted application of control measures towards areas with nematodes of concern. The nematode species and/or genera that parasitise coffee can be identified by analysing morphological features such as body length, stylet length, the number of lip annules and tail shape (Onkendi et al., 2014, Carneiro et al., 2004, Handoo et al., 2005). This method requires a high level of expertise and identifying a large number of individuals is time-consuming.

Isozyme phenotyping is an alternative identification method that detects differences in the biochemical properties of enzymes, such as non-specific esterases and malate dehydrogenase. Comparing the results to a range of known profiles can identify several *Pratylenchus* and *Meloidogyne* species (Esbenshade and Triantaphyllou, 1990, Sirias, 2011, Yu, 2012). The method is restricted to adult female nematodes as expression of the given gene product may alter during the life cycle (Onkendi et al., 2014).

Identifying and differentiating distinct inter-specific boundaries is becoming increasingly difficult as new species are reported (Onkendi et al., 2014). In addition, some nematode species display intra-specific variation in both morphology and isozyme phenotypes, which can undermine the results (Esbenshade and Triantaphyllou, 1990, Yu, 2012, Hunt and Handoo, 2009). Although sometimes unreliable, the results from morphological and biochemical techniques have provided a basis for future methods and can complement an integrated approach (Yu, 2012). Integrating approaches can enhance differentiation of nematode populations and provide further evidence for the classification. For example, *Meloidogyne paranaensis* was identified as *M. incognita* for many years in Central and Southern America by using morphological identification, however enzyme phenotyping then revealed that these samples were distinct and *M. paranaensis* was classified as a new species (Carneiro et al., 1996, Carneiro et al., 2004).

### 3.1.2. Nematode identification through molecular methods

A simple, quick and reliable identification method would allow targeted nematode management and conceivably reduce costs associated with coffee production. The development of molecular techniques has resulted in the identification of nematodes by the polymerase chain reaction (PCR). Identification by PCR-based methods has been shown to be consistent with results from morphological and biochemical techniques, sometimes offering further discrimination, and can be beneficial as they can be carried out on a single nematode from any life stage (Yu, 2012, Carneiro et al., 2004). All PCR based methods centre around amplifying genomic markers that are unique to a species.

#### 3.1.2.1. Ribosomal DNA as a genetic marker

Ribosomal DNA contains numerous regions that are repeated several hundred times throughout the genome and are conserved in different individuals of the same species/genus. The 18S and 28S rDNA sequences have been used to create phylogeny models for nematodes, including *Meloidogyne* and *Pratylenchus*, that provide greater discrimination than models based on previous identification methods (De Ley et al., 2002, Al-Banna et al., 1997, Blok, 2009, Floyd et al., 2002).

In addition to phylogeny, these regions can also be utilised to identify nematode populations from the field by analysing sequence length, by gel electrophoresis, or sequence structure (Blok et al., 1997, Blok, 2009, De Luca et al., 2011, Yan et al., 2008).

More rapid species differentiation can be obtained by designing species-specific primers based on these sequences which amplify unique products for the species. These have been used to identify both *Pratylenchus* and *Meloidogyne* species and can be used in mixed-genera samples (Uehara et al., 1998, Saeki et al., 2003, Machado et al., 2007). However, as with previous methods there can still be inconsistency due to variation within marker regions (Duncan et al., 1999, Al-Banna et al., 1997, Nguyen, 2010). Homology within a genus can also be an issue, such as the high level of sequence similarity between the 18S rDNA regions of *M. incognita*, *M. javanica* and *M. arenaria* (Kiewnick et al., 2014).

Obtaining markers that can quickly and reliably differentiate between species and populations can be of great use in field analysis.

#### 3.1.2.2. Sequence Characterised Amplified Region (SCAR) primers for species identification

Random Amplified Polymorphic DNA PCR (RAPD-PCR) has often been used to find novel variable sequences between nematode species. This uses several short primers

to produce multiple PCR products from genomic DNA. The products are visualised by gel electrophoresis and a species-specific product is identified, cloned and sequenced. This sequence is then used as a template for SCAR primers that are specific to the species. This method has been applied to develop primers that identify coffee parasitising nematodes (Tigano et al., 2010, Randig et al., 2002a, Correa et al., 2013, Akyazi and Felek, 2013, Zijlstra, 2000, Meng et al., 2004). The key benefit of these primer sets is that the PCR product does not need to be sequenced, it provides binary positive/negative results for species identification. Combining genus- and species-specific primers in a diagnostic key reduces the time and cost of sample diagnosis for *Meloidogyne* nematodes (Adam et al., 2007). No such diagnostic method has been described for *Pratylenchus* species and the creation of a method that identifies both genera would be greatly beneficial.

#### 3.1.2.3. Application to the field

Very little assessment of these molecular methods for diagnosis of *Pratylenchus* or *Meloidogyne* in coffee fields has been reported (Carneiro et al., 2005, Carneiro et al., 2004, Sirias and Cristina, 2011). A rapid, reliable and sensitive method for assessing the plant-parasitic nematode community would enable greater understanding of the soil fauna and highlight the major species of concern, not just for coffee but for other crops grown on the farms. Intercropping systems are common throughout coffee production and have many benefits to the grower (Jassogne et al., 2013). Two commonly grown intercrop plants are banana and black pepper but both are susceptible to nematode species that damage coffee (Gowen et al., 2005, Thuy et al., 2012). The impact of these hosts on nematode diversity in coffee fields is previously unexplored and increases the complexity of coffee nematode management. Accurate diagnosis of nematode prevalence and distribution in the soil of a plantation is important for pest management and will underpin future control efforts.

### 3.2. Aims

1. To confirm species-specificity of new and published primer sets towards species of *Meloidogyne* and *Pratylenchus*. Consequently, combine the primer sets with a procedure for soil sampling and DNA preparation to form a diagnostic method that offers a rapid and reliable output.
2. Apply the diagnostic method to a range of soil samples from coffee plantations in Brazil, Vietnam and Indonesia.
3. Establish a method for quantifying nematodes and apply to field samples.
4. To investigate the associations between the incidence and abundance of *Meloidogyne* and *Pratylenchus* species in coffee plantations.



### 3.3. Methods

#### 3.3.1. Testing the species-specificity of PCR primers

##### 3.3.1.1. Standard PCR

Primer sets for identification of several *Pratylenchus* and *Meloidogyne* species were obtained from published sources (Table 3-1) and tested for specificity through PCR screening with target and non-target DNA. Primer sets were chosen from the literature that successfully amplify from different nematode populations of the same species. Template DNA was extracted as above (section 2.1.4.1) from a range of reference nematode populations: *Pratylenchus coffeae* (populations from Ghana), *P. brachyurus* (USA), *P. zaeae*, *P. vulnus* (USA), *P. loosi* (Japan), *P. thornei* (USA), *Meloidogyne exigua* (Brazil), *M. paranaensis* (Brazil), *M. incognita* (Brazil), *M. hapla* (USA), *M. javanica* (Turkey) and *Radopholus similis* (Uganda). This DNA was used in PCR as described above (section 2.1.4.2) with primer pair and annealing temperature specified in (Table 3-1). The results prompted the design of new species-specific primers for *P. coffeae*, PC28sF/PC28sR Table 3-1, based upon 28S rDNA sequence data obtained from GenBank (Accession Number KY424281). This primer set was tested as stated previously.

##### 3.3.1.2. Quantitative PCR

Quantitative PCR primer pairs RKNf/r and Mh-f/r were confirmed to be specific for *M. incognita* and *M. hapla* respectively by testing with target and non-target DNA in qPCR (Toyota et al., 2008, Watanabe et al., 2013). Primer pairs were designed to be specific for *P. brachyurus* (PbqF/R), *P. coffeae* (Pce1qF/R), *M. exigua* (MeqF/R) and *M. paranaensis* (MpqF/R) based upon sequences present in GenBank (Accession Numbers KF537388.1, EU176871, AF435796, AF435798) (Primer information in Table 3-2). DNA was extracted from triplicate batches of 200, 100, 50, 20 and 5 individuals from each nematode species, as described above. These were used as standards in qPCR using SsoAdvanced™ Universal SYBR® Green Supermix (BioRad) to construct calibration curves of nematode number vs  $C_t$  values.

#### 3.3.2. Field sampling

The overall workflow of methods is outlined in Figure 3-1.

Soil samples were taken from six coffee fields in Minas Gerais, Brazil (06/2016), 14 coffee fields in Dak Lak, Vietnam (03/2017) and eight coffee fields in Lampung, Sumatra, Indonesia (03/2017) (Figure 3-2, Figure 3-3). In Brazil, 71 samples were obtained from soil surrounding the roots of coffee plants in monoculture plantations. In Vietnam,

samples (numbers in parentheses) were obtained from soil around the upper roots of coffee (82), plus those of two intercrops: black pepper (40) and banana (10). Similarly, in Indonesia, soil samples were taken from around coffee (42), black pepper (7) and banana (23). Each individual sample consisted of three 30 (deep) x 2.5 (diameter) cm soil cores that were taken from halfway between the stem and edge of the canopy of a single plant and pooled into one bag (Manzanilla-Lopez, 2012). The sampling depth should obtain a large proportion of *Meloidogyne* and *Pratylenchus* nematodes in the rhizosphere (Manzanilla-Lopez, 2012). The main aim was to detect nematode presence and therefore plants that showed signs of damage from some cause were selected where available (Manzanilla-Lopez, 2012). The Whitehead and Hemming (1965) tray extraction method was then applied and yielded vermiform nematodes from soil samples in 24 hours (Whitehead and Hemming, 1965b).

### **3.3.3. Application of diagnostic PCR primer sets to field sample nematode DNA**

#### **3.3.3.1. PCR**

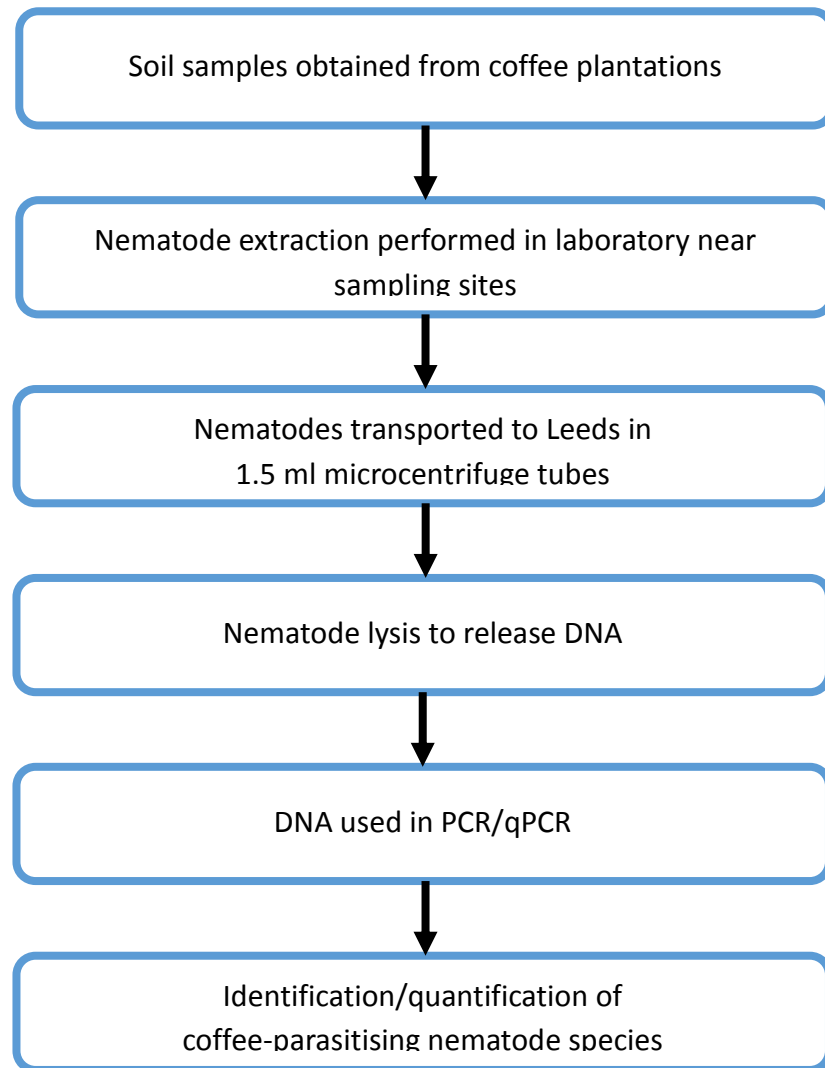
Generic nematode-specific primers (SSU18A/SSU26R, (Blaxter et al., 1998)) (Table 3-1) were utilised in PCR with a template DNA volume of 0.5 µl, as above, to determine the success of nematode DNA extraction from soil samples. Genus-specific primer sets were then used to identify the presence of *Pratylenchus* or *Meloidogyne* spp within a sample (Blok et al., 1997, Waeyenberge et al., 2000). Species-specific primer sets then detected the presence of *P. brachyurus* (Machado et al., 2007), *P. coffeae* (this work), *P. zae* (Berry et al., 2008), *P. loosi* (Uehara et al., 1998), *P. vulnus* (Al-Banna et al., 2004), *P. thornei* (Al-Banna et al., 2004), *M. javanica* (Zijlstra et al., 2000), *M. incognita* (Meng et al., 2004), *M. hapla* (Wishart et al., 2002), *M. paranaensis* (Randig et al., 2002a) or *M. exigua* (Randig et al., 2002a).

#### **3.3.3.2. Quantitative PCR**

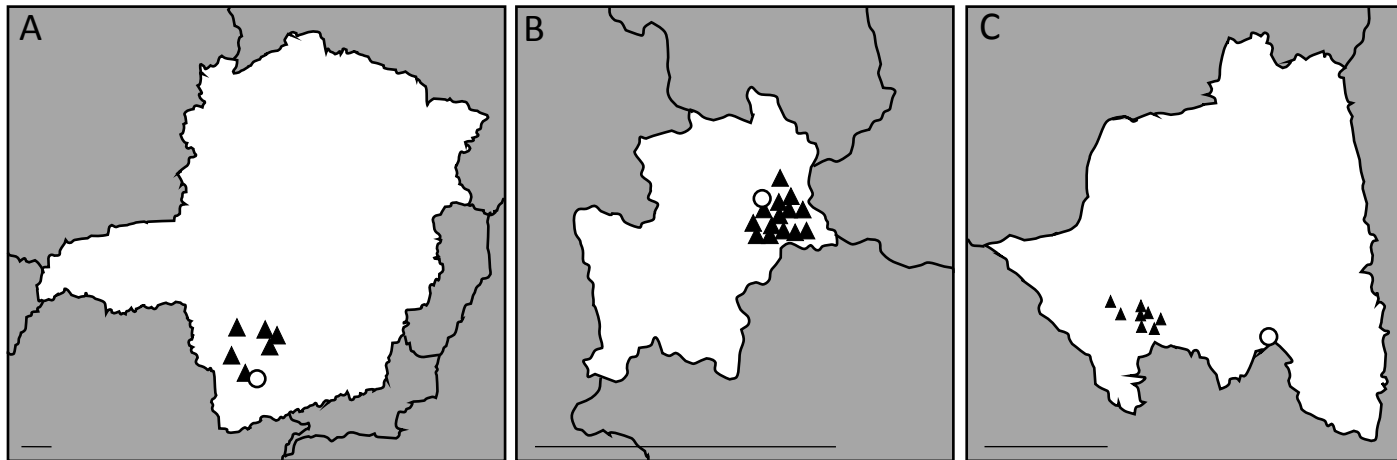
qPCR with species-specific primer sets was then applied to each field sample DNA with three technical replicates to obtain sample  $C_t$  values. These  $C_t$  values were aligned to the corresponding species calibration curve to obtain an estimate of nematode number per sample.

#### **3.3.4. Data analysis**

Data were analysed using t-test and Oneway-ANOVA for comparison of two and three means respectively in SPSS (SPSS v24; IBM Corporation Armonk, New York, USA). Correlations were determined using correspondence analysis in SPSS.



**Figure 3-1: Workflow to obtain the identification and quantification of coffee-parasitising nematodes present within soil samples from coffee plantations.**



**Figure 3-2: Field locations (▲) in (A) Minas Gerais, south-eastern Brazil, (B) Buon Ma Thuot, central-highlands Vietnam and (C) Lampung, southern Sumatra island, Indonesia.** Regions are in white and circles represent Lavras, Buon Ma Thuot and Bandar Lampung cities in the respective regions. Scale bar 100 km.

A



B



C



**Figure 3-3: Representative images of sampling locations in Brazil (A), Vietnam (B) and Indonesia (C).**

**Table 3-1: Primer sequences used for the identification of *Pratylenchus* and *Meloidogyne* species, alongside the annealing temperatures, product sizes and sources.**

Target	Primer set	Ta	Product size	Forward / reverse sequence (5' -> 3')	Reference
Nematode sp.	SSU18A SSU26R	52	1000	AAAGATTAAGCCATGCATG CATTCTTGGCAAATGCTTTTCG	Blaxter et al. (1998)
<i>Pratylenchus</i> sp.	P18sF P18sR	62	800-1500	TTGATTACGTCCTGCCCTTT GGAATCATTGCCGCTCACTTT	Waeyenberge et al. (2000)
<i>P. brachyurus</i>	18sF ACM7R	57	267	TTGATTACGTCCTGCCCTTT GCWCCATCCAACAAYGAG	Machado et al. 2007
<i>P. coffeae</i>	PC28sF PC28sR	62	530	CCGTGAGGGAAAGTTGAAAA GCTCCTAACGGAAACGTTCA	This study
<i>P. zaeae</i>	18sF Praty-R	57	250	TTGATTACGTCCTGCCCTTT CTGCATTGGAAGCGCGCTTG	Berry et al. 2008
<i>P. loosi</i>	PL1 PL2	65	668	CAGTCAGCTAGCTGCTGGAT TGAGAGCATAGTCGCTGTG	Uehara et al. 1998
<i>P. vulnus</i>	D3B PVULF	67	287	TCGGAAGGAACCAGCTACTA GAAAGTGAACGCATCCGCAA	Al-Banna et al. 2004
<i>P. thornei</i>	D3B PTHO	67	288	TCGGAAGGAACCAGCTACTA GAAAGTGAAGGTATCCCTCG	Al-Banna et al. 2004
<i>Meloidogyne</i> sp.	194 195	50	700/720	TTAACTTGCCAGATCGGACG TCTAATGAGCCGTACGC	Blok et al. (1997)
<i>M. javanica</i>	Fjav Rjav	64	720	CAGGCCCTTCAGTGGAACTATAC CTCTGCCCAATGAGCTGTCC	Zijlstra et al. (2000)
<i>M. incognita</i>	MI-F MI-R	62	999	GTGAGGATTCAGCTCCCCAG ACGAGGAACATACTTCTCCGTCC	Meng et al. (2004)
<i>M. hapla</i>	JMV1 JMVHapla	50	440	GGATGGCGTGCTTTCAAC AAAAATCCCTCGAAAAATCCACC	Wishart et al. (2002)
<i>M. paranaensis</i>	par-C09F par-C09R	63	208	GCCCCACTCCATTTGACGGA CCGTCCAGATCCATCGAAGTC	Randig et al. (2002)
<i>M. exigua</i>	Ex-D15-F ex-D15-R	63	562	CATCCGTGCTGTAGCTGCGAG CTCCGTGGGAAGAAAGACTG	Randig et al. (2002)

**Table 3-2: Primer sequences used for the quantification of *Pratylenchus* and *Meloidogyne* species, alongside the annealing temperatures and product sizes.**

Target	Primer set	Ta	Product size	Forward / reverse sequence (5' -> 3')	Reference
<i>P. brachyurus</i>	PbqF PbqR	60	106	CTGTGTGATAGATTATGGGCGAC ACATCGTCTTTGATCAACATCAAC	This study
<i>P. coffeae</i>	Pce1qF Pce1qR	61	73	TGCCAAAACCACAAAAGCC GTTCGGATTGGAGCCATATTGC	This study
<i>M. incognita</i>	RKNf RKNr	61	185	GCTGGTGTCTAAGTGTGCTGATAC GAGCCTAGTGATCCACCGATAAG	Toyota et al. (2008)
<i>M. hapla</i>	Mh-f Mh-r	61	87	ATGTTGGTACGCAGCGATTTGTA CAGCGGGTGATCTCGACTGA	Watanabe et al (2013)
<i>M. paranaensis</i>	MpqF MpqR	61	85	AGACCGTGAGGGAAAGTTGC CCGACTCTATCCGTTCCACC	This study
<i>M. exigua</i>	MexqF MexqR	62	129	GTGGGGATTTCTGAGACAGAT CAATCTATCTGACGCACGTAGG	This study

### 3.4. Results

#### 3.4.1. Testing the specificity of species-specific primers

Nematode 18S ribosomal DNA is highly conserved across the phylum. Therefore, primer sets for this region were selected as an indicator of successful nematode recovery from soil. If the samples amplified with this primer set, but not for the species of concern for coffee, the data would suggest an absence of *Pratylenchus* and *Meloidogyne* in the sample and not failure of the extraction method. PCR was carried out with primer set SSU18A/SSU26R to amplify nematode 18S ribosomal DNA from reference populations of *P. coffeae*, *P. brachyurus*, *P. zaeae*, *P. vulnus*, *P. loosi*, *P. thornei*, *M. exigua*, *M. paranaensis*, *M. incognita*, *M. hapla*, *M. javanica* and *Radopholus similis* (Figure 3-4). This confirmed the efficacy of the primers on selected nematodes.

Primer sets specific to both *Pratylenchus* and *Meloidogyne* were then obtained (Table 3-1) and tested for specificity. All primer sets, apart from *P. coffeae*, were confirmed to be specific for the species (Figure 3-5, Figure 3-6). New primers for *P. coffeae* (PC28sF / PC28sR, Table 3-1) were designed based on 28S rDNA sequence and were shown to amplify a 530 bp product from *P. coffeae* DNA with no amplification for any other species tested (Figure 3-7a). The broad utility of the primer set was verified following amplification of the species-specific product from DNA of six different *P. coffeae* populations from diverse geographic locations and multiple hosts (Figure 3-7b).

#### 3.4.2. Nematode detection in field samples

The Whitehead and Hemming (1965) tray extraction method yielded vermiform nematodes from soil samples in 24 hours. Following lysis steps these samples were then used immediately for identification. Presence of a species-specific PCR product established the detection of the plant-parasitic nematode species within the samples (Figure 3-8). The following results should not be interpreted as reflecting nationwide status of each nematode although, for simplicity, values are identified below by their country of origin. A total of two *Pratylenchus* species and four *Meloidogyne* species were detected in soil samples from Brazil, Vietnam and Indonesia (Table 3-3). *Pratylenchus brachyurus* and *P. coffeae* were detected in all three countries from soil surrounding coffee as well as the intercrops of black pepper and banana. *Pratylenchus* was detected in 6 fields in Brazil which were monocultures of coffee plants. *Meloidogyne exigua*, *M. paranaensis* and *M. incognita* were detected in samples from the coffee plantations in Brazil whereas *M. incognita* and *M. hapla* were identified in Vietnam from soil surrounding the roots of coffee and black pepper. Nematodes of both genera occurred



in 5 of the 6 Brazilian fields and 9 of the 14 Vietnamese fields. No *Meloidogyne* species were detected in samples from the Indonesian coffee fields.

Plant-parasitic nematodes from the genera *Meloidogyne* and *Pratylenchus* were detected in 75 % of the total samples obtained from coffee fields in Minas Gerais, Brazil (Table 3-4). *P. brachyurus* was present in more samples than *P. coffeae* (37 % and 7 % respectively). The frequency of detection for *M. exigua*, *M. paranaensis* and *M. incognita* was 35 %, 27 % and 17 % of samples respectively. *P. coffeae* was the more frequently detected species of that genus in Buon Ma Thuot, Vietnam and detected in 23 % and 35 % of samples taken from soil around coffee and black pepper, respectively. *M. incognita* was detected in 53 %, 53 % and 60 % of soil samples associated with coffee, black pepper and banana, respectively (Table 3-4). *P. brachyurus* and *P. coffeae* were present in 32 % and 34 % of samples from coffee in Indonesia and 26 % and 35 % of samples from banana. For black pepper, *P. coffeae* occurred in 29 % of soil samples but *P. brachyurus* was not detected. Another economic nematode, *Radopholus similis* was not detected in any sample from the three countries.

#### 3.4.3. Evaluation of primers for quantification

Primer sets for the quantification of *P. brachyurus*, *P. coffeae*, *M. exigua*, *M. paranaensis*, *M. hapla* and *M. incognita* (Table 3-2) were tested, and confirmed, for species-specificity (Figure 3-9, Figure 3-10). An increase in fluorescence was observed in wells with target DNA as a result of amplification. Lack of amplification with non-target DNA confirmed the species-specificity of the primers.

Calibration curves were generated from the  $C_t$  values of standards made from known numbers of nematodes (Figure 3-11). These displayed the expected negative correlation between  $C_t$  value and the number of nematodes ( $R^2 > 0.95$  for all primer sets). This provided the linear calibration from which the number of nematodes can be established from field samples.

#### 3.4.4. Quantification of plant-parasitic nematode species in field samples

*Pratylenchus* was detected in only 44 % of 71 samples obtained in Brazil but in the range of 54 - 482 individuals / 100 g soil per sample when present (Figure 3-12a). In fields in Vietnam the nematode was detected in only 25 % of the 82 samples from soil around coffee roots but when present ranged from 15 - 102 individuals / 100 g soil. In Indonesia, *Pratylenchus* was detected in 63 % of the 43 samples from soil around coffee roots in the range of 19 - 493 individuals/ 100 g soil. One or more *Meloidogyne* sp was present in 69 % of samples for the 5 Brazilian fields in which the genus was recorded at a range of 11 - 529 *Meloidogyne*/ 100 g soil (Figure 3-12b). Only *M. incognita* and *M. hapla* were

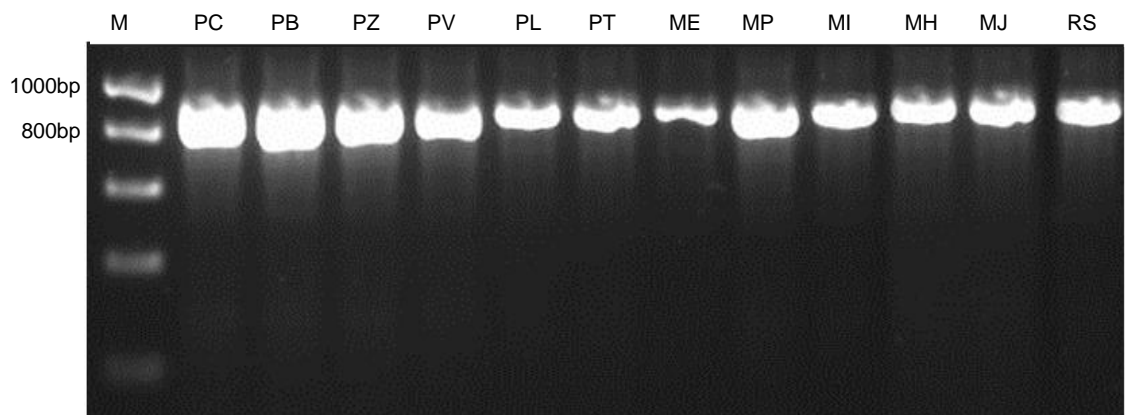
detected in Vietnam with a prevalence of 58 % of samples obtained from coffee in the range of 14 - 274 *Meloidogyne*/ 100 g soil.

The damage threshold is the number of nematodes per 100 g soil where the plant is negatively affected by the pest. This can be a measure of severity for field pathogens. In samples from the three countries, the mean population densities of detected species in soil around coffee plants were considerably greater than previously suggested damage thresholds for *P. brachyurus* (0), *P. coffeae* (0), *M. exigua* (25) and *M. incognita* (200) on coffee (Trinh et al., 2011, Oliveira et al., 1999, Rodrigues and Crozzoli, 1995, Vovlas and Di Vito, 1991) (Figure 3-13).

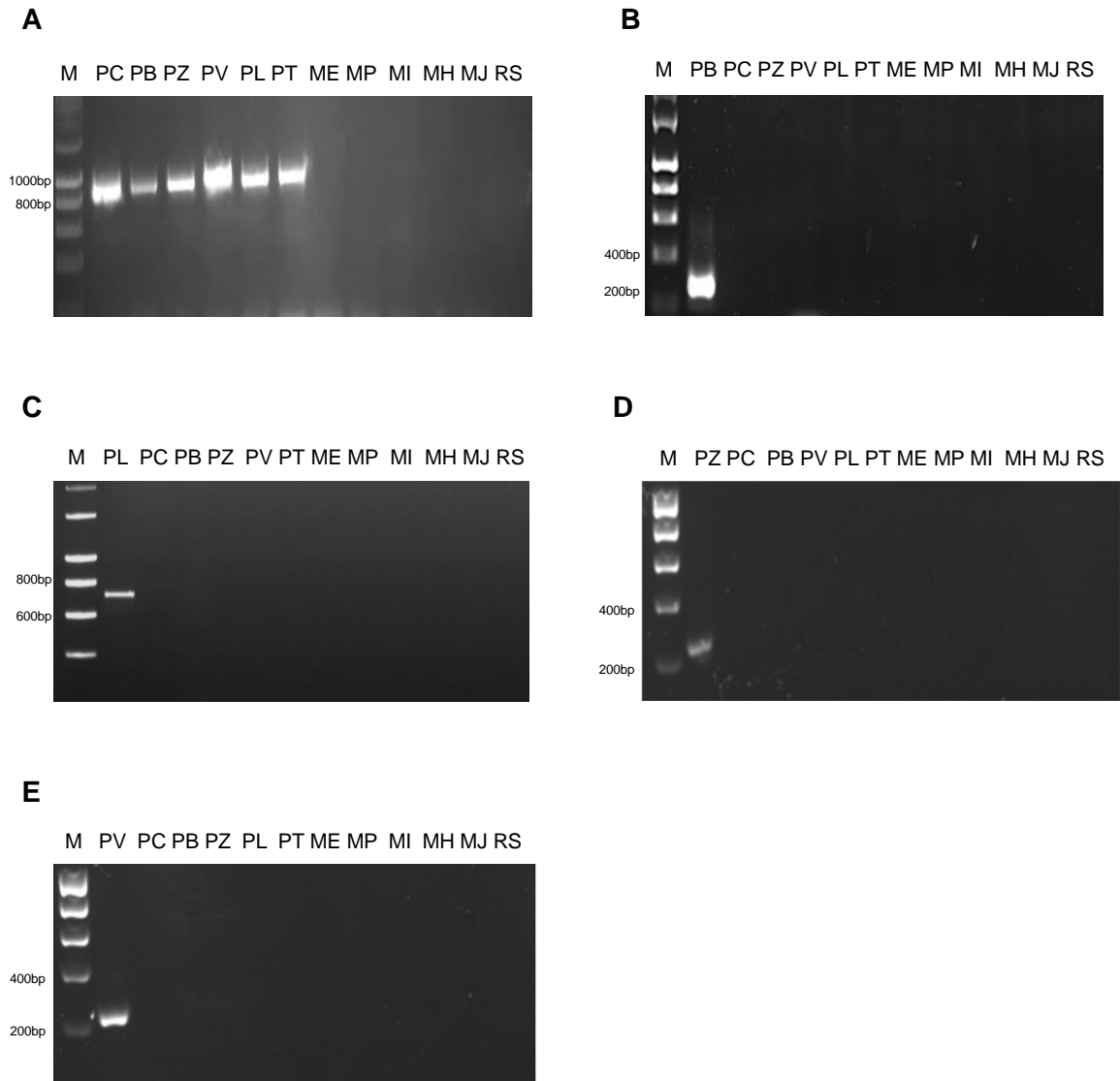
The densities of both *Pratylenchus* species were higher on coffee in Brazil than Vietnam or Indonesia (Figure 3-13) ( $P < 0.05$ , t-test). Both *Pratylenchus* species were similarly abundant in the sampled fields in Brazil and Vietnam, however *P. coffeae* was more numerous than *P. brachyurus* in Indonesian fields ( $P < 0.05$ , Oneway ANOVA). *Meloidogyne incognita* was more abundant than *M. hapla* in samples obtained from coffee ( $P < 0.01$ , t-test). Nematode populations were at higher densities in soil associated with black pepper and banana plants than coffee in both Vietnam and Indonesia (Figure 3-13) ( $P < 0.05$ , t-test and Oneway ANOVA for comparison of two and three means respectively).

#### 3.4.4.1. The relationship between *Pratylenchus* and *Meloidogyne* abundance in soil samples

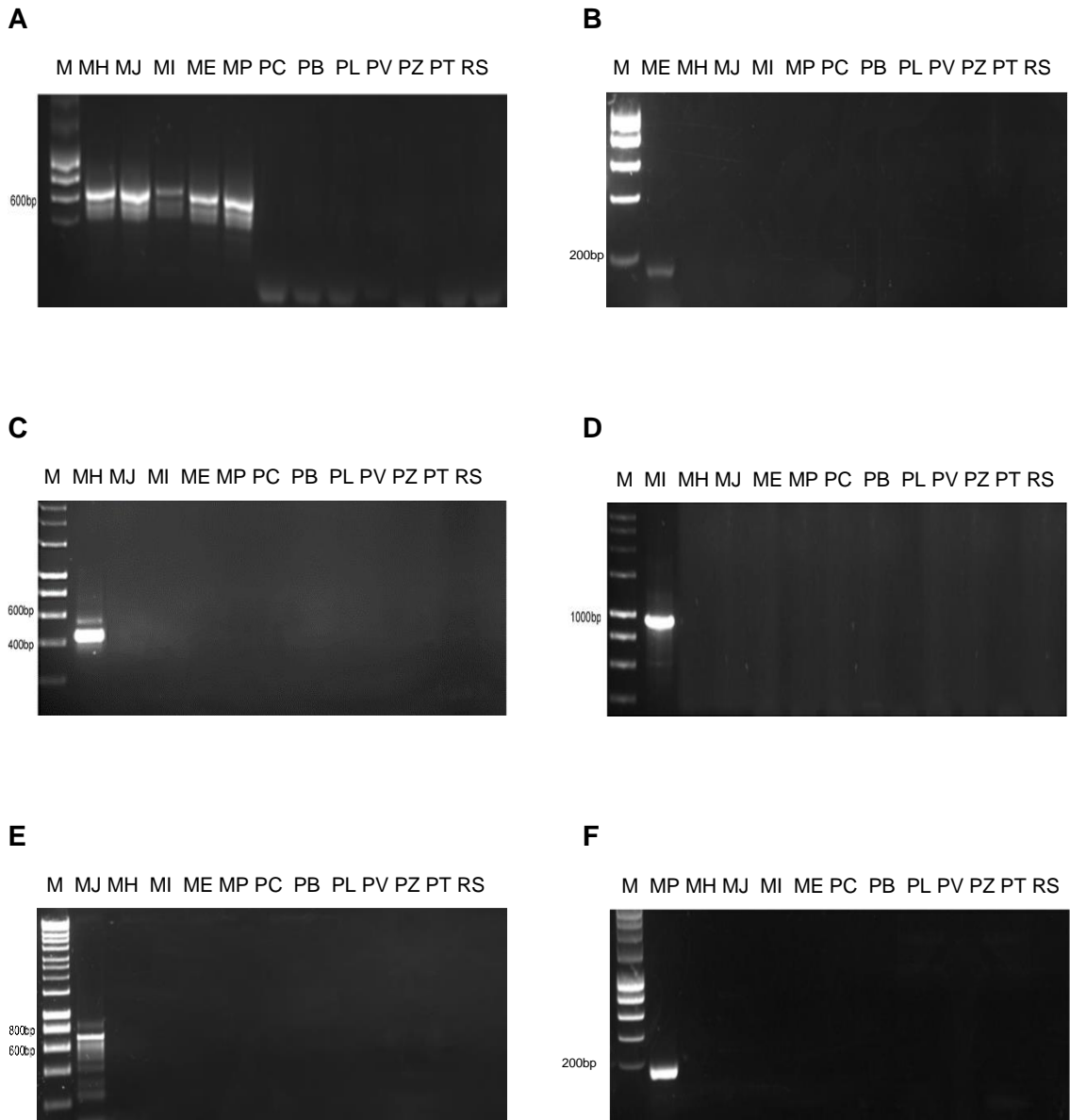
There was a significant negative correlation between numbers of *Pratylenchus* and *Meloidogyne* for 96 samples associated with coffee or black pepper for fields in which both genera were detected ( $R = -0.225$ ;  $P < 0.05$ , 2-tailed test). Correspondence analysis was then used to provide a graphical representation of the relationship (Figure 3-14). A significant summary  $\chi^2$  (23.5,  $P < 0.001$ ) was obtained and the resultant biplot represents 24 % of the variation in the data with most of that value (21%) represented by the horizontal axis of the graph. Therefore, the plot suggests that in fields where both genera were detected there is an association of high numbers of *Meloidogyne* where *Pratylenchus* was not detected. This is indicated by the proximity of the relevant data points in the horizontal axis ( $M_h$  and  $P_{nd}$  Figure 3-14).



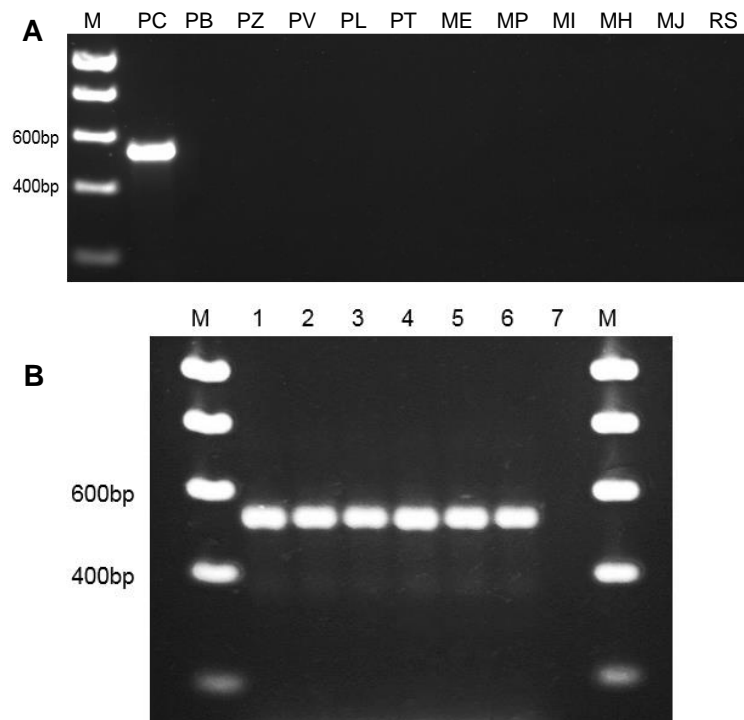
**Figure 3-4: Testing of primers that amplify nematode 18S sequence.** Primers SSU18A/SSU26R were used to amplify from DNA derived from different nematode species: *Pratylenchus coffeae* (PC), *P. brachyurus* (PB), *P. zae* (PZ), *P. vulnus* (PV), *P. loosi* (PL), *P. thornei* (PT), *Meloidogyne exigua* (ME), *M. paranaensis* (MP), *M. incognita* (MI), *M. hapla* (MH), *M. javanica* (MJ) and *Radopholus similis* (RS). M signifies HyperLadder1kb. PCR was carried out on 0.5  $\mu$ l of DNA from DNA of known nematode identity.



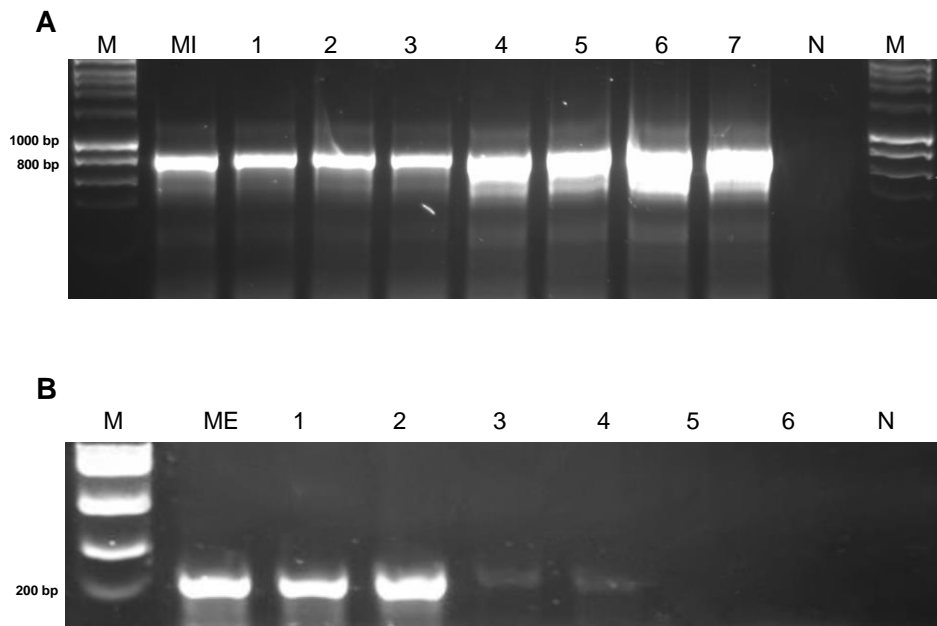
**Figure 3-5: Testing of primers specific to *Pratylenchus* spp.** Testing the specificity of primers to *Pratylenchus* (A, primers P18SF/P18SR), *P. brachyurus* (B, 18SF/ACM7R), *P. loosi* (C, PL1/PL2), *P. zaei* (D, 18SF/Praty-R) and *P. vulnus* (E, D3B/PVULF). In (A) template DNA was obtained from *Pratylenchus coffeae* (PC), *P. brachyurus* (PB), *P. zaei* (PZ), *P. vulnus* (PV), *P. loosi* (PL), *P. thornei* (PT), *Meloidogyne exigua* (ME), *M. paranaensis* (MP), *M. incognita* (MI), *M. hapla* (MH), *M. javanica* (MJ) and *Radopholus similis* (RS). The target species is always in lane 1 M signifies HyperLadder1kb. PCRs were carried out in triplicate with 0.5  $\mu$ l template DNA, however a single product is shown in the gel images.



**Figure 3-6: Testing of primers specific to *Meloidogyne* species.** Testing the specificity of primers to *Meloidogyne* (A, primers 194/195), *M. exigua* (B, Ex-D15F/Ex-D15R), *M. hapla* (C, JMV1/JMVHapla), *M. incognita* (D, MI-F/MI-R), *M. javanica* (E, Fjav/Rjav) and *M. paranaensis* (F, Par-C09F/Par-C09R). In (A) template DNA was obtained from *Meloidogyne hapla* (MH), *M. javanica* (MJ), *M. incognita* (MI), *M. exigua* (ME), *M. paranaensis* (MP), *Pratylenchus coffeae* (PC), *P. brachyurus* (PB), *P. zaei* (PZ), *P. vulnus* (PV), *P. loosi* (PL), *P. thornei* (PT) and *Radopholus similis* (RS). The target species is always in lane 1 M signifies HyperLadder1kb. PCRs were carried out in triplicate with 0.5  $\mu$ l template DNA, however a single product is shown in the gel images.



**Figure 3-7: Testing of primers specific to *Pratylenchus coffeae*.** (A) Specificity test of primers PC28sF/PC28sR on DNA derived from different nematode species: *Pratylenchus coffeae* (PC), *P. brachyurus* (PB), *P. zae* (PZ), *P. vulnus* (PV), *P. loosi* (PL), *P. thornei* (PT), *Meloidogyne exigua* (ME), *M. paranaensis* (MP), *M. incognita* (MI), *M. hapla* (MH), *M. javanica* (MJ) and *Radopholus similis* (RS). (B) PC28sF/PC28sR were tested on DNA from six populations of *P. coffeae* that were recovered from different hosts and locations: taro, Japan (lane 1), sweet potato, Japan (2), coffee, Guatemala (3), coffee, Guatemala (4), coffee, Uganda (5), unknown host, Ghana (6). Lane 7 is the no template control. M signifies HyperLadder1kb. PCRs were carried out in triplicate with 0.5  $\mu$ l template DNA however a single product is shown in the gel images.



**Figure 3-8: Identification of plant-parasitic nematodes in field samples.** This is a representative gel image of the PCR-based identification methodology that resulted in the data displayed in Table 3-3. (A) PCR to detect *Meloidogyne incognita* was carried out with primers MI-F/MI-R on DNA from *M. incognita* (MI, positive control), field samples originating from plantations in Brazil (1-7) and a no template control (N). This resulted in the detection of *M. incognita* in all of the tested field samples. (B) PCR to detect *Meloidogyne exigua* was carried out with primers Ex-D15F/Ex-D15R on DNA from *M. exigua* (ME, positive control) field samples originating from plantations in Brazil (lanes 1-6) and a no template control (N). This resulted in the detection of *M. exigua* in samples 1, 2, 3 and 4 and the absence of the species in sample 5 and 6. M signifies HyperLadder1kb. PCRs were carried out in triplicate with 0.5 µl template DNA however a single product is shown in the gel images.

**Table 3-3: The *Pratylenchus* and *Meloidogyne* species detected in coffee plantations.** Nematodes detected in soil surrounding coffee (C), black pepper (BP) and banana (B) crops in the 28 fields sampled, as determined by PCR identification. Percentage values indicate the proportion of field samples that yielded positive detection for *P. brachyurus* (PB), *P. coffeae* (PC), *M. exigua* (ME), *M. paranaensis* (MP), *M. incognita* (MI) and *M. hapla* (MH) respectively.

Area	Field	Crop <sup>b</sup>	Proportion (%) <sup>a</sup>												
			PB		PC			ME	MP	MI			MH		
			C	B	C	BP	B	C	C	C	BP	B	C	BP	
Minas Gerais, Brazil	1	C	67		33										
	2	C	42				58								
	3	C	25				63								
	4	C	57					57							
	5	C	21						79	76					
	6	C	14					71	15						
Buon Ma Thuot, Vietnam	7	C			40					50				10	
	8	C			40					70				10	
	9	C			60					50				20	
	10	C, BP			67	50				33	75			16	25
	11	C, BP			100	100				80	60			20	40
	12	C, BP			40	40				80	60				60
	13	C, BP			40	40				60	60				
	14	C, BP	40			20				40	60				20
	15	C, BP									40				20
	16	C, BP			20	20				40	20				
	17	C, B								100		67			
	18	C, BP								60	80				
	19	C, B								60		40			
	20	C								70					
Lampung, Indonesia	21	C, B	60	50											
	22	C, B	60	50	20		50								
	23	C, BP	40		100	50									
	24	C, B	40	75	40		25								
	25	C, B	40	50	20		25								
	26	C, B	20	25	40										
	27	C, B	20		80		75								
	28	C, BP, B	40	25	60	25	25								

<sup>a</sup> Percentage values indicate the proportion of field crop samples that yielded positive detection for the species. <sup>b</sup> Types of crops sampled.



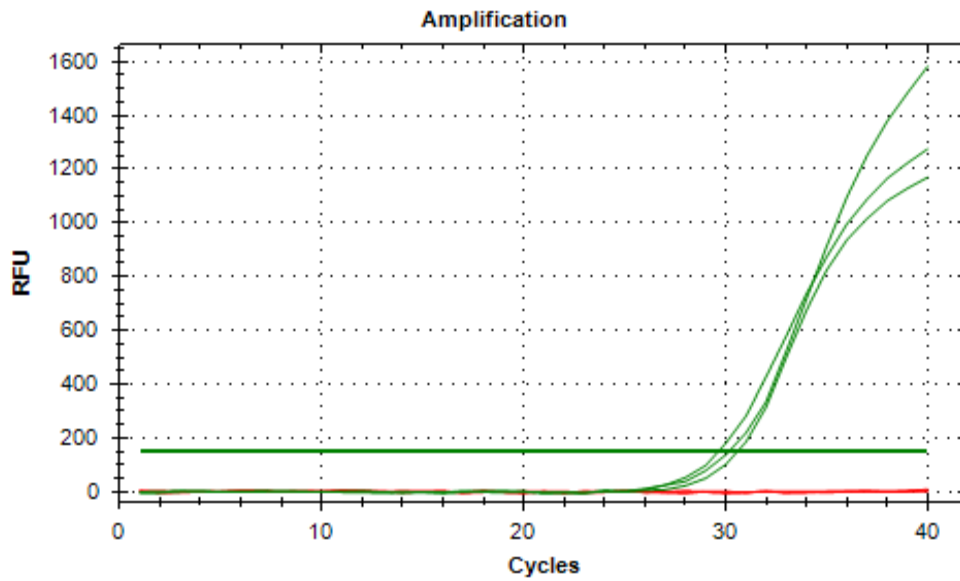
**Table 3-4: The *Pratylenchus* and *Meloidogyne* species detected in total samples.** Percentage of total samples obtained from soil around the roots of coffee, black pepper and banana in Minas Gerais (Brazil), Buon Ma Thuot (Vietnam) and Lampung (Indonesia) that contained each nematode species. PB, PC, ME, MP, MI and MH correspond to *P.brachyurus*, *P. coffeae*, *M. exigua*, *M. paranaensis*, *M. incognita* and *M. hapla* respectively.

Country	Crop sampled	Samples with nematode detected (%)							
		Total	PB	PC	ME	MP	MI	MH	Any*
Brazil	Coffee	71	37	7	35	27	17	0	75
Vietnam	Coffee	82	2	23	0	0	53	8	56
	Black pepper	40	0	35	0	0	53	18	61
	Banana	10	0	0	0	0	60	0	60
Indonesia	Coffee	43	32	34	0	0	0	0	63
	Black pepper	7	0	29	0	0	0	0	29
	Banana	23	26	35	0	0	0	0	65

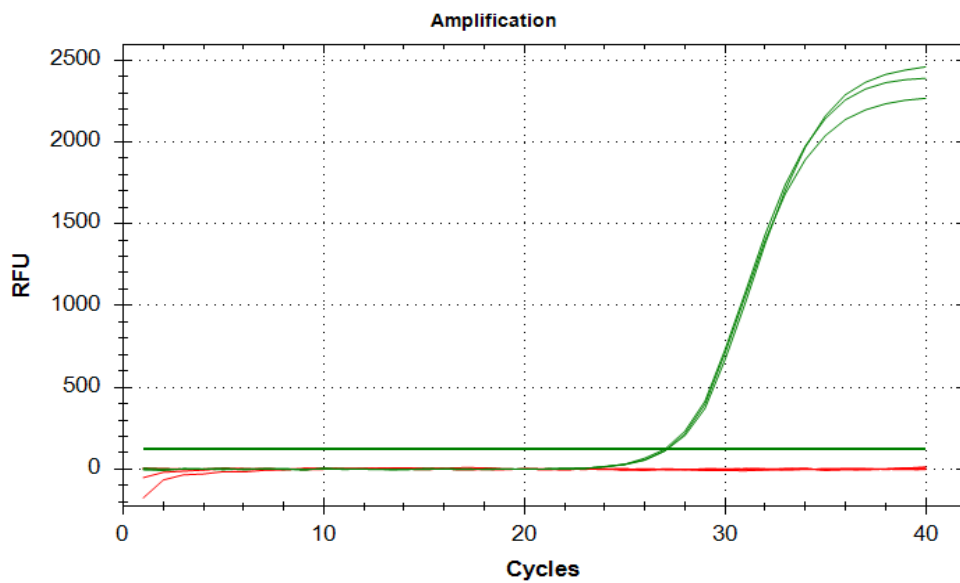
<sup>a</sup> Number of total crops sampled.

<sup>b</sup> Any of the six species detected.

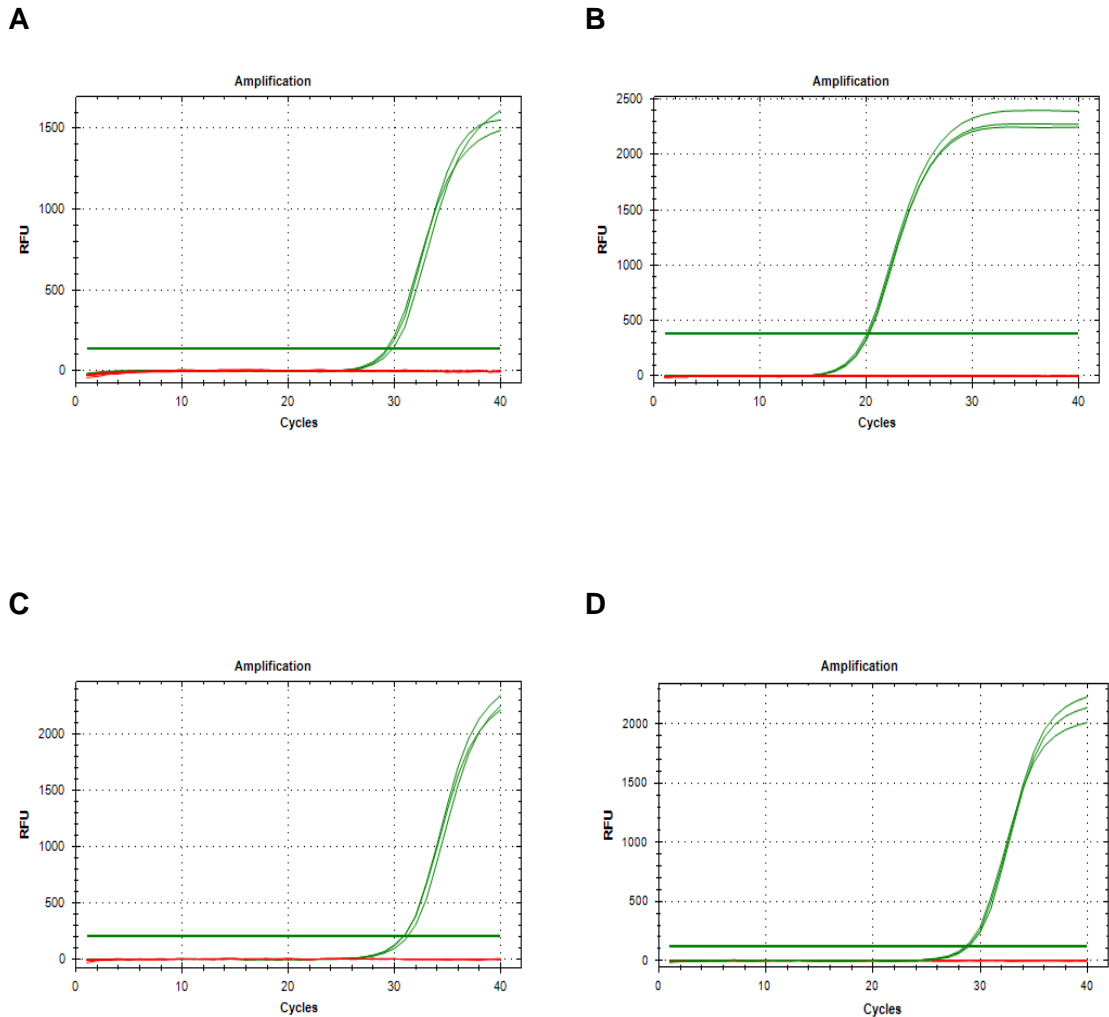
A



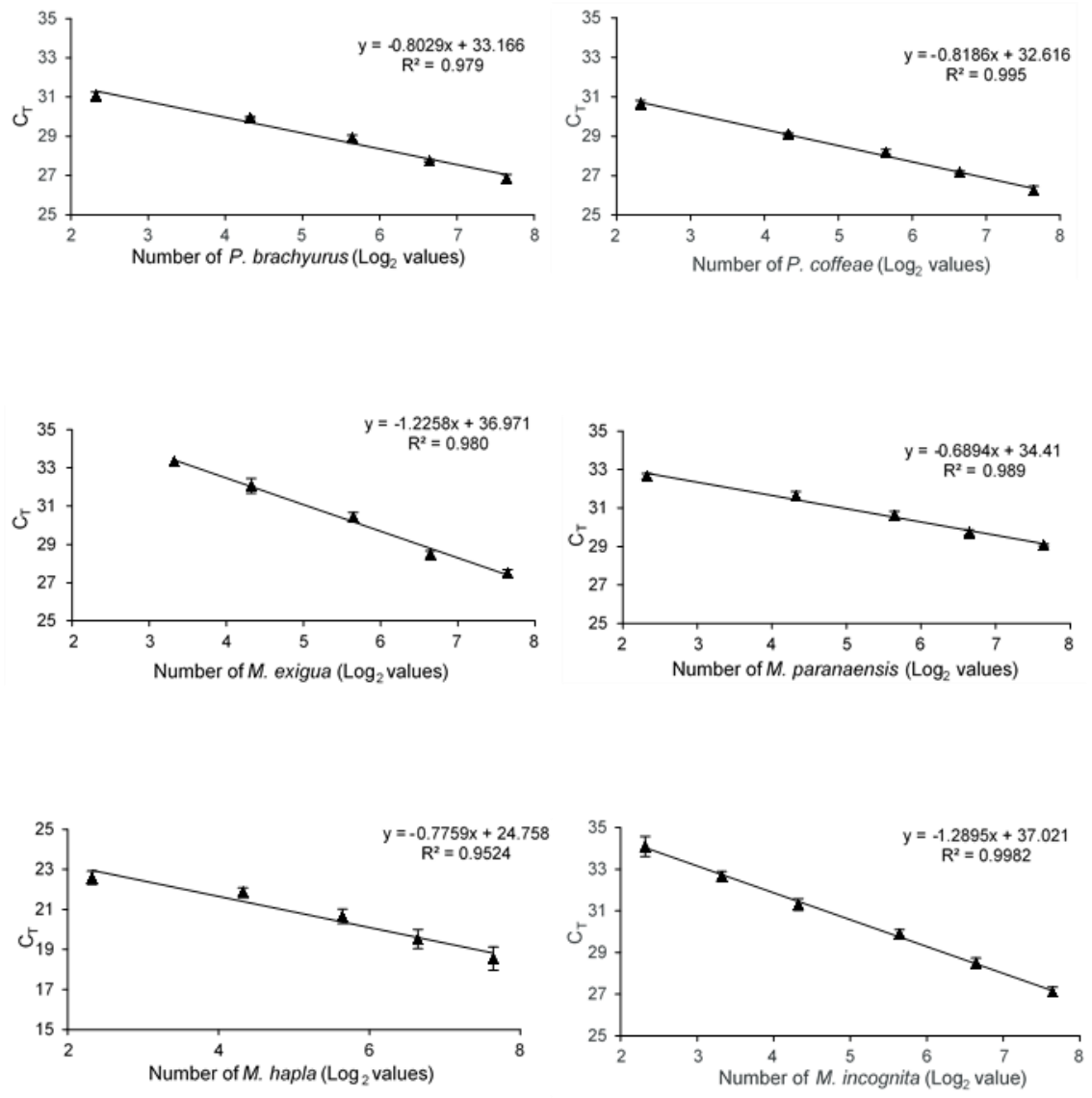
B



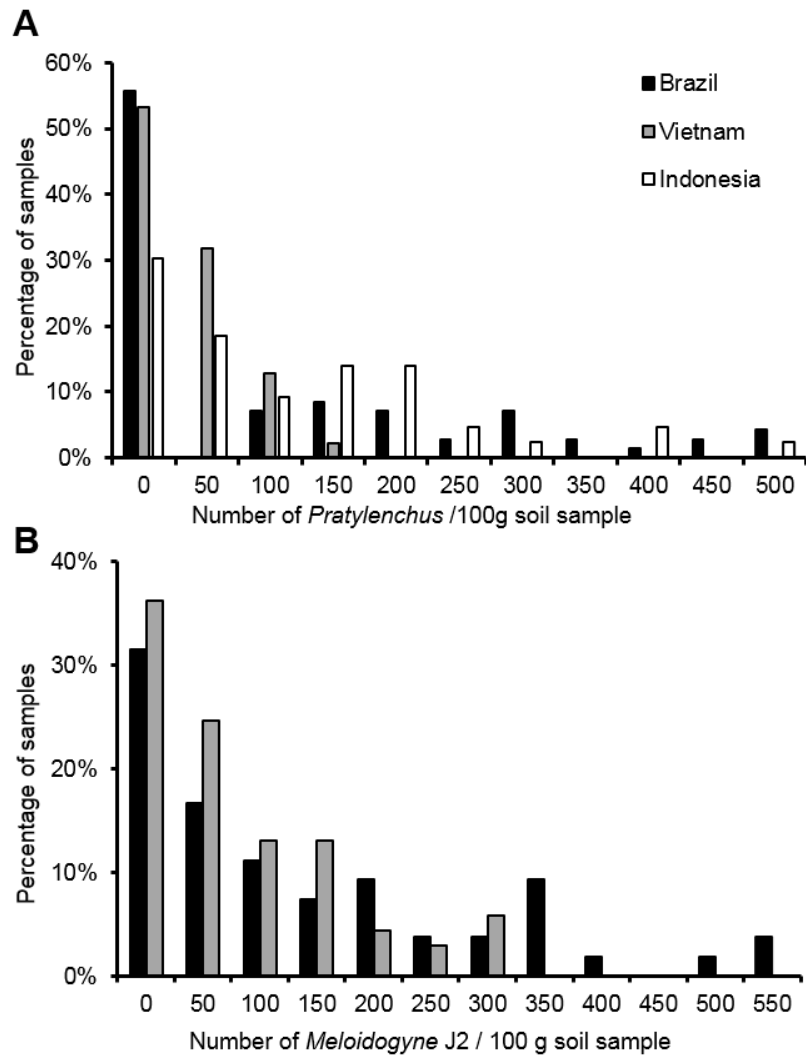
**Figure 3-9: Testing of qPCR primers specific to *Pratylenchus*.** Amplification of *P. brachyurus* DNA (A, primers PbqF/PbqR) and *P. coffeae* DNA (B, Pce1qF/Pce1qR) is represented by the sigmoidal curve (green), with amplification resulting in the accumulation of fluorescence. Curves represent three biological replicates. Non-target template DNA from reference populations of *P. coffeae*, *P. vulnus*, *P. zaeae*, *P. thornei*, *Meloidogyne exigua*, *M. paranaensis*, *M. incognita*, *M. hapla*, *M. javanica* and *Radopholus similis* are displayed by the straight curve, showing no amplification (red line).



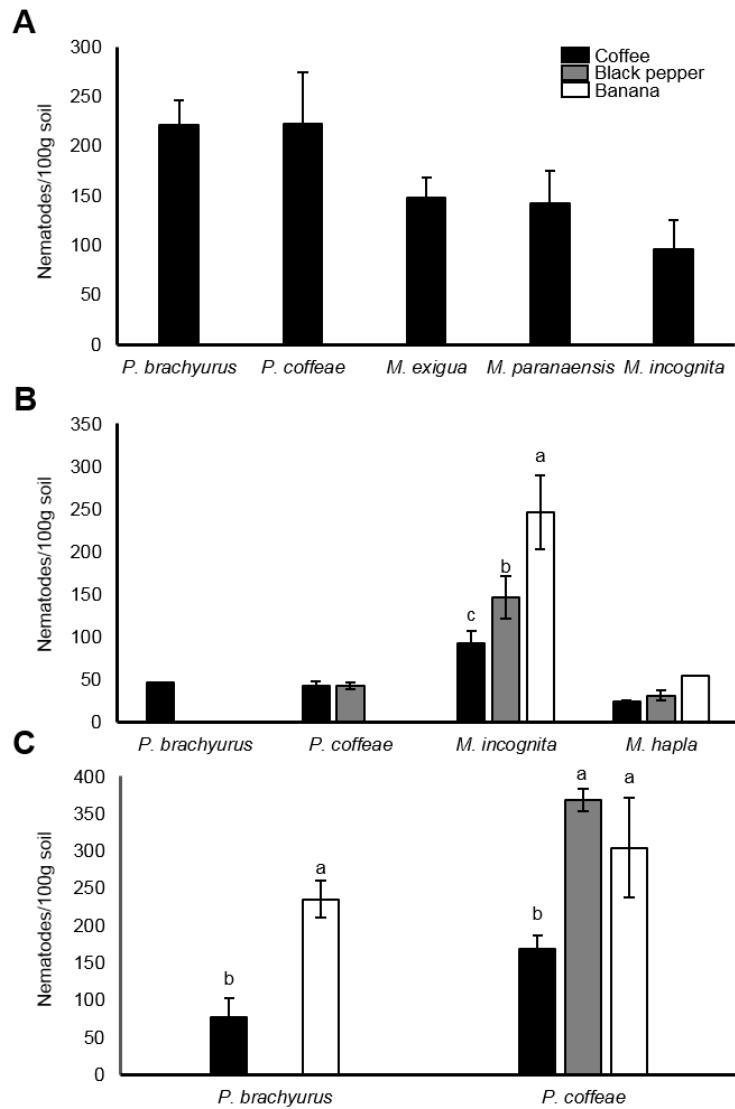
**Figure 3-10: Testing of qPCR primers specific to *Meloidogyne*.** Amplification of *M. exigua* (A, primers MexqF/MexqR), *M. hapla* (B, Mh-F/Mh-R), *M. incognita* DNA (A, RKNf/RKNr) and *M. paranaensis* (D, MpqF/MpqR) is represented by the sigmoidal curve (green), with amplification resulting in the accumulation of fluorescence. Curves represent three biological replicates. Non-target template DNA from reference populations of *P. coffeae*, *P. brachyurus*, *P. vulnus*, *P. zea*, *P. thornei*, *Meloidogyne exigua*, *M. paranaensis*, *M. hapla*, *M. javanica* and *Radopholus similis* are displayed by the straight curve, showing no amplification (red line).



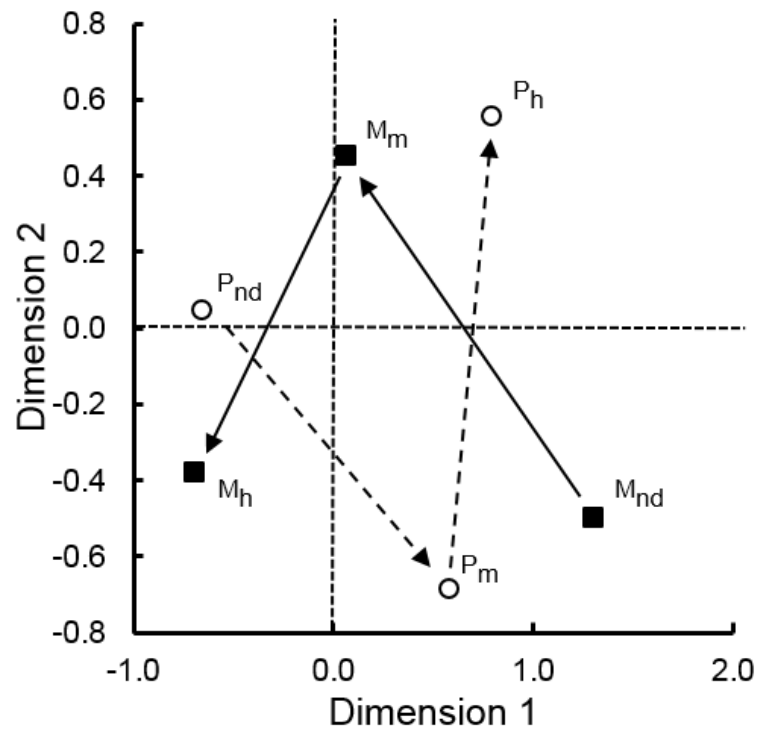
**Figure 3-11: Calibration curve of  $C_t$  values vs  $\log_2$  number of nematodes for quantification of *P. brachyurus*, *P. coffeae*, *M. exigua*, *M. paranaensis*, *M. hapla* and *M. incognita*. Error bars represent standard error of the mean for three biological replicates. Data points are larger than error bars in some instances.**



**Figure 3-12: Percentage of samples and the range of densities per 100 g soil sample.** Data for fields in Brazil, Vietnam and Indonesia where (A) *Pratylenchus* or (B) *Meloidogyne* were detected. The bar charts are based on 160 samples for *Pratylenchus* and 123 for *Meloidogyne*.



**Figure 3-13: Mean species abundance per 100 g soil obtained from each crop.** Data for samples from Minas Gerais, Brazil (A), Buon Ma Thuot, Vietnam (B) and Lampung, Indonesia (C). Letters note significant difference for a species between crops. Error bars represent SEM (absence indicates less than three samples contained the nematode species).



**Figure 3-14: Correspondence analysis showing association between *Pratylenchus* and *Meloidogyne* abundance.** Data represent values for soil from coffee or black pepper for 96 samples from fields in Brazil and Vietnam in which both genera were detected. Association is indicated by proximity of data points for the three categories. Account should be taken of the relative contributions to the overall variation in the data that is explained in dimension 1 (21.0 %) and dimension 2 (3.7 %) of *Pratylenchus* (P) and *Meloidogyne* (M) nematodes/ 100 g soil that were i) not detected in a sample (P<sub>nd</sub> and M<sub>nd</sub>), ii) moderate (P<sub>m</sub> 12-51 and M<sub>m</sub>11-111) and iii) high (P<sub>h</sub> 52-486 and M<sub>h</sub> 112-529).

### 3.5. Discussion

This results within this chapter demonstrate a molecular pipeline for rapid identification and estimation of soil populations of *Pratylenchus* and *Meloidogyne* nematode species that commonly damage coffee crops.

This study confirmed the ability of the Whitehead and Hemming tray method to extract high numbers of mobile *Pratylenchus* and *Meloidogyne* nematodes from soil, promoting the use of non-destructive sampling (Rodriguez-Kabana and Pope, 1981). The non-destructive approach is more favourable to growers and so may gain wide acceptance for routine screening for management decisions, particularly where crops with sensitive roots such as black pepper are grown. Usual practice is to take root samples and therefore cause harm to the plant by direct damage and exposing sites for secondary infection (Manzanilla-Lopez, 2012). Nematode extraction required minimal preparation time and equipment and the lysis method for DNA extraction provided sufficient extract for approximately 100 reactions and avoided the time-consuming DNA preparations of much previous work (Adam et al., 2007, Castagnone-Sereno et al., 1995, Stanton et al., 1998).

This is the first molecular-based study to assess the plant-parasitic nematode community within coffee fields by sampling multiple crop plants in three major coffee producing countries. The assay revealed that *P. brachyurus* and *P. coffeae* were similarly abundant in Brazil whereas *P. coffeae* was the more numerous species of the genus in Indonesia. Both of these species are known pathogens of coffee in these countries and can cause great damage to coffee roots and result in reduced plant growth (Oliveira et al., 1999, Trinh et al., 2011, Wiryadiputra, 2008). This study detected *M. exigua* and *M. paranaensis* in Brazil where they are widespread parasites of coffee plants (Barbosa et al., 2004, Carneiro et al., 1996, Salgado et al., 2015, Muniz et al., 2008). *Meloidogyne incognita* was detected in both Brazil and Vietnam where it is prevalent in coffee plantations (Carneiro et al., 2004, Trinh et al., 2009). This study reports the first detection of *M. hapla* in Vietnam, where it may have been previously identified as a different species or introduced through movement of cultivars. Although it has been reported in Hawaii, Guatemala, El Salvador, Brazil, India and several countries in Africa, the species is not widespread in coffee plantations (Campos, 2005, Handoo et al., 2005, Villain et al., 2013, Lordello, 1982). Although the presence of any parasitic-nematode species capable of damaging coffee is of interest, *M. hapla* has not been reported as widespread and it results in relatively low damage to coffee roots (Villain et al., 2013). Consequently



it may not represent as major a concern for the growers as some other species of this genus.

Genetically distinct populations of *M. incognita*, *M. paranaensis* and *M. exigua* are present in Central and South America, suggesting that genetic divergence has resulted in multiple species types (Carneiro et al., 2004, Randig et al., 2002a). The chances of false negatives due to genetic divergence is reduced as several primer sets used in this report have previously been applied to samples from widespread locations (Devran and Sogut, 2009, Hu et al., 2011, Randig et al., 2002b). Further molecular analysis could help elucidate the origins of populations detected in this study, map their distributions and assist in developing management strategies based on resistant cultivars. No *Meloidogyne* spp. were detected for the Indonesian samples which was unexpected given the abundance of the genus in Brazilian and Vietnamese samples and its known wide international distribution and polyphagy. Presence of *M. incognita* has been reported on other crops in the country, therefore it is of utmost importance that coffee fields are protected from introduction of the pathogen (Tuminem. et al., 2015). The lack of *Meloidogyne* species may also be due to the less structured farming system observed in Indonesia, compared to fields sampled in Brazil and Vietnam (personal observation during field sampling) (Figure 3-3). The irregular nature of planting may have had a negative impact on the establishment and spread of *Meloidogyne* throughout a field, whereas this may not prove to be as important for *Pratylenchus* that can migrate through soil at a greater rate than *Meloidogyne* second-stage juveniles (Njezic et al., 2014), thereby possibly allowing them to locate hosts at a greater distance.

The occurrence of the target nematodes in soils associated with intercrops at similar or higher densities than around coffee roots justifies re-consideration of appropriate crops to favour marginal or non-hosts. Furthermore, the greater abundance of several nematode species on the intercrop compared to the main crop raises the concern that an intercrop may not only be a suitable host, but it may provide tissue for nematode populations to increase in the field relative to densities associated with coffee plants. Predominance of *P. coffeae* in Vietnam may arise from conversion of fields from banana to coffee as both crops are hosts (Trinh et al., 2009). Currently there is an increase in the cropping of black pepper within Brazilian coffee fields due to its drought tolerance and high value (Terazono, 2017). This will influence the relative abundance of different nematodes present in the plantations, particularly as black pepper is not a known host for *P. brachyurus* and was also not indicated as such in this study.

The distribution of nematode field populations can frequently be described by negative binomial expression (Herve et al., 2005, Nyczepir, 2009). A balance is needed between the time and cost of taking many samples against the risk of not detecting a population that is present. The negative binomial suggests that 10 samples per field, as in this study, will reliably record a population if extensive sampling established that 40 % or more samples are expected to contain the target species. Therefore, the sampling strategy should reliably record the occurrence of a target species from a plantation. Sampling close to coffee plants that look damaged reduces the likelihood of reaching a false negative conclusion and more extensive sampling could be considered if the population is not detected but confidence in that outcome is important.

Although several nematode species were detected within fields there was an association of high numbers of *Meloidogyne* in soil samples in which *Pratylenchus* were low or not detected. Soil type, topography and climatic factors have a differential effect on *P. coffeae* and *M. exigua* on coffee roots in Costa Rica (Avelino et al., 2009). That work also indicated competition between the two species in the roots of coffee plants, resulting in negative correlation between their populations. An association of high *Meloidogyne* spp. populations and low density of *P. coffeae* was also reported previously in the roots of coffee in Costa Rica using correspondence analysis (Herve et al., 2005). Previous work on peach, onion, mung bean, sugarcane and barley roots has demonstrated competition between both genera of nematode with the effect and scale of effect differing with the host (BieYun, 2008, Fontana et al., 2015, Nyczepir, 2009, Pang et al., 2009, Umesh et al., 1994). It is of interest that the competition is observed in samples from both Brazil and Vietnam in this study, indicating its importance in global coffee farming systems. Intergeneric competition will affect the success of each species and therefore impact the entire nematode community with consequences on field output. Further analysis is required to determine the effects of coffee cultivars on the scale of competition.

The status of nematodes on coffee is often assessed by sampling roots, thereby disturbing the plants. However assessments are also made on soil populations (Barros et al., 2014, Herrera et al., 2011, Trinh et al., 2012). Additionally the presence of *Pratylenchus* species known to damage coffee is reason enough to initiate a management programme without considering its population level (Villain, 2008). Coffee growers should also be advised to remain vigilant for the presence of root-knot nematodes in their plantations (Campos and Silva, 2008).

Soil sampling of established coffee plants indicated similar mean soil densities for *P. brachyurus* and *P. coffeae* on coffee in all three countries. Alarmingly these densities are above the damage thresholds for these species on coffee, indicating that the crop is negatively affected by this genus. There is evidence that *M. exigua* in Brazil is severely damaging to coffee and the densities found in the samples reveal the frequent severity of infestations (Rodrigues and Crozzoli, 1995). More work is required in Vietnam to determine how often populations of *M. incognita* and *M. hapla* damage coffee and the damage thresholds of species complexes in different environments. The current work provides a rapid approach that can be applied with support from any competent molecular laboratory and therefore enables inexpensive widespread evaluation for many coffee plantations. It indicates that *Pratylenchus* may be widely damaging to coffee plantations whereas species of *Meloidogyne* have more limited distributions. Work is planned to relate results from the rapid estimation of soil populations to damage severity and thresholds for each nematode in a range of growing conditions. Additional primers could be designed to detect further species that occur in these countries, but not in the regions sampled in this study, such as *P. jaehni* (Inserra et al., 2001). Alongside the work studied here, this will underpin global efforts to manage populations and support selection of appropriate resistant cultivars for different localities.

### 3.6. Summary

- A high abundance of *Pratylenchus* and *Meloidogyne* were extracted from soil allowing for non-destructive sampling
- Molecular methods identified varying incidence and abundance of six coffee-parasitic nematode species in the regions sampled.
- Nematode species were present in higher abundance in soil surrounding intercrops, compared to coffee plants.
- *Meloidogyne* individuals were detected in high quantities in samples where *Pratylenchus* were low or not detected, suggesting possible competition between both genera on the host plant.

## **Chapter 4. Identification and characterisation of genes encoding cell wall degrading enzymes in *Pratylenchus coffeae***

---

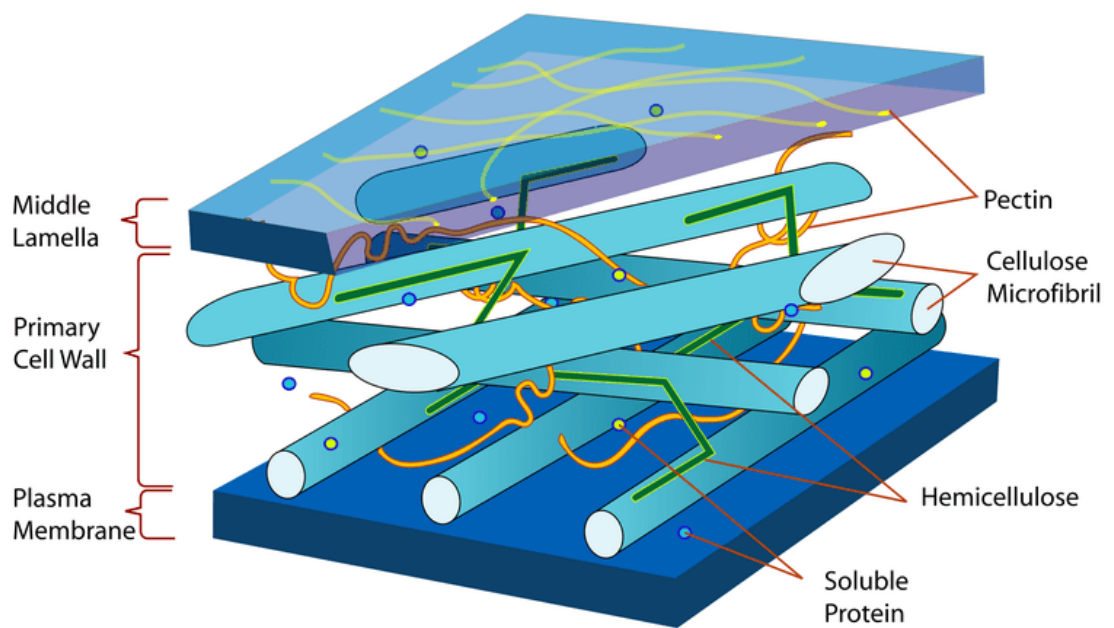
### **4.1. Introduction**

#### **4.1.1. The plant cell wall**

The plant cell wall is a rigid structure that maintains cell shape, provides a defensive barrier and facilitates cell-to-cell and cell-to-environment interactions (Carpita and Gibeaut, 1993). The primary cell wall is largely composed of cellulose, hemicellulose and pectin (Sticklen, 2008) (Figure 4-1). Over 2000 genes are suggested to be involved in the assembly and regular remodelling of the structure throughout growth and development of the plant cell (Hematy et al., 2009, Carpita et al., 2001). Cell wall components and their relative proportions are known to vary between plant species, cell types, developmental stages of tissue and in response to environmental stimuli (Sorensen et al., 2010, Zhong and Ye, 2015). Previously the structure was generally classified as 'Type I', which has more xyloglucan (a hemicellulose) and pectin, or 'Type II' which has more of the hemicellulose glucuronoarabinoxylan (Carpita and Gibeaut, 1993). However, plant species have been described that do not fit the models and now prevent the generalisation of plant cell walls based on phylogeny (Fry et al., 2008). In many cell types a secondary cell wall, much thicker than the primary, is formed after the cell reaches its final size and shape. It provides structural reinforcement to the cell and is common in xylem tissue that needs to resist pressure during water transport (Hofmann, 2017). The composition of the secondary cell wall also varies, for example woody tissue contains a higher lignin content whereas collenchyma contains more cellulose (Kumar et al., 2016).

#### **4.1.2. Pathogen attack on the plant cell wall**

Both primary and secondary cell walls provide a defence against an array of soil-borne pathogens, such as bacteria, viruses, fungi and nematodes (Brisson et al., 1994). All of these pathogens must overcome this obstacle in order to reproduce on the host. The structure not only provides defence as a physical barrier, it is also involved in inducing defence responses after detection of pathogen attack.



**Figure 4-1: Schematic diagram to show the cell wall structure containing cellulose, hemicellulose, pectin and soluble proteins (Sticklen, 2008).**

Pathogen associated molecular patterns (PAMPs) or damage associated molecular patterns (DAMPs, e.g. products of cell wall damage) are detected by the plant and induce responses by initiating defence pathways (Malinovsky et al., 2014). The defence responses at the cell wall can vary depending on the pathogen, however they all aim to limit progression into the host (Hematy et al., 2009). The PAMP signals of plant-parasitic nematodes (PPN) are ill-defined, however they are better-characterised for fungi and insect pathogens. For example, the polysaccharide chitin is present in the cell walls of fungi and exoskeletons of insects and is recognised on plant cell surfaces, leading to secretion of chitinases to degrade the pathogen (Malinovsky et al., 2014). Detection of a pathogen at the cell surface can also lead to defence responses throughout the cell, such as production of reactive oxygen species and cell death. Infection of plant roots by nematodes can result in production of reactive oxygen species and changes in gene expression (Wondafrash et al., 2013). Furthermore, nematode-derived proteinaceous secretions are capable of inducing PAMP-triggered immunity (Mendy et al., 2017). A receptor for these secretions has been detected but the exact component of the secretion is still unknown (Mendy et al., 2017). Another report has found that nematodes produce ascarosides that are capable of inducing pattern-triggered immunity (PTI), however in this case a plant-receptor is not defined (Manosalva et al., 2015).

Enhanced resistance to PPN has also been shown to correlate with overproduction of compounds that reinforce the cell wall, thereby preventing mechanical disruption via the nematode stylet (Holbein et al., 2016, Hofmann et al., 2010). Deposition of lignin, phenolic compounds and callose, a polysaccharide, at sites of attempted pathogen penetration strengthen the structure to resist pathogen entry (Voigt, 2014).

#### **4.1.3. Invasion of roots by plant-parasitic nematodes**

Invasion of the root is vital for the survival of endo-parasitic nematodes. Root invasion requires the production of a variety of cell wall degrading enzymes that break down the aforementioned cell wall constituents. The inability to degrade one or more cell wall component may result in failure to enter the root and death of the nematode. These enzymes are secreted into root tissue through the nematode stylet from the pharyngeal glands (Bohlmann and Sobczak, 2014). There is no indication that these enzymes are released in sequential order, as is observed in fungi where pectin degrading enzymes are usually secreted first (Bohlmann and Sobczak, 2014).

Several studies have identified cell wall degrading enzymes in a wide range of cyst, root-knot and migratory nematode species. The most commonly found genes are involved in the degradation of cellulose (beta-1,4-endoglucanases), xylan (beta-1,4-endoxylanases)

and pectin (alpha-1,4-galacturonan lyase) (Ali et al., 2017). Beta-1,4-endoglucanases, commonly referred to as cellulases, have been identified in the most economically important genera of PPN: *Meloidogyne*, *Globodera*, *Heterodera* and *Pratylenchus* (Rosso et al., 1999, Smant et al., 1998, Goellner et al., 2000, Fanelli et al., 2014). The high similarity of these genes to bacterial sequences suggests that they are derived from horizontal gene transfer events (Jones et al., 2005). Recent 'omics studies suggest that *Pratylenchus coffeae* has a reduced number of genes encoding cell wall degrading enzymes compared to other nematodes such as *M. incognita* or *G. pallida* (Burke et al., 2015, Haegeman et al., 2011b, Cotton et al., 2014, Abad et al., 2008). The reduced complement of these genes has been attributed to the smaller genome of the species (Burke et al., 2015).

Cell wall degrading enzyme genes are often expressed in the pharyngeal gland cells of PPN for secretion into the host, however expression of some has also been detected in the intestine, suggesting involvement in digestion of plant material (Rosso et al., 1999, Smant et al., 1998, Goellner et al., 2000, Fanelli et al., 2014). Highest expression of beta-1,4-endoglucanases is found within adult life stages of migratory species, presumably for increased migration to obtain sufficient food for reproduction (Fanelli et al., 2014). In contrast to this, expression of orthologous transcripts in sedentary nematodes decreases when feeding initiates as migration through plant tissue is no longer required (Gao et al., 2004, Wubben et al., 2010).

Further characterisation of these genes in *Pratylenchus coffeae* is necessary to investigate the mechanisms for parasitism and the role of the limited repertoire of cell wall degrading enzymes in this species.



#### 4.2. Aims

1. To assemble transcriptomic and genomic data available for *Pratylenchus coffeae* and identify a range of cell wall degrading enzymes.
2. Characterise the genes by determining the spatial and temporal expression of each transcript in the nematode.

### **4.3. Methods**

#### **4.3.1. Identification of cell wall degrading enzyme genes in *P. coffeae***

Raw genome and transcriptome sequencing data were downloaded from NCBI (BioProject Accession: PRJNA276478 and PRJNA79895 respectively). Both groups of reads were trimmed and assembled, separately, using GS De Novo Assembler (Roche) using default parameters to produce two assemblies. Sequence redundancy in the transcriptome assembly was reduced by using CD-HIT (Fu et al., 2012a). The transcriptome contigs were then submitted to the Carbohydrate Active Enzymes (CAZy) database to identify sequences related to cell wall degradation. CAZy hits were mapped on to the genome assembly using GS Reference Mapper to obtain genomic sequence data.

#### **4.3.2. Producing alignments**

Nucleotide sequences were translated to protein sequences using Expasy. Alignments between amino acid sequences was performed using the multiple-sequence alignment tool Clustal Omega, found at [www.ebi.ac.uk/Tools/msa/clustalo/](http://www.ebi.ac.uk/Tools/msa/clustalo/) (Sievers et al., 2011).

#### **4.3.3. Signal peptide prediction**

Translated transcript sequences were used with SignalP V4.1 to predict the presence of N-terminal signal peptides (Petersen et al., 2011). SignalP is available at [www.cbs.dtu.dk/services/SignalP/](http://www.cbs.dtu.dk/services/SignalP/).

#### **4.3.4. Phylogenetic trees**

Phylogenetic relationships for orthologous sequences in different PPN species were generated from Clustal Omega aligned sequence using TOPALI v2.5 (PhyML, WAG substitution model, bootstrap value: 500) (Milne et al., 2009). Topali v2.5 is available to download at [www.topali.org/](http://www.topali.org/). PPN sequences were obtained from Genbank.

#### **4.3.5. *In situ* hybridisation**

Single-strand digoxigenin-labelled anti-sense DNA probes were synthesised with DIG DNA labelling mix (Roche, Germany) from 50 ng cDNA fragments (150-250 bp) amplified by template specific primers (Table 4-1). Sense probe controls were synthesised in separate reactions. These probes were denatured (10 mins 99 °C) and used for *in situ* hybridisation to determine spatial expression patterns for *Pc-eng-1*, *Pc-eng-2*, *Pc-eng-3*, *Pc-eng-4*, *Pc-xyl* and *Pc-pel-1* (de Boer et al., 1998). Approximately 2000 mixed stage *P. coffeae* were fixed in 2% paraformaldehyde in M9 buffer for 18 hr at 4 °C followed by 4 hr at 22 °C. Fixed nematodes were cut into 2-3 pieces with a razor blade before washing with M9 buffer and proteinase-K treatment (0.5 mg/ml for 30 mins at 22 °C). Nematodes

were frozen and dehydrated with methanol for 1 min followed by acetone for 1 min before rehydration in RNase-free water. Treated nematodes were hybridised with the denatured probes overnight at 50 °C and then washed three x 15 minutes with 4x Saline Sodium Citrate (SSC) and three x 20 minutes with 0.1x SSC/ 0.1 % SDS at 50 °C. Nematodes were incubated at 22 °C in 1 % blocking reagent in maleic acid buffer (Roche, Germany) for 30 min and labelled for 2 hr with anti-digoxigenin-AP Fab fragments 1:1000 in 1 % blocking reagent. After three x 20 minute washes in maleic acid buffer the nematodes were stained overnight at 4 °C with 337 µg/ml nitroblue tetrazolium and 175 µg/ml 5-bromo-4-chloro-3-indolyl phosphate. Stained nematodes were washed in 0.01 % Tween-20 before viewing under the microscope (Olympus, BH2). Images were captured with a QIcam camera (QImaging) and Q-Capture software.

#### **4.3.6. Gene expression analysis throughout nematode development**

Triplicate groups of 100 eggs, juveniles, females and males of *P. coffeae* were individually selected from a mixed nematode pool, and total RNA was extracted to determine expression of genes at different nematode life stages. A sequence for *P. coffeae* elongation factor was selected from the genome assembly as the reference gene. All primers had an amplification efficiency of 95-100% (primer sequences in Table 4-1). The  $2^{(-\Delta\Delta Ct)}$  method was used to calculate relative expression between control and experimental samples from three technical and three biological replicates. One-way ANOVA with a Student-Newman-Keuls post hoc test was used to determine significant differences between groups unless otherwise stated.

#### **4.3.7. Confirming cellulase activity of identified beta-1,4-endoglucanase genes**

Total homogenate was prepared from 500 *P. coffeae* mixed stage individuals by crushing with an Eppendorf pestle in 500 µl autoclaved tap water. Stylet secretions were also collected for the same number of nematodes by soaking in 500 µl of 0.4 % resorcinol (Sigma-Aldrich, US) for 4 h at 22 °C, then filtering the solution through a 0.22 µm syringe filter to remove the nematodes. Resorcinol induces the secretion in another plant-parasitic nematode, *M. incognita* (Bellafiore et al., 2008). Flow through was then confirmed for absence of nematodes under the microscope.

Primers were designed to amplify the desired coding sequences of the beta-1,4-endoglucanase genes with the addition of restriction enzyme sites to facilitate direct cloning in to a vector for protein expression in *Escherichia coli*. Each PCR was carried out using template cDNA using primers with NdeI and BamHI sites, detailed in Table 4-2. PCR was performed as described in section 2.1.3.2 but with Phusion High fidelity DNA polymerase (NEB). Each PCR product was then purified, subsequently digested with the relevant

restriction enzymes and purified again (QIAquick Gel Extraction Kit, Qiagen). Fragments were then ligated into a digested pPET28(b) vector and transformed into *E. coli* BL21 DE3 cells. Colonies selected on kanamycin plates (50 µg/ml) were screened by PCR (see section 2.1.4.2) using gene specific primers to isolate positive transformants. These were transferred to 5 ml LB media containing 50 µg/ml kanamycin. Protein expression was induced by the addition of IPTG to a final concentration of 1 mM and returning to a shaking incubator for three hours at 37 °C.

To determine the cellulase activity, 5 µl of the homogenate and secretion solutions were applied to a 1 % carboxymethylcellulose (Sigma-Aldrich, US) plate and incubated at 37 °C for 16 h. Similarly, 5 µl of the media containing the induced-protein were applied to the plate. Plates were then stained with 0.1 % Congo Red solution for 30 min followed by washing with 5 M NaCl until a clear zone could be differentiated around application sites. A negative control with *E. coli* harbouring an empty pPET28(b) plasmid was included.

#### **4.3.8. Gene expression analysis in the nematode post-removal from the host**

Nematodes were collected from plant roots as described in section 2.1.2.4, washed three times in sterile tap water and kept in sterile tap water until required. After 12, 48, 48 96 and 192 hours post-removal from the host nematodes were frozen for RNA extraction and qPCR analysis of the *Pc-eng-1*, -2, -3 and -4 genes as described previously. This was performed in biological triplicate.

**Table 4-1: Primer sequences used for the temporal and spatial analysis of selected *P. coffeae* sequences.** Each of the primers was designed to be sequence-specific, using the sequence data obtained from genome and transcriptome assemblies.

Code	Purpose	Forward / Reverse primer sequences
<i>Pc-eng-1q</i>	qPCR	GCTTTGGTGCAAACCGTCAT/ CAGGCAATATGGCTCCAATCCG
<i>Pc-eng-2q</i>	qPCR	CACAAATGAATACACCGACTGG/ TCGGATTGCCTTAAAAATGAAT
<i>Pc-eng-3q</i>	qPCR	CTCACTTTGTTCAACGCAGTCT/ ACCAATTTGTGCTACACCCTTC
<i>Pc-eng-4q</i>	qPCR	CAAATGCCATTACAGGCAGC/ CATTGCGTTTTGGTTTTGATTC
<i>Pc-xyIq-is</i>	qPCR/ <i>in situ</i>	GCGTGTGGATGCGACCTATA/ CTGCTGGTAATATGCGGGGT
<i>Pc-pelq-is</i>	qPCR/ <i>in situ</i>	TTCCAACACAATGGCAAGGG/ CGCGCATATTGGTTCTCACA
<i>Pc-EFq</i>	qPCR	CAAGGAGGCCAAGCAATTCAC/ AGAGATTTGACCCGGGTGATTC
<i>Pc-eng-1-is</i>	<i>In situ</i>	GCTCACCCCTTCTATACGGCC/ TGGAGCCATATTGCTTGGCA
<i>Pc-eng-2-is</i>	<i>In situ</i>	CAGGCGGTCTCATTCTTCTC/ TAGCCAGTAATGGGGTTTGC
<i>Pc-eng-3-is</i>	<i>In situ</i>	ATTGTGGGCTCAAGTGGTTC/ CTTTTGTGGTTTTGGGCATT
<i>Pc-eng-4-is</i>	<i>In situ</i>	CCATTTTCGCCATTCACTTT/ CCTGCTGAATCCACGATTTT

**Table 4-2: Primer sequences for the cloning of *P. coffeae* beta-1,4-endoglucanase coding regions for expression in *E. coli*.** Restriction sites are underlined. Each of the primers was designed to be sequence-specific, using the sequence data obtained from genome and transcriptome assemblies.

Code	Forward / Reverse primer sequence	Restriction enzyme
<i>Pc-eng1-orf</i>	ACACATATGATGGGCTCGTGGATTGG/ TGTGGATCCTCACGCTCACAACCGTCACAG	NdeI/BamHI
<i>Pc-eng2-orf</i>	ACACATATGATGATTGGCACGAGACG/ TGTGGATCCAAAATTTATAATCAAATGTGC	NdeI/BamHI
<i>Pc-eng3-orf</i>	ACACATATGATGTGGATGTGGCGGCAAA/ TGTGGATCCTCAGATTATAAATTATTTTCACA	NdeI/BamHI
<i>Pc-eng4-orf</i>	ACACATATGATGAACGAATGGGGTGA/ TGTGGATCCTTACAAAATTAATTTATTCTC	NdeI/BamHI

## 4.4. Results

### 4.4.1. Identification of cell wall degrading enzymes in *P. coffeae*

Transcriptome data were assembled into 17,136 contigs with an N50 value of 1225 (Table 4-3). The genome assembly consisted of 62,672 contigs with an N50 value of 1127.

The contigs were searched against the Carbohydrate-active Enzyme database (CAZy), which identified numerous cell wall degrading enzyme genes from the transcriptome. These were filtered to identify four beta-1,4,-endoglucanase (cellulase) genes, one beta-1,4-endoxylanase (xylanase) gene and three alpha-1,4-galacturonan lyase (pectate lyase) genes that would be studied further (Table 4-4). The sequences of contig03393, contig05153 and contig07620 were identical and therefore these were classed as one beta-1,4,-endoglucanase gene in all future analysis. All of the predicted sequences contained Pfam domains consistent with their CAZyme designation. Homology with other PPN beta-1,4-endoglucanase sequences led to the naming of genes described in Table 4-4. The *Pc-eng-1*, *-2*, *-3* and *-4*, *Pc-xyl* and *Pc-pel-1* sequences were used for further analysis. Sequences were then mapped onto the genome assembly to obtain genomic sequence data. This resulted in full genomic and coding regions for all sequences. All transcripts, apart from *Pc-eng-4*, were predicted to encode proteins with N-terminal signal peptides.

**Table 4-3: Transcriptome and genome assembly comparisons between published data and this study.** *De novo* assemblies had to be built during this study as only the raw reads were available from the referenced papers. Some scores were not available (NA) from the published studies.

Assembly	Reference	Contigs	N50	G+C %
Transcriptome	PRJNA276478 Kyndt <i>et al</i> 2012	25,987	NA	NA
Transcriptome	This study	17,136	1,225	41.50
Genome	PRJNA276478 Burke <i>et al</i> 2015	5,821	10,000	38.10
Genome	This study	62,672	1,127	36.43



**Table 4-4: CAZy search output identifying cellulase, xylanase and pectate lyase genes in the transcriptome of *Pratylenchus coffeae*.** The submitted transcriptome assembly (query) and was aligned to the corresponding match in the database (subject) to provide description of the enzyme family. Protein family domains are used to identify the sequence based on protein function. The three types of proteins are classified as either Glycoside Hydrolase (GH) or Polysaccharide Lyase (PL) enzymes.

Query		Subject			CAZy family	Gene name
SequenceID	Pfam domain	Subject ID	Pfam domain	Organism		
contig11796	Cellulase	AER27790.1	Cellulase	<i>Pratylenchus vulnus</i>	GH5	<i>Pc-eng-2</i>
contig06163	Cellulase	ADM72857.1	Cellulase	<i>Rotylenchulus reniformis</i>	GH5	<i>Pc-eng-4</i>
contig07712	Cellulase	ACB38289.1	Cellulase	<i>Radopholus similis</i>	GH5	<i>Pc-eng-3</i>
contig03393	Cellulase	ABX79356.1	Cellulase	<i>Pratylenchus coffeae</i>	GH5	
contig05153	Cellulase	ABX79356.1	Cellulase	<i>Pratylenchus coffeae</i>	GH5	<i>Pc-eng-1</i>
contig07620	Cellulase	ABX79356.1	Cellulase	<i>Pratylenchus coffeae</i>	GH5	
contig05172	Xylanase	ABZ78968.1	Xylanase	<i>Radopholus similis</i>	GH30	<i>Pc-xyl</i>
contig06098	Pectate_lyase	AAS88579.1	Pectate_lyase	<i>Meloidogyne incognita</i>	PL3	<i>Pc-pel-1</i>
contig08457	Pectate_lyase	AAM74954.1	Pectate_lyase	<i>Heterodera glycines</i>	PL3	<i>Pc-pel-2</i>
contig01475	Pectate_lyase	ADW77534.1	Pectate_lyase	<i>Heterodera glycines</i>	PL3	<i>Pc-pel-3</i>

#### **4.4.2. Enzyme activity of beta-1,4-endoglucanase genes from *P. coffeae***

Four beta-1,4-endoglucanase genes were identified from *P. coffeae* which is one more than reported by Burke *et al* 2015. Also, *Pc-eng-4* was the only one predicted to lack a N-terminal signal peptide. Therefore, cellulase functionality of the encoded proteins was tested by expressing the coding regions in *E. coli* and growing the resulting bacteria in the presence of a cellulose substrate. All four of the coding regions were individually expressed in pPET28(b) vectors and transformed into *E. coli* BL21 DE3. The cell suspension, expressing the protein, was then administered to a cellulose-containing plate and secreted activity was detected by staining. Each of the four expressed proteins showed the predicted enzyme activity evidenced by clear 'halos' around the inoculated cells, indicating lack of cellulose (i.e. degradation) (Figure 4-2). Total nematode homogenate and nematode stylet secretions also showed cellulase activity, indicating that the nematode secretes one or more of these gene products. A negative control of *E. coli* harbouring an empty plasmid showed no activity.

#### **4.4.3. Relationship between beta-1,4-endoglucanase genes from *P. coffeae* and different plant-parasitic nematode species**

The relationship between the beta-1,4-endoglucanase sequences from *P. coffeae* and the identified orthologues in other PPN is described by a maximum likelihood phylogenetic tree (Figure 4-3). *Pc-ENG-1* and *Pc-ENG-3* cluster together with orthologues in *Pratylenchus* spp. *Pc-ENG-2* clusters with orthologues in *Pratylenchus* and *Radopholus*. *Pc-ENG-4* does not exhibit close homology to any PPN sequences, however the closest match is *ENG-2* from *Meloidogyne incognita*, which is also an outlier.

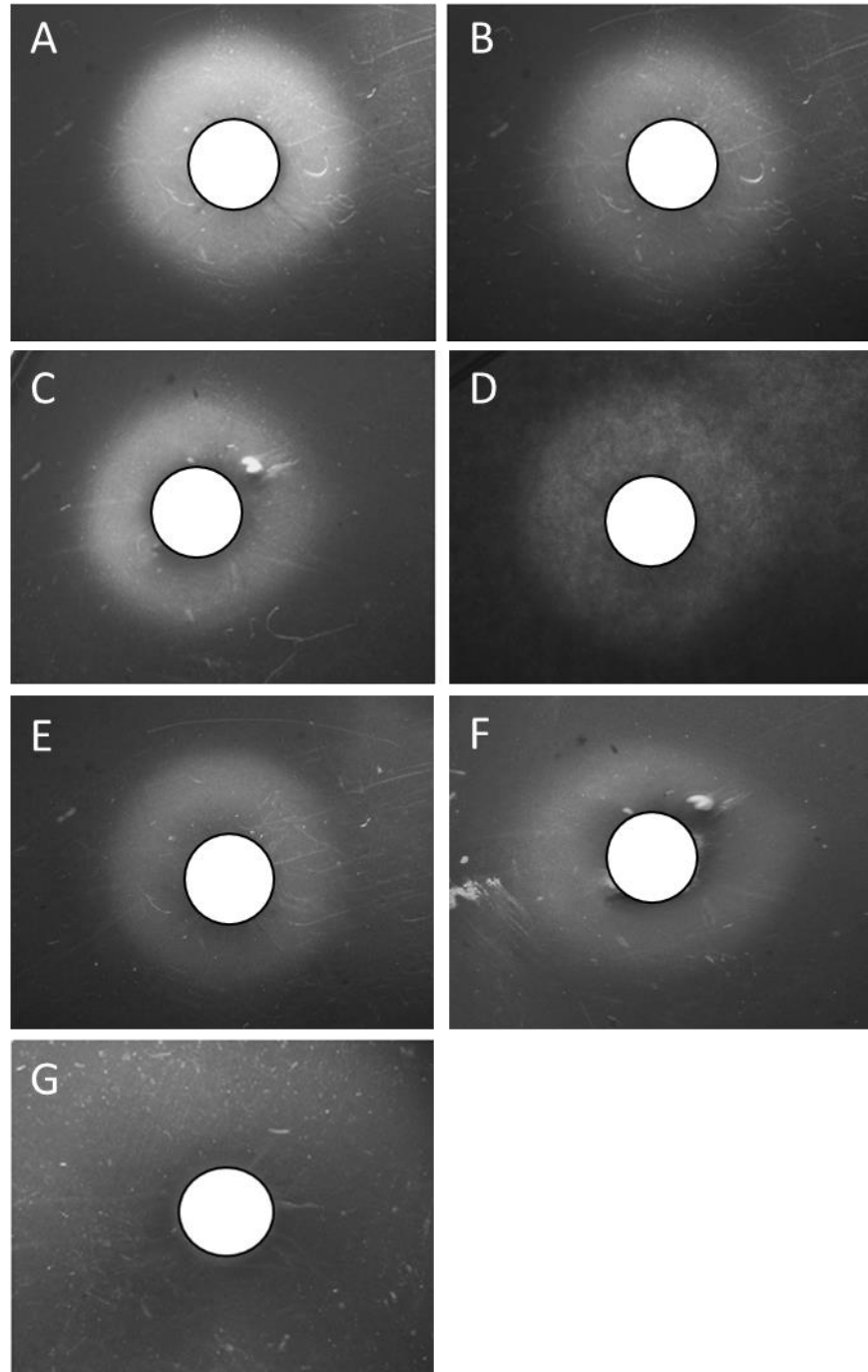
#### **4.4.4. Relationship between the beta-1,4-endoxylanase gene from *P. coffeae* and different plant-parasitic nematode species**

Beta-1,4-endoxylanase genes are poorly characterised in PPN, compared to beta-1,4-endoglucanases. Subsequently fewer sequences could be used to investigate phylogeny. Therefore, only the amino acid sequences identified from *P. coffeae* and orthologues in *Radopholus similis* and *Meloidogyne incognita* could be described by a phylogenetic tree (Figure 4-4). *Pc-XYL* clusters with that of another migratory endoparasite, *R. similis*, whilst the *M. incognita* sequences form a second clade.

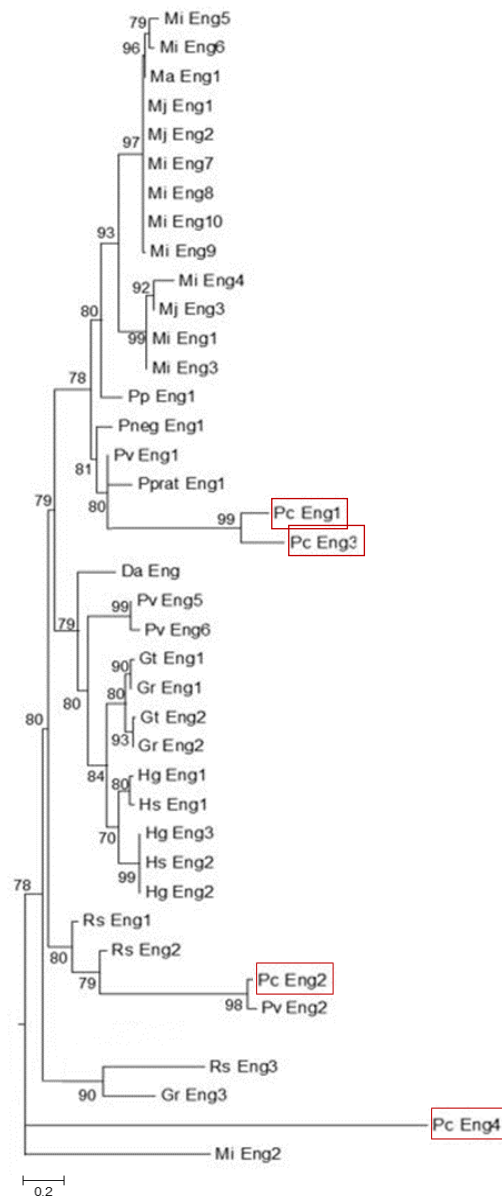
#### **4.4.5. Relationship between the alpha-1,4-galacturonan lyase genes from *P. coffeae* and different plant-parasitic nematode species**

A phylogenetic tree was generated from the amino acid sequences for known alpha-1,4-galacturonan lyases in PPN (Figure 4-5). This suggests that *Pc-PEL-1* and *Pc-PEL-3* are

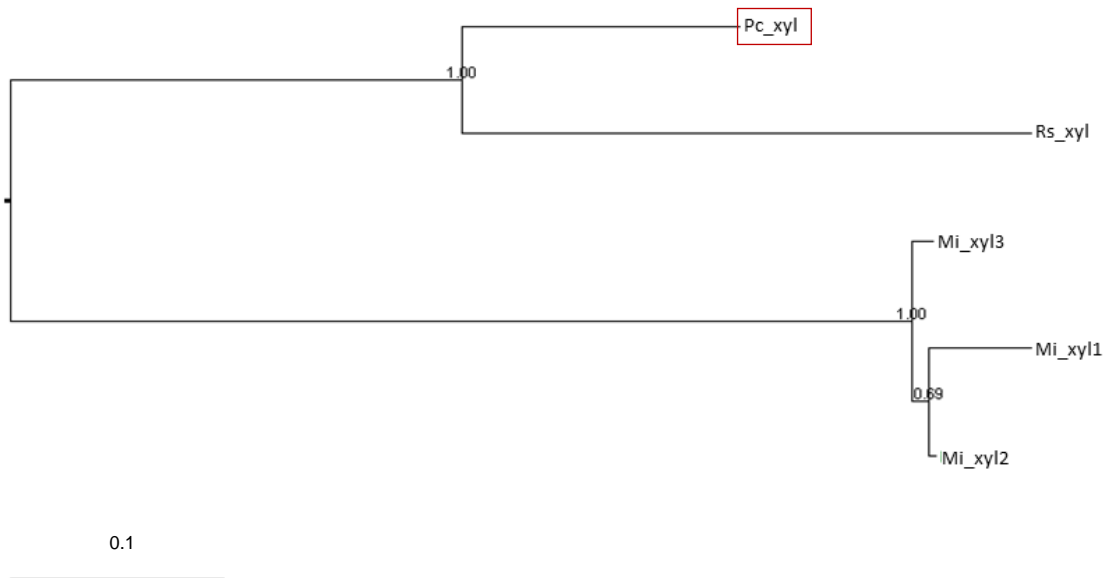
more closely related to orthologues in *Meloidogyne* species than those in cyst nematode species, whereas for Pc-PEL-2 the reverse is true. The sequence of Pc-PEL-1 was used for further work in this thesis.



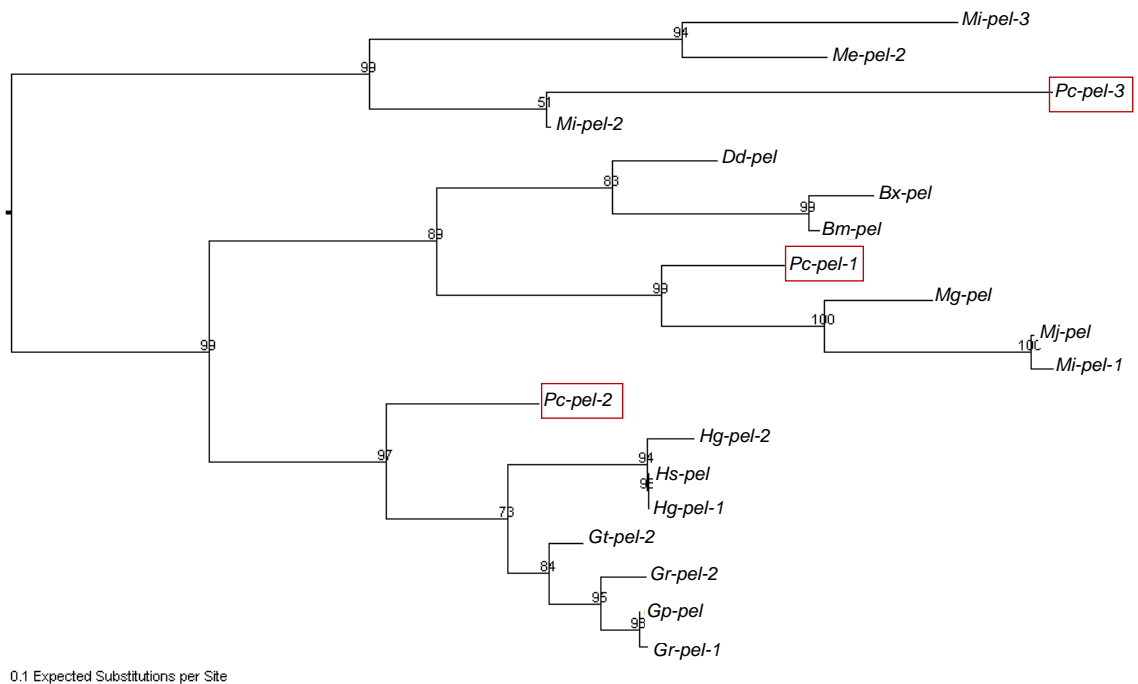
**Figure 4-2: Enzyme activity of *P. coffeae* homogenate (A), *P. coffeae* secretion (B), Pc-ENG-1 (C), Pc-ENG-2 (D), Pc-ENG-3 (E) and Pc-ENG-4 (F) on 0.5 % carboxymethyl cellulose agar.** Hydrolytic activity in the substrate is visualised as a clear halo by a Congo red stain. Nematode secretions were induced by 0.4 % resorcinol and recombinant nematode beta-1,4-endoglucanase (C-F) genes were expressed in *Escherichia coli* from the plasmid *pET-28a*. *E. coli* cell suspension was used as the application. No halo could be detected following application of *E. coli* harbouring the empty plasmid (G). White circles indicate where suspension was applied.



**Figure 4-3: Phylogenetic tree of the relationship between beta-1,4-endoglucanase genes from different plant-parasitic nematode species.** Red boxes represent *P. coffeae* sequences. Sequences from *Meloidogyne incognita* (Mi), *M. arenaria* (Ma), *M. javanica* (Mj), *Pratylenchus penetrans* (Pp), *P. neglectus* (Pn), *P. vulnus* (Pv), *P. pratensis* (Pprat), *P. coffeae* (Pc), *Ditylenchus africanus* (Da), *Globodera tabacum* (Gt), *G. rostochiensis* (Gr), *Heterodera glycines* (Hg), *H. schachtii* (Hs) and *Radopholus similis* (Rs) are also included. Maximum likelihood phylogeny using predicted protein alignments. Bootstrap values for 500 iterations are labelled on nodes. Scale bar represents branch times.



**Figure 4-4: Phylogenetic tree of the relationship between beta-1,4-endoxylnase genes from different plant-parasitic nematode species.** The red box represent *P. coffeae* sequences. Sequences from *Meloidogyne incognita* (Mi), *Pratylenchus coffeae* (Pc), and *Radopholus similis* (Rs) are also included. Maximum likelihood phylogeny using predicted protein alignments. Bootstrap values for 500 iterations are labelled on nodes. Scale bar represents branch times.



**Figure 4-5: Phylogenetic tree of the relationship between alpha-1,4-galacturonan lyase genes from different plant-parasitic nematode species.** Red boxes represent *P. coffeae* sequences. Sequences from *Meloidogyne incognita* (Mi), *M. exigua* (Me), *M. javanica* (Mj), *M. graminicola* (Mg), *Pratylenchus coffeae* (Pc), *Ditylenchus destructor* (Dd), *Globodera tabacum* (Gt), *G. rostochiensis* (Gr), *G. pallida* (Gp), *Heterodera glycines* (Hg), *H. schachtii* (Hs), *Bursaphelenchus xylophilus* (Bx) and *Bursaphelenchus mucronatus* (Bm) are also included. Maximum likelihood phylogeny using predicted protein alignments. Bootstrap values for 500 iterations are labelled on nodes. Scale bar represents branch times.

#### 4.4.6. Spatial expression of cell wall degrading enzyme genes from *P. coffeae*

*In situ* hybridisation was undertaken to determine the spatial expression of the four *P. coffeae* transcripts in the nematode. Each of the probes was designed to be sequence-specific, using the sequence data obtained from genome and transcriptome assemblies. Each of *Pc-eng-1*, *Pc-eng-2* and *Pc-eng-3* were found to be expressed in the region of the nematode where the pharyngeal gland cells are located (Figure 4-7, B, C, F). This is an indicator in PPN that the gene products are secreted through the stylet into the root. Expression of the *Pc-eng-4* transcript was observed from the pharyngeal gland cells towards the posterior of the nematode (Figure 4-7, G, H, I). This is indicative of the intestine region. Expression of *Pc-xyl* and *Pc-pel-1* transcripts were detected in the pharyngeal gland cells, again indicating secretion into the root (Figure 4-8, Figure 4-9). No hybridisation was observed with the negative control probes.

#### 4.4.7. Temporal expression of cell wall degrading enzyme genes from *P. coffeae*

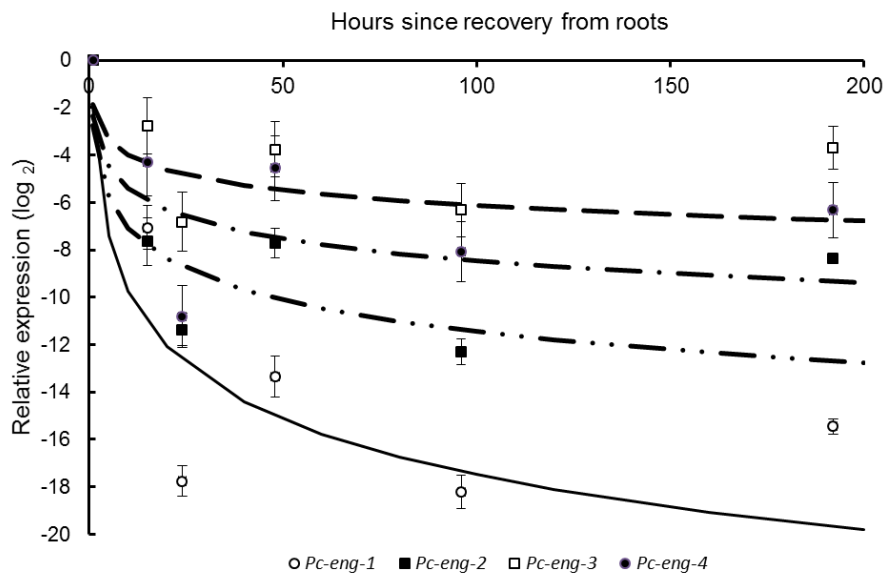
Analysis by qRT-PCR established that the four *Pc-eng* genes are expressed throughout different development stages of *P. coffeae* (Figure 4-10). Relative to eggs, the expression of *Pc-eng-1* and *Pc-eng-3* significantly increased as the nematode developed ( $P < 0.05$ ). The level of expression reached its maximum at the adult stage and did not differ significantly between males and females. The expression of *Pc-eng-2* showed a steady decrease throughout development, however there was no significant difference between values obtained. The expression of *Pc-eng-4* increased from eggs to juvenile stages ( $P < 0.05$ ) and then remained the same as the nematode developed into female or male. *Pc-eng-2* expression was lower than the other *Pc-eng* genes throughout development.

The transcripts of *Pc-xyl* and *Pc-pel-1* were also expressed in all stages studied and increased in expression as the nematodes developed (Figure 4-11).

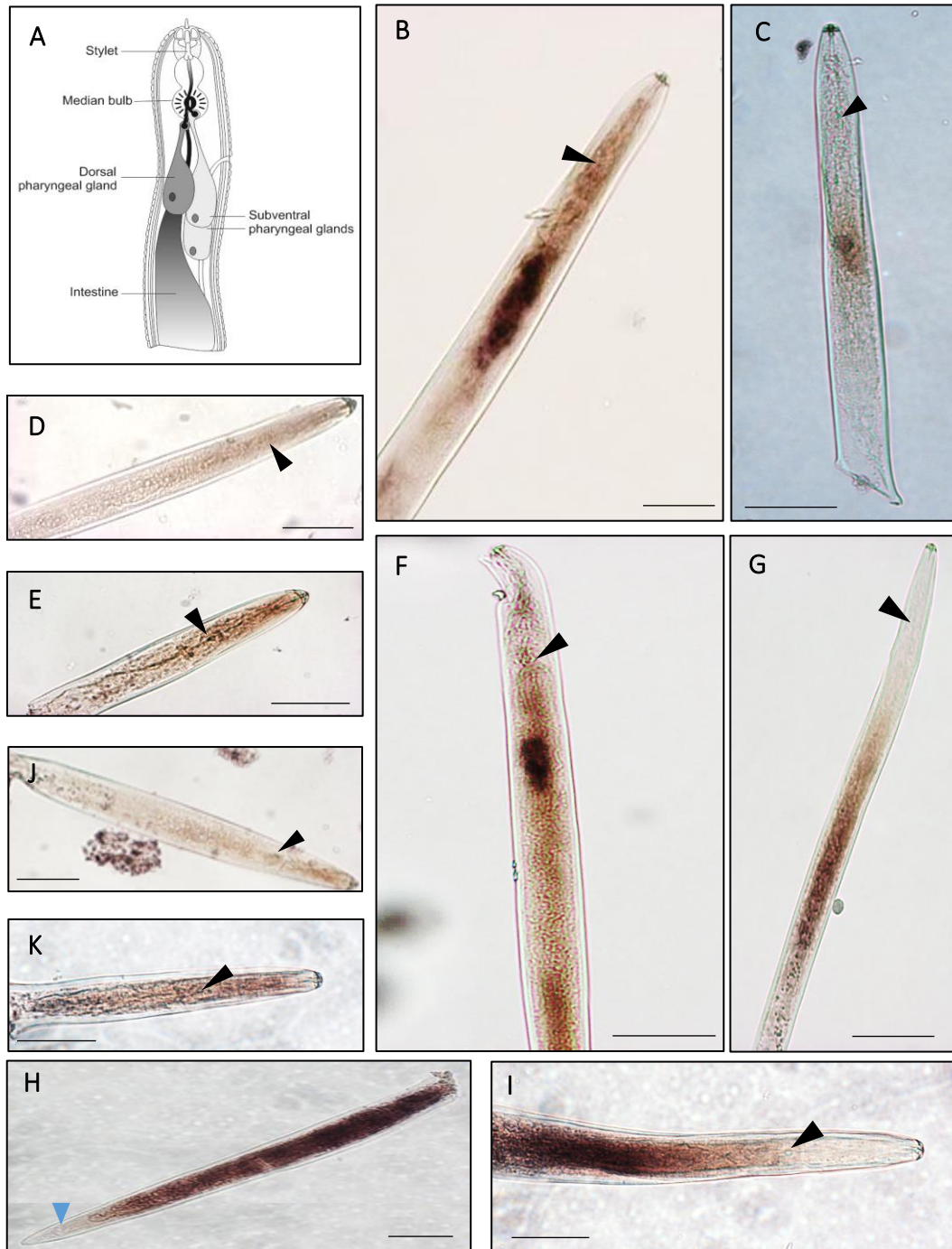
#### 4.4.8. Expression of beta-1,4-endoglucanase genes from *P. coffeae* post-removal from host tissue

The expression of cellulase sequences was investigated to determine the effect of prolonged absence of a host. Expression of all four sequences decreased post-removal from the host, with sharp declines until 24 h (Figure 4-6). A baseline level of expression as then observed throughout the remaining time points. The degree of down-regulation was different for each transcript, with *Pc-eng-1* decreasing the most.

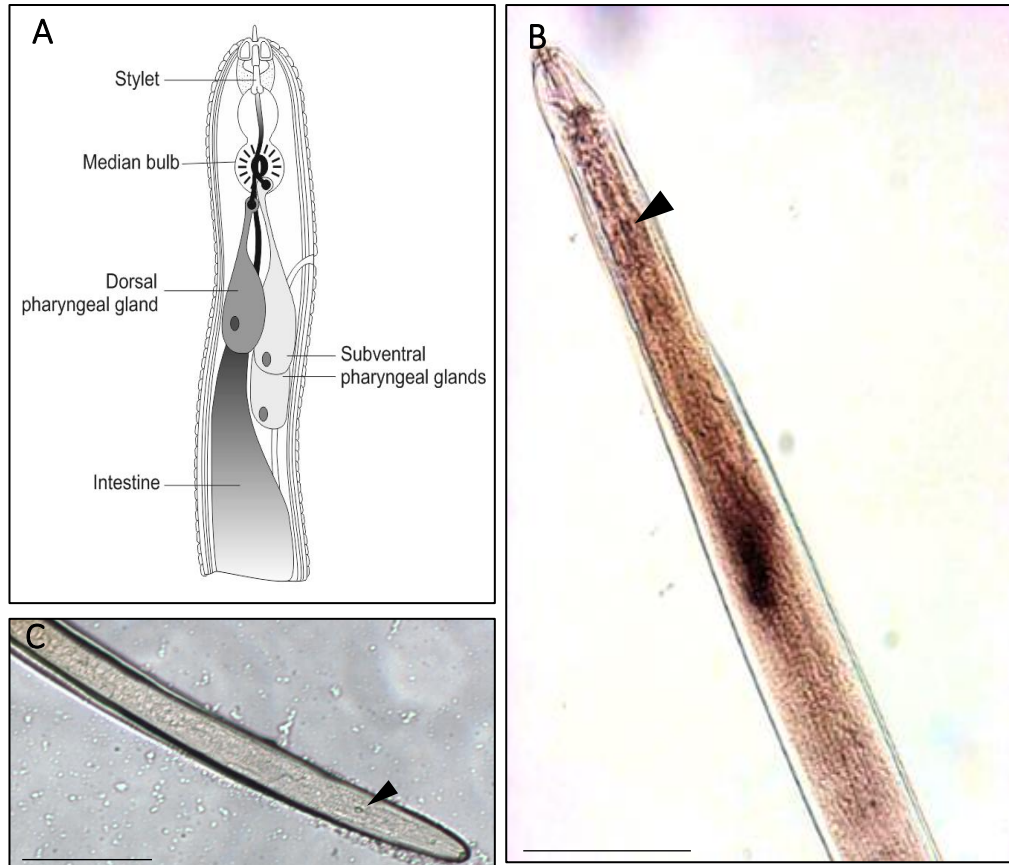




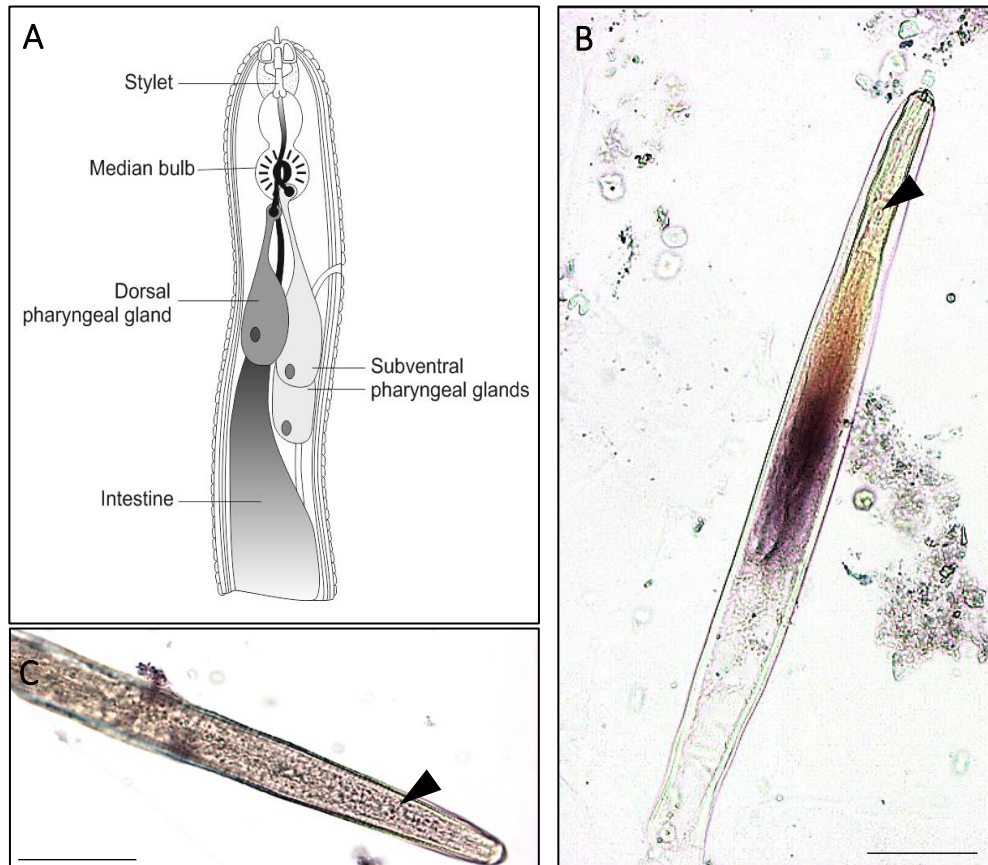
**Figure 4-6: Expression of beta-1,4-endoglucanase genes from *P. coffeae* post-removal from host roots.** *Pratylenchus coffeae* were removed from the roots of carrot and left in tap water for a period of eight days. Nematodes were removed at intervals and gene expression of beta-1,4-endoglucanase genes was determined by qPCR. Values are means  $\pm$  SEM (n =3 pools of individuals) and the curves represent regression analysis.



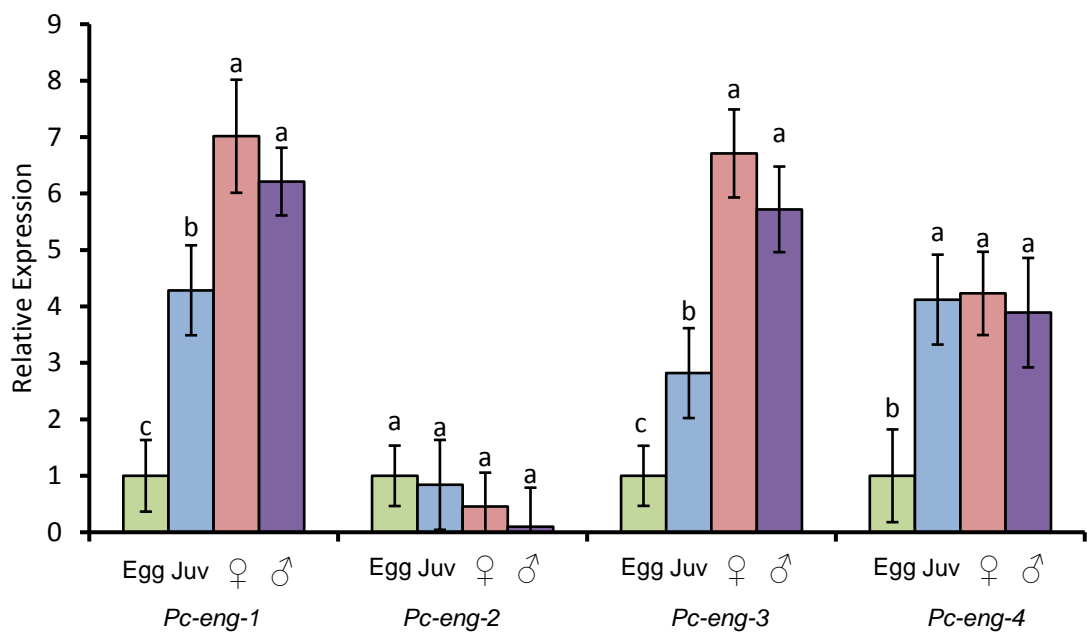
**Figure 4-7: *In situ* hybridisation of *Pc-eng-1*, *Pc-eng-2*, *Pc-eng-3* and *Pc-eng-4*.** Schematic representation of the anterior section of a plant-parasitic nematode (A). Digoxigenin-labeled anti-sense probes of *Pc-eng-1* (B), *Pc-eng-2* (C) and *Pc-eng-3* (F) reveal that expression of these genes is localised to the pharyngeal gland cells, posterior to the median bulb (black arrow). Probes of *Pc-eng-4* indicated expression in the intestine (G, H, I, blue arrow indicates tail of nematode). No corresponding staining occurred when the negative control probes were used (D, E, J and K for *Pc-eng-1*, -2, -3 and -4 respectively). Scale = 50µm.



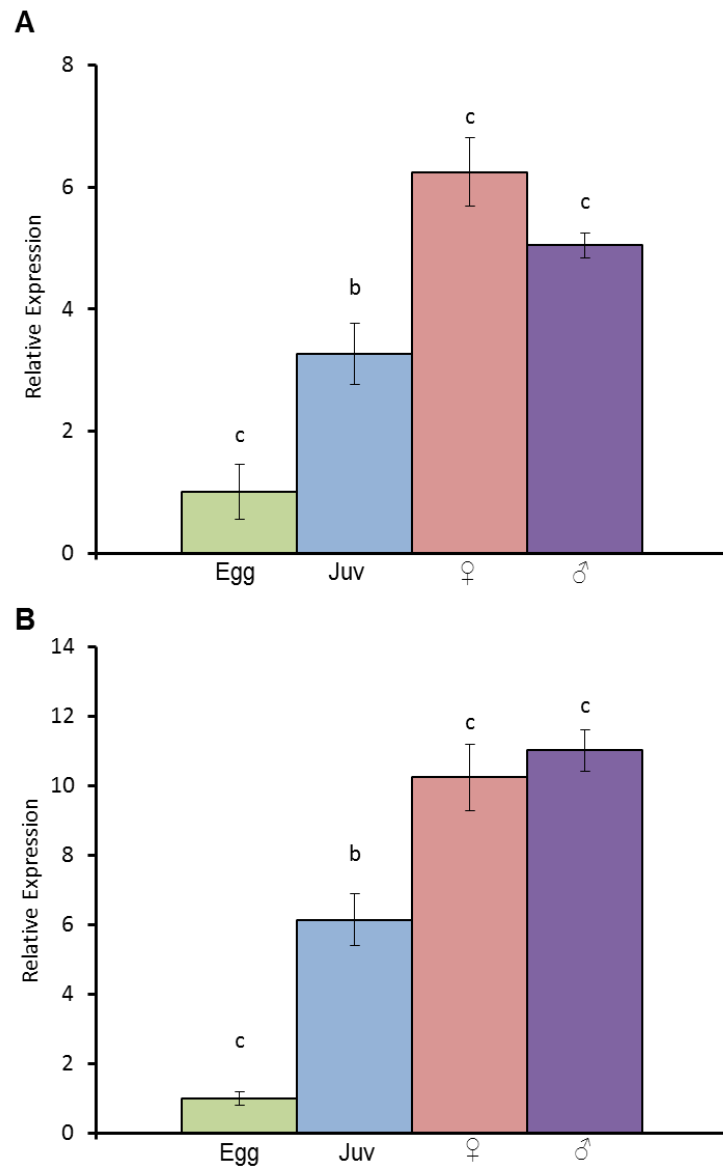
**Figure 4-8: *In situ* hybridisation of *Pc-xyl*.** Schematic representation of the anterior section of a plant-parasitic nematode (A). A digoxigenin-labeled anti-sense probe of *Pc-xyl* (B) reveal that expression of this gene is localised to the pharyngeal gland cells, posterior to the median bulb (arrowed). No corresponding staining occurred when the negative control probe was used (C). Scale = 50µm.



**Figure 4-9: *In situ* hybridisation of *Pc-pel-1*.** Schematic representation of the anterior section of a plant-parasitic nematode (A). A digoxigenin-labeled anti-sense probe of *Pc-pel-1* (B) indicate that expression of this gene is localised to the pharyngeal gland cells, posterior to the median bulb (arrowed). No corresponding staining occurred when the negative control probe was used (C). Scale = 50 $\mu$ m.



**Figure 4-10: Expression of *Pc-eng-1*, *Pc-eng-2*, *Pc-eng-3* and *Pc-eng-4* for selected life stages of *P. coffeae*.** Expression was normalised to Elongation Factor and presented relative to expression in eggs for each gene. Values are means  $\pm$  SEM (n =3 pools of individuals) with different letters indicating significant differences between egg, juvenile, female and male life stages for each gene (P<0.05 One-way ANOVA, SNK test).



**Figure 4-11: Expression of *Pc-xyl* (A) and *Pc-pel-1* (B) for selected life stages of *P. coffeae*.** Expression was normalised to Elongation Factor and presented relative to expression in eggs. Values are means  $\pm$  SEM (n =3 pools of individuals) with different letters indicating significant differences between between egg, juvenile, female and male life stages (P<0.05 One-way ANOVA, SNK test).

## 4.5. Discussion

For many years cell wall degrading enzymes have been a well-studied component of the arsenal of genes that plant-parasitic nematodes possess to assist plant invasion. To characterise this interaction in *P. coffeae*, a range of cell wall degrading enzyme genes were identified. The results describe the relationship between these genes and orthologues in other PPN and characterise their spatial and temporal expression.

The genome and transcriptome data for *P. coffeae* (Burke et al., 2015, Haegeman et al., 2011b) represent a wealth of resources for elucidating plant-nematode interactions, therefore they were utilised in this thesis. Unfortunately only the raw sequence files are publicly available for both 'omics studies, therefore a draft genome and transcriptome were assembled *de novo* for the purpose of this study. The genome and transcriptome assemblies constructed in this study allowed the identification of several cell wall degrading enzyme genes. When using files obtained from repositories it is important to bear in mind that there are many sources of error that could have been introduced in the production of these sequence files by the primary researcher. The data is reliant on the accurate classification of sample material, efforts to minimise contamination and obtaining sample material with low allelic variation.

This study identified and characterised four beta-1,4-endoglucanase, one beta-1,4-endoxyranase and one alpha-1,4-galacturonan lyase sequences. The genome study suggested that *Pratylenchus coffeae* has three beta-1,4-endoglucanase/beta-1,4-endoxyranase genes with another three genes encoding pectate lyases (Burke et al., 2015). Four beta-1,4-endoglucanase genes were identified in this work, including one previously cloned by Haegeman *et al* 2008 (*Pc-eng-1*), which is one more than reported in the genome study. Even so, this is a small number considering the wide host range of the species and the larger array of orthologues in host-limited nematode species such as the cyst nematodes *G. pallida* and *G. rostochiensis* (Cotton et al., 2014, Eves-van den Akker et al., 2016). Due to the disparity with the genome study, the cellulase activity of the encoded products of these genes was confirmed in *E. coli* using an established method (Figure 4-2) (Ledger et al., 2006, Zhang et al., 2013, Gao et al., 2004, Yan et al., 2001). Each expressed protein possessed clear cellulose-degrading activity, which may be unexpected due no cell lysis or protein purification step. The addition of bacterial cells expressing the protein onto the substrate was sufficient to result in substrate degradation. Cellulose-degrading gene products have previously been found to be secreted from *E. coli* upon treatment with IPTG and cDNA libraries can be screened for beta-1,4-endoglucanases simply by growing the *E. coli* expressing library with CMC

overlays (Yan et al., 2001). One possible explanation is the close similarity of nematode endoglucanase genes to bacteria which may allow for their recognition, translation and secretion in the bacterial system (Yan et al., 2001). An alternative explanation is that the CMC agarose or overlay may induce lysis of the bacterial colony. As the assay was not quantitative, it was not possible to determine the relative differences in activity between the four enzymes. Although in contrast to previous work, this reinforces the sequence assembly and annotation in this study to reveal four genes with cellulase function. These sequences, apart from *Pc-eng-4*, cluster with *Pratylenchus* cellulase genes from other species (Figure 4-3), have signal peptides and are expressed in the pharyngeal gland cells (Figure 4-7). The nucleotide sequences are of sufficient divergence to imply that these are separate, distinct sequences and not the same. Furthermore, each transcript maps to a separate genome contig and has differing intron sequences and positions. The activity and localisation of data infers that Pc-ENG-1, -2 and -3 proteins are secreted into the host roots in order to break down the cell wall structures and facilitate migration. The expression of *Pc-eng-1* and -3 increased as the nematode developed, promoting the suggested function in parasitism and root entry, as all vermiform stages can enter, leave and re-enter the root. Expression of these genes peaked at adult stages, presumably due to the higher fuel requirement for reproduction, as seen for females of *Radopholus similis* (Zhang et al., 2012). In contrast to *R. similis*, expression of cellulases is high in males of *P. coffeae*, suggesting that males of this species have a more active role in parasitism (Smant et al., 1998, Haegeman et al., 2008, Zhang et al., 2012).

Pc-ENG-4 was found to separate as an outlying group within the phylogenetic tree and has closer homology to bacterial sequences than nematode cellulases. This is similar to *Meloidogyne incognita* ENG-2 (also an outlier in the phylogenetic tree Figure 4-3) (Ledger et al., 2006). Beta-1,4-endoglucanases have been suggested to have arisen through horizontal gene transfer, which is defined as the asexual movement of genetic material between species and is common in bacteria but extremely rare between microorganisms and animals (Haegeman et al., 2011a). The acquisition of genes through this phenomena is suggested to have two roles in the nematode: assisting invasion of the host and digesting plant-derived products during feeding (Danchin et al., 2016). Cellulase genes are conserved across PPN in Clade 12 of the nematode phylogeny, which includes the most economically important genera (*Meloidogyne*, *Globodera*, *Heterodera*, *Pratylenchus* and *Radopholus*). It is suggested that these genes derived from a single or few horizontal gene transfer events that then led to expansion of the clade (Haegeman et al., 2011a). Although it is difficult to confirm horizontal gene transfer,



there are suggested incidents in different PPN (Danchin, 2011). The acquired genes provide functional advantages to the nematode and therefore are maintained in the population (Haegeman et al., 2011a). The bacterial similarity of *Pc-ENG-4* and *Mi-ENG-2* may suggest limited divergence from their bacterial origins or that they derive from a separate, more recent horizontal transfer event. In contrast to the other identified cellulase genes in *P. coffeae*, the predicted *Pc-eng-4* gene lacks a signal peptide and is expressed in the intestine (Figure 4-7). The gene data looks complete however it may lack an N-terminal region which facilitates secretion into the intestine, similar to cysteine proteases (Neveu et al., 2003). The expression pattern of *Pc-eng-4* is similar to that of *Pratylenchus vulnus eng-5* which is suggested to be involved in the later stages of development when the individual is required to feed in order to fuel reproduction (Fanelli et al., 2014). This is supported within this study as expression of *Pc-eng-4* increased from eggs to vermiform stage but was stable from juveniles to female/males (Figure 4-10).

The above data has shown that cellulase genes are present in *P. coffeae* and suggested to be involved in parasitism throughout the life cycle. Due to their likely role in assisting migration through the root, expression patterns were analysed post-removal of the nematodes from the host. Expression of all four *Pc-eng* genes decreased rapidly 24 h post-removal from the root and then reached a stable level. A range of nematode genes are known to increase in expression in the presence of host root exudate (Teillet et al., 2013) and when the individual initiates parasitism (Cotton et al., 2014, Eves-van den Akker et al., 2016). This is the first report to look at genetic responses to the removal of a host and consequential down-regulation of parasitism genes, supporting their requirement in host-nematode interactions. It is of interest that each gene decreases to a different base level. This indicates either the requirement of these products in the nematode even in the absence of a root or the differential increase in these genes in the presence of a host.

A beta-1,4-endoxylanase gene, encoding a product that degrades the hemicellulose xylan, was identified in *P. coffeae* and there are orthologues in *R. similis* and *Meloidogyne* spp but not cyst nematodes (Haegeman et al., 2009, Mitreva-Dautova et al., 2006, Danchin et al., 2010, Eves-van den Akker et al., 2016, Fosu-Nyarko et al., 2016). The incidence of a xylanase in *Pratylenchus* and *Meloidogyne* suggests a gene loss in cyst nematodes due to a conserved last common ancestor in these lineages (Danchin et al., 2010). Sequence data for *Pc-xyl* show closer homology to the orthologue in *R. similis* than *M. incognita* (Figure 4-4). This is unexpected due to the clustering of *Pratylenchus* and *Meloidogyne* spp in Clade 12 of the nematode phylogeny (Megen et

al., 2009). The sequences *Pc-xyl* and *Rs-xyl* are suggested to have derived from bacteria due to the inclusion of a carbohydrate binding domain (CBM), which are common in bacterial orthologues (Mitreva-Dautova et al., 2006). The three *Mi-xyl* genes are very similar and at least one lacks a CBM, suggesting they probably originated from the same ancestral gene through duplications and have lost the CBM through evolution (Haegeman et al., 2009, Mitreva-Dautova et al., 2006). Targeting the CBM of *Rs-xyl* with dsRNA significantly reduced the infection of individuals on *Medicago truncatula* roots, indicating that this domain has an important role in parasitism (Haegeman et al., 2009).

Pectate lyase genes are present in multiple plant-parasitic nematode genera and cluster with orthologues in bacteria, in comparison to plants and fungi (Dubey et al., 2010). The enzymes cleave pectin to assist in cell wall degradation and are the first class of enzymes produced by fungi during plant infection (Bohlmann and Sobczak, 2014, Alghisi and Favaron, 1995). Nematodes also regulate expression of pectate lyases but the mechanism behind this control is not known. For example, expression of *pel-2* in *G. rostochiensis* occurs in J2s in response to root exudate. This differs from *Gr-pel-1* expression which increases in eggs when rehydrated with tap water (Kudla et al., 2007). Pectate lyase genes were identified in each of *P. zaeae*, *P. thornei* and *P. penetrans* with expression localised to the gland cells in the latter, as observed in *P. coffeae* in this work (Vieira et al., 2016, Fosu-Nyarko et al., 2016, Nicol et al., 2012). Similar spatial expression patterns are observed in *Meloidogyne* (Haegeman et al., 2013, Huang et al., 2005, Doyle and Lambert, 2002). Orthologues are expressed in the juvenile stages of *Meloidogyne* but not adult females, suggesting that the gene product assists migration of the J2 nematodes (Huang et al., 2005). This role is indicated here for *P. coffeae* and the aforementioned cell wall degrading enzyme genes discussed in this chapter.

*Pratylenchus coffeae* produces a range of cell wall degrading enzymes in order to match the structural complexity of the plant cell wall to facilitate root entry and proliferation of the species. Better characterisation of the arsenal of genes the species possesses will allow understanding of the characteristics that render plant roots susceptible to these pathogens.

#### 4.6. Summary

- Four beta-1,4-endoglucanases, one beta-1,4-endoxylanase and three alpha-1,4-d galacturonan lyase genes were identified in *P. coffeae*.
- The enzyme activity of the four beta-1,4-endoglucanases was confirmed and expression of these genes decreased post-removal of the nematode from host roots.
- Expression of *Pc-eng-1*, *-2*, *-3*, *Pc-xyl* and *Pc-pel-1* was localised to the gland cells whereas *Pc-eng-4* was expressed in the intestine.
- Expression of *Pc-eng-1*, *-3*, *Pc-xyl* and *Pc-pel-1* increased throughout development of the nematode whereas *Pc-eng-2* decreased and *Pc-eng-4* was stable throughout vermiform stages.

## **Chapter 5. *Pratylenchus coffeae* respond to root exudate signals with host-specific gene expression patterns**

---

### **5.1. Introduction**

Plant pathogens must recognise and respond to host signals in order to survive, with root exudates particularly important for those that are soil-borne (Badri and Vivanco, 2009, Hawes et al., 2000, Walker et al., 2003). Root exudates contain up to 20% of the plant's photosynthetically fixed carbon in the form of sugars, amino acids, organic acids, proteins and carbohydrates, with the composition varying between plant species (Barber and Martin, 1976, Bertin et al., 2003). The polysaccharide components of exudates form a mucilaginous layer along the root, often gathering at the root tip (Badri and Vivanco, 2009). These components are released through the degradation of epidermal cells or secreted by root cap, root hair and root epidermal cells (Hawes et al., 2000, Walker et al., 2003). Transfer of these compounds across the cellular membrane has been suggested to occur through vesicular trafficking and/or ATP-binding cassette transporter proteins (Baetz and Martinoia, 2014, Walker et al., 2003). Although costly for the plant, constant communication with the rhizosphere is important in order to detect and respond to the presence of pathogens. It also sustains root-soil contact by altering the properties of the rhizosphere, contributing to root growth and plant survival (Walker et al., 2003). To prevent unnecessary energy loss, the biosynthesis and secretion of compounds is tightly regulated (Baetz and Martinoia, 2014). For example, some defence-related compounds are constitutively expressed (Vaughan et al., 2013), whereas others are induced when the roots are under pathogen attack (Lanoue et al., 2010).

Root exudates play an important role in host-pathogen interactions and may positively affect one organism whilst negatively effecting another (Hawes et al., 2000). Root exudates have been used in many studies to understand the effects of host plants on the nematode. Reports have shown that exudates induce nematode hatching and thrusting of the stylet, suggesting that nematodes prepare for root entry in response to these plant-signals (Grundler et al., 1991, Gaur et al., 2000, Pudasaini et al., 2008). Some host-selective nematodes are suggested to hatch only in exudate from host plants, indicating that nematodes can respond to host-specific signals present in exudate (Curtis, 2008). Plant parasitic nematodes (PPN) also orientate to plant roots in response to chemical gradients provided by root exudates (Yang et al., 2016). The effect of

exudates on nematode behaviour can be host- and tissue-dependent. *Meloidogyne incognita* juveniles were differentially attracted to the exudates from root epidermal and root tip exudates from different legume species (Zhao et al., 2000). The components of exudates that induce these responses in the nematode are ill-defined, however recent studies have found that reduced sugar exudation by tomato plants reduces the stylet thrusting and attraction of *M. incognita* juveniles (Warnock et al., 2016).

Infective stages of *Pratylenchus* are known to secrete a range of proteins that have putative roles in host/pathogen interactions such as facilitating cell wall degradation, reducing host defences and targeting regulation and signalling pathways (Fosu-Nyarko and Jones, 2016a). Several cell wall degrading enzyme genes were identified in Chapter 4 of this thesis. Secretion of these proteins requires either induced transcription of the corresponding genes, or triggered release of stored proteins, upon nematode contact with signals from the host. There is some evidence that changes in gene expression occur in response to host signals. Pre-parasitic J2s of the sedentary plant-parasitic nematode *M. incognita* differentially express genes (currently unannotated) in response to *Arabidopsis thaliana* roots and root exudate compared to when not exposed to a host (Teillet et al., 2013). Also, expression of a beta-1,4-endoglucanase in the foliar nematode *Aphelenchoides fragariae* decreases after change of food source from plant to fungal culture (Fu et al., 2012b). This indicates that nematodes regulate expression of genes involved in parasitism, however the effect of different host plants/exudates on transcription of these genes is unexplored.

Differential gene expression in response to various hosts is observed in other organisms such as aphids, bacteria and fungi. Transcriptional plasticity of multigene clusters underpins the ability of the peach potato aphid *Myzus persicae* to colonise diverse plant species rapidly and may contribute to the success of the generalist pathogen (Mathers et al., 2017). Non-pathogenic symbionts can also respond to particular plant partners. In *Pseudomonas aeruginosa*, the expression of genes responsible for metabolism, chemotaxis and protein secretion is differentially altered post-exposure to exudates from different varieties of *Beta vulgaris* (Mark et al., 2005). This is similar in arbuscular mycorrhizal fungi, which exhibit host-dependent expression of secreted proteins to control symbiotic efficiency in *Medicago truncatula*, *Nicotiana benthamiana* and *Allium schoenoprasum* (Zeng et al., 2018). These modulations in gene expression can be linked to host success in the various organisms and similar mechanisms could be present in PPN.

Consequently, these reports encouraged the work in this chapter to determine if expression of *P. coffeae* cell wall degrading enzyme genes is modulated by root exudates and if there is an additional differential effect of the host species from which the root exudate is derived. Any such observations could help rationalise the reduced complement of cell wall degrading enzymes found in *P. coffeae* compared to other PPN species (Burke et al., 2015).

## 5.2. Aims

- Investigate the expression of cell wall degrading enzyme genes in nematodes recovered from different host roots
- Determine if exudates from different host roots affect expression of cell wall degrading enzymes
- Identify components of root exudates that induce responses in nematodes
- Use RNA-interference to determine the importance of selected cell wall degrading enzymes in root penetration

### **5.3. Materials and Methods**

#### **5.3.1. Stylet thrusting assay**

Mixed stage nematodes of *P. coffeae* were removed from carrot disc cultures and washed multiple times. Groups of 100 mixed life stage *P. coffeae* nematodes then soaked in either 100  $\mu$ l sterile tap water, 5 mM 5-hydroxytryptamine (5-HT) or a root exudate for 1 h (Teillet et al., 2013). Ten nematodes per treatment were observed at a magnification of 80x and stylet thrusts of each nematode were counted for 30 seconds in triplicate to obtain an average count for each nematode. A single movement of the stylet forwards and then backwards to its original position was counted as a single stylet thrust. The complete experimental protocol was replicated three times to account for possible variation between batches of exudates and nematodes.

#### **5.3.2. Gene expression analysis**

##### **5.3.2.1. Nematodes in host roots**

Potato, banana, carrot, coffee and maize roots were infected with *P. coffeae* as described in section 2.1.2.5. Plants were grown for 8 weeks to allow for sufficient nematode infection and reproduction. The nematodes were recovered from the infected roots as described in section 2.1.2.4, with the exception of retrieving collected nematodes after 6 hours. Although fewer nematodes were obtained after this time point, there was sufficient numbers for analysis. These nematodes were immediately pelleted and frozen for RNA extraction and qPCR analysis, as described in section 2.1.3.5.

##### **5.3.2.2. Post-exposure to host root exudates**

Mixed stage nematodes of *P. coffeae* were removed from carrot disc cultures and washed multiple times. Samples of 500 mixed stage nematodes were left in water for 48 hours before exposure to either 500  $\mu$ l of host root exudate or fresh tap water for 4 hours. Total RNA was extracted immediately and qPCR was carried out to obtain gene expression values, as described in section 2.1.3.5. This was carried out four times for each treatment, with different pools of nematodes.

##### **5.3.2.3. Treatment of nematodes with cellulose and xylan**

Sets of 500 mixed stage *P. coffeae* were extracted from carrot discs, washed and maintained in water for 48 hours, as above. These nematodes were treated with a range of cellulose (0 - 18  $\mu$ g/ml) or xylan (0 - 1.2  $\mu$ g/ml) solutions (Sigma-Aldrich, US) for 4 hours. Concentration ranges were chosen based on respective polysaccharide concentrations detected in root exudates, described later. This was carried out four times per



concentration treatment and then total RNA was extracted for cDNA synthesis and qPCR analysis, as described in section 2.1.3.5.

### **5.3.3. Quantification of cellulose and xylan in root exudates**

Root exudates were collected as described previously (Chapter 2.1.3.2).

Cellulose was quantified in root exudates by a colorimetric assay (Updegraff, 1969). 1 ml of root exudates, prepared as described in section 2.1.2.2, were centrifuged at 10 000 rpm for 5 min and supernatant removed. 0.3 ml acetic/nitric reagent (8:1:2, acetic acid:nitric acid:water) was added. Samples were incubated for 30 min at 90 °C and then centrifuged again before washing the pellet with 0.5 ml water. Pelleted samples were resuspended in 0.5 ml sulfuric acid (67 %) and vortexed before mixing with 1 ml of cold anthrone reagent (0.2 % anthrone (Sigma-Aldrich, US) in sulfuric acid) and incubated at 90 °C for 16 min. Samples were then left to stand at 22 °C for 10 min before reading absorbance at 620 nm using a ELx800 microplate reader (Bio-tek instruments Inc.). The optical densities were used to generate cellulose equivalents using a standard curve. Three technical and four biological replicates of each exudate were assayed.

The monoclonal antibody LM11 was used in an enzyme-linked immunosorbent assay to detect xylan in the root exudates (McCartney et al., 2005). 200 µl of each exudate was incubated overnight at 4 °C with phosphate-buffered saline (PBS; Severn Biotech) to ensure efficient coating of microtitre plate wells. Samples were diluted fivefold in PBS prior to plate coating to ensure final absorbance readings in the range 0.1 - 1.0 optical density. Three technical and four biological replicates of each exudate were assayed. Plates were then blocked with 5 % w/v milk powder (Marvel) in PBS for two hours at 22 °C before incubation with LM11 (1 in 10 dilution) in 5 % blocking solution at 22 °C for 1 hour. The wells were then washed with tap water 9 times and then incubated with a horseradish peroxidase (HRP)-linked anti-rat secondary antibody (A9552; Sigma-Aldrich, US) diluted 1:1000 in PBS/5 % milk powder. To detect antibody binding, 100 µl HRP-substrate was added to each well (0.1 M sodium acetate buffer pH 6, 1% (v/v) tetramethyl benzidine, 0.006 % (v/v) H<sub>2</sub>O<sub>2</sub>). After 8 minutes 2.5 M sulphuric acid was added to stop the reaction. The absorbance values measured at 450 nm were used to calculate xylan concentration of the original root exudate samples using a standard curve constructed from xylan solutions in the range 0.2 – 1.2 µg/ml. Three technical and five biological replicates of each exudate were assayed.

### **5.3.4. RNA interference of *Pc-eng-1* and *Pc-xyl***

Complementary DNA (cDNA) from *P. coffeae* was used to amplify of 320 bp and 281bp templates for production of double-stranded RNA (dsRNA) complementary to *Pc-eng-1*

and *Pc-xyI*, respectively (Table 5-1). PCR was performed as described in section 2.1.3.2 but with Phusion High fidelity DNA polymerase (NEB). A green fluorescent protein (GFP) sequence (Haseloff et al., 1997) was amplified as a non-nematode gene for synthesis of a control (Roderick et al., 2018).

The DNA fragments were cloned between the XbaI and XhoI sites of the vector L4440 (pPD129.36 (Timmons and Fire, 1998)) using restriction sites present in the primer sequences. Complementary single-stranded RNAs (ssRNAs) were synthesised from T7 promoters in the L4440 constructs post-independent digestion with XbaI and XhoI. The synthesis of ssRNAs and subsequent production of double-stranded RNA (dsRNA) used a Megascript T7 RNAi kit (Invitrogen), according to the manufacturer's instructions. A total of 500 mixed stage *P. coffeae* nematodes were treated with 100 µg/ml dsRNA in M9 buffer for 16 hours at 25 °C. A control treatment was applied with no dsRNA. Three-hundred individuals were used for RNA extraction and cDNA synthesis, as described in section 2.1.3.3 and 2.1.3.4, to assess the reduction in target gene expression by qPCR. One-hundred of the treated nematodes were infected on to the roots of 8 day old maize or potato plantlets, grown in soil-free pouches described in section 2.1.2.1. The 100 nematodes were distributed between five root tips on the root system to reduce the chances of nematodes penetrating together. Each treatment was replicated six times. After 72 hours, root tissue was stained with acid fuchsin (Byrd et al., 1983) to visualise and count nematodes that had successfully invaded the roots.

**Table 5-1. Primer sequences used for dsRNA construct cloning.** Restriction sites are underlined.

Code	Forward / Reverse primer sequence
<i>Pc-eng1-RNAi</i>	ATCGT <u>CTAGAG</u> GCTCACCCCTTCTATACGGCC/ ATCG <u>CTCGAGT</u> GCCAAGCAATATGGCTCCA
<i>Pc-xyl-RNAi</i>	ATGCT <u>CTAGAG</u> ACACGAACCTGGGACCAAT/ ATGC <u>CTCGAGT</u> GGAAATCTTTTTGCTGCTGGA
<i>GFP-RNAi</i>	ATCGT <u>CTAGAG</u> CACTATTGCGGACTTGAAACA/ ATCG <u>CTCGAGC</u> CATATTACGCGCTCCAGTT

## 5.4. Results

### 5.4.1. Host root exudates stimulate a stylet thrusting response

Exposure to root exudate is known to stimulate thrusting of the stylet in some plant-parasitic nematodes (Teillet et al., 2013) although the response of *Pratylenchus* spp. has not been reported. *Pratylenchus coffeae* has a wide host range including both monocot and dicot plants from >30 different genera (Das and Das, 1986). Therefore, initial tests determined if root exudates from five different plants across its host spectrum (coffee, banana, maize, carrot and potato) induce stylet thrusting in this species. Incubation in root exudates of all five hosts stimulated a significant increase in stylet thrusting of mixed stages of *P. coffeae* by 9 fold relative to a very low frequency in water (Figure 5-1a). The proportion of nematodes showing any frequency of stylet thrusting also significantly increased and almost doubled for all root exudate treatments relative to water (Figure 5-1b, Oneway ANOVA, SNK,  $P < 0.001$ ). All root exudates induced the same response regardless of plant identity. As a positive control, *P. coffeae* were incubated in 5 mM 5-HT, which is known to stimulate stylet thrusting in plant-parasitic nematodes, including the related species *Pratylenchus penetrans* (Han et al., 2017). Exposure to 5-HT induced an even higher rate of thrusting (Figure 5-1a; Oneway ANOVA, SNK,  $P < 0.001$ ) but no significant, further increase to the high proportion of nematodes responding to root exudate (Figure 5-1b).

### 5.4.2. Expression of *Pc-eng*, *Pc-xyl* and *Pc-pel-1* is influenced by the host plant

Quantitative PCR was utilised to determine if the cell wall degrading enzyme genes identified previously were upregulated when *P. coffeae* is in host tissue and if that expression is influenced by host plant identity. A mixed population of life stages of *P. coffeae* showed significantly different expression of all *Pc-eng*, *Pc-xyl* and *Pc-pel-1* genes when extracted from roots of banana, carrot, coffee and maize than from roots of potato (Figure 5-2). The four *Pc-eng* genes each had different expression patterns in response to the different hosts (Figure 5-2a). Relative to expression in nematodes from roots of potato, *Pc-eng-1* expression was at a higher level when recovered from banana and maize and greatest when recovered from roots of carrot and coffee. Highest expression of *Pc-eng-2* and *Pc-eng-3* was observed in nematodes from maize roots whilst the lowest level of expression was seen in nematodes from the roots of carrot. *Pc-eng-4* was equally expressed during parasitism of all plant roots apart from carrot, when it was significantly lower. *Pc-xyl* expression for nematodes parasitising roots of maize was at a higher level than that for nematodes from roots of other plants studied (Figure 5-2b). Expression of *Pc-xyl* was also greater for individuals extracted from banana, carrot and coffee compared to nematodes from roots of potato. Highest expression of *Pc-pel-1* was

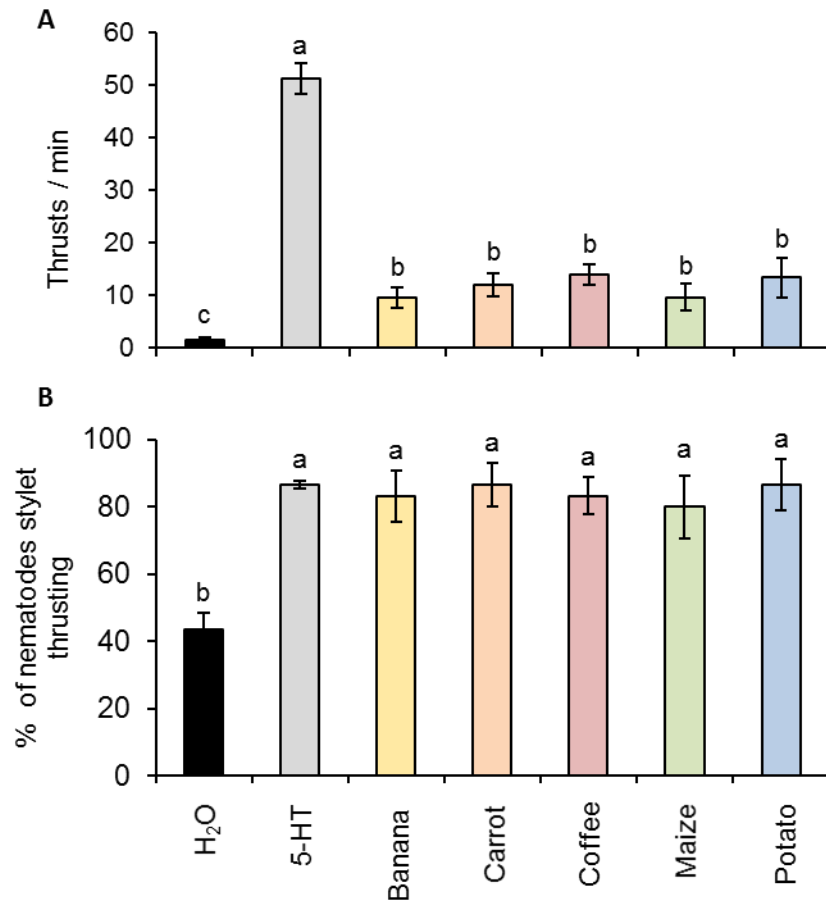
observed in nematodes from the roots of coffee, followed by maize with the lowest level of expression in nematodes from the roots of banana, carrot and potato (Figure 5-2c).

Differential induction of gene expression was not dependent on contact of the nematodes with host roots. When extracted nematodes cultured on the same host were maintained in water for 48 hours, subsequent exposure to different root exudates was sufficient to induce broadly similar expression profiles of *Pc-eng*, *Pc-xyI* and *Pc-pel-1* as root parasitism (Figure 5-3).

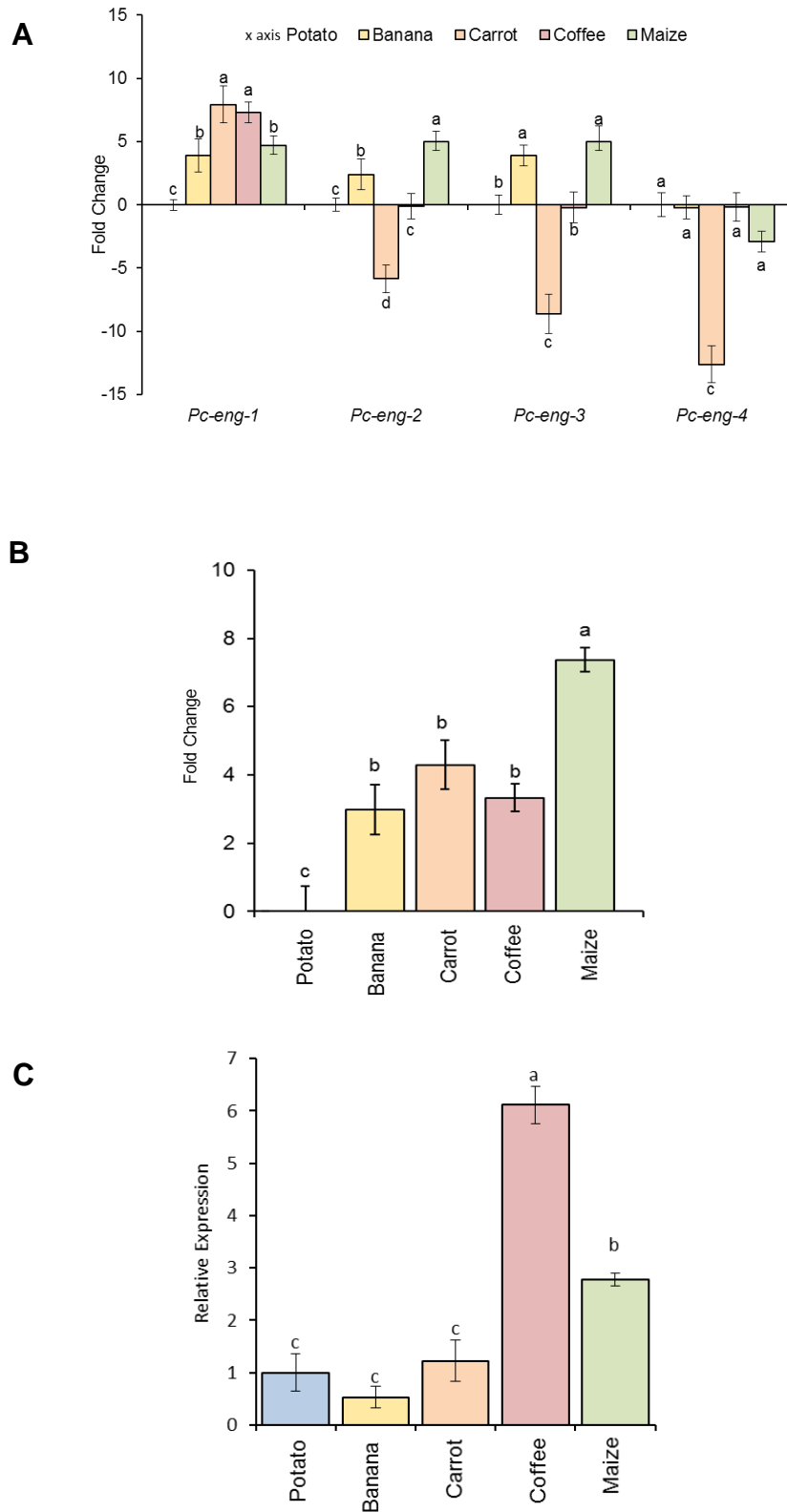
*Pc-eng* expression in mixed life stages of *P. coffeae* was significantly greater after incubation in any of the host exudates than in water (Figure 5-3a). The four *Pc-eng* genes each had different expression patterns in response to exudates from the different hosts. The magnitude of the increased expression of *Pc-eng-1* followed the pattern observed previously for nematodes extracted from host roots, carrot/coffee > banana/maize > potato (Figure 5-2a). The expression of *Pc-eng-2*, -3 and -4 varied slightly from that observed in roots. Expression of *Pc-eng-2* was higher in nematodes treated with maize root exudate and at the lowest level in nematodes treated with carrot root exudates. Expression of *Pc-eng-3* was greatest in nematodes treated with exudate from banana/maize roots and at the lowest level when treated with root exudates from potato/carrot. *Pc-eng-4* was equally expressed in nematodes exposed to exudate from the roots of potato/banana/maize but at a significantly lower level in those in exudates of coffee and carrot.

*Pc-xyI* expression in nematodes treated with root exudates followed a trend similar to that observed previously for nematodes extracted from host roots (Figure 5-3b, previous data for nematodes in root can be found in Figure 5-2b). Expression was greater in exudates from all plants compared to water. Highest expression was observed in nematodes exposed to exudates from the roots of maize. Expression of *Pc-xyI* was at a significantly lower level in nematodes treated with carrot/coffee exudates, but still greater than nematodes treated with root exudates from banana and potato.

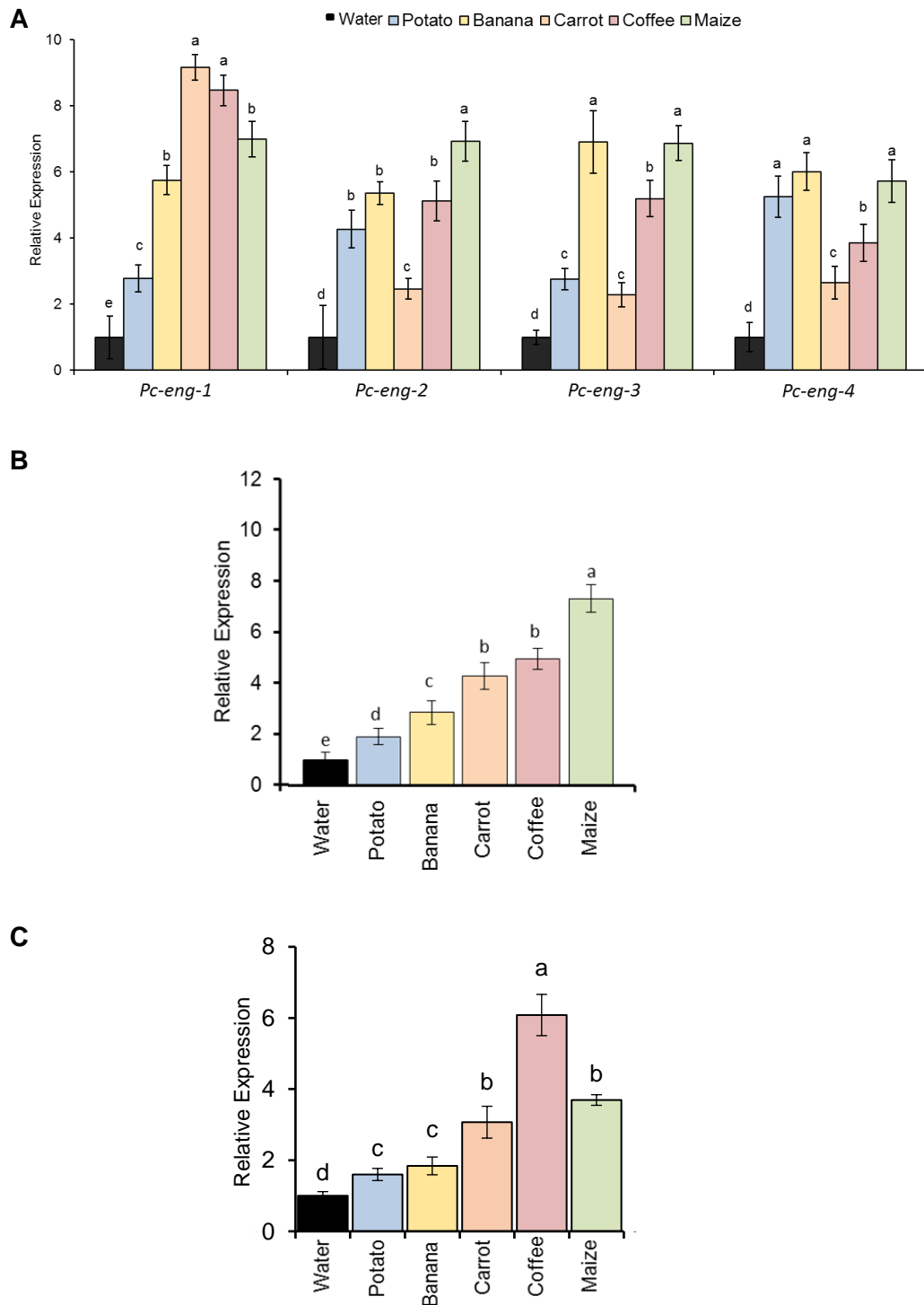
Expression of *Pc-pel-1* was significantly greater upon exposure to any plant root exudate, compared to water. Highest expression was found in nematodes from the roots of coffee and lowest level of expression in nematodes from the roots of banana/potato/carrot (Figure 5-3c).



**Figure 5-1. Effect of host root exudates on the stylet activity of *P. coffeae*.** Root exudates from the hosts banana, carrot, coffee, maize and potato were evaluated for their effects on the rate of stylet thrusting in individuals of mixed life stages (A) and the proportion of individuals of mixed life stages thrusting their stylets (B). H<sub>2</sub>O and 5 mM 5-HT were used as negative and positive controls, respectively. Values are means ± SEM with different letters indicating significant differences between treatments P < 0.01 (One-way ANOVA, SNK test, n = 30).



**Figure 5-2. Relative expression of *Pc-eng* genes (A), *Pc-xyl* (B) and *Pc-pel-1* (C) in *P. coffeae* recovered from host roots of potato, banana, carrot, coffee or maize. Values are means  $\pm$  SEM (n = 8 pools of mixed stages) relative to nematodes recovered from potato with different letters indicating significant differences between treatments  $P < 0.05$  (One-way ANOVA, SNK test).**



**Figure 5-3. Expression of *Pc-eng*, *Pc-xyl* and *Pc-pel-1* in *P. coffeae* after exposure to host root exudates of banana, carrot, coffee, maize or potato for 4 hours. Values are means  $\pm$  SEM (n = 4 pools of mixed stages) with different letters indicating significant differences between treatments  $P < 0.05$  (One-way ANOVA, SNK test).**

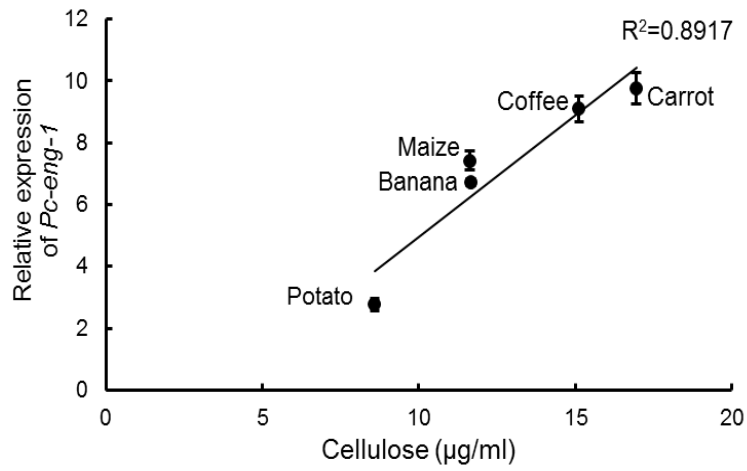


#### 5.4.3. *Pc-eng-1* and *Pc-xyl* expression correlates with cellulose and xylan quantities exuded by plant roots

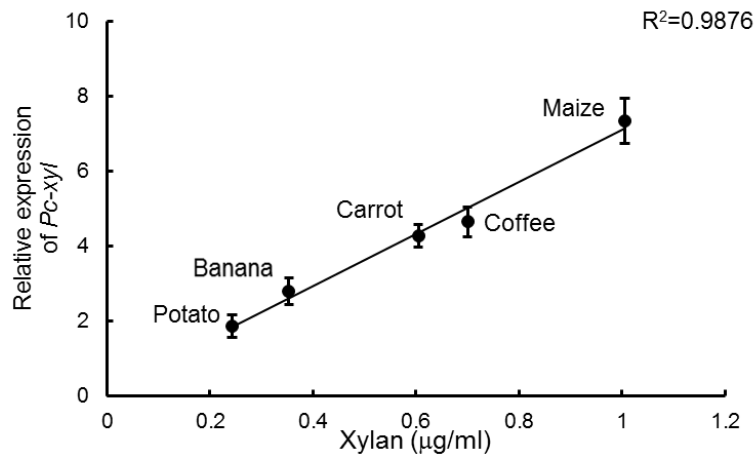
It was hypothesised that the host-related expression levels of *Pc-eng* and *Pc-xyl* genes might reflect relevant differences in root exudate composition. Therefore, cellulose (substrate for beta-1,4-endoglucanase) and xylan (substrate for beta-1,4-endoxyranase) were quantified in each exudate. Overall there was a linear regression between the quantity of cellulose in the exudates and the expression level of *Pc-eng-1* ( $P < 0.05$ ,  $R^2 = 0.89$ ; Figure 5-4a). The expression of *Pc-eng-2*, -3 and -4 did not correlate with the cellulose content of the exudates. A linear relationship was also evident in the parallel experiment with increasing amounts of xylan inducing significantly increased expression of *Pc-xyl* ( $P < 0.01$ ,  $R^2 = 0.988$ ; Figure 5-4b). There was not a significant rank correlation coefficient (Spearman test) for increased expression of the two genes by plant species because carrot and maize exudates had different ranks for concentration of the two substrates (Figure 5-4).

Mutant *Arabidopsis* plants deficient in either cellulose or xylan were used to provide further evidence that concentrations of these cell wall components in root exudate specifically regulate expression of *Pc-eng-1* and *Pc-xyl*. Initial analysis confirmed that the reported cellulose deficiency of *rsw1* mutant plant tissue (Peng et al., 2000) and the xylan deficiency of *glz1* plants (Lee et al., 2007) was reflected in reduced accumulation of these molecules in root exudates (Figure 5-5). Transcript abundance of both *Pc-eng-1* and *Pc-xyl* increased relative to expression in water after exposure of nematodes to root exudate from wildtype *Arabidopsis* plants (Figure 5-6). Expression of *Pc-eng-1* was only reduced significantly ( $P < 0.01$ ; oneway ANOVA) from this level when the nematodes were exposed to exudates of the *rsw1* mutant line that is deficient in cellulose. A similar specific effect was obtained for *Pc-xyl* expression when the root exudate was obtained from *glz1* mutant plants deficient in xylan ( $P < 0.01$ ; oneway ANOVA). The specificity of the response was confirmed by analysing a pectate lyase encoding gene (*Pc-pel-1*) and an additional *Arabidopsis* mutant (*mur3*). Pc-PEL-1 does not degrade cellulose or xylan and was therefore predicted to not respond to varying abundance of the two polysaccharides. The *mur3* mutant plants are deficient in fucose and galactose sidechains on the hemicellulose xyloglucan, thereby providing no changes to cellulose or xylan abundance but altering the cell wall structure. The expression of *Pc-pel-1* was upregulated in response to *Arabidopsis* root exudate but did not differ among the exudates from wildtype and mutant plants. The expression of all three genes studied was unaffected when the exudate was from the roots of *mur3* plants.

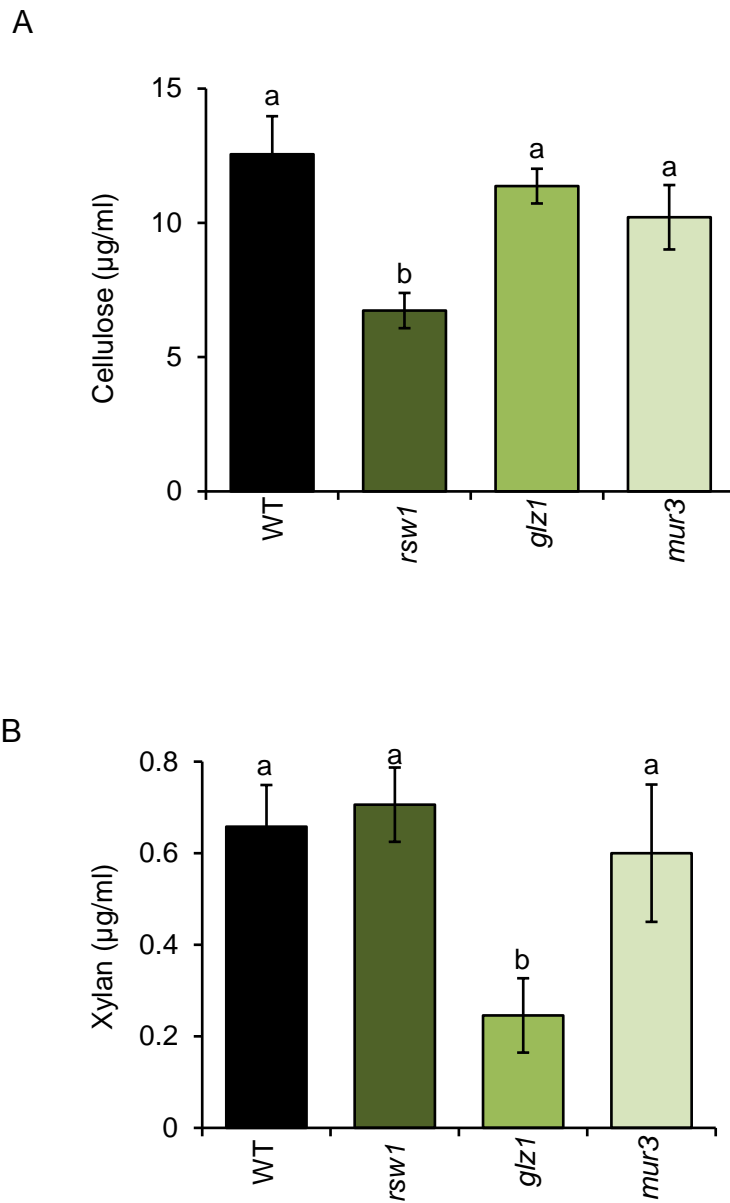
A



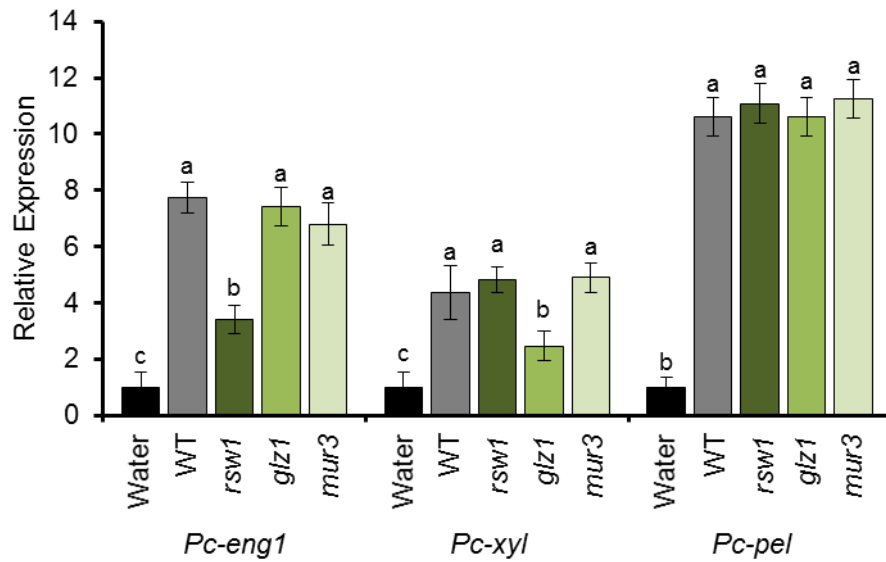
B



**Figure 5-4. Relationship between exudate induced *Pc-eng-1* (A) and *Pc-xyI* (B) expression with exudate cellulose and xylan content, respectively.** Linear regression establishes a significant relationship for both *Pc-eng-1* ( $P<0.05$ ) and *Pc-xyI* ( $P<0.01$ ). Values are means  $\pm$  SEM ( $n = 4$  pools of mixed stage *P. coffeae*).



**Figure 5-5. Quantification of cellulose (A) and xylan (B) in *Arabidopsis thaliana* mutants.** Cellulose and xylan quantities were determined for WT and mutants deficient in cellulose (*rsw1*), xylan (*glz1*) and xyloglucan (*mur3*). Values are means  $\pm$  SEM ( $n = 3$ ) with letters denoting significant differences ( $P < 0.05$ ).



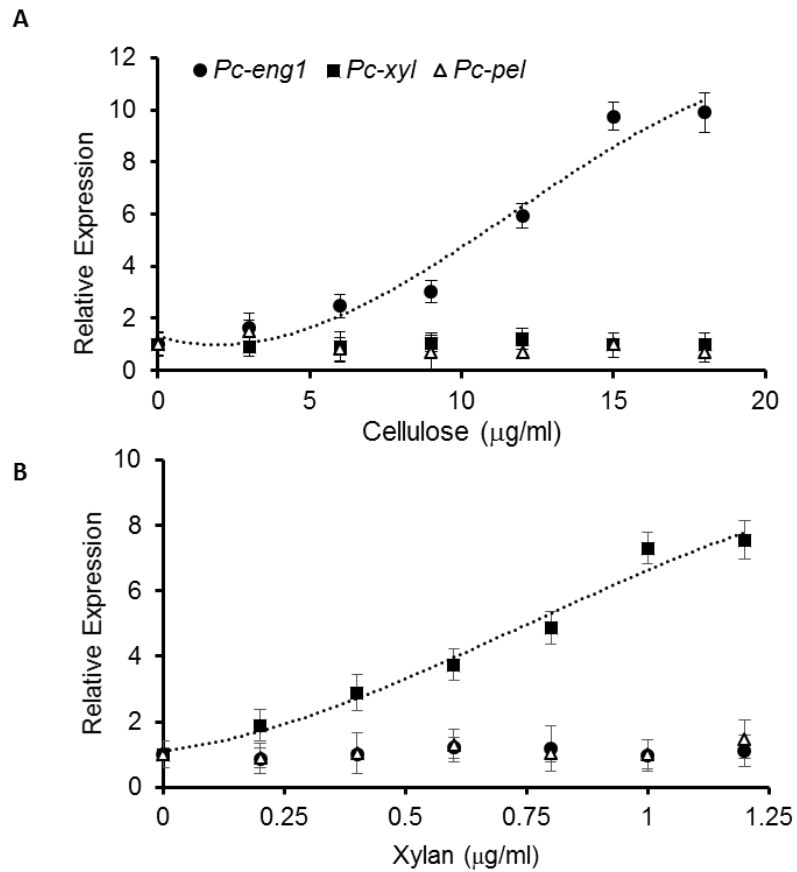
**Figure 5-6.** Expression of *Pc-eng-1*, *Pc-xyl* and *Pc-pel-1* in *P. coffeae* after 4 hours exposure to root exudates of mutant lines of *A. thaliana* that are deficient in cell wall cellulose (*rsw1*), xylan (*glz1*) or xyloglucan (*mur3*). Values are means  $\pm$  SEM ( $n = 4$  pools of mixed stage *P. coffeae*) with different letters indicating significant differences between treatments  $P < 0.05$  (One-way ANOVA, SNK test).

#### 5.4.4. Cellulose and xylan specifically up-regulate expression of *Pc-eng-1* and *Pc-xyl*, respectively.

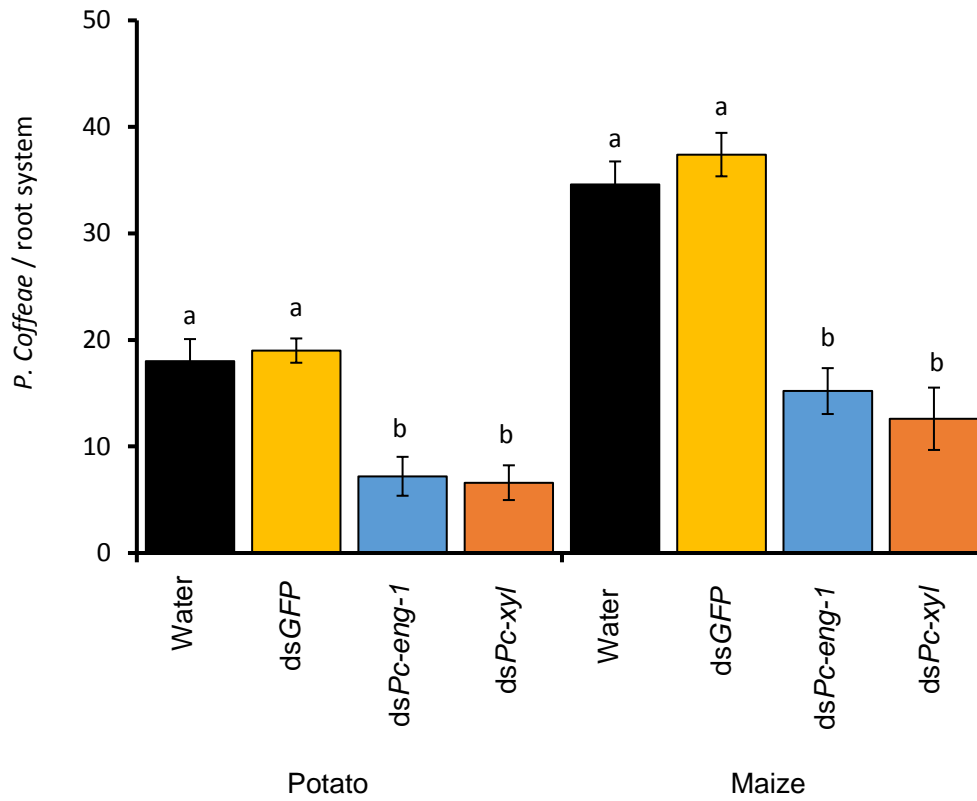
Pure solutions of cellulose or xylan were investigated to determine if they could induce expression of the nematode genes. Exposure of batches of mixed stages of *P. coffeae* to a range of cellulose solutions resulted in a significant linear increase in expression of *Pc-eng-1* but not *Pc-xyl* or *Pc-pel-1* (Figure 5-7a,  $P < 0.05$ ,  $R^2 = 0.975$ ). A parallel experiment with a range of xylan concentrations resulted in a linear increase in *Pc-xyl* expression (Figure 5-7b,  $P < 0.05$ ,  $R^2 = 0.955$ ) but not the other two genes.

#### 5.4.5. RNA interference of *Pc-eng-1* and *Pc-xyl* reduces infection of *P. coffeae*

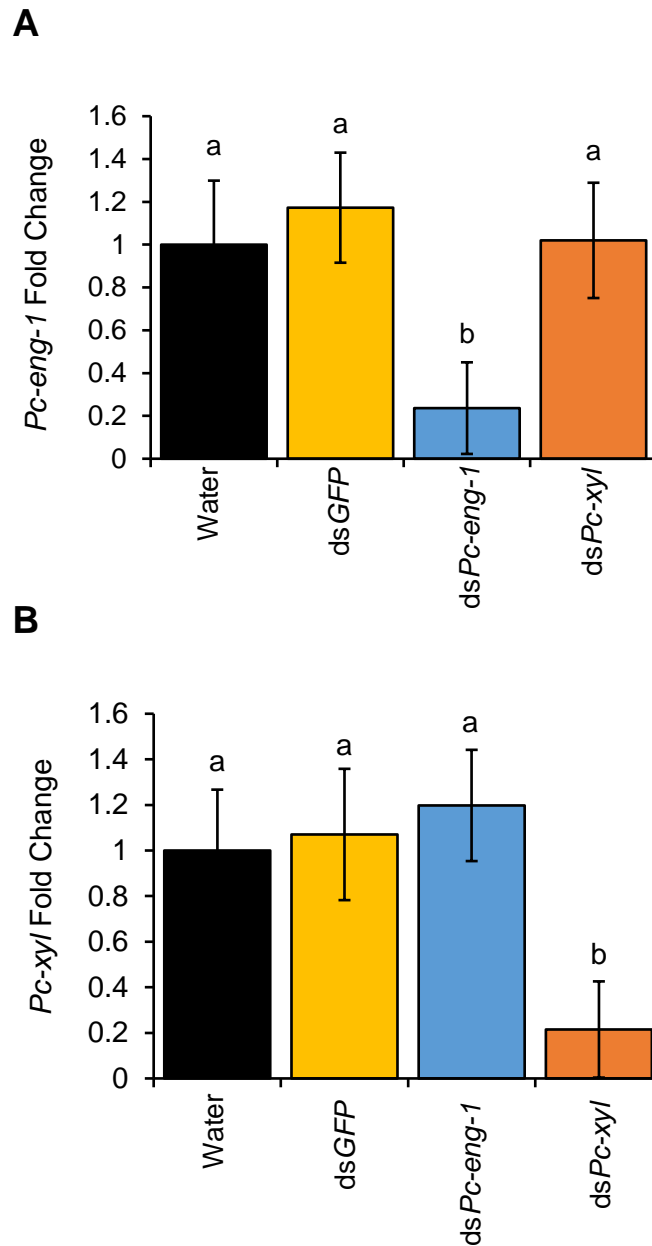
RNA interference was used to establish if the induced expression of the *P. coffeae* endoglucanase and endoxylanase genes was required for successful invasion of host roots (Figure 5-8). Two different hosts were tested: potato and maize. Potato was selected as its exudates contain the least cellulose and xylan whilst maize exudate has the highest xylan content. In the absence of RNAi, maize roots proved to be more readily invaded: a significantly greater number of nematodes were present in maize than potato roots after allowing a 72 hours period for root invasion (Figure 5-8,  $P < 0.01$ ; oneway ANOVA). Treatment of mixed stages of *P. coffeae* with a dsRNA solution targeting *Pc-eng-1* reduced expression of this gene by 76 % (Figure 5-9a). The number of ds*Pc-eng-1*-treated *P. coffeae* detected in maize or potato plants after access to their roots for 72 hours was reduced significantly by  $62.4 \pm 5.1$  and  $54.4 \pm 4.8$  % respectively relative to those nematodes pre-treated with M9 buffer only (Figure 5-8) ( $P < 0.001$  in both cases, SNK, oneway ANOVA). A dsRNA targeting *Pc-xyl* reduced expression of this gene by 79 % (Figure 5-9b). Targeting this gene reduced nematode numbers in maize and potato roots by  $68.2 \pm 6.1$  and  $41.1 \pm 6.7$  % respectively (Figure 5-8) ( $P < 0.001$  in both cases, SNK, oneway ANOVA). A control dsRNA treatment that targeted a *gfp* sequence not present in the nematodes was without effect on root invasion or expression of either gene.



**Figure 5-7. Effect of incubation in cellulose (A) and xylan (B) solutions for 4 hours on expression of *Pc-eng-1* (●), *Pc-xyl* (■) and *Pc-pel-1* (△) by *P. coffeae*.** Values are means  $\pm$  SEM ( $n = 4$  pools of mixed stage *P. coffeae*). Polynomial regression analysis establishes a significant increase in expression of *Pc-eng-1* and *Pc-xyl* with cellulose (A) and xylan (B) concentrations, respectively ( $P < 0.01$   $R^2 = 0.96$  and  $P < 0.001$  and  $R^2 = 0.98$ , respectively).



**Figure 5-8. Infection of potato and maize roots by *P. coffeae* after treatment in solutions designed to induce RNAi.** The dsRNA molecules targeted *Pc-eng-1* or *Pc-xyl* with control dsRNA against GFP (a gene that is absent from the nematode) plus incubation in M9 buffer only. Values are means  $\pm$  SEM (n = 3 pools of mixed stage *P. coffeae*) with different letters indicating significant differences between treatments  $P < 0.05$  (One-way ANOVA, SNK test).



**Figure 5-9. Expression of *Pc-eng-1* (A) and *Pc-xyl* (B) in *P. coffeae* treated with solutions designed to induce RNAi.** The dsRNA molecules targeted GFP (a gene that is absent from the nematode), *Pc-eng-1* or *Pc-xyl*. Values are means  $\pm$  SEM ( $n = 3$  pools of mixed stage *P. coffeae*) and represented relative to expression in nematodes in water. Expression is normalised to abundance of elongation factor and different letters denote significant differences between treatments  $P < 0.05$  (One-way ANOVA, SNK test).



## 5.5. Discussion

The results establish that expression of a number of genes encoding cell wall modifying enzymes is upregulated in *P. coffeae* both post-invasion of roots and post-exposure to exudates from host roots. Furthermore, the data demonstrates that this response is host-specific: exposure to root exudates from different host plants confers a differential gene response in this plant-parasitic nematode. The five host plants tested could be divided into significant groups with respect to their induction of expression of the beta-1,4-endoglucanase genes. These groupings were similar for *Pc-eng-2* and *-3* whilst *Pc-eng-1* and *-4* were distinct. For example, *Pc-eng-1* showed similar, significant expression groups for nematodes recovered from the host roots and nematodes exposed to the root exudates: (coffee and carrot) > (maize and banana) > potato. The groupings of all four *Pc-eng* genes were similar between analysis of nematode expression in root and in response to root exudates, suggesting that same or similar inducers are present in both. The *Pc-eng-1*, *-2* and *-3* genes contain N-terminal signal peptides and show expression in the pharyngeal glands, suggesting secretion out of the stylet (Chapter 4). On the other hand *Pc-eng-4* was found to be expressed in the intestine and lacked an N-terminal signal peptide (Chapter 4). As *Pc-eng-4* does not appear to be involved in root invasion and migration, the upregulation by root exudates may be in preparation to breakdown cell wall products that may be ingested. The stable expression patterns in the mobile life stages (Chapter 4) also suggests this function. Three different groups were also established for both *Pc-xyl* and *Pc-pel-1* expression for nematodes recovered from the host roots and nematodes exposed to root exudates.

The host-specific abundance of both *Pc-eng-1* and *Pc-xyl* in response to root exudate was linearly related to the level of cellulose and xylan respectively, with potato exudates having lower concentrations of both complex carbohydrates. The remaining *Pc-eng* genes did not relate to the concentration of cellulose within the exudate, thereby suggesting that another factor/s or mechanism contributes to the differential expression of these genes. As *Pc-eng-4* was found to be intestinal it may be only regulated by the amount of substrate that reaches this portion of the nematode, therefore not relating to concentrations in the observed exudates. The linear relationship for *Pc-eng-1* and *Pc-xyl* with cellulose and xylan led to further study on both of these genes throughout the chapter. The transcriptional responses were established as specific as the expression of *Pc-eng-1* increased with the concentration of cellulose but not xylan with a *vice versa* effect when *Pc-xyl* expression was measured. It would be of interest to look at the other *Pc-eng* gene in response to pure solutions of cellulose. This would determine if *Pc-eng-4* is also regulated by the component at concentrations that reach the intestine.

The expression of a pectate lyase gene (*Pc-pel-1*) was unaltered by exposure to either of these two complex carbohydrates, presumably due to the gene-product exhibiting no activity on either substrate. Pectate lyase catalyses the cleavage of unmethylated pectin and the nematode enzymes are predicted to aid in softening of the cell wall middle lamella so facilitating migration (Wieczorek, 2015). Determining whether or not individual exudate components have specific or broad effects on nematode gene expression is relevant to understanding the mechanism behind the response in not just *P. coffeae* but other plant-parasitic nematodes that upregulate genes in response to root exudates (Teillet et al., 2013). There is no indication that these enzymes are released in sequential order by the nematode, as observed in fungi which usually secrete pectin degrading enzymes first (Bohlmann and Sobczak, 2014).

Use of mutant lines of *A. thaliana* confirmed the specificity of the effect as expression of *Pc-eng-1* was reduced only when the nematode was exposed to exudate from a mutant deficient in cellulose (Arioli et al., 1998) and *Pc-xyl* only when exposed to exudate from a mutant deficient in xylan (Lee et al., 2007). Tissue from these mutants contains <50% of cellulose and xylan wild-type levels respectively (Brown et al., 2007, Arioli et al., 1998, de Azevedo Souza et al., 2017). A third mutant, deficient in fucose and galactose sidechains on the hemicellulose xyloglucan, has no effect on the expression level of either gene, confirming that any variation in cell wall composition *per se* does not necessarily incur changes in expression in the nematode. The use of root exudates from additional mutant lines, coupled with a panel of nematode genes, provides the opportunity to further analyse exudate components that elicit specific or broad responses in the nematode.

RNAi of *Pc-eng-1* and *Pc-xyl* caused reduction of its invasion on maize and potato roots establishing the importance of both gene products for the penetration of both hosts. This reflects the previously identified importance of cell wall degrading enzymes in parasitism of PPN (Rehman et al., 2016). The dsRNA was designed to be sequence-specific therefore should not have affected the expression of the other three *Pc-eng* genes. If *Pc-eng-4* is indeed expressed in the intestine then reducing transcript level through RNAi may have a different effect compared to the other *Pc-eng* genes: it may impair feeding and consequently reproduction rather than root invasion. An alternative approach could be to silence all *Pc-eng* genes simultaneously through one construct, thereby impacting the different roles of each *Pc-eng* gene and determining the effects of the gene family, as done previously for proteases in *M. incognita* (Antonino-de-Souza et al., 2014).

The polysaccharide components of exudates form a mucilaginous layer along the root, often accumulating at the root tip (Badri and Vivanco, 2009). These components are released through the degradation of or active-secretion by root epidermal cells (Hawes et al., 2000, Walker et al., 2003, Baetz and Martinoia, 2014). Transfer of polysaccharides across the cell membrane has been suggested to occur through vesicular trafficking and/or ATP-binding cassette transporter proteins (Baetz and Martinoia, 2014, Walker et al., 2003). Although costly for the plant, constant communication with the rhizosphere is important in order to detect and respond to the presence of pathogens (Badri and Vivanco, 2009). However, in this study it was found that these compounds may also be reliable indicators of close proximity of roots and so induce preparation of *P. coffeae* for root invasion. Expression of *Pc-eng-1* and *Pc-xyl* by all life stages studied is also appropriate as all mobile stages of this nematode invade roots during development. The host-specific concentration of these compounds is perceived by the nematode and consequently induces transcriptional shifts. This distinctive reaction to non-host specific complex carbohydrates may be an adaptation for plant invasion due to the polyphagous nature of *P. coffeae*.

Transcriptional plasticity in response to different plant hosts is known to occur for the generalist aphid *Myzus persicae* (Mathers et al., 2017) and may also be important for other polyphagous plant-feeding arthropods (Grbic et al., 2011). This project extends this response to a generalist plant-feeding nematode, suggesting it may be a common adaptation to tailor gene expression to a particular host plant. It would be interesting to investigate which nematode species and genera that are capable of such perception and determine if this relates to host generalisation rather than specialisation. Mitotic asexual species of *Meloidogyne* cause complex adaptive changes in plant cells, forming feeding sites as well as having wide host ranges. Their polyphagy is considered to relate to the plasticity afforded by their large, duplicated genomes (Blanc-Mathieu et al., 2017). This approach is an interesting contrast with that of *Pratylenchus*. This genus does not modify plant cells but achieves a wide host range while having the smallest genome of any nematode studied to date (Burke et al., 2015). Attempting to establish in any plant root encountered seems to be a beneficial adaptation given the nematode's limited locomotory range in soil. Subsequent success in feeding and reproduction may be determined after initial invasion of a potential host. The recent sequencing of the *P. coffeae* genome may enable genes involved in those aspects of the host/parasite interaction to be defined (Burke et al., 2015).

Direct chemoreception of carbohydrate polymers is not a commonly reported ability. Intracellular fluctuations in transcription factor binding due to external cellulose or xylan

have been reported for filamentous fungi (Coradetti et al., 2012). Transcription factors CLR-1 and XLR-1 in *Neurospora crassa* bind to promoters of genes encoding cellulases and xylanases, respectively, with binding enrichment observed for both when grown in cellulose or xylan conditions (Craig et al., 2015). Similar responses may occur in plant-parasitic nematodes that regulate the differential expression of cell wall-degrading enzyme genes. However, it is unclear from the fungal studies whether or not the polymer itself is detected, or if the observed effects occur in response to the presence of breakdown products.

Plants can perceive cellulose-derived oligomers as damage-associated molecular patterns (DAMPs) as a means to survey cell wall integrity and then respond by activating a signalling cascade that leads to induction of defence-related genes (de Azevedo Souza et al., 2017). Monosaccharides are also known to induce the upregulation of several genes, including an endoxylanase, in fungi (de Vries et al., 1999, Sun et al., 2012). Detection of these breakdown products by *P. coffeae* in root exudates may result in the host-specific expression of *Pc-eng-1* and *Pc-xyl*. Monosaccharides are present in root exudates and influence nematode chemo-attraction and stylet activity (Kamilova et al., 2006, Warnock et al., 2016). In the field, such breakdown products could arise from the activities of soil microbes or be generated in proximity to the nematode through the action of its own secreted enzymes. Given that sterile solutions of cellulose and xylan elicited similar induction of gene expression as root exudate-containing equivalent concentrations, it seems likely that soil microbes are not playing an important role in this case. Both *Pc-eng-1* and *Pc-xyl* were expressed at detectable basal levels when *P. coffeae* was maintained in water and the nematodes exhibited a low rate of stylet thrusting in these conditions. This activity might supply sufficient amounts of the enzymes to release soluble inducers from the carbohydrate polymers associated with the roots, as proposed for fungi (Amore et al., 2013). As for other typical  $\beta$ -1,4-endoglucanases, *Meloidogyne incognita* ENG-1 has been shown to cleave cellulose into glucose dimers/trimers rather than monosaccharides (Bera-Maillet et al., 2000). The conservation of GH5 cellulases suggests that the enzymes of other Clade 12 nematode species, such as *P. coffeae*, likely have similar activity (Kikuchi et al., 2017). The breakdown of these small glucose chains requires  $\beta$ -glucosidase, which have not been identified as being encoded in the genome or transcriptome data for *P. coffeae*. This suggests a system based on detection of either the cellulose polysaccharide or the short chain cellobiose/cellotriose breakdown products, rather than monosaccharides. A parallel effect is known for filamentous fungi which do not require the breakdown of oligosaccharides into glucose monomers for induction of  $\beta$ -1, 4-endoglucanase genes

(Znameroski et al., 2012). This data presents new insights into pathogen detection of carbohydrate polymers and its importance in the parasitism of an economically important nematode species.

## 5.6. Summary

- Root exudates from host plants induces stylet thrusting and upregulation of four beta-1,4-endoglucanases, one beta-1,4-endoxylanase and one alpha-1,4-d galacturonan lyase genes in *P. coffeae*.
- The concentration of cellulose and xylan within the exudate determined the level of *Pc-eng-1* and *Pc-xyl* upregulation, respectively.
- Treatment of *P. coffeae* with cellulose or xylan or with root exudates deficient in cellulose or xylan conferred a specific gene expression response of *Pc-eng-1* or *Pc-xyl* respectively with no effect on *Pc-pel*.
- RNA interference confirmed the importance of regulating these genes as lowered transcript levels reduced root penetration by the nematode.

## Chapter 6. Neuronal inhibition of *P. coffeae* responses to host root exudates

---

### 6.1. Introduction

#### 6.1.1. Host perception

Plant-parasitic nematodes (PPN) are obligate parasites that must sense the host and migrate through the soil towards it. Previous work in Chapter 5 showed that *Pratylenchus coffeae* exhibits host-specific gene expression patterns that are linked to the polysaccharide components of root exudates. It is currently unknown precisely how PPN detect and respond to different host factors and any insight into this area could reveal targets for novel control strategies.

The neuronal system of *Caenorhabditis elegans*, the model nematode species, is involved in sensing food and coordinating movement. Neurotransmitters are released into the synapse between two neurons in order to activate receptors on the post-synaptic membrane (Rand, 2007). Several kinds of neurotransmitters are involved in signal transduction such as acetylcholine,  $\gamma$ -Aminobutyric acid (GABA), glutamate, dopamine, serotonin, tyramine, octopamine and neuropeptides. The role of neurotransmitters in particular responses can be deduced by applying exogenous neurotransmitters or their agonists/antagonists and by determining the effect of mutants with decreased synthesis or perception.

Acetylcholine is an excitatory neurotransmitter in approximately 115 of the 302 neurons in the nervous system of *C. elegans* (Rand et al., 2000). There are different classes of receptors for this neurotransmitter, such as nicotinic acetylcholine receptors and G-protein coupled receptors. Neurons of this class are involved in movement, egg laying and sensory perception (Rand, 2007). The body wall muscle of *C. elegans* is innervated by cholinergic and inhibited by GABAergic neurons (McIntire et al., 1993). Levamisole is a cholinergic agonist that binds specifically to nicotinic acetylcholine receptors, leading to the hypercontraction of body wall muscle, causing paralysis and usually death (Lewis et al., 1980). The levamisole-sensitive nicotinic acetylcholine receptor is the main excitatory receptor at the neuromuscular junctions of *C. elegans* (Lewis et al., 1980). Due to similar effects on parasitic nematode species, it is commonly used as an anthelmintic compound. Uptake of levamisole is suggested to occur by absorption across the cuticle and transport along neurons of parasitic nematode species, such as the plant parasites *Globodera pallida* and *Heterodera glycines* (Ho et al., 1994, Winter et al.,

2002). Fluorescent tagging of a levamisole-mimetic peptide suggests uptake by the cilia of nematode chemoreceptive neurons before undergoing retrograde transport to their neuronal cell bodies. It is postulated that it then exerts its effect at the synapses of cholinergic interneurons (Wang et al., 2011). Pre-soaking juveniles in the mimetic peptide reduced root invasion of *H. glycines* in roots of aduki bean, indicating a role of these neurons in modulating behaviours vital for parasitism (Liu et al., 2005). Enhanced resistance to levamisole has been observed in plant-parasitic nematodes ( $EC_{50}$  for paralysis of 19.7 mM for *G. pallida*) compared to *C. elegans* ( $EC_{50}$  for paralysis of 9  $\mu$ M) and may be attributed to the difference in receptor composition (Marvin, 2015, Qian et al., 2008). Although PPN have a greater resistance to paralysis, the agonist can disrupt the chemoreceptive response at a much lower concentration of 1 nM, suggesting complex and possibly concentration-dependant roles for levamisole in PPN behaviour (Winter et al., 2002). The disruption of movement and/or perception rationalises the reduction in root invasion in roots that express and secrete the mimetic peptide (Liu et al., 2005).

Atropine is known to disrupt acetylcholine signalling by selectively binding to muscarinic acetylcholine receptors and consequently effecting the linked G-proteins (Lee et al., 1999b). These receptors are expressed in sensory neurons towards the anterior end of the nematode, such as head neurons (Lee et al., 2000b). Signalling through these receptors is thought to play a key role in pharyngeal muscle activity in *C. elegans* (Steger and Avery, 2004). Furthermore, muscarinic receptor-signalling is known to activate the mitogen-activated protein kinase (MAPK) pathway and this has the potential to affect protein phosphorylation and gene expression. The pathway is involved in food sensing in *C. elegans* and can be blocked by Atropine, indicating that muscarinic acetylcholine receptors are vital for nematode responses to food (You et al., 2006). Atropine has been shown to inhibit hatching of *G. pallida*, thereby revealing the presence of these receptors in PPN (Palomares-Rius et al., 2013).

5-hydroxytryptamine (5-HT), commonly referred to as serotonin, is a neurotransmitter that modulates behaviour in *C. elegans*. Exogenous serotonin is known to inhibit locomotion and stimulate egg laying and pharyngeal pumping (Chase and Koelle, 2007). The monoamine is synthesised in motor neurons with sensory endings in the lumen of the pharynx, therefore they are predicted to detect food sources and to coordinate movement (Chase and Koelle, 2007). The receptors that bind serotonin are characterised as either G-protein coupled receptors or serotonin-gated chloride channels (Olde and McCombie, 1997, Ranganathan et al., 2000). *Globodera pallida* is predicted to have two G-protein coupled 5-HT receptors and one 5-HT-gated ion channel (Cotton



et al., 2014). As with acetylcholine, there are compounds that selectively block the signalling of 5-HT across the synapse. Reserpine acts by selectively blocking the activity of the vesicular serotonin transporters and therefore the serotonergic neurotransmission (Erickson et al., 1992, Reckziegel et al., 2015). Methiothepin has been shown to have affinity towards 5-HT receptors on the post-synaptic membrane and affect nematode behaviour, such as stylet activity in *G. pallida* (Hobson et al., 2003, Kearn, 2015). However, stylet activity is not dictated entirely by 5-HT as it is also regulated by cholinergic signalling (Kearn, 2015). 5-HT is known to increase the release of acetylcholine onto the pharyngeal muscle in *C. elegans*, therefore highlighting the presence of multiple neurotransmitters in food-signalling pathways (Song and Avery, 2012).

## 6.2. Aims

- Investigate the mechanisms involved in host-perception in *Pratylenchus coffeae*.
- Determine the effects of anthelmintic drugs on the responses of *P. coffeae* to host root exudates.
- Determine the effects of serotonin on *P. coffeae*.

### 6.3. Methods

#### 6.3.1. Determining the EC<sub>50</sub> for paralysis with levamisole

Groups of one hundred mixed stages of *Pratylenchus coffeae* nematodes were treated with 100 µl of varying concentrations of levamisole dissolved in water for one hour at 22 °C. A water control was also set up and all treatments were conducted in triplicate. Nematodes were then observed under a compound microscope at 40x magnification and the number of paralysed individuals were counted. This data was plotted and the concentration at which 50 % of the population were paralysed was calculated (EC<sub>50</sub> value).

#### 6.3.2. Elucidating the effect of compounds that disrupt neuronal signalling in nematodes

Groups of mixed life stages of *P. coffeae* nematodes were soaked in 100 µl of either 1 nM levamisole (concentration used on PPN in (Winter et al., 2002)), 1 µM methiothepin (concentration used on PPN in *G. pallida* (Kearn, 2015)), 5 µM reserpine (concentration used on PPN in *G. pallida* (Kearn, 2015)), 10 mM atropine (concentration chosen for effectiveness on *C. elegans* in (You et al., 2006)) or sterile tap water for 1 h. The nematodes were then pelleted and washed three times in sterile tap water. Pre-treated nematodes were then soaked in either 100 µl sterile water, 5 mM 5-hydroxytryptamine (5-HT) or a root exudate.

##### 6.3.2.1. Stylet thrusting assays

After 1 h of treatment with 100 µl 5 mM 5-HT (Kearn, 2015), root exudate or water control for 1 h at 22 °C, ten nematodes per treatment were observed at a magnification of 80x and stylet thrusts of each nematode were counted for 30 seconds in triplicate to obtain an average count for each nematode. A single movement of the stylet forwards and then backwards to its original position was counted as a single stylet thrust.

##### 6.3.2.2. Expression of *Pc-eng-1*

After 4 h of treatment with 100 µl 5 mM 5-HT, root exudate or water for 4 h at 22 °C, total RNA was then extracted and qPCR was carried out to obtain gene expression values, as described previously in section 2.1.3.3. This was carried out four times for each treatment.

## 6.4. Results

### 6.4.1. EC<sub>50</sub> for paralysis for *P. coffeae*

The EC<sub>50</sub> is the concentration at which 50 % of individuals displayed paralysis. This parameter was calculated to determine the response of *P. coffeae* to the agonist. The EC<sub>50</sub> of levamisole in *P. coffeae* is 9.1 mM (Figure 6-1).

### 6.4.2. Levamisole inhibits stylet thrusting in *P. coffeae*

Levamisole was used to determine if nicotinic acetylcholine receptors are involved in 5-hydroxytryptamine (5-HT) and root exudate induced stylet thrusting, identified in Chapter 5. Pre-treatment with 1 mM levamisole for one hour significantly reduced stylet thrusting induced by 5-HT or root exudates (Figure 6-2) ( $P > 0.01$  oneway ANOVA). The reduced rate was similar to that observed in nematodes treated with water controls. Nematodes were inspected under a microscope and were otherwise visually unaffected by the agonist (data not shown).

### 6.4.3. Nicotinic acetylcholine receptor agonists inhibit the upregulation of *Pc-eng* in response to root exudates in *P. coffeae*

Exudates from the roots of host species were found to induce an upregulation of *Pc-eng* in *P. coffeae*, as identified in Chapter 5. This was again observed in *P. coffeae* mixed life stages treated with exudate from the roots of coffee plants (control treatment, Figure 6-3). As acetylcholine receptor agonists are known to affect nematode parasitism and stylet thrusting (Liu et al., 2005)(Figure 6-2), their effects on induced gene expression were investigated. The agonists levamisole and LEV-1-7.1 (Liu et al., 2005), a levamisole-mimetic peptide previously shown to reduce nematode root penetration, were found to inhibit the upregulation of *Pc-eng* in response to root exudates (Figure 6-3).

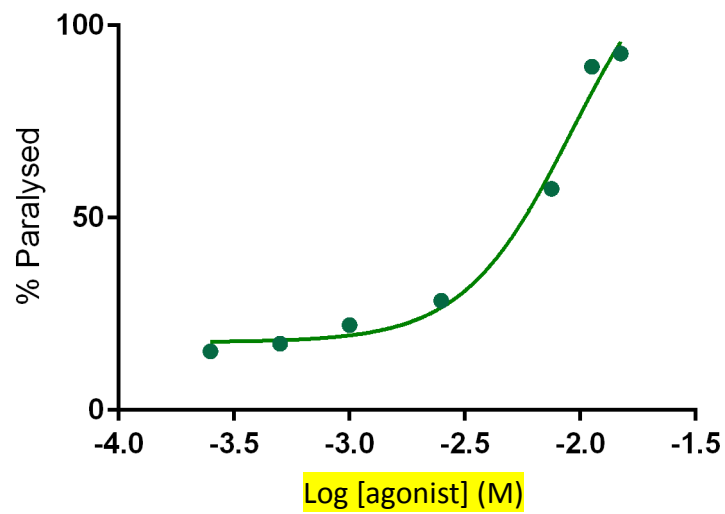
### 6.4.4. Atropine inhibits nematode responses to root exudates

Atropine is an antagonist of muscarinic acetylcholine receptors, which are intracellularly coupled with G-proteins. Due to the effects of G-proteins on intracellular signalling the effect of atropine on root exudate induced stylet thrusting and gene expression was investigated. As observed previously, treatment with coffee root exudate induced a significant increase in both stylet thrusting and expression of *Pc-eng-1* (Figure 6-4) ( $P > 0.01$  oneway ANOVA). Pre-treatment with 10 mM atropine prevented both increased stylet thrusting and increased gene expression, compared to the expression level in nematodes treated with water controls. Nematodes were inspected under a microscope and were otherwise visually unaffected by the agonist (data not shown).

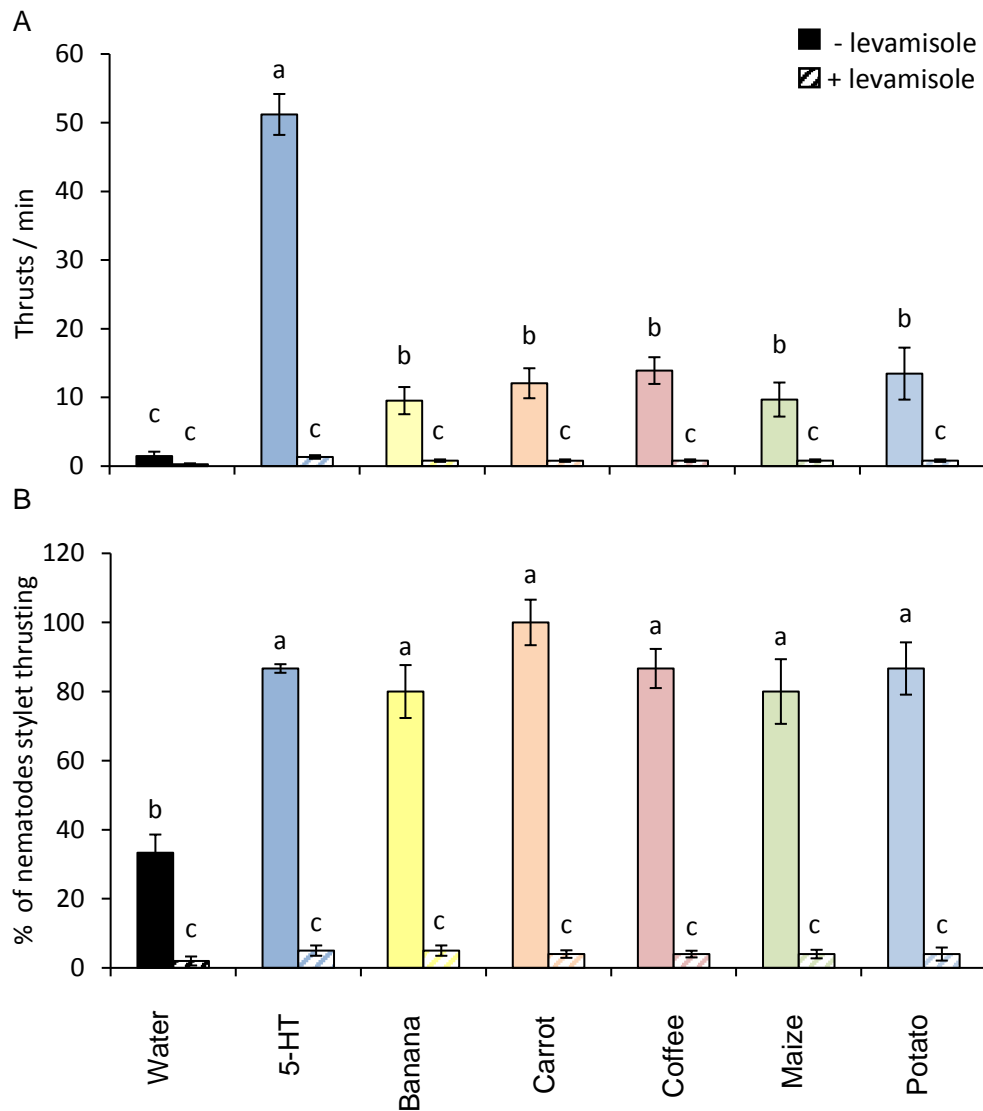
#### **6.4.5. Serotonin signalling is involved in the stylet thrusting and gene induction response to root exudates**

5-HT was observed to induce stylet thrusting of *P. coffeae* and is a common positive control for stylet thrusting assays. Stylet thrusting and gene expression were previously found to be inhibited by levamisole, therefore the role of 5-HT in gene induction was investigated. 5-HT at 5 mM was found to significantly upregulate expression of *Pc-eng-1* in mixed stages of *P. coffeae* after two hours (Figure 6-5a). Expression was significantly greater after three hours exposure to 5-HT ( $P > 0.05$  oneway ANOVA). Due to the impact of 5-HT on stylet thrusting and gene expression, two inhibitors of the signalling pathway were utilised: reserpine and methiothepin. Both of these inhibited the induction of stylet thrusting in response to coffee root exudate (Figure 6-5B). Reserpine was found to have no effect on 5-HT induced stylet resulting whereas methiothepin significantly reduced this response (Figure 6-5b) ( $P > 0.01$  oneway ANOVA).

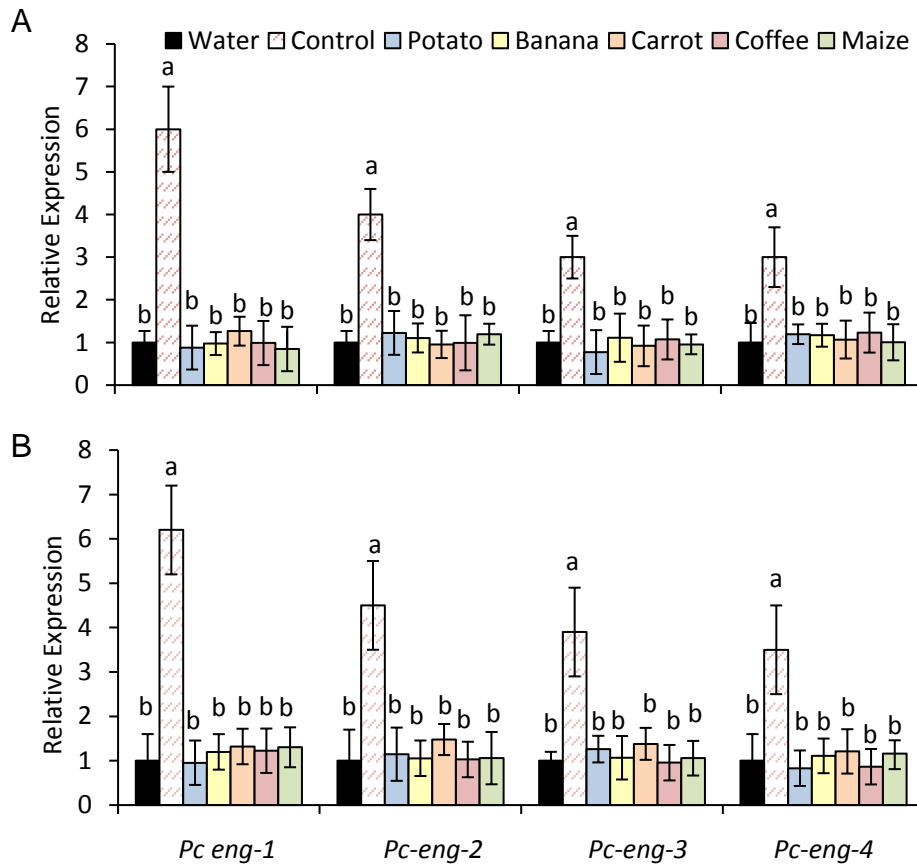
Similar effects were observed on the induction of *Pc-eng-1* expression of mixed life stages of *P. coffeae* (Figure 6-5c). Expression of the gene was upregulated after exposure to coffee root exudate, as observed in previous controls. However, pre-treatment with reserpine or methiothepin inhibited this response. Additionally, 5-HT induced upregulation of the gene. Reserpine pre-treatment led to a significant reduction in the upregulation response. Methiothepin resulted in a stronger reduction in gene expression.



**Figure 6-1. Effect of levamisole on *Pratylenchus coffeae* individuals.** The percentage of paralysed individuals at varying concentrations established the EC<sub>50</sub> of 9.1 mM by log(agonist) vs response calculations. Error bars represent SEM from 3 biological replicates and are smaller than the data points.

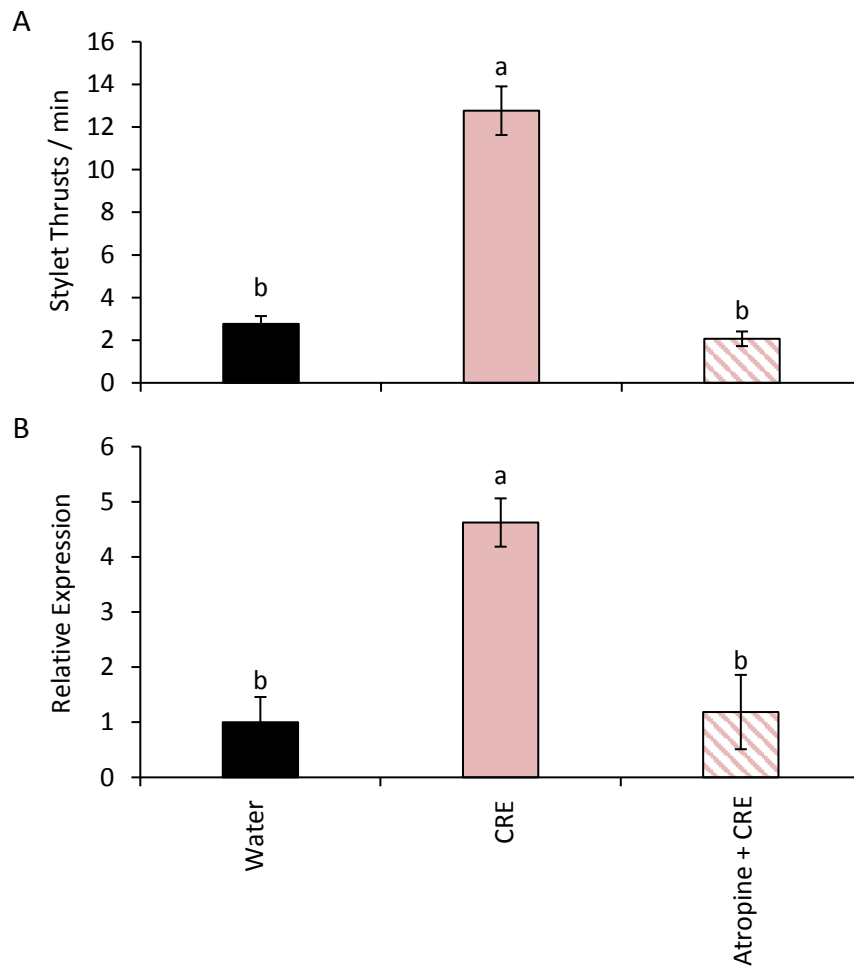


**Figure 6-2. Effect of host root exudates on the stylet activity of *P. coffeae*.** Levamisole was evaluated for its effect on 5-hydroxytryptamine (5-HT) and root exudate induced rate of stylet thrusting in individuals of mixed life stages (A) and the proportion of individuals of mixed life stages thrusting their stylets (B). Water and 5 mM 5-HT were used as negative and positive controls, respectively. Values are means  $\pm$  SEM with different letters indicating significant differences between treatments  $P < 0.01$  (One-way ANOVA, SNK test,  $n = 10$ ).

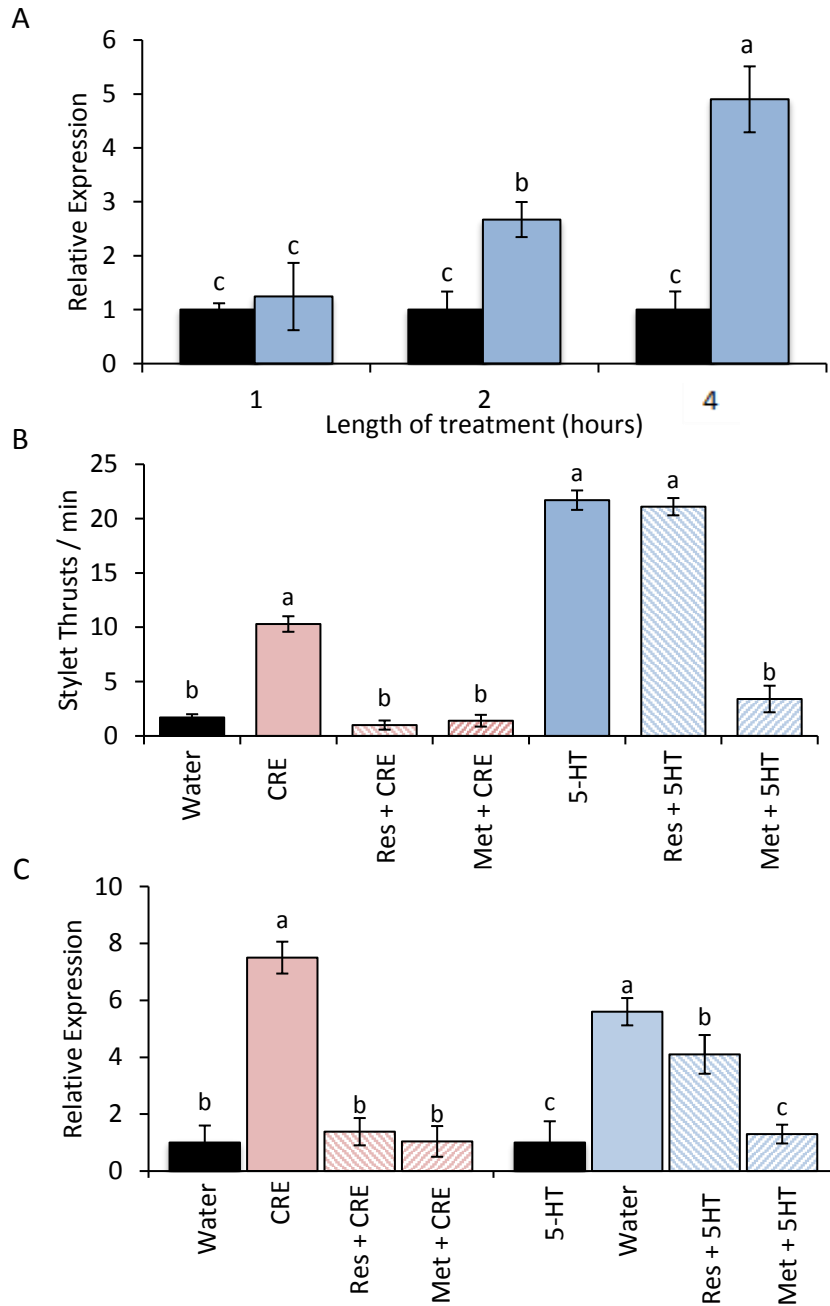


**Figure 6-3. Expression of *Pc-eng* in *P. coffeae* after pre-treatment with acetylcholine receptor agonists and subsequent exposure to host root exudates of potato, banana, carrot, coffee or maize for 4 hours.** 1 nM levamisole (A) and 1 nM LEV-1-7.1 (B) were used for pre-treatments of 4 hours. Values are means  $\pm$  SEM (n = 4 pools of mixed stages) with different letters indicating significant differences between treatments  $P < 0.05$  (One-way ANOVA, SNK test). Water and coffee root exudate without levamisole pre-treatment were used as controls.





**Figure 6-4. Effect of 10 mM atropine on the root exudate induced stylet thrusting (A) and *Pc-eng-1* upregulation (B).** Water and coffee root exudate (CRE) without atropine pre-treatment were used as controls. Values are means  $\pm$  SEM (n = 4 pools of mixed stages) with different letters indicating significant differences between treatments  $P < 0.05$  (One-way ANOVA, SNK test).



**Figure 6-5. Evaluating the influence of the 5-hydroxytryptamine (5-HT) signalling pathway on stylet thrusting and expression of *Pc-eng-1* in *P. coffeae*.** Expression of *Pc-eng-1* was determined in response to 5 mM 5-HT treatment over time (A). Nematodes were pre-treated with 5  $\mu$ M reserpine (res) and 1  $\mu$ M methiothepin (met) and exposed to 5 mM 5-HT or coffee root exudate (CRE) to determine the effects on stylet thrusting (B) and *Pc-eng-1* upregulation (C). Water and CRE with no pre-treatments were used as negative and positive controls respectively. Values are means  $\pm$  SEM with different letters indicating significant differences between treatments  $P < 0.05$  (One-way ANOVA, SNK test).

## 6.5. Discussion

### 6.5.1. Plant-parasitic nematodes are more resistant to levamisole than *C. elegans*

Plant-parasitic nematodes (PPN) are known to have increased resistance to levamisole compared to *C. elegans* (Marvin, 2015). The EC<sub>50</sub> for paralysis in response to levamisole was found to be 9.1 mM for *P. coffeae* which is much higher than *C. elegans* (9 µM), but varies from that observed for *Globodera pallida* (19.7 mM) and *G. rostochiensis* (5.6 mM) (Marvin, 2015, Qian et al., 2008). This indicates that the resistance differs across PPN genera (Marvin, 2015).

Levamisole is suggested to permeate through the cuticle of *Globodera* (Marvin, 2015). The cuticle protects the nematode, maintains body shape, aids locomotion and secretes/absorbs molecules in its environment (Davies and Curtis, 2011, Ho et al., 1994). Plant derived compounds, present in exudates, are known to trigger changes in the nematode cuticle that can also have influences on nematode behaviour. The dynamic cuticle may play a role in the permeability to levamisole and varying EC<sub>50</sub> values could reflect differences in cuticles between PPN (Marvin, 2015). Another possibility for enhanced resistance in PPN is the conformation of the levamisole-receptors. This was suggested to dictate enhanced resistance in *Globodera* and these receptors may be conserved through *Pratylenchus* (Marvin, 2015). The recent genome study allows further analysis of the receptors in *P. coffeae* (Burke et al., 2015), however initial analysis has been held back by fragmented contigs resulting in sequences of uncertain annotation (data not shown).

### 6.5.2. Cholinergic signalling is involved in mediating *P. coffeae* responses to host root exudates

Levamisole and atropine were utilised to determine if acetylcholine receptors are involved in 5-HT and root exudate induced stylet thrusting. Levamisole and atropine inhibit the signalling through nicotinic and muscarinic acetylcholine receptors, respectively and both were found to inhibit stylet thrusting responses in *P. coffeae*. The treatment had no other visible effects on the nematode, such as movement (data not shown). The apparent enhanced resistance to levamisole-induced paralysis coupled with reduction in stylet thrusting at low concentrations may indicate that levamisole enters the nematode through other systems in addition to the cuticle. The amphids are anterior, innervated sensory invaginations that are involved in host-recognition. They are suggested to secrete components that capture and transport chemotactic stimuli to the sensory neurons for detection (Curtis, 2007b). These sensory neurons are postulated to take-up levamisole and transport it along the neurons where it then can accumulate in

the central nerve ring (Winter et al., 2002, Wang et al., 2011). It is suggested that transport along the neurons takes the agonist from non-cholinergic neurons in the amphids towards cholinergic neurons in the nerve ring, where it may have an effect (Wang et al., 2011). Low concentrations of levamisole are suggested to be taken-up by this mechanism and affect the orientation of *G. pallida* to plant roots (Wang et al., 2011). It is logical that orientation and stylet thrusting responses may originate from the same signalling source as they are vital for feeding. Atropine may be transported in a similar manner. In *C. elegans* the drug is known to bind to G-protein coupled receptors in the anterior sensory neurons (Lee et al., 2000b, Lee et al., 1999a, Lee et al., 2000a). This class of receptor contributes to pharyngeal pumping in *C. elegans* and egg laying in PPN, therefore rationalises the inhibition observed in stylet thrusting in *P. coffeae* (Steger and Avery, 2004, Palomares-Rius et al., 2013). The inhibition of stylet thrusting by both drugs suggests both receptor types are involved in the response. It is unknown whether or not they both occur locally to the stylet or sequentially along the neuronal network.

Both levamisole and atropine were also found to inhibit the upregulation of *Pc-eng-1* in response to root exudate. There is a lack of information regarding the control of gene expression in PPN, however the mitogen-activated protein kinase (MAPK) pathway is initiated by acetylcholine G-coupled protein receptors in *C. elegans* and could be a possible mechanism for PPN in this instance (You et al., 2006). The pathway is involved in initiating pharyngeal pumping in *C. elegans* and therefore could be linked with stylet activity in PPN (You et al., 2006). It is logical to assume a link between the expression of effectors and the mechanism that secretes them from the individual, the stylet. MAPK is known to induce the expression of cellulases in a fungal plant-pathogen and has a pivotal role in the rate of infection (Lev and Horwitz, 2003). Transcription factors have been identified in fungi that specifically regulate cellulase expression, therefore the activation of these by the MAPK pathway is a possible explanation (Craig et al., 2015).

### **6.5.3. Serotonin induces responses in *P. coffeae***

5-HT (serotonin) was found to induce stylet thrusting in *P. coffeae*, as previously observed in other nematode species (Kearn, 2015, Masler, 2007, McClure and Vonmende, 1987, Han et al., 2017). This reinforces the proposal that the neurotransmitter is involved in feeding in nematodes. The rate of activity is much higher than that induced by root exudates, indicating that root exudate-stimulated activity may use either the 5-HT signalling pathway but with a lower efficiency, or an independent pathway. The inhibition of stylet thrusting in response to 5-HT and root exudates by levamisole suggests that either the signalling pathways require acetylcholine receptors in order to operate or that levamisole could be inducing its effects at the final

neuromuscular junction that controls stylet thrusting. 5-HT signalling can result in acetylcholine release and increase the rate of pharyngeal pumping, thereby suggesting that both receptor types can be involved in behavioural responses (McKay et al., 2004)

Reserpine and methiothepin were used to analyse further the role of 5-HT and root exudates in stylet thrusting. Reserpine blocks the vesicular transport of endogenous 5-HT into the synapse whereas methiothepin prevents the binding of 5-HT to the post-synaptic receptor (Kearn, 2015). Reserpine had no effect on stylet thrusting when nematodes were treated with 5-HT as the vesicular transporter is not required under exogenous application of serotonin. However, when treated with root exudates, reserpine blocked the stylet thrusting response, indicating that 5-HT is not present within the exudates but that serotonergic neurotransmission is required by a plant-inducible compound for stylet thrusting activity. Methiothepin inhibited the stylet thrusting activity of *P. coffeae* after both 5-HT or root exudate application. This reinforces that the neurotransmitter is involved in feeding and parasitism in PPN. The use of both of these compounds suggests presence of 5-HT receptors in the stylet thrusting induction pathway. The option to target specific receptors with specific drugs, is a future option that could reveal additional insights into the receptors regulating stylet activity. Furthermore, it has been shown that chloride-gated 5-HT channel receptors are specific to nematodes and therefore a good target for nematicide development (personal communication with Dr C J Lilley). Antibody staining of endogenous 5-HT revealed localisation to the nerve ring in *Pratylenchus penetrans* (Han et al., 2017). It is difficult to identify the neurons in *Pratylenchus* due to the lack of literature, however it was suggested that neurons similar to the ADF neurons in *C. elegans* showed antibody staining. These modulate feeding in *C. elegans* and so may also have similar roles in *Pratylenchus* (Han et al., 2017).

Incidence of serotonin-staining around the nerve ring in *Pratylenchus* (Han et al., 2017) indicates that these receptors may impact other neurons that induce downstream effects. These effects may result in upregulation of pharyngeal gland genes, as observed in this thesis. The upregulation of *Pc-eng-1* in nematodes treated with 5-HT suggests that this compound may play the role of root exudate by initiating responses. Reserpine partially reduced this response, whereas methiothepin inhibited it completely. This suggests that 5-HT signals are involved in mediating the gene upregulation and that in this instance reserpine reduces the effects of exogenous 5-HT, which is unexpected. This may infer that reserpine penetrates the nematode further than 5-HT and thereby effects areas where exogenous 5-HT cannot.

As these results discuss the induction of both behavioural and molecular responses, it would be of interest to determine if they occur sequentially or independently. Stylet thrusting provides mechanical disruption of plant tissue (Wyss and Zunke, 1986), thereby playing a role without the assistance of secretions. However, the gland cell products are required to be secreted in order to provide a function. Stylet activity itself may play a role in nematode perception and this may feedback to the gland cells and have consequences on expression of effectors. If transformation of PPN becomes commonplace it would be of interest to analyse genes encoding receptors for neuronal transmission through reporter and knockout lines. These lines can be utilised to determine the full behavioural and molecular effects of a host root exudate on the nematode.

## 6.6. Summary

- Levamisole inhibits the stylet thrusting and gene upregulation response in *P. coffeae* in response to root exudates.
- Similar to other plant-parasitic nematodes, *P. coffeae* has a greater resistance to levamisole compared to *C. elegans*.
- Muscarinic, as well as nicotinic, acetylcholine receptors are indicated to play a role in inducing stylet activity and gene upregulation in *P. coffeae* in response to root exudates.
- Responses to root exudates are mediated through serotonin signalling.

## Chapter 7. General Discussion

---

Plant-parasitic nematodes (PPN) of coffee must be able to locate and feed from their host in order to survive. The aims of this study were to identify the nematode pests of coffee that are prevalent in economically important fields and to determine the molecular and behavioural responses of the nematode in response to a host. Determining the mechanisms that underpin the wide host ranges of many of these nematodes is of great concern for the design of novel control strategies and selection of resistant varieties.

### 7.1. Improving field-based identification methods

The molecular pipeline designed in Chapter 2 was applied to several key economically important coffee regions and identified several nematode species across different crops. The non-destructive, high-throughput procedure and minimal technical requirements are likely to promote its acceptance by growers and local laboratories. Other accepted sampling techniques directly disturb the roots, thereby unnecessarily impacting plant health (Manzanilla-Lopez, 2012).

PCR-based assays as used in this work are common in nematode identification however the application of new technologies could progress this approach and provide further accuracy, precision and reliability. Digital PCR is re-emerging as a practical technique for DNA quantification. Partitioning the sample and detecting the number of positive partitions can provide absolute quantification for an extremely small number of target molecules without a standard curve (Morley, 2014, Pinheiro et al., 2012). This technology has been shown to be effective at detecting nematode species such as *Ascaris lumbricoides*, a parasitic nematode of humans, from the field (Acosta Soto et al., 2017). An alternative method is loop-mediated isothermal amplification (LAMP) which is a single tube technique for amplification of DNA and does not require a thermal cycler or gel electrophoresis, promoting its use for field conditions (Notomi et al., 2000). LAMP can be applied to identify plant-parasitic nematodes directly from infected root tissues (Peng et al., 2017, Kikuchi et al., 2009). The isothermal methodology has promoted its use for field diagnosis of human diseases and has allowed it to be developed as a point-of-care, hand-held and disposable system to detect the Zika virus in the field (Nicolini et al., 2017, Eboigbodin et al., 2016, Song et al., 2016). Hand-held devices are increasingly common in diagnosis of human diseases and present an extremely quick and useful advancement in the field. Hand-held real-time PCR devices have allowed for detection of minute quantities of the Ebola virus and the simplicity and size of such devices allows for distribution in large numbers (Ahrberg et al., 2016). These equipment are becoming



increasingly affordable for large scale studies (Mendoza-Gallegos et al., 2018) and optimisation can drastically reduce the run times, for example *E. coli* can be detected in 7 minutes (Furutani et al., 2016).

In addition to diagnosing the presence of nematodes, soil-nematode identification requires the isolation and/or preparation of nematode DNA from the soil, presenting an additional step that must remove components that may inhibit the sensitive equipment. DNA of *Spongospora subterranean*, a fungus that causes powdery scab disease of potato, can be extracted and quantified from soil or roots by combining a portable magnetic bead-based DNA preparation kit with a portable real time PCR machine (DeShields et al., 2018). This removes the requirement of lab-based equipment and although sensitivity is 10 times lower than that of conventional lab-based PCR, the portable technique can still detect very low quantities of target DNA in soil and roots (DeShields et al., 2018). Uptake of this technology for widespread diagnostics of nematodes could reduce costs associated with a diagnostic team/equipment whilst allowing a greater number of areas to be sampled in a shorter amount of time by distributing the devices directly to the growers.

As well as detecting the presence and quantity of a pathogen, recent advances have allowed sequencing data to be collected whilst in the field. The MinION (Oxford Nanopore Technologies) enables real-time next-generation sequencing in the field and has been shown to be effective at detecting human, as well as plant, viruses (Wang et al., 2015, Batovska et al., 2017, Adams et al., 2017). Although it is capable of sequencing nematodes (Tyson et al., 2018), uptake of this method has been held back, compared to portable real-time PCR devices, due to the associated price (Donoso and Valenzuela, 2018). The application of a field-based soil-nematode extraction kit with a portable sequencer could allow relatively quick identification of nematodes whose high level of genomic sequence identity reduces the precision of PCR-based methods. Isolating DNA of sufficient quality for sequencing may prove an issue with this approach, however there methods used for providing DNA for PCR that could be optimised for this technique (DeShields et al., 2018). Obtaining sequence data from field populations would also reveal the similarity with populations cultured in laboratories for multiple years. This would indicate the shift in the genomes of field populations and ultimately the field-relevance of studies conducted on inbred lines cultured in laboratory conditions.

## **7.2. Predicting shifts in nematode distribution**

Replication of the method conducted in this thesis could not only diagnose nematode populations but could help to determine the effects of different climates on the

abundance of each nematode genus/species. This can assist the current efforts to model changes in the distribution of key plant-parasitic nematode species.

Global temperatures and precipitation have changed dramatically in the past century and models predict that this will continue (Hansen et al., 2006). Growers of annual crops have the flexibility to select crops suited to their location every year. The selection can take into consideration the markets and changes in climate and pathogen-risk. In contrast, growers of coffee and other perennial crops have to remain with the same crop for numerous years in order to obtain plentiful harvests (Laderach et al., 2017). The prolonged delay until harvests increases these risks. Over 50% of the current robusta and arabica growing regions are predicted to be unsuitable for the crop by 2050 due to climate change (Magrath and Ghazoul, 2015). In Minas Gerais Brazil, the region sampled in Chapter 3, climate variability is the main factor contributing to the oscillations in coffee yield and it is predicted to become unsuitable for coffee production by 2070 (Camargo, 2010). Similarly, increasing temperature and shifts in precipitation in Dak Lak, Vietnam, are predicted to render the region unsuitable for Robusta production by 2050 (Laderach, 2012).

In addition to affecting the growth of the crop, changes in climate can influence pests and pathogens. Nematodes are among the most sensitive animals in soil ecosystems (Ruess et al., 1999). Changes in temperature and moisture of the soil influence the morphology, locomotion, reproduction and survival of plant-parasitic nematode species (Ruess et al., 1999). *In vitro* studies have indicated intraspecific variance in optimal temperatures for *Meloidogyne* and *Pratylenchus* nematodes (Thompson et al., 2015, Fourie et al., 2003, Khan et al., 2014, Bird and Wallace, 1965). The differential responses of species to changes in temperature may accelerate the distribution of specific PPN throughout the soil ecosystem as climates change, posing risks for previously uninfected regions (Somasekhar et al., 2010). Furthermore, increasing temperatures can lead to a rapid proliferation of other pathogens of coffee such as leaf rust (Toniutti et al., 2017). In other PPN species climate change has been predicted to severely affect survival and potentially induce a shift in distributions (Jones et al., 2017). If this is reflected in *Meloidogyne/Pratylenchus* in coffee plantations then there could be redistribution of these pathogens towards cooler regions. This could severely impact the more susceptible *C. arabica* cultivars that are grown in these climates. The method described in this thesis could be applied to a range of coffee fields within different climates, thereby providing data to predict the possible shift in nematode fauna. Sampling a range of climates could help infer the temperature ranges of these pests to supplement *in vitro* data and map their future potential distributions, thereby enabling

control measures to be targeted to current and future nematode concerns. This would assist the recommendation to breed and plant coffee varieties to suit the predicted climates (Laderach et al., 2017).

Furthermore, the shift in nematode fauna would not only affect coffee but could have wider implications for other crops grown in coffee plantations of which these nematode species are pathogens. Climate change may restrict the range of crops to be grown in a field thereby reducing the possibility of selecting crops for nematode tolerance or resistance.

### **7.3. Nematodes adapting to host exudates**

The correct conditions can be significant, but the foremost influence on nematode reproduction is the presence of a host and the identity of that host. One of the key nematode species detected in the field sampling within this thesis, *P. coffeae*, has a vast host range that includes many economically important crops. This is reflected by its presence in soil surrounding banana, black pepper and coffee plants. Although *Pratylenchus* species are polyphagous there are distinct host preferences between the individual species (Wilson, 2008). These preferences may arise through the differential response to the recognition of host-signals, the activity of effectors on different hosts, the ability to suppress host defences or through other means. The data in this thesis would suggest that the appropriate regulation of key genes that facilitate nematode entry into the root, such as those encoding cell wall degrading enzymes, may play a role. As discussed previously, it is seemingly beneficial for the nematode to regulate these key genes to enhance parasitism. Nematodes can distinguish a good from a poor host, through root exudate, and migrate accordingly (Reynolds et al., 2011). The selection of a good host and the preparation of enzymes to facilitate root entry is beneficial as the nematode has a finite lipid reserve that cannot be restored until feeding begins (Jones and Fosu-Nyarko, 2014). Migrating towards any plant and secreting enzymes that are not required at that instance would be counterproductive towards nematode success.

Behavioural responses to host root exudates are a widely reported ability in plant-parasitic nematodes and several genera respond to exudates by hatching (Gaur et al., 2000, Pudasaini et al., 2008, Forrest and Farrer, 1983), stylet thrusting (Grundler et al., 1991, Teillet et al., 2013), migration (Grundler et al., 1991) and upregulation of genes (Teillet et al., 2013, Duceppe et al., 2017). Regulation of specific genes by plant-derived signals has not been previously reported. *Pratylenchus* and *Meloidogyne* have previously been noted to show no variation in migration towards good or poor hosts when presented separately (Balhadere and Evans, 1994, McClure et al., 1974, Linsell et al.,

2014). However, when presented with both types of root simultaneously, nematodes from these genera will preferentially migrate towards the susceptible root (Linsell et al., 2014, Griffin and Waite, 1971).

Root exudates from naturally resistant crops contain components that deter the nematode or susceptible plants secrete more compounds that make them attractive. Understanding the attraction of nematodes to roots is a large aspect of the design of resistant crops. The secretion of a chemo-disruptive peptide from the roots of transgenic plants may interfere with nematode chemoreception in the near rhizosphere and rhizoplane and subsequently reduce root invasion (Winter et al., 2002). The same peptide, which was selected for its binding to nicotinic acetylcholine receptors, was found to inhibit gene upregulation in *P. coffeae* in response to root exudates (Chapter 6). It is unclear if the peptide interferes with perception of roots or disrupts mechanisms used in transcriptional regulation.

In addition to host-status of a plant, exudate signals may also infer the health and age of the host and whether or not it is the best, current target for the nematode. For example, exudates of younger potato plants ( $\leq 3$  weeks old) induce greater hatching of the potato cyst nematode, *G. pallida* (Rawsthorne and Brodie, 1986). The reduced carbon allocation to below ground tissue with increasing age (Badri and Vivanco, 2009, Andreas and Lutz, 2000) may provide a basis for this and indicate that these aging roots are not optimal for nematode parasitism. Nematode responses to younger plants may be beneficial to ensure that reproduction can occur before plant death. Exudation of a range of sugars is known to increase under higher temperatures and decrease upon root-detection of pathogens (Vancura, 1967, Koroney et al., 2016). This could suggest that sugars are indicators of plant growth/health or that the plant reduces exudation to try and avoid the attraction of additional pathogens. *Meloidogyne incognita* exhibits a decrease in stylet activity and attraction towards exudates from the roots of tomato plants that exude reduced amounts of sugars (Warnock et al., 2016), indicating that the detection of sugars by the nematode may be a mechanism to detect a healthy and developing host. It would be of interest to determine the effect of plant age and nematode infection on exudation of the two polysaccharides studied in this thesis.

A future aim would be to limit the material exuded by the host in the attempt to reduce the signals perceived by the nematode. However, fluctuations in exudate composition would have widespread effects on the soil ecosystem due to the complex plant-rhizosphere interactions. Exudates yield positive interactions for the plant, such as inducing herbivore resistance, root-root communication and plant-growth promoting

bacteria/mycorrhizae, therefore lack of these would negatively impact plant health (Walker et al., 2003, Duffy and Défago, 1999). The presence of sugars in root exudates were shown to increase production of antimicrobial compounds by *Pseudomonas fluorescens* in the rhizosphere (Vacheron et al., 2013, Duffy and Defago, 1999). Attempting to block the secretion of plant signals from roots needs careful consideration for the effects on root-beneficial organisms.

#### **7.4. Transcription alteration in insects towards different plants**

The colonisation of a diverse array of plant species by the generalist aphid *Myzus persicae* is suggested to be assisted by the transcriptional plasticity of clusters of genes (Mathers et al., 2017). Plasticity allows individuals of a genotype to rapidly adapt to diverse environmental conditions and provides a major source of variation within populations (Sultan and Spencer, 2002, Sultan, 1995). Adaptive population differentiation may influence ecotypes and ultimately result in speciation (Sultan, 2000). Transcriptional plasticity may be more beneficial in aphids due to their greater range of travel, compared to an individual nematode that may only encounter roots of a single host species in its lifetime. This may indicate that although the nematode has the capacity to quickly tailor gene expression, in the field this does not drastically alter during a single life cycle. Over time this regulation may have distinct effects on the nematode species. *Pratylenchus coffeae*, shown to have plastic gene regulation, is a broad species classification and often stated to be a 'species complex' that consists of multiple subspecies (Mizukubo et al., 2003, Duncan and Moens, 2013, Jones and Fosu-Nyarko, 2014). If some of these subspecies are genetically similar then divergence may have arisen through differential transcriptional regulation.

Differential expression of intestinal genes has been suggested to contribute to the fitness of plant-feeding insects by neutralizing host-plant defences (Anathakrishnan et al., 2014, Herde and Howe, 2014). The regulation of transcription in the gut is also suggested to adapt to different host nutritional values (Zhong et al., 2017). For example, the expression of ribosomal genes has been shown to alter in insects feeding on different hosts and suggested to counteract plant-derived ribosomal-inactivating proteins, thereby influencing the fitness of the pest (Zhong et al., 2017). Fitness on a new host is linked to transcriptional alteration in the guts of herbivores and the degree of adjustments can be linked to success (Roy et al., 2016, Yu et al., 2016). Therefore, if *P. coffeae* does not migrate far enough within a life cycle to reach a second host, the ability would enable it to rapidly colonise new locations when dispersed through other means, e.g. movement

of infected material. In turn, this may contribute to the wide geographical area of the pathogen and the species complex.

Differential expression may also occur in the intestine of *P. coffeae* when feeding in order to adapt to the host defences and nutrients in different host cytoplasm. Analysing the intestine of nematodes through broad techniques such as RNA sequencing would reveal such transcriptional adjustments and how they may attribute to fitness on the host. Analysis of a cathepsin B cysteine protease gene in the intestine of *Aphelenchoides besseyi* shows a 6.9 fold increase in expression in a population isolated from strawberry compared to a population from rice (Wang et al., 2018). The greater expression has been suggested to play a role in the quicker life cycle on strawberry (approximately 19 times). This analysis would be of additional interest as the intestine is a prime target for novel control measures as it is exposed to ingested xenobiotic compounds.

### **7.5. Nematode perception of host roots involves complex mechanisms**

Understanding of nematode feeding has come mainly through the study of *C. elegans*, the bacterivorous model species. In this species feeding is regulated by the presence and quality of food. When starved, nematodes seek food by increasing movement. Neuronal signalling mediates some of these changes in behaviour by activating mitogen-activated protein kinase (MAPK) pathways through muscarinic receptors (You et al., 2006). This pathway induces pharyngeal pumping to prepare the nematode for encountering food, similar to the stylet activity observed in *P. coffeae* in recognition of root signals (Chapter 5). In addition to this, *C. elegans* will preferentially seek out higher-quality food (defined by the ability to support growth) and this is enhanced in individuals that have previously experienced high-quality food (Shtonda and Avery, 2006). When satiated, *C. elegans* stop eating (observed through the lack of pharyngeal pumping), stop migrating and often become dormant. Dormancy is reversed upon starvation by suggested signals from the intestine (You et al., 2008). Sedentary plant-parasitic nematodes either form a feeding site in the root and remain in place to complete their life cycle, or the site fails and they die. Therefore, the switch between starvation-satiation may not arise. Migratory nematodes, such as *Pratylenchus*, may undergo such phases as they have the ability to enter, leave and re-enter the root throughout their lives. The individuals that do leave the root, may have a higher success at perceiving, migrating towards and re-entering the root upon starvation due to their previous experience of feeding. The limited knowledge on the neurons of PPN restricts the possible candidates for controlling these responses, whereas in *C. elegans* the AIY neuron has been attributed to controlling the roaming behaviour that allows new food sources to be identified (Shtonda and Avery, 2006).

As plant-parasitic nematodes are obligate parasites of plants it is difficult to observe feeding and select them at specific time points, as was done to isolate satiated *C. elegans* (Shtonda and Avery, 2006). If satiated *Pratylenchus* could be isolated then the effects on root parasitism, general movement and reproduction could be determined. It may be that these individuals do not respond to root exudates, in particular the cellulose and xylan components studied in Chapter 5, to the same extent as starved or freshly hatched nematodes as used in this project. The ability of *C. elegans* to preferentially move towards a higher quality food source may be reflected in *Pratylenchus* migrating out of the root and towards the rhizosphere as the plant becomes invaded by other organisms and the food source degrades (Mugniéry and Phillips, 2007). The recognition of new host-signals and starvation may be required to initiate movement through the soil towards a different root.

*Caenorhabditis elegans* uses chemosensation to detect a wide variety of volatile and water-soluble signals associated with food, other animals and harmful environments (Bargmann, 2006). A large proportion of its nervous system is involved in chemosensation, primarily the neurons located within the amphids. Neurons penetrate the cuticle to expose their sensory cilia to the environment, with each neuron expressing a specific set of receptor genes to detect a set of attractants, repellents or pheromones (Ward et al., 1975). Sixty percent of the ~100 chemoreceptors are expressed in the chemosensory neurons of the amphids (Bargmann, 2006). Although plant-parasitic nematodes are thought to use chemoreceptors to locate hosts and mates, it is an ill-defined area. The amphids are a conserved structure across PPN and contain the primary chemosensilla, however chemoreceptors are also thought to be located as far back as the pharyngeal gland ducts (Perry, 1996). It has been suggested that PPN, similar to insects, secrete proteins from the amphids that bind to attractants and transport them towards the receptors for recognition by the individual, before being degraded to prevent repeated stimulation (Perry, 1996). Such activity would seem logical and would give rise to nematode attraction along gradients towards the host (Reynolds et al., 2011). A basal expression of xylanase and cellulase in *P. coffeae*, as observed in Chapter 5, may act to degrade these signals to prevent repeated stimulation. A neuron in *C. elegans* can express several chemoreceptor genes, whereas each mammalian olfactory neuron usually only expresses one (Bargmann, 2006). The receptor types and number are unknown in PPN and the recognition of cellulose and xylan, discussed in this thesis, may occur at one or several. Recognition of plant signals through these receptors may occur to assist in migration towards the root and also selection of feeding sites within root

tissue, for sedentary nematodes (Curtis, 2007a). Therefore, the characterisation of such receptors are of utmost importance for crop protection strategies.

In conclusion, this study determined that plant-parasitic nematode species are prevalent and abundant in coffee plantations sampled in widespread and distinct locations. Certain species, such as *P. coffeae*, were found in several locations whereas others, such as *M. hapla*, were detected in a limited number of plantations. Nematode abundance was determined to be significantly higher around intercrops rather than coffee, suggesting that this practice may be negatively effecting the field through increasing the plant-parasitic nematode populations. Exudates from the roots of several plants, including coffee, were found to increase the rate of stylet thrusting and expression of cell wall-degrading enzyme genes. Presumably the nematode can detect host cues present in root exudates and respond to these in a manner that promotes the chances of gaining access to the root, feeding and reproducing. The expression of these genes were found to be effected by gene-specific cues present in the exudates and these responses could be inhibited by impairing aspects of the nematode's neuronal system.



## Chapter 8. References

---

- ABAD, P., CASTAGNONE-SERENO, P., ROSSO, M. N., ENGLER, J. D. A. & FAVERY, B. 2009. Invasion, feeding and development. In: PERRY, P. N., MOENS, M. & STARR, J. (eds.) Root-knot nematodes. CAB International.
- ABAD, P., GOUZY, J., AURY, J. M., CASTAGNONE-SERENO, P., DANCHIN, E. G. J., DELEURY, E., PERFUS-BARBEOCH, L., ANTHOUARD, V., ARTIGUENAVE, F., BLOK, V. C., CAILLAUD, M. C., COUTINHO, P. M., DASILVA, C., DE LUCA, F., DEAU, F., ESQUIBET, M., FLUTRE, T., GOLDSTONE, J. V., HAMAMOUCHE, N., HEWEZI, T., JAILLON, O., JUBIN, C., LEONETTI, P., MAGLIANO, M., MAIER, T. R., MARKOV, G. V., MCVEIGH, P., PESOLE, G., POULAIN, J., ROBINSON-RECHAVI, M., SALLET, E., SEGURENS, B., STEINBACH, D., TYTGAT, T., UGARTE, E., VAN GHELDER, C., VERONICO, P., BAUM, T. J., BLAXTER, M., BLEVE-ZACHEO, T., DAVIS, E. L., EWBANK, J. J., FAVERY, B., GRENIER, E., HENRISSAT, B., JONES, J. T., LAUDET, V., MAULE, A. G., QUESNEVILLE, H., ROSSO, M. N., SCHIEX, T., SMANT, G., WEISSENBACH, J. & WINCKER, P. 2008. Genome sequence of the metazoan plant-parasitic nematode *Meloidogyne incognita*. *Nature Biotechnology*, 26, 909-915.
- ABREGO, L. 1974. Ensayos de selectividad de nematocidas en el combate del *Pratylenchus coffeae* en almacigueras de café. *Nematropica*, 4.
- ACOSTA SOTO, L., SANTISIMA-TRINIDAD, A. B., BORNAY-LLINARES, F. J., MARTIN GONZALEZ, M., PASCUAL VALERO, J. A. & ROS MUNOZ, M. 2017. Quantitative PCR and Digital PCR for Detection of *Ascaris lumbricoides* Eggs in Reclaimed Water. *Biomed Res Int*, 2017, ID7515409.
- ADAM, M. A. M., PHILLIPS, M. S. & BLOK, V. C. 2007. Molecular diagnostic key for identification of single juveniles of seven common and economically important species of root-knot nematode (*Meloidogyne* spp.). *Plant Pathology*, 56, 190-197.
- ADAMS, I., BRAIDWOOD, L., STOMEIO, F., PHIRI, N., UWUMUKIZA, B., FEYISSA, B., MAHUKU, G., WANGAI, A., SMITH, J., MUMFORD, R. & BOONHAM, N. 2017. Characterising maize viruses associated with maize lethal necrosis symptoms in sub Saharan Africa. *bioRxiv*.
- AHRBERG, C. D., MANZ, A. & NEUZIL, P. 2016. Palm-Sized Device for Point-of-Care Ebola Detection. *Anal Chem*, 88, 4803-7.

- AKYAZI, F. & FELEK, A. F. 2013. Molecular identification of root-knot nematode *Meloidogyne incognita* from kiwi fruit orchards in Ordu province, Turkey. *Turkiye Entomoloji Dergisi-Turkish Journal of Entomology*, 37, 449-456.
- AL-BANNA, L., PLOEG, A. T., WILLIAMSON, V. M. & KALOSHIAN, I. 2004. Discrimination of six *Pratylenchus* species using PCR and species-specific primers. *Journal of Nematology*, 36, 142-146.
- AL-BANNA, L., WILLIAMSON, V. & GARDNER, S. L. 1997. Phylogenetic analysis of nematodes of the genus *Pratylenchus* using nuclear 26S rDNA. *Molecular Phylogenetics and Evolution*, 7, 94-102.
- ALBAN, R., GUERRERO, R. & TORO, M. 2013. Interactions between a Root Knot Nematode (*Meloidogyne exigua*) and Arbuscular Mycorrhizae in Coffee Plant Development (*Coffea arabica*). *American Journal of Plant Sciences*, 4, 19-23.
- ALGHISI, P. & FAVARON, F. 1995. Pectin-Degrading Enzymes and Plant-Parasite Interactions. *European Journal of Plant Pathology*, 101, 365-375.
- ALI, M. A., AZEEM, F., LI, H. J. & BOHLMANN, H. 2017. Smart Parasitic Nematodes Use Multifaceted Strategies to Parasitize Plants. *Frontiers in Plant Science*, 8.
- AMORE, A., GIACOBBE, S. & FARACO, V. 2013. Regulation of Cellulase and Hemicellulase Gene Expression in Fungi. *Current Genomics*, 14, 230-249.
- ANATHAKRISHNAN, R., SINHA, D. K., MURUGAN, M., ZHU, K. Y., CHEN, M. S., ZHU, Y. C. & SMITH, C. M. 2014. Comparative gut transcriptome analysis reveals differences between virulent and avirulent Russian wheat aphids, *Diuraphis noxia*. *Arthropod-Plant Interactions*, 8, 79-88.
- ANDREAS, G. & LUTZ, W. 2000. Qualitative and quantitative analysis of water-soluble root exudates in relation to plant species and development. *Journal of Plant Nutrition and Soil Science*, 163, 381-385.
- ANTONINO-DE-SOUZA, J. J. D., COELHO, R. R., LOURENCXO, I. T., FRAGOSO, R. R., VIANA, A. A. B., MACEDO, L. L. P., SILVA, M. C. M., CARNEIRO, R. M. D. G., ENGLER, G., DE ALMEIDA-ENGLER, J. & GROSSI-DE-SA, M. F. 2014. Knocking-down *Meloidogyne Incognita* Proteases by Plant-Delivered Dsrna Has Negative Pleiotropic Effect on Nematode Vigor. *Journal of Nematology*, 46, 135-135.
- ARIOLI, T., PENG, L. C., BETZNER, A. S., BURN, J., WITTKE, W., HERTH, W., CAMILLERI, C., HOFTE, H., PLAZINSKI, J., BIRCH, R., CORK, A., GLOVER, J.,

- REDMOND, J. & WILLIAMSON, R. E. 1998. Molecular analysis of cellulose biosynthesis in *Arabidopsis*. *Science*, 279, 717-720.
- ARISTIZABAL, L. F., BUSTILLO, A. E. & ARTHURS, S. P. 2016. Integrated Pest Management of Coffee Berry Borer: Strategies from Latin America that Could Be Useful for Coffee Farmers in Hawaii. *Insects*, 7.
- ARISTIZABAL, L. F., SALAZAR, H. M., MEJIA, C. G., JIMENEZ, M., BUSTILLO, A. E. & ARTHURS, S. P. 2012. Establishment of exotic parasitoids of the coffee berry borer *Hypothenemus hampei* (Coleoptera: Curculionidae: Scolytinae) in Colombia through farmer participatory research. *International Journal of Tropical Insect Science*, 32, 24-31.
- AVELINO, J., BOUVRET, M. E., SALAZAR, L. & CILAS, C. 2009. Relationships between agro-ecological factors and population densities of *Meloidogyne exigua* and *Pratylenchus coffeae sensu lato* in coffee roots, in Costa Rica. *Applied Soil Ecology*, 43, 95-105.
- AVELINO, J., WILLOCQUET, L. & SAVARY, S. 2004. Effects of crop management patterns on coffee rust epidemics. *Plant Pathology*, 53, 541-547.
- BADRI, D. V. & VIVANCO, J. M. 2009. Regulation and function of root exudates. *Plant Cell and Environment*, 32, 666-681.
- BAETZ, U. & MARTINOIA, E. 2014. Root exudates: the hidden part of plant defense. *Trends in Plant Science*, 19, 90-98.
- BALHADERE, P. & EVANS, A. A. F. 1994. Characterization of Attractiveness of Excised Root-Tips of Resistant and Susceptible Plants for *Meloidogyne Naasi*. *Fundamental and Applied Nematology*, 17, 527-536.
- BARBER, D. A. & MARTIN, J. K. 1976. Release of Organic-Substances by Cereal Roots into Soil. *New Phytologist*, 76, 69-80.
- BARBOSA, D. H. S. G., VIEIRA, H. D., SOUZA, R. M., VIANA, A. P. & SILVA, C. P. 2004. Field estimates of coffee yield losses and damage threshold by *Meloidogyne exigua*. *Nematologia Brasileira*, 28, 49-54.
- BARGMANN, C. 2006. Chemosensation in *C. elegans*. In: THE C. ELEGANS RESEARCH COMMUNITY, W. (ed.) Wormbook.
- BARROS, A. F., OLIVEIRA, R. D. L., LIMA, I. M., COUTINHO, R. R., FERREIRA, A. O. & COSTA, A. 2014. Root-knot nematodes, a growing problem for Conilon coffee in Espírito Santo state, Brazil. *Crop Protection*, 55, 74-79.

- BATOVSKA, J., LYNCH, S. E., RODONI, B. C., SAWBRIDGE, T. I. & COGAN, N. O. I. 2017. Metagenomic arbovirus detection using MinION nanopore sequencing. *Journal of Virological Methods*, 249, 79-84.
- BELLAFIORE, S., SHEN, Z., MARIE-NOELLE, R., ABAD, P., SHIH, P. & BRIGGS, S. P. 2008. Direction identification of the *Meloidogyne incognita* secretome reveals proteins with host cell reprogramming potential. *Plos Pathogens*.
- BERA-MAILLET, C., ARTHAUD, L., ABAD, P. & ROSSO, M. N. 2000. Biochemical characterization of MI-ENG1, a family 5 endoglucanase secreted by the root-knot nematode *Meloidogyne incognita*. *European Journal of Biochemistry*, 267, 3255-3263.
- BERG, R. H., FESTER, T. & TAYLOR, C. 2009. Development of the Root-Knot Nematode Feeding Cell. In: BERG, R. H. & TAYLOR, C. (eds.) *Cell Biology of Plant Nematode Parasitism*. Springer Berlin Heidelberg.
- BERRY, S. D., FARGETTE, M., SPAULL, V. W., MORAND, S. & CADET, P. 2008. Detection and quantification of root-knot nematode (*Meloidogyne javanica*), lesion nematode (*Pratylenchus zaeae*) and dagger nematode (*Xiphinema elongatum*) parasites of sugarcane using real-time PCR. *Molecular and Cellular Probes*, 22, 168-176.
- BERTIN, C., YANG, X. & WESTON, L. A. 2003. The role of root exudates and allelochemicals in the rhizosphere. *Plant and Soil*, 256, 67-83.
- BERTRAND, B. & ANTHONY, F. 2008. Genetics of Resistance to Root-Knot Nematodes (*Meloidogyne* spp.) and Breeding. *Plant-Parasitic Nematodes of Coffee*. Springer.
- BERTRAND, B., ANTHONY, F. & LASHERMES, P. 2001. Breeding for resistance to *Meloidogyne exigua* in *Coffea arabica* by introgression of resistance genes of *Coffea canephora*. *Plant Pathology*, 50, 637-643.
- BERTRAND, B., NUNEZ, C. & SARAH, J. L. 2000. Disease complex in coffee involving *Meloidogyne arabicida* and *Fusarium oxysporum*. *Plant Pathology*, 49, 383-388.
- BIEYUN, T. 2008. Competition between *Pratylenchus coffeae* and *Meloidogyne incognita*. *Plant Pathology Bulletin*, 17, 271-278.
- BIRD, A. & WALLACE, H. 1965. The influence of temperature on *Meloidogyne hapla* and *M. javanica*. *Nematologica*, 11, 581-589.
- BLANC-MATHIEU, R., PERFUS-BARBEOCH, L., AURY, J. M., DA ROCHA, M., GOUZY, J., SALLET, E., MARTIN-JIMENEZ, C., BAILLY-BECHET, M., CASTAGNONE-SERENO, P., FLOT, J. F., KOZLOWSKI, D. K., CAZARETH, J., COULOUX, A., DA SILVA, C., GUY, J., KIM-JO, Y. J., RANCUREL, C., SCHIEX, T., ABAD, P., WINCKER,

- P. & DANCHIN, E. G. J. 2017. Hybridization and polyploidy enable genomic plasticity without sex in the most devastating plant-parasitic nematodes. *Plos Genetics*, 13.
- BLAXTER, M. L., DE LEY, P., GAREY, J. R., LIU, L. X., SCHELDEMAN, P., VIERSTRAETE, A., VANFLETEREN, J. R., MACKEY, L. Y., DORRIS, M., FRISSE, L. M., VIDA, J. T. & THOMAS, W. K. 1998. A molecular evolutionary framework for the phylum *Nematoda*. *Nature*, 392, 71-75.
- BLOK, V. C., JONES, J. T., PHILLIPS, M. S. & TRUDGILL, D. L. 2008. Parasitism genes and host range disparities in biotrophic nematodes: the conundrum of polyphagy versus specialisation. *Bioessays*, 30, 249-59.
- BLOK, V. C., PHILLIPS, M. S. & FARGETTE, M. 1997. Comparison of sequences from the ribosomal DNA intergenic region of *Meloidogyne mayaguensis* and other major tropical root-knot nematodes. *Journal of Nematology*, 29, 16-22.
- BLOK, V. P., TO. 2009. Biochemical and Molecular Identification. In: PERRY, R., MOENS, M. STARR, J.L. (ed.) *Root-Knot Nematodes*. CAB International.
- BOHLMANN, H. & SOBCZAK, M. 2014. The plant cell wall in the feeding sites of cyst nematodes. *Frontiers in Plant Science*, 5.
- BRISSON, L. F., TENHAKEN, R. & LAMB, C. 1994. Function of Oxidative Cross-Linking of Cell-Wall Structural Proteins in Plant-Disease Resistance. *Plant Cell*, 6, 1703-1712.
- BROWN, D. M., GOUBET, F., VICKY, W. W. A., GOODACRE, R., STEPHENS, E., DUPREE, P. & TURNER, S. R. 2007. Comparison of five xylan synthesis mutants reveals new insight into the mechanisms of xylan synthesis. *Plant Journal*, 52, 1154-1168.
- BURKE, M., SCHOLL, E. H., BIRD, D. M., SCHAFF, J. E., COLMAN, S. D., CROWELL, R., DIENER, S., GORDON, O., GRAHAM, S., WANG, X. G., WINDHAM, E., WRIGHT, G. M. & OPPERMAN, C. H. 2015. The plant parasite *Pratylenchus coffeae* carries a minimal nematode genome. *Nematology*, 17, 621-637.
- BYRD, D. W., KIRKPATRICK, T. & BARKER, K. R. 1983. An Improved Technique for Clearing and Staining Plant-Tissues for Detection of Nematodes. *Journal of Nematology*, 15, 142-143.
- CABI. 2018. *Hypothenemus hampei* (coffee berry borer) [Online]. [Accessed].
- CAMARGO, M. B. P. 2010. The impact of climatic variability and climate change on arabic coffee crop in Brazil. *Bragantia*, 69, 239-247.

- CAMPOS, V. P. & SILVA, J. R. C. 2008. Management of *Meloidogyne* spp. in Coffee Plantations, Springer, Po Box 17, 3300 Aa Dordrecht, Netherlands.
- CAMPOS, V. P., VILLAIN, L. 2005. Nematodes parasites of coffee and cocoa. In: LUC, M., SIKORA, R. A., BRIDGE, J. (ed.) Plant parasitic nematodes in subtropical and tropical agriculture. .
- CAPUCHO, A. S., ZAMBOLIM, L., LOPES, U. N. & MILAGRES, N. S. 2013. Chemical control of coffee leaf rust in *Coffea canephora* cv. conilon. Australasian Plant Pathology, 42, 667-673.
- CARNEIRO, R. M. D., RANDIG, O., ALMEIDA, M. R. A. & GONCALVES, W. 2005. Identification and characterization of *Meloidogyne* species on coffee from Sao Paulo and Minas Gerais States of Brazil using esterase phenotypes and SCAR-PCR multiplex. . Nematologia Brasileira, 29, 233-241.
- CARNEIRO, R. M. D. G., CARNEIRO, R. G., ABRANTES, I. M. O., SANTOS, M. S. N. A. & ALMEIDA, M. R. A. 1996. *Meloidogyne paranaensis* n sp (Nemata: *Meloidogynidae*), a root-knot nematode parasitizing coffee in Brazil. Journal of Nematology, 28, 177-189.
- CARNEIRO, R. M. D. G. & COFCEWICZ, E. T. 2008. Taxonomy of coffee-parasitic root-knot nematodes, *Meloidogyne* spp. In: SOUZA, R. M. (ed.) Plant-parasitic nematodes of coffee. Springer.
- CARNEIRO, R. M. D. G., TIGANO, M. S., RANDIG, O., ALMEIDA, M. R. A. & SARAH, J. L. 2004. Identification and genetic diversity of *Meloidogyne* spp. (Tylenchida : *Meloidogynidae*) on coffee from Brazil, Central America and Hawaii. Nematology, 6, 287-298.
- CARPITA, N., TIERNEY, M. & CAMPBELL, M. 2001. Molecular biology of the plant cell wall: searching for the genes that define structure, architecture and dynamics. Plant Molecular Biology, 47, 1-5.
- CARPITA, N. C. & GIBEAUT, D. M. 1993. Structural Models of Primary-Cell Walls in Flowering Plants - Consistency of Molecular-Structure with the Physical-Properties of the Walls during Growth. Plant Journal, 3, 1-30.
- CASTAGNONE-SERENO, P., DANCHIN, E. G. J., PERFUS-BARBEOCH, L. & ABAD, P. 2013. Diversity and Evolution of Root-Knot Nematodes, Genus *Meloidogyne*: New Insights from the Genomic Era. Annual Review of Phytopathology, Vol 51, 51, 203-220.

- CASTAGNONE-SERENO, P., ESPARRAGO, G., ABAD, G., LEROY, F. & BONGIOVANNI, M. 1995. Satellite DNA as a target for PCR specific detection of the plant-parasitic nematode *Meloidogyne hapla*. *Current Genetics*, 28, 566-570.
- CASTILLO, P. & VOVLAS, N. 2007. *Pratylenchus* (Nematoda: *Pratylenchidae*): Diagnosis, Biology, Pathogenicity and Management. *Pratylenchus* (Nematoda: *Pratylenchidae*): Diagnosis, Biology, Pathogenicity and Management, 6, 1-529.
- CHASE, D. L. & KOELLE, M. R. 2007. Biogenic amine neurotransmitters in *C. elegans*. *WormBook*, 1-15.
- COFFEE RESEARCH INSTITUTE. 2006. Coffee Processing [Online]. Available: [coffeeresearch.org](http://coffeeresearch.org) [Accessed].
- CORADETTI, S. T., CRAIG, J. P., XIONG, Y., SHOCK, T., TIAN, C. G. & GLASS, N. L. 2012. Conserved and essential transcription factors for cellulase gene expression in ascomycete fungi. *Proceedings of the National Academy of Sciences of the United States of America*, 109, 7397-7402.
- CORREA, V. R., DOS SANTOS, M. F. A., ALMEIDA, M. R. A., PEIXOTO, J. R., CASTAGNONE-SERENO, P. & CARNEIRO, R. M. D. G. 2013. Species-specific DNA markers for identification of two root-knot nematodes of coffee: *Meloidogyne arabicida* and *M. izarcoensis*. *European Journal of Plant Pathology*, 137, 305-313.
- COTTON, J. A., LILLEY, C. J., JONES, L. M., KIKUCHI, T., REID, A. J., THORPE, P., TSAI, I. J., BEASLEY, H., BLOK, V., COCK, P. J. A., EVES-VAN DEN AKKER, S., HOLROYD, N., HUNT, M., MANTELIN, S., NAGHRA, H., PAIN, A., PALOMARES-RIUS, J. E., ZAROWIECKI, M., BERRIMAN, M., JONES, J. T. & URWIN, P. E. 2014. The genome and life-stage specific transcriptomes of *Globodera pallida* elucidate key aspects of plant parasitism by a cyst nematode. *Genome Biology*, 15.
- COUNCIL, L. R. & HANRAHAN, C. E. 2006. CRS Report: Brazil's agricultural production and exports: selected data. . *Nat Counc Sci Environ*, Washington.
- CRAIG, J. P., CORADETTI, S. T., STARR, T. L. & GLASS, N. L. 2015. Direct Target Network of the *Neurospora crassa* Plant Cell Wall Deconstruction Regulators CLR-1, CLR-2, and XLR-1. *Mbio*, 6.
- CURTIS, R. H. 2007a. Plant parasitic nematode proteins and the host parasite interaction. *Brief Funct Genomic Proteomic*, 6, 50-8.
- CURTIS, R. H. C. 2007b. Plant parasitic nematode proteins and the host–parasite interaction. *Briefings in Functional Genomics*, 6, 50-58.

- DAMON, A. 2000. A review of the biology and control of the coffee berry borer, *Hypothenemus hampei* (Coleoptera : Scolytidae). Bulletin of Entomological Research, 90, 453-465.
- DANCHIN, E. G., ROSSO, M. N., VIEIRA, P., DE ALMEIDA-ENGLER, J., COUTINHO, P. M., HENRISSAT, B. & ABAD, P. 2010. Multiple lateral gene transfers and duplications have promoted plant parasitism ability in nematodes. Proc Natl Acad Sci U S A, 107, 17651-6.
- DANCHIN, É. G. J. 2011. What Nematode genomes tell us about the importance of horizontal gene transfers in the evolutionary history of animals. Mobile Genetic Elements, 1, 269-292.
- DANCHIN, E. G. J., GUZEEVA, E. A., MANTELIN, S., BEREPIKI, A. & JONES, J. T. 2016. Horizontal Gene Transfer from Bacteria Has Enabled the Plant-Parasitic Nematode *Globodera pallida* to Feed on Host-Derived Sucrose. Molecular Biology and Evolution, 33, 1571-1579.
- DAS, S. & DAS, S. N. 1986. Host-range of *Pratylenchus coffeae*. Indian Journal of Nematology, 16, 180-184.
- DAVIES, K. G. & CURTIS, R. H. C. 2011. Cuticle Surface Coat of Plant-Parasitic Nematodes. Annual Review of Phytopathology, Vol 49, 49, 135-156.
- DAVIS, A. P., GOVAERTS, R., BRIDSON, D. M. & STOFFELEN, P. 2006. An annotated taxonomic conspectus of the genus *Coffea* (Rubiaceae). Botanical Journal of the Linnean Society, 152, 465-512.
- DE AZEVEDO SOUZA, C., LI, S., LIN, A. Z., BOUTROT, F., GROSSMANN, G., ZIPFEL, C. & SOMERVILLE, S. 2017. Cellulose-derived oligomers act as damage-associated molecular patterns and trigger defense-like responses. Plant Physiology.
- DE BOER, J. M., YAN, Y., SMANT, G., DAVIS, E. L. & BAUM, T. J. 1998. In-situ hybridization to messenger RNA in *Heterodera glycines*. Journal of Nematology, 30, 309-312.
- DE LEY, I. T., DE LEY, P., VIERSTRAETE, A., KARSSSEN, G., MOENS, M. & VANFLETEREN, J. 2002. Phylogenetic analyses of *Meloidogyne* small subunit rDNA. Journal of Nematology, 34, 319-327.
- DE LUCA, F., REYES, A., TROCCOLI, A. & CASTILLO, P. 2011. Molecular variability and phylogenetic relationships among different species and populations of *Pratylenchus*



(Nematoda: *Pratylenchidae*) as inferred from the analysis of the ITS rDNA. *European Journal of Plant Pathology*, 130, 415-426.

DE VRIES, R. P., VISSER, J. & DE GRAAFF, L. H. 1999. CreA modulates the XlnR-induced expression on xylose of *Aspergillus niger* genes involved in xylan degradation. *Research in Microbiology*, 150, 281-285.

DESHIELDS, J. B., BOMBERGER, R. A., WOODHALL, J. W., WHEELER, D. L., MOROZ, N., JOHNSON, D. A. & TANAKA, K. 2018. On-Site Molecular Detection of Soil-Borne Phytopathogens Using a Portable Real-Time PCR System. *Jove-Journal of Visualized Experiments*.

DEVIRAN, Z. & SOGUT, M. A. 2009. Distribution and Identification of Root-knot Nematodes from Turkey. *Journal of Nematology*, 41, 128-133.

DONOSO, A. & VALENZUELA, S. 2018. In-field molecular diagnosis of plant pathogens: recent trends and future perspectives. *Plant Pathology*, 67, 1451-1461.

DORRIS, M., DE LEY, P. & BLAXTER, M. L. 1999. Molecular analysis of nematode diversity and the evolution of parasitism. *Parasitology Today*, 15, 188-193.

DOYLE, E. A. & LAMBERT, K. N. 2002. Cloning and characterization of an esophageal-gland-specific pectate lyase from the root-knot nematode *Meloidogyne javanica*. *Molecular Plant-Microbe Interactions*, 15, 549-556.

DUBEY, A., YADAV, S., KUMAR, M., SINGH, V., SARANGI, B. & YADAV, D. 2010. In silico characterization of pectate lyase protein sequences from different source organisms. *Enzyme research*, 2010.

DUCEPPE, M.-O., LAFOND-LAPALME, J., PALOMARES-RIUS, J. E., SABEH, M., BLOK, V., MOFFETT, P. & MIMÉE, B. 2017. Analysis of survival and hatching transcriptomes from potato cyst nematodes, *Globodera rostochiensis* and *G. pallida*. *Scientific Reports*, 7, 3882.

DUFFY, B. K. & DEFAGO, G. 1999. Environmental factors modulating antibiotic and siderophore biosynthesis by *Pseudomonas fluorescens* biocontrol strains. *Applied and Environmental Microbiology*, 65, 2429-2438.

DUFFY, B. K. & DÉFAGO, G. 1999. Environmental Factors Modulating Antibiotic and Siderophore Biosynthesis by *Pseudomonas fluorescens* Biocontrol Strains. *Appl Environ Microbiol*, 65, 2429-38.

DUNCAN, L. W., INSERRA, R. N., THOMAS, W. K., DUNN, D., MUSTIKA, I., FRISSE, L. M., MENDES, M. L., MORRIS, K. & KAPLAN, D. T. 1999. Molecular and morphological

analysis of isolates of *Pratylenchus coffeae* and closely related species. *Nematropica*, 29, 61-80.

DUNCAN, L. W. & MOENS, M. 2013. Migratory endoparasitic nematodes. In: PERRY, R. N. & MOENS, M. (eds.) *Plant nematology*.

EBOIGBODIN, K. E., BRUMMER, M., OJALEHTO, T. & HOSER, M. 2016. Rapid molecular diagnostic test for Zika virus with low demands on sample preparation and instrumentation. *Diagnostic Microbiology and Infectious Disease*, 86, 369-371.

ESBENSHADE, P. R. & TRIANTAPHYLLOU, A. C. 1990. Isozyme Phenotypes for the Identification of *Meloidogyne* Species. *Journal of Nematology*, 22, 10-15.

EVES-VAN DEN AKKER, S., LAETSCH, D. R., THORPE, P., LILLEY, C. J., DANCHIN, E. G. J., DA ROCHA, M., RANCUREL, C., HOLROYD, N. E., COTTON, J. A., SZITENBERG, A., GRENIER, E., MONTARRY, J., MIMEE, B., DUCEPPE, M. O., BOYES, I., MARVIN, J. M. C., JONES, L. M., YUSUP, H. B., LAFOND-LAPALME, J., ESQUIBET, M., SABEH, M., ROTT, M., OVERMARS, H., FINKERS-TOMCZAK, A., SMANT, G., KOUTSOVOULOS, G., BLOK, V., MANTELIN, S., COCK, P. J. A., PHILLIPS, W., HENRISSAT, B., URWIN, P. E., BLAXTER, M. & JONES, J. T. 2016. The genome of the yellow potato cyst nematode, *Globodera rostochiensis*, reveals insights into the basis of parasitism and virulence. *Genome Biology*, 17.

FAIRTRADE FOUNDATION. 2018. About coffee [Online]. Fairtrade Foundations. [Accessed].

FANELLI, E., TROCCOLI, A., PICARDI, E., POUSIS, C. & LUCA, F. 2014. Molecular characterization and functional analysis of four beta-1,4-endoglucanases from the root-lesion nematode *Pratylenchus vulnus*. *Plant Pathology*, 63, 1436-1445.

FARAH, A. 2012. Coffee Constituents. In: CHU, Y. (ed.) *Coffee: Emerging Health Effects and Disease Prevention*. WILEY-BLACKWELL.

FARAH, A., DE PAULIS, T., TRUGO, L. C. & MARTIN, P. R. 2005. Effect of roasting on the formation of chlorogenic acid lactones in coffee. *J Agric Food Chem*, 53, 1505-13.

FERRAZ, L. C. C. B. 2008. Brazil. In: SOUZA, R. M. (ed.) *Plant-parasitic nematodes of coffee*. Springer.

FIGUEROA, A. 1978. Efectos de carbofuran 5G en la productividad del cafe Caturra. *Nematropica*, 8, 26-33.

FLOYD, R., ABEBE, E., PAPERT, A. & BLAXTER, M. 2002. Molecular barcodes for soil nematode identification. *Molecular Ecology*, 11, 839-850.

- FONTANA, L. F., R., D.-A. C., MATTEI, D., SEVERINO, J. J., BIELA, F. & JAILSON DE OLIVEIRA ARIEIRA, J. 2015. Competition between *Pratylenchus zae* and *Meloidogyne incognita* on sugarcane. *Nematropica*, 45.
- FORREST, J. M. S. & FARRER, L. A. 1983. The Response of Eggs of the White Potato Cyst Nematode *Globodera-Pallida* to Diffusate from Potato and Mustard Roots. *Annals of Applied Biology*, 103, 283-289.
- FOSU-NYARKO, J. & JONES, M. G. 2016a. Advances in Understanding the Molecular Mechanisms of Root Lesion Nematode Host Interactions. *Annu Rev Phytopathol*, 54, 253-78.
- FOSU-NYARKO, J., NICOL, P., NAZ, F., GILL, R. & JONES, M. G. 2016a. Analysis of the Transcriptome of the Infective Stage of the Beet Cyst Nematode, *H. schachtii*. *PLoS One*, 11, e0147511.
- FOSU-NYARKO, J., TAN, J. A., GILL, R., AGREZ, V. G., RAO, U. & JONES, M. G. 2016b. De novo analysis of the transcriptome of *Pratylenchus zae* to identify transcripts for proteins required for structural integrity, sensation, locomotion and parasitism. *Molecular Plant Pathology*, 17, 532-52.
- FOURIE, H., VENTER, G. A. & MC DONALD, A. H. 2003. Optimum temperature and inoculation levels for in vitro production of *Pratylenchus brachyurus* on carrot discs. *South African Journal of Plant and Soil*, 20, 44-45.
- FRY, S. C., NESSELRODE, B. H. W. A., MILLER, J. G. & MEWBURN, B. R. 2008. Mixed-linkage (1 -> 3,1 -> 4)-beta-D-glucan is a major hemicellulose of *Equisetum* (horsetail) cell walls. *New Phytologist*, 179, 104-115.
- FU, L. M., NIU, B. F., ZHU, Z. W., WU, S. T. & LI, W. Z. 2012a. CD-HIT: accelerated for clustering the next-generation sequencing data. *Bioinformatics*, 28, 3150-3152.
- FU, Z., AGUDELO, P. & WELLS, C. E. 2012b. Differential Expression of a beta-1,4-Endoglucanase Induced by Diet Change in the Foliar Nematode *Aphelenchoides fragariae*. *Phytopathology*, 102, 804-811.
- FURUTANI, S., NARUISHI, N., HAGIHARA, Y. & NAGAI, H. 2016. Development of an on-site rapid real-time polymerase chain reaction system and the characterization of suitable DNA polymerases for TaqMan probe technology. *Analytical and Bioanalytical Chemistry*, 408, 5641-5649.
- GAITAN, A. R., CA. CORTINA, H. 2008. Colombia. In: SOUZA, R. (ed.) *Plant-Parasitic Nematodes of Coffee*. Springer Science+Business Media B. V.

- GAO, B. L., ALLEN, R., DAVIS, E. L., BAUM, T. J. & HUSSEY, R. S. 2004. Developmental expression and biochemical properties of a beta-1,4-endoglucanase family in the soybean cyst nematode, *Heterodera glycines*. *Molecular Plant Pathology*, 5, 93-104.
- GAUR, H. S., BEANE, J. & PERRY, R. N. 2000. The influence of root diffusate, host age and water regimes on hatching of the root-knot nematode, *Meloidogyne triticoryzae*. *Nematology*, 2, 191-199.
- GOELLNER, M., SMANT, G., DE BOER, J. M., BAUM, T. J. & DAVIS, E. L. 2000. Isolation of beta-1,4-endoglucanase genes from *Globodera tabacum* and their expression during parasitism. *Journal of Nematology*, 32, 154-165.
- GOWEN, S. R., QUENEHERVE, P. & FOGAIN, R. 2005. Nematode parasites of bananas and plantains. In: LUC, M. S., RA. BRIDGE, J. (ed.) *Plant parasitic nematodes in subtropical and tropical agriculture*. Wallingford, U.K.: CAB International.
- GRBIC, M., VAN LEEUWEN, T., CLARK, R. M., ROMBAUTS, S., ROUZE, P., GRBIC, V., OSBORNE, E. J., DERMAUW, W., PHUONG, C. T. N., ORTEGO, F., HERNANDEZ-CRESPO, P., DIAZ, I., MARTINEZ, M., NAVAJAS, M., SUCENA, E., MAGALHAES, S., NAGY, L., PACE, R. M., DJURANOVIC, S., SMAGGHE, G., IGA, M., CHRISTIAENS, O., VEENSTRA, J. A., EWER, J., VILLALOBOS, R. M., HUTTER, J. L., HUDSON, S. D., VELEZ, M., YI, S. V., ZENG, J., PIRES-DASILVA, A., ROCH, F., CAZAUX, M., NAVARRO, M., ZHUROV, V., ACEVEDO, G., BJELICA, A., FAWCETT, J. A., BONNET, E., MARTENS, C., BAELE, G., WISSLER, L., SANCHEZ-RODRIGUEZ, A., TIRRY, L., BLAIS, C., DEMEESTERE, K., HENZ, S. R., GREGORY, T. R., MATHIEU, J., VERDON, L., FARINELLI, L., SCHMUTZ, J., LINDQUIST, E., FEYEREISEN, R. & VAN DE PEER, Y. 2011. The genome of *Tetranychus urticae* reveals herbivorous pest adaptations. *Nature*, 479, 487-492.
- GRIFFIN, G. D. & WAITE, W. W. 1971. Attraction of *Ditylenchus dipsaci* and *Meloidogyne hapla* by Resistant and Susceptible Alfalfa Seedlings. *Journal of Nematology*, 3, 215-&.
- GROOMBRIDGE, A. B. 1992. *Global Biodiversity. Status of the Earth's Living Resources*. , London, Chapman & Hall.
- GRUNDLER, F., SCHNIBBE, L. & WYSS, U. 1991. Invitro Studies on the Behavior of 2nd-Stage Juveniles of *Heterodera schachtii* (Nematoda, *Heteroderidae*) in Response to Host Plant-Root Exudates. *Parasitology*, 103, 149-155.

- HAEGEMAN, A., BAUTERS, L., KYNDT, T., RAHMAN, M. M. & GHEYSEN, G. 2013. Identification of candidate effector genes in the transcriptome of the rice root knot nematode *Meloidogyne graminicola*. *Molecular Plant Pathology*, 14, 379-390.
- HAEGEMAN, A., JACOB, J., VANHOLME, B., KYNDT, T. & GHEYSEN, G. 2008. A family of GHF5 endo-1,4-beta-glucanases in the migratory plant-parasitic nematode *Radopholus similis*. *Plant Pathology*, 57, 581-590.
- HAEGEMAN, A., JONES, J. T. & DANCHIN, E. G. J. 2011a. Horizontal Gene Transfer in Nematodes: A Catalyst for Plant Parasitism? *Molecular Plant-Microbe Interactions*, 24, 879-887.
- HAEGEMAN, A., JOSEPH, S. & GHEYSEN, G. 2011b. Analysis of the transcriptome of the root lesion nematode *Pratylenchus coffeae*. *Mol Biochem Parasitol*, 178, 7-14.
- HAEGEMAN, A., MANTELIN, S., JONES, J. T. & GHEYSEN, G. 2012. Functional roles of effectors of plant-parasitic nematodes. *Gene*, 492, 19-31.
- HAEGEMAN, A., VANHOLME, B. & GHEYSEN, G. 2009. Characterization of a putative endoxylanase in the migratory plant-parasitic nematode *Radopholus similis*. *Mol Plant Pathol*, 10, 389-401.
- HALLMAN, J., DAVIES, K. G. & SIKORA, R. 2009. Biological Control Using Microbial Pathogens, Endophytes and Antagonists. In: PERRY, R. N. (ed.) *Root-Knot Nematodes*. CAB International.
- HAN, Z. D., BOAS, S. & SCHROEDER, N. E. 2017. Serotonin Regulates the Feeding and Reproductive Behaviors of *Pratylenchus penetrans*. *Phytopathology*, 107, 872-877.
- HANDOO, Z. A., SKANTAR, A. M., CARTA, L. K. & SCHMITT, D. P. 2005. Morphological and molecular evaluation of a *Meloidogyne hapla* population damaging coffee (*Coffea arabica*) in Maul, Hawaii. *Journal of Nematology*, 37, 136-145.
- HANSEN, J., SATO, M., RUEDY, R., LO, K., LEA, D. W. & MEDINA-ELIZADE, M. 2006. Global temperature change. *Proceedings of the National Academy of Sciences of the United States of America*, 103, 14288-14293.
- HASELOFF, J., SIEMERING, K. R., PRASHER, D. C. & HODGE, S. 1997. Removal of a cryptic intron and subcellular localization of green fluorescent protein are required to mark transgenic Arabidopsis plants brightly. *Proc Natl Acad Sci U S A*, 94, 2122-7.
- HAWES, M. C., GUNAWARDENA, U., MIYASAKA, S. & ZHAO, X. W. 2000. The role of root border cells in plant defense. *Trends in Plant Science*, 5, 128-133.

- HEMATY, K., CHERK, C. & SOMERVILLE, S. 2009. Host-pathogen warfare at the plant cell wall. *Current Opinion in Plant Biology*, 12, 406-413.
- HERDE, M. & HOWE, G. A. 2014. Host plant-specific remodeling of midgut physiology in the generalist insect herbivore *Trichoplusia ni*. *Insect Biochemistry and Molecular Biology*, 50, 58-67.
- HERRERA, I., BRYNGELSSON, T. & MONZON, A. 2011. Occurrence of *Meloidogyne* sp and *Pratylenchus* sp in Conventional and Organic Coffee Systems in Nicaragua. *Nematropica*, 41, 82-90.
- HERVE, G., BERTRAND, B., VILLAIN, L., LICARDIE, D. & CILAS, C. 2005. Distribution analyses of *Meloidogyne* spp. and *Pratylenchus coffeae sensu lato* in coffee plots in Costa Rica and Guatemala. *Plant Pathology*, 54, 471-475.
- HO, N. F. H., SIMS, S. M., VIDMAR, T. J., DAY, J. S., BARSUHN, C. L., THOMAS, E. M., GEARY, T. G. & THOMPSON, D. P. 1994. Theoretical Perspectives on Anthelmintic Drug Discovery - Interplay of Transport Kinetics, Physicochemical Properties, and in-Vitro Activity of Anthelmintic Drugs. *Journal of Pharmaceutical Sciences*, 83, 1052-1059.
- HOBHOUSE, H., KNAPP, S. & LOWNDES, M. 2004. *Seeds of Trade*, Natural History Museum.
- HOBSON, R., GENG, J., GRAY, A. & KOMUNIECKI, R. 2003. SER-7b, a constitutively active G $\alpha$ s coupled 5-HT $_7$ -like receptor expressed in the *Caenorhabditis elegans* M4 pharyngeal motorneuron. *Journal of Neurochemistry*, 87, 22-29.
- HOFMANN, J., YOUSSEF-BANORA, M., DE ALMEIDA-ENGLER, J. & GRUNDLER, F. M. W. 2010. The Role of Callose Deposition Along Plasmodesmata in Nematode Feeding Sites. *Molecular Plant-Microbe Interactions*, 23, 549-557.
- HOFMANN, N. R. 2017. Evidence for Two Distinct Stages in Secondary Cell Wall Formation of Xylem. *Plant Cell*, 29, 2307-2308.
- HOLBEIN, J., GRUNDLER, F. M. W. & SIDDIQUE, S. 2016. Plant basal resistance to nematodes: an update. *Journal of Experimental Botany*, 67, 2049-2061.
- HU, M. X., ZHUO, K. & LIAO, J. L. 2011. Multiplex PCR for the Simultaneous Identification and Detection of *Meloidogyne incognita*, *M. enterolobii* and *M. javanica* Using DNA Extracted Directly from Individual Galls. *Phytopathology*, 101, 1270-1277.
- HUANG, G. Z., DONG, R. H., ALLEN, R., DAVIS, E. L., BAUM, T. J. & HUSSEY, R. S. 2005. Developmental expression and molecular analysis of two *Meloidogyne incognita* pectate lyase genes. *International Journal for Parasitology*, 35, 685-692.

- HUNT, D. J. & HANDOO, Z. A. 2009. Taxonomy, identification and principal species. In: PERRY, R. N., MOENS, M. & STARR, J. L. (eds.) Root-knot nematodes. Wallingford, U.K: Cab International.
- HUNT, D. J., LUC, M. & MANZANILLA-LOPEZ, R. 2005. Identification, Morphology and Biology of Plant Parasitic Nematodes. In: LUC, M. S., RA. BRIDGE, J. (ed.) Plant Parasitic Nematodes in Subtropical and Tropical Agriculture. Egham, UK.: CABI Bioscience.
- INOMOTO, M. M., KUBO, R. K., SILVA, R. A., OLIVEIRA, C. M. G., TOMAZINI, M. D. T. & MAZZAFERA, P. M. 2007. Pathogenicity of two *Pratylenchus coffeae* populations from Brazil on coffee plants. *Nematology*, 9, 853-858.
- INSERRA, R. N., DUNCAN, L. W., TROCCOLI, A., DUNN, D., DOS SANTOS, J. M., KAPLAN, D. & VOVLAS, N. 2001. *Pratylenchus jaehni* sp n. from citrus in Brazil and its relationship with *P. coffeae* and *P. loosi* (Nematoda: *Pratylenchidae*). *Nematology*, 3, 653-665.
- INTERNATIONAL COFFEE ORGANISATION 2016. Trends in coffee consumption in selected importing countries. International Coffee Council 5-10.
- INTERNATIONAL COFFEE ORGANISATION. 2018a. Country Data on the Global Coffee Trade [Online]. [Accessed].
- INTERNATIONAL COFFEE ORGANISATION 2018b. Coffee market report.
- INTERNATIONAL TRADE CENTRE 2011. The Coffee Exporter's Guide.
- JASSOGNE, L., VAN ASTEN, P. J. A., WANYAMA, I. & BARET, P. V. 2013. Perceptions and outlook on intercropping coffee with banana as an opportunity for smallholder coffee farmers in Uganda. *International Journal of Agricultural Sustainability*, 11, 144-158.
- JONES, J. T., FURLANETTO, C. & KIKUCHI, T. 2005. Horizontal gene transfer from bacteria and fungi as a driving force in the evolution of plant parasitism in nematodes. *Nematology*, 7, 641-646.
- JONES, J. T., HAEGEMAN, A., DANCHIN, E. G. J., GAUR, H. S., HELDER, J., JONES, M. G. K., KIKUCHI, T., MANZANILLA-LOPEZ, R., PALOMARES-RIUS, J. E., WESEMAEL, W. M. L. & PERRY, R. N. 2013. Top 10 plant-parasitic nematodes in molecular plant pathology. *Molecular Plant Pathology*, 14, 946-961.
- JONES, L. M., KOEHLER, A.-K., TRNKA, M., BALEK, J., CHALLINOR, A. J., ATKINSON, H. J. & URWIN, P. E. 2017. Climate change is predicted to alter the current

pest status of *Globodera pallida* and *G. rostochiensis* in the United Kingdom. *Global Change Biology*, n/a-n/a.

JONES, M. G. K. & FOSU-NYARKO, J. 2014. Molecular biology of root lesion nematodes (*Pratylenchus* spp.) and their interaction with host plants. *Annals of Applied Biology*, 164, 163-181.

JONES, M. G. K. & PAYNE, H. L. 1978. Early Stages of Nematode-Induced Giant-Cell Formation in Roots of Impatiens-Balsamina. *Journal of Nematology*, 10, 70-84.

JURGEN, H. A. & JANSSENS, M. J. J. 2010. Soils, plant growth and crop production. In: VERHEYE, W. H. (ed.) *Growth and production of coffee*. U.K: Eolss.

KAMILOVA, F., KRAVCHENKO, L. V., SHAPOSHNIKOV, A. I., AZAROVA, T., MAKAROVA, N. & LUGTENBERG, B. 2006. Organic acids, sugars, and L-tryptophane in exudates of vegetables growing on stonewool and their effects on activities of rhizosphere bacteria. *Mol Plant Microbe Interact*, 19, 250-6.

KEARN, J. 2015. Mode of action studies on the nematicide fluensulfone. University of Southampton.

KHAN, A., WESEMAEL, W. & MOENS, M. 2014. Influence of temperature on the development of the temperate root-knot nematodes *Meloidogyne chitwoodi* and *M. fallax*. *Russian Journal of Nematology*, 22, 1-9.

KIEWNICK, S., HOLTERMAN, M., VAN DEN ELSEN, S., VAN MEGEN, H., FREY, J. E. & HELDER, J. 2014. Comparison of two short DNA barcoding loci (COI and COII) and two longer ribosomal DNA genes (SSU & LSU rRNA) for specimen identification among quarantine root-knot nematodes (*Meloidogyne* spp.) and their close relatives. *European Journal of Plant Pathology*, 140, 97-110.

KIKUCHI, T., AIKAWA, T., OEDA, Y., KARIM, N. & KANZAKI, N. 2009. A Rapid and Precise Diagnostic Method for Detecting the Pinewood Nematode *Bursaphelenchus xylophilus* by Loop-Mediated Isothermal Amplification. *Phytopathology*, 99, 1365-1369.

KIKUCHI, T., EVES-VAN DEN AKKER, S. & JONES, J. T. 2017. Genome Evolution of Plant-Parasitic Nematodes. *Annual Review of Phytopathology*, Vol 55, 55, 333-354.

KORONEY, A. S., PLASSON, C., PAWLAK, B., SIDIKOU, R., DRIOUICH, A., MENU-BOUAOUICHE, L. & VICRE-GIBOUIN, M. 2016. Root exudate of *Solanum tuberosum* is enriched in galactose-containing molecules and impacts the growth of *Pectobacterium atrosepticum*. *Annals of Botany*, 118, 797-808.



- KUDLA, U., MILAC, A. L., QIN, L., OVERMARS, H., ROZE, E., HOLTERMAN, M., PETRESCU, A. J., GOVERSE, A., BAKKER, J., HELDER, J. & SMANT, G. 2007. Structural and functional characterization of a novel, host penetration-related pectate lyase from the potato cyst nematode *Globodera rostochiensis*. *Molecular Plant Pathology*, 8, 293-305.
- KUMAR, M., CAMPBELL, L. & TURNER, S. 2016. Secondary cell walls: biosynthesis and manipulation. *Journal of Experimental Botany*, 67, 515-531.
- KYNDT, T., HAEGEMAN, A. & GHEYSEN, G. 2008. Evolution of GHF5 endoglucanase gene structure in plant-parasitic nematodes: no evidence for an early domain shuffling event. *Bmc Evolutionary Biology*, 8.
- LADERACH, P. 2012. Future Climate Scenarios for Vietnam's Robusta Coffee Growing Areas. International Centre for Tropical Agriculture.
- LADERACH, P., RAMIREZ-VILLEGAS, J., NAVARRO-RACINES, C., ZELAYA, C., MARTINEZ-VALLE, A. & JARVIS, A. 2017. Climate change adaptation of coffee production in space and time. *Climatic Change*, 141, 47-62.
- LEDGER, T. N., JAUBERT, S., BOSSELUT, N., ABAD, P. & ROSSO, M. N. 2006. Characterization of a new beta-1,4-endoglucanase gene from the root-knot nematode *Meloidogyne incognita* and evolutionary scheme for phytonematode family 5 glycosyl hydrolases. *Gene*, 382, 121-128.
- LEE, C. H., ZHONG, R. Q., RICHARDSON, E. A., HIMMELSBACH, D. S., MCPHAIL, B. T. & YE, Z. H. 2007. The PARVUS gene is expressed in cells undergoing secondary wall thickening and is essential for glucuronoxylan biosynthesis. *Plant and Cell Physiology*, 48, 1659-1672.
- LEE, Y. S., PARK, Y. S., CHANG, D. J., HWANG, J. M., MIN, C. K., KAANG, B. K. & CHO, N. J. 1999b. Cloning and expression of a G protein-linked acetylcholine receptor from *Caenorhabditis elegans*. *J Neurochem*, 72, 58-65.
- LEE, Y. S., PARK, Y. S., NAM, S., SUH, S. J., LEE, J., KAANG, B. K. & CHO, N. J. 2000a. Characterization of GAR-2, a novel G protein-linked acetylcholine receptor from *Caenorhabditis elegans*. *J Neurochem*, 75, 1800-9.
- LEV, S. & HORWITZ, B. A. 2003. A mitogen-activated protein kinase pathway modulates the expression of two cellulase genes in *Cochliobolus heterostrophus* during plant infection. *Plant Cell*, 15, 835-44.

- LEWIS, J. A., WU, C. H., BERG, H. & LEVINE, J. H. 1980. The Genetics of Levamisole Resistance in the Nematode *Caenorhabditis elegans*. *Genetics*, 95, 905-928.
- LINSELL, K. J., RILEY, I. T., DAVIES, K. A. & OLDACH, K. H. 2014. Characterization of Resistance to *Pratylenchus thornei* (Nematoda) in Wheat (*Triticum aestivum*): Attraction, Penetration, Motility, and Reproduction. *Phytopathology*, 104, 174-187.
- LIU, B., HIBBARD, J. K., URWIN, P. E. & ATKINSON, H. J. 2005. The production of synthetic chemodisruptive peptides in planta disrupts the establishment of cyst nematodes. *Plant Biotechnology Journal*, 3, 487-496.
- LORDELLO, L. G. E. 1982. Nova ocorrência do nematoide *Meloidogyne hapla* em cafeeiro. *Revista de Agricultura*, 57.
- MACHADO, A. C. Z., FERRAZ, L. C. C. B. & OLIVEIRA, C. M. G. 2007. Development of a species-specific reverse primer for the molecular diagnostic of *Pratylenchus brachyurus*. *Nematropica*, 37, 249-257.
- MAGRACH, A. & GHAZOUL, J. 2015. Climate and Pest-Driven Geographic Shifts in Global Coffee Production: Implications for Forest Cover, Biodiversity and Carbon Storage. *Plos One*, 10.
- MALINOVSKY, F. G., FANGEL, J. U. & WILLATS, W. G. T. 2014. The role of the cell wall in plant immunity. *Frontiers in Plant Science*, 5.
- MANZANILLA-LOPEZ, R. 2012. Methodology and symtomaology. In: MANZANILLA-LOPEZ, R. & MARBAN-MENDOZA, N. (eds.) *Practical Plant Nematology*. Texcoco, Mexico: Editorial Colegio de Postgraduados.
- MARK, G. L., DOW, J. M., KIELY, P. D., HIGGINS, H., HAYNES, J., BAYSSE, C., ABBAS, A., FOLEY, T., FRANKS, A., MORRISSEY, J. & O'GARA, F. 2005. Transcriptome profiling of bacterial responses to root exudates identifies genes involved in microbe-plant interactions. *Proceedings of the National Academy of Sciences of the United States of America*, 102, 17454-17459.
- MARVIN, J. M. C. 2015. The levamisole-sensitive nicotinic acetylcholine receptor of the potato cyst-nematode *Globodera pallida*. The University of Leeds.
- MASLER, E. P. 2007. Responses of *Heterodera glycines* and *Meloidogyne incognita* to exogenously applied neuromodulators. *Journal of Helminthology*, 81, 421-427.
- MATHERS, T. C., CHEN, Y. Z., KAITHAKOTTIL, G., LEGEAI, F., MUGFORD, S. T., BAA-PUYOULET, P., BRETAUDEAU, A., CLAVIJO, B., COLELLA, S., COLLIN, O., DALMAY, T., DERRIEN, T., FENG, H. L., GABALDON, T., JORDAN, A., JULCA, I.,

- KETTLES, G. J., KOWITWANICH, K., LAVENIER, D., LENZI, P., LOPEZ-GOMOLLON, S., LOSKA, D., MAPLESON, D., MAUMUS, F., MOXON, S., PRICE, D. R. G., SUGIO, A., VAN MUNSTER, M., UZEST, M., WAITE, D., JANDER, G., TAGU, D., WILSON, A. C. C., VAN OOSTERHOUT, C., SWARBRECK, D. & HOGENHOUT, S. A. 2017. Rapid transcriptional plasticity of duplicated gene clusters enables a clonally reproducing aphid to colonise diverse plant species (vol 18, 27, 2017). *Genome Biology*, 18.
- MAXIMINIANO, C., CAMPOS, V. P. & SOUZA, R. M. 2011. Flutuacao populacional de *Meloidogyne exigua* em cafezal naturalmente infestado por *Pasteuria penetrans*. *Nematologia Brasileira*, 21.
- MCCARTNEY, L., MARCUS, S. E. & KNOX, J. P. 2005. Monoclonal antibodies to plant cell wall xylans and arabinoxylans. *Journal of Histochemistry & Cytochemistry*, 53, 543-546.
- MCCLURE, M. A., ELLIS, K. C. & NIGH, E. L. 1974. Post-Infection Development and Histopathology of *Meloidogyne incognita* in Resistant Cotton. *Journal of Nematology*, 6, 21-26.
- MCCLURE, M. A. & VONMENDE, N. 1987. Induced Salivation in Plant-Parasitic Nematodes. *Phytopathology*, 77, 1463-1469.
- MCCOOK, S. 2006. Global rust belt: *Hemileia vastatrix* and the ecological integration of world coffee production since 1850. *Journal of Global History*, 1, 177-195.
- MCINTIRE, S. L., JORGENSEN, E., KAPLAN, J. & HORVITZ, H. R. 1993. The GABAergic nervous system of *Caenorhabditis elegans*. *Nature*, 364, 337-41.
- MCKAY, J. P., RAIZEN, D. M., GOTTSCHALK, A., SCHAFER, W. R. & AVERY, L. 2004. eat-2 and eat-18 are required for nicotinic neurotransmission in the *Caenorhabditis elegans* pharynx. *Genetics*, 166, 161-9.
- MEGEN, H. H. B. V., ELSEN, S. J. J. V. D., HOLTERMAN, M. H. M., KARSSSEN, G., MOOIJMAN, P. J. W., BONGERS, A. M. T., HOLOVACHOV, O. V., BAKKER, J. & HELDER, J. 2009. A phylogenetic tree of nematodes based on about 1200 full-length small subunit ribosomal DNA sequences. *Nematology*, 11, 927-950.
- MENDOZA-GALLEGOS, R. A., RIOS, A. & GARCIA-CORDERO, J. L. 2018. An Affordable and Portable Thermocycler for Real-Time PCR Made of 3D-Printed Parts and Off-the-Shelf Electronics. *Analytical Chemistry*, 90, 5563-5568.

- MENG, Q., LONG, H. & QU, J. 2004. PCR assays for rapid and sensitive identification of three major root-knot nematodes, *Meloidogyne incognita*, *M. javanica* and *M. arenaria*. *Acta Phytopathologica Sinica*, 34, 204-210.
- MILNE, I., LINDNER, D., BAYER, M., HUSMEIER, D., MCGUIRE, G., MARSHALL, D. F. & WRIGHT, F. 2009. TOPALi v2: a rich graphical interface for evolutionary analyses of multiple alignments on HPC clusters and multi-core desktops. *Bioinformatics*, 25, 126-127.
- MITREVA-DAUTOVA, M., ROZE, E., OVERMARS, H., DE GRAAFF, L., SCHOTS, A., HELDER, J., GOVERSE, A., BAKKER, J. & SMANT, G. 2006. A symbiont-independent endo-1,4-beta-xylanase from the plant-parasitic nematode *Meloidogyne incognita*. *Mol Plant Microbe Interact*, 19, 521-9.
- MIZUKUBO, T., ORUI, Y., HANADA, K. & SANO, Z. 2003. Microevolutionary trend in *Pratylenchus coffeae sensu stricto* (Nematoda: *Pratylenchidae*): the diversity in PCR-RFLP phenotype, compatibility on host plants and reproductive segregation. *Nematological Research (Japanese Journal of Nematology)*, 33, 57-76.
- MOENS, M., PERRY, P. N. & STARR, J. L. 2009. *Meloidogyne* Species - a Diverse Group of Novel and Important Plant Parasites. In: PERRY, P. N. (ed.) *Root-knot Nematodes*. CAB International.
- MOENS, M. & PERRY, R. N. 2009. Migratory Plant Endoparasitic Nematodes: A Group Rich in Contrasts and Divergence. *Annual Review of Phytopathology*, 47, 313-332.
- MOON, J. K., YOO, H. S. & SHIBAMOTO, T. 2009. Role of Roasting Conditions in the Level of Chlorogenic Acid Content in Coffee Beans: Correlation with Coffee Acidity. *Journal of Agricultural and Food Chemistry*, 57, 5365-5369.
- MORLEY, A. A. 2014. Digital PCR: A brief history. *Biomolecular Detection and Quantification*, 1, 1-2.
- MUGNIÉRY, D. & PHILLIPS, M. S. 2007. Chapter 26 - The Nematode Parasites of Potato. In: VREUGDENHIL, D., BRADSHAW, J., GEBHARDT, C., GOVERS, F., MACKERRON, D. K. L., TAYLOR, M. A. & ROSS, H. A. (eds.) *Potato Biology and Biotechnology*. Amsterdam: Elsevier Science B.V.
- MUNIZ, M. D. S., CAMPOS, V. P., CASTAGNONE-SERENO, P., CASTRO, J. M. D. E., ALMEIDA, M. R. A. & CARNEIRO, R. M. D. G. 2008. Diversity of *Meloidogyne exigua* (Tylenchida: *Meloidogynidae*) populations from coffee and rubber tree. *Nematology*, 10, 897-910.

- NATIONAL COFFEE ASSOCIATION. 2015. From the Seed to the Cup [Online]. Available: ncausa.org [Accessed].
- NEVEU, C., ABAD, P. & CASTAGNONE-SERENO, P. 2003. Molecular cloning and characterization of an intestinal cathepsin L protease from the plant-parasitic nematode *Meloidogyne incognita*. *Physiological and Molecular Plant Pathology*, 63, 159-165.
- NGUYEN, T. 2010. A Comparative Polyphasic Study Of 10 *Pratylenchus Coffeae* Populations From Vietnam. University of Leuven.
- NICOL, J. M., TURNER, S. J., COYNE, D. L., DEN NIJS, L., HOCKLAND, S. & MAAFI, Z. T. 2011. Current Nematode Threats to World Agriculture. *Genomics and Molecular Genetics of Plant-Nematode Interactions*, 21-43.
- NICOL, P., GILL, R., FOSU-NYARKO, J. & JONES, M. G. K. 2012. de novo analysis and functional classification of the transcriptome of the root lesion nematode, *Pratylenchus thornei*, after 454 GS FLX sequencing. *International Journal for Parasitology*, 42, 225-237.
- NICOLINI, A. M., MCCRACKEN, K. E. & YOON, J. Y. 2017. Future developments in biosensors for field-ready Zika virus diagnostics. *Journal of Biological Engineering*, 11.
- NJEZIC, B., DE SUTTER, N. & MOENS, M. 2014. Interaction of *Tagetes patula* cv. Single Gold with the life cycle of the plant-parasitic nematodes *Meloidogyne chitwoodi* and *Pratylenchus penetrans*. *Russian Journal of Nematology*, 22, 101-108.
- NOIR, S., ANTHONY, F., BERTRAND, B., COMBES, M. C. & LASHERMES, P. 2003. Identification of a major gene (Mex-1) from *Coffea canephora* conferring resistance to *Meloidogyne exigua* in *Coffea arabica*. *Plant Pathology*, 52, 97-103.
- NOTOMI, T., OKAYAMA, H., MASUBUCHI, H., YONEKAWA, T., WATANABE, K., AMINO, N. & HASE, T. 2000. Loop-mediated isothermal amplification of DNA. *Nucleic Acids Res*, 28, E63.
- NYCZEPIR, A. & THOMAS, S. 2009. Current and Future Management Strategies in Intensive Crop Production Systems. In: PERRY, R. N. (ed.) *Root-Knot Nematodes*. CAB International
- NYCZEPIR, A. P. 2009. Dynamics of Concomitant Populations of *Pratylenchus Vulnus* and *Meloidogyne Incognita* on Peach. *Nematopica*, 39, 273-279.
- OLDE, B. & MCCOMBIE, W. R. 1997. Molecular cloning and functional expression of a serotonin receptor from *Caenorhabditis elegans*. *J Mol Neurosci*, 8, 53-62.

- OLIVEIRA, C. M., AUAD, A. M., MENDES, S. M. & FRIZZAS, M. R. 2013. Economic impact of exotic insect pests in Brazilian agriculture. *Journal of Applied Entomology*, 137, 1-15.
- OLIVEIRA, C. M. G., INOMOTO, M. M., VIEIRA, A. M. C. & MONTEIRO, A. R. 1999. Efeito de Densidades Populacionais de *Pratylenchus brachyurus* No Crescimento de Plantulas de *Coffea arabica* cv. Mundo Novo e *C. canephora* cv. Apoata. *Nematropica*, 29, 215-221.
- ONKENDI, E. M., KARIUKI, G. M., MARAIS, M. & MOLELEKI, L. N. 2014. The threat of root-knot nematodes (*Meloidogyne* spp.) in Africa: a review. *Plant Pathology*, 63, 727-737.
- OPPERMAN, C. H., BIRD, D. M., WILLIAMSON, V. M., ROKHSAR, D. S., BURKE, M., COHN, J., CROMER, J., DIENER, S., GAJAN, J., GRAHAM, S., HOUFEK, T. D., LIU, Q., MITROS, T., SCHAFF, J., SCHAFFER, R., SCHOLL, E., SOSINSKI, B. R., THOMAS, V. P. & WINDHAM, E. 2008. Sequence and genetic map of *Meloidogyne hapla*: A compact nematode genome for plant parasitism. *Proceedings of the National Academy of Sciences*, 105, 14802-14807.
- PAGANINI, J., CAMPAN-FOURNIER, A., DA ROCHA, M., GOURET, P., PONTAROTTI, P., WAJNBERG, E., ABAD, P. & DANCHIN, E. G. 2012. Contribution of lateral gene transfers to the genome composition and parasitic ability of root-knot nematodes. *PLoS One*, 7, e50875.
- PALOMARES-RIUS, J. E., ESCOBAR, C., CABRERA, J., VOVLAS, A. & CASTILLO, P. 2017. Anatomical Alterations in Plant Tissues Induced by Plant-Parasitic Nematodes. *Frontiers in Plant Science*, 8.
- PALOMARES-RIUS, J. E., JONES, J. T., COCK, P. J., CASTILLO, P. & BLOK, V. C. 2013. Activation of hatching in diapaused and quiescent *Globodera pallida*. *Parasitology*, 140, 445-454.
- PANG, W., HAFEZ, S. L. & SUNDARARAJ, P. 2009. Concomitant Interaction of *Pratylenchus Penetrans* and *Meloidogyne Hapla* on Onion. *Nematropica*, 39, 297-303.
- PENG, H., LONG, H. B., HUANG, W. K., LIU, J., CUI, J. K., KONG, L. A., HU, X. Q., GU, J. F. & PENG, D. L. 2017. Rapid, simple and direct detection of *Meloidogyne hapla* from infected root galls using loop-mediated isothermal amplification combined with FTA technology. *Scientific Reports*, 7.

- PENG, L. C., HOCART, C. H., REDMOND, J. W. & WILLIAMSON, R. E. 2000. Fractionation of carbohydrates in Arabidopsis root cell walls shows that three radial swelling loci are specifically involved in cellulose production. *Planta*, 211, 406-414.
- PERRY, R. N. 1996. Chemoreception in plant parasitic nematodes. *Annual Review of Phytopathology*, 34, 181-199.
- PETERSEN, T. N., BRUNAK, S., VON HEIJNE, G. & NIELSEN, H. 2011. SignalP 4.0: discriminating signal peptides from transmembrane regions. *Nature Methods*, 8, 785-786.
- PINHEIRO, L. B., COLEMAN, V. A., HINDSON, C. M., HERRMANN, J., HINDSON, B. J., BHAT, S. & EMSLIE, K. R. 2012. Evaluation of a droplet digital polymerase chain reaction format for DNA copy number quantification. *Anal Chem*, 84, 1003-11.
- PONTE, S. 2002. The 'latte revolution'? Regulation, markets and consumption in the global coffee chain. *World Development*, 30, 1099-1122.
- PUDASAINI, M. P., VIAENE, N. & MOENS, M. 2008. Hatching of the root-lesion nematode, *Pratylenchus penetrans*, under the influence of temperature and host. *Nematology*, 10, 47-54.
- QIAN, H., ROBERTSON, A. P., POWELL-COFFMAN, J. A. & MARTIN, R. J. 2008. Levamisole resistance resolved at the single-channel level in *Caenorhabditis elegans*. *Faseb Journal*, 22, 3247-3254.
- QUIST, C. W., SMANT, G. & HELDER, J. 2015. Evolution of plant parasitism in the phylum Nematoda. *Annu Rev Phytopathol*, 53, 289-310.
- RAND, J. 2007. Acetylcholine. In: COMMUNITY, T. C. E. R. (ed.) *Wormbook*.
- RAND, J. B., DUERR, J. S. & FRISBY, D. L. 2000. Neurogenetics of vesicular transporters in *C. elegans*. *Faseb Journal*, 14, 2414-2422.
- RANDIG, O., BONGIOVANNI, M., CARNEIRO, R. M. D. G. & CASTAGNONE-SERENO, P. 2002a. Genetic diversity of root-knot nematodes from Brazil and development of SCAR markers specific for the coffee-damaging species. *Genome*, 45, 862-870.
- RANDIG, O., BONGIOVANNI, M., CARNEIRO, R. M. D. G., SARAH, J. L. & CASTAGNONE-SERENO, P. 2002b. A species-specific satellite DNA family in the genome of the coffee root-knot nematode *Meloidogyne exigua*: application to molecular diagnostics of the parasite. *Molecular Plant Pathology*, 3, 431-437.

- RANGANATHAN, R., CANNON, S. C. & HORVITZ, H. R. 2000. MOD-1 is a serotonin-gated chloride channel that modulates locomotory behaviour in *C. elegans*. *Nature*, 408, 470-5.
- RAWSTHORNE, D. & BRODIE, B. B. 1986. Relationship between Root-Growth of Potato, Root Diffusate Production, and Hatching of *Globodera rostochiensis*. *Journal of Nematology*, 18, 379-384.
- REHMAN, S., GUPTA, V. K. & GOYAL, A. K. 2016. Identification and functional analysis of secreted effectors from phytoparasitic nematodes. *Bmc Microbiology*, 16.
- REYNOLDS, A. M., DUTTA, T. K., CURTIS, R. H. C., POWERS, S. J., GAUR, H. S. & KERRY, B. R. 2011. Chemotaxis can take plant-parasitic nematodes to the source of a chemo-attractant via the shortest possible routes. *Journal of the Royal Society Interface*, 8, 568-577.
- RODERICK, H., URWIN, P. E. & ATKINSON, H. J. 2018. Rational design of biosafe crop resistance to a range of nematodes using RNA interference. *Plant Biotechnology Journal*, 16, 520-529.
- RODRIGUES, I. & CROZZOLI, R. 1995. Efectos de Nematodos Agallador *Meloidogyne exigua* Sobre el Crecimiento de Plantas de Café en Vivero. *Nematologia Mediterranea*, 23, 325-328.
- RODRIGUEZ-KABANA, R. & POPE, M. H. 1981. A simple incubation method for the extraction of nematodes from soil. *Nematropica*, 11, 175-185.
- ROSSO, M. N., FAVERY, B., PIOTTE, C., ARTHAUD, L., DE BOER, J. M., HUSSEY, R. S., BAKKER, J., BAUM, T. J. & ABAD, P. 1999. Isolation of a cDNA encoding a beta-1,4-endoglucanase in the root-knot nematode *Meloidogyne incognita* and expression analysis during plant parasitism. *Molecular Plant-Microbe Interactions*, 12, 585-591.
- ROY, A., WALKER, W. B., VOGEL, H., CHATTINGTON, S., LARSSON, M. C., ANDERSON, P., HECKEL, D. G. & SCHLYTER, F. 2016. Diet dependent metabolic responses in three generalist insect herbivores *Spodoptera* spp. *Insect Biochemistry and Molecular Biology*, 71, 91-105.
- RUESS, L., MICHELSEN, A., SCHMIDT, I. K. & JONASSON, S. 1999. Simulated climate change affecting microorganisms, nematode density and biodiversity in subarctic soils. *Plant and Soil*, 212, 63-73.



- SAEED, I. A., MACGUIDWIN, A. E. & ROUSE, D. I. 1998. Effect of Initial Nematode Population Density on the Interaction of *Pratylenchus penetrans* and *Verticillium dahliae* on 'Russet Burbank' Potato. *J Nematol*, 30, 100-7.
- SAEKI, Y., KAWANO, E., YAMASHITA, C., AKAO, S. & NAGATOMO, Y. 2003. Detection of plant parasitic nematodes, *Meloidogyne incognita* and *Pratylenchus coffeae* by multiplex PCR using specific primers. *Soil Science and Plant Nutrition*, 49, 291-295.
- SALGADO, S. M. L., GUIMARÃES, N. M. R. B., BOTELHO, C. E., TASSONE, G. A. T., MARCELO, A. L., SOUZA, S. R., OLIVEIRA, R. D. L. & FERREIRA, D. F. 2015. *Meloidogyne paranaensis* and *Meloidogyne exigua* in coffee plantations from the south of Minas Gerais state. *Coffee Science*, 10, 475-481.
- SANZ, C., MAEZTU, L., ZAPELENA, M. J., BELLO, J. & CID, C. 2002. Profiles of volatile compounds and sensory analysis of three blends of coffee: influence of different proportions of Arabica and Robusta and influence of roasting coffee with sugar. *Journal of the Science of Food and Agriculture*, 82, 840-847.
- SHTONDA, B. B. & AVERY, L. 2006. Dietary choice behavior in *Caenorhabditis elegans*. *Journal of Experimental Biology*, 209, 89-102.
- SIEVERS, F., WILM, A., DINEEN, D., GIBSON, T. J., KARPLUS, K., LI, W. Z., LOPEZ, R., MCWILLIAM, H., REMMERT, M., SODING, J., THOMPSON, J. D. & HIGGINS, D. G. 2011. Fast, scalable generation of high-quality protein multiple sequence alignments using Clustal Omega. *Molecular Systems Biology*, 7.
- SILVA, M., VÁRZEA, V., GUERRA-GUIMARÃES, L., AZINHEIRA, H., FERNANDEZ, D., PETITOT, A., BERTRAND, B., LASHERMES, P. & NICOLE, M. 2006. Coffee resistance to the main diseases: leaf rust and coffee berry disease. *Brazil Journal of Plant Physiology*, 18, 118-147.
- SIRIAS, H. & CRISTINA, I. 2011. Root-knot nematodes and coffee in Nicaragua: management systems, species identification and genetic diversity *Acta Universitatis agriculturae Sueciae*.
- SIRIAS, I. 2011. Root-Knot Nematodes and Coffee in Nicaragua: Management Systems, Species Identification and Genetic Diversity. Swedish University of Agricultural Sciences.
- SMANT, G., STOKKERMANS, J. P. W. G., YAN, Y. T., DE BOER, J. M., BAUM, T. J., WANG, X. H., HUSSEY, R. S., GOMMERS, F. J., HENRISSAT, B., DAVIS, E. L., HELDER, J., SCHOTS, A. & BAKKER, J. 1998. Endogenous cellulases in animals: Isolation of beta-1,4-endoglucanase genes from two species of plant-parasitic cyst

nematodes. Proceedings of the National Academy of Sciences of the United States of America, 95, 4906-4911.

SOMASEKHAR, N., PRASAD, J. S. & GANGULY, A. K. 2010. Impact of Climate Change on Soil Nematodes - Implications for Sustainable Agriculture. Indian Journal of Nematology, 40, 125-134.

SONG, B. M. & AVERY, L. 2012. Serotonin Activates Overall Feeding by Activating Two Separate Neural Pathways in *Caenorhabditis elegans*. Journal of Neuroscience, 32, 1920-1931.

SONG, J., MAUK, M. G., HACKETT, B. A., CHERRY, S., BAU, H. H. & LIU, C. 2016. Instrument-Free Point-of-Care Molecular Detection of Zika Virus. Anal Chem, 88, 7289-94.

SORENSEN, I., DOMOZYCH, D. & WILLATS, W. G. T. 2010. How Have Plant Cell Walls Evolved? Plant Physiology, 153, 366-372.

STANTON, J. M., MCNICOL, C. D. & STEELE, V. 1998. Non-manual lysis of second-stage Meloidogyne juveniles for identification of pure and mixed samples based on the polymerase chain reaction. Australasian Plant Pathology, 27, 112-115.

STARR, J., COOK, R. & BRIDGE, J. 2002. Resistance to Plant Parasitic Nematodes. Plant Resistance to Parasitic Nematodes CABI.

STEGER, K. A. & AVERY, L. 2004. The GAR-3 muscarinic receptor cooperates with calcium signals to regulate muscle contraction in the *Caenorhabditis elegans* pharynx. Genetics, 167, 633-643.

STICKLEN, M. B. 2008. Plant genetic engineering for biofuel production: towards affordable cellulosic ethanol (Retracted article. See vol 11, pg 308, 2010). Nature Reviews Genetics, 9, 433-443.

SULTAN, S. E. 1995. Phenotypic plasticity and plant adaptation. Acta Botanica Neerlandica, 44, 363-383.

SULTAN, S. E. 2000. Phenotypic plasticity for plant development, function and life history. Trends in Plant Science, 5, 537-542.

SULTAN, S. E. & SPENCER, H. G. 2002. Metapopulation structure favors plasticity over local adaptation. American Naturalist, 160, 271-283.

SUN, J. P., TIAN, C. G., DIAMOND, S. & GLASS, N. L. 2012. Deciphering Transcriptional Regulatory Mechanisms Associated with Hemicellulose Degradation in *Neurospora crassa*. Eukaryotic Cell, 11, 482-493.

- TALHINHAS, P., BATISTA, D., DINIZ, I., VIEIRA, A., SILVA, D. N., LOUREIRO, A., TAVARES, S., PEREIRA, A. P., AZINHEIRA, H. G., GUERRA-GUIMARAES, L., VARZEA, V. & SILVA, M. D. 2017. The coffee leaf rust pathogen *Hemileia vastatrix*: one and a half centuries around the tropics. *Molecular Plant Pathology*, 18, 1039-1051.
- TEILLET, A., DYBAL, K., KERRY, B. R., MILLER, A. J., CURTIS, R. H. C. & HEDDEN, P. 2013. Transcriptional Changes of the Root-Knot Nematode *Meloidogyne incognita* in Response to *Arabidopsis thaliana* Root Signals. *Plos One*, 8.
- TERAZONO, E. 2017. Struggling Brazilian coffee farmers turn to pepper *Financial Times*, Agricultural Commodities.
- THE BRITISH COFFEE ASSOCIATION. 2018. Coffee facts [Online]. [Accessed].
- THOMPSON, J. P., CLEWETT, T. G. & O'REILLY, M. M. 2015. Temperature response of root-lesion nematode (*Pratylenchus thornei*) reproduction on wheat cultivars has implications for resistance screening and wheat production. *Annals of Applied Biology*, 167, 1-10.
- THUY, T. T. T., YEN, N. T., TUYET, N. T. A., TE, L. L. & DE WAELE, D. 2012. Plant-parasitic nematodes and yellowing of leaves associated with black pepper plants in Vietnam. *Archives of Phytopathology and Plant Protection*, 45, 1183-1200.
- TIGANO, M., DE SIQUEIRA, K., CASTAGNONE-SERENO, P., MULET, K., QUEIROZ, P., DOS SANTOS, M., TEIXEIRA, C., ALMEIDA, M., SILVA, J. & CARNEIRO, R. 2010. Genetic diversity of the root-knot nematode *Meloidogyne enterolobii* and development of a SCAR marker for this guava-damaging species. *Plant Pathology*, 59, 1054-1061.
- TIMMONS, L. & FIRE, A. 1998. Specific interference by ingested dsRNA. *Nature*, 395, 854.
- TIMPER, P. 2014. Conserving and Enhancing Biological Control of Nematodes. *Journal of Nematology*, 46, 75-89.
- TOMAZINI, M. D., FERRAZ, L. C. C. B. & INOMOTO, M. M. 2009. Evaluation of damage caused on *Coffea arabica* by a population of *Pratylenchus coffeae* considered non-pathogenic on coffee. *Tropical Plant Pathology*, 34, 412-415.
- TONIUTTI, L., BREITLER, J. C., ETIENNE, H., CAMPA, C., DOULBEAU, S., URBAN, L., LAMBOT, C., PINILLA, J. C. H. & BERTRAND, B. 2017. Influence of Environmental Conditions and Genetic Background of Arabica Coffee (*C. arabica* L) on Leaf Rust (*Hemileia vastatrix*) Pathogenesis. *Frontiers in Plant Science*, 8.

- TOYOTA, K., SHIRAKASHI, T., SATO, E., WADA, S. & MIN, Y. Y. 2008. Development of a real-time PCR method for the potato-cyst nematode *Globodera rostochiensis* and the root-knot nematode *Meloidogyne incognita*. *Soil Science & Plant Nutrition*, 54, 72-76.
- TRINH, P. Q., DE LA PENA, E., NGUYEN, C. N., NGUYEN, H. X. & MOENS, M. 2009. Plant-parasitic nematodes associated with coffee in Vietnam. *Russian Journal of Nematology*, 17, 73-82.
- TRINH, P. Q., WAEYENBERGE, L., NGUYEN, C. N. & MOENS, M. 2012. Morphological and molecular diversity of *Radopholus* on coffee in Vietnam and description of *R. daklakensis* sp. n. from Robusta coffee. *Nematology*, 14, 65-83.
- TRINH, P. Q., WESEMAEL, W. M. L., NGUYEN, S. T. T., NGUYEN, C. N. & MOENS, M. 2011. Pathogenicity and reproductive fitness of *Pratylenchus coffeae* and *Radopholus arabocoffeae* on Arabica coffee seedlings (*Coffea arabica* cv. Catimor) in Vietnam. *European Journal of Plant Pathology*, 130, 45-57.
- TRIPATHI, L., BABIRYE, A., RODERICK, H., TRIPATHI, J. N., CHANGA, C., URWIN, P. E., TUSHEMEREIRWE, W. K., COYNE, D. & ATKINSON, H. J. 2015. Field resistance of transgenic plantain to nematodes has potential for future African food security. *Scientific Reports*, 5.
- TRUDGILL, D. L. & BLOK, V. C. 2001. Apomictic, polyphagous root-knot nematodes: Exceptionally successful and damaging biotrophic root pathogens. *Annual Review of Phytopathology*, 39, 53-77.
- TUMINEM., SUPRAMANA., SINAGA, M. S. & GIYANTO. 2015. First Report on the Root Knot Nematodes *Meloidogyne* spp. of Sweetpotatoes in Sorong Regency, West Papua-Indonesia. *International Journal of Sciences: Basic and Applied Research*, 21.
- TYSON, J. R., O'NEIL, N. J., JAIN, M., OLSEN, H. E., HIETER, P. & SNUTCH, T. P. 2018. MinION-based long-read sequencing and assembly extends the *Caenorhabditis elegans* reference genome. *Genome Research*, 28, 266-274.
- UEHARA, T., MIZUKUBO, T., KUSHIDA, A. & MOMOTA, Y. 1998. Identification of *Pratylenchus coffeae* and *P. loosi* using specific primers for PCR amplification of ribosomal DNA. *Nematologica*, 44, 357-368.
- UMESH, K. C., FERRIS, H. & BAYER, D. E. 1994. Competition between the Plant-Parasitic Nematodes *Pratylenchus neglectus* and *Meloidogyne chitwoodi*. *Journal of Nematology*, 26, 286-295.

- UPDEGRAFF, D. M. 1969. Semimicro Determination of Cellulose in Biological Materials. *Analytical Biochemistry*, 32, 420-+.
- VACHERON, J., DESBROSSES, G., BOUFFAUD, M. L., TOURAINE, B., MOENNE-LOCCOZ, Y., MULLER, D., LEGENDRE, L., WISNIEWSKI-DYE, F. & PRIGENT-COMBARET, C. 2013. Plant growth-promoting rhizobacteria and root system functioning. *Frontiers in Plant Science*, 4.
- VANCURA, V. 1967. Root Exudates of Plants .3. Effect of Temperature and Cold Shock on Exudation of Various Compounds from Seeds and Seedlings of Maize and Cucumber. *Plant and Soil*, 27, 319-&.
- VANDERMEER, J., PERFECTO, I. & PHILPOTT, S. 2010. Ecological Complexity and Pest Control in Organic Coffee Production: Uncovering an Autonomous Ecosystem Service. *Bioscience*, 60, 527-537.
- VIEIRA, H. 2008. Coffee: The Plant and its Cultivation. In: SOUZA, R. M. (ed.) *Plant-Parasitic Nematodes of Coffee*. Springer.
- VIEIRA, P., EVES-VAN DEN AKKER, S., VERMA, R., WANTOCH, S., EISENBACK, J. D. & KAMO, K. 2015. The *Pratylenchus penetrans* Transcriptome as a Source for the Development of Alternative Control Strategies: Mining for Putative Genes Involved in Parasitism and Evaluation of in planta RNAi. *Plos One*, 10.
- VIEIRA, P., MAIER, T., ZASADA, I. A., BAUM, T., KAMO, K. & EISENBACK, J. D. 2016. Data Mining of the Root Lesion Nematode (*Pratylenchus Penetrans*) Transcriptome for Identification of Candidate Effector Genes. *Journal of Nematology*, 48, 380-380.
- VILLAIN, L. 2000. Caractérisation et bioécologie du complexe parasitaire du genre *Pratylenchus* (Nemata : *Pratylenchidae*) présent sur caféiers (*Coffea* spp.) au Guatemala.
- VILLAIN, L. 2008. Economic Importance, Epidemiology and Management of *Pratylenchus* sp. in Coffee Plantations. In: SOUZA, R. M. (ed.) *Plant-Parasitic Nematodes of Coffee*. Springer.
- VILLAIN, L., BAUJARD, P., ANZUETO, F., HERNANDEZ, A. & SARAH, J. L. 2002. Integrated protection of coffee plantings in Central America against nematodes Plantations, Recherche, Développement: research and coffee growing, 118-133.
- VILLAIN, L., MOLINA, A. & SIERRA, S. 2001. Evaluation of grafting and nematicide treatments for the management of a root lesion nematode, *Pratylenchus* sp., in *Coffea arabica* L. plantations in Guatemala. *Proceedings XIX Int Sci Colloq Coffee*.

- VILLAIN, L., MOLINA, A., SIERRA, S., DECAZY, B. & SARAH, J. L. 2000. Effect of grafting and nematicide treatments on damage by root-lesion nematodes (*Pratylenchus* spp.) to *Coffea arabica* L. in Guatemala. *Nematropica*, 30, 87-100.
- VILLAIN, L., SARAH, J. L., HERNANDEZ, A., BERTRAND, B., ANTHONY, F., LASHERMES, P., CHARMETANT, P., ANZUETO, F. & CARNEIRO, R. M. D. G. 2013. Diversity of Root-Knot Nematodes Parasitizing Coffee in Central America. *Nematropica*, 43, 194-206.
- VOIGT, C. A. 2014. Callose-mediated resistance to pathogenic intruders in plant defense-related papillae. *Frontiers in Plant Science*, 5.
- VOVLAS, N. & DI VITO, M. 1991. Effect of root-knot nematodes *Meloidogyne incognita* and *M. javanica* on the growth of coffee (*Coffea arabica* L.) in pots. *Nematologia Mediterranea*, 19, 253-258.
- WAEYENBERGE, L., RYSS, A., MOENS, M., PINOCHET, J. & VRAIN, T. C. 2000. Molecular characterisation of 18 *Pratylenchus* species using rDNA Restriction Fragment Length Polymorphism. *Nematology*, 2, 135-142.
- WALKER, T. S., BAIS, H. P., GROTEWOLD, E. & VIVANCO, J. M. 2003. Root exudation and rhizosphere biology. *Plant Physiology*, 132, 44-51.
- WANG, D., JONES, L. M., URWIN, P. E. & ATKINSON, H. J. 2011. A Synthetic Peptide Shows Retro- and Anterograde Neuronal Transport before Disrupting the Chemosensation of Plant-Pathogenic Nematodes. *Plos One*, 6.
- WANG, H. L., CHENG, X., DING, S. W., WANG, D. W., CHEN, C., XU, C. L. & XIE, H. 2018. Molecular identification and functional characterization of the cathepsin B gene (Ab-cb-1) in the plant parasitic nematode *Aphelenchoides besseyi*. *Plos One*, 13.
- WANG, J., MOORE, N. E., DENG, Y. M., ECCLES, D. A. & HALL, R. J. 2015. MinION nanopore sequencing of an influenza genome. *Frontiers in Microbiology*, 6.
- WARD, S., THOMSON, N., WHITE, J. G. & BRENNER, S. 1975. Electron microscopical reconstruction of the anterior sensory anatomy of the nematode *Caenorhabditis elegans*. *J Comp Neurol*, 160, 313-37.
- WARNOCK, N. D., WILSON, L., CANET-PEREZ, J. V., FLEMING, T., FLEMING, C. C., MAULE, A. G. & DALZELL, J. J. 2016. Exogenous RNA interference exposes contrasting roles for sugar exudation in host-finding by plant pathogens. *International Journal for Parasitology*, 46, 473-477.

- WATANABE, T., MASUMURA, H., KIOKA, Y., NOGUCHI, K., MIN, Y. Y., MURAKAMI, R. & TOYOTA, K. 2013. Development of a direct quantitative detection method for *Meloidogyne incognita* and *M. hapla* in andosol and analysis of relationship between the initial population of *Meloidogyne* spp. and yield of eggplant in an andosol. *Japanese Journal of Nematology*, 43, 21-29.
- WHITEHEAD, A. G. & HEMMING, J. R. 1965a. A Comparison of Some Quantitative Methods of Extracting Small Vermiform Nematodes from Soil. *Ann Appl Biol*, 55, 25-38.
- WIECZOREK, K. 2015. Cell wall alterations in nematode-infected roots. In: ESCOBAR, C. & FENOLL, C. (eds.) *Advances in Botanical Research: Plant Nematode Interactions: A View on Compatible Interrelationships*. Elsevier.
- WILLIAMSON, V. M. & GLEASON, C. A. 2003. Plant–nematode interactions. *Current Opinion in Plant Biology*, 6, 327-333.
- WILLSON, K. C. 1985. Climate and soil. In: CLIFFORD, M. N. & WILLSON, K. C. (eds.) *Coffee: botany, biochemistry and production of beans and beverage*. London, U.K.: Croom Helm.
- WILSON, M. 2008. *Pratylenchus* (Nematoda: *Pratylenchidae*): diagnosis, biology, pathogenicity and management. In: *Nematology Monographs and Perspectives*, Vol 6. *Forest Pathology*, 38, 429-430.
- WINTER, M. D., MCPHERSON, M. J. & ATKINSON, H. J. 2002. Neuronal uptake of pesticides disrupts chemosensory cells of nematodes. *Parasitology*, 125, 561-565.
- WIRYADIPUTRA, S. T., LK. 2008. Indonesia and Vietnam. In: SOUZA, R. (ed.) *Plant-Parasitic Nematodes of Coffee*. Springer Science+Business Media B. V.
- WISHART, J., PHILLIPS, M. S. & BLOK, V. C. 2002. Ribosomal intergenic spacer: A polymerase chain reaction diagnostic for *Meloidogyne chitwoodi*, *M. fallax*, and *M. hapla*. *Phytopathology*, 92, 884-892.
- WONDAFRASH, M., VAN DAM, N. M. & TYTGAT, T. O. G. 2013. Plant systemic induced responses mediate interactions between root parasitic nematodes and aboveground herbivorous insects. *Frontiers in Plant Science*, 4.
- WUBBEN, M. J., GANJI, S. & CALLAHAN, F. E. 2010. Identification and molecular characterization of a beta-1,4-endoglucanase gene (Rr-eng-1) from *Rotylenchulus reniformis*. *Journal of Nematology*, 42, 342-351.
- WYSS, U. & GRUNDLER, F. M. W. 1992. Feeding behavior of sedentary plant parasitic nematodes. *Netherlands Journal of Plant Pathology*, 98, 165-173.

- WYSS, U., GRUNDLER, F. M. W. & MUNCH, A. 1992. The Parasitic Behavior of 2nd-Stage Juveniles of *Meloidogyne incognita* in Roots of *Arabidopsis thaliana*. *Nematologica*, 38, 98-111.
- WYSS, U. & ZUNKE, U. 1986. Observations on the behaviour of second stage juveniles of *Heterodera schachtii* inside host roots. *Rev. Nématol.*, 9, 153-165.
- YAN, G., SMILEY, R. W. & OKUBARA, P. A. 2008. Detection and discrimination of *Pratylenchus neglectus* and *P. thornei* in DNA extracts from soil. *Phytopathology*, 98, S175-S176.
- YAN, Y. T., SMANT, G. & DAVIS, E. 2001. Functional screening yields a new beta-1,4-endoglucanase gene from *Heterodera glycines* that may be the product of recent gene duplication. *Molecular Plant-Microbe Interactions*, 14, 63-71.
- YANG, G. D., ZHOU, B. L., ZHANG, X. Y., ZHANG, Z. J., WU, Y. Y., ZHANG, Y. M., LU, S. W., ZOU, Q. D., GAO, Y. & TENG, L. 2016. Effects of Tomato Root Exudates on *Meloidogyne incognita*. *Plos One*, 11.
- YOU, Y. J., KIM, J., COBB, M. & AVERY, L. 2006. Starvation activates MAP kinase through the muscarinic acetylcholine pathway in *Caenorhabditis elegans* pharynx. *Cell Metabolism*, 3, 237-245.
- YOU, Y. J., KIM, J., RAIZEN, D. M. & AVERY, L. 2008. Insulin, cGMP, and TGF-beta signals regulate food intake and quiescence in *C. elegans*: A model for satiety. *Cell Metabolism*, 7, 249-257.
- YU, Q. Y., FANG, S. M., ZHANG, Z. & JIGGINS, C. D. 2016. The transcriptome response of *Heliconius melpomene* larvae to a novel host plant. *Molecular Ecology*, 25, 4850-4865.
- YU, Y. L., HL. ZHU, AG. ZHANG, G. ZENG, LB. XUE, SD 2012. A Review of Root Lesion Nematode: Identification and Plant Resistance. *Advances in Microbiology*, 2, 411-416.
- ZAMBOLIM, L. 2016. Current status and management of coffee leaf rust in Brazil. *Tropical Plant Pathology*, 41, 1-8.
- ZENG, T., HOLMER, R., HONTELEZ, J., TE LINTEL-HEKKERT, B., MARUFU, L., DE ZEEUW, T., WU, F. Y., SCHIJLEN, E., BISSELING, T. & LIMPENS, E. 2018. Host- and stage-dependent secretome of the arbuscular mycorrhizal fungus *Rhizophagus irregularis*. *Plant Journal*, 94, 411-425.
- ZHANG, C., XIE, H., XU, C. L., CHENG, X., LI, K. M. & LI, Y. 2012. Differential expression of Rs-eng-1b in two populations of *Radopholus similis* (Tylenchida:



*Pratylenchidae*) and its relationship to pathogenicity. *European Journal of Plant Pathology*, 133, 899-910.

ZHANG, L., FAN, Y. X., ZHENG, H. Y., DU, F. G., ZHANG, K. Q., HUANG, X. W., WANG, L. F., ZHANG, M. & NIU, Q. H. 2013. Isolation and Characterization of a Novel Endoglucanase from a *Bursaphelenchus xylophilus*. *Metagenomic Library*. *Plos One*, 8.

ZHAO, X. W., SCHMITT, M. & HAWES, M. C. 2000. Species-dependent effects of border cell and root tip exudates on nematode behavior. *Phytopathology*, 90, 1239-1245.

ZHONG, H. Y., LI, F. B., CHEN, J. M., ZHANG, J. F. & LI, F. 2017. Comparative transcriptome analysis reveals host-associated differentiation in *Chilo suppressalis* (Lepidoptera: *Crambidae*). *Scientific Reports*, 7.

ZHONG, R. Q. & YE, Z. H. 2015. Secondary Cell Walls: Biosynthesis, Patterned Deposition and Transcriptional Regulation. *Plant and Cell Physiology*, 56, 195-214.

ZIJLSTRA, C. 2000. Identification of *Meloidogyne chitwoodi*, *M. fallax* and *M. hapla* based on SCAR-PCR: a powerful way of enabling reliable identification of populations or individuals that share common traits. *European Journal of Plant Pathology*, 106, 283-290.

ZIJLSTRA, C., DONKERS-VENNE, D. T. H. M. & FARGETTE, M. 2000. Identification of *Meloidogyne incognita*, *M. javanica* and *M. arenaria* using sequence characterised amplified region (SCAR) based PCR assays. *Nematology*, 2, 847-853.

ZNAMEROSKI, E. A., CORADETTI, S. T., ROCHE, C. M., TSAI, J. C., IAVARONE, A. T., CATE, J. H. D. & GLASS, N. L. 2012. Induction of lignocellulose-degrading enzymes in *Neurospora crassa* by cellodextrins. *Proceedings of the National Academy of Sciences of the United States of America*, 109, 6012-6017.