

Aspects of Comparative Constructions
Comparative Syntax, Semantics & L1-acquisition

Maria-Margarita Makri, MPhil, MA (Res)

PhD

University of York

Language and Linguistic Science

June 2018

Abstract

This thesis examines the crosslinguistic variation and acquisition of comparative constructions and proposes a fine-grained AP periphery along with an analysis of comparatives as constructions involving subtraction. More specifically, it is proposed that gradable predicates incorporate a Q^0 and that comparative morphology is realised in two distinct heads above Q^0 : the higher C^0 assigns case to the differential argument whereas the lower one, which is immediately above Q^0 checks the case of the standard phrase. Furthermore, I provide novel evidence for two types of comparative markers, a ‘functional’ one, which is the realisation of $C2^0$ if the gradable predicate does not move to $C2^0$, and a ‘lexical’ one, which is the comparative form of the quantity word that adjoins to a positive adjective. This analysis explains morphological facts as well as variation in case assignment in Greek varieties. As far as standard phrases are concerned I propose that there are three distinct types of standard phrases: adjunct standard phrases introduced by the phrasal standard marker, argument standard phrases comprised of the phrasal standard marker and a nominal (DP or relative clause) and exceptive phrases. Furthermore, the study of the distribution of polarity items and comparative negation in Romance comparatives as well as the acquisition of Italian comparatives suggest that negation found in comparatives is an overt realisation of the negative operator. This analysis explains a (universal) gap in the distribution of comparative negation, namely the unavailability of languages that license comparative negation but not polarity items.

List of Contents

Abstract	2
List of Contents	3
List of Tables	6
List of Figures	8
Acknowledgements	10
Declaration	13
1 Introduction	16
1.1 Types of Comparatives	18
1.1.1 The constituents overtly realised	18
1.1.2 Types of comparative relation	18
1.1.3 The syntactic category of gradable expressions	19
1.1.4 Phrasal vs. Clausal Comparatives	20
1.2 Outline of this thesis	20
2 Previous Approaches to Comparatives	22
2.1 Typologies of comparatives	22
2.1.1 Stassen (1984, 1985)	22
2.1.2 Price (1990)	26
2.1.3 Beck et al. (2003, 2004, 2009, 2012); Hohaus et al. (2014)	28
2.1.4 Individual vs. Degree comparison, Implicit vs. Explicit comparison (Kennedy, 2007a,b)	30
2.1.5 Parametrising phrasal comparatives	34
2.2 The semantics of Comparatives	38
2.2.1 Maximality in the standard phrase	38
2.2.2 Extent based semantics	40
2.2.3 Scope and the (non-)quantificational nature of the comparative	41
2.2.4 Meaningful Standards	46
2.3 The syntax of Comparatives	53
2.3.1 The architecture of the Degree Phrase	53

2.3.1.1	The comparative phrase is a modifier of the gradable predicate . . .	54
2.3.1.2	The comparative phrase is an argument of the gradable predicate . .	58
2.3.1.3	The gradable predicate is an argument of the Degree	60
2.3.1.3.1	The status of <i>more</i> and its relation to the Degree ⁰	63
2.3.1.3.2	Coordination Structures	66
2.3.1.3.3	Late merger of degree clauses	67
2.3.2	The internal syntax of standard phrases: Phrasal vs. Clausal comparatives . .	71
2.3.2.1	Direct analyses	71
2.3.2.2	Reduction analyses	75
2.3.2.2.1	The small clause analysis	77
2.4	The proposal	79
3	Phrasal Comparatives	82
3.1	Introduction	82
3.2	Background on non-comparative adjectives	83
3.3	The status of comparative markers	89
3.3.1	Greek	89
3.3.1.1	The status of <i>pjo</i> ('more')	92
3.3.1.2	<i>perisotero(s)</i> 'more' and <i>lighotero(s)</i> 'less'	99
3.3.1.3	The status of <i>parapano</i> ('above, more')	103
3.3.2	Romance Languages	104
3.3.3	Interim Summary	105
3.4	Asymmetries between phrasal and clausal comparatives	106
3.5	Types of phrasal comparatives	108
3.5.1	Prepositional Standards	109
3.5.1.1	Phrasal (not clausal) standards	110
3.5.1.2	Predicative Standards	113
3.5.1.3	Measure Phrases	115
3.5.1.4	Other DPs	118
3.5.2	Oblique nominal standards	120
3.5.2.1	The distribution of oblique standards in varieties of Greek	121
3.5.2.2	Genitive/ Dative Standards	127
3.5.2.3	Case assignment in Greek oblique standards	130
3.5.2.4	Extension to Romance	131
3.6	Summary & Conclusions	133
4	Clausal Comparatives	134
4.1	Greek	134
4.1.1	Clausal Comparatives with <i>apo</i> ('from')	135
4.1.1.1	Clausal Standards introduced by <i>ap'oti</i>	135
4.1.1.2	Clausal Standards introduced by <i>ap' osos</i>	139
4.1.1.3	Interim summary: <i>apo</i> ('from') and relative clauses	141

4.1.2	Comparatives with <i>para</i> -standards	142
4.2	Romance Languages	143
4.2.1	Que/Che comparatives	144
4.2.2	Prepositional Standards with Relatives	147
4.2.3	<i>Que</i> as an exceptive	149
4.3	Conclusions	150
5	Polarity phenomena in Comparatives	151
5.1	Introduction	151
5.2	The empirical picture	151
5.2.1	French	151
5.2.2	Italian	153
5.2.3	Spanish	154
5.2.4	Catalan	156
5.2.5	Brazilian Portuguese	156
5.2.6	Greek	158
5.2.7	Interim Summary: Expletive Negation Licensing in Romance	159
5.3	Previous approaches to Comparative Negation	160
5.4	Italian: A case study	169
5.4.1	Predictions for the acquisition of Italian	170
5.4.2	The experiment	171
5.4.2.1	Method	171
5.4.2.1.1	Participants	171
5.4.2.1.2	Procedure	171
5.4.2.1.3	Materials	172
5.4.2.2	Expected Response Patterns	175
5.4.2.3	Results	175
5.4.3	Discussion	183
5.5	Bringing the facts together: The meaning of Comparative Negation	183
5.6	Implications for the typology of Comparative Negation	184
6	Conclusions	187
A	Appendix	189
A.1	Ordering of test items	190
A.2	Test Items	190
B	Abbreviations	212
	References	215

List of Tables

2.1	Price’s (1990) typology of Romance comparatives.	27
2.2	Beck et al.’s (2009) Typology and correspondence to Stassen’s (1984, 1985) Types. (The numbers in the parentheses refer to ‘secondary types’ and the star indicates lan- guages not included in Stassen’s (1984, 1985) sample.)	29
2.3	Age of Acquisition and Mean Length of Utterance (Hohaus et al., 2014, 228)	31
2.4	Classes of degree expressions (Neeleman et al., 2004)	57
2.5	Language types predicted by Alrenga and Kennedy’s (2014) semantics for the standard	75
2.6	Language types predicted by Kennedy’s (2007b) semantics for the standard	75
3.1	The distribution of quantity words in English (Rett, 2018)	85
3.2	Predicted Degree Paradigm for ‘much’/‘more’	93
3.3	Comparative Formation I	94
3.4	Comparative Formation II	94
3.5	Properties of <i>apo</i> vs. <i>ap’oti</i> (Merchant, 2009, (26))	110
3.6	The distribution of Oblique standards in Modern Greek varieties	126
5.1	Distribution of Negation in French Inequality Comparatives	153
5.2	Distribution of Negation in Italian Inequality Comparatives	154
5.3	Distribution of Negation in Spanish Inequality Comparatives	155
5.4	Distribution of Negation in Catalan Inequality Comparatives	156
5.5	Distribution of Negation in Brazilian Portuguese Inequality Comparatives	157
5.6	Distribution of CN in different types of standard phrases [N/A: the language doesn’t have this type of standard phrase, *: CN is ungrammatical, ✓: CN is grammatical]	160
5.7	Negation and N-words in comparatives across languages	160
5.8	Semantics of CCs & CN: The space of logical possibilities.	161
5.9	CN and Standard Markers	166
5.10	Semantics of CCs & CN: Theories of CN.	169
5.12	Response Summary - Descriptive Statistics	176
5.11	Kruskal-Wallis Test on test items	176
5.13	Summary of Mixed Effects Logistic Regression for Variables Predicting Participants’ Choice of Negation (N = 57)	178
5.14	Summary of Mixed Effects Logistic Regression for Variables Predicting Adults’ Choice of Negation (N = 28)	179

5.15	Summary of Mixed Effects Logistic Regression for Variables Predicting Children's Choice of Negation (N = 29)	181
5.16	Distribution of CN and N-Words in different types of clausal comparatives	184
A.1	Item ordering in all four versions presented [IND = Indicative, SBJ = Subjunctive, TST = Test, CTL = Control, TF = Truth Value, GR = Grammaticality].	190

List of Figures

2.1	Parametric steps in the acquisition of a [+DSP],[+DAP],[+DegPP]-language. (Hohaus et al., 2014, 225)	30
5.1	Target Item: Indicative	174
5.2	Target Item: Subjunctive	174
5.3	Grammaticality Judgement Control item – Picture for (411)	175
5.4	Truth Value Judgement Control item – Picture for (412)	175
5.5	Proportion of Responses with Negation (+SE) across Items	176
5.6	Proportion of Responses with Negation (+SE) for Adults ($n = 28$) and Children ($n = 29$) in Indicative and Subjunctive Condition.	177
5.7	Distribution of Adult ($n = 28$) and Child ($n = 29$) Participants based on the Proportion of Responses Containing Negation per Participant in Indicative and Subjunctive Condition.	177
5.8	Number of Times Each Adult Participant Selected Negation out of 6 Indicative and 6 Subjunctive Items ($N = 28$)	180
5.9	Number of Times Each Child Participant Selected Negation out of 6 Indicative and 6 Subjunctive Items ($N = 29$)	182
5.10	Number of Participants Children ($N = 29$)	182
A.1	Layout of experimental procedure	189
A.2	Training Item	191
A.3	IND.TST.1 - Critical Item with indicative mood	192
A.4	IND.TST.2 - Critical Item with indicative mood	193
A.5	IND.TST.3 - Critical Item with indicative mood	194
A.6	IND.TST.4 - Critical Item with indicative mood	195
A.7	IND.TST.5 - Critical Item with indicative mood	196
A.8	IND.TST.6 - Critical Item with indicative mood	197
A.9	SBJ.TST.1 - Critical Item with subjunctive mood	198
A.10	SBJ.TST.2 - Critical Item with subjunctive mood	199
A.11	SBJ.TST.3 - Critical Item with subjunctive mood	200
A.12	SBJ.TST.4 - Critical Item with subjunctive mood	201
A.13	SBJ.TST.5 - Critical Item with subjunctive mood	202
A.14	SBJ.TST.6 - Critical Item with subjunctive mood	203

A.15 SBJ.CTL.GR.1 - Control Item; Grammaticality Judgement; Subjunctive mood	204
A.16 SBJ.CTL.GR.2 - Control Item; Grammaticality Judgement; Subjunctive mood	205
A.17 IND.CTL.GR.1 - Control Item; Grammaticality Judgement; Indicative mood	206
A.18 IND.CTL.GR.2 - Control Item; Grammaticality Judgement; Indicative mood	207
A.19 IND.CTL.TF.1 - Control Item; Truth Value Judgement; Indicative mood	208
A.20 IND.CTL.TF.2 - Control Item; Truth Value Judgement; Indicative mood	209
A.21 SBJ.CTL.TF.1 - Control Item; Truth Value Judgement; Subjunctive mood	210
A.22 SBJ.CTL.TF.2 - Control Item; Truth Value Judgement; Subjunctive mood	211

Acknowledgements

I am not sure if any text could do justice to how much I have benefited from the people I met throughout this PhD course. This short section is meant as a small recognition of the massive impact many people had on this thesis and its author.

I would like to express my deepest gratitude to my supervisor George Tsoulas for his guidance and support throughout all these years. It will be hard to summarise in a few words how much I have benefited as a student as well as an academic from his supervision and, generally, from our interaction. I think that it is pretty self-explanatory the fact that, rather unconsciously, I refer to him as ‘ο δάσκαλος’ (‘the teacher’). George had always useful comments and feedback to provide no matter whether I was discussing syntax, semantics or acquisition. As for this thesis, his contribution is not restricted to the ample feedback and supervision: George was the one to bring the phenomenon of Expletive Negation to my attention, a small comment that during the years evolved into a master thesis and a chapter of this dissertation.

George was also the one to encourage me visit MIT —a venture that I would not have pursued by myself. During the time I spent in the US I enjoyed stimulating and challenging discussions on a variety of linguistic topics with Sabine Iatridou and had the opportunity to discuss my research, especially drafts that later evolved in Chapter 5 of this thesis, with Martin Hackl, Roger Schwarzschild, Jason Merchant and Chris Kennedy.

I am grateful to Martin Hackl and Jacopo Romoli for their input on the experimental design of the acquisition component of this thesis; Nino Grillo, Andrea Santi and Lyn Tieu for discussion and guidance on the analysis of the data and Kook-Hee Gill for insights regarding the acquisition of optional elements. Of course, this experiment could not have been conducted hadn’t it been Luca Rognoni who brought me in contact with schools in Modena and helped with recordings, my wonderful research assistant Giulia Colli and the heads of summer schools Stefagnia Sirginoffi and Suore Patricia for permission conducting my experiment in their premises, my participants and their parents.

This thesis has benefited from discussions with the YOLIPOers, Norman Yeo, Becky Woods, Nikki Chen and Ghada Alkuwaihes, and later on with Hanna de Vries. It has always been a privilege to have such a good friend and great colleague as Nikos Angelopoulos with whom we have spent hours and hours discussing my research and who had the kindness to read several half-finished drafts of this thesis. As for Greek oblique standard phrases, I am grateful to Elena Anagnostopoulou for encouraging me to pursue research on the topic and the valuable insights and comments. Thanks are also due to Dimitris Michelioudhakis, who I have bugged several times with questions on datives and who patiently answered all of them in a clear and encouraging way. Comments and discussion during Cosy III, Semantics in Athens II, and LFRG at MIT have improved several aspects of this thesis.

I am hugely indebted to Nino Grillo for Friday meetings that were both fun and stimulating. His comments and insights had a direct impact on the outputs of my research. Apart from that I enjoyed brainstorming together on various linguistic puzzles, the mentoring moments regarding academia and its challenges were a privilege. I am also largely grateful to him and Artemis Alexiadou for accepting to act as the examiners of this thesis. The examination was a smooth and stimulating discussion and their comments have improved both the content and the presentation of the final version of this thesis.

I am grateful to the Department of Language of Linguistic Science for funding several of my conference presentations and for awarding me an ESRC scholarship. My research trips to MIT and Modena would have never taken place hadn't it been the funding from the ESRC White Rose DTC, which exceptionally covered the full cost of these research expeditions. Finally, my research was funded by two yearly grants of the A. G. Leventis Foundation and conference bursaries from the Philological Society, the Linguistic Association of Great Britain and the White Rose College for the Arts and Humanities.

A PhD dissertation may be the sole tangible output of a PhD course, however, it also corresponds to several years, which would have been impossible to survive without good friends. I do not think that any words will ever be enough to thank Carla and Luca for their friendship and hospitality, for being there in the good and the bad. Of course, York would have never been the same hadn't it been for Miyuki, Becky and Ekali. On the other hand, my time at MIT couldn't have been as enjoyable without Despina & Konstantinos, Themis, Katerina, Manolis, Ilias, Konstantinos, Bill, Konstantina, Sophie and Eloisa. And luckily nowadays physical distance is no longer an obstacle for keeping in touch with good friends like Rita, Leonidas and Dima.

I am grateful to Ioannis who (im)patiently waited for me and supported me while I tried to excel myself. The deepest and most heartfelt gratitude is towards my wonderful, caring parents Michalis and Stela for whom my welfare has always been their top priority. They have always been there for me and they have supported me in any way I could have wished for. Of course, life would have been less fun and less interesting without my amazing brother Giorgos. Even though afar, thanks to them, I have never felt alone and I was always part of all family happenings, even via Skype. I think blowing in York and putting out birthday candles in Rhodes is something I will remember for a long time to come.

To Ioannis

αντίδωρο για όλα αυτά τα χρόνια

Declaration

I declare that this thesis is a presentation of original work and I am the sole author. This work has not previously been presented for an award at this, or any other, University. All sources are acknowledged as References.

Earlier versions of parts of this thesis have been presented in the following conferences:

- | | |
|--------------|--|
| 22 Dec. 2017 | Semantics in Athens II, University of Athens, Greece.
Typology meets acquisition: Evidence from comparatives. |
| 11 Dec. 2015 | LFRG, Massachusetts Institute of Technology, USA.
How negative are comparatives? Evidence from Romance. |
| 24 Jan. 2015 | 3rd Comparative Syntax (CoSy) Workshop, University of Cambridge & University of York, Cambridge, UK.
Comparing Comparatives. |
| 6 May 2015 | White Rose DTC Fourth Annual Spring Conference 2015
Linguistic Variation in Comparisons. |
| 19 May 2014 | External Engagement in the Arts and the Humanities, British Academy & White Rose College of the Arts and Humanities, York, UK
Are all languages the same? Comparing Comparisons. |

Other presentations during the PhD course the content of which is not included in this thesis:

- | | |
|-------------------|--|
| 27 – 29 Oct. 2017 | NELS 48 - 48th Annual Meeting of the North East Linguistic Society
The plural inferences of count and mass nouns are implicatures: Evidence from Greek
(Agata Renans, Jacopo Romoli, Maria Margarita Makri, Lyn Tieu, Hanna de Vries, Raffaella Folli and George Tsoulas.) |
| 7 – 9 Sep. 2017 | 12th International Conference on Greek Linguistics, University of Westminster, UK.
Non-presuppositional <i>pu</i> ? |
| 4 – 7 Sep. 2017 | Annual Conference of the Linguistic Association of Great Britain, Kent, UK.
Testing the abundance inference of pluralised mass nouns in Greek. (Agata Renans, Jacopo Romoli, Maria Margarita Makri, Lyn Tieu, Hanna de Vries, Raffaella Folli & George Tsoulas) |
| 28 Apr. 2017 | 38th annual meeting of the Department of Linguistics, Aristotle University of Thessaloniki, Greece. |

- Ερμηνεύοντας τις επιβιώσεις ιδεολογημάτων στην εκπαίδευση της ελληνικής γλώσσας: Το ζήτημα της αναγκαιότητας των αρχαίων για τη διδασκαλία των Νέων Ελληνικών. (with Ioannis V. Papageorgiou)
- 21 – 23 Apr. 2016 **52nd annual meeting of the Chicago Linguistic Society, University of Chicago, Chicago, IL, USA.**
Expletive Negation is might.
- 5 – 7 Apr. 2016 **GLOW 2016 - 39th Generative Linguistics in the Old World, LinG, Georg-August-Universität Göttingen, Germany.**
Expletive Negation, Epistemic Modality and Sentential Complementation.
- 5 Nov. 2015 **LingLunch, Massachusetts Institute of Technology, USA.**
Not as might.
- 16 – 19 Sep. 2015 **12th International Conference on Greek Linguistics (ICGL12), Centrum Modernes Griechenland, Freie Universität Berlin, Berlin, Germany.**
- Identity Comparatives in Greek: The case of *opos*.
 - Beyond Yes and No. Negative and Coordinating Particles in Modern Greek. (with George Tsoulas)
- 6 May 2015 **White Rose DTC Fourth Annual Spring Conference 2015, UK.**
Student-led Interdisciplinary Network: the PARLAY network.
- 26 – 28 Feb. 2015 **41st Incontro di Grammatica Generativa, Università per Stranieri di Perugia, Perugia, Italy.**
What ‘not’ might mean. Expletive Negation in Attitude Contexts.
- 8 – 11 Jan. 2015 **23rd Conference of the Student Organization of Linguistics in Europe, Université Paris Diderot-Paris VII, Paris, France.**
What *not* might mean. Expletive Negation in Attitude Contexts.
- 18 Dec. 2014 **Athens Workshop on Semantics and the Syntax-Semantics Interface, University of Athens, Greece.**
Modality and negation in the left periphery: Implications for sentential complementation.
- 5 – 9 Sep. 2014 **Annual Conference of the Linguistic Association of Great Britain, Oxford, UK.**
- Expletive Negation as an epistemic modal.
 - Modality, Negation and Patterns of Complementation in Greek. (with George Tsoulas)
- 23 – 25 May 2014 **3rd Patras International Conference of Graduate Students in Linguistics (PICGL3), Patras, Greece.**
How expletive is expletive negation?
- 8 – 10 May 2014 **35th Annual Meeting of the Department of Linguistics (AMGL35), Aristotle University of Thessaloniki, Thessaloniki, Greece.**
Expletive Negation beyond Romance. Negation as an epistemic modal.

- 13 Dec. 2013 **1st Comparative Syntax (CoSy) Workshop, University of Cambridge & University of York, Cambridge, UK.**
 Expletive negation beyond Romance: Implications for clausal complementation.
- 4 April 2014 **9th Newcastle upon Tyne Postgraduate Conference in Linguistics, Newcastle University, Newcastle, UK.**
 How expletive is expletive negation?

The publications published during this PhD course are listed below. The content of these publications is not part of this PhD thesis.

- Makri, M.M. (*under review*). Non-presuppositional *pu*? In: *Proceedings of the 13th International Conference on Greek Linguistics, 7-9 September 2017, University of Westminster, London, UK.*
- Renans, A., Romoli, J., Makri, M.M., Tieu, L., De Vries, H., Folli, R. & G. Tsoulas (2018). The abundance inference of pluralised mass nouns is an implicature: Evidence from Greek. *Glossa: A Journal of General Linguistics* 3(1), doi: 10.5334/gjgl.531.
- Makri, M. M. (2017) *Opos* identity comparatives in Greek: an experimental investigation. In: *Proceedings of the 12th International Conference on Greek Linguistics*, ed. by Thanasis Georgakopoulos, Theodossia-Soula Pavlidou, Miltos Pechlivanos, Artemis Alexiadou, Jannis Androutsopoulos, Alexis Kalokairinos, Stavros Skopeteas, and Katerina Stathi, pp. 629–645, Berlin, Germany: Edition Romiosini.
- Makri, M. M. (2016a) What ‘not’ might mean. In: *ConSOLE XXIII: Proceedings of the 23rd Conference of the Student Organization of Linguistics in Europe*, ed. by Kate Bellamy, Elena Karvovskaya, Martin Kohlberger, and George Saad, pp. 427–448, Leiden: Leiden University Centre for Linguistics.
- Makri, M. M. (2016b) What ‘not’ might mean: Expletive negation in attitude contexts. *Rivista di Grammatica Generativa*, pp. 187–200, Venezia: CSL. URL: <http://hdl.handle.net/11707/5689>.

Chapter 1

Introduction

Drawing comparisons is a universal of human cognition. Identity and difference, equality and inequality are basic notions based on which we perceive and categorise the world. Comparisons are used, consciously or not, to create groupings of objects, people, notions, etc. or to inform our choices. Taking into account the major importance of comparisons in our life, it is unsurprising that all languages have a wide array of grammatical constructions for expressing (different kinds of) comparison.

The meaning of comparative constructions or simply comparatives has been attracting the interest of linguists for decades. There has been a long standing debate whether comparisons involve different semantic objects and if so what is their nature (degrees, scales, intervals, extents, a.o.). Another prominent issue, which is also addressed in this thesis, is whether constructions expressing an inequality relation like (1) are interpreted as (1-a) or (1-b). In other words, whether they involve a negation or not. The relation of amongst (1), (2) and (3) is also debatable. Depending on the semantic analysis assumed, (1) may share the same semantic and/or syntactic representation with (2) or (3).

- (1) John ate more candies than Mary did.
 - a. There is a number of candies that John ate and Mary did not eat such a number of candies.
 - b. The number of candies John ate exceeds the number of candies Mary ate.
- (2) John ate more candies than Mary.
- (3) John ate more than 3 candies.

On the other hand, the syntax of comparatives is no less complex an issue. The question of how the comparative operator (*-er/more*) combines with the standard phrase (i.e. the *than*-phrase) and the gradable predicate (e.g. the adjective) has triggered numerous proposals regarding the head of the phrase (the adjective or the comparative operator) and the status of the *than*-constituent as an argument or an adjunct, as a clause or a PP, as a coordinated or a subordinated constituent. What has received less attention so far, is variation in the types of *than*-phrases across languages and within a given language.

This thesis investigates the syntax and semantics of inequality comparative constructions using cross-linguistic data (varieties of Greek, dialects of Italian, Brazilian Portuguese, Catalan and Spanish) and data from the acquisition of Italian. The aim of this thesis is to provide a compositional account

of comparative constructions, which will be free from construction-specific stipulations, to reveal loci of cross-linguistic variation in the comparative and to present the different ways that syntax interacts with the semantics of the construction.

In the remainder of this chapter, I will present the terminology used in this thesis and I will define the constructions that fall within the scope of this thesis.

Comparative Marker (Schwarzschild, 2010): The morpheme that marks an adjective as comparative. In English this corresponds to *-er* and *more*.

- (4) a. a **bigger** house
 b. a **more** beautiful girl

Comparative Phrase: The gradable predicate with the comparative marker.

- (5) a. a **bigger** house
 b. a **more beautiful** girl
 c. **more** candies

Standard Marker (SM) (Ultan, 1972): The particle that introduces the standard of comparison. *Than* is the standard marker of an English comparative.

- (6) Jack is more anxious **than** Jill.

Standard Phrase (Ultan, 1972): The phrase that denotes the standard of comparison. In the languages studied in this thesis, the standard phrase corresponds to the standard marker and its complement or an oblique DP.

- (7) a. John is more anxious **than Jill**
 b. John ate more cookies **than Jill** <ate> **candies**
 c. Cato **Cicero-ne** eloquentior est. Latin
 Cato Cicero-ABL eloquent.CMPR is
 ‘Cato is more eloquent than Cicero’

Pivot (Merchant, 2009): Any constituent that follows the standard marker. If the complement of the standard involves ellipsis, each remnant is one pivot (as opposed to the standard phrase which corresponds to the whole complement of the standard marker)

- (8) a. John is more anxious than **Jill**.
 b. John ate more cookies than [**Jill**]_{Pivot 1} [**candies**]_{Pivot 2}.
 c. Cato **Cicero-ne** eloquentior est. Latin
 Cato Cicero-ABL eloquent.CMPR is
 ‘Cato is more eloquent than Cicero.’

Correlate (Heim, 1985) or **associate** (Bhatt and Takahashi, 2011): The constituent in the main clause that is contrasted with the standard.

- (9) a. **John** is taller than Mary.
b. **John** loves Mary more than Jill.
Meaning: ‘John loves Mary more than Jill loves Mary.’
c. John loves **Mary** more than **Jill**.
Meaning: ‘John_i loves Mary more than he_i loves Jill.’

1.1 Types of Comparatives

There are several criteria based on which comparatives can be classified in different categories. To name a few, comparatives can be classified based on the constituents that are present in the construction, the type of comparison drawn, the syntactic category of the comparative phrase, and the type of the constituent selected by the standard marker. The sections below present each distinction in more detail.

1.1.1 The constituents overtly realised

Some of the constituents described above may be missing. Depending on which constituents are realised the following types of comparatives can be identified:

Bare comparatives: comparatives that lack the comparative marker. This type of comparative is not available in English but found in languages like Hindi or Japanese.

- (10) Miri xazaka mi- Yoni Hebrew
Miri strong.SG.FEM. SM- Yoni
‘Miri is stronger than Yoni.’ (Schwarzschild, 2010)

Absolute comparatives (Curme, 1931, 508): Comparatives that lack a standard of comparison. That standard is not syntactically present or retrievable from context;

- (11) higher education

Incomplete comparatives (Sheldon, 1945): comparatives that lack an overt standard phrase but that is syntactically present and retrievable from context.

- (12) a taller boy

1.1.2 Types of comparative relation

Depending on the type of comparison drawn between two entities or propositions and whether the comparison involves a scale or not, comparative constructions can be divided into degree comparatives, identity comparatives and metalinguistic comparatives.

Degree comparatives or **Scalar Comparatives** are expressions referring to a comparison of the degree to which individuals rank on the natural scale associated with a gradable expression. Depending on whether the position on the scale they assign to the entities is graded or not, they are further divided to inequality (13-a) and equality (13-b) comparatives respectively.

- (13) a. Mary is taller/less tall than Helen.
b. Mary is as tall as Helen.

Identity comparatives are expressions where the items compared can be entities of any sort (not just degrees) and the issue is simply whether they are the same or different. No further differentiation beyond this binary option arises unless the items compared happen to be arranged along some natural scale. (Heim, 1985)¹.

- (14) John bought the same car as Mary.

- (15) John bought a different car than Mary.

Metalinguistic comparatives differ from degree comparatives in that they compare the degree of appropriateness of two propositions (Milner, 1973; Giannakidou and Stavrou, 2009) or degrees of imprecision (Morzycki, 2011)²

The study of metalinguistic and difference/identity comparatives falls beyond the scope of this thesis. This thesis studies exclusively inequality comparatives. Henceforth, when I refer to comparative constructions I refer only to degree inequality comparatives (unless specified otherwise).

1.1.3 The syntactic category of gradable expressions

Depending on the category of the gradable expression that is used for the comparison, comparatives may be classified in adjective comparisons (16), where the Adjective may be in predicative (16-a) or attributive position (16-b), adverbial comparisons, Tense Phrase comparisons and NP-comparisons. The latter, because they represent a comparison between the cardinality of two sets, e.g. in (19) the number of candies eaten by Mary and the number of candies eaten by John, are also known as amount comparatives.

- (16) a. George is taller than Mary.
b. George bought a nicer car than Mary
- (17) a. George visits Mary more frequently than he did before.
b. George plays the guitar better than John.
- (18) Mary likes cinema more than she did.

¹For further discussion of their syntax and semantics the reader is referred to Heim (1985); Pancheva Izvorski (2000); Oxford (2010a,b); Makri (2017).

²For more information on the semantic properties of metalinguistic comparatives the reader is referred to Dieterich and Napoli (1982); Giannakidou and Stavrou (2009); Giannakidou and Yoon (2009, 2011); Lechner (2009).

(19) Mary ate more candies than John.

In this thesis, I will not discuss TP-comparisons. For parallels between TP and NP comparisons see Wellwood et al. (2012) and references there in.

1.1.4 Phrasal vs. Clausal Comparatives

Comparatives can be divided into phrasal and clausal ones based on whether the standard phrase contains a clause or not. The distinction between phrasal (20-a) and clausal (20-b) comparatives is sometimes blurred by Reduced Clausal Comparatives (20-c), which may look identical to phrasal ones. It has been proposed (Lechner, 2001, 2004; Bhatt and Takahashi, 2011, a.o.) that, at least in some languages, constructions that look like Phrasal Comparatives are in fact always reduced clausal ones. The syntax and semantics of phrasal comparatives will be discussed in Chapter 3 and clausal comparatives in chapters 4 and 5.

- | | | | |
|------|----|--------------------------------|------------------------------|
| (20) | a. | John is taller than Mary. | Phrasal Comparatives |
| | b. | John is taller than I thought. | Clausal Comparatives |
| | c. | John is taller than before. | Reduced Clausal Comparatives |

1.2 Outline of this thesis

Chapter 2 presents an overview of previous approaches to comparative constructions. It is divided in three parts: typological analyses of comparatives, different theories for the semantic representation of the comparative and theories for its syntactic representation. Some of the key questions that have imbued research in inequality comparatives is the number and type of arguments of the comparative operator, which category projects in the comparative phrase, the semantic content of the standard marker, the status of the standard phrase as an argument or an adjunct and the internal structure of the standard phrase. All these questions are interrelated hence any semantic analysis presupposes a specific syntactic analysis, however, for expository purposes, the proposals in question will be classified based on their main focus.

In Chapter 3, I review phrasal comparatives in Greek dialects, Italian, Spanish, Catalan, and Brazilian Portuguese. I present two new *loci* of variation: the comparative marker and the type and case of phrasal standard (predicate vs. argument, genitive vs. dative). Languages may employ a comparative head (e.g. English *-er*) or the comparative form of a quantity word (e.g. lexical *more* or *less*) to form comparatives. Greek allows both strategies and so do Romance languages. As far as phrasal standards are concerned, French, Spanish and Brazilian Portuguese phrasal standard markers introduce only measure phrases whereas Greek and Italian may introduce measure phrases, DPs and predicates (Adjective Phrases, Bare NPs and non-derived measure phrases). Overt realisation of case in Greek AdjPs and DPs reveals a previously unnoticed pattern: ‘Derived’ measure phrases³ and definite DPs always carry accusative case whereas Bare NPs and AdjPs agree with the associate. Non-derived measure phrases can appear in the same case as the gradable predicate or be assigned accusative case. Finally, I show that argument phrasal standards may be cliticised, so Greek is no longer an excep-

³Nominals that do not intrinsically denote quantity: e.g. *bag* as opposed to *inch*.

tion for allowing two types of phrasal standards (prepositional & oblique DP). As a result, it conforms with a well-established cross-linguistic universal according to which languages have only one standard marker for phrasal comparatives (Merchant, 2012). To explain the aforementioned patterns, I propose that the comparative phrase is split into two heads, the lower one assigning case to the standard phrase and the higher one to the differential. Furthermore, I argue that the only distinction encoded in the standard marker is that of the size of the syntactic constituent it selects (DP or CP) - the semantic choice between a degree or an individual is unrelated to the phrasal-clausal distinction.

In Chapter 4, I turn to clausal comparatives in Greek, Italian, French, Spanish and Brazilian Portuguese. I demonstrate that in all these languages there are two strategies for forming clausal comparatives: either a phrasal standard marker selects for a free/light headed relative clause or an exceptive construction.

In Chapter 5, I examine the meaning and licensing of comparative negation (also referred to as ‘expletive negation’) and negative polarity items in inequality comparatives. After a critical overview of the proposals that have been put forward so far regarding the nature of the negative particle that appears in some Romance comparatives without any obvious semantic effect, I demonstrate that licensing of expletive negation in comparatives is not directly predicted by negative polarity item licensing but it correlates with it in a systematic way. To adjudicate between analyses of negation in the comparative as an occurrence of the negative operator and analyses that consider it expletive or bearing some other non-negative meaning, I use experimental evidence from language acquisition. Data from the acquisition of Italian indicate that negation in comparatives marks another occurrence of the negative operator as does negation in declarative clauses, confirming the conclusion drawn from its cross-linguistic distribution. In light of these results, I discuss the implications for the distribution of negation in comparatives crosslinguistically.

Chapter 6 brings together the facts discussed in chapters 3, 4 and 5 and discusses residual issues and future directions.

Chapter 2

Previous Approaches to Comparatives

This chapter presents the challenges and most influential studies in inequality comparatives. Even though semantic and syntactic accounts are most of the times interwound to each other, for expository purposes they have been divided into three sections: §2.1 discusses the cross-linguistic variation of comparative constructions and reviews different typologies that have been put forward in order to explain cross-linguistic differences in comparative formation and their source. The second part of this chapter (§2.2) presents an overview of key ideas and problems in the analysis of the semantics of comparatives: the type of arguments of the comparative operator, the semantic content of the comparative operator and the standard marker, the existence of scope ambiguities and the existence of other covert operators in the comparative clause, such as the maximality and the negative operator. The third section of this chapter addresses the question of how the constituents of comparative combine and critically presents the different theories that have been put forward. The key issues related to the syntax of the construction pertain to the internal syntax of the comparative phrase, its relation to the standard phrase (subordination or coordination) and the internal structure of the standard phrase (phrasal vs. clausal). Finally, the last section of this chapter presents the proposal put forward in this thesis regarding the syntactic and the semantic representation of inequality comparatives.

2.1 Typologies of comparatives

2.1.1 Stassen (1984, 1985)

Stassen (1984, 1985) makes an extensive survey of the grammatical means used to express inequality comparisons cross-linguistically. As is clear from the definition in (21), Stassen's typology prototypically focuses on comparisons between individuals, which can be expressed either by phrasal comparatives or clausal comparatives.

- (21) A construction counts as a comparative construction (and will therefore be taken into account in our typology), if that construction has the semantic function of assigning a graded (i.e. non-identical) position on a predicative scale to two (possibly complex) objects.

(Stassen, 1984, 145; 1985, 15)

Stassen's (1984, 1985) studies of inequality comparatives in 110 languages identify six different Types of comparative constructions, shown in (22) below:

(22)

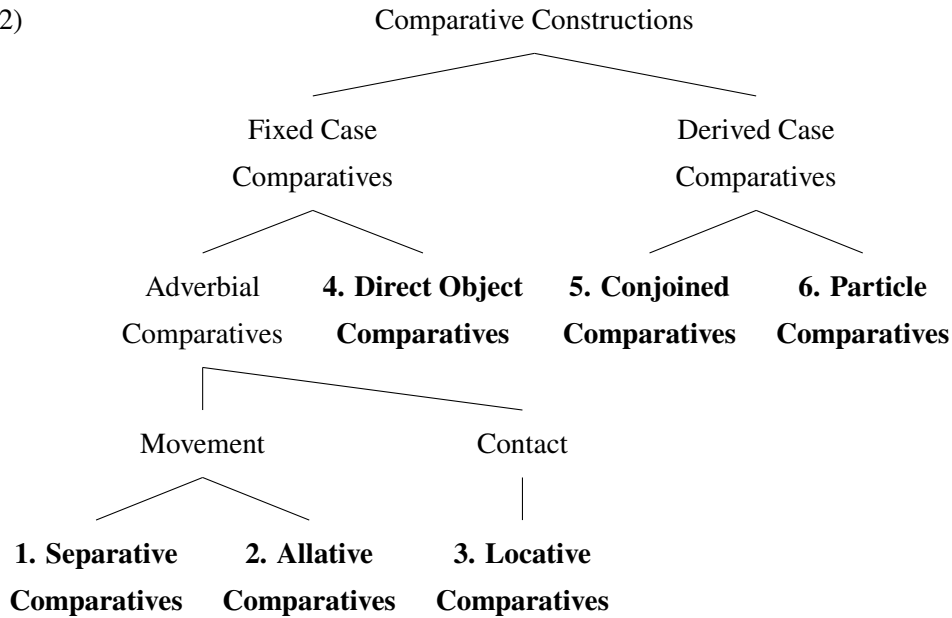

Fixed Case Comparatives. The standard NP is in oblique case, which remains invariable in all instances of comparison, no matter what is the case of the correlate. In other words, the case of the standard NP is independent of the case of the correlate in this type of construction. Fixed Case Comparatives are divided into two subclasses: Adverbial and Direct Object Comparatives.

Adverbial Comparatives: the standard NP has a fixed form and its marking is the same as the one involved in adverbials of the language. Adverbial comparatives are further split in three subclasses: Separative, Allative and Locative comparatives.

Separative Comparatives (Type 1): In Separative Comparatives the standard NP is invariably encoded as a constituent of an adverbial phrase with a separative ('source') interpretation.

- (23) a. Nihon-go wa doits-go yori muzukashi. JAPANESE
 Japanese TOP German from difficult
 'Japanese is more difficult than German.' (Stassen, 1985, 39:(12))
- b. Sen gül -den güzel -sin TURKISH
 Your rose-from beautiful-be-2SG
 'You are more beautiful than a rose.' (Stassen, 1985, 121:(15))

Allative Comparatives (Type 2): The standard NP is invariably encoded as a constituent of a (spatial or non-spatial) goal phrase.

- (24) Jazo bras-ox wid-on. BRETON
 he big-PRT for-me
 'He is bigger than me.'

Locative Comparatives (Type 3): The standard NP is invariably encoded as a constituent of an adverbial phrase, which is marked by an element with the basic meaning 'on' or 'at'.

- (25) Gamga-qla'ul-ik qetvu-ci-um.
 all-men-on strong-more-1SG
 'I am stronger than all men.'

CHUCKCHEE

'Exceed'/Direct Object Comparatives (Type 4) contain a transitive predicate by which the standard NP can be governed; The standard NP is invariably constructed as the direct object of a special transitive verb, which has the general meaning of 'to surpass', 'to excel', 'to exceed' or 'to be more than'. The correlate always functions as the grammatical subject of this 'exceed'-predicate. There are three subtypes:

1. A serial verb-construction, in which the correlate is constructed as the subject of a verbal complex which contains both the comparative predicate and the 'exceed'-verb.

- (26) a. Wo na p'i ma pi ni na p'i ma kwai MANDARIN
 I this CLASS horse exceed you this CLASS horse is-big
 'My horse is bigger than your horse.' (Stassen, 1985, 164:(12b))
- b. Khaw jaj kwaa phom THAI
 he big exceed me
 'He is bigger than me.' (Stassen, 1985, 165:(14b))

2. The 'exceed' verb is the only main predicate in the construction

- (27) Doki ya-fi rago girma. HAUSA
 horse it-exceed goat bigness
 'A horse is bigger than a goat.' (Stassen, 1985, 44:(20))

3. A construction where the comparative predicate is the sole main verb in the construction, while the 'exceed'-verb receives some subordinate form (e.g., the form of a participle, or of an infinitive):

- (28) Mit huu ni mrefu ku-shinda ule. SWAHILI
 Tree this is big INF-exceed that
 'This tree is taller than that tree.' (Stassen, 1985, 44:(21))

Derived Case Comparatives are constructions where the case of the standard NP co-varies with/ is the same as the case of the correlate. Derived case comparatives can be split into two subclasses, Conjoined Comparatives and Particle Comparatives.

Conjoined Comparatives (Type 5): In conjoined comparatives the matrix clause and the standard phrase exhibit a structural parallelism and are connected with adversative coordination. There are two subtypes:

1. Conjoined comparatives in which the two clauses contain antonymous predicates

- (29) Dzarang tica gahar, dzarang rei kesik. SIKI
 horse that **big** horse this **small**
 'That horse is bigger than this horse.' (Stassen, 1985, 44:(22))

2. Conjoined comparatives in which both clauses involve the same adjective but one of them is negated.

- (30) Kaw-ohra naha Waraka, kaw naha Kaywerye. HIXKARYANA
tall-not he-is W. **tall** he-is K.
 ‘Kaywerye is taller than Waraka.’ (Stassen, 1985, 44:(23))

Particle Comparatives (Type 6): In Particle comparatives the standard NP is introduced by a particle and its case co-varies with the case of the correlate. Unlike conjoined comparatives, however, the standard phrase does not involve a second scalar predicate. These particles vary widely as to their etymological origin and/ or their other functions as the comparative particle may be used to introduce other constructions. Depending on the etymological origin/ the other uses of the comparative particle in the language we can identify seven subclasses in particle comparatives:

- *and*-coordination, e.g. Javanese *karo*;
- adversative conjunction, e.g. Basque *baino/bainan* ‘but’;
- negative disjunction, e.g. Scottish Gaelic *na* ‘nor’, Scottish English *nor*;
- disjunction, e.g. Classical Greek *e*;
- temporal adverb with the meaning ‘then’, ‘after that’, e.g. *asa* ‘then’ in Toba Batak , *dan* in Standard Dutch ;
- similatives / identity comparatives, e.g. Sranan *leki* ‘as, like’;
- some form of the relative/interrogative pronoun, e.g. French *que*, Russian *cem*;

Stassen (1984, 1985) argues that a language may form comparatives of more than one Type. In those cases, he distinguishes between a “primary” and a “secondary” Type: the ‘primary’ Type refers to the type that is more widely used, namely the type that is used in more types of comparisons. For example, in Latin phrasal comparatives the standard phrase is either an Ablative NP (31-a) or a phrase introduced by the particle *quam* (‘than’ *wh-*) (31-b). Stassen (1984, 1985) classifies Latin as a primarily Type 6 language:

- (31) LATIN
- a. Cato eloquentior est quam Cicero.
 C. eloquent.CMPR is SM C.
 ‘Cato is more eloquent than Cicero.’
 - b. Cato Cicero-ne eloquentior est.
 C. C.-ABL eloquent.CMPR is
 ‘Cato is more eloquent than Cicero.’

As is evident from the classification of Latin in the typology, Stassen (1984, 1985) does not distinguish between phrasal and clausal comparatives. As the nominative case of the phrase following the SM in (31-a) shows, (31-a) is an instance of clausal comparative involving ellipsis. Therefore, it is expected that *quam*-inequality comparatives in Latin would be used for a wider array of comparisons than the phrasal comparatives (e.g. subcomparatives, TP-comparisons, etc). Even though Stassen’s typology has just scratched the surface of the syntax and semantics of comparisons, its extended empirical coverage (110 languages, controlled for family and area) allows for one safe assumption: the means for expressing comparison are interestingly limited.

2.1.2 Price (1990)

Price (1990), on the other hand, limits her study to Romance languages, with a focus on Spanish and French. The system she presents resembles an algorithm with sole aim to overtly distinguish inequality comparatives from equality comparatives and declarative complements. Her system, therefore, is largely based on the morphology of the standard marker and its (non) identity with other functional words. To be more specific, she argues that in French, for example, the SM for inequality and equality comparatives is the same hence negation in the comparative is licensed in order to overtly mark the inequality relation. On the other hand, in Spanish, the SM of inequality constructions is different than the SM of equality ones, therefore, there is no need for negation to be licensed. However, the inequality SM is morphologically identical with the declarative clause complementiser. To prevent any ambiguity, the so-called ‘tensed verb constraint’ (TVC) applies to the comparative. The TVC dictates obligatory deletion of a finite verb in the SP. The picture that emerges from her study is summarised in Table 2.1 in page 27.

Price’s (1990) extensive study of Romance comparatives faces two problems: the first one is related to the application of the Tensed Verb Constraint in Spanish - as she acknowledges herself, there are cases in Spanish that the tensed verb may appear, even though negation is not licensed. On the other hand, the *raison d’être* of comparative negation is incompatible with its optionality: if its sole purpose were to differentiate inequality comparatives from other types of constructions, such as equality comparatives, then we would expect that, the absence of negation in languages that it is grammatical in the comparative would result either in ungrammaticality or in ambiguity. However, negation in Romance comparatives is optional, and its absence does not render the construction ungrammatical or ambiguous to equality comparatives, free relatives or any other related construction. Therefore, Price’s (1990) typology seems to be both empirically and conceptually inadequate. The meaning and licensing of negation in inequality comparatives will be extensively studied in Chapter 5. To anticipate the discussion, using data from the distribution of comparative negation in Greek and Romance as well as data from the acquisition of negation in Italian, I will argue that negation in the comparative is the realisation of the negative operator in the standard phrase.

Table 2.1: Price's (1990) typology of Romance comparatives.

	Spanish	French	Italian	Portuguese	Rumanian	Catalan	Galician	Occitan	Walloon
Inequality SM	<i>que</i>	<i>que</i>	<i>che</i>	<i>que</i>	<i>că</i>	<i>que</i>	<i>ca</i>	<i>que</i>	<i>k'</i>
Equality SM	<i>como</i>	<i>que</i>	<i>quanto/come</i>	<i>quanto</i>	<i>cum</i>	<i>com</i>	<i>coma</i>	<i>que</i>	<i>k'</i>
→Inequality Marker ⁴ ?	<i>que</i>		<i>che</i> ₁	<i>que</i>	<i>că</i>	<i>que</i> ₁	<i>ca</i>		
Tensed clause Compl	<i>que</i>	<i>que</i>	<i>che</i>	<i>que</i>	<i>că</i>	<i>que</i>	<i>que</i>	<i>que</i>	<i>k'</i>
EN available?	-	<i>ne</i>	<i>non</i>	-	-	<i>no</i>	-	<i>non</i>	<i>ne</i>
→Inequality Marker?		<i>ne</i>	<i>non</i> ₂			<i>no</i> ₂		<i>non</i>	<i>ne</i>

Consequences

TVC	No	No	No	No	No	No	No	No	No
relativised construction	predominant	rare	frequent	predominant	predominant	frequent	predominant	rare	rare

⁴ Price (1990) refers to the 'Marker of Comparison', which is defined according to Andersen (1983, 104) as

“that specific element which distinguishes a comparison of inequality from a comparison of equality. It is, therefore, that element which expresses the specific result of inequality as opposed to the only other result possible, namely, that of equality. In the juxtapositional construction the marker [may be] the negative element NOT.”

A language can have more than one 'marker of comparison'. The elements that can function as 'markers of comparisons' are the comparative operator, the SM or EN. To avoid confusion with the terminology used here, where the comparative marker is the comparative operator (e.g. *-er* in English) the 'Marker of Comparison' will be referred to as the inequality marker.

2.1.3 Beck et al. (2003, 2004, 2009, 2012); Hohaus et al. (2014)

Beck et al. (2003, 2004) argue that English and Japanese comparatives differ in that Japanese *yori*-clauses are not standard phrases, as English *than*-clauses are, but context setters. The non-degree nature of the *yori*-constituent is a consequence a general lack of degree abstraction in Japanese, in contrast to English. The difference between the two languages reflects a difference in their setting of the Degree Abstraction Parameter (32-b). Beck et al. (2009) study the availability of several types of degree constructions (Degree Questions, Measure Phrases, Equatives, Superlatives, Difference Comparatives) in 15 languages,⁵ and extend Beck et al.'s (2004) typology by proposing two additional parameters in implicational relation with the DAP parameter:

- (32) a. **Degree Semantics Parameter (DSP)**
A language {does/does not} have gradable predicates (type $\langle d, \langle e, t \rangle \rangle$), i.e. lexical items that introduce degree arguments.
(Difference Comparatives and Comparison with a Degree are only available in languages with a positive DSP setting)
- b. **Degree Abstraction Parameter (DAP)** (Beck et al., 2004)
A language {does/does not} have binding of degree variables in the syntax
(Scope interaction with modals and NegIs are only expected in languages with a positive DAP setting)
- c. **Degree Phrase Parameter (DegPP):**
The degree argument position of a gradable predicate {may/may not} be overtly filled.
(Subcomparatives, Measure Phrases, Degree Questions are only expected to be available in languages with a positive DegPP setting).

Hohaus et al. (2014) attempt to corroborate Beck et al.'s (2009) typology using data from language acquisition. By applying Snyder's (2007, 74) theory of the relation between language variation and language acquisition to Beck et al.'s (2009) typology, they predict that the acquisition of degree constructions should follow the pathway specified in Figure 2.1.

By conducting a corpus study of American English and German child data (naturalistic production) they observe an unexpected difference between English and German: even though both languages have a positive value for all three parameters hence children should acquire the constructions following the same stages in both languages, phrasal *than*-constituents in German are not acquired concurrently with the pronominal measure phrase construction and significantly later than the superlative. Thus, these constructions are acquired considerably later than in English.

To explain this asymmetry, Hohaus et al. (2014) adopt Beck et al.'s (2012) theory that in English there is available one more variant of the comparative operator (33-b), which is acquired after the variant that introduces contextual comparatives (33-a) and before the variant that introduces clausal *than*-constituents (33-c). The comparative operator in (33-b) is used for all predicative comparisons,

⁵ Beck et al. (2009) acknowledge that Stassen's (1984, 1985) typological work provided significant input to their study, and that they make use only of "languages that use a verbal strategy — 'exceed'-type languages — and languages that use a conjunctive strategy to express comparison". However, as the first column of table 2.2 shows, the languages that Beck et al. (2009) study involve Type 1, 4, 5, 6 languages (cf. Stassen's (1984, 1985) typology in (22) in page 23.

Table 2.2: Beck et al.’s (2009) Typology and correspondence to Stassen’s (1984, 1985) Types. (The numbers in the parentheses refer to ‘secondary types’ and the star indicates languages not included in Stassen’s (1984, 1985) sample.)

Stassen’s Typology	Parameter/ Language	DSP	DAP	DegPP
Type 6	English	+	+	+
Type 6	German	+	+	+
	Bulgarian*	+	+	+
Type 1	Hindi-Urdu	+	+	+
Type 6	Hungarian	+	+	+
Type 4	Thai	+	+	+
	Romanian*	+	+	-
	Spanish*	+	+	-
Type 1	Guaraní	+	+	-
Type 1	Russian	+	+	-
Type 1	Turkish	+	+	-
	Chinese*	+	-	-
Type 1	Japanese	+	-	-
Type 4	Mooré*	+	-	-
Type 5 (3)	Samoan	+	-	-
Type 4	Yorùbá	+	-	-
Type 5	Motu	-	-	-

in other words for a proper subset of the comparisons derived by (33-c).

- (33) a. $\llbracket -er_1 \rrbracket = \lambda Adj_{\langle d, \langle e, t \rangle \rangle} . \lambda d' . \lambda x . \max(\lambda d(d)(x)) > d'$
b. $\llbracket -er_2 \rrbracket = \lambda Adj_{\langle d, \langle e, t \rangle \rangle} . \lambda d' . \lambda x . \max(\lambda d(d)(x)) > \max(\lambda d(d)(x))$
c. $\llbracket -er_3 \rrbracket = \lambda d_{\langle d \rangle} . \lambda D_{\langle d, t \rangle} . \text{MAX}(D) > d$

However, the evidence provided by Beck et al. (2012); Hohaus et al. (2014) for the existence of (33-b) is not strong enough: the stage where only predicative constructions are available can be explained in two ways: either, as Beck et al. (2012); Hohaus et al. (2014) assume, with the postulation of (33-b), or by assuming that antecedent contained deletion (or any other ellipsis operation involved) is acquired later than the (33-c). On the other hand, as table 2.3 shows, the age of acquisition of clausal *than*-constituents cannot be determined either in English or in German and therefore the evidence available is inconclusive. This might be an artefact of the methodology used: spontaneous speech data do not ‘target’ a specific construction hence they may not reflect accurately the ‘cut-off’ points of different developmental stages. If a construction is missing from the data it might have been acquired but be accidentally unattested. Furthermore, this study is not accompanied of a study of the acquisition of ellipsis in English or German, so there is not independent support for their proposal (Syrett,

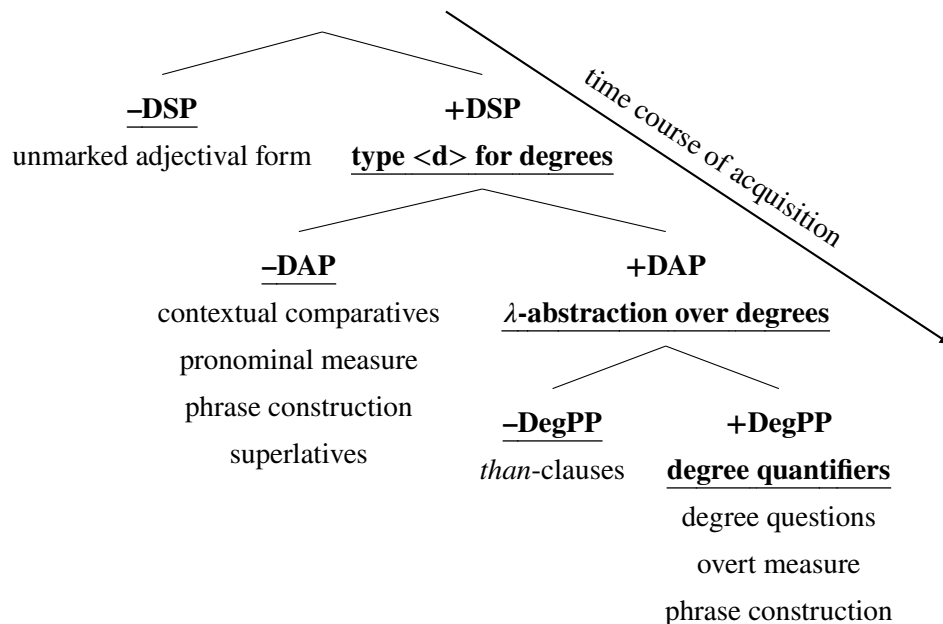

Figure 2.1: Parametric steps in the acquisition of a [+DSP],[+DAP],[+DegPP]-language. (Hohaus et al., 2014, 225)

2016). Finally, Lechner (2017) gives evidence that some German attributive phrasal comparatives are base generated.

2.1.4 Individual vs. Degree comparison, Implicit vs. Explicit comparison (Kennedy, 2007a,b)

Kennedy (2007a,b) shows that Beck et al.'s (2004, 2009) theory is problematic on theoretical grounds too. Beck et al.'s (2004) postulation of two parameters, namely DAP and the distinction between contextual and compositional comparisons, does not make the correct typological predictions: just DAP can capture the distinction between English and Japanese. He argues that the difference observed by Beck et al. (2004) between English and Japanese stems from whether a language allows both individual and degree comparisons or only one type of comparisons. He also recasts the compositional vs. contextual distinction as explicit vs. implicit comparison, as defined in (34). That parameter might be unnecessary for distinguishing English from Japanese but may have bearing on the study of typologically distinct languages like Stassen's (1984, 1985) conjoined comparatives (cf. (22)).

(34) **Implicit Comparison:** Establish an ordering between objects x and y with respect to gradable property g using the positive form by manipulating the context in such a way that the positive form true of x and false of y .

Explicit Comparison: Establish an ordering between objects x and y with respect to gradable property g using a morphosyntactic form whose conventional meaning has the consequence that the degree to which x is g exceeds the degree to which y is g .

Kennedy (2007b) explores the idea that the comparative marker is semantically vacuous, or more accurately, that its role is to make the adjective select for a standard. On the other hand, the meaning

Table 2.3: Age of Acquisition and Mean Length of Utterance (Hohaus et al., 2014, 228)

<i>FRU</i>	English			German		
	Adam (2;03-5;02)	Sarah (2;03-5;01)	Ross (1;0- 1;06,2;06- 7;05)	Cosima (0;00-7;02)	Pauline (0;00-7;07)	Sebastian (0;00-7;00)
Unmarked adjectival form	2;03 MLUw 2.12	2;03 MLUw 1.68	2;06 MLUw 2.79	2;00 MLUw 1.26	2;05 MLUw 2.21	2;00 MLUw 2.04
Contextual comparatives	3;04 MLUw 3.97	3;07 MLUw 3.62	2;06 MLUw 2.79	2;09 MLUw 2.91	2;08 MLUw 2.83	3;11 MLUw 3.15
Superlative morphology	4;02 MLUw 4.42	4;02 MLUw 3.44	4;08 MLUw 6.99	3;07 MLUw 4.24	4;05 MLUw 3.11	4;03 MLUw 4.20
Pronominal measure phrase constructions	4;00 MLUw 4.50	4;00 MLUw 3.46	4;01 MLUw 5.74	3;07 MLUw 4.24	3;00 MLUw 4.28	Cannot be determined
Phrasal <i>than</i> -constituents	4;02 MLUw 4.42	Cannot be determined	3;05 MLUw 4.56	Cannot be determined	6;06 MLUw 4.15	6;03 MLUw 3.93
Clausal <i>than</i> -constituents	Cannot be determined		Cannot be determined			
Overt measure phrase constructions	Cannot be determined	4;05 MLUw 3.72	Cannot be determined		Cannot be determined	
Degree Questions	Cannot be determined	Cannot be determined	Cannot be determined	Cannot be determined	6;10 MLUw 4.30	Cannot be determined

that ‘traditionally’ was attributed to the comparative marker is borne by the standard marker. The standard marker, depending on whether it selects for degrees or individuals has the meaning in (35-a) and (35-b) respectively:

- (35) a. $\llbracket \text{STANDARD-MORPHEME}_D \rrbracket = \lambda d \lambda g_{\langle d, et \rangle} \lambda x. \max(g)(x) > d$
 b. $\llbracket \text{STANDARD-MORPHEME}_I \rrbracket = \lambda y \lambda g_{\langle d, et \rangle} \lambda x. \max(g)(x) > \max(g)(y)$
 c. $\llbracket \text{STANDARD-MORPHEME}_I \rrbracket = \lambda y \lambda g_{\langle d, et \rangle} \lambda x.$
 $\llbracket \text{STANDARD-MORPHEME}_D \rrbracket (\max(g)(y))(g)(x)$

Given that (35-b) can be derived from (35-a) but not vice versa, as shown in (35-c), there are three possible typological options based on whether a language has individual and/ or degree comparison. These language types are articulated in (36)

- (36) a. A language may have a single standard morpheme that selects for a degree standard, with a meaning like (35-a). Since a meaning that accepts an individual standard can be derived from this (35-c), such a language should in principle have both degree and individual comparison.
 b. A language may have two standard morphemes that differ in whether they introduce individual or degree standards. Such a language should have both individual and degree

comparison, but they will be morphologically (and syntactically) distinguished.

- c. A language may have a single standard morpheme that selects for an individual standard, with a meaning like (35-b). Since a meaning that accepts a degree standard cannot be derived from this, such a language should have only individual comparison.

Shimoyama (2012) argues that both Beck et al.'s (2004, 2009) DAP parameter and its weaker version, namely Kennedy's (2007a) comparison type parameter, which are both largely based on the study of Japanese, make too strong empirical predictions.⁶ Shimoyama (2012) shows that Japanese does not have *only* comparisons of entities but also comparison of degrees, based on the following facts:

the availability of constructions like (37) and (38): Deriving the intended semantics for (37) and (38) is not straightforward if we assume that abstraction over degrees is not allowed in the language.

- (37) Hanako-no te-wa [Taro-ga omotta]-yori ookii
Hanako-GEN hand-WA Taro-NM thought-than big
'Hanako's hands are bigger than Taro thought (they were).' (Shimoyama, 2012, (11))
- (38) a. Kono musu-wa [me-de mi-eru]-yori tiisai
this bug-WA eye-with see-can-than small
'This bug is smaller than the eye can see.'
- b. Kono kagu-wa [natu-no boonasu-de ka-eru]-yori takai.
this furniture-WA summer-GEN bonus-with buy-can-than expensive
(lit)'This furniture is more expensive than (I) can buy with my summer bonus.'
(This furniture is more expensive than I can afford with my summer bonus.)
(Shimoyama, 2012, (12))

The element *no* 'one' cannot be freely omitted from the *yori*-clause: If Japanese standard clauses where uniformly entity free relatives we would not expect the ungrammaticality of (39-a).

- (39) a. *Kono hon-wa [Hanako-ga katta]-yori omosiroi.
this book-TOP Hanako-NOM bought-than interesting.
b. *This book is more interesting than Hanako bought.
c. This book is more interesting than what Hanako bought. (Shimoyama, 2012, (18))

On the other hand, if we assume that degree comparatives are also available in Japanese, the ungrammaticality of (39-a) and (39-b) is uniformly captured by conditions on ellipsis.

Availability of *de re/de dicto* interpretations: The degree-denoting analysis predicts that the SP will interact scopally with other scope bearing elements, whereas the entity-denoting analysis predicts that such interactions are not observed. In examples (40) the degree-denoting analysis predicts the availability of a *de dicto* interpretation whereas the entity-analysis does not.

⁶ Cf. Hayashishita (2009) and Shimoyama (2011) for earlier discussion.

- (40) a. Taro-wa [Hanako-ga hosigatteita]-yori takusan-no onigiri-o katta.
Taro-TOP Hanako-NOM wanted-than many-GEN rice.ball-ACC bought
'Taro bought more rice balls than Hanako wanted.'
- b. Taro-wa [Hanako-ga kai-tagatteita]-yori takusan-no onigiri-o katta.
Taro-TOP Hanako-NOM buy-wanted-than many-GEN rice.ball-ACC bought
'Taro bought more rice balls than Hanako wanted.' (Shimoyama, 2012, (24))

Indeed, the sentences in (40) allow for the *de dicto* interpretation, which is only predicted to be available if the language has abstraction over degrees.

Negative islands: Japanese comparatives involve negative islands on a par with their English counterparts.

- (41) a. *John bought a more expensive book than nobody did.
b. *John bought a more expensive book than Mary didn't buy.
c. *John-wa [dare-mo/ Mary-ga kawanakatta] -yori takai hon-o katta.
John-TOP anybody/ Mary-NOM didn't.buy -than expensive book-ACC bought.
'John bought a more expensive book than nobody did/Mary didn't buy.' (Example is from Beck et al., 2004, p. 315 but the judgement of the sentence from ?? to * is by Shimoyama (2012))

If Japanese did not have degree comparison, the occurrence of weak islands would remain a puzzle.

The (non-)available readings: Phrasal comparatives involve an additional reading, compared to clausal comparatives (42): in the reading shown in (42-a) the associate of the comparison is 'Ziro' while reading (42-b) is available if the associate is the object 'a smarter person'. If Japanese clausal comparatives were indeed phrasal, then they would be expected to be ambiguous like other phrasal comparatives. However, they are not (43). The sentence in (43) is unambiguous, and the reading in (43-b) is only available by the minimally different true phrasal comparative in (44) below.⁷

- (42) Taro-wa Ziro-yori kasikoi hito-o mituketa.
Taro-TOP Ziro-than smart person-ACC found
'Taro found a smarter person than Ziro.'
- a. Taro found a smarter person than Ziro did.
b. Taro found a person who is smarter than Ziro is.
- (43) Taro-wa [Hanako-ga tukutta]-yori ii kuruma-o tukutta
taro-TOP hanako-NOM made-than good car-ACC made.
a. 'Taro made a better car than Hanako did.' (*degree*)
b. *'Taro made a better car than what Hanako made. (*individual*)

⁷ For a similar point regarding the difference between the phrasal comparative and the supposed underlying clausal structure see Pinkham (1982); Kennedy (1999).

- (44) Taro-wa [[Hanako-ga tukutta]-no]-yori ii kuruma-o tukutta
 taro-TOP hanako-NOM made-NO-than good car-ACC made.
 'Taro made a better car than what Hanako made.'

Syntactic islands: Shimoyama (2012) also shows that the islands Japanese comparatives involve (Kikuchi, 1987; Ishii, 1991) pattern differently than other relative clause constructions, a fact straightforwardly captured by a degree analysis of Japanese comparatives.

Finally, Shimoyama (2012) shows that the unavailability of degree subcomparatives in Japanese does not follow from the assumption that Japanese lacks degree abstraction and the solution of analysing some plain clausal complements as internally headed relatives is not unproblematic.

In sum, the proposed parametrisation regarding the availability of abstraction over degrees is not supported by the Japanese data. However, as Kennedy (2007a,b) pointed out it may be relevant for Stassen's (1984, 1985) conjoined comparatives.

2.1.5 Parametrising phrasal comparatives

Bhatt and Takahashi (2011) argue that different languages employ different structures for phrasal constructions. They claim that the reason why the comparative marker is always the same across phrasal and clausal comparatives is that languages do not differ with respect to the availability of the 2-place *-er* and the 3-place *-er*. There are both projections of the same meaning and if a language has one then it has the other. The locus of cross-linguistic variation is the environments where each degree head may be used. They claim that the availability of reduction operations in a language partly defines whether a phrasal comparative in a given language uses a 2-place *-er* or a 3-place *-er* in that language. Additionally, the distribution of the degree head may also be defined by the morphosyntactic properties of the standard marker and driven by a preference for minimal structure. More specifically, they recognise 3 different types:

- (i) English and German: reduction operations are available and a two place *-er* is used;
- (ii) Hindi-Urdu (Bhatt and Takahashi, 2007a,b): reduction operations are not available hence the language uses both a 2- and a 3-place *-er*;
- (iii) Japanese: reduction operations are available in the language but it uses both a 2- and a 3-place *-er*.

Let us look into the properties of each type in more detail.

The two place *-er* (45) is used in clausal comparatives (46-a) and amount comparatives (46-b). In that sense, it can combine both with clausal and (some) phrasal comparatives.

(45) $-er(P)(Q) \leftrightarrow \exists d[Q(d) \wedge \neg P(d)]$, where P, Q are degree predicates (sets of degrees)

- (46) a. John is taller than [Bill is]
 b. John is taller than six feet.

On the other hand, the 3-place comparative head, under a direct analysis, combines with the standard phrase, a predicate of individuals and degrees and the associate (47). The predicate of individuals

and degree is created by movement of the associate and the degree phrase (48). The movement in (48-b) is covert in English, but overt in Japanese and Hindi-Urdu.

$$(47) \quad \text{-er}(x)(P)(y) \leftrightarrow \exists d[P(y, d) \wedge \neg P(x, d)]$$

(48) a. John is taller than Mary.

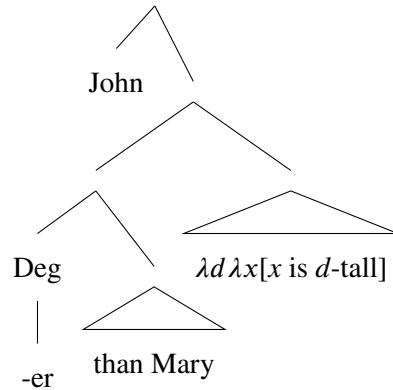

b. More students read LGB than the MP

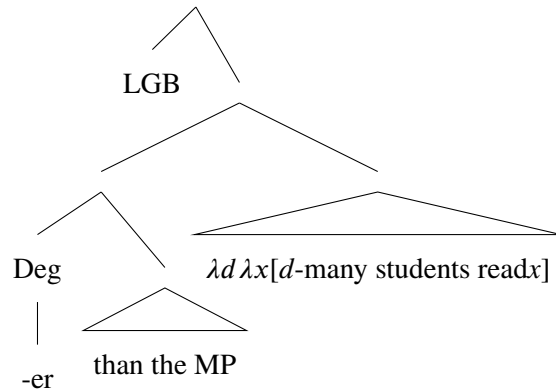

Even though it seems possible to pursue an analysis of English phrasal comparatives without resorting to a 3-place *-er* (Lechner, 2001, 2004), that is not the case for Hindi-Urdu.⁸ The comparative marker in Hindi-Urdu is optional only in adjectival comparatives and the standard phrase is always introduced by the postposition *-se* ('from'). The standard phrase is always a single bare DP (*single standard restriction*), regardless whether the associate is a PP or a DP, which sometimes can lead to ambiguity. Furthermore, the standard phrase always precedes the degree head. This *precedence restriction* follows from the fact that the standard phrase is an argument of the degree head and that Hindi-Urdu is a head final language. Additionally, the surface syntax reflects the required LF (48), which could not have been achieved through covert movement because in Hindi-Urdu only surface scope is available. In case the surface syntax does not feed the right scope relations, scrambling becomes obligatory.

⁸ As for English phrasal comparatives there has been an ongoing debate whether they are truly phrasal or involve ellipsis. As for German comparatives, especially after Lechner's (2004) work on ellipsis, it had been undisputed that they are never phrasal/base-generated (with the only exception of comparatives where the standard is a measure phrase so it already has the semantic type of a degree). However, as Lechner (2017) shows, German also has phrasal comparatives. Experimental evidence suggests that English does so too (Grant, 2013).

- (49) Atif-*ne* Mina-*ko* Tina-*se* zyaadaa tohfe diye.
 Atif-ERG Mina-DAT Tina-than more presents.M give.PFV.MPL
 a. 'Atif gave more presents to Mina than to Tina.'
 b. 'Atif gave more presents to Mina than Tina did.'

Finally, in terms of Binding, Hindi-Urdu phrasal comparatives present the same properties as PPs:

1. They pattern with arguments with respect to Principle B.
2. Subjects can bind reflexives and reflexive possessors. Pronominal possessors cannot be coreferent with the subject.
3. Co-arguments that precede the PP c-command it and the PP (and the DP immediately inside the PP) c-commands co-arguments that follow it.

The proposed syntactic derivation for Hindi-Urdu is given in (50-a)

- (50) a.
-
- b. Final step in the derivation: Scrambling of the standard over the subject
 LF: Boman-*se* λy . Atif-*ne*[[*y* -er] λd . λx [*x* [*d*-many books]]]
 Pronunciation: Boman-*se*_i Atif-*ne* [[*t*_i more] books] read

Finally, Hindi-Urdu differs from English with respect to scope of quantifiers embedded in the *than*-phrase. Whereas, quantifiers in the *than*-phrase can scope in the *than* phrase, a fact compatible with a reduction analysis of English phrasal comparatives, in Hindi Urdu, the quantifier must take scope out of it. The latter is expected, given that a 3-place *-er* combines directly with the standard and its associate hence any quantificational phrases need to scope out due to the type mismatch.

(51) [har syntax paper] [har semantics paper]-se syaadaa logō-ne parh-aa.
 every syntax paper every semantics paper-than more people-ERG read-PRFV

‘More people read every syntax paper than every semantics paper.’

English: *every > -er; ✓-er > every

Hindi-Urdu: ✓every > -er; *-er > every

Japanese differs from Hindi-Urdu in that the comparative marker is optional but the same precedence restriction is observed: the standard phrase, which is also introduced by the ablative preposition *yori* (‘from’), must precede the comparative marker. In contrast to Hindi-Urdu *-se* that only combines with bare DPs, *yori* can combine with case marked DPs or PPs. However, the precedence restriction is applied only when the standard phrase is a bare DP. Structural case is ungrammatical in the standard phrase. Multiple remnants are also allowed in Japanese, on the condition that a Dative phrase or a PP appears immediately before *yori*. Given the availability of multiple remnants in the *yori*-constituent it is clear that Japanese allows -at least in some cases- reduction operations. In that respect, Japanese is similar to English and not to Hindi-Urdu. On the other hand, data from binding suggest that a Direct Analysis should also be made available for Japanese. Scopal properties of quantificational *yori*-phrases corroborate that Japanese has phrasal comparatives, where the standard phrase directly merges with the standard marker: if the *yori*-phrase internal quantifier c-commands the comparative deletion site, which contains the degree variable, the quantifier scopes out the degree clause, like Hindi-Urdu phrasal comparatives; if the *yori*-phrase internal quantifier does not c-command the degree variable the reversed picture is observed.

Based on the aforementioned facts, Bhatt and Takahashi (2011) propose that 2-place and 3-place entries of the comparative operator are available crosslinguistically, but the syntactic environments where these entries may be used are restricted crosslinguistically by the subcategorisational properties of the standard marker. For instance, *than* which is exclusively used in comparatives only select for CPs, whereas *yori* and *-se* which also function as prepositions in other contexts can select for both. A constraint on Minimal Structure blocks the use of reduced clausal comparatives in environments where phrasal comparatives are allowed. Therefore, cross-linguistic variation is due to various factors, such as the properties of comparative markers (*than*, *yori*, *-se*), headedness of degree heads, a preference for minimal structure and a preference for a single sub-categorisation frame and the relative order between the standard phrase and the comparative marker.

The data and the analysis put forward in this thesis will confirm Bhatt and Takahashi’s (2011) thesis that the distinction between a 2- and a 3- place *-er* is not encoded in the standard marker (contra Kennedy, 2007a,b). The comparative study of Greek and Romance comparatives will show that the only distinction that the standard marker encoded is that of the syntactic category of its pivot (CP or DP) and it will reveal new loci of variation in the standard phrase and it will show that some language may not licence a 3-place comparative operator.

2.2 The semantics of Comparatives

2.2.1 Maximality in the standard phrase

Von Stechow (1984), inspired by Chomsky's (1977) proposal that standard phrases involve *wh*-movement, proposes that the sentence introduced by *than* is a predicate of degrees generated by *wh*-movement. This property is nominalised by applying Russell's (1905) definite description operator *the* defined in (52).⁹

- (52) Let P_1, P_2 be any first-order properties. $the(P_1)(P_2)$ is the proposition true in a world w if $(\exists x)(\forall y)[[w \in P_1(x) \leftrightarrow x = y] \& w \in P_2(x)]$

However, Russell's (1905) and Postal's (1974) accounts fail to derive the right truth-conditions, especially for comparatives that contain possibility modals in the standard phrase.¹⁰ Von Stechow (1984) attempts to amend that by introducing the *maximality* operator *max* in (53). The definite description operator *the* needs to be applied to the predicate of degrees after the maximality operator *max* (53) has been applied (54). Given that degrees are linearly ordered, $Max(P)$ corresponds to exactly one degree, namely the highest degree that makes the predicate P true (55).

- (53) Let P be any property of degrees. $Max(P)$ is true of d iff $P(d)$ and $\sim(\exists d')[P(d') \& d' > d]$.

- (54) $[[\bar{S}]] = the(Max(P))$

- (55) Let P be any property of degrees. *Than* $Max(P)$ is that property which is true of any degree d in a world w iff $P(d) \& \sim(\exists d')[w \in P(d') \& d' > d]$

More is analysed as a four place relation with two degrees among its arguments: the differential and the standard phrase. Either of them may be supplied by the context instead of being overtly expressed (57). To better illustrate the proposed analysis, an example is given in (58): the meaning of (58-a) is illustrated in (58-b)

- (56) $[[more/-er]]$

Let d_1, d_2 be any degrees, A^0 an appropriate relation of type $\langle 0, 1, 1 \rangle$, x an individual and w any world. Then

$w \in [[\{more/er\}]](d_1)(A^0)(d_2)(x)$ iff $w \in A^0(x, d_1 + d_2)$

- (57) a. Ede is **at least 6 inches taller than Otto**.
 b. Ede is taller than Otto.
 c. Plato is more boring.

- (58) a. John is at least six inches taller than Mary.
 b. the $\max.d [Mary \text{ is } d\text{-tall}] \lambda d_2 [\exists d (d \geq 6 \text{ inches}) \lambda d_1 [Ede \text{ is } d_1 + d_2\text{-tall}]]$

⁹ Von Stechow (1984) intends to provide such an account that is as neutral as possible with respect to theoretical framework. For that reason, I will maintain von Stechow's (1984) original notations, e.g. the definiteness operator will be represented as *the* and not for example as an iota function.

¹⁰ Von Stechow (1984) characterises his own account as "synthesis" of previous accounts.

Rullmann (1995) adopts von Stechow's (1984) maximality account of comparatives and extends it to all types of comparatives, including *less* comparatives and equatives, as well as other *wh*-constructions like *wh*-questions and free relatives. Core to Rullmann's (1995) analysis is the occurrence of weak islands (Ross, 1984; Rizzi, 1990; Cinque, 1990; Szabolcsi and Zwarts, 1991; Szabolcsi, 1992; Szabolcsi and Zwarts, 1993) in all the aforementioned constructions and he proposes that the reason why these constructions present island sensitivities is maximality. He uses the definition of maximality in (59):

(59) **Definition of the Maximality Operator *max***

Let DEG be a set of degrees ordered by the relation \leq , then

$$\text{max}(\text{DEG}) = \text{id}[d \in \text{DEG} \wedge \forall d' \in \text{DEG}[d' \leq d]].$$

By bringing together von Stechow's (1984) maximality account of comparatives and Szabolcsi and Zwarts's (1993) framework of weak islands, he proposes that the negative island effects observed in comparatives follow from the undefinedness of complement sets of maximal degrees.

The ambiguity of *less* comparatives, on the other hand, between a 'less-than-maximum' and a 'less-than-minimum' interpretation (60), originally observed by Seuren (1979), is proposed to be a scope ambiguity of the comparative operators exemplified in (61): in the less-than-maximum comparatives the comparative operator scopes only above the gradable adjective (61-a) whereas in less-than-minimum comparatives it scopes above a larger constituent also including *little* (61-b). Rullmann (1995) also shows that each construction presents a different behaviour with respect to polarity item licensing.

(60) The helicopter was flying less high than a plane can fly. (Rullmann, 1995, (71))

- a. The altitude at which the helicopter was flying was below the maximal altitude at which a plane can fly.
- b. The helicopter was flying at an altitude below the minimal altitude at which a plane can fly.

(61) (Rullmann, 1995, (91))

- a. The helicopter was flying -er little high than a plane can fly high
- b. The helicopter was flying -er little high than a plane can fly little high

Rullmann (1995) points out that the ambiguity of *less* comparatives is also found in comparatives with negative adjectives and modals.¹¹ He entertains the idea of lexically decomposing a negative adjective with 'little' and its positive counterpart, e.g. *lower* = *less high*, even though he considers this proposal weak due to the lack of independent motivation.

A pertinent question is whether comparatives involve maximality or universal quantification over degrees.¹² In a universal quantification analysis of comparatives, the standard phrase forms the restrictor of the quantifier. The definition of the maximality operator as proposed by Rullmann (1995)

¹¹ Negative and positive adjectives refer to adjectives representing opposite ends of a scale: for instance in the pair *short* and *tall*, *short* is the negative adjective and *tall* the positive one (cf. Kennedy, 1999).

¹² There is also a long standing debate on whether relative clauses involve maximality (Jacobson, 1995; Vlachou, 2003, 2004, 2005; Tredinnick, 2005, a.o.) or universal quantification (Alexiadou and Varlokosta, 1996, 2007; Iatridou and Varlokosta, 1998, a.o.).

has a universal quantifier as a component of its meaning (59),¹³ thus it is unsurprising that it makes the same predictions for *more* comparatives as accounts of comparatives that use a universal quantifier instead of the maximality operator (Cresswell, 1976; Hoeksema, 1983; Pinkal, 1989). Universal analyses, however, diverge from Rullmann's (1995) account with respect to their predictions for *less* comparatives (the latter predict only the less-than-minimum reading), differential comparatives and equatives (they only predict the 'at least' but not the 'exactly' readings).

2.2.2 Extent based semantics

Seuren (1973, 1984) argues for an extent based semantics that does not (need to) resort to maximality. EXTENTS, the type that operators involved in the comparative construction quantify over, are directional parts of parameters. A positive adjective like *tall* is represented by positive extents, which have as their starting point point 0 and as an endpoint some upper limit hence they are finite and positive, whereas their complement has only defined its lower limit and extends infinitely, so it is infinite and negative. Projection is a function that maps gradable properties to parameters. As for comparatives, they are all reduced to comparatives of quantity and refer to cognitive parameters, which are perceived as abstract linear representations of gradable properties. The semantic representation of a comparative is given in (64).

(62) "X have tallness to Y" is true iff:

Preconditions: X is the name of an entity that can be said to have tallness;

Y is the name of an extent on the parameter T;

Satisfaction condition: Y is the projection of X on T.

(63) "X be much to Y" is true iff

Precondition: There is a parameter P such that X and Y are extents on P;

Satisfaction condition $\forall v[v \in Y \supset \in X]$, where "v" is a variable ranging over values on P.

(64) (Seuren, 1973)

a. Jim is taller than Joe

$\exists e:\text{extent} [\text{the } f:\text{extent} [\text{Jim has tallness to } f] \text{ is much to } e \wedge \sim [\text{the } g:\text{extent} [\text{Joe has tallness to } g] \text{ is much to } e]]$

b. Jim is taller than six feet

$\exists e:\text{extent} [\text{the } f:\text{extent} [\text{Jim has tallness to } f] \text{ is much to } e \wedge \sim [\text{six feet is much to } e]]$

Kennedy (1999) argues for a scalar analysis of the semantics of gradable adjectives. He argues that 'vague predicate analyses' fail to explain phenomena such as comparatives of deviation (65-a), the unavailability of incommensurable comparatives (65-b) and the unavailability of measure phrases with 'negative' adjectives (65-c), hence a scale-based semantics is necessary.

(65) a. Robert is as short as William is tall.

b. #The class was longer than this table is.

¹³ Note that von Stechow's (1984) definition of the maximality operator did not involve a universal but a negated existential, cf. (53) above.

- c. John is 4 feet short.

Even though resorting to degrees can adequately account for the aforementioned phenomena, the occurrence of cross-polar anomalies (66) point towards an *extent*-based semantics (Seuren, 1973, 1984) instead of degree semantics. So, extents, in contrast to degrees, are not discrete points on a scale but intervals. Adjectives are functions from objects to extents and adjectives of different polarity measure objects to the same dimension but they represent complementary perspectives on their projection onto scale. In that system, the positive projection of an object on a scale is distinct from the negative projection of that object on the same scale and in that sense cross-polar anomalies are reduced to incommensurability.

(66) (Kennedy, 1999)

- a. #The *Brothers Karamazov* is longer than *The Idiot* is short.
 b. #The *Idiot* is shorter than *The Brothers Karamazov* is long.

2.2.3 Scope and the (non-)quantificational nature of the comparative

Kennedy (1999) also examines whether comparatives introduce degrees or denote relations between sets of degrees. If quantifiers denote relations between sets of degrees, i.e. they are generalised quantifiers over degrees, then they are expected to scopally interact with other quantificational elements (matrix negation, distributive quantifiers, intensional verbs). Sentence (67) contains a negative operator. If the quantificational account were correct, we would expect (67) to have reading (67-b) additionally to reading (67-a). However, this prediction is not borne out. Again, the same prediction is made for (68), however, only reading (68-a) is attested.¹⁴

(67) Max isn't taller than his brother is.

- a. $\neg\exists d[d > \max(\lambda d'.tall(Max's\ brother, d'))][tall(Max, d)]$
 b. $*\exists d[d > \max(\lambda d'.tall(Max's\ brother, d'))]\neg[tall(Max, d)]$

(68) Every planet in the solar system is larger than Earth's moon.

- a. $\forall x[planet(x)][\exists d[d > \max(\lambda d'.large(Earth's\ moon, d'))][large(x, d)]]$
 b. $*\exists d[d > \max(\lambda d'.large(Earth's\ moon, d'))][\forall x[planet(x)][large(x, d)]]$

Even though comparatives do not seem to present scope ambiguities with respect to negation or distributive quantifiers, they present ambiguities in intensional contexts, like (69) and (70). Following von Stechow (1984), Kennedy (1999) assumes that the ambiguity stems from the interaction of the standard phrase, which has definite semantics, with the intensional operator.

(69) Max thinks the moon is larger than it is.

- a. The size that Max thinks the moon is exceeds the size that it actually is.
 $\exists d[d > \max(\lambda d'.large(moon, d'))][think(Max, \hat{large}(moon, d))]$
 b. Max thinks that the size of the moon exceeds the size of the moon.
 $think(\exists d[d > \max(\lambda d'.large(moon, d'))][Max, \hat{large}(moon, d))]$

¹⁴ The unattested readings are marked with a star (*).

(70) If Jones had been taller than he was, he would have been decapitated by the flying saucer.

The unattested scope ambiguities between comparatives and other quantifiers can be explained in two ways: either for some independent reason comparatives must always take narrow scope or the comparative is not a quantifier. Kennedy (1999) argues that the latter is more likely because otherwise the comparative would be the first non-conservative quantificational determiner.

Heim (2000), on the other hand, argues that comparatives involve DegP movement subject to syntactic constraints. She shows that the apparent lack of movement observed by Kennedy (1999) is a result of several confounds. More specifically, she shows that the different readings derived by QR in the cases of upward monotone quantifiers in *more* comparatives of positive adjectives and equatives are equivalent and thus impossible to detect. In downward monotone contexts, e.g. negated comparatives, the reading that could possibly result from QR of the DegP is ruled out for independent reasons hence those examples are not refined enough to function as diagnostics for the existence of QR either. However, in sentences that these confounds are controlled for, we can detect ambiguities. More specifically, in contexts involving non-monotone quantifiers like *exactly*-differentials (71) or in *less*-comparatives (72), we observe that the two scopal possibilities are truth conditionally distinct. The ambiguities also arise in sentences involving intensional verbs (73).

(71) a. (John is 4' tall.) Some girl is exactly 1" taller than that.

b. [some girl]₁ [exactly 1" -er than 4']₂ t₁ is t₂ tall.

$\exists x[\text{girl}(x) \ \& \ \max\{d: \text{tall}(x,d)\} = 4' + 1'']$

c. [exactly 1" -er than 4']₂ [some girl]₁ t₁ is t₂ tall.

$\max\{d: \exists x[\text{girl}(x) \ \& \ \text{tall}(x,d)]\} = 4' + 1''$

(72) a. (John is 4' tall.) Every girl is less tall than that.

b. [every girl]₁ [less than 4']₂ t₁ is t₂ tall.

$\forall x[\text{girl}(x) \ \rightarrow \ \max\{d: \text{tall}(x,d)\} < 4']$

less than 4'₂ [every girl]₁ t₁ is t₂ tall.

$\max\{d: \forall x[\text{girl}(x) \ \rightarrow \ \text{tall}(x,d)]\} < 4'$

(73) a. (This draft is 10 pages.) The paper is required to be exactly 5 pages longer than that.

b. required [[exactly 5pp. -er than that] the paper be t long]

$\forall w \in \text{Acc}: \max\{d: \text{long}_w(p,d)\} = 15\text{pp.}$

c. [exactly 5 pp. -er than that] [required [the paper be t long]]

$\max\{d: \forall w \in \text{Acc}: \text{long}_w(p,d)\} = 15\text{pp.}$

Heim (2000) also observes that the intensional verbs present a mixed pattern. The verbs that also participate in split scope constructions allow for both a lower and a higher reading of the DegP, but neg-raising verbs (75) do not allow high scope for the DegP.

(74) a. John is able to run less fast than that.

'he is not able to run as fast as that.'

b. The paper needs to be exactly 5pp longer than that.

'the paper's required minimum length is exactly 5pp longer than that.'

- (75) The paper might be less long than that.
 *It's not possible for it to be as long as that.

A tentative analysis for the “neg-raising” pattern is proposed in terms of an excluded-middle presupposition. Verbs like *want* presuppose that the subject's desires regarding the embedded proposition are determinate. When the complement embedded under *want* has a free degree variable, then some of the possible values of the free variable will not be fulfilled. So (76) is false for $d \geq 5$, true for $d > 7$ but neither false or true for $d \in (5, 7)$. In light of this data, the maximality operator is redefined as in (77), so that it generates the right truth conditions for (78)

- (76) I want the paper to be at least 5 pages long and no longer than 7.

- (77) $\max(P) :=$ the greatest lower bound (glb) of $\{d: P(d) = 0\}$.

- (78) I want the paper to be less long than that.
 a. I want [[less than 10pp] the paper to be t long]
 b. [less than 10pp] I want the paper to be t long

The proposed DegP movement also generates the correct readings in environments that involve *de/re/de dicto* ambiguities (79) and antecedent contained deletion.

- (79) The box is required to be less wide than it is tall.
 a. *De dicto than*-clause & Low DegP: In order to satisfy the requirements, the box must be taller than wide.
 b. *De re than*-clause & Low DegP: The box should be less wide than the height that it actually happens to be.
 c. *De re than*-clause & High DegP: The box isn't required to be as wide as its actual height.
 d. **De dicto than*-clause & High DegP

In light of the aforementioned data, Heim (2000) proposes that DegP moves and that its movement is syntactically constraint. However, this thesis has not been undisputed. Oda (2008) and Beck (2009) argue that the comparative is not quantificational (in line with Kennedy (1999)); the observed ambiguities are derived because of the quantificational status and movement of the *exactly* differential. Assuming that the *exactly*-differential is quantificational, the scope ambiguity is derived via movement of the *exactly*-differential instead of movement of the DegP (80-a) hence the same scope ambiguities are predicted even if the comparative is not quantificational.

- (80) John is required to be exactly 2'' taller than 6'.
 a. required [[exactly 2'']₂ [[t₂ -er than 6']₁ [John be t₁ tall]]]
 b. (i) [exactly 2'']₂ [[t₂ -er than 6']₁ [required [John be t₁-tall]]]
 (ii) [exactly 2'']₂ [required [[t₂ -er than 6']₁ [John be t₁-tall]]]

However, even the fact that *exactly*-phrases are indeed quantificational and may QR does not suffice to prove that the comparative is not quantificational. As Heim (2000) showed, these ambiguities derive

two truth-conditionally equivalent LF representations. Consequently, it remains an open question whether the comparative is quantificational (Heim, 2000) or not (Kennedy, 1999). Breakstone et al. (2011) compare Heim’s (2000) proposal to Oda (2008) & Beck’s (2009) proposals using experimental evidence. In order to be able to compare the two proposals, Breakstone et al. (2011) revise Heim’s (2000) (81) to (82) so as to accommodate the analysis of *exactly*-differentials as generalised quantifiers over degrees.

$$(81) \quad \llbracket -er \rrbracket = \lambda d_d. \lambda P_{dt}. \lambda Q_{dt}. [\max(Q) \geq \max(P) + d]$$

$$(82) \quad \llbracket -er \rrbracket = \lambda M_{dt,t}. \lambda P_{dt}. \lambda Q_{dt}. [M(Measure)(QP)]$$

where $QP = \{x : x \in Q \wedge x \notin P\}$; and *Measure* takes an interval and returns an interval of the same size with 0 as its left edge.

Overall, the difference between the two theories boils down to the size of the constituent that QRs: in Heim’s (2000) it is the whole DegP that moves including the comparative operator, the standard phrase and the differential whereas in a non-quantificational *-er* account is only the differential. To tease apart those theories, Breakstone et al. (2011) consider comparatives where the standard phrase can receive *de re/de dicto* interpretation: when the *than*-PP receives a *de dicto* interpretation, namely scopes below the intensional verb, the differential cannot scope above the intensional verb, indicating that when it moves it moves along with the rest of the comparative phrase (83). Breakstone et al. (2011) provide experimental evidence for Heim’s (2000) quantificational theory of the comparative. Even though an *exactly* phrase is scope active in argument positions, it becomes scopally inert as a differential.

(83) A failed attempt to combine de dicto and inverted scope

Speaker A: What do I need to do in order to pay no taxes at all? Do I have to ear less than average?

Speaker B: #Not quite. You are allowed to earn exactly \$300 more than average.

Heim (2006), in her discussion of scope of comparatives, points out that existing analyses fail to assign the correct scope interpretation in comparative constructions that involve standards with quantificational phrases, like (84). Even though existing analyses assign the correct scope in constructions with necessity modals like *need*, *have to*, *be necessary*, *be required*, *be allowed*, they fail to predict that DP-quantifiers, floated quantifiers, quantificational adverbs, modals, and sentence connectives scope out of the *than*-clause. On the other hand, analyses that predict the right scope relations for the latter group (Larson, 1988; Schwarzschild and Wilkinson, 2002), fail to assign the correct scope on the former.

(84) John is taller than every girl is.

She observes that each group can be assigned the correct scope depending on whether the adjective is interpreted as a predicate of degrees $\langle d, \langle e, t \rangle \rangle$ or a predicate of degree predicates $\langle \langle d, t \rangle, \langle e, t \rangle \rangle$. Moving from one type to the other can be achieved through a p(oint)-(to)-i(intervals) operator Π , defined in (85). Π is generated in the degree-argument position of an adjective, where it combines

with whatever is generated in that slot, e.g. the *wh*-operator of the *than*-clause. In the main clause on the other hand, Π combines with the phrase that contains the comparative operator and the standard phrase. If the Π operator takes local scope in its host AdjP, the correct readings for quantificational DPs, floating quantifiers, quantificational adverbs, modals and sentence connectives are predicted. If it takes wide scope, then the correct readings are predicted for the other class of predicates including *need* (87).

$$(85) \quad \llbracket \Pi \rrbracket = \lambda D_{\langle d, t \rangle} . \lambda P_{\langle d, t \rangle} . \max(P) \in D$$

(86) a. *than*-clause: $[\Pi \text{ wh}]$

b. matrix clause: $[\Pi[-\text{er} + \text{than-clause}]]$ Π -phrase

(87) He is taller than he needs to be.

$[\text{wh}_3 [\Pi \text{ t}_3]_2 [\text{need-w}_0 \lambda_w [\text{he be t}_2\text{-tall-w}]]]_1 [[\Pi \text{ er than t}_1]_4 [\text{he t}_4 \text{ tall-w}_0]]$

$1 [[\Pi \text{ er than t}_1]_4 [\text{he t}_4 \text{ tall-w}_0]]: \lambda d_d . \text{his actual height} > d$

$2 [\text{need-w}_0 \lambda_w [\text{he be tall-w t}_2]]: \lambda d_d . \forall w \in \text{Acc}(w_0): \text{his height in } w \geq d$

$[\text{wh}_3 [\Pi \text{ t}_3]_2 [\text{need-w}_0 \lambda_w [\text{he be t}_2 \text{ tall-w}]]]: \lambda D_{\langle d, t \rangle} . [\max_d . \forall w \in \text{Acc}(w_0): \text{his height in } w \geq d] \in D$

His actual height $> [\max_d . \forall w \in \text{Acc}(w_0): \text{his height in } w \geq d]$

Even though, the Π operator can be used to generate the available readings, it is unclear how its scope is defined or —more accurately— restricted. In other words, even though low scope of Π generates correct readings for one class of quantifiers and high scope for the other, it is unclear how we can rule out the unattested readings (high scope for the former class and low scope for the latter). We can stipulate that it does not scope over a DP-quantifier, an adverb of quantification, an epistemic modal or attitude verb. Then we also have to stipulate that DP-quantifiers cannot reconstruct.

The problem of Π 's scope, however, further extends to the monotonicity properties of the comparative. Π and the comparative clause are upward entailing, while the Π -phrase can be proved to be downward entailing. It is unsurprising therefore, that negative polarity items (NPIs) and minimizers can be licensed in the scope of Π . However, we come to face a paradox: in order to account for the occurrence of NPIs in (88), we have to assume that Π takes wide scope and at the same time outscope elements that it normally does not or that it outscores *ever* but not any other quantificational adverb like *usually*, *sometimes*, *often*, *always*.

(88) a. He is richer than you care to know.

b. I am busier than I ever was before.

Heim (2006) leaves the issue open after entertaining several hypotheses that either are proved wrong or are not possible to corroborate.

Schwarzschild (2008) seems to handle better the variable scope of comparatives. He adopts a threshold account of adjectives and comparatives according to which a gradable adjective denotes a relation between an entity and a set of thresholds. Consequently the comparative corresponds to a statement that an entity *meets or exceeds* a threshold variable θ and another entity does not meet or exceed (89).

- (89) a. A is more expensive than B is.
 b. $\exists \theta \text{ expensive}(\mathbf{a}, \theta) \wedge \neg \text{expensive}(\mathbf{b}\theta)$
- (90) $\llbracket (\text{Deg}' (\text{more}_\theta \phi) \psi)^g = 1 \rrbracket$ IFF $\exists \theta \llbracket \phi \rrbracket^{g[\theta/\theta]} = \llbracket \psi \rrbracket^{g[\theta/\theta]} = 1$.
- (91) $\llbracket \text{NOT } \phi \rrbracket^g = 1$ IFF $\llbracket \phi \rrbracket^g = 0$.

The welcome consequence of this account is that it predicts the correct relative scope of negation with other quantificational elements: *should* (92), *supposed to*, *say* and *promise* (93) scope above negation whereas negative polarity items (96), *allowed* (94) and *have to* (95) below. In order to capture comparatives containing *exactly* and *only* a MAX operator is introduced in the comparative/matrix clause (97).

- (92) a. The ballon is higher than it should be
 b. The ballon meets or exceeds a hight threshold that it SHOULD **not** meet.
- (93) a. The scar is bigger than you promised it would be.
 b. The scar meets or exceeds a size threshold that you PROMISED it would **not** meet.
- (94) a. The ballon is higher than it is allowed to be
 b. The ballon meets or exceeds a threshold that it is **not** ALLOWED to meet.
- (95) a. The ballon was higher than it had to be
 b. The ballon meets or exceeds a threshold that it did **not** have to meet.
- (96) a. The balloon is higher today than it has been on any other day
 b. The ballon did **not** meet or exceed θ on any other day
- (97) (98) A_x is more θ MAX expensive $_{\langle x, \theta \rangle}$ than [exactly 1 of the hats] $_y$ was NOT expensive $_{\langle x, \theta \rangle}$.

2.2.4 Meaningful Standards

The majority of analyses of the comparative assign the core of comparative semantics to the comparative operator and assume that the standard marker is semantically vacuous. Kennedy (2007b) was the first to propose that the standard marker is not semantically vacuous. He points out that the languages that distinguish phrasal from clausal comparatives, in other words, languages that distinguish a 2-place from a 3-place degree operator do so in the standard marker; the comparative morpheme is invariable within a language and it remains the same across phrasal and clausal comparatives. In his analysis, he merely transfers the locus of the semantics of the comparative to the standard marker.

Schwarzschild (2010) also provides an analysis where the standard marker of the comparative is not semantically vacuous. However, instead of merely transferring the meaning from the comparative head to the standard marker, he shows that both particles have semantic contribution. With point of departure the optional standard marker in Hebrew as in (99), he demonstrates that the postulation of a silent MORE in sentences like (99-b) or the adoption of an ambiguity account for the gradable adjective make false predictions regarding the meaning of incomplete comparatives: if there is a silent MORE, or if the adjective is ambiguous between a positive and a comparative reading, then (100) is also expected to have a comparative reading (as in (101)) and (102) to be felicitous in the provided context. However, these predictions are not borne out, indicating that the standard marker is not semantically vacuous.

- (99) a. Miri yoter xazaka mi-Yoni
 Miri CM strong.3SG.FEM SM-Yoni
 ‘Miri is stronger than Yoni.’
- b. Miri xazaka mi-Yoni
 Miri strong.3SG.FEM SM-Yoni
 ‘Miri is stronger than Yoni.’
- (100) eize me-hem yoter kaše?
 which from-them CM difficult3SG.MASC.
 ‘Which of them is more difficult?’
- (101) eize me-hem kaše?
 which from-them difficult3SG.MASC.
 ‘Which of them difficult?’
- (102) Context: *We’re organising a play in a senior citizens home. I ask you: Why did you choose Esther over Ruth for the lead part? You reply:*
 ki hi #(yoter) tsə’ira
 because she CM young.3SG.FEM
 ‘because she’s younger.’

Further evidence against an ambiguity account of gradable predicates comes from the fact that they are not ambiguous when combined with change of state predicates: the comparative reading is lost if *yoter* is absent, cf. the minimal pair in (103) below.

- (103) a. hu niya yoter xazak.
 he becamePST.3SG.MASC CM strong.3SG.MASC
 ‘he got stronger.’
- b. hu niya xazak.
 he becamePST.3SG.MASC strong.3SG.MASC
 ‘he got strong.’

Finally, the absence of a covert comparative marker is also corroborated by the ungrammaticality of differentials in bare comparatives: differentials are merged in [Spec,DegP] (Abney, 1987); if there were a null *more* in bare comparatives, they would be licit.

- (104) *harbe xazak mi-Yoni
 a lot strong SM-Yoni
 ‘a lot stronger than Yoni.’

In Hebrew comparatives like the one in (105) the standard marker is a two-place degree quantifier ($\langle d, t \rangle$, $\langle d, t \rangle$, $t \rangle$) and its semantics is given in (106).

- (105) $Miri_x$ is strong $_{\langle x, d \rangle}$ [than $_d$ Yoni $_y$ is NOT strong $_{\langle y, d \rangle}$] $_d$

- (106) $\llbracket mi \rrbracket = \lambda\Theta\lambda\Theta' : \exists\theta(\theta \in \Theta \text{ and } \theta \in \Theta')$

In comparatives that are not bare, the comparative marker binds the degree variable of the gradable predicate. In an incomplete comparative, the standard of comparison is inferred by the context, and as such, it represents a domain restriction on the comparative quantifier (the C index in the VELF in

(107)). The degree argument of the gradable predicate is bound by the comparative head whereas the C argument of the comparative head is dependent on the discourse.

(107) Miri_x is more_{<C>,d} strong_{<x,d>}

In the Hebrew comparatives that both the comparative marker and the standard are present, the standard phrase works as a quantifier domain adverbial and it co-predicates the domain of the comparative marker. The meaning of *than* remains constant (repeated in (108) below) but now it has also a predicate type index, indicating that it has to combine with the value for the domain variable C as well as the set of thresholds indicated by its complement. In sum, the standard phrase imposes the requirement that the domain variable be assigned a set of thresholds containing at least one that satisfies the complement of the standard marker. Given that *more* is indexed with the same domain variable it follows that the domain of *more* includes a threshold that satisfies the complement of the standard marker. *More* is again a predicate quantifier thus it combines with the domain of quantification, i.e. the value for C, and the set of thresholds described by the matrix gradable predicate. Assuming that *more* introduces universal quantification over thresholds (109), the correct truth conditions are derived. The equivalence of the bare and the non-bare comparative with a standard phrase follows from the fact that the latter entails the former.

(108) $\llbracket mi \rrbracket = \lambda\Theta\lambda\Theta' : \exists\theta(\theta \in \Theta \text{ and } \theta \in \Theta')$

(109) $\llbracket more \rrbracket = \lambda\Theta\lambda\Theta'\forall\theta(\theta \in \Theta \rightarrow \theta \in \Theta')$

(110) Miri_x is more_{<C>,d} strong_{<x,d>} [than_{<C>,d} Yoni_y is NOT strong_{y,d}]

- a. There is a threshold in C that Yoni does not meet or exceed and Miri meets or exceeds every threshold in C.
- b. $\exists\theta(\theta \in C \wedge \neg\text{Strong}(\text{Yoni},\theta)) \wedge \forall\theta(\theta \in C \rightarrow \text{Strong}(\text{Miri},\theta))$

In English, *more* is an existential threshold quantifier. It is analysed as a two place quantifier that quantifies over the set of thresholds provided by the gradable predicate in the matrix and the set of thresholds provided by the standard phrase (112).¹⁵ In that sense, *more* has the same meaning as the standard marker in Hebrew bare quantifiers above (106). *Than*, on the other hand, is a predicate quantifier which binds the degree argument of the gradable predicate and it acts as a degree pronoun/argument of the matrix clause. *More* binds both the degree pronoun of *than* and the degree argument of the matrix gradable predicate.

(111) Jack_x is more_d (anxious_{<x,d>}) (than_{<d>,d'} Jill_y is NOT anxious_{<y,d'>})

(112) $\llbracket more \rrbracket = \lambda\Theta\lambda\Theta' : \exists\theta(\theta \in \Theta \text{ and } \theta \in \Theta')$

¹⁵ An alternative of a one-place *more* is also entertained. Schwarzschild (2010) argues that *more* could also be analysed as a one place quantifier that quantifies over the set of thresholds provided by the matrix gradable predicate after it has co-predicated with the standard phrase (i) and that the choice between the two alternatives could be based on syntactic grounds.

(i) $\llbracket more \rrbracket = \lambda\Theta : \exists\theta(\theta \in \Theta)$

$$(113) \quad \llbracket \text{than} \rrbracket = \lambda\theta\lambda\Theta' : \theta \in \Theta'$$

In sum, under the proposed analysis, both in English and Hebrew, neither the comparative marker nor the standard marker are semantically vacuous. The English comparative marker and the Hebrew standard marker are quantifiers that introduce existential quantification over sets of thresholds. In English comparatives, the standard functions as a degree pronoun. In Hebrew comparatives it can function either as an argument of the gradable predicate or as a quantifier domain adverbial that restricts the domain of quantification of the comparative marker.

A different account, which also argues for the semantic contribution being split between the comparative and the standard marker, comes from Alrenga et al. (2012). Alrenga et al. (2012) argue that the Extraposition-Scope Generalisation (for degree expressions) proposed by Bhatt and Pancheva (2004) in (114) (cf. also §2.3.1.3.3 below) can be derived without assuming counter-cyclic operations like late merger, if both the comparative morpheme and the standard marker contribute to the semantics of the comparison.

$$(114) \quad \text{Bhatt and Pancheva's (2004) Extraposition-Scope Generalisation (for degree expressions)}$$

When a degree clause β extraposes from a degree head α , the scope of α is *exactly as high* as the merger site of β .

The comparative morpheme combines with a gradable predicate to produce the comparative predicate (115-a) and the standard marker instead combines with a degree property to produce a generalised degree quantifier (115-b)

$$(115) \quad \begin{array}{l} \text{a. } \llbracket \text{COMP} \rrbracket = \lambda g_{\langle d,et \rangle} \lambda s_d \lambda x_e . \text{sup}(\lambda d . g(d)(x)) > s \\ \text{b. } \llbracket \text{THAN} \rrbracket = \lambda S_{\langle d,t \rangle} \lambda T_{\langle d,t \rangle} . \text{sup}(T) > \text{sup}(S) \\ \text{c. } \forall m \in D_{\langle e,d \rangle} . x \in D_e : \\ \quad \text{(i) } \text{sup}(\lambda d . m(x) \geq d) = m(x) \\ \quad \text{(ii) } \text{sup}(\lambda d . m(x) > d) = m(x) \end{array}$$

In comparatives that involve overt comparative and standard phrases, the COMP appears both in the standard and the matrix clause, the former being unpronounced/ elided. The semantics of the comparative are introduced in three separate positions: one per COMP head and one by THAN.

$$(116) \quad \text{Rod A is longer than Rod B is.}$$

a.

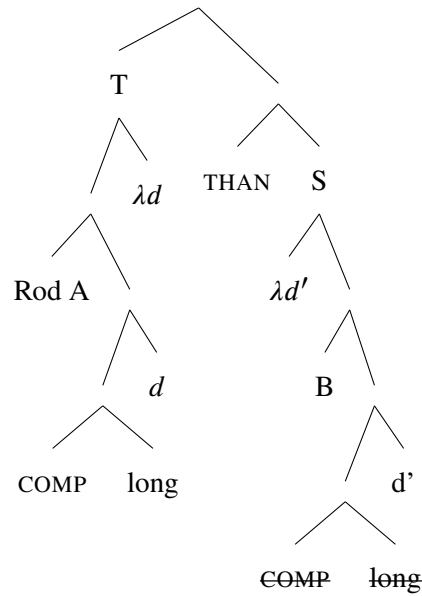

- b. (i) $\llbracket T \rrbracket$
 $= \lambda d. \llbracket \text{COMP} \rrbracket (\llbracket \text{long} \rrbracket) (d) (\llbracket \text{Rod A} \rrbracket)$
 $= \lambda d. \text{long}(\text{Rod-A}) > d$
- (ii) $\llbracket S \rrbracket$
 $= \lambda d'. \llbracket \text{COMP} \rrbracket (\llbracket \text{long} \rrbracket) (d') (\llbracket \text{Rod B} \rrbracket)$
 $= \lambda d'. \text{long}(\text{Rod-B}) > d'$
- (iii) $\llbracket \text{THAN} \rrbracket (\llbracket S \rrbracket) (\llbracket T \rrbracket)$
 $= 1 \text{ iff } \text{sup}(\lambda d. \text{long}(\text{Rod-A}) > d) > \text{sup}(\lambda d'. \text{long}(\text{Rod-B}) > d')$
 $= 1 \text{ iff } \text{long}(\text{Rod-A}) > \text{long}(\text{Rod-B})$

Given the proposed semantics of THAN as a generalised quantifier of degrees, which also introduces the comparative meaning in the clause, it follows that the site of attachment of the *than*-phrase will define the scope of the comparison. Another consequence of this analysis is that a variety of configurations, listed in (117), yield the same semantics. This is a welcome result in the sense that world languages may mark either the comparative, or the standard, or both, but it comes at cost: it over-generates within a given a language, in this case English. Alrenga et al. (2012) argue that the unattested sentences are excluded for independent factors and they attribute the additional constraints in syntax.

- (117) a. X is [COMP Adj₁][THAN Y is COMP Adj₂]
 b. X is [COMP Adj₁][THAN Y is Adj₂]
 c. X is [Adj₁][THAN Y is COMP Adj₂]
 d. X is [Adj₁][THAN Y is Adj₂]

This split semantics proposed by Alrenga et al. (2012) can also accommodate Kennedy's (2007b) observation that the selection of a phrasal or a clausal standard may be morphologically marked in the standard marker but not in the comparative marker. Alrenga et al.'s (2012) split analysis of phrasal and clausal comparatives will be further discussed in chapter 3.

Both Schwarzschild (2010) and Alrenga et. al. (2012)'s proposals propose that both the standard

and the comparative markers contribute to the semantics of the comparison. Under both proposals equivalences hold amongst bare comparatives, incomplete comparatives and comparatives with overt comparative and standard phrase. However, they present some significant differences with respect to their implementation. Both accounts analyse the standard marker as a generalised degree quantifier and need to generate a set of degrees/thresholds such that the entity of the standard does not meet them. Schwarzschild (2010) does so by adopting Schwarzschild's (2008) account for the semantics of the comparative that involves a negative operator in the standard, whereas Alrenga et al. (2012) do so by proposing the supremum function. The supremum function includes the degree that exceeds least the maximum degree described by the gradable predicate hence again they derive a degree in the complement of the set of degrees described by the gradable predicate. Schwarzschild (2010) extensively argues that the standard phrase may function as an adjunct or argument even within the same language, whereas Alrenga et al. (2012) assume that the standard phrase is not an adjunct. The standard marker is the one that selects the matrix and the embedded comparative phrases as arguments. Schwarzschild (2010) assumes that phrasal comparatives are reduced clausal ones, whereas Alrenga et al. (2012) argue that the clausal/phrasal distinction is a true semantic distinction reflected in the morphosyntax of the standard.

Alrenga and Kennedy (2014) argue that, even though Schwarzschild's (2008) analysis 'scores' better than Seuren's (1984) by dissociating negation from the comparative clause and allowing it to take variable scope, still makes wrong predictions for the relative scope of negation with universally quantified DPs and some modals. More specifically, universally quantified DPs may scope above or below negation outside the comparative but in the comparative clause they always scope above negation. On the other hand, deontic modals trigger an additional reading (above negation) in the comparative clause that they do not allow in other contexts. In that sense, the variable scope of negation as proposed by Schwarzschild (2008) fails to capture the correct truth-conditions of the related constructions.

Alrenga and Kennedy (2014) propose what they call the NO MORE analysis, according to which, the negation in the comparative is not the same as sentential negation but a negative degree quantifier that is sometimes realised overtly in constructions like (118).

(118) no more than three

According to that analysis, the comparative clause introduces a degree property (type $\langle d, t \rangle$) that describes the set of degrees that the standard does not exceed (119-b). This is achieved by assuming that the standard marker *than* is not semantically vacuous but it introduces existential quantification over degrees (120). The first argument of the standard marker is provided by its complement (the standard phrase) (119-b) and its scope is provided by abstracting over the first argument of the comparative adjective (the base position of the *than*-phrase) (119-c). The existential closure to the differential in (119-c) comes from a covert positive degree quantifier in (119-d).

- (119) a. Sarah is taller than Frank is.
 b. $\lambda d. \neg \exists d' [\text{tall}(f, d) \wedge d' > d]$
 c. $\lambda d. \exists d'' [\text{tall}(s, d + d'')]$
 d. $\llbracket \text{SOME} \rrbracket = \lambda P_{\langle d, t \rangle} . \{d \mid P(d)\} = \emptyset$

$$e. \quad \llbracket \text{Sarah is taller than Frank is} \rrbracket = \exists d[\text{height}(s) > d \wedge \text{height}(f) \leq d]$$

$$(120) \quad \llbracket \text{than} \rrbracket = \lambda P_{\langle d,t \rangle} \lambda Q_{\langle d,t \rangle} . \exists d [Q(d) \wedge P(d)]$$

When a differential is used, the region picked out by the scope expression is shifted by the amount expressed by the differential phrase in a direction appropriate for the polarity of the adjective. An example is illustrated in (121). The scope argument is (122-a), which is equivalent of (122-b), and the predicted truth conditions are in (123). They also adopt Alrenga et al.'s (2012) proposal that the gradable predicate in the standard phrase also carries comparative morphology with the consequence that the two arguments of the standard marker are identical.

(121) Sara is two centimeters taller than Frank is.

$$(122) \quad a. \quad \lambda d . \text{tall}(s, d + 2\text{cm})$$

$$b. \quad \lambda d . \text{height}(s) - 2\text{cm} \geq d$$

$$(123) \quad \llbracket (121) \rrbracket = \exists d . [\text{height}(s) - 2\text{cm} \geq d \wedge \text{height}(f) \geq d]$$

Returning to the negative quantifier of the *no more* analysis, it is a silent allomorph of the negative quantifier appearing in constructions like (124) that carries the meaning expressed in (125). The standard marker *than* selects for a C that has a *uNO* feature and thus the structure is rescued, in the sense of Zeijlstra (2008, 2009), by the selection of the covert operator NO which carries the required interpretable *iNO* feature.

(124) Sarah is no taller (than ...)

$$(125) \quad \llbracket \text{NO} \rrbracket = \lambda P_{\langle d,t \rangle} . \{d | P(d)\} = \emptyset$$

(126)

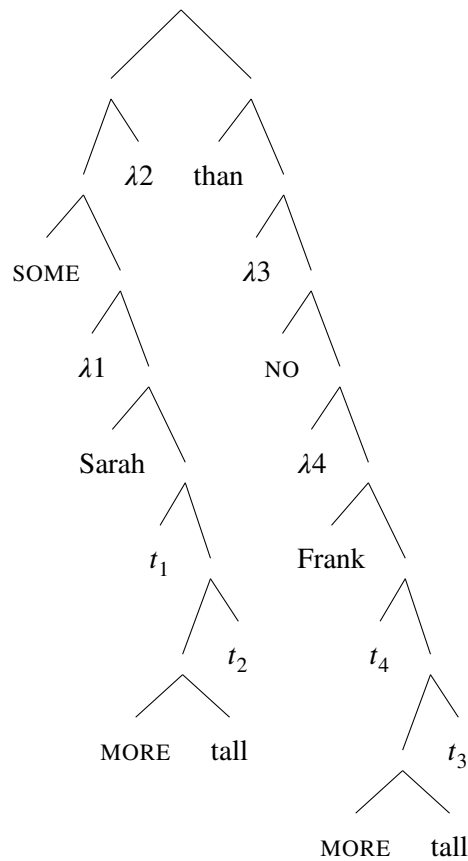

Alrenga and Kennedy's (2014) proposal has some welcome consequences: there is a complete parallel between the standard and the comparative clause satisfying the identity requirements for ellipsis. Furthermore, it accommodates differentials, which are not straightforwardly captured by other negative analyses; and, similar to Alrenga et al. (2012) and Schwarzschild (2010) the standard marker has semantic contribution. This will be further discussed in §2.3.2.

In sum, some of the issues debated in the semantic literature on inequality comparatives is the nature of the semantic objects/types involved in comparatives (degrees, extents, density or discreteness of scales, etc.), the (non-)quantificational status of the comparative operator, the existence of a negative or a maximality operator, and the semantic contribution of the standard marker, if any. The data that will be discussed in this thesis have bearing to many of those questions. More specifically, I will show that semantic representation of inequality comparatives involves a negative operator and that whether scales are discrete or dense is visible to grammar and manipulated by functional elements e.g. the definite determiner.

2.3 The syntax of Comparatives

2.3.1 The architecture of the Degree Phrase

The architecture of inequality comparatives has triggered a long-standing debate and has proved far from trivial. The issues under discussion are interwound but could be identified as:

The status of the comparative marker: The comparative marker has been analysed as an adjunct to the gradable predicate (Neeleman et al., 2004), a quantifier modifying a covert *much/many*

or a gradable adjective (Bresnan, 1973), an argument of the gradable adjective (Larson, 1988; Pancheva Izvorski, 2000) or the head of a Quantifier/Degree Phrase that selects a gradable predicate as its complement. (Abney, 1987; Corver, 1997, 2005; Kennedy, 1999)

The status of the standard phrase: The standard phrase has been analysed as an argument of the comparative phrase (Bresnan, 1973; Heim, 2000; Bhatt and Pancheva, 2004) or an adjunct (Abney, 1987; Kennedy, 1999; Larson and Wellwood, 2015).

The relation between the two clauses (Subordination or Coordination): Finally, the status of the standard phrase as a subordinate (Bresnan, 1973) or a coordinated clause (Lechner, 1999, 2001, 2004; Hankamer, 1973; Napoli, 1983) has also been disputed.

In this section, I will present the different possible internal structures of the comparative phrase along with some representative analyses of each one. Then I will turn to the standard phrase and focus on its internal structure and the debate over the underlying analysis of phrasal comparatives.

2.3.1.1 The comparative phrase is a modifier of the gradable predicate

Bresnan (1973) proposes that *-er* is a determiner, which combines with the quantifier *much*; *much* is only deleted if it precedes an adjective (127). The the standard phrase is base generated as a sister to the comparative operator (128-a) and then it extraposes (128-b). The standard marker *than* is analysed as a complementiser introducing a clause. All standard phrases are analysed as clausal. This analysis is further adopted by Carlson (1977) a.o.

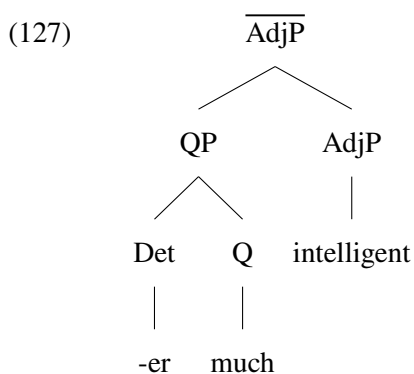

(128) (Bresnan, 1973, (294))

a. *before extraposition:*

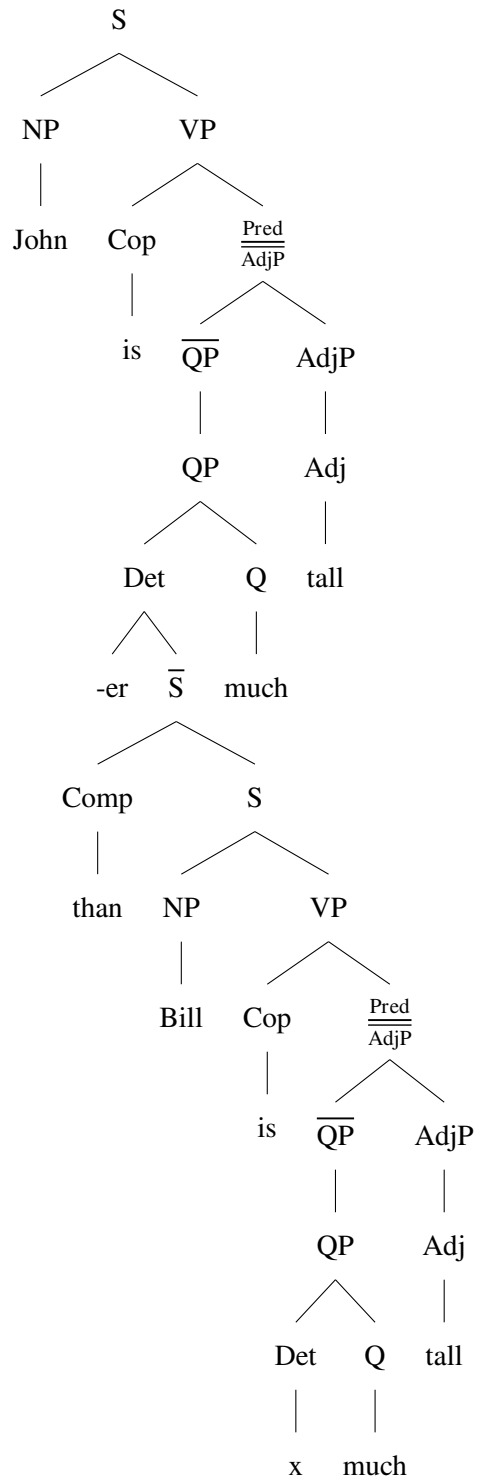

b. *after extraposition:*

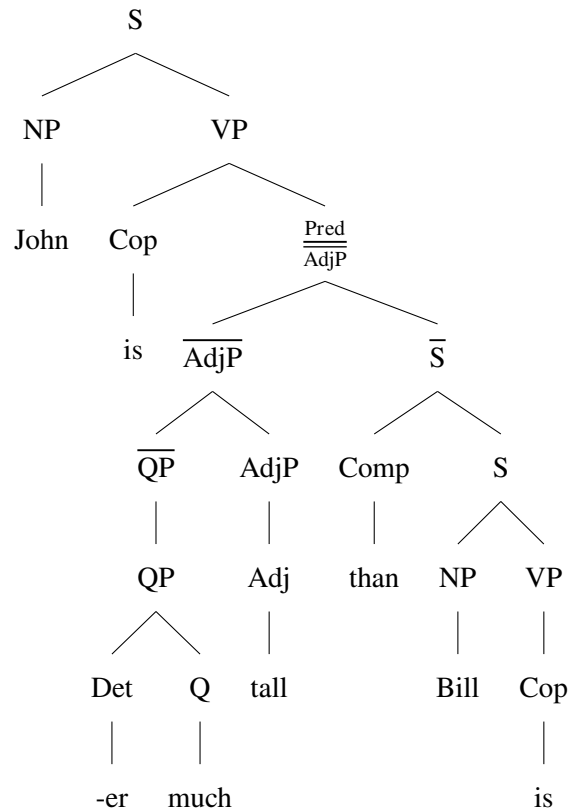

Contra to Bresnan (1973), who proposes a uniform analysis for (in)equality comparatives and other degree expressions like those involving *enough* or *too*, Neeleman et al. (2004) argue that degree expressions cannot receive a uniform syntactic analysis. As far as inequality comparatives are concerned, they propose that the phrase of *more* or *less* is an adjunct to the XP it modifies (129). They argue that the comparative directly modifies the gradable property and this relation is not mediated by a quantifier like *much*. They argue that the adjunct status of [_{DegP} *more/less*] explains the following properties of inequality degree constructions (examples (130) to (134) are from Neeleman et al., 2004):

1. not only can they directly combine with AdjPs but also, PPs, VPs and NPs (130);
2. they may have a more complex internal structure as opposed to heads;
3. since they are XPs, they may appear without a gradable predicate (131);
4. since they are adjuncts, they may not precede the AdjP they combine with (132);
5. for the same reason they can undergo topicalisation (133)¹⁶ and
6. they allow topicalisation of the AdjP they combine with Atopic.

¹⁶ Neeleman et al. (2004) study two classes of degree expressions 2.4 hence some examples do not involve *more* or *less* but other degree expressions.

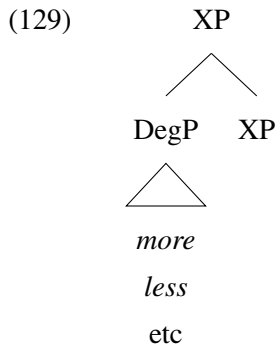

- (130)
- a. He is [_{DP} [_{DegP} as [_{AdjP} *(much)]] [_{DP} a typical Hollywood celebrity]] as Robin W.
 - b. This is [_{DP} less (*much) [_{DP} a typical Italian opera]] than most of Puccini's.
 - c. He is [_{PP} [_{DegP} as [_{AdjP} *(much)]] [_{PP} in the running]] as anyone I know.
 - d. He is [_{PP} less/more (*much) [_{PP} like his father]] than he used to be.

- (131)
- a. More is not always better.
 - b. *Half as would be better.

- (132)
- a. (More) fond of Mary (more) than Bill, only John can claim to be.
 - b. John is as indebted to his colleagues (*as) as Bill.

- (133)
- a. Ik acht hem [_{DegP} te [_{AdjP} afhankelijk van zijn vader]] om een eigen zaak te beginnen.
I consider him too dependent on his father for a own business to start
'I consider him too to dependent on his father to start his own business.'
 - b. *Te acht ik hem [_{DegP} t [_{AdjP} afhankelijk van zijn vader]] om een eigen zaak te beginnen.
too consider I him dependent on his father for a own business to start
'I consider him too to dependent on his father to start his own business.'
 - c. Ik acht hem [_{AdjP} minder [_{AdjP} afhankelijk van alcohol]] dan van andere drugs.
I consider him less dependent on alcohol than on other drugs
'I consider him less dependent on alcohol than on other drugs.'
 - d. ?Minder acht ik hem [_{AdjP} t [_{AdjP} afhankelijk van alcohol]] dan van andere drugs.
less consider I him dependent on alcohol than on other drugs
'I consider him less dependent on alcohol than on other drugs.'

Table 2.4: Classes of degree expressions (Neeleman et al., 2004)

Class I	Class II
too	enough
as	less/ more
very	a little
that	a good deal
how _{INTERROGATIVE}	

- (134) a. *Intelligent is hij [_{DegP} te [_{AdjP} t]] om enigszins normaal te functioneren.
 intelligent is he too for more-or-less normally to function
 ‘He is too intelligent to function more or less normally.’
 b. Intelligent is hij [_{AdjP} minder [_{AdjP} t]] dan de gemiddelde Nederlander.
 intelligent is he less than the average Dutchman
 ‘He is too intelligent to function more or less normally.’

Following a Kleinian semantics of adjectives where adjectives are sets of properties ordered by strength and degree modification is selection of a property from this scale, Neeleman et al. (2004) propose that the nominal argument of adjective merges after the degree expression (135). Neeleman et al. (2004) do not discuss the position or the status of the standard phrase.

- (135) a. *[Degree expression [subject [AdjP]]]
 b. [Subject [degree expression [AdjP]]]

Finally, Larson and Wellwood (2015) argue that the degree head (adjoined to the gradable predicate) carries an interpretable degree feature that agrees with the standard marker, which is an adjunct (136). They argue that the analysis of the standard phrase as an agreeing adjunct is superior to Bresnan’s (1973) extraposition analysis or Bhatt and Pancheva’s (2004) late merger analysis of comparatives (see §2.3.1.3.3 below).

- (136) (Larson and Wellwood, 2015)

a. *prior to agreement*

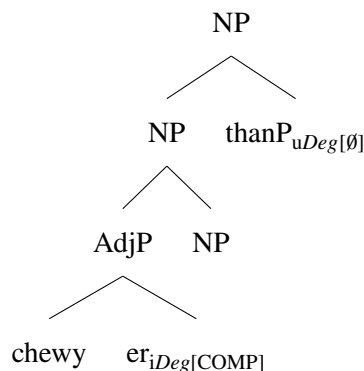

b. *after agreement*

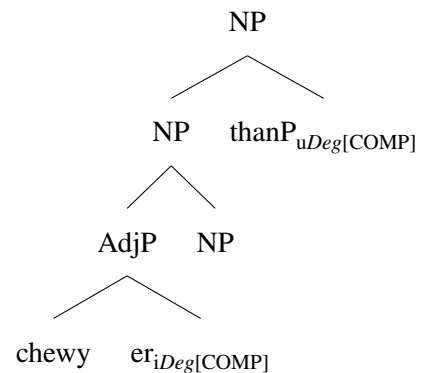

Larson and Wellwood’s (2015) theory lacks independent evidence regarding the status of standard phrases as agreeing adjuncts and, as we will see in chapter §3.5.1.4, standard phrases are not uniformly adjuncts; some of them arguments.

2.3.1.2 The comparative phrase is an argument of the gradable predicate

Larson (1988) suggests that the DegP is a complement to the adjective, and the standard marker is in the [Spec,AdjP]. Following Hankamer (1973), he argues for a uniform analysis of the English standard markers as prepositions that introduce nominal and clausal complements on a par with *before* and *after* (Larson, 1984). In clausal comparatives, the standard phrase contains an abstract *wh*-element that moves from inside the clause to the periphery (Chomsky, 1977). The proposed structures for clausal and phrasal comparatives are given in (137) below.

(137) a.

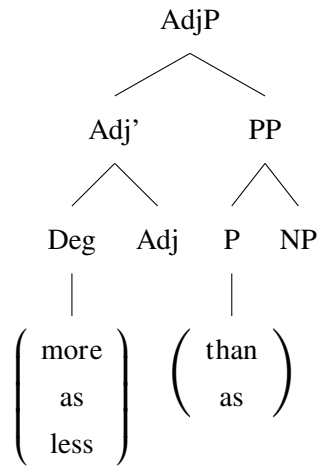

b.

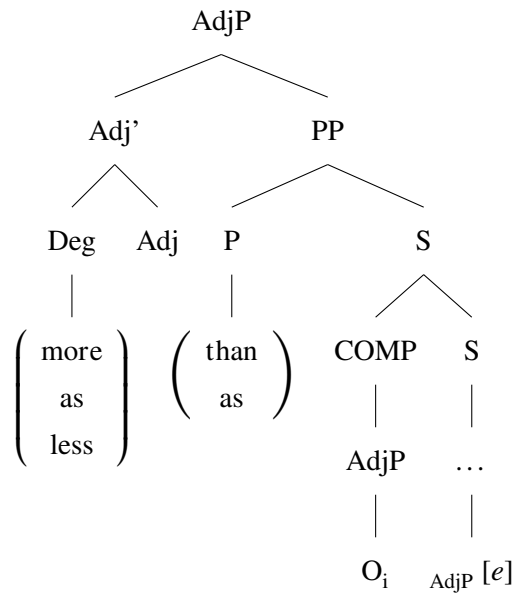

On the other hand, Pancheva Izvorski (2000) proposes that the degree phrase is the internal argument of the gradable predicate; the latter can be an adjective, an adverb or a noun (138). The XP is the extended projection of the gradable property X^0 , which can be an Adj^0 , an Adv^0 , or an N^0 . The YP is the external argument of the gradable predicate. The comparative operator (-er) is base generated as a sister to the standard phrase, and they form a constituent (DegP). The standard phrase, at least in English, is comprised of the preposition *than*, which may select for nominal complements. These nominal complements may be phrasal constituents or free relatives and either of them may denote an entity or a degree (139).

(138)

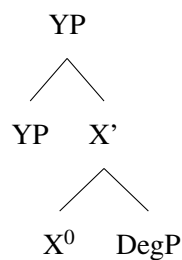

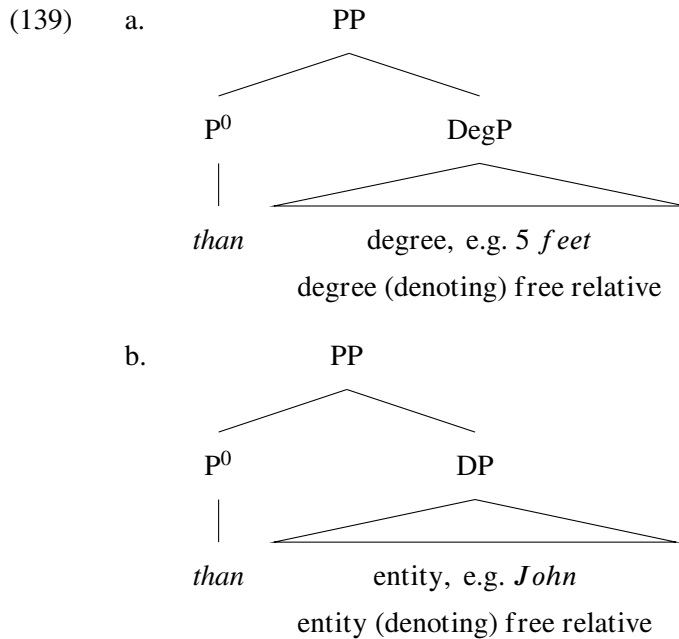

2.3.1.3 The gradable predicate is an argument of the Degree

All the aforementioned analyses in §2.3.1.1 and §2.3.1.2 assume that the gradable predicate is the one that projects. The analyses in this section present the reverse picture: the degree head is the one that projects and the gradable predicate is its argument.

Abney (1987) was the first to propose that the Degree is the functional head that selects an adjectival phrase hence that AdjP is an argument of the Degree^{0.17} The standard phrase of the comparative is also a complement of the Degree head.¹⁸ Abney's (1987) analysis, thanks to the use of non-binary branching (140), does not face the constituency problem of later analyses regarding the complement of the Degree (gradable predicate or standard phrase).

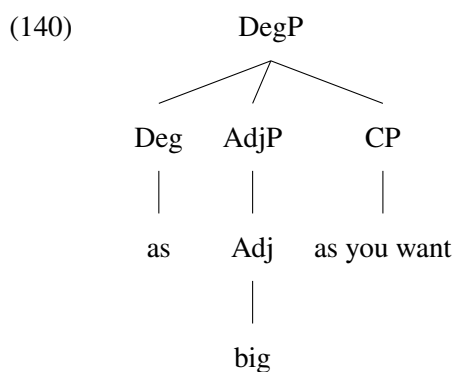

Kennedy (1999), following Abney (1987), assumes that adjectives, like other categories, project extended functional structure. The Degree Phrase is the extended projection of Adjectives. The Degree head, which is realised by elements including the positive degree, the comparative marker *-er/more*, *less*, *as*, *so*, *too*, *enough*, *how*, *this*, *that*, selects the AdjP as its complement and the standard phrase as a selected *adjunct*. Kennedy (1999, Chapter 2, fn. 13) clarifies that the status of the standard phrase

¹⁷ Abney (1987) in his discussion of attributive adjectives, also presents structural configurations where the adjective is selected by a Determiner and not by a Degree head.

¹⁸ Standard Phrases fall in the class of Abney's (1987) 'extent clauses'.

as a selected adjunct (as opposed to argument) does not have any consequences for his analysis. He only characterises the standard phrase as an adjunct due to argument/adjunct asymmetries observed in the extraction out of the nonfinite clauses introduced by *too* and *enough* (142).

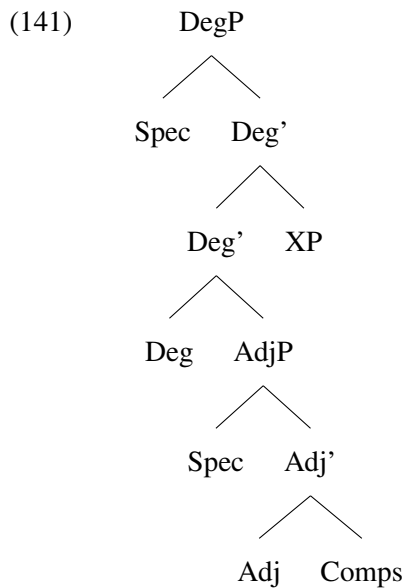

- (142)
- a. Who_i was Audrey angry enough [to criticize e_i]
 - b. *How obnoxiously_i was Audrey angry enough [to criticize her boss e_i]
 - c. Which car_i was Tim too scared [to drive e_i]
 - d. *How quickly_i was Tim too scared [to drive the Fiat e_i]

However, as was mentioned in the previous section in the discussion of Larson and Wellwood's (2015) theory of standard phrases as agreeing adjuncts, in this thesis I will show that some standard phrases are arguments of the comparative operator and that the unavailability of extraction is due to a requirement for ATB-movement.

Lechner (1998, 1999, 2004), on the other hand, departs from other approaches that posit the AdjP as the internal argument of the Degree head and proposes that the Deg⁰ selects for the standard phrase as its complement and the Adjective Phrase as its external argument in [Spec, DegP] (143). Comparative morphology can therefore be directly base generated on the adjectival head, and checked by a [+comparative] feature on Deg⁰ under Spec-Head agreement. This structure provides a straightforward solution to the *unhappier* bracketing paradox where morphology treats constituency different than semantics.

- (143) [DegP AdjP [Deg' Deg⁰_[+comparative] [than-XP than Peter]]] .

Lechner (2004) capitalises on the proposed architecture of the Degree Phrase as well as the strict locality and syntactic identity condition on comparative deletion and argues that comparative deletion consists in overt AdjP-Raising from [Spec, DegP] of the standard phrase to [Spec, DegP] of the matrix clause. Movement is triggered by the need to check off the [+comparative] feature of Deg⁰ by a categorial Adj-feature. Both copies are interpreted hence comparatives are an instance of *Move α without form chain*. A sample derivation is given in (144).

(144) a. Mary knows younger authors than Peter knows ◻

b.

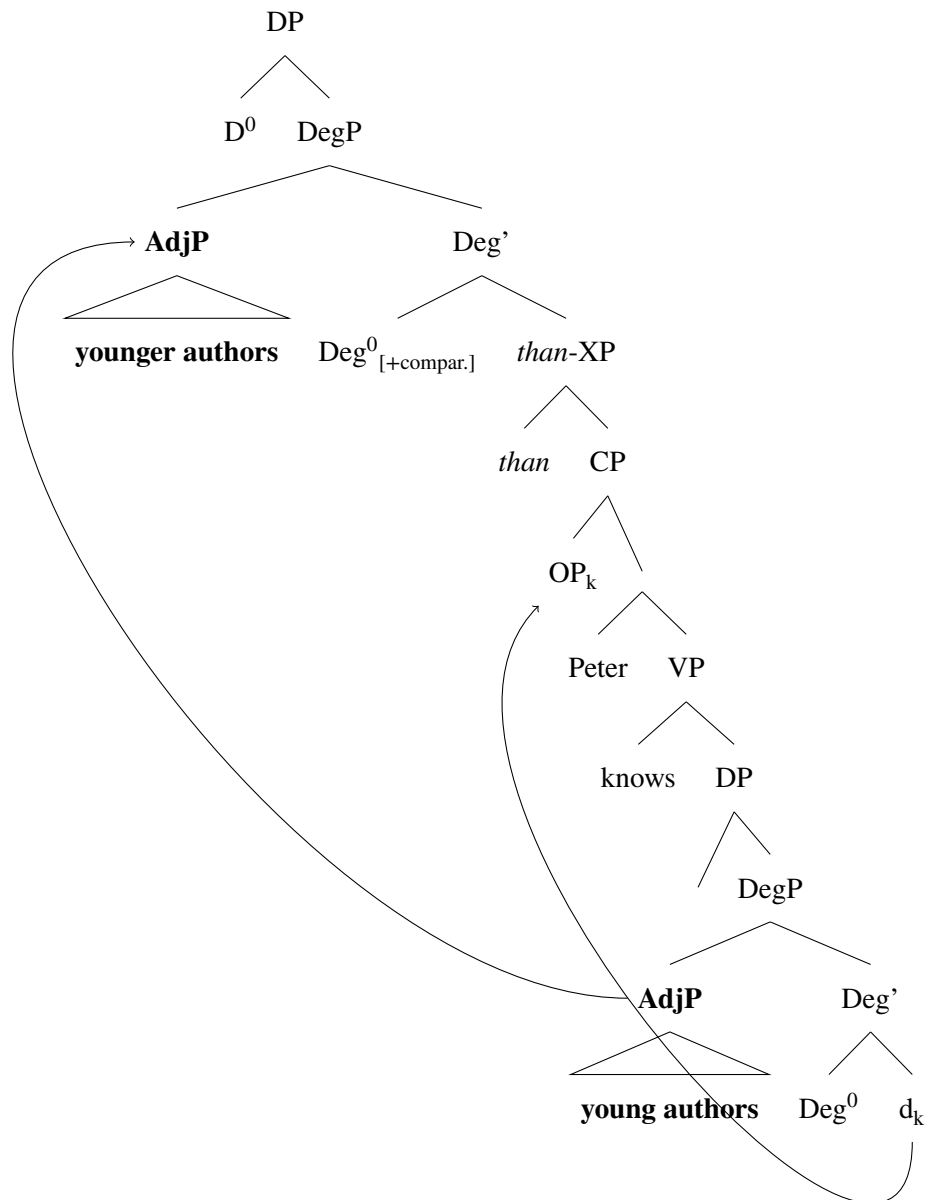

Lechner (2004) points out that the subordination proposal in (144) only captures part of the syntactic properties of comparatives. Even though comparatives in many respects pattern on a par with subordinate structures both in syntax (selection, AdjP-Raising) and semantics it also presents similarities with coordination: ATB movement, Gapping, Right Node Raising and scope ambiguities. This tension is solved by a further step in the derivation: the standard phrase extraposes and generates a coordinate structure (*than*-XP-raising).

A question pertinent to the constituency problem of the comparative that was addressed in the previous sections is whether *more* is a head or a phrase, whether it is the same as the bound morpheme used in synthetic comparatives (*-er*) and how it combines with the phrase containing the gradable predicate.

2.3.1.3.1 The status of *more* and its relation to the Degree⁰

In this section, we will see the different proposals that have been put forward regarding the status of *more* and *-er* and the distinction between synthetic and analytic comparatives. We have already seen theories that treat *more* as an adjunct (Neeleman et al., 2004) and others as the realisation of the Degree head (Kennedy, 1999). In this section we will focus in different proposals regarding *more* on the one hand and *-er* on the other. As we 'll see below, most proposals assume that both morphemes are realisations of a functional head; however, it has also been proposed that only *-er* is a head and *more* is in the specifier of its phrase.

Corver (1997) adopts Bresnan's (1973) split Degree system hypothesis, where a Quantifier Phrase (QP) is located between the Degree and the Adjective Phrase. Recast in Abney's (1987) functional head system, Bresnan's (1973) structure is reformulated by Corver (1997) as in (145). *More* and *less* are base generated as heads in Q⁰. Depending on whether the adjective has raised to Q or not, it is realised as *-er* or *more* respectively.

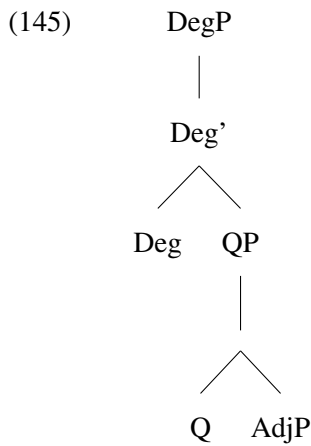

- (146)
- a. [QP [Q *-er*][_{AdjP} Adj⁰ XP]]
- b. [QP [Q *more*][_{AdjP} Adj⁰ XP]]

In light of double comparative formation (147), Corver (2005) revises his earlier proposal and argues that *more* is not a realisation of the Degree head like *-er* hence they are not in competition for the same structural position. While *-er* remains the realisation of the Degree⁰/Comparative⁰, *more* is an XP that fills in [Spec, DegP]. The non-cooccurrence of *more* and *-er* in many languages, such as Standard British English or Standard Dutch, is another exposition of a criterion condition (148) (Rizzi, 1996). In the case of comparatives, the feature F in question is [+comparative] (149). The head is the Degree head realised by *-er* and the relevant YP phrase is *more* (149).

- (147)
- a. **more** louder
- b. clever**er**

(148) Criterion Condition

- ◇ Each X_[F] must be in a Spec-Head relation with a [F]-operator
- ◇ Each [F]-operator must be in a Spec-Head relation with a X_[F]

(149) The Comparative Criterion

- ◇ Each $X_{[+comparative]}$ must be in a Spec-Head relation with a [+comparative] phrase YP
- ◇ Each [+comparative] phrase YP must be in a Spec-Head relation with a $X_{[+comparative]}$

In inequality comparatives, the bound morpheme *-er* encodes an ordering between $degree_i$ and $degree_j$. The free comparative morpheme *more/less* determines the ordering of that relation (*more* = $degree_i > degree_j$, *less* = $degree_i < degree_j$). Degree words like *more* and *less* are assumed to be base generated as predicates modifying the gradable adjective (Corver, 2000) and are first merged in a position following the gradable adjective. Then, they move to [Spec,ComparP] and maybe even higher (Heim, 2000; Kennedy, 1999; Lechner, 1998; Bhatt and Pancheva, 2004). A low base generation and movement analysis of *more* is further supported by postadjectival realisations of it, like in (151).

(150) Double comparative derivation
 $[_{\text{ComparP}} \text{more}_i [_{\text{Compar}} [_{\text{Compar}} \text{-er}] [_{\text{AdjP}} \text{Adj } t_i]]]$

(151) Middle Dutch (Corver, 2005)

- a. Hi es [sterker [vele [mee]]]
 he is stronger much more
 ‘He is much stronger.’
- b. Die vrocht soe es [beter meere]
 the fear PRT is better more
 ‘The fear is better.’

Turning back to the derivation of ‘regular’ and double comparatives, under the proposed theory the two constructions have the same LF representation. The only difference between the two is that in ‘regular’ comparatives either the criterial head position or the criterial Spec-position is lexicalised. Double lexicalisation is impossible (a doubly filled XP-effect).

(152) ‘Single’ comparative derivation

- a. $[_{\text{ComparP}} \emptyset [_{\text{Compar}} [_{\text{Compar}} \text{-er}] [_{\text{AdjP}} \dots \text{loud}]]]$
- b. $[_{\text{ComparP}} \text{more}_i [_{\text{Compar}} [_{\text{Compar}} \emptyset] [_{\text{AdjP}} \text{Adj } t_i]]]$

Bobaljik (2012), on the other hand, claims that periphrastic and synthetic comparative adjectives (*more polite* and *politer* respectively) are derived through the same representation that is input to lexical insertion but differ with respect to post-syntactic operations; (153-a) is the common syntactic representation for synthetic and periphrastic comparative. The periphrastic form arises when (153-a) is subject to vocabulary insertion, where the comparative element (pronounced as *more*) and the adjective are in separate maximal projections. If an operation M occurs the synthetic construction arises. M can be identified i.a. as Morphological Merger (Marantz, 1989) or head movement.^{19,20} The application of M yields (153-c).

¹⁹Morphological merger: At any level of syntactic analysis (D-structure, S-structure, phonological structure) a relation between X and Y may be replaced by (expressed by) the affixation of the lexical head of X to the lexical head of Y.

²⁰ See Matushansky (2013) for a critical analysis of proposals for postsyntactic derivations of synthetic comparatives and derivation through head-movement.

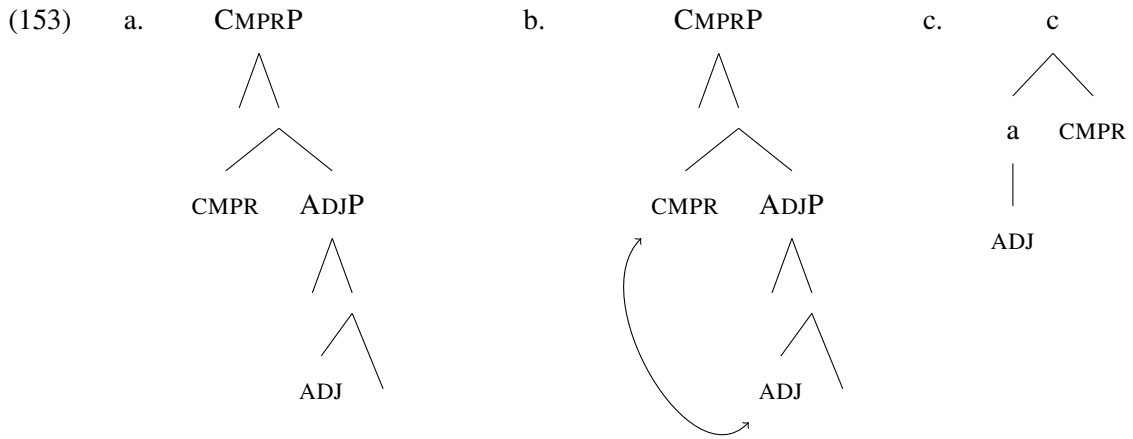

Double comparatives arise when more than one copy is spelled out. The lack of suppletive forms in the absence of a comparative affix (154) and the optionality of marker *more* are taken as evidence for the doubly spelled out head.

(154) *pjo cheiros Greek
 more bad_{SUPPLETIVE}
 ‘more bad’

(155) (pjo) cheiro-teros Greek
 more worse-CMPR
 ‘more worse’

The proposed structure intends to capture the Comparative-Superlative Generalisation (CSG), a language universal (156). The CSG predicts that when comparatives have a suppletive form, the superlative will also be suppletive and vice versa, i.e. there are no ABA-patterns. The CSG as such excludes ABA patterns; for AAB patterns to be excluded an independent principle is also required: a suppletive rule will be inserted whenever a CMPR head is adjacent to the root. This combined with the CSG derives also the ungrammaticality of AAB. If lexical insertion targets the constituent [[Adj] CMPR] an ABC pattern is obtained. Alternatively, the same result may be obtained by Fusion. To avoid derivation of AAB patterns through the mechanism that derives ABC ones, an additional rule is required: if there is a context-sensitive rule of exponence involving a node α , then there is also a context-free rule of exponence involving α

(156) Comparative-Superlative Generalisation:
 the representation of the superlative properly contains that of the comparative.

De Clercq and Vanden Wyngaerd (2017) propose an alternative way to obtain Bobaljik’s (2012) CSG that involves fewer operations and restrictions but a more fine grained extended projection of the adjectival spine. The proposed system not only is it conceptually simpler as it involves fewer operations and restrictions but it can also account for a broader set of facts. More specifically, it explains a previously unnoticed type of allomorphy; comparative and superlative suffixes may appear in a truncated form in the presence of a suppletive root. To account for these facts De Clercq and Vanden Wyngaerd (2017) split the comparative and the superlative head into two each, as in (157).

Then the suppletive allomorphs are actually analysed as port-manteau morphemes spelling out, in the case of the comparative, the adjectival stem and the lower of the comparative heads. This explains the truncated comparative suffix that combines with the suppletive form: it only spells out C2 (in contrast to suffixes that combine with non-suppletive forms and spell out both C1 and C2).

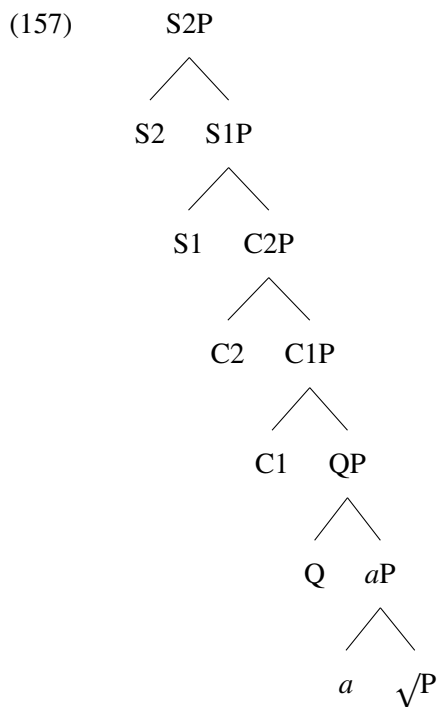

Taking the above into account, it is clear that the status of *more* as a head or a phrase is not settled either.

2.3.1.3.2 Coordination Structures

Hankamer (1973) studies the standard phrases of inequality comparatives in a number of languages including Latin and Classical Greek and observes that there are two different standard markers: one introducing nominals and one introducing clausal constituents. He observes that the choice of the standard marker correlates with a number of different properties attributable to a phrasal vs. clausal distinction. As far as clausal comparatives are concerned, he assigns to them a coordinate structure. For the standard marker *quam* in Latin he uses the label Conj(unction) though he notes that he is not sure whether there is any reason to posit such a label (Hankamer, 1973, fn. 4).

Napoli (1983) argues that *than* in English is ambiguous between a preposition that introduces phrasal comparatives and a coordinator that introduces the second conjunct of clausal comparatives. The existence of a coordinator *than* is used to explain that (i) more than NPs may appear after *than* (ii) a clausal *than*-phrase cannot be fronted (iii) the item immediately preceding coordinator *than* is necessarily in a syntactic island (v) there is a structural parallelism between the phrase preceding and following *than* (vi) gapping and RNR may apply to constructions with clausal *than* (vii) sequences of coordinator *than*-phrases are ungrammatical.

As also shown in §2.3.1.3, Lechner (2001, 2004, 2015), based on facts related to ellipsis, also argues for a coordination structure in (clausal) comparatives.

2.3.1.3.3 Late merger of degree clauses

Bhatt and Pancheva (2004) propose a different variant of the DegP hypothesis. They argue that both analyses that assume the Degree clause as a complement of the Degree head and analyses that assume the Degree clause as an adjunct face empirical and/or conceptual problems. In their analysis, the standard phrase is a complement of the Degree head. The originality of their proposal lies in that the standard phrase is merged countercyclically, after the Degree head has moved covertly to its scope position. Therefore, the Degree head starts out as a sister to the gradable predicate and later in the derivation it becomes a sister to the standard phrase (158). In other words, the DegP is generated in [Spec,AdjP] and then undergoes Quantifier Raising (QR), leaving behind a copy. It right-adjoins in a scope position of type <t> (Fox and Nissenbaum, 1999) but it is the tail of the chain that gets spelled out (Bobaljik, 1995, 2002; Fox and Nissenbaum, 1999; Pesetsky, 2000).

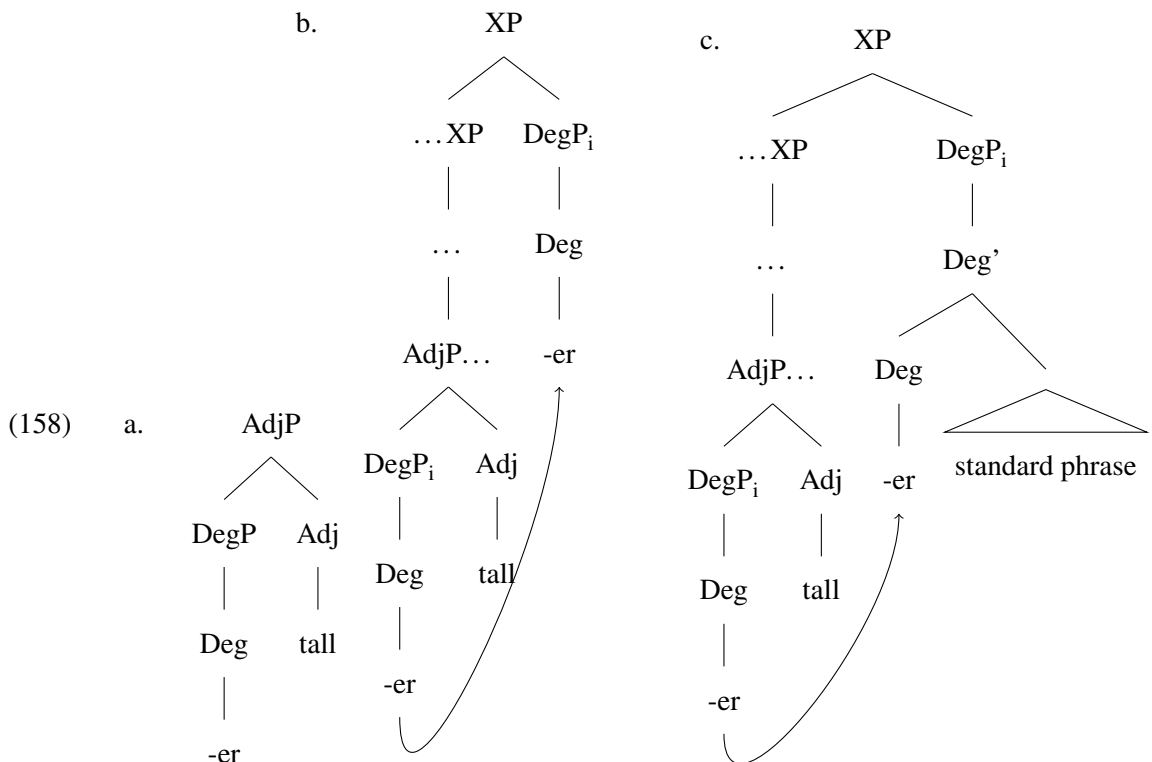

A question that arises is *why* the degree clause, if it is indeed a complement, *can* and *must* merge late, an option normally available only to adjuncts (Lebeaux, 1990; Fox and Nissenbaum, 1999). Trace conversion seems to be key in answering both of these questions. Beginning with the latter, namely why degree clauses must be merged late, Bhatt and Pancheva (2004) argue that not merging the standard phrase yields illicit LFs. Following Heim (2000), they analyse comparatives as constructions that involve QR of the Degree Phrase.

- (159) Bill wants to be taller than John is.
- Bill wants PRO_j to be [_{aP} [_{aP} t_j [_{AdjP} t_i tall] [-er_i [than John is tall]]]]
 - Bill wants [_{IP} [_{IP} PRO to be [_{AdjP} t_i tall]] [-er_i [than John is tall]]]

- c. $[_{IP} [_{IP} \text{Bill wants } [_{IP} \text{PRO to be } [_{\text{AdjP}} t_i \text{ tall}]]]] [-\text{er}_i [\text{than John is tall}]]]$

If copies are (obligatorily) interpreted through Trace Conversion (Fox, 2002), a mechanism that hinges on the conservativity of determiners, the movement of the non-conservative comparative quantifier after the degree clause has merged results in a contradiction (160); however, if the degree clause merges after the degree head has moved to its scope position, the LF is not contradictory (161).

(160) (Bhatt and Pancheva, 2004, ex. (87))

- a. *Before QR*
 $[\dots [-\text{er}[\text{Adj}]] \dots]$
 John is $[-\text{er}[\text{than Bill is tall}]]$ tall
- b. *After QR*
 $[-\text{er}[\text{Adj}]] [\dots [-\text{er}[\text{Adj}]] \dots]$
 $[-\text{er}[\text{than Bill is tall}]] [\text{John is } [-\text{er}[\text{than Bill is tall}]] \text{ tall}]$
- c. *Trace conversion*
 $[-\text{er}[\text{Adj}]] \lambda d [\dots [\text{the}[\text{Adj } d]] \dots]$
 $[-\text{er}[\text{than Bill is tall}]] \lambda d [\text{John is } [\text{the}[\lambda d_1 \text{ Bill is } d_1\text{-tall}]] d] \text{ tall}]$

(161) (Bhatt and Pancheva, 2004, ex. (88))

- a. *Before QR*
 $[\dots [-\text{er}] \dots]$
 John is $[-\text{er}]$ tall
- b. *After QR*
 $[-\text{er}] [\dots [-\text{er}] \dots]$
 $[-\text{er}] [\text{John is } [-\text{er}] \text{ tall}]$
- c. *Late merger of the degree clause*
 $[-\text{er}[\text{Adj}]] [\dots [-\text{er}] \dots]$
 $[-\text{er}[\text{than Bill is tall}]] [\text{John is } [-\text{er}] \text{ tall}]$
- d. *Trace conversion*
 $[-\text{er}[\text{Adj}]] \lambda d [\dots [\text{the}[\text{Adj } d]] \dots]$
 $[-\text{er}[\text{than Bill is tall}]] \lambda d [\text{John is } [\text{the } d] \text{ tall}]$

The reason why other complements cannot merge late is either because they need satisfy θ -role assignment e.g. in the case of verbal complements, or because they are complements of the restrictor of the determiner that is affected by the Determiner Replacement component of Trace conversion (162-a) and not of the determiner itself, as in the case of comparatives.

(162) a. ??Which rumor that John_i liked Mary did he_i later deny?

- b. LF structure with late merger:
 $[\text{which rumor that John liked Mary}] \lambda x [\text{he denied } [\text{the rumor } x]]$
 Higher *rumor* is of type $\langle e, e, t \rangle$, lower *rumor* is of type $\langle e, t \rangle$. (*reductio ad absurdum*).

The empirical motivation for their proposal comes from (i) Condition C phenomena (163) and (ii) a correlation between the scope of the degree head with the height of extraposition. In a system where bleeding of Condition C is explained through late merger, it is plausible to assume that bleeding of Condition C in comparatives also results from the same mechanism.

(163) (Grosu and Horvath, 2006)²¹

- a. I told him_i a sillier rumor (yesterday) [than John_i ever told ME].
- b. I sent him_i more books (yesterday) than John_i ever asked me to buy.

As far as the scope of *-er* is concerned, Bhatt and Pancheva (2004) propose a stronger variant of Williams's (1974) Scope generalisation (164), reiterated by Fox (2002) as in (165) as the Extraposition Scope Generalisation for Degree Constructions (166).

(164) *The Extraposition-Scope Generalisation* (Williams, 1974, 194-195)

If two scope items x and y with their determining clauses are represented in Deep Structure as: $[[x S_1] \dots [y S_2]]$ and if extraposition yields the structure $\dots x \dots y \dots S_1 S_2 \dots$ then semantically $(y(x))$; and if it yields $\dots x \dots y \dots S_2 S_1 \dots$ then semantically $(x(y))$.

(165) *Williams's Generalisation* (Fox, 2002, (19))

When an adjunct β is extraposed from a "source DP" α , the scope of α is at least as high as the attachment site of β (the extraposition site).

(166) *Bhatt and Pancheva's (2004) Extraposition-Scope Generalisation (for degree constructions)* [repeated from (114) above]

When a degree clause β is extraposed from a degree head α , the scope of α is *exactly* as high as the merger site of β .

Crucial to their argument is an alleged scope difference between (167-a) and (167-b). Example (167-b) shows that the *-er* can cross and scope above the intensional verb, whereas the lack of that reading in (167-a) is claimed to illustrate that the scope of the *-er* is marked by the height of the degree clause extraposition. The same facts are (claimed to be) replicated with the exactly differential in (168).

(167) (Bhatt and Pancheva, 2004, (53))

- a. John is **required** [to publish *fewer papers* this year [*than that number*] in a major journal] [to get tenure].
Simplified LF structure: *required* > [*fewer [than n]*]
required [fewer [than n] λd [PRO publish d -many papers]]
- b. John is **required** [to publish *fewer papers* this year in a major journal] [to get tenure] [*than that number*].
Simplified LF structure: [*fewer [than n]*] > *required*
fewer [than n] λd [required [PRO publish d -many papers]]

²¹ The acceptability of the data originally provided by Bhatt and Pancheva (2004) is disputed, however, the data in (163) also exemplify violation of Condition C, which is exactly Bhatt and Pancheva's (2004) empirical claim.

(168) (Bhatt and Pancheva, 2004, (54))

- a. John is **required** [to publish *exactly 5 more papers* this year [*than that number*] in a major journal] [to get tenure].

Simplified LF structure: *required* > [*exactly 5 more* [*than n*]]

required [[*exactly 5 -er*] [*than n*] λd [PRO publish *d*-many papers]]

- b. John is **required** [to publish *exactly 5 more papers* this year in a major journal] [to get tenure] [*than that number*]. Simplified LF structure: [[*exactly 5 more*] [*than n*]] > *required*

[*exactly 5 -er*] [*than n*] λd [required [PRO publish *d*-many papers]]

As Grosu and Horvath (2006) note, however, the sentences in (167) and (168) are extremely difficult to process let alone provide reliable judgements regarding scope. They overcome this problem by constructing the simpler to process but structurally equivalent sentences in (169). They observe that the wide scope reading exists and it is not hard to get provided that the bracketed constituent gets focus intonation and the italicised constituent is de-accented. Hence, comparative constructions pattern alike with other extraposition constructions (Williams's Generalisation) and no Degree specific version of it is required or motivated.

(169) Context: *Last year, junior faculty were required to {publish,submit} 5 papers.* (Grosu and Horvath, 2006, (23))

- a. This year, nontenured faculty members {**need, are required**} to publish fewer papers than {that, 5} *in LI* to get an extension of contract.

- b. This year, nontenured faculty members {**need, are required**} to submit fewer papers than {that, 5} *to LI* to get an extension of contract.

Overall, several facts discussed by Bhatt and Pancheva (2004) can be accommodated without resorting to counter-cyclic operations: Grosu and Horvath (2006) point towards some potential benefits of a theory with non-quantificational treatment of the degree head, whereas Alrenga et al. (2012) capture the facts by assigning quantificational meaning both to the comparative marker and the standard marker. So the proposal seems to be insufficiently motivated as both of its cornerstones are disputable. Even worse, it faces some even significant drawbacks, already pointed by Grosu and Horvath (2006). So apart from the lack of empirical motivation (see discussion about (169) above), it undergenerates: all degree constructions involve obligatory extraposition but some of them are conservative (170). If the non-conservativity of the degree quantifier is the reason why the degree clause needs to be merged late, it is impossible to explain why the conservative degree constructions, *at least/at most*-equatives,²² *enough*-and *so ... that*- constructions, involve obligatory extraposition.

²² Bhatt and Pancheva (2007) examine *as* comparatives and observe a split: factor comparatives with a factor greater than 1 are non-conservative exactly like inequality comparatives whereas *as* comparatives with a factor less than 1 are conservative.

- (ii) a. Ann is *twice* as tall as Sue is. (factor phrase > 1)
b. John is (*half*) as tall as Bill is. (factor phrase ≤ 1)

- (170) a. (i) *John has [{at least, at most} as many as Bill has (cars)] houses.
 (ii) John has {at least, at most} as many houses as Bill has (cars).
 b. (i) *John is [enough to make the basketball team] tall.
 (ii) John is tall enough to make the basketball team.
 c. (i) *John has [so (much) that his sanity is in danger] money.
 (ii) John has so much money that his sanity is in danger.

Furthermore, it mischaracterises the nature of the ill-formedness of degree constructions that the degree clause has not extraposed. Bhatt and Pancheva (2004) rule out a sentence like (171-a) as contradictory (160). However, the nature of unacceptability is completely different than (171-b) bringing into question whether a semantic mechanism should be used to derive extraposition.²³

- (171) a. *John is more than Bill is tall
 b. #Bill is taller than himself.

Overall, Bhatt and Pancheva's (2004) proposal achieves several of its goals, namely to accommodate the derivation of suppletive forms, the semantic constituency of the degree head with the standard phrase, and has further welcome consequences like dispensing with rightward \bar{A} -movement and a straightforward explanation of Condition C violations. However, it faces significant conceptual and empirical problems therefore it is not possible to maintain.

2.3.2 The internal syntax of standard phrases: Phrasal vs. Clausal comparatives

Even though comparatives with clausal material following the standard marker are easy to identify as clausal comparatives, it is less trivial whether comparatives with a standard phrase comprised of (the standard marker and) a single DP are indeed phrasal or involve elided structure within a given language. Depending on the answer to this question, analyses of phrasal comparatives can be classified as 'direct analyses' if the DP is base generated as a complement of the standard marker or 'clausal analyses' if the construction involves covert clausal material.

2.3.2.1 Direct analyses

Direct analyses argue that phrasal comparatives are not derived by ellipsis and they do not involve covert syntactic structure. One of the earliest ones was by Hankamer (1973). Based on a number of differences between comparatives with only one pivot after *than* and comparatives with a clausal structure as well as a wide range of cross-linguistic data, he was one of the first to propose that English has a prepositional *than* as well as a homophonous coordinator. Napoli (1983) reaches a similar conclusion.

They propose that syntax is not sensitive to the lexical semantics of the factor argument: the quantifier that moves is the degree head with the factor argument which, depending on the value of the factor argument, may or may not be conservative hence the syntax treats the *as* degree expression as non-conservative across the board.

²³ Bhatt and Pancheva (2007) in their discussion of equatives, revise their earlier proposal and argue that early merger of degree complements is not syntactically available at all, irrespective of whether they result to a contradictory meaning or not.

Hoeksema (1983) defines the comparative as a function from quantifiers to predicates.²⁴ By adopting an analysis of all DPs as generalised quantifiers (Barwise and Cooper, 1981) the DP may combine directly with the comparative.

- (172) a. $\llbracket \text{Adj-er than} \rrbracket(Q) =_{df} \{ x \in U \mid \{ y \in U \mid x >_{adj} y \} \in Q \}$
 b. $\llbracket \text{Adj-er than} \rrbracket(\llbracket NP \rrbracket)$ is the set of individuals such that the set of individuals that possess the property in question to a lesser degree, is a member of the quantifier $\llbracket NP \rrbracket$

He demonstrates that the phrasal comparative as defined is a Boolean homomorphism and as such it is always upwards monotone. The ungrammaticality of *ook mar* follows if we also assume Ladusaw's (1979) conditions on NPI licensing. The equivalence between phrasal and clausal comparatives follows from their definitions, the definition of degrees (173) and the definition of the inequality relation (174).

- (173) A DEGREE is a function from ordered pairs $(X, >)$, where $X \subseteq U$ and $>$ a grading relation on U , to subsets of U , such that $d_a(X, >) = \{ x \in U \mid \neg(x > a) \& \neg(a > x) \}$

- (174) Let D be any set of degrees. We define: $\llbracket \text{Adj-er than} \rrbracket(D) =_{df} \{ x \in U \mid \forall d_y \in D : d_x > d_y \}$

Hoeksema's (1983) analysis faces two problems: firstly, the comparative is a non-monotone environment not a downward entailing one (Heim, 2001). Secondly, it is not straightforward under the definition in (172) how the semantics of measure phrases or amount comparatives (175-a) can be captured. Scales themselves are defined as partition on entities, and each degree corresponds to a cell of the partition. Therefore, we cannot straightforwardly extend the system to accommodate the meaning of amount phrases—and consequently the way they combine with the comparative—the way degree is defined. Assume that the extension of *5ft* comprises of all individuals with a linear dimension of 5ft. (176-a) entails (176-b), therefore John should be a member for more than one cell of the height partition, which, given the definition of degrees, is a contradiction.²⁵

- (175) a. John is taller than 5ft.
 b. John is taller than Mary

- (176) a. John is 5ft tall.
 b. John is 4ft tall.

What is more, as we will see below, comparatives with measure phrases present the same syntactic properties as phrasal comparatives and, if a language employs a morphologically distinct phrasal standard marker, the standard marker used with measure phrases is the same as phrasal comparatives like (175-b), therefore, the semantics of the measure phrase needs to be combinable with the semantics given to *phrasal* comparatives, if such a distinction is made.

On the other hand, Pancheva Izvorski (2000) argues for a direct analysis of phrasal comparatives (cf. (139) in §2.3.1.2 above). Pancheva (2006), however, argues that *than* is a partitive preposition

²⁴ Hoeksema (1983) only studies adjectival comparatives with an overt standard phrase.

²⁵ This is a problem that, depending on the implementation, is shared by all the vague predicate analyses.

in the domain of degrees hence it directly combines with measure phrases like (175-a) above. By adopting Schwarzschild's (2005) proposal that measure phrases are ambiguous between a name of a point on a scale $\langle d \rangle$ and an interval of that scale $\langle d, t \rangle$, the partitive preposition *than* that combines with predicates of degrees ($\langle d, t \rangle$) can directly combine with the measure phrase. Even though she maintains a base-generation analysis for measure phrases on a par with her 2000 proposal, she argues that covert structure is employed for 'phrasal' comparatives like (175-b). Her analysis of those is discussed in more detail in §2.3.2.2.1 below.

Alrenga et al. (2012) propose an enriched semantics for *than* which allows them to accommodate a distinction between phrasal and clausal comparatives. Even though the intuition behind the proposal, namely that the phrasal vs. clausal distinction is always morphologically encoded in the standard not the comparative marker is on the right track,²⁶ the proposed semantics do not seem to make the right split. The proposed meaning (177-b) captures phrases like (175-b) but not (175-a). As we will see in the following sections, in many Romance languages the comparative marker that only introduces phrasal comparatives only combines with measure phrases.

- (177) a. $\llbracket \text{THAN}_{\text{CLAUSAL}} \rrbracket = \lambda S_{\langle d, t \rangle} \lambda T_{\langle d, t \rangle} . \text{sup}(T) > \text{sup}(S)$
 b. $\llbracket \text{THAN}_{\text{PHRASAL}} \rrbracket = \lambda S_e \lambda g_{\langle d, et \rangle} \lambda x_e . \text{sup}(\lambda d . g(d)(x)) > \text{sup}(\lambda d . g(d)(s))$

(178) French

- a. La maison est plus grande de 300m²
 the house is more big than.PHRASAL 300m²
 'The house is bigger than 300m².'
- b. Ma maison est plus grande que/*de la tienne.
 my house is more big than.CLAUSAL/PHRASAL the yours
 'My house is bigger than yours.'

Alrenga and Kennedy (2014) propose a three-way split of comparatives based on their complements: a standard marker for clausal comparatives ($\llbracket \text{than}_C \rrbracket$ in (179-a)), a standard marker for phrasal comparatives with DPs ($\llbracket \text{than}_P \rrbracket$ in (179-b)), and a standard marker for phrasal comparatives with measure phrases ($\llbracket \text{than}_M \rrbracket$ in (179-c)). *Than_P*, as shown in (179-b) is derived by *than_C* and it incorporates the negation over the differential argument that is normally supplied by NO (for more details of the NO MORE analysis, cf. §2.2.4). Finally, *than_M* is also derived by *than_C*.

- (179) a. $\llbracket \text{than}_C \rrbracket = \lambda P_{\langle d, t \rangle} \lambda Q_{\langle d, t \rangle} . \exists d [Q(d) \wedge P(d)]$
 b. $\llbracket \text{than}_P \rrbracket = \lambda x \lambda g_{\langle d, \langle d, \langle e, t \rangle \rangle \rangle} \lambda y . \exists d' [g(y, d', d) \wedge \{d'' | g(x, d', d'')\} = \emptyset] =$
 $\lambda x \lambda g_{\langle d, \langle d, \langle e, t \rangle \rangle \rangle} \lambda d \lambda y . \llbracket \text{than}_C \rrbracket (\lambda d' . \{d'' | g(x, d', d'')\} = \emptyset) (\lambda d' . g(y, d', d))$
 c. $\llbracket \text{than}_M \rrbracket = \lambda m \lambda g_{\langle d, \langle d, \langle e, t \rangle \rangle \rangle} \lambda d \lambda x . \exists d' [g(x, d', d) \wedge d' = m]$
 $\lambda m \lambda g_{\langle d, \langle d, \langle e, t \rangle \rangle \rangle} \lambda d \lambda x . \llbracket \text{than}_C \rrbracket (\lambda d' . d' = m) (\lambda d' . g(x, d', d))$

The fact that there are two phrasal *than*'s and both of them are derived from the semantics of the clausal has significant implications. Firstly, if we extend the relation of each phrasal standard marker to the clausal *than* in a fashion similar to Kennedy's (2007a,b) the following parameters are predicted:

²⁶ This line of analysis was first pursued by Kennedy (2007a) who transferred what was traditionally assumed the meaning of the comparative to the standard (cf. §2.1.4)

1. A language may have a single standard morpheme that selects for a clausal standard, with a meaning like (179-a). Since a meaning that accepts an individual standard (179-b) and a measure phrase standard (179-c) can be derived from this, such a language should in principle have all three types of comparison.
2. A language may have a single standard morpheme that selects either for an individual standard (179-b) or a measure phrase standard (179-c) but then it will only have the corresponding type of comparison. If it is the former, clausal constituents may be selected as standards by *than_P* after being nominalised.
3. A language may have two standard morphemes that differ in whether they introduce clausal, phrasal or measure standards.
 - If one of the standard morphemes is the clausal one then the third one can be derived.
 - If the clausal morpheme is not available, clausal standards may be available after nominalisation.
4. Finally, a language may realise all three standard morphemes.

This typology allows 8 different language types - Type 1 reflecting languages that do not have grammaticalised comparison, types 2-4 with a single standard morpheme, types 5-7 with two standard morphemes and type 8 with three distinct standard morphemes. Type 1 might refer to languages that do not have grammaticalised comparative morphemes and some of the languages described by Stassen (1984, 1985) might be good candidates for that,²⁷ and there are also several languages with one or two comparative morphemes. Therefore, it is an empirical question, whether languages are distributed across all these parameters or if there are gaps. What might prove more problematic though, is justifying the existence of a third *than*: to the best of my knowledge, there is no language that realises three different standard markers. Again, this is an empirical question.

²⁷ In that sense, this typology incorporates Kennedy's (2007a,b) parameter for implicit comparison. Kennedy (2007a,b) used a second parameter to distinguish between Type I from the rest of the languages (cf. §2.1.4 Implicit vs. Explicit comparison).

Table 2.5: Language types predicted by Alrenga and Kennedy’s (2014) semantics for the standard

Type	<i>than</i> _C	<i>than</i> _P	<i>than</i> _M
Type 1	*	*	*
Type 2	✓	(*)	(*)
Type 3	*	✓	*
Type 4	*	*	✓
Type 5	✓	✓	(*)
Type 6	✓	(*)	✓
Type 7	*	✓	✓
Type 8	✓	✓	✓

Table 2.6: Language types predicted by Kennedy’s (2007b) semantics for the standard

Type	<i>more</i> _{Deg}	<i>more</i> _{Ind}
Type I	*	*
Type II	✓	(*) ²⁸
Type III	*	✓
Type IV	✓	✓

2.3.2.2 Reduction analyses

One of the most prominent reduction analyses of phrasal comparatives is that of Lechner (2004). Lechner (2001, 2004, 2015) argues that all deletion in comparatives results from Conjunction Reduction, e.g. gapping, Right Node Raising, ATB-movement (cf. §2.3.1.3 above) and that phrasal comparatives are another instance of comparative ellipsis. Amongst the evidence that supports a reduced analysis of phrasal comparatives is the fact that in V2 languages, like German, verb ellipsis is prohibited from operating across overt complementizers, that the morphological case of the remnant matches that of the correlate, and the occurrence of ATB movement. However, Lechner (2017) notes that the application of the Attributive Comparative Generalisation (180) in German suggests that German also has phrasal comparatives. However, there is a split between amount PCs (*more composers* and degree comparatives (*better composers*), which suggest that the former but not the latter may still receive a reduced clause analysis.

(180) Attributive Comparative Generalisation

In attributive (degree) comparatives, the correlate c-commands the comparative DP.

Already in his (2004) book, Lechner pointed out that comparatives with measure phrases as standards can—at least optionally—be parsed as base generated phrasal comparatives. It is worth noting that even with this assumption there is no need to postulate ambiguity of the comparative operator: the measure phrase denotes a set of degrees and hence can function as the argument of the maximality operator.

Merchant (2009) puts forward a reduction proposal for Greek clausal comparatives. Based on island sensitivities observed in ‘phrasal’ comparatives introduced by *apo* (‘from’) not replicated by

²⁸ The asterisk in the parenthesis indicates that individual (Kennedy, 2007b,a; Alrenga and Kennedy, 2014)/measure comparison (Alrenga and Kennedy, 2014) can be derived by clausal (Alrenga and Kennedy, 2014)/degree (Kennedy, 2007b,a) comparison and, therefore, a language will have the former type(s) of comparison but not a designated morpheme for that.

clausal comparatives,²⁹ he argues for a sluicing analysis of reduced clausal comparatives and for a reduced analysis of phrasal ones. For phrasal comparatives he proposes two different variants that both involve covert structure:

- (i) an ellipsis proposal which involves overt movement outside an unpronounced structure; the standard phrase moves to [Spec,PP] and the preposition *apo* moves to a higher functional layer of the *pP* shell, namely *p*. The unexpected island effects are triggered by an illicit trace outside the ellipsis site:

(181) Phrasal comparative - Stripping

- a. I Maria pezi kithara kalitera apo ton Gianni.
 the Maria.NOM plays guitar better from the.ACC Giannis.ACC
 ‘Maria plays guitar better than Giannis.’

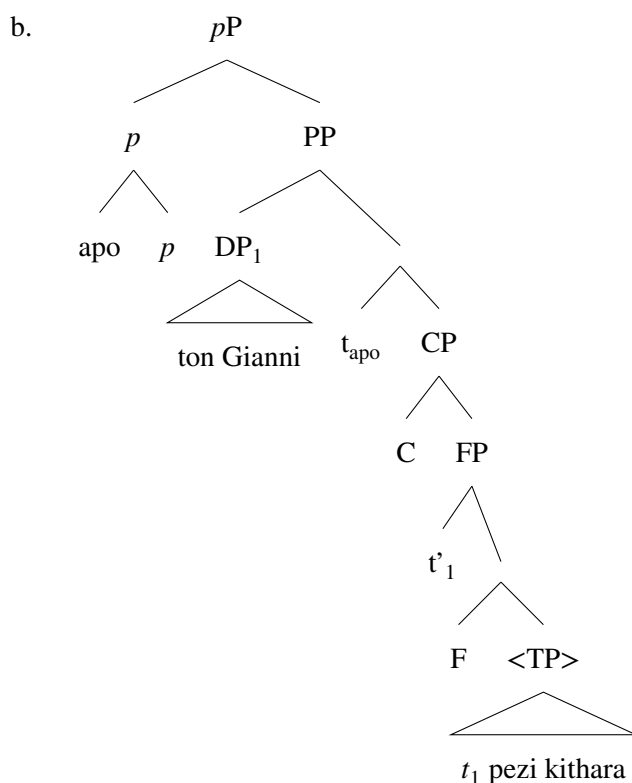

- (ii) an LF-movement approach where the correlate moves covertly in a structure which does not correspond to the structure pronounced.

(182) Phrasal Comparative - LF-movement

²⁹ Merchant (2009, fn. 5) notes that (at least) some of the sentences were tested with an informal questionnaire answered by 8 people in Katerini, Greece, in August 2007, and that the grammatical sentence of the minimal pair was rated with 3.5 in a 5 point scale whereas the ungrammatical one with 1.63. As regards the island effects (or the lack thereof) reported in the paper, I do not share the judgements reported in Merchant (2009) nor do they 5 speakers I have consulted from Athens and southern Greece. Given the size of both surveys it is not possible to generalise over the results. Either the data reported in Merchant (2009) are drawn from a different dialect (an unsurprising fact given the variation in phrasal comparatives in Standard Modern Greek and South Eastern Greek, see discussion below for more details) or the non-ceiling score reported in Merchant (2009) is not an artefact of the survey (it is quite common that grammatical sentences may receive less-than-perfect ratings in grammaticality judgement questionnaires) but it reflects a real deviance of the construction.

- a. I Maria pezi kithara pjo sixna apo violi.
 the Maria.NOM plays guitar more often from violin.ACC
 ‘Maria plays guitar more often than violin.’

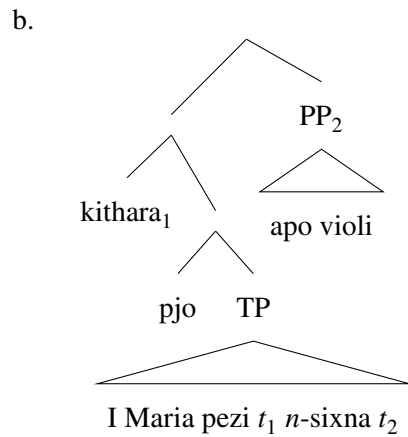

(183) Reduced clausal comparative (Merchant, 2009, ex. (43))

- a. Perisoteri anthropi nomisan oti psifisan ton Gore ap’ oti ton Bush.
 more people thought.3PL that voted.3PL the Gore.ACC from what the Bush.ACC
 ‘More people thought that they voted for Goren than (thought that they vote for) Bush.’

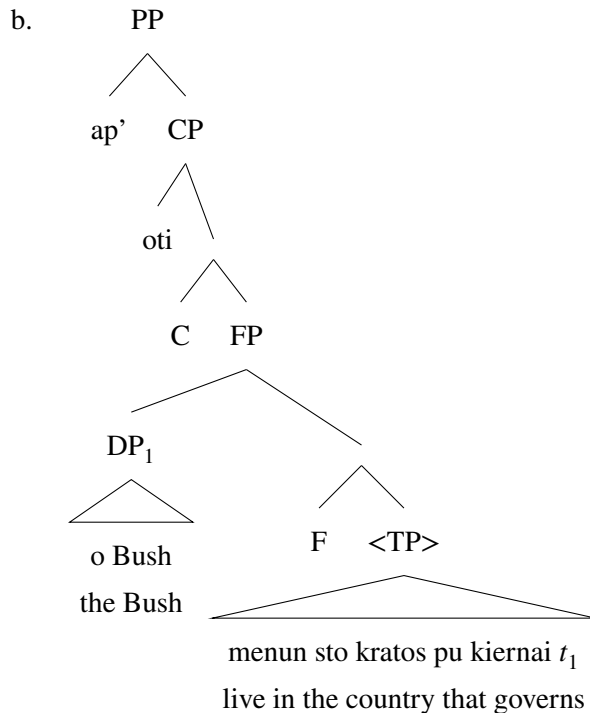

Even though Merchant (2009) claims that the Greek data do not provide sufficient evidence to choose between the two variants of analysis, the ellipsis proposal has a minor drawback: nested prepositions are indeed allowed in Greek but *apo* is a light preposition and it is the one that is normally selected by other prepositions (Theophanopoulou-Kontou, 1992). In that sense, the LF proposal is a shade superior.

2.3.2.2.1 The small clause analysis

Pancheva (2006) proposes a non uniform tripartite analysis of phrasal comparatives. The standard marker may combine directly with a measure phrase (*direct analysis*, cf. §2.3.2.1 above), a reduced

wh- clause *reduction analysis* or a *small clause*. The standard marker has a referential variant, which combines with a definite description of degree *d*, e.g a degree relative clause or a measure phrase, and a predicative variant, which combines with a predicate of degrees $\langle d, t \rangle$, e.g. a degree small clause or a measure phrase.

The comparative quantifier *-er* alone undergoes QR and leaves a degree variable behind in the matrix predicate. At LF, that predicate (d_1 -tall) is copied from the main clause into the small clause complement of *than*, as in (184-b). The small clause predicate in the *than*-PP now contains a degree variable, therefore it is interpreted as a predicate of degrees, of type $\langle d, t \rangle$. The subject of the small clause is ECM case marked by *than*.

- (184) PF and LF: Mary is taller than [_{SC} John *d*-tall] small clause standard phrase
- a. *than* [_{SC} John Δ]
- b. LF: [_{IP} [_{IP} Mary is d_1 -tall] [_{DegP} *-er*₁ [_{PP} *than* [_{SC} John *d*-tall]]]]

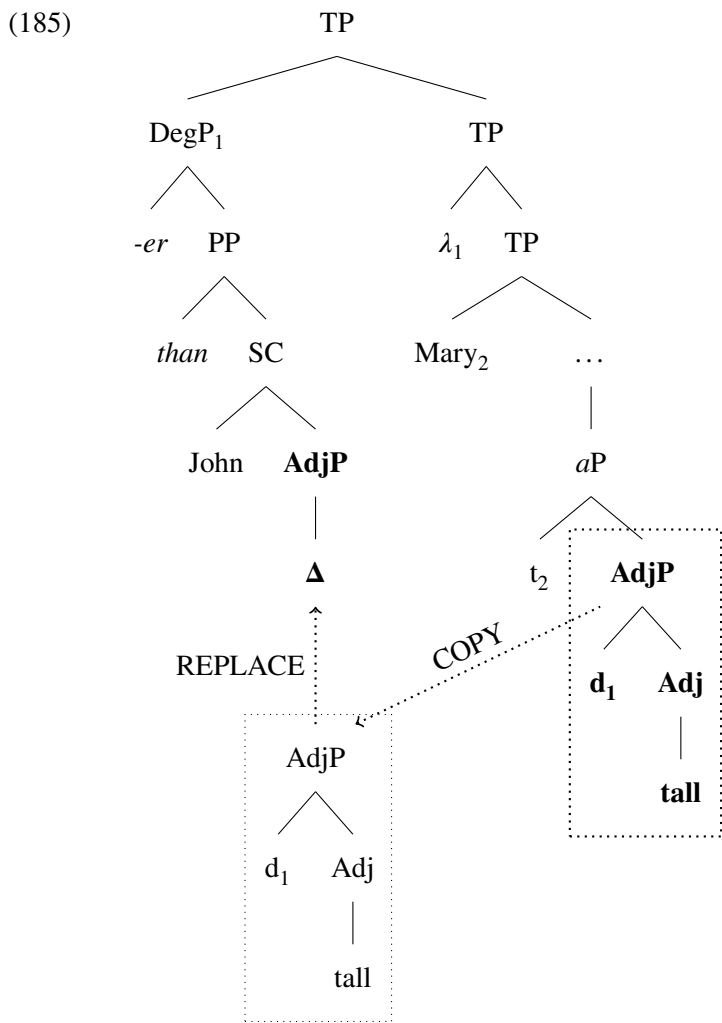

Pancheva (2009) proposes minor modifications to her 2006 proposal so as to capture the generalisation in (186), which holds for the Slavic languages, Greek, Hungarian and English. Under the revised analysis, the degree predicate is not copied from the matrix clause but it is generated through the movement of a *wh*-degree operator from a position parallel to that of *-er* in the matrix clause. In subject comparisons that position is [Spec,vP]. Under the revised analysis the difference between phrasal comparatives that do not contain a measure phrase and other clausal comparatives is that there is not a

complementiser and, consequently, the movement of the operator is not feature driven but type driven: *than* needs to combine with a degree predicate.³⁰

(186) In the Slavic languages, a *more*-NP cannot be an underlying subject (an external argument) in phrasal comparatives (Pancheva, 2009, (1))

As we will see in more detail in §3.5.1.2, Pancheva's (2006, 2009) accounts face conceptual problems and fail to capture the empirical patterns observed in Greek.

2.4 The proposal

In this thesis I propose that a fine grained adjectival spine is the only adequate structure to explain comparative formation in Modern Greek as well as dialectal variation in Case assignment. The proposed structure is given in (187-a) and (187-b) illustrates the position that arguments of the comparative phrase are merged.

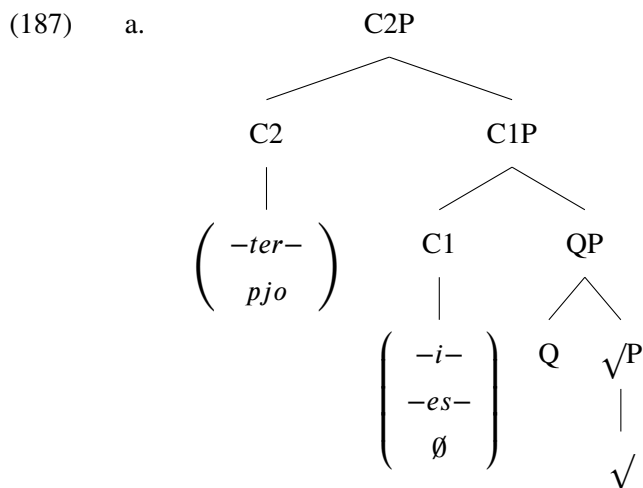

³⁰ Pancheva (2006) argues that measure phrases combine directly with *than* and this claim is not revised in the new theory.

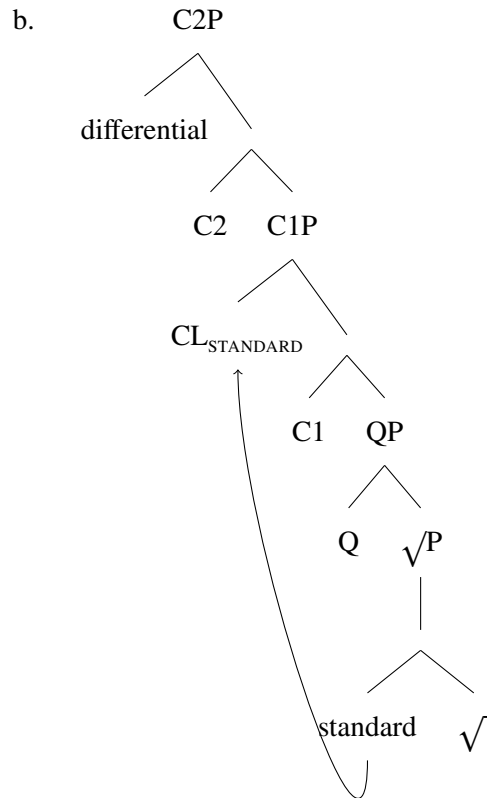

I also show that there is a second way to form comparatives, which involves modification of a positive adjective by the comparative form of a quantity word.

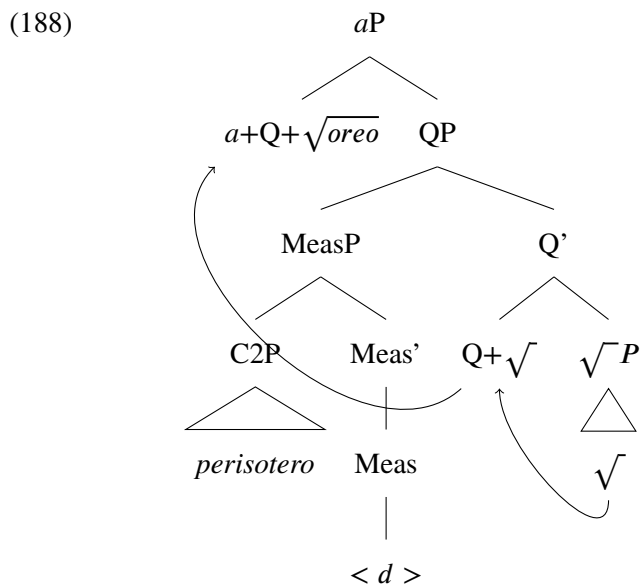

Furthermore, I propose that there are three distinct types of standard phrases; argument standard phrases introduced by the prepositional standard marker, as those in (187-b), predicative standard phrases also introduced by the phrasal standard marker and exceptive standard phrases introduced by the clausal standard marker.

As far as the meaning of comparative constructions is concerned, through the examination of the

crosslinguistic distribution of polarity items and negation in Greek and Romance comparatives, as well as the acquisition of Italian, I show that the negation found in clausal standard phrases is actually the overt exponent of a negative operator. This suggests that a negative analysis of comparatives, along the lines of Seuren (1973, 1984) and Schwarzschild (2008, 2010) is on the right track. This finding, along with the analysis of clausal standard markers as exceptives and phrasal ones as ablatives point towards understanding the meaning of comparatives in terms of subtraction.

Chapter 3

Phrasal Comparatives

3.1 Introduction

Aim of this chapter is to establish the syntactic architecture of the comparative phrase. Questions that will be addressed in the process are the status of comparative markers as heads or XPs, the label of the comparative phrase (AdjP or DegP), and the syntactic position of the comparative marker and the standard phrase as specifiers, adjuncts or complements. To that end, I focus on data of phrasal comparatives in Greek, Italian, Spanish and Brazilian Portuguese. Clausal comparatives will be discussed in chapter §4.

A pertinent question is the syntax and semantics of ‘phrasal comparatives’, namely comparatives that the standard phrase consists of a single DP (and a standard marker), like the ones in (189). The key question is whether they are base-generated or derived through ellipsis mechanisms, which are anyway employed for structures like (190). The decision between a base-generation analysis and an ellipsis analysis has significant consequences regarding the semantics of comparatives too: the number of arguments of the comparative operator and the semantic type of its complement are contingent on our assumptions for the nature of ‘phrasal comparatives’.

- (189) a. John is taller than Mary.
b. John is taller than 5 feet.

- (190) John is taller than Mary is.

In this chapter I will show that, even within the same language, there are more than one type of comparative markers and that base-generated comparatives are available in the languages in question. The investigation of each language yields results that further our understanding not only of the language in question but also the theory of comparatives. More specifically, I demonstrate that Greek has only one type of phrasal comparatives (contra Merchant, 2012); oblique standards are derivationally connected to prepositional ones. Therefore, Greek is no longer an exception to a robust cross-linguistic universal, namely that, if a language marks a phrasal vs. clausal distinction it employs only one phrasal standard marker. On the other hand, I argue that the availability of more than one standard marker in Romance comparatives does not necessitate the postulation of more than one meaning for *-er*, even if we assume that *-er* carries all the semantic burden of comparison: in Spanish and Brazilian Portuguese the existence of a prepositional standard marker does not necessitate the postulation of a three-place *-er*,

because the phrasal standard marker also combines with degree predicates on a par with the clausal one. These facts show that there is no one-to-one syntax-semantics mapping on the standard marker: more than one standard marker may introduce standards of the same semantic type whereas the same standard marker may introduce phrasal standards of different semantic type.

This chapter continues as follows: §3.2 spells out the background assumptions regarding the internal structure of positive adjective, the internal structure of the DP and the different positions adjectives may merge. §3.3 discusses different types of comparative markers and shows that, as for the languages under examination, there is a functional/grammatical comparative marker, which surfaces either as a suffix on the gradable predicate or as a free morpheme and a ‘lexical’ comparative marker that is the comparative form of quantity words. I also argue that the lexical semantics of *parapano* (‘above, more’) may involve a comparative interpretation however it is not a functional element used in comparative formation (yet). In §3.4, I review the empirical differences between phrasal and clausal comparatives and in §3.5 I demonstrate that standard phrases may function as arguments or predicates/adjuncts. Furthermore, I present new data from variation in case assignment in Modern Greek and I argue for a fine grained AdjP periphery, a direct analysis of standard phrases based on a derivational account of the alternation between standard PPs and standard DPs. Furthermore, I show that the density or discreteness of scales is visible to grammar and manipulated by other functional elements. §3.6 concludes.

3.2 Background on non-comparative adjectives

Aim of this section is to spell out the background assumptions regarding the syntax and semantics of non-comparative (positive) adjectives.³¹ Having the positive as a baseline it will be later possible to isolate and identify the syntactic and semantic contribution of the comparative.³² So, in this section, I will present the different positions that AdjPs can merge, a semantic analysis for the positive and measure phrases and the internal syntax of positive AdjPs.

Adjectives can be merged in both predicative and attributive positions. As far as predicative adjectives are concerned, I assume a small clause structure. I adopt Den Dikken’s (2006) representation of predicative constructions as relator phrases as in (191-c), however, nothing hinges on that choice. What is important is the predicative relation between the adjective and the NP.

- (191) a. Ta kulurakja ine strogila.
 the biscuits.NOM are round.NOM.
 ‘The biscuits are round.’
- b. Eplasa ta kulurakia strogila.
 form the.ACC biscuits.ACC round.ACC
 ‘I gave the biscuits a round shape.’ (lit. ‘I formed the biscuits round’).

³¹ In this chapter, unless differently specified, positive adjectives refer to adjectives in the positive degree and not just adjectives with positive polarity, cf. fn. 11.

³² This methodology stems from the assumption that the comparative form is built on the positive. Given the overwhelming crosslinguistic evidence presented by Bobaljik (2012), and the principle of compositionality, this is a rather safe assumption.

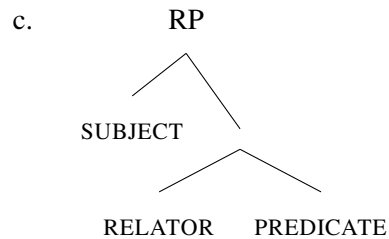

Adnominal adjectives can merge either as reduced relatives predicating over the NP or as adjuncts, directly modifying the NP (Cinque, 2010, 2014). Languages may differ with respect to the modification strategies they allow pre- or post-nominally: English prenominal AdjPs are ambiguous between direct modifiers to the NP and reduced relatives whereas Italian prenominal AdjPs are only direct modifiers. On the other hand, English postnominal AdjPs are always reduced relatives whereas Italian postnominal AdjPs are always modifying the NP directly. The attested patterns are illustrated in (192). Cinque (2014), largely based on Larson (1998, 1999, 2000) and Larson and Marušič (2004), argues that the ambiguity of English prenominal and Italian postnominal AdjPs is a structural ambiguity that stems from the constructions in (193). Cinque (2014) argues that the two structures are derived through movement from (194).

(192) (Cinque, 2014)

a.	English:	AdjP	N	(AdjP)
		ambiguous		unambiguous
b.	Italian:	AdjP	N	AdjP
		unambiguous		ambiguous

- (193) a. English: AdjP in a Reduced RC > direct modification AdjP > N > AdjP in a Reduced RC
 b. Italian: direct modification AdjP > N > direct modification AdjP > AdjP in a Reduced RC

(194) [DemonstrativeP ... [NumeralP ... [[ReducedRC AdjP*] ... [AdjP* ... NP]]]
reduced RC modification direct modification
 (* each of the two sources can contain more than one AdjP)

As noted in (194) more than one adjective can be merged in any given position. A pertinent question is the ordering of directly modifying adjectives cross-linguistically. Since Cinque's (1994) seminal work, it is common ground that the order that directly modifying adjectives are first merged in the DP is fixed and determined by semantic properties of the adjective. The semantic properties that determine the hierarchy are rather elusive hence several proposals arguing for a more or less fine grained adjective hierarchy have been put forward (195). Some of the properties that have been entertained to be at play are the classification of adjectives as intersective or subsective (Truswell, 2009), and subjectivity (Scontras et al., 2017). On the other hand, Svenonius (2008) proposes that the order of adjectives is determined by their relative order with respect to independent functional layers of the DP.

(195) a. Adj_{Quantification} > Adj_{Quality} > Adj_{Size} > Adj_{Shape} > Adj_{Color} > Adj_{Nationality} (Cinque, 1994)

- b. Adj_{Ordinal} > Adj_{Cardinal} > Adj_{Subject Comment} > Adj_{Evidential} > Adj_{Size} > Adj_{Length} > Adj_{Height} > Adj_{Speed} > Adj_{Depth} > Adj_{Width} > Adj_{Weight} > Adj_{Temperature} > Adj_{Wetness} > Adj_{Age} > Adj_{Shape} > Adj_{Color} > Adj_{Nationality/Origin} > Adj_{Material} (Scott, 2002)
- c. [Quantificational Adj_{Ordinal} > Adj_{Cardinal}] > [Speaker-Oriented Adj_{Subject Comment} > Adj_{Evidential}] > [Scalar Physical Property Adj_{Size} > Adj_{Length} > Adj_{Height} > Adj_{Speed} > Adj_{Depth} > Adj_{Width}] > [Measure Adj_{Weight} > Adj_{Temperature} > Adj_{Wetness} > Adj_{Age}] > [Non-Scalar Adj_{Shape} > Adj_{Color} > Adj_{Nationality/Origin} > Adj_{Material}] (Laenzlinger, 2005)

For the purposes of this thesis, how fine grained an order adjectives have is not as important; the semantic distinction of interest is gradability. As is clear from (195) non-scalar adjectives merge lower than gradable ones. Taking into account, Scontras et al.'s (2017) proposal that an adjective's semantics predicts its distance from the modified noun such that less subjective adjectives occur linearly closer to nouns they modify, and theories of emergent scalarity in absolute gradable adjectives (Leffel et al., *under revision*; Qing and Franke, 2014) a tripartite distinction emerges. Taking also into consideration that quantity words (*many, much, little, few*) are also gradable adjectives (Solt, 2015) the picture in (196) emerges.³³

³³ Rett (2018) evaluates the empirical coverage of accounts of quantity words as quantifiers (Hackl, 2000; Romero, 2015, a.o.) and as gradable predicates (Rett, 2008; Solt, 2009, 2015). She finds that neither class of accounts succeeds in predicting the use of quantity words as VP-modifiers (iii), PP-modifiers (iv) and differentials/comparative modifiers (v) (cf. Table 3.1). However, Rett's (2018) data do not really undermine an analysis of quantity words as gradable adjectives. As Greek translations of Rett's (2018) examples show, theories of quantity words as gradable adjectives correctly predict that gradable adjectives should be ungrammatical in these environments; these environments license gradable adverbials. (The English examples are Rett's (2018, ex. (15)-(17)); all examples that exemplify the first four columns of Table 3.1 are translated to gradable adjectives confirming the predictions of theories of quantity words as gradable adjectives. I do not include this data set for reasons of space.)

Table 3.1: The distribution of quantity words in English (Rett, 2018)

		Quantifiers	Adjectives	Quantity Words
Individual	Prenominaly	✓	✓	✓
	With a determiner	×	✓	✓
	Predicative position	×	✓	✓
	Degree Quantifier	×	✓	✓
Non-Indiv.	VP modifier	×	×	✓
	PP modifier	×	×	✓
	Comparative modifier	×	×	✓

- (iii) a. O Janis dhen pigheni poli sto sinema.
the John NEG goes much.ADV to.the cinema
'John doesn't go to the movies much.'
- b. O Janis kimate ligho.
the John sleeps little.ADV
'John sleeps little'

(196) $\overbrace{\text{Quantity Adj.} > \text{Relative Gr. Adj.} > \text{Absolute Gr. Adj.}} > \text{Non-Gradable Adj.}$

Having examined how adjectives can integrate in the DP, we can now turn to the internal structure of the AdjP and the semantics of positive adjectives.

There is a long standing debate whether gradable adjectives are semantically different than non-gradable ones. According to ‘vague predicate’ analyses (Klein, 1980, a.o.) gradable adjectives are the same semantic type as non-gradable ones. The only difference is that the domains of non-gradable adjectives are not ordered whereas gradable adjectives have inherently ordered domains — the ordering is determined by its dimensional parameter. The most compelling argument for a non-distinct analysis of gradable and non-gradable adjectives is that, until now, there has not been a language that marks gradability with a designated morpheme (Klein, 1980; Grano and Davis, 2018; Rett, prep). However, Kennedy (1999, *et seq.*) has convincingly shown that a ‘vague predicate’, i.e. degree-less, analysis fails to account for cross-polar anomalies, comparison of deviation, incommensurability and the unavailability of measure phrases with negative adjectives.

Even within the scalar analyses, there are a few different variants regarding the semantics of the positive. Any analysis of positive gradable adjectives should be able to accommodate the following set of facts:

- depending on the context, the same utterance may be judged as true or false (Kennedy, 1999, a.o);

(197) George is tall.

Context 1: The average man’s height in the population is between 1.70 and 1.80.

George is 1.85. (197) is TRUE

Context 2: The average basketball player’s height in a team is above 1.95. We are

considering whether George can join the team. (197) is FALSE

- (iv) a. To amaksi etrexe poli/ ligho parapano/ parakato apo to orio taxititas.
the car ran much.ADV/ little.ADV above/ below from the limit speed
‘The car drove much/little over/under the speed limit.’
- b. To kadhro dhen ine poli parapano apo ton kathrefti.
the picture NEG is much.ADV above from the mirror
‘The picture isn’t much above the mirror.’
- (v) a. O Janis ine poli/ ligho psiloteros apo tin Suzana.
the John is much.ADV/ little.ADV taller from the Sue
‘John is much/little taller than Sue.’
- b. O Janis odhighuse poli/ ligho pjo ghrighora apo tin Suzana.
the John drove much.ADV/ little.ADV CMPR fast from the Sue
‘John drove much/little faster than Sue.’
- c. To ghrafio ine poli/ ligho pjo makria ap’ oti o kanape.
the desk is much.ADV/ little.ADV CMPR far from whatever the couch
‘The desk is much/little farther away than the couch.’

So, the data discussed by Rett (2018) do not challenge an analysis of quantity words as gradable adjectives. The only modification required is to allow for homophony between the quantity adjectives and quantity adverbs. This is not an ad hoc stipulation as English has several adverbs that are homophonous to the adjectives they are derived from, cf. *fast, hard, late, straight, wrong, lively, early, daily*.

- in the absence of an overt measure phrase, a positive form indicates that the entity that the gradable predicate is applied to meets or exceeds a context sensitive standard (these readings are often described as *evaluative* readings (Brasoveanu and Rett, 2018; Rett, prep));
- measure phrases are not arguments of the gradable predicate but predicates/modifiers of its non-thematic argument (Schwarzschild, 2005; Kennedy, 2007c; Corver, 2009)
- *for*-phrases are not arguments of the gradable predicate either (cf. Georgala, 2011; Michelioudakis, 2011, 2012, for analyses of ‘estimative dative’/ ‘dativus judicantis’ as an adjunct and references therein); instead they manipulate the domain of the gradable predicate (Kennedy, 2007c). Den Dikken (2006) presents (198) and argues that

‘modification is predication is mediated by a relator’ approach *for/by American standards* is a subconstituent of an RP in which it serves as the predicate of the other *for*-headed RP, *skinny for a twelve-year-old* —with the predicate (which, after all, follows its modifiee) occupying the complement of the RELATOR. The entire constituent $[[\textit{skinny for a twelve-year-old}] \textit{for/by American standards}]$ (which qualifies as a predicate by virtue of the fact that the predicate nominal *a twelve-year-old* is still unsaturated) is finally predicated of Brian, with the copula *be* as the relator.

- (198) a. *Brian is skinny for a twelve-year-old for an American.
 b. Brian is skinny for a twelve-year-old/ by American standards.
- (199) a. $[_{RP_1} \text{Brian} [_{RELATOR=be} [_{RP_2} [_{RP_3} [_{AdjP} \textit{skinny}]][_{R'} \textit{RELATOR=for} [_{DP} \textit{a twelve-year-old}]]]] [_{RELATOR=for/by} [_{DP} \textit{American Standards}]]]]]$

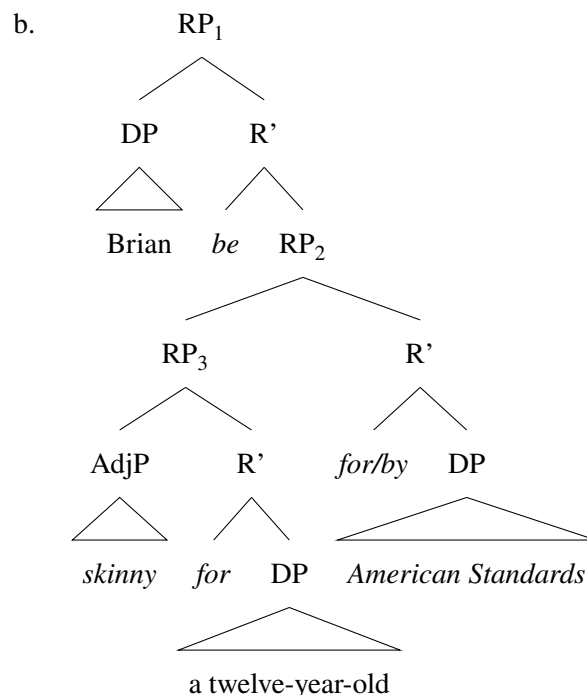

Instead, I would like to argue that whether a preposition functions as a relator or a case assigner to the phrase it selects depends on the properties of the phrase it selects. Given that the phrases

that may function as predicates vary crosslinguistically depending on the argumentising head (cf. Alexopoulou et al., 2013), we predict that a preposition can function as a relator or a case assigner depending on the type of phrase (DP, NumP, BareNP, etc.), its specification with respect to Chierchia's (1998) Nominal Mapping Parameter and the argumentising head of the language. Given that any functional head can function as a relator (but not a lexical one) we expect all light prepositions to be able to function as relators that introduce predicates or as case assigners that license arguments. Indeed this prediction is borne out:

- (200) a. O Janis milai san papus.
the John.NOM talks like grandfather.NOM
'He speaks like an old man.'
- b. O Janis milai san (ekinon) ton papu.
the John.NOM talks like (that) the grandfather.ACC
'He speaks like our grandfather/(that old man).'
- (201) a. Apo jatros eghine architektonas.
from doctor.NOM became architect.NOM
'From [being] a doctor he became an architect.'
- b. #Apo ton/enan jatro eghine architektonas.
from the/one doctor became architect
'From the doctor he became an architect.'

Additionally, we correctly predict the difference between estimative datives and predicative *for*-phrases and we allow for the former to cliticise.

Another point regarding measure phrases in the AdjP and *for*-phrases is now in order: measure phrases predicate over the degree argument of the positive adjective whereas *for*-phrases adjoin to/predicate (depending on whether it is a 'regular' PP or a RelatorP) to the gradable predicate. Thus, we correctly predict the co-occurrence of measure phrases and *for*-phrases but not of more than one measure phrase:

- (202) a. *ine 10 ekatosta 2 metra konto.
is 10 cm 2 mt short
'it is 10 cm 2 mt short.'
- b. ine ligho konto ja forema.
is little short for dress
'It is a little short for a dress.' (...I'll wear it as a blouse).

- gradable adjectives can lead to sorites paradoxes (Kennedy, 2007c)
- non-gradable adjectives may be coerced to gradable interpretations (Matushansky, 2002). This can happen through comparative morphology or in the complement of *seem* and equatives (Matushansky, 2002; Rett, 2014).

Based on the above considerations, I assume that the difference between a gradable and a non-gradable adjective boils down on whether the adjective spells out a quantificational functional layer, in other words whether little *a* (in the sense of Marantz, 2007) is inserted below or above Q.³⁴ This is in

³⁴ This functional layer could be named as G(radability) so that a quantifier does not merge right above a root. So as to maintain Corver's (1997) original intuition I will keep referring to that functional layer as Q.

line with many proposals that explain *much* support and scalarity coercion through the (un)availability of head movement of Adj to Q (Corver, 1997; Matushansky, 2002, a.o). The tree in (203-b) shows the internal structure of a gradable predicate and (203-a) of a non-gradable one. Scalarity coercion or *much* support, occurs when *a* is merged directly above the root and Q selects the *aP* (203-c). Q may be realised by *much* or be phonologically covert. The sister of the root is accupied by adjectival complements and the specifier by a degree deictic.

(203) ‘Positive’ Degree

a. Non-gradable predicate

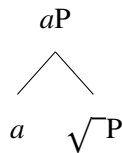

b. Gradable predicate

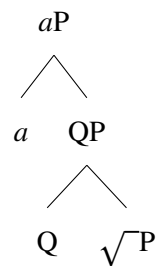

c. Scalarity coercion / *much*-support

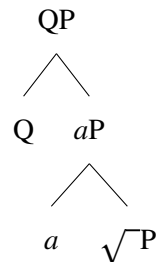

3.3 The status of comparative markers

3.3.1 Greek

As discussed in §2.3.1.3.1, the status of *more* as an XP or an X^0 has long been disputed. In this section, I will show that Greek *pjo* (CMPR) is a comparative head, whereas *perisotero* (ADV ‘more’) and *lighthotero* (ADV ‘less’) are quantificational phrases and *parapano* (‘above, more’) is a lexical (as opposed to functional) adverb that has a comparative interpretation. Let us now turn to the distribution of these items.³⁵

³⁵ *Perisotero* (ADV ‘more’) and *lighthotero* (ADV ‘fewer/less’) also have adjectival forms used in NP-comparisons (vi). For ease of exposition I will only refer to the adverbial forms, which can be used in most types of comparisons, however, I assume that the analysis of *perisotero* (ADV ‘more’) and *lighthotero* (ADV ‘less’) extends to *perisoteros-i-o* (ADJ ‘more’) and *lighthoteros-i-o* (ADJ ‘less’).

(vi) a. *perisoterēs/* *Lighoteres* *apo tris fititries perasan tis eksetasis.*
many.CMPR.ADJ.FEM.PL.NOM/ Few.CMPR.ADJ.FEM.PL.NOM from three students passed the exam.
‘More/Fewer than three female students passed the exam.’

1. *pjo* (CMPR) combines only with gradable adjectives and adverbs as well as predicative NPs that denote a gradable property; *perisotero(s)* ('more' ADJ/ADV) is used in any type of comparative (the adjectival form is used in NP comparisons whereas the adverbial form in all other types); *parapano* ('above, more') is found only in NP and VP comparisons.

(204) Predicative comparisons

- a. O Janis ine *pjo/ perisotero/ lighotero/ *parapano* eksipnos apo
the John is CMPR much.CMPR.ADV little.CMPR.ADV above smart than
ton Mihali.
the Michalis
'John is more/less smart than Michalis.'
- b. O Janis ine *pjo/ perisotero/ lighotero/ *parapano* nikokiris apo
the John is CMPR much.CMPR.ADV little.CMPR.ADV above tidy than
ton Mihali.
the Michalis
'John is more/less tidy than Michalis.'
- c. Ta koritsia ine **pjo/ perisotera/ lighotera/ ?parapano* apo ta
the girls are CMPR much.CMPR.ADV little.CMPR.ADV above than the
aghoria.
boys.
'The girls are more/fewer than the boys.'

- (205) a. O Janis ine *pjo/ perisotero/ lighotero/ *parapano* eksipnos mathitis
the John is CMPR much.CMPR.ADV little.CMPR.ADV above smart student
apo ton Mihali.
than the Michalis
'John is more/less smart student than Michalis.'
- b. Aghorasa **pjo/ perisoteres/ lighoteres/ ?parapano* karfitses apo
bought.1SG CMPR much.CMPR.ADV little.CMPR.ADV above pins than
velones.
needles
'I bought more pins than needles.'

(206) NP-comparisons

- a. O Janis ekane **pjo/ perisotera/ lighotera/ parapano* (lathi) apo
the John made CMPR/ many.CMPR.ADJ/ few.CMPR.ADJ/ above mistakes than
3 (lathi).
3 mistakes
'John made more/fewer than 3 mistakes.'
- b. O Janis ekane 3 (lathi) **pjo/ perisotera/ lighotera/ parapano*
the John made 3 mistakes CMPR/ many.CMPR.ADJ/ few.CMPR.ADJ/ above

-
- b. O Jannis echi *perisoteri/ lighoteri ipomoni* apo emena.
the John have much.CMPR.ADJ.F.SG.ACC/ little.CMPR.ADJ.F.SG.ACC patience from me.
'John is more/less patient than me.'

In English the count/mass distinction is marked in the stem form of the positive degree of the adjective ('many'/'few' vs. 'much'/'little') and in the comparative form of the negative adjective ('more'/'fewer' vs. 'more'/'less'). In Greek, the same stem form is used both for mass and count nouns; the difference between the two is marked through singular/ plural agreement (compare (vi-a) to (vi-b) above).

(lathi) apo ton Mihali.
 mistakes than the Michalis
 ‘John made 3 more/fewer mistakes than Michalis.’

(207) VP-comparisons

- a. Zighizi *pjo/ perisotero/ lighotero/ parapano apo 20kg.
 weigh CMPR/ much.CMPR.ADV/ little.CMPR.ADV/ above than 20kg
 ‘It weighs more/less than 20kg.’
- b. O Janis ipje 3 potiria *pjo/ perisotero/ lighotero/ parapano
 the John drank 3 glasses CMPR/ much.CMPR.ADV/ little.CMPR.ADV/ above
 apo ton Mihali.
 than the Michalis.
 ‘John drank 3 glasses more/less than Michalis.’

(208) AdvP-comparisons

ton episkeptete pjo/ perisotero/ lighotero/ *parapano sichna apo tin
 him visit CMPR/ much.CMPR/ little.CMPR.ADV/ above often than the
 kori tu.
 daughter his
 ‘S/he visits him more/less often than his daughter.’

2. *perisotero(s)* (‘more’ ADJ/ADV) and *parapano* (‘above, more’) have a more complex internal structure than *pjo* (‘more’), which is monosyllabic and non decomposable: *perisotero(s)* are the suppletive comparative forms of quantity words *poli(s)* (‘much’/‘many’) and *ligho(s)* (‘little, few’) (209) and *parapano* (‘above, more’) is a compound of the intensifier *para* (‘even’) and the adverb *pano* (‘above, over’).

(209)

Positive	Comparative
<i>poli</i> ‘much’ (ADV)	<i>perisotero</i> ‘more’ (ADV)
<i>pol-is,-i,-i</i> ‘much’ (ADJ)	<i>perisoter-os,-i,-o</i> ‘more’ (ADJ)
<i>ligho</i> ‘little’ (ADV)	<i>lighotero</i> ‘less’ (ADV)
<i>ligh-os,-i,-o</i> (ADJ)	<i>lighoter-os,-i,-o</i> (ADJ)

3. *perisotero(s)* (‘more’), *lighotero(s)* (‘more’), and *parapano* (‘above, more’) may appear without a gradable predicate, whereas *pjo* (‘more’) cannot;³⁶

³⁶ Actually, one could entertain the hypothesis that *pjo* is a clitic because it is monosyllabic, it is always adjacent to the gradable predicate it modifies and nothing can intervene in between. However, it can bear focal stress hence its characterisation as a clitic would not be accurate.

- (vii) a. PJO dhinata!
 CMPR strongly
 ‘With MORE force!’
- b. *TO edhosa.
 it.CL give
 ‘I gave it.’

- (210) 50% **pjo*/ perisotero/ lighthotero/ parapano tha itan kalitera.
 50% *CMPR*/ much.*CMPR*/ little.*CMPR*/ above FUT be.PST better.
 ‘More/Less would be better.’

So, based on the abovementioned facts, we can conclude that *pjo* (‘more’) is a head whereas the other comparative words are not. Let’s now examine the syntactic position of each element in more detail.

3.3.1.1 The status of *pjo* (‘more’)

Given the simple internal structure and the limited distribution of *pjo* (‘more’) we can safely assume that *pjo* (‘more’) is an X^0 . The question that arises is the type of head it is and how it is integrated in the comparative. There are three possible candidates: either it is the realisation of the Degree⁰ (as proposed by Kennedy, 1999, for English *more*), or a spell-out of the comparative head in a finer grained structure along the lines of De Clercq and Vanden Wyngaerd (2017) (211-b) or a quantifier, along the lines of Corver (2005).³⁷ Both constructions are illustrated in (211-a) and (211-c) respectively.

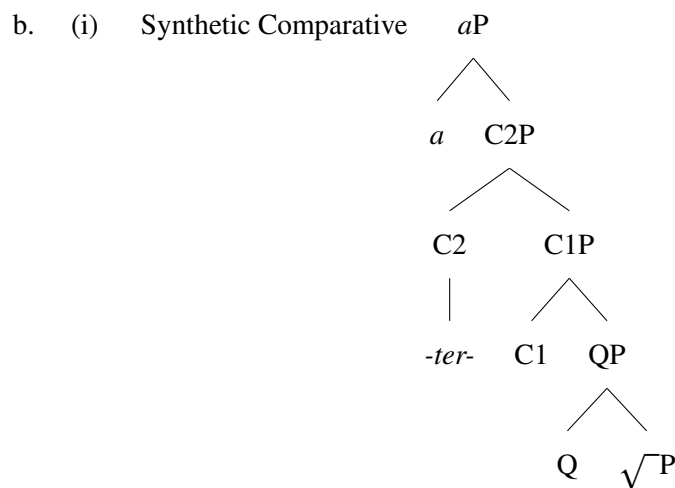
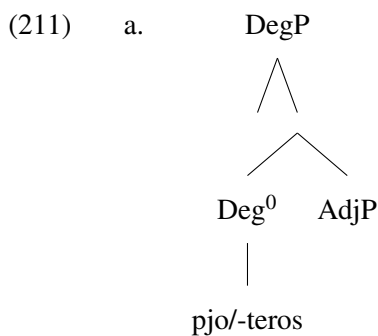

³⁷ De Clercq and Vanden Wyngaerd’s (2017) proposal was spelled out in a nano-syntactic framework hence the position of the *aP* was rigidly between C1 and Q. Based on the theoretical assumptions adopted in §3.2 little *a* can be inserted in different heights signifying a (possible) boundary for lexical insertion.

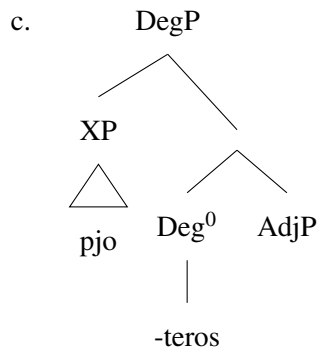
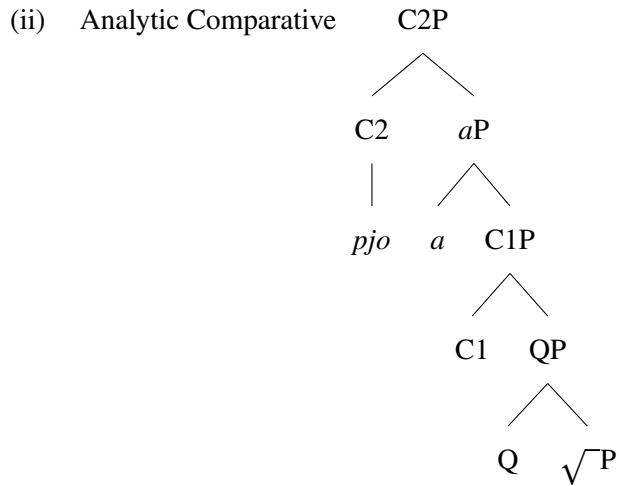

Let us examine first the latter construction in (211-c). In a configuration like (211-c) the comparative semantics is carried by the Degree head whereas *pjo* ('more') is an adverbial merging at the Spec, DegP.³⁸ According to a criterion condition only one of them is overtly realised. However, this seems to be rather problematic. Comparatives formed with *pjo* (CMPR) and comparatives form with -

³⁸ One could argue that the literary form *pjo-tero* ('more' (CMPR-CMPR)) is the comparative form of *pjo* ('more') hence the latter is not a functional head but a quantifier that forms a comparative form on a par with *poli* ('much'). However, if that were true, we would expect *pjo* ('more') to share the same distribution as other positive degree adverbs like *poli* ('much'), and to form synthetic and double comparatives (Table 3.2). However, neither prediction is borne out.

- (viii) Efagha poli/ *pjo.
 ate much/ much
 'I ate a lot.'

Table 3.2: Predicted Degree Paradigm for 'much'/'more'

positive	Synthetic Comparative	Analytic Comparative	Double comparative
<i>poli</i> ('much')	<i>pjo poli</i>	<i>perisotero</i>	<i>pjo perisotero</i>
<i>pjo</i>	* <i>pjo pjo</i>	<i>pjotero</i>	* <i>pjo pjotero</i>

Corroborating evidence against an analysis of *pjotero* ('more') as a comparative form of *pjo* ('more') comes from synchronic variation: *pjotero* ('more') alternates with *pljotero* ('more') whereas *pjo* (CMPR) does not alternate with **pljo* (CMPR). The form **pljo* (*CMPR) is unattested.

teros (CMPR) have exactly the same distribution and meaning.³⁹ It follows then that either *pjo* (‘more’) carries comparative degree semantics or it is expletive and the comparative meaning is imported by the covert Deg⁰. I refer to arguments of Schwarzschild (2010) against covert comparative heads discussed in §2.2.4. So the only alternative left is that *pjo* is also a Deg⁰ projecting a DegP and selected by a DegP. Such a construction predicts infinite recursion of DegPs to be possible, a prediction that is not borne out. Therefore, the only available hypothesis is that *pjo* (‘more’) is an element of the extended adjectival projection and what remains to be determined is whether the comparative is realised in one or two different heads.

I would like to adopt a split analysis for the comparative as, not only can it explain the suppletive patterns observed by De Clercq and Vanden Wyngaerd (2017), but it can also capture otherwise unexplained data in Modern Greek. More specifically, synthetic comparatives in Modern Greek are generally formed by the addition of the suffix *-ter-* (CMPR). The affix *-ter-* (CMPR) does not always adjoin to the adjectival stem directly - in some adjectives another vowel or affix is inserted. Even though this root most of the times can be associated to an allomorph of the adjective that appears overtly in e.g. the positive neuter form, shown in the first column of Table 3.3, this is not always the case: Table 3.4 shows that the *-ter-* (CMPR) attaches to a form not otherwise attested in the positive adjective paradigm. Based on these facts, the formation of comparatives is represented in (212). Corroborating evidence for a split comparative head from case assignment will be discussed in §3.5.2.3. To anticipate the discussion, I will show that Modern Greek has oblique standard phrases and for case reasons they need move to [Spec,C1] while the comparative adjective has moved up to C2⁰. So both the morphological evidence discussed below and the syntactic evidence discussed in §3.5.2.3 point towards the existence of two comparative heads in the adjectival periphery.

Table 3.3: Comparative Formation I

Positive	Comparative
<i>oreo</i> ‘nice’	<i>oreo-ter-o</i> ‘nicer’
<i>psilo</i> ‘tall’	<i>psilo-ter-o</i> ‘taller’
<i>metrio</i> ‘mediocre’	<i>metrio-ter-o</i> ‘more mediocre’
<i>ghliki/ghliki</i> ‘sweet’	<i>ghliki/ghliki-ter-o</i> ‘sweeter’
<i>sineches</i> ‘continuous’	<i>sineches-ter-o</i> ‘more continuous’

Table 3.4: Comparative Formation II

Positive	Comparative
<i>evghnomon</i> ‘grateful’	<i>evghnomon-es-ter-o</i> ‘more grateful’
<i>kal-o</i> ‘good/nice’	<i>kal-i-ter-o</i> ‘good/nice’
<i>prot-o</i> ‘first’	<i>prot-i-ter-o</i> ‘prior/earlier’
<i>plision</i> ‘close’	<i>plisi-es-ter-a</i> ‘closer’
<i>kont-o</i> ‘short’	<i>kont-i-ter-os</i> ‘shorter’

³⁹ As will be shown below, on constructions where the English periphrastic comparative has different meaning than the analytic one the periphrastic form corresponds to the comparative adverb *perisotero* (‘more’ - much.CMPR).

(212)

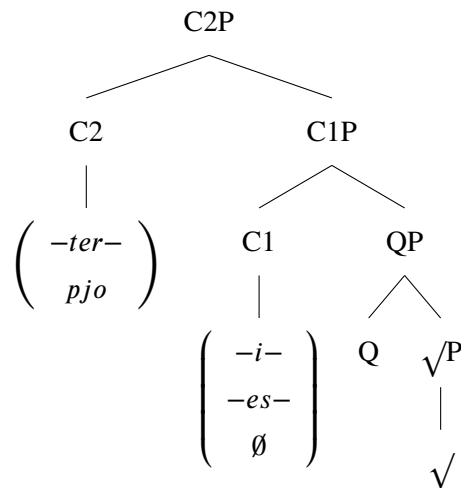

Departing from a degree analysis where both the positive and the comparative are merged in the same Degree head (e.g. Kennedy, 1999) not only does it reflect better the morphological facts but it allows to understand better (though not fully) a previously unnoticed difference between positive and comparative adjectives. As I will show below, positive adjectives merge both in attributive and predicative positions whereas comparative adjectives can only merge in the latter. Prenominal comparative adjectives cannot be ‘sandwiched’ amongst other (positive) attributive adjectives; if we do so, they are interpreted as *asyndeta*, in other words as reduced relatives. What is more, positive and comparative adjectives cannot be coordinated.

If both POS and CMPR are different heads merged in Deg^0 , then positive and comparative adjectives are expected to have the exact same distribution. An additional functional layer may not provide a straightforward explanation of why this does not happen, however, it does not force us to accept that positive gradable adjectives have identical distribution with comparative ones. If positive and comparative adjectives are of the same type of phrase and of the same semantic type (one can assume that the standard of comparison is covert and has already been saturated), then we would expect to be possible to coordinate a comparative and a positive adjective or to nest comparative and positive attributive adjectives. However, this is not possible, at least in Greek.

To demonstrate the above points, I will construct examples with gradable adjectives that merge at the same height in the DP (more specifically adjectives that belong to Laenzlinger’s (2005) scalar physical property category, cf. (195-c)), namely adjectives that can be merged as restrictive adjectives in either order without focus marking (213), adjectives that can form conjunctions in either order (214), and that can be merged in either order when they form a compound (215). So, having controlled for any confounds related to the adjective hierarchy, any observed difference between the comparative adjective and the positive will not be attributable to the different class of adjective. A pair of such adjectives is *stenos* ‘tight’ and *makris* ‘long’.

- (213) a. mia steni makria fusta
a tight long skirt
‘a tight long skirt’
- b. mia makria steni fusta
a long tight skirt
‘a long tight skirt’

- (214) a. Thelo na aghoraso mia steni kai makria fusta.
 want.1SG SBJ buy.1SG a tight and long skirt.
 ‘I want to buy a tight and long skirt.’
- b. Thelo na aghoraso mia steni kai makria fusta.
 want.1SG SBJ buy.1SG a tight and long skirt.
 ‘I want to buy long and a tight skirt.’
- (215) a. sten-o-makr-os
 tight-LNK-long-ADJ.M.SG
 ‘tight and long’
- b. makr-o-sten-os
 long-LNK-tight-ADJ.M.SG
 ‘long and tight’

When only one of the two adjectives is in comparative form (either of them) their conjunction is ungrammatical with flat intonation and the adjectives obligatorily receive a reduced relative interpretation (216).⁴⁰ This is also corroborated by the fact that in conjunctions with an analytic comparative as the first conjunct the only grammatical bracketing is the one that the comparative scopes over both conjuncts; otherwise a reduced relative interpretation for both conjuncts is forced (217). If the second conjunct is the one marked in comparative, again a reduced relative reading is forced like in (216). Finally, when multiple adjectives modify an NP the comparative one must be the outermost otherwise a reduced relative reading is forced (218).

- (216) Thelo na aghoraso mia stenoteri kai makria fusta.
 want.1SG SBJ buy.1SG a tight.CMPR and long skirt.
 ‘I want to buy a tight and long skirt.’ ✓ Reduced Rel. / *Restrictive
- (217) Thelo na aghoraso mia pjo steni kai makria fusta.
 want.1SG SBJ buy.1SG a tight.CMPR and long skirt.
 ‘I want to buy a more tight and long skirt.’
- I want to buy a [[more tight] and [long]] skirt. ✓ Reduced Rel. / *Restrictive
- I want to buy a [more [tight and long]] skirt.
- (218) mia makria stenoteri fusta
 a long tight.CMPR skirt
 ‘a long, tighter, skirt’ ✓ Reduced Rel. / *Restrictive

A question that arises is whether the observed differences are syntactic or semantic.

A tentative hypothesis could be that comparative adjectives are of a different syntactic category hence they cannot be coordinated with positive adjectives. Let’s assume for the sake of the argument that comparative adjectives projected an additional layer of projections, say CompP whereas positive adjectives were mere DegPs. Then we could correctly predict that the two phrases cannot be coordinated and that the CompPs cannot merge in the nominal spine among the restrictive adjectives. Assuming this line of reasoning, we would be forced to accept that comparative forms of adverbs are also CompPs. However, at this point our theory has started generating false predictions: if comparative adjectives and adverbs are of the same syntactic category, then we should be able to interchange

⁴⁰ The same judgements hold regardless the word order of the adjective or which adjective is the one in comparative form. For ease of exposition I will present only one option.

them within a given construction and to coordinate them. The same should apply to positive (gradable) adjectives and adverbs. At this point, it should be clear that attributing the abovementioned facts to a labelling/syntactic mismatch is not possible.

An alternative hypothesis that we could entertain, is that comparative adjectives are of a different semantic type than a positive one. A positive DegP has at most three arguments (the NP it modifies if it is predicative, the gradable property and the contextually supplied degree argument) whereas a comparative phrase can saturate up to four arguments (again the NP if it is a predicative one, the gradable property, the standard phrase and the differential). However, both the differential and the standard of comparison can be covert/supplied by context, so again no type mismatch is expected to occur and it should have been possible to conjoin the comparative adjective the positive one.

So, now we have concluded that positive and comparative adjectives are the same with respect to label and semantic type hence they should have been possible to conjoin, let's re-examine examples (216) to (218). The recurring pattern is that the comparative adjective cannot merge in a restrictive position. In other words, comparative adjectives in Greek, are only predicative adjectives. Corroborating evidence comes from adjectives that cannot be used in predicative and attributive contexts with the same meaning. Such an adjective is *stenos* ('close' or 'narrow/tight'): when used attributively it can have the meaning 'close' or 'narrow' but when used predicatively it can have only the latter meaning, cf. (219). Notice that in the comparative form, the collocation is pragmatically awkward like (220). Sentence (220) significantly improves if a synthetic comparative is used instead of an analytic one (221). This difference is reminiscent of (217). In (217) the comparative marker could scope above the conjunction. Similarly, (221) allows a parsing where the adjective is merged below little *n* (the boundary where idiosyncratic meaning is composed (Marantz, 2001, 2007)) but the comparative marker is merged above it. Examples (222) to (224) show the same effect.⁴¹

(219) (Holton et al., 2012, p. 368 ex. (33))

- a. *stenos filou mou*
close friend mine
'a close friend of mine'
- b. *?o filou mou ine stenos*
the friend mine is narrow
'my friend is narrow'

(220) a. *???O Janis kalese stenoterous filous tu apo ton Mihali.*
the John invited narrow.CMPR friends his from the Michail
'John invited closer friends of his than Mihalis.'

b. *???O Janis ine (enas) stenoteros filou mou apo ton Mihali.*
the John is a narrow.CMPR friend mine from the Michalis.
'John is a closer friend than Mihalis.'

(221) *?O Janis ine pjo stenos filou mou apo ton Mihali.*
the John is more narrow friend mine from the Michalis.
'John is a closer friend than Mihalis.'

(222) (Alexiadou, 2003, ex. (39-c))

⁴¹ There seems to be inter-speaker variation with respect to which adjectives have idiosyncratic meanings or if those are only available in attributive constructions.

- a. o ftochos anthropos
the poor man
'the poor man' (poor = 'impoverished' / 'pitiable')
- b. o anthropos ine ftochos.
the man is poor
'?he man is poor.' (poor = 'impoverished' / *'pitiable')
- (223) a. Vrike eki enan ftocho gherako ke ton ekmetalevete.
found there a poor old.man and him exploit
'he found a poor old man and he takes advantage of him. (poor = 'impoverished' / 'pitiable')
- b. Simera vrike ki enan (akomi) ftochotero anthropako ke ton ekmetalevete ki
today found and one even poor.CMPR man and him exploit and
afton.
him
'Today he found an (even) more poor man and he takes advantage of him too.' (poor = 'impoverished' / *'pitiable')
- (224) a. kathari tichi
'pure luck'
'pure luck'
- b. *i tichi ine kathari
'the luck is pure'
'the luck is clean'
- c. *katharoteri tichi
clean.CMPR luck
'purer luck'

A question that arises is whether the same restriction holds for *perisoteros* ('more' ADJ): quantity adverbs are merged high in the DP hence it is hard to detect whether they appear only in a reduced relative. I think though that the data in (225) suggests that *perisoteros* ('more' ADJ) is an exception to that. When *perisoteros* (much/many.CMPR) is used prenominally it can mean either 'more/ bigger in number' or 'additional' (225). If it is used predicatively, it can only have the former interpretation (226).

(225) Context: *There is a change of CEO in a company. We are commenting on the changes brought by the new CEO.*

Perisoteres alaghes anakinothikan sto dhipno tis tetartis.

many.CMPR changes announced in.the dinner the Wednesday

R1 (more salient): 'Additional changes were announced in Wednesday's dinner.'

R2 (with focus intonation): 'MORE changes (than a previously asserted number) were announced in Wednesday's dinner.'

(226) I alaghes pu anakinothikan sto dhipno tis tetartis itan perisoteres.
the changes that announced to.the dinner the Wednesday were

many.CMPR

'The changes that were announced in Wednesday's dinner were more (/ *additional).'

Additionally, there is a systematic exception to the generalisation the Greek comparative adjectives

are always predicative. In synthetic superlatives, which consist of the definite determiner and a synthetic/analytic comparative adjective, the comparative adjective is not interpreted as a reduced relative. Sentence in (227) does not mean ‘the player, who is tall and who is the best’ but rather ‘the player who among the tall players is the best’. Unsurprisingly, periphrastic superlatives of *stenos* (‘close’, ‘tight’) can have idiosyncratic meanings (228).

(227) O Michalis ine o kaliteros psilos pektis tis omadhas.
 the M. is the good.CMPR tall player the.GEN team
 ‘Mike is the best tall player of the team.’

(228) Sto parti kalesa tus stenoterus mu filus.
 to.the party invited.1SG the tight.CMPR mine friends
 ‘I invited my closest friends to the party.’

Matushansky (2002) observes that Russian synthetic comparatives are only available in predicative positions and she attributes their distribution in the lack of agreement marking. The Greek facts suggest the opposite causal relation: the lack of agreement marking in Russian comparatives is a reflex of the fact that they can only appear in predicative positions. Greek comparatives are case marked both in predicative and attributive positions yet they are only available in the former.

In sum, in this section I have shown that the comparative is realised in two heads and that *pjo* (CMPR) is the overt realisation of the higher one. I have also presented a new puzzle: comparative adjectives can only be predicative (in Greek and possibly Russian as well) and if they are prenominal they are interpreted as reduced relatives. Exceptions to this generalisation are the comparative forms of quantity adjectives and periphrastic superlatives.

3.3.1.2 *perisotero(s)* ‘more’ and *lighotero(s)* ‘less’

Based on the data in §3.3.1, we concluded that *perisotero(s)* ‘more’ and *lighotero(s)* ‘less’ are XPs and more specifically they are the comparative form of the quantity words *poli(s)* (‘many, much’) and *ligho(s)* (‘few, little’). The adjectival forms are used in NP comparisons whereas the adverbials in all other environments.

A question contingent on the XP status of the adverbial *perisotero* (‘more’) and *lighotero* (‘less’) is whether they are adjuncts to the gradable predicate they adjoin to (Bresnan, 1973; Neeleman et al., 2004) or not. If *more* is an adjunct, then it is expected to have a less rigid word-order with respect to the XP it modifies, e.g. to be able to precede or follow it. Furthermore, it is expected to extrapose independently from the XP it adjoins to and vice versa (Neeleman et al. (2004)). As expected, these predictions are borne out when *perisotero* (‘more’ ADV) and *lighotero* (‘less’ ADV) are used in VP comparisons, however, this is orthogonal to their status as comparative markers — the same pattern would be observed with any other (non-)comparative adverb (compare the a sentence to b and c sentences in (229) and (230) below). Sentences in (229) illustrate that the word-order of *more* and *less* is not rigid with respect to the phrase they modify and (230) shows that they can extrapose.

(229) a. I Maria (perisotero/ lighotero) aghapa ton Jani (perisotero/ lighotero).
 the Mary much.CMPR/ little.CMPR loves the John much.CMPR/ little.CMPR
 ‘Mary loves John more.’

- b. I Maria (pathiasmena) aghapa ton Jani (pathiasmena).
the Mary passionately loves the John passionately
'Mary loves John passionately.'
 - c. I Maria (pjo pathiasmena) aghapa ton Jani (pjo pathiasmena).
the Mary CMPR passionately love the John CMPR passionately
'Mary loves John more passionately.'
- (230)
- a. Perisotero/ lighotero aghapa i Maria ton Jani.
much.CMPR/ little.CMPR loves the Mary the John
'Mary loves John more.'
 - b. Pathiasmena aghapa i Maria ton Jani.
passionately the Mary the John
'Mary loves John passionately.'
 - c. I Maria (pathiasmena) aghapa ton Jani (pathiasmena).
the Mary passionately love the John passionately
'Mary loves John more passionately.'

As we can see, the same pattern is replicated even when the comparative quantity words modify adjectives: (231) shows that the adverb may precede or follow the adjective it modifies. Sentences (232-a) and (233-a) show that the gradable predicate may extrapose without the comparative word, (232-b) and (233-b) show that the comparative quantity words may extrapose without the gradable predicate.⁴² Finally, sentences (232-c) and (233-c) show that the comparative word forms a constituent with the standard - if it extraposes it must pied-pipe the standard.

- (231) O Janis ine (perisotero) efevretikos (perisotero) ap' oti nomiza.
the John is much.CMPR inventive much.CMPR from whatever thought
'John is more inventive than I thought.'
- (232)
- a. Efevretikos, theoro oti ine perisotero (apo ti Maria) o Janis.
inventive consider.1SG that is much.CMPR from the Mary the John
'Inventive, I believe that John is more than Mary.'
 - b. perisotero apo ti Maria, theoro oti ine efevretikos o Janis.
much.CMPR from the Mary consider that is inventive the John
'More than Mary, I believe that John is inventive.'
 - c. *perisotero theoro oti ine efevretikos apo ti Maria o Janis.
much.CMPR consider.1SG that is inventive from the Mary the John
'More than Mary, I believe that John is inventive.'
- (233)
- a. Efevretiko, theoro perisotero (apo ti Maria) ton Jani.
inventive consider much.CMPR from the Mary the John
'Inventive, I consider John more than Mary.'

⁴² Extraposition cannot work as a diagnostic if *perisotero* ('more') and *lighotero* ('lighter') modify an adverb — adjuncts are strong islands hence extraction out of them is expected to be ungrammatical.

- (ix)
- a. *Sixna, erhete perisotero/ lighotero o Janis.
Often come much.CMPR/ little.CMPR the John
Intended meaning: 'John is coming more/less often.'
 - b. *perisotero/ lighotero erchete o Janis sichna.
much.CMPR/ little.CMPR comes the John often
Intended meaning: 'John is coming more/less often.'

- b. *perisotero apo ti Maria, theoro efvretiko ton Jani.*
 much.CMPR than Mary, I consider John inventive
 ‘More than Mary, I consider John inventive.’⁴³
- c. **perisotero theoro efvretiko apo ti Maria ton Jani.*
 much.CMPR consider inventive from the Mary the John
 ‘I consider John more inventive than Mary.’

The obligatory extraposition of the standard phrase along with the comparative phrase suggests that they form a constituent. On the other hand, the fact that the gradable predicate on the one hand and the comparative phrase on the other may extrapose independently suggest that the comparative phrase is an adjunct to the gradable adjective.

I would like to propose that *perisotero* (‘more’ ADV) and *lighotero* (‘less’ ADV) are actually measure phrases modifying the VP or the *positive* AdjP. Therefore, *perisotero* and *lighotero* (‘less’ ADV) are merged in the same position as their non-comparative counterparts *poli* (‘much’ ADV) and *ligho* (‘little’ ADV), cf. (234) and (235). Such an analysis predicts that gradable adjectives and coerced non-gradable adjectives modified by *perisotero* (‘more’ ADV) or *lighotero* (‘less’ ADV) can have evaluative interpretations (in contrast to true comparatives, i.e. the equivalent of *pjo* ‘more’ in Greek). As far as their English counterparts are concerned, adjectives that cannot form a synthetic comparative (e.g. polysyllabic adjectives) are expected to be ambiguous between a true comparative and a positive form with a comparative measure phrase whereas synthetic comparatives should unambiguously correspond to a ‘true’ comparative.

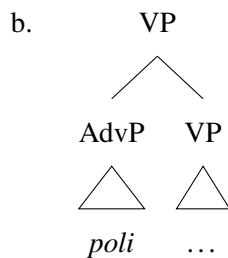
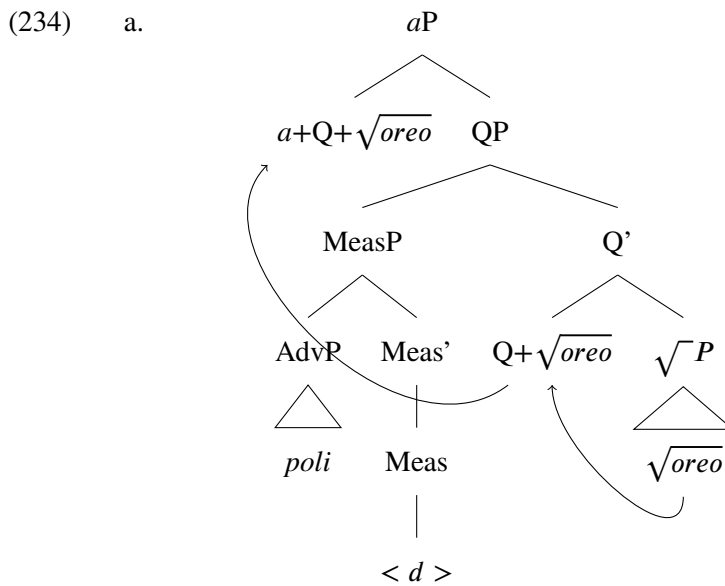

⁴³Sentence (233-b) is actually ambiguous as the extraposed comparative phrase can be construed as originally adjoined to the AdjP or the VP.

(235) a.

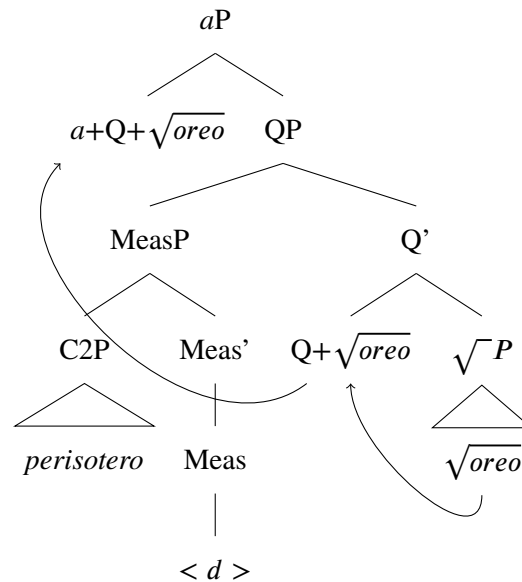

b.

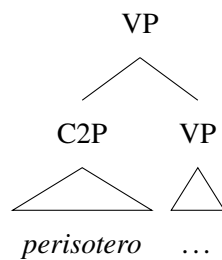

Indeed, Kennedy and McNally (2013), while discussing that *well* is unambiguously a manner adverb, they point out a difference between the use of a synthetic comparative and the use of an analytic one. The analytic form in (236) entails the positive degree, namely that the subject is well prepared, whereas the synthetic form does not. This is naturally explained with the analysis proposed in this section: *more* is the phrasal suppletive adverb equivalent to *perisotero* ‘more’ that adjoins to the positive degree therefore it entails the positive. On the other hand, *better* is the comparative form therefore the evaluative reading is not available. The question that arises is whether English has much-support and there is also an equivalent of *pjo* (‘more’). The pair in (236) is not informative regarding that: the reading of (236-a) is stronger than the reading of (236-b) so it always entails (236-b).

- (236) a. My brother was more well prepared for the events than the rest of us were.
b. My brother was better prepared for the events than the rest of us were.

Corroborating evidence for the existence of a comparative adjunct *more* comes from metalinguistic comparatives, which are only formed with *more* instead of the analytic comparative form of the gradable predicate (Hankamer, 1973, a.o.).

(237) *The army was richer than brave. (Hankamer, 1973)

In sum, Greek clearly shows that there are two ways to form a comparative construction: the former involves the use of a functional morpheme realised as *pjo* or *-teros*. The latter involves the use of the comparative form of a quantity word as a modifier to the positive adjective. Based on the asymmetries between synthetic and analytic comparatives in (236) and (237) above, we can extend this dual analysis

to English: *pjo* (CMPR) corresponds to a functional *more* (cf. *much*-support in Corver, 1997), whereas *perisotero* corresponds to a lexical *more* (much/many.CMPR).

3.3.1.3 The status of *parapano* ('above, more')

In contrast to *pjo* ('more'), the adjectival forms *perisotero(s)/ lighotero(s)* ('more'/'fewer') seem to share the distribution of any other comparative adjective and *perisotero/ lighotero* ('more'/'less') the distribution of adverbials, hence they are comparative XPs. The distribution of *parapano* ('above, more') might be puzzling at first sight: it does not participate in the formation of comparative forms of adjectives/adverbs, it does not carry comparative morphology and its distribution partly overlaps with the distribution of adjectives (it modifies NPs) and adverbs (it modifies VPs). I would like to propose that this mixed distribution stems from the fact that it is a lexical (as opposed to functional) comparative adverb. Its lexical status becomes clear when we take into consideration the other environments it may appear and its interpretations there.⁴⁴ *Parapano* ('above, more') may also function as:

1. a locative adverbial

- (238) a. Aneva ligho parapano.
ascend little above
'Go a little higher.'
- b. To spiti tus ine ligho parapano apo to dhiko mas.
the house their is little above from the POSS 1PL
'Their house is little further up from ours.'
- (239) a. Prohora ligho parapano.
move.on little above
'Go a bit further up.'/ 'Move on a little more.'
- b. Prochora ligho parakato.
move.on little further.down
'Go a bit further down.'/ *'Move on a little less.'

2. a nominal modifier

- (240) a. i parapano ghitionia
the above neighbourhood
'the neighbourhood further up'
- b. o parapano orofos
the above floor
'the floor two floors above the reference point'
- c. ta parapano kila
the above kilos
'the extra kilos'

So non-comparative *parapano* ('above, more') also functions as a VP and NP modifier sharing the same distribution as its comparative variant. So, if we take into account the distribution of *parapano* ('above, more') in non comparative contexts, its distribution in comparatives seems less puzzling. Its

⁴⁴ The meanings and examples are from Institutouto Neoellenikon Spoudon (1998).

internal structure and the fact that it still retains its locative uses indicate that it is a lexical (as opposed to functional) category. Corroborating evidence for its lexical status comes from derivation: *parapano* ('above, more') can be used as the stem for *parapan-isios* ('additional'), cf. (240-c) above. On the other hand, its comparative use seems to relate to another locative adverb which is also one of its constituents: *pano* ('over', 'above', 'on'):

- (241) a. Aneva pano (stin karekla)!
ascend on to.the chair
'Get on the chair!'
- b. o pano orofos
the above floor
'the floor above'
- c. Perimena pano apo mia ora.
wait over from an hour
'I waited over an hour.'

Given the lexical status of *parapano* ('above, more'), its distribution in comparatives does not fall in the scope of this thesis and I will not discuss its properties any further. Before concluding this section though, I would like to point out two parallels, which can provide us with directions for future investigation. The first one is the parallel with the use of manner adverbs like *well* as degree modifiers (cf. Kennedy and McNally, 1999, 2013). The second parallel is with the adjective *different*, which is under the process of grammaticalisation from Adjective⁰ to Degree⁰ (cf. Oxford, 2010a,b).⁴⁵ The appearance of *parapano* ('above, more') in comparative constructions indicates that it gradually loses its locative meaning (*semantic bleaching*) and is being reanalysed as a comparative marker.

3.3.2 Romance Languages

Romance languages form only a handful of synthetic comparatives, all of them suppletive; most gradable adjectives form analytic comparatives. Analytic comparatives are formed by the comparative form of *much* (or *little*) and the positive form of the gradable predicate, on a par with English. The existence of a lexical and a functional *more* is hard to detect as functional *more* appears in a proper subset of the contexts that lexical *more* appears. However, the very existence of synthetic comparatives proves the existence of a comparative functional head. On the other hand, extraposition facts suggest that a lexical *more* may also be available.

- (242) French (Fuchs, 2014, 90)
- a. Pierre est plus grand que Paul. (French)
Peter is (much.)CMPR big SM Paul
'Peter is more big/bigger than Paul.'
- b. Pierre est grand, plus que Paul. (French)
Peter is big much.CMPR SM Paul
'Peter is big, more than Paul.'

On a par with English analytic comparatives (237), French analytic comparative forms are used in metalinguistic comparatives, even if the adjective forms a synthetic one (Fuchs, 2014, 47) (243).

⁴⁵ The grammaticalisation theory adopted is that of Roberts and Roussou (2003).

- (243) En fait, il est plus bon/ (*meilleur) que méchant. (French)
 in fact he is much.CMPR good good.CMPR SM wicked
 ‘In fact, he is more good than bad.’

Corroborating evidence for the existence of two *more*s in Romance languages comes from French phonology. French *more* is pronounced differently depending on the construction it participates in; if it is in a metalinguistic comparative it does not form a liaison with the gradable predicate, hence *plus* ‘more’ in (244-a) is pronounced as [plys], whereas in (244-b) it is pronounced as [plyz] (Fuchs, 2014, 96). The analysis that has been put forward based on the Greek data correctly predicts this phonological distinction: functional *more* belongs to the extended functional projection of the adjective therefore morphophonological phenomena like liaison are expected, whereas ‘lexical’ *more* found in metalinguistic comparatives is an adjunct.

- (244) a. Il est plus [plys] idiot que méchant. (French)
 he is much.CMPR idiot SM wicked
 ‘He is more idiot than wicked.’ metalinguistic comparative
- b. Il est plus [plyz] idiot que méchant. (French)
 he is CMPR idiot SM wicked
 ‘He is more idiot than wicked.’ degree comparative

Based on these facts, we can conclude that Romance languages also use both strategies to form comparatives even though the homophony of lexical and functional *more* may prima facie blare the picture.

3.3.3 Interim Summary

To sum up, after examining the morphosyntax of Greek comparative markers, I have argued that Greek offers further evidence that the comparative is realised into two heads; the higher one in Standard Modern Greek consistently realised as *pjo* (CMPR) or *-ter-* (CMPR) depending on whether the gradable predicate has moved and adjoined to the comparative head C2. A system with two comparative heads can also accommodate double comparative formation. On the other hand, the comparative forms of quantity words, simply referred to as lexical *more*, are analysed as their non-comparative equivalents. Their distribution that they are adjuncts to the VP or the AdjP (based on our considerations for the structure of the positive, it modifies the degree variable introduced by the gradable predicate) whereas the adjectival forms of quantity words function as predicates of measurement/cardinality. The distinction of two *more*’s extends to English and Romance languages and explains asymmetries between the use of synthetic and analytic forms with predicates that allow both. Finally, I have shown that *parapano* (‘above, more’), which is studied in recent literature as a comparative marker (Arregi, 2013; Giannakidou and Yoon, 2011; Giannakidou, 2012; Matushansky and Ionin, 2011, a.o), is actually a lexical category that can receive degree interpretations; it is not a comparative marker. Finally, I have shown that comparative adjectives are always predicative, with the exception of periphrastic superlatives, and possibly comparative quantity adjectives.

3.4 Asymmetries between phrasal and clausal comparatives

As discussed in §2.3.2, the type and size of the constituent selected by the standard marker can vary (at least on the surface) and there is a long standing debate whether standard phrases that consist of (the standard marker and) an NP are remnants of larger constituents. The empirical differences that triggered the debate whether phrasal comparatives are different than clausal ones lie on:

- i) acceptability after extraction (Hankamer, 1973); the ungrammaticality of (245-b) indicates the existence of a *wh*-island not present in (245-a):

(245) (Hoeksema, 1983, examples from)

a. ?Who does she eat faster than?

b. *Who is John taller than — is?



- ii) the availability of multiple *wh*-items (Hoeksema, 1984, citing Brame (1983)); phrasal comparatives allow multiple *wh*-items, one of them replacing the standard phrase in parallel with transitive clauses containing two *wh*-items

(246) a. Who is taller than who?

b. *Who is taller than who is?

c. Who looks after who?

- iii) licensing of reflexives and reciprocals (Hankamer, 1973; Hoeksema, 1983); reflexives and reciprocals are grammatical in phrasal comparatives indicating a monoclausal domain:

(247) a. Nobody is stronger than himself.

b. Nobody is stronger than himself is.

(248) a. They cannot possibly be taller than each other.

b. *They cannot possibly be taller than each other are.

- iv) their monotonicity properties; NPIs that are normally licensed in downward entailing or, in the case of Dutch *ook maar* 'whatsoever, at all', antiadditive contexts (Hoeksema, 1983) are grammatical in clausal but not phrasal comparatives:

(249) a. Wim was minder vervelend, dan ook maar iemand voor hem was geweest.
W. was less obnoxious, than at all anyone before him (had) been
'Wim was less obnoxious than anyone at all before him had been.'

b. *Wim is gevaarlijker dan ook mar iemand. Wim is more dangerous than
W. is more-dangerous than whosoever anyone
anybody whosoever.

- v) licensing of negative concord; in phrasal comparatives matrix negation can license an *n*-word in the standard phrase whereas in clausal comparatives it cannot (Merchant, 2009; Bhatt and Takahashi, 2007b,b, 2011)

- vi) the number of pivots following the standard marker; phrasal comparatives are only followed by

one, clausal comparatives may be followed by more (Merchant, 2009)

- vii) the category of the pivot; in phrasal comparatives it is only a DP (Merchant, 2009)
- viii) case marking of the DP; the phrasal standard marker case marks the DP whereas the clausal does not. In clausal comparatives the DP carries the case that corresponds to its syntactic role in the standard clause and may even be marked in nominative (Hankamer, 1973; Merchant, 2009)
- ix) the availability of synthetic and analytic comparatives (Pancheva, 2006, based on an observation by (Matushansky, 2002)); In Russian a phrasal standard phrase may appear with the synthetic comparative but not with an analytic one.

(250) Germann byl sil'nee...
Germann_{NOM} was stronger
'Germann was stronger...'

- a. čem (byl) ego protivnik b. svoego protivnika
what_{INSTR} was his adversary_{NOM} [own adversary]_{GEN}
'...than his adversary (was).'

- x) the choice of standard marker in measure phrase comparatives; In Russian only the genitive standard marker is accepted in measure phrase comparatives; the clausal variant, even though not ungrammatical, is strongly unacceptable (Pancheva, 2006)

(251) 'Ivan measures in height more than 2m.'
a. #Ivan rostom bol'she, čem dva metra.
Ivan in-height more what two meters
b. Ivan rostom bol'she dvux metrov.
Ivan in-height more what [two meters]_{GEN}

- xi) the lack of equivalence between a phrasal comparative and their —assumed— non ellided counterpart; under an ellipsis analysis a sentence like (252-a) should be derived from (252-b), which does not make sense, and cannot be derived by the more plausible (252-c) (Pinkham, 1982). Again, an ellipsis account of phrasal comparatives would predict that the phrasal comparative in (253-a) should have the same interpretations as the non-phrasal one in (253-b), but it does not.

(252) a. Mary ran faster than the world record.
b. Mary ran faster than the world record ran.
c. Mary ran faster than the world record is.

(253) Kennedy (1999, ex. (225)-(226))
a. The table is longer than the rug is wide, and the rug is longer than the desk.
(i) 'The table is longer than the rug is wide and the rug is longer than the desk is long.'
(ii) *'The table is longer than the rug is wide, and the rug is longer than the desk is wide.'
b. The table is longer than the rug is wide, and the rug is longer than the desk is.

- (i) ‘The table is longer than the rug is wide, and the rug is longer than the desk is <long>.’
- (ii) ‘The table is longer than the rug is wide, and the rug is longer than the desk is <wide>.’

On the other hand, an idiom containing a phrasal comparative cannot be replaced by its — assumed— non ellided counterpart (Hoeksema, 1984, citing Brame (1983));

- (254) a. He seemed larger than life.
- b. *He seemed larger than life is.

As discussed in §2.3.2, both direct and ellipsis accounts take into account (some of) the aforementioned differences between the ‘phrasal’ comparatives and the clausal ones. The difference between the two lies on how those differences are derived: in clausal analyses they are derived due to the operation of some ellipsis mechanism whereas in direct ones through base generation of a smaller constituent. It is worth noting that the availability of scalar semantics is also pertinent to the postulation of one or more *-er*: analyses that resolve to degree semantics (for clausal comparatives) allow for base generation of measure phrase comparatives (189-b), as measure phrases have the same semantic type as clausal standards. Hence, resolving to ellipsis is only necessary for phrasal comparatives with other types of NPs, like (189-a) above. On the other hand, vague predicate analyses can accommodate phrases with NPs but they need some mechanism to derive measure phrase comparatives (189-b).

3.5 Types of phrasal comparatives

In this section I will examine the syntactic properties of the standard phrases that appear as complements of a prepositional standard marker or in oblique case. Careful examination of the types of phrasal standards allowed in Greek and Romance reveals that there is no one-to-one mapping between the phrasal vs. clausal distinction on the one hand and the choice between a two- and a three-place comparative operator on the other. French, Spanish, and Catalan phrasal standard markers select only for —degree— denoting Numeral Phrases, which do not necessitate the postulation of a distinct comparative operator. On the other hand, the Greek and Italian prepositional standard marker selects for DPs, NumPs, and AdjPs as complements irrespective of their semantic type.

Additionally, careful examination of Greek oblique nominal standards reveals a new locus of parametric variation within Greek varieties: nominal standards in Standard Modern Greek (SMG) are marked with Genitive whereas nominal standards in South Eastern varieties of Greek (SEG) are marked with dative. PP-DP alternations of Greek nominal standards and a strong requirement for an overt definite determiner reveal a weak island in phrasal comparatives and suggest that oblique standards are derivationally related to prepositional ones, a finding that restores a robust universal: no language employs more than one phrasal standard marker.

Greek oblique standards also provide novel evidence for the need of a fine grained Adjectival spine along the lines of De Clercq and Vanden Wyngaerd (2017) and the syntactic status of the synthetic vs. analytic alternation. Furthermore, weak islands in comparative and their interaction with definiteness gives us new insights regarding the ontology of degrees and their visibility to grammar. Finally, In

light of this data, I conclude that the choice of standard marker is syntactic and sensitive only to the syntactic type and size of the complement. Semantic restrictions on the standard are not encoded on the standard marker.

3.5.1 Prepositional Standards

In this section, I will examine phrasal standards in Greek, Italian, French, Spanish, Brazilian Portuguese and Catalan introduced by a preposition meaning ‘from’. I will show that languages are split into two categories: the former category consists of languages that the phrasal standard marker introduces all types of DPs as well as predicates and includes Greek and Italian whereas the latter class consists of languages that allow only measure phrases as phrasal standards and includes French, Spanish, Brazilian Portuguese and Catalan.

Overall, prepositional standards can be divided into two categories: ‘argument’ standards where the DP that is a complement of the preposition is an argument and it is case-marked by the preposition and ‘predicative’ standards that can be realised by predicates of various categories (Adjective Phrases, Bare noun phrases) and case transmission phenomena are observed. An interesting split appears amongst Measure phrases: measure phrases with semi lexical nouns, which always denote degrees, e.g. *three meters* and standards of amount comparatives, either agree in case with the comparative predicate or are marked in accusative, whereas other Numeral Phrases that receive a degree interpretation after the application of an operator, e.g. *three bags*, need to be case-licensed by the preposition, and receive accusative case. The different types of phrasal standards are exemplified in (255), (256) and (257).

- (255) a. O Janis ine meghaliteros apo ton Mihali. (Definite DP)
 the John is older from the.ACC Mike
 ‘John is older than Mike.’
- b. O Janis ine meghaliteros apo enan ghnosto mu. (Indefinite DP)
 the John is older from a acquaintance mine
 ‘John is older than one of my acquaintances.’
- (256) a. To rizi pu appetite ine perisotero apo 5 paketa. (Amount comparative - Individ-
 the rice that be.required is more from 5 packs.
 ual/Degree Measure Phrase)
 ‘The rice that is required is more than 5 packs.’
- b. To rizi pu appetite ine perisotero apo 5 kila. (Amount comparative -
 the rice that be.required is more from 5 kilograms.
 Degree Measure Phrase)
 ‘The rice that is required is more than 5kg.’
- c. O Janis ine psiloteros apo 1.90. (Degree Measure Phrase)
 the John is tall.CMPR from 1.90
 ‘John is taller than 1.90.’
- (257) a. Ine kaliteros ki apo dhaskalos. (Bare NP)
 be.3SG better.NOM even from teacher.NOM
 ‘He is even better than a teacher (in explaining things).’
- b. Ine kaliteros ki apo kalos. (Gradable AdjP)
 be.3SG better.NOM even from good.NOM
 ‘He is even better than (just) good.’

Before preceding to examine the syntactic properties of phrasal standards I will show that Greek and Italian phrasal comparatives pattern with prepositional phrases and the comparatives that contain them with a mono-clausal structure. As for the other Romance phrasal standards, the limited array of complements they combine with and the fact that they already denote degrees strongly suggest that they are phrasal, therefore, I will not elaborate further on that.

3.5.1.1 Phrasal (not clausal) standards

Standard phrases with *apo* ('of, from'), as opposed to standards introduced by *ap' oti* ('from what'), present properties typical of prepositional phrases and compatible with a monoclausal structure. Some of those were discussed by Merchant (2009) and are summarised in Table 3.5.

Table 3.5: Properties of *apo* vs. *ap' oti* (Merchant, 2009, (26))

	<i>apo</i>	<i>ap' oti</i>
Allows only one pivot?	Yes	No
Allows only DP pivot?	Yes	No
Always marks pivot with accusative?	Yes	No
Allows pied-piping?	Yes	No
Allows reflexive binding from matrix clause?	Yes	No
Licenses negative concord from matrix clause?	Yes	No

These are not the only properties that *apo* ('of, from') in comparatives behaves the same way as the preposition *apo* ('of, from') in other constructions. In general, *apo* ('of, from') cannot select for other prepositions. This limitation is also observed in phrasal comparatives introduced by *apo* ('of, from'): If the associate (and consequently the standard) is a prepositional phrase a clausal comparative is the only grammatical option:

- (258)
- a. O Janis pige sto scholio noritera apo *(oti) sto frontistirio.
The J. went to.the school earlier from wh to.the evening.school
'John went to school earlier than (he went) to the evening school.'
 - b. Perisoteri anthropi sistisan ton Jani stin Maria apo *(oti) ston Mihali.
more.ADJ people introduced.3PL the J. to.the M. from wh to.the Mike
'More people introduced John to Mary than to Mike.'
 - c. O Janis elave perisotera gramata apo tin Maria apo *(oti) apo ton Mixali.
the John receive more letters from the Mary from wh from Mike
'John received more letters from Mary than from Mike.'
 - d. O Janis milise ja tin perivalontiki katastrafi ektenestera apo *(oti) ja ta
the John talked for the environmental destruction longer from wh for the
pirinika opla.
nuclear weapons
'John talked for the environmental destruction longer than for the nuclear weapons.'

Apo (from/ than) does not necessarily assign accusative case in Greek (Cheila-Markopoulou, 1986). In predicative constructions it is followed by a nominative predicate. This pattern is also replicated in

comparative constructions:⁴⁶

- (259) a. Apo mikros kataghinotan me kataskeves. (Cheila-Markopoulou, 1986, (103))
from young be.occupied with constructions
'Since he was a child, he occupied himself with building things.'
b. Apo dhimarchos klitiras. (Cheila-Markopoulou, 1986, (104))
from mayor clerk
'From a mayor (he became) a clerk.'
- (260) Irthan perisoteri apo enas/ enan. (Cheila-Markopoulou, 1986, (105-b))
came.3PL more.PL from one.NOM/ one.ACC
'More than one came.'
- (261) a. Mu stathike kalitera (ki) apo pateras/ apo patera.
me.DAT stand better and from father.NOM from father.ACC
'He stood by me better than a father.' (Cheila-Markopoulou, 1986, (106))
b. Ine kaliteros ki apo kalos.
be.3SG better.NOM and from good.NOM
'He is better than (just) good.'
- (262) perisoteres apo mia karamela/ kameles
more than one candy/ candies
'more than one candy'

⁴⁶ Cheila-Markopoulou (1986) also includes (x-a) and (xi) as exceptional cases where *apo* ('from') does not assign accusative case. In (x-a) it seems that there is a covert DP *to maghazi* (the shop) and the genitive DP is a possessive. The fact that genitive is ungrammatical for shops that are not named after their owner's name shows that this line of analysis is on the right track (x-b):

- (x) (Cheila-Markopoulou, 1986, (102))
- a. Psonise apo tu Klaudatu.
shop from the.GEN Klaudatos.GEN
'He shopped from Klaudatos's (shop).'
- b. Psonise apo tin 'pexnidupoli'/*tis 'pexnidupolis'.
shop from the.ACC toyland.ACC/ the.gen toyland.GEN
'He shopped from 'Toyland'.'

On the other hand, the nominative in (xi) could be amenable to case mismatch effects typically found in relative clauses (xii) (Alexiadou and Varlokosta, 2007; Daskalaki, 2007, 2008, 2011, a.o.). If the *wh*-item *osus* is base generated as an object and there is no mismatch between the internal and the external case, nominative becomes ungrammatical (xiii):

- (xi) Irthan perisoteri ap' osus/ osi ixan dhilosi. (Cheila-Markopoulou, 1986, (105a))
came.3PL more.NOM than WH.REL.ACC/ WH.REL.NOM have.3PL signed.up
'There arrived more people than had signed up.'
- (xii) a. Aghapo opjon/ *opjos me aghapa.
love.1SG whoever.ACC/ *NOM me.ACC love.3SG
'I love whoever loves me.'
b. Irthan opji/ *opjus kalesa.
came.3PL WH.REL.NOM/ WH.REL.ACC invited
'Whoever I invited came.'
- (xiii) Irthan perisoteri ap' osus/ *osi kalesa.
came more than WH.REL.ACC/ WH.REL.NOM invited
'More people than I invited came.'

Applying the same diagnostics to Italian *di* ('from, of') comparatives suggest that *di* ('from, of') also introduces phrasal comparatives.

- case marking of the pivot

(263) Gianni ha mangiato più caramelle di te/ *tu. Italian
 John has eaten many.CMPR candies from.SM you.acc you.NOM
 'John has eaten more candies than you.'

- availability of non-DP pivots

(264) Spende più denaro che/ *di non guadagni. Italian
 Spends much.CMPR money that.SM from.SM NEG earn.SBJ
 'He spends more money than he earns. (Maiden and Robustelli, 2007)

- possibility of reflexive binding from the matrix clause

(265) Nessuno è più alto di/ *che se stesso. Italian
 n-person is CMPR tall from.SM/ that.SM him same
 'Nobody is taller than himself.'

- negative concord licensing from the matrix clause

(266) Non est più alto di/ *che nessuno. Italian
 NEG is CMPR tall from.SM that.SM n-person
 'S/ he isn't taller than anybody.'

Napoli and Nespors (1986) also argue that *di* ('from,of') in comparatives is the same as the preposition. They base their analysis on the fact that

- the standard marker is homophonous to the preposition;
- they select the same types of complements;
- the pivot of the standard marker cannot be extracted exactly as the preposition cannot be stranded;
- it can alternate with *ne* (CL);

(267) a. Ho comprato un pacchetto di sigarette.
 have.1SG bought a pack of cigarettes
 'I have bought a pack of cigarettes.'

b. Ne ho comprato un pacchetto.
 CL have bought a pack
 'I've bought a pack of them.'

(268) a. Sono molto fiero di lui.
 am much proud of him
 'I am very proud of him.'

b. Ne sono molto fiero.
 CL much proud of him
 'I am very proud of him.'

(269) (Napoli and Nespors, 1986)

- a. È migliore di Luca.
is good.CMPR from Luca
'S/He is better than Luca.'
- b. Ne è migliore.⁴⁷
CL is good.CMPR
'S/He is better than him.'

- both *di*-standards and prepositional phrases trigger structural ambiguities depending their height of attachment.

The data in this section clearly suggest that Greek and Italian standard markers *apo* and *di* are prepositional. In the next sections, I will examine the different types of standards they introduce.

3.5.1.2 Predicative Standards

As mentioned in §3.5.1, Greek and Italian allow for nominal or adjectival predicates to function as standard phrases. Greek examples were given in (261) above and (270) shows an example from Italian. Given the unavailability of case marking in DPs in Italian we cannot positively confirm that they can be used as predicates in comparatives.⁴⁸

- (270) È meglio di buono.
is good.CMPR from good
'It is better than (just) good.'/ 'He is even better than good.'

The existence of predicative standards at first glance might seem to lend support to Pancheva's (2006, 2009) analysis of phrasal comparatives as small clauses (cf. §2.3.2.2.1). However, if we examine more closely her analysis it does not extend to this data: it fails to account for nominative case assignment. Furthermore, there are several theoretical drawbacks with this analysis: Greek is a language that overtly realises *wh*-operators in clausal comparatives (cf. Chapter 4) hence their being phonologically null only in phrasal comparatives seems an ad hoc stipulation; Greek *wh*-small clauses are not available in other environments in Greek. Additionally, the identity between partitives and phrasal comparatives does not survive under scrutiny: firstly, partitives require a DP with an overt determiner as a complement of the preposition, cf. (271), and secondly, they denote the reverse subsethood relation: if comparatives had partitive semantics we would expect the standard to denote a higher degree than the correlate. Finally, the use of the same preposition in partitives and comparatives is a rather weak piece of evidence for a common analysis of the two constructions: *apo* ('from, of') and its Slavic cognates are light prepositions that participate in a wide variety of constructions with more or lesser semantic content.⁴⁹ The same preposition could be associated with a wide variety of constructions; if we were to draw such a link between *apo* ('from, of') in comparatives and other uses, cross-linguistic

⁴⁷ As we will see in 3.5.2 Greek standards also alternate with clitics. However, my Italian informants did not allow for cliticisation of the *di*-phrases.

⁴⁸ Given the availability of adjectives in the standard phrase and the parallels between Greek and Italian phrasal comparatives, the only reason why these two languages may differ is pertinent to whether bare NPs can function as predicates. In other words, any difference is not pertinent to the parametrization of the standard phrase or the comparative construction but rather to their interaction with other parameters.

⁴⁹ See Terzi (2010) for an example of merging an otherwise 'light' preposition in different positions within the locative phrase and the consequent semantic differences.

variation suggests that the most appropriate connection would be with locatives (cf. Stassen’s (1984, 1985) typology in §2.1.1, Schwarzschild’s (2012) analysis of degree expressions as directed scale segments and evidence for locative semantics provided therein as well as §3.5.2.2 below for the use of ablative case in Indo-European).

- (271) a. Ena ghlifitzuri ine akrivotero apo 5 karameles.
 a lollipop is expensive.CMPR from 5 candies
 ‘A lollipop is more expensive than 5 candies.’
 b. O Janis efaghe 3 apo *(tis) 5 karameles.
 the John ate 3 of the 5 candies
 ‘John ate 3 (out) of the 5 candies.’

I would like to propose that these constructions are another instance of a preposition functioning as a RELATOR and that the *apo*-phrase in these predicative constructions functions as a degree denoting adjunct. The degree denotation of the prepositional complement is derived by an operator like Rett’s (2014) Mes-Op, which maps a predicate of individuals to a set of degrees.

- (261) Greek
 a. Mu stathike kalitera (ki) apo pateras. (Cheila-Markopoulou, 1986,
 me.DAT stand well.CMPR and from father.NOM
 (106))
 ‘He stood by me better than a father.’
 b. Ine kaliteros (ki) apo kalos.
 be.3SG good.CMPR.NOM and from good.NOM
 ‘He is better than (just) good.’/ ‘He is even better than good.’

Rett (2014) argues that any DP can receive a degree interpretation as long as it is construed as part of a whole. Therefore, an expression like *heavy barbells* can receive a measure interpretation if construed as representing a degree of exertion.

- (272) Heavy barbells is not enough — to get in shape, you’ll need to do some cardio too.

In a similar fashion, the use of the predicate *father* in (271-a) associates the property of being a father with a (high) level/degree of support. As predicted by Rett’s (2014) analysis, the scale that the nominal is associated with is sensitive to context; indeed the same predicate in (273) is associated with a degree of control. In the case of adjectival predicates, the degree argument of the standard phrase is used as the standard of comparison.

- (273) Elegxi tis kinisis tu Jani afstirotera ki apo pateras.
 control the movements the John strictly.CMPR and from father
 ‘He is more controlling than a father.’

The acceptability comparatives like (261) significantly improves with the presence of the additive particle as it overtly introduces scalar alternatives and facilitates the monotonic construal.⁵⁰

⁵⁰ For the different aspects of the meaning of additive *ke/ki* (‘and, even, also, too’) in Greek the reader is referred to Chatzikyriakidis et al. (2015); Giannakidou (2007); Giannakidou and Yoon (2016); Iatridou and Tatevosov (2016). Even though the present analysis is not compatible with some of these analyses, the core idea, namely that *ke* is associated with

3.5.1.3 Measure Phrases

The prepositional standard marker of all Romance languages studied in this thesis may combine with degree denoting nominals or simply referred to as measure phrases. (256) and (274) exemplify sentences with a phrasal standard. Actually the Spanish, French and Brazilian Portuguese prepositional standard marker may only combine with measure phrases.⁵¹

- (256) a. To rizi pu appetite ine perisotero apo 5 paketa. (Individual/Degree MP)
the rice that be.required is much.CMPR from 5 packs.
'The rice that is required is more than 5 packs.'
- b. To rizi pu appetite ine perisotero apo 5 kila. (Degree Measure Phrase)
the rice that be.required is much.CMPR from 5 kilograms.
'The rice that is required is more than 5kg.'
- c. O Janis ine psiloteros apo 1.90.
the John is tall.CMPR from 1.90
'John is taller than 1.90.'
- (274) a. Gianni a mangiato pu di quattro caramele. Italian
John has eaten much.CMPR from 4 candies
'John ate more than 4 candies.'
- b. un village qui compte un peu plus de 4.000 habitants. French
a village that counts a bit many.CMPR from 4000 habitants
'a village that counts a bit more than 4.000 habitants.' (Batchelor and Chebli-Saadi, 2011)
- c. Faltan menos de tres semanas para la Navidad. Spanish
miss little.CMPR from.SM three weeks for the Christmas
'There are less than three weeks left before Christmas.' (Kattán-Ibarra and Pountain, 2003)
- d. més de mil rieres Catalan
more from.SM thousand stream
'more than a thousand streams'⁵²
- e. mais de cem mil pessoas. Br. Portuguese
much.CMPR of 100 thousand people
'more than a hundred thousand people.' (Whitlam, 2011)

A special case of measure phrase comparatives are amount comparatives. There has been a long standing debate whether amount comparatives for standards involve complex determiners or they are instances of phrasal comparatives. Most recent research has presented overwhelming semantic and syntactic evidence that the correct bracketing is the one in (275-a) and not (275-b) (Matushansky and Ionin, 2011; Hackl, 2000; Arregi, 2013, a.o). Number agreement on the NP is one of the strongest arguments against a complex determiner analysis of nominal NP comparatives (278-b).

- (275) a. John read [more [than [three books]]].
b. *John read [[more than three] books].

focus, is maintained.

⁵¹ *De/di* ('from') comparatives may combine with a *wh*-clause as well, however, these constructions are discussed in more detail in chapter 4.

⁵² <http://www.ccma.cat/tv3/Mes-de-mil-rieries/especial/550/> last accessed 28/ 12/ 2014

- (276) a. more than one book/ *books
 b. fewer than one books/ *book

However, Greek seems to challenge this broad cross-linguistic generalisation, as it allows NPs marked for either number. However, there is a crucial interpretational difference between the two: (277-a) means that the number of books that John read exceeds 1 whereas (277-b) means that John read more *things* (e.g. journals, papers, books, etc) than one book. The underlying structure for each sentence is given in (278).

- (277) a. O Janis diavase perisotera apo ena vivlia.
 the John read many.CMPR than one book.PL
 ‘John read more than one book.’
 b. O Janis diavase perisotera apo ena vivlio.
 the John read many.CMPR than one book
 ‘John read more than one book.’
- (278) a. [more [than [one \emptyset]] books]
 b. [\emptyset [more [than [one book]]]]

In the remainder of this section I will focus on Greek measure phrase comparatives because Greek DPs are overtly marked for case and number hence they can provide us with overt evidence for their internal structure. A fact that has been overlooked so far is the different agreement patterns of measure phrases with semi-lexical nouns and other number phrases as standards in amount comparatives. While ‘regular’ number phrases can only function as arguments, measure phrases with semi-lexical nouns can function either as cardinality/degree predicates or as arguments.

- (279) To rizi pu mirastike sto sisitio itan perisotero apo 5 toni/ tonus.
 the rice that distributed to.the soup.kitchen was many.CMPR than 5 tones.NOM/ tones.ACC
 ‘The rice served at the soup kitchen was more than 5 tones.’
- (280) To rizi pu mirastike sto sisitio itan perisotero apo 5 *sáki/ sakus.
 the rice that distributed to.the soup.kitchen was many.CMPR than 5 bags.NOM/ bags.ACC
 ‘The rice served at the soup kitchen was more than 5 bags.’

The ungrammaticality of the nominative (280) is better understood when we take into account that the measure phrase is actually part of a pseudopartitive construction: the head of the phrase is the content noun *rice* and that needs to be marked in accusative.⁵³ If the semi-lexical noun is used in the pseudopartitive construction nominative case marking is no longer available.

- (281) To rizi pu mirastike sto sisitio itan perisotero apo 5 *sáki/ sakus
 the rice that distributed to.the soup.kitchen was many.CMPR than 5 bags.NOM/ bags.ACC
 <rizi>
 rice
 ‘The rice served at the soup kitchen was more than 5 bags.’
- (282) To rizi pu mirastike sto sisitio zighize perisotero apo 5 *toni/ tonus
 the rice that distributed to.the soup.kitchen was many.CMPR than 5 tones.NOM/ tones.ACC

⁵³ For an overview of pseudopartitives cf. Csirmaz and Stavrou (2017) and references therein.

<rizi>.

rice

‘The rice served at the soup kitchen weighed more than 5 tones.’

The question that arises then is what is the source of the nominative in (279). I would like to propose that the nominative in (279) is another instance of a predicative comparative as those examined in §3.5.1.2. Further evidence that an analysis across these lines is on the right track comes from amount comparatives with count nouns as standards.

- (283) a. Irthan perisoteri apo enas kalesmenos.
came.3PL many.CMPR.NOM.PL from one.NOM invitee.NOM.SG
‘More than one guest came.’
- b. Irthan perisoteri apo enan kalesmeno.
came.3PL many.CMPR.NOM.PL from one.ACC invitee.ACC.SG
‘More than one guest came.’
- c. Irthan perisoteri apo enas kalesmeni.
came.3PL many.CMPR.NOM.PL from one.NOM invitee.NOM.PL
‘More than one guest came.’

Sentence (283-c) corresponds to (278-a); the standard that contains the numeral predicates over the comparative adjective on a par with (271-b) above. Sentences (283-a) and (283-b) correspond to the structure in (278-b); however they have a rather different interpretation; (283-a) is also a predicate of degrees, like (283-c) whereas (283-b) introduces an ‘argument’ DP. Their difference becomes clear if we take into account their acceptability in different contexts: in context (284-a) only the accusative NumP is allowed compatible with an entity interpretation whereas in (284-b) the predicative standard that receives a degree interpretation is preferred.

- (284) a. Ti mono o Janis irthe?
what only the John came
‘What? John was the only invitee who came?’
(283-a)# (283-b)✓
- b. Ti meta apo tous kalesmenus mono enas irthe?
what after from so.many invitees only one came
‘After so many invitees, only one guest came.’
(283-a)✓ (283-b)?#

The data studied in the last two sections are informative for two (interrelated) aspects of nominals: the argumentising head and the relation between individual and degree interpretations. The data from measure phrases with predicative uses suggest that a finer grained distinction is required with regard to argumentising heads. Alexopoulou et al. (2013) suggested that Number in Greek is specified as [+RefCard,+Typeshift] which means that it both argumentises the lexical noun and also provides information regarding referential cardinality. A tentative proposal could be that numerals in Greek can be merged either below number like attributive adjectives or above number argumentising the NP (for a semantic proposal of numerals as gradable adjectives cf. Ionin and Matushansky, 2006). In the former case the NP functions as a predicate of degrees whereas in the latter as an argument. I leave to future investigation the implications of such a proposal.

The data examined in the last two sections are also informative regarding the relation between degree and individual interpretations. There have been several proposals regarding the relation between the two and which one is the basic meaning. Brasoveanu (2009) argues that the degree reading of number words is the basic one and the entity interpretation is derived from it; Rett (2014) argues quite the opposite namely that the environments that allow degree interpretations of DPs are a proper subset of the environments that allow an individual interpretation hence the individual interpretation is the basic and the degree one is derived after the application of a measure operator; finally, Snyder and Barlew (2015) argue that NPs are divided into two classes: measure phrases that receive only a degree reading on the one hand and on the other atomizers and container nouns that can have both. As for the latter, the individual interpretation is the basic one and the degree interpretation is derived from the application of the Universal Measurer. The data studied in 3.5.1.3 suggest that Rett's (2014) measure operator is necessary to derive the degree interpretations of predicates whereas Snyder and Barlew's (2015) universal measurer undergenerates; on the other hand Rett's (2014) thesis that the entity interpretation is always the basic one and that all degree interpretations are derived fails to capture the fact that common nouns and degree denoting semi-lexical nouns like *tone* do not share the exact same distribution. In that sense, Brasoveanu's (2009) proposal seems to be more promising.

3.5.1.4 Other DPs

A question that often arises is whether *apo*-phrases are complements or adjuncts to the comparative phrase. The presence of incomplete comparatives, makes harder the characterisation of the standard phrase as an argument or an adjunct. Even though obligatoriness is a hallmark of arguments, optionality is not a hallmark of adjuncts: arguments may also be optional. However, as Meyers et al. (1996) point out, if an optional argument is omitted it is implied, in contrast to adjuncts, which are not recoverable. In (285-a) there is an implied standard of comparison on a par with (286-b).

(285) a. O Janis ine psiloteros.
the John is tall.CMPR
'John is taller.'

(286) (Meyers et al., 1996, (14))

- a. John ate [something].
- b. John ate.
- c. John ate [slowly].

Another common property of adjuncts is the possibility of merging more than one of them in contrast to arguments that are of a limited number and which carry (uniquely realised) theta-roles.(287).

- (287) a. I jineka apo to York apo tin Agglia.
the woman from the York from the England
'the woman from York from England.'
- b. *O Janis ine psiloteros apo ti Maria apo tin Eleni.
the John is taller from the Mary from Helen
'*John is taller than Mary than Helen.'

English equality comparatives are pretty much parallel to inequality comparatives hence the alterna-

tion between *as* and *than* provides a straightforward argument for c-selection and argumenthood. Unfortunately, Greek equality comparatives are formed rather differently than inequality ones therefore minimal pairs between equality and inequality comparatives is not informative regarding selection. However, one can still make an argument that the *apo*-phrase is selected by the comparative head, since it does not alternate with any other preposition. Compare to (198-b) where the adjunct to the positive adjective can be introduced by *for* or *by*.

- (288) O Janis ine meghaliteros apo/ *me/ *se/ *ja ... ton Mihali.
 the John is old.CMPR from to for the Mike
 'John is older than Mike.'

What is more, an adjunct may not intervene between a head and its complement. The adjective *good* selects for a prepositional complement in Greek as in English; what is interesting is that the complement of the adjective and the *apo* 'from' standard phrase may appear in either order, whereas any other adjunct cannot (289).

- (289) a. O Janis ine kakos sta mathimatika apo pedhi.
 the John is bad at.the math from child
 'John is bad at math since he was a child.'
- b. O Janis ine chiroteros (*apo pedhi) sta mathimatika (*apo pedhi) apo ti Maria
 the John is bad.CMPR from child at.the math from child from the Mary
 apo pedhi.
 from child
 'John is worse than Mary at math since he was a child.'
- c. O Janis ine chiroteros (*apo pedhi) apo ti Maria (*apo pedhi) sta mathimatika
 the John is bad.CMPR from child from the Mary from child at.the math
 apo pedhi.
 from child
 'John is worse than Mary at math since he was a child.'

A common diagnostic for argument/adjunct asymmetries is wh-extraction out of a weak island: extraction of an argument out of a weak island is possible or slightly degraded whereas extraction of an adjunct is entirely impossible. Indeed, extraction of a possessor out of the phrasal standard is impossible, *prima facie* suggesting that the PP is an adjunct to the comparative. However, across the board extraction makes the sentence grammatical (290-c). This is also replicated with extraction out of a factive island. ATB phenomena are not sensitive to argument adjunct asymmetries. On the contrary, they are sensitive to islands. If the *apo*-phrase were an adjunct, it would always be impossible to extract; in other words, ATB extraction could not remedy a weak-island violation. Examples (290-c) and (291), therefore, show that the *apo*-phrase is not an adjunct.

- (290) a. O Janis ine megaliteros apo ton patera tu Mihali.
 the John is old.CMPR from the father the Mihali
 'John is older than Mihali's father.'
- b. *Pianu dhen ine o Janis meghaliteros apo ton patera?
 whose NEG is the John old.CMPR from the father
 Intended meaning: 'Whose father isn't John older than?'

- c. Pianu dhen ine o thios meghaliteros apo ton adherfo?
 whose NEG is the uncle old.CMPR from the brother
 ‘Whose_k uncle isn’t older than their_k brother?’
- (291) a. *Rotisa pjanu itan pu o Janis aghapuse ti Maria perisotero apo tin mitera.
 asked whose was that the John loved the Mary more from the mother
 ‘*I asked whose was that John loved Mary more than the mother.’
 (Intended meaning: I asked whose mother it was that John loved Mary more than her.’
- b. Rotisa pjanu itan pu o Janis aghapuse ton patera perisotero apo tin mitera.
 asked whose was that the John loved the father more from the mother
 ‘I asked who_i was that John loved their_i father more than their_i mother.’

Based on the above facts, we can conclude that the (non-predicative) prepositional standard phrase is an argument of the comparative predicate.

3.5.2 Oblique nominal standards

Apart from prepositional standard phrases Modern Greek also has oblique nominal standards. In SMG and southern varieties of Greek there is syncretism between Genitive and Dative thus it is impossible to distinguish the two solely on morphological grounds (292). However, following analyses of traditional grammars it has always been assumed that the traditionally named γενική συγκριτική (‘comparative genitive’) is a genitive not a dative.

- (292) a. to vivlio tu Jorghu ine vareto. SMG
 the book the.GEN George is boring
 ‘George’s book is boring.’
- b. Edhosa to vivlio tu Jorghu. SMG
 gave the book the.DAT George
 ‘I gave John the book.’

This assumption stems from the fact that oblique standard phrases were already available in Classical Greek and they were marked with Genitive (even though dative was morphologically distinct back at the time). However, it seems that the picture is more complex: The singular ablatives and genitives of all but a-stem Sanskrit nouns were syncretic (Baerman, 2008) a change that was inherited and ‘completed’ in Ancient Greek, in which ablative and genitive were also syncretic even though ablative did not denote spatial relations (Creissels, 2008). Indeed, reference grammars of Classical Greek also classify ‘comparative genitive’ as a ‘genitive-ablative’ (Schwyzer, 2002). On the other hand, ablative is used in many languages to mark the standard of comparison (Creissels, 2008) and Latin was another example of such a language (Greenough and Allen, 1903).⁵⁴ In sum, historical data suggest that Sanskrit comparative ablative evolved into Ancient Greek comparative genitive and Latin ablative.

In the following section I will examine the distribution of oblique comparative standard phrases in 3 Greek varieties (Standard Modern Greek (SMG), South Eastern Greek (SEG) and high register Greek ([+learned])) and I will show that there is a split across Greek varieties; SMG and [+learned]

⁵⁴ Latin morphologically distinguishes genitive and ablative.

Greek standards are genitive whereas SEG are dative.^{55, 56} The dialectal variation in case assignment provides novel evidence for a fine grained extended projection of the adjective, the syntactic status of the synthetic vs. analytic distinction, the existence of an inner island in the Comparative AdjP and the ontology of degrees.

3.5.2.1 The distribution of oblique standards in varieties of Greek

The distribution of oblique standards is much more limited compared to *apo* ('from') prepositional standards, partly because in SMG they only combine with synthetic (not analytic) comparative forms (293). The latter can be formed only by a subset of the adjectives/ adverbs that can form analytic comparatives for reasons pertinent to the history of Greek: for instance the adjectival participles in *-menos* can only form an analytic comparative not a synthetic one hence they cannot combine with an oblique standard (Cheila-Markopoulou, 1986). A fact that has been missed so far though, is that in SEG an oblique standard phrase is compatible with periphrastic comparatives too.

- (293) a. Ine megaliteros tu. SMG
 is old.CMPR him.OBL.
 'He is older than him.' (Cheila-Markopoulou, 1986, (108-a))
- b. *Ine pjo megalos tu. SMG
 is CMPR old him.OBL.
 'He is older than him.' (Cheila-Markopoulou, 1986, (108-b))
- (294) O jannis ine (3 xronia) megali-teros/ pjo meghalos tis. SEG
 the John is (3 years) big-CMPR CMPR big 3OBL.CL
 'John is 3 years older than her.'

Merchant (2012) claims that oblique standards do not occur with comparisons of lesser value, based on example (295). However, the ungrammaticality of (295) does not seem to stem from the polarity of the adjective: if we reverse the polarity and we use *perisotero* 'more' the ungrammaticality of (295) is not remedied (296). On the other hand, oblique standards can be used with comparisons of lesser value as long as a synthetic form of the adjective is used (297). It seems that the ungrammaticality of (295) and (296) stems from the fact that *perisotero* 'more' and *lighotero* 'less' are synthetic comparative forms of the adverbs *much* and *little* respectively; they are not comparative markers like *pjo* (CMPR). So the difference observed by Merchant (2012) is actually a reflex of the requirement for a local relation between the comparative predicate and the oblique standard.

(295) (Merchant, 2012)

⁵⁵ The varieties spoken in Cyprus and some islands of the Dodecanese including Rhodes seem to have many similarities across all levels of representation, e.g. loss of voiced fricatives [v, γ, δ] in intervocalic positions (Newton, 1972, p. 60), velar palatalisation, final /n/ retention, geminates (Trudgill, 2003), second position clitics (Revithiadou and Spyropoulos, 2008) a.o. Trudgill (2003) distinguishes the Southeastern dialect, which refers to the idioms spoken in Cyprus and some islands of the Dodecanese, namely Rhodes, Karpathos, Kastellorizo, Kos, Leros and Patmos. The Dodecanese speakers I have consulted with are all from different areas of Rhodes, Dodecanese, Greece, and the author herself is a speaker of a Rhodian variety.

⁵⁶ Technically, Cypriot Greek and Dodecanese Greek are best characterised as idioms given the mutual intelligibility with speakers of other varieties of Greek (Research Center for Modern Greek Dialects and Idioms - I.L.N.E.). Nonetheless, in this thesis, I do not draw a distinction between idioms and dialects and refer to all geographical varieties as dialects.

- a. I Anna ine ligotero psili apo sena.
the Anna is little.CMPR tall from you.
'Anna is less tall than you.'
- b. *I Anna ine ligotero psili su.
the Anna is little.CMPR tall you.OBL
'Anna is less tall than you.'
- c. *I Anna ine ligotero su psili.
the Anna is little.CMPR you.OBL tall
'Anna is less tall than you.'
- (296) a. *I Anna ine perisotero/ pjo psili su. SMG
the Anna is much.CMPR/ CMPR tall you.OBL
'Anna is less tall than you.'
- b. *I Anna ine perisotero/ pjo su psili.
the Anna is much.CMPR/ CMPR you.OBL tall
'Anna is less tall than you.'
- (297) a. an ke safos ligoteri ton romeon, tus anagasan se
if and clearly fewer.ADJ.CMPR.NOM.PL the.OBL.PL Romans.OBL.PL them make in
ipoxorisi.
retreat
'Even though [they were] clearly fewer than the Romans, they made them retreat. (goo .
gl/oqfTP9 last accessed 8/ 3/ 2017)
- b. ligoteri ton anamenomenon i katavlitei fori.
less.CMPR.NOM.PL the.OBL.PL expected.OBL.PL the.NOM.PL payable taxes
'The payable taxes [are] less than the expected ones. goo .gl/6LgTHs
- c. xamiloteri ton prosdokion i anaptiksi ton
lower.CMPR.FEM the.OBL.PL expectations.OBL.PL the development.FEM.NOM.SG the
neon theseon ergasias.
new positions employment
Job growth [was] lower than the expectations
(<http://www.sofokleousin.gr/archives/320851.html> last accessed 7/ 3/ 2017)

Merchant (2012) argues that oblique standards combine freely with predicative adjectives in SMG (298-a). However, he claims that if the oblique standard is a full DP (not a pronoun) and combines with an attributive comparative adjective the sentence becomes ungrammatical (298-b). Based on the difference between (298-a) and (298-b) he draws an attributive-predicative distinction. However, speakers of SMG find (298-a) ungrammatical or highly marked. Furthermore, the minimally different (299) shows that the ungrammaticality of (298-b) is not related to some distributional property of oblique standards — using a PP standard does not render the sentence grammatical. Furthermore, as was shown in §3.3.1.1, comparative adjectives are always predicative and even in prenominal positions they are interpreted as reduced relatives, therefore any difference between prenominal and postnominal standards is not expected to reflect an attributive comparative distinction.

- (298) (Merchant, 2012)
- a. ?O Giannis ine psiloteros tu patera tu. SMG
the Giannis is taller the father.OBL his
'John is taller than his father.'

b. *Dhen ine psilotero tu patera tu pedi. SMG
 not is a taller the father.OBL his father
 'He is not a child taller than his father.'

(299) *Dhen ine psilotero apo ton patera tu pedi. Greek
 not is a taller from the father.ACC his father
 'He is not a child taller than his father.'

On the other hand, it seems impossible to separate the clitic from the comparative adjective (compare (300-b) to (300-c)). This suggests an adjacency requirement of the oblique standard to the comparative phrase.

- (300) Greek
- a. O Giannis ine psiloteros tis.
 the Giannis is taller her.OBL
 'Giannis is taller than her.'
- b. I Anna pandreftike enan psilotero tis andra.
 the Anna married.3S a taller her.OBL man
 'Anna married a man taller than her.'
- c. *I Anna pandreftike enan psilotero andra tis.
 the Anna married.3S a taller man her.OBL
 'Anna married a man taller than her.'

Oblique standards are also licensed with adverbial (301) and amount comparatives (302) but these constructions are marked for register ([+learned]) and are not productive in middle register Greek.

(301) ...anaptisomeni me rithmo 0,6% - taxitera ton ektimiseon...
 ...develop.PCPL.FEM. with rate 0,6% - fast.CMPR.ADV the.OBL.PL estimates.OBL.PL
 '...developing with a 0,6% rate - faster than expected...' (goo.gl/zC9aEH last accessed 8/ 3/ 2017)

- (302) a. den mporun na katachorithun epiloges perisoteres ton 3.
 NEG can.3PL SBJ submit.3PL selection.PL more the.OBL 3
 'no more than 3 options can be selected.' (http://inf.teiste.gr/wp-content/uploads/2016/10/inf_prakt_72.pdf last accessed 7/ 3/ 2017)
- b. ligoteri ton anamenomenon i thanati apo ti nea gripi.
 fewer the.OBL expected.OBL the deaths from the new flu
 'Fewer than expected the deaths from the new flu.' (<https://goo.gl/zC9aEH> last accessed 8/ 3/ 2017)

Personal pronouns are the most productive oblique standards (303) (Cheila-Markopoulou, 1986). DPs,⁵⁷ demonstratives (304) can also be used as oblique standards (Merchant, 2012). The speak-

⁵⁷Cheila-Markopoulou (1986) assumes that genitive common nouns in synchronically opaque expressions like (xiv) no longer function as standard phrases but as modifiers, on a par with Milner's (1973) analysis of latin ablative forms. (Cheila-Markopoulou, 1986, 103-104)

(xiv) a. fainotero iliu (Cheila-Markopoulou, 1986, (109-a))
 shiny.CMPR sun.OBL
 'shinier than the sun'

ers of SMG I have consulted find full DPs highly marked⁵⁸ (304) significantly improves if we change the colloquial genitive demonstrative with the [+learned] variant of it in (305). This indicates that oblique demonstratives, on a par with full DPs, are not productive in SMG but they are available in higher register Modern Greek.

- (303) O Giannis ine psiloteros mu/ su/ tu/ tis/ mas/ sas/ tus.
the Gianis is tall.CMPR 1SG/ 2SG/ 3M.SG/ 3FEM.SG./ 1PL/ 2PL/ 3PL
'John is taller than me/ you/ him/ it/ her/ us/ you/ them.' (Merchant, 2012)
- (304) *O Giannis ine psiloteros aftunu/ aftinis.
the Giannis is tall.CMPR DEM.OBL.M DEM.OBL.FEM
'John is taller than him/ her.' (Merchant, 2012)
- (305) ?O Giannis ine psiloteros aftu/ aftis.
the Giannis is tall.CMPR DEM.OBL.M DEM.OBL.FEM
'John is taller than him/ her.'

Measure phrases also occur frequently as oblique standards. Merchant (2012) claims the opposite based on example (306), however the problem with (306) is not the use of the measure phrase per se but the absence of the determiner. (306) significantly improves if the determiner is present, as in (307),⁵⁹ while we can find several naturally occurring examples with measure phrases (308). Note that all examples below are in higher register.

- (306) I Anna ine psiloteri { apo dio metra / *dio metron }.
the Anna is tall.CMPR than two meters two meters.OBL
'Anna is taller than two meters.'
- (307) I Anna ine psiloteri ton dio metron.
the Anna is tall.CMPR than the meters.OBL
'Anna is taller than two meters.'
- (308) a. O ipedhafios idhroforos orizontas dhen prepi se kamia periptosi na aneveni se
the underground aquifer area NEG must in any case SBJ rise in
stathmi psiloteri ton 2,5 metron kato apo tin epifania tu edhafus.
level higher the.OBL 2,5 meters.OBL below of the surface the.GEN ground.GEN

'The aquifer must not in any case rise in level higher than 2,5 meters below the sur-

-
- b. vasilikoteros tu vaseios (Cheila-Markopoulou, 1986, (109-b))
royal.CMPR the.OBL king.OBL
'overzealous'
- c. anoteros pasis ipopsias (Cheila-Markopoulou, 1986, (109-c))
high.CMPR every.OBL suspicion.OBL
'above all suspicions'

⁵⁸Merchant (2012) also argues that relative pronouns are grammatical oblique standards however I could not find a speaker replicating the judgement for (xv):

- (xv) Ime o andras tu opiu ine psiloteros o Giannis.
I.am the man the which.OBL is taller the Giannis
'I am the man whom Giannis is taller than.' (Merchant, 2012)

⁵⁹ Example (307) is still slightly awkward due to register though it is not ungrammatical.

face ground.’ (<https://dimos-amfipolis.gr/wp-content/uploads/2013/10/kanonismos-nekrotafeion.pdf> last accessed 6/ 3/ 2017)

- b. psinete ikanopiitika se thermokrasia psiloteri ton 90°C ghia tulaxiston 30 lepta. is.cooked sufficiently in temperature higher than 90°C for at.least 30 minutes ‘It is sufficiently cooked in temperature higher than 90°C for at least 30 minutes.’ (goo.gl/pWnGHF last accessed 8/ 3/ 2017)
- c. I thermokrasia tu dhomatiu ine **psiloteri ton +35°C**. the temperature the.OBL room.OBL is higher than 35°C ‘The room temperature is more than 35°C. (http://www.servicenet.gr/lyseis_psygeia.php last accessed 6/ 3/ 2017)
- d. parakratisi foru se **amivi mikroteri ton 300 evro**. deduction tax.OBL in salary smaller the.OBL 300 euros ‘tax deduction in salaries lower than 300 euros.’ (goo.gl/BiQRVX last accessed 8/ 3/ 2017)
- e. O idjos djetitis se dhio aghones me djafora **mikroteri ton 24 oron** the same referee in two games with difference smaller the.OBL 24 hours ‘the same referee in two games with less than 24 hours from each other’ (<https://goo.gl/Kf80cX> last accessed 8/ 3/ 2017)
- f. Dhiatirite ta trofima sti sosti tus thermokrasia, gia paradheighma afta pu prepri keep the food in.the right them temperature for example those that must na ine paghomena - kato apo thn thermokrasia ton 5°C ke ta maghirevmena SBJ are cold - below of the temperature the.OBL 5°C and the cooked **se thermokrasia psiloteri ton 60°C**. in temperature higher the.OBL 60°C ‘Keep the food in the appropriate temperature , for example those that must be cold - below the temperature of 5°C and the cooked ones in temperature higher than 60°C. (<https://goo.gl/zC9aEH> last accessed 8/ 3/ 2017)

(309) mikroteri *(ton) 18 minon i diapragmatefsi me tin Bretania ghia to Brexit. smaller the.OBL 18 months.OBL the negotiation with the Britain for the Brexit ‘Less than 18 months [will be] the negotiation with Britain about Brexit.’ (<https://goo.gl/YcSJzV> last accessed 8/ 3/ 2017)

So, in varieties that allow full DPs as Oblique Standards, like SEG and high register Greek, there seems to be a requirement for an overt determiner. Therefore, bare N(um)Ps are ungrammatical (309) in all varieties.

Finally, oblique Standard Phrases are mostly marked as [+learned] in SMG,⁶⁰ therefore they are productive in limited environments (and even more limited if the standard is not a personal pronoun): sports sites, newspapers (Merchant, 2012), legal and administrative texts. The grammaticality of example (301) above significantly deteriorates if we replace the adverb *tachitera* (faster) with its colloquial variant *ghrighorotera* (faster).

(310) ...*anaptisomeni me rithmo 0,6% - ghrighorotera ton ektimiseon...
...developing.PCPL.FEM with rate 0,6% - fast.CMPR.ADV the.OBL.PL estimates.OBL.PL
SMG/ SEG

⁶⁰ Merchant (2012) also assumes that the genitive marking on the standard is a calque from Classical Greek and that is also the reason why it is acquired late.

‘...developping with a 0,6% rate - faster than expected...’

The construction is highly marked as [+learned] if the standard phrase is an inanimate full DP. However, in SEG animate DPs are freely available, in contrast to inanimate ones (311). This animacy restriction, however, maybe flouted by clitics (312)

- (311) a. O Jannis ine ghrighoroteros tis Marias. SEG
 the John is fast.CMPR the.GEN Mary.GEN
 ‘John is faster than Mary.’
- b. *To aftokinito ine ghrighorotero tu podhilatu. SEG
 the car is fast.CMPR the.GEN bicycle.GEN
 ‘The car is faster than the bicycle.’

(312) Context: *A chair is in front of two boxes. The boxes are stuck one on top of the other but still their (cumulative) height is less than the height of the chair. I ask whether the boxes are labelled:*

Dhen ksero, i karekla ine pjo psili tus/ *ton kution kai dhen
 NEG know.1SG the chair is CMPR tall CL.3PL/ the.OBL.PL boxesOBL.PL and NEG
 vlepo. SEG
 see.1SG
 ‘I don’t know [whether the boxes are labelled], the chair is taller than the boxes and I can’t see.’

Table 3.6 below, summarises the distribution of oblique standard phrases in three varieties of Greek: [+learned] variety, SMG and SEG.

Table 3.6: The distribution of Oblique standards in Modern Greek varieties

	SMG	MG [+LEARNED]	SEG
Comparative Form			
Synthetic comparatives	✓	✓	✓
Analytic Comparatives	✗	✗	✓
Type of comparative			
Comparative AdjPs	✓	✓	✓
Comparative AdvPs	✗	✓	✗
Amount Comparatives	✗	✓	✗
Standard Phrase			
Clitic Personal Pronouns	✓	✓	✓
bare N(um)Ps	✗	✗	✗
full DPs	✗	✓ animate ✓ inanimate	✓ animate ✗ inanimate
differentials & factor phrases	✓	✓	✓

3.5.2.2 Genitive/ Dative Standards

As mentioned in the beginning of §3.5.2, regardless the syncretism between genitive and dative in southern varieties of Modern Greek, it has been taken for granted that oblique nominal standards are true genitives. In this section, I will show that there is a split amongst Greek varieties: oblique standards in SMG are genitives, as has been standardly assumed, but SEG oblique standards are datives.

Even though Greek Genitives and Datives have been extensively studied so far, there are very few clear-cut distinctions between the two and their identification is usually based on the construction they participate in: for example the oblique DP in a double object construction is a dative and the oblique DP in a possessive construction is a genitive. The diagnostics that have been used so far are:

The position of the clitic (enclitics vs proclitics) (Pancheva, 2004): In SMG possessive clitics follow their phonological host, whereas clausal clitics are proclitics, at least in indicative clauses. However, this diagnostic is unreliable in our case for the following reasons: (i) the formation of synthetic comparatives involves a movement operation (cf. §2.3.1.3.1) therefore their post-adjectival position may be derived in a way parallel to postverbal clitics in imperative constructions; and (ii) SEG clitics are ‘enclitics’ hence they follow their host even in indicative clauses.

The phrase which the CL_{GEN} alternates with: Pancheva (2004) while discussing clitics in possessives argues that the alternation of a clitic with a DP_{GEN} corroborates their analysis as true genitives (as opposed to datives). Despite the contrast observed between the DP_{GEN}s that Greek possessives alternate with and the phrases Balkan Slavic possessives alternate with, the picture is slightly more complicated. *Apo*-phrases alternate with genitive or dative clitics depending on the syntactic environment they are in. More specifically, *apo*-PPs that are complements of prepositions alternate with CL_{GEN} (Theophanopoulou-Kontou, 2000; Terzi, 2005, 2007, a.o.) whereas *apo*-PPs that realise a source theta role alternate with a —homophonous— dative clitic; compare sentences a and b in (313) and (314):

- (313) a. To kuti ine piso apo ton Jani.
the box is behind from the.ACC John.ACC
‘The box is behind John.’
b. To kuti ine piso tu
the box is behind CL.GEN
‘The box is behind him.’
- (314) a. Aferesa apo ton Jani 3 vathmus.
detract from the.ACC John.ACC 3 points
‘I detracted from John 3 points.’
b. Tu afaireisa 3 vathmus.
CL.DAT detract 3 points
‘I detracted him 3 points.’

However, there is an important difference between the two: the *apo*-PP in (313) alternates *only* with a CL_{GEN} whereas the *apo*-PP in (314) may also alternate with a full dative DP:

- (315) a. To kuti ine piso tu/ *tu Jani.
the box is behind CL.GEN/ the.GEN John.GEN
‘The box is behind him/*John.’

- b. Tu Jani/ tu afairesa 3 vathmus.
 the.DAT John.DAT/ CL.DAT detract 3 points
 ‘I detracted him/John 3 points.’

This pattern replicates a difference already observed between comparatives in Greek dialects: in SMG the standard *apo*-PP may alternate with a clitic but not with an overt DP, in contrast to SEG:

- (316) O Janis ine ghrighoteros apo tin Eleni.
 the John is fast.CMPR from the Helen
 ‘John is faster than Helen.’
- a. *O Janis ine ghrighoroteros tis Elenis. SMG
 the John is fast.CMPR the Helen
 ‘John is faster than Helen.’
- b. O Janis ine ghrighoroteros/ pjo ghrighoros tis Elenis. SEG
 the John is fast.CMPR/ CMPR fast the Helen
 ‘John is faster than Helen.’

Animacy: The availability of inanimate expressions can be used as a diagnostic between dative and genitive. Dative arguments are always animate (Anagnostopoulou, 2003, 2005; Michelioudakis, 2012) (317), therefore, the availability of an inanimate oblique DP as a standard marker shows that the DP is a genitive DP. So, given the availability of oblique inanimate standards (301) and measure phrases (308) in the MG[+learned] variety, it is safe to assume that in that variety they are true genitives. However, the unavailability of inanimate standards does not suffice to characterize a DP/Clitic as genitive or dative: genitive clitics attached to an adjective modifying a noun are also obligatorily animate (Alexiadou and Stavrou, 2000) (318).

- (317) a. Evala faghito stin Eleni/ sto psighio.
 put.PST.1SG food in.the Helen/ in.the fridge
 ‘I served Helen’. (literally: ‘I put food to Helen.’)/ ‘I put food in the fridge.’
- b. Evala tis Elenis/ *tu psighiu faghito.
 put.PST.1SG the.DAT Helen.DAT/ the.DAT fridge.DAT food
 ‘I served Helen’. (literally: ‘I put Helen food.’)/ ‘*I put food in the fridge.’
- (318) a. o omorfos (*tu) idjoktitis tu
 the handsome CL.GEN owner CL.GEN
 ‘its beautiful owner’
- b. to omorfo (mu) spiti (mu)
 the beautiful CL.GEN house CL.GEN
 ‘my beautiful house’

However, the animacy requirement of dative DPs may be ‘circumvented’ by dative clitics (Michelioudakis, 2012), a fact also observed in SEG oblique nominal standards above (312).

- (319) I porta; anikse ke tis; eriksa mia klotsia ya na tin; kliso.
 the door opened and CL.DAT. threw.1SG a kick for SBJ ACC.CL close
 ‘The door opened so I kicked it to close it.’ (ex. based on Michelioudakis, 2012, (53-b))

To sum up, based on the facts reviewed so far, the following picture emerges:

- ☞ MG[+Learned] oblique standards are *genitives*, since inanimate DPs are available
- ☞ SMG oblique standards are also *genitives*, since they present the same [_{PP} *apo* DP_{ACC}]-CL_{GEN} alternation observed with prepositional complements
- ☞ SEG oblique standards are *datives*, as they alternate with animate dative DPs and dative Clitics.

An interesting gap, observed in both SMG and SEG, is that it is impossible to cliticize bare measure phrases. Furthermore, as noted above, in [+learned] Greek the genitive measure phrase needs to be introduced by a determiner, whereas the measure phrase introduced by a preposition may be bare, cf. (306)-(308) above.⁶¹

- (320) A: I platforma sikoni mexri [30kg]_k.
 the platform lifts up-to 30kg
 A: ‘The platform can lift up to 30kg.’
 B: *Dhe ginetai na valume ta dhemata pano, ine varitera [tus]_k.
 NEG happen SBJ put the packages on, are heavier CL.PL
 B: ‘We can’t put them on it, they are heavier than that.’

The grammaticality of the clitic though improves, if it is referring to a definite measure phrase:

- (321) A: I platforma sikoni [ta 30kg]_k.
 the platform lifts the 30kg
 A: ‘The platform can lift 30kg.’
 B: ??Dhe ginetai na valume ta dhemata pano, ine varitera [tus]_k.
 NEG happen SBJ put the packages on, are heavier CL.PL
 B: ‘We can’t put them on it, they are heavier than that.’

This pattern replicates extraction out of weak islands:⁶²

- (322) a. *Apo poso ine o Jannis variteros?
 from how.much is the John heavier
 ‘How much is John heavier than?’

⁶¹ I will not comment on cliticization in the MG[+Learned] variety as it is impossible to tease apart whether clitics are considered acceptable from interference from SMG or because it allows cliticization of the genitive, indeed.

⁶² This ‘referentiality’ requirement is not exclusive to genitive clitics appearing in comparatives. Alexiadou and Stavrou (2000, 65) make the same point for genitive clitics that replace genitive modifiers. They show that the clitic is always referential, as it does not ‘refer’ to a property, as shown in (xvi); in other words it stands for an extensional and never an intensional or ‘kind’ modifier of the noun:

- (xvi) a. to vivlio tis istorias
 the book of-the history
 ‘the history book’
 b. *to vivlio-tis
 the book-her
 ‘her book’

In (xvi) the genitive DP following the head ‘vivlio’ denotes a property, a type of book, and is thus an intensional modifier; in this case it cannot be replaced by a clitic.

- b.??? Apo posa kila ine o Janis variteros?
 from how.many kilograms is the John heavier?
 ‘How many kilos is John heavier than?’
- c. Apo pjon ine o Jannis variteros?
 from who is the John heavier
 ‘Who is John heavier than?’

Given that it has been independently proposed that the standard phrase QRs out of its base position, it is reasonable to assume that the common pattern between extraction of *wh*-phrases and cliticization in the comparative is non accidental, but they both involve a weak island violation. This could also explain the requirement for an overt determiner in all genitive DPs in SMG and MG[+learned].

3.5.2.3 Case assignment in Greek oblique standards

I would like to argue that the data from Greek varieties provide corroborating evidence for a split Comparative Phrase. Within a system with two comparative heads, this complex pattern of case-assignment and cliticisation in Greek follows from standard assumptions with the addition of only one ingredient: SEG case is inherent.⁶³

The standard phrase of the comparative is base generated in [Spec,√P], the position that in positive adjectives is occupied by a free variable.⁶⁴ The adjective, head-moves until C1⁰ or C2⁰ depending on where little *a* is merged. The clitic is an en-clitic as clitics are in the Greek adjectival domain. In line with recent frameworks where arguments can be case licensed in different positions than their base-generation position (Michelioudakis, 2012; Biggs, 2014), I assume that the standard phrase checks oblique case in [Spec,C1P] whereas the differential argument in [Spec,C2P].

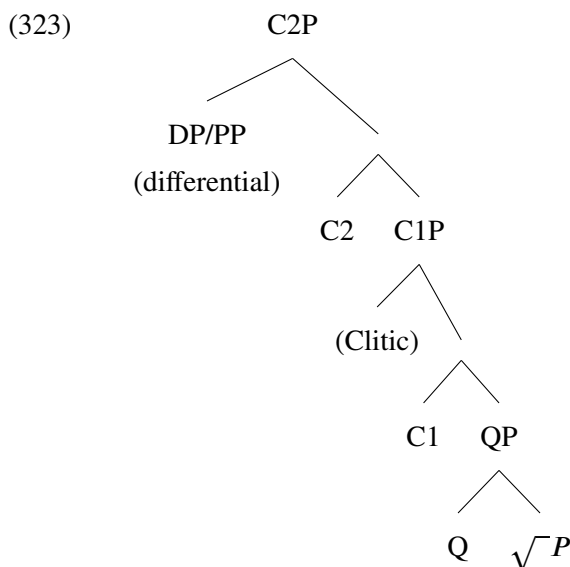

Let us begin with SEG Greek first: the Clitic or oblique phrase carries inherent case, therefore

⁶³ Inherent case is standardly associated with theta-role assignment. Biggs (2014) recasts inherent case as structural and provides ample evidence and conceptual arguments on why inherent case should be dissociated from theta-assignment.

⁶⁴ The standard may be analysed as an argument of the comparative gradable predicate in the place of the free degree variable introduced by positive ones. As mentioned in fn. 63 inherent case may also be analysed as structural case. For ease of exposition I will represent the standard as the external argument of the gradable predicate, yet I leave to future investigation adjudicating between the two options.

it does not need to move out of the \sqrt{P} . The correct word-order is predicted without any further stipulation. The unavailability of (300-c) follows from the fact that the comparative adjective is in a reduced relative that does not contain the NP therefore the clitic cannot cliticise on the NP.

(300-c)*I Anna pandreftike enan pilotero andra tis.
 the Anna married.3S a taller man her.OBL
 ‘Anna married a man taller than her.’

Let’s now turn to SMG. SMG imposes an additional restriction compared to SEG: cliticisation is only available with synthetic comparatives. Actually, this distinction follows from what we have proposed so far: the clitic is an enclitic therefore there is a phonological adjacency requirement that it linearly follows the adjective. On the other hand, it needs to check its case in [Spec,C1P]. The only way that these two requirements are met is iff the adjective head-moves all the way up to C2⁰ and the clitic checks its case in [Spec,C1P].

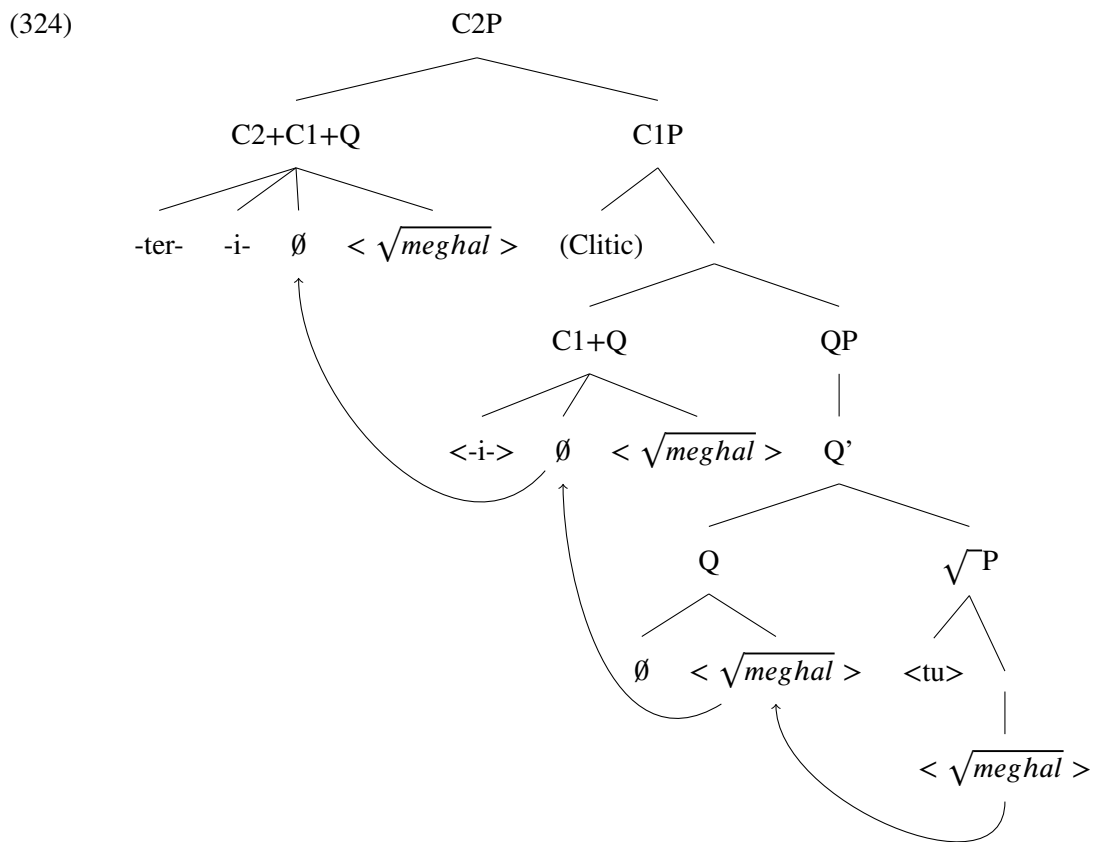

If the adjective stays in C1⁰ the enclitic will be able to check its case, however, it will precede the adjective hence the latter could not function as a phonological host. On the other hand, if it merges lower than C1 and satisfies its phonological requirement, it could not check its case with C1⁰. Therefore, the derivation again crashes.

3.5.2.4 Extension to Romance

Given the analysis of oblique standards pursued so far, the following predictions are made for Romance languages:

(325) Predictions for Romance Languages

- a. In Romance languages that allow phrasal comparatives only with measure phrases, like French, Spanish, Catalan and Brazilian Portuguese, cliticisation is ungrammatical due to inner islands;
- b. In languages that allow for phrasal comparisons with individual standards, cliticisation should be, in principle, available if clitics can cliticise PPs in other environments, like the prepositional complements of adverbials.

Indeed, these predictions seem to be borne out; Firstly, the *de*-phrase resists cliticisation in French (326), a fact consistent with (325-a).

(326) French

- a. J' ai mangé plus de trois gateaux.
I have eaten more than 3 desserts
'I ate more than three desserts.'
- b. Je (*en/eux) ai mangé plus (*en/eux).
I CL have eaten more 3 desserts CL
'I ate more than that.'

So, let us now turn to Italian, a language that allows phrasal comparatives with individuals or measure phrases so it should be possible to examine cliticization. As mentioned above, Napoli and Nespor (1986) argue that *di*-phrases can cliticize. Sentence (269) is repeated below for convenience.

(269) (Napoli and Nespor, 1986)

- a. È migliore di Luca.
is good.CMPR from Luca
'S/He is better than Luca.'
- b. Ne è migliore.
CL is good.CMPR
'S/He is better than him.'

The informant I have consulted with did not allow for cliticisation of *di*-phrases. However, this was not specific to comparatives: they did not allow cliticisation of locative complements either. On the other hand, they allowed cliticization of *a*-PPs both in locatives and the lexical comparatives *superiore* ('superior') and *inferiore* ('inferior').

- (327)
- a. Maria è superiore a Gianni
Maria is superior at John
'Mary is superior to John.'
 - b. Maria gli è superiore.
Maria CL is superior
'Mary is superior to him.'

Therefore, these two varieties of Italian are consistent with (325-b) above.

3.6 Summary & Conclusions

In this chapter I examined the comparative markers in Greek and Romance languages. I provided novel morphological and syntactic evidence for the existence of two comparative heads in the extended projection of the adjectives. Furthermore, Greek revealed the existence of more than one *more*: a functional one, which is an allomorph of the comparative suffix *-er*, and two lexical ones: one that is the comparative form of a quantity adverb and an adverbial. I argued that the former is an adjunct to a positive adjective whereas the latter is an adverbial.

In the remainder of this chapter I examined the distribution of phrasal standard phrases. Cross-linguistic evidence suggest that the phrasal vs. clausal distinction does not encode the distinction between a two-place and a three-place comparative operator. A single standard marker, e.g. Greek or Italian *from* may introduce both degree and individual comparisons whereas in the other languages merely combines with a degree standard exactly like the clausal standard marker. This evidence suggests that the distinction encoded in the standard marker is only a syntactic one not a semantic.

However, the standard marker is sensitive to the semantic type of the selected complement in a different way. The preposition may combine with a predicate, in which case it acts as a RELATOR and adjoins to the gradable predicate. On the other hand, what can function as a predicate and what cannot open new fields of inquiry in the semantics of nominals: number phrases may function either as predicates or as arguments—a finding that is unexpected under current assumptions—but this option is conditioned on the semantics of the noun.

On the other hand, I showed that non-predicative phrasal standards are arguments not adjuncts. Extraction out of them is banned not because they are (adjunct) islands but because the movement needs to happen ATB. Given that ATB movement does not rescue weak island violations, I concluded that DP prepositional standards are arguments of the comparative operator.

Finally, I examined oblique nominal standards in 3 varieties of Greek. Their distribution reveals a new locus of variation across Greek dialects and corroborates a split analysis of the comparative. Restrictions on the availability of oblique standards with synthetic/analytic comparatives suggest that synthetic comparative formation happens in syntax and it is an instance of head movement. Furthermore, the proposed system readily accommodates the formation of double comparatives.

Finally, weak islands in comparatives and their obviation with the addition of the definite operator are informative regarding the nature of degrees. Bare measure phrases denote dense intervals, i.e. for any set for two points, there is a third point that lies between them in the ordering, hence they cannot escape weak islands.⁶⁵ However, other operators, like the definite determiner may change that.

Finally, I presented a new puzzle regarding the distribution of comparative adjectives: comparative adjectives are always predicative. The only exceptions are analytic superlatives, which consist of the definite determiner and a comparative adjective, and the comparative form of quantity words.

⁶⁵ The definition of density is from Schwarzschild (2005).

Chapter 4

Clausal Comparatives

This chapter examines the types of clausal comparatives found in Greek and Romance languages. It reassesses data already discussed in the literature in light of previously unnoticed facts and shows that clausal comparative formation is more diverse but at the same time more regular than previously assumed. More specifically, it shows that there are two strategies for forming clausal comparatives; the former is to combine a ‘phrasal’ SM (e.g. Greek *apo* (‘from’), Italian *di* (‘from’) or other Romance languages’ *de* (‘from’)) with different types of relative clauses. What is more, I show that Greek *para* (EXCEPT) may also introduce degree comparatives (not just metalinguistic ones) and suggest that Romance *chelque* comparatives are also instances of exceptive phrases. This proposal explains why light headed relative clauses are available in Romance *chelque* comparatives, a fact that is problematic for standard analysis of Romance *chelque* SM as an instance of the homonymous relativizer.

This chapter is organised as follows: §4.1 examines Greek clausal comparatives, and contra to recent proposals (Theophanopoulou-Kontou, 2014, a.o.) argues that *ap’oti* has not been grammaticalised to a single lexical item but it consists of the phrasal SM and a relative *wh*-item. This finding is corroborated by the fact that a wide array of relative clauses may function as standard phrases, including concessive free relatives. Furthermore, I demonstrate that Greek *para* (EXCEPT) is not restricted to metalinguistic comparatives but it is used to introduce clausal degree comparatives. The following sections show that the same two configurations may be found in French, Italian, Spanish, Catalan and Brazilian Portuguese.

4.1 Greek

Three clausal SMs in Greek have been identified in the literature (Theophanopoulou-Kontou, 2014, a.o.): *ap’oti* (SM/‘from whatever’) which is analysed as a single lexical item that evolved from the reanalysis of the preposition/phrasal SM *apo* (‘from’) and the relativiser *o,ti* (‘what, whatever’); *ap’oso* (SM/‘from however’) clausal standards which consist of a degree free relative and the phrasal SM and *para* (EXCEPT), which is assumed to introduce only metalinguistic comparatives. However, I will show that *ap’oti* has not been reanalysed to a single lexical item that exclusively functions as a SM - instead it is comprised of the preposition *apo* (‘from’) and the relativiser *o,ti* (‘what, whatever’) and in that sense it is structurally the same as *ap’oso* (‘from however’) comparatives. I will argue that the preposition *apo* apart from DPs and AdjPs (cf. §3.5.1) selects a variety of relative clause

constructions including free relatives introduced by *oti* ('what, whatever') or *osos,-i,-o* ('however') and light headed relatives. ⁶⁶ On the other hand, I will show that *para* (EXCEPT) may also introduce degree comparatives not just metalinguistic ones. So a new picture of Greek standard phrases emerges: Greek has a prepositional SM *apo* ('from') which can combine with any type of nominal including different types of relative clauses (free relatives, light headed relatives, concessive free relatives) and a clausal SM which can introduce degree or metalinguistic clausal comparatives.

4.1.1 Clausal Comparatives with *apo* ('from')

4.1.1.1 Clausal Standards introduced by *ap'oti*

Ap'oti ('from *wh*') is the most widely used SM in the sense that it can be used in DP, ADJP and ADVP comparisons (Theophanopoulou-Kontou, 2014). *Ap'oti* ('from whatever') consists of the preposition *apo* (from, of), which also introduces phrasal comparatives, and the relativizer *oti*, which introduces a free relative clause. ⁶⁷

Cheila-Markopoulou (1986) was the first to argue that *ap'oti* ('from whatever') is compatible with such a wide array of comparatives (it combines with countable and uncountable nouns, amount and degree comparisons) because it is undergoing syntactic change and she predicted that it will become an opaque lexical item of the left periphery. More recently, Theophanopoulou-Kontou (2014) also argued that *apoti* was the head of a free relative selected by a preposition (like *ap' osos*) but it has now been grammaticalised to a SM. The arguments that have been put forward in favour of *apoti* being a synchronically opaque SM are the following:

1. many Greek complementizers have been formed from the continuous cooccurrence of prepositions with relativizers e.g. *afu* ('because, after') derived from *ap<o>* ('from') + *u* (*wh.GEN*), *afotu* ('as') derived from *ap<o>* ('from') + *hotu* (*wh.GEN*), *eno* ('while') derived from *en* ('in') + *ho* (*wh.DAT*), *kathoti* ('because' derived from *kat<a>* 'during' + *hoti* 'wh') (Cheila-Markopoulou, 1986); ⁶⁸
2. the same phenomenon is observed in other indo-european languages, e.g. the Dutch SM (Cheila-Markopoulou, 1986);
3. it is unclear how *oti* ('whatever') is a constituent in the standard clause whereas *oso* ('however') is a constituent of the clause following *apo* ('from') (Theophanopoulou-Kontou, 2014);

(328) O Janis ine pio psilos ap' oti/ oso ine ta ala pedia tis taksis tu
the John is more tall from whatever/ however is the other children the class his
'John is taller than the other children of his class' (Theophanopoulou-Kontou, 2014, (17))

⁶⁶ *Osos,-i,-o* is unambiguously a quantity denoting relative item and it does not have a manner reading, in contrast to its English *wh-* counterpart. The reason why it is glossed as 'however' instead of 'how much/many' is to highlight that this *wh-*item cannot be used in *wh-*questions. Its *wh-*question counterpart is *posos-i-o* 'how many/much'. For the same reason *oti* is glossed as *whatever* and not *what*.

⁶⁷ The relativizer *oti* 'what(ever)' should not be confused with the orthographically and supersegmentally different declarative complementizer *oti* 'that'.

⁶⁸ Cheila-Markopoulou (1986) also includes *dhioti* ('because') amongst the grammaticalised items and assumes that it is derived from *dhia* ('for') + *hoti* ('wh') however this etymology is not confirmed by Liddell and Scott (1940). According to Liddell and Scott (1940) dictionary, *dhioti* is already attested in Ancient Greek texts.

- a. *oti psila
whatever tall
'whatever tall'
- b. oso psila
however tall
'however tall'

4. *oti* is morphologically invariant and does not match the correlate of the comparison (Theophanopoulou-Kontou, 2014). In (329) the wh-item *osa* ('however') carries the same phi-features as the correlate of the comparison. On the other hand, *oti* remains invariant (cf. (330));

(329) Efetos ksodepsa lighotera lefta ja tis dhiakopes mu ap'
this-year spent less.NEUT.PL.ACC money.NEUT.PL.ACC for the holidays mine than
osa/ oti perisi
however.PL.ACC /whatever last-year
'This year I spend less money during holidays than I did last year.' Theophanopoulou-Kontou (2014, (18));

(330) Efetos aghorasa lighoteres kukles gia to orfanotrofia ap'
this-year bought fewer.FEM.PL.ACC dolls.FEM.PL.ACC for the orphanage than
oses/ oti perisi
however.PL.ACC /whatever last-year
'This year I bought fewer dolls for the orphanage than last year.'

5. *ap'oti* is under a grammaticalisation process and has been reanalysed as a single item. *oti* ('whatever') has been bleached to a relative, non-nominal item with indeterminate meaning and *apo* ('from') has been bleached from its prepositional nature. The whole complex is now bearing the special meaning of 'compared to' and a unique syntactic function (SM) (Theophanopoulou-Kontou, 2014);
6. the clause introduced by *ap'oti* has no longer the meaning of a relative clause but it is purely a comparative clause. (Theophanopoulou-Kontou, 2014).

However, I would like to argue that the claim that *ap'oti* has been grammaticalised to a SM and the arguments put forward in support of that claim do not hold if put under further scrutiny.

To begin with, Cheila-Markopoulou's (1986) arguments (see 1. and 2. above) support that a theory of grammaticalisation of *ap'oti* ('from whatever') is logically possible and could be even plausible, however, they do not prove that this grammaticalisation process has actually taken place or that it is complete. Furthermore, both constituents comprising *ap'oti* are productive in a wide array of constructions in Modern Greek in contrast to Cheila-Markopoulou's (1986) examples of reanalysed and grammaticalised phrases where at least one of the elements is no longer productive in Modern Greek (*dhia* ('for'), *u* (*wh.GEN*), *otu* (*wh.GEN*) and *o* (*wh.DAT*) are not transparent in Modern Greek). Therefore, *ap'oti* ('from whatever') and its constituents are synchronically transparent in contrast to the parallels mentioned by Cheila-Markopoulou (1986).

Secondly, the fact that *oti* ('whatever') does not seem to modify a constituent in the standard phrase (argument 3. above sentence (328)) does not entail that *oti* ('whatever') is no longer a free relative item. Notice the parallel between the comparatives in (331) and the free relative clauses in (332).

The difference between the *oti* ('whatever') and the *osos* ('however' ADJ) examples is that the former stands for the whole phrase while the latter is only a modifier of the (elided) ADJP/DP. The same applies to (328) too.

- (331) a. O Jorgos ine psiloteros ap' oti/ oso <psili> ine i Maria.
 the George is taller from whatever/ however tall is the Mary
 'George is taller than Mary is'
- b. O Jorgos efage perisoteres karameles ap' oti/ oses <karameles> efage i
 The George ate more candies from that/ however candies ate the
 Maria
 Mary
 'George ate more candies than Mary did.'
- (332) a. A: O Jorgos ine psilos.
 the George is tall.
 A: 'George is tall.'
- B: Oso psilos/ oti ki an ine, san ton Jani den ine.
 however tall/ whatever and SBJ is, like the John NEG is
 B: 'No matter how tall/ whatever he is, he isn't tall like John.'
- b. A: O Jorgos efage poles karameles.
 the George ate many candies
 A: 'George ate a lot of candies.'
- B: Oses <karameles> ki an efage, i Maria efage polaplasies.
 however candies and SBJ ate, the Mary ate multiple
 B: 'No matter how many/ what he ate, Mary ate multiple times [the candies he ate].'

Furthermore, the indeterminate character of *oti* ('whatever') is not confined to comparative constructions. The free relative *wh*-item *oti* ('whatever') may function as a modifier to a noun and in that case it does not present any marking of agreement with the NP. *Oti* ('whatever') agrees neither with the [+feminine,-plural] chair in (333-a) nor with the [+neuter,+plural] bed in (333-b). So, the fact that *o,ti* is not overtly marked for gender/case/number, even in cases that it is used as a modifier, is irrelevant to its status as a SM.

- (333) a. A: O Jorgos agorase mia anapftiki karekla.
 the George bought a.FEM.SG comfortable.FEM.SG chair.FEM.SG
 A: 'George bought a very comfortable chair.'
- B: oti karekla ke na agorase san ti diki mu
 whatever chair.FEM.SG and SBJ bought like the.FEM.SG mine.FEM.SG PR.1SG.GEN
 den ine.
 NEG is
 B: 'No matter what chair he bought, it is not like mine.'
- b. A: O Jorgos agorase dio anapftika krevatia.
 the George bought two comfortable.NEUT.PL. bed.NEUT.PL
 A: 'George bought two very comfortable beds.'
- B: oti krevatia ke na agorase san ta dika mu
 whatever beds and SBJ bought like the.NEUT.PL mine.NEUT.PL PR.1SG.GEN
 den ine.
 NEG is
 B: 'No matter what beds he bought, they are not like mine.'

Finally, Theophanopoulou-Kontou's (2014) last two points (items 5. and 6.) beg the question and do not provide any evidence in support of the grammaticalisation of *ap'oti* ('from whatever') to a single SM.

Taking the above facts into account, it is clear that there is not any evidence for the grammaticalisation of *ap'oti* ('from whatever') into a single lexical item functioning as a SM. On the contrary, *oti* ('whatever') in comparatives may stand for the whole DP or a nominal modifier and in the latter case it remains invariable exactly like what happens in *oti* ('whatever') free relatives.

Apart from the above-mentioned parallels between the free relative *oti* ('whatever') and *oti* ('whatever') used in the standard of comparison, further evidence against the reanalysis of *ap'oti* ('from whatever') to a single lexical item comes from apocope: namely the omission of the final sound of a word. Apocope is optional in Modern Greek and it does not trigger/mark any difference, in meaning or style. [o] in the end of the preposition in *ap'oti* ('from whatever') is optional both when *apo* introduces relative clauses and when *apo* introduces comparatives. This suggests that [o] in *ap<o>* ('from') is in a word boundary and that *apo* ('from') and *oti* ('whatever') are two distinct words that have not been reanalysed to a single SM.

- (334) a. Ap(o) oti katalava i Maria tha erthi avrio.
 from whatever understood.1SG the Mary will come.3SG tomorrow
 'As far as I understood, Mary will come tomorrow'
 b. xrostao ligotera mathimata ap(o) oti nomiza
 owe fewer classes than whatever thought.1SG
 'I have failed fewer classes than I thought.'⁶⁹

What is more, lengthening of the first vowel of *oti* can be used to focus the Universal quantification component of the *wh*-word, as in (335).⁷⁰ This is an instance of pragmatic enrichment via iconic modulation⁷¹. This strategy is not specific to *oti* ('whatever') but can be used with any simple free relative *wh*-item as well as in comparatives (337). The effect of pragmatic enrichment in comparatives is the same as in other relative clauses. It is also worth noting, that in that case, no apocope takes place, clearly showing that *ap'oti* ('from whatever') is synchronically decomposable.

- (335) tha kanis oooti (oooti) ki an su zitiso?
 will do.2SG whatever whatever and.ADD if 2SG.CL ask.1SG
 'Will you do whatever I ask no matter what?'

- (336) tha erthis oopu (oopu) ki an se kaleso?
 will come.2SG wherever wherever and.ADD if 2SG.CL invite.1SG
 'Will you come wherever I invite you [to come] no matter where?'

⁶⁹The example without apocope was found on <https://twitter.com/Foteineli/status/789814428753661960> (last accessed 20/02/2017)

⁷⁰Following Fintel (2000) and Tredinnick (2005) I assume the following semantic representation of free relative items:

(xvii) *whatever*(w)(F)(P)(Q)
Presupposes: $\forall w' \in \min_w [F \cap (\lambda w'. \text{ix.P}(w')(x) \neq \text{ix.P}(w)(x))] : Q(w')(\text{ix.P}(w')(x)) = Q(w)(\text{ix.P}(w)(x))$
Asserts: $Q(w)(\text{ix.P}(w)(x))$

⁷¹For more examples and discussion of iconic enrichments the reader is referred to Schlenker (2018) and references therein.

- (337) a. ap*(o) oooti tu zitusa tipota den eferne
of whatever him.CL ask.1SG anything NEG brought.3SG
‘He didn’t bring anything from whatever things I asked him (no matter what).’
b. eferne panta perisotera pragmata ap*(o) oooti tu zitusa
brought.3SG always more things than whatever him asked.3SG
‘He always brought more things than I ask him (no matter what).’

Iconic enrichment does not necessarily happen to lexical boundaries, however, it is another parallel between *oti*-free relatives and the SM in the comparative.

Based on the above parallels between free relative *oti* and *oti* in the standard clause of the comparative (syntactic position, morphological invariability, apocope, effects of iconic enrichment), it is clear that *ap’oti* (‘from whatever’) is not an opaque SM that introduces clausal comparatives but it is another instance of the phrasal SM *apo* (‘from, of’) that selects for a relative clause.

4.1.1.2 Clausal Standards introduced by *ap’ osos*

Standard phrases introduced by *ap’ osos* (‘from however’) are instances of free relative clauses (Theophanopoulou-Kontou 2014). This is evident from the following facts:

- they are introduced by the relative *wh*-item *osos* (‘however’) (Theophanopoulou-Kontou, 2014)
- *osos* is base-generated within the standard phrase and undergoes \bar{A} -movement, which results in island effects
- the phrase with *wh*-item is assigned (accusative) case by the preposition/SM *apo* (‘from’) on a par with other free relatives, where the *wh*-item is assigned case from the matrix clause (for matching phenomena in free relatives cf. Alexiadou and Varlokosta, 2007; Spyropoulos, 2007, 2011; Daskalaki, 2007, 2008, a.o.) (Theophanopoulou-Kontou, 2014)
- they can be paraphrased by a light-headed relative;⁷²

(338) Theophanopoulou-Kontou (2014)

- a. O Proedhros cheretise egardia aftus pu ixan erthi
the president greeted warmly those that had come
‘The President greeted warmly those who had come.’
b. Irthan ligoteri sti sinelefsi ap’ aftus pu irthan persi
came.3PL fewer in-the meeting than those that came last-year
‘Fewer people came in the meeting compared to those who came last year’

- *osos* (‘however’ ADJ) in NP-comparisons presents the same concord pattern as *osos* (‘however’ ADJ) in relative clauses, cf. (331-b) and (332-b) above for instance.⁷³
- they present case-mismatches, on a par with other free relatives.⁷⁴

⁷²Theophanopoulou-Kontou (2014) actually says that they can be paraphrased by restrictive relatives based on (338).

⁷³Theophanopoulou-Kontou (2014) argues that the fact that *osos* (‘however’) bares the same phi-features as the compared DP corroborates an analysis of *osos* (‘however’) as a free relative *wh*-item, in contrast to *oti* (‘whatever’). As shown in §4.1.1.1 however, morphological invariability or lack thereof is irrelevant to the *wh*-status of *osos* (‘however’)/*oti*(‘whatever’) in comparatives. What is at stake is whether these items present the same behaviour when used to introduce standard phrases and to introduce relative clauses.

⁷⁴(Daskalaki, 2007, 2008, 2011, For case-mismatches in Greek free relatives cf.)

- (339) Se simpathun perisoteri ap' osi/ osus nomizis
 CL.2SG.ACC like many.CMPR from however.NOM/ however.ACC think.2SG
 'More people than you think like you' (nominative variant found in <https://google.com/search?q=ap%27+osi> last accessed 8/2/2017)
- (340) Irthan oli osi/ osus kaleses.
 came.3PL all.NOM however.NOM/ however.ACC invite
 'All the people you invited arrived.'

Having rebutted current analyses of *ap'oti* ('from whatever') comparatives as 'purely comparative' clauses in §4.1.1.1 and having shown that they also involve free relatives (on a par with *ap'osos* ('from however') clauses), it is clear that the two constructions call for a uniform analysis along the lines of Pancheva Izvorski (2000): the phrasal SM, which in Greek is *apo* ('from, of') (cf. Chapter 3), may select for a nominal or a free relative clause. Schema (139) from Chapter 2 is repeated below for convenience.

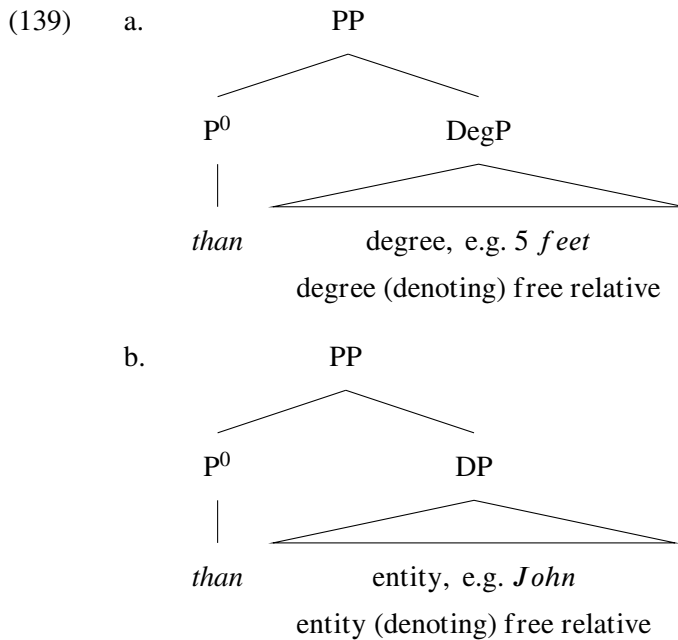

It should be highlighted though that there is no one-to-one mapping between *osos* ('however') and *oti* ('whatever') on the one hand and degree and entity interpretation on the other. Either item can have a degree or an individual interpretation.⁷⁵

- (341) a. Irthan perisoteri ap' osus ipologhiza. individual/degree
 came many.CMPR from however counted
 'More people came than those I expected.'
- b. Ipjame perisoteri sampania ap' osi chithike degree
 drank much.CMPR champagne from however spilt
 'We drank more champagne than was spilt.'
- (342) a. Irthan perisoteri ap' oti ipologhiza individual/degree
 came many.CMPR from whatever counted
 'More guests arrived than I expected.'

⁷⁵Cf. also Vlachou (2005) for a semantic analysis of *oso* ('however') and Carlson (1977) for an early analysis of amount relatives.

- b. O Janis mazepse perisotera fruta ap' oti o Michalis. degree
 the John collected many.CMPR fruit from whatever the Michalis
 'John collected more fruit than Michalis.'

Finally, before concluding this comparison between *ap' oti* ('from whatever') and *ap' oso* ('from however') standard phrases, we should discuss one difference between the two, namely the availability of ellipsis. The sentences with *osos-i-o* ('however' ADJ) seem to be much more restrictive with respect to ellipsis licensing if compared to *ap' oti* ('from whatever'): in (343) ellipsis is allowed with *oti* ('whatever') but not with *osos* ('however'). However, this fact does not challenge a uniform analysis of the two as free relatives: it can be easily explained if we take into account (331) and (332) above: *osos* ('however') is a modifier of the object NP whereas *oti* is the object DP. After *oti* ('whatever') moves to [Spec,CP] VP ellipsis applies and we get (343-a). In the case of *osos* ('however'), however, <karameles efaghe> ('candies ate') is not a constituent therefore it cannot be elided.

- (343) a. I Maria efaghe perisoteres karameles ap' oti o Janis.
 the Maria eat many.CMPR candies than.from whatever the John
 'Mary ate more candies than John.'
- b.??I Maria efaghe perisoteres karameles ap' oses o Janis.
 the Maria eat many.CMPR candies than.from however the John
 'Mary ate more candies than John.'
- c. I Maria efaghe perisoteres karameles ap' oses karameles efaghe o
 the Maria eat many.CMPR candies than.from however candies ate the
 Janis.
 John
 'Mary ate more candies than John.'

4.1.1.3 Interim summary: *apo* ('from') and relative clauses

In the previous two sections I showed that *ap' oti* ('from whatever') and *ap' oso* ('from however') are comprised of the phrasal SM and a *wh*-item introducing a free relative. If indeed *ap' oti* is not a clausal SM but the phrasal SM combined with a *wh*-item introducing a free relative, and *ap' oso* is the same, then we would expect that other types of relatives should be able to combine with the phrasal SM. Indeed, this prediction is borne out. As shown in (344), not only does the prepositional SM combine with *osos* ('however') and *oti* ('whatever') free relatives, but also with light headed relatives (344-b), nominal free relatives (344-c) and concessive free relatives (344-d). The free choice readings in (344-c) and (344-d) clearly suggest that the maximality operator usually postulated in the comparative standard phrase is not introduced by the *wh*-item (contra Rullmann, 1995).

- (344) To vivlio pu aghorase o Janis ine fthinotero apo...
 the book that bought the John is cheaper than
 'The book that John bought is cheaper than ...'
- a. ... osa aghorase o Michalis.
 however bought the Michalis
 ... however/ those that Michalis bought.'
- b. ... afto pu aghorase o Michalis.
 DEM.N that bought the Michalis
 ... that Michalis bought.'

- c. ... opjo vivlio aghorase o Michalis.
 which book bought the Michalis
 ... which book Michalis bought.'
- d. ... opjo vivlio ki an aghorase o Michalis
 which book and if bought the Michalis
 ... whichever book Michalis bought.'

In sum, in these sections I showed that clausal comparatives introduced by *apo* ('from') consistently correspond to a prepositional SM selecting for a relative clause. This analysis dispenses with the clausal standard marker *apoti* ('than') assumed by Cheila-Markopoulou (1986) and Theophanopoulou-Kontou (2014) and is compatible with the fact that a variety of relative clauses may follow *apo* ('from') in comparatives. However, I would like to show in the next section that Greek does have a SM introducing clausal comparatives but, in contrast to existing assumptions, this is *para* ('and not' EXCEPT) not *ap'oti* ('from whatever').

4.1.2 Comparatives with *para*-standards

Pa'ra (EXCEPT) in Greek is used in negative conjunctions as well as exceptive sentences.⁷⁶ *Para* (EXCEPT) exceptives are not hosted as opposed to other exceptives like *ektos* (EXCEPT), which assign case to their complements (von Fintel and Iatridou, 2007).

(345) (Institouto Neoellenikon Spoudon, 1998)

- a. Na min kathisis para na fighis amesos
 SBJ NEG sit.down EXCEPT SBJ leave immediately
 'Don't stay but leave immediately.'
- b. Dhen tu apomene para afti i parighoria
 NEG CL remain EXCEPT this the console
 'He had nothing else left but this console.'

Even though the use of *para* (EXCEPT) in degree comparatives has been spotted in early traditional grammars (Babiniotis and Kontos, 1967) modern linguistic literature identifies *para* (EXCEPT) as a SM that introduces exclusively metalinguistic comparatives (Cheila-Markopoulou, 1986; Giannakidou and Stavrou, 2009; Giannakidou and Yoon, 2009, 2011; Yoon, 2011a).⁷⁷

(346) O Michalis sistise se perisoterus kalesmenus ton Jani para ti Maria.
 the Michalis introduced to many.CMPR guests the John EXCEPT the Mary
 'Michalis introduced John to more guests than Mary.'

≠ 'It is more appropriate to say that Michalis introduced many guests to John than to say that Michalis introduced many guests to Mary.'

(347) Pjo oreo itan to forema pu aghorase i Maria para afto pu aghorase i
 CMPR beautiful was the dress that bought the Mary EXCEPT that that bought the

⁷⁶ *Pa'ra* is not the same item as the intensifier *'para* ('very'), which is used in the formation of *parapano* ('more') and was discussed in §3.3.1.3. For the remainder of this section I will refer only to *pa'ra* (EXCEPT).

⁷⁷ Even though Stavrou-Sifaki (1985) studies *para* (EXCEPT) comparatives extensively she only focuses on their syntax and she does not broach the semantics of *para* (EXCEPT) or the type(s) of comparatives it introduces.

Eleni.

Helen

‘The dress that Mary bought was nicer than what Helen bought.’

≠ ‘It is more appropriate to say that the dress Mary bought is a nice dress than to say that the dress Helen bought is a nice dress.’

Para (EXCEPT) introduces clausal comparatives (Stavrou-Sifaki, 1985; Cheila-Markopoulou, 1986) hence it cannot combine with measure phrases (Cheila-Markopoulou, 1986, 141) (348) and it does not assign case to its complement (349).

(348) *Efage se mia imera perisotera para pente paghota. (Cheila-Markopoulou, 1986, 141)
ate in one day many.CMPR EXCEPT five ice-creams

‘He ate more than 5 ice-creams in one day.’

(349) (Cheila-Markopoulou, 1986, 142)

a. O Nikos ine psiloteris para o Jorgos
the Nikos is tall.COMP EXCEPT the George.NOM
‘Nikos is taller than George’

b. *O Nikos ine psiloteris para ton Jorgo
the Nikos is tall.COMP EXCEPT the George.ACC
‘Nikos is taller than George’

However, I would like to argue that even though *para* (EXCEPT) can introduce clausal comparatives it may also introduce a single phrase on a par with other conjunctive elements.⁷⁸ The sentence in (350) is ungrammatical if the associate is a clitic (350-a) but it becomes grammatical if the associate is a full DP. Note that in (350-b) the associate is not focused (though it could be) and the unavailability of the comparison with a clitic cannot be attributed to some requirement that the associate be focused.

(350) a. *S’ aghapo perisotero para ti mama su.
2SG.CLACC love much.CMPR EXCEPT the mother.ACC your
‘I love you more than your mum.’

b. Aghapo esena perisotero para ti mama su.
love you.ACC much.CMPR EXCEPT the mother.ACC yours
‘I love you more than your mum.’

Based on the above facts, we can conclude that Greek *para* (EXCEPT), which is a connective in many respects equivalent to *but*, is the only SM that can introduce clausal comparatives without resorting to a relativisation strategy.

4.2 Romance Languages

In the next sections, I will argue that Romance comparatives are formed similarly to Greek ones: either the phrasal SM selects for a relative clause or *quelche* introduces a clausal comparative. *Quelche* is used in a variety of constructions in Romance, as a relativiser, an exceptive, a complementizer, etc. *Quelche* is standardly assumed to be an overt exponent of the *wh*-operator found in comparative

⁷⁸I leave aside the issue whether every conjunction is actually a conjunction of propositions.

clauses. However, I will argue that instead *quelche* is an exceptive similar to Greek *para* (EXCEPT). For that reason, I will gloss *quelche* simply as SM.

4.2.1 Que/Che comparatives

All Romance comparatives employ a SM *chelque* to introduce clausal comparatives. *Chelque* introduce clausal comparatives as

- they allow more than one pivot

- (351) a. *Émilie est plus/ moins intelligente que je ne le pensais.* French
 Emilie is CMPR/little.CMPR intelligent.ADJ. SM 1SG NEG it.CL thought.
 ‘Emilie is more/less intelligent than I thought.’ (Batchelor and Chebli-Saadi, 2011)
- b. *Ella leyó ayer más libros aquí que tu hoy revistas en casa.*
 She read yesterday many.CMPR books here than you today magazines at home
 Spanish
 ‘She read more books here yesterday than you read magazines at home today.’
 (Mendia, 2013)
- c. *Va resultar més facil que no semblava.* Catalan
 was prove CMPR easy SM NEG seemed
 ‘It proved to be easier than it looked. (Price, 1990)
- d. *Váreu tardar menys a fer-ho que no ens haviem imaginat* Catalan
 did take little.CMPR to do-CL SM NEG we had imagined
 ‘You took less time to do it than we had imagined. (Price, 1990)
- e. *Ela está falando inglês melhor que (falava) antes.* Br.
 she is speaking english well.CMPR SM spoke.3SG before.ADV
 Portuguese
 ‘She speaks english better than she did before. (Whitlam, 2011)

- they allow pivots other than DPs

- (352) a. *Christophe a mûri: il réfléchit plus qu’ avant quand il doit*
 Christophe has develop he think.3SG much.CMPR SM before when he must
 prendre une décision. French
 take a decision
 ‘Christophe has grown up: he thinks more than before when taking a decision.’
 (Batchelor and Chebli-Saadi, 2011)
- b. *Ha parlato più con Fransesco (*di)/ che con Maria* Italian
 have talked much.CMPR with Fransesco than.SM.from/ wh with Maria
 ‘He talked to Fransesco more than [she talked] to Mary.’ (Maiden and Robustelli,
 2007)
- c. *Es más grande que antes.* Spanish
 is.3SG CMPR big SM before
 ‘He is bigger than before. (Price, 1990)
- d. *Ela está falando inglês melhor que antes.* Br. Portuguese
 she is speaking english well.CMPR than before.ADV
 ‘She speaks English better than before.’

In Catalan dialects that human direct objects are introduced by the preposition *ənə* (to) the PP can follow *que* (353) and both (353) and (354) are unambiguous; in other dialects (354) becomes ambiguous and the associate of the comparative can be either be the subject or the object of the matrix clause (Hualde, 1992).⁷⁹

- (353) t' estimo més que ənə la Maria. Catalan
 2.SG love.1SG much.CMPR than to D Maria
 'I love you more than I love Mary. (Hualde, 1992)
 (available only in dialects with differential object marking)
- (354) t' estio més que la Maria.
 2.SG love.1SG much.CMPR than D Maria
 Catalan with DOM: 'I love you more than Mary does.'
 Catalan without DOM: 'I love you more than Mary does.' or 'I love you more than I love Mary.'

- they can be followed by a nominative pivot. In the Romance languages studied in this thesis, the only DPs that are marked for case are personal pronouns.⁸⁰

⁷⁹ Notice that in a phrasal comparative like (xviii) where the DP in the standard phrase is assigned case by the prepositional standard marker the sentence is ambiguous; in Reading 1 the associate is the subject of the matrix clause in Reading 2 the associate of the comparison is the object of the matrix clause.

- (xviii) a. Ti amo più di Maria Italian
 2CL.SG.ACC love.1SG much.CMPR from Mary
- b. Se aghapo perisotero apo tin Maria Greek
 2CL.SG.ACC love.1SG much.CMPR from Mary.ACC
 'I love you more than the Mary.'
Reading 1: I love you more than Mary does.
Reading 2: I love you more than I love Mary.

Each reading is derived by covert movement of the associate as in (48-a) and (48-b) respectively.

⁸⁰ Licensing of single (DP) pivots in Italian *che*-comparatives seems to be more restricted than other Romance languages, a fact that makes hard the application of some diagnostics.

- (xix) a. *È più grande che io/ Gianni.
 is CMPR big SM 1SG John
 'S/He is bigger than I/ John.'
- b. *Lei non è più grande che nessuno/ Maria.
 She NEG is MORE big SM n-person/ Maria
 'She isn't bigger than anybody/ Maria.'

However, DP pivots are not uniformly excluded from Italian (xx).

- (xx) a. Nessuno ci ha messo più impegno che Gianni.
 n-person CL have put much.CMPR commitment SM Gianni
 'Nobody is more committed than John.'
- b. Nessuno si è sforzato più che Gianni.
 n-person CL is try.PCPL more SM Gianni
 'Noone has tried more than Gianni.'

I leave to future investigation the exact licensing conditions.

- (355) a. Es más grande que yo. Spanish
 is CMPR big than 1SG.NOM
 ‘He is bigger than I (am).’
- b. Jo sóc més alt que tu. Catalan
 I am CMPR tall SM 2SG.NOM
 ‘I am taller than 2SG. (Hualde, 1992)’
- c. Meu irmão come mais que eu. Br. Portuguese
 My brother eats much.CMPR than 1SG
 ‘My brother eats more than me. (Whitlam, 2011)’

- they do not allow reflexive binding from the matrix clause

- (356) a. Personne n’ est plus grand que soi-même/ *lui-même. French
 n-person NEG is CMPR big SM himself/ himself
 ‘Nobody is taller than himself.’
- b. *Ninguém é mais alto que ele mesmo Brazilian Portuguese
 n-person is CMPR tall SM him self
 ‘Nobody is taller than himself.’

- they do not license negative concord from the matrix clause

- (357) a. *Elle n’ est plus grande que personne. French
 she NEG is CMPR tall SM nobody.
 intended reading: She isn’t taller than anybody.
- b. *Non est più alto che nessuno. Italian
 NEG is CMPR tall SM n-person
 ‘S/he isn’t taller than anybody.’
- c. *Você não é mais alto que ninguém Brazilian Portuguese
 you not are CMPR tall SM n-person
 ‘You aren’t taller than anyone.’

As sentences (351-a), (351-c) and (351-d) show, French and Catalan allow for a sentential negator to appear in the standard phrase, which does not seem to change the polarity of the proposition. As we will see in the next section, the same happens in Italian. This phenomenon will be extensively discussed in Chapter 5.

Before concluding this section, I would like to address two issues that seem to undermine a uniform analysis of Romance *que/che* comparatives as clausal. The former is related to French DP-pivots that follow *que* (SM). As with other Romance languages, French DPs are not overtly case marked with the only exception of personal pronouns. Price (1990) uses the minimal pair in (358) to argue that the French SM *que* (SM) is used to introduce phrasal comparatives, due to the ungrammaticality of the nominative pronoun *il* (‘personal pronoun.3SG).

- (358) a. Son père est plus riche que lui.
 his father is CMPR rich SM PR.3SG.
 ‘His father is richer than him.’
- b. *Son père est plus riche qu’ il.
 his father is CMPR rich SM he.3SG.CL
 ‘His father is richer than him.’

However, the ungrammaticality of (358-b) is expected irrespective of case, because the verb, which is the phonological host of the clitic, has been ellided. It is a well established fact that subject pronouns like *il* in French are clitics.⁸¹ Consequently, the ungrammaticality of (358-b) is expected even without assuming that *que* (SM) introduces phrasal comparatives. Furthermore, *lui* (personal pronoun.3SG) is not exclusively marked for ACCUSATIVE: *lui* (personal pronoun.3SG) may be used as a nominative subject, as in (359), therefore, its availability does not signify that *que* (SM) has assigned accusative case.

- (359) Pendant que je travaille, lui se repose.
 while that I work, he.3SG.NOM 3SG.RFL rest
 ‘While I work, he rests.’ (Lust and Pantelodemos, 1995)

So, *lui* is not necessarily an accusative pronoun — instead it is better understood as another instance of a not overtly case marked phrase that can indistinguishably appear both in subject and object positions, similar to other French DPs. Based on these facts, I would like to suggest that there is not strong enough evidence that *que* assigns case to the pivot following it. Given the uniform pattern observed in other Romance languages as well as uses of *que* in other environments in French (exceptive *ne ... que* (‘only’), connective *avant que* (‘before’), *sans que* (‘without’), relativizer, complementizer), the facts in (358) are better understood as reflecting variation in the status of nominative personal pronouns and not the properties of *que*.

Another problem for the proposed analysis might be constructions like (360). Sentences in (360) correspond to the Italian translation of (361-a) and (352-c) above. The Italian versions of those sentences are ungrammatical. I believe that this lack of uniformity does not undermine the proposed theory but the differences in the grammaticality of Italian sentences on the one hand and Romance sentences on the other are due to independent factors, e.g. ellipsis licensing conditions, interaction with the polarity of the matrix sentence, etc. (cf. also fn. 80 above). I leave the identification of those factors to future investigation.

- (360) a. *Parla inglese meglio che non parlasse prima.
 speaks English well.CMPR SM NEG spoke before
 ‘S/he speaks English better than before.’
 b. *E pi’u grande che prima.
 is more big than before
 ‘S/he/It is bigger than before.’

In sum, in this section I showed that Romance *che/que* (SM) introduces clausal comparatives and in light of the Greek data examined in the previous sections, I proposed that *che/que* (SM) in Romance comparatives introduces clausal standard phrases. Any differences amongst Romance languages are attributable to independent factors.

4.2.2 Prepositional Standards with Relatives

Similar to Greek, the Romance phrasal SM *de/di* (‘from, of’) may select for relative clauses.

⁸¹For the debate regarding the status of French subject clitics as arguments or morphological markers cf. de Cat (2002) and references therein.

- (361) a. Ela está falando inglês melhor do que (falava) antes. Br. Portug.
she is speaking english well.CMPR from.PR *wh* spoke.3SG before.ADV
'She is speaking english better than she did before. (Whitlam, 2011)
- b. O tempo estava pior do que no dia anterior. Br. Portuguese
the weather was bad.CMPR from.PR *wh* on-the day previous
'The weather was worse than on the previous day. (Whitlam, 2011)
- c. Meu irmão come mais do que eu. Br. Portuguese
My brother eats much.CMPR from.PR *wh* 1SG
'My brother eats more than me. (Whitlam, 2011)
- (362) a. Tengo más libros de cuantos tienes tú. Spanish
have many.CMPR books from however have you
'I have more books than you.
- b. Sé más de cuanto sabes tú. Spanish
know much.CMPR from however know you
'I know more than you know. (Mendia, 2013)
- (363) a. Requiere más tiempo del que dispongo. Spanish
require.3SG much.CMPR time.M.SG from.PR.M.SG SM provide.1SG
'It requires more time than I have. (Kattán-Ibarra and Pountain, 2003)
- b. Tiene más preparación de la que tenía cuando
have.3SG much.CMPR preparation.FEM.SG from that.FEM.PL that have.3SG when
ingresó en la empresa. Spanish
enter in the enterprise
'He/ she has more training than what he/ she had when he/ she joined the company.'
(Kattán-Ibarra and Pountain, 2003)
- c. Había menos personas de las que habíamos invitado. Spanish
had few.CMPR people.FEM.PL from PR.FEM.PL that had invited
'There were fewer people than we had invited. (Kattán-Ibarra and Pountain, 2003)
- d. Habla menos de lo que yo creía. Spanish
speak.3SG little.CMPR from that that I thought
'He/ She speaks less than I thought. (Kattán-Ibarra and Pountain, 2003)
- (364) a. Dóna més del que promet
give.3SG much.CMPR from.PR. that promise
'He gives more than he promises.' (Price, 1990)
- b. Aparenta més anys dels que té Catalan
seem many.CMPR years from-which.PL SM has
'He looks older than he is.' (Price, 1990)

Amongst the languages that allow negation in the standard phrase, Italian is the only one that also licenses it in relative clauses selected by the phrasal SM. When negation is licensed, the verb of the standard phrase must be in Subjunctive.

- (365) a. Il problema era più complesso di quel che sembrava. Italian
the problem was CMPR complex from that that seemed
'The problem was more complex than it seemed.
- b. Il problema era più complesso di quel che non sembrasse. Italian
the problem was CMPR complex from that that NEG seemed.SBJ
'The problem was more complex than it seemed. (Maiden and Robustelli, 2007)

- (366) a. Mario è più intelligente di quanto credevo/ credessi. Italian
 Mario is CMPR intelligent from how-much think.IND/ think.SBJ
 ‘Mario is more intelligent than I believed.’
- b. Mario è più intelligente di quanto non credessi. Italian
 Mario is CMPR intelligent from how-much NEG think.SBJ
 ‘Mario is more intelligent than I believed.’

4.2.3 *Que* as an exceptive

What is interesting though, is that *que* may also introduce relative clause standards. Similar facts are also observed in Spanish.

- (367) French
- a. Le père est plus riche que ce que le fils croyait.
 the father is CMPR rich SM that that the son thought.
 ‘The father is richer than the son thought.’
- b. Il a plus d’amis que ce qu’il avait.
 it has many.CMPR of friends SM that that he had
 ‘He has more friends than he used to have.’
- c. Il travaille plus que ce qu’il travaillait.
 He works much.CMPR SM that that he worked
 ‘He works more than he used to work.’ (Price, 1990)
- d. Il a plus d’amis que ceux que tu a rencontrés.
 he has many.CMPR of friends SM those.masc.PL that you have met.PCPL.masc.3PL.
 ‘He has more friends than you have met.’

Data in (367) seems puzzling under standard assumptions that *que* in comparatives is the relativizer *quelche*, an overt exponent of the covert *wh*-operator that moves, which can be found overt in some English dialects after *than* (cf. Chomsky, 1977). Instead, I would like to propose that this data suggests that *quelche* in Romance is an exceptive, equivalent to Greek *para* (EXCEPT) and English *but*, also found in constructions like (368).

- (368) a. Tu n’as qu’à aller au North End. French
 you NEG have EXCEPT to go to.the North End
 ‘You only have to go to the North End.’ (von Fintel and Iatridou, 2007, (55))
- b. No vio màs que à Juan. Spanish
 NEG saw.1SG more than PARTICLE Juan.
 ‘I saw only Juan’ (von Fintel and Iatridou, 2007, (138))
- c. Se vuoi una buona pizza non hai che da andare qui sotto. Italian
 if want a good pizza NEG have EXCEPT from go here down
 ‘If you want a good pizza, you only have to go downstairs.’

As von Fintel and Iatridou (2007) report from Jay Jasanoff (p.c.) French *ne... que* (‘only’) construction originates from Latin *quam* (‘than’), which is the Latin clausal SM (cf. (31-b) in §2.1.1) and not from Latin *quod* (the complementizer ‘that’). This corroborates that an analysis of *que/che* in comparatives on a par with *quelche* in exceptives is on the right track.

4.3 Conclusions

In this brief chapter, I discussed the distribution of clausal comparatives in Greek and Romance languages. I showed that Greek *ap'oti* actually corresponds to a phrasal SM selecting for a free relative clause, contra Theophanopoulou-Kontou (2014). On the other hand, I showed that Greek exceptive *para* not only does it introduce metalinguistic comparatives but also degree inequality comparatives. Its analysis as an exceptive is compatible with selecting sentential complements as well as nominal constituents with phi-features matching the associate on a par with other conjunctive elements. Furthermore, I argued that Romance *che/que* never assigns case to its complement (contra Price, 1990) but it is better understood as an equivalent of *but*, namely the same element that is used to introduce non-hosted exceptives and an equivalent to *para* (EXCEPT). This proposal is compatible with the diachronic development of *que* in comparatives from Latin *quam* as well as the fact that it can be followed by relative clauses. In sum, a uniform but simple picture emerges: clausal comparatives can be formed either by a phrasal/prepositional SM selecting for a relative clause or by an unhosted exceptive.

Chapter 5

Polarity phenomena in Comparatives

5.1 Introduction

This chapter discusses polarity phenomena in comparatives with a special emphasis on the meaning and licensing of a negative marker in the standard phrase of inequality comparatives, also known as ‘paratactic negation’, ‘parasitic negation’ or ‘expletive negation’. This negative marker does not seem to change the meaning of the comparative construction hence its characterisation in the previous literature as ‘expletive’. Since the main question addressed in this chapter is the status and meaning of this negative marker I will refer to it using the theoretically neutral term Comparative Negation (CN).

The analysis of CN in this chapter will unfold around two main axes: the former is polarity phenomena in the comparative construction, especially n-word licensing, and the latter is the semantic contribution of CN. The analysis will be based on data from the cross-linguistic distribution of CN in Romance languages and Greek (§5.2) and experimental data from the acquisition of Italian clausal comparatives (§5.4.2).

This chapter is organised as follows: §5.2 presents an overview of the distribution and interpretation of negation and n-words in inequality comparatives across French, Italian, Spanish, Catalan, Brazilian Portuguese and Greek. §5.3 critically presents previous accounts of the presence of comparative negation and classifies them in 6 different categories based on the meaning assigned to comparative negation and the semantics of the comparative. §5.4 presents a deeper investigation of comparative negation in Italian in light of experimental evidence from language acquisition and suggests that comparative negation is another occurrence of real negation. §5.5 brings together the typological and acquisitional data and §5.6 discusses the implications of these findings for a typology of comparative negation.

5.2 The empirical picture

5.2.1 French

French is a strict negative concord language and its sentential negation appears both pre- and post-verbally: the clitic *ne* precedes the inflected verb/auxiliary and the particle *pas* follows it. If an n-word, like *personne* (n-person) or *jamais* (n-time) is present, then the post verbal marker *pas* (NEG) is omitted:

- (369) a. Je n' ai pas vu Marie.
I NEG have NEG seen Mary
'I haven't seen Mary.'
- b. Je n' ai vu personne.
I NEG have seen n-person
'I have seen nobody.'
- c. —Qui a téléphoné? —Personne.
Who has telephoned n-person
'—Who called? —Nobody.'

French comparatives introduced by *que* (EXCEPT) license CN. French CN differs morphologically from real negation in that it is only the preverbal marker *ne* (NEG) that is being used without post verbal *pas* (NEG). If the verb is elided, so is CN (370). This stems from the fact that *ne* cliticizes on the verb (371).

- (370) a. Ce film est plus intéressant que je (ne) le pensais.
this film is CMPR interesting EXCEPT I NEG CL.N.SG thought
'This film is more interesting than I thought.' (Batchelor and Chebli-Saadi, 2011)
- b. Ta voiture est moins coûteuse que je (ne) le pensais.
your.f. car.f. is little.CMPR costly EXCEPT I NEG CL.N.SG.CL thought.
'Your car is less costly than I thought.' (Batchelor and Chebli-Saadi, 2011)
- (371) Paul est plus riche que (*ne) Marie.
Paul is CMPR rich EXCEPT NEG Mary
'Paul is richer than Mary.'

French n-words can be licensed in comparative clauses too. In inequality comparatives they receive a weak NPI interpretation whereas in equality comparatives a strong NPI interpretation, cf. (372) and (373). The same pattern is observed also in cases where the n-word is not a remnant (374). However, if the verb is not elided, CN becomes obligatory in the presence of an n-word (375).

- (372) a. Elle est plus belle que personne.
she is CMPR beautiful EXCEPT n-person
'She is more beautiful than anybody.'
- b. Elle est plus belle que jamais.
She is CMPR beautiful EXCEPT n-time
'She is more beautiful than ever.'
- (373) a. Elle est belle comme personne.
she is beautiful as.SM n-person
'She is beautiful like nobody.'
- b. Elle est belle comme jamais.
she is beautiful as.SM n-time.
'She is beautiful as never.'
- (374) a. Paul est plus riche que personne ne le sera jamais.
paul is CMPR rich EXCEPT n-person NEG it.CL be.FUT n-time
'Paul is richer than anyone will ever be.'
- b. Paul est riche comme personne ne le sera jamais.
paul is rich as.SM n-person NEG it.CL be.FUT n-time
'Paul is rich as no-one will ever be.' (Price, 1990)

- (375) a. Audrey a accompli la tâche mieux que je (ne) (le) croyais.
Audrey has completed the.FEM task.FEM well.CMPR EXCEPT I NEG CL.M.SG. thought

‘Audrey has completed the task better than I thought.’ (Batchelor and Chebli-Saadi, 2011)
- b. Audrey a accompli la tâche mieux que personne ne (le) croyait.
Audrey has accomplished the task well.CMPR EXCEPT n-person NEG CL.M.SG. thought
‘Audrey has accomplished the task better than anybody thought.’
- c. ??Audrey a accompli la tâche mieux que personne le croyait.
Audrey has accomplished the task well.CMPR EXCEPT n-person CL.M.SG. thought
‘Audrey has accomplished the task better than anybody thought.’

Table 5.1 summarizes the facts discussed in this section.

Table 5.1: Distribution of Negation in French Inequality Comparatives

	Negation	NC-parameter	SM	CN?	N-words?
French	<i>ne... V...pas</i>	strict NC	<i>que ...</i>	Yes	Yes
			<i>que ce que ...</i>	No	No
			<i>de MP</i>	No	No

5.2.2 Italian

Italian is a non-strict negative concord language. Therefore, n-words like *nessuno* (n-person) or *mai* (n-time) are interpreted as truly negative in preverbal position or, if they are in post verbal position and combined with preverbal negation, then they are interpreted as strong NPIs. In contexts known to license weak NPIs, like questions, conditionals, etc. Italian n-words are interpreted as weak NPIs (i.e. non-negative):

- (376) a. Hai visto nessuno ieri?
have seen n-person yesterday
‘Did you see anybody yesterday?’ (Donati, 2000)
- b. Se vedi nessuno, avverti Maria.
If see n-person warn Maria
‘If you see anybody, let Maria know.’ (Donati, 2000)

Italian n-words can be licensed in the standard phrase and they receive a weak-NPI interpretation, even if they are combined with CN (377). Similar to French, n-words are licensed both in superiority or inferiority inequality comparatives (compare (370)):

- (377) a. Ieri Maria ha mangiato più/ meno biscotti di quanti (non)
Yesterday Maria has eaten many.CMPR/ few.CMPR cookie of how.many NEG
ne avesse mai mangiati prima.
of-them has.SBJ ever eaten before
‘Yesterday Maria ate more cookies than ever before.’ (Donati, 2000)

- b. Maria mangia più/ meno biscotti di quanti (non) ne mangi
 Maria eats many.CMPR/ few.CMPR cookies of how.many NEG of.them eats.SBJ
 nessuno.
 n-person
 ‘Maria eats more cookies than anybody else.’ (Donati, 2000)

As shown above, the comparative clause no matter whether it is introduced by *di quanto* (366-b), *di quel* (365-b) or *che*, can license CN. CN does not necessarily precede the verb in *che* (EXCEPT) comparatives, but any phrase that survives ellipsis (378). In that respect, Italian differs from French, cf. (371) above.

- (378) a. Hanno molte più armi che non i francesi.
 have much many.CMPR weapons EXCEPT NEG the French.
 ‘They have many more weapons than the French.’ (Maiden and Robustelli, 2007)
- b. Non é affatto certo che il congiuntivo sia usato in italiano moderno in misura
 NEG is done sure that the subjunctive is used in italian modern in measure
 significativamente maggiore oppure minore che non nelle prime fasi
 significantly big.CMPR or small.CMPR EXCEPT NEG in-the previous phases
 della storia della lingua.
 of-the history of-the language
 ‘That the subjunctive is used in modern Italian to a significantly greater or smaller
 degree than in the earliest phases of the history of the language is not certain at all.’
 (Maiden and Robustelli, 2007)

Italian comparatives also differ from French in that CN is only licensed in Subjunctive SPs:

- (379) a. Maria è più intelligente di quanto (*non) credi.
 Maria is CMPR intelligent than how-much NEG think.IND
 ‘Maria is more intelligent than you think.’
- b. Maria è più intelligente di quanto (non) creda.
 Maria is CMPR intelligent than how-much NEG think.SBJ
 ‘Maria is more intelligent than you think.’

Table 5.2 summarizes the distribution of CN in Italian.

Table 5.2: Distribution of Negation in Italian Inequality Comparatives

	Negation	NC-parameter	SM	CN?	n-words?
Italian	<i>non</i> ... V	non-strict NC	<i>che</i> ...	Yes	Yes
			<i>di</i> DP	No	No
			<i>di quanto</i> ...	Yes	Yes
			<i>di quel che</i> ...	Yes	

5.2.3 Spanish

Spanish is another non-strict negative concord language. Similarly to Italian, n-words are interpreted as negative quantifiers if they are in preverbal position or if they are in post verbal position and they are

combined with preverbal negation. Alternatively, they can be licensed by other non-negative operators and in that case they have a weak NPI interpretation:

- (380) a. ¿Quién ha visto a nadie que trabaje más que él?
 who has seen at n-person that works much.CMPR EXCEPT he
 ‘Who has seen anybody that works more than he does?’ (Butt and Benjamin, 2011)
- b. ¿A usted cuándo le han preguntado nada?
 at you when you.ACC have asked n-thing
 ‘When did anyone ask you anything?’

CN is not licensed in Spanish Comparatives. Price (1990) argues that the ungrammaticality of CN in Spanish comparatives is the reason why a tensed verb is ungrammatical in the standard phrase. As I will show below, this is not supported by the cross linguistic distribution of CN (Brazilian Portuguese). On the other hand, n-words can be licensed in comparative clauses introduced by *que* (EXCEPT). In that case, they have the interpretation of weak NPIs:

- (381) Sabe cocinar mejor que nadie.
 know.3SG cook well.CMPR EXCEPT n-person.
 ‘He/she can cook better than anyone.’ (Kattán-Ibarra and Pountain, 2003)
- (382) En España son muchos los que se precian de asar el cordero mejor que nadie.
 in Spain be.3SG many PR that RFL pride of roast the lamb better EXCEPT n-person
 ‘There are many in Spain who pride themselves on roasting lamb better than anyone else.’
 (Butt and Benjamin, 2011)
- (383) Estás más joven que nunca/ *jamás.⁸²
 be.2SG CMPR young EXCEPT n-time/ n-time.
 ‘You are younger than ever.’ (Butt and Benjamin, 2011)

Table 5.3: Distribution of Negation in Spanish Inequality Comparatives

	Negation	NC-parameter	SM	CN?	N-words?
Spanish	<i>no ... V</i>	non-strict NC	<i>que ... (*V) ...</i>	No	Yes
			<i>que lo que ...</i>		
			<i>de MP</i>	No	No
			<i>de cuanto ...</i>	No	No
			<i>de lo que ...</i>	No	

⁸² Espinal (2000b) does not include *jamás* (never, ever) amongst Spanish n-words. From a preliminary investigation, the only environment that *jamás* (ever, never) cannot be used interchangeably with *nunca* (ever, never) is the comparative construction. I leave to future investigation the distribution of this particular lexical item.

5.2.4 Catalan

CN (*no* (NEG) or *no pas*(NEG NEG)) can be found in Catalan comparative clauses introduced by *que* (EXCEPT) on the condition that the matrix predicate is not negated.

- (384) a. En Joan té més vaques que no pas en Pere.
 D Joan have.3SG many.CMPR cows EXCEPT NEG NEG D Peter
 John has more cows than Peter. (Hualde, 1992)
- b. jo tinc més llibres que (no pas) tu bolígrafs.
 1SG have.1SG many.CMPR books EXCEPT NEG NEG ball-pens
 I have more books than you ball pens. (Hualde, 1992)
- c. En Joan té més vaques que el seu pare (no) tenia (pas)
 D John have.3SG many.CMPR cows EXCEPT the his.M father NEG have.3SG NEG
 ovelles.
 sheep
 John has more cows now than his father had sheep. (Hualde, 1992)
- d. jo guanyo més diners aquí que tu (no) guanyaràs (pas) a Amèrica.
 I earn.1SG much.CMPR money here EXCEPT you NEG earn.FU.2SG NEG in America
 I make more money here than you will make in America. (Hualde, 1992)

Compare (385) to the minimally different (351-c)

- (385) ??*No va resultar més fàcil que no semblava.
 NEG was prove CMPR easy EXCEPT NEG seemed
 ‘It did not prove to be easier than it looked.’ (Price, 1990)

In sum, Catalan, as other Romance languages, has two standard markers: *que* (EXCEPT) for clausal comparatives and *de* (from.SM) for phrasal ones. Clausal comparatives introduced by *que* (EXCEPT) license CN.

Table 5.4: Distribution of Negation in Catalan Inequality Comparatives

	Negation	NC-parameter	SM	CN?	N-words?
Catalan	<i>no ... V... (pas)</i>	non-strict NC	<i>que</i> ... <i>de</i> MP	Yes No	No

5.2.5 Brazilian Portuguese

Brazilian Portuguese is a non-strict negative concord language, like Italian and Spanish. An n-word can either precede the verb or it can follow it if it is combined with preverbal negation:

- (386) a. Eu não vi ninguém.
 I NEG saw n-person
 ‘I didn’t see anyone.’
- b. Ninguém me viu.
 n-person me saw
 ‘Nobody saw me.’

- (387) a. Eu nunca vou esquecer o que aconteceu.
I n-time will forget this that happened.
'I will never forget what happened.' (Whitlam, 2011)
- b. Ele não liga nunca.
He NEG call.3SG n-time
'He never calls.' (Whitlam, 2011)
- (388) a. Eu jamais faria uma coisa dessas.
i n-time(emph) do a thing such
'I would never ever do a thing like that.' (Whitlam, 2011)
- b. Você não deve jamais escrever sua senha num e-mail.
you NEG must n-time(emph) write your password in-a email
'You should never, ever write your password in an e-mail.' (Whitlam, 2011)

Brazilian Portuguese n-words are not licensed in other intentional contexts and they are not interpreted as weak NPIs.

- (389) a. Ontem Maria não viu ninguém.
Yesterday Maria NEG saw n-person
'Yesterday Maria didn't see anybody.'
- b. Você já viu alguém/ *ninguém ontem?
You already saw anybody/ n-person else
'Have you already seen anybody?'
- c. Se voce vir alguém/ *ninguém, deixe Maria saber.
if you see n-person let Maria know
'If you see anybody, let Maria know.'
- d. Pegue algum/*nenhum
Pick.IMP something/n-thing
'Pick anything!'

As far as comparatives are concerned, n-words are licensed in the standard phrase.

- (390) a. Maria comeu mais biscoito que qualquer outra pessoa/ ninguém.
Maria ate many.CMPR biscuits EXCEPT some other person/ n-person
'Maria has eaten more biscuits than anyone else.'
- b. Maria cozinha melhor que ninguém.
Maria cooks well.CMPR EXCEPT n-person
'Maria cooks better than anyone else.'
- c. Você está mais novo do que nunca.
you are CMPR young from what n-time
'You are younger than ever.'

Table 5.5: Distribution of Negation in Brazilian Portuguese Inequality Comparatives

	Negation	NC-parameter	SM	CN?	N-words?
Brazilian Portuguese	<i>não ... V</i>	non-strict NC	<i>que ...</i>	No	Yes
			<i>de MP</i>	No	
			<i>d[e] o que ...</i>	No	Yes

5.2.6 Greek

Similarly to French, Greek is a strict negative concord language (Giannakidou, 1998, *et seq.*) but it only has preverbal negation (391). In contrast to French, however, Greek n-words seem to be ungrammatical in the standard phrase of the comparative (Giannakidou and Yoon, 2014) Sentences in (392) and (393) show that an n-word cannot replace a DP in the standard phrase of the comparison neither in clausal nor in phrasal comparatives.

- (391) a. Dhen idha ti Maria.
NEG saw the Mary
'I did not see Mary.'
- b. *(Dhen) idha kanenan.
NEG saw n-person
'I didn't see anybody.'
- (392) a. I Maria etrekse grigorotera apo ton Gianni.
the Mary ran fast.CMPR from the.ACC John.
'Mary ran faster than John.'
- b. *I Maria etrekse grigorotera apo kanena.
the Mary ran fast.CMPR from n-person.
'*Mary ran faster than nobody.'
- (393) a. I Maria etrekse grigorotera apoti/para o Giannis.
the Mary ran fast.CMPR from the John.
'Mary ran faster than John (did).'
- b. *I Maria etrekse grigorotera ap' oti/ para kanis.
the Mary ran fast.CMPR from whatever/ EXCEPT n-person.
'*Mary ran faster than nobody.'

Giannakidou and Yoon (2014) show that greek n-words are not licensed in the comparatives but they claim that Greek NPIs can be *rescued* in this context (394). The distinction of licensing and rescuing is that made by Giannakidou (2006) according to which (strict) NPIs are *licensed* when they are in the scope of an antiveridical operator at LF and (weak) NPIs are *rescued* or *indirectly licensed* when they appear in the scope of a veridical expression, in violation of the LF condition, as long as the sentence globally allows a negative inference. These two ways are mutually exclusive and the NPIs that participate in one configuration never participate on the other. However, resort to NPI-rescuing in comparatives is problematic for two reasons. Firstly, Brazilian Portuguese n-words, which according to Giannakidou and Yoon's (2017) criteria are strong NPIs (they are only licensed in the scope of negation) are allowed in comparatives. Secondly, n-word licensing in Greek degree comparatives is even more restricted than Giannakidou and Yoon (2014, 2017) argue. If we change the embedding verb the n-word becomes ungrammatical.

- (394) I Maria etrekse grigorotera ap' oti perimene **kanenas**.
the Mary ran fast.CMPR from whatever expected n-person.
'Mary ran faster than anybody expected.' (Giannakidou and Yoon, 2014, (37))
- (395) Context: *The final draft of an agreement contains several changes compared to the initial draft and one comments that the changes were made to the worse.*

- a. *I teliki simfonia itan poli xiroteri ap' oti arxika simfonise kanis.
 the final agreement was much bad.CMPR from what initially agreed n-person
 'The final agreement was much worse than anybody originally agreed on.'
- b. I teliki simfonia itan poli xiroteri ap' oti arxika simfonisan ta simvalomena
 the final agreement was much bad.CMPR from what initially agreed the agreeing
 meri
 parties
 'The final agreement was much worse than the originally parties originally agreed.'

Actually, what we find is that n-word licensing in Greek comparatives correlates with n-word licensing under predicates in the scope of intensional operators. Sentence (396-a) shows that the predicates that can license n-words in contexts like (394) are also predicates that can license n-words if they are in the scope of some affective operator, e.g. the modal/future particle *tha*. On the other hand, predicates like *agree* that do not license n-words, even in the presence of some modal operator cannot license n-words in comparatives either, cf. (395).

- (396) a. [**(tha)*] perimene/ fantazotane kanis_i oti tha ton_{i/*k} sigkinuse mia toso lepsi
 FUT expect/ imagine n-person that FUT him move a so fine
 xironomia.
 gesture
 'One would expect/imagine that he would be moved by such a fine gesture.'
- b. **Tha* simfonuse kanis_i oti tha ton_{i/*k} sigkinuse mia toso lepsi xironomia.
 FUT agree n-person that FUT him move a so fine gesture
 'One would agree that he would be moved by such a fine gesture.'

This suggests that Greek is different than any other Romance language examined in this thesis, as it does not allow n-word licensing in the standard phrase, phrasal or clausal.

5.2.7 Interim Summary: Expletive Negation Licensing in Romance

The picture that emerges with regard to CN licensing so far is summarised in Table 5.6. The languages we have seen so far represent different parameter settings both for position of negation (French and Catalan have both pre- and post- verbal negation, Italian, Spanish, Brazilian Portuguese and Greek have only preverbal negation) and negative concord (French and Greek are strict negative concord languages whereas Italian, Spanish and Brazilian Portuguese are non-strict negative concord languages). However, these parameters do not help us predict whether CN will be licensed in a language: CN is licensed both in languages with pre- and post- verbal negation (French, Catalan) and languages with preverbal negation (Italian). On the other hand, languages with the same parameter setting do not present a uniform pattern: Italian, Spanish, Greek and Brazilian Portuguese have preverbal negation but only Italian licenses CN.

Table 5.6: Distribution of CN in different types of standard phrases [N/A: the language doesn't have this type of standard phrase, *: CN is ungrammatical, ✓: CN is grammatical]

	Comparative clause	Degree free relative	Light headed relative
Italian	✓	✓	✓
French	✓	N/A	*
Catalan	✓		
Spanish	*	*	*
Brazilian Portuguese	*		*
Greek	*	*	*

However, delving in the distribution of n-words in each language revealed two previously unnoticed facts about their crosslinguistic distribution in comparatives:

1. Licensing of n-words in the comparative clause is (partly) conditioned by the negative concord parameter setting of the language: in French which is a strict negative concord language, the, otherwise optional, CN becomes obligatory in the presence of an n-word. This does not happen in Italian, a non-strict negative concord language.
2. Brazilian Portuguese n-words are licensed only the presence of negation (i.e. an antiveridical/downward entailing operator) and cannot be licensed(/rescued) by other intentional operators. Yet they are licensed in the standard phrase of the comparative.

The picture that emerges is summarised in Table 5.7

Table 5.7: Negation and N-words in comparatives across languages

	CN	N-words weak NPI interpretation
French, Italian, Catalan	✓	✓
Spanish, Brazilian Portuguese	*	✓
Greek	*	*
—	✓	*

5.3 Previous approaches to Comparative Negation

As mentioned in the introduction of this chapter (§5.1), CN does not seem to have a semantic contribution hence it has been characterised in the past as ‘expletive’. On the other hand, as we also saw in chapter 2.2 there have been proposed two classes of semantic analyses for the comparative construction depending on whether they involve a negative logical operator or not. According to the ‘negative’ analyses there is a threshold that the compared entity in the matrix clause meets or exceeds

and the standard phrase does *not* meet or exceed that threshold (Seuren, 1973, 1984; Klein, 1980; Schwarzschild, 2008; Bhatt and Takahashi, 2011). According the second cluster of analyses (von Stechow, 1984; Kennedy, 1999; Hackl, 2001; Lechner, 2004; Beck et al., 2009; Alrenga et al., 2012) the comparative marker simply marks the inequality relation. It is unsurprising, therefore, that the meaning of CN is interwound with the meaning of the comparative construction.

On the other hand, regardless of the assumptions about the semantics of the comparative, existing analyses of CN can be divided into three classes based on the semantics they assign to CN itself: CN is the same as real negation; CN is really semantically vacuous/expletive, and CN has some meaning that is different than real negation. So, if we combine those two classification criteria, namely the meaning of the CC and meaning of the CN, we get 6 logical possibilities, illustrated in Table 5.8 below. In the remainder of this section, I will review the aforementioned possibilities and then I will examine where existing theories of CN fall.

Table 5.8: Semantics of CCs & CN: The space of logical possibilities.

[[<i>CN</i>]]	[[<i>Comparative</i>]]	
	>	¬
¬	1	2
expletive	3	4
some other meaning	5	6

To begin with, if we follow option 1 and assume that CN is an real negative operator additional to the comparative, we predict that a comparative construction with CN like (397) should mean (397-a) or (397-b), depending on the scope we assign to CN.

(397) Gianni ha mangiato più mele di quante non ne abbia mangiato Maria.
 John has eaten many.CMPR apples from how.many NEG CL have.SBJ eaten Mary
 ‘John ate more apples than Mary did.’

- a. ‘John ate more apples than the apples that Mary didn’t eat.’ (in a context where both Mary and John have 8 apples each, and John eats 6 of his apples whereas Mary eats only 2 of hers)
- b. ‘John didn’t eat more apples than Mary.’

This theory does not capture the correct interpretation, so it is not a viable option.

If a comparative construction involves a negative operator and CN is the overt exponent of it, like in option 2, it is straightforwardly predicted that a comparative construction with CN has the exact same truth conditions as a comparative without CN. As already discussed, some semantic theories of comparatives postulate the existence of a negative operator. Among those, Seuren (1973, 1984) is the only one to argue that the presence of CN corroborates a negative analysis of the comparative. To that end, Seuren (1984) cites evidence from several languages. More specifically, he refers to the etymological relation of English *than* to the Old English *þonne* ‘by which not’ proposed by Joly

(1967) and the existence of comparative negation in French and other Romance languages.⁸³ He also provides evidence from English dialects that use the negative conjunction *nor* as a standard marker, as well as from West Flemish and Classical Greek, which employ a disjunctive particle as a standard marker (398). Additionally, English dialects with ‘negative copying’ like Cockney English employ n-words in the place of the *any*-paradigm in Standard British English (399). Finally the distribution of NPIs and PPIs in the comparative also suggest the existence of a negative operator in the standard clause (400).

(398) *tolme:i meizoni e: dunamei* Classical Greek
 courage great.CMPR or power
 ‘with greater courage than power’ *Thucydides* 1.144

(399) She did a better job than what I *never* though she would. (Seuren, 1984, (3))

(400) *He has got more support than you ALREADY have. (Seuren, 1984, (5-a))

Delfitto’s (2018) proposal falls in the same topological space as Seuren’s (1984) theory, as he adopts Seuren’s (1984) semantics of the comparative including his proposal that comparative negation is an exponent of the negative logical operator found in inequality comparatives. His contribution is that he combines that with Collins and Postal’s (2015) neg-raising analysis of n-words and argues that the negation found in Italian comparatives (and *before* clauses) is the overt exponent of the covert neg-head Collins and Postal (2015) propose for English free choice *any*.⁸⁴

On the other hand, If CN is truly semantically vacuous/expletive (cells 3 & 4 in Table 5.8), then comparatives with CN should have the same truth conditions as comparatives without CN. According to Espinal (1992, 2000a, 2007) and Belletti (2001), CN is the same lexical item as real negation but the comparative does not contain negative operator to license it resulting in its expletive meaning.

More specifically, Espinal (1992, 2000a, 2007) assumes that comparative negation is an instance of Expletive Negation (EN) and she argues that it is the same as real negation. The reason why negation is rendered expletive is the configuration that it is involved. More specifically, the negative meaning of negation is ‘absorbed’ by the predicate/ adverb/ operator licensing expletive negation, which is specified for an F_{Neg} feature. In Espinal (2000a) this idea of logical absorption originally proposed in Espinal (1992) is implemented within a minimalist framework by resorting to feature checking. More specifically, EN involves dislocation of the F_{Neg} feature characterizing the negative marker and adjunction of this feature to a non-veridical operator (before, fear, the comparative). Once this movement has taken place, absorption applies.

⁸³ It seems that Joly’s (1967) etymology of *than* is wrong (Laker, 2008).

⁸⁴ Collins and Postal (2015) propose that English free choice *any* contains a covert negative head.

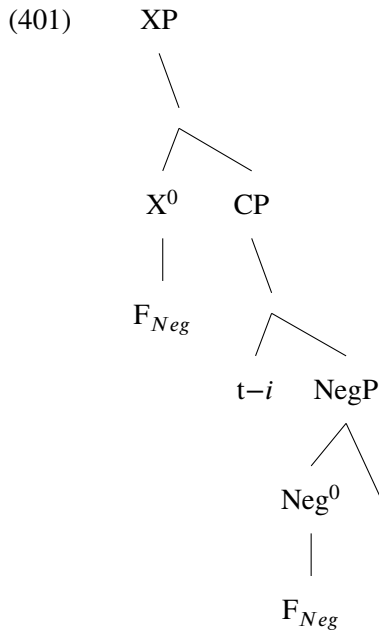

The difference between EN and negative concord, lies in that in EN negation is in the scope of a non-veridical operator (in the sense of Zwarts 1995; Giannakidou 1998) whereas negation in negative concord is in the scope of an antiveridical operator. Espinal's (1992, 2000a, 2007) theory of absorption postulates an ad hoc variant of feature checking which is hardly maintained in other grammatical phenomena where feature checking applies. What is more, the structural representation in (401) largely overgenerates: the non-veridical heads/operators are a superset of the elements licensing expletive negation.

Belletti (2001) entertains the idea that the comparative marker *più* (more) and comparative negation are the same as the n-word *più* (anymore) and negation in other contexts, respectively. More specifically, she argues that the n-word *più* moves from the [Spec,NegP] which is internal to the comparative AgrP into the [Spec,DegP] of the compared phrase. This movement is motivated by the necessity of checking the degree feature in the head of DegP, which is responsible for the availability of the comparative meaning. Since the adverb has left [Spec,NegP] it cannot activate the negative interpretation of the head *non*. In that case, a covert negative operator cannot be assumed to exist, since the [Spec,NegP] was previously occupied by the n-word. Instead, the negative marker in comparatives is licensed by the Subjunctive hence its expletive value: a modal operator moves from [Spec,ModP] to [Spec,NegP] licensing the CN. The feature at play is an "irrealis" feature.

(402)

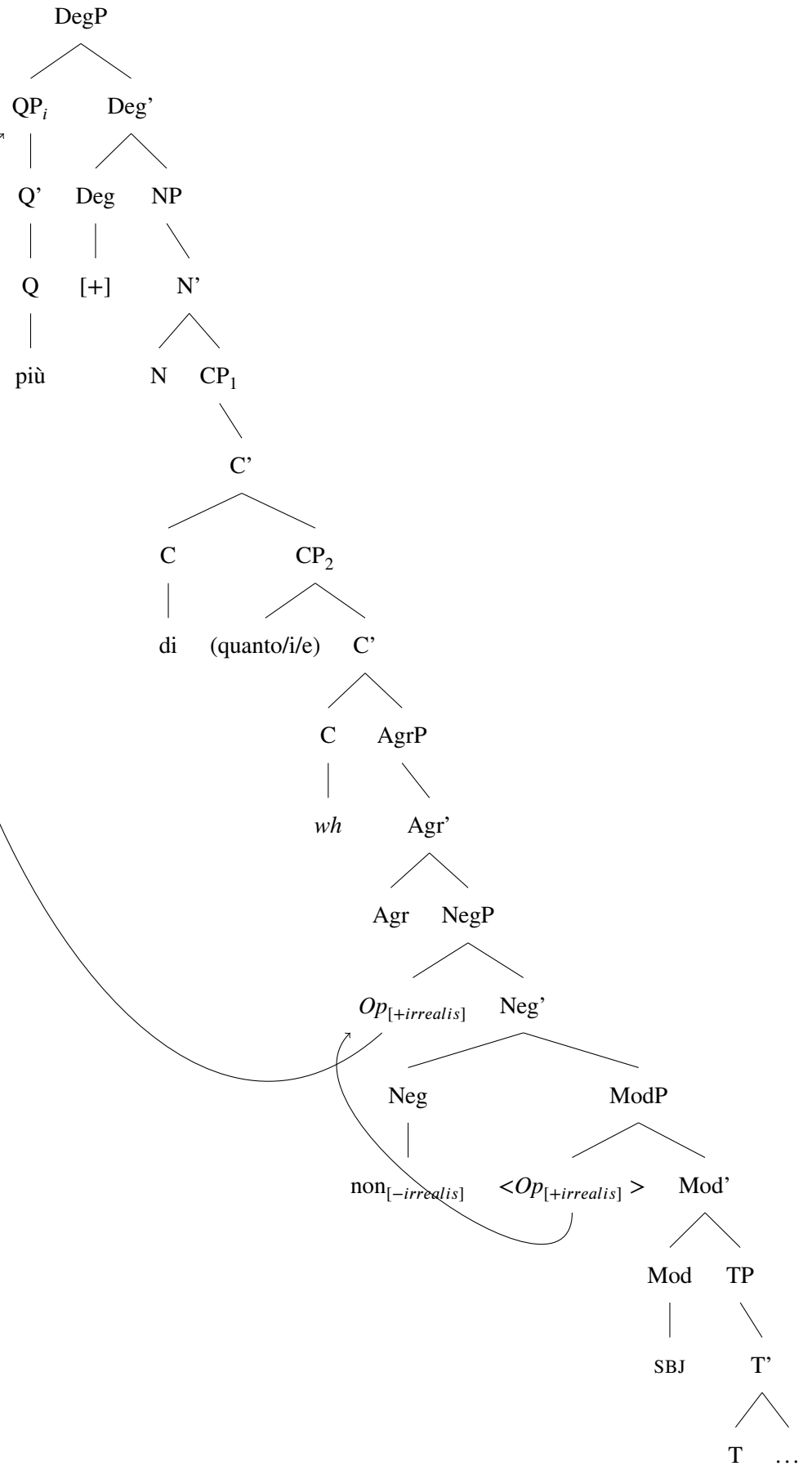

On the other hand, Wouden's (1994) theory falls in cell 4 of Table 5.8: similar to Espinal and Beletti he argues that CN is expletive; however his analysis is differs from theirs in that he assumes

that the comparative is negative. He argues that licensing of CN (and of polarity items) depends on the monotonicity properties of the context. As far as comparatives are concerned, negation is licensed there because comparatives are downward entailing (Hoeksema, 1983). He claims that the semantics of expletive negation is the identity function.

Finally, if negation in the standard phrase has some semantic contribution but that is not (related to) the negative operator (options 5 & 6), then the semantic interpretation of the comparative is irrelevant to the discussion of the meaning of CN. However, between the two, an analysis that involves a negative logical operator in the comparative but the negation overtly realised in the standard phrase is not related to it (namely 6) is highly implausible. It is thus reasonable why so far there has not been a theory that can be classified in cell 6.

Napoli and Nespors (1976) propose that negation appears in Italian comparatives when the speaker presupposes that his statement contradicts someone else's or his own previously held belief. The pairs they construct compare indicative comparatives without negation with subjunctive comparatives with negation, e.g. (403). So the pairs they construct are not actually minimal and the properties that Napoli and Nespors (1976) report as properties of comparative negation can be attributed to the Subjunctive. Indeed, independently proposed analysis of the subjunctive suggest that the choice of the Subjunctive is sensitive to the common ground and the accessibility of a modal base (Giorgi and Pianesi, 1997; Panzeri, 2006). The infelicity of (403-b) is hence expected as the subjunctive comparative needs to be evaluated against a (plural) modal base whereas in the context (403) it is evaluated against the real world.

- (403) Dario: Dimmi cosa pensi di Maria e Carlo.
 Tell.me what think.2SG of Mary and Carlo
 Dario: 'Tell me what you think of M and C.'
- a. Paolo: Maria è più intelligente di quanto è Carlo, ma lui è molto più simpatico.
 Mary is more intelligent of how-much be.IND Carlo but him is much more simpatico.
 nice
 Paolo: 'Maria is more intelligent than Carlo is, but he is much nicer.'
- b. Paolo: #Maria è più intelligente di quanto sia Carlo, ma lui è molto più simpatico.
 Mary is more intelligent of how-much be.SBJ Carlo but him is much more simpatico.
 nice
 Paolo: 'Maria is more intelligent than Carlo is, but he is much nicer.'

Furthermore, Napoli and Nespors (1976) argue that an optional rule deleting comparative negation may apply and that that seems semantically correct because subjunctive examples with negation can be used in the same context as subjunctive examples without negation. This corroborates that the properties Napoli and Nespors (1976) attribute to negation in the comparative are actually properties of the subjunctive.

Price (1990) argues that CN in French, Italian, and Catalan *ne*, *non* and *no (pas)* respectively, are different elements than sentential negation and that they function as markers of the inequality relation. Furthermore, she assumes that CN is what licenses a tensed verb in the comparative clause. More specifically, French requires CN in comparatives due to the 'formal identity' of the 'comparative

marker' (in the terminology we adopt here the standard marker) in equality and inequality comparatives. Price (1990) argues that *ne* (NEG) in French comparatives is distinct from CN in other environments based on two facts: firstly, the rest of CN constructions can be negated with *pas* (NEG) while *pas* (NEG) is ungrammatical in comparative constructions. Secondly, CN in other environments is in its way out while *ne* (NEG) in comparatives is still used. On the other hand, Spanish has distinct standard markers in equality and inequality comparatives and thus it does not need CN to distinguish the two. Due to the lack of CN though, it is not possible to license a tensed verb in the comparative clause. Since Italian has distinct standard markers in equality and inequality comparatives, CN is used to distinguish comparative clauses from relative clauses. Due to the morphological identity of CN and real negation in Italian, Subjunctive is also necessary for distinguishing the two constructions. Finally, in Catalan where equality and inequality comparatives have distinct markers, CN is used to distinguish relative from comparative clauses. In contrast to Italian though, subjunctive is not necessary regardless the morphological identity of real negation to CN. In Catalan reduced comparatives, CN is used for emphasis.

As must have been evident already, the correlation between CN and type of comparative can hardly be maintained. With the exception of French, where the standard is indeed identical in both equality and inequality comparatives, all other languages use a different standard marker in the two types of construction. Additionally, CN can also be licensed in French equality comparatives. Table 5.9 shows clearly that there is not any correlation between the morphology of the standard marker and CN licensing.

Table 5.9: CN and Standard Markers

Language	CN?	Equality marker	Inequality marker
French	Yes	que	que/ de
Italian	Yes	quanto/ como	che/ di
Catalan	Yes	com	que/ de
Spanish	No	como	que/ de
Brazilian Portuguese	No	quanto/como	que/ de

What Price (1990) calls the “tensed verb constraint”, namely that a tensed verb cannot appear in the standard phrase unless licensed by CN, is an interesting correlation. However, it is challenged by Brazilian Portuguese data where CN is ungrammatical but the comparative marker can be followed by a verb (352-d). Additionally, it is very hard thought to explain it how CN can license a verb. It might be more plausible to argue for the opposite, namely that being a sentential negator marker, CN cannot be licensed in the absence of a VP/TP.

Donati (2000) examines French and Italian comparative clauses and she argues that *ne* (NEG) in French, and *non* (NEG) are never negative; they are scope markers of some operator. Their apparent negative interpretation results when they are scope markers of negative operator. This lack of inherent negativity of *ne* (NEG) and *non* (NEG) naturally captures why they are licensed in comparatives while real negation is not. Being distinct from negation they do not form an island blocking *wh*-movement,

in contrast to what real negation does (Ross, 1980). In case of comparatives, CN is the scope marker of a focus operator. The existence of the latter is evidenced by the postverbal position of the subject in the standard phrase of the comparative, which is a typical focus position in Italian, the one-to-one correspondence of the phrases in the standard phrase and the comparative clause, weak-NPI licensing in comparatives and the fact that CN precedes the remnant in cases of ellipsis, as in (404).

- (404) Maria ha mangiato più biscotti che (non) Piero.
 Maria has eaten many.CMPR cookies EXCEPT NEG Piero.
 ‘Maria has eaten more cookies than Piero.’

If (404) is evidence for an analysis of CN as focus, then we would expect that *non* to immediately precede the contrasted subject in a standard phrase without ellipsis. However, this prediction is not borne out. Actually, *non* (NEG) is in preverbal position regardless it is the subject or the object of the sentence that is being compared (405). In other words, it does not necessarily precede the focused constituent but it always precedes the verb.

- (405) a. Maria mangia più biscotti di quanti (non) ne mangi Giovanni.
 Maria eats many.CMPR cookies from how-many NEG CL eats Giovanni.
 ‘Maria eats more cookies than Giovanni does.’
 b. Maria conosce la geografia meglio di quanto (non) conosca la storia.
 Maria knows the geography better from how-much NEG knows the history
 ‘Maria knows geography better than she knows history.’ (Donati, 2000)

What is more, the postverbal position of the subject that is used as evidence for the existence of the focus operator is not exclusive to focus constructions: subjects are postverbal in any construction involving *wh*-movement in Italian. Consequently, irrespective of the existence of a focus operator or not, subjects in (Italian) comparatives are expected to be postverbal since (Italian) comparatives involve *wh*-movement (Chomsky, 1977; Donati, 1997; Pancheva Izvorski, 2000, a.o.)

Therefore, it is hard to maintain that CN is the scope marker of focus in comparatives.

Yoon (2011b,c) identifies a distinct class of comparative constructions which she calls ‘Rhetorical Comparatives’ (RCs) because they have the same ‘rhetorical flavor’ as Rhetorical Questions. Rhetorical Comparatives are those comparatives that their standard contains a strong NPI,⁸⁵ CN or a modal combined with a weak NPI.⁸⁶ The ‘rhetorizing effects’ of RCs are summarized in (406).

- (406) Rhetorical effects in RCs
 a. Negative Implicature: RCs do not have referential standard. The degree of the standard cannot be defined within an appropriate domain in context.
 b. Large difference presupposition.: There is a large difference between the degree introduced by the standard and the degree in the main clause

Yoon (2011b,c) argues that domain adjustment is bidirectional: the domain of the standard can be ‘*enormously widened*’ by prosodically emphasizing regular domain extenders e.g. *any* (407-a) or by

⁸⁵ With the term strong NPIs Yoon (2011b,c) solely refers to emphatic NPIs like Greek *KANENAS* (anybody) and minimizers.

⁸⁶ Not all comparatives with CN are assumed to be RCs.

means of a modal combined with a weak NPI (407-b), or it can be ‘*excessively shrunked*’ by the use of a minimizer (407-c). Both strategies reduce the referentiality of the NPIs by either maximizing them to be non-specific or minimizing them to be non-existent. This bidirectional domain adjustment triggers the large difference presupposition which is a distinctive property of RCs.

- (407)
- a. Jack is taller than *ANYbody else* is.
 - (i) Negative implicature: Everybody else is not going to be as tall as Jack.
 - (ii) Large difference presupposition: There is a significantly large difference in degree of height between Jack and everyone else.
 - b. Jack is richer than you *'ll EVER* be.
 - (i) Negative implicature: You will never be as rich as Jack.
 - (ii) Large difference presupposition: There is a significantly large difference in degree of wealth between Jack and you in any foreseeable future.
 - c. Jack does volunteer works more often than he *lifts a finger* to help his wife.
 - (i) Negative implicature: Jack very rarely (or never) lifts a finger to help his wife.
 - (ii) Large difference presupposition: There is a significantly large difference in frequency between Jack doing volunteers works and him helping his wife.

Yoon (2011b) couches her analysis of RCs on Giannakidou and Stavrou’s (2009) analysis of NPIs. Giannakidou (1998) argued that NPIs introduce ‘dependent’ existential quantifier in the sense that the variable it binds is defective and cannot introduce a discourse referent. Giannakidou and Stavrou (2009) further proposes that a defective reference yields a polarity-sensitive expression if it is uninterpretable as a free variable. In that case, it can be rescued either by a negative operator or a non-veridical operator which is an embedding operator. (Yoon, 2011b, 239) further argues that the “defective variable can only be valued by being embedded by the negative attitude” of the RC and thus it is rescued. On the other hand, she argues that ‘negativity in the comparative is triggered only if a standard clause is non-referential’ (Yoon, 2011b, 240).

As far as CN is concerned, Yoon (2011b) argues that it conveys emphatic effects with regard to the contrast between the objects being compared. Thus, she pursues a uniform analysis of CN in all the environments that license it, as she also argues that in the rest of the environment CN triggers an emphatic effect by conveying a negative presupposition. However, Yoon points out that not all comparatives with CN are RCs. This is explained by assuming either that CN in some dialects/languages has spread from RQs to other degree comparatives or that it marks the inequality relation between the two degrees. If the latter approach is pursued, the double marking of the inequality relation emphasizes it.

Yoon’s (2011b) analysis of RQs and of CN in those faces two problems: The first one is the role of the “negative implicature”. Yoon (2011b) is begging the question by arguing that the negative implicature, which is a distinctive property of the RCs, is rescuing the defective variable of the NPI in the comparative clause but it is also a consequent of the presence of the NPI. In other words, the “negative implicature” simultaneously licenses and is triggered by the presence of CN. The second problem concerns the presence of CN in non-rhetorical comparatives. Its semantic contribution in those environments remains unexplained and insufficiently motivated. Therefore, proposing for a split analysis

of CN within the same environment, i.e. comparative constructions, is an unwelcome assumption for a theory of CN.

In sum, Table 5.10 summarises the available theories of the meaning of CN.

Table 5.10: Semantics of CCs & CN: Theories of CN.

[[<i>Comparative</i>]]	>	¬
[[<i>CN</i>]]		
¬	1	2 Seuren (1984) Delfitto (2018)
expletive	3 <i>negation in the scope of a non-veridical</i> (Espinal, 1992, 2000a, 2007) or <i>non-negative operator</i> (Belletti, 2001)	4 <i>identity function</i> (Wouden, 1994)
some other meaning:	5 <i>inequality marker</i> (Price, 1990) <i>scope marker of focus</i> (Donati, 2000) <i>emphasis on the inequality</i> (Yoon, 2011b)	6

5.4 Italian: A case study

Even though the aforementioned theories do not discuss the acquisition of CN their proposals can be extended to the acquisition domain. Actually, it has been a long-standing idea in the acquisition literature that children acquire first words with more semantic content (for an early discussion the reader is referred to Bellugi et al., 1964). This idea has also been corroborated by developmental/experimental studies on the acquisition of expletive elements, which have confirmed that expletive elements are indeed acquired relatively late (see a.o. Kirby and Becker (2007) for expletive *it*, Marinis (1998) for expletive determiners, Inoue (1991) for expletive *there*). Studies on expletive elements suggest that they are acquired later than their non-expletive counterparts. So, if we extended the same rationale to comparative negation, we would expect to be acquired around the same time as real negation if e.g. Seuren's (1973, 1984) were correct but later than that if it were expletive as proposed by Wouden (1994). However, such a comparison is not possible in the case of comparative negation; clausal comparative constructions are biclausal structures that involve *wh*-movement hence they are much more complex than a negated sentence. Therefore, the relative order that 'real negation' and comparative negation appear in naturalistic data cannot be informative regarding the status of comparative negation as 'real' or expletive.

Yet acquisition data can still provide us with evidence regarding the status of CN: depending on whether CN is analysed as an expletive element or regular negation we expect very distinct patterns in the acquisition of the comparative. A transparent mapping between overt elements and semantic

interpretation would be the ‘preferred’ option for children. Therefore, child language can be used as a testing ground for the abovementioned theories of CN. In the next section, I will spell out what predictions each theory makes for the acquisition of CN focusing on Italian.

5.4.1 Predictions for the acquisition of Italian

Before presenting the different predictions of the abovementioned theories for acquisition of comparatives, it should be highlighted that Italian allows CN in Subjunctive inequality comparatives, cf. also §5.2.2.

- (408) a. Maria è più intelligente di quanto (*non) credi.
 Maria is CMPR intelligent from how-much NEG think.IND
 ‘Maria is more intelligent than you think.’
- b. Maria è più intelligente di quanto (non) creda.
 Maria is CMPR intelligent from how-much NEG think.SBJ
 ‘Maria is more intelligent than you think.’

So let us now turn on what each theory predicts.

Theories in 2 (Seuren, 1984; Delfitto, 2018): If comparative negation is the overt realisation of the -otherwise covert- logical operator involved in the semantic representation of the comparatives then the following pattern is predicted for Italian child language:

- Earlier acquisition/Preference of comparatives with overt negation over comparatives with covert
- No predictions regarding the indicative/subjunctive distinction.

Theories in 3 & 4 (Wouden, 1994; Espinal, 1992, 2000a, 2007; Belletti, 2001): If negation in the comparative is a truly expletive element, then the following are predicted for the acquisition of Italian

- Earlier acquisition/Preference of comparatives without negation over comparatives with negation
- No difference between Indicative and Subjunctive comparatives

Theories in 5 & 6: Those theories dissociate the meaning of comparative negation from the meaning of the comparative construction. Data of the acquisition of the comparative negation can be informative for the logical form of the comparative as long as the theory of comparative negation hinges on the theory of the comparative. In other words, if comparative negation has some meaning that does not depend on the assumptions for the meaning of the comparative, then confirmation or falsification of that theory is only informative for the meaning of negation -not for the meaning of the comparative. Given the variability across those theories, each one of them makes different predictions for language acquisition. More specifically:

Price (1990): Price’s (1990) role of comparative negation is to differentiate the comparative from other constructions introduced by homophonous elements, either from the equative construction or other relative clauses. In Italian comparatives introduced by *che*, *che* is

used to distinguish inequality from equality comparatives and comparative negation with subjunctive inequality comparatives from other relative clauses. Therefore, this theory predicts a split in the acquisition of comparative negation in inequality comparatives. More specifically, comparative negation is only needed in inequality comparatives introduced by *che* and can only be functional if combined with the subjunctive - otherwise it fails to distinguish the type of sentence. Therefore, children are expected to strongly prefer Subjunctive comparatives with CN and have trouble interpreting indicative comparatives. On the other hand, CN is entirely redundant in inequality comparatives introduced by *di quanto*, since *di* marks the inequality relation, hence children are expected to not use it at all in those standard phrases.

Donati (2000): Donati's (2000) theory of comparative negation of comparative negation predicts that children should prefer constructions with comparative negation over constructions without it. However, no difference is expected between Subjunctive and Indicative comparatives.

Yoon (2011b): Yoon (2011b) does not provide a strict characterisation of the environments that license CN. She argues that CN triggers rhetorical effects only in a subset of comparatives with CN, therefore the predictions of her theory for language acquisition are not quite clear.

5.4.2 The experiment

5.4.2.1 Method

5.4.2.1.1 Participants

Thirty-four Italian children ranging in age from 4;5;0 to 7;9;25, as well as 28 adults, participated in the study. Data from 1 child was discarded from further analysis since they did not complete the task (age 4;5;0) and from other 5 children because they failed more than two control items (3 children failed 3 out of 8 control items and 2 children failed 4 out of 8 control items).

After excluding the aforementioned participants, the data analysed came from 29 children between 4;6;10 and 7;9;25 (mean = 6.33, SD = 1.19) and 28 adults between 18 and 33 years old (mean = 22.62, SD = 4.13).

All children were tested individually in Modena, Italy. Children were recruited and tested in summer camps based at two sites, the Gallileo Ferraris School ($n =$) and the Scuola Paritaria Figlie di Gesù Modena ($n =$). Adults were tested in groups of 1 to 3 people in three sites, the courtyard of Delfini Library in Modena, Italy ($n = 24$), a private house in Modena, Italy ($n = 3$), and the Department of language and linguistic science, University of York, UK ($n = 1$). This study was conducted in June 2017.

5.4.2.1.2 Procedure

I tested participants by means of a Forced Choice Judgment Task. Participants were presented with short animations on a laptop, prepared in a PowerPoint presentation. To begin, participants were familiarised with the pictures of two puppets Leo the lion and Pluto the dog. Participants were told

that these puppets are learners of Italian. They are the best students in their class, however, they still make production and comprehension errors. They are always competing to each other in class, so they decided to test their language skills. To do so, they asked a friend of theirs to ‘referee’ a competition judged by native speakers. The competition involved listening to a series of short animated stories; then both puppets had to answer in turn the question “What happened in the story?” after each story. In reality, the puppets’ utterances were prerecorded by two male native speakers of Italian from Modena. The experimental set-up with two puppets was based on methodology by Foppolo et al. (2012, Experiment 5).

Child data were collected by two experimenters: the first one (native speaker of Italian from Modena), explained the task, read the stories and ‘interacted’ with the puppets.⁸⁷ In order to reward the puppet, children moved cutouts of strawberries to Leo’s and Pluto’s boxes, in which the puppets were collecting their strawberry-rewards (see Figure A.1 in A, and the second experimenter recorded the participants’ answers. Occasionally, the second experimenter asked the child to explain what was wrong in the puppet’s reply.

Adult participants, on the other hand, received a response sheet and they were asked to tick the appropriate cell depending on the puppets’ performance. The response sheets also contained space for participants to give brief explanations for their responses. The task took about 20 minutes to complete for adults, and 30 minutes for children.

Adult participants were presented a audio-recorded version of the stories described in section 5.4.2.1.3. They were given a score sheet and were instructed to choose, for each story, the puppet the showed better language skills (comprehension of the story/production of the utterance). They were asked to optionally provide a brief justification for their answers. They were prompted to always choose only one puppet and to make a note if they felt that both puppets’ utterances were (in)correct.

5.4.2.1.3 Materials

There were three factors manipulated in the experiment: group (child vs. adult), mood (indicative vs. subjunctive, within subjects) and negation (puppet’s sentence with or without negation, within subjects).

Sentences with and without expletive negation were counterbalanced through “puppets”. Across the 12 target items (12 utterances for each puppet, 24 utterances in total) each puppet said 6 sentences with negation and six without. Those were evenly split among indicative and subjunctive clauses. Items were divided into two blocks of ten items: one group contained indicative comparatives and the other one subjunctive comparatives. Each group contained 6 target sentences, 2 grammaticality judgement controls and 2 truth value judgement controls. Six different lexical verbs were used for critical items in each block. Stories were randomly assigned to conditions. To counterbalance order effects, there were two versions of the test, in which items were randomly assigned two different orders with the only caveat that a truth value control item was the first item in each version. There were two variants of each version: in the first variant subjunctive items preceded indicative items in the second

⁸⁷ Children were prompted to count themselves the objects each animal acted on, so as to ensure that their choice was not influenced by other non-linguistic factors related to cognitive development. Indeed, children did not encounter problems in assessing the quantities of objects depicted.

version indicatives preceded subjunctives (see also A.1 in A.1).

To ensure the subjects did not give their answers by chance and understood the task, the stories were interspersed with eight fillers of two types: four truth value judgement controls (two indicative and two subjunctive) and four grammaticality judgement controls (two indicative and two subjunctive). The puppet utterances in the fillers did not differ with respect to negation. The test session was preceded by one warm-up story. If a subject performed poorly in more than two of the fillers, s/he was excluded from the analysis.

All trials displayed two animals performing an activity. The final slide of the story presented the animals with the output of that activity. When asked by the experimenter to describe what had happened in the story, the puppets answered using a CC. The puppets used both a clausal comparative in the same mood. The two utterances of the puppets in each target item differed with respect to negation (409) for 5.1 and (410) for 5.2. Each participant saw all items twice, once in the Indicative condition and once in the Subjunctive.

(409) Context: *The polar bear and the seal came across some broken ice. They were hungry so they decided to fish. The polar bear caught six fish and the seal three.*

a. l' orso polare ha pescato più pesci di quanti non ne abbia pescati
the bear polar has fished more fish than how-many NEG them.CL has.SBJ fished
la foca.
the seal
'The polar bear caught more fish than the seal did.'

b. *l' orso polare ha pescato più pesci di quanti ne abbia pescati la
the bear polar has fished more fish than how-many them.CL has.SBJ fished the
foca.
seal
'The polar bear caught more fish than the seal did.'

(410) Context: *The beaver and the cat are in the river shore today. They got hungry so they decided to fish. The beaver caught six fish and the cat three.*

a. *Il castoro ha pescato più pesci di quanti non ne ha pescati il
the otter has fished more fish than how-many NEG them.CL has.IND fished the
gatto.
cat
'The otter has caught more fish than the cat did.'

b. Il castoro ha pescato più pesci di quanti ne ha pescati il gatto.
the otter has fished more fish than how-many them.CL has.IND fished the cat
'The otter has caught more fish than the cat did.'

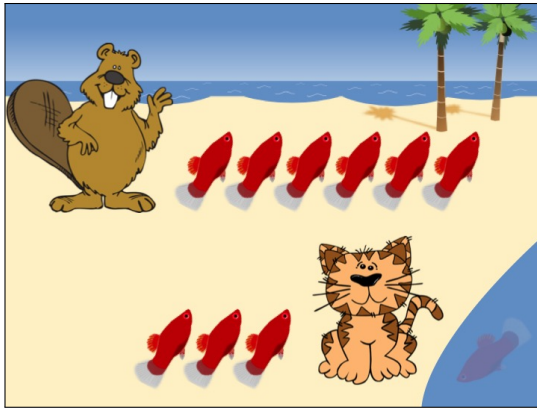

Figure 5.1: Target Item: Indicative

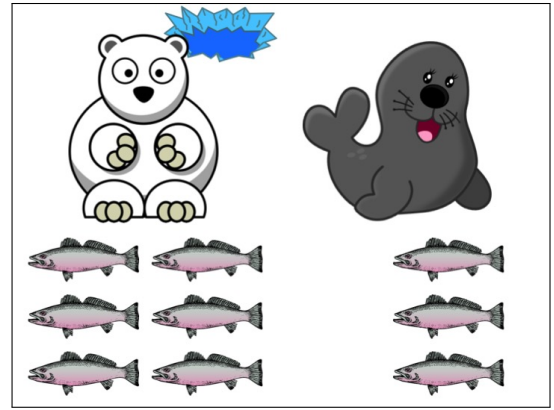

Figure 5.2: Target Item: Subjunctive

In all control items, none of the puppets used negation in the Indicative condition but both of them used it in the Subjunctive condition. In grammaticality judgement controls the utterances differed in Subject-Verb agreement of the matrix verb (411). In the truth value judgement controls one puppet said that an animal acted on more objects whereas in the story it actually acted on fewer, e.g. (412) was used to describe the picture in Figure 5.4.

(411) Cotnext: *The beaver and the scow went to the confectionary store today. They decided to buy some candies. The beaver bought four candies and the cow eight.*

- a. *La mucca **avete** comprato più caramelle di quante non ne abbia
 the cow **have.2PL** bought more candies than how-many NEG them.CL has.SBJ
 comprate il castoro.
 bought the otter
 ‘The cow bought more candies than the otter did.’
- b. La mucca ha comprato più caramelle di quante non ne abbia
 the cow **have.3SG** bought more candies than how-many NEG them.CL has.SBJ
 comprate il castoro.
 bought the otter
 ‘The cow bought more candies than the otter did.’

(412) Context: *The penguin and the giraffe attend a painting class. The teacher asked them to draw hearts. The penguin painted four hearts and the giraffe painted two hearts.*

- a. La giraffa ha dipinto più cuori di quanti ne ha dipinti il
 the giraffe has painted more hearts than how-many them.CL has.IND painted the
 pinguino.
 penguin.
 ‘The giraffe painted more hearts than the penguin did.’
- b. #Il pinguino ha dipinto più cuori di quanti ne ha dipinti la
 the penguin has painted more hearts than how-many them.CL has.IND painted the
 giraffa.
 giraffe.
 ‘The penguin painted more hearts than the giraffe did.’

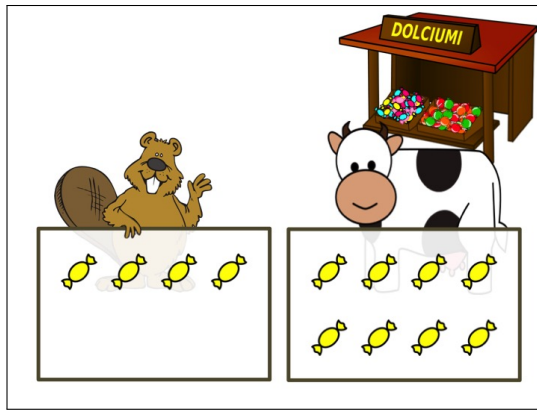

Figure 5.3: Grammaticality Judgement Control item – Picture for (411)

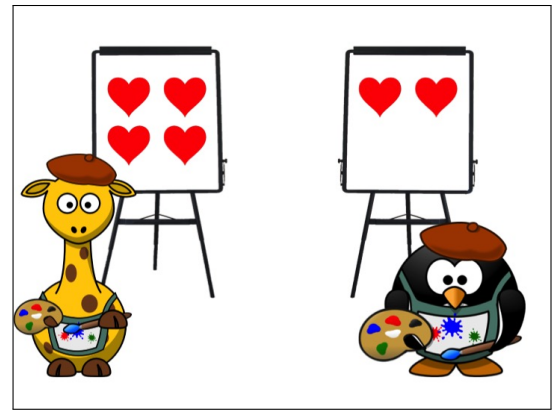

Figure 5.4: Truth Value Judgement Control item – Picture for (412)

5.4.2.2 Expected Response Patterns

Based on the §5.4.1 each proposal predicts the following response patterns in the experiment:

Theories in 2 (Seuren, 1984; Delfitto, 2018):

- Children choose negation more than adults;
- No predictions regarding the indicative/subjunctive distinction.

Theories in 3 & 4 (Wouden, 1994; Espinal, 1992, 2000a, 2007; Belletti, 2001):

- Children choose negation less than adults;
- No difference between Indicative and Subjunctive comparatives.

Theories in 5:

Price (1990): Price's (1990) predictions regarding differences between standard phrases are not tested in this experiment. As far as *di quanto* comparatives are concerned, though, the following are expected

- Children choose negation less than adults;
- No difference between Indicative and Subjunctive comparatives. On the other hand, Donati's (2000) theory predicts that
- Children should prefer sentences with an overt scope marker, in other words choose negation less than adults;
- but no difference between Indicative and Subjunctive comparatives is expected.

5.4.2.3 Results

For each condition the dependent measure was the puppets' utterances containing negation.⁸⁸ If the participant chose the puppet that uttered a comparative containing negation the response was coded as 1 and 0 otherwise. There were only two observations missing, both in adult participants: they were coded as NA and excluded from further analysis. This data is summarised in Table 5.12 and illustrated in Figures 5.6 & 5.7.

⁸⁸ A Kruskal-Wallis H test showed that there was not a statistically significant difference in negation responses across items, ($\chi^2 = 2.1673$, $p = 0.8255$). The results along with the mean rank per item are summarised in Table 5.11 and the distribution of responses with negation across items is illustrated in Figure 5.5.

Table 5.12: Response Summary - Descriptive Statistics

Group	Mood	N	Sum	M	SE	SD
Adults	Indicative	168	6	.04	.014	.186
	Subjunctive	166	34	.20	.031	.405
Children	Indicative	174	62	.36	.036	.480
	Subjunctive	174	81	.47	.038	.500

Table 5.11: Kruskal-Wallis Test on test items

(a) Ranks

Items	N	Mean Rank
raccogliere (collect) 1	114	339.7368
prendere (pick) 2	114	356.3158
preparare (prepare) 3	114	330.7632
mangiare (eat) 4	114	345.7193
comprare (buy) 5	114	351.7018
pescare (fish) 6	114	330.7632

(b) Test statistics

	Neg - Responses
χ^2	2.1673
df	5
Asymp. sig.	.8255

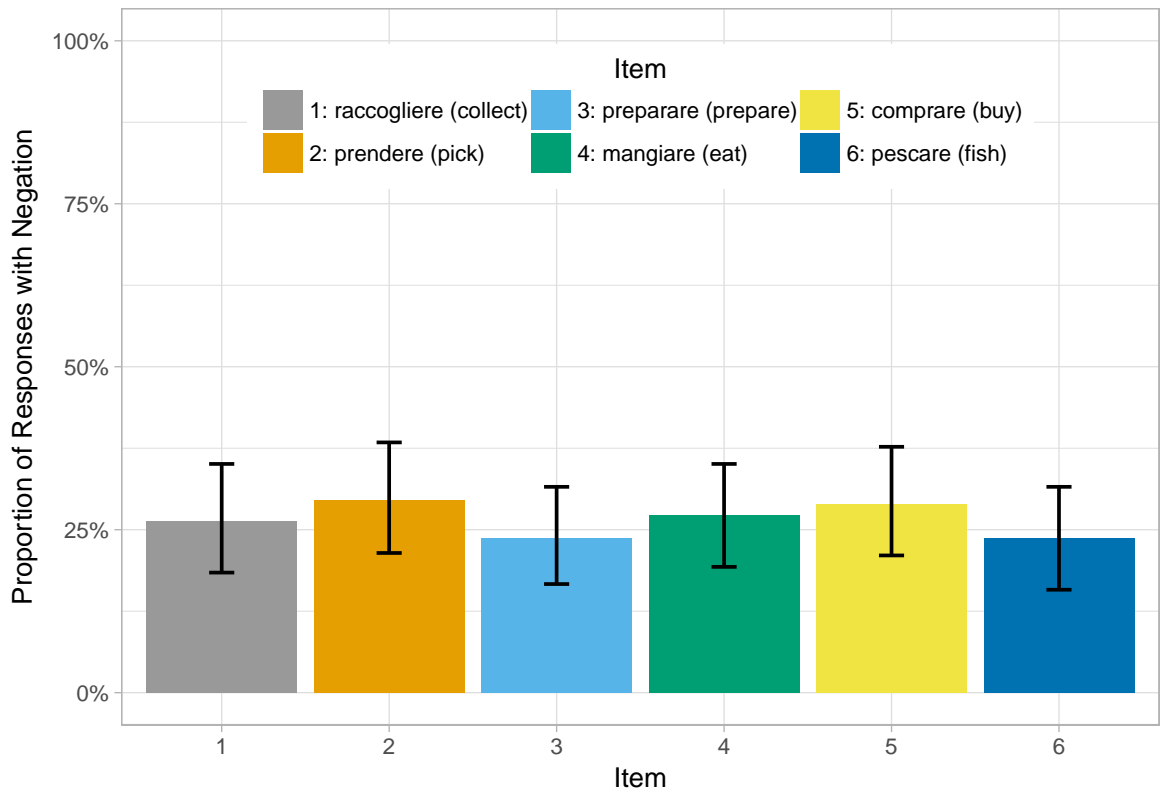

Figure 5.5: Proportion of Responses with Negation (+SE) across Items

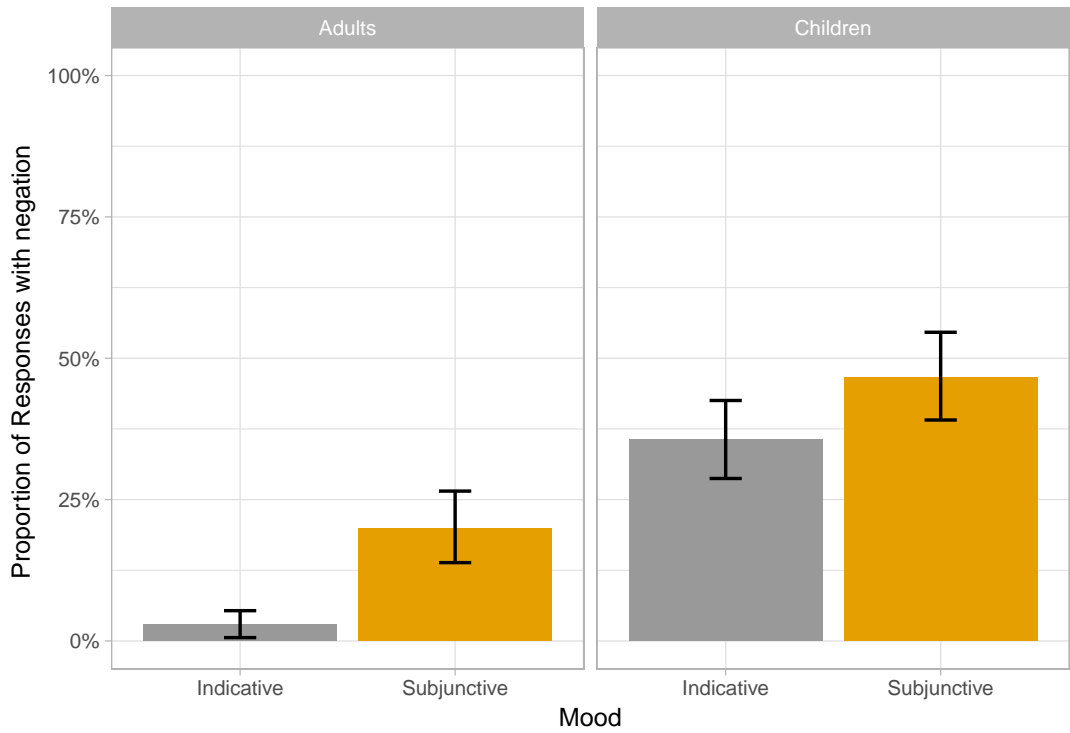

Figure 5.6: Proportion of Responses with Negation (+SE) for Adults ($n = 28$) and Children ($n = 29$) in Indicative and Subjunctive Condition.

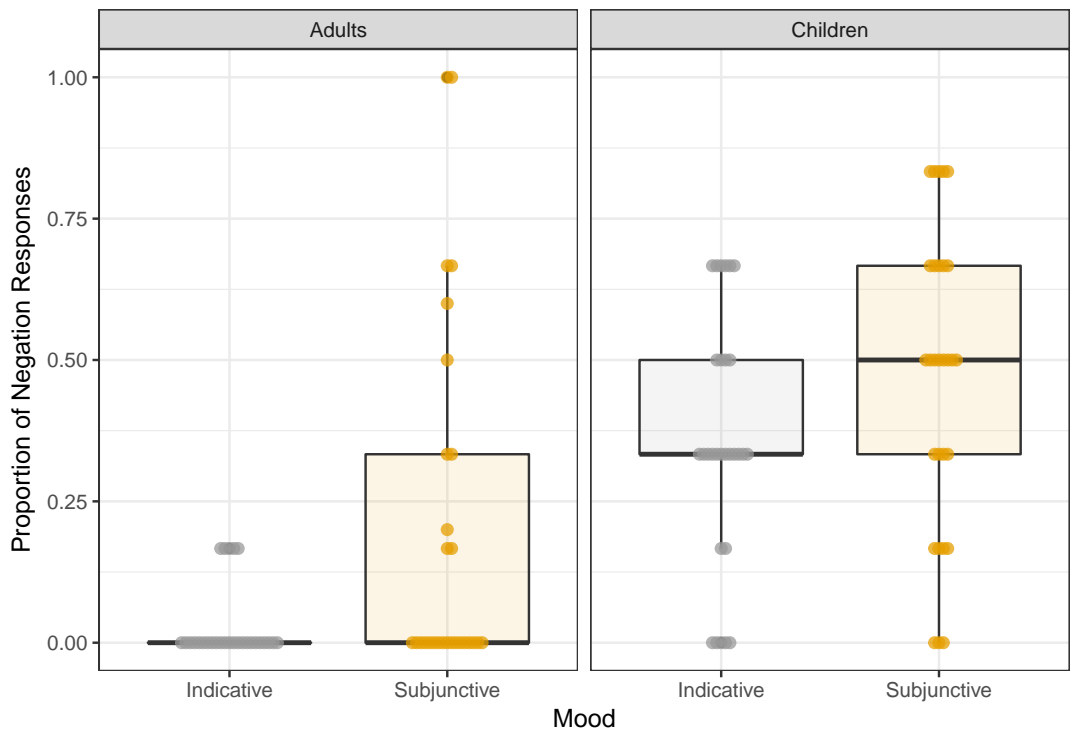

Figure 5.7: Distribution of Adult ($n = 28$) and Child ($n = 29$) Participants based on the Proportion of Responses Containing Negation per Participant in Indicative and Subjunctive Condition.

Data were fit with mixed effects logistic regression using the `glmer()` function of the `lme4` package

(Bates et al., 2015) of the R analysis program (R core development team). In the main model Mood and Group were fit as fixed factors, and Subject and Item as random factors. Random slopes were fit for both fixed effects and their interaction. The model revealed a significant effect of Group - children chose utterances with negation significantly more than adults and Mood - participants were more likely to chose negation in subjunctive items than in indicative ones and a significant interaction between Group and Mood: the difference between moods is significantly bigger in adult responses than child responses.

Table 5.13: Summary of Mixed Effects Logistic Regression for Variables Predicting Participants' Choice of Negation (N = 57)

(a) Random effects:

Groups	Name	Variance	SD
Subject	(Intercept)	1.14	1.068
Item	(Intercept)	0.00	0.000

Number of obs: 682, groups: Subject, 57; Item, 6

(b) Fixed Effects:

	Estimate	Std. Error	z value	Pr(> z)	
(Intercept)	-1.7055	0.2250	-7.579	3.49e-14	***
Mood	1.4536	0.2907	5.001	5.71e-07	***
Group	2.4944	0.4333	5.757	8.58e-09	***
Mood*Group	-1.8454	0.5777	-3.194	0.0014	**

Signif. codes: 0 '***' 0.001 '**' 0.01 '*' 0.05 '.' 0.1 ' ' 1

(c) Correlation of Fixed Effects:

(Intr)	Mood	Group	
Mood	-0.423		
Group	-0.439	0.412	
Mood*Group	0.401	-0.662	-0.411

Table 5.14: Summary of Mixed Effects Logistic Regression for Variables Predicting Adults' Choice of Negation (N = 28)

(a) Random effects:

Groups	Name	Variance	SD
Subject	(Intercept)	2.955e+00	1.719e+00
Item	(Intercept)	1.590e-09	3.987e-05

Number of obs: 334, groups: Subject, 28; Item, 6

(b) Fixed Effects:

	Estimate	Std. Error	z value	Pr(> z)	
(Intercept)	-4.7197	0.7259	-6.502	7.93e-11	***
MoodSBJ	2.5997	0.5634	4.615	3.94e-06	***

Signif. codes: 0 '***' 0.001 '**' 0.01 '*' 0.05 '.' 0.1 ' ' 1

(c) Correlation of Fixed Effects:

	(Intr)
MoodSBJ	-0.737

Adult data were fit with mixed effects logistic regression using the `glmer()` function of the `lme4` package (Bates et al., 2015) of the R analysis program (R core development team). In the model Mood were fit as a fixed factor, and Subject and Item as random factors. Random slopes were fit for both fixed effects and their interaction. The results confirmed a significant effect of Mood: adults select negation significantly more in Subjunctive comparatives.

Figure 5.8 divides the participants into groups based on their rate of selection of negation responses in each mood. It reveals that adults uniformly reject negation on the indicative condition: 82% of the participants never select for negation on the indicative response and 18% do so only for one item out of six, which clearly can be attributed to noise.⁸⁹

In the subjunctive condition the distribution of participants is right-skewed with mode 0. The distribution of the participants based on the number of times they selected an utterance containing negation along with the participants' comments on their choice reveal that there are two different populations in the sample: one that allows CN in Subjunctive comparatives and one that does not. In other words, there is a population that allows CN *only* in subjunctive comparatives and one that does not allow CN *at all*.

⁸⁹ Two out of the five participants in question give a truth conditional interpretation to the negation and compare the number of objects that one animal acted on to the number of objects the other animal did not act on, namely the objects left in the background.

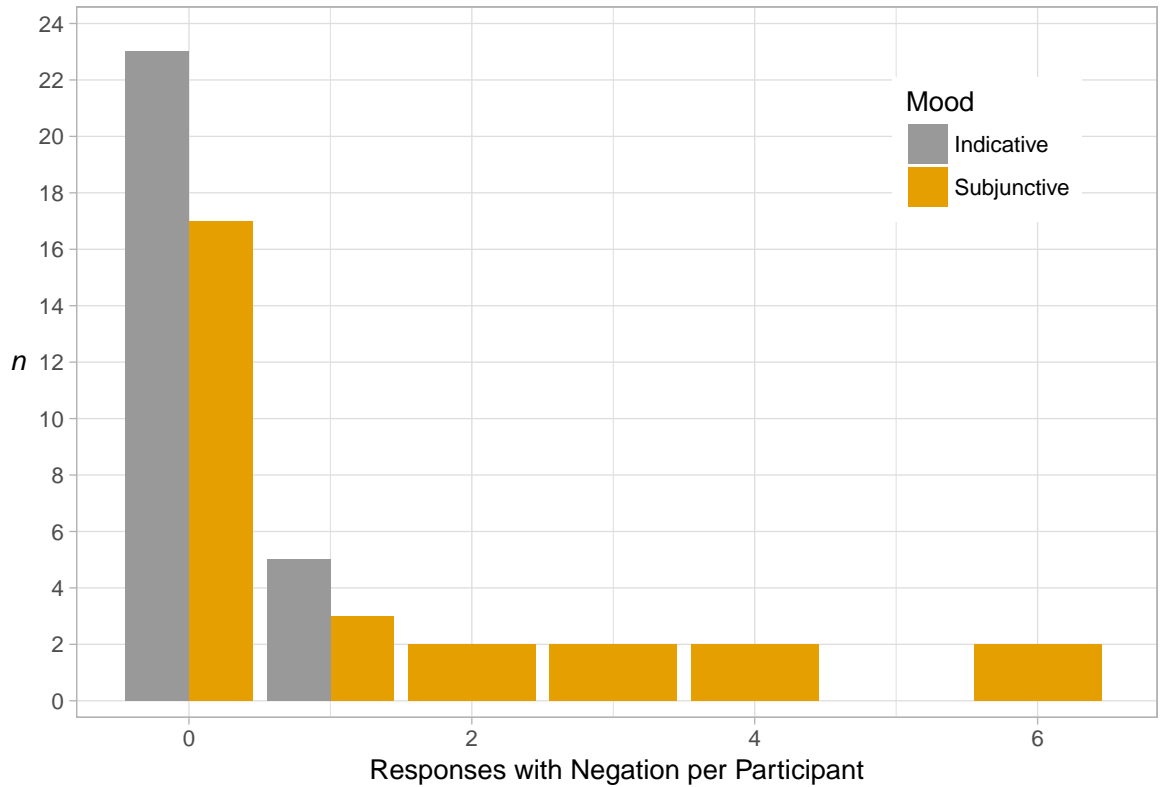

Figure 5.8: Number of Times Each Adult Participant Selected Negation out of 6 Indicative and 6 Subjunctive Items (N = 28)

Child data were fit with mixed effects logistic regression using the `glmer()` function of the `lme4` package (Bates et al., 2015) of the R analysis program (R core development team). In the model Mood were fit as a fixed factor, and Subject and Item as random factors. Random slopes were fit for both fixed effects and their interaction. The results confirmed a significant effect of Mood: children choose negation significantly more in subjunctive comparatives than in indicative ones.

Table 5.15: Summary of Mixed Effects Logistic Regression for Variables Predicting Children’s Choice of Negation (N = 29)

(a) Random effects:

Groups	Name	Variance	SD
Subject	(Intercept)	0.5163	0.7186
Item	(Intercept)	0.0000	0.0000

Number of obs: 348, groups: Subject, 29; Item, 6

(b) Fixed Effects:

	Estimate	Std. Error	z value	Pr(> z)	
(Intercept)	-0.6675	0.2159	-3.092	0.00199	**
MoodsBJ	0.5037	0.2317	2.174	0.02968	*

Signif. codes: 0 ‘***’ 0.001 ‘**’ 0.01 ‘*’ 0.05 ‘.’ 0.1 ‘ ’ 1

(c) Correlation of Fixed Effects:

	(Intr)
MoodsBJ	-0.564

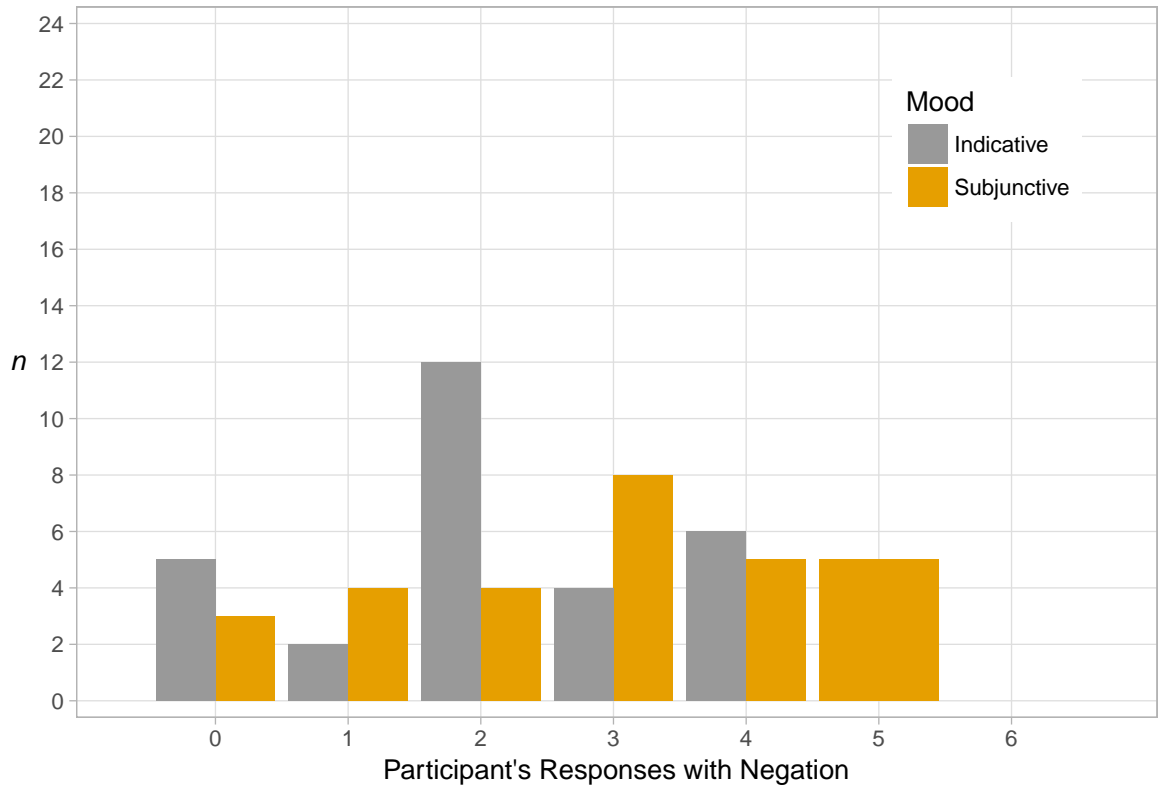

Figure 5.9: Number of Times Each Child Participant Selected Negation out of 6 Indicative and 6 Subjunctive Items (N = 29)

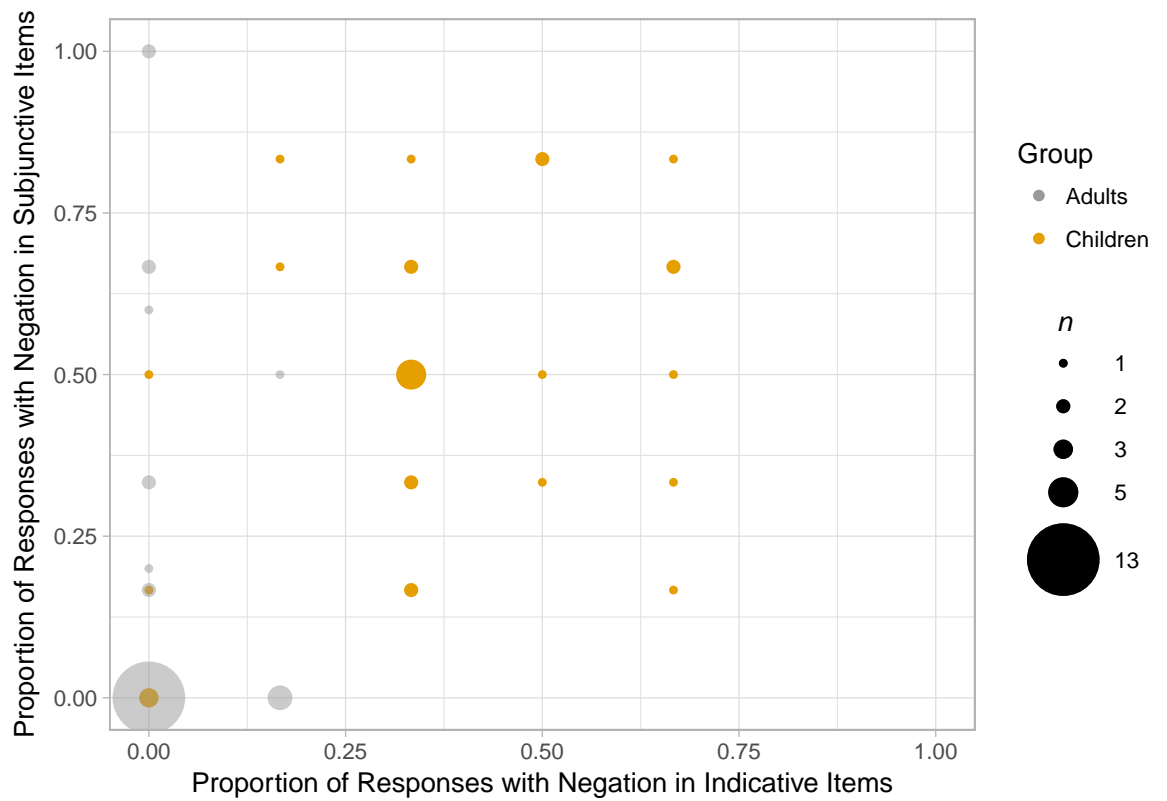

Figure 5.10: Number of Participants Children (N = 29)

5.4.3 Discussion

Comparing the results of the experiment to the predictions of the different theories of CN in §5.4.1 and the consequent expected patterns §5.4.2.2, it is evident that the predictions of theories that assume CN to be semantically vacuous/expletive are not borne out: children used CN significantly more than adults did. On the other hand the experimental results are compatible with the prediction of Seuren's (1984) theory and corroborate the proposal that the comparative construction involves a negative logical operator and comparative negation is the overt exponent of it.⁹⁰

On the other hand, the experimental results are interesting in two more ways. Firstly, they revealed a new locus of dialectal variation in Italian: amongst modenese speakers there are two different grammars: one that optionally licenses CN in the Subjunctive and one that does not license CN at all on a par with Spanish and Brazilian Portuguese.⁹¹ This result can be enlightening of the bearing of language acquisition processes to language change: children acquire negation in the presence of positive evidence, namely licensing of n-words in the comparative and CN. Given that CN is licensed in a subset of comparatives -namely clausal comparatives- and that even in those constructions it is optional and it may be elided along with the VP, it is expected that some speakers may not encounter CN in the primary linguistic data and they only postulate a covert negative operator triggered by the presence of n-words.⁹²

Secondly, given that children rarely use the subjunctive in spoken language (p. c. M. T. Guasti) it is particularly interesting that their behaviour was significantly different between the Indicative and the Subjunctive condition.

5.5 Bringing the facts together: The meaning of Comparative Negation

In the previous sections I examined the distribution of polarity items and CN in comparatives in French, Italian, Spanish, Brazilian Portuguese and Catalan. The licensing of n-words in the comparative has been used in the past as evidence both for theories that argue that CN is real negation and theories that argue that CN is expletive. More specifically, the former class of theories uses the mere fact of n-word licensing in the comparative as evidence for a negative operator and the latter class the interpretation of n-words in the comparative as free choice items as evidence for the opposite.

Through the cross-linguistic comparison of n-word licensing in the comparative I provided two new pieces of evidence towards the existence of a negative operator in the comparative: firstly, I showed that postverbal Brazilian portuguese n-words, in contrast to their Romance counterparts, can only be licensed in the scope of negation - they cannot be licensed in conditionals or other intensional operators; nevertheless they are licensed in the standard phrase of the comparative. Secondly, I showed that CN and n-word licensing interact in a way conditioned by the negative concord parameter: if

⁹⁰ Delfitto (2018), compared to Seuren (1984), does not present a novel proposal with respect to the semantics of the comparative or comparative negation but adopts Seuren's (1984) theory. Consequently, the predictions regarding acquisition are identical.

⁹¹ Technically, this result forces us to distinguish between Italian₁ that licenses CN and Italian₂ that does not. Given that the Italian₂ language type is already exemplified in this chapter by other languages (Spanish, Brazilian Portuguese) when I refer to Italian I will refer to Italian₁.

⁹² For a similar example where two different grammars arise in the lack of evidence in the primary linguistic data the reader is referred to Han et al. (2007).

a strict negative concord language licenses CN in the comparative, CN becomes obligatory in the presence of an n-word. This does not happen though in languages with non-strict negative concord.

Finally, I ran a language acquisition experiment that also corroborated Seuren's (1984) analysis of CN as the overt exponent of the negation in the comparative. More specifically, it was demonstrated that children choose negation significantly more than adults, a finding that cannot be explained by other theories of CN.

In sum, through a wide set of cross-linguistic and acquisition data I showed that comparatives involve a negative operator and that CN is the exponent of it. In the next section, I will re-examine the attested patterns in the light of this finding.

5.6 Implications for the typology of Comparative Negation

As demonstrated in §5.2, CN appears only in clausal comparatives, in fact, in a proper subset of those that license n-words. The distribution is summarised in Table 5.16 below.

Table 5.16: Distribution of CN and N-Words in different types of clausal comparatives

	Comparative clause		Degree Free Relative		Light headed Relative	
Italian	✓ CN	✓ N-words	✓ CN	✓ N-words	✓ CN	
French	✓ CN	✓ N-words	N/A		* CN	* N-words
Catalan	✓ CN					
Spanish	* CN	✓ N-words	* CN	* N-words	* CN	
Brazilian Portuguese	* CN	✓ N-words	N/A		* CN	✓ N-words
Greek	* CN	* N-words	* CN	* N-words	* CN	* N-words

The availability of Comparative Negation in all types of clausal comparatives and not just those introduced by *che* ('that') suggests the negative operator is licensed by the inequality standard marker in the matrix clause. The question that arises then, is whether this indicates that there are two different semantic representations for the comparative, in other words, whether the comparative operator is ambiguous between a variant that introduces negation and one that does not, or there is a uniform semantic representation of the comparative and the locus of variation lies in the licensing mechanism of the overt negation. I would like to argue that the latter option fits the data best. In languages that allow CN, CN is optional. Yet, no semantic difference between a comparative with CN and without CN is reported neither by informants nor in the existing literature. The only reported difference is that by Napoli and Nespor (1976) but, as demonstrated above, what Napoli and Nespor (1976) actually described was the semantic contribution of the Subjunctive. Therefore, it seems more plausible to attribute variation in licensing CN to syntactic variation.

A step towards that direction is to adopt Sabel's (2000) theory of expletives and scope marking, according to which expletive/ scope marking elements are realisations of extracted feature bundles. Within this line of analysis, we can correctly account for the fact that negation is introduced by the comparative operator in the matrix clause but it is actually realised in the embedded clause and main-

tain that CN signifies the existence of a negative operator.

In this line of reasoning, one could reduce the difference between Greek comparatives introduced by *para* and Romance comparatives introduced by *que/che* to the fact that the former — but not the latter — lexicalises negation, based on the fact that *para* can be used in non-comparative clauses as a negative conjunction equivalent to *ke ochi* ('and not'). N-words in the scope of *para* are interpreted as negative quantifiers yielding uninterpretable standards hence they are ruled out in *para* clauses. Then, we would need to postulate some independent reason that the Italian, French and Catalan n-words are compatible with the overt realisation of CN and receive a weak-NPI interpretation (French even require it). However, the available data does not provide any independent evidence for it.

In a similar fashion, we could derive the difference between Greek free-relative standards on the one hand and Romance ones on the other based on definiteness. Greek free relative items incorporate the definite determiner whereas Romance ones do not. This morphological distinction has been shown to be at play in the choice of particles in concessive free relative clauses, therefore, it would not be a completely ungrounded connection (Pancheva Izvorski, 2000). On the other hand, Italian Subjunctive clauses have been proposed to represent indefinite T as opposed to their Indicative counterparts that are definite Manzini (1993). In that sense the difference between Italian Indicative clauses and Italian Subjunctive ones is reduced to the same difference that Greek and French relative clauses present. Yet, we still fail to account for the ungrammaticality of CN in Spanish and Brazilian Portuguese. As the available data does not support any principled theory of variation in CN licensing, I will not pursue this any further, however, I would like to show how the existing analysis of CN as negation correctly predicts the gap in the distribution.

More specifically, in the data set we have examined so far we have not encountered a language that licenses comparative negation but does not license n-words. A question that arises then is whether this is an accidental gap – given also that our sample consists of languages belonging to the same language family – or it reveals a real gap in the distribution of comparative negation/ n-words. I would like to propose that the gap observed in this small set of languages reflects an actual gap in the distribution of CN.

If a language is a negative concord language and licenses CN, which according to the proposed analysis is the same as real negation, then it follows that n-words will also be licensed in the standard phrase. So if there is a language that licenses CN and does not license n-words it cannot be a negative concord language.

So what happens if a language does not have negative concord and licenses CN? In that case, the n-words of the language will correspond to the n-paradigm in English (*nobody, nothing, nowhere, etc.*) and it should be impossible for them to co-occur with CN/sentential negation. Therefore, if CN is obligatory and the language does not license negative concord then it follows that n-words will be ungrammatical.

However, in the languages we have examined so far, CN seems to always be optional. Yoon (2011b, p. 2) that a hallmark of Expletive Negation -an instance of which is supposed to be Comparative Negation- is that it is never obligatory. In other words, expletive negation (including comparative negation) is always optional regardless the language or the environment.⁹³ So, if CN is also optional

⁹³ Abels (2002, 2005); Brown and Franks (1995) claim that Expletive Negation in Russian is obligatory. Russian does

in that hypothetical language, there is no principled reason why the negative logical operator that CN represents cannot be introduced by an n-word instead of CN. In other words, if a language optionally licenses CN and does not license negative concord, n-words should also be grammatical in the place of CN.

In sum, there are two possibilities that a language may license CN but not n-words: The language is a language without negative concord and

- (i) CN is obligatory - so the presence of n-words triggers double negation effects; or
- (ii) n-words are ruled out for an independent reason.

Based on the above, it is unsurprising that such a language has not been reported in the literature so far.

not license CN, therefore, if one is to argue that CN is not necessarily optional, it needs to be proved why findings pertinent to occurrences of (the Russian) Expletive Negation can be extended to Comparative Negation.

Chapter 6

Conclusions

This thesis examined the cross-linguistic realisation of inequality comparatives in Greek and Italian varieties, French, Catalan, Spanish and Brazilian Portuguese. As for the syntax of comparatives, I argued for a fine-grained AdjP periphery, a direct analysis of phrasal comparatives, the availability of both argument and predicative standard phrases, the distinction between a lexical and a functional *more*, and the analysis of clausal comparatives as exceptive phrases. As for their semantics, I argued that the semantic representation of the comparative is better understood in terms of subtraction and that clausal comparatives involve a negative operator. These findings have implications not only for the comparative but also for other domains in grammar so let us review them in more detail.

Largely based on data from Greek, and less from Romance languages, I showed that the long debate regarding the status of *more* as an adjunct or a functional head is largely blurred by the accidental homophony of the comparative form of the quantity word *much/many* ('lexical *more*') and the comparative head ('functional *more*'). Either of them may be used to form a comparative construction. Focusing on constructions with functional *more*, I presented novel morphological evidence from comparative formation in Greek, morphophonological evidence from French, morpho-semantic evidence from French and English as well as syntactic evidence from PP-DP alternations in Greek and Italian. The proposed analysis can also be extended to double comparatives without any further postulations. The only difference between dialects with double comparatives and dialects without is in the phonetic realisation of each comparative head. I also presented a novel puzzle regarding the distribution of comparatives in Greek: comparative adjectives are always predicative, a fact that could not be accommodated in an analysis where the positive and the comparative degree are merged in the same functional head. There are two exceptions in that rule: the use of comparative adjective for the formation of periphrastic superlatives and the comparative form of quantity adjectives. This restriction also detected in Russian does not follow from any existing account of comparatives.

Based on the cross-linguistic distribution of phrasal standards in Greek and Romance, I argued that, contra to recent developments, the choice of a phrasal or clausal standard marker is only sensitive to the syntactic (not semantic) properties of the standard: French, Italian, Catalan and Brazilian Portuguese employ both a phrasal and a clausal standard marker yet the phrasal standard marker only selects for degrees. This indicates that classic analyses that locate the choice of two or three semantic arguments in the semantics of the comparative operator correctly account for the observed cross-linguistic distribution. Furthermore, I revealed a new locus of variation: the Indo-European ablative collapsed

with Genitives in higher register Greek and SMG whereas in SEG with datives. By analysing Greek oblique standards in terms of cliticisation (for SMG) and PP-DP alternations (for high register Greek and SEG), I showed that Greek does not challenge a rather robust universal, namely that a language has at most one phrasal standard marker. Furthermore, I demonstrated that synthetic comparative formation happens in syntax as head movement.

The examination of phrasal standards had also implications for our understanding of the semantics of Measure Phrases and degrees. More specifically, Greek, which is not a classifier language, proved sensitive to the status of a noun as lexical or semi-lexical, with the latter having a broader distribution than the former. The observed patterns are only partially accounted for by existing theories on degree interpretations of nominals. Furthermore, the occurrence of measure phrases in predicative standard phrases points towards a finer distinction with respect to argumentising heads, as Number is the Greek argumentising head. Prepositions were also shown to be sensitive to the predicate/argument distinction functioning as relators when selecting a predicate but as case assigners when selecting an argument DP. As far as scales are concerned, a definiteness requirement of oblique standards indicated that there is a weak island trigger within the comparative phrase and that bare measure phrases denote dense sets of degrees. However, different operators, e.g. the definite operator, may alter that. These facts can only be accommodated under an ontology enriched for degrees/extent and suggests that degrees/extent are visible to grammar.

As for clausal comparatives, I argued that there are two ways to be formed: either with the use of (an exceptive) clausal standard marker or if the phrasal comparative marker combines with a relative clause. I showed that a broader set of relative clause types can appear in the latter type of clausal comparatives, which corroborates that this is a productive process. The availability of concessive free relatives in comparatives casts doubt on existing analyses of maximality in comparatives and of its source. A cross-linguistic comparison of the distribution of polarity items in clausal comparatives coupled with data from the acquisition of Italian comparative negation showed the existence of a negative operator in the standard phrase. An analysis of comparative negation as real negation explains a universal gap in the distribution of comparative negation. If a language licenses negation then it must also license NPIs. Furthermore, the analysis of comparative negation as a realisation of the negative operator, in combination with the proposed analysis of clausal standard markers as exceptives and of phrasal ones as ablatives, points towards a new direction for future research in the semantics of comparatives: the meaning of comparatives is best understood in terms of subtraction.

Appendix A

Appendix

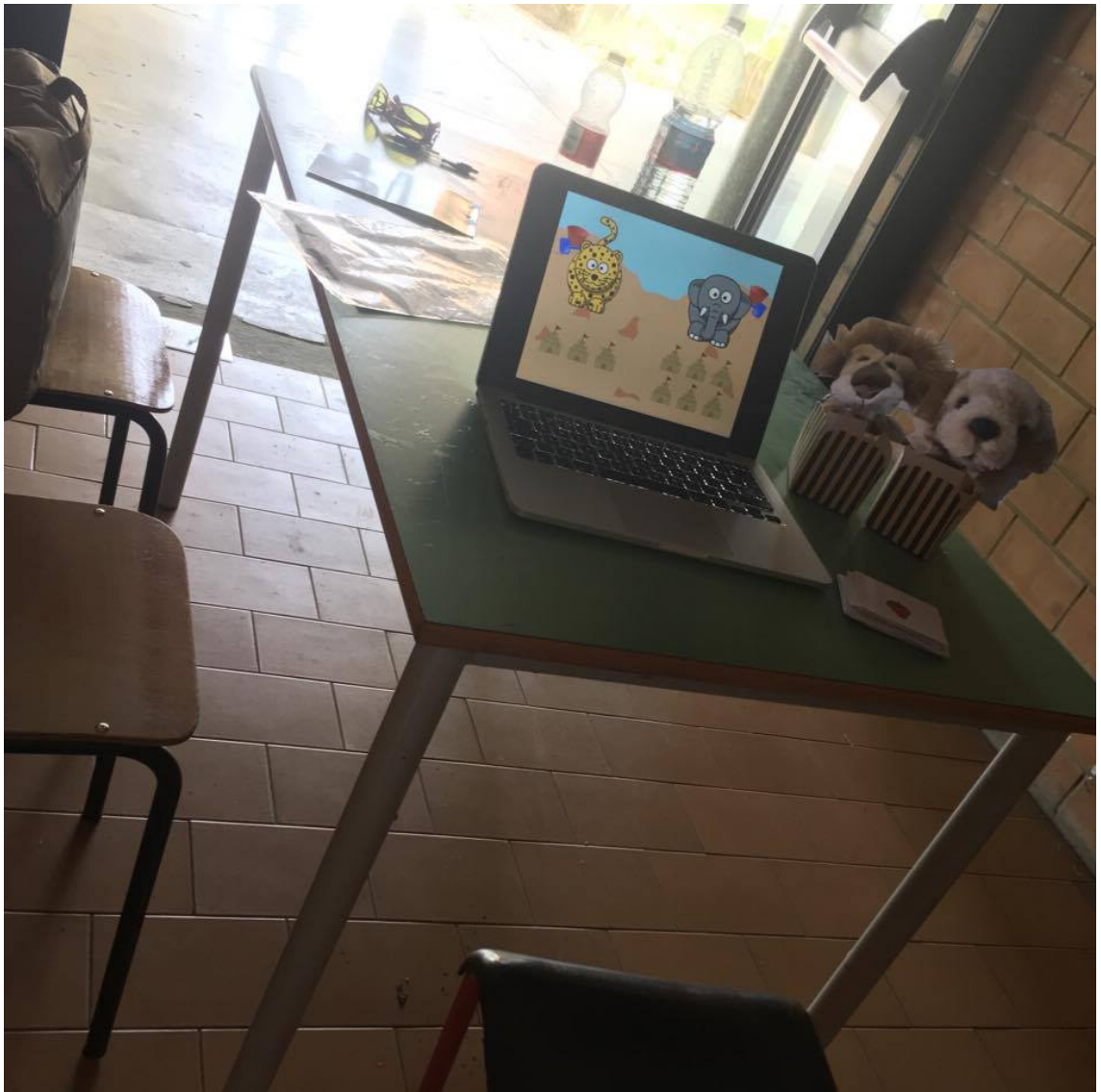

Figure A.1: Layout of experimental procedure

A.1 Ordering of test items

Table A.1: Item ordering in all four versions presented [IND = Indicative, SBJ = Subjunctive, TST = Test, CTL = Control, TF = Truth Value, GR = Grammaticality].

Version:	A1	A2	B1	B2
Items	trial			
	SBJ.CTL.TF.2	IND.CTL.TF.2	IND.CTL.TF.1	SBJ.CTL.TF.1
	SBJ.TST.4	IND.TST.4	IND.CTL.GR.1	SBJ.CTL.GR.1
	SBJ.TST.6	IND.TST.6	IND.TST.1	SBJ.TST.1
	SBJ.TST.3	IND.TST.3	IND.CTL.TF.2	SBJ.CTL.TF.2
	SBJ.TST.2	IND.TST.2	IND.TST.2	SBJ.TST.2
	SBJ.CTL.GR.1	IND.CTL.GR.1	IND.TST.3	SBJ.TST.3
	SBJ.TST.5	IND.TST.5	IND.TST.4	SBJ.TST.4
	SBJ.CTL.TF.1	IND.CTL.TF.1	IND.TST.5	SBJ.TST.5
	SBJ.CTL.GR.2	IND.CTL.GR.2	IND.CTL.GR.2	SBJ.CTL.GR.2
	SBJ.TST.1	IND.TST.1	IND.TST.6	SBJ.TST.6
	IND.CTL.TF.2	SBJ.CTL.TF.2	SBJ.CTL.TF.1	IND.CTL.TF.1
	IND.TST.4	SBJ.TST.4	SBJ.CTL.GR.1	IND.CTL.GR.1
	IND.TST.6	SBJ.TST.6	SBJ.TST.1	IND.TST.1
	IND.TST.3	SBJ.TST.3	SBJ.CTL.TF.2	IND.CTL.TF.2
	IND.TST.2	SBJ.TST.2	SBJ.TST.2	IND.TST.2
	IND.CTL.GR.1	SBJ.CTL.GR.1	SBJ.TST.3	IND.TST.3
	IND.TST.5	SBJ.TST.5	SBJ.TST.4	IND.TST.4
	IND.CTL.TF.1	SBJ.CTL.TF.1	SBJ.TST.5	IND.TST.5
	IND.CTL.GR.2	SBJ.CTL.GR.2	SBJ.CTL.GR.2	IND.CTL.GR.2
IND.TST.1	SBJ.TST.1	SBJ.TST.6	IND.TST.6	

A.2 Test Items

Figure A.2: Training Item

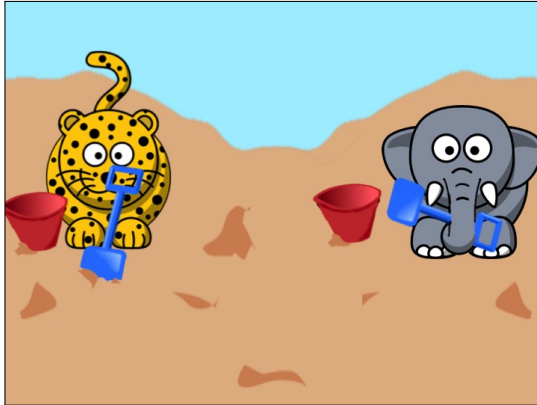

Oggi il leopardo e l'elefante sono andati in spiaggia.

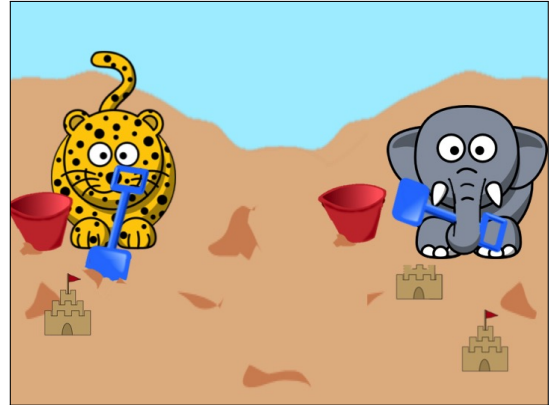

Hanno deciso di fare dei castelli di sabbia.

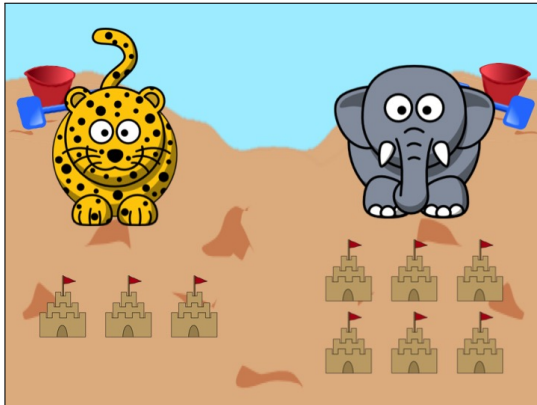

Il leopardo ha fatto tre castelli di sabbia, l'elefante ne ha fatti sei. Cos'è successo oggi?

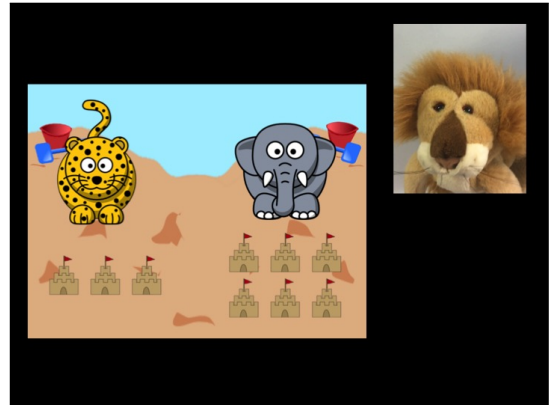

Leo: L'elefante ha fatto più castelli di sabbia di quanti ne ha fatto il leopardo.

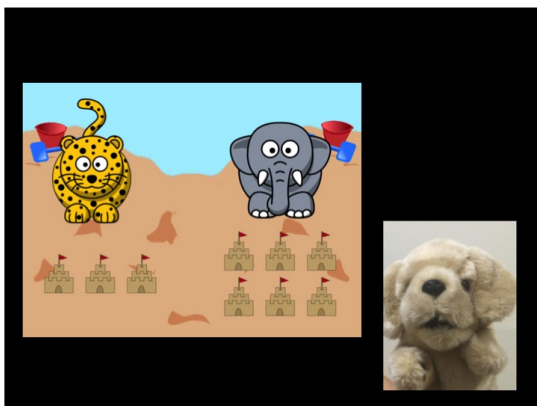

Pluto: L'elefante ha fatto più castelli di sabbia di quanti non ne ha fatto il leopardo.

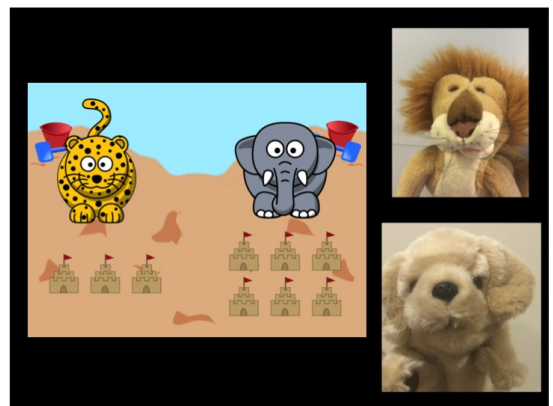

The child is prompted to choose.

Figure A.3: IND.TST.1 - Critical Item with indicative mood



Oggi la tigre e il leone sonno andati in spiaggia.



Vogliono raccogliere delle conchiglie.



La tigre ha raccolto tre conchiglie. Il leone sei conchiglie. Che cos'è successo oggi?

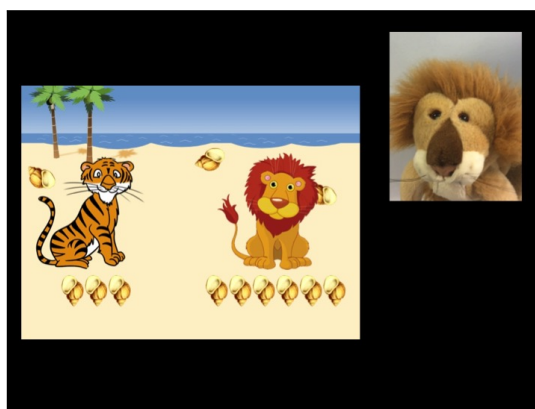

Leo: Il leone ha raccolto più conchiglie di quanti ne ha raccolte la tigre.

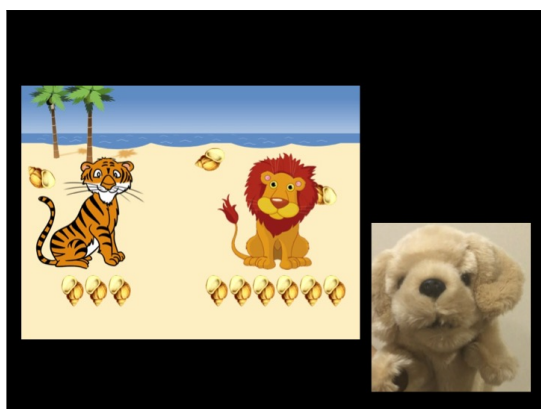

Pluto: Il leone ha raccolto più conchiglie di quanti non ne ha raccolte la tigre.

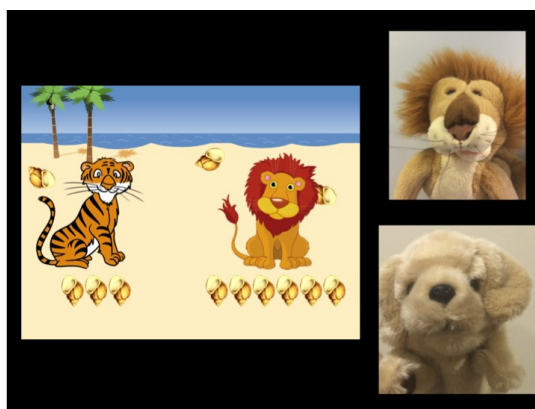

The child is prompted to choose.

Figure A.4: IND.TST.2 - Critical Item with indicative mood

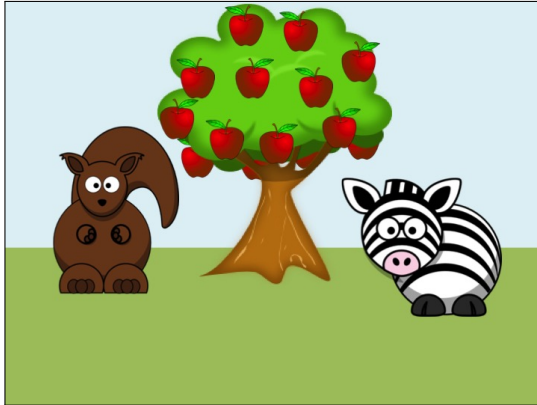

Oggi lo scoiattolo e la zebra sono andati in campagna.



Vogliono fare una torta e devono prendere le mele del' arberro.

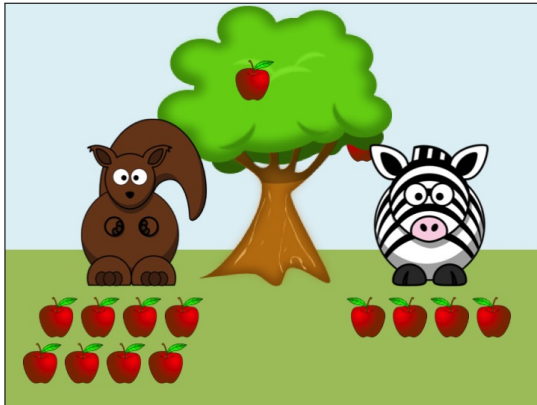

Lo scoiattolo ha preso otto mele mentre la zebra ne ha prese quattro. Che cosè successo oggi?

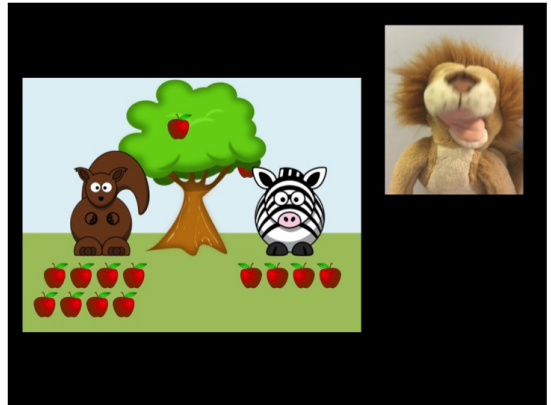

Leo: Lo scoiattolo ha preso più mele di quante ne ha prese la zebra.

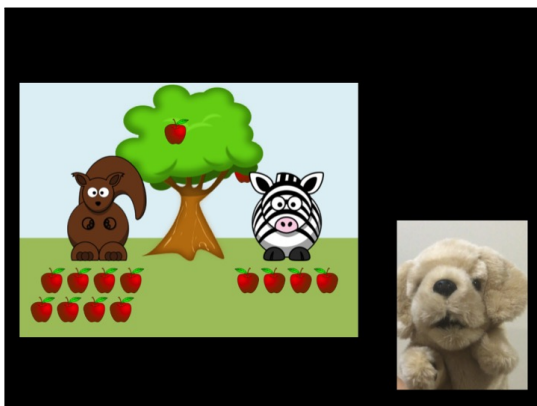

Pluto: Lo scoiattolo ha preso più mele di quante non ne ha prese la zebra.

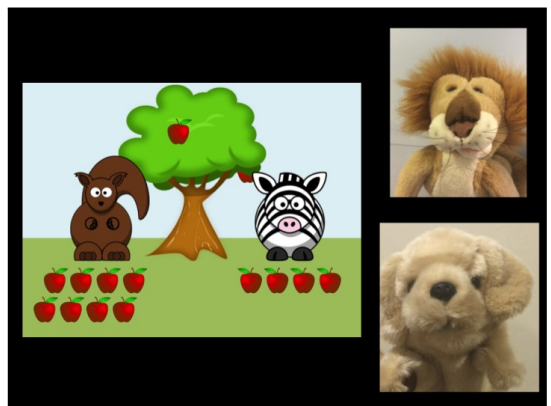

The child is prompted to choose.

Figure A.5: IND.TST.3 - Critical Item with indicative mood

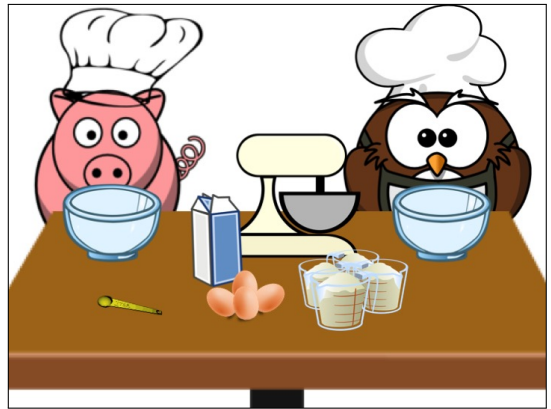
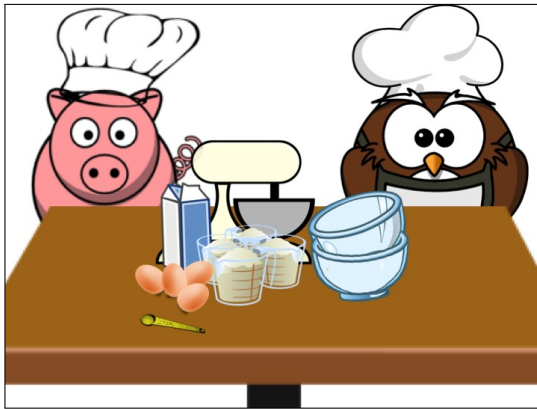

Oggi, il maiale e il gufo sono a un corso di cucina.

Devono imparare a fare dei pasticcini.

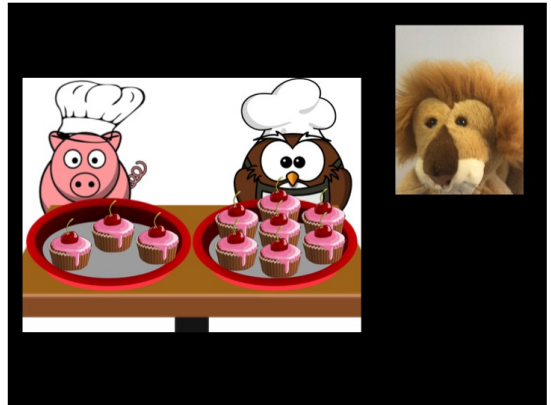

Il maiale prepara 3 pasticcini, il gufo 7 pasticcini. Che cos' è successo oggi?

Leo: Il gufo ha preparato più pasticcini di quanti ne ha preparati il maiale.

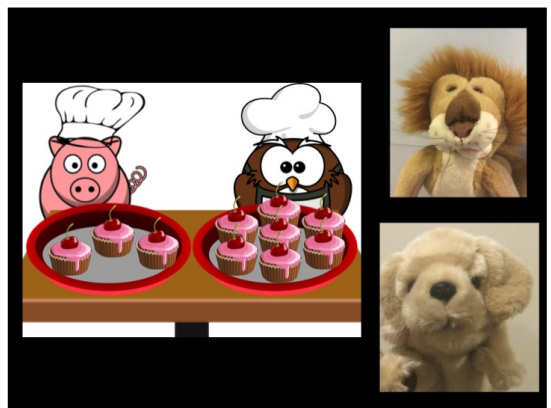
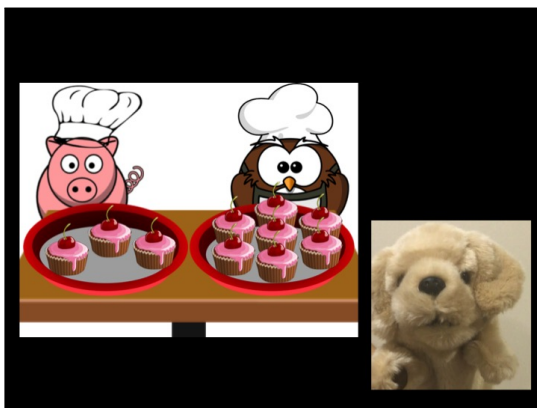

Pluto: Il gufo ha preparato più pasticcini di quanti non ne ha preparati il maiale.

The child is prompted to choose.

Figure A.6: IND.TST.4 - Critical Item with indicative mood

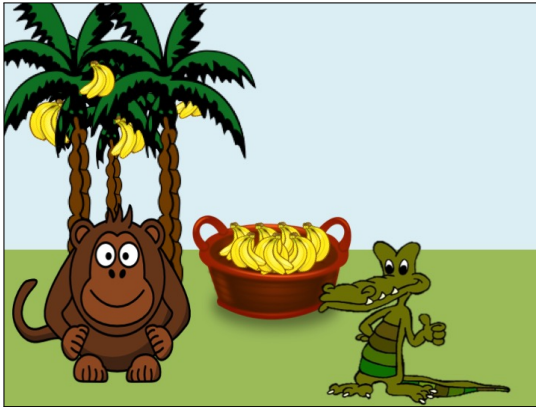

Oggi la scimmia e il coccodrillo si trovano nella giungla.



Hanno fame e decidono di mangiare quelle di queste gustose banane che sono nella cesta.

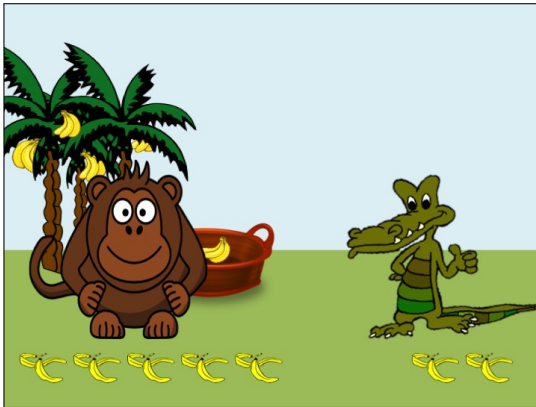

La scimmia mangia cinque banane mentre il coccodrillo ne mangia due. Che cos' è successo oggi?



Leo: La scimmia ha mangiato più banane di quante ne ha mangiate il coccodrillo.



Pluto: La scimmia ha mangiato più banane di quante non ne ha mangiate il coccodrillo.

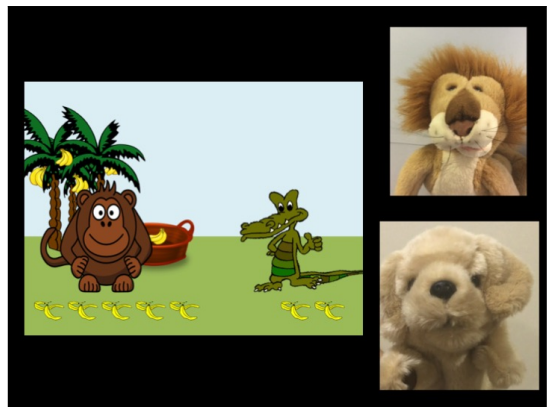

The child is prompted to choose.

Figure A.7: IND.TST.5 - Critical Item with indicative mood



Oggi il coniglietto e l'orso sono al negozio di giocattoli.

Hanno deciso di comprare delle barchette.

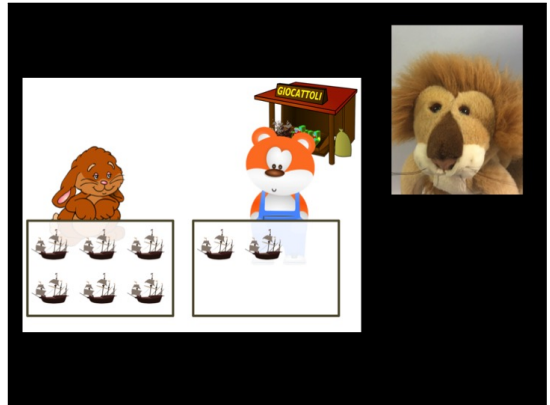

Il coniglietto ha comprato sei barchette, l'orso due barchette. Che cos' è successo oggi?

Leo: Il coniglio ha comprato più barchette di quante non ne ha comprate l'orso.

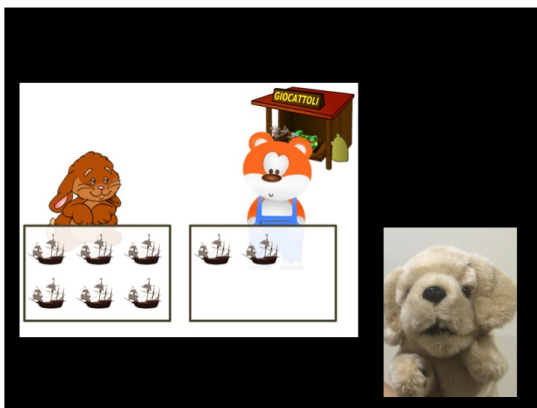

Pluto: Il coniglio ha comprato più barchette di quante ne ha comprate l'orso.

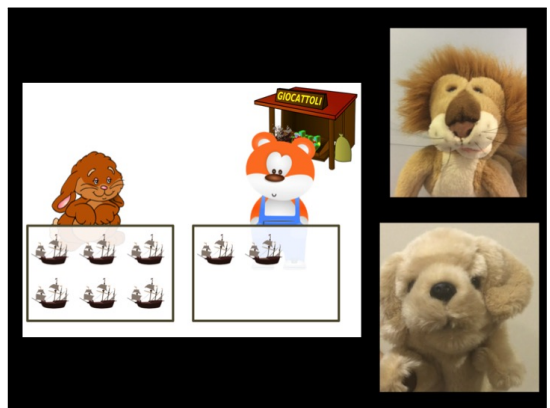

The child is prompted to choose.

Figure A.8: IND.TST.6 - Critical Item with indicative mood



Oggi il castoro e il gatto sono sulla riva di un fiume.

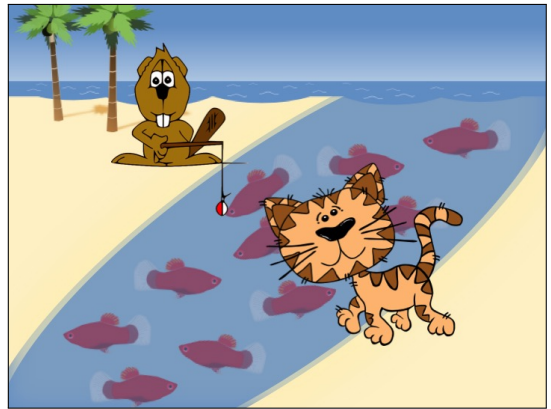

Hanno fame e decidono di pescare.

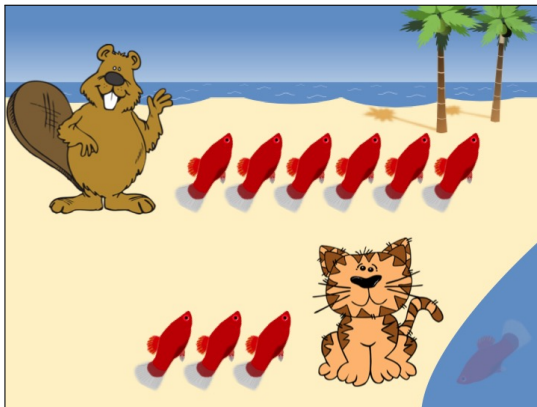

Il castoro pesca sei pesci mentre il gatto ne pesca tre. Che cos' è successo oggi?

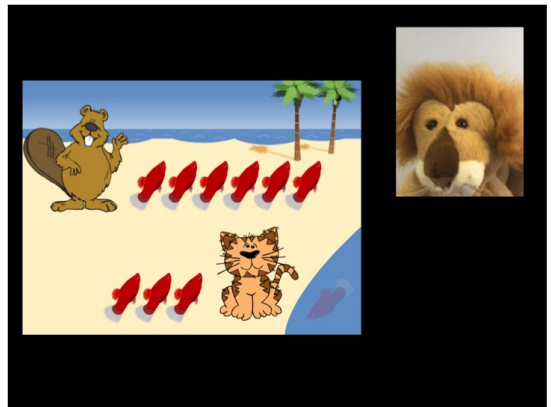

Leo: Il castoro ha pescato più pesci di quanti non ne ha pescati il gatto.

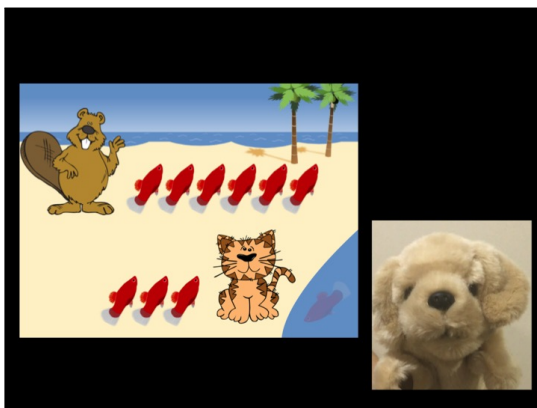

Pluto: Il castoro ha pescato più pesci di quanti ne ha pescati il gatto

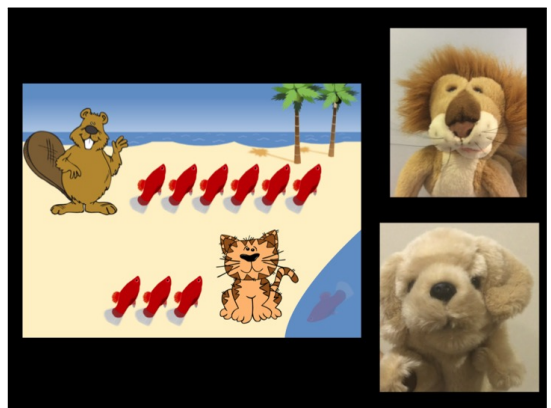

The child is prompted to choose.

Figure A.9: SBJ.TST.1 - Critical Item with subjunctive mood



Il cane e il cocodrillo sono andati oggi in spiaggia.



Decisero di raccogliere stelle marine.



Il cane ha raccolto tre stelle marine e il cocodrillo sei.



Leo: Il cocodrillo ha raccolto più stelle marine di quante ne abbia raccolte il cane.



Pluto: Il cocodrillo ha raccolto più stelle marine di quante ne **abbia** raccolte il cane.



The child is prompted to choose.

Figure A.10: SBJ.TST.2 - Critical Item with subjunctive mood

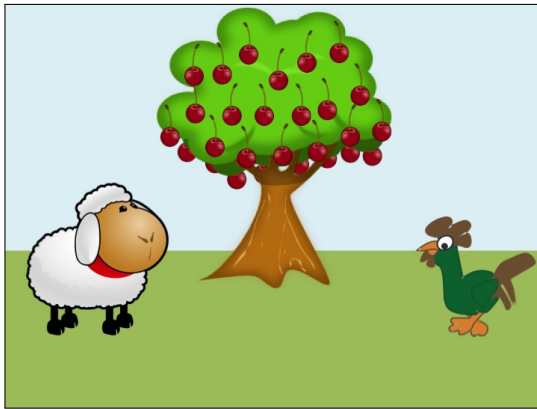

Oggi la pecora e il gallo sono in campagna.

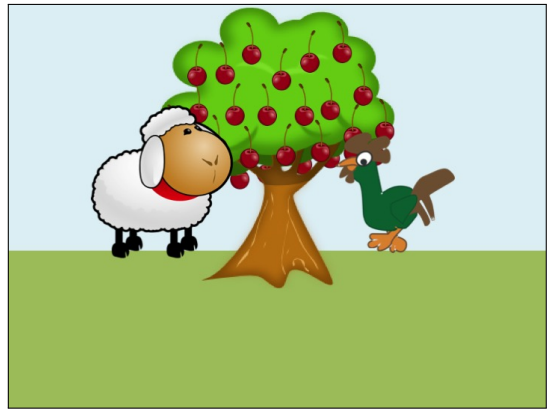

Vogliono fare una marmellata e devono raccogliere le ciliegie dal' arbero.

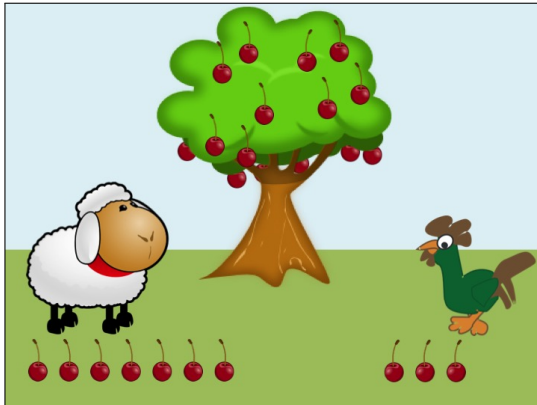

La pecora ha preso sette ciliegie mentrè il gallo ne ha prese tre.

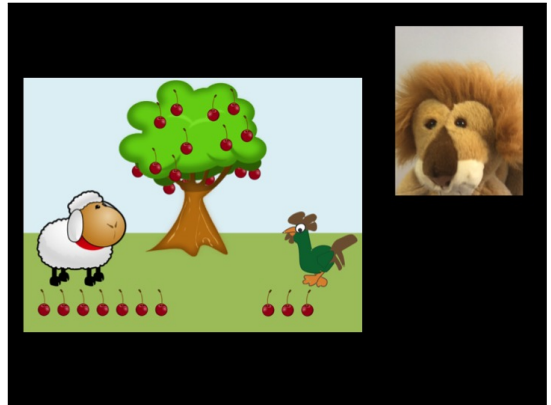

Leo: La pecora ha preso più ciliegie di quante ne abbia prese il gallo.

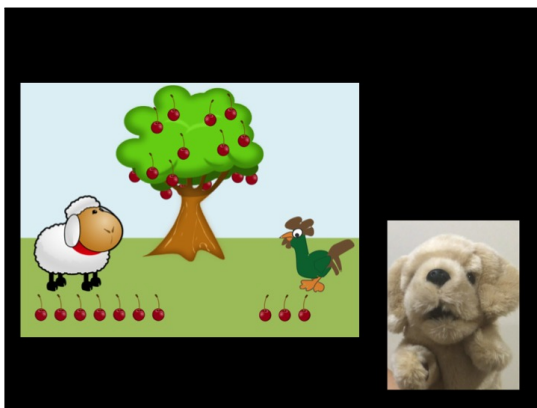

Pluto: La pecora ha preso più ciliegie di quante non ne abbia prese il gallo.

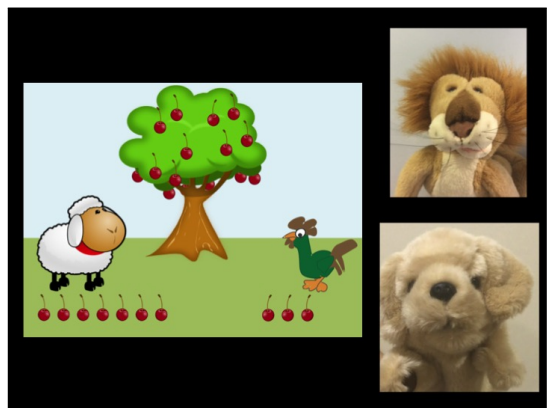

The child is prompted to choose.

Figure A.11: SBJ.TST.3 - Critical Item with subjunctive mood

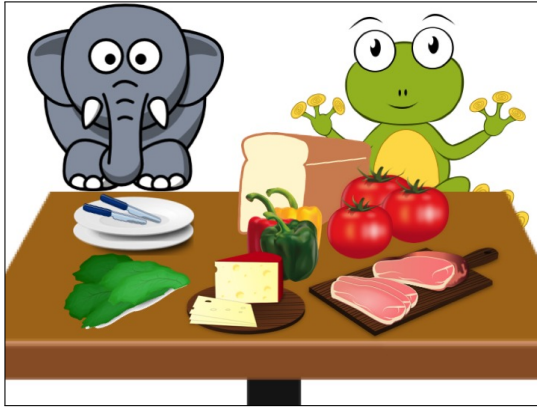

L' elefante e la rana sono molto affamati.

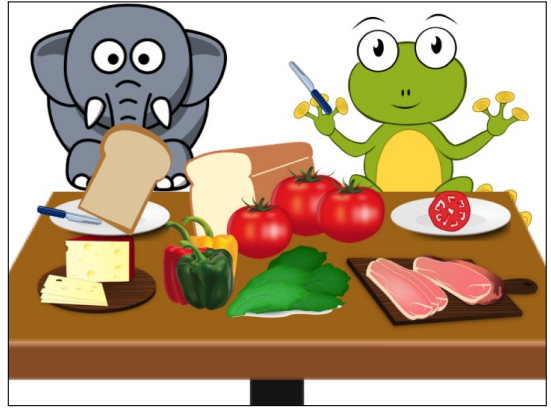

Così hanno deciso di preparare dei panini.

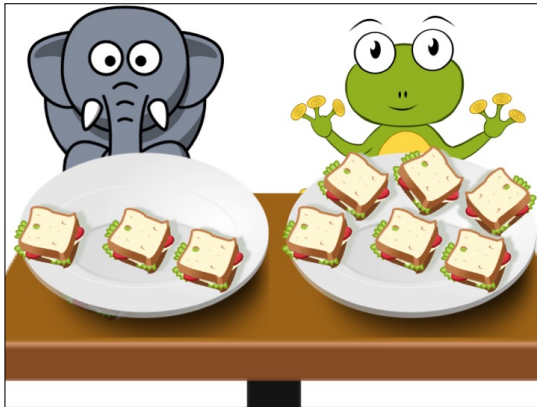

L' elefante ha preparato tre panini e la rana sei

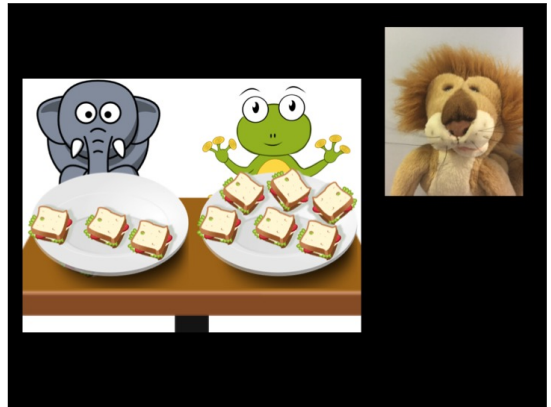

Leo: La rana ha preparato più panini di quanti non ne abbia preparati l' elefante.

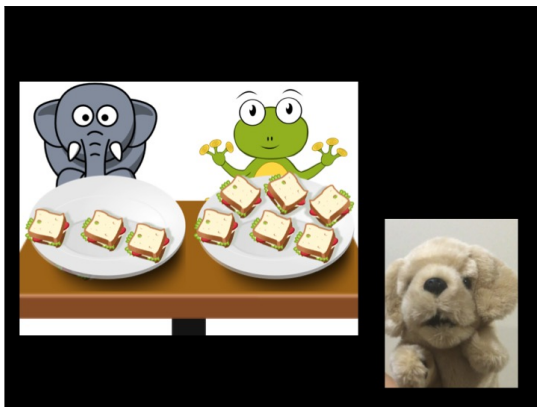

Pluto: La rana ha preparato più panini di quanti ne **abbia** preparati l' elefante.

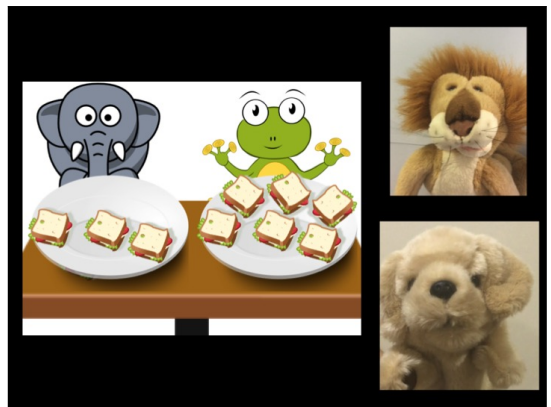

The child is prompted to choose.

Figure A.12: SBJ.TST.4 - Critical Item with subjunctive mood

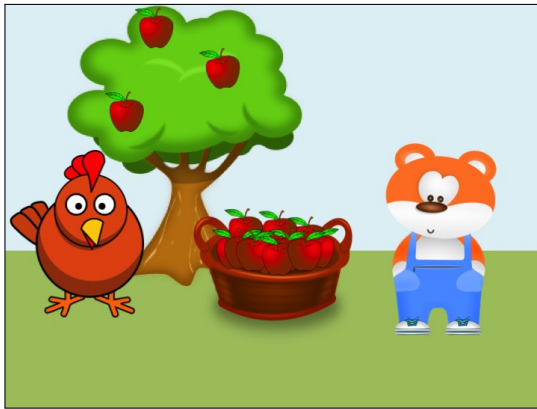

La gallina e l'orso si trovano oggi in campagna.

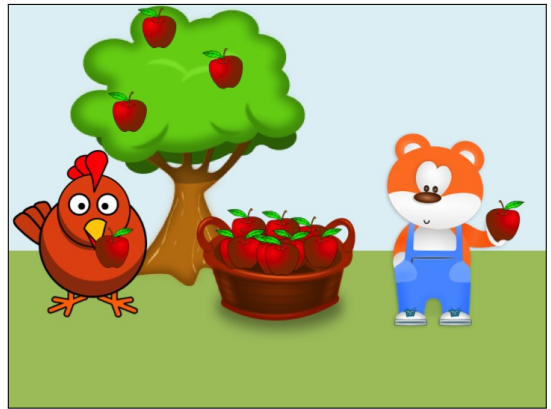

Si affamano così decidono di mangiare alcune di quelle deliziose mele.

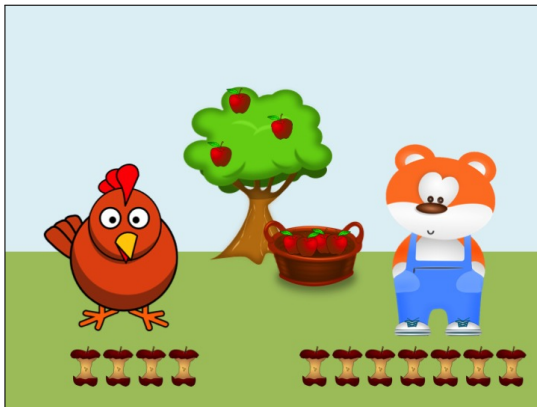

La gallina mangia quattro mele e l'orso sette.

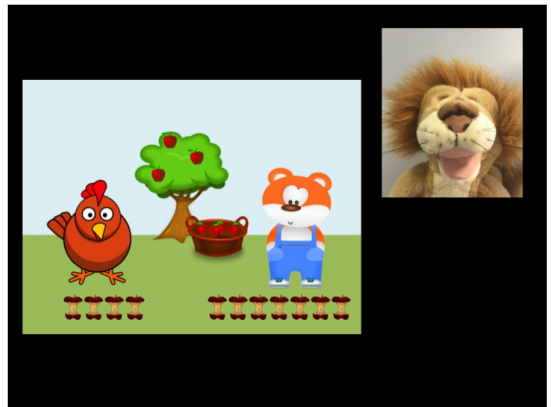

Leo: L'orso ha mangiato più mele di quante ne abbia mangiate la gallina.

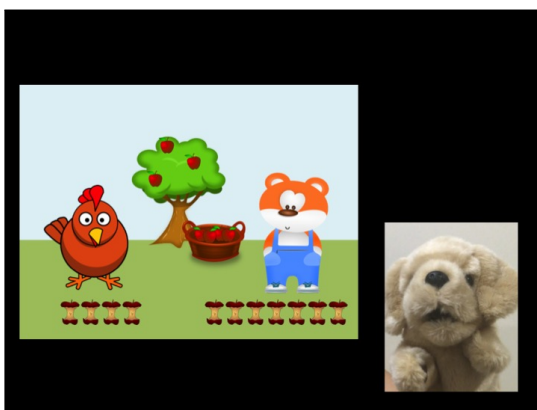

Pluto: L'orso ha mangiato più mele di quante non ne abbia mangiate la gallina.

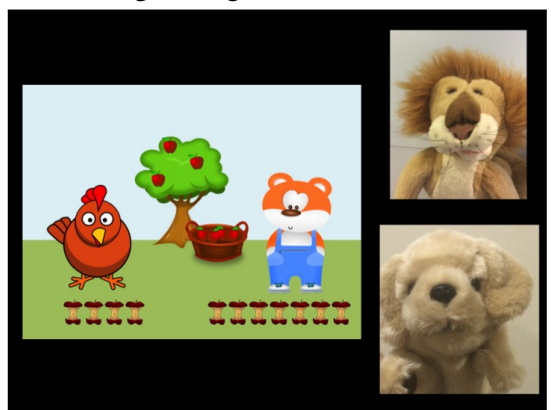

The child is prompted to choose.

Figure A.13: SBJ.TST.5 - Critical Item with subjunctive mood



Il cane e il topo sono andati oggi al negozio di giocattoli.

Decisero di comprare alcuni trenini.

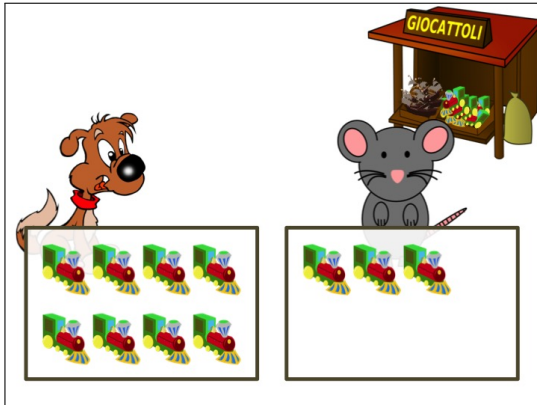

Il cane ha comprato otto trenini e il topo tre.

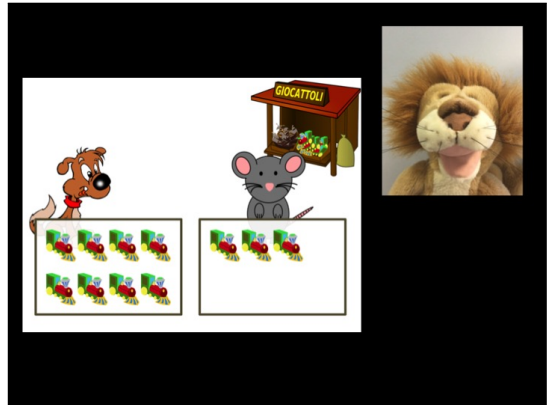

Leo: *Il cane ha comprato più trenini di quanti ne abbia comprati il topo.

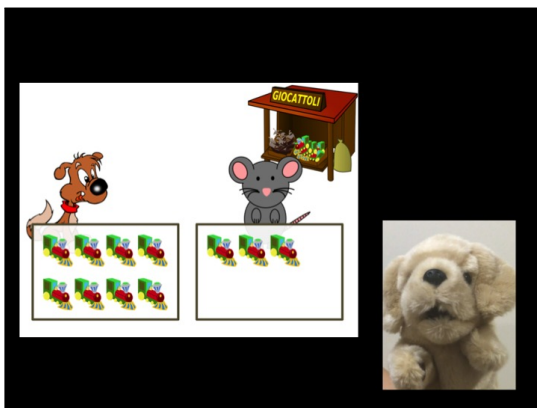

Pluto: Il cane ha comprato più trenini di quanti non ne abbia comprati il topo.

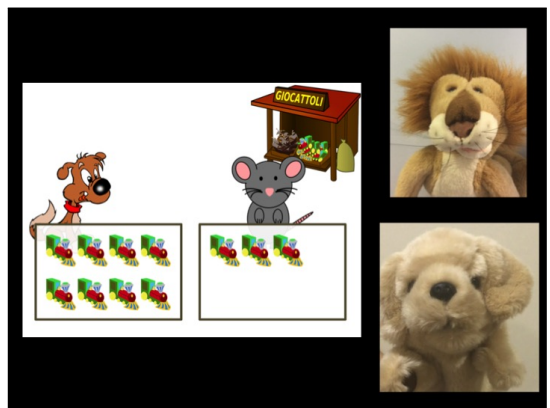

The child is prompted to choose.

Figure A.14: SBJ.TST.6 - Critical Item with subjunctive mood

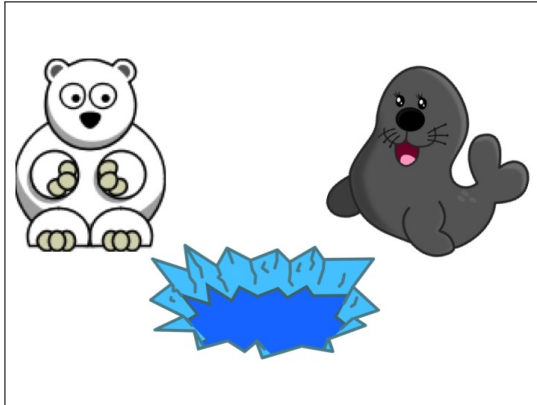

L'orso polare e la foca

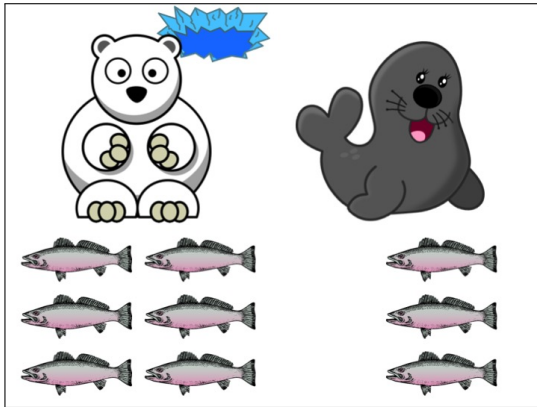

L'orso polare ha pescato sei pesci e la foca tre.

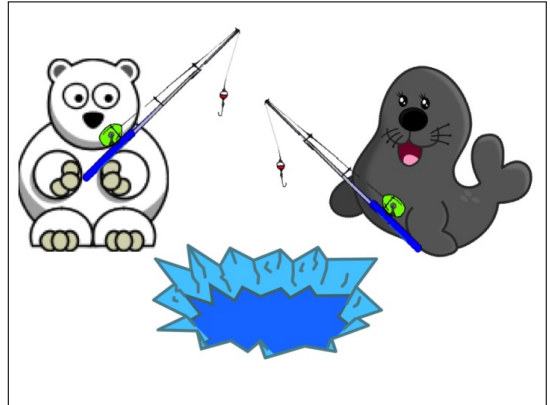

Si affamano e hanno deciso di pescare.

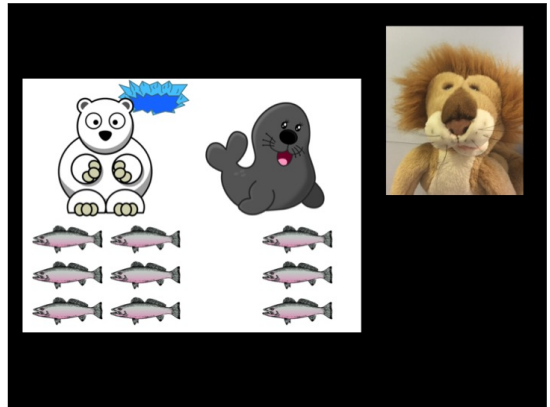

Leo: l'orso polare ha pescato più pesci di quanti non ne abbia pescati la foca.

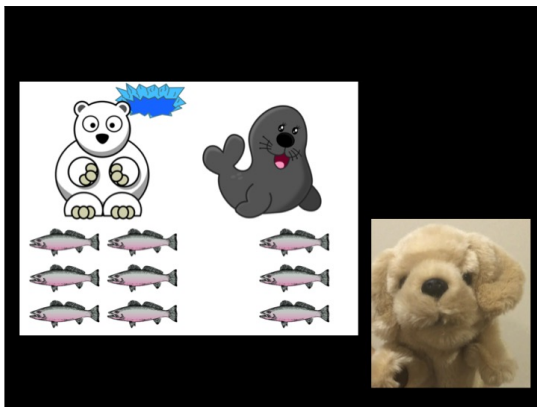

Pluto: l'orso polare ha pescato più pesci di quanti ne **abbia** pescati la foca.

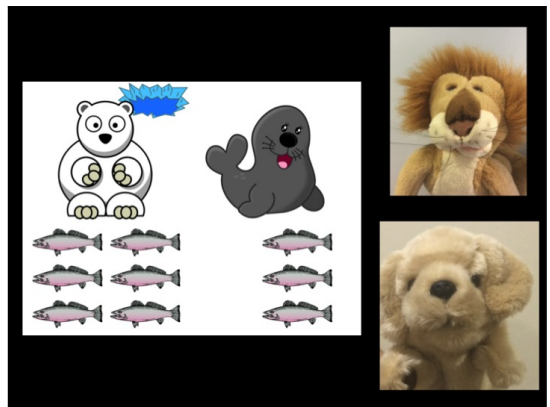

The child is prompted to choose.

Figure A.15: SBJ.CTL.GR.1 - Control Item; Grammaticality Judgement; Subjunctive mood

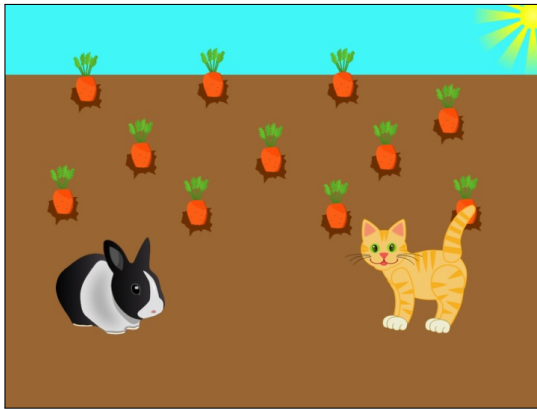

Oggi il gatto e il coniglietto sono andati nell'orto.

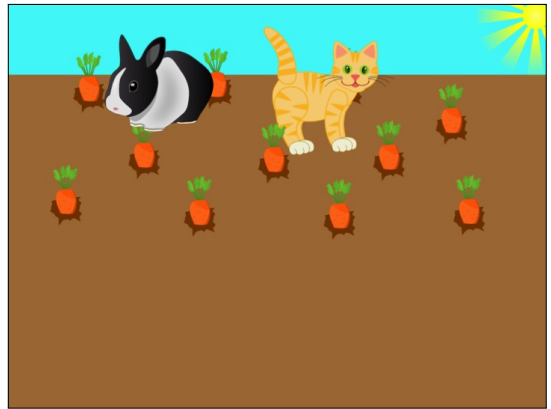

Vogliono fare una zuppa di carote e hanno bisogno di raccogliere le carote.

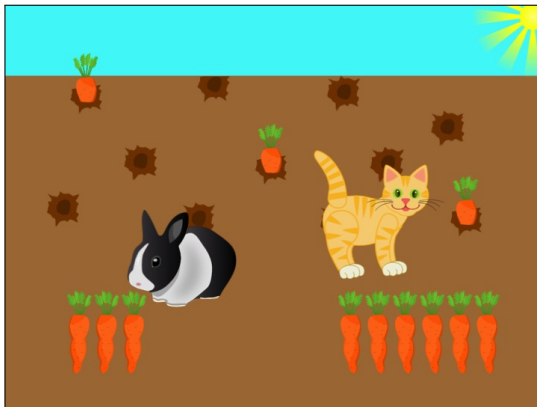

Il gatto ha raccolto sei carote e il coniglietto tre

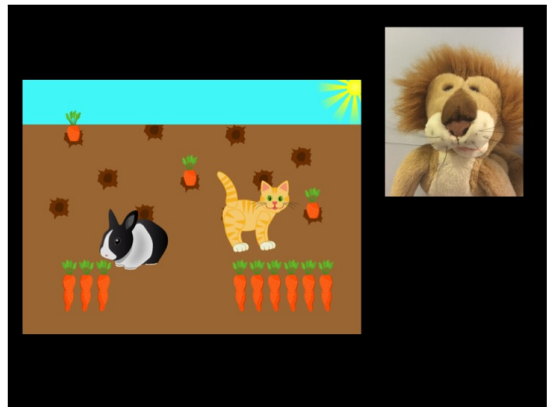

Leo: Il gatto ha preso più carote di quante non ne abbia prese il coniglietto.

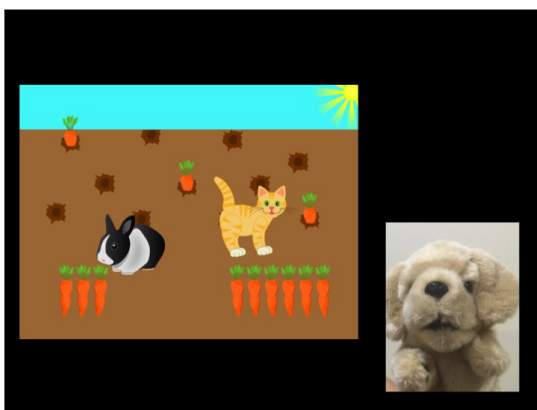

Pluto: Il gatto **hanno** preso più carote di quante non ne abbia prese il coniglietto.

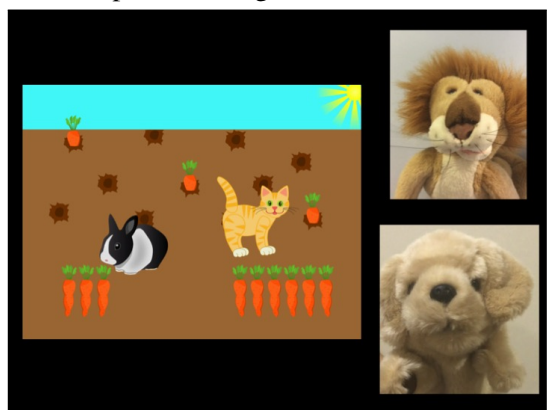

The child is prompted to choose.

Figure A.16: SBJ.CTL.GR.2 - Control Item; Grammaticality Judgement; Subjunctive mood

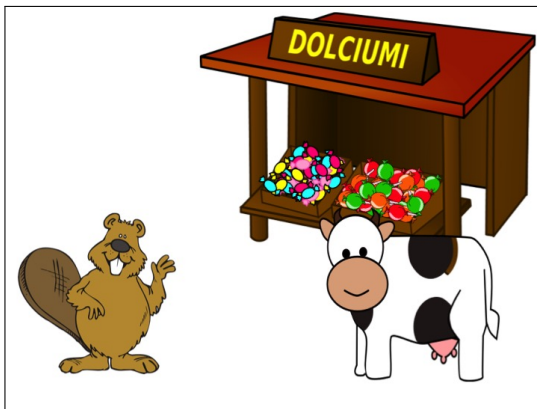

Il castoro e la mucca sono andati oggi al negozio di dolciumi.

Decisero di comprare alcune caramelle.

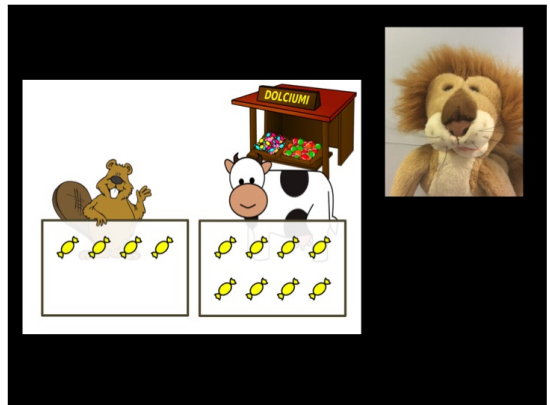
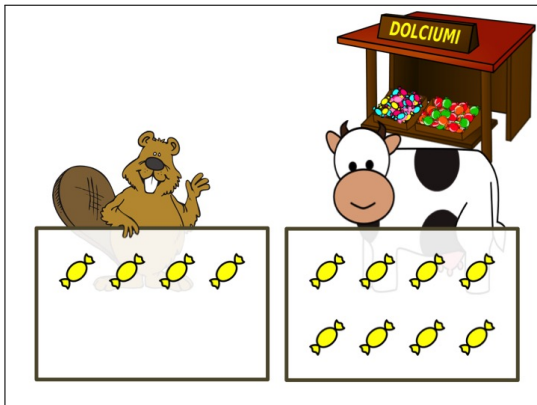

Il castoro compra quattro caramelle e la mucca otto.

Leo: La mucca **avete** comprato più caramelle di quante non ne abbia comprate il castoro.

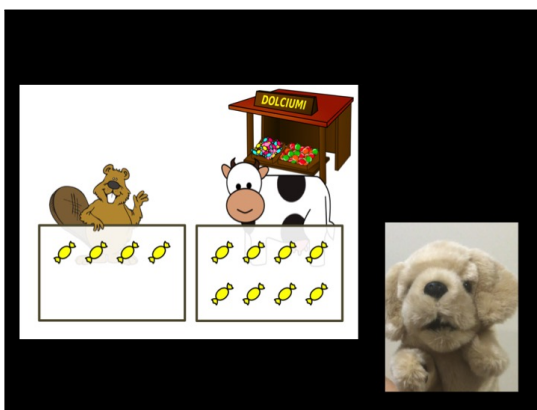

Pluto: La mucca ha comprato più caramelle di quante non ne abbia comprate il castoro.

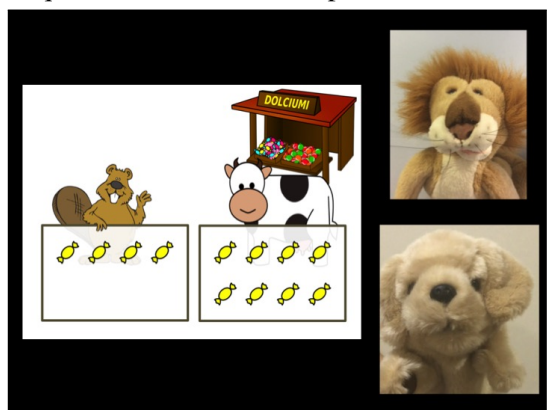

The child is prompted to choose.

Figure A.17: IND.CTL.GR.1 - Control Item; Grammaticality Judgement; Indicative mood

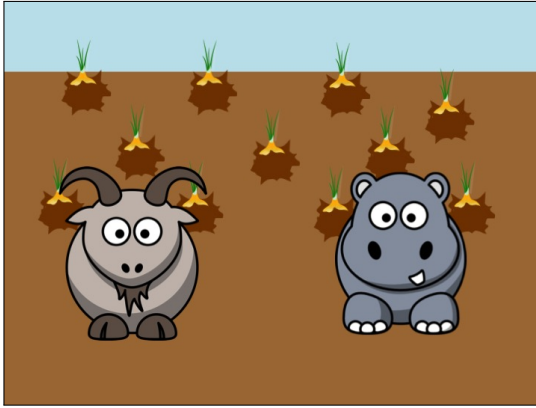

Oggi la capra e l' ippopotamo fanno un giro nell' orto

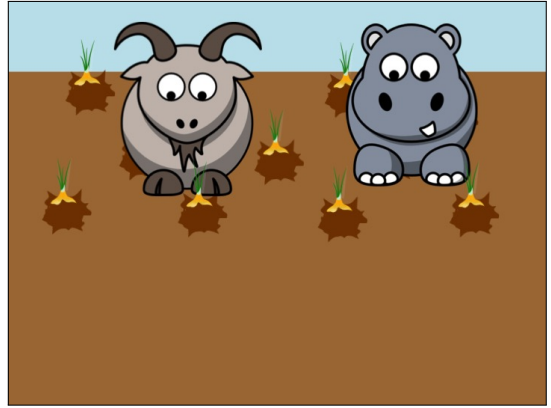

Vogliono fare un minestrone e hanno deciso di raccogliere le cipolle.



La capra ha raccolto sei cipolle e l' ippopotamo tre.



Leo: *La capra **hanno** preso più cipolle di quante ne ha prese l' ippopotamo.



Pluto: La capra ha preso più cipolle di quante ne ha prese l' ippopotamo.

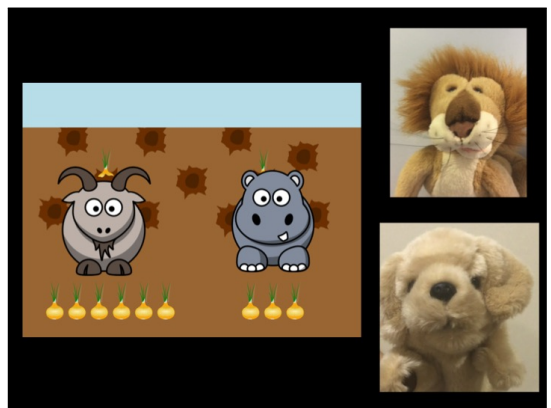

The child is prompted to choose.

Figure A.18: IND.CTL.GR.2 - Control Item; Grammaticality Judgement; Indicative mood



Il pappagallo e la pecora sono andati al negozio di dolciumi.



Decidono di comprare alcuni lecca-lecca.

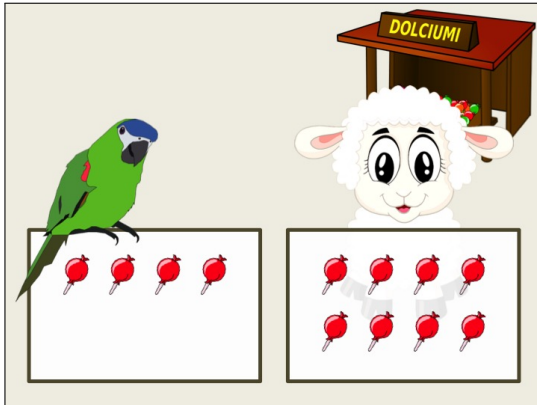

Il pappagallo ha comprato quattro lecca-lecca, la pecora otto.

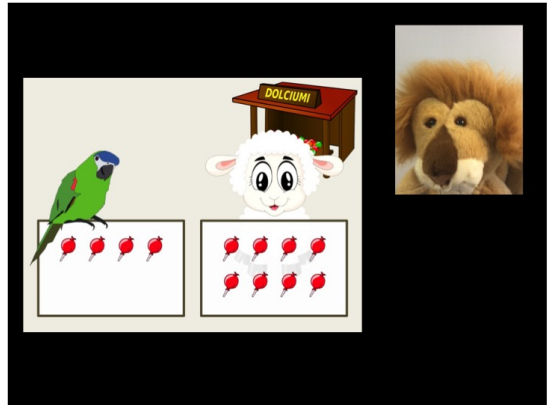

Leo: La pecora ha comprato più lecca-lecca di quanti ne ha comprati il pappagallo.

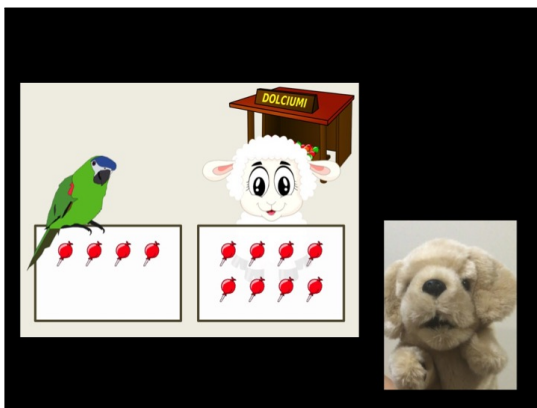

Pluto: *La pecora **avete** comprato più lecca-lecca di quanti ne ha comprati il pappagallo.

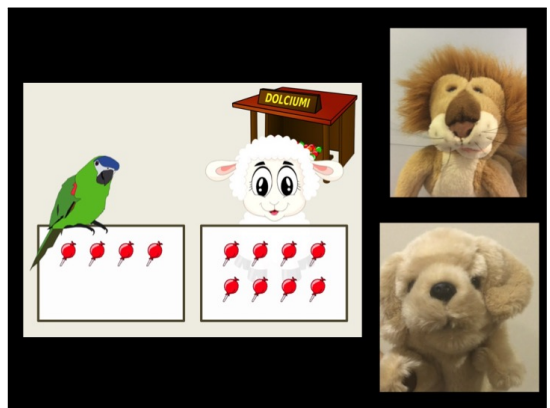

The child is prompted to choose.

Figure A.19: IND.CTL.TF.1 - Control Item; Truth Value Judgement; Indicative mood

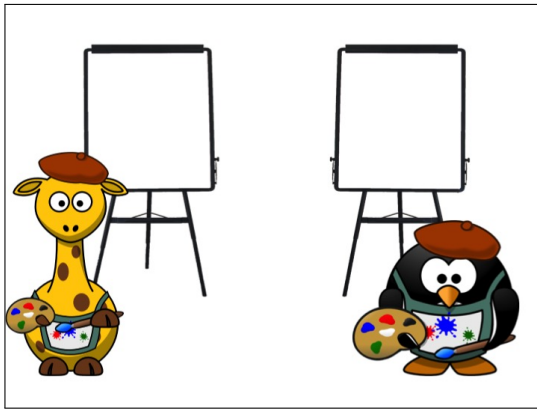

La giraffa e il pinguino sono ad un corso di pittura.

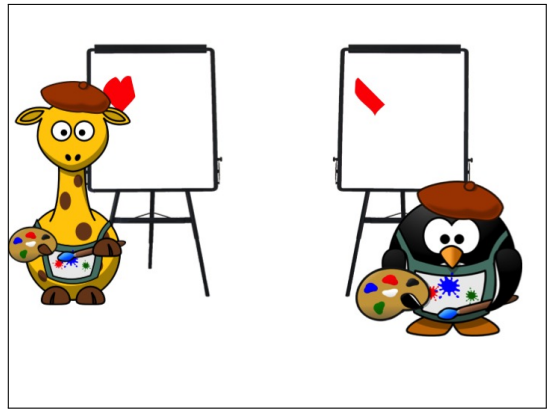

L' insegnante ha chiesto loro di dipingere dei cuori.

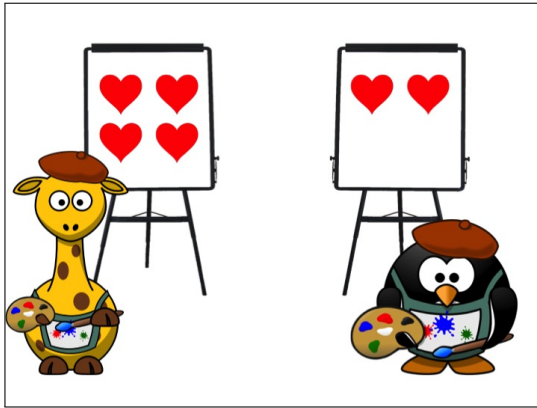

La giraffa ha dipinto quattro cuori e il pinguino due.

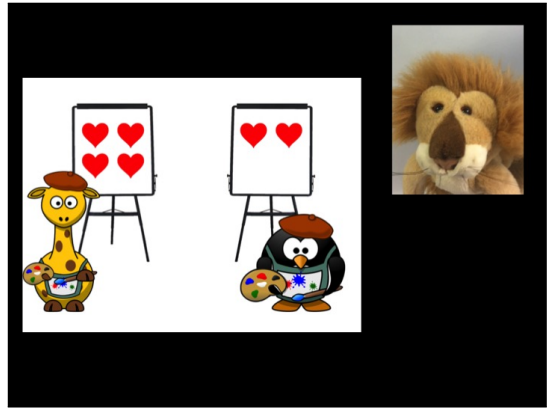

Leo: La giraffa ha dipinto più cuori di quanti ne ha dipinti il pinguino.

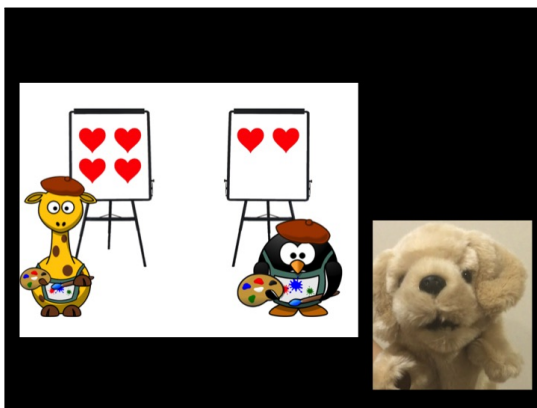

Pluto: Il pinguino ha dipinto più cuori di quanti ne ha dipinti la giraffa.

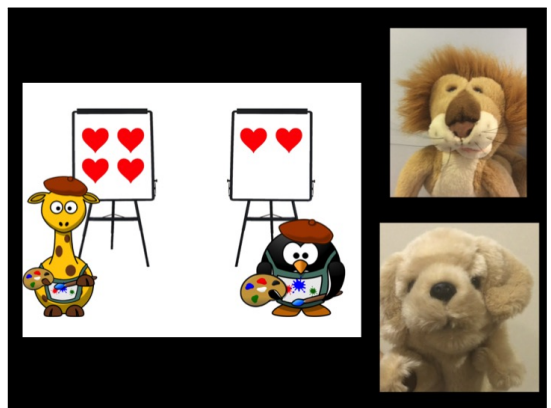

The child is prompted to choose.

Figure A.20: IND.CTL.TF.2 - Control Item; Truth Value Judgement; Indicative mood

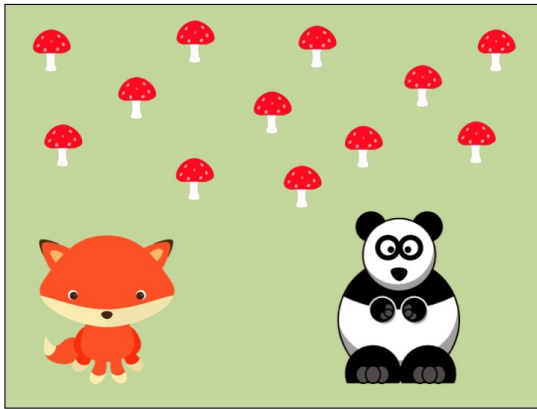

Oggi, la volpe e il panda sono andati in campagna oggi.

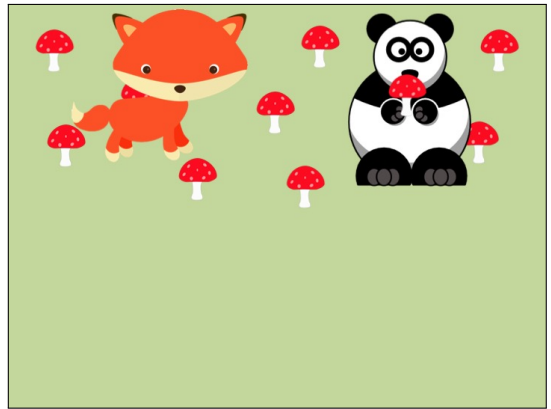

Hanno fame, così decidono di raccogliere dei funghi.

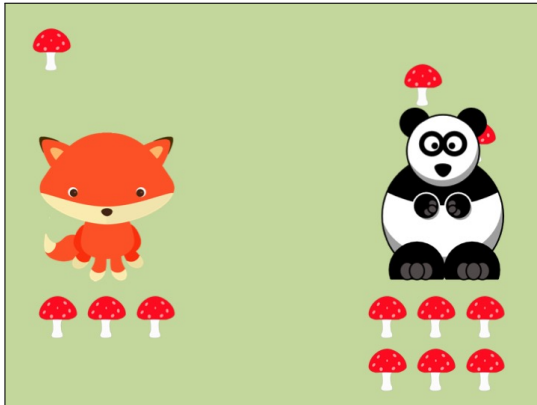

La volpe ha raccolto tre funghi e il panda sei.

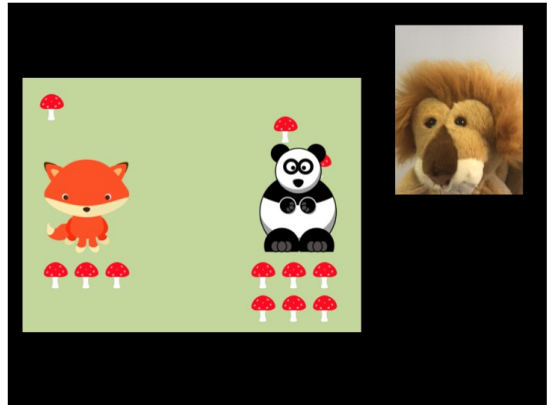

Leo: La volpe ha raccolto più funghi di quanti ne ha raccolti il panda.

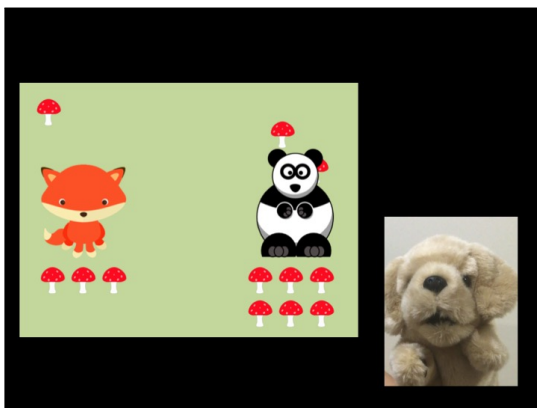

Pluto: Il panda ha raccolto più funghi di quanti ne ha raccolti la volpe.

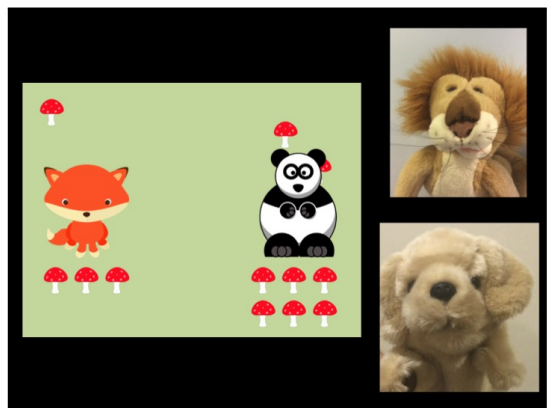

The child is prompted to choose.

Figure A.21: SBJ.CTL.TF.1 - Control Item; Truth Value Judgement; Subjunctive mood

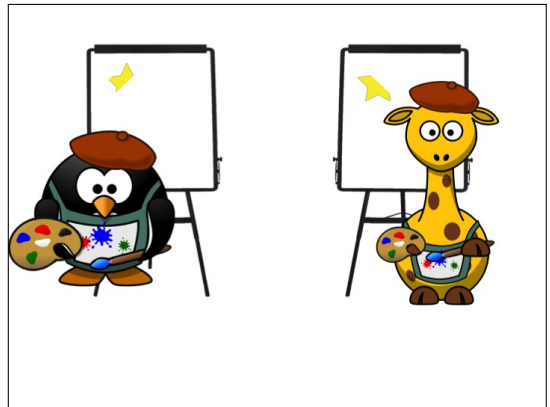
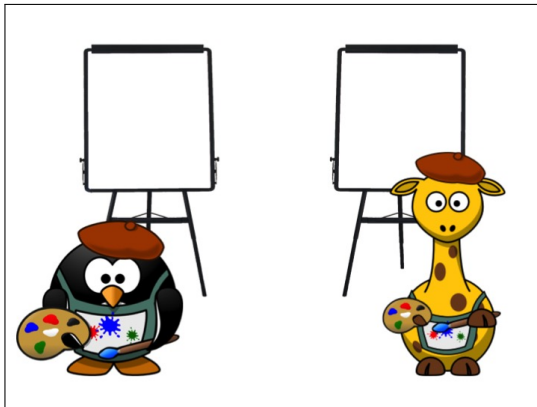

La giraffa e il pinguino sono ad un corso di pittura.

L' insegnante ha chiesto loro di dipingere delle stelle.

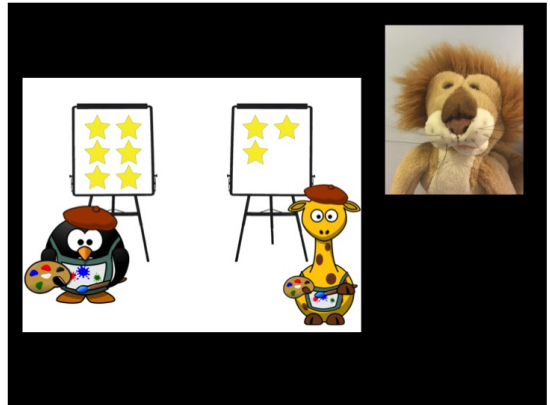
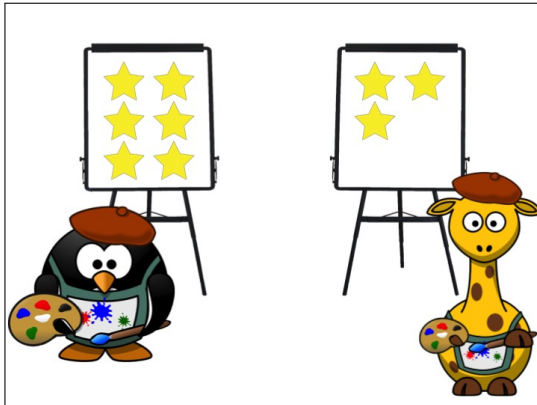

La giraffa ha dipinto sei stelle e il pinguino tre.

Leo: La giraffa ha dipinto più stelle di quante non ne abbia dipinte il pinguino.

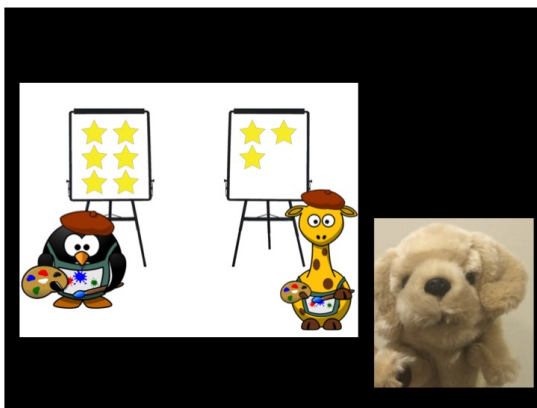

Pluto: Il pinguino ha dipinto più stelle di quante non ne abbia dipinte la giraffa.

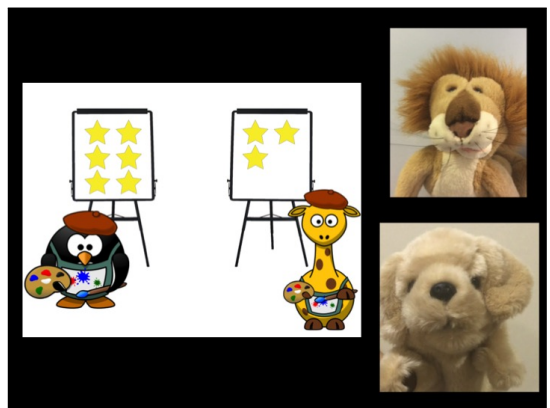

The child is prompted to choose.

Figure A.22: SBJ.CTL.TF.2 - Control Item; Truth Value Judgement; Subjunctive mood

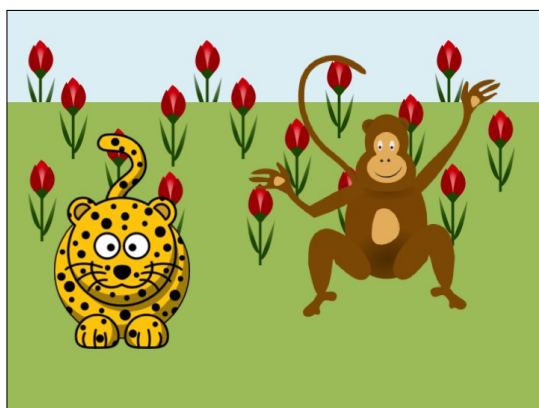

Il leopardo e la scimmia sono andati in campagna oggi.

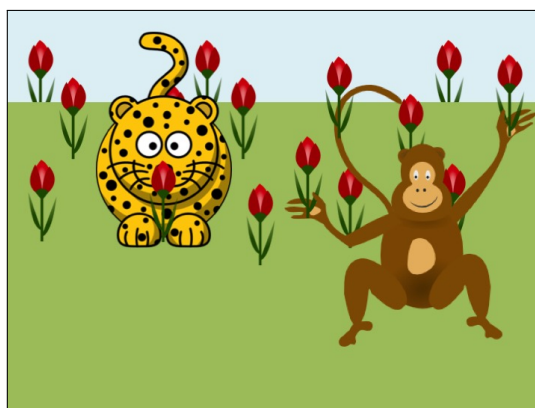

Volevano fare un mazzo di fiori e hanno deciso di raccogliere alcuni fiori.

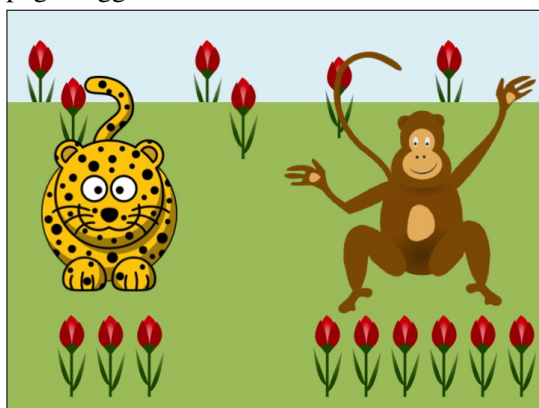

Il leopardo ha raccolto tre fiori e la scimmia sei.

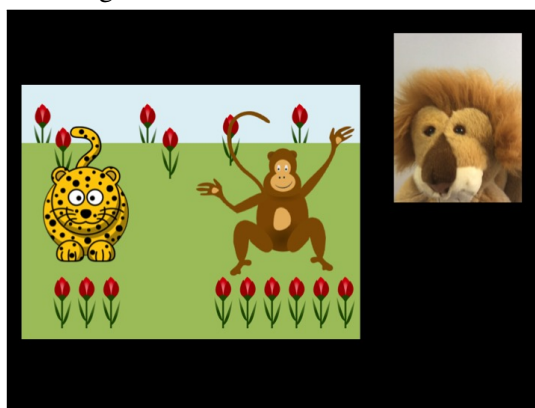

Leo: La scimmia ha raccolto più fiori di quanti non ne abbia raccolti il leopardo.

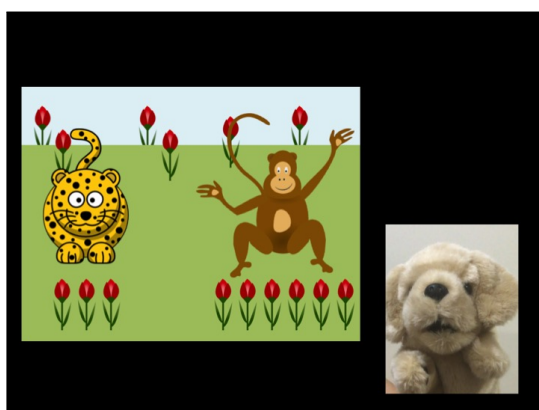

Pluto: Il leopardo ha raccolto più fiori di quanti non ne abbia raccolti la scimmia.

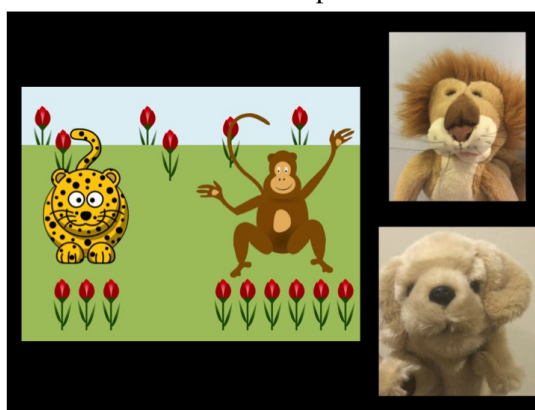

The child is prompted to choose.

Appendix B

Abbreviations

Glosses

ADD	Additive
ADJ	Adjective
ADV	Adverb
CL	Clitic
D	Determiner
DAT	Dative
DEM	Demonstrative
FEM	Feminine
FUT	Future
GEN	Genitive
IMP	Imperative
LNK	Linking Vowel
M	Masculine
NEG	Negation
NEUT	Neuter
OBL	Oblique
PCPL	Participle
PST	Past
PL	Plural
POSS	Possessive
PR	Pronoun
RFL	Reflexive
SBJ	Subjunctive
SG	Singular
TOP	Topic

Mathematical and Statistical Abbreviations and Symbols

<i>N</i>	Number of members in a total sample
<i>n</i>	Number of members in a subsample
<i>df</i>	degree of freedom
<i>H</i>	used in Kruskal-Wallis test
<i>M</i>	Mean
<i>Mdn</i>	Median
<i>SD</i>	Standard deviation
<i>SE</i>	Standard Error (of measurement)
<i>z</i>	A standard score; difference between one value in a distribution and the mean of the distribution divided by the SD
χ^2	Computed value of chi-square test
no.	number

Other Abbreviations

a.o.	among others
ATB	Across-the-board
Br	Brazilian
CN	Comparative Negation
CSG	Comparative Superlative Generalisation
CTL	CTL
GR	Grammaticality
MP	Measure Phrase
NPI	Negative Polarity Item
p.c.	personal communication
Portug.	Portuguese
pos	positive
RC	Rhetorical Comparatives
RNR	Right Node Raising
SEG	South Eastern Greek
SMG	Standard Modern Greek
SM	Standard Marker
TF	Truth Value
TST	Test
TVC	Tensed Verb Constraint

References

- Abels, K. (2002). Expletive (?) Negation. In J. Toman (Ed.), *Formal Approaches to Slavic Linguistics 10: The second Ann Arbor Meeting 2001*, Volume 10, Bloomington, ID, pp. 1–21. Michigan Slavic Publications.
- Abels, K. (2005). ‘Expletive Negation’ in Russian: A Conspiracy Theory. *Journal of Slavic Linguistics* 13(1), 5–74.
- Abney, S. P. (1987). *The English Noun Phrase in its Sentential Aspect*. Phd, MIT.
- Alexiadou, A. (2003). Adjective syntax and (the absence of) noun raising in the DP. In A. Mahajan (Ed.), *Syntax at Sunset 3: Head movement and syntactic theory*, pp. 1–39. Los Angeles, CA: University of California Press.
- Alexiadou, A. and M. Stavrou (2000). Adjective-clitic combinations in the Greek DP. In B. Gerlach and J. Grijzenhout (Eds.), *Clitics in Phonology, Morphology and Syntax*, *Linguistik Aktuell/Linguistics Today* 36, pp. 63–84. Amsterdam/Philadelphia: John Benjamins Publishing Company.
- Alexiadou, A. and S. Varlokosta (1996). The Syntactic and Semantic Properties of Free Relatives in Modern Greek. *ZAS Working Papers in Linguistics* 5, 1–36.
- Alexiadou, A. and S. Varlokosta (2007). On the Structure and Matching Effects of Free Relatives in Greek. In A. Alexiadou (Ed.), *Studies in the Morphosyntax of Modern Greek*, pp. 222–249. Cambridge: Cambridge Scholars Publishing.
- Alexopoulou, T., R. Folli, and G. Tsoulas (2013). Bare number. In R. Folli, C. Sevdali, and R. Trusswell (Eds.), *Syntax and its limits*. Oxford: Oxford University Press.
- Alrenga, P. and C. Kennedy (2014). No more shall we part: Quantifiers in English comparatives. *Natural Language Semantics* 22(1), 1–53.
- Alrenga, P., C. Kennedy, and J. Merchant (2012). A New Standard of Comparison. In N. Arnett and R. Bennett (Eds.), *Proceedings of the 30th West Coast Conference on Formal Linguistics*, Somerville, MA, pp. 32–42. Cascadilla Proceedings Project.
- Anagnostopoulou, E. (2003). *The Syntax of Ditransitives: Evidence from Clitics*. *Studies in Generative Grammar* 54. Berlin/New York: Mouton de Gruyter.
- Anagnostopoulou, E. (2005). Cross-linguistic and Cross-categorial variation of datives. In M. Stavrou and A. Terzi (Eds.), *Advances in Greek Generative Syntax: In honor of Dimitra Theophanopoulou*

- Kontou*, *Linguistik Aktuell/Linguistics Today* 76, pp. 61–126. Amsterdam/Philadelphia: John Benjamins Publishing Company.
- Andersen, P. K. (1983). *Word order typology and comparative constructions*. *Current Issues in Linguistic Theory* 25. Amsterdam: John Benjamins.
- Arregi, K. (2013). The syntax of Comparative Numerals. In S. Kan, C. Moore-Cantwell, and R. Staubs (Eds.), *NELS 40: Proceedings of the 40th Annual Meeting of the North East Linguistic Society*, Volume 1, Cambridge, MA. MIT.
- Babinotiotis, G. and P. Kontos (1967). Συγχρονική γραμματική τῆς κοινῆς νέας ἑλληνικῆς: θεωρία - ἀσκήσεις (*Contemporary grammar of Standard Modern Greek: Theory and Exercises*). Athens: Distributed by Zeno, London.
- Baerman, M. (2008). Case Syncretism. In A. L. Malchukov and A. Spencer (Eds.), *The Oxford Handbook of Case*. Oxford: Oxford University Press.
- Barwise, J. and R. Cooper (1981). Generalized Quantifiers and Natural Language. *Linguistics and Philosophy* 4(2), 159–219.
- Batchelor, R. E. and M. Chebli-Saadi (2011). *A Reference Grammar of French* (First ed.). Cambridge: Cambridge University Press.
- Bates, D., M. Mächler, B. Bolker, and S. Walker (2015). Fitting linear mixed-effects models using lme4. *Journal of Statistical Software* 67(1), 1–48.
- Beck, S. (2009). DegP scope revisited.
- Beck, S., V. Hohaus, and S. Tiemann (2012). A note on phrasal comparatives. In A. Chereches (Ed.), *Proceedings of SALT 22*, Chicago, pp. 146–165. University of Chicago, Illinois: Linguistic Society of America.
- Beck, S., S. Krasikova, D. Fleischer, R. Gergel, S. Hofstetter, C. Savelsberg, J. Vanderelst, and E. Villalta (2009). Crosslinguistic Variation in Comparison Constructions. *Linguistic Variation Yearbook* 9, 1–66.
- Beck, S., T. Oda, and K. Sugisaki (2003). Comparative Constructions in Japanese vs. English. In M. Kadowaki and S. Kawahara (Eds.), *Proceedings of the North East Linguistic Society 33*, Amherst, MA., pp. 51–66. Massachusetts Institute of Technology: GLSA (Graduate Linguistic Student Association), Dept. of Linguistics, South College, University of Massachusetts.
- Beck, S., T. Oda, and K. Sugisaki (2004). Parametric Variation in the Semantics of Comparison: Japanese vs. English. *Journal of East Asian Linguistics* 13(4), 289–344.
- Belletti, A. (2001). Speculations on the Possible Source of Expletive Negation in Italian Comparative Clauses. In G. Cinque and G. Salvi (Eds.), *Current Studies in Italian Syntax: Essays offered to Lorenzo Renzi*, North-Holland Linguistic Series: Linguistic Variations, pp. 19–38. Oxford: Elsevier.

- Bellugi, U., R. Brown, S. S. R. Council., and S. f. R. i. C. Development (1964). *Monographs of the Society for Research in Child Development. Vol. 29, no. 1 : The acquisition of language : report of the Fourth Conference Sponsored by the Committee on Intellectual Processes Research of the Social Science Research Council / ed. by Ursul.* Chicago, ILL: Society for Research in Child Development.
- Bhatt, R. and R. Pancheva (2004). Late Merger of Degree Clauses. *Linguistic Inquiry* 35(1), 1–45.
- Bhatt, R. and R. Pancheva (2007). Degree Quantifiers, Position of Merger Effects with their Restrictors, and Conservativity. In C. Barker and P. Jacobson (Eds.), *Direct Compositionality*, pp. 306–355. Oxford: Oxford University Press.
- Bhatt, R. and S. Takahashi (2007a). Direct Comparisons: Resurrecting the Direct Analysis of Phrasal Comparatives. *Semantics and Linguistic Theory* 17, 19–36.
- Bhatt, R. and S. Takahashi (2007b). Systematic ambiguity. In *GLOW XXX*, Tromsø. University of Tromsø.
- Bhatt, R. and S. Takahashi (2011). Reduced and unreduced phrasal comparatives. *Natural Language & Linguistic Theory* 29(3), 581–620.
- Biggs, A. (2014). *Dissociating Case from Theta-roles: A comparative investigation.* Phd, King's College, University of Cambridge.
- Bobaljik, J. D. (1995). *Morphosyntax: The syntax of verbal inflection.* Phd, Massachusetts Institute of Technology.
- Bobaljik, J. D. (2002). A-Chains at the PF-Interface: Copies and 'Covert' Movement. *Natural Language and Linguistic Theory* 20(2), 197–267.
- Bobaljik, J. D. (2012). *Universals in Comparative Morphology: Suppletion, Superlatives, and the Structure of Words.* Current Studies in Linguistics 50. Cambridge, MA: Mit Press.
- Brame, M. K. (1983). Ungrammatical notes 4: smarter than me. *Linguistic Analysis* 12(3), 323–338.
- Brasoveanu, A. (2009). Measure noun polysemy and monotonicity: Evidence from Romanian pseudopartitives. In A. Schardl, M. Walkow, and M. Abdurrahman (Eds.), *NELS 38: proceedings of the 38th Annual Meeting of the North East Linguistic Society, University of Ottawa, [October 26-28, 2007]*, Amherst, MA, pp. 139–150. GLSA (Graduate Linguistic Student Association), Dept. of Linguistics, South College, University of Massachusetts.
- Brasoveanu, A. and J. Rett (2018). Evaluativity across adjective and construction types: An experimental study. *Journal of Linguistics* 54(02), 263–329.
- Breakstone, M. Y., A. Cremers, D. Fox, and M. Hackl (2011). On The Analysis of Scope Ambiguities in Comparative Constructions: Converging Evidence from Real-Time Sentence Processing and Offline Data. *Semantics and Linguistic Theory* 21, 712–731.
- Bresnan, J. W. (1973). Syntax of the Comparative Clause Construction in English. *Linguistic Inquiry* 4(3), 275–343.

- Brown, S. and S. Franks (1995). Asymmetries in the Scope of Russian Negation. *Journal of Slavic Linguistics* 3(2), 239–287.
- Butt, J. and C. Benjamin (2011). *A new reference grammar of Modern Spanish* (Fifth ed.). London: Hodder Education.
- Carlson, G. N. (1977). Amount Relatives. *Language* 53(3), 520–542.
- Chatzikiyiakidis, S., D. Michelioudakis, and G. Spathas (2015). Greek Focus operators and their associates. In *Proceedings of AMGL35*, Thessaloniki. University of Thessaloniki.
- Cheila-Markopoulou, D. (1986). Τά συγκριτικά της Νέας Έλληνικής: Συντακτική ανάλυση του συγκριτικού βαθμού των επιθέτων και επιρρημάτων (*The Modern Greek Comparatives: A syntactic analysis of the comparative form of MG adjectives and adverbs*). Phd, National Kapodistrian University of Athens.
- Chierchia, G. (1998). Reference to kinds across languages. *Natural Language Semantics* 6(4), 339–405.
- Chomsky, N. (1977). On wh-movement. In P. Culicover, T. Wasow, and A. Akmajian (Eds.), *Formal Syntax*, pp. 71–132. New York: Academic Press.
- Cinque, G. (1990). *Types of A'-Dependencies*. Cambridge, MA: MIT Press.
- Cinque, G. (1994). On the evidence for partial N-movement in the Romance DP. In G. Cinque, J. Koster, J.-Y. Pollock, L. Rizzi, and R. Zanuttini (Eds.), *Paths towards Universal Grammar: Studies in honor of Richard S. Kayne*, pp. 85–110. Washington, DC: Georgetown University Press.
- Cinque, G. (2010). *The Syntax of Adjectives: A comparative study*. Cambridge, MA: MIT Press.
- Cinque, G. (2014). The Semantic Classification of Adjectives: A View from Syntax. *Studies in Chinese Linguistics* 35(1), 1–30.
- Collins, C. and P. M. Postal (2015). *Classical NEG-raising. An essay on the syntax of negation*. Cambridge, MA: MIT Press.
- Corver, N. (1997). Much-Support as a Last Resort. *Linguistic Inquiry* 28(1), 119–164.
- Corver, N. (2000). Degree adverbs as displaced predicates. *Rivista di Linguistica* 12(1), 155–191.
- Corver, N. (2005). Double comparatives and the comparative criterion. *Recherches linguistiques de Vincennes* 34, 165–190.
- Corver, N. (2009). Getting the (syntactic) measure of Measure Phrases. *The Linguistic Review* 26(1), 67–134.
- Creissels, D. (2008). Spatial Cases. In A. L. Malchukov and A. Spencer (Eds.), *Oxford Handbook of Case*. Oxford University Press.
- Cresswell, M. J. (1976). The semantics of degree. In B. H. Partee (Ed.), *Montague Grammar*, pp. 261–292. New York, NY: Academic Press.

- Csirmaz, A. and M. Stavrou (2017). Measure Phrases and Semi-Lexical Nouns. In M. Everaert and H. C. van Riemsdijk (Eds.), *The Wiley Blackwell Companion to Syntax*, pp. 1–66. Hoboken, NJ, USA: John Wiley & Sons, Inc.
- Curme, G. O. (1931). *A Grammar of the English Language: Syntax*, Volume III. Boston, MA: D. C. Heath.
- Daskalaki, E. (2007). Free Relatives in Greek: the interaction between case (mis)matches and relativization strategies. In A. Alexiadou (Ed.), *Studies in the Morpho-Syntax of Greek*, pp. 251–293. Cambridge: Cambridge Scholars Publishing.
- Daskalaki, E. (2008). *(Mis)Matching Patterns in Greek Free Relatives*. Phd, University of Cambridge.
- Daskalaki, E. (2011). Case Mis-matching as Case Stranding. *University of Pennsylvania Working Papers in Linguistics* 17(1), Article 10.
- de Cat, C. (2002). *French Dislocation*. Ph. D. thesis, University of York.
- De Clercq, K. and G. Vanden Wyngaerd (2017). *ABA revisited: Evidence from Czech and Latin degree morphology. *Glossa: a journal of general linguistics* 2(1), 69.
- Delfitto, D. (2018). Negation as a window on the non-sequential nature of language interpretation and processing. In A. Capone, M. Carapezza, and F. Lo Piparo (Eds.), *Further Advances in Pragmatics and Philosophy*, Perspectives in Pragmatics, Philosophy & Psychology, 18, pp. 81–95. Cham: Springer.
- Den Dikken, M. (2006). *Relators and Linkers: The Syntax of Predication, Predicate Inversion, and Copulas*. Linguistic Inquiry Monograph 47. Cambridge, MA: The MIT Press.
- Dieterich, T. G. and D. J. Napoli (1982). Comparative *rather*. *Journal of Linguistics* 18(01), 137–165.
- Donati, C. (1997). Comparative clauses as free relatives: A raising analysis. *Probus* 9(2), 145–166.
- Donati, C. (2000). A note on negation in comparison. *Quaderni del Dipartimento di Linguistica* 10, 55–68.
- Espinal, M. T. (1992). Expletive Negation and Logical Absorption. *The Linguistic Review* 9(4), 333–358.
- Espinal, M. T. (2000a). Expletive Negation, Negative Concord and Feature Checking. *Catalan Working Papers in Linguistics* 8, 47–69.
- Espinal, M. T. (2000b). On the semantic status of n-words in Catalan and Spanish. *Lingua* 110, 557–580.
- Espinal, M. T. (2007). Licensing Expletive Negation and Negative Concord in Catalan and Spanish. In F. Floricic (Ed.), *La négation dans les langues Romanes*, pp. 49–74. John Benjamins.
- Fintel, K. (2000). Whatever. *Semantics and Linguistic Theory* 10, 27–40.

- Foppolo, F., M. T. Guasti, and G. Chierchia (2012). Scalar Implicatures in Child Language: Give Children a Chance. *Language Learning and Development* 8(4), 365–394.
- Fox, D. (2002). Antecedent-Contained Deletion and the Copy Theory of Movement. *Linguistic Inquiry* 33(1), 63–96.
- Fox, D. and J. Nissenbaum (1999). Extraposition and scope: A case for overt QR. In S. Bird, A. Carnie, J. D. Haugen, and P. Norquest (Eds.), *WCCFL 18: Proceedings of the West Coast Conference on Formal Linguistics*, Somerville, MA, pp. 132–144. University of Arizona: Cascadia Press.
- Fuchs, C. (2014). *La comparaison et son expression en français* ('The comparison and its expression in French'). *L'Essentiel français*. Paris: Éditions Ophrys.
- Georgala, E. (2011). Scrambling Verb-Final Languages and the Underlying Order of Objects in Ditransitive Constructions. In *Proceedings of the 34th Annual Penn Linguistics Colloquium*, Volume 17, pp. 105–114. University of Pennsylvania.
- Giannakidou, A. (1998). *Polarity Sensitivity as (Non)veridical Dependency*. Amsterdam-Philadelphia: John Benjamins.
- Giannakidou, A. (2006). Only, emotive factives, and the dual nature of polarity dependency. *Language* 82, 575–603.
- Giannakidou, A. (2007). The landscape of EVEN. *Natural Language & Linguistic Theory* 25(1), 39–81.
- Giannakidou, A. (2012). The Landscape of Greek Quantifiers. In D. Paperno and E. L. Keenan (Eds.), *Handbook of Quantifiers in Natural Language*, Studies in Linguistics and Philosophy 90, Chapter 6, pp. 285–346. Dordrecht: Springer.
- Giannakidou, A. and M. Stavrou (2009). On metalinguistic comparatives and negation in Greek. In C. Halpert, J. Hartman, and D. Hill (Eds.), *Proceedings of the 2007 Workshop on Greek Syntax and Semantics*, Volume 57 of *MIT Working Papers in Linguistics* 57, Cambridge, MA, pp. 57–74. MIT.
- Giannakidou, A. and S. Yoon (2009). Metalinguistic Comparatives and the expressive dimension: evidence from Greek and Korean. In A. Riester and T. Solstad (Eds.), *Proceedings of Sinn und Bedeutung 13*, Stuttgart, pp. 141–156. University of Stuttgart: Online Publikationsverbund der Universität Stuttgart (OPUS).
- Giannakidou, A. and S. Yoon (2011). The subjective mode of comparison: Metalinguistic comparatives in Greek and Korean. *Natural Language & Linguistic Theory* 29(3), 621–655.
- Giannakidou, A. and S. Yoon (2014). No NPI licensing in comparatives. In R. Baglini, T. Grinsell, J. Keane, A. R. Singerman, and J. Thomas (Eds.), *CLS 46: 2010: Proceedings of the forty-sixth annual meeting of the Chicago Linguistic Society* 46, Chicago, ILL. University of Chicago: Chicago Linguistic Society.
- Giannakidou, A. and S. Yoon (2016). Scalar marking without scalar meaning: Nonscalar, nonexhaustive even-marked NPIs in Greek and Korean. *Language* 92(3), 522–556.

- Giannakidou, A. and S. Yoon (2017). Rethinking negative polarity and free choice in comparatives: a crosslinguistic perspective.
- Giorgi, A. and F. Pianesi (1997). *Tense and Aspect: From semantics to morphosyntax*. Oxford studies in comparative syntax. New York: Oxford University Press.
- Grano, T. and S. Davis (2018). Universal markedness in gradable adjectives revisited. *Natural Language & Linguistic Theory* 36(1), 131–147.
- Grant, M. A. (2013). *The Parsing and Interpretation of Comparatives: More than Meets the Eye*. Phd, University of Massachusetts Amherst.
- Greenough, J. B. and J. H. Allen (1903). *New Latin Grammar for schools and colleges*. Boston, MA/ London: Ginn & Company.
- Grosu, A. and J. Horvath (2006). Reply to Bhatt and Pancheva’s “Late Merger of Degree Clauses”: The Irrelevance of (Non)conservativity. *Linguistic Inquiry* 37(3), 457–483.
- Hackl, M. (2000). *Comparative Quantifiers*. Phd, MIT.
- Hackl, M. (2001). Comparative Quantifiers and Plural Predication. In K. Magerdoomian and L. A. Bar-el (Eds.), *WCCFL 20: Proceedings of the 20th West Coast Conference on Formal Linguistics*, Somerville, MA, pp. 234–247. University of Southern California: Cascadilla Press.
- Han, C.-h., J. Lidz, and J. Musolino (2007). V-Raising and Grammar Competition in Korean: Evidence from Negation and Quantifier Scope. *Linguistic Inquiry* 38(1), 1–47.
- Hankamer, J. (1973). Why there are two than’s in English. In C. Corum, P. C. Smith-Stark, and A. Weiser (Eds.), *Papers from the Ninth Meeting of the Chicago Linguistic Society*, Chicago, ILL, pp. 179–191. University of Chicago: Chicago Linguistic Society.
- Hayashishita, J. R. (2009). Yori-comparatives: A reply to Beck et al. (2004). *Journal of East Asian Linguistics* 18(2), 65–100.
- Heim, I. (1985). Notes on Comparatives and related matters.
- Heim, I. (2000). Degree Operators and Scope. *Semantics and Linguistic Theory* 10, 40–64.
- Heim, I. (2001). Degree Operators and Scope. In C. Féry and W. Sternefeld (Eds.), *Audiatur Vox Sapientiae. A Festschrift for Arnim von Stechow*, pp. 214–239. Berlin: Akademie Verlag.
- Heim, I. (2006). Remarks on comparative clauses as generalized quantifiers.
- Hoeksema, J. (1983). Negative Polarity and the comparative. *Natural Language and Linguistic Theory* 1(3), 403–434.
- Hoeksema, J. (1984). To Be Continued: The story of the comparative. *Journal of Semantics* 3, 93–107.
- Hohaus, V., S. Tiemann, and S. Beck (2014). Acquisition of Comparison Constructions. *Language Acquisition* 21(3), 215–249.

- Holton, D., P. Mackridge, I. Philippaki-Warbuton, revised by, and V. Spyropoulos (2012). *Greek: A Comprehensive Grammar* (Second ed.). Oxford: Routledge.
- Hualde, J. I. (1992). *Catalan* (First ed.). Descriptive Grammars. London: Routledge.
- Iatridou, S. and S. Tatevosov (2016). Our even. *Linguistics and Philosophy* 39(4), 295–331.
- Iatridou, S. and S. Varlokosta (1998). Pseudoclefts crosslinguistically. In *Proceedings of NELS 26*, pp. 117–131.
- Inoue, I. (1991). On the genesis of *there*-constructions. *English Linguistics* 8, 34–51.
- Institutouto Neoellenikon Spoudon, I. M. T. (1998). *Lexiko tes koines neoellenikes* (First ed.). Thessaloniki: Institutouto Neoellenikon Spoudon, Aristoteleio Panepistimio Thessalonikis.
- Ionin, T. and O. Matushansky (2006). The Composition of Complex Cardinals. *Journal of Semantics* 23(4), 315–360.
- Ishii, Y. (1991). *Operators and empty categories in Japanese*. Phd, University of Connecticut.
- Jacobson, P. (1995). On the Quantificational Force of English Greek Relatives. In E. Bach, J. Eloise, K. Angelika, and B. Partee (Eds.), *Quantification in Natural Language, Vol.2*, pp. 451–486. Dordrecht: Kluwer Academic Publishers.
- Joly, A. (1967). *Negation and the Comparative Particle in English*. Quebec: Les Presses de l'Université Laval.
- Kattán-Ibarra, J. and C. J. Pountain (2003). *Modern Spanish Grammar. A Practical Grammar* (Second ed.). Routledge modern grammars. London: Routledge.
- Kennedy, C. (1999). *Projecting the adjective: The syntax and semantics of gradability and comparison*. New York: Garland Press.
- Kennedy, C. (2007a). Modes of Comparison. In M. Elliott, J. Kirby, O. Sawada, and E. Staraki (Eds.), *Proceedings of the 43rd Annual Meeting of the Chicago Linguistic Society (CLS)*, Chicago, Ill., pp. 141–165. Chicago Linguistic Society.
- Kennedy, C. (2007b). Standards of Comparison. In *Colloque de Syntaxe et Semantique de Paris*, Paris. Ecole Normale Superieure.
- Kennedy, C. (2007c). Vagueness and grammar: the semantics of relative and absolute gradable adjectives. *Linguistics and Philosophy* 30(1), 1–45.
- Kennedy, C. and L. McNally (1999). From Event Structure to Scale Structure: Degree Modification in Deverbal Adjectives. In T. Matthews and D. Strolovitch (Eds.), *Proceedings of SALT 9*, Ithaca, NY, pp. 163–180. University of California, Santa Cruz: CLC Publications.
- Kennedy, C. and L. McNally (2013). Degree vs. Manner Well: A Case Study in Selective Binding. In J. Pustejovsky, P. Bouillon, H. Isahara, K. Kanzaki, and C. Lee (Eds.), *Advances in Generative Lexicon Theory*, Volume 46 of *Text, Speech and Language Technology*, Chapter 11, pp. 247–262. Dordrecht: Springer Netherlands.

- Kikuchi, A. (1987). Comparative deletion in Japanese.
- Kirby, S. and M. Becker (2007). Which it is it? The acquisition of referential and expletive it. *Journal of Child Language* 34(3), 571.
- Klein, E. (1980). A Semantics for Positive and Comparative Adjectives. *Linguistics and Philosophy* 4, 1–45.
- Ladusaw, W. (1979). *Polarity Sensitivity as Inherent Scope Relations*. Phd, University of Texas.
- Laenzlinger, C. (2005). French adjective ordering: perspectives on DP-internal movement types. *Lingua* 115(5), 645–689.
- Laker, S. (2008). The English Negative Comparative Particle. *Transactions of the Philological Society* 106, 1–28.
- Larson, B. and A. Wellwood (2015). Constituency, Implicit Arguments, and Scope in the Syntax-Semantics of Degree Constructions.
- Larson, R. K. (1984). Extraction and Multiple Selection in PP.
- Larson, R. K. (1988). Scope and comparatives. *Linguistics and Philosophy* 11(1), 1–26.
- Larson, R. K. (1998). Events and Modification in Nominals. *Semantics and Linguistic Theory* 8, 145.
- Larson, R. K. (1999). Semantics of adjectival modification.
- Larson, R. K. (2000). ACD in AP? In *19th West Coast Conference of Formal Linguistics (WCCFL 19)*. Los Angeles, CA, Los Angeles, CA.
- Larson, R. K. and F. Marušič (2004). On Indefinite Pronoun Structures with APs: Reply to Kishimoto. *Linguistic Inquiry* 35(2), 268–287.
- Lebeaux, D. (1990). Relative clauses, licensing, and the nature of the derivation. In J. Carter, R.-M. Déchaine, B. Philip, and T. Sherer (Eds.), *Proceedings of NELS 20*, Volume 2, Amherst, MA, pp. 318–332. Carnegie-Mellon University: GLSA (Graduate Linguistic Student Association), Dept. of Linguistics, South College, University of Massachusetts.
- Lechner, W. (1998). Phrasal Comparatives and DP-Structure. In P. N. Tamanji and K. Kusumoto (Eds.), *Proceedings of the North East Linguistic Society* 28, Volume 1, Amherst, MA, pp. 237–252. University of Toronto: GLSA (Graduate Linguistic Student Association), Dept. of Linguistics, South College, University of Massachusetts.
- Lechner, W. (1999). Ellipsis Resolution in Phrasal Comparatives and the Right Periphery of the DP. In K. N. Shahin, S. Blake, and E.-S. Kim (Eds.), *WCCFL 17: The Proceedings of the Seventeenth West Coast Conference on Formal Linguistics*, Vancouver, pp. 420–435. University of British Columbia: CSLI Publications.
- Lechner, W. (2001). Reduced and Phrasal Comparatives. *Natural Language and Linguistic Theory* 19(4), 683–735.

- Lechner, W. (2004). *Ellipsis in Comparatives*. Studies in Generative Grammar 72. New York, NY: Mouton de Gruyter.
- Lechner, W. (2009). Metametacomparatives. Comments on ‘Metalinguistic contrast in the grammar of Greek’ by Giannakidou & Stavrou. In C. Halpern, J. Hartman, and D. Hill (Eds.), *MIT Working Papers in Linguistics 57*, Cambridge, MA, pp. 75–91. MIT: MIT Press.
- Lechner, W. (2015). Clausal vs. Phrasal Comparatives. In L. Matthewson, C. Meier, H. Rullmann, and T. E. Zimmermann (Eds.), *The Blackwell Companion to Semantics*. Oxford: Blackwell.
- Lechner, W. (2017). Phrasal comparatives and parasitic scope. In C. Mayr and E. S. Williams (Eds.), *11-11-17. Festschrift für Martin Prinzhorn*, Wiener Linguistische Gazette (WLG) 82, pp. 181–191. Wien: Universität Wien - Institut für Sprachwissenschaft.
- Leffel, T., M. Xiang, and C. Kennedy (*under revision*). Interpreting gradable adjectives in context: Domain distribution vs. scalar representation.
- Liddell, H. G. and R. Scott (1940). *A Greek-English Lexicon* (2nd ed.). Oxford: Clarendon Press.
- Lust, C. and D. Pantelodemos (1995). *Dictionnaire français-grec moderne*. (Twenty-second ed.). Athens: Librairie Kauffmann.
- Maiden, M. and C. Robustelli (2007). *A reference grammar of modern Italian* (Second ed.). London: Hodder Education.
- Makri, M. M. (2017). *Opos* identity comparatives in Greek: an experimental investigation. In T. Georgakopoulos, T.-S. Pavlidou, M. Pechlivanos, A. Alexiadou, J. Androutsopoulos, A. Kalokairinos, S. Skopeteas, and K. Stathi (Eds.), *Proceedings of the 12th International Conference on Greek Linguistics*, Berlin, pp. 629–645. Freie Universität Berlin: Edition Romiosini.
- Manzini, R. (1993). The Subjunctive.
- Marantz, A. (1989). Clitics and phrase structure. In M. Baltin and A. Kroch (Eds.), *Alternative conceptions of phrase structure*, pp. 99–116. Chicago, ILL: University of Chicago Press.
- Marantz, A. (2001). Words.
- Marantz, A. (2007). Phases and words. In S. Choe (Ed.), *Phases in the Theory of Grammar*, pp. 191–222. Seoul: Dong-In Publishing Co.
- Marinis, T. (1998). The acquisition of expletive definite articles in Modern Greek. In T. Cambier-Langeveld, A. Lipták, and M. Radford (Eds.), *ConSOLE VI: Proceedings of the 6th Conference of the Student Organization of Linguistics in Europe.*, Lisbon, pp. 169–184.
- Matushansky, O. (2002). More of a good thing: Russian synthetic and analytic comparatives. In J. Toman (Ed.), *Formal Approaches to Slavic Linguistics 10: The second Ann Arbor Meeting 2001*, Ann Arbor. Michigan Slavic Publications.

- Matushansky, O. (2013). More or better: on the derivation of synthetic comparatives and superlatives in English. In O. Matushansky and A. Marantz (Eds.), *Distributed morphology today: morphemes for Morris Halle*, pp. 59–78. Cambridge, MA: The MIT Press.
- Matushansky, O. and T. Ionin (2011). More than one solution. In *Proceedings of the 47th Annual Meeting of the Chicago Linguistic Society*, Volume 1, Chicago, Ill., pp. 231–245. Chicago Linguistic Society.
- Mendia, J. A. (2013). Phrasal and Clausal Comparatives. The de/que alternation in Spanish.
- Merchant, J. (2009). Phrasal and clausal comparatives in Greek and the abstractness of syntax. *Journal of Greek Linguistics* 9(1), 134–164.
- Merchant, J. (2012). The two phrasal comparatives of Greek.
- Meyers, A., C. Macleod, and R. Grishman (1996). Standardization of the Complement/Adjunct Distinction. In M. Gellerstam, J. Järborg, S.-G. Malmgren, K. Norén, L. Rogström, and C. R. Papmehl (Eds.), *Euralex '96 Proceedings: Papers submitted to the Seventh EURALEX International Congress on Lexicography in Göteborg, Sweden.*, Volume Part I, Göteborg, pp. 141–150. Göteborg University: Göteborg University.
- Michelioudakis, D. (2011). The split identity of genitive in Modern Greek: evidence from 'datives' in APs/NPs. In *Proceedings of the 2nd Patras International Conference of Graduate Students in Linguistics*, Patras, pp. 105–111.
- Michelioudakis, D. (2012). *Dative Arguments and Abstract Case in Greek*. Phd, University of Cambridge.
- Milner, J. C. (1973). *Arguments linguistiques*. Repères. Série bleue. Linguistique, 2. Paris: Mame.
- Morzycki, M. (2011). Metalinguistic comparison in an alternative semantics for imprecision. *Natural Language Semantics* 19(1), 39–86.
- Napoli, D. J. (1983). Comparative Ellipsis: A phrase structure analysis. *Linguistic Inquiry* 14(4), 675–694.
- Napoli, D. J. and M. Nespors (1976). Negatives in Comparatives. *Language* 52(4), 811–838.
- Napoli, D. J. and M. Nespors (1986). Comparative Structures in Italian. *Language* 62(3), 622–653.
- Neeleman, A., H. van de Koot, and J. Doetjes (2004). Degree expressions. *The Linguistic Review* 21(1), 1–66.
- Newton, B. (1972). *The Generative Interpretation of Dialect: A study of modern Greek phonology*. Cambridge: Cambridge University Press.
- Oda, T. (2008). *Degree constructions in Japanese*. Phd, University of Connecticut.
- Oxford, W. (2010a). Same, different and other: a first look at the microsyntax of identity adjectives. In M. Heijl (Ed.), *Proceedings of the 2010 annual conference of the Canadian Linguistic Association*.

- Oxford, W. (2010b). *Same, different, and other: The microsyntax of identity adjectives*. Phd generals paper, University of Toronto.
- Pancheva, R. (2004). Balkan possessive clitics. In O. Mišeska Tomić (Ed.), *Balkan Syntax and Semantics*, *Linguistik Aktuell/Linguistics Today* 67, pp. 175–220. Amsterdam/Philadelphia: John Benjamins Publishing Company.
- Pancheva, R. (2006). Phrasal and Clausal Comparatives in Slavic. In J. E. Lavine, S. Franks, and M. Tasseva-Kurktchieva (Eds.), *Formal Approaches to Slavic Linguistics 14: The Princeton Meeting*, Ann Arbor, pp. 236–257. University of Michigan: Michigan Slavic Publications.
- Pancheva, R. (2009). More students attended FASL than ConSOLE. In W. Browne (Ed.), *Formal Approaches to Slavic Linguistics 18: The Cornell Meeting, 2009*, New York, NY, pp. 382–399. Cornell University: ACM Digital Library.
- Pancheva Izvorski, R. (2000). *Free relatives and related matters*. Phd, University of Pennsylvania.
- Panzeri, F. (2006). Subjunctive Relative Clauses. In P. Denis, E. McCready, A. Palmer, and B. Reese (Eds.), *Proceedings of the 2004 Texas Linguistics Society Conference: Issues at the Semantics-Pragmatics Interface*, Somerville, MA, pp. 60–68. University of Texas at Austin: Cascadilla Proceedings Project.
- Pesetsky, D. (2000). *Phrasal movement and its kin*. Cambridge, MA: MIT Press.
- Pinkal, M. (1989). Die semantik von satzkomparativen. *Zeitschrift für Sprachwissenschaft* 8(2), 206–256.
- Pinkham, J. (1982). *The Formation of Comparative Clauses in French and English*. Phd, Harvard University.
- Postal, P. M. (1974). On certain ambiguities. *Linguistic Inquiry* 5, 367–425.
- Price, S. (1990). *Comparative Constructions in Spanish and French Syntax*. London: Routledge.
- Qing, C. and M. Franke (2014). Gradable adjectives, vagueness, and optimal language use: A speaker-oriented model. *Semantics and Linguistic Theory* 23-41, 24.
- Research Center for Modern Greek Dialects and Idioms - I.L.N.E. The Modern Greek Dialects.
- Rett, J. (2008). *Degree modification in natural language*. Phd, Rutgers University.
- Rett, J. (2014). The polysemy of measurement. *Lingua* 143, 242–266.
- Rett, J. (2018). The semantics of many, much, few, and little. *Language and Linguistics Compass* 12(1), e12269.
- Rett, J. (*in prep.*). Consequences of an implicature-based account of evaluativity.
- Revithiadou, A. and V. Spyropoulos (2008). Greek object clitic pronouns: A typological survey of their grammatical properties. *STUF - Language Typology and Universals* 61, 39–53.

- Rizzi, L. (1990). *Relativised Minimality*. Cambridge, MA: MIT Press.
- Rizzi, L. (1996). Residual verb second and the wh-criterion. In A. Belletti and L. Rizzi (Eds.), *Parameters and functional heads*, Chapter 2, pp. 63–90. Oxford: Oxford University Press.
- Roberts, I. and A. Roussou (2003). *Syntactic change: A minimalist approach to grammaticalization*. Cambridge Studies in Linguistics 100. Cambridge: Cambridge University Press.
- Romero, M. (2015). The Conservativity of *many*. In T. Brochhagen, F. Roelofsen, and N. Theiler (Eds.), *Proceedings of the 20th Amsterdam Colloquium*, Amsterdam, pp. 20–29. University of Amsterdam.
- Ross, J. R. (1980). No Negative in Than-Clauses, More often than Not. *Studies in Language* 4, 119–123.
- Ross, J. R. (1984). Inner Islands. In C. Brugmann and M. Macaulay (Eds.), *Proceedings of the Tenth Annual Meeting of the Berkeley Linguistic Society*, Berkeley, CA. Berkeley Linguistic Society.
- Rullmann, H. (1995). *Maximality in the Semantics of WH-Constructions*. Phd, University of Massachusetts, Amherst.
- Russell, B. (1905). On Denoting. *Mind* XIV(4), 479–493.
- Sabel, J. (2000). Expletives as features. In R. Billerey and B. D. Lillehaugen (Eds.), *WCCFL 19: Proceedings of the 19th West Coast Conference on Formal Linguistics*, Somerville, Mass., pp. 411–424. UCLA: Cascadilla Press.
- Schlenker, P. (2018, aug). Iconic pragmatics. *Natural Language & Linguistic Theory* 36(3), 877–936.
- Schwarzschild, R. (2005). Measure phrases as modifiers of adjectives. *Recherches linguistiques de Vincennes* 34, 207–228.
- Schwarzschild, R. (2008). The Semantics of Comparatives and Other Degree Constructions. *Language and Linguistics Compass* 2(2), 308–33.
- Schwarzschild, R. (2010). Comparative Markers and Standard Markers. In M. Y. Erlewine and Y. Sudo (Eds.), *Proceedings of the MIT workshop on comparatives*, Cambridge, MA, pp. 87–105. MIT: MITWPL.
- Schwarzschild, R. (2012, apr). Directed Scale Segments. *Semantics and Linguistic Theory* 22, 65.
- Schwarzschild, R. and K. Wilkinson (2002). Quantifiers in Comparatives: A semantics of Degree Based on Intervals. *Natural Language Semantics* 10(1), 1–41.
- Schwyzer, E. (2002). Η Σύνταξη της αρχαίας Ελληνικής Γλώσσας [*I Sintaxi tis Arheas Elinikis Ghlosas*], Volume 2. Athens: Papademas.
- Scontras, G., J. Degen, and N. D. Goodman (2017). Subjectivity Predicts Adjective Ordering Preferences. *Open Mind* 1(1), 53–66.

- Scott, G. (2002). Stacked adjectival modification and the structure of nominal phrases. In G. Cinque (Ed.), *Functional Structure in DP and IP: The cartography of syntactic structures*, pp. 91–120. Oxford: Oxford University Press.
- Seuren, P. A. (1973). The comparative. In F. Kiefer and N. Ruwet (Eds.), *Generative Grammar in Europe.*, pp. 528–564. Dordrecht: Reidel.
- Seuren, P. A. (1979). Meer over minder dan hoeft. *De Nieuwe Taalgids* 71(6), 236.
- Seuren, P. A. (1984). The Comparative Revisited. *Journal of Semantics* 3(1-2), 109–141.
- Sheldon, E. K. (1945). The Rise of the Incomplete Comparative. *American Speech* 20(3), 161–167.
- Shimoyama, J. (2011). Clausal comparatives and cross-linguistic variation. In S. Lima, K. Mullin, and B. Smith (Eds.), *Proceedings of the 39th Meeting of the North East Linguistic Society (NELS39)*, Amherst, MA, pp. 677–690. Cornell University: GLSA (Graduate Linguistic Student Association), Dept. of Linguistics, South College, University of Massachusetts.
- Shimoyama, J. (2012). Reassessing crosslinguistic variation in clausal comparatives. *Natural Language Semantics* 20(1), 83–113.
- Snyder, E. and J. Barlew (2015). The universal measurer. In *Proceedings of Sinn und Bedeutung 20*, Tübingen, pp. 658–675. University of Tübingen.
- Snyder, W. (2007). *Child language: the parametric approach*. Oxford: Oxford University Press.
- Solt, S. (2009). *The Semantics of Adjectives of Quantity*. Phd, The City University of New York.
- Solt, S. (2015). Q-Adjectives and the Semantics of Quantity. *Journal of Semantics* 32(2), 221–273.
- Spyropoulos, V. (2007). Case conflict in Greek free relatives. In A. Alexiadou (Ed.), *Studies in the Morpho-Syntax of Greek*, pp. 294–313. Cambridge: Cambridge Scholars Publishing.
- Spyropoulos, V. (2011). Case conflict in Greek free relatives. In A. Galani, G. Hicks, and G. Tsoulas (Eds.), *Morphology and Its Interfaces*, pp. 21–56. Amsterdam-Philadelphia: John Benjamins.
- Stassen, L. (1984). The comparative compared. *Journal of Semantics* 3(1-2), 143–182.
- Stassen, L. (1985). *Comparison and Universal Grammar*. New York: Blackwell.
- Stavrou-Sifaki, M. (1985). Μερικές παρατηρήσεις για τὰ συμπληρώματα που ἔκφραζουν σύγκριση στὰ Νέα Ἑλληνικά [Some observations about the complements that express comparison in Modern Greek]. In *Studies in Greek Linguistics: Proceedings of the 3rd Annual Meeting of the Department of Linguistics, Faculty of Philosophy, Aristotelian University of Thessaloniki, 26–28 April 1982*, Thessaloniki, pp. 73–103. Aristotelian University of Thessaloniki: Aristotelian University of Thessaloniki.
- Svenonius, P. (2008). The position of adjectives and other phrasal modifiers in the decomposition of DP. In L. McNally and C. Kennedy (Eds.), *Adjectives and Adverbs: Syntax, Semantics, and Discourse*, Oxford Studies in Theoretical Linguistics, pp. 16–42. Oxford: Oxford University Press.

- Syrett, K. (2016). Acquisition of Comparative and Degree Constructions. In J. Lidz, W. Snyder, and J. Pater (Eds.), *Oxford Handbook of Developmental Linguistics.*, pp. 463–497. Oxford: Oxford University Press.
- Szabolcsi, A. (1992). Weak Islands, Individuals, and Scope. *Semantics and Linguistic Theory 2*, 407–438.
- Szabolcsi, A. and F. Zwarts (1991). Unbounded dependencies and algebraic semantics. In *Third European Summer School in Language, Logic and Information*. University of Saarbrücken.
- Szabolcsi, A. and F. Zwarts (1993). Weak islands and an algebraic semantics for scope taking. *Natural Language Semantics 1*(3), 235–284.
- Terzi, A. (2005). Locative prepositions as possessums. In M. Mattheoudakis and A. Psaltou-Joycey (Eds.), *Selected papers from the 16th international symposium on Theoretical and Applied Linguistics*, Thessaloniki, pp. 132–144. Aristotle University.
- Terzi, A. (2007). Locative prepositions, predicate inversion and Full Interpretation. In E. Agathopoulou, M. Dimitrakopoulou, and D. Papadopoulou (Eds.), *Selected papers from the 17th international symposium on Theoretical and Applied Linguistics*, Thessaloniki. Aristotle University.
- Terzi, A. (2010). Locative Prepositions and Place. In G. Cinque and L. Rizzi (Eds.), *Mapping Spatial PPs: The Cartography of Syntactic Structures, Volume 6*, Oxford Studies in Comparative Syntax, pp. 196–225. Oxford: Oxford University Press.
- Theophanopoulou-Kontou, D. (1992). The complex prepositional phrases of modern greek and their structure [οι σύνθετες προθετικές φράσεις της νέας ελληνικής και η δομή τους]. In *Studies in Greek Linguistics. Proceedings of the 13th Annual Meeting of the Department of Linguistics*, Thessaloniki, pp. 311–331. University of Thessaloniki.
- Theophanopoulou-Kontou, D. (2000). Locative adverbs and “Case” in Greek: A diachronic approach [Τοπικά επιρρήματα και ‘Πτώση’ στην Ελληνική: Διαχρονική προσέγγιση]. *Glossologia 11-12*, 1–40.
- Theophanopoulou-Kontou, D. (2014). Προτασιακές Συγκριτικές Δομές της Νέας Ελληνικής: Οι δείκτες απ’ όσο(ς), απ’ ό,τι (Modern Greek Clausal comparative constructions: The markers *ap’osos*, *ap’oti*). In G. Kotzoglou, K. Nikolou, E. Karantzola, K. Frantzi, I. Galantomos, M. Georgalidou, V. Kourti-Kazoullis, C. Papadopoulou, and E. Vlachou (Eds.), *Selected Papers of the 11th International Conference on Greek Linguistics, (Rhodes, 26–29 September 2013)*, Rhodes, pp. 512–523. University of the Aegean: Laboratory of Linguistics of the Southeastern Mediterranean.
- Tredinnick, V.-A. (2005). *On the semantics of Free Relatives with -ever*. Ph. D. thesis, University of Chicago.
- Trudgill, P. (2003). Modern Greek dialects: A preliminary classification. *Journal of Greek Linguistics 4*(1), 45–63.

- Truswell, R. (2009). Attributive Adjectives and Nominal Templates. *Linguistic Inquiry* 40(3), 525–533.
- Ultan, R. (1972). Some features of Basic Comparative Constructions. *Working Papers on Language Universals* 9, 117–162.
- Vlachou, E. (2003). Greek universal concessive conditionals. In *Proceedings of the 6th International Conference of Greek Linguistics*.
- Vlachou, E. (2004). Greek bare wh-items: evidence from *otan* and *opote*. *Studies in Greek Linguistics* 24, 728–738.
- Vlachou, E. (2005). The semantic properties of a definite maximal item in Modern Greek. In M. Mattheoudakis and A. Psaltou-Joycey (Eds.), *Selected papers from the 16th international symposium on Theoretical and Applied Linguistics*, Thessaloniki, pp. 203–220. Aristotle University of Thessaloniki.
- von Stechow, K. and S. Iatridou (2007, jul). Anatomy of a Modal Construction. *Linguistic Inquiry* 38(3), 445–483.
- von Stechow, A. (1984). Comparing Semantic Theories of Comparison. *Journal of Semantics* 3(1-2), 1–77.
- Wellwood, A., V. Hacquard, and R. Pancheva (2012). Measuring and comparing individuals and events. *Journal of Semantics* 29(2), 207–228.
- Whitlam, J. (2011). *Modern Brazilian Portuguese Grammar: a practical guide*. London: Routledge.
- Williams, E. S. (1974). *Rule ordering in syntax*. Phd, Massachusetts Institute of Technology.
- Wouden, T. V. D. (1994). Polarity and 'Illogical Negation'. In M. Kanazawa and C. J. Pinon (Eds.), *Dynamics, Polarity, and Quantification*, pp. 17–45. Stanford: CSLI Publications.
- Yoon, S. (2011a). Metalinguistic Comparatives: from Greek to Korean. In K. Chatzopoulou, A. Ioannidou, and S. Yoon (Eds.), *Proceedings of the 9th International Conference on Greek Linguistics*, Chicago, ILL, pp. 287–300. University of Chicago and Ohio State University.
- Yoon, S. (2011b). *'Not' in the Mood: The Syntax, Semantics, and Pragmatics of Evaluative Negation*. Ph. D. thesis, The University of Chicago, Chicago.
- Yoon, S. (2011c). Rhetorical comparatives: Polarity items, expletive negation, and subjunctive mood. *Journal of Pragmatics* 43(7), 2012–2033.
- Zeijlstra, H. (2008). On the syntactic flexibility of formal features. In T. Biberauer (Ed.), *The limits of syntactic variation*, pp. 143–173. Amsterdam: John Benjamins.
- Zeijlstra, H. (2009). Dislocation effects, uninterpretable features, functional heads, and parametric variation: Consequences of conflicting interface conditions. In K. Grohmann (Ed.), *Interphases: Phase-theoretic investigations of linguistic interfaces*, pp. 82–113. Oxford: Oxford University Press.

Zwarts, F. (1995). Nonveridical contexts. *Linguistic Analysis* 25(3-4), 286–312.