

CLOTHWORKERS' LIBRARY  
UNIVERSITY OF LEEDS

TWIST CHANGES IN THREADLINES MOVING  
OVER SURFACES

A thesis presented for the degree of  
Doctor of Philosophy

by

AHMAD ELSAYED <sup>9</sup>ELTAHAN  
<sub>2</sub>

being an account of the work carried out under the  
supervision of Dr. M.J. Denton, B.Sc., D.Sc., C.Text.,  
F.T.I., F.Inst.P.

Department of Textile Industries  
The University  
Leeds LS2 9JT.

CLASS MARK

**IN THE NAME OF ALLAH, THE BENEFICIENT,**

**THE MERCIFUL.**

## ACKNOWLEDGEMENTS

It is a pleasure to record my sincere gratitude to Dr. M.J. Denton, B.Sc., D.Sc., C.Text., F.T.I., F.Inst.P., for his continued advice, unlimited help and encouragement throughout the direction of this work.

I am also grateful to Professor P. Grosberg, Head of the Department of Textile Industries, for financial assistance.

My thanks are also due to Mr. G.A.V. Leaf for valuable discussions concerning various aspects of the work.

Special thanks are also due to Mrs. McClelland for her understanding, encouragement and help through the difficult periods of my stay at Leeds University.

Thanks are also due to Mrs. McOwat for the time she spent typing this thesis.

I would like to take this opportunity to express my sincere gratitude to Dr. Ahmad S.E. Deeb, Dr. Ahmad Y. Abd-Allah, and Dr. Mazin A.E. Balila for their constant financial and moral support. Without their support it would have been impossible to complete this work.

ABSTRACT

An investigation has been carried out into the twist blockage which may occur when yarns pass over guides or other surfaces.

The influence of primary physical parameters such as surface curvature, arc and length of contact, yarn twist level and tension and yarn/surface friction have been investigated together with secondary parameters such as yarn surface, pressure, angle of approach etc.

As a result of these investigations, three mechanisms of blockage have been identified. The first of these occurs especially with doubled yarn in which the components lie side by side on the guide surface and blocked twist builds up until sufficient torque is developed to turn the yarn over against the couple generated by the components of yarn tension and reaction on the guide surface.

In the second mechanism blocking torque is generated by components of friction on the yarn surface at right angles to the yarn axis. These orthogonal friction components may arise from interaction between the topography of the twisted yarn surface and the guide surface or may be generated by forces arising from an angular orientation of yarn to guide.

The third mechanism is intermediate between the other two where a single yarn (or its equivalent) is flattened on the surface and resistance to twist transmission is generated partly by internal friction within the yarn and partly by yarn/guide frictional forces.

The main circumstances under which these different mechanisms may operate, have been identified and suggestions made for minimising the blockage of twist.

## CONTENTS

	<u>Page</u>
CHAPTER 1 GUIDES AND TEXTILE MANUFACTURING	1
1.0 Introduction	2
1.1 What is twist blockage?	8
CHAPTER 2 TWIST BLOCKAGE IN INDUSTRIAL YARN AND FABRIC PROCESSING	14
2.1 Yarn manufacturing	15
2.1.1 Winding	15
2.1.2 Ring spinning	15
2.1.3 Repco spinning	20
2.1.4 O.E. spinning	20
2.1.5 Two-for-one twister	22
2.1.6 False-twist texturing	25
2.2 Fabric manufacture and other processes	28
2.2.1 Warping	28
2.2.2 Warp sizing	29
2.2.3 Weaving	30
2.2.4 Sewing	31
✓ 2.2.5 Tension measurement	33
2.3 Possible effects of twist blockage in finishing of woven fabric	33
2.3.1 Effect of twist in yarns	33
2.3.2 Scouring of fabric	34
2.3.2.1 Rope scouring machine	34
2.3.3 Mercerization	34
2.3.4 Bleaching	35
2.4 Summary and discussion	36

	<u>Page</u>
CHAPTER 3 SURVEY OF LITERATURE RELATING TO TWIST BLOCKAGE	39
3.1 Introduction	40
3.2 Factors affecting twist congestion	40
3.2.1 Downstream twist congestion in non-rotating threadlines	40
3.2.1.1 Introduction	40
3.2.1.2 Effect of guide size (diameter)	40
3.2.1.3 Effect of guide shape	43
3.2.1.4 Effect of angle of deflection	45
3.2.1.5 Effect of input twist	46
✓3.2.1.6 Effect of the initial tension	48
3.2.1.7 Twist congestion in the rope processing of fabrics	50
3.2.2 Upstream twist congestion in rotating threadlines	52
3.2.2.1 Introduction	52
3.2.2.2 Effect of angle of deflection	53
3.2.2.3 Effect of guide diameter	56
3.2.2.4 Effect of input twist	57
✓3.2.2.5 Effect of draw ratio (pre-tension)	60
3.2.3 Downstream twist blockage in a rotating threadline	61
3.2.3.1 Repco self-twisted yarn (STY)	61
3.2.3.2 O.E. spinning	62
3.2.4 Simultaneous upstream and downstream twist movement	62
3.3 Discussion	66
3.4 Scope and objective of the present work	69
CHAPTER 4 APPARATUS AND TECHNIQUES	72
4.1 Description of the apparatus	73
✓4.1.1 Tension device	73
4.1.2 Magnetic gripper attachments	73

CHAPTER 4 (continued)	<u>Page</u>
4.1.3 Yarn guides	75
4.1.4 Guide assembly	78
4.1.5 Low friction pulleys	78
4.1.6 Measuring the angle of wrap	78
4.1.7 Adjusting the angle of orientation	80
4.1.8 Driving unit	84
4.1.9 The yarn suction unit	84
4.2 Yarn used in the experiments and twist insertion	86
4.3 Yarn testing technique	88
4.3.1 Method of twist testing	88
4.3.2 Number of samples	90
✓ 4.4 Tension measurement	91
4.4.1 The measuring head (H)	91
4.4.2 The indicator apparatus (R-T)	92
4.4.3 The microprocessor voltmeter	93
4.4.4 Simultaneous tension measurement	94
4.4.5 Function command circuit	95
4.4.6 Power supply	98
4.4.7 Circuit operation	98
4.5 Simultaneous measurement of the coefficient of friction	100
 CHAPTER 5 EXPERIMENTAL OBSERVATION OF TWIST BLOCKAGE	 101
5.1 Outline of the experimental work	102
5.2 Preliminary investigation	103
5.3 Effect of length of yarn before contact surface on twist blockage	103
5.3.1 Observations	104
5.3.2 Results	105
5.4 Effect of angle of wrap on twist blockage	105
5.4.1 Experiments and results	105
5.4.2 Discussion	110



## CHAPTER 5 (continued)

Page

✓ 5.5	The relation between the twist blockage, tension and pressure	112
5.5.1	Effect of initial pressure with variable guide diameter at various levels of initial tension	113
5.5.2	Effect of initial pressure with variable initial tension at various guide diameters	116
5.5.3	Effect of initial tension at various levels of initial pressure	122
5.5.4	Effect of guide diameter on twist blockage at various levels of initial pressure	122
5.6	Relation between arc of contact and twist blockage	125
5.6.1	Observations	126
5.6.2	Effect of arc of contact at various angles of wrap	128
5.6.3	Effect of arc of contact at various guide diameters	128
5.6.4	Conclusions	131
✓ 5.7	Effect of pressure	132
5.7.1	Effect of initial pressure	133
5.7.1.1	Discussion	136
5.7.2	Effect of mean and final pressure	138
5.7.3	Conclusions	139
5.8	Effect of length of one turn	144
5.8.1	Results	147
5.8.2	Discussion	155
5.9	Effect of angle of wrap at constant mean pressure and arc of contact	156
5.9.1	Results	156
5.9.2	Effect of frictional force over the contact region	160
5.9.3	Conclusions	160
5.10	Effect of length of contact at constant mean pressure	162

CHAPTER 5 (continued)	<u>Page</u>
5.10.1 Results	164
5.10.2 Effect of angle of wrap and guide radius	169
5.11 Effect of forces causing yarn rotation and yarn behaviour over the contact surface	173
5.11.1 Results	174
5.12 Forces causing yarn displacement	183
5.13 Effect of number of contact points on reaction force $\xi$	186
5.14 Relationship between twist accumulation and torque required to release blocked twist	188
5.14.1 Effect of $1/\sqrt{R}$ and $T_i$ on twist accumulation and the theoretical torque required	196
5.14.2 Initial input twist and twist blockage torque relationship	197
5.14.3 Discussion	203
 CHAPTER 6 YARN ORIENTATION OVER THE CONTACT SURFACE	 208
6.1 Introduction	209
6.2 Effect of yarn orientation on twist blockage	209
6.2.1 Definition of angle of orientation	210
6.2.2 Preliminary observations	213
6.2.3 General observations	213
6.2.4 Effect of angle of orientation on twist blockage	214
6.2.4.1 Effect of the mean pressure on twist gain	218
6.2.4.2 Effect of length of contact	221
6.2.4.3 Effect of frictional force	221
6.3 Effect of angle of orientation on twist blockage for S and Z yarn twist	226
6.3.1 Discussion	233
6.4 The effect of singles twist	235
6.4.1 Discussion	239

CHAPTER 6 (continued)	<u>Page</u>
6.5 Effect of the surface direction of the fibres of the singles relative to the yarn axis	240
6.5.1 Results and discussion	240
6.6 Conclusions	244
6.6.1 Mechanical interpretation	246
6.7 Effect of single's twist with the same and opposite doubling twists	251
6.7.1 Results for (ZZ)Z and (SS)S yarns	252
6.7.2 Results for (SS)Z and (ZZ)S yarns	256
6.7.3 Discussion	256
6.8 Conclusions	259
6.9 Twist blockage mechanism in terms of the angle of orientation	262
6.10 Comparison of twist blockage behaviour of spun staple and continuous filament yarn	265
6.10.1 Effect of singles twist factor	266
6.10.2 Effect of plied twist factor	269
6.10.3 Results	269
6.11 Discussion	271
6.12 An interpretation of visual observations	274
6.13 Conclusions	275
6.14 Effect of deflection angle $\theta^0$ on twist blockage at constant arc of contact, mean pressure, and angle of orientation, $\beta$	277
6.14.1 Results and discussion	277
6.15 Effect of $\beta$ on twist blockage at different levels of angle of wrap $\theta$	279
6.15.1 Results	281
6.15.1.1 Effect of $\beta$ on twist blockage in terms of length of arc of contact	284
6.16 Effect of angle of orientation on twist blockage at constant frictional force over the contact region	287

	<u>Page</u>
CHAPTER 6 (continued)	
6.17 Discussion	291
6.18 Effect of angle of orientation at constant mean pressure and constant length of arc of contact	291
6.18.1 Results and discussion	292
6.19 Final conclusions	296
CHAPTER 7 SUMMARY AND CONCLUSIONS	297
7.1 Summary and conclusions	298
7.2 Final summary	306
7.3 Future work	307
REFERENCES	310
APPENDICES	316
APPENDIX I	
1. A derivation of capstan friction with reference to the frictional angle over the contact surface	317
2. Estimation of the radius of curvature at angles of orientation $\neq 90^\circ$	320
APPENDIX II A brief outline of a theory of twist blockage	324

MAJOR SYMBOLS USED

$T$	= local yarn tension	(gf)
$T_i$	= initial yarn tension	(gf)
$T_o$	= outgoing yarn tension	(gf)
$P$	= local, normal force/unit length (local pressure)	(gf/cm)
$P_i$	= initial, normal force/unit length (initial pressure)	(gf/cm)
$P_m$	= mean linear pressure	(gf/cm)
$P_f$	= maximum (final) linear pressure	(gf/cm)
$F$	= frictional drag	(gf)
$K$	= multi-coefficient of friction	(m.c.f.)
$n$	= friction index of yarn surface	
$m$	= friction coefficient of contact surface	
$R$	= guide radius	(cm)
$D$	= guide diameter	(cm)
$N_o$	= nominal yarn twist	(t/m)
$N_B$	= twist before the contact surface	(t/m)
$N_A$	= twist after the contact surface	(t/m)
$N$	= twist gain ( $N_B - N_A$ )	(t/m)
$S$	= length of arc of contact	(cm)
$L_o$	= length of one turn	(cm)
$C$	= torque	( $\mu.N.m$ )
$\beta$	= angle of orientation	(degrees)
$\phi$	= angle of friction	(radian)

GI = torsional stiffness (N/radian)

$\theta$  = angle of wrap (radian)

$D_y$  = yarn diameter (cm)

r = yarn radius (cm)

CHAPTER 1

GUIDES AND TEXTILE MANUFACTURING

## 1.0 Introduction

Textile guides are widely used in most textile manufacturing processes. The greater number are used as yarn guides.

Yarn, after it is first produced by twisting staple fibre together in spinning or by extrusion, usually has to be processed through one or more further steps to convert it into a useful product.

In yarn production and subsequent processes, the yarn may have to move through a relatively long machine path and usually will have to change its direction with the help of yarn guides. Plate 1.1, Figs. 1.1, 1.2, 1.3, 1.4 illustrate changes of direction of yarn path for several different yarn processes.

Guides may be of two types: stationary or rotating. With stationary guides the most commonly used, the yarn simply slides over its surface. With rotating guides, there is no slip between yarn and guide as the latter rotate freely like a pulley wheel. Although the traveller in ring spinning or the sapphire pin in the twist tube of the false twisting process are in motion, the yarn slides on their surface so they may effectively operate as stationary guides.

Obviously, the reaction of a yarn passing over guides may be sensitive to the guide surface finish, curvature, arc of contact, yarn speed, initial tension, amount and viscosity of any lubricant and the yarn twist level. In addition to this, the properties of guide materials can be a very important factor governing the yarn quality. Friction between yarn and guides, for example, can cause either damage to the guide, or an abrasion to the yarn or may change the twist regularity of the yarn [1,2].



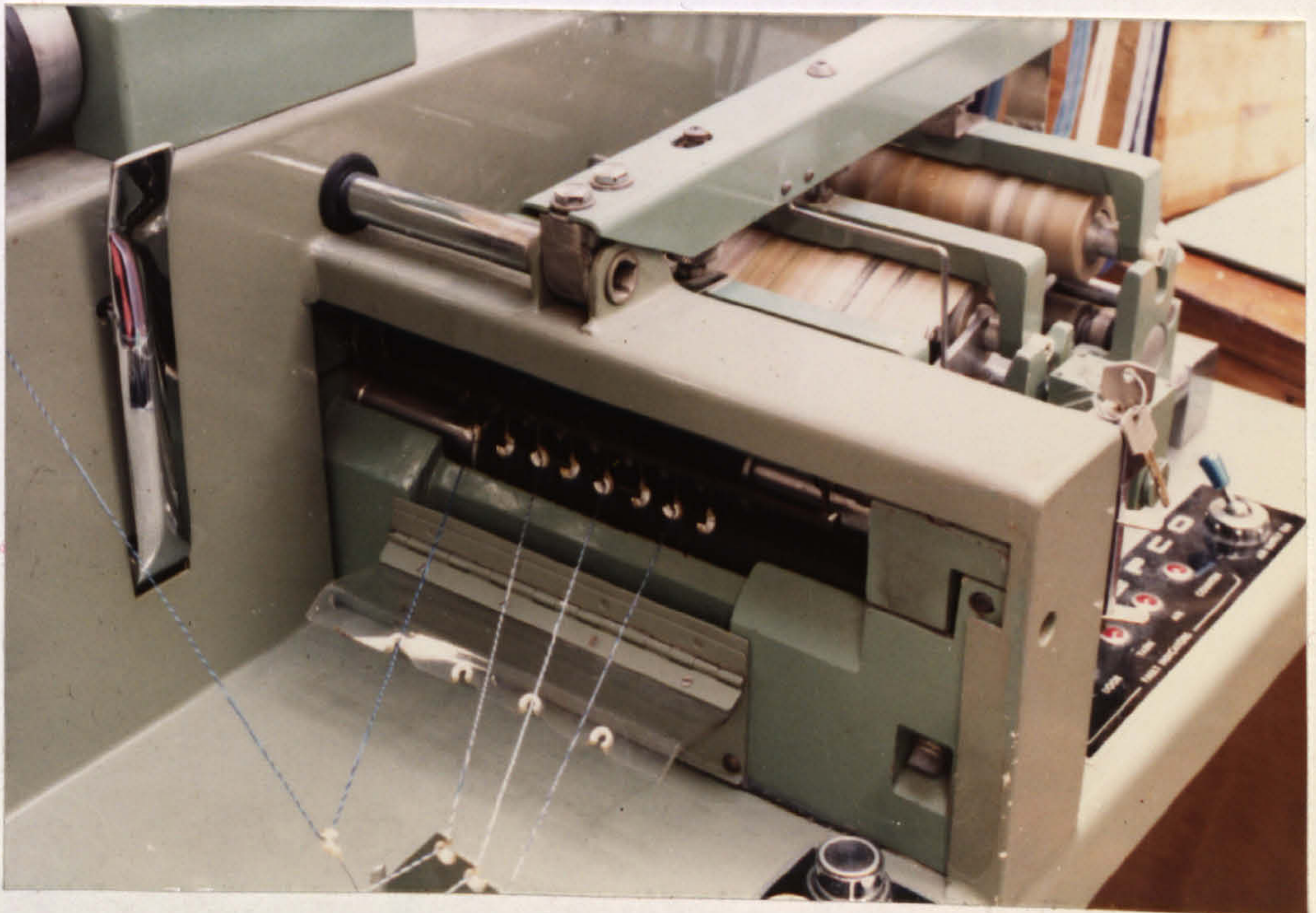
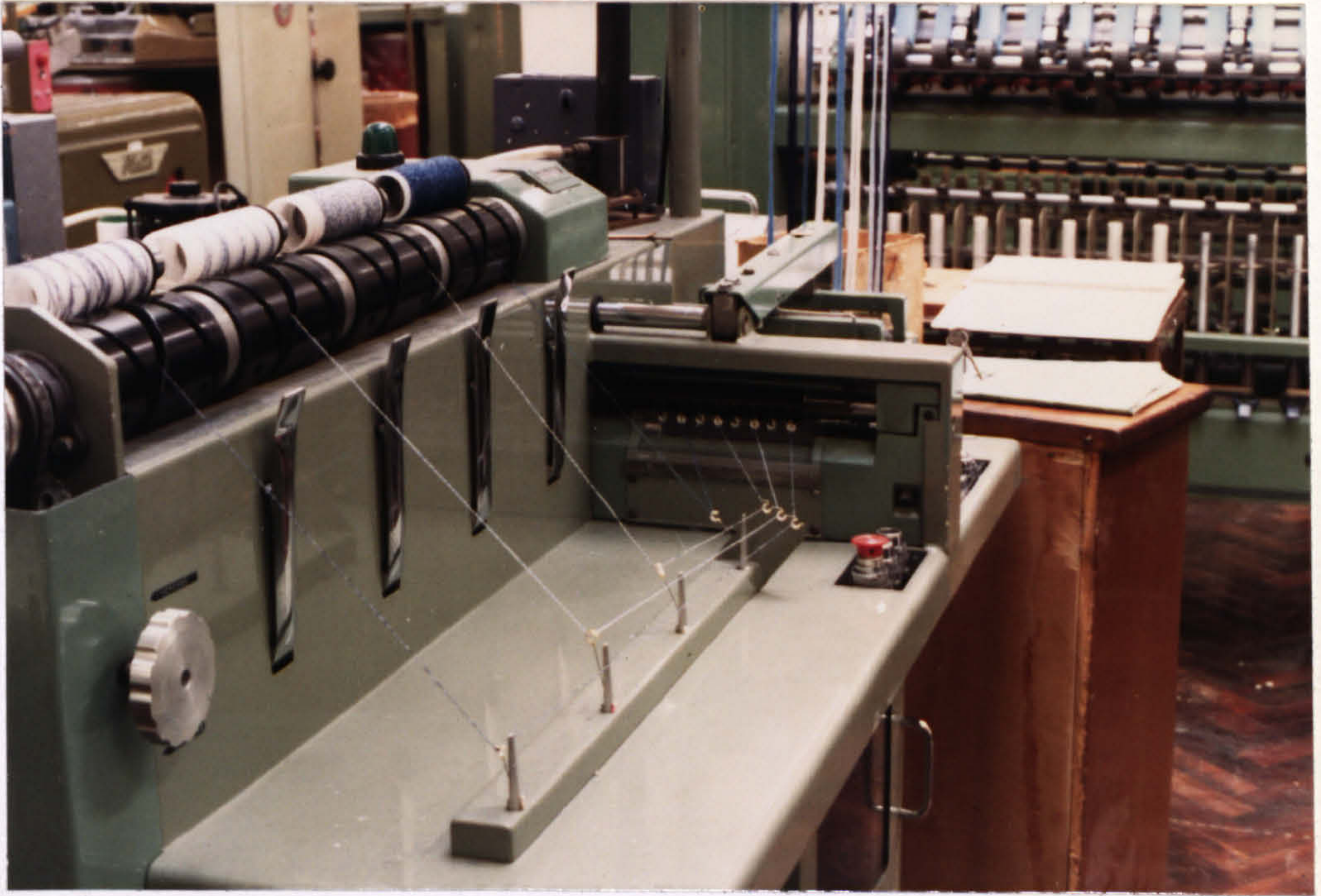

General arrangement of the self-twist  
(RepcO) threadline

FIG. 1.1: Yarn path of Bentley's ST4 single jersey machine

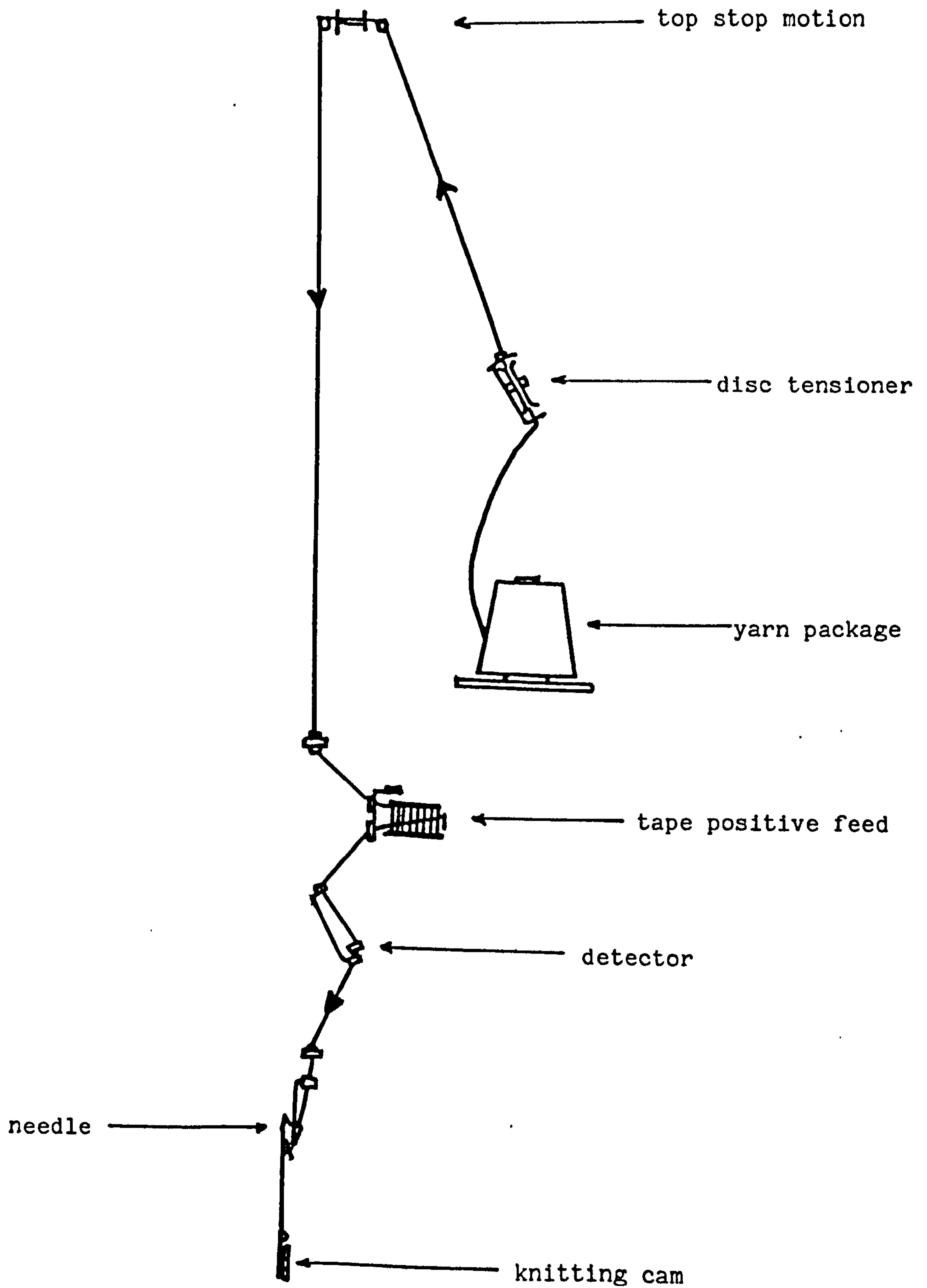

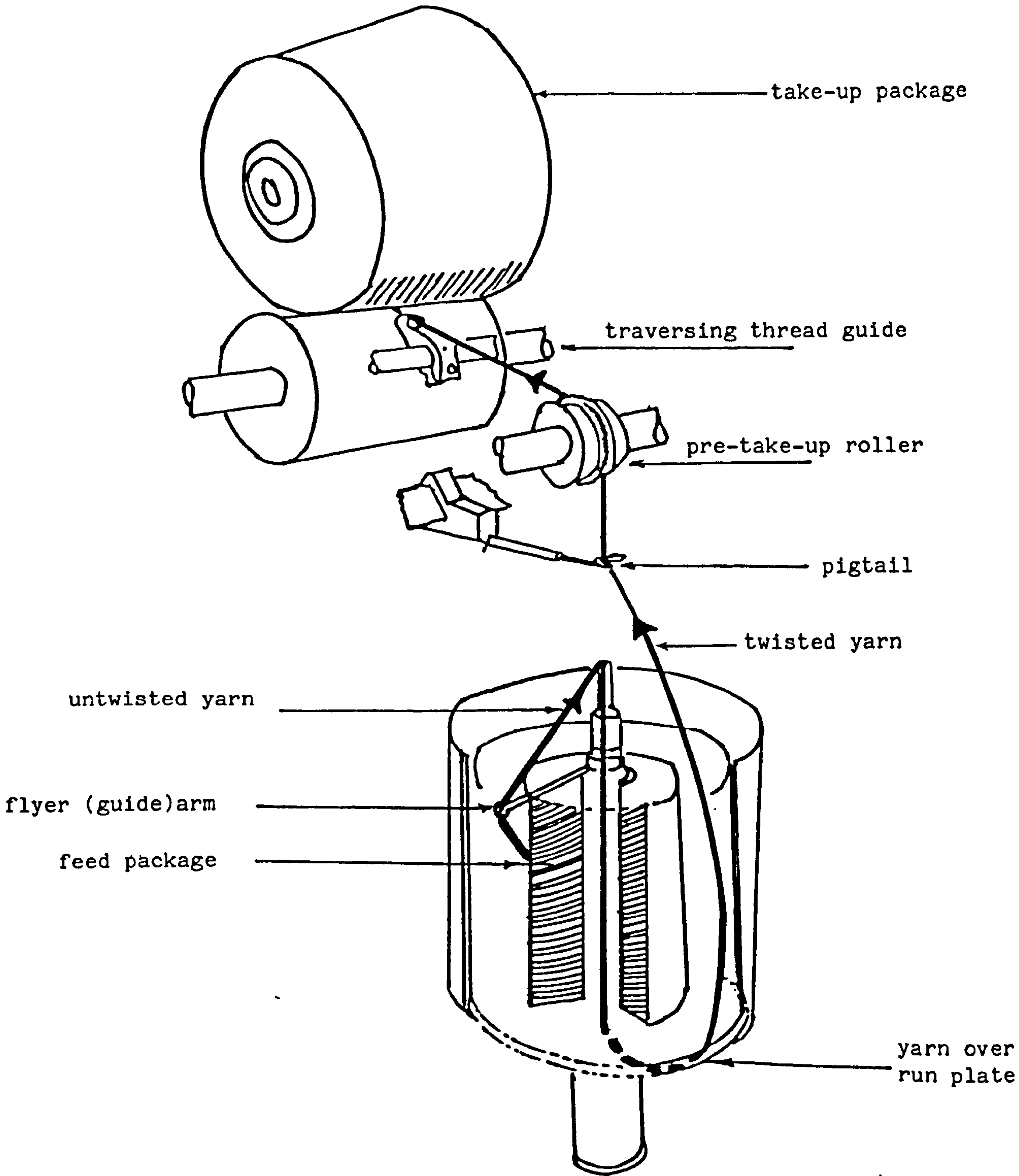

FIG. 1.2: Volkmann VTS-07 two-for-one spindle

1. Creel
2. Input feed system
3. Vapour-phase primary heater
4. Cooling zone
5. Positorq MK2 friction twist units
6. Feed system
7. Final heater
8. Output feed system with yarn transverse
9. Three tier take-up
10. Yarn oiling

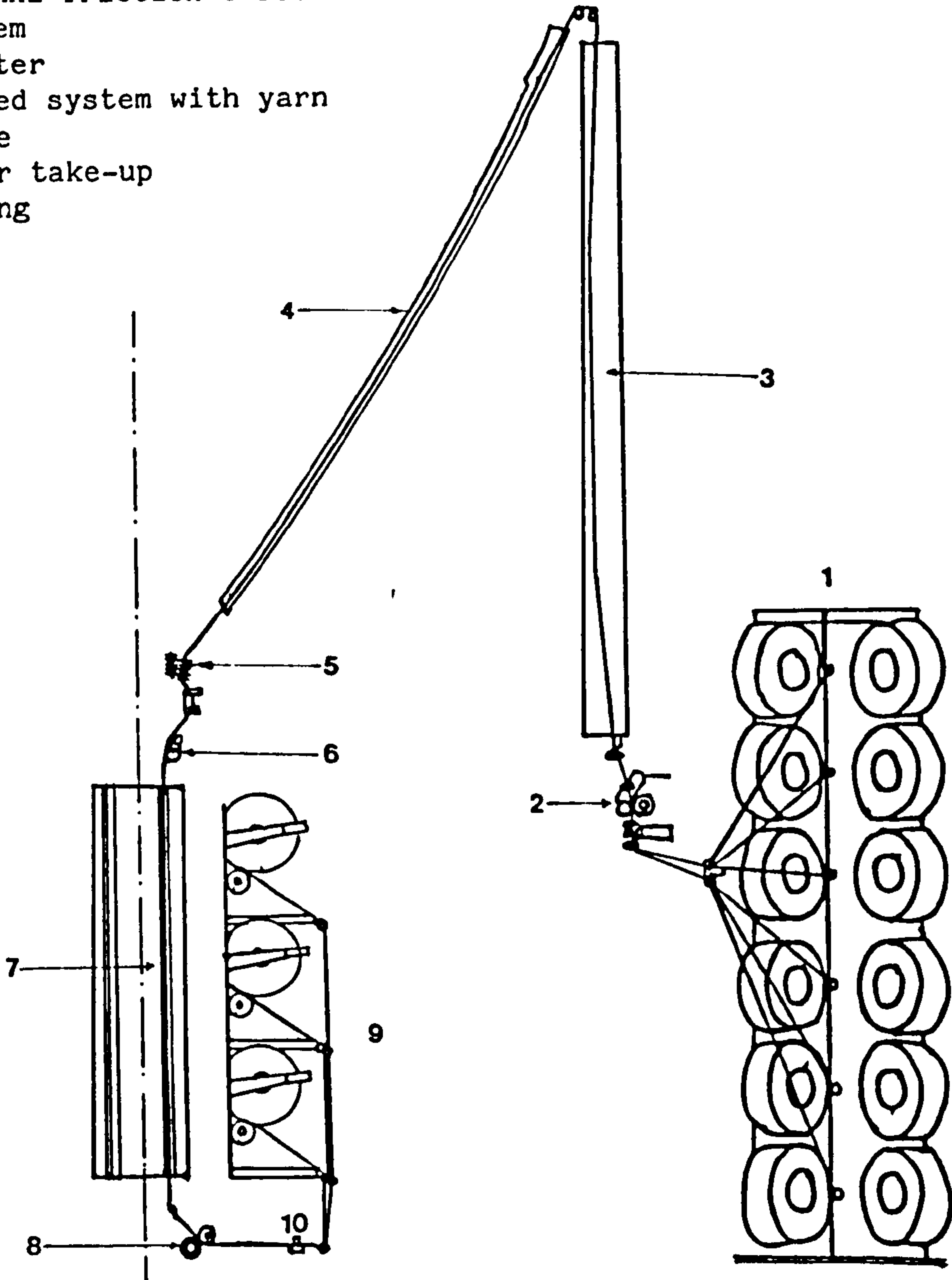

FIG. 1.3: False-twist texturing: threadline diagram (Rieter-Scragg SDS8 machine)

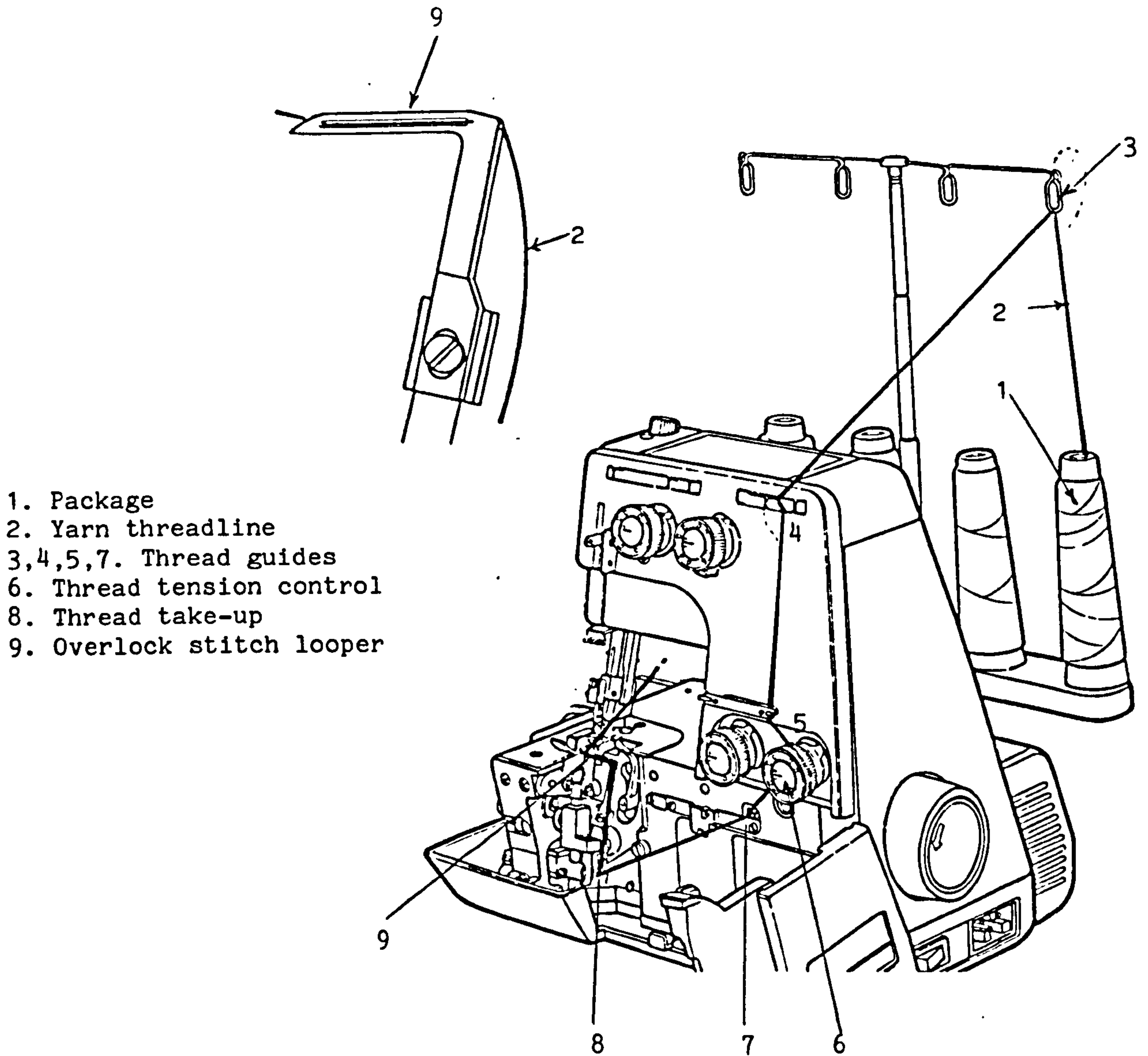

FIG. 1.4: General arrangements of the overlock (Frister-Lock 4 machine) threadline

From these observations and other examples discussed in the next chapter, it will be seen that when a yarn is drawn over a guide surface, a number of phenomena may occur. The tension ratio across the guide increases, heat is generated due to the friction, the guide may act as a barrier to twist, and damage may be caused to the fibres or filaments.

In fact, much has been reported concerning the friction and wear aspects of yarn moving over guides, but most of these studies have been concerned with the effects of yarns on guides rather than the effect of guides on yarns. Thus in some of the most recent studies [3] it has been shown that there is a significant relationship between the structure or geometry of the yarn and the wear patterns they generate on surfaces over which they pass.

On the other hand, little attention has been devoted to the influence of contact with surfaces on the structure and properties of yarns. It is one aspect of this: the phenomenon of twist blockage or twist congestion which is the subject of this thesis.

### 1.1 What is twist blockage?

During the movement of twisted yarn over a guide surface it is frequently noticed that there is an accumulation of twist in front of the contact region due to the contact forces pushing the twist back, along the yarn, against the direction of yarn movement, Plate 1.2. This zone before the guide may be regarded as a false-twist region and the yarn rotates in this zone.

The direction of the false-twist depends, however, on the nominal twist in the incoming yarn. If the yarn twist is S twist,

## PLATE 1.2

Twist accumulation in front of a  
contact surface

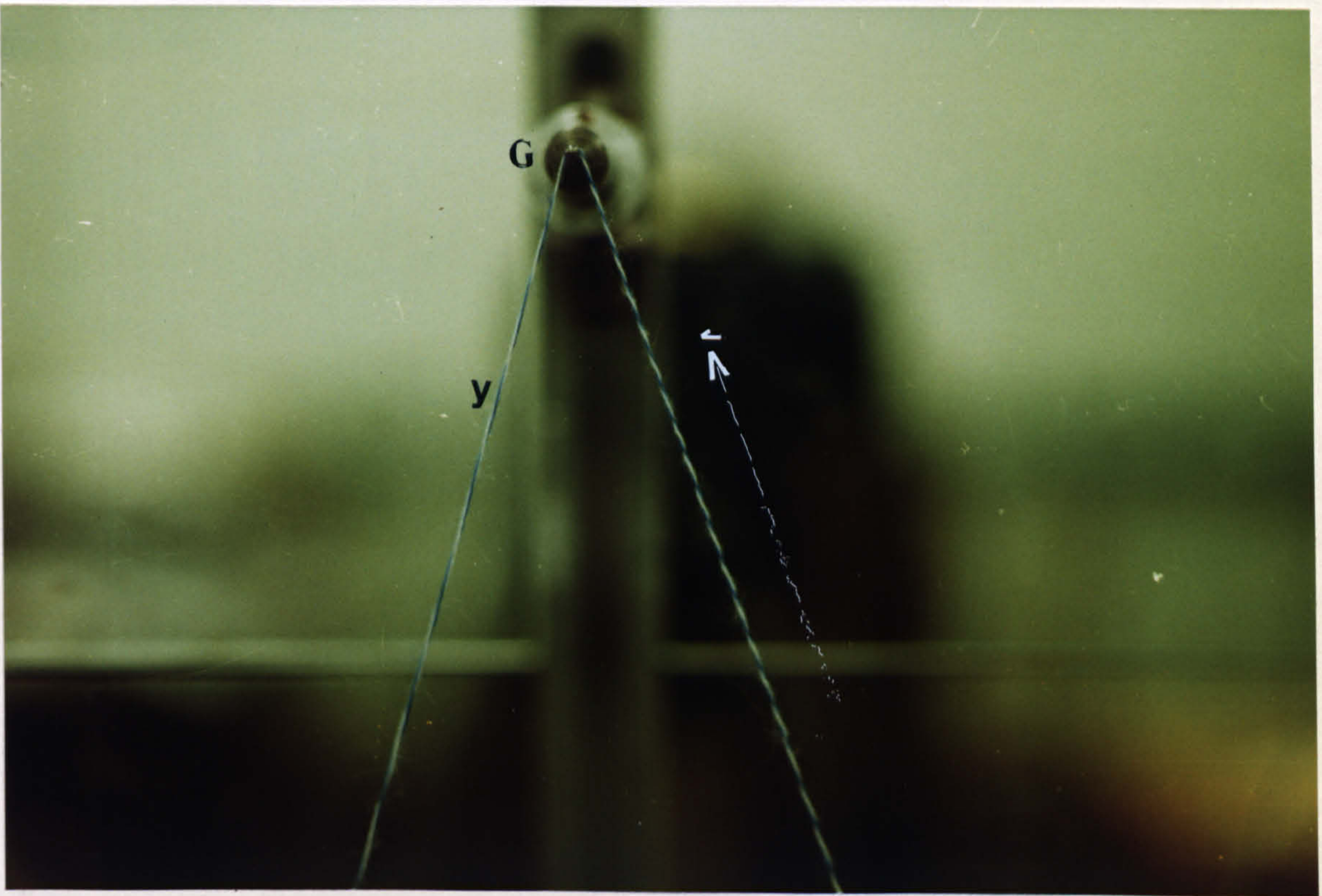

**G** = yarn guide

**y** = yarn

✓ the congested or blocked (false) twist will also be 'S' twist; if the twist is 'Z' the blocked twist will also be 'Z' twist.✓

Another type of twist blockage can occur when a deliberate real twisting or false twisting operation is carried out. In ring spinning or false-twist texturing, for example, a spindle rotates the yarn and twist is deliberately fed upstream against the flow of yarn. The upstream movement of this twist may also be blocked to a greater or <sup>less</sup> lesser degree if the yarn passes over a guide or similar surface. Thus, according to the type of processing, twist in a yarn may be pushed either against the direction of yarn movement or may be prevented from moving in that direction along the threadline.✓ Downstream blockage is defined as the prevention of the transmission of yarn twist in the same direction as the yarn flow; upstream blockage is defined as the prevention of twist propagation in a direction opposite to the yarn flow.✓

Figure 1.5 illustrates diagrammatically downstream twist blockage. In nonrotating threadlines(i.e. no positive false twist device), 'AB' is considered as the blocked zone where an additional false twist (twist congestion) is added to the initial twist. The additional false twist is generated or caused by guide 'B' which is acting as a passive false-twist element. It is obvious that the desired flow of twist is downstream with the direction of the yarn (indicated by the arrows).

Figure 1.6 shows diagrammatically a rotating threadline: 6a where real twist is being generated e.g. ring spinning, 6b with a positive false twist device. The twist inserted in the yarn by the



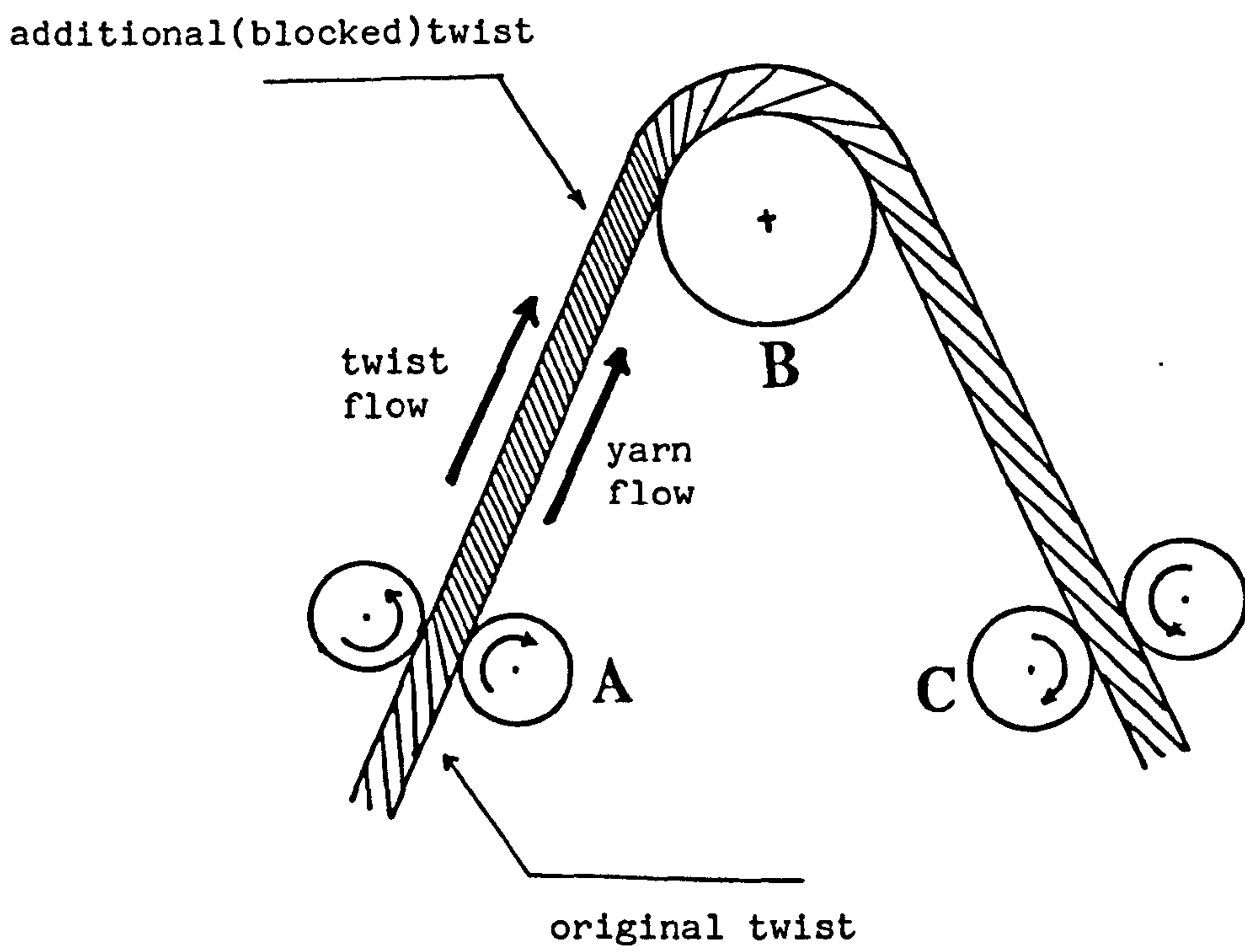

FIG. 1.5: Downstream blockage

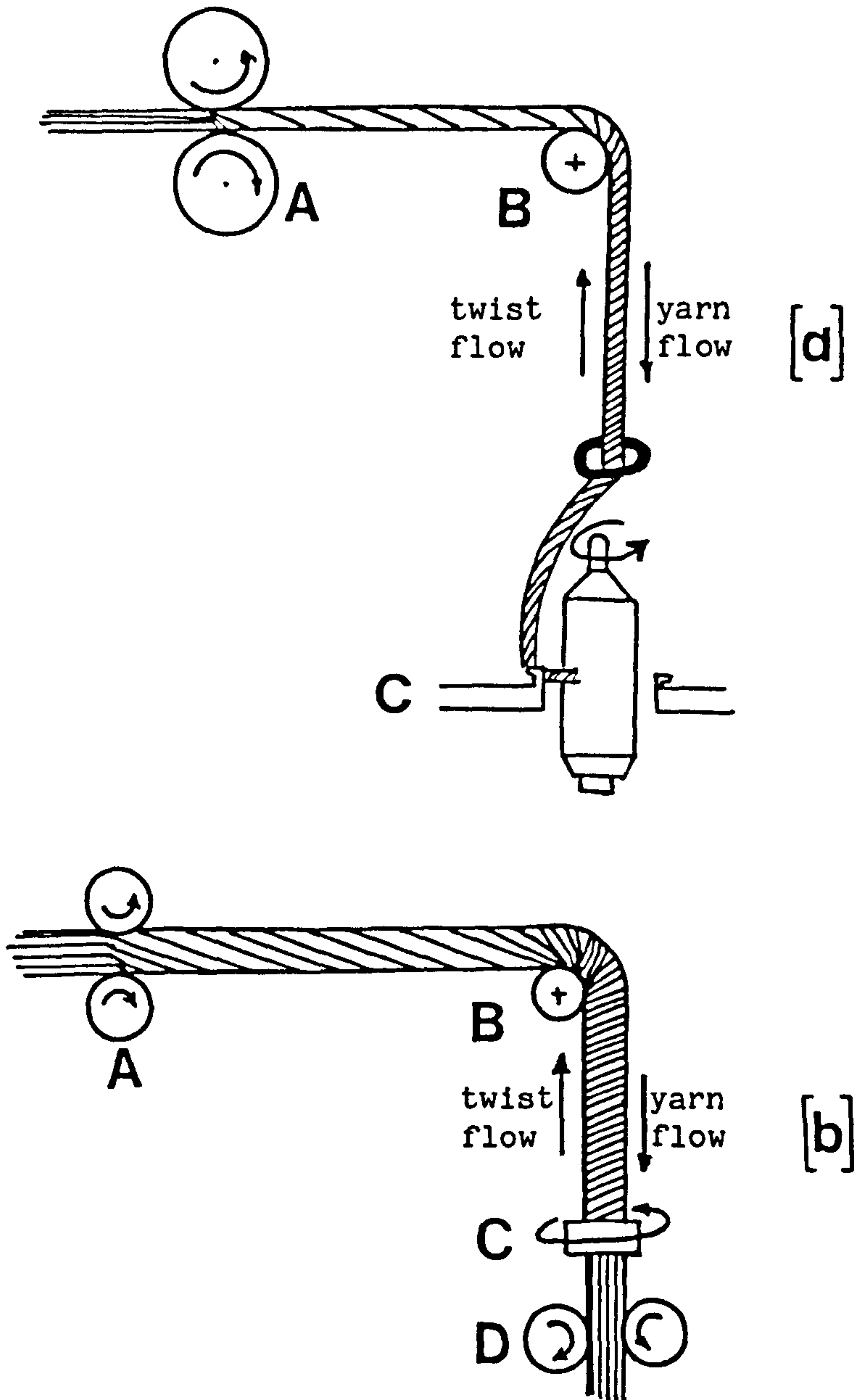

Fig. 1.6: Upstream blockage

twister is fed upstream from 'C' towards 'A' across the guide 'B'. Under such circumstances the desired movement of twist is upstream in the opposite direction of the yarn flow (indicated by the arrows). However, the twist movement may be inhibited by the guide 'B' rather than transmitted freely to the point 'A'.

In both cases the magnitude of the blocked twist depends on the torque generated by the frictional or other forces over the contact region. Thus, the torque [2] values can be varied by changing the configuration and the position of the yarn over the contact surface, as well as by changing the levels of friction or tension and other yarn parameters.

Some examples of twist blockage in industrial processes will be described in the next Chapter.

CHAPTER 2

TWIST BLOCKAGE IN INDUSTRIAL  
YARN AND FABRIC PROCESSING

## 2.1 Yarn manufacturing

### 2.1.1 Winding

The winding of yarn packages of various types (cheeses, cones etc.) either as a process in itself or as an integral part of other processes is found throughout yarn production and processing. Some winding processes operate at speeds up to 6000 m/min, in high speed extrusion for example, although speeds of up to 2000 m/min are more common in other processes. /Because of the high speed and the effect of the movement of the twisted yarn over the surface of the machine elements (tension devices, pigtail, traverse guide etc.) twist blockage may occur either at random frequency or at the frequency of traverse/

Redistribution of the twist along the yarn will be inhibited because of the relatively short distances between machine elements. Thus in adverse circumstances, a significant twist variation (irregular or cyclic) along the yarn may take place.

### 2.1.2 Ring spinning

One preparatory process for spinning where twist blockage was reported is in the production of roving [4] from sliver. As the fibres are in the form of a loose rope, it is necessary to insert some twist to hold the fibres together adequately for the next process of spinning.

/It was observed that twist accumulation occurred at the region between the draft system and the flyer causing a higher level of twist than generated by the flyer rotation/ In fact periodic escape of this twist may lead to some twist variation in the wound roving and difficulty may then occur, in subsequent spinning processes, in the highly twisted

portions, with their lower drafting tendency. In practice, this may lead to a high breakage rate, with more waste of material and lower spinning efficiency.

In ring spinning, a similar observation was made. The yarn passes from the draft roller, through the balloon limiting ring. A twist variation [5,6] was observed within these regions. It was claimed that this twist variation was due to the friction between the rotating yarn and the balloon limiting ring which causes twist reduction in the spinning zone. Figure 2.1A shows diagrammatically the twist distribution in different portions of the spinning region in the absence of the limiting ring. The 'C' and 'D' portions represent a higher and lower twist value respectively than portion 'A' (nominal twist). Figure 2.1B shows the twist distribution for the same regions, when the balloon limiting ring is used, whereby the lowest twist insertion is at the region between the nip point (d) and the guide eye (c). The highest twist (due to the additional false twist) is at portion 'B', in comparison with the nominal twist (portion A). It was stated [7] that the variation in twist has two undesirable effects. Firstly, the lower twist in the spinning zone produces a lower torsional stress, which may be insufficient under certain circumstances to pack the fibres closely together. This can lead to a lower strength in the yarn at the yarn formation point and the rate of end breaks may increase. Secondly, the twist propagation will effectively cause an irregular twist distribution to occur along the yarn between the nose and the shoulder of the yarn package during the building of the package.

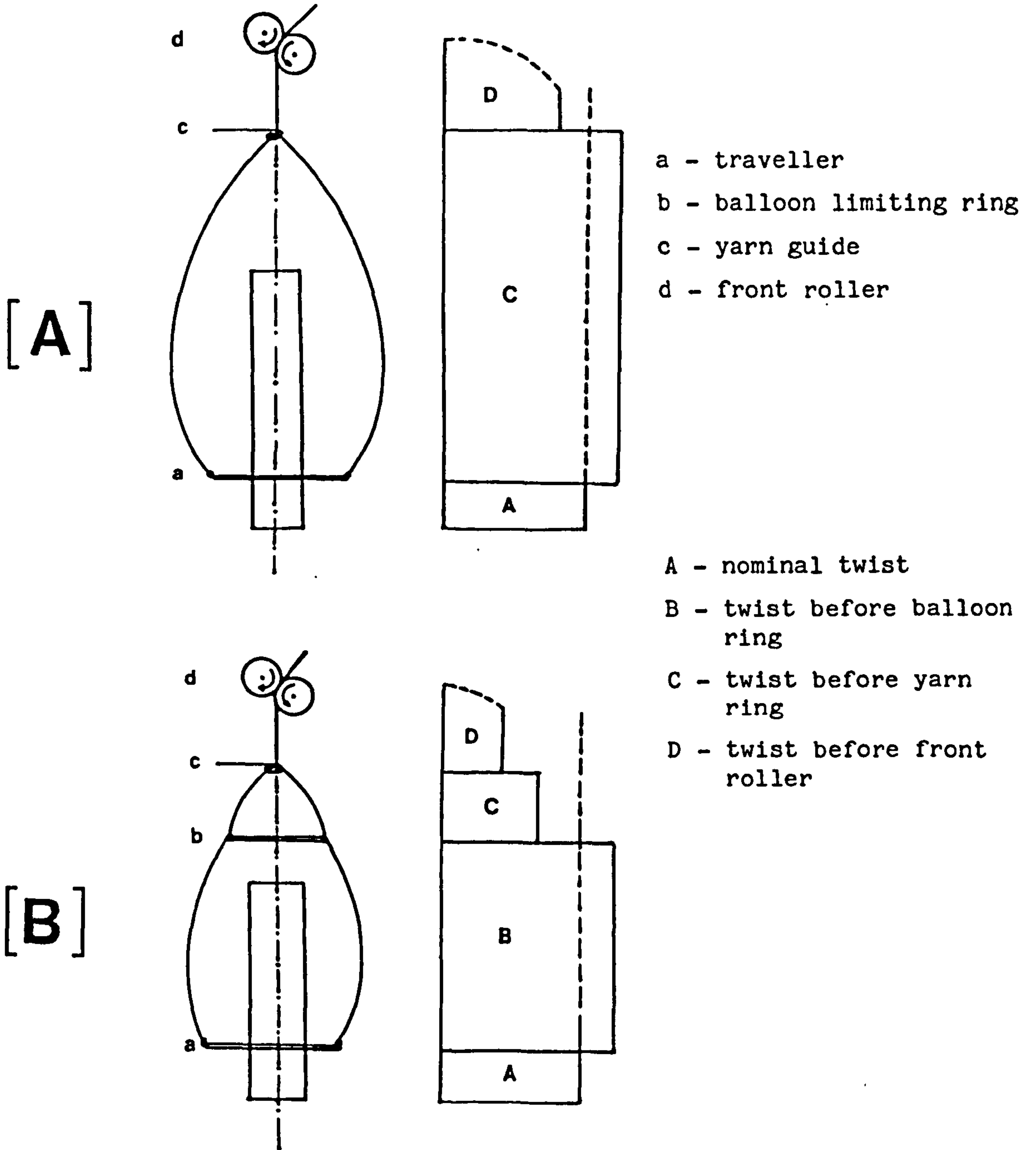

FIG. 2.1: Twist distribution in ring spinning process

Actually, the twist blockage portions in the yarn wound on the package are due to a periodic change of the spinning tension, which permit the twist to move in a surge beyond the traveller. This fact is supported by De-Barr et al [6,8,9]; they have shown that there is a higher twist in the yarn balloon than in the spun yarn, also they pointed out that it is necessary to build up a torque in the yarn to overcome the friction between the yarn and traveller.

It was mentioned elsewhere [7] that the thread guide and traveller contribute a friction resistance to the yarn movement through them and the tension of the yarn in the downstream region must be equal to or greater than in the upstream region. However, as Fig. 2.2 demonstrates, the twist flows through the traveller in the same direction as the yarn flow, while the yarn and twist are moving in opposite directions across the thread guide.

Regarding the effect of spindle speed and spinning tension on the number of end-breaks, it was suggested [10,11] that the eyelet (yarn guide) in the lappet tends to act as a moderate twist barrier with the result that the twist generated by the rotating traveller rarely or never reaches its full amount in portion 'A' near the nip of the front roller. Consequently this small region has less twist and forms a weak place in the emerging thread. The instantaneous strength of the yarn at the roller nip is, therefore, affected by the twist. In fact these assumptions are in conflict with the reported observation [7] that the thread guide offers considerably lower resistance to the movement of twist than does the traveller. This is attributed to the radius of curvature of the thread guide and its angle of wrap being



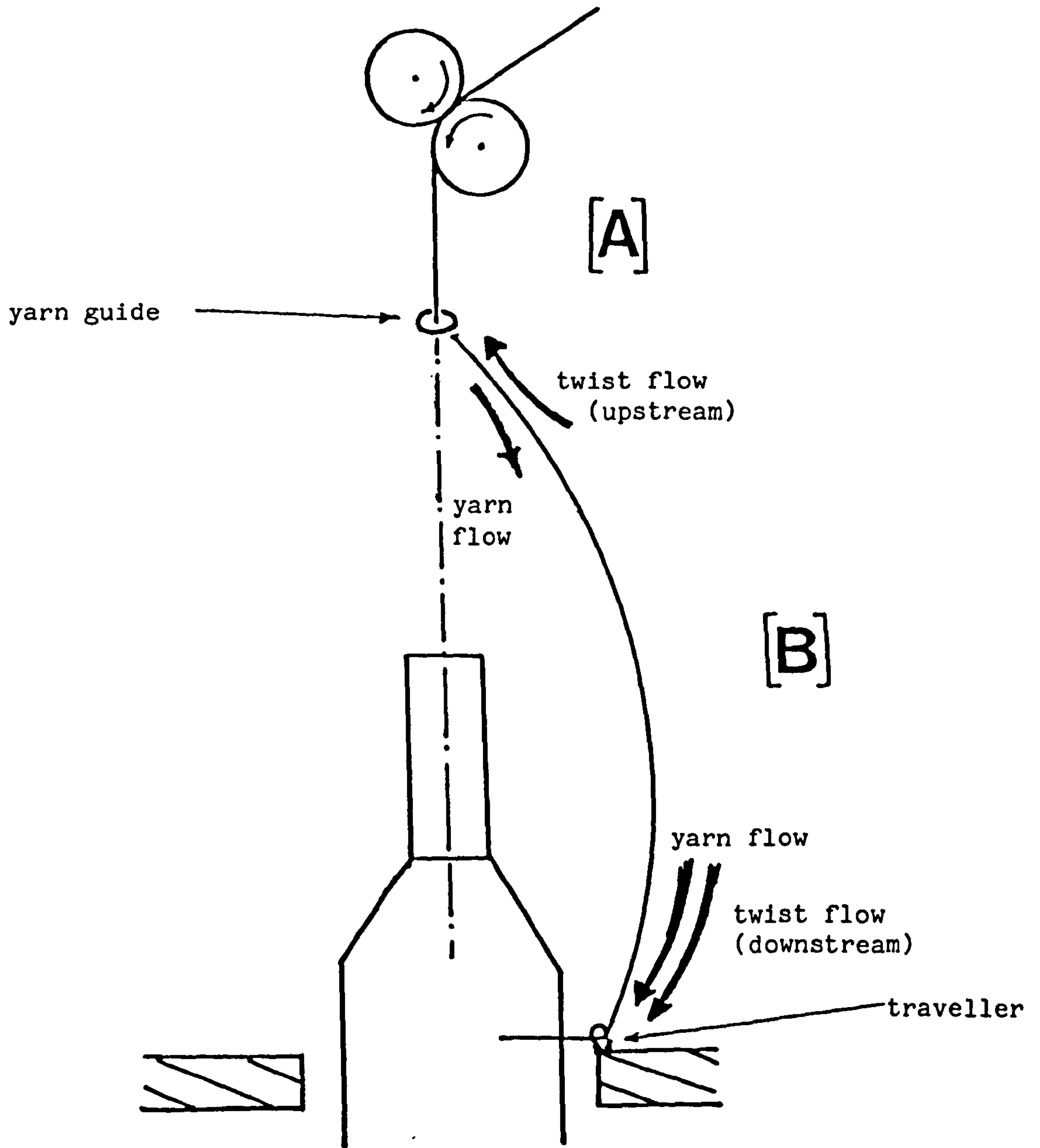

FIG. 2.2: Simultaneous up and down twist flow in ring spinning

greater and smaller respectively. However, twist blockage may be considered advantageous in relation to the strengthening of yarn in the spinning zone, as it helps to reduce the end breakage rate.

This has been applied by Kampen [12], for the purpose of improving yarn breaks in the ring process; he tried to impart a false twist or reduce the friction against the yarn guide.

### 2.1.3 Repco spinning

In Repco or self-twist spinning [13] the twist distribution in the yarn was found to depend, not only on the condition of spinning or the actual level of the self-twist, but also to depend on the winding tension and twist-blockage at guides. The combined effects of these parameters modify the twist on the package. As the strands come from the twisting roller to lap over a pair of convergence guides, it was found that the length of the twist changeover was influenced by the shape and the form of these guides. However, Fig. 2.3 shows diagrammatically the effect of the overlapped convergence guide which in turn increased the angle and the length of contact. This type of guide gives a significantly shorter changeover than the simple form (a) of convergence guide. On the other hand, self-twisted yarn is not capable of withstanding the warping and weaving process [14,15] where, due to tension and drag over contact surfaces on the weaving machine, the ply twist is greatly reduced.

### 2.1.4 Open-end spinning

In rotor spinning, a higher twist factor than that normally used in ring spinning has to be employed. It is possible to use a low

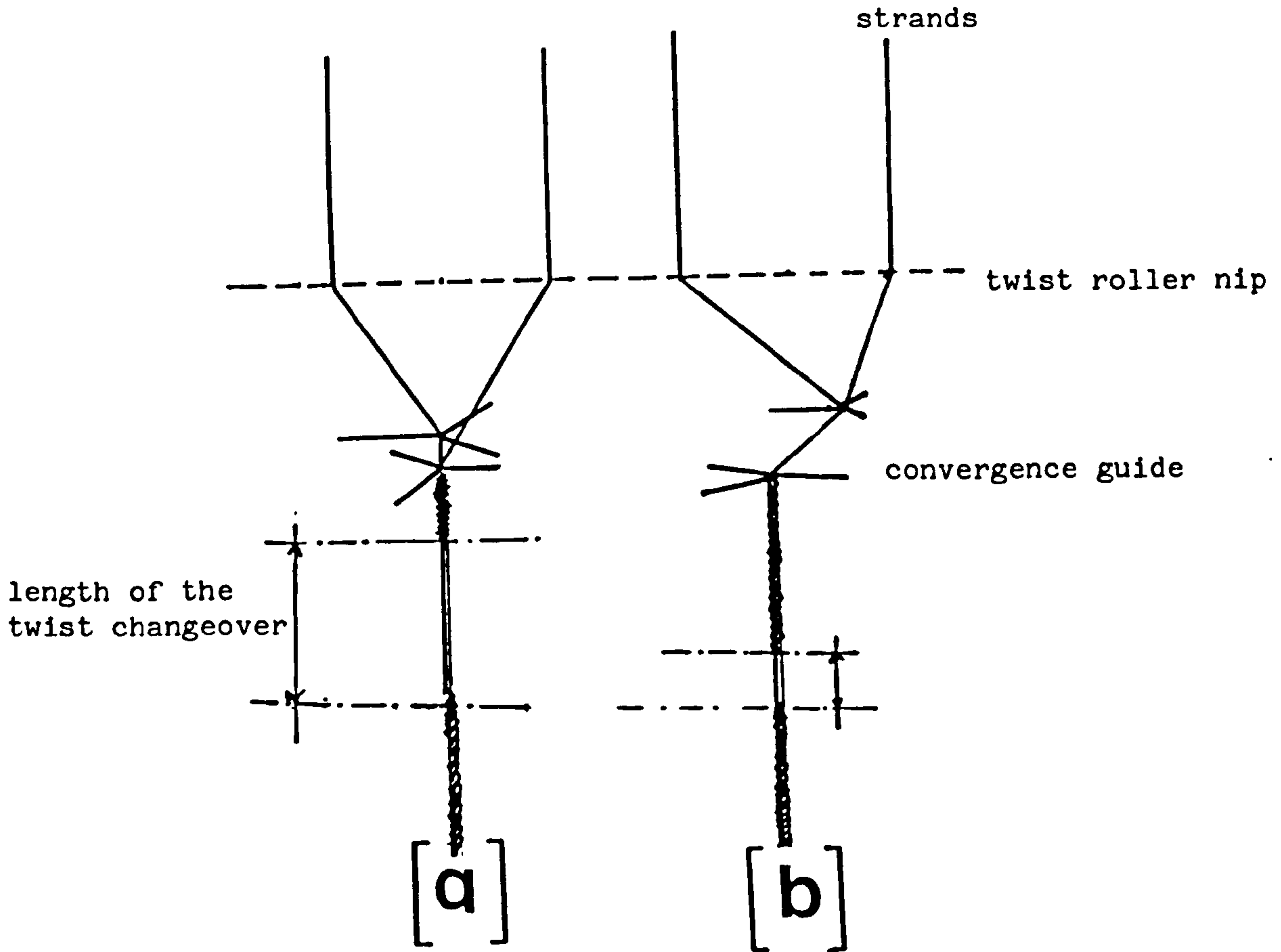

- a - original simple guide  
 b - overlapped convergence guide

FIG. 2.3: Diagrammatic representation of convergence guides (Recco spinning)(Henshaw)

twist multiplier as a result of true twist running back from the yarn and the presence of temporary additional twist in the yarn end [16,17]. This additional twist (false twist) arises from the effect of frictional contact of the rotating yarn with both the doffing tube and yarn guide of the winding system [18,19].

Table 2.1 shows that the direction of the additional twist (accumulated twist) is the same direction of the true twist [20] insertion (i.e. downstream blockage), whether the yarn is withdrawn from the front or back of the rotor, or with clockwise or anticlockwise rotation.

However, the advantage of this false twist is, that the running back of the twist to the twistless portion of the peeling point tends to strengthen the fibre assembly which, in turn, enables it to withstand the centrifugal forces and decreases the end breakage rate.

It was also reported [21,22] that if deeply grooved navels are used, then there is a possibility of twist waves occurring. The nature of the fibre, the geometry of the navel and the condition of spinning, all affect the false twist developed inside the rotor.

#### 2.1.5 Two-for-one twister

In two-for-one twisting systems, the yarn passes from the stationary supply package (Fig. 1.2) down the package centre to the rotor situated underneath the packages, it then passes radially outwards and is caused to balloon around the package holders by the rotation of the rotor. Two turns of twist are inserted in the yarn for each revolution of the rotor, one in the centre tube and one in the balloon.

TABLE 2.1

Rotor direction	Yarn take-off	Twist in yarn arm	
		Permanent	Twist blockage
Clockwise	Front	Z	Z
	Back	S	S
Anti-clockwise	Front	S	S
	Back	Z	Z

During its passage, the yarn passes over a number of machine elements which may generate twist blockage, causing twist variation. These include the tensioning devices or entry guide at the top of the centre tube, the rotor exit orifice, the pigtail guide above the package, the take-up roller and the traverse guide. Due to the interaction between these elements and the twisted yarn, twist accumulation might occur. At the top of the centre tube, upstream blockage may occur, but at all other points the twist is inhibited from moving forward along with the yarn movement [23] and, therefore, downstream blockage occurs.

The twist blockage phenomenon in the two-for-one process can be observed in the wound yarn package. Obviously, as there is insufficient length of twisted yarn between the friction drum and the package, any escaping accumulated twist is incapable of redistributing itself, thus resulting in twist waves in the yarn. However, not only the elements in contact with the yarn cause twist blockage but blockage may also arise from the tension variation during the yarn traversing motion. The tension increases as long as the traverse guide moves from the middle position to either of the two ends of its stroke, but reduces in its return to the centre. Intermittent twist blockage governed by the reversals thus might occur.

When a conical take-up package is used, take-up speed will vary and again tension will not be constant. In these two cases blockage may occur at single or double traverse frequency, respectively [24]. In accordance with this, it has been stated that streakiness [23] has been observed in woven fabric made from two-for-one doubled twisted yarn. This fault has been attributed to the twist irregularity in the yarn. It was also claimed [25] that the

cockling phenomenon in plain knitted single jersey fully fashioned garments is connected with twist variation in low doubling-twist, twisted yarn of a relatively high linear yarn density and that the form of twisting machine [26] (two-for-one, ring twister etc.) used for plying and twisting the yarn can have a significant influence on the variation of the twist.

#### 2.1.6 False-twist texturing

False-twist texturing is an example of a process where twist propagation is in the opposite direction to the yarn movement.

In the modern false-twist texturing processes, the yarn has a relatively long path (Fig. 1.3) also, in most cases, changes its direction. It was observed [27] that the deflection in the yarn path between the exit of the heater and the entrance to the cooling zone, before the false-twisting device, causes a twist reduction on the heater i.e. twist is blocked in front of the deflection point. In addition, it is explained that the yarn tension between this point and (friction) false-twisting head was increased due to twist accumulation, while tension is reduced at the draw point. It has been thought that the threadline must run straight [28] with a minimum number of yarn guides between the draw point and the twister. Each of these between the draw region and twister is capable of preventing twist running upstream satisfactorily. It is recognised, however, that the major problem in the primary zone [29,30,31] is that the path deflection acts as an obstacle to the transmission of twist upstream from the twister to the primary heater and the draw point. The twist accumulation not only depends on the existence of a guide in the

yarn path but also depends on the twist level, the tension and the angular deflection round the guide. Another factor influencing twist hold-back, is the type and diameter of guides around which the path changes direction.

Of these factors, the last is probably the most important because on a guide of small radius, the yarn is forced to bend more on rolling, and the pressure on the yarn causing it to deform in cross-section is greater. The initial energy loss on dragging and bending is, therefore, increased. Twist loss may thus become critical when guide radii are very small.

With the pin spindle [32,33] used on older texturing machines, it was reported that the nature of the eyelet guide (Fig. 2.4) may influence the twist formation; factors such as degree of polishing also have their effects.

It is also expected that an increase of yarn tension makes it difficult for the twist in the yarn to pass through the eyelet guide and this hinders the inserted twist from moving forward with the yarn. An accumulation (or rolling) of the twist takes place which causes an overtwisting. On the other hand it was pointed out [34] that a high yarn twist level tends to develop high torque which is sufficient to overcome the frictional resistance in the pin spindle. The yarn is, therefore, able to slip over the pin. This behaviour causes a reduction of yarn tension as well as in the absolute twist in the yarn, and the effect is cumulative, leading to instability. Lower twist levels would produce a coarse and harsh crepe-like effect in fabric. The yarn strength may also decrease due to a draw ratio variation along the yarn



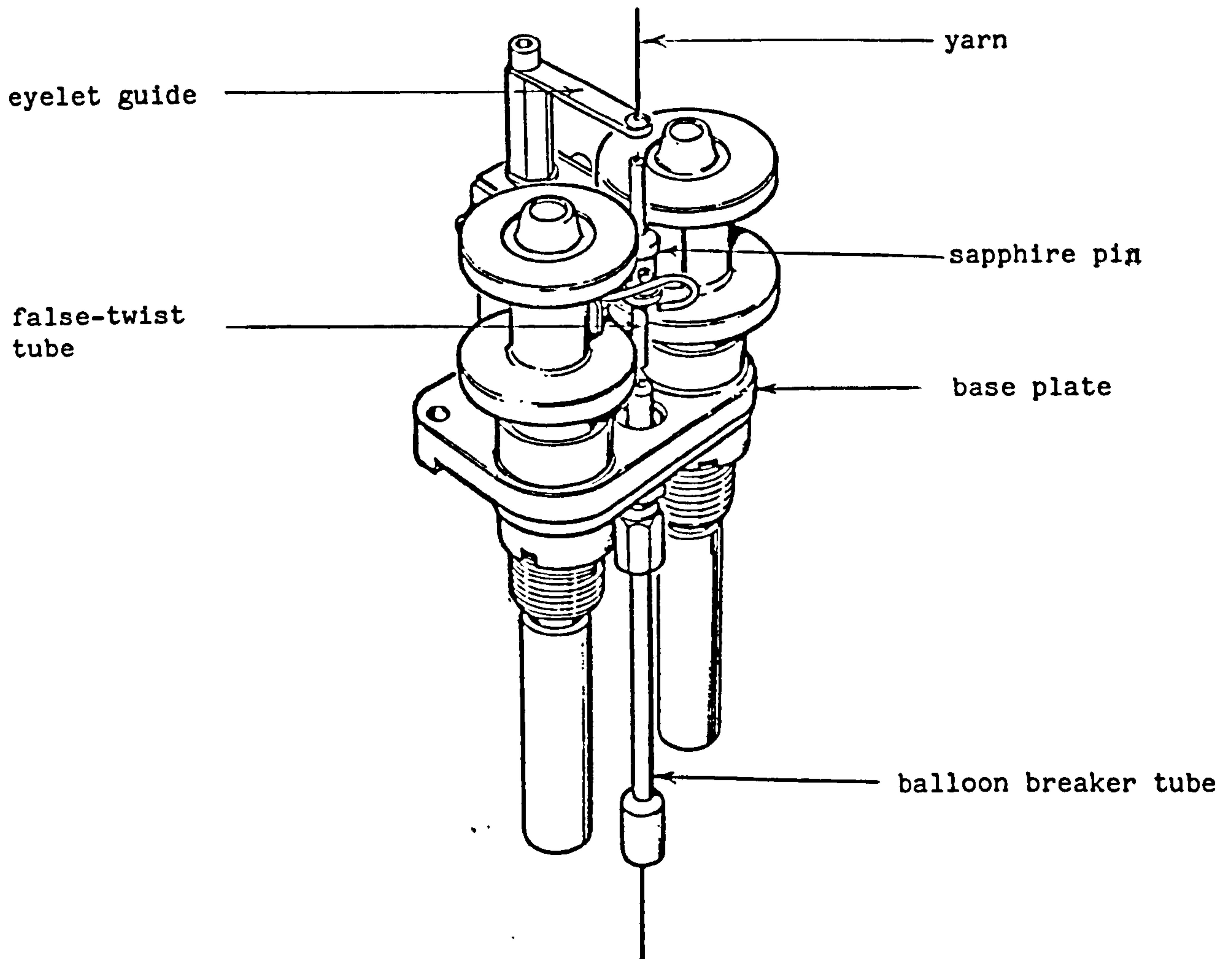

FIG. 2.4: Magnetic false-twist spindle

resulting from the tension variation, this results in an increase in end breakage rate and gives rise to variable dye affinity and other problems.

## 2.2 Fabric manufacture and other processes

### 2.2.1 Warping

There is perhaps no part of the textile industry which requires more precise control, than that concerned with the processing of synthetic yarns. It is very important that the tension be controlled in manufacturing these types of yarns in such processes as spinning, in twisting and in winding.

However, of all the processes encountered, the tension in warping is perhaps the most critical. It is essential therefore to control the warping tension by using adequate tensioning devices. It was observed that [35,36] variation in twist along the length of the yarn caused by the snubbing action of guides and the tension device affected the final tension in warping.

It was also stated that [36], as the twist builds up in front of the guide (or tension device), the final tension increased. It was emphasised that low twisted yarn registered a higher final tension. It is therefore a basic necessity when applying tension for the purpose of successfully performing the warping process to choose the proper tension device with a yarn guide of suitable shape. Any variation in the average tension in warping will affect the density of the beam and will show up as ridges on the surface of the beam.

Obviously, when this yarn is withdrawn from the beam to be woven, some of the ends will be tighter in fabric since a shorter

length of yarn has been wound in the valleys between the ridges than on the ridges.

Actually this condition, if of sufficiently great magnitude, may cause stretching of the tight ends and under any circumstances it may cause warp streaks.

Generally for the purpose of weaving and production of high quality fabric, the yarn path [36] in beaming should be as simple as possible and the number of contact points kept to a minimum to minimize the effect of twist accumulation.

### 2.2.2 Warp sizing

In preparing yarn for sizing process, mills are using different systems [37] of beam creeling and methods of threading such as overhead, single beam with guide roller, over and under creeling.

The passage of the yarn through these processes presents no difficulties, but the apparent problem occurs when the yarn moves under tension over the lease rods and the rollers of the size box. Although these rollers, which in some cases can be 1.5" in diameter, are rotating around their own axes, because the yarn is under strain, it is possible for it to flatten over the rollers. This is particularly true of low-twist yarn. Thus yarn flattening [38] may force the yarn twist to run back and leave the yarn in a condition of twist deficiency. This problem can be amplified when the negative tension application method is used in which the tension should gradually decrease as the beam to be sized decreases in diameter. With the existence of twist variation due to twist congestion the yarn will be weakened; this, in turn, might give rise to increases in the end breakage rate at the weaving process.

### 2.2.3 Weaving

There are several points in weaving where either warp or weft yarn rubs on machine components, or machine parts rub along the surface of yarns. In either case, twist displacement is possible. For example [39], twist displacement may take place at the heald eye (particularly when the shed is open at the time of the beating up operation). Because the radius of curvature of the contact surface of the heald eye is comparatively small, and due to the sudden high tension during the beat up operation, the pressure on the yarn tends to be high over the contact surface. Consequently, thread strength might be decreased as a result of twist displacement.

In conventional weaving during the period of picking (shuttle acceleration) the weft yarn could be under relatively high tension, passing through the shuttle eye[40]. It has been reported that twist accumulation occurred between the shuttle eye and the pirn [41]. This twist accumulation may appear as snarls resulting in weft slubs in cloth.

Traditionally, shuttle manufacturers always tried to keep weft yarn unwinding under constant tension during the time of picking by fixing a pair of fur pieces inside the shuttle in the weft path, nevertheless, such snarls (loops) tend to appear at the time of the shuttle deceleration. The problem may be complicated by the snarls forming a knot at the loop base.

Twist stopping is seen also in some unconventional looms, such as rapier and other similar looms [42]. The weft is supplied from a cone magazine, under a relatively high tension with a speed

of approximately 600 m/min through a guide eye and during the period of weft insertion, the weft slides over the edge of the two rapier heads. It was reported [43] that under these circumstances, either twist displacements or twist loss may occur.

The twist may also be pushed back in front of the guide eye as well as in front of the edge of the rapier heads and thus cause downstream blockage at this point also.

In view of these facts, twist congestion is greatly influenced by the nominal twist, the shape of the guide, the type of tension device, the initial yarn tension and angle of deflection. All factors have an influence on the twist regularity in the yarn which may affect the yarn strength and dyed appearance which in turn will reflect on the fabric properties.

#### 2.2.4 Sewing

Threads of three folded yarn with a high level of twist are commonly used in sewing. In relation to this and because of

1. The large number of points of deflection in the sewing threadline
2. The relatively high value of tension
3. The radius of curvature of the thread needle eye being not greater than 0.5 mm,

twist holdback can easily occur.

It was reported that [44] a significant loss in sewing yarn strength has been experienced during the sewing process. The loss of strength was attributed to the thread abrasion, and variation of twist. It was demonstrated [45] that the needle eye, in particular, tends to push the twist back. Figure 2.5A shows that the twist is accumulated

(A)

The arrow shows the twist blockage region (between the pigtail and the thread needle eye)

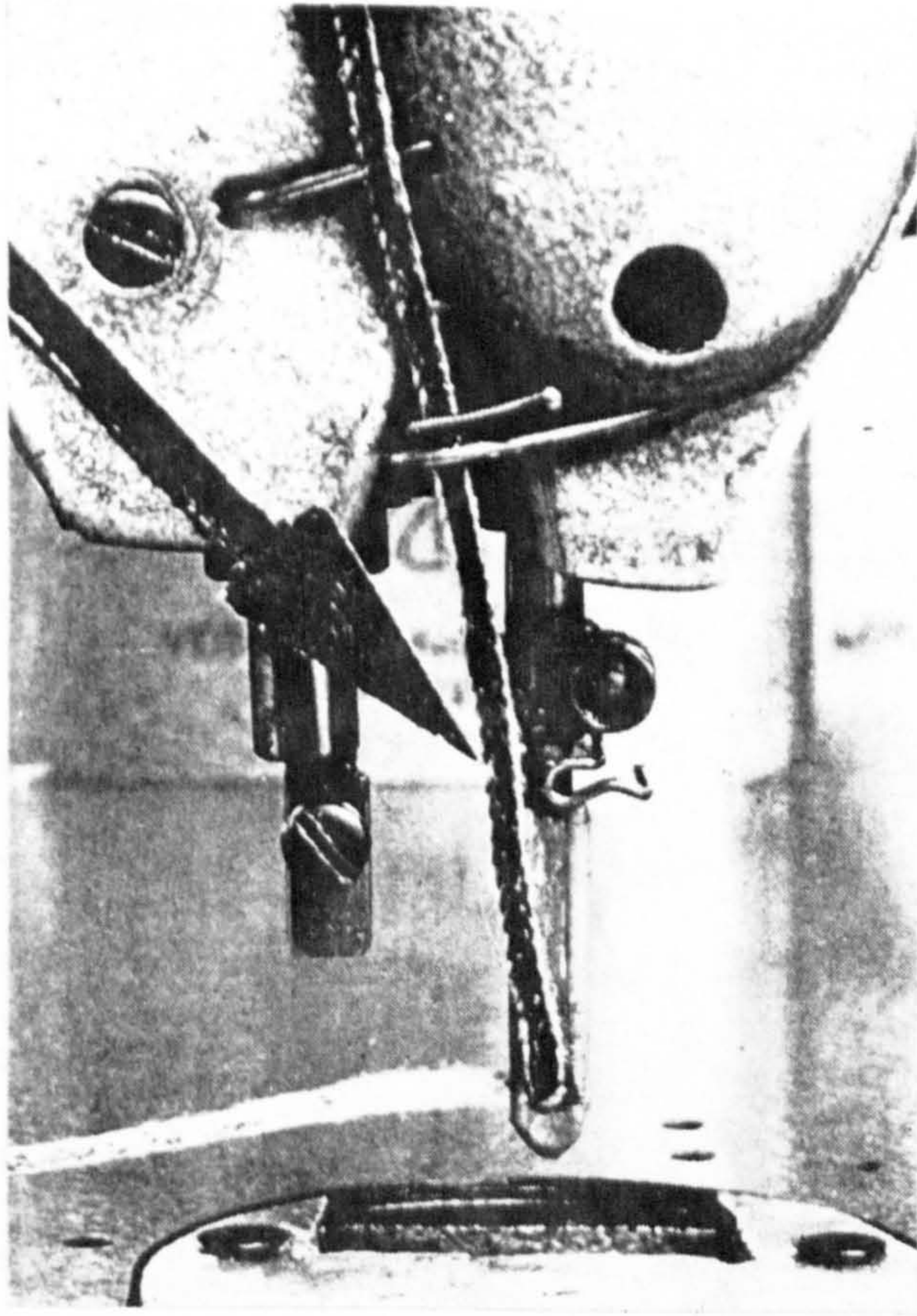

(B)

Yarn under high tension and twist extension

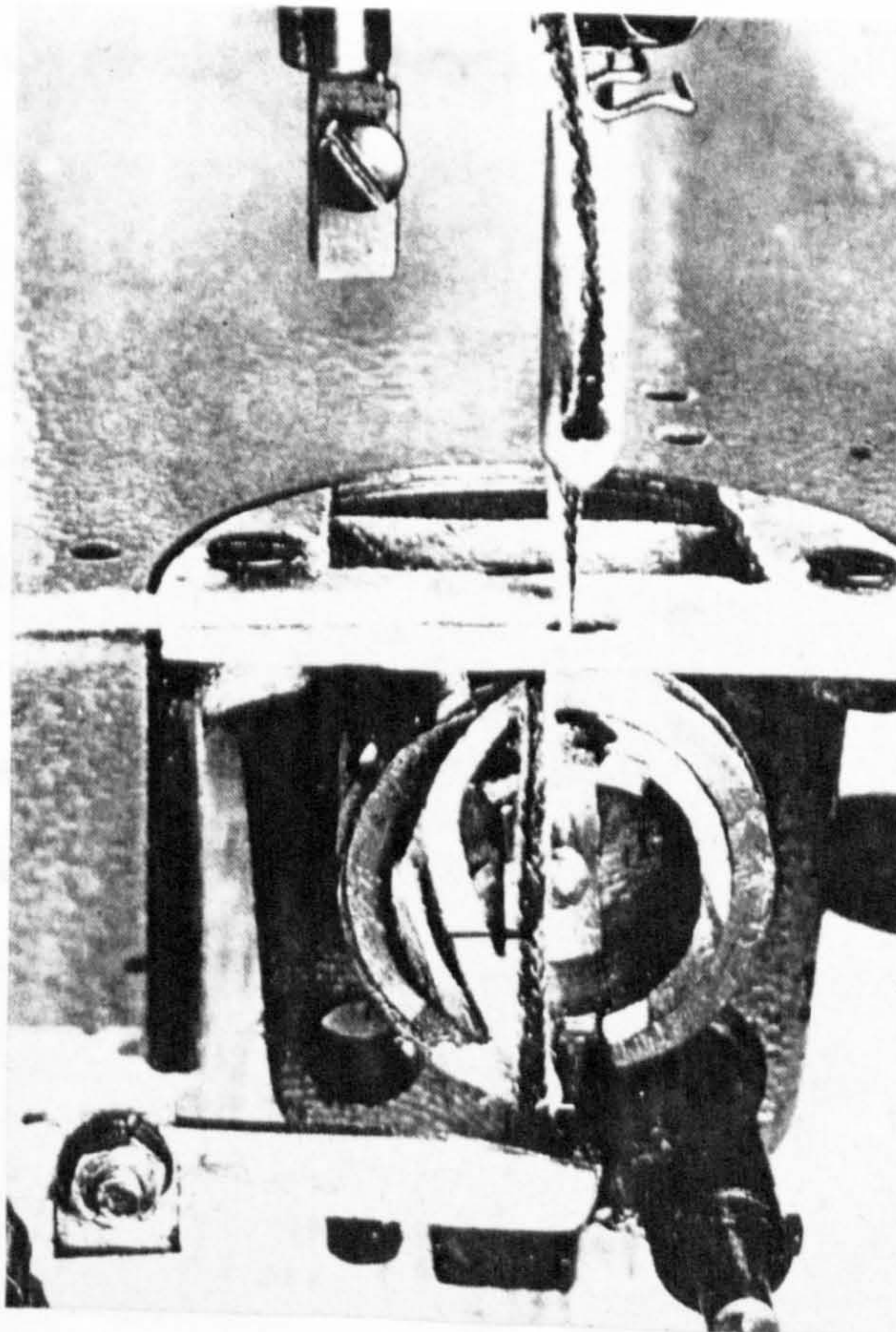

Fig. 2.5: Twist accumulation in sewing process

in the region between the yarn guide and the thread needle eye. The accumulation was very high at the moment of high tension, Fig. 2.5B, which at the time of picking up of the thread by the rotary hook. The other guiding elements such as tension device and rotary hook itself may also cause twist holdback. These changes in twist considerably influence the sewing thread properties, leading to higher breakage rates.

#### 2.2.5 Tension measurement

Measurement of threadline tensions are normally carried out by conventional means such as the Rothschild tensionmeter. The introduction of the measuring head does influence the threadline. It may act to an extent as a twist trap [46]. In a non-rotating threadline the twist is held back rather than moving forward with the yarn flow (downstream blockage) but in tension measurements on rotating yarns in spinning, twisting or false-twist texturing, a tensiometer may block twist in the upstream direction.

### 2.3 Possible effect of twist blockage in finishing of woven fabric

#### 2.3.1 Effect of twist in yarns

During the finishing of fabric, it was found that the amount of twist inserted in the yarn has an influence on the shrinking, felting and lustrous properties of the fabric whatever its constitution and type. The fibres of less twisted yarn have a better opportunity to shrink and felt than fibres of higher twisted yarn.

The apparent variation in the finished fabric is frequently attributed to the twist variation (twist surging) [47] in the yarn itself as well as to the mechanical processes of manufacturing the fabric itself.

### 2.3.2 Scouring of fabric

#### 2.3.2.1 Rope scouring machine

In this type of machine the fabric passes through an apparatus in the form of a loose rope. No attempt is made to keep the fabric in an open-width form and consequently it becomes irregularly folded [48].

In practice, whilst the rope is moving over the machine guide it tends to rotate around itself [49], some false twist is, therefore, added to it.

During the scouring process, the rope moves through pressure rollers (squeeze rollers). The pressure rollers tend to run back any twist present in the rope, and this twist accumulates in front of the rollers. Unfortunately, the thickness of the fabric rope tends to increase at the accumulated-twist parts. Therefore the rope passing through the pressure rollers will be subjected to considerably more pressure at the twisted parts than the parts with less rope twist. Although these parts will have less liquor, dirty nipped suds will be trapped more effectively, and, also, the more effective the scouring, the more shrinkage will be developed. On the other hand, however, the greater the pressure the more the damage to the fabric.

### 2.3.3 Mercerization

Mercerized cotton is extensively employed in the production of woven fabrics either to give a general lustrous appearance or where



it is intended to show crimped blistered or crepon effects. The highest degree of lustre is obtained not only in yarns containing a certain specific number of turns, but also depends on the regularity of the twist along the yarn. In other words, the lustre is based on the inclination angle of the turns.

Twist waves (twist congestion) will, therefore, give [49] rise to different angles of inclination and consequently different degrees of lustre. Also during tensioning the yarn, the greater the angle of twist, the less the influence of the strain on the fibres in the yarn.

The congested twist portions will have less tendency to shrink and felt than the non-congested portions, and may prevent the development of lustre. It was reported [50] that in an ordinary twisted warp, a certain degree of lustre may be developed during mercerization whereas, as the number of turns is increased, the lustre will decrease.

During the manufacture of fabric the yarn undergoes a number of different processes which may disturb the twist in the yarn. Such fabric after mercerization will give an irregular lustre.

#### 2.3.4 Bleaching

Yarn may be bleached in a variety of forms, such as cops, spools or cheeses, beamed wraps, skeins and warps in rope form. The efficiency of bleaching of cotton warps, for example, will depend upon the method selected for running the warps and the degree to which the yarn may become twisted, compressed, entangled etc. One of the methods of bleaching is to run the warps in rope form [48,51] through a machine

consisting of a series of tanks (boxes), provided with suitable guides to carry the material through the solution and also through guide pins and squeeze rollers.

The problem of twist congestion arises from the inherent nature of the process involving moving a yarn or even rope over a guide.

The tendency of the yarn (rope) to rotate around itself [49] will lead to the formation of a false twisting effect. The twist tends to run back and to accumulate in front of the guide.

When the accumulated twist portions of the rope, which are often larger in diameter, pass through squeeze rollers, which have been adjusted so as to leave the proper amount of chemicals in the rope to facilitate the bleaching process, these twist portions will retain less of the chemicals and may become dry.

It has been emphasised that [51] care must be taken to avoid drying of warps in spots, as this will lead to tender yarns and defective bleaching.

Faults in fabric bleaching, due to uneven weaving, arise from the fact that twist waves (surging) in warp and weft yarn may be present due to the effect of twist congestion. This will show up as a slight difference in colour or surface appearance and will become more apparent when the fabric is held towards the light.

#### 2.4 Summary and discussion

The foregoing short review of the effects of twist congestion in textile manufacture has confirmed that there are two types of twist congestion which can occur in textile processing.

Firstly twist congestion may occur in non-rotating thread line in such processes as winding, warping, weaving etc. where the twist transmission is moving with the direction of the yarn movement and is defined as downstream blockage.

Secondly, twist congestion may occur in rotating threadlines, such as in ring spinning or false twist texturing where the twist transmission is moving against the direction of the movement of the yarn. The type of movement here is defined as upstream blockage.

Twist congestion may be involved in many processes of converting textile fibres into finished materials. It is realised through the limited information available that the effect of the phenomenon on the yarn structure might influence some of the yarn physical properties. It is recognised, however, that twist congestion may be an advantage or a disadvantage, depending upon the nature of the process.

Twist congestion can be usefully employed in rotating threadlines in such processes as O.E. spinning. The running of the twist back inside the rotor will provide a greater cohesion of the fibrous assembly in the twistless portion at the peeling point. Twist congestion also strengthens the yarn temporarily in the rotating threadline of the ring spinning processes.

In false twist draw-texturing, twist congestion may inhibit full generation of twist on the heater and may cause a periodic variation of the yarn tension in the draw zone, resulting in crimp level and draw ratio variations along the yarn length. This will affect the final fabric in the form barré [47] which is particularly

noticeable in dyed fabrics, in which it may have the form of dye shade or texture variation.

In non-rotating threadlines (weaving, knitting etc.) twist variation can be noticed in the fabric as structural or shade variation. In manufacturing of woven cloth from low twist filament yarns, twist congestion may affect the weft thread in the form of loops of yarn during weaving. These loops are sufficient to cause the yarn to snarl which in turn affects the appearance of the fabric.

In the light of these observations, it is now firmly believed that a proper understanding of the effect of the various process parameters on twist congestion is of primary importance.

Nevertheless, in order to facilitate a better interpretation of the experimental work, it was thought that a brief summary of the previous investigations in the twist blockage field would throw some light on the major parameters influencing this phenomenon.

The research to be reported in this thesis is, however, restricted to an investigation of the problem of twist blockage in a non-rotating threadline i.e. downstream blockage. A practical approach towards minimizing or solving this problem is hoped for.

The twist blockage phenomenon has been investigated in the light of factors already mentioned. The findings of this investigation initiated a basic approach to the study of the interaction of the structural characteristic of the yarn with the guide surface. This finally led to an improved understanding of the phenomenon.

CHAPTER 3

SURVEY OF LITERATURE  
RELATING TO TWIST BLOCKAGE

### 3.1 Introduction

In the previous chapter, the types and sources of twist blockage have been considered. It is now pertinent to consider briefly the previously known effects of factors affecting twist blockage, in both rotating and non-rotating threadlines, as discussed in the published literature.

Before reviewing the literature it is of importance to note that the terms twist blockage, twist congestion, twist runback, twist accumulation, twist displacement are generally synonymous.

### 3.2 Factors affecting twist congestion

#### 3.2.1 Downstream twist congestion in non-rotating threadlines

##### 3.2.1.1 Introduction

In considering this type of twist congestion, the Shirley Institute [40] found that the guide shape and size, the initial tension and angle of wrap, have a very marked effect. The desirability of a low initial yarn tension is appreciated whilst the final tension increases with the angle of wrap, this increase of tension will tend to compensate for the effect of a large angle of wrap on twist displacement.

In reviewing the factors affecting the twist congestion it is logical however, to consider each factor separately as this may help to clarify how the various factors might influence the phenomenon.

##### 3.2.1.2 Effect of guide size (diameter)

The Shirley Institute [40] in a preliminary investigation found that with a relatively small guide diameter, the accumulated twist in front of a contact region could be several times greater than the nominal

twist, but that even with guide diameter in excess of 25 mm, there is still some pushing back of twist. Figure 3.1 shows the effect of varying the guide diameter, on twist before the guide. In the same way a highly significant positive correlation between the guide diameter and twist accumulation was reported by Chan [52]. He studied this factor at an arbitrarily selected angle of wrap of  $75^{\circ}$ , using 167 decitex, 32 filament, 7.8 t.p.m. continuous filament polyester yarn. Chan used six different guide diameters ranging from 2 to 16 mm. His conclusion indicated that the normal force or pressure which is expressed in terms of force per unit length,  $\frac{T_1}{R}$  (where  $T_1$  is the initial tension and  $R$  is the guide radius), had a major influence. It will be seen that the pressure is highest with the smallest guide diameter. The twist displacement, therefore, reduces as the guide diameter is increased. The same findings have been reported by Trommer [53]. He derived a quite complicated theoretical analysis supported by experimental results showing that twist accumulation in front of the contact surface decreased as the guide diameter increased. He used a range of guide diameters with different levels of yarn twist. In agreement with the Shirley Institute's observations, he also observed that at the higher twist levels and large guide diameters there is still some twist accumulation in front of the contact region. These workers, however, neglected the factor of pressure over the guide surface. This factor may be considered as a major parameter influencing twist blockage behaviour.

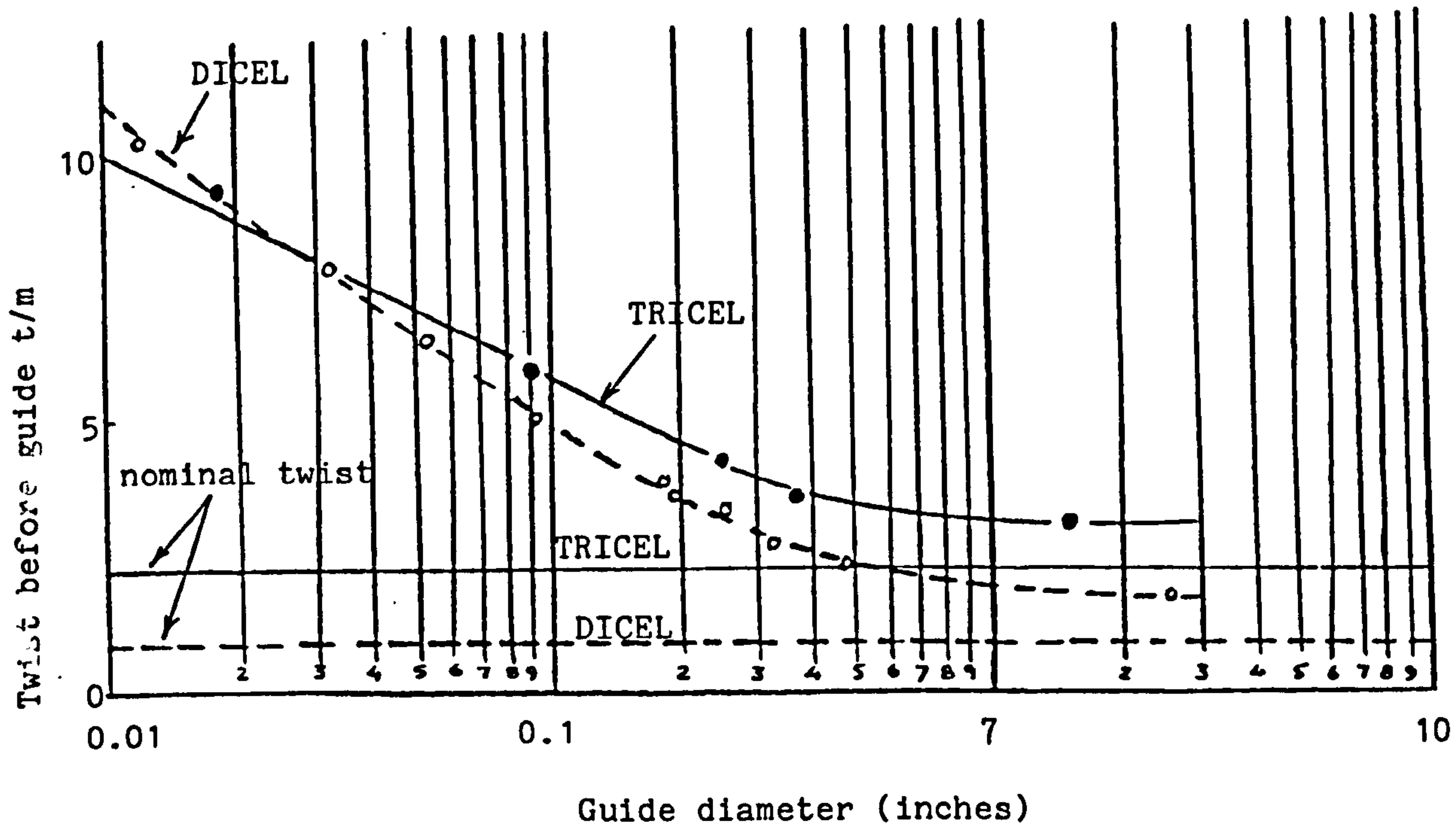

FIG. 3.1: Effect of guide diameter on twist blockage (Shirley Institute)



### 3.2.1.3 Effect of guide shape

Pavlov and Finkel'shtein [54] investigated the effect of guide shape on the twist blockage phenomenon. They used two types of guides, of a cylindrical and bracket form, with two methods of threading a twisted cord over the surfaces. During the cord movement over the contact surface, they found that it tends to rotate around its axis producing a false twist in front of the contact region. In further movement of the cord, the twist in front of the guide surface reversed its direction at its departure from the contact region. In addition to this, it was also demonstrated that the method of threading over the guide, had the effect of reversing the twist direction i.e. 'S' changed to 'Z' or vice versa. Pavlov [54] tried to establish a relationship between the developed torque (M) and the twist of the space curve ( $\Upsilon$ ) with an equation:

$$M = \frac{T_1}{2} R_c^2 \cdot \Upsilon$$

where

$T_1$  is the initial tension

$R_c$  is the cord radius.

Pavlov and Finkel'shtein proved that the magnitude of twist accumulation (false twist) and also the torque developed in the cord are dependent upon the configuration of the guide and the radius and position of the cord over the contact regions. When the cord is arranged over the contact region the twist accumulation and the developed torque along the cord may reach zero or maximum depending on the orientation of the yarn on the guide surface.

Pavlov [55] continued the same investigation with a complicated guide shape, trying to establish the relationship between the shape of the guide, the frictional properties of the cord/guide surfaces, the torque developed in the cord, and the twist over the contact surface. He used a hollow cylindrical guide with holes in its side and passed a twistless cord with a longitudinal coloured marked strand through the guide with a particular threading direction. He found that the results agreed with the earlier findings.

An equation relating the elastic properties of the cord and the other parameters mentioned above was developed. It was claimed that if the frictional moment is equal to or greater than the torque developed in the cord, the cord will rotate in front of the guide and no rotation will occur over the contact surface. Thus twist accumulation will occur.

In a further investigation, Pavlov [56] assumed a relationship between the torque developed in the cord (moment of torsional resistance) and the twist accumulated in front of the guide surface ( $A = \text{twist/unit length}$ ) by an equation of the form

$$M = 2\pi GIA$$

where  $GI$  is the torsional stiffness of the cord.

Relating to his theoretical analysis, he found the minimum length of arc of contact to produce a stable twist in a thick product like cord (4 mm diameter) is greater than 1.7 mm. Of course, for a fine yarn it will be less.

Possibly, it can be concluded from his observations and theoretical analysis that the factors which can affect twist blockage are:

1. Radius of curvature of the guide surface.
2. Frictional force over the contact region.
3. Guide shape and surface configuration.
4. Yarn linear density.
5. Yarn initial twist.
6. Yarn torsional stiffness.
7. Level of twist over the contact region.
8. Length of arc of contact as a relationship between the guide diameter and angle of wrap.
9. Angle of orientation.
10. Method of yarn threading.

#### 3.2.1.4 Effect of angle of deflection

It would be expected that the angle of deflection can have a major influence on the inhibition of twist transmission over a surface of contact if only because of its effect on the length of contact. The Shirley Institute [40] investigation, tested two types of yarn (140 decitex, 26 filament, 2.5 t.p.i. Tricel and 140 decitex, 26 filament 1.0 t.p.i. Dixel) at ten angles of wrap, ranging from zero to  $90^{\circ}$  at a speed 75 ft/min, using polished cylindrical steel pins as guides. The results show that any reduction in angle of wrap will only produce a significant reduction in twist accumulation, if the angle of wrap is reduced to less than approximately  $45^{\circ}$ . It was suggested that for the purpose of avoidance or reduction of twist accumulation, the angle of wrap should be as small as possible.

Trommer [53] experimentally illustrated that the twist accumulation increased as the angle of wrap increased from zero to  $60^{\circ}$ .

However, a further increase from  $60^{\circ}$  to  $120^{\circ}$  caused a rapid decrease in twist blockage.

The above experimental results are, however, at variance with those of Chan [52], who reported that twist blockage decreases as the angle of wrap increases. Chan's results were obtained using different angles of wrap ranging from  $30^{\circ}$  to  $130^{\circ}$  for each of six guides at different diameters. The yarn used was 167 decitex polyester at a transmission speed of 100 ft/min.

The difference between the (Shirley, Trommer) and Chan observations may be due to the input tension being constant in the former and output tension being constant in the latter.

It has been shown [57] that, when positive feed systems are used as in Chan's experiments, the effect of drag in a threadline is to lower the tension before the drag point, and not to increase the tension after the drag. Other factors influencing the differences in results of the above investigators may be the different yarns, the different twist levels or differences in the methods of carrying out the experiments.

### 3.2.1.5 Effect of input twist

Results reported by several investigators [2,40,53] indicated that the input twist in singles or in folded yarns is a very important factor influencing twist congestion. Dyer [36], in studying the warping process, used the phenomenon of the twist blockage as a means of measuring the variation of coefficient of friction of different surfaces with yarns of different twist. His idea was based on the assumption that twisted yarn may acquire a significant twist variation along the

yarn caused by the snubbing action of the guide surface (or tension device), which tends to push back the twist and permit it to move forward in surges. The resulting variation in twist might affect the frictional drag and hence the final tension.

He used a yarn with three different levels of twist such as 0.3, 2.0 and 3.0 t.p.i. The yarn was passed over each of seven different tension devices at a constant tension input of 10 gf with a yarn speed of 300 ft/min. The final tension was recorded by means of a G.E. recorder.

The results indicated that the higher twist congestion was recorded with the post, gate and disc tensioners. This was indicated by a higher final tension using the lower yarn twist of 0.3 t.p.i. Dyer claimed that the characteristic behaviour of these three tensioners is probably due to the snubbing action of the surface of the devices pushing the twist back while the yarn is passing with little or no twist. In gate tension devices, the yarn moves over a number of fingers (or posts), each of these fingers represents a small guide (with a small diameter). Thus the increase in tension caused by these fingers tends to increase the yarn pressure over the successive fingers surface, whilst the yarn pressure on the surfaces of plate, whorl and regulator tensioners tends to remain at a quite low value. The observations obtained from these types of tensioners had no significant variation of final tension as recorded. Probably the main conclusion from Dyer's work is that twist congestion can be significantly influenced by

1. A low level of yarn twist.
2. The guide shape, size and type.

However, the observation of Dyer, that the twist accumulation decreases with increase of the input twist, does not agree with the results reported by Chan [52] who found that an increase of the input twist directly affects the twist accumulation, Fig. 3.2.

The disagreement between Chan and Dyer may arise from their different techniques.

#### 3.2.1.6 Effect of the initial tension

The influence of initial tension on twist congestion was also considered by the Shirley Institute [40]. The reported results were obtained using a guide diameter 0.24 cm (0.09") at a constant angle of wrap of  $90^{\circ}$ , with the two types of yarn mentioned earlier, the tension applied to the yarn ranged from 5 to 90 gf. Actually in the experiments described, only a limited number of combinations of guide diameter with yarn initial tension were investigated. It was found, however, that at low tension values, the tensions had a very marked effect on twist congestion, but at higher values, the effect is very small and a large increase in tension causes only a slight increase in twist accumulation.

A similar high correlation was found by Chan [52]. He used guides of different diameters at angle of wrap  $75^{\circ}$ , and varied values of initial tension (from 5 to 80 gf) for each guide diameter. He stated that as the tension increases, the twist held back by the guide also increases. Chan proposed that the combination of curvature of the guides surface with tension has a striking effect on the twist blockage. He found a good correlation between the pressure over the guide surface and twist blockage, and subsequently suggested that the twist blockage is largely governed by this pressure.

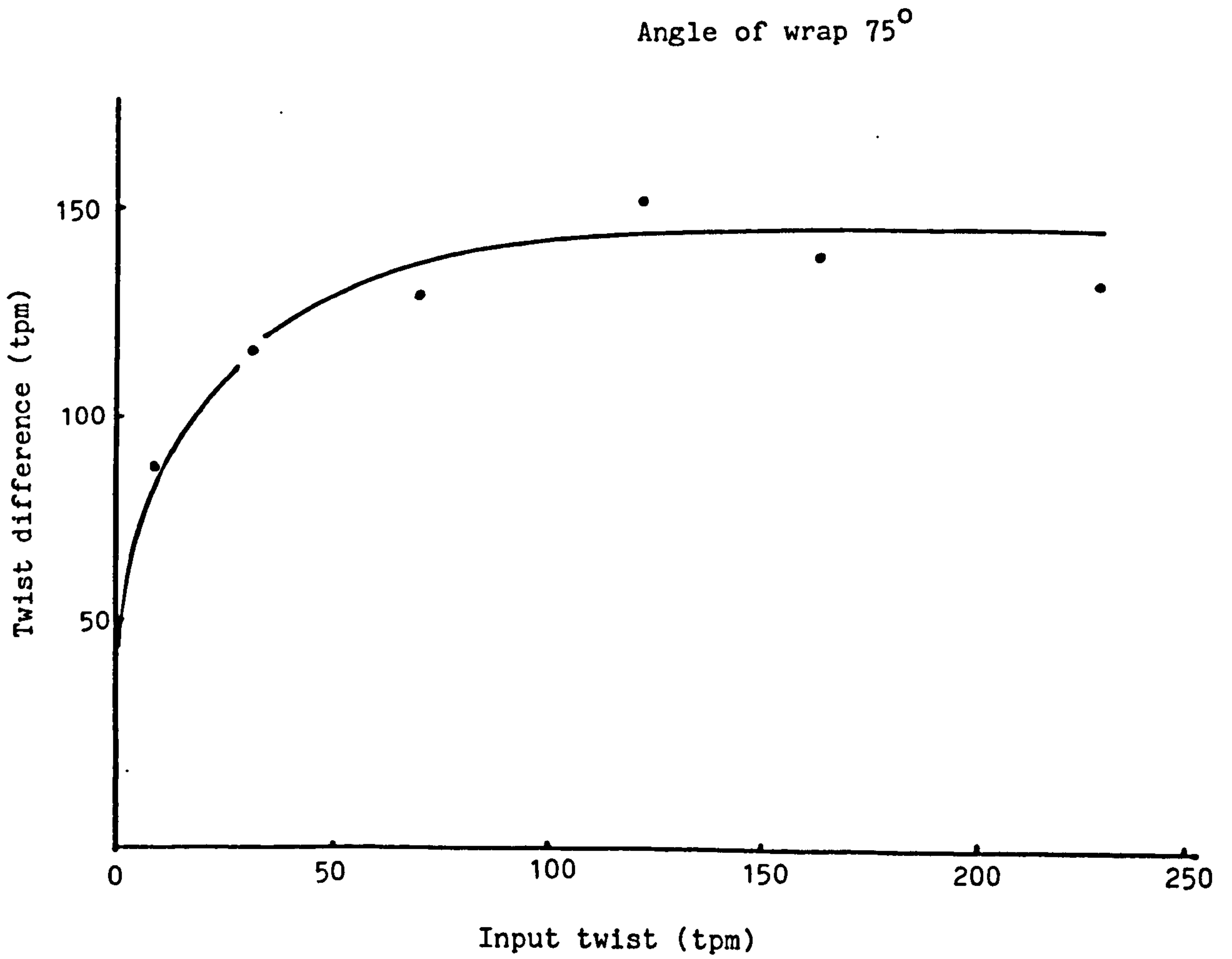

FIG. 3.2: Effect of input twist on twist blockage (Chan)

The conclusion will be questioned in more detail when the effect of the pressure is again discussed in the course of this thesis.

Baird et al [2] observed the twist blockage phenomenon during their investigation on the relationship between the degree of polishing of a yarn guide and the coefficient of friction. They used 30 denier, 10 filament nylon yarn, with a very low level of yarn twist ( $\frac{1}{2}$  t.p.i. Z twist), and found that independently of the level of initial tension, the filaments behaved individually and moved over the guide surface (contact region) side by side, as if they were independent of each other. The twist was completely pushed back leaving the yarn flat over the contact surface. This flattening of filaments returned after the accumulated twist had reached a sufficient level so as to escape over the contact region. The phenomenon was not observed when a yarn with higher level of twist was used. Such behaviour was attributed to the interlocking between the geometry of the guide surface and the yarn surface and was considered as the prime factor causing twist accumulation in front of the contact surface.

It can be concluded from the above observations that the twist blockage behaviour is directly affected by:

1. The pressure over the contact region.
2. The yarn and guide surface configuration.
3. The relationship between yarn twist and the length of contact region.

#### 3.2.1.7 Twist congestion in the rope processing of fabric

The investigation of Miura et al [58] of twist blockage in the rope treatment of fabric was mentioned in the previous chapter. They



tried to determine the factors that cause twist generation in fabric. They reported that when a fabric moves over a surface of guides such as poteyes, and changes its direction through angle ( $\theta_1, \theta_2, \theta_3 \dots$  etc.) of deflection, it starts to take up a more tightly twisted rope formation. As long as this level of twist is low, it will be difficult for the twist to be transferred beyond the contact surface. They found that the average twist ( $\bar{C}$ ) generated in the fabric length ( $l$ ) can follow the equation:

$$\bar{C} = \frac{\Sigma\theta}{2\pi l} \quad t/m$$

where  $\Sigma\theta = \theta_1 + \theta_2 + \theta_3 \dots$

Using graphical methods, the same workers showed that increase of the fabric speed caused increased accumulation of twist. They also investigated the use of correctors [59] and developed equations relating the elastic properties of the rope to the level of twist accumulation. They concluded from this investigation that the parameters which influence twist congestion when processing fabric in rope form are:

1. The diameter of the fabric rope.
2. The total angle of deflection.
3. Fabric tension.
4. Initial twist in the fabric
5. The time of the fabric movement
6. The fabric velocity.

### 3.2.2 Upstream twist congestion in rotating threadlines

#### 3.2.2.1 Introduction

It will be appreciated that the upstream twist blocking effect of yarn guides on a rotating yarn has a more complicated mechanism than the general situation of the non-rotating yarn [60] discussed previously.

Invariably the twist will be generated by some device such as a ring spindle or false-twist spindle which causes the yarn to rotate and feeds twist upstream into the threadline against the direction of yarn longitudinal movement.

The yarn bending angle around any guide prior to the twist generator, the tension in the yarn, the yarn's modulus, the yarn speed and twisting rate are again expected to exert a different degree of influence on twist congestion [61]. In addition, in processes such as false-twist texturing, where a heat setting is involved, the thermal condition may also influence twist blockage.

Most studies of this type of twist congestion [28,29,62,63] have been concerned with the phenomenon at relatively high twist and speed levels such as occur in modern textile spinning, in the false-twist process and other continuous filament yarn processing where it may be commercially important.

One of the investigators [64] has, however, carried out some experimental studies at low speed in connection with a quite complicated theoretical analysis. This may help, nevertheless, in clarification of the nature of the parameters influencing this type of phenomenon at higher speed.

### 3.2.2.2 Effect of angle of deflection

The major problem associated with path deflection in the primary zone in the false-twisting draw-texturing process is that the yarn deflection points tend to inhibit the transmission of the twist upstream from the spindle to the draw point on the primary heater [29,65,66]. The importance of this angle of deflection has attracted the attention of many researchers.

Denton [28] investigated the effect of the yarn deflection on the twist congestion using angles of wrap of  $90^\circ$ ,  $180^\circ$ ,  $270^\circ$ ,  $360^\circ$ , with different guide diameters, at constant draw ratio. He found that twist loss increased when the angle of wrap increased. At small guide diameters, (<5 mm) twist loss was found to be 15%.

Bachkaniwala [62] in his study using angles of wrap  $50^\circ$ ,  $76^\circ$  and  $82^\circ$ , did not reach the same conclusion as Denton. He found the twist loss at any size of guide diameter does not exceed 1%. The differences between the two investigators may be due to the technique, the level of the angle of wrap, or the draw ratio used.

An attempt was made by A.R.C.T. [67] to minimise the effect of yarn deflection points in the false-twisting texturing process. The phenomenon was investigated using different types of yarn such as 150/30, 50/25 polyester and 50/48 multilobal polyester and 100/34 den. multilobal nylon yarn, at angles of wrap ranging from zero to  $180^\circ$ . It was found the twist before the yarn deflection point decreased when the angle of deflection increased.

A.R.C.T. stated that angles in the yarn path between the exit of the heater and a friction twisting device influenced the twist

distribution and increased the yarn tension between the deflection points in the yarn path and the friction head.

However, the above results are in agreement with those of Sasaki [68]. He established a simple model for the purpose of investigating the twist distribution in the false-twist texturing zone. Using two different coloured multifilaments 75 den. polyester yarns together, he measured the twist distribution in the heater from photographs. He observed that the apparent twist decreases as the yarn bending angle increases. He attributed the alteration of twist distribution to increase of the tension before the spindle and slippage occurring on the spindle. Because of this, the mode of twist insertion in the yarn will change and will effectively decrease as the yarn deflection increases. It was suggested that care is required in choosing the position of yarn guides. In many cases when such an angle of deflection exists in the yarn path, it is necessary to reduce the draw ratio in order to keep tension at a reasonable level. This in turn amplifies the influence of the deflection.

Denton and others [57,67] reported that the path angular deviation not only affected the transmission of the twist upstream of the heater, but also causes irregular yarn drawing. This, consequently, influences the yarn properties such as tenacity and dye affinity and the Uster CV% and also causes a higher breakage rate.

More recently, the influence of thread deflections in the texturing zone on the torsion in the threadline, was studied by Lünenschloss [69] et al. They measured the thread torsion with and without a deflected threadline under otherwise fixed texturing

conditions (spindle speed, draw ratio, heater temperature, texturing speed). They reported that the torque generated tends to decrease with threadline deflection. However, part of the torque reduction is explained by the lower torsion occurring in the heater zone with twist accumulation downstream of the deflection points.

The results obtained by Heung [63] are in agreement with the results of the above investigators. By using nine different angles, ranging from  $35^{\circ}$  to  $80^{\circ}$  on 76/22 decitex polyester and 22/12 decitex nylon yarn, with draw ratios of 1.507 and 1 respectively, and with theoretical twist levels of 3350 and 1950 t/m for a polyester and 3150 for a nylon yarn, he confirmed that the twist blockage increased as the angle of wrap was increased. In these experiments he, too, observed that the smaller the guide diameter, the higher the twist blockage. Surprisingly even with a small guide diameter (1.26 mm), for angles of wrap from zero to  $50^{\circ}$ , twist blockage was not significant. Above this level of angle of wrap, an opposite behaviour was observed. The twist blockage rapidly increased with the smaller guide diameter (1.26 mm), while it generally decreased to zero level with the larger guides (2 and 12 mm).

Fischer [29] also has investigated the effect of the deflections and points of contact on twist transmission through the false-twist texturing threadline. He found that these points tend to brake the rotation of the yarn, and consequently a lower level of twist is transferred. He also found that with a straight yarn path (i.e. without deflection points), the twist is propagated uniformly as the yarn passes through the heating zone. Obviously, increase of the number of points of contact tend to increase the frictional effect over the contact

region, which in turn can disturb the twist uniformity along the yarn.

Trommer [70] found through his investigation, a dramatic effect on twist loss with a smaller guide and higher angle of wrap. The twist loss was doubled when he used a 0.5 mm guide with a  $100^{\circ}$  angle of wrap compared with 2.5 mm guide radius with the same wrap. He found, in general, that the higher the angle of wrap, the higher the twist loss.

### 3.2.2.3 Effect of guide diameter

As already indicated, several researchers [33,71] have investigated the effect of guide diameter on twist congestion in the false-twist texturing process.

Bachkaniwala [62] studied the deflect between the heating and cooling zones. He used seven guide diameters ranging from 1.26 to 16 mm with two types of yarn. He concluded that there is a significant influence of the deflecting guide diameter on the percentage twist loss, and that twist loss was generally higher at lower twist levels (Fig. 3.3I). Although curve (A) indicates a higher percentage loss than curve (B), the actual loss is lower because of its lower twist level (2575 t.p.m. and 5550 t.p.m. for A and B respectively). In addition, the value of the draw ratio for each of 'A' and 'B' is also different (1.9 and 1.6 respectively). It is, therefore, not possible to be sure that the difference was only due to the different twist levels; tension difference may also have made a contribution.

The results are in agreement with the results obtained by Heung [63], who used seven guide diameters ranging from 1.26 to 16 mm

with two yarns of different linear density 22 decitex nylon and 76 decitex polyester at a twist level 3350 t/m. He found that the twist blockage behaviour of 76 decitex is significantly influenced by the guide diameter. A high twist blockage reduction was observed by changing the diameter from 1.26 to 6 mm, but no significant further twist blockage reduction was noticed at larger diameters. Heung also found that the lower the yarn linear density the higher the twist blockage (Fig. 3.3II).

The above experimental results are however supported by Denton [28] who stated that a high correlation exists between the twist loss and diameter of the guide by which the yarn is deflected. Denton's conclusion was obtained from results based on experimental evidence, using guides of four diameters, namely 3,6,9 and 12 mm at various angles of wrap.

Trommer [70] in his investigation used five different guide radii, ranging from 1 to 5 mm. He found that the twist loss significantly decreased with increase of guide radius. At 1 mm guide radius, the twist loss was approximately 55%, whilst at 5 mm, the twist loss was only 15%. His theoretical analysis supported this relationship between twist loss and guide radius and predicted higher values than those found in the practical observation.

#### 3.2.2.4 Effect of input twist

In texturing synthetic filament yarn, the twist level of the yarn in the processing zone is an important factor which significantly influences the characteristics and quality of the resulting yarn.

(Bachkaniwala)

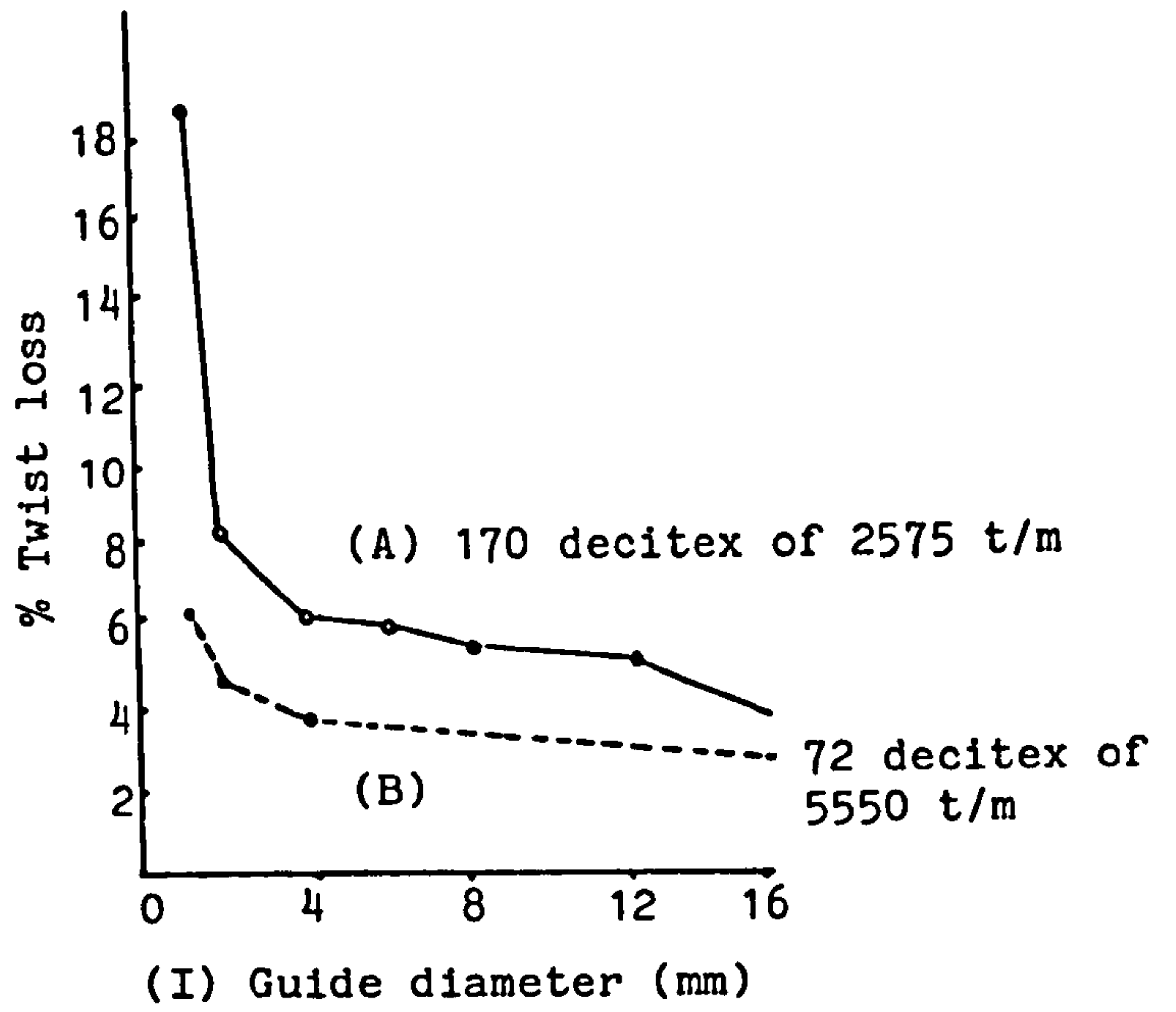

(Heung)

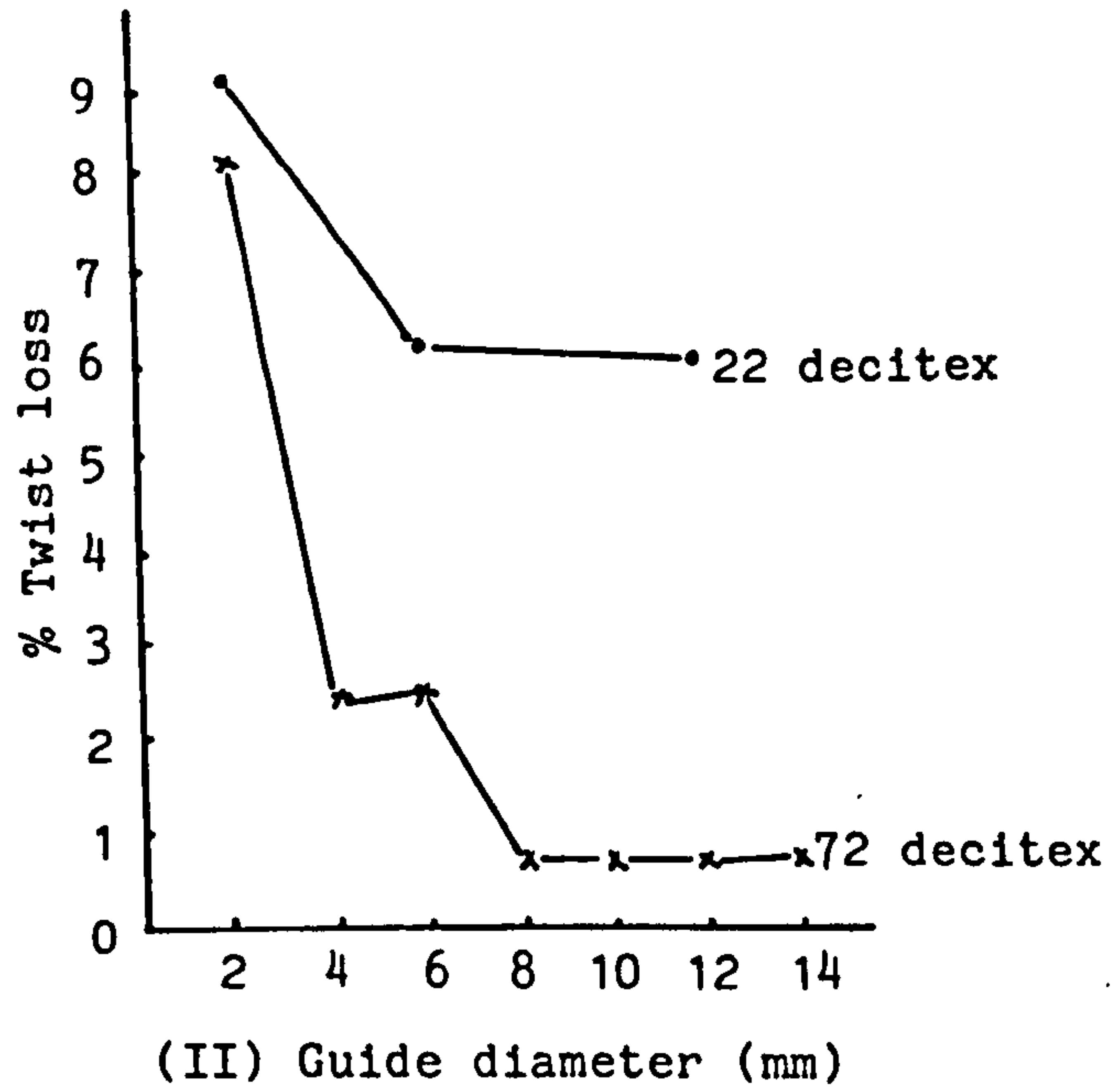

FIG. 3.3: Effect of guide diameter on twist blockage



Bachkaniwala [62] prepared samples using seven ceramic guides of diameter ranging from 1.26 to 16 mm, when texturing 170/30 decitex polyester POY at a draw of 1.9. He observed that, as the input twist increases, the twist loss decreases, but above a level of twist 1975 t/m it increases again.

Denton [28] also reported an unexpected and curious observation. He found, below a twist level 1730 t/m, very little twist was transmitted upstream beyond a deflection point. He commented that low twist levels contribute a major problem in the false twisting process particularly on machines with substantial deflection along the threadline of the primary texturing zone.

The conclusion is that, although the results showed that as the input twist increased, the percentage twist loss generally decreased slightly at any low values of input twist, the twist transmission over the surface of contact tends to change and losses are much greater.

Heung extended Bachkaniwala's experiments to a finer range of yarn. He pointed out that at a given twist level, the surface helix angle of the filament is smaller for finer yarns, and thus that the lower twist level might have much more effect on the twist blockage behaviour. In general, however, Heung's conclusions were similar.

It should be noted that the same twist sampling technique has been used by most of the researchers [62,63,72,73]; this involves a snatching of the yarn over the primary heater, either by hand or by an especially constructed device; the yarn is then transferred to a stiff card, and from thence to a twist tester. In this technique, the taking of samples should involve gripping the yarn at both ends at the

same time. However, if one end is gripped before the other, the sample might have more or less twist than in its running condition. In the case of draw texturing, there is also the possibility of twist movement through the (soft) draw region. These possible sources of error must be taken into account, and their effect minimized.

However, Trommer [70], constructing a special means of rotating the yarn, demonstrated that twist blockage is considerably influenced by the level of yarn twist. He used five different levels of input twist (or helix angle) ranging from  $40^\circ$  to  $240^\circ$  at constant yarn linear density and constant tension over a guide radius of 1.25 mm. He found that the lower the yarn twist level, the higher the twist loss. Also his theoretical analysis has predicted the general pattern of twist loss behaviour, but with the practical measurements at a lower value.

#### 3.2.2.5 Effect of draw ratio (pre-tension)

The required level of tension is contributed by the feed/delivery speed ratio of the yarn. Piller [61] has reported that any increase of yarn tension in texturing can cause a congestion or rolling of twist in the region immediately before the twist tube, leading to overtwisting.

However, Bachkaniwala [62] investigated the effect of initial tension on twist blockage under various draw ratios using a range of guide diameters. The results indicated that an increase of draw ratio from 1.45 to 1.6 gives a slight increase in percentage twist loss. These results are in agreement with the results of Sasaki [68] who also found that the twist blockage increased as the tension increased.

Trommer [70] in his research also demonstrated that the twist blockage is significantly affected by the initial tension. He used five different levels of yarn tension ranging from 20 to 100 pond over a guide radius of 1.25 mm. He found that the higher the initial tension, the higher the twist loss. Again his theoretical analysis predicts a higher loss than is observed in practice.

### 3.2.3 Downstream twist blockage in a rotating threadline

#### 3.2.3.1 Repco self-twisted yarn (STY)

In self-twisted yarn, the number of turns of twist in two consecutive zones (i.e. S zone and Z zone) are nominally equal. Hassanian [74] has found practically that there is no relationship between the levels of 'S' twist and the values of 'Z' twist. He attributed this behaviour mainly to the effect of twist blockage on the formation of self-twisted yarn zones. As a result of the twisted yarn passing over guides, the twist can have two possible forms:

1. If the twist is congested before the end of the stroke of the twisting roller, a higher twist density in one zone will occur.
2. If the twist is congested at the end of the stroke, a lower twist density will occur in one particular cycle.

However, Henshaw [14] in his testing of twist distribution in self-twisted yarn has confirmed that the twist variation along the yarn can be attributed to variation in the winding tension together with twist blockage at the convergence guides. He found that, even under normal tensions, the length of the zero twist zone was changed by varying the form of these guides (i.e. simple and overlapped guide Fig. 2.3). The overlapped convergence guides cause the two strands

to be combined together before self-twisting occurs. This increases the interlocking mechanism between the two strands.

### 3.2.3.2 Open-end spinning

#### Effect of friction over the guide

In O.E. spinning processes, the centrifugal force of the rotating yarn end generates a relatively high tension. The development of frictional force between the rotating yarn and the outlet navel of the spinning pot causes the yarn to roll against the inner stationary surface. Thus either false twist may be created or twist blockage may occur; both will give rise to a higher twist level in the spinning pot than would be expected from its rate of rotation. The actual mechanism of this higher twist in O.E. has, however, not been fully explained. Some investigators [75,76,77,78,79] define it as false twist whilst others [80,81,82] define it as twist blockage.

Singh and others [21,22,83] have reported that the twist inside the rotor increases with increase the frictional contact between yarn and navels. The introduction of notches over the navel-surface was found to increase the frictional contact between yarn and navel, and as a result, the false twisting effect was increased. Singh also demonstrated that the twist held back in the rotor tends to increase with lower yarn twist. Nevertheless he claimed that the level of blocked twist inside the rotor is more dependent on the frictional characteristics of the navel than on the level of the twist.

### 3.2.4 Simultaneous upstream and downstream twist movement

Finkel'shtein [4] examined twist formation in roving. He reported that a false-twist is generated in the roving between the

drafting system and the flyer head arising from the accumulation of the twist due to the dragging of the roving over the flyer head and when the twisting roving is pulled through the hole of the flyer head.

Figure 3.4 shows twist accumulation resulting from two different ways of inserting the yarn through the hole of the flyer head (3.4a from left to right and 3.4b from left to the centre of the flyer). Arrows indicate the yarn and twist flows. It is obvious that the method of threading the roving created either of the two types of twist accumulation, downstream (3.4a) and upstream (3.4b) twist flow. Finkel'shtein reported that the twistless portions of the yarn (AB and BC Fig. 3.4) rotate in opposite directions.

If the roving is pulled in the direction of the dotted arrow (D), the total number of turns increases in portion AB and decreases in portion BC or disappear altogether. In Fig. 3.4b the conditions will be reversed, i.e. higher twist in BC and lower or zero twist in AB.

Subramanian [24] investigated the twist flow in ring spinning by measuring the twist distribution at two portions of take-up bobbin, such as the nose and shoulder. In addition measurements were carried out at the start, in the middle and on the full bobbin. The study showed that the angle of wrap between the yarn and the traveller (and the yarn guide) has a significant effect in generating resistance to the flow of twist across them. This is shown in Table 3.1 which illustrates the variation of twist at different positions. It is clear from these results that the deflection in the yarn path has an effect on the twist distribution along the yarn.

Subramanian suggested that the smaller the angle of inclination of the spinning zone thread to the vertical, the better the twist flow

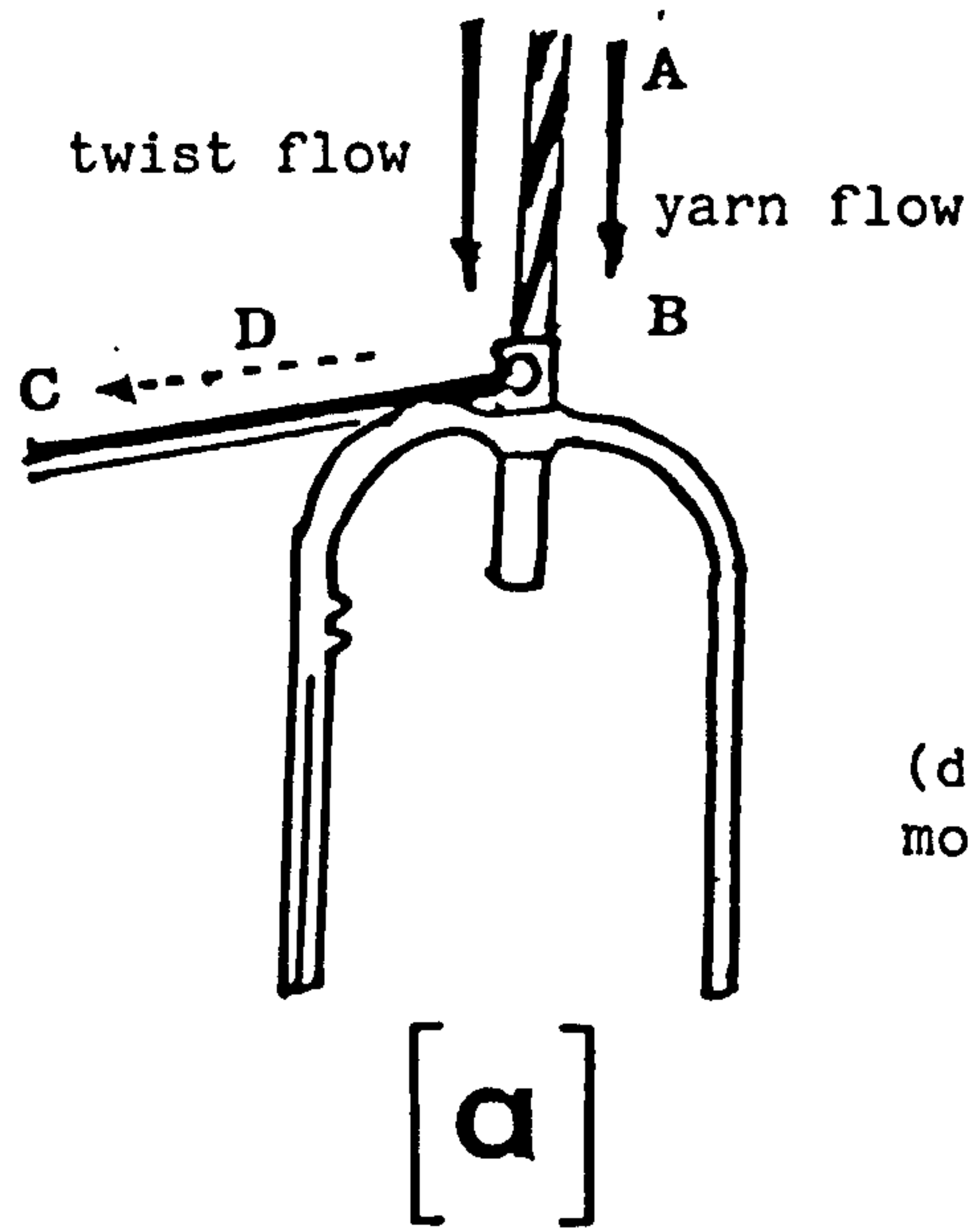

(downstream twist movement)

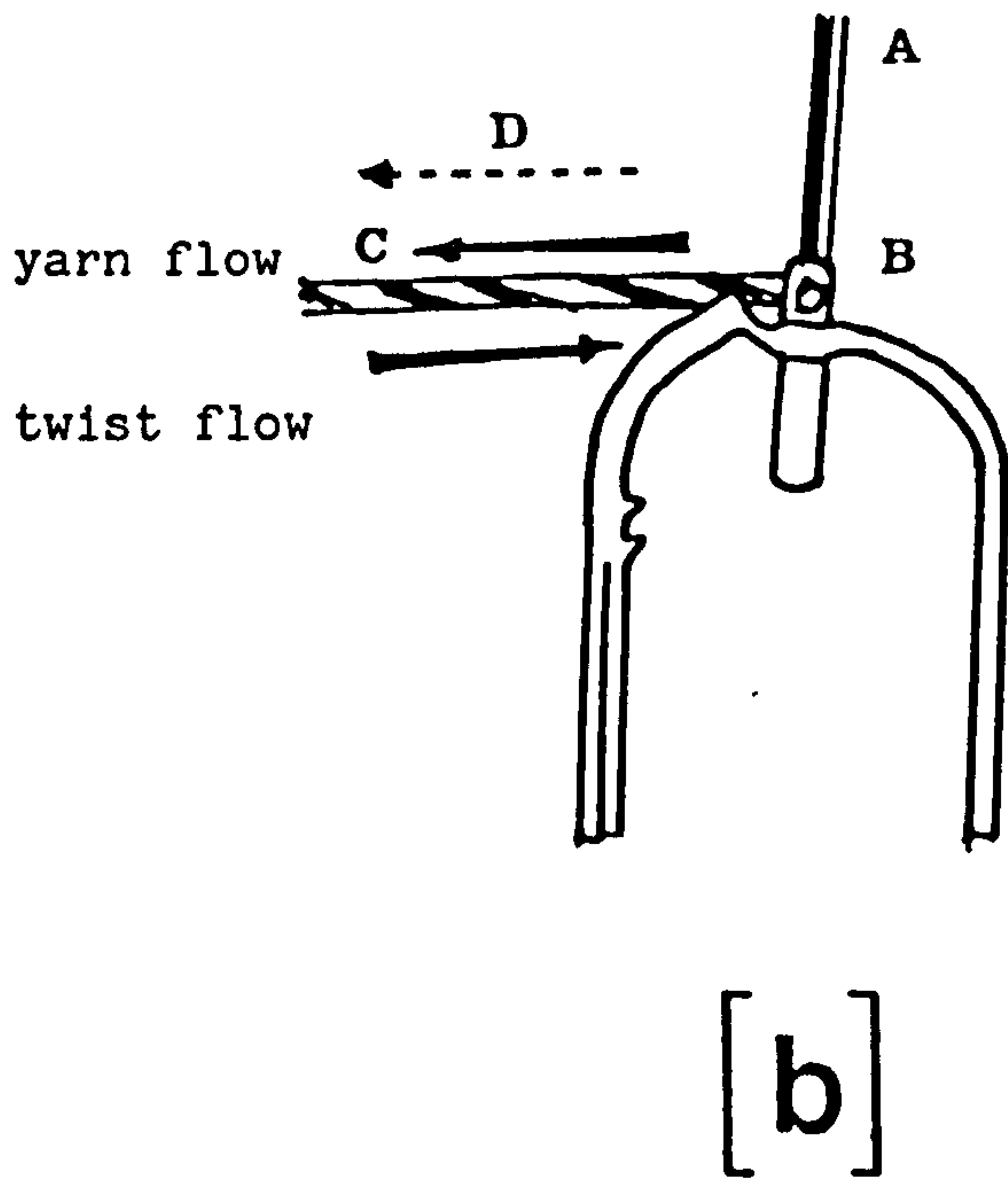

(upstream twist movement)

(Finkel'shtein)

FIG. 3.4

TABLE 3.1

Measurement stage	Nose	Shoulder
Start	38.5	31.7
Middle	39.0	31.0
End	38.5	32.0

Number of turns in  $2\frac{1}{4}$ "

Spun yarn 16s (37 tex)

Mechanical twist  $35.6/2\frac{1}{4}$ "

Average of 20 measurements

(Subramanian)

to the spinning region. As the yarn tension at the maximum balloon height tends to be lower than at the minimum height, the twist is higher at the nose than at the shoulder because the contact pressure between the yarn and traveller increases from the shoulder to the nose. At the same time, as the balloon becomes more conical, the angle of wrap around the traveller becomes larger and around the thread guide becomes smaller at the nose than at the shoulder. The twist thus gradually increases from the shoulder to the nose.

These results are in agreement with the results of Wegener and his colleague [84.85]. They used four different diameters of thread guide, 1.5, 3, 5, 10 mm at different angles of inclination ranging from zero to  $40^{\circ}$ . They found that the most significant effect of twist hold back is at the smaller guide diameter and with the highest value of the angle of inclination.

### 3.3 Discussion

It is evident from the above survey that the twist congestion phenomenon is very complicated. It has been explained that for both rotated and non-rotated threadlines, thread guides offer a resistance to the passage of the twist in the yarn which may prevent some or all of the twist from moving forward with or against the yarn flow over the contact region.

In downstream twist blockage the rotation of the yarn resulting from the pushed-back twist will generate some false twist in the twisted yarn in the same direction as the yarn's original twist. With rotated threadlines, twist congestion at a guide surface may cause a



major problem in preventing upstream flow of twist. For example, in the primary zone of the false-twist texturing process, path deflections tend to inhibit the transmission of twist upstream from the spindle to draw point on the primary heater [28,29].

The precise mechanism by which the twist is pushed back is still somewhat obscure. However, it is generally accepted that twist-transmission is effectively governed by the contact configuration, and pressure between the guide and the yarn as well as their surface characteristics all of which may have a considerable effect on generating or preventing the rotational behaviour of the yarn around its axis [55,56].

Although the phenomenon is considerably affected by the nominal yarn twist and, in particular, yarns with a low twist, usually tend to generate a higher blockage twist, the study of the effect of input twist on twist congestion in rotated and non-rotated threadlines has yielded inconclusive evidence [49,58,60] and conflicting results [40,52] of twist congestion behaviour respectively.

The effect of angle of wrap is another factor which has not yet been comprehensively investigated. The combined effect of variation in guide diameter with either angle of wrap or yarn tension will also give rise to changes in two factors, the length of the contact region and the pressure over the contact surface. The study of these two factors must, therefore, be made together.

The yarn parameters will also play an important part. In particular, the internal energy loss which occurs when the rotating, twisted yarn is bent round a guide surface, and the interfibre

friction in low twist continuous filament yarns are especially expected to have a major influence.

Unfortunately, observations made up to the present time do not fully explain the twist blockage phenomenon for either of the two types of blocking twist.

The parameters influencing twist accumulation may be classified as follows:

### I. Guide factors

A) The coefficient of friction will be influenced by

1. Guide material.
2. Guide surface topography (configuration), in relation to yarn material and structure.

B) Geometrical and mechanical factors:

1. Guide size.
2. Shape and location of the guide.
3. The relative and rotational movement between yarn and guide.

### II. Yarn factors

1. Fibre composition.
2. Number and linear density and cross-section of filaments or fibres.
3. Yarn singles and folding twist.
4. Yarn density and rigidity.
5. Yarn cross-section.
6. Lubricant applied to the yarn.
7. Yarn speed.
8. Yarn tension.

9. Temperature of the yarn at the point of contact particularly with thermoplastic yarns.
10. Yarn moisture content.

### III. Yarn/guide factors

1. Angle of wrap.
2. Contact length (a function of guide diameter and angle of  $R \theta$  wrap).
3. Yarn orientation relative to guide axis.
4. Yarn/guide pressure (a function of yarn tension and guide surface curvature).
5. Friction drag (a function of yarn/guide pressure and coefficient of friction).

#### 3.4 Scope and objective of the present work

The summary of the published literature presented above reveals that only a small amount of data has been published on the fundamentals of twist congestion in rotating and non-rotating threadlines.

Such information as is available is more readily applicable to Mill practice than to basic scientific investigation. The need for a more fundamental approach to understand the parameters affecting twist congestion in both types of yarn threadline and their influences on the mechanism is apparent.

Earlier work performed on twist blockage has dealt superficially with the effect of guide radius, angle of wrap and initial tension whether of rotating or non-rotating threadlines. These

parameters are limited compared with what could be investigated.

The study of the effect of, for example, number of filaments in the yarn, filament cross-section and yarn density on twist congestion are undoubtedly of great importance.

The relation between twist congestion and other parameters such as yarn twist and number of turns over the contact region, represents an important field of investigation.

As regards the effect of interaction parameters i.e. guide/yarn factors, there is some limited information available, the effect of pressure [52,62] and the frictional force [21,22] over the contact surface on twist congestion.

As far as has been found there is only report [55,56] of the relation between the angle of orientation (angle between the yarn axis and the guide axis) on twist blockage.

However, no fully satisfactory model from which twist blockage behaviour can be predicted has been proposed.

In view of these facts, it is the intention of this investigation to study in more detail twist accumulation in non-rotating threadlines and the effect of some variables such as guide size and angle of wrap. It has been suggested that the relation of the length of the arc of contact with the length of one turn of the yarn twist, over the surface of contact may be of significant importance.

This factor will be investigated in some detail, followed by an investigation, on a wider scale, of the effect of the yarn directional movement over the contact region on the twist blockage phenomenon.

Generally, the purpose of the present work has been to study the reasons why, and under what conditions, twist blockage takes place, identifying and establishing the factors which contribute to this phenomenon.

CHAPTER 4

APPARATUS AND TECHNIQUES

#### 4.1 Description of the apparatus

The apparatus as used in the present investigation is shown in Plate 4.1; this consists of:

1. Two hysteresis tension devices.
2. Two magnetic gripper attachments.
3. Four low-friction pulleys.
4. Yarn guide and guide assembly.
5. Take-off unit.
6. Air-suction unit.

##### 4.1.1 Tension device

The initial tension ( $T_1$ ) was applied by running the yarn through an alumina (sintered aluminium oxide) disc tensioner and around the pulley of an hysteresis brake, where the torque exerted by the yarn tension is opposed by the torque between a ferromagnetic disc fixed to the pulley and two permanent magnets.

A pair of magnetic hysteresis tension devices were used in order to minimise the effects of any fluctuations in tension in the yarn as it leaves the package and to avoid their transfer into the system.

##### 4.1.2 Magnetic gripper attachments

Magnetic gripper attachments were fitted on either side of the guide in order to provide a rapid grip on the running yarn.

These devices were found necessary for the following reasons:

1. It was observed that the yarn does not stop immediately when

## PLATE 4.1

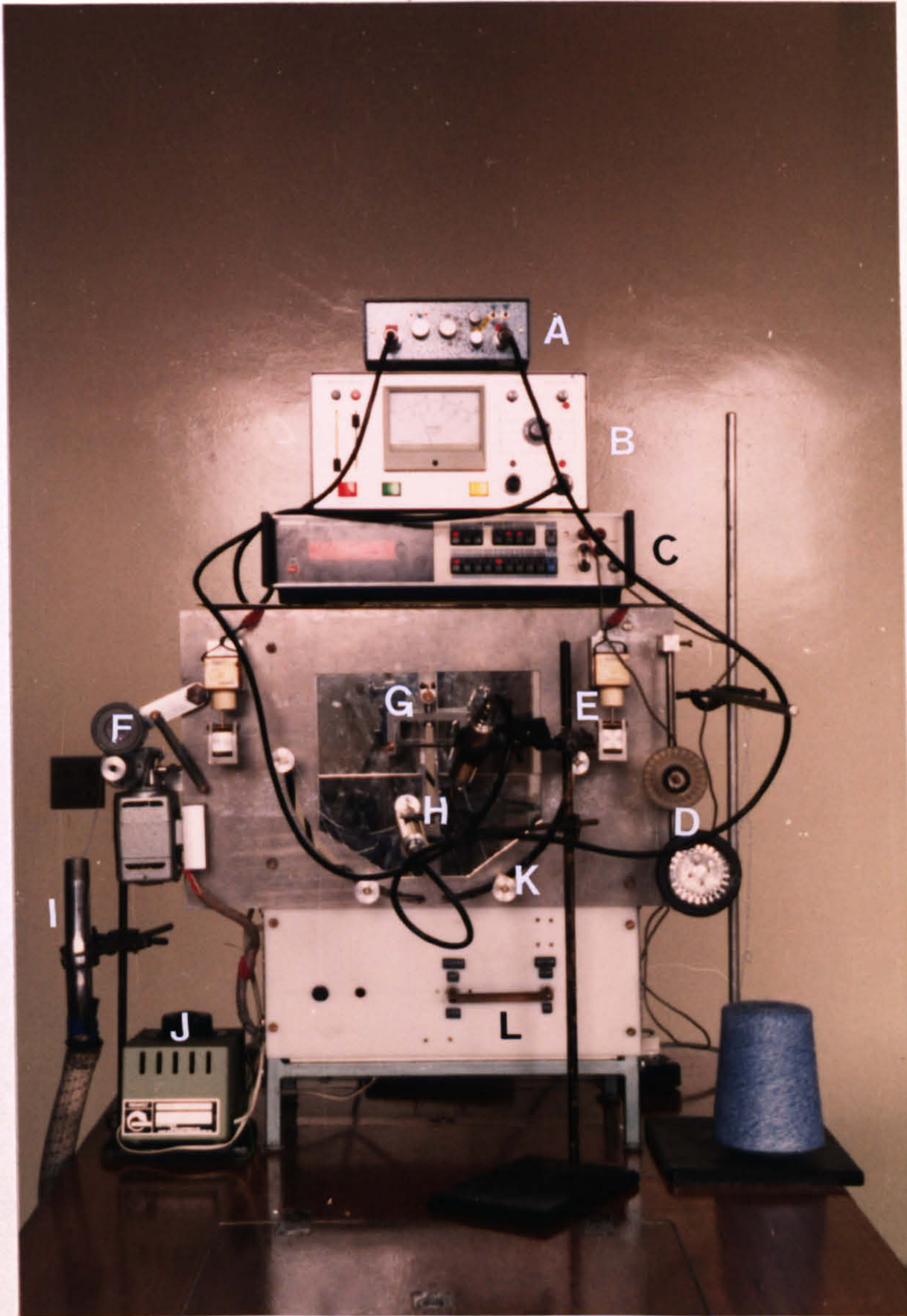

- A Function command apparatus
- B Yarn tension indicator
- C Micro-processor voltmeter
- D Hysteresis tension device
- E Magnetic gripper attachments
- F Take-off unit
- G Yarn guide
- H Head transducer
- I Air suction unit
- J Voltage regulator (speed controller)
- K Low-friction pulley
- L On-off switch



power is switched off and some turns of blocked twist may, therefore, escape to the other side of the contact region.

2. The yarn tends to slacken and loose its tension.
3. When tension is applied, the yarn becomes elongated and the twist distribution along the yarn might be different from that of an untensioned condition.
4. It is desired to examine the samples in their running condition.

Phil-trol, Solenoid-35, units, continuous duty (all time ON) were chosen for this purpose. The two jaws of the gripper were modified with two pieces of high resilient rubber bonded on the upper and lower surfaces of the two jaws of each of the two grippers. The electrical circuit of grippers is shown in Fig. 4.1.

The unit works on 2x24 volts D.C. 1 amp.

Both gripper units must operate immediately the yarn is stopped. This could be arranged by using a thin rod connected between the switches of the yarn motor and the grippers. On pressing the rod down, the motor turns off, and simultaneously the grippers close. By this method, none of the turns in the threadline in front of the contact region is lost.

#### 4.1.3 Yarn guides

Five steel capstans of 2,4,6,8 and 10 mm diameter were chosen to demonstrate the effect of yarn/guide surface contact on twist blockage. The rods were polished so that their surface was as smooth as possible (Plate 4.2).

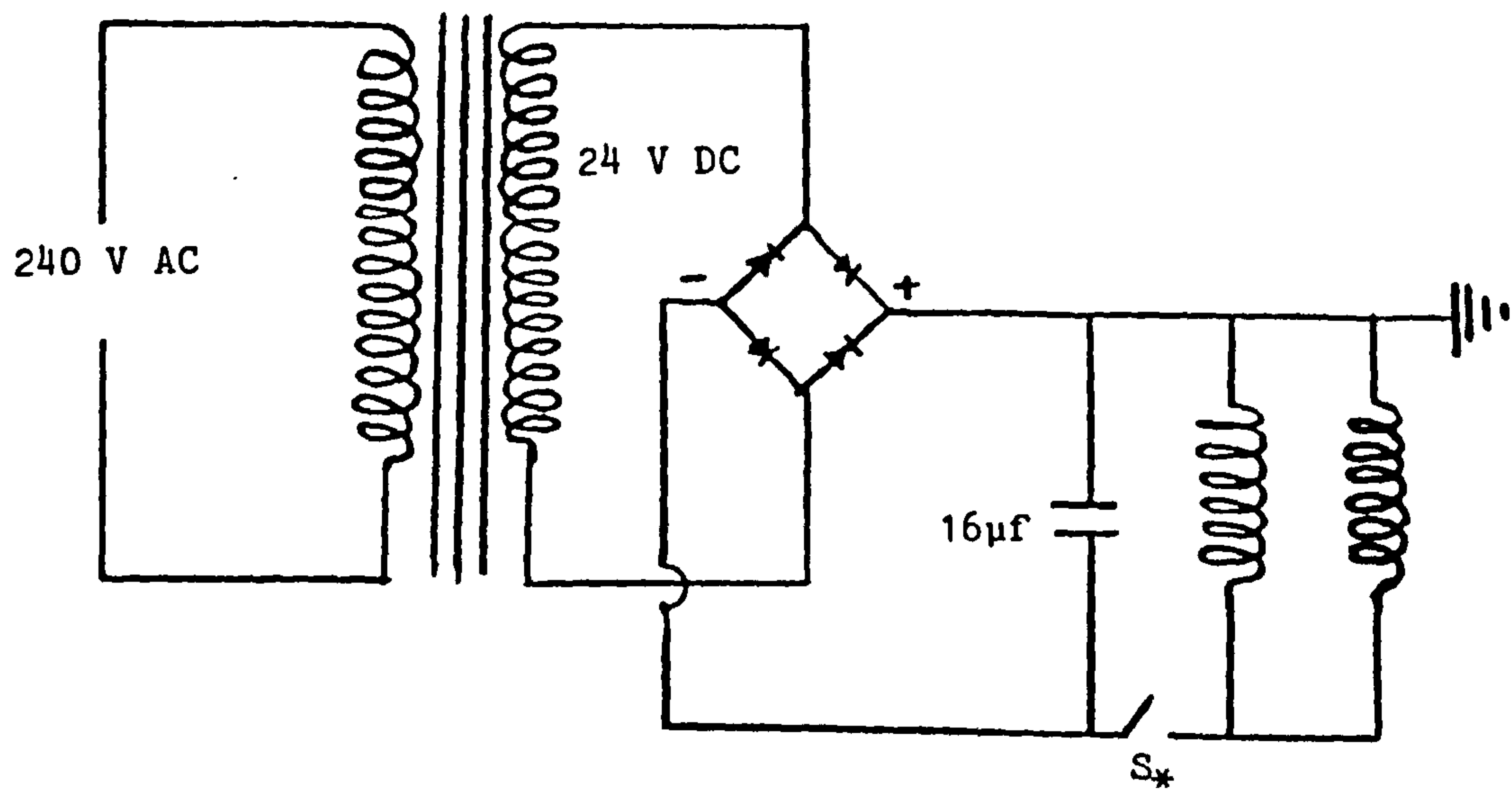

S\* - Switch

FIG. 4.1: Electrical circuit diagram of the magnetic gripper

## PLATE 4.2

## Yarn guides

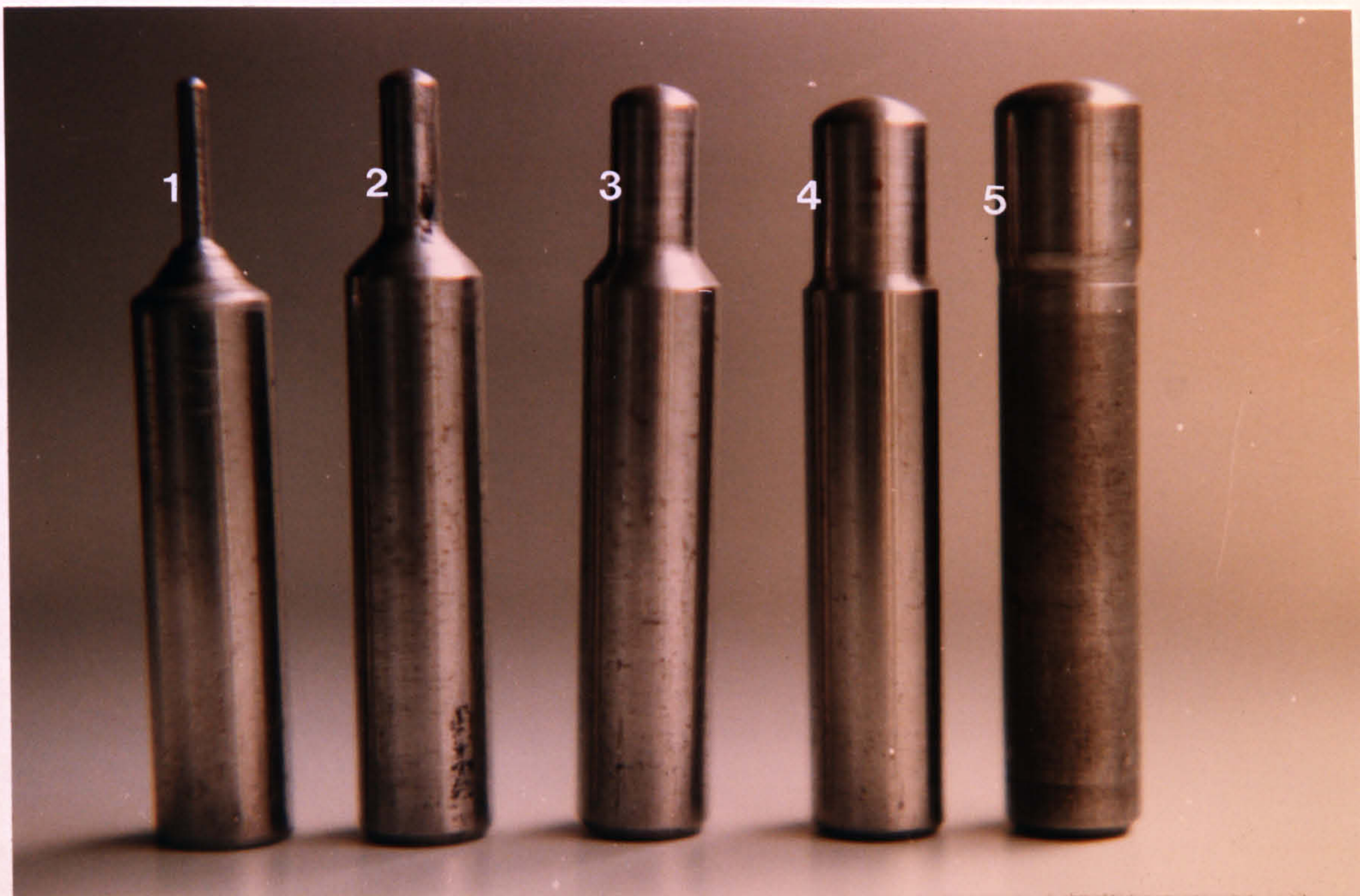

- 1 - 2 mm diameter
- 2 - 4 mm diameter
- 3 - 6 mm diameter
- 4 - 8 mm diameter
- 5 - 10 mm diameter

#### 4.1.4 Guide assembly

A guide assembly was designed to make it possible to examine the effect of angle of wrap on twist blockage. To achieve this, pulleys or guides could be adjusted in slots ( $S_1$ ,  $S_2$  and  $S_3$ ) to give the required deflection, (Fig. 4.2). The inclination of the guide under test could also be adjusted to examine the effects of this parameter.

#### 4.1.5 Low-friction pulleys

Four low-friction pulleys ( $P_1$ ,  $P_2$ ,  $P_3$ ,  $P_4$ ) were fitted in slots ( $S_2$  and  $S_3$ ). Two of them ( $P_1$ ,  $P_4$ ) are fixed while the others are movable as required. It can be seen from the figure that the pulleys ( $P_2$  and  $P_3$ ) can move in a circular path, at the centre of which is the yarn guide. The reasons for these pulleys and their slots are:

1. To vary easily and efficiently the value of the angle of wrap between zero to  $360^\circ$ .
2. To sustain a sufficient yarn length for testing.

#### 4.1.6 Measuring the angle of wrap

After adjusting the angle of wrap by using the slots ( $S_1$ ,  $S_2$ ,  $S_3$ ), the angle of wrap around the yarn guide could be measured simply and accurately. Steel templates together with a mirror fixed on the apparatus frame were used. The required angle of wrap was set-up first on the templates, then one leg of the templates was placed along the incoming yarn (between the guide (G) and the pulley ( $P_2$ )), the other leg along the outgoing yarn (between the guide (G) and the pulley ( $P_3$ )). When the image of the templates, the templates themselves, and the yarn path appeared to coincide the required angle was achieved.

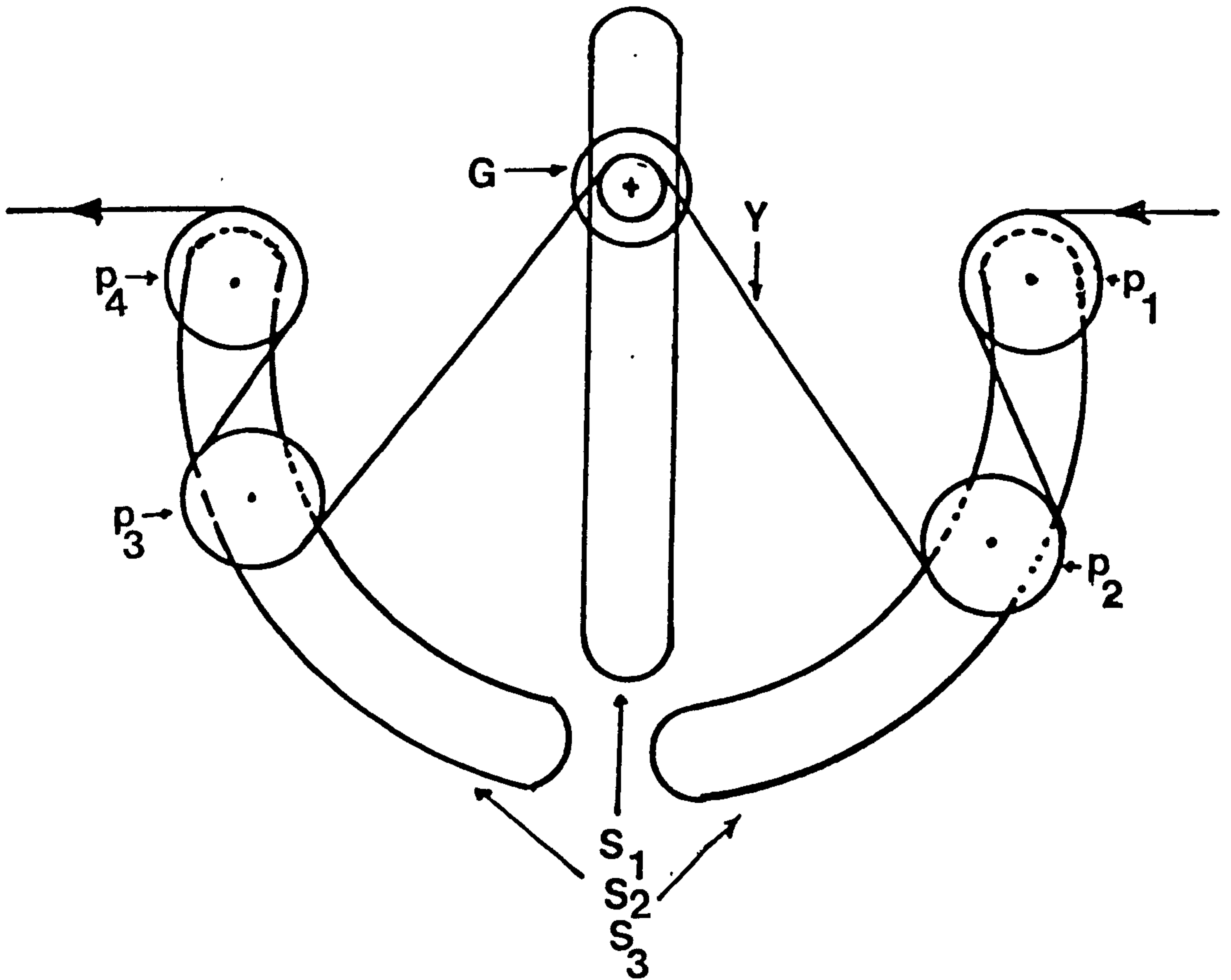

$P_{1,2,3,4}$  - low-friction pulleys  
 $S_{1,2,3}$  - slots  
 $G$  - yarn guide and guide assembly  
 $Y$  - yarn

FIG. 4.2

#### 4.1.7 Adjusting the angle of orientation

It was found easier to incline the guide to the threadline (i.e. to turn the guide through an angle relative to the threadline rather than vice versa). The initial construction is shown in Fig. 4.3. The guide was fixed into the assembly (B) by a small screw (C). It could move right or left around the axis (XX). A protractor ( $P_r$ ) was fixed on the centre of movement (i.e. XX). Any rotation of the guide could, therefore, be measured by means of the protractor.

Unfortunately, it was observed that the protractor does not measure the actual angle of orientation. The reason is illustrated in Fig. 4.4. When the guide is oriented at an angle  $\hat{\beta}$  (i.e. the guide at the  $XG_1$  position) the yarn, instead of taking the position (YY) over the guide surface, took the position ( $Y\bar{Y}$ ) where the actual angle of orientation is  $\beta$ , whereas the protractor measures the angle  $\bar{\beta}$ . Because the guide deflected the yarn aside, in this way an angle was generated between the planes containing the old and new threadline.

This difficulty arose because the guide does not rotate around the point of yarn/guide contact, and consequently, a wrong measurement of angle of orientation occurs.

To achieve the correct measurement of angle of orientation, it was decided to design another guide assembly where the guide can rotate around the axis (XX) i.e. around the point of contact between the yarn and the guide. This axis can also be made to pass through the centre of the protractor. The correct angle of orientation can, therefore, be measured accurately. This second guide assembly is shown in Plate 4.3.

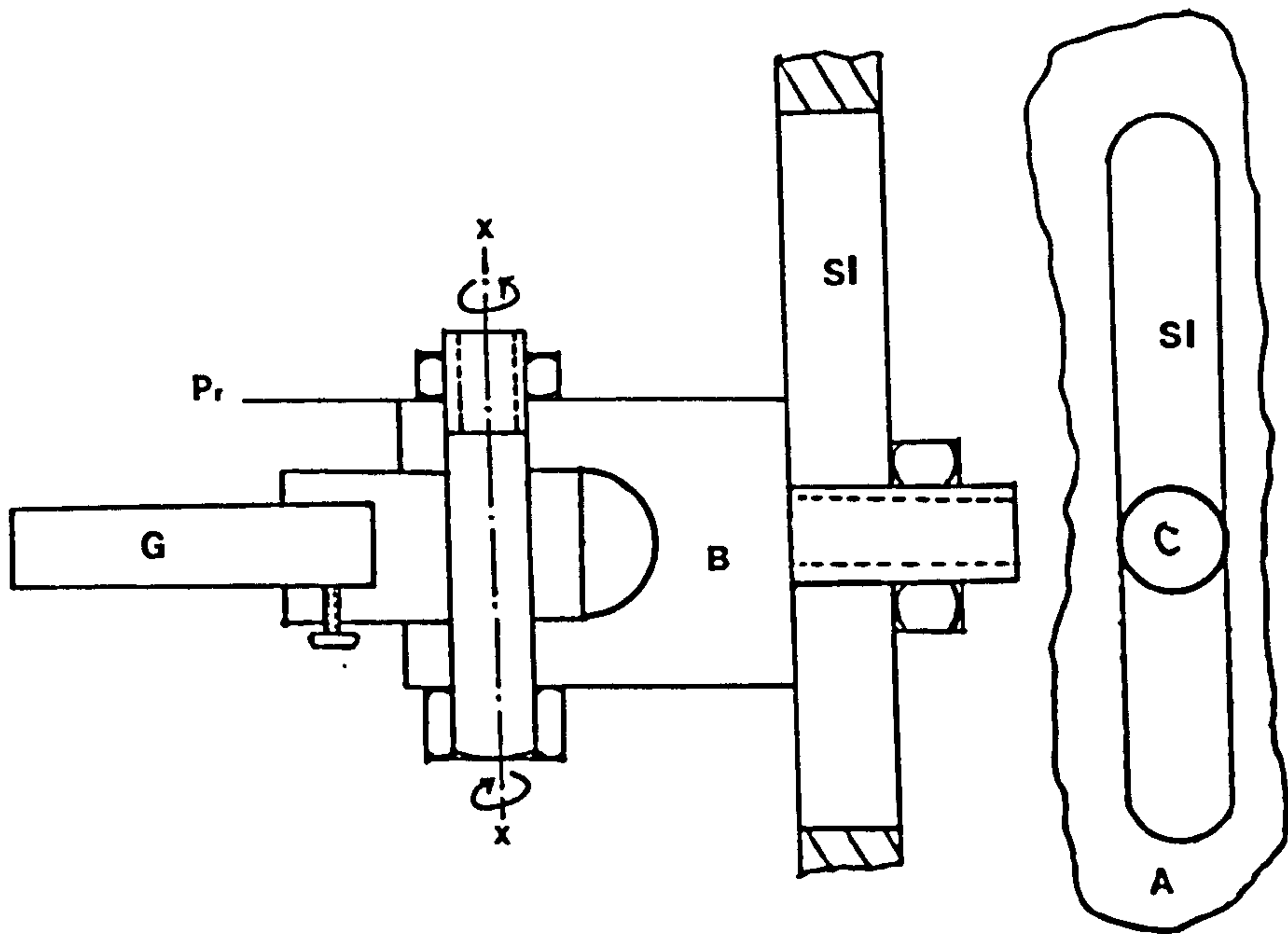

- Pr - protractor
- G - yarn guide
- XX - line of guide rotation
- B - guide assembly
- SI - slot
- C - screw
- A - apparatus frame

FIG. 4.3

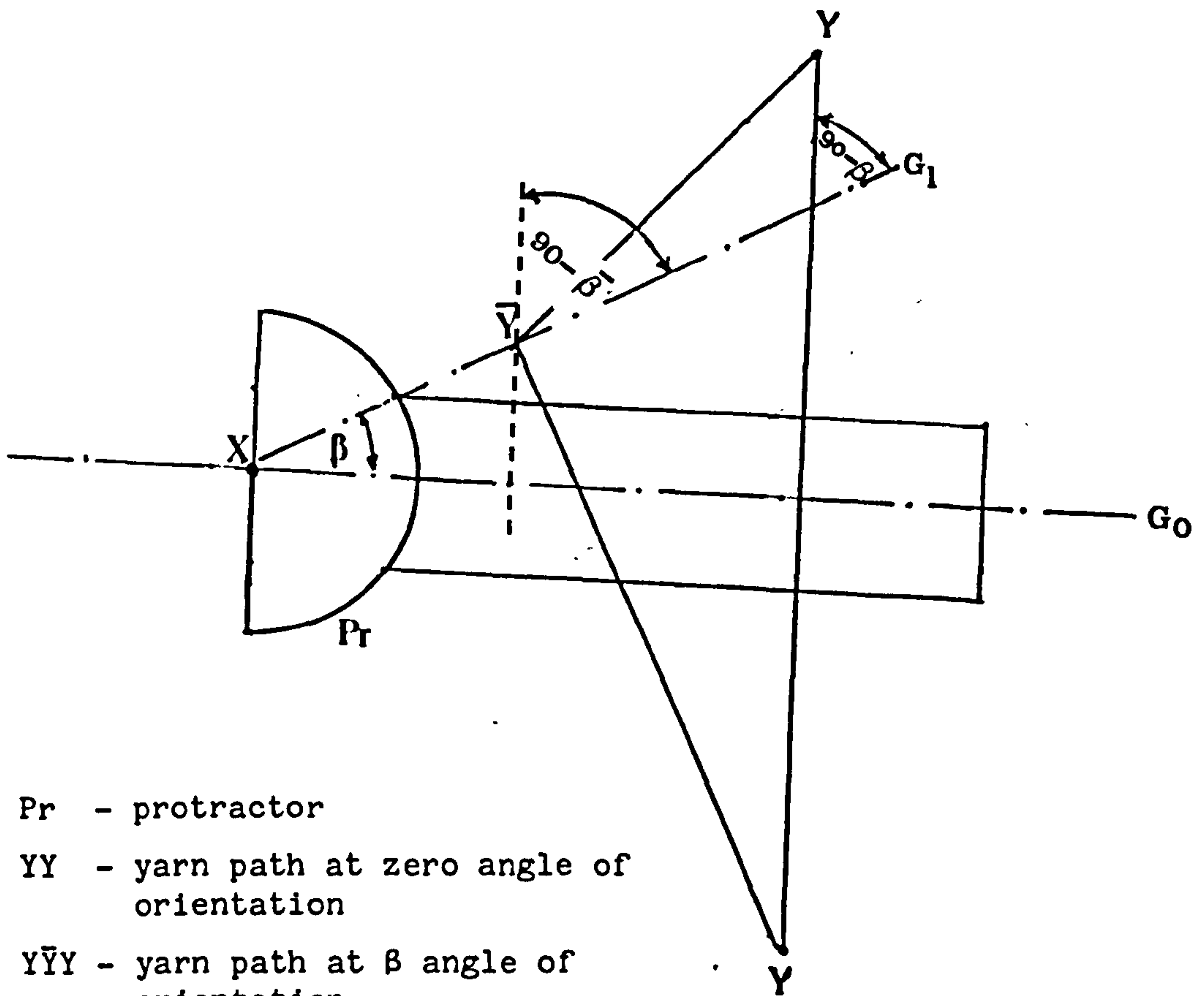

- Pr - protractor
- YY - yarn path at zero angle of orientation
- $\bar{Y}Y$  - yarn path at  $\beta$  angle of orientation
- $XG_0$  - guide axis at zero angle of orientation
- $XG_1$  - guide axis at  $\beta$  angle of orientation

FIG. 4.4: Schematic diagram of the actual angle of orientation



## PLATE 4.3

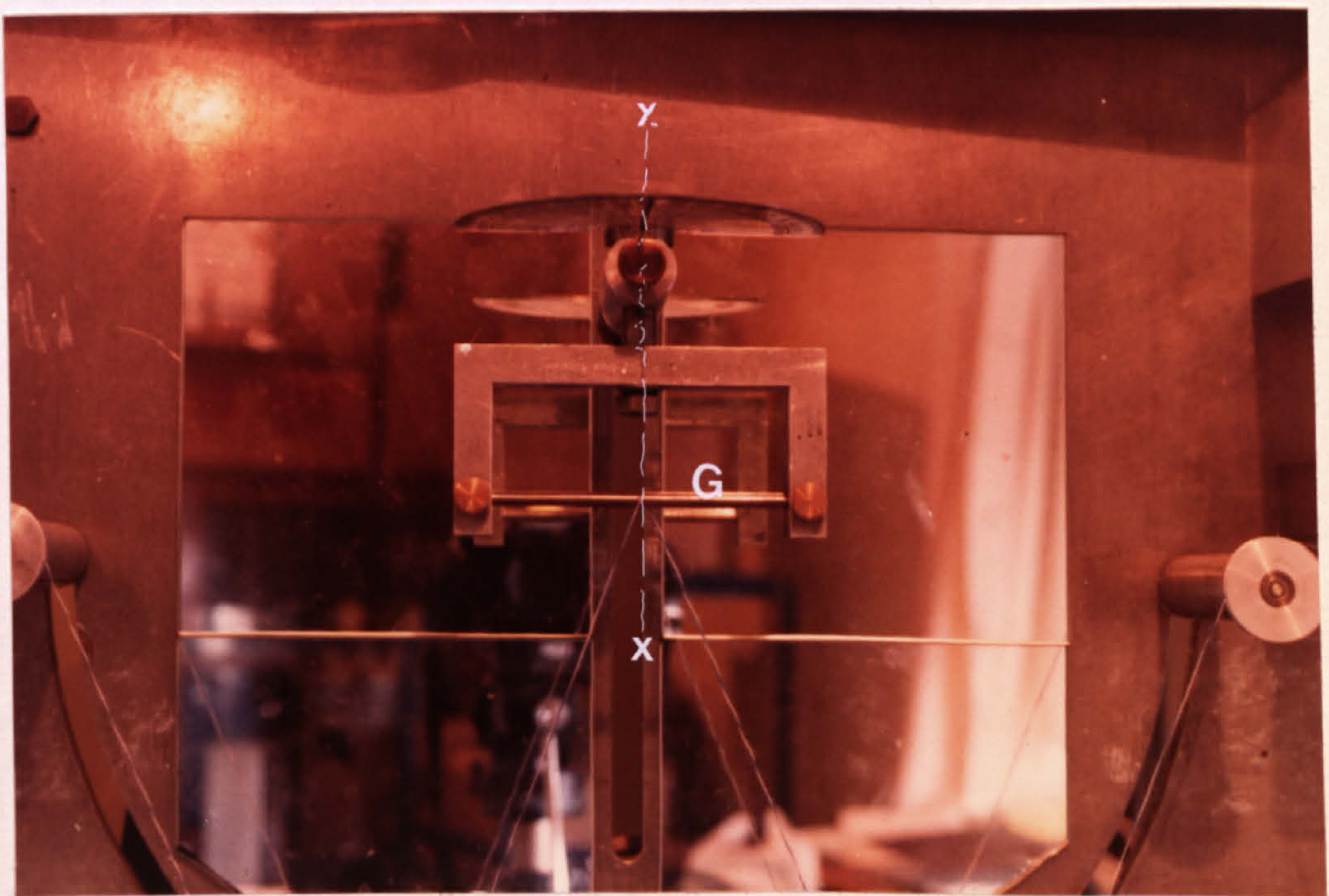
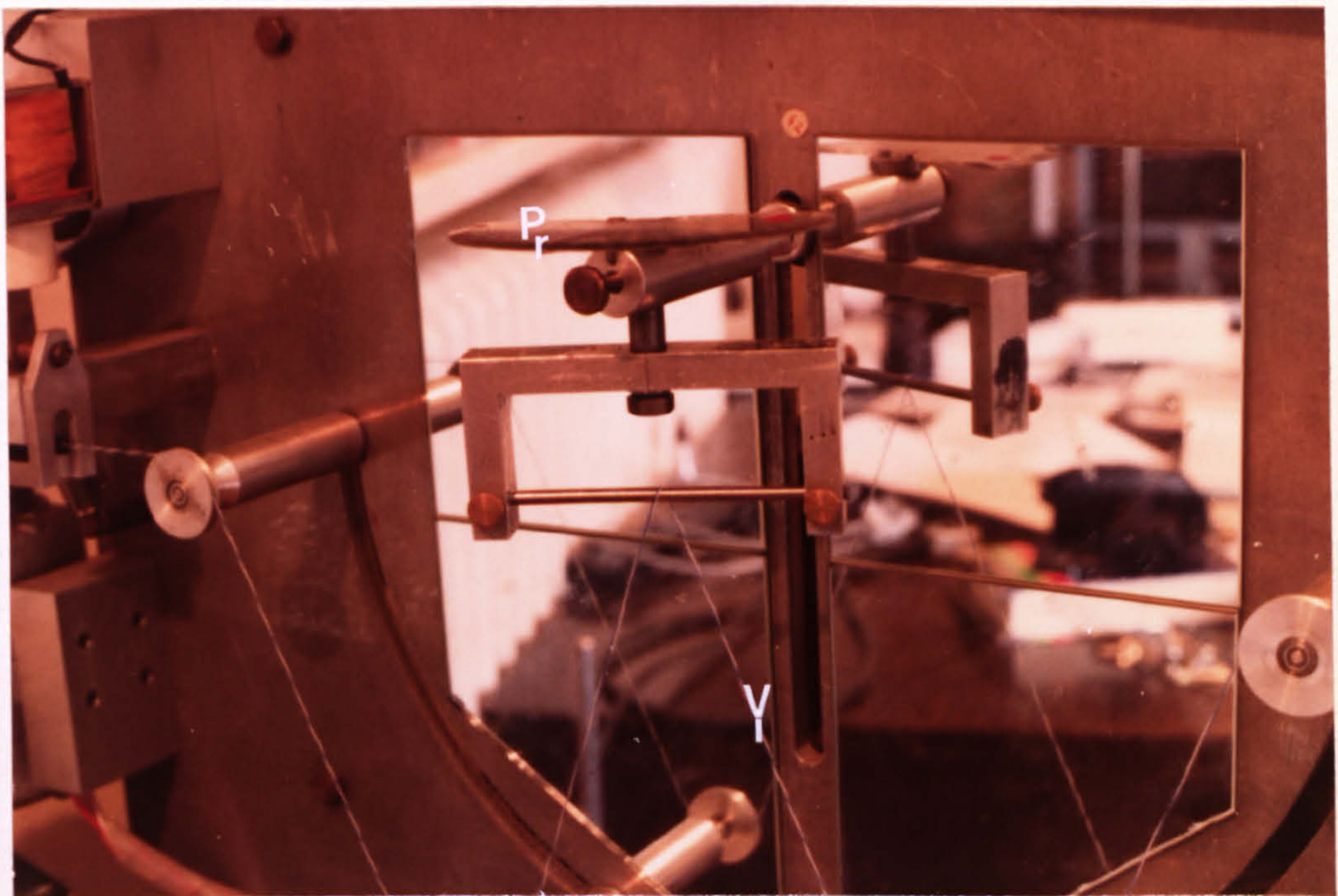

- P<sub>r</sub> Protractor  
G Yarn guide  
Y Yarn  
X-X Line of guide rotation

#### 4.1.8 Driving unit

The yarn was driven by a variable speed motor. The motor is 220 V AC, 50 watt (1/15 HP) DC shunt, 0.15 amp and 4000 r.p.m. maximum. For the purpose of reducing the speed a gear box was attached. Its maximum torque is 3 kg·cm at 960 r.p.m. Two rollers are attached to achieve a variable yarn speed from zero to 136 m/min.

In order to facilitate observation of the yarn movement over the guide surface, the twist, the twist congestion and yarn rotation, a low speed of 4 m/min was used. It was necessary to increase the magnitude of the power supplied to the driving motor in order to sustain a constant speed when increasing yarn tension, otherwise the motor speed would decrease as the tension increases. The required speed was controlled by a voltage regulator (Variac type 42A). A constant check on the motor speed was carried out during the experiments.

At high tension, the yarn tends to slip over the surface of the driving rollers. The yarn was, therefore, wound around the rollers as shown in Fig. 4.5.

#### 4.1.9 The yarn suction unit

The yarn after passing over the test apparatus was removed by using an air suction device. It included 0.33 HP, AC motor driving a suction fan. Between the suction unit and driving motor, a yarn trap was placed in a container, which allowed only air to pass through a hose to the fan. The capacity of the fan was  $0.15 \text{ m}^3/\text{min}$ .

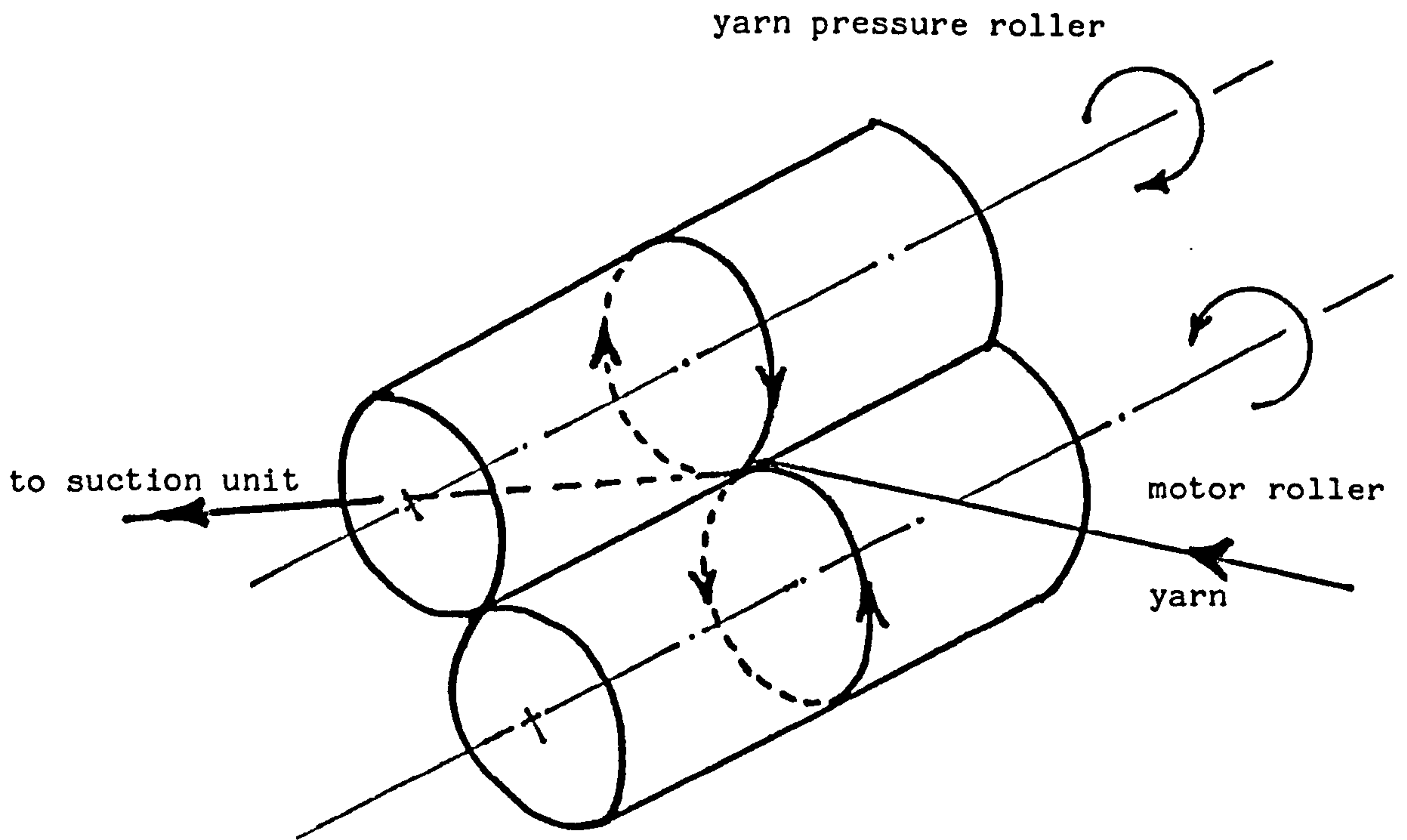

FIG. 4.5: The yarn path over the yarn pulley roller unit

#### 4.2 Yarn used in the experiments and twist insertion

Yarn from two types of material was used. 30 tex acrylic worsted spun yarn (fawn and blue), and 16.7 tex, 30 filament, continuous filament textured yarn (beige and dark brown) of Polyester.

The different colours of each yarn were doubled and twisted for different ranges of twist from 50 to 1000 t/m.

The higher levels of twist were inserted by a Volkmann two-for-one machine whilst the lower level (under 100 t/m) was carried out by the universal ring twisting machine.

Initially, sufficient information concerning the universal ring twisting machine was not available to facilitate, for example, the setting up of the spindle speed and the yarn delivery speed. This caused difficulty in achieving the required twist. The twist was, therefore, set up by trial and error, changing the gears of the yarn delivery until the appropriate combination was found. This in accordance with the expression  $\frac{N_1}{N_2} \times \frac{N_3}{N_4} = \text{turns/cm}$ . Figure 4.6 shows the gear layout; the N's are the gear wheel teeth numbers of the ring twister.

Because of the significant twist variation occurring in the ring-twisted yarn and due to other variations produced by the rewinding of the twisted yarn from the spool of the ring twister onto cone, where the yarn passes over several guides under tension, the twist distribution through the yarn may vary. Such yarn was rejected.

In order to minimise this problem a larger traveller than normal was used in ring twisting so that twist blockage at the

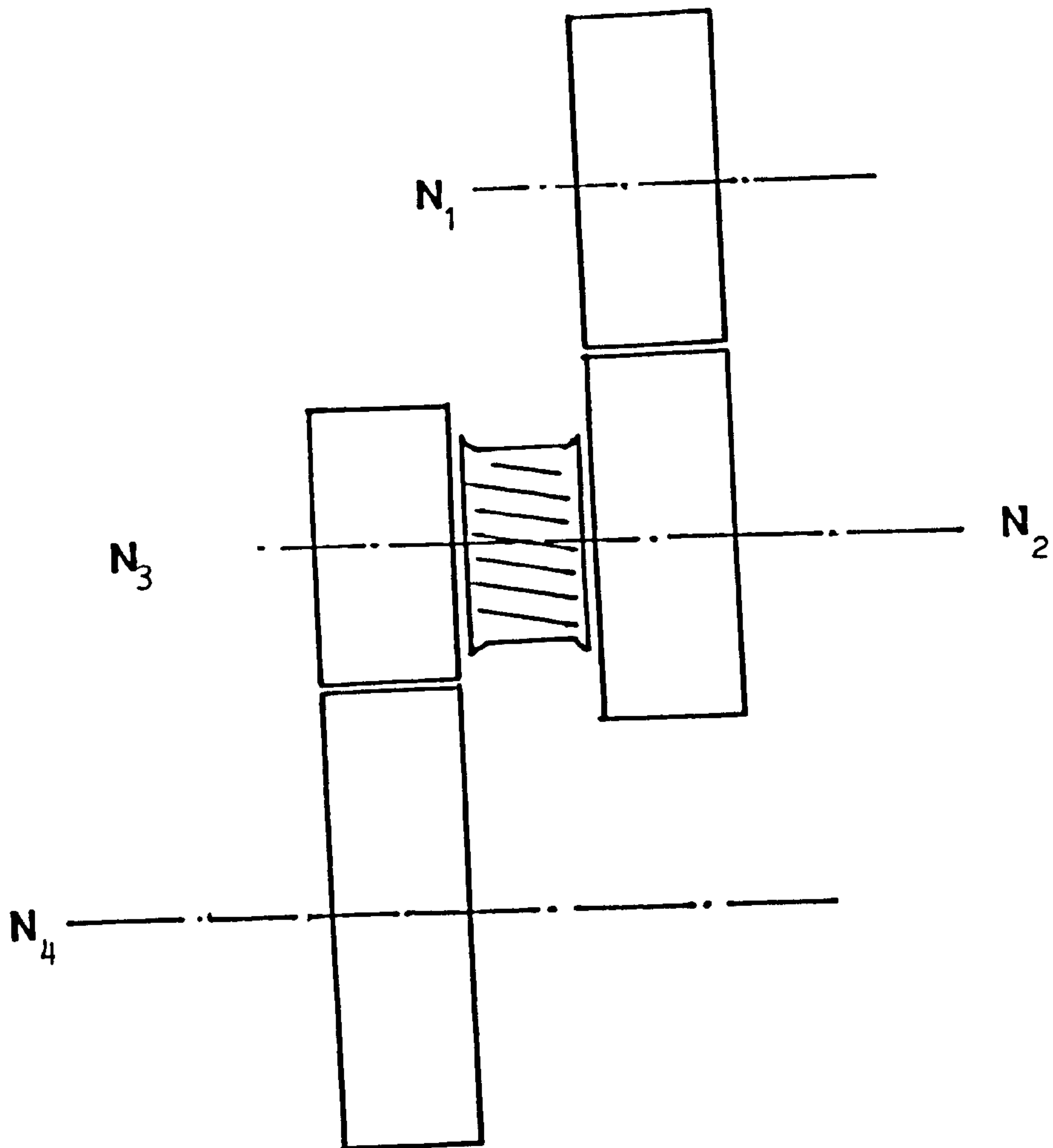

$$N_1 = 38$$

$$N_2 = 60\frac{1}{2}$$

$$N_3 = 44$$

$$N_4 = 72\frac{1}{2}$$

FIG. 4.6: Schematic diagram of the gear layout

traveller was reduced. In addition, yarn was tested straight from the ring twister spool and there was no rewinding. Plate 4.5 shows the two types of traveller. The first type (No. 19 steel 21/32" RR) is the common type for this yarn count. The second one (No. 6 steel 21/32" RR) was used in the research. The radius of the curvature of the second type is nearly four times that of the first. In addition an attempt was made to use a plastic traveller (Temlon) of the same diameter because this is lighter than the steel traveller. Unfortunately, the twist regularity through the yarn was again found to be poor. This may be attributed to the high coefficient of friction between the Temlon traveller and the yarn. The traveller was tending to push the twist back along the yarn i.e. to cause twist blockage.

### 4.3 Yarn testing technique

#### 4.3.1 Method of twist testing

The commonly used methods of twist measurement rely on taking samples and untwisting until the twist practically reaches a zero level as indicated by the parallelism of the yarn components or fibres.

To overcome the possibility of losing a few turns during the taking of the sample and transferring it to a twist tester, an ideal method could be where no untwisting is involved or where there is no other possibility of influencing twist by, for example, changes in parameters such as yarn tension. There are two possibilities:

Firstly, the optical method, not involving any physical operation on the yarn for twist estimation. The twist in the yarn ( $N_y$ ) may be expressed in terms of the twist angle  $\hat{\alpha}$  as:

## PLATE 4.5

Types of traveller used

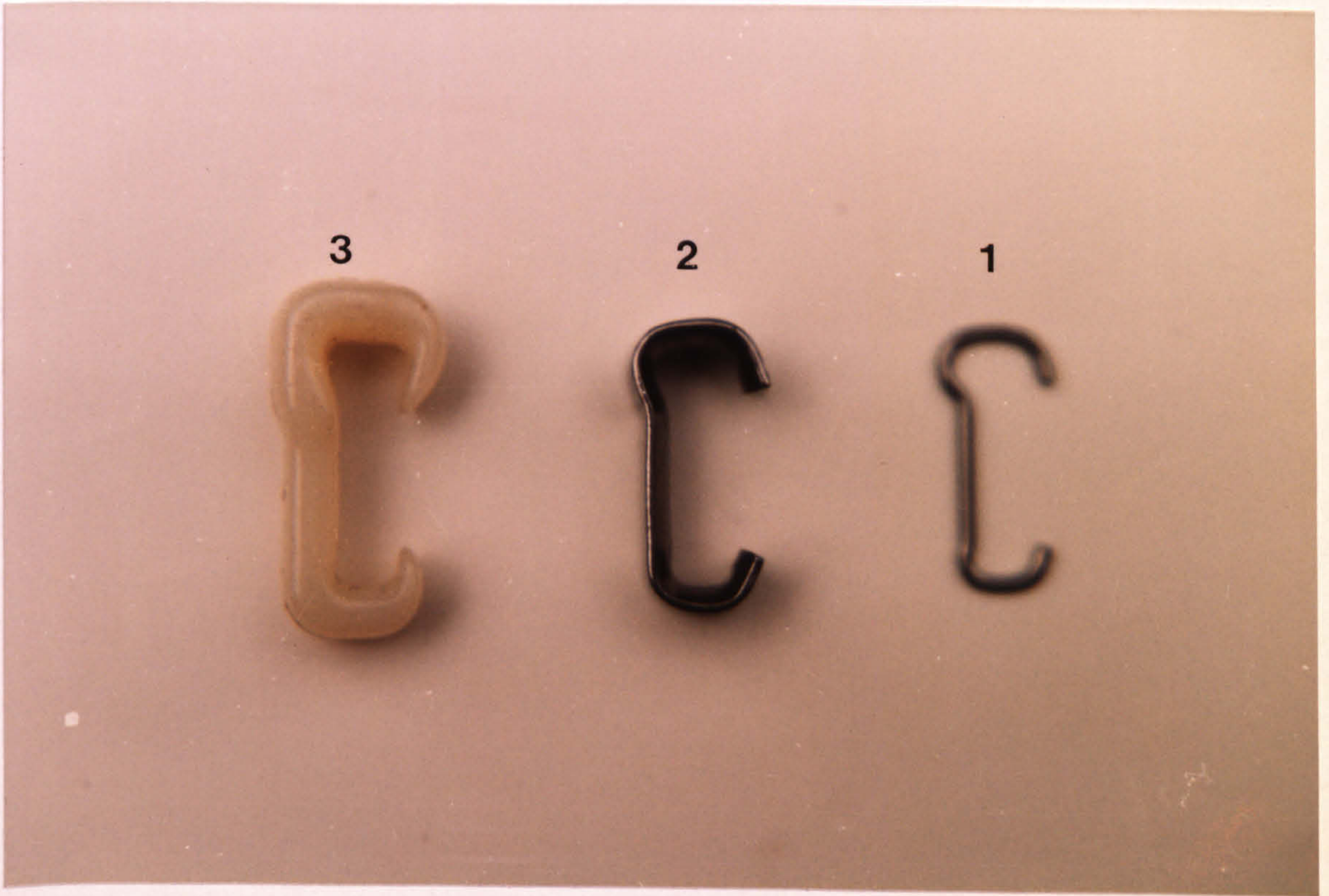

1. No. 19 steel 21/32" RR
2. No. 6 steel 21/32" RR
3. No. 6 Temlon 21/32" RR

$$N_y = \tan\alpha / \pi D_y$$

where  $D_y$  is the yarn diameter.

If the twist angle  $\hat{\alpha}$  is measured together with the corresponding diameter of the yarn with the help of an optical microscope, the absolute yarn twist may easily be calculated without actually untwisting the yarn. The main difficulty is in estimating the true twist angle and true yarn diameter.

Secondly, samples can be taken directly from the yarn under test and mounted on glass slides with the help of adhesive tape such as Sellotape. The twist can be measured by means of a travelling microscope.

The second method was adopted as being simpler and more accurate.

A glass slide of 10 cm length was chosen, two black lines, 8 cm apart being drawn on the slide. Two pieces of Sellotape were partially fixed on the slide beyond the 8 cm marking. The slide was placed in contact with the yarn and the sample fixed by pressing the Sellotape into place. The slide with the sample was then cut away from the threadline. The slides were mounted on a travelling microscope. The number of turns between the black lines was observed and the twist in turns/metre was calculated.

#### 4.3.2 Number of samples

The sample size was calculated to give a precision of the mean of the test results of  $\pm 5\%$  at a probability of 95% using the relation [86]



$$U = 0.154 \sigma^2$$

where  $U$  is the number of test specimens, and  $\sigma$  the coefficient of variation of individual test results. 10 to 40 slides were prepared for each of the yarn samples according to this equation. The standard error also was observed to be not more than 3 t/m.

#### 4.4 Tension measurement

The effect of tension on twist blockage during yarn processing has been a major point of attention of many investigators.

Because of the importance of this parameter and its dependencies such as frictional drag between the yarn and the contact surface, an accurate and reliable method for its measurement was very necessary.

In the present experiments, the ingoing tension ( $T_i$ ) and the outgoing tension ( $T_o$ ) were measured with two separate transducer heads, one for  $T_i$  and the other for  $T_o$ , of a Rothschild Tensiometer (R-T) coupled with a Micro-Processor Volt-meter (MPV).

##### 4.4.1 The measuring head (H)

The measuring head (Rothschild type R-1095) illustrated in Plate 4.1 makes direct contact with the yarn. A central measuring pin and two yarn guides on either side of it protrude from one end, and a plug-type connection with the Rothschild indicator from the other end. The angle of wrap of yarn around the measuring pin is equal to  $30^\circ$  and the maximum deflection of its pin is 0.1 mm. The deflection of the centre pin is detected through a differential capacitor. Two different measuring heads were available which cover a total measuring range from 0-to-100 gf and from 0-to-400 gf. These have responses up to

300 and 200 Hertz respectively.

When the measuring head is placed in the yarn path it is necessary to make sure that the path of the incoming and outgoing yarn is exactly in the same line otherwise the tension measurement may be affected.

It was observed that the values of measurements changed slightly with time, and to obtain a precise reading it was necessary to calibrate the indicator meter (Rothschild device) regularly.

#### 4.4.2 The indicator apparatus (R-T)

The Rothschild type R-1192 yarn tension indicator was designed in such a way that the most important control buttons and indicator units are on its front panel. This apparatus was used for direct indication of the measured yarn tension values in gram force. These measured values can be integrated for the desired times in seconds. This facility was not used, however, but a non-integrated signal was fed to the MPV for further processing, thus taking maximum advantage of the sensitivity of the MPV. The measured yarn tension values may be indicated on three different ranges, so that the reading on the apparatus scale corresponding to either the nominal value, half or the one-quarter of the measured tension may be shown. This yarn tension indicator was used as a useful part in the electronic yarn tensiometer device and was a means of transferring the input signal from the transducer to the MPV. This also gave a useful indication of tension level enabling the Rothschild output to be adjusted before making a permanent recording by means of the MPV.

#### 4.4.3 The microprocessor voltmeter

The MPV is able to make conventional [87] measurements and display them at the time of processing, or measurements may be recalled at the end of a run. The three programs used were as follows:

##### 1. Program 1 multiply $\Lambda = EX$

where  $\Lambda$  = measurement,  $E$  = constant and  $X$  the value of the voltage transmitted to the MPV by the transducer head.

Each measurement is multiplied by a constant ( $E$ ) which is inserted into the instrument through the keyboard. A different value of  $E$  is required when the transducer head is changed.

To enter the constant ( $E$ ) into the MPV, the indicator of the Rothschild device is first set at say  $A$  g tension, using either the zero adjustment of the function command unit or of the Rothschild. A display reading ( $B$ ) will appear on the MPV. Thence  $E = \frac{A}{B}$ . This ratio is then entered into the MPV. The resultant reading displayed is then equal to  $\Lambda = EX$ .

##### 2. Program 7 statistics

This program has 5 options, option '0' display each measurement, option 1 the average value, 2 the variance, 3 the standard deviation and option 4 root mean square deviation.

Option 1 was used, but at the end of any run, other options can be recalled from the memory of the MPV.

##### 3. Program 9 time

The MPV brings all measurement and processing under a comprehensive time control through the action of an internal clock.

The program has two options; option '0' was used to display at intervals of one minute.

The average of 300 observations were displayed each minute and this provided one measurement. The process was repeated five times and the average calculated.

#### 4.4.4 Simultaneous tension measurement

As previously indicated, in order to study the effect of tension and friction around a guide on twist blockage, a simultaneous reading of  $T_1$  and  $T_0$  is required. Difficulties in achieving this could be attributed to the following:

1. Friction is generated by the tension transducer head at the input side of the threadline, which increases the value of the outgoing tension measurement by up to 30 gf.
2. The MPV has only one channel and thus can measure only one of the two tension values.
3. Owing to the different sensitivities of the head transducers, it is necessary to calibrate the indicator and change the insertion constant (E) of the MPV.

Because of these difficulties it was decided to build an electronic circuit (function command circuit) which operated with the Rothschild (R-T) and MPV to achieve the required function.

A schematic diagram for the measuring system is shown in Fig. 4.7 and Fig. 4.8.

#### 4.4.5 Function command circuit

As pointed out (Appendix I) the friction drag (F) over the guide can be obtained from the tension difference (i.e.  $F = T_o - T_i$ ) and the coefficient of friction (K) can be calculated from the logarithmic ratio of  $T_o$  and  $T_i$ , thus, the basic purpose of the function command circuit is to display the difference between two input signals as well as the logarithm of their ratio. The circuit consists of two parts. The first part consists of three similar ICs op-amps of type LM308. The first two of them take their input signals from the two head transducers ( $H_1$  and  $H_2$ ), while the third is fed by the previous ICs. The output signal is connected to the input of Rothschild indicator (R-T) channel 1, via a diode (to isolate any negative signal that may exist) Fig. 4.7.

The output response of this part is the difference between the input-tension and the output-tension (i.e. frictional drag over the contact surface) displayed on the MPV.

The second part is a log-amplifier IC of type LM0094 which has been constructed to generate the logarithmic value of the ratio of the above two input signals. Scaling resistors are added to the output as shown in Fig. 4.8.

As a matter of fact, the sensitivity difference between the two heads causes a practical problem of zero error, it was essential, therefore, to provide the circuit with a zero adjustment facility. This is achieved by shunting the amplifiers IC 1 and 2 by a suitable resistance  $R_9$ .

Because of the inclusion of the modified circuit, the meter of the Rothschild Tensiometer was deviated from the zero position.

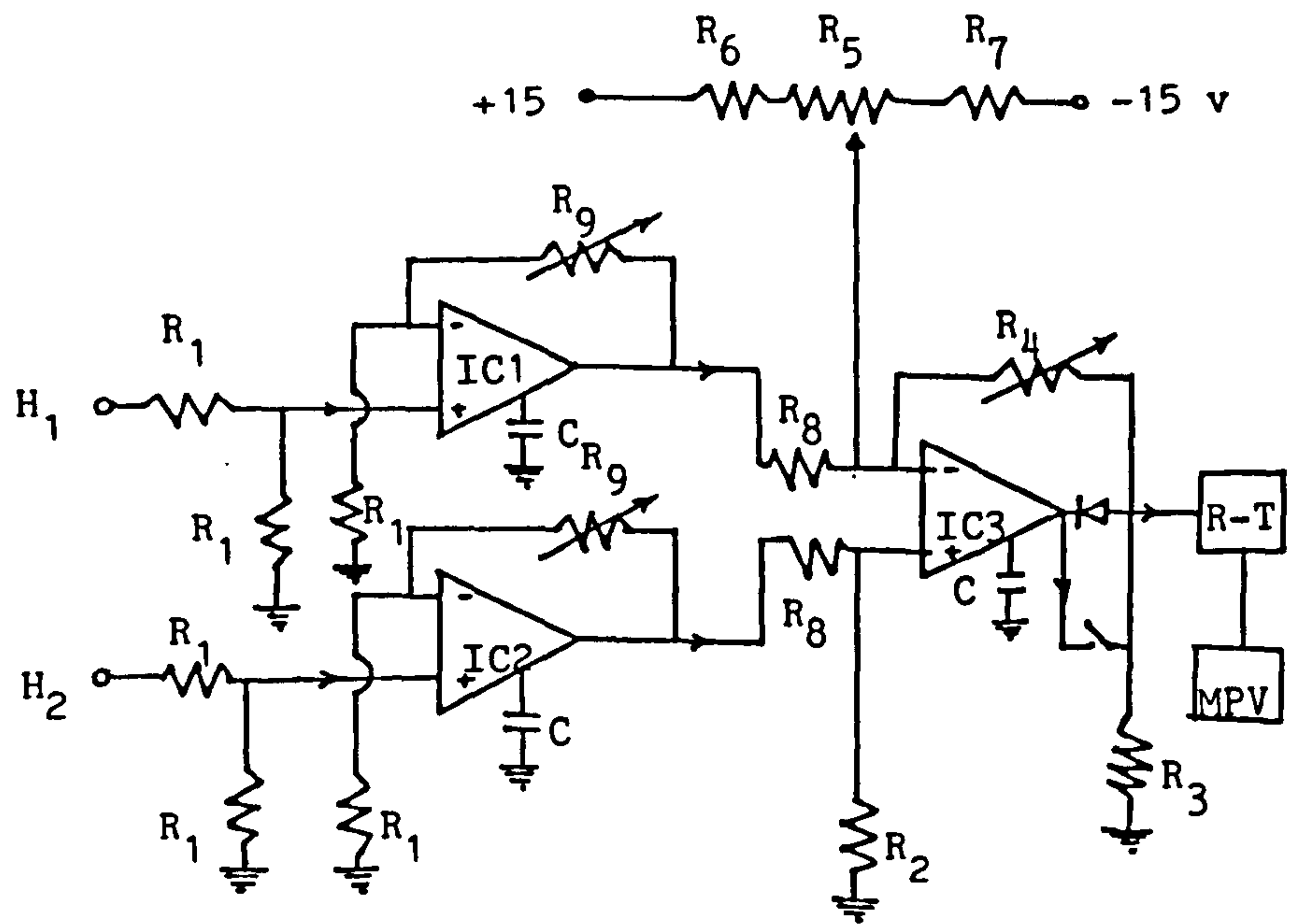

$R_1 = 10 \text{ K}\Omega$   
 $R_2 = 100 \text{ K}\Omega$   
 $R_3 = 1.0 \text{ K}\Omega$   
 $R_4 = 100 \text{ K}\Omega$   
 $R_5 = 150 \text{ K}\Omega$   
 $R_6 = 100 \text{ K}\Omega$   
 $R_7 = 100 \text{ K}\Omega$   
 $R_8 = 100 \text{ K}\Omega$   
 $R_9 = 10 \text{ K}\Omega$

$C_1 = 1 \text{ pF}$   
 $H_1$  and  $H_2 =$  head transducer  
 $R-T =$  Rothschild tensiometer  
 $MPV =$  Microprocessor voltmeter

FIG. 4.7: Electronic circuit diagram of friction unit

FIG. 4.8: Electronic circuit diagram for measuring the coefficient of friction

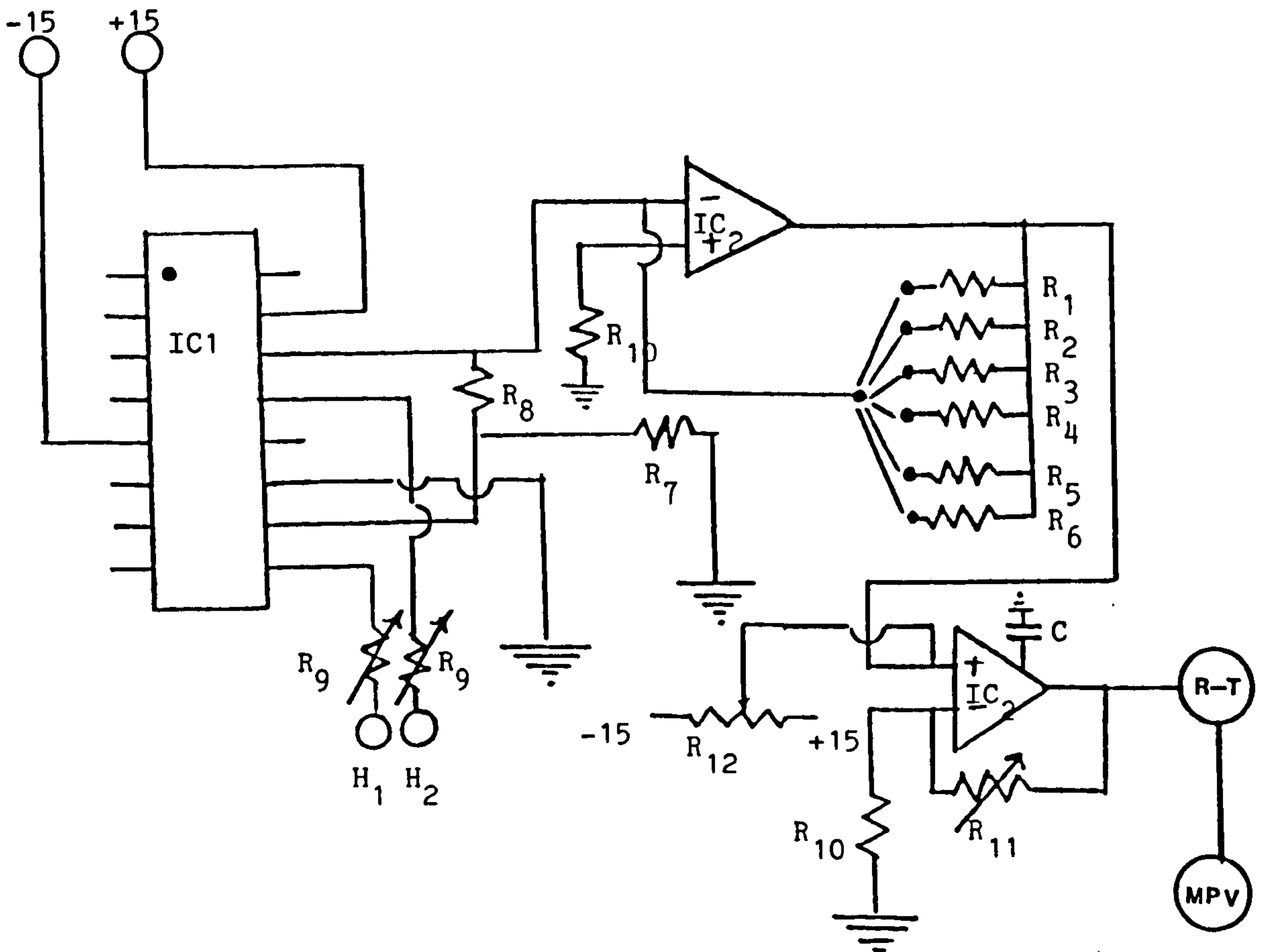

$R_1$	-	4.397 K $\Omega$	for $\theta = 30^\circ$
$R_2$	-	2.199 K $\Omega$	for $\theta = 60^\circ$
$R_3$	-	1.466 K $\Omega$	for $\theta = 90^\circ$
$R_4$	-	1.099 K $\Omega$	for $\theta = 120^\circ$
$R_5$	-	0.8795 K $\Omega$	for $\theta = 150^\circ$
$R_6$	-	0.732 K $\Omega$	for $\theta = 180^\circ$
$R_7$	-	0.45 K $\Omega$	(Thermistor)
$R_8$	-	6.9 K $\Omega$	
$R_9$	-	10 K $\Omega$	
$R_{10}$	-	1 K $\Omega$	
$R_{11}$	-	100 K $\Omega$	
$R_{12}$	-	250 K $\Omega$	

$H_1$ and $H_2$	-	Head transducer
R-T	-	Rothschild tensiometer
MPV	-	Micro-processor voltameter
IC <sub>1</sub>	-	LH 0094
IC <sub>2</sub>	-	LM 308
C	-	1 pf

To remedy this, variable resistance ( $R_4$ ) and potentiometer ( $R_5$ ) were added.  $R_4$  is to control the signal response of the Rothschild indicator, while  $R_5$  acts as a zero adjustment for the system (Fig. 4.7),  $R_{12}$  for the system of Fig. 4.8.

#### 4.4.6 Power supply

The power supply required for the operation of the function command circuit is shown in Fig. 4.9. An AC line voltage of 240 volt is supplied to a step-down power transformer. The output of the power transformer is applied to a full wave rectifier bridge type (261-328) and smoothed by condenser  $C_1$  and  $C_2$ . To ensure more stable DC supplier, a voltage regulator IC LM325 was used. The output voltage of the regulator is  $\pm 15$  VDC.

#### 4.4.7 Circuit operation

The procedure of operating this circuit was as follows:

1. After a proper adjustment of both Rothschild and MPV, the initial tension can be measured with a single head.
2. By using two heads ( $H_1$  and  $H_2$ ) at a time, the difference between the simultaneous measurement of  $T_1$  and  $T_0$  which is the frictional force ( $F$ ), can be obtained.
3. As stated above, the frictional force  $F = T_0 - T_1$ , thus the outgoing tension ( $T_0$ ) can be deducted by the sum of  $F$  and  $T_1$ .
4. After selecting the required angle of wrap ( $\theta$ ) according to the scaling output resistance (Fig. 4.8), the simultaneous measurements of the coefficient of friction can be achieved by the aid of the logarithmic Op.Amp.



IC<sub>1</sub> - LM 325  
IC<sub>2</sub> - Rectifier bridge (261-328)  
C<sub>1</sub> - 1 pf  
C<sub>2</sub> - 0.1 μf

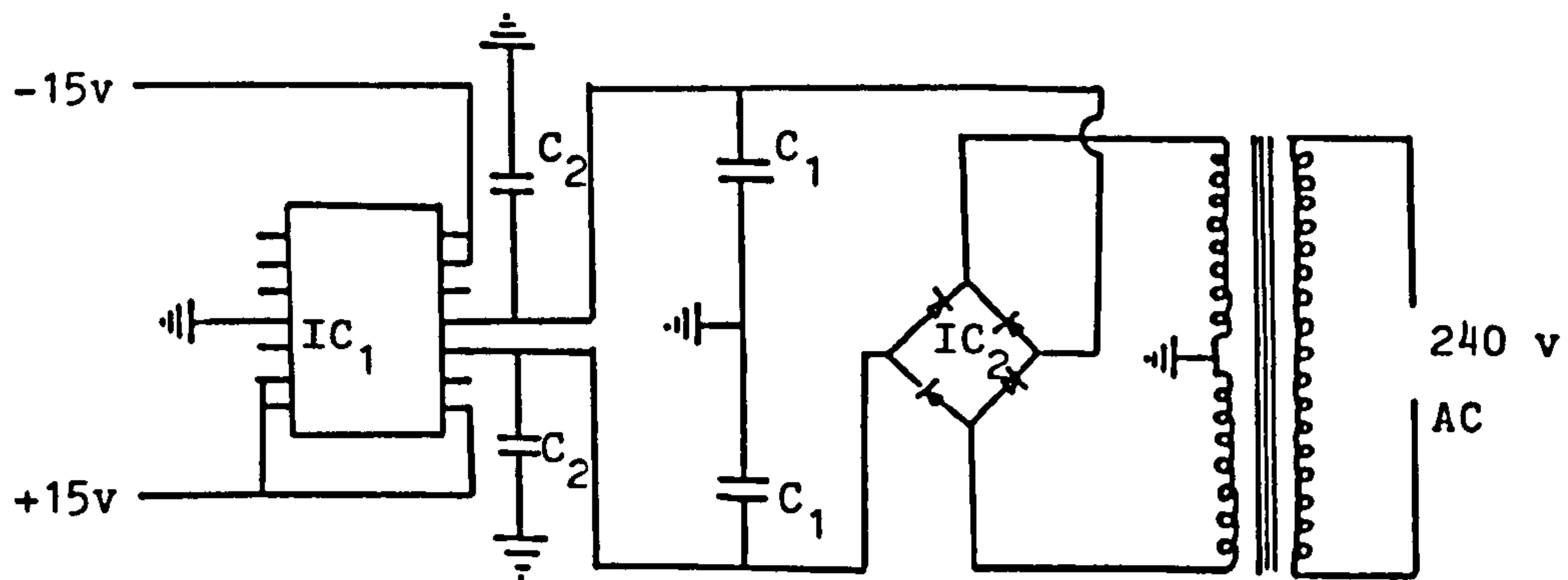

FIG. 4.9: Power supply unit

#### 4.5 Simultaneous measurement of the coefficient of friction

$T_i$ ,  $T_o$  and the angle of wrap are related exponentially with the coefficient of friction ( $K$ ) as follows [88,89]:

$$\frac{T_o}{T_i} = e^{K\theta} \quad \text{Thus } K = \frac{1}{\theta} \ln \frac{T_o}{T_i}$$

where  $K = m \left[ \frac{R}{T_i} \right]^{1-n}$

The coefficient of friction can be measured under three sets of conditions in which a different parameter is varied.

1. Guide radius ( $R$ ) and the angle of wrap ( $\theta$ ) constant whilst input tension ( $T_i$ ) is varied.
2.  $R$  and  $T_i$  are constant while ( $\theta$ ) is varied.
3.  $\theta$  and  $T_i$  are constant while  $R$  is varied.

In the present investigation, the coefficient of friction was measured in accordance with the variables of the experiment, i.e. since most experiments involved variation of  $T_i$  and  $\theta$ , methods (1) and (2) were used. These measurements are reported where appropriate.

CHAPTER 5

EXPERIMENTAL OBSERVATION OF  
TWIST BLOCKAGE

## 5.1 Outline of the experimental work

This section is intended to prepare the reader for the following two chapters in which experimental results are presented.

In order that the results are presented in a logical sequence such that their full implications can be understood, they are given here in a different order to that in which they were obtained. Chapter 5 deals with the variables considered most likely to affect twist blockage in terms of the three parameters: pressure, length of one turn of twist and length of contact region.

Based on the observations, different mechanisms are postulated and various interpretations are suggested and discussed.

The yarn used in the experiments described here was acrylic 30x2 tex worsted with ring spun Z twist singles doubled with S twist. Six levels of low doubling twist were used from 50 t/m to 1000 t/m. Experiments were carried out using five different yarn guides of diameter 0.2 to 1.0 cm.

There was a limited supply of the acrylic yarn first used.

For this reason, this yarn has been used solely to examine the effects of twist on twist blockage rather than the effects of other less basic parameters such as pressure, arc of contact etc.

Chapter 6 examines the effect of the orientation of the direction of the yarn movement over the contact surface on the basis of the mechanisms postulated in the previous chapter.

A continuous filament textured polyester yarn 16.7 tex singles was used as two flat singles doubled with different levels of twist. The singles also were twisted with S or Z twist up to 600 t/m, and

doubled with relatively low twist (up to 70 t/m) S and Z. In other words, yarns with S.S and Z.Z singles are doubled S or Z to obtain a total of four combinations of yarn twist direction at various twist levels i.e. (0+0)+S, (0+0)+Z, (S+S)+S, (S+S)+Z, (Z+Z)+S and (Z+Z)+Z.

The guide diameter used in this chapter was 0.4 cm.

From these results several conclusions are drawn and further explanations of the twist blockage phenomenon are proposed.

## 5.2 Preliminary investigation

Before examining the parameters affecting twist blockage it was considered desirable to check the effects of the length of the zone in which the blocked twist was to be accumulated. Although in certain industrial processes where twist blockage is important (such as the Repco process [13] and in ring twisting [7]) it is known that the length of this zone has a considerable effect on twist levels; intuitively one would not expect this to be true here. In these other processes there is some intermediate factor which determines the effect of zone length: twist sharing in the case of the self-twist process and balloon tension in the case of ring twisting.

## 5.3 Effect of length of yarn before contact surface on twist blockage

As has been explained in Chapter 4, the yarn guide (G) of the apparatus can move up and down while the low friction pulleys ( $P_2$  and  $P_3$ ) on either side of the guide can move in curves centred at the guide (G).

However, the yarn path may be lengthened or shortened according to the desired wrap angle (i.e. the length between the pulleys and yarn guide).

This length may vary between 10 to 25 cm, and the higher the angle of wrap the longer the length before the guide.

A yarn of low twist (50 t/m) was used in order to more effectively demonstrate the influence of this factor. The angle of wrap was  $170^{\circ}$  with a guide diameter 1.0 cm. The initial tension was 75 gf.

The length of yarn before and after the guide was the same.

#### 5.3.1 Observations

Visual observation of yarn twist before and after the guide showed that the development of twist blockage had two phases. Initially the nominal twist before and after the guide is the same, then the yarn begins to rotate around its axis in such a way that the twist increases before the guide and decreases after the guide. This is due to the development of false-twist in the yarn and will continue until a maximum twist congestion is achieved. At this stage some of the congested twist before the guide may suddenly escape to give a reduced twist gain, i.e. the difference between the nominal twists before and after the guide. Twist again begins to build up to a new (but lower) maximum and the process is repeated. It was this lower blocked-twist level which was used here.

In addition to this observation, it may be mentioned that during the experiments, the twist immediately after the guide was less than the original twist in the yarn. This was particularly noticeable

when the twist blockage was greatest and when a high degree of flattening of yarn on the guide had occurred. As the yarn moved away from the guide its original twist gradually recovered; except at fairly low twist, the yarn leaves the contact surface with a periodical accumulated twist i.e. it moves in surges.

### 5.3.2 Results

The results of experiments on the effects of zone lengths are reported in Table 5.1 and shown graphically in Fig. 5.1. Taking into account the errors in the observation, it will be seen that the twist blockage is not greatly influenced by the length of the zone. At most, an increase of 7% was observed with a doubling of the length (Y).

The scatter in the points may be attributed to twist irregularity in the supply yarn or to the tension device which itself caused twist blockage in the yarn. In addition, the tension fluctuation also has a great influence on twist blockage behaviour.

From the above results, it may be considered that the investigation of the variation of the angle of wrap and the other parameters would not be significantly influenced by the small variation of yarn length before the guide which occurred when these parameters were changed.

## 5.4 Effect of angle of wrap on twist blockage

### 5.4.1 Experiments and results

Eleven angles of wrap were employed ranging from  $10^{\circ}$  to  $180^{\circ}$ . A twist level of 116 t/m (measured twist) has been used with a 1 cm diameter yarn guide. Table 5.2 shows the results obtained and Fig. 5.2

TABLE 5.1

Y	N
12.5	125.0
14.5	132.5
16.5	135.0
18.5	132.5
20.5	132.0
22.5	140.0

Y = yarn length before guide surface (cm)

N = twist gain (t/m)



FIG. 5.1: Effect of yarn length before the guide surface on twist gain

$$N_0 = 50 \text{ (t/m)}$$

$$D = 1 \text{ (cm)}$$

$$T_1 = 75 \text{ gf}$$

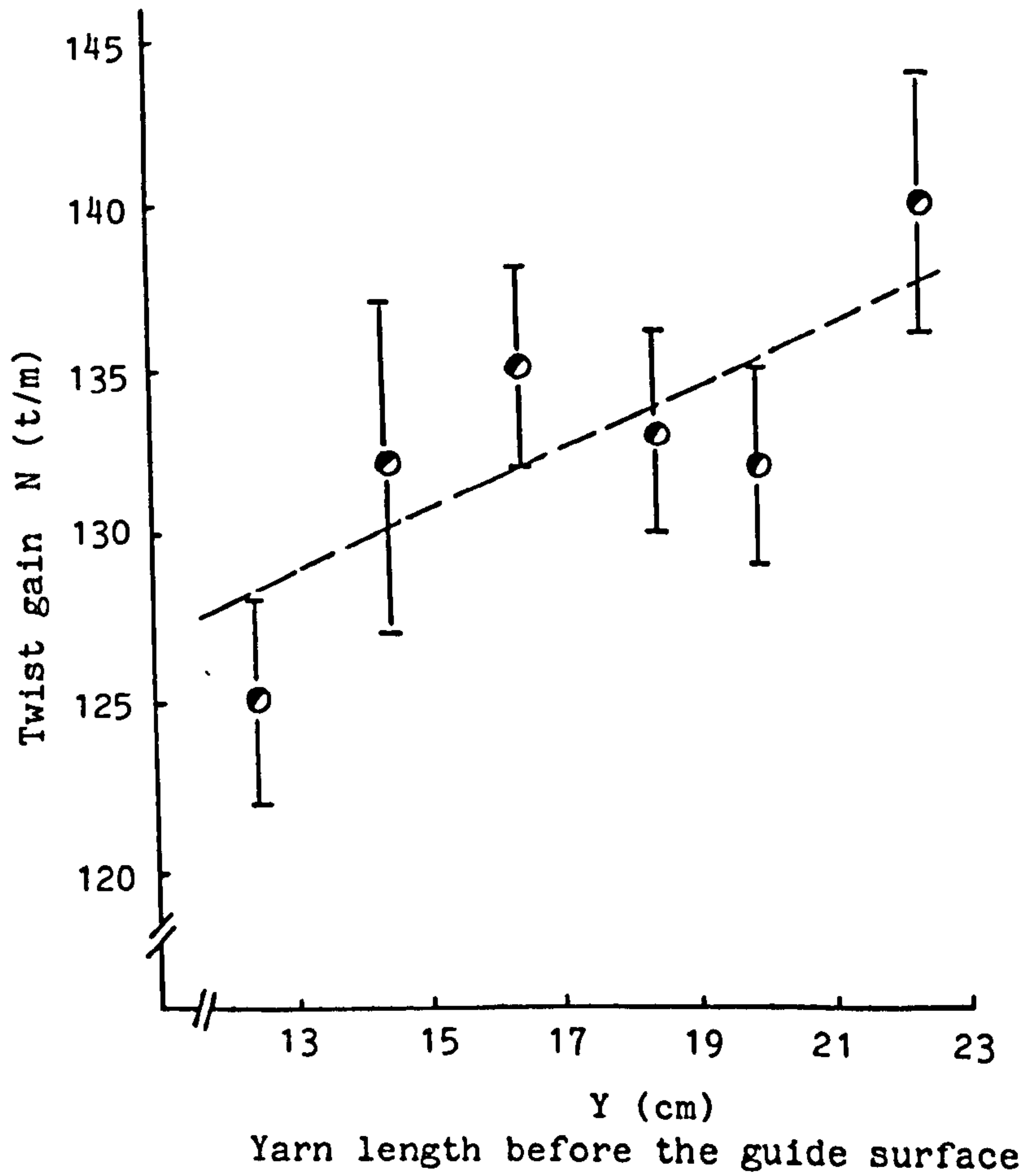

TABLE 5.2

$\theta$	N
10	23
20	19
30	17
40	19
50	13
60	10
80	25
100	9
120	9
140	2
180	10

$\theta^\circ$  = angle of wrap

N = twist gain (t/m)

FIG. 5.2: Effect of angle of wrap on twist gain,  $N$ , at constant initial tension and guide diameter

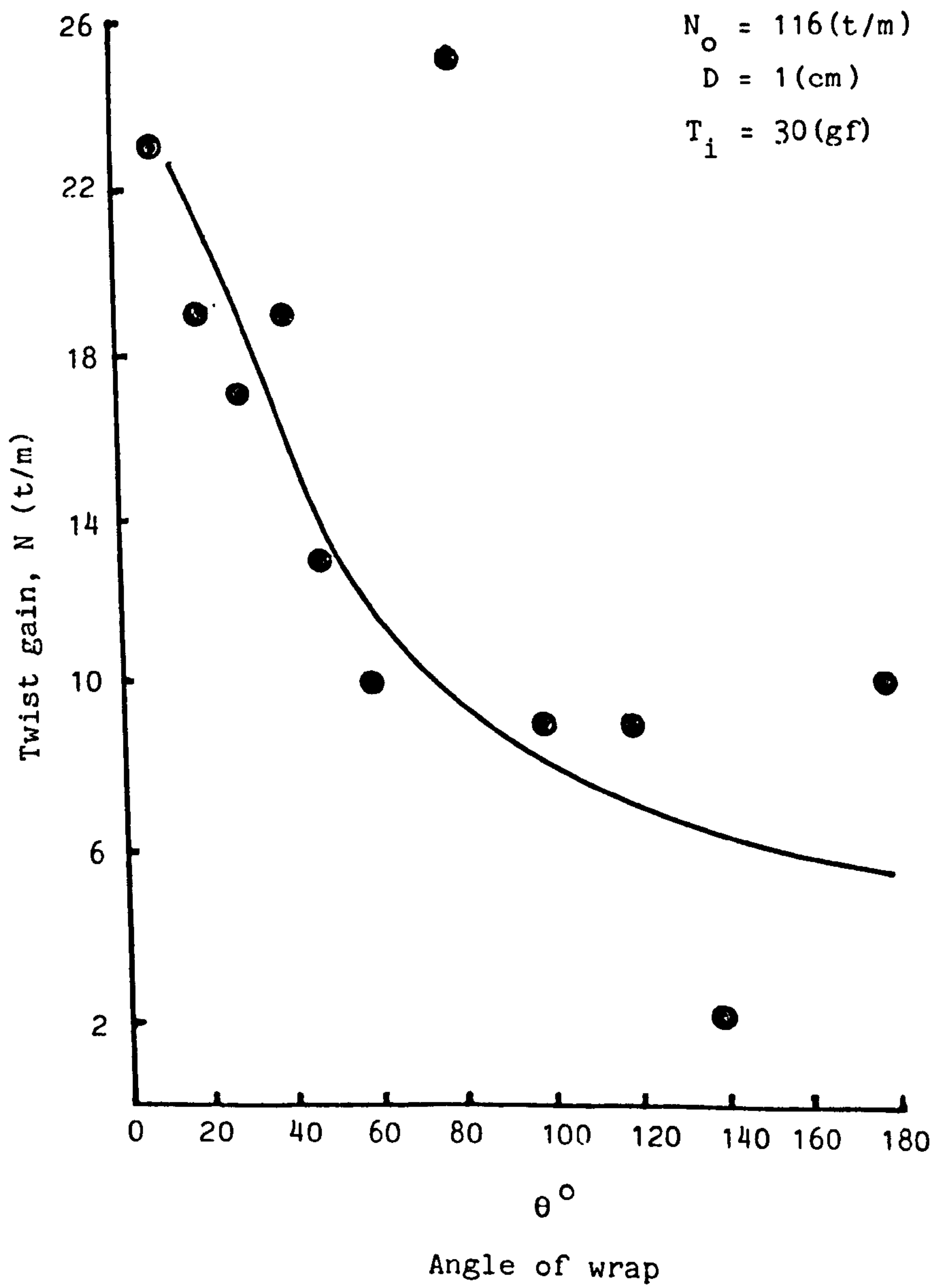

illustrates the effect of angle of wrap ( $\theta$ ) vs twist gain (N) when this is a maximum i.e. just before escape. It will be seen that the twist gain decreases as the angle of wrap increases. The twist gain dropped until an angle of wrap of  $80^\circ$  is reached; above this angle of wrap the rate of decrease of twist gain is reduced.

It was also observed that the apparent rate of yarn rotation before the guide is higher than that, in the opposite sense, after it. This is particularly noticeable when the angle of wrap is small, i.e. when the twist blockage is greatest and is in accordance with false twist theory. It was also observed that at small angles of wrap the yarn tends to be more flattened over the contact region, until a significant twist congestion has been reached. As the twist before the guide builds up, the yarn attempts to rotate over the contact region in order to move the accumulated twist forward with the yarn. But such a movement does not occur until a sufficient twist and associated torque have been developed. At the same time, the yarn will have become rounder and more compact because of the binding effect of the twist.

#### 5.4.2 Discussion

The low yarn speed used in the experiment made it possible to observe the characteristic behaviour of the twist over the contact region clearly. It also provided the opportunity to observe the yarn twist helices during the pushing back of twist in the opposite direction to the yarn movement. This facilitated the taking of samples at the optimum (maximum) twist congestion.

It was surprising, however, that at large angles of wrap, the difference between the twist before and after the guide became insignificant, in other words, the twist congestion was minimal.

The graph shows a consistent trend in that the points are rather scattered. Actually this feature may be attributed to external factors which are difficult to control, such as the initial twist variation in the yarn itself, or the twist disturbance occurring prior to the contact region due to the tension device and other yarn contact points upstream of the guide.

However, a similar relation between twist gain and angle of wrap was reported by Chan [52]. He suggested that decrease of twist gain with <sup>↑</sup>the angle of wrap is due to decrease of the yarn tension in front of the guide.

Chan, however, used a positive feed system, so his conditions were different in this respect to those in the present experiments. Chan's interpretation may be related to release of the stresses imposed on the yarn during twist build up in front of the guide.

On the other hand, the above observations are at variance with the reported observation by The Shirley Institute [40], in which twist accumulation was reported always to increase with increase of the angle of wrap.

The decrease in twist blockage with increase of angle of wrap is difficult to explain, but the following factors will influence the twist gain:

1. The bending induced in the yarn around the guide will change with angle of wrap and this would be expected to influence the yarn contact length and frictional force as well as the pressure.

2. As contact length increases, the greater the number of turns of twist in contact with the guide surface. This may also influence the magnitude of the normal force at the contact points over the contact region (see page 186).

It is not possible to state with certainty that any one of the bending angle, the length of arc of contact or the pressure distribution is the main source of this unexpected behaviour.

It is considered helpful to start with a study of the apparently more complex relationships between the pressure, length of arc of contact and yarn twist. The reason for this will become clear later in the investigation.

#### 5.5 The relation between the twist, tension and pressure

In order to investigate the relation between the tension and pressure, on the twist congestion, all five guides were used.

Using each of the guides, twist blockage tests were carried out using a yarn twist of 211 t/m. The initial tension was set at 20, 40, 60 and 80 gf, but the angle of wrap was kept constant at  $90^\circ$  for each of the guides. Thus, the state of contact between the yarn and the guides changes as both guide diameter and the initial tension change. Four levels of initial pressure ( $P_1$ ) were thus investigated for each of the five guides, where the pressure here depends on two factors, initial tension ( $T_1$ ) and guide diameter (D).

It was again observed that the yarn rotates around its axis in front of the guide especially when the tension is high and with a small guide diameter.

The tendency to push the twist back was, therefore, higher with small diameter guides than with those of large diameter [40,52].

#### 5.5.1 Effect of initial pressure with variable guide diameter at various levels of initial tension

Table 5.3 shows the relation between the initial pressure ( $P_1 = \frac{T_1}{R}$ ) and twist gain and these results are plotted in Fig. 5.3. In this graph the pressure is varying according to the variation of the guide diameter with approximately constant initial tension ( $T_1$ ). It was demonstrated in this experiment that the highest twist blockage was caused by the small diameter guide (0.2 cm), with a maximum initial tension.

Approximately 50% of the twist was blocked and pushed back under these conditions. On the other hand, at the same initial tension with a large diameter guide (1.0 cm), the twist gain was found to be approximately only 7% of the nominal twist.

The relationships between initial pressure,  $P_1$ , and twist blockage,  $N$ , appears to be roughly linear in most cases and to be independent of any other factors. This is shown in Table 5.4 where the linear regression equations between the initial pressure and the twist gain along with the values of the coefficient of correlation at given levels of initial tension, confirm the above observation. It should be borne in mind, of course, that although the regression equations show a small negative intercept on the  $N$  axis, the true curve must pass through (0,0) because twist gain will be zero at zero pressure.

TABLE 5.3: Effect of initial pressure,  $P_i$ , on twist blockage with respect to initial tension,  $T_i$ , and guide diameter,  $D$

$T_i$	20		40		60		80	
$D$	$P_i$	$N$	$P_i$	$N$	$P_i$	$N$	$P_i$	$N$
0.2	200.0	28.6	400.0	67.5	600.0	80.0	800.0	105.6
0.4	100.0	13.4	200.0	31.6	300.0	40.0	400.0	57.0
0.6	66.6	4.5	133.3	13.0	200.0	20.0	266.7	27.6
0.8	50.0	2.4	100.0	6.0	150.0	12.0	200.0	19.6
1.0	40.0	2.5	80.0	5.0	120.0	7.4	160.0	19.0

$D$  = guide diameter (cm)

$T_i$  = initial tension (gf)

$P_i$  = initial pressure (gf/cm)

$N$  = twist gain (t/m)



FIG 5.3: Effect of initial pressure on twist gain at various levels of initial tension

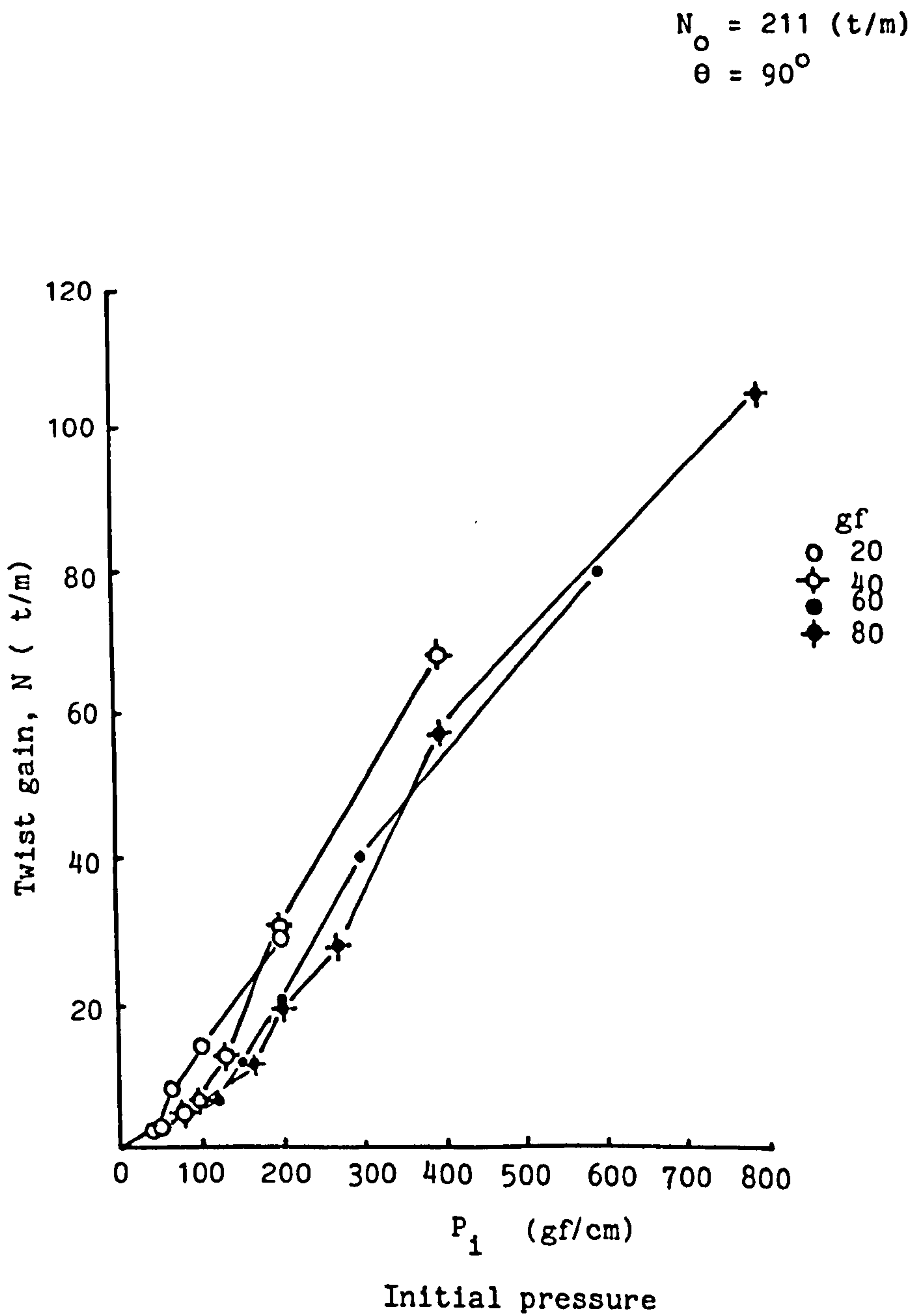

### 5.5.2 Effect of initial pressure with variable initial tension at various guide diameters

It is now necessary to examine the effect of pressure on twist blockage behaviour when the pressure was changed by varying the initial tension. Figure 5.4 shows the same results as were plotted in Fig. 5.3 except that the twist blockage is plotted against the initial pressure for constant guide diameter conditions. In this case the points appear to lie in two groups. The first group are those relating to the 0.2 and 0.4 cm guides, the second group relate to the guides of 0.6, 0.8 and 1.0 cm diameter. It can be seen from this graph that the first group (i.e. the two smaller diameters) introduce the most significant twist blockage behaviour whilst for the other group the contribution of twist gain appears to be roughly 30% less over the pressure range up to 300 gf/cm.

It can be concluded, therefore, from the combined results, Figs. 5.3 and 5.4, that the main factor causing blockage in this experiment was pressure, but there is some evidence that there may be an independent contribution from guide diameter, the blockage increasing as diameter is reduced.

Table 5.5 shows the linear regression equations between the twist gain ( $N$ ) and initial pressure ( $P_1$ ) along with the values of coefficient of correlation for the various guide diameters ( $D$ ). The gradients in these equations do not appear to show the grouping of the results mentioned above.

However, as the lines must once again pass through the origin, the validity of these regressions may be questioned.

FIG. 5.4: Effect of initial pressure on twist blockage at various guide diameters

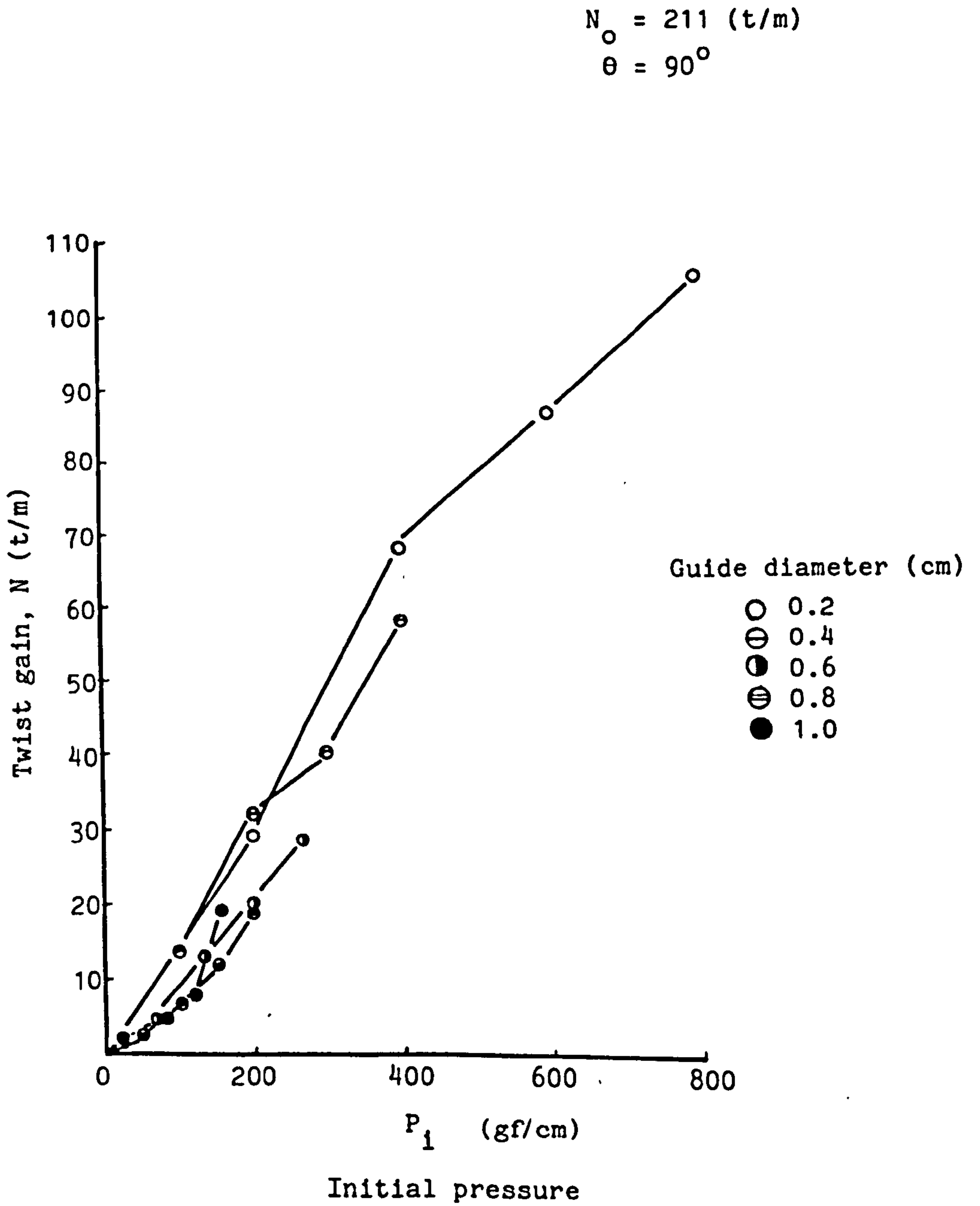

TABLE 5.4

Initial tension $T_1$	Linear regression equations	Coefficient of correlation $\rho$
20	$N = 0.17 P_1 - 5.33$	0.993
40	$N = 0.20 P_1 - 12.18$	0.996
60	$N = 0.15 P_1 - 9.73$	0.997
80	$N = 0.14 P_1 - 5.80$	0.993

$N$  = twist gain (t/m)

$P_1$  = initial pressure (gf/cm)

TABLE 5.5

Guide diameter $D$ (cm)	Linear regression equations	Coefficient of correlation $\rho$
0.2	$N = 0.122 P_1 + 9.6$	0.980
0.4	$N = 0.140 P_1 + 0.7$	0.990
0.6	$N = 0.144 P_1 - 2.8$	0.999
0.8	$N = 0.155 P_1 - 4.4$	0.988
1.0	$N = 0.130 P_1 - 4.5$	0.920

The combined effect of the input tension  $T_1$  and the variation of the guide diameter is demonstrated by the three dimensional representation of Fig.5.5.

The dotted lines are contours of equal initial pressure  $\frac{T_1}{R}$ . The three dimensional representation confirms that the highest twist gain occurs at the highest pressure as derived from the highest tension and the smallest guide. It is also evident that guide diameter plays a more significant role than tension.

Turning now to a general consideration of these results; it has been pointed out above that the relation between pressure and twist gain appears to be fairly linear but must pass through the origin. If straight lines are fitted to the points of Figs. 5.3 and 5.4, taking into account the following equation derived from Fig. 5.3

$N = 0.080 P_1$	for 20 gf initial tension
$N = 0.096 P_1$	40 " " "
$N = 0.083 P_1$	60 " " "
$N = 0.090 P_1$	80 " " "

from Fig. 5.4

$N = 0.147 P_1$	for guide diameter 0.2 cm
$N = 0.148 P_1$	" " " 0.4 cm
$N = 0.102 P_1$	" " " 0.6 cm
$N = 0.083 P_1$	" " " 0.8 cm
$N = 0.088 P_1$	" " " 1.0 cm

These equations have been used to calculate the data again in Tables 5.6 and 5.7 and plotted in Figs. 5.6 and 5.7.

FIG. 5.5: Effect of input tension and the variation of guide diameter

[The dotted lines are contours of equal initial pressure]

$$N_o = 211 \text{ (t/m)}$$

Angle of wrap  $90^\circ$

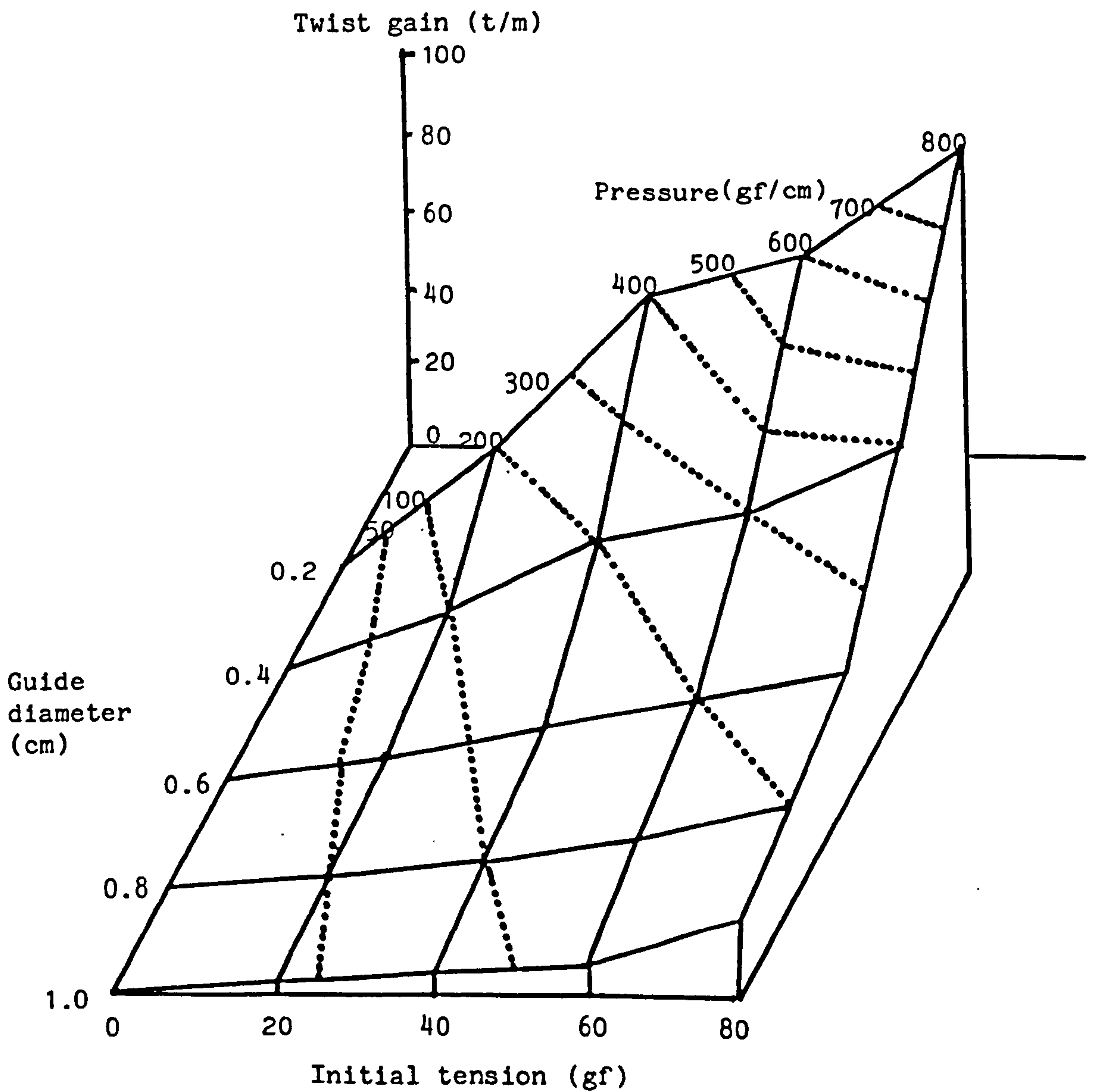

TABLE 5.6: Effect of initial tension on twist blockage at various initial pressures

		N				
$T_i$	$P_i$	50	100	150	200	300
20		4.0	8.0	12.0	16.0	24.0
40		5.0	9.6	14.0	19.0	29.0
60		4.0	8.3	12.5	17.0	25.0
80		4.5	8.3	12.5	17.0	27.0

TABLE 5.7: Effect of guide diameter on twist blockage at various initial pressures

		N				
D	$P_i$	50	100	150	200	300
0.2		7.1	14.7	22.0	29.4	44.0
0.4		7.4	14.8	22.0	29.6	44.4
0.6		5.1	10.0	15.3	20.0	30.5
0.8		4.2	8.3	12.5	16.7	(25.0)
1.0		4.4	8.8	13.0	(17.6)	(26.4)

N = twist gain (t/m)

$P_i$  = initial pressure (gf/cm)

$T_i$  = initial tension (gf)

D = guide diameter (cm)

Figures in brackets have been calculated from an extrapolation outside the range of observation.

### 5.5.3 Effect of initial tension at various levels of initial pressure

It can be seen from Fig. 5.6 that although the initial tension increases by a factor of four at constant initial pressure, there is no significant independent influence of tension on twist blockage. In other words at constant pressure twist blockage seems to be more or less constant with varying ingoing tension. Perhaps this is because both the couple generating twist blockage and the torque resisting the resulting increase in yarn twist both depend on tension in the same way.

### 5.5.4 Effect of guide diameter on twist blockage at various levels of initial pressure

It can be seen from Fig. 5.7 that the twist blockage decreases as the guide diameter increases. It is also clear that the reduction in twist gain is not a steady reduction but that there is a rapid change between guide diameters of 0.4 and 0.6 cm, the gain in each case being about 50% less with guides above 0.6 cm in diameter, than with the smaller guides. This confirms the grouping observed in Fig. 5.4.

In the light of the results of the twist blockage experiments and with the aid of the regression analysis, the following general conclusions may be drawn:

1. The relation between initial pressure and twist gain is substantially linear and the initial tension (with varied guide diameter) had only a minor influence.
2. Although the pressure appears to be the dominant factor, there is some evidence that the guide diameter had some independent influence



FIG. 5.6: Effect of initial tension on twist gain at various levels of initial pressure,  $P_1$

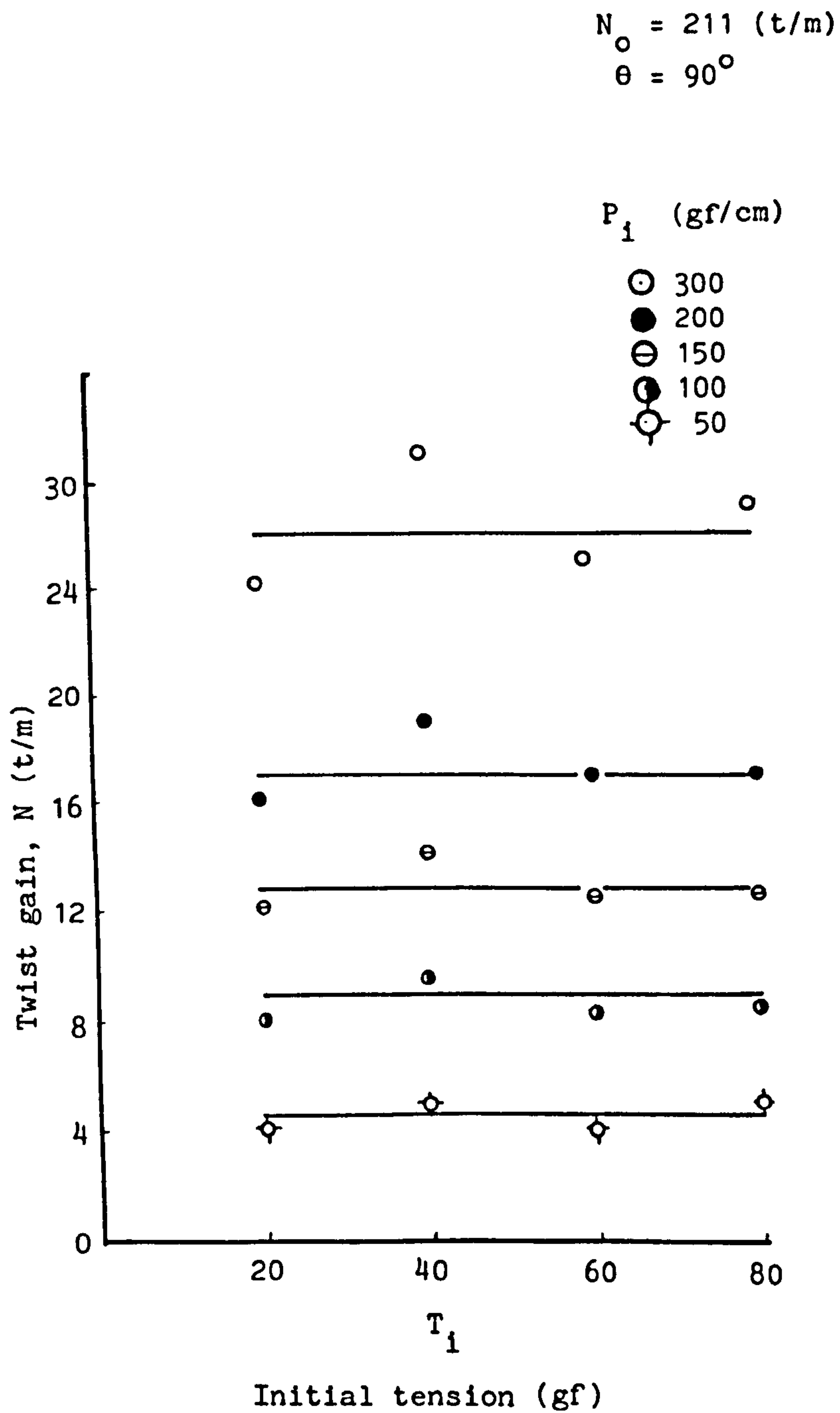
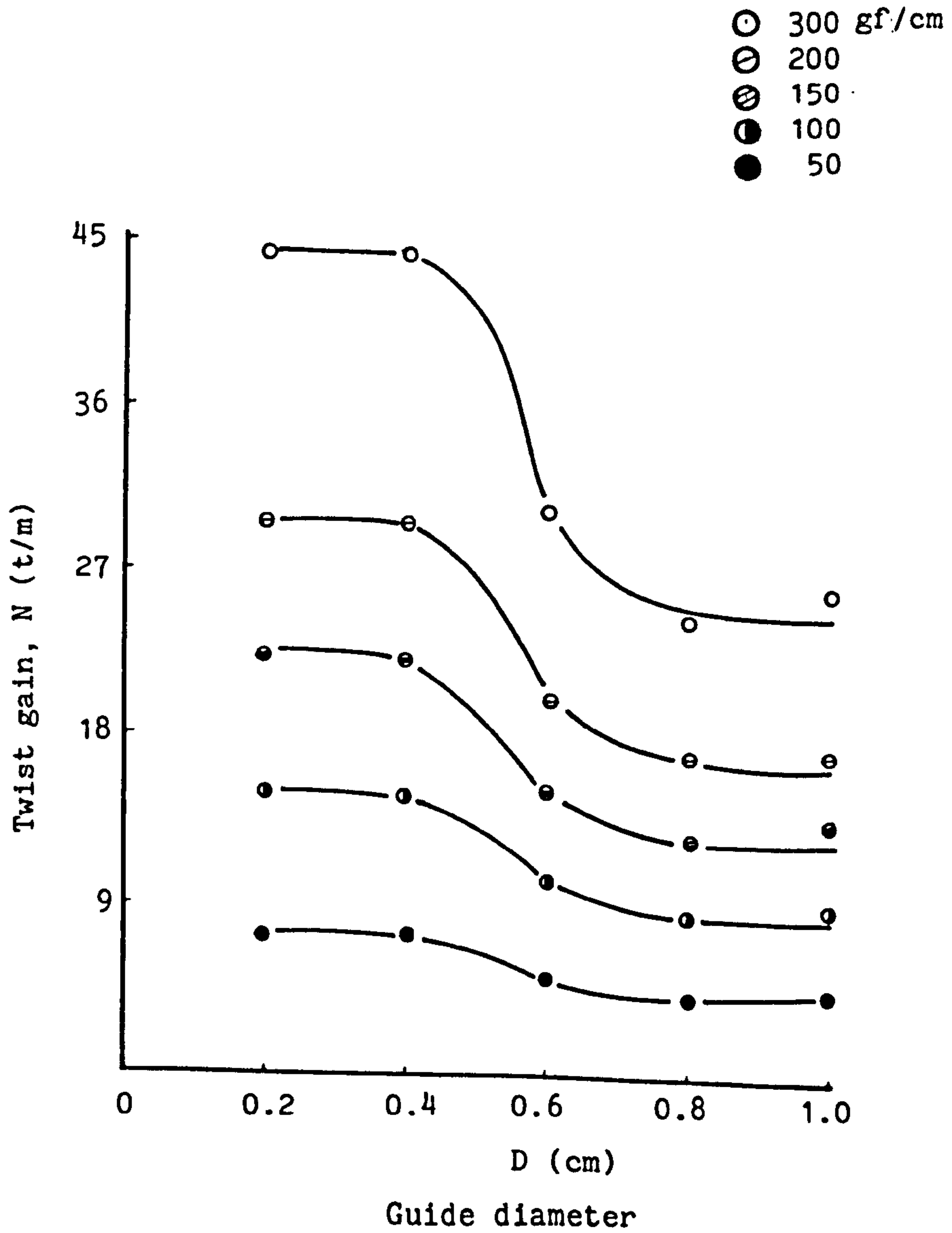

FIG. 5.7: Effect of guide diameter on twist blockage at various levels of initial pressure

$$N_0 = 211 \text{ (t/m)}$$

$$\theta = 90^\circ$$



on twist blockage at any given value of initial pressure.

3. In the present experiment, the length of arc of contact increased as the guide diameter increased as the angle of wrap was constant. It is possible, therefore, that the independent effect of guide diameter may be due to the relation between the arc of contact and features of the yarn structure such as the length of one turn of twist.

In the present experiment, it is not possible to make a complete interpretation of the effect of the guide diameters on the twist blockage behaviour, since the pressure and arc of contact are also both dependent on the guide diameter.

It is, therefore, necessary to investigate the effects of each of the pressure, and length of arc of contact separately.

#### 5.6 Relation between the arc of contact and twist blockage

The influence of arc of contact ( $S$ ) on twist blockage behaviour has not directly attracted the attention of previous investigators. They have examined the effect of angle of wrap ( $\theta$ ) or guide diameter ( $2R$ ) as separate factors. The length of arc of contact ( $S = R\theta$ ) is, in fact, a function of these two variables and can be changed by altering one or both of them. As suggested in the previous section, it is possible that the length of contact could have some influence on blockage through its relationship with the twist geometry of the yarn. An experiment was, therefore, carried out using, as previously, the five guides of different diameters with six different angles of wrap 30, 60, 90, 120, 150 and 180<sup>o</sup>: each of the angles of wrap and guide diameters being combined in turn.

Any given set of values of arc of contact ( $S$ ) could, therefore, be achieved in two different ways: firstly with a constant angle of wrap ( $\theta$ ) and varying guide diameter ( $2R$ ), and secondly with a constant guide diameter and a varying angle of wrap.

The experiment was carried out at a constant initial pressure of 200 gf/cm . In order to achieve the constant initial pressure, the yarn initial tension, 20 gf for guide diameter 0.2 cm, was varied proportionally with the guide diameter. The yarn twist was 120 t/m ( $S$ ) (0.83 cm/turn).

#### 5.6.1 Observations

It was first observed that with small arcs of contact and small guide diameters, e.g. with a guide diameter 0.2 cm and angle of wrap  $30^\circ$ , the yarn had a fairly high rate of rotation around its axis in front of the guide. On the other hand, the yarn rotation after the guide was negligible.

It was again found that the direction of rotation was dependent upon the direction of the twist caused by blockage in the yarn, the rotation of the present yarn was in the S-twist direction.

A most interesting observation was that the speed of the rotation of the yarn decreased as the length of the contact region increased. Also the rate of rotation appears greater at thin places than at thick places. An observation, surprising at first sight, was that the rate of rotation before the guide appeared greater at the beginning of the yarn running than when the yarn had been running for a while. Presumably this observation was made during the period of build-up of blocked twist. The results are shown in Table 5.8.

TABLE 5.8

D	$\theta$	S	$T_1$	N
0.2	30	0.05	20	77.0
	60	0.11		72.0
	90	0.16		72.0
	120	0.21		64.5
	150	0.26		67.5
	180	0.32		5.7
0.4	30	0.11	40	76.0
	60	0.21		59.0
	90	0.32		59.5
	120	0.42		58.0
	150	0.52		56.7
	180	0.63		56.0
0.6	30	0.16	60	71.3
	60	0.32		53.0
	90	0.47		52.0
	120	0.63		55.6
	150	0.79		48.6
	180	0.94		50.0
0.8	30	0.21	80	61.5
	60	0.42		51.0
	90	0.63		52.0
	120	0.84		51.0
	150	1.10		46.7
	180	1.30		52.0
1.0	30	0.26	100	60.0
	60	0.50		54.0
	90	0.79		53.0
	120	1.10		62.0
	150	1.30		41.6
	180	1.60		55.0

D = guide diameter (cm)

$\theta^\circ$  = angle of wrap

S = length of arc of contact (cm)

$T_1$  = initial tension (gf)

N = twist gain (t/m)

### 5.6.2 Arc of contact and twist blockage at various angles of wrap

Figure 5.8 shows plots of twist gain  $N$  at constant initial pressure against arc of contact, when the arc of contact was adjusted by varying guide diameter, for different levels of angles of wrap. It may be observed that a rapid reduction in blocked twist occurred for smaller lengths of arc of contact up to 0.4 cm. Any further increase above this length, gives rise to much smaller reduction in twist blockage.

### 5.6.3 Effect of arc of contact at various guide diameters

In this case the arc of contact was adjusted by changing angle of wrap at constant guide diameter. The results of the measurements are shown in Fig. 5.9. The graph is drawn in terms of twist gain against length of arc of contact. As observed previously, it can be seen that, as, the length of arc of contact increases, the twist gain decreases.

There is also some indication that, the smaller the guide diameter, the higher the twist gain. In fact these findings are in good agreement with the earlier observation [52] that the larger guide diameters (at constant initial pressure) give the lower twist gain.

Generally, in both cases (i.e. constant angle of wrap or guide diameter), the outstanding observation is that, at short arcs of contact, the twist blockage is initially at a high level of more than 60% of nominal twist, but decreases rapidly until at an arc of contact of roughly 0.4 cm, it is at a level of approximately 40% of the initial

FIG. 5.8: Effect of arc of contact at various angles of wrap ( $\theta$ )

$$N_o = 120 \text{ (t/m)}$$

$$P_i = 200 \text{ (gf/cm)}$$

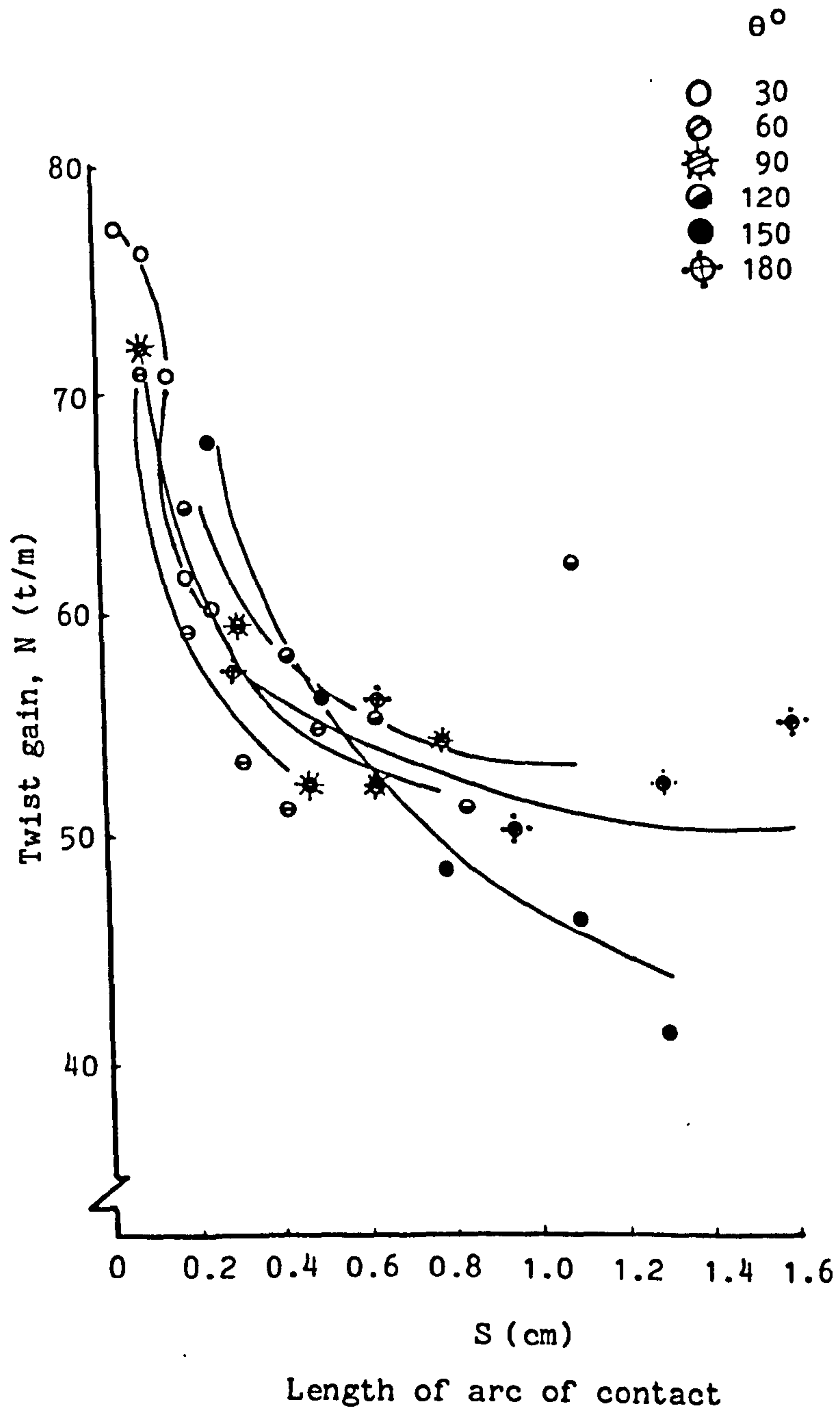
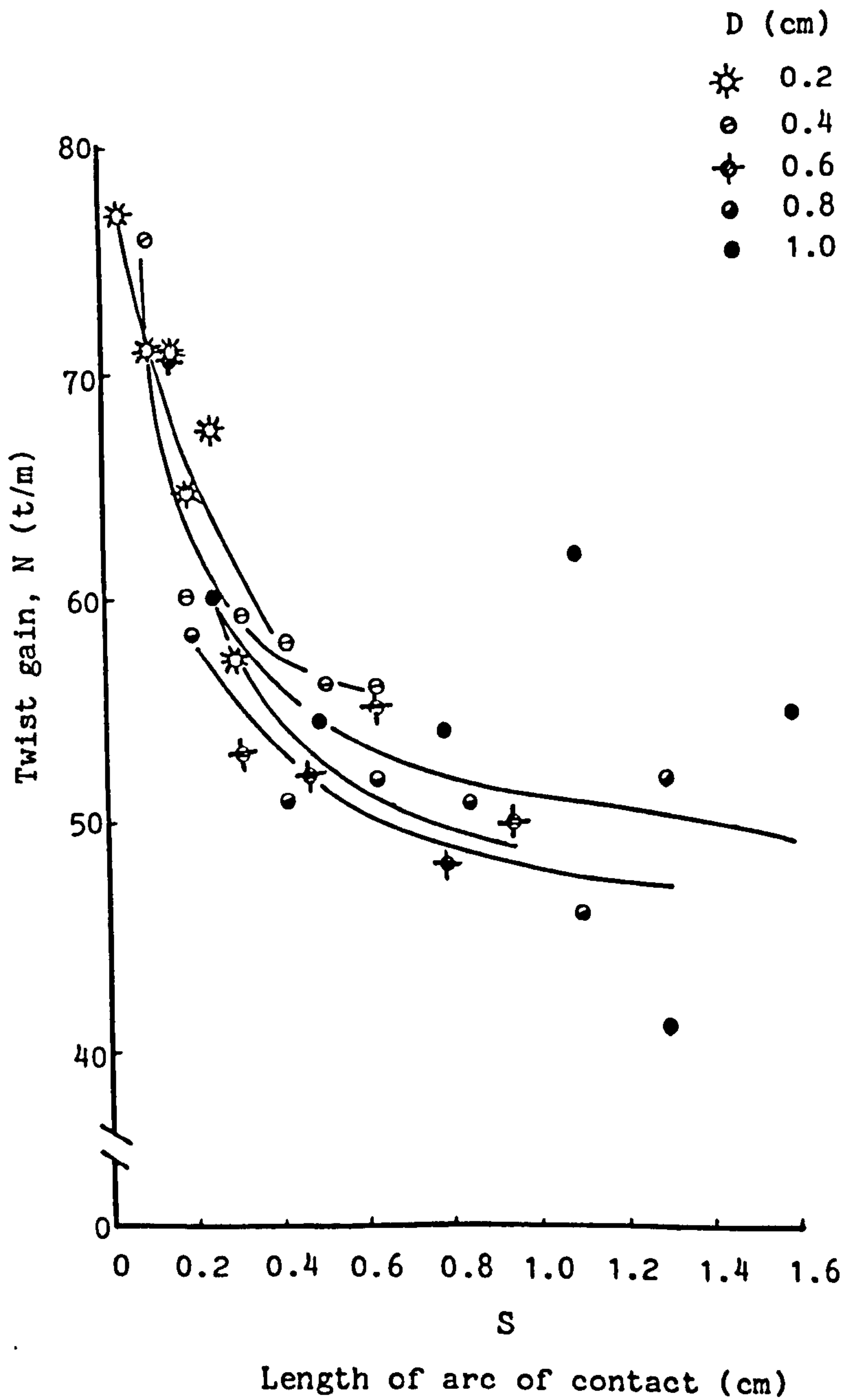

FIG. 5.9: Effect of arc of contact at various guide diameters

$N_0 = 120$  (t/m)  
 $P_1 = 200$  (gf/cm)





twist. The rate of decrease of blockage with further increase of length of contact is then much reduced and even with arcs as long as 1.0 cm, the average blockage is not significantly less than 40% of supply twist. The scatter of results when the arc length was varied by changing diameter was greater than those plotted with constant diameters and varying angles of wrap.

However, the significance of the point at which the twist blockage curves flatten is a major matter of interest. It seems not impossible that this point may be determined by the relation between the length of one turn of twist in the yarn and the contact length. In fact 0.4 cm represents approximately the length of one-half turn of nominal twist.

From a consideration of the mechanics of the system, one might expect the yarn to rotate less freely on the guide surface when contact length was less than half the twist length, because under these conditions, the yarn could be more effectively flattened.

It should be remembered that, in all these experiments there was a considerable oscillation of build-up and escape of blocked twist and in each case the observations were of the maximum twist congestion.

It may be concluded that at constant initial pressure, the twist gain decreases as the length of arc of contact increases. Any increase of length of arc of contact above the length of one turn leads to no significant further reduction in twist gain.

#### 5.6.4 Conclusions

It was found that under a constant initial pressure there is a significant indication that the twist gain may be governed by

interaction between twist of the yarn and the guide surface so that when more than one-half turn of twist is in contact with the guide, so that two or more high spots of the yarn (due to twist cross-over) generally support the yarn on the surface, the twist-blocking torque generated in the yarn is reduced. Increase of contact length will then have less influence on blockage.

Previous experiments have examined the effect of contact pressure, but in these earlier experiments the contact length also varied. It would therefore be of interest to examine the effect of pressure with constant arc of contact, before carrying out further studies of the effect of contact length.

In any event it is clear that the relationship between contact length and twist length merits further examination.

### 5.7 Effect of pressure

Earlier observations have shown that pressure has a considerable influence on twist blockage behaviour. In fact Subramanian et al [24] reported that the contact pressure between yarn and traveller or thread guide in ring spinning determines the resistance to the flow of twist across them. The Shirley Institute [40] also emphasised that at the same angle of wrap and initial tension, a small diameter guide displaces much more twist than a large one because it generates a higher pressure. Our earlier experiments have in general confirmed these observations, although there is some doubt whether the initial pressure, the mean pressure, or the final (maximum) pressure has the most influence on twist blockage.

### 5.7.1 Effect of initial pressure

It is reasonable initially to examine the effect of the initial pressure ( $P_1$ ), although it is recognised that other pressures, such as mean or final pressure, will be dependent on initial pressure.

In investigating the effect of initial pressure  $\left[ \frac{T_1}{R} \right]$  on twist blockage, at constant arc of contact, it was hoped that the experiments could be carried out with a constant initial tension ( $T_1$ ) using the guide diameters as in the earlier experiments. However, a sufficiently wide range of pressure could not be obtained with this restriction and, in order to allow a wider range of pressures, it was necessary to vary both guide diameter and initial tension.

The trials were carried out for four different arcs of contact of 0.26, 0.63, 0.84 and 1.0 cm respectively. As a result of using the five guide diameters, it was necessary, of course, to vary the angle of wrap in order to maintain a constant arc of contact. The yarn twist was 120 t/m, i.e. with a length of one turn of 0.83 cm.

Table 5.9 gives the requisite angles of wrap corresponding to the stated guide diameters. The table shows also the four lengths of arc of contact in addition to the values of the initial tension from 10 to 75 gf. The measured outgoing tension ( $T_0$ ) is also reported.

In Fig. 5.10 it will be seen that the twist gain rises steadily as initial pressure ( $P_1$ ) increases, but the rate of increase of twist gain ( $N$ ) due to increase in the initial pressure is different for each of the four lengths of the arc of contact. The smallest arc of contact gives higher values of twist gain. The most interesting observation in contrast to the earlier experiments is that there is no sudden large increase in twist gain when the length of one-half turn is less than the

TABLE 5.9

D	$\theta$	S	$T_1$	$T_o$
0.2	150.0		15	24.0
0.2	150.0		10	14.4
0.4	75.0		25	30.0
0.4	75.0	0.26	10	12.5
0.6	50.0		20	23.5
0.6	50.0		10	12.0
0.8	37.5		10	16.0
1.0	30.0		20	22.3
1.0	30.0		10	11.5
0.2	360.0		15	41.5
0.2	360.0		10	25.0
0.4	180.0		25	43.0
0.4	180.0	0.63	10	16.5
0.6	120.0		20	28.3
0.6	120.0		10	13.5
0.8	90.0		10	13.5
1.0	72.2		20	24.0
1.0	72.2		10	12.5
0.4	240.0		20	41.0
0.4	240.0		10	16.0
0.6	160.5		45	75.0
0.6	160.5	0.83	20	31.0
0.6	160.5		10	15.0
0.8	120.0		50	70.0
0.8	120.0		10	21.5
1.0	96.0		20	25.5
1.0	96.0		10	11.8
0.4	286.5		20	40.0
0.4	286.5		10	20.5
0.6	191.0		20	32.0
0.8	143.0	1.00	50	86.0
0.8	143.0		10	18.0
1.0	115.0		75	120.0
1.0	115.0		10	14.5

D = guide diameter (cm)

$\theta^\circ$  = angle of wrap

S = length of arc of contact (cm)

$T_1$  = initial tension (gf)

$T_o$  = outgoing tension (gf)

FIG. 5.10: Effect of initial pressure on twist gain at various lengths of arc of contact

$$N_0 = 120 \text{ (t/m)}$$

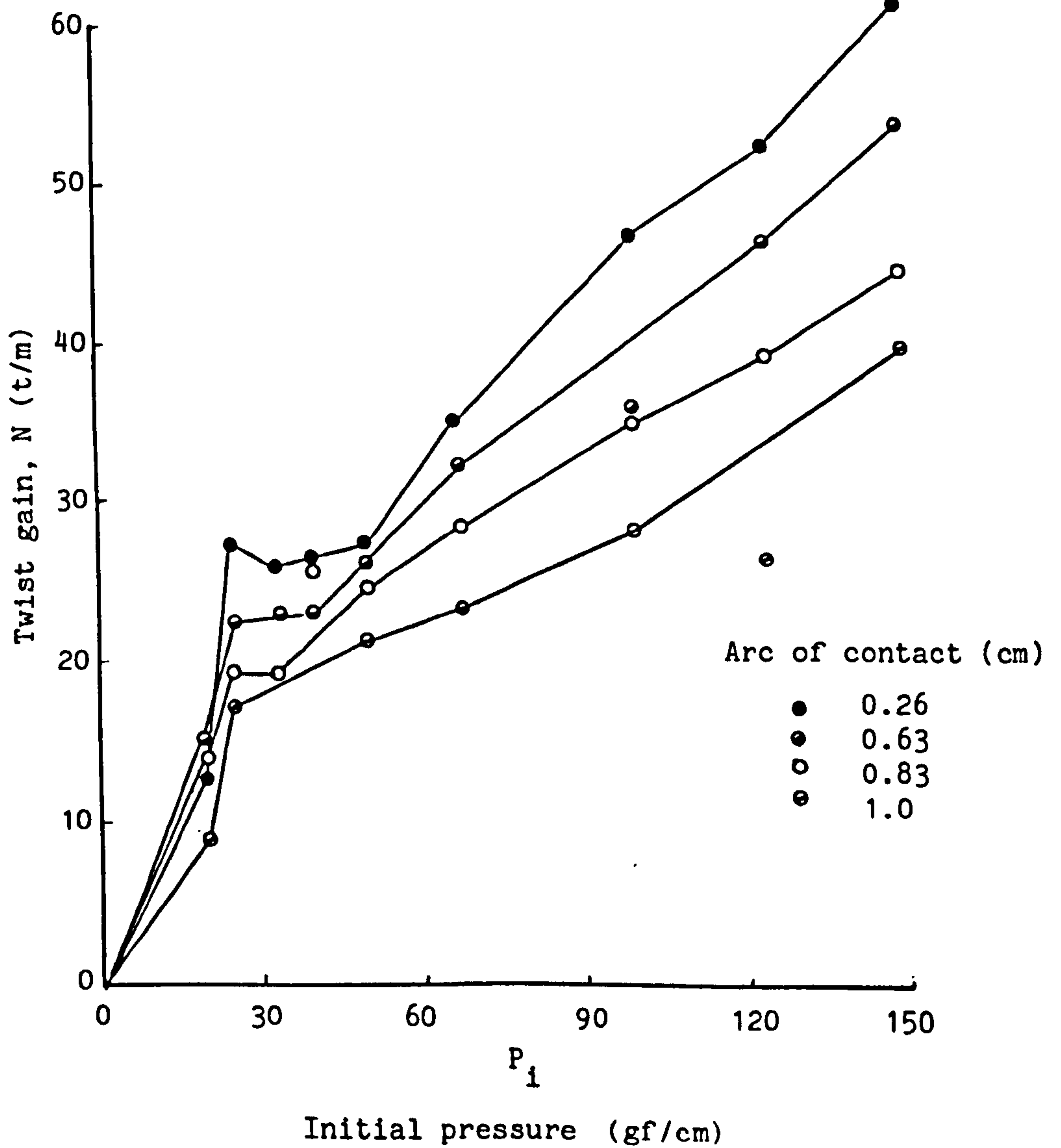

length of the arc of contact. On the other hand, in agreement with earlier results, twist gain decreases as arc of contact increases.

A surprising visual observation of the behaviour of the twisted yarn over the contact region is that, when the yarn had an angle of wrap  $360^\circ$  or more, using a 0.2 cm guide, the behaviour of the yarn was different from its behaviour at smaller angles of wrap.

Figure 5.11 A,B shows the expected position of the yarn over the guide surface for angles less than or equal to  $360^\circ$  respectively, whilst Fig. 5.11 C,D shows the observed behaviour of the yarn at a  $360^\circ$  angle of wrap, depending on whether the incoming yarn was behind or in front of the outgoing yarn.

It may be suggested that this deflection of the yarn path in the direction of the guide axis is due to the rolling of the yarn on the guide surface complicated by the effect of the yarn rolling on itself. An associated observation was reported [3] in relation to investigations of the wear of textile guide materials, in which it was found that the wear direction is directly dependent upon the direction of the yarn twist insertion (S or Z). In addition, the importance of the direction of threading of false-twist spindles in the texturing process is well known.

#### 5.7.1.1 Discussion

In the experiments described in section 5.5.2, that as the initial tension increased, the twist congestion increased; but the twist blockage also depended on guide radius.

The possibility has to be considered that blockage may be dependent on mean pressure ( $P_m$ ) or final pressure ( $P_f$ ) rather than

FIG. 5.11: Yarn behaviour over a contact surface at  $360^\circ$  angle of wrap

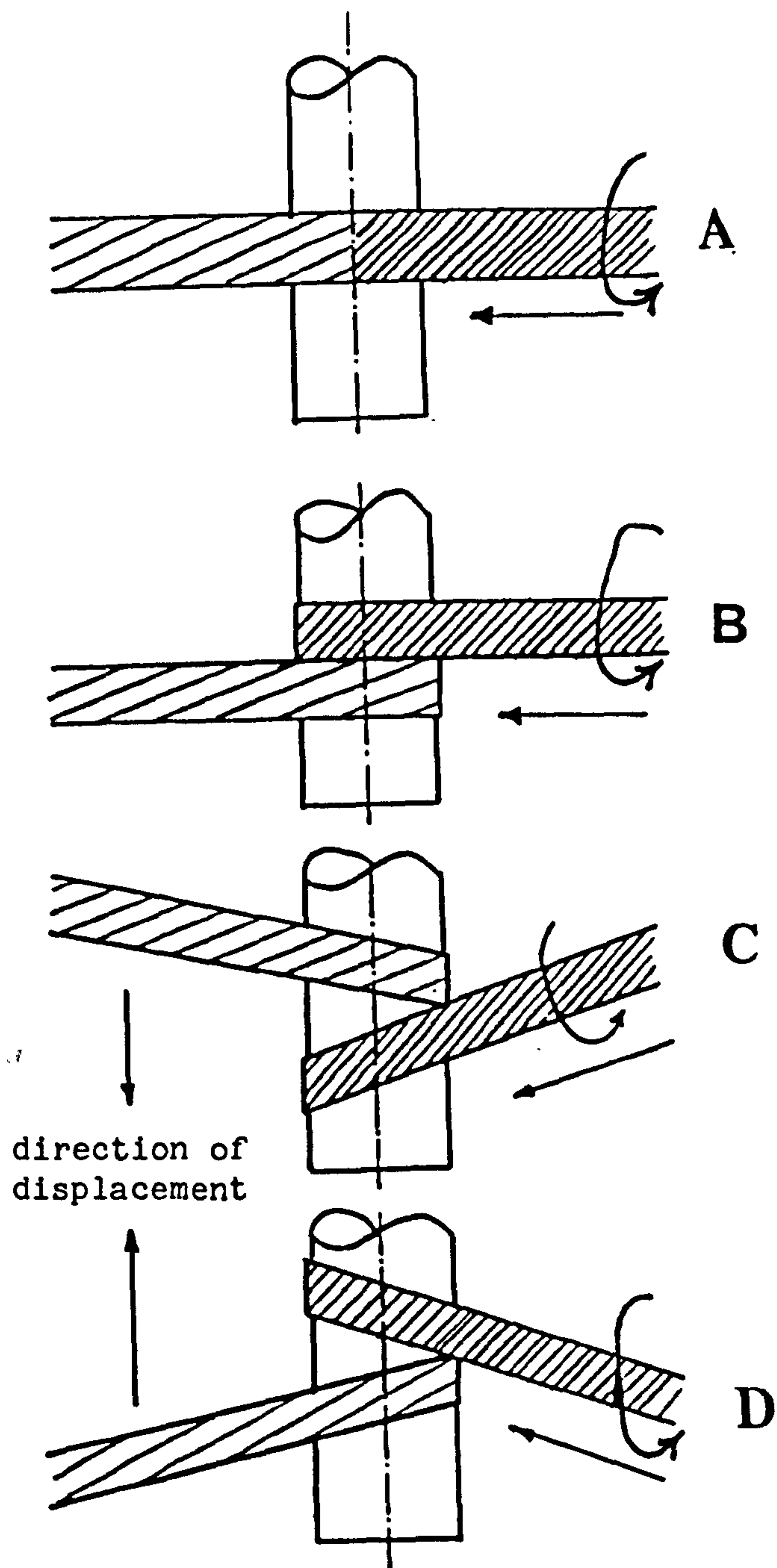

initial pressure ( $P_1$ ). The final tension ( $T_0$ ) will of course depend on the angle of wrap which in turn depends on length of arc of contact and guide radius.

The average and final pressure at constant value of  $\left[ \frac{T_i}{R} \right]$  varies, therefore, with angle of wrap, and the tension variation over the guide surface also has to be considered.

### 5.7.2 Effect of mean and final pressure

What interests us now is the relation between pressure and angle of wrap for given values of  $R$  and  $T_1$ , where the tension distribution along the contact surface is expressed by equation 8, Appendix I, where  $K$ , the coefficient of friction, may or may not be constant. As this is an exponential relation it cannot be expected that the relation between twist blockage and mean or final pressure will be linear as it was in the case of initial pressure.

In order to calculate the mean and final pressures, it was necessary to investigate the dependence of coefficient of friction upon pressure. The coefficient of friction was, therefore, measured for every guide diameter and angle of wrap at the initial tension as shown in Table 5.10.

The mean pressure ( $P_m$ ) is calculated by substitution in equation 9, Appendix I, with the assumption that the angle ( $\phi$ ) of the frictional force relative to the yarn axis is assumed to be zero. Assumption was made on the basis that the value of the friction angle does not have a major influence on the tension ratio over the guide and thus mean pressure is primarily dependent on input tension.



It is instructive to calculate the values of  $P_m$  by using the measured values of  $K$  over the contact surface.

On the basis of the above, the final pressure  $\left[ P_f = \frac{T_o}{R} \right]$  also is calculated from  $T_o$ , the outgoing tension, and the guide radius  $R$ . The corresponding values of  $P_m$  and  $P_f$  are shown in Table 5.10, in comparison with the values of the initial pressure,  $P_i$ .

Figure 5.12 shows the relationship between the twist gain,  $N$ , and the mean pressure,  $P_m$ , and Fig. 5.13 shows the relation between twist gain and final pressure.

It is interesting to compare the curves when the initial pressure, the mean pressure and the final pressure are used.

The maximum initial pressure for all arcs of contact is 150 gf/cm, but at the same initial tension and angle of wrap, the maximum mean pressure and final pressure are 260 and 415 gf/cm respectively.

Figure 5.14 compares the effect on twist blockage of the three values of pressure at an arc of contact equal to 0.63 cm.

The curves are displaced somewhat along the pressure axis, but in other respects they show similar relationships with blockage.

### 5.7.3 Conclusions

It is quite clear from Figs. 5.11-5.14 that the twist gain is not uniquely determined by either the initial pressure, the mean pressure or even the final pressure, though as might be expected, there is a more rapid increase of twist gain with increase of initial pressure than with either of the mean and final pressures.

It was clear, however, from visual observations that the twist

TABLE 5.10

S	K	P <sub>i</sub>	P <sub>M</sub>	P <sub>F</sub>	N
0.26	0.176	150.0	191.5	240.0	61.0
	0.139	125.0	127.6	144.0	52.2
	0.139	100.0	141.0	150.0	47.0
	0.185	66.7	56.4	62.5	34.4
	0.170	50.0	72.0	78.3	27.0
	0.200	40.0	42.0	44.5	26.4
	0.300	33.3	36.6	40.0	26.0
	0.270	25.0	32.0	44.5	27.0
	0.267	20.0	21.5	23.0	12.0
0.63	0.162	150.0	260.0	415.0	54.0
	0.146	125.0	163.0	242.5	46.0
	0.173	100.0	166.0	215.0	35.6
	0.159	66.7	65.0	82.5	32.5
	0.496	50.0	59.0	94.0	26.0
	0.143	40.0	39.0	45.0	23.0
	0.144	33.3	29.0	34.0	23.0
	0.176	25.0	44.0	45.0	22.5
	0.177	20.0	22.4	15.0	15.0
0.83	0.180	150.0	195.0	250.0	44.0
	0.160	125.0	149.0	175.0	39.0
	0.171	100.0	146.0	205.0	35.0
	0.156	66.7	83.7	103.0	28.0
	0.112	50.0	64.0	80.0	24.5
	0.145	40.0	45.0	51.0	26.0
	0.145	33.3	41.0	50.0	19.0
	0.360	25.0	37.6	54.0	19.4
	0.100	20.0	22.0	23.5	14.0
1.00	0.234	150.0	192.0	240.0	36.0
	0.217	125.0	166.0	215.0	26.0
	0.138	100.0	144.0	200.0	28.0
	0.141	66.7	85.0	107.0	23.0
	0.143	50.0	73.0	102.5	21.0
	0.236	25.0	34.0	45.0	17.0
	0.185	20.0	24.0	29.0	8.5

S = length of arc of contact (cm)

K = coefficient of friction

P<sub>i</sub> = initial pressure (gf/cm)

P<sub>M</sub> = mean pressure (gf/cm)

P<sub>F</sub> = final pressure (gf/cm)

N = twist gain (t/m)

FIG. 5.12: Effect of the mean pressure on twist gain at various levels of length of arc of contact ( $S$ )

$$N_0 = 120 \text{ (t/m)}$$

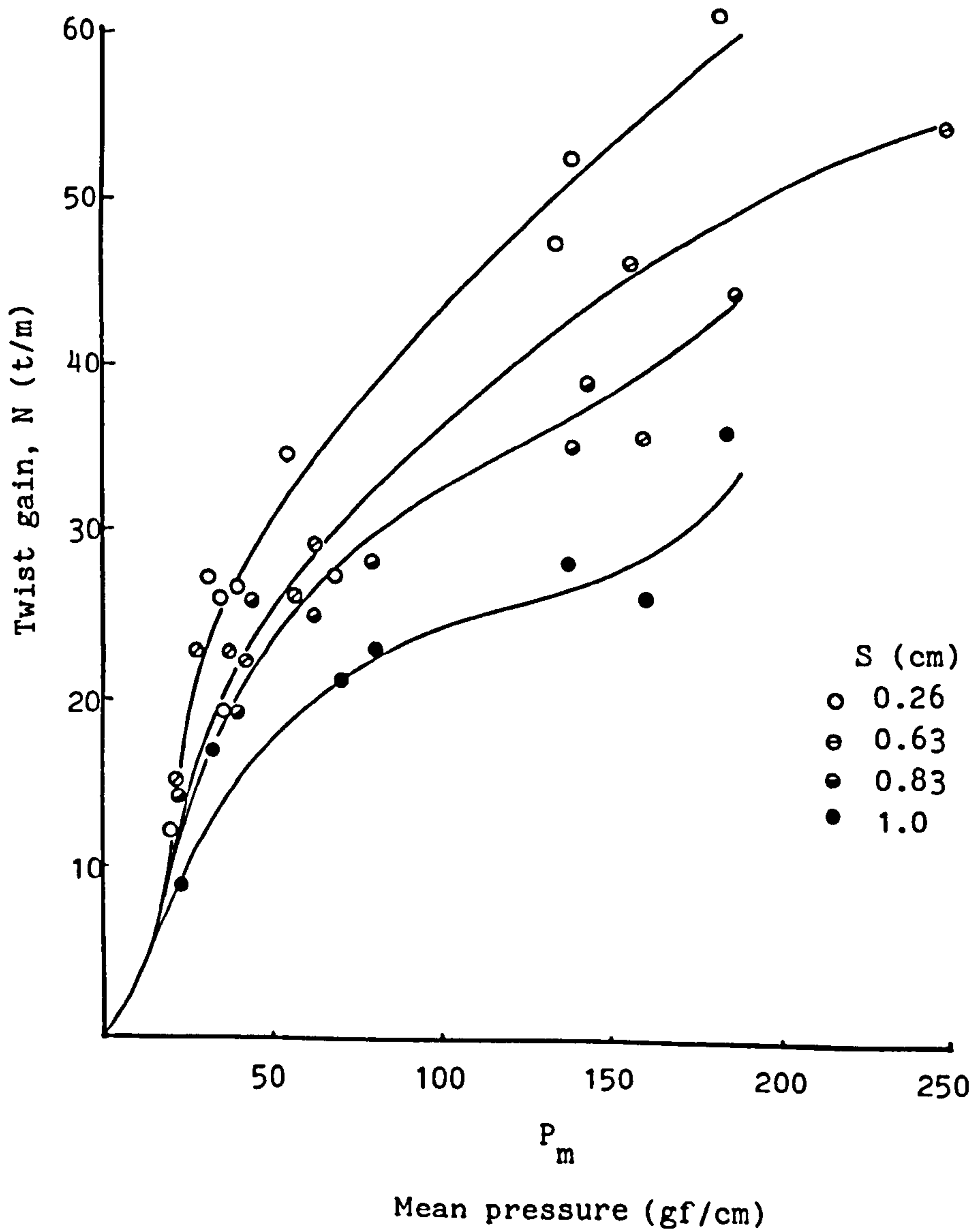

FIG. 5.13: Effect of the final pressure on twist gain at various levels of length of arc of contact (S)

$$N_0 = 120 \text{ (t/m)}$$

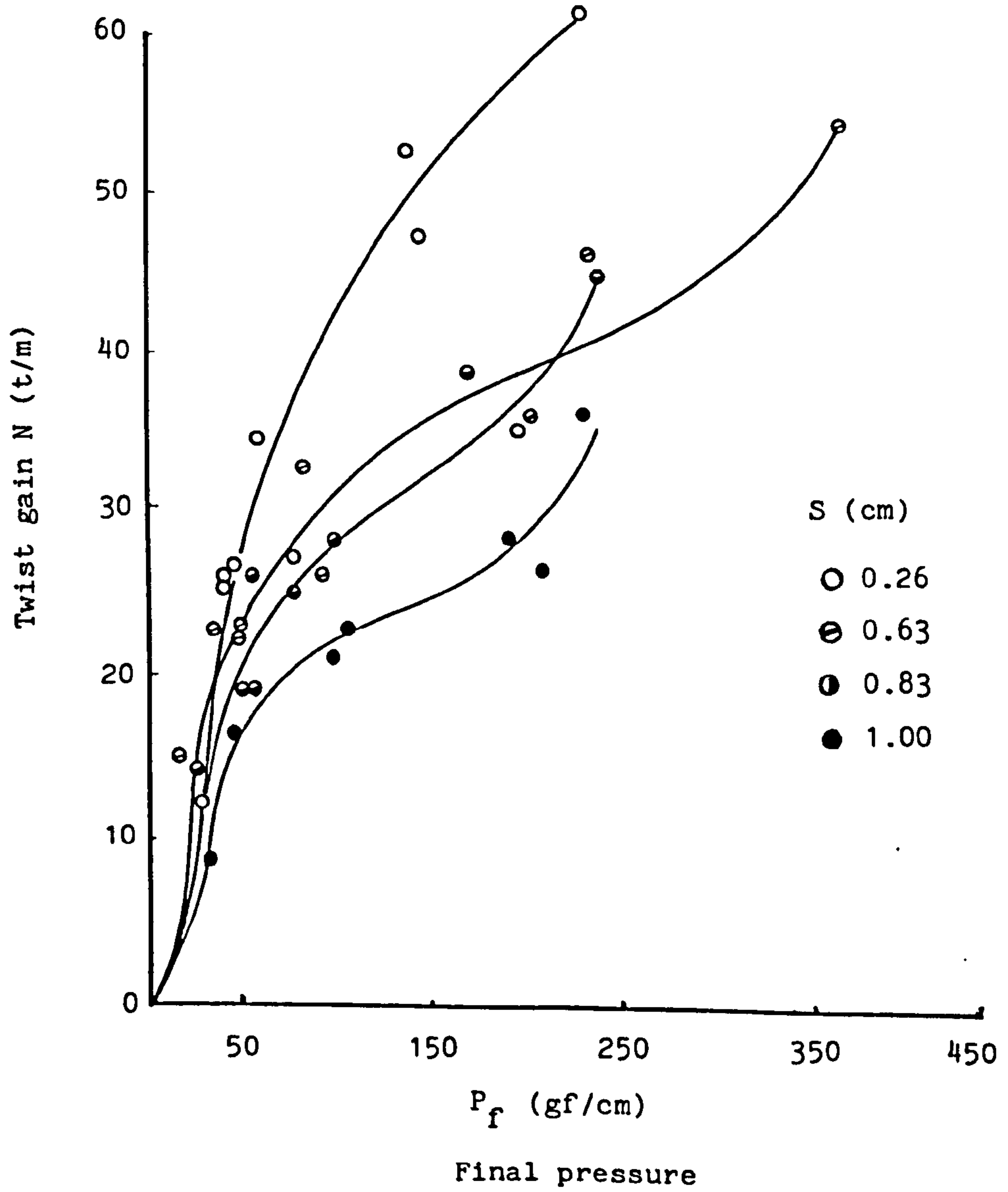
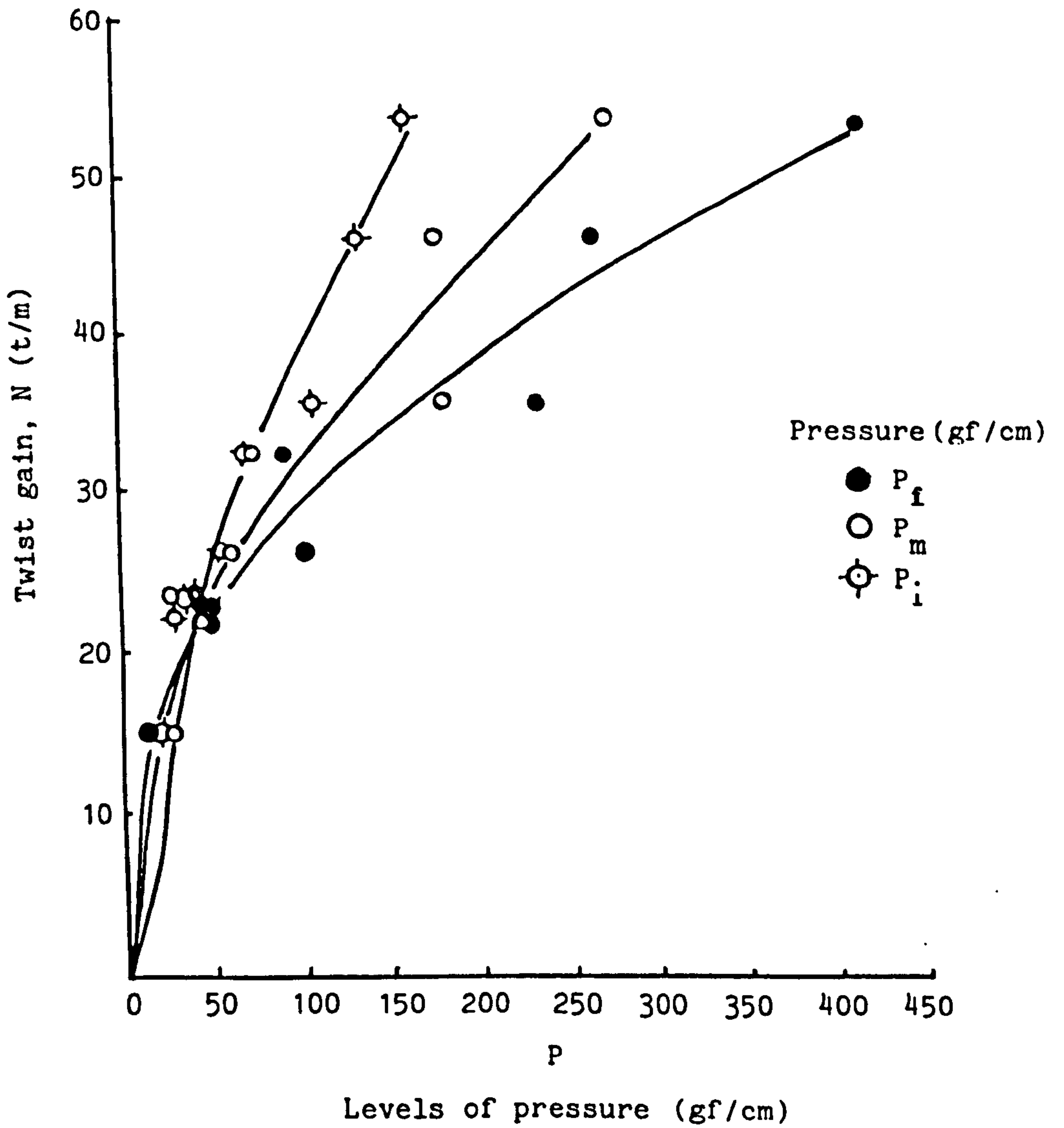

FIG. 5.14: Effect of three levels of pressure (initial, final, mean) on twist gain at constant length of arc of contact (0.63 cm)

$$N_0 = 120 \text{ (t/m)}$$



blockage was generated at the front region of the contact surface rather than at the middle or the end region.

In spite of this, it is not considered adequate to use only the initial pressure in investigating the pressure/blockage relationship as for a given input tension, initial pressure takes no account of angle of wrap. For this reason and because it takes into account the effect of yarn/surface coefficient of friction and the effect of length of arc of contact,  $S$ , the mean pressure is preferred as a parameter to be considered. It should also be remembered that there is evidence that the twist blockage over a contact region is also considerably influenced by the length of contact region on the one hand, and the length of one turn of twist on the other.

In the experiments reported so far, investigating the relation between twist geometry and length of contact, the former has been kept constant and the latter varied. To test the hypothesis presented above in explanation of the results, it will be of interest to observe the effect of keeping the contact geometry fixed whilst varying the twist of the yarn.

### 5.8 Effect of length of one turn

Following the previous experiments, it was pointed out that among the testing parameters, the length of one turn interrelated with the length of the arc of contact may affect the characteristic behaviour of twist congestion.

Unfortunately, no previous study of this variable has been carried out from which it was possible to know whether this may be a significant factor or not.

In this experiment, investigation of the effect of the length of one turn is, therefore considered.

Five yarns of different twists were used viz. 50, 120, 192, 392 and 584 t/m.

As yarns of different twist may behave differently over the contact region where their frictional properties are concerned [36,90] it was necessary to measure the coefficient of friction corresponding to the different yarn twists. In addition, the friction coefficient is itself likely to affect the magnitude of the pressure. Because of this, the initial tension required to maintain pressure constant also might change.

As a compromise, the mean of the five values of the friction coefficient of the yarn, Table 5.11, was used. It was calculated that the tension change required to take account of the variation of  $K$  on either side of the mean was negligible, about  $\pm 0.01\%$ .

In any event, as has been mentioned [36], none of the available tension devices is capable of maintaining a uniform tension throughout the wide range of variation in the required input tension. It was decided, therefore, to keep the initial tension the same for the five yarns except where it was necessary to change tension to keep pressure constant as guide diameter changed. Three arcs of contact, 0.21, 0.42 and 0.63 cm, were used with a constant angle of wrap  $120^\circ$  and using three guides of diameters 0.2, 0.4 and 0.6 cm.

For a constant mean pressure of 476 gf/cm, the initial tension was 40, 80 and 120 gf for each of the above guide diameters respectively.

TABLE 5.11

Length of one turn (cm/turn)	2	0.83	0.474	0.26	0.17
Nominal twist (t/m)	50	120	192	392	584
K*	0.15	0.19	0.152	0.143	0.166

\*The mean value of coefficient of friction

$$K = 0.16$$



### 5.8.1 Results

It was observed that a higher value of twist blockage occurred when the length of one turn was long (low twist) and, as would be expected, the rotation of the yarn before the guide also increases. Because, in these circumstances, the incoming twist is low, a long time is required for the twist before the guide to build up to a level where it will escape over the surface. Conversely, higher twist yarn reaches a maximum blocking twist more rapidly.

Twist blockage behaviour due to variation of length of one turn is recorded in Table 5.12. Using these results, graphs, 5.15, 5.16 and 5.17 were produced. Examining Fig. 5.15 shows that the twist gain,  $N$ , increases as the length of one turn increases, whilst, as the arc of contact increases, it decreases.

It is clearly demonstrated in this graph that the twist blockage is considerably influenced by a relationship between the length of arc of contact  $S$  and length of one turn,  $L_0$ . Roughly the same gain is achieved when the length of one half-turn is the same as the arc of contact. This is supported by Fig. 5.16, which shows a quite good linear relationship between the input twist,  $N_0$ , and twist gain,  $N$ . The corresponding linear regression equations are as follows:

$$N = 97.95 - 0.096 N_0 \quad (1)$$

$$N = 82.40 - 0.098 N_0 \quad (2)$$

$$N = 71.00 - 0.094 N_0 \quad (3)$$

giving the value of coefficient of correlation  $r = 0.992, 0.95$  and  $0.99$  for the arcs of contact  $S = 0.21, 0.42$  and  $0.63$  cm respectively.

TABLE 5.12

Twist (t/m)	Length of one turn (cm)	S=0.21	S=0.42	S=0.63
		N	N	N
50	2.00	95.0	88.0	70.0
120	0.83	87.5	65.0	57.0
192	0.52	75.0	59.0	50.0
392	0.26	62.0	42.0	36.0
584	0.17	42.0	29.0	16.0

S = length of arc of contact (cm)

N = twist gain (t/m)

Handwritten notes:  $2.5$  and  $1.5$

FIG. 5.15: Effect of length of one turn of input yarn twist on twist gain at various levels of length of arc of contact (S)

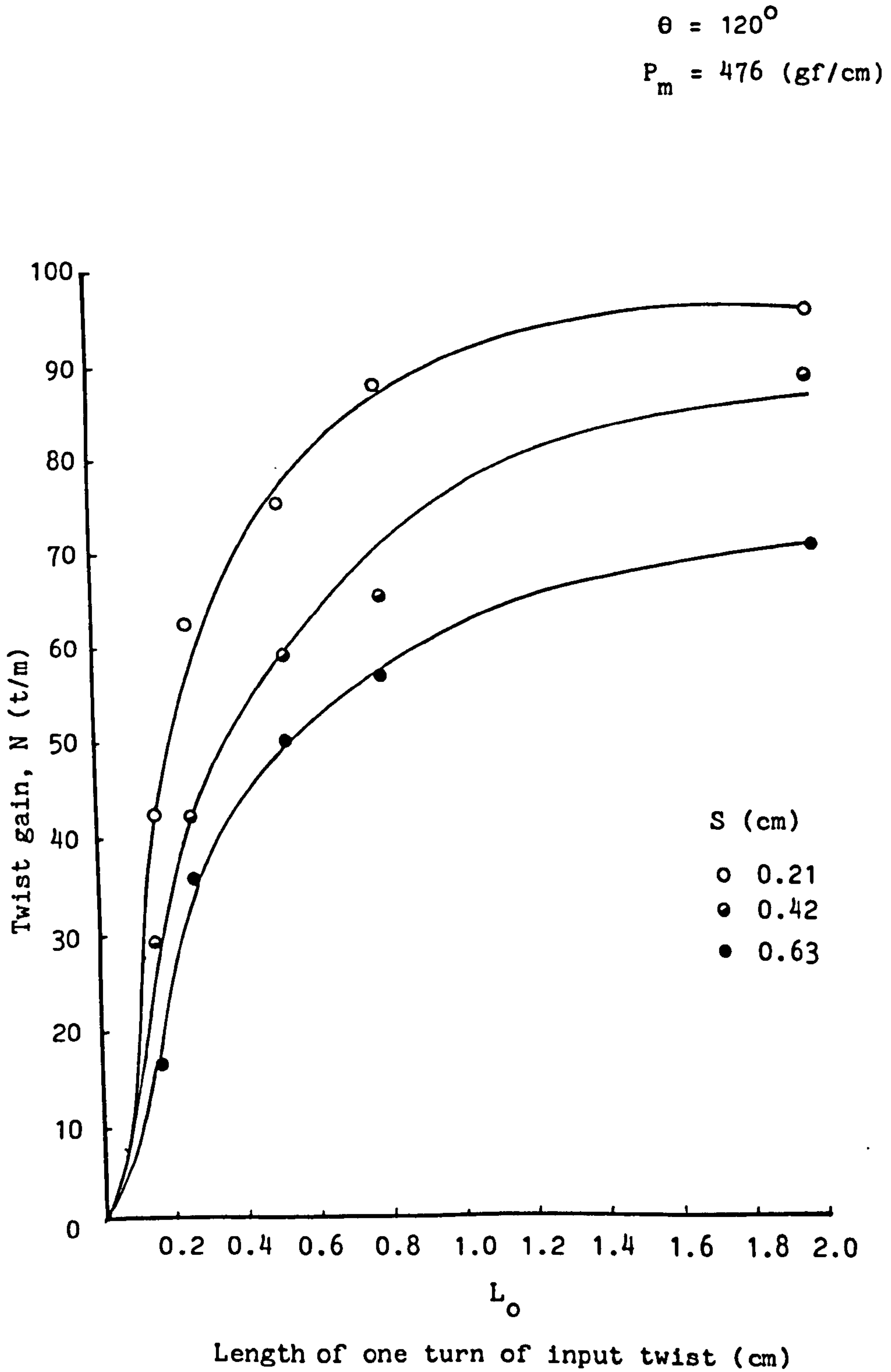
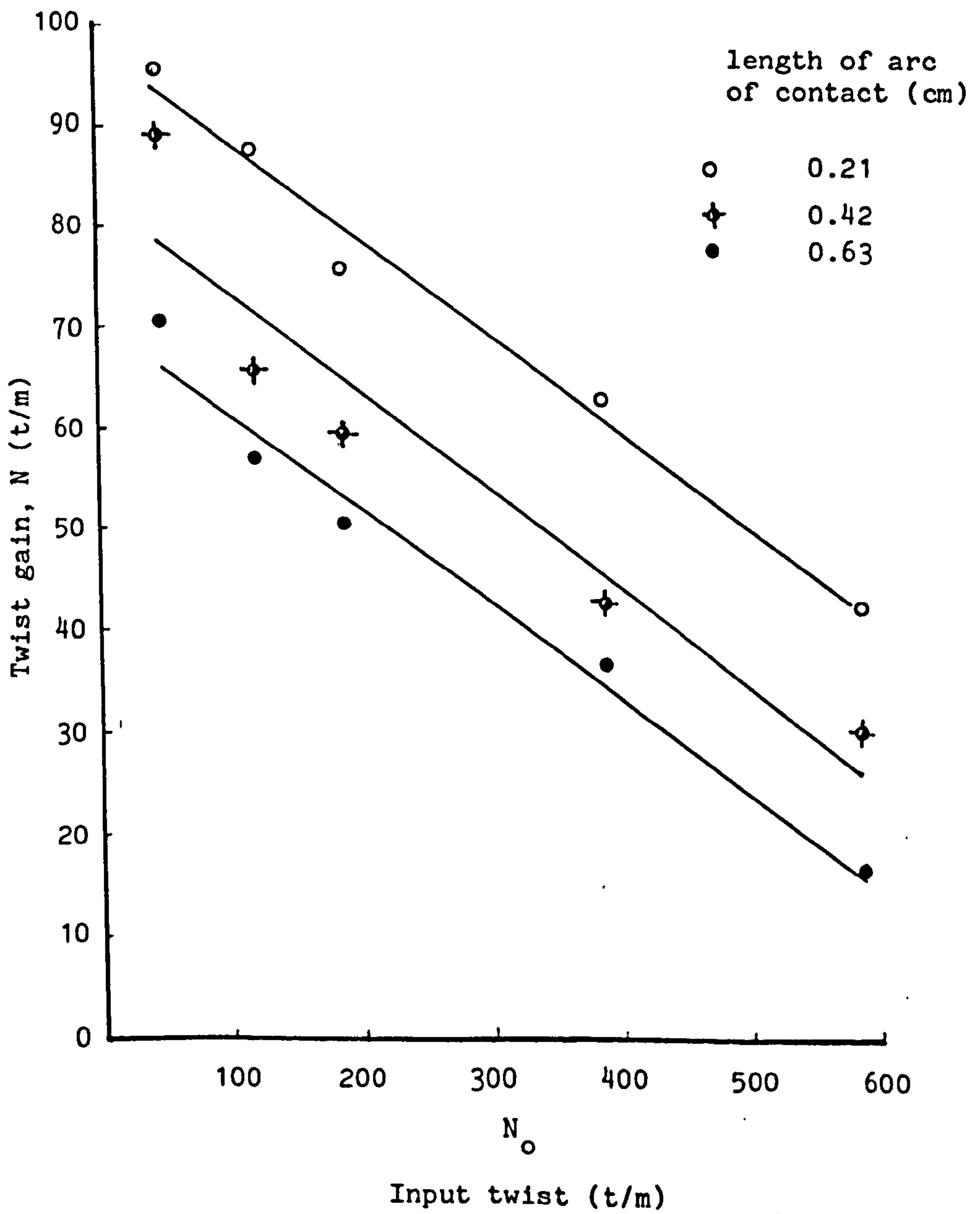

FIG. 5.16: Effect of input twist on twist gain at various levels of length of arc of contact

$$\theta = 120^\circ$$

$$P_m = 476 \text{ (gf/cm)}$$



It is obvious that the negative sign indicates that as the input twist,  $N_o$ , increases, the twist gain,  $N$ , decreases. It would be unwise, however, to conclude that these lines can be extrapolated outside the range of observation.

In particular there may be a rapid increase in  $N$  as  $N_o$  is reduced below 50 t/m. It can be said, however, that the amount of false-twist or the twist accumulated in front of the contact region can be as high as roughly 200% of the nominal yarn twist. Because of this high twist, supported by observation, it may be postulated that the yarn was moving over the contact region under the conditions of a flattened mechanism in which the twist is completely pushed back in front of the yarn guide. This maximum blockage in fact occurred at an input twist of 50 t/m with a fairly low length of arc of contact (0.21 cm).

As previously, this mechanism continued until the twist reached a level at which it could transfer over the contact region. The process was then repeated.

At this stage the way in which twist blockage is defined is of some interest and importance. Some previous investigators [62,63] always defined the amount of twist gain (false-twist) either as the difference between the accumulated twist before the contact surface,  $N_B$ , and the nominal twist,  $N_o$ , or between the theoretical machine-inserted twist as in the O-E spinning process [21,23] and the measured twist, rather than taking the twist difference before ( $N_B$ ) and after ( $N_A$ ) the contact region. It is desirable to show the difference between the two methods of estimating twist gain. These are shown below. In

addition, the ratio (Q) between length of one turn of nominal twist,  $L_0$ , and length of arc of contact, S, is of interest. The three parameters are defined as follows:

$$\Delta_1 = \frac{N_B - N_A}{N_A} \%$$

$$\Delta_2 = \frac{N_B - N_0}{N_0} \%$$

$$Q = \frac{L_0}{S} \quad \text{PhA}$$

The observed relationships between Q and  $\Delta_1$ ,  $\Delta_2$  are shown in Table 5.13 and graphically illustrated in Fig. 5.17.

A scattered relationship was found between Q and  $\Delta_1$  and  $\Delta_2$ . However, the graph demonstrates that as Q increases, the percentage twist gain,  $\Delta_1$  and  $\Delta_2$ , increases. The corresponding equations of linear regression for  $\Delta_1$  and  $\Delta_2$  are:

$$\Delta_1 = 29.7 Q + 0.26$$

$$\Delta_2 = 20.4 Q + 1.32$$

giving a good correlation of coefficient 0.913 and 0.882 for  $\Delta_1$  and  $\Delta_2$  respectively. The representation shows that there is a significant difference in magnitude of twist gain between the method of calculation used in the present investigation (i.e.  $\Delta_1$ ) and the method used by previous investigators (i.e.  $\Delta_2$ ).

It is obvious that at the same Q ratio, there is roughly a 30% difference between  $\Delta_1$  and  $\Delta_2$  due to the twist after the guide being

TABLE 5.13

Q	$N_0$	$N_B$	$N_A$	N	$\Delta_1$	$\Delta_2$
9.50	50	134.0	39.0	95.0	243.6	168.0
4.80	50	127.0	39.0	88.0	225.6	154.0
4.00	120	187.5	100.0	87.5	87.5	56.3
3.20	50	116.0	46.0	70.0	152.2	132.0
2.50	192	237.5	162.5	75.0	46.2	23.7
2.00	120	168.0	101.0	67.0	66.3	40.0
1.34	120	164.0	107.0	57.0	53.3	36.7
1.24	392	450.0	387.5	62.5	16.0	15.0
1.24	192	225.0	166.0	59.0	35.5	17.2
0.83	192	220.0	170.0	50.0	29.4	14.6
0.81	584	650.0	609.0	41.0	6.7	11.3
0.62	392	425.0	383.0	42.0	11.0	8.4
0.41	584	625.0	596.0	29.0	5.0	7.0
0.41	392	417.5	390.0	38.5	7.0	6.5
0.27	584	621.0	605.0	16.0	2.6	6.3

Q = ratio between length of one turn of twist and length of arc of contact

$N_0$  = nominal twist (t/m)

$N_B$  = twist before the contact surface (t/m)

$N_A$  = twist after the contact surface (t/m)

N = twist gain ( $=N_B - N_A$ ) (t/m)

$\Delta_1$  = percentage twist gain relative to twist after the contact surface

$\Delta_2$  = percentage twist gain relative to the nominal twist

FIG. 5.17: Relation between twist gain (N) and the ratio of length of one turn of nominal yarn twist ( $L_0$ ) and length of the contact region (S)

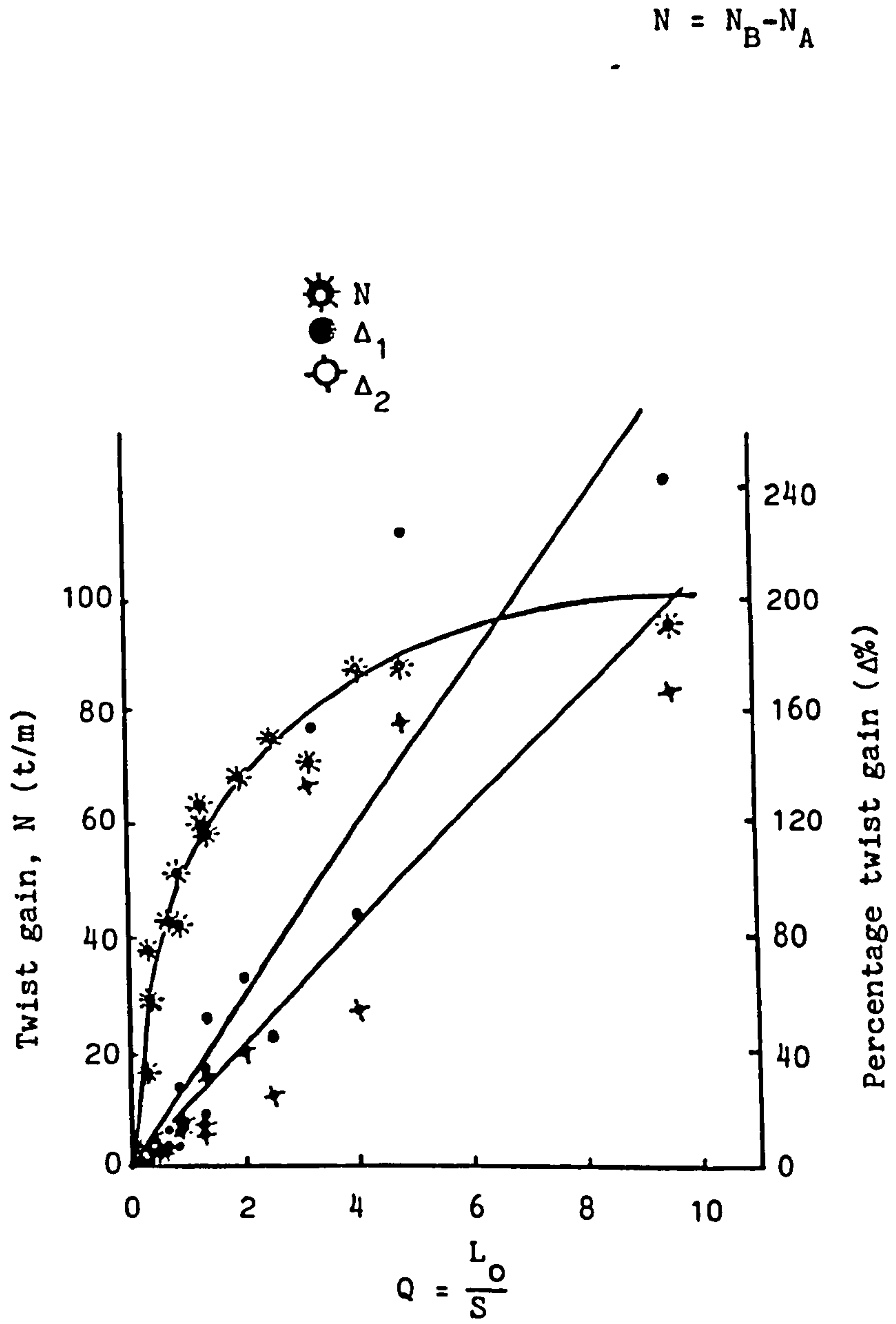

Ratio of length of one turn of nominal twist and length of arc of contact



less than the nominal, in conditions of oscillating false-twist generation.

However, when this effect is viewed in terms of the amount of twist gain (N) instead of ( $\Delta$ ) as shown in the graph, a quite different picture emerges. It may be seen that twist gain (N) is significantly dependent on Q when Q is small. For Q ratio of 2 or less, corresponding to a twist of 120 t/m, a rapid increase of twist gain occurs. Further increase of Q gives a much reduced rate of increase of N.

### 5.8.2 Discussion

It may be concluded from the results and graphical representations that the twist blockage behaviour is considerably influenced by the ratio of the length of one turn and the length of the contact region. A reasonably highly correlated relationship between the % twist blockage and the ratio  $\frac{L_0}{S}$  confirms this belief.

The behaviour of the twisted yarn over the contact region has, therefore, been clarified to some extent. This study has confirmed the earlier finding that the twist blockage characteristic is not only significantly dependent on the length of one turn (yarn twist) but also is related to the length of arc of contact. Thus a detailed study in which length of arc of contact is a variable under constant mean pressure could provide an even more complete interpretation of the general conclusion reached earlier.

The effect of frictional force and normal force arising from the physical interaction between the contact surface and the points of contact over the contact region can also be examined. Such experiments would depend to some extent upon different levels of angles of wrap. It is, therefore, necessary first to examine the

influence of the angle of wrap on twist blockage, taking into account the mean pressure and factors on which it depends.

### 5.9 Effect of angle of wrap at constant mean pressure and arc of contact

The experiments were set up at three levels of arc of contact ( $S = R\theta$ ) namely 0.15, 0.22 and 0.32 cm at a constant mean pressure roughly equal to 500 gf/cm.

Five different angles of wrap with the five guide diameters were used according to the length of arc of contact. In addition, to sustain the same mean value of pressure over the contact surface, the initial tension,  $T_1$ , was varied depending on both the guide diameter and the measured coefficient of friction (friction index  $n = 0.991$  and friction coefficient  $m = 0.151$ ). Initial tension 40 gf with guide diameter 0.2 cm was chosen with a corresponding arc of contact 0.32 cm.

The same yarn as in previous experiments, with twist 50 t/m, was used. Table 5.14 demonstrates these inter-related values and results are listed in Table 5.15.

#### 5.9.1 Results

Figure 5.18 illustrates the effect of angle of wrap ( $\theta$ ) on the twist gain (N) for the three levels of arc of contact. It may be observed that the twist gain is not significantly changed with change of angle of wrap.

As previously, any scatter of points may be attributed to the twist irregularity of the yarn or the input tension variation which

TABLE 5.14

S	R	$\theta$	$T_1$
0.32	0.1	180.0	40
	0.2	90.0	90
	0.3	60.0	140
	0.4	45.0	190
	0.5	36.0	245
0.22	0.1	125.0	43
	0.2	62.5	90
	0.3	41.7	140
	0.4	31.3	190
	0.5	25.0	245
0.15	0.1	75.0	40
	0.2	37.5	90
	0.3	25.0	140
	0.4	18.8	190
	0.5	15.0	245

S = length of arc of contact (cm)

R = guide radius (cm)

$\theta$  = angle of wrap (degrees)

$T_1$  = initial tension (gf)

Multi-coefficient of friction = 0.143

TABLE 5.15

Arc of contact		$S_1=0.32$ cm		$S_2=0.22$ cm			$S_3=0.15$ cm		
R	$\theta$	F	N	$\theta$	F	N	$\theta$	F	N
0.1	180	22.7	80.5	125.0	14.8	92.0	75.0	8.3	92.0
0.2	90	20.2	84.8	62.5	13.7	100.5	37.5	8.0	106.0
0.3	60	19.2	80.0	41.7	13.3	82.0	25.0	7.8	89.5
0.4	45	19.0	82.3	31.3	13.0	85.0	18.8	7.7	100.0
0.5	36	19.0	75.0	25.0	13.0	81.0	15.0	7.7	89.5

R = guide radius (cm)

$\theta$  = angle of wrap (degrees)

F = frictional force (gf)

N = twist gain (t/m)

FIG. 5.18: Effect of angle of wrap on twist gain at various levels of length of arc of contact

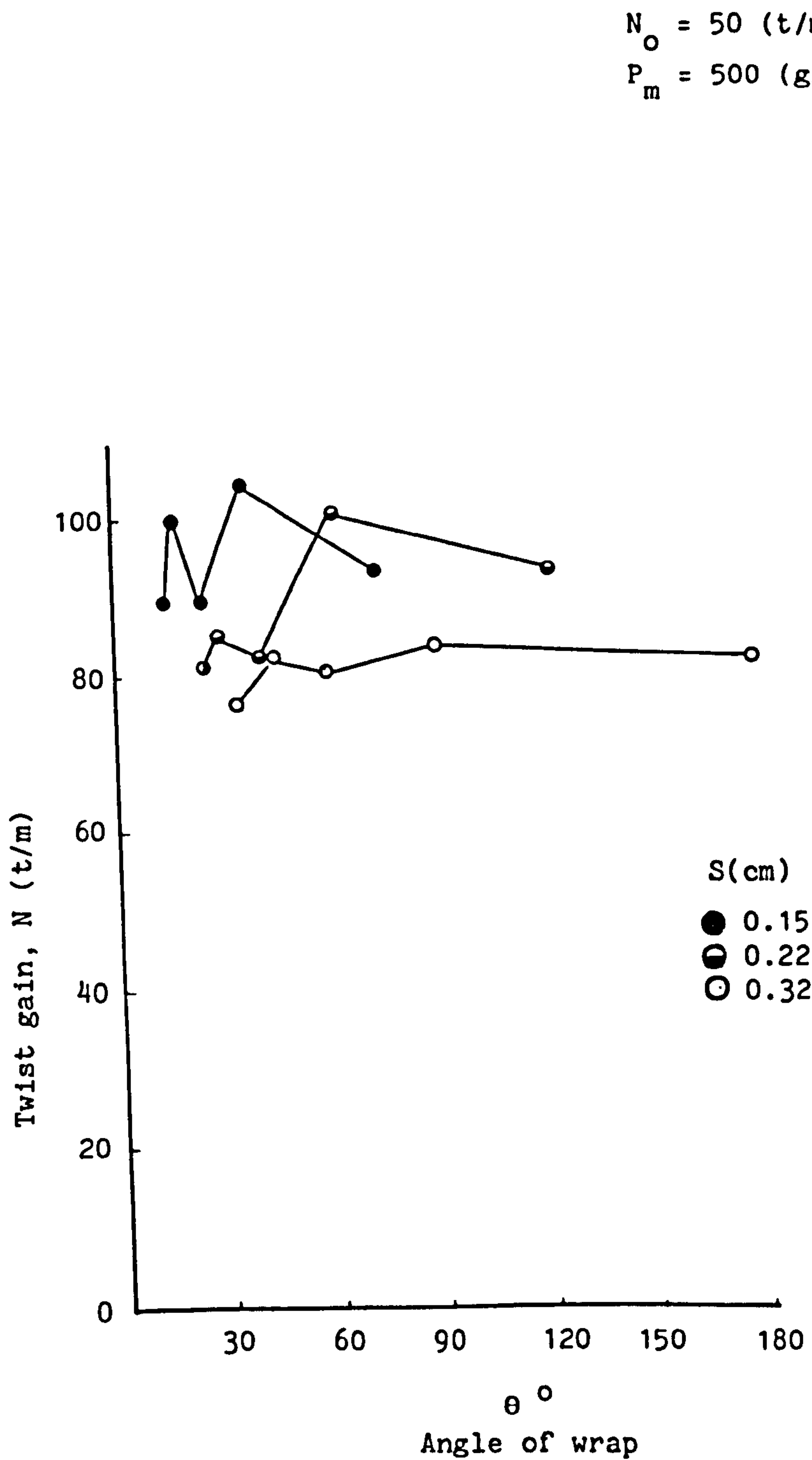

was difficult to control. In addition, there may have been some variation in the surface characteristics of the guides.

The observation of a roughly constant twist blockage at different angles of wrap may be due to the fact that in each case the length of the arc of contact and mean pressure were unchanged, thus again confirming the prime dependence of blockage on these factors.

### 5.9.2 Effect of frictional force over the contact region

The magnitude of the frictional drag, calculated from tension change in the present experiment, is tabulated in Table 5.15. Figure 5.19 represents the magnitude of the frictional force at the three levels of arc of contact at different angles of wrap.

It is clearly seen that at constant arc of contact the frictional force is roughly constant, but it changes its level when the contact angle is changed.

It should be borne in mind that earlier observations have shown that twist blockage decreases as length of arc of contact increases, the input tension being constant. Under these conditions, frictional force would increase as length of contact increases. It appears, paradoxically, therefore, that twist blockage decreases as frictional force increases. This relationship between frictional force and twist blockage will be discussed more fully later.

### 5.9.3 Conclusions

Earlier investigations of the effect of angle of wrap have widely shown that the twist blockage is highly influenced by this parameter. In this respect the present investigation has produced

FIG. 5.19: Measured values of frictional force over the length of arc of contact at different angles of wrap

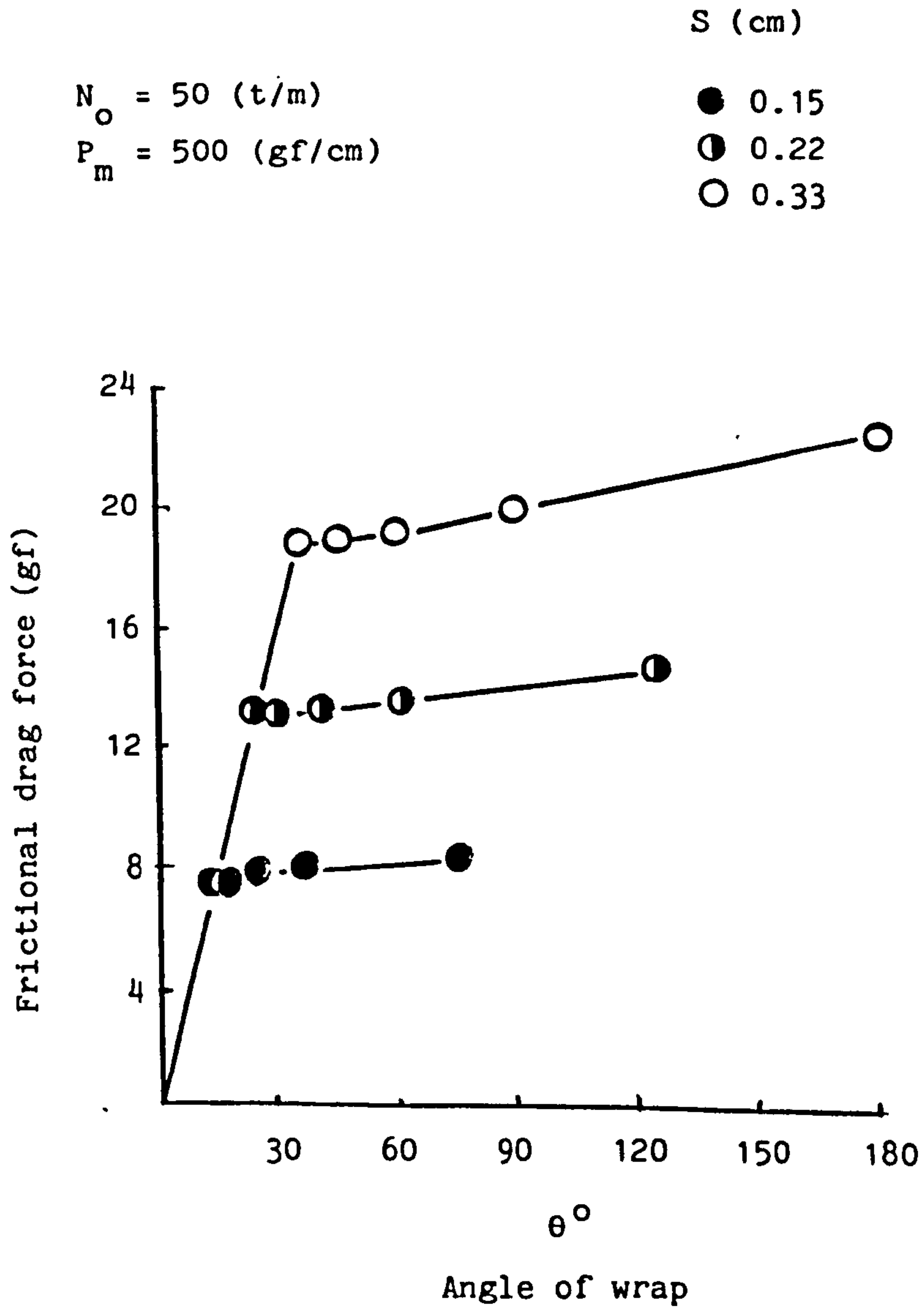

results which contradict those of earlier investigators [28,62,63].

In fact these earlier investigations were carried out under conditions of constant initial tension with very small guide diameters (i.e. with small length of contact) neglecting the change of pressure distribution over the contact region and the increase of the length of arc of contact caused by an increase of the angle of wrap. On the other hand, Chan [52] kept the final tension constant under the conditions where mean pressure over the contact region is reduced (due to a reduction of the initial tension) as the angle of wrap is increased; nevertheless, his observations were in agreement with our results.

Generally, as has been indicated, the angle of wrap has no significant independent influence on twist blockage in the conditions of the present experiments.

#### 5.10 Effect of length of contact at constant mean pressure

As discussed in section 5.7.3, it was considered that mean pressure over the guide surface rather than initial pressure should be used as a relevant parameter. This seems reasonable because it takes account of coefficient of friction as well as initial tension, guide diameter, and angle of wrap.

In the present experiment, the same yarn with a twist level of 120 t/m and the usual guides were used as in the previous experiments, using wrap angles over the range 30 to 180° in 30° steps. By this means, thirty different values of arc of contact could be achieved.



The experiment was carried out at constant mean pressure equal to 208 gf/cm at different lengths of arc of contact (S). The variation of arc of contact was set either by altering the angle of wrap ( $\theta$ ) or by changing the guide diameter (D). The mean pressure will, of course, change as a result of changing either  $\theta$  or D. The initial tension,  $T_1$ , was, therefore, changed in order to achieve a constant mean pressure, when D was varied.

As Howell's formula was adopted, and since the multi-coefficient of friction (m.c.f.) is a function of the ratio of the initial tension ( $T_1$ ) and guide diameter (D) (Appendix I)

$$K = m \left[ \frac{R}{T_1} \right]^{1-n}$$

The magnitude of K will remain constant as long as the ratio  $\frac{R}{T_1}$  is unchanged. However, a change in  $T_1$  alone causes a change of the value of K. It was, therefore, difficult to adjust the initial tension to keep the mean pressure constant since the m.c.f. is not constant and is dependent on  $T_1$ .

A small computer program was written to calculate the value of  $T_1$  to compensate for the alteration of the angle of wrap.

In an experiment to determine the mean value of the m.c.f. and, in turn, the friction coefficient, m, of the guide and the friction index, n, of the yarn, it was found that m and n are equal to 0.17 and 0.97 respectively.

The following values were chosen

Initial tension  $T_1 = 20$  gf at guide diameter  $D = 0.2$  cm  
 mean pressure = 208 gf/cm.

Table 5.16 shows the values of the initial tension used with the different angles of wrap. The table illustrates also the different arcs of contact (S) corresponding to the varied guide diameters, D. For guides of other diameters, the initial tension,  $T_1$ , was calculated from the relation  $\frac{D_1}{D_2} = \frac{T_{i1}}{T_{i2}}$  as shown in Fig. 5.20.

Referring to the above table, it is very obvious that the change in  $T_1$  due to changes in  $\theta$  is not very great; less than 5% for each  $30^\circ$  change in wrap angle. Obviously, the tension fluctuation may be greater than the required tension adjustment over the whole range from  $30^\circ$  to  $180^\circ$  wrap angle. This is especially true at a guide diameter of 0.2 cm where the total tension changes are relatively small. However, two options are available:

1. To neglect the change of  $T_1$  due to the change of  $\theta$  or
2. To attempt to make the small adjustment in average  $T_1$  required to compensate for altering  $\theta$ .

This is possible by using the M.P.V. where this device gives an accurate measurement of mean tension (see Chapter 4, section 4.4). The second option was, therefore, adopted.

#### 5.10.1 Results

The results of the twist blockage experiments are shown in Table 5.16 and plotted in Fig. 5.21.

A highly significant relationship is found between arc of contact, S, and twist gain, N, where increase of arc of contact causes the twist gain to decrease irrespective of guide diameter. It is seen that the twist gain, N, is higher with very short length of S, but decreases rapidly as S is increased until at a length of approximately

TABLE 5.16

D	$\theta$	S	$T_1$
0.2	30	0.05	20.0
	60	0.11	19.0
	90	0.16	18.6
	120	0.21	18.0
	150	0.26	17.0
	180	0.32	16.5
0.4	30	0.11	40.0
	60	0.21	38.6
	90	0.32	37.0
	120	0.42	36.0
	150	0.52	34.0
	180	0.63	31.0
0.6	30	0.16	60.0
	60	0.32	58.0
	90	0.47	55.6
	120	0.63	53.6
	150	0.79	51.5
	180	0.94	49.5
0.8	30	0.21	80.0
	60	0.42	77.0
	90	0.63	74.0
	120	0.84	71.0
	150	1.10	68.4
	180	1.30	66.0
1.0	30	0.26	100.0
	60	0.52	96.5
	90	0.79	93.0
	120	1.10	89.0
	150	1.30	86.0
	180	1.60	82.5

D = guide diameter (cm)

$\theta$  = angle of wrap (degrees)

S = length of arc of contact (cm)

$T_1$  = initial tension (gf)

Multi-coefficient of friction = 0.119

FIG. 5.20: Calculated values of initial tension dependent on the variation of angle of wrap for various guide diameters (D)

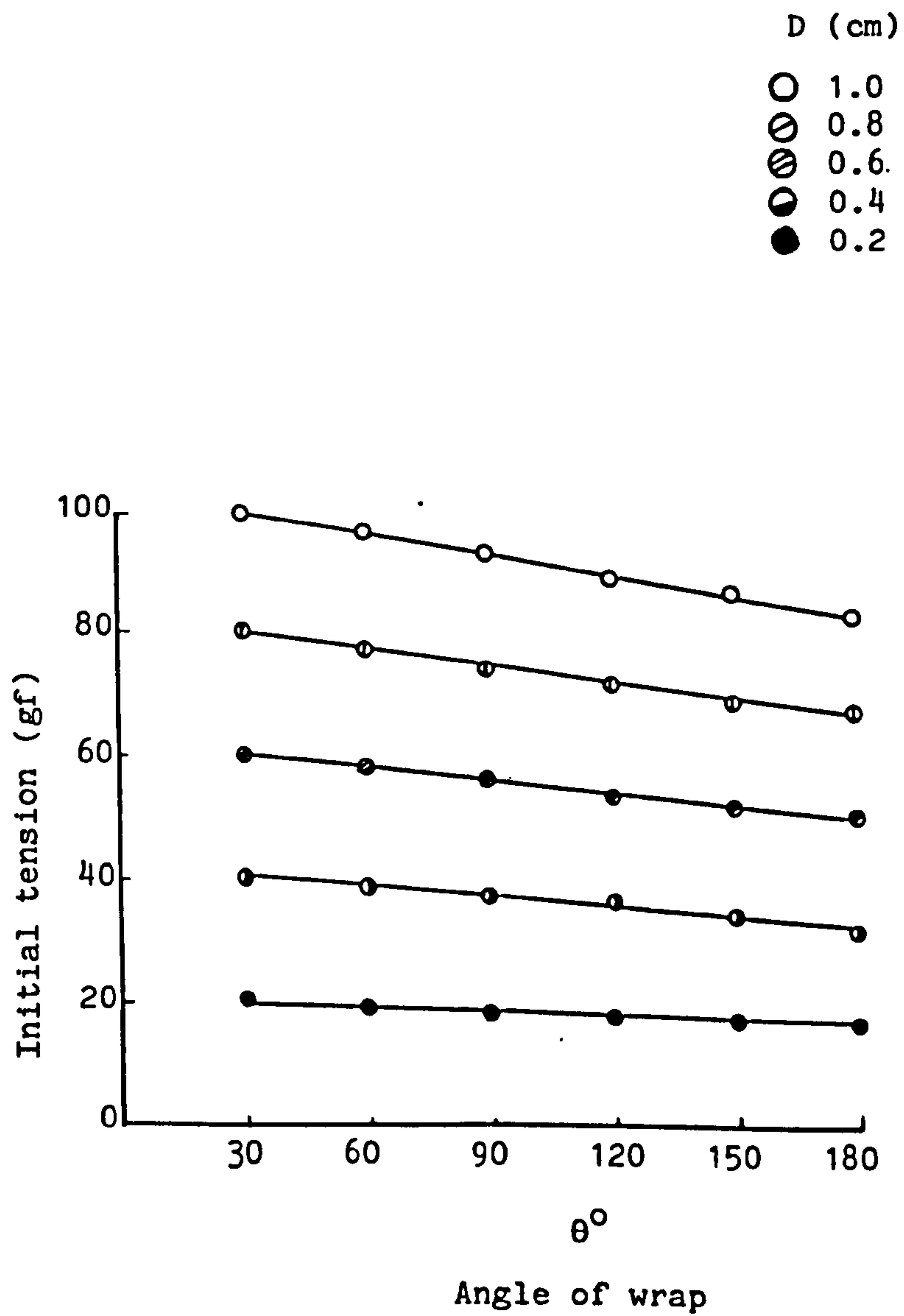
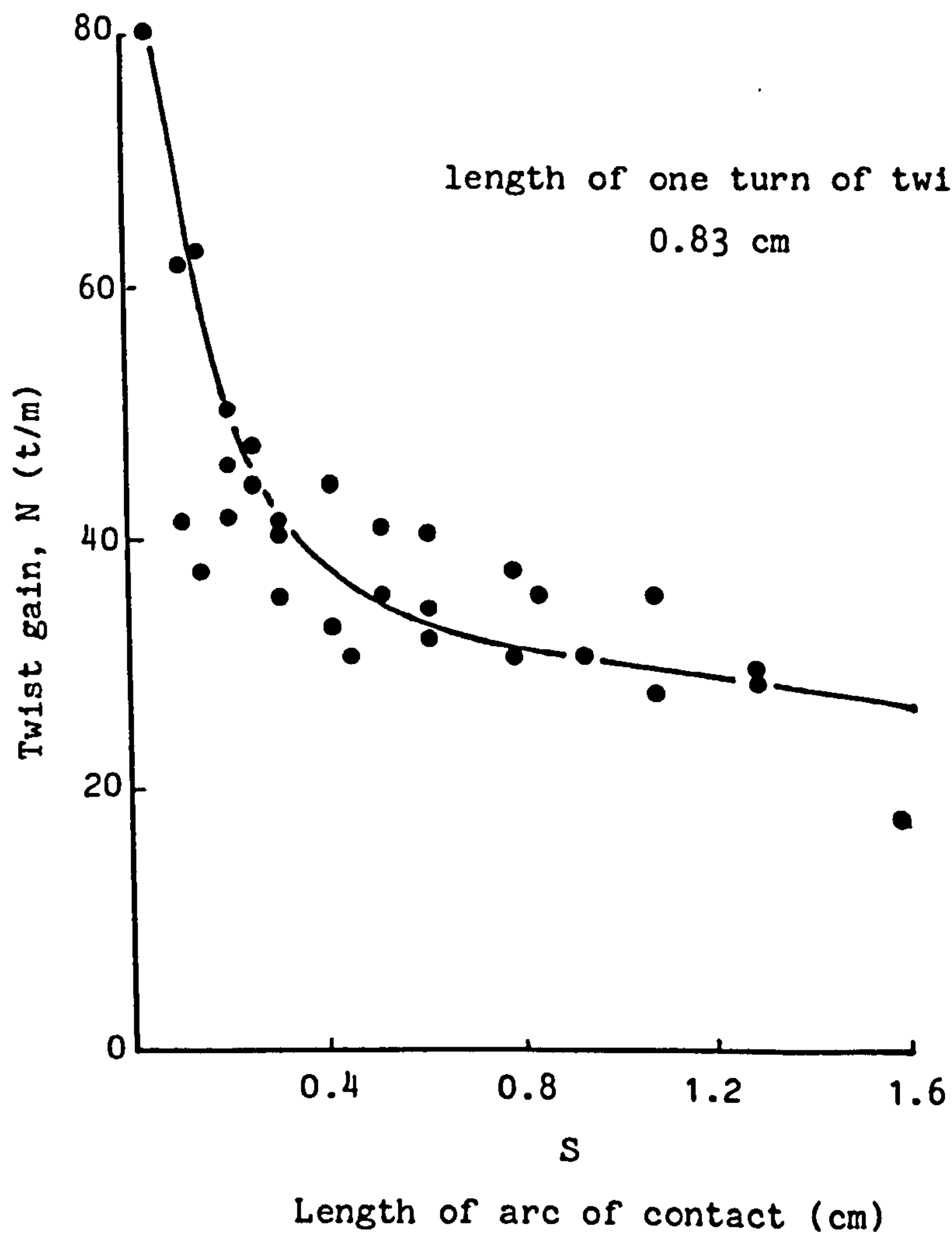

FIG. 5.21: Effect of contact length on the twist gain at constant mean pressure

$$N_0 = 120 \text{ (t/m)}$$

$$P_m = 208 \text{ (gf/cm)}$$



0.4 cm, the rate of decrease of twist gain is much reduced. Of course, it is recognised that an anomaly occurs with zero arc of contact taking into account the pre-condition of the experiment of constant pressure. Once again it may be significant that the change in slope of the curve occurs when  $S$  is roughly the length of one-half turn of the original yarn twist.

The impression has been gained from these results that two mechanisms could contribute to the twist gain depending on the length of contact.

The first mechanism is a flattening mechanism which applies when the length,  $S$ , is less than the length of one-half turn of nominal twist,  $N_0$ .

It would be expected that the second mechanism (rotating mechanism) would apply when  $S$  is greater than one-half turn. This mechanism could arise from the friction generated by the orientation of the twisted yarn components relative to the direction of the movement. At this point the twist gain is reduced to approximately 20% of the maximum.

It is evident that the rotating mechanism is thus capable of sustaining a much lower level of twist gain than the flattening mechanism. As discussed previously, this is because a greater torque can be generated when the yarn lies on the guide surface in a flattened condition, with the guide lying in a valley between two twist cross-overs of the yarn. When the contact length is increased, this condition is no longer possible, the yarn can rotate on the guide surface more freely, and the couple generating twist blockage becomes more dependent on yarn/guide frictional force.

However, there will not be a sudden transition from one mechanism to the other.

#### 5.10.2 Effect of angle of wrap and guide radius

It is possible to show the combined influence of the variation of angle of wrap  $\theta$  and guide diameter,  $2R$ , on the twist gain,  $N$ , in a three dimensional diagram as in Fig. 5.22. The three axes of the graph,  $\theta$ ,  $2R$  and  $N$  clearly show the effect of the two independent parameters on the twist gain.

As observed previously, it is apparent that an increase of the angle of wrap gives rise to a decrease in the twist gain. Similarly, the twist gain decreases as the guide radius increases. The effect of any combination of  $R$  and  $\theta$  can easily be read from the graph. The effect of length of arc of contact  $S = R.\theta$  can also be illustrated by contours of equal values of  $S$  drawn on the surface (Fig. 5.23). These contours confirm the view that for constant pressure over a constant arc of contact the twist gain remains roughly constant.

However, though a relatively small angle of wrap over a very fine guide might contribute a very small arc of contact, this condition might flatten the yarn and thus generate a very significant blockage of twist. It seems, therefore, a theoretical discontinuity may exist when the arc of contact is zero.

However, the observational evidence has shown that the blocked twist is not capable of transferring over the contact region steadily, but, with either the flattening or rotating mechanism, reaches a maximum congestion level before escaping over the guide. This escape occurs more readily when there is one or more points of twist cross-over in contact with the guide surface.

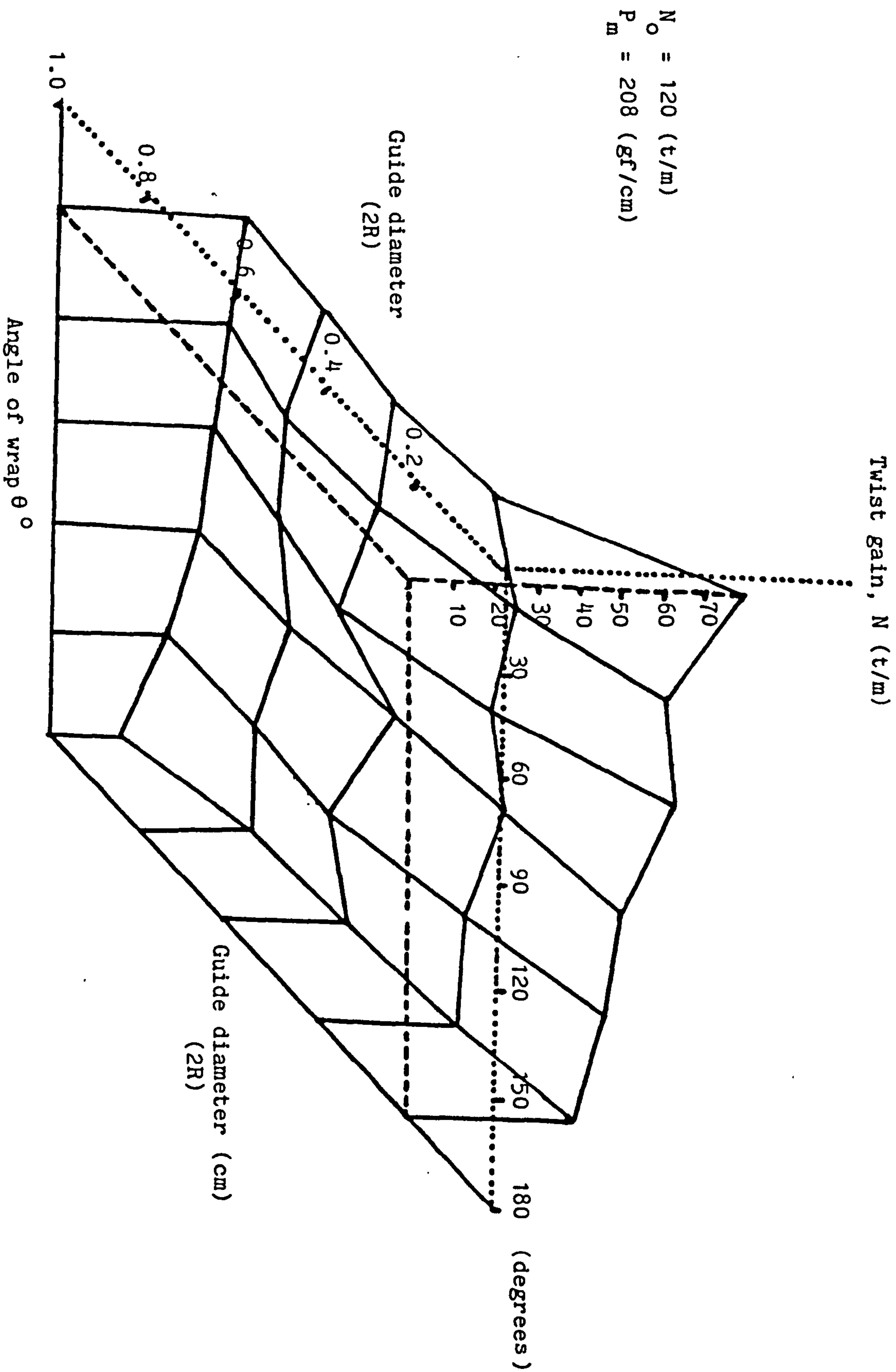

FIG. 5.22: The three dimensional representation of the effect of guide diameter and angle of wrap on twist gain at constant mean pressure



$N_o = 120$  (t/m)  
 $P_m = 208$  (gf/cm)

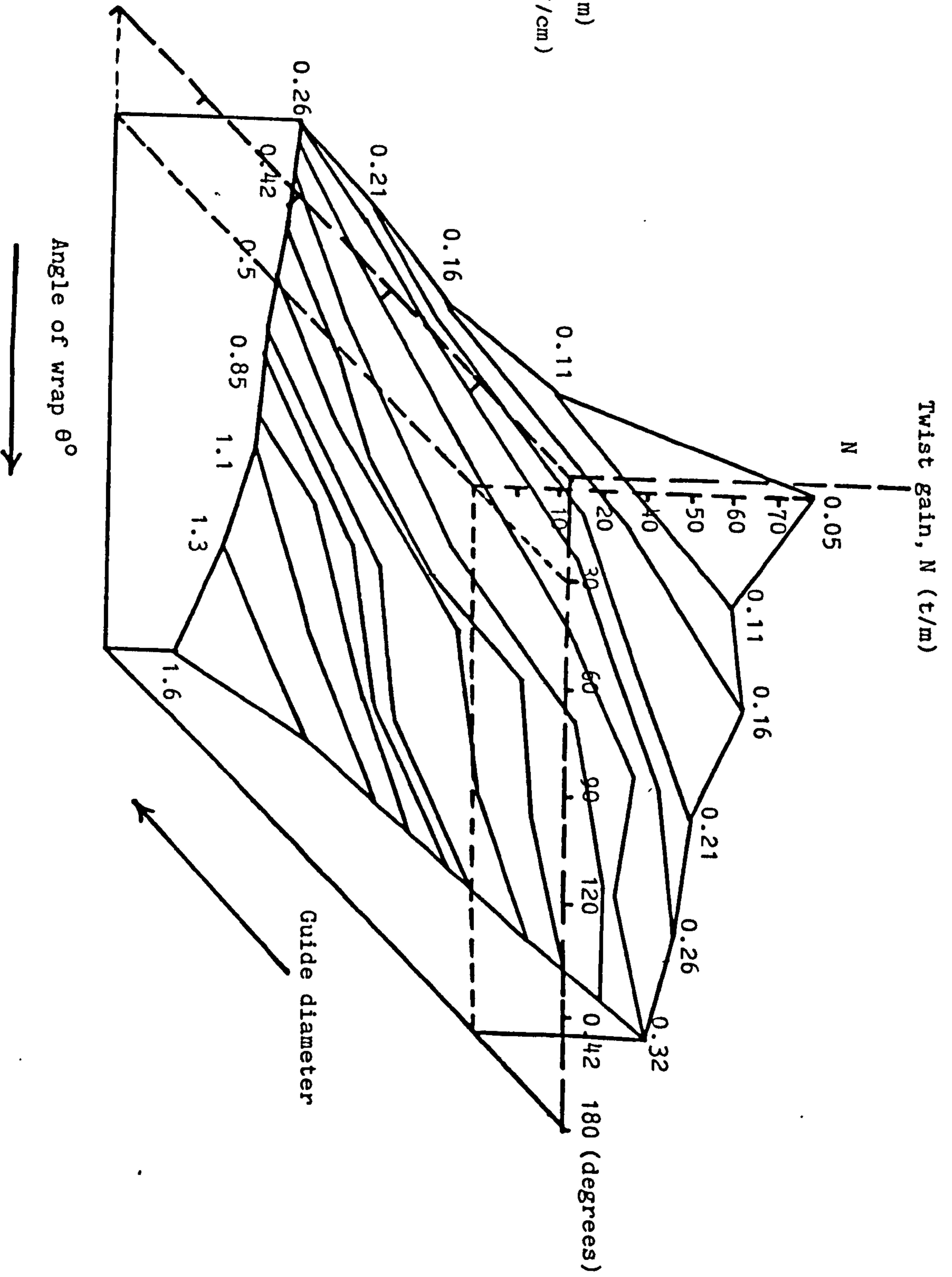

FIG. 5.23: Effect of guide diameter and angle of wrap ( $\theta$ ) on twist gain at equal values of length of arc of contact

For the purpose of justifying this latest assumption, the number of points of twist cross-over over the contact surface at the time of escape of blocked twist, should be examined.

Unfortunately, because of the small lengths of arcs of contact (0.05-1.6 cm), it was very difficult to measure this, and impossible when the twist is fairly low.

Trommer [53] has estimated this factor by assuming that the twist over the contact zone is the sum of the nominal twist and twist gain. This gives the impression that the twist over the contact zone is less than the nominal twist. Although he measured this parameter, nevertheless, he did not mention the technique under which the experiment was carried out.

Such cases, i.e. lower twist over the contact zone than the nominal twist, can only occur when a yarn with a fairly low twist is moving over a very short contact region: bearing in mind that, in the post contact zone, (at the equilibrium condition), the twist should be the same as the nominal twist of the original yarn.

Generally, it would be expected that the twist over the contact zone would have an intermediate value between the value of the twists of pre- and post-contact zones.

It was only possible, however, to consider that the accumulated twist before the contact zone at the time of escape is the twist existing over the contact region. In other words, the twist builds up until it reaches a level where the number of turns over the contact zone increases, and as a consequence the blocking torque reduces. The yarn torque in the blocked region then becomes greater than what is required to overcome the blocking torque, thus causing the yarn to rotate and the twist to escape.

In order to explain the effect of the number of points of contact ( $x$  factor), it is necessary to clarify the relationship between this factor, the pressure of the points of contact and the forces which may be generated to cause or prevent rotation.

#### 5.11 Effect of forces causing yarn rotation and yarn behaviour over the contact surface

As reported in section 5.7.1, it was observed experimentally that the yarn is displaced from its central position over the guide surface to an equilibrium position as illustrated in Fig. 5.11. Observations of displacement are useful in determining the probable mechanism of twist blockage. Obviously, it is of interest to investigate whether the yarn is displaced due to a rolling effect or as a result of the interaction of the surface roughness of the guide with the yarn surface ridges.

Experiments based on pulling a twisted yarn under constant load in two directions of movement over the contact surface have been carried out. The same yarn was used as in previous experiments, with different levels of twist: 0, 200, 400, 600 and 1000 t/m with yarn of both S and Z twist, using the pulleys of the test apparatus to maintain the yarn path in the same plane. The yarn was dragged manually over the steel guide.

The yarn could have been tensioned using a disc or hysteresis tensioner as in the main experiments, but, in this case, in order to minimise tension fluctuations, it was convenient to tension the yarn by a suspended weight of the required magnitude. The guide surface was cleaned carefully and using a marker pen, a mark was drawn on the

guide surface. This mark was rubbed off by the yarn and the extent of the yarn displacement could thus be clearly seen and could be measured by a vernier gauge.

A guide of 0.4 cm diameter was used in this experiment with different levels of mean pressure of 14, 72 and 147 g /cm (initial tension of 2, 10, 20 g at constant length of contact  $S = 0.63$  cm (angle of wrap  $180^\circ$ ). A second set of experiments was performed under mean pressure of 12, 61 and 122 g /cm (initial tension of 2, 10 and 20 g ) at a constant length of arc of contact 0.314 cm (angle of wrap  $90^\circ$ ).

A total of 24 experiments were carried out.

Figure 5.24 shows the displacement of the yarn over the contact surface. The arrows show the direction of the displacement corresponding to the type of twist (S and Z) and yarn movement direction (forward or backward). The mean value of four readings for each test was taken.

Each table or graph recording the sets of experimental results indicates that the magnitude of yarn displacement for either S or Z twist is the same though in the opposite direction. Yarn of zero twist gave no displacement, and this was used to determine the zero line of measurement.

#### 5.11.1 Results

Table 5.17 shows the data of the input twist ( $N_0$ ) and the yarn displacement at various values of initial tension for the two arcs of contact.

FIG. 5.24: Yarn displacement over the contact surface at different directions of twist and yarn movement

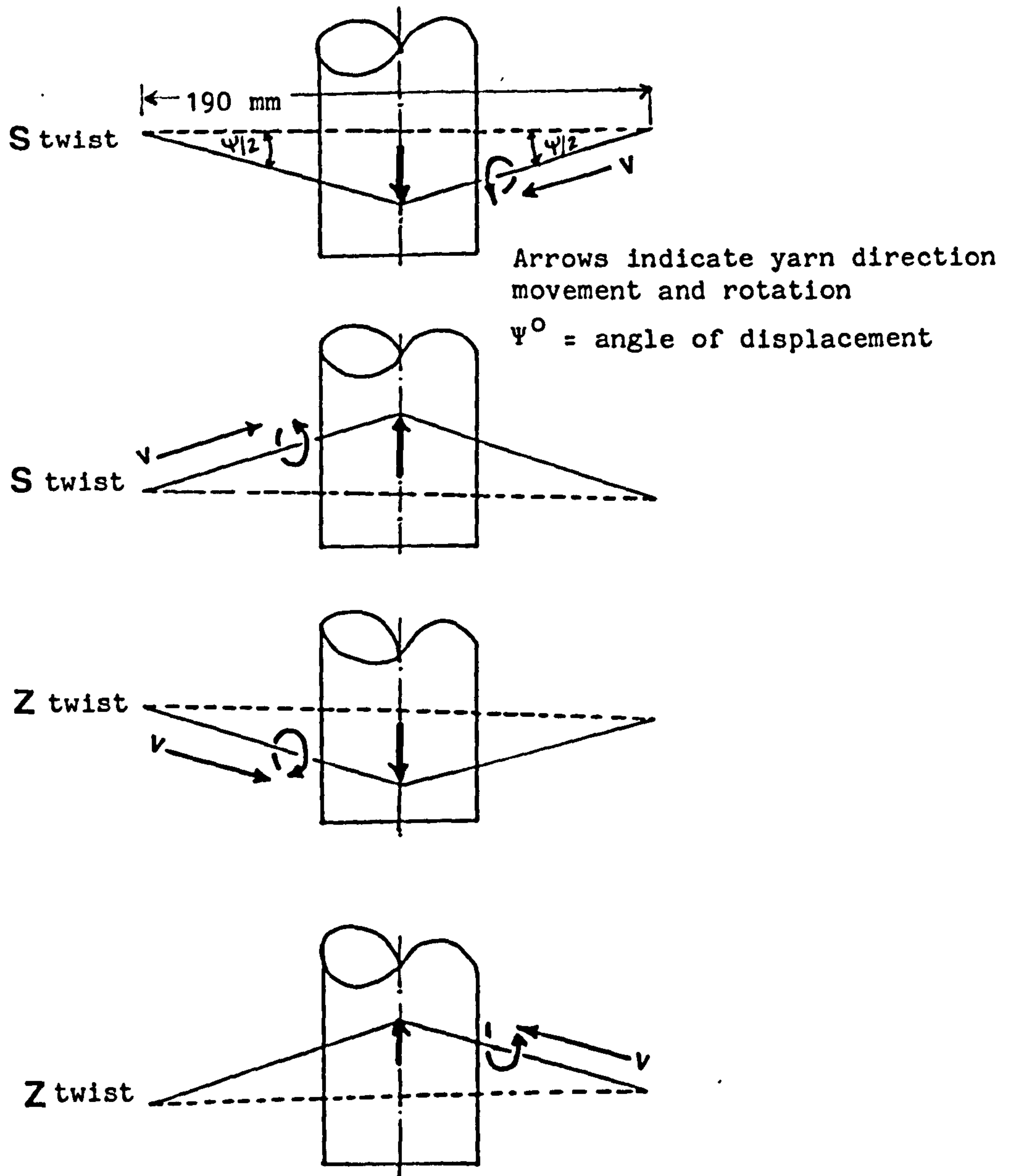

TABLE 5.17

Input twist (t/m)	Displacement (mm)					
	Arc of contact 6.3 (mm)			Arc of contact 3.14 (mm)		
	Initial tension (gf)			Initial tension (gf)		
	2	10	20	2	10	20
1000	7.60	4.35	4.35	4.55	3.35	2.10
600	3.85	2.80	2.20	3.25	2.35	1.80
400	3.30	1.95	1.95	3.60	2.40	1.25
200	2.95	1.60	1.45	2.75	2.10	0.80
00.0	0	0	0	0	0	0

Distance between pulleys and yarn guide = 190 mm

Figures 5.25 and 5.26 illustrate the relation. It will be seen that as the input twist increases, the displacement of the yarn over the contact surface increases. In addition, the higher the tension (mean pressure), the smaller the displacement.

Figures 5.27, 5.28 and 5.29 show the same relationship at an initial tension of 2, 10 and 20 g respectively for the two levels of length of arc of contact 0.3 and 0.63 cm. The values obtained in these graphs provide some evidence to suggest that the displacement of the yarn over the contact surface increases as the length of contact increases. It can be argued that at low levels of yarn twist (up to 600 t/m), the relative difference of the displacement between the two lengths of arc of contact is not significant. After this level of yarn twist, some difference of displacement is observed.

Thus it can be concluded from the relationships between the three parameters (twist, mean pressure and length of contact) that the displacement is a maximum for high twist and low yarn tension, probably in conjunction with a long length of contact. The pressure however, is itself generated by yarn tension, a component of which is the restoring force, which balances the lateral frictional force.

It may be postulated that the larger number of points of contact round a long length of contact or with a higher twist, generated a greater lateral force over the surface, thus causing a larger yarn deflection.

The question which arises is, what is the source of the forces causing yarn displacement?

FIG. 5.25: Effect of input twist against yarn displacement at length of arc of contact 0.3 cm for various values of initial tension

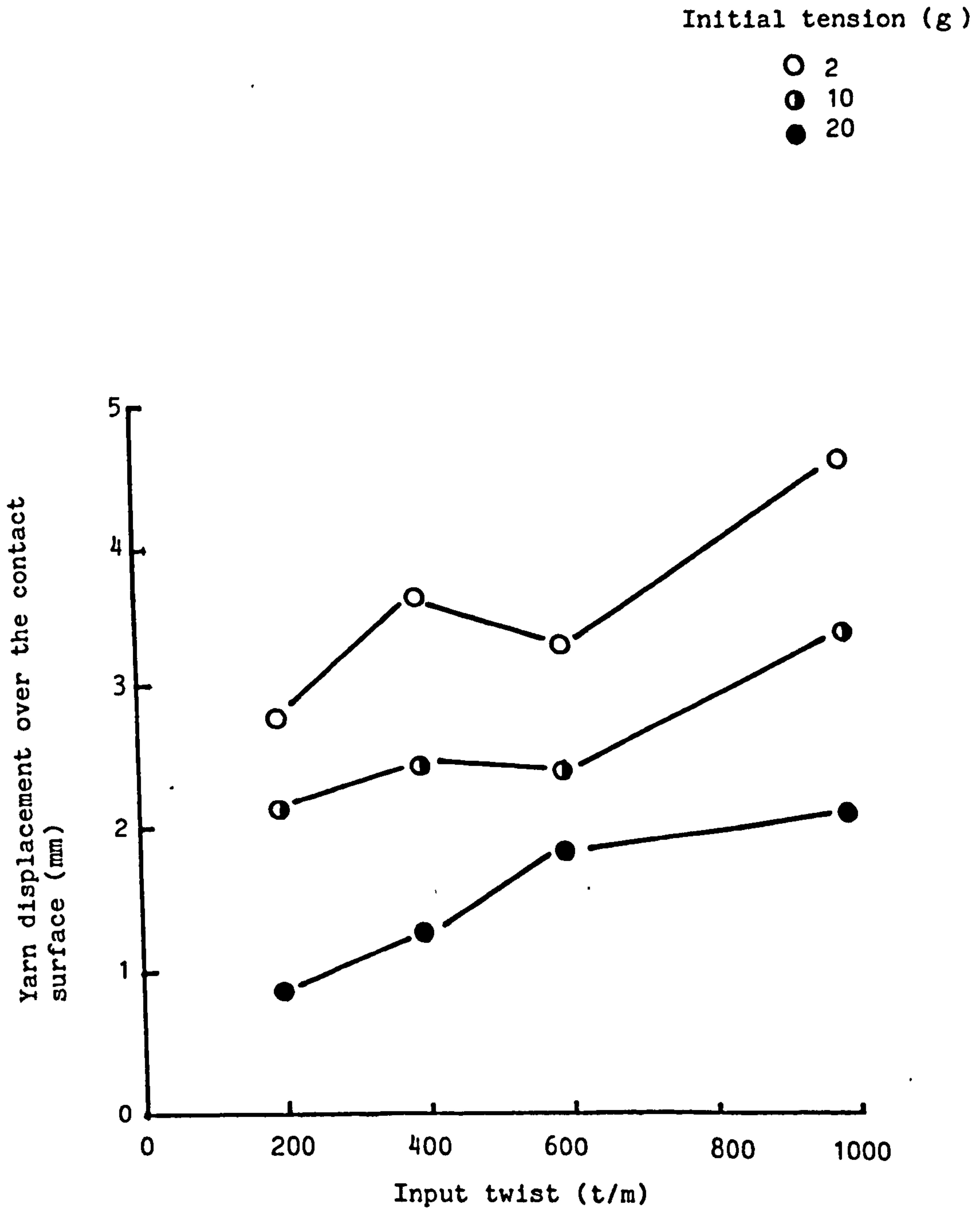



FIG. 5.26: Effect of input twist against yarn displacement at length of arc of contact = 0.63 cm for various values of initial tension

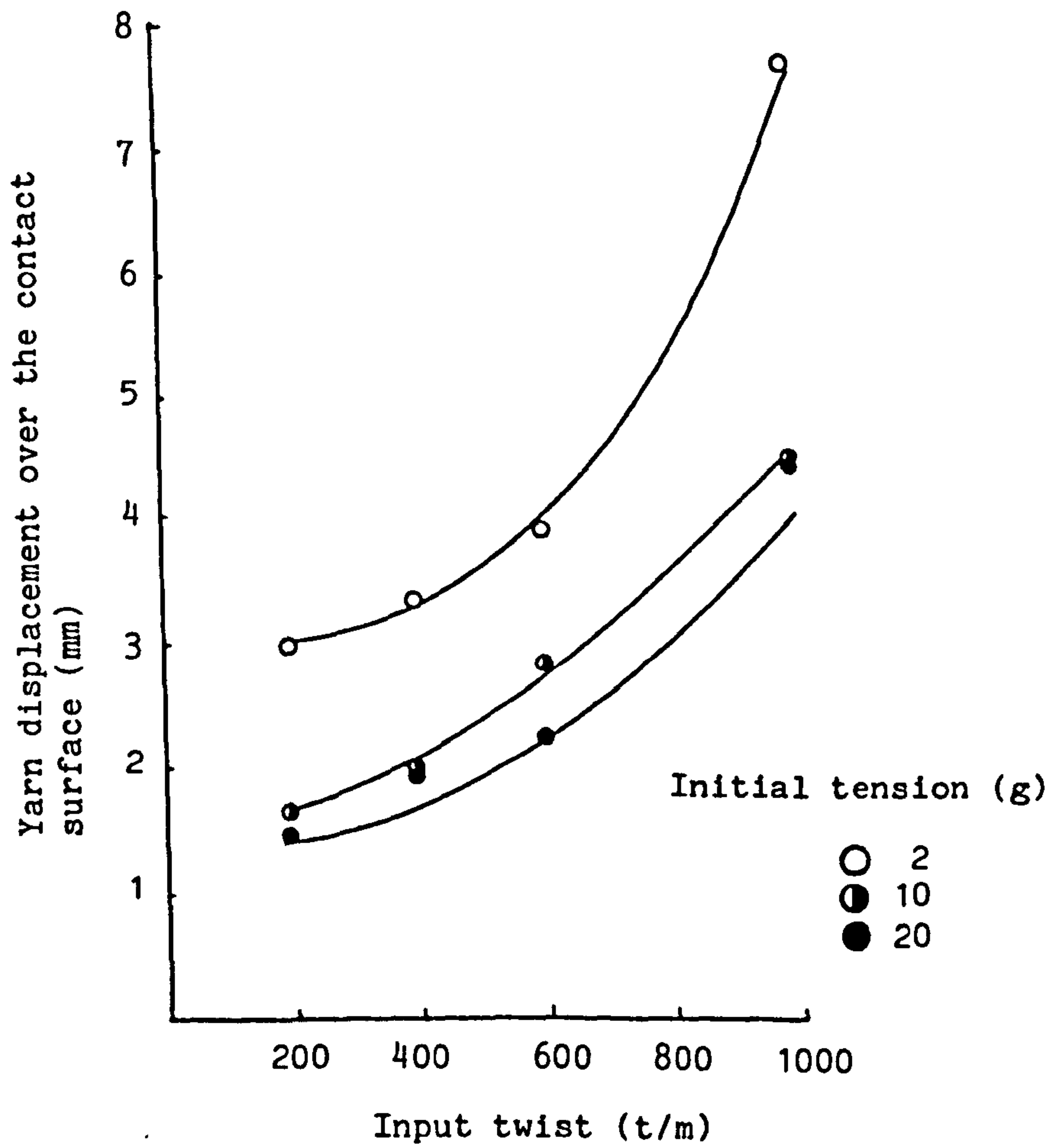

FIG. 5.27: Effect of input twist on the yarn displacement at two different levels of arc of contact for a constant initial tension (20 g)

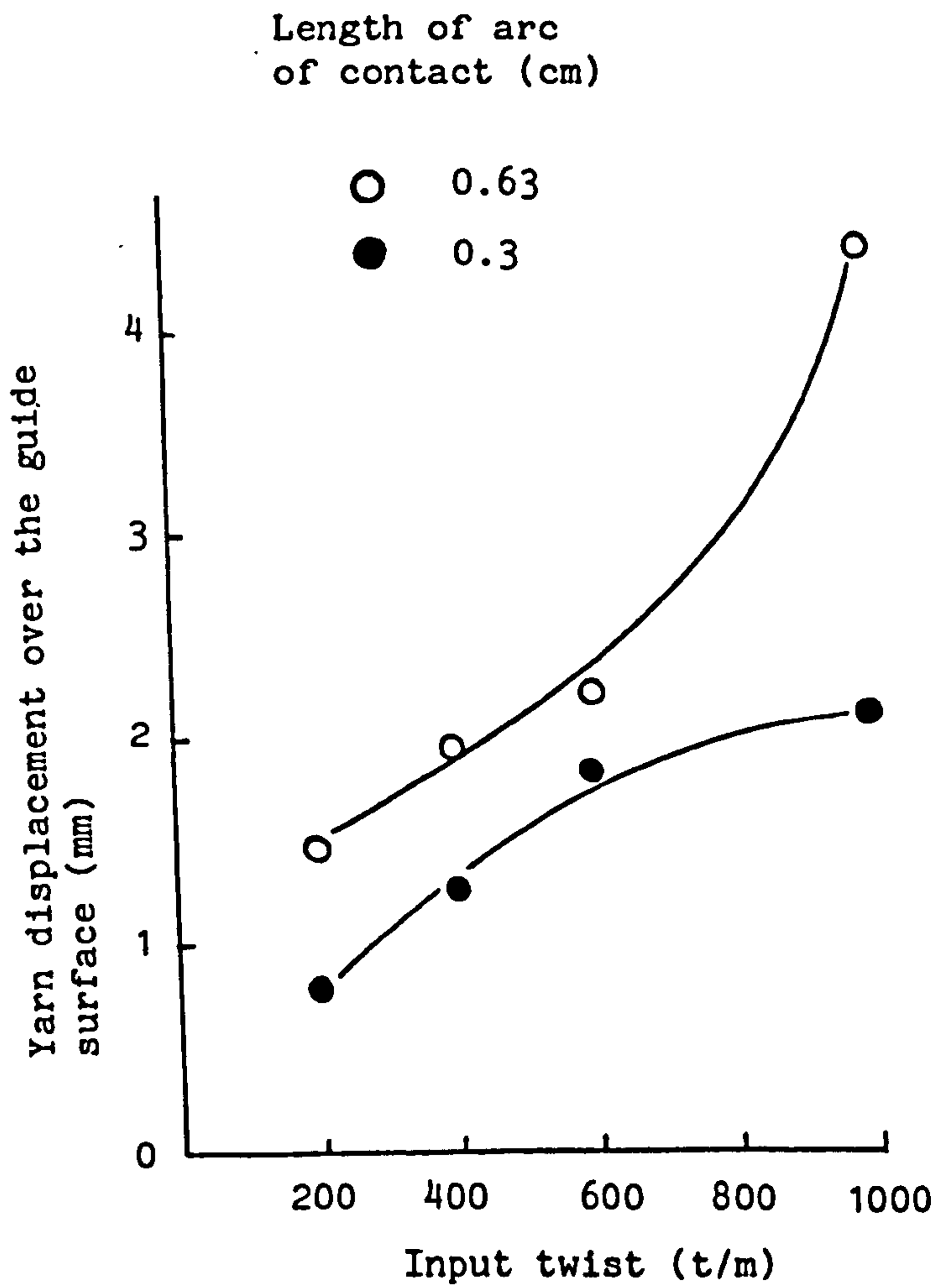

FIG. 5.28: Effect of input twist on the yarn displacement at two different levels of arc of contact for a constant initial tension (10 g)

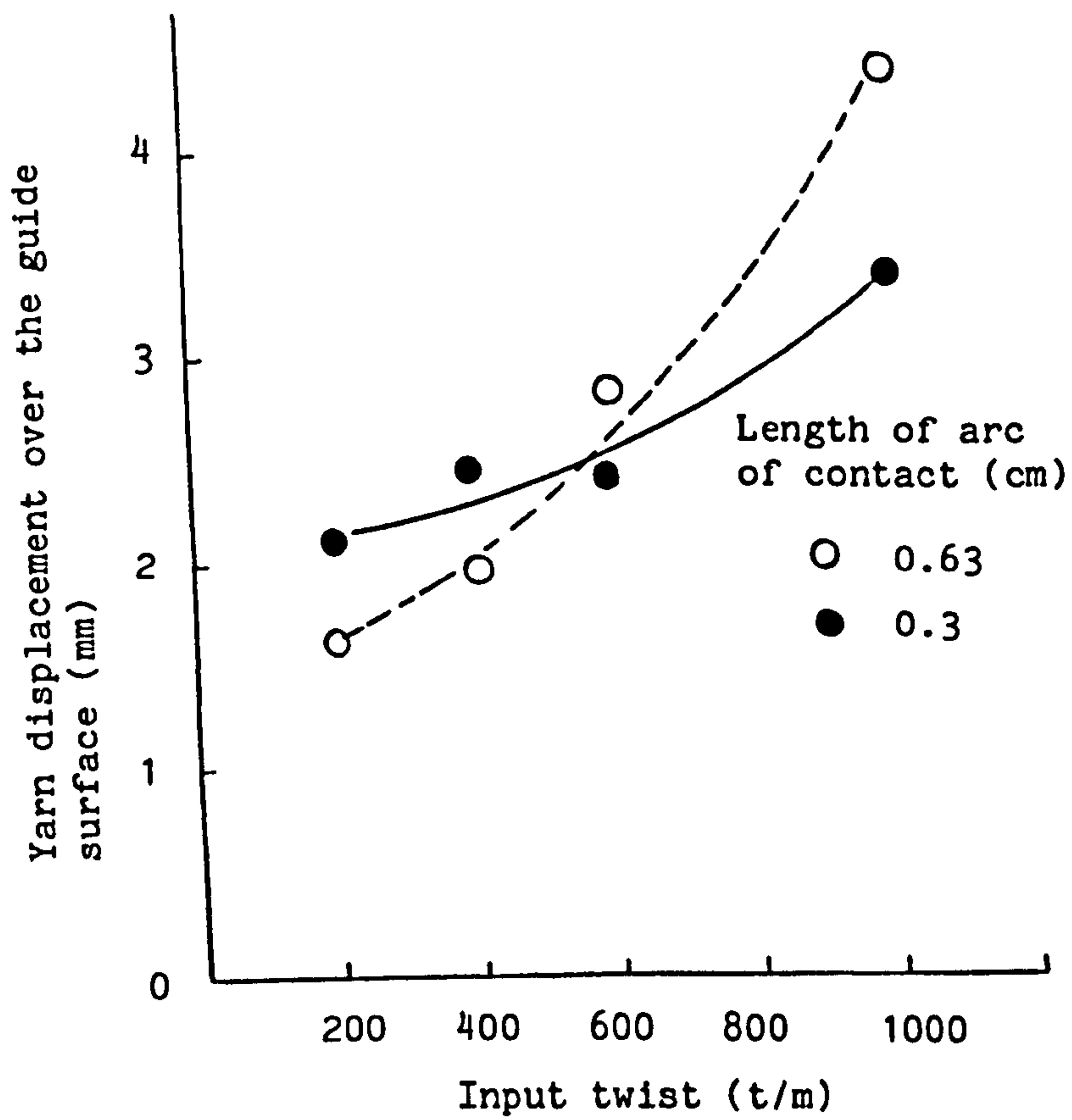
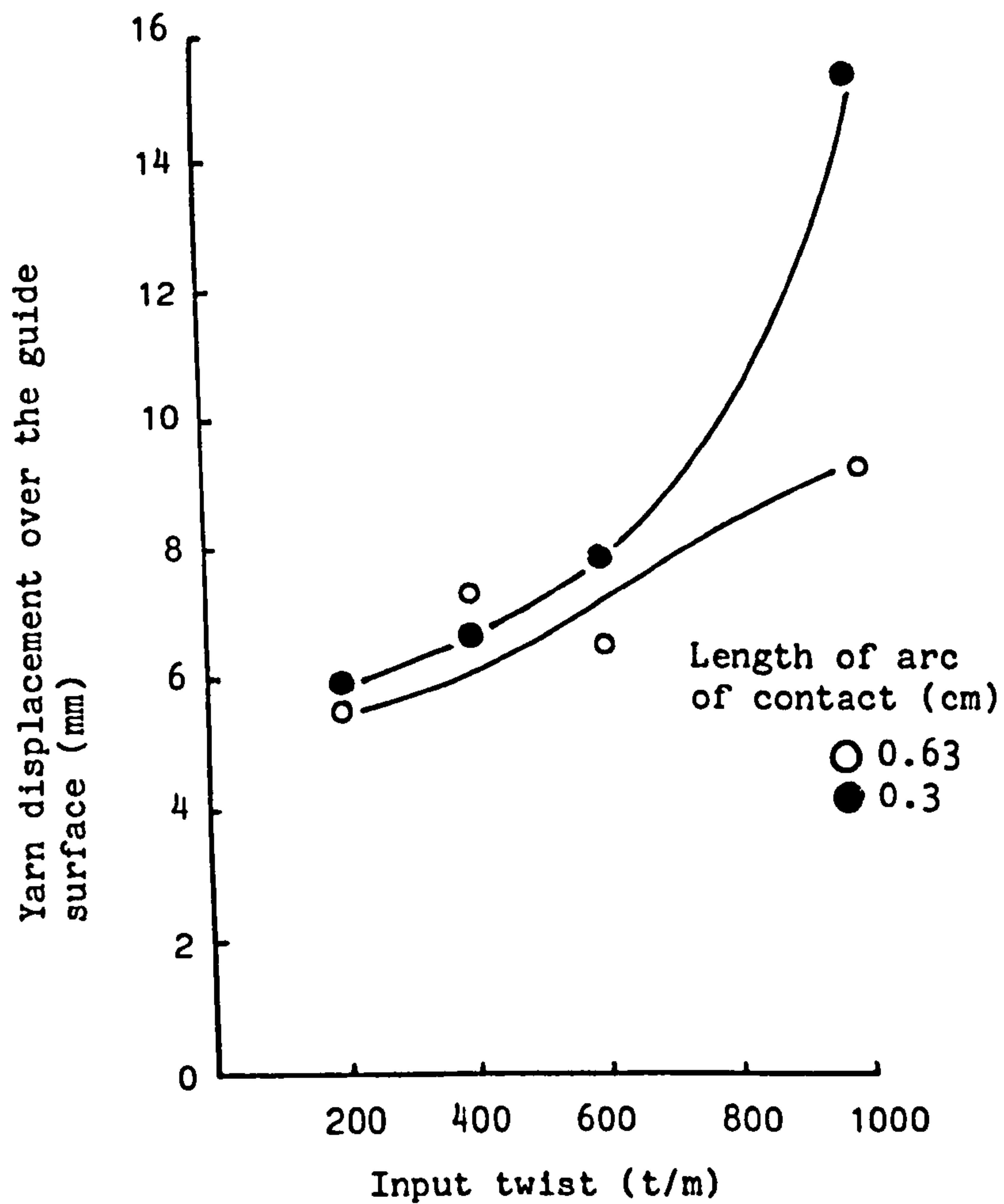

FIG. 5.29: Effect of input twist on the yarn displacement at two different levels of arc of contact for a constant initial tension (2 g)



### 5.12 Forces causing yarn displacement

These forces will depend on the relative movement between the yarn and guide surface.

Before discussing the mechanism of yarn displacement in connection with twist blockage it will be useful to compare two possible mechanisms of yarn displacement.

The first possibility is that the yarn displacement is caused by a lateral frictional force generated by the helical surface structure of the yarn. It is postulated that, by the interaction of the surface asperities of the guide with the yarn surface (surface ridges due to twist) a lateral force can be generated. In this case, the total frictional force would not necessarily act in a direction opposite to the direction of the yarn surface movement.

The second possibility is that the yarn displacement is caused by the rotation and rolling of the yarn arising from the false twist generated by the twist blockage i.e. due to the yarn rolling over the contact surface, there will be a component of relative velocity orthogonal to the yarn axis, and a lateral frictional force will operate.

These two possibilities are illustrated in Fig. 5.30, a and b.

It is generally recognised that the direction of the yarn rotation over the contact surface is the same as the direction of yarn displacement.

It is possible, therefore, by examining the direction of deflection to deduce that the second possibility is applicable to the present experiment.

FIG. 5.30: Two possible mechanisms of yarn displacement

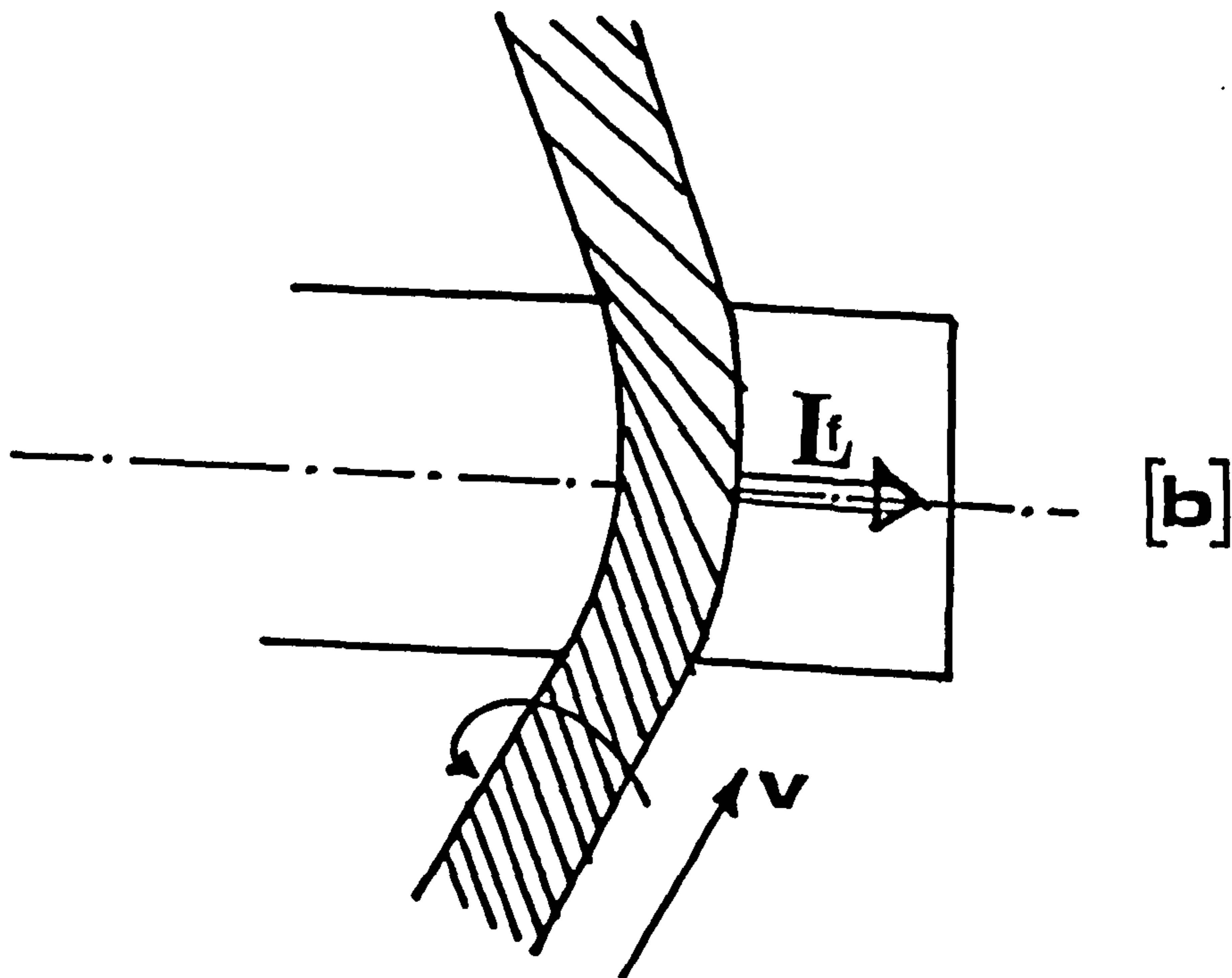
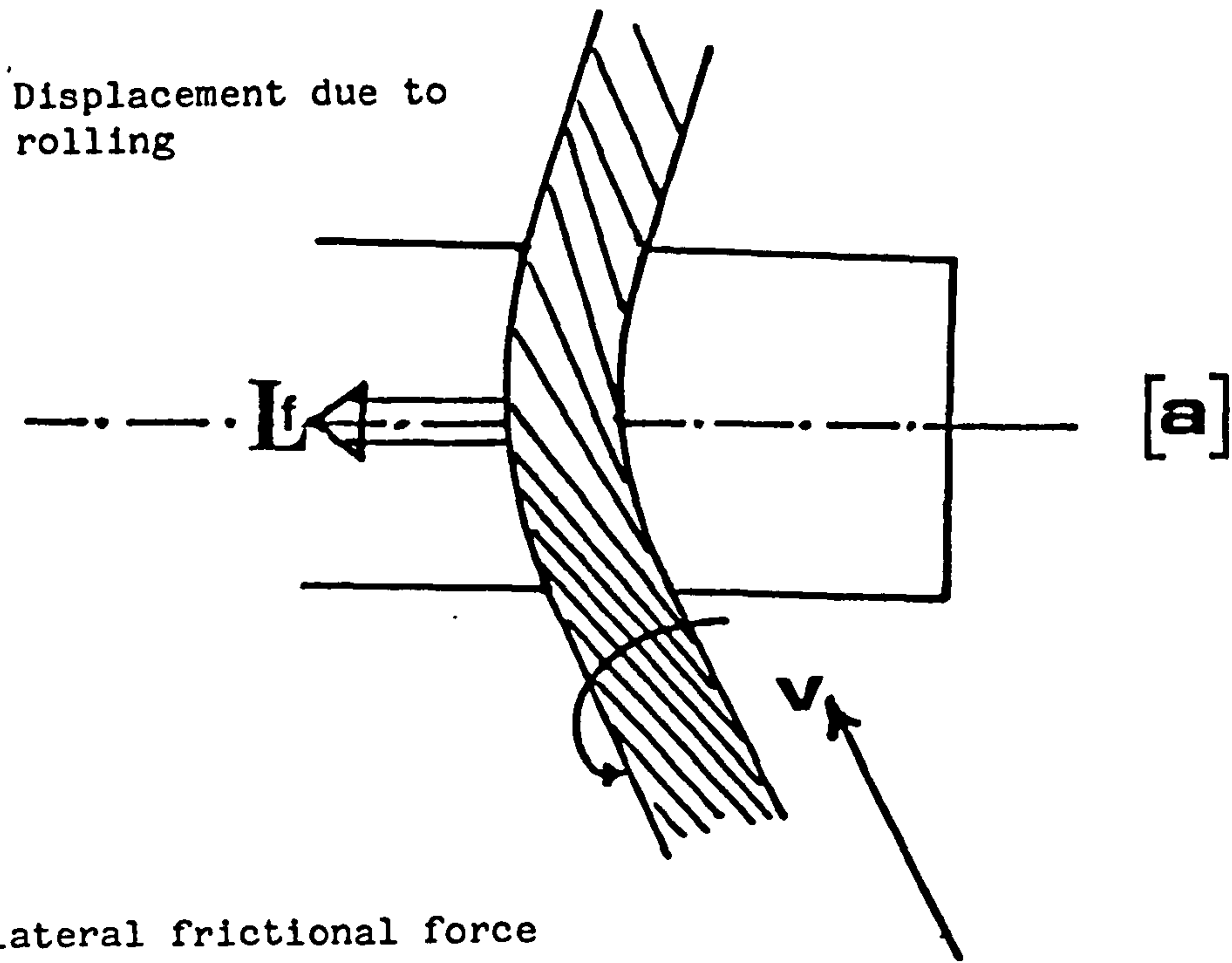

Displacement due to surface irregularity

[Note: The twist ridges of the yarn in contact with the guide surface will have the opposite inclination to that shown in the diagram

As the second case is adopted, i.e. the yarn is rotating and rolling over the contact zone, two interactions have to be considered:

1. The yarn has to slide axially over the contact zone in order to move forward, and obviously a dragging (frictional) force is generated.
2. As the yarn rolls on the contact zone, it is displaced from the central position to an equilibrium location. As mentioned above, a lateral frictional force is generated and its direction is in the same direction as the yarn displacement.

The vector sum of the frictional forces determines the magnitude and inclination of the total force relative to the yarn axis. The yarn displacement over the contact surface from the central position is determined by the balance of this force with components of tension (restoring force).

As stated earlier, the frictional force over the contact zone in any particular case will depend upon the twist level, tension and length of contact. A small length of contact is not desirable especially at low level of twist, as the distortion force will be very high, discouraging rolling, a large length of contact with a high level of twist will facilitate rolling. A rolling of yarn over the contact surface is required to facilitate the transmission of the blocked twist.

### 5.13 Effect of number of contact points on reaction forces $\xi$

Let us consider a few turns of twisted yarn in contact with the guide, Fig. 5.31. As the two components of the yarn cross-over due to the twist, they will alternately lie one on top of the other as at  $M_1$  and side by side as at  $M_2$ . At point  $M_1$  there will be complete contact between yarn and guide, and reaction force,  $\xi$ , will be maximum.

At point  $M_2$  the contact force  $\xi$  will be probably lower as the points will, to some extent, be supported by the adjacent points  $M_1$ . The degree to which this is true, of course, depends on the guide diameter, the arc of contact, the twist present on the guide surface and the resistance of the yarn components to compression.

If no twist were present (or the length of one turn is greater than the length of contact region), the yarn would effectively be supported by a pressure (given by the ratio  $T/R$  as a local pressure) along its length. If the twist is present, this will be replaced by a number of reaction forces acting primarily around points  $M_1$ . The greater the twist, therefore, the smaller the share of reaction force (contact force) borne by each point of contact.

At first sight it seems probable that as the number of points of contact increases, this will facilitate the rotation and rolling of the yarn, allowing blocked twist to escape. However, the effectiveness of the forces resisting yarn rotation over the contact region will depend on two factors:

1. Increase of number of points of contact ( $x$ ) over the contact surface.



FIGURE 5.31

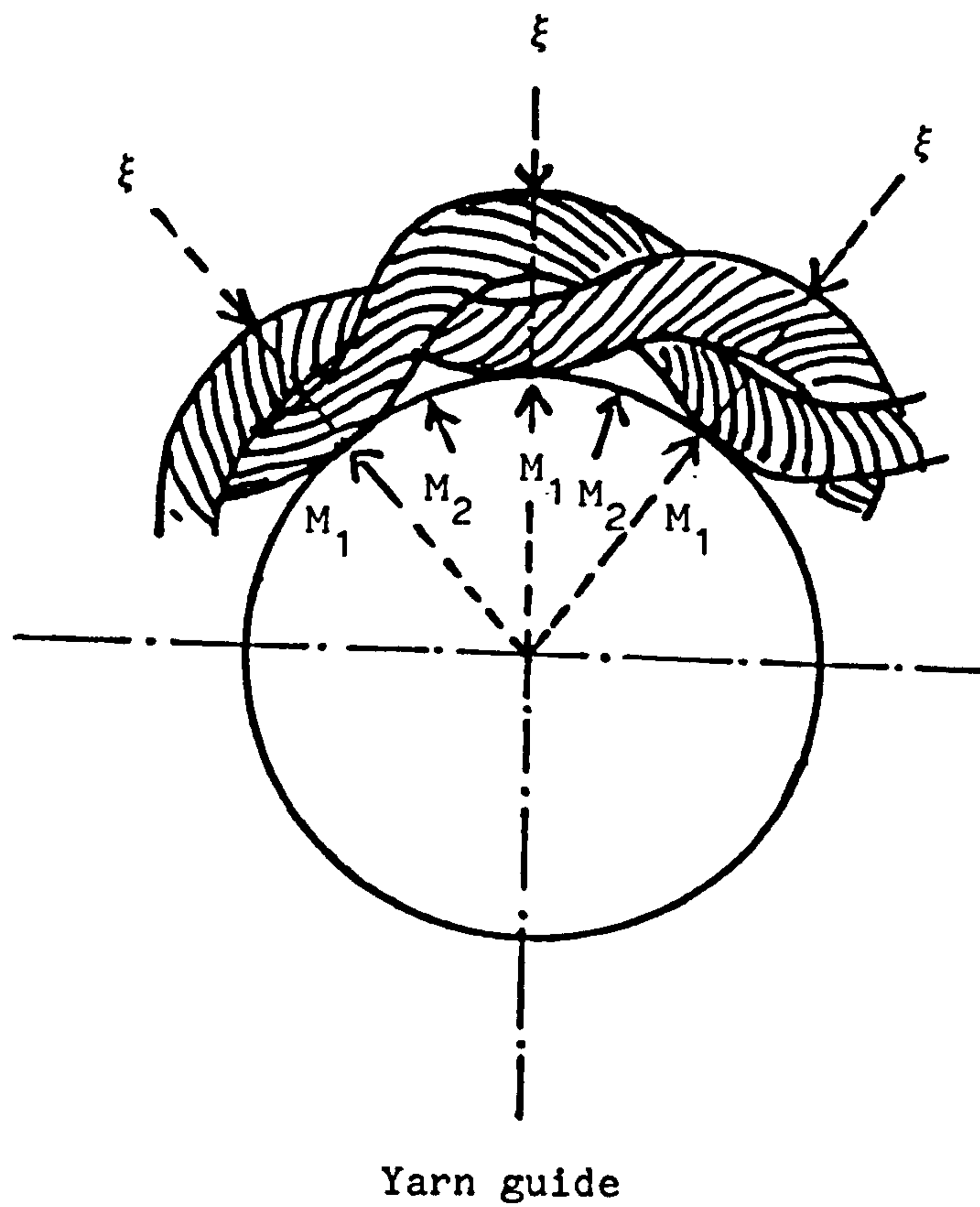

- $M_1$  = contact points
- $M_2$  = non-contact points
- $\xi$  = load/turn

2. Reduction of the reaction force (contact force) dependent upon the increase in the points of contact, guide curvature etc.

At the regions  $M_2$ , however, the yarn components lie side by side and a greater couple is required to turn the yarn over, unless the pressure between yarn/surface is significantly lower at these points. This will generate a tendency for such points to slide axially along the yarn causing the yarn to rotate before the guide, thereby maintaining or increasing blocked twist.

The twist flattened region at the input to the guide will be of particular interest in this respect and will be briefly considered in the next section.

#### 5.14 Relationship between twist accumulation and torque required to release blocked twist

To examine the torque required to [102] turn over the two components of doubled, twisted yarn moving along a contact surface, consider a section of the yarn AB, Fig. 5.32, approaching and lying on a surface with a radius of curvature,  $R_T$ , and angle of wrap  $\gamma$ .

The yarn consists of two components, I and II. At A, component I is about to arrive on the surface and the two components I and II lie over each other at an angle  $\Psi$  (Fig. 5.32 END). At B the components I and II lie side by side (as sketched in Fig. 5.32 END). As a result of twist accumulation, a torque is developed in the yarn prior to the guide surface, when this torque reaches a critical level, it will rotate the yarn on the contact zone, thus relieving the accumulation process.

FIG. 5.32: Schematic diagram of a twisted yarn moving over a surface with a radius of curvature,  $R_T$ , and angle of wrap ( $\gamma$ )

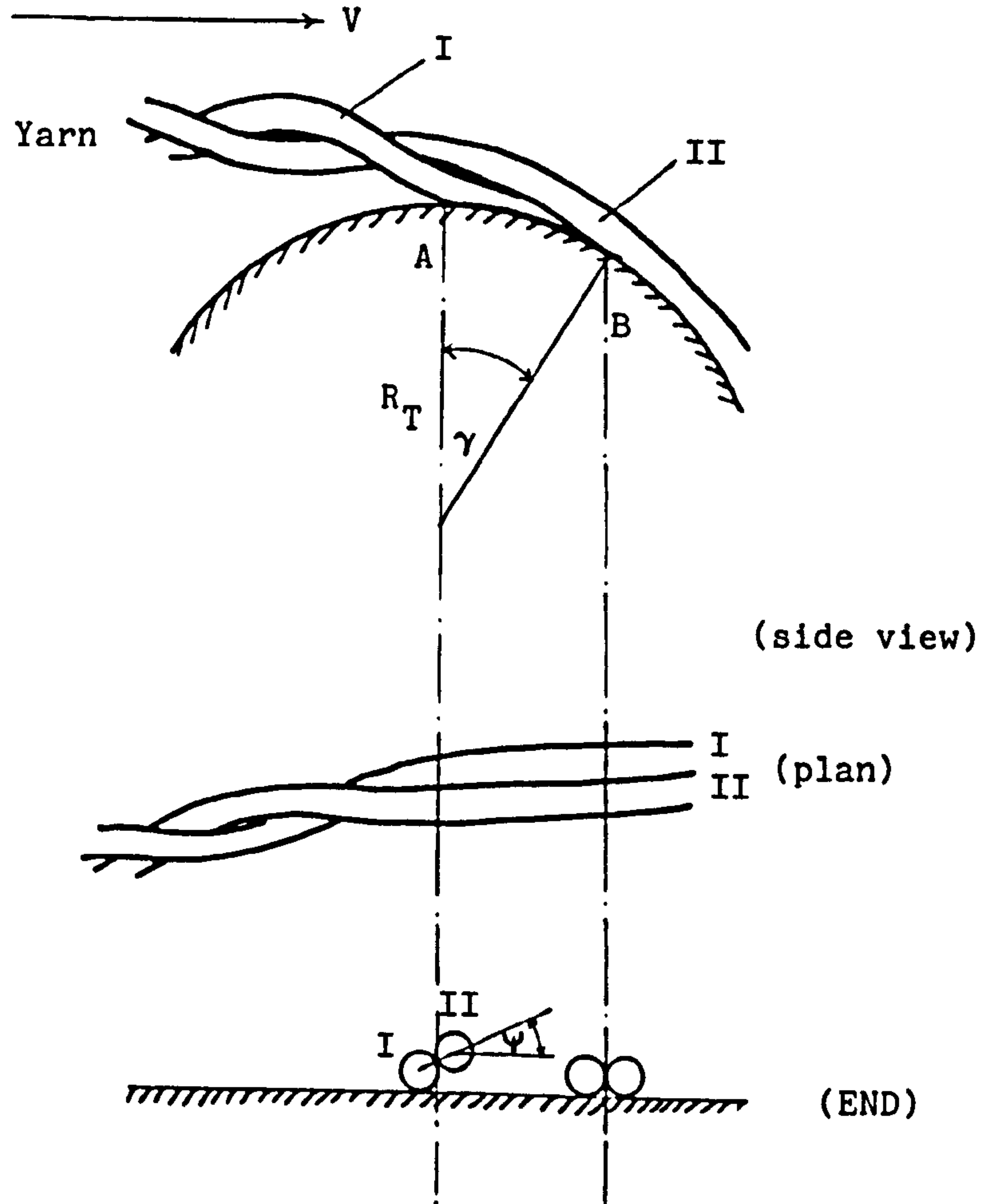

$\hat{\Psi}$  = deflection angle

The torque generated due to twist accumulation tends to riasse the section AB (Fig. 5.32) of one component of the yarn against a couple generated by the tensile force.

One component of the yarn, I, is tangential to the guide surface at A. The second component, II, is tangential at B. Yarn paths in the section AB cannot be constant-angle helices because of the requirements for the tangential approach of II.

It is evident that, to a first approximation, the axis of II may be regarded as following a shortest path on the surface of a (distorted) toriod of major radius  $R_T+r$  and minor radius  $2r$ . This is determined by II wrapping around I in a helix of varying angle. The flattened toriod surface is sketched in Fig. 5.33.

$R_T$  is the radius of the yarn guide while  $2r$  is the yarn radius.  $\hat{\Psi}$  is the deflection at A of one component over the other. The value of  $\hat{\Psi}$  is estimated as follows:

From Figs. 5.33, 5.34

$$O_2 O_3 = 2r\Psi \quad (1)$$

From Fig. 5.33

$$O_1 O_3 \cdot O_3 O_2 = \frac{O_3 O_4^2}{2} \quad (2)$$

$$\begin{aligned} O_1 O_3 &= O_1 O_2 + O_2 O_3 \\ &= 2(R_T+r) + 2r\Psi \end{aligned} \quad (3)$$

Substituting in equation 2, assuming  $R_T \gg r$  and  $(\gamma)$  is small.

FIG. 5.33: Sketch of the flattened toriod surface

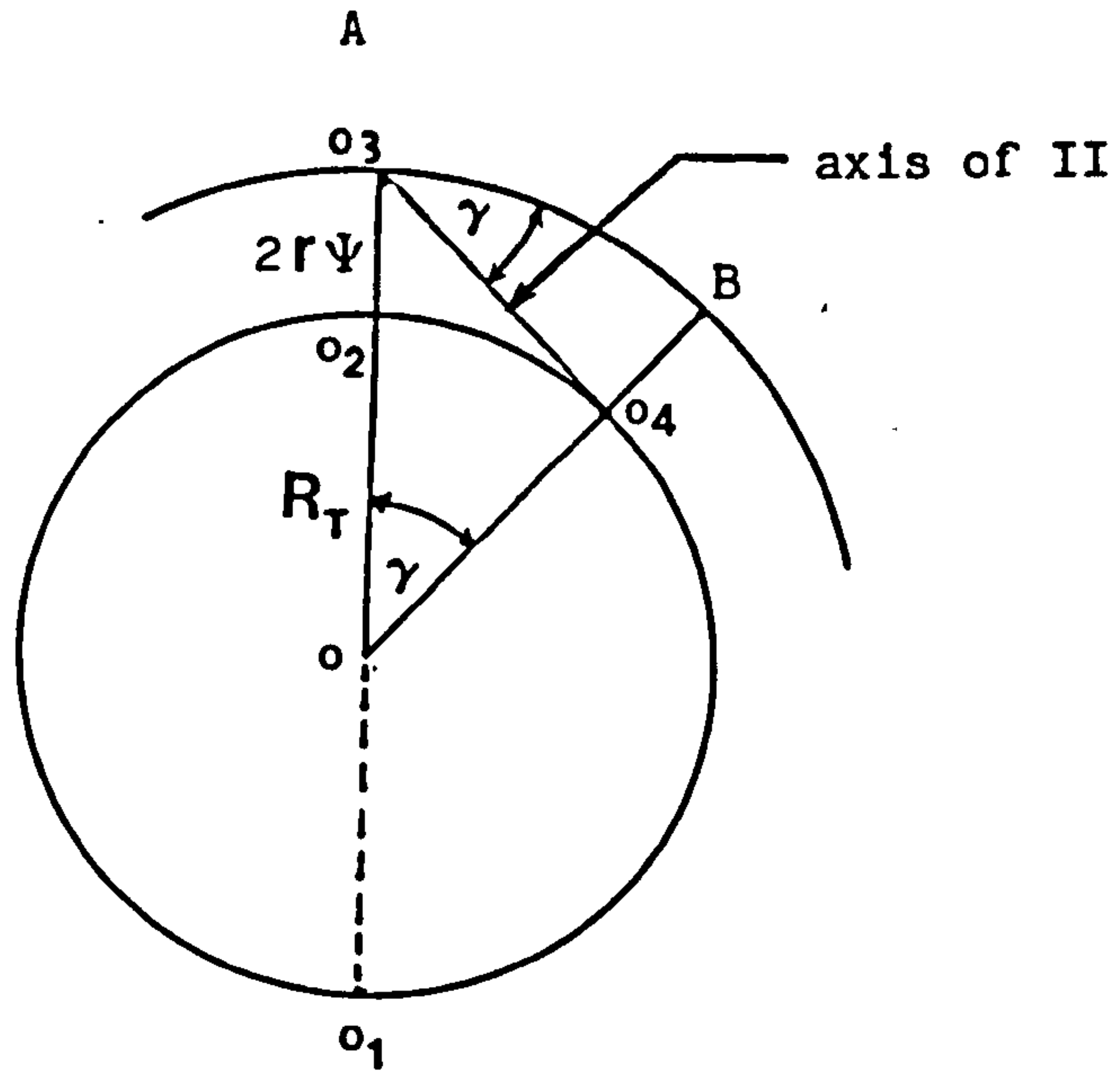
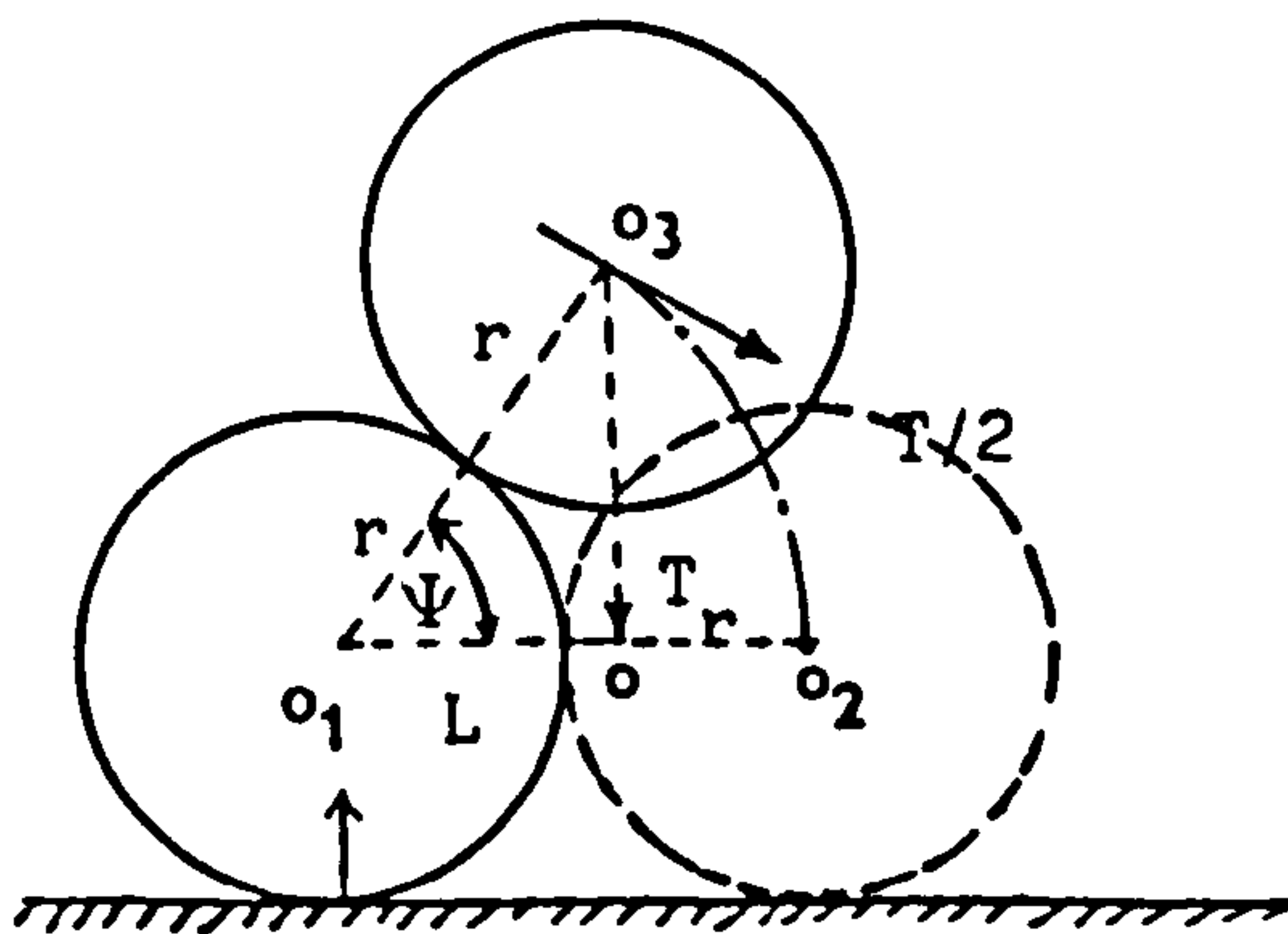

FIG. 5.34: Yarn components cross-section over the contact surface showing the angle of deflection  $\Psi$



$$\frac{O_3 O_4}{3}^2 = (2R_T + 2r\Psi) \cdot 2r \Psi = R_T^2 \gamma^2$$

$$\therefore 4rR_T\Psi \simeq R_T^2\gamma^2$$

$$\therefore \gamma = \left[ \frac{4r\Psi}{R_T} \right]^{\frac{1}{2}} \quad (4)$$

At the point  $O_2$  where the yarn leaves the guide surface, the axis of II is seen to make an angle of  $\gamma$  with the axis of I. The effective instantaneous helix angle of I and II at this point may, therefore, be regarded as  $(\frac{\gamma}{2})$  approximately.

If it is now assumed that the lateral friction on the guide is small and that the reaction on the surface generates a torque which tends to flatten the yarn at AB, then:

Couple C resisting rotation of AB is given by the moment of the lateral force,  $T_r$ , around point  $O_1$ , Fig. 5.34, plus a couple  $M_G$  due to the torsional rigidity of the yarn, thus:

$$C = \frac{T}{2} \frac{\gamma}{2} \cos \Psi \cdot L + M_G \quad (5)$$

where T is the total yarn tension.

L is the torque length ( $O_1 O$ ) and equal to

$$2r \cos \Psi \quad (6)$$

From equations 4 and 6 substituting in equation 5, thus:

$$C = \frac{T}{2} \left[ \frac{r\Psi}{R_T} \right]^{\frac{1}{2}} \cdot 2r \cos^2 \Psi + M_G \quad (7)$$

For the small deflections involved, it is assumed that the torsional rigidity components will be small and may be ignored in the analysis.

Equation 7 will, therefore, become:

$$C = T_i \left[ \frac{r^3 \Psi}{R_T} \right]^{\frac{1}{2}} \cos^2 \Psi \quad (8)$$

The above equation can be written in the form:

$$C = \frac{T_i}{R_T} \left[ r^3 R_T \Psi \right]^{\frac{1}{2}} \cos^2 \Psi \quad (9)$$

where  $\frac{T_i}{R}$  represents the values of the initial pressure,  $P_1$ .

This torque increases until the torque generated by blocked twist equals the torque generated by the tensile force. The maximum value of the twist blockage torque can be found by differentiating equation 8 with respect to  $\Psi$  and equating to zero. We get:

$$\frac{d}{d\Psi} \left[ \Psi^{\frac{1}{2}} \cos^2 \Psi \right] = 0$$

differentiating equation 8 gives

$$\frac{1}{2} \Psi^{-\frac{1}{2}} \cdot \cos^2 \Psi - 2 \Psi^{\frac{1}{2}} \cos \Psi \cdot \sin \Psi = 0$$

which reduces to

$$4 \tan \Psi = 1 \quad (10)$$

This maximum occurs at approximately  $\Psi = 27.5^\circ$  as in Table 5.18 and as shown graphically in Fig. 5.35.

On the basis of this simple model, therefore, twist and torque would build up before the guide until sufficient torque is developed to generate an angle  $\Psi \approx 30^\circ$  at A. After this value is achieved, the yarn flips over and loss of blocked twist commences.

It is noted that, on the basis of this simple theory, the critical value of  $\Psi$  is independent of both T and the radii r and R.

TABLE 5.18

$\psi^\circ$	$\psi^{\frac{1}{2}} \cos^2 \psi$
1	0.13
2	0.19
4	0.26
6	0.32
8	0.37
10	0.41
20	0.52
30	0.54
40	0.49
50	0.39
60	0.26
70	0.13
80	0.04
85	0.009

$\hat{\Psi}$  = a deflection angle at A of one component about the other



FIG. 5.35: Effect of deflection angle on torque required to rotate yarn

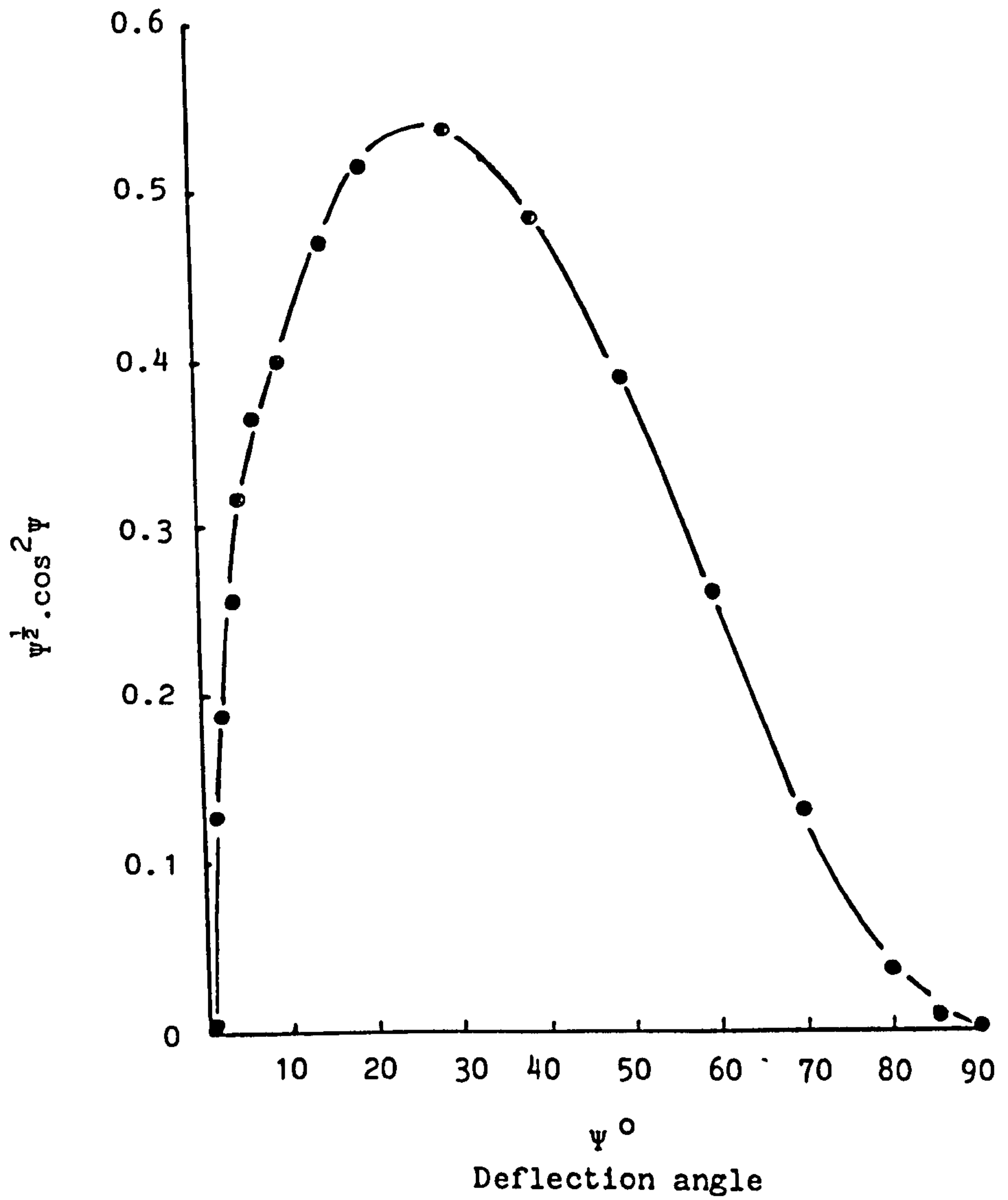

For any given value of tension, however, the torque depends inversely on  $\sqrt{R}$ ; a small radius of guide thus gives rise to a higher torque requirement and hence to greater twist blockage. The importance of yarn component diameter will also be noted.

In principle, it should be possible to calculate the level of blocked twist by balancing the torque generated in the yarn by blocked twist against the torque, analysed above, required to turn the yarn over on the guide surface. This is complex, however, as the yarn torque will depend on a combination of torsional, bending and tensional stresses in the twisted structure, the precise contributions depending on the moduli, the setting conditions of the yarn (intended or inadvertent), internal friction and other factors.

The dependence of these types of stress on the twist angle ( $\epsilon$ ) will be given by expression of the form [91,92]

$$\text{Torsional, } \frac{\sin \epsilon \cos^2 \epsilon}{R} \quad (11)$$

$$\text{Bending, } \frac{\sin^3 \epsilon}{r} \quad (12)$$

$$\text{Tensional, } T.r \tan \epsilon \quad (13)$$

It is interesting to note that in circumstances when torsional and bending forces are negligible, the twist blockage would be independent of tension. This situation is rarely, if ever, likely to arise.

#### 5.14.1 Effect of $1/\sqrt{R}$ and $T_1$ on twist accumulation and the theoretical torque required

According to equation 8, the torque required to overcome twist blockage is proportional to  $1/\sqrt{R}$  and it is of interest to record the influence of  $1/\sqrt{R}$  and of the initial tension on twist accumulated

in front of the guide surface,  $N_B$ . At the same time the torque can be calculated from a knowledge of guide and yarn radius (0.0123 cm measured) and tension.

An experiment similar to the experiment of section 5.5 was carried out with a yarn of 116 t/m.

Table 5.19 shows the results of the effect of the initial tension and  $1/\sqrt{R}$  with the corresponding values of the accumulated twist in front of the guide surface. Figure 5.36 illustrates the relationship between  $1/\sqrt{R}$  and the twist before the guide at various levels of initial tension. Figure 5.37 also shows the same relationship for the effect of the initial tension at various values of the guide radius. It can be seen from the two figures that the twist accumulation increases due to either increase of the initial tension or  $1/\sqrt{R}$ , but not proportionally as yarn torque is itself not proportional to twist. To explain this more clearly, Table 5.20 and Fig. 5.38 were produced. The values of the tensile force,  $T_1$ , and guide radius were substituted in equation 8 and the calculated required torque was plotted against the experimental values of the twist accumulation in front of the guide surface. It can be seen that as the torque required to overturn the yarn increases, the twist accumulated also increases when the guide radius is reduced but is, in most cases, relatively independent of tension.

#### 5.14.2 Initial input twist and twist blockage torque relationship

As pointed out earlier, the twist blocking torque generated by the guide surface is dependent on both the initial tension and the

TABLE 5.19: Effect of both the initial tension and guide radius on twist before the guide surface for the yarn 116 t/m at angle of wrap  $90^\circ$

$T_i$	20	40	60	80
$1/\sqrt{R}$	$N_B$	$N_B$	$N_B$	$N_B$
3.16	162.5	188.0	196.0	205.0
2.24	145.0	154.0	158.0	160.0
1.83	129.0	136.0	138.0	144.0
1.58	127.5	137.0	136.5	142.5
1.41	123.0	125.0	129.0	132.0

$T_i$  = initial tension (gf)

$N_B$  = twist before the guide (t/m)

R = guide radius (cm)

FIG. 5.36: Effect of guide radius,  $R$ , on twist accumulation before the guide surface at constant angle of wrap with various levels of initial tension

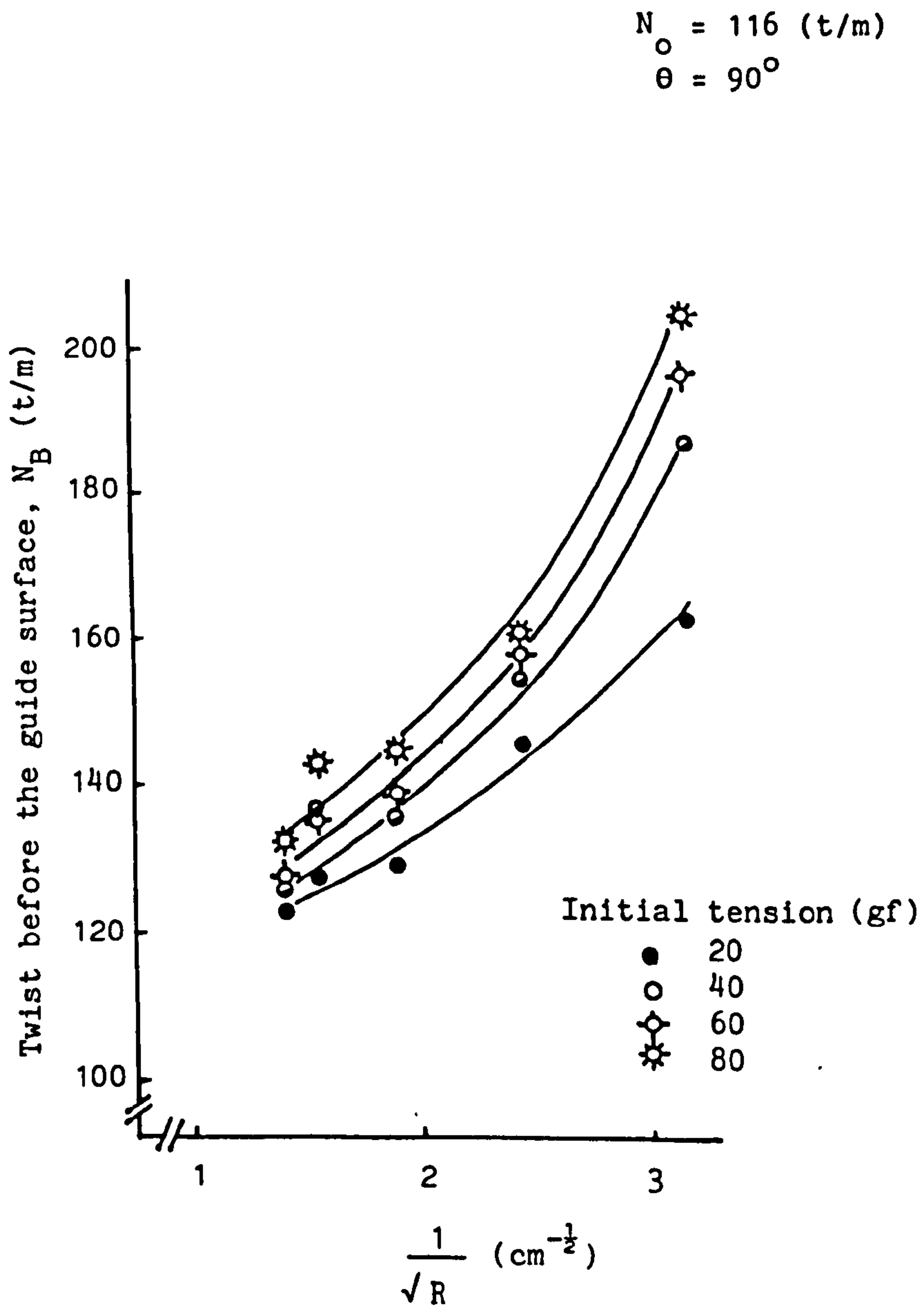

FIG. 5.37: Effect of input tension on twist blockage at constant angle of wrap ( $90^\circ$ ) with various values of guide radius

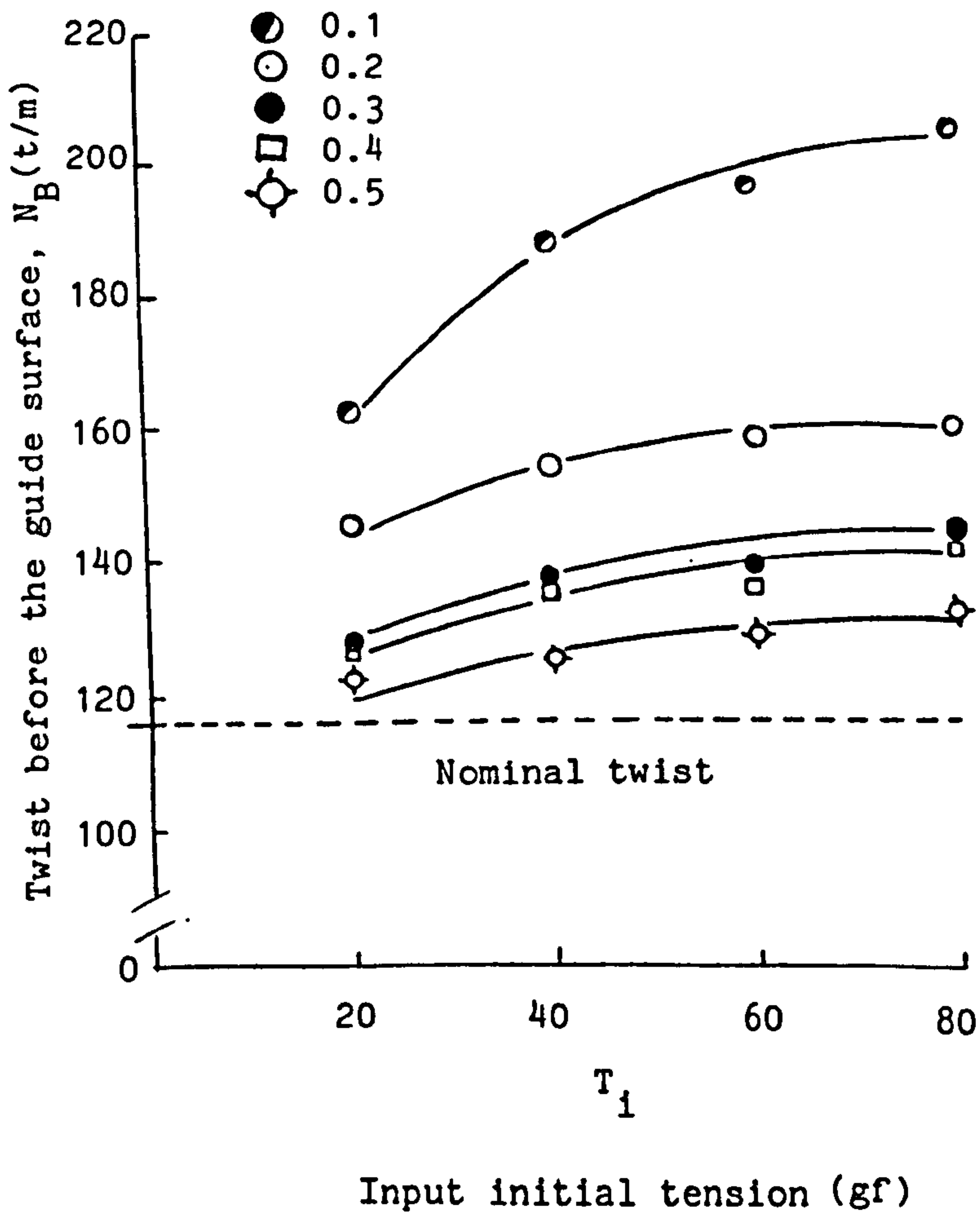

TABLE 5.20

R	0.1		0.2		0.3		0.4		0.5	
$T_i$	C	$N_B$	C	$N_B$	C	$N_B$	C	$N_B$	C	$N_B$
20	0.81	162.5	0.57	145.0	0.47	129.0	0.40	127.5	0.36	123.0
40	1.62	188.0	1.14	154.0	0.93	136.0	0.81	137.0	0.72	125.0
60	2.43	196.0	1.72	158.0	1.40	138.0	1.21	136.5	1.10	129.0
80	3.24	205.0	2.30	160.0	1.87	144.0	1.62	142.5	1.45	132.0

R = guide radius (cm)

$T_i$  = initial tension (gf)

C = theoretical torque required ( $\mu\text{N}\cdot\text{m}$ )

$N_B$  = twist before the guide (t/m)

The above values were estimated at  $\Psi^0 = 30^\circ$

FIG. 5.38: The relationship between the torque required and the twist before the guide surface at various initial tensions with various levels of guide radius  
 [deflection angle =  $30^\circ$ ]

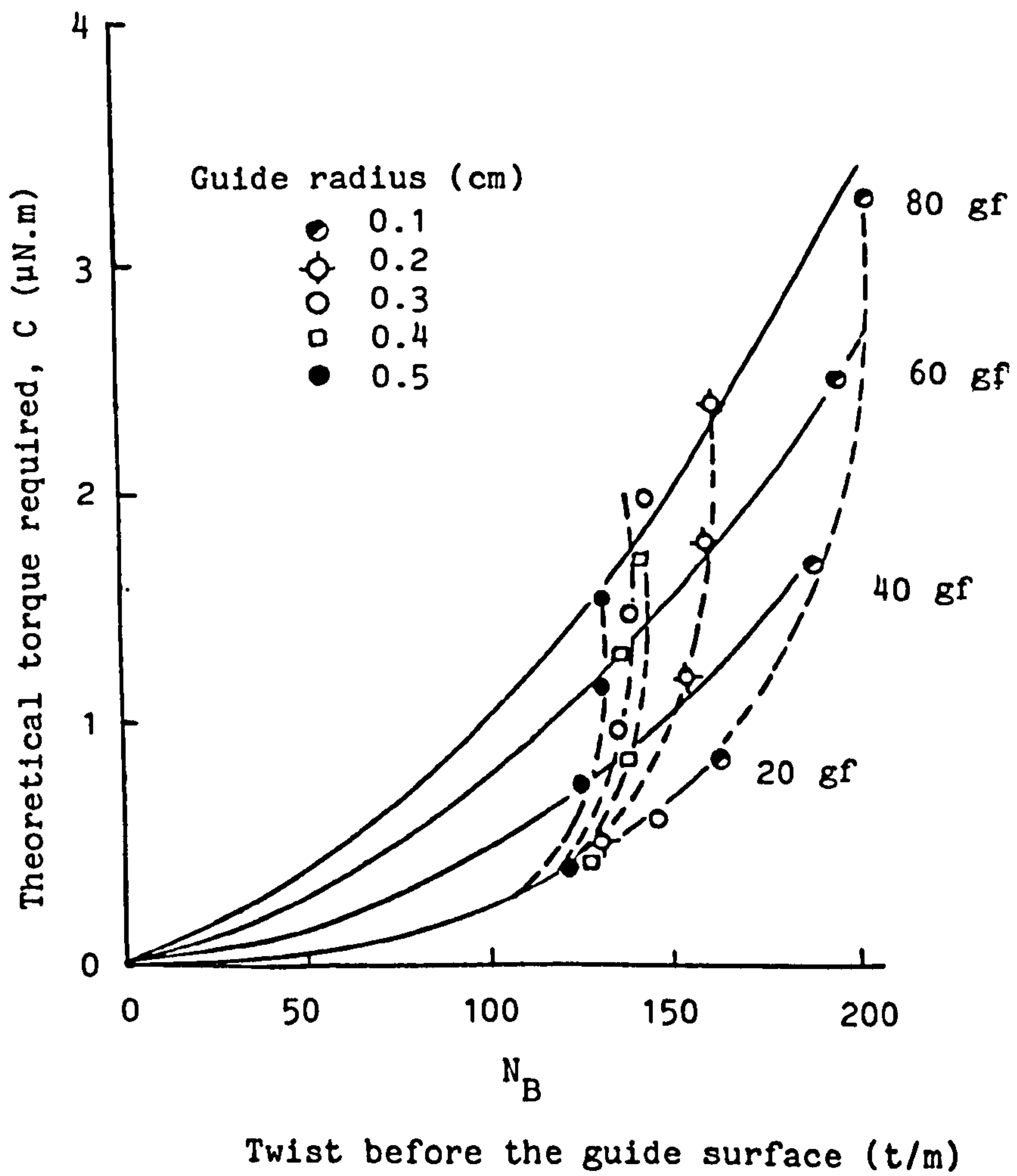



guide radius and, depending on the mechanism of blocking, may depend on the length of contact also. The foregoing analysis did not show the effect of the initial twist on the required torque but a situation could be envisaged where the deflection angles of the initial twist could help to generate a value of  $\Psi$  greater than the critical value. However, Table 5.21 and Fig. 5.39 illustrate the practical effect of initial tension on twist blockage at various twist levels. The graph shows the twist accumulated before the guide surface (0.2 cm diameter) for three levels of twist: 50, 116 and 210 t/m, relative to an increase of the initial tension 20 to 80 gf. It can be seen from the graph that due to the increase in initial tension, the theoretical twist blocking torque rapidly increases whilst the accumulated twist increases by a relatively small amount. This occurs particularly at the two higher twist levels where the increase is about 14% rather than at the lower level (50 t/m) where the increase is over 30%. In addition, at the higher twist levels, the average blocked twist is about 25% above the initial twist whereas at the lower twist it is roughly  $3\frac{1}{2}$  times the initial twist.

#### 5.14.3 Discussion

Equation 8 together with Fig. 5.39 implies that the theoretical torque required to overturn the yarn components on the contact surface increases proportionally as the initial tension increases. However, the observations show that at high levels of input twist (210, 116 t/m), the twist accumulation behaviour shows less sensitivity to the input tension. It also appears from the

TABLE 5.21

$R^{-\frac{1}{2}}$	3.16			C
	Initial twist (t/m)			
$T_i$	210	116	50	
	$N_B$	$N_B$	$N_B$	
20	225.0	162.5	137.5	0.81
40	262.0	188.0	146.0	1.62
60	251.0	196.0	184.4	2.43
80	264.0	205.0	192.0	3.24

R = guide radius (cm)

$N_B$  = twist before guide (t/m)

C = torque ( $\mu$ N.m)(calculated)

$T_i$  = initial tension (gf)

FIG. 5.39: Effect of initial tension on both twist accumulation and theoretical twist blockage torque at various initial twist levels

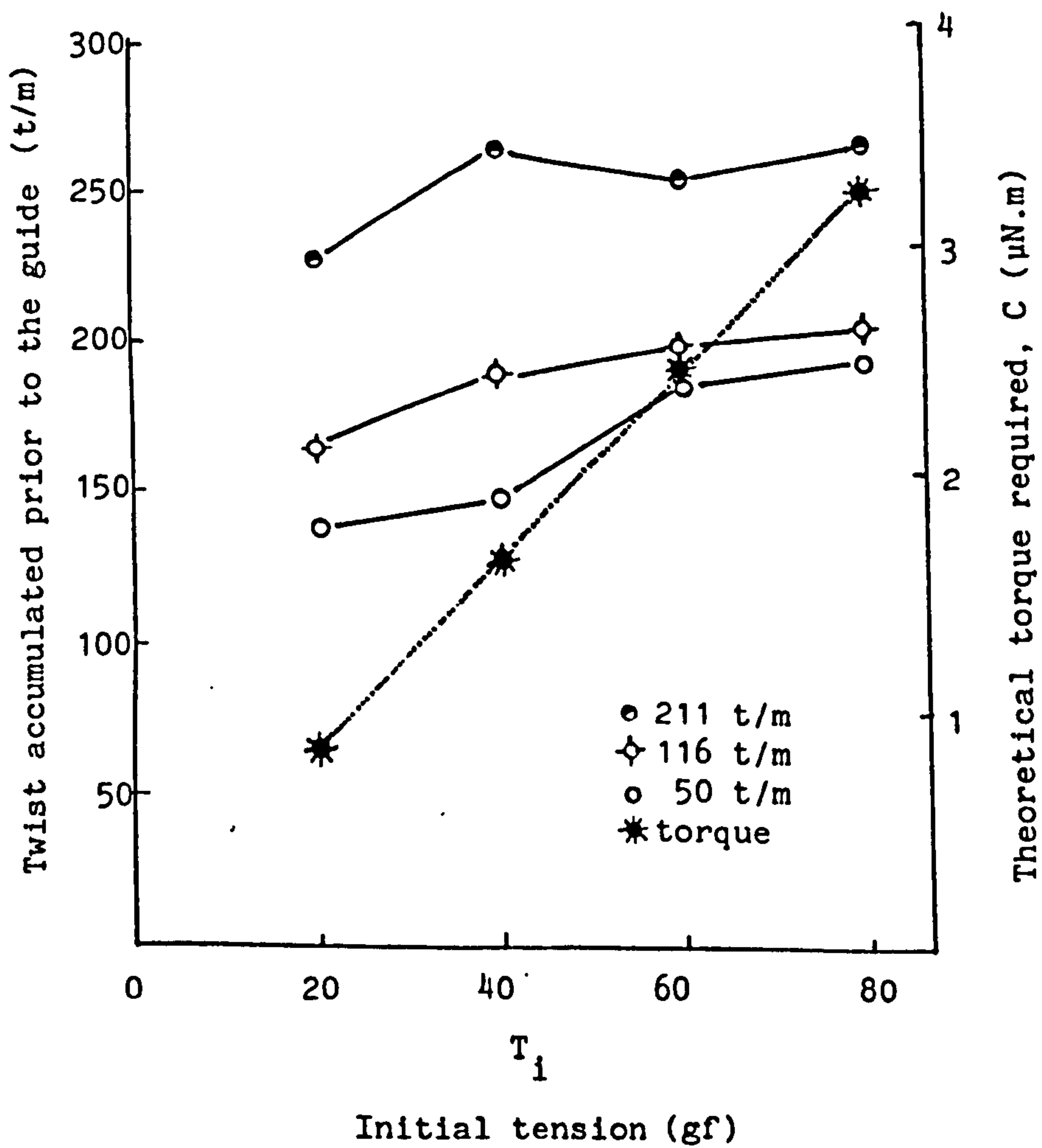

present experiment that the initial tension has a different effect on twist accumulation for different twist levels. This may be attributed to the fact that the yarns will have different elastic properties or might have been subjected to different stresses during processing, or might have different levels of stress relaxation. In addition to this, different levels of torsional stiffness exist at different initial twist levels.

Furthermore, when the highly twisted single yarns are doubled, the magnitude of the force holding the two singles component together, will depend to a great extent upon the twist level. The pressure on the contact surface tends to spread out the two singles and to separate them from one another. This is more likely to occur at low levels of twist when the bending forces are lower. In such a case, the twist is more likely to be pushed back.

Conversely, at higher levels of twist, the tendency of the twist to be held back will be reduced and there will be a minimum twist accumulation.

In summary, when the yarn comes in contact with the guide surface two conditions may exist:

1. At high levels of doubling twist, it may have a deflection angle equal to or greater than required to generate the critical angle required to overcome the suggested mechanism of twist accumulation (i.e.  $\Psi > 30^\circ$ ), in these circumstances twist blockage can only occur by other mechanisms.
2. At a lower level of doubling twist, this situation may not be

achieved (i.e.  $\Psi < 30^\circ$  until a significant level of blockage has occurred), and therefore, the twist blockage process will continue until the level of this angle is reached.

CHAPTER 6

YARN ORIENTATION OVER THE CONTACT SURFACE

## 6.1 Introduction

The present chapter is concerned with a further aspect of the yarn/guide interaction and describes an investigation of the effect of the direction of the yarn movement over the contact region relative to the axis of the guide.

The effect of the surface topology and surface direction (i.e. S or Z) of the twisted yarn on the degree of twist blockage are investigated, together with the effects, relative to yarn/guide orientation of the relative mobility of the yarn components or fibres within the yarn.

## 6.2 Effect of yarn orientation on twist blockage

It was indicated in sections 5.7.1 and 5.11 that the twisted yarn tends to be deflected laterally over the contact surface, and this deflection was found to be dependent, to a great extent, upon the direction and magnitude of the yarn twist as well as the manner of threading the yarn around the guide [54,55].

Further evidence for the generation of torque when a yarn is inclined to a surface is provided by one method of measuring the level of false-twist in the twisted zone of the false-twist texturing process. An instrument is used [93,94] in which a freely rotatable cylinder is held against the running yarn and the cylinder rotates unless its axis is exactly parallel to the direction of the yarn surface movement.

Furthermore, Pavlov [56] found that torque and twist were produced when a yarn was pulled at an angle over a cylindrical

surface, the twist developed depending on the dimensions of the surface of the cylinder and the angle of threading the yarn along the surface (angle of orientation).

### 6.2.1 Definition of angle of orientation

The angle of orientation (or approach angle) may be defined as the angle between the plane of the incoming and outgoing yarn axis and the plane drawn perpendicular to the guide axis.

Figure 6.1A,B shows the position of the yarn over the yarn guide at zero and  $\hat{\beta}$  angle of orientation. The guide may be moved from the  $\beta = 0$  position in two ways, clockwise and anti-clockwise. These will be expected to have different effects because of their relations to the yarn twist direction, S or Z.

For convenience the term positive angle of orientation (or  $\hat{\beta}$  positive) and the negative angle of orientation (or  $\hat{\beta}$  negative) will be used in referring to the cases of the clockwise and anti-clockwise deflection respectively.

This factor does not appear to have been investigated in any depth by previous workers. Pavlov [55] is the only investigator known to have examined the generation of false twist by an especially shaped guide (Fig. 6.1C) where the yarn orientation was deliberately oblique. In his experiments the twist was changed from S to Z or vice-versa, on passing through the guide, but he did not show the influence of the angle on the twist accumulation.

It is difficult to decide from Pavlov's work whether the reversing of the twist is as a result of the yarn orientation or due to the unusual shape of his yarn guide.



FIGURE 6.1

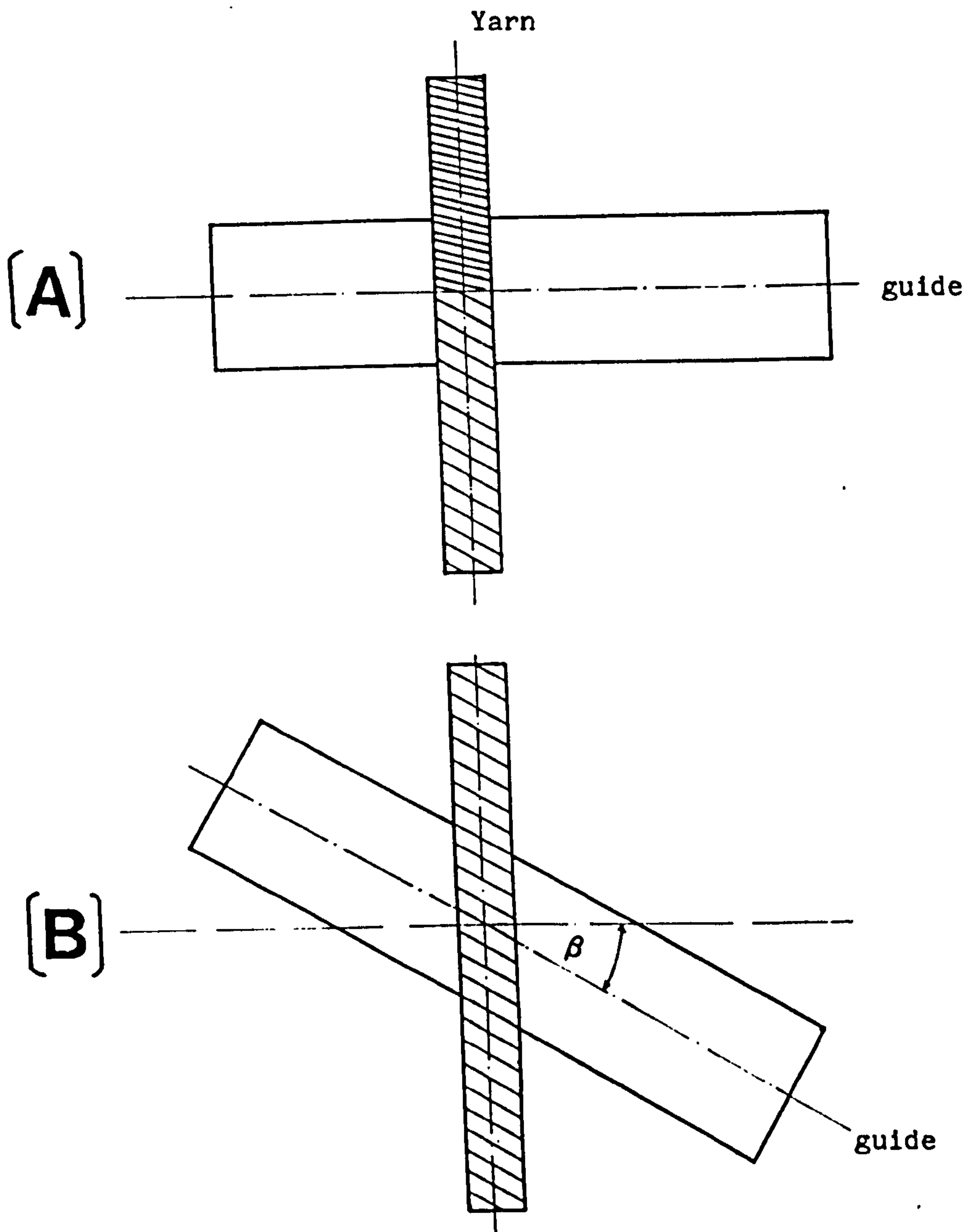

(A) zero angle of orientation

(B) an arbitrary angle of orientation  
to the direction of the yarn axis

Schematic diagram illustrating the angle of  
orientation

[C]

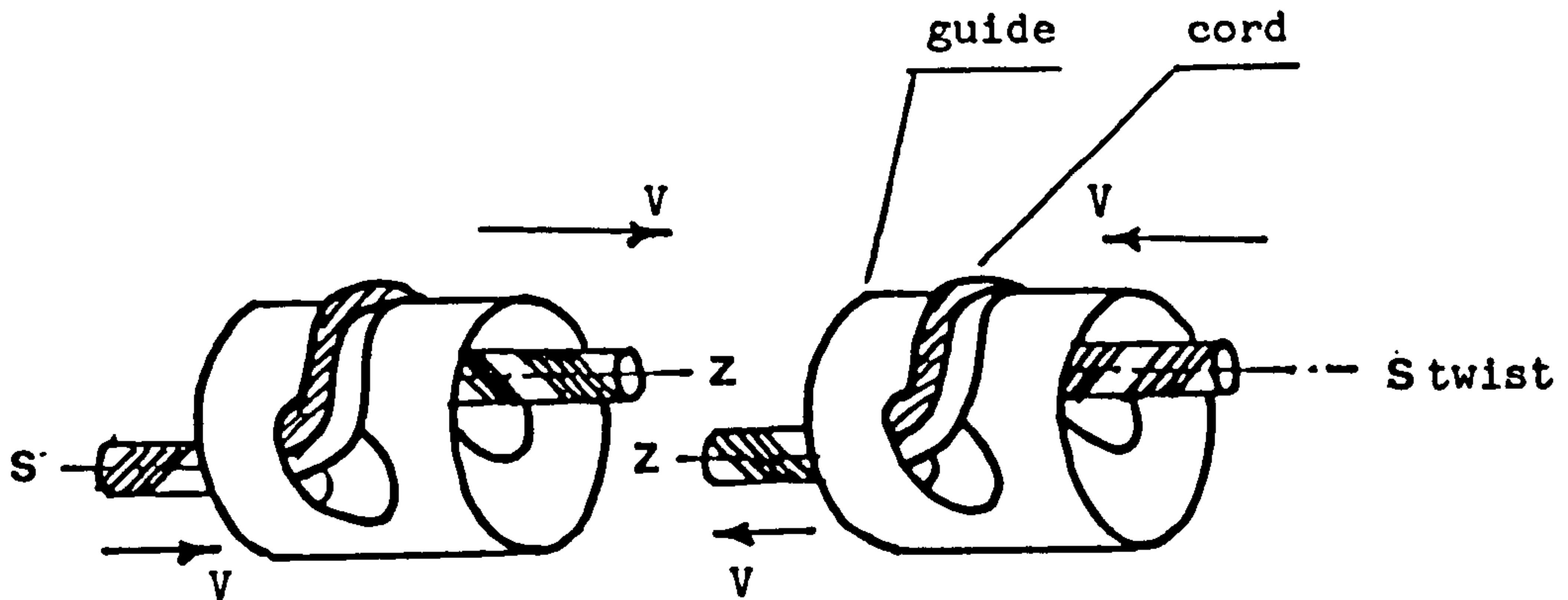

The cord is moving over a geodesic line of the same nature as the cord twist

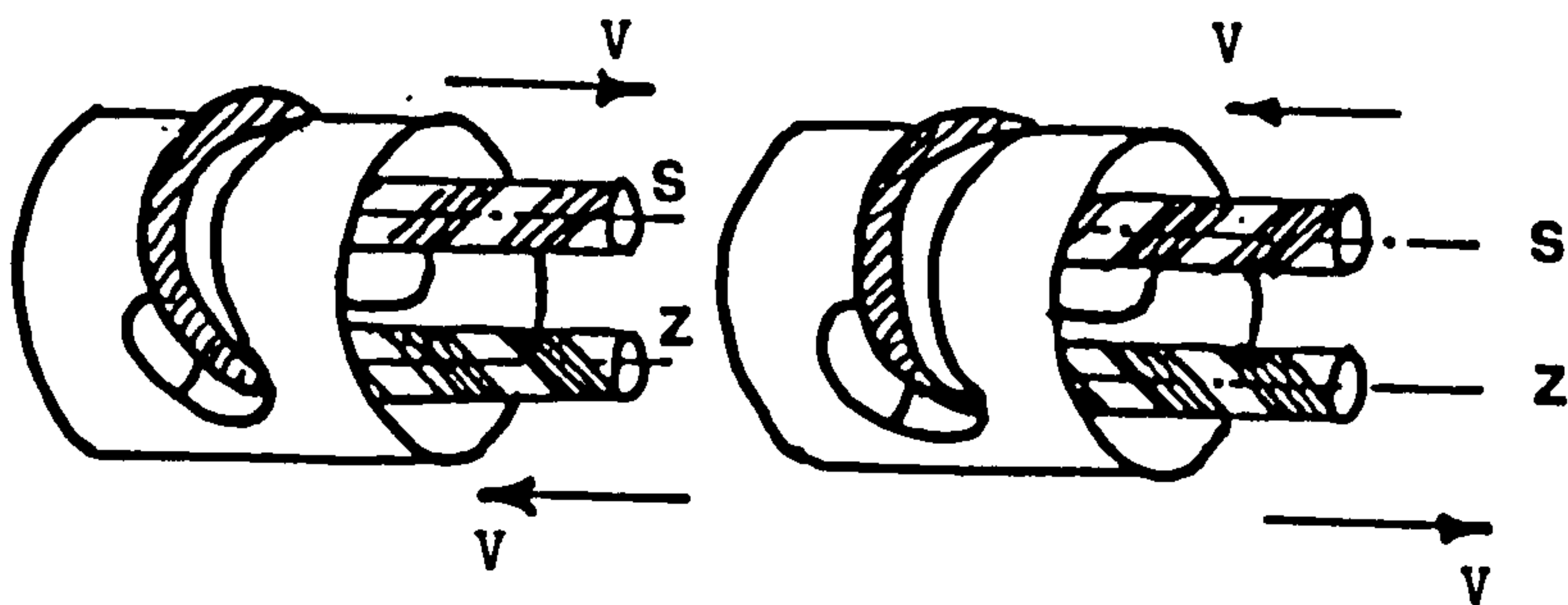

The cord is moving over a geodesic line of opposite nature to the cord twist

Schematic diagram illustrating the generation of false-twist in a cord moving over a guide [Pavlov]

### 6.2.2 Preliminary observation

It was observed in preliminary tests that twist transmission over the guide was influenced by the orientation factor regardless of the length of the arc of contact. In the earlier experiments it was observed that the yarn invariably rotated about its axis on the guide. In the present experiments, no rotation was observed for some angles of orientation, i.e. there was no twist blockage. It was felt therefore, that the angle of orientation might play an important part in controlling the phenomenon or even eliminating it.

For these experiments a doubled, textured polyester yarn 2x16.7 tex - 30 filaments with 50 t/m was used.

### 6.2.3 General observation

Due to the very low twist of the yarn, together with the zero twist in the singles yarn, the yarn tends to flatten over the guide surface. This is particularly true at the highest extension of 80 gf (i.e. about 440 gf/cm mean pressure).

Due to the high degree of interfibre mobility, it was obvious that as the yarn moved in a ribbon over the contact surface, instead of rotating freely and circularly around its axis, the rotation was achieved by the layers of filaments sliding over each other in a lateral movement as the yarn moved forward. This type of behaviour may be attributed to the low interfibre pressure which in a yarn with more highly twisted singles tends to hold the fibres together [95]. For this reason significant differences of behaviour would, therefore, be expected from an easily flattened yarn but with

mobile fibre components, as compared with a yarn with highly twisted, compact and circular singles components.

Considering this situation, the doubled textured polyester yarn made from zero twist singles was relatively easily rotated on the guide surface and consequently, the twist blockage is quite low.

The surprising observation was that this type of "ribbon" movement was completely different from that observed in the doubled yarn made from twisted singles, or even the spun yarn used previously.

With the spun yarn, the twist in front of the contact surface built up to a certain level without twist transfer over the contact region, and then suddenly the accumulated twist escaped; the accumulation cycle was then repeated. With the flat polyester textured yarn a certain level of equilibrium twist accumulation occurs in front of the guide, whilst there is a steady leakage of blocked twist transferred over the contact region. Of course the above observations were made at similar levels of pressure, arc of contact and length of one turn for the two types of yarn used.

It has already been mentioned, that as the angle of orientation  $\hat{\beta}$  increased positively, the twist accumulation decreased, whilst as the angle of orientation increased negatively the twist accumulation increased.

#### 6.2.4 Effect of angle of orientation on twist blockage

The initial experiment was carried out under the condition of angle of wrap  $\theta = 30^\circ$ , with a guide diameter 0.4 cm and initial

tension 80 gf (i.e. mean pressure 440 gf/cm).

The results are tabulated in Table 6.1 and plotted in Fig. 6.2. The figure shows two curves, the upper curve represents the twist level before the contact region. The lower curve represents the difference in twist before and after the contact region (i.e. twist gain, N).

It is clear, however, from the graph that the twist accumulation is greatly influenced by the direction of the guide surface relative to the yarn twist, and, therefore by, the angle between the surface twist helix and the guide axis at the points of contact.

This pair of curves provides full information on the twist before and after the guide over the range of orientations used in the experiment. It should be made clear that the observed twist after the guide was usually less than the original nominal doubling twist of the supply yarn. It is seen, therefore, that the twist gain curve (the lower curve) did not indicate the net twist gain relative to the original twist. The reason for this apparent anomaly may be either because a twist disturbance is caused by the next component downstream in the yarn path, i.e. one of the pulleys guiding the yarn, or because the twist immediately after the guide does not reach its equilibrium level of the original twist. The best representation of the behaviour of the twist accumulation is, therefore, probably the lower curve.

In fact this experiment investigates a combination of two parameters which were discussed in detail in the earlier experiments. The two parameters are the pressure and the length of the contact region (arc of contact).

TABLE 6.1

$\beta^\circ$	$P_i$	$N_B$	$N_A$	$N$
70	51.5	53.0	44.5	8.5
60	110.0	53.0	45.0	8.0
50	182.0	58.0	49.0	9.0
40	258.0	55.0	48.0	7.0
30	330.0	55.6	48.0	7.6
20	388.5	63.0	52.5	10.5
10	427.0	70.0	49.0	21.0
0	440.0	73.0	52.5	20.5
-10	427.0	75.0	49.0	26.0
-20	388.5	77.5	48.0	29.5
-30	330.0	87.0	47.5	39.5
-40	258.0	88.0	41.0	47.0
-50	182.0	89.0	49.0	40.0
-60	110.0	85.0	40.0	45.0
-70	51.5	84.0	39.0	45.0

$N_B$  = twist before the contact surface (t/m)

$N_A$  = twist after the contact surface (t/m)

$N$  = twist gain (t/m)

$P_i$  = mean pressure (gf/cm)

$\beta$  = angle of orientation (degrees)

FIG. 6.2: Effect of angles of orientation on twist gain at constant input twist (50 t/m)

$$T_1 = 80 \text{ (gf)}$$

$$P_m = 440 \text{ (gf)}$$

$$\theta = 30^\circ$$

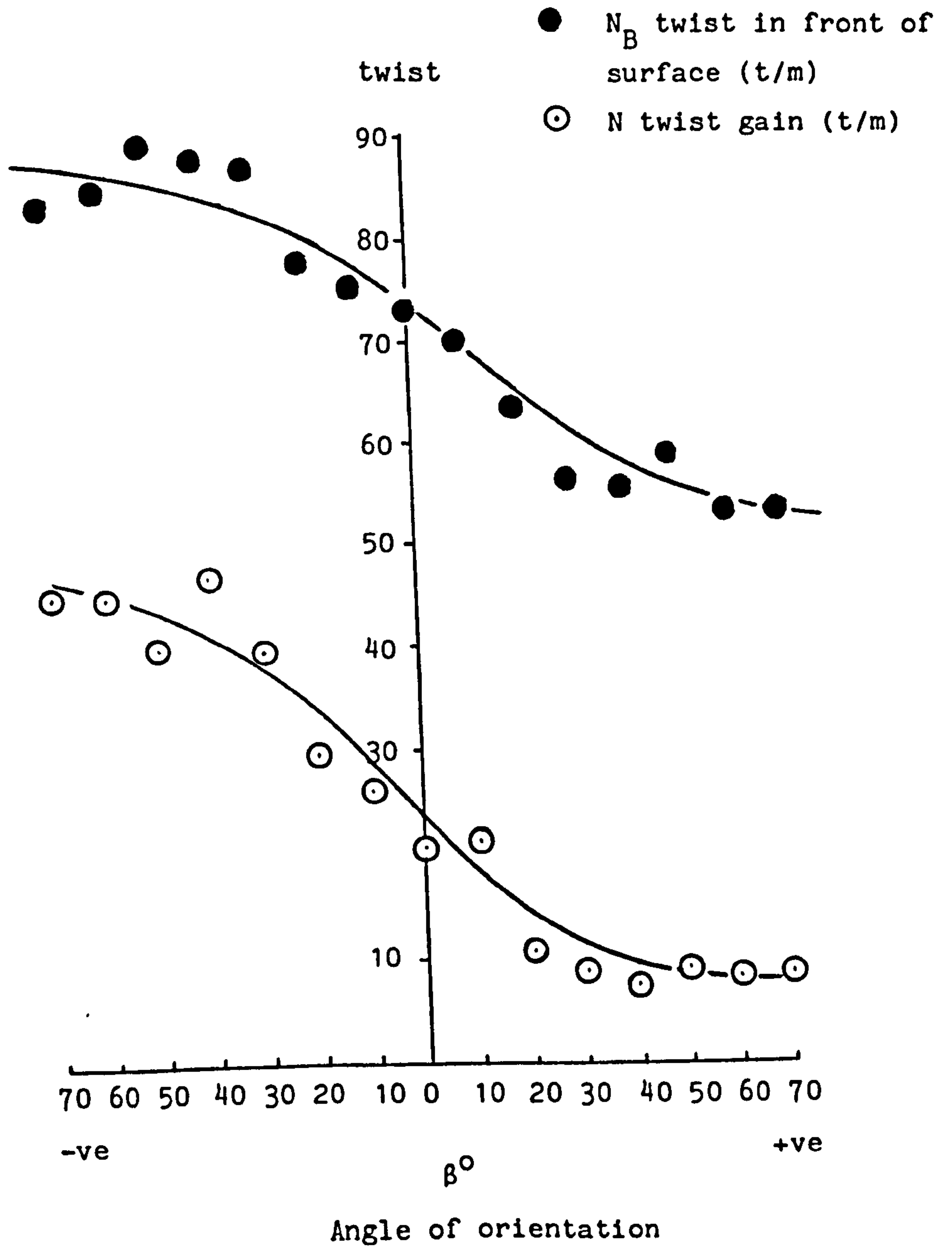

$$N = N_B - N_A$$

In the present experiment the first parameter is decreasing according to the increase of the radius of curvature of the yarn path as a function of the angle of orientation  $\beta$ , i.e.  $P \propto \cos^2 \beta$ .

(Appendix I)

The second parameter, the length of contact region increases as the angle of orientation increases, i.e.  $S \propto \sec^2 \beta$ .

As previously shown, the influence of the pressure on twist blockage is that decrease of the pressure over the contact region tends to decrease the twist blockage. In the present experiment, the pressure has the same effect when the direction of  $\beta$  is positive but an increase of blocked twist occurs when the direction of  $\beta$  is negative. Figure 6.3 shows for constant  $T_i$  the variation of the pressure due to the variation of the angle of orientation in both positive and negative directions, taking into account the change in  $T_o$ . The maximum value of the pressure is achieved at zero angle of orientation when the curvature is a maximum, whilst the pressure was a minimum when the angle  $\beta$  was the maximum achievable with the apparatus, i.e.  $70^\circ$ .

Zero mean pressure is of course achieved when  $\beta = 90^\circ$  but there is no means of achieving this in practice.

#### 6.2.4.1 Effect of the mean pressure on twist gain

For the purpose of comparison of the twist gain at the two equal values of the mean pressure due to  $\beta$  positive and negative, graph 6.4 shows the relationship between the mean pressure  $P_m$  and the twist gain,  $N$ . It is clear that as the mean pressure increases as a consequence of the decrease of  $\beta$  positive, the twist gain



FIG. 6.3: Effect of angles of orientation on the mean pressure at positive and negative  $\beta$

$T_i = 80 \text{ gf}$   
 $D = 0.4 \text{ cm}$   
 $\theta = 30^\circ$

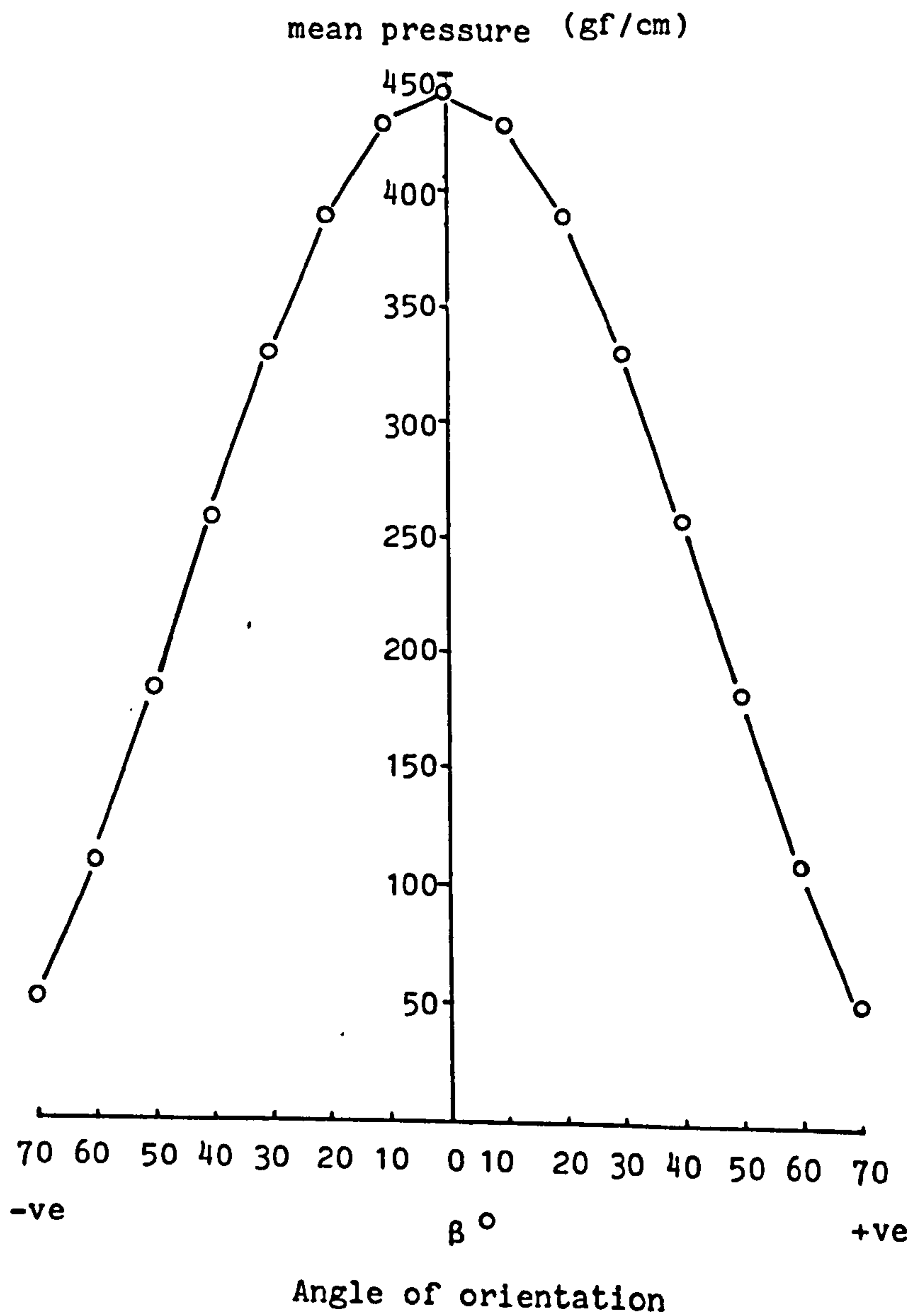
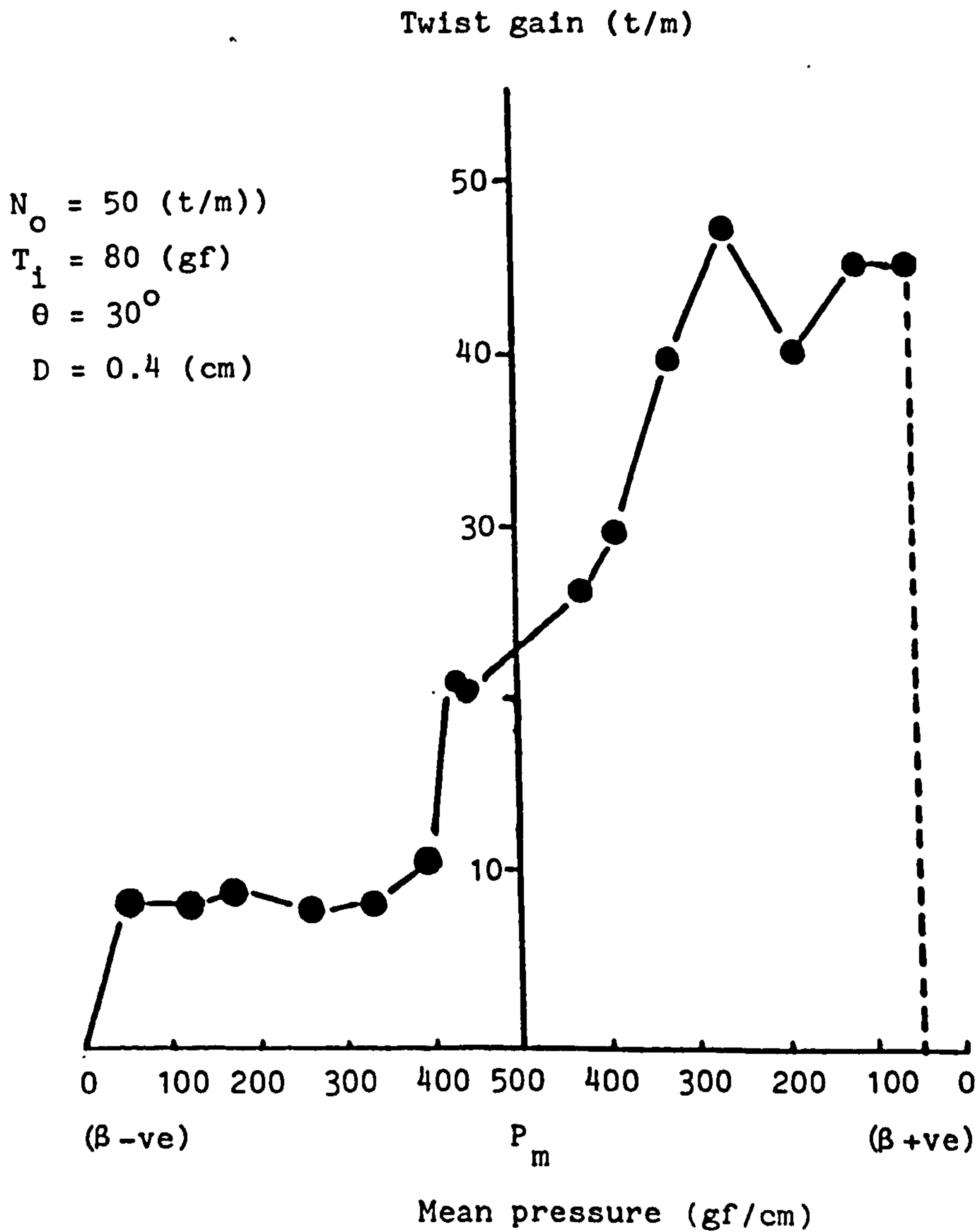

FIG. 6.4: Mean pressure and twist gain at positive and negative angles of orientation



increases, whilst as the mean pressure increases as a consequence of decrease of  $\beta$  negative, the twist gain decreases. The interpretation of this observation will be considered with the discussion of the effect of the length of the contact region.

#### 6.2.4.2 Effect of length of contact

The twist gain  $N$ , Table 6.2, is plotted in graph 6.5 against the length of the arc of contact  $S$  for both positive and negative value of  $\beta$ . The graph shows an opposite behaviour for the same length of the arc of contact depending whether  $\beta$  is positive or negative. For  $\beta$  positive as the arc of contact increases, the twist gain decreases, but for  $\beta$  negative, as the arc of contact increases, the twist gain increases. This contrary behaviour of the twist gain with respect to both mean pressure and the length of arc of contact indicates that a third factor must be involved, possibly the frictional force  $F$  over the contact region.

#### 6.2.4.3 Effect of frictional force

As pointed out in Chapter 3, work by previous investigators [21,52,56] in the field of twist blockage showed that friction is an important parameter influencing twist blockage particularly if 'flattening' mechanism does not apply. The importance of the nature and direction of the frictional force can not be emphasized too often as it is very dependent on the surface textures or both the yarn and the guide. When two surfaces are moving over each other it is impossible for there to be slipping in one direction and gripping in another direction at the point of contact. When the two surfaces are slipping

TABLE 6.2

$\beta$	S	F	N
70	0.310	23.3	8.5
60	0.210	22.3	8.0
50	0.163	23.8	9.0
40	0.137	19.7	7.0
30	0.121	22.0	7.6
20	0.112	18.3	10.5
10	0.106	17.4	21.0
0	0.105	16.0	20.5
-10	0.106	17.2	26.0
-20	0.112	16.9	29.5
-30	0.121	23.8	39.5
-40	0.137	23.8	47.0
-50	0.163	19.9	40.0
-60	0.210	18.8	45.0
-70	0.310	24.8	45.0

$\beta^\circ$  = angle of orientation (degrees)

S = length of arc of contact (cm)

F = frictional drag (gf)

N = twist gain (t/m)

FIG. 6.5: Effect of arc of contact on twist gain at positive and negative angles of orientation

$$N_o = 50 \text{ (t/m)}$$

$$T_1 = 80 \text{ (gf)}$$

$$\theta = 30^\circ$$

$$D = 0.4 \text{ (cm)}$$

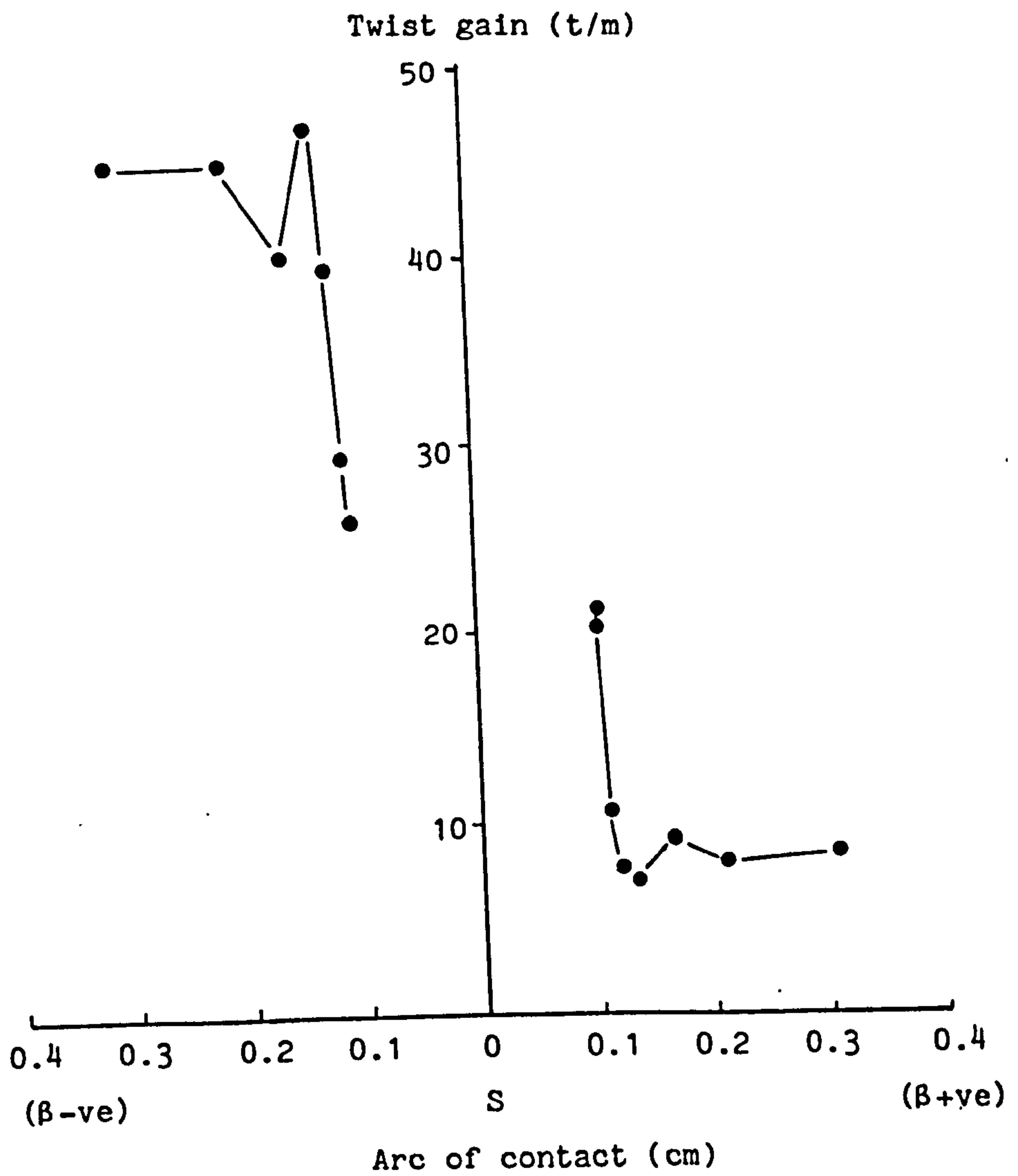

over one another, the frictional force will have a more or less constant magnitude but may change in direction so as to oppose the relative motion. Many investigators set out to determine the magnitude of the frictional force but make the mistake of not considering its direction.

However, Hearle [60] points out that as the relative direction of the movement of two surfaces in contact changes, the problem of the frictional behaviour becomes more complex, and a good example of this is the frictional behaviour between yarn and surfaces causing twist blockage.

It is of most interest in the present experiment to examine the relation between the frictional behaviour over the contact surface and the twist blockage. The frictional force was measured as a difference between simultaneous measurements of  $T_1$  and  $T_0$  made by an electronic circuit attached to the Rothschild tension meter and read directly by the M.P.V. (see section 4.6).

The apparent frictional force (Table 6.2) was plotted in graph 6.6 vs the twist gain. It will be seen from the graph that an increasing frictional force when  $\beta$  is positive is associated with a reduction of the twist accumulation in front of the guide. Conversely, as the frictional force increases when  $\beta$  is negative, the twist gain increased rapidly to a level of about 100% greater than that observed with zero angle of orientation  $\beta$ .

As mentioned earlier, when the yarn is inclined over the contact surface with the direction of  $\beta$  positive, the direction of the surface helices at the points of contact is more orthogonal to

FIG. 6.6: Frictional drag and twist gain at both positive and negative angles of orientation

$$N_0 = 50 \text{ (t/m)}$$

$$T_1 = 80 \text{ (gf)}$$

$$\theta = 30^\circ$$

$$D = 0.4 \text{ (cm)}$$

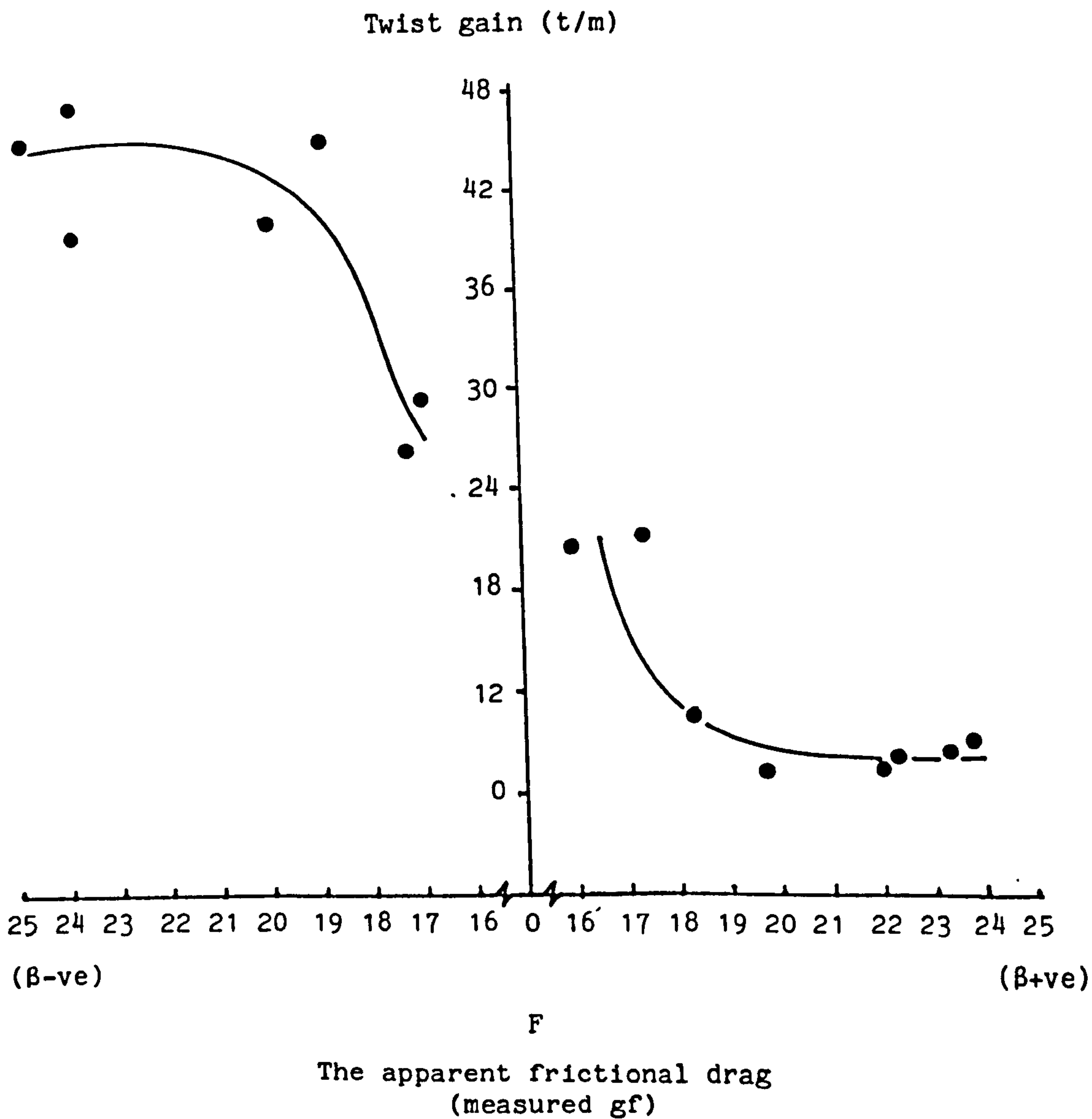

S

the guide axis and, therefore, the frictional force is less likely to generate a twisting couple. The twist accumulation, therefore, tends to be minimized.

When  $\beta$  is negative, however, the direction of the twist helices will be less inclined to the axis of the guide, so, the ridge of the guide surface over which the yarn runs, tend to lie between the surface ridges of the yarn. The frictional force at the point of contact is, therefore, more likely to generate blocked twist.

Figure 6.7 illustrates this point, (a) shows the guide axis with  $\beta$  positive, whilst (b) shows guide axis with  $\beta$  negative.

If this is a correct explanation of the observation, then the opposite effect should be observed when using a yarn with Z twist instead of S twist.

### 6.3 Effect of angle of orientation on twist blockage for S and Z yarn twist

To confirm this, the same singles yarns were twisted on the universal ring twisting machine into doubled yarns with both Z and S twist. These S and Z twist yarns were produced simultaneously with 50 t/m at the same tension and machine speed.

Two experiments similar to those described above, were carried out except the angles of wrap were  $90^\circ$  and  $120^\circ$ .

The results are shown in Table 6.3 and illustrated by graphs 6.8 and 6.9 for both S and Z twisted yarn. The general features of the graphs are as expected, the Z twist behaviour is generally opposite in direction to S twist behaviour. As with the S twist, the



FIG. 6.7: View, through the guide, of yarn surface ridges relative to guide orientation

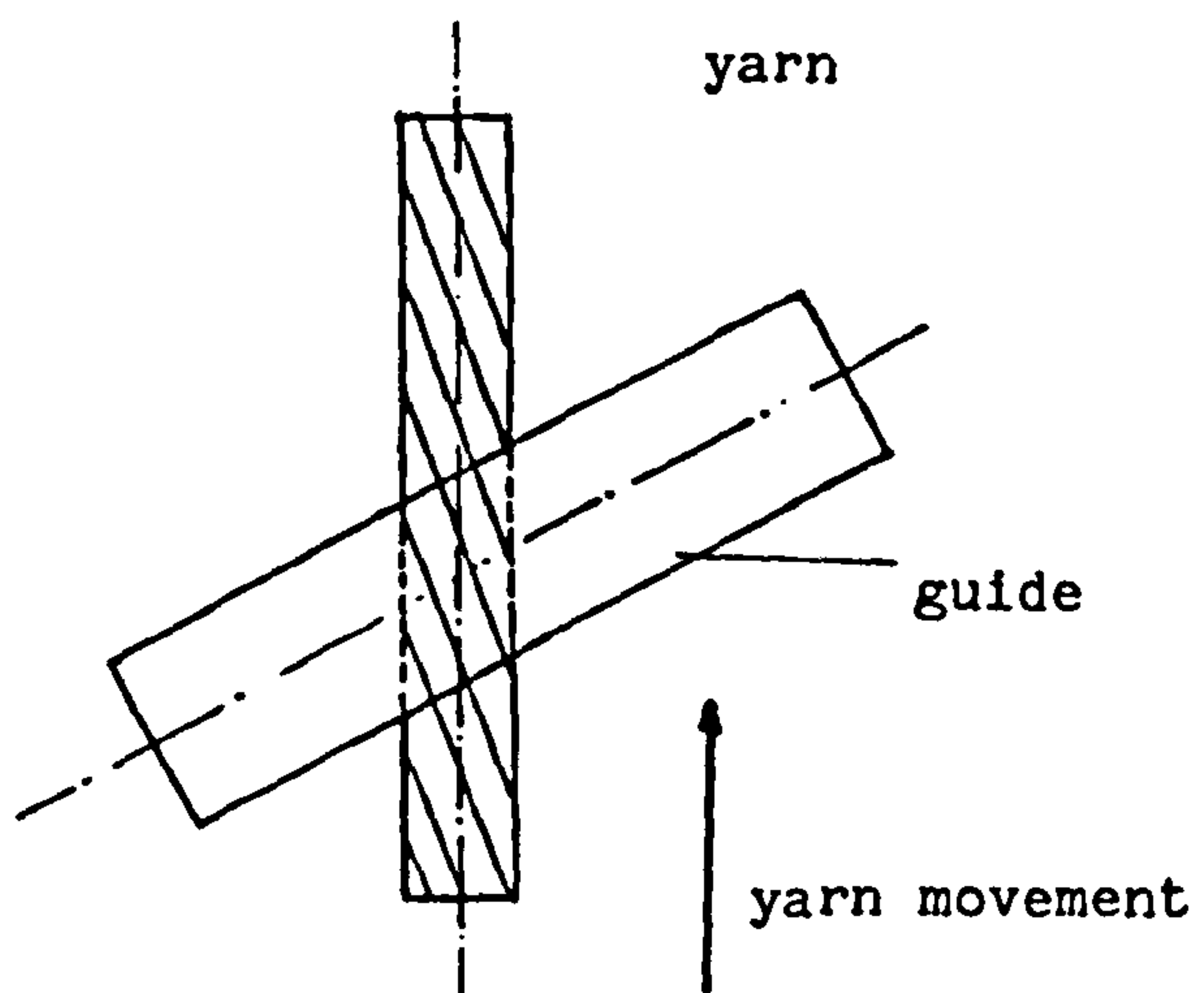

[a]

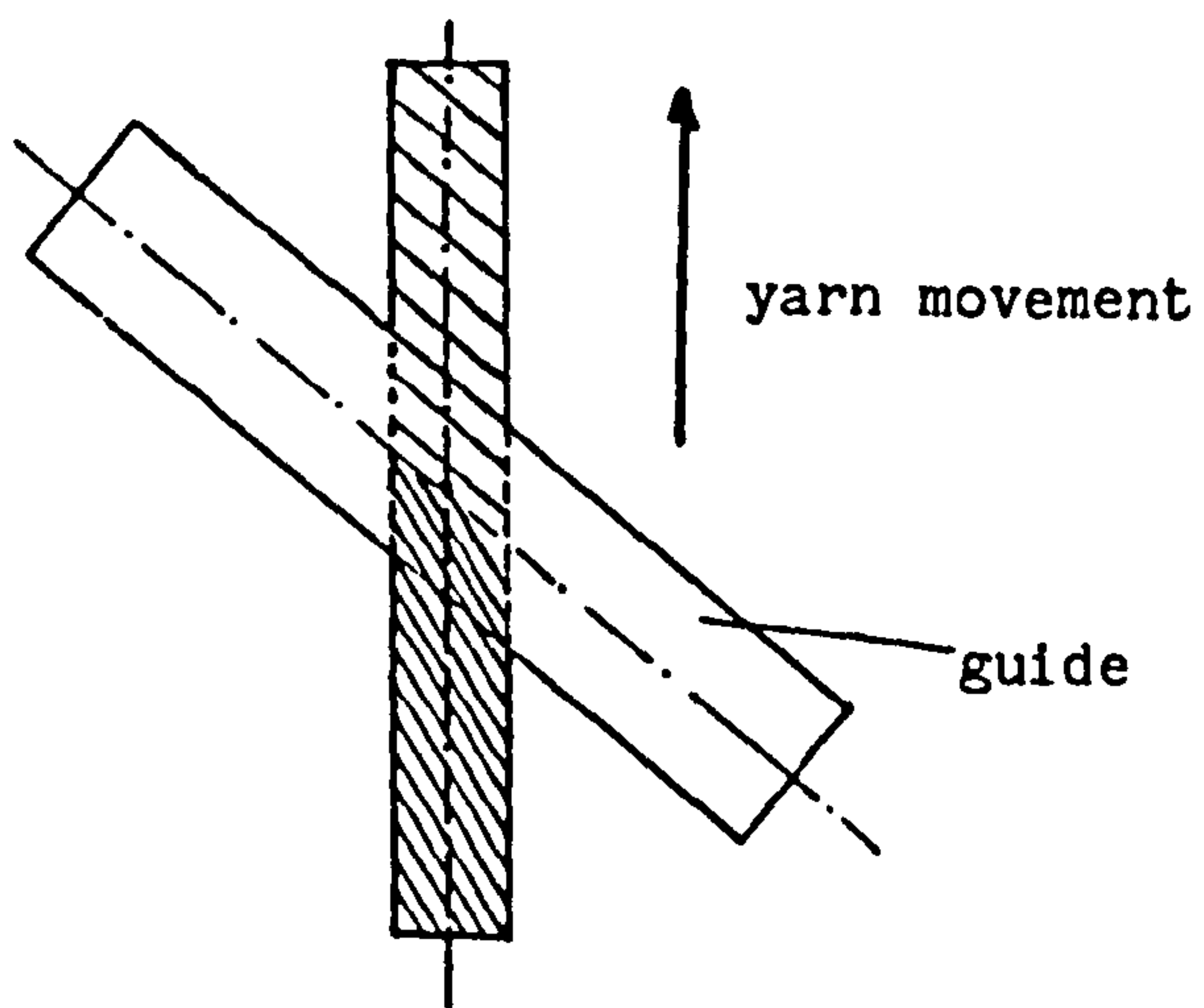

[b]

TABLE 6.3

Doubled twist				
50 t/m				
$\theta$	$90^\circ$		$120^\circ$	
Twist direction	S	Z	S	Z
$\beta$	N	N	N	N
70	9.0	48.5	23.0	47.0
60	5.6	52.0	16.6	59.4
50	10.0	61.0	24.0	63.4
40	8.4	64.4	15.0	74.0
30	12.5	65.0	21.0	86.0
20	10.6	64.0	27.0	60.0
10	16.6	56.6	21.3	58.0
0	21.0	55.6	30.6	<u>54.7</u>
-10	26.0	54.0	26.0	68.4
-20	33.0	47.0	29.0	66.6
-30	41.3	45.0	34.0	64.0
-40	36.8	38.0	40.6	48.0
-50	44.7	24.0	41.3	61.0
-60	49.0	20.0	42.5	49.4
-70	46.6	20.0	42.2	54.0

$\theta$  = angle of wrap (degrees)

$\beta$  = angle of orientation (degrees)

N = twist gain (t/m)

FIG. 6.8: Effect of angles of orientation on twist gain for Z and S yarn twist direction, at angle of wrap  $90^\circ$

$$N_0 = 50 \text{ (t/m)}$$

$$T_1 = 80 \text{ (gf)}$$

$$D = 0.4 \text{ (cm)}$$



FIG. 6.9: Effect of angles of orientation on twist gain for S and Z yarn twist direction at  $120^\circ$  angle of wrap

$N_0 = 50$  (t/m)  
 $T_i = 80$  (gf)  
 $D = 0.4$  (cm)

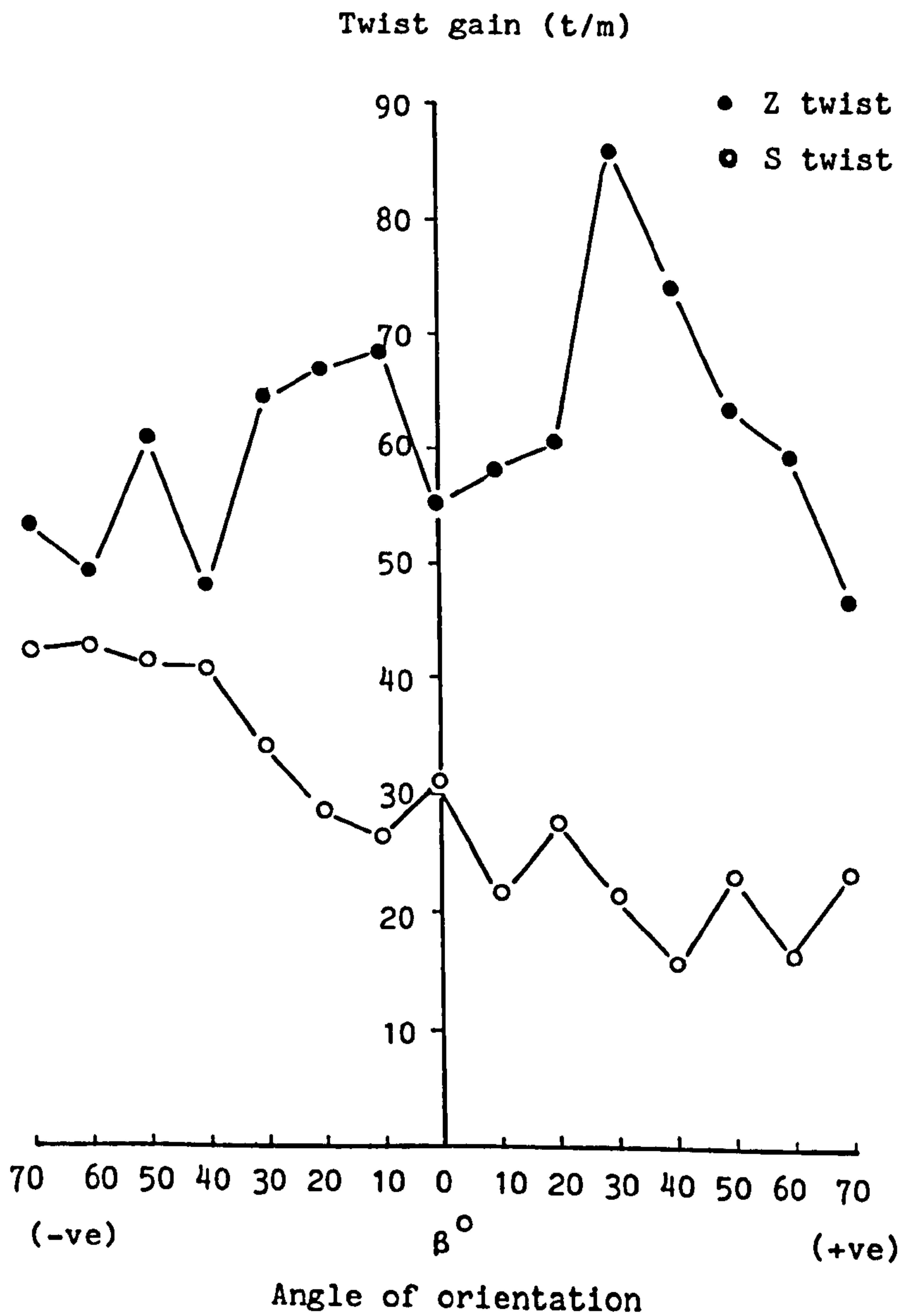

Z twist shows that the twist accumulation increases as  $\beta$  increases positively, whilst the twist accumulation decreases as  $\beta$  increases negatively. It will be noted, however, that the S and Z twist yarns do not give the same twist blockage when  $\beta = 0^\circ$ , but this occurred at  $\beta = -40^\circ$  approximately when the angle of wrap was  $90^\circ$  (Fig. 6.8), or at an angle of orientation more than  $70^\circ$  negative when the angle of wrap was  $120^\circ$  (Fig. 6.9).

Since any unsymmetricality must be associated with the yarn, it can only be assumed that the relatively small S singles of 16 t/m (measured) was exerting an exaggerated influence on the twist blockage behaviour, either because of its effect on the surface structure of the doubled yarn or, more probably, because of residual torque instability in the S on S yarn as compared with the Z on Z yarns. Nevertheless, when the angle of wrap  $\theta$  exceeds  $90^\circ$  the accurate setting of angle of  $\beta$  is difficult because the yarn has a tendency to roll on the guide which distorts the yarn path on the guide surface into a partially-crossed position where it is twisted around the horizontal plane in which the incoming and outgoing yarn path are contained. This situation, unfortunately, may give rise to a longer contact surface than the change in  $\beta$  would be expected to generate.

To show the percentage difference between the two characteristics of twist accumulation of S and Z twist, graph 6.10 was produced. The graph represents the same results of graph 6.8, as a percentage relationship between the twist before and after the guide against the  $\beta_S$  variation. This percentage difference is given by  $\frac{N_B - N_A}{N_A} \%$ , where

FIG. 6.10: The relationship between the variation of the angle of orientation and the percentage differences between twist before and after the guide surface for both S and Z twist

$N_0 = 50$  (t/m)  
 $T_1 = 80$  (gf)  
 $D = 0.4$  (cm).

\* Z twist

◇ S twist

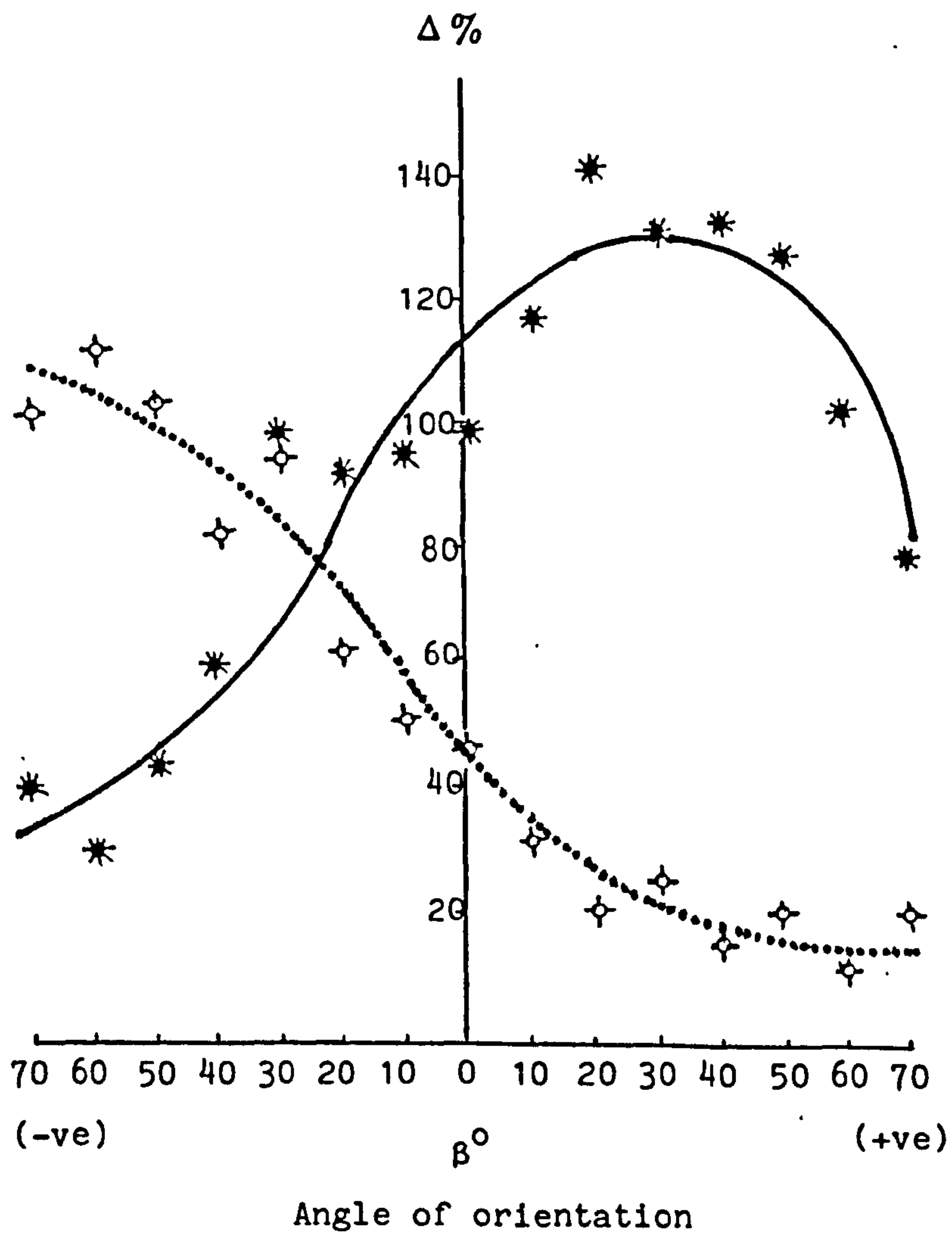

$N_B$  and  $N_A$  are the twist before and after the guide respectively.

Of course, the curves on this graph have a similar form to those of graph 6.8 although the point of intersection appears to be transferred from  $\beta = -40^\circ$  to  $\beta = -30^\circ$  approximately. Graph 6.8 shows a difference of 35 t/m twist gain between S and Z twist at  $\beta = 0^\circ$ , which is equivalent to a 52% difference as on graph 6.10.

### 6.3.1 Discussion

From the two previous experiments it can be concluded, in agreement with Hearle [56], that to a certain extent, the direction of the frictional force developed over the contact surface influences the twist blockage.

Unfortunately, the yarn surface/guide surface interaction is very complex, not only because of the unsymmetrical nature of the yarn surface due to twist, but also because the relative size of the surface roughnesses of the yarn and the guide, and the coefficients of friction associated with their interaction will considerably influence both the magnitude and direction of the resulting frictional force. Both of these will be very difficult to determine, but in order to completely confirm both Hearle's and the present assumption further work in this area is desirable.

It can be stated with certainty that, the drag of the yarn on a surface or vice-versa, will not be the same at all orientations to the yarn axis but will probably be different in a direction along the surface helices compared with that applying in a direction at right angles to the surface helices.

The need for greater understanding of the effect of frictional direction on the twist blockage phenomenon can not be stressed strongly enough. However, an examination of the data available in the literature suggests that the surface topography of the yarn determines the frictional direction behaviour [60]. However, as yet, no explicit reference has been found on the effect of friction force direction on twist blockage.

It has been generally recognised that both the flat ribbon-like shape of the yarn pulled over the curved surface of a guide or the change of the fibres or filaments orientation on the yarn surface due to twist may govern the mechanism of twist blockage.

In one investigation [96], in which the variation of the frictional force developed along a convoluted fibre surface was shown to be primarily responsible for determining their frictional behaviour, it was observed that the frictional force developed when a fibre was forced to slide over the edge of a probe was related to the angle of the surface convolutions or ridges and, therefore, to the frequency of ridges on the fibre surface. The undulations on the guide surface interlock with the surface convolutions of the fibres, thus contributing a higher frictional drag.

By analogy it is clear that the orientation of the fibres or filaments relative to the axis of a yarn can play an important part in cyclic changes in the value of the directional force and thus, in turn, affect the generation of twist blockage.

Since the twist blockage mechanism during yarn/guide contact tends to change as the surface topography of the yarn changes, it is



of interest to investigate different yarn surfaces generated by inserting different values of twist in the singles of the S or Z-twisted, doubled yarn.

#### 6.4 The effect of singles twist

In the investigation previously described (section 6.2.3) using a twistless singles in the two-fold polyester yarn, it was found that the twist blockage was relatively low, even though the pressure over the contact surface was quite high (440 gf/cm). This may be due to the relatively low (near zero) singles twist not providing the situation described above and, therefore, not generating a large twist-blocking torque. To investigate this, singles twist was increased to values of 203 and 570 t/m i.e. 830 and 2329 metric twist factor respectively.

Twisting of the singles polyester yarn was carried out on the two-for-one machine. Unfortunately during the subsequent doubling of the twisted singles yarn using the ring twister, some difficulty was experienced due to snarling of the singles. This occurred particularly at the higher twist of 570 t/m. This behaviour occurred when the path length of the singles yarn between the package and first guide of the machine was short. This length was extended by moving the supply package further away and also more tension was added to minimise the snarls.

It was also found to be difficult to carry out experimental work with this yarn on the twist blockage test apparatus. It was thus concluded that by setting the twist in the yarn, one might

facilitate the experimental work. In order to achieve this, the package of the doubled twisted yarn was steamed in an autoclave, thus reducing the effect of any residual torque inside the yarn. Steaming was carried out at 20 p.s.i. and  $120^{\circ}\text{C}$  for a period of 20 minutes. Although this overcame the snarling problems, it was found that the twist distribution along the yarn was very irregular and varied between 30 t/m and 70 t/m. It was decided therefore to set the twist before the process of doubling.

By doing this and by using a steel No. 6 (see section 4.2) traveller, one could achieve a very high twist regularity with no snarling in the twisting machine.

The twist blockage experiment was carried out at angle of wrap of  $30^{\circ}$  and initial tension of 80 gf.

The results are recorded in Table 6.4 and plotted in Fig. 6.11 together with those of the previous experiment (6.2.4) using low-twist singles. This graph shows the relationship between the twist gain and angle of orientation,  $\hat{\beta}$ , for the three levels of the twist inserted in the singles of the doubled yarn, zero twist, 203 and 570 t/m.

It can be seen that the effect of increasing the twist of the singles over this range is to increase the twist gain by up to four times. It was observed that the additional twist imparted to the singles increased its circularity, and as the twist of the singles of the doubled yarn was increased, the twist blockage increased. However, in all three cases the twisted singles yarn tends to show only a very small twist gain at  $\beta = 70^{\circ}$  positive.

TABLE 6.4

Doubled twist		50 t/m (ZZ)S		
Singles twist	zero	200 t/m	570 t/m	
$\beta$	N	N	N	
70	8.5	3.6	5.0	
60	8.0	13.5	16.3	
50	9.0	16.0	28.0	
40	7.0	23.4	40.3	
30	7.6	37.2	60.0	
20	10.5	40.3	79.5	
10	20.6	52.5	97.5	
0	20.4	52.5	95.6	
-10	26.0	61.0	110.3	
-20	29.5	65.0	104.0	
-30	39.5	72.0	119.0	
-40	47.0	78.0	105.3	
-50	40.0	63.4	91.0	
-60	54.0	46.0	73.0	
-70	45.0	24.4	51.6	

$\beta$  = angle of orientation (degrees)

N = twist gain (t/m)

FIG. 6.11: Doubled yarn: effect of angle of orientation on twist gain at different levels of singles twist

$T_1 = 80$  (gf)  
 $\theta = 30^\circ$   
 $D = 0.4$  (cm)

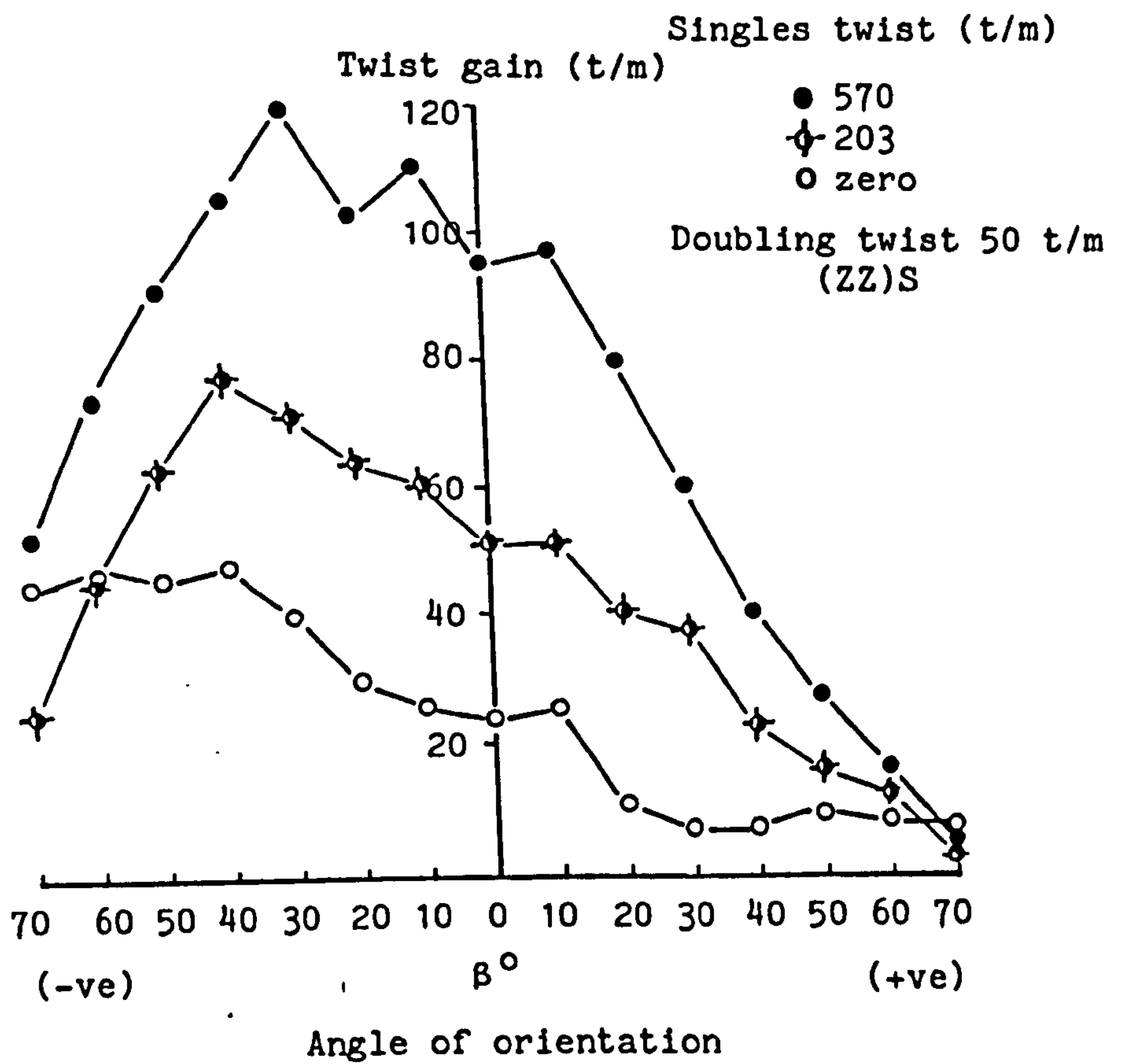

One significant point of interest concerned the manner in which the twist accumulated in front of the guide. As mentioned previously, the nature of the twist accumulation of the doubled yarn made from twistless singles was that, the twist accumulates in front of the guide surface with a steady leakage of congested twist. In contrast to this, the twist blockage behaviour of the doubled filament yarn made from twisted singles yarn was more like than of the previously studied spun acrylic yarn, in so far as the twist accumulation and leakage of twist were cyclic: a build-up of blocked twist being followed by a sudden loss past the guide, followed by a further build-up, and so on.

#### 6.4.1 Discussion

As the graph shows, all the yarns give little or no twist blockage at  $\hat{\beta} = +70^\circ$ . As  $\beta$  was decreased to zero, there was a gradual increase in twist blockage, the yarn with the highly twisted singles showing the greatest increase, its blocked twist being nearly four times as great as that of the yarn with zero-twist singles.

As the value of  $\beta$  was further decreased, the blockage continued to increase until  $\beta$  was between  $-35^\circ$  and  $-40^\circ$ . Beyond this point, the yarns with twisted singles showed a rapid decrease in blockage with further negative increase in  $\beta$ , whereas the yarn with zero-twist singles showed no further significant change in twist blockage.

It may be expected that the value of the frictional force would tend to decrease [90] as the singles twist in the yarn was increased and the yarn components consequently changed from a flattened

to a circular shape. The magnitude of the yarn surface friction also may vary due to the processing conditions such as twist, steaming or the direction of the twist insertion.

### 6.5 Effect of the relative surface direction of the singles relative to the yarn axis

The present experiment was designed to demonstrate the relationship between the twist blockage and the two different types of yarn surface topology resulting from S and Z twist at different angles of orientation.

The orientation of the undulations of the yarn surface, which will be twist dependent, will, in effect, determine the extent of actual yarn/guide contact and thus the frictional drag between the two.

Two singles yarns were twisted to 200 t/m Z using the two-for-one machine and doubled by the universal twister to give doubled yarns with 50 t/m Z twist and yarn 50 t/m S twist.

For simplicity, the first yarn will be designated by (ZZ)Z and the second by (ZZ)S, i.e. two singles Z with either Z or S doubling twist.

Other experimental conditions were the same as in the previous experiment.

#### 6.5.1 Results and discussion

The results are recorded in Table 6.5 whilst Fig. 6.12 shows the relationship between the angle of orientation,  $\beta$ , and the twist gain N for the samples (ZZ)Z and (ZZ)S.

TABLE 6.5

Plied twist	50 t/m	
	Twist direction	
	(ZZ)S	(ZZ)Z
$\beta^\circ$	N	N
70	3.6	52.0
60	13.5	88.0
50	16.0	97.0
40	23.4	102.0
30	37.0	87.5
20	40.0	99.4
10	52.5	101.0
0	52.5	110.6
-10	61.0	83.0
-20	65.0	92.0
-30	72.0	76.0
-40	78.9	57.0
-50	63.4	50.0
-60	46.0	29.4
-70	24.4	16.0

$\beta$  = angle of orientation (degrees)

N = twist gain (t/m)

(ZZ)S }  
 (ZZ)Z } twist direction

FIG. 6.12: The relationship between the twist gain and  $\beta$  factor for yarns with (ZZ)Z and (ZZ)S twist

$$N_0 = 50 \text{ (t/m)}$$

$$T_i = 80 \text{ (gf)}$$

$$\theta = 30^\circ$$

$$D = 0.4 \text{ (cm)}$$

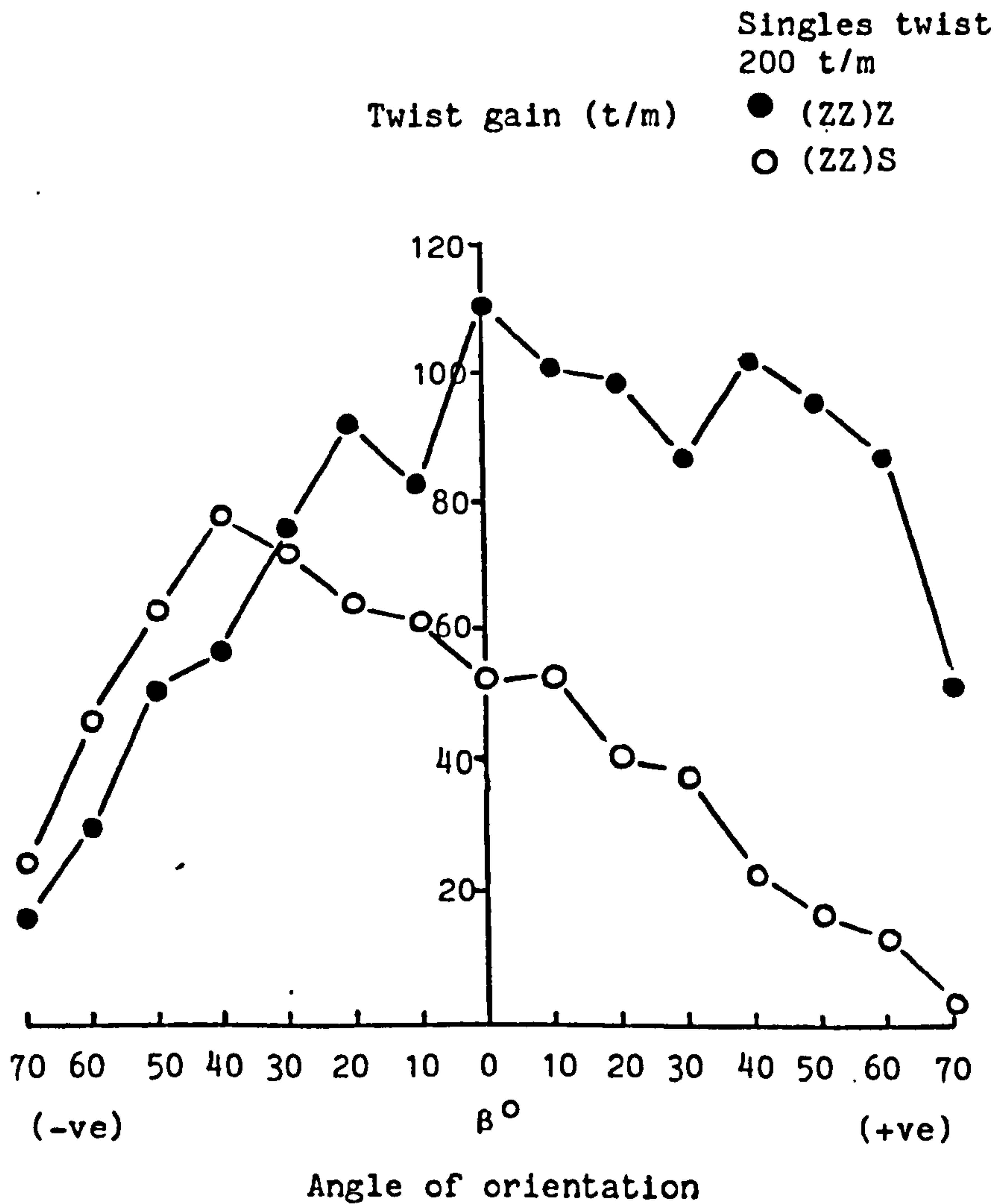



The magnitude of the differences of the twist blockage between the two samples is considerably greater than one would might have anticipated as a result of simply reversing the yarn twist direction.

As observed in the previous experiments, when the yarn moves over the contact surface with an angle of orientation nearly equal to the doubled yarn helix angle, the twist accumulation in front of the contact surface is very small.

Although the behaviour of the twist blockage (ZZ)Z yarn resulting from the variation of the angle of orientation is, to some extent, symmetrical with that of (ZZ)S yarn, it is also observed that the contribution of twist gain for (ZZ)Z at  $\beta = 0$  is twice that of the (ZZ)S.

It has been established that the twist in doubled yarns, to some degree, influences the singles twist. A doubled yarn obtained by twisting singles of the same twist direction (i.e. Z on ZZ or S on SS) will have a higher torque than a doubled yarn of the same level of twist obtained by using a doubling twist of the opposite direction (i.e. Z on SS or S on ZZ). Therefore, the latter should accept more twist (or twist accumulation) than the former which is in conflict with the experimental results.

On the other hand, an increase in twist due to twist blockage in, for example, a (ZZ)Z yarn, would tend to increase the coherence of the singles, whereas in a (ZZ)S the decrease in singles twist would loosen the single components and perhaps reduce the twist blocking tendency.

As expected from experiment 6.3, the twist blockage (ZZ)Z tends to increase positively with increase of the angle of orientation. However, in the present experiment, a significant difference within the region  $\beta = 0^\circ$  up to  $\beta \approx +30^\circ$  is found. The corresponding twist blockage for this region tends to decrease in comparison with the same region for the (ZZ)S yarn, hence the (ZZ)Z started to show some flattening of the curve, perhaps as a result of sustaining the higher value of the twist blockage. Figure 6.13, in which the Z twist curve has been reversed, shows clearly the differences between the behaviour of the two yarns.

## 6.6 Conclusions

Previous work on twist blockage has examined the effect of mechanical parameters including the influence of axial tension and compression, bending behaviour etc. and surface properties, such as roughness, friction and resistance to stress concentration.

Unfortunately, adequate data on the relation between twist blockage and surface structure of twisted yarns is not available in the published literature.

Any comparison with the data obtained from these other publications is not always justified as in the present study, a different range of parameters has been considered.

In this respect, it is difficult to favour any particular previously described mechanism that may be held responsible for the observed increase in twist blockage resulting from different configurations of yarn cross-section derived as a consequence of different ranges of singles twist.

FIG. 6.13: Relationship between twist gain and  $\beta$  factor for yarns with (ZZ)Z and (ZZ)S twist.  
 [The  $\beta$  scale for the (ZZ)Z curve is reversed]

$$N_0 = 50 \text{ (t/m)}$$

$$T_1 = 80 \text{ (gf)}$$

$$\theta = 30^\circ$$

$$D = 0.4 \text{ (cm)}$$

● (ZZ)Z

○ (ZZ)S

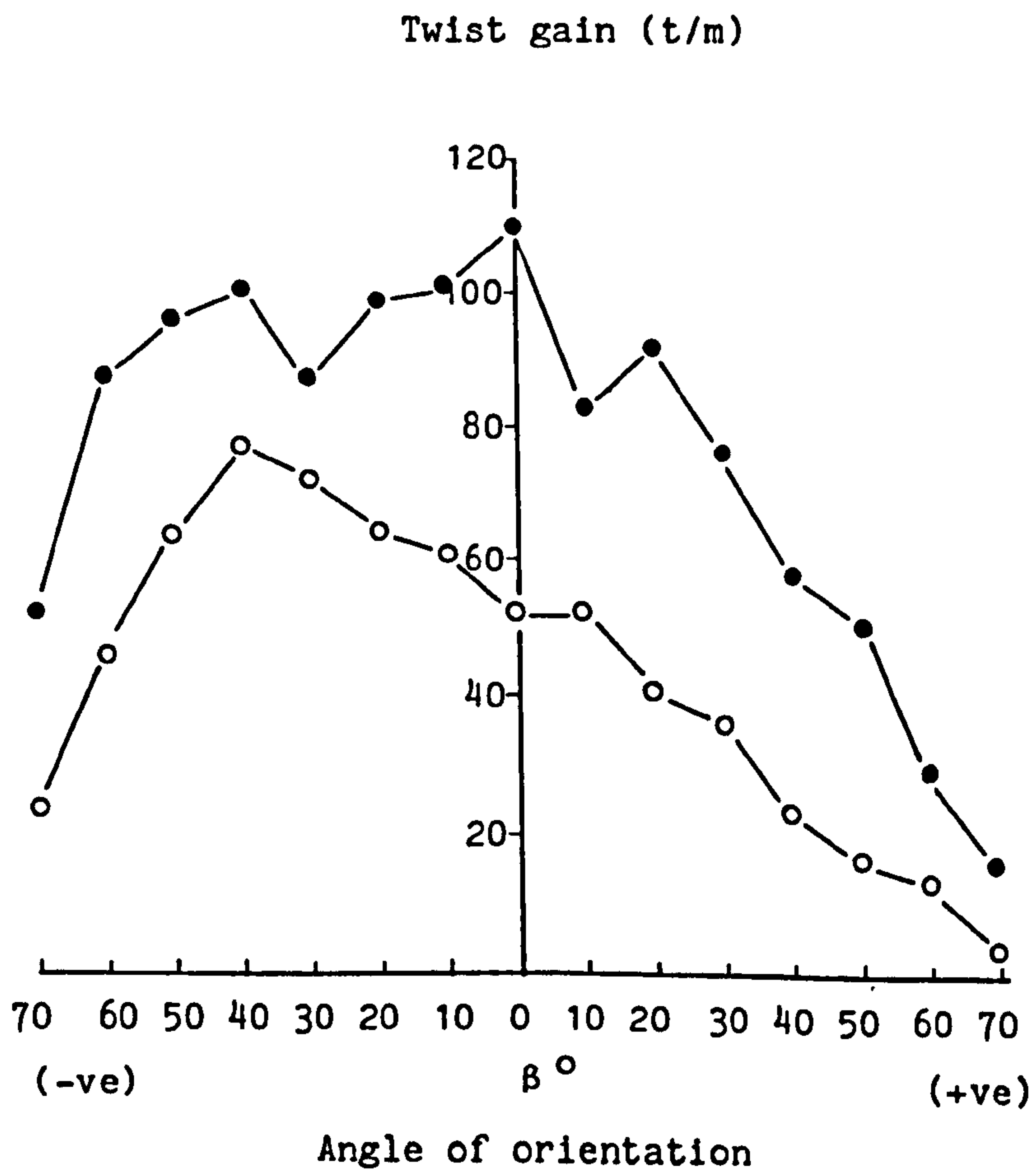

At zero angle of orientation, it can be said that, since the singles yarn configuration changes from semi-elliptical to circular as the twist is increased, there could be a significant reduction in the magnitude of the internal frictional force over the contact region. This is associated with the behaviour changing from one of lateral movement of the filament layers to one of rotation of the yarn as a whole. Yarn rotation occurs both over and before the contact region, but it is more easily observed when the singles twist is high as the components of the yarn are then more easily distinguished. As discussed elsewhere (section 6.12. ) it may be possible for the yarn not to rotate over most of the contact area, this is more likely to occur when the singles bundles are more compact.

Increase in the singles twist tends to cause an increase in the torque generation over the contact region and to force the yarn to rotate, the twist blockage consequently increases. This occurs especially with a higher twist singles and a lower twist of the plied yarn.

#### 6.6.1 Mechanical interpretation

When the twistless singles yarn first contacts the guide surface, it would collapse to a ribbon shape and a lateral movement of the twistless singles within the yarn over the contact region occurs. In other words, the surface layer of the filaments in contact with the guide changes frequently as the bundle rotates. The subsequent relative positions of the two filament components as the ribbon rotates are drawn diagrammatically step by step at A,B,C,D

FIG. 6.15: Lateral movement of flat singles components in a doubled yarn

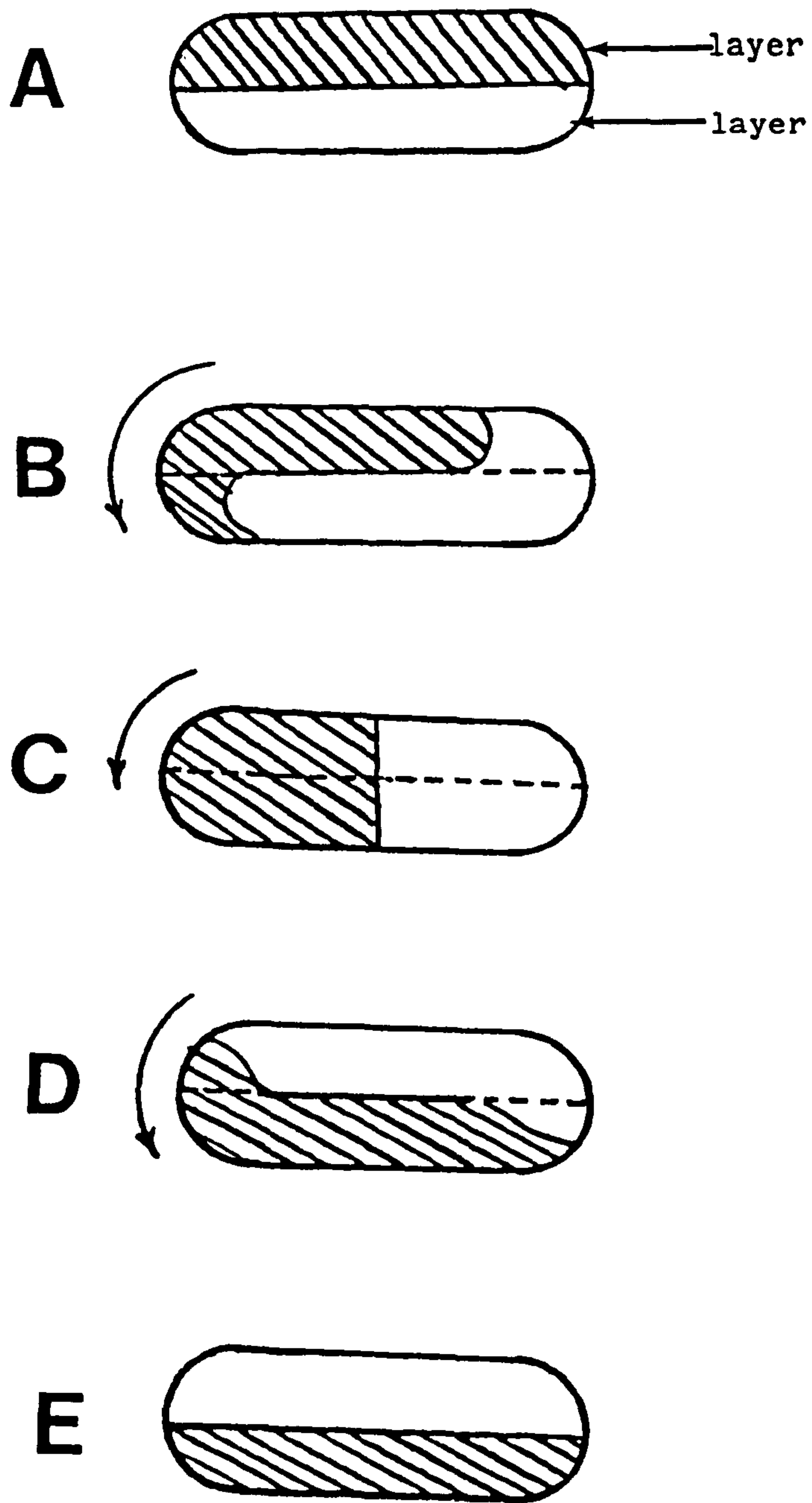

and E respectively in Fig. 6.15. In the twisted-singles doubled yarn (especially for low doubling twist), the singles initially lie side-by-side in the yarn during its passage over the contact region, accumulating the twist, whilst the yarn is rotating in front of the guide.

Baird et al [2] stated that the application of twist may decrease the area of contact but, at the same time, the interlocking of the irregularities of the guide surface with the undulations of the multifilament yarn surface may be the predominant factor.

In this event, the twist blockage behaviour may depend originally on the filament inclination relative to the singles axis and in turn relative to both the yarn axis and the guide axis.

With flat yarn (zero twist-singles) the filaments in the singles are parallel to each other, whereas in the twisted-singles the filaments are inclined with a helix angle corresponding to the twist insertion. The higher the singles twist, therefore, the more inclined the filament helices. As a corollary to this deduction, the number of transverse ridges on the surface structure of the doubled yarn increases as the twist of the singles increases provided the single and doubling twist are in the same direction or the singles twist is much greater than the doubling twist.

The conclusion which also can be reached as a consequence of the above explanation and the experimental work is that the relative increase of the twist accumulation with singles twist (Fig. 6.11) at  $\beta = 0^\circ$ , may be influenced by both the inclination of the singles yarn

to the axis of the doubled yarn and the inclination of the filaments in the singles yarn relative to the axis of the singles yarn. These two helix angles will in turn influence the twist blockage behaviour associated with the relative angular position of the yarn guide axis, i.e. the angles, at the point of contact, between the surface filaments and the line of contact on the guide.

Eventually, as the angle of the guide is increased until the angle of orientation is nearly equal to the helix angle of the doubled yarn, the effect of the helical orientation of both the yarn components and the filaments within the yarn will be a minimum and the blocking torque reduces to approach zero, as shown in Fig. 6.11 at  $\beta = +70^\circ$ .

A further factor which might influence twist blockage is the variation of the singles diameters due to twist insertion. The variation of diameter is, however, very small and is therefore, not expected to influence the twist blockage significantly, at least in the present experiments.

However, it is also necessary to consider whether these suggested mechanisms can explain the unsymmetrical behaviour for the three different yarn structures.

At this point it is relevant to return to the interesting observation concerning the different twist blockage of the (ZZ)Z and (ZZ)S yarns.

Stable or torque free yarn, may be achieved by stress relaxation or setting treatments. A balanced structure is also commonly produced by plying two or more singles yarns together

in the opposite direction to the initial yarn twist, until torsional stresses are reduced to zero, i.e. by using such structures as (ZZ)S yarn. Obviously the insertion of the same continuous unidirectional twist as that of the singles component into a doubled yarn (i.e. structure such as (ZZ)Z yarn), generates a higher torsional stress, and has a considerable effect on the stability and the mechanical performance of the yarn.

It would be expected that the combined twist directions and associated yarn properties would influence significantly the characteristic twist blockage behaviour.

Originally, it was expected that the balanced yarn would accept more twist in the doubling directions at the same level of torque. However, it was surprisingly found that the (ZZ)Z yarn showed a higher acceptance of twist in the twist blockage situation. This different behaviour may, therefore, depend on not only the torsional properties, but also on the surface structure of the two yarns.

It is clear that the twist blockage process will continue until the torque required for further twisting becomes greater than the torque generated as a result of the geometrical configuration at the yarn/guide surface. It was observed that a high twist variation could occur in some circumstances as the twist in the supply yarn was somewhat irregular even though the yarn may be subjected to a constant torque during its passage over the contact region. As a consequence, twist was found to be blocked and generated in the portion of the lower twist whilst in the more highly twisted portions, the original twist moved forward with the yarn.



One could observe, therefore, two types of twist movement in front of the guide, one a backward propagation with lower twist regions and the other a forward movement with the yarn movement in regions where the twist was high.

Thus, on the basis of the ability of the yarn to accept twist, it was expected that the (ZZ)Z yarn would give a lower twist blockage, but in fact a higher blockage was observed. It can only be concluded that, because of the different interface characteristics of the two yarns, the torque generated by the surface contact of (ZZ)Z is greater than that of the (ZZ)S by an amount which overcomes the greater twist-resisting torque generated in the (ZZ)Z.

#### 6.7 Effect of the single's twist with the same and opposite doubling twists

To try to confirm the above suggestion and to provide more complete experimental evidence concerning the symmetry behaviour, it was decided to carry out further experiments with oppositely twisted yarns.

Two singles were twisted in the S and Z directions. To obtain additional information, 300 t/m was selected instead of the previous 200 t/m for the singles twist. The two singles were doubled at 54 t/m (measured) in the (SS)S, (ZZ)Z, (SS)Z and (ZZ)S configuration. The method for producing these yarns was the same as discussed for the previous experiments. It was hoped to verify that the yarn will behave symmetrically and the same but opposite magnitude of twist blockage would occur under the influence of the yarn orientation

over the contact region, when the twist directions were reversed.

#### 6.7.1 Results for (ZZ)Z and (SS)S yarns

Table 6.6 shows the relationship between the angle of orientation and the twist gain for the (ZZ)Z and (SS)S yarns respectively.

Graph 6.16 shows the effect of  $\beta$  on the twist gain for the (ZZ)Z and (SS)S yarns. Overall, the graph appears fairly symmetrical about the N axis, but there is some deviation.

To test the symmetry one of the curves has been reversed in Fig. 6.17 which confirms that the behaviour is reasonably symmetrical. Furthermore, it is possible to compare these results with the results shown previously in Fig. 6.12 which indicate a much greater difference between the (ZZ)Z and (ZZ)S than between the (ZZ)S and (SS)S of the present experiments. It should be remembered, however, that the singles twist of Fig. 6.12 was 200 t/m instead of 300 t/m.

Because of the expected lower torque resistance of (SS)Z and (ZZ)S yarns, it was expected that their twist blockage would be greater. The opposite effect had, in fact, been observed previously.

In order to give a complete picture of the influence of singles and doubling twist, yarns with a (ZZ)S structure and (SS)Z structure were tested, the twist levels being the same as those of the (SS)S and (ZZ)Z yarns of the previous experiment i.e. 300 t/m singles, 54 t/m doubled.

TABLE 6.6

Doubled twist		54 t/m			
Single twist		300 t/m			
Angle of orientation	Twist gain (t/m)				
	(ZZ)Z	(SS)S	(ZZ)S	(SS)Z	
70	58.0	15.0	1.3	55.6	
60	57.0	20.0	16.0	77.0	
50	88.4	27.0	23.4	86.0	
40	100.0	47.5	34.0	94.4	
30	99.0	54.0	56.6	110.0	
20	96.0	67.5	66.4	110.0	
10	99.0	73.0	79.4	113.0	
0	97.5	83.0	81.6	85.0	
-10	94.4	84.4	99.0	77.0	
-20	74.4	92.0	105.0	75.0	
-30	66.0	83.4	87.0	65.0	
-40	56.0	80.0	105.6	51.0	
-50	47.5	92.0	86.0	38.0	
-60	26.0	64.4	75.0	23.0	
-70	14.0	51.0	63.0	7.5	

(ZZ)Z, (SS)S, (ZZ)S and (SS)Z = twist direction of (singles) and doubled structure

FIG. 6.16: Effect of angle of orientation on twist gain at (SS)S and (ZZ)Z yarn twist direction for positive and negative angle  $\beta$

$N_0 = 54$  (t/m)  
 $T_1 = 80$  (gf)  
 $\theta = 30^\circ$

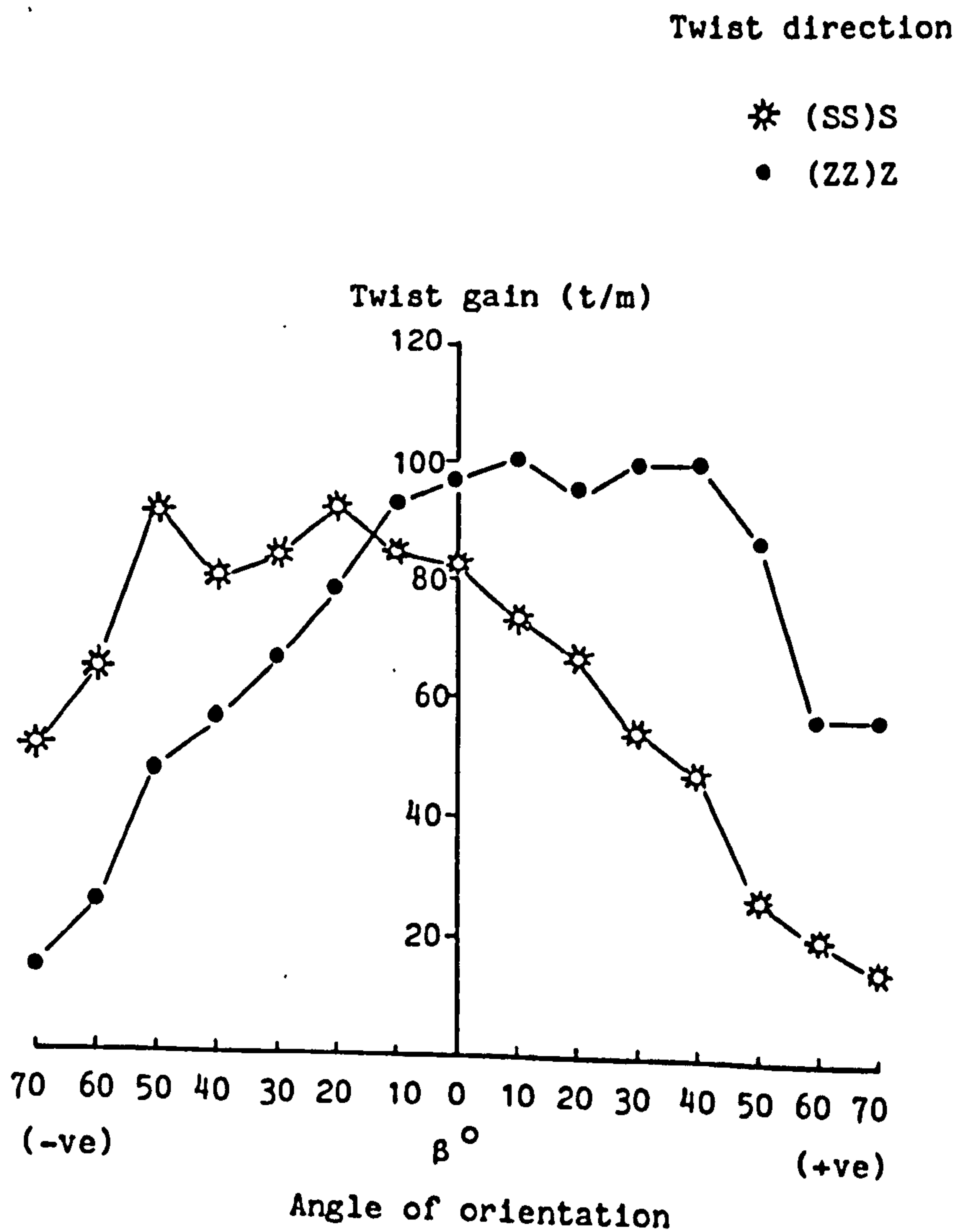
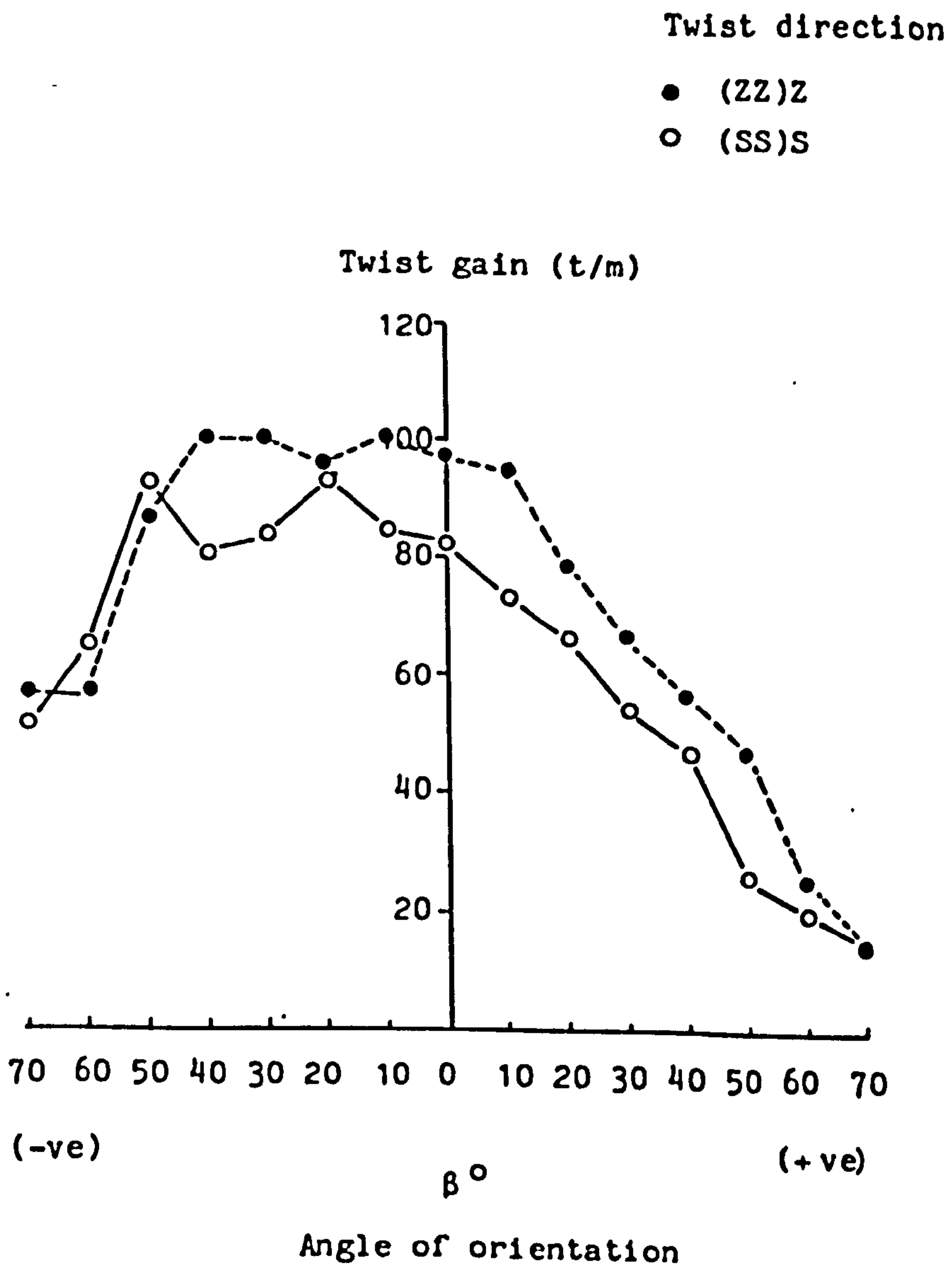

FIG. 6.17: Effect of positive and negative angles of orientation on twist gain for (SS)S and (ZZ)Z yarn twist direction. The (ZZ)Z is inversely plotted

$$N_o = 54 \text{ (t/m)}$$

$$T_1 = 80 \text{ (gf)}$$

$$\theta = 30^\circ$$



### 6.7.2 Results for (SS)Z and (ZZ)S yarns

The results are tabulated in Table 6.6 and illustrated in graph 6.18. This shows a great agreement with the conclusion which has been reached earlier that any two yarns of opposite twists will behave symmetrically. It is further to be expected that the doubled yarn twist blockage behaviour might be influenced by the filaments inclination relative to the singles axis.

### 6.7.3 Discussion

A comparison between the various results indicates that the unidirectionally twisted and doubled structures (ZZ)Z or (SS)S do not reach zero twist blockage at  $\beta = 70^\circ$  whilst those with singles twist opposite to the doubling twist (ZZ)S or (SS)Z do generate zero blockage at this angle of orientation. The blockage in the former case is not large, however, and may not be significant.

Referring to Fig. 6.18, the twist blockage decreases to zero as  $\beta$ , the angle of orientation, increases positively for the yarn (ZZ)S whilst for the (SS)Z yarn, it decreases to zero as  $\beta$  increases negatively. On the other hand, as  $\beta$  increases positively, twist blockage for the (SS)Z falls to approximately 40% of the maximum at  $\beta = 70^\circ$ , the (ZZ)S yarn again showing a symmetrical behaviour. The close symmetry for these structures which appears better than that for the (SS)S and (ZZ)Z yarns, may be related to the stability of the yarn structure.

Figure 6.19 illustrates the same results except the data for the (SS)Z yarn has been reversed. It is clearly demonstrated

FIG. 6.18: Effect of positive and negative angle of orientation on twist gain for (ZZ)S and (SS)S yarn twist direction

$N_0 = 54$  (t/m)  
 $T_1 = 80$  (gf)  
 $\theta = 30^\circ$

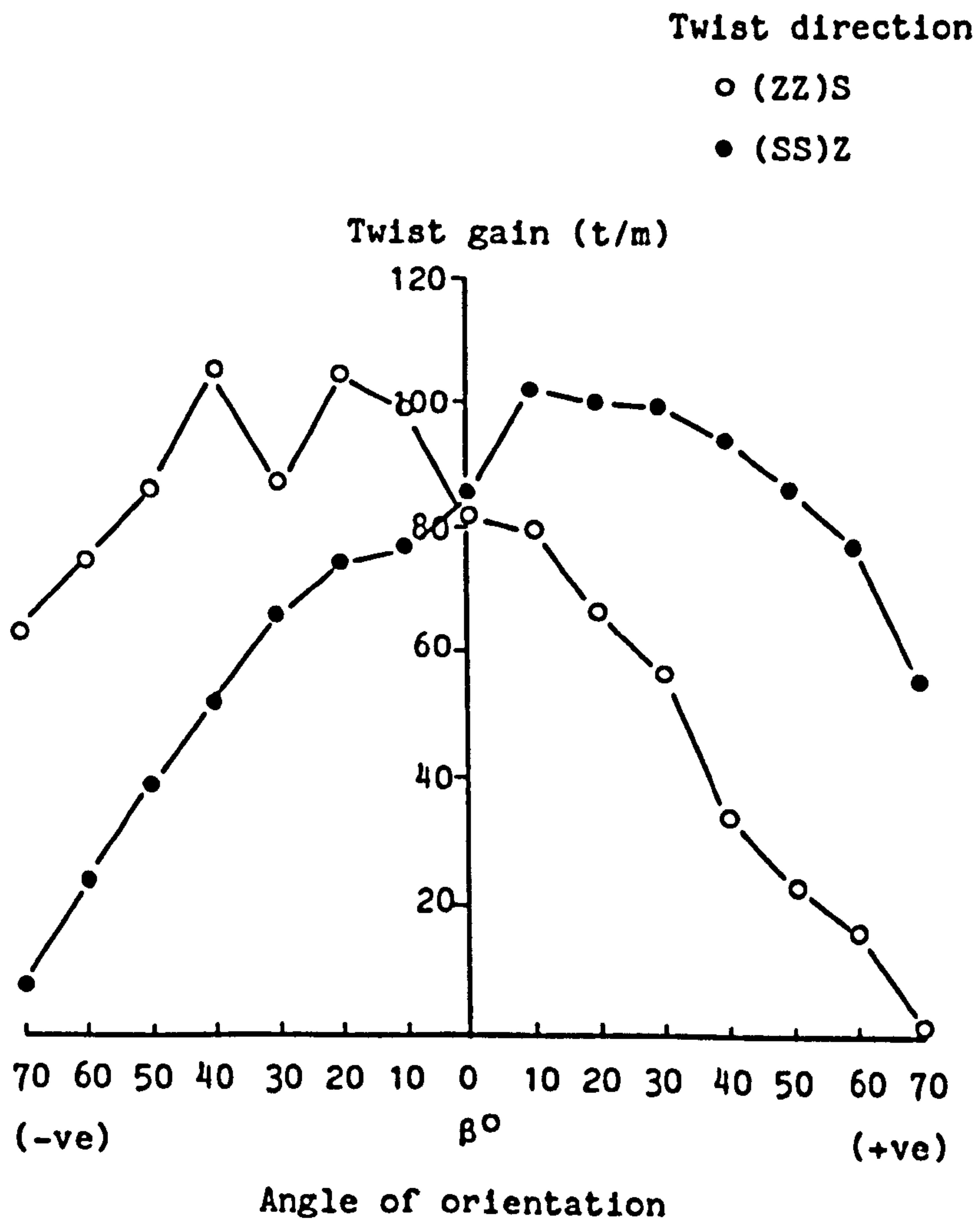
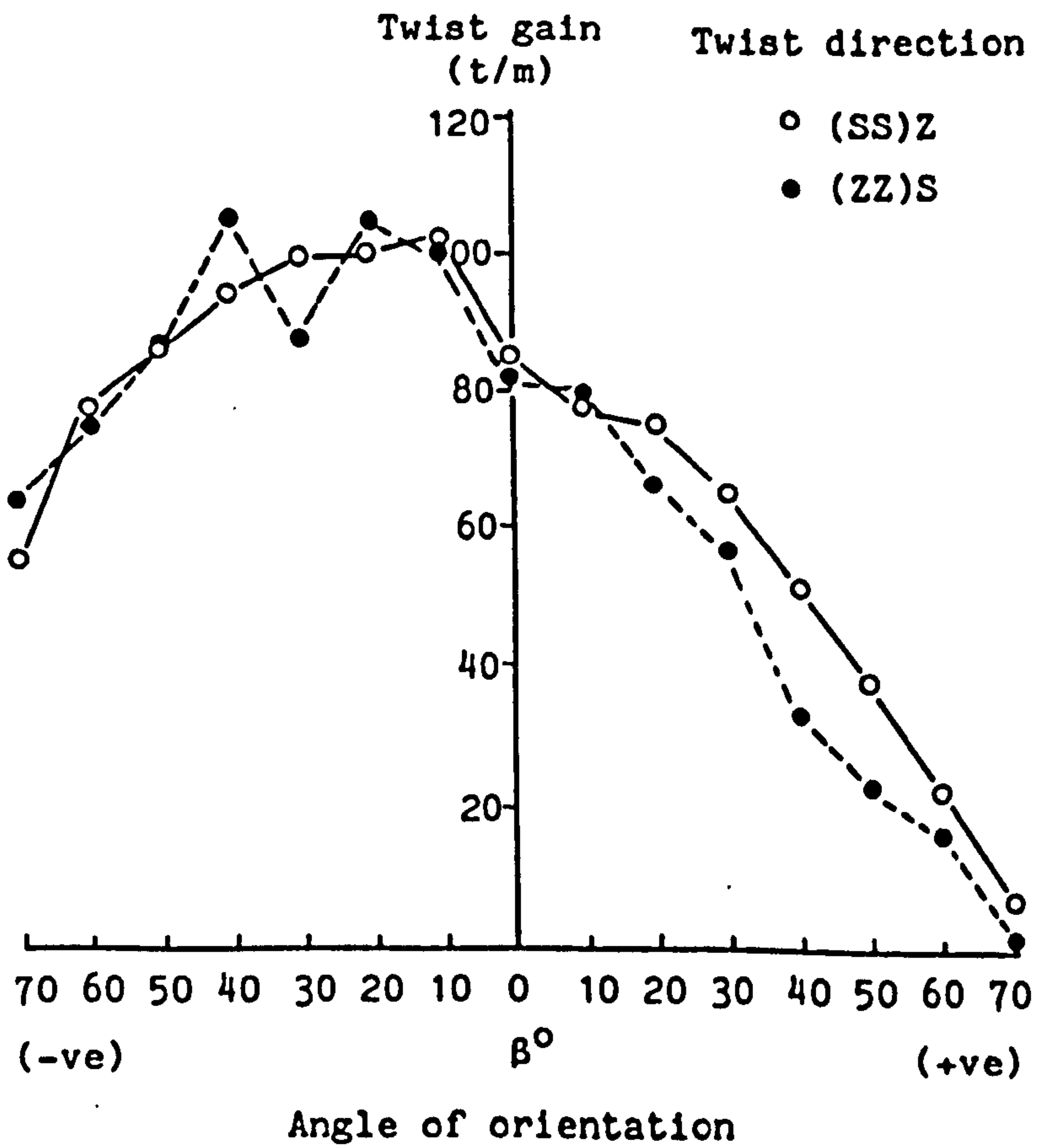

FIG. 6.19: Effect of angle of orientation on twist gain for (ZZ)S and (SS)Z yarn twist direction. The (SS)Z is inversely plotted





in this graph that the two behaviours are closely symmetrical.

A comparison of all these results indicates that it is the doubling twist which has the major influence on the twist blockage  $\beta$  curves, but in order to try to accentuate the differences between the blockage figures for the yarns with the same singles and doubling twist and those with opposite singles and doubling twist, Table 6.7 and Fig. 6.20 illustrate the mean value of the twist gain  $N$  for the two doubled structures [(ZZ)Z and (SS)S] and [(ZZ)S and (SS)Z].

The graph demonstrates, taking account of the symmetrical reversals, that there is no significant difference between the two sets of results. In both cases, the twist gain decreases linearly as  $\beta$  increases in one direction, but for the other direction, the relations seem to be slightly different. As  $\beta$  increases, there is a small increase in twist blockage up to a maximum at  $\beta = -25^\circ$ . It then drops about 60% of the peak value at  $\beta = -70^\circ$ .

In general it may be concluded that the singles twist direction has had little or no influence on the blockage.

## 6.8 Conclusions

Generally speaking, the influence of the angle of orientation on twist blockage behaviour for both of the two directions of the yarn twist remains unchanged (i.e. twist blockage decreased as  $\beta$  increased positively).

When the yarn moves over the contact region with  $\beta > 0$ , the torque generating mechanism may change or the direction of the frictional force may change relative to the yarn axis, and, therefore,

TABLE 6.7

Angle of orientation $\beta$	Mean value of twist gain N	
	(ZZ)S and (SS)Z	(ZZ)Z and (SS)S
70	4.4	54.4
60	20.0	61.0
50	37.4	90.0
40	42.0	90.0
30	61.0	92.0
20	70.5	93.6
10	78.0	92.0
0	83.0	90.0
-10	106.0	84.0
-20	107.5	73.0
-30	98.4	60.0
-40	100.0	52.0
-50	86.0	37.0
-60	76.0	22.5
-70	59.0	14.5

(ZZ)Z  
 (SS)Z  
 (ZZ)S  
 (SS)S

Yarn twist direction

FIG. 6.20: The relation between angle of orientation and the mean value of (ZZ)Z and (SS)S and (ZZ)S and (SS)Z twist gain

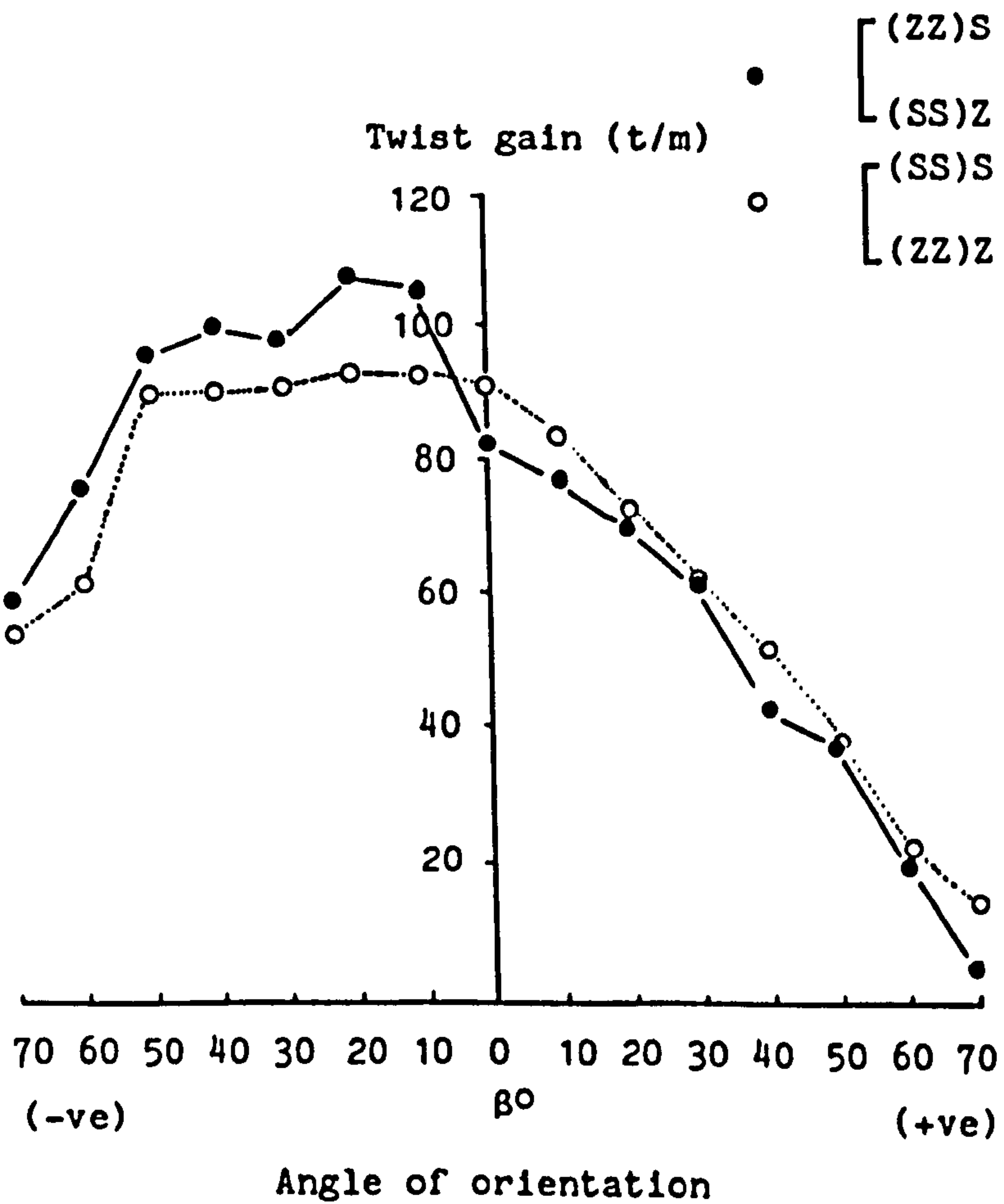

the perpendicular component may change too.

To a certain extent, if a flat-singles doubled yarn is considered as one singles yarn twisted to a fairly low twist (e.g. 50 t/m), the filaments will act as an array parallel to the axis of the yarn. This type of twist yarn was shown to generate a low twist blockage in comparison with the twisted-singles doubled structure.

Because of the greater rigidity of the cross-section of the latter or because of the greater inclination of the filaments relative to the singles axis, the twist blockage behaviour may depend on both the singles and doubled twist level.

#### 6.9 Twist blockage mechanism in terms of the angle of orientation

Section 6.2.4.3 has already briefly discussed this subject which will now be considered in greater detail.

In order to try to explain satisfactorily the mechanism of the behaviour of twisted yarns over the contact region under the influence of the angle of orientation. It is advantageous to consider three positions of the 'edge' of the guide relative to one turn of twist in the yarn for the cases of S and Z twist direction as follows:

When the yarn lies at an angle to the guide axis other than  $90^\circ$  ( $\beta = 0^\circ$ ) the interaction of the yarn surface geometry with the guide surface will be different depending on whether the angle of orientation,  $\beta$ , is positive or negative, Fig. 6.21 attempts to illustrate this. In each case, the line  $G_0$  represents the edge of the guide

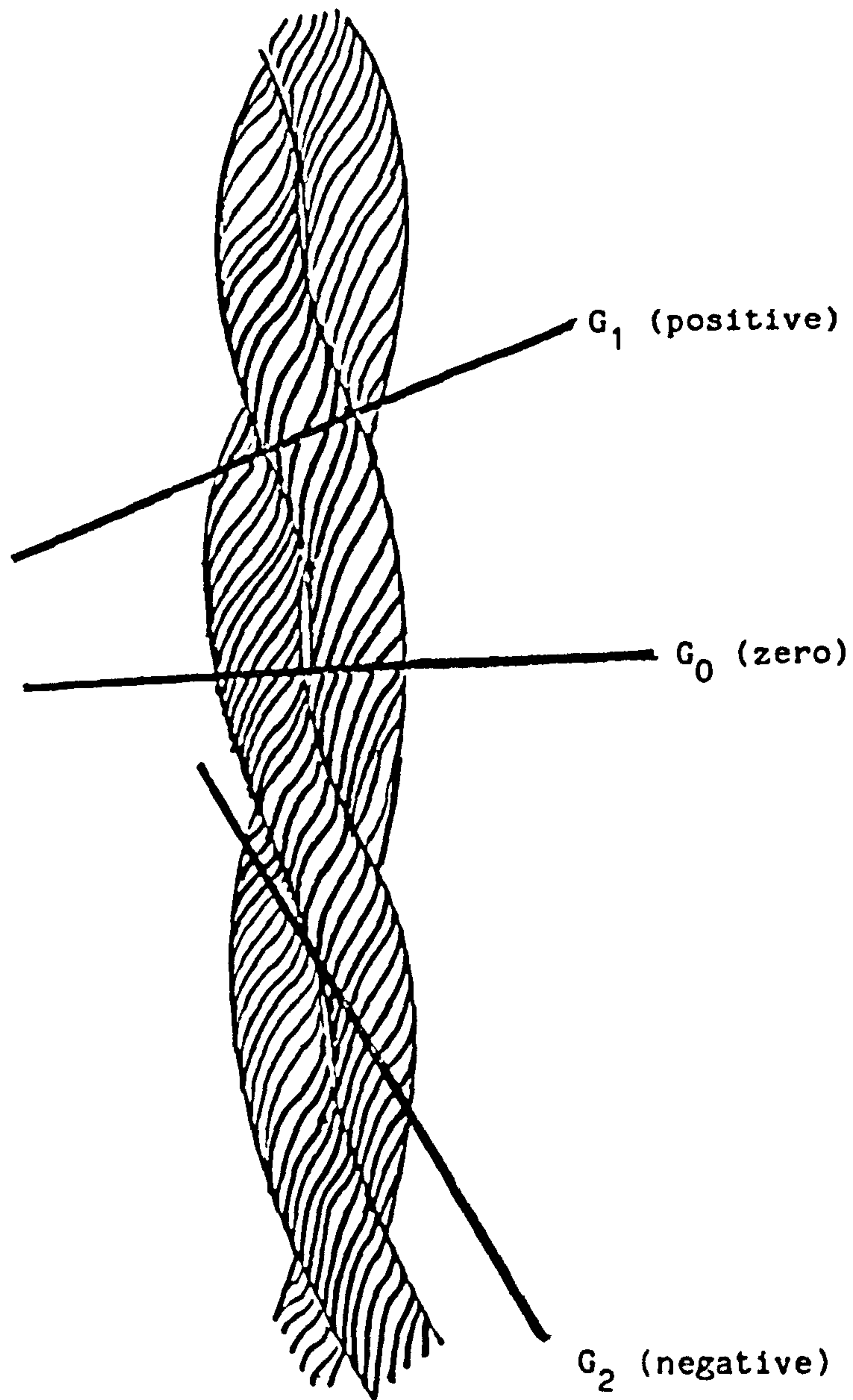

FIG. 6.21: Interaction of the yarn surface geometry with the guide generator for positive and negative angles of orientation

surface,  $G_1$  and  $G_2$  are two successive positions of this edge relative to the axis of the yarn. In the case of  $G_2$ , the guide edge can lie in the valley formed between the twisted singles components of the doubled yarn whereas in the case of  $G_1$ , the guide edge lies on the peaks of the doubled structure. A greater twist blockage torque is therefore likely to be generated in the former case (i.e.  $G_2$ ). This illustrates why the twist blockage observed in Fig. 6.8 is seen to be nonsymmetrical about  $\beta = 0^\circ$ , but to increase when  $\beta$  is negative and decrease when  $\beta$  is positive; the twist in the yarn is more likely to be pushed back in the former case. When  $\beta$  is large and positive, a situation may exist where the yarn is almost always supported on the guide by the peaks of one or other of the singles components. In these circumstances, the torque will be a minimum and the twist blockage will be very small. In the example shown, this occurs at about  $\beta = 70^\circ$ .

It thus may be postulated that the undulation of the twist on the surface of the doubled structure yarns acts as a series of ridges. When the ridges interlock with the edge of the guide (as  $G_2$ ), motion of the yarn surface over the contact surface would be strongly resisted, since it would involve deformation of these ridges or lifting the yarn over the intersecting edge. In order to overcome this effect the guide must try to push the yarn ridges back. This is also true when the edge of the guide is perpendicular to the yarn axis (position  $G_0$ ). On the other hand, when the edge of the guide is more perpendicular to the axis of the singles component on the surface, there is less opposition to yarn movement and, therefore, less

obstruction of twist and twist will transfer over the guide edge without accumulation (as  $G_1$ ).

The above mechanism verifies the effect of increase in  $\beta$  positive. As seen from the experimental results, a low level of blockage can be achieved by a large  $\beta$  negative. This may occur when the angle of orientation of the yarn to the guide is such that this approaches the helix angle of the singles in the doubled yarn. The yarn is, therefore, supported along significant lengths of its singles.

This suggested mechanism, although supported by the earlier experiments, requires further experimental confirmation. It was suggested, however, that the surface structure of the continuous filament yarn played a significant role in determining the characteristic twist blockage behaviour.

It is useful to compare these results with results obtained using a spun yarn such as the yarn used in the preliminary experiments (i.e. acrylic yarn 30 tex worsted, Chapter 5).

A comparison of observations gained from these two very different types of yarn should be useful in predicting the level of twist blockage and in improving process control where twist blockage may be a problem.

#### 6.10 Comparison of twist blockage behaviour of spun staple and continuous filament yarn

The previous experiments on the effects of the single yarn twist demonstrated that the twist blockage behaviour considerably depends

on the degree of flatness of the yarn cross-section. Similarly, it is expected that the nature of the surface topography of the yarn due to the type of processing and/or material, may also have its own effect. Such a difference, however, would be found between a spun and a continuous filament yarn. The latter is also likely to develop a higher friction than the equivalent spun yarn.

The following experiment was intended to test the effect of the difference between continuous filament and spun yarns on the twist blockage phenomenon.

#### 6.10.1 Effect of singles twist factor

Some evidence of the effect of singles twist can be obtained by comparing a doubled yarn made from the twistless singles textured polyester with the doubled acrylic spun yarn. The doubling twist factor of the polyester being roughly the same as that of the acrylic.

Table 6.8 lists the results, and it shows the ratio of the twist gain  $N$  to the nominal twist inserted in the yarn,  $N_0$ , against the angle of orientation  $\beta$  for both acrylic and polyester yarn.

Figure 6.22 illustrates this relation, and it shows, generally, a considerable reduction in the level of corresponding twist blockage values while the behaviour with regard to the effect of  $\beta$  shows the previous general pattern, i.e. the twist blockage increases as  $\beta$  decreases from  $\beta = +70^\circ$  up to  $\beta = 0^\circ$ . On the other hand, as  $\beta$  increases, the blockage takes a constant value up to  $\beta$  equal  $-50^\circ$  and then there is a large reduction up to  $\beta = -70^\circ$ .

The twist blockage differences between the twisted singles spun yarn, the twisted singles polyester yarn, and the flat-singles polyester yarn (about 66% at  $\beta = 0^\circ$ ) indicates again that the most



TABLE 6.8

Twist factor (metric)	355.7	
Twist ratio	$N/N_o$	
Angle of orientation $\beta$	Type of yarn	
	Acrylic ST	Polyester CF
70	0.07	0.00
60	0.15	0.04
50	0.26	0.28
40	0.36	0.50
30	0.42	0.79
20	0.53	1.10
10	0.57	1.54
0	0.64	1.74
-10	0.78	1.60
-20	0.79	1.71
-30	0.86	1.61
-40	0.84	1.56
-50	0.83	1.57
-60	0.65	1.57
-70	0.24	0.97

$N$  = twist gain (t/m)

$N_o$  = nominal twist (t/m)

ST = spun stable yarn

CF = continuous filament yarn

FIG. 6.22: Effect of angle of orientation on the ratio of twist gain and nominal twist for acrylic and polyester yarns at the same plied twist factor

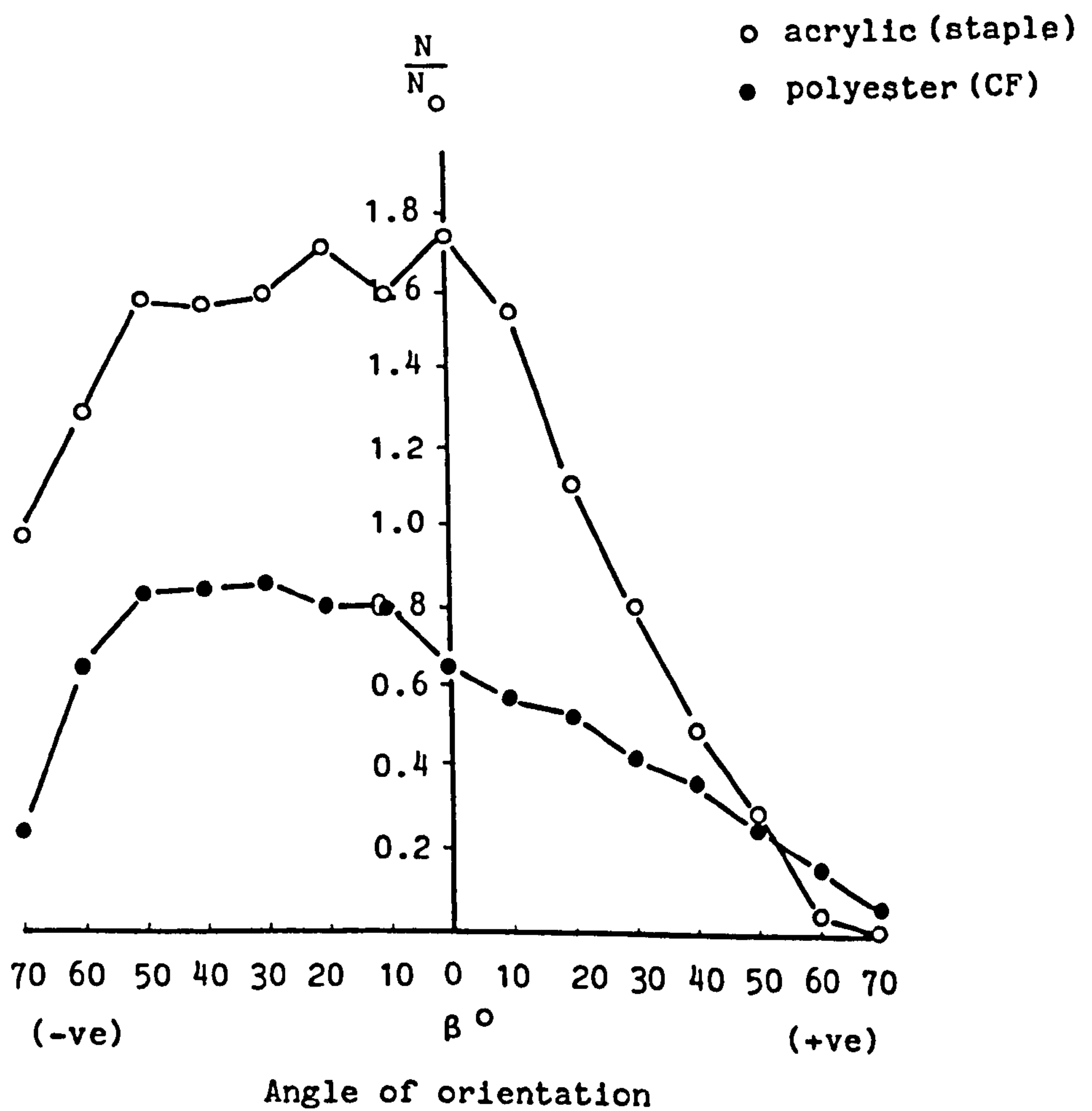

effective parameter influencing the twist blockage in addition to the doubling helix angle is the singles twist through its effect on the degree of circularity of the singles yarn.

This conclusion is supported by the previous experiments in which the singles twist was varied, described in section 6.4. Obviously the singles twist has a major influence on the capability of the yarn to form a cross-section that behaves as one bundle of fibres or filaments as compared with two separate bundles, as in a doubled yarn with high singles twist.

#### 6.10.2 Effect of plied twist factor

In order to make the comparison as close as possible, the two types of yarn already examined using the same singles twist factors were now doubled with the same twist factor in doubling. As previously, the continuous filament yarn was a 16.7 tex textured polyester and the spun yarn was a 30 tex acrylic. To attain the same twist factor, 50 t/m and 63 t/m (the measured twist was found to be 65 t/m) were added to the acrylic and polyester yarn respectively in the doubling process.

During the doubling and twisting, twist variation occurred with both yarns, particularly at low twist. The same precautionary steps were taken, therefore, as when processing the previous textured polyester yarn. Twist blockage experiments were then carried out using, where possible, the same conditions as with the previous experiment, i.e. initial tension of the yarn 80 gf, a guide diameter 4 mm with  $30^{\circ}$  an angle of wrap.

TABLE 6.9

(1)	(2)		(3)	
Twist ratio	$N/N_o$		$N_B/N_o$	
Angle of orientation $\beta$	Type of yarn			
	acrylic ST	polyester CF	acrylic ST	polyester CF
70	1.22	1.11	1.22	1.12
60	1.31	1.23	1.31	1.27
50	1.64	1.60	1.64	1.38
40	1.83	2.00	1.83	1.47
30	2.13	2.30	2.13	1.40
20	2.44	2.40	2.44	1.54
10	2.74	2.60	2.74	1.60
0	2.94	2.80	2.94	1.84
-10	2.78	2.70	2.78	1.85
-20	2.78	3.00	2.78	1.75
-30	2.74	2.88	2.74	2.10
-40	2.71	2.75	2.71	2.00
-50	2.62	2.53	2.62	1.85
-60	2.32	2.19	1.73	2.32
-70	2.11	2.02	2.11	1.58

$N$  = twist gain (t/m)

$N_o$  = nominal twist (t/m)

$N_B$  = twist before the contact surface (t/m)

ST = spun staple yarn

CF = continuous filament yarn

### 6.10.3 Results

Table 6.9 lists the results; column 2 shows the ratio of the twist gain  $N$  to the nominal twist  $N_0$  against the angle of orientation  $\beta$  for both the acrylic and polyester yarns. Figure 6.23 plots this relation.

The general features of the graphs indicate that the behaviour of the two yarns is very close for both positive and negative angle of orientation. Obviously there is a slight difference between the two twist blockage performances. This could be attributed to the difference in the yarn structure or to differences in between yarn count. Nevertheless, the differences reverse their direction at extreme positive and negative values of  $\beta$  the angle of orientation.

As previously found when  $\beta$  is positive, a decreasing linear relationship is found between  $\frac{N}{N_0}$  and the angle of orientation. On the other hand, when  $\beta$  is negative the twist remains roughly constant until at  $\beta = -50^\circ$ , a rapid decrease occurs.

The closely similar twist blockage behaviour for the two different yarns is demonstrated even more clearly in Fig. 6.24. The graph shows the effect of angle of orientation against the ratio of the twist accumulation,  $N_B$ , before the guide, to the nominal twist,  $N_0$ , for the two yarns.

### 6.11 Discussion ,

From this limited result it may be concluded that the most important parameter may be the twist factor rather than the type of processing or type of yarn material.

FIG. 6.23: Effect of angles of orientation on twist gain for the spun and continuous filament yarn at the same twist factor

$$T_1 = 80 \text{ (gf)}$$

$$\theta = 30^\circ$$

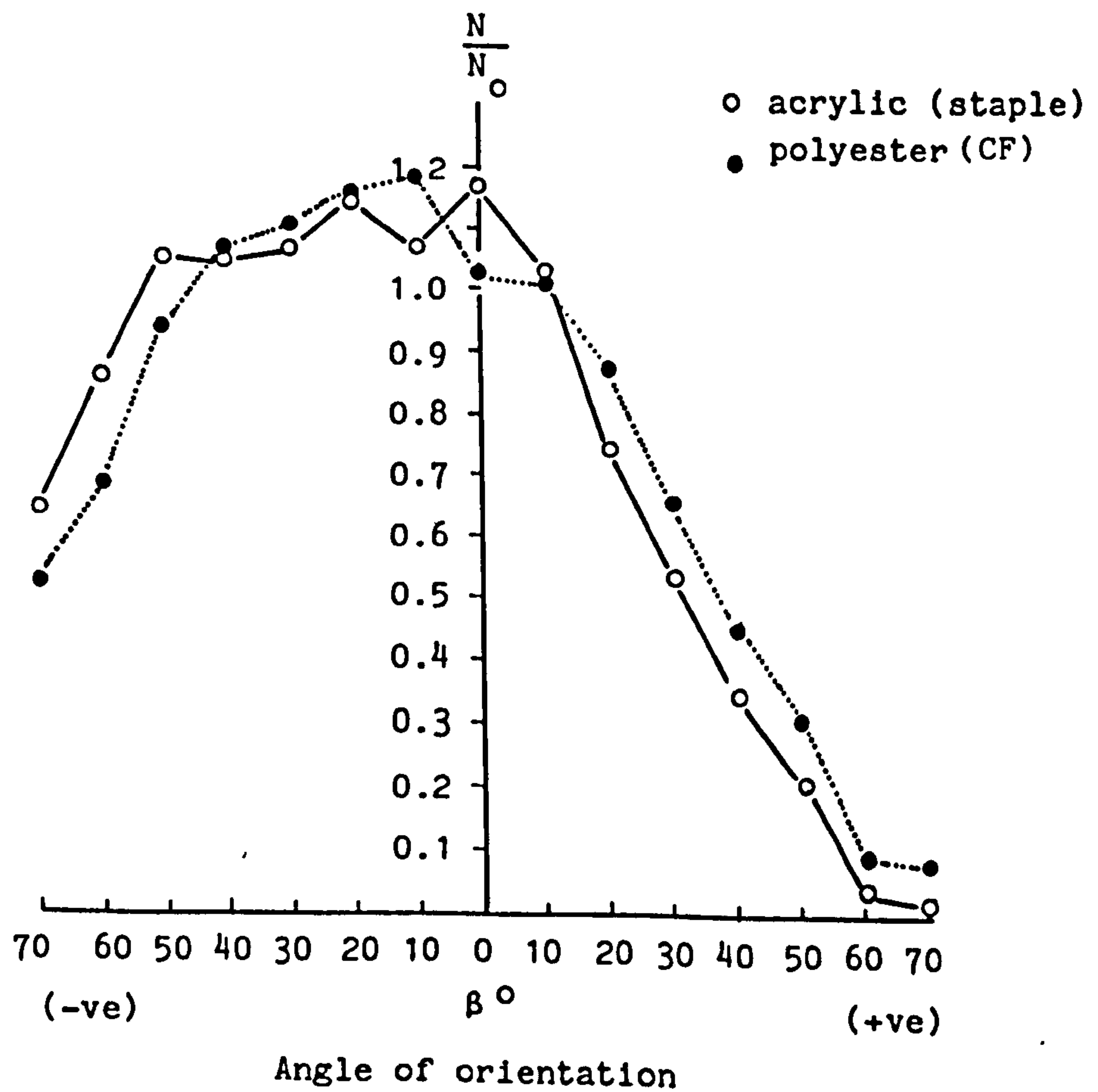

$N$  = twist gain (t/m)

$N_0$  = nominal twist (t/m)

FIG. 6.24: Effect of angle of orientation on twist accumulation in front of the guide surface in terms of the ratio of twist before the guide to the nominal twist

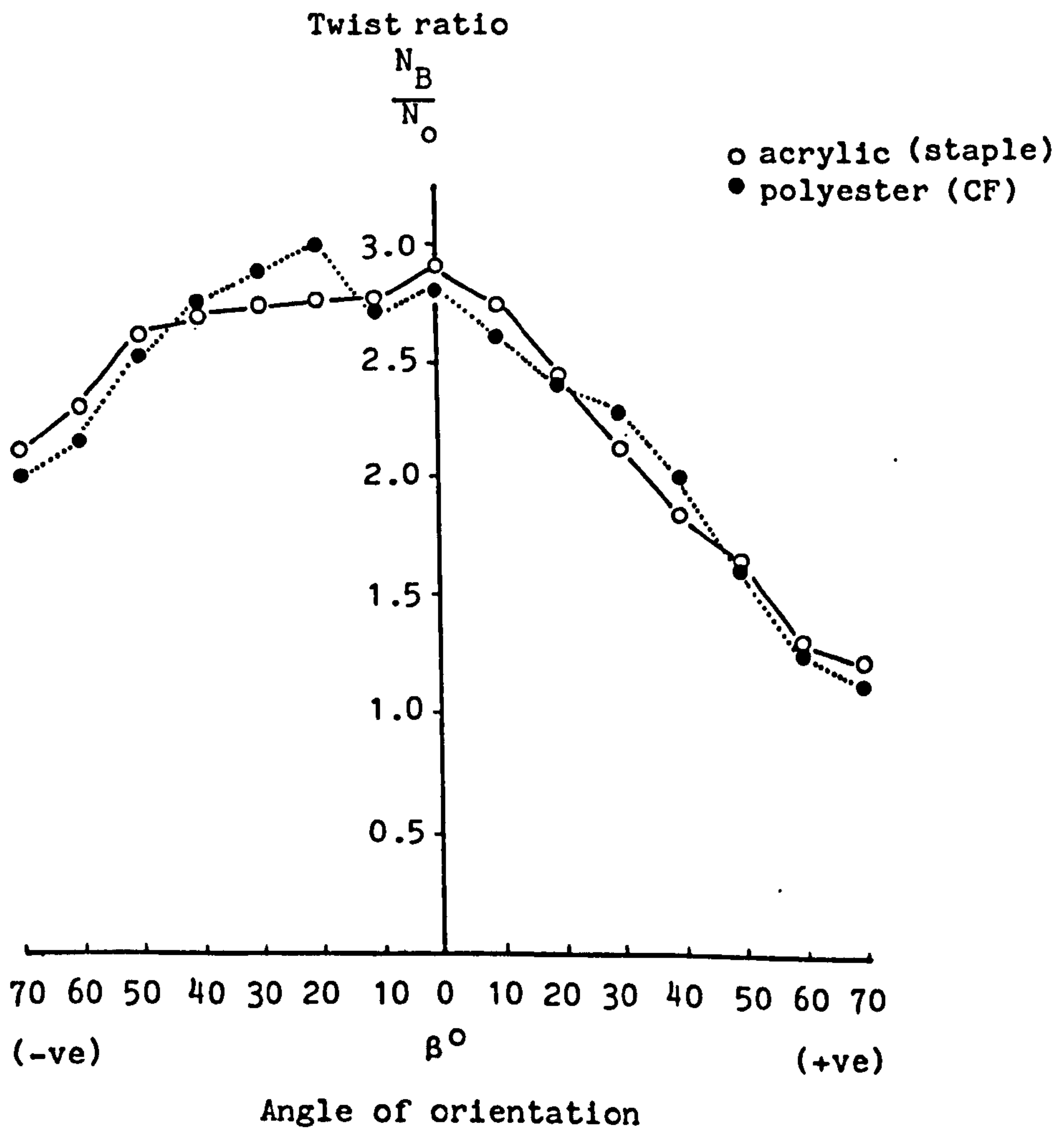

Furthermore, a conclusion can be built up from these and previous results concerning the symmetry of the two twist blockage behaviours. It appears that an equal but opposite twist blockage is generated when, for example, (ZZ)S yarn is compared with (SS)Z and the behaviour of (SS)S and (ZZ)Z is similar to the above.

In the light of this evidence and because the supply of the spun yarn was limited, it was felt to be unnecessary to repeat the previous experiments in order to further verify the results.

#### 6.12 An interpretation of visual observation

Visual observation of the yarn behaviour with respect to guide orientation has shown that there are three possible modes of behaviour of yarn passing over a guide surface and perhaps generating twist blockage.

1. The twisted yarn is only rotating in front of the guide, not over the contact region where it is flattened, as in the case of the twisted-singles doubled yarn.
2. The twisted yarn is rotating in front of the contact region while simultaneously rotating over the contact region itself, i.e. the leakage mechanism as observed in the case of flat-singles-doubled yarn.
3. The yarn is sliding over the contact region with no rotation anywhere (i.e. zero twist accumulation) as in the case of yarns at very high twist and of most yarns at  $\beta = 70^\circ$ .



In some cases, as the positive angle of orientation increases, the mode has been observed to change from the 'flattened' mechanism (1) to leakage (2) to the 'sliding' mechanism (3).

Figure 6.25 illustrates these three modes. For convenience the terms of flattened, leakage and sliding mode will refer to the three different twist blockage or transmission behaviours respectively.

The arrows illustrate that the magnitude of the rotation ( $\uparrow$  higher and  $\uparrow$  lower) of the yarn depends on the type of twist blockage mode.

### 6.13 Conclusions

As has already been stated, both of the doubled yarns with singles twist exhibited the flattened mode at  $\beta = 0^\circ$ . The reason why the doubled yarn with flat singles components operated with the leakage mode is probably associated with the relative ease with which the filaments could roll around each other as discussed in section 6.12. In this case, the frictional forces generating twist blockage are distributed over the whole contact surface whereas in the case of the rotating mode sufficient frictional torque is generated over a relatively short distance when the yarn first comes into contact with the guide.

Especially in the case of the leakage mechanism, the transmission of the yarn twist over the contact surface may thus depend, to some extent, on the deflection of the yarn path and the

FIG. 6.25: Modes of the behaviour of yarns passing over a guide surface

Generated torque direction {  $\uparrow$  (high rotation)  
 $\uparrow$  (low rotation)

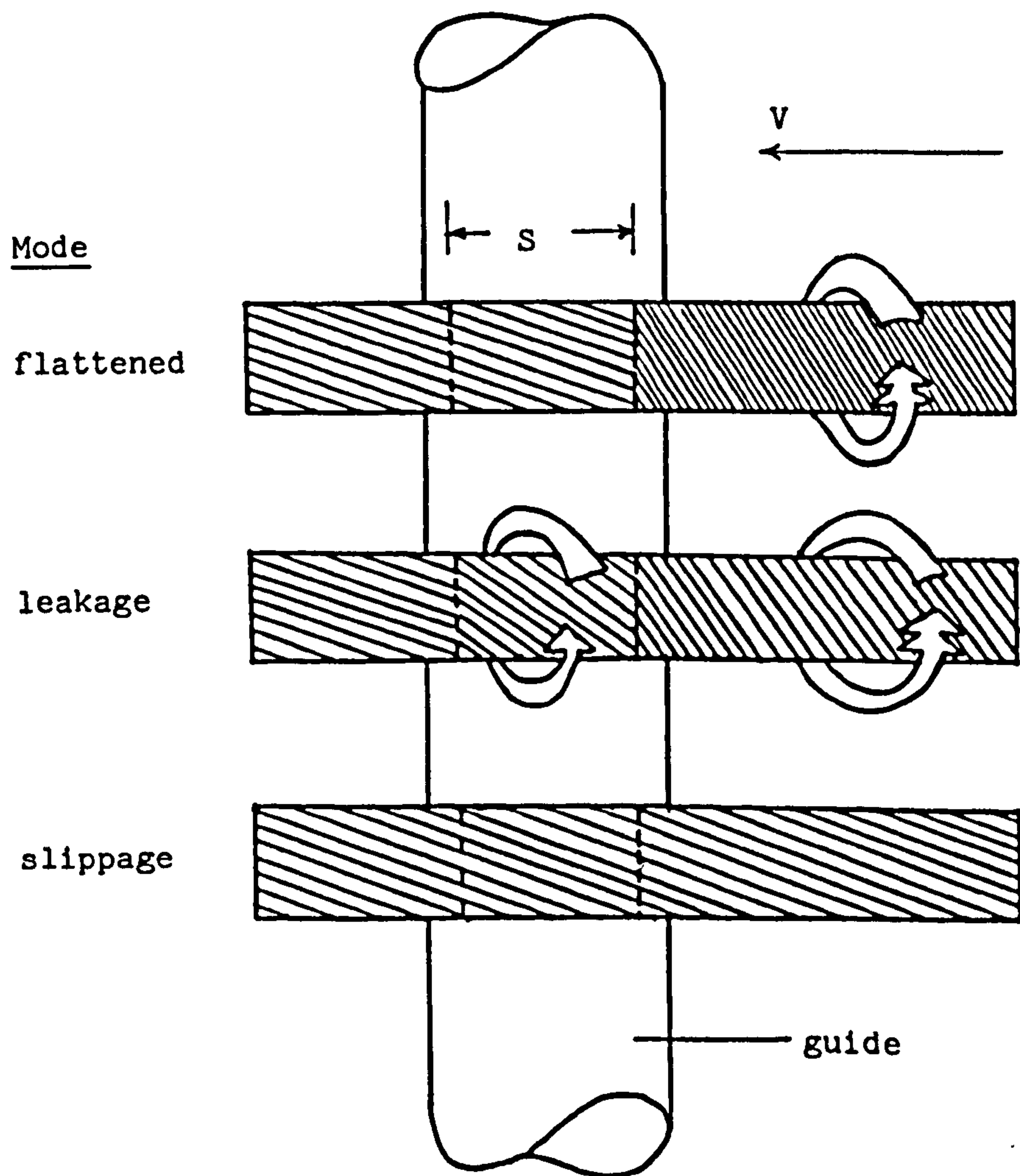

$S$  = length of arc of contact

length of contact. The greater the yarn deflection and contact length the greater the torque required in the yarn before the guide to generate twist transmission and consequently, the higher the twist hold-back.

It is of interest, therefore, to investigate the effect of the yarn orientation over the contact surface under different levels of angular deflection and contact length. Initially, however, an experiment was set up to investigate the effect of deflection angle  $\theta$  on twist blockage at constant mean pressure, length of arc of contact  $S$ , and fixed angle of orientation  $\beta$ .

#### 6.14 Effect of deflection angle $\theta^\circ$ on twist blockage at constant arc of contact, mean pressure and angle of orientation

Five different deflection angles 90, 45, 30, 22.5 and 18 $^\circ$  were used with five different guide diameters 2, 4, 6, 8 and 10 mm. The arc of contact was kept constant at 1.57 mm.

In order to maintain constant mean pressure, it was necessary to know the coefficient of friction so that the initial tension  $T_1$  would be adjusted correctly. The coefficient of friction of the polyester 570/71 t/m yarn against the guide was measured by the procedure previously described (section 4.5) and was found to be roughly constant and of average value = 0.211. The pressure was kept constant at 130 gf/cm.

##### 6.14.1 Results and discussion

Table 6.10 shows the magnitude of the initial tension  $T_1$  for the values of the angle of wrap  $\theta$  and guide diameter  $D$ , together

TABLE 6.10

Angle of wrap $\theta$	Guide diameter D(cm)	Initial tension $T_1$ (gf)	Twist gain N (t/m)
18.0	1.0	63	48.5
22.5	0.8	50	34.7
30.0	0.6	37	49.4
45.0	0.4	24	36.6
90.0	0.2	11	41.0

Mean pressure = 130 (gf/cm)

Length of arc of contact = 1.57 (cm)

Measured coefficient of friction  $K = 0.211$

with corresponding values of twist gain  $N$ . Figure 6.26 illustrates the relation between the deflection angle  $\theta$  and the twist gain  $N$ , and shows that there is no significant effect of deflection angle on the twist gain behaviour.

Earlier observations have shown that the twist blockage behaviour is greatly influenced by the major parameters such as the length of arc of contact, the pressure over the contact surface, the level of angle of orientation etc.

In the present experiment, as a result of keeping the above parameters constant, the frictional force generated over the contact region was also kept almost constant and when the angle of deflection was increased from  $15^\circ$  to  $90^\circ$  (i.e. 5 times) the mean value of the twist blockage was found to be roughly constant.

In fact, the torque generated over the contact region is greatly dependent on the yarn/guide interaction over the contact surface. Hence, if the frictional force is constant, the torque generated might not have changed. The twist blockage behaviour would then be constant, as observed.

This result, however, relates to the similar experiment which was carried out on the acrylic yarn and which was discussed in detail in the previous chapter (section 5.9).

#### 6.15 Effect of $\beta$ on twist blockage at different levels of angle of wrap $\theta$

Early studies in the present thesis suggested that there is a correlation between the twist blockage and the ratio of the length of the contact region to the length of one turn of twist in the yarn.

FIG. 6.26: Effect of angle of wrap on twist gain at constant arc of contact, mean pressure and angle of orientation

length of arc of contact = 1.57 (cm)  
mean pressure = 130 (gf/cm)  
yarn twist 570/2/71 (t/m)

Twist gain (t/m)

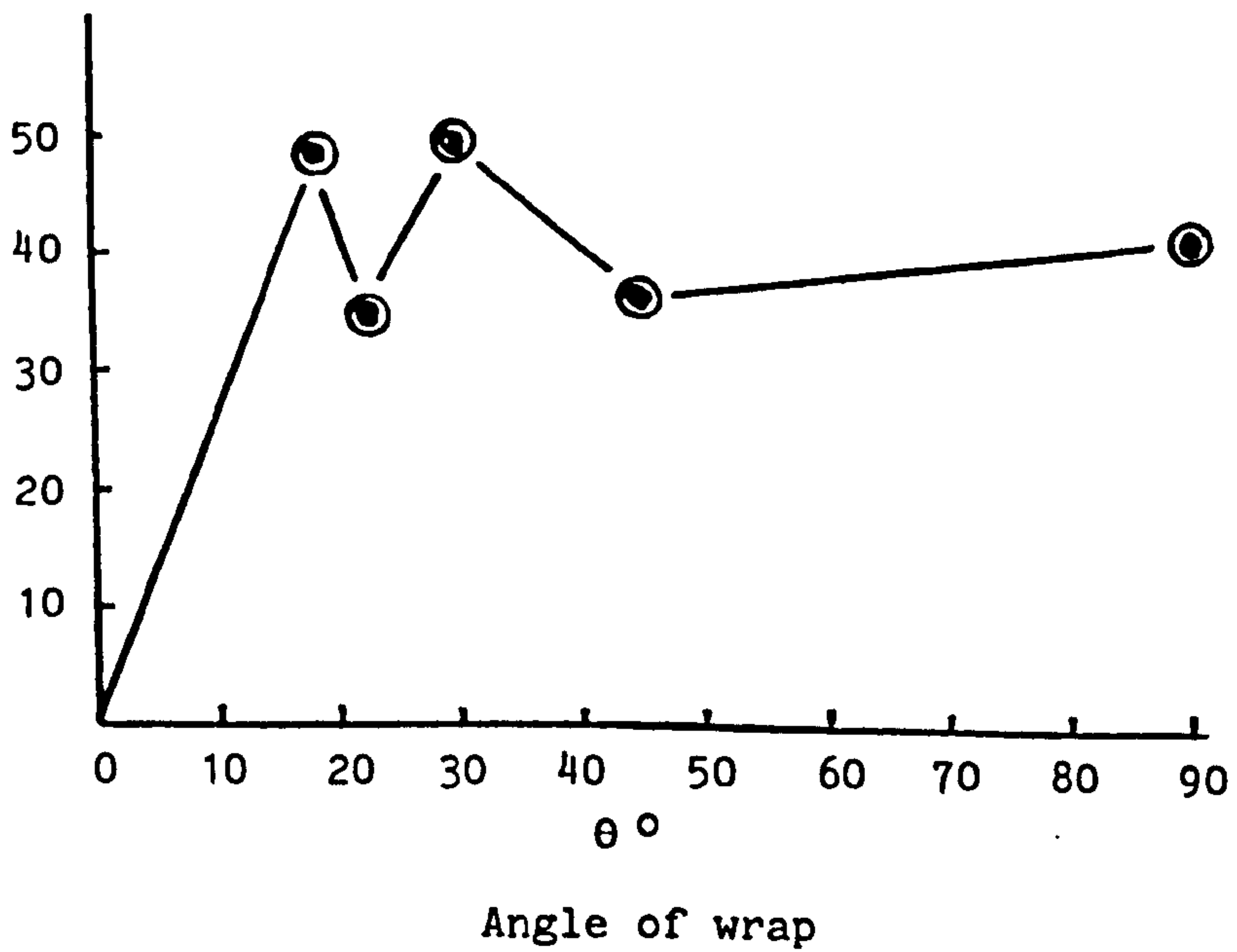

It was suggested, therefore, that the increasing arc of contact, as angle of wrap increases, may affect the twist blockage in the case of continuous filament yarn also. It is necessary, therefore, at this stage to determine experimentally the combined effect of varying the angle of wrap (deflection angle) and the angle of orientation  $\beta$  on twist blockage since they both affect arc of contact and their separate effects have been studied earlier.

A flat doubled 50 t/m continuous filament yarn (textured polyester) was used. The procedure was the same as in the previous experiments.

It was easy to vary  $\beta$  within  $\pm 70^\circ$  with 15 settings. For  $\theta$  the angles  $30^\circ$ ,  $60^\circ$  and  $90^\circ$  were chosen. This brings the total number of observations to 45.

#### 6.15.1 Results

Table 6.11 shows the relation between the three levels of angle of wrap  $\theta$  and the twist gain  $N$  with different angles of orientation  $\beta$ .

The results are plotted in Fig. 6.27. The general features of the graph show that  $\theta$  has only a minor effect on twist blockage behaviour.

As seen in the previous section, the effect of  $\theta$  seems to be insignificant at  $\beta = 0^\circ$ , and for positive values of  $\beta$ . On the other hand, with  $\beta$  negative, a lower twist blockage was observed for  $\theta = 60^\circ$ , the blockage at  $\theta = 30^\circ$  and  $90^\circ$  being similar. This lower blockage at  $\beta = 60^\circ$  cannot be explained. However, the pressure will

TABLE 6.11

$\theta^\circ$	30		60		90	
$\beta$	S	N	S	N	S	N
70	0.90	6.0	1.84	10.6	2.70	9.0
60	0.42	8.0	0.84	7.5	1.26	5.6
50	0.25	9.0	0.51	9.0	0.76	10.0
40	0.18	7.0	0.36	11.0	0.54	8.4
30	0.14	7.0	0.28	8.0	0.42	12.5
20	0.12	11.0	0.24	16.6	0.36	10.6
10	0.11	21.0	0.22	18.4	0.31	16.6
0	0.11	20.0	0.21	20.6	0.31	21.0
-10	0.11	25.0	0.22	23.0	0.32	26.0
-20	0.12	30.0	0.24	28.5	0.36	33.0
-30	0.14	40.0	0.28	31.0	0.42	41.0
-40	0.18	47.0	0.36	25.0	0.54	37.0
-50	0.25	41.0	0.51	39.0	0.76	45.0
-60	0.42	45.0	0.84	34.4	1.26	49.0
-70	0.90	44.0	1.80	40.0	2.70	46.6

$\theta$  = angle of wrap (degrees)

$\beta$  = angle of orientation (degrees)

S = length of arc of contact (cm)

N = twist gain (t/m)



FIG. 6.27: Effect of positive and negative angles of orientation on twist gain at various levels of angle of wrap

$N = 50$  (t/m)

$T_i = 80$  (gf)

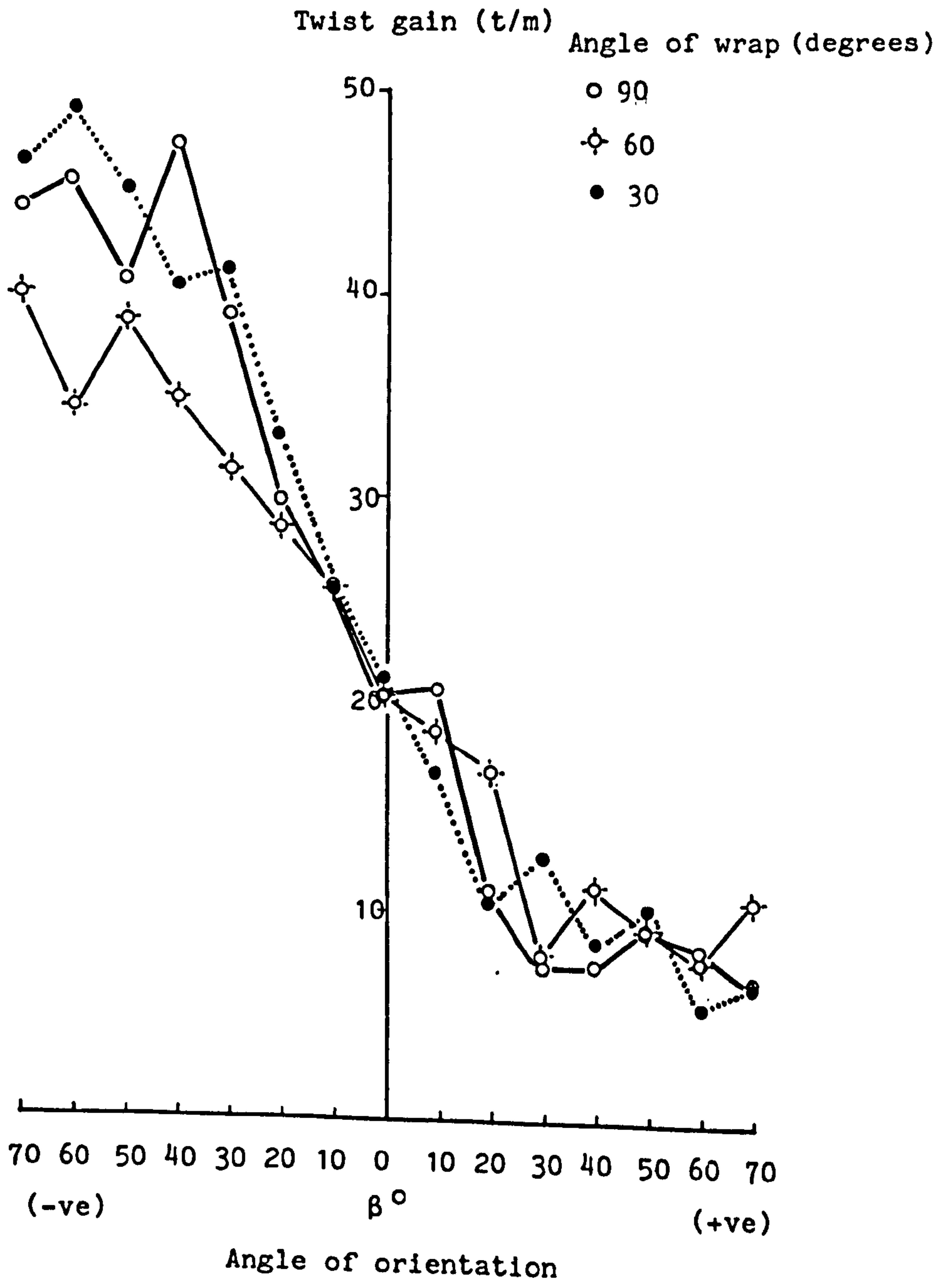

vary over the contact region corresponding to the variation in the factors:  $\beta$  (the angle of orientation),  $\theta$  (the deflection angle) and  $S$  (the arc of contact) [Appendix I]. Thus, the magnitude of the twist blockage will be influenced by these factors.

#### 6.15.1.1 Effect of $\beta$ on twist blockage in terms of length of arc of contact

Table 6.11 shows also the relation between the length of arc of contact and twist gain  $N$  for the three levels of the deflection angle. Figure 6.28 demonstrates this relation. The graph shows that at  $\beta$  positive there is a little difference between the twist blockage values for the three levels of deflection angle provided the length of contact is greater than 0.6 cm, but the arc of contact has a significant effect where  $S$  is shorter than this.

On the other hand, for  $\beta$  negative, although the difference between the blockage levels for  $\theta = 30^\circ$  and  $\theta = 90^\circ$  is small for  $S > 0.6$  cm, a lower blockage is again observed when  $\theta = 60^\circ$ .

Table 6.12 shows the relation between the angle of orientation and the mean pressure for the three levels of bending angle together with the corresponding values of the twist gain.

In fact, the pressure differences between the  $30^\circ$  and  $90^\circ$  deflection angle is about 10% throughout the observation.

A further result is, however, of particular interest. This concerns the isolation of the influence of the frictional force as it develops over the contact region corresponding to the variation of the length of arc of contact.

FIG. 6.28: Effect of positive and negative angles of orientation on twist gain in terms of the length of arc of contact at various levels of angle of wrap

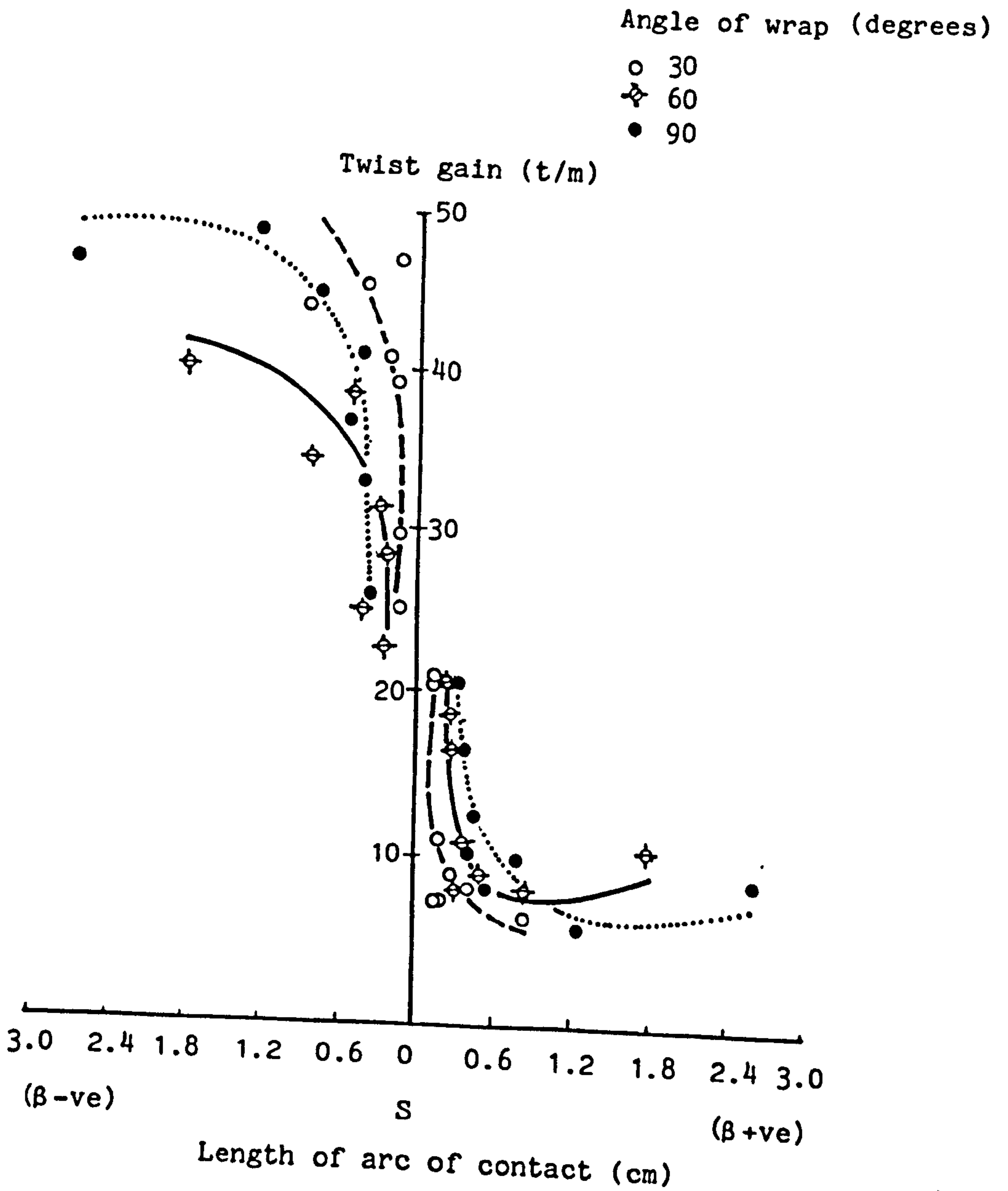

TABLE 6.12

$\theta$	30		60		90	
$\beta$	$P_m$	N	$P_m$	N	$P_m$	N
70	49.0	6.0	52.0	10.6	54.0	9.0
60	105.0	8.0	110.0	7.5	116.0	5.6
50	137.5	9.0	182.0	9.0	191.5	10.0
40	246.0	7.0	259.0	11.0	272.0	8.4
30	315.0	7.0	331.0	7.8	348.0	12.5
20	371.0	11.0	389.0	16.6	409.0	10.6
10	407.0	21.0	428.0	18.4	450.0	16.6
0	420.0	20.0	441.0	20.6	463.0	21.0
-10	407.0	25.0	428.0	23.0	450.0	26.0
-20	371.0	30.0	389.0	28.5	409.0	33.0
-30	315.0	40.0	331.0	31.3	348.0	44.3
-40	246.0	47.0	259.0	24.7	272.0	36.8
-50	137.5	41.0	182.0	38.8	191.5	44.7
-60	105.0	45.0	110.0	34.4	116.0	49.0
-70	49.0	44.4	52.0	40.3	54.0	46.6

$\theta$  = angle of wrap(degrees)

$\beta$  = angle of orientation (degrees)

$P_m$  = mean pressure (gf/cm)

N = twist gain (t/m)

6.16 Effect of angle of orientation on twist blockage  
at constant frictional force over the  
contact region

In some of the previous experiments it had been thought that the effect of angle of orientation on twist blockage might have been influenced by variation in friction force arising from the change in  $\beta$ . An experiment was, therefore, set up in which an effort was made to keep the frictional force constant ( $\approx 11$  gf) whilst  $\beta$  was varied. In order to do this it was necessary to adjust  $T_1$  and  $\theta$  as  $\beta$  was changed.

Eight values of  $T_1$  and  $\theta$  were chosen for the eight values of  $\beta$  based on a subsidiary experiment to measure the coefficient of friction (Chapter 4, section 4.5). The yarn was 570/61 t/m singles and ply twist respectively (PET).

Results are shown in Table 6.13 and in graphical form in Fig. 6.29. The figure shows the mean pressure  $P_m$  and the length of arc of contact  $S$  plotted against the angle of orientation  $\beta$  and corresponding angle of wrap  $\theta$  (equation 17, Appendix I). The graph illustrates the reduction of the mean pressure  $P_m$  and the increase in the length of arc of contact  $S$  respectively, as  $\beta$  is increased negatively or positively.

The curves were used to set up the appropriate values of  $T_1$  and  $\theta$  for the investigation of the effect of  $\beta$  at constant frictional force.

From Table 6.13, Fig. 6.30 is produced.

TABLE 6.13

$\beta$	$R_B$	$T_i$	$\theta$	$P_m$	S	N
70	1.70	245	10.0	147	0.31	6.6
60	0.80	164	15.0	212	0.21	13.4
50	0.48	125	19.0	270	0.16	32.5
40	0.34	103	23.0	318	0.14	44.0
30	0.27	90	26.0	358	0.12	57.2
20	0.23	82	28.5	387	0.11	62.0
10	0.21	78	29.5	403	0.11	97.2
0	0.20	77	30.0	409	0.11	97.0
-10	0.21	78	29.5	403	0.11	102.0
-20	0.23	82	28.5	387	0.11	87.2
-30	0.27	90	26.0	358	0.12	97.0
-40	0.34	103	23.0	318	0.14	109.0
-50	0.48	125	19.0	270	0.16	105.3
-60	0.80	164	15.0	212	0.21	77.8
-70	1.70	245	10.0	147	0.31	49.7

$\beta$  = angle of orientation (degrees)

$R_B$  = radius of curvature (cm)

$T_i$  = initial tension (gf)

$\theta$  = angle of wrap (degrees)

$P_m$  = mean pressure (gf/cm)

S = length of arc of contact (cm)

N = twist gain (t/m)

FIG. 6.29: The relationship between the angle of orientation, the arc of contact and mean pressure with varied angle of wrap at constant frictional force (11 gf measured)

D = 0.4 (cm)

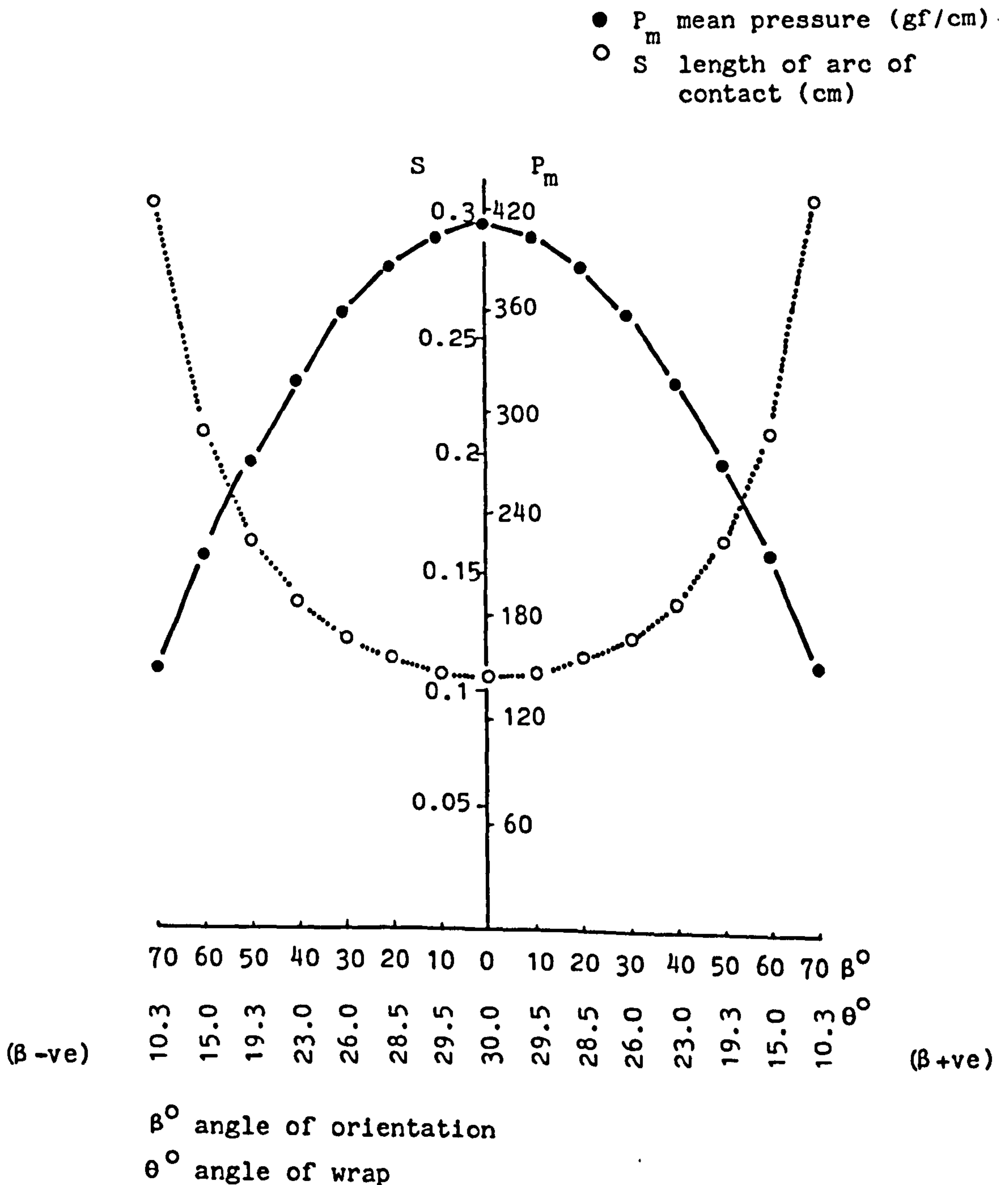
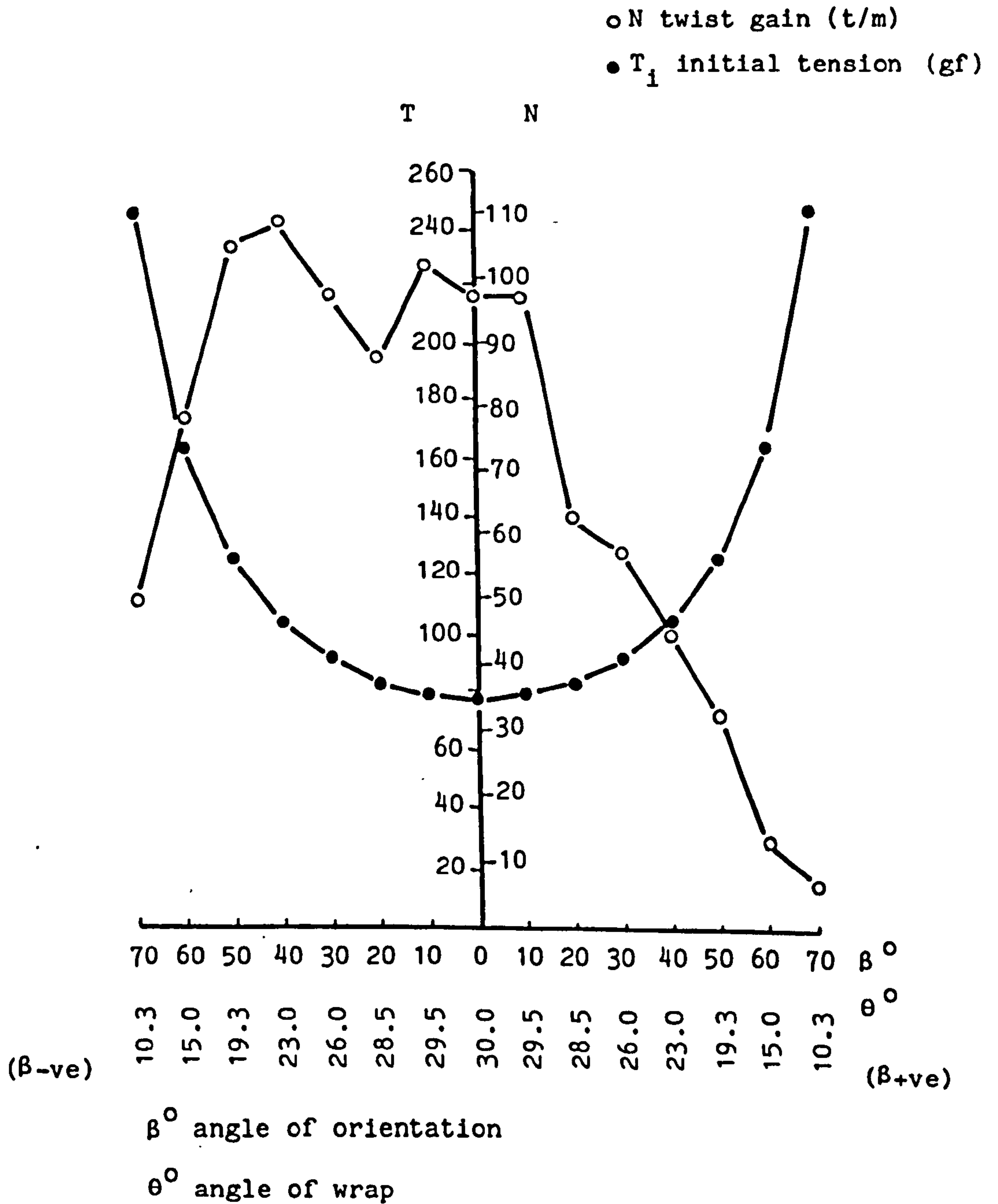

FIG. 6.30: Effect of angle of orientation on twist gain and the relationship between the initial tension and angle of wrap at constant frictional force over the contact region

$N_0 = 61$  (t/m)  
 $D = 0.4$  (cm)





The experimental results indicate that the general characteristic behaviour of the twist blockage has been insignificantly changed from that observed previously.

The change of the initial tension  $T_1$  is also plotted against  $\beta$  and  $\theta$ , and it is also of interest to note that the alteration of the yarn tension  $T_1$  as  $\beta$  has been changed, has had no effect on the twist blockage behaviour. In fact the lowest value of twist gain  $N$  is at the highest value of the initial tension i.e. at  $\beta$  equal to  $+70^\circ$ .

#### 6.17 Discussion

On the evidence of this experimental data, the highest and lowest values of twist gain  $N$  were always at  $0 > \beta > 30^\circ$  and  $\beta = +70^\circ$  respectively in most of the previous experiments. It may be concluded, therefore, that the variation of the frictional force was not a major factor in determining the effect of  $\beta$  on twist blockage in the previous experiments.

However, at this stage it may be also argued that the pressure reduction and/or the increase in lengths of arc of contact Fig.6.29 may also have had an influence. In order to eliminate the effects of these two parameters, it was decided to extend the investigation with a constant mean pressure and length of arc of contact.

#### 6.18 Effect of angle of orientation at constant mean pressure and constant length of arc of contact

To carry out this experiment two levels of pressure had been set up at  $P \approx 130$  and  $195$  gf/cm, at a constant arc of contact equal

to 0.157 cm.

The yarn used was the textured polyester (16.7 tex) 570/2/71 t/m as previously. The values of the angle of wrap were calculated, according to the values of the angle of orientation, in order to keep the arc of contact constant (Appendix I).

From values of  $\theta$  and  $\beta$ , the value of the initial tension to keep the mean pressure over the contact region constant was calculated, assuming the coefficient of friction to be 0.211.

#### 6.18.1 Results and discussion

The results are tabulated in Tables 6.14 and 6.15 where the initial tension  $T_1$  and twist gain  $N$  were plotted in Fig. 6.31 against the angle of orientation  $\beta$ .

The graph shows that the twist gain decreases with positive increase of  $\beta$ . On the other hand, the twist gain increases as  $\beta$  is increased negatively up to roughly  $\beta = -40^\circ$ , and  $-50^\circ$  for the lower and higher levels of the pressures respectively. This is followed by a rapid decrease of twist gain of about 60% and 70% for the lower and higher levels of pressure respectively. These relatively small differences between the sets of results for the two pressure levels are not regarded as significant.

The data obtained from this experiment indicates that the reduction of the twist blockage is significantly dependent on neither the pressure nor the length of arc of contact. It is, in fact, considerably dependent on the effect of angle of orientation, in other words, it is primarily influenced by the yarn's direction

TABLE 6.14

$\beta$	$\theta$	$T_i$	N
70	5.3	330	12.5
60	11.3	153	22.2
50	18.6	91	33.2
40	26.4	63	35.4
30	33.8	49	43.8
20	39.7	41	55.6
10	43.7	37	59.0
0	45.0	36	73.0
-10	43.7	37	74.7
-20	39.7	41	85.3
-30	33.8	49	85.6
-40	26.4	63	86.6
-50	18.6	91	86.6
-60	11.3	153	71.0
-70	5.3	330	53.0

Mean pressure  $P_m = 195$  (gf/cm)

Length of arc of contact  $S = 0.157$  (cm)

Frictional force (measured)  $F = 6.5$  (gf)

TABLE 6.15

$\beta$	$\theta$	$R_B$	$T_i$	$N_B$	$N$
70	5.3	1.70	218.5	102.2	16.0
60	11.3	0.80	101.4	113.0	30.6
50	18.6	0.48	60.7	116.6	35.6
40	26.4	0.34	42.0	120.3	37.0
30	33.8	0.27	32.5	121.3	40.3
20	39.7	0.23	27.4	125.6	45.3
10	43.7	0.21	24.7	127.8	51.6
0	45.0	0.20	24.0	130.0	66.6
-10	43.7	0.21	24.7	142.5	68.5
-20	39.7	0.23	27.4	149.0	80.0
-30	33.8	0.27	32.5	145.6	74.4
-40	26.4	0.34	42.0	151.3	85.6
-50	18.6	0.48	60.7	151.3	77.8
-60	11.3	0.80	101.4	141.0	72.0
-70	5.3	1.70	218.5	126.0	41.6

Length of arc of contact  $S = 0.157$  (cm)

Mean pressure  $P_m = 130$  (gf/cm)

Mean frictional force  
(measured)  $F = 4.3$  (gf)

FIG. 6.31: Effect of angle of orientation on twist gain and relationship between the initial tension, angle of wrap and angle of orientation at constant value of length of arc of contact (0.157 cm) with two levels of mean pressure (195 and 130 gf/cm)

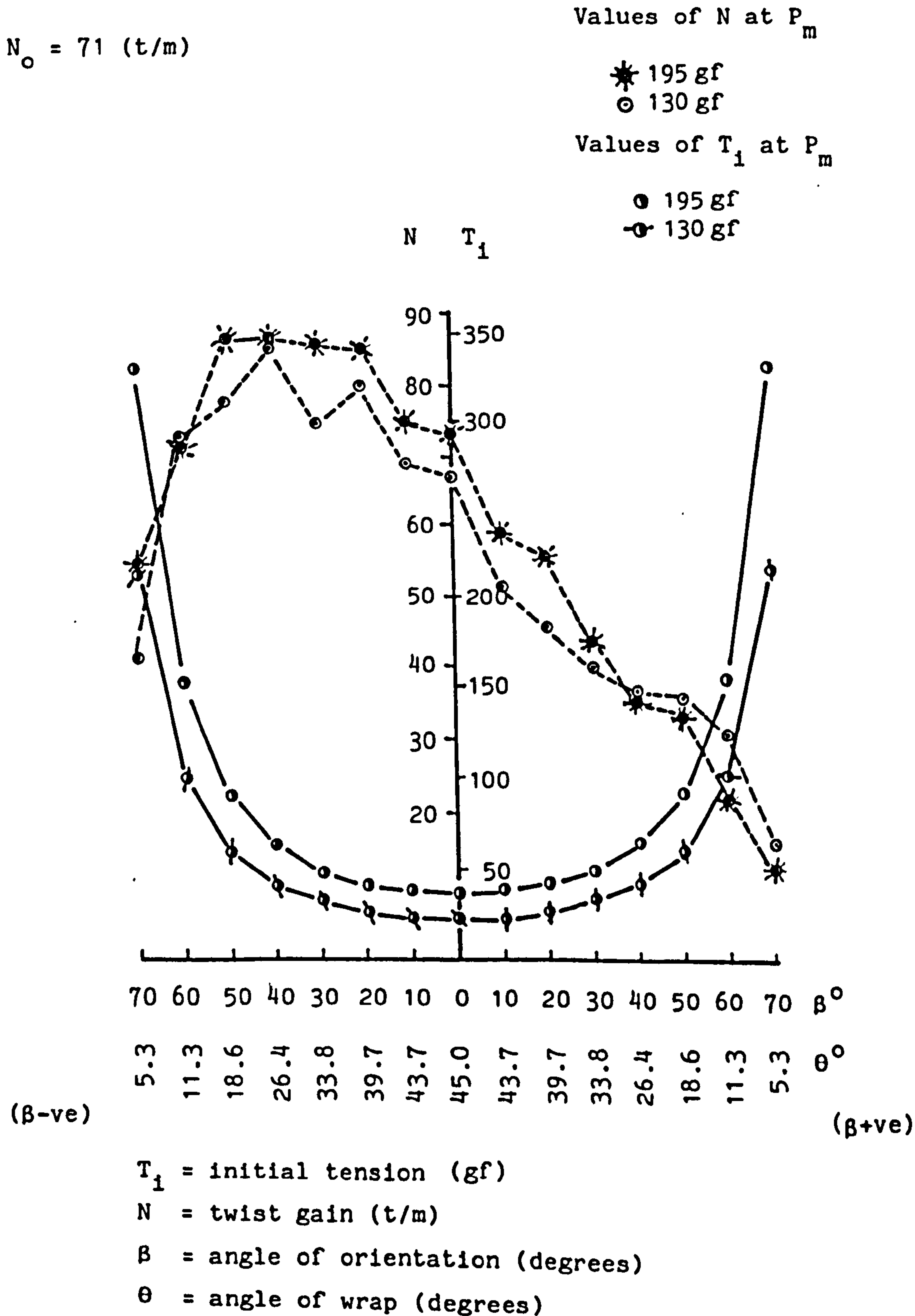

of movement relative to the contact region.

The graph obviously shows that the initial tension has increased roughly about nine times from  $\beta = 0^\circ$  up to  $70^\circ$  in order to maintain constant pressure, but the twist gain still decreases as  $\beta$  positive increases.

It was not possible to choose a higher value of the pressure because the values of the initial tension at  $\beta = 70^\circ$  would then be very high, possibly causing yarn or filament breaks. Lower values of tension could not be used at  $\beta = 0^\circ$ , the initial tension would be too small to generate consistent twist blockage.

#### 6.19 Final conclusion

The major factor influencing the twist blockage behaviour is the angle of orientation (i.e. the yarn's directional movement over the contact region); the lowest twist blockage always occurred at  $\beta = 70^\circ$  under the conditions discussed before.

CHAPTER 7

SUMMARY AND CONCLUSIONS

## 7.1 Summary and conclusions

In processes of yarn and fabric production, twist blockage is one of the important factors that may affect the quality of production for, in most such processes, yarn will have to change its direction around guides. This is increasingly true in modern yarn production for, with the increase of machine speeds, the yarn must change its direction, perhaps several times. If machine dimensions are to contain the necessarily longer processing zones.

The work described in this thesis has been designed to investigate and to consider the interaction between threadline parameters and different guide variables and their influence on twist blockage. The investigation can be divided into two parts. Firstly, the more basic parameters influencing the twist blockage over a contact surface have been considered. These have included angle of wrap, guide diameter, yarn tension and twist, but also combined parameters such as contact length, pressure over the contact region associated with the length of one turn of twist, and the frictional drag generated over the contact surface.

Secondly, the interaction of yarn twist and direction (S or Z) with its orientation to the guide surface has been examined.

These investigations have provided possible means for minimising or even overcoming the twist blockage problem.

An apparatus was especially constructed to enable easy changes to be made in the process variables.

Magnetic grippers were attached to the apparatus to achieve an accurate collection of twist samples before and after the contact



region. Snatched samples were transferred to glass plates and twist was directly measured using a travelling microscope. Means were provided for simultaneous measurement of input and output tensions.

The investigation was carried out at a fairly low speed which helped in the observation of yarn rotation and the behaviour of the twist before and after the contact surface. Wherever possible, samples were taken as the blocked twist reached its maximum level.

It was recognised in a preliminary investigation that the length of the yarn in the testing zone might change according to the required testing conditions. With this in mind, the effect of variation of the length in the testing zone was examined. It was confirmed that there was no significant influence of test zone length on twist blockage behaviour.

Earlier workers have suggested that the angle of wrap has the major influence on the twist blockage characteristic and that blockage increases with angle of wrap. In the present investigation, a different behaviour has been found, which contrasted with the previous data published in the literature. The results showed that the higher the angle of wrap, the lower the twist blockage. In fact, the combined effect of the angle of wrap ( $\theta$ ) and guide radius ( $R$ ) on increasing the length of contact,  $S = R.\theta$ , consistently showed a lower tendency to generate twist blockage provided contact pressure was not increased.

Most significantly, it was found that a marked twist blockage reduction was achieved when the length of arc of contact was greater than the length of one-half turn of the twist of the yarn under test, with a reduction of accumulation to approximately 50% of the highest

value. In effect the twist blockage was dependent on the comparative length of the contact zone and one half-turn of twist almost irrespective of the angle of wrap or guide diameter.

It was considered that the prime factor was probably the number of contacts (cross-overs) arising from the interchange of yarn components due to twist over the contact surface.

Before examining this factor in greater detail, however, it was necessary first to examine the effect of threadline tension, because tension influences the pressure forces between yarn and guide. Observation confirmed that the higher the initial tension, the higher the twist accumulation, especially with small-diameter guides, and the same tension with a guide of larger diameter gives a lower magnitude of twist accumulation. Thus, twist blockage is not only initial-tension dependent, but also depends on the size of the guide ( $R$ ). The combination of the two factors determines the pressure ( $P$ ) over the contact surface through the relation  $P = \frac{T}{R}$ . By varying the guide diameter with constant initial tension or vice versa, it was clearly demonstrated that the highest values of twist blockage occurred with the highest initial tension and smallest guide diameter; i.e., at highest initial pressure. In fact, the pressure over the contact surface is not constant and dependent only upon the initial tension and guide size but also varies with the tension distribution over the contact surface which is influenced by the guide/yarn friction. This is a function of the angle of wrap and the coefficient of friction.

The "mean pressure" was chosen as the realistic and convenient parameter since it takes into account the effect of the yarn/surface coefficient of friction in addition to the effect of the length of arc of contact.

Following the information gained from investigation of the effects of mean pressure and length of arc of contact, the effect of angle of wrap was again examined.

The mistake of previous investigators [40,54,55,62,63,65] was to investigate this parameter without regard to the other factors, such as the mean pressure and the length of contact region. A most interesting result was obtained when this factor was examined separately as it was confirmed that there was no significant independent effect of wrap angle on twist blockage behaviour. This result was obtained, of course, with the length of arc of contact and mean pressure as well as the frictional force over the contact surface held constant.

The movement of twist in a yarn over a surface was found to be governed by two separate mechanisms. These were designated as the flattened and rotating or leakage mechanisms.

The first mechanism occurs with low twisted yarn where the twist is insufficient to maintain a round cross-section, or with doubled structures. In this case, the movement of the twist, across the contact surface with the yarn flow, was hindered by the yarn flattening and consequent difficulty of interchange of yarn components. It was noticed, however, that because of the way in which the twist is pushed back upstream along the yarn, the yarn rotates rapidly before

the contact surface. The yarn moves substantially flat over the contact region. This behaviour was thus designated as the flattened mechanism.

At medium or high pre-twist levels, in singles yarn, there will be a reduced tendency towards flattening and it will be easier for some twist to move forward with the flow of yarn. It was found that twist blockage levels were generally lower and, as a consequence, the yarn rotation in front of the contact region is less than at a lower pre-twist. Twist is more likely to be transferred with the yarn flow. The twist blockage forces appeared to be developed gradually over the contact surface and there was some yarn rotation on the surface and often a steady loss of blocked twist. The mechanism here was defined as the rotating or leakage mechanism.

As the twist level in the yarn increases, the yarn will develop a more circular cross-sectional shape and the helical orientation of the surface fibres to the yarn axis will increase. Thus, the surface of the yarn appears to be a series of ridges at an angle to the direction of movement. In these circumstances, the yarn will be supported by these ridges and they will prevent the yarn components from lying side by side in contact with the surface, but it is postulated that lateral friction force may be generated causing the yarn to rotate. At this stage, the mechanism of blockage described as the rotating mechanism will exist. As mentioned above, it has been observed that when the length of arc of contact was more than the length of one-half turn, flattening was less likely to occur, and the twist transfers with the yarn flow with a reduced twist congestion.

The two mechanisms, however, depend on a balance between the blocking torque generated on the guide surface and the torque required to rotate the yarn over the contact region. This rotating torque can only be generated by the accumulated twist. The flattened mechanism requires a greater generated torque to turn the yarn over.

With the idea of better understanding the effect of the number of points of contact and helical surface structure on twist blockage mechanisms, a twisted yarn was pulled manually over a guide under a very low load. The yarn was found to displace laterally over the contact surface. This lateral movement of the yarn could be attributed to two possible but conflicting mechanisms.

First, because of the interaction of the surface asperities of the guide with the helical yarn structure, a lateral frictional force might be generated as described above.

Secondly, if the yarn is rolling and rotating over the contact surface due to the false-twist effect of blocked twist, a component of frictional force orthogonal to the yarn axis could be generated. Only the second possibility was found to be compatible with the direction of forces and movements involved. To some extent, this throws into doubt the possibility of what has been described as the 'rotating mechanism' of twist blockage.

In order to study the torque required within the yarn to transfer the twist in the flattened mechanism a simple theory was developed to describe how an ideal two-fold yarn might rotate on a curved surface. The analysis revealed the existence of a critical deflection angle between the two yarn components, required to turn

the yarn over on the surface, of approximately  $30^{\circ}$ . This angle is independent of tension, yarn radius and guide radius. On the other hand, the torque required depends inversely on the square root of the guide radius. On the basis of this simple model, yarn with a high level of doubling twist may already generate an angle equal to or greater than required to overcome this mechanism of accumulation. At low levels of twist, however, the twist may be less than is required, then the blocking process will proceed until it reaches a sufficient value to generate this angle.

It was discovered that another important feature of the twist blockage phenomenon is that, the twist blockage behaviour is highly sensitive to the relative orientation of the guide axis to the yarn, and to the direction of the yarn twist helix (S or Z). When these parameters were investigated at constant initial tension, guide diameter and angle of wrap, surprising results were found. When the angle of orientation  $\beta$  was increased positively, the twist blockage steadily decreased to zero in most cases, whilst when the angle was increased negatively, the twist blockage increased at first prior to a rapid decrease, but never reached zero over the range studied.

When the angle of orientation  $\beta$ , is increased, the pressure decreases and length of arc of contact increases. In addition, the frictional force generated over the contact surface increases as the contact length increases. It was expected, therefore, that as the pressure decreases and the arc of contact increases, the twist blockage would decrease with increase of the angle of orientation whether positive or negative.

However, the data indicated that the reduction of twist blockage is substantially independent of either the pressure or the length of contact.

When the  $\beta$  factor was investigated using S and Z doubled yarn, it was found that the twist blockage behaviour of Z twisted yarn is generally opposite in direction to S twist. Although the twist blockage behaviour of S compared with Z doubled structures made from twistless singles was not fully symmetrical, symmetricality was achieved when the singles were twisted.

After investigating various combinations of singles and doubling twist [(SS)S, (SS)Z, (ZZ)S and (ZZ)Z], it was concluded that the doubling twist is the dominant factor influencing the relationship between twist blockage and  $\beta$ , regardless of whether the singles twist was in the same or opposite sense to the direction of the doubling twist.

Mechanisms have been postulated to explain the effect of yarn/guide orientation on blockage behaviour based on the interaction of the generators of the cylindrical guide with the twist of the yarn. When the guide generators lie in the valleys between the twisted singles components, a greater twist blockage is generated, but when the yarn is supported on the peaks of the twisted structure, blockage is reduced.

To complete the picture of twist blockage behaviour under the influence of the  $\beta$  factor, a comparison of a spun yarn and continuous filament yarn was made. The data obtained indicated that as long as the two yarns have the same twist factors in their singles and the

same doubling twist factors, the twist blockage behaviour will be the same.

## 7.2 Final summary

1. Twist blockage in a yarn depends on the generation of a torque due to contact between the yarn and guide surface.
2. The level of blockage is determined by a balance between this torque and the torque generated within the yarn due to the increased twist.
3. Two main mechanisms of blockage have been identified:
  - (a) A flattening of the yarn on the guide surface pushes back twist until sufficient torque is generated within the yarn to rotate the yarn on the guide surface. 106
  - (b) Lateral frictional forces may be generated due to interaction between the helical yarn surface structure and the guide surface generators or its surface roughness. These give rise to a twist blocking couple.
4. In some cases the two mechanisms may be combined.
5. The important basic parameters governing blockage are the angle of wrap, guide diameter, yarn tension and twist and orientation of yarn to guide.
6. Although some of these parameters may have little independent effect, their combined effect in determining, for example, pressure between yarn and guide and length of yarn to guide contact are important.
7. The orientation of yarn to guide has been shown to have a major influence and blockage can be minimised by choosing a suitable sense and angle of orientation.



### 7.3 Future work

Although the present investigation has led to a greatly improved understanding of some of the mechanisms of twist blockage, its scope has necessarily been restricted both in respect of the yarns and the guide geometries and surfaces used in the experiments.

Where the yarns are concerned, although one was a staple and the other a continuous filament material, both were of a relatively fine decitex value. The types and linear densities of the yarns used in the experiments could be usefully extended in any future investigation.

The set of polished steel guides used in the experiments (from 2 mm to 10 mm in diameter) made it possible to study the effects of surface pressure and contact length over a relatively wide range. Their surface characteristics were, however, relatively unvarying. In contrast, the wide variety of size and surfaces of guides used in industrial practice will, almost certainly, have an equally wide range of surface finishes and frictional properties. Although one of the blockage mechanisms identified in the experiments is probably friction-independent to a substantial degree, yarn/guide friction played an important part in the other, both inherently, through the coefficient of friction, and also through the interaction of yarn surface texture with guide-surface asperities. An investigation of the effects of guide surface material and finish would, therefore, be of great value. Allied to this, a study of the effects of yarn lubricants could be considered.

Industrial guides are rarely cylindrical in shape. In its passage over the surface of, for example, a grooved or flanged guide the orientation of the yarn to the surface could be continually varying. The experiments have shown the importance of the orientation of the yarn to the guide surface. It would be of great interest and practical value to establish whether the principles revealed in the experiments could be shown to apply to commercial guides of complicated shapes.

The effect of yarn speed on twist blockage has only been investigated at speeds well below those commonly used in modern yarn processing. This was necessary in order to study the phenomenon adequately. Speeds closer to those used in modern processing could be usefully investigated, in spite of the apparent practical difficulties of experimentation.

There are, however, two further major areas for future academic study. The first of these is to confirm that the forces and associated mechanisms of blockage, which have been postulated in the present study, operate quantitatively in the manner described. This can only be done by simultaneous measurement of the twist-blockage torque generated on the guide surface and the torque present in the twisted yarn itself. It has been pointed out that there is significant doubt as to the nature of the 'rotating' mechanism, in particular.

The second, and more important area, concerns the dynamics of the process or the manner in which the blocking couples generate a gradual build-up of twist in the yarn to the point where the twist

begins to escape, perhaps suddenly, across the guide surface, and an oscillation may develop. On the one hand, during the blocking stage a gradual increase in yarn twist may, depending on yarn feed conditions, be accompanied by a gradual increase in tension and, as the blocked twist escapes, by a rapid decrease in tension, with associated change in yarn length, pressure on the surface etc. These dynamic considerations will play an important part in determining the amplitude and frequency of twist irregularity in any yarns which have been subjected to blocked twist. This, in turn, could have an important influence on yarn processability and on final fabric appearance and acceptability.

REFERENCES

REFERENCES

1. Brunnschweiler, D., Text.Mfr., 1957, 83, No. 990, 271.
2. Baird, M.E., Mieszkis, K.W., J.Text.Inst., 1955, 46, 101.
3. Fujino, K., Nakajima, K., Inone, T., J.Text.Mach.Soc. Japan, 1963, 9, No. 1, 20 (Eng.Ed.).
4. Finkel'shtein, I.I., Tech.Text.Industr. U.S.S.R., 1966, No. 1, 72.
5. Wegner, W., Wulfhorst, B., Melliand Textilberichte, 1964, 7/12, 1326.
6. Catling, H., Text.Mfr., 1961, 87, No. 1035, 96.
- De-  
7. Barr, A., Catling, H., Manual of Cotton Spinning, Vol. 5, The Principle and Theory of Ring Spinning, The Text.Inst. and Butterworth, 1955, 129-133.
- De-  
8. Barr, A., Catling, H., J.Text.Inst., 1959, 50, 239.
9. Du Bios, W.F., Reit, D.F., J.Text.Inst., 1959, 50, 423.
10. Mitchell, J., Text.Mfr., 1961, 87, No. 1038, 227.
11. Mitchell, J., Text.Mfr., 1961, 87, No. 1044, 489.
12. Kampen, W., Melliand Textilberichte, 1979, 8, No. 6, 477 EE 433.
13. Henshaw, D.E., J.Text.Inst., 1970, 60, 269.
14. Henshaw, D.E., Self-twist Yarn, Alternative Spinning Systems Utilizing Self-twist, Merrow, England, 1971, 102.
15. Goswami, B.C., Martindale, J.G., Scardino, F.L., Textile Yarns Technology, Structure and Applications, Wiley, New York, London, 1977, 332 and 402.
16. Lord, P., Grady, P.L., Text.Asia, 1976, 7, No. 8, 42.
17. Lord, P., Grady, P.L., 15th Canadian Textile Seminar, 1976, 32.
18. Kampen, W., Lünenschloss, J., Phea. T., Rossbach, D., Int.Text. Bull. Spinning, 1979, 373.
19. Dyson, E., J.Text.Inst., 1974, 65, 632.
20. Neild, R., Abadeer, E.F., J.Text.Inst., 1979, 70, 275.

21. Singh, V.P., Ph.D. Thesis, Leeds University, 1981.
22. Yossif, F.M., Ph.D. Thesis, Leeds University, 1982.
23. Caliskan, O., M.Phil. Thesis, Leeds University, 1982.
24. Subramanian, T.A., Salhorta, K.R., Bhaduri, S.N., Text.Res.J., 1967, 37, 195.
25. Hunter, I.M., SAWTRI Bull., 1971, 5, No.1, 7.
26. Loralamia, E., Diploma Thesis, Leeds University, 1964.
27. Denton, M.J., Paper Presented at The Ninth Shirley International Seminar 10-12 May 1977, Polyester Textiles, Shirley Inst. Publication S26, 1977, 31.
28. Denton, M.J., Text.Month, July 1979, 52.
29. Fischer, K., Chemiefasern/Textilindustrie, 1977, 27/79, 895 EE 147.
30. Denton, M.J., J.Text.Inst., 1975, 66, 282.
31. Denton, M.J., Text.Asia, 1977, 8, No. 10, 38.
32. Piller, B., Bulked Yarns - Production, Processing and Applications, The Textile Trade Press, Manchester, 1973, 351.
33. Michelitsch, M., Melliand Textilberichte, 1959, 40, No. 5, 487.
34. Piller, B., Bulked Yarns, Production, Processing and Applications, The Textile Trade Press, Manchester, 1973, 89.
35. De Barr, A.E., Text.Mfr., 1961, 87, No. 1034, 54.
36. Dyer, R.F., Faw, W.G., Beard, R.L., Text.Res.J., 1952, 22, 487.
37. Seydel, P.V., Textile Warp Sizing, Creeling - Long and Clopton Inc., Atlanta, Georgia, 1972, 227.
38. Trauter, J., Bötte, H., Text.Praxis, 1982, 37, 221 EE 5.
39. El-Deeb, A.S., Private Communication, Leeds University.
40. B.C.I.R.A. Shirley Institute Bull., 1963, 36, 12.
41. Lord, R., Perez, M.E., Text.Res.J., 1981, 51, 45.
42. Aitken, J.B., Automatic Weaving, Columbine Press, Manchester, 1964, 111.

43. Vincent, J.J., Shuttleless Looms, The Textile Institute, Manchester 1980, 33 and 110.
44. Dakin, G., J. Text.Inst., 1957, 48, 321.
45. Nestler, R., Kautz, J., Faserforschung und Textil Technik, 1973, 24, 418.
46. Thwaites, J., Hooper, C.W., J.Text.Inst., 1981, 6, 239.
47. Willingham, W.L., Textured Yarn Association of America, Inc., Papers presented at The Spring Meeting, May 27-30, 1973.
48. Trotmanan, E.R., Textile Scouring and Bleaching, Charley-Griffin, London, 1968, 99-225-226.
49. Robinson, G.A., Cawood, M.P., Dobson, D.A., Proceedings - The Production and Properties of Fabrics, Carpets and Garments, Vol. IV, 26 Aug-3Sept. 1980, 126.
50. Midgley, E., The Finishing of Woven Fabrics, Technical Factors and Principles, Edward Arnold & Co., London, 1929, 129.
51. Matthews, J.M., Bleaching and Related Processes, Faults arising in Bleaching, J.J. Little and Ives Company, New York, U.S.A, 1921, 467.
52. Chan, S.F., M.Sc., Dissertation, Leeds University, 1978.
53. Trommer, G., Faserforschung und Textiltechnik, 1967, 18, 37.
54. Pavlov, Y.V., Finkel'shtein, I.I., Tech.Text.Industr., U.S.S.R., 1970, No. 3, 25.
55. Pavlov, Y.V., Tech.Text.Industr., U.S.S.R., 1971, No. 5, 25.
56. Pavlov, Y.V., Tech.Text.Industr., U.S.S.R., 1972, No. 3, 44.
57. Denton, M.J., Text.Inst. and Indust., 1978, 16, 274.
58. Miura, Y., Hasakawa, J., Text.Res.J., 1976, 46, 734.
59. Text.Praxis, (Editorial), 1982, 37, No. 6, English Edition, p. XXIV.
60. Hearle, J.W.S., J.Text.Inst., 1979, 70, 287.
61. Piller, B., Bulked Yarn, Production, Processing and Applications, The Text.Trad.Press, Manchester, 1973, 348.
62. Bachkaniwala, D., M.Sc., Dissertation, Leeds University, 1979.

63. Heung, C.M., M.Sc., Dissertation, Leeds University, 1980.
64. Trommer, G., Faserforschung und Textiltechnik, 1966, 17, 335.
65. Bauer, K., Shirley Institute Conference on Texturing, Shirley Institute Publication, S25, 1976, 19.
66. Jammers, H.C., Shirley Institute Conference on Texturing, Shirley Institute Publication, S25, 1976, 20.
67. Du Peuble, J.C. (A.R.C.T.), Fibre Producer, 1979, 7, No. 2, 18.
68. Sasaki, I., Kuroda, K., Suminokura, T., Tech.Mach.Soc., Japan, 1976, 16, No. 4, 119.
69. Lünenschloss, J.W., Fisher, K., Int.Text.Bull.Spining, 1977, 135.
70. Trommer, G., Faserforschung und Textiltechnik, 1967, 18, 115.
71. Weigert, H., Int.Text.Bull.Spining, 1977, 237.
72. Basu, S.K., Ph.D. Thesis, Leeds University, 1982.
73. Cannon, C.G., J.Text.Inst., 1979, 70, 105.
74. Hassanin, H.M.M., Ph.D. Thesis, Leeds University, 1982.
75. Cormack, D., Grosberg, P., Ho, K.H., J.Text.Inst., 1979, 70, 380.
76. Lord, P.R., Giorgis, T., 17th Canadian Textile Seminar, 1980, 51.
77. Lord, P.R., Text.Month, Dec. 1980, 45.
78. Nield, R., Abadeer, E.F., J.Text.Inst., 1979, 70, 282.
79. Lünenschloss, J., Rossbach, D., Text.Praxis, 1983, 38, No. 5, 433, (English Translation, p.X).
80. Nield, R., Abadeer, E.F., J.Text.Inst., 1979, 70, 367.
81. Wulfhorst, B., Melliand Textilberichte, 1979, 8, No. 12, 983 EE 994.
82. Smith, P.A., Lord, P.R., Spinning in the 70's, Merrow, England, 1970, 196.
83. Grosberg, P., Ho, K.H., Appl.Polymer.Symp., 1977, 31, 83.
84. Wegner, W., Landwehrkamp, H., Text.Praxis, 1962, 17, No. 12, 995.



85. Wegner, W., Wulfhorst, B., Text.Praxis, 1962, 17, No. 10, 1218.
86. Amer.Soc.Test Mat. Method, D.1423-76, Book of ASTM Standards, Part 32, Philadelphia, 1976.
87. Microprocessor Voltmeter 7055 and 7065, Operation Manual Solartorn Instrumentation Group Issue 5, Apr. 1979.
88. Howell, H.G., Nature, 1953, 171, 220.
89. Howell, H.G., J.Text.Inst., 1953, 44, 359.
90. The Wira Text.Data Book, Wira, The Leeds-based Research and Technical Centre, Leeds, England, 1977, B123.
91. Platt, M.M., Klein, W.G., Hamburger, W.J., Text.Res.J., 1958, 28, 1.
92. Bennett, J.M., Postle, R., Text.Res.J., 1979, 49, 499.
93. Hölz, W., Chemiefasern/Textilindustrie, 1979, 29/81, 473 EE 65.
94. Schierenbeck, C.D., Sholly, W., Modern Textiles, 1975, 56, No. 7, 30.
95. Booth, J.E., Principle of Textile Testing, 3rd Edition, Newnes-Butterworths, London, 1968, 233.
96. Basu, B.C., Hamza, A.A., Sikorski, J., J.Text.Inst., 1978, 69, 68.
97. Gupta, B.S., Chang, P., Text.Res.J., 1976, 46, 90.
98. Biot, M.A., J.App.Phys, 1939, 10, 860.
99. Goodier, J.N., J.App.Mech., 1950, 17, 383.
100. Chu, C., App.Mech.Proc., 1st Nature Congr. 1952, 265.
101. Freeston, W.D., Platt, J.M., Butterworth, G., Text.Res.J., 1966, 36, 12.
102. Denton, M.J., private communication, Leeds University.
103. Denton, M.J., Lecture handout, Leeds University.

APPENDICES

APPENDIX I

1. A derivation of capstan friction with reference to the frictional angle over the contact surface

Figure I.1 shows an element of yarn ( $ds$ ) with a total angle of-wrap  $\theta_0$  around a cylinder of radius  $R$ . The tension at the ends of  $ds$  being  $T$  and  $T+\Delta T$ . Due to the twist helix on the yarn surface, a frictional force  $F$  per unit length is assumed to be generated at an angle  $\hat{\phi}$  to the yarn axis in a direction opposite to the direction of the yarn movement. This frictional force may be resolved into two components, one opposite to the yarn movement direction and the other in a direction perpendicular to the yarn movement. If  $P$  is the normal (pressure) force/unit length, then the usual equilibrium equations can be written.

$$F \cos \hat{\phi} = \frac{dT}{ds} = \frac{1}{R} \frac{dT}{d\theta} \quad (1)$$

$$P = \frac{T}{R} \quad (2)$$

writing  $F = m[\eta]^n$   (3)

then  $F = m \left[ \frac{T}{R} \right]^n$  (4)

from equation (1)

$$\frac{1}{R} \left[ \frac{dT}{d\theta} \right] = m \left[ \frac{T}{R} \right]^n \cos \hat{\phi} \quad (5)$$

FIG. I.1: Schematic diagram illustrating the direction of the frictional force over the contact surface

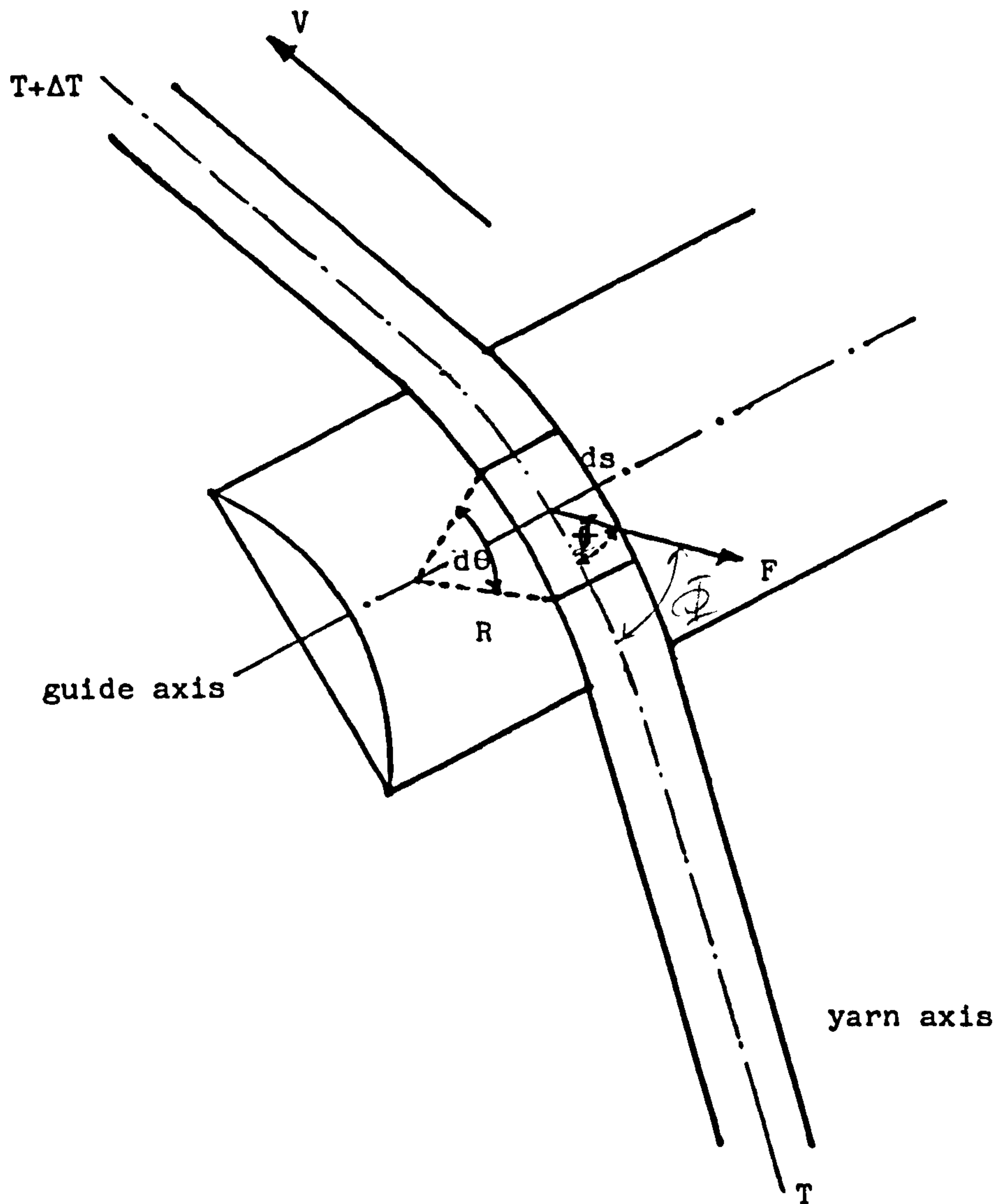

$\hat{F}$  = frictional force (gf / u.L)

$\hat{\Phi}$  = angle between the yarn axis and frictional force (radian)

ds = unit length of the yarn (cm)

T = tension (gf)

$\hat{\theta}$  = angle of wrap (radian)

Thus 
$$dT/T^n = m R^{1-n} \cos\phi d\theta \quad (5.1)$$

$$\int_{T_1}^{T_0} \frac{dT}{T^n} = m R^{1-n} \cos\phi \int_0^{\theta_0} d\theta$$

$$\frac{1}{1-n} \left[ (T_0)^{1-n} - (T_1)^{1-n} \right] = m R^{1-n} \cos\phi \cdot \theta_0$$

$$T_0^{1-n} - T_1^{1-n} = m(1-n) R^{1-n} \cos\phi \cdot \theta_0$$

or 
$$\left[ \frac{T_0}{T_1} \right]^{1-n} = 1 + (1-n)m \left[ \frac{R}{T_1} \right]^{1-n} \cos\phi \cdot \theta_0 \quad (6)$$

In the limit as  $n$  approaches unity the equation can take [84,85] the form of

$$T_0 = T_1 \exp m \left[ \frac{R}{T_1} \right]^{1-n} \cos\phi \cdot \theta_0$$

or 
$$\frac{T_0}{T_1} = \exp K\theta_0 \cos\phi$$

which is similar to the usual capstan equation, where

$$K = m \left[ \frac{R}{T_1} \right]^{1-n} \quad (7)$$

If the effective normal force (pressure/unit length) over the contact surface is assumed to be equal to  $\left[ \frac{T_m}{R} \right]$  where  $T_m$  is the mean value of the total tension over the guide surface then:

$$T_m = \frac{\int_0^{\theta_0} T d\theta}{\int_0^{\theta_0} d\theta} = \frac{\int_0^{\theta_0} T_1 \exp K \cdot \cos\phi \cdot \theta \cdot d\theta}{\theta_0}$$

$$= \left[ \frac{T_1}{K \theta_0 \cos\phi} \exp K \cos\phi \cdot \theta \right]_0^{\theta_0}$$

thus

$$T_m = \frac{T_1 \left[ e^{K \theta_0 \cos\phi} - 1 \right]}{K \cdot \theta_0 \cos\phi} \quad (8)$$

and

$$P_m = \frac{T_m}{R} = \frac{T_1 \left[ e^{K \theta_0 \cos\phi} - 1 \right]}{R \cdot K \cdot \theta_0 \cos\phi} = \frac{F}{R \cdot K \cdot \theta_0 \cos\phi} \quad (9)$$

where  $F$  = the frictional force over the contact surface

## 2. Estimation of the radius of curvature at angle of orientation $\neq 90^\circ$

Assume that the yarn is moving over the guide surface with a helical path and with a (helix) angle ( $\hat{\delta}$ ) between the yarn axis and guide axis [103].

In Fig. I.2a, AB is an intermediate section of yarn of length  $ds$  lying on the guide. The radius of curvature of the yarn path is derived as follows:

MOQN is the axis of the yarn guide and ACD describes a circle of radius  $R$  and centre  $O$  in a plane perpendicular to the axis.

FIG. I.2: A geometrical representation of the yarn helical path over a contact surface with an angle of orientation  $\neq 90^\circ$

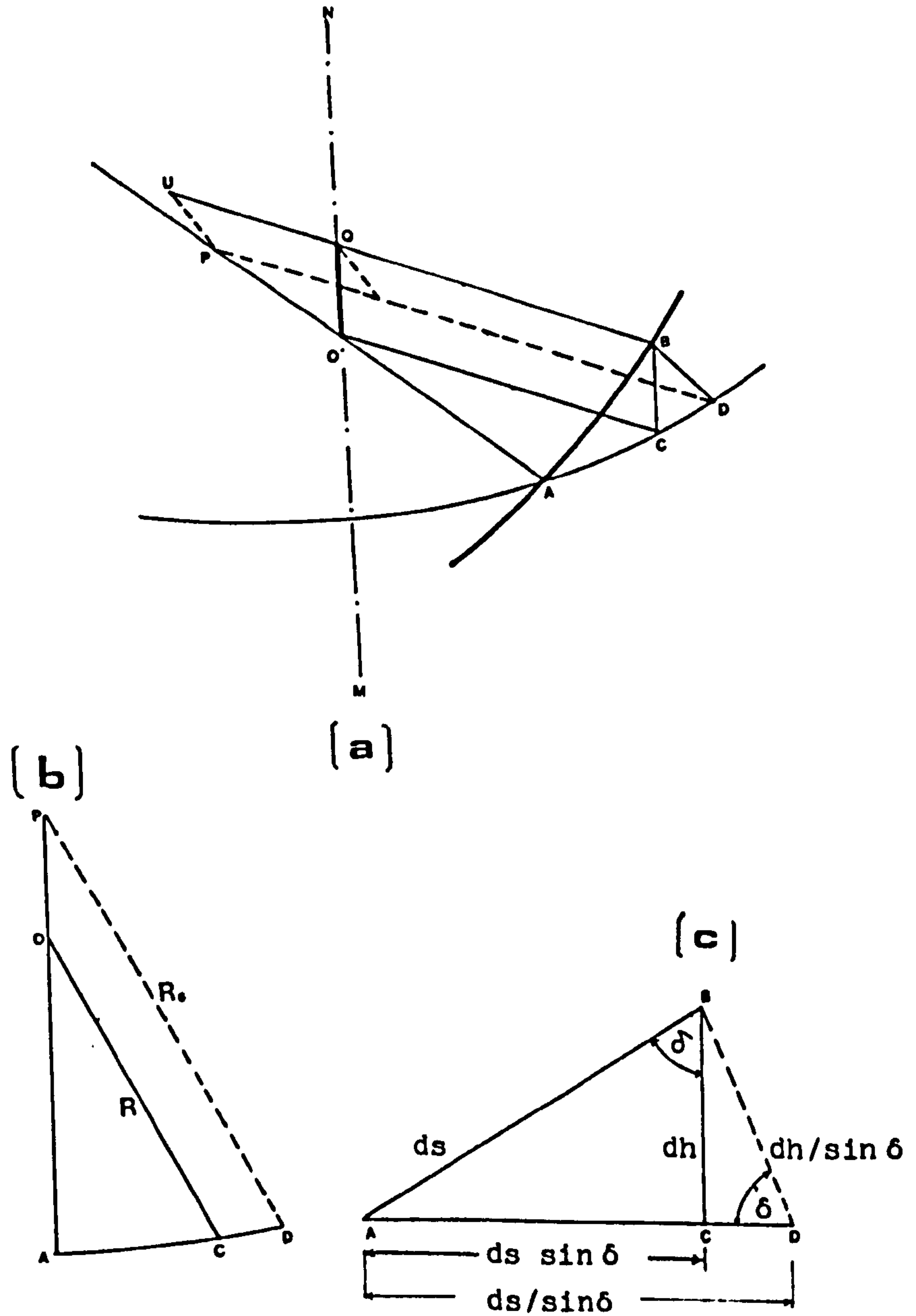

open shape of the helical path

A parallel circle of radius  $R$  and centre  $Q$  passes through  $B$ .  $R_s$  is the radius of curvature of the coil, where the centre of curvature at  $A$  is at  $P$  and at  $B$  is at  $U$ ; from Fig. I.2b

$$\frac{R_s}{R} = \frac{AD}{AC} \quad (10)$$

From Fig. I.2c

$$AD = ds \cdot \csc \delta \quad \text{and} \quad AC = dS \cdot \sin \delta$$

$$\therefore \frac{R_s}{R} = \frac{1}{\sin^2 \delta} = \csc^2 \delta$$

$$\text{then} \quad R_s = R \cdot \csc^2 \delta \quad (11)$$

The angle of orientation which is experimentally measured is equal to  $\hat{\beta}$ , where  $\delta = 90 - \beta^\circ$  (12)

Then substituting from (12) in (11)

$$R_s = R \cdot \csc^2 (90 - \beta) = R \sec^2 \beta \quad (13)$$

Now consider the relationship

$$S = R\theta_o \quad (14)$$

$S$  = length of arc of contact

However, when the yarn is inclined over the contact surface at angle  $\beta$ , the angle of wrap will no longer be  $\theta_o$ , but will be  $\bar{\theta}$ . This is because the angle of wrap is a function of the angle of orientation  $\hat{\beta}$ .



As long as the angle of orientation increases, the radius of curvature  $R_s$  increases. If the length of contact increases, due to increase of radius of curvature, the arc will, therefore, be:

$$\bar{S} = R_s \theta_o \quad (15)$$

If however, the length of arc of contact is constant and  $\beta$  is varying, the angle of wrap will vary as well as the radius of curvature, i.e.  $\bar{\theta} < \theta_o$  and  $R < R_s$ .

$$\text{When } S = \bar{S} \text{ then } S = R_s \bar{\theta} \quad (16)$$

Substituting from (13) in (16) and equating with (14) then we get

$$S = R \sec^2 \beta \cdot \bar{\theta} = R \theta_o$$

$$\therefore \bar{\theta} = \theta_o / \sec^2 \beta$$

$$\text{or } \bar{\theta} = \theta_o \cos^2 \beta \quad (17)$$

APPENDIX IIA brief outline of a theory of twist blockage

The purpose of this section is to review basic mechanics through which a theory of twist blockage might be developed.

Basic problem

A twisted yarn moves over a contact surface such as a guide, under tension. The twist tends to accumulate in front of the contact region leaving the yarn with a redistributed twist such that the twist over or after the contact surface is a minimum, whilst in front of the contact surface is a maximum.

For the twist to move forward with the yarn movement without accumulation the yarn has to overcome the forces generated over the contact surface which are pushing back the twist. This can be understood by studying the torsional-stresses over the contact surface which might affect the twist transfer, balanced against the stresses developed in the yarn by the twist accumulation in front of the contact surface.

Theory

It is convenient to divide the stresses acting on the yarn in contact with the surface into two contributions.

The first contribution involves the tensile force and its dependencies over the contact surface, such as the normal force (pressure/unit length), and the frictional force generated between the yarn and the contact region.

Generally speaking, the frictional drag over the contact surface has shown [90] a reduction in its magnitude as twist increases. During the measuring by other workers of frictional force generated between fibres, it was found [97] that the value of the frictional force was significantly influenced by the angle of inclination formed between the axes of fibres or bundles of fibres.

In the present research, the total frictional force ( $\bar{F}$ ) generated by the sliding and rolling actions of the yarn over the contact surface was observed to be dependent upon the interaction between the yarn and contact surface geometry, (see section 5.11). In other words, the direction and level of the resultant frictional force is a function of the type (S or Z) and the level of the yarn twist ( $\lambda$ )

$$\text{i.e. } \bar{F} = f(\lambda) \quad (1)$$

In the calculation of the normal force (appendix I), instead of supposing the normal force to be applied to the total length of contact region, the normal force can be assumed to be distributed over the number of points or regions of contact of the twisted yarn over the contact length. In other words, the reaction force (contact force) over the number of points of contact (cross-overs) may decrease as the twist increases.

$$\text{i.e. } P = f(\lambda) \quad (2)$$

In addition, the geometrical cross-section of the yarn over the contact region will be different from the cross-section in front of it.

In fact, because of the pressure between the yarn and guide surface, the yarn cross-section may be assumed to be flattened to a more or less elliptical or race track section in the case of singles or a compressed side-by-side configuration in the case of two-fold.

In the case of this distortion of the cross-section it will tend to inhibit yarn rotation because of the internal friction which would be generated over the contact surface. In two-fold, the main mechanism may relate more closely to the components lying side-by-side on the guide surface but distortion may also play a part.

In considering the stresses which will exist in the twisted yarn in front of the contact region a model of yarn structure must be used. Most investigators have considered the textile yarn as a uniform rod subjected to the laws of classical mechanics.

The most appropriate equation which can be applied to the yarn subjected to tensile stresses has been derived by both Biot [98] and Goodier [99].

The equation is concerning the torsional stiffness of a thin rod under an axial stress. The change of torque in a uniform elastic rod of twist ( $\lambda$ ) when subjected to a twist change ( $d\lambda$ ) may be expressed as:

$$dM = (GJ + \delta I)d\lambda \quad (3)$$

where  $G$  = the shear modulus of material

$J$  = the torsional stiffness factor

$\delta$  = the axial stress

$I$  = the polar moment of inertia of rod

In the case of a pre-twisted yarn, Chu [100] has shown that the torsional stiffness ( $J$ ) could be a function of the twist and may be expressed as follows:

If the torsional stiffness factor of untwisted rod is  $J_0$ , then  $J$  is the torsional stiffness factor with a pretwist ( $\lambda_0$ ).

For a circular cross-section rod, the equation may be written as follows:

$$J = J_0 \left[ 1 + \frac{r_s^2 \lambda_0^2}{2} \right] \quad (4)$$

It is assumed that under the tensile forces, the yarn will act as a thin solid rod, and in the case of plied yarn ( $n$  ply) the torque generated is shared equally between the number of singles twisted yarn.

Bennett [92] and his colleague calculated the torques generated in the single and plied yarn by the two following equations:

1. The torque generated in the single yarn is equal to

$$\frac{dM}{dT_s} = \frac{2}{3\pi} \frac{I_s \lambda_s}{r_s} \quad (5)$$

2. The torque generated in the plied yarn is equal to

$$\frac{dM}{dT_p} = \frac{2}{3} \frac{I_p \lambda_p}{\pi n r_s} \quad (6)$$

Then the total torque generated in the plied yarn will be:

$$\frac{dM}{dT} = \frac{2}{3\pi r_s} \left[ I_s \lambda_s + \frac{I_p \lambda_p}{n} \right] \quad (7)$$

where  $T_s$  and  $T_p$  are the tension in the single and plied yarn respectively.

$I_p$  and  $I_s$  are the polar moment of inertia of the plied and single yarn respectively.

$\lambda_p$  and  $\lambda_s$  are the twist in the plied and single yarn respectively.

$r_s$  is the single yarn radius.

When Bennett and his colleague considered the condition at which the torsion in the plied yarn becomes insensitive to changes in tension i.e. for which

$$\frac{dM}{dT} = 0$$

The relationship between the polar moment of inertia of the single and plied yarn was deduced as follows:

By equating equation (7) with zero, then

$$\frac{I_s}{I_p} = -n \frac{\lambda_p}{\lambda_s} \quad (8)$$

The negative sign depends on the direction of the ply yarn twist relative to the single yarn twist.

By substituting equations (4,8) in equation (3), it can be written as:

$$dM = \left\{ GJ_o \left( 1 + \frac{r_s^2 \lambda_{os}}{2} \right) + \left( -n\sigma \frac{I_p \lambda_p}{\lambda_s} \right) \right\} d\lambda_s \quad (9)$$

where  $\lambda_{os}$  is the pretwist of the single yarn

If  $A_p$  is the cross-section area of the plied yarn, the tensile stress ( $\sigma$ ) will be equal to:

$$\sigma = \frac{T_1}{A_p} \quad (10)$$

where  $T_1$  is the initial tension.

By substituting equation (10) in equation (9) we get:

$$dM = \left\{ G J_o \left( \frac{1+r_s^2 \lambda_{os}}{2} \right) + \left( -n \frac{T_1}{A_p} \frac{I_p \lambda_p}{\lambda_s} \right) \right\} d\lambda_s \quad (11)$$

The torque in any real yarn will be the sum of the three torque components, i.e. due to torsion, shear and bending. The first two are given in equation (11). The third component (bending) can be considered to be negligible with respect to other torque components. This is because torsion is the major contributor [101], especially at low helix angles.

Depending on the situation over the contact surface, a torque  $M_o$  is generated which tends to prevent the twist from moving forward with the yarn movement. Nevertheless, the torque generated within the twisted yarn in front of the contact region, given by equation (11), tends to push the twist forward with the yarn.

In principle, by equating these two moments it should be possible to predict the twist blockage behaviour.

However, there are so many 'unknowns' that this is not possible in practice.