

Touch in Sound

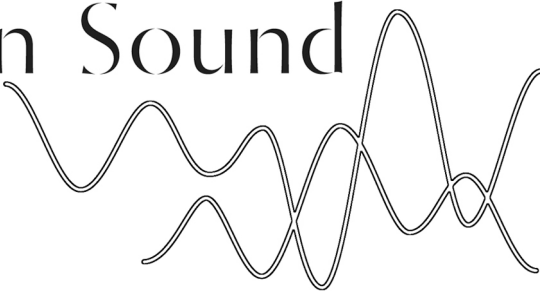

Portfolio of Original Compositions with a Written Commentary

JOANNE LOUISE ARMITAGE

Submitted in accordance with the
requirements for the degree of
Doctor of Philosophy

The University of Leeds
School of Music
April 2017

The candidate confirms that the work submitted is her own, except where work which has formed part of jointly-authored publications has been included. The contribution of the candidate and the other authors to this work has been explicitly indicated below. The candidate confirms that appropriate credit has been given within the thesis where reference has been made to the work of others.

Two pieces of practice detailed in chapter 4 (*Unheard Sounds* and *Enclosed I*), have been discussed in the following jointly authored papers: Joanne Armitage and Kia Ng, “Unheard Sounds” (paper presented at Electronic Visualisation and the Arts, London, 2015). Joanne Armitage and Kia Ng, “Feeling Sound: Exploring a Haptic-Audio Relationship,” in *Music, Mind, and Embodiment*, ed. Richard Kronland-Martinet, Mitsuko Aramaki and Sølvi Ystad (Springer International Publishing, 2016): 146–152. doi: 10.1007/978-3-319-46282-0. The work was entirely my own with the oversight of my supervisor, Kia Ng.

Early research into the thresholds of the skin and the initial development of technologies (discussed in chapter 2 and 3) was originally presented in Joanne Armitage and Kia Ng, “Multimodal Music Composition” (paper presented at Electronic Visualisation and the Arts, London, 2015) and Joanne Armitage and Kia Ng, Tactile Composition: Configurations and Communications for a Musical Haptic Chair” (paper presented at International Computer Music Conference, Sound and Music, Athens, 2014). The development of prototype one and the latency test discussed in chapter 3, formed the discussion in the following paper: Joanne Armitage and Kia Ng, “Configuring a Haptic Interface for Music Performance” (paper presented at Electronic Visualisation and the Arts, London, 2015). doi: 10.14236/ewic/eva2015.4. All this work was entirely my own with the oversight of my supervisor, Kia Ng.

This copy has been supplied on the understanding that it is copyright material and that no quotation from the thesis may be published without proper acknowledgement.

© 2017 The University of Leeds and Joanne Louise Armitage

The right of Joanne Armitage to be identified as Author of this work has been asserted by her in accordance with the Copyright, Designs and Patents Act 1988

ACKNOWLEDGEMENTS

This PhD, and all my future work, are forever indebted to my recently retired supervisor, Kia Ng. I am honoured to have studied with you, and will always treasure our time working together.

I am also very grateful to Mic Spencer for his guidance the past years and encouraging me to embark on this study. Another huge thanks in this domain to Alex McLean who has acted as an informal supervisor, and my peers Shelly Knotts and Oliver Thurley. I would also like to thank colleagues at the University of Leeds, particularly those who worked in the Interdisciplinary Centre for Scientific Research in Music and the Digital Cultures Research Group. I have been privileged to receive a University Research Scholarship, and additional funding from institutions including Sound and Music, Music and Letters, and Centre for Practice Based Research in the Arts.

During this period of study, I have shared time and space with some outstanding artists and practitioners in, around and beyond West Yorkshire. Some of these relationships have evolved into rich collaborations, including those with Greta Eacott and Sarah Maria Cook that are discussed in this commentary. In this vein, my thanks go to members of the Listening Group, and the live coding community, who have shared time, thoughts and sounds so generously. Huge thanks to Anya Stewart-Maggs for video editing and Anna Peaker for graphics.

Eternal gratitude to my Mum, Dad, and siblings Sarah, Robert, Hannah, Michael and Rebecca who have provided me with both practical and emotional support, energy and inspiration. I will take this opportunity to celebrate their future achievements, but also their resilience in overcoming the various challenges the past years have presented, together with my Nan and Pa. Thanks to my partner's family—Ros, Paul, Beck, Dave and Jack.

My thanks and love to my ever patient and supportive partner Bobby.

ABSTRACT

Sound propagates through space as a series of vibrations which are mediated, perceived and interpreted by the listening body. Whilst the body receives the physicality of sound, we predominantly focus on our listening experience through audition. In this work, I propose approaches to employing haptics, or vibration technologies, as a mechanism through which we can extend our experience of sound across the body and achieve a greater control of its physical presence. I will discuss ideas pertaining to sound as a physical and embodied practice, and the ways that I have explored this through developing conceptual systems relating sonic and physical materials. During the production of this work, themes of embodiment, mediation and immersion emerge which are unpacked through this commentary. Many of the works in this portfolio employ an audio and a haptic element that controls sound and vibration in synchrony, with the physical element rendered on bespoke haptic displays. A latter work explores the development of and performances with an algorithmic language for choreography. In this commentary, I reflect on each individual piece, documenting the process of making and subsequent outcomes to my creative thinking. Overall this project is underlined by a reflexive methodology where each new piece of practice influences the formation of the next—revealing new opportunities, concepts and technological approaches. I do not present a framework for the development of audio-haptic works, instead, I document and reflect on the processes through which my own practice has found connections, tensions and opportunities between the two forms. I conclude that whilst the inclusion of haptics heavily mediates and reconfigures the experience of listening, it can function as an immersive addition to sound that provokes presence, aura and tangibility in abstraction.

TABLE OF CONTENTS

ACKNOWLEDGEMENTS.....	II
ABSTRACT	III
TABLE OF CONTENTS.....	IV
APPENDICES.....	VI
PORTFOLIO	VII
LIST OF ILLUSTRATIONS.....	VIII
1. INTRODUCTION.....	1
1.1 The Practitioner and their Practice	5
1.2 Methodology.....	6
1.3 Original Contribution	7
1.4 Portfolio Overview.....	8
1.5 Commentary Structure	10
2. TOUCH AND HAPTICS	11
2.1 The Body, Touch and Technology.....	12
2.2 Haptics and the Feeling Body.....	15
2.3 Crossmodality and Sensory Substitution	16
2.4 Technologies of Touch	18
2.5 Audio-Haptics in Practice.....	20
3. WORKING WITH HAPTICS.....	23
3.1 Configuring Haptics.....	23
3.1.1 Drivers	24
3.1.2 Motor types.....	25
3.2 Prototype One: ERM with TLC5940	27
3.3 Prototype Two: ERM and LRA with DRV2605.....	30
3.4 Crafting Mountings for Motors	31
3.5 Conclusions.....	35
4. INSTALLATION WORKS.....	36
4.1 <i>Enclosed I and II</i>	37
4.1.1 Context	37
4.1.2 <i>Enclosed I</i>	39
4.1.3 <i>Enclosed II</i>	40
4.1.4 Reflections and Outcomes	41
4.2 <i>Unheard Sounds</i>	42
4.2.1 Background and Context.....	43
4.2.2 Outline of the Work	43
4.2.3 Reflections and Outcomes	45
4.3 Other Works	46
4.3.1 <i>My Back Catalogue Rendered as Vibrations on Your Body</i>	46
4.3.2 <i>Piano Stool Droning Around 33 Hz</i>	48
4.3.3 <i>Bone Music</i>	49
4.3.4 Reflections.....	50

5. HAPTICS IN PERFORMANCE	52
5.1 Silent Metronome.....	53
5.1.1 Related Work	54
5.1.2 Design Overview	54
5.1.3 Experimentation in Performance	55
5.1.4 Conclusions	60
5.2 <i>Key</i>	61
5.2.1 Instruments, Performative Gestures and Live Coding	61
5.2.2 Design and Development	65
5.2.3 Reflections in Performance	66
5.2.4 Further Developments	69
5.2.6 Conclusions	70
5.3 <i>It is only MIDI</i>	71
5.3.1 Algorithmic Music, Automation and Complexity	72
5.3.2 MIDI: Friend. Enemy. Protocol.	73
5.3.3 Design and Development	74
5.3.4 Reflection in Performance.....	75
5.3.5 Conclusions	77
6. AN ALTERNATIVE TAKE ON THE BODY: A LANGUAGE FOR ALGORITHMIC CHOREOGRAPHY	78
6.1 Related Works.....	79
6.2 Design and Development	80
6.3 Performances and Reflections	86
6.4 Conclusions and Next Steps	89
7. CONCLUSIONS	90
7.1 Final Reflections.....	90
7.2 Touching on the Future	93
7.3 Closing Thoughts	94
BIBLIOGRAPHY	95

APPENDICES

Included as files with this thesis.

Appendix A. Libraries

Appendix B. Datasheets

Appendix C. *Enclosed I* project files and audio example

Appendix D. *Enclosed II* project files and example

Appendix E. ‘The Body in Sound’ summative video

Appendix F. *MBCRVYB* project files

Appendix G. *33 Hz* audio file

Appendix H. *Bone Music* project file

Appendix I. Silent Metronome

Appendix J. Silent Metronome Eacott and McLean performance video

Appendix K. Silent Metronome Eacott and Armitage practice audio recordings

Appendix L. Rytmisk Musikkonservatorium workshop video

Appendix M. *Key* project files

Appendix N. di.stanze performance video with *Key*

Appendix O. Euler Room performance with *Key*

Appendix P. *It is Only MIDI* project files

PORTFOLIO

Audio and video examples of portfolio works are included as files with this thesis as follows:

Silent Metronome (2013)
Enclosed I and II (2014-17)
Unheard Sounds (2015)
Key (2015)
It is Only MIDI (2016)
My Back Catalogue Rendered as Vibrations on Your Body (2016)
Piano Stool Vibrating at 33 Hz (2016)
Bone Music (2017)
m1 = [la,ra] (ongoing)

LIST OF ILLUSTRATIONS

Figure 1. Block diagram of hardware components required in a haptic design.	24
Figure 2. Box plot to show average latency, standard deviation and outliers for C10-100, 310-101 and 308-102 motors (left to right).	28
Figure 3. Schematic design for prototype one.	29
Figure 4. Stripboard design and motor array grid.	30
Figure 5. Schematic design for prototype two.	31
Figure 6. Motors mounted in backrest. From a performance of <i>It is only MIDI</i> .	32
Figure 7. Hand-sewn waist belt with 310-101 ERM motors.	33
Figure 8. 308-102 inside straw (left). 308-102 encased and attached to cushion (right).	34
Figure 9. Tactile transducer installed in the piano stool.	34
Figure 10. <i>Enclosed II</i> , Fuse Art Space, Bradford.	41
Figure 11. <i>Unheard Sounds</i> , LimeWharf Gallery, London.	45
Figure 12. <i>MBCRVYB</i> , Fuse Art Space, Bradford.	47
Figure 13. <i>Piano Stool Droning Around 33 Hz</i> , Fuse Art Space, Bradford.	49
Figure 14. Bone conductive headphones building up vibrations.	50
Figure 15. Requirement analysis at Canute rehearsal, Goldsmiths, London.	56
Figure 16. Greta Eacott and Alex McLean at iscMME 2014, Leeds.	57
Figure 17. Greta Eacott and myself performing with the Silent Metronome, pre-ICLC Algorave, Access Space, Sheffield	58
Figure 18. Rehearsing with Collectress and Chris Keifer, Sussex University.	59
Figure 19. Greta Eacott and myself, <i>The Body in Sound</i> , Fuse Art Space, Bradford.	60
Figure 20. Setting up vibration motors for <i>Key</i> , Everyman Bistro, Liverpool.	67
Figure 21. Steaming on Euler Room.	69
Figure 22. <i>It is only MIDI</i> , McMaster University, Hamilton, Canada.	76
Figure 23. $m1 = [la, ra]$ rehearsals using the pattern language.	83
Figure 24. Diagram of the overall performance setup for $m1=[la, ra]$.	85
Figure 25. $m1 = [la, ra]$, ProDanceLeeds. Reproduced with permission from Camille Lagrange.	87
Table 1. Vibration motor amplitude and response data.	26
Table 2. Motor index (top) and frequency array (bottom) for first section.	44

Chapter One

INTRODUCTION

We hear in order to listen. We listen in order to interpret our world and experience meaning. Our world is a complex matrix of vibrating energy, matter and air just as we are made of vibrations. Vibration connects us with all beings and connects us to all things interdependently.¹

- Pauline Oliveros, *Quantum Listening*

Sound is grounded in the body. It is a corporeal form in its production and reception. Instigated by a kinaesthetic motion, a physical movement of an object in space—a step, a tap, a stroke, a speaker. Sound moves through space as vibration. Sound is actuated and propagated through materials; through objects, air and you. It enters you and is interpreted by you. Whilst complex mechanisms in the ear allow you to hear sound, your body feels it. Your body mediates your experience of sound.² We interact with sound, it embeds within us and is sculpted by our physicality as we form it. Sound is physical, it is formed and received as vibration. When the physical sensations of sound go unnoticed they are still embedded within us. Through sound we place and displace ourselves. Music imparts a visceral impression upon the body, the emotional impact of this experience is a psychophysical response, but the physical is inherent, integral and absorbed.

In practice, music composition focuses on creating an environment for the listening ear to explore, and for this reason, its primary concern is with the auditory perception of sonic events. The composer defines sonic parameters. For instrumental performance practice, a score can provide a means of visually communicating these parameters to the performer. The performer interprets these instructions and a sonic goal is rendered through gesture. This action is embedded in the body as a kinaesthetic movement.

¹ Pauline Oliveros, “Quantum Listening: From Practice to Theory” (address presented at MusicWorks #75, Chinese University, Hong Kong, 2000).

² I note that other factors outside the body, including assemblages of the social, cultural, and technological mediate sound, but these are outside the remit of this study. See Georgina Born, “On Musical Mediation: Ontology, Technology and Creativity,” *Twentieth Century Music* 2, no 1 (2005): 7–36. doi: 10.1017/S147857220500023X

Approaches to creating sound and sonic possibilities have been significantly extended through digital tools. Critics consider digital technologies to act as agents of interference in musical experiences, as lacking in authenticity and a sense of liveness, in opposition to nature, community and art.³ Such discourse is now the minority, with digital media forms ubiquitous within many aspects of music practice. Whilst the laptop can remove you from direct contact with a sound, relocating its physical realisation to an actuator, the possibilities afforded by such technologies wildly extends the scope of music creation. As technology continues to permeate performance practices, it is critical to interrogate the ways in which the body and technologies interact through music.⁴

Physicality and embodiment have been continually explored facets of live digital music creation, with designers working to unpick the performer-instrument relationship in the digital realm. This work has produced a plethora of weird and wonderful new interfaces for musical expression, from the 'Radio Baton' to the 'Reactable'.⁵ As a practice that, since its inception, has worked with associated genres, sounds and technologies, live coding has presented another shift and set of challenges to traditional ideas of expressive digital musical performance. In terms of audiences, these approaches look to augment their understanding and engagement through exposing performance processes and narratives, projecting code or heightening gesture, to visually communicate a tangible sense of liveness.

This work looks to haptics, or technologies of touch, as a means of incorporating the body into an experience through a physical connection. Haptic feedback techniques are regularly employed in commercial and research applications, but to a lesser extent, in artistic works. Within research, a significant and ongoing body of work has examined how haptic force feedback can instil a sense of user-presence in virtual systems. This strand of research incorporates work in teleoperation where haptic

³ Simon Frith, "Art versus technology: the strange case of popular music," *Media, Culture & Society* 8, no 3 (1986): 263 – 279. doi: 10.1177/016344386008003002

⁴ Don Idhe, "Technologies—Musics—Embodiments," *Janus Head* 10, no 1 (2007): 7–24. <https://philpapers.org/rec/IHDT>

⁵ See Max Matthews, "The Radio Baton and Conductor Program, or: Pitch, the Most Important and Least Expressive Part of Music," *Computer Music Journal* 15, no 8 (1991): 37–46. doi: 10.2307/3681070 and Sergi Jorda, "On stage: The Reactable and Other Musical Tangibles go Real," *International Journal of Arts and Technology* 1, no 3 (2008): 268–287. doi: 10.1504/IJART.2008.022363

feedback systems are designed to give the user a sense of a distant object's physicality.⁶ These haptic technologies have been used for remote handling in potentially hazardous industrial applications (i.e. nuclear, military and aerospace). Connected to this is the use of haptics in virtual environments where they have been employed to create a sense of immersion allowing users to manipulate virtual objects.⁷ They have also been applied to critical training scenarios for example surgery and land mine clearance.⁸ With their ability to instil a sense of ergonomic space in virtual systems, they have been used as interfaces for ceramic and design applications.⁹ Many of these projects employ the PHANToM haptic interface, a force feedback device, that has evolved through iterations to the present commercial model, Geomagic Touch.¹⁰ These are used as interfaces into virtual and distant spaces to reproduce real-world feelings and interactions for the user. Whilst these active force feedback devices have been the subject of much research, as industrial machines, their passive equivalents have become a physical trope.

We encounter commercial devices that are embedded with small vibrating motors daily, including mobile phones, games controllers, laptops and sex toys—to navigate us, notify us of incoming communication and pleasure us. Yet, the majority of these devices are closed systems and the technologies that drive them are only available at a low-level. This means that a certain amount of knowledge and labour is required to reconfigure and build new, experimental systems with them. Devices built using these motors offer low fidelity interactions when compared to force feedback devices, however, they are low cost and small. Individually these motors present a simple interaction—a vibration that can be controlled in time and amplitude—but additional complexity can be achieved through arrays with multiple motors. Such setups allow motors to be distributed across the body, providing multiple points of actuation. The potential for these techniques in accessibility scenarios has been explored, including

⁶ Gareth J. Monkman, "An Electrorheological Tactile Display," *Presence: Teleoperators & Virtual Environments* 1, no 2 (1992): 219–228.

⁷ Mandayam A. Srinivasan and Cagatay Basdogan, "Haptics in Virtual Environments: Taxonomy, Research status, and Challenges," *Computers & Graphics* 21, no 4 (1997): 393–404, doi: [https://doi.org/10.1016/S0097-8493\(97\)00030-7](https://doi.org/10.1016/S0097-8493(97)00030-7).

⁸ Stone, Robert, "Haptic Feedback: A Brief History from Telepresence to Virtual Reality," *Haptic Human-Computer Interaction* (2001): 1–16.

⁹ *Ibid.*, 4.

¹⁰ See "Geomagic Touch", accessed April 20, 2017, <http://www.geomagic.com/en/products/phantom-omni/overview>

navigation belt for the blind and in listening systems for the hearing impaired.¹¹ These techniques also present exciting possibilities for creators of digital interfaces.

This work is concerned with using arrays of vibrating, or haptic motors in conjunction with sound to develop novel multimedia experiences. The integration of a vibrating motor element into such a context is not in itself a novel concept. In 1959, director William Castle introduced the ‘Percepto’ seat for watching the film *The Tingler*. The seat incorporated vibrating motors salvaged from World War II aircraft that were activated at random during a specific scene in the movie.¹² This idea, to provide a physical sensation to cinematic audience members, endured through smaller scale productions in entertainment parks and has recently been revived through 4D cinema—where physical effects are incorporated into the movie experience.¹³ In terms of music listening and performance, haptic techniques have been used in the design of interfaces, for timing and communicating musical structures and as a means of extending the listening experience to the body.¹⁴ Despite these antecedents, touch-based or tactile art is still not an established form.¹⁵

This portfolio and supporting commentary explore how the electronic composer and performer can obtain a greater control of the physical experience of their music through additional sensory stimulation. Central to this work is the body—the body of the performer, the body of the listener and their relationship to sound and the

¹¹ Linda R. Elliott et al., "Field-based Validation of a Tactile Navigation Device." *IEEE Transactions on Haptics* 3, no 2 (2010): 78–87. Suranga Chandima Nanayakkara et al. "Enhancing Musical Experience for the Hearing-impaired using Visual and Haptic Displays," *Human-Computer Interaction* 28, no 2 (2013): 115–160.

¹² Craig Fischer, "Castle, William," in *The Guide to United States Popular Culture*, ed. Ray Broadus Browne and Pat Browne (Madison: The University of Wisconsin Press, 2001), 143–144.

¹³ In the UK, these can be found at Cineworld cinemas across the country, accessed April 20, 2017, <https://www.cineworld.co.uk/4dx>

¹⁴ Haptics in musical interfaces, Maura Sile O’Modhrain, "Playing by Feel: Incorporating Haptic Feedback into Computer-Based Musical Instruments," (PhD diss., Stanford University, 2000) and Claude Cadoz, Leszek Lisowski, and Jean-Loup Florens, "A Modular Feedback Keyboard Design," *Computer Music Journal* 14, no 2 (1990): 47–51; timing Joanne Armitage and Kia Ng, "mConduct: A Multi-sensor Interface for the Capture and Analysis of Conducting Gesture," in *Electronic Visualisation in Arts and Culture*, ed. Jonathan Bowen, Suzanne Keene and Kia Ng (London: Springer, 2013): 153–165; communicating musical structures, Lauren Hayes, and Christos Michalakos. "Imposing a Networked Vibrotactile Communication System for Improvisational Suggestion." *Organised Sound* 17, no 1 (2012): 36–44. doi: 10.1017/S1355771811000495; composition, Eric Louis Gunther, "Skinscape: A Tool for Composition in the Tactile Modality," (PhD diss., Massachusetts Institute of Technology, 2001). A further discussion on this is given in section 2 of this commentary.

¹⁵ Adam Gopnik, "Feel me," *The New Yorker* May 16 2016, accessed April 20, 2017, <https://www.newyorker.com/magazine/2016/05/16/what-the-science-of-touch-says-about-us>

instrument. It is a practice-based investigation, which probes these spaces to garner further understanding of the role the body plays in directing our musical experiences.

1.1 The Practitioner and their Practice

I began the process of this research as someone with an interest in embedded systems and computation exploring composition; most of the work I had previously created looked at approaches to mapping data and developing processes for instrumental compositions. Through the process of this study, I hoped to embed my interests in physical computing with my practice in sound. Having worked with haptics on previous projects, I was interested in how they could be incorporated into such a schema. What transpired early on in this project, was that I stopped being a composer in a conventional sense, which was initiated, in part, by my interest in live coding, but also as a political response to diversity issues in the field. I found myself becoming increasingly productive developing works through digital means, removing the need for an instrumental performer. The work I was developing was not concerned with a sonic outcome as such, but how sound could be related to vibrations impacting an overall experience. Whilst composition, as I had practiced it in the past, was concerned with controlling temporal structures and internal processes, I began to draw inspiration from new media arts and the way in which digital technologies can reframe our experiences of performative or live media.

This work is concerned with using vibration, or haptic technologies, in sonic practice. I commenced this aspect of the study attempting to relate somatic and auditory emotion via haptic and sonic stimuli, but this proved challenging as I discovered how much scope there was for developing methods to understand these complex relationships. From this point onwards, tensions have driven the production of this work, and I feel that I have been in a constant spiral attempting to inform engineering through art and vice versa. The formulation of the compositional work was dependent on engineering technologies for touch, but the development of technological work was dependent on the conception of some creative, performative and/or aesthetic outcome. As such, this project is not a blueprint for creating physical renderings of sound, instead aiming to explore relationships between sound and the body, by presenting performers and listeners with novel opportunities to engage with and experience sound as the physical.

During the time of this practice, I have performed regularly and collaborated with other musicians and artists in different areas including, Anna Peaker, Bryony

Pritchard (Movement from the Mills), percussionist Greta Eacott, dancer Sarah Maria Cook and computer musician Shelly Knotts (ALGOBABEZ).¹⁶ Through my involvement as a founding member of the group, Orchestra for Females and/at Laptops (OFFAL), I have worked with international artists performing worldwide.¹⁷ I have attended several conferences in electronic and computer music, and given workshops at institutions including, National Media Museum, Rensselaer Polytechnic Institute, Wesleyan University and Huddersfield University. Throughout this time, I have performed at, and occasionally organised, over 70 live music events, encompassing Algoraves, festivals and DIY gigs at arts spaces and clubs across the UK, Europe, and further afield in Canada and North America.¹⁸

1.2 Methodology

The overarching approach of this research is that of a practice-based investigation whereby theoretical ideas guide the development of a new piece of practical work that is then iteratively refined ahead of performance, interrogated through performance, and reflected upon. The nature of this investigation is inherently iterative, each new piece of practice has been informed by the previous, and for this reason, works are structured chronologically within this commentary. Some engineering methods have been utilised in designing the haptic prototypes—requirement analysis, hardware surveys and a system evaluation of different motors—no formal evaluation has been conducted on the portfolio works. The central aim of this project is not to evaluate audio-haptic experiences, but to develop original works and examine how they influence my own creative practice. To clarify, this is not a thesis on human computer interaction with or perception of haptics—it is a commentary on practice-based research that uses haptic technologies in performance.

At the outset, I conducted a contextual review including research into haptic devices (consumer, research and artistic), supported by research into the philosophy and physiology of perception. Alongside this, I developed an understanding of the physics of vibration and how it is produced, and engineering approaches to designing and developing haptic devices. The hardware and software for each work developed through iterative refinement, by designing and implementing prototypes, and then

¹⁶ Bryony Pritchard, aka Bryony Artfever, “Gujarati Binary Dancing,” Vimeo video, 01:58. Posted [October 2016], accessed April 20, 2017, <https://vimeo.com/189288985>.

¹⁷ See OFFAL (<http://offal.github.io/>).

¹⁸ A full list of my performances since July 2014 can be found here (<http://joannne.github.io/>).

conducting testing to inform a refined version of the system. This occurred during micro and macro stages of the development process. The former, for example, during laboratory tests of circuit designs, and the latter, after a public exhibition that revealed an issue with the design, or a conceptual issue with the piece. Due to the nature of my development environment, a music lab with limited electronic tools and technical support, much of my approach employed hacking and crafting methods to achieve technological aims.

I documented the practice process through several media forms, to reflect in (during events) and on (after events) my actions. I kept extensive handwritten and typed notes through rehearsals and periods of making that document pathways, thoughts and actions. Particularly in rehearsals, I recorded audio segments of the discussion, interactions and thought processes revealed through collaboration. From this documentation, in this commentary, I have reflected upon the development of my practice and how technologies have influenced its outcomes. This commentary is constructed from these records to build a narrative around the processes I undertook in realising creative and technical goals. In doing so, it places myself and my practice at the centre of the enquiry, allowing me to reflect critically upon my work post-event. Where available and appropriate, this reflection and analysis incorporates comments from collaborators and the public. I will relay this process in a way that celebrates the experimental nature of my approach, the challenges I encountered, and the unforeseen paths that my research revealed, to reflect the heuristic and open nature of my enquiry.

1.3 Original Contribution

This commentary looks at work developed over the course of this study, from developing haptic prototypes to designing experiences and performing with them. It contributes to research in the following ways:

- This project contributes new perspectives on haptics in a vast body of research that looks at the application of technologies in electronic music performance. With this, I have developed new knowledge through the technologies created including circuit and enclosure design, approaches to mapping and audio-haptic techniques

- Much research connecting haptics and musical applications looks towards new interfaces for musical expression and how vibrations can be employed to improve interactions with controllers.¹⁹ In contrast, this work elaborates on audio-haptic techniques to examine how we can extend the physical experience of existing interfaces (i.e. laptop) for performance.
- Through documenting and examining the use of haptic in practice, I contribute to the field of music performance, offering new experiences and interactions. I have developed new experiences for audiences that pose questions about our interactions with machines and how we interpret them.
- This commentary provides some documentation of the process of making haptic devices from a DIY perspective—something that I found lacking in my own initial research.
- It explores new possibilities in the design of haptic systems through novel mappings and interfaces.

To summarise, this work proposes new technologies, frameworks and aesthetic means of incorporating tactility into sound. Furthermore, it contributes to discussions in haptic design through the development of novel, immersive and innovative experiences.

1.4 Portfolio Overview

Although titled ‘A Portfolio of Compositions with a Written Commentary’, the portfolio itself consists of a mix of installation works and improvisatory performance systems, and the commentary undulates between a lab report and reflective log. Much of the work described within can only be truly experienced through the bespoke vibrating interfaces I have developed as part of this process, consequently, there are some challenges in documenting the ‘overall experience’ of my portfolio. Two USB drives are included in this submission, one labelled ‘Portfolio’ and the other ‘Appendices’. The former contains audio and/or video documentation of each work described herein, and the latter contains supporting media such as code, and other

¹⁹ Examples of work looking at haptic interfaces for music making can be found in the following three articles. Mark Marshall and Marcelo Wanderley, “Examining the Effects of Embedded Vibrotactile Feed-back on the Feel of a Digital Musical Instrument” (paper presented at New Interfaces for Musical Expression, Oslo, Norway, 2011). Maura Sile O’Modhrain, “Playing by Feel: Incorporating Haptic Feedback into Computer-Based Musical Instruments” (PhD diss., Stanford University, 2000). Edgar Berdahl, Hans-Christoph Steiner and Colin Oldham, “Practical Hardware and Algorithms for Creating Haptic Musical Instruments” (paper presented at New Interfaces for Musical Expression, Genova, Italy, 2008).

materials that will be referred to in the course of the discussion. The following installations and performance systems are discussed in this document, presented here in a chronological order.

Silent Metronome (2013), as an early and enduring performance system, comprises of a vibrating element that communicates tempo and time signature between instrumental and laptop performers.

Enclosed I and II (2014–17), an installation work that moves sound around space in synchrony with vibrations. Listeners navigate through an audio-haptic space of sonic drones and uncertainty.

Unheard Sounds (2015) was developed alongside *Enclosed*, where a grid of actuators vibrate to highlight the presence of delicate sinewaves that may go unheard.

Key (2015) is a performance system that renders the keystrokes of an improvising live coder as vibrations to the audience, highlighting typing gestures to amplify the coding timeline for audiences.

It is only MIDI (2016), looks to how MIDI note data in my live coding performances can be rendered as vibration, exposing a data process that can be abstracted from sound through synthesis. In doing so, it presents an approach to live coding vibration as pattern.

My Back Catalogue Rendered as Vibration on Your Body (2016) is a remix of my back catalogue of recordings for two channels of sound and four channels of vibration. This installation re-mediate my production work, rendering it as a multisensory form.

Piano Stool Droning at 33 Hz (2016) where a tactile transducer gently vibrates the user at various low frequencies.

Bone Music (2017) uses bone conductive headphones that do not occlude the ear, transmitting sounds through bone directly to the eardrum, allowing a ‘distorted’ and ‘true’ version of the sonic environment to be presented to the listener.

m1 = [la, ra] (ongoing) is a collaboration with dancer Sarah Maria Cook. This work is a live coding dance and sound improvisation that explores how code can represent and then be embodied as sensation.

1.5 Commentary Structure

In this commentary, I describe and reflect upon a series of installations and performance systems developed as part of my practice-based PhD. I will disentangle and repackage my endeavours over the past few years and present it as a tangible whole by examining themes, processes and concepts that have influenced my practice. This chapter has given an overview of the conceptual thinking behind the work and presents the basis for the forthcoming chapters. In chapter 2, I present philosophical theories of touch and haptics pertinent to my portfolio, and reflect on themes of presence, absence and embodiment that will emerge throughout this document. I will outline current technological approaches and innovations in developing haptic systems and subsequently, discuss and analyse existing audio-haptic works to suggest challenges and opportunities for individuals designing related systems. In chapter 3, I detail the development of various haptic systems used in my work, referring to current trends in haptic design and their affordances, contextualised within DIY electronics.

In the latter half of the document, I present a commentary on the works that I have developed, which is split into three chapters, with chapter 4 focussing on installation works, chapter 5 on performance systems and chapter 6 which discusses a project that explores a new direction on the body in performance. Each work has an individual commentary which discusses its conceptual and technical development and use in a performative scenario to reveal the processes explored, and outcomes for my compositional thinking. Through this, I will propose various means of incorporating additional stimulation to the physical body in the acts of performing and listening, and consider how it can be employed as an extension of the compositional schema. In doing so, I will also reflect on performance systems that have facilitated my collaborative and solo work by considering the role of the physical body and machine in practice.

I will conclude in chapter 7 by first summarising the contents of this commentary, then reflect on themes that have permeated throughout the portfolio, and finally consider ways in which I anticipate my practice developing.

Chapter Two

TOUCH AND HAPTICS

An oculacentric paradigm is pertinent throughout society and frames how we design, analyse and interact with media. Through time our entire bodies are becoming intertwined with our digital technologies. As information and communication is evermore digitised, and haptic technologies improve, the touch channel will become increasingly ubiquitous in our digital devices. With this, we must begin to consider more critically the relationship between our bodies and devices, and how this can be transformed and extended through haptic interactions. In both research and entertainment contexts, haptic devices are conceived to augment our sensory experience of objects, but concrete methods for developing and analysing these experiences have not yet emerged. Imminent innovations in areas such as teledildonics, will force us to reconceive the role that our sense of touch plays in digital media experiences.¹

This chapter will explore ideas related to touch from physiological and philosophical perspectives, and contemplate how the haptic is embodied in interactive media experiences. This will lead into a discussion of crossmodality and sensory substitution to consider the relationships between our sensory domains. An understanding of the physiology of touch will reveal the mechanisms and constraints of feeling, establishing technical requirements for building systems that can be employed for touch. From this, I will consider the role that haptic interactions play in technology systems, and close by discussing multisensory art work and several haptic installations that are related to my own. Much of this chapter is influenced by Paterson, which proves a valuable resource in the limited discourse that connects philosophical ideas of touch

¹ Nicola Liberati, "Teledildonics and New Ways of "Being in Touch": A Phenomenological Analysis of the use of Haptic Devices for Intimate Relations," *Science and Engineering Ethics* (2016): 1–23. doi: 10.1007/s11948-016-9827-5.

to haptic technologies, it has been incredibly beneficial to my understanding the function of haptics within my own schema.²

2.1 The Body, Touch and Technology

This project's phenomenological concern arises from its focus on examining the place of the touching body in the listening experience. Phenomenology places the body central to our experiences of the world, through our body we sense, perceive and are affected. Spiegelberg suggests that phenomenology is a move towards 'the enlarging and deepening of the range of our immediate experience.'³ The body is a vessel through which experience channels into meaning. Phenomenology accounts for component parts of an experience, not the continuous flow of information. It sums an experience as a textually descriptive and analytical whole to extract meaning, rather than by relaying perceptual information as it is received. Paterson suggests that a phenomenological analysis describes 'manifold contents, intentions and relations inherent in the experience of touching, and [...] list(s) the forms of presence and absence that are possible for the object in question.'⁴ Paterson discusses the challenges of a phenomenology of touch as something that is unfamiliar, requiring words that we do not possess in its description. Through increased exploration and exposure to users and audiences, haptic systems can receive a more rigorous phenomenological basis. Towards this, there is much interest in phenomenology in contemporary arts practice, which could be seen as a response to the ubiquity of the visual and its limitations in the analysis of body-centred works.⁵

The primacy of vision has eroded our dialogue relating to the sense of touch. Philosophically, touch has been regarded as a bestial or carnal sense, but conversely as the sense of the greatest profundity. To a certain extent, baser readings of touch, are born out of its complexity as a sense with no localised sensory organ. Touch informs us of information regarding our bodies relationship to the world, perceiving temperature, pain, pressure and movement, and through these means it also acts as a form of close, interpersonal communication. Touch is with us through stillness, it goes unnoticed and unfelt, but is inherent in our every movement and interaction. Paterson

² Mark Paterson, *The Senses of Touch: Haptics Affects and Technologies* (Oxford: Berg, 2007).

³ Herbert Spiegelberg, *The Phenomenological Movement: A Historical Perspective* (Dordrecht: Kluwer Academic Publishers, 1994), 679.

⁴ *Ibid.*, 24.

⁵ Susan Kozel, *Closer* (Cambridge: MIT Press, 2008). doi: 10.7551/mitpress/9780262113106.001.0001

discusses how societally, touch concerns tangibility, revealing a sense of truth and solidity through proximity and intimacy. In doing so, he also notes that the psychological qualifications of touch, as something measurable, do not account for both the internal (proprioceptive) and external (exteroceptive) relationship between touch and the body. Touch can be decoupled from sensation and emerge as affect and emotion with, or metaphorically without, a physical interaction. It communicates presence through the immediacy of its interface and is integral to our embodied experience.

Wearing a glove, we may still stroke an animal or imprecisely sense an object's texture; similarly, when walking with a stick we apprehend the roughness of the ground. The fleshy medium is corporeal then, and extendable through prosthetic means.⁶

In much engineering discourse, there is an assumption that embodiment is an unequivocal outcome to being touched. Whilst haptic sensations are tangible forms that are embodied, so are the rest of our senses. Transmitting sensations or information as vibrations through the flesh is much more complex than the physiology of touch itself. Systems of touch need to consider the ways in which they navigate the gap between structure and meaning through the augmented sensory experience they are designing. This conception of embodiment removes affect and simplifies the dichotomy between the internal and external body, conceiving the skin as a layer between outer and self that vibrations can simply be 'meaningfully' transmitted through. Furthermore, such connotations imply that other senses are less embodied, if at all. In doing so, haptic engineers do not approach their work from the phenomenological perspective. This negates the phenomenal body and through this, designers of haptic systems are removing human subjectivity from the experience of their systems.

What comes to the fore in this reimagining is the central role played by the body in the interface to the virtual. With the convergence of physical and virtual spaces informing today's corporate and entertainment environments, researchers and artists have come to recognize that motor activity — not representation verisimilitude — holds the key to fluid and functional crossings between the virtual and physical realms.⁷

Much discourse regarding the haptic in digital environments is centred around virtual reality (VR), which is generally an inexplicably ocularcentric form. Above, Hansen argues for a greater consideration of the body in VR, specifically motor activity. Supporting this, Srinivasan and Basdogan suggest that the application of haptics goes

⁶ Paterson, *The Senses of Touch*, 17.

⁷ Mark Hansen, *Bodies in Code* (New York: Routledge, 2006), 2.

beyond the user's aesthetic interpretations of visual quality and is a key element.⁸ The level to which that immersion occurs is still subject to the fidelity or quality of the haptic interactions. Hansen suggests that work in VR will amount to a reimagining of the role of touch, resulting in digital experiences becoming tactile and further embodied. Boothroyd supported this notion, suggesting that such techniques will result in a reimagining of communication, and that the inclusion of touch draws the body in to a truer representation of reality:

At the same time, it provokes us to rethink what we understand by communicative contact as such: we must think of it as essentially embodied, sensory and tactile, rather than as the disembodied, symbolically structured representation of experience. [...] to the idea of 'digital communications' in general as inaugurating a new stage of evolution of what could usefully be referred to as the haptic body-machine assemblage.⁹

From the concepts above, artists interpret that increased bodily stimulation, through cutaneous or kinaesthetic means, contributes to an increased immersion within a media experience. Hansen and Boothroyd are discussing task-based interactions in VR and although there is nothing to suggest that haptics could not influence immersion and engagement outside of a task oriented scenario, in a more abstract media environment, there is little empirical evidence to support this. In many instances, practitioners look to concepts of crossmodality, discussed later in this chapter, to create immersive experiences for the sensational body.

The technical problems facing haptic media engineers and data algorithmists may well be taken to dealing with matters of how best the sense of touch can be represented (in other words, simulated.) But, I am suggesting, the digitization of 'touch data' amounts, in effect to an 'evolution' *in the materiality* of what has hitherto been designated as 'the sense of touch' as such. And, once haptic media become a part of our 'normal' communicative practices — once this technology, is literally, incorporated — touching will, I suggest, be in the process of undergoing a transformation by way of acquiring a new form of materiality.¹⁰

Above, Boothroyd voices the internalised concerns of practitioners attempting to develop meaningful haptic experiences where mapping is often based on an exploratory assumption, or an attempt to render realistic interactions. He suggests a new paradigm for designing touch. Rather than centring motor-activity on skin, Boothroyd expands on Hansen to argue for a reimagining of touch, which is not purely representational or mimetic, but extends what we consider touch beyond the

⁸ Paterson, *The Senses of Touch*, 133.

⁹ Dave Boothroyd, "Touch, Time and Technics: Levinas and the Ethics of Haptic Communications," *Theory Culture and Society* 26, no 2–3 (2009): 330–345. doi: 10.1177/0263276409103123

¹⁰ *Ibid.*, 338.

biological confines of the skin. Whilst this is challenging to conceive of and likely not a technical possibility at present, it raises interesting questions as to how ‘touch data’ can be employed in the future.

2.2 Haptics and the Feeling Body

The basic anatomical receptors, or sensory organs, of touch are mechanoreceptors located within the skin and subcutaneous tissues. There are four different types of mechanoreceptors located within the skin and subcutaneous tissues. Receptors, or nerve endings are located all over the body, covering most areas. Denser receptor clusters are often found in the skin, particularly around hair follicles, but also around joints, muscles, and blood vessels and within the ear. Stimulating different combinations of these receptor distributions affects the dimensions of our sensation. In that, a ‘cutaneous’ sensation stimulates receptors in the skin, and is different to a kinaesthetic movement, where receptors in the skin, muscle and joints are stimulated.¹¹ Touch is more than what we physically feel. In addition to informing us practically about our environment and movement, our sense of touch reflects intimacy and often plays a significant role in how we communicate emotionally and interpersonally: touch can be loving, but it can also be violent. To ensure characteristics of vibration do not produce pain, but are perceptible, they need to be within detectable and sensitive ranges of the skin.

The vibration parameters primarily explored through vibrotactile perception research are: frequency, timing, amplitude and location. Akin to the auditory system, tactile sensation is achieved when vibrations surpass various thresholds. This is dependent on several factors: area of skin, hair density, frequency, duration, mass and waveform. The minimum movement detectable as a tactile sensation is generally considered to be 0.04 G.¹² In terms of the skins vibration sensitivity range, the upper limit is often considered to be 1 KHz, although Wyse et al. report that the use of more complex vibrotactile signals applied to the hand can be felt up to 4000 Hz when produced at

¹¹ A deeper understanding of these structures can be garnered from Anthony W. Goodwin and Heather E. Wheat, “Physiological Mechanisms of the Receptor System,” in *Human Haptic Perception: Basics and Applications*, ed. Martin Grunwald (Berlin: Birkhäuser, 2008), 93–102.

¹² Precision Microdrives Staff, “Adding and Improving Haptics.” Precision Microdrives Application Bulletin, accessed March 15, 2015, <http://www.precisionmicrodrives.com/haptics-haptic-feedback-vibration-alerting/haptic-feedback-in-detail/adding-and-improving-haptic-feedback>

an increased amplitude.¹³ Generally, it is agreed that the greatest sensitivity is felt at around the range of 200 to 250 Hz. When coding discrete information through the tactile channel, only four levels of amplitude are identifiable between the pain and comfort threshold, and nine levels of frequency with a difference of around 20%.¹⁴ Similarly to audition, haptic signals are not relative between frequency and amplitude. This work does attempt to code discrete haptic information, rather is employs an expressive gestural approach to haptic interactions, these figures provide a model through which the vibration of motors can be constrained.

2.3 Crossmodality and Sensory Substitution

The interrelation of the senses has have been a debated area of perceptual theory since Aristotle.¹⁵ The senses can be considered as an integrated whole with distinct component parts, but conversely, many theorists suggest they act as a single unit. What motivates much research into crossmodality and sensory substitution, is the relationship between different sensory channels and whether an individual can directly translate between them, or whether such perceptual relationships are formed through experiential learning. Systems of tactile sensory substitution have long been employed in assistive scenarios, as additional channels of communication for individuals with hearing or visual impairment. Examples of this include non-digital approaches such as Braille, which represents visual characters in the tactile domain as raised dots, and sign language to translate spoken word as gestures. These systems demonstrate a learned form of cross-modality, where language-based communication is rendered in an alternative sensory domain, however, they are limited in terms of what the can communicate about more abstract notions such as the environmental space an individual is occupying.

Electronic systems enable cross-modal communication to occur in more abstract ways by rendering data as opposed to language. In this area, the work of neuroscientist Paul Bach-y-Rita, is notable. Bach-y-Rita treated patients' neurological problems with

¹³ Lonce Wyse et al., "Perception of Vibrotactile Stimuli Above 1 kHz by the Hearing-impaired" (paper presented at New Interfaces in Musical Expression, Michigan, USA, 2012).

¹⁴ Jan B. F. van Erp, "Guidelines for the use of Vibro-Tactile Displays in Human Computer Interaction" (paper presented at Eurohaptics, Edinburgh, UK, 2002). <http://www.eurohaptics.vision.ee.ethz.ch/2002/vanerp.pdf>

¹⁵ It is famously demonstrated in Molyneux's problem: 'Imagine that a congenitally blind person has learnt to distinguish and name of a sphere and a cube by touch alone. Then imagine that this person suddenly recovers the faculty of sight. Will they be able to distinguish both objects by sight and to say which is the sphere and which the cube?' Marjolein Degenaar, Molyneux's Problem (Netherlands: Springer, 1996), 13. doi: 10.1007/978-0-585-28424-8

forms of sensory substitution. His seminal ‘Vision Substitution by Tactile Image Projection’ discusses the rendering of visual information as a tactile representation using a large grid of solenoid actuators. Participants were trained to discriminate between different shapes and objects. With increased exposure to the chair, participants were found to noticeably improve their time taken to identify an object.¹⁶ Whilst the work of Bach-y-Rita demonstrated a learned form of sensory substitution, an inherent relationship between the senses is demonstrated through the phenomenon, synaesthesia.

Synaesthesia is a condition whereby one sensory impression renders a sensation in another domain. Such associations have a rich history in the arts, whereby numerous practitioners, from Messiaen to Mary J. Blige, have reported experiencing it.¹⁷ By studying accounts of synesthetic individuals, artists have attempted to explore commonalities between the senses and develop immersive sensory environments that reflect a synesthetic experience.¹⁸ Merleau-Ponty suggests that we are all, to a certain extent, synaesthetes: the unity of the body renders all perceptual experiences as implicitly integrated.¹⁹ The senses are co-present working together as part of the lived body, synthesising information, to decode meaning. We should consider the primacy of touch, as the first sense to develop, but also the concept of touch, as the fundamental basis of our other senses. Boothroyd expands on this, suggesting that commonalities exist between the senses to the degree that they could all be considered haptic. Perception occurs through movement, a change in the orientation of the environment, which is received through ‘skin’.

In terms of affect theory, touch can be viewed as being fundamental to each of the other senses it is traditionally distinguished from: ‘all’ of the senses are in a sense haptic in that they are dependent on the transmission of movement, and all movement is ultimately registered on the surface of ‘skins’. The retina of the eye, the tympanum of the ear, the mucous membranes of the nose and mouth are all sites and surfaces of affective intensity. In this respect, all of the senses

¹⁶ Paul Bach-y-Rita et al., “Vision Substitution by Tactile Image Projection,” *Letters to Nature* 221 (1969): 963–964. doi:10.1038/221963a0

¹⁷ See Jack Dutton, “The Surprising World of Synaesthesia.” *The Psychologist*, last modified January 19, 2016, accessed April 20, 2017, <https://thepsychologist.bps.org.uk/volume-28/february-2015/surprising-world-synaesthesia>

¹⁸ Kia Ng, Joanne Armitage and Alex McLean, “The Colour of Music: Real-time Music Visualisation with Synaesthetic Sound-colour Mapping” (paper presented at Electronic Visualisation and the Arts, London, 2013). doi: <http://dx.doi.org/10.14236/ewic/eva2014.3>

¹⁹ Maurice Merleau-Ponty, *Phenomenology of Perception*, trans. Colin Smith (Taylor & Francis eBooks), 272. doi: 10.4324/9780203994610

(plural) are perhaps just one (singular); they are all, so to speak, in one sense.²⁰

Although it is beyond the remit of this study to philosophise deeply about the unity or dualism of the senses, interesting comparisons, and approaches to developing multisensory experiences, can be drawn from these concepts. Hence, I will conclude this subsection reflecting on Evelyn Glennie's statement that I have touched on in my earlier writing, 'hearing is basically a specialized form of touch.'²¹ This quote is often presented as an argument towards an audio-haptic sensibility, however, Glennie is talking about the vibrations that are already inherent in sound. She is insinuating that complex structures of the ear render vibration as sound, whilst the body in its entirety receives it concurrently. Glennie is raising awareness of the role our entire body plays in the mediation of our musical experiences and centring the body in how we frame such activities. But if sound already contains a physical element, why develop audio-haptic works? In this commentary, I will argue that haptics facilitate an increased sense of physicality in sound and function to enhance a sense of presence within a sonic experience, increase the aura of a media form, and can be an approach to presenting the abstract as something tangible.

2.4 Technologies of Touch

In recent years, there has been a significant increase in the research and development of systems for tactile communication, with this has come a simultaneous broadening of the scope of their application. These technologies create different relationships between user and device by reconstructing different forms of physical touch, including active touch, or *touching*, where the environment and surrounding objects are decoded through exploratory feel. Conversely, passive touch, or *being touched*, presents a tactile communication channel for information to be relayed through stimulating the skin without movement from the receiving body.²² When working with passive touch, or cutaneous sensation, the skin is stimulated and the body is generally not engaged within a kinaesthetic dimension.

²⁰ Boothroyd, "Touch Time Technics," 337.

²¹ Evelyn Glennie, "Hearing Essay." Artist's personal website, last modified January 1, 2015, accessed April 20, 2017, <https://www.evelyn.co.uk/hearing-essay/>

²² James J. Gibson, "Observations on Active Touch," *Psychological Review* 69, no 6 (1962): 477–491.

The word ‘haptic’ derives from the Greek *haptesthai*, meaning of or pertaining to the sense of touch.²³ It encapsulates all forms of tactile sensations including those that are exteroceptive, as cutaneous or kinaesthetic touch, but also encompasses proprioceptive sensations and embodied somatics. Parallel to this, in its utilitarian form, haptics is used commonly in psychology, engineering and robotics. Conversely, the term is frequently referred to metaphorically as an aesthetic element in visual arts (particularly cinematic) and architecture.²⁴ A utilitarian approach to haptics looks at how technologies can be embedded with mechanisms that could enhance the physical engagement of the human body, for example, in an assistive technology or an immersive device. As will be discussed below, research in the field of haptics and entertainment predominantly focuses on the enhancement of user experience and immersion in a media form.

In our increasingly digital world, haptic technologies look to connect physically with users by imparting tactile sensations on their body. In consumer electronics, products such as mobile phones and games controllers often incorporate some element of haptic feedback. Mobile phones are perhaps the most prevalent haptic devices, integrating a small actuator that vibrates to alert the user of a communication, for example. Games controllers often include a vibration notification system, but they focus on heightening a user’s bodily connection with in-game activity. These examples employ a passive approach to touch, but an example of an active touch device is the joystick, which acts as a force feedback device, allowing a user to gain a sense of tangible control whilst kinaesthetically interacting within a virtual system.

Several developments in the field of haptics have derived from its potential as an assistive technology. I have previously discussed the work of Bach-y-Rita, where the visual is transformed into the haptic. From an audio-haptic perspective, similar approaches have been developed to enhance the listening experience for the hearing-impaired. Nanayakkara’s haptic chair explored the relationship between auditory, visual and the somatic sensory modalities with speakers integrated into the chair render audio as vibration.²⁵ Such analogous haptic relationships between sound and

²³ Paterson, *The Senses of Touch*, 4.

²⁴ Yoshitaka Ohta, “What is the ‘Haptic’?: Consideration of Logique de la Sensation and Deleuze’s Theory of Sensation,” *Bigaku* 49, no 1 (2008): 29–42.

²⁵ Suranga Nanayakkara, “Enhancing Musical Experience for the Hearing-Impaired Using Visual and Haptic Displays” (PhD diss., University of Singapore, 2009).

haptics in arts practice are discussed in the next sections. Other examples of assistive haptic technology systems are those that assist the visually impaired with navigation.²⁶

These approaches implement passive touch-based systems that stimulate the sense of touch through cutaneous triggers. In robotics, active haptic devices are defined as those that exchange force ‘through contact with some part of the user’s body, following a programmed interactive algorithm.’²⁷ Much development in haptic technologies encompasses this area of research. These haptic systems are designed to remove an individual from their environment and transport them to the virtual space. In such applications, haptic representations are often designed to reflect real life interactions that can be measured and recorded, then simulated on a mechanical device. An example of this is the ‘PHANToM’ device, whereby users can telematically input and output gestures. These devices are often found in medicine and dentistry to simulate the physical sensations of a surgical procedure, or to create a sense of physical presence at a distance.²⁸ Such systems are interested in representing or moving an object, approaching haptics in a representational sense, but what if you are trying to represent something more abstract and less tangible like an algorithm, a process, or a set of data? In my practice, I am primarily concerned with developing cutaneous technological systems, and using them to consider the possibility for a haptic sensation to become something more transformative, abstracted and embodied.

2.5 Audio-Haptics in Practice

Developing multisensory systems can be riddled with semantic and conceptual hurdles for the interdisciplinary practitioner. As soon as your work becomes perceptual, you are negotiating territories of the physiological, philosophical, and neurophysiological.²⁹ We are disambiguating terminology used by both the engineer and philosopher, and the complex relationships between sensation, affect and emotion. It is difficult not to make assumptions. Still, many artworks play with the senses, and core to most creative practice is a concern with the perception of the

²⁶ Koslover et al. developed a mobile navigation device that outputs visual, audio and vibrotactile cues, finding that navigation cues could be effectively reconstructed through multiple actuators placed on the torso. Rebecca L. Koslover et al., “Mobile Navigation Using Haptic, Audio, and Visual Direction Cues with a Handheld Test Platform,” *IEEE Transactions on Haptics* 5, no 1 (2011): 33–38. doi: 10.1109/TOH.2011.58

²⁷ Karon E. MacLean, “Haptic Interaction Design for Everyday Interfaces,” *Reviews of Human Factors and Ergonomics* 4, no 1 (2008): 149–194.

²⁸ Paterson, *The Senses of Touch*, 129.

²⁹ This list could go on and become considerably more nuanced.

sensory body where media and material are formed then displayed through performance or exhibition. In the context of this work, haptics are viewed as something that is connective, immersive, engaging and augmenting. These suppositions are echoed by Paterson who suggests:

These unfolding technologies are a set of augmentations that begin to play with an emerging multisensory realm, one that talks of the engendering and engineering of 'immersion', of 'presence', of 'aura' through the addition of touch.³⁰

Several other artists have developed work for bespoke vibrating interfaces, most of which use speakers to reproduce sounds at a low frequency. *Sonic Bed* developed by sound artist Kaffe Matthews grew from her earlier installation work where she enclosed speakers in furniture, playing low frequencies through them.³¹ In *Sonic Bed*, an architecturally designed bed, embedded with twelve speakers, is constructed for listeners to lie in as sound is diffused around the multiple channels at different locations. Similarly, Dewey-Hagborg's work *Buried Sound 2: Haptic Resonance*, uses sound to produce vibration, exploring sound in its physical form as an instrument of the somatic.³² The work employs an analogous audio-haptic relationship where a speaker is placed directly under the floorboards of a gallery space. Inspired by the deaf experience of sound as 'pure-vibration', it seeks to transform sonic material by augmenting its inherent tactility on the body. Another example of sound being rendered directly as vibration is the work of Salick, who uses vibrations to invite participants to *Feel a Bit Like Beethoven* using a wooden sculpture integrated with speakers. Participants place their hands over the installation, which allows them to explore the tactility of Beethoven's oeuvre, akin to the composer's deteriorated hearing.³³

Hayes' *Skin Music* utilises a similar technique where a haptic-augmented *chaise longue* vibrates the body.³⁴ Sound is transmitted through actuators in the chair to the body via its wooden struts. Motors are placed on the arms of the chair for the participant to hold on to, at the back of the head and the lower back. *Organ Organ*, a

³⁰ Paterson, *The Senses of Touch*, 128.

³¹ Kaffe Matthews, "Music for Bodies." *Sonic Bed Project Website*, date modified May 12, 2016, accessed April 20, 2017 <http://www.musicforbodies.net>

³² Heather Dewey-Hagborg. "Buried Sound 2: Haptic Resonance." Artist's personal website, 2011, accessed April 20, 2017, <http://www.deweyhagborg.com/projects/haptic-resonance>

³³ Oliver Salkic. "Feel a Bit Like Beethoven." Artist's personal website, accessed April 20, 2017, <http://www.oliversalkic.com/feel-a-bit-like-beethoven>

³⁴ Lauren Hayes, "Skin Music (2012): An Audio-Haptic Composition for Ears and Body" (paper presented at ACM SIGCHI Conference on Creativity and Cognition, Glasgow, 2015).

work by Eric Gunther, is another example of music for the body, employing a mouldable twelve channel vibrotactile surface that produces low-frequency vibrations together with a two-minute electronic music composition.³⁵ The artist briefly describes his process: ‘Spatial ideas led to musical phrases while rhythms and melodies motivated phrases of choreography on the space of the body.’ This system grew out of Gunther’s earlier audio-haptic collaborations, including a full body suit interwoven with actuators to render audio waveforms physically across the body.³⁶ A more recent system, developed by Hattwick et al. adopts a similar schema whereby a garment housing thirty ERM motors is worn exterior to the user’s clothes.³⁷ These systems allow a close proximity between actuator and body, and the placement of actuators on areas that do not have contact with a chair or bed. They present obvious disadvantages in terms of configurability for different sized users, and the awkward and cumbersome need for the user to dress themselves in the device.

These works employ haptics in similar ways by using sound itself as the control signal for physical vibration. Essentially, these artists are writing music and exploring the body as a sound-absorbing, vibration-reactive artefact. This approach means that sound is considered primarily, with sonic parameters being manipulated to define the characteristics of the haptic. Approaches that employ sound directly as vibration are assuming the skin operates within similar conditions to the ear—it does not. Still, this idea is pervasive through mappings in audio-haptic artworks where the participant’s body is considered as an instrument or vessel, that when excited by sound can render meaning in vibration.

³⁵ Eric Gunther. “Organ, Organ.” Artist’s personal website, accessed July 20, 2015, <http://www.ericgunther.info/projects/organOrgan.html>

³⁶ Eric Gunther, and Sile O’Modhrain, “Cutaneous Grooves: Composing for the Sense of Touch,” *Journal of New Music Research* 32, no 4 (2003): 369–381.

³⁷ Ian Hattwick et al., “Composition Techniques for the Ilinx Vibrotactile Garment” (paper presented at International Computer Music Conference, Denton, Texas, 2015). <http://hdl.handle.net/2027/spo.bbp2372.2015.088>

Chapter Three

WORKING WITH HAPTICS

Through the first few years of this study, I began investigating available haptic technologies that I could use in my work. To my knowledge, there are no consumer available or affordable devices that could work for these purposes. Initially, I developed prototype-one from arrays of eccentric rotating mass (ERM) motors, but with improvements to the availability of devices like linear resonant actuators (LRA) and bespoke haptic driver units, I refined my design and developed prototype two in mid-2015. In addition to this, I have also employed some pre-made devices such as bone conductive actuators and tactile transducers.

Haptic technologies are not as prevalent as other forms of embedded system output device (LEDs, screens and speakers), requiring specialist drivers to operate effectively and efficiently. In this chapter, I will discuss the component parts required to configure, develop and implement haptic circuits and how this design process influenced the applications I used them in. I will then present an overview of two prototypes that were developed for use in my practice. Through this, I will discuss the advantages and limitations of different configurations, and the challenges presented in designing mountings and enclosures for DIY multi-actuator haptic installation works.

3.1 Configuring Haptics

I required my haptic circuit designs to be configurable, extensible and modular to be cost effective and reusable in multiple scenarios. As I was intending to use my system for live performances, I was also concerned with the latency and jitter of the setup. Another consideration that limited the scope of my design was the necessity to prototype with through-hole components so that installations were easily repairable and hackable. Designing systems for haptic interactions requires several component parts that are outlined in Figure 1. In the systems I was developing, I needed to consider the type of haptic feedback I would be presenting to the user. Although at first I was unsure exactly what that would be, I was clear that it would reflect musical parameters that were likely controlled and triggered by a computer so the input would

be coming from a laptop. The input would need to be received by a microcontroller, which would then communicate with a haptic driver to generate haptic waveforms from the input information. A haptic driver circumvents the current limitations of microcontrollers to provide higher quality vibration output. In turn, the drivers control motors, or haptic actuators that render the inputted information as vibrations for the user.



Figure 1. Block diagram of hardware components required in a haptic design.

I have extensive experience working with the Arduino microcontroller, so opted to use it in this project. The Arduino allows rapid prototyping through libraries, an extensive community of technical support and a serial communication interface with the computer through USB.¹ The specifics of the drivers and motor types are discussed in the following section.

3.1.1 Drivers

Applying a constant voltage to the ERM terminals from a direct current (DC) source is the most basic way to control a motor. This approach drives the motor at constant frequency and vibration amplitude, however, haptic motors are generally driven by additional circuitry to gain greater control of vibration characteristics. The simplest driver is a single transistor that controls power to the motor when used in conjunction with microcontrollers. As will be discussed in the next section in greater detail, manufacturers of haptic devices indicate a lag, rise and stop time. The addition of drivers to the control of a motor allows a *crisper* and *clearer* vibration output by overdriving the voltage applied to the motor for a short burst at the start of an impulse. Another factor effecting vibration clarity is the stop time of the motor, where drivers apply a reverse polarity, forcing the motor to stop.

H-bridges allow bi-directional motor control, and early driver experiments were conducted with a ULN2803A Darlington transistor array. A range of vibration amplitudes can be achieved through controlling pulse width modulation (PWM), the only control parameter of the motor. PWM works by turning a digital signal on and off rapidly to replicate a square wave. In LEDs, this translates to a dimming of brightness when the off-time of signal is increased. When applied to a vibration

¹ All libraries used in this project are available in Appendix A.

motor, an increased off-time results in a decrease of what will henceforth be referred to as vibration amplitude. If the PWM value is set too low, not enough voltage is applied to the motor and it will not excite. The point of excitation will henceforth be referred to as the threshold of the motor in relation to mappings. The Arduino Uno has six PWM output channels, to expand this additional circuitry is required. Prototype one uses a TLC5940 driver to allow the Arduino to control 16 channels of PWM. Together with PWM, haptic effects are generated by defining the onset, duration and location of the vibration.

You can acquire purpose built haptic drivers that offer an expanded range of features and increased control of vibration waveforms. I found implementing dedicated haptic motor drivers problematic initially, as all available integrated circuits (ICs) are packaged as surface-mount devices (SMDs). Mainstream electronic component manufacturers prioritising component size for commercial devices has resulted in SMD technologies becoming standardised. Concurrently, the de-mystification of embedded system design instigated by the Arduino, has exposed the possibilities of these technologies to a new and curious user base without access to the facilities to produce printed circuit boards and solder SMD-size ICs. It could be argued that the move to SMDs, without an option for through-hole devices that are compatible with breadboard prototyping, is out of line with current trends in the wider, and expanding electronics community.

This issue is somewhat addressed by American companies such as Adafruit and Sparkfun creating 'break-out boards', whereby popular and coveted SMD chips are placed on PCBs and connected to through-hole headers, retailed at a commercial cost. Bespoke haptic drivers like the Texas Instrument DRV2605, released in SMD form in 2012, only became available as Adafruit breakout boards in late 2014. This enabled me to acquire sixteen driver breakouts when they became available in the UK during February 2015.

3.1.2 Motor types

ERMs are DC motors that are the type most commonly found in commercial devices and vibration alerting systems. Their construction consists of a shaft with a non-symmetrical, or offset mass attached to it. As it rotates, the mass displaces the motor causing it to vibrate on two axes. As mentioned previously, a basic control of the motor, can be achieved by applying a constant voltage from a DC to the motor terminals. Linear resonant actuators (LRA) are driven similarly to a speaker, but differ

in that instead of driving a cone to produce sound, they drive a mass to produce vibration on one axis.

At the outset of this work, I worked with ERM motors as they are easier to implement and lower cost than other devices, with many different form factors available. LRAs could be considered advantageous over ERM motors in terms of their reliability and longevity, but this comes at the cost of additional complexity in their implementation. By 2015, I had acquired three different motors for this project (see Table 1), all from Precision Microdrives, a small ERM coin-type motor (310-101), a larger ERM motor (308-102) and an LRA (C10-100). Each motor datasheet specifies operational requirements such as rated current and voltage, specifying dimensions and weight.² Additionally, it specifies the response of the motor, which is an important consideration for those designing haptics and indicated through lag, rise and stop times, and vibration amplitude. Lag time is the time between switching voltage on and the vibration being perceptible, rise time is defined as the point at which 50% of the peak amplitude is reached and stop time is the time between the peak amplitude and the vibrations reaching an imperceptible level.³

Motor	Amplitude (G)	Lag (ms)	Rise (ms)	Stop (ms)
<i>C10-100</i>	1.40	8	34	73
<i>310-101</i>	0.80	37	92	116
<i>308-102</i>	5.50	9	21	49

Table 1. Vibration motor amplitude and response data.

Latency itself isn't necessarily a problem in the scenarios I have investigated, and depending on the setup, is imperceptible.⁴ For use cases that require synchronisation,

² Datasheets for all motors and drivers can be found in Appendix B.

³ For more information see Precision Microdrives Staff, "Adding and Improving Haptics."

⁴ Previous auditory-tactile research reported sending tactile impulses to the tip of a participant's index finger alongside auditory white noise. Delays of auditory noise were presented randomly before and after the tactile stimulus between ± 150 ms, and participants were asked to report whether the stimuli were synchronous or asynchronous (see Mehmet E. Altinsoy, "Perceptual Aspects of Auditory-Tactile Asynchrony" (paper presented at International Congress on Sound and Vibration, Stockholm, 2003). It was found that participants reported the signals were synchronised when the audio appeared 24 ms ahead of the tactile impulse, and up to 50 ms after it (i.e. within range of -24 to +50 ms). Levitin et al. found that in active touch stimuli between -25 and +42 ms are found to be asynchronous. Altinsoy later suggests that although these thresholds are given, many experiments report participants with significantly higher

understanding the latency caused by moving parts is critical. In the Silent Metronome system, discussed in chapter 5, I address this by adding a slight delay to the audio output of my laptop that compensates for delays in the vibration reaching my acoustic collaborator. To gain a clearer idea of the role latency would play in my system, I conducted an experiment to measure the latency and jitter of each of the three motors when connected to a DRV2605 driver and Arduino, a summary of which is presented here, but further detail of the experimental setup can be found in Armitage and Ng.⁵

I followed the experimental design specified in the Precision Microdrives application notes, whereby a motor and accelerometer is connected to a test sled.⁶ The accelerometer is used to measure the motor's vibration output for 10 minutes, or around 630 independent and consistent pulses. Latency was measured as being the time between when the voltage was initially sent from the microcontroller to the first peak (+ve or -ve) in the accelerometer data. The average time between peaks was computed alongside the standard deviation. The average latency for the 308-102 ERM motor was 24.76 ms, the 310-101 ERM motor averaged 137.75 ms and C10-100 LRA motor 28.20 ms. These results, together with outliers, are shown in Figure 2. From the results, it became clear that the 308-102 motors offer both the lowest latency and considerably less jitter than the other motors. They also produce the greatest vibration amplitude, but with this, an audibly greater amount of mechanical noise compared to the C10-100. Due to this being a musical application minimal noise is beneficial as it reduces the overall auditory distraction of the hardware. Another design-related consideration when using the 308-102 is its moving external parts that require special mounting.

3.2 Prototype One: ERM with TLC5940

As I began to increase the number of motors in the arrays I was building, I required additional circuitry to independently control them. This prototype consists of an Arduino microcontroller and sixteen ERM (310-101) motors that are driven by a

sensitivity of up to 10 ms, see Mehmet E. Altinsoy, "The Quality of Auditory-Tactile Virtual Environments," *Journal of the Audio Engineering Society* 60, no 1 (2012): 38–46.

⁵ Joanne Armitage and Kia Ng, "Configuring a Haptic Interface for Music Performance" (paper presented at Electronic Visualisation and the Arts, London, 2015). doi: 10.14236/ewic/eva2015.4

⁶ Precision Microdrives Staff, "Measuring Vibration Strength a Quick Method." Precision Microdrives application bulletin, accessed March 15, 2015, <http://www.precisionmicrodrives.com/tech-blog/2014/06/03/measuring-vibration-strength-a-quick-method>

TLC5940 controlled by an Arduino Uno.⁷ On a previous project, I had used an Arduino and a TLC5940 driver to control a matrix of sixteen LED lights with individually programmable PWM, I realised that, with lower current ERM motors, I could use the same driver to control the ERM motors with some minor alterations.

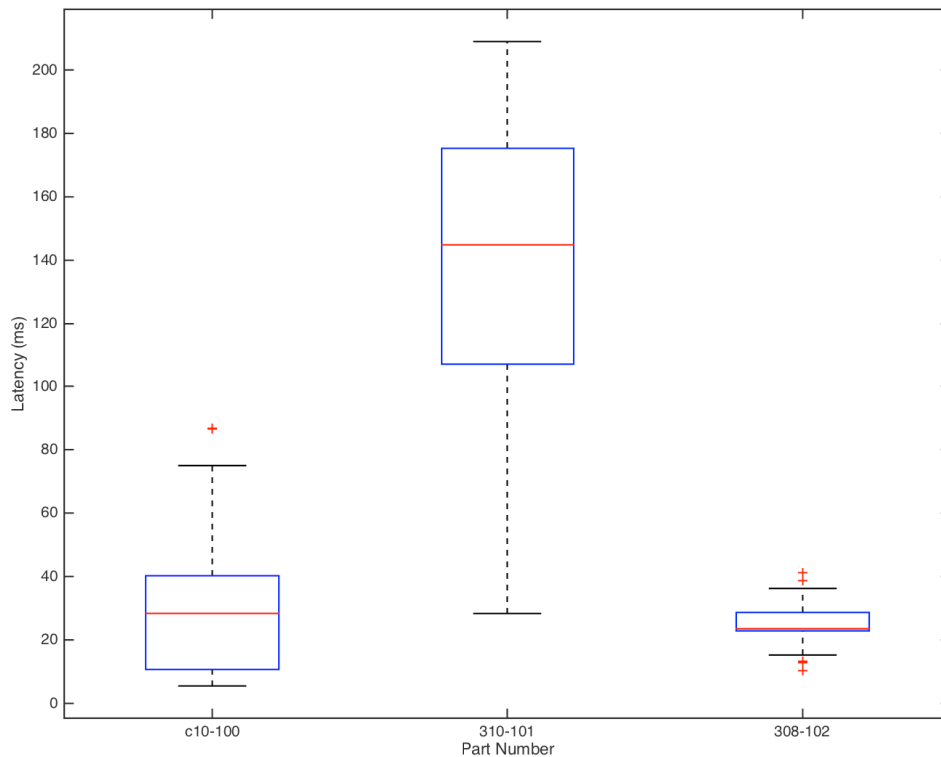

Figure 2. Box plot to show average latency, standard deviation and outliers for C10-100, 310-101 and 308-102 motors (left to right).

To supply the rated current of 75 mA to each motor, I required a 520 ohm current programming resistor (R1), which connects the IREF pin on the TLC5940 to ground (see Figure 3).⁸ Due to the current requirement of the motors, external power was necessary as the maximum DC current for each digital pin of the Arduino is rated at 40 mA. Drawing too much current from the Arduino could result in damage to the board. The circuit is powered by four AA batteries that provide 4.8 V, within the operating voltage of the TLC5940, which can provide a current of up to 120 mA per pin when the supply voltage is greater than 3.6 V. To reduce power dissipation, a resistor (18 ohm) is placed between the TLC5940 output and the motor. A decoupling

⁷ I received funding from the Sound and Music, Frances Chagrin Award to cover the cost of the first prototype circuit I developed.

⁸ 523 ohm is used in this design as it was the closest resistor value available. These motors were purchased in January 2014. As of 2016 the 310-101 motors from Precision Microdrives have been superseded by a lower profile, lower current and higher vibration amplitude version.

0.1 uF ceramic capacitor is placed close to the supply voltage (VCC) and ground line to suppress high frequency noise from the power supply signal. I also added a flyback diode to each motor to protect the driver from potential voltage spikes.⁹

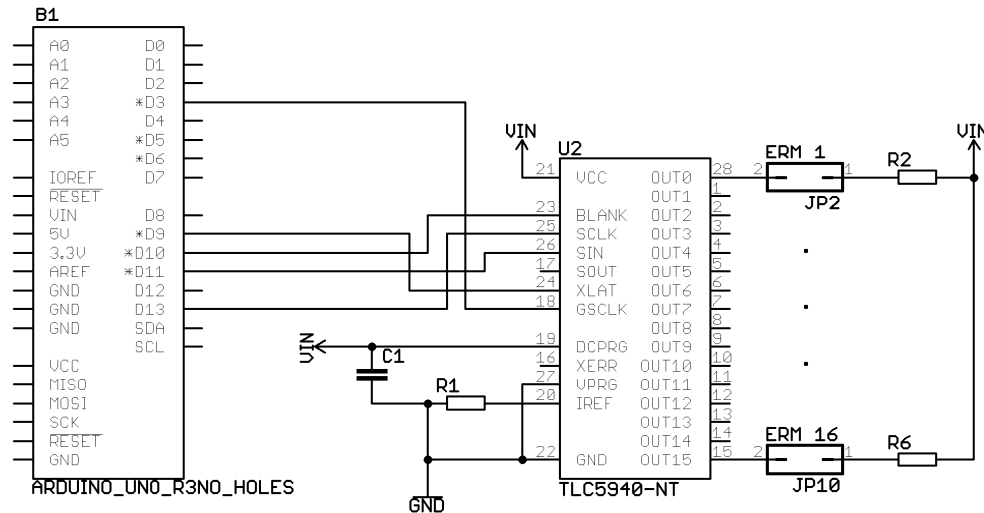

Figure 3. Schematic design for prototype one.

After initial prototyping, testing and debugging on solderless breadboard, I developed the circuit design on soldered stripboard to ensure that components were secure (see Figure 4). The TLC5940 is connected via header pins, as it is sensitive to the heat of soldering, but this also means the chip can easily be removed and replaced if damaged.¹⁰ This design allowed independent PWM control of sixteen ERM motors, and I have used in various configurations throughout this project. I will henceforth refer to the selected motor through the term ‘motor index’, which is used to control the location of vibration on the array. This design has several limitations, however, including the low vibration amplitude of the motors, which are rated at 0.8 G, and the lack of configurability with different haptic motors. Ultimately, this design was a serviceable hack, but I was determined to develop the system further should appropriate haptic prototyping tools become available.

⁹ I later found that due to the low voltage requirements and inductance of the Precision Microdrives Pico Vibe range, the flyback circuit can be omitted.

¹⁰ I travel with a spare driver chip to installations in case of this.

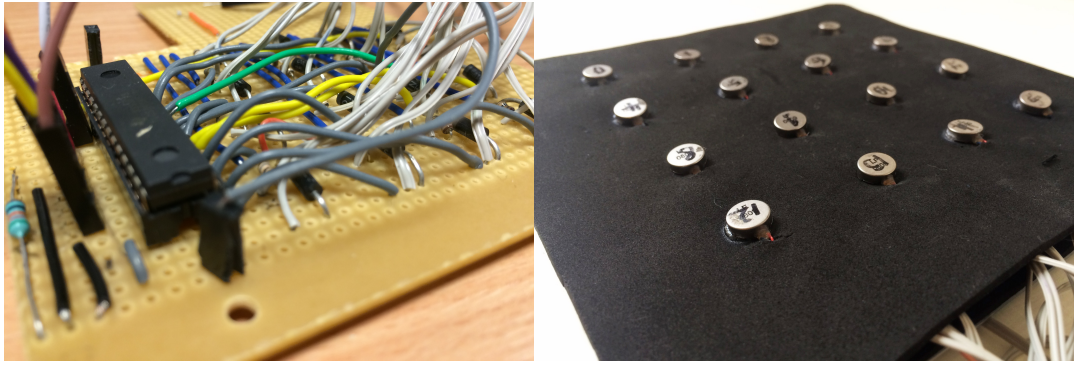

Figure 4. Stripboard design and motor array grid.

3.3 Prototype Two: ERM and LRA with DRV2605

Prototype one proved effective for driving the 310-101 motors, but its maximum current output of 120 mA wasn't great enough for the 308-102 motors, with a typical rated operating current of 145 mA. Furthermore, it could not be interfaced with an LRA motor driven by an AC signal. Thus, the most recent prototype employs the Texas Instruments DRV2605 driver, which was selected for two main reasons: firstly, it interfaces with both ERM and LRA motor types, at a range of operating currents and voltages, which is advantageous for testing and comparison purposes; secondly, it affords a wider range of bespoke controls including an integrated library of haptic effects and a bespoke 'audio-to-vibe' algorithm that renders an audio signal as vibration. One DRV2605 driver can only control one motor independently, meaning a driver is required per motor.

I have previously mentioned the challenges of acquiring the DRV2605 driver due to its SMD package, but there are further challenges to implementing it due to a design oversight in the Adafruit breakout: the device enable pin on the chip has not been included in the breakout, which means that multiple devices are not individually addressable without additional circuitry. To address individual devices through serial communication, an I²C multiplexer is required as each DRV2605 has the same, fixed I²C address.¹¹ I used the TCA9548A multiplexer, which has eight bi-directional switches controllable through the I²C bus (labelled SCL and SDA 0–7 in Figure 5). This enables control of up to eight motors independently via the DRV2605, with the possibility to expand this by multiplexing the multiplexers.

¹¹ I²C is the standard serial protocol for two-wire interfaces that allows microcontrollers, such as the Arduino to communicate with peripheral devices.

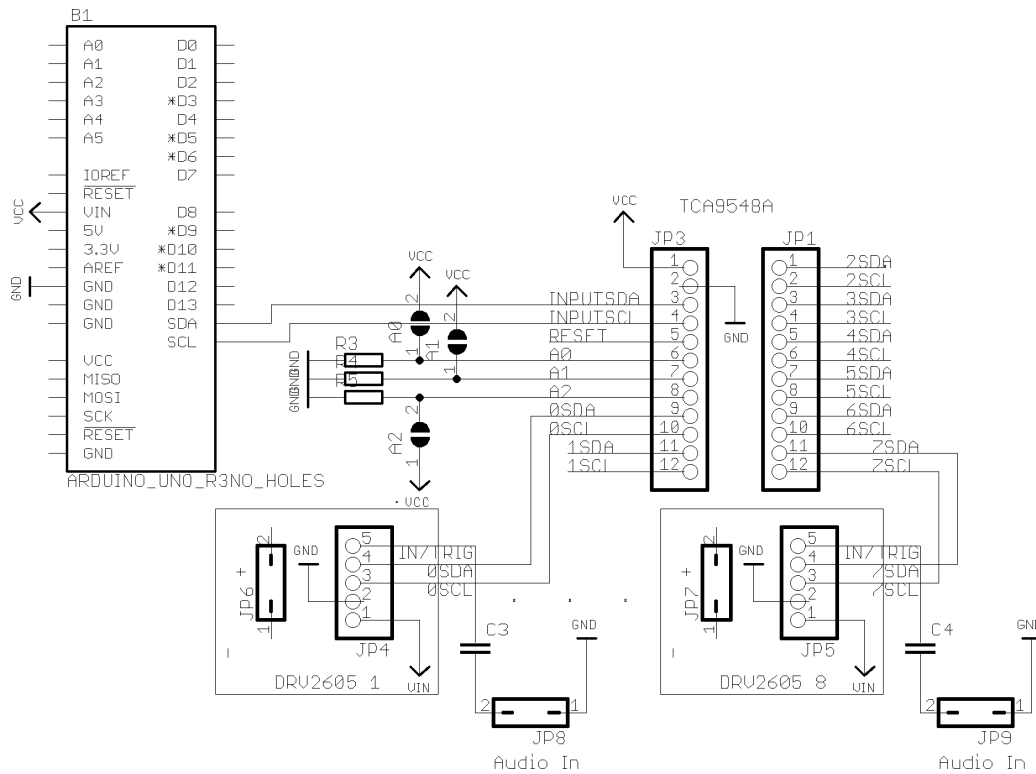

Figure 5. Schematic design for prototype two.

Although Adafruit developed a library for the DRV2605, this was only configured to work with ERM-type motors. I hacked the library to allow me to select the registers that indicated the motor type and other related settings, enabling me to develop a system that was configurable with both ERM and LRA motors. Due to the breakout board containing most of the circuitry, the only additional components required were 1 uF capacitors on the audio input to the DRV2605 to couple the AC audio source. Through this design, I had a greater control of the motors, it was easier to configure waveforms, and I could easily switch between different motor types.

3.4 Crafting Mountings for Motors

In this section I will give some details as to how I developed enclosures and connected different hardware elements. The vibrations themselves needed to be detectable through clothing and the actuators embedded to fit within a design or attached to the body. I found there was limited documentation as to how to approach haptic designs from the perspective of wearable technologies. I experienced many breakages and issues in the design, including too much dampening of vibration, run-away motors and things generally falling apart. Through this process, I have used the circuits above in various configurations for different pieces of practice, and developed enclosures through iterative refinement. Unlike the assistive technologies described in the

previous chapter, I was aware that the haptic interactions in the context of this work could be relatively short-lived as I was designing for installations and performance systems. This meant that the vibrations themselves needed to be intuitive, and the circuits rendering them needed to be housed in easy to use, robust, repairable and reconfigurable enclosures. This process was complicated by the fact that bodies come in so many different shapes and sizes and ideally, designs would be easily adaptable to compliment everyone's shape.



Figure 6. Motors mounted in backrest. From a performance of *It is only MIDI*.

Most of the motors, apart from the 308-102, arrived with short AWG 32 wire leads attached to each of the (two) motor terminals. To allow greater flexibility in their placement, I connected motors to longer and stronger ribbon cable. I ensured secure connections were made between the very thin and delicate AWG 32 leads of the motor, and the longer ribbon cable by plaiting the multicore together, soldering it, and further supporting it with shrink wrap. I experienced some issues with the leads I soldered to the 308-102 becoming detached due to the motor moving very forcefully when unmounted.

The earliest configurations consisted of the motors being stuck directly to the body with tape, but this was not sustainable long-term as it could be quite painful to remove them from hairy, fatty skin. The first design I built was for prototype one, a grid of sixteen actuators in a 4 x 4 configuration. I mounted them on a piece of foam with glue, which was attached to a sheet of silicone and supported by strips of

aluminium (see Figure 4). Velcro straps were affixed to the rear of the enclosure and could be attached directly to the body or to a chair.

The vibrations were dampened by the pressure of the body when attached to a chair, causing them to become weak and making it hard to differentiate between different vibration amplitudes. Eventually, it fell to pieces as the glue holding everything together became unstuck by the heat generated from the motor movements. This design was used for early installations of *Enclosed I* and *Unheard Sounds*. I built a final glue-based housing, securing the motors to a dimpled backrest. Although it was more portable, secure and transferred vibration more effectively, it did not house the motors securely long-term, and placed them too close to one another (see Figure 6). The advantage of this layout was that the space between the back rest and the chair back meant that vibrations were not absorbed by the chair itself.

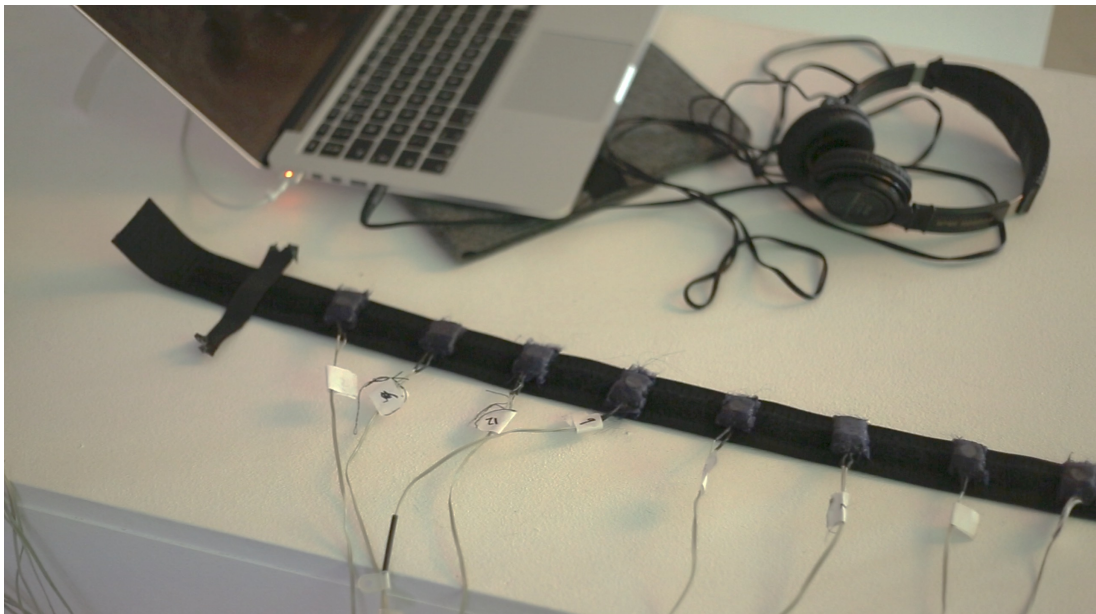

Figure 7. Hand-sewn waist belt with 310-101 ERM motors.

As this design fell apart, I resolved myself to develop more resilient sewing skills and build a more secure design. I reconfigured the layout of the motors for *Enclosed II*, where I used twelve motors from the array, surrounded them in foam and sewed them into small foam pockets. A piece of Velcro was attached to each motor pocket allowing it to be attached to an adjustable waistband, this removed the need for glue and the motors stayed securely in place. This design allowed listeners to reconfigure the layout of the motors to best suit their body (see Figure 7).



Figure 8. 308-102 inside straw (left). 308-102 encased and attached to cushion (right).

Like the previous design, for prototype two, I enclosed motors in foam, then attached covers and Velcro, resulting in a design where motors were both secure and configurable in different layouts. In the previous section, I mentioned issues with external moving parts on the 308-102 motors. I eventually managed to resolve this DIY-style using a novel Ikea hack: they supply unusually wide diameter (8 mm) straws that the motors slotted into perfectly, protecting their moving parts (see Figure 8). For this design, I purchased a memory foam back support cushion with a removable cover, into which I sewed Velcro. This allowed multiple motors to be flexibly attached, removed and placed as desired on the surface of the cushion (see Figure 8). Finally, I had built something that was adaptable, comfortable and sturdy!

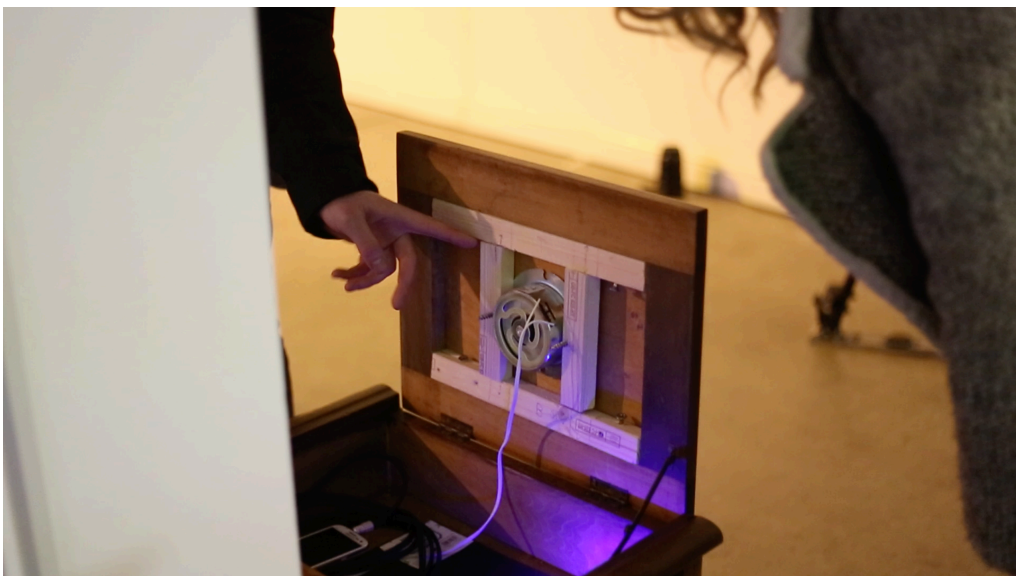

Figure 9. Tactile transducer installed in the piano stool.

For the work, *Piano Stool Droning at 33 Hz*, I designed a tactile transducer support frame to be installed inside the piano stool in which an audio player, and sub-amplifier were also housed (see Figure 9). The piano stool was placed on a rubber mat to reduce the amount of vibration travelling through the wood into the ground.

3.5 Conclusions

In this chapter, I have documented, detailed and reflected on the development of several vibrating interfaces built through the course of this study. Starting from the primary constituent components of haptic setups, I have presented the rationale behind component choice and the development process. Finally, I have discussed methods of enclosing motors for the purposes of haptic installations. Overall, this development process was the most challenging and time consuming element of the project, battling with resources and access to equipment. Reflecting on this now, I feel that I have established a basis through which I can develop further designs with the appropriate funding and design consultation. As this work continued, I felt a constant tension with the technological system design and the creative practice. Eventually, I stopped designing circuits and gluing things, and started conceiving of musical applications for my designs which are detailed in the forthcoming chapters. In the future, I hope to work with a designer to further refine these enclosures with bespoke 3D printed casing and specialist materials.

Chapter Four

INSTALLATION WORKS

This chapter will detail haptic installation works that incorporate elements of sonic and tactile technologies to probe relationships between sound and the physical body. I will discuss the process of developing *Enclosed I* and *II* in greater depth as it is a project that I have developed throughout this research process. This work explores the relationship between sound, space and the body through real-time haptic rendering of spatial sound data, using haptics as a guide, to establish a greater feeling of connect between auditory spatial data via synchronous somatic stimulation. I will also give an overview, and more briefly reflect upon other works that I have installed throughout the PhD including *Unheard Sounds* and several more recent works developed for the event, ‘The Body in Sound’ including, *Bone Music*, *My Back Catalogue Rendered as Vibrations on Your Body* and *Piano Stool Vibrating Around 33 Hz*.

A difficulty with haptic-based art is that it requires a certain immediacy and bodily proximity to the vibration object. As detailed in the previous chapter, considerable time and labour is required to develop systems for rendering haptics which meant that developing short installation pieces became a logical outcome of my practice. Most of the works I have developed can only be experienced by one individual at a time. Throughout this, the role and placement of the haptic communication channel varies. Initially it is considered as a means of guiding a listener’s experience of sound, or as a means of rendering aspects of a sound. More recent works in ‘The Body in Sound’ exhibition employ haptics and vibrations in a more conceptual manner. Within this, the role of the haptic channel changes as a way of engaging, immersing and subverting relationships between the body and an experience. Each of these works explores how haptics can act as part of the listening experience. Using simple concepts, such as relating single auditory and tactile parameters, allowed me to explore the relationship between sound and the physical and investigate effective combinations of the different sensory domains in an artistic context. A small part of this project has been exploring the haptic, itself, acting as an instrument.

4.1 Enclosed I and II

Enclosed I and *II* (2014-16), are installation works that explore the spatial relationship between our senses of touch and hearing. This was the first work I developed to probe the connection between physical and audible parameters, a theme of intuitive crossmodality that is developed in the portfolio. As sound is moved around the auditory space, an array of vibration motors follow this motion, causing the listener to experience a parallel sensation of sound and vibration moving around their body. The work was first installed at Computer Music Multidisciplinary Research (CMMR) 2015, Plymouth, where a paper discussing it was awarded best paper prize (PhD).¹ Subsequently, in 2016, I redeveloped the concept, employing a waist belt-style array of actuators in conjunction with a revised version of the software system.

4.1.1 Context

Whilst both touch and hearing hold a high-acuity to spatiality, environmental factors such as noise and auditory illusions impact our perception of sound source location.² As our body uses combinations of the senses to engage with and decipher its surroundings, this work seeks to explore ideas of sensory integration to immerse the body within the spatial characteristics of a musical experience. This work employs binaural sound techniques to move sound around a constrained space and mirrors this in the movement of vibrating motors around the surface of the skin. In terms of the haptic element, the initial concept for this piece derived from some feedback from a New Interfaces for Music Expression conference reviewer, who suggested that the haptic illusion techniques I had discussed, possessed a clear auditory equivalent in stereo sound. The illusion is known as vibrotactile (or tactile) apparent movement (or motion) (VAM), and describes the virtual sensation that individuals feel between two vibrating actuators. Independently alternating the onset and amplitude of two vibration motors, causes the virtual vibration to move across the skin. Extending this to multiple actuators allows a more complex array of effects to be produced.³ Such techniques allow for a range of tactile motions to be elicited from a minimal hardware

¹ Joanne Armitage and Kia Ng, "Feeling Sound: Exploring a Haptic-Audio Relationship," in *Music, Mind, and Embodiment*, ed. Richard Kronland-Martinet, Mitsuko Aramaki and Sølvi Ystad (Springer International Publishing, 2016): 146–152. doi: 10.1007/978-3-319-46282-0

² van Erp, "Guidelines for the use of Vibro-Tactile Displays."

³ Jacob H. Kirman, "Tactile Apparent Movement: The Effects of Interstimulus Onset Interval and Stimulus duration," *Perception & Psychophysics* 15, no 1 (1974): 1–6.

setup, demonstrated by Israr and Poupyrev in their ‘Haptic Blur’ algorithm.⁴ This technique reflects clear similarities to stereo sound where the location of sound can be moved through auditor space by panning.

Such audio techniques became embedded in the compositional palette through the advent of speaker technologies and technologies for sound diffusion, allowing the composer a greater control of the location from which a sound emanates. The spatial position of sound is now a key compositional consideration in electronic music and diffusion is often central to performance. In this context, spatialisation is often described as the ‘live’ or gestural element of a work and an essential element of the listening experience. Diffusion in electroacoustic performance is used as a dynamic and physical entity that can shape the listener’s interpretation of sonic events.⁵

Our auditory system decodes the spatial qualities of sound to identify its location in relation to the sound source. It takes a holistic approach accounting for other sensory stimuli and contextual knowledge-based information. We hear in three-dimensional space, along three planes from left to right (x), above to below (y), and front to back (z). Location of a sound is ascertained by interpreting cues from these axes. The horizontal plane (x, y) is most accurate for locating sounds when facing the source of a sound and this is generally ineffective for frequencies below 500 Hz. The median (y, z) plane allows us to determine both the elevation of the sound location front or rear. Loudness, the ratio between reverberated and dry signal, and absorption of high frequencies all contribute towards our perception of a sound’s distance. Other cues, including the diffusion of a sound, allow us to determine the properties of the space we find ourselves in.⁶

To generate a sense of space in music, the electronic composer considers both the location of the sound, i.e. the sound source and the perceiving body, and the container of the sound or environment. The former is controlled through panning across channels and the latter by incorporation of effects such as reverb. There are clear

⁴ Ali Israr and Ivan Poupyrev, “Tactile Brush: Drawing on Skin with a Tactile Grid Display” (paper presented at SIGCHI Conference on Human Factors in Computing Systems, Vancouver, Canada, 2011). doi: 10.1145/1978942.1979235

⁵ Enda Bates, “The Composition and Performance of Spatial Music,” (PhD diss., Trinity College Dublin, 2009).

⁶ Oscar Pablo Di Liscia, “Spatial Listening and its Computer Simulation in Electronic Music.” Accessed April 20, 2017, https://ccrma.stanford.edu/courses/tu/space2008/topics/auditory_cues/materials/spatial-listening.pdf

interdependencies between these two approaches to placing sound within space, and a heavy reverb effect will blur location. Another consideration for the composer is the movement of sound, for which one cue is the Doppler effect whereby movement is detected but location is not.

It has been suggested by Barrett that acousmatic listening can be impaired by ‘spatial tangibility’—an inability for the listeners to absorb themselves into the spatial form of the composition.⁷ Barrett suggests that works including visual elements avoid this by providing a distraction, or ‘shifted perceptual focus’ from the unnatural sound-space phenomena enshrouding their environment. Inspired by the above and its resonance with haptic illusions I began to consider the structural space of sound and how it could be reflected physically through vibration. I hoped to investigate similarities between stereo sound and vibrotactile apparent motion (VAM) as illusions of hearing and touch.⁸

4.1.2 *Enclosed I*

For this work, I required a means of spatializing and playing back audio, communicating with the Arduino and rendering vibrations on the haptic grid. A Pure Data (Pd) patch was designed using the ~earplug library to binaurally spatialize audio files in real-time.⁹ The binaural processing and amplitude data from Pd are controlled by the Arduino, triggering different motors at random intervals, which results in a corresponding movement in the location of the sound.¹⁰ Loudness is mapped to vibration amplitude by altering PWM values of motor onset triggers. This version of the installation was designed so that any audio file could be randomly and discretely spatialized with parallel vibrations across the grid of vibration motors described in chapter 3. For public demonstrations, I created an audio file of low frequency sounds with glitches to create a low, somatic sound with a semi-unpredictable shifting timbre.¹¹ In the live rendering of the work there are some digital distortions due to the binaural filtering of the sample file, I felt these contributed to the aesthetic of the

⁷ Natasha Barrett, "Ambisonics and Acousmatic Space: A Composer's Framework for Investigating Spatial Ontology." (paper presented at Electroacoustic Music Studios Conference, Shanghai, China, 2010).

⁸ Susan J. Lederman and Lynette A. Jones, "Tactile and Haptic Illusions," *IEEE Transactions on Haptics* 4, no 4 (2011): 273–294. doi: 10.1109/TOH.2011.2

⁹ Earplug~ is a Pd library (available here: <https://puredata.info/downloads/earplug/>), based on Bill Gardner and Keith Martin, "HRTF measurements of a KEMAR dummy-head microphone," *Massachusetts Institute of Technology* 280 (1994): 1–7.

¹⁰ The Arduino code and Pd patch for this project are available in Appendix C.

¹¹ A spatialized rendering of this can be found in my portfolio.

sound, emphasising its movement around space in a semi-disruptive and discrete manner.

In this first iteration of the work, I had intended to transmit serial data from Pd to the Arduino, but initial testing found that a packet of data could only be sent from Pd every second. This slow sampling rate was insufficient for a live audio application, and despite significant time testing and debugging, I was unable to resolve the issue. I found that sending serial data from Arduino to Pd was more efficient. Although this made the system more responsive, it limited the amount of audio processing and the rate at which data could be transmitted was still inadequate. The haptic mapping algorithm was intended to employ the previously mentioned haptic illusion techniques to ‘draw’ the movement of the sound on to the haptic array, but due to these complications, I was unable to render VAM in this system. The installation of this work at CMMR was the first time that the haptic grid display had been taken out the lab. Shortly into the installation time, the display hardware was broken. The circuitry was not mounted into a suitable enclosure, and a participant, with the motors strapped to their body, stood up and short circuited the prototype.¹²

4.1.3 Enclosed II

From these frustrating beginnings, the design and concept were further improved by redeveloping the system using the Ambisonic Toolkit (ATK) in SuperCollider.¹³ The serial connection between SuperCollider and Arduino is more reliable than that with Pd. For the implementation of this work in SuperCollider, a SynthDef is built to control samples and define their binaural location, duration, playback rate and loudness. Any sample can be loaded into the buffer and spatialized in this system. Mappings between the twelve motor indices and twelve corresponding audio locations are stored in a 2D array. A task controls the rendering of sound, spatializing it according to the selected array index and sending corresponding vibration information (motor index and PWM) to the Arduino. The Arduino maps PWM between the onset threshold of the motor and maximum vibration amplitude. The movement of the vibration and sound is controlled by loops. I have included an

¹² On debugging I found that the TLC5940 driver chip had been overloaded and I did not have a spare. From this experience, I learnt to fully enclose and mount my circuits and to always carry a spare TLC5940 driver.

¹³ SuperCollider and Arduino code for this project can be found in Appendix D. For more information see Ambisonic Toolkit Staff, “Introducing the Ambisonic Toolkit.” ATK for SuperCollider, last modified November 9, 2016, accessed April 20, 2017, <http://www.ambisonic toolkit.net/documentation/supercollider/>

example rendering from the system in my portfolio using low drones that reflect the intensity of the vibration.

In *Enclosed I* there were some conceptual issue with the piece as I was attempting to project a 3D space onto a 2D grid. I worked around this by focussing the binaural sound at the back of the listener and used the changes in the location the motors vibration as an approximate reflection of the sonic movement rather than a direct representation. To create a more realistic vibratory rendering of the sonic space, I designed a waist belt (discussed in chapter 3, see Figure 10) that would allow vibrations to move around the body on the horizontal plane together with sound. Each of the twelve motors has an independently controllable amplitude, allowing the vibrations to move round your body—it is quite an extraordinary sensation.



Figure 10. *Enclosed II*, Fuse Art Space, Bradford.

4.1.4 Reflections and Outcomes

The video of *Enclosed II* in situ at Fuse Art Space contains comments from three people that experienced the vibration belt. One person describes their experience of the belt suggesting that they felt the pitch of each note in their body as well as hearing it—on removing the headphones they found they could still feel the pitch in their body. This is a surprising comment as the pitch was randomised and not accounted for in the haptic mapping strategy. Through the mirroring of amplitude and spatial location, this user has constructed a relationship between pitch and vibration. This suggests a certain perceptual confusion has been caused through the mapping strategy that results in imagined connections between sound and vibration. This user also suggests that they felt the vibration ‘in’ rather than ‘on’ their body. Whilst the belt

produced a cutaneous vibration, this comment highlights that the vibrations produced are embedded beyond the surface of the skin. A subsequent comment from a different user likened the experience to a graphic notation for the body. This suggests that the rendering on the body resulted in a structurally significant relationship between the audio and the haptic and underlines my initial idea of haptic stimulation acting as a guide through auditory space. This is further supported by a third user who suggests the sounds ‘move with the vibration’.

Whilst spatial audio techniques allow listeners a more immersive and gestural listening environment, at times they can become perceived as somewhat intangible. In this work, I employed a haptic interface as an audio-tactile installation first as *Enclosed I*, and revised through the development of *Enclosed II*, to provide users with a more accurate reflection of sonic movement, using tactile gestures to reflect spatial location of a sound. With our sense of touch being perceived through the largest of our sensory organs, addressing it spatially presents a great, but complex canvas. From the development of this work I began to consider how I could use vibrations to transform the listener to an alternative space. I also began to consider more deeply how vibrations could be symbolic and reflect change in a sound rather than behave analogously to it as many previous works, detailed in chapter 2, have explored.

4.2 Unheard Sounds

Unheard Sounds (2015), is an installation for a single listener that explores the relationship between the auditory and somatic sensory systems by highlighting unheard aspects of sound, such as masked noises that appear less apparent in an audio mix. Through headphones, a listener hears a piece of music composed of sine waves that occlude and interact with each other, whilst experiencing parallel vibrations that reflect the onset time, duration and loudness of the sounds. The mappings switch between direct and inverted renderings of the sonic to haptic to subvert the listener’s experience, highlight quieter aspects of the sound through vibration, and present the unheard element as a physical entity to enhance aura.

The work probes the relationship between perceived auditory loudness and physical vibration amplitude by rendering sounds as haptic feedback on the listener’s back. In *Unheard Sounds* audio is synthesized and played back in SuperCollider. Alongside producing the sonic element of the piece, SuperCollider is also employed to trigger patterns of vibration to vibrating motors placed on the rear of a seat. This installation

was built for V&A Digital Futures exhibition as part of Electronic Visualisation and the Arts 2015, London.¹⁴

4.2.1 Background and Context

At the start of this study I considered obvious mappings, exploring territories that could be conceived as *intuitive*, for example, looking at relationships between the frequency of vibration and sound, the rhythm of sound and vibration, and the stereo location of sound and the location of physical vibration, as discussed in the previous section. With these ideas in mind, I began thinking about loudness: how it is relative, and dependent on frequency. I decided on four key ideas to explore, and wrote the sound and haptic elements simultaneously as four miniatures for the ears and body that each focussed on a different aspect of unheard sounds i.e. ultrasonic, infrasonic, inaudible and masked sounds.

Like other phenomena, sound, as a medium, can be present in a space and remain undetected by an observer. There are some obvious factors that obstruct what sounds we hear, including those imposed by the limitations of our bodily thresholds and the presence of additional sounds. It is generally accepted that humans can hear frequencies between 20–20,000 Hz, and that this range deteriorates over time. Sounds of frequencies that fall below or above that frequency range are referred to as infrasonic and ultrasonic respectively. As well as hearing within the specified frequency range, our ears have loudness thresholds, from a sound being audible to it becoming painful with increased loudness. Our perception of loudness is frequency dependent. Furthermore, sounds can be obstructed and occluded by other sounds that occupy the same sonic environment; in digital audio, this is commonly described as auditory masking. As such, this type of unheard sound is caused by the presence of one sound impacting the perception of another and can be caused by too great a difference in signal level.

4.2.2 Outline of the Work

This work consists of an auditory and a haptic element that are written in SuperCollider. Vibration parameter data is sent from SuperCollider to the Arduino,

¹⁴ It was installed on the afternoon of 6th July 2015 at LimeWharf Gallery, London and exhibited publically throughout the evening. The text for this section is significantly expanded upon from a short abstract submitted to the conference and published in the proceedings. Joanne Armitage and Kia Ng, "Unheard Sounds" (paper presented at Electronic Visualisation and the Arts, London, 2015).

mapped and then rendered as vibration. For this work, I used the haptic grid described in chapter 3 that consists of sixteen ERM motors aligned in a 4 x 4 grid array. The listener is encouraged to remove thick clothing allowing as close contact to skin as they are comfortable with. *Unheard Sounds*, employs a limited sonic palette and at the start, is on the verge of resembling a listening test. The work is divided into four main sections that employ varying frequencies and amplitudes to explore facets of the concepts discussed above.

The first section of the piece was written to ‘normalise’ the listener to the system, familiarising them with the simultaneity of the vibrating and sonic elements. Musical parameters are generated from a pre-defined array of frequencies, amplitudes and note durations. To expose the mapping as part of the works narrative, only one note is played at any time to allow the relationship between note and vibration to be clear to the listener. Each array of four pitches corresponds to one of the four columns of motors from left to right (see Table 2). The algorithm selects a motor that it will vibrate (only one is chosen, at random, from each column), and then chooses a frequency from an array (f1 to f4 in the table) and applies a predefined amplitude. The amplitude of the vibration is then inverted and sent to the Arduino via the Serial port where it is mapped to a PWM value.

Subsequent sections build upon this concept and develop into multiple concurrent sounds with increasing complexity. For example, in the second section, two tones interact masking each other. Amplitude for the second tone is calculated to be 1 minus the amplitude of the first tone which means that the loudness difference between each note varies between note changes. An additional vibration channel is used to signify the occurrence of two notes, and again the vibration amplitude rendering is inverted with the amplitude of the sound.

1	2	3	4
f1.choose	f1.choose	f1.choose	f1.choose
5	6	7	8
f2.choose	f2.choose	f2.choose	f2.choose
9	10	11	12
f3.choose	f3.choose	f3.choose	f3.choose
13	14	15	16
f4.choose	f4.choose	f4.choose	f4.choose

Table 2. Motor index (top) and frequency array (bottom) for first section.

4.2.3 Reflections and Outcomes

There were several issues in the realisation of this work, particularly the loudness of the motors themselves, which can work against the system to distract from the sonic element. Although headphones occlude some environmental and motor sound, the hardware setup could be improved to reduce motor noise (Figure 11). In some ways, it does act as an interesting compositional device; when the vibrations are at their highest intensity they are at their loudest, when this is mapped to the inverse of the loudness of a sine wave it further occludes it. The irony of this is that the system alerting you to the presence of a sound ends up reducing its presence auditorily. Linear resonant actuators produce significantly less noise when activated and could be employed to reduce the overall amount of hardware noise in the piece.

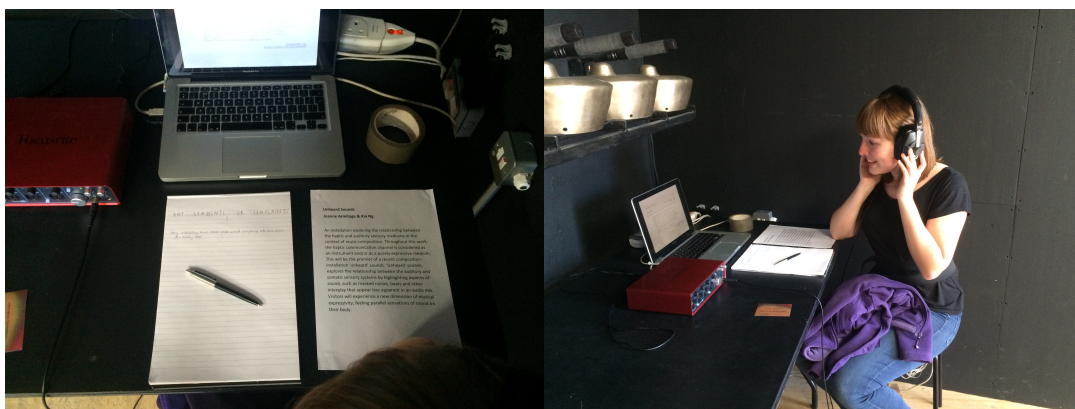

Figure 11. *Unheard Sounds*, LimeWharf Gallery, London.

Although I have not specifically addressed these issues in a further iteration, I still believe the concept of employing haptics as both a form of sensory substitution, and method of highlighting the unperceived, requires further investigation. These concepts have been touched upon in further installation works, for example, *My Back Catalogue Rendered as Vibration on Your Body*, where elements of sound are filtered across the body, dispersed through headphones and vibrations are employed to enhance the aura of a fixed media listening experience. This piece was developed as an initial step to explore ways in which unheard or experienced sounds could be exposed through additional sensory stimulation. Although anecdotal feedback from those that attended the installation was generally positive, it is hard to disambiguate whether this was due to the novelty of the overall experience, or the effect of the sonic-haptic mappings. I would not suggest that this augments an individual's perception of a particularly quiet or high-pitched sound, but it does work to alert the user as to its potential presence.

4.3 Other Works

In March 2017, I organised the event ‘The Body in Sound’, at Fuse Art Space, Bradford with support from the Centre for Practice Based Research in the Arts. Overall the aim of the evening was to focus on experiences of sound from the perspective of the body.¹⁵ Together with percussionist Greta Eacott, I curated an evening of installation works and performances that placed the body of the performer and listener at the core of the activities. Through the evening, members of a feminist listening group based in Leeds, performed listening exercises from Pauline Oliveros’, ‘Deep Listening’.¹⁶ For this event, I developed several new installations to challenge the technologies, methods and concepts that I had previously used and explored in my practice. In doing so, I redeveloped *Enclosed*, as discussed in the previous section, and produced three new works, included in the portfolio and discussed below.

4.3.1 *My Back Catalogue Rendered as Vibrations on Your Body*

My Back Catalogue Rendered as Vibration on Your Body (hereafter *MBCRVYB*), is a little self-explanatory. During the time of this research, I have been producing a lot of algorithmic music, most of which has been unreleased and stowed away on a hard drive. Although I keep social media updated with some live recordings of my music projects, I have some anxieties around the concept of ‘releasing’ music.¹⁷ Although I enjoy imperfection in my improvisation, recorded media cements and decontextualizes it. Furthermore, I do not want to produce work that is finished; my work is in a constant cycle of iteration and is inherently unfinished. My aim is not to produce finite articles, but to create new environments that present different opportunities for listening that grow and develop through their interaction with human bodies.

In *MBCRVYB*, I hoped to reclaim my back catalogue of live recordings as physical entities that can be listened to and felt within the body. For this installation, I selected four recordings of my various live sets and home recordings. Outside *MBCRVYB*, my production work explores the somatic. I work with low bass sounds that rupture, grow and decompose by algorithmically controlled synthesis parameters. To render the works as vibration I developed a new haptic system that used DRV2605 chips to drive large ERM motors (see Figure 8). The DRV2605 chips have an integrated audio-to-vibe algorithm that can be set to render an incoming audio input as vibration. The

¹⁵ A summative video of the event can be found in Appendix E.

¹⁶ Pauline Oliveros. *Deep listening: a composer's sound practice* (New York: IUniverse, 2005).

¹⁷ ALGOBABEZ released their debut album ‘Burning Circuits’ on Fractal Meat in April 2017.



Figure 12. *MBCRVYB*, Fuse Art Space, Bradford.

audio-to-vibe algorithm is not documented in the datasheet, but it indicates that it renders the bass element of the vibration as ‘meaningful’ haptic feedback. From working with the algorithm, I believe it consists of a low pass filter and a bass boosting equaliser.¹⁸ Motors were arranged in a 2 x 2 grid with a left and right channel for each corresponding side of the body.¹⁹ The memory foam back was then strapped round a chair as seen in Figure 12. Each DRV2605 driver chip was connected to an output channel of an audio interface. Output audio was rendered as vibration by the motor. To create a greater sense of movement in the tracks, I applied filtering and panning so that sound would move across the body and applied a high pass filter to act in conjunction with the haptic element as a cross-over filter so that low frequencies were rendered as vibrations on the body and higher frequencies as sound to the ear.²⁰ Although I did not have a direct control of the haptic algorithm itself, I was able to manipulate the audio signal it was processing to achieve the desired physical result.

¹⁸ This approach renders a similar effect to that described by users of the ‘Basslet’ (<https://lofelt.com/>), a Bluetooth subwoofer for the body. Jeremy White, “Hands-on with the £109 wearable subwoofer Basslet.” *Wired*, last modified June 21, 2016, accessed April 24, 2017, <http://www.wired.co.uk/article/hands-on-basslet-wearable-subwoofer>

¹⁹ The number of vibrating channels could easily be expanded with increased audio outputs from the computer.

²⁰ The Ableton project and Arduino code for *MBCRVYB* are available in Appendix F.

Several people who were more familiar with my live coding work were engaged by how I had linked familiar sounds with my work in haptics. The development of *MBCRVYB*, has allowed me to directly connect my production work with my research and has revealed new pathways and possibilities to explore. There is the potential for this system to be scaled up for a larger audience, but this would be limited by the number of audio output channels available. Through this it would be possible to perform live with the setup. I am interested in producing more of these cushions and using them as a means of distributing my production work in the future.

4.3.2 *Piano Stool Droning Around 33 Hz*

Piano Stool Droning Around 33 Hz, is a single channel sound installation for tactile speaker. In this work, an audio file consisting of drones around the frequency of 33Hz is played back through a large tactile transducer, or ‘bodyshaker’ that is installed in a piano stool. Such transducers are often used in home cinema systems to vibrate sofas, or cars to enhance the bass vibration of sound. Within these examples, and discussions of how to setup and employ the speakers, there is a strong sense of masculinity. Delving deeper into these forums, you find anecdotal account of failed experiments around the ‘33 Hz Trick’. This is a completely unsubstantiated ‘phenomenon’ whereby frequencies of 33 Hz ‘resonate with the clitoris’ and induce vaginal orgasms. The only discussion on the clitoral-use of this frequency is on these car and technology forums where dialogue is often aggressive, lewd and misogynistic. One artist, has developed a work inspired by it. Wagner’s uncomfortably titled *33 Hz ‘Come With Me’*, attempts to induce clitoral orgasms by improvising electronics played back through a chair embedded with subwoofers. The only documentation of the work is a video where someone is performing (who I suppose to be Wagner) and a woman is sat on the chair writhing, a little.²¹

I have not explored themes of sexuality in depth in my research, although it is rare that I can present my work mentioning a phrase such as ‘virtual vibrator nodes’ without evoking sniggers. Outside the innocuous and semi-mundane roles of vibrating motor as an alerting device in phones, or their slightly more immersive function in games controllers, most vibrating devices live in the top drawers of bedside cabinets.

²¹ Mark Wagner, “33Hz ‘Come With Me.’” YouTube video, 03:12. Posted July 23, 2015, accessed April 15, 2017, <https://www.youtube.com/watch?v=Q7xEWx6JU-c>



Figure 13. *Piano Stool Droning Around 33 Hz*, Fuse Art Space, Bradford.

The most pertinent connotation of the term ‘vibrators’, and uses for them, is in the sex toy industry. In 2011, when I first began searching online for motors using the search terms ‘vibrators’ and ‘vibrator device’, my screen was awash with vibrator porn and shopping links to sex toys. Yet in my practice, I have not fully engaged with themes of sexuality.

Through *Piano Stool Droning Around 33 Hz*, I intend to reclaim low frequency vibrations as a more feminine form by embedding the device in a red-pink piano stool (Figure 13). In this work I enclose the transducer, audio amplifier and audio playback device in the storage compartment of the piano stool, occluding the technologies. An audio file is played back generated of multiple saw waves that drone on and around the frequency of 33 Hz.²² The transducer excites the piano stool as it renders the drones, but does not stimulate the user beyond a gentle hum that although not unpleasant, is unlikely to result in climax.

4.3.3 *Bone Music*

Bone Music, is an environmentally reactive sound installation that uses audio input from a microphone to transform sound and play it back to listeners. The piece is an initial step in a concept I am interested in developing with bone conductive headphones. These headphones transmit sound through the bone directly to the eardrum, opening up the auditory canal and reducing the occlusion of external sounds

²² This audio file can be found in Appendix G.

to the eardrum. Cyclists and runners use them as they enable them to listen to music whilst still being aurally engaged with their environment. They render sound as vibration and if playing back sound of a high amplitude and low frequency, they produce a very physical sensation on the side of the head (see Figure 14).

This work uses an audio input signal from a microphone and transforms the inputted sound using audio processing techniques. The transformed sound is played back to the listener through bone conductive headphones, allowing them to hear ‘true’ and ‘distorted’ versions of their environmental noise. A series of comb filters are applied and panned left and right to etch a memory of a sonic event to the listener that echoes through time and across space. When a threshold level is reached on the microphone input, an additional low frequency sound is triggered, building the physical intensity of the vibrations on the listener’s skin.²³

Through this work, I have begun to explore how sound can place and displace the body in space, particularly when the listener’s head is not in alignment with the input microphone, and a more extreme sense of disorientation is provoked. The sound rendered by the bone conducting headphones is physically embedded into the listener’s bone via vibration, circumventing the outer parts of the ear. From this work, I envisage developing an immersive, or whole body bone installation where vibrations of the bone transmit sonic energy to the eardrums.



Figure 14. Bone conductive headphones building up vibrations.

4.3.4 Reflections

‘The Body in Sound’ presented an evening of installation works, performances and participatory activities for the audience to immerse their body in the act of listening.

²³ The code for *Bone Music* can be found in Appendix H.

Throughout the evening installations were left running. *Enclosed II* is not as intuitive for the user to interact with as the waist belt must be affixed to the body in the correct orientation. This resulted in people who had used it previously instructing and attaching the device to the next person. This added an interesting intimacy to the occasion, as individuals re-explained how they had interpreted the system to work, and relay what the next person should expect to feel. This opportunity instilled a confidence in me regarding my work, as those participating seemed really engaged and truly ‘vibing’ it.²⁴ From the video documentation, it is apparent that those who attended experienced sound in new ways that emerged as physical experiences.

In terms of organising similar events, I learnt several things. Although I scheduled a whole afternoon for setup, due to the large number of works I was sharing, I could have benefited from a whole day to ensure that everything was working correctly. I also realised how my work is very dependent on laptops, which meant one installation was taken apart for my live coding performances. This has made me consider opportunities for lower tech routes, or employing devices such as the BeagleBone Black.

²⁴ Sorry.

Chapter Five

HAPTICS IN PERFORMANCE

As in all long periods of study, as a practitioner, my interests and focus evolved to reveal a new direction. Through early experimentation with acoustic instruments, I became frustrated—my work was not concerned with notations in a traditional sense. Their imprecision, and the necessity to engage a performer, particularly when iteratively developing works and technologies was challenging. From this I became increasingly concerned with electronic music production. A significant tangential change in this work grew from an interest in live coding.¹ From working with algorithms to produce instrumental and fixed media scores using data, I became focussed on live coding as a post-autonomous practice. Whilst at first I considered it an aside from my research, I quickly established an active performance profile, and as I began to explore the area more critically, I saw opportunities to develop connections between my work with live coding and research in physical computing. In chapter 4, I discussed how aspects of sound could be rendered as vibration in installation scenarios. This chapter will focus on how I have translated these concepts into my performance practice. Through this, I began using haptic tools to collaborate with instrumentalists to explore how haptics can be embedded in performance practice. This is demonstrated in the first system discussed in this chapter, ‘Silent Metronome’.

Later into the chapter, I discuss the utility of haptics in my solo practice as a live coder. As I refined my skills, performances became increasingly static, with minimal errors and faster debugging resulting in less expressive ‘contortions’ of my face. I became concerned with how my ostensibly inanimate performance practice was embodied as a creative process, through the code I was projecting, management of error, and in collaboration. Whilst playing small intimate settings, I began to want an additional connection with audiences outside of my screen and bodily stillness. I saw how vibrating technologies could play a part in this and began to employ them in a manner that revealed my process to audience members. Furthermore, these

¹ See TOPLAP website (<https://toplap.org/>).

approaches allowed me to contemplate and investigate notions of liveness, authenticity and expression in my live coding performance practice. As part of this, I have been using vibrating motors to connect physically with audience members. Presenting the audience with vibrating technologies adds an infrequently experienced level of physical intimacy at the ‘receiver’ end. Rather than sound being solely embodied via a listener’s physical response (i.e. swaying or dancing), aspects of the sound and data producing it are imparted via touch.

5.1 Silent Metronome

The Silent Metronome project follows on directly from my undergraduate work that used vibrating motors to communicate beat information to musicians in distributed ensembles.² This project involved the development of an augmented conductor baton to translate conducting gesture beat points into temporal haptic feedback for distributed performances. As my practice became primarily focussed on creating laptop music, this work was extended to form a performance system that allows computer musicians to share their clock with a performer as vibration.

Performers can synchronise by aurally responding to sound as it is produced, however, this does not always allow anticipation of sudden changes in tempo or maintaining a beat when there is no sound, particularly in improvised performance. Further challenges are presented in distributed, or spatialized performances, and those involving technological instruments, which require visual attention, limiting visual interaction. In beat-oriented music a typical solution is the click-track, but this is unsuitable for adaptive, or improvised performances where temporal flexibility is essential. Additionally, in-ear devices can obstruct the performer’s auditory perception, masking the subtleties of the sound they are producing.

This section describes the development of the Silent Metronome project and its application in live coding collaborations with laptop musicians using Tidal and SuperCollider, and instrumentalists using acoustic and digital pitched and unpitched percussion. Silent Metronome conveys inaudible, haptic temporal directions to live performers. The test-bed for its development was a series of collaborative live coding and live percussion performances, which require precise, yet flexible, tempo and beat synchronisation between the human performers, mediated by technology. Using small

² Joanne Armitage and Kia Ng, “mConduct: A Multi-sensor Interface for the Capture and Analysis of Conducting Gesture,” in *Electronic Visualisation in Arts and Culture*, ed. Jonathan Bowen, Suzanne Keene and Kia Ng (London: Springer, 2013): 153–165.

vibrating motors to convey a sense of beat, through vibration, I have designed a series of prototypes that can be used to communicate tempo between a computer and instrumental performer.³

5.1.1 Related Work

Since early experiments in developing the Silent Metronome, several consumer products have been developed including bespoke vibration-based metronomes, and more utilitarian products that can be used to a similar effect. The Apple watch, originally released in April 2015, falls into the latter category. The device includes a vibration-based notification system and several developers have made vibrating metronome applications using this.⁴ The ‘Soundbrenner Pulse’ is an example of a bespoke haptic metronome device.⁵ First released in late 2015, it houses a vibration motor that they claim to be seven times stronger than that of a smartphone. The device also boasts additional features, such as integration with DAWs through MIDI and a tap tempo function. Retailing at \$99 it is considerably cheaper than an Apple watch, but more expensive than Silent Metronome, whose parts total around £22. Although these devices can interface with DAWs via MIDI, they are very closed, and it is not clear if they are configurable through an API. Another similar device is the Moment by Somatic Labs, a watch-style wrist appendage that houses four LRAs.⁶ This device claims to improve your sense of time, direction, presence and rhythm, but there is no clear empirical evidence on their website that supports these claims. Although employing haptics to create a greater sense of grounding to time and space is certainly an exciting notion, significant research would be required to substantiate such declarations.

5.1.2 Design Overview

The primary hardware components for Silent Metronome are motor(s) that can be positioned on performers using combinations of Velcro straps and tape. This is controlled by an Arduino that triggers the motor(s) to control onset, amplitude and

³ This project was funded by a University of Leeds, Ignite grant, overseen by Kia Ng, researched and designed by myself, and developed through rehearsals and performances with Alex McLean, Matthew Yee-King and Greta Eacott.

⁴ Vibrating metronome applications available from the iTunes application store include ‘Pulse’, ‘tacet’ and ‘Beet’.

⁵ See Soundbrenner “Soundbrenner Pulse.” accessed April 20, 2017, <http://www.soundbrenner.com>

⁶ See Somatic Labs, “Moment.” accessed April 20, 2017, <https://wearmoment.com>

duration of the vibration.⁷ Onsets are triggered through the serial port, requiring the microcontroller to be connected to the USB port of the laptop performer's machine. An initial prototype used a single enclosed motor, however, after a requirement analysis it became clear that stronger and multiple motors were required to ensure that vibrations were effectively transferred to the skin. For later performances with the work, I used the grid of motors discussed in chapter 3. In the final performance discussed in this section, a tap tempo system was developed to allow the instrumental performer control of rhythm.

5.1.3 Experimentation in Performance

Silent Metronome has been tested in collaborations between Alex McLean and Matthew Yee-King (performing together as Canute), Alex McLean and Greta Eacott, and a collaboration between Eacott and myself. For the latter, Eacott and I spent a week improvising with the system and subsequently presented and workshopped our endeavours to students at Rytmisk Musikkonservatorium, Copenhagen, Denmark. Details of these trials are given below. This was an extremely useful exercise, yielding new ideas relating to the development of the work, particularly when vibrations were used to relay tempo in very physical or fast performances.

5.1.3.1 Canute, Rehearsal, March 2014

I observed a practice session for Canute, a collaboration between Alex McLean (laptop) and Matthew Yee-King (electronic drums and laptop), to better understand how the metronome worked in practice (Figure 15). In this case study, it was found that the vibration did not provide enough feedback for the drummer who felt that the impulses of their physical interaction with the drum counteracted that of the motors. Considering the feedback received during this session, it became clear that the prototype would need to become increasingly powerful by creating more detailed and clear impulses with a higher vibration amplitude. This would be particularly useful for performers engaging with very physical or somatic instruments like percussion. An improved design would incorporate more advanced and powerful vibrating motors, allowing greater coverage of the body. This was expected to negate the effect of other tactile events on the body whilst performers are physically engaged with their instrument.

⁷ Relevant project code is available in Appendix I.



Figure 15. Requirement analysis at Canute rehearsal, Goldsmiths, London.

5.1.3.2 Alex McLean and Greta Eacott, iscMME 2014, Leeds, 10th June 2014

According to suggested improvements, a refined design was used for performance incorporating a more powerful motor and driver at iscMME2014 (Figure 16) with Alex McLean (Tidal) and Greta Eacott (marimba).⁸ The performers improvised together after only one short rehearsal, but their collaboration was very effective with moments where they audibly connected as performers. They played with the affordances of the motors, allowing Eacott to begin improvising before the laptop music began, and McLean to drop out at junctures with Eacott still receiving the pulse. McLean changed the tempo drastically at points, playing complex rhythms whilst Eacott maintained beat-synchronised syncopations.

With the limited rehearsal time, the performers were unable to devise complex performance schema that would have reflected the comparably improved listening affordances of the vibrating motor as compared to the traditional click track. There is a moment at 10:09 in their performance where McLean stops his sound and restarts from scratch employing a sound that complements Eacott's current refrain on the marimba. This results in a clear moment of sonic interplay between them. Although two highly skilled improvisers, at the time, I felt that the conditions of the performance with the Silent Metronome encouraged these connected moments, allowing Eacott to more intently focus on the electronic element of the sound.

⁸ A video of the performance can be found in Appendix J



Figure 16. Greta Eacott and Alex McLean at iscMME 2014, Leeds.

Although the vibration motors appeared to afford a greater freedom of temporal expression than timekeeping through audition, it was not clear as to whether there was a benefit when compared to an audio click track. The computer controlled tempo at times resulted in a sense of hierarchy where it felt that Eacott was following McLean’s directions. Developing a democratically controllable pulse between laptop and instrumental performer is something that warrants further investigation. Again, this collaboration provided exciting new ideas and directions for the project, with Eacott stating:

Was quite the experience, feeling a silent groove pulsate through my body even when there was no sound in the room. I definitely feel that the technology has something really exciting to offer for all kinds of performance/composition/studio and other work!⁹

5.1.3.3 Greta Eacott and Myself, Rytmisk Musikkonservatorium, Copenhagen, 16-22nd April 2015

In April 2015, I spent a week intensely improvising with Eacott at the Rytmisk Musikkonservatorium, Copenhagen, Denmark. Together we spent most days practicing with the metronome and developing a series of short improvisations around single concepts. This included playing in different time signatures over the top of each other, where I would send a separate coded time-signature to Eacott. We explored other interactions such as Eacott playing for seven beats and me remaining quiet, and Eacott remaining quiet whilst I played for five beats. This was coded into the

⁹ Greta Eacott. “Silent Metronome.” Artist’s personal website, date accessed March 21, 2017, <http://www.gretaeacott.com/n-e-w-s--d-a-t-e-s/live-coding-marimba-and-silent-metronome-performance-at-iscmee>

metronome to give more intense vibrations on the seven beats Eacott was playing for.¹⁰ We experimented with dramatic changes in tempo working at very fast and slow speeds and performing in marginally different tempi. Eacott and I subsequently performed with the Silent Metronome at an Algorave (see Figure 17). Early in the performance, SuperCollider crashed, but what could have been a challenging moment ended up an opportunity to demonstrate the device's efficiency at relating tempo.¹¹ Whilst at Rytmisk Musikkonservatorium, the system was workshopped with two other improvisers, Knut Nesheim (percussionist) and Rasmus Kjærgård Lund (tuba).¹² Performing the drum kit, Nesheim, found the vibrations painful even when their amplitude was significantly reduced—contrasting the experience of Yee-King in the earlier rehearsal phase. This reveals the different thresholds of tolerance people experience with the vibrations with Nesheim clearly possessing a greater sensitivity to them.

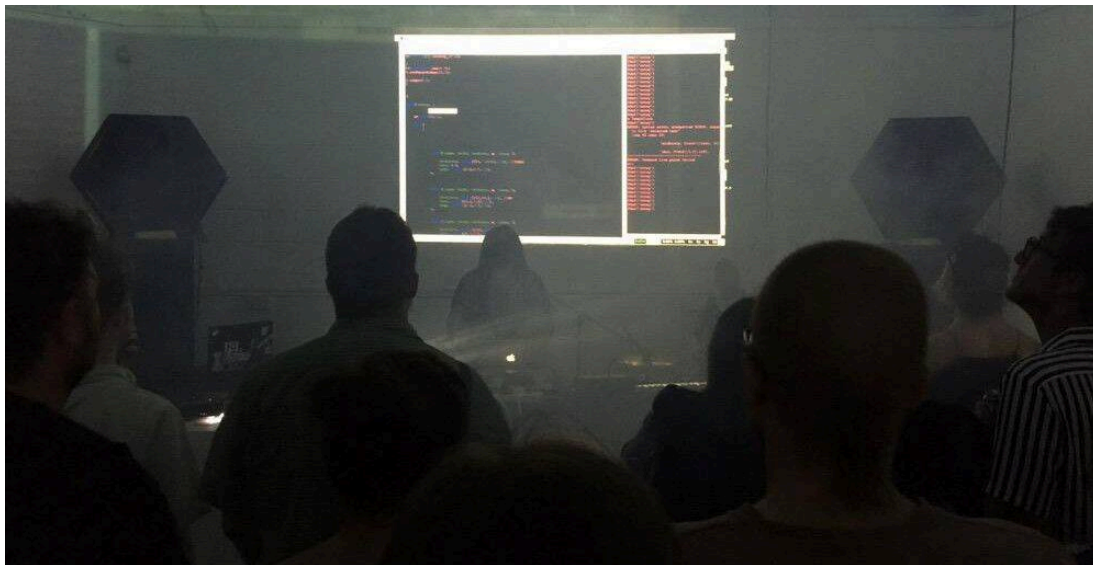

Figure 17. Greta Eacott and myself performing with the Silent Metronome, pre-ICLC Algorave, Access Space, Sheffield

5.1.3.4 Collectress and Miss Represented, Sussex University, 25th November 2015

I was involved in a day of collaborative performance between Collectress and community group-collective Miss Represented exploring synchronisation, performance and exploratory notations (see Figure 18). Whilst I was coding tempo and patterns on vibration motors, Chris Kiefer controlled a series of coloured LED

¹⁰ Some sample recordings from this rehearsal period are available in Appendix K.

¹¹ A video of Greta and I performing with the Silent Metronome can be found in the portfolio.

¹² Videos of these improvisations are available in Appendix L.

lights using code to reflect aspects of notation. We had hoped to work with Miss Represented to play in an iPad ensemble generating sounds inspired by the coloured LEDs and vibration patterns. We were using the motors for timing briefly and, one young person complained that they hurt them. Rather than focussing on the digital technologies in the practice space, the young women were more interested in the acoustic instruments so instead we focussed on them. Overall the day was quite intense, comprising of several different activities.

I did manage to spend a short amount of time working with Collectress to explore the vibration motors as a form of live notation as opposed to timekeeping—something I hope to embed further into my practice and collaborations. Members of the Collectress ensemble preferred working with subtle shifts and changes. Through practice, it became clear that the vibration motors were distracting when setup to render discrete rhythmic structures. They did however, respond well to fades in ambient light which were interpreted as changes in loudness by the performers. Ultimately the multisensory notations worked better within a continuous as opposed to discrete framework.



Figure 18. Rehearsing with Collectress and Chris Keifer, Sussex University.

5.1.3.5 Greta Eacott and Myself, Fuse, Bradford, 29th March 2017

Eacott and I intended to revive the Silent Metronome for this performance, however, through rehearsal, we became more interested in developing a texturally influenced performance. Prior to this period of rehearsals, I had developed a more ‘democratic’ approach to the Silent Metronome’s temporal control whereby Eacott could control

the tempo of my machine via a MIDI interface and tap tempo algorithm. I have included the recordings from this gig in my portfolio, as the performances reflect a very sensitive improvisation that I felt truly embodied within. In parts, it is challenging to differentiate between the live percussion and the electronic sounds (see Figure 19). After the performance, an audience member asked if I was live processing Eacott's sound, which I was not, reflecting the audible connection between us in performance.

5.1.4 Conclusions

This section has described the Silent Metronome and its use in live coding performance practice. I have discussed the development of the work in the context of case studies with laptop musicians and performers. Through this process, it became clear that individual users, playing different instruments, have different sensitivities and preferences to the intensity and strength of the vibrations. This has highlighted a need for the setup to be flexible and configurable for different performers. Whilst the Silent Metronome hardware has been superseded by several consumer products, this bespoke approach to vibration timekeeping affords a greater flexibility allowing me to customize vibration patterns for my collaborative performance practice. As a tool, Silent Metronome gave me the confidence to improvise with performers of different instruments by connecting with them through vibrations.



Figure 19. Greta Eacott and myself, The Body in Sound, Fuse Art Space, Bradford.

5.2 Key

Key (2015), is a performance system that extends the connection between the physical gestures of laptop performance and the listener using haptic feedback. As a highly-mediatised laptop-based improvisation practice, the physical human gestures of live coding are often just small motions. Between the performer and their instrument, this interaction is a small surface area of skin on the finger making singular temporal connections with a computer keyboard. To summarise, it is a kinaesthetic movement with a haptic interaction.

The temporal detachment and disconnect within live coding movements, when viewed as a performance gesture, is fertile ground for exploration; not only the notion that the performer reveals their plans prior to their inception, but the disconnect inherent in temporal flow being mediated by the laptop. The performer can try to release themselves from the visual absorption of the screen, looking up to survey audience response, but a critical aspect of what makes a live coding a performance is each finger manoeuvring the keyboard, individually pressing keys. For this reason, I began to consider the typing gesture more critically in performance and developed the novel performance system documented in this section.

This section will outline the conceptual development of *Key*, including theoretical background and related works. Further to this, I will detail the design of the performance system and reflect on three performances using it to analyse its limitations and suggest how the concept could develop further. The discussion contained within this Chapter is adapted from a paper entitled ‘Revealing Timelines: Live Coding and its Gestures’.¹³

5.2.1 Instruments, Performative Gestures and Live Coding

Live coders are often somewhat teased for the lack of ‘expressivity’ in their physical performance.¹⁴ The stasis of the live coder presents an interesting contrast to the physical acuity demonstrated by instrumental or vocal sound. Emmerson, who analyses the place of the human performer in electronic music, identifies two contrasting approaches that can be taken to address this disparity: those that amplify

¹³ Joanne Armitage, “Revealing Timelines: Live Coding and its Gestures” (paper presented at International Conference on Live Coding, Hamilton, Canada, 2016).

¹⁴ Oliver Brown, Renick Bell and Adam Parkinson, “Examining the Perception of Liveness and Activity in Laptop Music” (paper presented at New Interfaces for Musical Expression, London, 2014). http://www.nime.org/proceedings/2014/nime2014_538.pdf

the presence of the body through gesture and those that embrace the lack of it.¹⁵ Live coding clearly falls into the former category where projection of the code is often considered an approach to amplifying performativity and rendering a sense of liveness in performance. Such notions are discussed by Collins, who presents arguments in favour of, and against the requisite for there to be a revelatory aspect of laptop performance.¹⁶ These thoughts are elucidated by McLean et al. who present approaches to visualisation of and in live coding, and in the process, intimating that the projection of code could be considered as something that could be distracting or exclusionary.¹⁷ In *Key*, I consider the keystrokes of live coding in the context of expressive performance gesture, and present a technological approach to amplifying, or highlighting them in live performance.

As a performer moving from instrumental practice to a text-based laptop performance interface, the most striking difference is the addition of the typing time line and how that gesture connects (or not) with the sound being produced. This idea extends into queries relating to the placement and location of the *instrument* and *score* in live coding practice.¹⁸ As a performer who live codes hardware synthesizers, from my personal perspective, the location of the instrument is clearer. I expect users of samples would not necessarily consider the sample bank they address as their ‘instrument’, and would perhaps consider there to be no (clear) instrument in their performance. What these considerations bring to light are the tensions and nuances that lie within such a dynamic field of interdisciplinary practitioners.

The production of music has been historically grounded in the body. The relationship between instrumentalist gesture and the sound it produces has been a long-considered topic of research in musicology. Gesture has been traditionally described in these terms as a visceral force that is inherent in sound because of the characteristics of a motion.¹⁹ Such traditional performance paradigms present an interesting lens through which to consider live coding as a practice. When we examine live coding within

¹⁵ Simon Emmerson, “‘Losing touch?’: The Human Performer and Electronics,” in *Music, Electronic Media and Culture*, ed. Simon Emmerson (Routledge: London, 2000), 194–216.

¹⁶ Nick Collins, “Generative Music and Laptop Performance,” *Contemporary Music Review* 22, no 4 (2003): 67–69. doi: 10.1080/0749446032000156919

¹⁷ Alex Mclean et al, “Visualisation of Live Code” (paper presented at Electronic Visualisation and the Arts, London, 2010).

¹⁸ Thor Magnusson, “Algorithms as Scores: Coding Live Music,” *Leonardo Music Journal* 21 (2011): 19–23.

¹⁹ Arnie Cox, “Hearing, Feeling, Grasping Gestures,” in *Music and Gesture* ed. Anthony Gritten and Elaine King (Hampshire: Ashgate, 2006), 46.

traditional performance paradigms, critical questions arise as to its nature as a live and improvised practice.

Whilst in traditional instrument performance practice the body connects with the instrument in multiple dimensions to generate sound, the keystrokes of live coding always occur prior to an audible change in sound.²⁰ In live coding such gestures are inaudible and less visible; perhaps only apparent in a temporal context when performance *flow* is impacted i.e. the disruption caused by a clumsy keystroke/syntax error. Unlike a vocalist, for example who has an immediate physical control over the qualities of the sound they are producing, there is a temporal obfuscation between the performer as a container of their embodied thought, their resulting performative actions (typing), and the resultant sonic outcome. Live coders must think ahead to plan changes to the sonic texture.

A plays to B and the less technology lies between them the closer they are, the more honest their relationship and the fewer the opportunities for manipulation and falsehoods.²¹

This gap is considered perhaps the most significant disparity between the laptop performer and their instrumental or vocal counterparts.²² It is often criticised, and viewed as something negative, inauthentic or non-live.²³ Criticisms such as these relate to conceptions that sound, as a form directly malleable to musicians, facilitates a greater authenticity or clearer sound. My response is that this gap is one of tactility or visio-tactility. Laptop musicians enjoy it as an opportunity to further explore sound, employing algorithms to cover new sonic ground.

Typing is a mechanical and precise action that has evolved into a ubiquitous digital practice and is one of the primary methods of interfacing with machines in this present day. As the word processor replaced the typewriter, the flexibility and reproducibility of typing expanded, resulting in non-linearity through an ability to delete and re-word materials. Bolter reflects on this, describing the computer keyboard as ‘a great refashioner [... that] shares with the wax tablet or chalkboard the quality

²⁰ Some instrumental techniques require a performer to make advanced preparation—percussionists stick movements, preparation of breathing for vocalists, brass and wind, and the latencies inherent in the organ that the performer must adapt to. In all these scenarios, there is a direct and manipulable physical connection between the instrument and the body.

²¹ Simon Frith, “Art versus technology,” 269.

²² Although a number of instruments, including the Organ have considerable latency

²³ Bob Ostertag, “Human Bodies, Computer Music,” *Leonardo Music Journal* 12 (2002): 11–14.

of rapid and easy change.²⁴ Whilst operating on a calendar, word processor and web browser, the keyboard serves a clear purpose as an interface to input, structure and present information. The keyboard can also act as an interface to control, reform, and trigger sound through keypresses, clicks and dragging motions.

Research in new interfaces for musical expression aims to produce gestural methods of interfacing with a computer, as attempts to reflect more ‘tangible’ and ‘expressive’ performance gestures.²⁵ Still, as the continual surge in interest around live coding demonstrates, the pervasiveness of the keyboard interface is accepted and celebrated. Collins notes, in his discussion on the limits of performance, the ‘haptic rates’ for motor production in several different contexts.²⁶ Whilst the haptic rate of the instrumental performer may indicate a level of virtuosity, the haptic rate of the live coder does not necessarily denote a mastery of their ‘instrument’. The skilled typist embodies the typewriter, incorporating it into their body schema.²⁷ As Merleau-Ponty suggests:

When the typist performs the necessary movements on the typewriter, these movements are governed by an intention, but the intention does not posit the keys as objective locations. It is literally true that the subject who learns to type incorporates the key-bank space into his bodily space.²⁸

Historically, the keystroke has been considered in several works, most famously *The Typewriter* (1950) by Leroy Anderson: A novel work that uses the mechanical sound of the typewriter as a rhythmic device. Notable in this context, is a computer rendition of the work by Amy Alexander that brings it to the (then) contemporary office space, capturing keystrokes with a microphone.²⁹ In terms of live coding practice, keystrokes have been previously explored by Baalman in *Live CodeLive Code*, which brings the auditory elements of typing into the performance via the

²⁴ Jay D. Bolter, *Writing Space: The Computer, Hypertext, and the History of Writing*. (Routledge, 2001), 23.

²⁵ A thorough phenomenological analysis of this area is presented in Thor Magnusson, “Epistemic Tools: The Phenomenology of Digital Musical Instruments” (PhD diss., University of Sussex, 2009).

²⁶ Nick Collins, “Relating Superhuman Virtuosity to Human Performance” (paper presented at MAXIS, Sheffield 2002). <https://community.dur.ac.uk/nick.collins/research/transhuman.pdf>

²⁷ Phillip Brey, “Technology and Embodiment in Ihde and Merleau-Ponty,” *Metaphysics, Epistemology, and Technology. Research in Philosophy and Technology* 19 (2000): 45–58.

²⁸ Merleau-Ponty, *Phenomenology of Perception*, 145

²⁹ Amy Alexander aka uebergeek, “The Typewriter.” YouTube video, 01:50, posted December 6, 2009, accessed April 20, 2017, <https://youtu.be/2qk1eZWofP0>

internal microphone of the laptop that is being coded on.³⁰ The captured audio is used as the main auditory element of the performance whilst the code, characters of the keystrokes themselves and additional sensors manipulate and affect it. Another example of a performance bringing keystrokes to the fore is *SK_Computer* where Shelly Knotts visualises them during performance.³¹

5.2.2 Design and Development

Key explores a simple idea whereby the keystrokes produced by a live coder (or laptop performer) are rendered as vibrations felt by the listener. In doing this, I hoped to:

- Highlight awareness of typing gestures
- Increase the listener's 'connection' with the performance
- Augment audience experience with additional sensory stimuli

Setting the physical kinaesthetic motion and posture of the hands aside, it is incredibly easy to measure the keystrokes of a live coder as the resultant aspect of live coding gesture as a flow of values/characters that occur across time. Aspects of the hand's movements across the keyboard could be captured with combinations of flex sensors, accelerometers or cameras; however, they have little direct effect on the sound. The system captures the live coder's keystrokes in the SuperCollider environment, maps them to haptic parameters and then renders them as vibrations on the display detailed in chapter 3. For this system, the vibrators are removed from their grid alignment allowing up to sixteen audience members to hold a vibrating motor for the duration of the performance.³² As only one vibration channel is received by a listener, the parameters of vibration are limited to onset, duration and vibration amplitude. In the first iteration of *Key*, characters are considered equally and elicit the same vibrational response. Although this reflects the rhythm of the typing, it gives no weight to the significance of each gesture, resulting in a mechanical feeling. I felt vibrations could be used to reveal a deeper sense of flow, expression and rhythm in performance.

In the second vibration mapping development of the piece I began to consider how vibration duration could signify an action and how vibration amplitude could be

³⁰ Marije Baalman, "Embodiment of Code" (paper presented at International Conference on Live Coding, Leeds, 2015). doi: 10.5281/zenodo.18748

³¹ Taller de Audio del CENART, 'Shelly Knotts Concierto.' Vimeo video, 1:48, posted December 11, 2014, <https://vimeo.com/114298725>

³² Three versions of *Key* are discussed in this section: (i) di.stanze, (ii) Deep Hedonia and (iii) Euler Room. Project files for each can be found in Appendix M.

related to the flow of the typing. I added a timestamp to each keypress and calculated windows of time differences between keystrokes to determine typing rate, which was then mapped to vibration intensity. For each keystroke, one vibration is rendered with varying duration and vibration intensity depending on the character pressed. The duration of a vibration is limited by the rate of typing, if the duration is too long the vibrations won't reflect distinct keypresses, but vibrations need to be long enough to allow for the peak amplitude to be reached i.e. longer than the rise time. The vibration amplitude cannot be lower than the start-up voltage of the motor: at low PWM values, the motor does not vibrate, but makes an audible click, which means that mappings need to occur above a threshold value that physically excites the motor. Although projected code denotes some combined keystrokes as an integrated action (i.e. Shift + A), the physical gesture itself involves two separate movements. This is reflected in the mapping as it better represents the flow and rhythm of typing. Execution of code is one of the most significant gestures made by the live coder and is thus given a stronger vibration in the mapping. In turn, this amplification can highlight an error, when code does not compile.

5.2.3 Reflections in Performance

The system has been used in several performances in both the first (i) and second (ii) iterations of the design described here, an additional approach (iii) is also discussed in this section. This final version sonically spatializes keystrokes in live performance without haptics, and is suited for a club environment. I will describe the use of this system in three performances, and conclude with some thoughts as to how this idea could further progress.

5.2.3.1 di.stanze, Leeds, 14th November 2014

Around the time I conceived of *Key*, I was sending SysEx messages to a Juno 106 synthesizer. These are strings of hexadecimal numbers that can control most parameters on the instrument. I was fascinated by how I could address the instrument using code in this way, and momentarily appreciated the often-criticised MIDI implementation in the instrument. I did encounter a slight problem with this new way of interfacing with my instrument. The SysEx messages on the Juno 106 are strings of seven hexadecimal values. In terms of what I *then* believed to be an 'authentic' blank screen live coding performance, I felt I must type them out from scratch at least once. Using the motors allowed me to represent my performance to the listener in a more immediate way. Not only that, but it made the typing aspect performative, allowing me to connect with the audience. I setup three motors on the seats in front of me

instructing audience members to hold them in their hands.³³ Post-event commentaries online included the following:

The haptic element of Joanne Armitage's performance (a buzzer held during the performance) ultimately drew attention to changes that she made in the music by typing (which didn't always signal changes in sound).³⁴

This comment reflects how the system placed what were errors in my code at the foreground of my performance. Feeling that things didn't go to plan, and a little self-conscious as a new live coding practitioner, I began to think the concept was unsuccessful. I subsequently developed the system and reworked it as the concept of gesture and alternate temporal flow became more pertinent in my practice. From this, I advanced the idea and presented two more performances of the work.

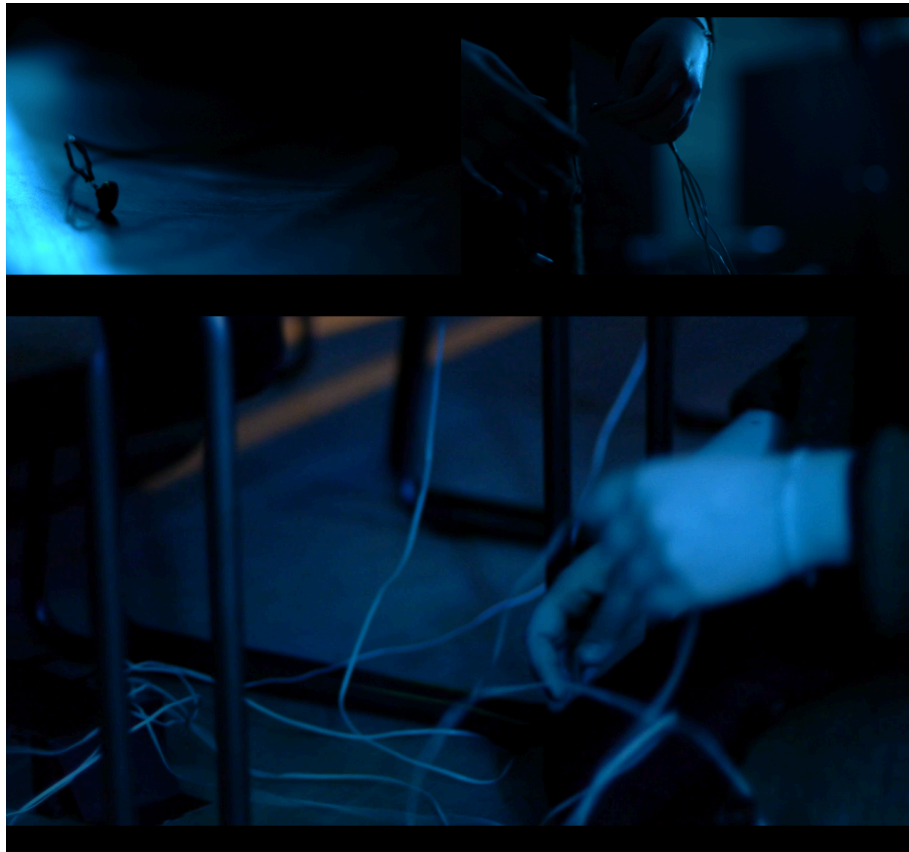

Figure 20. Setting up vibration motors for Key, Everyman Bistro, Liverpool.

³³ A recording of the first performance can be found in Appendix N.

³⁴ Lauren Redhead, "di_stanze festival: Modes of Listening." Blog entry, date modified November 2, 2014, accessed April 20, 2017. <http://weblog.laurenredhead.eu/post/101608521587/distanze-festival-modes-of-listening>

5.2.3.2 Deep Hedonia, Liverpool, 18th March 2016

Using the second mapping strategy that amplified execution of code and reflects flow through mapping vibration intensity to typing rate, I employed the system again in performance (see Figure 20).³⁵ In this attempt to reveal my flow better to the listener, vibrations were strong when I typed characters in quick succession, becoming weaker as I slowed down. The weaker vibration for slow typing was set to reflect the uncertainty, in performance. It ended up reflecting my debugging process quite interestingly as I located errors, corrected and worked my way back towards performing ‘confidently’. For this performance, I was invited to play an ambient set. After the performance, an audience member approached me and described the sensation of closing their eyes, whilst knowing that the performance was still ongoing through holding the motors. This expresses how the vibrations, connecting my gestures to the listener, instil a sense of liveness, presence and activity in my performance. In turn, this reveals an interesting connection between the temporal dissonance of live coding and the authenticity and liveness of its performance, discussed in Parkinson and Bell.³⁶

5.2.3.3 Euler Room, Sheffield, 9th April 2016

I have included a short reflection on this performance that uses keystrokes in a slightly different context to consider how my bodily movements and gestures can be incorporated and embedded into sound non-invasively, or without the need for additional hardware technologies. This approach suits club environments, where delicate handmade electronic circuits would not fare well. The audio setup for this gig included a quadrophonic sound system and it was streamed on Euler Room (see Figure 21).³⁷

I developed a system whereby keypresses were mapped to an approximate representation in sound space to suggest the movement of my hands across the keyboard through the sound. A high-pass filter was applied to the incoming audio signal, which was then modulated through chorus effects and spatialized across four channels according to the location of the character depressed on the computer

³⁵ There is video documentation and an audio recording of the performance available in my portfolio.

³⁶ Adam Parkinson and Renick Bell, “Deadmau5, Derek Bailey, and the Laptop Instrument — Improvisation, Composition and Liveness in Live Coding” (paper presented at International Conference on Live Coding, Leeds, 2015). doi: 10.5281/zenodo.19350

³⁷ A video of the performance is in Appendix O. A further stereo studio version can be found in my portfolio, with corresponding code and audio setup in Appendix M.

keyboard. I had intended for this effect to evoke a sense of gesture in the sound through the panning movement, however, the resultant sound of this performance is quite choppy. The technique had a negative effect on the sound as the cut-off frequency of the high-pass filter was set too high, and the quad-panner object I had built was not optimized for the layout of the speakers in the venue. I further developed the mappings and have rendered a stereo studio performance with this system that can be found in my portfolio.

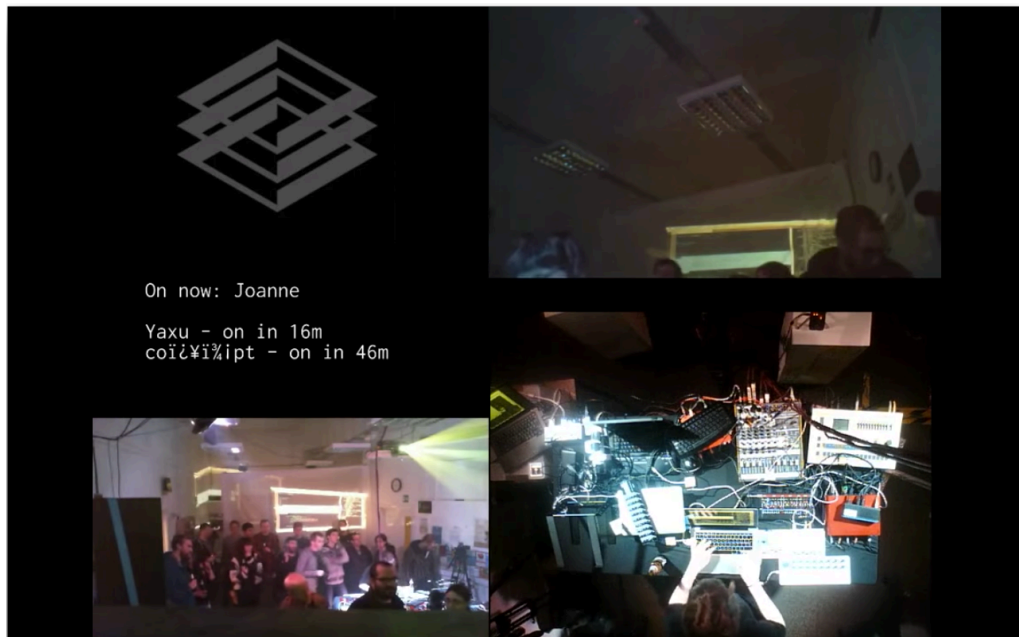

Figure 21. Steaming on Euler Room.

5.2.4 Further Developments

Several developments can be made to the system to further unpick it conceptually and reduce its invasiveness by decreasing (or eradicating) the hardware requirement. First, the work could be developed for a mobile platform whereby keystrokes are used to trigger vibrations on the audience members' mobile phones. This would be better suited to a livelier environment and allow audience members to move around the space. Secondly, I am interested in using the computer keyboard *against* the performer to disrupt their flow, challenging them to work outside the usual patterns they employ in performance. This could be achieved by triggering a delete keystroke when a character or string of characters is measured to be 'overused'. Whilst this could be challenging if a regularly-used key such as 'e' became immobilised, the performer could hack around this using copy and paste. A system such as this would operate to

disrupt the performer's flow—something that has been explored by Knotts (2015).³⁸ This concept raises interesting questions about the performer's effort to utilise more efficient or verbose code through a direct link to their tactile reception. In the future, I hope to introduce this system to other live coders and consider how we can use an amplification of their performance gestures to better represent the flow of their performance. For example, sensors could be employed to capture the gesture 'detail', performer engagement with the screen, and we could also capture movements of the mouse or track pad.

5.2.6 Conclusions

This chapter has discussed the work *Key*, in the context of gesture in live coding performance practice. It has provided some detail as to the development of the system and considered its role in several performances. With live coding a somewhat emergent practice, there is space for greater discussion around the performative effect of typing as a timeline, and how the editing code relates to the sound. This idea raises critical questions as to how coders produce sound, how their typing responds to it, and the place and role of the body in the coding environment. When reflecting further on this work I began to reconsider my initial thoughts. If we consider our code as a form of 'live score', as Magnusson suggests, our typing is not an additional timeline; it is a relocation of the compositional design process to the performance.³⁹ Thinking from this perspective, it becomes less clear as to where our expressive performance gestures exist, or whether they do at all.

Whilst the sound-controlling gestures of live coding are often occluded from the audience by a laptop screen, they can be revealed to the listener through the projection of text being edited. The necessity to see the screen is a limitation to the revelatory nature of unravelling the improvisation process and timeline. First, audience members may be unable to see the screen due to visual impairment, secondly an audience member may wish to close their eyes, removing them from their surroundings. These visual concerns are applicable in all live music performances that include a visual element, although projection of code is often positioned as core to the 'live' element of live coding.

³⁸ Shelly Knotts, "Flow." Vimeo video, 17:04. Posted January 17, 2016, accessed April 15, 2017, <https://vimeo.com/152100026>

³⁹ Magnusson, "Algorithms as Scores."

Live coding practice can consider projection of screens to counteract and disambiguate the abstraction of digital technologies. Despite this attempted transparency, there is still an interesting phenomenon whereby most of the physicality of the performance gesture is somewhat removed from the sound being produced. This temporal disconnect subverts traditional performance ideas of ‘playing in time’ and relinquishes the processing of temporal control to the computer. As a performer, I reflect on the challenges of this. As the gap creates a space between my hands, body and direct manipulation of the sound, I embrace the extended aesthetic of imperfection this affords. This aesthetic is integral to improvisation practice, but in live coding it is sustained, exposed and at times explicit whilst typed language re-stabilises you after error. Although the gap can impede ‘flow’ it affords thoughts realised as algorithms to extend your own sense of self within your sound.

Adding the vibratory channel to this timeline allows the listener to experience a non-visual sensation of the performance gesture. When feeling my keystrokes in this haptic way, audience members are offered a small sense of my presence at a distance; a near-field kind of telepresence, which reveals my small motions as objects of semantic and coded significance.

5.3 *It is only MIDI*

It is only MIDI (2016) is an improvisation system for live coding (or other) performances that involves MIDI data being transmitted between a computer and instrument. The work explores and exposes the relationships between electronic sounds and the data that produces them by rendering aspects of the MIDI data sent to the instrument as vibrations. In this work, MIDI note on messages are rendered as vibrations, the duration of which is determined by the system receiving a corresponding note off message. Accordingly, velocity data is mapped to vibration intensity. In performance, I have employed the system to explore and subvert ideas around complexity in live coding and improvisatory performance practice. Specifically, the work looks to underline the intricacy of the synthesis techniques I employ in my own practice through MIDI control change (CC) messages, and to disambiguate between this and the note data that drives these sounds. The work celebrates the difference between notation and sound and furthermore identifies how sound itself can form structures within notation. In this section, I will reflect on the contextual background of the work and then discuss the design and development of

the system, its application in performance and consider the limitations it imposes on the performer.⁴⁰

5.3.1 Algorithmic Music, Automation and Complexity

Interleaving patterns in live coding can cause interferences that create abstractions and add complexity to an outputted sound. Exploiting this potential allows the live coder a more diverse sonic palette and further extends their range of musical possibilities. In addition to this, it is syntactically slick—allowing minimal textual input to generate maximal movement and change. As a listener, such abstractions can present a visual-auditory challenge or conflict between the code and resultant music. This is unsurprising when we consider how the complexity of polyphony in Western Art music can at times throw off the most attuned sight-reader.

Hinkle-Turner discusses an interview with algorithmic musician Laurie Spiegel where she suggests the musical possibilities that algorithmic automation of parameters affords. Using the GROOVE (Generated Real-time Output Operations on Voltage-controlled Equipment), Spiegel could choose elements of the sound to be automated whilst improvising parameter changes manually in real-time.⁴¹ Such a combination of computer coded algorithmic automation and human intervention is echoed in my own practice, whilst I have a greater control of the automation of parameters due to modern technologies. Using the GROOVE system Spiegel would have been able to control up to fourteen functions and interact with them in real-time, significantly less than modern machines afford. In her first piece written on the GROOVE system, *Appalachian Grove I* (1974), Spiegel explores the power of automation by developing a complex soundscape from a simple pitch and rhythm, altering envelopes and filters to build and evolve textures.

Spiegel has shared that she likes to automate some aspects of her musical decision-making processes to allow greater focus on the real-time control of others [...] Essentially, she uses logic and automation as a means of supporting and enhancing aspects of music making that she sees as intuitive and non-automatic. She has said, 'I automate whatever can be automated to be freer to focus on those aspects of music that can't be automated. The challenge is to figure out which is which.'⁴²

⁴⁰ This work was first performed and subsequently installed/workshopped at ICLC2016 in Hamilton (see video). Video documentation is available in my portfolio.

⁴¹ Matthew V. Matthews and Franklin R. Moore, "GROOVE—A Program to Compose, Store, and Edit Functions of Time," *Communications of the ACM* 12, no 12 (1970): 715–721. doi: 10.1145/362814.362817

⁴² Elizabeth Hinkle-Turner, *Women Composers and Music Technology in the United States: Crossing the Line*, (Ashgate, 2006), 47. doi: 10.1017/S1355771807001719

Spiegel and others at Bell Labs were employing these techniques in Fortran using control voltages, a technology employed in many present day modular synthesis units. Less than a decade later, MIDI heralded a new opportunity for real-time automation of musical machines, developing a standard that is still ubiquitous. Whilst modern computation allows innumerable sonic possibilities, a challenge for the live electronic improviser is to balance this within their own musical-aesthetic goal. Automation of synthesizer parameters affords the instigation of drastic, and sometimes uncertain changes to the timbral qualities of a sound that can radically transform elements of rhythm and pitch.

5.3.2 MIDI: Friend. Enemy. Protocol.

MIDI (or Musical Instrument Digital Interface) is a well-known specification for communication between digital music tools (computers, audio interfaces, hardware synthesizers). Since its inception in 1983, the MIDI standard has been pervasive as a method for connecting humans and machines musically, and has been integrated into weird and wonderful devices.⁴³ Although lauded for its ubiquity as a standard that allows many devices created by different manufacturers to be networked, the implementation itself is often criticised and has been through several revisions. Original criticisms of the MIDI 1.0 specification concern its limited bandwidth. Much reproach was centred around the implementation being fixed within the piano keyboard paradigm, with a limited set of pitches, and its time resolution.⁴⁴ Some of these limitations were addressed in MIDI 2.0, although the 12ET scale remains.

Not only did MIDI allow a greater communication between instruments, but the interface allowed a greater access to music making. The piano roll, as a notation, is to many individuals a clearer representation of musical information than standard Western notation. It's visuality has, in part, led to an online surge of 'impossible music' known as 'Black MIDI', where artists are revered based on their ability to incorporate as many notes into a discernible tune as possible.⁴⁵ In a similar vein, several live coders (myself included) found their way into the practice through

⁴³ Here, I am particularly referring to 'MIDI Sprout' (<http://midisprout.com/>), which sleekly combines my love of plants and MIDI.

⁴⁴ Gareth Loy, "Musicians Make and Standard: The MIDI Phenomenon," *Computer Music Journal* 9, no 4 (1985): 8–26.

⁴⁵ Michael Connor, "The Impossible Music of Black MIDI." Rhizome, date modified September 23, 2013, accessed April 20, 2017. <http://rhizome.org/editorial/2013/sep/23/impossible-music-black-midi/>

‘hacking’ MIDI by sending ‘too much’ data to their hardware synthesizers.⁴⁶ A recent development in live coding MIDI is ‘SendMIDI’, a command-line tool built on JUCE that promises to speedily send messages to devices.⁴⁷ MIDI is data, so it is more flexible and logical to code it than to use a piano keyboard interface.

My own practice in MIDI coding developed programming my Juno 106, but I soon became tired of its limited implementation and started playing a Waldorf Blofeld, a more recent and advanced synthesizer. For me, using hardware synthesizers presented many opportunities, for not only did it result in a reduced computational load on my ageing laptop, but I was also able to control a familiar and tangible interface. At the same time, live coding allowed me to extend the sonic capabilities of my synthesizers and approach sequencing in a live, flexible and dynamic way. I also seem to deeply enjoy spending sunny afternoons working out the MIDI CC mappings of old Casio keyboards and making them scream. Several other live coders perform with hardware synthesizers, notably Matthew Yee-King, Charles Hutchins, Polinski, Kindohm and Heavy Lifting.⁴⁸

This work is in part motivated by some feedback I received for a performance submission to a conference that suggested coding sound using MIDI was a quick and easy shortcut—‘It is only MIDI’—comments I took issue with, knowing that a large majority of live coding environments are reliant on samples. I endeavoured to design a system that revealed the complexity of the synthesis I was performing through live coding MIDI CC data.

5.3.3 Design and Development

This system is designed to render MIDI data, live coded to control hardware synthesizers, as vibrations. In synchronisation with the sound, MIDI note information is converted into data values and mapped to haptic parameters that can be transcribed on the body of the listener. By rendering note data, as opposed to the sound itself, the system endeavours to further unravel MIDI-based performances, allowing the audience to gain additional insight into the performance process. As I edit patterns,

⁴⁶ Emma Sugarman, “Alex McLean on Music Coding and Algorave” British Music Collection, 2016, accessed April 20, 2017. <http://britishmusiccollection.org.uk/article/alex-mclean-music-coding-and-algorave>

⁴⁷ See ‘SendMIDI’ website, Geert Bevin aka gbevin, “SendMIDI.” Developer’s GitHub repository, date modified April 14, 2017, accessed April 24, 2017, <https://github.com/gbevin/SendMIDI/blob/master/README.md>

⁴⁸ An observation from performing alongside these artists.

MIDI data is sent out of SuperCollider to various MIDI devices and channels, and processed and mapped in SuperCollider to trigger vibration events.⁴⁹

A vibration is rendered when a note on message is received and stopped on receiving a note off message. The velocity of the note is used to determine the amplitude of the vibration. In performance, one seat is made prominent for an audience member to sit on and feel the vibrations using the haptic grid discussed in chapter 3, affixed to the rear of the seat. By highlighting this data, the work seeks to reveal the connections and disparities between the ‘raw’ note data and the sounds that it drives. Ostensibly, the rendering on the haptic grid is focused on mapping vibration intensity with MIDI velocity, and vibration duration with note on and off data. It will render up to four channels of MIDI data four rows of vibration on the back of the listener. It can be thought of as a vibrotactile piano roll that does not represent pitch.

I spent time practicing using the system as in performance, I would not be in contact with the motors and unable to feel the haptic element. I found there were limits to vibrations due to rise and lag time resulting in short and low velocity MIDI notes being rendered ineffectively, despite making improvements to the mapping strategy that allowed greater scaling between quieter and louder sounds. I found that the system highlighted some issues with our perception of vibrations; hard and long vibrations proved to occlude quieter and shorter ones that occurred nearby. These limitations relating to vibration perception ended up placing limitations on the MIDI material I was coding and sending to my synthesizers and acted as a constraint on my improvisation.

5.3.4 Reflection in Performance

This system has been demonstrated at the International Conference on Live Coding, McMaster University, Canada. It was also workshopped at the conference during breaks to enable a larger number of audience members to experience it (see Figure 22). In the performance and demonstrations, I sent MIDI data, coded in SuperCollider, to the Waldorf Blofeld.⁵⁰

⁴⁹ Project files are available in Appendix P.

⁵⁰ I normally use the ‘Multi Mode’ functionality where different voices can be assigned to sixteen different parts by specifying different MIDI channels.



Figure 22. *It is only MIDI*, McMaster University, Hamilton, Canada.

For this performance, I used four voices of the synthesizer with varying timbral qualities, where each different channel was assigned to a row of actuators on the haptic grid. In terms of the sound quality of the piece, I had planned to code drones and then control parameters such as noise and filter drive, to create rhythmic movement through synthesis rather than note data. As a performer, I had anticipated that the performative challenge would be to explore creating a disparity, and sense of abstraction between the ‘heard’ and ‘felt’ versions of the MIDI note information by altering timbral parameters on the synthesizer. This changed through the testing described previously, and by it becoming apparent in performance that the novelty of the experience was engaging listeners, rather than the conceptual issues the work was attempting to address.

Originating as an approach to comprehending the data being sent out of the machine, in performance, the system grew to be a novel way of reflecting pattern. In relation to this, I found that the system allowed me a flexible way of coding SuperCollider patterns into vibration. Moreover, I found that it directly influenced my performance decisions, thus narratives, through connecting the listener’s body to the underlying performance process. Audience members were mediating the performance by responding to the motors visually, which influenced microstructures of my improvisation, but also by leaving and entering the chair on stage, which caused me to change my flow to affect macrostructures. I began to consider performing something that is physically interesting that could be separate from the sound.

5.3.5 Conclusions

Overall this work looks to explore the relationship between notation and synthesis in live coding by allowing audience members to have a physical experience of the notation. Whilst first masquerading as an approach to allowing the listener a greater access to an improviser's process, the work raises questions of the intelligibility of 'open processes' in performance practice. In the system's realisation, *It is only MIDI*, extends the complex relationship between improviser and audience through the integration of an additional sensory channel. A key discussion in this work is that of complexity, and tensions between simplicity and complexity in live coding: the note data controlling a sound can be simple, but its realisation as a sound can be complex and shifting. Without this note data, there is no sound.

This work furthers concepts explored in *Key*, where performance gestures or unsounded aspects of laptop performance are rendered as vibrations. Through this performance system, I am connecting the listener to another aspect of the data that is driving a performance; this work reveals the output of the computer in performance. By bringing abstracted data into the fore, the haptics in this work function to create a sense of presence for the underlying processes controlling a sound.

Chapter Six

AN ALTERNATIVE TAKE ON THE BODY: A LANGUAGE FOR ALGORITHMIC CHOREOGRAPHY

m1 = [la, ra] (2015–ongoing) is a collaboration between dancer Sarah Maria Cook and myself. The development of the work was a formative part of my practice-based endeavours through late 2015 to Summer 2016, and will resume in Autumn 2017. Because of the project’s formative importance, it is included in the thesis, but also because it encompasses a new way of considering the body in performance with the ‘actuator’ being a human body that feeds back in to and controls the sound. To support this collaboration, we developed a language for choreography and a set of mappings for the dancer to control sonic parameters. The focus of this work was on exploring areas of communication and interpretation between code and the body. Instead of approaching the cutaneous body, as in previous works, here I consider the kinaesthetic body feeling within, and actuating throughout, the temporal space. We were interested in using the technologies I had been employing together with Cook’s dance improvisation skills, and considering how coupled together, they could act as an extension of self. I was also interested in challenging my technologies and exploring how they could facilitate communication in the unfamiliar domain of dance.

In this section, I will discuss the collaborative development of a language to communicate movement, first as patterns, and then as sensations. From this, I will discuss the implementation of the language in an interactive system designed by Cook and myself. I will then reflect on performances and rehearsals with the system, suggesting ways in which we envisage the work developing. Finally, I will conclude with an overview of the work and summary of the next steps. In my portfolio, you will find two video examples of Cook and I performing and rehearsing with the system.

6.1 Related Works

Whilst improvisation, open form, and symbolic notations have been prevalent in dance through the twentieth century to today, notions of algorithms and computation being employed in dance practice, and live choreography became connected through the work of Kate Sicchio.⁵¹ Sicchio employs live notation of computer code to ‘hack’ choreography live, as part of a performance. For this purpose, she has developed several mini languages and environments of interaction to instruct movement, and facilitate novel approaches to choreography. From this initial work, she has developed various iterations and further collaborations that employ wearable sensor technologies and haptic feedback with a central theme of hacking that works to unravel not only choreography itself, but raises critical questions pertaining to embodiment and data privacy.⁵²

With respect to live coding, Sicchio’s work, through iterations of *Hacking the Body*, has forged an alternate creative pathway through the musically dominated field. Together with the ‘Live Notation Unit’, a collaboration between live coders and live artists, such work has opened a diversity of praxis in the domain on live coding.⁵³ Collaborations formed in this way allow new trajectories and confluences, and tensions and ruptures to be unpicked and probed by exchanging roles and methods through improvisation. These processes are revealed and explicit, and as a revelatory form uncover and decode something unknown, as noted by Cocker:

To describe a practice as revelatory is not to offer judgement on the nature of insight afforded therein but rather signals towards the possibilities of revealing, exposing or bringing something hidden to the surface, operative at a more tactical level. Revelatory practices strive to shed light on the hidden workings of thinking and making, unveiling the decision-making processes, the unfolding of labour. To expose the inner workings of a practice is to foreground process, emphasizing the methods and mechanics of production, the durational ‘taking place’ of something happening live.⁵⁴

Joana Chicau’s work explores the relationship between web design and choreography as mediums that are connected through mutual concerns of spatial-temporal domains, networks and interactions. Her work *WebPage Act I, II, III*, demonstrates how a

⁵¹ Kate Sicchio, “Hacking Choreography, Dance and Live Coding,” *Computer Music Journal* 38, no 1 (2014): 31–39.

⁵² Camille Barker and Kate Sicchio, “Stitch, Bitch, Make/Perform: Wearables and Performance” (paper presented at Electronic Visualisation and the Arts, London, 2015). doi: 10.14236/ewic/eva2015.26

⁵³ Emma Cocker, “Live Notation: —Reflections on a Kairotic Practice,” *Performance Research* 18, no 5 (2013): 69–76. doi: 10.1080/13528165.2013.828930

⁵⁴ Cocker, “Live Notation,” 70.

choreographic language for movement can be used to ‘perform’ a webpage.⁵⁵ Editing choreographic functions in the console of a webpage, Chicau plays with movement across time and space, using repetition to transform the mundane graphical space of a webpage into a dynamic performance environment. On attending a performance of the work, I was struck by how Chicau so effectively mediated the relationships between her body, code, and the performative graphical space. As choreography directed elements on screen, she spoke out descriptions of functions whilst she edited her code. This verbalisation of the relationship between choreographic thinking and resultant motions on screen resulted in an explicitly open, interconnected and intimate audience experience.⁵⁶

Several other languages have been developed to explore the relationship between live notation and performance including ‘Extempore’ by Andrew Sorensen, that the developer describes as ‘cyberphysical programming’ and ‘Code Music Notation’ by Thor Magnusson as a language for instructing human music performers.⁵⁷

6.2 Design and Development

Having seen me perform music several times, Cook approached me about collaborating on a project. I had some trepidations arising from a lack of familiarity with choreographic forms, but was simultaneously captivated by the opportunity to be challenged outside of my own domain, whilst also interested in the work of Sicchio and others mentioned in the previous section. Principally, I was concerned with the process of the collaboration and how it could transform my understanding of my own practice. Additionally, I was enthralled by Cook’s post-humanist ideations and enjoyed her philosophy on the relationship between technology and the kinetic body, as she describes below:

Technology is too dynamic to be captured by fixed definition. Instead, it is best understood as a process; technology is what it does, and how it does it. Any perception of technological processes will depend upon how we are using it. In my creative practice, I understand technology as a framework for communication. It develops systems and techniques for sharing information, ideas, and experiences. Using technology as a framework creates boundaries

⁵⁵ Joana Chicau, “Choreographic Design and/or Designing Choreographies.” Artist’s personal website, last modified February 2, 2017, accessed April 20, 2017, <https://jobcb.github.io/>

⁵⁶ Joana Chicau aka jochicau, “ChoreoGraphic Coding.” TOPLAP, date modified October 24, 2016, accessed April 20, 2017, <https://toplap.org/choreographic-coding/>

⁵⁷ Andrew Sorensen and Henry Gardner, “Programming with Time: Cyber-physical Programming with Impromptu” (paper presented at ACM international conference on Object oriented programming systems languages and applications, Nevada, 2010). Thor Magnusson, “CMN (Code Music Notation).” Developer’s Github repository, date modified August 5, 2015, accessed April 20, 2017, <https://github.com/thormagnusson/cmn>

and limitations. As a free improviser, I am interested in working with these boundaries; asking how the incorporation of different ideas and physical elements can transform the body and/or environment to constitute new experiences of embodiment.

Adopting a wide, post-humanist, understanding of embodiment – as the experience of becoming and moving through time – has enabled me to re-think my body not just in relation to technology, but as technology. ‘My’ bodily technology is immersed within numerous technological processes that go beyond the boundaries of skin. While I have always been interested in finding new ways of communicating – through, for example, sound and movement – this interest has recently led me to consider how electronic technology mirrors bodily processes; working with digital sensors and bodily impulses to embody creativity.⁵⁸

What bound our improvisatory practices was an interest in the revelatory, how our thought processes could be exposed through technologies and the body to other bodies. We were interested in how Cook’s body could communicate with my code and sound, and how code could be used to communicate with her body. Our collaboration was centred upon this and developed through an iterative cycle of rehearsal, performance and reflection. Together we probed the affordances, restrictions and limitations of the paradigms we were developing through exchanging control of our expertise. We removed sound and added sound. We switched control of the sound between us. I danced (conceived broadly!) and Cook coded. We added sensors. We removed sensors. Cook drove the sound whilst my code framed the qualities of her bodily movement. Ultimately, we developed a language and framework through which we could communicate. Cook, with her gestures and control of sound, and myself through text. We documented rehearsals with audio and video recordings and each kept extensive notes that reflected in and on our actions.

6.2.1 Patterns for the Body

The first iteration of the language that we developed together was built to mirror patterns in SuperCollider. I was interested in using interacting patterns to explore how Cook could interpret and respond to increasing complexity with her body. In the code written below, Cook would first engage in a movement in the head (h) and foot (f). Each movement of the head would be faster than a movement in the foot. We determined speed to be relative as interpreted by the dancer. The first head movement would be a downward (D) motion and the second upwards (U). Overall the dancer would complete 5 full loops of ‘m1’ on execution of the code (see Figure 23).

⁵⁸ Statement from email communications with collaborator Sarah Maria Cook.

```

5.do {
    m1 = (
        bp:[h, f, h, f], //body part
        s: [3, 1, 3, 1], //speed
        d: [D, U, U, D]) //direction
    }

```

The code, as written above, was easy for Sarah to interpret. The pattern is aligned both visually and schematically, however, if another value was added to speed, for example, realising the pattern proved more challenging. With this polyrhythmic-like effect, Sarah would have to re-interpret the interconnections between each patterning element on every cycle. Whilst working within this pattern approach, we then began thinking about conditions that would allow the dancer greater sentience in performance. Inspired by Magnusson's, *Encoding the Marimbist*, we began to think of conditional statements that could prove playful.⁵⁹ Although fun to work with, we felt that this approach did not circumvent the challenges, limitations and hierarchy implicit within the language we had created and technologies we were using. We found the limitations of conditional programming (i.e. if happy do x, if sad do y) limited Cook's expressivity and required considerable interpretation time. Superimposing unfelt or unconsidered emotions on to the dancer resulted in a quasi-improvisation, or something more akin to puppetry. Although this had the potential to be comical and engaging, we felt that it placed hierarchies between us resulting in Cook having to answer to, rather than interpret, what I was coding.

Movements of the body are not discrete, they are fluid and completely interdependent on each other. The way we were defining movement within the language was incompatible with this at times, for example, moving one leg north and upwards and the other leg south and upwards for a sustained period. Although possible to perform with this language through intensive rehearsal, we agreed that the nature of this approach restricted Cook's agency within the performance, which restricted the realisation of her movement and skewed the balance we hoped to achieve in our collaboration. Ultimately, it reduced the improvisatory element of our performance. Out of these experiences and ideas, we began to rethink how we were approaching the language.

⁵⁹ International Conference on Live Coding, "Performances A 3 3 1." YouTube video, 09:35. Posted August 5, 2015, accessed April 24, 2017, <https://youtu.be/JV-Vhimg8-Y>

6.2.2 Coding Sensation

Around this time, Cook attended a workshop led by Elisabeth Schilling, who discussed how the body is conceived in her own practice. Schilling's research is influenced by contemporary music and employs graphic notations to express movement as sensation and texture. Within this she describes the architectural body, how the body related to space and shape; the rhythmical body, related to time; the textural body, related to layers of the body; the transitional body, moving through space and time; the sensational body, outside and feeling; the resonating body, movement as it passes through the body.⁶⁰

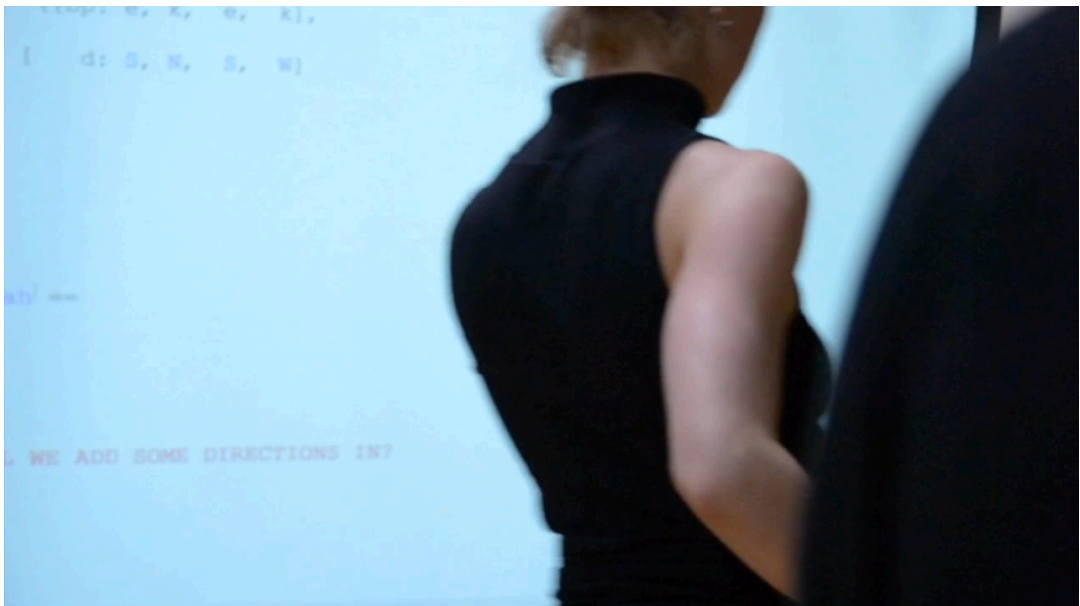

Figure 23. $m1 = [la, ra]$ rehearsals using the pattern language.

Through these notions, we began to reconsider how we could explore the relationship between the body and code. How could a movement be achieved using gesture less precisely and more fluidly? In this way, we began looking at how we could initiate movement through feeling and sensation rather than by creating a shape or gesture. Instead of considering discrete body parts and directions, we began thinking about quality, texture and sensation of movement. Conceiving the body in this way, we began to rewrite our language and to encompass how a gesture could be achieved through sensation. We considered how elements such as *gravity* and *body-layer-texture* could act as directions that effect how a performer embodies instructions as a sensation to achieve movement and gesture, in a more abstract and raw manner.

⁶⁰ Elisabeth Schilling, "The Sixfold Body." Artist's personal page, accessed April 20, 2017, <http://www.elisabethschilling.com/en/project/the-sixfold-body-2/>

```

inf.do{
  m1 = [la, mt, 8, <<],
  m2 = [ra, bt, 2, >>>>],
  m3 = [h, st, 16, -],
}

```

The code above describes three actions for Sarah to interpret. The first involves moving from the left arm (la) through the texture of the muscle (mt) for a period of 8 relative units with a low-medium force upwards (<<). The second suggests a movement in the right arm (ra) from the bone (bt) for a period of 2 relative units with a strong force downwards (>>>>), whilst the final movement is from the head (h) with a texture moving from the skin for 16 units with a neutral force upon the body. Using the shortened versions of the body texture i.e. muscle texture as ‘mt’ was an aesthetic choice and designed to codify the explicit actions, but further work with this representation could present an interesting opportunity for the project.⁶¹ This would be repeated infinitely. If a parameter was left out, Cook would interpret her own default value. Through this approach to coding the body, we hoped to transcribe and realise sensations as gestures. Movement would be instigated from a point of the body, through a layer within the body, with a force felt in the body for a duration of time felt in the body. We chose to denote time as opposed to speed to allow the dancer to have a greater agency over their movement speed across time.

6.2.3 System Design

The system we developed for our collaboration constituted several parts, first the language for sensation based movement described above, coded by myself at a laptop and projected (ideally) multiple times around the performance space. Secondly, two control devices for Sarah, and thirdly, an audio setup through which sound was initiated by myself and controlled by Sarah. A diagram of the performance setup is given below (Figure 24).

We employed two wireless controllers that allowed Sarah to control aspects of the sound, these were the I-CubeX Push2D and ReachFar. The former is an X-Y controller pad that Cook held in one hand and the latter is an ultrasonic distance sensor that she attached to her other. Data from these sensors was transmitted to the

⁶¹ The most common textures used were skin (st), muscle (mt) and bone (bt).

laptop via Bluetooth using the I-CubeX Wi-microDig.⁶² This data was then processed by a Max patch and mapped to MIDI parameters. Audio mappings were workshopped extensively between Cook and myself to give her a substantial amount of control over the sound (through a low pass filter, delay and distortion) that reflected the control I had over her movement. This allowed her control of the timbral quality of the sound by manipulating its frequency content, the movement of the sound through a delay and its texture via controlling modulation parameters. The low pass filter also enabled Cook to stop the sound completely.

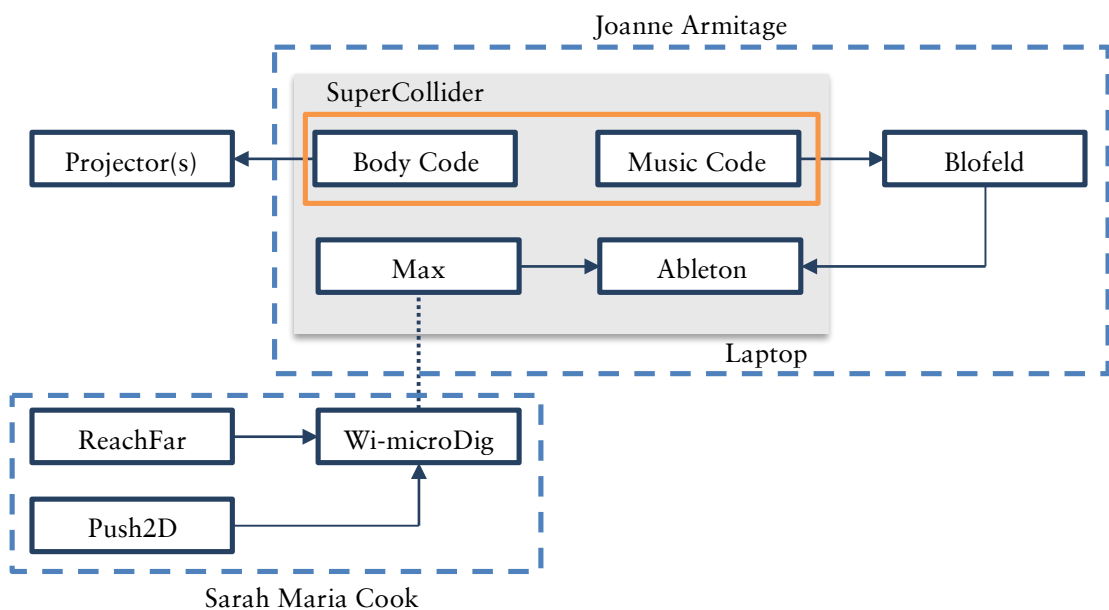

Figure 24. Diagram of the overall performance setup for $m1=[la, ra]$.

The repetition of movement(s) was instructed by simple do loops to suggest the number of times a movement constructed of arguments would be iterated. We found this approach placed a lighter cognitive load on the dancer than other control structures. With the focus of this work being the elicitation of movement, this worked effectively, as it enabled the performer to focus on the core sensations of the movement rather than interpreting more complex and interactive control structures. The inclusion of while and if loops is certainly possible, and would add an interesting element of control, particularly in multi-performer scenarios. Loops were initiated on execution and this was clarified with a percussive sound and flashing colours in the code. Code inside the loop was edited and executed, interrupting Cook and resetting the loop. We also agreed to have some dialogue relating to structure and end points

⁶² All I-CubeX parts can be found on the I-CubeX 'Infusion Systems' website (<http://infusionsystems.com/catalog/>).

using comments, finding this a more natural communication than setting up conditions. We communicated error by connecting as performers; Cook would stop moving if she interpreted an error in my code, I would stop coding and try and catch Cook's eye if I found error in her interpretation. In these performances, I wrote the code in the SuperCollider IDE with the post window hidden, but hope to develop an environment where errors can be posted to a window to assist the dancer and coder in debugging.

6.3 Performances and Reflections

We performed the work publically on two occasions, firstly at Live Art Bistro as part of an event organised by ProDanceLeeds (see Figure 25) and secondly at iscMMME 2016 (ICSRiM Student Conference on Music, Multimedia and Electronics).⁶³ The full iscMME performance is included in my portfolio. Both events were attended by quite different crowds, with the first being predominantly dancers, and the latter predominantly music technologists. We found these varying perspectives provided a fertile ground to explore our ideas with those from different specialisms.

We wanted to employ clear processes in the performances and structured our improvisation so that it would slowly build up and unfold. Each performance began by identifying a single area of the body that Cook would move from. Parameters of sensation and movements would slowly be added to introduce new techniques with increasing complexity. Whilst this worked as a device to make the connections between and roles of each performer more explicit, it also allowed Cook time to anticipate changes in the code. My coding would mostly achieve change through adapting and editing existing code. Particularly when the complexity of the code grew, Sarah would be unable to remember a large sequence of movements that were deleted. I tried to leave code that Cook was currently performing visible, but sometimes coding new movements resulted in some text no longer being visible. Such issues placed an interesting limitation on the performance, in that Cook's perceiving body dictated how the code was edited.

⁶³ 'Sarah Maria Cook and Joanne Armitage offered a futuristic approach to dance. A piece where live computer programming shapes the movement of the dancer, giving constant information about steps, speeds, directions...through three screens that created the frame of the stage.' ProDanceLeeds Staff, "Remember the Leeds Culture Gathering?" ProDanceLeeds Blog, date modified October 15, 2016, accessed April 24, 2017, <http://www.prodanceleeds.com/friends/2016/10/8/remember-the-leeds-culture-gathering>



Figure 25. $m1 = [la, ra]$, ProDanceLeeds. Reproduced with permission from Camille Lagrange.

During performance, we would agree a point to turn the sound and sensors on and I would begin coding more freely. At iscMME 2016, we began the performance with no sound, and Cook decided the point at which sound was turned on. In the video from the event, you can see that at 04.22, Cook walks over to me—at this point she turned down the volume on my audio interface. At around 09.25, Cook agrees to turn the sensors on and we begin making sound. We had considered working silently with choreography, however, chose to include sound as an additional mode of exchange in performance. Through the performances, we enacted tensions between easy and more complex moments, to push and extend the body. A section of the performance would often involve me attempting to code sound whilst Cook was controlling it. The performance would end naturally or when one of us quit. We hoped to create an environmental of uncertainty around technology, sound and the body.

In both dance and sound we could override and interfere with each other's directions: I could turn off Cook's controllers and she could refuse a movement. This exchange was important in balancing control issues within our collaboration, with Cook as the choreographer and dancer controlling qualities of the sonic elements and myself as a composer and musician controlling qualities of movement and the sound available for manipulation. Although there are still issues in this setup, in particular that the system is reactive as opposed to interactive—in further iterations of the work we hope to develop a system where Cook has greater control of my coding actions.

This collaborative setup allowed us to begin embodying technology as an extension of our awareness by placing in us, a sense of togetherness through code. The notation we developed was less certain and more free because it allowed us to develop a way of being that internalised code as sensation, that was embodied, as opposed to the code being external or separate from the body. Cook described how it allowed her to feel a sense of presence within the technology, melding action and perception. In this way, I suggest that our collaboration allowed us to explore what code feels like.

Through rehearsals and performance, I noticed that Cook would, at times, speak the code, sounding her interpretation process— this exposes another timeline and rhythm within the performance. It formed a part of her debugging process and in future performances we intend to amplify this. In performance, Cook would encase her body in bubble wrap to further amplify her movements. In future collaborations, we hope to extend this through contact microphones and devices with which Cook can interact and make her own sound. Through this development, we hope to unravel the process further to allow the performance environment to act internally and externally as an extension of the dancer's body.

Together we designed a performance process that intended to be explicit; however, we did not manage to achieve this in performance. Having attended many such performances as an audience member this is a common issue with technology-infused performances. We found that the audience at dance events, with little experience of coding, found the technological framing of the work to be a barrier to their understanding. This was also an issue for some audience members with experience of code, where people saw invisible technologies at play. Audience members in both scenarios were devising and developing their own meanings through our interactions on stage.

In part, I felt the limitation of the work was in my own inexperience with choreographic forms and limited understanding of the body moving in space, and I often felt quite nervous on stage and got 'stuck'. This is something that I do not experience in my music performance work. Through this, I transformed my own practice by experiencing connections with dance. Our practices are connected through conceptions of texture, movement, time and space and I felt that Cook's indeterminate, human reaction to code allowed me to reconceive the interactions I have with sounds, reflecting more upon the quality of sound and movement in my solo performances. Her sentience and aesthetic preference are/were an enjoyable

element of this coding experience in contrast to the logical and compliant machines I normally work with.

6.4 Conclusions and Next Steps

The above gives some description and analysis of my collaboration with dancer Sarah Maria Cook that considers the relationship between code, the body, technology and sound. Projects that are related to this and that have inspired it have been discussed, particularly those that use forms of live notation to algorithmically instruct a performer. I have discussed the development of a mini language that facilitates our collaboration and allows us to investigate how algorithms, can be employed choreographically. This also includes a consideration as to how the coding of gesture can restrict, extend and break the body.

The approach we have employed allows a test bed from which new ideas and pathways can grow. In the further development of this work, we hope to expand upon the technologies that we are using. In particular we intend to begin developing a network of haptic actuators and develop a haptic choreographic language. In turn, we hope to apply a richer range of sensors to further embed the performer's body into the technology as a responsive mechanism. We have also discussed how sensors and machine learning could be employed in the work to allow Sarah to generate or control elements of the code using her body. Finally, we look to develop the performance of the work to include multiple dancers to explore and expose varying interpretations of the code as movement and gesture.

Chapter Seven

CONCLUSIONS

This commentary has discussed the development of a portfolio of practice that integrates haptic, or touch based technologies into musical performance and listening environments. In doing this, it has unravelled questions as to the relationship between the body and sound and the role that the physical body plays in performance. Central to this has been a consideration of how haptics can reflect a sense of immersion and bodily presence in sound. Chapter 2 explored the theoretical context of the study by considering the relationship between the body, touch and technology, revealing tensions between uses of terms and concepts, and framing the upcoming materials. Related systems were also presented, alongside the concepts and technologies behind them. Subsequently, in chapter 3, the design and development of the haptic interfaces developed as part of this work are documented, presenting design rationale and contextualising it within the DIY embedded systems design process.

In chapter 4 the installation works developed over the period of study were discussed, with a reflection on their application, limitations and opportunities for further development. Following this, in chapter 5, performance systems employed during this time are documented, including consideration of how the use of haptics and other technological systems transformed, but also constrained, my practice in live coding. In chapter 6, I reflect on an alternative take on the body in sound through my work with dancer Sarah Maria Cook. Within these chapters, I considered how presence, aura and immersion exist and emerge as effects of the haptic channel. In this final chapter, a summary of the work is presented, and as a final reflection, I will consider themes that have arisen in the creation of this work; those that have been thoroughly investigated, touched upon and skirted around. I will close by looking to the future directions of my practice based research.

7.1 Final Reflections

The theme of embodiment has continually appeared throughout this work. By using haptics to place the body central to the sonic experience, I provoke the listener to

reframe their experience of sound as something that is embodied through tactile contact. In live coding performances using *Key*, where my disembodied sound is represented symbolically as coded projections, the haptics are provoking a new tactile communication that is essentially embodied. Rendering the action of coding as something physical to the audience members reconfigures the role code plays in the digital realm as the haptic element brings the physical body to the fore of the experience. I embedded myself into the work through the vibrations and used technology to extend my reach to those that I was playing with and for. The works encourage bodies to be aware of themselves in relation to the sonic environment. Haptics can reframe the flow of our sensory interactions to rupture, and recode how we experience a phenomenon.

My work is neither representational nor mimetic of real world tactile interactions, but instead echoes and synthesizes aspects and dimensions of *other* to relocate a ‘form’, transcribing it as touch. It intends to engender a sense of presence in the user, within which, I hope it gives rise to a greater physical embodiment for their experience. Instead of asking, ‘What do we feel?’ my work considers ‘What could we feel?’ Within that, I reveal techno-futures and synthetic ways of being within a creative artefact. Play is core to my approach and haptics allow me to ‘play’ the body to explore new configurations and ideas.

Mediation has also been a recurrent theme in this project. To realise most of my performances, mediation and remediation is required, and further work is needed to establish and understand the possible distortions and abstractions that occur within this. I had intended to focus on remediating the experience of listening through extra technologies. In turn, this has resulted in technologies heavily mediating my own creative practice through their prerequisites, characteristics and limitations. I required bespoke technologies, which aren’t yet established, and I found it frustrating, exhausting, time-consuming and expensive to develop them.

The physical interactions I conceived using haptics ended up limiting the sounds that I could create, whether it be in *It is only MIDI*, where I couldn’t play very fast, or *m1 = [la, ra]* where we collaboratively agreed to exchange control of our familiar mediums. In other instances, technologies could act obstructively, working against attempts to reveal processes that were open and discernible. In *m1 = [la, ra]* performances, my collaborator, Sarah Marah Cook and I would attempt to design simple and explicit improvisational structures that would allow our systems to gradually build up with

clarity. However, people with highly technical perceptions of me superimpose new, invisible and non-existent technologies into the performances. Through this, audience members develop their own meanings from the interactions before them and develop, or invent their own relationships between the onstage bodies and technologies.

Mark Paterson notes that '[touch] can bring distant objects and people in to proximity.'¹ Here, Paterson is describing a sense of presence at a distance, but what I am concerned with in my use of haptics, is for touch to being a sense of presence in abstraction. The nature of that presence varies between the different works I have produced, whether it be the presence of my performative actions within *Key*, or a data process in *It is only MIDI*, or the presence of a change in a sonic parameter in *Enclosed I and II*. This is also present in *Unheard Sounds* where the absence of a sound results in the presence of vibration, imparting upon the body a phantom notion of the sonic.

Themes of pleasure and pain emanate from anecdotal accounts and my own observations of people interacting with my work. Vibrations can also be a source of great pleasure to the body, another terrain that I am interested in negotiating in my practice. Particularly in *MBCRVYB*, listeners clearly derived great pleasure from the strong vibrations on the comfortable cushion. However, not everyone who has engaged with my technologies has had a pleasant experience including, those who found the vibrations of the Silent Metronome system painful, and reports of mild electric shocks from members of Miss Represented in Sussex. Furthermore, in *m1 = [la, ra]*, there lies the potential to realise violence in a more active way, where I could write code that could cause Sarah Maria Cook to experience sensations from mild discomfort of pain—to thrash her body on the ground indefinitely—though she always has the choice to deny this by free will.

Such risks are apparent in visual and aural settings, when immersing oneself in a media experience.² Whilst the Arduino at 5V is unlikely to cause fire, or anything more significant than a mild electric shock, thresholds of pain vary. Whilst vibration at such low levels should not physically hurt the body, for some, the level of vibration

¹ Paterson, *The Senses of Touch*, 1.

² Excessively loud noise can cause permanent damage to the hearing and tinnitus. Strobe lights are so often used at events, but have the potential to trigger a seizure in an individual with photosensitive epilepsy. A gentle warning can be given, or earbuds handed out to the crowd, but these two scenarios already present an opportunity for violence to occur in a typical experience mediated by technology.

amplitudes I have been working with, cause physical pain. Infrasonic frequencies in mechanical working environments have been known to cause serious injuries to workers in mechanical settings.³ Yet, some artists employ these frequencies in their systems to stimulate the body.⁴ With this, I have been unable to answer the few individuals who have asked me whether there are any long-term implications of interacting short-term with the technologies in my systems.

7.2 Touching on the Future

I have reached a point where I want to further investigate the theoretical concepts that my work touches on, particularly those relating to gender and politics. Music and media do not exist in a purely artistic landscape. Within the technologies I have developed, my personal identity as an artist has had a huge impact on the work I have produced. Through the past few years, gender identity has informed a significant political element to my work and other activities. I would like to acknowledge gender in my approach, but do not have the language to do so yet. With the significant growth in cyberfeminist sonic activities, I am interested to see how this dialogue develops.⁵ I can feel a currently intangible connection between employing an embodied approach to music making and feminism, which I hope to unpick through discourse with other feminist sound practitioners.

Alongside further investigation of the theoretical perspectives in my process, there are several practical improvements that can be made to the hardware and software I use. Over the past few years, I have developed skills in web programming, and I am interested in seeing how this can be connected to the hardware I have developed to act as devices of convergence between the digital and physical realms. With this, I am interested in how I can develop my work through collaboration with researchers working in digital intimacy and teledildonics. In future, I hope to develop more participatory and active works to embed interaction into systems using techniques such as machine learning. With this extended interaction could come a greater sense of immersion by exploring the possibility for incorporating VR techniques in my systems: in what ways could tactility be rendered to remove the ocular element from

³ Norm Broner, "The Effects of Low Frequency Noise on People—A review," *Journal of Sound and Vibration* 58, no 4 (1978): 483–500. doi: 10.1016/0022-460X(78)90354-1

⁴ Cat Hope, "Infrasonic Music," *Leonardo Music Journal* 19 (2009): 51–56.

⁵ Annie Goh, "Sonic Cyberfeminism and its Discontents," in *CTM 2014: Dis continuity magazine*, ed. Jan Rohlf (CTM: Berlin, 2014): 56–59. Marie Thompson, "Feminised Noise and the 'Dotted Line' of Sonic Experimentalism," *Contemporary Music Review* 35, no 1 (2016): 85–101. doi: 10.1080/07494467.2016.1176773

VR? In terms of interactions, at this late stage of study, I am now considering how this work could provoke a sense of ‘copresence’ through which a haptic relationship can facilitate a non-verbal or visual communication channel between the listener and performer(s). Particularly, I am interested in to what extent data from my physical body could be relayed to audience members, and how they could interact with this data to influence my process or physicality in performance.

7.3 Closing Thoughts

Through this practice, I have gained both technical and creative skills in designing and developing systems for novel media experiences. I have mediated the listener’s tactile perception by introducing additional technologies and augmented modalities into the listening experience. In the systems I have designed, audiences are presented with a device that directly connects with their body and imparts vibrations. This works to increase the body’s physical engagement through prosthetic means and expands the sensory nature of the musical experience. In turn, these technologies have heavily mediated the work I have produced, placing limitations on the sounds and processes employed. This project allowed me to look outside of my practice by considering the experiential rather than the schematic, and in doing so, I felt released from the development of internal processes and schemas. I demonstrate, through analysis of existing literature and works that touch and hearing are inseparable, but this project does not use vibration to create analogous representations of sound (except for *MBCRVYB*). Instead, it sought to unpick ways in which vibrations could be used in synchrony with sound to (re)configure our experience, and reveal uncommunicated and unapparent aspects of the sonic. It synthetically moves the tactile channel towards the realm of *otherness*. This process has revealed a central theme of embodiment in my work. Probing this has led to shifts in focus where I have, through collaboration, incorporated the kinaesthetic body. Using cutaneous and kinaesthetic means, I have absorbed the body schema into the uncertainty of tactility, rendering embodied and immersive experiences that look to the future of innovations in haptic technologies and techniques.

BIBLIOGRAPHY

Altinsoy, Mehmet E. "The Quality of Auditory-Tactile Virtual Environments." *Journal of the Audio Engineering Society* 60, no.1 (2012): 38–46.

Altinsoy, Mehmet E. "Perceptual Aspects of Auditory-Tactile Asynchrony." Paper presented at International Congress on Sound and Vibration, Stockholm, 2003.

Ambisonic Toolkit Staff, "Introducing the Ambisonic Toolkit." ATK for SuperCollider, last modified November 9, 2016, accessed April 20, 2017, <http://www.ambisonictoolkit.net/documentation/supercollider/>.

Armitage, Joanne and Ng, Kia. "Configuring a Haptic Interface for Music Performance." Paper presented at Electronic Visualisation and the Arts, London, 2015. doi: 10.14236/ewic/eva2015.4

Armitage, Joanne and Ng, Kia. "mConduct: A Multi-sensor Interface for the Capture and Analysis of Conducting Gesture." In *Electronic Visualisation in Arts and Culture*, edited by Jonathan Bowen, Suzanne Keene and Kia Ng, 153–165. London: Springer, 2013.

Armitage, Joanne and Ng, Kia. "Unheard Sounds." Paper presented at Electronic Visualisation and the Arts, London, 2015.

Baalman, Marije. "Embodiment of Code." Paper presented at International Conference on Live Coding, Leeds, 2015. doi: 10.5281/zenodo.18748

Bach-y-Rita, Paul, Collins, Carter C., Saunders, Frank A., White, Benjamin and Scadden, Lawrence. "Vision Substitution by Tactile Image Projection." *Letters to Nature* 221 (1969): 963-964. doi:10.1038/221963a0

Barker, Camille and Sicchio, Kate. "Stitch, Bitch, Make/Perform: Wearables and Performance." Paper presented at Electronic Visualisation and the Arts, London, 2015. doi: 10.14236/ewic/eva2015.26

Barrett, Natasha. "Ambisonics and Acousmatic Space: A Composer's Framework for Investigating Spatial Ontology." Paper presented at Electroacoustic Music Studios Conference, Shanghai, China, 2010.

Bates, Enda. "The Composition and Performance of Spatial Music." PhD diss., Trinity College Dublin, 2009.

Berdahl, Edgar, Steiner, Hans-Christoph and Oldham, Colin. "Practical Hardware and Algorithms for Creating Haptic Musical Instruments." Paper presented at New Interfaces for Musical Expression, Genova, Italy, 2008.

Bevin, Geert aka gbevin, "SendMIDI." Developer's GitHub repository, date modified April 14, 2017, accessed April 24, 2017, <https://github.com/gbevin/SendMIDI/blob/master/README.md>

Bolter, Jay D. *Writing Space: The Computer, Hypertext, and the History of Writing*, Routledge, 2001.

Boothroyd, Dave. "Touch, Time and Technics: Levinas and the Ethics of Haptic Communications." *Theory Culture and Society* 26, no.2 (2009): 330–345. doi: 10.1177/0263276409103123

Born, Georgina. "On Musical Mediation: Ontology, Technology and Creativity." *Twentieth Century Music* 2, no.1 (2005): 7–36. doi: 10.1017/S147857220500023X

Brey, Phillip. "Technology and Embodiment in Ihde and Merleau-Ponty." *Metaphysics, Epistemology, and Technology. Research in Philosophy and Technology* 19 (2000): 45–58.

Broner, Norm. "The Effects of Low Frequency Noise on People—A review." *Journal of Sound and Vibration* 58, no.4 (1978): 483–500. doi: 10.1016/0022-460X(78)90354-1

Cadoz, Claude, Lisowski, Leszek, and Florets, Jean-Loup. "A Modular Feedback Keyboard Design." *Computer Music Journal* 14, no. 2 (1990): 47–51.

Brown, Oliver, Bell, Renick and Parkinson, Adam. "Examining the Perception of Liveness and Activity in Laptop Music." Paper presented at New Interfaces for Musical Expression, London, 2014. http://www.nime.org/proceedings/2014/nime2014_538.pdf

Chicau, Joana aka jochicau. "ChoreoGraphic Coding." TOPLAP, date modified October 24, 2016, accessed April 20, 2017, <https://toplap.org/choreographic-coding/>

Chicau, Joana. "Choreographic Design and/or Designing Choreographies." Artist's personal website, last modified February 2, 2017, accessed April 20, 2017, <https://jobcb.github.io/>

Cocker, Emma. "Live Notation: —Reflections on a Kairotic Practice." *Performance Research* 18, no.5 (2013): 69–76. doi: 10.1080/13528165.2013.828930

Collins, Nick, "Relating Superhuman Virtuosity to Human Performance." Paper presented at MAXIS, Sheffield 2002. <https://community.dur.ac.uk/nick.collins/research/transhuman.pdf>

Collins, Nick. "Generative Music and Laptop Performance." *Contemporary Music Review* 22, no.4 (2003): 67–69. doi: 10.1080/0749446032000156919

Connor, Michael. "The Impossible Music of Black MIDI." *Rhizome*, date modified September 23, 2013, accessed April 20, 2017. <http://rhizome.org/editorial/2013/sep/23/impossible-music-black-midi/>

Cox, Arnie. "Hearing, Feeling, Grasping Gestures." In *Music and Gesture*, edited by Anthony Gritten and Elaine King, 45–60. Hampshire: Ashgate, 2006.

Degenaar, Marjolein. *Molyneux's Problem*. Netherlands: Springer, 1996. doi: 10.1007/978-0-585-28424-8

Dewey-Hagborg, Heather. "Buried Sound 2: Haptic Resonance." Artist's personal website, 2011, accessed April 20, 2017, <http://www.deweyhagborg.com/projects/haptic-resonance>

Di Liscia, Oscar Pablo. "Spatial Listening and its Computer Simulation in Electronic Music." Accessed April 20, 2017, https://ccrma.stanford.edu/courses/tu/space2008/topics/auditory_cues/materials/spatial-listening.pdf

Dutton, Jack. "The Surprising World of Synaesthesia." *The Psychologist*, last modified January 19, 2016, accessed April 20, 2017, <https://thepsychologist.bps.org.uk/volume-28/february-2015/surprising-world-synaesthesia>

Eacott, Greta. "Silent Metronome." Artist's personal website, accessed March 21, 2017, <http://www.gretaeacott.com/n-e-w-s--d-a-t-e-s/live-coding-marimba-and-silent-metronome-performance-at-iscmee>

Elliott, Linda R., van Erp, Jan, Redden, Elizabeth S., and Duistermaat, Maaike. "Field-based Validation of a Tactile Navigation Device." *IEEE Transactions on Haptics* 3, no. 2 (2010): 78-87.

Emmerson, Simon. "“Losing touch?”: The Human Performer and Electronics." In *Music, Electronic Media and Culture*, edited by Simon Emmerson 194–216. London: Routledge, 2000.

Fischer, Craig. "Castle, William." In *The Guide to United States Popular Culture*, edited by Ray Broadus Browne and Pat Browne, 143–144. Madison: The University of Wisconsin Press, 2001.

Frith, Simon. "Art versus technology: the strange case of popular music." *Media, Culture & Society* 8, no.3 (1986): 263 – 279. doi: 10.1177/016344386008003002

Gardner, Bill and Martin, Keith. "HRTF measurements of a KEMAR dummy-head microphone." *Massachusetts Institute of Technology* 280, no.280 (1994): 1–7.

Gibson, James J. "Observations on Active Touch." *Psychological Review* 69, no.6 (1962): 477–491.

Glennie, Evelyn. "Hearing Essay." Artist’s personal website, last modified January 1, 2015, accessed April 20, 2017, <https://www.evelyn.co.uk/hearing-essay/>

Goh, Annie. "Sonic Cyberfeminism and its Discontents." In *CTM 2014: Dis Continuity Magazine*, edited by Jan Rohlf, 56–59. Berlin: CTM, 2014.

Goodwin, Anthony and Wheat, Heather. "Physiological Mechanisms of the Receptor System." In *Human Haptic Perception: Basics and Applications*, edited by Martin Grunwald, 93–102. Berlin: Birkhäuser, 2008.

Gopnik, Adam. "Feel me." *The New Yorker* May 16 2016, accessed April 20, 2017 <https://www.newyorker.com/magazine/2016/05/16/what-the-science-of-touch-says-about-us>

Gunther, Eric Louis. "Skinscape: A Tool for Composition in the Tactile Modality." PhD diss., Massachusetts Institute of Technology, 2001.

Gunther, Eric, and O’Modhrain, Silé. "Cutaneous Grooves: Composing for the Sense of Touch." *Journal of New Music Research* 32, no.4 (2003): 369–381.

Gunther, Eric. "Organ, Organ." Artist’s personal website, accessed July 20, 2015, <http://www.ericgunther.info/projects/organOrgan.html>

Hansen, Mark. *Bodies in Code*. New York: Routledge, 2006.

Hattwick, Ian, Franco, Ivan, Giordano, Marcello, Egloff, Deborah, Wanderley, Marcelo M., Lamontagne, Valerie, Arawjo, Ian, Salter, Chris, Martinucci, Maurizio. "Composition Techniques for the Ilinx Vibrotactile Garment." Paper presented at International Computer Music Conference, Denton, Texas, 2015. <http://hdl.handle.net/2027/spo.bbp2372.2015.088>

Hayes, Lauren. "Skin Music (2012): An Audio-Haptic Composition for Ears and Body." Paper presented at ACM SIGCHI Conference on Creativity and Cognition, Glasgow, 2015.

Hayes, Lauren and Michalakos, Christos. "Imposing a Networked Vibrotactile Communication System for Improvisational Suggestion." *Organised Sound* 17, no. 1 (2012): 36–44. doi: 10.1017/S1355771811000495.

Hinkle-Turner, Elizabeth, *Women Composers and Music Technology in the United States: Crossing the Line*. Ashgate, 2006. doi: 10.1017/S1355771807001719

Hope, Cat. "Infrasonic Music." *Leonardo Music Journal* 19 (2009): 51–56.

Idhe, Don. "Technologies-Musics-Embodiments." *Janus Head* 10, no.1 (2007): 7–24. <https://philpapers.org/rec/IHDT>

Israr, Ali and Poupyrev, Ivan. "Tactile Brush: Drawing on Skin with a Tactile Grid Display." Paper presented at SIGCHI Conference on Human Factors in Computing Systems, Vancouver, Canada, 2011. doi: 10.1145/1978942.1979235

Jorda, Sergi. "On stage: The Reactable and Other Musical Tangibles go Real." *International Journal of Arts and Technology* 1, no.3 (2008): 268–287. doi: 10.1504/IJART.2008.022363

Kirman, Jacob H. "Tactile Apparent Movement: The Effects of Interstimulus Onset Interval and Stimulus Duration." *Perception & Psychophysics* 15, no.1 (1974): 1–6.

Koslover, Rebecca L., Gleeson, Brian T., de Bever, Joshua T. and Provancher, William R. "Mobile Navigation Using Haptic, Audio, and Visual Direction Cues with a Handheld Test Platform." *IEEE Transactions on Haptics* 5, no.1 (2011): 33–38. doi: 10.1109/TOH.2011.58

Kozel, Susan. *Closer*. Cambridge: MIT Press, 2008. doi: 10.7551/mitpress/9780262113106.001.0001

Lederman, Susan J. and Jones, Lynette A. "Tactile and Haptic Illusions," *IEEE Transactions on Haptics* 4, no.4 (2011): 273–294. doi: 10.1109/TOH.2011.2

Liberati, Nicola. "Teledildonics and New Ways of "Being in Touch": A Phenomenological Analysis of the use of Haptic Devices for Intimate Relations." *Science and Engineering Ethics* (2016): 1–23. doi: 10.1007/s11948-016-9827-5.

Loy, Gareth. "Musicians Make and Standard: The MIDI Phenomenon," *Computer Music Journal* 9, no.4 (1985): 8–26.

MacLean, Karon E. "Haptic Interaction Design for Everyday Interfaces." *Reviews of Human Factors and Ergonomics* 4, no.1 (2008): 149–194.

Thor Magnusson, "Epistemic Tools: The Phenomenology of Digital Musical Instruments." PhD diss., University of Sussex, 2009.

Magnusson, Thor. "Algorithms as Scores: Coding Live Music." *Leonardo Music Journal* 21 (2011): 19–23.

Magnusson, Thor. "CMN (Code Music Notation." Developer's Github repository, date modified August 5, 2015, accessed April 20, 2017, <https://github.com/thormagnusson/cmn>

Marshall, Mark and Wanderley, Marcelo. "Examining the Effects of Embedded Vibrotactile Feed-back on the Feel of a Digital Musical Instrument." Paper presented at New Interfaces for Musical Expression, Oslo, Norway, 2011.

Matthews, Kaffe. "Music for Bodies." Sonic Bed Project Website, date modified May 12, 2016, accessed April 20, 2017, <http://www.musicforbodies.net>

Matthews, Max and Moore, Franklin R. "GROOVE—A Program to Compose, Store, and Edit Functions of Time." *Communications of the ACM* 12, no.12 (1970): 715–721. doi: 10.1145/362814.362817

Matthews, Max. "The Radio Baton and Conductor Program, or: Pitch, the Most Important and Least Expressive Part of Music." *Computer Music Journal* 15, no.8 (1991): 37–46. doi: 10.2307/3681070

Mclean, Alex, Griffiths, Dave, Collins, Nick and Wiggins, Geraint. "Visualisation of Live Code" Paper presented at Electronic Visualisation and the Arts, London, 2010.

Merleau-Ponty, Maurice. *Phenomenology of Perception*. Translated by Colin Smith, Taylor & Francis eBooks. doi: 10.4324/9780203994610

Monkman, Gareth J. "An Electrorheological Tactile Display." *Presence: Teleoperators & Virtual Environments* 1, no. 2 (1992): 219–228.

Nanayakkara, Suranga Chandima, Wyse, Lonce, Ong, Sim Heng, and Taylor, Elizabeth A. "Enhancing Musical Experience for the Hearing-impaired using Visual and Haptic Displays." *Human-Computer Interaction* 28, no. 2 (2013): 115-160.

Nanayakkara, Suranga. "Enhancing Musical Experience for the Hearing-Impaired Using Visual and Haptic Displays." PhD diss., University of Singapore, 2009.

Ng, Kia, Armitage, Joanne and McLean, Alex. "The Colour of Music: Real-time Music Visualisation with Synaesthetic Sound-colour Mapping." Paper presented at Electronic Visualisation and the Arts, London, 2013. doi: <http://dx.doi.org/10.14236/ewic/eva2014.3>

O'Modhrain, Maura Sile. "Playing by Feel: Incorporating Haptic Feedback into Computer-Based Musical Instruments." PhD diss., Stanford University, 2000.

Ohta, Yoshitaka. "What is the 'Haptic?': Consideration of Logique de la Sensation and Deleuze's Theory of Sensation." *Bigaku* 49, no.1 (2008): 29–42.

Oliveros, Pauline. "Quantum Listening: From Practice to Theory." Address presented at MusicWorks #75, Chinese University, Hong Kong, 2000.

Ostertag, Bob. "Human Bodies, Computer Music." *Leonardo Music Journal* 12 (2002): 11–14.

Parkinson, Adam and Bell, Renick. "Deadmau5, Derek Bailey, and the Laptop Instrument – Improvisation, Composition and Liveness in Live Coding." Paper presented at International Conference on Live Coding, Leeds, 2015. doi: 10.5281/zenodo.19350

Paterson, Mark, *The Senses of Touch: Haptics Affects and Technologies*. Oxford: Berg, 2007.

Precision Microdrives Staff, "Adding and Improving Haptics." Precision Microdrives Application Bulletin, accessed March 15, 2015, <http://www.precisionmicrodrives.com/haptics-haptic-feedback-vibration-alerting/haptic-feedback-in-detail/adding-and-improving-haptic-feedback>

Precision Microdrives Staff, "Measuring Vibration Strength a Quick Method." Precision Microdrives application bulletin, accessed March 15, 2015, <http://www.precisionmicrodrives.com/tech-blog/2014/06/03/measuring-vibration-strength-a-quick-method>

ProDanceLeeds Staff. "Remember the Leeds Culture Gathering?" ProDanceLeeds Blog, date modified October 15, 2016, accessed April 24, 2017, <http://www.prodanceleeds.com/friends/2016/10/8/remember-the-leeds-culture-gathering>

Redhead, Lauren, "di_stanze festival: Modes of Listening." Blog entry, date modified November 2, 2014, date accessed April 20, 2017. <http://weblog.laurenredhead.eu/post/101608521587/distanze-festival-modes-of-listening>

Salkic, Oliver. "Feel a Bit Like Beethoven." Artist's personal website, accessed April 20, 2017, <http://www.oliversalkic.com/feel-a-bit-like-beethoven>

Schilling, Elisabeth. "The Sixfold Body." Artist's personal website, accessed April 20, 2017, <http://www.elisabethschilling.com/en/project/the-sixfold-body-2/>

Srinivasan, Mandayam A. and Basdogan, Cagatay. "Haptics in Virtual Environments: Taxonomy, Research status, and Challenges." *Computers & Graphics* 21, no. 4 (1997): 393–404, doi: [https://doi.org/10.1016/S0097-8493\(97\)00030-7](https://doi.org/10.1016/S0097-8493(97)00030-7).

Sicchio, Kate. "Hacking Choreography, Dance and Live Coding." *Computer Music Journal* 38, no.1 (2014): 31–39.

Sorensen, Andrew and Gardner, Henry. "Programming with Time: Cyber-physical Programming with Impromptu." Paper presented at ACM International Conference on Object Oriented Programming Systems Languages and Applications, Nevada, 2010.

Spiegelberg, Herbert. *The Phenomenological Movement: A Historical Perspective*. Dordrecht: Kluwer Academic Publishers, 1994.

Stone, Robert. "Haptic Feedback: A Brief History from Telepresence to Virtual Reality." *Haptic Human-Computer Interaction* (2001): 1–16.

Sugarman, Emma. "Alex McLean on Music Coding and Algorave" British Music Collection, 2016, accessed April 20, 2017. <http://britishmusiccollection.org.uk/article/alex-mclean-music-coding-and-algorave>

Thompson, Marie. "Feminised Noise and the 'Dotted Line' of Sonic Experimentalism." *Contemporary Music Review* 35, no.1 (2016): 85–101. doi: 10.1080/07494467.2016.1176773

van Erp, Jan B. F. "Guidelines for the use of Vibro-Tactile Displays in Human Computer Interaction." Paper presented at Eurohaptics, Edinburgh, UK, 2002. <http://www.eurohaptics.vision.ee.ethz.ch/2002/vanerp.pdf>

White, Jeremy. "Hands-on with the £109 wearable subwoofer Basslet." *Wired*, last modified June 21, 2016, accessed April 24, 2017, <http://www.wired.co.uk/article/hands-on-basslet-wearable-subwoofer>

Wyse, Lonce, Nanayakkara, Suranga, Seekings, Paul, Ong, S. H., and Taylor, Elizabeth. "Perception of Vibrotactile Stimuli Above 1 kHz by the Hearing-impaired." Paper presented at New Interfaces in Musical Expression, Michigan, USA, 2012.