

**AN INVESTIGATION OF CONSUMPTION PATTERNS
AND CONSUMER SATISFACTION WITH THE PROVISION
OF PHARMACEUTICAL PRODUCTS IN THE EGYPTIAN MARKET:
AN EMPIRICAL STUDY**

BY

AISHA NOUSTAFA EL-MENIAWY

B.com., M.A., (MARKETING)

THE UNIVERSITY OF AIN-SHAMS, CAIRO

**A THESIS SUBMITTED TO THE UNIVERSITY OF SHEFFIELD
IN FULFILMENT OF THE REQUIREMENT FOR THE DEGREE OF
DOCTOR OF PHILOSOPHY**

January, 1991

TO

My Mother

and

The Memory Of My Father; and

Brother In Law, Omer

My Husband, Mohammed

and

My children, Hebat-Allah and Hady

ACKNOWLEDGMENTS

I owe a special debt of gratitude to Dr. Anne Tomes for her supervision and careful guidance throughout all the phases of this research. Dr. Tomes's suggestions, which proved invaluable support, are also greatly appreciated. This thesis would not have been possible without her assistance and encouragement. Sincere gratitude is also extended to Professor Arthur Meidan, for his insightful comments and remarks on the theoretical aspects of this research.

A special word of thanks goes to my colleague Dr. Thabt Edris in Egypt for stimulating my interest in this topic and his primary assistance.

I owe my gratitude to a number of people, in Cairo-Egypt, for providing a great help in collecting the data required for this study: Dr. Gomah Gamal, the production manager, Arab Medical Packing Company; Dr. Aly El-Shikh, manager of the Scientific Department, Hoechst Orient; and Dr. Abdel-Al Avad, sales manager, El-Masryia For Medicine Trade And Distribution Company. I would like also to thank Drug Organization For Chemical And Medical Appliance (DOCMA), for allowing me access to the data required for this research.

Many thanks are due to the staff of the Crookesmoor Library, for their assistance. I wish, as well, to thank the secretarial staff of the School Of Management, University Of Sheffield. I also appreciate the special skills of Miss Elizabeth Fox, who served in drawing tables and figures of this manuscript. The help I received from Mrs Diane Brook in word processing is acknowledged.

My most bountiful gratitude goes to my mother, sisters, and brothers, for their encouragement and endurance for being away from them.

Last but certainly not the least, I owe a special debt of gratitude to my husband, for being a true partner in this effort. No words can adequately express my appreciation of his moral support, understanding, patience, sacrifice, and co-operation throughout the preparation of this project. I am deeply grateful to my children for their tolerance during the time this work was undertaken.

A. El-Meniawy
School Of Management

**AN INVESTIGATION OF CONSUMPTION PATTERNS
AND CONSUMER SATISFACTION WITH THE PROVISION
OF PHARMACEUTICAL PRODUCTS IN THE EGYPTIAN MARKET:**

AN EMPIRICAL STUDY

ABSTRACT

This study is an empirical investigation of consumer satisfaction with the provision of medicine in Egypt.

One way to look at consumer protection in the medicine market is to explore consumer satisfaction with the provision of medicine. A further way is to investigate the various consumption patterns of medicines (in terms of expenditures). Both ways are combined together in this investigation to gain an insight into the protection provided to the Egyptian consumers in the medicine market. The findings are then used to make recommendations in order to improve medicine provision and protection in Egypt. In addition, the study aims to contribute theoretically by presenting a conceptual model of consumer satisfaction. Further, the work tries to determine the components of consumer satisfaction with respect to the underlying factors and the degree of satisfaction experienced by the Egyptian consumers.

The rationale of the second objective of this study was to investigate whether consumer segments exist in the Egyptian market on the basis of consumer satisfaction with the provision of medicine products with particular demographic and socio-economic characteristics. No such clear segments emerged.

It was hypothesized that: (1) there are no significant differences among Egyptian consumers with different demographic and socio-economic characteristics on the basis of their satisfaction with the provision of medicine products and (2) there is no significant relationship between the consumption patterns of medicines (in terms of expenditure) and consumer demographic and socio-economic (in terms of sex, age, income, education, occupation, marital status, family size).

The primary data required was collected via personal interviews using a structure questionnaire. Information was collected on consumer attitudes, opinions and demography / socio-economy. A random multi-stage area sample of 1300 consumers was chosen. Respondents were selected from two cities, Cairo and Giza.

From that sample, 938 usable cases of data were obtained and analysed.

Two scales of measurement are employed in this study. First, an interval scale to measure consumer satisfaction on a set of variables and statements as well as to investigate consumption patterns of medicines. Second, a nominal scale was used to record information on consumers' demographics and socio-economics.

The reliability of the satisfaction scale employed in this study was statistically tested using Cronbach's Alpha. In addition, five different types of analysis are used to achieve the research objectives (i.e., factor analysis, cluster analysis, discriminant analysis, ANOVA, multiple regression analysis). Factor analysis is used to analyse the set of satisfaction variables to determine the underlying factors of consumer satisfaction. The degree of satisfaction with those factors is also calculated to determine the extent to which consumers are satisfied with each factor. It was found that packaging and labelling contribute most to the variance explained and are the factors with which consumers are most satisfied. Consumers are least satisfied with medicine price and availability of medicines.

Cluster analysis is utilized in this study to explore the similarities and dissimilarities between the Egyptian consumers segments on the basis of their satisfaction with respect to the twelve factors identified and the statements. However, this analysis did not bring out segments. This was confirmed by discriminant analysis. ANOVA was therefore employed to investigate the similarities and dissimilarities among consumers with different demographic and socio-economic characteristics. Multiple regression analysis was used to determine the relationship between consumption patterns (dependent variable) and consumer demographic and socio-economic. The study found that sex, age, income, education, family size and marital status do affect satisfaction with, and consumption of, medicine products. In addition, the research hypotheses are tested via ANOVA (F Ratio) and T tests.

The study makes a contribution to knowledge in three areas, theoretical, empirical and practical. The main theoretical contribution is the building of a conceptual model of consumer satisfaction, while the empirical contribution is that this type of

study has not been carried out before into consumer satisfaction with medicines in a developing country.

Finally, the practical contribution is the significant implications arising from the work for all the players in the medicine arena, especially the Egyptian government, since, the study reveals that the Egyptian consumers feel that the provision of medicine is less than satisfactory.

The thesis concludes with recommendations for further consumer behaviour research, empirical studies of consumer satisfaction and actions which need to be taken by the Egyptian government, particularly to improve the medicine provision situation in Egypt and provide the Egyptian consumer with adequate protection.

TABLE OF CONTENTS

	<u>PAGE</u>
LIST OF TABLES.	1
LIST OF FIGURES.	3
<u>CHAPTER ONE - INTRODUCTION.</u>	
1.1. Preface.	5
1.2. Problem Recognition And The Research Questions.	7
1.3. Research Objectives.	9
1.4. Research Hypotheses.	10
1.5. Organization Of The Thesis.	11
<u>CHAPTER TWO - REVIEW OF THE LITERATURE</u>	
<u>PART ONE: THE GLOBAL PERSPECTIVES OF THE</u>	
<u>PHARMACEUTICAL MARKETING.</u>	
2.1. Introduction.	16
2.2. Structure Of The Global Pharmaceutical Industry.	17
2.3. Characteristics Of The Pharmaceutical Marketing.	19
2.3.1. The Prescription Pharmaceutical Market.	19
2.3.2. Over-The-Counter Market.	21
2.4. Identification Of The Market.	23
2.4.1. The Patient / Consumer.	24
2.4.2. The Doctor As Distributor.	26
2.4.3. Patterns Of Relationships In The Pharmaceutical Marketing.	28
2.5. The Global Strategies Of Pharmaceutical Marketing.	30
2.5.1. Advertising And Promotion.	31
2.5.2. The Channel Of Distribution.	34

	<u>PAGE</u>
2.5.3. Pricing.	35
2.5.4. Patterns Of Competition.	37
2.6. The International Governments's Regulations For The Marketing Of Pharmaceuticals.	39
2.6.1. Medicines' Safety.	39
2.6.2. Medicines' Advertising / Promotion, Pricing And Distribution.	41
2.6.3. Post-Marketing Surveillance (PMS).	43
2.7. The World-Wide Health-Care.	45
2.7.1. The Consumption Of Medicines.	45
2.8. Summary Of Part One.	46
 <u>PART TWO: THE EGYPTIAN PHARMACEUTICAL PRODUCTS' MARKET.</u>	
2.9. The Pharmaceutical Industry In Egypt.	48
2.10. An Overview Of The Historical Development Of The Pharmaceutical Sector In Egypt.	49
2.10.1. The First Phase (1939 - 1961).	49
2.10.2. The Second Phase (1962 - 1975).	50
2.10.3. The Third Phase (1976 - 1982).	51
2.10.4. The Fourth Phase (1983 -).	53
2.11. The Major Elements Of The Pharmaceutical Policy.	55
2.11.1. The Selection Of Medicines.	55
2.11.2. The Increase Of Local Production Share.	55
2.11.3. Consumption Rationalization.	57
2.11.4. Distribution And Storage Policy.	59
2.11.5. Importation Policy.	61
2.11.6. Control Over Medicine Prices.	62
2.11.7. Medical Control.	63

	<u>PAGE</u>
2.12. Recent Developments In The Pharmaceutical Sector.	64
2.12.1. The Development In The Field Of Technology.	64
2.12.2. The Development Of The Raw Materials Industry.	65
2.12.3. The Development Of The Export Policy.	66
2.12.4. The Development Of The pharmaceutical Packaging Industry.	67
2.13. Summary Of Part Two	70

CHAPTER THREE - CONSUMER SATISFACTION /

DISSATISFACTION

3.1. Introduction To Consumer Satisfaction / Dissatisfaction.	73
3.2. Classification Of Consumer Satisfaction.	77
3.3. Conceptualization Of Consumer Satisfaction / Dissatisfaction.	79
3.3.1. Satisfaction Defined.	79
3.3.2. Dissatisfaction Defined.	81
3.3.3. Consumer Satisfaction And Attitudes.	83
3.3.4. Approaches To Consumer Satisfaction.	90
3.3.4.1. Antecedents Of Satisfaction.	90
3.3.4.1.1. Expectation - The Primary Determinant Of Satisfaction.	91
3.3.4.1.2. Performance.	95
3.3.4.1.3. The Concept Of Disconfirmation And Inequity.	95
3.3.4.1.4. A Model Of Consumer Satisfaction.	97
3.3.4.2. Post Evaluation And Satisfaction.	100

	<u>PAGE</u>
3.3.5. Psychological Theory Of Consumer Satisfaction.	105
3.3.6. Sociological Interpretation of Consumer Satisfaction/Dissatisfaction.	110
3.3.6.1. Alienation.	110
3.3.6.2. Communication - Effect Theory.	112
3.3.7. Utility Theory Of Consumer Satisfaction / Dissatisfaction.	113
3.4. The Relationship Between Satisfaction And Dissatisfaction.	116
3.5. Measurement Of Consumer Satisfaction / Dissatisfaction.	120
3.5.1. Measurement Problems.	123
3.6. Summary.	124
<u>CHAPTER FOUR - CONSUMER CHARACTERISTICS RELATER CONSUMPTION PATTERNS / SATISFACTION / COMPLAINT BEHAVIOUR.</u>	
4.1. Introduction.	127
4.2. An Overview Of Consumer Characteristics.	128
4.2.1. Demographic Characteristics.	129
4.2.2. Socio-economic Characteristics.	130
4.3. Consumer Characteristics And Consumption Patterns.	131
4.4. Consumer Characteristics And Satisfaction / Dissatisfaction.	135
4.5. Consumer Characteristics And Propensity To Complain.	141

	<u>PAGE</u>
4.6. Consumerism.	147
4.7. Summary.	152

CHAPTER FIVE - A CONCEPTUAL MODEL OF CONSUMER

SATISFACTION.

5.1. Introduction.	155
5.2. Consumer Involvement.	156
5.3. Personal Values.	160
5.4. A Framework Of Relationships.	164
5.5. conclusion.	169

CHAPTER SIX - RESEARCH DESIGN.

6.1. Introduction.	172
6.2. Data Source.	172
6.2.1. Secondary Data.	172
6.2.2. Primary Data.	173
6.3. Research Approaches.	173
6.3.1. Exploratory Study.	173
6.3.2. Empirical Investigations.	174
6.4. Scales Of Measurement.	174
6.4.1. Attitude Rating Scales.	175
6.5. Questionnaire Design.	177
6.5.1. Phrasing Of Questions.	178
6.5.2. Sequence Of Questions.	178
6.5.3. Questionnaire Structure.	179
6.5.4. Questionnaire Instructions.	181
6.6. Data Collection.	182
6.6.1. Pilot Survey.	182

	<u>PAGE</u>
6.6.1. Personal Interviews.	182
6.7. Sampling Plan.	184
6.7.1. Defining The Population.	184
6.7.2. Sample Size.	185
6.7.3. Sampling Procedures.	186
6.7.4. Sampling Control.	189
6.8. Response Rate Of Consumer Survey.	190
6.9. Criteria For Good Measurement.	191
6.9.1. Reliability.	193
6.9.2. Validity.	197
6.10. Summary.	200

CHAPTER SEVEN - MULTIVARIATE TECHNIQUES OF ANALYSIS.

7.1. Introduction.	202
7.2. Factor Analysis.	204
7.2.1. Factor Analysis Input / Output.	205
7.2.2. Extracting Initial Factors.	207
7.2.3. Determination Of The Appropriateness Of Factor Analysis.	208
7.2.4. Advantages Of Factor Analysis.	208
7.2.5. Use Of Factor Analysis In This Study.	209
7.3. Cluster Analysis.	209
7.3.1. Cluster Analysis Measures.	211
7.3.1.1. Euclidean Distance Measures.	211
7.3.1.2. Similarity Measures.	211
7.3.2. Hierarchical Clustering Procedures.	212
7.3.3. Deciding On The Number Of Clusters.	215

	<u>PAGE</u>
7.3.4. Use Of Cluster Analysis In This Study.	215
7.4. Multiple Regression Analysis.	216
7.4.1. Multicollinearity And Related Problems.	218
7.4.2. Multiple Regression Analysis Using Dummy Variables.	219
7.4.3. Use Of Regression Analysis In This Study.	219
7.5. Statistical Tests Of The Research Hypotheses.	220
7.5.1 Friedmans "Two-Way" Analysis Of Variance By Ranks.	222
7.5.2. Analysis Of Variance ANOVA "F-Ratio".	222
7.5.3. T-Test.	223
7.6. Summary.	224

CHAPTER EIGHT - RESEARCH FINDINGS.

8.1. Data Analysis Procedure.	228
8.2. Reliability Of The Satisfaction Scale.	229
8.3. Factor Analysis Findings.	232
8.3.1. Factor Labelling.	232
8.3.2. Degree Of Satisfaction With The Factors Identified.	241
8.3.3. Conclusion.	243
8.4. Finding Segments: Cluster / Discriminant Analysis.	244
8.5. Testing The Differences (ANOVA).	246
8.6. Analysis Of Variance (ANOVA) Findings.	246
8.6.1. Interpretation Of The ANOVA Results Of The Factors Identified.	247
8.6.2. Similarities Across The Factors Identified.	252

	<u>PAGE</u>
8.6.3. Interpretation Of The ANOVA Results Of The Statements.	254
8.6.4. Similarities Across The Statements.	259
8.6.5. Conclusion About Similarities / Differences With Respect To Consumer Characteristics.	261
8.6.6. The Link Between The Conceptual Model Of Consumer Satisfaction And The Research Findings.	263
8.7. Multiple Regression Results.	263
8.7.1. Findings Of The Multiple Regression Analysis.	264
8.7.2. Testing The Relationship - T Test.	266
8.7.3. The Relative Importance Of The Predictors.	270
8.7.4. Interpretation Of The Variables Retained.	271
8.7.5. Conclusion.	274
8.8. Summary.	274
 <u>CHAPTER NINE - SUMMARY, IMPLICATIONS, RECOMMENDATIONS, AND CONCLUSIONS.</u>	
9.1. Summary Of Findings.	277
9.2. Comparison Of Study With The Previous Literature.	278
9.3. Implications Of This Study.	280
9.3.1. Implications For Researchers And Theorists.	280
9.3.2. Implications For Marketing Practitioners.	280
9.3.3. Implications For The Government.	282
9.4. Contributions Of The Study.	284
9.4.1. Theoretical Contribution.	284
9.4.2. Empirical Contribution.	285
9.4.3. Practical Contribution.	285

	<u>PAGE</u>
9.5. Recommendations For Future Research.	287
9.6. Concluding Comments.	288
REFERENCES.	289
BIBLIOGRAPHY.	310
APPENDIX (1) QUESTIONNAIRE ENGLISH VERSION.	315
APPENDIX (2) QUESTIONNAIRE ARABIC VERSION.	324
APPENDIX (3) ROTATED FACTOR MATRIX	333
APPENDIX (4) CLUSTER / DISCRIMINANT ANALYSIS OUTPUT.	336
APPENDIX (5) ANOVA TABLES.	343

LIST OF TABLES

	<u>PAGE</u>
<u>Table 2.1:</u> The World's Ethical Pharmaceutical Companies Ranked By Estimated 1988 Revenues (US \$ Million).	18
<u>Table 2.2:</u> National Production Share (in million, L.E).	56
<u>Table 2.3:</u> The Study For The Increase In Consumption (in million, L.E).	58
<u>Table 2.4:</u> Increase In Annual Medicine Consumption Per Capita (Egyptian Pound L.E.).	59
<u>Table 2.5:</u> Direct And Indirect Subsidy (in million, L.E).	60
<u>Table 2.6:</u> Increase In Annual Imported Raw Materials (in million, L.E).	62
<u>Table 2.7:</u> The Development In The Field Of Raw Materials (in million, L.E).	66
<u>Table 2.8:</u> The Development In The Field Of Exportation (in million, L.E).	67
<u>Table 2.9:</u> The Value Of Medical Packaging production (in million, L.E).	68
<u>Table 6.1:</u> The Percentages Of The Composition Of The Sample Size.	188
<u>Table 6.2:</u> The Results Of Respose Rate.	191
<u>Table 8.1:</u> Attributes And Reliability Coefficients Of Scale Of Satisfaction.	230
<u>Table 8.2:</u> Varimax Rotated Factor Matrix.	237
<u>Table 8.3:</u> Degree Of Satisfaction With Each Factor.	242

	<u>PAGE</u>
<u>Table 8.4:</u> The Influence Of Sample Predictors On The Full Regression Model.	266
<u>Table 8.5:</u> Regression Analysis: Demographic / Socio-economic Predictors For Consumption Categories.	269

LIST OF FIGURES

	<u>PAGE</u>
<u>Figure 2.1:</u> International Comparision Of Expenditures Of Medicines.	18
<u>Figure 2.2:</u> DOCMA Organizational Structure.	58
<u>Figure 3.1:</u> Purchase And Its Outcomes.	87
<u>Figure 3.2:</u> The Howard-Sheth Model Of Buyer Behaviour.	89
<u>Figure 3.3:</u> Expectation And Level Of Performance.	98
<u>Figure 3.4:</u> The Flow Diagram Of The Purchase Decision Process.	104
<u>Figure 3.5:</u> The Relationship Between Expectations Level And Performance Levels.	109
<u>Figure 3.6:</u> The Single Dimension Of Satisfaction /Dissatisfaction Feelings.	116
<u>Figure 3.7:</u> The Independent Dimension Of Satisfaction / Dissatisfaction Feelings.	117
<u>Figure 3.8:</u> Effects Of A Change In Price Or Quality On A Single Continuum.	118
<u>Figure 3.9:</u> Effects Of Increase In Quality And Price On Dual-Factor Continua.	118
<u>Figure 4.1:</u> Consumer Reaction To Dissatisfied.	144
<u>Figure 5.1:</u> A Conceptual Model Of Consumer Satisfaction.	170

CHAPTER ONE

INTRODUCTION

- 1.1. Preface.
- 1.2. Problem Recognition And The Research Questions.
- 1.3. Research Objectives.
- 1.4. Research Hypotheses.
- 1.5. Organisation Of The Thesis.

1.1. PREFACE:

This study arose out the concern of the Egyptian government to protect consumers from marketing malpractices by all the players in the pharmaceutical arena.

The concept of consumer protection is wide and complex in scope in all societies even in an affluent society where the basic needs and wants are met already. It has emerged as an issue area on the public policy agenda of many advanced and developing societies to eliminate hazardous products (Pestoff 1988) and the exploitation of consumers for profit. Therefore, consumer protection is considered to be a critical question in our lives. For that reason, it is seen by the researcher as something beyond a marketing problem.

This study is centred on a questionnaire relating to consumer behaviour and attitudes that can be answered with confidence by the Egyptian consumers, the results of which can be used to explore the protection provided in the pharmaceutical market. Medicines are vital consumer goods required by various categories of consumers to satisfy urgent needs. Further, consumers are always unclear about the medicine quality which should be offered, since medicines are usually purchased without a word being said and the performance characteristics therefore not spelt out. Many medicines are dispensed by doctor's prescription. The consumer / patient therefore relies primarily on the doctor's judgement. Yet, this does not mean the doctor is not addressing himself to the needs of the patient. The doctors' unique offering is that special capability to identify and satisfy the patients' needs (Houston 1986). The problem of consumer protection in the medicine field therefore has various facets that should be considered. These

include not only manufacturers' and distributors' responsibilities but also doctors and finally pharmacists responsibilities. The present study focuses on two major aspects. First, an exploration of consumer satisfaction as an indicator of the extent of consumer protection. Second, an investigation of the relationships between consumers' consumption patterns (in terms of expenditure) and consumers' demographic and socio-economic variables in the Egyptian society that may influence these consumption patterns.

The study of consumer satisfaction creates particular problems. A consumer clearly knows the ideal benefits he / she seeks from a medicine but he / she does not necessarily expect these benefits to accrue. The level of expectation will depend on the degree of success or failure of his / her past treatments of a variety of medical conditions and the benefits the doctor prescribing the medicines tells the consumer he / she can expect. Fortunately for the empirical researcher seeking to determine the extent of perceived consumer satisfaction, a consumer having experienced satisfaction or dissatisfaction with a medicine is able, at an intuitive level, to express the extent of the satisfaction / dissatisfaction with the various performance characteristics of that medicine, without necessarily understanding the criteria he / she used in making his / her judgement.

In order to explore the above criteria, the intention is to identify the key elements that underlie the level of satisfaction of the Egyptian consumers with medicine products. The researcher has developed a number of variables which reflect the previously mentioned elements of consumer satisfaction in the medicine market namely, packaging, labelling, quality, pricing, quantity, availability, medicines' negative / side effects and doctor's

experiences with medicines. Some of these variables were developed by the researcher, since no research had been undertaken in Egypt in the area of consumer satisfaction with the provision of medicine, while other variables were extracted from the literature, and modified for the purpose of this study.

For the second aspect of this research, an exploratory study demonstrated that the consumption rate of medicines is increasing rapidly in Egypt in recent years (see chapter 2). It was felt that more research effort into consumer behaviour to investigate this phenomenon was required. Thus another set of variables of the Egyptian demography and socio-economy have been generated (e.g., sex, age, income) to measure the relationships among these variables and the consumption patterns of medicines (in terms of expenditure). More precisely, several studies have indicated that demographic and socio-economic variables are considered one of the most important dimensions in understanding consumer satisfaction (Cohen 1981). In addition, the problem of consumer dissatisfaction has become identified and associated with specific problems such as low income consumers who suffer from excessive prices and poor quality in medicines and services. Poorly educated consumers are often unaware of the characteristics of medicines which are able to satisfy their needs.

1.2. PROBLEM RECOGNITION AND THE RESEARCH QUESTIONS:

There has been much progress in recent years in developing standards of consumer goods which are responsive to the needs of consumers. For instance, pharmaceutical companies in Egypt penetrated significantly the markets of different types of medicines (see chapter 2). In the exploratory study, it was found

that there are obvious advances in the packaging of medicines which can increase consumer satisfaction, but many consumer complaints are still received about such products. In addition, there are several medicines which are offered free through general hospitals, but it seems that these medicines are unlabelled and thus generate the subsequent problem of insufficient instruction. The researcher felt that special attention should be given in the proper use of medicines and informing consumers of the risks involved in their use.

Account must be taken of the fact that the quality of medicines has a bearing on performance and fitness for the purpose as well. Consumers seek for safety in medicines however several types have been found to have adverse effects. These effects are the main criteria of consumer protection.

The shortage of raw materials for medicines is putting great pressure on price. Further, price levels have risen during the recent period of rapidly increasing inflation, despite the fact that medicine prices are often bounded and subsidised by the Egyptian government.

The problem of the price of medicines has an effect on the availability of many kinds of medicine and several types cannot be obtained at all. Distribution patterns also play an important role and are responsible in part for the availability and scarcity of medicines. In addition, the scarcity is being increased due to the growth of the rate of consumption (see chapter 2).

Two critical questions stem from the above discussion, they are:

- (1) To what extent are consumers satisfied (in terms of packaging, labelling, quality, etc.) with the provision of medicines in the Egyptian market?
- (2) Are there any relationships among the various levels of consumers' consumption patterns (in terms of their expenditure) and the Egyptian demography and socio-economy (e.g., sex, age)?

1.3. RESEARCH OBJECTIVES:

This empirical investigation is mainly concerned with consumer satisfaction with medicine products in Egypt. In other words, consumer satisfaction is explored in this study to find out how much Egyptian consumers are being protected in this vital sector of consumer goods. The relationship between consumer's consumption patterns of medicines and their demographic and socio-economic characteristics is also of particular interest in this study.

Accordingly, the major objectives of this research are as follows:

- (1) To identify and quantify the key elements that underlie consumer satisfaction (e.g., packaging, labelling, quality) with medicine products in Egypt.

Such identification and quantification of consumer satisfaction will enable us to answer the question of how much Egyptian consumers are being protected in the market of medicines.

- (2) To explore the similarity and dissimilarity among the various categories of Egyptian consumers in their satisfaction with the provision of medicines.

This exploration will help the government reconsider and evaluate the current regulations with respect to its policy regarding the manufacture and marketing of medicines. Distributors would also

benefit from such information if they wish to increase the effectiveness of their marketing strategies.

- (3) To investigate the relationship between consumption patterns of medicines (in terms of expenditure) and the various characteristics of the Egyptian consumers (i.e., demographic / socio-economic).

Knowledge about consumption patterns in this vital market is considered very important to find out how much consumer segments spend on medicines.

Although principally an empirical study, the researcher aims to make a theoretical contribution to consumer behaviour knowledge by developing a conceptual model of consumer satisfaction.

1.4. RESEARCH HYPOTHESES:

The following are the key research hypotheses:

- (1) There are no significant differences among Egyptian consumers with different demographic and socio-economic characteristics on the basis of their satisfaction with the provision of medicine products.
- (2) There is no significant relationship between consumption patterns of medicines and consumer's demographic and socio-economic characteristics in terms of:
- 2.1. Sex.
 - 2.2. Age.
 - 2.3. Income.
 - 2.4. Education.
 - 2.5. Occupation.
 - 2.6. Marital Status.
 - 2.7. Family Size.

1.5. ORGANISATION OF THE THESIS:

This thesis is organised into nine chapters, each chapter comprises the stages in the process.

After beginning with a preface, explaining the rationale behind the work, we continued this first chapter by presenting the research problem and formulating the basic research questions and the objectives of the study. This was followed by the hypotheses to be tested.

Chapter two consists of two parts and deals with the review of the literature on pharmaceutical marketing.

Part one describes the different issues of the global marketing of pharmaceuticals. It starts with an introduction followed by a short review of the structure of the pharmaceutical industry. A discussion of the characteristics of pharmaceutical marketing in the prescription market and the over-the-counter market is presented. Also the discussion expands to the different arguments regarding the role of the consumer / patient and the doctor in the market. The global marketing strategies of pharmaceutical companies are then discussed, particular attention is concentrated on the national and international regulations imposed on the marketing of pharmaceuticals. This part is concluded by a very brief view of world health-care.

Part two provides an overview of the pharmaceutical market in Egypt. The chapter highlights the historical development of the pharmaceutical sector, followed by the key aspects of the pharmaceutical policy. This is continued by tracing the recent technological developments in the pharmaceutical industry.

Chapter three comprises a review of the literature on consumer satisfaction. The chapter primarily focuses on the

conceptualisation of consumer satisfaction. It begins with an introduction of consumer satisfaction / dissatisfaction and different controversial issues are discussed. In this chapter particular consideration is devoted to expectation, performance, disconfirmation and inequity as a major bases of emerging satisfaction / dissatisfaction. The chapter concludes with a discussion of the measurement of consumer satisfaction and its major problems.

Chapter four is concerned with a survey of the literature on consumer characteristics regarding consumption patterns, satisfaction and complaining behaviour. It is necessary to look at similar studies to ours which prove helpful in determining the role of consumer variables on satisfaction, consumption patterns and complaining behaviour. We conclude this chapter by reviewing the concept of consumerism.

Chapter five describes the researcher's attempt to develop a model of consumer satisfaction with new dimensions.

Chapter six deals with the nature of the research design to ensure that the research addresses the appropriate questions and treats them in an efficient manner. The concern is with the process of data collection which is gathered from a multi-stage random sample of respondents by structured questionnaire using the personal interviewing technique. A section is devoted to investigating the reliability and validity of the research design.

Once the data have been collected, the emphasis turns logically to the methodology of analysis. Therefore, chapter seven reviews three different multivariate techniques of analysis to be used to achieve the three research objectives (factor analysis,

cluster analysis and multiple regression analysis). The appropriate statistical tests are also highlighted.

Chapter eight begins with testing the reliability of the satisfaction scale, then it goes on to the research findings and interpretation based on the computer output of factor analysis, cluster analysis, discriminant analysis, ANOVA (F Ratio) and multiple regression analysis. In this chapter we use ANOVA and T tests to test the eight hypotheses of the study.

In chapter nine, we present a comparison between our study and the literature reviewed, followed by the major implications for researchers, theorists, marketing practitioners and the Egyptian government. The chapter highlights the theoretical, empirical and practical contributions of the study. In addition, recommendations for further research are reported.

CHAPTER TWO

REVIEW OF THE LITERATURE

PART ONE: THE GLOBAL PERSPECTIVES OF THE PHARMACEUTICAL MARKETING.

- 2.1. Introduction.
- 2.2. Structure of The Global Pharmaceutical Industry.
- 2.3. Characteristics Of The Pharmaceutical Marketing.
 - 2.3.1. The Prescription Pharmaceutical Market.
 - 2.3.2. Over-The-Counter (OTC) Market.
- 2.4. Identification Of The Market.
 - 2.4.1. The Patient / Consumer.
 - 2.4.2. The Doctor As Distributor.
 - 2.4.3. Patterns Of The Relationships In The Pharmaceutical Marketing.
- 2.5. The Global Strategies Of Pharmaceutical Marketing.
 - 2.5.1. Advertising And Promotion.
 - 2.5.2. The Channel Of Distribution.
 - 2.5.3. Pricing.
 - 2.5.4. Patterns Of Competition.
- 2.6. The International Governments' Regulations For The Marketing Of Pharmaceuticals.
 - 2.6.1. Medicines' Safety.
 - 2.6.2. Medicines' Advertising / Promotion, Pricing And Distribution.
 - 2.6.3. Post-Marketing Surveillance (PMS).
- 2.7. The World-Wide Health-Care.
 - 2.7.1. The Consumption Of Medicines.
- 2.8. Summary Of Part One.

PART TWO: THE EGYPTIAN PHARMACEUTICAL PRODUCTS' MARKET.

- 2.9. The Pharmaceutical Industry In Egypt.
- 2.10. An Overview Of The Historical Development Of The Pharmaceutical Sector In Egypt.
 - 2.10.1. The First Phase (1939 - 1961) .
 - 2.10.2. The Second Phase (1962 - 1975).
 - 2.10.3. The Third Phase (1976 - 1982).
 - 2.10.4. The Fourth Phase (1983 -).
- 2.11. The Major Elements Of The Pharmaceutical Policy.
 - 2.11.1. The Selection Of Medicines.
 - 2.11.2. The Increase Of Local Production Share.
 - 2.11.3. Consumption Rationalization.
 - 2.11.4. Distribution And Storage Policy.
 - 2.11.5. Importation Policy.
 - 2.11.6. Control Over Medicine Prices.
 - 2.11.7. Medical Control.
- 2.12. Recent Developments In The Pharmaceutical Sector.
 - 2.12.1. The Development In The Field Of Technology.
 - 2.12.2. The Development Of The Raw Materials Industry.
 - 2.12.3. The Development Of The Export Policy.
 - 2.12.4. The Development Of The Pharmaceutical Packaging Industry.
- 2.13. Summary Of part Two.

PART ONE.

THE GLOBAL PERSPECTIVES OF THE PHARMACEUTICAL MARKETING.

2.1. INTRODUCTION:

The preservation of health is certainly one of the most vital and ancient concerns of mankind. Yet, it is precisely in this area that some of the greatest inequalities among nations, as well as between demographic and socio-economic groups within nations, can be shown to exist. The global strategy for health to all countries first focused its attention on the issue of health as a fundamental right of mankind and laid the foundations for world-wide action in this field.

Although everyone, whether patient or pharmaceutical professional recognizes the contribution of the pharmaceuticals' industry to the health and welfare of the public, it is important to realize that all the development in the pharmaceutical field and the availability of pharmaceuticals to the general public have not merely occurred by chance. Although most of the praise is accorded to those in the pharmaceutical industry concerned with research and development (R&D), few appreciate the contribution made by the pharmaceutical marketing system in making these medicines available at the right time, at the right place, in the right quantity, at a reasonable price, and with the right information.

The pharmaceutical industry depends heavily on the role of the marketing. The nature of the product requires that companies interact with many heterogeneous publics, including educated professionals faced with important tasks. Unlike many other sectors of the world-wide economy, the pharmaceutical industry is not involved with producing and distributing items of convenience, ease or luxury. Medicines are used to cure and prevent disease,

alleviate suffering, and sometimes sustain life itself. Therefore, the business of pharmaceutical marketing is human health.

Ultimately, patient benefits from medicines accrue from proper diagnosis, prescribing, manufacture, distribution and consumption. Pharmaceutical marketing is therefore a highly personal form of business where accuracy in meeting a consumer's needs is of prime consideration.

2.2. STRUCTURE OF THE GLOBAL PHARMACEUTICAL INDUSTRY:

A look at the structure of the pharmaceutical industry reveals a high degree of concentration. Although, there are about 10,000 companies involved in pharmaceuticals around the world. Of these, the top 100 account for roughly 80 percent of total sales, according to the World Health Organization.

At the top of the pharmaceutical world, there are a group of 10 or so large companies with marketing and production operations in all the main countries and annual sales in the £3 billion range (before the mergers). These companies are often highly profitable, with net profits running at 45-50 per cent of sales (Financial times 1990). So far at least Japan is not a major world player in medicines. Although the country has some big medicine companies (the largest of which is Takeda), they operate mainly in Japan, which is the world's second largest pharmaceutical market after the US (see table 2.1).

The total Western European's expenditures on medicines expressed as a percentage of Gross Domestic Product (GDP) are shown in figure 2.1. Japan represents the highest country in expenditures with 1.4 per cent of GDP.

Table 2.1: The World's Ethical Pharmaceutical Companies Ranked

By Estimated 1988 Revenues (US \$ Million).

Rank 1987	Rank 1988	Company	Country of origin	Adjusted pharmaceutical revenue (US\$m)	Market Share (%)
1	1	Merck	US	4,983.7	3.6
4	2	Glaxo	UK	3,966.5	2.8
2	3	Ciba-Gelgy	Switz	3,294.8	2.4
3	4	Hoechst	W Germany	3,180.4	2.3
8	5	Takeda	Japan	2,714.0	1.9
6	6	Sandoz	Switz	2,674.9	1.9
7	7	Eli Lilly	US	2,608.0	1.9
5	8	Pfizer	US	2,539.7	1.8
13	9	Bayer	W Germany	2,526.6	1.8
10	10	Roche	Switz	2,397.4	1.7
12	10	J & Johnson	US	2,338.0	1.7
14	12	Squibb	US	2,173.0	1.6
11	13	American Home	US	2,168.0	1.6
16	14	Rhone-Poulenc	France	2,079.5	1.5
6	15	SmithKline	US	1,996.0	1.5
15	16	Upjohn	US	1,963.0	1.4
17	17	ICI	UK	1,936.1	1.4
18	18	Boehringer Ingelheim	W Germany	1,911.1	1.4
19	19	Bristol-Myers	US	1,808.8	1.3
20	20	Sankyo	Japan	1,779.2	1.3

Source: Barclays de Zoate Wedd (BZW) Research, (1990).

Figure 2.1: International Comparisons Of Expenditures On Medicines

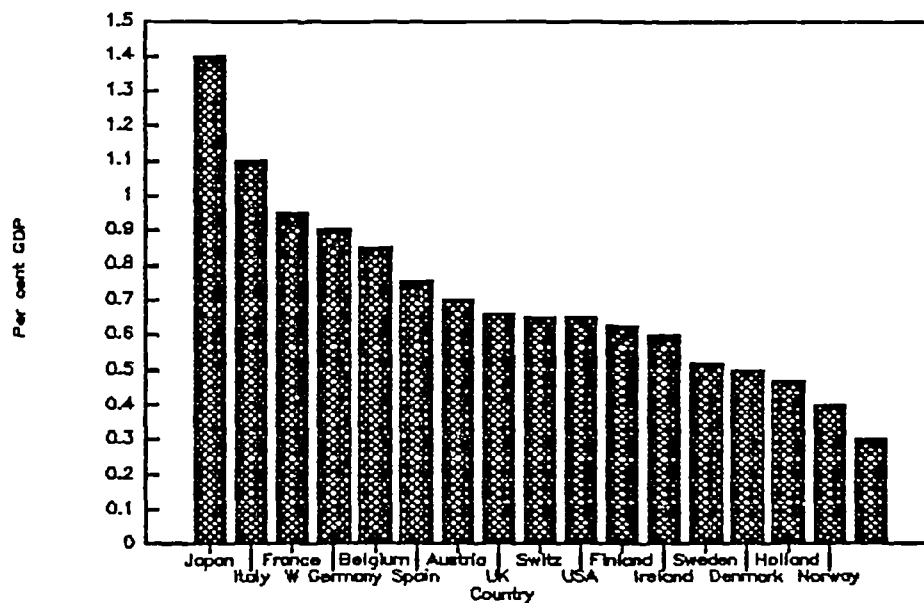

Source: Association of British Pharmaceutical Industry.

2.3. CHARACTERISTICS OF THE PHARMACEUTICAL MARKETING:

Slatter (1977) categorised pharmaceutical marketing into four classifications:

1. Prescription pharmaceutical market.
2. Over-The-Counter (OTC) market.
3. Animal health medicines market i.e. medicines designed for use in treating animals, and preventing diseases in animals.
4. Intermediate pharmaceutical market i.e. products such as bulk chemicals, capsules etc. are sold by one manufacturer to another at an intermediate stage in the pharmaceutical manufacturing process.

In this study, the discussion is confined to the first two categories, since the pharmaceutical companies in a broad sense around the world produce and market these two types. The prescription pharmaceutical market is concerned with medicines which are obtained by the consumer / patient only upon the doctor's authorization. The other type is the over-the-counter (OTC) medicines that may be purchased without a prescription.

There has been an expansion of the OTC pharmaceutical market in recent years, but the most fundamental business of pharmaceutical companies still remains the production and marketing of the prescription medicines (Chappell 1983).

2.3.1. THE PRESCRIPTION PHARMACEUTICAL MARKET:

Darvall (1980) emphasises that prescription medicines are complex chemical substances which, despite their undoubted benefits, are capable of causing severe and in some cases irreversible injuries, and the adverse effect can extend to an unborn child.

Slatter (1977) pointed out that the aggregate demand for prescription medicines at any time is primarily dependent on the standard of living and the incidence of disease. The key feature influencing the demand for any individual product is the extent to which the product gains doctors' acceptance. This will depend on a large number of factors including the medicine's therapeutic value (i.e. medicine quality) and sales promotion undertaken by the manufacturer to the doctor. Quite clearly, the marketing of prescription medicines is unique in that the manufacturer does not market his product to the ultimate consumer / patient, but instead to an intermediary (doctor). Although it is the patient who ultimately purchases and consumes a prescription medicine, it is the doctor who makes the decision as to which the patient is to have, how much he / she is to have, in what form he / she is to take it, and for how long. Chappell (1983) adds that in the prescription market the primary target is therefore the licensed prescribers rather than the consumers of the product. Another target of the marketing effort for prescription pharmaceuticals is the licensed pharmacists. This group having assumed more importance recently because of their increased role as decision maker with regard to the specific brand of medicine to be dispensed to the patient.

Because of the risk of injury to consumers if a medicine is unappropriately prescribed, it would be reasonable to suppose that advertisements would inform doctors of the possible side effects and adverse reactions associated with particular medicines. Stimson (1975) stressed that in many instances, prescription medicine advertisements do not provide adequate prescribing information, but

instead employ image appeals and extravagant and excessive claims in order to persuade a doctor to prescribe the advertised medicine.

2.3.2. OVER-THE-COUNTER (OTC) MARKET:

OTC medicines are bought and taken on the consumer's own initiative. The choice of medicine may be guided by some general knowledge but, more often, is inspired by advice given to potential consumers by publicity or, sometimes, by specific advice given by pharmacists, neighbours, relatives or friends. The nonprescription medicines (OTC) are lawfully sold without professional supervision on the basis of labelling that provides adequate direction for the proper use. In addition, the specific information on a medicine purchased without medical prescription, is usually in package inserts. The contents of such package inserts vary widely from medicine to medicine, from one producer to another and from one country to another (Peter 1981).

Self-medication (OTC) is most prevalent in the developed countries in which consumers have a wide range of information sources on nonprescription medicines and self-medication, such as advertising, product labelling, advice of health professionals including pharmacists, books and mass media. All these sources can play an important part in the education of consumers for the proper self-medication and self-care.

The World Health Organization (WHO) conducted an international study which confirmed the findings of numerous investigations and indicate that in the USA and UK, only quarter to one third of cases of illness or injury are seen by doctors (Kohn and White 1976). In general, the markets across the EC vary widely and are characterised by the growing movement from prescribed medicines to

OTC, especially the UK market which is the most advanced in its approach to self-medication. Herxheimer and Stimson (1981) found that for the UK pharmaceutical industry nonprescription medicines account for two-thirds of sales. In contrast, Southern European countries such as Italy and Spain have a small nonprescription market (Tacey 1990). Mercill (1983) adds that the nonprescription market in the US is considered the consumer's first line of defence in health care. Herxheimer and Stimson (1981) suggest several different reasons for the increase in the self-medication market. Firstly, when the illness experienced is not of the sort that is usually taken to the doctor. Secondly, when the doctor is not available because he / she is not easily accessible, or because of financial or other barriers to consultations. Thirdly, self-medication may be used as a stop-gap to relieve symptoms until medical advice can be sought. Fourthly, when illness is seen to be not of the sort that doctors can do much about. Fifthly, when "official" medicine has proved to be ineffective, people may resort to self-medication.

Because the OTC products differ substantially from the prescription medicines, Slatter (1977) determined three key factors that distinguish the OTC. First, no OTC product has patent protection. Second, all the leading OTC products are heavily promoted. The nature of the advertised products and the competition in the market require companies to use both "push through" and "pull through" marketing techniques. The former aims to sell products to the retailer or wholesaler and therefore include marketing variables such as incentive discounts. Whereas the latter is designed to create consumer demand. Third, OTC products are characterised by multi-channel distribution such as grocery stores,

department stores and discount stores. These have become increasingly important channels of distribution for OTC products in addition to the traditional pharmacy outlets.

Briefly, the issue of whether medicines should be treated as consumer products is, however, confused by the usual market division between OTC and prescription markets. Government regulations vary from country to country and particularly between developed and less developed countries. A medicine which may be only purchased on prescription in one country may often be obtained over-the-counter in a neighbouring country, and a single brand of medicine may be marked as a prescription medicine to doctors only in one country and as a consumer product (OTC) in other country. Obviously, this aspect of the market is related to the state of the economy.

2.4. IDENTIFICATION OF THE MARKET:

The pharmaceutical products' market is, in comparison with other consumer goods and services, characterised by some specific features. These concern the characteristics of the medical product as a good, as well as its supply and demand. The medical product as a good is marked by its fundamental hazardousness. Medicines aid and cure, they must, however, at the same time be regarded as "life hazards" (Harts 1989).

The supply side of the market which is represented by the manufacturer, is highly professionalised, well organized, and scientifically sophisticated. The demand side of the market is divided into three parts: the patient as the consumer of medical product, the doctor as the distributor and the government as the provider.

Because of the almost limitless possibilities in identifying the various pharmaceutical markets, it is perhaps best for us to limit our discussion to the consumer (patient) and the prescriber (doctor), since the pharmaceutical market is unique in the importance of the influence of nonpurchaser (doctor) on the purchasing habits of the ultimate consumer. The different patterns of relationships involved in pharmaceutical marketing also are described below.

2.4.1. THE PATIENT / CONSUMER:

Despite the importance of the doctor as a director in the choice of prescription medication, consumer choice still demands thorough consideration (Smith 1983a), since consumers make the final decision to use or not use a medicine. He / she is the one who may personally suffer the adverse effects or adverse interactions of medicines and as well as symptomatic or therapeutic benefit.

According to Peter (1981) consumers should be entitled to the fullest possible information on medicines which they are using on their own initiative or because they have been advised to do so by medical personnel. However, no other information in pharmaceutical marketing, unfortunately, is as difficult as that for consumers, mainly because they vary in their literacy, their general education and their medical knowledge.

Although the patient is clearly important in the medicine market either prescription or OTC, pharmaceutical companies tend to see the market they operate in as one which the choice of the individual plays a minor role. They often publicly portray such a view, pulling the onus of decision making on the medical services.

The European Community (EC) listed six aspects of the marketing environment for medicines which tend to distance the individual consumer (patient) from the medicine supplier (manufacturer). That list, presented by Tucker (1984), is as follows:

- 1) Demand on the health service originated only partly from the patient, because the medicine industry comes from many sources such as national public health institutions rather than from individuals.
- 2) Normally the patient cannot himself / herself decide on the type of treatment. The fact that the patient has made a decision to visit his / her doctor with the expectation in most cases that he / she will be prescribed a medicine.
- 3) The consumer cannot always decide when the demand for treatment should end. Here it is important to distinguish clearly between courses of treatments. The patient undergoing a course of treatment for an infection is too often likely to stop taking the tablets at the first sign of relief of symptoms. Whereas the patient on a course of pain-killers, is more likely to continue to demand further prescription renewals.
- 4) The patient can rarely evaluate the quality of services offered. While this issue is acceptable in general terms, it is in many cases irrelevant as far as the demand for medicine is concerned. The point obviously ignores the fact that so many patients become psychologically reliant on their regular medicines.
- 5) The patient is not interested in cost and prices, because he / she does not have to pay directly, although the disinterest in cost and prices on the individual in the EC cannot be applied universally. In the USA and other developed countries the interest in prices is far higher.

6) Purchasing power should not play a role in the field of care. However, whereas this can be applied as a real aspect of medical treatment in most EC countries, it is merely an ideal which is rarely attained if the broader view is taken.

2.4.2. THE DOCTOR AS DISTRIBUTOR:

The doctor is a distributor in pharmaceutical marketing, since the use of ethical pharmaceuticals is generally dependent on the prescribing doctor.

Although, there is an argument that the patient does behave as a direct consumer of prescription medicines as well as OTC. There is still another argument based on the view that the prescribing doctor acts as the consumer in making his / her individual choice of how many medicines, what types of medicines and which brands of medicines to prescribe. Gagnon (1983) explains some interacting variables that influence a doctor's ultimate selection of a medicine such as the clinical and behavioural characteristics of the patient, the patient's needs and expectation regarding treatment in the use of medication, and the organizational constraints placed upon the doctors.

A literature review of doctors' prescribing behaviour was published by Hemminki (1975) who reported four factors which influence the doctor in prescribing:

- 1) Education appears to influence the quality of prescribing positively.
- 2) The contribution of advertising to prescribing is debatable in that a positive attitude towards advertising can be expected to influence prescribing.

3) The control and regulatory measures may have positive effects on prescribing.

4) Patient and society demands on doctors for medicines may be exaggerated in the case of ethical medicines.

The need of the medical profession for medicine information has been discussed by Peter (1981). No doctor should ever prescribe or administer a medicine on which he / she is not thoroughly informed. The doctors' minimum information should comprise knowledge of the following:

1) The pharmacological effect and, if relevant the mechanisms of action of the medicine.

2) The usefulness of the medicine against the condition to be treated or the symptom to be eliminated.

3) The established merit of medicines as compared to that of other medicines used for the same purpose and that of other therapeutic procedures.

4) Possible dangers of the medicine under particular physiological conditions.

5) Adverse effects on organ systems.

Furthermore, the doctors must be informed on:

6) The range of useful and tolerated doses of his / her patient, the usual dosing interval, the average duration of treatment.

7) The symptoms of poisoning by overdoses and the treatment of such poisoning.

Gardner and Watson (1970) explained some reasons which may lead to doctors being inadequately informed:

1) Adverse effects of a medicine or adverse interactions with other medicine given to a patient may have been observed previously.

This danger exists, of course, to a particularly large extent with new medicines.

- 2) Information on detrimental effects or interactions or the absence of a therapeutic benefit of a medicine may be available in principle but may not have been published.
- 3) Positive or negative information on medicines may be available and even have been published in some journals, without reaching a prescribers's attention.
- 4) Prescribing doctors when supplied with adequate information on merits and demerits of medicines may be either unwilling to, or incapable of, acting according to the information given to them.

Whatever one argues about the general merits of pushing more power either to the patient or to the doctor, people are not qualified to decide on medicines without the involvement of a doctor.

2.4.3. PATTERNS OF RELATIONSHIPS IN THE PHARMACEUTICAL MARKETING:

Some literature suggests that, the only thing which creates a good relationship between patient and doctor is the prescription and the patients are described as prescription-oriented, as many doctors believe. However, an empirical study by Wartman et al (1981) found that the patient-doctor relationship may have a more important role in producing a satisfied patient than the previously thought. The findings show that when prescriptions are given, the patient-doctor relationship, as reported by the patient is less satisfying. Conversely, the relationship is more satisfying when prescriptions tend not to be given. The findings also suggest that a patient with anxiety may have a different set of expectations of the visit than less anxious patients. Wartman et al go further and

state that the doctor who gives verbal attention to the patient's problem by taking time to understand and answer questions, give explanations and show a friendly interest in the patient has a satisfying effect, and may have a psychologically therapeutic effect on the patient.

Doctors also have a relationship with the pharmaceutical industry (manufacturer) which as explained by Pike (1990), is a complex relationship, since research on a new medicine is carried out by the industry and relies on the medical profession to evaluate its products in patients. Such a relationship is required to be close in order to improve the treatment of patients and for the development and assessment of new medicines.

Medawar (1984) explains the relationship among the medical profession, the medicine producers and government as typically close and exclusive. But such a relationship is very delicate because:

- 1) The producers depends on favourable treatment from government, and the doctors' approval of their products.
- 2) Doctors depend on the producers for new medicines and for information about how to use them. Doctors depend on government, if not as an employer, then as a major influence on their terms and conditions of work.
- 3) Government depends on the other two for support for its health policies.

Finally, Marsh (1990) emphasises the importance of a good relationship between government and pharmaceutical companies. Medicines companies spend a lot of time and trouble trying to get on good terms with governments because on the one hand, health agencies are the target purchasers of medicines and have a big part

in selling price. On the other hand, the medicine products are subject to government regulations to ensure they work safely (see section 2.6).

2.5. THE GLOBAL STRATEGIES OF PHARMACEUTICAL MARKETING:

Marketing strategies can be defined as "a set of principles that adjust the company's marketing mix to react to the environment changes over time" (Slatter 1977).

The significant issue in pharmaceutical marketing in many developing and developed countries is whether medicines should be sold by brand names or generic names. The recognition of both is therefore worth mentioning in this context before discussing the different marketing practices.

Schneller (1970) and Fern (1983) distinguish between the brand and generic names. The brand names are owned by a company and used to identify and differentiate the product from competitors. They can be justified because their use reflects the doctor's confidence in a certain product produced by a particular manufacturer. Although the finite definition of "generic" means a class of substances having the same biologic properties, "generic" has customarily been used a synonym for established or nonproprietary names. The generic names are used because scientific nomenclature is unwieldy. Scientific names are meaningless to those who do not have expertise in a specific field. Generally, the pharmaceutical marketing of generics could increase the availability of, and decrease the prices of, medicines in the future.

The differentiation between the brand and generic names along with the two medicine categories (i.e. prescription, OTC medicines)

play an important role in guiding the marketing strategies world-wide.

2.5.1. ADVERTISING AND PROMOTION:

Advertising and promotion in the pharmaceutical market have two major functions. One is to make known the company's products directly to the consumers and persuade them to buy the products (in the case of OTC). The other is to inform the doctors about new medicines and developments in therapeutics as well as reminding the doctors of the established medicines (in the case of prescription).

The purpose of advertising of prescription pharmaceuticals is no different from that of advertising any other products. However, the major differences lie in the restrictions placed upon the prescription medicines (i.e., ethical) by the availability of suitable advertising media and government regulation.

The advertising strategy is controlled by law in most countries to the extent that it is illegal to advertise prescription medicines to the general public through the mass media. Such advertising is limited to publications aimed at the medical profession. This restriction is not contested by the industry for two important reasons (Tucker 1984). First, doctors are the "customers" for prescription medicines. Second, even the most aggressive marketers of medicines would think twice about advertising prescription medicines direct to the public.

The advertising of OTC medicines is aimed mainly at the general public. Such advertising supports self-medication by informing consumers about the nature and benefit of nonprescription medicines and making marked products, their ingredients, and their indication for use highly recognizable. Advertising of

nonprescription medicines helps consumers to decide which medicine will alleviate their particular symptom (Mercill 1983). Mercill further emphasises that such a task is accomplished by: 1) making consumers aware of their health and the symptoms of minor illnesses that might affect them; 2) helping identify some causes of those illnesses; and 3) helping consumers to decide whether or not to utilize a nonprescription medicine and seek professional care.

The promotion of pharmaceuticals in most countries follows the same pattern, that is, prescription medicines are promoted to the health-care professionals only and nonprescription medicines to the general public. The promotional mix consists of personal selling, journal advertising, direct mail and samples. Pradhan (1983) shows the differences in promotional efforts in some countries. In the US, efforts are directed towards doctors, pharmacists working in hospitals and the retail stores. In Japan, almost every major pharmaceutical manufacturer publishes a magazine or external house organ containing articles on a wide variety of technical subjects, as well as advertisements for company products. While OTC medicines are promoted to the general public through regular media.

In consonance with the above promotional methods, other promotional strategies by a number of manufacturers are aimed at retaining the product loyalty of generic medicines by adopting visual differentiation in their packaging to distinguish their products from other generics. These changes according to Quraeshi et al (1983) are of three basic types: 1) making the company name more prominent on the package; 2) emphasizing, through the use of colours or bold print, certain parts of generic name; and 3) using symbols or other graphic illustrations to differentiate the product from other generic equivalents.

The market behaviour in the US ethical pharmaceutical industry shows broad similarities with that of UK (Slatter 1977). In both countries a few products and a few companies have important positions in each therapeutic class, and the overall success of individual companies depends on having a few important products. In both countries high promotional expenditure is a prerequisite to obtaining a high market share in the initial years after product entry. The British-based medicine companies spend some £200 million per annum on promoting their products to British doctors (Hancher 1987). Brand differentiation, always a crucial aspect of pharmaceutical marketing, is increasingly vital as fewer genuinely new products are being brought onto the market.

In general, the high promotion of advertising and promotion spending on pharmaceuticals is probably related to some of the reasons outlined below:

- 1) The unique market mechanism for prescription medicines. The patient does not exercise consumer choice, and in many countries pays little or nothing for the prescribed medicine; the doctor selects the medicine and the brand but does not pay for it; while the health care authorities have to pay but cannot select medicines for which they pay. Therefore, there is no direct pressure on the effective decision maker.
- 2) The sharp distinction between products marked under generic names and those sold under brand names makes the bulk of advertising and promotion different. The patent protection for the branded-medicine helps to advertise and promote a product and secure it for a long periods even after protection has expired.

3) The marketing practice of pharmaceuticals involves certainly an amount of risk which does not exist in other consumer products' markets. Therefore, most people generally assume that only the doctor, rather than the consumer himself, has the expertise to make judgments over the choice of medication for a specific condition.

2.5.2. THE CHANNEL OF DISTRIBUTION:

An efficient distribution system is required to ensure that medicines are promptly and easily available to those who need them. Any breakdown in the distribution system will interfere with the delivery of health care.

The organization of a pharmaceutical supply either in developing or developed countries satisfying the needs of all segments of the population is by no means an easy task. Each organization must decide how it will operate within the supply system. For the manufacturer of the prescription medicines, Smith (1983a) stresses that the US law requires that at least one intermediary stands between the manufacturer and the consumer (i.e. the doctor). It is illegal for the manufacturer to sell medicines directly to the patients.

The medicine wholesaler acts as the middleman in the distribution of medicines and represents the main channels of distribution in most countries (Lidstone and Collier 1987). For example, in the UK most manufacturers rely on pharmaceutical wholesalers to distribute the bulk of their sales. This is in sharp contrast to the situation in the US, where the selection of the right distribution channel has a major impact on marketing effectiveness (Slatter 1977). Nevertheless, the wholesalers are of

central importance in the chain of medicine distribution for almost all pharmaceutical companies world-wide.

At the retail level, the most important class in the medicine field is the one known to the public as the pharmacy or drugstore for the sale of prescription and patent medicines. Pradhan (1983) explains that the role of the retailer as a part of the distribution chain differs from one country to another. In France and Switzerland, medicines are distributed through pharmacies and hospitals. Pharmacists must have a licence to work in pharmacies. In Japan, medicine products are distributed through retail pharmacies, hospitals and clinics, with some OTC products marketed through supermarket and door-to-door salesmen. Medicine manufacturers distribute these products to such outlets by using direct or indirect methods, since the pharmaceutical industry uses wholesalers as exclusive outlets.

In brief, the choice of the distribution system is a matter of government policy, but whatever that system, it should be efficient so that medicines are available wherever they are needed. The organization of the distribution system should include storage facilities, proper inventory control and good transport facilities and maintenance services.

2.5.3. PRICING:

Pricing is a most important and controversial issue in the world-wide pharmaceutical market. The unique characteristics of the pharmaceutical industry give rise to misunderstandings, contradictions and conflicts in this area. The unique features are, first, the huge amount spent on research and development (R&D) in order to develop new products to alleviate pain and prevent, cure

or treat disease. Second, the industry has to depend on patent protection to safeguard its "invention" for certain periods of time. Another unique characteristic in the pharmaceutical market as mentioned earlier is that the consumer / patient seldom exercises any choice in product selection. A doctor acts as purchasing agent for the patient, and it is he or she who selects the most effective medicine for a particular course of treatment. (For OTC medicines, the patient selects the product, but only after consultation with members of the health profession). As a general rule, then, the patient acquires medicines either without any charge or with some minimal payment in some countries e.g. UK.

In spite of the unique characteristics of the pharmaceutical market, market forces play some role in determining the price of medical products Pradhan (1983):

- 1) The demand of medicines depends on the incidence of disease or a need to prevent certain types of illness.
- 2) The effective use of medicines, to some extent, reduces the incidence of disease which in turn reduces potential demand for these types of medicines.
- 3) The degree of innovation which the medicine embodies over existing products along with the degree of medicine substitution.

General speaking, the prices of the global pharmaceuticals differ from one country to another. The comparisons are extremely difficult because the range of preparations on sale in different countries varies considerably. Each country has its own system of taxes, import duty and other imposed control (see section 2.6). In addition, currency fluctuations considerably influence individual

national prices and the value of money differs from country to country (Chew 1985).

2.5.4. PATTERNS OF COMPETITION:

Competition is dynamic and one must therefore expect the observed patterns and relationships to change overtime.

Since competitive forces in the market place are a function of both a company's action and the activities of outside forces, a company can influence its competitive position by utilizing either or both internal strategies (e.g., pricing, advertising and promotion, physical differentiation) and external strategies which are concerned with restructuring the external environment in such a way that company can achieve its competitive objectives (James 1979).

Mercill (1983) emphasises that there is much evidence to show that the global pharmaceutical market is, in fact, highly competitive. Many products are close substitutes for one another, often containing identical or similar formulae. Medicines are rejected when substantial numbers of consumers discover their adverse qualities and characteristics and demonstrate dissatisfaction by turning to competing products.

Due to the many companies in competition within the pharmaceutical industry and the lack of overall dominance by any single one, this would be suggestive of intense price competition and fluctuating price at the manufacturer level. However, Slatter (1977) argues that in the British market, price competition takes places at the wholesale and retail level. Further, price competition is also found in the hospital market, where bulk buying of certain generic medicines on a competitive bidding basis assures

price competition. But most pharmaceutical manufacturers do not engage in price competition because of the nature of the product and the nature of the marketing process (i.e., the process by which neither the prescriber nor the consumer pays for the product). In addition, Pradhan (1983) reports that price competition in Australia is observed in the pharmaceutical industry particularly when such sales are by tenders or bids.

In contrast, the US pharmaceutical manufacturers are relatively free of price control and this has an impact on pricing strategies and on competition and sales. Cocks (1983) shows therefore a much greater price flexibility and thus price competition in the US pharmaceutical industry is greater than has generally been assumed. Competition in prices within several sets of competing medicines has produced a downward trend in prices in relation to the prices of other consumer products.

Advertising also makes the consumer / patient aware of the existence and attributes of more brands, and it is essential to sellers of new brands to promote competition. Therefore, medicine promotion is another issue that should be addressed in the context of competition. Telser et al (1975) stated that promotion is designed to inform doctors and persuade them to choose a particular product among products that are roughly equivalent in the therapeutic sense. They added that medicine promotion has been expanding recently which may induce price competition in the medicine market.

Finally, product competition is a prevailing strategy of a large pharmaceutical companies. Through R&D efforts, companies have been able to produce a continuous stream of new products thereby engaging in innovatory competition. A product is considered "new"

when a new medicine is launched on the market by the manufacturer under a brand name. New medicines are highly important for the prescriber and the competitive position of the manufacturer.

2.6. THE INTERNATIONAL GOVERNMENTS' REGULATIONS FOR THE MARKETING OF PHARMACEUTICALS:

The international governments' regulations play a significant role in guiding and monitoring the marketing practices in the field of pharmaceuticals.

2.6.1. MEDICINES' SAFETY:

Medicine safety is an issue of considerable public interest, for obvious reasons. The level of safety can only to a limited extent be raised by means of legal regulation. It depends mainly on the interpretation of the safety standards, doctors's behaviour and attitudes concerning health policy, cultural and medical traditions and the internal and external structures governing administrative behaviour. Therefore, in this section and the following one, we examine the ways in which governments' decisions impinge on the freedom of pharmaceutical companies in selling products. Our attention is on the interventions in medicine-selling brought about by individual governments with particular reference to the interventions such as they are, in developed countries.

In the US, the Food And Drug Administration (FDA) embarked on a major program to ensure the safety, effectiveness, and adequate packaging and labelling for all nonprescription medicines (OTC). The tamper-resistant packaging was brought in to assure safety. In the US in 1983 approximately 10 to 30 per cent of OTC products were estimated to be packaged in tamper-resistant packaging (Pradhan

1983). A label serves as a source of information about the medicine product. OTC medicine products must bear a label giving complete dose, and other necessary information. The label for these products should be so clear that any person can read and follow the instructions. According to the United States Federal Regulation, a label should include seven points: 1) the name of the product; 2) the name and address of the manufacturer or distributor; 3) the net content of the package; 4) active ingredients and the quality of certain ingredients; 5) the name of any habit-forming medicine contained in it; 6) caution and warning needed for the protection of the user; and 7) adequate direction for safe and effective use.

Darvall (1980) explains that the American and Canadian controls over the prescription medicines are subject to the provisions of (FDA). A new medicine may not be commercially marketed in the US or in Canada unless it has been approved as safe and effective by the FDA. The FDA refuses marketing approval for any medicine not proven safe and effective for use under the conditions prescribed recommended or suggested on its labelling. Generally speaking, if the benefit associated with the use of a particular medicine outweighs possible risk of injury or death, a medicine will receive marketing approval. Braithwaite (1983) concludes that the control of the American and Canadian governments over prescriptive medicines has been viewed as the most stringent in the western world. Given that context one would assume that the probability of potentially harmful medicines reaching a patient would be extremely low.

Harts (1989) states that the laws governing medical products in the EC Member States acknowledge substantive legal protection in the form of safety standards for the prescription medicines. That

law indicates the right of the consumer / patient to information about hazardous medical products.

In Australia, because the majority of medicines available on the Australian market are imported, they fall within the Commonwealth's customs power. The customs regulations prohibit the importation of any therapeutic substances into Australia unless the importer is licensed or permission has been obtained from the Director-General of Health.

The World Health Assembly (WHA) was set up to consider the development of a code of marketing practices with special emphasis on the essential pharmaceutical products for developing countries (Schoepe and Molinda 1984). The purpose of the code for pharmaceutical marketing which is still not in force in 1990 would be the establishment of a standard of pharmaceutical marketing practices to promote medicine quality, especially the quality of medicines needed by developing countries. The code would apply to the marketing of all medicine products and the availability of information concerning the use of these products. Code provisions would probably restrict the advertising and promotion of medicine products, establish quality standards that the products must meet, and control packaging and labelling so that all products' ingredients appear on labels.

2.6.2. MEDICINES' ADVERTISING, PROMOTION, PRICING AND

DISTRIBUTION:

The issue of medicine abuse and advertising of nonprescription medicines has been studied by the US Federal Trade Commission, the government agency having jurisdiction over consumer advertising (Mercill 1983). Leffler (1981) stresses that intensive advertising

of medicines results in excessive use of high-priced, heavily promoted brand name products even though equivalent low priced products are available. Those viewing pharmaceutical advertising with disfavour insist that these ads are frequently uninformative and seem simply to harp on the product's name in order to persuade doctors to select that product out of habit rather than by evaluative choice. For OTC products in Japan, regulations take care of that market, check on advertising claims and truthfulness. Doctors and other health-professional organization scrutinize the quality and quantity of advertising material and detailing used by the pharmaceutical companies (Pradhan 1983).

In many pharmaceutical markets, Pradhan (1983) emphasises that pricing is no longer an area of marketing freedom. The government agencies directly intervene in pricing in order to support local manufacturers, control inflation, reduce balance of payments deficits or improve the balance of payments position, maintain price levels at the desired level, and not subsidize export market prices. The governments have various means of achieving these goals. Some impose direct price control, some have voluntary price guide-lines, while some restrict the prices of active ingredients or components of products. Pradhan adds that Germany and the US have the least formal direct price control. Tucker (1984) concludes that in countries which have a fairly strong domestic industry in medicines, the government regulations find it far easier to control medicine prices than in countries which are more heavily dependent on imports.

Finally Tucker (1984) mentions the control over distribution as a goal among those related directly to health considerations. The regulations involved in attaining this goal are related to safety

and efficient supply, with the aim being that access to dangerous medicines is restricted to licensed medicine outlets, of which there should be a sufficient number to serve the population.

2.6.3. POST-MARKETING SURVEILLANCE:

It is well known that the medicines which are available are not always used in the correct way. Therefore, while it is important to provide prescribers with continuing information on medicines efficacy and safety, it is also necessary to assess the effects of giving them such information.

Many government officials have considered the need for a better monitoring system which they felt would be an asset to the public as well as to the pharmaceutical industry. This system is popularly known as Post-Marketing Surveillance (PMS). PMS is defined by Strom and Melmon (1979) as "a process that systematically and comprehensively monitors the patterns of use and benefits of prescription medicines as they are applied in medical practices". In other words, it is the task of PMS to supervise medical products already on the market (Hart 1989). A new system was developed by the US Joint Commission On Prescription Drug Use in conjunction with the Health Protection Branch of Canada. The commission also recommended that a permanent "Centre For Drug Surveillance" be established to speed up cooperation among existing PMS programs and to develop new methods for carrying out PMS (Hanson 1979).

A rationale for PMS is argued on the grounds that consumers do not select the product but rather follow the advice of their doctors. Also, consumers do not receive nor can they comprehend information on medicines, thereby creating a classic case of

externally forced choice. The voluntary reporting system is explained by Strom and Melmon (1979) as one of the most important techniques of PMS which is organized to collect, amplify and distribute the information available from the collective experiences of both doctors and patients. This technique has advantages, some of them are: 1) it automatically assesses every new medicine as it enters the market; 2) it is relatively inexpensive to maintain; and 3) it cuts down on the amount of time a doctor has to wait in order to receive feedback on a certain medicine. However, the technique has some disadvantages such as the difficulty for a patient to determine the role of utilization of the medicine.

The subject of government regulation is not foreign to the pharmaceutical industry. Therefore, it is not surprising that a proposed PMS system faced strong reaction from many pharmaceutical executives. Tucker (1984) demonstrates that the pharmaceutical industry fears that governments might act unilaterally to legislate their desired PMS, thereby clashing with the industry's own medicine surveillance program, free from government interference.

Whatever the different views of the governments and the reactions of pharmaceutical industries of PMS, Hart (1989) concludes that at any rate, the effectiveness and workability of PMS of medical products is extremely important because it alone can guarantee a high level of safety.

2.7. THE WORLD-WIDE HEALTH CARE:

The increasing availability of health-care to a large section of the world's population, particularly in the industrialized nations, has greatly affected the demand for medicines.

2.7.1. THE CONSUMPTION OF MEDICINES:

Many health-care systems around the world have introduced measures to reduce overprescribing by the doctor and overconsumption by the patient.

The overconsumption and wastage of medicines is rapidly becoming a major issue in most countries, and there is strong evidence that most governments of industrialized nations will develop sophisticated data banks and undertake detailed prescription analysis to control both prescribing and consumption. Slatter (1977) demonstrated that the overconsumption of antibiotics is a major problem in many countries particularly so in the UK where antibiotics account for 14 per cent of ethical pharmaceutical sales compared to only about 8 per cent in other countries in western Europe. Medavar (1984) emphasises that one of the greatest medicine-related world health problems is overconsumption, despite the underconsumption in some countries. However, the WHO has yet to emphasise the essential medicine policies which are fundamental to the control of both under and over consumption of medicines. There is a universal acceptance of the principle that essential medicines should be available for use whenever needed.

Generally speaking, the consumption of medicines varies from one country to another, James (1983) introduces two conditions which lead to different demand levels of medicines. One is the climatic conditions, e.g., whether medicines are seasonal. Another

is the quality and quantity of medicines available in different countries, this influences also consumption patterns. Tucker (1984) adds another condition, that is the economic state of a country affects the rate of medicine consumption. In developed countries medicine consumption is clearly related to per capita income, thus medicines are one of the consumer products for which the demand is tied in with standard of living.

Although medicine consumption has increased faster in the poor countries, it has nevertheless continued to rise in the developed countries, despite the virtual eradication of many diseases and the general improvement in health standards which has prevented most people in developed countries from contracting these diseases. In terms of overall consumption, medicine consumption is concentrated with 25 per cent of the world's population living in the developed countries responsible for about three-quarters of medicine purchases.

2.8. SUMMARY OF PART ONE:

This part was mainly devoted to the different issues of world-wide pharmaceutical marketing. We presented a short review of the structure of the global pharmaceutical industry followed by the characteristics of global pharmaceutical marketing which is categorised into the prescription pharmaceutical market and the over-the-counter market.

This part also presented the identification of the market of pharmaceuticals which consists of consumer / patient and the doctor. Different arguments are introduced to show the merits of pushing more power either to the patient or the doctor in that market.

The next section focused on several aspects of the marketing strategies (i.e., advertising and promotion, distribution, pricing, patterns of consumption). A review of governments' regulations over pharmaceutical marketing world-wide was presented in terms of guidelines and monitoring systems covering various marketing practices. Post-Marketing Surveillance was introduced to supervise medicines already in the market.

This part was concluded by a brief presentation of world-wide health-care through the patterns of consumption of medicines.

PART TWO.

THE EGYPTIAN PHARMACEUTICAL PRODUCTS' MARKET.

2.9. THE PHARMACEUTICAL INDUSTRY IN EGYPT:

Medicine has been given deep consideration as it is a sensitive product evidently related to human life , in addition to its importance in terms of technological and economic dimensions. Most societies are handicapped in their attempts to define whether medicine is a product or a service - is it available for purchase only by consumers who are able to do so or is it considered as a basic human right and should be available when the need arises.

The pharmaceutical industry in Egypt has made good progress, so that it is now able to cover about 80 per cent of the consumption by local production. The United Nations recorded such success and therefore, selected the pharmaceutical industry in Egypt as a good example to all the industries in the developing countries.

Generally, the medical industry is one of the most important industries in the world. It depends primarily on continuous scientific research and development in order to attain better treatment for human relief.

Briefly, the medical industry has several characteristics. First, the importance of medicine as a product related to consumer health. Second, the great variety of the combinations of raw material in each finished medicine. Third, the high accuracy required to get the right medical formulation. Fourth, the number of different industrial operations each pharmaceutical product needs.

2.10. AN OVERVIEW OF THE HISTORICAL DEVELOPMENT OF THE

PHARMACEUTICAL SECTOR IN EGYPT:

A series of changes and developments have been taking place in the pharmaceutical sector since 1939.

The pharmaceutical industry exerts a profound influence over the effectiveness of policies to protect people's health. Thus it may be useful to consider the four phases which the medicine sector has gone through.

2.10.1. THE FIRST PHASE (1939 - 1961):

The first attempts to establish a modern pharmaceutical industry were pioneered in 1939 when the bank of Egypt established a small pharmaceutical company (Misr Company). Another two small companies were formed (Memphis in 1940 and CID in 1947). Moreover, there were sixteen other small companies owned by individuals as well as twenty two small laboratories producing some simple pharmaceutical products.

Before 1952, the local medicine industry was five million L.E that covered about 10% of the medical needs at that period. Then the medicine industry at that time achieved two important goals, acquiring good experience on one hand, and establishing a degree of confidence among consumers and medical personnel on the other hand. The first revolutionary action was the establishment of the Service and Production Committee in 1953. In that committee it was found that the medicine problem was related to economic and industrial problems as well as the social and health problems in Egypt. The production committee was concerned with the medical industry, while the service committee was concerned with health services. In 1955 both committees were concerned with medicine

problems and an associate committee was established to study those problems and to suggest possible ways of coordinating activities between the industry and other services.

In 1956, the Development Committee Of The Medicine Industry was established according to Decision Number 5. That act was followed up by the establishment of a Superior Industry Of Medicine and the decision to develop an exhaustive medicine policy with regard to the economic and health plan. In July 1960, the Republic Decision Number 212 restricted the import of medicine by the Egyptian Trade And Distribution Organisation For Pharmaceuticals. The major role of that organisation was the distribution of local and imported medicine.

In 1961, the government achieved full control over 90% of national production through mandatory state capital sharing in sizable companies. That step implemented a reduction of all the difficulties of finance and credit as well as operational and structure constraints. In a short period, the success was remarkable.

2.10.2. THE SECOND PHASE (1962 - 1975):

The substantial growth of the Egyptian medical industry started at the beginning of 1962, by the nationalisation of the medicine industry. That was implemented through the establishment of the Egyptian General Organisation For Pharmaceutical Chemicals And Appliances (GOPCA) with full authority over planning, production, importation and distribution under policy guidance of Ministry Of Health. Similar action was taken in all the other industrial and bulk trade sectors. The financial institutions were nationalised as well. The Egyptian pharmaceutical industry

successfully implemented the Republic Decision Number 216 in the period from 1962 to 1975. That decision had been complemented by the establishment of several pharmaceutical companies (El Kahira, El Arabia, Alexandria, El Nile) in 1962 and El Nasr in 1963. Moreover, two trading companies had been established, El Gomhoria for the importation and distribution of medical appliances in 1962, and El Masryia for the importation and distribution of medicines. The Medical Packaging Company was set up in 1965. Added to these, another three Egyptian / foreign companies (i.e, joint- ventures) had been set up in the medicine market (Phizer Egypt and Hoechst Orient in 1962 and Swisspharma in 1965).

Finally in that stage, a centre for medical control and research had been established in 1964 and staffed by experts in the area of research and development (R&D). With accurate planning and clear objectives therefore, the medical sector achieved good progress during that period. The production covered about 72% of the market needs while in 1950's it covered only 10%.

2.10.3. THE THIRD PHASE (1976 - 1982):

Because of the political / economic shift namely the open door policy, a new turn in medicine policy took place during that time. GOPCA was cancelled in order to give local manufacturers, brokers, and private and public importers some self reliance, self liberation as well as to allow for rationalised competition among the companies and to face the difficulties created by the circumstances of the open market economy. In order to face the open door policy, a Superior Committee of the medical sector had been established in which the open importation policy was considered as a part of national production. However, the local market was

greatly shaken by the open door policy, probably that problem along with others, were in a sense a natural consequence that forced the health authority to establish the Ministariate Committee For the Pharmaceutical Sector helped by the technical secretariat to supervise private sector importers. Later on, the American company (Squibb Egypt) was established in 1979 according to law 43 of 1974. In the beginning of 1980, the pharmaceutical public sector shared other Arabic countries' financial, managerial and technological experiences by the construction of ACDIMA companies (Egyptian, Arabic investment). The principal goals of ACDIMA groups are:

- 1) To complete the market needs of products that are not covered completely by the local production of the public sector.
- 2) To produce new products that can replace the imported ones.
- 3) To increase availability of raw materials in order to overcome the problem of hard currency.
- 4) To apply new technology in the pharmaceutical industry and research by making licence agreements with some international pharmaceutical companies for the acquisition of technology and know-how.

In reality ACDIMA contributed heavily to the expansion of the medicine sector in Egypt. It has three different groups of companies. First, two companies for medicine production (Egyptian International Pharmaceutical Industries Co. EIPCO, and Upper Egypt Pharmaceutical Industries Co. UEPICO). Second, two companies for medical packaging production (Arab Medical Co. FLEXIPACK and Arab Pharmaceutical Glass Co. APGCO). Third, three companies for raw materials' production (Arab Medical Plant Co. MIPACO, Arab Medical

Gelatine production Co. ARABCAPS and Arab Medical Raw Material Co. ACOPHARMA).

Finally, the investment policy encouraged some experts and consultants in the field of medicine products to construct other companies such as:

- 1) Islamic Medical Industry Co. PHARCO (Egyptian / Italian investment).
- 2) Advanced Biochemical Industries Co. ABI (Private Egyptian investment).

2.10.4. THE FOURTH PHASE (1983-):

The political targets of social justice for the administration of safe and effective medicines and reasonable prices required a major reorganisation of GOPCA and the establishment of Drug Organisation For Chemical And Medical Appliance (DOCHA) which is responsible for strategic planning, monitoring and evaluation of most activities of the medicine sector. DOCHA owns eleven pharmaceutical companies for production, trading and distribution of medicines and medical appliances, while the others as we can see in figure (2.2) are completely economically independent but under the supervision of the DOCHA board. The main function of DOCHA is to act as the main authority on various national pharmaceutical companies either public, joint-venture, or public or private investment companies, to attain the coordination objective of the health planning and policies of the country. The major objectives of DOCHA are:

- 1) To set up the necessary legal framework and administrative machinery as an attempt to evaluate and standardise all activities of public sector companies, aiming at quick self

sufficiency in the output of medicine with a view to reducing the quantity of imports and providing a leadership role to the public sector.

- 2) To prepare a list of essential medicines under their generic names and provide administrative and legislative support for ensuring their quality and availability, which are of relevance to the needs of the majority of population.
- 3) To develop an effective pre-marketing and post-marketing surveillance monitoring system.
- 4) To prepare price lists for medicines launched and registered in the Egyptian market.

Figure 2.2: DOCMA Organisational Structure

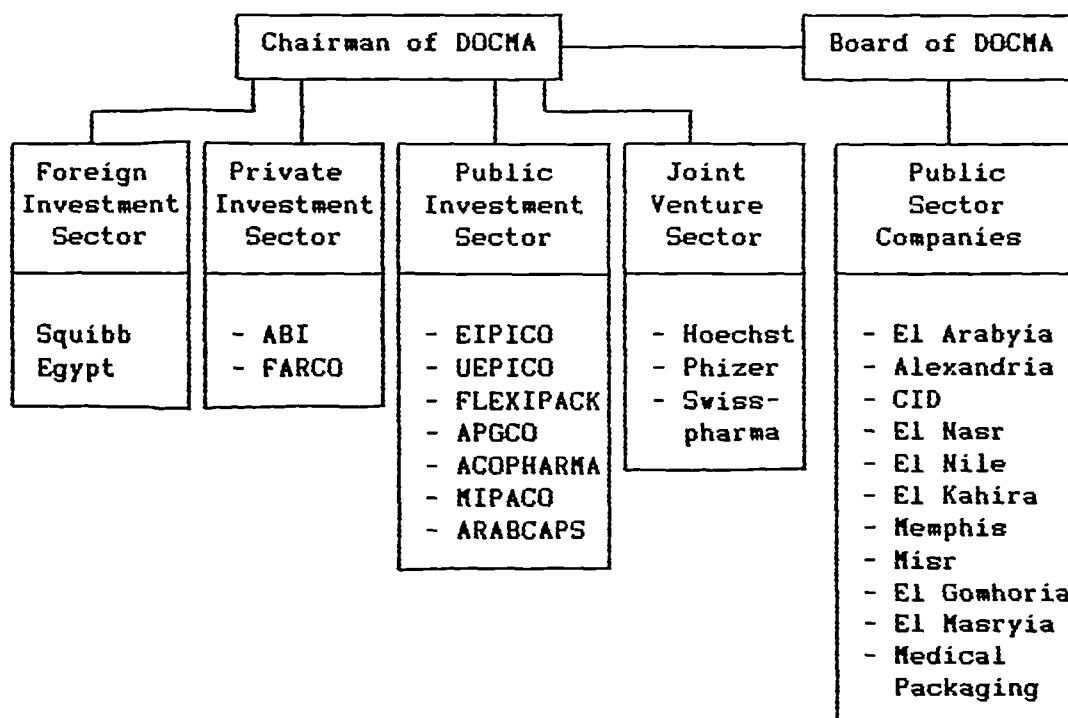

2.11. THE MAJOR ELEMENTS OF THE PHARMACEUTICAL POLICY:

Undoubtedly, the pharmaceutical policy is integrated with the national health policy, it is considered therefore as a part of an exhaustive development plan. In the following sections we discuss the major elements of that policy.

2.11.1. THE SELECTION OF MEDICINES:

The policy of selection of any kind of medicine to be an item in the drug list occupies a great deal of time in the pharmaceutical policy agenda. Selection depends on many aspects. First is the economic cost of the item. However, the goal is to cancel the kinds that are expensive in comparison with their importance in achieving a remedy. Second, the pharmaceutical policy gives deep consideration to the side / adverse effects of medicines use in order to protect the consumer, especially the disadvantaged patients who use medicine regularly (e.g., diabetics, unbalanced blood pressure patients). Third, the policy aims also to study the extent of the side / adverse effects which come with some kinds of medicines .

2.11.2. THE INCREASE OF THE LOCAL PRODUCTION SHARE:

The productivity of the medicine public sector is the biggest concern of the pharmaceutical policy, namely that the public sector should be the basic source of medicines in the market place. Local production showed up well in producing new and important therapeutic groups (i.e, essential medicines) which nearly satisfy the national consumption requirement. The essential medicine list was prepared by DOOMA and issued officially in 1988, it is revised annually by a committee of experts. The choice of

that list depends on many factors such as the pattern of prevalent diseases, the treatment facilities, the training and experience of the available personnel, the financial resources and the demographic factors. Medicines on the list are given priority in terms of input provision and supplied in sufficient quantities throughout the year. Their prices are frozen and supported by a subsidised program.

In fact, the increase in local production has been substantial, as we can see in table 2.2, showing the development of the national production share since 1962. In 1952 the national industry share was 10% while in 1962/63 it rose to 41% reaching 73.8% by the end of 1970 then declined to 65.5% by the end of 1975. By the end of 1981 the local production rose again to 72.2% in spite of the increasing breakdown in the Egyptian economy and political changes that took place at that time, which had an indirect impact on the medicine industry. The national industry grew again with the expansion of the pharmaceutical sector and local production rose to 82.2% by the end of 1988.

* Table 2.2: National Production Share (in millions, L.E.)

Year	Public Sector	Joint Venture Public/Private Investment	Total	Consumption Value	Percentage (%) of Production Share
62/63	8.2	1.2	9.4	22.5	41.0
65/66	20.7	4.3	25.0	34.0	73.5
69/70	27.3	6.0	33.3	45.1	73.8
75	46.1	11.8	57.9	88.4	65.5
80/81	115.5	96.0	211.5	293.0	72.2
81/82	178.3	116.8	295.1	407.0	72.5
82/83	216.0	137.2	353.2	484.0	73.0
83/84	248.3	208.6	456.9	571.1	80.0
84/85	287.6	255.9	543.5	672.7	81.0

Table 2.2 (continued)

85/86	311.2	314.8	626.0	750.0	83.0
86/87	339.4	424.3	763.7	899.6	84.9
87/88	388.5	412.0	800.5	940.0	85.2

* Source: Planning Department (DOCMA)

2.11.3 CONSUMPTION RATIONALISATION:

An important government achievement was the decrease in the gap between national and international consumption of medicines which has changed year by year with the national consumption approaching more closely the international one. It has been shown that in developed countries, the annual medicine consumption per capita is estimated at \$35.2 while in Egypt it is only \$7, (Hafez 1989), thus the first objective is to reduce the gap between national and international annual consumption per capita and second to rationalise medicine consumption. Moreover, the greatest increase in international consumption rate is in cardiac and vascularitic, while in Egypt the greatest increase is in the consumption of antibiotics, vitamins and mineral.

The consumption in 1952 was five million L.E with a local production covering only the 10% while in 1980 the consumption reached to 293 million L.E and the local production covered about 72% (see table 2.2). Such an increase represents a burden on the local industry as well as on the importation policy in order to cover that demand.

Many countries provide types of medicines out of prescription to cure prevailing and simple diseases. But all medicines may produce side effects and these could be the start of dangerous

diseases. Therefore, consumption rationalisation should cover all available kinds of medicine on the market. The report of the Specialist National Committee in 1982 calculated the estimated needs of medicine in the Egyptian market until year 2000 (table 2.3), on the basis of the actual consumption, the increase in income, the increase in perception for better health among the Egyptian families and the expected increase in population. The annual medicine consumption per capita per year rose during the period 1960-87 from .650 to 17.130 Egyptian Pounds, L.E. (see table 2.4).

* Table 2.3: The Study for the Expected Increase in Consumption
(in millions, L.E.)

Year	Total Consumption	Consumption Value of Local Production	Percentage of Consumption of Local Production (%)	Consumption Value of Imported Medicine
89/90	1040	890	85.6	150
90/91	1145	982	85.8	163
91/92	1290	1100	86.0	180
2000	1500	1215	81.0	285

* Source: Specialist National Committee, Fundamentals of Strategic Industry, Republic Presidency, Cairo, Egypt, 1982.

Finally in this section, there are several major contributions to the consumption of medicine. Firstly, the change in climatic conditions brings different seasonal demands for medicines. Secondly, changes in social conditions such as marital status, age category and changes in the habits and customs of society affect consumption. Thirdly, different factors such as the provision of medicine without a doctor's prescription, intensive

medical publicity for some kinds of medicines and doctors' habits of prescribing medicine when not needed also increase consumption.

* Table 2.4: Increase in Annual Medicine Consumption Per Capita (Egyptian Pound L.E.)

Year	Consumption Per Capita
60	.650
70	1.400
80/81	6.640
81/82	9.040
82/83	11.100
83/84	12.420
84/85	14.310
85/86	15.440
86/87	17.310
87/88	20.000

* Source: Planning Department (DOCMA)

2.11.4. DISTRIBUTION AND STORAGE POLICY:

The aims of establishing a list of essential medicines are to improve health and reduce medicine costs in developing countries. The use of this list should be either preceded by or developed together with an adequate supply and distribution system and procurement procedures. Further, the policy of the government is to put the health needs of the majority before the commercial interests of the minority, but for these policies to succeed, it is necessary therefore to increase public sector distribution outlets at all levels, including the retail level, to reach the majority of people even in the rural areas. It is obvious that medical policy includes economic and trade dimensions beside the industrial and technical ones. On this point, medicine distribution has somewhat different problems to the distribution of other

products. Medicine should be available at all times in adequate amounts and in the appropriate dosage forms.

Storage of medicine needs technical experts in order to keep control over the medicine production / expiry dates especially for antibiotics. El Masryia For Medicine Trade And Distribution Company is the body responsible for achieving sufficiency and distribution in order to make medicine available to all citizens. According to the pharmaceutical policy, El Masryia Co. distributes about 40% of the public sector production through its forty eight branches and thirty public chemists around all the country. While the remaining 60% is distributed by the production companies themselves. In contrast, El Masryia Co. undertakes the distribution of all imported medicines (i.e, 100%). Thus, this company always has obtained a direct government subsidy to keep the prices of essential medicines at the desired level. It also receives another indirect subsidy supplied by the Egyptian Central Bank (see table 2.5) in order to cover the differences between the Egyptian and the foreign currency.

* Table 2.5: Direct and Indirect Subsidy (in millions, L.E.)

Year	Direct Subsidy From The Ministry of Health	Indirect Subsidy From The Egyptian Central Bank	Total
77	12.0	-	12.0
78	-	-	-
79	6.0	-	6.0
80	4.5	-	4.5
81/82	6.0	-	6.0
82/83	6.0	-	6.0
83/84	6.0	30	36.0

Table 2.5 (continued)

84/85	7.5	35	42.5
85/86	8.2	40	48.2
86/87	5.0	40	45.0
87/88	15.9	45	60.0
88/89	15.0	50	65.0

* Source: Planning Department (DOCMA)

2.11.5. IMPORTATION POLICY:

Pharmaceutical policy aims to restrict import activity and considers its role as an integrated activity rather than a competing role in order to complete the market needs of medicine that are not available by the local production of the pharmaceutical sector. The strategy ensures that dependence on imports is reduced to the minimum. A high priority is given to new international medicines which could complete the current medicines groups. On the other hand, it attempts to exclude high price imports that are similar to current local products in the market.

It is quite clear that the policy goal is to continue to import a small percentage of all finished medicines, particularly since the world-wide pharmaceutical industry can take advantages of the rapid developments in the medicine field in providing new products.

El Masryia For Trade And Distribution Company is the corner stone for importation to satisfy the health care needs that cannot be met by local production, by keeping private importation at a minimum and directed towards the highly therapeutic vital products. Thus the scarcity of some kinds of medicine is due to the decision to exclude some 126 items from the importation list.

Regarding the need for imported raw materials to avoid the short fall in the domestic plan, the data shows an increase of imported raw materials during the period 1983-1989. The importation in 83/84 was 77.2 million L.E while in 88/89 it was 291.3 million L.E (see table 2.6). When considering these figures it must be borne in mind that the Egyptian Pound (L.E) has been steadily losing value compared with the currency of those countries from which Egypt imports raw materials.

* Table 2.6: Increase in Annual Imported Raw Materials (in millions, L.E.)

Year	Value of Imported Raw Materials
83/84	77.2
84/85	82.3
85/86	85.9
86/87	181.3
87/88	207.1
88/89	291.3

* Source: Planning Department (DOCMA)

2.11.6. CONTROL OVER MEDICINE PRICES:

Medicine prices have risen with the recent increasing inflation and the increased value of imported raw materials, despite the fact that the Egyptian government sets constraints in an attempt to control medicine costs, especially the medicines offered at no charge from public hospitals. The pharmaceutical policy is to study the prices regularly and allow price increases only after considering the increase in raw materials' costs and the increase in income level in Egyptian society.

The Minister of Health emphasised that great efforts are usually necessary to keep medicine prices at a reasonable level (Dwyddar, El Ahram, 1989). Regarding the many complaints that have been received about the increase of medicine prices, he also stressed that the imported medicines are the source of complaints, but these kinds represent only about 20% of all medicines. Further, he added that the unique reason for the high prices of imported medicines is the increase in cost in obtaining them. In fact, the imported medicines are usually placed on the market at the real prices (i.e, without subsidies) especially the ones not on the essential drug list, whilst, the essential groups are often bounded and subsidised to secure their availability at appropriate prices. Additionally, the Minister of Health ensures that the pharmacists and other experts in the medicine industry make efforts to produce alternatives to imported medicines with the same mode of action as well as of vital therapeutic potency.

Briefly, the control over prices comes in the form of a fixed price list set by the Pricing Committee in the Ministry Of Health. The prices usually have been set in the light of the prices of the other alternatives in the market.

2.11.7. MEDICAL CONTROL:

All medicines either locally produced or imported are firmly and comprehensively controlled to reduce associated health risks before permission for sale is granted. The control authority within the Ministry Of Health is the Central Administration Of Pharmacy Department (CAPD). Medicine control in Egypt concentrates on four main areas. First, all medicine products are subject to registration procedures to ensure: 1) safe, effective and

inexpensive medicine of good quality reaches the consumer and 2) the abuse and misuse of medicine is discouraged. Second, licensing of the premises became a basic requirement owing to the wide expansion of the pharmaceutical industry within both public and private sectors. The need arose for more specific control. Through the World Health Organisation (WHO) specification for good manufacturing practices efforts were directed to establish basic requirements and standards for licensing medicine companies in Egypt. Third, an inspection of medicines has to be carried out during and after the manufacturing cycle. CAPD is responsible for such inspections. Fourth, the control of importation and exportation is a critical stage in the medical control program. Samples of imported batches are tested by The National Control Laboratories. Medicines for export require many control checks by the manufacturer and official authorities at CAPD before an export certificate is issued.

2.12. RECENT DEVELOPMENTS IN THE PHARMACEUTICAL SECTOR:

The pharmaceutical industry has been successful in implementing a substantial program with respect to different aspects of technology over the last few years.

2.12.1. THE DEVELOPMENT IN THE FIELD OF TECHNOLOGY:

The majority of the current medicine companies make extensive use of new industrial automation. However, the Egyptian pharmaceutical sector is considered a pioneer in using computer facilities for its data processing activities such as evaluation and updating the annual plan, consumption, forecasting and information systems which have been developed since 1983 by the

Egyptian Drug Information Centre (EDIC). This centre has carried out tasks such as collection, classification, processing, storage, retrieval and dissemination of pharmaceutical information in the Egyptian market.

Further, good progress has been made in the area of new and important pharmaceutical groups and forms (e.g., tablets, syrups) especially, by the investment sector. Production now covers about 23 dosage forms and includes new forms that have never been produced in Egypt before. It also covers about 21 new therapeutical groups. Additionally, the manufacturers not only focused their attention on production development but also on quality assurance procedures using the most recent technology in this area such as the expansion of quality control activities to fulfil the assurance programs on raw materials and finished products.

Finally in this section, it is worthwhile mentioning that the Egyptian experts contributed by transferring technology to a number of Arabic countries such as Iraq, Syria, Lebanon, Jordan and Kuwait.

2.12.2. THE DEVELOPMENT OF THE RAW MATERIALS INDUSTRY:

Undoubtedly, the raw materials industry is considered a high technology industry. The public sector manufacturer (El Nasr Company) succeeded in manufacturing close to 12% of raw materials used in medicine production in 1987, the remaining 88% was produced by investment companies (ACOPHARMA, NIPACO, ARABCAPS). These companies secured the availability of raw materials at low prices and reduced the dependence on the imported raw materials. Table 2.7

shows the development of the national industry in the field of raw materials.

*** Table 2.7: The Development in the Field of Local Raw Materials
(in millions, L.E.)**

Year	* Value of Imported Raw Materials	Value of Raw Materials Locally Produced	Total Value	Local Share %
83/84	77.2	16.9	94.1	18.0
84/85	82.3	19.4	101.7	19.1
85/86	85.9	22.5	108.4	20.8
86/87	181.3	26.5	207.8	12.8
87/88	207.1	30.0	237.1	12.7
88/89	291.3	33.2	324.5	10.2

* Source: Planning Department (DOCMA)

2.12.3. THE DEVELOPMENT OF THE EXPORT POLICY:

The government encouraged local companies to develop and upgrade their export activities. In spite of powerful international competition in the African and Arabian market, the national industry was able to expand its export share in such markets from 2.4 million in 1977 to 26.3 million E.L in 1988 (see table 2.8). But there is still a wide gap between exports and imports which can only get smaller year by year by expanding the investment sector. The government therefore, has tried to maximise the use of foreign exchange resources by promoting the establishment of new pharmaceutical projects and encouraging national industry to join with other investors. In other words, the expansion of local production by investment is a feature of the development of exports as well as the policy of consumption rationalisation.

* Table 2.8: The Development in the Field of Exportation
(in millions, L.E.)

Year	Production Value	Exportation Value	Exportation Share %
77	81.9	2.4	2.9
78	81.6	2.4	2.9
79	89.0	2.9	3.3
80/81	211.5	3.5	1.7
81/82	295.1	4.2	1.4
82/83	353.2	9.5	2.7
83/84	456.9	7.9	1.7
84/85	543.5	8.6	1.6
85/86	626.0	10.4	1.7
86/87	763.7	12.6	1.6
87/88	800.5	26.3	3.3

* Source: Planning Department (DOCMA)

2.12.4. THE DEVELOPMENT OF THE PHARMACEUTICAL PACKAGING INDUSTRY:

Packaging used to be considered as an after thought but nowadays the role of the pack in the pharmaceutical industry has become increasingly recognised to the point where the packaging has become synonymous with the products. Packaging is an important element in the marketing mix. Moreover, it is considered as an integral component of a pharmaceutical product whose shelf life can only be considered in its packaged state. Packaging protects medicine from different climatic conditions, and preserves the manufacturer's preparation. It must provide the maximum product protection beside good presentation, clear identification and consumer convenience.

The medical packaging industry has developed through different stages with the development in the forms of packaging and the increase in consumption rate. Such changes required automation because in the past, the packaging industry just used glass

containers, but with the expansion of production, it became necessary to consider packaging carefully beginning with the raw materials, through manufacturing, finished product packaging, transportation, handling, and ending with the ease and consequences of disposal.

In view of the fast development of packaging automation and the requirement to provide the necessary protection for the packaged product, the packaging industry had recourse to use flexible packaging on a large scale for packaging numerous pharmaceutical products. Such a development contributed to consumption rationalisation by making available the unit dose, and producing different sizes of packaging to suit different doses for different ages at an economic price, to ensure the right medicine at right dosage goes to patient in the right place at the right time

It is worth mentioning in this context that Flexipack Company is a leader in developing the field of flexipack packaging (i.e., a combination of several materials). Table 2.9 exhibits the value of Flexipack Co.'s share in the total packaging industry during the period 1983-88.

*** Table 2.9: The Value of Medical Packaging Production
(in millions, L.E.)**

Year	Medical Packaging	Flexipack Co.	APG Co.	Total	Flexipack Co. Share %
83/84	8.2	-	-	8.2	-
84/85	8.5	1.7	-	10.2	16.7
85/86	10.7	4.8	-	15.5	31.0
86/87	12.0	9.8	-	21.8	45.0
87/88	14.4	15.4	12.0	41.8	36.9

* Source: Planning Department (DOCMA) and Account Department of Arab Medical Packing Co.

To summarise, packaging is a means of economically providing protection, presentation, identification / information, convenience and containment of a product during storage, carriage, display and use until it is used or administered. Good presentation enhances patient confidence with positive visual impact. Further, medicines are handled by professional people (i.e., doctors, pharmacists). It is equally important therefore that their confidence in a product is not downgraded by the pack. Flexible packing provides convenience e.g., the use of Blister or Strip packs for unit doses. The protective function of a pack is to guard against various hazards. Additionally, it should be stressed that the pack must contain maximum product information, especially the mode by which a product may deteriorate or degrade.

Security of the medicine packaging should be mentioned in this section as a feature of packaging development. However, the guarantee of complete medicine safety from production to the site of action in the body is an essential factor in the medicine industry in Egypt. A patient wants to feel secure with regard to his health and is particularly sensitive in this respect. The doctor has to take this increased need into account in his consultation, while the manufacturer must pay attention to other aspects centred around active ingredients and packaging information.

In summary, the manufacturers have made good progress in the production of securely packaged medicines using different methods for securing the various types of packaging and types of dosage forms. Pharmacists have always had a responsibility to provide medicines which are suitable for the purpose in appropriate and secure packs, and consumers must know how to identify resistant

features of packages. The pharmaceutical industry has succeeded in manufacturing several packaging types such as:

- 1) Plastic containers and Blister Packs for solids. These kinds are unit dose packs.
- 2) Glass containers with Pilfer Proof Caps for solids and liquids, in order to assure product purity. Closures can be made easy to open and close and accommodate the dispensing requirements.
- 3) Tamper-evident packaging technology. This is an additional factor in protecting consumers.
- 4) Sleeves used as protection for packages.

2.13. Summary Of Part Two:

In this chapter, we have presented an overall view of the pharmaceutical market in Egypt. It is clear that the pharmaceutical industry has made considerable progress in recent years.

To fully understand the historical development of the pharmaceutical sector, four stages of changes and expansion were described.

The chapter focused also on several key aspects of the pharmaceutical policy. One of these was the increase of consumption of medicine and the need for a rationalisation policy. Also, medical control procedures have become increasingly important with the recent changes in export policy.

The last section of this chapter examined the technological developments in the pharmaceutical sector. The most dramatic development was shown in the new technology of the packaging industry, especially in the field of flexible packaging which was

launched in the market several years in order to bring better protection for the Egyptian consumers.

CHAPTER THREE

CONSUMER SATISFACTION / DISSATISFACTION

- 3.1. Introduction To Consumer Satisfaction / Dissatisfaction.
- 3.2. Classification Of Consumer Satisfaction.
- 3.3. Conceptualization Of Consumer Satisfaction / Dissatisfaction.
 - 3.3.1. Satisfaction Defined.
 - 3.3.2. Dissatisfaction Defined.
 - 3.3.3. Consumer Satisfaction And Attitudes.
 - 3.3.4. Approaches to Consumer Satisfaction .
 - 3.3.4.1. Antecedents Of Satisfaction.
 - 3.3.4.1.1. Expectation - The Primary
Determinant Of Satisfaction.
 - 3.3.4.1.2. Performance.
 - 3.3.4.1.3. The Concept of Disconfirmation
And Inequity.
 - 3.3.4.1.4. A Model Of Consumer Satisfaction.
 - 3.3.4.2. Post Evaluation And Satisfaction.
 - 3.3.5. Psychological Theory Of Consumer Satisfaction.
 - 3.3.6. Sociological Interpretation Of Consumer Satisfaction.
 - 3.3.6.1. Alienation.
 - 3.3.6.2. Communication - Effect Theory.
 - 3.3.7. Utility Theory Of Consumer Satisfaction /
Dissatisfaction.
- 3.4. The Relationship Between Satisfaction / Dissatisfaction.
- 3.5. Measurement Of Consumer Satisfaction / Dissatisfaction.
 - 3.5.1. Measurement Problems.
- 3.6. Summary.

3.1. INTRODUCTION TO CONSUMER SATISFACTION / DISSATISFACTION (CS/D):

Marketing academics have long been concerned about satisfaction / dissatisfaction and a considerable body of academic literature has been formed around this topic.

For that reason, the concept of consumer satisfaction occupies a central position in marketing thought and practice. Churchill and Suprenant (1982) remind us that satisfaction is a major outcome of marketing activity and serves to link the purchase and consumption process with post purchase phenomena such as attitude change, repeat purchase and brand loyalty. Kotler (1984) describes satisfaction as the starting point for the discipline of marketing activities. Further the marketing philosophy of business tells us that it is the function of business to satisfy consumer needs at a profit. Despite such assertions, Howard and Hulbert (1973) submit that managers are disposed to accept sales dollars, market share or profit as a substitute for the yardstick of true consumer satisfaction. In addition, most corporations have assumed the vast majority of their customers are satisfied. Stokes (1973) considered the small minority which actually complains to be an atypical segment.

Conversely Kotler (1976) suggested that consumer satisfaction has long been a central concern of modern marketing practitioners and more recently a major concern of various government agencies engaged in consumer protection activities. The consumerist movement had made consumer satisfaction an ever salient concern for both business and government by calling attention to consumer dissatisfaction with products, services and marketing practices. Oliver (1979) suggests that if the most fundamental of reinforcement theories is to be believed, the subject of consumer

satisfaction / dissatisfaction (CS/D) should occupy a prominent position in the conversation of academics and practitioners alike.

The lack of adequate conceptualization and measurement of CS/D is definitely a major hindrance to public policy staff, to legislators, to marketing managers, to consumerists and to consumer behaviour theorists, although each group recognizes the need for the development and implementation of that concept. For instance, if consumers are dissatisfied, a business may face declining sales (London 1977a). Business should therefore become interested in measures of consumer satisfaction. Consumer satisfaction measures, may be helpful in determining the potential market of a product. Moreover, marketing management should be interested in consumer satisfaction because that has been held their ultimate goal as well as their intermediate goals (e.g., profit, sales volumes, market share, etc). Pratt (1972) suggested that, organizations' research should be devoted therefore to the topic of satisfaction.

For this to come about Czepiel and Rosenberg, (1976) have developed the following series of research questions which should be addressed:

- (1) What is the relationship between satisfaction and sales, brand loyalty, profit?.
- (2) Can satisfaction be predicted or can it be used to predict outcomes?.
- (3) How sensitive is consumer satisfaction to changes in the competitive environment?.
- (4) What are the specific product and service variables that have the greatest influence on consumer satisfaction for a given product / service?.

- (5) Can a measure of consumer satisfaction provide useful diagnostic measures which explain states or marketing problems?.
- (6) How often and how should satisfaction be monitored or measured?.
- (7) Are there general principles with respect to consumer satisfaction which can be used in the initial design of products or marketing strategies or is its usefulness restricted to exploring factors for diagnostic purposes?.

Czepiel and Rosenberg (1976) added three reasons which dictate that research should be directed to these questions:

- (1) Product proliferation in almost all categories gives consumers a greater opportunity to choose those products which yield a higher level of satisfaction
- (2) The generally increasing level of consumer sophistication and the awareness of sound buying practices and strategies subject products to a closer pre-purchase scrutiny.
- (3) The increasing interest of government and consumer spokes persons demands that business be knowledgeable regarding its own performance.

Those who favour government intervention in the market place on the consumer's behalf believe that the economic system is not completely capable of serving the public interest through the profit motive. So the government seeks to identify and isolate those products and industries where governmental action is desirable to enhance consumer welfare.

Hughes (1976) explored four factors which are important to any general program of consumer satisfaction, these are:

- (1) The monetary importance of the product to the consumer. Generally, consumers carefully investigate the available merchandise before making a purchase.
- (2) The price point or level of quality which a consumer decides upon for a particular purchase. Do those consumers who paid the highest price generally express higher satisfaction than those consumers who have paid lower prices?.
- (3) The possibility that satisfaction levels are related to certain demographic characteristics. If demography is a consideration, then some products if purchased heavily by certain demographic segments will of necessity have above or below average satisfaction.
- (4) The possibility that there are segments of the consumer population which may be quite easily satisfied and will give high ratings to many purchases.

In the light of the above factors, satisfaction is considered an important phenomenon. It is a key concept in any theory of consumer behaviour. Leavitt (1976) continued this notion and stated that satisfaction represents an opportunity to other areas of applied psychology. More specifically, the consumer decision making process can be considered a key to post purchase evaluation and hence influential upon further behaviour (Engel et al 1986). Second, Czepiel et al (1974) presented the doctrine of consumer sovereignty as one of the above mentioned factors which leads economists to equate satisfaction with utility in order to enjoy the use of goods and services. Hunt (1976) considered the satisfaction of different groups and emphasized that a comparison of those groups is very much culture bound. However, various social

groups, especially, broad cultural groups, have different learning processes and experiences.

In concluding this introduction, it is important to acknowledge several basic assumptions regarding consumer satisfaction before moving on (Plummer 1974, Andreasen 1976, Day 1977). First, the actual experience with a product / service is possibly the major factor influencing consumer satisfaction. That experience often determines whether or not a subsequent purchase or some form of redress will occur. Second, a distinction between a generalized feeling of satisfaction and specific events or experiences must be made. Third, there are variables external to the actual experience (before, during, after) which play an important role in determining consumer satisfaction.

3.2. CLASSIFICATION OF CONSUMER SATISFACTION:

For the purpose of marketing management, CS/D may be classified in several ways. Czepiel et al (1974) identified three sorts of consumer satisfaction: system satisfaction, enterprise satisfaction and product / service satisfaction.

System Satisfaction may be defined as the consumer's subjective evaluation of the total benefits they derive from the operation of the marketing system. In developing an index of consumer satisfaction Pfaff (1972) viewed system satisfaction as a measure of the subjective welfare of consumers as influenced by the attributes and circumstances under which goods and services are offered in the market, such as prices, availability and image of products. Renoux (1973) discriminated between two dimensions of system satisfaction (Macro-Marketing System / Micro-Marketing System). Whereas in the Macro-Marketing System, the level of

satisfaction is not associated with specific producers, dealers or products, the Micro-Marketing System is the level of satisfaction / dissatisfaction with specific aspects of the marketing system. Furthermore, Renoux, advocated the following three sorts of consumer satisfaction in the Micro-Marketing system:

- (1) The Shopping-System involves the availability of products and types of retail outlets.
- (2) The Buying-System is concerned with the process of selecting purchasing and receiving products from stores patronized.
- (3) The Consuming-System results from problems in using and consuming goods and services.

Enterprise Satisfaction refers to what is gained by consumers in dealing with complex product / service organisations (e.g., health care facilities). Czepiel et al (1974) described the enterprises system as a function of the consumption of a wide range of products and service, and their surrounding factors such as products assortment, atmosphere, location, etc.

Product / Service Satisfaction refers to the favorability of the individual's subjective evaluation of the various outcomes and experiences associated with using or consuming products or services (Westbrook 1980a). This level of satisfaction is concerned with the evaluation which occurs when a product / service offering interacts with the internal processes of the consumer. More precisely, the evaluation is based on a cognitive process in which consumers compare their prior expectations with product outcomes (i.e., product performance).

The three sorts of consumer satisfaction seem interchangeable, since System-Satisfaction embraces all of the individual Product /

Service Satisfaction and the Enterprise Satisfaction components accumulated by the consumer.

3.3. CONCEPTUALIZATION OF CONSUMER SATISFACTION / DISSATISFACTION (CS/D):

As our economy, society and the market place become more complex and interrelated, the need to put phenomena such as consumer satisfaction into a broader framework becomes more pronounced. In other words, before CS/D can play a positive role in public issues, it must be based on adequate conceptualization and suitable measurement methodologies, which most researchers, policymakers, marketers and consumerists agree are presently lacking.

Before discussing the conceptualization of CS/D, it is useful to consider the definition of consumer satisfaction and how satisfaction differs from attitudes.

3.3.1. SATISFACTION DEFINED:

Undoubtedly, any consumer satisfaction research is designed to answer one question: are consumers pleased or displeased with products in the market place?

Wilton (1985) states that, the notion of satisfaction became more obvious and specific subsequent to the birth of modern social science. Satisfaction is also important in the development of modern marketing thought. In all basic marketing texts, consumer satisfaction has always been defined as the means through which marketers can achieve their organisational objectives (Kotler 1972a).

Definitions and conceptualizations of consumer satisfaction show substantial variety. The following literature is worth mentioning here.

Plummer (1974) gives us a starting point for a definition "business, government and other nonprofit organisations need measures of how products and services are meeting client needs and wants, so that they can enhance their own and / or society's well-being". The extent to which these needs and wants are met has come to be called consumer satisfaction.

Some 20 years ago Howard and Sheth (1969) defined satisfaction as "the buyers' cognitive state of being adequately or inadequately rewarded for the sacrifice he / she has undergone". They added, satisfaction is not necessarily the same objective evaluation of reward, it can vary among people and for a given person over time. Pfaff (1976) defined consumer satisfaction as the inverse of the difference between the ideal and the actual combination of attributes. Miller (1976) saw consumer satisfaction as perceived performance. While Hample (1977) stated that consumer satisfaction is defined as the extent to which expected product benefits are realized; it reflects a degree of congruence between actual outcomes and expected consequences.

Other attempts have been made to define consumer satisfaction. Several researchers (Day 1977, Oliver 1977, Swan and Travick 1981) have used many techniques and models from studies of job satisfaction. Locke (1976) adopted Howard and Sheth's definition (1969) in which satisfaction is defined as "a positive emotional state resulting from the appraisal of one's job and as a function of the perceived relationship between what one wants from one's job

and one perceives it as offering", and put it into a consumer context.

More recently, Oliver (1981) defines satisfaction more broadly as "the summary psychological state resulting when emotion surrounding disconfirmed expectation is coupled with the consumer's prior feeling about consumption experience". Engel et al (1986) bring with their definition not only expectation but also the concept of comparison with alternatives, defining satisfaction as a "post consumption evaluation that the chosen alternatives is consistent with prior beliefs and expectation with respect to that alternatives". Whilst Goodman (1989) defines satisfaction as "the state in which consumer needs, wants and expectations are met or exceeded resulting in purchase and continuing loyalty".

3.3.2. DISSATISFACTION DEFINED:

The recognition of dissatisfaction is as important as satisfaction. Nevertheless, the literature is poor in defining dissatisfaction and concentrates on satisfaction. Handy (1976) defined consumer dissatisfaction as "the gap or distance between the consumer's (ideal) attribute combination for a product or service and the attribute combination of the product or service offered in the market place which should come closest to this (ideal).

Cohen (1981) relates dissatisfaction and expectation, he suggests that dissatisfaction stems in part from consumer's rising expectations which may be due to the increase in consumer affluence and sophistication. Moreover, Cohen used the Random House Dictionary in developing a definition of dissatisfaction which was quite similar to his definition. It stated "dissatisfaction results

from contemplating what falls short of one's wishes or expectation". Engel et al (1986) give an exhaustive definition of dissatisfaction, explaining dissatisfaction as the outcome when the confirmation of product or service does not take place. Vinson and Pearson (1978) tell us that, "while consumers have experienced, unprecedented affluence, unlimited consumption opportunities and improved products, they are nevertheless beginning to display dissatisfaction".

Other writers offer further reasons for dissatisfaction. La Tour and Peat (1979) cited an important and direct reason for consumer dissatisfaction that is, that the quality of products are inferior. While Miller, (1976) identified another two reasons for dissatisfaction. One is the raising expectation which is an obvious source of discontent. Expectations of product reliability and performance are more sophisticated now more than ever before (Diener 1975). The other reason lies in the decrease of consumer options available. Consumers may have the resources for buying the product or service that "fits their needs". It is conceivable that the options available in the market place do not satisfy their needs as they would like. Further, many alternatives of some products categories may exist and an average consumer then is frequently unqualified to judge or evaluate which product alternative is best for his / her needs.

3.3.3. CONSUMER SATISFACTION AND ATTITUDES:

In order to understand the similarity and dissimilarity between satisfaction and attitudes, it is necessary to give an insight into the nature of attitudes with respect to the earlier stages in the buying process. Engel et al (1986) developed a model presented in figure (3.1) which shows the evaluation stages starting with beliefs and attitudes and resulting in a possible shift of intention. This is followed by the purchase stage which leads to satisfaction / dissatisfaction. Earlier work by Lutz (1975) portrays beliefs as the immediate causal antecedents of attitude, while intentions are the immediate causal consequences being one step removed from attitude.

The concept of attitudes has occupied a central place in the explanatory system of the theories in human behaviour. Hence, there are quite number of definitions of attitude, the most frequently used definition is presented by Fishbein and Ajzen, (1975). They defined attitudes as a "learned predisposition to respond in a consistently favourable or unfavourable manner with respect to a given object". Engel et al (1986) define attitudes as "the mental and neural state of readiness to respond that is organized through experience and exerts a directive and / or dynamic influence on behaviour". Assael (1987) proposes the model of complex decision making where attitudes are a central component of a consumer's psychological set and one of two thought variables. The other thought is need. Attitudes are seen as the consumer's evaluation of the ability of alternative brand or product categories to satisfy these needs. Needs therefore, influence attitudes and attitudes influence purchase. Attitudes are seen as being made up of three underlying components (Lutz 1975, Roberston et al 1984,

and Elbeck 1987). First is the cognitive component which refers to the beliefs an individual holds about object. Second, is the affective component i.e, a person has a positive affect (like) or negative affect (dislike) toward an object. Finally, there is the conative component which refers to the tendency to act, the readiness of an individual to behave toward object. Fishbein and Ajzen (1975) explained attitude under the unidimensionalist approach, the cognitive and conative components are "pulled out" of attitude; cognition is relabelled beliefs and conation is relabelled intention and behaviour. Thus, under such an approach attitude consists of affect only.

Cohen (1981) represents the functional conceptualization of Daniel Katz (1960). Katz felt that attitudes can serve four basic functions within the individual. First, the utilitarian function: a recognition that attitudes can be instrumental in achieving desirable goals and avoiding undesirable alternatives. Second, the ego-defensive function which serves to help the individual deal with his inner conflicts. Third, the expressive function by which attitudes give positive expression to the individual's values and to the type of person he conceives himself to be. Fourth, the knowledge function which helps the individual cope with a complex world that cannot be grasped in its entirety.

Hustad and Pressemier (1971) defined attitudes as a "learned and enduring predisposition to act. It may be the product of such components as perception, beliefs, values, motives and preferences". Beliefs then are components of attitudes. In order to show the interaction between beliefs and attitudes Petrof (1971) introduced two definitions of an attitude. First, he defined the term as "an enduring learned predisposition to behave a consistent

way towards a given class of objects" (similar to Husted and Pressemier 1971). The second definition is "an enduring system of positive or negative evaluation, emotional feeling and pro or con action tendencies with respect to a social object". Both definitions indicate that the nature of beliefs that an individual holds toward object and his associated evaluation determine his attitude toward that object.

Regarding intention, Howard and Sheth (1969) defined intention as "a cognitive state that reflects the buyer's plan to buy units of a particular brand in some specified time period, this intention reflects his attitude". Frank et al (1972) support the Howard and Sheth definition, they state that intention to buy may be viewed as one of the three basic components of any attitude system (i.e., cognitive, affective, conative). Obviously, the above discussion presents beliefs and intention as components of attitudes.

The next point to be touched upon here is the similarity and dissimilarity between attitudes and satisfaction. Hunt (1976) suggested that consumer satisfaction is an attitude in the sense that it is "an evaluative orientation which can be measured". He added "consumer satisfaction is a special kind of attitude because by definition it cannot exist prior to the purchase or consumption of the attitude object". Czepiel and Rosenberg (1976) agreed with Hunt's view that consumer satisfaction is an attitude in that it is an evaluative orientation (affective) which can be measured. Many researchers (Czepiel and Rosenberg 1976, Pfaff 1976, Miller 1977, Oliver 1981) agreed that satisfaction to a great extent is analogous to attitude. Pfaff 1976 suggested that satisfaction can be denoted in part by all components of attitudes. The cognitive component indicates the confirmation or disconfirmation of

expectation and performance of the product, the affective component indicates whether the consumer is satisfied or dissatisfied with the product, and the conative component whether to stop or arouse future purchase in the post-purchase situation. Therefore, satisfaction is not only an attitude, it is a richer concept than attitude. Further, consumer satisfaction is more experience specific than attitude, it gives additional insights into attitude. Czepiel and Rosenberg (1976) regarded consumer satisfaction as an indicator of product performance. A further distinction has been raised by La Tour and Peat (1979) that the primary distinction between satisfaction and attitude derives from temporal positioning: attitude is positioned as a pre-decision construct, while satisfaction is a post-decision construct.

FIGURE 3.1: PURCHASE AND ITS OUTCOME

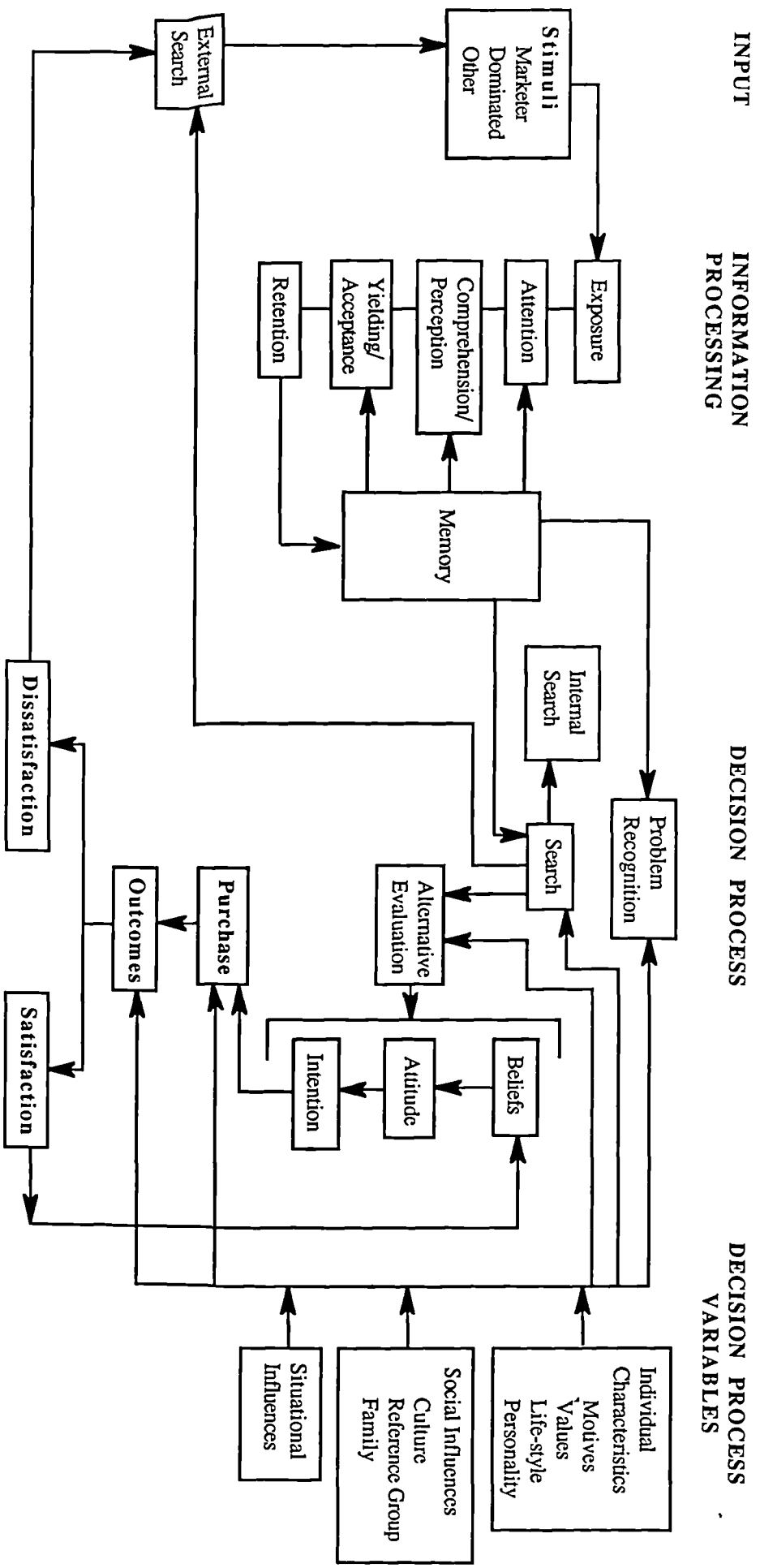

Source: Engel et al, 1986, p.146

Howard And Sheth Model (1969):

The Howard and Sheth model (Kassarjian and Robertson, 1973) is the first systematic effort to develop a comparison theory of consumer behaviour (figure 3.2). By investigating the Howard and Sheth model, it is clear that they distinguish between satisfaction and attitude. Satisfaction and attitude appear as two of the six distinct learning constructs (i.e, confidence, motives, intention, attitude, choice criteria, brand comprehension and satisfaction) suggesting that satisfaction and attitude play an equal role in the circle of learning constructs. In other words, satisfaction "serves as a controlling system linking through its impact on brand comprehension, attitude and confidence". In addition, "satisfaction within the theory of consumer behaviour refers to the degree of congruence between the actual consequences of purchase and consumption of a brand, and what was expected from it by the buyer at the time of purchase" (Kassarjian and Roberston, 1973). If the actual outcomes are judged by the buyer to be better than or equal to the expected, the buyer will feel satisfied. If on the other hand, the actual outcomes are judged to be less than what he expected, the buyer will feel dissatisfaction.

FIGURE 3.2: THE HOWARD-SHETH MODEL OF BUYER BEHAVIOUR

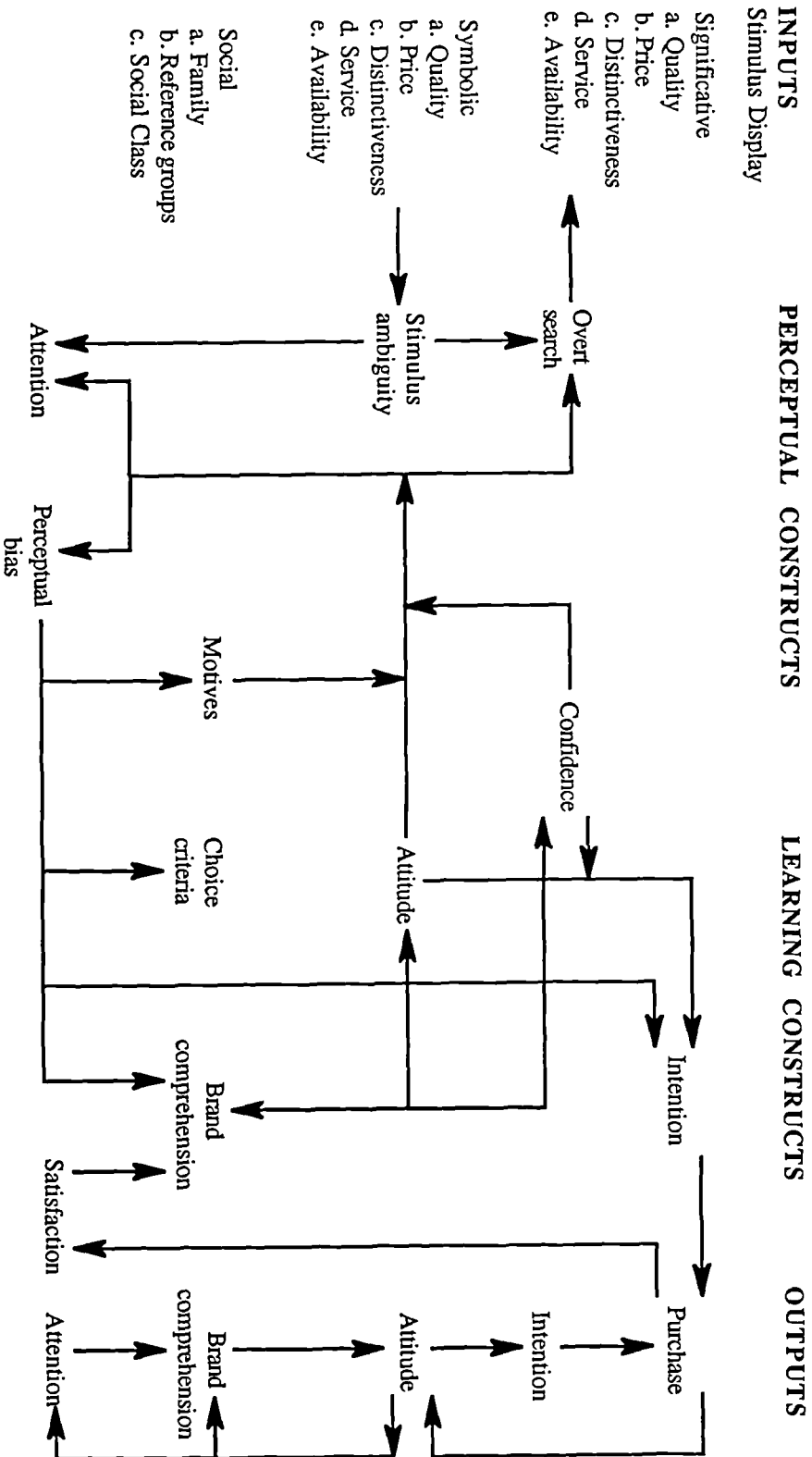

Source: Cohen, D., 1981, p.10

3.3.4. APPROACHES TO CONSUMER SATISFACTION :

There appear to be two distinct approaches to the study of satisfaction / dissatisfaction. The first approach is primarily concerned with the antecedents (causes) of the state of satisfaction, where the critical variables of interest are a consumer's level of expectation regarding product, performance and the subsequent confirmation / disconfirmation and the feeling of inequity (positive or negative). The second approach is post evaluation.

3.3.4.1. ANTECEDENTS OF SATISFACTION:

Numerous theoretical structures have been proposed to examine the antecedents of satisfaction and develop meaningful measures of the construct. Churchill and Suprenant (1982) express that the vast majority of these studies have used some variant of the disconfirmation theory which holds that satisfaction is related to the size and direction of the disconfirmation experience, where disconfirmation is related to a person's initial expectation. More specifically, an individual's expectation is: a) confirmed when a product performs as expected, b) negatively disconfirmed when the product performs more poorly than expected, c) positively disconfirmed when the product performs better than expected. Dissatisfaction results when a subject's expectations are disconfirmed. The full disconfirmation encompasses five constructs: expectation, performance, disconfirmation, inequity and satisfaction.

3.3.4.1.1. EXPECTATION - THE PRIMARY DETERMINANT OF SATISFACTION:

Day (1977) has explained expectation as "the consumer's estimate at the time of purchase, or prior to usage, of how well or poorly the product will supply the benefit of interest to the consumer". Shiffman and Kanuf (1983) try to bring in reasons behind expectations "people usually see what they expect to see, and what they expect to see is usually based on familiarity, on previous experience, or on preconditioned (set)". Ross et al (1987) suggested that expectation reflects "a generally optimistic or pessimistic viewpoint about a specific situation". Pitts and Woodside (1984) present three major types of expectation according to the literature on consumer satisfaction:

- (1) Predictive expectation deals with beliefs on the likelihood of the performance level. Barbeau(1985) brings with his definition not only the performance level, but also the prior expectation and other information about how the product will perform. He adds that predictive expectation is seen as a cognitive construct representing the levels of attributes that the consumer thinks will be found in a particular product.
- (2) Normative expectation is concerned with the ideal standards about how a product should perform. Barbeau (1985) states that the ideal standards may be independent of a particular brand or product.
- (3) Comparative expectation deals with the performance of the brand compared to other similar brands.

The literature further shows that normative expectations are the most appropriate determinants of satisfaction. Olson and Dover (1976) defined expectation as the consumer's belief about the level of attributes possessed by a product. Miller's paper (1977)

discussed carefully the role of expectation in CS/D. However, most of the expectation studies which utilize the confirmation of expectation approach to consumer satisfaction have assumed either implicitly or explicitly that an evaluative reaction will automatically ensue after a consumption experience and will result in either positive feeling about the experience (satisfaction) or negative feeling (dissatisfaction). The results of these feelings are irrelevant to the magnitude of the difference between the perceived performance of product and the level of expectation with which the consumer entered the consumption process.

There seems therefore a uniform acceptance of the importance of expectation to CS/D studies. In thinking about expectations Day (1977) proposed three categories in which expectation should be broken down:

(1) Expectation About The Nature And Performance Of The Product
(attributes of the product):

In general, expectation about the nature and performance of the product will be based on previous experience with that particular item. The consumer who has a lot of experience with a product can be expected to have a well-formed expectation about the item which has been learned over time. But the inexperienced user will have a relatively weak expectation of the attributes and performance of a product. He will tend to rely on advertising, sales presentation and advice of others more than the experienced consumer, and his expectations are likely to be more incomplete as well as less stable than those of experienced user. In the case of ambiguous attributes, La Tour and Peat (1979) have stressed that the more ambiguous the attribute, the more the consumer will be forced to

rely on the expectation -producing information rather than judgement in forming a belief about the attribute level. The more ambiguous the attribute, the smaller the discrepancy between the subjectively obtained level and the expected level, and thus the more effective high expectation would be in producing greater satisfaction.

(2) Expected Cost:

The price paid for an item can have a rather complex effect on the consumer's evaluative reaction. Price is often interpreted as an index of the quality of an item. So that, a high price tends to create high expectation of performance while low price leads to low expectation of performance. Barksdale and Perreault (1980) carried out an empirical study to explore whether consumers were satisfied or dissatisfied with prices of consumer goods. Responses were collected through mail questionnaires consisting of a series of Likert-type statements. Those statements were arranged in several groups, among them a group measuring attitude toward the price of some consumer goods. Over one-half of the respondents disagreed with the statement that the most important problem facing them is the high price of consumer goods.

Day (1976,1977) considered the effect of price and the importance of the purchase to consumer. The expected cost of an item can have an influence on the pre-purchase seeking and thus may lead to better formed expectation.

(3) Social Benefit Of Purchase / Use:

For many products, there are benefits of purchase and consumption quite independent of the attributes of the product, those products which are jointly consumed with others, or are publicly consumed. They may have sufficient social significance that the purchaser will have formed an expectation about the reaction of others whose approval is important to him.

(4) Expectation With Respect To Pharmaceutical Products:

In pharmaceutical marketing, mostly the target of the salesmanship is the prescribing doctor and not the final purchaser. Therefore, some writers consider doctors as consumers as did Knapp and Oeltjen (1972) in an experimental study of risk-benefit assessment by practitioners regarding medicine selection. They posited that the probability of a practitioner prescribing a medicine for a particular patient was a function of several kinds of expectation: 1) doctor expectancy that a beneficial effect on a patient's condition would occur if the medicines were prescribed; 2) expectation of the amount of beneficial effect to be gained; 3) expectancy of medicine side-effects; and 4) expectation of the magnitude of these side-effects. In addition, Smith (1983a) mentions many considerations which are involved in determining what medicine costs really mean to the patient. Some of them are considered to be in the context of expectation such as the perceived cost, the expected cost, and the post cost experiences.

3.3.4.1.2. PERFORMANCE

Churchill and Suprenant (1982) saw the primary importance of performance in the satisfaction literature as a standard of comparison by which to assess disconfirmation. Olshavsky and Miller (1972) and Olson and Dover (1976) manipulated actual performance, but their emphasis was on how performance rating was influenced by expectation rather than on the impact of changes in performance level on satisfaction (see figure 3.3), though it is reasonable to assume that increasing performance should increase satisfaction. Day (1982) has questioned "acceptable performance", demonstrating that there is no obvious way to establish a consensus standard on the acceptance level of satisfaction or dissatisfaction at any point of time.

3.3.4.1.3. THE CONCEPT OF DISCONFIRMATION AND INEQUITY:

The disconfirmation concept has been viewed in many studies as the net change in attribute rating or belief probabilities before and after exposure to the product (Olson and Dover 1976, and Swan 1977). Westbrook and Reilly (1983) add that disconfirmation involves consumer comparison between pre-purchase beliefs about a product with post-purchase beliefs formed during consumption of the product. The extent to which post-purchase beliefs disconfirm their pre-purchase counterparts is theorised to be the principal determinant of satisfaction / dissatisfaction.

Oliver (1980) defines two dimensions of disconfirmation. One is positive disconfirmation which results when low-probability desirable attribute states are realized or when high-probability undesirable states are avoided. Negative disconfirmation can be

expected when high-probability desirable states do not occur or when low-probability undesirable states do.

Recently equity theory has been considered as one of the components of satisfaction. Swan and Mercer (1981) explain the fundamental idea behind that theory, they define equity and inequity as a "feeling of well being or fairness or that distributive justice has occurred or a feeling of distress if the person is a victim or beneficiary or inequity". They add that equity and inequity is a social exchange between two persons, each one will compare his relative gains (outcomes minus inputs) to the relative gains of the other person. In other words, equity theory attempts to explain the process by which people compare and evaluate outcomes (Tyagi 1982).

Whereas disconfirmation involves comparison between performance and expectation of a product and service, equity involves the comparison between the net gain of the marketer vs net gain of the consumer in the purchase situation. The concept of disconfirmation and inequity both therefore increase the understanding of, and ability to, predict satisfaction. We therefore conclude that both disconfirmation and inequity may be antecedents of satisfaction, satisfaction results from confirmation or positive disconfirmation as well as equity or positive inequity (Swan 1985), (see figure 3.4).

3.3.4.1.4. A MODEL OF CONSUMER SATISFACTION:

The basic model of consumer satisfaction consists of two major elements of determinant satisfaction: a) expected performance and b) evaluation of perceived actual performance. In this instance, satisfaction defined by Miller (1977) results from the interaction of levels of expectation and perceived performance. Hample, (1977), defined consumer satisfaction as the extent to which expected product benefits are realized. It reflects a degree of congruence between actual outcomes and expected consequences. As mentioned earlier, Pfaff (1976) defined consumer satisfaction as the inverse of the difference between the ideal and actual combinations. Thus, both expectation and the ideal are thought to be performance standards against which actual performance is measured in arriving at satisfaction, and expectation is compared to perceived performance in order to arrive at an evaluation. More recently, Gronroos (1983) suggests that perceived performance is composed of two qualities, technical and functional. Technical quality has to do with what the consumer receives from the purchase of the product. Functional quality has to do with how the consumer receives or purchases the product.

Miller (1977) modified this model to recognize four potentially different types of expectation an individual might have regarding anticipated performance levels, i.e., ideal, expected, minimum tolerable and deserved. A brief explanation of each follows.

The ideal is the "wished for" level, it reflects what the consumer feels the performance of the product "can be", it is a function of prior expectation, learning, information, advertising, etc... The expected is thought of as having no effective

calculation of probability, its bases are similar to the experience and information inputs determining the level of the ideal. The expected level reflects what the consumer feels performance of the product probably "will be". The minimum tolerable is the least acceptable level, which reflects the minimum level the consumer feels performance "must be", the inputs to this expectation level are similar to the ideal and expected level. The deserved reflects what the individual in the light of his investment feels performance "should be". Unlike the other expectation levels, the deserved level is critically determined by the individual's evaluation of his / her investment in the purchase. This investment would include all the costs associated with the time, money and effort involved in purchasing the product.

FIGURE 3.3: EXPECTATION AND LEVEL OF PERFORMANCE

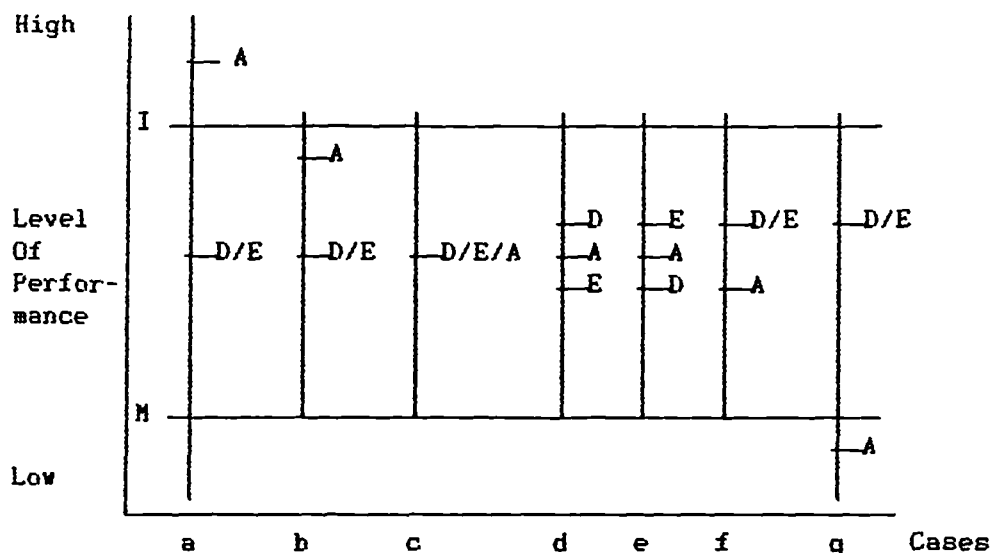

A = Actual Performance
 I = Ideal Performance
 E = Expected Performance
 D = Deserved Performance
 M = Minimum Tolerable Performance

Source: Miller, 1977

Conceptually, the ideal would always represent the highest expectation level, and the minimum tolerable would always represent the lowest level as can be seen in figure (3.3). On the other hand, the deserved might be higher than the expected as in case "d" when the individual pays a premium price or invests a great deal of time and effort. Alternatively, the deserved may be lower than expected as in case "e" when the product is "a steal" requiring little time or effort to obtain. When actual performance "A" appears to be above the consumer ideal performance "I", he will be satisfied, "case a". If "A" is higher than deserved "D" or expected "E" but less than "I", the consumer is still satisfied in "case b". Where "A" is the same as "D" or "E", the consumer feels neutral, "case c", that means there would probably be no change in purchasing behaviour. If "A" is above "D" and below "E", the consumer may feel strongly dissatisfied, "case e". When "A" falls below "D" and "E" but still above the minimum tolerable, "case f", the consumer will still dissatisfied. Finally, where performance "A" does not even meet the minimum tolerable level, "case g", the consumer is greatly dissatisfied.

While, Miller (1977) was interested in the expectation of consumer buying products, Barry et al(1982) were concerned with the expectation of students about their performance in examinations. By the same argument the ideal would represent the best grade a student feels he / she could possibly get on a test. The expected would reflect the student's objective of the grade. Minimum tolerable would be the worst possible grade the student thinks he / she could have got. Finally, the deserved would reflect the grade the student feels he / she should get. In this context, Barry, et al

carried out an empirical investigation on groups of students. The level of student satisfaction (five levels ranging from very dissatisfied to very satisfied) was predicted from either the actual examination score or the various differences. The results showed that the expected score minus actual exam. score exhibited the greatest amount of variation across the five levels of satisfaction by applying one way analysis of variance. Further, inspection of the data found that the actual exam. score alone is better predictor of satisfaction than the expected score minus actual exam. score. It is clear therefore that expectation types are useful for analysing satisfaction.

3.3.4.2. POST EVALUATION AND SATISFACTION:

The second approach of particular interest for this study is post evaluation and its effects on satisfaction / dissatisfaction. Czepiel et al (1974) are among several researchers who have investigated this subject. They stated that, satisfaction is the consumer's subjective evaluation of benefit, objective and otherwise, obtained from the consumption of a specific product or service. They added, it is his evaluation of the extent to which the product or service fulfils the complete set of wants and needs which the consumption act was expected to meet.

Several aspects of evaluation should be noted. The evaluation process is important and implies a two level sort of an appraisal. First, outcomes are compared to expectation. Second, the seriousness of any discrepancy is noted or judged according to some unspecified sort of a standard.

Other writers have dealt with evaluation as a basis of satisfaction / dissatisfaction. Hunt (1976) emphasised that

satisfaction is not the pleasurable nature of experience, it is the evaluation rendered that the experience was at least as good as it was supposed to be. One could have a pleasurable experience that caused dissatisfaction because even though pleasurable, it was not as pleasurable as it was supposed or expected to do. So, satisfaction / dissatisfaction is not an emotion, it is the evaluation of an emotion. According to Day (1977) there are some circumstances which might trigger the evaluation process:

- (1) The item and / or the purchase has some special significance for the consumer.
- (2) The consumer has had previous experience with the product.
- (3) The consumer has been advised to be careful in making the purchase by friends, consumer organisations or consumer protection agencies.

Czepiel and Rosenberg (1976) with other researchers have found that evaluation of outcomes may be affected by several aspects. First, the perceived alternatives, satisfaction or dissatisfaction with a product, would depend on what the alternatives were perceived to be. The product may be evaluated as yielding satisfaction compared to no alternatives. But if the alternatives are quite readily available, the same product would yield dissatisfaction. Second, evaluation may be affected by the amount of effort spent in shopping to acquire the product. Engledow (1977) added that the consumer who has expended considerable time and energy seems to say to himself "If I worked that hard, I surely must have picked out a pretty good product". This ties in with Miller's concept (1977) of a deserved level of expectation affecting satisfaction (case d and e in figure 3.3). Engledow emphasises the role of effort. He argued that Knowledge about

consumer efforts is very important, since this effort includes physical, mental and financial resources expended to obtain a product. A further study on effort was carried out through a laboratory experiment on consumer behaviour by Cardozo (1964). That experiment showed that consumer satisfaction with a product was affected not only by expectation but also by efforts. The principal results of this experiment were: a) that a subject who expended "high effort" and b) that a subject for whom the product came up to expectation rated the product more favourably than did a subject for whom the product did not come up to expectation.

It is important to consider the influence of the kind of product (simple / complex) on consumer evaluation. Day (1977) distinguished between the influence of a simple and complex product on evaluation. Simple products are those which are purchased routinely and consumed soon after purchase. A great variety of consumer products fall into this category. In fact Day when presenting an extended concept of CS/D reported that for many simple products the consumer may not make an evaluation at all. Complex products make the consumer's evaluation task more difficult. Several aspects can contribute complexity to the consumer's evaluation of products such as:

- (1) The product is used over a considerable period of time so that the evaluation process may vary over time.
- (2) The product involves many different features, some of which may be highly satisfactory while other are unsatisfactory.
- (3) Complementary products which are purchased separately and used together in such a way that independent evaluation is difficult.

With respect to the evaluation of pharmaceutical products, Lidstone and Collier (1987) follow the footsteps of earlier writers (i.e., Knapp and Deltjen 1972) who considered doctors as consumers. Lidstone and Collier define medicine adoption (awareness and evaluation) as a process consisting of cognitive stages through which a potential doctor must pass. The awareness of a new medicine is generally thought of as a passive activity, while a new medicine is evaluated according to a variety of sources of information.

Generally, the evaluation process is multidimensional in nature even for the simplest products, because a product (simple or complex) usually has more than one attribute or feature which can influence the level of satisfaction of the user. Post purchase evaluation gives an insight into the relationship between consumer's attitudinal dimensions and market behaviour. Most researchers have viewed consumer post evaluation as an "outcome" within an encompassing buying behaviour process (Anderson 1973, Hunt 1976, Swan 1977) as well as an effort to determine the level of rightness or wrongness of the purchase decision. Ortinau (1978) identified four distinguishable stages in his post purchase evaluation model, namely, new ownership, early consumption, subsequent consumption and disposition. Pre-purchase expectation has generally therefore been compared with purchase satisfaction (Anderson 1973, Cardozo 1974, Andreasen 1977a)

The relationships involved in this approach are depicted in figure (3.4). If benefits received from a purchase are equal to expectations, confirmation and equity occur and satisfaction results. If benefits received are greater than those expected, positive disconfirmation and positive inequity occur. Negative disconfirmation and negative inequity occur when benefits received

are less than expected. Thus dissatisfied consumers are assumed to be those persons who receive negative disconfirmation and negative inequity in their purchase and consumption of products and services.

FIGURE 3.4: THE FLOW DIAGRAM OF THE PURCHASE DECISION PROCESS

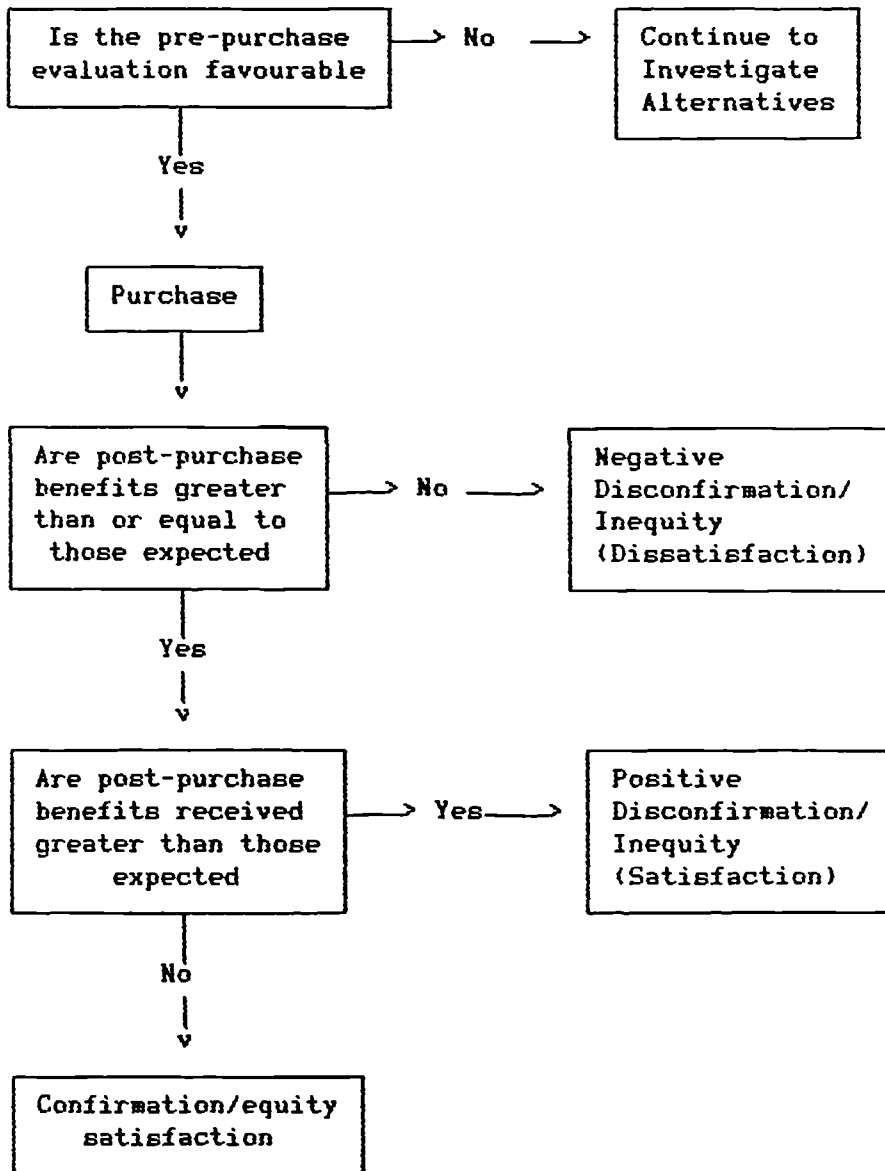

Source: Clabough, Mason and Bearden, 1978 and the Researcher

3.3.5. PSYCHOLOGICAL THEORY OF CONSUMER SATISFACTION:

A considerable amount of theoretical research has been done in recent years on the psychological process associated with the assessment of consequences of decisions. Consumer psychologists and marketing researchers have applied some of these theories to product evaluation and the assessment of satisfaction in the consumer decision making context. Engel et al (1986) consider the traditionally accepted components of attitudes which were mentioned earlier a) cognitive, "beliefs about the attitude object" b) affective, "feeling of like or dislike" and c) behavioural conative, "action tendencies toward the attitude object".

Pfaff (1976) pointed out in his paper that there are three significant factors in any satisfaction measure: one cognitive and two affective. The two affective factors are the positive and negative aspects. Pfaff developed both cognitive and affective models of psychological consumer satisfaction. He focused not only on price and quantities but also on a wide range of attributes with a given product or service. The cognitive model is based on the difference between an ideal set of attributes combination which a particular individual considers to be relevant for himself and his perception of the actual combination of attributes. Consumer satisfaction can therefore be viewed as the inverse of the difference between the ideal and actual combination of such attributes. An index of consumer satisfaction interpreted in a cognitive model would measure therefore discrepancy between what an individual would like to see realized in the market and what the market actually offers to them (Pfaff 1976).

The affective model is an alternative to the cognitive model. In this model, the individual evaluates goods and services not

simply on the basis of some kind of rational calculus but also on subjectively felt needs, aspiration and experience. An affective model would therefore focus on aspiration levels and learning behaviour in order to explain changes in the satisfaction level over time even when the real world has not changed at all. Moreover, an affective model is based on the observation that an individual may be satisfied with products which are characterised by real problems, at least in the eyes of experts. The affective model has come to outweigh the cognitive model in psychological theory. Thus it has been considered by researchers as an essential aspect of attitude. Indeed it is sometimes treated as attitude itself.

Hunt (1976) discussed the relationship between the cognitive and affective model. He commented that there is a correlation between the cognitive and affective. But the correlation is low enough, so that we can consider them independent. In contrast, Swan and Mercer, (1981), define cognition and affection as two concepts that seem correlated with each other. However, the cognitive model encompasses elements such as judgement that the product has performed well or poorly or that decision to buy the product was wise or unwise. While the affective dimension refers to a feeling about the product such as pleased / displeased or a very warm to very cold feeling about the purchase.

According to Cohen (1981) there are four psychological theories which must be considered when trying to predict how the disparity between expectation and actual performance influences consumer satisfaction. Such theories provide alternative predictions of how the consumer behaves when his perception of the

performance of the product is at variance with the prior expectation of the product (Anderson 1973).

(1) Contrast Theory:

Contrast theory predicts that when a difference exists between expectation and performance, the consumer will exaggerate the disparity (Spector 1956). If the objective performance of the product fails to meet expectation, the consumer will evaluate the product less favourably than he would if he had no experience with it. Anderson (1973) showed the sensitivity of that theory. Thus if the product performs some what better than expected, the relation will be highly favourable, but if performance falls short of expectation the relation will be highly unfavourable. Anderson also demonstrated what he labelled a "contrast effect". When expectation was extremely high, judgement of product quality was somewhat lower than when expectation was moderately high. According to contrast theory, the discrepancy, which remains subjective, and the expected attribute level will contribute to dissatisfaction (La Tour and Peat 1979). Hence the gain in satisfaction obtained by increasing perceived quality through the creation of high expectation might be eliminated by dissatisfaction associated with the discrepancy.

(2) Dissonance (assimilation) Theory:

This theory has received the greatest attention in consumer behaviour and marketing circles. Olshavsky and Miller (1972), explained that this theory would predict the opposite effect from contrast theory i.e., the consumer tends to minimize the difference between expectation and performance. Dissonance theory leads to the supposition that expectation before the purchase is made might

be quite different from expectation after purchase, especially if the actual experience was substantially different from the expected experience (Hunt 1976).

Robertson et al (1984) presented comments on this theory made by Festinger (1957). Festinger tells us that "dissonance creates a state of psychological tension which motivates the individual to attempt to reduce that tension and return to a state of psychological balance". Kassajin and Robertson (1973) concluded that dissonance theory may sound similar to cognitive consistency theory, since people according to this theory strive to achieve consistency within their cognitive system and between their cognitive system and overt behaviour.

(3) Generalized Negativity Theory:

Anderson (1973) summarized this theory. Any disparity in expectation and performance will result in less satisfaction than if expectation is met. More precisely, it indicates that any discrepancy between expectation and performance results in a generalized negative state. If a consumer expects a particular performance from a product but a different performance occurs, he will judge the product to be less pleasant than had he had no previous expectancy (Carlsmith and Aronson 1963). In addition, "A generally negative attitude will cause the product to be perceived as less satisfying than its performance would indicate" (Cohen 1981).

(4) Assimilation - Contrast Theory:

Sirgy (1984) explains this theory which was originated by Hovland et al (1957). They argued that messages when perceived may fall within the individual's latitude of acceptance or rejection,

if the message falls in the acceptance region, it will be assimilated into the individual's cognitive framework and conversely, if it falls in the rejection region, the individual will experience a contrast effect and therefore reject the message. Thus if the perceived product performance falls in the acceptance region, it will be assimilated producing satisfaction, a contrast effect will be experienced if it falls in the rejection region, the consumer will feel dissatisfied. Figure (3.5) illustrates the relationship between level of performance and level of expectation for all these psychological theories.

Whatever one concludes about these theories, it seems clear that the evaluation of satisfaction or dissatisfaction is complex. The extent to which marketing activities influence expectation appears to vary widely over individuals and it seems that sensitivity to disparity between expectation and perceived performance also varies over individuals.

FIGURE 3.5 THE RELATIONSHIP BETWEEN EXPECTATIONS AND PERFORMANCE LEVELS

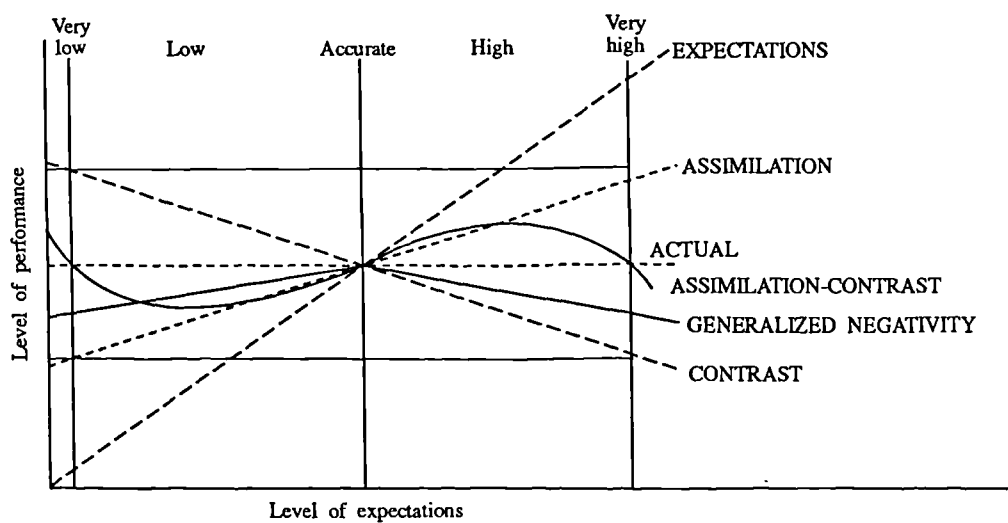

Source: Anderson, 1973

3.3.6. SOCIOLOGICAL INTERPRETATION OF CONSUMER SATISFACTION / DISSATISFACTION

Satisfaction / dissatisfaction is not only a term in marketing literature. It also exists in the sociological literature under the heading of alienation and communication - effect theory. These two concepts have been extensively used in marketing literature to interpret CS/D. Both of them are discussed below in turn.

3.3.6.1. ALIENATION:

Clarke (1959) defined alienation as "the psychological state of an individual". He described an alienated person as one who is estranged from his society and the culture it carries". Seeman (1959) reported that alienation is typically viewed as a generalized socialization phenomenon which results from a persons's efforts to cope with perceived environmental inequalities and imbalances. Alienation is defined by Hajda (1961) as "an individual's feeling of discomfort which reflects his exclusion or self-exclusion from social and cultural participation".

Although alienation has sometimes been conceptualized as an objective condition of society or a collective experience, it can be examined as a subjective state of mind consisting of certain attitudes, beliefs and feeling. In attempts to clarify the concept of alienation, Seeman (1971) has proposed five different variants of the concept: powerlessness, meaninglessness, normlessness, isolation and self-estrangement. Each variant refers to a different subjectively felt psychological state of the individual, caused by different environmental conditions.

Seeman (1971) reported that the idea of alienation used powerlessness frequently in broad terms as "the expectancy or

probability held by the individual that his own behaviour cannot determine the occurrence of the outcomes or reinforcements, he seeks". In terms of marketing consumer powerlessness is a feeling that one cannot exert influence on a seller's behaviour with regard to prices, products, services, credit procedures, warranty decisions and other actions that affect a buyer (Scott and Lamont 1973a).

Levin (1960) stated that meaninglessness is apt to vary with the difference in the amount of information an individual considers necessary to make an intelligent decision and the amount perceived to be available. Lambert and Kniffin (1975) suggested that meaninglessness occurs when consumers feel shackled and incapable of judging and choosing intelligently from among alternative products, brands or dealers because of inadequate information.

The third form of alienation according to Seeman (1971) is normlessness. Kanungo (1979) stated that an individual may develop a sense of normlessness when he finds that previously approved social norms are no longer effective in guiding behaviour for the attainment of personal goals. The individual finds that to achieve given goals, it is necessary to use socially unapproved behaviour. Consumer normlessness is characterized by Peterson (1974) in terms of marketing as the danger feeling of being ripped off by a business community that is motivated by self-interest and unwilling to assume its responsibilities either to its customers or society at large.

Kanungo (1979) felt that the terms of social isolation and self-estrangement could be used interchangeably. Lambert and Kniffin (1975) clarified isolation and self-estrangement as a person who perceives things, beliefs and goals that are very important to most

members of society as lacking value and validity, as providing little or no meaningful satisfaction, as being purposeless.

The main stimulus in presenting the above recognition of the concept of alienation is to provide an insight into the link between alienation and the feeling of dissatisfaction. Since a consumer with a strong feeling of alienation may have a greater tendency to make external attribution of blame when dissatisfaction occurs (Krishnan and Valerie 1979). So far, Lundstorm and Kerin (1976) have demonstrated that consumer dissatisfaction is positively correlated with the alienation dimensions of powerlessness, normlessness and social isolation. In addition, a study's findings by Lambert (1980) imply that consumer alienation may be a common denominator in general feelings of dissatisfaction with the market place and in numerous consumerism concerns that may seem unrelated on the surface.

3.3.6.2. COMMUNICATION - EFFECT THEORY:

Communication is the second facet of the sociological interpretation of consumer satisfaction. Pfaff (1976) tied this up with psychological theory (cognitive - affective). Individuals evaluate products cognitively or affectively or both and are likely to respond to changes in persuasive communication. Accordingly, observed changes in consumer satisfaction may be simply the result of some communication (e.g., messages, which have been received in either an interpersonal, intergroup, or mass communication situation). Sirgy (1984) also used Hovland et al's theory (1957) of message acceptance / rejection to illustrate the linkage between communication and psychological theories, (as previously mentioned in the section on assimilation-contrast theory). Consequently, any

attempt at explaining the reasons for changes in satisfaction would have to cope with a wide network of interaction and communication within which any individual is placed. Pfaff added that, if there are observable changes in the actual attributes of the product, it is therefore very difficult to disentangle the effect of any single source of messages from the individual's preexisting attitudes.

This would suggest that the measurement of consumer satisfaction should concentrate on formulating descriptive measures, without necessarily entering into the more difficult question of why consumer satisfaction or dissatisfaction has actually changed.

3.3.7. UTILITY THEORY OF CONSUMER SATISFACTION / DISSATISFACTION:

Consumer satisfaction / dissatisfaction can also be conceptualised in terms of economic theory. There is but little doubt that the examination of consumer satisfaction is considered by most economists to be the ultimate goal of the market economy. Indeed, the advantages of competition and decentralised coordination of the economic system are generally stated in terms of their effects on consumer welfare (Pfaff 1976).

The literature distinguishes between satisfaction and utility. Whereas the confirmation of expectations approach to satisfaction is related to cognitive psychology, the utility theory approach is based more on ideas from economics. Economists equate satisfaction with utility, the two terms are often used interchangeably, for example Samuelson (1967) tells us a consumer buys a good because it gives him satisfaction or utility. Day (1976) states that economists visualize a consumer as a rational decision-maker who seeks to maximize his total or overall satisfaction. More specifically, utility theory assumes that for any product there is

a combination of levels of the salient attributes of the product which provide the individual consumer the highest possible level of utility. In general, economists emphasise that an individual is defined as acting rationally if his behaviour is directed towards maximizing his satisfaction or utility.

Traditionally, economists have viewed utility as inherent in the good involved. Consumer satisfaction can be viewed as the form, time, place and possession of utility. The four types of utility are not separated (Walters 1974). That concept was extended by Lancaster (1969) who pointed out that the utility is the collection of economic reasons for consuming a product (i.e., the various product characteristics). Consumers possess preferences for a collection of some characteristics, and preferences for products are indirect or derived in the sense that products are required in order to produce the characteristics. Lancaster (1971) proposed a new approach which criticized the traditional theory. He stated that utility or satisfaction is derived from the properties or characteristics which the goods possess, rather than the good themselves. Goods are viewed as vehicles for obtaining these characteristics or benefits and thus analogous to inputs to a production process. Obviously the consumer may have to combine several sets of such inputs, including his own time and effort in order to derive the desired bundle of utilities or satisfaction.

The issue of generic prescriptions can well be considered under the economic theory as explained more recently by Blum and Kreitman (1981). They assume that the consumer / patient is both knowledgeable and rational, seeking the same medicine product at a lower price, then the availability of a generic medicine may be a factor in consumer decision. Similarly, it is assumed that doctors

are cost conscious, then the generic medicine ought to be selected according to the economic model of rational decision-making based on low cost as a "utility".

Although economists have attempted to provide further insight into the concept of utility, and these are described below, they do not contribute measurably to the task of conceptualising consumer satisfaction. Consumer surplus is considered an important branch of economic theory, because the rational consumer will allocate his / her scarce resources in such a way that the ratio of marginal utilities to the prices of all products will be equal. Hence, the total utility which he / she derives from all products is at its maximum. If there any changes in the price of product, his / her resources have to be reallocated in order to reach a new equilibrium. Cavusgil and Kaynak (1982) suggest that the chief concern of consumers in any society is to obtain desirable location and time and reasonable prices. Pfaff (1976) clarified the benefits of consumer surplus in the case of an undifferentiated market (i.e., one-segment) where all consumers pay the same price. Among them a group of consumers who might in fact be prepared to pay higher prices, obtains a subjective benefit. This benefit is termed consumer surplus. Consumer surplus therefore, measures the difference between the prices individuals would have been willing to pay and that which they actually paid on the basis of the going market prices. It is clear that, the larger the surplus, the more satisfied the consumer will be with the product.

Although the consumer surplus concept is the cornerstone of economic theory, it is an incomplete picture of the concept. Consumer surplus expresses a consumer's reaction with regard to the price and quantity relationship only. It ignores other product

attributes such as quality, packaging, labelling, etc. which in fact play a part in the consumer's total experience of the product.

3.4. THE RELATIONSHIP BETWEEN SATISFACTION AND DISSATISFACTION:

It is necessary to examine the relationship between satisfaction and dissatisfaction since different viewpoints have arisen. Whereas most researchers consider them extremes of a single bipolar continuum, others believe satisfaction and dissatisfaction refer to independent aspects in the individual's perceptual space. The controversy is worth of discussion.

This controversy arose first in the job satisfaction field. The traditional view of job satisfaction dissatisfaction is as a unidimensional concept. Bockman (1971) reported that satisfaction and dissatisfaction corresponding to positive feeling and negative feeling, marked the extremes of a single affective continuum as shown in figure (3.6). Midway between a person's dissatisfaction (negative feeling) and satisfaction (positive feeling) is a condition of neutrality in which the individual is neither satisfied nor dissatisfied. A person's overall feeling about his job was determined by summing his attitudinal responses to many specific aspects of his work and work situation.

FIGURE 3.6: THE SINGLE DIMENSION OF SATISFACTION/DISSATISFACTION FEELINGS

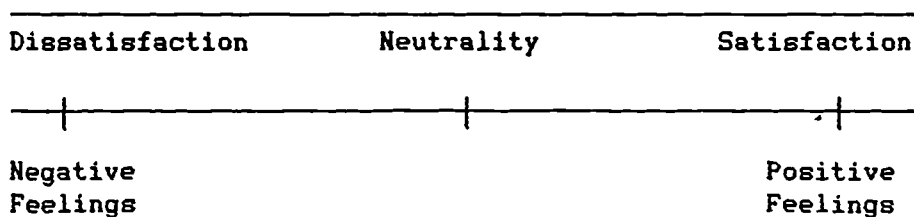

Source: Leavitt, 1976

Herzberg et al (1959) developed a two-factor theory, that satisfaction and dissatisfaction are quite different constructs, since they are caused by different facets of interaction between a stimulus (job, product) and an individual. Herzberg and his colleagues argued that job satisfaction and dissatisfaction result from different causes. Satisfaction depends on motivators while dissatisfaction is the result of hygiene factors. They argued further that these two sets of needs operate in different ways. Since the constructs are unrelated, an individual may be simultaneously satisfied and dissatisfied or putting it another way one's level of satisfaction is independent of the level of dissatisfaction. Bockman (1971) represented this view in figure (3.7). The opposite of job satisfaction is not dissatisfaction, and similarly, the opposite job dissatisfaction is not satisfaction but no job dissatisfaction.

FIGURE 3.7: THE INDEPENDENT DIMENSION OF SATISFACTION/DISSATISFACTION FEELINGS

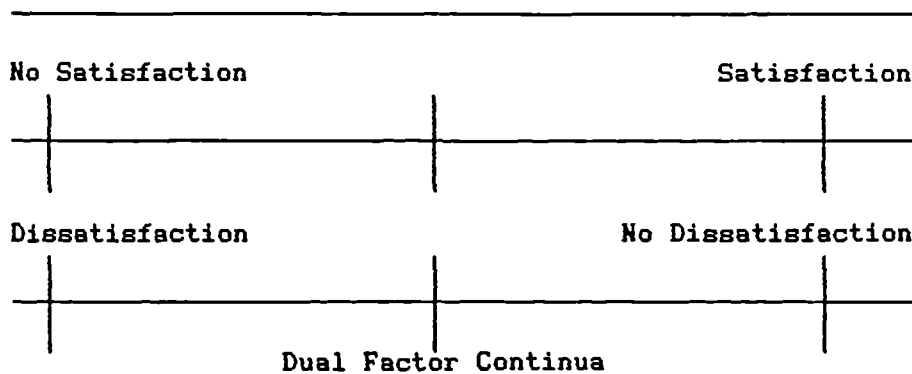

Source: Bockman, 1971

Stokes (1973) illustrated distinction between the satisfaction and dissatisfaction as a single dimension and satisfaction and dissatisfaction as independent dimensions. He assumed that a product can be described by just two facets: price and quality (P.Q). In the single continuum theory a consumer who was moderately satisfied with the quality of the product and moderately dissatisfied with price, would experience an overall satisfaction (O.S) which can be expressed in terms of a single dimension. This O.S could be enhanced by either a reduction in price causing his satisfaction with price move from P to P' or an equivalent increase in quality (Q to Q') (see figures 3.8 and 3.9).

FIGURE 3.8: EFFECTS OF A CHANGE IN PRICE OR QUALITY ON A SINGLE CONTINUUM

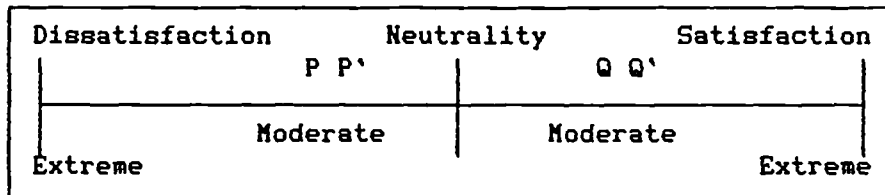

Source: Stokes, 1973

FIGURE 3.9: EFFECTS OF INCREASE IN QUALITY AND PRICE ON DUAL-FACTOR CONTINUA

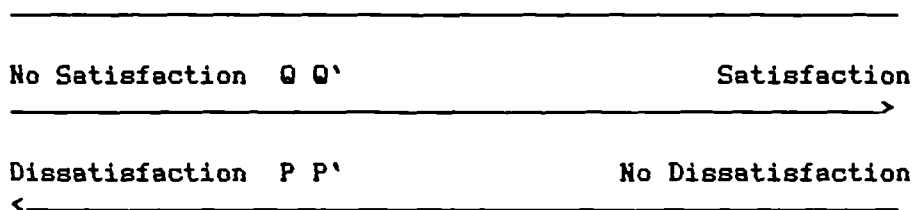

Source: Stokes, 1973

If satisfaction and dissatisfaction are independent, Stokes (1974) stated that, " No amount of improvement in quality, with price held constant, would influence the individual's feelings of dissatisfaction due to price". Increase in quality, no matter how great, that results in any perceptible increase in price could actually increase the consumer's level of dissatisfaction even if he was being offered a much "better buy". Similarly, if a consumer expresses a very low degree of satisfaction with quality, no price reduction could raise his level of satisfaction. Stokes illustrated the two concepts without reaching a conclusion.

Herzberg's two factors theory however encountered much criticisms as reported by Locke (1976). Whitsett and Winslow (1967) found that the two factors (i.e., motivator and hygiene) correlated with both satisfaction and dissatisfaction. Waters and Waters (1969); Hulin and Waters (1971); Waters and Roach (1971) employed satisfaction and dissatisfaction scales, and also failed to show consistent support of Herzberg's theory. Schneider and Locke (1971) found out that, the effects of motivators and hygiene factors were similar rather than opposite. However, one interprets these results, one cannot support Herzberg's theory.

In summary, it seems that satisfaction and dissatisfaction are not independent but they are causally interrelated. In other words, the satisfaction and dissatisfaction scale is unidimensional.

3.5. MEASUREMENT OF CONSUMER SATISFACTION / DISSATISFACTION:

The development of consumer satisfaction measures have not received much attention in the marketing and consumer behaviour literature. The most frequently used measures of consumer satisfaction are simply the binary variable (satisfied - not satisfied), or a threefold classification (completely satisfied, partially satisfied and not satisfied). An excellent discussion of the measurement methodology for an index of consumer satisfaction is presented by Handy (1976) who states that satisfaction can be measured by assigning a set of numbers to various points of the satisfaction scale, and computing the average satisfaction response by all respondents. A weight can be given to: a) always satisfied b) almost always satisfied c) sometimes satisfied d) rarely satisfied and e) never satisfied. From these weights a dissatisfaction measure can be derived, since the higher the score for a particular product or service, the higher level of dissatisfaction. Swan and Longman (1972) evaluate consumer satisfaction with automobile performance using a three point scale whose end points are satisfied - dissatisfied. Andreasen (1976) in his paper identified an important question in measuring consumer satisfaction / dissatisfaction. He developed three questions:

(1) What is the goal? Do we wish to maximise satisfaction or just minimise dissatisfaction?

In answering this question, he stressed that minimising dissatisfaction may be involved for practical reasons, because maximising satisfaction is an elusive goal. It is difficult to conceive of ever making people fully satisfied and achieving a performance free of defects.

(2) Are individuals to be allowed to define their own satisfaction or dissatisfaction or is some objective measure preferred?

In the context of the social indicators' literature a distinction is made between, on the one hand, measures which build upon reports from individual citizens about their feeling of satisfaction (subjective measurement). And on the other hand, such measures which gauge welfare independently of the individuals's appraisal of this own situation (objective measurement). Hunt (1976) demonstrated that most empirical studies of consumer satisfaction have focused on the consumer's subjective evaluation of the benefits obtained from the consumption of a specific product or service.

(3) At what point in the purchase process do we wish to measure consumer satisfaction or dissatisfaction, soon after the purchase or after the possible complaints have been resolved?

With respect to the alternative ways of measuring consumer satisfaction and dissatisfaction, Miller (1976) defined three ways. First, satisfaction may be measured simply as a self reported categorical response on a single-dimensioned scale e.g., how satisfied are you?, with responses ranging from extremely dissatisfied through extremely satisfied. Howes and Arndt (1979) argued that single measures are usually used, because it has been found these measures do produce useful findings. Westbrook and Oliver (1981) agree with Howes and Arndt that simple single item rating scales are most often employed. But there has been little uniformity in the number of scale divisions or the nature of verbal anchoring, especially as consumer perception changes over time. Scales range from 3-point fully-labelled rating scales to 10- and 11-point variants labelled only at the extremes and midpoint. Pfaff

(1972) who developed perhaps the most advanced methodology in satisfaction measurement to date, through the index of consumer satisfaction, measured satisfaction on a seven point scale ranging from very satisfied (A) to very dissatisfied (G). Respondents were asked how important each of the attributes were for the purchasing decision, i.e., the end points are very important and not important. The second way to measure satisfaction according to Miller (1976) is a multidimensional scale, by which satisfaction and dissatisfaction may be measured as the result of multidimensioned-interaction among a number of variables comprising the criteria against which a shopper evaluates a product (in this case a store). Criteria are weighted by the consumer's report of how important they are, these weights are multiplied by the satisfaction scores for those specific criteria, and the sum of the weighted criteria scores provide the measures of satisfaction level. Westbrook and Oliver (1981) add that the multidimensional rating scale measures of product / service, have found applications only infrequently, despite their potential to reduce measurement error because of uncertainty in combining attributes into an overall satisfaction judgement. Finally satisfaction / dissatisfaction also may be measured by the number of complaints which could suggest the level of consumer dissatisfaction.

3.5.1. MEASUREMENT PROBLEMS:

In attempting to implement measures of expectation as well as the perceived actual performance of the object / concept being studied, the satisfaction researcher encounters a number of problems (Miller 1977) they are:

- (1) Timing: when one measures the various types of expectation or performance, there are several strong effects on the measurement, such as the right time to measure expectation, one should be careful to include all efforts, investment or costs the subject might include in his cognitive computation. perhaps it requires measurement of "actual" performance.
- (2) Interaction: it is very likely that the various types of expectations (i.e., ideal, expected, minimum tolerable, deserved) influence each other. Moreover, high expectation can raise the evaluation of actual performance and low expectation lower it at least for complex ambiguous stimuli.
- (3) Consumption coincidence: the situation attendant on consumption of the object (product / service). This potential problem threatens measurement of the perceived "actual" performance more than it does the expectation.

Hample (1977) defined two basic problems in developing of consumer satisfaction measure

- (1) *Aggregation of individual satisfaction measures into an indicator of total family or household satisfaction.*
- (2) Separation of satisfaction measures concerning a particular product / service system from the broader consumption and market system which influence consumer's evaluations

Thus many problems exist for the researcher when measuring satisfaction should he / she use the single dimension or

multidimensional approaches and what scale should he / she use; should he / she look at causes of satisfaction or post-evaluation. If the former should he / she try to measure expectation, if the latter when should the satisfaction be measured. The approach finally adopted in this work was a post-evaluation approach to satisfaction using an equally weighted multidimensional scale of 41 attributes and 10 statements, using 7 point interval scales to denote satisfaction. This approach is described in detail in chapter 6.

3.6. SUMMARY:

This chapter provided a discussion of five issues relevant to consumer satisfaction / dissatisfaction which emerged from the literature review of marketing and consumer behaviour namely the nature of consumer satisfaction / dissatisfaction CS/D, the conceptualization of CS/D, classification of consumer satisfaction, the relationship between satisfaction / dissatisfaction and the measurement of CS/D.

The introduction was concerned with the nature of the satisfaction phenomena raising the controversial issues of the importance of satisfaction to marketing practitioners and various government agencies.

The second section examined the major three levels of CS/D (system satisfaction, enterprise satisfaction, product / service satisfaction). It was concluded that those levels interact each other.

The conceptualization of CS/D was then presented, citing different definitions of consumer satisfaction and dissatisfaction. The similarity / dissimilarity between satisfaction and attitudes

were discussed. Two major approaches to consumer satisfaction were proposed (causes of satisfaction, post-evaluation satisfaction). It was determined that, the literature showed expectation as the primary cause of satisfaction / dissatisfaction feeling, followed by performance and disconfirmation and inequity. The influence of the causes of satisfaction was supported by a model which built on expected performance and evaluation of perceived actual performance. The discussion of post-evaluation satisfaction emphasised the factors which might trigger the evaluation process and the section concluded by presenting a description of simple / complex products which have an important influence on evaluation. Four psychological theories were presented (contrast theory, dissonance theory, generalized negatively theory and assimilation-contrast theory) to show how each dealt with satisfaction. The sociological concept of CS/D was also discussed under the heading of alienation and communication-effect theory. The conceptualization of CS/D was concluded by the distinction between utility theory and the satisfaction concept.

The fourth section assessed the relationship between satisfaction and dissatisfaction. It presented the single continuum-dual factor argument. The section concluded that there is a relationship between satisfaction and dissatisfaction and the dual factor model is inappropriate.

Section five dealt with measurement of CS/D using single dimensioned scale / multidimensioned scale. This section was concluded by the major problems of measurement and a very brief description of the measurement method to be adopted in this work.

CHAPTER FOUR
CONSUMER CHARACTERISTICS RELATED
CONSUMPTION PATTERNS / SATISFACTION /
COMPLAINT BEHAVIOUR

- 4.1. Introduction.
- 4.2. An Overview Of Consumer Characteristics.
 - 4.2.1. Demographic Characteristics.
 - 4.2.2. Socio-economic Characteristics.
- 4.3. Consumer Characteristics And Consumption Patterns.
- 4.4. Consumer Characteristics And Satisfaction / Dissatisfaction.
- 4.5. Consumer Characteristics And Propensity To Complain.
- 4.6. Consumerism.
- 4.7. Summary.

4.1. INTRODUCTION:

There is no doubt that the starting point in defining a market is people. Over the past years, a number of studies have been constructed for the better understanding of consumers, and the most popular characteristics examined have been demographic and socio-economic.

Demographic and socio-economic characteristics are routinely used as identifiers of key target market segments. Buzzell et al (1969) stated that the demographic and socio-economic characteristics have been referred to as "states of being" because they identify attributes or profiles of people. In addition Settle et al (1978) related demographic and socio-economic to other types of variables and demonstrated that, demographic and socio-economic characteristics are often "enabling" variables that make possible various forms of consumer buying behaviour. Earlier studies attempted to show that a consumer's characteristics are related to his buying behaviour (Kopenon 1960; Robert 1962; Ronald et al 1967 and Myers 1967). Most of those studies used linear regression analysis in which demographic and socio-economic measures were used as the independent variables and buying behaviour was used as the dependent variable. Further Plummer (1974) reminds us that the broad acceptance of consumer demographic and socio-economic variables is because they lend themselves to quantification and consumer classification. Demographics alone lack richness and often need to be supplemented by other data. Hence socio-economic variables are added to provide more depth. Traditionally, marketing researchers have used demographic and socio-economic data to develop market segments and predict the market behaviour of individuals.

In the language of marketing, however, there is inconsistency in nomenclature regarding demographic and socio-economic variables. Some researchers use the terms of demographic and socio-economic variables interchangeably (Churchill 1976; Schiffman and Kanuk 1983 and Kotler 1984). While other writers draw a clear differentiation between the two sets (Frank et al 1972 and Settle et al 1978).

It is worth mentioning here that other characteristics are widely applied e.g., psychographics which are used in the measurement of life style. However, in this work we have concentrated on demographic and socio-economic variables for two reasons. First, in the Egyptian society, the respondents would have much less difficulty in providing information on their demographics / socio-economic than on their life style or personality. Second, the researcher felt that information on consumer demographic / socio-economic was more useful in measuring consumer satisfaction with, and consumption patterns of, the pharmaceutical products.

4.2. AN OVERVIEW ON CONSUMER CHARACTERISTICS:

In order to highlight the role of consumer profiles in behaviours, an overview of these profiles (i.e., demographic and socio-economic) are be presented separately.

4.2.1. DEMOGRAPHIC CHARACTERISTICS:

Dividing the market into segments based on demographic variables (i.e., sex, age, family size, marital status) are the most popular bases for distinguishing consumer groups. Kotler (1984) puts forward two reasons. One is that consumer wants, preferences and usage rates are highly associated with demographic variables. Another is that demographic variables are easier to measure than other types of variables. Earlier, Frank et al (1972) identified more reasons such as, the accessibility to these segments by various communication and distribution media as well as the relatively large size segments based on any of these variables. Few marketers anywhere can afford to ignore the study of demographic characteristics, if their products are bought more by some demography than by others.

The differences between the buying behaviour of males and females have been reported in a number of studies. Many earlier studies had attempted to interpret, understand male-female buying behaviour and examine the role of men and women (Nuttall 1962 Kollat and Willet 1967). Green and Cunningham (1975) found the differences between the roles of men and women in contemporary and traditional role perceptions had an effect upon family decision-making patterns. More recently an empirical study was conducted by Qualls (1982) on 117 households. Six product decisions were selected on the basis of their potential for being decisions jointly determined by husbands and wives. The six products included (family vacations, family automobile, children's education, family housing, family insurance and family saving). The analysis illustrated the mean ratings of perceived influence by husbands and wives. It was found that the husbands' rating of their

perceived influence are consistently higher than the wives reported perceptions.

Because product needs often vary with age and life cycle, researchers have found age to be a useful variable in distinguishing segments. Frank et al (1972) raised the critical question: whether or not different age groups really buy differently. Life cycle is defined in terms of a composite of demographic characteristics, especially marital status and age. In this respect, Kollatt and Willett (1967), in a study of unplanned purchasing, found that couples married less than ten years have the lowest rate of unplanned purchasing. Furthermore, the percentage of unplanned purchases increases irregularly as the length of marriage increases.

4.2.2. SOCIO-ECONOMIC CHARACTERISTICS:

Wind (1969) reminds us that socio-economic variables in general, and a combination of variables known as social class in particular, have often been used to explain consumers' buying behaviour. Frank et al (1972) go further in presenting various bases for market segmentation and define two groups. The first, those which focus on each of the variables (income, education, or occupation). The second those which assume interaction among various socio-economic variables and take them simultaneously in the form of some complete index of social class. Engel et al (1986) discuss the stability of social class against income, since the controversy has been debated in the marketing literature for years. They conclude that income is adequate for some products but social class is superior for others. In addition, social classes are often

expressed either in terms of income, education and occupation or in terms of lower / upper classes.

Carmen (1965) argued that even the empirical definitions of social class typically involve education and income. Cohen (1981), after he had reviewed many sociological studies, pointed out that the sociologists have used a number of indicators as determinants of social class such as occupation and income. Further Robertson et al (1984) show the role of occupation, and stress that the one variable with which social class is most highly correlated is occupation, which is in turn highly correlated with education and income.

General speaking therefore, demographics and socio-economics play an important role in family decision making and buying behaviour.

4.3. CONSUMER CHARACTERISTICS AND CONSUMPTION PATTERNS:

Consumption patterns are considered one of the major facets of market behaviour. The effect of consumer characteristics on the pattern of consumption has received appropriate attention ranging from the practitioners in the market place through the academic marketing literature. Gist (1974) identified consumption patterns as "any of several observable features or characteristics of consumer behaviour". He further defined consumption patterns as a "symptom of attitudes, values, beliefs and motives of a consumer or group of consumers". It is a symptom as distinct from a cause of consumer behaviour. Kinnear and Bernhardt (1986) support Gist's views with respect to the importance of consumption patterns, stating that demographic factors of sex, age, family size, marital status often are not sufficient to explain variations in consumer

buying behaviour. However, there is much evidence in the literature to refute this statement and show that consumer characteristics have a significant role in consumption patterns. In a survey study, Arndt (1978) grouped income under family life cycle and pointed out that income varies over the life cycle. He then examined the size and composition of consumption and expenditures by stage in family life cycle by carrying out a study on a sample of 4707 households selected by a stratified method. In general, the results of the study tend to support the notion that size and composition of household expenditure are systematically related to stage in family life cycle.

In an earlier study by Crockett and Fried (1960) found that age and family size to be the most highly correlated demographic variables with consumption of consumer goods. Goldstein's study (1968) focused on the aged population's share of aggregate expenditures for various categories of goods and services. The study relied on the availability of data in the mid - 1950's and 1960-1961 from the American Bureau Of Labour Statistics. The results demonstrated that, expenditure of goods and services (food, housing, medical care) became increasingly larger with rising age of family head, especially after the age of 65. Goldstein concluded that, there appears to be no such thing as an "age" of acquisition, that is an age group which dominates the consumer market with intensive purchase of a wide variety of consumer goods.

The effect of life cycle on consumer behaviour was also investigated and reported by Frank et al (1972). They presented the results of some social researches, one in 1962, a furniture study for Kroehler Manufacturing Company. It was found that, interest in furniture buying is highest during the early years of marriage as

well as when children have reached adolescence or have left home to establish families of their own.

Coleman (1960) concluded in his study that, income is a good predictor of consumption of some products. Gist (1974) also considered income as a main component of consumption patterns. In marketing and consumer behaviour, the concept of social class as a major determinant of consumption patterns has been widely accepted and used as a basis for segmenting consumer-product markets. Income, education and occupation are considered by some writers as components of social class (Coleman 1960, Martineau 1958). Wasson (1969) attempted to examine the differences in the allocation of the family budget to food, shelter and education for families of various social classes and incomes. He concluded that social class was superior to income and contended that marketers should abandon income and use social class as a segmentation base. However, the relative superiority of income versus social class as a segmentation base is still an unresolved controversy.

The contribution of twelve demographic and socio-economic variables on consumption were discussed by Freedman (1968) in a study designed to investigate consumer behaviour in Taiwan. Interviews were obtained from a probability sample of 2713, and information was collected on nine consumer durable goods. The findings showed that socio-economic variables (e.g., husband's education, husband's income, husband's occupation, wife's education) have the strongest relationship with consumption of durable goods. Those twelve variables (husband's education, wife's education, household income, husband's occupation, use of family planning, wife's traditional attitude scale, couple's rural background, length of marriage, number of children, family type,

ethnic background, age of wife) used in the analysis explained 52 per cent of the variation in consumption. Education was the most important determinant of consumption patterns followed closely by occupation and income. Thus, Freedman concluded that income is not an important determinant of consumption of durable goods in Taiwan.

Recently, Smith (1983a) discussed the manufacturer's consideration regarding the role of some demographic and socio-economic characteristics (sex, age, income) in the market of prescription medicines. Sex seems an important demographic characteristic, it has been shown that women have a higher consumption of health care products and prescription medicines than men. The consumer in 0-19 years and 60-79 years categories demand proportionally more health-care than do the other age categories. A further consideration is the importance of income level in determining the type and level of health care purchases. For example, the greater the affluence of a given family unit, the more its members seek medical attention. In addition, in a study by the US National Centre For Statistics, Smith found proportionally a greater number of doctors' visits were made to those higher income groups.

Graner (1983) also found that demographic and socio-economic characteristics influence the amount of medicine purchased from drugstores. The elderly and the extremely young are the greatest users of medicines. Females do most of the purchasing from pharmacies.

From the findings above, we conclude that demographic and socio-economic variables have a significant role in determining consumption patterns.

4.4. CONSUMER CHARACTERISTICS AND SATISFACTION / DISSATISFACTION:

In recent years, many consumers have expressed discontent with many products and services. Consumer frustration and dissatisfaction persists despite achievements made over the past years. Barksdal and Perreault (1980) describe a series of studies that have been conducted to monitor the public's attitude toward marketing, consumerism and government regulation and found that consumer discontent high and buyer dissatisfaction is widespread.

In the consumer behaviour literature, numerous studies have focused on identifying demographic / socio-economic correlates of consumer satisfaction / dissatisfaction and complaining behaviour with mixed results. Two types of research have been found in the literature. First, studies concerned with identifying the extent of consumer satisfaction or dissatisfaction. Second, studies of consumers who complain about their treatment in the market place. In both types of studies the emphasis was to explore the extent of the relationship between satisfaction / dissatisfaction, complaining behaviour and consumer characteristics. The structure of those studies was built on the basis of a dependent variable that represented behaviour, either complaining action or inaction, satisfaction / dissatisfaction or attitudes, and the independent variables were consumer characteristics. This section is assigned to review studies which show the extent of satisfaction / dissatisfaction by different demography / socio-economy, while the next section will touch upon the extent of consumer complaining by consumer profiles.

Regarding the first group of studies. A study by Wall et al (1978) investigated the degree of satisfaction with clothing performance on the basis of demographic / socio-economic patterns.

The results indicated that product performance as well as consumer variables are important in explaining consumer satisfaction. Cross tabulations and correlations were computed to examine the individual relationship between a consumer's level of clothing performance satisfaction and selected demographic / socio-economic variables (i.e., age social class, education, income). The relationship between social class and clothing performance satisfaction level showed that lower social class consumers were more satisfied than consumers with higher class levels. This may reflect a greater awareness and higher product performance expectation on the part of higher social class consumers. Based upon the cross tabulations of education levels and satisfaction levels, no significant relationship was found between levels of clothing performance satisfaction and level of education. In the context of income variations, the visual analysis of cross tabulation did not show a clear relationship between higher levels of income and higher level of satisfaction, but the two lowest income categories seem to have relatively high levels of satisfaction. The relationship for low income groups may indicate that persons with very low income accept the clothing products they purchase and within the scope of their experience find their clothing satisfactory. Finally in this study, the cross tabulations between age and satisfaction levels yielded a significant chi-square statistic. Younger consumers displayed less satisfaction than did older consumers. This may be due to the lack of experience and different sets of expectations.

Pfaff (1976) discussed the results of a study by the US Department Of Agriculture in planning to rerun the index of consumer satisfaction with food products within the years 1976/77.

The conclusion demonstrated that consumer satisfaction with food does indeed relate significantly to different demographic / socio-economic descriptors. As age increases so does satisfaction. Participants from large households tend to be more dissatisfied than those from smaller ones. As education and income increase, satisfaction decreases.

Another earlier study by Mason and Himes (1973) provided additional insight into the characteristics of consumers experiencing dissatisfaction with some household appliances in the preceding twelve-month period. The study hypothesized significant differences between some variables (family size, income, age, education level, marital status), and several patterns resulted. The level of education and marital status did not reflect statistically significant differences. In contrast, the number of people in the household, income and age did reflect statistically significant differences. The income levels of households which experienced dissatisfaction with appliances were higher than the households which did not experience dissatisfaction. The same patterns were observed in terms of age, more than 50 per cent of households who experienced dissatisfaction relative to their appliances were 40-50 years of age.

Ash (1978) carried out a survey to examine the possibility that certain consumer profiles reflected different levels of satisfaction / dissatisfaction with various kinds of durable goods. The actual data were acquired from self administered questionnaires from a sample of 119 respondents. Correlation analysis was used to examine the association between the satisfaction / dissatisfaction scores and demographic data. The results of that study indirectly support the results of Mason and Himes (1973). However, the results

showed that all demographic variables are significantly correlated with at least three of the durable product categories. Examination of the results also showed varying patterns of relationships between demographic variables and satisfaction. Although none of the coefficients were large, most of the categories exhibited some relationship between demographic variables and satisfaction scores. The variables with the largest number of significant relationships were marital status, employment status and income. Ash concluded that, the relationship between demographic variables and satisfaction were generally weak.

In addition to the above studies, more researchers have explored the area of consumer goods. Pickle and Bruce (1972) carried out a survey for the purpose of discovering the extent of consumer dissatisfaction with major appliances, automobiles and small appliances. Their findings were somewhat consistent with the results of other studies described. Data was generated from a random sample of 173 households. A significant difference in product satisfaction / dissatisfaction between age groups existed in the sample, the younger the age group the higher the degree of dissatisfaction. Significant differences were found between various education levels. With exception of the college graduates the higher the level of education, the higher the degree of product dissatisfaction experienced. With respect to income, the sample exhibited no significant differences.

The study of consumer satisfaction / dissatisfaction vs consumer profiles has recently been expanded beyond the scope of consumer goods to such areas as satisfaction / dissatisfaction with quality of life and business practices. Andrew and Withey (1976) showed variations in the life domain satisfaction associated with

demographic / socio-economic variables. Domain satisfaction scores are shown to vary with age, marital status, family composition and race. Some of the variation is a result of constraints that prevent achievement of satisfactory conditions.

Lundstrom et al (1978) measured the extent of consumer satisfaction / dissatisfaction with business practices. The research involved questionnaires for 600 people using a six-point Likert scale with 41 items related to a variety of business practices. Analysis of the difference between groups of consumer satisfaction / dissatisfaction scores were examined for several demographic variables. The greatest disparity came from married versus single / divorced groups. Married persons were considerably more dissatisfied than their unmarried counterparts. Significant differences were also found for age, income and education. Older people were found to be more dissatisfied than younger people, lower income respondents had a much higher level of dissatisfaction as opposed to higher income families. In addition, the less educated person was found to be less satisfied than the better educated individual. On the other hand, the researchers found the less educated are more likely to have a lower income and to feel alienation from the economic system in terms of feeling a sense of powerlessness which is considered a major contributor to dissatisfaction.

There is a shortage of consumer behaviour studies, and in particular consumer satisfaction studies, in the area of pharmaceutical products. However, the researcher has found one empirical study done by Rapoport (1979) to explore consumer expectations of a remedy by doctor's prescription and his / her intention to self-medication regarding some demographic and socio-

economic characteristics (age, sex, social class). The results demonstrated that there was little variation in expectation of a doctor's prescription according to age, sex, and social class. Whilst, demographic and socio-economic variables relating to different intentions to self-medication showed a higher intention in the lower social class. Males were more likely to buy remedies than females. Analysis of age showed that elderly patients were least likely to try self-medication but these differences according to age were not statistically significant.

It is clear that more work is needed to look at consumer satisfaction in this important field and this thesis addresses this problem.

If we try to aggregate comments on the extent of the relationship between consumer profiles and satisfaction. We find some disagreement. Several of the studies described related to consumer goods (Pickle and Bruce 1972 "appliances"; Pfaff 1976 "food products"; Wall et al 1978 "clothing performance") support each other in finding that the younger consumers display more dissatisfaction than others. However, the results of Lundstrom et al (1978) showed the older respondents to be more dissatisfied than younger, while Mason and Himes (1973) "household appliances" study reported that the middle aged express most dissatisfaction. With respect to education, the findings of the some studies were slightly similar, Pickle and Bruce (1972) and Pfaff (1976) concluded that, the higher educated people are more dissatisfied. But Lundstrom et al (1978) again reached contrasting results, they reported that the less educated a person is the less satisfied he / she is. The finding that dissatisfaction increased with the higher income categories received general support.

General speaking therefore, we cannot ignore the extent of the relationship between consumer variables and satisfaction / dissatisfaction and the influencing role of those profiles on consumer attitudes. However, the role of some variables seem to be product specific.

4.5. CONSUMER CHARACTERISTICS AND PROPENSITY TO COMPLAIN:

A further approach to consumer satisfaction / dissatisfaction is to assess complaining behaviour, which may viewed as manifestation-thought representative of consumer dissatisfaction. London (1977b) presented a model of complaining behaviour. He considered dissatisfaction as an important component of this model and suggested that complaining behaviour may be related to personal characteristics. In addition, the model predicts that the dissatisfied consumer's tendency to complain will be affected by his / her expectation concerning the benefit from complaining. Gilly (1980) in his model of the post-purchase consumer process recognises "complaint expectation" as influencing the way in which the dissatisfied consumer deals with his / her unhappiness. Gilly goes further and points out that the evaluation of alternatives forms certain expectations by which the consumer may decide to voice the dissatisfaction to the seller in the form of a complaint.

In the marketing of products and services, there are many consumers who are upset with the way they have been treated in the market place. The most frequent action is to complain to someone in the responsible organisation. Action is taken as a result of dissatisfaction in order to achieve satisfaction. Consumer complaints have occupied an important position in the market, Richins and Verhage (1985) report for three reasons. First, if a

dissatisfied consumer complains about defective products or an inadequate level of service, that individual will benefit if the complaint is handled satisfactorily. Second, there is a benefit to the seller or producer who receives the complaint, in a sense that the organisation is granted a second chance to do its job well - to have a satisfied consumer. Third, there are societal benefits of consumer complaint action. Complaints are a form of feedback to business institutions. If consumers consistently complain about unsatisfactory services, poor product design or inadequate quality, firms will be better able to correct the cause of those problems. For instance, Bearden (1983) demonstrates that failure to express justified dissatisfaction is disappointing to both consumers and marketers. For consumers, redress or restitution is only possible if problems are expressed. For marketers, hidden discontent prevents problems from being corrected and may cause the firm to lose market share to competing products and services. In general, consumers with unresolved problems will undoubtedly develop more negative attitudes toward business firms and support additional governmental restrictions on their operations.

In evaluating the role of complaining behaviour it is important to know the factors which influence the quantity of complaining. Day and London (1976) reviewed four factors in this respect. First, the value of the product, many products are so low in value that dissatisfaction is overlooked. They might be important to the user but are used by only a small segment of the population. Second, the ease with which an individual can obtain redress locally and conveniently in the event of extreme dissatisfaction. In other words, if the source of the product or service is physically distant or otherwise difficult to contact a

complaint is unlikely to be made. Third, Day (1980) also identifies the prestige of a product as a factor which influences the quantity of complaining; such as the economic importance of the product, its social importance and its complexity. In general, the more expensive the purchase, the more likely a consumer will act upon dissatisfaction and complain. Fourth, the consumer's knowledge contributes to the quantity of complaining, because the less knowledgeable consumer will be less able to judge product performance and evaluate the products and services he consumes. He will also be unfamiliar with procedures for seeking redress and in registering complaints.

The classification of responses to dissatisfaction has been of particular concern to several researchers (Warland et al 1975; Day 1980; Bearden 1983). Day (1980) classifies the responses into three categories: (a) redress seeking in which a specific remedy is sought, (b) complaining for reasons other than redress seeking and (c) boycotting or a personal decision to discontinue usage or patronage. Bearden (1983) exhibits the range of possible consumer reactions to dissatisfaction as shown in figure 4.1. The various actions that consumers may take are either public or private responses. Whereas private responses may impact on the source of dissatisfaction, public action may lead to resolution of the problems.

There are a variety of empirical studies that have sought to expand the understanding of consumer complaining behaviour. Some studies focus on the differences between complainers and non-complainers on the basis of demographic / socio-economic variables. Other studies have concentrated on the direct relationship between

complaining and other consumer characteristics. Several studies found that the likelihood of complaining is related to personal characteristics. A study by Thomas and Shuptrine (1975) focused primarily on a selected list of consumer durables. They specified many objectives, among them, two are of particular concern in the context of this discussion. One is to determine how many consumers attempt to do something about the product that has given them the most trouble within the last year. Two, to contrast demographically those complainers who achieved successful complaint resolution with who did not succeed. The results of the study showed that not every consumer who indicated that he / she had some products that had given him / her the most trouble during the last year actual took any kind of action to get his / her problem resolved. In

FIGURE 4.1: CONSUMER REACTION TO DISSATISFIED

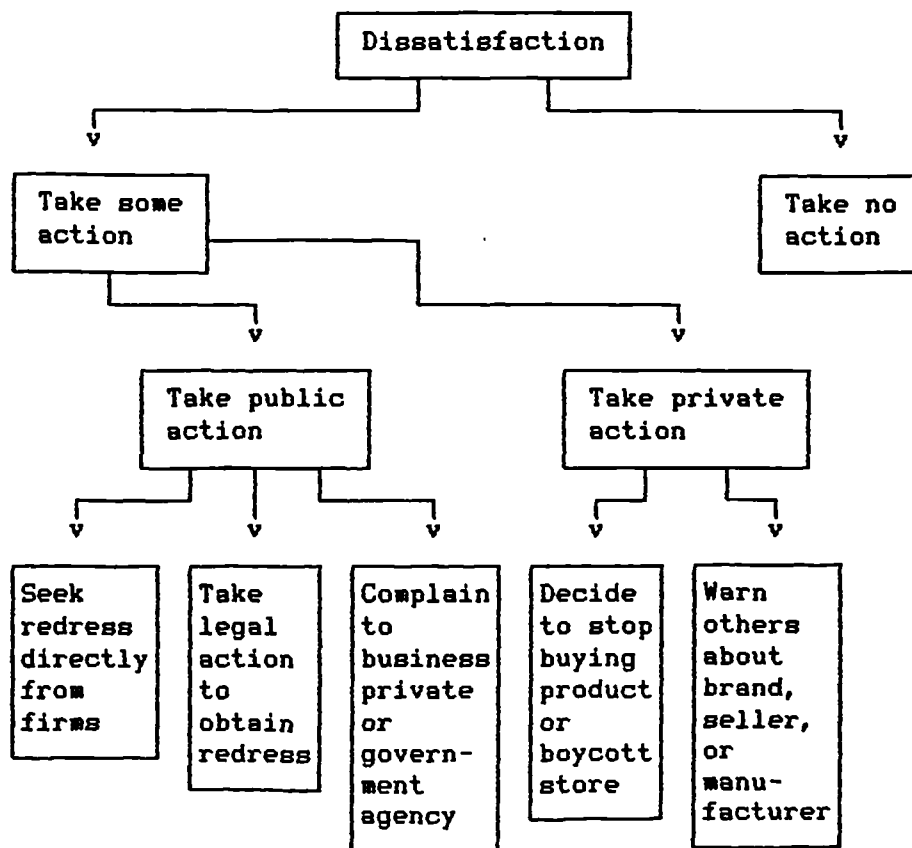

Source: Bearden, O.W., 1983, p.317

determining whether there were any differences between complainers and non-complainers on the grounds of their demographic / socio-economic profiles, males were involved in making complaints more than females. Consumers with a college education seemed to be more prone to complain about durables giving them major problems than were consumers with less education. Based on the different categories of income, age, occupation there does not seem to be any discernible difference in complaining behaviour. Thus, the percentages of non-complainers are higher than complainers in respect of two characteristics, sex and education.

It was suggested by Hunt (1976) that some people might complain because they think it is expected of them or they may complain too little because they think it is inappropriate to complain. Robinson (1978) described in his paper a study by Warland et al (1975). Warland et al researched the demographic and attitudinal differences between non-complainers and complainers. The results of that study suggested that non-complainers are often unaware of available resources, feel powerless to act or do not feel that complaining is worth the trouble. They also tend to be different from complainers in income (lower), educational level (lower) and social class (lower). Moreover, Warland et al reviewed other data that were obtained in 1972 by telephone interviews of 1215 adults from a stratified random sample. The study first differentiated among three groups of consumer dissatisfaction: (a) upset-action group, (b) upset-no action group and (c) not upset group. Second, their study presented a comparison of the three groups with regard to demographic and socio-economic variables. Those classified as "upset action" appear to be a distinct group, they were better educated, earned higher incomes, and were more

frequently in the top social classes. They were also younger than the other groups, while the profiles of "upset-no action" and "not upset groups" are quite similar.

Another survey study was carried out by Liefeld et al (1975) on 17000 Canadian consumers. Respondents were asked to indicate their age, education, family income, marital status, occupation of family head, sex and the number of complaining letters they have written to agencies. The results showed that middle aged consumers complain more than younger and older. Consumers with a lower level of education complain less than their counterparts. Further, consumers with a family income over \$8000 per annum complain more than the lower income classes. Married consumers complain more than single. High education level and unemployed consumers complain more than their counterparts. With respect to sex, no difference was found between male and female. Cross tabulation was used to count the frequency of complaining on aggregation of different profiles. The results indicated that consumers with a university education, family income over \$10000 or under \$400 and professional categories were highly complaining and respondents who were 35-69 years of age had a university education and married were also highly complaining. Gaedeke (1972) also aimed to shed some light on complainer's characteristics. The main results demonstrated that complainers are for the most part, a heterogeneous group coming from all socio-economic classes, geographic locations and age groups.

Although, again little work seems to have been done on consumer complaining behaviour in the pharmaceutical market, however, a review study of complaints carried out by Mikael and Sharpe (1974) has shown a relationship between complaints and the

income and cost of medicines. They found that the patient who pays a high price for a medicine item is more likely to complain, as is the patient with a higher income.

Summarising the above findings it seems that most of those studies demonstrated that complaining behaviour increases as education level increases. Consumers who complain tend to be younger or perhaps middle-aged and of higher socio-economic status than those who do not. Furthermore, all the previous studies were completely homogeneous with respect to income status, i.e., high income is usually accompanied by high complaining behaviour.

In concluding this section, we can easily see that demographic / socio-economic characteristics affect consumer complaining.

4.6. CONSUMERISM:

Consumerism is a fitting conclusion to this chapter. Engel et al (1986) explain the consumerism concept which has ancient roots. However, increases in voiced complaint and redress-seeking have been both causes and effects of the dramatic growth of consumerism over the past two decades. The purpose of this section is to show a different insightful explanation for consumerism. This is not presented as the researcher's unique alternative explanation but as a supplement to the prior explanations of consumer dissatisfaction and complaining behaviour.

In order to discuss the concept of consumerism, we must have reference to a commonly accepted definition so as to ensure that all marketers are discussing the same phenomenon. Despite this, there is as yet no generally accepted definition of consumerism in the marketing literature. For example, Buskirk and Rothe (1970)

defined consumerism as "the organised efforts of consumers seeking redress, restitution and remedy for dissatisfaction they have accumulated in the acquisition of their standard of living". Kotler (1972b) brings in to his definition rights, defining consumerism as "a social movement seeking to augment the rights and powers of buyers in relation to sellers". Buskirk and Rothe (1970) present Drucker's definition of consumerism. Drucker (1969) stated that "consumerism means that the consumer looks upon the manufacturer as somebody who is interested but really does not know what consumer's realities are". A consumer regards the manufacturer as somebody who has not made the effort to find out, who does not understand the world in which the consumer lives and expects the consumer to be able to make distinctions which he is neither willing nor able to make. More recently, Mayer (1981) presented a broader definition, "consumerism is a social movement to inform consumers so that they can make knowledgeable judgments regarding purchases of private and public goods. It is a movement to further corrective action against the misuse of both market and political power held by the suppliers of these goods. It is also a movement to make consumers aware of their responsibilities to deal openly and honourably with those from whom they purchase goods and services". Obviously, this definition includes issues of concern such as: (a) public goods, (b) the misuse of political in addition to economic power and (c) consumer responsibilities. Generally, consumerism emphasis has been on the quality of goods and services rendered commercially or by the government.

Of particular interest for this work, consumerism has begun to examine the quality of professional services including what doctors and pharmacists do. Further, consumers' unions have encouraged

patients to adopt a more active and questioning role, which of course requires education of the patients as well as confidence in the doctor (Woodcock 1981). Precise information is essential for the correct use of medicines. Medavar (1984) determines several basic democratic rights the patients should receive from the experts. Apart from the right to health, these include the right to information and education.

Brochert (1989) explains the situation in the developed countries in which consumerism is highly developed with respect to OTC medicines. How can one provide the patient with the correct information, when the patient may not know whether or not a helpful medicine exists, how to apply a given medicine, and how there is always the hope that there is a medicine which can restore the patient to perfect health?. The patient tends to trust almost every promise and pays almost price in the hope that the trouble may disappear. Despite the fact that a lot of information on OTC medicines is available: advertising in newspaper and television, newspaper, magazine articles and package leaflets and even oral information from family members, neighbours, doctors and pharmacists, consumer organizations still seek more information on OTC products.

The definition of consumerism expands into consumer protection when Day and Aaker (1970) linked different activities under the heading of consumerism. They stated that, consumerism is the "activities of government, business and independent organisations that are designed to protect individuals from practices of both business and government that infringe upon their rights as consumers". Assael (1987) supports Day and Aaker's definition and summarises the vehicle of consumer protection in three types of

organisations: (a) consumer-oriented groups concerned primarily with increasing consumer consciousness and providing consumer information to improve their basis of choice, (b) government through legislation and regulation and (c) business through competition and self-regulation.

With respect to the pharmaceutical industry, Borgenhammer (1989) stresses that in the area of public health, the fundamental responsibility of government is to protect the interest of consumers who are likely to become more critical towards the health service system. The new situation calls for more information and more concern for communication in order to create better understanding between health services personnel and patients. To provide more information some companies have introduced the "patient package insert" "PPI", which is considered an important source of information (Herxheimer and Davies 1982). However, at the same time PPI cannot be an effective for what the doctor tells the patient, or for what the pharmacist says or puts on label, that could be because the patient either does not yet have the insert or will not have had the opportunity to read it.

Consumerism is a clearly complex force, it is interrelated with other ecological, social, political, economic and technological problems. Andreasen (1976) suggested that sources of consumer satisfaction are important in exploring the consumerism phenomenon. In the last chapter we showed that a great variation exists among consumers in the extent of their dissatisfaction with the provision of medicines and there is a wide variety of underlying causes. Nevertheless, it is possible to determine specific sources of dissatisfaction in the marketing as well as economic environment. Several marketing researchers have tried to

isolate factors as the cause of consumerism (Buskirk and Rothe 1970; Day and Aaker 1970; Broffman 1971; Morin 1971; Kotler 1972b; Straver 1977/78). For instance, the variety of products in the market place as well as high expectation by consumers are two aspects which influence consumerism. The demands for product improvement have led to an increase in product complexity. Such complexity has been stimulated by the emergence of new technology. The problem is most severe for products which are purchased infrequently, exhibit a rapid rate of technology change, and whose performance characteristics are not readily apparent. In addition to that, the new technology is not accompanied by enough information. Imperfect information in the eyes of some authors is considered the main reason for dissatisfaction. Even more, product policies have come under attack to a large extent because of problems such as the quality / price relationship. This leads the writers previously mentioned (Buskirk and Rothe 1970; Day and Aaker 1970; Broffman 1971; Morin 1971; Kotler 1972b; Straver 1977/78) to state that more empirical evidence is needed on this topic to facilitate the price / quality comparison.

Inflation has added to this problem. Rising prices have been singled out for attack as well as leading consumers to increase quality expectations which are not achieved, thus again contributing to the frustration of consumers.

Alienation is another triggering factor (Engel et al 1986). A feeling of powerlessness and isolation leads to essentially defensive responses in the form of boycotts, pressures for legislation, and so on.

Demography and socio-economy should be included in any study of consumerism. As previously mentioned consumer profiles play a

significant role in consumer satisfaction / dissatisfaction. Thus Cohen (1981) tells us to look to demographic and socio-economic factors for a deeper understanding of consumerism, and Day and Aaker (1970) demonstrated that consumerism has become identified with problems associated with social fabric, particularly those of low income consumers who are suffering excessive price and poor quality in products and services.

Finally, Becker (1972) refutes the argument that consumerism has been a result of the success of the marketing concept, the core of which is the satisfaction of human needs and wants (Kotler 1984). He suggests that perhaps the growth of consumerism indicates the failure of business to grasp the marketing concept.

4.7. SUMMARY:

The purpose of this chapter has been to propose consumer characteristics as an important influence on consumer behaviour. Demographic and socio-economic variables are two basic groups which play an important role in family decision making and buying behaviour.

The role of consumer variables was shown in different behaviours such as consumption, satisfaction and complaining through a detailed presentation of many empirical studies. The effect on consumption of, and satisfaction with, different products were assessed by several consumer characteristics. The results of those empirical studies will be utilised in chapter 9 to compare with our empirical results of this research.

The propensity to complain was cited as a subsequent action to dissatisfaction. The degree of propensity to complain is also

influenced by consumer characteristics and was proven by some empirical studies.

The chapter concluded by shifting the focus to consumerism as an integrated concept with consumer dissatisfaction and complaining behaviour. The literature exhibited a variety of definitions, all of them in general defining consumerism in terms of rights and powers of consumers or organised efforts by consumers to seek redress.

CHAPTER FIVE
A CONCEPTUAL MODEL OF
CONSUMER SATISFACTION

- 5.1. Introduction.
- 5.2. Consumer Involvement.
- 5.3. Personal Values.
- 5.4. A Framework Of Relationships.
- 5.5. Conclusion.

5.1. INTRODUCTION:

It is clear to the researcher that there exists a need for a significant amount of further research in the area of consumer satisfaction. Such research needs to explore new dimensions such as consumer involvement and personal values and build them into the existing theoretical framework of other relationships. The recent literature shows that consumer involvement and personal values affect directly or indirectly the feeling of satisfaction / dissatisfaction. The researcher suggests therefore that these two dimensions are critical variables like expectation, experiences, performance, disconfirmation and inequity in determining satisfaction / dissatisfaction.

The purpose of this chapter is to critically review the most important empirical evidence and theoretical arguments regarding the role of consumer involvement and personal values in consumer satisfaction. A conceptual framework is presented which describes the interrelationships among a set of variables (i.e., consumer involvement, personal values, expectations, experiences, personal characteristics). Our emphasis is twofold, first the concepts of consumer involvement and personal values as new dimensions of consumer satisfaction are discussed individually and the background literature is reviewed. Second, these concepts are built into a model of consumer satisfaction.

5.2. CONSUMER INVOLVEMENT:

The concept of involvement has received much attention in social psychology and more recently in consumer behaviour studies. Basically, the concept of product involvement is "a recognition that certain products may be more or less central to an individual's life, his / her attitudes about himself / herself, his / her sense of identity and his / her relationship to the rest of the world" (Traylor 1981). Engel and Light (1968) characterised involvement as "the important values or motives". Day (1970) provided a definition of involvement that derived from Freedman (1964) and Ostrom and Brock (1968). Involvement according to Day is defined as "the general level of interest in the object or the centrality of the object to the person's ego-structure". Hansen (1981) defines involvement as "variations in the extent to which the individual is more or less motivated toward a specific piece of information, product, or the like". Slawa and Tashchian (1985) define involvement as "the degree to which consumers are interested, concerned or involved in the consumer decision process". The concept of consumer involvement is considered therefore by Sherrell and Shimp (1982) as one of the most important scientific units in consumer behaviour.

Considerable progress has recently been made by consumer researchers in understanding the nature of product involvement. Mittal and Lee (1988) state that, "product involvement is the degree of interest of a consumer in a product category on an on-going basis".

Researchers and practitioners tend not to use the word "involvement" alone, but rather imply a distinction between types of involvement. Houston and Rothschild (1978) make a distinction

between enduring involvement and situational involvement. The former stems from the individual and reflects a general and permanent concern with the product class. While the latter reflects concern with a specific situation such as the purchase occasion. Further, involvement theory has considered a basic dichotomy: high involvement and low involvement. Bloch (1982) and Schiffman and Kanuf (1983) conclude that, when a purchase is considered by the consumer to be important as in the case of a high risk product the consumer is willing to exert effort to acquire information, then a high involvement state exists leading to the processing and evaluation of relevant marketing communications and relatively complex decision making. On the other hand, when a consumer believes a purchase is unimportant and sees little reason to secure information, that leads to simple decision making. Such concern is considered to be indicative of low involvement. Bloch (1982) reminds us that researchers commonly warn that low involvement is associated with most consumer purchase decisions.

High and low involvement are operationally distinguished by Oliver and Bearden (1983). They present an empirical study by Bowen and Chaffee (1974) which brought evidence that a high involvement consumer makes different pre-purchase judgements from a low involvement consumer. Oliver and Bearden therefore conclude that involvement is related to the absolute level of pre and post evaluation for reasons which are not entirely clear. High involvement decreases one's sensitivity to pre-usage phenomenon, while low involvement causes the general tone of pre-usage affect (attitude) to influence post-usage evaluations.

Despite such distinctions between high and low involvement, Kapferer and Laurent (1985) found in an empirical analysis across

20 contrasted markets that high and low involvement represented only 25 per cent of the purchase situations. 75 per cent are described by other types of involvement.

Some recent evidence has shown that there are various components of consumer involvement in a product. Traylor 1981 describes two components normative importance / product involvement and commitment to a brand. "Normative importance refers to how connected or engaged a product class is to an individual's values". Commitment is defined as "the pledging or binding of an individual to his brand choice". Traylor goes further and indicates that brand commitment and product involvement / normative importance seem to be completely unrelated phenomena for some individuals. Traylor concludes that intuitively a consumer may be highly involved in a product without having committed himself / herself to a particular brand, or that he / she may be strongly committed to a brand for what he / she considers an uninvolved product class.

Muncy and Hunt (1983) propose five types of involvement (ego involvement, commitment to a brand, communication involvement, purchase involvement, response involvement). Ego involvement is defined as a concept related to one's value system. Ego involvement precedes the commitment, but commitment can exist without ego involvement. Communication involvement is based on the nature of connections a person makes between a communication and something existing in his life. Purchase involvement is defined in terms of high and low response in obtaining information, in the first case, individuals use information to arrive at the optimum choice, while in the second case they minimize the physical and psychological effort required to obtain a product.

Kapferer and Laurent (1985) describe Park and Young's (1984) distinction between cognitive involvement and affective involvement. The first one stems from utilitarian motives, the second from emotional motives. Park and Young see consumer involvement as a composite of cognitive and affective factors, since the motivational state is potentially triggered by one or more of the following antecedents: perceived importance of the product, perceived risk and perceived pleasure value. These antecedents may trigger by turn either enduring or situational involvement. The pleasure value is mostly a factor of enduring involvement. While perceived importance of the product and perceived risk may apply to both.

Mittal (1986) present high and low involvement in terms of high and low cognitive and affective types. High involvement occurs "when a product's performance dimensions are important" i.e., high cognitive and "when a product's image dimensions are important" i.e., high affective. Low involvement occurs "when neither performance nor image dimensions are much important" i.e., low cognitive and low affective. Finally, Rothschild (1979) reported that, generally in marketing, price is probably the most commonly used indicator of involvement. Because the risks of a mispurchase are high when price is high, consumers are likely to be involved.

In summary, it seems to the researcher from the above literature review that consumer involvement would be an element which affects directly or indirectly the feeling of consumer satisfaction / dissatisfaction.

5.3. PERSONAL VALUES:

The field of consumer research has not given much attention to personal values, despite the fact that many studies of consumer behaviour have argued that values play an important role in social and cultural activity.

Personal values are generally accepted as a major influence on human behaviour (Rokeach 1968a). Personal value is viewed by England (1967) as "a relatively permanent perceptual framework which shapes and influences the general nature of an individual's behaviour". Rokeach (1968b) has defined a value as "the enduring belief that a specific mode of conduct or end state of existence is personally and socially preferable to alternative modes of conduct or end states of existence". Rokeach (1968a) developed the definition of personal values that do not tie in to any situation or object. He defined personal values as "abstract ideals, positive or negative, not tied to any specific object or situation, representing a person's beliefs about modes of conduct and ideal terminal modes".

Vinson et al (1977) viewed the conceptualization of the term "value" as reflecting the interests of three disciplines (anthropology, sociology, psychology). Anthropologists are interested in life styles and cultural patterns and psychologists examine values from the standpoints of attitudes and personal motives as defined by Rokeach's approach (1968a).

England (1967) defined two major classes of personal values "operative" and "intended and adopted" values. While operative values have the greatest influence on behaviour, intended and adopted values may be professed but do not directly influence behaviour to any great degree. Rokeach (1968c) differentiated

between "instrumental" and "terminal" values. Instrumental values relate to modes of conduct and represent single beliefs which are personally and socially preferable in all situations with respect to all objects (e.g., ambition, independence and self-control). Terminal values are single beliefs that some end-state of existence is personally and socially worth striving for (e.g., leading an exciting life, family security and pleasure). Rokeach added that terminal values are more stable, because they are acquired early in life while instrumental values are more susceptible to change in the socialization process.

In terms of marketing, Howard (1977) differentiated between instrumental and terminal values. Whereas terminal values are guiding choice among classes, instrumental values are guiding choice among brands. In addition, he concluded that, if consumers are to be grouped on the basis of values, the entire system of values (both instrumental and terminal) of individuals must be considered.

Values are viewed as existing at two distinct levels. The first level referred to as "global values" or "generalized personal values". These values are of salience to individuals and provide a basis for assessing dominant or overall need orientation. The second level deals with values which refer to desired product attributes and market place transactions and behaviours. That level is termed "domain specific values" or "generalized economic values" by which attitudes and behaviour cannot be understood or efficiently predicted except in the context of a specific environment (Scott and Lamont 1973b and Vinson et al 1977). Vinson (1977) suggested that differential value orientations represent an important underlying dimension of consumer discontent.

More recently, personal values have been conceptualized by Bozinoff and Cohen (1982) as forming a belief system which serves to guide behaviour across situations. Personal values include more than the individual's own needs. They also capture the effects of societal and institutional demands upon a person. Bozinoff and Cohen go further and suggest that consumer behaviour is a function of both the situation and what the individual brings to the situation (i.e., personal values).

Consumer behaviour literature shows the relationship between values and both attitudes and beliefs. Rokeach ((1968c)) was concerned about the relationship between values and attitudes. He stated three major considerations which show that the value concept is broader than the attitude concept. First, value is clearly a more dynamic concept than attitude, having a strong motivational component as well as cognitive, affective and behavioural components. Second, while attitude and value are both widely assumed to be determinants of social behaviour, value is a determinant of attitude as well as behaviour. Third, attitudes seem to be a specialized concern mainly of psychology and sociology, values have long been a centre of theoretical attention across many disciplines in philosophy, education, political science, economics, anthropology as well as in psychology and sociology.

Boote (1981a) presents a new approach to market segmentation which relies on personal values. He describes values as "more general than attitudes, in that they guide the choice of modes of behaviour of the individual, while attitudes are object specific (e.g., the degree to which a particular object is liked or disliked). Moreover, values are more durable than attitudes, because, as Becker and Connor (1981) state, attitudes result from

"the application of a general value to concrete objects or situations". In addition, "values are acquired over a longer period of the individual's socialization and they are likely to be thoroughly internalized by the time the individual reaches adulthood".

Lessing (1976) deals with the relationship between values and beliefs. He defined personal values as "abstract beliefs centrally located within the beliefs system. Values are not directed toward any specific object, idea or situation; rather, they provide standards relating to modes of conduct, goals and evaluation". Lessing added that values therefore, lead to a certain amount of stability across an individual's attitudes and behaviour .

In brief, personal values seem to be able to be placed within the causes of the feeling of consumer satisfaction / dissatisfaction. Vinson (1977) has suggested that personal values represent an important dimension of consumer discontent. In addition, the relationships between values and both attitudes and beliefs could indicate to the extent of a relationship between personal values and satisfaction. In the next section therefore, we try to explore such relationships.

5.4. A FRAMEWORK OF RELATIONSHIPS:

It is our hope in the following paragraphs to shift from the individual concepts of consumer involvement and personal values and to fit them into a broad framework of relationships involving consumer satisfaction and dissatisfaction. Many relationships have been found which enable the researcher to suggest that consumer involvement and personal values are two dimensions among other causes of satisfaction / dissatisfaction. The developed framework shown in figure (5.1) is based on cause and effect relationships between sets of variables. First, the relationships between values and involvement. Pitts and Woodside (1984) demonstrate that "the activation of the involvement mechanism is accomplished by the connections of the particular stimulus situation to the individual's value hierarchy". The decision to label a situation as high or low involvement should come from the inspection of the centrality or the number of values affected by the situation of the stimulus. Pitts and Woodside question whether an individual's value structure influences the cognitive processes entirely through the mechanism of involvement. In this context, they present an empirical study carried out by Rokeach (1973). Although the results did not show a direct empirical relationship, the study hinted at the nature of such a relationship. The results suggested that the involvement mechanism is activated for those situations in which the stimulus information is seen to be instrumental to some goal the individual has or possess some intrinsic importance for the person due to the particular value structure in force.

Second, with respect to the relationship between values and expectation, Scott and Lawont (1973b) introduced the concept that changes in personal values affect the expectations consumers hold

regarding the criteria used to evaluate the products and services in the market place. Rokeach (1979) also raised the possibility of a causal relationship between personal values and expectation. He suggested personal values represent standards and beliefs regarding product performance. Vinson and Muson (1976) in introducing the concept of personal values as a new approach to market segmentation, stated that marketers generally agree that the process of marketing exchange is predicted largely upon the firms' ability to recognize and satisfy consumer needs, which in turn are largely based on personal values. Rokeach (1979) carried out a study using 206 respondents (white and black) with different personal values (instrumental and terminal) and different levels of expectation. The respondents were asked to indicate normative expectation on 5-point scales. Product moment correlation coefficients between value dimensions and expectation from product attributes were obtained. The hypotheses of this study were largely supported, since a significant correlation was found between expectation and personal values. The researcher concludes therefore that value dimensions have an important impact on satisfaction because of their significant association with product expectation.

Third, regarding the relationship between consumer involvement and expectation, Swan and Combs (1976), proposed indirectly a relationship between satisfaction and involvement by introducing two dimensions of performance that became important in determining the satisfaction with high and low involvement products. One is the functional or instrumental performance of the product, the other is the expressive or psychological performance of the product. Both dimensions have been explained by Assael (1987) among factors with which consumers are likely to be involved. Further, the functional

performance is important for high or low involvement products, while the expressive performance is relevant for high involvement products. Consumer involvement and expectation therefore seem to be related.

Fourth, Houston and Rothschild (1978) discussed product involvement as relative to consumer experience. They demonstrated that situational involvement is dependent on the individual's prior experiences in the strength of the values which are relevant to the particular situation.

Fifthly, the work of Vinson et al (1977) suggests a relationship between personal values and experience. They state people acquire their values through experiences in specific situations or domains of activity and that behaviour cannot be understood or efficiently predicted except in the context of a specific environment. We conclude from the above paragraphs that consumer involvement, personal values, expectation and consumer experience are all interlinked as shown in figure (5.1).

The next relationship to be touched upon here is the relationship between consumer characteristics and consumer involvement. Slama and Tashchian (1985) present the relationship originated by Kassarian (1981). They state that several characteristics seem to merit discussion regarding involvement. Those characteristics such as: family life cycle, education and income were analysed for the purpose of exploring that relationship. ANOVA was applied, and the results indicated that the mean value of purchasing involvement for retirees is lower than other groups in the life cycle. A positive and direct relationship between education and purchasing involvement was hypothesized and the results of ANOVA strongly support that hypothesis. The same

computation was done with income and the results showed that moderate levels of income lead to the highest level of involvement. The analysis exhibited also that, women have higher involvement than men while the working status of wives was not associated with purchasing involvement. Accordingly, we can conclude from that study that consumer characteristics do indeed influence purchasing involvement.

Finally, regarding the relationship between consumer characteristics and personal values. Rokeach (1973) maintained that while ethnic and cultural background is the predominant source of personal values, income, education, age and sex should be taken in consideration. Munson and McIntyre (1979) report Rokeach's work (1973) in which he demonstrated that different value structures (instrumental and terminal) have been found which significantly differentiate men from women. Further, Vinson et al (1977) argued that personal values vary by age, education, income and other consumer demographic and socio-economic variables. Boote (1981a) in his attempt to describe market segmentation by personal values, shows the impact of demographic variables (sex, age, income) on personal values. He applied factor analysis for male and female respondents on 45 value items. The value structure of the factors identified for male and female were different. Then a statistical clustering technique was used to find out if there were differences in personal values and brand preferences on the basis of male and female. The results suggested that brand preferences were not significantly different on the basis of male and female, while among personal value items, brand preferences exhibited differences on the basis of male and female. In addition, Pitts (1981) demonstrated that homogeneous groups of individuals with similar

value systems may effectively be developed and differentiated from dissimilar groups on the basis of education and income. Moreover, age and life cycle status have also been shown to have a unique effect on individual values (Crosby et al 1983).

It is also important to know how our model contributes to the satisfaction / dissatisfaction topic. The most appropriate model found in the literature search was Miller's model (see chapter 3). Miller (1977) describes the two most popular variables (expectation, performance) which appear in all the literature studies of consumer satisfaction. His model shows the interaction of four types of expectation (ideal, expected, minimum tolerable, deserved) with the level of performance that leads to a different level of consumer satisfaction / dissatisfaction.

Our model widens the scope and brings a broader meaning to the consumer satisfaction / dissatisfaction topic by introducing the new variables of consumer involvement and personal values which have not been used before in the previous studies of consumer satisfaction. The main concern of this model is potentially to show that consumers not only receive their feeling of satisfaction / dissatisfaction by the interaction of expectation and performance, but also that expectation is affected by involvement and personal values both directly and indirectly through experiences. Hence, the model offers the new idea that satisfaction / dissatisfaction is dependent on consumer involvement and personal values.

In brief, if we accept the above relationships, we are involved in a framework of interrelationships between different components as shown in the conceptual model of consumer satisfaction / dissatisfaction which is exhibited in figure (5.1).

5.5. CONCLUSION:

The theoretical arguments and empirical evidence which have been reported in this chapter now embolden the researcher to place personal values and consumer involvement within the discipline of the topic of satisfaction.

Consumer satisfaction is indeed a complex phenomenon, as are attempts to model it in a new framework. The value of this conceptual model is that it helps to better define and understand consumer satisfaction. Unfortunately, it was not possible to test this model completely in this PhD thesis, since as the reader will recall the main thrust of this thesis was to investigate consumer satisfaction with the provision of medicine in Egypt, with a view to better protecting the Egyptian consumers. The literature survey in chapter 3 nonetheless showed the subject of CS/D was ripe for theoretical development and the proposed model grew out of the researcher's desire to better understand the CS/D concept.

Complete testing would have required the development of quantitative measures for all of the variables and the collection of vast quantities of information from respondents, more than could be collected in a large scale survey which had a rather different primary purpose. Nonetheless, the researcher feels this conceptual model is a valuable framework for further studies of consumer satisfaction / dissatisfaction.

FIGURE 5.1: A CONCEPTUAL MODEL OF CONSUMER SATISFACTION

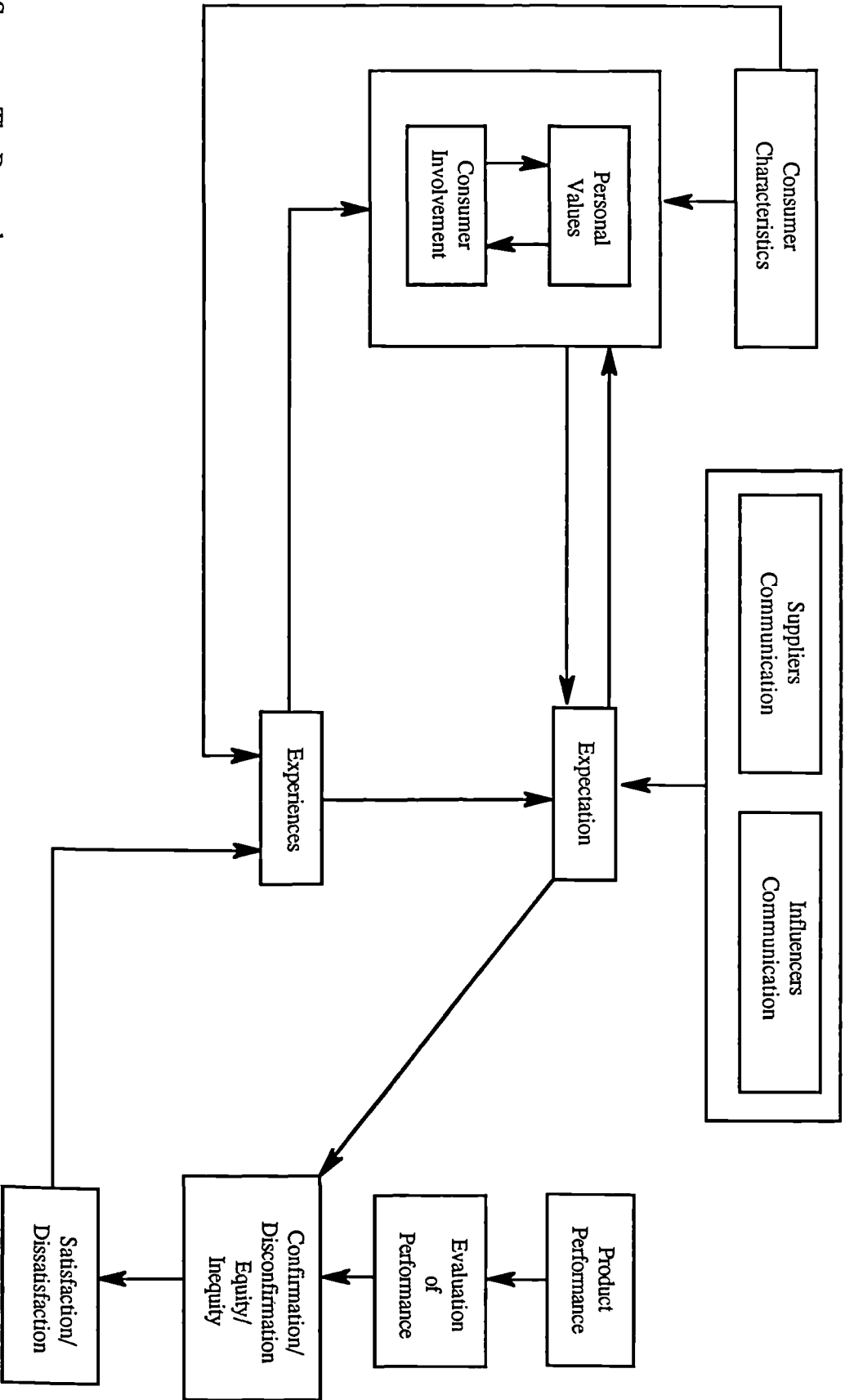

Source: The Researcher

CHAPTER SIX

RESEARCH DESIGN

- 6.1. Introduction.
- 6.2. Data Sources.
 - 6.2.1. Secondary Data.
 - 6.2.2. Primary Data.
- 6.3. Research Approaches.
 - 6.3.1. Exploratory Study.
 - 6.3.2. Empirical Investigations.
- 6.4. Scales Of Measurement.
 - 6.4.1. Attitude Rating Scales.
- 6.5. Questionnaire Design.
 - 6.5.1. Phrasing Of Questions.
 - 6.5.2. Sequence Of Questions.
 - 6.5.3. Questionnaire Structure.
 - 6.5.4. Questionnaire Instructions.
- 6.6. Data Collection.
 - 6.6.1. Pilot Survey.
 - 6.6.2. Personal Interviews.
- 6.7. Sampling Plan.
 - 6.7.1. Defining The Population.
 - 6.7.2. Sample Size.
 - 6.7.3. Sampling Procedures.
 - 6.7.4. Sampling Control.
- 6.8. Response Rate Of Consumer Survey.
- 6.9. Criteria For Good Measurement.
 - 6.9.1. Reliability.
 - 6.9.2. Validity.
- 6.10. Summary.

6.1. INTRODUCTION:

The research plan is the basic framework which guides the analysis procedures of the research. It serves as a bridge between the research objectives and the carrying out of the study by specifying the source of data, research approaches, designing the research instrument and data collection procedure. Moreover, a successful research plan requires a good sample plan and suitable scale of measurement.

6.2. DATA SOURCES:

When confronted by a new problem the researcher first attempts to find existing data from secondary sources and then moves on to collect primary data, should the secondary sources prove inadequate in any way. Both secondary and primary data were required in this study to satisfy the research objectives.

6.2.1. SECONDARY DATA:

Secondary data is readily available and is sometimes sufficient to answer the research question. The fundamental rule in using secondary data is to secure data directly from the original source rather than using acquired sources (Kinnear and Taylor 1987). Oppenheim (1966) stated that, secondary sources may facilitate the research process by:

- (1) Expanding the understanding of the problem.
- (2) Suggesting hypotheses and research objectives.
- (3) Helping to plan the sample and to provide a basis for validating the obtained sample.

In this context, the researcher relied on several kinds of secondary data such as library sources (i.e, text books, periodical), external data were collected from reports of the Egyptian government, and internal data from pharmaceutical companies records. These sources are documented in the references and bibliography sections of this thesis.

6.2.2. PRIMARY DATA:

Primary data may be described as that data which has been observed and recorded by the researchers for the first time, to their knowledge. Researchers typically find that primary data must be collected to supplement the secondary data. This study relies strongly on primary data to explore consumer satisfaction in the Egyptian market of pharmaceutical products. Since no previous studies have been conducted on this topic in Egypt.

6.3. RESEARCH APPROACHES:

This research employed a two stage approach, first an exploratory study followed by a large scale empirical investigation. Each stage is discussed below.

6.3.1. EXPLORATORY STUDY:

This study began with an exploratory study into the pharmaceutical market to seek insights into the general nature of the problems in that market, the possible decision alternatives and relevant variables that need to be considered. Oppenheim (1966) concluded that the exploratory research is useful for establishing the research question and for learning about the practical problems of carrying out the research . In general, any exploratory research

is conducted to understand and formulate the problem as well as to state the research objectives and hypotheses.

6.3.2. EMPIRICAL INVESTIGATIONS:

Empirical investigations include the study of marketing phenomenon such as consumer reaction, attitudes, opinions to products and consumer behaviour in purchasing those products.

This empirical investigation was undertaken in Egypt to enable us to identify the extent of consumer satisfaction as well as to describe the relationship between consumers' consumption patterns (in terms of their expenditure) and consumers' demographic / socio-economic characteristics.

6.4. SCALES OF MEASUREMENT:

The objective of measurement is to transform the characteristics of objects into a form that can be analysed by the researcher. Several text books define a scale of measurement as "the assignment of numbers to characteristics of objects, persons, states or events according to rules". Numbers are used as symbols to represent certain characteristics of objects or people (Tull and Hawkins 1987 and Kinnear and Taylor 1987). There are four levels of measurement, nominal, ordinal, interval and ratio*. A nominal scale is the level of measurement where numbers are used only as labels. It is used for the lowest form of measurement, namely classification and identification. An ordinal scale "represents a number, letter or other symbols used to rank items. Such items can be classified not only as to whether they share some characteristic with another item

* The specific nature of this scale is out the scope of this study.

but also whether they have more or less of this characteristic than some other object" (Tull and Hawkins 1987). An interval scale not only separates individuals or items by ranks, but also measures the distance between rank positions in equal units. Therefore, numbers used to rank the objects also represent an equal increase of the attributes being measured. This means that differences can be compared.

Brown (1980) expresses the view that any attempt by a researcher to assign numerical values to words is technically justified, and arguments rage among marketing researchers regarding the assumption that attitudinal, satisfaction and agreement scales possess true interval properties. For our study, we follow in the footsteps of such respected names as Green and Tull (1978), Aaker and Day (1986) and Kinnear and Taylor (1987). We have made such an assumption with respect to consumer satisfaction scales. Nominal scales were used to measure the demographic and socio-economic characteristics of respondents.

6.4.1. ATTITUDE RATING SCALES:

Attitude variables such as beliefs, preferences, intentions and opinions are measured using rating scales. In a rating scale the respondent is asked to rate himself / herself by choosing the point at which he / she would fall on a scale running from one extreme of the attitude in question to the other. Boote (1981b) decides to restrict the scale to only five-points and seven-points scales. On the one hand, he explains that, any fewer than five points would reduce the scale's ability to discriminate since respondents would be unable to express refined gradations. On the other hand, more than seven points could be less than optimum,

because the increase in information gathered becomes smaller with longer scales.

The attitude rating scales used in this study are described below.

(i) Itemized Rating Scale:

This kind of attitude scale is widely used in marketing research as well as being the basic building block for complex attitude scales (Tull and Hawkins 1987). Further, all recent sociological research suggests that the best method to employ to study consumer satisfaction is an itemized rating scale (Westbrook 1980b). In this context, we used seven point rating scales ranging from very dissatisfied to very satisfied (see appendix 1) to indicate the degree of satisfaction / dissatisfaction with a group of attributes.

(ii) Likert Scale:

Attitudes towards a complex objects (i.e, consumer's opinions towards the use of medicine) can be measured using a Likert scale. This scale requires a respondent to indicate a degree of agreement or disagreement with a variety of statements related to the attitude object. The original Likert format has five rating categories (Luck and Rubin 1987), but in this study, we drew a seven category scale (strongly disagree which was assigned a score of 1 to strongly agree which was assigned a score of 7) for the purpose of increasing accuracy (see appendix 1).

6.5. QUESTIONNAIRE DESIGN:

As with most steps in the research process, the design of the questionnaire is highly iterative, because, it is an integral part of the research design. A questionnaire was used to collect the primary data required. According to Parasuraman (1986) the logical starting point for conducting a questionnaire is to translate the data requirement of a project into a set of questions for eliciting information. This is further explained by Boyd et al (1977). They demonstrated that a questionnaire must serve two basic functions. First, it must translate research objectives into questions which respondents can answer. Second, it must motivate the respondent to cooperate with the survey.

Regarding the questionnaire length, Naryana (1977) suggested that a questionnaire should be long enough to include all the information essential to the study, but not so long that the respondent will reject it as being too time consuming. A short questionnaire usually stands a better chance of being answered honestly without the respondent feeling boredom. Generally, questionnaires should be designed to maximise the willingness and ability of people to respond.

In designing a questionnaire, consideration must be given to many factors such as phrasing, sequence and simplicity of questions. In developing the questionnaire all these points were borne in mind.

6.5.1. PHRASING OF QUESTIONS:

The phrasing of questions is a major problem. If the wording is too simple it will insult respondents. On the other hand, if it is too complicated, the question is likely to be misunderstood. Thus, questions should be worded so that they are clear without being over simplified. Belson (1985) warns against asking questions that may be leading or suggestive. The researcher was aware of the dangers of leading and suggestive questions i.e., that answers to these questions are often of dubious value in the analysis process. Such questions were therefore avoided.

In order to examine the phrasing of the questions, the questionnaire was discussed in detail with fifteen respondents through a pilot study described in detail in section (6.6.1).

6.5.2. SEQUENCE OF QUESTIONS:

The sequence of questions is an essential step in questionnaire development. The sequence necessarily begins with a statement which indicates that this particular survey has a worthwhile purpose and that the person who is asked to respond should feel secure in doing so. Most authors agree that questions on threatening topics should not be placed at the beginning of questionnaire. In contrast, questions placed at the beginning should be simple and straight forward. Dijkstra and Zouwen (1982) point out that the early items should be interesting to the respondent and clearly related to the stated topics. These items help to create respondent motivation. Therefore, they suggested that demographic and socio-economic (e.g, age, income, sex) should be asked at the end rather than the beginning of the questionnaire. Thus, a refusal to answer a question such as income will not affect

responses to other questions if income is the last question in the questionnaire.

There are two rules in question sequence according to Sudman and Bradburn (1982). First, questions should flow smoothly and logically from one to another and starting with simple questions and moving progressively to the more complex ones. This helps to establish rapport and build the confidence of a respondent in his / her ability to answer. Second, questions should be arranged in such a way that respondents can interpret later questions in the light of the earlier ones. Luck et al (1982) suggest the best sequence for questionnaire is as follows:

- (1) Simple questions to start the flow of responses and gain rapport.
- (2) Specifics on feelings or information sought by the study.
- (3) Demographic and socio-economic questions to describe the person who responded.

Bearing this in mind, we started the questionnaire with fifty one attitudinal questions (i.e, satisfaction variables and statements), next a factual question (i.e, consumer expenditure on medicine), and finally the classification information (i.e, demographic / socio-economic).

6.5.3. QUESTIONNAIRE STRUCTURE:

Most questionnaires used in marketing research studies are structured and are not disguised. That means, questions are presented with exactly the same wording and in exactly the same order to all respondents. Collection of data in a structured interview has definite advantages in marketing research. It is simple to administer, easy to tabulate, analyse, and is especially

appropriate for a large sample size empirical study (Green and Tull 1978).

In this research we used undisguised questions and all questions were structured. The questionnaire was developed with closed-ended questions (see appendix 1). These questions have proven themselves to be more efficient and ultimately more reliable than open-ended questions (Fink and Kosecoff 1985). Their efficiency comes from being easy to use, score and code (for analysis by computer). There are several types of closed-ended questions such as dichotomous questions, checklists, scale responses and multiple choice questions.

Our questionnaire falls into three sections. In the first section, the questions were designed to explore consumer satisfaction (e.g, packaging, labelling, quality) using itemized rating and Likert scales (as described in section 6.4.1) in which the respondents were given a range of categories to express their attitudes and opinions. The questions were arranged on a seven point scale ranging from very dissatisfied to very satisfied and another ranging from strongly disagree to strongly agree. Such questions endeavoured to provide a direct measure of respondents' attitudes and opinions.

In the second section, a question was designed to investigate the different consumption patterns of medicine (in terms of expenditure). That question consists of five response categories to provide the answers. Its advantages lay in enabling the respondent to express herself / himself whilst the researcher obtained all the replies in similar wording.

In the third section, the questions were designed to secure the demographic and socio-economic information needed on the

Egyptian consumers. Several categories were developed for each characteristic and the respondents selected that category into which he / she fitted.

Respondents were finally encouraged to offer their own reasons for either satisfaction or dissatisfaction with the provision of medicine in the Egyptian market.

6.5.4 QUESTIONNAIRE INSTRUCTIONS:

Instructions regarding the answering of questions is considered a significant section of any questionnaire. Platek et al (1985) state that the instruction given to respondents is an important issue. The instruction can motivate the respondent by indicating the purpose of interview, clarifying his or her role and thereby increasing the value of the information obtained. In this context, each section of the questionnaire in this study included instructions. These instructions appeared also on the Arabic version (see appendix 2) which was actually administered. These instructions explained the purpose of the research and include the right way to complete the questionnaire. Respondents were assured that any information provided would be treated confidentially and used only in the respondents best interest. We emphasised therefore, there was no need for a respondent to give his / her name.

6.6. DATA COLLECTION:

A pilot study survey was carried out followed up by the large scale personal interview survey.

6.6.1. PILOT SURVEY:

Good survey researchers carry out as a matter of course, a pilot of their questionnaire. No questionnaire is ready to present to the field without pilot work. Belson (1985) described the procedure followed in this work. The researcher delivers the questionnaire in the way planned to a small group of people of the sort that the questionnaire was designed for. Belson (1982) explains that pilot work aims to (a) investigate the particular way in which survey respondents understand / misunderstand a wide range of questions put to them in a survey interview, (b) determine the level of understanding of each respondent on a number of questions to establish the relationship between understanding and various characteristics of the respondents. A test of 15-50 is usually sufficient to discover the major flaws in a questionnaire before the main study (Sudman 1976).

In this work, we conducted a small survey of 15 Egyptian nationals living in Sheffield to ensure that the wording of the questionnaire was simple to understand. But it was felt that those respondents did not represent the different classes of the whole population. Another further pilot survey of 20 respondents was therefore carried out by the researcher in Egypt before conducting the main survey in August (1989).

The researcher noted carefully things like, how long the questionnaire took to answer, whether the respondents found any difficulty in interpreting the meaning of any of the questions. The

pilot survey helped to discover ways to improve the response rate and eliminate some poor wording. The final version is presented in appendix (1). Rewording was necessary for some attributes and statements (e.g., attributes 12, 34 to 36, 39 to 41 and statement 7) to eliminate misunderstanding and increase response rate.

6.6.2. PERSONAL INTERVIEWS:

The primary data was collected by face to face personal interviews in 27 different areas in Cairo and Giza. Respondents completed the questionnaires at home with exception of a few respondents with whom the researcher could not communicate at home, an advance arrangement was therefore made to fill in questionnaires in their work location.

The telephone interview method was eliminated because such interviews are limited to those respondents with a telephone, so that this creates bias against lower income households without telephones. A mail questionnaire method was also excluded because of the limited time which was allowed to complete the survey (the survey had to be completed during three months). Personal interviews also have many advantages over other methods. They are more flexible and allow the collection of greater variety of data than other approaches for obtaining consumer reaction to satisfaction variables (e.g, quantity, availability). Face to face interviews often increase the rate of participation and establish rapport because of the social relationship developed between the respondents and the interviewer. Therefore, personal interviews are recommended by Dijkstra and Zouwen (1982) as a relatively easy way to obtain data on attitudes, opinions, motivation and other characteristics that are not directly observable.

However, personal interviews can be subject to interview bias. In order to avoid a bias problem in this study, the researcher asked the respondents to fill in the questionnaires by themselves (with the interviewer present). However, the researcher was forced to record the non-educated respondents' answers.

6.7. SAMPLING PLAN:

Luck et al (1982) propose three useful steps in drawing up a sampling plan, they are:

- (1) Define the population from which the sample is to be drawn.
- (2) Establish a frame of that population.
- (3) Choose the method of selecting the sample units (i.e, probability, nonprobability.
- (4) Determine the size of sample that is needed.

6.7.1. DEFINING THE POPULATION:

When the research objectives are thought out, the target population definition is a part of them (Aaker and Day 1983). Each objective should contribute to refining the definition of the population. Sudman (1976) suggested at least two basic steps in defining the population under study. The first step, is to decide whether the population is of individual households, or some other categories. The second step, is to decide the unit to use. In order to do that, he suggested the following criteria for consideration.

(i) Geography:

The population of this study was defined as all households, regardless of whether a single individual or family. and the survey population was defined as those living in the capital Cairo and

Giza city. The reasons for limiting the study to those areas were to save time and cost as well as to enhance the efficiency of the administration of the survey.

(ii) Age Of Individual:

Sudman (1976) suggested the minimum age is usually 18 for attitude research. The age categories of this study began at 18 years of age (see questionnaire design, appendix 1)

(iii) Other Demographic / Socio-economic variables:

Sex, marital status, family size and education, were defined carefully by different categories (see appendix 1)

(IV) Household Variables:

If the unit of analysis chosen was the household. The sampling frame included only the Egyptian households who had purchased or used a medicine over the twelve months preceding the period of field study (between August and October, 1989).

6.7.2. SAMPLE SIZE:

According to the latest population census in 1990, the whole population of Egypt is 55 million people. Cairo includes about a quarter of the whole population (i.e, close to 14 million), while Giza includes about 3 million. Usually, there are two ways to determine sample size as Tull and Hawkins (1987) state. First, is to set an arbitrary size within the constraint of the research budget, and to measure the precision of the sample at the analysis stage, if probability sampling is used. Second, is to calculate the optimum sample size given a desired level of precision and cost according to the standard error formula. Sudman (1976) indicated

that, the most common sample size used for attitudes research range from 400 to 1000. It should be remembered that the size of population has no direct effect on the size of sample (Churchill 1987).

We decided on a sample of 1300. This was as big as possible within constraints of time and cost. since the researcher was allowed by the Egyptian government only three months (from August to October, 1989) to collect the data from Egypt.

6.7.3. SAMPLE PROCEDURES:

There are many different procedures by which researchers may select their samples. We decided therefore, on using a probability sample for two reasons as Brown (1980) demonstrates.

- (1) Probability sampling is the only method that provides essentially unbiased estimates and measurable precision.
- (2) Probability sampling permits the researcher to evaluate in quantitative terms.

In the absence of a readily available sample and their distribution over different districts of Cairo and Giza, it was decided to use a random multi-stage area sample. This type was found appropriate to the nature and the purpose of research. In this form of sampling the clusters were made up of individual units which constituted mutually exclusive and exhaustive categories. From these clusters, the researcher randomly selected those categories to be included in the sample.

A multi-stage area sample is much less statistically efficient than simple random sample. Kinnear and Taylor (1987) indicate that in a simple random sample a single sampling error can be calculated. A two-stage, area sample is subject to two sampling

errors. The authors therefore suggested two ways by which the multi-stage area sample error will decrease, by an increase in (a) sample size, (b) homogeneity of the elements being sampled. So, the sample size of this research was already large enough (i.e, 1300), and several stages were developed which achieved homogeneity (i.e, small number of elements within each stage).

It should be noted that the sampling procedures were dependent on the classification and geographical information about population in Cairo and Giza. This information was obtained in advance by contacting the Central Agency For Public Mobilisation And Statistics in Cairo. Thereby, the researcher conducted the survey as follows:

First step was developing a random sample of geographic areas in Cairo and Giza.

Second step was selecting a random sample of suburbs within those geographic areas.

Third step was to select streets randomly from each suburb.

Fourth step, each street was weighted by the number of house-units, then the houses selected randomly.

Fifth step, a random sample of households in each house was obtained.

The respondent was not necessarily the head of the household. The member of the household who answered the door to the interviewer was interviewed, providing he / she was 18 years old and over. This was a deliberate move to ensure that different categories of the population e.g. women and young people were adequately represented in the sample.

Table 6.1 displays the percentages of the composition of the sample size.

TABLE 6.1 THE PERCENTAGES OF THE COMPOSITION OF THE SAMPLE SIZE

Characteristics		Sample Size	Percentages %
Sex:	Male	578	61.6
	Female	360	38.4
Age:	18 - 24	169	18.0
	25 - 34	316	33.7
	35 - 44	264	28.1
	45 - 54	112	11.9
	55 - 60	50	5.3
	Over 60	27	3.0
Education:	Primary	55	5.9
	Grade School	226	24.1
	High School	157	16.7
	College	37.4	39.9
	Postgraduate	87	9.3
	Non-Educated	39	4.1
Income:	Less than *£900	246	26
	£ 900 - £1200	259	27.6
	£1201 - £2999	244	26
	£3000 - £4999	108	11.5
	£5000 - £6999	37	3.9
	£7000 and over	44	5
Occupation:	Labourer	139	14.8
	Unemployed	15	1.6
	Professional	180	19.2
	Retired	29	3.1
	Official	451	48
	Student	56	6
	Proprietor	26	2.8
	Housewife	42	4.5
Family Size:	1 - 2	163	17.4
	3 - 4	433	46.2
	5 - 6	257	27.4
	Over 6	85	9
Marital Status:	Single	294	31
	Married	590	63
	Other	54	6

* Egyptian Pound

6.7.4. SAMPLING CONTROL:

Sampling control refers to the ability to collect information from a sample that adequately represents relevant segments of population of interest. Green and Tull (1978) pointed out that the degree to which data can be obtained from a representative sample in a questionnaire administration on two attributes:

- (1) The ability to identify and reach appropriate sample respondents.
- (2) The ability to secure cooperation from each respondent contacted.

Further, Kinnear and Taylor emphasise that personal interviews allow a substantial level of control. Despite this, there is evidence to suggest that the potential for sample control in personal interviewing is seldom realised because such control may be quite expensive (Tull and Hawkins 1987).

In this study care was taken to identify appropriate respondents as explained in sampling procedures (section 6.7.3). To try to reach the respondents selected, sometimes the researcher had to go to the work location for interviews. Cooperation was secured by putting respondents at their ease by discussing the purpose of the research and stressing confidentiality.

6.8. RESPONSE RATE OF CONSUMER SURVEY:

Response rate refers to the percentage of the original sample that is actually interviewed. Nonresponse is considered one of the obstacles in the field of consumer surveys. Nonresponse can be a serious problem. It means of course that the sample size has to be large enough to allow for nonresponse (Aaker and Day 1983). In general, nonresponse can result from two sources: (a) not-at-home and (b) refusals. Thus, the researcher should focus on various aspects of nonresponse. Skelton (1963) found substantial refusals only with respect to questions relating to income.

In conducting this consumer survey, we faced two problems. One is the availability to be interviewed. In addition, some respondents refused to answer the questionnaire after the researcher introduced herself. Another problem is accessibility. There were a few inaccessible places, especially the rural ones in Giza.

A total of 938 completed questionnaires were obtained, a completion rate of 72 per cent. Table 6.2 shows the response rate.

TABLE 6.2 THE RESULTS OF RESPONSE RATE

Identification	Number of Respondents	Percentages
Distributed Questionnaires	1300	
Incompleted Questionnaires	309	
Completed/Unusable Questionnaires	53	
Completed/Usable Questionnaires	938	72.2
Total Response	938+53 = 991	76.0

6.9. CRITERIA FOR GOOD MEASUREMENT:

The development of a reliable and valid scale presents a useful starting point for improving the quality of marketing research. The term "scale" is used here to mean a multi-item scale and not a single item. This section deals with the measurement of reliability and validity of multi-item measures such as those used in this work.

Bending, (1953) argued that, one of the first problems faced by the constructor of the rating scale is the effect of the variation in the number of scale categories and in the amount of verbal definition of categories upon both the reliability and validity of the scale. He concluded that, the reliability of the scale should increase as the number of scale categories increases, but that the increase in reliability is minor above nine categories.

Reliability and validity provide the essential language of measurement (Carmines and Zeller 1979) and the distinction between them is worthy of mention. Churchill (1987) distinguishes between reliability and validity. Whereas validity is represented in the agreement between two attempts to measure the same trait through maximally different methods, reliability is the agreement between two efforts to measure the same trait through maximally similar methods. More simply reliability refers to consistency, the ability to obtain the same results again, while validity tells us whether the question or item really measures what it is supposed to measure (Oppenheim 1966). Kinnear and Taylor (1987) distinguish between validity and reliability in terms of errors of measurement. Whilst the validity of a measure refers to the extent to which the measurement process is free from both systematic and random errors, the reliability of a measure refers to the extent to which the measurement is free from random errors.

Obviously, measurement error can be in the form of either a systematic bias or random errors. The error score is increased or decreased from the true score resulting from measurement error. Measurement error is the source of unreliability error (random error) and its primary cause is that items in the scale are not measuring the same phenomenon (Peter 1979). "Random error of measurement are never completely eliminated, but to portray nature in its ultimate lawfulness, efforts are made to reduce such errors as much as possible, since the extent to which measurement error is slight, a measure is said to be reliable" (Nunnally 1967). In other words, the amount of random error is inversely related to the degree of reliability of the measurement instrument. Systematic error has an effect on the measuring instrument. Such error lies at

the very heart of validity, for such error prevents indicators from representing what they are intended to: the theoretical concept (Carmines and Zeller 1979).

High reliability does not necessarily mean high validity, because validity can not rise above a certain point if the measure is inconsistent to some degree (Oppenheim 1966). Nunnally (1967) added that, the amount of measurement error places a limit on the amount of validity that an instrument can have. Reliability is a necessary but not sufficient condition for validity. In general, if a measure were valid, there would be little need to worry about its reliability, because a valid measurement is free from errors. Conversely, a measure could be reliable and still not valid. Carmines and Zeller (1979) emphasise that, reliability is basically an empirical issue, focusing on the performance of empirical measures. Validity in contrast, is usually more of a theoretical issue because it inevitably raises the question "valid for what purpose".

In this context, we explain below the different approaches to the estimation of reliability and validity.

6.9.1. RELIABILITY:

The achievement of scale reliability is of course dependent upon how consistent are the characteristics being measured, and how stable the characteristics remain over time (Green and Tull 1978). If a replication of the same technique on a similar population did not yield the same measurement as the first data gathering, it would mean that it is marked by random errors (Luck and Rubin 1987). To ascertain reliability, Oppenheim (1966) distinguished between two kind of questions: (a) factual questions, and (b)

attitudinal questions. In the case of factual questions, he suggested a number of internal checks, but so as not to annoy the respondent, one must refrain from asking the same questions repeatedly in the same way. Since attitudinal questions are more sensitive than factual questions to changes in content, and so on, it becomes almost impossible to assess reliability by asking the same question in another form. For this reason, marketing researchers should not rely on single-item measures when they come to measure attitudes. They should gain the advantage of multi-item scales that allow measurement errors to cancel out against each other, and thus the reliability of the scale can be increased (Peter 1979). There are three basic methods for assessing the reliability of a measurement scale: test-retest, alternative forms and internal consistency (i.e, split half and alpha correlation coefficient).

Test-retest of reliability estimates (measure of stability) are obtained when the same scale is measured under two or more similar situations. The results of two separate administrations are then compared by computing the correlation coefficient on an item-by-item basis. The smaller the differences between corresponding items, the higher the reliability. However, a number of practical and computational difficulties are involved in measuring test-retest reliability. First, different results may occur depending upon the length of time between measurement and remeasurement. In general, the longer the time interval, the lower the reliability estimate (Bohrstedt 1977). Second, some items can be measured only once for example, initial reaction to an new advertisement (Tull and Hawkins 1987). Third, factors extraneous to the measuring process may cause shifts in the characteristic being measured. For

example, a favourable experience with a brand during the period between the test and re-test might cause a shift in an individual's rating of that brand (Tull and Hawkins 1987). Fourth, the problem of reactivity which refers to the fact that sometimes the very process of measuring a phenomenon can induce change in the phenomenon itself (Carmines and Zeller 1979). In such situations, there is no way to distinguish between change and unreliability (Peter 1979).

These four problems may operate to increase or decrease the measured reliability coefficient. In addition to the elapsed time between the two tests.

The alternative forms method involves giving the respondents two forms which are judged equivalent, but are not identical (Kinneer and Taylor 1987). Hence, the basic logic of this approach is similar to the test re-test. The alternative form method requires two testing situations with the same people, but alternative forms of the same test are administered. The correlation between the alternative forms provides the estimate of reliability (Carmines and Zeller 1979). Two basic limitations are involved in this approach. First, is the extra time, expense and trouble involved in obtaining two equivalent forms (Tull and Hawkins 1987). Second, is the practical difficulty of developing equivalent alternative forms that are parallel.

Internal consistency estimates of reliability based on the average correlation among items within a test said to concern the "internal consistency" (Nunnally 1967). Internal consistency is estimated by the intercorrelation among the scores of the items on a multiple-item index. All items must be designed to measure precisely the same thing (Tull and Hawkins 1987). The earliest and

simplest type of internal consistency of a set of items is the split-half reliability, the total set of items is divided into equivalent groups (say, odd versus even numbers). The total scores for the two halves are correlated and this is taken as the measure of reliability of the instrument (Churchill 1987). Though split-half is a basic form of internal consistency estimate, there is one problem with using it; that is, correlation coefficients between halves will vary depending on how the items are divided into halves.

Thus, none of the above approaches of reliability estimates were used in this study. It seemed more sensible to the researcher to utilise the alpha correlation coefficient method. McKennell (1978) reminds us that "alpha is a label given by Cronbach (1951) to a particular type of coefficient which measures the reliability of a test or item battery, in the special sense of its internal consistency". "Coefficient alpha absolutely should be the first measure one calculates to assess the quality of the instrument". "It is pregnant with meaning because the square root of coefficient alpha is the estimated correlation of a K-item test with errorless true scores" (Nunnally 1967).

Cronbach's Alpha is the most commonly accepted formula for assessing the reliability of a measurement with multi-point items (Peter 1979). Tull and Hawkins (1987) have also recommended the use of Cronbach's Alpha Coefficient to measure internal consistency. Therefore, it was decided to assess the reliability of the satisfaction scale in this study by employing Cronbach Alpha Coefficient. A low coefficient alpha indicates the sample of items performs poorly in capturing the construct which motivated the measure. A large alpha indicates that the K-item test correlates

well with true scores and the scale can be quite reliable (Churchill 1979).

Regarding the acceptable level of the alpha coefficient, the literature reveals some arguments. Levels of 0.5 to 0.6 were recommended by Nunnally (1967) for early stages of basic research. While Churchill and Peter (1984) stress that a value of 0.6 or less is usually viewed as unsatisfactory. Carmines and Zeller (1979) believe that the reliability should not be below 0.8 for a widely used scale.

6.9.2. VALIDITY:

Validity is one of the important facets involved in evaluating the worth of a scale. The validity of a scaling procedure can be viewed in terms of its freedom from systematic error. According to Green and Tull (1978) systematic error may arise from the instrument itself, the user of the instrument, the subject or the environment in which scaling procedure is being administered. Although random error reduces the validity of any measuring instrument, far more important in validity assessment is systematic error (Carmines and Zeller (1979). Further, systematic error does not yield easily to statistical solution.

Therefore, validity is a broader and more difficult problem than reliability. Holbert (1974) emphasised this difficulty, noting that validity is seldom reported in marketing research at least not in ways useful to practitioners. Perhaps this is because there is no simple and certain way to assure the validity of marketing research.

Validity is classified into three forms: content validity (face validity), construct validity and criterion-related validity (concurrent/predictive validity).

Churchill (1987) explains the assessments of content validity by examining the measure with an eye towards ascertaining the domain of the characteristic that is captured by such a measure. Churchill argues that the researcher can never guarantee the content validity, but he can diminish the objection of the critics. The key to content validity lies in the procedures that are used to develop the instrument. However, Carmines and Zeller (1979) stress the limitations of content validity in attitude measurement. One, is the difficulty to deal with any abstract theoretical concept including most topics in attitude studies since the theoretical concepts in the social sciences have simply not been described with the required exactness. Another, is that in measuring most concepts in social science, it is impossible to sample content.

Construct validity is directly concerned with the question of what the instrument is, in fact, measuring. Construct validity is evaluated by investigating what qualities a test measures, that is, by determining the degree to which certain explanatory concepts or constructs account for performance on the test (Bohrstedt 1977). Bohranstedt further indicates that, studies of construct validity are done to validate the theory underlying the scale, score or test constructed. Construct validity requires that the researcher should have a sound theory of the nature of the concept (Tull and Hawkins 1987). However, constructs vary widely in the extent to which the domain of related observable variables is large or small. The larger the domain of observables related to a construct, the more difficult it tends to be to define which variables belong or do not

in the domain (Nunnally 1967). Campbell and Fiske (1959) suggested two types fall under the heading of construct validity they are: convergent validity and discriminant validity. Tull and Hawkins (1987) explain the role of those kinds of construct validity. Whereas convergent validity is generally ensuring that the measure correlates positively with other measure of the same construct, discriminant validity ensures that the measure does not correlate with theoretically unrelated constructs. Lehmann (1989) gives a further explanation of convergent validity stating that a measure has convergent validity if it follows the same patterns as other measures of the same construct. For example, three different measures of attitude would be said to have convergent validity if they were highly correlated with each other. A construct should also possess a discriminant validity, which means the construct should be sufficiently distinct from other constructs to justify its existence (Peter 1981). It is quite clear that, construct validity is the most difficult to pursue for scale construction.

Criterion-related validity is ascertained by correlating one's measure with a direct measure of the characteristic under investigation. Criteria are generally divided into those which are concurrent and those which are predictive on the basis of the element time (Bohrnstedt 1977). Heller and Ray (1972) reported that attitude-behaviour research shows some of the shortcomings of predictive validity in determining the meaning of marketing measures. Generally speaking, measure validation is practical, but seldom used, especially when new measures of marketing phenomenon are proposed.

The researcher attempted to achieve content validity in this study through three different methods. First, the literature was

searched to determine how each variable is defined and used (e.g., packaging, labelling, pricing). In addition, some items were formulated that represent each variable. For example the first seven items in the questionnaire represent packaging (see questionnaire design in appendix 1). Second, the pilot study which was done to enable us to check the face validity of the attitudinal variables, so that the variables used were appropriate to the domain of medicine products. Third, in order to achieve content validity for the factual questions, we compared the classification categories of the designed questionnaire with the classification census figures through the Central Agency For Public Mobilization And Statistics.

6.10. SUMMARY:

The theme of this chapter is the research design. Secondary and primary data were required. The researcher relied on libraries, external data from the government and the pharmaceutical companies for secondary data. The research is however built basically on primary data.

Exploratory research was carried out to define the problem and build the objectives and hypotheses of the study. A large empirical study was then used to find answers to the research questions.

Because the questionnaire is an integral part of the research design, consideration was given to the choice of phrasing, sequencing, structure and instruction.

Two scales of attitude measurement were used in this study (itemized rating scale and Likert scale). There were explained in this chapter.

In collecting the research data, the researcher adopting face to face personal interviews via structured questionnaire. Good results were obtained with response rate of 72.2 per cent.

Regarding the design of sample, a random multi-stage area sample of 1300 consumers was chosen. Respondents were selected from two cities (Cairo, Giza).

Finally, the chapter concluded with an explanation of reliability and validity. The three basic methods of reliability were mentioned and details were given of Cronbach's Alpha which was used to test the scale of satisfaction in the context of the research findings. Also, the three major approaches of validity were presented, the methods used to attempt to achieve valid findings were explained.

CHAPTER SEVEN
MULTIVARIATE TECHNIQUES
OF ANALYSIS

- 7.1. Introduction.
- 7.2. Factor Analysis.
 - 7.2.1. Factor Analysis Input / Output.
 - 7.2.2. Extracting Initial Factors.
 - 7.2.3. Determination Of The Appropriateness Of Factor Analysis
 - 7.2.4. Advantages Of Factor Analysis.
 - 7.2.5. Use Of Factor Analysis In This Study.
- 7.3. Cluster Analysis.
 - 7.3.1. Cluster Analysis Measures.
 - 7.3.1.1. Euclidean Distance Measures.
 - 7.3.1.2.. Similarity Measures.
 - 7.3.2. Hierarchical Clustering Procedures.
 - 7.3.3. Deciding On The Number Of Clusters.
 - 7.3.4. Use Of Cluster Analysis In This Study.
- 7.4. Multiple Regression Analysis.
 - 7.4.1. Multicollinearity And Related Problems.
 - 7.4.2. Multiple Regression Analysis Using Dummy variables.
 - 7.4.3. Use Of Regression Analysis In This Study.
- 7.5. Statistical Tests Of The Research Hypotheses.
 - 7.5.1. Friedmans"Two-Way" Analysis Of Variance By Ranks.
 - 7.5.2. Analysis Of Variance ANOVA "F-Ratio".
 - 7.5.3. T-Test.
- 7.6. Summary.

7.1. INTRODUCTION:

Multivariate methods are consistent with modern marketing concepts, and the pressing need of marketing research is the ability to analyse complex data.

It is useful to draw a distinction between the two approaches of multivariate analysis namely "dependence / interdependence". In the latter we are interested in how a group of variables are related among themselves, no one being marked by the condition of the problems as of greater prior importance than the others. Whereas, in the analysis of dependence we are interested in how a certain special group "the dependent variables" are designated as being predicted or explained by a set of independent variables.

Now, there is a growing understanding in marketing research of the need for, and usefulness of multivariate data analysis procedures. Kinnear and Taylor (1987) stated two reasons for this trend. First, marketing problems are usually not completely described by one or two variables. Many variables combine to yield marketing outcomes. Second, the advent of the high-speed computer and associated analysis software has made the solution of multivariate statistical procedures relatively easy.

The research objectives were first addressed by applying three different multivariate analysis techniques: factor analysis, cluster analysis and multiple regression analysis.

All techniques used are well documented by texts and articles. It is the intention here to give only a brief overview of each technique and how it was used in this work.

7.2. FACTOR ANALYSIS:

Factor analysis is an interdependence multivariate technique which was used to accomplish the first objective "to identify and quantify the key elements that underlie consumer satisfaction with medicine products in Egypt". Factor analysis is concerned with the identification of structure within a set of observed variables. It addresses itself to the study of interrelationships among a set of variables, as an attempt to find factors that provide a dimensional structure of data (Stewart 1981). One can look at each factor as the dependent variable which is a function of observed variables. In other words, factor analysis focuses on the whole set of interrelationships displayed by the number of variables.

In applying factor analysis one is interested in examining the strength of the overall association among variables in terms of smaller set of linear composites of the original variables that preserve most of the information in the full data (Aaker and Day 1983). In other words, (Massy et al 1968) the factor analysis procedure involves finding a way of linearly transforming the original variables into a new smaller set of independent factors, which multiplied together in a special manner will produce the original correlation matrix as closely as possible.

Factor analysis can be applied for two major functions. One function, is to identify underlying constructs in the data (Aaker and Day 1983), by deriving dimensions in the data which combine each group of similar variables under specific termed factors. A second function of factor analysis is simply to reduce a large number of variables to a more manageable set (Brown 1980). The smaller set of variables express that which is common among the original variables. Generally speaking, factor analysis can be

useful to the analyst in three ways (Wells and Sheth 1971). First, it can point out the latent factors or dimensions that determine the relationship among a set of observed or manifest values. Second, factor analysis can be helpful by pointing out relationships among observed values that were there all the time but not easy to see. Third, factor analysis useful when things need to be grouped.

7.2.1. FACTOR ANALYSIS INPUT / OUTPUT:

The input of factor analysis is usually a set of variable values for each individual or object in the sample. In this present study, the input is a set of medicine attributes from which the researcher derived groups of variables that express the dimensions consumers use for judging their satisfaction with medicine provision. Factor analysis uses a derived matrix of correlation, the components of which provide a measure of similarity between variables. Factor analysis has value only when correlation among subset of variables really exists. The higher these intraset correlations are, the better defined are the resulting factor dimensions. The most important outputs are factor loadings, the factor scores and variance explained percentages. Each of the original variables has a factor loading on each factor. The factor loading is the correlation between the factors and the variables. These are used to interpret the factors. Further, the nearer to one the factor loading is the stronger the association between the variable and the factor (Crawford and Lomas 1980). Normally, factor loadings are crystallized by using a rotation procedure. The most commonly used is the varimax orthogonal rotation which attempts to

produce some high loadings and some near zero loadings on each factor.

Thus, the varimax orthogonal technique leads to a new set of uncorrelated factors. The interpretability of factors is facilitated when individual factor loadings are high or low (Cattell 1978). Aaker (1971) also reminds us that while it attempts to maximize the number of factor / variables correlations that are either high or low, it also minimizes the number of factors with which a variable is associated.

One output of most factor analysis programs is factor scores which can be used as input to other multivariate techniques which require the input variables to be uncorrelated (e.g, cluster analysis, multiple regression analysis, multiple discriminant analysis). This is not always satisfactory, because a factor score contains elements of the variables which do not load heavily on that factor. Frequently, a variable is chosen that has the highest loading on the factor to represent the factor and respondents scores on that variable are used as input to further techniques (Hair et al 1987). Alternatively, a weighted average of the scores of all the variables loading heavily on a factor can be used.

The percent of variance-explained by the factors helps to determine the number of factors to include and the quality of their representation of the original variables. Luck and Rubin (1987) suggested that if a factor has an eigenvalue greater than one, it is candidated for further interpretation.

7.2.2. EXTRACTING INITIAL FACTORS:

Principal components analysis is the most commonly used technique in marketing for extracting initial factors. The main reason for its popularity is that, unlike some of the less structured factor analytical procedures, it leads to unique reproducible results (Crawford and Lomas 1980).

The extracted factors should adequately explain the correlation among the observed variables in best linear combination. The best combination is in the sense that the particular combination of original variables would account for more of the variance in the data as a whole than any other linear combination of variables (Hair et al 1987).

In using factor analysis the researcher must in one way or another specify the number of factors to be considered, since, we normally begin an analysis without knowing how many factors or which factors underlie a set of manifest variables. Jackson (1983) stresses the importance for the investigator not to leave out any important factors. If this happens, the results will be basically worthless. On the other hand, if the researcher instructs the program for many factors more than the important ones, those factors will appear on the program output but contribute little to the explanatory power of the factor model.

In fact, carrying the analysis too far has penalties, it is wasteful of computer time as well as obscures the meaning of the findings. Corsuch (1973) and Luck and Rubin (1987) suggest that the extraction process should stop when all factors with eigenvalue greater than 1 have been removed. The rationale for the eigenvalue to be not less than 1 is that any individual factor should account

for at least the variance of a single variable, if it is to be retained for interpretation (Hair et al 1987).

7.2.3. DETERMINATION OF THE APPROPRIATENESS OF FACTOR ANALYSIS:

Stewart (1981) stated several useful methods for determining whether a factor analysis should be applied to a set of data. First, is the examination of the correlation matrix. If the correlation coefficients are small throughout the matrix, factoring may be inappropriate. Second, a plot of latent roots obtained from a factoring procedure should ordinarily contain at least one sharp break. This break may represent the point where residual factors are separated from the true factors. Third, an examination of communality estimates should reveal moderate to large communalities. Consistently small values may be an indication that factor analysis is inappropriate.

7.2.4. ADVANTAGES OF FACTOR ANALYSIS:

Factor analysis has two major advantages:

- 1) Summarization of correlated variables into a set of explanatory factors to remove collinearity in subsequent regression or discriminant analysis. In other words, this is a way to minimize the correlated variables for further research while the amount of information in the analysis is maximized.
- 2) Factor analysis might be used with other analytic techniques such as cluster analysis to group people into market segments. More precisely, in cluster analysis individuals are often assigned to groups on the basis of their factor scores.

Factor analysis is subject to limitations, since no statistical tests are regularly employed to test the findings, despite considerable efforts expended by mathematical statisticians to develop such tests (Green and Tull 1978). As a result, it is often difficult to know whether the results are merely an accident or reflect something meaningful.

7.2.5. USE OF FACTOR ANALYSIS IN THIS STUDY:

Factor analysis was used in this study to identify the elements which are grouped under major groups (e.g, pricing, quality). The goal was to generate combinations of sets of variables under specific termed factors. The emphasis was on in interpreting the significant dimensions of consumer satisfaction. The researcher used a principal components analysis followed by varimax rotation. Further analysis was carried out to determine the degree of satisfaction of respondents with the major factors and to determine those with which they are most satisfied and those with which they are least satisfied.

7.3. CLUSTER ANALYSIS:

Cluster analysis is a multivariate technique which was applied to attempt to accomplish the second objective "to explore the similarity among the various categories of Egyptian consumers in their satisfaction with the provision of medicines". Cluster analysis has become a common tool for marketing researchers for developing empirical grouping of persons or products (Punj and Stewart 1983) on the basis of their similarity to each other. Cluster analysis searches for natural groupings among objects described by several variables. The emphasis is on placing together

those objects that are similar with respect to the variables under study.

Cluster analysis therefore is able to classify a population of entities into a small number of mutually exclusive groups based on the similarity of profiles among entities. Each set of objects is defined by the value of a set of attributes associated with them, such that members of a cluster "look like" each other but do not look much like objects outside the cluster. Cluster analysis is a statistical method of classification. Unlike other statistical methods for classification such as discriminant analysis and automatic interaction detection, it makes no prior assumptions about important differences within a population (Punj and Stewart 1983). Aaker (1971) proposed that the purpose of cluster analysis is that it is able to identify objects. The resulting objects should have internal (within cluster) homogeneity and high external (between cluster) heterogeneity.

It is worth emphasising that, the primary use of cluster analysis is in market segmentation, since all segmentation research, regardless of the method used, is designed to identify groups of entities (people, markets, organisations). Lessing and Tollefson (1971) demonstrated that one approach often used is to define segments by socio-economic and demographic characteristics based upon the individuals attitudes, opinions, purchase propensities, etc....

7.3.1. CLUSTER ANALYSIS MEASURES:

In this section, our discussion reviews the most common approaches of measurement in the application of cluster analysis, euclidean distance measures and similarity measures.

7.3.1.1. EUCLIDEAN DISTANCE MEASURES:

Although many studies have been done using euclidean distance as a measure of difference between individuals it is theoretically only applicable under certain conditions. The condition which most concerns us according to Inglis and Johnson (1970) is that, it measures distance between items in a space with uncorrelated axes. In marketing research studies attitudes, which are frequently accepted as being correlated, represent the axes. In addition, Aaker (1971) reminds us that distance measures are usually restricted to instances in which the objects to be measured are interval-scaled. Thus there are limitations in using euclidean distance measures.

7.3.1.2. SIMILARITY MEASURES:

Similarity measures are often used in clustering when the characteristics of each object are only nominally scaled. These measures are flexible since they can handle nominal, ordinal and interval scaled data. Moreover, similarity measures are generally less sensitive to the impact of single characteristics on the resultant dissimilarity of two objects than are the euclidean distance measures. On the other hand, similarity measures have a set of limitations (Aaker and Day 1983). First, if a large number of characteristics are involved, objects which match may do so for accidental reasons reflecting the noise in the data. Second, if

some variables are dichotomous and others are multichotomous the two-state attributes will tend to be more heavily weighted in the similarity measures. Third, if continuous data are separated in order to similarity, valuable information can be lost.

7.3.2. HIERARCHICAL CLUSTERING PROCEDURES:

Once the cluster analysis measures have determined, the clustering can begin. Several approaches are possible. Hierarchical clustering procedures are widely used in marketing studies to place similar objects into groups or clusters. There are basically two types of hierarchical clustering procedures, agglomerative and divisive methods. Agglomerative methods "bottom-up" are the most commonly used computer packages.

The divisive method "top-down" starts with all objects in one cluster and divides and subdivides them until all objects are in their own single-object clusters (Aaker and Day 1986). Agglomerative methods in contrast, begin with the computation of a similarity or distance matrix between the entities and end with a dendrogram at the stage where all the individuals are in one group (Everitt 1980). In other words, each object or observation starts out as its own cluster, and the two that are most alike are then combined to form a new composite cluster. In subsequent steps, the two clusters are then compared to find the next most alike pair, then they are combined. This sequence is repeated until all the original clusters / respondents have been combined into one (Saunders 1980). Five popular agglomerative procedures used to develop clusters are: single linkage, complete linkage, average linkage, Ward's method and the centroid method.

Regarding the first two methods (i.e, single and complete linkage), single linkage first joins the two objects which are the most similar. The distance similarity between objects is then systematically scanned and objects are joined as the scanning level (distance) is raised. The single linkage algorithm links an object with any other object or cluster of objects if the distance between the pair of objects or any member in the cluster is equal to the scanning level. Similarly, two clusters join when any pair of objects (from each cluster) have a distance equal to the scanning level. Complete linkage on the other hand, requires that, an object joining a cluster at certain scanning level must have relations at that level with every member of the cluster (Churchill 1987).

Average linkage is an attempt to walk a middle ground between the single and complete methods. The average of all similarities between an object and a class of objects or between the members of two classes has to be above the given level for linkage to occur (Churchill 1987). This method defines distance between groups as the average of distance between all pairs of individuals in two groups (Everitt 1980). In addition, in the average linkage method each member of a cluster has a smaller average of dissimilarity with other members of the same cluster than with members of any other cluster (Maurice 1983).

Ward's method is another hierarchical clustering method based on within group variance rather than linkage (Anderberg 1973). That method is designed to optimise the minimum variance within clusters, which is known as error sum of squares (Aldenderfer and Blashfield 1984). Anderberg (1973) added that, Ward's method may or may not give the minimum possible sets of clusters formed from

the data. However, the solution is usually very good even if it is not optimum on this criterion.

In the centroid method, every time individuals are grouped, a new centroid (mean) is computed. Cluster centroids migrate every time a new individual or group of individuals is added to an existing cluster (Hair et al 1987).

Regarding the mechanism of each of the above methods, the complete linkage algorithm is particularly suited to finding very tight compact and homogeneous clusters under the similarity-within-clusters objective. Complete linkage is poorly suited for finding naturally separated but nonhomogeneous clusters, while single linkage methods which form straggling clusters, are poor at finding homogeneous groups (Jackson 1983). Average linkage measures all combinations of pairs between two clusters thus it tends to form spherical clusters. The centroid method is popular but exhibits chaining. The mean position of subjects in a cluster (the centroid) is calculated and the distance between the centroids is the measure of likeness. Ward's method like the centroid method is only suitable for use with distance measures and forms spherical clusters (Saunders 1980).

Overall, every analyst should keep in mind that the objective underlying each method is the same, to assign objects to groups so there will be as much similarity within groups and as much difference among groups as possible (Churchill 1987). The results of a particular cluster analysis therefore, must be interpreted in the context of a particular situation and the particular purpose of the analysis (Jackson 1983).

7.3.3. DECIDING ON THE NUMBER OF CLUSTERS:

A crucial step in cluster analysis is to decide on the number of clusters. Mair (1986) demonstrated that a trade-off has to be made between an accurate identification of distinct subgroups among the population and a limitation to a manageable number of clusters. Several authors have suggested (Friedman and Rubin 1967) that the appropriate number of clusters should be taken from the point where further combining of clusters gives a large increase in the error sum of squares. Aaker and Day (1983) state several possible approaches in the determination of the appropriate number of clusters. First, the analyst can specify in advance the number of clusters. Second, the analyst can specify the level of clustering with respect to the average within cluster similarity by establishing a certain level that would dictate the number of clusters. Third, is to determine the number of clusters from the pattern of clusters generated by the program.

7.3.4. USE CLUSTER ANALYSIS IN THIS STUDY:

In this study, hierarchical grouping methods of single, complete, average and Ward's were utilized using factor scores of individuals and statements as input to attempt to develop segments of respondents whose profiles of satisfaction / dissatisfaction with various attributes of medicine provision are similar within each segment and different among these segments. The homogeneity of groups should then enable us to gain insight into characteristics (e.g, sex, age, income) groups with different attitudes. The results should enable us to achieve a better understanding of consumer attitudes and opinions.

7.4. MULTIPLE REGRESSION ANALYSIS:

Multiple regression analysis is a multivariate dependence technique which was used to attempt to accomplish the third objective "to investigate the relationship between consumption patterns of medicines and the various characteristics of the Egyptian consumers (i.e, demographic and socio-economic)".

Multiple regression analysis attempts to determine the functional relationship between a single metric dependence variable (criterion) and a number of independent (explanatory variables) (Jain et al 1986). Multiple regression is the appropriate method analysis when the researcher has a single dependent variable which is presumed to be a function of other independent variables. Usually, the dependent variable (criterion) is predicted by or explained by a group of independent variables. Aaker and Day (1983) have proposed two different concepts of independent variables on the basis of the study goal. First, The independent variables (explanatory) sometimes are called the predictor variables when prediction is the goal. They help to predict values of dependent variable (criterion). Second, they are called the explanatory variables because they explain variation in the dependent variable. When constructing the model, the analyst must include all relevant variables. If an important variable is omitted, the power of the model is reduced.

In multiple regression analysis the relationship is assumed to be linear and additive. However, these are important assumptions. Linearity is the assumption that for each independent variable, the amount of change in the mean value of the dependent variable associated with a unit increase in the independent variable "holding all other independent variables constant" is regardless of

the level of the independent variable. While, additivity is the assumption that for each independent variable, the amount of change in the expected value of the dependent variable associated with a unit increase in the independent variable "holding all other independent variables constant" is the same regardless of values of the other independent variables in the regression equation (Berry and Feldman 1985).

When regression analysis is used to gain understanding of the other relationship between variables, the primary question is "which of the independent variables has the greatest influence upon the dependent variable". This can be answered by obtaining the partial regression coefficient; the Beta coefficient; which measures the degree of association between each independent and the dependent variable. Since, the Beta coefficients can be compared with each other in order to evaluate the independent variables, the larger the Beta coefficient, the stronger the impact of that variable upon the dependent variable. In addition, the Beta weight enables the researcher to see how well the set of explanatory variables explain the criterion variable and to determine the most influential explanatory variables. The coefficient of multiple determination R^2 measures the proportion of the variation in the dependent variable (criterion) which is associated with the variation in the explanatory variables. In summary, multiple regression is often used to gain an understanding of the relationship between variables by:

- (1) Finding a function or formula by which we can estimate the value of criterion variable from the predictor variables (Green 1978).

(2) Determining which of the independent variables has the greatest influence upon the dependent variable (Kinnear and Taylor 1987).

7.4.1. MULTICOLLINEARITY AND RELATED PROBLEMS:

Multicollinearity refers to the common problem in applied regression studies in which the independent variables (explanatory) are highly correlated. In other words, when independent variables are related to each other and not truly independent of each other, multicollinearity is said to exist. Such correlation between the explanatory variables in the regression equation makes the identification of structural relationships difficult or impossible. Berry and Feldman (1985) distinguish between two forms of multicollinearity. First, is perfect collinearity in which some independent variables regressed against the other independent variables in the model yield an R^2 of precisely 1.00. This arises with very small data sets (i.e, small samples). The second is less extreme multicollinearity in which the independent variables in a regression equation are intercorrelated but not perfectly. The study of multicollinearity in data analysis evolves around two major problems (Green and Tull 1978): a) how it can be detected and b) what can be done about it. These problems are particularly relevant to marketing research where one often faces the dilemma of needing a number of variables to achieve accuracy of explanatory variables.

Multicollinearity can be dealt with by different approaches. Tull and Hawkins (1987) suggest several ways for dealing with such situations. First, it can be ignored particularly when multicollinearity may be prominent in only a subset of the

explanatory variables and when this subset does not account for large proportion of the variance in the data. The second approach, is to delete one of the correlated explanatory variables if they have a high intercorrelation with the retained variables. Third, the correlated variables can be combined or transformed to produce uncorrelated variables. Finally, the correlated explanatory variables can be summarized in a set of explanatory factors using factor analysis. Further, Kinnear and Taylor (1987) add that another way to avoid multicollinearity is by increasing the sample size.

7.4.2. MULTIPLE REGRESSION ANALYSIS USING DUMMY VARIABLES:

The dummy variable is a simple and useful method of introducing into a regression model information on variables which are not conventionally measured on a numerical scale (e.g, sex, occupation, marital status).

Briefly, the analyst who is interpreting the output from a regression run must pay close attention to the coding of each variable (i.e, 0 or 1).

7.4.3. USE OF REGRESSION ANALYSIS IN THIS STUDY:

This technique was applied to investigate the relationship between consumers' consumption patterns and consumers' characteristics "to investigate the relationship between consumption patterns of medicines and various characteristics of the Egyptian consumers (i.e, demographic and socio-economic)". By using multiple regression, the thirty five categories of explanatory variables (demographic and socio-economic) are regressed against each category of the dependent variable. The

primary interest of this technique is to determine the extent to which the independent variables (e.g, sex, age, family size) can explain the variation in the dependent variable (i.e, consumption patterns), and to conclude whether these explanatory variables are strongly related to the various consumption levels. Finally, multiple regression allows us to determine the most important explanatory variables explaining the variation in the dependent variable.

7.5. STATISTICAL TESTS OF THE RESEARCH HYPOTHESES:

There are alternative statistical tests available for any given research design and it is necessary to employ some rationale for choosing among them. In hypothesis testing, we must state the hypothesized value of a population parameter before we begin sampling. The assumption we wish to test is the null hypothesis "Ho". A statistical test is a good one if it has a small probability of rejecting Ho when it is true, but a large probability of rejecting Ho when it is false. If our sample results fail to support the null hypothesis, we must conclude that something else is true. In other words, whenever we reject the null hypothesis, we accept the alternative hypothesis "H₁". Siegal (1956) indicated that there are two major considerations in selecting a statistical test. First, the researcher must consider the manner in which the sample was drawn and the nature of its population. Second, the kind of scale of measurement (i.e, nominal, ordinal, interval, ratio) which was employed in the definition of the variables involved in the study. Luck and Rubin (1987) add another consideration which must be taken into account in deciding on the appropriate statistical test such as: a) how many samples

are involved in the problem? "one, two, or many (k) samples" b) are the samples independent or related to each other?

In this study, the following null hypotheses were tested:

- Ho (1) There are no significant differences among Egyptian consumers with different demographic and socio-economic characteristics on basis of their satisfaction with the provision of medicine products.
- Ho (2) There is no significant relationship among the consumption patterns of medicine and the consumer's sex.
- Ho (3) There is no significant relationship among the consumption patterns of medicine and the various categories of consumers' age.
- Ho (4) There is no significant relationship among the consumption patterns of medicine and the various categories of consumers' income.
- Ho (5) There is no significant relationship among the consumption patterns of medicine and the various categories of consumers' education.
- Ho (6) There is no significant relationship among the consumption patterns of medicine and the various categories of consumers' occupation.
- Ho (7) There is no significant relationship among the consumption patterns of medicine and consumers' marital status.
- Ho (8) There is no significant relationship among the consumption patterns of medicine and the various categories of family size.

In order to determine the acceptability of the above hypotheses which derived from a theoretical basis, (see chapters 3

and 4) three appropriate statistical tests were selected on the basis of the previous considerations. These tests are:

7.5.1. FRIEDMAN "TWO-WAY" ANALYSIS OF VARIANCE BY RANKS:

This test is used for the purpose of testing the significant differences for the first hypothesis. It is a non-parametric statistical test, and can be applied when the K samples are related (Siegal 1956). Thus, the researcher planned to use the Friedman test to test the output for clustering procedures. The Friedman test is useful when the measurement of variables is on at least an ordinal scale, and the samples have been drawn from the same population. Most of the non-parametric tests however, apply to ordinal scales, and the Friedman test also applies to data on a nominal scale. Therefore, the Friedman test is appropriate to represent the groups of consumers' variables under the various level of satisfaction, to determine whether or not these observed groups are different (on the basis of satisfaction level), at the .05 significance level.

7.5.2. ANALYSIS OF VARIANCE ANOVA "F-RATIO"

As it will be mentioned in the next chapter, the results of cluster analysis did not show distinct groups. Our attention turned therefore, to ANOVA to replace the Friedman- two way analysis of variance by ranks to test the significant differences for the first hypothesis with a level of significance of .05.

ANOVA used in this study to test the null hypothesis that there are no significant differences among Egyptian consumers with different demographic and socio-economic characteristics on the basis of their satisfaction with the provision of medicine

products. ANOVA can find whether or not there are differences among the various categories of each of the demographic and socio-economic characteristic at the .05 significance level.

ANOVA is applicable when there are more than two means being compared. Actually, the objective of ANOVA is to test the statistical significance of differences among average responses due to controlled variables, after allowance is made for influences on response due to uncontrolled variables (Churchill 1987 and Green and Tull 1978). The basic idea of ANOVA is to compare the variation of among-samples sum of squares to the variation of within-samples sum of squares in terms of an F ratio (Luck and Rubin 1987). The variation of the response within groups is assumed to consist solely of random error, while the variation between groups is mixture of random and systematic errors due to the variation in the different intragroups (Anderberg 1973).

7.5.3. T TEST:

This test is employed for testing the other hypotheses Ho 2 to Ho 8. The T test is provided as output from the multiple regression computer program.

A T test is a parametric statistical test. Parametric statistical tests are the most powerful when all its assumption are valid (Siegal 1956). All the assumptions are satisfied in this work i.e.,:

- 1) The several samples have come from an identical population.
- 2) The observations are independently drawn from a normally distributed population (the sample had been drawn randomly).
- 3) The population must have the same variance as the sample or a known ratio of variance.

- 4) The means of these normal distributions are linear combinations and additive.
- 5) The scale of measurement should be at least interval*.

A T test can determine whether or not the criterion variable (consumption pattern) is associated with each explanatory variable (e.g, sex, age, income). This data is measured with a level of significance Alpha = .05.

Finally, it is important to emphasise that, the researcher did not develop a hypothesis for factor analysis. For this reason the researcher did not use a statistical test. The researcher's interest in employing of factor analysis was:

- (a) To reduce the large number of variables into a smaller set of uncorrelated variables.
- (b) To extract the underlying dimensions in the data representing the construct under study.

7.6. SUMMARY:

Three analysis techniques increasingly being advocated in the marketing literature for the solution of marketing research problems were reviewed in this chapter. The chapter began by distinguishing between the two approaches of multivariate techniques analysis (dependence, interdependence). With respect to the interdependence multivariate techniques, factor analysis used to identify underlying dimensions or constructs in the data to reduce the number of variables by eliminating redundancy, was explained. Principal components analysis was shown as a popular method for extracting initial factors and the varimax rotation of

* The nominal variables had been converted to dummy variables which should be equivalent to intervally scaled variables.

these factors was discussed. Two advantages of factor analysis were presented and the use of this technique to achieve the first objective was also cited.

Cluster analysis was the second interdependence multivariate technique described. Cluster analysis provides a direct approach to grouping variables, objects, or people. The popular hierarchical methods (single linkage, complete linkage, average linkage, Ward's method, centroid method) were explained by which one can form clusters of objects on the basis of their between-objects similarity. Deciding on the number of clusters was explained as a crucial step for the investigator. The use of cluster analysis to accomplish the second objective of this study was reported.

We then turn our attention to multiple regression, a dependence multivariate analysis technique. Because of the wide use of multiple regression in marketing research, we illustrated it in some detail as a technique for analysing the association between a single dependent variable and a set of independent variables. The regression model outputs coefficients and their associated Beta coefficient and T-value, in addition to R^2 which provide a measure of predictive ability of the model. Multicollinearity was proposed as a significant problem, by which the interpretation of regression model could be sometimes difficult. Dummy variables were also introduced as an acceptable method allowing nominally scaled variables in the regression equation. The utilisation of multiple regression to achieve the third objective was cited.

The last section of this chapter stressed the statistical hypotheses. The major considerations in selecting statistical tests were also provided followed by the research hypotheses of the study. The appropriate statistical tests for the fundamental

hypotheses were also examined. For the first hypothesis it was planned to use Friedman's two-way analysis of variance by ranks to test the significant difference among consumer segments according to their demography and socio-economy, but it was necessary to replace this with ANOVA. While for the other hypotheses (i.e, Ho 2 to Ho 8) a T test was employed to test the significant relationship between each consumer characteristic and the various categories of consumption patterns of medicine.

CHAPTER EIGHT
RESEARCH FINDINGS.

- 8.1. Data Analysis Procedure.
- 8.2. Reliability Of The Satisfaction Scale.
- 8.3. Factor Analysis Findings.
 - 8.3.1. Factor Labelling.
 - 8.3.2. Degree Of Satisfaction With The Factors Identified.
 - 8.3.3. Conclusion.
- 8.4. Finding Segments: Cluster / Discriminant Analysis.
- 8.5. Testing The Differences (ANOVA).
- 8.6. Analysis Of Variance (ANOVA) Findings.
 - 8.6.1. Interpretation Of The ANOVA Results Of The Factors Identified.
 - 8.6.2. Similarities Across The Factors Identified.
 - 8.6.3. Interpretation Of The ANOVA Results Of The Statements.
 - 8.6.4. Similarities Across The Statements.
 - 8.6.5. Conclusion About Similarities/Differences With Respect To Consumer Characteristics.
 - 8.6.6. The Link Between The Conceptual Model Of Consumer And The Research Findings.
- 8.7. Multiple Regression Results.
 - 8.7.1. The Findings Of The Multiple Regression Analysis.
 - 8.7.2. Testing The Relationship - T test.
 - 8.7.3. The Relative Importance Of The Predictors.
 - 8.7.4. Interpretation Of The Variables Retained.
 - 8.7.5. Conclusion.
- 8.8. Summary.

8.1. DATA ANALYSIS PROCEDURE:

The data analysis procedure involved four major phases. In the first phase the reliability of the scale of satisfaction for the first forty one attributes of satisfaction was measured using Cronbach's Alpha (Carmines and Zeller 1979). The second phase identified the key elements that underlie consumer satisfaction (in terms of packaging, labelling, etc) by reducing the forty one attributes into factors that could be used in subsequent analysis, the degree of satisfaction with each factor was then calculated. The third phase involved the use of one way analysis of variance (ANOVA) in an attempt to explore the similarities as well as dissimilarities in terms of satisfaction across consumer demographic and socio-economic characteristics of sex, age, income, etc. In fact, this phase included two sub-stages: 1. ANOVA was performed with the extracted factors and 2. ANOVA was used with the ten statements (see questionnaire design appendix 1). ANOVA, also was employed to test the null hypothesis that, there are no significant differences among Egyptian consumers with different demographic and socio-economic characteristics on the basis of their satisfaction with the provision of medicine products. The fourth phase incorporated multiple regression analysis in order to examine the relationship between consumption patterns of medicine and consumers' demography / socio-economy. In addition, T tests were used to test the null hypothesis that there was no relationship between the consumption patterns of medicine and consumer's demographic / socio-economic characteristics.

8.2. RELIABILITY OF THE SATISFACTION SCALE:

In order to assess the internal consistency of the items contained in the first forty one attributes Cronbach's coefficient alpha was computed and is shown in table 8.1.

The scale exhibited a high degree of reliability indicated by Cronbach's Alpha (Carmines and Zeller, 1979). Table 8.1 shows the value of Cronbach's Alpha if all 41 items are retained as well as the values if any item deleted systematically. The elimination of any item reduced, although only marginally, the reliability of the scale and therefore all were retained and as good indicators of satisfaction.

TABLE 8.1: ATTRIBUTES AND RELIABILITY COEFFICIENTS OF SCALE OF SATISFACTION

Attributes	Coefficient Alpha If Item Deleted
1. Tightness of packing to prevent spoilage	.8952
2. Ease of opening and reclosing the cap of medicine containers	.8953
3. Ease of getting medicines out of the packing	.8944
4. Durability of packing during the period of consumption	.8953
5. Degree of convenience of taking some doses away from home	.8948
6. Size of medicine packing	.8948
7. Possibility of re-using the empty packing, e.g. as container	.8976
8. Prominence of manufacturer's name on medicine labels	.8945
9. Legibility of production date	.8932
10. Legibility of expiry date of medicine shelf life	.8925
11. Information about storage	.8937
12. Position of storage information on labels	.8942
13. Clarity of description contents	.8941
14. Simplicity of description contents	.8940
15. Amount of instruction in enclosed leaflets such as: the interval between doses - the maximum daily dose - the right way to use the medicine safely	.8941
16. Your ability to understand the instruction language in case of imported medicines	.8949
17. Simplicity of instructions in enclosed leaflet	.8962
18. Taste of medicine	.8955
19. Smell of medicine	.8950
20. Fitness of medicine for its purpose	.8945
21. Price of each item of medicine related to your income	.8948
22. Degree of control over the price of medicine	.8947
23. Quantity of medicine supplied in the packing	.8943
24. Suitability of the packing size for the quantity	.8951
25. Suitability of the quantity for the price	.8940
26. Number of chemists in your area	.8963

Table 8.1 (Continued)	
27. Availability of wide range of medicines in your areas' chemists	.8943
28. Availability of scarce medicines in your areas' chemists	.8944
29. Possibility of obtaining your needs from chemists during weekends and holidays	.8949
30. Number of night service chemists in your area	.8946
31. Number of public chemists in your city	.8942
32. Availability of wide range of medicines in your chemists in public sector	.8936
33. Availability of scarce medicines in public sector	.8941
34. Getting the right prescription (in terms of accurate diagnosis) from doctors in public hospitals	.8953
35. Getting the right prescription (in terms of accurate diagnosis) from doctors in public clinics	.8954
36. Getting the right prescription (in terms of accurate diagnosis) from doctors in private surgeries	.8951
37. Amount of medicine side-effects	.8963
38. Amount of medicine adverse-effects	.8966
39. Clarity of written prescriptions by doctors in public hospitals	.8945
40. Clarity of written prescriptions by doctors in public clinics	.8944
41. Clarity of written prescriptions by doctors in private surgeries	.8968
 Cronbach's Alpha with all 41 items retained	 .8978

8.3. FACTOR ANALYSIS FINDINGS:

In order to gain an understanding of the factors underlying the consumer satisfaction with medicine provision, factor analysis is employed to reduce the large number of attributes. Each factor extracted will be interpreted in turn.

8.3.1. FACTOR LABELLING:

Principal components analysis followed by a varimax rotation was performed on the first forty one attributes to generate a solution (see the complete factor tables in appendix 3) . Table 8.2 contains the results. The results suggest a twelve factor solution. Thus, these factors can be candidated for further interpretation (Luck and Rubin 1987).

Also, it is worth pointing out that the twelve factors explained close to 63 per cent of the total variation in the data. The remaining variance therefore, is the unique variance of the attributes indicating that there may be unspecified attributes influencing consumer satisfaction. Almost, all the attributes are captured nicely by the twelve factor solution. Eleven out of twelve of factors (excluding factor 9) seem to have a clear and unambiguous meaning.

To make the interpretation easier, the attributes have been grouped in terms of their factor loading on a specific factor i.e., the attributes are grouped with other attributes also loading on the same factor. Bearing in mind that factors are interpreted mainly on the basis of factor contents, the twelve factors that emerged in the data may be characterized as follows:

- 1) Packing quality.
- 2) Description / instruction.

- 3) Availability of services of, and products in, public chemists.
- 4) Legibility of production / expiry date.
- 5) Price.
- 6) Clarity of written prescription.
- 7) Availability of services of, and products in, private chemists.
- 8) Quantity of medicine and packaging.
- 9) Taste / smell of medicine.
- 10) Adverse / side effects of medicine.
- 11) Doctors' experience.
- 12) Potential for re-use of the medicine containers.

Note in table 8.2 that the variation of a number of attributes is well explained by the twelve factors. In particular, attributes 9, 10, 18, 19, 37, and 38 have communalities over 80 per cent and thus, their meaning is well reflected by the twelve factors. In contrast, attribute 20 has a communality of only 33 per cent hence, its meaning is not reflected well by these factors. This attribute (Fitness of medicine for purpose) cannot be ignored. However, the low loading of the attribute does not mean it is worthless, it might be an important dimension to consumers. The factor analysis simply shows that none of the other attributes are highly correlated with it, it is a unique feature.

The attributes highly correlated with the first factor suggests that this factor is a (packing quality) dimension. That factor has high attribute loadings a maximum .77 for the second attribute, and a minimum .57 for the fifth attribute. At this point it is necessary to examine the contribution of each original attribute. The second one (ease of opening and reclosing the cap of medicine packing) is the most important attribute in defining that factor. Follow by the first, third, fourth, and fifth. This factor also

contributes most to the variance in the satisfaction (20 per cent). Factor 1 combines all the packing attributes in the questionnaire (see appendix 1) except two (i.e, attributes 6, 7) which load each on different factors.

Factor 2 appears to reflect consumer satisfaction / dissatisfaction with (description / instruction) involving the clarity and simplicity of the description of the contents, the amount of instruction enclosed, ability to understand and the simplicity of those instructions as suggested by the loading of these attributes. This factor explained 6.7 per cent of the variance. Attributes 13 and 14 are the highest loading .72, .69 respectively. Moreover, they have higher communalities than the others, 62 and 59 per cent respectively.

In factor 3, note that attribute 30 has a low loading and should contribute little to the interpretation of that factor. Hence, the third factor is termed availability of, and products in, public chemists on the basis of the loading of attributes 31, 32, and 33. We can see from table 8.2 that the most important attributes contributing to satisfaction / dissatisfaction with this factor are the availability of a wide range of medicines in the public chemists .80, and the availability of scarce medicines in those chemists .77. Both of them have highly communalities (74 , and 71 per cent) respectively.

Factor 4 appears to deal with the degree of satisfaction / dissatisfaction with the outer part of medicine labels. The highest loading attributes are legibility of production date as well as expiry date both .87, while the smallest are the prominence of the manufacturer's name on medicine labels, information about storage and position of storage information on labels. Further, the

strongest two attributes have the highest communality of all the 41 attributes (i.e., 86, 87 per cent respectively). The researcher identified this factor as representing the highly loading attributes (legibility of production / expiry date).

Factor 5 clearly is a price related factor the suited name therefore is price. Factor 6 is an entirely homogeneous dimension, three attributes i.e., 39, 40, 41, load highly on that factor. Those attributes reflect the clarity of prescriptions from doctors with different positions (i.e., in public hospitals, public clinic, private surgery).

Factor 7 contains a group of homogeneous attributes with somewhat high loadings. This factor is tentatively interpreted as availability of services of, and products, in private chemists. This factor seems to be related to factor 3. However, the consumers distinguish between the role of public and private chemists in their satisfaction with medicine availability / scarcity.

Factor 8, as can be seen from table 8.2, characterizes the attribute judgments on medicine quantity and size of packing. Factor 9 clearly centres on the taste / smell of medicines. Attributes 18 and 19, are highly correlated and combine to produce that factor. Conversely, attribute 20 has a fairly low absolute factor loading, .26. The low loading, indicates that it should not be considered in the interpretation of factor 9.

Factor 10 appears to cover adverse / side effects. Although few attributes load on that factor, they clearly define, as well as strongly explain it. We see in table 8.2, the three attributes loading on factor 11 are exploring the extent of satisfaction, with obtaining the right prescription from different doctor sources.

Attributes 35 and 36 are highly correlated whilst attribute 34 relating to doctors in public hospitals has a low loading of only .38 and therefore is less worthy of retention in the factor. The factor has been named doctors' experience.

The final factor, factor 12 includes a unique attribute with quite high loading .72 as shown in table 8.2 and has been named potential for re-use of the medicine containers.

TABLE 8.2: VARIMAX ROTATED FACTOR MATRIX

Attributes	F1	F2	F3	F4	F5	F6	Commun- ality
1. Tightness of packing to prevent spoilage - in case of medicine syrup	.74						.60
2. Ease of opening and reclosing the cap of medicine packing	.77						.65
3. Ease of getting the medicine out of the packing	.70						.56
4. Durability of packing during the period of consumption	.70						.54
5. Degree of convenience of taking some doses away from home	.57						.54
8. Prominence of manufacturers name on medicine labels				.41			.42
9. Legibility of production date				.87			.86
10. Legibility of expiry date of medicine shelf life				.87			.87
11. Information about storage				.47			.63
12. Position of storage information on labels				.42			.63
13. Clarity of description contents		.72					.62

Table 8.2 (Continued)

14. Simplicity of description contents	.69				.59
15. Amount of instruction in enclosed leaflet	.61				.49
16. Your ability to understand the instruction language in case of imported medicine	.49				.54
17. Simplicity of instruction in enclosed leaflet	.60				.53
21. Price of each item of medicine related to your income				.78	.67
22. Degree of control over the price of medicine				.74	.61
25. Suitability of the quantity for price				.57	.57
30. Number of night service chemists in your area		.42			.51
31. Number of public chemists in your city		.65			.58
32. Availability of wide range of medicines in chemists in public sector		.80			.74
33. Availability of scarce medicines in chemists in public sector		.77			.71
39. Clarity of written prescription by doctors in public hospitals				.74	.69

40. Clarity of written prescription by doctors in public clinics						.83	.78
41. Clarity of written prescription by doctors in private surgeries						.77	.64
Eigenvalues	8.2	2.7	2.1	2.0	1.7	1.7	
Percent of variance explained	20	6.7	5.0	4.8	4.2	4.0	
Cumulative variance explained	20	26.6	31.6	36.5	40.7	44.7	

Table 8.2 (Continued)

Attributes	F7	F8	F9	F10	F11	F12	Communality
6. Size of medicine packing		.52					.54
7. Possibility of re-using the empty packing eg. as container						.72	.58
18. Taste of medicine			.89				.83
19. Smell of medicine			.87				.83
20. Fitness of medicine for its purpose			.26				.33
23. Quantity of medicine supplied in the packing		.64					.61

Table 8.2 (Continued)

24. Suitability of packing size for the quantity		.70				.59
26. Number of chemists in your area	.59					.52
27. Availability of wide range of medicine in your areas' chemists	.68					.61
28. Availability of scarce medicines in your areas' chemists	.57					.58
29. Possibility of obtaining your needs from chemists during weekends and holidays	.70					.58
34. Getting the right prescription (in terms of accurate diagnosis) from doctors in public hospitals					.38	.55
35. Getting the right prescription (in terms of accurate diagnosis) from doctors in public clinics					.78	.72
36. Getting the right prescription (in terms of accurate diagnosis) from doctors in private surgeries					.65	.59
37. Amount of medicine side-effects				.88		.82

38. Amount of medicine adverse-effects				.89			.82
Eigenvalues	1.4	1.3	1.3	1.1	1.1	1.0	
Percent of variance explained	3.5	3.3	3.2	2.8	2.6	2.5	
Cumulative variance explained	48.2	51.5	54.7	57.4	60.1	62.6	

8.3.2. DEGREE OF SATISFACTION WITH THE FACTOR IDENTIFIED:

We continue to fulfil the first objective of the study to determine the extent to which consumers are satisfied with each of the twelve factors. The researcher calculated each average factor score using weighted factor loadings. The results are shown in table 8.3. Four factors, packing quality, description / instruction, taste / smell of medicine and doctors' experience achieved slightly better than neutral ratings. Three factors achieved a neutral rating and on the remaining five factors consumers showed dissatisfaction, the lowest rating going to price of medicine.

However, the level of satisfaction with the best - rated factor (packing quality) fell below the "slightly satisfied" level. It does not seem unreasonable to suggest that the consumers feel that the provision of medicine in Egypt is less than satisfactory in respect of the twelve factors identified.

TABLE 8.3: DEGREE OF SATISFACTION WITH EACH FACTOR

Factor Names	Attribute Loading	Attribute Means	Average Factor Score
1. Packing Quality	.74	4.658	4.6
	.77	5.081	
	.70	4.709	
	.70	4.435	
	.57	4.176	
2. Description/ Instructions	.72	4.850	4.4
	.62	4.351	
	.61	4.948	
	.49	3.163	
	.60	4.365	
3. Taste/Smell of Medicines	.89	4.300	4.2
	.87	4.145	
	.26	4.419	
4. Doctors' Experience	.38	2.506	4.2
	.78	4.009	
	.65	5.333	
5. Availability of services of, and products in, private chemists	.59	5.260	4.0
	.68	3.473	
	.57	3.096	
	.70	3.989	
6. Quantity of medicine and packing	.52	4.135	4.0
	.64	3.567	
	.70	4.335	
7. Adverse/Side effects of medicines	.88	3.916	4.0
	.89	3.948	
8. Legibility of Production/Expiry Date	.41	4.896	3.7
	.87	3.786	
	.87	3.681	
	.47	4.669	
	.42	4.360	
9. Clarity of written prescription	.74	2.471	3.2
	.83	2.904	
	.77	4.195	

Table 8.3 (Continued)			
10. Availability of services of, and products in, public chemists	.40	2.942	3.0
	.62	2.791	
	.80	2.959	
	.77	2.979	
11. Potential for re-use of the medicine containers	.72	2.913	3.0
12. Medicine price	.74	2.471	2.2
	.83	2.906	
	.77	4.195	

8.3.3. CONCLUSION:

The results of the above analysis not only throw light on consumer satisfaction, but more importantly provide knowledge regarding the crucial attributes of the medicine products i.e., attributes which determine consumer satisfaction.

The study indicates that consumer satisfaction with medicine provision can be best described in terms of twelve factors. The results showed that consumers distinguish easily between the inside and the outside labelling. In addition, the degree of satisfaction with factors identified showed that consumers were most satisfied with packaging and labelling. Whilst consumers were most dissatisfied with price, availability of services of, and products in, public chemists and the potential for re-use of the medicine containers.

8.4. FINDING SEGMENTS: CLUSTER / DISCRIMINANT ANALYSIS:

It was planned to achieve the second objective of the study utilizing cluster analysis for both the twelve factors identified and the other statements (see questionnaire appendix 1). Different clustering methods available on the SPSSX program (single, complete, average linkage and Ward's method) were used. However, none of the methods seems to convincingly identify groups of consumers based on their level of satisfaction with factors and statements. The researcher then focused on a linear discriminant analysis to see if membership of the clusters obtained, although unconvincing could be predicted on the basis of some linear combinations of the consumers' demographic and socio-economic variables. The results obtained from both cluster and discriminant analysis are presented in appendix 4. From the last few steps in the agglomeration schedules presented in tables 8.6 to 8.13, appendix 4, we can see why we could not obtain meaningful clusters. No clear breaks are obvious in the search. However, it was decided to explore the most promising possibilities.

In table 8.6, clustering on the basis of the factors identified using the complete linkage method, the increase in the coefficient tells us that probably the two cluster solution is the best. However, only 8 people were placed in cluster 2 and 930 in cluster 1. The results therefore seem meaningless. We then investigated the 5 cluster solution using discriminant analysis with the demographic and socio-economic variables as predictors of group membership. Table 8.14 shows that only one function was significant and table 8.15 shows us that these results also are meaningless.

In table 8.10, relating to the statements using the complete linkage method, the increase in the coefficient in the agglomeration schedule tells us again that the two cluster solution is the most promising. The subsequent discriminant analysis (table 8.16) shows that the function is significant but the results in table 8.17 shows us that the predictive ability of the function is useless since only 2 respondents are placed in group 2.

Regarding the agglomeration schedule in table 8.13 (statements using average linkage method), the increase in the coefficient could suggest four groups. But the discriminant analysis in table 8.18 shows that only one function is significant. Moreover, table 8.19 shows that although the prediction of group membership is better than by chance, at 34 per cent it cannot be regarded as acceptable.

We conclude therefore that clusters which were initially unconvincingly cannot be predicted on the basis of demographic and socio-economic variables. Our attention therefore turned to look at the demographic and socio-economic characteristics of consumers individually with respect to each factor / statement using one way analysis of variance (ANOVA). By ANOVA, we therefore explored some similarities and differences among the Egyptian consumers with different characteristics. This work is discribed in the following section.

8.5. TESTING THE DIFFERENCES (ANOVA):

ANOVA was used to test the null hypothesis in this study that there are no significant differences among Egyptian consumers with different demographic and socio-economic characteristics on the basis of their satisfaction with the provision of medicine products. The findings shown in tables 8.20 to 8.32 in appendix 5 did show up fifty one significant differences at >95% confidence level between various categories of consumer variables with respect to the twelve factors identified and the statements. The null hypothesis H_0 is therefore rejected and the alternative one accepted i.e., there are significant differences among Egyptian consumers with different demographic and socio-economic characteristics (sex, age, income, education, occupation, family size, marital status) on the basis of their satisfaction with the provision of medicine products. The details are presented in the following sections.

8.6. ANALYSIS OF VARIANCE (ANOVA) FINDINGS:

Tables 8.33 to 8.45 in appendix 5 present the significant differences that were detected using ANOVA. In the following sections an attempt is made to explore the similarity / dissimilarity among consumers with different demographic / socio-economic characteristics on the basis of their satisfaction.

8.6.1. INTERPRETATION OF THE ANOVA RESULTS OF THE FACTORS IDENTIFIED

Considerable efforts needed to be made to gain a firm grasp of these findings. The interpretation of consumer characteristics can be followed through tables 8.33 to 8.39 in appendix 5.

We first look at sex which has significant differences with respect to factors 2, 6, 12 as presented in table 8.33. In terms of factors 2, 6 (i.e., description / instruction and clarity of written prescription), the mean factor scores show that females were more satisfied than males. This might be due to the differences between men and women, often, men are more rational, willing to concentrate harder. They seek clear instruction on medicine labels, and perceive that it is their right to have a clear prescription form. Women were also more satisfied than men with the possibility of using empty packing e.g., containers. That seems to be easy to interpret due to the experience of women in Egypt they know how to use the empty containers for kitchen purposes.

In terms of age, it is obvious from table 8.34 that older people are more satisfied than younger ones with factor 3 and factor 7 which are named availability of services of, and products in, public chemists - availability of services of, and products in, private chemists. In the first case, consumers of 55-60 years of age were more satisfied than those in the 25-34 age group. The same pattern can be observed in the second case, consumers in the 35-44 age group were more satisfied than the slightly younger in the previous category (i.e., 25-34). This is probably due to the fact that, younger people are more critical and expect more of life in general and products in particular. In addition, consumers of middle age (i.e., 45-54) and 55-60 were more satisfied than the

youngest in the 18-24 years of age group with factor 4, legibility of production / expiry date. The results seems reasonable, although the older consumers are more mature as far as they know the importance of the presence of production and expiry date on the medicine labels, the youngest (i.e., 18-24) are less satisfied. That could due to the fact that most of them are students at the secondary schools and different universities, they are more optimistic in their life and expect manufacturers to give careful consideration to this important aspect. In contrast, the younger consumers (25-35 years) were more satisfied than the older 45-54 years with respect to the second factor, description / instruction. The researcher finds this results clear to interpret, simply because younger people are better educated, they can read and understand the description and instruction on medicine labels. While older people in many cases are less educated and may also be dissatisfied because of their inability to read well.

With respect to education level, as the results given in table 8.35 show the less educated reported more satisfaction than the higher educated with factors 3, 4, 6, and 12, however, for factor 2, the more educated were the more satisfied. The interpretation of these results seems somewhat easy. Factor 3, is the availability of services of, and products in, public chemists, we conclude that the higher educated were less satisfied because they are concerned to receive better service from the public chemists as the availability of medicines in those chemists is important to them. While the less educated people almost all have a low income and they get their treatment from the general hospitals. They are not aware of the availability of medicines in such chemists. In factor 4 which is concerned with legibility of production and expiry date,

the output looks interesting. The more educated were less satisfied. This is possibly due to: on the one hand, the noneducated and very low educated (i.e., primary school) do not mind about the legibility of production and expiry date on medicine labels. They have no expectations about such aspects. On the other hand, the more educated are less satisfied due to their deep attention to such aspects as the presence of production and expiry date on medicine labels. Carrying the analysis further to factor 6, clarity of the written prescription, the possible interpretation could be the greater awareness of the higher educated about the necessity of a written prescription to be clear. They feel that a clear prescription is an important form of patient protection and therefore are less satisfied.

It came as no surprise that we found the less educated consumers were more satisfied with factor 12 (potential for re-use of medicine containers) because the higher educated are usually careful about what to use. Factor 2, description / instruction contrasts the above general pattern, because the more educated consumers the more satisfied. That might be due to the greater experience, higher ability of those classes to read and understand the description / instruction easily.

The next variable to be considered is family size which shows only one difference throughout the factors. As displayed in table 8.36, the larger families (5-6 members) were more satisfied than the smaller families (3-4 members) in terms of factor 3, availability of services of, and products in, public chemists. The interpretation seems slightly unclear, but it could be due to the different social life of the smaller and larger families. The

smaller families are often looking for better service and expecting a wide range of medicines in the public chemists.

In terms of family income, table 8.37 shows two significant differences. First, the higher income classes (£5000-6999, over £7000) per annum were more satisfied than the lowest classes (less than £900, £1201-2999) and the middle classes (£3000-4999) with regard to factor 5 and 7. Second, the highest income classes (over £7000 and £5000-6999) per annum are less satisfied than the lowest income classes (less than £900 and £900-1200) in respect of factor 6. The picture of the high income respondents who were more satisfied with price as well as the availability of services of, and products in, private chemists is very interesting to interpret. Since, the higher income consumers are able to pay whatever the price of medicine, they do not feel a wide gap between their income and such prices. Additionally, the high classes often live in modern areas, that are characterized by providing better services (e.g., chemists, clinics, schools) in comparison with the poor areas. On the other hand, the higher income classes were less satisfied with the clarity of written prescriptions. That could be due to the high expectation of such classes, their attitudes are influenced by the high cost paid to the private doctors.

The next analysis involves occupation as can be seen in table 8.38, the professionals express more satisfaction than labourers in terms of factor 2, description / instruction. The difference in satisfaction / dissatisfaction may be due to the different incomes of each group. Professionals are often of higher income classes than labourers who have limited incomes. For that reason, labourers have more experience with the medicine provided by the general hospitals whereas professional classes frequently use private

sources. Added to this, the professionals reported more satisfaction than officials with prices. This results deserves a special remark, because professionals almost all have higher incomes, while officials with their limited income sources are suffering from an inability to get their satisfaction needs from medicines. Generally professional classes were more satisfied than other groups with the description / instruction and prices. Furthermore, the output detected that labourers were more satisfied than students in terms of factor 4, legibility of production / expiry date. The results seem very reasonable to interpret because the labourers are often poorly educated. It is hard for them to understand the importance of production and expiry date on medicine labels. In contrast, students have the ability to grasp and judge that brings in turn higher expectations in this regard.

The last point to be discussed in this section is marital status. As shown in table 8.39, single respondents were less satisfied than the others (i.e., separated, divorced, widowed) in terms of factor 4, legibility of production / expiry date. Such results could be interpreted in relation to age. Single people are usually younger, they are more aware, would have a higher expectation of labelling. Again, the single consumers reported less satisfaction than married consumers with respect to taste / smell of medicine. There is no doubt that, the married consumers purchase more medicine than single and other groups. Therefore their attitude towards medicine taste / smell is influenced by their greater experience.

8.6.2. SIMILARITIES ACROSS THE FACTORS IDENTIFIED:

Next, our attention turns to explore the similarities among consumers in respect of their demographic and socio-economic characteristics (i.e., sex, age, etc). Some similarities can be noted among consumer characteristics as follows:

- 1) Females are similar to younger consumers as well as to the less educated in terms of the greater satisfaction with description / instruction. In open questioning* it was detected that the consumers who expressed less satisfaction reported specific reasons for this feeling, the instruction does not always include an important statement, namely the interval dose of the medicine. Further, the majority of consumers mentioned that they do not understand the instructions on imported medicines. Some of them suggested an Arabic translation should be enclosed. Some were very dissatisfied with the description content, explaining that it is, often too small to read.
- 2) The older households are similar to the less educated and larger families in terms of their satisfaction with availability of services of, and products in, public chemists. In open questioning, they commented that, there was an adequate service / response for diabetics in public chemists. Conversely, the dissatisfied counterparts are very unhappy because the public chemists are located in the city centre only. Others were dissatisfied with the scarcity of several kinds of medicine in those chemists.
- 3) The older consumers, the less educated and the separated, divorced, widowed group are similar to each other in terms of

* The respondents were requested to state their own reasons for either satisfaction or dissatisfaction.

their satisfaction with legibility of production / expiry date. The less satisfied reported their unhappiness due to the absence of information about storage and felt that manufacturers did not seem concerned about supplying such information. Some consumers who were slightly satisfied with the labels also felt a lack of concern by manufacturers about supplying this information.

- 4) The higher income households and those in the higher occupation groups have similar trends of satisfaction with medicine price. Those dissatisfied with price emphasized the problem of the rapid change in prices, more than once a year, with particular reference to the increase in antibiotic prices. Other consumers are unhappy with the degree of control over the price of medicine especially with imported medicines which sell without a fixed price.
- 5) Women, less educated households and the lower income classes have a similar degree of satisfaction with the clarity of written prescriptions. In contrast, the dissatisfied patients mentioned that, written prescriptions were hard to read and looked like symbols rather than whole words. In addition, some doctors do not use a proper prescription form stamped by the doctors' union.
- 6) The older people are similar to the higher income classes in respect of their view on the availability of service of, and products in, private chemists. In open questioning, consumers who are very dissatisfied reported reasons such as: a) the scarcity of INSULIN for diabetics. b) sometimes domestic products are not available in stock therefore pharmacists offer alternative imported medicines which are more expensive than the domestic products and c) the medicines are only widely available

in the chemists in the modern areas for example, Heliopolis, Zamalik, Garden-City.

- 7) Females as well as the less educated consumers are more satisfied with potential for re-use of medicine containers.
- 8) Finally, married consumers are more satisfied than the single consumers and other status consumers in terms of taste / smell of medicine. On the other hand, all other groups expressed dissatisfaction especially with children's medicines. Another point deserves special attention. Some consumers reported that, they do not like the taste and smell of medicine in plastic containers. It could indicate that such containers may affect medicine quality.

8.6.3. INTERPRETATION OF THE ANOVA RESULTS OF THE STATEMENTS:

In reviewing the differences between males and females in this section, presented in table 8.40 in appendix 5, we note that females are more satisfied in terms of three statements 2, 3, and 9 while males are more satisfied than females with statement 1. The tendency to express dissatisfaction appears to be higher among men, especially their opinion towards the presence of warning statements as well as their concern that doctors should provide instruction information in the prescription. Perhaps this is due to expectation levels. Men expect adequate labels and are concerned with the importance of instruction information in prescriptions and are less satisfied with these features. On the other hand, the result with respect to the statement (there is an obvious improvement in medicine packaging over the last five years) shows the reverse, males are more satisfied than females.

Table 8.41 shows that the 55-60 years of age group are significantly different from the other age categories. In general, they tend to be more satisfied than the younger. With regard to the second statement, the difference between the 18-24 and 55-60 years of age group could be due to the different expectation of the two groups. The elderly simply are more apt to be satisfied than younger consumers with similar conditions. In addition, the 55-60 group along with the oldest group (i.e, over 60 years) are more satisfied than the younger, 25-34 and 35-44 years of age group in terms of statements eight and nine. That issue might be due to the greater concern of the younger patients. They are looking for more information about a medicine's positive / negative effects. Further, they prefer more doctor's instructions in the prescriptions in order to use the medicine in the right way. Such results must not be brushed aside, because the younger consumers look on everything with a critical eye, want the best job from the doctors towards their patients. The findings of statement 10 brings a somewhat different interpretation since the older consumers are more in agreement with the statement that the pharmacists do not sell medicine out of prescription. It might be that: a) the older patients are more careful and prefer a doctor's consultation, so they do not ask the pharmacists for medicine without a doctor's prescription, and b) they receive little opportunity to buy medicine by themselves.

In terms of education level, we can see generally in table 8.42, the less educated consumers display more satisfaction than do their higher educated counterparts, with the exception of statement 1 with which the higher educated are more satisfied. That finding looks easy to interpret. Although higher educated

consumers are able to distinguish between good and bad packing, it is quite easy for those groups to follow such improvements. It is worth reemphasising that, the improvement of packing in medicine sector has been discussed as one of the most important issues from the exploratory study of this research (see chapters one and two).

It is interesting also to turn the coin over and show the results in which the higher educated classes (high school, colleges, postgraduates) tend to be less satisfied than the lower educated in critical aspects (i.e., statements 2,4,8,9,10).

With respect to the second and the fourth statements the higher educated are agreed that the public hospitals offer free medicine with insufficient instruction on labels. Furthermore, they do not feel that adequate caution statements are issued. This demonstrates the high awareness of the educated classes, their concern with the presence of such instructions even on the medicines which are offered free. Also they give much attention to the enclosed leaflet. They realise the importance of the caution statement in order to avoid problems during the period of medicine use. Carrying the analysis further with respect to statement 8 and 9, educated patients expect more explanation from their doctors about the effects of medicines as well as instruction information in the doctor's prescription. Whilst the less educated (i.e, noneducated, primary) do not understand the meaning of medicine effects so clearly. So far as they are concerned the only effect of medicine is curing them. Finally, as we can follow in table 8.42 the noneducated and the primary grade educated are more agreed that the pharmacists do not sell medicines out of prescription. The interpretation of this results seems unclear, but it may be that the lack of experience of the less educated prevents them from

dealing with pharmacists without a doctor's prescription. Whereas the higher educated with their previous experiences about the right way to use medicines, matching the recommended dose to different ages and the right medicine to cure a specific illness do buy direct from pharmacists.

In respect of consumers' income, three statements show significant differences. Table 8.43 shows that the rich consumers (i.e, £7000 and over per annum) reported dissatisfaction more often than the lower income classes in regard to statements 2 and 3. It is surprising that we found the high income consumers are less satisfied with the presence of instructions on medicine labels offered free by public hospitals. However, we might assume that such classes have never tried the public hospitals services, they are almost always dealing with private surgeries. A similar trend was observed on statement 3, the higher income groups are unhappy with the existence of warning statements on medicine labels. It is reasonable to say such groups often obtain imported medicines as alternatives to domestic products by asking their doctors to prescribe them. Thus their greater experience with imported medicines affects their expectation towards better and sufficient warning statement on medicine labels of the domestic products. That brings in turn unsatisfactory feelings.

Statements 4 shows the reverse results, the higher income groups express themselves to be more satisfied with the presence of particular caution statements on medicine labels. This finding seems in contradiction with the above interpretation, we suppose that the higher income groups have not enough experience with domestic medicines.

From the results of table 8.44 we can easily see that statement 3 should be viewed with particular concern. It demonstrates a significant difference between labourers and officials, the former are more satisfied than the latter with the presence of warning statements on medicines. The possible interpretation for this results could due to the different education level between the two groups. Labourers are often noneducated or educated only to a very low level hence they cannot recognise such warning statements, and that may sometimes lead to misuse of medicines. In contrast, officials are usually educated enough, to study the medicine labels as well as the enclosed leaflet and follow the instructions carefully.

Ultimately, with respect to marital status in table 8.45 a complicated significant difference is observed among single, married and "other" status(i.e, separated, divorced, widowed) in respect to their tendency of agreement / disagreement with the insufficient instruction on medicine labels offered free by the public hospitals. The most satisfied group are divorced, separated or widowed, followed by married, and single are the least satisfied group. Further, the average satisfaction dropped between "others" status and married / single consumers. We can say simply that this might be due to the different circumstances of "other" status and married / single which create a different set of experiences as well as different expectation levels.

Carrying the analysis on, the divorced,....etc groups are more satisfied than the married consumers in regard to whether the pharmacists do or do not sell medicine out of prescription. We think it is reasonable to interpret that this trend is due to the "other" status habit of avoiding possible danger or trouble. They

follow the right way to buy medicine (i.e, by doctor's prescription). Their experience therefore does not help them to judge. In addition, the married consumers are more satisfied than single in terms of the presence on medicine labels of a particular caution statement. Such a finding looks slightly unclear, but a reasonable interpretation would be due to the different feelings and levels of responsibility of married and single consumers. The married households who are therefore in a position of responsibility are more aware and read such cautions in order to keep them on the safe side.

8.6.4. SIMILARITIES ACROSS THE STATEMENTS:

The findings address some similarities among consumer groups on the basis of their satisfaction with the ten statements, they are summarised as follows:

- 1) Males as well as the higher educated are more satisfied with the improvement in medicine packing. It is worth considering here that males and the higher educated reported more comments on the questionnaire about that matter. They did stress that such improvements are quite clear in the case of Capsule and Tablet packaging. Moreover, they expressed more satisfaction with the improvement in packaging of local and foreign investment companies (see chapter 2) rather than with the public sector ones.
- 2) Females, older, lower income and "other" status (i.e, separated, divorced, widowed) show a similar trend of satisfaction in respect of the instructions on medicine labels which is offered by public hospitals. In addition, their counterparts reported that medicine labels of these hospitals not only have

insufficient instructions but also have no identification, not even the medicine name.

- 3) Females, lower income and higher occupation have similar trends of satisfaction to the presence of warning statements on medicine labels. For instance, they reported their satisfaction with such statements with one exception (keep the medicine out of the reach of children).
- 4) The higher income, the married and the less educated are similar to each other in terms of their satisfaction with the presence on medicine labels of particular caution statements. While their counterparts strongly disagreed and felt that the majority of medicine companies were not concerned about such important cautions.
- 5) The older and the less educated patients have a tendency to be more satisfied with the adequacy of doctors to explain the medicine positive / negative effects as well as with the interest of most doctors in providing instruction information in prescription.
- 6) The older, less educated and the "other" status (i.e, divorced, separated, widowed) have a tendency to believe that the majority of pharmacists do not sell medicine out of prescription. Whereas, the opinion of their counterparts (i.e, younger, higher educated, single, married) emphasised that the majority of the pharmacists sell different kinds of medicine out of prescription even ANTIBIOTICS, which they sometimes prescribe to patients.

8.6.5. CONCLUSIONS ABOUT SIMILARITIES/ DIFFERENCES WITH RESPECT TO

CONSUMER CHARACTERISTICS:

Several major similarities and differences can be drawn with respect to all consumer characteristics. Firstly, the older, less educated are the two most satisfied groups, regarding: a) factor 3 "availability of services of, and products in, public chemists", b) factor 4, "legibility of production / expiry date", c) statement 2, "it seems that public hospitals offer free medicine with insufficient instruction on labels", d) statement 8, "doctors adequately explain to me the medicine positive / negative effects", e) statement 9, "most doctors are concerned about instruction information in prescription" and f) statement 10, "the majority of pharmacists do not sell medicine out of prescription". Secondly, the picture of females, lower income groups is straightforward. It is obvious from the previous analysis that both groups do appear to be satisfied regarding: a) factor 6, "clarity of written prescription", b) statement 2, "it seems that public hospitals offer free medicine with insufficient instruction on labels", c) statement 3, "there are usually warning statement statements on medicine labels". Thirdly, of particular interest is the agreement of males and the highly educated with the first statement "there is an obvious improvement in medicine packing over the last five years".

In summary, four consumer variables (i.e, sex, age, income, education) out of the seven under study contribute heavily to the degree of satisfaction / dissatisfaction with the attributes and statements.

The younger consumers are fairly dissatisfied with the exception of their satisfaction with factor 2 "description /

instruction". On the whole, members of higher educated groups are basically dissatisfied with the exception of statement 1, "the improvement of medicine packing".

So far, the analysis procedure has detected that males are less satisfied than females across several factors and statements. Regarding the higher income classes, they did express satisfaction with factor 5 "price", and statement 4, "medicine labels usually contain particular caution statement". "Other" status in terms of divorced, separated,....etc. groups are more satisfied than their counterparts (i.e, single, married). In addition, the higher a consumer's position in terms of occupation generally the more satisfied the consumer is. Family size has little effect on the degree of satisfaction / dissatisfaction with the attributes / statements, except the larger families reported a greater satisfaction with factor 3 "availability of services of, and products in, public chemists".

There are still some intuitive remarks which should be mentioned referring the most important consumer characteristics (i.e, sex, age, income, education). On the basis of sex, females seem to be more prone to be the ones to express positive attitudes. In the comparison between younger and older status, in general, the younger households express less satisfaction, whereas the consumers in 55-60 years are the most satisfied age group. The higher educated classes generally express feelings of dissatisfaction. Lastly, different income classes have different degrees of satisfaction / dissatisfaction, of particular interest is the high dissatisfaction level of the highest income classes (i.e, £7000 and over per annum).

8.6.6. THE LINK BETWEEN THE CONCEPTUAL MODEL OF CONSUMER

SATISFACTION AND THE RESEARCH FINDINGS:

Although the conceptual model of consumer satisfaction (chapter 5) has not been tested, our research findings give some support to the model. Since, the findings of this study showed that four consumer characteristics (sex, age, income, education) contribute heavily to the degree of satisfaction and dissatisfaction with different aspects of medicine provision. The influence of some consumer characteristics (sex, education, income) on consumer involvement and personal values also has been shown empirically by the work of other authors (i.e., Slama and Tashchian 1985, and Boote 1981a) through the context of the framework of the presented relationships in chapter 5. Such issues along with the other theoretical arguments support our view regarding the suggestion that consumer involvement and personal values are critical variables like expectation, performance, disconfirmation and inequity in determining satisfaction and dissatisfaction feelings.

8.7. MULTIPLE REGRESSION RESULTS:

Multiple regression attempts to investigate the relationship between demographic and socio-economic variable (i.e, sex, age, income, education, occupation, family size, marital status) and the amount of medicine purchased by the respondents in the sample.

The purpose of the regression in this study is not to derive a regression function capable of predicting the individual consumption of medicine, but rather to gain insight into different consumption level of segments of consumers. We use multiple regression to attain two different objectives. First, to assess the

overall combined contribution of independent variables (consumer characteristics) in explaining the dependent variable (consumption of medicine). Thus, using the multiple correlation coefficient squared (R^2) to estimate how much of the overall consumption variance is explained by the individual characteristic. In other words, we measure the ability of all predictors (e.g, sex, age) to account for the amount of medicine purchased. The significant relationship is measured by the F-value with the probability set at .05 level. Second, we use this analysis to test null hypotheses H_0 (2) to H_0 (8). We evaluate the contribution of a given independent variable when the effects of the other independent variables are controlled. For that, we use the T-value statistic to measure the ability of the predictor variable to explain variation in the consumption level. For the purpose of this study, the latter objective is more important, although the first is not ignored.

Three different statistics are used therefore to report the interpretations which appear in the following sections. They are the multiple correlation coefficient, T-value and the partial correlation coefficient(B).

8.7.1. FINDINGS OF THE MULTIPLE REGRESSION ANALYSIS:

Table 8.4 presents the multiple regression statistics. This analysis is based on questionnaire item 3 (see appendix 1).

Obviously, it is desirable to have a high R^2 for it implies a high explanation of the phenomenon under study. For instance, the regression analysis equation in table 8.4 shows a low R^2 value (15 per cent) indicating that demographic and socio-economic variables explain only a small proportion of the total variance of medicine

consumption. It is clear that, the low R^2 offers very useful information for it implies that the criterion variable has other predictors which account for 85 per cent of the variation in that variable (consumption of medicine). More precisely, the results suggest that the most variation in amount purchased medicine is not explained by the set of demographic / socio-economic variables used. However, the low R^2 value may have arisen because the variance within cells is great not because the relationship is weak (Frank et al 1967). Since the F-statistic for the full model is significant i.e, there is a relationship between the various consumption levels and the consumer variables.

**TABLE 8.4: THE INFLUENCE OF SAMPLE PREDICTORS ON THE FULL
REGRESSION MODEL**

Analysis Of Variance	Degrees Of Freedom D.F.	Sum Of Squares SS	Mean Squares MS	F Ratio	P * Value
Regression	14	281.37	20.1	11.81	.0000
Residual	923	1571.06	1.7		
<p>Multiple R 0.39</p> <p> 2</p> <p>Multiple R 0.15</p> <p> 2</p> <p>Adjusted R 0.14</p> <p>Standard Error SE 1.3</p>					

* Denoted significance at or below .05

8.7.2. TESTING THE RELATIONSHIP - T TEST:

Additional regression analyses were run for consumption categories in order to determine if demographic and socio-economic data adds significantly to the explanation of such consumption. The regression procedure employed entered variables one at a time. It is worth emphasising that the nominal scaled variables (i.e, sex, occupation, marital status) are specified as dummy variables, while the interval scaled variables (i.e, age, income, education, family size) are specified by their midpoint in an attempt to obtain accurate results. The null hypothesis in each test is that the particular independent variable is not associated with the

dependent variable. If the null hypothesis is rejected, the variable should be included in the equation, but if the null hypothesis is accepted the variable should be deleted from the equation (Brown 1980).

By scanning the last column in table 8.5, we can assess the acceptability of the null hypotheses as follow:

Ho(2) There is no significant relationship between the consumption patterns of medicine and consumers' sex.

"We accept Ho, T-value (.740) is not significant.

Ho(3) There is no significant relationship between the consumption patterns of medicine and consumers' age.

"We reject Ho, T-value (4.106) is significant.

Ho(4) There is no significant relationship between the consumption patterns of medicine and consumers' income.

"We reject Ho, T-value (3.231) is significant.

Ho(5) There is no significant relationship between the consumption patterns of medicine and consumers' occupation.

"We accept Ho, T-value (1.072, .294, -1.307, 1.580, -1.297, -.259, .267) is not significant.

Ho(6) There is no significant relationship between the consumption patterns of medicine and consumers' education.

"We accept Ho, T-value (-.251) is not significant.

Ho(7) There is no significant relationship between the consumption patterns of medicine and marital status.

"We reject Ho, T-value (5.319) is significant.

Ho(8) There is no significant relationship between the consumption patterns of medicine and family size.

"We reject Ho, T-value (2.046) is significant.

From the above hypotheses, we can detect that four variables out of seven are significant at the .05 level (age, income, marital status, family size). The question of which variables are candidates to retain according to Green and Tull (1978) is guided by the number of predictors that are statistically significant.

**TABLE 8.5 REGRESSION ANALYSIS: DEMOGRAPHIC/SOCIOECONOMIC
PREDICTORS FOR CONSUMPTION CATEGORIES**

Predictor Variables	Partial Coefficient (B)	Standard Error (SE)	T Value (B) Weight	P Value
Marital Status (Others)	.324218	.229699	1.411	.1584
Unemployment	.390302	.364203	1.072	.2842
Student	-.299369	.230743	-1.297	.1948
Retired	-.368854	.282301	-1.307	.1917
Proprietor	-.074409	.287624	-0.259	.7959
Family Size	.050077	.024474	2.046	.0410 *
Professional	.046613	.158550	0.294	.7688
Sex (Female)	.071218	.096264	0.740	.4596
Education	-.022416	.009637	-0.251	.8021
Income	.000084	.000026	3.231	.0013 *
Housewife	.066800	.250053	0.267	.7894
Married	.599746	.112766	5.319	.0000 *
Age	.019844	.004833	4.106	.0000 *
Official	.220056	.139316	1.580	.1146
Intercept (Constant)	1.652977	.267296	6.184	.0000 *

* Denoted significant at or below .05

8.7.3. THE RELATIVE IMPORTANCE OF THE PREDICTORS:

The second purpose of regression analysis in the study is determining which variable best fits a regression line through the total score (i.e, that explains the most variance). The various independent variables are considered to be unbiased, consistent, and efficient under the assumption of correct model specification, having a normally distributed error term with a mean of zero.

Aaker and Day (1983) suggest two major approaches to consider the relative importance of various predictors. First, the obvious procedure is to compare the magnitudes of the partial slopes. Simply, the partial correlation measures the degree of association between the dependent (i.e, consumption level) and one particular variable while holding the others constant. Further, the principal value of such coefficient is that it shows the direction of the relationship, or whether the variable is positively or negatively associated with the consumption of medicine.

The regression analysis in table 8.5 shows that the most explanatory variable is "married status" as evidenced by its B value of .06. Next in magnitude is the coefficient for occupational status (Unemployment) with a B value=.39. Next in magnitude are four variables (Retired, Marital "other", Students, Officials) with values -.37, .32, -.29, and .22, respectively, while the remaining variables exhibit smaller coefficients. However interpretation of B values are often thwarted by the different variances of variables (Lewis-Beck 1980). The second approach to consider therefore, according to Aaker and Day (1983) is Beta weight rather than slope coefficient (see column 4, table 8.5). The B weight is simply the ratio of B (i.e, slope coefficient) to its own standard error (SE). The larger the variance in a particular variable, the larger the B

weight. In other words, the one with the largest T-value can be interpreted to be the one that is the least likely to have a zero parameter.

Using the Beta weight, one would evaluate whether there is a statistically significant relationship. The most influential variables using this criterion therefore are: 1) married status (B=5.319), 2) age (B=4.106), 3) income (B=3.231), and 4) family size (B=2.046).

As we observed earlier from P-values (the last column) married status, age, income, and family size are significant at the .05 level. They provide a direct answer to the question: To what extent are demographic and socio-economic associated with different level of consumption categories ?

8.7.4. INTERPRETATION OF THE VARIABLES RETAINED:

Four variables (i.e, married status, age, income, family size) are worthy of note regarding the results of the previous section which indicated that these variables do play a positively significant role on medicine consumption. Married status appears to play the greatest role while age comes in next in importance, followed by income and family size. An attempt is made in this section to rationalise these findings.

(i) Married Respondents:

Married respondents impact heavily on medicine consumption. The married category dummy variable coefficient is significant and positive indicating that in comparison with single and "other" (i.e, divorced, separated, widowed), this category tends to spend more on medicine. This result is not surprising because the married

group consume more medicine than their counterparts. On the one hand, those married without children are almost always younger starting their married life, they could worry about their health and consume more medicine. On the other hand, married with children tend to consume more medicine due to: a) the increase of family members with the presence of children, and b) the majority of families with children less than five years take their children regularly to visit the doctors, so, the more visits to the doctor, therefore the more the consumption of medicines.

The positive significance of the amount of medicine purchased by married consumers confirms that this group of people can be considered as one of the most important groups with respect to consumption of medicine.

(ii) Respondents' Age:

The positive sign of the B-value indicates the older the respondent the greater the consumption of medicine. This result seems reasonable and can be interpreted as follows: a) generally, it could be assumed that the older a person gets the more he/she needs medicine and b) more specifically, the older consumers might have incurable diseases such as diabetes or heart problems which require regular consumption of medicine.

Generally speaking, the older consumers are an important group which should be thought about, especially if we accept the above assumed reasons.

(iii) Respondents' Income:

The positive sign shows that the consumption of medicine increases as the income increases. There is no doubt that the higher the income, the more the purchasing power. It is reasonable to say that, on the one hand, the high income people are more careful about their health, they can buy more VITAMINS or another kinds of medicine out of prescription. On the other hand, as far as the researcher knows, the higher income classes tend to visit their physician or dentist regularly. The doctors might prescribe more than one item to those patients. Furthermore, they could recommend the imported items instead of the domestic ones. Therefore, the switching from the domestic to the imported medicine (i.e, the more expensive) increases the expenditure on medicine (our measure of consumption). We can continue the interpretation further and say that the higher income group consumes a greater quantity and quality of food, this could be accompanied by some health problems so the more health problems the more need of medicine.

It is interesting to turn the coin over and see the reverse pattern(i.e, the poorer consumers have a lower consumption of medicine). Such a result deserves a special remark. The lower income people cannot overcome the scarcity of some kinds of medicine by replacing the domestic products with imported medicines. But medicine, unlike the other products it is a vital consumer good, the high as well as the low income classes should obtain their needs.

(IV) Family Size:

The results in table 8.5 shows how the increase of an extra person in the family affects medicine consumption positively. This finding comes as no surprise.

8.7.5. CONCLUSION:

There is a temptation to conclude that, the results of multiple regression indicate four consumer characteristics impact on medicine consumption. Generally, it appears that, marriage has the greatest influence on consumption. In addition, the results provide an answer to one of the two basic research questions in this study: "Are there any relationship among the various level of consumer consumption patterns and the Egyptian demography and socio-economy?. The answer seems to be yes. However, the findings do suggest that, the consumption of medicine is a function of broader influences than the consumer characteristics investigated. It must be remmbered that consumer characteristics were adopted not because they were initially presumed to be the major causes of medicine consumption, but because the relationship among consumption patterns and each of consumer variable might form a basis of market segmentation.

8.8. SUMMARY:

In this chapter, we presented the findings and interpretation of the data analysis in five major phases: a) reliability of satisfaction scale, b) factor analysis findings, c) testing the differences (ANOVA), d) ANOVA findings and e) multiple regression analysis.

For testing the reliability of satisfaction scale, Cronbach's Alpha was employed and showed that the researcher had developed a good reliable scale.

Twelve factors were extracted and employed in the interpretation of the underlying dimensions of satisfaction / dissatisfaction. In addition, the degree of satisfaction with each factor was calculated to determine how satisfied the Egyptian consumers are with the provision of medicine.

ANOVA was utilized to test one of the fundamental hypotheses of this study (i.e, there are no significant differences among Egyptian consumers with different demographic and socio-economic characteristics on the basis of their satisfaction with medicine provision), the hypothesis was rejected. ANOVA was employed also to explore the similarities / differences among Egyptian consumers with different demographic and socio-economic characteristics on the basis of their satisfaction with the twelve factors and the statements.

Based upon the results of the multiple regression analysis, T-tests were used to measure the other hypotheses of this research (there is no significant relationship between consumer characteristics and consumption patterns of medicine "in terms of expenditure"), four of those hypotheses were rejected. In addition, the relative importance of the predictors of regression model were approached by calculating B weights and interpreted (see summary of findings in chapter 9).

CHAPTER NINE

SUMMARY, IMPLICATIONS,

RECOMMENDATIONS AND CONCLUSIONS

- 9.1. Summary Of Findings.
- 9.2. Comparison Of This Study With The Previous Literature.
- 9.3. Implications Of The Study.
 - 9.3.1. Implications For Researchers And Theorists.
 - 9.3.2. Implications For Marketing Practitioners.
 - 9.3.3. Implications For The Government.
- 9.4. Contributions Of The Study.
 - 9.4.1. Theoretical Contribution.
 - 9.4.2. Empirical Contribution.
 - 9.4.3. Practical Contribution.
- 9.5. Recommendations For Future Research.
- 9.6. Concluding Comments.

9.1. SUMMARY OF THE FINDINGS:

Three types of analysis i.e, factor analysis, ANOVA, and multiple regression analysis have been used to achieve the three research objectives. In addition, the scale of satisfaction derived from 41 attributes was tested using CRONBACH'S ALPHA. The results indicated that this scale provides a reliable measure of satisfaction. Satisfaction attributes were factor analysed to determine the underlying dimensions of consumer satisfaction with the provision of medicines in the Egyptian market. The results identified twelve factors (dimensions), packaging and labelling, contributed most to the variance and were the factors with which consumers were most satisfied. Consumers were least satisfied with medicine price and availability of medicines.

ANOVA was used to test differences among Egyptian consumers on the basis of their satisfaction with medicines. The findings show there are differences in satisfaction among the consumers with different demographic and socio-economic characteristics. ANOVA was used to explore the nature of these differences and similarities among the various categories of the Egyptian consumers in their satisfaction with medicines. Sex and consumers from different age groups, income levels and education levels did exhibit different levels of satisfaction with some aspects of medicine provision. But it is difficult to summarise the findings as they were not clear cut and the results were explained in detail in chapter 8.

Of the seven demographic / socio-economic variables employed in the regression analysis, four were significant (i.e, married status, age, income, family size). In other words the results indicate that these variables affect the consumption of medicines,

while the other variables (i.e, education, occupation, sex) do not influence on such consumption.

More importantly, two consumer variables (i.e, age, income) affect the level of satisfaction / dissatisfaction and contribute to the consumption of medicine. However, education levels and sex which affect the level of satisfaction / dissatisfaction did not explain the variation in consumption of medicine. Conversely, family size which had the least effect on satisfaction / dissatisfaction plays a significant role in the consumption of medicine. Finally, concerning the variable marital status, married people had the greatest influence on consumption while marital status did not appear among the variables which affect the level of satisfaction / dissatisfaction.

9.2. COMPARISON OF THIS STUDY WITH THE PREVIOUS LITERATURE:

The findings of the study are in line with the some of the reviewed studies of the role of demographics and socio-economics in consumer satisfaction which were presented in the fourth chapter. However, as far as the researcher knows no studies have been reported which measure consumer satisfaction in the area of pharmaceuticals. The results of this work have therefore been compared with those from other product fields.

Regarding the results of the extent of consumer satisfaction / dissatisfaction, Wall et al (1978) investigated product performance and consumer satisfaction. They found results which support our findings such as: 1) the lower income categories exhibit a relatively high level of satisfaction 2) younger consumers display less satisfaction that do older consumers and 3) satisfaction decreases as the level of education increases. Another earlier

studies in the field of consumer goods by Pickle and Bruce (1972) and Pfaff (1976) concluded some results which confirm our findings such as: 1) the younger the age group the higher the degree of dissatisfaction, 2) the higher the level of education the higher the level of dissatisfaction and (3) the higher the level of income the higher the level of dissatisfaction (Pfaff 1976). The work of Mason and Himes (1973) found that the higher incomes classes expressed themselves to be less satisfied than the lower income groups with respect to some household appliances. Finally, the findings of Lundstrom et al (1978) also support our work to some degree they found that lower income people experience a much higher level of dissatisfaction as opposed to higher income families.

Regarding the investigation of the relationship between consumption patterns and consumer variables. Three earlier studies are in agreement with our research finding. Firstly, family size and age are demonstrated to be highly correlated with consumption in the Crockett and Fried study in (1960). Secondly, the Goldstein study (1968) focussed on consumer age and expenditure on various categories of goods and services. The results demonstrated that expenditure increased with increasing age of the head of the family especially after 65. Thirdly, Coleman(1960) concluded that income is a good predictor of consumption patterns.

Other recent studies by Graner (1983) and Smith (1983a) in the pharmaceutical field are also in line with our work. These studies show that: 1) the elderly are the greatest users of medicines; 2) the higher income the family, the more likely for its members to seek medical attention (Smith 1983a).

9.3. IMPLICATIONS OF THE STUDY:

The findings of this study should be of concern to various parties who have an interest in this field of study namely marketing researchers, theorists, practitioners and the Egyptian government.

9.3.1. IMPLICATIONS FOR RESEARCHERS AND THEORISTS:

To the marketing researcher, it should be of interest to note the demographic and socio-economic variables found to be important in discriminating between satisfied and dissatisfied consumers as well as influencing the consumption of medicine. This is useful for further research. The study also provides explicit evidence that demographic and socio-economic variables are associated with the consumption of medicine, supporting the prevailing of marketing theory.

This work will also be of interest to marketing theorists because, it provides considerable support for the conceptualization of the satisfaction topic advanced throughout the literature review and proposes a model of CS/D in chapter 5 which the researcher feels is worthy of further verification.

9.3.2. IMPLICATIONS FOR MARKETING PRACTITIONERS:

The implication for marketing practice are more thought provoking. It was been suggested (Howard and Hulbert 1973) that the notion of consumer satisfaction as a part of the marketing concept and good management in general is not widely accepted as a primary company goal. This study tends to reinforce the importance of consumer satisfaction. Four groups play an important role in the market of medicines in Egypt, manufacturers, distributors, doctors

and chemists and the results of this study have important implications for each.

The findings may provide useful guide-lines for the pharmaceutical companies (manufacturers). It is important for manufacturers to give prime consideration to the price of medicines and clarity of production and expiry dates on medicine labels with which consumers exhibited a high degree of dissatisfaction. The marketers may choose to adjust their programs to increase the satisfaction of the already satisfied consumers while at the same time increasing the satisfaction of the consumers who are at present dissatisfied.

The findings have also implications for the distributors because the results demonstrated the need for greater availability of medicines without which levels of dissatisfaction will remain high. The finding that consumers in the poor areas are less satisfied with the availability of medicines has several implications. One way to deal with this would be to determine the range and the volume to be distributed in all areas on the basis of the density of population in each area. Another way would be an effective inventory of the flow of medicines through the distribution cycle.

Generally, manufacturers and distributors have to strive to increase medicine facilities in terms of products and outlets. However, before taking specific action, further special studies may be necessary.

Regarding doctors, the study found a high trend of dissatisfaction in respect of doctors' failure to provide basic information on the prescription form and to explain medicines' positive / negative effects. Such findings have several

implications. On the one hand, doctors know that good prescribing does not only mean choosing the right medicine, but also it involves providing information which ensures that the medicine is effectively used. On the other hand, there is no doubt that medicines can be potentially harmful, many have side effects and in some cases some patients become the victims of such medicines. Many of these cases may have been avoided if the doctors had only been a little bit more careful and more cautious about the side / adverse effects of a medicine. It has been clearly shown that patients who are told about the treatment are less anxious and take medicines more sensibly and safely.

The ease with which medicine could be obtained without prescription from chemists gives cause for concern. Pharmacists should be more reluctant to sell medicine without doctors' prescriptions. Many consumers feared inaccurate diagnoses and were worried about the unnecessary and potentially harmful effects of unsupervised long-term use of medicine. Pharmacists must be dissuaded from such practices and government intervention seems to be the only feasible approach to the problem.

9.3.3. IMPLICATIONS FOR THE GOVERNMENT:

The role of government in the market of medicines comes to outweigh all the above roles. The government has a strong humanitarian, political, and economic interest in maintaining and restoring the health of its people. It must play a leading role in protecting consumers and ensuring that consumers have access to safe medicines. The findings of this thesis, summarised in the first section have a number of important implications for the government.

First, the problem of medicines' scarcity is not solely the responsibility of the manufacturers and distributors. The government must strive to ensure that consumers especially the disadvantaged, have access to outlets with adequate stocks to enable them to obtain at least the essential medicines.

Second, the problem of scarcity has been exacerbated by the growth in the rate of consumption in recent years (see table 2.2). Thus the government should encourage rational and economic use of medicines. Efforts to solve this problem might include the following:

- A) Intensifying efforts to prevent doctors prescribing mainly to please patients rather than to cure them.
- B) Setting up education / guidance programs for consumers to help ensure that medicines are used when needed.

Such programs would achieve the important benefits from medicines and the consumer might understand his / her role as both patient and consumer better.

Third, government could maintain its policy of making clear the responsibility of the manufacturers and ensuring that medicines suit the purpose for which they are intended. Consumers should have the right to access to non-hazardous medicines. This is being increasingly debated in the mass media.

Fourth, the price of medicine is clearly a problem. Over ninety nine per cent of consumers stated their dissatisfaction with the price of medicines. Undoubtedly, the shortage of raw material in Egypt has an impact on the increase in medicine prices. This is compounded by the fact that Egypt has had a serious foreign exchange problem making imported raw materials expensive (see table 2.6). But accessible prices depends ultimately on how resources are

distributed and the degree of control over the prices throughout the distribution cycle. Thus, the government cannot attribute the whole price problem to the exchange rate.

Fifth, the findings detected that all the respondents in the sample reported dissatisfaction with the plight of the elderly who cannot get medicines at lower prices. A special study is needed to determine the merit of this group, particularly the low income elderly people.

Sixth, the results of the trend of dissatisfaction with the services of the general hospitals deserve great consideration from the government. More efforts to remedy this situation might include a special study from the Ministry of Health.

In summary, this study has implications for all players in the medicine arena. We have shown considerable consumer dissatisfaction with medicines' provision in Egypt. The government must work with manufacturers, distributors, doctors, and pharmacists, decide which studies, strategies are the most acceptable to ensure an adequate protection and better services for the Egyptian consumers.

9.4. CONTRIBUTIONS OF THE STUDY:

The contributions of this study to consumer behaviour research are theoretical, empirical and practical.

9.4.1. THEORETICAL CONTRIBUTION:

The bulk of the past studies have investigated the role of consumer satisfaction with different products and consumer characteristics. This study pointed out the need to investigate consumer satisfaction as well as consumption patterns of a vital

product (medicine) . This research contributed to increase the knowledge of consumer attitudes and behaviour in relation to demographic and socio-economic variables in the critical area of consumer health. In addition, the research contributed theoretically by building a conceptual model of consumer satisfaction.

9.4.2. EMPIRICAL CONTRIBUTION:

This study is an empirical study using analysis techniques not used before in the market of medicines in Egypt. It is a small part of the growing body of published work in marketing research utilizing statistical analysis. Further, the derived satisfaction scale with such a high reliability is itself a major contribution of this study, that could be used in further research. There have been no published studies to the researcher's knowledge which deal empirically with the question of the extent of consumer satisfaction with medicine provision and whether or not there are relationships between consumer characteristics and consumption of these important consumer products.

9.4.3. PRACTICAL CONTRIBUTION:

The results of this study are of particular interest to the Egyptian government giving the government grounds for increasing control over the medicine sector in Egypt and supporting consumers' health and public welfare by:

- 1) Reviewing and improving the current legislation on packaging and labelling to increase consumer satisfaction in this sector. That consists of the following actions:

- a) The government's regulations could ensure that tamper-resistant packaging is in force in all the pharmaceutical companies of the public sector. So far, the tamper-resistant packaging has been brought on a small scale into the investment sector of pharmaceuticals (see part two in chapter 2).
 - b) To ensure adequate safety and effectiveness for all kinds of medicines, the label on medicines' packaging should be improved to provide the consumer / patient with complete and necessary information.
- 2) Developing new legislation on manufacturing practices through raising the requirements for licensing pharmaceutical companies. Such action along with the current medical control (see part two in chapter 2) will reduce the possibility of a harmful medicine reaching a patient and thereby might improve the health of society.
 - 3) Guiding the pharmaceutical companies to avoid marketing malpractice in the provision of medicine and offering the best service possible. That could be achieved through:
 - a) Establishment of a market research department in DOCMA able to identify the needs and wants of consumers. That department could take demographic and socio-economic characteristics into consideration and ensure that a wide range of medicines was offered by the pharmaceutical companies to most important segments of consumers who represent the heavy consumers of medicines (i.e., married people, older consumer, higher income, larger families).
 - b) Reorganization of the distribution system of the investment sector of pharmaceuticals through the supervision of DOCMA,

since the distribution policy at present varies according to the company's main objectives in the market place.

D) Providing a deeper insight into the role of doctors and pharmacists in increasing society relief. The Ministry of Health should have a special department directly responsible for supervising and following the action of all doctors and pharmacists. On the one hand to prevent doctors from the habit of overprescribing; on the other hand to encourage pharmacists not to dispense any kind of medicine unless on the doctors' prescription.

9.5. RECOMMENDATIONS FOR FUTURE RESEARCH:

The results of this study should potentially encourage scholars, especially as this study is the first empirical project investigating consumer behaviour in the medicine market and exploring the phenomenon of satisfaction and consumer attitudes and opinion in Egypt in this product field.

The new model of consumer satisfaction needs further verification through further consumer satisfaction studies which concentrate on the role of consumer involvement and personal values in satisfaction. The link between consumption patterns of medicine and demographic socio-economic variables will hopefully encourage a reexamination of the role of these variables for further research.

A significant question that remains for future research in respect of the strength of the relationship in the regression model is: "can the variation explained in the consumption increase if we added other predictor variables to the regression equation"?. Thus there is still a need for more research to know whether the

analysis can be enriched by expanding the number of the explanatory variables in the equation.

It is important that marketing researchers continue research in this area so that the entire picture of consumer satisfaction of the provision of medicine can be described. In general, the results of this work offer many opportunities for further research.

9.6. CONCLUDING COMMENTS:

The main stimulus for this thesis was a research study which purported to identify satisfaction / consumption segments. Although no clear segments emerged, the study found that sex, age, income and education affected the degree of satisfaction and dissatisfaction with different aspects of medicine provision. Whilst, marital status, age, income and family size influence the consumption of medicine products. Also, the medicine attributes examined in this study were shown to provide a highly reliable scale of satisfaction.

The large size of the sample and the careful selection of the sample elements give us confidence that our findings are representative of the whole Egyptian population.

It is satisfying to report that the research directly answered the two research questions:

- 1) To what extent are consumer satisfied with the provision of medicines in the Egyptian market?
- 2) Are there any relationships among the various levels of consumers' consumption patterns and the Egyptian demography and socio- economy?

REFERENCES

- Aaker, D. A., (1971), Multivariate Analysis In Marketing Theory And Application, Wadsworth, Inc., California.
- Aaker, D. A., and Day, G. S., (1983), Marketing Research, 2nd. ed., John Wiley and Sons, New York.
- Aaker, D. A., and Day, G. S., (1986), Marketing Research, 3rd. ed., John Wiley and Sons, New York.
- Allport, G. W., (1935), Attitudes, In Handbook Of Social Psychology, Murchinson, Worcester eds., Mass: Clark University Press.
- Aldenderfer, M. S., and Blashfield, R. K., (1984), Cluster Analysis, Series, Quantitative Application In The Social Sciences, Sage Publications, Inc., U. S.
- Anderberg, M. R., (1973), Cluster Analysis For Application, Academic Press, New York.
- Anderson, R. E., 1973, Consumer Dissatisfaction: The Effect of Disconfirmed Expectancy Of Perceived Product Performance Journal Of Marketing Research, 10, February, PP 38-44.
- Andreasen, A. R., (1976), A Taxonomy Of Consumer Satisfaction / Dissatisfaction Measures, In Hunt, H. K. ed., Conceptualization and Measurement Of CS/D, Proceeding Of Conference, Marketing Science Institution,
- Andreasen, A. R., (1977a), Consumer Dissatisfaction And Market Performance, In Sheth, powl and Leonardi, eds., Proceeding Of The Fourth International Research Seminar In Marketing, Foundation For Management Education.
- Andreasen, A. R., (1977b), Consumer Dissatisfaction As A Measure Of Market Performance, Journal Of Consumer Policy, 1, Fall, PP 309-21.
- Andrew, F., and Withey, S. B., (1976), Social Indicators Of Well -Being, Plenum, New York.
- Arndt, J., (1978), Family Life Cycle As Determinant Of Size And Composition Of Household Expenditures, In William And Wilkie eds., Advances In Consumer Research, Proceeding Of The Association For Consumer Research, Florida.
- Ash, S. B., (1978), A Comprehensive Study Of Consumer Satisfaction With Durable Products, In Advances In Consumer Research, In Hunt, H. K., ed., An Arbor: Michigan, Association For Consumer Research.
- Assael, H., (1987), Consumer Behaviour, 3rd. ed., Wadsworth, Inc., U. S.

- Barbeau, J. B., (1985), Predictive and Normative Expectation in Consumer satisfaction: Autilization Of Adoption And Comparison In An Unified Framework, In Hunt and Day eds., combined Proceeding Conference, Louis State University, Phoenix, Arizona.
- Barksdale, H. C., and Perreault, W. D., (1980), Can Consumer Be Satisfied, MSU Business Topics, Spring, PP 19-30.
- Barry, T. E.; Gilly, M. C., and William, R., (1982), Students As Consumers Predicting Satisfaction , In Walker, Bearden, Murphy, Nevin And Olson eds., An Assessment Of Marketing Thought And Practice, American Marketing Association, Chicago, Illinois.
- Bearden, O. W., (1983), Profiling Consumers Who Register Complaints Against Auto Repair Services, Journal Of consumer Affairs, 17, 2, Winter, PP 313-35.
- Becker, B. W., (1972), Consumerism: An Interpretation, Journal Of Marketing, 36, October, PP 61-5.
- Becker, B. W., and Connor, P. E., (1981), Personal Values Of The Heavy User Of Mass Media, Journal Of Advertising Research, 21, 5, October, PP 37-43.
- Belson, W. A., (1982), The Design And Understanding Of Survey Questions, Gower Publishing Co., Britain.
- Belson, W. A., (1985), Validity In Survey Research, Gower Publishing Co., Britain.
- Bending, A. v., (1953), The Reliability Of Self Rating As A Function Of The Amount Of Verbal Anchoring And Of The Number Of Categories One The Scale, Journal Of Applied Psychology, 37, 1, PP 38-41.
- Berry, W. D. and Feldman, S., (1985), Multiple Regression In Practice, Series Quantitative Application In The Social Science, Sage Publication, Inc, U.S.
- Bloch, P. H., (1982), Involvement Beyond The Purchase Process: Conceptual Issues And Empirical Investigation, In Advances In Consumer Research, Mitchell, A. A., ed., An Arbor, Mich: Association For Consumer Research.
- Blum, R. and Kreitman, K., (1981), Factors Affecting Individual Use Of Medicines, In Blum; Herxheimer; Stenzl; and Woodcock eds., Pharmaceutical And Health Policy: International Perspectives On Provision And Control Of Medicines, Croom Helm, London.
- Bockman, V. M., (1971), The Herzberg Controversy, Personnel Psychology, 24, Summer, PP 155-89.
- Bohrnstedt, G. W., (1977), Reliability And Validity Assessment In Attitude Measurement, In Summer, G. F., ed., Kershaw Publishing co., London.

- Boote, A.S., (1981a), Market Segmentation By Values And Salient Product Attributes, Journal Of Advertising Research, 21, 1, February, PP 29-35.
- Boote, A.S., (1981b), Reliability Testing Of Psychographic Scale, Journal Of Advertising Research, 21, 5, October, PP 53-60.
- Borchert, G., (1989), Drug Information In TV Advertising, Journal Of Consumer Policy, 12, PP 371-380.
- Borgenhammer, E., (1989), Patients' Right And Informed Consent: Swedish Experiences, Journal Of Consumer Policy, 12, PP 277-294.
- Bowen, L., and Chaffee, S.H., (1974), Product Involvement And Pertinent Advertising Appeals, Journalism Quarterly, 51, PP 613-21.
- Boyd, H.W.; Westfall, R. and Stach, S.F., (1977), Marketing Research: Text And Cases, Richard, D. Irwin, U.S.
- Bozinoff, L., and Cohen, R., (1982), The Effects Of Personal Values And Situation On Product Attribute Importance, In Assessment Of Marketing Thought And Practice, Edited By Waker, Bearden, Darden, Murphy, Mevin, Olson And Weitz, American Marketing Association, Chicago.
- Braithwaite, J., (1983), Corporate Crime In The Pharmaceutical Industry, Routledge And Kegan, London.
- Broffman, M.H., (1971), Is Consumerism Merely Another Marketing Concept?, MUS Business Topics, Winter, PP 15-21.
- Brown, F.E., (1980), Marketing Research: A Structure For Decision Making, Addison, Wesley Publishing Co., Inc., U.S.
- Buskirk, R.H., and Rothe, J.T., (1970), Consumerism: An Interpretation, Journal Of Marketing, 34, October, PP 61-5.
- Buzzell, R.D.; Cox, D.F., and Brown, R.V., (1969), Marketing Research And Information System: Text And Cases, MC Graw Hill, New York.
- Campbell, D.T., and Fiske, D.W., (1959), Convergent And Discriminant Validation By Mltitraite-Multi-Methods Matrix, Psychological Bulletin, March, PP 81-105.
- Cardozo, R.M., (1964), Customer Satisfaction: Laboratory Study And Marketing Action, In Kaplan, R.M., ed., Proceeding Of Conference, American Marketing Association, Chicago.
- Carlsmith, J.M., and Aronson, E., (1963), Some Hedonice Consequences Of The Confirmation And Disconfirmation Of Expectation, Journal Of Abnormal And Social Psychology, 66, February, PP 151-6.

- Carmen, J.A., (1965), The Application Of Social Class In Market Segmentation, Institute Of Business And Economic Research, University Of California, U.S.
- Carmines, E.G., and Zeller, R.A., (1979), Reliability And Validity Assessment, Quantitative Application In The Social Science Sage Publication, Inc., U.S.
- Cavusgil, S.T., and Kaynak, E., (1982), A Framework Of Cross-Cultural Measurement Of Consumer Dissatisfaction, In Hunt And Day eds, New Finding On Consumer Satisfaction And Complaining Behaviour, Proceeding Of Conference, Bloomington, Indiana.
- Cattell, R.B., (1978), The Scientific Use Of Factor Analysis In Behaviour And Life Science, Plenum Press, New York.
- Chappell, S.C., (1983), Market Analysis, In Smith, M.C. ed., Principles Of Pharmaceutical Marketing, Lea And Febiger, US.
- Chew, R., (1985), Pharmaceuticals In Seven Nations, Office Of Health Economics, London.
- Churchill, G.A., (1976), Marketing Research, The Dryden Press, Illinois, U.S.
- Churchill, G.A., (1979), A Paradigm For Developing Better Measures Of Marketing Constructs, Journal Of Marketing Research, 16 February, PP 64-73.
- Churchill, G.A., and Suprenant, C., (1982), An Investigation Into The Determinant Of Customer Satisfaction, Journal Of Marketing Research, 19, November, PP 419-504.
- Churchill, G.A., and Peter, J.P., (1984), Research Design Effects On The Reliability Of Rating: A Meta-Analysis, Journal Of Marketing Research, 16, November, PP 360-75.
- Churchill, G.A., (1987), Marketing Research: Methodological Foundation, 4th ed., Holt, Rinehart And Wilsion, New York.
- Clarke, J., (1959), Measuring Alienation Within A Social System, American Sociological Review, 24, December, PP 53-62.
- Cocks, D.L., (1983), Economic And Competitive Aspects Of The Pharmaceutical Industry, In Smith, M.C. ed., Principles Of Pharmaceutical Marketing, Lea And Febiger, US.
- Cohen, D., (1981), Consumer Behaviour, 1st ed., Random House, Inc., New York.
- Coleman, R.P., (1960), The Significance Of Social Stratification In Selling: A Maturing Discipline, In Martin, L.B., ed., American Marketing Association, Chicago.
- Corsuch, A., (1973), Using Bartlett's Significance Test To Determine The Number Of Factors To Extract, Educational And Psychological Measurement, 33, Summer, PP 361-64.

- Crawford, I.M., and Lomas, R.A., (1980), Factor Analysis: A Tool For Data Reduction, European Journal Of Marketing, 14, PP 414-21
- Crockett, J., and Fried, I., (1960), A Complete Set Of Consumer Demand Relationships, In Fried And Jones eds., Consumption And Saving, Study Of Consumer Expenditure, University Of Philadelphia
- Crosby, L.A.; Gill, J.D., and Lee, R., (1983), Life Style And Age As Surrogate Predictors Of Value Orientation, Paper Presented At The Personal Values And Consumer Behaviour Workshop, University Of Mississippi.
- Czepiel, J.A.; Rosenberg, L.J., and Akerele, A., (1974), Perspective On Consumer Satisfaction, In Curhanied, R.C. ed., Proceeding Of Conference, American Marketing Association, Chicago.
- Czepiel, J.A., and Rosenberg, L.J., (1976), The Study Of Consumer Satisfaction: Addressing The "So What Question", In Hunt, H.K. ed., Proceeding Of Conference, Marketing Science Institute
- Darvall, L.W., (1980), The Pharmaceutical Industry: Prescription Drug Information Control In Australia And The United States, Monash University Law Review, 7, PP 39-51.
- Day, G.S., and Aaker, D.A., (1970), A guide To Consumerism, Journal Of Marketing, 34, July, PP 12-19.
- Day, G.S., (1970), Buyers Attitude And Brand Choice, Free Press, New York.
- Day, R.L., (1976), Toward A Process Model Of Consumer Satisfaction, Conceptulization And Measurement Of CS/D, In Hunt, H.K. ed., Proceeding Of Conference, Marketing Science Institute.
- Day, R.L., and London, E.L., (1976), Collecting Comprehensive Consumer Complaint Data By Survey Research, In Beverlee And Anderson eds., Advances In Consumer Research, Association For Marketing Research.
- Day, R.L., (1977), Extending The Concept Of Consumer Satisfaction, In William, P. ed., Advances In Consumer Research, Atlanta, Association For Consumer Research.
- Day, R.L., (1980), Research Perspectives On Consumer Complaining Behaviour, In Lam and Dunne eds., Theoretical Development, Marketing Association, Chicago.
- Day, G.S., (1982), Are Consumers Satisfied, In Aaker and Day eds., Consumerism: Search For The Consumer Interest, 4th ed., Free Press, New York.
- Dean, D.G., (1960), Alienation: Its Meaning And Measurement, American Sociological Review, 26, PP 753-58.

- Diener, B. J., (1975), Information And Redrees: Consumer Needs And Company Response, The Case Of The Personal Care Industry, Marketing Science Institute, Cambridge.
- Dijkstra, W. and Zouwen, J. V., (1982), Response Behaviour In The Survey-Interview, Academic Press, London.
- Druker, P., (1969), Consumerism In Marketing, A Speach To National Association Of Manufacturers, New York.
- Dwyddar, R., (1989), The Availability Of Medicine And Methods For Remedy, Journal Of El-Ahram, January, 27.
- Elbeck, M., (1987), An Approach To Client Satisfaction Measurement As An Attribute Of Health Services Quality, Health Care Management Review, 12,3, PP 47-52.
- Engel, J. F., and Light, M. L., (1968), The Role Of Psychological Commitment In Consumer Behaviour: An Evaluation Of The Role Of Cognitive Dissonance, In King And Pressimies eds., Application Of The Sciences In Marketing, Bass, In King and Pressimier eds., New York.
- Engel, J. F.; Blackwell, R. D., and Miniard, P. W., (1986), Consumer Behaviour, 5th ed., The Dryden Press, U.S.
- England, G. W., (1967), Personal Values System Of The American Mangers, Academy Of Management Journal, 16, March, PP 53-68.
- Engledow, J. L., (1977), "Was Consumer Satisfaction A Pig In A Poke?" Business Horizons, 20, April, PP 87-97.
- Everitt, B., (1980), Cluster Analysis, 2nd ed., Halsted Press, John Wiley And Sons, New York.
- Ferm, M. A., (1983), Marketing Generic Drugs, In Smith, M. C. ed., Principles Of Pharmaceutical Marketing, Lea And Febiger, US.
- Festinger, L., (1957), A Theory Of Cognitive Dissonance, Stanford University Press, U.S.
- Fink, A., and Kosecoff, J., (1985), How To Conduct Surveys: A Step By Step Guide, Sage Publication, Inc., U.S.
- Fishbein, M., and Ajzen, I., (1975), Attitude Intention And Behaviour: An Introduction To The Theory And Research, Reading, Mass: Addison-Wesley, U.S.
- Frank, R. M.; Douglas, J. T. and Ronald, T. L., (1967), An Analysis Of Socio-economic - Related Market Segments For Grocery Products, In Krannert, H. C. ed., School Of Industrial Administration Purdue University, Indiana.
- Frank, R. E.; Massy, W. F., and Wind, Y., (1972), Market Segmentation, Prentice Hall, Inc, Cliffs, New York.

- Freedman, J.L., (1964), Involvement, Discrepancy, And Chang, Journal Of Social Psychology, 69, September, PP 290-95.
- Freedman, D.S., (1968), The Impact On The Consumption Of Modern Durables, In King, K.L. ed., Marketing And New Science Of Planning, Virginia Polytechnic Institution, Proceeding Of Conference.
- Friedman, H.P., and Rubin, J., (1967), On Some Invariant Criteria For Grouping Data, Journal Of American Statistical Association, 62, 1159-75.
- Gagnon, J.P., (1983), Physician Prescribing Habits, In Smith, M.C. ed., Principles Of Pharmaceutical Marketing, Lea And Febiger, US.
- Gaedeke, R.M., (1972), Filling And Disposition Of Complaints: Some Empirical Evidence, Journal Of Consumer Affairs, 6, Summer, PP 45-56.
- Gardner, P., and Watson, L., (1970), Adverse Drug Reaction: A Pharmacist-Based Monitoring System, Clinical Pharmacology Therapeutics, 11, PP 802-808.
- Gilly, M.C., (1980), Complaining Consumers And The Concept Of Expectation, In Refining Concepts And Measures Of Consumer Satisfaction Behaviour, Hunt And Day eds., Proceeding Of Conference, Bloomington, Indiana.
- Gist, R.r., (1974), Marketing And Society: Text And Cases, 2nd, ed., Dryden Press, U.S.
- Goldstein, S., (1968), The Aged Segment Of The Market, 1950 And 1960, Journal Of Marketing, 32, April, PP 62-8.
- Goodman, J., (1989), The Nature Of Consumer Satisfaction, Quality Progress, February, PP 37-40.
- Graner, D.D., (1983), The Retailer, In Smith, M.C. ed., Principles Of Pharmaceutical Marketing, Lea And Febiger, US.
- Green, R.T., and Cunningham, I.C., (1975), Feminine Role Perception And Family Purchasing Decision, Journal Of Marketing Research, 12, August, PP 325-32.
- Green, P.E., (1978), Analyzing Multivariate Data, Dryden Press, New York.
- Green, P.E., and Tull, D.S., (1978), Research For Marketing Decisions, 4th ed., Prentice Hall, Inc, Englewood, Cliffs, New Jersey.
- Gronroos, C., (1983), Strategic Management In The Service Sector, Cambridge MA, Marketing Science Institute.
- Hajda, J., (1961), Alienation And Integration Of Student Intellectuals, American Sociological Review, 26, PP 758-78.

- Hafez, A., (1989), The Historical Development Of The Pharmaceutical Sector In Egypt, A Series Studies In The Pharmaceutical Industry In Egypt.
- Hair, J.F.; Anderson, R.E., and Tatham, R.L., (1987), Multivariate Data Analysis, 2nd ed., Macmillan Publishing Co., U.S.
- Handy, C.R., (1976), Monitoring Consumer Satisfaction, Conceptualization And Measurement Of CS/D, In Hunt, H.K. ed., Proceeding Of Conference, Marketing Science Institute.
- Hample, D.J., (1977), Consumer Satisfaction With The Home Buying Process, Conceptualization Of CS/D, In Hunt, H.K. ed., Marketing Science Institute, Cambridge.
- Hancher, L., (1987), Regulation Drug Promotion: The UK Experience, Journal Of Consumer Policy, 10, 4, December, PP 383-407.
- Hansen, F., (1981), Hemispherical Lateralization: Implication For Understanding Consumer Behaviour, Journal Of Consumer Research, 8, PP 23-36.
- Hanson, R., (1979), The Pharmaceutical Development Process: Estimate Of Development Costs And Times And The Effects Of Proposed Regulatory Changes, In Issues In Pharmaceutical Economics, Chien, R.I. ed., Lexington Mass: Lexington Books.
- Hart, D., (1989), Drug Safety As A Means Of Consumer Protection: The Approximation Of Laws In The EC Medical Products Market And Its Limitation, Journal Of Consumer Policy, 12, PP 343-355.
- Haves, D.K., and Arndt, A., (1979), Determining Consumer Satisfaction Thought And Benefit Profiling, European Journal Of Marketing, 13, 8, PP 285-98.
- Heller, R.M., and Ray, M.L., (1972), Measure Validation In Marketing, Journal Of Marketing Research, 9, November, PP 361-70.
- Hemminki, C., (1975), Review Of Literature On The Factors Affecting Drug Prescribing, Social Science And Medicine, PP 90-111.
- Herxheimer, A., and Stimson, G., (1981), The Use Of Medicines For Illness, In Blum; Herxheimer; Stenzl; And Woodcock eds., Pharmaceutical And Health Policy: International Perspectives On Provision And Control Of Medicines, Croom Helm, London.
- Herxheimer, A., and Davies, C., (1982), Drug Information For Patients: Bring Together The Messages From Prescriber, Pharmacist And Manufacturer, Journal Of The Royal College Of General Practitioners, 32, February, PP 93-97.
- Herzberg, F; Mausner, B., and Snyderman, A., (1959), The Motivation To Work, Wiley, Inc., New York.
- Holbert, N.B., (1974), Point Of View: On Validity In Research, Journal Of Advertising Research, 14, February, PP 51-2.

- Houston, M. J., and Rothschild, M. J., (1978), Conceptual And Methodological Foundation Of Involvement, Research Frontiers In Marketing, In Jain, S. C., ed., American Marketing Association, Chicago.
- Houston, F. S., (1986), Marketing Concept: What It Is And What It Is Not, Journal Of Marketing, 50, April, PP 81-7.
- Hovland, C. I.; Harvey, O. J., and Sherif, M., (1957), Assimilation And Contrast Effect In Reaction To Communication And Attitude Change, Journal Of Abnormal Psychology, 55, PP 244-52.
- Howard, J. A., and Sheth, J. N., (1969), The Theory Of Buyer Behaviour, John Wiley And Sons, Inc., New York.
- Howard, J. A., and Hulbert, J., (1973), Advertising And Public Interest, Staff Report To The Federal Trade Commission, Washington.
- Howard, J. A., (1977), Consumer Behaviour: Application Of Theory, Mc Graw Book Co., New York.
- Hughes, D. A., (1976), An Investigation Of The Relation Of Selected Factors To Consumer Socialization, Conceptulization And Measurement Of CS/D, In Hunt, H. K. ed., Proceeding Of Conference, Marketing Science Institute.
- Hunt, H. K., (1976), Overview And Research Direction, Conceptualization Of CS/D, In Hunt, H. K. ed., Proceeding Of Conference, Marketing Science Institute.
- Hulin, C. L., and Waters, L. K., (1971), Regression Analysis Of Three Variation Of The Two Factors Theory Of Job Satisfaction, Journal Of Applied Psychology, 55, PP 211-17.
- Hustad, T. P., and Pessmier, E. A., (1971), Industry Use Of Life Style Analysis: Segmenting Consumer Market With Activity And Measures, Combined Conference Proceeding, In William, A. ed., American Marketing Association.
- Inglis, J., and Johnson, D., (1970), Some Observation And Development In The Analysis Of Multivariate Survey Data, Journal Of The Market Research Society, 12, April, PP 75-98.
- Jackson, B. B., (1983), Multivariate Data Analysis, Richard D., Irwin Inc., U. S.
- Jain, A. K.; Pinson, C., and Ratchford, B. T., (1986), Marketing Research: Application And Problems, John Wiley And Sons, New York.
- James, B. G., (1979), Pharmaceuticals: Re-thinking Our Business, Medical Marketing And Media, June, PP 19-24.
- James, B. G., (1983), International Marketing, In Smith, M. C. ed., Principles Of Pharmaceutical Marketing, Lea And Febiber, US.

- Kanungo, R.N., (1979), The Concept Of Alienation And Involvement Revisited, Psychological Bulletin, 86, PP 119-38.
- kapferer, J.N., and Laurent, G., (1985), Consumer Involvement Profiles: A New Practical Approach To Consumer Involvement, Journal Of Advertising Research, 25, December, 6, PP 48-56.
- Kassarjian, H.H., and Robertson, T.S., (1973), Perspective In Consumer Behaviour, Scott, Foeman And Co., U.S.
- kassarjian, H.H., (1981), Low Involvement: A Second Look, In Monroe, K.B ed., Advances In Consumer Research, Ann Arbor, Mich., Association Of Consumer Research.
- Katz, D., (1960), The Functional Approach To Study Of Attitudes, Public Opinion Quarterly, 24, Summer, PP 163-204.
- Kinney, T.C., and Bernhart, K.L., (1986), Principals Of Marketing, 2nd ed., Scott, Forman And Co., U.S.
- kinney, T.C., and Taylor, J.R., (1987), Marketing Research: Applied Approach, 3rd ed., McGraw Hill, New York.
- Knapp, D.E., and Oeltjen, P.D., (1972), Benefits To Risks Ratio In Physician Drug Selection, American Journal Of Public Health, 62, 10, PP 1346-1352.
- Kohn, R., and White, K., (1976), Health Care: An International Study, Report Of The World Health Organization, International Collaborative Study Of Medical Care Utilization, Oxford University Press, London.
- Kollat, D.T., and Willett, R.P., (1967), Customer Impulse Purchasing Behaviour, Journal Of Marketing Research, 4, February, PP 21-31
- Koponen, A., (1960), Personality Characteristics Of Purchasers, Journal Of Advertising Research, 1, PP 6-12.
- Kotler, P., (1972a), Marketing Management, 2nd ed., Prentice Hall U.S.
- Kotler, P., (1972b), What Consumerism Means For Marketers, Harvard Business Review, May-June, PP 48-57.
- Kotler, P., (1976/84), Marketing Management: Analysis, Planning And Control, Englewood Cliffs, Prentice Hall, U.S.
- Krishnan, S. and Valerie, A., (1979), Dissatisfaction Attribution And Consumer Complaint Behaviour, In William, L.W. ed., Advances In Consumer Research, Ann Arbor: Association For Consumer Research.
- Lambert, Z.V., and Kniffin, F.W., (1975), Consumer Discontent: A Social Perspectives, California Management Review, Fall, PP 36-44.

- Lambert, Z.V., (1980), Consumer Alienation, General Dissatisfaction And Consumerism Issues: Conceptual And Managerial Perspectives, Journal Of Retailing, 56, 2, Summer, PP 3-24.
- Lancaster, K., (1969), Introduction To Modern Micro-Economics, Rand McNally And Company, Chicago.
- Lancaster, K., (1971), Consumer Demand: A New Approach, Columbia University Press, New York.
- La Tour, S.A., and Peat, N.C., (1979), Conceptual And Methodological Issues In Consumer Satisfaction Research, Advances Of Consumer Research, In William, L.W., ed., Proceeding Of Conference, Association Of Marketing Research.
- Leavitt, C., (1976), Consumer Satisfaction As The Ultimate Life Force, In Anderson, B.B., ed., Advances In Consumer Research, Association For Marketing Research.
- Leffler, K.B., (1981), Persuasion Or Information? The Economics Of Prescription Drug Advertising, Journal Of Law And Economics, 24, PP 45-74.
- Lehmann, D.R., (1989), Market Research And Analysis, 3 ed., Richard D Irwin, U.S.
- Lessing, V.P., and Tollefson, J.O., (1971), Marketing Segmentation Through Numerical Taxonomy, Journal Of Marketing Research, 8, November, PP 480-87.
- Lessing, V.P., (1976), Measurement Of Dependencies Between Values And Other Levels Of Consumer's Beliefs Space, Journal Of Business Research, 3, 3, PP 227-239.
- Levin, M.B., (1960), The Alienation Voter, Holt, Rinehart And Winston, New York.
- Levis-Beck, (1980), Applied Regression: An Introduction, Series Of Quantitative Application In The Social Sciences, Sage Publication, Beverly Hills, London.
- Lidstone, J., and Collier, T., (1987), Marketing Planning For The Pharmaceutical Industry, Gower Publishing, Great Britain.
- Liefeld, J.P.; Edgecombe, F.H., and Wolfe, L., (1975), Demographic Characteristics Of Canadian Consumer Complainers, Journal Of Consumer Affairs, 9, Summer, PP 73-80.
- Locke, E.A., (1976), The Nature And Cases Of Job Satisfaction, In Dunnette ed., Handbook Of Industrial And Organization Psychology, Rand Mc Nally College Publishing Co., U.S.
- London, E.L., (1977a), Consumer Research Orientation Differences Between Industry And Government, Conceptualization And Measurement Of CS/D, In Hunt, H.K. ed., Proceeding Of Conference, Marketing Science Institute.

- London, E.L., (1977b), A Model Of Consumer Complaint Behaviour, In CS/D And Complaining Behaviour, Day, L. ed., Proceeding Of Conference, School Of Business, University Of Indiana.
- Luck, D.J.; Wales, H.G.; Taylor, D.A., and Rubin, R.S., (1982), Marketing Research, 6th ed., Prentice Hall, Inc., U.S.
- Luck, D.J., and Rubin, R.S., (1987), Marketing Research, 7th ed., Prentice Hall, Inc, U.S.
- Lundstorm, W.J and Kerin, R., (1976), Psychological And Demographic Correlates Of Consumer Discontent, Proceeding Of Conference Of The American Institute Of Decision Sciences.
- Lundstrom, W.J.; Skelly, G.U., and Sciglimpaglia, D., (1978), How Deep The Roots Of Consumer Discontent?: A Study Of Rural Consumers, In Day And Hunt eds., New Dimensions Of CS/D And Complaining Behaviour Bloomington, Indiana.
- Lutz, R.J., (1975), Changing Brand Attitudes Through Modification Of Cognitive Structure, Journal Of Consumer Research, 1, PP 49-59.
- Maier, J.R., (1986), Segmentation Allocation And Direction In The Pharmaceutical Industry, In Cowell And Collis eds., Marketing Education Group, Proceeding Of Conference, July.
- Marsh, P., (1990), On How The Minister Is Enjoying The Cut And Thrust Of Dealing With The Pharmaceuticals, Financial Times, July, 6.
- Martineau, P., (1958), Social Class And Spending Behaviour, Journal Of Marketing, 23, PP 121-41.
- Mason, J.B., and Himes, S.H., (1973), An Exploratory Behavioural And Socio-economic Profile Of Consumer Action About Dissatisfaction With Selected Household Appliances, Journal Of Consumer Affairs, Winter, 7, PP 121-27.
- Massy, W.F.; Frank, R.E., and Tolodohi, A., (1968), Purchasing Behaviour And Personal Attitudes, Trustess Of The University Of Pennsylvania, U.S.
- Maurice, L., (1983), Cluster Analysis For Social Scientists, Jossey Bass. Inc., California, U.S.
- Mayer, R.N., (1981), Consumerism In The 70's: The Emergence Of New Issues, Journal OF Consumer Affairs, 15, Winter, PP 375-91.
- Mckennell, A.C., (1978), Attitude Scale Construction, In The Analysis Survey Data: Exploring Data Structure, O' Muircheartaugh, C.A., ed., John Wiley Sons, New York.
- Medawar, C., (1984), Drugs And World Health: An International Consumer Perspectives, Consumer Association Social Audit, Holand.

- Mercill, A.W., (1983), Nonprescription Drugs, In Smith, M.C. ed., Principles Of Pharmaceutical Marketing, Lea And Febiger, US.
- Mikeal, R.I., and Sharpe, T., (1974), Patient Complaine, In Wertheimer And Smith eds., Pharmacy Practice, University Park Press, PP 170-194.
- Miller, J.A., (1976), Store Satisfaction And Aspiration Theory: A Conceptual Basis For Studying Consumer Discontent, Journal, Of Retailing, 52, 3, Fall, PP 65-84.
- Miller, J.A., (1977), Studying Satisfaction: Modifying Models Eliciting Expectation, Posing Problem And Marketing Meaningful Measurement, In Hunt, H.K. ed., Conceptualization Of CS/D, Marketing Science Institute, Cambridge.
- Mittal, B., (1986), A Framework For Retailing Consumer Involvement To Lateral Brain Functioning, Advances In Consumer Research, American Marketing Association, Chicago.
- Mittal, B. and Lee, M., (1988), Separating Brand-choice Involvement Via Consumer Involvement Profiles, In Houston, M. ed., Advances In Consumer Research, Association For Marketing Research.
- Morin, B.A., (1971), Consumerism Revisited, MSU, Business Topics, Summer, PP 47-51.
- Muncy, A.A., and Hunt, S.D., (1983), Consumer Involvement : Definitional Issues And Research Direction, In Kinnear, T. ed., Advances In Consumer Research, American Marketing Association.
- Munson, J.M., and McIntyre, S.H., (1979), Developing Practical Procedures For The Measurement Of Values In Cross-Cultural Marketing, Journal Of Marketing Research, 16, Febraury, PP 48-52.
- Myers, J.G., (1967), Determinant Of Private Brand Attitude, Journal Of Marketing Research, 4, Febraury, PP 73-81.
- Naryana, C.L., (1977), Graphic Positioning Scale: An Economical Instrument For Survey, Journal Of Marketing Research, 14, Febraury, PP 118-22.
- Nunnally, J.C., (1967), Psychometric Theory, McGraw Hill Co. New York.
- Nuttall, C.G., (1962), T.V. Commercial Audiences In The United Kingdom, Journal Of Advertising Research, 6, September, PP 19-28.
- Oliver, R.L., (1977), A Theoretical Reinterpretation Of Expectation And Disconfirmation Effects Of Post Product Evaluation: Experiences In The Field, CS/D And Complaining Behaviour, In Day, R. ed., Bloomington, Indiana.

- Oliver, R.L., (1979), Product Satisfaction As A Function Of Prior Expectation And Subsequent Disconfirmation: New Evidence, In Day, R. And Hunt, H. eds., New Dimensions Of CS/D And Complaining Behaviour, Bloomington, Indiana.
- Oliver, R.L., (1980), Conceptualizing And Measurement Of Disconfirmation Perceptions In The Prediction Of Consumer Satisfaction And Complaining Behaviour, In Hunt And Day eds., Proceeding Of Conference On CS/D And Complaining Behaviour, Bloomington, Indiana.
- Oliver, R.L., (1981), Measurement And Evaluation Of Satisfaction Process In Retail Setting, Journal Of Retailing, 57, 3, Fall, PP 25-48.
- Oliver, R.L., and Bearden, W.O., (1983), The Role Of Involvement In Satisfaction Process, In Bagozzi And Tybout eds., Advances In Consumer Research, Proceeding Of Association For Consumer Research.
- Olshavsky, R.W., and Miller, J.C., (1972), Consumer Expectation, Product Performance And Perceived Product Quality, Journal Of Marketing Research, 9, Febraury, PP 19-21.
- Olson, J.C., and Dover, P., (1976), Effects Of Expectation, Product Performance And Disconfirmation On Belief Elements Of Cognitive Structure, In Beverlee And Anderson eds., Advances In Consumer Research, Association For Marketing Research.
- Oppenheim, A.N., (1966), Questionnaire Design And Attitude Measurement, Heinemann Educational Books, Great Britain.
- Ortinou, D.J., (1978), Conceptual Model Of Consumer's Post Purchase Satisfaction / Dissatisfaction Decision Process, In Day And Hunt, New Dimensions Of CS/D And Complaiing Behaviour.
- Ostrom, T.M., and Brock, T.C., (1968), A Cognitive Model Of Attitudinal Involvement, In Theories Of Cognitive Consistency: Sourcebook Abelson, Aronson, McGuire, Newcomb And Rosenberg eds., Rand Muc Nally, Chicago.
- Park, C.W., and Young, S.M., (1984), The Effects Of Involvement And Executional Factors Of A Television Commercial On Brand Attitude Formation, Working Paper, Marketing Science Institute, PP 84-100.
- Parasuraman, A., (1986), Marketing Research, Addison Wesley Publishing Co. Inc., U.S.
- Pestoff, A.V., (1988), Exit Voice And Collective Action In Swedish Consular Policy, Journal Of Consumer Policy, 12, March, PP 1-27.
- Peter, J.P., (1979), Reliability: A Review Of Psychometric Basics And Recent Marketing Practices, Journal Of Marketing Research, 16, Febraury, PP 6-17.

- Peter, J.P., (1981), Construct Validity: A Review Of Basic Issues And Marketing Practices, Journal Of Marketing Research, 19, May, PP 133-45.
- Peter, G., (1981), Information And Education About Drugs, In Blum; Herxheimer; Stenzl; And Woodcock eds., Pharmaceutical And Health Policy: International Perspectives On Provision And Control Of Medicines, Croom Helm, London.
- Petrof, J.V., (1971), Attitudes Of The Urban Poor Towards Their Neighbourhood Supermarkets, Journal Of Retailing, 47, Spring, PP 3-17.
- Peterson, E., (1974), Consumerism As A Retailer Asset, Harvard Business Review, 52, May-June, PP 91-101.
- Pickle, H.B., and Bruce, R., (1972), Consumerism, Product Satisfaction / Dissatisfaction: An Empirical Investigation, The Southern Journal Of Business, pp 87-100.
- Pike, A., (1990), Smart Marketing, Financial Times, November, 21.
- Pitts, R.E., (1981), Value Group Analysis Of Cultural Values In Heterogeneous Population, Journal Of Psychology, 117, PP 109-124.
- Pitts, R.E., and Woodside, A.G., (1984), Personal Values And Consumer Psychology, Health And Co., U.S.
- Pfaff, A.B., (1972), An Index Of Consumer Satisfaction, In Venkatesan, M. ed., Proceeding Of Conference, Association Of Marketing Research, Chicago.
- Pfaff, M., (1976), The Index Of Consumer Satisfaction: Measurement Problems And Opportunities, In Hunt, H.K. ed., Conceptualization Of CS/D, Marketing Science Institute, Cambridge.
- Platek, R.; Pierre, F.K., and Stevens, P., (1985), Development And Design Of Survey Questionnaires, Published Under The Authority Of Minister Of Supply And Services, Canada.
- Plummer, J.T., (1974), The Concept And Application Of Life Style Segmentation, Journal Of Marketing, 38, January, PP 33-37.
- Pradhan, S.B., (1983), International Pharmaceutical Marketing, Quorum Books, US.
- Pratt, R.W., (1972), The Index Of Consumer Satisfaction And Corporate Policy, In Venkatean, M ed., Proceeding Of Conference, Association For Consumer Research.
- Prescribing All The Way To The Banks, (1990), Financial Times, August, 4.
- Punj, G., and Stewart, D.W., (1983), Cluster Analysis In Marketing Research: Review And Application, Journal Of Marketing Research, 20, May, PP 134-48.

- Qualls, W. J., (1982), Changing Sex Roles: Its Impact Upon Family Decision Making, In Mitchell, A. ed., Advances In Consumer Research, American Marketing Association.
- Quraeshi, Z.; Luqmani, M.; and Malhotra, N., (1983), Brands Or Generics: The Dilemma Of Pharmaceutical Marketing In Developing Countries, Journal Of Health Care Marketing, 3, 4, Fall, PP 27-37.
- Rapoport, J., (1979), Patients' Expectation And Intention To Self-Medicare, Journal Of The Royal College Of General Practitioners, 29, PP 468-472.
- Renoux, Y., (1973), Consumer Dissatisfaction And Public Policy, In Public Policy And Marketing Practices, In Allvine, F.C. ed., American Marketing Association, Chicago.
- Richins, M.L., and Verhange, B.J., (1985), Seeking Redress For Consumer Dissatisfaction: The Role Of Attitudes And Situational Factors, Journal Of Consumer Policy, 8, PP 29-44.
- Robert, F., (1962), Research On Household Behaviour, American Economic Review, 52, March, PP 19-63.
- Robertson, T.S.; Zielinski, J., and Ward, S., (1984), Consumer Behaviour, Scott, Forman And Co., U.S.
- Robinson, L.M., (1978), Consumer Complaint Behaviour: A Review With Implication For Further Research, In Day And Hunt eds., New Dimensions Of CS/D And Complianing Behaviour.
- Rokeach, M.J., (1968a), Beliefs, Attitudes And Values, San Francisco, Jossey-Bass, Inc., U.S.
- Rokeach, M.J., (1968b), The Role Of Values In Public Opinion Research, Public Opinion Quarterly, 32, PP 547-9.
- Rokeach, M.J., (1968c), A Theory Of Organization And Change Within Value / Attitude System, Journal Of Social Issues, 24, PP 13-33.
- Rokeach, M.J., (1973), The Nature Of Human Values, New York, The Free Press, U.S.
- Rokeach, M.J., (1979), Understanding Human Values: Individual And Societal, Free Press, U.S.
- Ronald, F.E.; Massy, W.F., and Boyd, H., (1967), Correlates Of Grocery Product Implication For Further Research, In Day, R. ed., New Dimensions Of CS/D, American Marketing Association.
- Ross, C.K.; Frommett, G.; Hazelwood, L., and Chang, R., (1987), The Role Of Expectation In Patient Satisfaction With Medical Care, Journal Of Health Care Marketing, 7, 4, December, PP 16-26.

- Rothschild, M.L., (1979), Advertising Strategies For High And Low Involvement, In Maloney And Silvoman eds., Attitude Research Plays For High Stakes, American Marketing Association, PP 74-93.
- Samuelson, P.A., (1967), Economics, 7th ed., McGraw Hill Book Co., New York.
- Saunders, J.A., (1980), Cluster Analysis For Market Segmentation, European Journal Of Marketing, 14, 7, PP 422-35.
- Schiffman, L.G., and Kanuf, L.L., (1983), Consumer Behaviour, 2nd ed, Prentice Hall, Inc., Englewood, Cliffs, U.S.
- Schneider, J., and Locke, E., (1971), A Critique Of Herzberg's Incident Classification System And Suggested Revision, Organizational And Behaviour Human Performance, 16, PP 441-57.
- Schneller, G.H., (1970), Status Report On Bio-Availability, American Journal Of Hospital Pharmacy, 27, June, PP 30-36.
- Schoepe, A., and Molinda, J., (1984), International Regulation Of Pharmaceuticals: A WHO International Code Of Conduct For The Marketing Of Pharmaceutical, Journal Of International Law And Commerce, 11, Summer, PP 121-141.
- Scott, J.E., and Lamont, L.M., (1973a), Consumerism: A Theoretical Framework For Analysis, In Boris.W. And Helmut.B. eds., Combined Of Proceeding, American Marketing Association, Chicago.
- Scott, J.E., and Lamont, L.M., (1973b), Relating Consumer Values To Consumer Behaviour: A Model And Methods For Investigation, In Greer, T.V. ed., Advances In Consumer Research, American Marketing Association.
- Seeman, M., (1959), On The Meaning Of Alienation, American Sociological Review, 24, PP 783-91.
- Seeman, M., (1971), Alienation: A Map, Psychological Today, August, PP 83-94.
- Settle, R.B.; Alreck, P.L., and Blech, M.A., (1978), Social Class Determinant Of Leisure Activity, Advances In Consumer Research, In William, L.W. ed., Proceeding Of Conference, Association For Consumer Research, Florida.
- Sherrell, D.L., and Shimp, T.A., (1982), Consumer Involvement In A Laboratory Setting, In Walker, Bearden, Murphy, Nevin, And Olson eds., Assessment Of Marketing Thought And Practice, Educators Conference Proceedings, Chicago.
- Siegal, S., (1956), Non-Parametric Statistical For The Behavioural Sciences, McGraw Hill, Inc., New York.
- Sirgy, M.J., (1984), Marketing And Social Behaviour: A General System Theory, Praeger Publishers, U.S.

- Skelton, V.C., (1963), Patterns Behind Income Refusals, Journal Of Marketing, 27, PP 38-41.
- Slama, M.E., and Tashchian, A., (1985), Selected Socio-economic And Demographic Characteristics Associated With Purchasing Involvement, Journal Of Marketing, 49, Winter, PP 72-82.
- Slatter, S., (1977), Competitive And Marketing Strategies In The Pharmaceutical Industry, Redwood Burn Limited, Croom Helm, London.
- Smith, M.C., (1983a), Identification Of The Market, In Smith, M.C. ed., Principles Of Pharmaceutical Marketing, Lea And Febiger, US.
- Smith, M.C., (1983b), The Manufacturer, In Smith, M.C. ed., Principles Of Pharmaceutical Marketing, Lea And Febiger, US.
- Spector, A.J., (1959), Expectation, Fulfilment And Moral, Journal Of Abnormal And Social Psychology, 52, January, PP 51-6.
- Stewart, D.W., (1981), The Application And Misapplication Of Factor Analysis In Marketing Research, Journal Of Marketing Research, 18, February, PP 51-62.
- Stimson, G.V., (1977), Do Drug Advertisements Provide Therapeutic Information, Journal Of Medical Ethics, 3, PP 7-11.
- Stokes, R.C., (1973), Consumerism And The Measurement Of Consumer Satisfaction, Paper Presented At The American Marketing Association, Attitude Research Conference, Madrid, Spain.
- Stokes, R.C., (1974), Consumer Complaint And Consumer Dissatisfaction, Presentation To The Food And Drug Law Institute, Phoenix, Arizona.
- Straver, W.C., (1977), The International Consumerist Movement, European Journal Of Marketing, 11, PP 93-117.
- Straver, W.C., (1978), The Consumerist Movement In Europe: Challenges And Opportunities For Marketing Strategy, European Journal Of Marketing, 12, 4, pp 316-25.
- Strom, B., and Melmon, K., (1979), Can Post Marketing Surveillance Help To Effect Optimal Drug Therapy, Journal Of The American Medical Association, 30, November, PP 242-246.
- Sudman, S., (1976), Applied Sampling, Academic Press, Inc., New York.
- Sudman, S., and Bradburn, N.M., (1982), Asking Questions, Jossey-Bass Publishers, U.S.
- Swan, J.E., and Longman, A., (1972), Consumer Satisfaction With Automobile Repair Performance, Attitude Towards The Industry And Governmental Control, Paper Presented To The American Marketing Association.

- Swan, J.E., and Combs, L.J., (1976), Product Performance And Consumer Satisfaction: A New Concept, Journal Of Marketing, 40, April, PP 25-33.
- Swan, J.E., (1977), Consumer Satisfaction With Retail Store Related To The Fulfilment Of Expectation On An Initial Shopping Trip, Consumer Satisfaction And Complaining Behaviour, In Day, R.L., ed., Bloomington, Indiana.
- Swan, J.E., and Mercer, (1981), Consumer Satisfaction As A Function Of Equity And Disconfermation, Conceptual And Empirical Contribution To Consumer Satisfaction And Complaining Behaviour, In Hunt And Day eds., Proceeding Of Conference, Bloomington, Indiana.
- Swan, J.E., and Travick, F., (1981), Disconfermation Of Expectation And Satisfaction With A Retail Service, Journal Of Retailing, 57, 3, Fall, PP 49-67.
- Swan, J.E., (1985), Automobile Buyers Satisfaction With Salesperson Related To Equity And Disconfirmation, Consumer Satisfaction / Dissatisfaction And Complaining Behaviour, Hunt And Day eds., Proceeding Of Conference, Phoenix, Arizona.
- Tacey, E., (1990), Over-The-Counter, Financial Times, November, 21.
- Tayagi, P.K., (1982), Combining The Equity / Inequity Model And The Expectancy-Value Model For predicting Satisfaction Motivation And Performance, In Walker, Bearden, Murphy, Nevin And Alson eds., Assessment Of Marketing Thought And Practice, Educators Conference Proceedings, Chicago.
- Telser, L.; Best, W.; Egan, J.; and Higinbotham, H., (1975), The Theory Of Supply With Application To The Ethical Pharmaceutical Industry, Journal Of Law And Economics, 18, PP 449-455.
- The World Drug Situation, World Health Organization (WHO), 1989.
- Thomas, W.R., and Shuptrine, F.K., (1975), The Consumer Complaint Process: Communication And Resolution, Business And Economic Review, 21, June, PP 13-22.
- Traylor, M.B., (1981), Product Involvement And Brand Commitment, Journal Of Advertising Research, 21, 6, December PP 51-56.
- Tucker, D., (1984), The World Health Market: The Future Of The Pharmaceutical Industry, Euromonitor Publication, US.
- Tull, D.S., and Hawkins, D.I., (1987), Marketing Research: Measurement And Methods, 4th ed., Macimillan, New York.
- Vinson, D.E. and Munson, J., (1976), Personal Values: An Approach To Market Segmentation, In Bernhardt, K. ed., Marketing: 1776-1976 And Beyond, Proceedings Of Conference, American Marketing-Association, Chicago.

- Vinson, D.E.; Scott, J.E., and Lamont, L.M., (1977), The Role Of Personal In Marketing And Consumer Behaviour, Journal Of Marketing, 14, April, PP 44-50.
- Vinson, D.E., (1977), Personal Values As A Dimension Of Consumer Discontent, In Greenberg And Bellenger eds., Contemporary Marketing Thought, American Marketing Association, Chicago.
- Vinson, D.E., and Pearson, J.B., (1978), The Anxiety Effect Of Overstimulation On The Consumption Decision Process, Business And Society, Spring, PP 28-35.
- Wall, M.; Dickey, L.E., and Talarzyk, W.W., (1978), Correlates Of Satisfaction And Dissatisfaction With Clothing Performance, Journal Of Consumer Affairs, 12, 1, Summer, PP 104-115.
- Walters, G., (1974), Consumer Behaviour: Theory And Practice, Homewood Illinois, Richard, D., Irwin, U.S.
- Warland, R.H.; Herrman, R.O., and Willits, J., (1975), Dissatisfied Consumers: Who Gets Upset And Who Takes Action, Journal Of Consumer Affairs, 9, PP 148-63.
- Wartman, S.A.; Morlock, L.L.; and Malitz, F.E., (1981), Do Prescription Adversely Affect Doctor-Patient Interaction, American Journal Of Health Policy, 71, 12, PP 1358-1361.
- Wasson, C.R., (1969), Is It Time To Quit Thinking Of Income Classes?, Journal Of Marketing Research, 33, PP 54-57.
- Waters, L.K., and Waters, C.W., (1969), Correlates Of Job Satisfaction Among Female Clerical Workers, Journal Of Applied Psychology, 53, PP 388-91.
- Waters, L.K., and Roach, D., (1971), The Two Factors Theories Of Job Satisfaction: Empirical Tests For Four Samples Of Insurance Company Employees, Personnel Psychology, 24, PP 697-705.
- Waters, L.K., and Waters, C.W., (1972), An Empirical Test Of Five Versions Of Job Satisfaction, Organizational Behaviour And Human Performance, 7, PP 18-24.
- Wells, W.D., and Sheth, J.N., (1971), Factor Analysis In Marketing Research, McGraw Hill, U.S.
- Westbrook, R.A., (1980a), Interpersonal Effective Influences On Consumer Satisfaction With Products, Journal Of Consumer Research, 7, June, PP 49-54.
- Westbrook, R.A., (1980b), A Rating Scale For Measuring Product / Service Satisfaction, Journal Of Marketing, 44, Fall, PP 68-72.
- Westbrook, R.A., and Oliver, R.L., (1981), Developing Better Measures Of Consumer Satisfaction: Some Preliminary Results, In Monroe, K.B ed., Advances In Consumer Research, American Marketing Association.

- Westbrook, R.A., and Reilly, M.D., (1983), Value-Percept Disparity: An Alternative Of The Disconfirmation Expectation Theory Of Consumer Satisfaction, Advances In Consumer Research, In Bagozzi And Tybout eds., Proceeding Of Conference, Association Of Consumer Research.
- Whitsett, D.A., and Winslow, E.K., (1967), An Analysis Of Studies: Critical Of The Motivation / Hygiene Theory, Personnel Psychology, 20, PP 391-415.
- Wilton, P.C., (1985), History And Future Of Consumer Satisfaction Research, In Tan, C And Sheth, J eds., Historical Perspectives In Consumer Research, National And International Perspectives, Proceeding Of Conference, Association For Consumer Research, Singapore.
- Wind, Y., (1969), Incongruency Of Socio-economic Variables And Buying Behaviour, In Philp, R., And McDoland eds., Proceeding Of Conference, American Marketing Association.
- Woodcock, J., (1981), Medicines: The Interested Parties, In Blum; Herxheimer; Stenzl; And Woodcock eds., Pharmaceutical And Health Policy: International Perspectives On Provision And Control Of Medicines, Croom Helm, London.

BIBLIOGRAPHY

- Aaker, D. A., and Day, G. S., (1982), Consumerism: Search For The Consumer Interest, 4th ed., Free Press, New York.
- Assael, H., (1975), Evaluating New Product And Developing Early Prediction Of Trial, New York University.
- Backer, M. J., (1985), Marketing: An Introductory Text, 4th ed., Macmillan Co., Great Britain.
- Beranrd, K., (1988), Consumer Demand Or Customer Satisfaction? European Journal Of Marketing, 22, 3, PP 61-72.
- Bonner, R. E., (1964), Some Clustering Techniques, Journal Of Marketing Research, 8, January, PP 22-32.
- Broedling, L. A., (1974), On More Reliability Employing The Concept Of Reliability, Public Opinion Quarterly, Fall, PP 372-78.
- Cardoz, R. N., (1965), An Experimental Study Of Customer Efforts, Expectation And Satisfaction, Journal Of Marketing Research, 2, August, PP 244-49.
- Chappell, S. C., (1980), The Prescription Decline Sense Or Nonsense? Medical Marketing And Media, 15, PP 15-21.
- Chetely, A., (1986), Not Good Enough For Us But Fit For Them: An Examination Of The Chemical And Pharmaceutical Export Trades, Journal Of Consumer Policy, 9, PP 155-180.
- Clabaugh, M; Mason, J. and Bearden, W., (1978), Consumer Alienation And Causal Attributes As Moderator, In Hunt And Day eds., New Dimensions Of CS/D And Complaining Behaviour, Proceeding Of Conference, Bloomington, Indiana.
- Daniel, W. W., (1978), Applied Non-Parametric Statistics, Boston, Mass, Houghton Mifflin Co., U.S.
- Diener, B. J., (1976), The Fulfilment Of Consumer Promotions As A Source Of Consumer Dissatisfaction, Conceptualization And Measurement Of CS/D, In Hunt, H. K. ed., Proceeding Of Conference, Marketing Science Institute.
- Dhalla, N. K., and Mahatto, W. H., (1976), Expanding The Scope Of Segmentation Research, Journal Of Marketing, 40, April, PP 34-41.
- Darvall, L. W., (1986), Consumer Praticipation In Government Decision Making: New Drug Evaluation In Australia And United States, Journal Of Consumer Policy, 6, PP 41-55.
- Edgar, M., (1982), Infectious Diseases And Health In Costa Rica: The Development Of A New Paradigm, Pediatric Infectious Disease, 1, 3, May, 212-216.
- EL-Asffury, A. M., (1989), Journal Of The Egyptian Packaging Development Association, 47, 5.

- EL-Kattan, M., (1985), Medicine In Egypt, The Committee Of Medical Publicity, DOOMA.
- EL-Kattan, M., (1986), Journal Of Medicine, 1, June.
- EL-Kattan, M., (1987), Journal Of Medicine, 2, October.
- EL-Sharkawy, A., (1989), Journal Of Medicine, 3, March.
- Fenwick, J. and Quelch, J.A., (1984), Consumer Behaviour For Marketing Managers, Newton, Allyn And Bacon, U.S.
- Fiedler, F.E., (1978), The Culture Assimilator: An Approach To Cross Cultural Training, Journal Of Applied Psychology, 55, PP 95-102.
- Fink, J.L., (1979), Marketing In A Generic Environment: A Pharmacist's View, Medical Marketing And Media, 14, PP 40-46.
- Fundamentals Of The Strategy Of Industry, (1982), The Specialist National Committee, Republic Presidency, Cairo, Egypt.
- Gioia, D.A., and Stearns, J.M., (1980), An Unified Expectancy Approach To Consumer Satisfaction / Dissatisfaction And Complaining Behaviour, In Refining Concepts And Measures Of Consumer Satisfaction And Complaining Behaviour, Hunt And Day eds., Proceeding Of Conference, Bloomington, Indiana.
- Glassman, M., and Smith, T., (1980), On The Process Of Consumer Satisfaction, In Refining Concepts And Measures Of Consumer Satisfaction And Complaining Behaviour, Hunt And Day eds., Proceeding Of Conference, Bloomington, Indiana.
- Green, M.J., (1974), Appropriateness And Responsiveness: Can The Government Protect The Consumer?, Journal Of Economic Issues, 8, 2, June, PP 309-28.
- Green, M.J., (1977), New Approach To Market Segmentation, Business Horizons, February, PP 61-73.
- Greenberg, B.A.; Goldstrucker, J.L., and Bellenger, D.N., (1977), What Techniques Are used By Marketing Researchers In Business, Journal Of Marketing, 41, April, PP 62-8.
- Guertin, W., (1966), The Research For Recurring Among Individual Profiles, Educational And Psychology Measurement, 26, PP 151-65.
- Hamburg, M., (1987), Statistical Analysis For Decision Making, 4th ed., Harcourt Brace Jovanovich, Inc., New York.
- Harmer, R., and Cunnigham, J., (1981), Cluster Analysis Profile Data Confounded With Interrater Differences: A Comparison Of Profiles Association Measures, Applied Psychological Measurement, 5, PP 63-72.

- Hook, J., and Ward, J.R., (1963), Hierarchical Grouping To Optimize An Objective Function, Journal Of The American Statistical Association, 58, PP 236-43.
- Kim, J.O., and Muller, C.W., (1978), Introduction To Factor Analysis, What It is And How To DO it, Series Quantitative Application In Social Sciences, Sage Publication, Inc., U.S.
- Klasatorin, T.D., (1983), Assessing Cluster Analysis Results, Journal Of Marketing Research, 20, February, PP 92-8.
- Krugaman, A., (1965), The Impact Of Television Advertising: Learning With Involvement, Public Opinion Quarterly, 29, PP 349-56.
- Leach, C., (1979), Introduction To Statistics: A Non Parametric Approach For Social Sciences, John Wiley And Sons, New York.
- Leavitt, C., (1977), Consumer Satisfaction And Dissatisfaction: Bi-Polar Or Independent, In Hunt, H.K. ed., Conceptualization And Measurement Of CS/D, Proceeding Of Conference, Marketing Science Institute.
- Maddox, N., (1980), Two Factors Theory And Consumer Satisfaction: A Replication And Measures Of CS/D And Complaining Behaviour, In Hunt And Day eds., Proceeding Of Conference, Bloomington, Indiana.
- Marjorie, F., and Victor, J., (1984), Demographic And The Propensity To Consume, In Kinnear, T. ed., Advances In Consumer Research, Association For Marketing Research.
- McMurry, R.N., (1963), Conflicts In Human Values, Harvard Business Review, May-June PP 130-45.
- Medawar, C., (1984), The Wrong Kind Of Medicine?, Consumer Association And Social Audit, US.
- Morganosky, M.A., and Buckely, H.M., (1986), Complaint Behaviour: Analysis By Demographic, Life Style And Consumer Values, Advances In Consumer Research, Association For Marketing Research.
- Myers, J.H., and Alpert, M.I., (1968), Determinant Attributes: Meaning And Measurement, Journal Of Marketing, 32, October, PP 13-20.
- Peltzman, S., (1975), The Diffusion Of Pharmaceutical Innovotion, In Helms And Washington eds., American Enterprise Insitutue.
- Pitts, R.E., and Woodside, A.G., (1983), Personal Value Influences On Consumer Product Class And Brand Performance, Journal Of Psychology, 119, PP 37-53.
- Prakash, V. and Lounsbury, J., (1983), A Reliability Problem In The Measurement Of Disconfirmation Of Expectation, In Bagozzi And Tybout eds., Advances In Consumer Research, Proceeding Of Conference, Association For Marketing Research.

- Raju, P. S., (1980), Optimum Stimulation Level: Its Relationship To Personality, Demographic And Exploratory Behaviour, Journal Of Consumer Research, 7, December, PP 272-82.
- Reekie, W. D., (1981), Price And Quality Competition In Drug Markets: Evidence From The United States And Netherlands, In Helms And Washington eds., American Enterprise Institute.
- Sallah, G., (1988), The Modern Trends Of, And The Role Of, Flexible Packaging In Medicine Wrapping, The Twenty Sixth International Conference, Meredian Hotel, Cairo, 3-5 December.
- Schuman, H., and Presser, S., (1981), Questions And Answers In Attitude Survey Experiments On Question Form, Wording And Context, Academic Press, Inc., New York.
- Schwartz, D. J., Marketing Today: A Basic Approach, Harcourt Brace Jovanovich, Inc., New York.
- Sethna, B. N., (1980), Some Important Determinants Of Consumer Satisfaction / Dissatisfaction, In Refining Concepts And Measures Of Consumer Satisfaction And Complaining Behaviour, Hunt And Day eds., Proceeding Of Conference, Bloomington, Indiana.
- Sheth, J. N., (1971), Multivariate Revolution In Marketing Research, Journal Of Marketing, 35, January, PP 13-19.
- Siecker, B. R., (1981), The Wholesaler Effect In Pharmacy Management, American Pharmacy, 21, 11, November, PP 34-36.
- Smith, M. C., (1973), General Practice Pharmacy In The United Kingdom And United States Of America: Some Comparisons And Contrasts, The Pharmaceutical Journal, 6, January, PP 9-12.
- Stafford, J. E; Cox, K. L., and Higginbotham, J. M., (1968), Some Consumption Pattern Differences Between Urban White And Negroes, Social Science Quarterly, December, PP 619-30.
- Stewart, D. W., (1981), The Application And Misapplication Of Factor Analysis In Marketing Research, Journal Of Marketing Research, 18, February, PP 51-62.
- Taviss, I., (1969), Changes In The Form Of Alienation, American Sociological Review, 34, PP 46-59.
- The Strategy Of Medical Policy, (1981), Series Studies Of The Specialists National Committee, Republic Presidency, Cairo.
- The Use Of Essential Drugs, (1988), Third Report Of The World Health Organization (WHO), Geneva.
- Trucker, W. T., (1959), Marketing And Society, Paper Delivered To The Southern Economic Association.

- Vermeer, R.S., (1980), Consumerism: A Rich Man's Movement?, In Consumer Action In Developing Countries, International Organization Of Consumer Unions, Panang, Malaysia.
- Wall, M; Dickey, L.E., and Talarzyk, W.W., (1977), Predicting And Profiling Consumer Satisfaction And Propensity To Complain, Paper From A Marketing Research Symposium, In Day, R. ed., School Of Business, Bloomington, Indiana.
- Walters, H.A., (1976), Cultural Values Do Correlate With Consumer Behaviour, Journal Of Marketing Research, 13, May, PP 121-27.
- Weller, T., (1983), Too Few And Too Little: Barricades To The Pursuit Of Health, Review Of Infectious Disease, 5, 6. November-December, PP 994-1002.
- Williams, L., and Kelly, E.J., (1973), Social Marketing: Perspectives And View Points, Richard, D. Irwin, Inc, U.S.
- Wood, D.A., and William, K.L., (1970), The Multivariate Nature Of Job Satisfaction, Personnel Psychology, 23, Summer, PP 173-89.

A P P E N D I X 1

QUESTIONNAIRE - ENGLISH VERSION

Dear Egyptian citizen:

I am looking for your co-operation with the research work which is currently being undertaken on the pharmaceutical market in Egypt.

The rationale behind this study is to recognize the problems which the consumers encounter in the provision of medicine in Egypt.

The particular concern of this study is to know your degree of satisfaction with respect to some aspects of medicine provision. In addition, I would like to obtain your judgments about some statements relating to the same aspects.

I shall be grateful for your co-operation by completing this questionnaire which will take just a few minutes. The data collected will be treated in the strictest confidence and analysed in aggregate for the purpose of the study. No need therefore to address the questionnaire by your name after you have filled it in.

Aisha Moustafa El-Meniawey Lecturer Assistant
At The Faculty Of Commerce, Ain-Shams University
And Currently A Doctoral Student At The University
Of Sheffield, England.

1. Please indicate by a tick your level of satisfaction/dissatisfaction with the aspects of medicine provision. Here is a scale ranging from 1 to 7. 1 stands for very dissatisfied, 7 for very satisfied.

	1	2	3	4	5	6	7			
	very dis-satisfied	dis-satisfied	slightly dis-satisfied	neither satisfied nor dis-satisfied	slightly satisfied	satisfied	very satisfied			
1. Tightness of packing to prevent spoilage - in case of medicine syrup.				1	2	3	4	5	6	7
2. Ease of opening and reclosing the cap of medicine packing.				1	2	3	4	5	6	7
3. Ease of getting the medicine out of the packing.				1	2	3	4	5	6	7
4. Durability of packing during the consuming period.				1	2	3	4	5	6	7
5. Degree of convenience to handle medicine packing - in case of taking some doses away from home.				1	2	3	4	5	6	7
6. Size of medicine packing.				1	2	3	4	5	6	7
7. Possibility of using the empty packing, e.g. as container.				1	2	3	4	5	6	7
8. Prominence of manufacturer name on medicine labels.				1	2	3	4	5	6	7
9. Legibility of production date.				1	2	3	4	5	6	7
10. Legibility of expiry date of medicine on shelf.				1	2	3	4	5	6	7

11.	Information about storage.	1	2	3	4	5	6	7
12.	Position of storage information on labels.	1	2	3	4	5	6	7
13.	Clearness of description contents.	1	2	3	4	5	6	7
14.	Simplicity of description contents.	1	2	3	4	5	6	7
15.	Amount of instruction in enclosed leaflet such as:-							
	- The interval dose of medicine.	1	2	3	4	5	6	7
	- The maximum daily dose.	1	2	3	4	5	6	7
	- The right way to use medicine safely.	1	2	3	4	5	6	7
16.	Your ability to understand the instruction language (in case of imported medicines).	1	2	3	4	5	6	7
17.	Simplicity of instruction in enclosed leaflet.	1	2	3	4	5	6	7
18.	Taste of medicine.	1	2	3	4	5	6	7
19.	Smell of medicine.	1	2	3	4	5	6	7
20.	Fitness of medicine for its purpose.	1	2	3	4	5	6	7
21.	Price of each item of medicine related to your income.	1	2	3	4	5	6	7
22.	Degree of control over the price of medicine.	1	2	3	4	5	6	7

23.	Quantity of medicine supplied in the packing.	1	2	3	4	5	6	7
24.	Suitability of the packing size with quantity.	1	2	3	4	5	6	7
25.	Suitability of the quantity with price.	1	2	3	4	5	6	7
26.	Number of chemists in your area.	1	2	3	4	5	6	7
27.	Availability of wide range of medicines in your areas chemists.	1	2	3	4	5	6	7
28.	Availability of scarce medicines in your areas chemists (such as medicines for diabetes and heart disease).	1	2	3	4	5	6	7
29.	Possibility of obtaining your needs from chemists during weekends and holidays.	1	2	3	4	5	6	7
30.	Number of night service chemists in your area.	1	2	3	4	5	6	7
31.	Number of public chemists in your city.	1	2	3	4	5	6	7
32.	Availability of wide range of medicine in chemists of public sector.	1	2	3	4	5	6	7
33.	Availability of scarce medicines in chemists of public sector.	1	2	3	4	5	6	7
34.	Having the right prescription (in terms of							

	accurate diagnosis) from doctors in public hospitals.	1	2	3	4	5	6	7
35.	Having the right prescription (in terms of accurate diagnosis) from doctors in public clinics.	1	2	3	4	5	6	7
36.	Having the right prescription (in terms of accurate diagnosis) from doctors in private surgery.	1	2	3	4	5	6	7
37.	Amount of medicine side- effects.	1	2	3	4	5	6	7
38.	Amount of medicine adverse effects.	1	2	3	4	5	6	7
39.	Clearness of written prescription by doctors in public hospitals.	1	2	3	4	5	6	7
40.	Clearness of written prescription by doctors in public clinic.	1	2	3	4	5	6	7
41.	Clearness of written prescription by doctors in private surgery.	1	2	3	4	5	6	7

2. Now, please indicate your to opinion as the extent to which you agree or disagree with the following statements. The scale is ranging from 1 to 7. 1 stands for strongly disagree, 7 stands for strongly agree.

1	2	3	4	5	6	7
strongly disagree	disagree	slightly disagree	neutral	slightly agree	agree	strongly agree

1.	There is an obvious improve- ment in medicine packing over the last five years.	1	2	3	4	5	6	7
2.	It seems that public hospitals offer free							

	medicine with insufficient instruction on labels.	1	2	3	4	5	6	7
3.	There are usually warning statements on medicine labels such as:-							
	- Use the medicine only accordance with doctors direction.	1	2	3	4	5	6	7
	- Keep the medicine out of the reach of children.	1	2	3	4	5	6	7
	- Never share prescribed medicine with others.	1	2	3	4	5	6	7
4.	Medicine labels usually contain particular caution statements, e.g. do not drive or operate machinery at the same time as using this medicine.	1	2	3	4	5	6	7
5.	Prices of medicine are consistent with the income of low classes.	1	2	3	4	5	6	7
6.	Usually elderly get the same medicines at a lower price.	1	2	3	4	5	6	7
7.	There are often large differences in price of various medicines which have similar action.	1	2	3	4	5	6	7
8.	Doctors adequately explain to me the medicine positive/negative effects.	1	2	3	4	5	6	7
9.	Most doctors are concerned about providing instruction information in prescription.	1	2	3	4	5	6	7
10.	The majority of pharmacists do not sell							

medicines out of
prescription, e.g.
as antibiotics.

1 2 3 4 5 6 7

3. How much in total did you spend on medicines in the last twelve months? Please check mark a category which best indicates your expenditure.

Less than £ 20
£ 21 - 40
£ 41 - 80
£ 81 - 160
£ 161 and over

4. In order to help with analysis of data, please give the following information about yourself. All answers are anonymous and will be held completely confidential.

1. Male Female

2. Which of the following categories includes your age?

From 18 - 24 years	1
25 - 34	2
35 - 44	3
45 - 54	4
55 - 60	5
Over 60	6

3. Your education level.

Primary School	1
Grade School	2
High School	3
College School	4
Postgraduate	5
Non-Educated	6

4. Which of the following categories best describe your total family income a year, from all sources? Please check mark a category.

Less than £ 900	1
£ 900 - 1200	2
£ 1201 - 2999	3
£ 3000 - 4999	4
£ 5000 - 6999	5
£ 7000 and over	6

5. Your current occupation

- 1 Labour
- 2 Unemployment
- 3 Professional
- 4 Retired
- 5 Official
- 6 Student
- 7 Proprietor
- 8 Housewife

6. How many persons are your family including?

- From 1 - 2
- 3 - 4
- 5 - 6
- over 6

7. Your marital status.

Single

Married

Others

Thank you very much for completing this survey, your help in this study is greatly appreciated.

A P P E N D I X 2

QUESTIONNAIRE - ARABIC VERSION

استمارة
استطلاع رأى

=====

عزيزى المواطن الممصرى :

اننى اقوم ببحث الدكتوراه عن المشاكل التى تواجه المستهلكين فى سوق
الدواء الممصرى ، فالهدف الاساسى لهذه الدراسة هى محاولة
التعرف على درجة رضاك فيما يتعلق بخصائص مختلفة فى مجال استعمال
الدواء بالاضافة الى استطلاع رأىك فى بعض العبارات فى هذا المجال ايضا .

ان مساهمتك باستيفاء هذه الاستمارة التى تستغرق اقل
من خمس دقائق سوف يكون لها عظيم الاثر فى حل كثير من مشاكلك
فى سوق استهلاك الدواء مع الاخذ فى الاعتبار ان الاستثمارات ليس لها
اى مدلول يثير الى الشخص الذى استوفاهها ، وسنقوم
تعالج جميع بياناتها بصورة اجمالية بهدف
خدمة البحث فقط .

مع وافر الشكر

عائشة مصطفى حسن المنياوى
المدرس المساعد بكلية التجارة - جامعة عين شمس
وعضو البعثة الحكومية بجامعة شيفلد / انجلترا

المرجو وضع ملاحظة (✓) في الخانة التي تشير من درجة رضاك فيما يتعلق
 بالخصائص التالية في مجال استعمال الدواء المقرر عن طريق الطبيب المعالج، ولما بيان كل
 خاصية تحتوي على درجات رضاء مختلفة تبعاً من غير مرضى جداً (1) وتنتهي بمرضى جداً (7) وباقى
 الأرقام بينها.

ملاحظات	مريض جداً (7)	مريض (6)	مريض الى حد ما (5)	لا مريض ولا غير مريض "تبادل" (4)	غير مريض الى حد ما (3)	ليس مريضاً (2)	غير مريض جداً (1)
1 - جودة العبوة لمنع تسرب الدواء " في حالة الدواء السائل "							
2 - درجة السهولة في اخراج الدواء من العبوة							
3 - درجة تحمل عبوة الدواء للتداول خلال فترة الاستعمال							
4 - درجة السهولة في فتح وعلق غطاء العبوة							
5 - درجة السهولة في حمل عبوة الدواء " اذا تطلب الامر لطلب بعض جرعات خارج المنزل "							
6 - درجة رضاك من حجم مسوات العبوة							
7 - درجة إمكانية استعمال عبوة الدواء الطارئة في امراض منزلية اخرى.							
8 - درجة السهولة في رؤية اسم منتج الدواء على العبوة الخارجية							
9 - مدى وضوح تاريخ انتاج الدواء على العبوة الخارجية							
10 - مدى وضوح تاريخ انتهاء استعمال الدواء على العبوة الخارجية							

ملاحظة	مرضى جدد (٧)	مرضى (٦)	مرضى التي خدمنا "تعدادل" (٥)	لامرضى ولاغير مرضى "تعدادل" (٤)	غير مرضى التي حد من (٣)	غير مرضى (٢)	غير مرضى جدد (١١)

ملاحظات	مرفى جدا (٧)	مرفى (٦)	مرفى التي خدمها (٥)	امرفى ولاغير مرفى "تعال" (٤)	غير مرفى التي خدمها (٣)	غير مرفى (٢)	غير مرفى جدا (١)

- ٢٧ - مقدار الامراض الجانبيه التي تصاب بها مع استعمال السموم .
- ٢٨ - مقدار الامراض المعكبه التي تصاب بها مع استعمال السموم .
- ٢٩ - درجة ونوع الخط بالروثنة المكتوبه عن طريق المستشفيات العامة .
- ٣٠ - درجة ونوع الخط بالروثنة المكتوبه عن طريق اطباء الوجودات العلاجي .
- ٣١ - درجة ونوع الخط بالروثنة المكتوبه من طريق اطباء العيادات العامة .

٢) المرجو وضع علامة (✓) في الخانة التي تعبر عن رأيك في الجمل التالية في مجــــــــــــــــال استعمال الدواء المقترح من طريق الطبيب المعالج .

ملاحظات	موافق تماماً (٧)	موافق (٦)	موافق الى حد ما (٥)	لا موافق ولا غير موافق "محايد" (٤)	غير موافق الى حد ما (٣)	غير موافق تماماً (٢)	غير موافق تماماً (١)

- ١- يوجد تطور ملحوظ في تصميم عبوات الدواء خلال الخمس سنوات الماضية .
- ٢- يبدو ان المستشفيات العامة تقدم ادوية مجانية بدون تعليمات كافية على العبوة الخارجية .
- ٣- ان العبوة الخارجية للدواء دائما لا تغلظ من عبارات التحذير التالية :-
 - استعمال الدواء طبقا لإرشادات الطبيب .
 - احفظ الادوية بعيدا عن متناول الاطفال .
- ٤- ان العبوة الخارجية للدواء دائما تشمل عبارات تنبيه معينة اذ لا تغلب الامر " مثل تجنب قيادة السيارة في فترات تناول هذا الدواء " .
- ٥- ان اسعار الادوية في السوق تتناسب مع لوى الدخول المنخفضة .
- ٦- دائما كبار السن يحملون على نفس الادوية بسعر منخفض .
- ٧- دائما هناك اختلافات ملحوظة بين اسعار الادوية ذات المفعول المتكافئ .
- ٨- الاطباء دائما يشرعون للمريض بكعاية الاعراض الجانبيه والمكسبه للدواء .
- ٩- غالبية الصيدليات ترفض بيع ادوية بدون روثة طبيب " مثل في حاله المعاداة الحيويستة " .
- ١٠- معظم الاطباء يهتمون بإعطاء المريض تعليمات كافية من كيفية استعمال الدواء .

٣ - مامقدار السيلج التي انقلقت عليه عشرًا ، مختلف انواع الدواء ، خلال الاثنى عشر شهر المارفيها .

ارحو ان تقع علامة امام اللمعة المتناسية والتي تعبر تماما و من مقدارها انقلقت .

* الكل من ٢٠ حنيها _____

* ٤١ - ٨٠ حنيها _____

* ١٦٠ حنيها لأكثر _____

٤- الجنس : انثى ذكر

٥ - لغة العمر :

١٨ - ٢٤ ٢٥ - ٣٥ ٤٤ ٤٥ - ٥٥ ٦٠ فأكثر

٦ - مستوى التعليم :

دون المتوسط متوسط فوق المتوسط عالى فوق العالى غير متعلم

٧ - حجم الأسرة :

١ - ٢ ٣ - ٤ ٥ - ٦ ٦ فأكثر

٨ - مامقدار ذلك السنوى الاحمالى " من كافة المعمار " :

ارحو وضع علامة امام اللمعة التي تعبر تماما من مقدار ذلك الاحمالى

اقل من ٩٠٠ حنه ٩٠٠ - ١٢٠٠ حنيها

٥٠٠٠ - ١٩٩٩ حنيها ٧٠٠٠ فأكثر حنيها

٩ - مهنتك الحالية :

بالمنشأش مهنتي المهنية عامل " بدون عمل " عامسمل

سيدة منسرك صاحب امسلاك طالسبب موطسلف

١٠ - الحالة الاجتماعية :-

حالات افسرى متزوج امسرب

شكرا على استجابتك بملئ هذه الاستمارة

APPENDIX (3)

ROTATED FACTOR MATRIX

	FACTOR 1	FACTOR 2	FACTOR 3	FACTOR 4	FACTOR 5	FACTOR 6	FACTOR 7	FACTOR 8
PACKVAR1	•73642	•15697	•05830	•09777	•06469	•02888	•00112	•01537
PACKVAR2	•77301	•07728	•02960	•04307	•05973	•01952	•05900	•08287
PACKVAR3	•70095	•07513	•01474	•06660	•05653	•07527	•14609	•09644
PACKVAR4	•70109	•00821	•00310	•15511	•02171	•04354	•04355	•09391
PACKVAR5	•56706	•10498	•10498	•09822	•01449	•16221	•02219	•07962
PACKVAR6	•24804	•09229	•00715	•05457	•11686	•05712	•09025	•52484
PACKVAR7	•06439	•16392	•06033	•05215	•02054	•13445	•04012	•06446
LABVAR8	•27650	•17891	•02024	•41496	•05519	•14510	•20437	•13851
LABVAR9	•13002	•07319	•12312	•97312	•14168	•06702	•12309	•00161
LABVAR10	•15366	•07260	•12937	•87495	•13882	•07701	•11468	•00711
LABVAR11	•18920	•43255	•08044	•47303	•00674	•22678	•03848	•21275
LABVAR12	•16315	•42171	•11473	•42396	•07519	•18542	•04092	•34547
LABVAR13	•12535	•72031	•12872	•14155	•00030	•00621	•01289	•14354
LABVAR14	•05443	•60944	•10452	•14551	•09169	•08639	•03508	•00534
LABVAR15	•13958	•60929	•15445	•06474	•02233	•00815	•15142	•07459
LABVAR16	•63556	•49049	•09988	•05372	•44339	•14295	•18792	•08612
LABVAR17	•09142	•09632	•19102	•11541	•16524	•02966	•10682	•01128
LABVAR18	•09142	•11689	•03539	•07824	•04779	•05771	•05633	•06902
QUAVAR19	•12449	•10349	•07446	•08556	•11595	•07026	•02790	•07371
QUAVAR20	•14375	•14755	•16706	•22014	•14374	•05078	•05462	•21263
PRIVAR21	•05210	•12913	•12477	•08412	•78093	•07316	•06711	•09271
PRIVAR22	•05060	•09805	•11897	•10910	•73558	•01193	•03086	•14936
QUUNVAR23	•05951	•13032	•12599	•06493	•36725	•04554	•14276	•63959
QUUNVAR24	•14315	•10068	•02602	•03161	•09596	•02131	•05319	•70344
QUUNVAR25	•10099	•04486	•17444	•07069	•57380	•07486	•14413	•37708
AVAVAR26	•12061	•13156	•06730	•01326	•15790	•01598	•58677	•18564
AVAVAR27	•05838	•08098	•21922	•13839	•20457	•00210	•68060	•02222
AVAVAR28	•05460	•00102	•35626	•17982	•18911	•14442	•56629	•06018
AVAVAR29	•08997	•06256	•19266	•06704	•05319	•02978	•70372	•11010
AVAVAR30	•02392	•15801	•42257	•09223	•15019	•18222	•41920	•19335
AVAVAR31	•01943	•17054	•65055	•01239	•17021	•19270	•21697	•07207
AVAVAR32	•08665	•05405	•80469	•11705	•10209	•07565	•17455	•06679
AVAVAR33	•04174	•02231	•77241	•14461	•07533	•04308	•12781	•02727
DEAVAR34	•03771	•14131	•31198	•01135	•36588	•34292	•04077	•05112
DEAVAR35	•04370	•12892	•11454	•13937	•09780	•10618	•19535	•21370
DEAVAR36	•07959	•11947	•06324	•01553	•00568	•05362	•06223	•10881
MEFVAR37	•07774	•09049	•01553	•01286	•08244	•05152	•06484	•04911
MEFVAR38	•05953	•07405	•04534	•01286	•06586	•05152	•03243	•04339
DEAVAR39	•09241	•05694	•22337	•04226	•20548	•74031	•03843	•02182
DEAVAR40	•06784	•12896	•12896	•03649	•13365	•82918	•04832	•02182
DEAVAR41	•02980	•06130	•01011	•06981	•10449	•76660	•06038	•13144

	FACTOR 9	FACTOR 10	FACTOR 11	FACTOR 12
PACVVAR1	-.00331	.10731	.03938	-.07238
PACVVAR2	-.00385	.00792	.06793	-.12562
PACVVAR3	.12257	.03480	.04090	.04493
PACVVAR4	.00344	.03459	-.00420	.08190
PACVVAR5	.06206	-.04367	-.01982	.36979
PACVVAR6	.02394	.04116	.00985	.39365
PACVVAR7	.06812	-.00941	-.00560	.72067
LABVAR8	.03429	.009273	.21344	-.04944
LABVAR9	.05920	-.00659	.05531	.12597
LABVAR10	.10060	.02782	.05019	.10856
LABVAR11	.06922	-.11072	-.09802	-.23821
LABVAR12	.05444	-.07029	-.07532	-.23163
LABVAR13	-.02988	.00899	.13229	-.01939
LABVAR14	.02579	.04297	.04292	.19407
LABVAR15	.07645	.10957	.09403	.10569
LABVAR16	.12994	.02459	-.06568	.04027
LABVAR17	.26034	-.00831	.15022	.05628
LABVAR18	.09715	.04031	.02317	.04669
QUAVAR19	.07132	.07901	.02700	.04998
QUAVAR20	.25712	.19009	.19149	-.04933
PRIVAR21	.03983	.08293	.04331	.02338
PRIVAR22	.05973	.03089	.07125	.02919
QUVVAR23	.01054	.03859	.06183	.12803
QUVVAR24	.12608	.11766	.13920	-.05134
QUVVAR25	.08981	.08298	-.05289	-.05825
AVAVAR26	.10408	.03030	.25287	-.08505
AVAVAR27	.01269	.03684	.03950	.11547
AVAVAR28	-.02721	.06444	-.04379	.16224
AVAVAR29	.05066	.01032	.07415	-.09778
AVAVAR30	-.05500	.00799	-.12279	-.13219
AVAVAR31	.07347	-.06147	-.06198	-.02326
AVAVAR32	.03328	.05513	.12128	.00528
AVAVAR33	.05773	.07204	.19659	.13724
DEKVAR34	.03656	-.02665	.37534	.08183
DEKVAR35	.01961	-.03051	.78070	.01763
DEKVAR36	.03451	.11021	.65111	-.00389
MEFVAR37	.07620	.39024	.01786	-.01948
MEFVAR39	.04869	.09763	.03784	-.01743
DEKVAR39	.02796	.09863	.12485	.06643
DEKVAR40	.03486	.04747	.20457	.02296
DEKVAR41	.05581	-.00725	.01110	.10065

A P P E N D I X 4

CLUSTER/DISCRIMINANT ANALYSIS OUTPUT

APPENDIX 4

AGGLOMERATION SCHEDULES

TABLE 8.6: Cluster Analysis On The Basis Of The Factors Identified
Using The Complete Method

Number Of Cluster	Coefficient	Increase In Coefficient
5	82.722061	1.673675
4	92.493118	9.771057
3	97.771759	5.278641
2	108.328384	10.55663
1	127.161560	18.83318

TABLE 8.7: Cluster Analysis On The Basis Of The Factors Identified
Using The Single Method

Number Of Cluster	Coefficient	Increase In Coefficient
5	15.206787	0.336526
4	16.514816	1.308029
3	17.940338	1.425522
2	19.630890	1.690552
1	19.978821	0.347931

TABLE 8.8: Cluster Analysis On The Basis Of The Factors Identified
Using The Ward Method

Number Of Cluster	Coefficient	Increase In Coefficient
5	9827.339844	278.5781
4	10141.695313	314.356
3	10489.902344	348.207
2	10855.156250	365.254
1	11243.648438	388.492

**TABLE 8.9: Cluster Analysis On The Basis Of The Factors Identified
Used The Average Method**

Number Of Cluster	Coefficient	Increase In Coefficient
5	41.464722	0.18422
4	44.709702	3.24498
3	47.278091	2.568389
2	48.093445	0.815354
1	50.954346	2.860901

**TABLE 8.10: Cluster Analysis On The Basis Of The Sample Statements
Using The Complete Method**

Number Of Cluster	Coefficient	Increase In Coefficient
5	208.999985	13.99998
4	225.00000	16.00002
3	225.999985	0.99998
2	236.00000	10.00002
1	313.999756	77.99975

**TABLE 8.11: Cluster Analysis On The Basis Of The Sample Statements
Using The Single Method**

Number Of Cluster	Coefficient	Increase In Coefficient
5	25.999985	0.000000
4	29.999985	4.000000
3	32.000000	2.000015
2	32.000000	0.000000
1	35.999985	3.999985

**TABLE 8.12: Cluster Analysis On The Basis Of The Sample Statements
Using The Ward Method**

Number Of Cluster	Coefficient	Increase In Coefficient
5	23615.285156	1152.821
4	24861.683594	1246.398
3	27091.464844	2229.781
2	29483.433594	29483.433
1	34376.542969	4893.109

**TABLE 8.13: Cluster Analysis On The Basis Of The Sample Statements
Using The Average Method**

Number Of Cluster	Coefficient	Increase In Coefficient
5	85.180573	1.87497
4	86.100998	0.920425
3	110.210648	24.10965
2	121.362030	11.15139
1	127.301804	5.93977

DISCRIMINANT ANALYSIS OUTPUT

TABLE: 8.14

CANONICAL DISCRIMINANT FUNCTIONS

FCN	EIGEN-VALUE	PCT OF VARIANCE	CUM PCT	CANONICAL CORR	AFTER FCN	WILKS' LAMBDA	CHI-SQURE	DF	SIG
					: 0	0.9595	38.467	28	0.0899
1*	0.0221	53.03	53.03	0.1470	: 1	0.9807	18.122	18	0.4476
2*	0.0133	32.03	85.06	0.1148	: 2	0.9938	5.780	10	0.8339
3*	0.0060	14.35	99.41	0.0771	: 3	0.9998	0.228	4	0.9940
4*	0.0002	0.59	100.00	0.0157	:				

* MARKS THE 4 CANONICAL DISCRIMINANT FUNCTIONS REMAINING IN THE ANALYSIS.

TABLE: 8.15

CLASSIFICATION RESULTS

ACTUAL GROUP	NO. OF CASES	PREDICTED GROUP MEMBERSHIP			
		1	2	3	4
GROUP 1	502	451 89.8%	51 10.2%	0 0.0%	0 0.0%
GROUP 2	374	307 82.1%	67 17.9%	0 0.0%	0 0.0%
GROUP 3	46	40 87.0%	6 13.0%	0 0.0%	0 0.0%
GROUP 4	8	7 87.5%	1 12.5%	0 0.0%	0 0.0%
GROUP 5	8	7 87.5%	1 12.5%	0 0.0%	0 0.0%

ACTUAL GROUP	NO. OF CASES	PREDICTED GROUP MEMBERSHIP 5
GROUP 1	502	0 0.0%
GROUP 2	374	0 0.0%
GROUP 3	46	0 0.0%
GROUP 4	8	0 0.0%
GROUP 5	8	0 0.0%

PERCENT OF "GROUPED" CASES CORRECTLY CLASSIFIED: 55.22%

TABLE: 8.16

CANONICAL DISCRIMINANT FUNCTIONS

FCN	EIGEN-VALUE	PCT OF VARIANCE	CUM PCT	CANONICAL CORR	AFTER FCN	WILKS' LAMBDA	CHI-SQUARE	DF	SIG
					: 0	0.9708	27.601	7	0.0003
1*	0.0300	100.00	100.00	0.1708	:				

* MARKS THE 1 CANONICAL DISCRIMINANT FUNCTIONS REMAINING IN THE ANALYSIS.

TABLE: 8.17

CLASSIFICATION RESULTS

ACTUAL GROUP	NO. OF CASES	PREDICTED GROUP MEMBERSHIP	
		1	2
GROUP 1	715	715 100.0%	0 0.0%
GROUP 2	223	221 99.1%	2 0.9%

PERCENT OF *GROUPED* CASES CORRECTLY CLASSIFIED: 76.44%

TABLE: 8.18

CANONICAL DISCRIMINANT FUNCTIONS

FCN	EIGEN-VALUE	PCT OF VARIANCE	CUM PCT	CANONICAL CORR	AFTER FCN	WILKS' LAMBDA	CHI-SQUARE	DF	SIG
					: 0	0.9365	61.128	21	0.0000
1*	0.0513	76.60	76.60	0.2209	: 1	0.9845	14.534	12	0.2679
2*	0.0091	13.64	90.25	0.0951	: 2	0.9935	6.063	5	0.3001
3*	0.0065	9.75	100.00	0.0805	:				

* MARKS THE 3 CANONICAL DISCRIMINANT FUNCTIONS REMAINING IN THE ANALYSIS.

TABLE: 8.19

CLASSIFICATION RESULTS

<u>ACTUAL GROUP</u>		<u>NO. OF</u>	<u>PREDICTED GROUP MEMBERSHIP</u>			
		<u>CASES</u>	<u>1</u>	<u>2</u>	<u>3</u>	<u>4</u>
GROUP	1	207	18	72	56	61
			8.7%	34.8%	27.1%	29.5%
GROUP	2	248	14	133	37	64
			5.6%	53.6%	14.9%	25.8%
GROUP	3	223	20	69	79	55
			9.0%	30.9%	35.4%	24.7%
GROUP	4	260	15	98	56	91
			5.8%	37.7%	21.5%	35.0%

PERCENT OF 'GROUPED' CASES CORRECTLY CLASSIFIED: 34.22%

APPENDIX 5

ANOVA TABLES

APPENDIX 5

Table 8.20
Analysis Of Variance: Between The Extracted Factors And SEX
Sample (n = 937)

Factors	Source	D.F.	Sum Of Squares	Mean Squares	F Ratio	P * Value
Factor 2	Between Groups	1	6.62	6.26	6.66	.0100
	Within Groups	936	930.38	.99		
Factor 6	Between Groups	1	8.41	8.41	8.48	.0037
	Within Groups	936	928.59	.99		
Factor 12	Between Groups	1	14.03	14.03	14.23	.0002
	Within Groups	936	922.97	.99		

* Denotes significance at or below .05

Table 8.21
Analysis Of Variance: Between The Extracted Factors And AGE
Sample (n = 937)

Factors	Source	D.F.	Sum Of Squares	Mean Squares	F Ratio	P * Value
Factor 2	Between Groups	5	20.93	4.19	4.26	.0008
	Within Groups	932	916.07	.98		

Table 8.21 (Continued)

Factor 3	Between Groups	5	24.23	4.85	4.95	.0002
	Within Groups	932	912.77	.98		
Factor 4	Between Groups	5	35.54	7.11	7.35	.0000
	Within Groups	932	901.46	.97		
Factor 7	Between Groups	5	20.57	4.11	4.18	.0009
	Within Groups	932	916.43	.98		
Factor 9	Between Groups	5	14.02	2.80	2.83	.0152
	Within Groups	932	922.98	.99		

* Denotes significance at or below .05

Table 8.22
Analysis Of Variance: Between Extracted Factors And EDUCATION
Sample (n = 937)

Factors	Source	D.F.	Sum Of Squares	Mean Squares	F Ratio	P * Value
Factor 1	Between Groups	5	11.64	2.33	2.34	.0396
	Within Groups	932	925.36	.99		

Table 8.22 (Continued)

Factor 2	Between Groups	5	17.66	3.53	3.58	.0033
	Within Groups	932	919.34	.99		
Factor 3	Between Groups	5	35.55	7.11	7.35	.0000
	Within Groups	932	901.45	.97		
Factor 4	Between Groups	5	53.67	10.73	11.32	.0000
	Within Groups	932	883.33	.95		
Factor 5	Between Groups	5	12.04	2.53	2.55	.0266
	Within Groups	932	924.36	.99		
Factor 6	Between Groups	5	35.35	7.07	7.31	.0000
	Within Groups	932	901.65	.97		
Factor 10	Between Groups	5	13.53	2.71	2.73	.0185
	Within Groups	932	923.47	.99		
Factor 12	Between Groups	5	15.40	3.08	3.11	.0085
	Within Groups	932	921.60	.99		

* Denotes significance at or below .05

Table 8.23
Analysis Of Variance: Between Extracted Factors And FAMILY SIZE
Sample (n = 937)

Factors	Source	D.F.	Sum Of Squares	Mean Squares	F Ratio	P * Value
Factor 3	Between Groups	3	9.82	3.27	3.30	.0200
	Within Groups	934	927.18	.99		

* Denotes significance at or below .05

Table 8.24
Analysis Of Variance: Between The Extracted Factors And INCOME
Sample (n = 937)

Factors	Source	D.F.	Sum Of Squares	Mean Squares	F Ratio	P * Value
Factor 5	Between Groups	5	51.68	10.34	10.88	.0000
	Within Groups	932	8885.32	.94		
Factor 6	Between Groups	5	37.88	7.58	7.85	.0000
	Within Groups	932	899.12	.96		
Factor 7	Between Groups	5	18.24	3.65	3.70	.0025
	Within Groups	932	918.76	.99		

Table 8.24 (Continued)

Factor 10	Between Groups	5	11.67	2.33	2.35	.0391
	Within Groups	932	925.33	.99		

* Denotes significance at or below .05

Table 8.25
Analysis Of Variance: Between The Extracted Factors And OCCUPATION
Sample (n = 937)

Factors	Source	D.F.	Sum Of Squares	Mean Squares	F Ratio	P * Value
Factor 2	Between Groups	7	22.00	3.14	3.19	.0024
	Within Groups	930	915.00	.98		
Factor 4	Between Groups	7	23.37	3.34	3.40	.0041
	Within Groups	930	913.63	.98		
Factor 5	Between Groups	7	29.31	4.19	4.29	.0001
	Within Groups	930	907.69	.98		
Factor 6	Between Groups	7	18.06	2.58	2.61	.0113
	Within Groups	930	918.94	.99		

* Denotes significance at or below .05

Table 8.26
Analysis Of Variance: Between The Extracted Factors And MARITAL
STATUS
Sample (n = 937)

Factors	Source	D.F.	Sum Of Squares	Mean Squares	F Ratio	P * Value
Factor 4	Between Groups	2	10.29	5.15	5.19	.0057
	Within Groups	935	926.71	.99		
Factor 9	Between Groups	2	11.45	5.72	5.78	.0032
	Within Groups	935	925.55	.99		

* Denotes significance at or below .05

Table 8.27
Analysis Of Variance: Between The Statements And SEX
Sample (n = 937)

Statements	Source	D.F.	Sum Of Squares	Mean Squares	F Ratio	P * Value
Statement 1	Between Groups	1	13.91	13.91	5.12	.0238
	Within Groups	936	2541.41	2.72		
Statement 2	Between Groups	1	28.66	28.66	5.60	.0182
	Within Groups	936	4791.14	5.12		

Table 8.27 (Continued)

Statement 3	Between Groups	1	18.15	18.15	5.77	.0165
	Within Groups	936	2946.26	3.15		
Statement 9	Between Groups	1	26.85	26.85	5.39	.0205
	Within Groups	936	4665.42	4.98		

* Denotes significance at or below .05

Table 8.28
Analysis Of Variance: Between The Statements And AGE
Sample (n = 937)

Statements	Source	D.F.	Sum Of Squares	Mean Squares	F Ratio	P * Value
Statement 2	Between Groups	5	81.52	16.30	3.21	.0071
	Within Groups	932	4738.29	5.08		
Statement 4	Between Groups	5	61.58	12.32	2.74	.0181
	Within Groups	932	4185.90	4.49		
Statement 8	Between Groups	5	145.30	29.06	6.82	.0000
	Within Groups	932	3973.89	4.26		

Table 8.28 (Continued)

Statement 9	Between Groups	5	121.83	24.37	4.97	.0002
	Within Groups	932	4570.44	4.90		
Statement 10	Between Groups	5	103.94	20.79	4.84	.0002
	Within Groups	932	4004.25	4.30		

* Denotes significance at or below .05

Table 8.29
Analysis Of Variance: Between The Statements And EDUCATION
Sample (n = 937)

Statements	Source	D.F.	Sum Of Squares	Mean Squares	F Ratio	P * Value
Statement 1	Between Groups	5	36.66	7.33	2.71	.0192
	Within Groups	932	2518.66	2.70		
Statement 2	Between Groups	5	256.32	51.26	10.47	.0000
	Within Groups	932	4563.49	4.90		
Statement 4	Between Groups	5	82.18	16.44	3.68	.0027
	Within Groups	932	4165.30	4.47		

Table 8.29 (Continued)

Statement 8	Between Groups	5	137.98	27.60	6.46	.0000
	Within Groups	932	3981.20	4.27		
Statement 9	Between Groups	5	144.24	28.85	5.91	.0000
	Within Groups	932	4578.03	4.88		
Statement 10	Between Groups	5	141.13	28.23	6.63	.0000
	Within Groups	932	3967.06	4.26		

* Denotes significance at or below .05

Table 8.30
Analysis Of Variance: Between The Statements And INCOME
Sample (n = 937)

Statements	Source	D. F.	Sum Of Squares	Mean Squares	F Ratio	P * Value
Statement 2	Between Groups	5	84.04	16.81	3.31	.0057
	Within Groups	932	4735.77	5.08		
Statement 3	Between Groups	5	47.14	9.43	3.01	.0105
	Within Groups	932	2917.27	3.13		

Table 8.30 (Continued)

Statement 4	Between Groups	5	119.18	23.84	5.38	.0001
	Within Groups	932	4128.30	4.43		

* Denotes significance at or below .05

Table 8.31
Analysis Of Variance: Between The Statements and OCCUPATION
Sample (n = 937)

Statements	Source	D.F.	Sum Of Squares	Mean Squares	F Ratio	P * Value
Statement 3	Between Groups	7	64.38	9.20	2.95	.0046
	Within Groups	930	2900.03	3.12		
Statement 4	Between Groups	7	69.78	9.97	2.22	.0307
	Within Groups	930	4177.70	4.49		
Statement 8	Between Groups	7	68.96	9.85	2.26	.0276
	Within Groups	930	4050.23	4.36		

* Denotes significance at or below .05

Table 8.32
Analysis Of Variance: Between The Statements And MARITAL STATUS
Sample (n = 937)

Statements	Source	D. F.	Sum Of Squares.	Mean Squares	F Ratio	P * Value
Statement 2	Between Groups	2	145.90	72.95	14.59	.0000
	Within Groups	935	4673.91	4.99		
Statement 4	Between Groups	2	58.69	29.35	6.55	.0015
	Within Groups	935	4188.78	4.48		
Statement 10	Between Groups	2	30.14	15.07	3.45	.0320
	Within Groups	935	4078.06	4.36		

* Denotes significance at or below .05

Table 8.33
Analysis Of Variance At Alpha = .05 - Significant Groups Of SEX By
Factors 2, 6, 12

Factors Name	Mean	Name/ Number Of Groups	Number of Groups		Total Cases 938
			1	2	
2. Description/ Instruction	-.066 .106	Male 1 Female 2		*	578 360
6. Clarity Of Written Prescription	-.075 .220	Male 1 Female 2		*	578 360

Table 8.33 (Continued)

12. Potential For Re-use Of Medicine Containers	-.097	Male 1	*	578
	.155	Female 2		360

* Denotes significance between groups

Table 8.34
Analysis Of Variance At Alpha = .05 - Significant Groups Of AGE By
Factors 2, 3, 4, 7

Factors Name	Mean	Name/Number Of Groups	Number of Groups						Total Cases 938
			1	2	3	4	5	6	
2. Description/ Instruction	-.349	45-54 years 4							112
	-.133	over 60 years 6					*		27
	-.124	55-60 years 5							50
	.003	18-24 years 1							169
	.018	35-44 years 3							264
	.138	25-35 years 2							316
3. Availability Of Service Of, And Products In, Public Chemists	-.149	25-34 years 2							316
	-.049	35-44 years 3							264
	.058	45-54 years 4							112
	.125	18-24 years 1							169
	.396	over 60 years 6							27
	.433	55-60 years 5						*	50
4. Legibility Of Production/Expiry Date	-.253	18-24 years 1							169
	-.096	25-34 years 2							316
	.041	35-44 years 3							264
	.278	45-54 years 4					*	*	112
	.353	over 60 years 6							27
	.433	55-60 years 5					*	*	50
7. Availability Of Service Of, And Products In, Private Chemists	-.192	25-34 years 2							316
	.025	18-24 years 1							169
	.096	35-44 years 3						*	264
	.107	45-54 years 4							112
	.194	55-60 years 5							50
	.348	over 60 years 6							27

* Denotes significance between groups

Table 8.35
Analysis Of Variance At Alpha = .05 - Significant Groups Of
EDUCATION by Factors 2, 3, 4, 6, 12

Factors Name	Mean	Name/Number Of Groups	Number of Groups						Total Cases 938
			1	2	3	4	5	6	
2. Description/ Instruction	-.558	Non-Educated 6							39
	-.258	Primary School 1							55
	.026	Grade School 2					*		226
	.038	College 4					*		374
	.047	High School 3					*		157
	.095	Postgraduate 5					*		87
3. Availability Of Service Of, And Products In, Public Chemists	-.196	Postgraduate 5							87
	-.072	College 4							374
	-.019	Grade School 2							226
	.025	High School 3							157
	.206	Primary School 1							55
	.844	Non-Educated 6			*	*	*	*	39
4. Legibility Of Product- ion/Expiry Date	-.245	Postgraduate 5		*			*		87
	-.149	College 4		*			*		374
	-.122	High School 3		*			*		157
	.238	Grade School 2							226
	.249	Primary School 1							55
	.742	Non-Educated 6							39
6. Clarity Of Written Prescription	-.342	Non-Educated 6		*					39
	-.252	Postgraduate 5		*					87
	-.134	College 4		*					374
	.111	Primary School 1							55
	.132	High School 3							157
	.259	Grade School 2							226
12. Potential For Re-use Of The Medicine Containers	-.439	Non-Educated 6	*						39
	-.075	Postgraduate 5							87
	-.054	College 4							374
	.062	High School 3							157
	.085	Grade School 2							226
	.272	Primary School 1							55

* Denotes significance between groups

Table 8.36
Analysis Of Variance At Alpha = .05 - Significant Groups Of FAMILY
SIZE By Factor 3

Factors Name	Mean	Name/Number Of Groups	Number of Groups				Total Cases 938
			1	2	3	4	
3. Availability Of Service Of, And Products In, Public Chemists	-.081	From 1-2	1				163
	-.076	From 3-4	2				433
	.101	Over 6	4				85
	.145	From 5-6	3		*		257

* Denotes significance between groups

Table 8.37
Analysis Of Variance At Alpha = .05 - Significant Groups Of INCOME
By Factors 5, 6, 7

Factors Name	Mean	Name/Number Of Groups	Number of Groups						Total Cases 938
			1	2	3	4	5	6	
5. Medicine Price	-.125	£ 1201-2999	3						244
	-.117	£ 900-1200	2						259
	.006	Less than 900	1						246
	.009	£ 3000-4999	4						108
	.524	£ 5000-6999	5			*	*		37
	.881	£ 7000 & over	6			*	*	*	44
6. Clarity Of Written Prescription	-.596	£ 5000-6999	5			*	*		37
	-.527	£ 7000 & over	6			*	*		44
	-.102	£ 3000-4999	4						108
	-.061	£ 1201-2999	3						244
	.115	£ 900-1200	2						259
.169	Less than 900	1						246	
7. Availability Of Service Of, And Products In, Private Chemists	-.161	£ 900-1200	2						259
	.002	Less than 900	1						246
	.008	£ 1201-2999	3						244
	.121	£ 3000-4999	4						108
	.174	£ 5000-6999	5						37
	.448	£ 7000 & over	6			*			44

* Denotes significance between groups

Table 8.38
Analysis Of Variance At Alpha = .05 - Significant Groups Of
OCCUPATION By Factors 2, 4, 5

Factors Name	Mean	Name/Number Of Groups	Number of Groups								Total Cases 938
			1	2	3	4	5	6	7	8	
2. Description/ Instruction	-.294	Labour 1				*					139
	-.186	Retired 4									29
	-.010	Official 5									451
	.085	Student 6									56
	.144	Professional 3									180
	.196	Unemployed 2									15
	.246	Housewife 8									42
	.258	Proprietor 7									26
4. Legibility Of Product- ion/Expiry Date	-.401	Unemployed 2				*					15
	-.377	Student 6									56
	-.042	Official 5									451
	-.023	Professional 3									180
	.009	Proprietor 7									26
	.155	Retired 4									29
	.202	Housewife 8									42
	.265	Labour 1									139
5. Medicine Price	-.291	Housewife 8				*					42
	-.123	Official 5									451
	.021	Labour 1									139
	.034	Retired 4									29
	.087	Unemployed 2									15
	.101	Student 6									56
	.231	Professional 3									180
	.575	Proprietor 7									26

* Denotes significance between groups

Table 8.39
Analysis Of Variance At Alpha = .05 - Significant Groups Of MARITAL STATUS By Factors 4, 9

Factors Name	Mean	Name/Number Of Groups	Number of Groups			Total Cases 938
			1	2	3	
4. Legibility Of Production/Expiry Date	-.101	Single 1				294
	-.017	Married 2				590
	-.363	Others 3	*			54
9. Taste/Smell Of Medicine	-.157	Single 1		*		294
	-.051	Others 3				54
	-.083	Married 2				590

* Denotes significance between groups

Table 8.40
Analysis Of Variance At Alpha = .05 - Significant Groups Of SEX By Statements 1, 2, 3, 9

Statements	Mean	Name/Number Of Groups	Number of Groups		Total Cases 938
			1	2	
1. There is obvious improvement in medicine packing over the last five years	4.88	Male 1			578
	4.63	Female 2		*	360
^a 2. It seems that public hospitals offer free medicine with insufficient instruction on labels	4.27	Male 1			578
	3.91	Female 2		*	360
3. There are usually warning statements on medicine labels	5.38	Male 1			578
	5.67	Female 2		*	360

Table 8.40 (Continued)

4. Most doctors are concerned about providing instruction information in prescription	3.30	Male 1		578
	4.65	Female 2	*	360

* Denotes significance between groups

a Note: the higher the mean score, the more negative satisfaction

Table 8.41

Analysis Of Variance At Alpha = .05 - Significant Groups Of AGE By Statements 2, 8, 9, 10

Statements	Mean	Name/ Number Of Groups	Number of Groups						Total Cases 938
			1	2	3	4	5	6	
a 2. It seems that public hospitals offer free medicine with insufficient instruction on labels	3.28	55-60 yrs 5							50
	3.63	over 60 yrs 6						*	27
	3.96	45-54 yrs 4							112
	4.12	35-44 yrs 3							264
	4.15	25-34 yrs 2							316
	4.59	18-24 yrs 1							169
8. Doctors adequately explain to me the medicine positive/negative effects	3.03	25-34 yrs 2							316
	3.04	35-44 yrs 3							264
	3.51	18-24 yrs 1							169
	3.72	45-54 yrs 4							112
	4.10	55-60 yrs 5					*	*	50
	4.59	over 60 yrs 6					*	*	27
9. Most doctors are concerned about providing instruction information in prescription	3.09	35-44 yrs 3							264
	3.34	25-34 yrs 2							316
	3.53	18-24 yrs 1							169
	3.72	45-54 yrs 4							112
	3.93	over 60 yrs 6							27
	4.62	55-60 yrs 5					*	*	50

Table 8.41 (Continued)

10. The majority of pharmacists do not sell medicine out of prescription	4.07	25-34 yrs	2	*	316
	4.19	35-44 yrs	3		264
	4.50	18-24 yrs	1		169
	4.56	45-54 yrs	4		112
	5.22	55-60 yrs	5		50
	5.33	over 60 yrs	6		27

* Denotes significance between groups

a Note: the higher the mean score, the more negative satisfaction

Table 8.42
Analysis Of Variance At Alpha = .05 - Significant Groups Of
EDUCATION By Statements 1, 2, 4, 8, 9, 10

Statements	Mean	Name/ Number Of Groups	Number of Groups						Total Cases 938
			1	2	3	4	5	6	
1. There is obvious improvement in medicine packing over the last few years	4.38	High School	3						157
	4.62	Primary School	1						55
	4.79	Postgraduate	5						87
	4.80	Grade School	2						226
	4.90	Non-Educated	6						39
	4.94	College	4	*					374
a 2. It seems that public hospitals offer free medicine with insufficient instruction on labels	2.67	Non-Educated	6						39
	3.36	Primary School	1						55
	3.73	Grade School	2						226
	3.99	High School	3				*		157
	4.52	Postgraduate	5				*		87
	4.62	College	4	*	*		*		374
4. Medicine labels usually contain particular statements	4.03	Postgraduate	5						87
	4.53	College	4						374
	4.55	Primary School	1						55
	4.69	Non-Educated	6						39
	4.90	High School	3						157
	5.03	Grade School	2				*		226

Table 8.42 (Continued)

8. Doctors adequately explain to me the medicine positive/negative effects	2.75	Postgraduate	5		87
	3.04	College	4		374
	3.47	Grade School	2		226
	3.50	High School	3		157
	4.15	Primary School	1	* *	55
	4.23	Non-Educated	6	* *	39
9. Most doctors are concerned about providing instruction information in prescription	2.89	Postgraduate	5		87
	3.09	College	4	*	374
	3.63	High School	3		157
	3.81	Grade School	2		226
	3.98	Primary School	1		55
	4.15	Non-Educated	6		39
10. The majority of pharmacists do not sell medicine out of prescription	3.92	Postgraduate	5		87
	4.02	College	4	* *	374
	4.49	High School	3		157
	4.58	Grade School	2		226
	5.02	Primary School	1		55
	5.41	Non-Educated	6	*	39

* Denotes significance between groups

a Note: the higher the mean score, the more negative satisfaction

Table 8.43
Analysis Of Variance At Alpha = .05 - Significant Groups Of INCOME
By Statements 2, 3, 4

Statements	Mean	Name/ Number Of Groups	Number of Groups						Total Cases 938
			1	2	3	4	5	6	
a 2. It seems that public hospitals offer free medicine with insufficient instruction on labels	3.93	£ 900-1200	2						259
	3.96	£ 1201-2999	3						244
	4.07	£ 3000-4999	4						108
	4.29	Less than £900	1						246
	4.68	£ 5000-6999	5						37
	5.18	£ 7000 & over	6	*					44

Table 8.43 (Continued)

3. There are usually warning statements on medicine labels	4.57	£ 7000 & over	6	* *	44
	5.45	£ 900-1200	2		259
	5.46	Less than £900	1		246
	5.62	£ 1201-2999	3		244
	5.65	£ 3000-4999	4		108
	5.73	£ 5000-6999	5		37
4. Medicine labels usually contain particular caution statements	3.86	£ 7000 & over	6		44
	4.23	Less than £900	1		246
	4.46	£ 5000-6999	5		37
	4.91	£ 900-1200	2	*	259
	4.93	£ 3000-4999	4		108
	4.95	£ 1201-2999	3	*	244

* Denotes significance between groups

a Note: the higher the mean score, the more negative satisfaction

Table 8.44
Analysis Of Variance At Alpha = .05 - Significant Groups Of
OCCUPATION By Statement 3

Statement	Mean	Name/ Number Of Groups	Number of Groups								Total Cases 938	
			1	2	3	4	5	6	7	8		
3. There are usually warning statements on medicine labels	4.88	Labour	1									139
	5.45	Retired	4									29
	5.50	Proprietor	7									26
	5.51	Professional	3									180
	5.62	Official	5	*								451
	5.64	Housewife	8									42
	5.71	Student	6									56
	5.87	Unemployment	2									15

* Denotes significance between groups

Table 8.45
Analysis Of Variance At Alpha = .05 - Significant Groups Of MARITAL
STATUS By Statements 2, 4, 10

Statements	Mean	Name/ Number Of Groups	Number of Groups			Total Cases 938
			1	2	3	
^a 2. It seems that public hospitals offer free medicine with insufficient instruction on labels	2.83	Others 3				54
	4.05	Married 2		*		590
	4.55	Single 1		*	*	294
4. Medicine labels usually contain particular caution statements	4.31	Single 1				294
	4.80	Others 3				54
	4.85	Married 2		*		590
10. The majority of pharmacists do not sell medicine out of prescription	4.26	Married 2				590
	4.37	Single 1				294
	5.04	Others 3		*		54

* Denotes significance between groups

^a Note: the higher the mean score, the more negative satisfaction