

To Hold Infinity in the Palm of your Hand

The Insular Pocket Gospel Books Re-evaluated

II Volumes: Volume II

Eleanor Elisabeth Jackson

PhD

University of York

History of Art

January, 2017

Contents

Volume II

Contents	222
APPENDIX. Catalogue of Manuscripts	223
— Catalogue Introduction	223
— Bern, Burgerbibliothek, Cod. 671	227
— Book of Deer (Cambridge, University Library, MS Ii.6.32)	233
— Stowe St John and Missal (Dublin, RIA, MS D II 3)	239
— Book of Armagh (Dublin, TCD 52)	247
— Book of Dimma (Dublin, TCD, 59)	259
— Book of Mulling (Dublin, TCD, 60)	266
— Cadmug Gospels (Fulda, Landesbibliothek, Cod. Bonifatianus 3)	272
— London, BL, Add. MS 40618	379
— Cuthbert Gospel of St John (London, BL, Add. MS 89000)	384
— MacDurnan Gospels (London, Lambeth Palace Library, MS 1370)	300
Abbreviations	310
Manuscripts	311
Bibliography	315
— Published Primary Sources	315
— Published Secondary Sources	320
— Unpublished Secondary Sources	342
Figures	343

APPENDIX: Catalogue of Manuscripts

Catalogue Introduction

In the following catalogue entries, the information about the physical structure, contents, decoration and provenances of the principal manuscripts discussed in this study are laid out. The catalogue is intended to provide more detailed information about the features mentioned in the body of this work in order to support the points made and, more broadly, to make better known the many unusual features of these manuscripts.

The template for this catalogue has been developed specially to suit the manuscripts under consideration; however, it is ultimately modelled on the catalogue guidelines provided in *Introduction to Manuscript Studies* by Raymond Clemens and Timothy Graham, pp. 129-34, in which more detailed information can be found about many of the conventions adopted herein. The following presents a brief guide to the use of this catalogue.

Heading

The manuscripts are arranged alphabetically by city. The catalogue number, library shelf mark and common name of the manuscript are given, followed by a summary description of its contents and its place and date of origin. For the majority of manuscripts described, date and place of origin are uncertain, so the heading provides the most convincing opinion presented with more detailed discussion in the *Provenance* section. If uncertain, place of origin is preceded by “?” and the broadest span of likely dates are given, specifying centuries and part-centuries where possible (for example, early-9th century, or first-half of 9th century), or date ranges if the manuscript could date from any time between two periods (for example, late-8th to mid-9th century). When a specific date is provided (for example, c.807), it indicates that there is an objective reason for assigning this date, as discussed in the *Provenance* section. This is followed by a summary account of any additions with their place and date, as above.

Physical Description

Codicological information about the features of the manuscripts is provided here. For terminology, see Clemens and Graham, *Introduction to Manuscript Studies*; Michelle Brown, *Understanding Illuminated Manuscripts: A Guide to Technical Terms*; and the British Library’s online version at:

<https://www.bl.uk/catalogues/illuminatedmanuscripts/glossary.asp>

The description first notes the support, which in all cases is parchment, meaning animals skins prepared for writing. As it is difficult to establish the species of origin, parchment is used as a generic term. The number of leaves and flyleaves is shown by the

following formula: flyleaves at beginning of volume (roman numeral) + leaves in main part of volume (arabic numeral) + flyleaves at end of volume (roman numeral). Flyleaves are defined as any leaves at the beginning or end of the volume that are not part of the structure of the first or last quire (generally added by modern binders). Pastedowns are mentioned only if they are part of the first or last quire of the manuscript. Rough dates and materials of flyleaves are included, and the foliation is provided in brackets along with any necessary explanation or clarification.

The dimensions of leaves are measured along the fore-edge and head-edge, and the dimensions of the written space are measured wherever possible between the vertical ruled lines at each side (width), and from the bases of the minims on the last line to the tops of the minims on the first line (height). However, since many of the manuscripts described have irregular layouts, the dimensions often varying fractionally and sometimes considerably from leaf to leaf, and thus the values given are only intended to be approximate. Where variation is significant, a range of dimensions is indicated or a *c.* figure is used. Evidence of trimming is included if present.

Details about the ruling of the manuscript are provided next. As is usual for this period, the ruling medium in all the manuscripts described is hard point, meaning that the lines were impressed into the leaves with a blunt-pointed instrument. The ruling pattern is described in order to show the considerable variation in the preparation of the manuscripts. In most cases, the lines of text are written so that the bases of the minims sit on the ruled line; only the employment of different configurations are noted. The term “frame ruling” applies to lines that are only ruled along the top, bottom and left and right sides of the written space, without horizontal text lines. The prickings/slits used to guide ruling are noted where present.

It is recorded whether the manuscript is written in a single column or in two columns, along with the approximate number of lines of text per page. This is only intended to be approximate as the exact number varies throughout the manuscripts discussed. Particular variation is expressed by a range of values or a *c.* figure.

The number of original hands and their division within the manuscripts are supplied next. Where different scholarly interpretations are possible, these are summarised. The names of any scribes that are signed in the manuscript are also provided. The same information is given regarding additional hands. This is followed by a brief description of the script(s), the main text followed by any additions, as before. For detailed discussion of the scripts, as well as the terminology used, see Chapter 3.

Other features of note are also recorded, such as Eusebian section numbers, if present, and any glosses and headers, which are taken broadly to include running titles,

numeration, corrections and marginal and interlinear inscriptions of various kinds. Locations and descriptions of quire signatures are also provided if present.

Collation

After a summary of the number and regularity of the quires, details of each quire are given in sequence, numbered consecutively (1, 2, 3...). The original number of leaves is written subscript (for example, 1¹⁰, indicating that the first quire originally contained 10 leaves). After this, any added leaves are noted along with their position within the quire and their type (for example, '+1 after 3', indicating that one leaf has been added after the third leaf of the quire). The types of added leaf are: insertion= a leaf added by the original scribe; addition= a leaf added later. Any lost leaves are then similarly noted (for example, 'wants 5', indicating that the fifth leaf of the quire is missing). Types of missing leaf are: cancellation=removed by scribe; excised=deliberately cut out; missing=reason unclear, potentially accidental. A run of quires of the same length with no losses or additions is shown by the number of the first quire in the run, followed by a hyphen, then the last quire in the run, and then the number of leaves in each quire in subscript (for example, 3-5⁸, indicating that quires 3, 4 and 5 each contain eight leaves with no additions or losses). The details of each quire are ordinarily followed by a comma, except if the manuscript is composite, in which case a semi-colon is used to distinguish consecutive quires belonging to different sections of the manuscript. For further clarity, quire diagrams are provided for the manuscripts at the end of each catalogue entry.

Texts

The textual contents of the manuscript are listed in order of appearance, numbered consecutively. For each text, the folio numbers are provided followed by the title (a descriptive title in English if it does not have an accepted title). If imperfect, this is noted along with the span of the surviving text. Where clarification is needed, for example in the case of charters and liturgical texts, the language is included. References to editions of texts are given if they exist, and short texts are transcribed and translated if lacking an edition. Additional texts are indented and supplied with their likely date of addition. If the text is followed by a colophon, this is also transcribed and translated.

The transcription conventions employed are based on those from Raymond Clemens and Timothy Graham, *Introduction to Manuscript Studies*, pp. 75-77. Transcriptions preserve the spelling, punctuation and capitalisation of the originals. Abbreviations are expanded with the supplied letters enclosed in parentheses, for example: d(omi)ni. Text that has been lost by damage to the manuscript is indicated using pointed brackets < >. A word

written in square brackets after a forward slash shows that it is an insertion over an erasure, for example [/dimmu]; if the original reading is legible it is placed to the left of the slash.

The references to editions can be found either in the individual bibliographies of the catalogue entries, if particular to the manuscript under discussion, or else in the main bibliography. Charters are referenced by their “Sawyer number” and can be accessed on *The Electronic Sawyer, the Online Catalogue of Anglo-Saxon Charters*, <http://www.esawyer.org.uk>, based on Peter Sawyer, *Anglo-Saxon Charters: an Annotated List and Bibliography* (London, 1968).

Decoration

Original decoration is recorded first, followed by any additional decoration. Decoration is ordered by type: full-page miniatures, half-page miniatures, decorated initials, minor initials and textual decoration, with frames described last. Within each category, any common properties are described first, followed by any individual features. Brief descriptions are given of each example, using established scholarly terminology. The size of decorated initials is roughly indicated by giving the number of lines of text indented in order to accommodate the initial on the page. The measurements of frames are given in millimetres where possible.

Binding

Cursory descriptions of modern bindings or more detailed descriptions of medieval bindings are given.

Shrine

If a shrine exists, this is described along with any provenance information it offers.

Provenance

This provides an account of the internal and external evidence that reveals as much as can be told about the history of the manuscript. Information is arranged chronologically according to the age of the evidence, so a piece of evidence that has implications for the early history of the manuscript is placed nearer the end of the account if it is of a late date itself. Relevant passages are transcribed (see transcription guidelines above). The most likely interpretations of the evidence are discussed, attempting to prioritise evidence over interpretation.

Bibliography

This is not intended to be exhaustive, but merely to point in the direction of the most extensive scholarly discussions of these manuscripts. See also the chapters of this thesis.

(1) Bern, Burgerbibliothek, Cod. 671

Gospel book in Latin; additional poems in Latin; charter, rules of a guild and 2 manumission documents in Old English; lists of names and description of reliquaries in Latin.

?Wales or Cornwall, early 9th century.

Additions in Wessex, late 9th century and c.920s-30s, and France, 11th-12th century.

Physical Description

Support: parchment.

Number of leaves and flyleaves: ii (modern paper) + 78 (modern foliation 1-78) + ii (modern paper).

Dimensions of leaves: 161 x 116 mm.

Dimensions of written space: 117 x 82 mm.

Ruling medium: hard point.

Ruling pattern: vertical bounding lines, single at inner margin double at outer, and horizontal text lines level with tops of minims, several leaves at a time, after folding, prickings in inner and outer margins on some pages.

Columns and lines: c.34 lines, single column.

Scribes: 2 (1v-43r, 43r-74v) +additions.

Script: Insular minuscule +additions in Insular half-uncial (fol. 74v), early English square minuscule (fols 75v-76v) and continental minuscule (fol. 77v).

Glosses and Headers: occasional insertions in upper margin (fol. 16r, Matthew 21:31 (regum [sic])-32 (credidistis ei); fol. 24r, Luke 5:38).

Eusebian Sections: marked in outlined boxes in the margin, fols 38v-43r only (Luke sections 9-78; i.e. Luke 3:10-8:10).

Collation

8 quires, regular collation except for the last.

1-7¹⁰, 8⁶ (+2 after 6, addition).

Texts

1. Fols 1r-22v, Gospel of Matthew; colophons, fol. 1r, “finit p(ro)logus amen amen”, fol. 22v, “amen amen”.
2. Fols 23r-35v, Gospel of Mark; colophon, fol. 35v, “finit amen”.
3. Fols 36r-58v, Gospel of Luke; colophon, fol. 58v, “amen finit amen”.
4. Fols 59r-74v, Gospel of John; added inscription in rustic capitals, fol. 58v, “INITIUM S(AN)C(T)I EVVANGELII S(E)C(UN)D(U)M IOHANNEM”; colophon, fol. 74v, “amen finit”.

5. Fol. 74v, 2 acrostic poems in praise of King Alfred, Latin, late-9th century (Lindsay 1912, 10-11).
6. Fol 75v, charter concerning directions from one Athelweard to one Ceolberht to distribute tithes from Bedwyn, Wiltshire, and Lambourn, Berkshire, to “God’s servants” at Bedwyn (ends imperfectly), Old English, c.920s (S 1446a).
7. Fols 75v-76r, rules of a guild concerning compensation payments and fines for members, Old English, c.920s (Merrit 1937, 344-346).
8. Fol. 76v, manumission document concerning permission granted to Wynsig and Athelnoth for the release of a woman, Byrhtgyth, for ten mancuses, sanctioned by one Eadwine and witnessed by Aelfsig the reeve, Wynstan the deputy reeve, Aelfheah the mass-priest, Aetheldrythe the nun, Titsig, Taetig, all the “servants of God” at Bedwyn, Ceolbyrht’s sons Sigestan and Aethelstan, and “all the people”, Old English, c.930s (Merrit 1934, 346-7).
9. Fol. 76v, manumission document concerning the release of a woman, Ecgwynn, who freed herself for ten mancuses, sanctioned by one Eadwine and witnessed by Aelfsig the reeve, Wynstan the deputy reeve, Aelfheah the mass-priest, all the “servants of God” at Bedwyn and “all the people”, Old English, c. 930s (Merrit 1934, 346-7).
10. Fol. 77v, list of names, “Aub(er)tus. Gauterius. Amelina. Conidos”; list of apocryphal Seven Sleepers of Ephesus, “Nomina VIIte(m) dormientu(m). Maximianus. Malchus. Marthinianus. Dyonisius. Johannes. Serapion. Constantinus”; and descriptions of reliquaries (ends imperfectly), “Descriptio filacteriorum uel uasorum auri et argenti quae habet capicherius sub custodia sua. habet enim filacteria aurea IIII alia uero quorum opercula < >”, ?11th-12th century.

Decoration

Decorated initials: pen-drawn, (fol. 1r) *Matthew incipit*, 3 lines, letters outlined and decorated with pellets; (fol. 1v), *Chi-rho*, 8 lines, outlined and terminating in 2 beast-heads; (fol. 23r) *Mark incipit*, 6 lines, “knotted-wire” letters with animal-head terminals; (fol. 36r) *Luke incipit*, 7 lines, bowl of q filled with cross and pellet design, animal-head terminals; (fol. 59r) *John incipit*, 4 lines, cross-shape between the horizontal strokes of N, letters outlined and decorated with pellets.

Textual decoration: Arabesques on some letters (e.g. fol. 1v, 12v, 42v, 47v, 62v); lengthened descenders on lowest line of text on some pages (e.g. fols 30-33).

Minor initials: numerous, enlarged in margin.

Binding

Modern, wooden boards covered in white paper.

Provenance

Palaeographical and art-historical evidence points to a date in the ninth century. Lindsay noted that its abbreviations cannot be later than the earlier part of the ninth century (Lindsay 1912, 12), yet its initials are of the type that Françoise Henry named “knotted-wire” initials (Henry 1960, 32-3), that appear in manuscripts from around the beginning of the ninth century onwards including pocket gospels such as the Book of Armagh (c.807) and Book of Deer (9th/10th century).

The addition of acrostic poems in praise of King Alfred (d. 899) (fol. 74v), and documents in Old English referring to Bedwyn, Wiltshire, and Lambourn, Berkshire, (fols 75v-76v), suggest that by the late-ninth century and through the first half of the tenth, the manuscript was kept in Anglo-Saxon Wessex. These additions led Lindsay to suppose that the manuscript was made in Cornwall which at that time was largely under West-Saxon rule (Lindsay 1912, 10-16). However, it is equally possible that the manuscript was made elsewhere and brought to Wessex. No manuscripts of this date known to have been made in Cornwall have survived for comparison.

Because of its relative proximity, Wales is often suggested as a possible place of creation. Lindsay noted that the v-form for “u” found in the manuscript is a Welsh characteristic (Lindsay 1912, 12), yet it appears in numerous manuscripts of non-Welsh provenance including pocket gospels such as the MacDurnan Gospels and Book of Deer. Dumville stated that “the criterion which would cause its ascription to (English-influenced) Cornwall rather than Wales would be the regularity of its quires” (Dumville 1999, 123); however, the Hereford Gospels (Hereford Cathedral Library MS P. I. 2), which Gameson convincingly argues to be Welsh, also has regular quires (each of 12 folios). Furthermore, Bern 671 and the Hereford Gospels share a unique textual variant (Gameson 2002, 57).

The Old English documents (fols 75v-76v), palaeographically dated to around the 920s and 30s (Dumville 1987, 170-173; 1992, 79-81, 94), are particularly concerned with matters relating to Bedwyn, Wiltshire, and it is highly likely that the manuscript was kept there at the time of their entry. “God’s servants at Bedwyn”, to whom the Old English documents refer, were probably the clergy of the large minster church at Bedwyn, where it seems likely the manuscript was kept. The guild that is the subject of (7) (fols 75v-76r) was probably a parish guild (Brentnall 1948, 363-4).

Bedwyn was probably a royal estate when the documents were entered into the manuscript. It is included in the will of King Alfred, c.873-888 (S 1507), where it is bequeathed to his eldest son and successor Edward (d. 924); it later belonged to King Edgar (d. 975) who, as a charter of Aethelred (S 937) reveals, granted it to Abingdon Abbey, though

after his death it was promptly confiscated by King Edward (d. 978). Given that it was an estate of King Alfred, it would also make sense if Bedwyn was the home of the manuscript when the acrostic poems in his praise were entered in the late-ninth century (fol. 74v).

Entries on fol. 77v in a continental minuscule hand, which list names and describe reliquaries, show that the manuscript had arrived in France by the 11th-12th centuries. Dumville sees this as part of a larger movement of high-status manuscripts out of England and into France as a result of the Norman Conquest (Dumville 1994, 89-90).

An ownership inscription on fol. 78, names “Bourietus Vincent de Cyrerio”, along with an elaborate monogram; these are probably 16th century.

The manuscript came to Bern Stadtbibliothek (later Burgerbibliothek) with the collection of Jacques Bongars (1554-1612). A library stamp “Bibliotheca Bernensis”, is found on fol. 1r.

Bibliography

Brentnall, H. C. 1948. “Bedwyn in the Tenth Century”, *Wiltshire Archaeological and Natural History Magazine* 52, 189: 360-368.

Burgerbibliothek Bern, Online Archives Catalogue, retrieved on 31/07/14 from:

<http://katalog.burgerbib.ch/detail.aspx?ID=129694>

Dumville, David N. 1994. “Anglo-Saxon Books: treasure in Norman hands?”, in *Anglo-Norman Studies, Proceedings of the Battle Conference 1993*, ed. Marjorie Chibnall, 83-99. Woodbridge: Boydell and Brewer.

Dumville, David N. 1987. “English Square Minuscule Script: The Background and Earliest Phases”, *Anglo-Saxon England* 16: 147-179, at 160 and 170-173.

Dumville, David N. 1992. *Wessex and England from Alfred to Edgar*, 79-82. Woodbridge: Boydell.

Förster, M. 1941. “De Flussname Themse und seine Sippe: Studien zur Anglisierung keltischer Eigennamen und zur Lautchronologie des Altbritischen”, in *Sitzungsberichte der Bayerischen Akademie der Wissenschaften, Phil.-hist. Abteilung*. Munich. 793-4.

Gameson, Richard. 2002. “The Insular Gospel Book at Hereford Cathedral”, *Scriptorium* 56: 48-79, at 57.

Gneuss, Helmut. 2001. *Handlist of Anglo-Saxon Manuscripts: A List of Manuscripts and Manuscript Fragments Written or Owned in England up to 1100*, 794. Tempe: Arizona Center for Medieval and Renaissance Studies.

Homburger, O. 1962. *Die illustrierten Handschriften der Burgerbibliothek Bern*, 31. Bern: Burgerbibliothek, 1962.

Ker, N. R. 1957. *Catalogue of Manuscripts Containing Anglo-Saxon*, 6. Oxford: Clarendon Press, 1957.

- Lindsay, Wallace M. 1911. "A Relic of a 'Cornish' scriptorium", *Athenaeum*: 795-96.
- Lindsay, Wallace M. 1912. *Early Welsh Script*. St Andrews University Publications 10, 10-16.
Oxford: James Parker, 1912.
- Lindsay, Wallace M. 1915. *Notae Latinae: An Account of Abbreviation in Latin MSS. of the Early Minuscule Period (c. 700-850)*, 448. Cambridge: Cambridge University Press.
- McGurk, Patrick. 1956. "The Irish Pocket Gospel", *Sacris Erudiri* 8, 2: 249-270, at 250, 269.
- McGurk, Patrick. 1987. "The Gospel Book in Celtic Lands Before A.D. 850: Contents and Arrangement", in *Irland und die Christenheit, Bibelstudien und Mission*, ed. Próinséas Ní Chatháin and Michael Richter, 165-89, at 174-5. Stuttgart: Klett-Cotta.
- Meritt, Herbert. 1934. "Old English Entries in a Manuscript at Bern", *Journal of English and Germanic Philology* 33, 3: 343-351
- Pelteret, David A. E. 2001. *Slavery in Early Mediaeval England: From the Reign of Alfred until the Twelfth Century*, 152 and 157-8. Woodbridge: Boydell.

Bern 671 Quire Diagrams

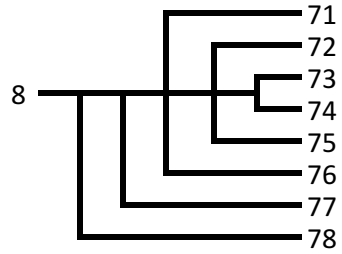
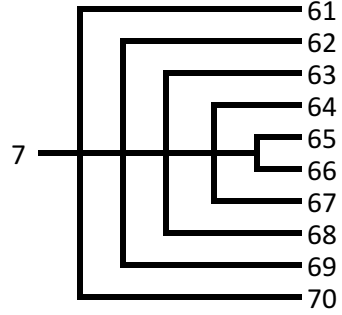
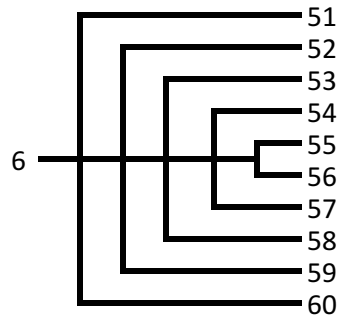
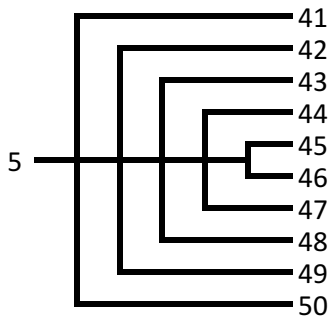
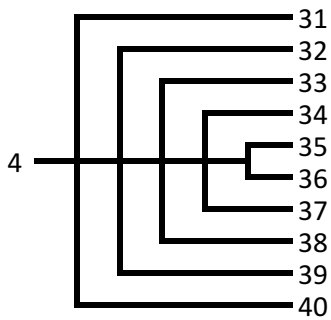
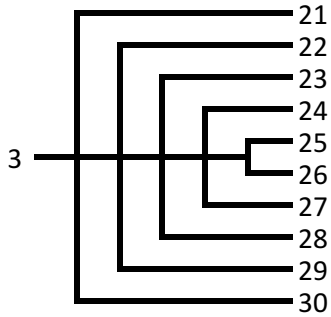
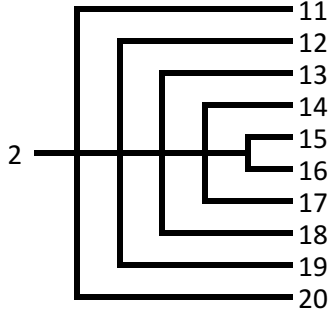
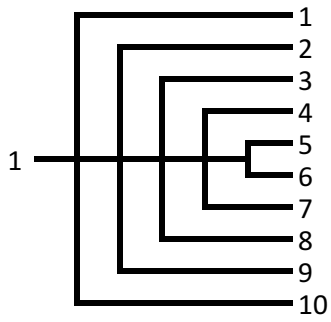

(2) Cambridge, University Library, MS II.6.32

“Book of Deer”

Excerpts from the Gospels of Matthew, Mark and Luke, complete Gospel of John and Apostles' Creed in Latin; additional communion for the sick in Latin with Old Irish and charters in Gaelic and Latin.

?Deer, Aberdeenshire, 2nd half of 9th to 10th century.

Additions in Deer, 2nd half of 9th to 10th century and 12th century.

Physical Description

Support: parchment.

Number of leaves and flyleaves: 86 (modern foliation 1-86; no flyleaves).

Dimensions of leaves: 157 x 108 mm.

Dimensions of written space: 108 x 71 mm.

Ruling medium: hard point.

Ruling pattern: double vertical bounding lines and horizontal text lines level with tops of minims, several leaves at a time, after folding; no prickings or slits visible.

Columns and lines: 21-23 lines, single column.

Scribes: 1 +additions.

Script: Insular minuscule, showing features of Late Celtic minuscule +additions in Late Celtic minuscule (fols 28v-29r).

Collation

8 quires, mostly of 12:

1⁴ (wants 2, ?cancellation), 2-3¹², 4¹² (+1 before 1, addition), 5-7¹², 8¹⁰.

Texts

1. Fols 2r-15r, excerpt from Gospel of Matthew, 1:1-7:23; colophon, fol. 3r, “finit prologus item incipit nunc evangelium secundum matheum” (the prologue finishes, now the gospel according to Matthew begins).
2. Fol. 3r-v, account concerning foundation of religious settlement “Déar” by Saint Columba and Saint Drostan, Gaelic, first half of 12th century (Jackson 1972, 19, 30, 33; Ó Maolalaigh 2008, 121-2; Forsyth, Brown and Clancy 2008, 136-7).
3. Fols 3v-5r, land grants, Gaelic, first half of 12th century (Jackson 1972, 19-22, 30-2, 33-6; Ó Maolalaigh 2008, 122-6; Forsyth, Brown and Clancy 2008, 136-43).
4. Fols 17r-27r, excerpt from Gospel of Mark, 1:1-5:35.
5. Fols 28v-29r, communion for the sick, Latin with Old Irish, ?2nd half of 9th to 10th century (Márkus 2008, 68-69).

6. Fols 30r-40r, excerpt from Gospel of Luke, 1:1-4:2.
7. Fol. 40r, charter of King David I concerning immunity of the “clerics of Deer” from lay service and improper exaction, Latin, c.1124–1153 (Jackson 1972, 22-23, 32, 36; Forsyth, Brown and Clancy 2008, 142-143).
8. Fols 42r-84v, Gospel of John; colophon, fol. 84v, “explicit evangeliu(m) johannem” (the gospel of John ends).
9. Fol. 85r, Apostles’s Creed; colophon in Old Irish, “For chubus caich duini i mbia arrath in lebrán collí ara tardda a bendacht for anmain in truagain ro-d scríbai” (May it be on the conscience of everyone with whom the splendid little book shall be, that he should give his blessing on the soul of the poor wretch who has written it; Jackson 1972, 8-9).

Decoration

Full page miniatures: tinted in yellow and pink, (fol. 1v) *cruciform miniature*, four figures around a cross, the lower two hold books, marigold motif in centre; (fol. 4v) *Matthew portrait*, standing and forward-facing, bearded, holding sword and flanked by two small figures; (fol. 16v) *Mark portrait*, standing and forward-facing with halo and book; (fol. 29v) *Luke portrait*, standing and forward-facing with halo and book, arms extended through frame; (fol. 41v) *John portrait*, standing and forward-facing with book, flanked by six small figures, small cross below; (fol. 85v) *cruciform miniature*, four figures around a cross, three with their hands outstretched through frame, circle in centre; (fol. 86v) *cruciform miniature*, four figures around superimposed axial cross and *chi*-cross, lower two with books, superimposed circles at centre containing marigold motif.

Half page miniatures: tinted in yellow and pink, (fol. 84v) *two figures with books*.

Marginal drawings: some tinted in yellow and pink, quadrupeds (fols 41v, 54v, 67r, 76r) others isolated beast-heads (fols 1v, 2r, 17r, 23r, 66v, 72v, 77r, 84v, 85r); beasts with calligraphic flourishes (fols 41v, 44r, 45v, 51v, 75v, 83v); bird with object in its beak (fol. 54v); beast head joined to a human hand (fol. 70v); human figure with outstretched arms (fol. 71v).

Decorated initials: zoomorphic “knotted-wire” letters with geometric infill (2-5 lines), tinted in yellow and pink: gospel incipits (fols 2r, 5r, 17r, 30r) and Creed (fol. 42r).

Minor initials: numerous, tinted in yellow and pink.

Textual decoration: arabesques on initials, some tinted in yellow and pink (fols 26r, 43r, 51v, 67r, 73r); inter-textual drawing of hand (fol. 20r).

Full page frames: found on all full-page miniatures and gospel incipits, tinted yellow and pink: plain double-border (fols 1v, 2r, 85v, 86r); decorated with fretwork and/or geometric patterns and/or interlace (fols 4v, 5r, 16v, 17r, 29v, 30r, 41v, 42r).

Half page frame: found on half-page miniature, decorated with hatching and linear patterns, tinted yellow and pink (fol. 84v).

Binding

Modern, red goatskin over oak boards (Douglas Cockerell & Son, Letchworth, 1963), replacing binding of 18th-19th century (kept with manuscript).

Provenance

The date of production is disputed with anywhere between 850 and 1000 having been suggested, although it is generally dated to the second half of the ninth century or the tenth century on art-historical and palaeographical grounds (e.g. Hughes 1980; Dumville 2007, 204-5, 211).

A communion ritual for the sick was added on a new leaf (fol. 28) and on the originally blank recto of the Luke portrait (fol. 29r), although the date and place of this addition are unclear. While it has sometimes been dated as late as the twelfth century (e.g. Howlett, 2000), earlier dates seem more convincing. Dumville dated the “late celtic minuscule” script with some transitional features of “Gaelic National minuscule” to the second half of the tenth century (Dumville 2007, 210-1). Márkus argued that the “Old Gaelic” rubric to the text suggests a date in the earlier part of this period, around the second half of the ninth to the tenth century, and probably not long after the manuscript was made (Márkus, 2008).

Additions in Gaelic from the first half of the twelfth century show a concern for matters relating to Deer, Aberdeenshire, suggesting that the manuscript was kept there at the time. They include, for example, an account of the foundation of a religious settlement by St Columba and his pupil St Drostan, which is named Déar after the tears (*déara*) that Drostan wept when Columba parted from him (fols 3r-v), and a brieve of King David I in favour of the clerics of Deer (*clerici de Der*), granting them immunity from lay control and unjust exactions (fol. 40r). One gives the date as the eighth year in the reign of David I (1131-32). These documents probably relate to an institution that was the precursor of the Cistercian Abbey founded at Deer in 1219, since some of the abbey’s lands recorded at its dissolution in 1587 were the same as those granted to the foundation in the Book of Deer (Zutshi 2008, 99).

Scholars usually suggest that the manuscript may also have been made at Deer based on its later history there. In support of this they have pointed to its simple decoration, error-filled text, and seeming misunderstanding of Eusebian sections, suggesting that these may

indicate its production in a provincial scriptorium such as Deer (Hughes 1980, 24; O’Loughlin 2008, 13). Although little is known about the early history of Deer, it is possible that it was an early enough foundation to have been the production place of the manuscript. Although the foundation legend given in the Book of Deer (no. 2) associating the manuscript with St Columba (521-597) and St Drostan (dates unknown) cannot be taken as a reliable historical record, Clancy has drawn attention to the death of one “Drostan Dairtaighe” in 719 in the Annals of Ulster, speculating that this may be the Drostan of Deer described in the manuscript (Clancy 2008, 382-384).

The next evidence for the history of the manuscript is an entry in John Evelyn’s *Diary* for 10th March, 1695, which records that Thomas Gale “shewed me a MS of some parts of the New Test. in vulg: Lect: that had belonged to a Monastery in the north of Scotland, which he esteemed to be above 800 years old: some considerable various readings observable as in i. John: & genealogies of St Luke, left out &c:”. This is likely to be the Book of Deer. Gale also owned a sixteenth-century register of Deer Abbey, which he donated to Trinity College, Cambridge (MS O.7.42 [1370]). This register bears the ownership inscription of the antiquary and writer, John Aubrey. Thus it seems possible that Gale received these two manuscripts together from his close friend Aubrey, who may have acquired them as part of a collection that had come from Deer Abbey after its dissolution (Zutshi, 2008).

In Edward Bernard’s *Catalogi*, printed 1698, the manuscript appears in the library of John Moore, Bishop of Ely, in the main catalogue, no. 663, and the “Addenda & Emendanda”: “Codex hic vetustissimo Hibernorum Characteribus exaratus, continet tantum principia Evangeliorum secundum Mathaeum, Marcum, & Lucam, integrum vero Evangelium Johannis. Habentur in margine quaedam Geneologiae Hibernicae” (Zutshi 2008, 103).

After Moore died in 1714, King George I bought his library for £6,450 and presented it to the University of Cambridge. The manuscript features in James Nasmith’s catalogue of the University Library’s manuscripts of 1798. In 1857 Henry Bradshaw came across the manuscript and began to produce an edition which he never completed. He was the unattributed author of the entry on the manuscript in the catalogue of the University Library’s western manuscripts, 1856-67.

Bibliography

- Binski, Paul, and Patrick Zutshi. 2011. *Western Illuminated Manuscripts: A Catalogue of the Collection in Cambridge University Library*, 2-6, cat. 2. Cambridge: Cambridge University Press.
- Dumville, David N. 2007. “Palaeography of the ‘Book of Deer’: The Original Manuscript and the Liturgical Addition”, in *Celtic Essays 2001-2007*, 1, 183-212. Aberdeen: Centre for Celtic Studies, University of Aberdeen.

- Forsyth, Katherine, Dauvit Broun and Thomas Clancy. 2008. "The Property Records: Text and Translation", in *Studies on the Book of Deer*, ed. Katherine Forsyth, 131-44. Dublin: Four Courts.
- Forsyth, Katherine. 2008. *Studies on the Book of Deer*. Dublin: Four Courts Press.
- Geddes, Jane. 1998. "The Art of the Book of Deer", *Society of Antiquaries of Scotland* 128: 537-49.
- Hughes, Kathleen. 1980. "The Book of Deer (Cambridge University Library MS Ii.6.32)", in *Celtic Britain in the Early Middle Ages: Studies in Scottish and Welsh Sources*, Studies in Celtic History 2, ed. David Dumville, 22-37. Woodbridge: The Boydell Press.
- Jackson, Kenneth. 1972. *The Gaelic Notes in the Book of Deer*. Cambridge: Cambridge University Press.
- Kenney, James F. rpt. 1997. *The Sources for the Early History of Ireland: Ecclesiastical*, 656, cat. 502. Dublin: Four Courts.
- Márkus, Gilbert. 2008. "The Sick and the Dying in the Book of Deer", in *Studies on the Book of Deer*, ed. Katherine Forsyth, 67-97. Dublin: Four Courts Press.
- Marner, Dominic. 2002. "The Sword of the Spirit, the Word of God and the Book of Deer", *Medieval Archaeology* 46, 1: 1-28.
- Ó Maolalaigh, Roibeard. 2008. "The Property Records: Diplomatic Edition including accents", in *Studies on the Book of Deer* ed. Katherine Forsyth, 67-97. Dublin: Four Courts Press, 119-130. Dublin: Four Courts Press.
- O'Loughlin, Thomas. 2008. "The Biblical Text of the Book of Deer (C.U.L. Ii.6.32): Evidence for the Remains of a Division System from its Manuscript Ancestry", in *Studies on the Book of Deer*, ed. Katherine Forsyth, 3-31. Dublin: Four Courts Press.
- Pulliam, Heather. 2013. "Beasts of the Desert: Marginalia in the Book of Deer", *Medieval Archaeology* 57: 83-110.
- Zutshi, Patrick. 2008. "The Book of Deer After c. 1150", in *Studies on the Book of Deer* ed. Katherine Forsyth, 98-115. Dublin: Four Courts Press.

The Book of Deer Quire Diagrams

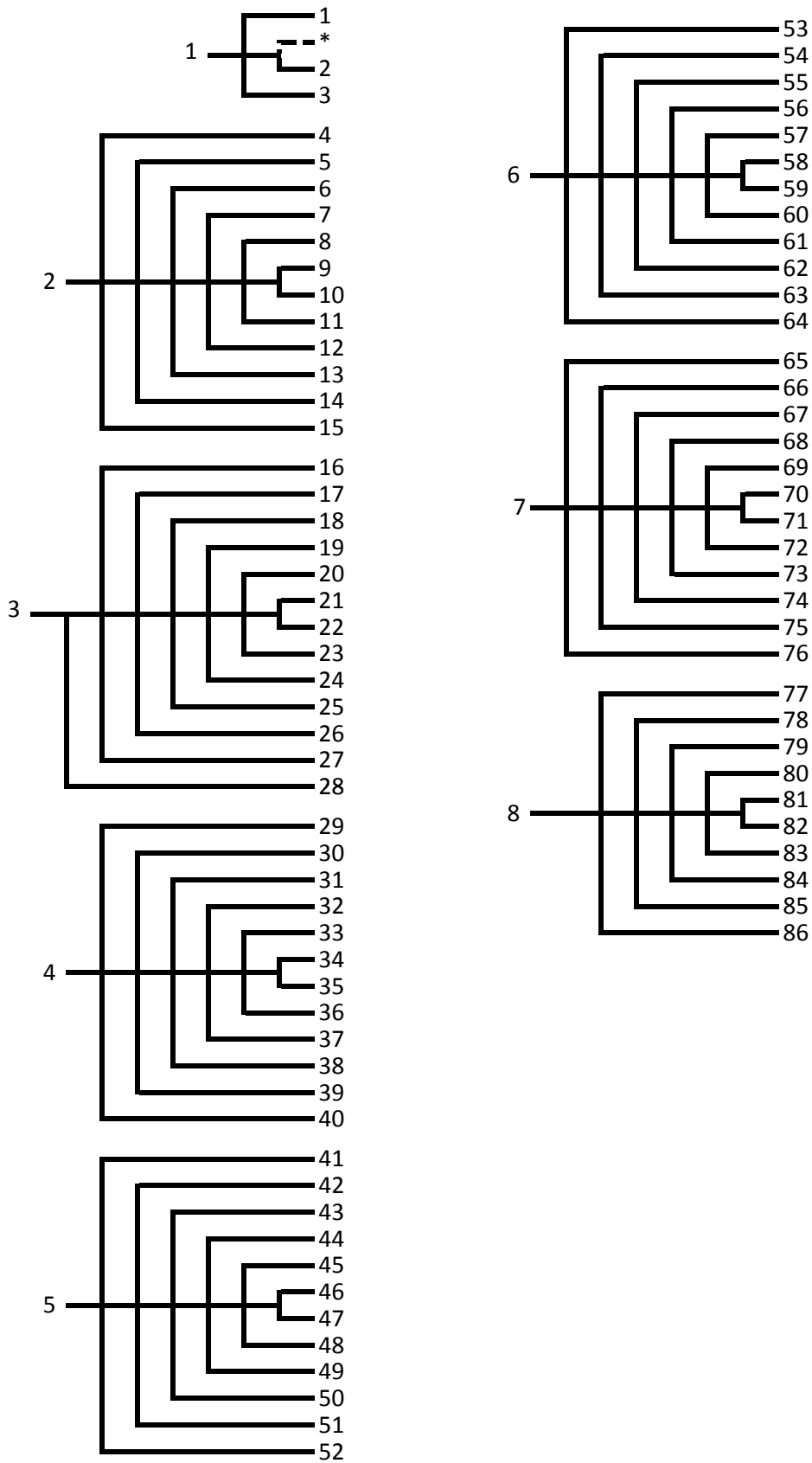

(3) Dublin, Royal Irish Academy, D II 3

I, “Stowe St John”; II, “Stowe Missal”

I (fols 1–11), excerpts from the Gospel of John in Latin; II (fols 12–67), missal in Latin and Old Irish.

I & II: ?Tallaght, Co. S. Dublin, or ?Lorrha, Co. Tipperary.

I: 2nd half of 8th century; II: c.792 to early 9th century; additions in ?Tallaght or Lorrha, 9th century.

Physical Description

Support: parchment.

Number of leaves and flyleaves: ii (modern parchment) + 11 + 56 (modern foliation, 1-67).

Dimensions of leaves: I, 145 x 112 mm; II, 140 x 109 mm.

Dimensions of written space: I, 120 x 90 mm; II, 105 x 840 mm.

Ruling medium: I & II, hard point.

Ruling pattern: I, single vertical bounding lines and horizontal text lines, several leaves at a time, after folding, prickings and occasionally dots of purple ink in inner and outer margins (e.g. fols 1v, 2r); II, single vertical bounding lines, and horizontal text ruling, 2 ruled lines per line of script, level with top and bottom of minims, several leaves at a time, after folding; prickings in inner and outer margins (more elaborate ruling on display pages).

Columns and lines: I, 31 and 28 lines, single column; II, 12, 13 or 14 lines, single column.

Scribes: I, 1, named in Ogam as Sonid (signed fol. 11r); II, uncertain, 5 original +4 additional hands (Warner 1915, II xii-xxii), or 1 original (using differently cut quills) +additional hands (O’Neill 2009, 45-46). 1 additional scribe named as Moelcaich (fol. 37r). Division of hands according to Warner: A¹, fols 12r-28v, ?52r-v; A², fols 29r-46v; A³, fols 47r-51v; A⁴, fols 53r-64r; A⁵, fols 64v-65r; +B¹ (Moelcaich), fols 14r-v, 18r-19r, 22r-25v, 30r-31v, 35r-36v (added leaves), fols 16v, 28r, 28v (marginal insertions), fol. 46v (blank page), fols 13r, 15r, 17v, 21r, 21v, 26r, 26v, 34r, 37r (palimpsests); +B², fols 12r, 13r, 13v, 15r, 19r (marginal insertions); +B³ (or ?B¹), fols 13r, 15v (interlinear corrections); +B⁴, fols 51r, 58r (marginal rubrics) (Warner 1915, II xii-xxii).

Script: I, Insular minuscule; II, compressed Insular majuscule with an unusually rectangular aspect +additions in Insular minuscule.

Collation

5 quires of irregular collation:

I: 1¹² (wants 1 before 1, excised);

II: 2¹² (+ 1 after 2, addition; + 2 after 5, addition; + 4 after 7, addition; wants 6 and 7, missing), 3¹⁴ (+ 2 after 1, addition; 2 after 4, addition), 4¹², 5¹⁰ (10 is unfoliated pastedown).

Texts

I

1. Fols 1r-11r, excerpts from the Gospel of John, 1-6:30, 7:45-8:14, 8:19-33 (umquam), 8:53 (qui)-59, 12:9-39 (credere), 17:11 (Pater sancte)-18:1, 18:4-13, 18:15 (discipulus)-23, 19:40-20:23, 20:26-21:6, 21:9-25; colophon, fol. 11r, Latin with scribe's name in Ogam, "deo gratias. ago. Amen. Finit. Amen. Rogo qui cunque hunc librum legeris. utmemineris mei peccatoris. scriptoris. i. (Sonid) peregrinus Amen sanus sit qui scripsit (et) cui scriptum (est). Amen" (To God I give thanks. Amen. It ends. Amen. I ask whoever may read this book that you be mindful of me, a sinner, a writer, that is Sonid, a pilgrim. Amen. Sound may he be who has written and he for whom it has been written, Amen; trans. Howlett 2014, 94-5).

II

2. Fols 12r-38r, order and canon of the Mass, Latin with Old Irish, with additional alterations, 9th century; additional colophon, fol. 37v, "Moelcaich scripsit", 9th century (Warner 1915, II 1-19).
3. Fols 38r-41v, mass of the apostles and martyrs and saints and holy virgins, Latin (Warner 1915, II 19-21)
4. Fols 42r-44v, mass for the penitent lives, Latin (Warner 1915, II 21-2).
5. Fols 44v-46r, mass for the many dead, Latin (Warner 1915, II 23).
6. Fols 46v-60r, order for baptism and communion of the newly baptised, Latin with Old Irish (Warner 1915, II 24-33).
7. Fols 60r-65r, communion for the sick, Latin (Warner, 1915, II: 33-6; Márkus 2008, 91-5).
8. Fols 65v-67r, treatise on the Mass, Old Irish (Warner 1915, II 37-9, 40-2).
9. Fol. 67v, three spells against loss of eyesight, injury by thorns, and urinary infections, Old Irish (Warner 1915, II 39, 42).

Decoration

I

Decorated initials: (fol. 1r) *John incipit*, 18 lines, zoomorphic and interlace terminals with geometric and fret-pattern infill, tinted red-purple, blue-purple, yellow, pink and white.

Minor initials: numerous, enlarged in the margin.

Full page frames: (verso of unnumbered stub preceding fol. 1, conjugate with fol. 11) fragmentary frame, tinted yellow; (fol. 1r) *John incipit*, 107 x 81 mm, zoomorphic, narrow at

the inner edge, expanded on the three outer edges with panels of fret patterns, tinted red-purple, blue-purple, yellow, pink and white.

II

Full page miniatures: (fol. 11v) *John portrait*, standing, facing forward, holding a book, flanked by short striped curtains, eagle symbol positioned above, projecting beyond the upper edge of the frame, tinted in yellow and red.

Decorated initials: (fol. 12r) *missal incipit*, 4 lines, panels of lozenge and fret pattern within body of letter, tinted yellow and red.

Minor initials: numerous, enlarged in the text, occasionally with pen-drawn decoration incorporating spirals, interlace, and human and animal heads (fols 12v, 13v, 47r, 48r, 49r, 49v, 50r, 50v).

Full page frames: (fol. 11v) *John portrait*, 98 x 76 mm, slim on upper and lower edges and expanded at the sides to contain panels of interlace and fret patterns, tinted yellow on all but the upper edge; (fol. 12r) *missal incipit*, 98 x 76 mm, three outer edges only, zoomorphic with panels of zoomorphic interlace, tinted yellow, red and brown.

Binding

Medieval boards (possibly early-medieval or even original) with modern sewing. Wooden boards covered with vellum and strips of red leather folded around the borders at the fore, head and tail.

In his conservator's notes, Cains wrote that the date of the boards was "unsure", although he observed that the pastedown on the back board is conjoint with fol. 59, which he suggested might indicate that the boards are contemporary with the missal: the scribal practice of leaving blank leaves at the end of a manuscript to be pasted onto the boards as an attachment is attested elsewhere in the Insular world (see Cuthbert Gospel, cat. 10); if the blank leaves at the end of the missal were deliberately left by the scribe for this purpose, it would indicate that the surviving boards are original (Cains, 1995). Siobhán Fitzpatrick has also suggested that the boards are original (Fitzpatrick, 2007), and Mullarkey agreed that they are probably contemporary with the manuscript or else possibly date from around the time of the enshrinement in 1033 (Mullarkey 2007, 67, n. 93). It is also notable that the strips of leather folded around the borders of the boards appear to be of a similar colour and glossy texture to the early medieval leather coverings on the boards of the Cuthbert and Cadmug Gospels (cats 7 and 9).

The manuscript was rebound by the British Museum in the 1920s, retaining the original boards. It was disbound, cleaned and rebound by Anthony Cains using a medieval horn-back binding method, with work completed on the 18th April 1996.

Shrine

A book shrine survives, 185 mm x 155 mm x 56 mm (Royal Irish Academy; on permanent display in the National Museum of Ireland, Kildare Street). Its inscriptions, amended and analysed by Ó Riain, 1991, show that the earliest parts date from c.1026-1033, with significant additions in the years preceding 1381, and that it was kept in Lorrha, Co. Tipperary, providing invaluable clues to the provenance of the manuscript (see below). It is made of wood covered with plates of gilt and silvered bronze, with enamelling and inlaid glass and jewels. Various inscriptions are found on the shrine as well as figural, animal, vegetal, interlace and geometric motifs.

Provenance

I (gospel of John) and II (missal) were found together in the shrine when it was opened in 1730. It is generally assumed that they were associated from a much earlier time. If the boards are indeed early-medieval, it suggests that these portions of the manuscript were bound together since the ninth century. However, I and II have never been regarded as belonging to the same original project because the scribal practices in each are so notably different: the scripts, size of writing, rulings, and placement of minor initials all vary greatly.

Nevertheless, it seems likely that II was specifically designed to complement I, suggesting that they have been together since the time of II's creation. As Henry noted (Henry 1957, 154), there are strong decorative correspondences between the two, particularly their incipit pages which both feature zoomorphic frames and near-identical fret and lozenge patterns. Moreover, it appears that the evangelist portrait (fol. 11v) was part of the same phase of work as the missal, rather than the rest of the gospel. The pigments used for the evangelist portrait appear to be entirely different from those used for the gospel incipit (fol. 1r), but identical to those used for the missal incipit (fol. 12r). Likewise, the frame of the evangelist portrait is of different dimensions to that of the gospel incipit, but of equal dimensions to the missal incipit. The addition of the evangelist portrait in the same phase as the missal would explain its unusual positioning at the end of the gospel text, facing the missal incipit, which was perhaps designed to harmonise the parts of the manuscript together.

This sequence of production indicates that I is earlier in date than II, although the date and location of neither portion is entirely secure. A *terminus post quem* for II is indicated by the inclusion of a commemoration for St Máel Ruain in the text of the Mass (fol. 33r), demonstrating that II must have been created after his death in 792. This inclusion has also given rise to the suggestion that the manuscript was written Máel Ruain's foundation, the monastery of Tallaght, Co. Dublin (Warner, 1915; O'Rahilly, 1926; *CLA* 268). That Máel Ruain's successor as abbot of Tallaght, Eochaid, is not commemorated in the manuscript has led scholars to suppose that it must have been made before his death in 812 (e.g. O'Rahilly

1926, 95). However, it is possible that Máel Ruain was venerated at other centres, so that this *terminus ante quem* is not certain. For example, Ó Riain suggested that the manuscript could have been made at Lorrha, Co. Tipperary, where he showed that the manuscript was kept for all its later medieval history (Ó Riain 1991, 294-95). Indeed, Lorrha would have been a particularly appropriate place for the commemoration of Máel Ruain since he was probably a monk at Lorrha before founding Tallaght (his name translates as “tonsured-one of Rúadán”, which may mean that he was a monk of St Rúadán's monastery, Lorrha). If II was not made at Tallaght, it could have been created any time after 792, although probably no later than the early ninth century, since the closest extant examples to the script date from the mid eighth to early ninth century (see O’Sullivan, 2005: 533). I is almost certainly earlier, although its script and decoration suggest that this is probably by no more than a few decades.

The earliest inscriptions on the shrine indicate that it was created at Lorrha, Co. Tipperary, c.1026-1033. As Ó Riain demonstrated, they refer to people who appear in the annals in connection with Lorrha: the Munster Annals of Inisfallen record that Mathgamain, grandson of Cathall, who had the shrine made and was perhaps the abbot of Lorrha, was slain there in 1037 (*AI* 1037.3); the Annals of Ulster record that Find Ua Dúngalaig, king of Múscraige, (r.911-1033), for whom a prayer is requested on the shrine, slew another chief in the vicinity of Lorrha on behalf of Brian Bóru in 1007 (*AU* 1007.5). The inscriptions on the shrine also ask for prayers for the leaders of two antagonistic families whose territories met uncomfortably close to Lorrha—Dondchadh, son of Brian Bóru, of the Dál Cais family (d. 1064), and MacRaith Ua Donnchada, of the Eóganacht family (d. 1052)—perhaps as part of a pragmatic attempt by the monastery to appease both sides during the conflict. Based on the identifications of the people named in these inscriptions, Ó Riain suggested the earliest date for the shrine as c.1026, the beginning of the period in which the hostility between Dondchadh and MacRaith was most intense, and the latest date as 1033, when Find Ua Dúngalaig died. Since the shrine was almost certainly made for the manuscript, this strongly suggests that it too was present in Lorrha at that time.

The later inscriptions on the shrine demonstrate that it remained in Lorrha in the fourteenth century. They show that Pilib Ó Ceinnéidigh, King of Ormond (d. 1381) and Giolla Ruadhan Ua Mecain, *coarb*, (d. unknown) were patrons of the shrine’s refurbishment. It is probable that Giolla Ruadhan was abbot of Lorrha: the only abbey in fourteenth-century Ormond that could claim to have a *coarb* (O’Rahilly 1926, 97). The inscriptions also mention Pilib’s wife Aine (d. 1381) and an unidentified craftsman, Domhnall Ua Tolari.

The next record of the manuscript does not occur until 1735, when some versions of a poem written by Aindrias Mac Cruitún were published with prefixed titles that describe the rediscovery of the manuscript (Dublin, Royal Irish Academy MSs: 23 K 51, p. 33; 23 M 14, p.

327; 23 L 31, p. 143; 23 B 38, p. 127; 23 G 20, p. 292. See O’Rahilly 1926, appendices A-E). They recount that Mac Cruitún wrote the poem after returning from a trip to examine a manuscript that had been found built into the wall of Lackeen castle in the parish of Lorrha, close to where one of the monastic churches had stood, and that was now in the possession of a man named O’Kennedy.

By 1819 the manuscript was owned by the Marquess of Buckingham and kept in his library at Stowe House, Buckinghamshire, from which it acquired its epithet. It was recorded by Charles O’Conor, Buckingham’s librarian, in the appendix to the first volume of his catalogue of the Stowe manuscripts (O’Conor, 1819). His description includes an erroneous provenance involving the manuscript’s acquisition in Germany by an army officer, which was debunked by O’Rahilly (1926).

The manuscript and shrine were sold in 1849 to the 4th Earl of Ashburnham and in 1883 were purchased from him by the British Government on behalf of the Royal Irish Academy (see Fitzpatrick, 2007).

Bibliography

- Alexander, Jonathan J. 1978. *Insular Manuscripts, 6th to the 9th Century*, A Survey of Manuscripts Illuminated in the British Isles 1, 68-9 and 70-71, cats 47 and 51. London: Harvey-Miller.
- Byrne, Francis J. 1967. “The Stowe Missal”, in *Great Books of Ireland*, ed. Liam de Paor, 38-50. Dublin, Clonmore and Reynolds ltd.
- Cains, Anthony. 1995. Unpublished conservator’s notes, Dublin, Royal Irish Academy, MS D ii 3.
- Catalogue of Irish Manuscripts in Royal Irish Academy, Irish Script on Screen, <http://www.isos.dias.ie/english/index.html>
- Crawford, H. S. 1923. “A Descriptive List of Irish Shrines and Reliquaries, Part II”, *JRSAI* 13, 2: 151-176.
- Fitzpatrick, Siobhán. 2007. “The Stowe Missal: Its Provenance and Recent History”, in *The Roscrea Conference, Commemorating Forty Conferences 1987-2007 at Mount St Joseph Abbey*, ed. by George Cunningham, 1-6. Parkmore, Roscrea: Roscrea People.
- Henry, Françoise. 1957. “An Irish Manuscript in the British Museum (Add. 40.618)”, *JRSAI* 87, 2: 147-166.
- Howlett, David. 2014. “Sonid’s Ogam Signature”, in *Rhetoric and Reality in Medieval Celtic Literature: Studies in Honor of Daniel F. Melia*, CSANA Yearbook 11-12, ed. Georgia Henley and Paul Russell, 94-7. New York: Colgate University Press.

- Kenney, James F. rpt. 1997. *The Sources for the Early History of Ireland: Ecclesiastical*, 692-99, cat. 555. Dublin: Four Courts.
- Lowe, Elias A., ed. 1935. *Codices Latini Antiquiores: A Palaeographical Guide to the Latin MSS. prior to the IXth Century*, 11 parts, 1 Great Britain and Ireland, 41, cats 267 and 268. Oxford: Clarendon.
- McGurk, Patrick. 1956. "The Irish Pocket Gospel", *Sacris Erudiri* 8, 2: 249-270, at 249-270.
- McGurk, Patrick. 1961. *Latin Gospel Books from A.D. 400 to A.D. 800*, Publications de Scriptorium 5, 83-84, cat. 82. Paris and Brussels: Aux Éditions "Érasme"; Anvers and Amsterdam: Standaard-Boekhandel.
- Mullarkey, Paul. 2007. "The Figural Iconography of the Soiscéal Molaise and Stowe Missal Book Shrines", in *Making and Meaning in Insular Art, Proceedings of the Fifth International Conference on Insular Art Held at Trinity College Dublin, 25-28 August 2005*, ed. Rachel Moss, 50-69. Dublin: Four Courts.
- Ó Floinn, Raghnaill. 1985. 'The Shrine of the Stowe Missal (Lothra, Co Tipperary)', in *Treasures of Ireland*, ed. Michael Ryan, 163-5. Dublin: Royal Irish Academy.
- O'Neill, Timothy. 2014. *The Irish Hand. Scribes and their Manuscripts from the Earliest Times*, 2nd edn., 18 and 80-81. Cork: Cork University Press.
- O'Neill, Timothy. 2009. "Quills, Inks and Vellums", in *Treasures of the Royal Irish Academy Library*, ed. Bernadette Cunningham and Siobhán Fitzpatrick, 45-48. Dublin: Royal Irish Academy.
- Ó Riain, P. 1991. "The Shrine of the Stowe Missal, Redated", *PRIA* 91C: 285-295.
- O'Rahilly, T. F. 1926-1928. "The History of the Stowe Missal", *Ériu* 10: 95-109.
- O'Connor, C. 1819. "Appendix", *Bibliotheca Ms. Stowensis: A Descriptive Catalogue of the Manuscripts in the Stowe Library*. Buckingham: Seeley.
- Royal Irish Academy, online catalogue of medieval manuscripts, retrieved 31/07/2014, from: <http://www.ria.ie/library/special-collections/manuscripts/stow-missal.aspx>
- Todd, James Henthorn. 1856. "On the Ancient Irish Missal, and Its Silver Box, Described by Dr. O'Connor in His Catalogue of the Stowe MSS., and Now the Property of the Earl of Ashburnham", *Transactions of the Royal Irish Academy* 23: 3-37.
- Warner, George F. 1906-1915 *The Stowe Missal*, 2 vols. London: Henry Bradshaw Society.
- Márkus, Gilbert. 2008. "The Sick and Dying in the Book of Deer", in Katherine Forsyth, ed., *Studies on the Book of Deer*, 67-97. Dublin: Four Courts Press.
- Kenney, James F. rpt. 1997. *The Sources for the Early History of Ireland: Ecclesiastical*, 637-38 and 692-699, cat. 466 and 555. Dublin: Four Courts.

The Stowe St John and Missal Quire Diagrams

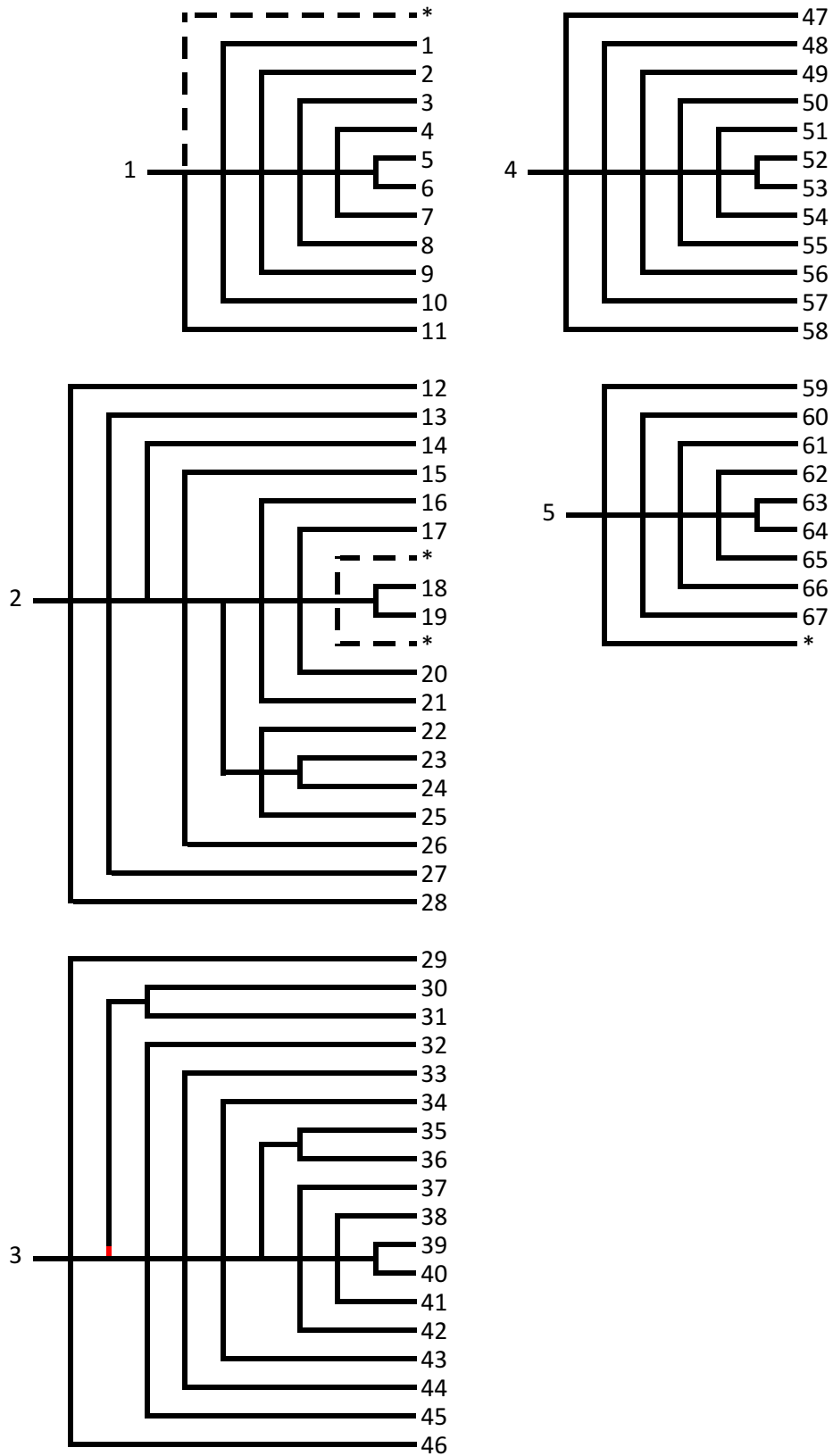

(4) Dublin, Trinity College Library, MS 52

“Book of Armagh”

New Testament and texts relating to Sts Patrick and Martin of Tours in Latin with Old Irish; additional charter in Latin.

Armagh, Co. Armagh, c.807.

Addition in Armagh, c.1002-1010.

Physical Description

Support: parchment.

Number of leaves and flyleaves: 217 (modern foliation, 2-221; fols 1 and 42-44 are missing but included in foliation, see *Notes*; no flyleaves). Gospel section, 70 leaves (foliated 32-105).

Dimensions of leaves: c.197 x 146.

Dimensions of written space: c.140-160 x 105-120.

Ruling medium: hard point.

Ruling pattern: single bounding lines only in much of the manuscript, with horizontal text ruling in some portions (fols 109r-150r, 171r-190v), several leaves at a time, after folding, prickings or slits in inner and outer margins (more elaborate ruling on display pages).

Columns and lines: 34-40 lines (variable throughout), two columns.

Scribes: 3, one named Ferdomnach (signed, fols 67v, 89r, 214r, 220r). Several variant divisions of hands proposed: Scribe 1, fols 2-19; Scribe 2, fols 20-104, 213-221; Scribe 3, fols 105-212 (*CLA* 270); Scribe A, fols 2-19, 106-08, 151-71, 192-213; Scribe F (Ferdomnach), fols 20-24, 25-105, 214-22; Scribe B, fols 109-150 (Sharpe, 1982); all by Ferdomnach except portions by “notulae hand”, fols 18v-19r, top section of fol. 103r, and 3rd Scribe, fols 108r-148r (Brown, forthcoming).

Script: Insular minuscule.

Glosses and Headers: running titles frequent in gospel section, sometimes in Greek or Greek letters; occasional numeration (e.g. fols 34v, 81v, 85v, 102v); corrections and suggested alternative words in margins; occasional Old Irish marginal glosses (fols 2-24, 31-190; Stokes 1903, 474 and 478; II: 45 and 238; and 1872, 83).

Quire Signatures: quires 5, 6, 8-14 signed on the verso of the last leaf, in the centre of the lower margin, “Q” with a stroke through the tail, and a Roman numeral (xi-xx), sometimes with dots after or before the letter or numeral. On fols 61v and 104v the word “caternio” appears in the left corner.

Collation

27 quires of irregular collation (the following based on Brown, forthcoming):

1¹² (wants 1, missing), 2⁸ (wants 8, cancellation), 3⁶ (wants 6, cancellation), 4⁸ (wants 1, cancellation), 5⁸, 6⁸ (wants ?3, ?4, ?5 and ?6, missing), 7⁸ (wants 7, cancellation), 8⁸, 9⁶, 10⁸,

11⁸, 12⁶, 13¹⁰ (wants 8, cancellation), 14⁶, 15⁴ (wants ?), 16¹⁰, 17⁸, 18⁸ (wants 8, cancellation), 19¹⁰ (wants 10, cancellation), 20⁸, 21¹⁰, 22¹² (wants 1, cancellation), 23¹⁰, 24¹⁰, 25¹⁰, 26¹², 27¹⁰ (wants 1, cancellation).

Texts

1. Fols 2r-8v, Muichú, *Vita Patricii* (begins imperfectly), Latin (Bieler 1979, 61-123).
2. Fols 8v-9r, short pieces concerning the life of St Patrick, Latin (Bieler 1979, 122-25).
3. Fol. 9r, *Dicta Patricii*, Latin (Bieler 1979, 124-25).
4. Fols 9r-15v, Tírechán, *Collectanea De Vita S. Patricii*, Latin (Bieler 1979, 124-67).
5. Fols 15v-16v, short pieces and grants concerning St Patrick, Latin and Old Irish (Bieler 1979, 164-171).
6. Fol. 16v, Charter concerning King Brian Boru and the rights of the church of Armagh, Latin, c. 1002-1010 (see *Provenance*).
7. Fols 17r-19r, no. 5 cont. (see above).
8. Fol. 20r-v, preface and list of contents to no. 1 (see above).
9. Fols 20v-22r, *Liber Angeli*, Latin (Bieler 1979, 184-91).
10. Fols. 22r-24v, Patrick, *Confessio* (Bieler 1993, 56-91).
11. Fol. 25r, Jerome, *Epistle to Pope Damasus*.
12. Fols 26r-29r, Eusebian canon tables.
13. Fols 29r-31v, summaries for each Gospel.
14. Fols 31v-32r, interpretation of Hebrew names in Gospel of Matthew.
15. Fol. 32r, Monarchian prologue to Gospel of Matthew.
16. Fols 33r-52v, Gospel of Matthew (imperfect), 1:1-14:33 (venerunt et), 14:33 (per prophetam)-end; colophon (some letters Greek), fol. 52v, “explicit · aevangelion · kata · matteum · scriptum · atqve finitum · in feria · matthei”; prayer regarding Matthew, fol. 52v, “Deus in mensae [...] saecula saeculorum amen” (Gwynn 1913, 100); colophon (barely legible), fol. 52v, “<ferdomn>ach hunc <libru>m < >e dictante <Tor>bach herede patricii scripsit” (Graves 1844-1847, 319-20), (Ferdornach wrote this book at the command of Torbach, the heir of Patrick).
17. Fol. 53r, Monarchian prologue to Gospel of Mark.
18. Fol. 53r, interpretation of Hebrew names in Gospel of Mark
19. Fols 54r-67v, Gospel of Mark; colophon (barely legible), fol. 67v, ?“Pro Ferdornacho ores”.
20. Fols 67v-68r, Monarchian prologue to Gospel of Luke.
21. Fol 68r-v, interpretation of Hebrew names in Gospel of Luke.
22. Fols 69r-89r, Gospel of Luke; colophon, fol. 89r: ?“Pro Ferdornacho ores” (barely legible).
23. Fol. 89v, Monarchian prologue to Gospel of John.

24. Fol. 89v, interpretation of Hebrew names in Gospel of John.
25. Fols 90r-103r, Gospel of John.
26. Fol. 103r, extracts from Gregory, *Moralia in Iob* (Lib. VI., xxxvii. 56, on Iob v. 26; Lib. V., vi. 9, on Iob iii. 20; Lib. V., iii. 4, on Gal. vi. 14; Lib. IV., xxxvii, 52; Lib. IV., xxxvii, 52, on Luke ix. 60; *CCSL* 143b).
27. Fol. 103v, calculations concerning the number of verses in the gospels.
28. Fols 105r-107v, prologues to Pauline Epistles.
29. Fols 108r-148r, Pauline Epistles.
30. Fols 150r-158r, Catholic Epistles.
31. Fol. 159v, Revelation vision-list (O’Loughlin 2000, 23-38).
32. Fols 160r-170r, Revelation; colophon, fol. 170r, erased (illegible).
33. Fols 171r-190v, Acts; colophon, fol. 190r, erased (illegible).
34. Fols 191r-200r, Sulpicius Severus, *Vita Sancti Martini* (*PL* 20, cols 159-76).
35. Fols 200v-219r, Sulpicius Severus, *Dialogi De S. Martino* (*PL* 20, cols 183-222); colophons, fols 214v and 220r, erased.
36. Fols 219v-220r, Sulpicius Severus, *Epistola Ad Eusebium* (*PL* 20, cols 175-78).
37. Fols 220v-221v, Sulpicius Severus, *Epistola Ad Aurelium* (*PL* 20, cols 178-80).
38. Fol. 221v, prayer, “Te domine sancte pater omnipotens ante saecula sine initio per unigenitum filium tuum[...] praemia in caelesti gaudio inuenire merear per omnia saeculorum amen” (Gwynn 1913, 438).

Decoration

Full-page miniatures: pen-drawn, (fol. 32v) *four symbols page*, symbols arranged in quadrants, the man forward-facing but the lion, calf and eagle in profile, each with four wings, overlapping frame, the man holds a book, the eagle a fish, inscribed above each creature, “homo”, “leo”, “vitulus”, “aquila”; (fol. 53v) *lion symbol of Mark*, in profile, facing viewer’s right, left fore-leg raised, mouth open with tongue emerging, four wings, one overlapping the right side of the frame; (fol. 68v) *calf symbol of Luke*, in profile, facing viewer’s right, 4 wings out-spread and embellished with medallions containing heads of the other three symbols.

Three-quarter-page miniatures: (fol. 170r) *diagrammatic image of the Heavenly Jerusalem*, pen-drawn, walls represented as rectangles filled with interlace, gaps represent its 12 gates, each inscribed with the name of a precious stone, one of the tribes of Israel and an Apostle, cardinal directions labelled at the corners, double-bordered rectangle inscribed “D(omi)n(u)s noster Ie(su)s Chr(istu)s” in the interior.

Bas-de-page miniatures: (fol. 90r) *eagle of John*, pen-drawn, in profile, clutching a fish in its talons, 4 wings outspread, heads of the other three symbols in medallions on its wings and body.

Decorated initials: featuring combinations of animal- and bird-head terminals, interlace, geometric motifs, trumpet and spiral motifs, fret patterns and dotting, occasionally human-head terminals (fol. 122r, 159v, 219v), terminals in form of horned sheep/goat (fol. 122r, fol. 154r, 191r), superscript fish (fols 33v, 69r), full-bodied birds/animals inhabiting letter (fol. 90r, 150r, 158r, fol. 160r), or letter in the form of a contorted quadruped (fol. 135v); pen-drawn up to fol. 90r, tinted in yellow, red, green and blue from fol. 105v onward: (fol. 20r), *Preface to Muichú*, 6 lines; (fol. 25r) *Epistle to Pope Damasus*, 10 lines; (fol. 33r) *Matthew incipit*, 8 lines; (fol. 33v) *Chi-Rho*, 10 lines; (fol. 54r) *Mark incipit*, 16 lines; (fol. 69r) *Luke incipit*, 12 lines; (fol. 90r) *John incipit*, 18 lines; (fol. 105r) *Prologues to Pauline Epistles*, 11 lines; (fol. 108r) *Romans*, 18 lines; (fol. 115r) *1 Corinthians*, 9 lines; (fol. 122r) *2 Corinthians*, 14 lines; (fol. 127r) *Galatians*, 11 lines; (fol. 129v), *Ephesians*, 14 lines; (fol. 132r) *Philippians*, 12 lines; (fol. 134r) *1 Thessalonians*, 12 lines; (fol. 135v) *2 Thessalonians*, 15 lines; (fol. 136v) *Colossians*, 13 lines; (fol. 138r), *Laodiceans*, 11 lines; (fol. 138v) *1 Timothy*, 12 lines; (fol. 140r) *2 Timothy*, 14 lines; (fol. 141v) *Titus*, 13 lines; (fol. 142r) *Philemon*, 10 lines; (fol. 143r) *Hebrews*, 6 lines; (fol. 150r) *1 James*, 11 lines; (fol. 152r) *1 Peter*, 13 lines; (fol. 154r) *2 Peter*; (fol. 155r) *1 John*, 13 lines; (fol. 157r), *2 John*, 11 lines; (fol. 157v) *3 John*, 2 lines; (fol. 158r) *Jude*, 12 lines; (fol. 159v) Revelation vision-list, 2 lines and above text; (fol. 160r) Revelation, 8 lines and above text, with full line of display script; (fol. 171r) *Acts*, 14 lines; (fol. 191r, col. a) *Vita Martini*, 9 lines; (fol. 191r, col.b) *Vita Martini*, 10 lines; (fol. 191v, col. a) *Vita Martini*, 7 lines; (fol. 191v, col. b.) *Vita Martini*, 3 lines; (fol. 200v) *Dialogi*, 9 lines; (fol. 214r) *Dialogi*, 6 lines; (fol. 218v), *Dialogi*, 6 lines; (fol. 219v) *Epistola Ad Eusebium*, 4 lines.

Minor initials: numerous, enlarged and sometimes flourished.

Textual decoration: Occasional marginal crosses (E.g. fols 51v and 52r); text block arranged in lozenge shape (fols 103r and 159v).

Frames: single line in black ink (fols 32v and 53v).

Binding

Modern (Roger Powell, 1957), replacing 19th-century binding. Medieval boards, possibly original, survive separately: oak, lined with vellum and covered in pink-stained goat skin decorated with blind lines and stamps (Meehan 1998, 91; O'Neill 2014, 6). A satchel also survives, dated variously to the 1st half of the 11th century (Alexander 1978, 76-77, cat. 53), the 15th century (Sharpe 1982, 5) and as late-medieval (Meehan 1998, 91).

Provenance

The manuscript's date and place of creation are confidently established by its colophons. In these, the main scribe records his name as Ferdornach and requests prayers at the end of the Gospel of Matthew (fol. 52v), Gospel of Mark (fol. 67v, now barely legible), Gospel of Luke (fol. 89r, now barely legible), book 2 of the Life of St Martin (fol. 214r) and the Epistle of Sulpicius (fol. 220r). This Ferdornach has been identified with the record in 846 in the Annals of Ulster of the death of "Ferdornach sapiens et scriba optimus Airddmachae" (Ferdornach the wise man and best scribe of Armagh; *AU* 846.1). The partially-erased colophon on fol. 52v, which Charles Graves succeeded in deciphering in 1846, further states that the manuscript was written at the request of a "herede Patricii" (heir of Patrick, that is, abbot of Armagh) whose name ended in "bach". Graves deduced that the only abbot of Armagh whose name ended in "bach" and who was contemporary with a Ferdornach, was Torbach, who became abbot in 807 (*AU* 807.1) and died in 808 (*AU* 808.1), thus dating the production of the manuscript to this year. Another entry, also on fol. 52v, reveals that the scribe finished writing the page on the feast day of St Matthew, an event thus dateable to the 21st of September, 807.

The next probable record of the manuscript is in the Annals of the Four Masters, when in 937 the "Canoin-Phadraig" was covered by Donnchadh, son of Flann, King of Ireland, 919-944 (*AFM* 937.13). It has generally been assumed that this refers to the Book of Armagh, which contains a collection of the most important documents relating to Patrick and was clearly venerated as a relic of Patrick in its later history (Gwynn 1913, cii). The entry does not make clear whether the manuscript was given a shrine or treasure binding; in either case, it no longer exists.

On fol. 16v is the record of the ratification of the privileges of the church of Armagh by Brian Boru, King of Ireland 1002-1014, written by Brian's advisor and amanuensis Maelsuthain (d. 1010) who signs himself with the Latin translation of his name, Calvus Perennis (ever-bald).

S(an)ctu(s) patri(ci)us iens ad c(a)elv(m) mandavit totum fructv(m) laboris
sui ta(m) babtismi ta(m) causar(um) q(uam) elemoisinarum deferendum
e(ss)e apostolicæ urbi q(uae) scotice nominat(ur) ardd macha · Síc reperi i(n)
bebliot\h/ic(i)s scotor(um) ego scripsi id (est) caluus p(er)ennis i(n) conspectu
brian imp(er)atoris scotor(um) et q(uod) scripsi finituit p(ro) omnib(us)
regib(us) maceriae

(St Patrick, while going to heaven, ordered that the entire fruit of his labour, so of baptism, so of legal suits as of alms, to be conveyed to the apostolic city

which in Scottic is called Ard Macha. Thus have I found in the libraries of the Scots. I have written, i.e. Calvus Perennis, in the sight of Brian, emperor of the Scots, and what I have written he has determined on behalf of all the kings of Cashel; Casey and Meehan 2014, 28).

In St Bernard of Clairvaux's account of the *Life of St Malachy* (written 1148-1153), he describes how in 1134 Malachy finally managed to drive out his rival for the coarbate of St Patrick (i.e. the abbacy of Armagh), Niall mac Aedh (or "Nigellus", as Bernard calls him). His account of Niall's exile includes the passage:

Nigellus videns sibi imminere fugam, tulit secum insignia quaedam Sedis illius: textum scilicet Evangeliorum qui fuit beati Patricii; baculumque auro tectum et gemmis pretiosissimis adornatum quern nominant Baculum Iesu eo quod ipse Dominus (ut fert opinio) eum suis manibus tenuerit atque formauerit. Et haec summae dignitatis et venerationis in gente illa. Notissima sunt celeberrimaque in populis, atque in ea reverentia apud omnes sunt, ut qui illa habere visus fuerit, ipsum habeat episcopum populus stultus et insipiens. (Gwynn 1913, civ)

(Niall, seeing that flight was imminent, took with him certain insignia of that See, namely, the text of the Gospels which was the blessed Patrick's, and the staff covered with gold and adorned with most precious gems, which they call the staff of Jesus because the Lord himself, as report confirms, has held it in his hands and formed it. And these are of the highest rank and veneration in the nation. Indeed, they are well known and much celebrated among the people, and so revered by all, that he who is seen to have them is held to be their bishop by the foolish and unwise people; trans. based on Lawlor 1920, 53-4)

The "text of the Gospels which was the blessed Patrick's" with which Niall departed is likely to be the Book of Armagh. Later Bernard recounts that Niall surrendered to St Malachy and returned the insignia, though the Annals of the Four Masters record that St Malachy bought the Staff of Jesus in 1135 following the death of its keeper, Flann Ua Sinaich (AFM 1135.7 and 10). Bernard does not mention the manuscript again. It is notable that St Bernard's account describes it as a gospel book, despite the numerous other texts comprising the manuscript.

In the twelfth century a handful of annal entries show that the manuscript was being used for the swearing of oaths, for example in 1179 the Annals of Ulster report that "Ua

Ruadhacain, king of Ui-Echach, died after three nights' illness, after his expulsion and after his profanation of the Canon of Patrick" (AU 1179.3). In 1196 the Annals of Ulster report that Muirchertach, son of Muirchertach O'Lachlainn, Lord of Cenel Eoghain, was killed by Donnchadh, son of Bloschadh O'Cathain, at the instigation of Cenel Eoghain, who had sworn allegiance to him before the three shrines and the Canoin Patraic (AU 1196.3).

The manuscript eventually came into the hands of one Florence MacMoyné (MacMoyre?), who signed his name and the date, June 29th, 1662, on fol. 104v, a leaf originally left blank. MacMoyné had inherited the manuscript, and it seems that his family had been its keepers for some centuries, although who was the first is unclear. In c. 1680 he sold or pledged the manuscript for £5.

A detailed account of the manuscript, written by Edward Lhywd, Keeper of the Ashmolean Museum, Oxford, was found among his papers after his death in 1709; it was subsequently published by Charles O'Connor in the prefix of the first volume of his *Rerum Hibernicarum Scriptores* of 1813. Lhywd revealed that after being pledged by Florence MacMoyre, the manuscript was bought by one Arthur Brownlow. He explained that Brownlow repaired and foliated the manuscript:

Hinc ad manus Arthuri Brownlowe gratissime pervenit qui, non sine magno labore, disjuncta tunc folia debito suo ordine struxit, numeros in summo libri posuit folia designantes, aliosque in margine addidit capita distinguentes, eademque folia sic disposita prisco suo velamine (ut jam videre licet) compingi curavit, et in prisca sua theca conservari fecit, una cum bulla quadam Romani Pontificis cum eodem inventa (Gwynn, cxi-cxii).

(Hence it most thankfully arrived in the hands of Arthur Brownlowe who, not without great effort, repaired the separated leaves in their proper order, placed numbers at the top of the book designating the leaves, and added others in the margin distinguishing the chapters, and caused the arranged leaves to be bound together with their former covering (as we can see), and he caused [them] to be preserved in their former case, together with a certain bull of the Roman Pontiff [which] was discovered with the same).

Lhywd also noted the lacuna in the Gospel of Matthew, demonstrating that these leaves were lost before his time. He suggested, probably correctly, that this consisted of four missing leaves, in contrast to the foliation of the manuscript which only accounts for the loss of three. He does not comment on the absent first leaf, although he does refer vaguely to "quaedam fragmenta Vitae S. Patricii" (certain fragments of a Life of St Patrick), which may,

as Gwynn thought, indicate that the first leaf, the only loss in the *Life of St Patrick*, was already wanting in Lhywd's time, but the mention is too cursory to be conclusive. It appears, therefore, that Brownlow's foliation postdates the loss of at least the leaves between fols 41 and 45 and perhaps also that of fol. 1; the fact that they are included in the foliation is presumably because he wanted to acknowledge their absence.

The manuscript remained in the Brownlow family, who housed it at the Royal Irish Academy, till it was sold to Bishop William Reeves in 1853, who in turn sold it to John George Beresford, archbishop of Armagh, on the condition that he should leave it to Trinity College on his death, which occurred in 1892.

Notes

Gwynn published his facsimile of the Book of Armagh in 1913. Whilst being an invaluable resource, this book has notable flaws, particularly regarding its treatment of the foliation of the manuscript. Originally the Book of Armagh had 222 leaves, though it now wants the first leaf and four leaves between fols 41 and 45. The foliation appears to have been added to the manuscript after the losses but was made to retrospectively include the missing first leaf and three of the four missing leaves between fols 41 and 45. Recognising that a further leaf was missing, Gwynn sought to "correct" the foliation in his facsimile, by reproducing fol. 45 with the label fol. 46, and every folio thereafter as one greater than the figure that is actually found in the manuscript, the result being great confusion in the subsequent scholarship (E.g. Sharpe, 1982; O Loughlin, 2000). Here I use the foliation found in the manuscript, not in Gwynn's facsimile.

Bibliography

- Alexander, Jonathan J. 1978. *Insular Manuscripts, 6th to the 9th Century*, A Survey of Manuscripts Illuminated in the British Isles 1, 76-77, cat. 53. London: Harvey-Miller.
- Abbott, Thomas K. and Edward J. Gwynn. 1921. *Catalogue of the Irish Manuscripts in the Library of Trinity College Dublin*, 1. Dublin and London: Hodges, Figgis & Co.
- Bieler, Ludwig. 1979. *The Patrician Texts in the Book of Armagh*, *Scriptores Latini Hiberniae* Series 10. Dublin Institute for Advanced Studies, School of Celtic Studies,
- Bieler, Ludwig. 1967. "The Book of Armagh", in *Great Books of Ireland*, 51-63. Dublin, Clonmore and Reynolds Ltd.
- Brown, Michelle P. Forthcoming. "Ferdornach and the Ninth to Twelfth-Century Books of Armagh: exuberant exhibitionist or accomplished antiquary?", in *Mapping New Territories in Art and Architectural History: essays in honour of Roger Stalley*, ed. F. Narkiewicz, N. NicGhabhann and D. O'Donovan. Brepols: Turnhout,

- Casey, Denis, and Bernard Meehan. 2014. "Manuscripts: Brian Boru and the Book of Armagh", *History Ireland*, 22, 2: 28-29.
- Colker, Marvin L. 1991. *Trinity College Library Dublin Descriptive Catalogue of the Mediaeval and Renaissance Latin Manuscripts*, 93-97, cat. 52. Aldershot: Scolar.
- Graves, Charles. 1844-1847. "On the Date of the MS. Called the Book of Armagh", *PRIA* 3: 316-324.
- Gwynn, John. 1913. *Liber Ardmachanus: The Book of Armagh*. Dublin: Royal Irish Academy.
- Henry, Françoise. 1957. "An Irish Manuscript in the British Museum (Add. 40.618)", *JRSAI* 87, 2: 147-166.
- Kenney, James F. rpt. 1997. *The Sources for the Early History of Ireland: Ecclesiastical*, 337-39, cat. 131. Dublin: Four Courts.
- Lowe, Elias A. 1935. ed. *Codices Latini Antiquiores: A Palaeographical Guide to the Latin MSS. prior to the IXth Century*, 11 parts, 1 Great Britain and Ireland, 42, cat. 270. Oxford: Clarendon.
- McGurk, Patrick. 1961. *Latin Gospel Books from A.D. 400 to A.D. 800*, Publications de Scriptorium 5, 67-68, cat. 68. Paris and Brussels: Aux Éditions "Érasme"; Anvers and Amsterdam: Standaard-Boekhandel.
- Meehan, Bernard. 1998. "'A Melody of Curves Across the Page': Art and Calligraphy in the Book of Armagh", *Irish Arts Review Yearbook* 14: 90-101.
- O'Loughlin, Thomas. 2000. "The Plan of the New Jerusalem in the Book of Armagh", *Cambrian Medieval Celtic Studies* 39: 23-38.
- O'Loughlin, Thomas. 2015. "The So-called *Capitula* for the Book of the Apocalypse in the Book of Armagh (Dublin, Trinity College, 52) and Latin Exegesis", in *Early Medieval Ireland and Europe: Chronology, Contacts, Scholarship*, ed. Pádraic Moran and Immo Warntjes, *Studia Traditionis Theologiae* 14, 405-23. Turnhout: Brepols.
- O'Neill, Timothy. 2014. *The Irish Hand: Scribes and their Manuscripts from the Earliest Times*, 20 and 82. 2nd edn., Cork: Cork University Press.
- Richardson, Hilary. 2002. "Biblical Imagery and the Heavenly Jerusalem in the Book of Armagh and Book of Kells", in *Ireland and Europe in the Early Middle Ages: Texts and Transmissions / Irland und Europa im Früheren Mittelalter: Texte und Überlieferung*, ed. Próinséas Ní Chatháin and Michael Richter, 205-214. Dublin: Four Courts Press,
- Sharpe, Richard. 1982. "Palaeographical Considerations in the Study of the Patrician Documents in the Book of Armagh", *Scriptorium* 36: 3-28.

Book of Armagh Quire Diagrams

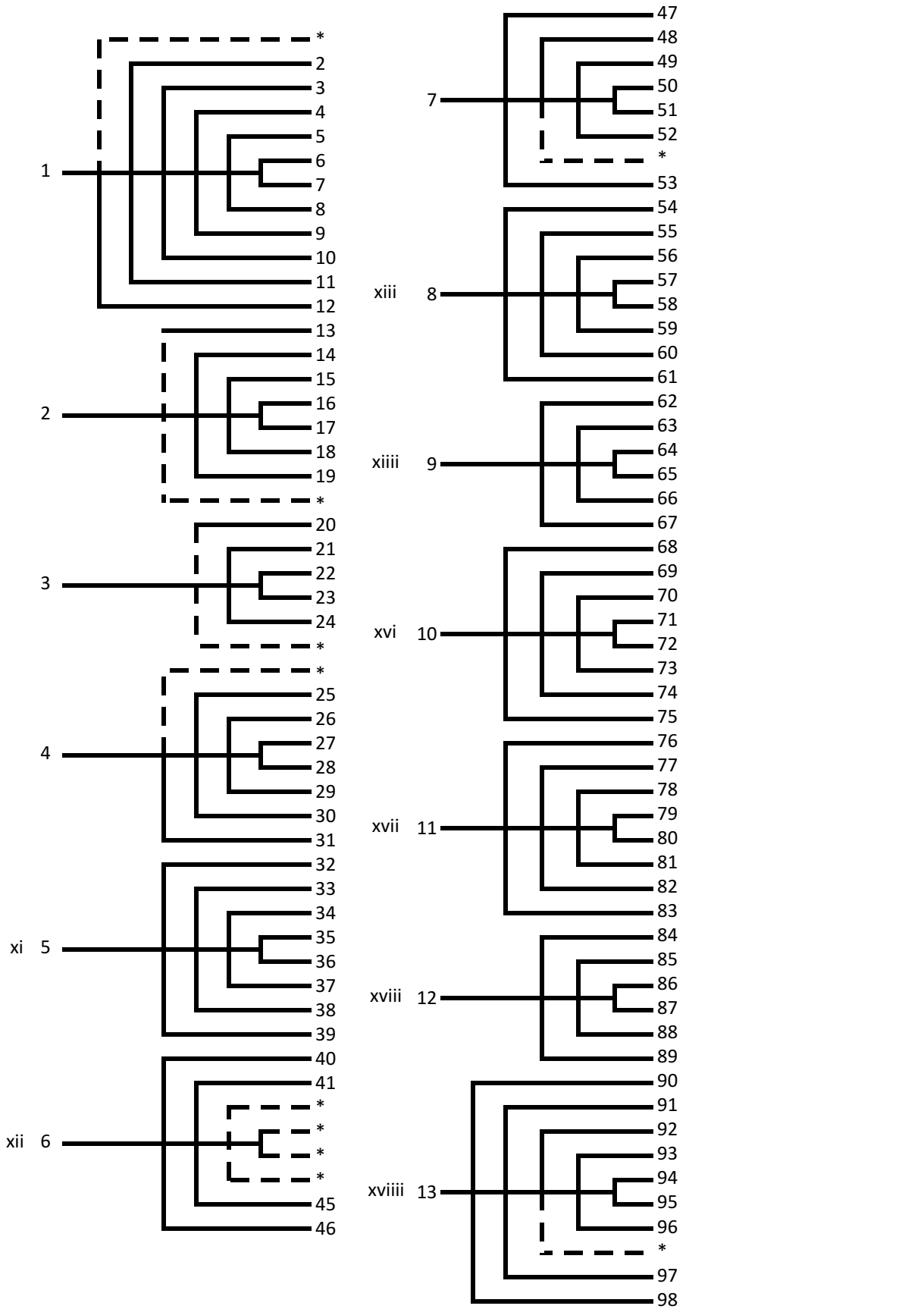

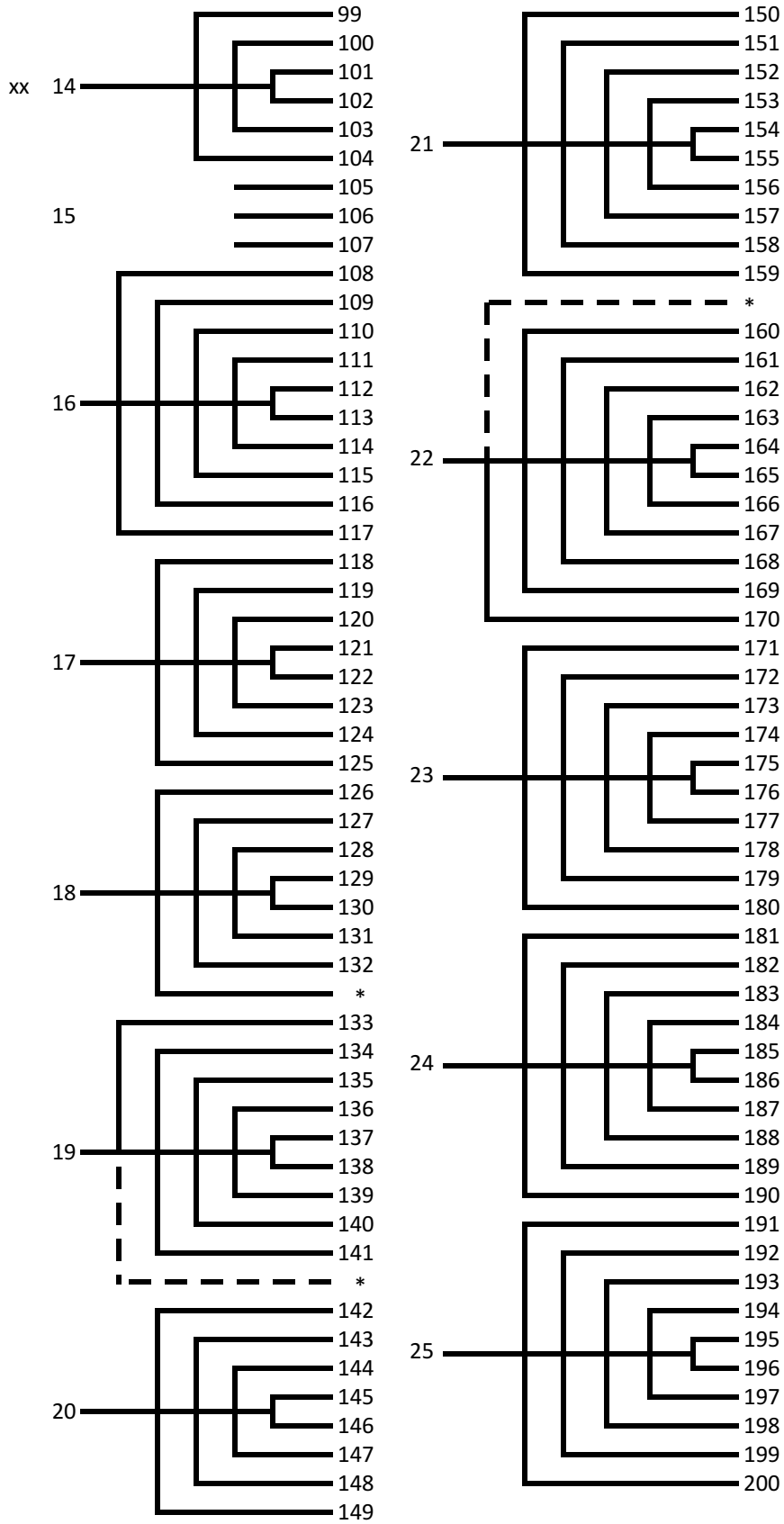

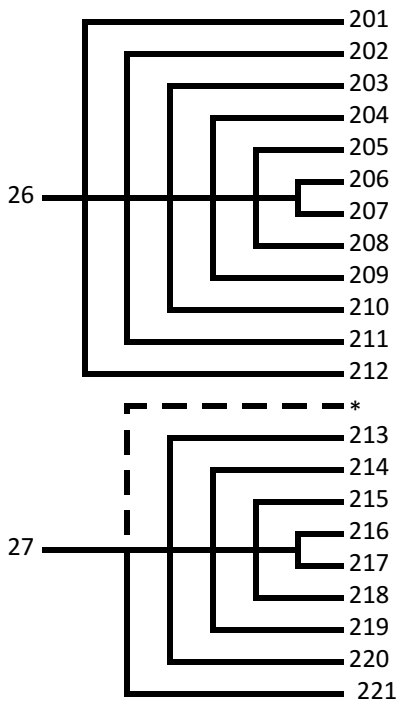

(5) Dublin, Trinity College Library, MS 59

“Book of Dimma”

Gospel book in Latin with Old Irish; additional communion for the sick in Latin.

?Roscrea, Co. Tipperary, 2nd half of 8th or early 9th century.

Additions in ?Roscrea, Co. Tipperary, ?mid 9th century to c.1000

Physical Description

Support: parchment.

Number of leaves and flyleaves: i (modern parchment) + 74 (modern pagination 1-148) + i (modern parchment).

Dimensions of leaves: 175 x 142 mm.

Dimensions of written space: c.145 x 115 mm.

Ruling medium: hard point.

Ruling pattern: mostly single vertical bounding lines only (double found on p. 57 and after), horizontal text ruling visible only in the Gospel of John (e.g. p. 111), several leaves at a time, after folding; prickings sometimes visible in inner and outer margins.

Columns and lines: 30-31 lines, two columns, except pp. 55, 105 and 148, single column (Luke and John incipits and John explicit), as well as pp. 100-03 (later addition, no. 4).

Scribes: uncertain, Gospel of John in distinct hand, ?1 or 2 hands in synoptic gospels.

Script: Insular minuscule, cursive and unsteady in parts of the gospels of Matthew, Mark and Luke, with a bolder, more regular aspect in the Gospel of John.

Collation

6 quires of irregular collation (the following based on McGurk 1961, cat. 88):

1¹⁸ (wants 7, 10 and 13, missing), 2¹⁴ (wants 2, 5 and 11, missing), 3¹⁶ (wants 15 and 16, missing), 4¹⁰ (+ 1 after 10, addition), 5¹², 6¹² (wants 4, missing).

Texts

1. Pp. 3-29, Gospel of Matthew; colophon in Latin and Old Irish, p. 29, “finit. oróit do [/dimmu] rodscib p(ro) d(e)o (et) b(ene)dictione” (It is finished. A prayer for Dimma who has written it for God and blessing; Best 1926, 85).
2. Pp. 31-52, Gospel of Mark; colophon in Latin and Old Irish, p. 52, “finit amen d(e)o gratias ago oroit do Dimmu < >” (It is finished, amen, I thank God. A prayer for Dimma; Best 1926, 85).
3. Pp. 55-99, Gospel of Luke; colophon in Latin and Old Irish, p. 99, “finit amen d(e)o gratias ago · · oroit do dianchridu diaroscibad hic lib(er) (et) do dmmu [sic] scribenti. amen” (It is finished, amen. I thank God. A Prayer for Dianchride for whom this book has been written, and for Dimma who wrote it, amen; Best 1926, 85).

4. Pp. 99-103, communion for the sick, Latin, 9th century (Warren 1881, 167-171; Márkus 2008, 91-5).
5. Pp. 105-148, Gospel of John; colophon, p. 148, “finit amen ... dimma macc nathi” (it is finished, amen. Dimma Mac Nathi), followed by a small cross; on a new line, “ernn dom hilluag mo saethir. a iohain alt cen dichill mo brithemnect cen acrad ocus atrab ind richith..,” (Grant unto me as a reward of my labour, O John, without neglect, my judgement without torment and a dwelling in the heavenly kingdom; Best 1926, 85-86).

Decoration

Full page miniatures: (p. 2), *Matthew portrait*, standing and facing forward, bearded, holding book, tinted yellow, pink and green; (p. 30), *Mark portrait*, facing forwards, holding book, feet extending beyond the frame, behind figure a throne with bird’s-head terminals, tinted yellow, pink and green, “Marcus” inscribed in the upper margin (?later hand); (p. 54) *Luke portrait*, standing and facing forward, holding book, tinted yellow, orange, and green, inscription at feet “reliquie Petri et Pauli” (?later hand); (p. 104) *eagle symbol of John*, body facing forward, head in profile, four wings outstretched, holding a book, tinted blue, yellow and red, erased inscription in red above the head.

Decorated initials: (p. 3) *Matthew incipit*, 9 lines, bird’s head terminals, interlace and dotting, and *Chi-Rho*, 10 lines, bird’s head terminals, interlace and cruciform infill, tinted green, pink, yellow; (p. 31) *Mark incipit*, 7 lines, coloured infill, adjacent marginal cross, tinted green, orange, pink and yellow; (p. 55) *Luke incipit*, 12 lines, interlaced terminals, tinted yellow, orange, pink and green; (p. 105) *John incipit*, 24 lines, zoomorphic terminals and dotting, the bar of the N forms a key pattern.

Minor initials: numerous enlarged in text and margins, occasionally tinted (e.g. pp. 3-5, 31, 107).

Textual decoration: occasional marginal crosses, e.g. p. 48 (Mark 14:1) and p. 145 (John 20:1).

Full page frames: found on all full-page miniatures and three incipit pages: (pp. 2, 55 and 104), panels of interlace and fret motifs, tinted pink and yellow; (pp. 30 and 54), plain band tinted red.

Binding

Modern, 100% cotton fibre-board laminate covered in white alum tawed leather (John Gillis, Preservation and Conservation Department, Trinity College, Dublin, 2016).

Shrine

A medieval book shrine exists, now at Trinity College, Dublin. Measurements, 190 x 161 x 44 mm. Mid-twelfth-century with additions from the fourteenth, fifteenth and nineteenth centuries. Detailed descriptions of the construction and history of the shrine can be found in Ó Floinn 1982, and Murray 2014, 274-78, cat. 5. Constructed of plain bronze plates with, on the front and back, silver openwork plaques decorated with interlace, crosses and Urnes style interlaced beasts (12th-century), set with glass and stones (14th/15th-century), and a crucifixion scene (15th-century); on the sides, incised silver sheet decorated with zoomorphic interlace and zig-zag patterns (probably 12th-century), gilt silver plates with stamped decoration (probably early-15th-century). The shrine was designed not to be opened when the manuscript was inside and had to be damaged to remove the manuscript. A fourteenth-century inscription, written in Latin in a Lombardic script, names Thadeus Ua Cearbaill, Coarb Domnall Ua Cuanáin and Tomás the craftsman. A 19th-century inscription reads: “The inclosed [sic] Copy of the Four Gospels was written by Dimma the son of Nathi who died about A.D. 620”.

Provenance

The manuscript is generally dated to the second half of the eighth century on art historical and palaeographical grounds although a date in the early ninth century also seems possible. However, the clear contrast between the portion of the manuscript containing the Gospel of John and that containing the synoptic gospels strongly suggests that they were not made as part of the same phase of work: the script, scribal practices, subject and style of illuminations and the pigments used are all entirely different. This may suggest that they were made in separate phases, with the Gospel of John probably made first as a standalone booklet, and other three gospels added later to make it into a full gospel book (for fuller discussion, see Chapter 2). If this was the case, the synoptic gospels cannot have been added more than a few decades after the creation of the Gospel of John, probably in the late eighth or early ninth century, as the script shows none of the late symptoms (such as bird-silhouette u or angular a) found in pocket gospels from the mid-ninth century onwards, such as the MacDurnan Gospels and Book of Deer.

The synoptic gospels of the manuscript were furnished with original colophons naming a scribe (pp. 29, 52) as well as one Dianchríde, “for whom this book has been written” (p. 52). O’Sullivan has noted that the unusual name Dianchríde occurs Uí Corcráin genealogy in the Book of Ballymote (O’Sullivan 2005, 536, n. 127), however the personage remains unidentified. As Best demonstrated, the name of the scribe was later erased and replaced with the name Dimma Mac Nathi, whose name was also added to the originally anonymous colophon at the end of the Gospel of John (p. 99). A mid-twelfth-century life of

St Crónán (d. 640) recounts the story of the miraculous creation of a gospel book for the saint by a scribe named Dimma in forty days and forty nights without rest (ed. Plummer 1910, vol. 2, 24). It seems likely that the inscriptions naming Dimma in the manuscript are intended to associate it with the one in the story, suggesting that these inscriptions were probably added at St Crónán's foundation, the monastery of Roscrea, Co. Tipperary. From this, scholars have tended to extrapolate that the manuscript was also made at Roscrea, which is possible if unverifiable.

The date at which the manuscript was doctored to associate it with Dimma is unclear. Best thought that the hand of the Dimma inscriptions was the same as that which added the communion for the sick between the gospels of Luke and John (no. 4), both of which he dated to the late tenth or early eleventh century (Best 1926, 97-8). Although the communion for the sick is often dated to the late-eighth or early ninth century (Kenney 1997, 703-4; Márkus, 2008), both texts are clearly later than the script of the main part of the manuscript since they include later letter forms such as the distinctive angular form of a. They appear to belong to the type of Late Celtic minuscule script used from the mid-ninth century until c.1000, although it is notoriously difficult to date such scripts within this period. In the case of the Book of Dimma, the problem of palaeographical dating is made even more difficult because the Dimma inscriptions are no more than isolated words.

The inscriptions on the shrine suggest that it was kept in Roscrea in the fourteenth century. They name a king of Éile, a small territory in north Munster in which the monastery of Roscrea was situated, and a *coarb* of the Ua Cuanáin family, who were hereditary abbots of Roscrea. Thadeus Ua Cearbaill may be one of two kings of Éile named Tadhg Ua Cerbaill, one recorded as dying in 1348, and the other as ruling between 1380 and 1407 (Ó Floinn, 1982). Since it is generally agreed that the shrine was always intended to hold the manuscript, it is likely that it too was here at that time.

The manuscript and shrine were discovered in Roscrea in the late eighteenth or early nineteenth century. In 1819 they were exhibited at the Royal Irish Academy and were published in the Academy's *Proceedings*, in an essay written by their then-owner, Henry Monck Mason. In it he explains that he had bought them from one Dr Harrison who had told him they had been found among the rocks of Devil's Bit Mountain in North Tipperary thirty years earlier. This tale was repeated in later literature (e.g. Abbott, 1892) though some scholars, beginning with Betham (1826), were sceptical. It was disproved by Ó Floinn (1982) when he unearthed two items of correspondence among the papers of antiquarian Thomas L. Cook, relating to Mason's essay, both dated 1822 (National Library of Ireland, MS. 19. 822). One letter is written by Cook to Mason, after having read his paper, informing him that Harrison had misled him about the provenance of the manuscript and its shrine, and that they were in fact lent to Harrison by Revd Philip Meagher, who had inherited them from his

deceased uncle, a priest in Roscrea. Another letter is from Revd Philip Meagher to Cook, confirming that the objects described in Mason's essay are the same as those he had lent to Harrison which were never returned, and that he had found them among the books of his uncle, the Roscrea priest. This latter account is far more credible than the story of the objects' discovery on a mountainside, as they are far too well preserved to have been exposed to the elements for any amount of time.

Mason sold the manuscript and shrine to Sir W. Betham, who also published on them (1826). Betham's financial problems forced him to sell them again. They were lot 444 in his house sale of July 1830 when they were bought back for him by his nephew. However, by 1836 they had clearly been put to sale again, since the Board Register of Trinity College, Dublin, vol. 7 (MUN/V/7 p.117) notes for the 29th March 1836 that the Book of Dimma was purchased from Sir W. Betham for £150. A note added to John Lyon's c. 1743 catalogue of the Trinity manuscripts (Dublin, Trinity College, MUN/LIB/1/53) reads: "Purchased from Sir W. Betham for 200 £" (Colker, 1991).

Bibliography

- Abbott, Thomas K. 1892. "The Library", in *The Book of Trinity College, Dublin, 1591-1891*, 147-181. Belfast: M. Ward.
- Abbott, Thomas K. and Edward J. Gwynn. 1921. *Catalogue of the Irish Manuscripts in the Library of Trinity College Dublin*, 2, cat. 59. Dublin and London: Hodges, Figgis & Co.
- Abbott, Thomas K. 1900. *Catalogue of the Manuscripts in the Library of Trinity College, Dublin*, 8, cat. 59. Dublin and London.
- Alexander, Jonathan J. 1978. *Insular Manuscripts, 6th to the 9th Century*, A Survey of Manuscripts Illuminated in the British Isles 1, 69, cat. 48. London: Harvey-Miller.
- Best, R. I. 1926. "On the Subscriptions of the 'Book of Dimma'", *Hermathena* 44: 84-100.
- Betham, William. 1826. *Irish Antiquarian Researches* 1. Dublin: William Curry.
- Colker, Marvin L. 1991. *Trinity College Library Dublin Descriptive Catalogue of the Mediaeval and Renaissance Latin Manuscripts*, 108, cat. 59. Aldershot: Scolar.
- Henry, Françoise. 1957. "An Irish Manuscript in the British Museum (Add. 40.618)", *JRSAI* 87, 2: 147-166.
- Kenney, James F. rpt. 1997. *The Sources for the Early History of Ireland: Ecclesiastical*, 458, cat. 633. Dublin: Four Courts.
- Lindsay, Wallace M. 1910. *Early Irish Minuscule Script*, St Andrews University Publications 6, 12-16. Oxford: James Parker.

- Lowe, Elias A., ed. 1935. *Codices Latini Antiquiores: A Palaeographical Guide to the Latin MSS. prior to the IXth Century*, 11 parts, 1 Great Britain and Ireland, 44, cat. 275. Oxford: Clarendon.
- Márkus, Gilbert. 2008. "The Sick and Dying in the Book of Deer", in Katherine Forsyth, ed., *Studies on the Book of Deer*, 67-97. Dublin: Four Courts Press.
- McGurk, Patrick. 1956. "The Irish Pocket Gospel", *Sacris Erudiri* 8, 2: 249-270, at 249-270.
- McGurk, Patrick. 1961. *Latin Gospel Books from A.D. 400 to A.D. 800*, Publications de Scriptorium 5, 82-83, cat. 88. Paris and Brussels: Aux Éditions "Érasme"; Anvers and Amsterdam: Standaard-Boekhandel.
- Murray, Griffin. 2014. *The Cross of Cong: A Masterpiece of Medieval Irish Art*, 274-78. Sallins, Co. Kildare: Irish Academic Press.
- Ó Floinn, Ragnall. 1982. "The Shrine of the Book of Dimma", *Éile, Journal of Roscrea Heritage Society*, 1: 25-39.
- O'Sullivan, William. 2005. "Manuscripts and Palaeography", in *A New History of Ireland: Prehistoric and Early Ireland*, ed. Theodore William Moody, Dáibhí Ó Cróinín and Francis X. Martin, 535-36. Oxford: Oxford University Press.

The Book of Dimma Quire Diagrams

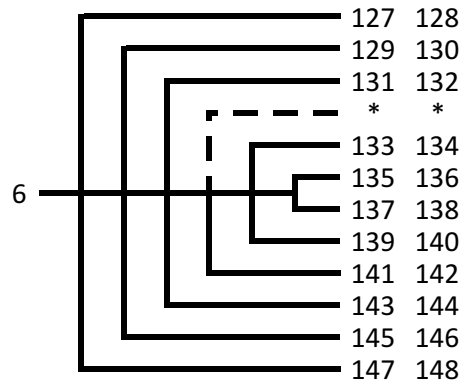
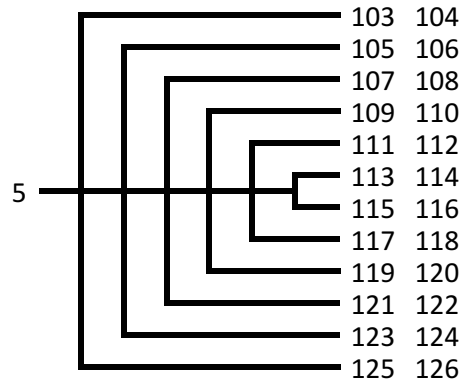
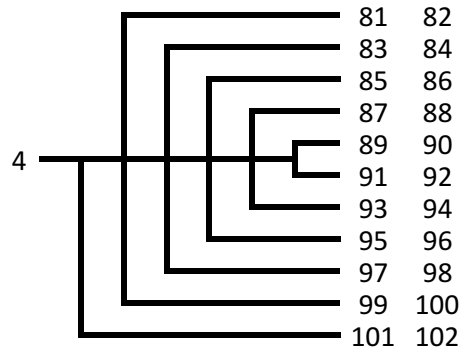
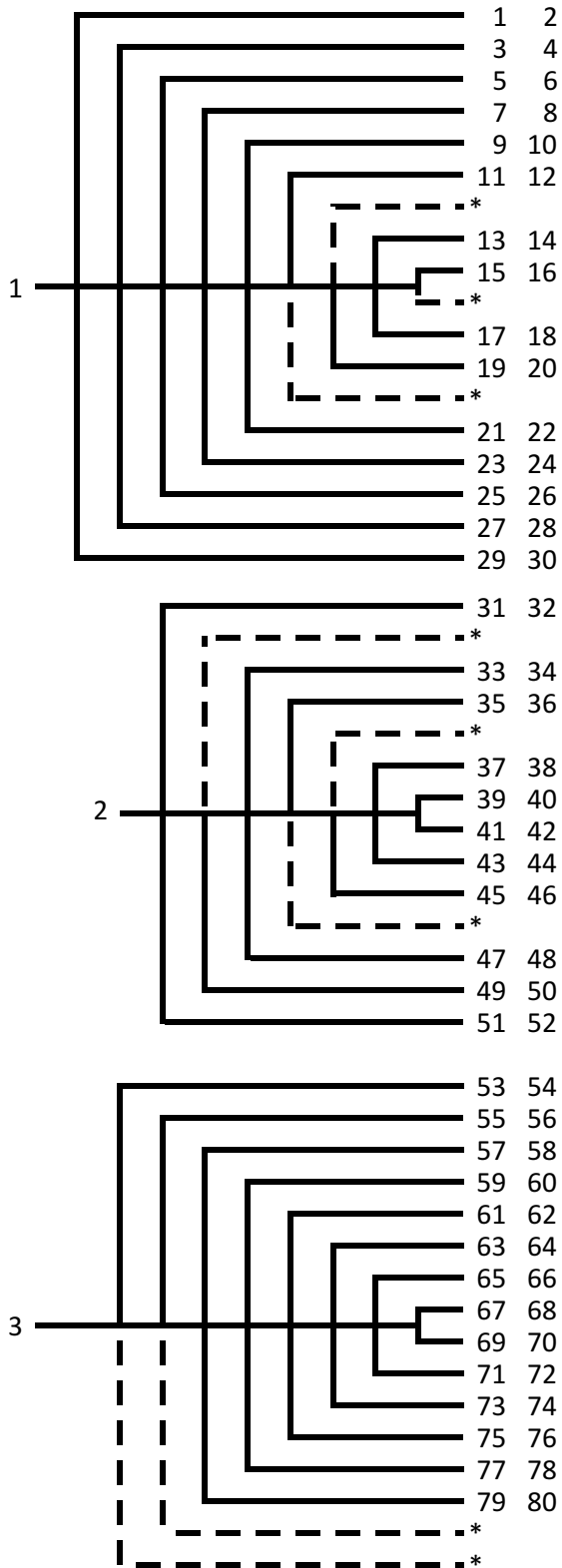

(6) Dublin, Trinity College Library, MS 60

I, “Book of Mulling”; II, “Mulling Fragment”

I (fols 1-94), gospel book in Latin with liturgical texts in Latin with Old Irish; additional communion for the sick in Latin with Old Irish; II (fols 96-99), gospel book in Latin (fragment).

I & II: ?St Mullins, Co. Carlow.

I: second half of 8th century to early 9th century; II: 8th/9th century.

I: Additions in ?St Mullins, Co. Carlow, ?mid 9th century to c.1000.

Physical Description

Support: parchment.

Number of leaves and flyleaves: iii (modern parchment) + 94 + 1 (medieval parchment, blank page) + 4 (modern foliation 1-99; 1890s foliation, 18-28, 51, 29-50, 52, 1-17, 54-81, 53, 82-94, 95-98) + ii (modern parchment).

Dimensions of leaves: I, 165 x 120 mm; II, 155 x 120 mm.

Dimensions of written space: I, 130 x 90 mm; II, 120-130 x 95-105 mm.

Ruling medium: I, hard point; II, no visible ruling.

Ruling pattern: I, single vertical bounding lines and horizontal text lines, several leaves at a time, after folding; slits in inner and outer margins; II, no visible ruling.

Columns and lines: I, 28-47 lines (mostly 28), two columns except fols 18-28 in single column, and fol. 93 in three columns; II, 36 and 33 lines, single column.

Scribes: I, uncertain, Gospel of John in 1 distinct hand; ?1 or 2 hands in synoptic gospels; II, 1.

Script: I & II: Insular minuscule.

Glosses and Headers: formula “in nomine s(an)c(t)ae trinitatis” in some upper margins (fol. 23r, 24r, 24v, 25r, 26r-29r, some partly effaced); additional corrections, interlinear and marginal, intended to assimilate the text to the Vulgate, probably only slightly after original creation of manuscript, second half of 8th century to early 9th century (Lawlor, 1897: 42-43, 70-74).

Eusebian Sections: additional section numbers marked in margins of most pages and the beginnings and ends of sections marked with punctuation in the text (apparently concurrent with correction of text, see above).

Collation

In its present state, all leaves are single. In the mid-1890s all bifolia were split at the centre fold and reordered. The quire structure had, however, been previously recorded by Lawlor in 1893. When the manuscript was once again rebound in 1977, it was rearranged based on

Lawlor's description, although the leaves remain split. The following is the supposed original collation of the manuscript according to Lawlor's account:

6 quires of irregular collation:

I: 1¹⁴ (wants 2, 13 and 14, missing; 1 is a single leaf), 2²² (1 and 22 single, ?once conjugate), 3¹⁴ (+ 1 after 3, insertion, + 2 after 13, insertion; 7 and 8 single, ?once conjugate), 4²⁶ (+ 1 after 22, insertion, + 1 after 24, insertion), 5¹² (+ 1 after 12, insertion; 3, 4, 10 and 11 single, ?once conjugate);

II: 6⁶ (wants 2 and 5, missing; 1 and 6 single, ?once conjugate).

Further, 3 evangelist portraits on single leaves were reported to have been found by Lawlor at the end of I, although in present binding they are placed before the openings of the gospels of Matthew (2), Mark (3) and John (5). A blank medieval parchment leaf is also bound between I and II.

Texts

I

1. Fol. 1r-v, Jerome, *Epistle to Pope Damasus* (ends imperfectly).
2. Fols 2r-4v, Monarchian prologues to the gospels (Matthew's begins imperfectly); colophon, fol. 4v, "finit <argum>en<tum evangeliorium>".
3. Fols 5v-11v, Eusebian Canon Tables (tenth imperfect).
4. Fols 13r-33v, Gospel of Matthew; colophon, fol. 33v, "finit amen finit".
5. Fols 33v-34r, communion for the sick, Latin, ?mid-9th century-c.1000 (Warren 1881, 171-3; Kenney 1997, Márkus 2008, 91-5).
6. Fols 36r-52v, Gospel of Mark; colophon, fol.52v, "finit".
7. Fols 53r-80v, Gospel of Luke; colophon, fol. 80v, "finit amen finit".
8. Fols 82r-94r, Gospel of John; colophon, fol. 94r, Latin with the Greek *Phi*, "Φinit amen Φinit. o tu quicu(m)q(ue) scripseris (ve)l scrutatus fueris (ve)l etia(m) videris h(aec) volumina d(eu)m ora < mi>ssericordia(m) sua(m) < > p(er) clivosam mundi viam < > altissimum <n>omen (autem) scriptoris mulling dicitur. finiunt quator evangelia" (It is finished, amen, it is finished. O you who write, or examine, or even see these volumes, pray to God < > his mercy < > through the hilly path of the world < > highest. Mulling is the name of the scribe. The end of the four gospels).
9. Fol. 94v, liturgical text comprising excerpts from 13 prayers, Latin and Old Irish, (Lawlor 1897, 145-66; Nees 1983, 86-88).

II

10. Fol. 96r-v, Gospel of Matthew (imperfect), 26:42-27:35 (mittentes).

11. Fols 97r-99v, Gospel of Mark (imperfect), 1:1-4:8 (dabit), 5:18 (nauem)-6:35 (eius).

Decoration: Original

I

Full page miniatures: evangelist portraits, standing and facing forward, holding book, halo projecting beyond the frame: (fol. 12v) *unknown evangelist*, dips a pen in an inkwell, tinted blue, yellow, green, pink, red, white and orange; (fol. 35v) *unknown evangelist*, tinted blue, purple, yellow, green, pink, red, white and orange; (fol. 81v) *unknown evangelist (?John)*, tinted in blue, purple, yellow, orange, brown, and white.

Colophon drawing: (fol. 94v), pen-drawn, two concentric, compass-drawn circles with crosses, inscribed in Old Irish with the names of evangelists, Old Testament prophets and cardinal directions around the edge of the circles, and the Holy Spirit, angels, Christ and apostles on the interior.

Decorated initials: pen-drawn through prefaces, thereafter tinted blue, white, yellow, orange, green, pink and red: (fol. 1r) *Epistle to Pope Damasus*, 4 lines, partly effaced (fol. 2r) *Monarchian prologue to Mark*, 3 lines, animal-head terminals; (fol. 3r) *Monarchian prologue to Luke*, 3 lines, geometric infill; (fol. 3v) *Monarchian prologue to John*, 3 lines, interlace and animal-head terminal; (fol. 13r) *Matthew incipit*, 15 lines, interlace and dotting, animal-head terminal; (fol. 13v) *Chi-Rho*, 13 lines, interlace, dotting, spiral and pelta patterns, animal-head terminals; (fol. 36r) *Mark incipit*, 10 lines, interlace, dotting, spiral, trumpet and pelta patterns, animal-head terminal; (fol. 53r) *Luke incipit*, 11 lines, human interlace with two back-to-back figures; (fol. 82r) *John incipit*, interlace, spiral patterns, animal-head terminals.

Minor initials: numerous, enlarged in margin.

Full page frames: found on all full-page miniatures, slim on upper and lower edges and expanded at the sides with panels of decorative patterns: (fol. 12v) panels of fine filigree-like interlace and zoomorphic interlace, tinted in pink, yellow, red and orange; (fol. 35v) panels of zoomorphic interlace and trumpet and spiral patterns tinted in purple, red, orange, blue and yellow; (fol. 81v) panels of fine filigree-like interlace and zoomorphic interlace, tinted blue, purple, yellow, black and brown.

II

Decorated initial: fol. 97r, Mark incipit, 6 lines, “knotted-wire” letters with animal-head terminals, contains geometric infill and dotting.

Binding

Modern, oak boards covered with white alum-tawed leather in a quarter-style, leaving most of the timber boards visible (Anthony Cains, 1977).

Shrine

A medieval book shrine survives, now kept at National Museum of Ireland: measurements 190 x 153 x 76 mm; made of bronze cased in silver; c.1402. The top is decorated with crystals and glass in filigree settings. The large, central crystal is backed by a plate of silver foil with a nielloed inscription naming King Arthur, Lord of Leinster, and his wife Elizabeth, along with a date of 1402 (Abbott 1892, 166). This apparently refers to Art MacMurrough-Kavanagh, King of Leinster (d. 1416/17).

Provenance

I and II have been together for all their recorded history and it has been noted that their scripts are so similar that they were likely to have been made in the same scriptorium (Lowe 1935, 44, cat. 277). They are both dated art-historically and paleographically between the second half of 8th century to early 9th century, with II probably slightly later in that period than I.

The original colophon of I (Book of Mulling, fol. 94r) claims that the manuscript was copied by St Moling (d. c.694), Bishop of Ferns and founder of the monastery of St Mullins, Co. Carlow. While the manuscript was certainly created after St Moling's lifetime, it is possible, as Lawlor suggested, that the colophon was copied from a genuine autograph of the saint (Lawlor 1897, 15). This colophon also indicates that the manuscript's place of origin was most likely at Moling's foundation, St Mullins, with which it is also associated in its later history.

The connection between the manuscript and St Mullins is reinforced by its ownership from at least the fifteenth to the eighteenth centuries by the Kavanagh family, of whom St Moling was a member and whose seat, Borris Idrone, is only a few miles from the monastery. This is first attested by the c.1402 inscription on the book shrine referring to Art MacMurrough-Kavanagh. At the close of the eighteenth century the family gave the manuscript and shrine to Trinity College, Dublin. At this stage the leaves were kept loose and unbound inside the shrine, as observed by Lawlor in 1893 (Lawlor, 1897). The shrine was returned to the Kavanagh family in 1895, but was subsequently re-donated to Trinity College. It is now on long-term loan to the National Museum of Ireland and is on permanent display in the *Medieval Ireland 1150–1550* galleries at its branch on Kildare Street, Dublin. The manuscript has remained at Trinity College.

Bibliography

- Abbott, Thomas K. 1892. "The Library", in *The Book of Trinity College, Dublin, 1591-1891*, 147-181. Belfast: M. Ward.
- Abbott, Thomas K. and Edward J. Gwynn. 1921. *Catalogue of the Irish Manuscripts in the Library of Trinity College Dublin*, 3, cat. 60. Dublin and London: Hodges, Figgis & Co.
- Abbott, Thomas K. 1900. *Catalogue of the Manuscripts in the Library of Trinity College, Dublin*, 8, cat. 60. Dublin and London.
- Alexander, Jonathan J. 1978. *Insular Manuscripts, 6th to the 9th Century*, A Survey of Manuscripts Illuminated in the British Isles 1, 67-68, cat. 45. London: Harvey-Miller.
- Colker, Marvin L. 1991. *Trinity College Library Dublin Descriptive Catalogue of the Mediaeval and Renaissance Latin Manuscripts*, 110, cat. 60. Aldershot: Scolar.
- Crawford, H. S. 1923. "A Descriptive List of Irish Shrines and Reliquaries, Part II", *JRSAI* 13, 2: 151-176, at 152.
- Henry, Françoise. 1957. "An Irish Manuscript in the British Museum (Add. 40.618)", *JRSAI* 87, 2: 147-166.
- Kenney, James F. rpt. 1997. *The Sources for the Early History of Ireland: Ecclesiastical*, 632-33, cats 456 and 457. Dublin: Four Courts.
- Lawlor, Hugh J. 1897. *Chapters on the Book of Mulling*. Edinburgh: David Douglas,
- Lindsay, Wallace M. 1910. *Early Irish Minuscule Script*, St Andrews University Publications 6, 16-24. Oxford: James Parker.
- Lowe, Elias A., ed. 1935. *Codices Latini Antiquiores: A Palaeographical Guide to the Latin MSS. prior to the IXth Century*, 11 parts, 1 Great Britain and Ireland, 44, cats 276 and 277. Oxford: Clarendon.
- Márkus, Gilbert. 2008. "The Sick and Dying in the Book of Deer", in Katherine Forsyth, ed., *Studies on the Book of Deer*, 67-97. Dublin: Four Courts Press.
- McGurk, Patrick. 1956. "The Irish Pocket Gospel", *Sacris Erudiri* 8, 2: 249-270, at 249-270.
- McGurk, Patrick. 1961. *Latin Gospel Books from A.D. 400 to A.D. 800*, Publications de Scriptorium 5, 83-84, cat. 84. Paris and Brussels: Aux Éditions "Érasme"; Anvers and Amsterdam: Standaard-Boekhandel.
- Nees, Lawrence. 1983. "The Colophon Drawing in the Book of Mulling: A Supposed Irish Monastery Plan and the Tradition of Terminal Illustration in Early Medieval Manuscripts", *Cambridge Medieval Celtic Studies* 5: 67-91.

The Book of Mulling and Mulling Fragment quire diagrams

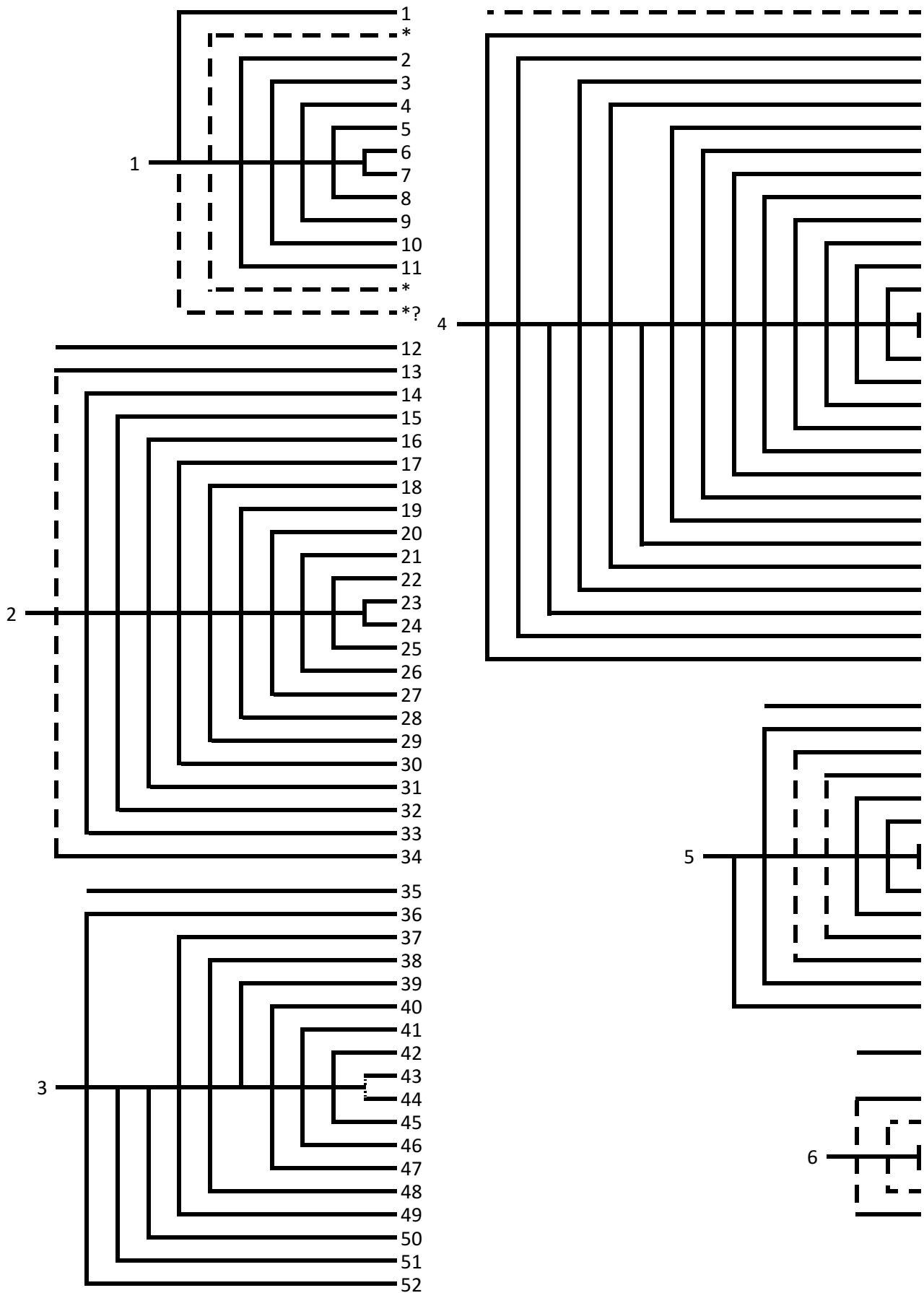

(7) Fulda, Landesbibliothek, Codex Bonifatianus 3

“Cadmug Gospels”

Gospel book in Latin with Old Irish.

?Ireland or Fulda, 8th century.

Addition in Fulda, late 9th to early 10th century.

Physical Description

Support: parchment.

Number of leaves and flyleaves: 65 (modern foliation 1-65; no flyleaves).

Dimensions of leaves: 126 x 100 mm.

Dimensions of written space: 97-104 x 72-84 mm.

Ruling medium: hard point.

Ruling pattern: mostly frame ruling only on pages written in a single column and single vertical bounding lines to the left and right of each column only on pages written in two columns, horizontal text ruling occasionally apparent (e.g. fols 43r, 45r-47r, 50r), 1 leaf at a time, after folding; no prickings or slits visible.

Columns and lines: 24-45 lines, alternating between two columns (fols 2v-18v, 23v-24v, 27v, 29v, 52v-62v), long lines (fols 2r, 19v, 19r, 20r, 25r-27r, 28r-29r, 30r-33r, 34r-51r, 52r, 63r-65r) and long lines for the first 3-4 and last 2-6 lines, with two columns for the 23-31 lines between (fols 20v-23r).

Scribes: uncertain, script is erratic throughout; obvious changes in appearance of script (e.g. fols 54v and 64r) may indicate change of hand or simply be caused by a change of pen, ink and time of writing. 1 named Cadmug (signed fol. 65r).

Script: cursive Insular minuscule + addition in Carolingian minuscule (fol. 65v).

Glosses and Headers: occasional interlinear Old-Irish glosses (fols 3v, 4r, 7v, 11v, 12r, 14r, 15v, 18r, 39r; Meyer 1912, 173-74); Latin invocations in some upper margins, “o emanuel”/“ó emanúel”/“o emanu(el)” (fols 3v, 15r, 16r, 38v, 42r, 45r, 50r, 53r, 56v, 57r, 57v, 58r, 58v, fol. 60r), “in nomine” (fol. 4r); gloss, upper margin, “id malus est” (fol. 44v); running titles in some upper margins, “lib(ri) Mathei” (fol. 14v), “Marcus amat” (fol. 23r), “Marcus” (fol. 29v), “Lucas” (fol. 35r), “lib(ri) Lucae” (fols 43v, 45r), “Johan(nis)” (fol. 58v), “Joh(annis)” (fol. 60v), “Jóhannís” (fol. 61v), “Johannis” (fol. 62r); trimmed illegible (fols 34v, 46v).

Collation

4 quires of irregular collation:

1¹⁸, 2¹⁴, 3¹⁸, 4¹⁶ (wants 1 after 13, missing).

Texts

1. Fols 2r-18v, excerpts from Gospel of Matthew, 1:1-9:27 “et tr(an)siunte [sic]” (fols 2r-6rb7), 11:25-28:20 (fols 6r-18v), 28:11-20 (fol.18r-v); headers, fol. 2r, “incipit liber secun(dum)” (above initials), “libri mattei” (beneath initials); header, fol. 2v, “incipit evange(lium) s(ecundum) matheu(s)”; colophons, fol. 18v, “finit” (lower right, after gospel text), “d(e)o gratias ago finit hunc librum” (upper left diagonal), “matheus marcus lucas iohannis” (upper right diagonal) and “amen” (between lower diagonals).
2. Fols 18v-19r, excerpt from Pseudo-Juvencus, *Versus in Libros IV Evangeliorum*, “matheus instituit virtutu(m) tramite” (fol. 18v, lower right diagonal), “mores, et bene vivendi justo dedit” (fol. 18v, lower left diagonal), “ordine le(g)es” (fol. 18v, between lower diagonals), “marcus amat/ terras inter ce/lumque [sic] volare/ vechimens [sic]/ aquilla [sic] stricta secat/ omnia laphsu [sic]” (fol. 19r).
3. Fols 20r-32v, excerpts from Gospel of Mark, 1:1-10:1 (fols 20r-27vb20), 12:1-12:37 (fols 27v-29ra6), 14:1-16:20 (fols 29r-32v); header, fol. 20r, “marcus” (beneath initial).
4. Fol. 33r, invocation, “in nomine d(e)i patris (et) filii (et) sp(iritu)s s(an)c(t)i matheus homo marcus leo lucas vitulus iohannis aquilla [sic]” (In the name of God, the Father, Son and Holy Spirit, Matthew man, Mark lion, Luke calf, John eagle).
5. Fol. 33r, excerpt from Pseudo-Juvencus, *Versus in Libros IV Evangeliorum*, “lucas uberius describit proelia chr(ist)i jure sacer v(i)tulus qui habita menia fatur” (Luke describes the battles of Christ more fully, a sacred calf by right, since he speaks the office of the ancient prophets; McBrine 2008, 106).
6. Fols 34r-50v, Gospel of Luke; inscription, fol. 34r, “sive (con)sur(gens) lucas elivans [sic]” (Luke [means] rising or elevating); colophon, fol. 50v, “finit amen d(e)o gratias ago”.
7. Fol. 51r, excerpt from Pseudo-Juvencus, *Versus in Libros IV Evangeliorum*, “mathius instituit virtutum tramite mores et bene vivendi justo dedit ordine legas Marcus amat terras inter celumq(ae) volare et vechimens aquilla stricto secat om(ni)a laphsu Lucas uberius describit proelia chr(ist)i jure sacer vitulus qui habita moenia fat(ur)” (Matthew has established morals with a path of virtue and laws for living well in a proper order. Mark loves to fly between the earth and sky, and, a soaring eagle, he cuts through everything with his strict flight. Luke describes the battles of Christ more fully, a sacred calf by right, since he speaks the office of the ancient prophets; McBrine 2008, 106).
8. Fol. 52r-65r, Gospel of John (imperfect), 1:1-18:15 (Simon Petrus), 19:27-end; inscription, fol. 52r: “ioh(annis) gratia dei (inter)p(re)tat(ur)” (John means “the grace

of God”); colophon, fol.65r, “finit amen d(e)o gratias ago Cadmug scripsit” (It is finished, amen. I thank God. Cadmug wrote it).

9. Fol. 65v, inscription concerning the restitution of MS to Abbey of Fulda by King Arnulf at the petition of Abbot Huoggi, including claim that the MS was written by St Boniface, Latin, late 9th/early 10th century: “Hoc evangelium s(an)c(tu)s bonifatius martyr D(omi)ni gloriosus ut nobis seniorum relatione compertu(m) e(st) propriis conscripsit manibus quod etiam venerabilis abba huoggi obnixis p(re)cibus a rege piissimo arnolfo impetravit et s(an)c(t)ae fuldensi aeclesiae honorabiliter restituit. cui salvator Ie(s)u Chr(ist)i p(rae)mia sempiterna p(ro) devotione sua in celestib(us) clementer redde eumq(ue) nobis feliciter dominari tempora longa concede” (This gospel, as it was discovered from the report of our elders, St Boniface the glorious martyr of the Lord wrote with his own hands, which also the venerable Abbot Huoggi obtained with earnest entreaties from the most pious King Arnulf and honourably restored to the holy church of Fulda; to our saviour Jesus Christ, mercifully repay him eternal rewards in heaven for his devotion and grant him happily to rule over us for a long time).
10. Pastedown, inside back cover, transcription of no. 9, 15th century.

Decoration

Full page miniatures: evangelist portraits, standing and forward-facing, each holding book and small forked rod, bare feet projecting beyond the lower edge of the frame, inscribed in red majuscule at sides of heads, “imago Matthei”, “imago Marci”, “imago Lucae”, “imago Johannis”, tinted white, yellow, red, blue-purple, red-purple: (fol.1v) *Matthew*; (fol.19v) *Mark*; (fol.33v) *Luke*; (fol.51v) *John*.

Decorated initials: gospel incipit pages, letters outlined with rows of dots, majuscule letters with *diminuendo* effect and infill, tinted yellow, red and purple: (fol.2r) *Matthew*, above text block; (fol.20r) *Mark*, 5 lines and above text block, erasure of purple colour between vertical strokes of N with faint inscription (illegible); (fol.34r) *Luke*, above text block; (fol.52r) *John*, above text block; (fol.2v) *Chi-Rho* (34mm), 9 lines, pen-drawn, expanded terminals, the lower legs of the X surround a triangle with capped corners, containing a small cross.

Minor initials: numerous, enlarged in the text, sometimes outlined with black dots (e.g. fols 15v, 16r, 43v, 52v and 53r), in one instance, stem of letter terminates in two crosses (fol. 40r), in another, letter has appended banner-like motif (fol. 10v).

Textual decoration: text block arranged in diagonal quadrants, (fol. 18v, Matthew explicit, colophon and extract from Pseudo-Juvencus); frequent arabesques and descenders elongated in the lower margins (e.g. fols 5v, 6r, 9r, 10r, 10v, 11r, 14v-16v, 22r, 23r, 41r, 42v,

50v, 56r, 56v); dots and zigzag lines in side margins (fols 15v, 16v-18v, 55r-62r); pen-drawn bird heads in the lower margin, (fols 12v and 13v).

Full page frames: found on all miniatures and gospel incipits, containing panels of stepped patterns, tinted yellow, red, green, purple and black: (fol. 1v) 98 x 74 mm; (fol. 2r), 98 x 74 mm; (fol. 19v) 97 x 74 mm; (fol. 20r), 97 x 73 mm; (fol. 33v) 97 x 74 mm; (fol. 34r) 98 x 74 mm; (fol. 51v) 97 x 74 mm; (fol. 52r) 97 x 74 mm; extracts from Pseudo-Juvencus, pen-drawn, traced over the outline of the frames of the miniatures showing through from the reverse, containing panels of cruciform patterns (fols 19r and 51r).

Binding

8th century, original or near original. Thin wooden boards covered with red leather (discoloured to brown where exposed), and reinforced with modern leather at the spine. The leather is impressed on both boards with an identical design: a diagonal cross with a double, rectangular border, each quadrant containing a triquetra with a triangular border. The indentations are filled with a yellow pigment. Traces of a fastening remain: 3 nails secure a leather strap at the fore-edge of the back board, its end now severed; 2 small perforations in equivalent positions near the fore-edge of the front board indicate the prior existence of a corresponding fastening component. Leaf-tab markers in similar red leather to the covers pasted to the fore-edges of the leaves on all four gospel incipits, second page of each quire (fols 2, 20, 34 and 52); possibly contemporary with binding given the close resemblance of the leather. Berthe Van Regemorter reported in 1949 that the manuscript retained its original sewing which revealed the same unusual unsupported sewing structure as the Cuthbert Gospel. However, the manuscript was re-sewn in the 1960s without any detailed record being made of the previous structure.

Provenance

The manuscript is one of three preserved at Fulda as relics of St Boniface (d. 754) and held by tradition to have been his personal possessions. This association between the manuscript and the saint existed as early as the late ninth or early tenth century when the inscription on fol. 65v was added at the instruction of Abbot Huoggi (elected 891; d. 915), claiming that Boniface wrote the manuscript with his own hands.

The scribal attribution to Boniface has been regarded with general scepticism, not least because the only scribe named in the original portion of the text is Cadmug (fol.65r), an Irish name consistent with the Old Irish glosses that appear in the same hand as the gospel text. However, the tradition that the manuscript was once the property of the saint has often been advocated (e.g. Lindsay, 1910; Lowe, 1972; Brown, 1972; Van Regemorter, 1949). This would place its creation in the first half of the eighth century, a date that has been supported by scholars on palaeographic grounds (Lindsay, 1910; Scherer, 1905), stylistic assessment of

the artwork (Scherer, 1905) and comparison of the manuscript's binding technique with the Cuthbert Gospel (Van Regemorter 1949, 46).

Other scholars, however, have dated the manuscript stylistically to the second half of the eighth century, dismissing the Boniface connection as apocryphal. Such datings have been both art-historical (Alexander 1978, 70, cat. 49; Spilling 1982, 886) and palaeographical (Spilling 1982, 887; McGurk 1987, 168). A minority of scholars have proposed later dates still. Meyer suggested that the Old Irish glosses show signs of being linguistically later in date, especially *sodain* instead *sodin* (fol. 14r), a form which he claims to belong more in the ninth than the eighth century (Meyer 1912, 175). The manuscript is so unusual in its script and illumination that it is difficult to make a comparative assessment; however, a date in the eighth-century seems likely.

The manuscript may have been produced in Ireland or by Irish monks on the Continent. The inscription on fol. 65v further claims that the manuscript had belonged to Fulda Abbey at an early date and passed from there into the possession of the Carolingian King and Holy Roman Emperor Arnulf (king, 887; emperor, 896; d. 899). Arnulf eventually returned the manuscript to Fulda at the petitions of Abbott Huoggi. This must have occurred between Huoggi's election in 891 and Arnulf's death in 899.

It has been kept at Fulda for all its recorded history, excluding the Arnulf episode. An *ex libris* plate of 1776 for the public library of Fulda is pasted onto the inner front board. According to Hausmann, the manuscript was presented to the newly founded public library by Fulda Cathedral treasury on the orders of Heinrich von Bibra (1711–1788), Prince-Bishop and Abbot of Fulda (1759-1788), (Hausmann 1992, 11).

Bibliography

- Alexander, Jonathan J. 1978. *Insular Manuscripts, 6th to the 9th Century*, A Survey of Manuscripts Illuminated in the British Isles 1, 70, cat. 49. London: Harvey-Miller.
- Aris, Marc-Aeilko. 2004. "Der *Trost der Bucher* Bonifatius und seine Bibliothek", in *Bonifatius: Vom angelsächsischen Missionar zum Apostel der Deutschen*, ed. Michael Imhof and Gregor K. Stasch, 95-110. Petersberg: Imhof.
- Hausmann, Regina. 1992. *Die Theologischen Handschriften der Hessischen Landesbibliothek Fulda bis zum Jahr 1600*, 11-13. Wiesbaden: Harrassowitz.
- Henry, Françoise. 1957. "An Irish Manuscript in the British Museum (Add. 40.618)", *JRSAI* 87, 2: 147-166.
- Jakobi-Mirwald, Christine. 1993. *Die Illuminierten Handschriften der Hessischen Landesbibliothek Fulda, Teil I, Handschriften Des 6. Bis 13. Jahrhunderts*. Stuttgart: Anton Hiersemann.
- Kenney, James F. rpt. 1997. *The Sources for the Early History of Ireland: Ecclesiastical*, 652-53, cat. 491. Dublin: Four Courts.

- Köllner, Herbert. 1976. *Die Illuminierten Handschriften Der Hessischen Landesbibliothek Fulda, I: Handschriften Des 6. Bis 13. Jahrhunderts*, 10, cat. 3. Stuttgart: Hiersemann.
- Lindsay, Wallace M. 1910. *Early Irish Minuscule Script*, St Andrews University Publications 6, 4-10. Oxford: James Parker.
- Lowe, Elias A., ed. 1935. *Codices Latini Antiquiores: A Palaeographical Guide to the Latin MSS. prior to the IXth Century*, 11 parts, 1 Great Britain and Ireland, 49, cat. 1198. Oxford: Clarendon.
- McGurk, Patrick. 1956. "The Irish Pocket Gospel", *Sacris Erudiri* 8, 2: 249-270, at 249-270.
- McGurk, Patrick. 1961. *Latin Gospel Books from A.D. 400 to A.D. 800*, Publications de Scriptorium 5, 67-68, cat. 68. Paris and Brussels: Aux Éditions "Érasme"; Anvers and Amsterdam: Standaard-Boekhandel.
- Meyer, Kuno. 1912. "Neu Aufgefundene Altirische Glossen", *Zeitschrift für Celtische Philologie* 8: 173-177.
- Scherer, Carl. 1905. "Die Codices Bonifatiani in der Landesbibliothek zu Fulda", in *Festgabe zum Bonifatiusjubiläum II*, ed. Gregor Richter and Carl Scherer, 30-34. Fulda: Fuldaer Actiendruckerei.
- Spilling, Herrad. 1982. "Irische Handschriftenüberlieferung in Fulda, Mainz und Würzburg", in *Die Iren in Europa im früheren Mittelalter* 2, ed. Heinz Löwe, 876-902. Stuttgart: Klett-Cotta.
- Stiegemann, Christoph, and Matthias Wemhoff. 1999. *799: Kunst und Kultur der Karolingerzeit*, 3 vols, 2, 473-475. Mainz: Philipp von Zabern.
- Van Regemorter, Berthe. 1992. "The Binding of the manuscripts of the Saints Cuthbert and Boniface", in Berthe Van Regemorter, *Binding Structures in the Middle Ages: A Selection of Studies*, trans. Jane Greenfield, 43-51. Brussels: Bibliotheca Wittockiana; London: Maggs Bros. Ltd.
- Von Padberg, Lutz E. 2003. "Der Abschluss der Missionsphase in Skandinavien durch die Errichtung der Kirchenprovinzen im 12 Jahrhundert", in *Vom Umbruch zur Erneuerung? Das 11. und beginnende 12. Jahrhundert*, ed. Jörg Jarnut and Matthias Wemhoff, 469-485. Munich Wilhelm Fink.

The Cadmug Gospels Quire Diagrams

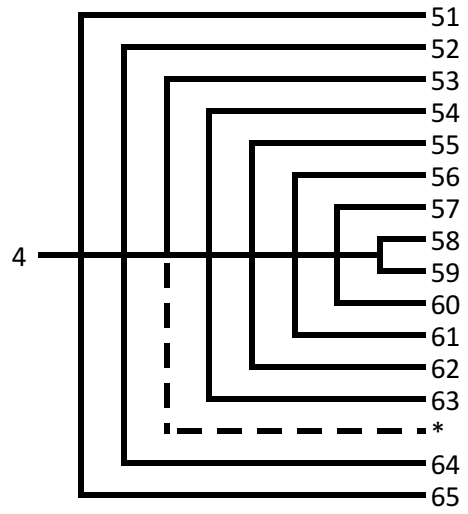
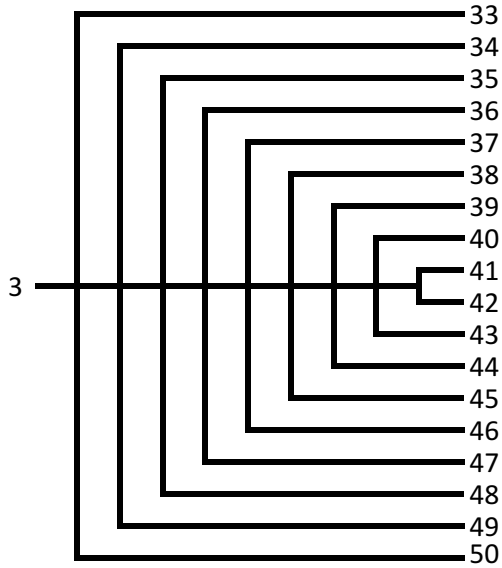
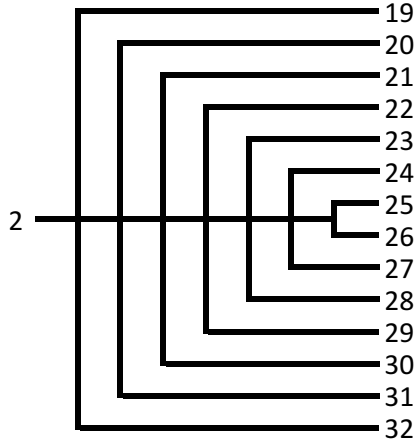
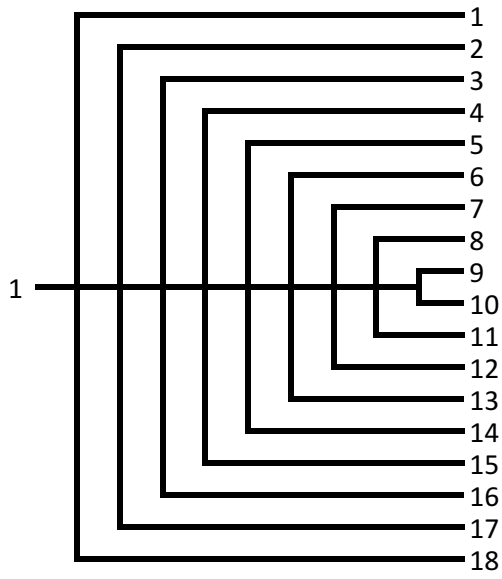

(8) London, British Library, Add. MS 40618

Gospel book in Latin (fragment).

?Ireland, mid 8th to early 9th century.

Additions and remodelling in southern England, 10th century.

Physical Description

Support: parchment.

Number of leaves and flyleaves: iii (modern paper) + 66 (modern foliation 1-66) + iii (modern paper).

Dimensions of leaves: 129 x 105 mm.

Dimensions of written space: 100 x 75 mm.

Ruling medium: hard point.

Ruling pattern: single vertical bounding lines to left and right of each column and horizontal text lines, several leaves at a time, after folding; slits in inner and outer margins marking text lines and in upper and lower margins marking the bounding lines of the columns.

Columns and lines: 36 lines, two columns.

Scribes: 2 original (fols 1r-51ra14, 51ra15-65v) +1 additional named Edward the Deacon (signed fol. 66r).

Script: Insular minuscule +addition in 10th-century Anglo-Saxon minuscule with Caroline features and rustic capitals (fol. 66r).

Collation

5 incomplete quires of irregular collation survive, but two further lost gatherings can be inferred from stubs recorded by Henry (1957) in the now lost 11th/12th century binding:

i¹⁰ (wants all, excised), ii⁴ (wants all, excised), 1^{16/18?} (wants 1-14 or 16, missing), 2²⁰ (wants 6 and 7, excised), 3²² (wants 21, cancellation) or 3²⁰ (+ 1 after 1), 4¹⁸ (wants 8 and 9, excised), 5⁸ (+1 after 8, addition) the original final leaf of the Gospel of John is also missing, although it is unclear how it would have fitted into the quire structure.

Texts

1. Fols 1r-7v, Gospel of Matthew (imperfect), 21:32-28:11 (venerunt in civita).
2. Fols 8r-21r, Gospel of Mark, 2:4-end; colophon, fol.21r, “explicit evangelium secundum marcu(m) incipit evangelium secundu(m) lucam”.
3. Fols 23r-48v, Gospel of Luke; colophon, fol.48v, “explicit evangelium s(ecundum) lucam”.
4. Fols 50r-65v, Gospel of John (ends imperfectly), 1:1-21:16 (diligis me).

5. Fol. 66r, final verses of Gospel of John, 21:16 (ait ei [sic] etia(m))-end, 10th century; colophon, “Qui legat orat [sic] p(ro) scriptore Eaduuardo diac(on)e” (Whoever may read, pray for the scribe, Edward the deacon).

Decoration: Original

Full page miniatures: (fol. 21v) *evangelist portrait, Luke*, standing, forward-facing, figure with nimbus and book, tinted pink, yellow, purple and green.

Decorated initials: gospel incipits, erased and palimpsested, (fol. 23r) *Luke*, 14 lines, traces of interlace discernible; (fol. 50r) *John*, 25 lines.

Full page frames: (fol. 21v), 98 x 72 mm, slim on upper and lower edges and expanded at the sides with panels of zoomorphic interlace, tinted pink and yellow; (fol. 22v) 98 x 73 mm, double-border, erased and over-painted; (fol. 49r and v) 98 x 70 mm, double-border, tinted yellow and incorporated into later miniature.

Decoration: Additional (England, 10th century)

Full page miniatures: tinted in yellow, red, orange, brown and blue, and painted with shell gold and silver: (fol. 22v) *Luke portrait*, bearded, in three-quarter profile, writing in codex, seated on architectural throne, haloed, calf-symbol emerging from draperies above, holding book; (fol. 49v) *John portrait*, bearded, forward-facing figure, writing in codex, seated on architectural throne, eagle-symbol emerging from draperies above.

Decorated initials, gospel incipits: (fol. 23r) *Luke*, 14 lines, capitals in frame, foliate flourish on Q, tinted blue and red and painted with shell gold; (fol. 50r) *John*, 25 lines, interlace, zoomorphic and foliate motifs, tinted red, blue and green and painted with shell gold.

Minor initials: numerous capitals in the margin, in shell gold.

Full page frames: (fol. 22v) double intersecting ellipses, emanating from the mouths of paired animal heads at left and right, with foliate bosses at top and bottom, tinted red, green and blue and painted with shell gold; (fol. 49v) double-bordered rectangle with circular pellets around edges, tinted red and blue and painted with shell gold.

? *Fragmentary frames and patterns (possibly from canon tables?):* discerned by Henry (1957) on the stubs of a lost quire adhering to the manuscript's old binding, now lost.

Binding

Modern (1932-33), blue leather over wooden boards. The remains of a previous medieval binding (British Museum, Add MS 40618A), 11th/12th century(?), have been mislaid in recent years. A parchment chemise, taken from another book and used as a wrapper, survives (Add MS 40618B).

Provenance

Palaeographic and art-historical evidence suggests that it was made in the mid eighth to early ninth century. The place of origin is generally assumed to be Ireland, as suggested by the close correspondence between its surviving original evangelist portrait and those in the Book of Mulling. The likeness is so close that it is likely that one of the artists knew the other manuscript, or that both artists were inspired by the same model. Since the Book of Mulling has a strong Irish provenance, this close relationship suggests that Add. 40618 was also made in Ireland.

By the tenth century Add. 40618 had arrived in southern England where it was extensively remodelled. The addition of the final leaf completing the Gospel of John by a scribe who signed himself Edward the Deacon may have occurred first (Farr 2011: 95), then a second phase involved the addition of new evangelist portraits, the erasure and replacement of decorated initials at the gospel incipits, and the addition (and in some places over-writing) of minor initials in the margins. Possible centres at which this may have taken place have been suggested as St Augustine's Canterbury (Temple 1976, 43) or more frequently, Winchester (Wormald 1971, 309; Farr 2011, 96; Brown and Clark 2004, 10).

A series of inscriptions are found on fol. 66v: a 13th or 14th-century *ex libris* inscription, partially erased, "Iste est liber [...] me liquis mun [...]"; the signature of one William Newman and the date of 1528; the signature of a Robert Lancaster along with the date 1662.

The manuscript was sold at Sotheby's, London, on the 27th of March, 1922, by E. Mitchel Crosse of Glen Andred, Groombridge, lot 439. It was bought for £115 by Quaritch, the book dealers, on behalf of the British Museum. A note on fol. iir gives the purchase date as 1 April, 1922. British Museum stamps occur frequently throughout the book (e.g. fols 1v, 10v, 21r, 23v, 50v, 57v).

Bibliography

- Alexander, Jonathan J. 1978. *Insular Manuscripts, 6th to the 9th Century*, A Survey of Manuscripts Illuminated in the British Isles 1, 68, cat. 46. London: Harvey-Miller.
- Brown, Michelle, 1991. *Anglo-Saxon Manuscripts*, 70, pl. 69. London: British Library.
- Brown, K.L., and R. J Clark. 2004. "The Lindisfarne Gospels and two other 8th century Anglo-Saxon/Insular manuscripts: pigment identification by Raman microscopy", *Journal of Raman Spectroscopy*, 35: 4-12.
- Farr, Carol A. 2011. "Irish Pocket Gospels in Anglo-Saxon England" in *Anglo-Saxon Traces, Collected Papers of the 2007 Meeting of the International Society of Anglo-Saxonists*, ed. Jane Roberts and Leslie Webster, 87-100. Arizona: Tempe.

- Gneuss, Helmut. 2001. *Handlist of Anglo-Saxon Manuscripts: A List of Manuscripts and Manuscript Fragments Written or Owned in England up to 1100*, 299. Tempe: Arizona Center for Medieval and Renaissance Studies.
- Henry, Françoise. 1957. "An Irish Manuscript in the British Museum (Add. 40.618)", *JRSAI* 87, 2: 147-166.
- Lowe, E. A., ed. 1935. *Codices Latini Antiquiores, A Palaeographical Guide to the Latin MSS. prior to the IXth Century*, 11 parts, 2, Great Britain and Ireland, cat. 179. Oxford, 1934–1966, 2nd edn. 1972.
- McGurk, Patrick. 1956. "The Irish Pocket Gospel", *Sacris Erudiri* 8, 2: 249-270, at 249-270.
- McGurk, Patrick. 1961. *Latin Gospel Books from A.D. 400 to A.D. 800*, Publications de Scriptorium 5, 32, cat. 20. Paris and Brussels: Aux Éditions "Érasme"; Anvers and Amsterdam: Standaard-Boekhandel.
- Temple, Elżbieta. 1976. *Anglo-Saxon Manuscripts 900-1066, A Survey of Manuscripts Illuminated in the British Isles* 2, 43, cat. 15. London: Harvey Miller.

Add 40618 Quire Diagrams

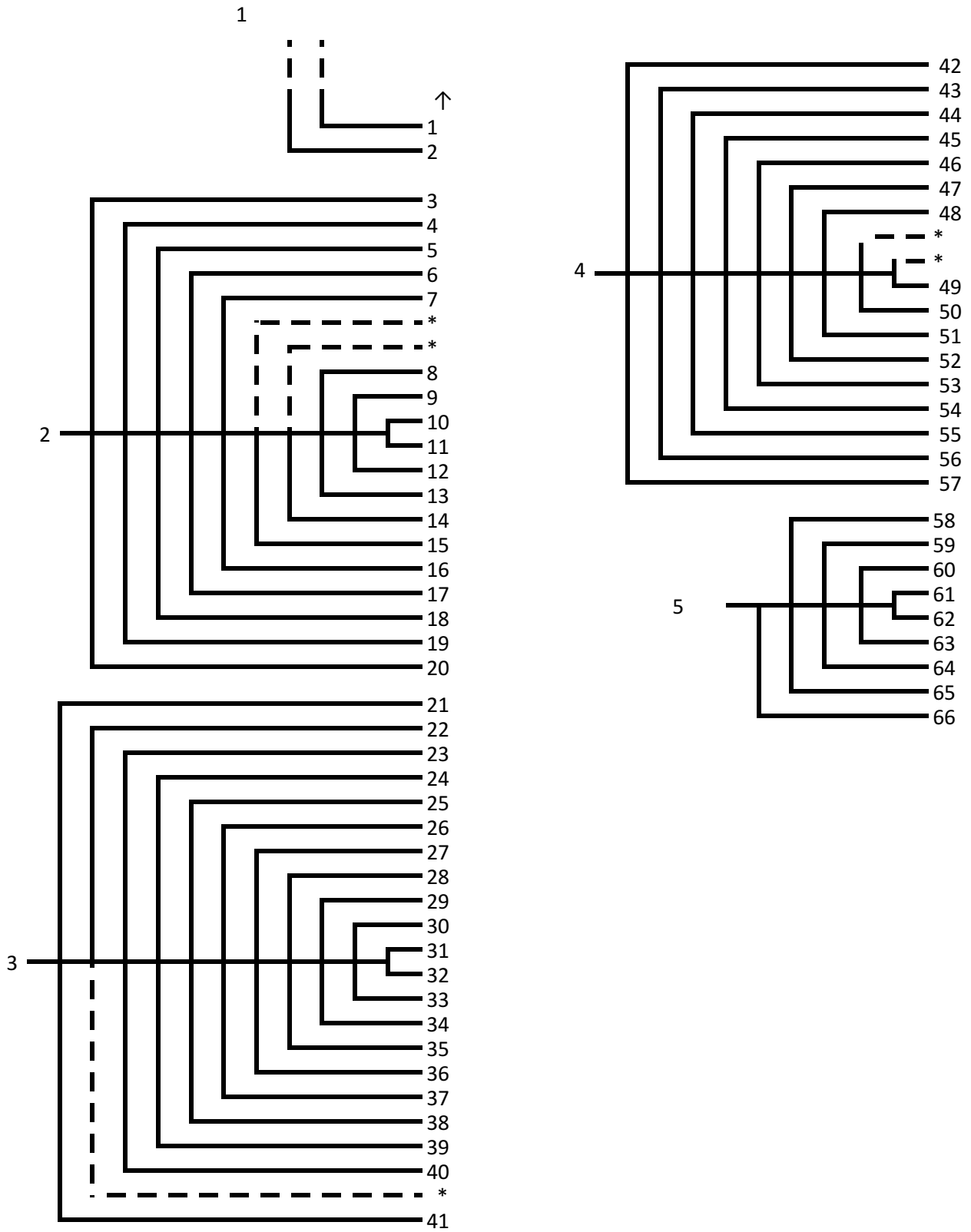

(10) British Library, Add MS 89000

“St Cuthbert Gospel” (formerly “Stonyhurst Gospel”).

Gospel of St John in Latin.

Wearmouth-Jarrow, late 7th to early 8th century.

Addition, ?Northumbria, first half of 8th century.

Physical Description

Support: parchment.

Number of leaves and flyleaves: ii (pastedown and flyleaf, medieval parchment) + 93 (modern foliation 1-90; the first, penultimate and ultimate leaves are unfoliated, the latter two pasted to the back cover) + i (pastedown, modern paper).

Dimensions of leaves: c.138 x 92 mm.

Dimensions of written space: 95 x 65 mm.

Ruling medium: hard point.

Ruling pattern: double vertical bounding lines and horizontal text lines, several leaves at a time, after folding; prickings in inner and outer margins.

Columns and lines: 19 (fols 1-42) or 20 (fols 43-end) lines, single column, arranged *per cola et commata*.

Scribes: 1 +additions.

Script: capitular uncial, with a few initials and red letters in text uncial +additional marginalia written in Insular cursive minuscule (fols 20v, 27r, 28v, 51r).

Glosses and Headers: marginal “k” indicates beginning of Capitulum XXIII (fol. 37v); +additional marginalia marking offices for the dead, first half of 8th century, (fol. 20v) “pro defunctis”, beside John 5:21; (fol. 27r) “pro defunctis”, beside John 6:37; (fol. 28v) “de mortuorum”, beside John 6:51; (fol. 51r) “de mortuorum”, beside John 11:21.

Quire Signatures: recto of first leaf sometimes marked by small cross at top left (fols 1r, 17r, 25r, 41r, 81r).

Collation

1⁸ (+1 before 1), 2-11⁸, 12⁴.

Texts

1. Fol. i r–v, court-roll of the prior of Durham, c.1264.
2. Fol. ii v, transcription of erased 12th-century inscription on fol. 1r, 14th-century: “Ewangelium Iohannis quod inuentum fuerat ad capud beati patris nostri Cuthberti in sepulcro iacens anno translacionis ipsius”.
3. Fols 1r–90v, Gospel of John; colophon, fol. 90v, “amen”.

4. Lower pastedown (formerly fol. 91), record of donation of manuscript to the English Jesuit College at Liège, 18th century: “Hunc Evangelii Codicem dono accepit ab Henrico Comite de Litchfield, et dono dedit Patribus Societatis Iesu, Collegii Anglicani, Leodii, Anno 1769; rectore eiusdem Collegii Ioanne Howard: Thomas Phillips Sac. Can. Ton.”

Decoration

Initials: enlarged letters in black mark Ammonian sections and sometimes periods; enlarged initials in red mark capitula.

Binding

Late 7th or first few decades of 8th century. 138 x 92 mm. For detailed analysis of the construction, see Powell 1956, 362-374; Powell 1969, 45-55; Pickwoad 2015, 41-63; Szirzmai 1999, 95-96. Birch boards covered in leather (either goat- or sheep-skin), stained red on the outer surface and decorated with moulding, tooling and colouring. The upper board is decorated with a rectangular frame and interlace patterns impressed into the leather, and a moulded design of a vine bearing fruits or buds; the indentations are filled in blue-grey, bright yellow and pale yellow, which Powell suggest may have once been green (Powell 1956, 370-1). The lower board is decorated with tooling and colouring. It features a design of impressed, concentric rectangles, the innermost containing a grid-pattern incorporating two step-crosses; the lines filled with blue-grey and bright yellow.

The method of sewing is unusual: there are no cords or thongs around which the sewing passes, instead the linen thread alone holds the leaves and boards together. The sewing was done by a method involving two needles, each threaded with four threads, which pass through the boards and join the quires together with series of kettle-stitches (Powell 1956, 364-5). The sewing of the first quire has been inexpertly repaired with green linen thread in modern times.

Provenance

Generally agreed to have been made at Wearmouth-Jarrow, with dates suggested in the late seventh or first few decades of the eighth century. Its script, capitular uncial, and text, a close rendering of the Vulgate, are both strongly associated with Wearmouth-Jarrow manuscripts such as the Codex Amiatinus, one of the pandects commissioned by Ceolfrith, abbot of Wearmouth-Jarrow from 689-716. Brown thought that the capitular uncial in the Cuthbert Gospel was more evolved than that used for the *capitula* of the Codex Amiatinus, and thus that it was later in date (Brown 1969, 12). More recently, Richard Gameson has suggested based on the sequence of the development of scripts and word-separation in Wearmouth-Jarrow manuscripts, that the manuscript was probably made c.710-30 (Gameson 2015, 33).

Marginal notes in a near-contemporary Insular minuscule hand mark four passages of the text to be read at a mass for the dead (fol. 20v, John 5:21-4, and fol. 27r-v, John 6:37-9, “pro defunctis”; fol. 28v-29r, John 6:51-4, and fol. 51r-v, John 11:21-7, “de mortuorum”; beginning and end of each section marked by four/five dots in a lozenge arrangement). These are the four *pericopae* for masses for the dead found in the mid-seventh-century Roman lectionary (Brown 1969, 25). They appear not to have been entered with the care that distinguishes the rest of the manuscript’s creation as most have left offsets on the facing pages. The use of what Julian Brown termed “Phase I” Insular minuscule script indicates that these notes were unlikely to have been added after the mid-eighth century, when this script was succeeded by “Phase II” Insular minuscule in Northumbria.

The manuscript was discovered in the coffin of St Cuthbert in Durham at the saint’s translation in 1104. The upper margin of fol. 1r bears the erased but still visible inscription in a twelfth-century hand: “Euangelium Iohannis quod inuentum fuerat ad capud beati patris nostri Chutb(erti) in sepulcro iacentis anno translacionis ipsius” (St John’s Gospel, found lying by the head of our father St Cuthbert in his tomb in the year of his translation; Mynors 1956, 357). This was copied onto the flyleaf (fol. ii v) in a fourteenth-century hand, presumably at the time that the older inscription was erased.

Two further accounts survive, of which the earlier, composed after 1123 and known as Miracles 18-20, records that when the coffin lid was removed the first object that could be seen was a “book of the gospels” (*librum euangeliorum*), lying near the head on the inner lid of the coffin. Despite the manuscript being a single gospel of St John, it has nevertheless always been accepted as the subject of the account. The same text describes further miracles associated with the manuscript that strengthen this identification: Miracle 20 tells that when Cuthbert was reburied, Bishop Flambard showed a Gospel of John in miraculously perfect condition, which had a satchel-like container of red leather and a badly-frayed sling made of silk threads (“Est autem huic, in quo ponitur, ex pelle rubricata in modum perae locus, habens ex serico, quod iam vetustas dissolvit in fila, suspendiculum quo per colla, ut dicitur, Sanctorum, videlicet beati magistri et post eum discipuli sui, pii heredis, liber circumferebatur pendulus”, Brown 1969, 3, n. 2; from Arnold, *Symeonis Opera*, II, 361-2). It also quotes the passage in Bede’s *Prose Life* in which the young Cuthbert reads the Gospel of John with his dying mentor, Boisil, thus identifying the manuscript with the copy owned by Boisil and Cuthbert.

Based on its discovery in Cuthbert’s coffin, scholars have often supposed that the manuscript was interred with the saint at his Elevation at Lindisfarne in 698, and that the marginal notes indicating the passages to be read at masses for the dead were added in order to furnish the manuscript for liturgical use on this occasion. However, Richard Gameson has recently challenged such assumptions, pointing out that the manuscript could have been

interred at any date between its creation in the late seventh century and its discovery in 1104 (Gameson 2015, 129-30). Nevertheless, the excellent condition of the manuscript indicates that it was probably entombed with the saint in the earlier part of this period, quite possibly at Lindisfarne. The relics of St Cuthbert were taken from Lindisfarne in 875 because of Viking raids, and they and the monastic community eventually settled in Durham in 995.

After its rediscovery, the manuscript became an important relic at Durham and is mentioned in various texts. In Reginald's book on the Miracles of St Cuthbert (Chpt. 91) he describes how William, Archbishop of York, visited Durham in 1153-4 and was shown by Bishop Hugh du Puiset a "beati Cuthberti libellus precipui honoris" (most precious book of St Cuthbert's; Mynors, p. 360). This was kept in a box, protected by three satchels of red leather, one inside the other. The Bishop hung it around the Archbishop's neck, who opened it and showed it to those present, before hanging it around the necks of various members of his household. Afterwards, one of these, a lay-brother and scribe named John, secretly removed the book from its satchels to examine it; he was soon taken ill and had to repent to Cuthbert.

While at Durham, the manuscript seems to have been associated with that which Bede described the young Cuthbert studying with his mention Boisil (ed. Colgrave, *Two lives of Saint Cuthbert*, pp. 180-185), since a fourteenth-century inventory of Durham relics includes "liber sancti Boisili magistri sancti Cuthberti" (Mynors 1956, 359). Also, at some time the front cover was relined with a fragment of a late thirteenth-century Durham court-roll (fol. i).

It is unclear what happened to the manuscript at the dissolution. A notebook of Archbishop Ussher (d. 1656) (Oxford, BodL. Rawl. MS D 280, fol. 41b) records that the gospel of John that was found under the head of St Cuthbert was in the library of antiquary Thomas Allen (d. 1632). Yet the manuscript does not feature in the list of Allen's manuscripts made in 1622 (BodL. MS Wood F 26[8488]). Alternatively, the Rev. Frederick George Lee wrote in a letter dated 1878 that the manuscript was "purloined" by his ancestor Dr. Thomas Lee (d. 1545), a principal commissioner in the dissolution of the monasteries, and that it was passed down the family for several generations until it came to George Henry Lee, 3rd Earl of Lichfield (d. 1743), who presented it to Rev. Thomas Phillips (d. 1774). However, Mynors has questioned the reliability of this account, suggesting that Frederick Lee may have had an interest in establishing a connexion between himself and the Earls of Lichfield (Mynors 1956, 161).

Nevertheless, the manuscript came into the possession of Thomas Phillips, who in 1769, as the eighteenth-century inscription on the lower paste-down corroborates, gave it to the community of the Society of Jesus in Liège, later called Stonyhurst College. "Hunc Evangelii Codicem dono accepit ab Henricus Comite de Litchfield [sic], et dono dedit

Patribus Societatis Jesu, Collegii Anglicani, Leodii; Anno 1769; Rectore eiusdem Collegii Joanne Howard: Thomas Phillips, Sac: Can. Ton.”

From 1979 it was placed in British Library on long-term loan, and in 2012 after an extensive fundraising campaign, the British Library bought it from the Jesuit British Province for £9 million.

Bibliography

- Breay, Claire, and Bernard Meehan, eds. 2015. *The St Cuthbert Gospel: Studies on the Insular Manuscript of the Gospel of John (BL, Additional MS 89000)*. London: The British Library.
- Brown, T. Julian, ed. 1969. *The Stonyhurst Gospel of Saint John*. Oxford: Roxburghe Club.
- Gameson, Richard. 2015. “Materials, Text, Layout and Script”, in *The St Cuthbert Gospel: Studies on the Insular Manuscript of the Gospel of John (BL, Additional MS 89000)*, ed. Claire Breay and Bernard Meehan, 13-40. London: The British Library.
- Gameson, Richard. 2015. “History of the Manuscript to the Reformation”, in *The St Cuthbert Gospel: Studies on the Insular Manuscript of the Gospel of John (BL, Additional MS 89000)*, ed. Claire Breay and Bernard Meehan, 129-36. London: The British Library.
- Mynors, R. A. B. 1956. “The Stonyhurst Gospel: Textual Description and History of the Manuscript” in *The Relics of Saint Cuthbert*, ed. Christopher F. Battiscombe, 356-362. Oxford: Oxford University Press.
- Pickwood, Nicholas. 2015. “Binding”, in *The Cuthbert Gospel: Studies on the Insular Manuscript of the Gospel of John (BL, Additional MS 89000)*, ed. Claire Breay and Bernard Meehan, 41-63. London: British Library.
- Powell, Roger. 1956. “The Binding”, in *The Relics of Saint Cuthbert*, ed. C. F. Battiscomb, 362-74. Oxford, Oxford University Press.
- Powell, Roger, and Peter Waters. 1969. “Technical Description of the Binding”, in *The Stonyhurst Gospel of Saint John*, ed. T. Julian Brown, 45-55. Oxford: Oxford University Press.
- Van Regemorter, Berthe. 1992. “The Binding of the manuscripts of the Saints Cuthbert and Boniface”, in Berthe Van Regemorter, *Binding Structures in the Middle Ages: A Selection of Studies*, trans. Jane Greenfield, 43-51. Brussels: Bibliotheca Wittockiana; London: Maggs Bros. Ltd.

Cuthbert Gospel Quire Diagrams

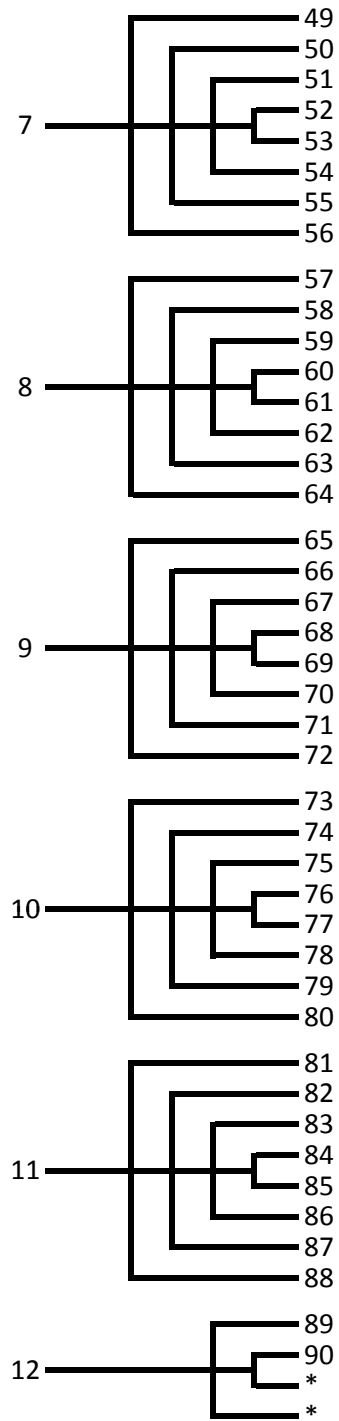
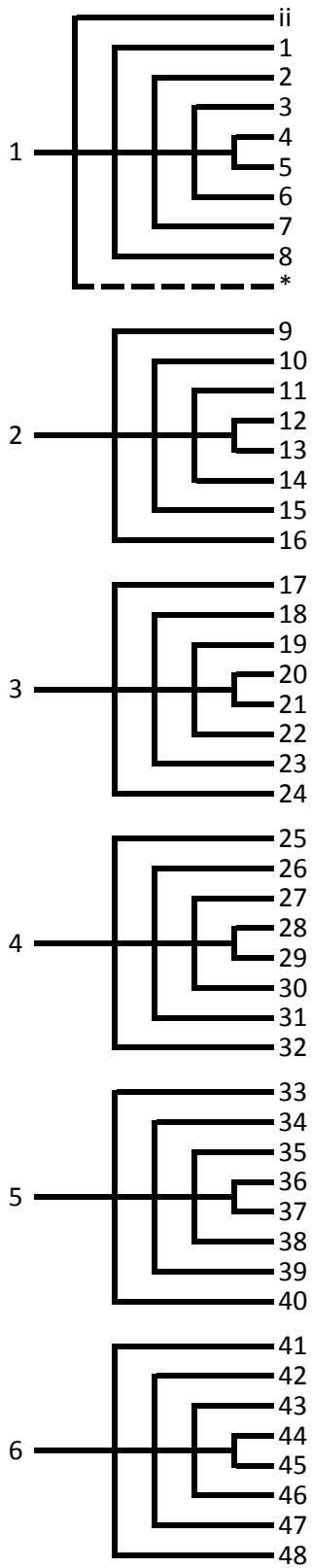

(10) London, Lambeth Palace Library, MS 1370

“MacDurnan Gospels”

Gospel Book in Latin with Old Irish; additional poems in Latin and Charters in Old English and Latin.

Armagh, 9th century.

Additions in Canterbury, 11th, 12th and 16th centuries.

Physical Description

Support: parchment.

Number of leaves and flyleaves: ii (modern parchment) + 217 (modern foliation 1-4, 4*, 5-216; fol. 4* is an original unfoliated leaf, the current fol. 4 is a later addition, formerly pasted to the recto of fol. 4*; the leaves are now separated) + iv (modern parchment).

Dimensions of leaves: 158 x 111 mm (trimmed, e.g. partial Eusebian section numbers on fols 10v and 165v, and gloss on fol. 48r).

Dimensions of written space: 89 x 46 mm.

Ruling medium: hard point.

Ruling pattern: single vertical bounding lines and horizontal text lines for text block, single vertical bounding line for initials in left margin, sometimes also single vertical bounding lines and horizontal text lines for Eusebian section numbers in margins.

Columns and lines: 20-25 lines (variable throughout), single column.

Scribes: uncertain, ?1 original + 1 additional (final 4 lines of Gospel of John, fol. 216v).

Script: Insular minuscule + addition in Insular minuscule with elements of Caroline minuscule (more rounded aspect and some Caroline letterforms, especially g with looped top and et-ligature resembling ampersand; final 4 lines fol. 216v).

Quire Signatures: quires 8 and 16-18, signed on the recto of the first leaf in the lower left margin, h, q, r and s. Traces of a letter can be discerned in the equivalent position on quire 9, now trimmed and illegible; others almost certainly lost to trimming.

Glosses and Headers: (fol. 65v) gloss in Old Irish, lower margin, beside Matthew 27:24-32, “mór assársa f(or) coimdid nime (agus) talman” (Great dishonour this upon the Incarnate God of heaven and earth; J. H. T. 1838, 144); (fol. 93v) inscription in Latin, lower margin, beside Mark 9:16-17, “signum crucis” (sign of the cross), along with crosses in the left, right and lower margins; (fol. 48r) gloss, right margin, partly trimmed ?“iega[...]”; prayer formula xb, upper margin of some pages (e.g. fols 88v, 108v); marginal numbers iiii, u, iii (fol. 18r-v).

Eusebian Sections: marked in outlined boxes in margins of most pages.

Collation

18 quires of irregular collation:

1¹⁸ (+ 1 after 3, addition; wants 14, 15 and 18, cancellation), 2¹⁰, 3¹⁰, 4¹² (wants 9, cancellation), 5¹² (wants 2, 7, 9, cancellation), 6¹⁴ (wants 9, cancellation), 7¹⁶ (+ 1 after 2, addition; wants 15, cancellation), 8¹², 9¹² (wants 10, cancellation), 10⁶, 11¹⁴ (+ 1 after 2, addition; wants 13, cancellation), 12¹⁴ (wants 1, cancellation), 13¹⁶ (wants 2, cancellation), 14¹⁴, 15¹² (+ 1 after 1, addition), 16¹⁰, 17¹⁰, 18¹⁶ (wants 6, cancellation).

Texts

1. Fol. 1r, *De evangelistis*, four lines from Sedulius's *Carmen Pascale*, "Hoc mattheus agens hominem [...] Aquile verbo petit astra Joh(anne)s", and six lines from Pseudo-Juvencus, *Versus in Libros IV Evangeliorum*, "Mattheus instituit virtutum tramite mores [...] jure sacer vitulus qui mema fatur avita", 16th- or 17th-century hand (Lawlor 1897, 24)
2. Fols 2r-3r, Gospel of Matthew, 1:1-17.
3. Fol. 3v, poem commemorating the donation of the MS to Christ Church, Canterbury, by King Æthelstan and implying previous ownership by Irish ecclesiast Mael Brigte mac Tornáin, Latin, 924-939 (Keynes 1985, 153; see *Provenance*).
4. Fols 5r-69r, Gospel of Matthew, 1:18-end; colophon, fol. 69r, "amen: d(e)o g(ra)tias ago".
5. Fol. 69v, charter of Archbishop Wulfstan of York concerning the consecration of Archbishop Æthelnoth of Canterbury, Old English, c. 1020 (S1386).
6. Fol. 70r, charter of King Cnut concerning gifts to Christ Church, Canterbury, Latin, 12th century (S959x).
7. Fol. 72r-113v, Gospel of Mark; colophon, fol. 113v, "finit, amen, finit".
8. Fol. 114r, charter concerning the boundary between the dioceses of Canterbury and Rochester, Old English, 11th century (S1564).
9. Fol. 114r, charter of Archbishop Eadsige of Canterbury concerning land agreements, Old English, 1038-1050 (S1466).
10. Fol. 114v, charter of King Cnut granting judicial and financial rights to Archbishop Æthelnoth of Canterbury, Old English, c. 1020 (S986).
11. Fol. 115r, charter of Archbishop Æthelnoth of Canterbury concerning land agreements, Old English, 1020-1038 (S1464).
12. Fol. 117r-170r, Gospel of Luke; colophon, fol. 170, "d(e)o g(ra)tias ago".

13. Fol. 172r-216v, Gospel of John.

Decoration: Original

Full page miniatures: (fol.1v) *four symbols page*, symbols each with four wings arranged in quadrants around a cross extending from the frame, tinted yellow, orange, green, purple, red; (fol. 4*v) *Matthew portrait*, standing, facing forward, holding book and long crooked staff, tinted purple, orange, green, yellow, white and red; (fol. 70v) *Mark portrait*, standing, facing forward, holding book, flanked by two beasts standing on their hind legs and licking the sides of his head, a further animal emerging from above frame, tinted green, purple, yellow, white, orange and red; (fol. 115v) *Luke portrait*, standing, facing forward, holding book and short crooked staff, tinted yellow, red, pink, orange, green, white, dark purple; (fol. 170v) *John portrait*, standing, facing forward, holding book and knife and dipping quill-pen in inkwell, tinted purple, mauve, orange, green, yellow, white and red.

Decorated initials: (fol. 2r) *Matthew incipit*, 5 lines, knotted-wire letters with zoomorphic and interlace terminals, geometric infill and dotting, tinted red, yellow and purple; (fol. 72r) *Mark incipit*, 17 lines, knotted-wire letters with interlace terminals, geometric and fret-pattern infill and dotting, tinted red, green, yellow and orange; (fol. 117r) *Luke incipit*, 8 lines, knotted-wire letters with zoomorphic terminal, fret-pattern infill and dotting, tinted mauve, green, yellow, red, white and orange; (fol. 172r) *John incipit*, with full line of display script, knotted-wire letters with interlace terminals, geometric and fret-pattern infill and dotting, tinted purple, green, yellow, red and orange; (fol. 5r) *Chi-rho*, full-page, knotted-wire letters with zoomorphic, anthropomorphic and interlace terminals, geometric infill and dotting, tinted yellow, white, red, purple, mauve and green.

Minor initials: numerous, enlarged in the margin, with tinted infill.

Text decoration: Eusebian section numbers and marginal gloss (fol. 65v) set in orange frames, occasionally with decorative finials (e.g. fols 9r, 10v, 14v, 22r, 23v); occasional marginal crosses (fols 111r, 193v); rows of red dots as line-filler (fols 19v, 21r, 23v, 24r) and to divide passages of text on a page (fol. 46v, 58r, 77v, 79r, 84v, 89v, 92v, 93r, 98v, 123r-124v, 129r, 136r, 156r)

Full page frames, (fol.1v) panels of lozenge and fret pattern, tinted yellow, red and green, 115 x 76 mm; (fol. 2r) double-border of dots, 98 x 53 mm; (fol. 4*v) panels of fret-pattern and zoomorphic interlace, tinted yellow, purple, red, orange, green, 130 x 81 mm; (fol. 5r) panels of fret pattern and zoomorphic interlace, tinted yellow, purple, mauve, red, orange, green, 120 x 82 mm; (fol. 70v) panels of fret pattern with ellipses at corners, tinted red, yellow, green and purple, 113 x 70 mm; (fol. 72r) zoomorphic with interlace at the corners and panels of interlace, zoomorphic interlace and fret patterns, tinted red, yellow, green, orange, mauve

and white, 116 x 72 mm; (fol. 115v) panels of interlace and fret patterns, tinted yellow, red, pink, orange and green, 125 x 73 mm; (fol. 117r) panels of zoomorphic interlace, tinted yellow, green, orange, purple, mauve, 125 x 82 mm; (fol. 170v) panels of fret patterns, tinted yellow, purple, mauve, orange and green, 115 x 79 mm; (fol. 172r) interlace at the corners and trios of pellets around edges, panels of interlace and fret patterns, tinted green, orange, purple, mauve and yellow, 110 x 72 mm.

Decoration: Additional (13th century, added 16th century)

Full page miniatures: (fol. 4r) *Crucifixion*, Christ on the Cross flanked by Mary and John, sun and moon, tinted blue, pink, green, red and white with gold leaf; (fol. 71r) *Scourging*, Christ standing behind the column with his hands crossed before it, flanked by two flagellants, tinted blue, pink, red, green and white with gold leaf; (fol. 116r) *Betrayal*, Christ embraced by Judas, surrounded by soldiers and apostles including Peter with a sword, tinted blue, pink, red, green and white with gold leaf; (fol. 171r) *Entombment*, the body of Christ laid out surrounded by Mary and the Apostles, tinted blue, pink, red, green and white with gold leaf.

Full page frames, (fol. 4r) 129 x 93 mm; (fol. 71r) 130 x 92 mm; (fol. 116r) 128 x 94 mm; (fol. 171r) 128 x 92 mm.

Binding

Gilt leather with two clasps (one broken), the edges of the leaves painted in gold and decorated with a design of foliate scrolls; sixteenth-century, probably commissioned by Archbishop Matthew Parker (d. 1575), as it is like others from his collection (e.g. Cambridge, University Library, Ff. 1. 23). Leaf-tab markers of red-brown leather pasted to tail-edge of leaves at opening of gospels of Mark, Luke and John (fols 70v, 117r and 172r) similar to those found in Cadmug Gospels (cat. 7); possibly original.

Provenance

Scholars have noted the manuscript's palaeographical, textual and art-historical affinities with the Book of Armagh and, to a lesser extent, the later Armagh manuscripts, BL Harley MSs 1802 and 1023. These strongly suggest an origin for the MacDurnan Gospels at Armagh (Bieler 1949, 276; James 1930, 843; Henry 1967, 104; MacNamara 1987, 217-222; Brown forthcoming).

An Armagh provenance is further supported by the inscription on fol. 3v:

+ MÆIELBRIDVS · MAC/DVRNANI · ISTV(M) · TEXTV(M)/ PER ·
TRIQVADRV(M) · D(E)O ·/ DIGNE · DOGMATIZAT ·/ + AST ·

ÆTHELSTANVS · / ANGLOSÆXANA · REX · ET · / RECTOR ·
DORVERNENSI · / METROPOLI · DAT · P(ER) ÆVV(M) :

(Mael Brigte mac Tornáin propounds this gospel-book throughout the world, in a manner worthy of God; but Æthelstan, king and ruler of the Anglo-Saxons, gives it for ever to the metropolitan see of Canterbury; trans. Keynes 1985, 153).

This implies that the manuscript belonged to Mael Brigte mac Tornáin (d. 927), who was abbot of Armagh among a number of other houses (on Mael Brigte's career, see Dumville, 2004). It also reveals that the manuscript was acquired by King Æthelstan (r.924-939), and given by him to Christ Church, Canterbury.

The final four lines of the Gospel of John (fol. 216v) are written in a different hand that shows Caroline influence, perhaps added in Anglo-Saxon England. It is likely this replaces a lost leaf on which the lines were originally written. The leaf must have been a singleton, unless there were further texts after the gospels, as the final quire of the manuscript appears to be complete. This has a parallel in Add. 40618 in which the final leaf of the Gospel of John, also apparently a singleton, was lost and replaced in Anglo-Saxon England by a scribe who signed himself Edward the deacon.

The manuscript remained in Canterbury through the eleventh century, as shown by the inserted charters (fols 69v, 114r, 114v, 115r), relating to the incumbencies of archbishops of Canterbury Æthelnoth (1020-1038) and Eadsige (1038-1050). A further charter added at some point in the twelfth century (fol. 70r) is also concerned with matters specific to Canterbury, indicating that the MS also remained there in this period.

In the sixteenth century, the manuscript evidently entered the possession of Archbishop Matthew Parker (d. 1575), since although it does not seem to appear in any of his inventories, his name "Matthæus Parker" is signed in red chalk on the flyleaf. Modern chapter divisions to the biblical text were also added in the upper margins in the same distinctive chalk. Parker was probably also responsible for commissioning the current binding and for adding the miniatures from a thirteenth-century manuscript (fols 4r, 71r, 116r, 171r), from which miniatures are also found in other Parker manuscripts (Cambridge, Corpus Christi College, MSs 419 and 452).

At some point the Sedulius/Juvenius verses were added on fol. 1r (number 1). The italic script dates from the sixteenth or seventeenth century and may have been added by Parker or a later hand. Though Parker's handwriting in his ownership inscription in the manuscript is more or less an italic script, it is not quite the same as the verses: the M is notably similar but the form of the h, e and r are different. However, the difference in

medium and context makes a definitive assessment difficult and it is worth noting that “Matthæus” is spelled the same unusual way in both the verses and in Parker’s ownership inscription.

In 1760, antiquary Lewis Morris published a description of the manuscript in *Y Cymmrodor* II. (1878), p. 56, in which he claimed that it was in the possession of a mathematical instrument maker and member of the Cymmrodorion Society named Fr. Howel in London.

Entered Lambeth Palace library at an unknown date. Though apparently absent from H. J. Todd’s 1812 catalogue of Lambeth’s manuscripts, an annotation to the archivists’ copy states that it is the missing MS 771. If so, the catalogue indicates that it was one of the *Codices Tenisoniani*, those manuscripts collected and given to Lambeth by Archbishop Thomas Tenison (archbishop from 1694, d. 1715).

Bibliography

- Alexander, Jonathan J. 1978. *Insular Manuscripts, 6th to the 9th Century*, A Survey of Manuscripts Illuminated in the British Isles 1, 86, cat. 70. London: Harvey-Miller.
- Brown, Michelle P. Forthcoming. “Ferdornach and the Ninth to Twelfth-Century Books of Armagh: exuberant exhibitionist or accomplished antiquary?”, in *Mapping New Territories in Art and Architectural History: essays in honour of Roger Stalley*, ed. F. Narkiewicz, N. NicGhabhann and D. O’Donovan. Brepols: Turnhout.
- Dumville, David N. 2004. “Mael Brigte mac Tornáin, Pluralist coarb (d. 927)”, *Journal of Celtic Studies* 4: 97-116.
- Farr, Carol A. 2011. “Irish Pocket Gospels in Anglo-Saxon England” in *Anglo-Saxon Traces, Collected Papers of the 2007 Meeting of the International Society of Anglo-Saxonists*, ed. Jane Roberts and Leslie Webster, 87-100. Arizona: Tempe.
- Ganz, David, and Jane Roberts, eds. 2007. *Lambeth Palace Library and its Anglo-Saxon Manuscripts*, Biennial Conference of the International Society of Anglo-Saxonists, 3rd August 2007. London: Taderon Press.
- Henry, Françoise. 1957. “An Irish Manuscript in the British Museum (Add. 40.618)”, *JRSAI* 87, 2: 147-166.
- J. H. T. 1838. “King Athelstan’s copy of the Gospels, in Lambeth Library”, in *The British Magazine and Monthly Register of Religious and Ecclesiastical Information, Parochial History, and Documents Respecting the State of the Poor, Progress of Education, Etc*, 14, ed. H. J. Rose & S. R. Maitland, 141-147.
- James, M. R., and C. Jenkins. 1930. *A Descriptive Catalogue of the Manuscripts in the Library of Lambeth Palace*, V, 843-845. Cambridge: Cambridge University Press.

- Kenney, James F. rpt. 1997. *The Sources for the Early History of Ireland: Ecclesiastical*, 644-45, cat. 475. Dublin: Four Courts.
- Keynes, Simon. 1985. "King Athelstan's Books", in *Learning and Literature in Anglo-Saxon England, Studies Presented to Peter Clemoes on the Occasion of his Sixty-Fifth Birthday*, ed. Michael Lapidge and Helmut Gneuss, 153-159. Cambridge: Cambridge University Press.
- Lambeth Palace Library, online catalogue (based on James & Jenkins, 1930):
<http://archives.lambethpalacelibrary.org.uk/CalmView/Record.aspx?src=CalmView.Catalog&id=MSS%2f1370&pos=1>
- McGurk, Patrick. 1956. "The Irish Pocket Gospel", *Sacris Erudiri* 8, 2: 249-270, at 249-270.
- McNamara, Martin. 1987. "The Echternach and Mac Durnan Gospels: Some Common Readings and their Significance", *Peritia* 6, 1: 217-222.
- Page, R. I. 1993. *Matthew Parker and his Books, Sandars Lectures in Bibliography, Delivered on 14, 16, and 18 May 1990 at the University of Cambridge*. Kalamazoo: Medieval Institute Publications.
- Palmer, Richard, and Michelle P. Brown, eds. 2010. *Lambeth Palace Library, Treasures from the Collection of the Archbishops of Canterbury*. London, Scala.

MacDurnan Gospels Quire Diagrams

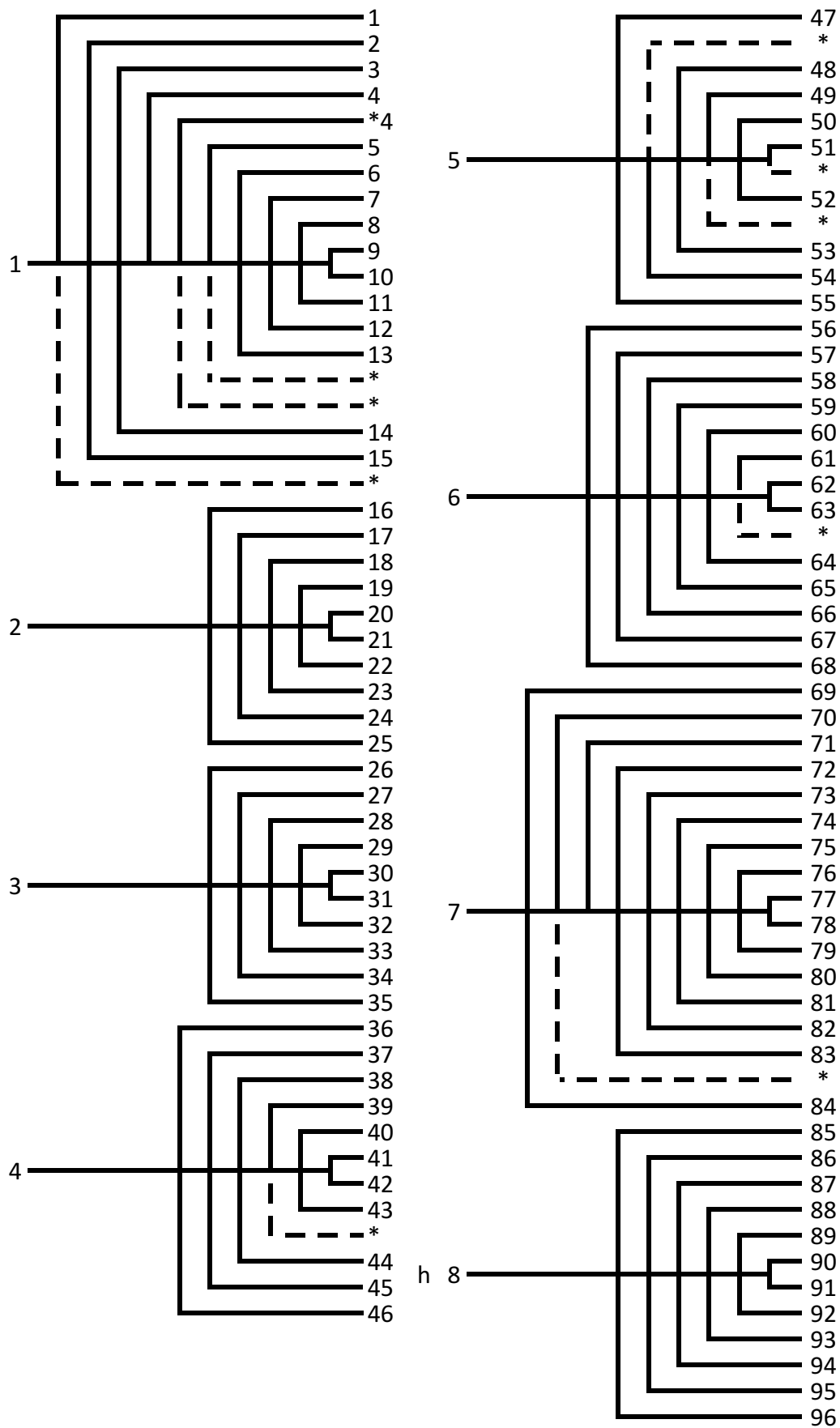

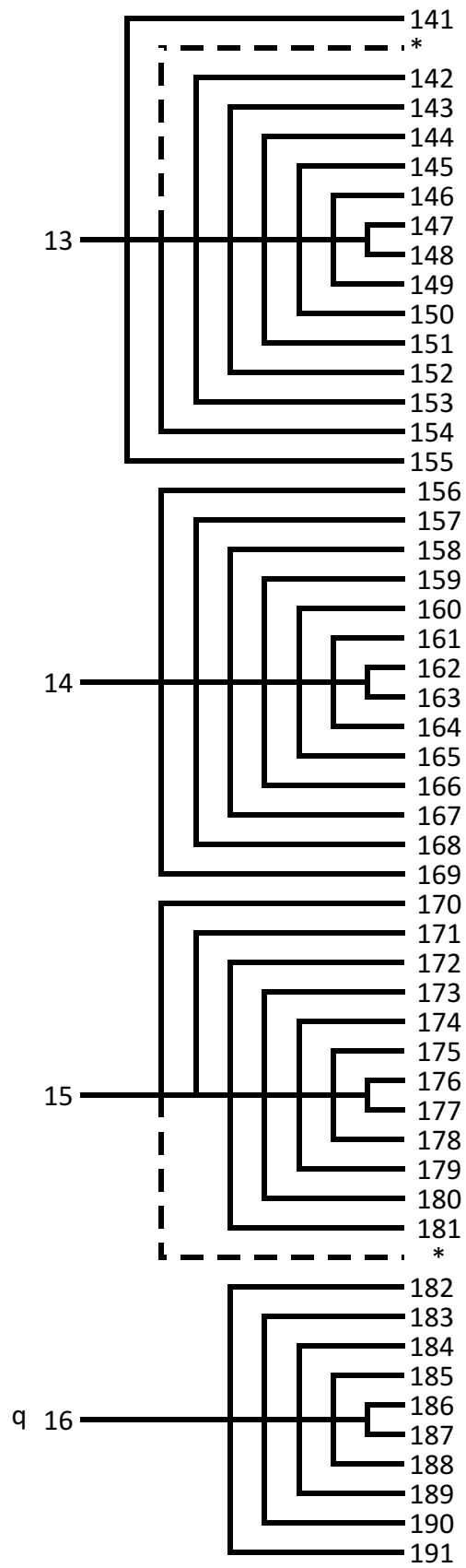
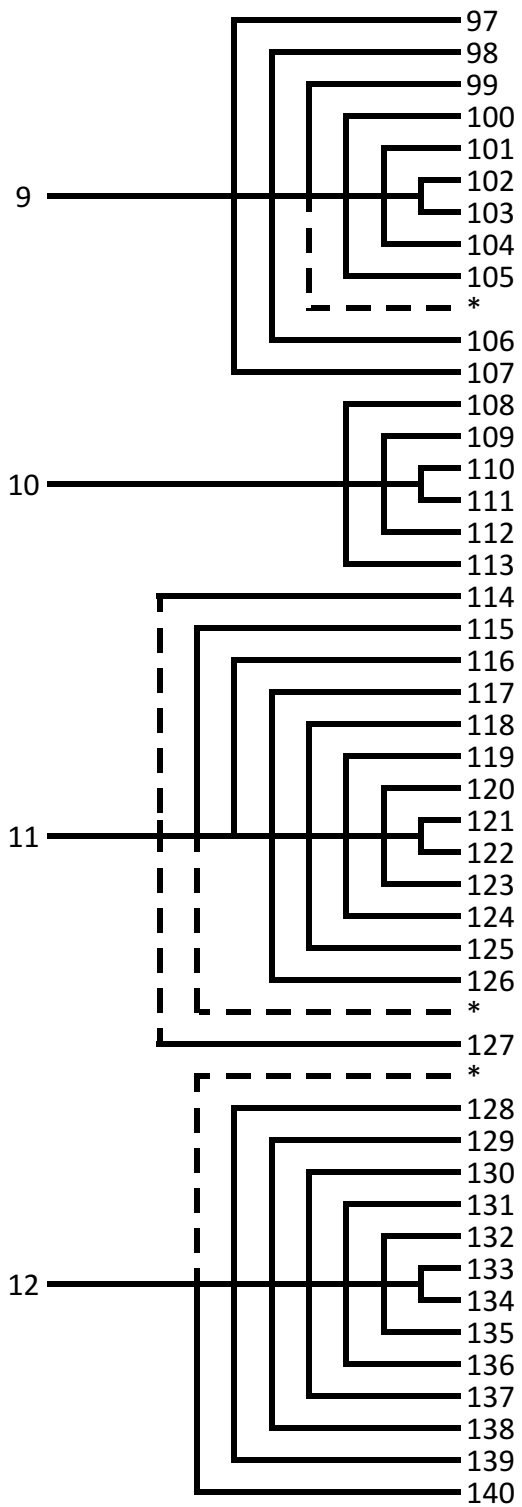

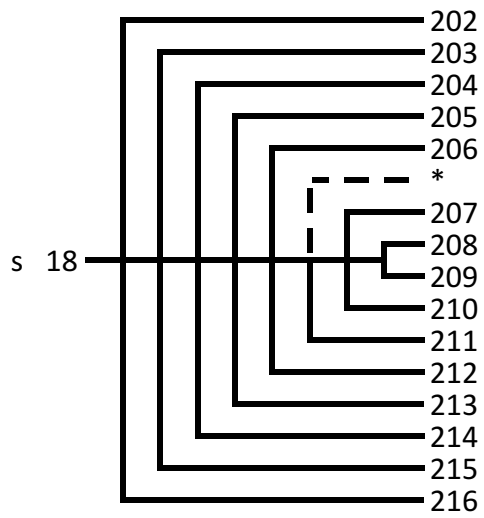
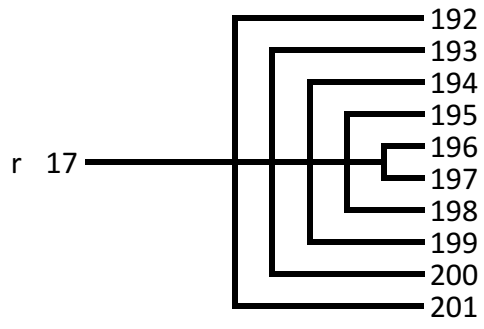

Abbreviations

Libraries

RIA	Dublin, Royal Irish Academy
TCD	Trinity College Dublin
NMI	National Museum of Ireland
BodL.	Oxford, Bodleian Library
BNF	Paris, Bibliothèque Nationale de France
BL	London, British Library
DCL	Durham Cathedral Library
BAV	Vatican City, Biblioteca Apostolica Vaticana

Works and Series

<i>AFM</i>	<i>Annals of the Four Masters</i>
<i>AU</i>	<i>Annals of Ulster</i>
CCSL	Corpus Christianorum, Series Latina
CELT	Corpus of Electronic Texts Edition, University College Cork
<i>CLA</i>	<i>Codices Latini Antiquiores</i> , ed. E. A. Lowe, 11 vols. and supplement (Oxford, 1934-71; 2nd edn. of vol. 2, 1972)
CPL	Clavis Patrum Latinorum
EEMF	Early English Manuscripts in Facsimile
<i>JRSAI</i>	<i>Journal of the Royal Society of Antiquaries of Ireland</i>
MGH	Monumenta Germaniae Historica
PL	Patrologiae Cursus Completus, Series Latina
<i>PRIA</i>	<i>Proceedings of the Royal Irish Academy</i>
SC	Sources Chrétiennes

Manuscripts

Abuna Garima Monastery, MS 2

Augsburg, Universitätsbibl. Cod. I.2.4°.2 (Augsburg Gospels)

Autun, Bibliothèque Municipale, MS 3 (Gundohinus Gospels)

Bamberg Staatsbibliothek, Msc. Bibl. 1

Baltimore, Walters Art Museum, MS W.537 (Walters Gospels)

Basel, Universitätsbibliothek

Cod. F III 15b

Cod. F III 15c

Cod. F III 15d

Cod. F III 15f

Cod. F III 15l

Berlin, Staatsbibliothek Diezianus B Sant. 66

Bern, Burgerbibliothek, Cod. 671

Bückeburg, Niedersächsisches Staatsarchiv, dep. 3, Bedafragment III-VI B

Cambridge, Corpus Christi College, MS 286 (St Augustine Gospels)

Cambridge, St John's College, MS C. 9 (Southampton Psalter)

Cambridge, University Library

MS ii.6.32 (Book of Deer)

MS Ll.I.10 (Book of Cerne)

Chatsworth, Derbyshire, Chatsworth House (MS in private hands)

Colmar, Bibliothèque Municipale, MS 15 (Previously Colmar, Stadtbibliothek MS 38; Ratfrid Gospels)

Cologne, Dombibliothek MS 213

Darmstadt, Hessische Landes- und Hochschulbibl. MS 4262

Dublin, NMI, 06E0786:13 (Faddan More Psalter)

Dublin, RIA

MS 12 R 33 (Cathach of Columba)

MS D II 3 (Stowe St John and Missal)

Dublin, TCD

MS 50 (Ricemarch Psalter)

MS 52 (Book of Armagh)

MS 57 (Book of Durrow)

MS 58 (Book of Kells)

MS 59 (Book of Dimma)

MS 60 (Book of Mulling and Mulling fragment)

Durham, DCL

MS A. II. 10

MS A. II. 17 (Durham Gospels)

MS B. II. 30 (Durham Cassiodorus)

Edinburgh University Library MS 50

Einsiedeln, Stiftsbibliothek, Cod. 17

Florence, Biblioteca Medicea Laurenziana

MS Amiatino 1 (Codex Amiatinus)

MS Plut. I. 56 (Rabbula Gospels)

Fulda, Landesbibliothek

Codex Bonifatianus 1 (Victor Codex)

Codex Bonifatianus 3 (Cadmug Gospels)

Hanover, Kestner-Museum Cul. I. 44 (365)

Leiden, University Library, BPL 67 (Leiden Priscian)

London, BL

Add. MS 10546 (Moutier-Grandval Bible)

Add. MS 11848 (Carolingian Gospels)

Add. MS 24142

Add. MS 40618

Add. MS 89000 (St Cuthbert Gospel of John, formerly Stonyhurst Gospel)

Cotton MS Augustus II 18

Cotton MS Galba A XVIII

Cotton MS Nero D IV (Lindisfarne Gospels)

Cotton MS Tiberius A II (Athelstan Gospels)

Cotton MS Vespasian A I (Vespasian Psalter)

Cotton MS Vitellius F XI (Cotton Psalter)

Egerton MS 93

Harley MS 1023

Harley MS 1775

Harley MS 1802 (Gospels of Mael Brigte)

Harley MS 2795

Harley MS 2965 (Book of Nunnaminster)

Harley MS 7653 (Harley Prayer Book)

Royal MS 1 B VII (Royal Gospels)

Royal MS 1 E VI

Royal MS 2 A XX (Royal Prayer Book)

London, Lambeth Palace Library, MS 1370 (MacDurnan Gospels).

Maaseik, Kerkschatten van Sint-Catharina, Codex Eyckensis (Maaseik Gospels).
Montpellier, Bibliothèque de l'Université Montpellier, MS 409 (Montpellier Psalter).
Munich, Bayerische Staatsbibliothek
 Clm 210
 Clm 14000 (Codex Aureus of St Emmeram)
 Clm 6237
Münster-in-Westfalen, Staatsarchiv, MSC 1243
New York, Morgan Library, MS M. 1 (Lindau Gospels)
Nuremberg, Germanisches Nationalmuseum Kupferstichkabinett, Kapsel 536 SD 285
Oxford, BodL.
 MS Auct. D. 2. 19 (MacRegol Gospels)
 MS Laud. Misc. 126
Paris, BNF
 MS Français 2452
 MS Lat. 1 (Vivian Bible)
 MS Lat. 10439 (Chartres Gospel of John)
 MS Lat. 12048 (Sacramentary of Gellone)
 MS Lat. 13246
 MS Lat. 816
 MS Lat. 8878
 MS Lat. 9008
 MS Lat. 9382
 MS Lat. 9389 (Echternach Gospels)
 MS Lat. 9428 (Drogo Sacramentary)
Rheims, Bibliothèque Municipale MS 875
Rouen, Bibliothèque Municipale, MS 24 [A. 41] (Rouen Psalter)
Schatzkammer der Residenz, MS s.n., fols 38v-39r
St. Gallen, Stiftsbibliothek
 Cod. Sang. 250
 Cod. Sang. 51 (St Gall Gospels)
 Cod. Sang. 60
 Cod. Sang. 728
 Cod. Sang. 904 (St Gall Priscian)
St. Paul im Lavanttal, Benediktinerstift, Cod. 86a/1 (Reichenau Primer)
Stockholm, Kungliga Biblioteket, MS A. 135 (Stockholm Codex Aureus)
Stuttgart, Württembergische Landesbibliothek, MS HB II. 16
Trier, Cathedral Treasury, MS 61 (Trier Gospels)

Turin, Biblioteca Nazionale

MS G. VII. 15 (Codex Bobiensis)

MS O. IV. 20 (Turin Gospels)

Utrecht, Universiteitsbibliotheek MS 32 (Utrecht Psalter)

Valenciennes, Bibliothèque Municipale, MS 99 (Valenciennes Apocalypse)

Vatican City, BAV

Vat. reg. 316 (Barberini Gospels)

Barb. lat. 570

Pal. lat. 493

Vienna, Österreichische Nationalbibliothek

Cod. 1861 (Dagulf Psalter)

Cod. 387

Cod. 15298

Cod. 458

Washington, D.C., Freer Gallery of Art, F1906.298

Zürich, Staatsarchiv, W3.19.XI

Bibliography

Published Primary Sources¹

- Adomnán. *Adomnan's Life of Columba*, ed. Alan O. Anderson and Marjorie O. Anderson. London: Nelson, 1961.
- Adomnán. *De Locis Sanctis*, ed. Ludwig Bieler, CCSL 175, 183-234. Turnhout: Brepols, 1965.
- Adomnán. *Life of St Columba*, trans. Richard Sharpe. Harmondsworth, Middlesex: Penguin Books, 1995.
- Æthelwulf. *De Abbatibus*, ed. and trans. A. Campbell. Oxford: Clarendon Press, 1967.
- Alcuin. *Epistolae*, ed. Ernst Dümmler, *MGH Epistolae Karolini aevi* II, 1-481. Berlin: Weidmann, 1895.
- Annals of the Four Masters*, ed. Donnchadh Ó Corráin, Mavis Cournane, CELT, <http://www.ucc.ie/celt/online/G100005A/>
- Annals of the Four Masters*, trans. John O'Donovan, CELT, <http://www.ucc.ie/celt/online/T100005A/>
- Annals of Ulster*, ed. Donnchadh Ó Corráin and Mavis Cournane, CELT, <http://www.ucc.ie/celt/online/G100001A/>
- Annals of Ulster*, trans. Pádraig Bambury and Stephen Beechinor, CELT, <http://www.ucc.ie/celt/online/T100001A/>
- Asser. *Asser's Life of King Alfred*, ed. William Henry Stevenson. Oxford: Clarendon Press, 1904.
- Asser. *Life of King Alfred*, trans. Simon Keynes and Michael Lapidge, in *Alfred the Great: Asser's Life of King Alfred and Other Contemporary Sources*. Harmondsworth, Middlesex: Penguin Books, 1983.
- Augustine. *City of God*, trans. Marcus Dods, NPNF 1, 2, 1-511. Buffalo: Christian Literature Co., 1887.
- Augustine. *De Civitate Dei*, ed. Bernard Dombart and Alphonse Kalb, CCSL 48. Turnhout: Brepols, 1955.
- Augustine. *De consensu evangelistarum*, ed. F. Wehrich, CSEL 43. Turnhout: Brepols, 1904.
- Augustine. *Enchiridion de fide, spe et caritate*, ed. E. Evans, CCSL 46, 49-114. Turnhout: Brepols, 1969.
- Augustine. *Enchiridion*, trans. Albert C. Outler, Library of Christian Classics VII. London: SCM Press, 1955.

¹ Where no source is given, transcriptions and translations are my own.

- Augustine. *In Iohannis Evangelium Tractatus CXXIV*, ed. Radbodus Willems, CCSL 36. Turnhout: Brepols, 1954.
- Augustine. *The Harmony of the Gospels*, trans. S. D. Salmond, NPNF 6. New York: Christian Literature Company, 1888.
- Augustine. *Tractates on the Gospel of John 112-24; Tractates on the first Epistle of John*, trans. John W. Rettig, The Fathers of the Church 92. Washington: Catholic University of America Press, 1995.
- Bede. *Commentary on Revelation*, trans. Faith Wallis. Farnham and Burlington: Ashgate, 2014.
- Bede. *De Locis Sanctis*, ed. Jean Fraipont, CCSL 175, 251-80. Turnhout: Brepols, 1965.
- Bede. *De Tabernaculo*, ed. David Hurst, CCSL 119A. Turnhout: Brepols, 1969.
- Bede. *De Templo*, ed. David Hurst, CCSL 119A, 143-234. Turnhout: Brepols, 1969.
- Bede. *Ecclesiastical History of the English People*, trans. Bertram Colgrave and Roger A. B. Mynors. Oxford: Clarendon Press, 1993.
- Bede. *Expositio Apocalypseos*, ed. Roger Gryson, CCSL 121a. Turnhout: Brepols, 2001.
- Bede. *Homiliae*, ed. David Hurst, CCSL 122. Turnhout: Brepols, 1955.
- Bede. *Homilies on the Gospels*, trans. Lawrence T. Martin and David Hurst, 2 vols, Cistercian Studies Series 110. Kalamazoo: Cistercian Publications: 1991.
- Bede. *On the Holy Places*, trans. William Trent Foley and Arthur G. Holder, *Bede: A Biblical Miscellany*, 5-25. Liverpool: Liverpool University Press, 1999.
- Bede. *On the Temple*, trans. Seán Conolly, Translated Texts for Historians 21. Liverpool: Liverpool University Press, 1995.
- Bede. *Prose Life of Saint Cuthbert*, ed. and trans. Bertram Colgrave, *Two Lives of Saint Cuthbert: A Life by an Anonymous Monk of Lindisfarne and Bede's Prose Life*. Cambridge: Cambridge University Press, 1969.
- Bede. *Vita et miracula sancti Cuthberti*, ed. Joseph Stevenson, *Venerabilis Bedae opera historica minora*. London: Sumptibus Societatis, 1841.
- Benedict of Nursia. *The Rule of St Benedict*, ed. and trans. Justin McCann. London: Sheed and Ward, 1972.
- Bernard of Clairvaux. *Life of St. Malachy of Armagh*, trans. Hugh J. Lawlor, Translations of Christian Literature V, Lives of Celtic Saints. London and New York: Macmillan Company, 1920.
- Bible*, trans. Douai-Rheims 1899 American Edition, online edition, www.biblegateway.com.
- Biblia Sacra Vulgata*, online edition, www.biblegateway.com.
- Boniface. *Epistolae*, ed. Michael Tangl, *Die Briefe des Heiligen Bonifatius und Lullus*, MGH Selectae 1. Berlin: Weidmann, 1916.

- Boniface. *The Letters of Saint Boniface*, trans. Ephraim Emerton. New York: Columbia University Press, 1940, repr. 2000.
- Cassiodorus. *Institutiones*, ed. Roger A. B. Mynors, CPL 906. Oxford: Clarendon Press, 1961.
- Cassiodorus. *Institutions of Divine and Secular Learning and On the Soul*, trans. James W. Halporn, Translated Texts for Historians 42. Liverpool: Liverpool University Press, 2004.
- Concilium Germanicum*, ed. Philippe Labbé and Gabriel Cossart, Sacrosancta Concilia Ad Regiam Editionem Exacta VI, Tomus sextus ab anno DCXLIX ad annum DCCLXXXVII. Venice: Antonio Zatta, 1671.
- Electronic Sawyer, the Online Catalogue of Anglo-Saxon Charters*: British Academy-Royal Historical Society Joint Committee on Anglo-Saxon Charters. Retrieved 21 Jan., 2014, from: <http://www.esawyer.org.uk>.
- The Exeter Book*, ed. George Philip Krapp and Elliott Van Kirk Dobbie, Anglo-Saxon Poetic Records. New York: Columbia University Press, 1936.
- Godescalc. *Versus*, ed. Ernst Dümmler, *MGH Poetae* 1, 94-95. Berlin: Weidmann, 1881.
- Gregory I, Pope. *Dialogorum Libri IV*, ed. Jacques-Paul Migne, PL 77, 149-430. Paris: Migne, 1862.
- Gregory I, Pope. *Dialogues*, trans. Odo John Zimmermann, Fathers of the Church 39. New York: Fathers of the Church, 1959.
- Gregory I, Pope. *Homiliae in evangelia*, ed. Raymond Étaix, CCSL 141. Turnhout: Brepols, 1999.
- Gregory I, Pope. *Homiliae in Hiezechiehelem Prophetam*, ed. Marcus Adriaen, CCSL 142. Turhout: Brepols, 1971.
- Gregory I, Pope. *Moralia in Iob Libri I-X*, ed. Marcus Adriaen, CCSL 143. Turnhout: Brepols, 1979.
- Gregory I, Pope. *Morals on the Book of Job*, trans. James Bliss, Library of the Fathers of the Holy Church 18, 3 vols. Oxford: J.H. Parker, 1844-1850.
- Gregory I, Pope. *Pastoral Rule*, trans. James Barmby, NPNF 2, 12. New York: Christian Literature Company, 1895.
- Gregory I, Pope. *Regula pastoralis*, ed. Floribert Rommel and R. W. Clement, CCSL 141. Turnhout: Brepols, 1953.
- Gregory of Tours. *Glory of the Confessors*, trans. Raymond Van Dam, Translated Texts for Historians 5. Liverpool: Liverpool University Press, 1988.
- Gregory of Tours. *Liber Vitae Patrum*, in *Gregorii Episcopi Turonensis Miracula et Opera Minora* III, ed. Bruno Krusch, *MGH, Scriptorum Rerum Merovingicarum* I, 2. Hanover: Hahn, 1885.

- Gregory of Tours. *Life of the Fathers*, trans. Edward James, Translated Texts for Historians 1. Liverpool: Liverpool University Press, 1985, 2nd edn. 1991.
- Isidore of Seville. *De ecclesiasticis officiis*, ed. Christopher M. Lawson, CCSL 113. Turnhout: Brepols, 1989.
- Isidore of Seville. *Etymologiarum sive originum libri XX*, ed. Wallace M. Lindsay. Oxford: Clarendon, 1911.
- Isidore of Seville. *The Etymologies of Isidore of Seville*, trans. Stephen A. Barney, W. J. Lewis, J. A. Beach and Oliver Berghof. Cambridge: Cambridge University Press, 2006.
- Jerome. *Breviarium In Psalmos*, ed. Jacques-Paul Migne, PL 23. Paris: Migne, 1845.
- Jerome. *Commentarium in Evangelium Matthaei*, ed. Jacques-Paul Migne, PL 26. Paris: Migne, 1845.
- Jerome. *Commentary on Matthew*, trans. Thomas P. Scheck, The Fathers of the Church 117. Washington, D.C.: Catholic University of America Press, 2014.
- Jerome. *Epistulae*, ed. Isidor Hilberg, CSEL 54. Turnhout: Brepols, 1910.
- Jerome. *Letters*, trans. W. H. Fremantle, G. Lewis and W. G. Martley, NPNF 2, 6, ed. Philip Schaff and Henry Wace. Buffalo, N.Y.: Christian Literature Publishing, 1893.
- Jerome. *Vita Sancti Hilarionis Eremitae*, in *Hieronymi Opera Omnia*, ed. Jacques-Paul Migne, PL 23, 29-54. Paris: Migne: 1845.
- Jonas of Bobbio. *Vitae Sanctorum Columbani*, ed. Bruno Krusch in *Ionae Vitae Sanctorum Columbani, Vedastis, Iohannis*, MGH, *Scriptores Rerum Germanicarum*. Hanover and Leipzig: Hahn, 1905.
- Kemble, the Anglo-Saxon Charters Website*, The British Academy and Royal Historical Society, Department of Anglo-Saxon, Norse, and Celtic, University of Cambridge, <http://www.kemble.asnc.cam.ac.uk>.
- Les Ordines Romani du haut Moyen Âge*, ed. Michel Andrieu, 6 vols. Louvain: Spicilegium Sacrum Lovaniense, 1931-1963.
- Lives of Saints from the Book of Lismore*, ed. Whitley Stokes. Oxford: Clarendon Press, 1890.
- Monarchian Prologues to the Gospels*, ed. Peter Corsen, *Monarchianische Prologe zu den vier Evangelien*, 5-10. Leipzig: J. C. Hinrichs'sche Buchhandlung, 1896.
- Monarchian Prologues to the Gospels*, trans. Daniel J. Theron, *Evidence of Tradition: Selected Source Material for the Study of the History of the Early Church, the New Testament Books, and the New Testament Canon*, 56-63. Eugene, Oregon: Wipf and Stock, 1957.

- Patrick. *Confessio*, in *Libri Epistolarum Sancti Patricii Episcopi*, ed. Ludwig Bieler, Royal Irish Academy Dictionary of Medieval Latin from Celtic Sources, Ancillary Publications IV, 56-90. Dublin: Royal Irish Academy, 1993.
- Patrick. *Confession*, trans. Pádraig McCarthy, 2003, http://www.confessio.ie/etexts/confessio_english#01.
- Pseudo-Bede. *Collectanea*, ed. Jacques-Paul Migne, PL 94, 539-60. Paris: Migne, 1862.
- Rabanus Maurus. *De clericorum institutione*, ed. Jacques-Paul Migne, PL 107, 293-420. Paris: Migne, 1864.
- Reginald of Durham. *Libellus de Admirandis Beati Cuthberti Virtutibus*, ed. James Raine, Surtees Society 1. London: Nichols, 1835.
- La Règle du Maître*, ed. Adalbert de Vogüé, 2 vols, SC 106. Paris: Editions du Cerf, 1964.
- Rule of Tallaght*, ed. and trans. Edward Gwynn, *Hermathena* 44, sup. 2. Dublin: Hodges, Figgis and Co.; London: Longmans, Green and Co., 1927.
- The Rule of the Master*, trans. Luke Eberle, Kalamazoo, MI: Cistercian Publications, 1977.
- Sedulius. *The Paschal Song and Hymns*, ed. Carl Springer. Atlanta: Society of Biblical Literature, 2013.
- St Gall Library Catalogue*, Lehmann, Paul, *Mittelalterliche Bibliothekskataloge Deutschlands und der Schweiz, I Die Bistümer Konstanz und Chur*. München: C. H. Beck'sche Verlagsbuchhandlung, 1918, rpt. 1969.
- Sulpicius Severus. *Dialogi*, ed. Jacques-Paul Migne, PL 20, 183-222. Paris: Migne, 1845.
- Sulpicius Severus. *Dialogues*, trans. Alexander Roberts in *Sulpitius Severus, Vincent of Lerins, John Cassian*, ed. Philip Schaff and Henry Wallace, *NFPF* 2, 11, 53-119. Oxford and New York: James Parker and Christian Literature Co., 1894.
- Sulpicius Severus. *Epistola II. Ad Aurelium Diaconum*, ed. Jacques-Paul Migne, PL 20, 178-80. Paris: Migne, 1845.
- Sulpicius Severus. *Letter II, To the Deacon Aurelius*, trans. Alexander Roberts in *Sulpitius Severus, Vincent of Lerins, John Cassian*, ed. Philip Schaff and Henry Wallace, *NFPF* 2, 11, 44-47. Oxford and New York: James Parker and Christian Literature Co., 1894.
- Sulpicius Severus. *Life of St Martin*, trans. Carolinne White, in *Early Christian Lives: Life of Antony by Athanasius, Life of Paul of Thebes by Jerome, Life of Hilarion by Jerome, Life of Malchus by Jerome, Life of Martin of Tours by Sulpicius Severus, Life of Benedict by Gregory the Great*, 129-60. London: Penguin Books, 1998.
- Sulpicius Severus. *Vita Martini*, ed. Jacques Fontaine, *Vie de Saint Martin*, 3 vols, SC 133-35. Paris: Cerf, 1967-69.
- Vitae Sanctorum Hiberniae: Partim Hactenus Ineditae*, ed. Charles Plummer, 2 vols (Oxford: Clarendon Press, 1910).

Published Secondary Sources

- “Language of Bindings Thesaurus”, accessed 26/06/2016, <http://www.ligatus.org.uk/lob>.
- Abbott, Thomas K. “The Library”, in *The Book of Trinity College, Dublin, 1591-1891*. Belfast: M. Ward, 1892.
- Abbott, Thomas K. *Catalogue of the Manuscripts in the Library of Trinity College, Dublin*. Dublin and London, 1900.
- Abbott, Thomas K. and Edward J. Gwynn, *Catalogue of the Irish Manuscripts in the Library of Trinity College Dublin*. Dublin and London: Hodges, Figgis & Co., 1921.
- Alexander, Jonathan J. *Insular Manuscripts, 6th to the 9th Century*, A Survey of Manuscripts Illuminated in the British Isles 1. London: Harvey Miller, 1978.
- Belting, Hans. *Likeness and Presence: A History of the Image Before the Era of Art*, trans. Edmund Jephcott. Chicago and London: University of Chicago Press, 1994.
- Best, R. I. “On the Subscriptions of the ‘Book of Dimma’”, *Hermathena* 44 (1926): 84-100.
- Betham, William. *Irish Antiquarian Researches* 1. Dublin: William Curry, 1826.
- Bieler, Ludwig. “Insular Palaeography: Present State and Problems”, *Scriptorium* 3 (1949): 267-289.
- Bieler, Ludwig. “The ‘Notulae’ in the Book of Armagh”, *Scriptorium* 8, 1. (1954): 89-97.
- Bieler, Ludwig. “The Book of Armagh”, in *Great Books of Ireland*, 51-63. Dublin, Clonmore and Reynolds, 1967.
- Bieler, Ludwig. *Four Lives of St. Patrick: Colgan’s Vita Secunda, Quarta, Tertia, and Quinta, Scriptorum Latini Hiberniae* 8. Dublin: Dublin Institute for Advanced Studies, 1971.
- Bieler, Ludwig. *The Patrician Texts in the Book of Armagh, Scriptorum Latini Hiberniae* Series 10. Dublin Institute for Advanced Studies, School of Celtic Studies, 1979.
- Binski, Paul, and Patrick Zutshi. *Western Illuminated Manuscripts: A Catalogue of the Collection in Cambridge University Library*. Cambridge: Cambridge University Press, 2011.
- Bioletti, Susie, and Allyson Smith. “Shining a light on the pigments of early Irish manuscripts”, paper delivered at The Wandering Word: The Travels of Insular Manuscripts conference, Trinity College Dublin, 5th May, 2016.
- Bischoff, Bernhard. *Latin Palaeography: Antiquity and the Middle Ages*, trans. Dáibhí Ó Cróinín and David Ganz. Cambridge: Cambridge University Press, 1990; rpt. 2003.
- Bitel, Lisa M. “Tools and Scripts for Cursing in Medieval Ireland”, *Memoirs of the American Academy in Rome* 51/52 (2006/2007): 5-27.
- Bosworth, Joseph, and Thomas N. Toller. *An Anglo-Saxon Dictionary*. Oxford: Oxford University Press, 1898.

- Bourke, Cormac. *Patrick: The Archaeology of a Saint*. Belfast: Ulster Museum, 1993.
- Bovey, Alixe, and John Lowden, eds. *Under the Influence: the Concept of Influence and the Study of Illuminated Manuscripts*. Turnhout: Brepols, 2007.
- Breay, Claire, and Bernard Meehan, eds. *The St Cuthbert Gospel: Studies on the Insular Manuscript of the Gospel of John (BL, Additional MS 89000)*. London: The British Library, 2015.
- Brooks, Nicholas. *The Early History of the Church of Canterbury, Christ Church from 597 to 1066*. Leicester: Leicester University Press, 1989.
- Brown, K. L., & R. J. Clark. "The Lindisfarne Gospels and two other 8th century Anglo-Saxon/Insular manuscripts: pigment identification by Raman microscopy", *Journal of Raman Spectroscopy* 35 (2004): 4-12.
- Brown, Michelle P. *A Guide to Western Scripts from Antiquity to 1600*. London: British Library, 1990.
- Brown, Michelle P. *Anglo-Saxon Manuscripts*. London: British Library, 1991.
- Brown, Michelle P. *Understanding Illuminated Manuscripts: A Guide to Technical Terms*. Malibu and London: Getty Museum and British Library, 1994.
- Brown, Michelle P. *The Book of Cerne, Prayer, Patronage and Power in Ninth-Century England*. London and Toronto: British Library and University of Toronto Press, 1996.
- Brown, Michelle P. "Embodying Exegesis: Depictions of the Evangelists in Insular Manuscripts" in *Le Isole Britanniche e Roma in Età Romanobarbarica*, ed. Anna M. Luiselli Fadda and Éamonn Ó Carragáin, 109-27. Rome: Herder, 1998.
- Brown, Michelle P. *The Lindisfarne Gospels: Society, Spirituality and the Scribe*. London: British Library, 2003.
- Brown, Michelle P. "Building Babel: The Architecture of the Early Written Western Vernaculars", in *Omnia Disce: Medieval Studies in Memory of Leonard Boyle, O.P.*, ed. Anne J. Duggan, Joan Greatrex and Brenda Bolton, 109-128. Aldershot: Ashgate, 2005.
- Brown, Michelle P. "Spreading the Word", in *In the Beginning: Bibles Before the Year 1000*, ed. Michelle P. Brown, 45-75. Washington D.C.: Freer Gallery of Art and Arthur M. Sackler Gallery, Smithsonian Institution, 2006.
- Brown, Michelle P. "From Columba to Cormac: The Contribution of Irish Scribes to the Insular System of Scripts", *L'Irlanda E Gli Irlandesi Nell'Alto Medioevo, Spoleto, 16-21 Aprile 2009*, Settimane Di Studio Della Fondazione Centro Italiano Di Studi Sull'Alto Medioevo LVII, 623-49. Spoleto: Presso La Sede Della Fondazione, 2010.

- Brown, Michelle P. "House Style in the Scriptorium, Scribal Reality, and Scholarly Myth", in *Anglo-Saxon Styles*, ed. Catherine E. Karkov and George H. Brown, 131-150. New York: SUNY Press, 2012.
- Brown, Michelle P. "The Eastwardness of Things: Relationships between the Christian Cultures of the Middle East and the Insular World," in *The Genesis of Books: Studies in the Interactions of Words, Text, and Print in Honor of A. N. Doane*, ed. M. T. Hussey and J. D. Niles, 17-49. Turnhout: Brepols, 2012.
- Brown, Michelle P. "Writing in the Insular World", in *The Cambridge History of the Book in Britain 1*, ed. Richard Gameson, 121-166. Cambridge: Cambridge University Press, 2011.
- Brown, Michelle P. "Images to be Read and Words to be Seen", in *Iconic Books and Texts*, ed. James W. Watts, 93-118. Sheffield, South Yorkshire, and Bristol, CT: Equinox Publishing, 2013.
- Brown, Michelle P. "Ferdornach and the Ninth to Twelfth-Century Books of Armagh: exuberant exhibitionist or accomplished antiquary?", in *Mapping New Territories in Art and Architectural History: essays in honour of Roger Stalley*, ed. F. Narkiewicz, N. NicGhabhann and D. O'Donovan. Brepols: Turnhout, forthcoming.
- Brown, Peter. "A Dark-Age Crisis: Aspects of the Iconoclastic Controversy", *English Historical Review* 346 (1973): 1-34.
- Brown, Peter. *The Cult of the Saints: Its Rise and Function in Latin Christianity*. Chicago: University of Chicago Press, 1981.
- Brown, Peter. "Images as a Substitute for Writing", in *East and West: Modes of Communication, Proceedings from the First Plenary Conference at Merida*, ed. by Evangelos Chrysos and Ian Wood, 15-34. Leiden, Boston, Köln: Brill, 1999.
- Brown, T. Julian, ed. *The Stonyhurst Gospel of Saint John*. Oxford: Roxburghe Club, 1969.
- Brown, T. Julian. "Northumbria and the Book of Kells", *Anglo-Saxon England* 1 (1972): 219-246.
- Brown, T. Julian. "Tradition, Imitation and Invention in Insular Handwriting of the Seventh and Eighth Centuries", in T. Julian Brown, *A Palaeographer's View: The Selected Writings of Julian Brown*, ed. Janet Bately, Michelle Brown, Albinia C. de la Mare, 179-200. London: Harvey Miller, 1993.
- Brown, T. Julian. "The Irish Element in the Insular System of Scripts to c. AD 850," in T. Julian Brown, *A Palaeographer's View: The Selected Writings of Julian Brown*, ed. Janet Bately, Michelle Brown, Albinia C. de la Mare, 201-20. London: Harvey Miller, 1993.
- Brown, T. Julian. "The Earliest Irish Manuscripts and their Late Antique Background" in T. Julian Brown, *A Palaeographer's View: The Selected Writings of Julian Brown*, ed.

- Janet Bately, Michelle Brown, Albinia C. de la Mare, 221-41. London: Harvey Miller, 1993.
- Bynum, Caroline Walker. *Wonderful Blood. Theology and Practice in Late Medieval Northern Germany and Beyond*. Philadelphia: University of Pennsylvania Press, 2007.
- Bynum, Caroline Walker. *Christian Materiality, An Essay in Religion in Late Medieval Europe*. New York: Zone Books, 2011.
- Byrne, Francis J. "The Stowe Missal", in *Great Books of Ireland*, ed. Liam de Paor, 38-50. Dublin, Clonmore and Reynolds ltd., 1967.
- Byrne, Francis J. and Pádraig Francis, "Two Lives of Saint Patrick: 'Vita Secunda' and 'Vita Quarta'", *JRSAI* 124 (1994): 5-117.
- Byrne, Francis J. "XVIII Church and Politics, c.750-c.1100", in *A New History of Ireland 1*, ed. Dáibhí Ó Cróinín, 656-79. Oxford: Oxford University Press, 2005.
- Carruthers, Mary. *The Book of Memory, A Study of Memory in Medieval Culture*. Cambridge: Cambridge University Press, 1990; 2nd edn., 2008.
- Carruthers, Mary. *The Craft of Thought: Meditation, Rhetoric, and the Making of Images, 400-1200*. Cambridge: Cambridge University Press, 1998.
- Caviness, Madeline H. "Images of Divine Order and the Third Mode of Seeing", *Gesta* 22, 2 (1983): 99-120.
- Charles-Edwards, Thomas M. "The Primatial Claims of Armagh, Kildare and Canterbury", *Early Christian Ireland*. Cambridge: Cambridge University Press, 2000: 416-440.
- Chazelle, Celia. *The Crucified God in the Carolingian Era: Theology and Art of Christ's Passion*. Cambridge: Cambridge University Press, 2001.
- Clancy, Thomas. "Deer and the Early Church in North-Eastern Scotland", in *Studies on the Book of Deer*, ed. Katherine Forsyth, 363-397. Dublin: Four Courts Press, 2008.
- Clarkson, Christopher. "Some Representations of the Book and Book-Making, from the Earliest Codex Forms to Jost Amman", in *The Bible as Book: The Manuscript Tradition*, ed. John Lawrence Sharpe and Kimberly Van Kampen, 197-203. London and New Castle, DE: British Library and Oak Knoll Press, 1998.
- Clay, John-Henry Wilson. "Gift-giving and Books in the Letters of St Boniface and Lul", *Journal of Medieval History* 35 (2009): 313-325.
- Clemens, Raymond, and Timothy Graham. *Introduction to Manuscript Studies*. Ithaca and London: Cornell University Press, 2007.
- Colker, Marvin L. *Trinity College Library Dublin Descriptive Catalogue of the Mediaeval and Renaissance Latin Manuscripts*. Aldershot: Scolar, 1991.
- Corsano, Karen. "The First Quire of the Codex Amiatinus and the Institutiones of Cassiodorus", *Scriptorium* 41, 1 (1987): 3-34.

- Cotter, James Finn. "The Book Within the Book in Medieval Illumination", *Florilegium* 12 (1993): 107-140.
- Crawford, H. S. "A Descriptive List of Irish Shrines and Reliquaries, Part II", *JRSAI* 13, 2 (1923): 151-176.
- Crawford, Sally. "Votive Deposition, Religion and the Anglo-Saxon Furnished Burial Ritual", *World Archaeology* 36, 1 (March 2004): 87-102.
- Davis-Weyer, Caecilia. *Early Medieval Art, 300-1150: Sources and Documents*. Toronto, Buffalo, London: Toronto University Press, 1971, repr. 2003.
- De Hamel, Christopher. *A History of Illuminated Manuscripts*. Oxford: Phaidon, 1986.
- De Hamel, Christopher. *The Book: A History of the Bible*. London: Phaidon, 2001.
- Depreux, Phillipe. "Investitura per anulum et baculum: Ring und Stab als Zeichen der Investitur bis zum Investiturstreit", in *Vom Umbruch zur Erneuerung?* ed. Jörg Jarnut & Matthias Wemhoff, 169-183. Munich: Fink, 2006.
- Derolez, Albert. *The Palaeography of Gothic Manuscript Books from the Twelfth to the Early Sixteenth Century*. Cambridge, Cambridge University Press, 2003.
- Derrida, Jacques. "Parergon", in *Truth in Painting*, trans. Geoff Bennington and Ian McLeod. Chicago and London: University of Chicago Press, 1987.
- Deshman, Robert. "The Galba Psalter: Pictures, Texts and Context in an Early Medieval Prayerbook", *Anglo-Saxon England* 26 (December 1997): 109-138.
- Doyle, Anthony Ian. "A Fragment of an Eighth-Century Office Book", in *Words, Texts and Manuscripts: Studies in Anglo-Saxon Culture Presented to Helmut Gneuss on the Occasion of his Sixty-Fifth Birthday*, ed. Karl Reichl and Hans Sauer, 11-27. Cambridge: DS Brewer, 1992.
- Duffy, Seán, ed. *Medieval Ireland: An Encyclopedia*. New York: Routledge, 2005.
- Dumville, David N. "Some Aspects of Annalistic Writing at Canterbury in the Eleventh and Early Twelfth Centuries", *Peritia* 2 (1983): 23-57.
- Dumville, David N. "English Square Minuscule Script: the background and earliest phases", *Anglo-Saxon England* 16 (Dec. 1987): 147-179.
- Dumville, David N. *Wessex and England from Alfred to Edgar*. Woodbridge: Boydell, 1992.
- Dumville, David N. "Anglo-Saxon Books: Treasure in Norman Hands?", in *Anglo-Norman Studies, Proceedings of the Battle Conference 1993*, ed. M. Chibnall, 83-99. Woodbridge: Boydell, 1994.
- Dumville, David N. *A Palaeographer's Review: The Insular System of Scripts in the Early Middle Ages*. Osaka: Kansai University, 1999.
- Dumville, David N. "Mael Brigte mac Tornáin, Pluralist coarb (d. 927)", *Journal of Celtic Studies* 4 (2004): 97-116.

- Dumville, David N. "Palaeography of the 'Book of Deer': The Original Manuscript and the Liturgical Addition", in *Celtic Essays 2001-2007*, 1, 183-212. Aberdeen: Centre for Celtic Studies, University of Aberdeen, 2007.
- Duncan, Elizabeth. "*The Southampton Psalter*": a Palaeographical and Codicological Exploration, Anglo-Saxon, Norse and Celtic Manuscript Studies 4. Cambridge: Department of Anglo-Saxon, Norse and Celtic, 2004.
- Duncan, Elizabeth. "Contextualising "The Rouen Psalter": Palaeography, Codicology, and Form", *The Journal of Celtic Studies* 5 (2005): 17-60.
- Dutton, Paul Edward, and Édouard Jeuneau. *The Autograph of Eriugena*, CC Autographa Medii Aevi, 3. Turnhout: Brepols, 1996.
- Dutton, Paul Edward. "Eriugena's Workshop: The Making of the Periphyseon in Rheims 875", in *History and Eschatology in John Scottus Eriugena and his Time: Proceedings of the Tenth International Congress of SPES*, ed. James McEvoy and Michael Dunne, *Ancient and Medieval Philosophy* 1, 30, 141-67. Leuven: Leuven University Press, 2002.
- Esmeijer, Anna. *Divina Quaternitas: A Preliminary Study in the Method and Application of Visual Exegesis*. Assen and Amsterdam: Van Gorcum, 1978.
- Farr, Carol A. *The Book of Kells, Its Function and Audience*. London and Toronto, 1997.
- Farr, Carol A. "The Shape of Learning at Wearmouth-Jarrow: The Diagram Pages in the Codex Amiatinus", in *Northumbria's Golden Age*, ed. Jane Hawkes and Susan Mills, 336-344. Stroud: Sutton Publishing, 1999.
- Farr, Carol A. "Commas and Columba, Power and Patrick: Restating the Archaic in the Book of Kells", in *Omnia Disce: Medieval Studies in Memory of Leonard Boyle, O.P.*, ed. Anne J. Duggan, Joan Greatrex and Brenda Bolton, 129-54. Aldershot: Ashgate, 2005.
- Farr, Carol A. "The Incipit Pages of the MacRegol Gospels", in *Making and Meaning in Insular Art: Proceedings of the Fifth International Conference on Insular Art held at Trinity College Dublin, 25-28 August 2005*, ed. Rachel Moss, 275-287. Dublin: Four Courts, 2007.
- Farr, Carol A. "The Sign at the Cross-roads: the Matthean Nomen Sacrum in Anglo-Saxon Gospel Books Before Alfred the Great", in *Anglo-Saxon Studies in Archaeology and History* 16 (2009): 77-86.
- Farr, Carol A. "Irish Pocket Gospels in Anglo-Saxon England" in *Anglo-Saxon Traces, Collected Papers of the 2007 Meeting of the International Society of Anglo-Saxonists*, ed. Jane Roberts and Leslie Webster, 87-100. Arizona: Tempe, 2011.
- Farr, Carol A. "In Time, Out of Time: Two Case Studies of Recycled Evangelist Pictures", in *The Art, Literature and Material Culture of the Medieval World: Transition*,

- Transformation and Taxonomy*, ed. Meg Boulton, Jane Hawkes and Melissa Herman, 249-263. Dublin: Four Courts, 2015.
- Fischer, Bonifatius. "Die lateinischen Evangelien bis zum 10. Jahrhundert: Zwei Untersuchungen zum Text", ed. Patrick McGurk und Florentine Mütterich, *Zeitschrift fuer die Neutestamentliche Wissenschaft und die Kunde der aelteren Kirche* 101 (2010): 119-144.
- Fitzpatrick, Siobhán. "The Stowe Missal: Its Provenance and Recent History", in *The Roscrea Conference, Commemorating Forty Conferences 1987-2007 at Mount St Joseph Abbey*, ed. George Cunningham, 1-6. Parkmore, Roscrea: Roscrea People, 2007.
- Flower, Robin. *The Irish Tradition*. Oxford: Clarendon Press 1979.
- Forsyth, Katherine. *Studies on the Book of Deer*. Dublin: Four Courts Press, 2008.
- Freedberg, David. *The Power of Images: Studies in the History and Theory of Response*. Chicago and London: University of Chicago Press, 1989.
- Friend, Jr., Albert M. "The Portraits of the Evangelists in Greek and Latin Manuscripts" 1, *Art Studies* 5 (1927): 115-147.
- Gamble, Harry Y. *Books and Readers in the Early Church: A History of Early Christian Texts*. London and New Haven: Yale University Press, 1995.
- Gamble, Harry Y. "Bible and Book", in *In the Beginning: Bibles Before the Year 1000*, ed. Michelle P. Brown, 15-35. Washington D.C.: Freer Gallery of Art and Arthur M. Sackler Gallery, Smithsonian Institution, 2006.
- Gameson, Richard. "The Royal 1. B. vii Gospels and English Book Production in the Seventh and Eighth Centuries", *The Early Medieval Bible, Its Production, Decoration and Use*, ed. Richard Gameson, 24-52. Cambridge: Cambridge University Press: 1994.
- Gameson, Richard. *The Codex Aureus an Eighth-Century Gospel Book: Stockholm, Kungliga Bibliotek, A. 135*, EEMF 28. Rosenkilde and Bagger: Copenhagen, 2001.
- Gameson, Richard. *The Scribe Speaks? Colophons in Early English Manuscripts*. Cambridge: Department of Anglo-Saxon, Norse and Celtic, 2001.
- Gameson, Richard. "The Insular Gospel Book at Hereford Cathedral", *Scriptorium* 56, 1 (2002): 48-79.
- Gameson, Richard. "Anglo-Saxon Scribes and Scriptoria", in *The Cambridge History of the Book in Britain 1, c.400-1100*, ed. Richard Gameson, 94-120. Cambridge, Cambridge University Press, 2011.
- Gameson, Richard. "The Material Fabric of Early British Books", in *The Cambridge History of the Book in Britain 1, c.400-1100*, ed. Richard Gameson, 21-27. Cambridge: Cambridge University Press, 2011.

- Gameson, Richard. "Materials, Text, Layout and Script", in *The St Cuthbert Gospel: Studies on the Insular Manuscript of the Gospel of John (BL, Additional MS 89000)*, ed. Claire Breay and Bernard Meehan, 13-40. London: The British Library, 2015.
- Gameson, Richard. "History of the Manuscript to the Reformation", in *The St Cuthbert Gospel: Studies on the Insular Manuscript of the Gospel of John (BL, Additional MS 89000)*, ed. Claire Breay and Bernard Meehan, 129-36. London: The British Library, 2015.
- Ganz, David. "The Preconditions for Caroline Minuscule", *Viator* 18 (1987): 23-44.
- Ganz, David. "The Ideology of Sharing: Apostolic Community and Ecclesiastical Property in the Early Middle Ages", in *Property and Power in the Early Middle Ages*, ed. Wendy Davies and Paul Fouracre, 17-31. Cambridge: Cambridge University Press, 1995.
- Ganz, David. "The Study of Caroline Minuscule 1953-2004", *Archiv fur Diplomatik* 50 (2004): 387-98.
- Ganz, David, and Jane Roberts, eds. *Lambeth Palace Library and its Anglo-Saxon Manuscripts*, Biennial Conference of the International Society of Anglo-Saxonists, 3rd August 2007. London: Taderon Press, 2007.
- Ganz, David. "Risk and Fluidity in Script: An Insular Instance", in *Teaching, Writing, Learning to Write: Proceedings of the XVIth Colloquium of the Comité International de Paléographie Latine Held at the Institute of English Studies, University of London, 2-5 September 2008*, ed. Pamela R. Robinson, 17-23. London: King's College London, Centre for Late Antique & Medieval Studies, 2010.
- Ganz, David. "The Earliest Manuscript of Lathcen's *Eclogae Moralium Gregorii* and The Dating Of Irish Cursive Minuscule Script", in *Early Medieval Ireland and Europe: Chronology, Contacts, Scholarship: Festschrift for Dáibhí Ó Cróinín*, ed. Pádraic Moran and Immo Warntjes, 597-624. Turnhout: Brepols Publishers, 2015.
- Garrison, Mary. "An Insular Copy of Pliny's *Naturalis Historia*. Leiden VLF 4 (fols 4-33)", in *Writing in Context: Insular Manuscript Culture 500-1200*, ed. Erik Kwakkel, 67-125. Leiden: Leiden University Press, 2013.
- Geake, Helen. "Invisible Kingdoms: The Use of Grave-goods in Seventh-century England", in *The Making of Kingdoms*, Anglo-Saxon Studies in Archaeology and History 10, ed. T. M. Dickinson and D. Griffiths, 203-215. Oxford: Oxford University School of Archaeology, 1999.
- Geddes, Jane. "The Art of the Book of Deer", *Society of Antiquaries of Scotland* 128 (1998): 537-49.
- Graves, Charles. "On the Date of the MS. Called the Book of Armagh", *PRIA* 3 (1844-1847): 316-324.
- Gumbert, Johann P. "The Irish Priscian in Leiden", *Quaerendo* 27, 4 (1997): 280-99.

- Gumbert, Johann P. "One Book with Many Texts: the Latin Tradition", in *Codices Miscellaneorum: Brussels Van Hulthem Colloquium 1999*, ed. R. Jansen-Sieben and H. van Dijk, 27-36. Brussels: Bibliothèque Royale de Belgique, 1999.
- Gwynn, John. *Liber Ardmachanus: The Book of Armagh*. Dublin: Royal Irish Academy, 1913.
- Hahn, Cynthia. "Seeing and Believing: The Construction of Sanctity in Early-Medieval Saints' Shrines", *Speculum* 72, 4 (Oct., 1997): 1079-1106.
- Hahn, Cynthia. *Portrayed on the Heart: Narrative Effect in Pictorial Lives of Saints from the Tenth Through the Thirteenth Century*. Berkeley, L.A.: University of California Press, 2001.
- Hahn, Cynthia. "What Do Reliquaries Do for Relics?", *Numen* 57 (2010): 284-316.
- Hahn, Cynthia. "The Letter and the Spirit, The Power of the Letter, the Enlivenment of the Word in Medieval Art", in *Visible Writings: Cultures, Forms, Readings*, ed. Marija Dabello and Mary L. Shaw, 55-76. New Brunswick, New Jersey and London: Rutgers University Press, 2011.
- Halsall, Guy. "The Viking Presence in England? The Burial Evidence Reconsidered", in *Cultures in Contact: Scandinavian Settlement in England in the Ninth and Tenth Centuries*, ed. D. M. Hadley and J. D. Richards, 259-76. Turnhout: Brepols, 2000.
- Hamburger, Jeffrey F. *Script and Image*. Paris, Leuven and Walpole, MA: Peeters, 2014.
- Hanna III, Ralph. "Booklets in Medieval Manuscripts: Further Considerations", in Ralph Hanna III, *Pursuing History: Middle English Manuscripts and Their Texts*, 21-34. Stanford University Press, 1996.
- Harbison, Peter. *Pilgrimage in Ireland: The Monuments and the People*. Syracuse, NY, and London: Syracuse University Press, 1995.
- Harbison, Peter. *The Golden Age of Irish Art: The Medieval Achievement, 600-1200*. New York: Thames and Hudson, 1999.
- Hausmann, Regina. *Die Theologischen Handschriften der Hessischen Landesbibliothek Fulda bis zum Jahr 1600*. Wiesbaden: Harrassowitz, 1992.
- Hawkes, Jane. "The Road to Hell: The Art of Damnation in Anglo-Saxon Sculpture", in "Listen, O Isles, unto Me", *Studies in Medieval Word and Image in Honour of Jennifer O'Reilly*, ed. E. Mullins and D. Scully, 230-242. Cork: Cork University Press, 2011.
- Head, Pauline E. *Representation and Design, Tracing the Hermeneutics of Old English Poetry*. New York: State University of New York Press, 1997.
- Henderson, George and Isabel. *The Art of the Picts: Sculpture and Metalwork in Early Medieval Scotland*. New York, 2004.

- Henderson, Isabel. "Understanding the Figurative Style and Decorative Programme of the Book of Deer", in *Studies on the Book of Deer*, ed. Katherine Forsyth, 32-66. Dublin: Four Courts Press, 2008.
- Henry, Françoise. *Irish Art in the Early Christian Period (to 800 A.D.)*. London: Methuen, 1940.
- Henry, Françoise. *Early Christian Irish Art*. Dublin: Colm O Lochlainn, 1954.
- Henry, Françoise. "An Irish Manuscript in the British Museum (Add. 40.618)", *JRSAI* 87, 2 (1957): 147-166.
- Henry, Françoise. "Remarks on the Decoration of Three Irish Psalters", *PRIA* 61, c, 2 (1960): 23-40.
- Henry, Françoise. *Irish art during the Viking invasions (800-1020 A.D.)*. London: Methuen 1967.
- Hofman, Rijcklof. *The Sankt Gall Priscian Commentary*, 1. Münster: Nodus, 1996.
- Howlett, David. "Hellenic learning in Insular Latin: an essay on supported claims", *Peritia* 12 (1998): 54-78.
- Hughes, Kathleen. "The Distribution of Irish Scriptoria and Centres of Learning from 730 to 1111", in *Studies in the Early British Church*, ed. Nora Chadwick, 243-72. Cambridge: Cambridge University Press, 1958.
- Hughes, Kathleen. "The Changing Theory and Practice of Irish Pilgrimage", *Journal of Ecclesiastical History* 11, 2 (1960): 143-151.
- Hughes, Kathleen. "The Book of Deer (Cambridge University Library MS Ii.6.32)", in *Celtic Britain in the Early Middle Ages: Studies in Scottish and Welsh Sources*, Studies in Celtic History 2, ed. David Dumville, 22-37. Woodbridge: The Boydell Press, 1980.
- Ireland, Colin A. "Boisil: An Irishman Hidden in the Works of Bede", *Peritia* 5 (1986): 400-403.
- J. H. T. "King Athelstan's copy of the Gospels, in Lambeth Library", in *The British Magazine and Monthly Register of Religious and Ecclesiastical Information, Parochial History, and Documents Respecting the State of the Poor, Progress of Education, Etc*, 14, ed. H. J. Rose & S. R. Maitland, 141-147. London: Rivington, 1838.
- Jackson, Eleanor. "Picturing the Pious Reader: Examples from Insular Textual Ornament", *Pecia: Le Livre et l'Écrit* 17, Le Manuscrit, Entre Écriture et Texte 1 (2014): 65-91.
- Jackson, Kenneth. *The Gaelic Notes in the Book of Deer*. Cambridge: Cambridge University Press, 1972.
- James, M. R. *The Western Manuscripts in the Library of Trinity College, Cambridge: A Descriptive Catalogue*. Cambridge: Cambridge University Press, 1900.
- James, M. R. *A Descriptive Catalogue of the Manuscripts in the Library of Corpus Christi College Cambridge*, I. Cambridge: Cambridge University Press, 1912.

- James, M. R., and C. Jenkins. *A Descriptive Catalogue of the Manuscripts in the Library of Lambeth Palace*, V. Cambridge: Cambridge University Press, 1930.
- Keil, Heinrich. *Grammatici Latini 2: Prisciani Institutionum Grammaticarum*. Leipzig: Teubner, 1855.
- Kelly, E. P. "The Manuscript Discovered", *Archaeology Ireland* 20, 3, Supplement: The Faddan More Psalter (Autumn, 2006): S4-S7.
- Kendrick, Laura. *Animating the Letter: The Figurative Embodiment of Writing from Late Antiquity to the Renaissance*. Columbus, Ohio: Ohio State University Press, 1999.
- Kenney, James F. *The Sources for the Early History of Ireland: Ecclesiastical*. Dublin: Four Courts, rpt. 1997.
- Kessler, Herbert L. *Spiritual Seeing: Picturing God's Invisibility in Medieval Art*. Philadelphia: University of Pennsylvania Press, 2000.
- Kessler, Herbert L. "The Icon in the Narrative", in Herbert Kessler, *Spiritual Seeing: Picturing God's Invisibility in Medieval Art*, 1-18. Philadelphia: University of Pennsylvania Press, 2000.
- Kessler, Herbert L. "'Facies Bibliothecae Revelata': Carolingian Art as Spiritual Seeing", in Herbert Kessler, *Spiritual Seeing: Picturing God's Invisibility in Medieval Art*, 149-89. Philadelphia: University of Pennsylvania Press, 2000.
- Kessler, Herbert L. "The Book as Icon", in *In the Beginning: Bibles Before the Year 1000*, ed. Michelle P. Brown, 77-103. Washington D.C.: Freer Gallery of Art and Arthur M. Sackler Gallery, Smithsonian Institution, 2006.
- Kessler, Herbert L. "A Sanctifying Serpent: Crucifixion as Cure", in *Studies on Medieval Empathies*, ed. Karl F. Morrison and Rudolph M. Bell, 161-185. Turnhout: Brepols, 2013.
- Kessler, Herbert L. "Medietas/Mediator and the Geometry of Incarnation", in *Image and Incarnation: The Early Modern Doctrine of the Pictorial Image*, ed. Walter S Melion and Lee Palmer Wandel, 17-75. Leiden and Boston: Brill, 2015.
- Keynes, Simon. "King Athelstan's Books", in *Learning and Literature in Anglo-Saxon England, Studies Presented to Peter Clemoes on the Occasion of his Sixty-Fifth Birthday*, ed. Michael Lapidge and Helmut Gneuss, 153-159. Cambridge: Cambridge University Press, 1985.
- Kilpatrick, K. A. "The Iconography of the Papil Stone: Sculptural and Literary Comparisons with a Pictish Motif", *Proc. Soc. Antiq. Scot.* 141 (2011): 159-205.
- Kitzinger, Ernst. "The Coffin-reliquary", in *The Relics of Saint Cuthbert*, ed. Christopher F. Battiscombe, 202-307. Oxford: Oxford University Press, 1956.
- Klein, Peter. *Apocalipsis de Valenciennes: Facsimile Edition*, 2 vols. Madrid: Orbis Mediaevalis, 2009.

- Köllner, Herbert. *Die Illuminierten Handschriften Der Hessischen Landesbibliothek Fulda, I: Handschriften Des 6. Bis 13. Jahrhunderts*. Stuttgart: Hiersemann, 1976.
- Kühnel, Bianca. *From the Earthly to the Heavenly Jerusalem: Representations of the Holy City in Christian Art of the First Millennium*. Rome, Freiburg and Vienna: Herder, 1987.
- Kühnel, Bianca. *The End of Time in the Order of Things: Science and Eschatology in Early Medieval Art*. Regensburg: Schnell and Steiner, 2003.
- Kuypers, Dom A. B. *The Prayer Book of Aedeluald the Bishop, Commonly Called the Book of Cerne*. Cambridge: Cambridge University Press: 1902.
- Kwakkel, Erik. "Towards a Terminology for the Analysis of Composite Manuscripts", *Gazette du Livre Médiéval* 41 (Autumn 2002): 12-17.
- Laing, David. "An Obituary and Calendar of Scottish Saints, Extracted from the Martyrology for the Use of the Church Of Aberdeen, A Ms. of the Sixteenth Century", *Proceedings of the Society of Antiquaries of Scotland* 2 (1855-56): 256-272.
- Lapidge, Michael. *The Anglo-Saxon Library*. Oxford: Oxford University Press, 2006.
- Law, Vivien. *Wisdom, Authority and Grammar in the Seventh Century: Decoding Virgilius Maro Grammaticus*. Cambridge: Cambridge University Press, 1995.
- Lawlor, Hugh J. *Chapters on the Book of Mulling*. Edinburgh: David Douglas, 1897.
- Leclercq, Jean. *The Love of Learning and the Desire for God: A Study of Monastic Culture*, trans. Catharine Misrahi. New York: Fordham University Press, 1982.
- Lehmann, Paul. *Mittelalterliche Bibliothekskataloge Deutschlands und der Schweiz, I Die Bistümer Konstanz und Chur*. München: C. H. Beck'sche Verlagsbuchhandlung, 1918, rpt. 1969.
- Lewis, Suzanne. "Sacred Calligraphy: The Chi Rho Page in the Book of Kells", *Traditio* 36 (1980): 139-159.
- Light, Laura. "The Thirteenth Century and the Paris Bible", in *The New Cambridge History of the Bible*, ed. E. Ann Matter and Richard Marsden, 380-391. Cambridge: Cambridge University Press, 2012.
- Lilley, Keith D. *City and Cosmos: The Medieval World in Urban Form*. London: Reaktion Books, 2009.
- Lindsay, Wallace M. *Early Irish Minuscule Script*, St Andrews University Publications 6. Oxford: James Parker, 1910.
- Lindsay, Wallace M. *Early Welsh Script*, St Andrews University Publications 10. Oxford: James Parker, 1912.
- Lindsay, Wallace M. "Irish Cursive Script", *Zeitschrift für Celtische Philologie* 9 (1913): 301-308.

- Lindsay, Wallace M. *Notae Latinae: An Account of Abbreviation in Latin MSS. of the Early Minuscule Period (c. 700-850)*. Cambridge: Cambridge University Press, 1915.
- Lindsay, Wallace M. "Scribes and their Ways", in *Palaeographia Latina* 2, St Andrews University Publications XVI, 20-30. London etc.: Oxford University Press, 1923.
- Louth, Andrew. "The Theology of the Word Made Flesh", in *The Bible as Book*, ed. John L. Sharpe and Kimberly Van Kampen, 223-28. London: British Library and Oak Knoll Press, 1998.
- Lowden, John. "The Word Made Visible: The Exterior of the Early Christian Book as Visual Argument", in *The Early Christian Book (CUA Studies in Early Christianity)*, ed. William E. Klingshirn and Linda Safran, 13-47. Washington: The Catholic University of America Press, 2012.
- Lowe, Elias A., ed. *Codices Latini Antiquiores: A Palaeographical Guide to the Latin MSS. prior to the IXth Century*, 11 parts. Oxford: Clarendon, 1934-1966.
- Lucas, A. T. "The Social Role of Relics and Reliquaries in Ancient Ireland", *JRSAI* 116 (1986): 5-37.
- Luce, Arthur. George Otto Simms, Peter Meyer and Ludwig Bieler, eds, *Evangeliorum Quattuor Codex Durmarchensis*. Olten, Lausanne and Freiburg: Urs Graf-Verlag, 1960.
- Madan, F. "Uncial or Uncinal?", *The Classical Review* 18, 1 (1904): 48-49.
- Maddern, Christine. *Raising the Dead: Early Medieval Name Stones in Northumbria*. Turnhout: Brepols, 2013.
- Márkus, Gilbert. "The Sick and the Dying in the Book of Deer", in *Studies on the Book of Deer*, ed. Katherine Forsyth, 67-97. Dublin: Four Courts Press, 2008.
- Marner, Dominic. "The Sword of the Spirit, the Word of God and the Book of Deer", *Medieval Archaeology* 46, 1 (2002): 1-28.
- McCormick, Michael. "The Birth of the Codex and the Apostolic Life-Style", *Scriptorium* 39, 1 (1985): 150-158.
- McGurk, Patrick. "The Irish Pocket Gospel Book", *Sacris Erudiri* 8, 2 (1956): 249-70.
- McGurk, Patrick. *Latin Gospel Books from A.D. 400 to A.D. 800*, Publications de Scriptorium 5. Paris and Brussels: Aux Éditions "Érasme"; Anvers and Amsterdam: Standaard-Boekhandel, 1961.
- McGurk, Patrick. "An Anglo-Saxon Bible Fragment of the Late Eighth Century, Royal 1 E.VI", *Journal of the Warburg and Courtauld Institutes*, 25 (1962): 23-24.
- McGurk, Patrick. "The Gospel Book in Celtic Lands Before A.D. 850: Contents and Arrangement", in *Irland und die Christenheit, Bibelstudien und Mission*, ed. Próinséas Ní Chatháin and Michael Richter, 165-89. Stuttgart: Klett-Cotta, 1987.

- McKee, Helen. "Script in Wales, Scotland and Cornwall", in *The Cambridge History of the Book in Britain* 1, ed. Richard Gameson, 167-73. Cambridge: Cambridge University Press, 2011.
- McKitterick, Rosamund. *The Carolingians and the Written Word*. Cambridge: Cambridge University Press, 1989.
- McKitterick, Rosamund. *Charlemagne: The Formation of a European Identity*. Cambridge: Cambridge University Press, 2008.
- McNamara, Martin, and Maurice Sheehy. "Psalter Text and Psalter Study in the Early Irish Church (A.D. 600-1200)", *PRIA* C 73 (1973): 201-298.
- McNamara, Martin. "The Echternach and Mac Durnan Gospels: Some Common Readings and their Significance", *Peritia* 6, 1 (1987): 217-222.
- Meehan, Bernard. "'A Melody of Curves Across the Page': Art and Calligraphy in the Book of Armagh", *Irish Arts Review Yearbook* 14 (1998): 90-101.
- Meehan, Bernard. *The Book of Kells: An Illustrated Introduction to the Manuscript in Trinity College, Dublin*. New York: Thames and Hudson 1994.
- Meehan, Bernard. "Irish Pocket Gospel Books", in *The St Cuthbert Gospel: Studies on the Insular Manuscript of the Gospel of John (BL, Additional MS 89000)*, ed. Claire Breay and Bernard Meehan, 83-102. London: The British Library, 2015.
- Melia, Daniel F. "On the Form and Function of the 'Old-Irish verse' in the Thesaurus Palaeohibernicus", in *Heroic Poets and Poetic Heroes in Celtic Tradition: A Festschrift for Patrick K. Ford*, CSANA Yearbook 3, 4, ed. Joseph Falaky Nagy and Leslie Ellen Jones, 283-290. Dublin: Four Courts Press, 2005.
- Meyer, Kuno. "Neu Aufgefundene Altirische Glossen", *Zeitschrift für Celtische Philologie* 8 (1912): 173-177.
- Meyvaert, Paul. "'Uncial letters': Jerome's meaning of the term", *Journal of Theological Studies* 34, 1 (1983): 185-188.
- Meyvaert, Paul. "Bede, Cassiodorus, and the Codex Amiatinus", *Speculum* 71, 4 (Oct., 1996): 827-883.
- Meyvaert, Paul. "The Date of Bede's 'In Ezram' and His Image of Ezra in the Codex Amiatinus", *Speculum* 80, 4 (Oct., 2005): 1087-1133.
- Morris, William. "Some Notes on the Illuminated Books of the Middle Ages", *Magazine of Art* 17 (1894): 83-88.
- Mullarkey, Paul. "The Figural Iconography of the Soiscéal Molaise and Stowe Missal Book Shrines", in *Making and Meaning in Insular Art, Proceedings of the Fifth International Conference on Insular Art Held at Trinity College Dublin, 25-28 August 2005*, ed. Rachel Moss, 50-69. Dublin: Four Courts, 2007.

- Murray, Griffin. "Insular-type Crosiers: Their Construction and Characteristics", in *Making and Meaning in Insular Art, Proceedings of the Fifth International Conference on Insular Art Held at Trinity College Dublin, 25-28 August 2005*, ed. Rachel Moss, 79-94. Dublin: Four Courts, 2007.
- Murray, Griffin. *The Cross of Cong: A Masterpiece of Medieval Irish Art*. Sallins, Co. Kildare: Irish Academic Press, 2014.
- Nees, Lawrence. "The Colophon Drawing in the Book of Mulling: A Supposed Irish Monastery Plan and the Tradition of Terminal Illustration in Early Medieval Manuscripts", *Cambridge Medieval Celtic Studies* 5 (1983): 67-91.
- Nees, Lawrence. *The Gundohinus Gospels*. Cambridge, MA: The Medieval Academy of America, 1987.
- Nees, Lawrence. "Ultán the scribe", *Anglo-Saxon England* 22 (1993): 127-46.
- Nees, Lawrence. "Words and Images, Texts and Commentaries", in *Irish Art Historical Studies in Honour of Peter Harbison*, ed. Colum Hourihane, 47-69. Dublin: Index of Christian Art, Princeton University, in association with Four Courts, 2004.
- Nelson, Janet L. "The Settings of the Gift in the Reign of Charlemagne", in *The Languages of Gift in the Early Middle Ages*, ed. Wendy Davies and Paul Fouracre, 116-48. Cambridge: Cambridge University Press, 2010.
- Netzer, Nancy. *Cultural Interplay in the Eighth Century: The Trier Gospels and the Making of a Scriptorium at Echternach*. Cambridge and New York: Cambridge University Press, 1994.
- Netzer, Nancy. "The Book of Durrow: The Northumbrian Connection", in *Northumbria's Golden Age*, ed. Jane Hawkes and S Mills, 315-26. Stroud: Sutton, 1999.
- Netzer, Nancy. "Style: A History of Uses and Abuses in the Study of Insular Art", in *Pattern and Purpose in Insular Art*, ed. M. Redknap, N. Edwards, S. Youngs et. al., 169-78. Oxford: Oxbow, 2001.
- Netzer, Nancy. "Framing the Book of Durrow Inside/Outside the Anglo-Saxon World", *Anglo-Saxon Studies in Archaeology and History* 16 (2009): 65-78.
- Netzer, Nancy. "The Design and Decoration of Insular Gospel-Books and Other Liturgical Manuscripts, c.600-c.900", in *The Cambridge History of the Book in Britain 1, c.400-1100*, ed. Richard Gameson, 225-43. Cambridge: Cambridge University Press, 2011.
- Neuman De Vegvar, Carol. *The Northumbrian Renaissance: A Study in the Transmission of Style*. Selinsgrove: Susquehanna University Press, 1987.
- Nordenfalk, Carl. *Die Spätantiken Zierbuchstaben*, 2 vols. Stockholm: Egnellska, 1970.
- Nordenfalk, Carl. *Celtic and Anglo-Saxon Painting, Book Illumination in the British Isles 600-800*. London: Chatto and Windus, 1977.

- Nordhagen, Per Jonas. *The frescoes of John VII, A.D. 705-707, in S. Maria Antiqua in Rome*. Rome: Bretschneider, 1968.
- Ó Carragáin, Éamonn. "'Traditio Evangeliorum' and 'Sustenatio': The Relevance of Liturgical Ceremonies to the Book of Kells", in *The Book of Kells: Proceedings of a Conference at Trinity College Dublin, 6-9th September 1992*, ed. Felicity O'Mahoney, 398-436. Aldershot: Scholar Press, 1994.
- Ó Carragáin, Éamonn. *Ritual and the Rood, Liturgical Images and the Old English Poems of the Dream of the Rood Tradition*. London: British Library, 2005.
- Ó Corráin, Donnchadh. "What Happened to Ireland's Medieval Manuscripts?", *Peritia* 22-23 (2011-12): 191-223.
- Ó Floinn, Ragnall. "The Shrine of the Book of Dimma", *Éile, Journal of Roscrea Heritage Society* 1 (1982): 25-39.
- Ó Floinn, Ragnall. "The Soiscél Molaisse", *Clogher Record* 13, 2 (1989): 51-63.
- O Laoghaire, Diarmuid. "The Celtic Monk at Prayer", in *Celtic Monasticism*, ed. L. Freeman, *Monastic Studies* 14 (1983): 123-43.
- Ó Riain, P. "The Shrine of the Stowe Missal, Redated", *PRIA* 91C (1991): 285-295.
- O'Rahilly, T. F. "The History of the Stowe Missal", *Ériu* 10, (1926-1928): 95-109.
- O'Connor, C. "Appendix", *Bibliotheca Ms. Stowensis: A Descriptive Catalogue of the Manuscripts in the Stowe Library*. Buckingham: Seeley, 1819.
- O'Dwyer, Peter. *Céilí Dé: Spiritual Reform in Ireland 750-900*. Dublin: Carmelite Publications, 1981.
- O'Loughlin, Thomas. "The Plan of the New Jerusalem in the Book of Armagh", *Cambrian Medieval Celtic Studies* 39 (Summer, 2000): 23-38.
- O'Loughlin, Thomas. "The Biblical Text of the Book of Deer (C.U.L. Ii.6.32): Evidence for the Remains of a Division System from its Manuscript Ancestry", in *Studies on the Book of Deer*, ed. Katherine Forsyth, 3-31. Dublin: Four Courts Press, 2008.
- O'Loughlin, Thomas. "Adomnán's Plans in the Context of his Imagining 'the Most Famous City'", in *Imagining Jerusalem in the Medieval West*, ed. Lucy Donkin and Hanna Vorholt, 15-40. Oxford: Oxford University Press, 2012.
- O'Loughlin, Thomas. "The So-called *Capitula* for the Book of the Apocalypse in the Book of Armagh (Dublin, Trinity College, 52) and Latin Exegesis", in *Early Medieval Ireland and Europe: Chronology, Contacts, Scholarship*, ed. Pádraic Moran and Immo Warntjes, *Studia Traditionis Theologiae* 14, 405-23. Turnhout: Brepols, 2015.
- O'Neill, Timothy. "Quills, Inks and Vellums", in *Treasures of the Royal Irish Academy Library*, ed. Bernadette Cunningham and Siobhán Fitzpatrick, 45-48. Dublin: Royal Irish Academy, 2009.

- O'Neill, Timothy. *The Irish Hand: Scribes and their Manuscripts from the Earliest Times*. 2nd edn., Cork: Cork University Press, 2014.
- O'Reilly, Jennifer. "The Hiberno-Latin Tradition of the Evangelists and the Gospels of Mael Brigte", *Peritia* 9 (1995): 290-309.
- O'Reilly, Jennifer. "Gospel Harmony and the Names of Christ", in *The Bible as Book: The Manuscript Tradition*, ed. Kimberly Van Kampen and John L. Sharpe, 73-88. London: British Library & Oak Knoll Press, 1998.
- O'Reilly, Jennifer. "Patristic and Insular Traditions of the Evangelists: Exegesis and Iconography of the Four-Symbols Page", in *Le Isole Britanniche e Roma in Età Romanobarbarica*, ed. Anna M. Luiselli Fadda and Éamonn Ó Carragáin, 49-94. Rome: Herder, 1998.
- O'Reilly, Jennifer. "The Wisdom of the Scribe and the Fear of the Lord in the Life of St Columba", in *Spes Scotorum: Hope of Scots*, ed. Dauvit Broun and Thomas Owen Clancy, 159-211. Edinburgh: T&T Clark, 1999.
- O'Reilly, Jennifer, "The Library of Scripture: Views from Vivarium and Wearmouth-Jarrow", in *New Offerings, Ancient Treasures*, ed. Paul Binski and William Noel, 3-39. Stroud: Sutton, 2001.
- O'Reilly, Jennifer. "Islands and Idols at the Ends of the Earth: Exegesis and Conversion in Bede's *Historia Ecclesiastica*", in *Bède le Vénérable: Entre Tradition et Postérité*, ed. Stéphane Lebecq, Michel Perrin and Olivier Szerwiniak, 119-145. Villeneuve d'Ascq: IRHiS-Institut de Recherches Historiques du Septentrion, 2005.
- O'Reilly, Jennifer. "Bede on Seeing the God of Gods in Zion", in *Text, Image, Interpretation: Studies in Anglo-Saxon Literature and its Insular Context in Honour of Éamonn Ó Carragáin*, ed. Alastair Minnis and Jane Roberts, *Studies in the Early Middle Ages* 18, 3-29. Turnhout: Brepols, 2007.
- O'Reilly, Jennifer. "The Image of Orthodoxy, The Mysterium Christi and Insular Gospel Books", in *L'Irlanda E Gli Irlandesi Nell'Alto Medioevo, Spoleto, 16-21 Aprile 2009*, *Settimane Di Studio Della Fondazione Centro Italiano Di Studi Sull'Alto Medioevo* LVII, 651-705. Spoleto: Presso La Sede Della Fondazione, 2010.
- O'Reilly, Jennifer. "St. John the Evangelist: Between Two Worlds", in *Insular and Anglo-Saxon Art and Thought in the Early Medieval Period*, ed. Colum Hourihane, 189-218. Princeton, N.J.: Index of Christian Art, Dept. of Art and Archaeology, Princeton University, 2011.
- O'Sullivan, William. "Insular Calligraphy: Current State and Problems", *Peritia* 4 (1985): 346-399.

- O'Sullivan, William. "Manuscripts and Palaeography", in *A New History of Ireland: Prehistoric and Early Ireland*, ed. Theodore William Moody, Dáibhí Ó Cróinín and Francis X. Martin, 511-48. Oxford: Oxford University Press, 2005.
- Page, R. I. *Matthew Parker and his Books, Sandars Lectures in Bibliography, Delivered on 14, 16, and 18 May 1990 at the University of Cambridge*. Kalamazoo: Medieval Institute Publications, 1993.
- Palazzo, Eric. "Le Livre dans les Trésors du Moyen Age. Contribution à l'histoire de la Memoria Médiévale", *Annales Histoire, Sciences Sociales* (1997): 93-118.
- Palazzo, Eric. "Art, Liturgy and the Five Senses in the Early Middle Ages", *Viator* 41, 1 (2010): 25-56.
- Palazzo, Eric. "La Mise en Action des Images dans l'illustration du Sacramentaire de Gellone: le Canon de la Messe et le Rituel Baptismal", *Codex Aquilarensis. Cuadernos de Investigación del Monasterio de Santa María la Real* 29 (2013): 49-60.
- Palmer, Richard, and Michelle P. Brown, eds. *Lambeth Palace Library, Treasures from the Collection of the Archbishops of Canterbury*. London, Scala: 2010.
- Parkes, Malcolm. "The Contribution of Insular Scribes of the Seventh and Eighth Centuries to the 'Grammar of Legibility'" in Malcolm Parkes, *Scribes, Scripts and Readers: Studies in the Communication, Presentation and Dissemination of Medieval Texts*, 1-18. London: Hambledon, 1991.
- Parkes, Malcolm B. "The Scriptorium of Wearmouth-Jarrow", in Malcolm Parkes, *Scribes, Scripts and Readers: Studies in the Communication, Presentation and Dissemination of Medieval Texts*, 93-120. London: Hambledon, 1991.
- Parkes, Malcolm B. "The Handwriting of St Boniface: A Reassessment of the Problems", in Malcolm Parkes, *Scribes, Scripts and Readers: Studies in the Communication, Presentation and Dissemination of Medieval Texts*, 121-42. London: Hambledon, 1991.
- Petrucci, Armando. "From Unitary Book to Miscellany", in Armando Petrucci, *Writers and Readers in Medieval Italy, Studies in the History of Written Culture*, ed. and trans. Charles M. Radding, 1-18. New Haven and London: Yale University Press, 1995.
- Petrucci, Armando. "The Christian Conception of the Book in the Sixth and Seventh Centuries", in Armando Petrucci, *Writers and Readers in Medieval Italy*, ed. and trans. Charles M. Radding, 19-42. New Haven and London: Yale University Press, 1995.
- Petrucci, Armando. "Literacy and Graphic Culture of Early Medieval Scribes" in Armando Petrucci, *Writers and Readers in Medieval Italy*, ed. and trans. Charles M. Radding, 77-102. New Haven and London: Yale University Press, 1995.

- Pickwood, Nicholas. "Binding", in *The Cuthbert Gospel: Studies on the Insular Manuscript of the Gospel of John (BL, Additional MS 89000)*, ed. Claire Breay and Bernard Meehan, 41-63. London: British Library: 2015.
- Powell, Roger. "The Binding", in *The Relics of Saint Cuthbert*, ed. C. F. Battiscomb, 362-74. Oxford, Oxford University Press: 1956.
- Powell, Roger, and Peter Waters. "Technical Description of the Binding", in *The Stonyhurst Gospel of Saint John*, ed. T. Julian Brown, 45-55. Oxford: Oxford University Press, 1969.
- Pulliam, Heather. *Word and Image in the Book of Kells*. Dublin: Four Courts, 2006.
- Pulliam, Heather. "Beasts of the Desert: Marginalia in the Book of Deer", *Medieval Archaeology* 57 (2013): 83-110.
- Pulliam, Heather. "Eyes of Light: Colour in the Lindisfarne Gospels", in *Newcastle and Northumberland: Roman and Medieval Architecture and Art*, British Archaeological Association Conference Transactions 36, ed. Jeremy Ashbee and Julian M. Luxford, 54-72. Leeds: Maney, 2013.
- Rambridge, Kate. "Alcuin, Willibrord, and the Cultivation of Faith", *The Haskins Society Journal* 14, Studies in Medieval History, ed. Stephen Morillo, 15-32. Woodbridge, Boydell and Brewer, 2003.
- Ramirez, Janina. "Sub Culmine Gazas: The Iconography of the Armarium on the Ezra Page of the Codex Amiatinus", *Gesta* 48, 1 (2009): 1-18.
- Rapp, Claudia. "Holy Texts, Holy Men, and Holy Scribes: Aspects of Scriptural Holiness in Late Antiquity", in *The Early Christian Book*, CUA Studies in Early Christianity, ed. William E. Klingshirn and Linda Safran, 194-222. Washington: Catholic University of America Press, 2012.
- Raw, Barbara. "Anglo-Saxon Prayerbooks", in *The Cambridge History of the Book in Britain* 1, c.400-1100, ed. Richard Gameson, 460-67. Cambridge: Cambridge University Press, 2011.
- Richardson, Hilary. "Lozenged and Logos", *Archaeology Ireland* 10, 2 (1996): 24-25.
- Richardson, Hilary. "Biblical Imagery and the Heavenly Jerusalem in the Book of Armagh and Book of Kells", in *Ireland and Europe in the Early Middle Ages: Texts and Transmissions / Irland und Europa im Früheren Mittelalter: Texte und Überlieferung*, ed. Próinséas Ní Chatháin and Michael Richter, 205-214. Dublin: Four Courts Press, 2002.
- Richter, Michael. *Bobbio in the Early Middle Ages: The Abiding Legacy of Columbanus*. Dublin: Four Courts, 2008.
- Roberts, Colin. "The Codex", *Proceedings of the British Academy* 40 (1st Jan, 1954): 169-204.

- Roberts, Colin H., and T. C. Skeat. *The Birth of the Codex*. London: Oxford University Press, 1983.
- Robinson, Pamela R. "The 'Booklet': A Self-Contained Unit in Composite Manuscripts", in *Codicologica 3: Essais Typologiques*, ed. A. Gruys and J. P. Gumbert, 46-69. Leiden: Brill, 1980.
- Robinson, Pamela R. "Self-contained Units in Composite Manuscripts of the Anglo-Saxon Period", in *Anglo-Saxon Manuscripts: Basic Readings*, ed. Mary P. Richards, 25-35. New York: Routledge, 1994.
- Rust, Martha. "Blood and Tears as Ink: Writing the Pictorial Sense of the Text", *The Chaucer Review* 47, 4 (2013): 390-415.
- Ruzzier, Chiara. "The Miniaturisation of Bible Manuscripts in the Thirteenth Century: A Comparative Study", in *Form and Function in the Late Medieval Bible*, ed. Eyal Poleg and Laura Light, *Library of the Written Word* 27, 105-125. Leiden: Brill, 2013.
- Saenger, Paul. *Space Between Words: The Origins of Silent Reading*. Stanford, CA: Stanford University Press, 1997.
- Schapiro, Mayer. "On Some Problems in the Semiotics of Visual Art: Field and Vehicle in Image-Signs", *Simiolus: Netherlands Quarterly for the History of Art* 6, 1 (1972-1973): 9-19.
- Scherer, Carl. "Die Codices Bonifatiani in der Landesbibliothek zu Fulda", in *Festgabe zum Bonifatiusjubiläum II*, ed. Gregor Richter and Carl Scherer, 30-34. Fulda: Fuldaer Actiendruckerei, 1905.
- Sharpe, Richard. "Palaeographical Considerations in the Study of the Patrician Documents in the Book of Armagh", *Scriptorium* 36 (1982): 3-28.
- Sharpe, Richard. "Armagh and Rome in the Seventh Century", in *Irland und Europa: Die Kirche im Frühmittelalter* ed. Próinséas Ní Chatháin and Michael Richter, 58-72. Stuttgart: Klett-Cotta, 1984.
- Sharpe, Richard. "Books from Ireland, Fifth to Ninth Centuries", *Peritia* 21 (2010): 1-55.
- Sims-Williams, Patrick, *Religion and Literature in Western England, 600-800*. Cambridge: Cambridge University Press, 2005.
- Skemer, Don C. *Binding Words: Textual Amulets in the Middle Ages*. University Park, PA: Penn State Press, 2006.
- Spearman, Michael, and John Higgett, eds. *The Age of Migrating Ideas: Early Medieval Art in Northern Britain and Ireland. Proceedings of the Second International Conference on Insular Art held in the National Museums of Scotland in Edinburgh, 3-6 January 1991*. Edinburgh and Stroud: National Museums of Scotland and Sutton, 1993.

- Spilling, Herrad. "Irische Handschriftenüberlieferung in Fulda, Mainz und Würzburg", in *Die Iren in Europa im früheren Mittelalter 2*, ed. Heinz Löwe, 876-902. Stuttgart: Klett-Cotta, 1982.
- Stancliffe, Clare. "Red, White and Blue Martyrdom", in *Ireland in Early Medieval Europe: Studies in Memory of Kathleen Hughes*, ed. Dorothy Whitelock, Rosamond McKitterick and David Dumville, 21-46. Cambridge: Cambridge University Press, 1982.
- Stevick, Robert D. "The Plan of the Evangelist Portrait Pages in the 'Book of Mulling'", *JRSAI* 121 (1991): 27-44.
- Stiegemann, Christoph, and Matthias Wemhoff. *799: Kunst und Kultur der Karolingerzeit*, 3 vols. Mainz: Philipp von Zabern, 1999.
- Stokes, Whitley. *Goidelica: Old and Early-middle-Irish Glosses, Prose and Verse*. London: Trübner, 1872.
- Stokes, Whitley, and John Strachan, eds. *Thesaurus Palaeohibernicus: A Collection of Old-Irish Glosses, Scholia Prose and Verse*, 2 vols. Cambridge: Cambridge University Press, 1903.
- Szirmai, John A. *The Archaeology of Medieval Bookbinding* (Aldershot: Ashgate, 1999).
- Teeuwen, Mariken, *The Vocabulary of Intellectual Life in the Middle Ages*. Turnhout: Brepols, 2003.
- Temple, Elzbieta. *Anglo-Saxon Manuscripts 900-1066, A Survey of Manuscripts Illuminated in the British Isles 2*. London: Harvey Miller, 1976.
- Tilghman, Ben C. "The Shape of the Word: Extralinguistic Meaning in Insular Display Lettering", *Word & Image: A Journal of Verbal/Visual Enquiry* 27, 3 (2011): 292-308.
- Todd, James Henthorn. *A Catalogue of the Archiepiscopal Manuscripts in the Library at Lambeth Palace*. 1812; rpt. London: Gregg, 1965.
- Todd, James Henthorn. "On the Ancient Irish Missal, and Its Silver Box, Described by Dr. O'Connor in His Catalogue of the Stowe MSS., and Now the Property of the Earl of Ashburnham", *Transactions of the Royal Irish Academy* 23 (1856): 3-37.
- Traube, Ludwig. *Perrona Scottorum: ein Beitrag zur Ueberlieferungsgeschichte und zur Palaeographie des Mittelalters*. Munich: Verlag der K. Akademie, 1900.
- Travis, J. "A Druidic Prophecy—the First 'Irish' Satire", *Publications of the Modern Language Association of America* 57, 4 (Dec. 1942): 909-15.
- Unterkircher, Franz. *A Treasury of Illuminated Manuscripts: A Selection of Miniatures from Manuscripts in the Austrian National Library*. New York: Putnam, 1967.
- Van Regemorter, Berthe. "The Binding of the manuscripts of the Saints Cuthbert and Boniface", in Berthe Van Regemorter, *Binding Structures in the Middle Ages: A*

- Selection of Studies*, trans. Jane Greenfield, 43-51. Brussels: Bibliotheca Wittockiana; London: Maggs Bros. Ltd, 1992.
- Van Regemorter, Berthe. "The Limp Bindings of Carolingian Manuscripts from Fulda", in Berthe Van Regemorter, *Binding Structures in the Middle Ages*, trans. Jane Greenfield, 139-150. Brussels: Bibliotheca Wittockiana; London: Maggs Bros. Ltd, 1992.
- Veelenturf, Kees. *Dia Brátha: Eschatological Theophanies and Irish High Crosses*. Amsterdam: Stichting Amsterdamse Historische Reeks, 1997.
- Verey, Christopher. "Notes on the Gospel Text", in *The Durham Gospels: Together with Fragments of a Gospel Book in Uncial, Durham, Cathedral Library, MS A. II.17*, ed. Christopher D. Verey, T. Julian Brown and Elizabeth Coatsworth, EEMF 20, 68-73. Copenhagen: Rosenkilde and Bagger, 1980.
- Vezein, Jean. "Les Livres Utilisé comme Amulettes et comme Reliques", in *Das Buch als Magisches und als Repräsentationsobjekt*, ed. Peter Ganz, 101-15. Wiesbaden: Otto Harrassowitz, 1992.
- Wallis, Faith. "8. Mathematics: 3. Fraction and Abacus Tables", *The Calendar and the Cloister: Oxford, St John's College MS17, 2007*, McGill University Library, Digital Collections Program, accessed 21st October, 2016, <http://digital.library.mcgill.ca/ms-17>.
- Warner, George F. *The Stowe Missal*, 2 vols. London: Henry Bradshaw Society, 1906 and 1915.
- Warren, Frederick E. *The Liturgy and Ritual of the Celtic Church*. Oxford: Clarendon, 1881.
- Webster, Leslie. "The Decoration of the Binding", in *The St Cuthbert Gospel: Studies on the Insular Manuscript of the Gospel of John (BL, Additional MS 89000)*, ed. Claire Breay and Bernard Meehan, 65-82. London: The British Library, 2015.
- Werner, Martin. "The Binding of the Stonyhurst Gospel of St. John", in *Insular and Anglo-Saxon Art and Thought in the Early Medieval Period*, ed. Colum Hourihane, 286-311. Princeton, NJ: Index of Christian Art and Penn State University Press, 2011.
- Westwood, John O. "On the Peculiarities Exhibited by the Miniatures and Ornamentation of Ancient Irish Illuminated MSS", *The Archaeological Journal* 7 (1850): 17-25.
- Westwood, John O. *Fac-similes of the Miniatures & Ornaments of Anglo-Saxon & Irish Manuscripts*. London: Bernard Quaritch, 1868.
- Withers, Benjamin C. "A Sense of Englishness: Claudius B. iv, Colonialism, and the History of Anglo-Saxon Art in the Mid-Twentieth Century", *The Old English Hexateuch: Aspects and Approaches*, ed. Rebecca Barnhouse and Benjamin C. Withers, 317-50. Kalamazoo: Medieval Institute, 2000.

Wordsworth, John, and Henry J. White. *Novum Testamentum Domini Nostri Iesu Christi Latine*, pars prior - Quattuor Evangelia,. Oxford: Clarendon, 1889-1898.

Wright, David. review of *Latin Gospel Books from A.D. 400 to A.D. 800* by Patrick McGurk, *Speculum* 37, 4 (Oct., 1962): 637-6.

Unpublished Secondary Sources

Baker, Nick. "The Evangelists in Insular Culture, c. 600-c. 800 AD", 2 vols, PhD thesis, University of York, 2011.

Cains, Anthony. Conservator's notes (1995), Dublin, Royal Irish Academy, MS D ii 3.

Constantinou, Meghan Read. "Books, Book Satchels, and Shrines in the Book of Deer (Cambridge University Library, MS Ii.6.32)", MA dissertation, University of Delaware, 2010.

Farr, Carol A. "Reused, Rescued, Recycled: Art Historical Contexts of the Irish Fragments, St Gall Codex 1395". paper presented The Wandering Word conference, Trinity College Dublin, 5th May, 2016.

Gillis, John. "The Faddan More Psalter', a 9th-century Manuscript Discovered in a Peat Bog in 2006", lecture at the Grolier Club of New York, March 31 2016, online recording, <https://vimeo.com/164540291>.

Flechner, Roy. "A study and edition of the Collectio canonum Hibernensis", PhD thesis, University of Oxford, 2006.

MacGabhann, Donncha. "The Making of the Book of Kells: Two Masters and Two Campaigns", PhD thesis, SAS University of London, 2016.

Maddern, Christine. "The Northumbrian Name Stones of Early Christian Anglo-Saxon England", PhD Thesis, University of York, 2007.

McBrine, Patrick. "The English Inheritance of Biblical Verse", PhD Thesis, University of Toronto, 2008.

McGurk, Patrick. "The Architecture of Latin Gospel Books Before A.D. 800", PhD Thesis, University of London, 1953.

Mullarkey, Paul. "Irish Book Shrines: A Reassessment", PhD. thesis, Trinity College Dublin, 2000.

Mullarkey, Paul. "Keeping our Word: The Book Shrines of Dimma and Mulling and their Relationship with other Manuscripts, Covers and Shrines", conference paper at "The Wandering Word: The Travels of Insular Manuscripts", Trinity College Dublin, Friday 6th May, 2016.

Tunbridge, Genny Louise. "A Study of Scribal Practices in Early Irish and Anglo-Saxon Manuscripts", DPhil. thesis, University of Oxford, 1992.

FIGURES

Graph 1: All Manuscripts in *CLA* with Leaves Measuring under 200mm in Height

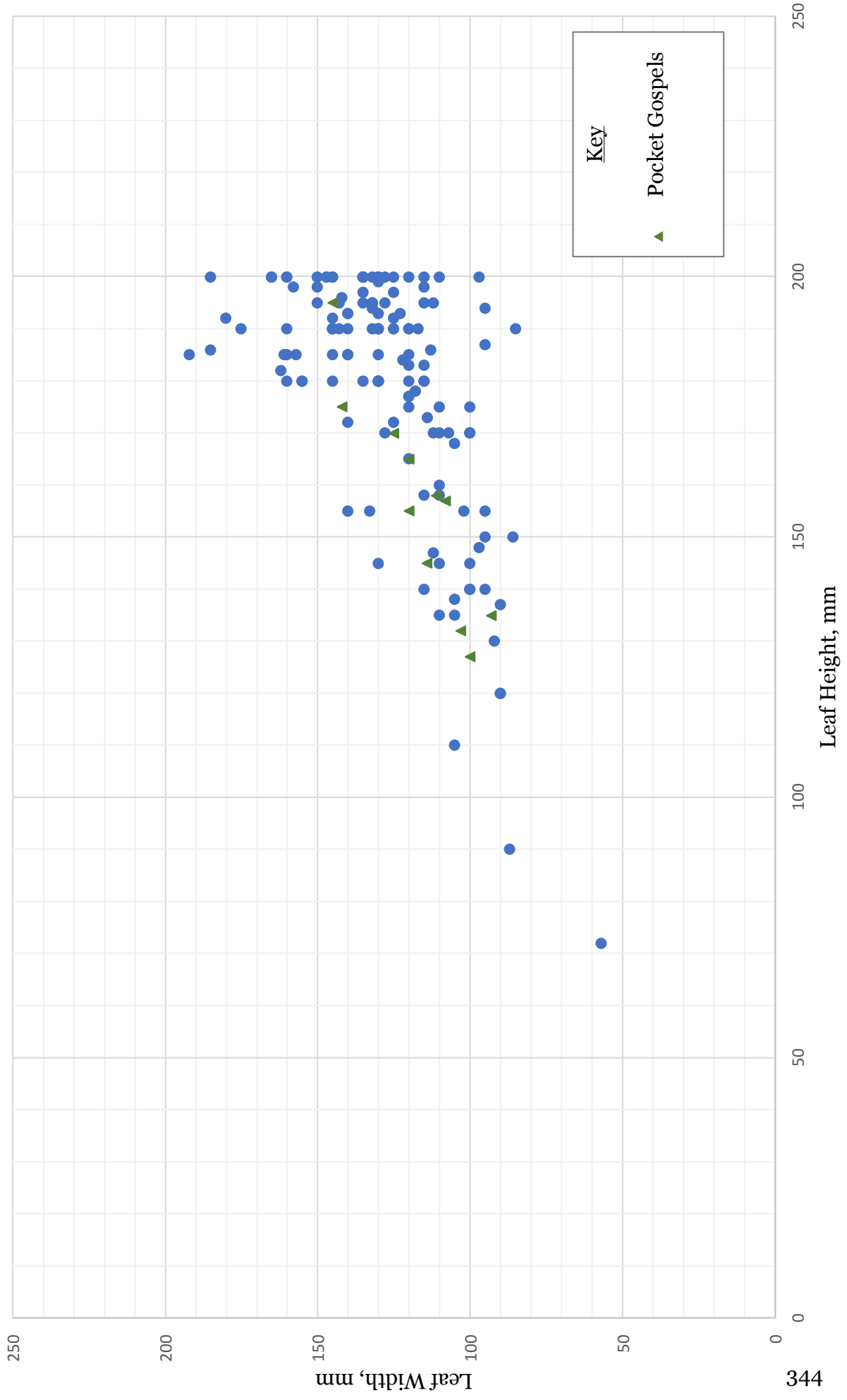

Graph 2: Size and Script of Insular Gospel Books in *CLA*

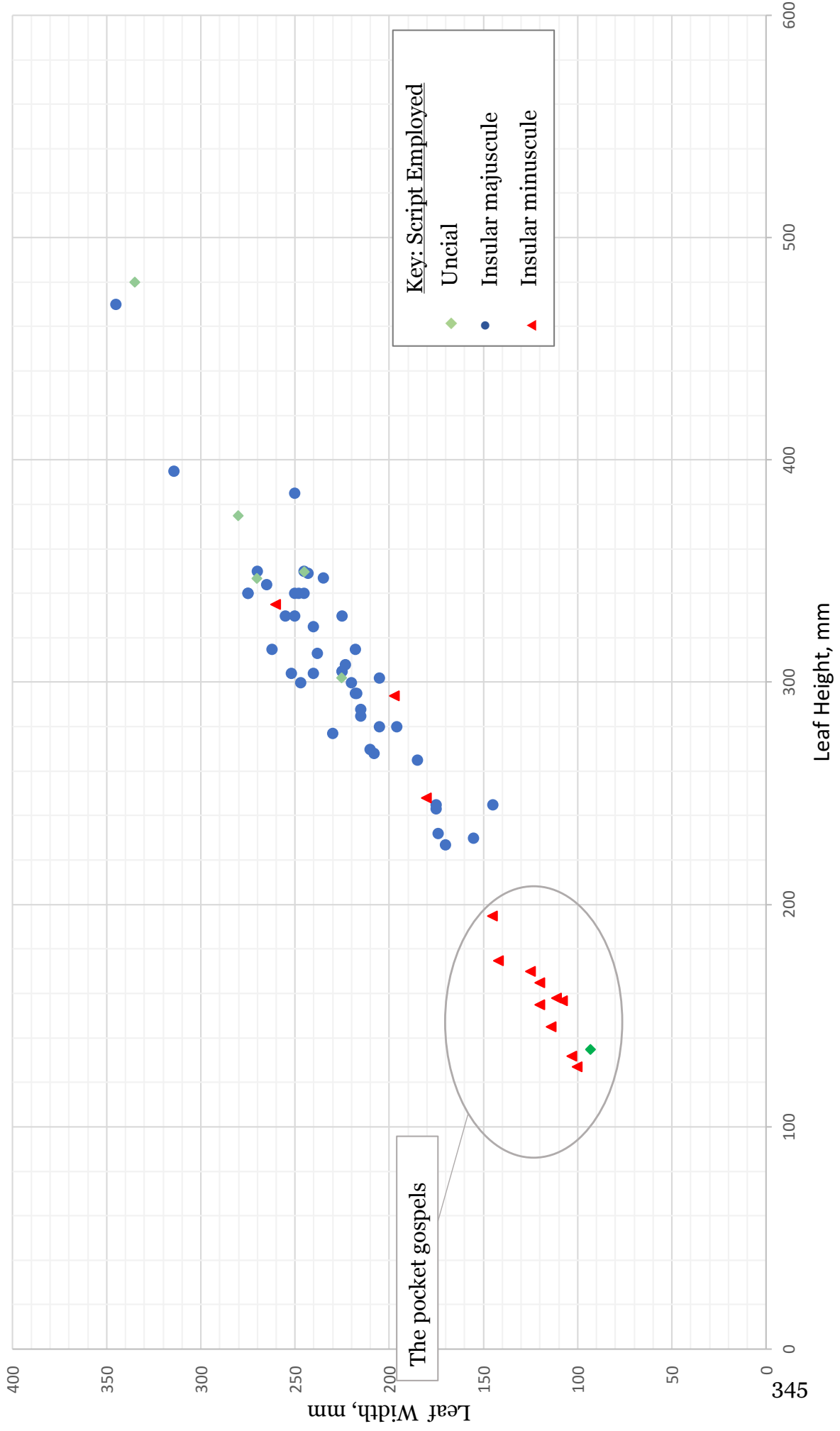

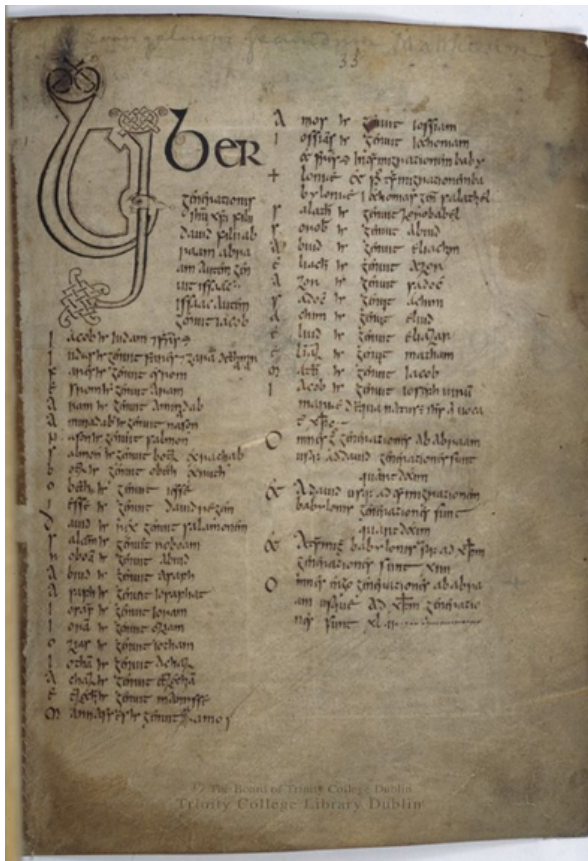

(Fig. 1) Book of Armagh, Matthew incipit, fol. 33r



(Fig. 2) MacDurnan Gospels, Matthew incipit, fol. 2r

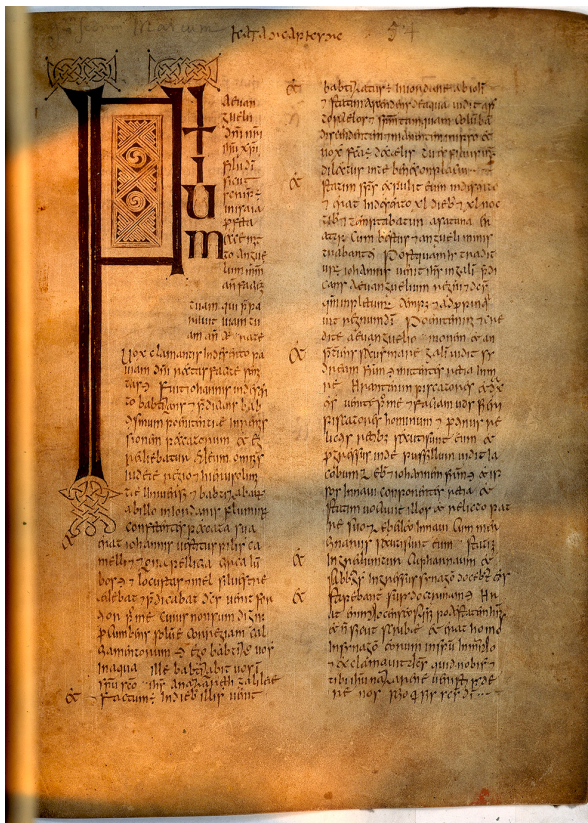

(Fig. 3) Book of Armagh, Mark incipit, fol. 54r



(Fig. 4) MacDurnan Gospels, Mark incipit, fol. 72r



(Fig. 5) Add. MS 40618, Luke portrait, fol. 21v

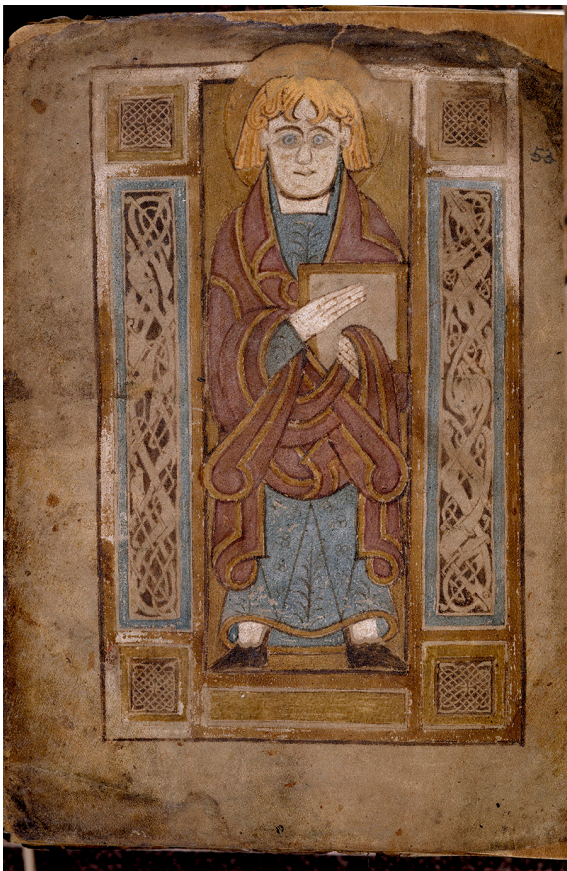

(Fig. 6) Book of Mulling, evangelist portrait, fol. 81v



(Fig. 7) Book of Mulling, evangelist portrait, fol. 35v



(Fig. 8) Book of Deer, Mark portrait, fol. 16v



(Fig. 9) Book of Deer, Luke portrait, fol. 29v



(Fig. 10) Covers from Dagulf Psalter (Paris, Musée du Louvre, M.R.370 et M.R.371)

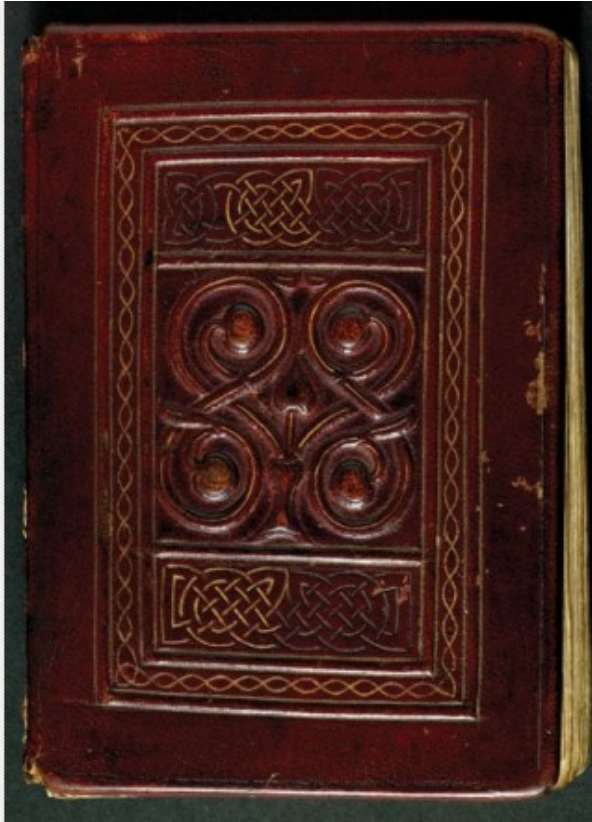

(Fig. 11) Cuthbert Gospel, front cover

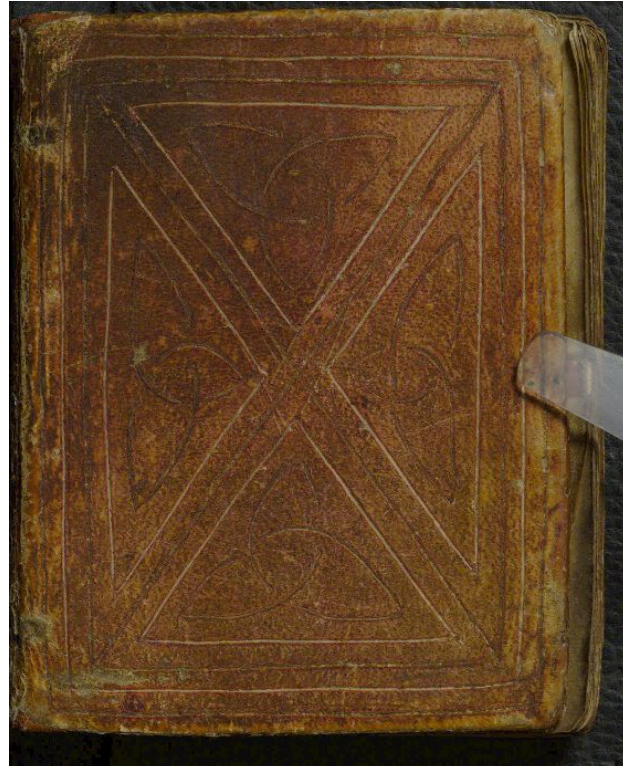

(Fig. 12) Cadmug Gospels, front cover

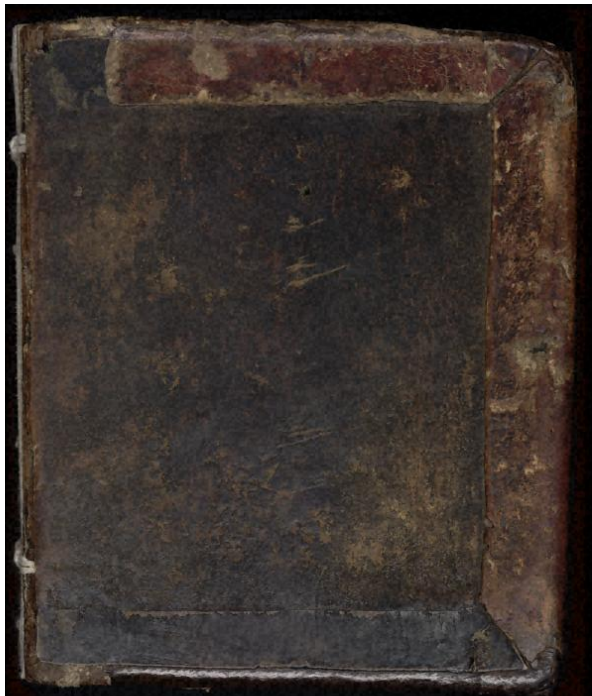

(Fig. 13) Stowe St John and Missal, front cover



(Fig. 14) The Cadmug Gospels, tail



(Fig. 15) Book of Dimma, Luke portrait and *incipit*, pp. 54-55



(Fig. 16) Book of Dimma, John symbol page and *incipit*, pp. 104-5

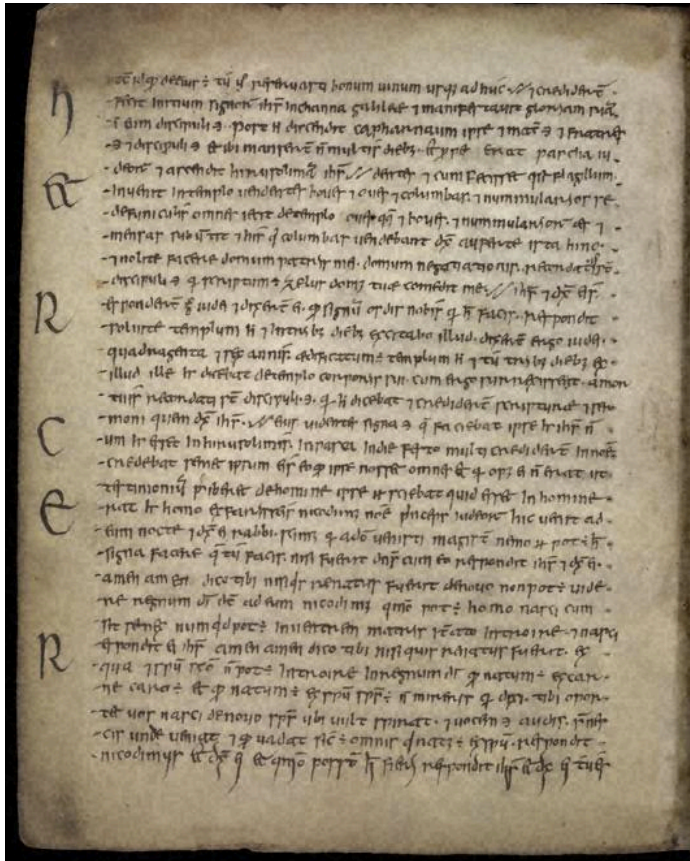

(Fig. 17) Stowe St John, fol. 2v

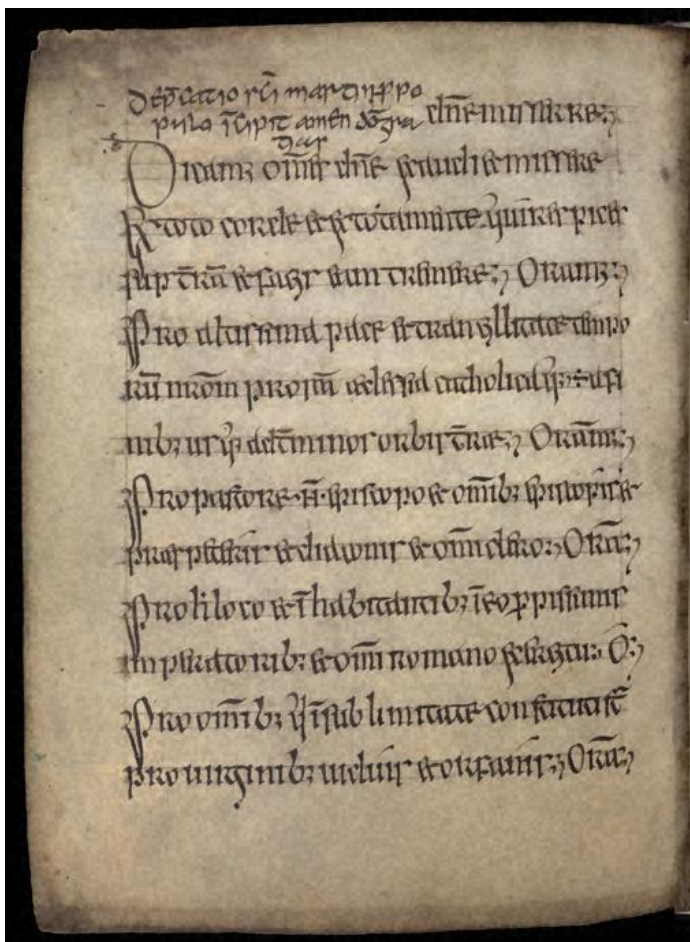

(Fig. 18) Stowe Missal, fol. 16v

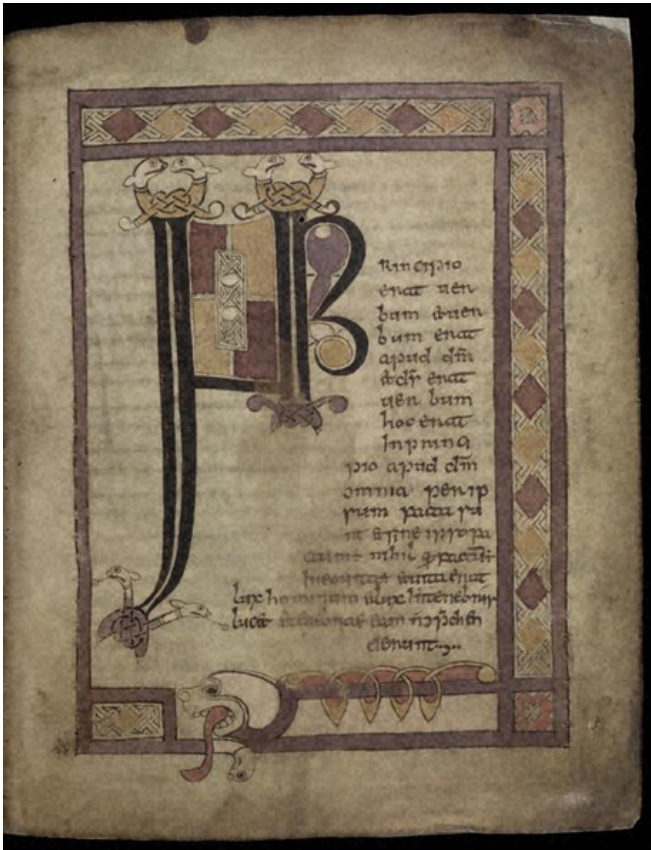

(Fig. 19) Stowe St John, gospel *incipit*, fol.1r



(Fig. 20) Stowe St John and Missal, evangelist portrait of John and missal *incipit*, fols 11v-12r



(Fig. 21) Ravenna, Mausoleum of Galla Placidia, *armarium* mosaic



(Fig. 22) Codex Amiatinus, Ezra miniature, fol. 5r

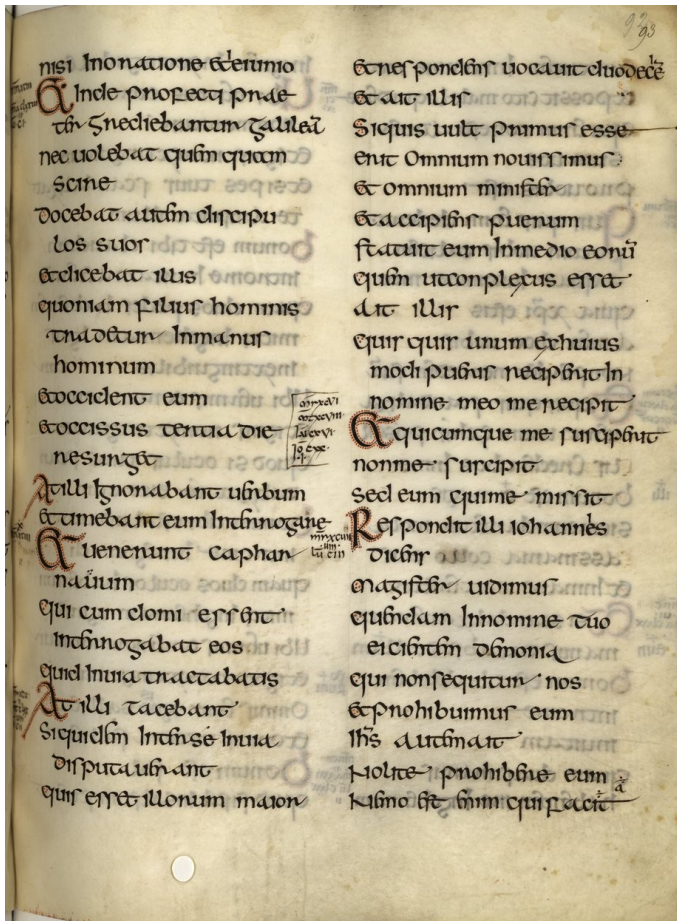

(Fig. 23) Echternach Gospels, fol. 93r

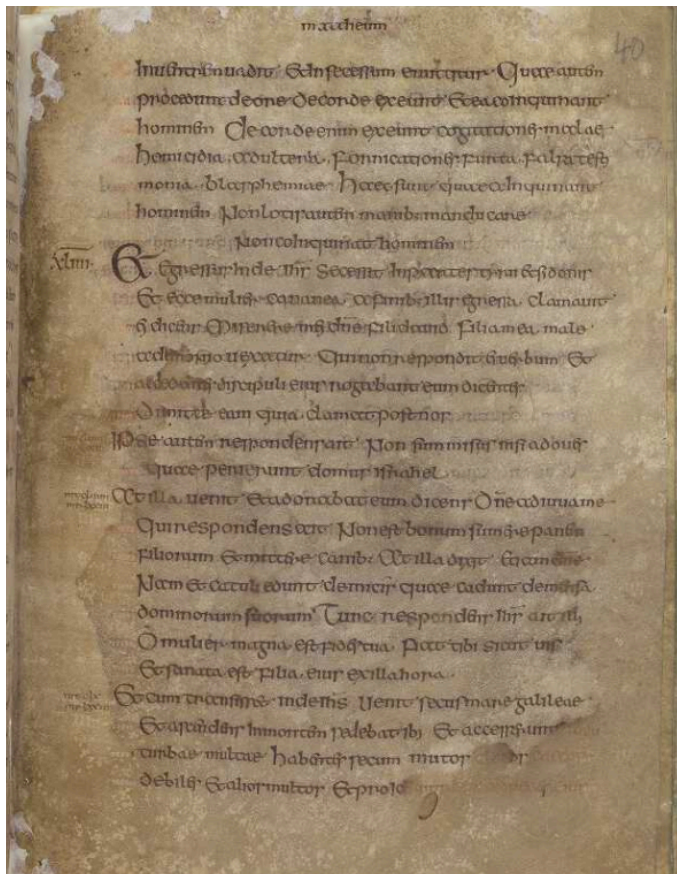

(Fig. 24) Maaseik Gospels, fol. 20v

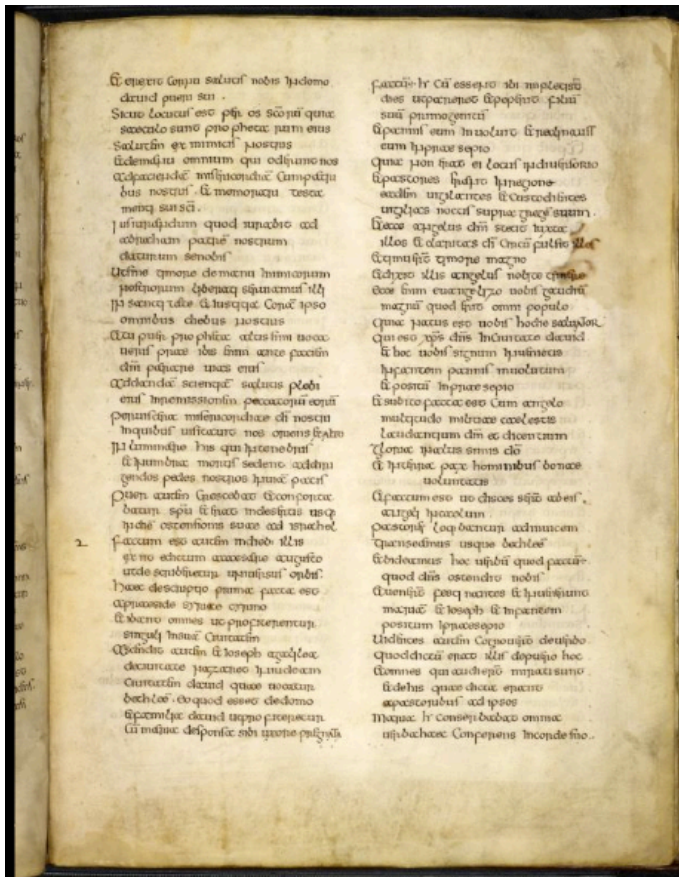

(Fig. 25) Royal Gospels, fol. 46r

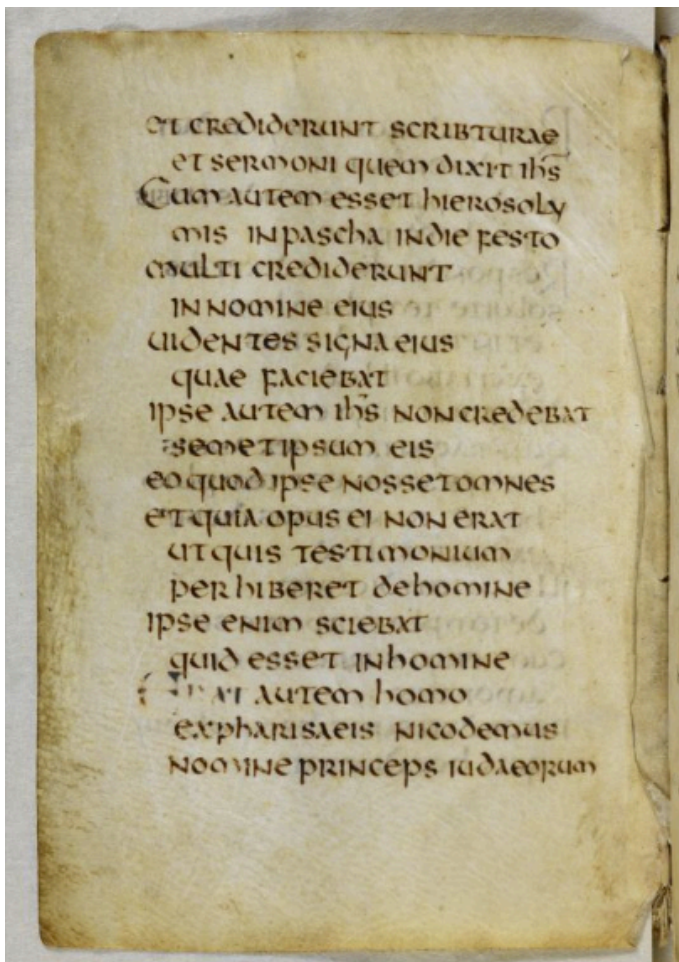

(Fig. 26) Cuthbert Gospel, fol. 8v

ET CREDIDERUNT SCRIBTURAE
 ET SERMONI QUEM DIXIT IHS
 QUAMQUAM ESSET HIERSOLY
 MIS IMPASCHA INDIE FESTO
 ANATI CREDIDERUNT
 IN NOAMIE EIUS
 UIDENTES SIGNA EIUS
 QUAE FACIEBAT
 IPSE AUTEM IHS NON CREDEBAT
 SE HABERE IPSUM EIS
 EO QUOD IPSE NOSSET OMNES
 ET QUIA OPUS EI NON ERAT
 UT QUIS TESTIMONIUM
 PERHIBERET DE HOMINE
 IPSE ENIM SCIEBAT
 QUID ESSET IN HOMINE
 ET MI AUTEM HOMO
 EX PHARISAEIS NICODEMUS
 NOAMIE PRINCEPS IUDAEORUM

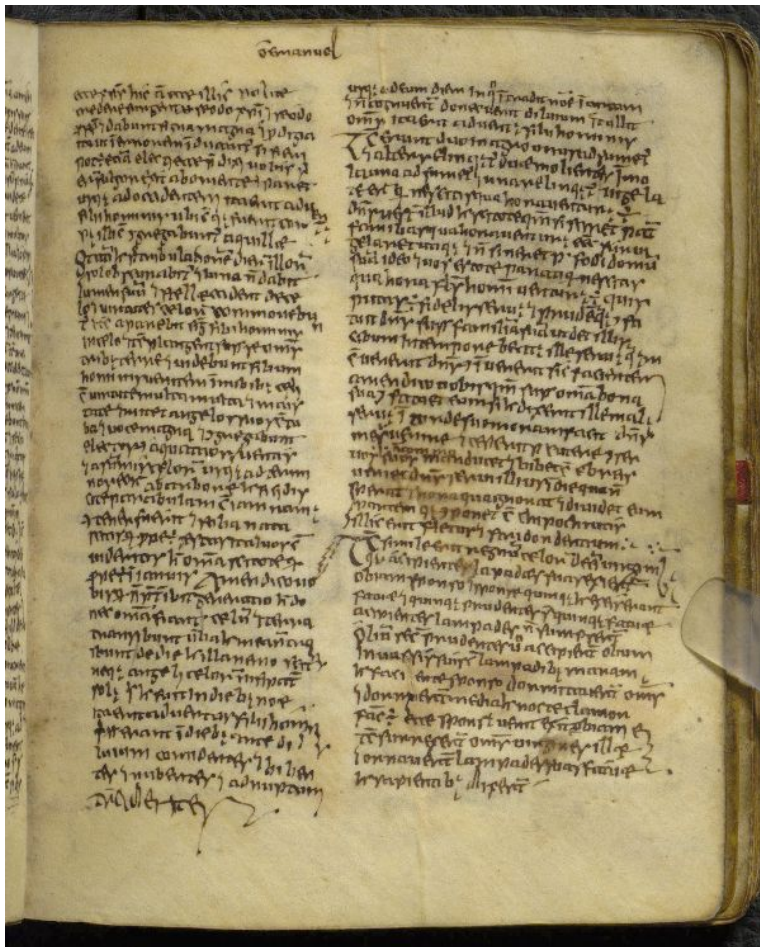

(Fig. 29) Cadmug Gospels, fol. 15r

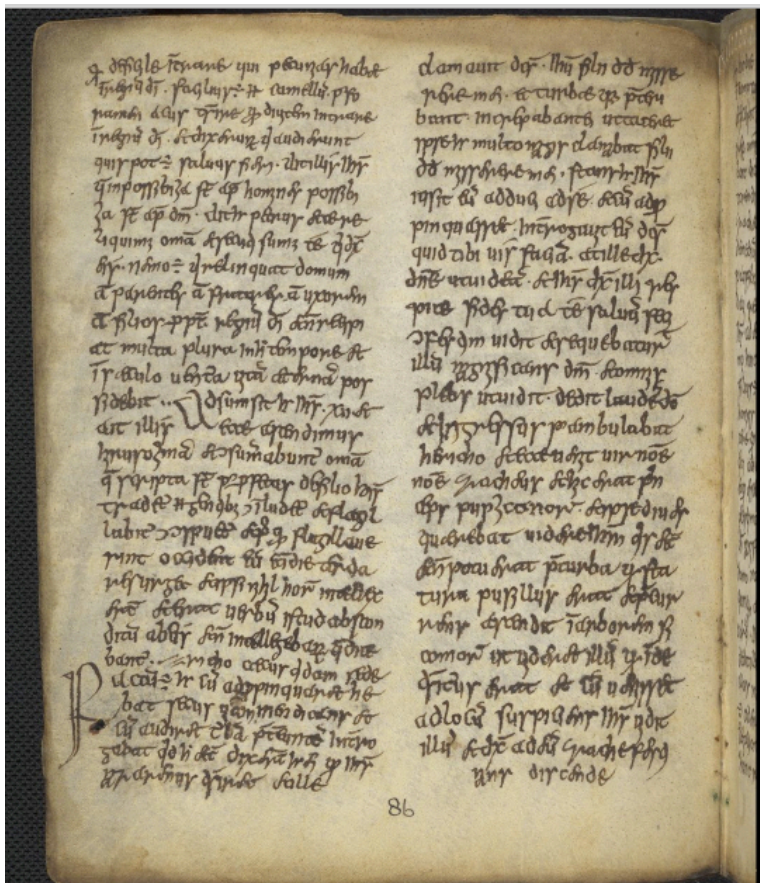

(Fig. 30) Book of Dimma, p. 86

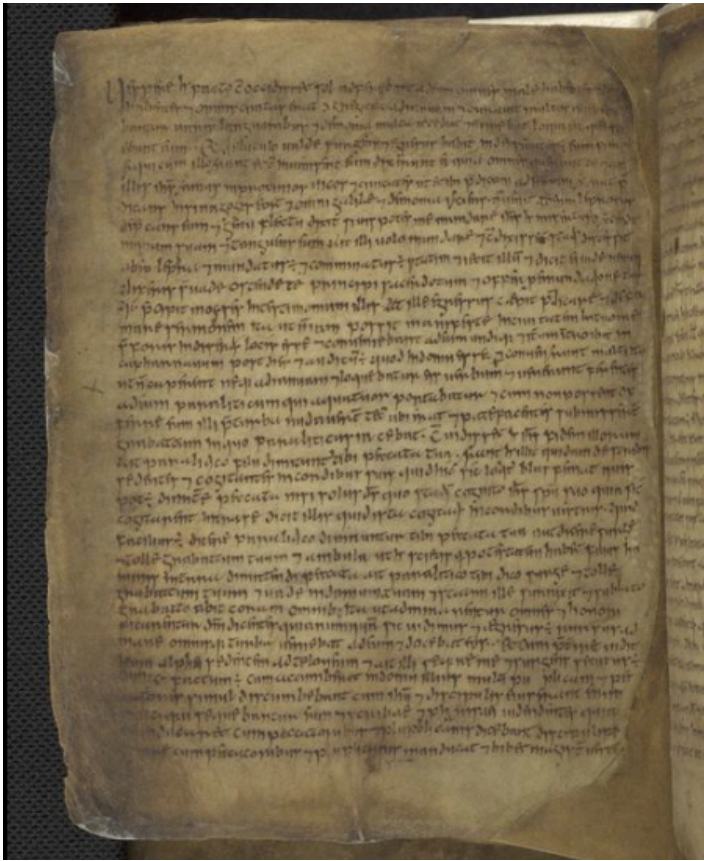

(Fig. 31) Mulling Fragment, fol. 97v

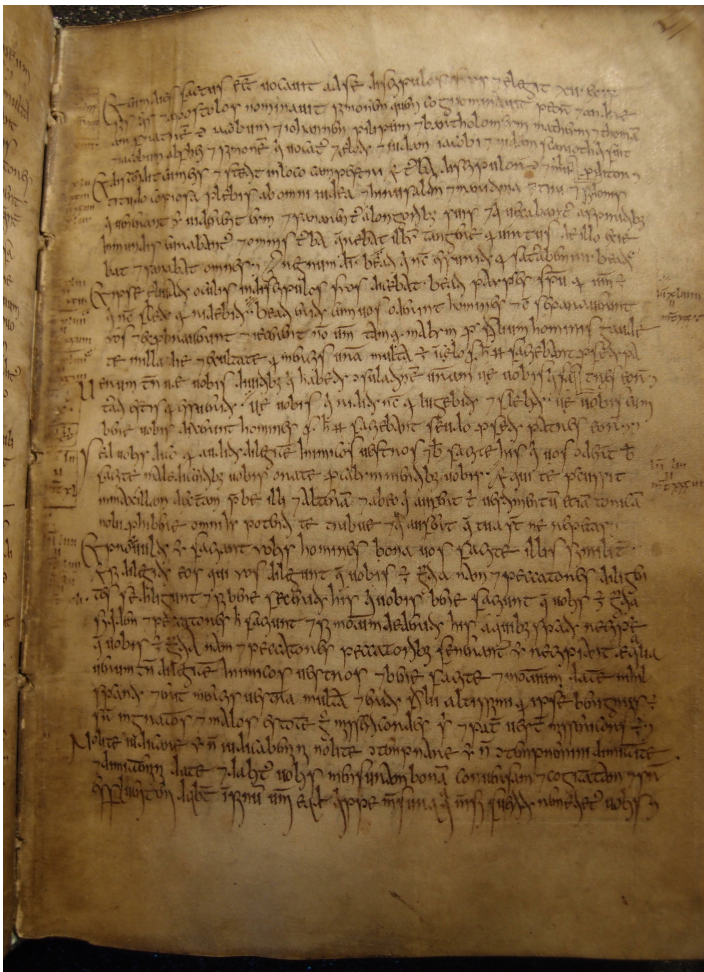

(Fig. 32) Bern 671, fol. 41r

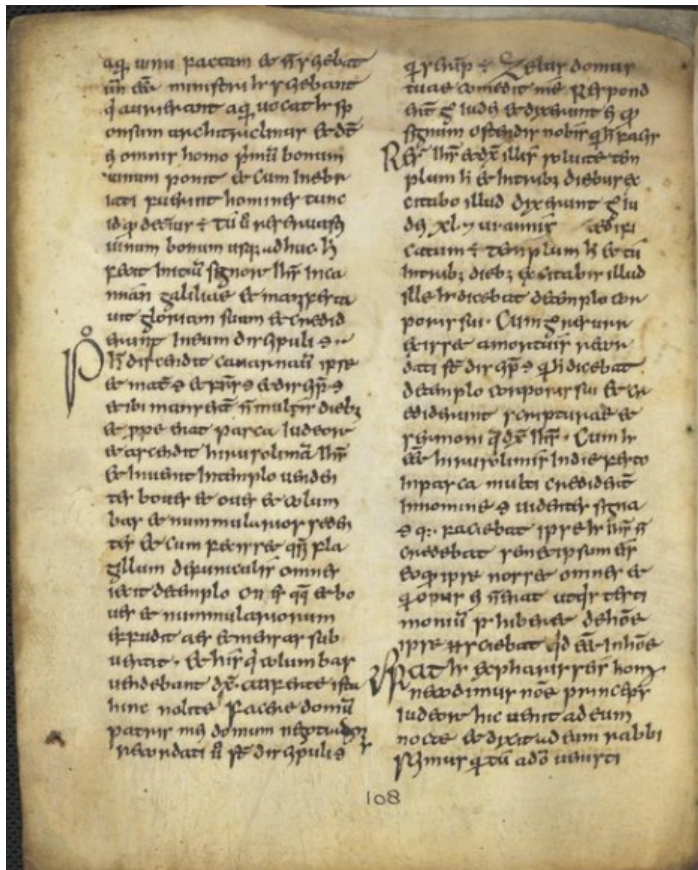

(Fig. 33) Book of Dimma, Gospel of John, p. 108

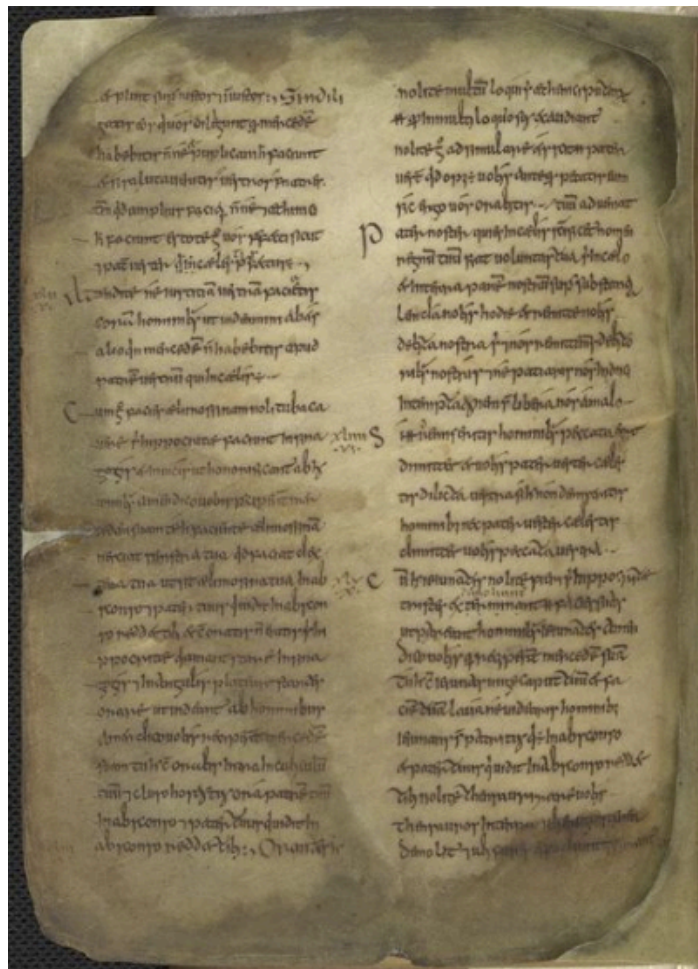

(Fig. 34) Book of Mulling, fol. 16v

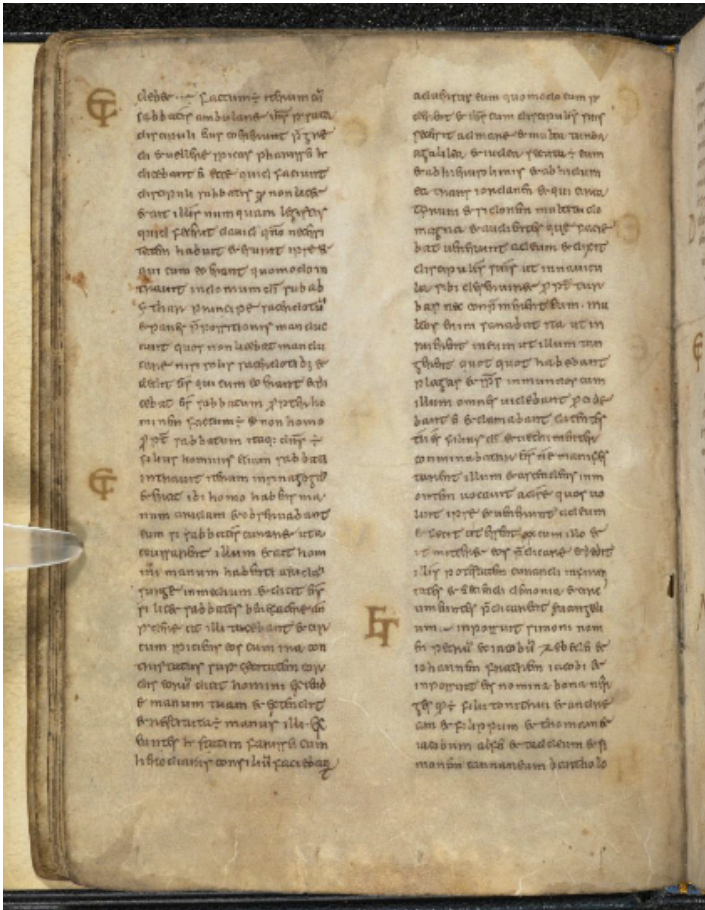

(Fig. 37) Add. 40618, fol. 8v

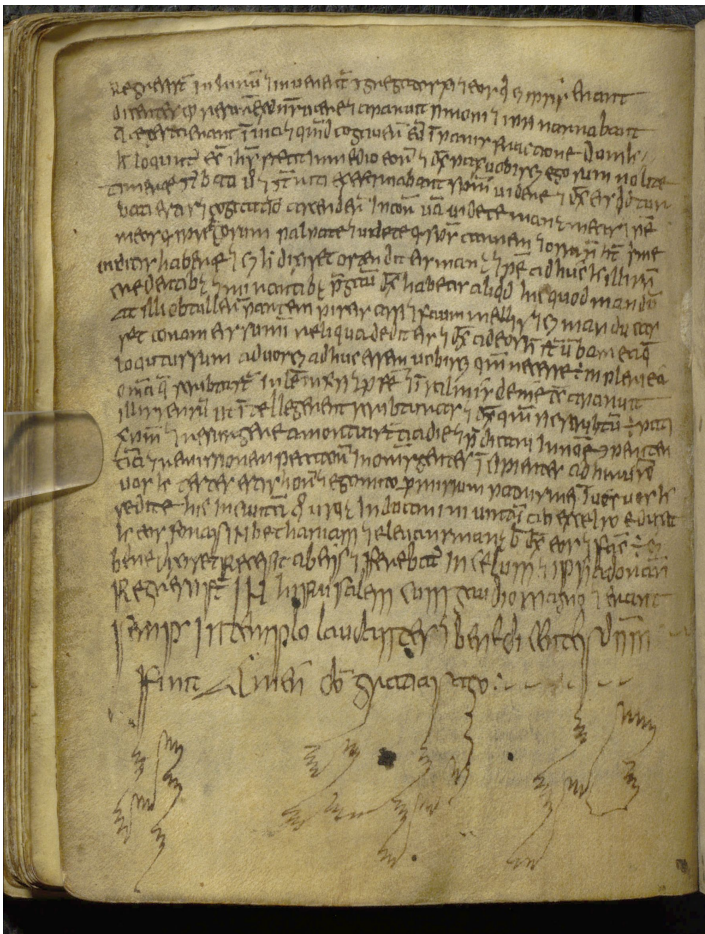

(Fig. 38) Cadmug Gospels, fol. 50v

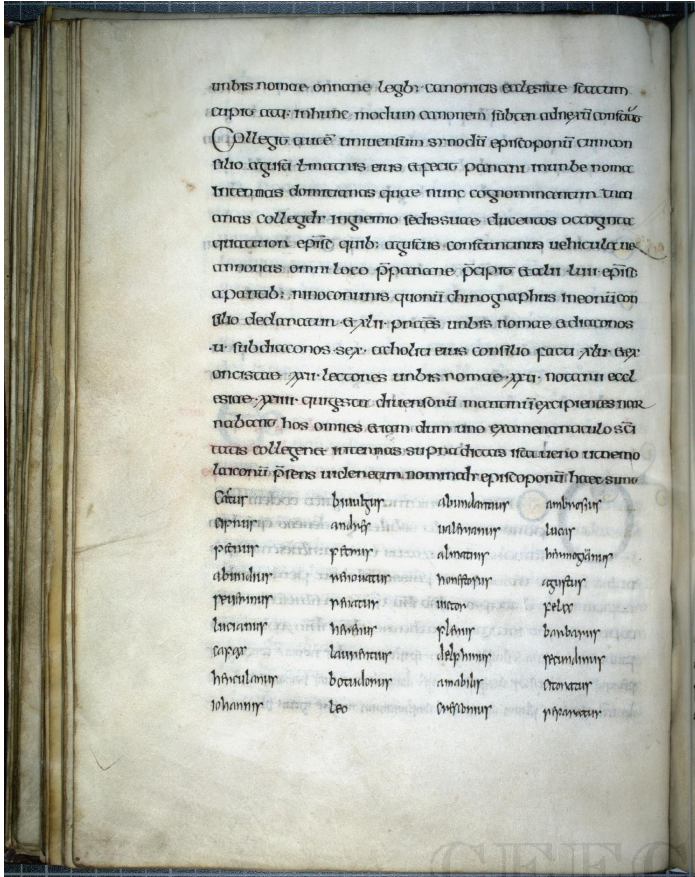

(Fig. 39) Cologne Dombibliothek 213, Symmachian constitution of Silvester I, fol. 76v

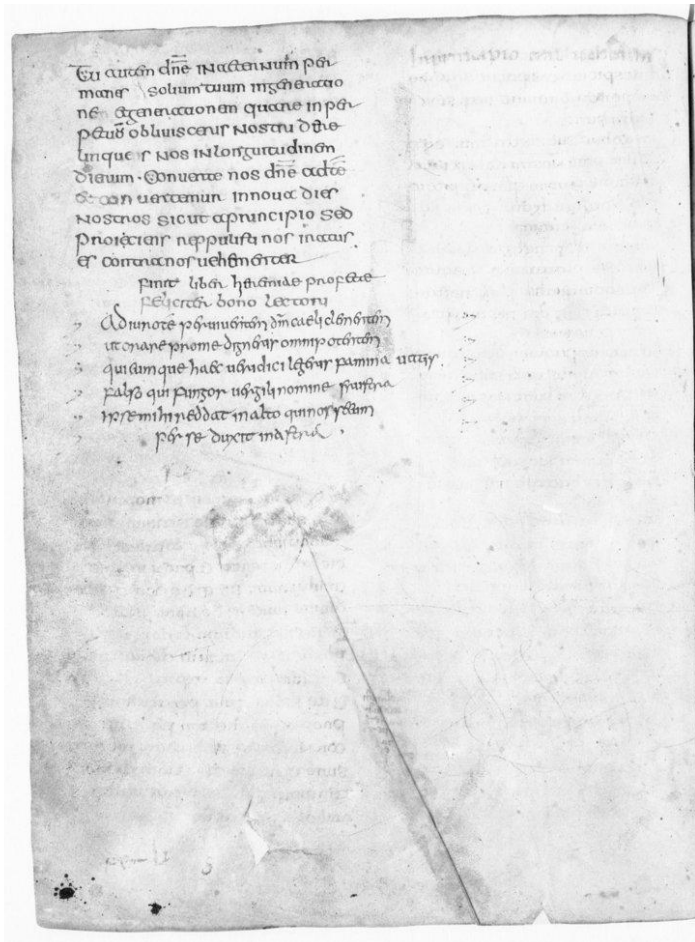

(Fig. 40) BNF MS Latin 9382, fol. 45v

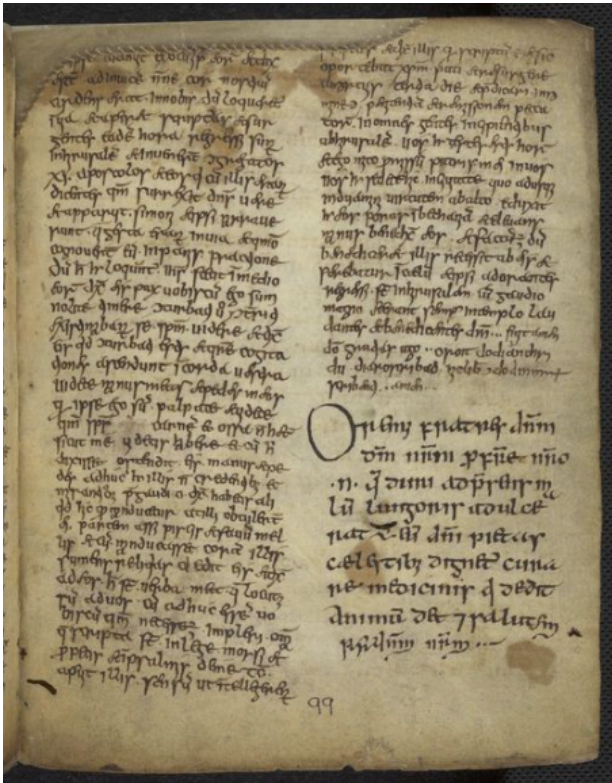

(Fig. 42) Book of Dimma, Luke explicit and colophon (and incipit to communion for the sick), p. 99

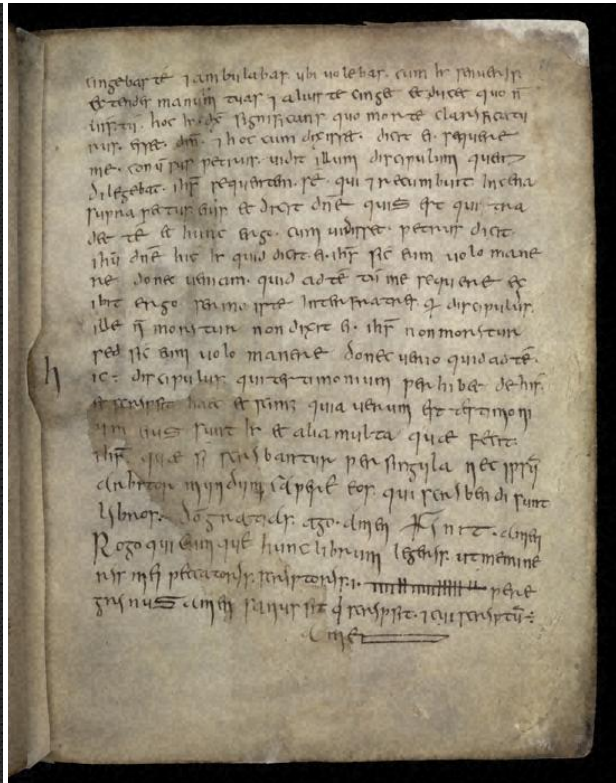

(Fig. 43) Stowe St John, colophon, fol. 11r

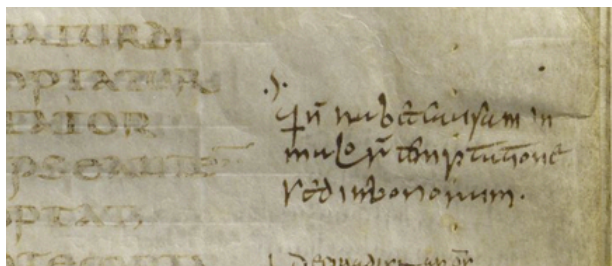

(Fig. 44) Victor Codex, annotations probably in the hand of Boniface, fols 43r and 436v

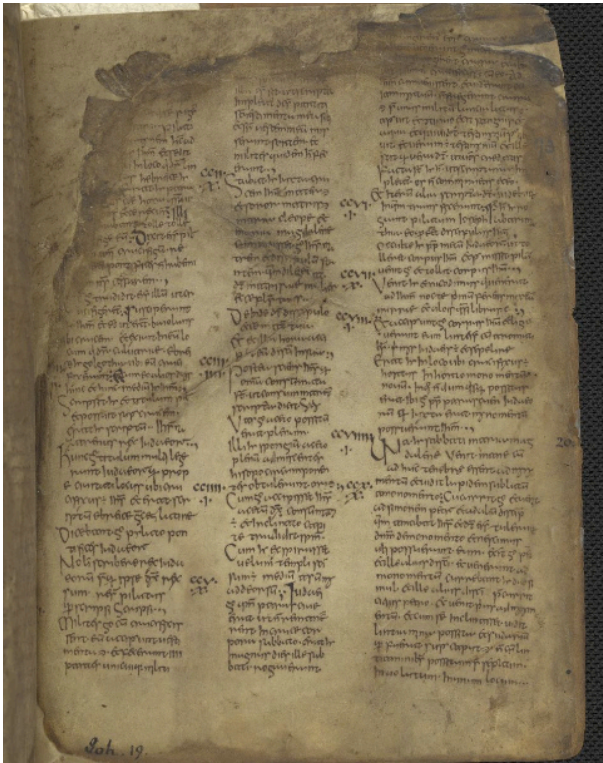

(Fig. 45) Book of Mulling, three-column page layout, fol. 93r



(Fig. 46) DCL, MS A. II. 10, fol. 3v Matthew explicit,

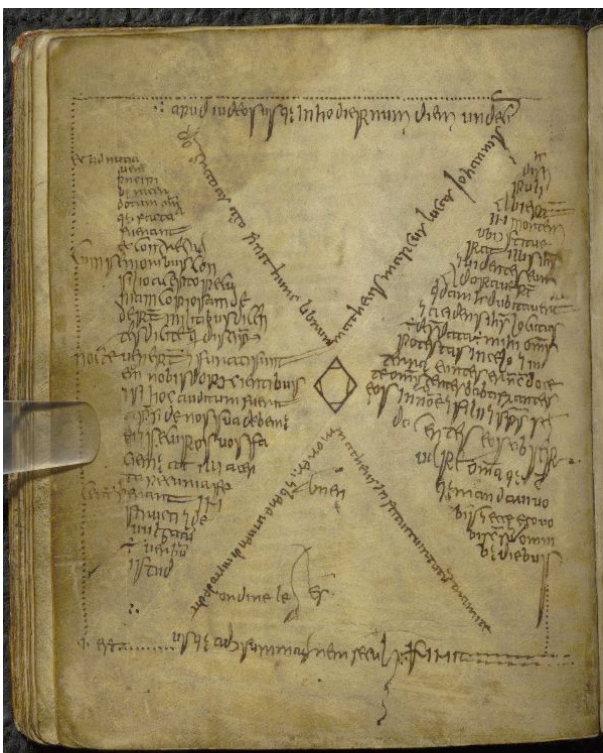

(Fig. 47) Cadmug Gospels, Matthew explicit, fol. 18v

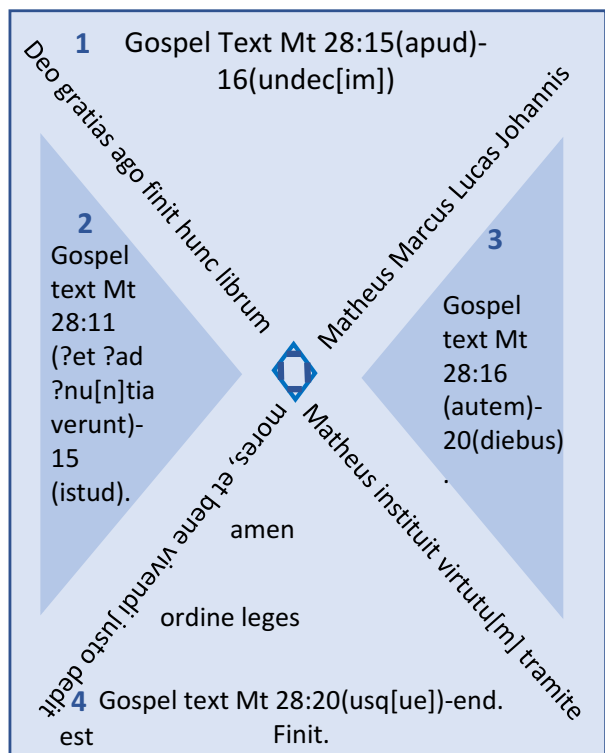

(Fig. 48) Diagram showing the order of text on fol. 18v of the Cadmug Gospels



(Fig. 49) Book of Kells, *Chi-rho* page, fol. 34r



(Fig. 50) Book of Kells, four-symbols page preceding John's Gospel, fol. 290v



(Fig. 51) MacRegol Gospels, colophon page, fol. 169v

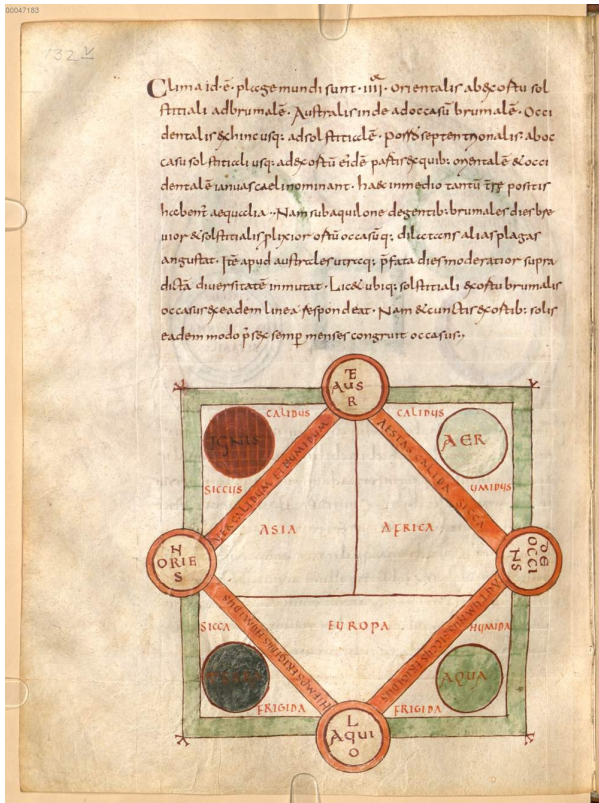

(Fig. 52) Munich, Bayerische Staatsbibliothek, Clm 210, fol. 132v

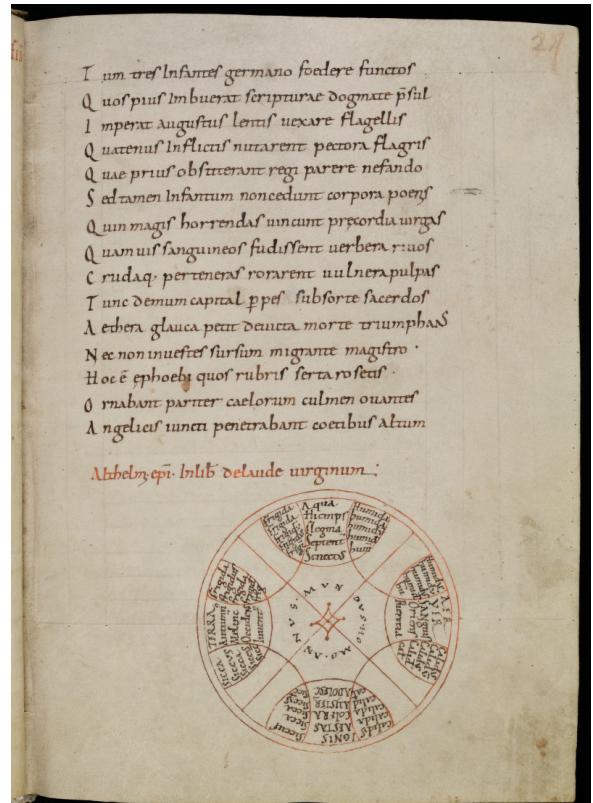

(Fig. 53) St. Gallen, Stiftsbibliothek, Cod. Sang. 250, p. 27

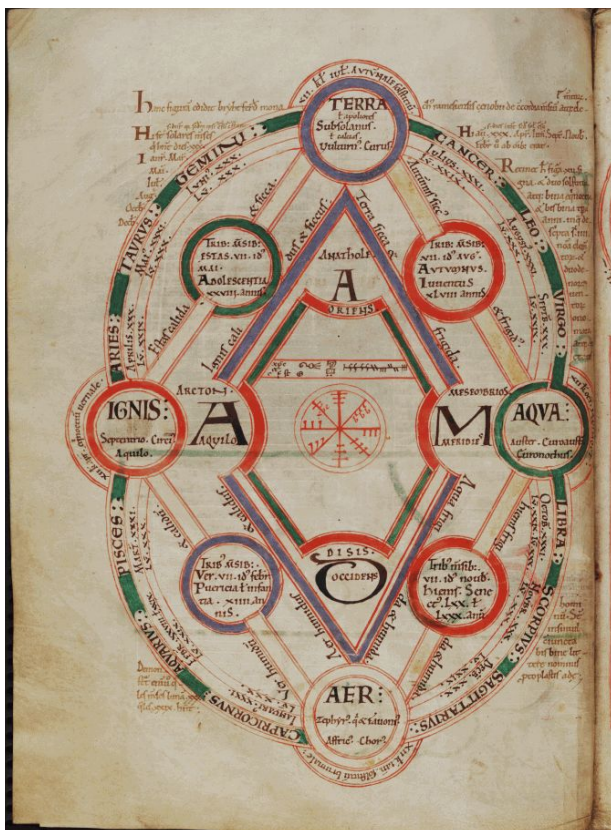

(Fig. 54) Oxford St John's College 17, Byrhtferth diagram, fol. 7v



(Fig. 55) Codex Aureus of St. Emmeram, *Maiestas* miniature, fol. 6v



(Fig. 56) Bamberg Bible, *Maiestas* miniature, fol. 339v



(Fig. 57) Vivian Bible, *Maiestas* miniature, fol. 329v



(Fig. 58) Moutier-Grandval Bible, *Maiestas* miniature, fol. 352v

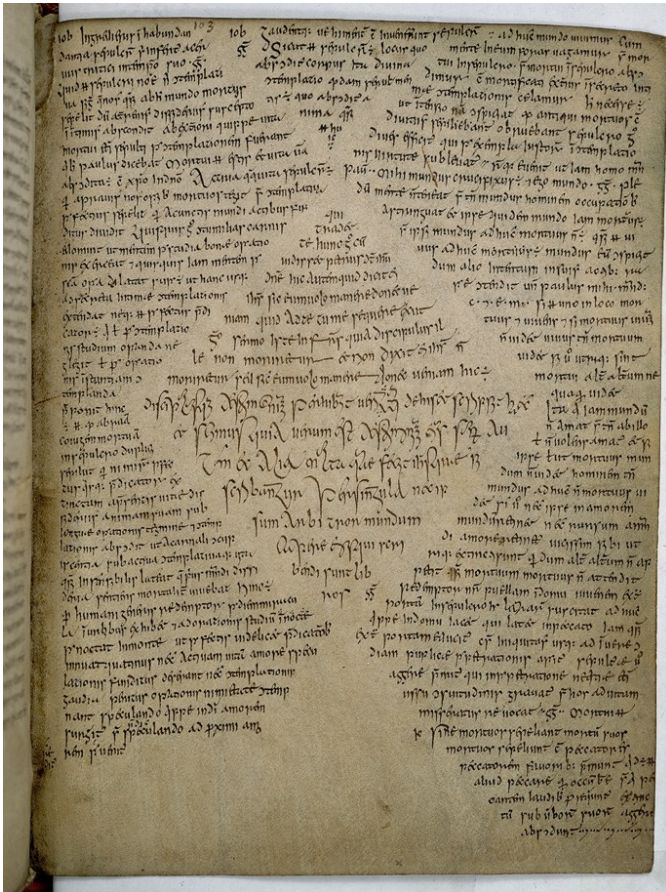

(Fig. 61) Book of Armagh, John explicit, fol. 103r

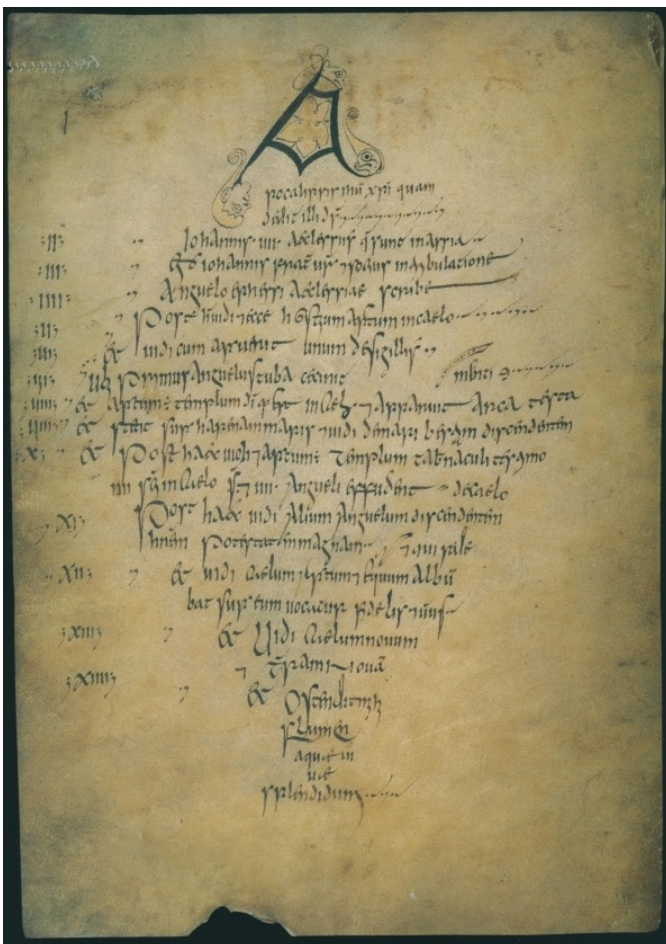

(Fig. 62) Book of Armagh, Revelation capitula/vision-list, fol. 159v

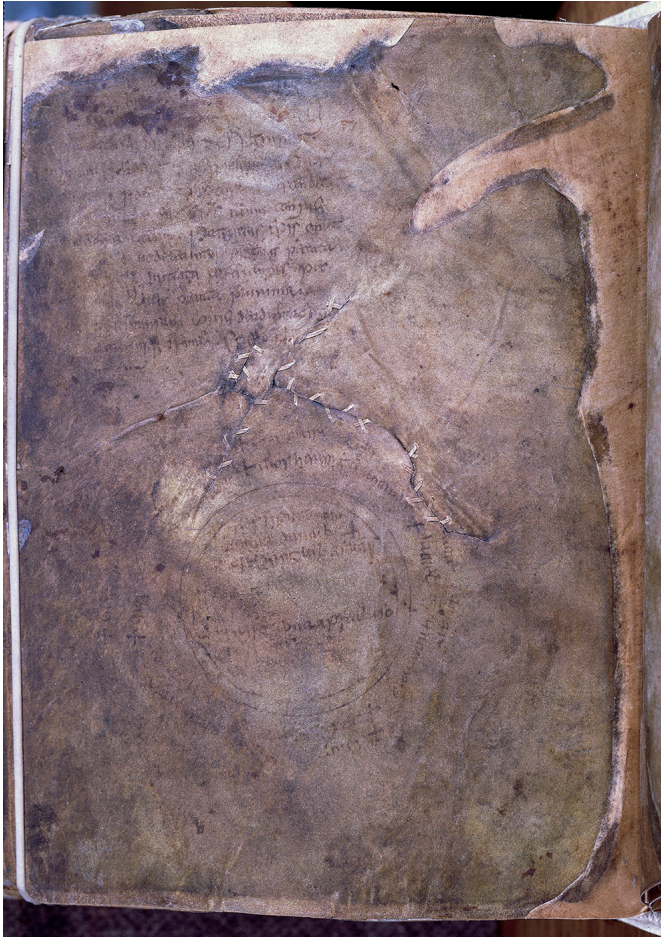

(Fig. 65) Book of Mulling, circular diagram, fol. 94v

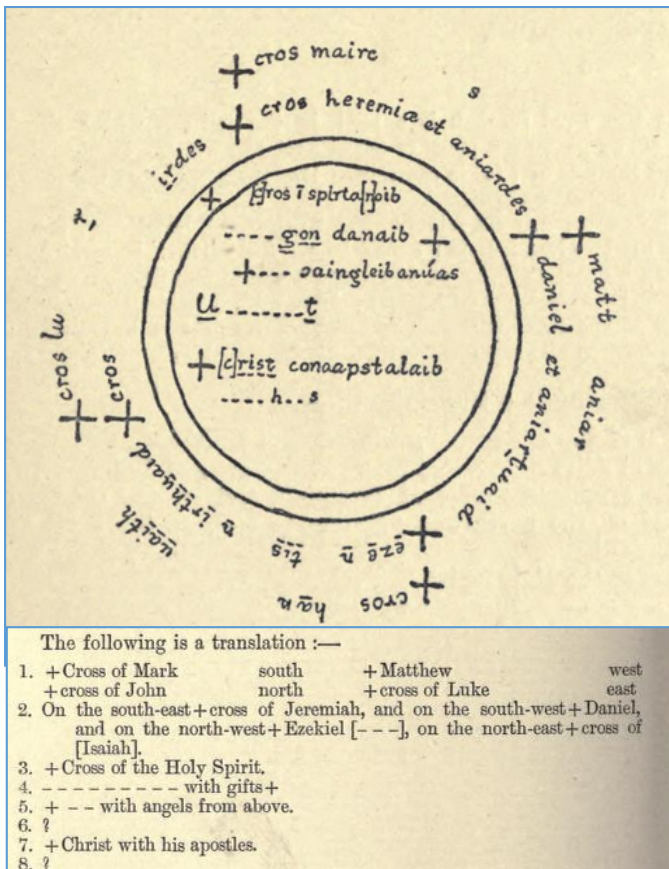

(Fig. 66) Sketch of 'the Circular Device', from Lawlor, *Chapters*, 167 (note, this does not accurately portray the angles of the text)



(Fig. 67) Codex Amiatinus, *Maiestas* miniature, fol. 796v



(Fig. 68) Gundohinus Gospels, *Maiestas* miniature, fol. 12v



(Fig. 69) Turin Gospels, Ascension miniature, fol. 1r,

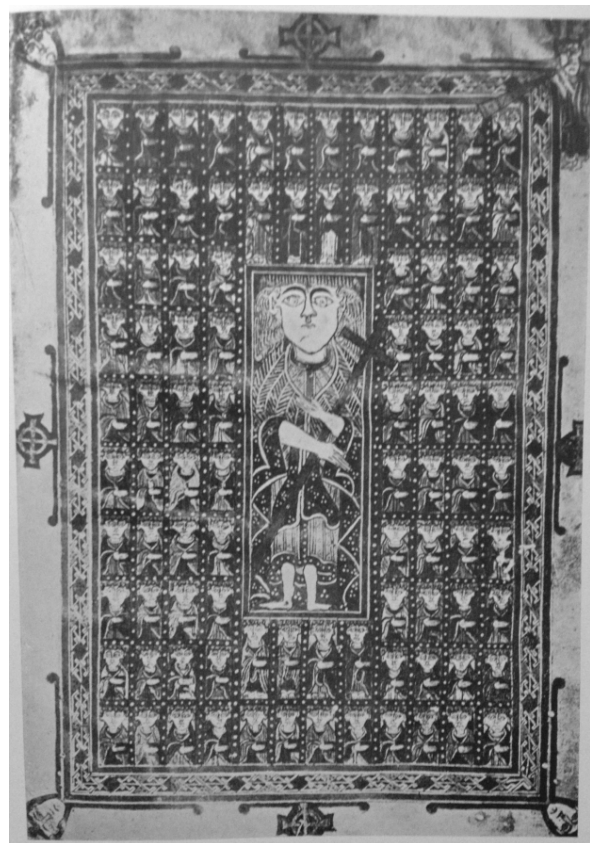

(Fig. 70) Turin Gospels, Second Coming miniature, fol. 2r



(Fig. 71) Valenciennes Apocalypse, diagram of the Heavenly Jerusalem, fol. 38r

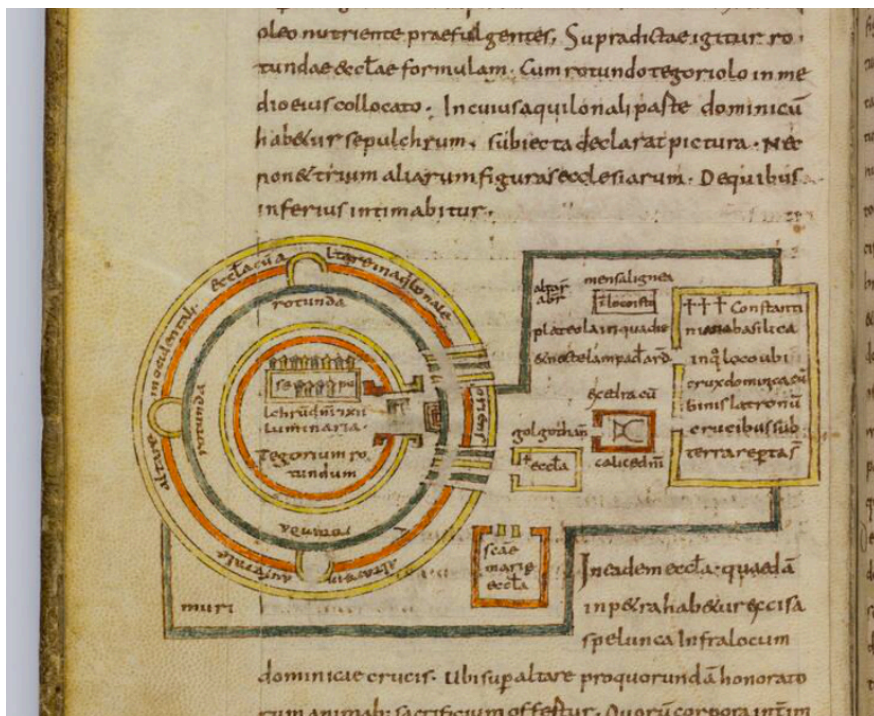

(Fig. 72) Vienna, Österreichischen Nationalbibliothek, Cod. 458, De Locis Sanctis diagram of the Holy Sepulchre, fol. 4v

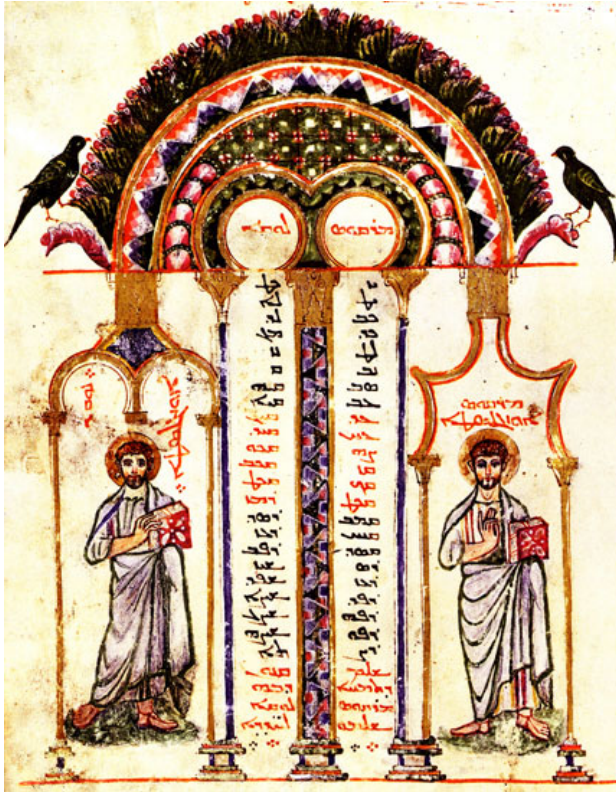

(Fig. 73) Rabbula Gospels, evangelists in canon tables, fol. 10r



(Fig. 74) Abuna Garmina Gospels, evangelist portait



(Fig. 75) Freer Gospels, cover painted with evangelists



(Fig. 76) Book of Mulling,
evangelist portrait, fol.12v

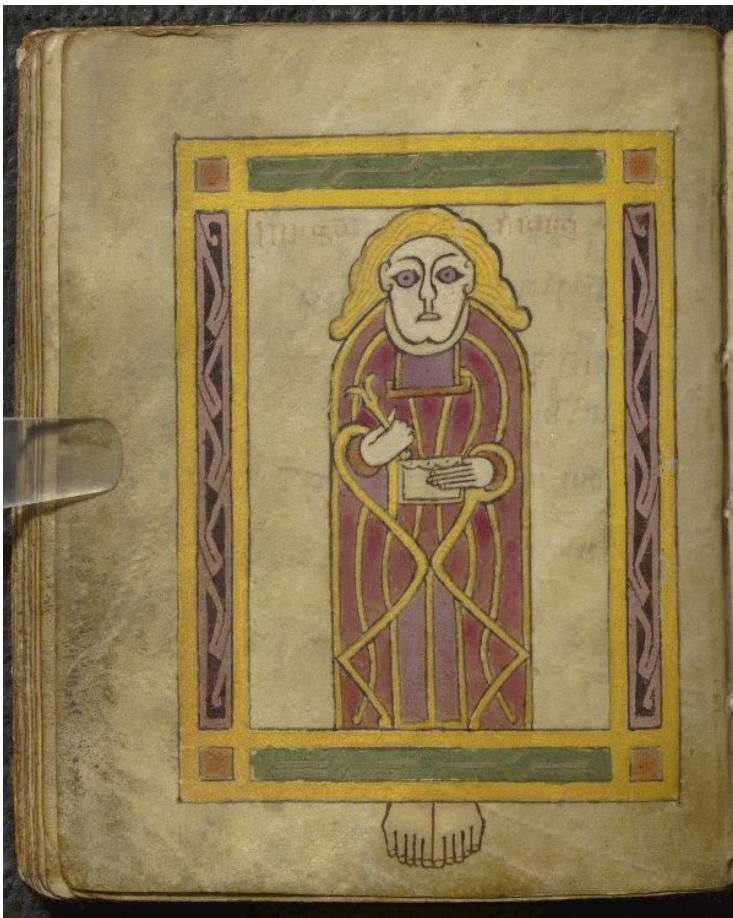

(Fig. 77) Cadmug Gospels,
Mark portrait, fol. 19v



(Fig. 78) Book of Kells, Matthew portrait, fol. 28v



(Fig. 79) Book of Cerne, Luke portrait, fol. 21v



(Fig. 80) Stockholm Codex Aureus, John portrait, fol. 150v



(Fig. 81) Augustine Gospels, Luke portrait, fol. 129v



(Fig. 82) Santa Maria Antiqua, Rome, Virgin in the Niche, hole for an attachment top right



(Fig. 83) Book of Dimma, Mark portrait, p. 30



(Fig. 84) MacDurnan Gospels, Mark portrait, fol. 70v



(Fig. 85) Lindau Gospels back cover, detail



(Fig. 86) Faddan More Psalter cover

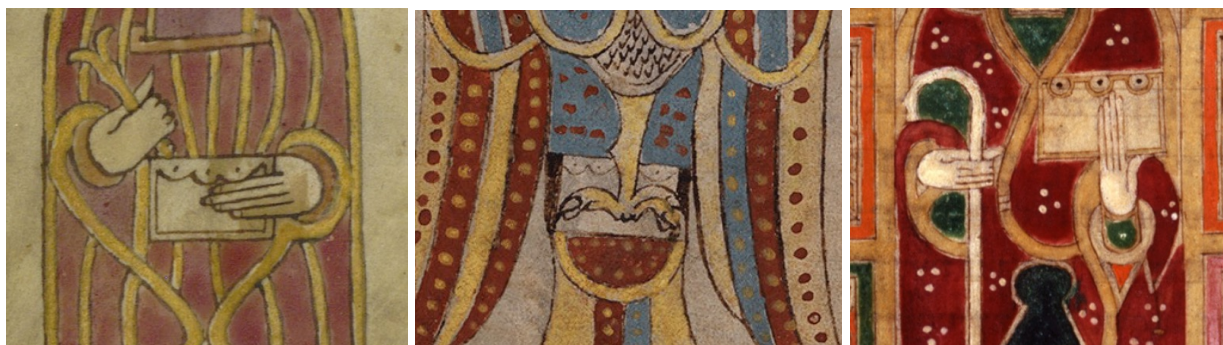

Cadmug Gospels,
Matthew Portrait, fol. 1v

Book of Dimma, John
Symbol, p. 104

MacDurnan Gospels,
Luke Portrait, fol. 115v.

(Fig. 87) Details of buttoned books in pocket-gospel evangelist miniatures



(Fig. 90) MacDurnan Gospels, Matthew portrait, fol. 4*v



(Fig. 91) MacDurnan Gospels, Luke portrait, 115v



(Fig. 92) Cross of Scriptures, Clonmacnois, Co. Offaly, cross shaft, south side, unidentified figure with angel



(Fig. 93) Muiredach's Cross, Monasterboice, Co. Louth, upper cross arm, north side, Saints Paul and Anthony



(Fig. 94) Papil Stone, Shetland, ecclesiastics processing towards a cross



(Fig. 95) Monk's Stone, Shetland, ecclesiastics processing towards a cross



(Fig. 96) Drogo Sacramentary, decorated initial showing St Arnulf exorcising demons, baptising and preaching, fol. 91r

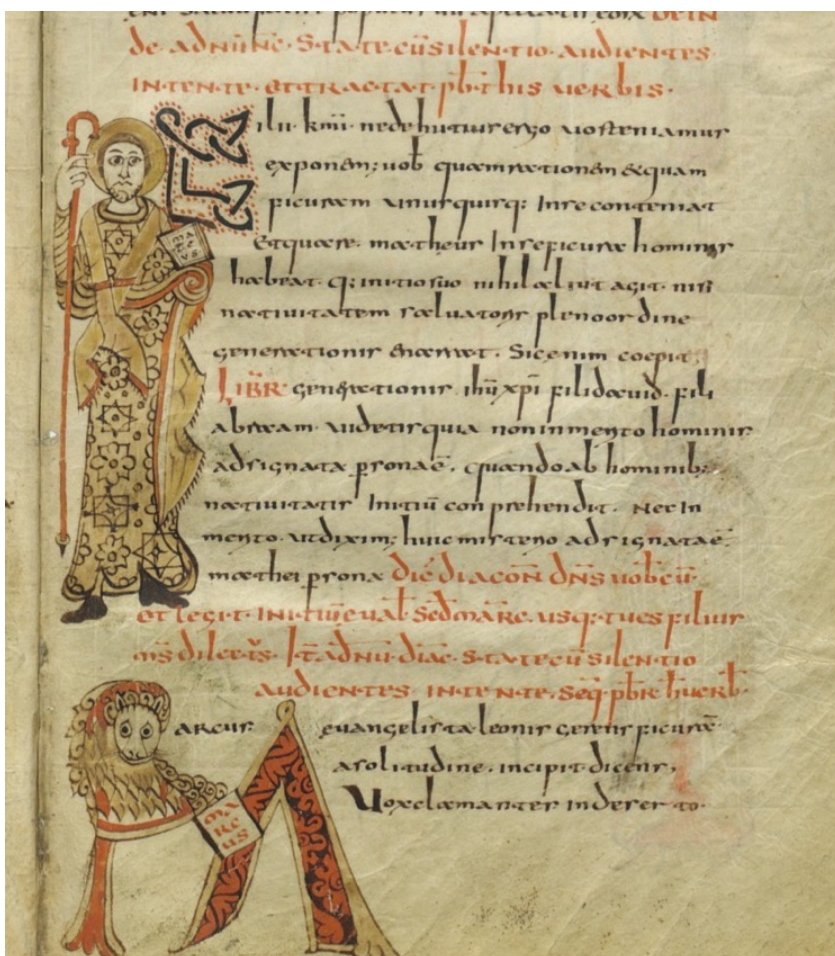

(Fig. 97) Gellone Sacramentary, anthropomorphic initial of Matthew man-symbol, fol. 42r



(Fig. 98) Wooden staff/crozier, Castlearmstrong, Co. Offaly



(Fig. 99) Mausoleum of Galla Placidia, mosaic of Christ as prince of pastors



(Fig. 100) Book of Durrow, Matthew symbol, fol. 21v



(Fig. 101) Book of Kells, John incipit, fol. 292r



(Fig. 102) MacDurnan Gospels, John portrait and incipit, fols 170v-172r



(Fig. 103) Book of Kells, John portrait, fol. 291v.

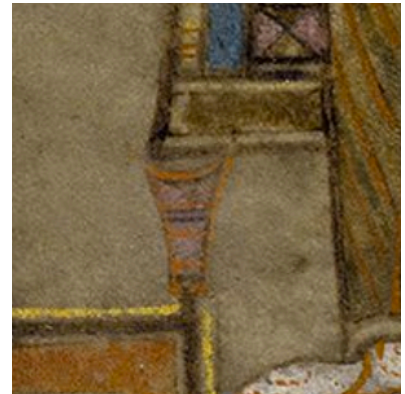

(Fig. 104) Codex Amiatinus, Ezra portrait, fol. 5v

(Fig. 105) Details of inkwells/dishes: Book of Mulling, fol. 12v; Book of Kells, fol. 291v; Codex Amiatinus, fol. 5v



(Fig. 108) Prayerbook of Charles the Bald, Crucifixion miniature fols 38v–39r



(Fig. 109) Book of Kells , detail of lion with red dots, fol. 277r