



The
University
Of
Sheffield.

Gait monitoring: from the clinics to the daily life

A thesis submitted in partial fulfilment of the requirements for the degree of
Doctor of Philosophy

The University of Sheffield
Faculty of Engineering
Department of Mechanical Engineering

Fabio Alexander Storm, M.Sc.

Supervisor
Dr. Claudia Mazzà

DDP Supervisor
Dr. Matt Carré

External examiner:
Prof. Andrea Cereatti

Internal examiner:
Prof. Marco Viceconti

September 2016

Acknowledgements

I would like to thank my supervisor Dr. Claudia Mazzà for her continuous support, advice and input throughout all the stages of my research work, for giving me the opportunity to participate in many conferences, and for establishing several collaborations which have helped me to develop professionally and personally. I would also like to thank my second supervisor Dr. Matt Carré for his guidance during the course of my postgraduate studies.

I would like to thank the University of Sheffield, which allowed me to undertake my doctoral studies, and the Insigneo research group, which welcomed me during my research.

My thanks go also to Silvia Pancani and Chris Buckley for their help during the data collections on healthy participants, included in Chapters 3 and 4.

The research on multiple sclerosis patients was conducted in collaboration with the Department of Neurology of the Sheffield Teaching Hospitals. Many thanks to Dr. Siva Nair for making this collaboration possible, and to Ms. Alison Clarke, Dr. Jill van der Meulen, and Mr S. Periyasamy for their help during the data collection.

The research on diabetes patients was conducted in collaboration with the Department of Human Metabolism of the Sheffield Teaching Hospitals. I would like to thank Dr. Dinesh Selvarajah, Dr. Jefferson LB Marques, Dr. Leanne Hunt, and Mr. Joseph Harding, for their support during the data collection.

I gratefully acknowledge the financial support from the European Union through the EC contract FP7-ICT-2011-9, No. 600803 (MISSION-T2D), the Sheffield National Centre for Sport and Exercise Medicine, and the EPSRC Frontier Engineering Award, Grant Reference No. EP/K03877X/1.

A special thank you goes to all my family for their support and understanding, allowing me to be who I am now.

Publications and presentations resulting from this study

Scientific publications

F. A. Storm, B. W. Heller, C. Mazzà, *Step detection and activity recognition accuracy of seven physical activity monitors*. **PLoS ONE 10(3): e0118723**.

doi:10.1371/journal.pone.0118723

M. Morettini, F. A. Storm, M. Sacchetti, A. Cappozzo, C. Mazzà, *Effects of walking on low-grade inflammation and their implications for Type 2 Diabetes*. **Preventive Medicine Reports 2 (2015) 538–547**, doi:10.1016/j.pmedr.2015.06.012

F. A. Storm, C. Buckley, C. Mazzà, *Gait event detection in laboratory and real life settings: Accuracy of ankle and waist sensor based methods*. **Gait and Posture 50:42-46**,

doi:10.1016/j.gaitpost.2016.08.012

Oral presentations in conferences

F. Storm, S. Nair, A. J. Clarke, J. M. Van der Meulen, C. Mazzà, *A reliable protocol for the assessment of step count accuracy of physical activity monitors in multiple sclerosis*. **25th Congress of the International Society of Biomechanics (ISB 2015)**, Glasgow, UK, July 12-16, 2015.

Poster presentations in conferences

F. A. Storm, B. W. Heller, C. Mazzà, *Comparison of 7 physical activity monitors: a validation study*. **2014 International Society of Posture and Gait Research World Congress (ISPGR 2014)**, Vancouver, Canada, June 29 – July 3, 2014.

F. A. Storm, S. Pancani, B. W. Heller, C. Mazzà, *Activity Monitors: are we there?* **13th International Symposium on 3D Analysis of Human Movement (3d-AHM 2014)**, Lausanne, CH, July 14-17, 2014.

F. A. Storm, S. Nair, A. J. Clarke, J. M. Van der Meulen, C. Mazzà, *Step detection accuracy in multiple sclerosis: patient-specific error propagation in long-term monitoring of physical*

activity. **4th International Conference on Ambulatory Monitoring of Physical Activity and Movement (ICAMPAM 2015)**, Limerick, Ireland, June 10-12, 2015.

F. A. Storm, C. Buckley, C. Mazzà, *Accuracy of two algorithms for gait events detection in free-living settings*. **14th International Symposium on 3D Analysis of Human Movement (3d-AHM 2016)**, Taipei, Taiwan, July 18-21, 2016.

Abstract

Monitoring of gait in daily living allows a quantitative analysis of walking in unrestricted conditions, with many potential clinical applications. This thesis aims at addressing the limitations that still hinder the wider adoption of this approach in clinical practice, providing healthcare professionals and researchers new tools which may impact on current gait assessment procedures and improve the treatment of many diseases leading to – or generated by – mobility impairments. The thesis comprises four experimental sections:

Accuracy of commercially-available devices. Step detection accuracy in currently available physical activity monitors was assessed in healthy individuals. The best performing device was then tested in multiple sclerosis patients, showing reliability but highly speed-dependent accuracy. These findings suggest that a short set of tests performed in controlled conditions could inform researchers before starting unsupervised monitoring of gait in patients.

Differences between laboratory and free-living gait parameters. The study assessed the accuracy of two algorithms for gait event detection, and provided normative values of gait temporal parameters for healthy subjects in different environments and types of walking.

A pilot study toward clinical application. This pilot study compared laboratory based tests with daily living assessment of gait features in multiple sclerosis patients. Results provided clear evidence that in this population clinical gait tests might not represent typical gait patterns of daily living.

Analysis of free-living walking in patients with Diabetes. A systematic review is presented looking for evidence of the effectiveness of walking as physical activity to reduce inflammation. Then, cadence and step duration variability are examined during free-living walking in a group of patients with diabetes.

This thesis systematically highlighted potential and actual limitations in the use of wearable sensors for gait monitoring in daily life, providing clear practical indications and normative values which are essential for the widespread informed and effective clinical adoption of this technology.

Table of Contents

LIST OF FIGURES	I
LIST OF TABLES	II
NOMENCLATURE	III
CHAPTER 1 - INTRODUCTION	1
1.1 Monitoring Gait in Daily Life – General Background	1
1.2 Aim of the Thesis	3
CHAPTER 2 - MONITORING PHYSICAL ACTIVITY AND WALKING USING WEARABLE SENSORS – STATE OF THE ART	5
2.1 Monitoring of physical activity	5
2.2 Wearable motion sensors for physical activity and gait monitoring	6
2.2.1 Pedometers	7
2.2.2 Footswitches	7
2.2.3 Pressure insoles	8
2.2.4 Micro-Electro-Mechanical systems	9
2.2.5 Other physical activity sensors	17
2.3 The quantification of gait using wearable motion sensors	17
2.3.1 Gait cycle and temporal-spatial parameters of walking	18
2.3.2 A brief historical excursus	20
2.3.3 Activity counts	23
2.3.4 Energy expenditure	23
2.3.5 Step detection and counting	25
2.3.6 Gait events and temporal parameters	28
2.3.7 Gait spatial parameters	32
2.3.8 Measures of gait variability and stability	34
2.4 Wearable MIMU sensors and musculoskeletal models	36
2.5 Conclusions	37
CHAPTER 3 - PHYSICAL ACTIVITY MONITORS: ACCURACY ASSESSMENT	38
3.1 Accuracy of step detection and activity recognition in healthy individuals	38
3.1.1 Introduction	39
3.1.2 Physical activity monitors	40
3.1.3 Materials and methods	46
3.1.4 Results	51
3.1.5 Discussion	57

3.1.6	Limitations	60
3.1.7	Conclusions	61
3.2	Step detection accuracy in patients with multiple sclerosis	61
3.2.1	Introduction	61
3.2.2	Materials and methods	63
3.2.3	Results	65
3.2.4	Discussion	66
3.2.5	Limitations	67
3.2.6	Conclusions	68
CHAPTER 4 - ANALYSIS OF THE DIFFERENCES IN GAIT PARAMETERS OBTAINED FROM SCRIPTED AND FREE WALKING		69
4.1	Accuracy of algorithms for the detection of gait events in free-living walking	70
4.1.1	Introduction	70
4.1.2	Materials and methods	74
4.1.3	Results	78
4.1.4	Discussion	81
4.1.5	Limitations	83
4.1.6	Conclusions	83
4.2	Influence of environment and walking conditions on gait parameters	84
4.2.1	Introduction	84
4.2.2	Materials and methods	86
4.2.3	Results	88
4.2.4	Discussion	91
4.2.5	Limitations	92
4.2.6	Conclusions	93
CHAPTER 5 - A PILOT STUDY TOWARD CLINICAL APPLICATION		94
5.1	Introduction	94
5.2	Materials and methods	96
5.2.1	Experimental protocol	96
5.2.2	Data processing	97
5.3	Results	98
5.3.1	Analysis of walking bouts performed in the clinics	98
5.3.2	Comparison between free-living and gait lab walking bouts	100
5.4	Discussion	101
5.5	Conclusions	104
CHAPTER 6 - ONGOING AND FUTURE WORK		105
6.1	Analysis of free living walking in patients with Type 1 and Type 2 Diabetes	105
6.1.1	Diabetes	105
6.1.2	Diabetes and physical activity	107

6.1.3	The effects of walking on low-grade inflammation and Type 2 Diabetes – A systematic review	108
6.1.4	Objective monitoring of free-living walking in Type 1 and Type 2 Diabetes: preliminary data from an ongoing feasibility study	115
6.2	Future work	123
6.3	Conclusive remarks	124
	BIBLIOGRAPHY	126

List of Figures

Figure 2-1. Force Sensitive Resistor voltage divider circuit (Lowe & Ólaighin 2014).	8
Figure 2-2. Pressure map generated by a pressure insole system during standing.	9
Figure 2-3. MEMS piezoresistive accelerometer (T. K. Bhattacharyya & A. L. Roy).	11
Figure 2-4. Piezoelectric accelerometer (PCB Group 2016).	12
Figure 2-5. Structure of a MEMS capacitive accelerometer (Lowe & Ólaighin 2014).	12
Figure 2-6. Structure of MEMS gyroscope (Lowe & Ólaighin 2014).	14
Figure 2-7. Resonance Magnetometer (Lowe & Ólaighin 2014).	15
Figure 2-8. Phases in a normal gait cycle	27
Figure 2-9. Gait temporal parameters	28
Figure 2-10. Step event detection algorithms (Najafi et al. 2003, Goyal et al. 2011).	26
Figure 2-11. Acceleration signals collected at the sternum and respective power spectrums (Ichinoseki-Sekine et al. 2006).	27
Figure 2-12. Initial and final contact events identified as local minima of the raw thigh acceleration signal (Aminian et al. 1999).	29
Figure 2-13. Anterior-posterior trunk acceleration data with foot contact events detected by zero-crossing method and peak detection method (Zijlstra & Hof 2003).	31
Figure 2-14. Heel strike events identified by peaks greater than 0.5 m/s^2 in the level 4 and 5 wavelet details (Brodie et al. 2016).	32
Figure 3-1. Sensor placement (Storm et al. 2015).	47
Figure 3-2. Typical angular velocity signal of the shank in the sagittal plane during consecutive steps (Storm et al. 2015).	48
Figure 3-3. Summary of MPE for the 7 PAMs included in the study (Storm et al. 2015).	52
Figure 3-4. Bland-Altman plots (Storm et al. 2015).	54
Figure 3-5. Prevalence of Multiple Sclerosis morbidity by country (The Atlas of MS 2013).	62
Figure 3-6. Relationship between MPE and WS during free and controlled straight walking.	66
Figure 4-1. Gait event detection for the tested algorithms (Storm et al. 2016).	76
Figure 4-2. Procedure for the detection of regular and irregular intervals during free walking.	88
Figure 5-1. Results of the step detection accuracy for the PAM in the clinical walking bouts.	99
Figure 5-2. Descriptive statistics for all the temporal parameters and all walking bouts investigated in the study.	101
Figure 6-1. Glucose intake mechanism in normal, T1D and T2D situations (Diab. Atlas 2015).	106
Figure 6-2. Development of inflammation in type 2 diabetes (Donath & Shoelson 2011).	107
Figure 6-3. Cadence and step duration variability of a walking bout against the number of consecutive steps of that bout, for all walking bouts.	120
Figure 6-4. Cadence and step duration variability against walking bout length and number of bouts in predefined bands.	121
Figure 6-5. Cadence and step duration variability accumulation curves of steps.	122

List of Tables

Table 3-1. Details of the PAMs tested in the study (Storm et al. 2015).	45
Table 3-2. Sample characteristics of the study group (mean \pm SD) (Storm et al. 2015).	46
Table 3-3. Summary of the activities performed during the step detection protocol, their duration and the step count (as obtained by the OPAL sensors) for each walking speed (Storm et al. 2015).	49
Table 3-4. Summary of the activities performed during the activity recognition protocol (Storm et al. 2015).	50
Table 3-5. Step count for the PAMs and the reference method (Storm et al. 2015).	53
Table 3-6. Mean absolute percentage error (MPE) for the PAMs (Storm et al. 2015).	53
Table 3-7. Mean over- or underestimation of step count (D) for the PAMs (Storm et al. 2015).	53
Table 3-8. Classification of the performed activities for the ActivPAL sensor (Storm et al. 2015).	56
Table 3-9. Classification of the performed activities for the MoveMonitor sensor (Storm et al. 2015).	56
Table 3-10. Summary of step count (mean \pm SD) measured by the PAM (N_{PAM}), the reference MIMUs (N_{REF}), and the resulting mean percentage error (MPE).	65
Table 4-1. Published algorithms for GE detection for two sensors positioned on the shanks.	72
Table 4-2. Published algorithms for GE detection for one sensor positioned at the waist.	73
Table 4-3. Summary of the walking conditions performed during the experimental protocol, with acronym, a brief description, and the duration or repetition.	77
Table 4-4. Mean and SD values of temporal gait parameters for all walking conditions.	79
Table 4-5. Mean (\pm SD) values of the absolute error $ E $ for IC timing, FC timing, and temporal parameters (mean and CV) of both methods (SHANK and WAIST).	80
Table 4-6. Effects of environment and protocol. Mean values and variability for all the investigated temporal parameters.	89
Table 4-7. Effects of environment and protocol. Results of the two-way repeated measures ANOVA. Statistically significant differences are highlighted in red.	89
Table 4-8. Effects of environment and type of walking bout. Mean values and variability for all the investigated temporal parameters.	90
Table 4-9. Effects of environment and type of walking bout. Results of the two-way repeated measures ANOVA. Statistically significant differences are highlighted in red.	91
Table 5-1. Mean values for all the investigated temporal parameters. Statistically significant differences between methods are highlighted in brackets. Values are mean \pm sd.	100
Table 5-2. Coefficient of variation values for all the investigated temporal parameters. Statistically significant differences between methods are highlighted in brackets. Values are mean \pm sd.	100
Table 6-1. Chronic effect studies using quantitative physical activity monitoring: study design, type, methods, data analysis details and outcomes (Morettini et al. 2015).	111
Table 6-2. Patient groups characteristics and 6-Minutes Walking Test outcomes.	119

Nomenclature

PAM: Physical Activity Monitor

PA: Physical Activity

IMU: Inertial Measurement Unit

MIMU: Magneto-Inertial Measurement Unit

MS: Multiple Sclerosis

EDSS: Expanded Disability Status Scale

MPE: Mean Absolute Percentage Error

WS: Walking Speed

ICC: Intraclass Correlation Coefficient

IC: Initial Contact

FC: Final Contact

GE: Gait Event

CV: Coefficient of Variation

6MWT: 6-Minutes Walking Test

T1D: Type 1 Diabetes

T2D: Type 2 Diabetes

IL6: Interleukin 6

CRP: C-Reactive Protein

TNF- α : Tumour Necrosis Factor alpha

Chapter 1

Introduction

1.1 Monitoring Gait in Daily Life – General Background

The important relationship between physical activity and health is known and has been recognized by philosophers and physicians as early as in the Hellenistic period. Hippocrates, one of the most outstanding figures of medicine in the history, stated that a correct amount of physical activity is the ‘safest way to health’. Benefits of physical activity include the prevention of several chronic diseases, often responsible of premature death, including cardiovascular disease, diabetes, cancer, hypertension, obesity, depression and osteoporosis (Warburton et al., 2006).

For humans, the characteristic mode of locomotion is walking, which is a crucial aspect of physical activity. During a whole lifetime, a moderately active person living until the age of 80 years will walk a distance of around 180,000 kilometres, which is equivalent to walking five times around the Earth.

Our interest in understanding human walking has been significant since Aristoteles, centuries before scientific research was born (Baker, 2007). The systematic application of scientific methods to the study of human motion started in the late 19th century (Marey, 1873), and technological advances throughout the 20th century allowed to refine systems and improve our understanding, creating a whole new area of research, called human movement or gait analysis. Modern gait analysis systems considered as the gold standard methodology are based on the use of technologies such as stereophotogrammetry and force platforms. They allow the detailed evaluation of gait functions by determining the kinematic and kinetic parameters of human gait. Gait analysis has been employed extensively in orthopaedics, rehabilitation, health diagnostics, and sports (Cappozzo et al., 2005; Chiari et al., 2005; Winter, 1995), and can facilitate the assessment of motor capacity and performance (Cereatti et al., 2015). According to the World Health

Organization, capacity describes what a person can do in a standardized, controlled environment, while performance describes what a person actually does do in his/her daily environment (World Health Organization, 2006). However, standard gait analysis laboratories based on the aforementioned technologies require research facilities with sophisticated and expensive equipment. The collection of the gait data occurs while the subject performs repeated walking trials in confined conditions over limited distances, and are based on the observation of few consecutive gait cycles, providing outcomes that may not recreate real-life scenarios (Mulder et al., 2002; Shull et al., 2014). Further limitations of standard gait analysis are lengthy set-up and processing times (Tao et al., 2012).

These limitations have led researchers to identify possible alternatives to fixed laboratory equipment. Recently, objective methods for the assessment of physical activity and gait outcomes based on wearable sensors, often referred to as physical activity monitors (PAMs), are becoming commonly used tools in fitness and health care, thanks to their ease of use, wearability and low power consumption, allowing assessment in free living conditions over prolonged periods of time (Bonomi and Westerterp, 2012). Several alternative technologies based on these systems have recently been developed, such as pedometers, foot-switches, accelerometers, rate gyroscopes, force sensors, and pressure sensors. The sensors are worn directly on the body of the participant, such as the foot, shank, waist, or trunk. The advantage of these systems is that they allow the analysis of data collected outside the laboratory, obtaining information during free-living activities. Accelerometers and inertial measurement units are currently the most widely used wearable devices to measure and assess physical activity and gait in free-living conditions (Yang and Hsu, 2010).

Validation studies have shown that a combination of multiple sensors can be used in a controlled laboratory environment for quantitative gait analysis including gait phase detection and leg segment orientation estimation (Tao et al. 2012; Liu et al. 2009), showing similar accuracy to standard gait analysis methods. However, the potential ability to objectively quantify clinically relevant outcomes in free living conditions has led researchers towards solutions that are minimally cumbersome and invasive, often minimizing the instrumentation setup to a single device, which has obvious benefits both in terms of comfort, and minimal alteration of the subject's gait. Further advantages of monitoring gait in daily life include walking assessment over prolonged time periods, with low environmental and contextual barriers,

improving the ecological validity of the tests (Maetzler and Rochester, 2015). Furthermore, the widespread availability of these sensors and the relatively contained cost make their use for population studies economically feasible.

Despite the widespread adoption of wearable technology for physical activity monitors and fitness tracking devices, testified by the growth of this market in recent years (Swan, 2012), clinical use of wearable devices for quantitative assessment of motor function in daily life is still uncommon (Maetzler and Rochester, 2015). This is due to concerns regarding validity of the measures obtained with these devices in conditions of free-living. In research, validity is defined as the extent to which a measurement represents the object of interest. To be valid, a measure needs to be accurate, precise and reliable. Accuracy describes the closeness of a measurement to the true value. Precision is the closeness of agreement among a set of results. Reliability is the extent to which a measurement is repeatable under identical conditions. Only overcoming existing limitations will allow quantitative monitoring in daily life to accurately detect and monitor diseases, which is a critical feature for the widespread adoption of this technology in clinical practice.

1.2 Aim of the Thesis

Recent advances in miniaturization, battery life and signal processing have allowed a new generation of wearable devices to challenge the modality in which quantitative gait analysis has been carried out since its development and diffusion in the clinics. These monitoring systems have the potential to investigate gait as it occurs in daily life. The aim of this thesis is to contribute to the validation of these devices in the field of gait monitoring in daily life. This will be achieved by assessing criterion-related validity of existing technology, quantifying test-retest reliability of error estimates in a patient population, and validating existing algorithms in free-living walking. In detail, the following aspects will be addressed in this work:

In chapter 2, a literature review of the main concepts of gait monitoring using wearable sensors is presented. This includes an introduction on methods to quantitatively measure physical activity, and a description of the existing wearable sensor technology. After a brief review of the studies performed on daily life gait

monitoring, the chapter ends with a description and critical assessment of the most common outcomes of gait analysis using wearable sensors, with the methods and algorithms proposed in the literature.

In chapter 3, the accuracy of state-of-the-art technology in the field of PAMs is experimentally tested. Firstly, seven commercially available PAMs are tested in healthy individuals and the accuracy of their step detection and posture classification algorithms is investigated. Then, the reliability of the best performing device is assessed in a group of patients with mobility problems due to multiple sclerosis. The relationship between walking speed and sensor accuracy in this population is also investigated.

In chapter 4, a validation study of two algorithms for the detection of gait events applied to acceleration and angular velocity signals during indoor and outdoor walking in healthy subjects is presented. The second part of the chapter describes an experiment which builds on the previous validation work to investigate the influence of environment and type of walking on gait parameters.

In chapter 5 a pilot study on activity monitoring in a group of patients with multiple sclerosis is presented. The accuracy of a method for gait event and temporal parameter estimation is tested in controlled laboratory conditions, and then used to investigate differences between outcomes of walking bouts of different duration and frequency collected in daily life and in standard laboratory conditions.

Chapter 6 presents ongoing work completed within the framework of the ‘Mission-T2D’ European research project. Evidence for the effectiveness of walking as physical activity to reduce chronic inflammation in patients with Type 2 Diabetes is reviewed. The second part of the chapter proposes an event-based approach to examine cadence and step duration variability in free-living walking in a group of patients with Type 1 and Type 2 Diabetes. The chapter ends with future prospects and conclusive remarks of this thesis.

Chapter 2

Monitoring physical activity and walking using wearable sensors – State of the art

2.1 Monitoring of physical activity

In modern physiology, physical activity is defined as any body movement, produced by skeletal muscles, resulting in energy expenditure that is positively correlated with physical fitness (Caspersen et al., 1985). According to the World Health Organization, “physical inactivity has been identified as the fourth leading risk factor for global mortality causing an estimated 3.2 million (annual) deaths globally” (World Health Organization, 2016). In the UK, the Department of Health estimated that the cost of physical inactivity in England was £8.2 billion for 2004 (Department of Health of The United Kingdom, 2004). A study concluded that the total cost on Canadian health care of physical inactivity was \$6.8 billion, representing 3.7% of the total health care cost (Janssen, 2012). In a similar study, Zhang and Chabaan concluded that the prevalence of the five most prevalent non-communicable diseases (coronary heart disease, stroke, hypertension, cancer, and type 2 diabetes) highly correlated to increased physical inactivity, and that in China the costs related to physical inactivity in 2007 reached more than \$6.7 billion (Zhang and Chaaban, 2013).

Methodologies to measure physical activity can be broadly classified into subjective and objective approaches. Subjective methods include questionnaires, activity diaries and direct observation. These approaches are inexpensive and can be very useful tools in large-scale studies but can be biased and cannot provide the various quantitative aspects necessary to assess physical activity (Bonomi and Westerterp, 2012). Objective methods measure physiological quantities such as energy expenditure, heart rate, body temperature, or biomechanical outcomes of

physical activity like displacement, rotation and acceleration by means of sensors, devices capable of converting a physical measure into a signal that is read and subsequently processed (Chen et al., 2012).

The standard reference for the assessment of physical activity is the measure of energy expenditure (LaPorte et al., 1985). To facilitate this, physical activities are often classified into categories, such as walking, leisure, exercise, sedentary activity, or work. Alternatively, physical activity can also be classified by frequency, duration, intensity, by contextualizing where the activity is taking place, or by position and posture. For an accurate assessment of daily physical activity, the techniques that are used need to be necessarily objective and reliable when used in free-living conditions. Currently, physical activity components that can be measured with various degrees of accuracy using wearable sensors are the following (Butte et al., 2012):

- 1.3 Prediction of total and physical activity-related energy expenditure
- 1.4 Duration, frequency, and intensity of physical activity
- 1.5 Sleep time
- 1.6 Sedentary, light, moderate, and vigorous levels of physical activity
- 1.7 Posture (lying, sitting, standing)
- 1.8 Classification of locomotive activities such as walking and running

The following of this chapter will introduce the working principles of most commonly adopted wearable sensors, reviewing the current technology in the field, and providing an outlook on their clinical applications, with particular focus on the assessment of walking in daily life. The features and parameters that have been used to characterize and quantify walking behaviour using wearable sensors will then be illustrated, with particular focus on solutions and methods based on inertial measurement units (IMUs).

2.2 Wearable motion sensors for physical activity and gait monitoring

Wearable sensors are placed on various body segments, such as the feet, knees or hips, and measure various components of physical activity. This section summarizes the different types of sensors which are most frequently used in

research, highlighting advantages and disadvantages of each of them, with particular focus on the analysis of human gait.

2.2.1 Pedometers

Pedometers are activity monitors allowing the detection of steps taken during walking. They are very cheap and unobtrusive and have become very popular in programs aiming at improving physical activity levels in the wider community, and positive motivational effects of their use have been proved in literature (Bravata et al., 2007). The pedometer was one of the first instruments used to measure physical activity (Lauter, 1926). The first generation of devices used a spring-loaded system, but studies showed that these devices significantly undercounted steps by approximately 50-90% below 4.5 km/h (Melanson et al., 2004). These pedometers further developed to estimate energy expenditure, but have shown over- and under-prediction limitations (Bassett et al., 2000). Recently developed inertial pedometers, based on piezoelectric sensors, are less dependent on subject characteristics and placement, but are still inaccurate at slow walking speeds. Insensitivity to non-ambulatory activities has also limited their use (Crouter et al., 2005). Several pedometer models are currently available, and vary in cost, mechanism, data storage, and sensitivity (Butte et al., 2012). Although they are often accurate at step counting, they are less accurate in the estimation of distance and energy expenditure (Schneider et al., 2003). Further weaknesses of pedometers are the absence of upper body movement recordings, no sensitivity to variations in gait parameters, such as stride length, and difficult comparison between outputs of different models due to underlying differences in algorithms and sensor characteristics.

2.2.2 Footswitches

Footswitches are able to directly detect the foot contact with the ground during a gait cycle, and represent the gold standard technology for the detection of gait phases (Taborri et al., 2016). Footswitches detect forces applied on the sole of the foot using sensors called force sensitive resistors (Figure 2-1). They are very thin transducers ($\approx 1\text{mm}$), which act as variable resistors using the force-resistance relationship to generate a voltage that is proportional to the exerted force (Lowe and Ólaighin, 2014).

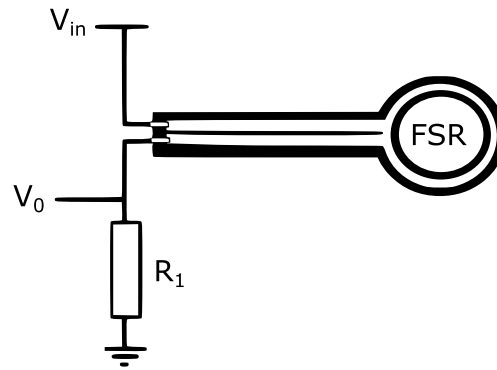

Figure 2-1. Force Sensitive Resistor voltage divider circuit (adapted from Medical Engineering & Physics, Vol 36, Issue 2, Lowe & Ólaighin, Monitoring human health behaviour in one’s living environment: A technological review, Pages 147-168, Copyright (2014), with permission from Elsevier).

Footswitches are relatively cheap, and do not require heavy signal pre- and post-processing. However, they are often used only to validate methods based on other types of sensors (Abaid et al., 2013). This is because of several disadvantages, such as missing information during the swing phase of walking, accuracy and reliability in pathological gait dependent on sensor location, limited system service life due to wired connections (Taborri et al., 2015), and impossible separation of the detected force into sub-components (Pappas et al., 2004). Footswitches have been used to quantify gait activity in varied conditions (Freedson et al., 2008). These devices can be mounted on shoes and ankles to record foot acceleration, allowing the analysis of patterns of movement, and the estimation of various gait parameters, such as stride lengths, frequency, and estimate speed and distance of level walking and running. However, these devices have not been consistently tested in habitual physical activity contexts (Butte et al., 2012).

2.2.3 Pressure insoles

Pedobarography is the study of the pressure acting between the foot and a support surface during everyday locomotion (Abdul Razak et al., 2012). There are a variety of commercially available plantar pressure measurement systems. For brevity, this paragraph will focus on in-shoe systems, which are relevant for this thesis.

The sensors are embedded in the shoes so that the measure reflects the pressure occurring at the interface between the shoe and the foot (Figure 2-2). This system has higher efficiency, flexibility, mobility and reduced cost in comparison to

platform systems, allowing a wider variety of studies (MacWilliams and Armstrong, 2000). Typical technologies used to manufacture pressure insoles are capacitive, resistive, piezoelectric and piezoresistive sensors.

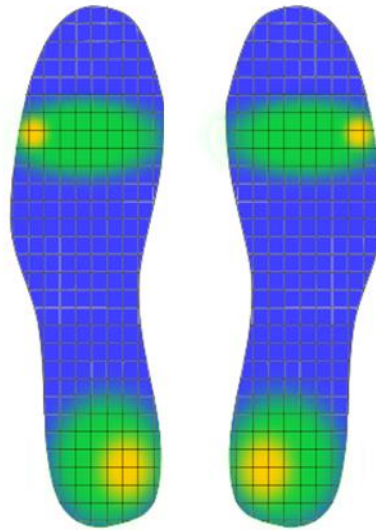

Figure 2-2. Pressure map generated by a pressure insole system during standing.

Capacitive sensors consist of two conductive electrically charged plates separated by a dielectric elastic film. The applied pressure bends the elastic film, shortening the distance between the two plates and resulting in a change in voltage which is proportional to the applied pressure (Gefen, 2007). Resistive sensors contain a conductive polymer that changes resistance with force. When pressure is applied, current increases through the sensor due to the interaction of conductive particles (Urry, 1999). The strengths and drawbacks of gait analysis methods based on foot pressure insoles are comparable to those associated with the use of footswitches. However, plantar pressure systems provide a punctual measure since they record the contact of the full foot with the ground. This characteristic allows a more effective gait phase partitioning (Taborri et al., 2016).

2.2.4 Micro-Electro-Mechanical systems

Micro-electro-mechanical systems (MEMS) are electro-mechanical elements developed through microfabrication techniques. These structures are usually made of silicon and obtained using various techniques typical of integrated circuit manufacturing (Ciuti et al., 2015), such as isotropic and anisotropic etching, thin film deposition, anodic bonding, masking and doping (Gad-el-Hak, 2001).

The origins of the MEMS technology are in the 1950s, when the first paper describing a “piezoresistance” effect in silicon was published (Smith, 1954). The piezoresistive effect is a phenomenon which causes a change in the electrical resistivity of a material due to an applied mechanical strain. Briefly after its discovery, researchers realized the potential of replacing the existing cumbersome electromechanical sensors with smaller units (Paul and Pearson, 1955). However, the first proper MEMS made their appearance in the early 1970s, thanks to developments in silicon processing techniques and micromachining (Bogue, 2007). At the current time, MEMS-based devices have established as the most successfully exploited technology in the physical activity context, with a large range of small, highly performing and often cheap sensors. Latest technological advancement in information and wireless communication, low power circuits and wireless sensor networks has enabled the design of a new generation of compact, high performance, low power and low cost MEMS transducers for a wide range of applications (Magno et al., 2013).

Accelerometers, gyroscopes and magnetometers are the most common wearable MEMS sensors used in physical activity monitoring and can be combined in devices called magneto-inertial measurement units (MIMUs), which are gaining increasing popularity in human motion analysis and physical activity monitoring.

Accelerometers

Accelerometers sense linear acceleration along one or several axis and are composed by a proof mass, also called seismic mass, attached to a mechanically suspended reference frame. When the mass is deflected due to a force, the acceleration generated can be quantified by measuring the electrical properties of the reference frame (Yang and Hsu, 2010). This is often described in terms of a mass-spring system operating according to the principles of Hooke’s law:

$$F = kx$$

and Newton’s 2nd law of motion:

$$F = ma$$

thus:

$$F = \frac{kx}{m}$$

Accelerometers are the most widespread sensors used in physical activity monitoring and ambulatory gait analysis, because they are miniaturized, low powered, durable, inexpensive, highly mobile, and readily available (Kavanagh and Menz, 2008). Accelerometers can be grouped into three categories, according to the sensing technology: piezoresistive, piezoelectric and differential capacitive.

Piezoresistive accelerometers incorporate cantilever crystal beams, with a test mass on the end (Figure 2-3). The base portions have strain gauges arranged in the form of a Wheatstone bridge. When the beam is displaced by an external force, the resistance changes proportionally, according to the acceleration intensity. The change in electrical resistance is translated into a change in voltage, which is measured and stored. These sensors, however, are exposed to temperature drifts and are sensitive to variations in input voltage (Takeda et al., 2009).

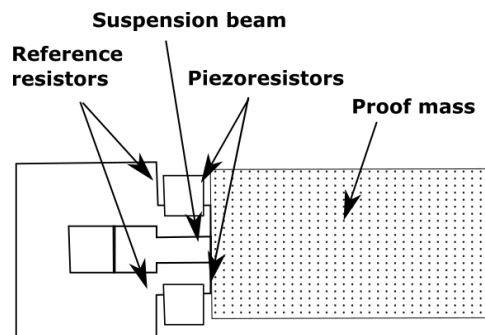

Figure 2-3. MEMS piezoresistive accelerometer developed at the University of California, Irvine (Micro and Smart Devices and Systems, MEMS Piezoresistive Accelerometers, 2014, pp. 19-34, Figure 1, T. K. Bhattacharyya & A. L. Roy, © Springer India 2014. With permission of Springer).

Piezoelectric accelerometers are sensors made of a mass supported by a spring positioned on a piezo crystal (Figure 2-4). These sensors are common in vibration analysis applications. The frequency at which the mass vibrates is converted to an electrical signal and then transferred for further processing and analysis (Narayanan et al., 2010). These sensors excel in linearity and reactivity but are larger than other types of MEMS sensors.

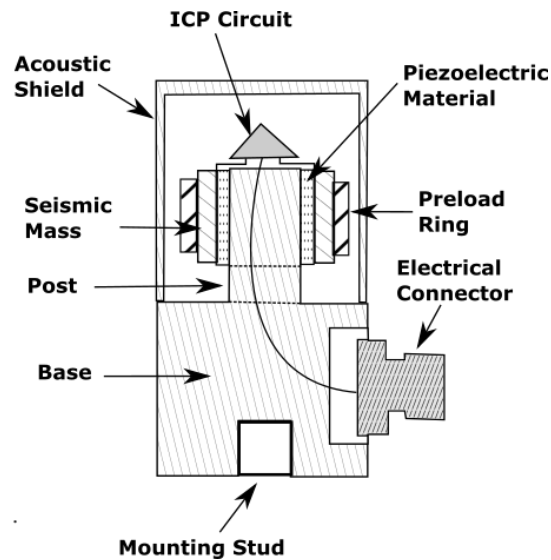

Figure 2-4. Piezoelectric accelerometer (adapted from PCB Group 2016).

Differential capacitive accelerometers are widely used in most applications (Yang and Hsu, 2010), thanks to their low power consumption, large output level, fast response, and low noise level (Takeda et al., 2009), replacing piezoresistive and piezoelectric technologies (Lowe and Ólaighin, 2014). The displacement of the seismic mass between two electrodes is proportional to the difference in capacitance, which indicates the direction and intensity of the acceleration (Figure 2-5).

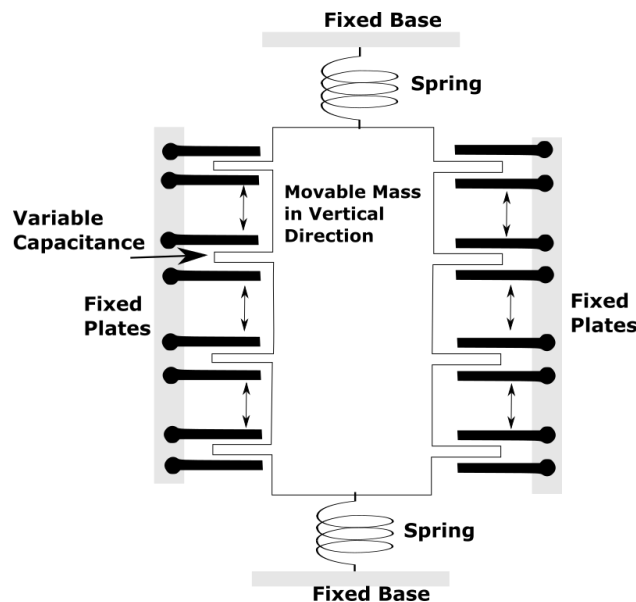

Figure 2-5. Structure of a MEMS capacitive accelerometer (In these devices, the mass is suspended between fixed and floating arms. The change in distance between the arms generates a difference in capacitance proportional to acceleration. (adapted from Medical Engineering & Physics, Vol 36, Issue 2, Lowe & Ólaighin, Monitoring human health behaviour in one's living environment: A technological review, Pages 147-168, Copyright (2014), with permission from Elsevier).

To determine the relationship between electric output and accelerations, calibration procedures need to be completed. Static calibration involves the comparison between the output of a stationary accelerometer with a known constant acceleration, typically 1 g. Assuming linearity between raw output and acceleration, a number of calibration techniques can be used, including two-point linear calibration, zero-span and slope-intercept methods. Periodic calibration requires harmonic shaking of the accelerometer to determine the frequency response of the device (Sinha, 2005).

The main characteristics of the accelerometer signal that need to be considered when collecting human movement data are sensitivity and frequency response. Measurement range should not be of concern, since some accelerometers may reach a range of up to 100g, well above the typical values obtained during human everyday activity. Concerning the frequency, although accelerations at the foot occurring during initial contact can reach up to 60 Hz (Cappozzo, 1982), 99% of the acceleration power during walking is concentrated below 15 Hz (Antonsson and Mann, 1985). Studies on physiological tremors and impacts, however, may require sensing accelerations at up to 25-60 Hz (Mizrahi et al., 2000; Morrison and Newell, 1999). Besides the linear acceleration, which is the measure of interest, the output of a body-mounted accelerometer embeds a static component due to gravity, and noise generated by biological or environmental sources. Further sources of errors generating signal offset may be due to fluctuations in gain, wear and changes in temperature (Luinje and Veltink, 2004).

Currently there are no standardised procedures for accelerometer-based devices for physical activity and gait monitoring, although efforts have been done to develop best practices (Freedson et al., 2012). The accurate selection of the place and method of fixation might reduce the unwanted contribution of tangential acceleration due to rotational motion (Elble, 2005). Waist-placement is often preferred for single sensor configurations, because close to the centre of mass of the human body, and hence thought to be better representing human motions (Yang and Hsu, 2010). Attachment techniques such as elastic bandages and velcro straps have been extensively used for body-fixation of accelerometers, however, there is evidence of a low-pass filter effect of skin mounted accelerometers with respect to bone-mounted devices (Lafortune, 1991). A further consideration to be made when using accelerometers is that the post-processing computation load may be elevated

(Kavanagh and Menz, 2008) due to factors such as compensation for gravity when computing body segment accelerations, dynamical tilt of the sensor during movement, and crosstalk between sensing axis. The social impact of wearing a sensor has also been the focus of recent research. Issues with physical design and aesthetics have also been highlighted and point to a need for further investigations. Gender differences in the adoption of these devices have also been understudied (Shih et al., 2015).

Gyroscopes

Modern gyroscopes all rely on the Coriolis Effect, related to the apparent deflection of a moving object when viewed from a moving reference point, to measure angular velocity about one or several axes. Modern gyroscopes are produced in different forms: vibrating fork, vibrating ring, piezoelectric plate, or laser ring, the first being the most common.

In a vibrating fork gyroscope, two tines of the fork vibrate at high frequencies in a given direction as shown in Figure 2-6. When the tines rotate, a force is experienced by the tines in opposite directions, which is proportional to the angular velocity of the rotation, according to:

$$F_c = -2m(\omega \times v)$$

where F_c is the Coriolis force, ω is the angular velocity, m is the mass of the moving object and v is the linear velocity (Lowe and Ólaighin, 2014).

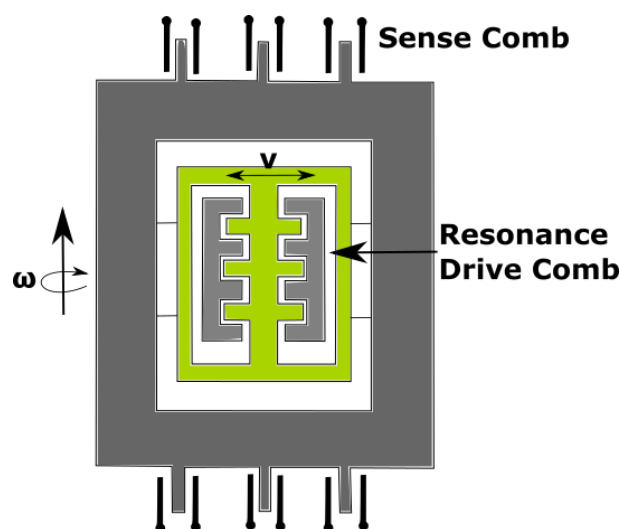

Figure 2-6. Structure of MEMS gyroscope. The tines of the outer frame and the sense comb act as the ‘tuning fork’. (adapted from Medical Engineering & Physics, Vol 36, Issue 2, Lowe & Ólaighin, Monitoring human health behaviour in one’s living environment: A technological review, Pages 147-168, Copyright (2014), with permission from Elsevier).

Angular velocities measured by a gyroscope are usually in the range of hundreds of degrees/s, while bandwidths are typically in the range of several kHz, generally adequate for human movement applications (Tong and Granat, 1999). Gyroscopes are affected by many of the same sources of errors as accelerometers, but are in general more marked, and include constant bias, thermo-mechanical noise, bias drift, temperature errors and calibration errors. A number of techniques can be used to compensate for these errors. They include the use of on board temperature sensors to correct for temperature bias, accurate calibration, and compensation algorithms (Lowe and Ólaighin, 2014). Recently, gyroscopes have become available at reasonable costs and are often used in combination with accelerometers.

Magnetometers

Most magnetometers measure magnetic fields exploiting the principle of the Lorentz force, which is the force felt by a current-conducting wire inside a magnetic field. This force increases the displacement of a resonating structure (Figure 2-7). The displacement of this structure can then be measured with optical, piezoresistive, and capacitive sensing techniques (Herrera-May et al., 2009).

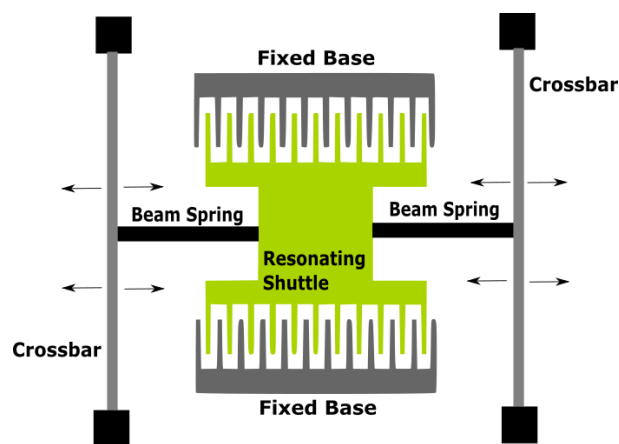

Figure 2-7. Resonance Magnetometer (adapted from Medical Engineering & Physics, Vol 36, Issue 2, Lowe & Ólaighin, Monitoring human health behaviour in one's living environment: A technological review, Pages 147-168, Copyright (2014), with permission from Elsevier).

The most common types of sensor are capacitive resonance magnetometers, which are generally composed of a central resonating mass, called shuttle. Crossbars are connected to fixed points and conduct a DC current. When a magnetic field is sensed, a Lorentz force is felt on the crossbars, which is transferred to the shuttle through the beam springs. The resonance of the shuttle is modified accordingly and is proportional to the magnetic field. This change in resonance causes a change in

capacitance at the arms of the comb structure of the fixed points. This measured change is used to calculate the magnetic field (Lowe and Ólaighin, 2014). Magnetometers can be used in activity monitoring to identify a person's orientation from the detection of the earth's magnetic field and as a consequence to gain knowledge about its orientation with respect to the surrounding environment (Bahreyni and Shafai, 2007).

Magneto-inertial measurement units

Magneto-inertial measurement units (MIMUs) are devices integrating triaxial MEMS accelerometers, gyroscopes and magnetometers, and are becoming increasingly popular in human movement analysis (Picerno et al., 2011; Saber-Sheikh et al., 2010) thanks to their small size, reduced power consumption and wearability (Chen et al., 2012).

Accelerations, angular velocities and magnetic fields are measured with respect to the axes of a local frame, associated with the MIMU. In static conditions, the estimation of the orientation of a fixed global frame with respect to the local frame is achieved by combining accelerometer and magnetometer readings, while more advanced algorithms are needed in dynamic conditions. These methods combining data obtained from different sensors are typically implemented into fusion algorithms and are often proprietary in commercially available MIMUs.

A well-established technique makes use of Kalman filters to combine the outputs of the sensors in order to obtain an estimate of orientation based on quaternions (Sabatini, 2006). Quaternions are an extension of complex numbers, and are often preferred to other orientation descriptors, such as Euler angles, because of their lower computation time and because they are independent from a conventional cardinal order. More recently, studies tackling issues related to sensor orientation accuracy have been published (Picerno et al., 2011). These methods, however, will not be reviewed in detail because the accurate estimation of sensor orientation is not the focus of the present thesis. Common sources of errors in MIMUs are the alteration of the sensor calibration parameters (Brodie et al., 2008), shocks, and local magnetic field vector distortions due to ferromagnetic disturbances in the proximity of the device (Roetenberg et al., 2005; Sabatini, 2006).

2.2.5 Other physical activity sensors

Various other sensors have been designed and tested, mainly for the estimation of energy expenditure. The most widespread are heart rate monitors, which generally combine standard electrodes for electrocardiography and processing techniques including amplification of the electric signal, analog-to-digital conversion and data reduction in epochs of different durations to optimize memory consumption. This information has been used to predict physical activity levels on the basis of the linear relationship existing between heart rate and energy expenditure. However, these sensors are poor predictors of low-levels of physical activity. For this reason, they have been recently combined with accelerometers to improve accuracy and precision, with prediction errors for group means below 3% (Leonard, 2003).

Other sensors include heat flux, galvanic skin response and skin temperature measurement devices, but validation of these systems in free living conditions is limited (Bonomi and Westerterp, 2012). Contextual information on someone's location, mode of transportation, and speed of locomotion has also been combined with accelerometers and showed promising results (Troped et al., 2008), but the disadvantages of complex data collection, processing, analysis, cost, and the limitation to outdoor activities are still of concern.

2.3 The quantification of gait using wearable motion sensors

The goal of locomotion, and of walking in particular, is to transport the body. This is achieved by our neuromotor control system by operating over multiple cost functions, including maximising speed, stability and protection of muscles and joints. However, implicitly in this goal there is also the aim to minimize energy consumption (Kuo, 2007). Depending on the pace, walking can be considered a light or moderately intense physical activity (Ainsworth et al., 2011). Evidence demonstrates that regular physical activity contributes to the prevention of chronic diseases and reduces the risks of premature death (Warburton et al., 2006). As a result, the amount of daily walking is indicative for the level of physical activity (Zijlstra, 2004). Moreover, the quality of the walking pattern can also provide valuable information related to health status, and changes in gait patterns can reveal

changes in an individual's quality of life. Accurate quantification of gait parameters, and their monitoring over time, can enable early recognition of diseases and may help to find the best treatment (Muro-de-la-Herran et al., 2014). Among activities of daily living, gait is a major marker of initial disease manifestation and progression (Del Din et al., 2015).

The systematic study of human locomotion is called gait analysis (Whittle, 2007). It involves the quantification, description and analysis of variables that characterize human locomotion. Standard gait analysis, conducted in controlled research facilities, has been employed extensively for performance analysis in sports (Watanabe and Hokari, 2006), to monitor patient progression in orthopaedics and rehabilitation (Kimmeskamp and Hennig, 2001), and to discriminate between asymptomatic subjects and patients in health diagnostics (Turcot et al., 2008).

2.3.1 Gait cycle and temporal-spatial parameters of walking

Human walking is a periodic movement which includes cyclic motions performed by body segments, to support the erect position and maintain balance during human locomotion. A gait cycle is defined as the period of time between the initial contact of one foot and the following initial contact of the same foot. Depending on the application and the specific interest of the investigation, several gait partitioning models have been used to divide the gait cycle into different phases (Figure 2-8). Two main phases, stance and swing, are generally always identified, although typically a walking gait cycle can be divided into eight parts: initial contact, loading response, mid-stance, terminal stance, pre-swing, initial swing, mid-swing, and terminal swing (Parry, 1992):

- (1) Initial contact: this phase includes the moment when the foot touches the floor.
- (2) Loading response: during this phase the initial double-stance phase takes place. The phase begins at initial contact and ends when the alternate foot is lifted for swing. During this phase, the knee is flexed for shock absorption and the ankle plantar-flexes.
- (3) Mid-stance: this phase corresponds to the first single-limb support interval. The limb advances through ankle dorsiflexion, while the knee and hip extend. Mid-stance ends when the body weight is aligned over the forefoot.

- (4) Terminal stance: this phase concludes the single-limb support. It begins with the heel rising and terminates at the time of initial contact of the other foot with the ground. During this phase the body weight moves ahead of the forefoot.
- (5) Pre-swing: during this phase the second double-stance phase takes place. Pre-swing begins with the initial contact of the opposite foot and ends with the ipsilateral toe-off.
- (6) Initial swing: this phase is approximately the first third of the swing period. It begins when the foot lifts from the floor and ends when the swinging foot is opposite to the stance foot.
- (7) Mid-swing: this phase starts as the swinging limb is opposite to the stance limb and ends when the swinging limb is forward and the tibia is vertical.
- (8) Terminal swing: this final phase of swing begins with the vertical tibia and ends when the foot strikes the floor.

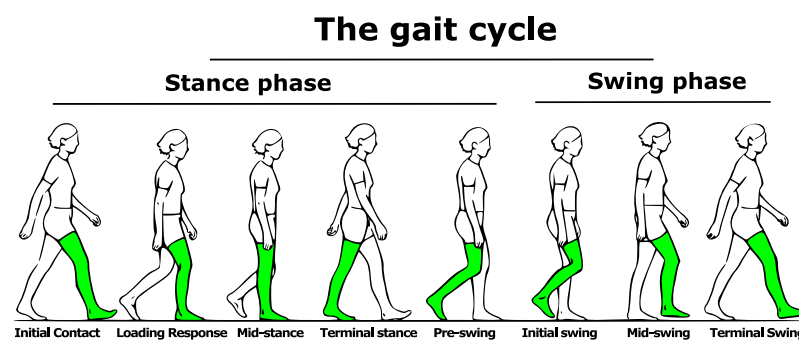

Figure 2-8. Phases in a normal gait cycle

The different aspects that characterize human gait and that may be of interest vary depending on the field of research (Muro-de-la-Herran et al., 2014). Basic temporal parameters, obtained after simple gait segmentation based on the detection of initial contacts (IC) and final contacts (FC) are the following (Figure 2-9):

- Stride duration: Time between two consecutive IC events of the same limb.
- Step duration: Time between two consecutive IC events of different limbs.
- Stance duration: Time between IC and FC of the same foot.
- Swing duration: Time between FC and IC of the same foot.
- Double support phase: time between right IC and left FC + time between left IC and right FC.

- Single support phase: time between right FC and right IC + time between left FC and left IC.

Stance, swing and support phases are often also defined as a relative percentage value of the whole gait cycle (or stride duration).

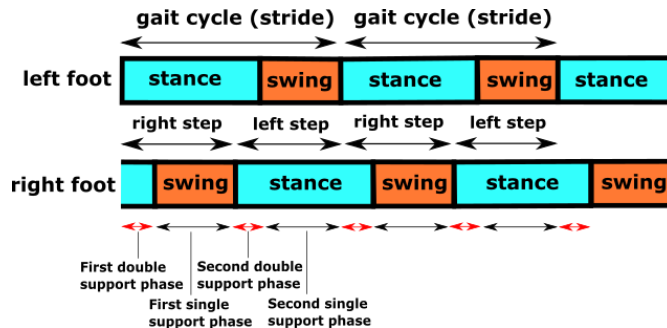

Figure 2-9. Gait temporal parameters

The basic spatial parameters, which are the most frequently investigated in gait analysis, are the following:

- Stride length: the distance between two successive placements of the same foot.
- Step length: the distance that a foot travels in front of the other foot during each step.
- Walking velocity: the product of cadence and stride length.

Further spatial parameters are foot clearance, turning angles, stride and step widths, but the complexity of their estimate using inertial sensors makes them less common in gait analysis studies using this technology (Whittle, 2007).

2.3.2 A brief historical excursus

Monitoring gait in daily life has been a research interest since sensors capable of detecting objective parameters of locomotion have become available. The first mention of a quantitative measure related to walking in free-living conditions was reported in 1926, when Lauter expressed his surprise when reporting the amount of his physical activity measured by a pedometer (Lauter, 1926). In 1949, Larsen used a pedometer to report differences in the amount of walking between obese and non-obese subjects (Larsen, 1949). In a later time, Stunkard measured the daily distance walked by subjects for up to twenty-three consecutive days using a mechanical

pedometer to study the correlation between physical activity, occupational status, emotions and obesity (Stunkard, 1960, 1958).

In 1959, Schulman and Reisman proposed a modified wristwatch called actometer, which measured physical activity, interpreted from the time displayed on the watch. The device showed reasonably good correlation with energy expenditure (Schulman and Reisman, 1959).

The first study using accelerometry for the investigation of walking were performed by Liberson in the 1930s (Kavanagh and Menz, 2008). He realized that accelerations of body segments were powerful tools to understand normal and pathological gait (Liberson, 1936). Although electronic accelerometers were introduced in the 1950s, initially they were found to be inferior to methods of displacement and velocity integration (Saunders et al., 1953). However, soon they were recognized as the most promising movement sensors for the assessment of physical activity in real life settings because they could respond to both frequency and intensity of movement, while pedometers and actometers would count body movement only if a certain threshold was passed (Bouten et al., 1997). Trunk acceleration data was investigated by researchers in the 1960s to estimate external mechanical work (Cavagna et al., 1963) and rhythmicity of walking patterns (Gage, 1964).

It was not before the 1970s that systematic measures of human motion using wearable accelerometers started to be carried out. Studies included the investigation of lower limb segmental velocities, heel strike, foot flat, heel off and toe off (Morris, 1973), and the assessment of body movement in psychiatric patients (Colburn et al., 1976). However, only with the widespread introduction of technology based on MEMS, sensors have become miniaturised and inexpensive enough to combine a range of sensing technologies in the same device (Lowe and Ólaighin, 2014). The first accelerometers based on MEMS technology were reported in 1979 (Roylance and Angell, 1979). Accelerometric techniques were extensively used in the 1980s and early 1990s by researchers studying the shock transmission aspects of impact forces, focusing in particular on tibial shock during walking using skin-mounted (Voloshin et al., 1981; Wosk and Voloshin, 1981) and bone-fixed (Lafortune, 1991; Light et al., 1980) accelerometers.

At the beginning of the 1990s, accelerometry studies were still confined to gait analysis laboratories, studying mechanisms of walking from several different

perspectives. Measures of gait using an accelerometer on a walkway showed correlation between forward velocity change in each step and walking speed (Currie et al., 1992), and methods were proposed to calculate joint angles from accelerometers mounted on the lower limbs (Willemsen et al., 1991, 1990). A growing interest in analysing data in complex environments was testified by a number of research studies, looking into stride and force data during obstacle negotiation (Patla et al., 1991), or studying gait and walking speed in visually impaired subjects walking on different surfaces and in different light conditions (Spaulding et al., 1994). Further studies investigated the effects of virtual obstacles on step length (Chen et al., 1994), or looked at the influence of approaching fixed obstacles on swing and stance gait phases (McFadyen et al., 1993). However, it became clear that many of the measurement methods applied in the increasing number of established gait laboratories could be regarded as valid only under controlled and invariant settings. Despite this fact, research on human walking carried out in unconstrained settings outside the laboratory was still scarce, and the first study was only published in 1995 (Aminian et al., 1995). New methods for improved inertial sensor signal processing were also proposed. Moe-Nilssen published an algorithm for the transformation of the linear acceleration data of the trunk collected in the local frame of the sensors to a horizontal-vertical global coordinate system. This method allowed correcting for the gravity component which affects a sensing axis when it deviates from the horizontal plane, due to anatomical constraints or inaccurate positioning (Moe-Nilssen, 1998a). New protocols to assess balance by trunk accelerometry during walking (Moe-Nilssen, 1998b) and standing (Moe-Nilssen, 1998c; Yack and Berger, 1993) were also published, which would allow testing in a variety of different environmental conditions, such as uneven surfaces, various distances, or obstacle negotiation, improving existing approaches based on simple and standardised settings.

Recent work demonstrated that the analysis of the gait cycle and its parameters can be made using data obtained by wearable sensors at free walking speeds (Moe-Nilssen and Helbostad, 2004). Furthermore, the combination of data derived from different sensor types into fusion algorithms allowed to refine and improve the determination of important walking features, including stride duration and relative stance.

A recent review outlining the clinical impact of wearable sensors for gait analysis identified 76 articles that satisfied the inclusion criteria, with 70% of the papers published in the last 10 years (Shull et al., 2014).

2.3.3 Activity counts

In 1978, Reswick and colleagues collected walking data on a large walkway using a head-mounted accelerometer. They found that the integral of the absolute accelerometer output correlated linearly with energy expenditure and could predict oxygen consumption (Reswick et al., 1978). These findings led several research groups to hypothesize that the integral of the acceleration, especially in the vertical direction, could be used to predict physical activity energy expenditure (Bouten et al., 1997). In 1981, a sensor named Caltrac was developed to measure energy expenditure (Wong et al., 1981). This waist worn piezo-electric accelerometer collected vertical accelerations, which were integrated and summed over predefined periods of time to obtain a measure that was defined accelerometer count. The accelerometer count is still one of the most common energy expenditure metrics. Counts have been generated by applying a set threshold to a filtered accelerometer signal and counting the positive transitions of the threshold (Cooper, 1993). Another approach is to window the signal into short intervals, typically one second, and to define counts as the maximum or average value of the signal within that window (Puyau et al., 2004). In the last decades, however, its use has been questioned because its definition has become less univocal due to the generation of several methods to compute it.

2.3.4 Energy expenditure

The gold standard to determine total energy expenditure is currently the doubly labeled water technique, while indirect calorimetry, such as oxygen uptake, is the reference method for the measure of basal metabolic rate (Byrne et al., 2005). The doubly labelled water protocol consists in loading a known amount of water with stable isotopes of ^2H and ^{18}O and administering it to the participant. Then, the rate of disappearance of the two isotopes is measured by mass spectrometry analysis of body fluids such as saliva, blood or urine (Schoeller and van Santen, 1982). Limitations of this technique are high cost, relative complexity and the requirement

of trained personnel and sophisticated equipment for its correct use (Ainslie et al., 2003; Pinheiro Volp et al., 2011). For these reasons, the measurement of physical activity using doubly labelled water is not feasible in conditions of daily living in for population studies. Several alternatives have been proposed, based on observations, questionnaires, heart rate recordings, or movement registration (Bouten et al., 1997).

Accelerometer counts have been used to predict energy expenditure with two main techniques: the simplest is to use published equations relating energy expenditure at rest (defined as resting metabolic rate) with height, weight and age of a person. Examples of these equations have been published by Schofield (Schofield, 1985). The result is then multiplied by a scaling factor that accounts for the level of physical activity, typically measured by a wearable sensor (De Lorenzo et al., 2001; Frankenfield et al., 2005). The second method is more accurate and consists in using a gold standard to measure energy expenditure and then directly applying regression analysis on the sensor output to generate a predictive algorithm. Studies, such as the one by Bouten and colleagues demonstrated a significant relationship ($r = 0.89$) between accelerometry and energy expenditure in gait analysis studies (Bouten et al., 1997). A recent protocol used to validate a triaxial accelerometer consisted in identifying a set of standardized tasks to be carried out while energy expenditure was measured using a facemask indirect calorimetric technique. The activities were chosen to represent different levels of intensity for lying, standing, walking, and sitting. The total energy expenditure for each activity was derived from well-known relationships (Weir, 1949). The accelerometer raw signals in each of the three axes were band-pass filtered using a fourth order Butterworth filter and combined by taking the root of the summed squared values to obtain a metric defined movement intensity. Then, a best-fit linear equation between movement intensity and active energy expenditure was generated for each of the four activities (van Hees et al., 2009). This method has the disadvantages of needing a large number of participants and being expensive to carry out due to the cost of the methods used as reference measures (Lowe and Ólaighin, 2014). Successive work by Najafi and colleagues showed that other types of inertial sensors, such as gyroscopes, could be used to integrate this information with the detection of postural transitions (Najafi et al., 2002), leading to the use of inertial measurement units (del Rosario et al., 2015). Currently, several accelerometer-based physical activity monitors validated against doubly labelled water are commercially available (Westerterp, 2013).

2.3.5 Step detection and counting

The first attempts to measure physical activity levels in humans focused on the detection of steps, when mechanical pedometers were used to detect impulses generated by steps during walking (Stunkard, 1960). Step counting has been used as motivational tool within physical activity interventions in various populations: systematic reviews of studies in adults showed that they can lead to moderate increases in the order of 2-3,000 steps walked per day with respect to controls (Bravata et al., 2007; Kang et al., 2009), and increases in the order of 2,000-2,500 steps/day have been associated with lower waist circumference (Dwyer et al., 2007). Data from studies performed in children show that increases in physical activity can be in the range of 300-3,000 steps per day (Hardman et al., 2011; Horne et al., 2009; Kang and Brinthaup, 2009). Furthermore, the use of wearable sensors for step detection in self-monitoring has been associated with increased levels of physical activity in cardiac patients (Butler et al., 2009; Furber et al., 2010; Pinto et al., 2011), older adults with chronic stroke (Pang et al., 2005), and individuals with type 2 diabetes (De Greef et al., 2010).

Accurate step counting is an essential feature for mobility assessment using activity monitoring devices, and its measure using wearable sensors has become one of the most widespread methods used to quantitatively measure physical activity. Furthermore, current physical activity guidelines often provide step-based recommendations: a recent one, for example, indicates 10,000 steps/day as a reasonable amount for normative populations (Tudor-Locke et al., 2011b).

A large amount of literature concerning the development of algorithms for step detection and counting has been published in the last decades. The choice of the optimal method depends on the type and number of sensors that will be used, the body placement of the sensor, the computational cost, and the specific application.

Step detection has been performed using foot-switches, pressure insoles, gyroscopes, magnetometers, and accelerometers (Lowe and Ólaighin, 2014). Footswitches and pressure insoles allow to directly detect foot contact with the ground corresponding to a step (Jeffrey M. Hausdorff et al., 1995). Angular velocity collected using gyroscopes at the shank and thigh have been proven to be viable to detect foot strikes (Aminian et al., 2002; Tong and Granat, 1999). Magnetometers have also been used to estimate shank angular velocity and count steps using

windowing and thresholding (Raffin et al., 2012). However, among inertial sensors, accelerometers have been the most exploited sensors for this purpose, and the most common algorithms will be reviewed in this section.

Common locations for the placement of accelerometers in step detection studies are the ankles and thigh (Aminian and Hinckson, 2012; Crouter et al., 2003; Ryan et al., 2006), waist (Esliger et al., 2011; Le Masurier and Tudor-Locke, 2003; Yang et al., 2011), lower back (Dijkstra et al., 2008), trunk (Zijlstra and Hof, 2003) and wrist (Fortune et al., 2014).

The simplest methods, often based on thresholding, take advantage of well-known characteristics of the accelerometer signal (Brajdic and Harle, 2013; Najafi et al., 2003) (Figure 2-10). For example, the vertical displacement of the pelvis can be estimated by double integrating the vertical acceleration measured by an accelerometer positioned at the waist. To remove the integration drift, a zero-lag high-pass Butterworth filter with a cut-off frequency of 0.1 Hz is then used. Finally, steps are detected as peaks in the resulting vertical displacement (Goyal et al., 2011). This type of algorithms have been improved by introducing pattern recognition techniques that overcome the limitations that arise from the selection of the optimal threshold value, which can vary between users, surfaces and shoes (Kim et al., 2004).

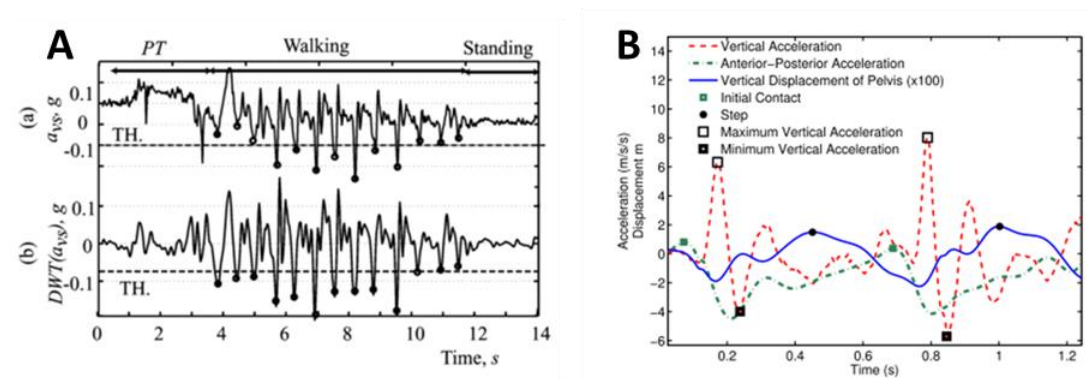

Figure 2-10. Step event detection algorithms. A) Successive peaks with intervals of 0.25–2.25 s in the discrete wavelet transformed vertical acceleration were chosen as possible walking steps (Najafi et al., 2003, Copyright © 2003, IEEE). B) Steps are detected as peaks in the vertical displacement of the pelvis (Goyal et al., 2011, Copyright © 2011, IEEE).

Some algorithms focus instead on the periodicity of the gait cycle. Since typical stride frequencies are around 1–2 Hz (Brajdic and Harle, 2013), zero-crossing counting on low-pass filtered accelerometer signals have also been used for step detection (Beauregard, 2006; Ladetto, 2000). Adaptations of the Pan-Tompkins

algorithms for acceleration signals and combined dual-axis methods that are applied to global vertical acceleration (Ying et al., 2007) provide better performance (Marschollek et al., 2008), but depend on being able to isolate the orthogonal accelerations in the global frame.

Frequency analysis can also be applied: the short-term Fourier transform has been used to evaluate the frequency content of successive data windows (Barralon et al., 2006). Ichinoseki and colleagues, for example, calculated the power spectrum of each sensing axis of a triaxial accelerometer placed on the sternum in the range of 0.5–3.0 Hz for a temporal window of 4 s. After normalization with the maximum power of each window, the power spectrums were composited. Finally, the frequency at the maximum power was considered as the cadence, from which the number of steps were estimated (Ichinoseki-Sekine et al., 2006) (Figure 2-11). However, resolution issues due to windowing have led researchers to methods based on wavelet transforms, which repeatedly correlate a ‘mother’ wavelet with the signal by compression or dilation (Wang et al., 2012). These techniques, however, are computationally more expensive (Figo et al., 2010).

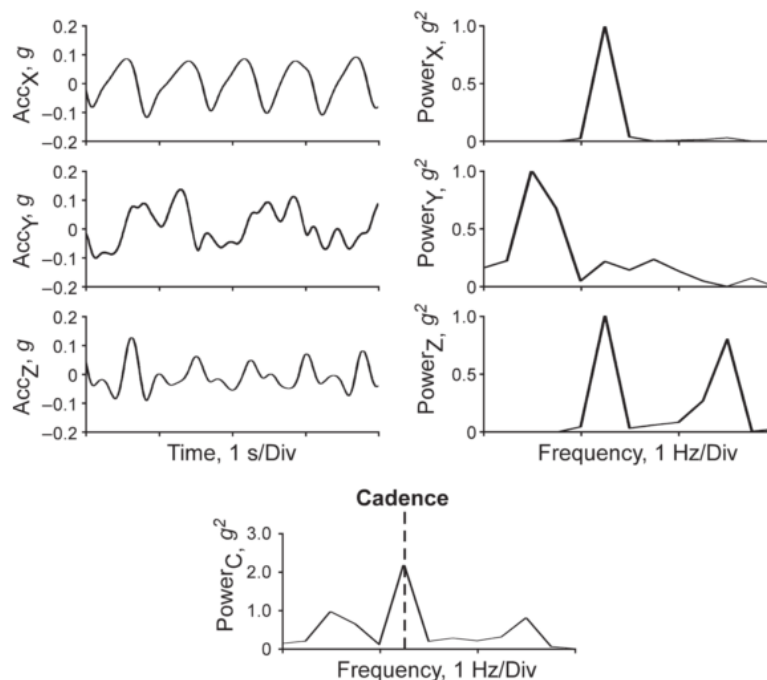

Figure 2-11. Acceleration signals collected at the sternum and respective power spectrums. Orthogonal acceleration signals, Acc_X , Acc_Y , Acc_Z , and their normalized power spectrum, $power_X$, $power_Y$, and $power_Z$. The frequency at the maximum power of the composite power spectrum, $power_C$, was used as an estimate of the cadence of each window (Ichinoseki-Sekine et al., Improving the Accuracy of Pedometer Used by the Elderly with the FFT Algorithm, *Medicine & Science in Sports & Exercise*, Vol. 38, Issue 9, Pages 1674-81).

Less demanding alternatives from a computational perspective are auto-correlation (Yang et al., 2011) and cross-correlation techniques, which detect steps directly in the time domain (Marschollek et al., 2008). A disadvantage of these algorithms is that movements generating similar periodicity to that of walking may act as confounders and generate errors. Dynamic time warping is a technique that performs a non-linear mapping between two signals and overcomes these issues (Makihara et al., 2011).

2.3.6 Gait events and temporal parameters

The analysis of signals collected with inertial sensors for the characterization of gait has become a popular field of study in wearable sensors' research, since this technology has shown to allow identifying a higher number of sub-phases of the gait cycle, with respect to footswitches or foot pressure insoles (Taborri et al., 2016). From the perspective of investigating walking during daily living, it is crucial that discomfort is minimized and ease of use is secured. This is generally accomplished by using the smallest amount of devices which guarantees the desired accuracy of the outcome measure. This section briefly reviews the development of methods for the analysis of the gait cycle to obtain gait event timings, limiting its examination to the estimation of temporal parameters.

Multiple MIMUs configuration.

A typical configuration for the detection of gait events using inertial sensors is the one based on two or more devices attached to the lower limbs. One of the first methods proposed in the literature (Aminian et al., 1999) used a couple of uniaxial accelerometers located on the thigh just above the knee, and measured the tangential component of each thigh acceleration in the sagittal plane. The authors gave a comprehensive description of the signal during the gait cycle and identified peculiar features corresponding to initial and final contact events. In both cases, a sharp negative acceleration is observed: when the foot leaves the contact with the floor, the negative acceleration is due to a quick backward movement of the hip and knee joints, while at the end of the swing phase, the contact of the foot with the ground stops the forward movement of the foot generating the negative peak. After a low-pass filter at 3Hz, the time of global maximum was found for each gait cycle, corresponding to mid-swing. Then, local minima of the filtered signal were

identified. Finally, the minima of the unfiltered signal were obtained, which were the timings of initial and final contact. Results showed a good agreement ($r > 0.99$) for stance duration and gait cycle time between accelerometer and footswitch data. A successive study by the same group (Aminian et al., 2002) proposed an original method based on wavelet transform to identify gait events and compute gait parameters from the angular velocity of the shanks (Figure 2-12). An early example of application in a clinical setting was also proposed by the same group, detecting gait cycle phases using two accelerometers attached to the lower legs (Aminian et al., 1998) for the functional evaluation of gait improvement after arthroplasty in patients with unilateral hip osteoarthritis.

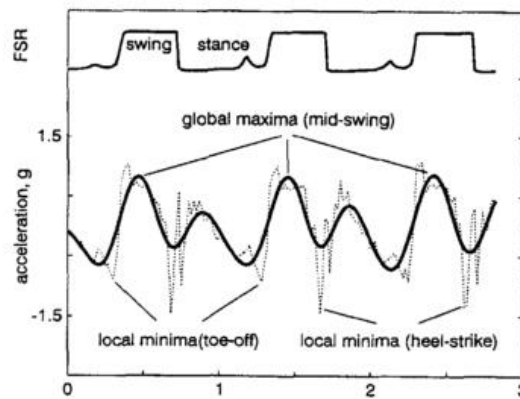

Figure 2-12. Raw and filtered thigh acceleration compared with output of FSR sensors during two gait cycles. (...) Raw signal, (—) filtered signal. (Medical and Biological Engineering and Computing, Temporal feature estimation during walking using miniature accelerometers: an analysis of gait improvement after hip arthroplasty, Vol. 37, 1999, pages 686-691, Aminian et al., "With permission of Springer").

In 2004, the same research group proposed a novel algorithm for the detection of gait events in patients with Parkinson's disease treated with deep brain stimulation using four gyroscopes attached to the lower limbs. After a high-pass filter, the peak angular velocity corresponding to mid-swing was detected, and the nearest local minimum after the peak was selected as initial contact. As the negative peak associated to the final contact event was generally difficult to detect, the signal was additionally low-pass filtered and the minimum prior to the mid-swing peak was selected as final contact. Recent studies extended the clinical application of these methods. In 2006, a study was published comparing the accuracy of gait event estimation in both healthy normal and spinal-cord injured individuals (Jasiewicz et al., 2006) by using a system of four sensors positioned on each foot and shank using three different algorithms based on foot linear accelerations, or foot sagittal angular

velocity, or shank sagittal angular velocity data. The results showed that the three algorithms were as accurate as foot switches in estimating initial and final contact timings for normal gait, while the estimates based on angular velocities were less accurate in spinal-cord injured subject. Another study tested a method based on four gyroscopes located on the lower limbs in poliomyelitis patients using adaptive thresholds calculation and artefact rejection techniques (Greene et al., 2010). A gait phase detection system was also successfully developed using two sensors on the upper shanks to replace heel switches used for triggering drop foot stimulators (Kotiadis et al., 2010; Veltink et al., 2003). A study by Mariani and colleagues further refined previous algorithms by detecting both initial and final contact events, and determining stance sub-phases, by using two inertial sensors positioned on the forefoot (Mariani et al., 2013). Similar approaches were used to analyse temporal parameters in independently walking children with cerebral palsy (Bourgeois et al., 2014) and post-stroke hemiparetic gait (Yang et al., 2013). Recently, methods for the estimation of temporal parameters have also been proposed and tested in wider ranges of clinical populations. For example, a method combining angular velocity and acceleration signals of the shanks has been tested in elderly, hemiparetic, parkinsonian and choreic gait, with high levels of precision and accuracy (Trojaniello et al., 2014b).

Single MIMU configuration.

A single device positioned on the lower trunk has also been used extensively in research studies to propose gait event detection algorithms. Initially, published methods explored trunk accelerometry features to assess gait events and temporal parameters. Inspections of acceleration signals generated at the lower trunk by inertial sensors had already been studied more than two decades ago in order to obtain estimates of stride durations based on initial contact detection in healthy participants (Evans et al., 1991). A more refined algorithm was proposed by Zijlstra and Hof a few years later (Zijlstra and Hof, 1997). Based on the findings of a previous article describing the three-dimensional displacement of the pelvis during human walking, they designed an algorithm based on the shape of the acceleration signal at the lower trunk (Zijlstra and Hof, 2003). According to their model, human walking is described as an inverted pendulum movement, where during single support, after mid-swing, the body is falling forward and downward, hence

accelerating. During foot contact, the forward movement decelerates, which corresponds to a change of sign of the forward acceleration of the lower trunk. Based on these findings, two similar algorithms were tested in a successive research by the same authors. In one algorithm, after low-pass filtering of the anterior-posterior acceleration signal with a fourth-order zero-lag Butterworth filter, the change from positive to negative was taken as the instant of initial contact. In the second algorithm, the peak acceleration preceding the change of sign was taken as initial contact (Figure 2-13). The results showed that both methods produced small errors when compared to ground reaction force data, although in the zero-crossing method the initial contact timing was consistently delayed in comparison to the reference method. The methods proposed were later improved by the authors by aligning the device to the vertical direction during an upright posture (Zijlstra, 2004).

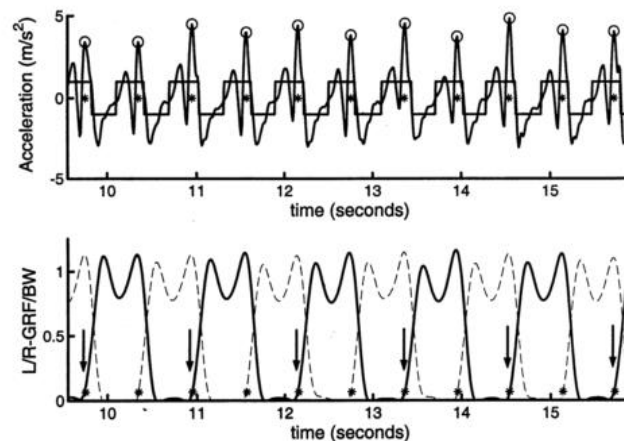

Figure 2-13. Anterior-posterior trunk acceleration data with foot contact events detected by zero-crossing method (black circles) and peak detection method (open circles). Asterisks indicate foot contact as detected by ground reaction force (Gait & Posture, Vol 36, Issue 2, Zijlstra & Hof, Assessment of spatiotemporal gait parameters from trunk accelerations during human walking, Pages 1-10, Copyright (2003), with permission from Elsevier).

Real-time gait event detection was proposed by a successive study, in which the authors created search windows in regions of the signal defined by positive values of the filtered anterior-posterior acceleration. Empirical rules were applied to select the local maximum identified as initial contact. The final contact was identified as the first minimum occurring after the initial contact (González et al., 2010). Limitations of these methods include incorrect identification of peaks corresponding to initial contact, and inability to detect events in case of irregular signal patterns (López et al., 2008). Methods based on wavelet transformation of the accelerometer signal have also been published, with the purpose of overcoming these

issues. McCamley and colleagues (McCamley et al., 2012) applied a Gaussian continuous wavelet transformation to the vertical acceleration recorded on the lower lumbar spine, and initial contact was identified as the local minimum. After further differentiation, the final contact was identified as the instant of maximum of the resulting signal. With a similar procedure, a method was proposed to obtain gait event timings by processing the acceleration obtained from a wearable sensor attached on a subject's belt reconstructing the signal with the first three levels of detail of a stationary wavelet decomposition of the vertical acceleration (Kose et al., 2012). As previously proposed by Zijlstra and Hof, distinctive features in the sensor signals were matched with the appropriate gait events. Recently, a wearable pendant device with a wavelet-based method for the analysis of gait has also been described (Brodie et al., 2016). The heel strikes were identified by peaks greater than 0.5 m/s^2 in the level 4 and 5 details using of a Daubechies 'db5' wavelet decomposition (Figure 2-14).

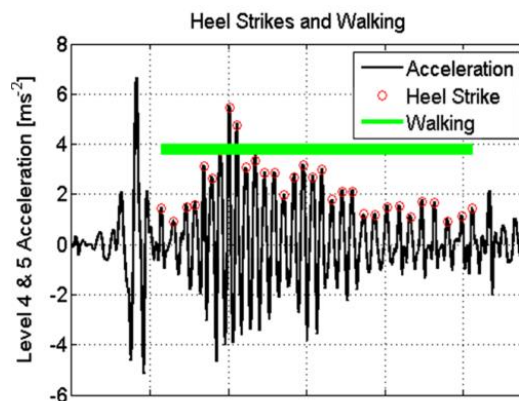

Figure 2-14. Heel strikes identified by peaks greater than 0.5 m/s^2 in the level 4 and 5 (mid-pseudo-frequencies 1 and 2 Hz) wavelet details (circles), and a walk by 10 or more consecutive steps (thick line). (Medical and Biological Engineering and Computing, Wearable pendant device monitoring using new wavelet-based methods shows daily life and laboratory gaits are different, Vol. 54, 2016, pages 663-674, Brodie et al., "With permission of Springer").

2.3.7 Gait spatial parameters

In one of the first studies aiming at quantifying physical activity by means of wearable devices, Stunkard calibrated a mechanical pedometer for the length of the strides of walking subjects. Converting impulses into distances, the author claimed to measure walked distances with errors of less than 15% (Stunkard, 1960).

Currently, the relationship between inertial sensors signals, and spatial gait parameters, is mostly achieved by indirect methods. Using a simple symmetric gait model, stride length has been estimated using a gyroscope on the thigh (Miyazaki, 1997). An indirect method (Aminian et al., 1995) developed by Aminian and colleagues showed that it was possible to estimate walking speed and incline in overground walking based on twenty trunk and heel acceleration parameters, combined with the use of artificial neural network. The results showed good agreement between actual and predicted values, with a variability of 2.6% for the estimated incline, and a 6% variability in speed estimation. A few years later, the same author also proposed a double segment model based on wavelet transforms using gyroscopes on the shanks and on the right thigh (Aminian et al., 2002). This double segment model provided an estimate of walking speed and stride length with a root mean square error of 0.06 m/s (6.7%) and 0.07m (7.2%), respectively.

A subsequent study used a double inverted pendulum model to estimate spatial parameters from trunk accelerometry (Zijlstra and Hof, 2003). The model assumed a compass gait type, where changes of height of the centre of mass were related to variations in step length. However, the method highlighted a systematic underestimation of step length and walking speed which was addressed with a fixed correction factor of 1.25, later improved by identifying individual correction values (Zijlstra, 2004).

The alternative to indirect methods is the double integration of the accelerometric signal. This technique is difficult to implement in practice due to uncertain initial conditions of position and velocity, and inaccuracies due to orientation of the sensors. In the algorithm he proposed, Moe-Nilssen tried to overcome these issues by transforming the signal into a fixed global frame, then calculated twice the cumulative sum of data series obtained from trunk accelerometry, subtracted the mean and choose a subset of the data to minimize drift in the integration process (Moe-Nilssen, 1998a). Results showed a quadratic relationship ($r^2=0.99$) between acceleration root mean square and walking speed. Another study presented a method to estimate right and left stride lengths using a single IMU attached to the pelvis by a combination of direct and reverse integrations of a filtered acceleration (Kose et al., 2012; Zok et al., 2004). Results showed errors in step length of less than 3%, and errors in distance covered of less than 2%.

A different approach to overcome the limitations of previous methods is to use machine learning techniques. Mannini and Sabatini estimated walking speed using Support Vector Machines, a pattern-recognition technique. Features for the classifiers were considered the mean values of each of the three measurement axes and the Pearson's correlation coefficients between each pair of them. The results of this on-line algorithm were comparable to existing off-line techniques (Mannini and Sabatini, 2011). An adaptive algorithm determined step length by using a linear combination of walking frequency and acceleration variance (Shin and Park, 2011), with a measurement error of 4.8% with respect to the actual walking distance.

2.3.8 Measures of gait variability and stability

Close examination of the gait pattern reveals fluctuations even under constant environmental conditions. Gait dynamics include the measures of stride-to-stride variability as well as other fluctuations in the gait pattern over time (Hausdorff, 2007). Qualitative indexes of gait unsteadiness were already been introduced into clinical scales in the late 1980s (Tinetti, 1986; Wolfson et al., 1990), but quantitative research has now demonstrated that the investigation of gait dynamics provides useful information about locomotor control and has clinical applications (Hausdorff et al., 2003). This section briefly reviews variability and stability metrics, although the latter are not the focus of the research presented in this thesis.

Coefficient of variation. The coefficient of variation (CV) is a standardized measure of dispersion of a probability distribution, defined as the ratio of the standard deviation to the mean of a frequency distribution. The coefficient of variation of many gait parameters has been studied as a measure of variability in human walking since the 1980s, when an early quantitative study showed an increase in step length variability during a six-meter walk in community-dwelling elderly fallers (Guimaraes and Isaacs, 1980) in comparison with healthy individuals. However, a systematic approach to the study of the variability of human walking started only in the 1990s. A study published in 1992 showed an inverse relationship between heart rate variability and stride rate variability (Hausdorff et al., 1992). Later studies confirmed that gait variability is related to cardiovascular health. In healthy adults, the coefficient of variation of many gait parameters is generally in the order of a few percent (Hausdorff et al., 1997a), but is altered in clinically relevant

syndromes, such as Parkinson's disease (Blin et al., 1990), basal ganglia disorder (Hausdorff et al., 1998), amyotrophic lateral sclerosis (Hausdorff et al., 2000), and Alzheimer's disease (Sheridan et al., 2003), while in healthy older adults stride-to-stride fluctuations appear to be altered only in specific parameters, such as step width (Owings and Grabiner, 2004). Gait variability may predict falls in elderly fallers and populations at high fall risk (Hausdorff et al., 2001). Improvements in muscle function and rehabilitation interventions are associated with better gait variability measures (Frenkel-Toledo et al., 2005; Nakamura et al., 1996).

Detrended fluctuation analysis. Detrended fluctuation analysis is a method to determine the statistical self-affinity of a signal. The fractal scaling index obtained from gait time series was found to be in the order of 0.75, which testifies the presence of long-range correlations (J M Hausdorff et al., 1995). This means that there is a dependency in the locomotor system and that fluctuations in the stride interval are related to variations in gait cycles which occur hundreds of strides earlier in time (Hausdorff, 2007). Studies in neurological disorders suggest that the central nervous system mechanisms contribute to these long-term fluctuations (Gates and Dingwell, 2007; Hausdorff et al., 1997b).

Gait stability. Many clinical stability indexes have been proposed, none of which has been widely accepted (Hamacher et al., 2011). Recently, some authors used methods of nonlinear dynamics system analysis to obtain metrics of gait stability. Dynamic orbital stability quantifies discretely the tendency of the system to return to its periodic limit cycle orbit after perturbations, and is defined using Floquet multipliers (Nayfeh and Holden, 2004). The first description of stability indexes explicitly applied to human walking was published over two decades ago (Hurmuzlu and Basdogan, 1994). However, as highlighted by a recent review, there is still lack of uniformity in the computation of this parameter (Riva et al., 2013a). Local dynamic stability is defined by quantifying how a system's state responds continuously to small perturbations. It is calculated by estimating the average rate of divergence of neighbouring trajectories in real time. Positive values of the divergence exponents indicate local instability (Dingwell and Kang, 2007). Recent work has established that these metrics are not influenced by directional changes (Riva et al., 2014), and that a minimum number of 130 strides should be used for a reliable measure of orbital stability (Riva et al., 2013b).

Further metrics that are currently used to quantify stability in gait include Recurrence Quantification Analysis, which provides a characterization of deterministic and non-stationarity structures (Sylos Labini et al., 2012), Multiscale Entropy, which quantifies a time series' complexity (Costa et al., 2003), Harmonic Ratio, a measure associated to whole body balance (Lowry et al., 2009).

2.4 Wearable MIMU sensors and musculoskeletal models

A recent review has highlighted the extensive research carried out since the 1990s to develop MIMU systems capable of estimating joint angular kinematics and segment orientations (Picerno, 2017), concluding that, overall, the analysed approaches were found to be accurate in comparison to standard motion analysis techniques. Furthermore, wearable sensor systems capable of assessing lower limb kinetics have also been recently developed (Liu et al., 2009; Schepers et al., 2007; Zheng et al., 2008)

These approaches, based on wearable inertial sensors, could benefit from current developments in musculoskeletal models such as the AnyBody Modeling System (Damsgaard et al., 2006), and OpenSim (Delp et al., 2007). These subject-specific models are more refined and contain more complex, anatomical, kinematic information than sensor fusion algorithms currently used for multiple MIMUs. Furthermore, they allow movement between segments and modelled sensor positions, for example as a consequence of soft-tissue artefacts. On the other hand, musculoskeletal models can be driven by kinematic and kinetic models based on MIMUs, allowing dynamic modelling in outdoor environments. An attempt to provide an integrated routine to drive musculoskeletal models using MIMU data has been recently published (Koning et al., 2013). Further developments of these methods would facilitate the use of MIMU-based orientation estimates in existing biomechanical models, contributing to the growth of biomechanical analysis applied to daily life.

2.5 Conclusions

The growing interest in quantifying physical activity, and specifically walking, in an objective manner has generated in the last few decades an exponential increase in research, design, and commercialization of wearable devices to measure physiological quantities. Improvements in miniaturization, memory and battery life has recently allowed their use for prolonged periods of time in conditions of free living. The most commonly adopted wearable sensors include footswitches, pressure insoles and micro-electro-mechanical systems. Inertial sensors are currently the most popular devices thanks to their ease of use and low power consumption. Systematic measures of human walking using wearable accelerometers started to be carried out in the 1970s, while only two decades later new methods for improved signal processing allowed the investigation of walking in free-living conditions. Typical outcomes obtainable from inertial sensor-based wearable devices include activity counts, energy expenditure, step detection, gait event identification, spatial and temporal gait parameter, and metrics of gait dynamics. The potential to investigate gait in daily life, however, is still hindered by limited validity and reliability of current methods, and lack of knowledge regarding typical walking patterns typical of daily living scenarios. The aim of this thesis is to address the limitations that make this approach uncommon, and contribute to the development of knowledge in the field of gait monitoring in daily life.

Chapter 3

Physical Activity Monitors: accuracy assessment

An objective and reliable method for the classification and quantification of free-living motor activity is a prerequisite for the understanding of the complex relationship between health and physical activity. As discussed in detail in the previous chapter, the use of physical activity monitors for its estimation has gained widespread recognition, and accelerometry is currently the most exploited technology in this field (Chen et al., 2012). The study described in this chapter aims at assessing the accuracy of state-of-the-art technology in the field of PAMs, in both healthy individuals, and in patients with locomotion difficulties due to a neurological condition. In the first part of the study, seven commercially available PAMs were tested in healthy individuals walking at different gait speeds and performing different basic activities of everyday living, and the accuracy of their step detection and posture classification algorithms was investigated. In the second part of the study, the best performing device was tested in patients with mobility problems due to multiple sclerosis, with the aim of proposing a method to reliably assess the accuracy of step detection in this population, and investigating the relationship between walking speed and sensor accuracy.

3.1 Accuracy of step detection and activity recognition in healthy individuals

A substantial part of the material presented in section 3.1 has been published in:

F. A. Storm, B. W. Heller, C. Mazzà, *Step detection and activity recognition accuracy of seven physical activity monitors. PLoS ONE 10(3): e0118723. doi:10.1371/journal.pone.0118723.*

Written permission was obtained from all the co-authors.

3.1.1 Introduction

Physical activity monitors (PAMs) can be classified into research-grade and consumer-based devices. Research-grade monitors have generally accepted reliability and validity of physical activity measured in free-living conditions, achieved through validation against a reference method, such as the doubly labeled water for energy expenditure. This scientific evidence allows them to be used in research and clinical settings. Consumer-based monitors are often considerably cheaper and less cumbersome, include displays for immediate feedback and are associated with internet- and/or smartphone-based applications. They can also be worn on a larger variety of body locations, such as wrist or neck. Typical metrics of both types of sensors are step count, energy expenditure, distance travelled, and sleep time. According to a recent market research, the annual 2015 unit sale of fitness activity trackers specifically designed and produced for the consumer market has grown by 85% with respect to 2014, and demand is rising despite the average selling prices of these devices is increasing. Fitbit is the leading brand in 2015, with 79% of market share. In the U.S. market, nearly 33 million devices are owned (The NPD Group, 2016).

A recent review, focusing on protocol equivalency, emphasized the “emerging measurement challenge” caused by the increasing availability of these low cost PAMs, along with the chronic difficulty in comparison and standardization of data from different models of accelerometry-based sensors (Welk et al., 2012). Activity type-specific equations are generally implemented into PAMs to model energy expenditure (Brandes et al., 2012). As far as is known to the author, at the time of the data collection only one study had investigated consumer-based PAMs (Lee et al., 2014). The study tested eight consumer-based PAMs in their accuracy for estimating energy expenditure during a 69-minute protocol in sixty adults using indirect calorimetry as reference. The accuracy results, with the devices ranked based on percent error, were as follows: BodyMedia FIT (9.3% error), Fitbit Zip (10.1%), Fitbit One (10.4%), Jawbone UP (12.2%), Actigraph GT3X (12.6%), DirectLife (12.8%), Nike Fuelband (13%) and Basis BI Band (13.5%).

More recently, some studies attempted to examine the concurrent validity of various outputs of consumer-based PAMs. In one of the most comprehensive, Ferguson and colleagues compared seven consumer-level devices against two

research-grade monitors in free-living adults, concluding that the consumer-level devices showed strong validity for step detection and sleep time, and moderate validity for total daily energy expenditure and moderate to vigorous physical activity (Ferguson et al., 2015).

Interestingly, despite the fact that in these devices the application of the activity-dependent equations relies on step detection, only a few studies have focused specifically on the accuracy of this estimate. Furthermore, the robustness of step detection during walking at slow speed is of particular interest in clinical research (Harrison et al., 2013). An additional factor that could affect the accuracy of step detection is, of course, the walking environment. To our knowledge, however, the accuracy of step count in PAMs has never been compared between indoor and outdoor settings. The objectives of this study are the following:

1) Identify appropriate protocols for subject-specific assessment of a PAM's accuracy.

Step detection is a common feature for PAMs, but its accuracy can be affected by the walking environment. Different walking protocols, including indoor and outdoor walking at different speeds will be used to test the accuracy of the PAMs. The identified protocol could be used in future as a spot check for patient specific calibration and reliability assessment, before the PAM is given to a patient for long-term monitoring.

2) Validation and comparison of different PAMs.

The objective of this part of the study is to compare the step count detection accuracy of seven different PAMs, covering a range of technologies and prices, in healthy adults. Among these monitors, those that allow recognition of common everyday tasks will be further tested in their ability to discriminate and classify basic activities within more composite motor tasks. The results of this study will provide a reference value for the error to be expected when the investigated PAMs are used for long-term recording of physical activity.

3.1.2 Physical activity monitors

This section describes the technical characteristics of the seven PAMs that were assessed in this study. Scientific evidence on the accuracy of their outcomes based on work published on peer-reviewed journals is also briefly reviewed,

including studies published up to April 2016. Further details for each sensor are provided in Table 3-1.

MoveMonitor

The MoveMonitor (Mc Roberts, The Hague, The Netherlands) is a research-grade commercially available PAM, which gives a report with information about the performed activities/postures (lying down, sitting, standing, walking and shuffling), movement parameters (step count, movement duration, intensity and frequency of transitions, e.g. sit-to-stand), and energy expenditure. Its dimensions are 106.6 x 58 x 11.5 cm and its weight 55 g. The device is worn around the waist using an elastic strap, and features a triaxial accelerometer with a selectable full scale of $\pm 2g$ or $\pm 6g$, measuring acceleration over a bandwidth of 640 Hz for all axes. The resolution is $\pm 1mg$ in the 2g range and $\pm 3mg$ in the 6g range. The sample frequency is 100Hz. The lithium polymer battery allows 204 hours of recording.

The regression equations used to relate sensor output with energy expenditure have been published and improved in the years (Brandes et al., 2012; van Hees et al., 2009). The MoveMonitor has been validated in an elderly group (Dijkstra et al., 2009) and in clinical populations: a study looked at the validity of posture recognition of the MoveMonitor in Parkinson's disease (Dijkstra et al., 2010), where high agreement was found for lying, sitting at home, and walking, while lower values were found for sitting in the laboratory, standing, and shuffling. A further study highlighted that accurate information could be gained from a set of postures in patients with peripheral arterial disease with intermittent claudication, but shuffling and sitting-to-standing transition accuracy was still of concern (Fokkenrood et al., 2014). The device has also been validated for daytime physical activity in patients with chronic obstructive pulmonary disease: the MoveMonitor showed in this population significant correlations with active energy expenditure ($r=0.70$ $p<0.0001$) (Rabinovich et al., 2013; Van Remoortel et al., 2012). The reliability for the step count during a set of standardized tasks in able-bodied participants was found to be weak to moderate (de Groot and Nieuwenhuizen, 2013).

ActivPAL

The ActivPAL (PAL Technologies Ltd., Glasgow, UK) is a PAM with dimensions of 53 x 35 x 7 mm and weighing 15 g, which is attached to the anterior

aspect of the thigh. The triaxial accelerometer has a range of $\pm 2g$, with a sampling frequency of 20Hz and a memory of 16MB, allowing a recording period of 10 days. The ActivPAL has been validated for the discrimination of sedentary (sitting or lying), standing and ambulatory activity, where it showed detection accuracies for static and dynamic activities of approximately 98% (Godfrey et al., 2007; Grant et al., 2006). Another study found that the absolute percentage error for step cadence and step number was 1.11%, regardless of walking speed (Ryan et al., 2006). It has also been used in various clinical studies, including back pain (Ryan et al., 2008), elderly adults (Grant et al., 2010, 2008), cardiology (Tigbe et al., 2007) stroke (Harris et al., 2005) and venous ulceration (Clarke-Moloney et al., 2007).

Sensewear Mini Armband

The Sensewear Mini Armband (Bodymedia, Pittsburgh, USA) is a multi-sensor PAM worn over the triceps of the right arm. It includes a biaxial accelerometer, a skin temperature sensor, a near-body temperature sensor, a heat flux sensor, and a galvanic skin response sensor. The signals are combined to obtain estimates of step count, energy expenditure, and sedentary time. A Naive Bayes classifier is used to classify the data to an activity class (walking, running, cycling, rest, resistance, and other activities). A different linear regression model for each of the sensor classifications is then used to estimate energy expenditure. A validation study testing two models of Armband showed that the device had an absolute error rate of $8.1\% \pm 6.8\%$ in estimating energy expenditure in thirty healthy individuals under free living conditions during fourteen consecutive days (Johannsen et al., 2010). A further study evaluated the performance of this device under free-living conditions in children using the doubly labelled water method as reference, obtaining a mean percentage error over fourteen days of 10.9% (Calabró et al., 2013). The Sensewear Armband has also been used in an intervention study looking at weight loss in a group of 197 obese adults, where its use showed an improvement of body weight and waist circumference with respect to a group of patients receiving standard care (Shuger et al., 2011). A study comparing six PAMs with indirect calorimetry in patients with chronic obstructive pulmonary disease showed that the Sensewear Pro Armband had high correlation in both minute-by-minute and mean correlations ($r=0.73$ and $r=0.76$, respectively) (Rabinovich et al., 2013; Van Remoortel et al., 2012). However, a study comparing the Sensewear Mini Armband

with a pedometer (Digiwalker SW701) in the same type of patients and in healthy elderly showed that at slow speeds (1.6 ± 0.2 km/h) neither of the two systems was adequately accurate (Furlanetto et al., 2010). The device has also been used to study depression in chronic obstructive pulmonary disease patients (Venkata et al., 2012), pregnant women (Smith et al., 2012) and hyperthyroidism (Ulas et al., 2012). The Sensewear Armbands have been discontinued in 2015.

UP

The UP (Jawbone, San Francisco, USA) is a wrist-worn accelerometry-based device that can assess physical activity and sleep patterns throughout the day. The UP can synchronize data to smartphones via a 3.5-mm standard cable. It is water resistant up to 1 m and the battery can last for up to 10 days. The UP contains a triaxial accelerometer, collecting data at 30 Hz. Proprietary algorithms are used to estimate steps, distance walked, type of physical activity, energy expenditure, and sleep. Several validation studies have investigated the accuracy of the UP device looking at different aspects: for laboratory-based validity studies using step counting as the criterion, correlation with steps collected from a reference sensor was generally high for treadmill walking (Takacs et al., 2014), running (Diaz et al., 2015), and elliptical exercise (Stackpool et al., 2015). Neither reliability studies nor studies on patient populations have been published using this device. The UP is now no longer for sale on the company's website, and has been updated by the UP2 and UP3 devices.

One

The One (Fitbit, San Francisco, USA) is a physical activity monitor containing a 3-axis accelerometer and an altimeter, with a silicon clip allowing the user to clip it to a belt, pocket or bra. The lithium-polymer battery allows 10-14 days of recording, while the memory tracks 7 days of minute by minute, and 23 days of daily totals data. Measures include walked steps, physical activity, energy expenditure and sleep monitoring. In a laboratory-based study investigating step count accuracy, correlation with steps from a reference method was >0.80 (Case et al., 2015). However, in a free-living study on twenty-one participants wearing the One for two days, it generally over-counted steps (Ferguson et al., 2015). Using direct observation as criterion, Takacs and colleagues obtained excellent validity (0.97-

1.00) and inter-device reliability (99% agreement) for step detection accuracy during treadmill walking at five different speeds among thirty healthy adults (Takacs et al., 2014). Finally, a study found less error for the ankle-worn compared to the waist-worn sensor (Simpson et al., 2015). Fitbit One has only been tested in healthy individuals and older adults.

Nike+ Fuelband

The Nike+ Fuelband (Nike Inc., Beaverton, OR), released in 2012, is a wrist-worn PAM allowing users to track physical activity. It includes a three-axial accelerometer, and can assess body movement, steps, and distance. A proprietary algorithm combining raw accelerometer counts and demographic characteristics also allows estimating physical activity energy expenditure. Two lithium polymer batteries allow continuous recording for up to four days. A study reported good agreement at the group level in comparison to total energy expenditure measured by indirect calorimetry (87% accuracy), however, at individual level the correlation was low (0.35), and proportional systematic bias was also reported (Lee et al., 2014). A recent study comparing two PAMs and a pedometer in step detection in fifty patients with stroke and traumatic brain injury found that the Nike+ Fuelband was the least accurate (66% accuracy) during a two minute walk (Fulk et al., 2014). A further study tested the step count accuracy of four activity monitors, including the Nike+ Fuelband, in seventeen patients with idiopathic normal pressure hydrocephalus, with the device resulting the poorest in the results (Gaglani et al., 2015). The Fuelband has been discontinued in 2014.

Tractivity

The Tractivity (Kineteks Corp., Vancouver, Canada) is a commercially available, triaxial accelerometer for use on the foot/ankle. The device allows the self-monitoring of distance walked, steps, time and energy expenditure during physical activities. The only published validation study of the Tractivity examined its accuracy in measuring steps across different walking speeds in ten healthy participants. The Tractivity explained >99% of the variance in the number of observed steps, with no evidence of systematic bias (Warburton et al., 2013).

Table 3-1. Details of the PAMs tested in the study (Storm et al., 2015).

Instrument	Sensor Type	Location	Tested Outputs	Output Data Aggregation	Data Interface and Version	Price
DynaPort MoveMonitor (Mc Roberts)	Triaxial accelerometer	Lower back	Time sitting, lying, standing, locomotion, shuffling, steps	1s epochs	<i>Dyrector Ver. 1.0.7.17</i> - Web based data server	800 €
UP (Jawbone)	Triaxial accelerometer	Wrist (right)	Steps	60s epochs data and graphics by day or min	<i>UP Ver. 2.8.8.3.7.1</i> - App	114 €
One (Fitbit)	Triaxial accelerometer	Waist (left)	Steps	60s epochs data and graphics by day or 15 min aggregation	<i>Connect Ver. 1.0.0.4022</i> - Web based software	106 €
ActivPAL (PAL Technologies)	Triaxial accelerometer	Shank (right)	Time sitting and lying, standing, stepping, steps	1s epochs	<i>ActivPAL Ver. 7.1.18</i> - PC based software	1,277 €
Tractivity (Kineteks Corporations)	Uniaxial accelerometer	Ankle (right)	Steps	60s epochs data and graphics by day or hour	<i>Connect Ver. 2.12</i> - Web based software	18 €
Nike+ Fuelband (Nike)	Triaxial accelerometer	Wrist (left)	Steps	60s epochs data and graphics by day or hour	<i>Nike+ Connect Ver. 3.8</i> - Web based software	171 €
Sensewear Mini Armband (Bodymedia)	Triaxial accelerometer, heat flux, galvanic skin response, skin temperature	Upper left arm at triceps	Steps	60s epochs data and graphics by day or hours or minutes	<i>Sensewear Ver. 7.0.0.2378</i> - PC based software	2,400 €

3.1.3 Materials and methods

Participants

Sixteen participants were recruited for the study. The sample characteristics are shown in Table 3-2. Participants did not report any impairment or morbidity that could interfere with the assessment of physical activity. Approval from the University of Sheffield Research Ethics Committee was obtained for the study and participants were asked to read carefully an information sheet before giving written informed consent.

Table 3-2. Sample characteristics of the study group (mean \pm SD) (Storm et al., 2015).

Characteristic	Value
Men/Women	10/6
Age (y)	28.9 \pm 2.7
Weight (kg)	72.0 \pm 9.2
Height (m)	1.75 \pm 0.09
BMI (kg/m²)	23.5 \pm 2.3

Experimental protocol

After having their anthropometric characteristics recorded, the subjects were fitted with the sensors, which were all positioned at the manufacturer's recommended locations (Figure 3-1). The participants were asked to perform two protocols, one including different locomotion tasks and one including different postural transitions and complex motor activities.

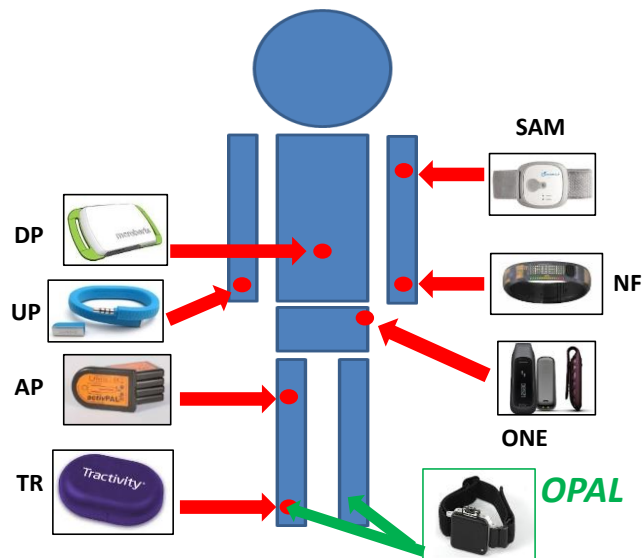

Figure 3-1. Sensor placement (adapted from Storm et al. 2015). The figure shows the location of the sensors on a subject's body: MoveMonitor (DP), Up (UP), One (ONE), ActivPAL (AP) Tractivity (TR), Nike+ Fuelband (NF), Sensewear Mini Armband (SAM), and OPAL sensors used as reference system.

In addition to the PAMs, two wireless inertial measurement units (OPAL, ADPM Inc., Portland, OR, USA) were positioned on the left and right shanks, just above the ankle, by means of an elastic strap. Data from the OPAL sensors collecting data at a sampling rate of 128 Hz were used as a gold standard for step detection. An algorithm using the gyroscopic signals was implemented in Matlab R2013a (The Mathworks Inc., USA). This algorithm is directly derived from the one proposed by Aminian and colleagues (Aminian et al., 2002), which has been extensively validated to detect heel strike and toe off in healthy individuals during straight walking, and identifies the maxima of the angular velocity around the mediolateral axis of the shank corresponding to the swing phases of the leg from the data (Figure 3-2). Not being interested in detecting a specific phase in the gait cycle, we used the maxima instead of the heel strike peak used by Aminian et al. as a conservative solution. The main feature of the gyroscope signal in the sagittal plane during the swing phase of walking is a peak generated by the counter-clockwise rotation of the shank, whose maximum occurs approximately at mid-swing (Sabatini et al., 2005). Peaks larger than $50^{\circ}/s$ ($0.9 \text{ rad}/s$) were selected as candidates. The highest peak was selected in case of multiple peaks occurring within a maximum distance of 500 ms. This peak was retained and taken as the midswing (Aminian et al., 2002; Salarian et al., 2004).

The sensitivity and the positive prediction value in detecting gait cycles for healthy subjects using this method were reported as 100% (Salarian et al., 2004).

Nevertheless, the presence of a heel strike between two subsequent strides was always verified and the independent information from the sensors on the two ankles was used as a cross-check to verify the alternate presence of left and right steps. For each session, step counts for left and right shanks were computed and the total number of steps (N) was obtained by summing up the number of right and left steps.

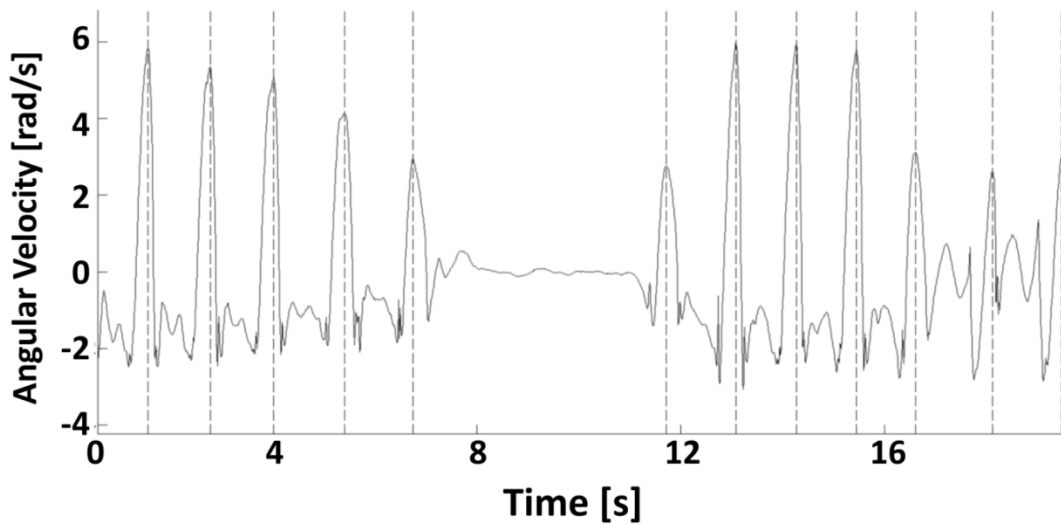

Figure 3-2. Typical angular velocity signal of the shank in the sagittal plane during consecutive steps (adapted from Storm et al. 2015). The figure shows the angular velocity signal as measured by one of the shank sensors in the sagittal plane during a portion of an arbitrarily selected indoor walking trial. The portion shown includes walking, stopping and turning. The maxima detected by the algorithm used to detect single steps are also highlighted with dotted vertical lines.

During the first protocol, which tested the accuracy of the PAMs for step detection under different walking conditions, each participant simultaneously wore all the seven monitors. The protocol lasted 11-minutes and included the following tasks: a) walking along a 20-meter long indoor straight walkway; b) descending 24 steps (4 flights of 5,12,3 and 4 steps respectively); c) free outdoor walking; d) ascending 24 steps and e) free walking in an indoor setting. During the free indoor walking the participants were asked to walk inside a 300 m² office space filled with lines of desks and separated by rectilinear corridors, without following any predefined path (they were free to decide which way to go, provided that they would not stop nor make abrupt turns). During the outdoor walking they were instructed to walk along a regularly crowded sidewalk, following a pre-defined route that included straight paths and turns around blocks. This was repeated three times, with the participants being instructed to walk at self-selected natural, slow, and fast speeds.

The order of the walking speeds was randomized. A detailed description of the protocol is presented in Table 3-3.

Table 3-3. Summary of the activities performed during the step detection protocol, their duration and the step count (as obtained by the OPAL sensors) for each walking speed (Storm et al., 2015).

Activity Type – Step Detection Protocol	Duration	Slow speed (N)	Self-selected Speed (N)	Fast speed (N)
Indoor walking on a straight walkway	3 min	260 ± 42	313 ± 44	353 ± 37
Descending 24 steps	1 min	70 ± 11	72 ± 7	66 ± 11
Outdoor walking	3 min	330 ± 81	378 ± 56	460 ± 69
Ascending 24 steps	1 min	67 ± 6	65 ± 7	63 ± 7
Free indoor walking	3 min	267 ± 53	309 ± 38	350 ± 35
TOTAL	11 mins	986 ± 127	1127 ± 103	1289 ± 115

The number of steps, as estimated by each sensor (\tilde{N}), was recorded at the end of each trial and saved for further analysis. An additional analysis was performed in order to investigate differences in step count accuracy between the five different walking phases of the protocol. This phase analysis was performed on the MoveMonitor and the ActivPAL data only, since the outputs of the other PAMs do not lend themselves to the extraction of the number of steps in sub-intervals.

During the second protocol, in addition to the two OPAL sensors, the subjects wore the two PAMs (MoveMonitor and ActivPAL) that are able to discriminate other activities besides walking. Initially, eleven activities were completed by the participants, and their classification into the PAMs categories was expressed as percentage of the total duration of each activity. However, since most of the investigated activities were difficult to classify accurately into the categories used by the PAMs.

This activity recognition protocol lasted 19 minutes and is described in Table 3-4. This protocol included motor activities designed to challenge the recognition of basic tasks (e.g. introducing upper body movements while sitting or external accelerations affecting the entire body). Each activity was completed once and one

minute of free indoor walking was performed between them to facilitate their classification. The order of the activities was previously randomized. The MoveMonitor classifies the activities into five categories (lying, sitting, standing, locomotion and shuffling) and the ActivPAL into three categories (sedentary, standing and stepping). Using the previously described algorithm, the data from the OPAL sensors were used to identify the beginning and end of each activity by detecting the walking phases that separated them.

Table 3-4. Summary of the activities performed during the activity recognition protocol (adapted from Storm et al., 2015).

Activity Type – Activity Recognition Protocol	Duration
Standing	2 min
Taking the lift	2 min
Sitting and working at a computer	2 min
Lying	2 min
Ascending and descending steps	1 min
Walking	2 min
Working in the kitchen	2 min
Sitting	2 min
Sweeping	2 min
Lifting objects from the floor	2 min
TOTAL	19 mins

Statistical Analyses

Data analysis was performed using SPSS Statistics 21.0 (IBM Corporation, New York, USA). For the investigation of step detection accuracy in the seven PAMs, the mean absolute percentage error¹ (MPE) for each sensor was computed as:

$$MPE = \frac{|\tilde{N} - N|}{N} * 100$$

¹ The terminology was chosen consistently with existing literature, although it could also be defined as “mean absolute percentage difference”.

The Kolmogorov-Smirnov test was used to analyse normality of data. As the MPE values of the participants for each sensor were normally distributed, parametric tests were used and data were presented as mean and standard deviation (SD). Differences in group estimates between sensor outcomes were tested using a mixed-model ANOVA with a significance level of $p=0.05$ and post-hoc follow up analysis. Bland-Altman plots were used to assess the agreement between the measures and evaluate bias between the scores of the PAMs, where the difference (D) and the average (A) for each sensor were computed as:

$$D = \tilde{N} - N$$

$$M = \frac{\tilde{N} + N}{2}$$

For the activity recognition protocol, the posture classifications given by the two PAMs were extracted and expressed as a percentage of the duration as computed by the reference signals collected at the shanks.

3.1.4 Results

The following results are relative to all walking conditions together, and was necessary because five out of seven sensors did not allow a the separate extraction of step count by walking phase. The ANOVA showed significant differences in step count between the three walking speed conditions ($p<0.05$, see Table 3-5 for values). For all sensors, planned contrasts revealed that the number of steps recorded at the self-selected speed was significantly lower than that at slow walking speed ($p<0.01$) and higher than that at fast walking speed ($p<0.01$).

There was a significant underestimation of \tilde{N} for the MoveMonitor, One, ActivPAL, Nike+ Fuelband and Sensewear Mini Armband, whereas the Tractivity significantly overestimated step count. The observed power was 0.99 for the overall ANOVA and ranged from 0.83 to 0.99 for the significantly different contrast tests. The UP sensor did not show any systematic over- or underestimation. These findings were confirmed also when the data were separated by walking speed. Figure 3-3 summarises mean and SD of the mean percentage error (MPE) at all walking speeds for each of the seven PAMs. The best performing device in terms of MPE was the MoveMonitor, with $MPE<2.0\%$ at every speed, followed by One and ActivPAL, with $MPE <2.6\%$ and $<3.2\%$, respectively. These three sensors presented also the

smallest SD ($\leq 1.7\%$, $\leq 2.5\%$ and $\leq 1.5\%$, respectively). The total number of steps, and MPE values for all the PAMs included in the study, are shown in Table 3-5 and 3-6, respectively.

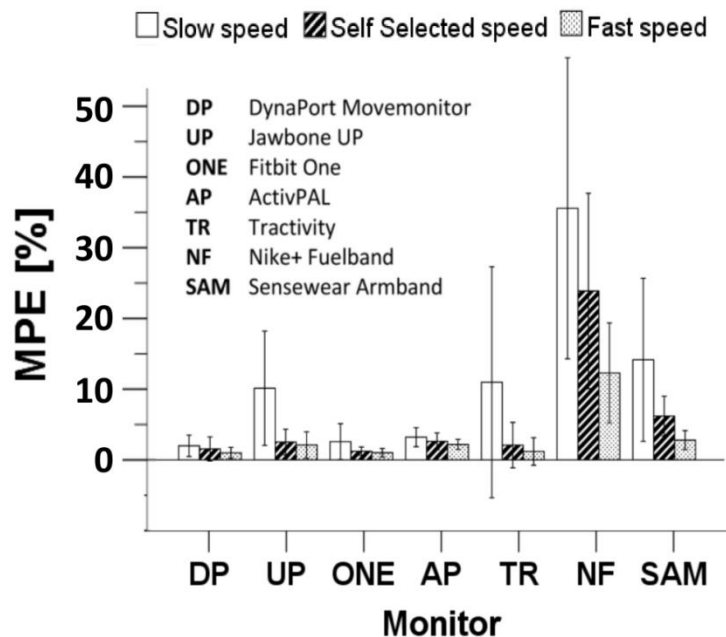

Figure 3-3. Summary of MPE for the 7 PAMs included in the study (Storm et al., 2015). The figure shows the mean percentage error (MPE) during slow, self-selected and fast walking speed trials for all the sensors included in the study. Error bars are mean \pm SD.

The Bland-Altman plots for the number of steps (\tilde{N}), depicted in Figure 3-4, showed an average \pm limits of agreement ($1.96 \times SD$) underestimation of 15 ± 33 , 15 ± 35 , 29 ± 20 , 16 ± 135 , 36 ± 178 , 253 ± 331 and 77 ± 127 steps for the MoveMonitor, One, ActivPAL, UP, Tractivity, Nike+ Fuelband and Sensewear Mini Armband, respectively. The values of step count over- or underestimation for all the sensors at all walking speeds are shown in Table 3-7. The correlation analysis (see regression lines on the Bland-Altman plots) highlighted also that for the Nike+ Fuelband and the Sensewear Mini Armband the underestimation was affected by the number of steps taken: the statistically significant ($p < 0.05$) correlations between D and M were $r = 0.72$ and $r = 0.77$, respectively.

Table 3-5. Step count for the PAMs and the reference method (Storm et al., 2015). Values are mean \pm SD.

Walking Speed	MoveMonitor	Up	One	ActivPAL	Tractivity	Nike+ Fuelband	Sensewear Mini Armband	OPAL
Slow	968 \pm 131	952 \pm 197	962 \pm 128	955 \pm 131	1081 \pm 114	644 \pm 246	858 \pm 197	986 \pm 127
Self-selected	1110 \pm 100	1123 \pm 107	1119 \pm 103	1097 \pm 111	1132 \pm 108	865 \pm 200	1059 \pm 111	1127 \pm 103
Fast	1283 \pm 117	1280 \pm 117	1280 \pm 112	1259 \pm 120	1299 \pm 117	1134 \pm 159	1254 \pm 119	1289 \pm 115

Table 3-6. Mean absolute percentage error (MPE) for the PAMs (Storm et al., 2015). Values are mean \pm SD.

Walking Speed	MoveMonitor	Up	One	ActivPAL	Tractivity	Nike+ Fuelband	Sensewear Mini Armband
Slow	1.98 \pm 1.50	10.08 \pm 8.04	2.56 \pm 2.53	2.99 \pm 1.51	10.92 \pm 16.26	35.39 \pm 21.17	14.08 \pm 11.47
Self-selected	1.54 \pm 1.69	2.51 \pm 1.80	1.13 \pm 0.65	2.45 \pm 1.31	2.07 \pm 3.20	23.76 \pm 13.75	6.16 \pm 2.79
Fast	0.93 \pm 0.79	2.10 \pm 1.85	1.01 \pm 0.59	2.04 \pm .88	1.17 \pm 1.94	12.22 \pm 7.04	2.77 \pm 1.34

Table 3-7. Mean over- or underestimation of step count (D) for the PAMs (Storm et al., 2015). Values are mean \pm SD.

Walking Speed	MoveMonitor	Up	One	ActivPAL	Tractivity	Nike+ Fuelband	Sensewear Mini Armband
Slow	-19 \pm 13	-35 \pm 110	-25 \pm 26	-31 \pm 12	95 \pm 134	-343 \pm 204	-129 \pm 86
Self-selected	-17 \pm 21	-4 \pm 34	-12 \pm 10	-29 \pm 11	4 \pm 40	-262 \pm 147	-68 \pm 28
Fast	-9 \pm 14	-9 \pm 34	-9 \pm 12	-28 \pm 8	10 \pm 28	-155 \pm 88	-35 \pm 17
Overall	-15 \pm 17	-16 \pm 69	-15 \pm 18	-29 \pm 10	39 \pm 91	-253 \pm 169	-77 \pm 65

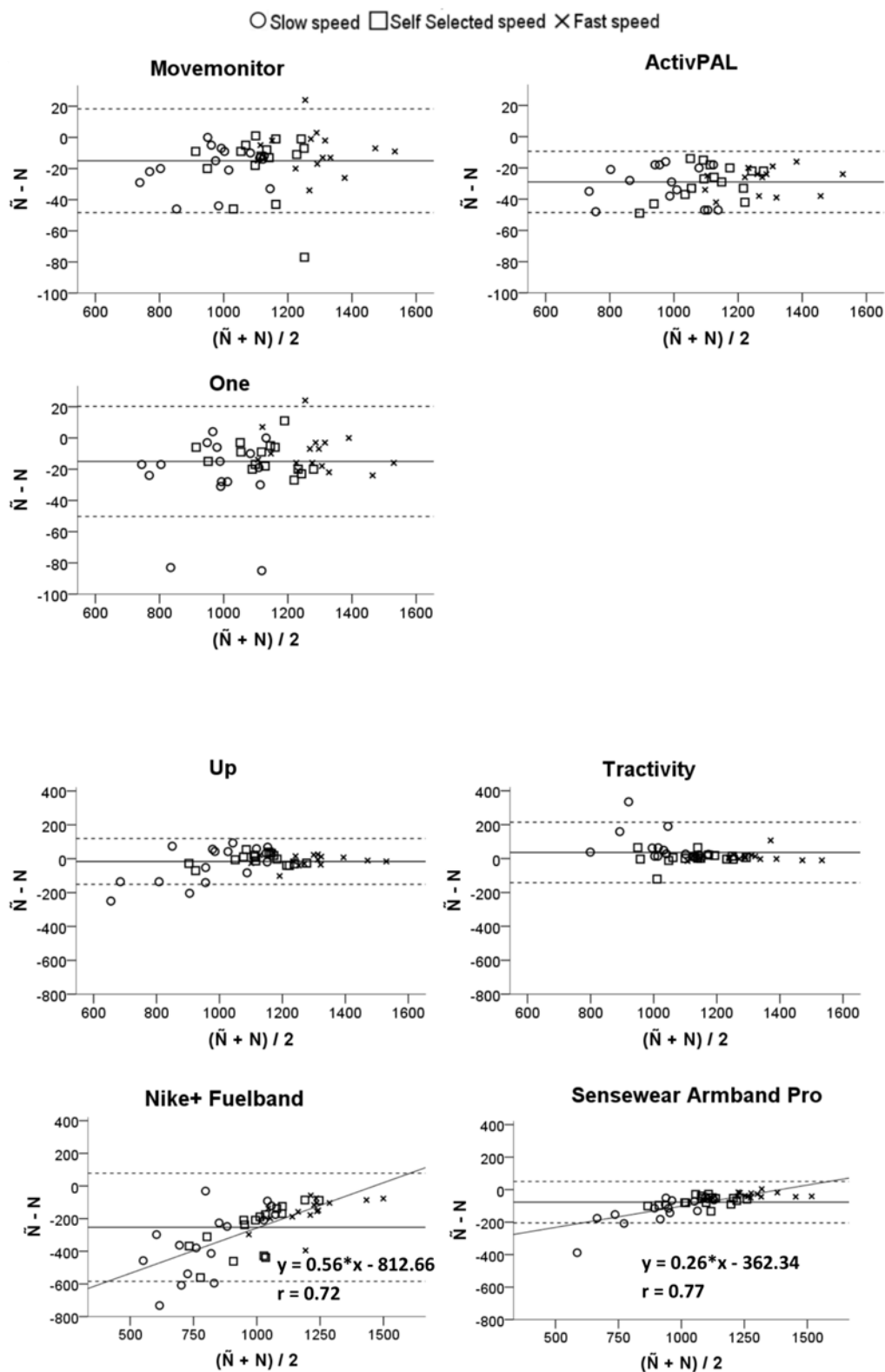

Figure 3-4. Bland-Altman plots for step count for the MoveMonitor, ActivPAL and One, and for the Up, Tractivity, Nike+ Fuelband and Sensewear Mini Armband (Storm et al., 2015). The solid lines indicate the mean step count difference between the OPAL sensor and each monitor. The dashed lines indicate mean \pm limits of agreement ($1.96 * SD$). Regression lines, relevant equations and Pearson's correlation coefficients (r) are shown for the Nike+ Fuelband and the Sensewear Mini Armband.

The results of the phase analysis performed on MoveMonitor and ActivPAL data showed that, for both sensors, the best performance in terms of MPE was obtained during the outdoor walking: for the MoveMonitor, MPE values ranged between $0.38\pm 0.35\%$ at natural walking speed and $0.54\pm 0.65\%$ at slow walking speed; for the ActivPAL, values ranged between $1.0\pm 0.7\%$ at fast walking speed and $1.4\pm 0.8\%$ at slow walking speed, respectively. The mixed-model ANOVA showed that the MoveMonitor sensor was more accurate than the ActivPAL ($p < 0.05$) in terms of MPE. The MPE also significantly differed in the five walking phases ($p < 0.001$). There was also a significant interaction between speed and phase ($p < 0.01$). Planned contrasts revealed that during the first transition phase (descending stairs), regardless of the sensor used, accuracy in step detection was higher during slow walking than at self-selected speed, while during the second transition phase (ascending stairs), MPE was lower at the self-selected speed than at slow walking speed, ($p < 0.05$). Equally, accuracy in step detection was higher during the first transition phase at self-selected walking speed than at fast speed, while during the second transition phase, MPE was lower at the self-selected speed than at fast walking speed ($p < 0.05$).

Finally, Figure 3-5 summarizes the classification of all the activities performed by the participants. The accuracy of the ActivPAL monitor in the classification of the activities performed during the 19-minutes activity recognition protocol (Table 3-8) ranged between 97.1% and 99.6% for standing, taking the lift, sitting and working at a computer, lying and stair walking. Sitting while working at a computer was mainly categorized as sedentary activity (98.7%, excluding one outlier); taking the lift was mostly classified as standing (99.6% of the time). Working in the kitchen and sweeping were classified mainly as standing, while lifting objects from the floor was mainly classified in the stepping category. The accuracy of the MoveMonitor device (Table 3-9) in classifying lying, sitting while working at a computer and stair walking ranged between 96.0 and 98.8%. Taking the lift was categorized either as standing or shuffling. Standing was categorized correctly only for 10.8% of the time; instead, it was mainly classified as sitting (88.4%). Working in the kitchen, sweeping and lifting objects from the floor were mainly classified as standing.

Table 3-8. Classification of the performed activities for the ActivPAL sensor. Data is presented as percentage of the total duration of the activity (mean \pm SD) (Storm et al., 2015).

Activity	ActivPAL Categories		
	Sedentary	Standing	Stepping
Standing	0.0 \pm 0.0	99.6 \pm 0.8	0.4 \pm 0.8
Taking the lift	0.0 \pm 0.0	97.1 \pm 3.2	2.9 \pm 3.2
Sitting and working at a computer	98.7 \pm 1.3	0.7 \pm 0.6	0.6 \pm 1.0
Lying	98.8 \pm 1.6	0.7 \pm 0.9	0.5 \pm 1.1
Ascending and descending steps	0.0 \pm 0.0	1.4 \pm 1.8	98.6 \pm 1.8
Walking	0.4 \pm 0.7	2.2 \pm 1.5	97.4 \pm 1.3
Working in the kitchen	0.0 \pm 0.0	89.8 \pm 14.0	10.2 \pm 14.0
Sitting	98.4 \pm 1.6	1.0 \pm 0.9	0.6 \pm 1.1
Sweeping	0.0 \pm 0.0	73.3 \pm 25.0	26.7 \pm 25.0
Lifting objects from the floor	17.0 \pm 35.4	22.5 \pm 13.8	60.5 \pm 33.7

Table 3-9. Classification of the performed activities for the MoveMonitor sensor. Data is presented as percentage of the total duration of the activity (mean \pm SD) (Storm et al., 2015).

Activity	MoveMonitor Categories				
	Standing	Sitting	Lying	Locomotion	Shuffling
Standing	10.8 \pm 26.9	88.4 \pm 26.6	0.0 \pm 0.0	0.7 \pm 0.6	0.1 \pm 0.3
Taking the lift	80.5 \pm 5.8	1.7 \pm 6.5	0.0 \pm 0.0	3.0 \pm 2.0	14.9 \pm 3.5
Sitting and working at a computer	0.4 \pm 0.5	98.6 \pm 1.4	0.0 \pm 0.0	0.7 \pm 0.8	0.3 \pm 0.6
Lying	0.0 \pm 0.0	0.8 \pm 1.1	98.8 \pm 1.4	0.4 \pm 0.6	0.0 \pm 0.0
Ascending and descending steps	0.7 \pm 1.0	0.0 \pm 0.0	0.0 \pm 0.0	99.2 \pm 1.3	0.1 \pm 0.3
Walking	3.5 \pm 11.0	0.4 \pm 0.9	0.0 \pm 0.0	95.0 \pm 16.4	1.1 \pm 4.6
Working in the kitchen	68.6 \pm 21.7	8.2 \pm 25.0	0.0 \pm 0.0	12.2 \pm 12.5	11.1 \pm 8.6
Sitting	0.4 \pm 0.7	98.9 \pm 1.6	0.0 \pm 0.0	0.6 \pm 0.9	0.2 \pm 0.6
Sweeping	51.0 \pm 23.4	0.6 \pm 1.7	0.0 \pm 0.0	25.1 \pm 25.4	23.2 \pm 14.7
Lifting objects from the floor	47.1 \pm 26.1	32.1 \pm 30.2	0.0 \pm 0.0	6.4 \pm 5.7	14.4 \pm 13.6

3.1.5 Discussion

It has been recently suggested that in activity monitoring research multiple comparison of monitors should be adopted to provide a better understanding of advantages or disadvantages of technology on the market (Welk et al., 2012). The first aim of this study was to compare step counts of research and consumer-oriented physical activity monitors during a short protocol including indoor and outdoor walking phases and stair climbing and descending. The second aim was to further characterise two of the chosen sensors in their ability to discriminate between simple and complex tasks and postures.

The experimental protocol adopted in this study proved to be suitable to investigate the accuracy of PAMs. The chosen 11-minutes duration for the data collection allowed the highlighting of differences in the step count throughout the three walking speeds. Our experimental design did not include a quantitative measure of walking speed, which prevents us from making observations regarding the specific relationship between speed and accuracy of the PAMs. This could be of interest for applications involving patients or elderly individuals.

Five out of seven PAMs underestimated the number of steps in all the three observed walking speeds (MoveMonitor, One, ActivPAL, Nike+ Fuelband and Sensewear Mini Armband). The first three above-mentioned PAMs were also the three best performing in terms of MPE. For these three devices, no trend was found in the error, whereas for the latter two (Nike+ Fuelband and Sensewear Mini Armband), the underestimation was higher at the lower paces. This corroborates previous literature findings about the difficulty of step detection at slow walking speeds (Furlanetto et al., 2010; Harrison et al., 2013). The reason for the poor performance of some PAMs is likely to be due to the fact that the products were originally developed for running. Also the UP accelerometer was markedly inaccurate at the lowest pace. The Tractivity was the only device that overestimated the steps at all walking speeds. The reason for this is not easily identifiable, since not enough information is available about the data processing techniques and algorithms, a problem also highlighted by Chen and colleagues (Chen et al., 2012).

The three best performing PAMs included the two devices explicitly designed for clinical use (MoveMonitor and ActivPAL). These devices provide also the most complex activity reports including the classification of different activities such as

lying, walking and standing. The One was the best consumer-based device in terms of MPE and might be the best low-cost option for step count monitoring.

When interpreting data measured from PAMs in real life conditions, careful consideration should be paid to the consequences of the bias existing between actual and measured steps. Since prolonged physical activity monitoring in clinical trials typically lasts up to one week (Motl et al., 2010), small underestimation of the time spent in an energy- and movement-demanding activity such as walking may be an amplifier for errors. For example, the one-week use of PAMs leading to underestimation errors higher than 14%, might translate into errors corresponding to ignoring more than one entire day of walking activity out of a seven-days observation period. Smaller errors, such as those found for the best performing monitors (1-3%), may be clinically irrelevant in the case of research studies involving sedentary populations, but might still need to be taken into account when investigating physical activity interventions. The phase analysis revealed that the best accuracy in step count was obtained during outdoor walking. This result might be explained by the fact that during indoor walking the likelihood of miscounting steps was higher than outdoor, since the participants had to stop-and-start to turn around at the end of the walkway, and the path they followed during free indoor walking was generally more tortuous than the one they walked outdoors. Nevertheless, the good performance of the sensors is encouraging for applications involving prolonged outdoor data collection.

The ActivPAL and MoveMonitor performances in detecting steps were also examined in stair climbing during the two transition phases. Interestingly, for both sensors, at slow walking speed MPE was higher when ascending stairs than when descending. Conversely, at fast walking speed, MPE was higher when descending stairs than when ascending. At self-selected walking speed, the accuracy was not affected by whether the participant was ascending or descending stairs. This finding is in agreement with a previously reported study using pedometers (Ayabe et al., 2008) and should be the aim of further investigation to clarify what are the signal and software characteristics that might influence such an outcome.

The activity recognition protocol included all the activities indicated as recognisable by the manufacturers of the two tested sensors. Activities such as working at a computer or taking the lift were adopted to generate possible significant variations in the measured accelerations, so to include features entailing a realistic

perturbation to the system. The results of this protocol showed that the position of the MoveMonitor on the lower back of the participants leads to a high chance of misclassification of the standing posture, often confused with sitting. This problem, already highlighted in a previous validity study (de Groot and Nieuwenhuizen, 2013), is caused by the similar inclination of the accelerometers with respect to the gravity line during these two static activities (van Hees et al., 2013). Interestingly, despite the MoveMonitor widely misclassified quiet standing, it correctly classified taking the lift as standing. Investigating the recognition capabilities of the MoveMonitor during short activities (<5s), Dijkstra and colleagues (Dijkstra et al., 2010) highlighted that short standing periods were well detected. Activity recognition methods employed in PAMs often rely on specific features in the signal to detect transitions between postures. Rapid and brief deceleration and acceleration of the lift may have helped the algorithm employed in the MoveMonitor to correctly classify the standing posture during that specific task. Conversely, the location of the ActivPAL sensor on the thigh clearly overcomes the problem of static standing classification, but doesn't allow separation of sitting from lying. For both sensors the most challenging activity in terms of classification was the one which involved lifting objects from the floor. The participants were allowed to choose their preferred technique to accomplish this task, and results reflect this, with large variability in the classification into each category. Further studies should investigate the classification capabilities of these sensors in other groups such as older people or people with disability, to investigate how the activity recognition algorithms perform when pathologies hinder normal movement patterns.

PAMs are becoming increasingly available on the market and these devices are being used for research purposes in field-based applications and to promote population-wide physical activity. Within this framework, the information about the absolute error and variability of the output measures provided by this study could be used to model errors in PAMs' data, in order to provide a better estimate of long-term physical activity, similarly to what was done by Nusser and colleagues, who developed a measurement error model to match physical activity recall data based on questionnaires with an individual's usual physical activity (Nusser et al., 2012). In addition, end-users aware of the inaccuracy of different PAMs might make better informed decision regarding the choice of the device to use for specific applications. A similar approach to what has been done in this study, in which the reference step

count is performed using protocols including the same tasks but for shorter periods than the ones used in this study, could be implemented as a spot check for patient specific calibration and reliability assessment of activity monitoring devices, before giving them to patients for long-term monitoring.

3.1.6 Limitations

The specific proprietary step detection algorithms used in most of the tested PAMs is unpublished. As highlighted already in previous reviews on this topic, this makes comparison problematic (Kavanagh and Menz, 2008; Rowlands and Stiles, 2012) and acts as a confounder. Although literature suggests to select monitors without proprietary algorithms for use in the field (Freedson et al., 2012), validation studies are necessary to compare PAMs outcomes in this category of devices. This study is considered as a valuable contribution towards understanding inter-monitor differences in step count detection accuracy at different walking speeds. The walking speed of the participants was self-selected and not measured. As a consequence, the classification into each of the three walking speed ranges (slow, medium, fast) was only an indication of the gait speed. However, results showing accuracy differences between the categories suggest that an appropriate range of speeds was tested.

The gold standard used to detect steps was obtained using the method proposed by Aminian et al. (2002). This method was developed and tested during straight walking, however the protocol used to test the PAMs also included free walking (indoor and outdoor). In these conditions, the reliability of the estimates may worsen. Further studies are advised to test if the characteristic peak in midswing is retained also in more varied walking conditions. The number of extra and missed events should also be provided in future studies; however, for most of the investigated PAM this information is not easily available due to limitations of the proprietary software.

Only two sensors allowed the separate analysis of walking phases in the protocol. This was due to data aggregation features in most of the PAMs tested. Future work could extend the validation of these sensors to investigate their accuracy in specific conditions, including stair walking.

3.1.7 Conclusions

The overall step detection error for the seven PAMs included in the study ranged between 0.9% (MoveMonitor, fast walking speed) and 36.4% (Nike+ Fuelband, slow walking speed). The majority of the sensors underestimated the step count and MoveMonitor, ActivPAL and One were the best performing PAMs in step count recognition. MoveMonitor was the best performing device overall, but failed in the recognition of standing posture, usually misclassified as sitting. ActivPAL showed a good accuracy overall, although it is limited in not being able to discriminate between sitting and lying. One might be a valid low cost solution for monitoring the effect of interventions aiming at increasing the number of steps walked per day. Stair ascending and descending significantly affect step recognition accuracy, with a speed-dependent effect.

3.2 Step detection accuracy in patients with multiple sclerosis

3.2.1 Introduction

Multiple sclerosis (MS) is a chronic autoimmune inflammatory demyelinating disease of the central nervous system. According to the Multiple Sclerosis International Federation, the estimated number of people with MS has increased from 2.1 million in 2008 to 2.3 million in 2013 (Multiple Sclerosis International Federation, 2013). The prevalence of morbidity by country is shown in Figure 3-5. While the life expectancy for people with MS approaches that of the general population, they do suffer from multiple disabilities, including spasticity, weakness, tremor, fatigue, cognitive disabilities, bowel problems and difficulties in performing daily activities (Schapiro, 2012). Furthermore, patients with MS also suffer from mobility problems, with a prevalence around 75%-90% (Hemmett et al., 2004; Swingler and Compston, 1992). At 15 years after diagnosis, 40% of MS patients require assistance for walking and 25% will be restricted to wheel chair (Myhr et al., 2001). Among people in early stages of MS, mobility is the most important concern (Hobart et al., 2003). Limitation of mobility leads to activity limitation and restricts

social participation. It contributes negatively to general health status, quality of life and productivity (Zwibel, 2009).

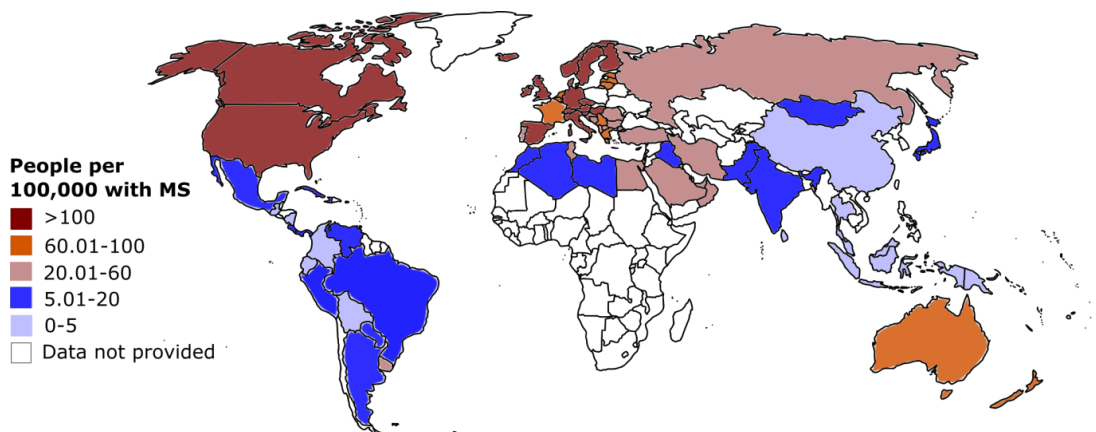

Figure 3-5. Prevalence of Multiple Sclerosis morbidity by country (2013) (adapted from The Atlas of MS 2013, Multiple Sclerosis International Federation 2013).

Physical activity provides considerable benefits for symptom management and rehabilitation of functions in individuals with MS (Carter et al., 2014; Garrett and Coote, 2009), and behavioural interventions addressing physical activity patterns are hence gaining popularity (Motl and Pilutti, 2012). In parallel, as in other musculoskeletal patient populations, measures of physical activity are increasingly being used as outcomes for assessing the effectiveness of these interventions (Saxton et al., 2013), and there is a broad consensus in the research community that wearable PAMs are very promising tools in this context. Although the validation of PAMs is often based on their ability to estimate energy expenditure, using gold standard techniques such as doubly labelled water indirect calorimetry (Rabinovich et al., 2013) or average oxygen uptake (de Groot and Nieuwenhuizen, 2013), these methods are cumbersome and not typically available in a clinical setting. Alternative metrics of physical activity have been recently explored in literature. In a cross-sectional study, 26 patients with MS were asked to wear a PAM for seven days. The accelerometer counts correlated significantly with both self-reported and objective markers of mobility, such as the Multiple Sclerosis Walking Scale-12 ($r=-0.68$, $p=0.001$), the Patient Determined Disease Steps scale ($r=-0.61$, $p=0.001$), the 6-minutes walking distance ($r=0.52$, $p=0.003$), and oxygen cost of walking ($r=-0.54$, $p=0.002$) (Motl et al., 2010).

A few recent studies have also specifically examined the accuracy in step detection of PAMs in people with MS. One reported an accuracy of 98.1% for an ankle-worn PAM measuring the number of strides along a 15m indoor walkway in

20 persons with Parkinson's disease and MS (Schmidt et al., 2011). A second study tested the performance of a wrist-worn PAM on 24 adults with mild MS walking on a treadmill at different speeds, obtaining accuracy rates for step count of 99.7%, 99.8% and 95.9% at 4.8, 4.0 and 3.2 km/h, respectively (Motl et al., 2011). A third study directly compared two accelerometers, worn at the waist and at the ankle, in 63 patients with MS during three six-minute walk tests at different walking speeds, reporting highly accurate measurements of steps for both sensors only at fast and comfortable walking speeds (Sandroff et al., 2014). These findings clearly indicate the presence of a relationship between step count accuracy in PAMs and walking speed in patient with MS. Precautions should be taken to minimize errors during data collections using PAMs, and a possible approach would be the definition of a method to easily and reliably quantify these errors and establish whether a given PAM might be accurate enough for a given patient. As a first step in this direction, the aim of this study is to provide additional insight into validity and reliability of PAMs within a population whose gait characteristics may challenge the step detection features of these sensors. The objectives of this study are the following:

- 1) To test the reliability of a method for the assessment of patient-specific step detection accuracy of a commercially available PAM in a group of patients with MS.**
- 2) To test the accuracy of the PAM under controlled conditions and to investigate its relationship with walking speed of the patients.**

3.2.2 Materials and methods

Recruitment and data collection took place at the Gait Laboratory, Northern General Hospital, Sheffield, UK. Inclusion criteria for the participation in the study were: diagnosis of MS using McDonald's criteria (Polman et al., 2011), three months since last relapse, and ability to independently walk for 10 meters. A convenience sample of twenty participants was originally recruited, of which seventeen (eight men and nine women, age: 54.8 ± 11.0 years) completed the study, while one withdrew due to the discomfort in long-term wear of the monitor, for one participant the reasons for abandoning the study are unknown, and for one participant the PAM data was not collected due to technical issues. Written informed consent was

obtained from the participants, and ethical approval was obtained from NRES Committees - North of Scotland.

The severity of MS was measured using Expanded Disability Status Scale (EDSS) (Kurtzke, 1983). For three participants, the EDSS score was not measured due to lack of clinical staff. Physical activity was measured using the DynaPort MoveMonitor (Version 2.8.1, Mc Roberts, The Hague, The Netherlands). Although no published research in MS has used this particular device, it has been validated in clinical practice in patients with chronic obstructive pulmonary disease (Rabinovich et al., 2013; Van Remoortel et al., 2012), and its high accuracy in step detection in healthy participants was proved previously in this chapter (see par. 3.1). The PAM was positioned on the lower back of the participants using an elastic strap as suggested by the manufacturer. Two MIMUs (Opal, APDM Inc., Portland, OR, USA) were attached to the left and right shank, just above the ankles, by means of an elastic strap. The participants were asked to walk four times along a predefined 15m straight walkway at their normal, comfortable speed, while two light-gates recorded their walking speed. Then, they were asked to freely walk for one minute in a 100 m² empty room, without following any predefined path. The same protocol was repeated after seven days.

During both the straight walking and the free walking tasks, the number of steps recorded by the PAM (N_{PAM}) was collected. An algorithm using the gyroscopic signals of the MIMU sensors was created using Matlab (Version R2013a, Mathworks, Natick, MA, USA), based on the work of Aminian et al. (2002). This algorithm identified the maximum angular velocity around the mediolateral axis of the shank corresponding to the swing phases of the leg and was used as reference step count (N_{REF}). Since this algorithm has not been previously specifically validated for patients with MS, the total number of steps was also counted through visual observation of two independent observers (the author of this work and an experienced physiotherapist). The two data coincided for all patients. The statistical analysis was conducted using SPSS (Version 21; SPSS Inc., Portsmouth, UK). For the investigation of step detection accuracy, the mean absolute percentage error (MPE) for each patient and each condition (controlled straight and free walking) was computed as:

$$MPE = \frac{|N_{PAM} - N_{REF}|}{N_{REF}} * 100$$

A Shapiro–Wilk test was performed to check for data normality. A Mauchly’s Test of Sphericity was also performed. As the assumptions were not violated, parametric tests were used and data were presented as mean and SD. A paired t-test was performed to detect differences in walking speed between sessions, with a significance level of $p=0.05$.

The reliability of the MPE between the two sessions was calculated using the Intraclass Correlation Coefficient, ICC(3.1) (Rankin and Stokes, 1998). The ICC was interpreted as 0.90-1.00 = very high correlation, 0.70-0.89 = high correlation, 0.50-0.69 = moderate correlation (Munro, 2005). The relationship between walking speed and the MPE was also investigated using a correlation analysis.

3.2.3 Results

All participants took part in the two sessions. Only twelve patients managed to complete the free walking tests. The EDSS score ranged between 5.0 (person able to walk without aid or rest for 200m) and 6.5 (person requiring two walking aids to walk 20m without resting), with a median value of 6.0. A summary of the number of steps recorded by the PAM (N_{PAM}) and the reference MIMUs (N_{REF}), as well as the mean absolute percentage error (MPE) are shown in Table 3-10 for each session and each walking condition.

Table 3-10. Summary of step count (mean \pm SD) measured by the PAM (N_{PAM}), the reference MIMUs (N_{REF}), and the resulting mean percentage error (MPE).

Measure	SESSION 1		SESSION 2	
	Controlled Walking	Free Walking	Controlled Walking	Free Walking
N_{REF} [steps]	80 \pm 21	79 \pm 27	65 \pm 37	78 \pm 24
N_{PAM} [steps]	65 \pm 37	65 \pm 40	58 \pm 31	61 \pm 42
MPE [%]	20.1 \pm 34.6	28.7 \pm 35.3	23.4 \pm 31.3	30.9 \pm 39.5

The t-test performed on the walking speed measured during the controlled straight walking condition highlighted that the participants walked faster during the second session (mean \pm SD of 0.79 \pm 0.37 m/s and 0.83 \pm 0.37 m/s for sessions 1 and 2, respectively; $p<0.001$, Cohen’s d: 0.92). The test-retest reliability values for MPE were high for both controlled straight walking (ICC=0.80) and free walking (ICC=0.89). The relationship between walking speed and MPE during the controlled

straight and the free walking phases is shown in Figure 3-6. The power trendline used to best fit the data showed a Pearson's $r=0.44$ for free walking and $r=0.51$ for controlled straight walking, respectively.

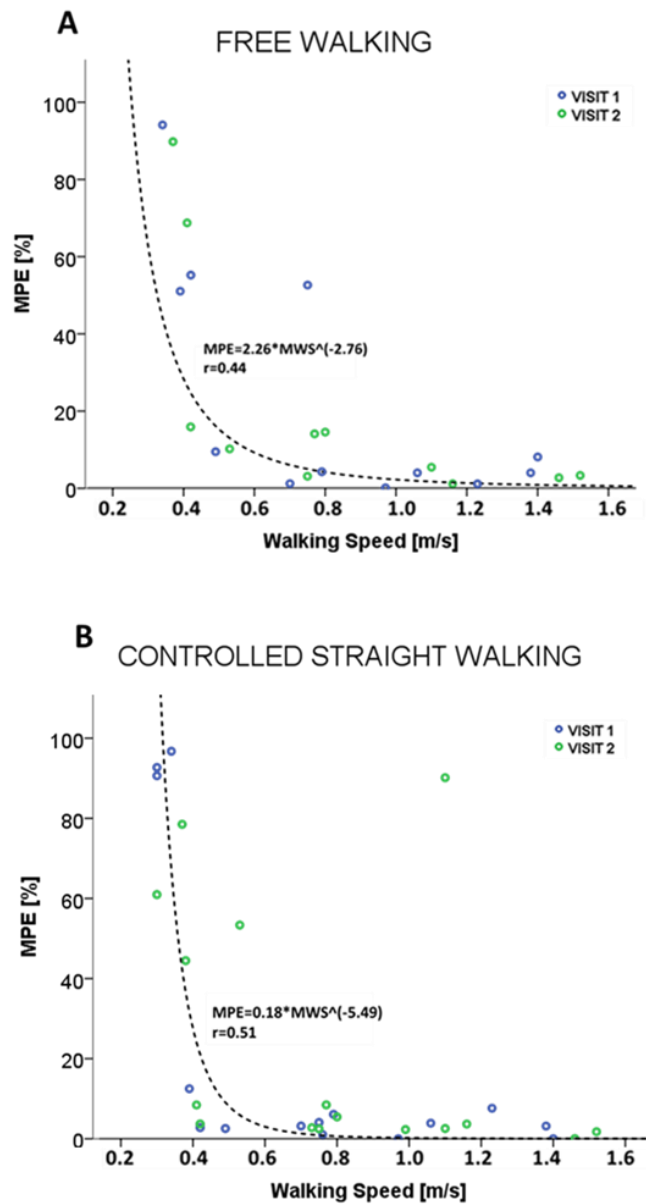

Figure 3-6. Relationship between MPE and walking speed during free (A) and controlled straight (B) walking. The dashed line is the power trendline used to best fit the data. Relevant equations and Pearson's correlation coefficients (r) are shown on the graph.

3.2.4 Discussion

This study aimed at proposing a method for the reliable assessment of patient-specific step detection accuracy when using a PAM during walking in laboratory conditions. The method has been tested in patients with moderate to severe

ambulatory impairment due to MS and it has been shown that it was possible to reliably quantify a patient-specific error in step count.

The MPE did not vary significantly between walking conditions and the most impaired patients managed to complete only the straight walking task, suggesting that this task might be sufficiently informative in future applications. In addition, due to patients' ambulatory restrictions, the majority of the free walking activity data were collected for a limited period (1 minute) during both sessions. The high ICC values suggested that this factor did not affect the reliability of the error estimate and a longer period of walking might even improve this measure. On the other hand, cumulative errors from longer trials might not be suitable for correcting short walking bouts, which are those most likely to be walked by patients with limited mobility. Further studies are needed to verify this assumption.

The relationship between the walking speed of the participants and the MPE was investigated using walking speed-MPE plots for each session and walking condition. Despite one outlier, the results indicated high errors in step detection for patients walking at 0.5 m/s or slower using the PAM adopted in the study. Stansfield and colleagues recently demonstrated that for the ActivPAL sensor in healthy individuals a similar reduction in performance below 0.5m/s walking speed exists (Stansfield et al., 2015). This may suggest that important changes in walking style occur below this speed which prevents algorithms to work. Overall, the power trendline fitted well the data collected, showing that a non-linear, inverse relationship exists between the two variables during both walking conditions. The walking speed recorded by the light-gate during the straight walking condition was higher during the second session of data collection. A likely explanation for this is familiarisation of the participants to the environment and the setting of the data collection. However, the increase in walking speed was only marginal, with an average value of 0.04 m/s, not marked enough to influence the accuracy of the PAM, as shown by the high ICC values reported for the MPE.

3.2.5 Limitations

Due to mobility limitations, participants only completed four straight walking trails and one minute of continuous walking. Although the reliability of the step detection accuracy was high in both walking conditions, and similar numbers of gait

cycles have been reported in the literature to be sufficient for reliable measures of gait temporal parameters (Hollman et al., 2011), future studies could test if longer walking trials would improve the reliability.

The method used to detect steps was derived from Aminian et al. (2002). Since it has not been tested in patient with multiple sclerosis, the total number of steps was also counted through visual observation of two independent observers.

The analysis of the free and fixed walking used different populations. This may have biased the results as those with higher disability may have not completed the free walking, meaning that the reliability was representative of the most able walkers only. A comparison of outcomes using a consistent group would allow more insight into relative performance in the two walking tests.

The ICC metric used in this study only evaluated “consistency”. Better interpretation of reliability could be achieved by evaluating also “absolute agreement”, for example calculating the standard error of the mean and the coefficient of repeatability (Dahlgren et al., 2010).

3.2.6 Conclusions

The method presented in this study was used to assess the reliability of step detection accuracy of the MoveMonitor PAM in patients with MS. High ICC values were obtained for both straight and free walking sessions. Reported results suggest that extreme care should be used when interpreting outcomes of this PAM obtained from patients walking at significantly reduced speed, since patients walking at 0.5 m/s or slower are likely to be associated to high step detection error. In the future, the outcome of short controlled tests such as the one here proposed, easy to be adopted in both research and clinical settings, may also be used to model errors of long-term physical activity monitoring in this and other patient populations.

Chapter 4

Analysis of the differences in gait parameters obtained from scripted and free walking

The interest in objective daily monitoring of physical activity in habitual environments is growing for both clinical and research purposes. Among activities of daily living, gait is a major marker of disease progression (Del Din et al., 2015), and the step-by-step determination of gait parameters is required for the analysis and characterization of quasi-periodic motions (Kavanagh and Menz, 2008), both in terms of absolute values and of their variability (Hausdorff, 2007).

To avoid altering a subject's natural movement, a necessary requirement during daily physical activity monitoring is that the smallest number of sensors should be positioned in minimally cumbersome locations. Thanks to recent technological advances, wearable sensors based on inertial measurement units have become an ideal choice to capture continuous gait data, playing a crucial role in the transition of gait analysis from traditional assessment carried out in specialised gait laboratories to daily life monitoring (Lowe and Ólaighin, 2014). Some researchers have also recently questioned the assumption that laboratory gait data obtained in controlled steady-state walking conditions reproduces real life behaviour.

This chapter will present a study divided into 2 parts: the first part investigates the accuracy of two algorithms for gait event detection applied to acceleration and angular velocity signals, respectively. The second part of the study will focus on using the most accurate among these two methods to establish the influence of environment (indoor vs outdoor) and type of walking (scripted versus free) on gait parameters. Data were collected with inertial sensors during walking of healthy individuals in different experimental conditions, including free-living walking.

4.1 Accuracy of algorithms for the detection of gait events in free-living walking

A substantial part of the material presented in this section has been included in:

F. A. Storm, C. Buckley, C. Mazzà, *Gait event detection in laboratory and real life settings: Accuracy of ankle and waist sensor based methods. Gait and Posture* 50:42-46, doi:10.1016/j.gaitpost.2016.08.012.

Written permission was obtained from all the co-authors.

4.1.1 Introduction

To determine temporal gait parameters, the accurate detection of two gait events, initial foot contact (IC) and final foot contact (FC), is required. Generally, the closer the sensor is to the impact point, the higher are the chances of correctly detecting the GEs (Alvarez et al., 2012). Hence, methods to obtain IC and FC timings from two synchronized inertial measurement units (IMUs) on the lower limbs have been proposed in both normal and pathologic gait. The shanks are the most popular location because they allow firm attachment of the sensor (Catalfamo et al., 2010), and the recorded signals are less variable than those from foot-worn IMUs (Wu, 1995). The method proposed by Trojaniello and colleagues (Trojaniello et al., 2014b, 2013) was applied to young healthy, elderly, hemiparetic, parkinsonian, and choreic gait. The results showed that it was extremely robust to variations in gait speed and that both missed and extra gait events were avoided. Furthermore, the temporal parameters estimates errors were smaller than those reported in previous studies. In order to minimize the number of devices used, several authors have also proposed the use of a single IMU positioned on the lower trunk. This position is close to the centre of mass during walking and contains information about the movement of both limbs (Zijlstra and Hof, 2003). The method proposed by McCamley and colleagues (McCamley et al., 2012) was originally tested on eighteen young healthy individuals and its accuracy was compared with two other methods (González et al., 2010; Zijlstra and Hof, 2003). Results showed that the newly proposed algorithm identified the timings of initial and final contacts with the ground, with the smallest average error. A later study comparing five methods based on lower trunk accelerations on fourteen healthy subjects showed that the same

method showed the highest robustness for both stride and step duration (Trojaniello et al., 2014a). Finally, the same research group tested this algorithm on groups of elderly, post-stroke, Parkinson's disease and Huntington's disease subjects (Trojaniello et al., 2015). The results were comparable between the tested methods in all patient populations. However, the selected method was the only capable of detecting both initial and final contact events.

Summary tables have been created listing the existing algorithms for GE detection for shank-worn (Table 4-1) and waist-worn (Table 4-2) sensors. The validity of these methods has generally been tested in laboratory settings, during straight walking, and against references such as instrumented mats (McCamley et al., 2012), force platforms (Zijlstra and Hof, 2003), and motion capture systems (Trojaniello et al., 2014b), often relying on a limited number of consecutive strides. Currently it is not known whether the acceleration and angular velocity patterns generated during real life behaviour can affect the accuracy of algorithms tested in controlled laboratory conditions. Walking strategies may be affected by different experimental conditions, and this might reflect into different patterns of the signals used to estimate IC and FC event. However, the accuracy of the estimates of both IC and FC events in free living gait, i.e. carried out in an urban environment has not been yet assessed.

The aim of this part of the study was to test the performance of two different IMU-based methods for gait temporal parameters estimation during gait in free living conditions. One method is based on the use of two shank-worn IMUs (Trojaniello et al., 2014b), and the other on a single waist-worn IMU (McCamley et al., 2012). These algorithms were selected for their previously reported robustness to changes in IMU attachments and to an individual's gait speed, and for their reported high accuracy (Trojaniello et al., 2015). The algorithms were applied to gait data from ten healthy subjects walking in different daily life environments, both indoor and outdoor, and completing protocols that entailed both straight and free walking, and their outputs were compared to data obtained from pressure insoles.

Table 4-1. Published algorithms for GE detection for two sensors positioned on the shanks (Acc=accelerometer; Gyro=gyroscope).

Authors	Sensor type	Sensor position	Algorithm type	Population	Reference system	Tested conditions
Mariani et al. 2013	Acc	Feet/Shoes	Features of foot kinematic patterns	42 subjects (healthy and patients before and after surgical treatments for ankle osteoarthritis)	Pressure insoles	50-m walking trials
Mannini, Sabatini. 2012	Gyro	Feet/Shoes	hidden Markov model	Six healthy, young subjects	Motion analysis	Treadmill walking and jogging at five different speeds
Veltink et al 2003	Acc + Gyro	Feet/Shoes	Features of foot kinematic patterns	One male stroke patient	Footswitches	Straight indoor walking
Sabatini et al. 2005	Gyro	Feet/Shoes	Features of foot kinematic patterns	Five healthy adult males	Footswitches	Treadmill walking at different speeds and inclinations
Catalfamo et al. 2010	Gyro	Shanks	Features of foot kinematic patterns	One unimpaired subject and one subject with cerebral palsy (children)	Pressure insoles	Level ground and incline overground walking
Greene et al. 2010	Gyro	Shanks	Adaptive threshold calculation and artefact rejection	Nine healthy adult subjects and one poliomyelitis patient	Optical motion analysis	15-m walkway in a motion analysis laboratory
Trojaniello et al. 2014	Acc + Gyro	Shanks	Features of foot kinematic patterns	Ten hemiparetic subjects, ten subjects with a choreic movement disorder, ten subjects with Parkinson's disease and ten healthy elderly.	Instrumented mat	12-m walkway with an instrumented mat
Hanlon, Anderson. 2009	Acc	Shanks	Features of foot kinematic patterns	Twelve healthy subjects	Force platform	8-m walking in normal, slow, and reduced knee ROM walking
Salarian et al. 2004	Gyro	Shanks	Features of foot kinematic patterns	Ten Parkinson's disease patients with subthalamic nucleus deep brain stimulation and ten age-matched controls.	Force platform	20-m walkway
Shimada et al. 2005	Acc	Thighs	Neural Network machine learning.	Five healthy males and three stroke patients.	Footswitches	Laboratory floor

Authors	Sensor type	Sensor position	Algorithm type	Population	Reference system	Tested conditions
Lau, Tong. 2008	Acc + Gyro	Shank and thighs	Threshold detection	Three non-impaired subjects and ten hemiparetic patients with dropped foot following stroke.	Footswitches	10-m long pathway at a self-determined comfortable speed
Aminian et al. 2002	Gyro	Shank and thighs	Wavelet transform	Nine young and eleven elderly subjects.	Footswitches	Treadmill and 30-m long walkway

Table 4-2. Published algorithms for GE detection for one sensor positioned at the waist. (Acc=accelerometer; Gyro=gyroscope).

Authors	Sensor type	Sensor position	Algorithm type	Population	Reference system	Tested conditions
Zijlstra, Hof. 2003	Acc	S2	Features of waist kinematic patterns	Fifteen healthy subjects.	Force platform	Treadmill walking and 25-m overground walking.
Gonzalez et al. 2010	Acc + Gyro	L3	Features of waist kinematic patterns	Eleven healthy subjects.	Force platform	25-m in a straight flat corridor.
Shin, Park. 2011	Acc	Waist	Zero-crossing method	One healthy subject.	Not reported	70-m straight walking
McCamley et al. 2012	Acc	L5	Wavelet transform	Eighteen healthy subjects.	Instrumented mat	12-m walkway with 4-m instrumented mat.
Kose et al. 2012	Acc + Gyro	Right side waist	Kalman filter	Nine healthy subjects.	Optical motion analysis	4-m straight walking

4.1.2 Materials and methods

Ten healthy volunteers (3 females, 7 males, age 28 ± 3 y.o.) were recruited for the study. Ethical approval from the University of Sheffield's Research Ethics Committee was obtained, and the research was conducted according to the declaration of Helsinki. All participants provided informed written consent.

Each participant was asked to wear three IMUs (Opal, APDM; weight 22 g, size 48.5 mm x 36.5 mm x 13.5 mm) containing a 3-axis accelerometer, a 3-axis gyroscope, and a 3-axis magnetometer. One IMU was positioned on the lower trunk on the fifth lumbar vertebra (McCamley et al., 2012), with its sensing axes X, Y and Z pointing downward, to the left, and forward, respectively. The other two IMUs were positioned at each ankle, just above the malleoli (Trojaniello et al., 2014b), with X, Y and Z pointing downward, to the right, and backward, respectively. The devices measured accelerations and angular velocities at a sampling frequency of 128 Hz, and the accelerometer range was set at $\pm 6g$. Two pressure-sensing insoles (F-Scan 3000E, Tekscan) were used to obtain IC and FC reference timings. The insoles were cut to fit tightly into each participant's shoe. They were calibrated using a step calibration technique according to manufacturer instructions. Sampling frequency was set at 128Hz and the gait events were obtained using the ground reaction force, with a 10 N threshold (Ghoussayni et al., 2004). A vertical jump was used as a synchronizing event between the IMUs and the insoles in order to realign the two signals coming from both instruments at the beginning of each trial. The equivalency of the nominal sampling frequency of the two instruments was verified on three separate 20-minute recordings, where at 1 minute intervals a series of impacts clearly detected by both instruments were generated, and showed a consistent mismatch between signals of one sample each two minutes recording (7.8 ms). This mismatch was corrected for in the 15-minutes free outdoor walking data by realigning the signals each two minutes. This procedure was not needed in the other walking conditions, which lasted less than two minutes.

Figure 4-1 shows typical signals collected at the shank and pelvis, and the corresponding IC and FC instants for worst case scenarios of both methods used to compute the temporal gait parameters. In the shank-based method (SHANK), the peak in the angular velocity signals in the sagittal plane during mid-swing is used to

identify windows in the signal where no gait events can occur. When coupled with the alternate shank, these intervals allow the identification of search windows for IC and FC events. The IC is identified as the instant of minimum angular velocity in the sagittal plane between the beginning of the IC search window and the instant of maximum anterior-posterior acceleration. The FC is identified as the instant of minimum anterior-posterior acceleration in the FC search window (Trojaniello et al., 2014b). In the present study, the data were additionally segmented in separate walking events using an empirically determined threshold of 1 second as maximum time delay between consecutive mid-swing peaks. For the waist-based method (WAIST), data is collected from a single IMU positioned on the lower trunk at L5 level. A first Gaussian continuous wavelet transformation is applied to the vertical acceleration signal, and the minima are identified as the IC timings. The resulting signal is then differentiated and the FC timings are identified as the instants of its maxima (McCamley et al., 2012). Only the walking portions of the data, segmented into separate walking events as described previously, were processed for the WAIST method. This was considered necessary because the WAIST method relies on minima and maxima of the transformed acceleration signal to obtain gait event timings which may occur also during non-gait portions of the test.

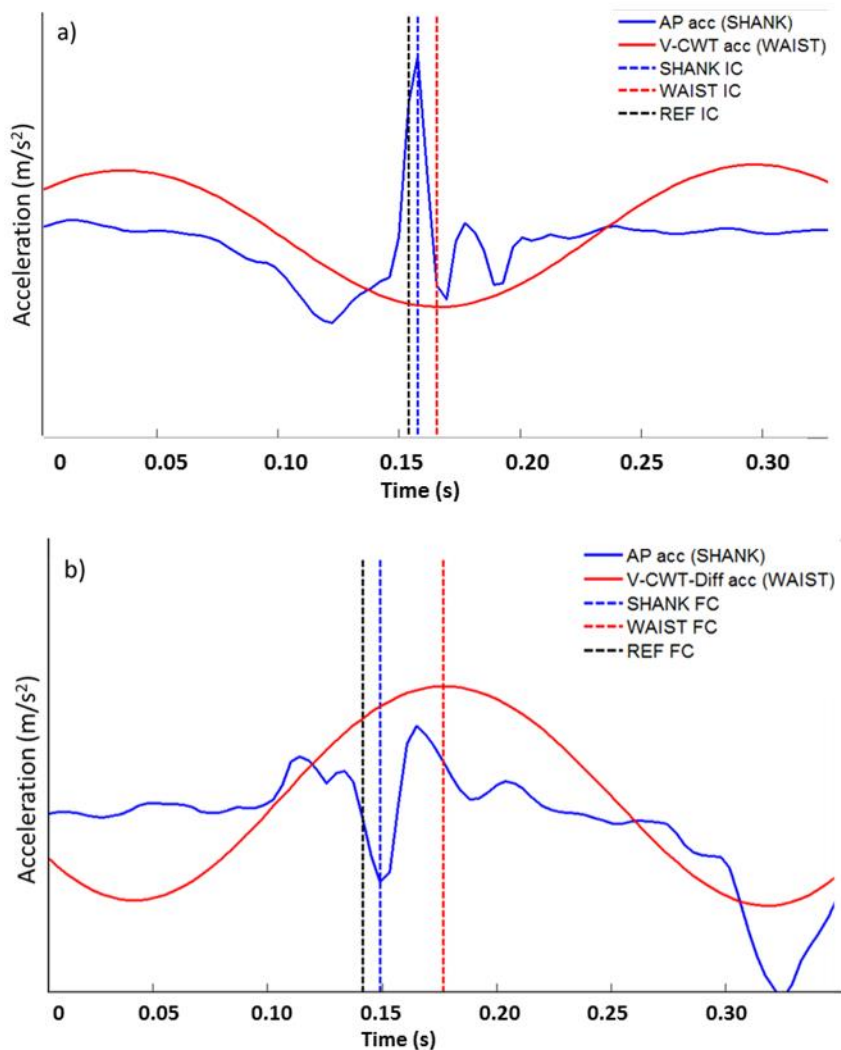

Figure 4-1. Gait event detection for the tested algorithms. (a) Anterior-posterior acceleration signal of the shank (*AP acc*, solid blue line), with corresponding IC timings (*SHANK IC*, dashed blue vertical line). Wavelet-filtered pelvis acceleration signal in the vertical axis (*V-CWT acc*, solid red line), with corresponding IC timings (*WAIST IC*, red dashed vertical line). Reference IC timings are also shown (*REF IC*, black dashed vertical line). (b) Anterior-posterior acceleration signal of the shank (*AP acc*, solid blue line), with corresponding FC timings (*SHANK FC*, blue dashed vertical line). Derivative of the wavelet-filtered pelvis acceleration signal in the vertical axis (*V-CWT-Diff acc*, solid red line), with corresponding FC timings (*WAIST FC*, red vertical lines). Reference FC timings are also shown (*REF FC*, black dashed vertical line) (Storm et al., 2016).

Subjects completed four walking tasks in the conditions detailed in Table 4-3, and the IMU and pressure insoles data were collected during each task. A stopwatch was used to measure walking time and compute average walking speed during the indoor and outdoor straight walking conditions.

For the outdoor free walking task, participants were instructed to walk freely in the city centre without any restrictions regarding route or walking speed, and

avoiding stairs. Both the indoor free walking and outdoor free walking conditions had the potential of recording the participant's turns in addition to straight line walking, both of which were included in the analysis. On the contrary, data recorded during resting or transitory periods, where no continuous walking occurred, were excluded from the analysis. These were defined as time intervals where no steps were recorded for $> 1s$, and could also include slow turnings without stepping. For the scripted walking conditions, transitory periods at the start and end of each repetition were removed.

Table 4-3. Summary of the walking conditions performed during the experimental protocol, with acronym, description, and duration or repetition (Storm et al., 2016).

Condition	Acronym	Description	Duration/Repetitions
Indoor scripted walking	ISW	Walking at preferred speed along a 20.0m long walkway.	Eight repetitions.
Outdoor scripted walking	OSW	Walking at preferred speed along a 50.0m long walkway.	Six repetitions.
Indoor free walking	IFW	Walking along corridors within a university building.	Two minutes.
Outdoor free walking (Short)	OFWS	Walking along footpaths open to the public in the city centre without any restrictions in route or walking speed, avoiding stairs.	Two minutes selected from a fifteen minute walk.
Outdoor free walking (Long)	OFWL	Walking along footpaths open to the public in the city centre without any restrictions in route or walking speed, avoiding stairs.	Fifteen minutes.

For each condition and method, the IC and FC timings were obtained from the IMUs, and used to compute stride, step and stance durations. Mean values and their coefficient of variation (CV) were computed. The coefficient of variation is a standardized measure of dispersion and is the ratio of the standard deviation to the mean for each temporal parameter.

For the statistical analysis, the outdoor free walking data was split into two datasets. To allow a comparable amount of strides and a fair comparison with the other tested walking conditions, the OFWS data included two minutes of arbitrarily selected outdoor free walking data. This analysis period was chosen for each participant by selecting an interval of two consecutive minutes starting from a randomly identified sampled instant of time between the beginning of the trial and

the end of the 13th minute of test. Missing and extra gait events were also counted and included in the study. For each method, the absolute error for each estimated parameter (IC, FC, stride duration (mean and CV), step duration (mean and CV), and swing duration (mean and CV)) was determined as follows:

$$|E| = |p - p_r|$$

where p_r is the reference value of the parameter p . Descriptive statistics for $|E|$ (mean and standard deviation values) were determined for each subject, and the resulting group averages and standard deviations were finally computed.

A Shapiro–Wilk test was performed to check for data normality. For each method and each parameter a Friedman Test for non-normal distribution was then used to compare the $|E|$ values obtained in the different walking conditions, with a significance level of 0.05. Post-hoc tests with Bonferroni correction were also performed to test if there were significant differences between indoor controlled walking (ICW) and the remaining walking conditions.

4.1.3 Results

The total number of gait cycles analysed in the ISW, OSW, IFW, OFWS, and OFWL conditions were 94 ± 17 , 121 ± 11 , 188 ± 16 , 132 ± 40 , and 767 ± 119 , respectively. The participants completed a median of 120 consecutive strides during the OFWL condition, while during the indoor free walking task, the median number of consecutive strides was 30. The SHANK method detected 100% of both IC and FC events. The WAIST method showed 29 missing IC events in each of both OFWS and IFW condition, corresponding to 1.3% of the total number of analysed steps. In the OFWL condition, a total number of 124 missing IC events over the 10 participants were detected, corresponding to 0.7% of the total analysed steps. The missing events were evenly distributed across participants, with the exception of one outlier, adding up 58 missing IC events. No missing events were found in the OSW and ISW conditions. Furthermore, no missing FC events were found for the WAIST method in any of the investigated walking conditions. Average recorded walking speeds during indoor and outdoor scripted walking were 1.44 ± 0.10 m/s and 1.51 ± 0.11 m/s, respectively. The descriptive statistics for stride, step and stance duration as estimated by the pressure insoles used as reference are shown in Table 4-4.

Table 4-4. Mean and SD values of temporal gait parameters for all walking conditions (Storm et al., 2016).

Parameter	ISW	IFW	OSW	OFWS	OFWL
Stride Duration (s)	1.05±0.06	1.06±0.06	1.03±0.05	1.05±0.07	1.06±0.08
Step Duration (s)	0.53±0.03	0.53±0.03	0.52±0.02	0.52±0.03	0.53±0.04
Stance Duration (s)	0.64±0.05	0.64±0.05	0.63±0.04	0.64±0.05	0.64±0.06
Stride Duration CV (%)	1.54±0.37	2.88±1.08	2.21±0.30	3.02±0.95	3.99±1.21
Step Duration CV (%)	2.58±0.91	3.87±1.40	3.21±0.57	4.32±1.09	5.11±1.33
Stance Duration CV (%)	2.44±0.84	3.58±1.29	2.91±0.44	3.94±1.27	4.99±1.31

Descriptive statistics (mean and SD) for gait events (IC and FC) and temporal parameters absolute error (|E|) are listed in Table 4-5. For the SHANK method, the Friedman test showed that the absolute errors associated with FC timing, stride duration, step duration and stance duration were significantly different between conditions ($p < 0.05$). Pairwise comparisons showed that |E| were significantly smaller during indoor scripted walking (ISW) than those obtained in the outdoor free condition for stride duration (both OFWS and OSWL) and step duration (only OSWS). For FC timing and stance duration, errors were significantly larger in the indoor scripted condition (ISW) than those obtained in the outdoor scripted condition (OSWS). In addition, stance duration absolute error during indoor scripted walking (ISW) was also significantly larger than during outdoor free walking (OSWS). There were no statistically significant differences in CV absolute errors between walking conditions for any of the temporal parameters investigated.

For the WAIST method, the Friedman test showed that the absolute errors associated with stride duration and step duration were significantly different between conditions ($p < 0.05$). Both parameters were significantly smaller during indoor scripted walking (ISW) than during outdoor free walking (OFWS and OFWL). In addition, step duration error in the indoor scripted condition (ISW) was smaller than during indoor free walking (IFW). For gait variability measures, the |E| associated with stride duration CV was found to be significantly different between the ISW and the OFWS condition.

Table 4-5. Mean (\pm SD) values of the absolute error |E| for IC timing, FC timing, and temporal parameters (mean and CV) of both methods (SHANK and WAIST). *Statistically significant difference between walking conditions ($p < 0.05$) (Storm et al., 2016).

Method	Condition	IC (ms)	FC (ms)	Stride duration (ms)	Step duration (ms)	Stance duration (ms)	Stride duration CV (%)	Step duration CV (%)	Stance duration CV (%)
SHANK	ISW	12 \pm 11	51 \pm 21	6 \pm 2	9 \pm 4	44 \pm 13	0.11 \pm 0.06	0.33 \pm 0.30	0.47 \pm 0.52
	IFW	11 \pm 9	50 \pm 19	* 6 \pm 2	9 \pm 3	43 \pm 14	0.09 \pm 0.10	0.39 \pm 0.26	0.44 \pm 0.45
	OSW	12 \pm 7	37 \pm 16	7 \pm 3	10 \pm 5	28 \pm 12	0.13 \pm 0.08	0.49 \pm 0.32	0.36 \pm 0.35
	OFWS	14 \pm 9	41 \pm 22	9 \pm 4	14 \pm 8	32 \pm 16	0.10 \pm 0.14	0.89 \pm 1.49	0.54 \pm 0.62
	OFWL	14 \pm 8	41 \pm 20	9 \pm 4	13 \pm 6	37 \pm 15	0.09 \pm 0.06	0.46 \pm 0.65	0.52 \pm 0.36
WAIST	ISW	46 \pm 20	76 \pm 21	6 \pm 1	9 \pm 3	31 \pm 12	0.08 \pm 0.07	0.64 \pm 0.38	0.43 \pm 0.32
	IFW	49 \pm 19	79 \pm 19	8 \pm 1	10 \pm 3	31 \pm 10	0.10 \pm 0.10	0.37 \pm 0.21	0.46 \pm 0.39
	OSW	50 \pm 17	75 \pm 16	8 \pm 1	9 \pm 2	26 \pm 9	0.09 \pm 0.04	0.29 \pm 0.22	0.29 \pm 0.25
	OFWS	53 \pm 22	77 \pm 21	11 \pm 3	12 \pm 2	30 \pm 11	0.31 \pm 0.25	0.62 \pm 0.37	0.30 \pm 0.25
	OFWL	48 \pm 21	77 \pm 23	11 \pm 2	13 \pm 3	32 \pm 10	0.15 \pm 0.13	0.48 \pm 0.21	0.37 \pm 0.26

4.1.4 Discussion

This study aimed to evaluate the accuracy of two IMU-based algorithms for the detection of gait events during free living gait, which is a necessary step towards the implementation of these methods for prolonged physical activity monitoring. Two methods were selected, named the SHANK, which was applied to data from shank-worn sensors, and the WAIST, which was applied to data from a waist-worn IMU. The SHANK method resulted more accurate than the WAIST method for both IC and FC timings. This was an expected finding since sensors that are in closer proximity to the foot-ground contact point have been already shown to be facilitated in gait events detection (Trojaniello et al., 2014b).

The results for the SHANK method across all the walking conditions provided further evidence for the robustness of this algorithm in limiting the risks of extra or missed events. In contrast to a previously published validation study in healthy subjects (Trojaniello et al., 2015), including only straight walking conditions, the WAIST method showed some missed gait events during the free walking conditions. This confirms that attention should be paid when interpreting data collected from just one sensor on the pelvis to quantify the number of steps walked over a certain period of time (Storm et al., 2015), with an error of about 1% to be expected if using the method here investigated.

For the SHANK method, the FC timings were less accurate than the IC timings throughout all the tested conditions. This has previously been reported in literature for the indoor controlled conditions, and is likely due to the smoother movement occurring during FC making the gait event less apparent to detect (Trojaniello et al., 2014b). For the WAIST method, IC and FC absolute errors were similar: this is likely to be due to stricter filtering applied to the signal in this algorithm.

The accuracy of the SHANK method in estimating IC timings was similar to that reported by the authors who proposed it during scripted straight walking (Trojaniello et al., 2014b), however FC timings in the present study were relatively less accurate in all the walking conditions. Accuracy estimates of the WAIST method were poorer than those reported by the original paper (McCamley et al., 2012) for both IC timings and FC timings, obtained during indoor scripted walking, but similar to those reported in a subsequent validation study (Trojaniello et al.,

2014a). Possible reasons for these inconsistencies include the use of different measurement instruments, different reference methods, different path lengths between protocols, and population characteristics. Overall, stride and step duration absolute errors for both methods were limited to absolute error values between 6 ms and 14 ms, while stance duration error increased to up to 44 ms (SHANK) and 32 ms (WAIST). These results suggest that stride and step durations were reasonably accurate, while stance duration should be interpreted with more caution. For the WAIST method, stride duration and step duration absolute error estimates were less accurate during outdoor free walking (OFWS and OFWL). Although these differences were consistent and resulted to be statistically significant, they generated only a small increase in absolute error (6 ms to 11 ms for stride duration, 9 ms to 13 ms for step duration). This outcome suggests that the accuracy of the algorithm is affected by the walking conditions tested. However, it is encouraging to note that the increase in gait event timing and relevant temporal parameter errors were only moderate and should not prevent the use of this method to collect data during prolonged free living gait. Similar to the WAIST method, the stride and step duration absolute errors recorded using the SHANK method were higher during outdoor free walking (OFWS and OFWL), but generated only a small increase in percentage error (6 ms to 9 ms for stride duration, and 9 ms to 14 ms for step duration). Surprisingly, the errors generated for FC timings and stance durations were significantly higher during indoor than during outdoor straight walking. The delayed detection of FC events (as shown in Figure 1) increased in the ISW task as a consequence of a delayed appearance of the minimum in the anterior-posterior acceleration identified as the instant of FC. If confirmed by further studies, this finding may suggest that the environment plays a role in generating different walking patterns and signals, influencing the accuracy of the FC detection.

The absolute errors generated in the computation of CV values for both methods were acceptable and similar across walking conditions, with maximum $|E|$ of 0.13% and 0.31% in stride duration CV, 0.89% and 0.64% in step duration CV, and 0.54 and 0.46% in stance duration CV (values are for SHANK and WAIST methods, respectively). In terms of accuracy in estimating variability of the investigated temporal parameters, generally the two methods appeared to perform similarly. Previous studies have shown that small errors in gait event detection may affect variability measures more than mean values (Beijer et al., 2013). The fact that

no significant differences in accuracy were found between walking conditions for the SHANK method is encouraging and provides evidence for the appropriateness of its use in free-living studies.

The results of this study might represent a normative reference for future investigations of real life gait monitoring in healthy adults. However, if aiming at different applications, such as those involving patient populations, these results cannot be generalised and the accuracy of the algorithms should be specifically tested to account for possible additional errors.

4.1.5 Limitations

Only the signal portions characterized by consecutive strides, automatically detected, were used for the analysis. In order to obtain the walking bouts to analyse, the peaks in the angular velocity corresponding to the swing phase of a gait cycle were used to detect the first step of a walking bout. All the following steps were then included in the analysis as part of the same walking bout until when the time distance between subsequent steps was lower than 1s (arbitrary threshold). This approach limits the evaluation of extra and missing events only to walking portions of the signal. However, the aim of the study was to validate two methods for gait events and temporal parameter estimation in free-living walking, disregarding the performance of the two methods in classifying activities into walking/no walking portions.

The study was performed in healthy young individuals, which means that additional data are required if these methods intend to be used in the future for a particular clinical population. However, the main limitation of existing validation studies is the lack of accuracy assessment of the tested algorithms in free-living settings, and the author believes that the validation of these methods in varied conditions is necessary, and will serve as reference for future studies investigating specific patient populations in controlled and free-living settings.

4.1.6 Conclusions

Overall, both methods tested in the present study showed small differences in accuracy of gait event timings and temporal parameter estimation, for both mean and

variability measures, between different environments and different walking protocols. This is encouraging for the application of these methods to free living gait.

During outdoor free walking, the SHANK method showed very accurate initial contact timing detection, leading to low errors for stride duration and step duration. Relative to the IC timing, the final contact timing was less accurate. The WAIST method performed worse than the SHANK method in both step detection and in initial and final contact detection; however, these errors only marginally affected the temporal parameter estimation during outdoor free walking.

4.2 Influence of environment and walking conditions on gait parameters

4.2.1 Introduction

In recent years, a much debated question is whether laboratory gait data obtained in controlled steady-state walking conditions reproduces real life locomotor behaviour, and current gait analysis research is investigating the influence of the environment on quantitative outcomes of gait using wearable devices, trying to establish to what extent laboratory gait is an ecologically valid representation of real-life scenarios. However, as highlighted by a recent review (Del Din et al., 2016b), there is no fully validated system capable of monitoring physical activities and clinical outcomes in free-living environments.

In studies on healthy participants using wearable sensors, Najafi and colleagues observed that the variability of stride velocity and gait cycle time during scripted straight walking was higher over longer (>20 m) than shorter (<10 m) distances (Najafi et al., 2009), and that the increase in gait speed was due to increasing walking distance, and not to the fact that subjects were walking outside of a gait lab (Najafi et al., 2011). A study in healthy young females walking on an instrumented mat in a gait laboratory also showed that repeated straight walking trials generated lower variability in gait parameters with respect to continuous overground walking (Paterson et al., 2009). Results of a study investigating prolonged (thirty minutes) walking in healthy individuals using the ActivPAL sensor showed that participants walked at higher cadence in a park than in an urban environment (Sellers et al., 2012). These findings were confirmed by a recent study

using a wearable accelerometry-based pendant, showing that variability of step duration during activities of daily living performed in a semi-controlled environment, validated with video observation, was higher and did not correlate with laboratory gait in older people (Brodie et al., 2016). A study looking at the performance of a laboratory-calibrated algorithm for the discrimination of physical activity classes showed that when the algorithm was applied to data collected in free-living conditions its performance decreased for several activities, and a recalibration using free-living data was required (Bastian et al., 2015).

Some studies have also been carried out in clinical populations. In stroke patients, for example, a study showed that a clinic-based 10-m walk test predicted walking speed in the community for patients walking at 0.8 m/s or faster, but was likely to overestimate walking velocity in the patients walking slower than 0.8 m/s (Taylor et al., 2006). In another randomized comparison study, the influence of environment on gait parameters of a group of stroke survivors was assessed using a PAM (StepWatch Step Activity Monitor). The participants completed a six-minute walk test in each setting (a clinic environment, a suburban street and a shopping mall). Results showed that gait speed was slower and step length smaller in the mall, faster and larger in the street, and intermediate in the clinic, but the magnitude of the differences was small (Donovan et al., 2008). In a study aiming at quantifying the true cadence of free-living walking, Granat and colleagues investigated a population with intermittent claudication and a healthy matched control group. Their findings suggested that cadence variability was higher in an urban environment due to external stimuli which forced the participants to alter their preferred cadence (Granat et al., 2015). A study using wearable sensors found association between in-clinic and in-home gait parameters in healthy participants, but not in a group with Parkinson's Disease (Toosizadeh et al., 2015). Finally, a recent study investigating the impact of environment and length of walking bouts on fourteen gait characteristics in patients with Parkinson's disease and matched controls using a single waist-worn sensor showed that both groups walked with slower pace and higher variability, rhythm and asymmetry compared to laboratory gait (Del Din et al., 2016a).

These recent findings provide evidence for differences in temporal gait parameters between controlled steady-state straight walking conditions that are obtained in a laboratory, and real life behaviour. However, limitations of previous studies include the use of systems which may alter natural walking patterns, and the

investigation of a limited number of consecutive strides (Najafi et al., 2009). Moreover, all the above studies focused only on step and stride cadence and did not separately investigate the various phases of the gait cycle (stance, swing, and single support phases). The aim of this study was to determine if gait temporal parameters are influenced by the environment (indoor or outdoor), by the type of walking experiment (scripted or free), and by the type of investigated walking bouts (regular or irregular walking), using a set of unobtrusive inertial-based wearable sensors in a group of healthy volunteers.

4.2.2 Materials and methods

A convenience sample of nineteen healthy volunteers (5 females, 14 males, age 28 ± 3 y.o.) was recruited for the study. Ethical approval was obtained from the University of Sheffield's Research Ethics Committee, and the research was conducted according to the declaration of Helsinki. All participants provided informed written consent. The experimental protocol was the same described in section 4.1.2, and subjects completed the four walking tasks as detailed in Table 4-3. On the contrary, data recorded during resting or transitory periods, where no continuous walking occurred, were excluded from the analysis. These were defined as time intervals where no steps were recorded for > 1 s. The SHANK method (Trojaniello et al., 2014b) was selected to determine the timings of IC and FC, due to its higher level of accuracy in comparison to the WAIST method (see Section 4.1.3) in all walking conditions. Then, for each participant and each walking condition, the GEs were used to compute a mean and a CV value for stride, step, stance duration and single support phase, which were finally pooled together across participants to obtain average values for each walking condition.

Effects of environment and protocol

The computed gait parameters were tested for normality through the Shapiro-Wilk test (Shapiro and Wilk, 1965). Successively, the effects of environment (indoor, outdoor) and type of walking experiment (scripted, free) on gait temporal parameters were investigated using a two-way repeated measures ANOVA design (factors: environment and protocol, two levels each). Statistical significance was set at $p=0.05$, and a Bonferroni's test for multiple comparisons was performed when significant differences were found. The statistical analysis was performed using

SPSS Statistics 21.0 (IBM Corporation, New York, USA). For each test, the effect sizes were calculated to determine the importance of the statistical differences, with 0.2 defined as a small effect, 0.5 as a medium effect, and 0.8 as a large effect (Cohen, 1988).

Effects of environment and type of walking bout

As a second step, the free walking datasets were divided into bouts of “regular” and “irregular” walking, using an approach which has already been proposed for the detection and quantification of turns in instrumented clinical tests (Salarian et al., 2010). The yaw angular velocity was collected from the sensor positioned at the waist. The signal was numerically integrated to obtain the relative waist angle in the horizontal plane, and was then de-drifted applying a linear drift correction (Sabatini et al., 2005). The only purpose of this procedure was to highlight the transitions in the signal due to rotations of the trunk, without aiming at an accurate estimate of the horizontal rotation angle, which would need further post-processing steps, including adjustment for accelerometer tilt and step-by-step drift correction. The resulting signal was then low-pass filtered using a 4th order Butterworth filter with a low cutoff frequency (0.38 Hz), to remove the movements of the trunk due to walking (Salarian et al., 2007). Using a sliding window, stable periods were identified as intervals in which the relative waist angle was within an empirically determined range of $\pm 5^\circ$ of its mean value, and regular walking intervals were identified as stable periods lasting at least 40 s. Irregular walking intervals were identified as periods lasting at least 40s in which the relative waist angle exceeded the $\pm 5^\circ$ range. The procedure to obtain these intervals is presented in Figure 4-2. Then, the effects of environment (indoor, outdoor) and type of walking behaviour (regular and irregular) on stride duration, step duration, stance duration, single support phase, and the respective coefficients of variation were investigated using two-way repeated measures ANOVA (factors: environment and type of walking bout, two levels each). Statistical significance was set at $p=0.05$, and a Bonferroni’s test for multiple comparisons was performed when significant differences were found, and the effect sizes were calculated.

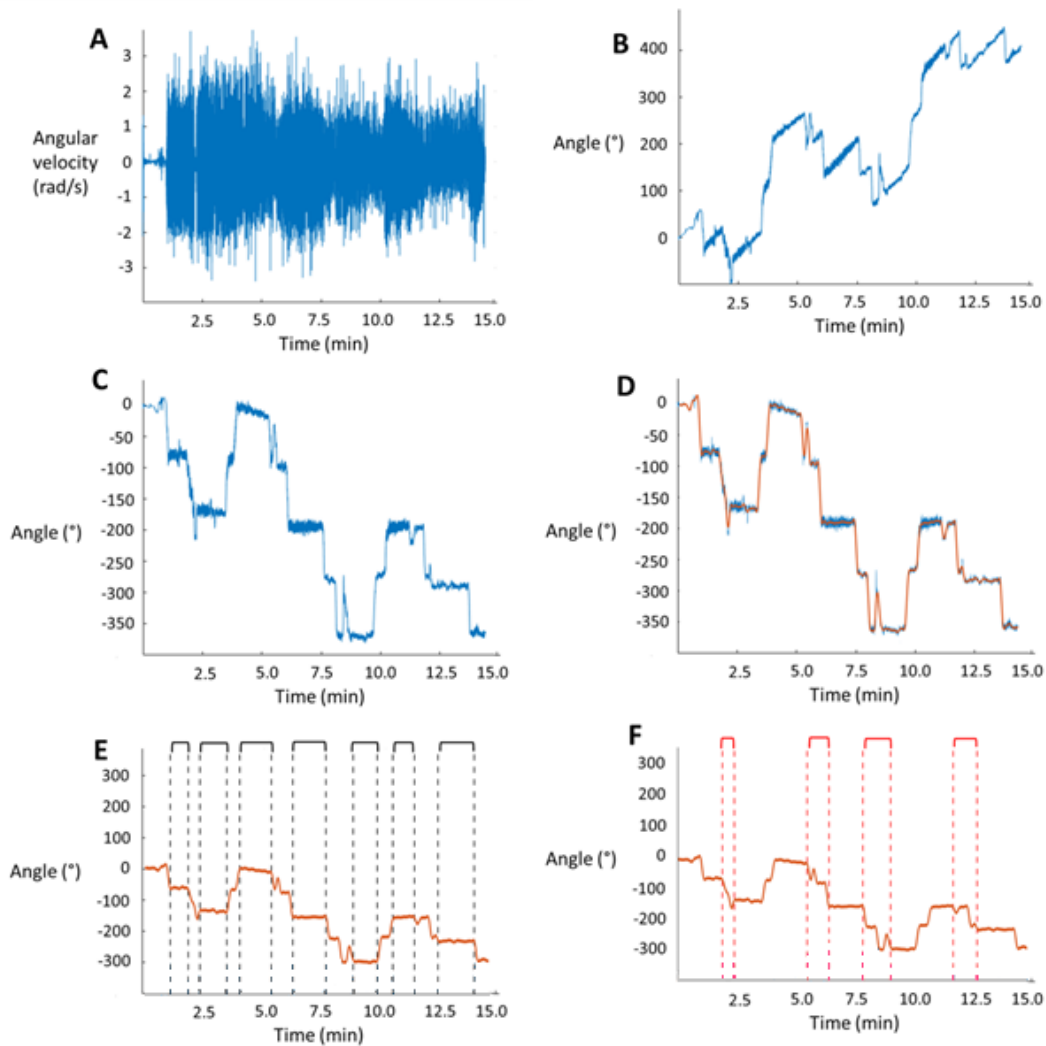

Figure 4-2. Procedure for the detection of regular and irregular walking intervals during free walking. A) Angular velocity around the vertical axis (yaw) collected from the sensor positioned at the waist. B) Relative waist angle obtained by numerical integration of the angular velocity. C) Relative waist angle after linear drift correction. D) De-drifted relative waist angle (blue) with superimposed low-pass filtered signal. E) Filtered relative waist angle and identified regular walking intervals (black vertical dashed lines and brackets). F) Filtered relative waist angle and identified irregular walking intervals (red vertical dashed lines and brackets).

4.2.3 Results

Effects of environment and protocol

The results for the mean temporal parameters across all walking conditions are summarized in Table 4-6, and the results of the ANOVA test are summarized in Table 4-7. No interaction effects between environment and protocol were observed. There was a significant main effect of environment for all the investigated mean temporal parameters, with lower stride duration (-1.9%), step duration (-1.9%) and stance duration (-3.2%) observed during outdoor walking, and larger single support

phase (+2.4%) during outdoor walking. None of the observed parameters was influenced by the protocol. The results for the variability showed that there was a statistically significant interaction between environment and protocol for all the investigated parameters. The analysis of the simple main effects showed that the CVs of all investigated parameters were statistically significantly lower in controlled walking compared to free walking when the participants were walking in the indoor environment, with differences ranging from 1.1% (stride duration CV) to 0.3% (single support phase), while during outdoor walking only the single support phase variability was statistically significantly different between protocols (0.8% higher in free walking with respect to controlled).

Table 4-6. Effects of environment and protocol. Mean values and variability for all the investigated temporal parameters.

	MEANS			
	Environment: Indoor		Environment: Outdoor	
	Protocol: Controlled	Protocol: Free	Protocol: Controlled	Protocol: Free
Stride duration (s)	1.06 ± 0.05	1.06 ± 0.05	1.03 ± 0.05	1.05 ± 0.07
Step duration (s)	0.53 ± 0.03	0.53 ± 0.03	0.52 ± 0.02	0.53 ± 0.03
Stance duration (s)	0.68 ± 0.04	0.69 ± 0.05	0.65 ± 0.04	0.67 ± 0.05
Single support phase (%)	71.4 ± 2.2	71.3 ± 2.4	73.1 ± 1.8	73.2 ± 2.6
VARIABILITY (CV ± SD)				
Stride duration (%)	2.2 ± 0.6	3.3 ± 1.1	2.7 ± 0.7	2.6 ± 0.9
Step duration (%)	2.7 ± 0.6	3.8 ± 1.3	3.2 ± 0.7	3.5 ± 1.0
Stance duration (%)	3.1 ± 0.7	4.2 ± 1.1	3.6 ± 0.8	3.7 ± 1.0
Single support phase (%)	2.2 ± 0.7	2.5 ± 0.8	2.4 ± 0.7	3.16 ± 1.1

Table 4-7. Effects of environment and protocol. Results of the two-way repeated measures ANOVA. Statistically significant differences are highlighted in red.

	MEANS				
	Environment		Protocol		Interaction
	P-Value	Effect Size	P-Value	Effect Size	P-Value
Stride duration	<0.01	0.42	0.08	0.16	0.54
Step duration	<0.01	0.42	0.07	0.17	0.55
Stance duration	<0.001	0.55	0.10	0.14	0.59
Single support phase	<0.001	0.69	0.91	0.01	0.75
VARIABILITY (CV)					
Stride duration	0.60	0.02	0.01	0.23	<0.01
Step duration	0.75	0.01	<0.01	0.44	0.03
Stance duration	0.82	0.01	<0.01	0.38	<0.01
Single support phase	0.01	0.29	<0.001	0.66	<0.01

Effects of environment and type of walking bout

The results for the mean temporal parameters across all walking conditions are summarized in Table 4-8, and the results of the ANOVA test are summarized in Table 4-9. Interaction effects between environment and type of walking bout were observed for stride duration, step duration and stance duration. Therefore, simple main effects were run. Stride duration and step duration were statistically significantly lower during regular walking compared to irregular walking during both indoor and outdoor gait, and were also statistically significantly higher in the indoor environment compared to outdoor during irregular walking. Stance duration was statistically significantly lower during regular walking compared to irregular walking during indoor walking, but not outdoor walking, and was statistically significantly lower during outdoor walking compared to indoor walking during both regular and irregular walking. There was a significant main effect of environment for single support phase, which was smaller during indoor walking.

The results for the variability analysis showed that there was no statistically significant interaction between environment and type of walking. A significant main effect of type of walking bout was observed for all the investigated temporal parameters, with larger coefficients of variation during irregular walking. There was also a significant main effect of environment for all parameters except stride duration, with larger coefficients of variation during outdoor walking.

Table 4-8. Effects of environment and type of walking bout. Mean values and variability for all the investigated temporal parameters.

	MEANS			
	Environment: Indoor		Environment: Outdoor	
	Type of walking: Regular	Type of walking: Irregular	Type of walking: Regular	Type of walking: Irregular
Stride duration (s)	1.06 ± 0.05	1.08 ± 0.05	1.04 ± 0.06	1.05 ± 0.06
Step duration (s)	0.53 ± 0.03	0.54 ± 0.02	0.52 ± 0.03	0.53 ± 0.03
Stance duration (s)	0.68 ± 0.05	0.69 ± 0.04	0.66 ± 0.05	0.67 ± 0.05
Single support phase (%)	71.3 ± 2.6	71.2 ± 2.2	72.9 ± 2.3	73.2 ± 2.4
	VARIABILITY (CV ± SD)			
Stride duration (s)	1.4 ± 0.4	2.8 ± 1.3	1.8 ± 0.3	2.9 ± 0.6
Step duration (s)	1.7 ± 0.5	3.4 ± 1.7	2.5 ± 0.5	3.8 ± 1.6
Stance duration (s)	2.1 ± 0.7	3.8 ± 1.6	2.8 ± 0.7	4.1 ± 0.9
Single support phase (%)	1.7 ± 0.8	2.3 ± 1.0	2.2 ± 0.9	2.8 ± 0.9

Table 4-9. Effects of environment and type of walking bout. Results of the two-way repeated measures ANOVA. Statistically significant differences are highlighted in red.

	MEANS				
	Environment		Type of walking		Interaction
	P-Value	Effect Size	P-Value	Effect Size	P-Value
Stride duration	0.04	0.21	<0.001	0.68	0.02
Step duration	0.04	0.21	<0.001	0.69	0.02
Stance duration	<0.01	0.38	<0.001	0.65	0.02
Single support phase	<0.001	0.70	0.43	0.04	0.15
	VARIABILITY (CV)				
Stride duration	0.16	0.11	<0.001	0.81	0.29
Step duration	0.02	0.27	<0.001	0.77	0.33
Stance duration	0.02	0.26	<0.001	0.79	0.41
Single support phase	<0.001	0.67	<0.001	0.76	0.90

4.2.4 Discussion

Recent evidence is suggesting that people walk differently in gait labs with respect to uncontrolled environments. This research extends our knowledge of the influence of environment, protocol and type of walking bout on gait temporal parameters of healthy individuals using wearable inertial measurement units, performing an innovative investigation by testing a combination of indoor and outdoor settings during free and controlled walking, and analysing regular and irregular walking bouts.

The analysis of environment and protocol showed that participants walked with shorter stride, step and stance durations during outdoor walking than during indoor walking, with medium to small effect sizes. The variations, in the order of 2-3%, indicated that participants walked slightly faster outdoors. This result is in agreement with the findings of Donovan and colleagues, reporting a not significant increase of 1.7% in gait speed in a group of stroke survivors when walking in a street in comparison to a clinical environment (Donovan et al., 2008). This confirms that environment plays a significant role in altering mean gait parameters in both healthy participants and people with locomotion difficulties.

In terms of variability, the analysis showed a significant increase in CV values from controlled to free walking in the indoor environment, while these differences were not significant when walking outdoor. This interaction between environment and protocol highlighted a levelling effect of the outdoor environment for all the variability parameters. The complexity of outdoor environments, possible

disturbances and external perturbations might all play a role in reducing differences between protocols. The walking condition which showed the lowest levels of variability in the investigated parameters was the indoor controlled bout. This result might support the idea that gait parameters assessed in controlled environments reflect motor capacity rather than performance.

Previous findings highlighted that increases in gait variability during repeated straight walking trials may be due to the frequent stoppages in the walking protocol (Paterson et al., 2009). On the contrary, in this study, the variability of the temporal parameters was lower during the controlled straight compared to the free walking protocol. This possible increase in variability might have been mitigated by the removal from the data analysis of the transitory walking sections at the start and end of the scripted walking bouts.

Stride duration variability of controlled walking was higher in the outdoor environment. A possible factor influencing this outcome is the different straight walking distance in the two conditions (20-m indoors, and 50-m outdoors). This finding would be in agreement with a previous study reporting a not statistically significant reduction of 1% in gait cycle time variability between short (<10 m) and long (>20 m) walking distances (Najafi et al., 2009).

Between 20-50% of steps performed during daily activities are reported to be turns (Glaister et al., 2007; Segal et al., 2008). When comparing intervals of regular straight walking and irregular walking intervals which included turns, similarly to the first analysis, the mean temporal parameters varied between indoor and outdoor walking, with medium effect sizes, while only stride and step durations were significantly different between regular and irregular walking, with small effect sizes. The analysis of the CV values showed no interaction effect, with variability being influenced by the type of walking but not by the environment. These results suggest that the irregular walking intervals are the walking phases that have the largest influence on gait variability, and might be the most informative for real life gait monitoring.

4.2.5 Limitations

In daily life, about sixty percent of all walking bouts last 30s or less (Orendurff et al., 2008). However, in this study the walking bouts during the free walking

condition lasted more than 40s. Future protocols might therefore also consider validating short walks of a few steps inter-dispersed with postural transfers.

The algorithm used to classify regular and irregular walking periods depends on empirically determined thresholds. Although a similar approach has already been proposed for the detection and quantification of turns in instrumented clinical tests (Salarian et al., 2010), the method might need additional validation for walking in different environments and conditions.

Due to the small sample size, these results should be confirmed in a larger sample of healthy adults. Furthermore, the gait parameters were relatively homogeneous and thus might not represent the whole range of healthy population.

4.2.6 Conclusions

In conclusion, this study found that participants walked at shorter stride, step, and stance durations during outdoor walking compared to indoor walking. Outdoor walking had a levelling effect on differences between controlled and free walking, particularly in terms of variability of temporal parameters. As values obtained from different settings cannot be used interchangeably, a need for normative values in a variety of specific environments and conditions is needed. This is a crucial step in order to propose free-living gait variables as biomarkers, especially in pathological populations, where these differences may be exacerbated.

Chapter 5

A pilot study toward clinical application

The use of wearable devices for physical activity monitoring is still uncommon in clinical applications, and mainly limited to research level, although increasing evidence suggests the potential benefits of objectively assessing clinically relevant characteristics of movement and locomotion in patients (Maetzler and Rochester, 2015). Building on the work previously presented in this thesis, this chapter describes a pilot study on a group of patients with multiple sclerosis. The accuracy of a method for gait event and temporal parameter estimation was tested in controlled laboratory conditions, and then used to investigate differences between outcomes of walking bouts collected in standard gait analysis conditions and daily life.

5.1 Introduction

The consequences which multiple sclerosis (MS) has on mobility and physical activity have been described in detail in section 3.2.1 of this thesis. Patients with MS suffer from mobility problems with a very high prevalence (Swingler and Compston, 1992), restricting 25% of patients at 15 years after diagnosis to wheel chair (Myhr et al., 2001), and contributing negatively to their quality of life (Zwibel, 2009). Physical activity has been shown to be very beneficial for this population, and in the last decades, objective methods to quantify physical activity using wearable sensors have been developed and used for rehabilitation (Carter et al., 2014; Garrett and Coote, 2009), and to assess the effectiveness of behavioural interventions (Saxton et al., 2013).

Previous studies examining free-living walking behaviour of patients with multiple sclerosis have investigated the relationship between steps/day and risks of

falls (Sebastião et al., 2016), and compared levels of physical activity intensity with compliance to public health guidelines (Klaren et al., 2016). However, these studies only classified activity based on overall metrics of activity (activity intensity, steps/day, or energy expenditure), rather than investigating in detail duration and characteristics of activity periods, such as walking bouts. In a recent work, this event-based approach to free-living locomotion was tackled in a systematic way (Granat et al. 2015) to characterise a population with intermittent claudication and a group of matched controls. Cadence, number of steps and duration of individual walking bouts were extracted from an accelerometry-based PAM, and the relationship of these outcomes with each other was investigated and compared between the two groups. In this type of approach, the signals from the sensors were pre-processed by proprietary algorithms, and the outputs were used to obtain quantitative outcomes to be compared between groups. In general, as the walking bouts became longer, the cadence increased, but the inter-bout variability decreased, suggesting that participants might walk at their preferred cadence during walking bouts which are longer than a set duration. These bouts were defined “purposeful walking”, and occurred at a higher cadence than the average. The study also showed statistically significant differences between the two groups, characterized with the newly proposed outcomes.

Patients with MS typically present altered gait temporal parameters with respect to healthy individuals (Cameron and Wagner, 2011) and a degree of gait variability that increases early in the pathology progression (Socie and Sosnoff, 2013). Recent studies have examined and shown a relationship between gait variability and fall risks, using an electronic walkway (Socie et al., 2013), and by instrumenting with accelerometer-based sensors a group of patients performing a 6-minute walk test (Moon et al., 2015). However, a limitation of the mentioned studies is that they were all carried out in controlled laboratory settings. The results of the validation study presented in chapter 4 (see par. 4.3) showed that existing methods for gait event detection might be used to evaluate differences between temporal parameters of walking performed in controlled conditions and unrestricted free walking. In healthy individuals, results showed that the environment and the type of walking have an influence on variability of gait temporal parameters. Furthermore, the work presented in chapter 3 (see par 3.2) showed that commercially available wearable sensors for physical activity monitoring should be used with caution in

patients with multiple sclerosis due to the strong relationship found between walking speed and accuracy of the sensor outcomes. However, short controlled tests performed in laboratory conditions may provide a reliable accuracy assessment of these devices, before prolonged gait monitoring in unsupervised settings takes place.

The aim of this pilot study was to compare temporal parameters associated to walking bouts performed during a one week of unsupervised physical activity monitoring with parameters of bouts obtained in a clinical gait laboratory in a group of patients with MS..

5.2 Materials and methods

5.2.1 Experimental protocol

Recruitment and data collection took place at the Gait Laboratory, Northern General Hospital, Sheffield, UK. Written informed consent was obtained from the participants, and ethical approval was obtained from NRES Committees - North of Scotland. The data used for this pilot study was collected during two successive visits of the patients to the clinic, and details of recruitment, inclusion criteria and patient characteristics have already been reported in detail in chapter 3 (see par. 3.2.2). The severity of MS was measured using Expanded Disability Status Scale (EDSS) (Kurtzke, 1983). The MoveMonitor PAM (Version 2.8.1, Mc Roberts, The Hague, The Netherlands) was positioned on the lower back of each participant by means of an elastic strap. In addition, during the tests performed in the clinical gait lab, two magneto-inertial measurement units (Opal, APDM Inc., Portland, OR, USA) were attached to each shank. Data of fourteen participants were included in this pilot study. During each visit, the participants completed a straight walking and the free walking task. During each visit, the participants walked four times along a predefined 15m straight walkway at their normal, comfortable speed, while two light-gates recorded their walking speed. Then, they were asked to freely walk for one minute in a 100 m² empty room, without following any predefined path.

Between the two sessions, the PAM was given to the participants for one week of continuous recording of their physical activity. They were asked to wear the device during the day and, if comfortable, also overnight. A valid day of wear time was defined as having ten or more hours of recorded data (Troiano et al., 2008).

5.2.2 Data processing

Analysis of walking bouts performed in the clinics

Data from the straight and free walking bouts performed in the clinics were processed as follows. The data from the PAM were extracted and the number of steps extracted as estimated by the proprietary algorithm. Step detection accuracy of the PAM was evaluated by calculating the mean percentage error (MPE), using the SHANK method as reference for step count (N):

$$MPE = \frac{|\tilde{N} - N|}{N} * 100$$

Participants for which the MPE value was above the value of 6% in any of the two conditions tested in the clinics (straight or free walking) were regarded as unsuitable for prolonged assessment of walking in daily living conditions and were excluded from further analysis, although it is important to highlight the fact that the SHANK method has been validated only during straight walking in pathological populations.

The total number, and the timings of the initial contact (IC) and final contact (FC) gait events were extracted from the raw accelerations and angular velocity signals using the WAIST (McCamley et al., 2012) and SHANK (Trojaniello et al., 2014b) algorithms, previously tested in free walking conditions (see Chapter 4, par. 4.2).

Stride duration, step duration, stance phase percentage, single support phase percentage, and the respective coefficients of variations (CVs) were computed for each gait cycle, and then pooled to obtain mean values for each parameter and each walking condition. A paired-samples t-test was performed to test for differences between the temporal parameters calculated with the WAIST and the SHANK methods.

Comparison between free-living and gait lab walking bouts

After the seven consecutive days of physical activity monitoring, data from the PAM was downloaded and the walking bouts were extracted using the McRoberts proprietary online processing platform (MyMcRoberts, accessible at <http://www.mcroberts.nl>). Triaxial raw accelerometry data were extracted for all walking bouts longer than or equal to five steps, together with relevant start time,

duration, and number of steps, as calculated by the proprietary algorithm. Data corresponding to walking bouts shorter than five steps were discarded to avoid misinterpretation of intermittent stepping (Dall et al., 2013; Stansfield et al., 2015). For each bout, IC and FC events were extracted using the WAIST algorithm (McCamley et al. 2012, par. 4.2.2) and mean, standard deviation and CV values of stride, step, stance and single support phase durations were calculated. The walking bouts were then classified according to the number of consecutive steps, and mean and CV values of each parameter were finally calculated for each of the following four identified groups:

- S5-8 = Bouts where the patient performed between 5 and 8 consecutive steps.
- S20 = Bouts where the patient performed between 9 and 20 consecutive steps.
- S200 = Bouts where the patient performed between 21 and 200 consecutive steps.
- LW = Bouts where the patient performed more than 200 consecutive steps.

A repeated measures ANOVA design with a significance level of $p=0.05$ and post-hoc follow up analysis was used to compare the data from the different walking bouts.

5.3 Results

5.3.1 Analysis of walking bouts performed in the clinics

The mean absolute percentage error (MPE) associated to the PAM is shown in Figure 5-1. Nine participants had a MPE below 6% in both walking conditions, and these were the only ones included in further analysis. For this group, the average (\pm SD) MPE values in the straight and free walking conditions were 3.5% (\pm 2.6%) and 2.9% (\pm 2.2%), respectively.

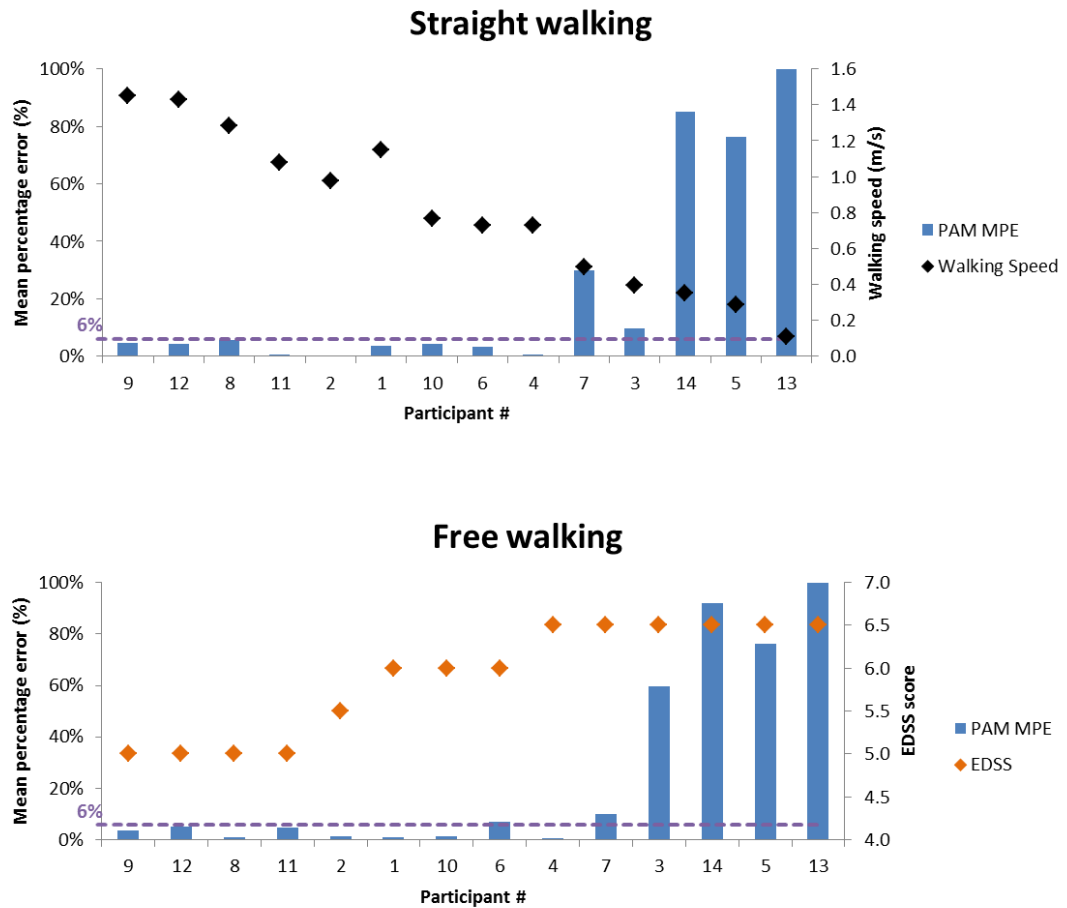

Figure 5-1. Results of the step detection accuracy for the PAM in the clinical walking bouts. Mean percentage errors are shown for each participant. The horizontal dashed purple lines indicate the threshold for inclusion/exclusion of the participants in the free-living analysis. The black squares in the straight walking chart (A) indicate the walking speed of the participants. The orange squares in the free walking chart (B) correspond to the EDSS score of each participant. Participants are ordered by increasing EDSS score.

Descriptive statistics of the temporal parameters calculated on the basis of the IC and FC timings obtained from the WAIST and the SHANK method in the two walking conditions are shown in Tables 5-1 and 5-2, respectively. No statistically significant differences were found between the SHANK and WAIST methods in the estimation of stride and step durations. However, a statistically significant difference ($p < 0.05$) between methods was found in stance phase and single support phase, with 8.5%-9.0% longer stance phase, and 13%-18% shorter single support phase measured by the SHANK method. No statistically significant differences were found between methods in any of the variability measures.

Table 5-1. Mean values for all the investigated temporal parameters. Statistically significant differences between methods are highlighted in brackets. Values are mean \pm SD.

Parameter	STRAIGHT		FREE	
	SHANK	WAIST	SHANK	WAIST
Stride duration (s)	1.14 \pm 0.11	1.13 \pm 0.09	1.25 \pm 0.09	1.23 \pm 0.09
Step duration (s)	0.58 \pm 0.06	0.57 \pm 0.04	0.63 \pm 0.05	0.62 \pm 0.02
Stance phase (%)	0.68 \pm 0.02	0.62 \pm 0.01	0.69 \pm 0.02	0.63 \pm 0.01
Single support phase (%)	0.65 \pm 0.05	0.75 \pm 0.02	0.61 \pm 0.05	0.75 \pm 0.01

Table 5-2. Coefficient of variation values for all the investigated temporal parameters. Statistically significant differences between methods are highlighted in brackets. Values are mean \pm SD.

Parameter	STRAIGHT		FREE	
	SHANK	WAIST	SHANK	WAIST
Stride duration (%)	5.2 \pm 2.2	7.1 \pm 2.5	7.5 \pm 1.6	7.5 \pm 1.8
Step duration (%)	13.4 \pm 6.3	13.5 \pm 6.5	12.8 \pm 4.0	10.9 \pm 2.6
Stance phase (%)	8.3 \pm 3.8	7.5 \pm 6.0	7.2 \pm 2.3	6.8 \pm 2.8
Single support phase (%)	4.6 \pm 3.1	3.8 \pm 2.3	5.2 \pm 2.0	4.4 \pm 1.7

5.3.2 Comparison between free-living and gait lab walking bouts

The descriptive statistics of the temporal parameters characterizing the investigated walking bouts, and the statistically significant differences are summarized in Figure 5-2. As highlighted in the figure, stride and step durations were between 8% and 13% smaller during straight lab walking in comparison to daily living walking bouts, while no differences in stance phase or single support phase were found between conditions. The variability analysis showed that the stride duration CV of straight and free controlled walking were up to 46% smaller in comparison to daily living walking bouts. Variability of step duration showed similar results, with straight and free controlled walking bouts displaying between 5% and 55% smaller CV than daily living walking bouts. The stance phase variability of the S5-8 walking bout was significantly larger than most of the other walking conditions, with differences of up to 56%.

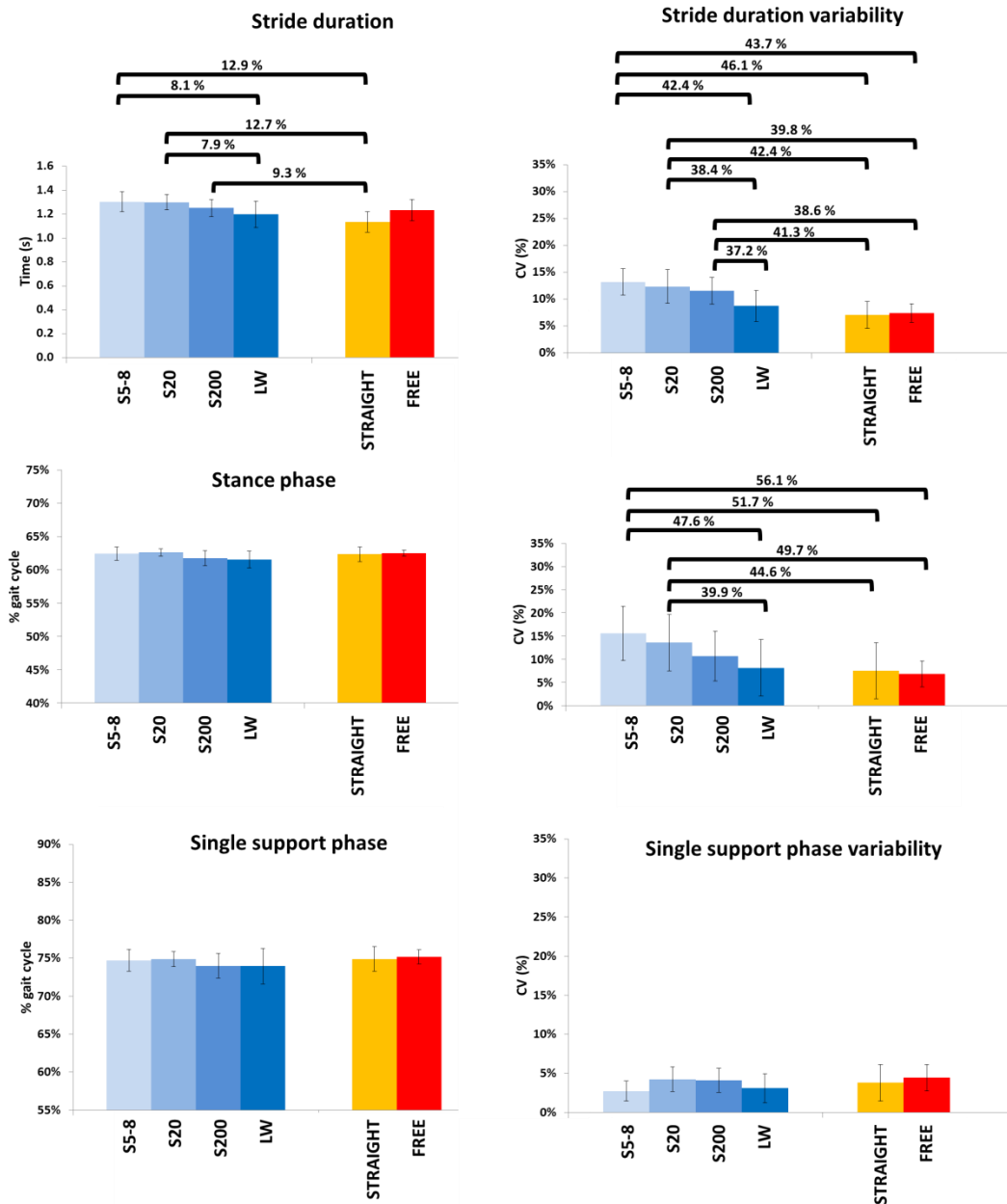

Figure 5-2. Descriptive statistics for stride, stance and single support phase for all the walking groups investigated in the study. Statistically significant differences ($p < 0.05$) between walking bouts are highlighted by black brackets. Corresponding percentage differences are shown above each bracket. S5-8= 5 to 8 consecutive steps; S20=9 to 20 consecutive steps; S200= 21 to 200 consecutive steps; LW=more than 200 consecutive steps; STR=straight walking in controlled lab conditions; FREE=free walking in controlled lab conditions.

5.4 Discussion

Since the identification of the daily living walking bouts relied on the classification performed by the PAM, the results of its step detection accuracy were

examined. All the participants with an MPE value for the WAIST method above 6% during the tests performed in the clinics were excluded from further analysis. This applied threshold was more restrictive than the value reported in chapter 4, where a MPE value of 20% was highlighted as a possible threshold to identify two groups of participants from the MPE-walking speed relationship (see par. 3.2.3). This reduction was imposed for improved accuracy. Furthermore, this study was designed as a pilot test to demonstrate the potential of the method, and improvements of the algorithms should be the objective of further research. After excluding unsuitable patients from the analysis, the sample size, initially of fourteen subjects, was reduced to nine for the comparison between clinical tests and free-living walking. Therefore, further studies on a larger population are needed to confirm the findings of this pilot study.

Since the WAIST method has not yet been validated in patients with MS, for additional verification the temporal parameters estimated during the controlled lab tests using this method were compared with those obtained from the SHANK method. It is worth noting, however, that although the SHANK method has shown high accuracy in a number of populations (Trojaniello et al., 2014b), including healthy elderly, hemiparetic patients, people with Parkinson's disease, and subjects with a choreic movement disorder, it has not been validated specifically in a population with MS walking in a protocol which includes non-straight sections. Typical characteristics of gait in MS include decreased distance and speed of walking, stride length and limited joints range of motion (Crenshaw et al., 2006; Kelleher et al., 2010). These gait impairments may limit clearance of the foot, and therefore the ability of this method to identify the windows in the signal necessary to determine the gait events, limiting its accuracy. Furthermore, the coefficient of variability has been shown to be more sensitive to errors in gait event timing estimation (Beijer et al., 2013) in comparison to mean values of the temporal parameters. Nonetheless, the comparison between the SHANK and the WAIST clearly showed an equivalence between the two methods in determining the metrics relying on the correct identification of IC events (stride and step duration), while differences were highlighted in the stance and single support phases estimations, where a correct identification of the FC events is also needed, suggesting that its determination might be critical in MS patients. This suggests that the latter metrics

should be considered with caution and further studies are recommended to establish the cause of these differences.

The possible source of inaccuracy in the WAIST method might be due to inherent weakness of methods based on wavelet transforms to rely on the periodicity of walking (Brajdic and Harle, 2013). In fact, the gait events identified by the WAIST method correspond to local minima and maxima of the wavelet-transformed signals. When the participants walk at slower paces the periodicity of the signal becomes weaker, increasing the probability of double peaks which lead to extra event detection. However, for the less compromised patients, the method's performance deviated only marginally from the step detection error obtained from the algorithm embedded in the PAM device.

Free-living walking bouts of different length and frequencies were selected and compared with gait performed in laboratory settings. As expected, the most frequently occurring walking bouts corresponded to the shortest included in the analysis, namely 5 to 8 consecutive steps. This is in agreement with previous studies reporting incidental or sporadic stepping as the most frequent during free-living activity monitoring (Tudor-Locke et al., 2011a).

The potential risk of the inaccuracy of the WAIST method acting as a potential confounder was excluded when inspecting differences between walking bouts as the magnitude of these differences was generally much larger. The participants walked with shorter stride and step duration during the controlled straight walking bouts performed in the lab. The faster gait pace performed in indoor controlled laboratory conditions has already been reported in previous studies (Taylor et al., 2006), and similar findings have been reported in chapter 4 (see par. 4.3.3) for healthy participants. Interestingly, the free walking bout performed in the clinic appears to better mimic the mean temporal parameters obtained during daily living walking. The directional changes and longer walking distance may contribute to the generation of a walking pattern that better resembles everyday gait.

The coefficient of variation has been extensively used as a descriptor of gait variability (Hausdorff, 2007), and was selected as a metric for this pilot study. Unsurprisingly, the variability of the parameters associated to the S5-8 bout, showed that sporadic stepping generates higher variability than walking in controlled laboratory condition. Interestingly, differences in gait variability were also evident and statistically significant for stride duration, step duration and stance phase when

comparing straight walking with bouts of similar length (S20) performed in daily living. The CV values corresponding to the S200 and LW groups were the most similar to those obtained in controlled laboratory conditions. However, although not statistically significant, CV values were still higher than in the clinics. These findings provide preliminary evidence that controlled clinical conditions are likely to represent ‘best-case’ scenarios, where the performance of a patient population is likely to represent the ‘best’ achievable performance (Brodie et al., 2016). This translates into gait patterns characterized by faster walking and smaller variability with respect to usual performances.

5.5 Conclusions

This pilot study showed that an algorithm to estimate gait events during walking from accelerations of the lower trunk, can be used to estimate temporal parameters in a population with multiple sclerosis, and investigate differences in gait temporal parameters between walking bouts performed in controlled laboratory conditions and locomotion in daily living. The study showed that the performance of the participants during the tests in the clinic might be characterised by shorter stride and step duration and smaller variability, and do not match with the typical temporal parameters obtained in free living during walking bouts of similar length. However, they are comparable with the longest walking bouts completed during daily living, providing evidence that clinical gait analysis tests are likely to represent the performance of a subject during prolonged purposeful walking performed in daily living conditions.

Chapter 6

Ongoing and future work

6.1 Analysis of free living walking in patients with Type 1 and Type 2 Diabetes

Most of the work presented in this chapter has been carried out in the framework of the European project 'Mission-T2D: Multiscale Immune System Simulator for the Onset of Type 2 Diabetes Integrating Genetic, Metabolic and Nutritional Data', which aimed at developing and validating an integrated, multilevel patient-specific model for the simulation and prediction of metabolic and inflammatory processes in the onset and progress of type 2 diabetes (T2D), in order to identify early diagnostic parameters for T2D. Firstly, a systematic review of the literature was completed, looking for evidence of the effectiveness of walking as physical activity to reduce inflammation. In this chapter, the attention will be focused on those studies that used an objective monitoring of the gait. The second part of the chapter presents preliminary data of an ongoing feasibility study, proposing an event-based approach to examine cadence and step duration variability in free-living walking in a group of patients with type 1 and type 2 diabetes.

The chapter ends with an overview of future prospects and conclusive remarks of this thesis.

6.1.1 Diabetes

The American Diabetes Association defines Diabetes mellitus as “a group of metabolic diseases characterized by hyperglycaemia resulting from defects in insulin secretion, insulin action, or both”. As shown in Figure 6-1, in the first case the diabetes mellitus is of type 1 (T1D), in the second case it is type 2 (T2D). The prolonged alteration in glucose levels due to diabetes is associated with long-term damage, of eyes, kidneys, nerves, heart, and blood vessels (American Diabetes

Association, 2004). According to the 2015 diabetes atlas 382 million people in the world have diabetes and by 2035 this number will increase by 55% (International Diabetes Federation, 2015).

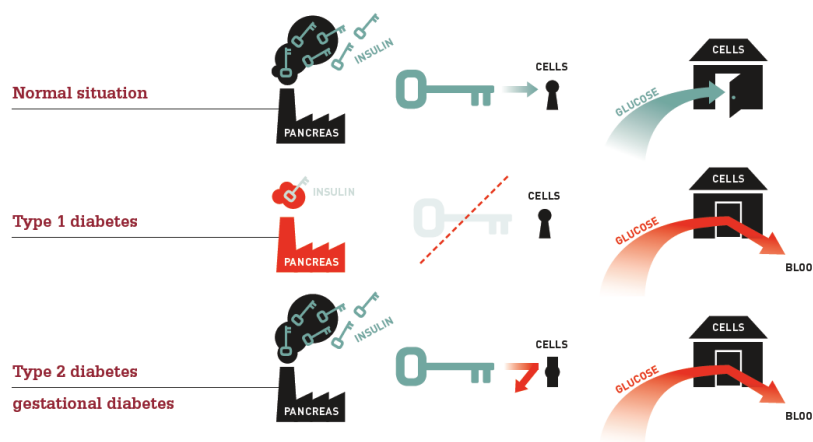

Figure 6-1. Glucose intake mechanism in normal, T1D and T2D situations (Diabetes Atlas 2015, International Diabetes Federation).

The metabolic dysfunctions determined by Type 2 Diabetes (T2D) are associated with changes in the immune system. The altered plasma levels of specific pro-inflammatory proteins leads to a phenomenon known as “systemic low grade inflammation”, which is typical for T2D (Duncan et al., 2003; Hotamisligil, 2006; Kolb and Mandrup-Poulsen, 2005; Schmidt et al., 1999). Investigating patients with T2D, several prospective and cross-sectional studies have described high levels of proteins involved in acute-phase inflammation response, sialic acid, cytokines and chemokines (Herder et al., 2009, 2005; Pickup, 2004; Spranger et al., 2003). Furthermore, elevated levels of interleukin-1 β , interleukin-6 and C-reactive protein have been found to be predictive of T2D (Pradhan et al., 2001; Spranger et al., 2003). Serum concentrations of IL-1 receptor antagonist (IL-1RA) are also elevated in obesity and prediabetes (Meier et al., 2002), with an accelerated increase in IL-1RA levels before the onset of T2D (Carstensen et al., 2010; Herder et al., 2009; Marculescu et al., 2002). For this reason T2D has been classified as an inflammatory disease (Donath and Shoelson, 2011; Pradhan et al., 2001) (Figure 6-2).

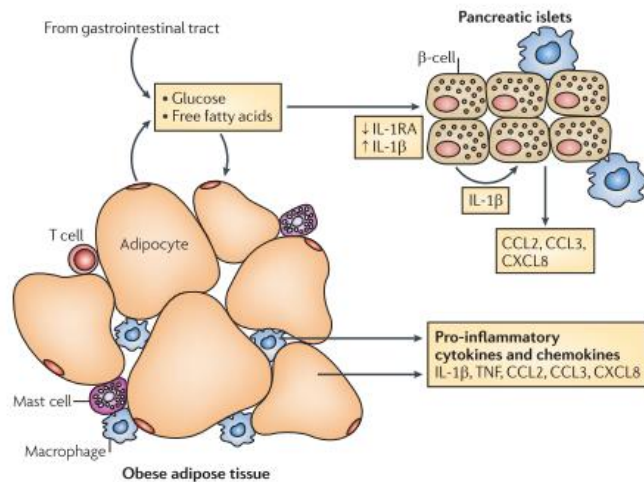

Figure 6-2. Development of inflammation in type 2 diabetes. Reprinted by permission from Macmillan Publishers Ltd: Nature Reviews Immunology (Donath and Shoelson, 2011), copyright (2011).

6.1.2 Diabetes and physical activity

The role of exercise and physical activity in the prevention and control of insulin resistance, pre-diabetes, diabetes related health complications and chronic inflammation is widely recognized. A randomized clinical trial in 557 individuals with impaired glucose tolerance showed a reduction in risk of developing diabetes when subjects were assigned to diet, exercise, or diet-plus-exercise intervention groups (Pan et al., 1997). Intensive lifestyle interventions in a group of 522 middle-aged and overweight adults with impaired glucose tolerance showed higher weight reductions and better measures of glycaemia and lipemia after three years in the intervention group compared to the control group (Lindström et al., 2003). Further evidence suggests that the prescription of as little as 30 min/day of moderate-intensity activity reduces the risk of contracting T2D, thanks to protective mechanisms which are triggered, such as regulation of body weight, and reduction of hypertension and insulin resistance (Bassuk and Manson, 2005). These individuals have up to 30-50% lower risk of contracting T2D (Skerrett and Manson, 2002). Typically, public health initiatives have promoted increases in physical activity, with intervention studies in T2D recommending patients to walk at least 10,000 steps/day (Tudor-Locke et al., 2011b).

6.1.3 The effects of walking on low-grade inflammation and Type 2 Diabetes – A systematic review

A substantial part of the material presented in this section has been published in:

M. Morettini, F. A. Storm, M. Sacchetti, A. Cappozzo, C. Mazzà, *Effects of walking on low-grade inflammation and their implications for Type 2 Diabetes. Preventive Medicine Reports 2 (2015) 538–547*

Written permission was obtained from all the co-authors. The author of this thesis contributed to the selection of the search criteria, the acquisition and analysis of suitable papers, the draft and critical revision of the manuscript, and the approval of the final version.

Among types of physical activity, walking has been shown to be suitable in preventing many risk factors for T2D, improving body mass index, diastolic and systolic blood pressure, and high-density or low-density lipoprotein cholesterol levels (Murtagh et al., 2015; Qiu et al., 2014). However, although there is extensive evidence of the positive influence of exercise on markers of low-grade inflammation associated with T2D, there has been little attempt to establish the effects that walking can have on inflammation. For this reason, within the framework of the European project 'Mission-T2D', a systematic review was performed on PubMed, Scopus and ISI Web of Science, with the aim of reviewing current evidence on the effect that walking can have on inflammation, and to systematize the existing knowledge on the effectiveness of walking in the reduction of the inflammatory status associated to T2D. A combination of the following keywords was used: inflammation mediators, cytokines, motor activities, locomotor activity, physical activity, walking, and ambulatory activity. Randomized clinical trials, experimental and cross-sectional studies up to December 2014 were included in the search, and the primary markers included in the study were C-reactive protein (CRP), Interleukin 6 (IL-6) and tumour necrosis factor alpha (TNF- α), due to their relevance in the inflammatory process (Pickup, 2004; Shoelson et al., 2006). Thirty-two studies were found matching the inclusion criteria, five looking at acute effects of walking, and twenty-seven focusing on chronic effects, of which twenty-one were interventional studies and six observational studies.

Acute effects. Only one study on acute effects showed statistically significant variations in at least one marker of inflammation. A significant increase of IL-6 was

observed after 1 h of an intervention consisting in 30-minute of treadmill walking at 60-65% VO₂ max in a group of fifteen non-obese women (Nieman et al., 2005). The remaining four studies did not show any statistically significant changes in the levels of the investigated markers (Davis et al., 2008; Markovitch et al., 2008; Murtagh and Boreham, 2005; Nelson and Horowitz, 2014).

Chronic effects. Eighteen of the twenty-seven papers investigating chronic effects were carried out in free-living conditions. To quantify physical activity, four used self-reporting assessment tools, five used a pedometer, two used an accelerometer and one a heart rate monitor, while the remaining used a combination of self-reporting and objective measurement techniques. Table 5-1 shows only those studies where quantitative monitoring has been used.

Only eight interventional studies produced statistically significant variations in at least one of the investigated inflammatory markers. Sixty minutes of treadmill walking or jogging at 60% VO₂ max induced an IL-6 concentration decrease of 52%, 32% and 17% in groups of T2D, lean and obese participants, respectively (Dekker et al., 2007). A second study also showed a significant IL-6 decrease of 33% after an eight-week exercise programme consisting in walking 10,000 steps/day for at least 3 days a week (Yakeu et al., 2010). A statistically significant decrease in CRP levels was found in a 24-week walking intervention in a group of 176 patients with metabolic syndrome (Di Raimondo et al., 2013). Other two studies showed significant improvements in CRP values, one in a group of 33 women assigned to a 14-weeks programme combining diet and exercise (Giannopoulou et al., 2016), and the second in a 12-week treadmill intervention in 20 elderly women (Taghian et al., 2012). Three studies showed an improvement in TNF- α level after the intervention. Ho and colleagues showed that after a 12-week moderate intensity treadmill walking programme the levels of TNF- α decreased significantly in overweight and obese individuals (Ho et al., 2012). The level also decreased in 32 post-menopausal women performing 13 weeks of walking training at moderate intensity (Izzicupo et al., 2013), and in a randomized controlled trial on 41 sedentary individuals after 16 weeks of internet delivered physical activity (Smith et al., 2009).

All the six observational studies showed some correlation between physical activity and markers of inflammation: participants reporting at least 30 min of walking 5 days a week had lower concentrations of CRP, IL-6 and TNF- α than the group reporting lower walking activity (Yates et al., 2008). Multiple linear

regressions also showed that time spent walking was inversely related to TNF- α levels (Hamer and Steptoe, 2008). When classifying a group of 327 individuals with T2D in four groups based on steps/day, a study showed a significant inverse relationship between steps/day and CRP and IL-6 levels (Jennersjö et al., 2012). In a study measuring physical activity by means of an accelerometer in 1838 middle-aged individuals, step count was inversely associated with TNF- α (Nishida et al., 2014). A further cross-sectional study showed that 30 active T2D patients had significantly lower CRP levels than 53 inactive patients (Neuparth et al., 2014). A cohort study also found that adding 10 minutes of walking per day to habitual physical activity can trigger a significant reduction of CRP levels (Klenk et al., 2013).

Overall, these results showed that a decrease in body weight was often associated with a reduction in TNF- α , and that the most effective studies were those in which the walking activity was performed at a moderate-intensity level, and where physical activity was supervised or quantified objectively by means of sensors. However, due to the limited amount of studies showing statistically significant changes in inflammation status, although the potential benefits of walking to reduce chronic inflammation cannot be excluded, no definitive conclusion regarding its efficacy can be drawn. Future studies should focus on a quantitative objective monitoring of physical activity to answer this question.

Table 6-1. Chronic effect studies using quantitative physical activity monitoring: study design, type (interventional or observational), methods, data analysis details and outcomes (adapted from Morettini et al. 2015).

Author/year	Study design	Type	Method	Data analysis	Outcome related to inflammation
Di Raimondo et al. (2013)	176 patients affected by metabolic syndrome (95 M and 81 F, mean age 59 ± 7 years; BMI 32 ± 5 kg/m ²) completed a 24-week walking intervention (1 hour/day, 5 days/week) at a walking velocity higher than the comfortable one.	Interventional	Pedometers	Blood concentration of CRP before and after the intervention	↓ BMI ↓ Waist circumference. ↓ CRP
Dixon et al. (2013)	9 active lean (age 52 ± 1 years; BMI 24 ± 1 kg/m ² ; waist circumference <84cm) and 9 active central overweight men (age 49 ± 1 years; BMI 29 ± 1 ; waist circumference >94cm) reduced their walking activity to less than 4000 steps/day for one week.	Interventional	Pedometers	Blood concentration of TNF- α , IL-6 and CRP before and after the intervention	↔ TNF- α ↔ IL-6 ↔ CRP
Gano et al. (2011)	11 middle-aged/older adults (5 M and 6 F, age 57–70 years; BMI 26 ± 1 kg/m ²) completed a 2-months brisk walking intervention (6 days/week, 50 minutes/day) at 70% HRmax.	Interventional	Diaries + HR monitors	Blood concentrations of TNF- α , IL-6 and CRP before and after the intervention	↔ TNF- α ↔ IL-6 ↔ CRP ↓ BMI ↓ total body fat
Gray et al. (2009)	Randomized controlled trial. Control group (6 M, 18 F; age 51 ± 8 years; BMI 29 ± 6 kg/m ²), intervention group (5 M, 19 F; age 48 ± 9 years; BMI 28 ± 5 kg/m ²). 12 weeks pedometer-based walking program. Intervention is designed to increase mean daily step count by 3,000 steps/day on at least 5 days of the week program	Interventional	Pedometers	Blood concentrations at baseline and after 12 weeks of TNF- α , CRP, IL-6	↔ TNF- α , CRP, IL-6 ↔ BMI, body fat percentage

Author/year	Study design	Type	Method	Data analysis	Outcome related to inflammation
Hamer et al. (2008)	Cross sectional analysis including 185 healthy participants (107 M, 78 F) aged 45 - 59 years	Observational	Questionnaires and weekly minutes of walking	Blood concentrations of TNF- α and IL-6	<p>↓ Time spent walking inversely related to TNF-α.</p> <p>↘ Trend observed for IL-6 to decrease.</p>
Izzicupo et al. (2013)	Non randomized trial. 32 post-menopausal women (age 56.4 \pm 4.3 years; BMI 26.9 \pm 4.3 kg/m ²) performed 13 weeks of walking training at moderate intensity (40-50 min, 4 days/week)	Interventional	Activity monitors + diaries	Plasma concentrations of TNF- α and CRP	<p>↓ TNF-α</p> <p>↔ CRP</p> <p>↔ BMI, waist circumference and fat mass percentage.</p>
Jennersjo et al. (2012)	Observational cross-sectional analysis including 327 individuals with T2D (224 M, 103 F; age 54 - 66 years). Individuals wore the pedometer for 3 days. Classification of physical activity in 4 groups	Observational	Pedometers and diaries	Blood concentrations of CRP and IL-6	<p>Steps/day significantly associated with lower levels of CRP and IL-6.</p> <p>When adjusted for waist circumference, the association between steps and IL-6 remains statistically significant but the association between steps and CRP does not.</p>
Klenk et al. (2013)	Population-based cohort study. Community-dwelling individuals aged over 65 underwent a baseline assessment. 710 M and 543 F (mean age 76 \pm 7 years)	Observational	Accelerometer (1 week) to determine average duration of daily walking	Blood concentration of CRP at baseline	<p>↔ For CRP quartiles 1 and 2, no significant difference was present followed by a dose response association</p>

Author/year	Study design	Type	Method	Data analysis	Outcome related to inflammation
Krause et al. (2014)	Randomized controlled trial. Twenty-five sedentary, obese (BMI > 30 kg/m ²) males (52.8 ± 7.2 years); 12 controls versus 13 T2D subjects were randomly allocated to four groups that exercised for 16 weeks. Exercise consisted in 30 min/day, three times per week either at low (30 – 40 % $\dot{V}O_2$ max) or moderate (55 – 65 % $\dot{V}O_2$ max) intensity.	Interventional	HR monitors	Blood concentrations of CRP, TNF- α and IL-6 at baseline and after 16 weeks of intervention	↔ CRP, TNF- α , IL-6
Krogh-Madsen et al. (2010)	Clinical trial. Ten healthy human males (mean age 24 ± 2 years; BMI 22 ± 1 kg/m ²). None of the participants walked less than 3,500 steps/day. Decrease the number of daily steps to 1,500 for 14 days	Interventional	Pedometer	Blood concentrations of TNF- α and IL-6 at baseline and after 2 weeks	↔ TNF- α , IL-6 ↓ Total body mass reduced.
McNeilly et al. (2012)	Eleven participants (6 M and 5 F; age 49 ± 9 years; BMI 32 ± 7 kg/m ²) with impaired glucose tolerance, completed a 12-week brisk walking intervention (30 minutes/day, five days/week at 65% of HR _{max})	Interventional	HR monitors + diaries	Blood concentration of CRP	↔ CRP ↔ Dietary intake. ↓ BMI and total body fat.
Nishida et al. (2014)	Cross-sectional study. 737 middle-aged male subjects (age 57 ± 8 years; BMI 24 ± 3 kg/m ²) and 1838 middle-aged female subjects (age 56 ± 8 years; BMI 23 ± 3 kg/m ²) were monitored for 10 days to determine their physical activity level.	Observational	Accelerometers	Blood concentrations of TNF- α and IL-6	↓ Number of steps was inversely associated with TNF- α even after adjusting for BMI. ↔ IL-6
Puglisi et al. (2008)	Randomized controlled trial. 12 out of 34 subjects (6 M and 6 F; age 55 ± 4 years, BMI 28 ± 4 kg/m ²) assigned to a walk group for 6 week.	Interventional	Pedometers	Blood concentration of TNF- α .	↑ Daily steps for 6 week from 6,000 to 11,000 steps/day. ↔ TNF- α . ↔ Body mass and waist circumference.

Author/year	Study design	Type	Method	Data analysis	Outcome related to inflammation
Smith et al. (2008)	Randomized controlled trial involving 41 sedentary adults (8 M, 33 F). 2 groups: 1) 16 weeks of internet delivered physical activity intervention (age 40 ± 2 years; BMI 31 ± 1 kg/m ²); 2) usual care (age 47 ± 1 years; BMI 31 ± 1 kg/m ²).	Interventional	Pedometer and questionnaires	Blood concentration of TNF- α and CRP	<p>↑ Increased mean number of steps/day by 1,404 in intervention group.</p> <p>↔ CRP.</p> <p>↓ TNF-α in the intervention group after adjustment for baseline group differences.</p> <p>↓ waist circumference in the intervention group after controlling for age and baseline differences.</p>
Yates et al. (2010)	Randomized controlled trial including 74 participants (age 65 ± 8 years) with impaired glucose tolerance and BMI over 25. 3 groups: 1) pedometer; 2) without pedometer; 3) usual care. 12 months	Interventional	Pedometer and questionnaire	Blood concentrations of IL-6 and CRP at baseline and after 12 months	<p>↔ IL-6 and CRP</p> <p>Ambulatory activity was significantly and inversely associated with IL-6 after adjustment for potential confounders (age, ethnicity, sex, group, medication status, baseline and change in BMI).</p>

Abbreviations: M: male; F: female; T2D: Type 2 Diabetes; CRP: C-Reactive Protein; TNF- α : Tumour Necrosis Factor α ; IL-6: Interleukin 6; $\dot{V}O_2$ max: Maximal Oxygen Uptake; BMI: Body Mass Index.

Symbols: ↑ Significant increase; ↗ Trend to increase (not significant); ↔ No variation; ↘ Trend to decrease (not significant); ↓ Significant decrease.

6.1.4 Objective monitoring of free-living walking in Type 1 and Type 2 Diabetes: preliminary data from an ongoing feasibility study

Introduction

The recent development of wearable technology, the publication of guidelines for field-based research using accelerometers (Troost et al., 2005), and the development of common strategies to treat this type of data (Wijndaele et al., 2015) have generated an increase of studies designed to objectively quantify physical activity in patients with type 2 diabetes (T2D), mostly to discriminate between levels of physical activity. Public health recommendations usually suggest participation in moderate-intensity physical activity to reduce risks in developing T2D (Haskell et al., 2007; Pate et al., 1995). However, emerging evidence suggests that behaviours such as prolonged inactivity and absence of whole body movement are correlated to risk of chronic diseases (Hamilton et al., 2007). For example, a cross-sectional study in 168 participants with T2D used an accelerometer to measure sedentary time, providing evidence of the importance of breaks in prolonged sedentary time in order to decrease metabolic risk (Healy et al., 2008). A subsequent study investigating levels of physical activity in 878 participants at risk of contracting T2D showed that outcomes such as breaks in sedentary time, total physical activity and moderate to vigorous physical activity were directly associated with decrease in body mass index (Henson et al., 2013). Furthermore, Manohar and colleagues used the correlation of acceleration signals with prolonged glucose monitoring to explore the feasibility of including PAMs data as input for an artificial endocrine pancreas for T1D treatment (Manohar et al., 2013).

In recent years, physical activity monitoring is experiencing a shift from classification based on overall metrics of activity (counts, movement indexes, or energy expenditure), to devices capable of robust posture classification, addressing the need of determining with accuracy sedentary behaviour and durations of activity periods (Granat, 2012). In a recent work, this event-based approach to free-living walking events was proposed in a systematic way (Granat et al., 2015). The study characterised a population with intermittent claudication and a group of matched controls (n=30). Cadence, number of steps and duration of individual walking events

were extracted from an accelerometry-based PAM, and the relationship of these outcomes with each other was investigated and compared between the two groups. In general, as the walking events became longer, the cadence increased, but the inter-event variability decreased, suggesting that participants might walk at their preferred cadence during walking events which are longer than a set duration. These events were defined “purposeful walking”, and occurred at a higher cadence than the average. The study also showed statistically significant differences between the two groups, characterized with the newly proposed outcomes. In this type of approach, the signals from the sensors were pre-processed by proprietary algorithms, and the outputs were used to obtain quantitative outcomes to be compared between groups. No assessment was performed on the robustness of these outputs, which needs to be validated separately.

The data analysed in this section originates from the study STH18049 “Validation and Feasibility Study of Physical Activity Monitors in Diabetes”, sponsored by the Sheffield Teaching Hospitals NHS Foundation Trust. The aim of this study is to examine the utility and feasibility of PAM to assist and facilitate patients in daily living and healthcare professionals in routine diabetes care. Specific aims of this study are: 1) to determine the precision and accuracy of activity monitors in patients with diabetes. This will be performed in two distinct settings: initial laboratory validation (physical performance tests and six-minute walking test under strict experimental conditions) followed by field observational studies (where laboratory findings will be tested in the real-world); 2) to establish the mutual relationships existing between PA and insulin sensitivity, endothelial function and inflammation.

Preliminary data on a subset of patients was used in the present work with the aim of testing if a refined event-based approach allows describing patterns of daily living walking activity. The relationship between cadence, variability of step duration, and duration of daily living walking bouts was investigated in a small group of T1D and T2D participants.

Methods

Experimental procedure. Preliminary data on a subset of nine patients (five patients with T1D and four patients with T2D) was analysed. Patients were recruited from the diabetes outpatient clinic at the Royal Hallamshire Hospital, Sheffield, UK.

Ethical approval was obtained from the Research Department of the Sheffield Teaching Hospital NHS Foundation Trust. Exclusion criteria were: chronic illness other than diabetes, unstable angina, recent myocardial infarction (within 3 months), severe ischaemic heart disease (unstable angina or exertion angina), chronic painful condition or physical disability restricting physical activity or mobility, uncontrolled diabetes with glycated haemoglobin (HbA1c>11%), alcohol consumption (>3 units/day for men and >2 units/day for women), current smokers, patients with T2D on insulin therapy.

Data collection took place at the Diabetes Research Facility, Royal Hallamshire Hospital, Sheffield, UK. The participants were asked to wear a waist-worn PAM (DynaPort MoveMonitor, Version 2.8.1, Mc Roberts, The Hague, The Netherlands), and two ankle-worn MIMUs (Opal, APDM Inc., Portland, OR, USA), attached to the left and right shank, just above the ankles, by means of an elastic strap. The participants completed a 6-minutes walking test (6MWT). In the 6MWT the patient is asked to walk as far as possible in six minutes on a hard, flat surface. The patient is allowed to self-pace and rest as needed while traversing back and forth along a marked walkway. At the end of the visit, patients were provided with the PAM, and instructed on how to use it. They were asked to wear the instrument every day for seven consecutive days but not to wear it whilst bathing or swimming. Patients were instructed not to alter their normal weekly routine.

Data analysis. Data from the 6MWT was processed as follows. The timings of the initial contact (IC) gait events were extracted from the raw accelerations and angular velocity signals using the WAIST (McCamley et al., 2012) and the SHANK algorithms (Trojaniello et al., 2014b) previously tested in healthy individuals (see Chapter 4) and in patients with multiple sclerosis (see Chapter 5). Similarly to the procedure outlined in par. 5.2.2.1, the accuracy of the WAIST method and the PAM in the detection of steps was assessed in controlled conditions by calculating the mean percentage error (MPE) using the SHANK data as reference. Using the IC timings, cadence and step duration variability, measured using the coefficient of variation (CV), were finally computed for each participant and each method. The number of steps detected by the PAM during each 6MWT was also obtained. Walking speed of the participants was calculated by dividing the distance walked by the time (6 minutes).

After the seven days of consecutive physical activity monitoring, data from the PAM was downloaded and the walking bouts were extracted using the same procedure used for the data presented in Chapter 5 (see par. 5.2.2). Briefly, all walking bouts were extracted together with start time, duration, and number of steps. In addition, the triaxial raw accelerometry data corresponding to each walking event lasting 10 seconds or more was extracted. The threshold was chosen to reduce the possible inaccuracies of PAM data corresponding to very short walking bouts (Dall et al., 2013; Stansfield et al., 2015). The timings of the initial contact events occurring during each walking bout were extracted using the WAIST algorithm. From the IC timings, each individual step duration was estimated and pooled within each walking event to obtain mean cadence and step duration coefficient of variation (CV).

The distribution of mean cadence by walking bout was calculated. Each bout was also allocated to cadence and step variability bands according to the corresponding mean cadence and CV value. This allows to examine the distribution of walking bout durations at each cadence and variability band (Granat et al., 2015).

The accumulation of walking by increasing cadence and step duration variability was also examined. For each participant, all walking bouts were ordered by cadence, from lowest to highest, and the cumulative sum of the steps taken was calculated. The plot of steps taken was then standardised to 100% of all steps taken, to allow comparison between participants. The same procedure was applied to produce accumulation curves of walking by step duration variability.

Preliminary results

The group did not have any major reported mobility limitations. Detailed group characteristics, mean cadence and step duration variability values obtained from the 6MWT performed during the visit are shown in Table 6-2. The MPE values (mean \pm sd) for the WAIST algorithm and the PAM for step detection in the 6MWT across the cohort were $3.5\% \pm 2.2\%$ and $1.0\% \pm 0.8\%$. Complete six days recordings were obtained from all participants.

Table 6-2. Patient groups characteristics and 6-Minutes Walking Test outcomes.

Group characteristics	Parameter	Value
	Age (years)	48.4 ± 13.5
	Height (m)	176.8 ± 7.9
	Weight (kg)	90.8 ± 17.0
	BMI (kg/m²)	29.1 ± 5.4
6-Minutes Walking Test	Parameter	Value
	Cadence (steps/min)	119.3 ± 10.4
	Step time CV (%)	2.07 ± 0.5
	Walking speed (m/s)	1.6 ± 0.2

The plots of walking bout length against cadence showed that for short walking bouts there was a wide spread of cadences, but for longer walking bouts the range decreased markedly (Figure 6-3A). When plotting the walking bout length against the step duration variability, the plots showed a high concentration of walking bouts with CV values below 20%, with a wide range of CVs for shorter walking bouts (Figure 6-3B). When the walking events were pooled into cadence bands, the plots showed that for walking bouts of longer duration, the frequency occurrence of the bouts was smaller and the range of cadence was narrower.

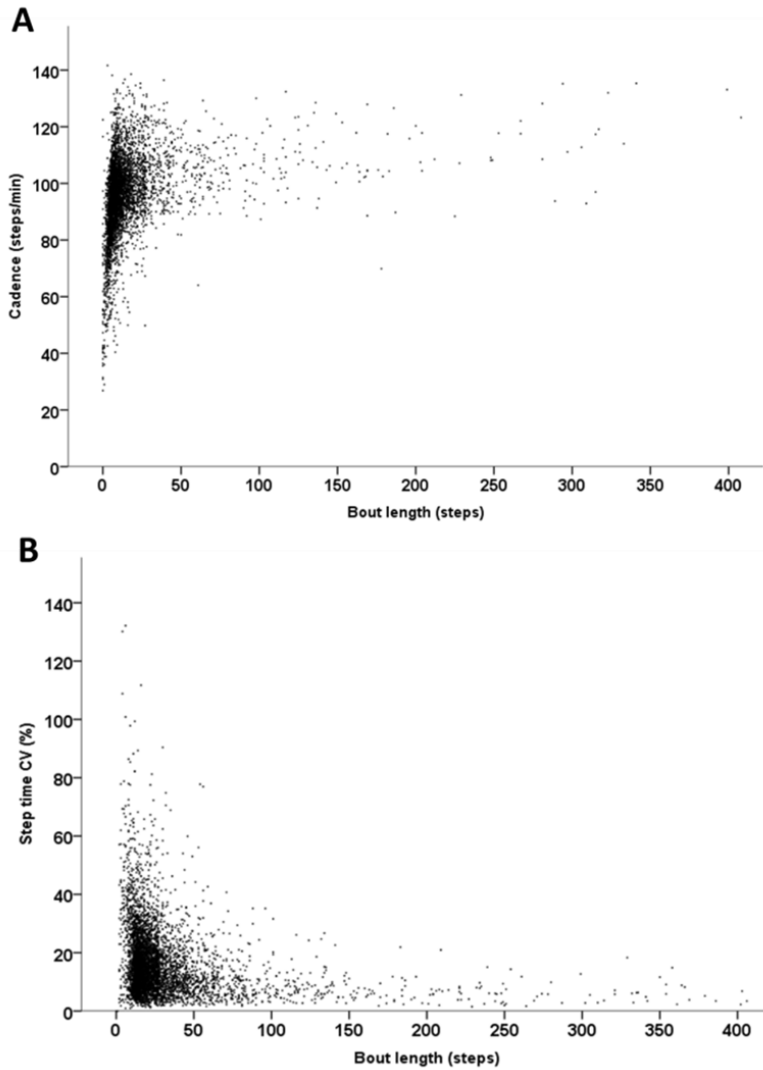

Figure 6-3. Cadence (A) and step duration variability (B) of a walking bout against the number of consecutive steps of that bout, for all walking bouts.

When pooling the walking bouts into bands of CV values, as the number of bouts decreased the CV range was smaller as the walking bout length increased (Figure 6-4). The accumulation curves for cadence and step duration variability are shown in Figure 6-5.

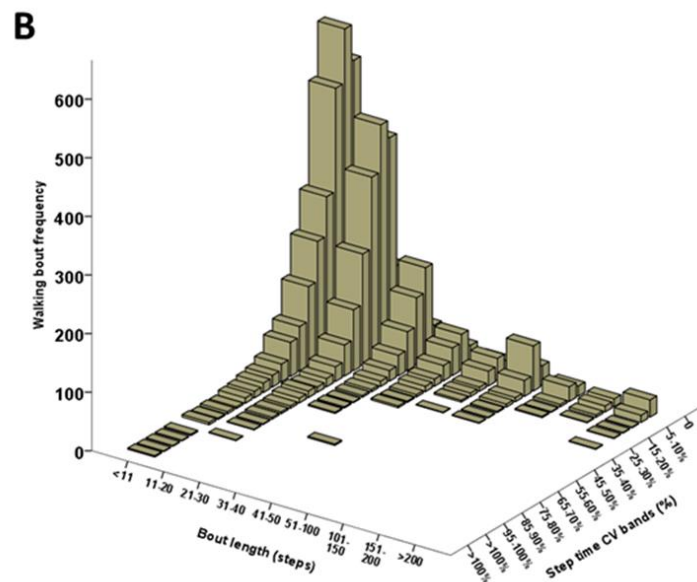
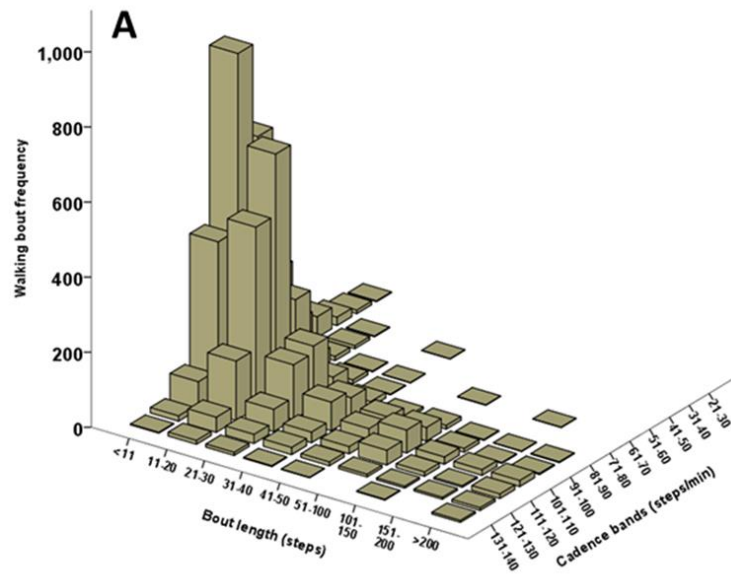

Figure 6-4. Cadence (A) and step duration variability (B) against walking bout length and number of bouts in predefined bands. The cadence bands were defined by cadences from 20 to 140 steps/min in increments of 10 steps/min. The step duration variability bands were defined by CV values from 5 to 100 % in increments of 5%.

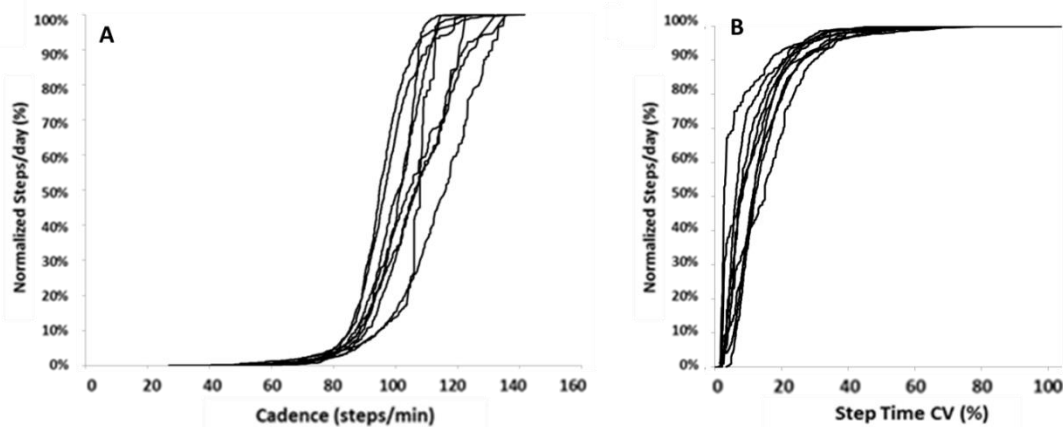

Figure 6-5. Cadence (A) and step duration variability (B) accumulation curves of steps. The curves show the normalized accumulation of steps for each individual.

Discussion

The aim of this work is to present preliminary data of an ongoing feasibility study examining the utility and feasibility of PAMs to assist patients with diabetes. For this purpose, an accurate and detailed quantification of daily living walking is necessary. Free living walking was quantified both in terms of cadence and step duration variability during continuous walking periods in a subset T1D and T2D patients. The small sample size of the two groups is due to the ongoing nature of the study. Since recruitment is not under the control of the author, it will be beyond reasonable time to wait until the whole cohort of patients (20 with T1D and 20 with T2D) takes part in the study. The pilot data analysed in this section is used to demonstrate the potential of the methodology adopted, and its usefulness for the investigation of free-living gait.

The results of the 6MWT performed in the clinics showed that the both the WAIST algorithm and the PAM performed well for this cohort, with errors in step detection accuracy lower than those reported in chapter 5 for the MS patients (see par. 5.3.1), and similar to those obtained for healthy participants (see chapter 4). The walking speed of the participants was well above the threshold of 0.5 m/s identified for the MS group as critical for the accuracy of the PAM (see par. 3.2.3). For these reasons, this pilot data may suggest that no participant will need to be excluded from the analysis of daily living data. The variability of step duration during free living walking bouts was larger than during the 6MWT. This held true also for the longest walking bouts, which general show smaller variability. This may provide further

evidence that outcomes of walking typically seen in controlled environment are likely to be not realistic in free-living conditions.

The plots associating the cadence/variability with the walking bout, and the classification into bands will allow comparing the frequency of these predefined cadence or variability bands between groups. Defined outcomes generated from the accumulation curves could be the percentage of steps taken above a given cadence/variability, and the cadence/variability below which a set percentage of steps was taken. The present work expands existing similar approaches (Granat et al., 2015) because the use of step-by-step values allows the analysis of the intra-event variability, in this case of step duration, for each walking bout.

6.2 Future work

Some of the limitations which have been brought up within the context of each chapter are the ground basis for further developments that were not accomplished in this thesis. In addition, the following recommendations may be the focus of future research.

The recent tendency toward sensor fusion approaches in research-grade monitors is now extending also to the areas of consumer-based fitness trackers. The increasing complexity and interest of the general public in this area is testified by discussions in media and specialized press regarding accuracy claims of the companies producing these devices, some of which have eventually generated class actions and legal suits (Lamkin, 2016a, 2016b; Steinberg, 2016). This increased awareness may challenge wearable sensor makers to provide strong evidence for their claims by supporting and funding evidence-based research grounded on strong methodological bases. In this context, the work presented in chapter 3 represents a starting point to further develop validation protocols.

In chapter 4, the algorithm for the detection was successfully used to discriminate between regular and irregular walking bouts. However, further tests in varied walking conditions may be beneficial to potentially extending its use, for example to detect the type of walking performed during shorter walks than those assessed in the presented study. The longer term aim would be to use it for specific patient populations in data collected during daily-living walking. Further research is

also needed in order to establish if the separate analysis of regular and irregular walking intervals during real-life gait monitoring can provide additional information on daily life walking.

Chapter 5 presented pilot data to propose a novel approach to analyse walking in daily living in a group of patients with multiple sclerosis. The investigation should be extended to larger sample sizes. Furthermore, the methodology should be tested in patient populations with different gait characteristics, but could also be extended to check for differences between this diabetic population, only mildly affected by mobility problems, and healthy volunteers. The investigation could also be extended to gait spatial parameters; however, the method may need additional tuning to make their estimate accurate in patient populations.

6.3 Conclusive remarks

In the last decades, technological advances in wearable sensor technology, and the increasing interest in the quantitative assessment of physical activity and walking, have facilitated the development of a novel field of research, aiming at providing clinicians and researchers with a new generation of wearable devices and methodologies capable of shifting clinical gait analysis from controlled, standardized environments to free living conditions. The aim of this thesis was to contribute to the progress in this area by addressing several aspects of validation, algorithm development, and data analysis, in both healthy participants and clinical populations.

A significant contribution of this thesis has been that of proving that the accuracy of physical activity monitors currently available on the market depends on a subjects' walking speed, even in healthy participants. These devices should hence be experimentally tested on every patient before being used for unsupervised monitoring of their gait. This could be obtained by using a short battery of controlled tests performed in controlled conditions, which can provide a reliable assessment of the errors of such devices, even on patient populations with mobility limitations. This information should be used to avoid monitoring patients for which the data can be expected to be inaccurate and to further improve the interpretation of real-life gait data.

This thesis also showed, for the first time, that current approaches to detect gait event timings and temporal parameters in controlled settings are suitable for the investigation of walking in daily life, at least in healthy individuals, objectively and quantitatively showing that wearable sensors are indeed suitable tools to overcome the limitations of confined laboratory tests and investigate walking in everyday life. In addition, by investigating the influence of environment and type of walking on gait temporal parameters, differences between controlled and free walking were quantified, providing a normative reference that could be used by the scientific community for interpreting differences eventually observed in patients.

Finally, this thesis also provided original and unique results for what concerns the comparison between laboratory based and daily living assessment of gait features in both healthy individuals and patients with multiple sclerosis. It was shown, in particular, that the quantitative outcomes of gait observed during walking bouts performed in controlled gait lab tests do not represent the typical walking pattern of daily living, but more likely represent a subject's top performance.

Bibliography

- Abaid, N., Cappa, P., Palermo, E., Petrarca, M., Porfiri, M., 2013. Gait Detection in Children with and without Hemiplegia Using Single-Axis Wearable Gyroscopes. *PLoS One* 8.
- Abdul Razak, A.H., Zayegh, A., Begg, R.K., Wahab, Y., 2012. Foot plantar pressure measurement system: A review. *Sensors (Switzerland)* 12, 9884–9912.
- Ainslie, P.N., Reilly, T., Westerterp, K.R., 2003. Estimating human energy expenditure: A review of techniques with particular reference to doubly labelled water. *Sport. Med.*
- Ainsworth, B.E., Haskell, W.L., Herrmann, S.D., Meckes, N., Bassett, D.R., Tudor-Locke, C., Greer, J.L., Vezina, J., Whitt-Glover, M.C., Leon, A.S., 2011. 2011 compendium of physical activities: A second update of codes and MET values. *Med. Sci. Sports Exerc.* 43, 1575–1581.
- Alvarez, J.C., Álvarez, D., López, A., González, R.C., 2012. Pedestrian Navigation Based on a Waist-Worn Inertial Sensor. *Sensors* 12, 10536–10549.
- American Diabetes Association, 2004. Diagnosis and Classification of Diabetes Mellitus. *Diabetes Care* 27, S5–S10.
- Aminian, K., Najafi, B., Büla, C., Leyvraz, P., Robert, P., 2002. Spatio-temporal parameters of gait measured by an ambulatory system using miniature gyroscopes. *J. Biomech.* 35, 689–699.
- Aminian, K., Rezakhanlou, K., De Andres, E., Fritsch, C., Leyvraz, P.F., Robert, P., 1999. Temporal feature estimation during walking using miniature accelerometers: an analysis of gait improvement after hip arthroplasty. *Med. Biol. Eng. Comput.* 37, 686–691.
- Aminian, K., Robert, P., Jequier, E., Schutz, Y., 1995. Incline, speed, and distance assessment during unconstrained walking. *Med. Sci. Sports Exerc.*
- Aminian, S., Hinckson, E.A., 2012. Examining the validity of the ActivPAL monitor in measuring posture and ambulatory movement in children. *Int. J. Behav. Nutr. Phys. Act.* 9.
- Antonsson, E.K., Mann, R.W., 1985. The frequency content of gait. *J. Biomech.* 18, 39–47.
- Ayabe, M., Aoki, J., Ishii, K., Takayama, K., Tanaka, H., 2008. Pedometer accuracy during stair climbing and bench stepping exercises. *J. Sports Sci. Med.* 7, 249–54.
- Bahreyni, B., Shafai, C., 2007. A resonant micromachined magnetic field sensor. *IEEE Sens. J.* 7, 1326–1334.
- Baker, R., 2007. The history of gait analysis before the advent of modern computers. *Gait Posture.*
- Barralon, P., Vuillerme, N., Noury, N., 2006. Walk detection with a kinematic sensor: Frequency and wavelet comparison. In: *Annual International Conference of the IEEE Engineering in Medicine and Biology - Proceedings.* pp. 1711–1714.
- Bassett, D.R., Ainsworth, B.E., Swartz, A.M., Strath, S.J., O'Brien, W.L., King, G.A., 2000. Validity of four motion sensors in measuring moderate intensity physical activity. *Med.*

Sci. Sports Exerc. 32, S471–S480.

- Bassuk, S.S., Manson, J.E., 2005. Epidemiological evidence for the role of physical activity in reducing risk of type 2 diabetes and cardiovascular disease. *J. Appl. Physiol.* 99, 1193–1204.
- Bastian, T., Maire, A., Dugas, J., Ataya, A., Villars, C., Gris, F., Perrin, E., Caritu, Y., Doron, M., Blanc, S., Jallon, P., Simon, C., 2015. Automatic identification of physical activity types and sedentary behaviors from triaxial accelerometer: laboratory-based calibrations are not enough. *J. Appl. Physiol.* 118, 716–22.
- Beauregard, S., 2006. A helmet-mounted pedestrian dead reckoning system. *Appl. Wearable Comput.* 1–11.
- Beijer, T.R., Lord, S.R., Brodie, M.A.D., 2013. Comparison of handheld video camera and GAITRite measurement of gait impairment in people with early stage Parkinson's disease: A pilot study. *J. Parkinsons. Dis.* 3, 199–203.
- Bhattacharyya, T.K., Roy, A.L., 2014. MEMS Piezoresistive Accelerometers. Springer India, pp. 19–34.
- Blin, O., Ferrandez, A.M., Serratrice, G., 1990. Quantitative analysis of gait in Parkinson patients: increased variability of stride length. *J. Neurol. Sci.* 98, 91–7.
- Bogue, R., 2007. MEMS sensors: past, present and future. *Sens. Rev.* 27, 7–13.
- Bonomi, a G., Westerterp, K.R., 2012. Advances in physical activity monitoring and lifestyle interventions in obesity: a review. *Int. J. Obes. (Lond).* 36, 167–77.
- Bourgeois, B. a, Mariani, B., Aminian, K., Zambelli, P.Y., Newman, C.J., 2014. Spatio-temporal gait analysis in children with cerebral palsy using, foot-worn inertial sensors. *Gait Posture* 39, 436–42.
- Bouten, C. V, Koekkoek, K.T., Verduin, M., Kodde, R., Janssen, J.D., 1997. A triaxial accelerometer and portable data processing unit for the assessment of daily physical activity. *IEEE Trans. Biomed. Eng.* 44, 136–47.
- Brajdic, A., Harle, R., 2013. Walk Detection and Step Counting on Unconstrained Smartphones. In: SIGCHI Conference Proceedings.
- Brandes, M., VAN Hees, V.T., Hannöver, V., Brage, S., 2012. Estimating energy expenditure from raw accelerometry in three types of locomotion. *Med. Sci. Sports Exerc.* 44, 2235–42.
- Bravata, D.M., Smith-Spangler, C., Sundaram, V., Gienger, A.L., Lin, N., Lewis, R., Stave, C.D., Olkin, I., Sirard, J.R., 2007. Using pedometers to increase physical activity and improve health: a systematic review. *JAMA* 298, 2296–2304.
- Brodie, M., Coppens, M., Lord, S.R., Lovell, N.H., Gschwind, Y.J., Redmond, S.J., Del Rosario, M.B., Wang, K., Sturnieks, D.L., Persiani, M., Delbaere, K., 2016. Wearable pendant device monitoring using new wavelet-based methods shows daily life and laboratory gaits are different. *Med. Biol. Eng. Comput.* 54, 663–74.
- Brodie, M., Walmsley, A., Page, W., 2008. The static accuracy and calibration of inertial measurement units for 3D orientation. *Comput. Methods Biomech. Biomed. Engin.* 11, 641–648.
- Butler, L., Furber, S., Phongsavan, P., Mark, A., Bauman, A., 2009. Effects of a pedometer-

- based intervention on physical activity levels after cardiac rehabilitation: a randomized controlled trial. *J. Cardiopulm. Rehabil. Prev.* 29, 105–14.
- Butte, N.F., Ekelund, U., Westerterp, K.R., 2012. Assessing physical activity using wearable monitors: measures of physical activity. *Med. Sci. Sports Exerc.* 44, S5-12.
- Byrne, N.M., Hills, A.P., Hunter, G.R., Weinsier, R.L., Schutz, Y., 2005. Metabolic equivalent: one size does not fit all. *J. Appl. Physiol.* 99, 1112–9.
- Calabró, M.A., Stewart, J.M., Welk, G.J., 2013. Validation of pattern-recognition monitors in children using doubly labeled water. *Med. Sci. Sports Exerc.* 45, 1313–1322.
- Cameron, M.H., Wagner, J.M., 2011. Gait abnormalities in multiple sclerosis: Pathogenesis, evaluation, and advances in treatment. *Curr. Neurol. Neurosci. Rep.* 11, 507–515.
- Cappozzo, A., 1982. Low frequency self-generated vibration during ambulation in normal men. *J. Biomech.* 15, 599–609.
- Cappozzo, A., Della Croce, U., Leardini, A., Chiari, L., 2005. Human movement analysis using stereophotogrammetry. Part 1: theoretical background. *Gait Posture* 21, 186–196.
- Carstensen, M., Herder, C., Kivimäki, M., Jokela, M., Roden, M., Shipley, M.J., Witte, D.R., Brunner, E.J., Tabák, A.G., 2010. Accelerated Increase in Serum Interleukin-1 Receptor Antagonist Starts 6 Years Before Diagnosis of Type 2 Diabetes Whitehall II Prospective Cohort Study. *Diabetes* 59, 1222–1227.
- Carter, a, Daley, a, Humphreys, L., Snowdon, N., Woodroffe, N., Petty, J., Roalfe, a, Tosh, J., Sharrack, B., Saxton, J., 2014. Pragmatic intervention for increasing self-directed exercise behaviour and improving important health outcomes in people with multiple sclerosis: a randomised controlled trial. *Mult. Scler.* 20, 1112–1122.
- Case, M.A., Burwick, H.A., Volpp, K.G., Patel, M.S., 2015. Accuracy of Smartphone Applications and Wearable Devices for Tracking Physical Activity Data. *J. Am. Med. Assoc.* 313, 625.
- Caspersen, C.J., Powell, K.E., Christenson, G.M., 1985. Physical activity, exercise, and physical fitness: definitions and distinctions for health-related research. *Public Health Rep.* 100, 126–31.
- Catalfamo, P., Ghousayni, S., Ewins, D., 2010. Gait event detection on level ground and incline walking using a rate gyroscope. *Sensors (Basel).* 10, 5683–702.
- Cavagna, G., Saibene, F.P., Margaria, R., 1963. External work in walking. *J. Appl. Physiol.* 18, 1–9.
- Cereatti, A., Trojaniello, D., Croce, U. Della, 2015. Accurately measuring human movement using magneto-inertial sensors: Techniques and challenges. In: 2nd IEEE International Symposium on Inertial Sensors and Systems, IEEE ISISS 2015 - Proceedings. Institute of Electrical and Electronics Engineers Inc.
- Chen, H.C., Ashton-Miller, J., Alexander, N., Schultz, A., 1994. Age effects on strategies used to avoid obstacles. *Gait Posture* 2, 139–146.
- Chen, K.Y., Janz, K.F., Zhu, W., Brychta, R.J., 2012. Redefining the roles of sensors in objective physical activity monitoring. *Med. Sci. Sports Exerc.* 44, S13-23.
- Chiari, L., Della Croce, U., Leardini, A., Cappozzo, A., 2005. Human movement analysis using stereophotogrammetry. Part 2: Instrumental errors. *Gait Posture*.

- Ciuti, G., Ricotti, L., Menciassi, A., Dario, P., 2015. MEMS sensor technologies for human centred applications in healthcare, physical activities, safety and environmental sensing: A review on research activities in Italy. *Sensors (Switzerland)* 15, 6441–6468.
- Clarke-Moloney, M., Godfrey, A., O'Connor, V., Meagher, H., Burke, P.E., Kavanagh, E.G., Grace, P.A., Lyons, G.M., 2007. Mobility in patients with venous leg ulceration. *Eur. J. Vasc. Endovasc. Surg.* 33, 488–93.
- Cohen, J., 1988. Statistical power analysis for the behavioral sciences. *Stat. Power Anal. Behav. Sci.*
- Colburn, T.R., Smith, B.M., Guarini, J.J., Simmons, N.N., 1976. An ambulatory activity monitor with solid state memory. *Biomed. Sci. Instrum.* 12, 117–122.
- Cooper, D., 1993. Comparison of Activity Sensors and Algorithms for Rate Responsive Pacemakers Using Ambulatory Monitoring. *Proc. Comput. Cardiol.* 851–854.
- Costa, M., Peng, C.K., Goldberger, A.L., Hausdorff, J.M., 2003. Multiscale entropy analysis of human gait dynamics. In: *Physica A: Statistical Mechanics and Its Applications*. pp. 53–60.
- Crenshaw, S.J., Royer, T.D., Richards, J.G., Hudson, D.J., 2006. Gait variability in people with multiple sclerosis. *Mult. Scler.* 12, 613–619.
- Crouter, S.E., Schneider, P.L., Bassett, D.R., 2005. Spring-levered versus piezo-electric pedometer accuracy in overweight and obese adults. *Med. Sci. Sports Exerc.* 37, 1673–1679.
- Crouter, S.E., Schneider, P.L., Karabulut, M., Bassett, D.R., 2003. Validity of 10 electronic pedometers for measuring steps, distance, and energy cost. *Med. Sci. Sports Exerc.* 35, 1455–1460.
- Currie, G., Rafferty, D., Duncan, G., Bell, F., Evans, A.L., 1992. Measurement of gait by accelerometer and walkway: A comparison study. *Med. Biol. Eng. Comput.* 30, 669–670.
- Dahlgren, G., Carlsson, D., Moorhead, A., Häger-Ross, C., McDonough, S.M., 2010. Test-retest reliability of step counts with the ActivPAL™ device in common daily activities. *Gait Posture* 32, 386–90.
- Dall, P.M., McCrorie, P.R.W., Granat, M.H., Stansfield, B.W., 2013. Step accumulation per minute epoch is not the same as cadence for free-living adults. *Med. Sci. Sports Exerc.* 45, 1995–2001.
- Damsgaard, M., Rasmussen, J., Christensen, S.T., Surma, E., de Zee, M., 2006. Analysis of musculoskeletal systems in the AnyBody Modeling System. *Simul. Model. Pract. Theory* 14, 1100–1111.
- Davis, J., Murphy, M., Trinick, T., Duly, E., Nevill, A., Davison, G., 2008. Acute effects of walking on inflammatory and cardiovascular risk in sedentary post-menopausal women. *J. Sports Sci.* 26, 303–9.
- De Greef, K., Deforche, B., Tudor-Locke, C., De Bourdeaudhuij, I., 2010. A cognitive-behavioural pedometer-based group intervention on physical activity and sedentary behaviour in individuals with type 2 diabetes. *Health Educ. Res.* 25, 724–36.
- de Groot, S., Nieuwenhuizen, M.G., 2013. Validity and reliability of measuring activities, movement intensity and energy expenditure with the DynaPort MoveMonitor. *Med.*

Eng. Phys. 35, 1499–505.

- De Lorenzo, A., Tagliabue, A., Andreoli, A., Testolin, G., Comelli, M., Deurenberg, P., 2001. Measured and predicted resting metabolic rate in Italian males and females, aged 18–59 y. *Eur. J. Clin. Nutr.* 55, 208–14.
- Dekker, M.J., Lee, S., Hudson, R., Kilpatrick, K., Graham, T.E., Ross, R., Robinson, L.E., 2007. An exercise intervention without weight loss decreases circulating interleukin-6 in lean and obese men with and without type 2 diabetes mellitus. *Metabolism*. 56, 332–338.
- Del Din, S., Godfrey, A., Galna, B., Lord, S., Rochester, L., 2016a. Free-living gait characteristics in ageing and Parkinson’s disease: impact of environment and ambulatory bout length. *J. Neuroeng. Rehabil.* 13, 46.
- Del Din, S., Godfrey, A., Mazzà, C., Lord, S., Rochester, L., 2016b. Free-living monitoring of Parkinson’s disease: Lessons from the field. *Mov. Disord.*
- Del Din, S., Godfrey, A., Rochester, L., 2015. Validation of an accelerometer to quantify a comprehensive battery of gait characteristics in healthy older adults and Parkinson’s disease: toward clinical and at home use. *IEEE J. Biomed. Heal. informatics* 2194, 1–10.
- del Rosario, M.B., Redmond, S.J., Lovell, N.H., 2015. Tracking the Evolution of Smartphone Sensing for Monitoring Human Movement. *Sensors (Basel)*. 15, 18901–33.
- Delp, S.L., Anderson, F.C., Arnold, A.S., Loan, P., Habib, A., John, C.T., Guendelman, E., Thelen, D.G., 2007. OpenSim: Open-Source Software to Create and Analyze Dynamic Simulations of Movement. *IEEE Trans. Biomed. Eng.* 54, 1940–1950.
- Department of Health of The United Kingdom, 2004. Publications policy and guidance: at least five weeks: evidence on the impact of physical activity and its relationship to health [WWW Document].
- Di Raimondo, D., Tuttolomondo, A., Buttà, C., Casuccio, A., Giarrusso, L., Miceli, G., Licata, G., Pinto, A., 2013. Metabolic and anti-inflammatory effects of a home-based programme of aerobic physical exercise. *Int. J. Clin. Pract.* 67, 1247–1253.
- Diaz, K.M., Krupka, D.J., Chang, M.J., Peacock, J., Ma, Y., Goldsmith, J., Schwartz, J.E., Davidson, K.W., 2015. Fitbit: An accurate and reliable device for wireless physical activity tracking. *Int. J. Cardiol.*
- Dijkstra, B., Kamsma, Y., Zijlstra, W., 2009. Detection of gait and postures using a miniaturised triaxial accelerometer-based system: Accuracy in community-dwelling older adults. *Age Ageing* 39, 259–262.
- Dijkstra, B., Kamsma, Y.P., Zijlstra, W., 2010. Detection of gait and postures using a miniaturized triaxial accelerometer-based system: accuracy in patients with mild to moderate Parkinson’s disease. *Arch. Phys. Med. Rehabil.* 91, 1272–7.
- Dijkstra, B., Zijlstra, W., Scherder, E., Kamsma, Y., 2008. Detection of walking periods and number of steps in older adults and patients with Parkinson’s disease: accuracy of a pedometer and an accelerometry-based method. *Age Ageing* 37, 436–41.
- Dingwell, J.B., Kang, H.G., 2007. Differences between local and orbital dynamic stability during human walking. *J. Biomech. Eng.* 129, 586–593.

- Dixon, N.C., Hurst, T.L., Talbot, D.C.S., Tyrrell, R.M., Thompson, D., 2013. Effect of short-term reduced physical activity on cardiovascular risk factors in active lean and overweight middle-aged men. *Metabolism*. 62, 361–368.
- Donath, M.Y., Shoelson, S.E., 2011. Type 2 diabetes as an inflammatory disease. *Nat. Rev. Immunol.* 11, 98–107.
- Donovan, K., Lord, S.E., McNaughton, H.K., Weatherall, M., 2008. Mobility beyond the clinic: the effect of environment on gait and its measurement in community-ambulant stroke survivors. *Clin. Rehabil.* 22, 556–563.
- Duncan, B.B., Schmidt, M.I., Pankow, J.S., Ballantyne, C.M., Couper, D., Vigo, a., Hoogeveen, R., Folsom, a. R., Heiss, G., 2003. Low-Grade Systemic Inflammation and the Development of Type 2 Diabetes: The Atherosclerosis Risk in Communities Study. *Diabetes* 52, 1799–1805.
- Dwyer, T., Hosmer, D., Hosmer, T., Venn, A.J., Blizzard, C.L., Granger, R.H., Cochrane, J.A., Blair, S.N., Shaw, J.E., Zimmet, P.Z., Dunstan, D., 2007. The inverse relationship between number of steps per day and obesity in a population-based sample: the AusDiab study. *Int. J. Obes. (Lond)*. 31, 797–804.
- Elble, R.J., 2005. Gravitational artifact in accelerometric measurements of tremor. *Clin. Neurophysiol.* 116, 1638–1643.
- Esliger, D.W., Rowlands, A. V., Hurst, T.L., Catt, M., Murray, P., Eston, R.G., 2011. Validation of the GENE accelerometer. *Med. Sci. Sports Exerc.* 43, 1085–1093.
- Evans, A.L., Duncan, G., Gilchrist, W., 1991. Recording accelerations in body movements. *Med. Biol. Eng. Comput.* 29, 102–104.
- Ferguson, T., Rowlands, A. V, Olds, T., Maher, C., 2015. The validity of consumer-level, activity monitors in healthy adults worn in free-living conditions: a cross-sectional study. *Int. J. Behav. Nutr. Phys. Act.* 12, 42.
- Figo, D., Diniz, P.C., Ferreira, D.R., Cardoso, J.M.P., 2010. Preprocessing techniques for context recognition from accelerometer data. *Pers. Ubiquitous Comput.* 14, 645–662.
- Fokkenrood, H.J.P., Verhofstad, N., van den Houten, M.M.L., Lauret, G.J., Wittens, C., Scheltinga, M.R.M., Teijink, J.A.W., 2014. Physical Activity Monitoring in Patients with Peripheral Arterial Disease: Validation of an Activity Monitor. *Eur. J. Vasc. Endovasc. Surg.*
- Fortune, E., Lugade, V., Morrow, M., Kaufman, K., 2014. Validity of using tri-axial accelerometers to measure human movement - Part II: Step counts at a wide range of gait velocities. *Med. Eng. Phys.* 36, 659–69.
- Frankenfield, D., Roth-Yousey, L., Compher, C., 2005. Comparison of predictive equations for resting metabolic rate in healthy nonobese and obese adults: a systematic review. *J. Am. Diet. Assoc.* 105, 775–89.
- Freedson, P., Bowles, H.R., Troiano, R., Haskell, W., 2012. Assessment of physical activity using wearable monitors: recommendations for monitor calibration and use in the field. *Med. Sci. Sports Exerc.* 44, S1-4.
- Freedson, P.S., Brendley, K., Ainsworth, B.E., Kohl, H.W., Leslie, E., Owen, N., 2008. New techniques and issues in assessing walking behavior and its contexts. *Med. Sci. Sports Exerc.*

- Frenkel-Toledo, S., Giladi, N., Peretz, C., Herman, T., Gruendlinger, L., Hausdorff, J.M., 2005. Treadmill walking as an external pacemaker to improve gait rhythm and stability in Parkinson's disease. *Mov. Disord.* 20, 1109–14.
- Fulk, G.D., Combs, S.A., Danks, K.A., Nirider, C.D., Raja, B., Reisman, D.S., 2014. Accuracy of 2 Activity Monitors in Detecting Steps in People With Stroke and Traumatic Brain Injury. *Phys. Ther.* 94, 222–229.
- Furber, S., Butler, L., Phongsavan, P., Mark, A., Bauman, A., 2010. Randomised controlled trial of a pedometer-based telephone intervention to increase physical activity among cardiac patients not attending cardiac rehabilitation. *Patient Educ. Couns.* 80, 212–8.
- Furlanetto, K.C., Bisca, G.W., Oldemberg, N., Sant'anna, T.J., Morakami, F.K., Camillo, C. a, Cavalheri, V., Hernandez, N. a, Probst, V.S., Ramos, E.M., Brunetto, A.F., Pitta, F., 2010. Step counting and energy expenditure estimation in patients with chronic obstructive pulmonary disease and healthy elderly: accuracy of 2 motion sensors. *Arch. Phys. Med. Rehabil.* 91, 261–7.
- Gad-el-Hak, M., 2001. *The MEMS Handbook, Mechanics of Composite Materials.*
- Gage, H., 1964. Accelerographic analysis of human gait. *Am. Soc. Mech. Eng.* 1–12.
- Gaglani, S., Moore, J., Haynes, M.R., Hoffberger, J.B., Rigamonti, D., 2015. Using Commercial Activity Monitors to Measure Gait in Patients with Suspected iNPH: Implications for Ambulatory Monitoring. *Curēus* 7, e382.
- Gano, L.B., Donato, A.J., Pierce, G.L., Pasha, H.M., Magerko, K. a, Roeca, C., Seals, D.R., 2011. Increased proinflammatory and oxidant gene expression in circulating mononuclear cells in older adults: amelioration by habitual exercise. *Physiol. Genomics* 43, 895–902.
- Garrett, M., Coote, S., 2009. Multiple sclerosis and exercise in people with minimal gait impairment – a review. *Phys. Ther. Rev.*
- Gates, D.H., Dingwell, J.B., 2007. Peripheral neuropathy does not alter the fractal dynamics of stride intervals of gait. *J. Appl. Physiol.* 102, 965–71.
- Gefen, A., 2007. Pressure-Sensing Devices for Assessment of Soft Tissue Loading Under Bony Prominences: Technological Concepts and Clinical Utilization. *Wounds* 19, 350–362.
- Ghoussayni, S., Stevens, C., Durham, S., Ewins, D., 2004. Assessment and validation of a simple automated method for the detection of gait events and intervals. *Gait Posture* 20, 266–272.
- Giannopoulou, I., Fernhall, B., Carhart, R., Weinstock, R.S., Baynard, T., Figueroa, A., Kanaley, J.A., 2016. Effects of diet and/or exercise on the adipocytokine and inflammatory cytokine levels of postmenopausal women with type 2 diabetes. *Metab. - Clin. Exp.* 54, 866–875.
- Glaister, B.C., Bernatz, G.C., Klute, G.K., Orendurff, M.S., 2007. Video task analysis of turning during activities of daily living. *Gait Posture* 25, 289–294.
- Godfrey, A., Culhane, K.M., Lyons, G.M., 2007. Comparison of the performance of the activPAL Professional physical activity logger to a discrete accelerometer-based activity monitor. *Med. Eng. Phys.* 29, 930–4.
- González, R.C., López, A.M., Rodríguez-Uría, J., Álvarez, D., Alvarez, J.C., 2010. Real-

- time gait event detection for normal subjects from lower trunk accelerations. *Gait Posture* 31, 322–325.
- Goyal, P., Ribeiro, V.J., Saran, H., Kumar, A., 2011. Strap-Down Pedestrian Dead-Reckoning System 21–23.
- Granat, M., Clarke, C., Holdsworth, R., Stansfield, B., Dall, P., 2015. Quantifying the cadence of free-living walking using event-based analysis. *Gait Posture* 42, 85–90.
- Granat, M.H., 2012. Event-based analysis of free-living behaviour. *Physiol. Meas.* 33, 1785–1800.
- Grant, P.M., Dall, P.M., Mitchell, S.L., Granat, M.H., 2008. Activity-monitor accuracy in measuring step number and cadence in community-dwelling older adults. *J. Aging Phys. Act.* 16, 201–14.
- Grant, P.M., Granat, M.H., Thow, M.K., Maclaren, W.M., 2010. Analyzing Free-Living Physical Activity of Older Adults in Different Environments Using Body-Worn Activity Monitors. *J. Aging Phys. Act.* 18, 171–184.
- Grant, P.M., Ryan, C.G., Tigbe, W.W., Granat, M.H., 2006. The validation of a novel activity monitor in the measurement of posture and motion during everyday activities. *Br. J. Sports Med.* 40, 992–997.
- Gray, S.R., Baker, G., Wright, A., Fitzsimons, C.F., Mutrie, N., Nimmo, M.A., 2009. The effect of a 12-week walking intervention on markers of insulin resistance and systemic inflammation. *Prev. Med. (Baltim.)* 48, 39–44.
- Greene, B.R., McGrath, D., O’Neill, R., O’Donovan, K.J., Burns, A., Caulfield, B., 2010. An adaptive gyroscope-based algorithm for temporal gait analysis. *Med. Biol. Eng. Comput.* 48, 1251–1260.
- Guimaraes, R.M., Isaacs, B., 1980. Characteristics of the gait in old people who fall. *Int. Rehabil. Med.* 2, 177–80.
- Hamacher, D., Singh, N.B., Van Dieen, J.H., Heller, M.O., Taylor, W.R., 2011. Kinematic measures for assessing gait stability in elderly individuals: a systematic review. *J. R. Soc. Interface* 8, 1682–1698.
- Hamer, M., Steptoe, A., 2008. Walking, vigorous physical activity, and markers of hemostasis and inflammation in healthy men and women. *Scand. J. Med. Sci. Sport.* 18, 736–741.
- Hamilton, M., Hamilton, D., Zderic, T., 2007. Role of low energy expenditure and sitting in obesity, metabolic syndrome, type 2 diabetes, and cardiovascular disease. *Diabetes* 56, 2655–2667.
- Hardman, C. a, Horne, P.J., Fergus Lowe, C., 2011. Effects of rewards, peer-modelling and pedometer targets on children’s physical activity: a school-based intervention study. *Psychol. Health* 26, 3–21.
- Harris, N., Britton, E., Turton, A., 2005. Evaluation of a single axis accelerometry system for monitoring sit to stand activity in stroke patients. In: *Proceedings of the Society for Research in Rehabilitation (SSR) Summer Meeting.*
- Harrison, S.L., Horton, E.J., Smith, R., Sandland, C.J., Steiner, M.C., Morgan, M.D.L., Singh, S.J., 2013. Physical activity monitoring: Addressing the difficulties of accurately detecting slow walking speeds. *Heart Lung* 42, 361–364.e1.

- Haskell, W.L., Lee, I.-M., Pate, R.R., Powell, K.E., Blair, S.N., Franklin, B. a, Macera, C. a, Heath, G.W., Thompson, P.D., Bauman, A., 2007. Physical activity and public health: updated recommendation for adults from the American College of Sports Medicine and the American Heart Association. *Circulation* 116, 1081–93.
- Hausdorff, J.M., 2007. Gait dynamics, fractals and falls: Finding meaning in the stride-to-stride fluctuations of human walking. *Hum. Mov. Sci.* 26, 555–589.
- Hausdorff, J.M., Cudkowicz, M.E., Firtion, R., Wei, J.Y., Goldberger, A.L., 1998. Gait variability and basal ganglia disorders: Stride-to-stride variations of gait cycle timing in Parkinson's disease and Huntington's disease. *Mov. Disord.* 13, 428–437.
- Hausdorff, J.M., Edelberg, H.K., Mitchell, S.L., Goldberger, A.L., Wei, J.Y., 1997a. Increased gait unsteadiness in community-dwelling elderly fallers. *Arch. Phys. Med. Rehabil.* 78, 278–283.
- Hausdorff, J.M., Forman, D.E., Pilgrim, D.M., Rigney, D.R., Wei, J.Y., 1992. A new technique for simultaneous monitoring of electrocardiogram and walking cadence. *Am. J. Cardiol.* 70, 1064–1071.
- Hausdorff, J.M., Herman, T., Baltadjieva, R., Gurevich, T., Giladi, N., 2003. Balance and Gait in Older Adults With Systemic Hypertension. *Am. J. Cardiol.* 91, 643–645.
- Hausdorff, J.M., Ladin, Z., Wei, J.Y., 1995. Footswitch system for measurement of the temporal parameters of gait. *J. Biomech.* 28, 347–351.
- Hausdorff, J.M., Lertratanakul, a, Cudkowicz, M.E., Peterson, a L., Kaliton, D., Goldberger, a L., 2000. Dynamic markers of altered gait rhythm in amyotrophic lateral sclerosis. *J. Appl. Physiol.* 88, 2045–2053.
- Hausdorff, J.M., Mitchell, S.L., Firtion, R., Peng, C.K., Cudkowicz, M.E., Wei, J.Y., Goldberger, a L., 1997b. Altered fractal dynamics of gait: reduced stride-interval correlations with aging and Huntington's disease. *J. Appl. Physiol.* 82, 262–269.
- Hausdorff, J.M., Peng, C.K., Ladin, Z., Wei, J.Y., Goldberger, A.L., 1995. Is walking a random walk? Evidence for long-range correlations in stride interval of human gait. *J. Appl. Physiol.* 78, 349–58.
- Hausdorff, J.M., Rios, D.A., Edelberg, H.K., 2001. Gait variability and fall risk in community-living older adults: a 1-year prospective study. *Arch. Phys. Med. Rehabil.* 82, 1050–6.
- Healy, G., Dunstan, D.W., Salmon, J., Cerin, E., Shaw, J., Zimmet, P., Owen, N., 2008. Beneficial associations with metabolic risk. *Diabetes Care* 31, 661–666.
- Hemmett, L., Holmes, J., Barnes, M., Russell, N., 2004. What drives quality of life in multiple sclerosis? *QJM - Mon. J. Assoc. Physicians* 97, 671–676.
- Henson, J., Yates, T., Biddle, S.J.H., Edwardson, C.L., Khunti, K., Wilmot, E.G., Gray, L.J., Gorely, T., Nimmo, M.A., Davies, M.J., 2013. Associations of objectively measured sedentary behaviour and physical activity with markers of cardiometabolic health. *Diabetologia* 56, 1012–1020.
- Herder, C., Brunner, E.J., Rathmann, W., Strassburger, K., Tab??k, A.G., Schloot, N.C., Witte, D.R., 2009. Elevated levels of the anti-inflammatory interleukin-1 receptor antagonist precede the onset of type 2 diabetes: The whitehall II study. *Diabetes Care* 32, 421–423.

- Herder, C., Illig, T., Rathmann, W., Martin, S., Haastert, B., Müller-Scholze, S., Holle, R., Thorand, B., Koenig, W., Wichmann, H.E., Kolb, H., 2005. Inflammation and type 2 diabetes: Results from KORA Augsburg. *Gesundheitswesen*.
- Herrera-May, A.L., Aguilera-Cortés, L.A., García-Ramírez, P.J., Manjarrez, E., 2009. Resonant magnetic field sensors based on MEMS technology. *Sensors* 9, 7785–7813.
- Ho, S.S., Dhaliwal, S.S., Hills, A.P., Pal, S., 2012. Effects of Chronic Exercise Training on Inflammatory Markers in Australian Overweight and Obese Individuals in a Randomized Controlled Trial. *Inflammation*.
- Hobart, J.C., Riazi, A., Lamping, D.L., Fitzpatrick, R., Thompson, A.J., 2003. Measuring the impact of MS on walking ability: the 12-Item MS Walking Scale (MSWS-12). *Neurology* 60, 31–36.
- Hollman, J.H., McDade, E.M., Petersen, R.C., 2011. Normative spatiotemporal gait parameters in older adults. *Gait Posture* 34, 111–118.
- Horne, P.J., Hardman, C. a, Lowe, C.F., Rowlands, a V, 2009. Increasing children's physical activity: a peer modelling, rewards and pedometer-based intervention. *Eur. J. Clin. Nutr.* 63, 191–198.
- Hotamisligil, G.S., 2006. Inflammation and metabolic disorders 1. *Nature* 444, 860–867.
- Hurmuzlu, Y., Basdogan, C., 1994. On the measurement of dynamic stability of human locomotion. *J. Biomech. Eng.* 116, 30–36.
- Ichinoseki-Sekine, N., Kuwae, Y., Higashi, Y., Fujimoto, T., Sekine, M., Tamura, T., 2006. Improving the accuracy of pedometer used by the elderly with the FFT algorithm. *Med. Sci. Sports Exerc.* 38, 1674–81.
- International Diabetes Federation, 2015. *Idf Diabetes Atlas*, *Idf Diabetes Atlas*.
- Izzicupo, P., D'Amico, M.A., Bascelli, A., Di Fonso, A., D'Angelo, E., Di Blasio, A., Bucci, I., Napolitano, G., Gallina, S., Di Baldassarre, A., 2013. Walking training affects dehydroepiandrosterone sulfate and inflammation independent of changes in spontaneous physical activity. *Menopause* 20, 455–63.
- Janssen, I., 2012. Health care costs of physical inactivity in Canadian adults. *Appl. Physiol. Nutr. Metab.* 37, 803–806.
- Jasiewicz, J.M., Allum, J.H.J., Middleton, J.W., Barriskill, A., Condie, P., Purcell, B., Li, R.C.T., 2006. Gait event detection using linear accelerometers or angular velocity transducers in able-bodied and spinal-cord injured individuals. *Gait Posture* 24, 502–509.
- Jennersjö, P., Ludvigsson, J., Länne, T., Nystrom, F.H., Ernerudh, J., Östgren, C.J., 2012. Pedometer-determined physical activity is linked to low systemic inflammation and low arterial stiffness in Type 2 diabetes. *Diabet. Med.* 29, 1119–1125.
- Jiang, Y., Larson, J.L., 2013. IDEEA activity monitor: validity of activity recognition for lying, reclining, sitting and standing. *Front. Med.* 7, 126–31.
- Johannsen, D.L., Calabro, M.A., Stewart, J., Franke, W., Rood, J.C., Welk, G.J., 2010. Accuracy of armband monitors for measuring daily energy expenditure in healthy adults. *Med. Sci. Sports Exerc.* 42, 2134–40.
- Kang, M., Brinthaup, T.M., 2009. Effects of group and individual-based step goals on

- children's physical activity levels in school. *Pediatr. Exerc. Sci.* 21, 148–158.
- Kang, M., Marshall, S.J., Barreira, T. V, Lee, J.-O., 2009. Effect of pedometer-based physical activity interventions: a meta-analysis. *Res. Q. Exerc. Sport* 80, 648–655.
- Kavanagh, J.J., Menz, H.B., 2008. Accelerometry: A technique for quantifying movement patterns during walking. *Gait Posture*.
- Kelleher, K.J., Spence, W., Solomonidis, S., Apatsidis, D., 2010. The characterisation of gait patterns of people with multiple sclerosis. *Disabil. Rehabil.* 32, 1242–1250.
- Kim, J.W., Jang, H.J., Hwang, D.-H., Park, C., 2004. A Step, Stride and Heading Determination for the Pedestrian Navigation System. *J. Glob. Position. Syst.* 3, 273–279.
- Kimmeskamp, S., Hennig, E.M., 2001. Heel to toe motion characteristics in Parkinson patients during free walking. *Clin. Biomech.* 16, 806–812.
- Klaren, R.E., Sebastiao, E., Chiu, C.-Y., Kinnett-Hopkins, D., McAuley, E., Motl, R.W., 2016. Levels and Rates of Physical Activity in Older Adults with Multiple Sclerosis. *Aging Dis.* 7, 278–284.
- Klenk, J., Denking, M., Nikolaus, T., Peter, R., Rothenbacher, D., Koenig, W., 2013. Association of objectively measured physical activity with established and novel cardiovascular biomarkers in elderly subjects: every step counts. *J. Epidemiol. Community Health* 67, 194–7.
- Kolb, H., Mandrup-Poulsen, T., 2005. An immune origin of type 2 diabetes? *Diabetologia*.
- Koning, B.H.W., van der Krogt, M.M., Baten, C.T.M., Koopman, B.F.J.M., 2013. Driving a musculoskeletal model with inertial and magnetic measurement units. *Comput. Methods Biomech. Biomed. Engin.* 5842, 37–41.
- Kose, A., Cereatti, A., Della Croce, U., 2012. Bilateral step length estimation using a single inertial measurement unit attached to the pelvis. *J. Neuroeng. Rehabil.* 9, 9.
- Kotiadis, D., Hermens, H.J., Veltink, P.H., 2010. Inertial Gait Phase Detection for control of a drop foot stimulator. *Inertial sensing for gait phase detection. Med. Eng. Phys.* 32, 287–297.
- Krause, M., Rodrigues-Krause, J., O'Hagan, C., Medlow, P., Davison, G., Susta, D., Boreham, C., Newsholme, P., O'Donnell, M., Murphy, C., De Vito, G., 2014. The effects of aerobic exercise training at two different intensities in obesity and type 2 diabetes: Implications for oxidative stress, low-grade inflammation and nitric oxide production. *Eur. J. Appl. Physiol.* 114, 251–260.
- Krogh-Madsen, R., Thyfault, J.P., Broholm, C., Mortensen, O.H., Olsen, R.H., Mounier, R., Plomgaard, P., van Hall, G., Booth, F.W., Pedersen, B.K., 2010. A 2-wk reduction of ambulatory activity attenuates peripheral insulin sensitivity. *J. Appl. Physiol.* 108, 1034–1040.
- Kuo, A.D., 2007. The six determinants of gait and the inverted pendulum analogy: A dynamic walking perspective. *Hum. Mov. Sci.* 26, 617–56.
- Kurtzke, J.F., 1983. Rating neurologic impairment in multiple sclerosis: an expanded disability status scale (EDSS). *Neurology* 33, 1444–1452.
- Ladetto, Q., 2000. On foot navigation : continuous step calibration using both

- complementary recursive prediction and adaptive Kalman filtering. *Ion Gps* 2000, 1735–1740.
- Lafortune, M.A., 1991. Three-dimensional acceleration of the tibia during walking and running. *J. Biomech.* 24.
- Lamkin, P., 2016a. Fitbit heart rate tech “puts consumers at risk” according to lawsuit scientist. *Wearable*.
- Lamkin, P., 2016b. MyZone boss: Step-counting fitness trackers days are numbered. *Wearable*.
- LaPorte, R.E., Montoye, H.J., Caspersen, C.J., 1985. Assessment of physical activity in epidemiologic research: problems and prospects. *Public Health Rep.* 100, 131–46.
- Larsen, G., 1949. Behandling av adipositas. *Tidsskr. Nor. laegefor.* 17.
- Lauter, S., 1926. Zur Genese der Fettsucht [The genesis of obesity]. *Dtsch. Arch. Klin. Med.* 315–365.
- Le Masurier, G.C., Tudor-Locke, C., 2003. Comparison of pedometer and accelerometer accuracy under controlled conditions. *Med. Sci. Sports Exerc.* 35, 867–871.
- Lee, J.-M., Kim, Y., Welk, G.J., 2014. Validity of Consumer-Based Physical Activity Monitors. *Med. Sci. Sports Exerc.* 1840–1848.
- Leonard, W.R., 2003. Measuring human energy expenditure: What have we learned from the flex-heart rate method? *Am. J. Hum. Biol.*
- Liberson, W.T., 1936. Une nouvelle application du quartz piézoélectrique: piézoélectrographie de la marche et des mouvements volontaires [WWW Document]. *Trav. Hum.* URL <http://search.proquest.com/openview/d7f33a8bf2623eaa050452275853c330/1?pq-origsite=gscholar> (accessed 3.18.16).
- Light, L.H., McLellan, G.E., Klenerman, L., 1980. Skeletal transients on heel strike in normal walking with different footwear. *J. Biomech.* 13, 477–480.
- Lindström, J., Louheranta, A., Mannelin, M., Rastas, M., Salminen, V., Eriksson, J., Uusitupa, M., Tuomilehto, J., 2003. The Finnish Diabetes Prevention Study (DPS): Lifestyle intervention and 3-year results on diet and physical activity., *Diabetes care*.
- Liu, T., Inoue, Y., Shibata, K., 2009. Development of a wearable sensor system for quantitative gait analysis. *Meas. J. Int. Meas. Confed.* 42, 978–988.
- López, A.M., Álvarez, D., González, R.C., Alvarez, J.C., 2008. Validity of four gait models to estimate walked distance from vertical COG acceleration. *J. Appl. Biomech.* 24, 360–367.
- Lowe, S. a, Ólaighin, G., 2014. Monitoring human health behaviour in one’s living environment: a technological review. *Med. Eng. Phys.* 36, 147–68.
- Lowry, K.A., Smiley-Oyen, A.L., Carrel, A.J., Kerr, J.P., 2009. Walking stability using harmonic ratios in Parkinson’s disease. *Mov. Disord.* 24, 261–267.
- Luinge, H.J., Veltink, P.H., 2004. Inclination measurement of human movement using a 3-D accelerometer with autocalibration. *IEEE Trans. Neural Syst. Rehabil. Eng.* 12, 112–121.

- MacWilliams, B.A., Armstrong, P.F., 2000. Clinical applications of plantar pressure measurement in pediatric orthopedics, *Pediatric Gait A New Millennium in Clinical Care and Motion Analysis Technology*.
- Maetzler, W., Rochester, L., 2015. Body-worn sensors--the brave new world of clinical measurement? *Mov. Disord.* 30, 1203–5.
- Magno, M., Benini, L., Spagnol, C., Popovici, E., 2013. Wearable low power dry surface wireless sensor node for healthcare monitoring application. In: *International Conference on Wireless and Mobile Computing, Networking and Communications*. pp. 189–195.
- Makihara, Y., Trung, N.T., Nagahara, H., Sagawa, R., Mukaigawa, Y., Yagi, Y., 2011. Phase registration of a single quasi-periodic signal using self dynamic time warping. *Lect. Notes Comput. Sci. (including Subser. Lect. Notes Artif. Intell. Lect. Notes Bioinformatics)* 6494 LNCS, 667–678.
- Mannini, A., Sabatini, A.M., 2011. On-line classification of human activity and estimation of walk-run speed from acceleration data using support vector machines. *Proc. Annu. Int. Conf. IEEE Eng. Med. Biol. Soc. EMBS* 3302–3305.
- Manohar, C., O’Keeffe, D.T., Hinshaw, L., Lingineni, R., McCrady-Spitzer, S.K., Levine, J.A., Carter, R.E., Basu, A., Kudva, Y.C., 2013. Comparison of Physical Activity Sensors and Heart Rate Monitoring for Real-Time Activity Detection in Type 1 Diabetes and Control Subjects. *Diabetes Technol. Ther.* 15, 751–757.
- Marculescu, R., Endler, G., Schillinger, M., Iordanova, N., Exner, M., Hayden, E., Huber, K., Wagner, O., Mannhalter, C., 2002. Interleukin-1 receptor antagonist genotype is associated with coronary atherosclerosis in patients with type 2 diabetes. *Diabetes* 51, 3582–3585.
- Marey, E.-J., 1873. *La machine animale, locomotion terrestre et aérienne*. G. Baillie, Paris.
- Mariani, B., Rouhani, H., Crevoisier, X., Aminian, K., 2013. Quantitative estimation of foot-flat and stance phase of gait using foot-worn inertial sensors. *Gait Posture* 37, 229–234.
- Markovitch, D., Tyrrell, R.M., Thompson, D., 2008. Acute moderate-intensity exercise in middle-aged men has neither an anti- nor proinflammatory effect. *J Appl Physiol* 105, 260–265.
- Marschollek, M., Goevercin, M., Wolf, K.-H., Song, B., Gietzelt, M., Haux, R., Steinhagen-Thiessen, E., 2008. A performance comparison of accelerometry-based step detection algorithms on a large, non-laboratory sample of healthy and mobility-impaired persons. *Conf. Proc. ... Annu. Int. Conf. IEEE Eng. Med. Biol. Soc. IEEE Eng. Med. Biol. Soc. Annu. Conf.* 2008, 1319–22.
- McCamley, J., Donati, M., Grimpampi, E., Mazzà, C., 2012. An enhanced estimate of initial contact and final contact instants of time using lower trunk inertial sensor data. *Gait Posture* 36, 316–318.
- McFadyen, B.J., Magnan, G.A., Boucher, J.P., 1993. Anticipatory locomotor adjustments for avoiding visible, fixed obstacles of varying proximity. *Hum. Mov. Sci.* 12, 259–272.
- McNeilly, A.M., McClean, C., Murphy, M., McEneny, J., Trinick, T., Burke, G., Duly, E., McLaughlin, J., Davison, G., 2012. Exercise training and impaired glucose tolerance in obese humans. *J. Sports Sci.* 30, 725–32.

- Meier, C.A., Bobbioni, E., Gabay, C., Assimacopoulos-Jeannet, F., Golay, A., Dayer, J.-M., 2002. IL-1 receptor antagonist serum levels are increased in human obesity: a possible link to the resistance to leptin? *J. Clin. Endocrinol. Metab.* 87, 1184–8.
- Melanson, E.L., Knoll, J.R., Bell, M.L., Donahoo, W.T., Hill, J.O., Nysse, L.J., Lanningham-Foster, L., Peters, J.C., Levine, J.A., 2004. Commercially available pedometers: Considerations for accurate step counting. *Prev. Med. (Baltim).* 39, 361–368.
- Miyazaki, S., 1997. Long-term unrestrained measurement of stride length and walking velocity utilizing a piezoelectric gyroscope. *IEEE Trans. Biomed. Eng.*
- Mizrahi, J., Verbitsky, O., Isakov, E., 2000. Shock accelerations and attenuation in downhill and level running. *Clin. Biomech.* 15, 15–20.
- Moe-Nilssen, R., 1998a. A new method for evaluating motor control in gait under real-life environmental conditions. Part 1: The Instrument. *Clin. Biomech.* 13, 328–335.
- Moe-Nilssen, R., 1998b. A new method for evaluating motor control in gait under real-life environmental conditions. Part 2: Gait analysis. *Clin. Biomech. (Bristol, Avon)* 13, 328–335.
- Moe-Nilssen, R., 1998c. Test-retest reliability of trunk accelerometry during standing and walking. *Arch. Phys. Med. Rehabil.* 79, 1377–1385.
- Moe-Nilssen, R., Helbostad, J.L., 2004. Estimation of gait cycle characteristics by trunk accelerometry. *J. Biomech.* 37, 121–126.
- Moon, Y., Wajda, D.A., Motl, R.W., Sosnoff, J.J., 2015. Stride-Time Variability and Fall Risk in Persons with Multiple Sclerosis. *Mult. Scler. Int.* 2015, 964790.
- Morettini, M., Storm, F., Sacchetti, M., Cappozzo, A., Mazzà, C., 2015. Effects of walking on low-grade inflammation and their implications for Type 2 Diabetes. *Prev. Med. Reports* 2, 538–547.
- Morris, J.R.W., 1973. Accelerometry—A technique for the measurement of human body movements. *J. Biomech.* 6, 729–736.
- Morrison, S., Newell, K.M., 1999. Bilateral organization of physiological tremor in the upper limb. *Eur. J. Appl. Physiol. Occup. Physiol.* 80, 564–574.
- Motl, R.W., Dlugonski, D., Suh, Y., Weikert, M., Fernhall, B., Goldman, M., 2010. Accelerometry and its association with objective markers of walking limitations in ambulatory adults with multiple sclerosis. *Arch. Phys. Med. Rehabil.* 91, 1942–1947.
- Motl, R.W., Pilutti, L.A., 2012. The benefits of exercise training in multiple sclerosis. *Nat. Rev. Neurol.*
- Motl, R.W., Snook, E.M., Agiovlasitis, S., 2011. Does an accelerometer accurately measure steps taken under controlled conditions in adults with mild multiple sclerosis? *Disabil. Health J.* 4, 52–57.
- Mulder, T., Zijlstra, W., Geurts, A., 2002. Assessment of motor recovery and decline. *Gait Posture* 16, 198–210.
- Multiple Sclerosis International Federation, 2013. Atlas of MS 2013.
- Munro, B.H., 2005. *Statistical Methods for Health Care Research*. Lippincott Williams &

Wilkins.

- Muro-de-la-Herran, A., García-Zapirain, B., Méndez-Zorrilla, A., 2014. Gait analysis methods: An overview of wearable and non-wearable systems, highlighting clinical applications. *Sensors (Switzerland)* 14, 3362–3394.
- Murtagh, E., Boreham, C., 2005. Acute responses of inflammatory markers of cardiovascular disease risk to a single walking session. *J. Phys.* ... 324–332.
- Murtagh, E.M., Nichols, L., Mohammed, M.A., Holder, R., Nevill, A.M., Murphy, M.H., 2015. The effect of walking on risk factors for cardiovascular disease: An updated systematic review and meta-analysis of randomised control trials. *Prev. Med. (Baltim)*.
- Myhr, K.M., Riise, T., Vedeler, C., Nortvedt, M.W., Grønning, R., Midgard, R., Nyland, H.I., 2001. Disability and prognosis in multiple sclerosis: demographic and clinical variables important for the ability to walk and awarding of disability pension. *Mult. Scler.* 7, 59–65.
- Najafi, B., Aminian, K., Loew, F., Blanc, Y., Robert, P. a, Member, S., 2002. Measurement of Stand – Sit and Sit – Stand Transitions Using a Miniature Gyroscope and Its Application in Fall Risk Evaluation in the Elderly. *IEEE Trans. Biomed. Eng.* 49, 843–851.
- Najafi, B., Aminian, K., Paraschiv-Ionescu, A., Loew, F., B??la, C.J., Robert, P., 2003. Ambulatory system for human motion analysis using a kinematic sensor: Monitoring of daily physical activity in the elderly. *IEEE Trans. Biomed. Eng.* 50, 711–723.
- Najafi, B., Helbostad, J.L., Moe-Nilssen, R., Zijlstra, W., Aminian, K., 2009. Does walking strategy in older people change as a function of walking distance? *Gait Posture* 29, 261–266.
- Najafi, B., Khan, T., Wrobel, J., 2011. Laboratory in a box: Wearable sensors and its advantages for gait analysis. *Proc. Annu. Int. Conf. IEEE Eng. Med. Biol. Soc. EMBS* 6507–6510.
- Nakamura, T., Meguro, K., Sasaki, H., 1996. Relationship between falls and stride length variability in senile dementia of the Alzheimer type. *Gerontology* 42, 108–113.
- Narayanan, M.R., Redmond, S.J., Scalzi, M.E., Lord, S.R., Celler, B.G., Lovell, N.H., 2010. Longitudinal falls-risk estimation using triaxial accelerometry. *IEEE Trans. Biomed. Eng.* 57, 534–541.
- Nayfeh, A.H., Holden, A. V., 2004. *Applied Nonlinear Dynamics: Analytical, Computational, and Experimental Methods.* Methods 685.
- Nelson, R.K., Horowitz, J.F., 2014. Acute exercise ameliorates differences in insulin resistance between physically active and sedentary overweight adults. *Appl. Physiol. Nutr. Metab.* 39, 811–818.
- Neuparth, M.J., Proença, J.B., Santos-Silva, A., Coimbra, S., 2014. The positive effect of moderate walking exercise on chemerin levels in Portuguese patients with type 2 diabetes mellitus. *J. Investig. Med.* 62, 350–3.
- Nieman, D.C., Henson, D.A., Austin, M.D., Brown, V.A., 2005. Immune response to a 30-minute walk. *Med. Sci. Sports Exerc.* 37, 57–62.
- Nishida, Y., Higaki, Y., Taguchi, N., Hara, M., Nakamura, K., Nanri, H., Imaizumi, T., Sakamoto, T., Horita, M., Shinchi, K., Tanaka, K., 2014. Objectively measured

- physical activity and inflammatory cytokine levels in middle-aged Japanese people. *Prev. Med. (Baltim)*. 64, 81–87.
- Nusser, S.M., Beyler, N.K., Welk, G.J., Carriquiry, A.L., Fuller, W.A., King, B.M., 2012. Modeling errors in physical activity recall data. *J. Phys. Act. Heal.* 9 Suppl 1, S56–67.
- Orendurff, M.S., Schoen, J.A., Bernatz, G.C., Segal, A.D., Klute, G.K., 2008. How humans walk: bout duration, steps per bout, and rest duration. *J. Rehabil. Res. Dev.* 45, 1077–1089.
- Owings, T.M., Grabiner, M.D., 2004. Step width variability, but not step length variability or step time variability, discriminates gait of healthy young and older adults during treadmill locomotion. *J. Biomech.* 37, 935–938.
- Pan, X.R., Li, G.W., Hu, Y.H., Wang, J.X., Yang, W.Y., An, Z.X., Hu, Z.X., Lin, J., Xiao, J.Z., Cao, H.B., Liu, P.A., Jiang, X.G., Jiang, Y.Y., Wang, J.P., Zheng, H., Zhang, H., Bennett, P.H., Howard, B. V, 1997. Effects of diet and exercise in preventing NIDDM in people with impaired glucose tolerance. The Da Qing IGT and Diabetes Study., *Diabetes care*.
- Pang, M.Y.C., Eng, J.J., Dawson, A.S., McKay, H.A., Harris, J.E., 2005. A community-based fitness and mobility exercise program for older adults with chronic stroke: a randomized, controlled trial. *J. Am. Geriatr. Soc.* 53, 1667–74.
- Pappas, I.P.I., Keller, T., Mangold, S., Popovic, M.R., Dietz, V., Morari, M., 2004. A Reliable Gyroscope-Based Gait-Phase Detection Sensor Embedded in a Shoe Insole. *IEEE Sens. J.* 4, 268–274.
- Parry, J., 1992. *Gait Analysis Normal and Pathological Function*. Slack Incorporated, Thorofare, NJ, USA.
- Pate, R.R., Pratt, M., Blair, S.N., Haskell, W.L., Macera, C. a, Bouchard, C., Buchner, D., Ettinger, W., Heath, G.W., King, a C., 1995. Physical activity and public health. A recommendation from the Centers for Disease Control and Prevention and the American College of Sports Medicine. *JAMA*.
- Paterson, K.L., Lythgo, N.D., Hill, K.D., 2009. Gait variability in younger and older adult women is altered by overground walking protocol. *Age Ageing* 38, 745–8.
- Patla, A.E., Prentice, S.D., Robinson, C., Neufeld, J., 1991. Visual control of locomotion: strategies for changing direction and for going over obstacles. *J. Exp. Psychol. Hum. Percept. Perform.* 17, 603–634.
- Paul, W., Pearson, G.L., 1955. Pressure dependence of the resistivity of silicon. *Phys. Rev.* 98, 1755–1757.
- PCB Group, 2016. Introduction to PCB Accelerometers [WWW Document]. URL http://www.pcb.com/techsupport/tech_accel (accessed 3.3.16).
- Picerno, P., 2017. 25 years of lower limb joint kinematics by using inertial and magnetic sensors: A review of methodological approaches. *Gait Posture* 51, 239–246.
- Picerno, P., Cereatti, A., Cappozzo, A., 2011. A spot check for assessing static orientation consistency of inertial and magnetic sensing units. *Gait Posture* 33, 373–378.
- Pickup, J.C., 2004. Inflammation and activated innate immunity in the pathogenesis of type 2 diabetes. *Diabetes Care* 27, 813–823.

- Pinheiro Volp, a C., Esteves de Oliveira, F.C., Duarte Moreira Alves, R., Esteves, E. a, Bressan, J., 2011. Energy expenditure: components and evaluation methods. *Nutr. Hosp.* 26, 430–440.
- Pinto, B.M., Goldstein, M.G., Papandonatos, G.D., Farrell, N., Tilkemeier, P., Marcus, B.H., Todaro, J.F., 2011. Maintenance of exercise after phase II cardiac rehabilitation: a randomized controlled trial. *Am. J. Prev. Med.* 41, 274–83.
- Polman, C.H., Reingold, S.C., Banwell, B., Clanet, M., Cohen, J.A., Filippi, M., Fujihara, K., Havrdova, E., Hutchinson, M., Kappos, L., Lublin, F.D., Montalban, X., O'Connor, P., Sandberg-Wollheim, M., Thompson, A.J., Waubant, E., Weinshenker, B., Wolinsky, J.S., 2011. Diagnostic criteria for multiple sclerosis: 2010 Revisions to the McDonald criteria. *Ann. Neurol.* 69, 292–302.
- Pradhan, a D., Manson, J.E., Rifai, N., Buring, J.E., Ridker, P.M., 2001. C-reactive protein, interleukin 6, and risk of developing type 2 diabetes mellitus. *Jama* 286, 327–34.
- Puglisi, M.J., Vaishnav, U., Shrestha, S., Torres-Gonzalez, M., Wood, R.J., Volek, J.S., Fernandez, M.L., 2008. Raisins and additional walking have distinct effects on plasma lipids and inflammatory cytokines. *Lipids Health Dis.* 7, 14.
- Puyau, M.R., Adolph, A.L., Vohra, F.A., Zakeri, I., Butte, N.F., 2004. Prediction of activity energy expenditure using accelerometers in children. *Med. Sci. Sports Exerc.* 36, 1625–1631.
- Qiu, S., Cai, X., Schumann, U., Velders, M., Sun, Z., Steinacker, J.M., 2014. Impact of walking on glycemic control and other cardiovascular risk factors in type 2 diabetes: A meta-analysis. *PLoS One* 9.
- Rabinovich, R. a, Louvaris, Z., Raste, Y., Langer, D., Remoortel, H. Van, Giavedoni, S., Burtin, C., Regueiro, E.M.G., Vogiatzis, I., Hopkinson, N.S., Polkey, M.I., Wilson, F.J., Macnee, W., Westerterp, K.R., Troosters, T., 2013. Validity of physical activity monitors during daily life in patients with COPD. *Eur. Respir. J. Off. J. Eur. Soc. Clin. Respir. Physiol.*
- Raffin, E., Bonnet, S., Giroux, P., 2012. Concurrent validation of a magnetometer-based step counter in various walking surfaces. *Gait Posture* 35, 18–22.
- Rankin, G., Stokes, M., 1998. Reliability of assessment tools in rehabilitation: an illustration of appropriate statistical analyses. *Clin. Rehabil.* 12, 187–199.
- Reswick, J., Perry, J., Antonelli, D., Su, N., Freeborn, C., 1978. Preliminary evaluation of the vertical acceleration gait analyzer (VAGA). In: *Proc. 6th Annu. Symp. External Control Extremities*. Dubrovnik, pp. 305–314.
- Riva, F., Bisi, M.C., Stagni, R., 2013a. Orbital stability analysis in biomechanics: A systematic review of a nonlinear technique to detect instability of motor tasks. *Gait Posture* 37, 1–11.
- Riva, F., Bisi, M.C., Stagni, R., 2013b. Influence of input parameters on dynamic orbital stability of walking: In-silico and experimental evaluation. *PLoS One* 8, 1–7.
- Riva, F., Grimpampi, E., Mazzà, C., Stagni, R., 2014. Are gait variability and stability measures influenced by directional changes? *Biomed. Eng. Online* 13, 56.
- Roetenberg, D., Luinge, H.J., Baten, C.T.M., Veltink, P.H., 2005. Compensation of magnetic disturbances improves inertial and magnetic sensing of human body segment

- orientation. *IEEE Trans. Neural Syst. Rehabil. Eng.* 13, 395–405.
- Rowlands, A. V., Stiles, V.H., 2012. Accelerometer counts and raw acceleration output in relation to mechanical loading. *J. Biomech.* 45, 448–454.
- Roylance, L.M., Angell, J.B., 1979. A batch-fabricated silicon accelerometer. *IEEE Trans. Electron Devices* 26, 1911–1917.
- Ryan, C., Gray, H., Newton, M., Granat, M., 2008. The convergent validity of free-living physical activity monitoring as an outcome measure of functional ability in people with chronic low back pain. *J. Back Musculoskelet. Rehabil.* 21, 137–142.
- Ryan, C.G., Grant, P.M., Tigbe, W.W., Granat, M.H., 2006. The validity and reliability of a novel activity monitor as a measure of walking. *Br. J. Sports Med.* 40, 779–84.
- Sabatini, A.M., 2006. Quaternion-based extended Kalman filter for determining orientation by inertial and magnetic sensing. *IEEE Trans. Biomed. Eng.* 53, 1346–1356.
- Sabatini, A.M., Martelloni, C., Scapellato, S., Cavallo, F., 2005. Assessment of walking features from foot inertial sensing. *IEEE Trans. Biomed. Eng.* 52, 486–494.
- Saber-Sheikh, K., Bryant, E.C., Glazzard, C., Hamel, A., Lee, R.Y.W., 2010. Feasibility of using inertial sensors to assess human movement. *Man. Ther.* 15, 122–125.
- Salarian, A., Horak, F., Zampieri, C., Carlson-kuhta, P., Nutt, J.G., Aminian, K., 2010. iTUG, a Sensitive and Reliable Measure of Mobility. *IEEE Trans. Neural Syst. Rehabil. Eng.* 18, 303–310.
- Salarian, A., Russmann, H., Vingerhoets, F.J.G., Burkhard, P.R., Aminian, K., 2007. Ambulatory Monitoring of Physical Activities in Patients With Parkinson’s Disease. *IEEE Trans. Biomed. Eng.* 54, 2296–2299.
- Salarian, A., Russmann, H., Vingerhoets, F.J.G., Dehollain, C., Blanc, Y., Burkhard, P.R., Aminian, K., 2004. Gait assessment in Parkinson’s disease: Toward an ambulatory system for long-term monitoring. *IEEE Trans. Biomed. Eng.* 51, 1434–1443.
- Sandroff, B.M., Motl, R.W., Pilutti, L. a, Learmonth, Y.C., Ensari, I., Dlugonski, D., Klaren, R.E., Balantrapu, S., Riskin, B.J., 2014. Accuracy of StepWatch™ and ActiGraph accelerometers for measuring steps taken among persons with multiple sclerosis. *PLoS One* 9, e93511.
- Saunders, J.B.M., Inman, V.T., Eberhart, H.D., 1953. the Major Determinants in Normal and Pathological Gait. *J. Bone Joint Surg. Am.* 35–A, 543–558.
- Saxton, J.M., Carter, a., Daley, a. J., Snowdon, N., Woodroofe, M.N., Petty, J., Roalfe, a., Tosh, J., Sharrack, B., 2013. Pragmatic exercise intervention for people with multiple sclerosis (ExIMS Trial): Study protocol for a randomised controlled trial. *Contemp. Clin. Trials* 34, 205–211.
- Schapiro, R.T., 2012. *Managing the Symptoms of Multiple Sclerosis, Fifth Edit.* ed. Demos Medical Publishing.
- Schepers, H.M., Koopman, H.F.J.M., Veltink, P.H., 2007. Ambulatory assessment of ankle and foot dynamics. *IEEE Trans. Biomed. Eng.* 54, 895–902.
- Schmidt, A.L., Pennypacker, M.L., Thrush, A.H., Leiper, C.I., Craik, R.L., 2011. Validity of the StepWatch Step Activity Monitor: preliminary findings for use in persons with Parkinson disease and multiple sclerosis. *J. Geriatr. Phys. Ther.* 34, 41–5.

- Schmidt, M.I., Duncan, B.B., Sharrett, A.R., Lindberg, G., Savage, P.J., Offenbacher, S., Azambuja, M.I., Tracy, R.P., Heiss, G., 1999. Markers of inflammation and prediction of diabetes mellitus in adults (Atherosclerosis Risk in Communities study): a cohort study. *Lancet* (London, England) 353, 1649–52.
- Schneider, P.L., Crouter, S.E., Lukajic, O., Bassett, D.R., 2003. Accuracy and reliability of 10 pedometers for measuring steps over a 400-m walk. *Med. Sci. Sports Exerc.* 35, 1779–1784.
- Schoeller, D.A., van Santen, E., 1982. Measurement of energy expenditure in humans by doubly labeled water method. *J Appl Physiol* 53, 955–959.
- Schofield, W.N., 1985. Predicting basal metabolic rate, new standards and review of previous work. *Hum. Nutr. Clin. Nutr.* 39 Suppl 1, 5–41.
- Schulman, J.L., Reisman, J.M., 1959. An objective measure of hyperactivity. *Amer. J. Ment. Dejac.* 64, 455–456.
- Sebastião, E., Sandroff, B.M., Learmonth, Y.C., Motl, R.W., 2016. Free-living Walking Behavior in Persons with Multiple Sclerosis at Increased and Normal Fall Risk. *Med. Sci. Sports Exerc.* 48, 233.
- Segal, A.D., Orendurff, M.S., Czerniecki, J.M., Shofer, J.B., Klute, G.K., 2008. Local dynamic stability in turning and straight-line gait. *J. Biomech.* 41, 1486–1493.
- Sellers, C.E., Grant, P.M., Ryan, C.G., O’Kane, C., Raw, K., Conn, D., 2012. Take a walk in the park? A cross-over pilot trial comparing brisk walking in two different environments: Park and urban. *Prev. Med. (Baltim).* 55, 438–443.
- Shapiro, S.S., Wilk, M.B., 1965. An analysis of variance test for normality (complete samples). *Biometrika* 52, 591–611.
- Sheridan, P.L., Solomont, J., Kowall, N., Hausdorff, J.M., 2003. Influence of Executive Function on Locomotor Function: Divided Attention Increases Gait Variability in Alzheimer’s Disease. *J. Am. Geriatr. Soc.* 51, 1633–1637.
- Shih, P.C., Rosson, M.B., Carroll, J.M., 2015. Use and Adoption Challenges of Wearable Activity Trackers. In: *iConference*. Newport Beach.
- Shin, S.H., Park, C.G., 2011. Adaptive step length estimation algorithm using optimal parameters and movement status awareness. *Med. Eng. Phys.* 33, 1064–1071.
- Shoelson, S.E., Lee, J., Goldfine, A.B., 2006. Inflammation and insulin resistance. *J Clin Invest* 116, 1793–1801.
- Shuger, S.L., Barry, V.W., Sui, X., McClain, A., Hand, G.A., Wilcox, S., Meriwether, R.A., Hardin, J.W., Blair, S.N., 2011. Electronic feedback in a diet- and physical activity-based lifestyle intervention for weight loss: a randomized controlled trial. *Int. J. Behav. Nutr. Phys. Act.* 8, 41.
- Shull, P.B., Jirattigalachote, W., Hunt, M.A., Cutkosky, M.R., Delp, S.L., 2014. Quantified self and human movement: A review on the clinical impact of wearable sensing and feedback for gait analysis and intervention. *Gait Posture* 40, 11–19.
- Simpson, L.A., Eng, J.J., Klassen, T.D., Lim, S.B., Louie, D.R., Parappilly, B., Sakakibara, B.M., Zbogor, D., 2015. Capturing step counts at slow walking speeds in older adults: comparison of ankle and waist placement of measuring device. *J. Rehabil. Med.* 47, 830–5.

- Sinha, J.K., 2005. On standardisation of calibration procedure for accelerometer. *J. Sound Vib.* 286, 417–427.
- Skerrett, P., Manson, J., 2002. Reduction in risk of coronary heart disease and diabetes. In: Ruderman, N., Devlin, J., Schneider, S., Kriska, A. (Eds.), *Handbook of Exercise in Diabetes*. American Diabetes Association, Alexandria, VA.
- Smith, C.S., 1954. Piezoresistance effect in germanium and silicon. *Phys. Rev.* 94, 42–49.
- Smith, D.T., Carr, L.J., Dorozynski, C., Gomashe, C., 2009. Internet-delivered lifestyle physical activity intervention: limited inflammation and antioxidant capacity efficacy in overweight adults. *J. Appl. Physiol.* 106, 49–56.
- Smith, K.M., Lanningham-Foster, L.M., Welk, G.J., Campbell, C.G., 2012. Validity of the SenseWear?? armband to predict energy expenditure in pregnant women. *Med. Sci. Sports Exerc.* 44, 2001–2008.
- Socie, M.J., Sandroff, B.M., Pula, J.H., Hsiao-Wecksler, E.T., Motl, R.W., Sosnoff, J.J., 2013. Footfall placement variability and falls in multiple sclerosis. *Ann. Biomed. Eng.* 41, 1740–1747.
- Socie, M.J., Sosnoff, J., 2013. Gait variability and multiple sclerosis. *Mult. Scler. Int.* 2013, 645197.
- Spaulding, S.J., Patla, A.E., Elliott, D.B., Flanagan, J., Rietdyk, S., Brown, S., 1994. Waterloo Vision and Mobility Study: gait adaptations to altered surfaces in individuals with age-related maculopathy. *Optom. Vis. Sci.* 71, 770–7.
- Spranger, J., Kroke, A., Mohlig, M., Hoffmann, K., Bergmann, M.M., Ristow, M., Boeing, H., Pfeiffer, A.F.H., 2003. Inflammatory Cytokines and the Risk to Develop Type 2 Diabetes: Results of the Prospective Population-Based European Prospective Investigation into Cancer and Nutrition (EPIC)-Potsdam Study. *Diabetes* 52, 812–817.
- Stackpool, C.M., Porcari, J.P., Mikat, R.P., Gillette, C., Foster, C., 2015. The accuracy of various activity trackers in estimating steps taken and energy expenditure. *J. Fit. Res.* 3.
- Stansfield, B., Hajarnis, M., Sudarshan, R., 2015. Characteristics of very slow stepping in healthy adults and validity of the activPAL3™ activity monitor in detecting these steps. *Med. Eng. Phys.* 37, 42–7.
- Steinberg, J.A., 2016. *Fitbit Sleep-Tracker Suit Survives Dismissal Bid*. Bloom. Law.
- Storm, F.A., Buckley, C., Mazzà, C., 2016. Gait event detection in laboratory and real life settings: Accuracy of ankle and waist sensor based methods. *Gait Posture* 50, 42–46.
- Storm, F.A., Heller, B.W., Mazzà, C., 2015. Step Detection and Activity Recognition Accuracy of Seven Physical Activity Monitors. *PLoS One* 10, e0118723.
- Stunkard, A., 1958. Physical activity, emotions and human obesity. *Psychosom. Med.* 20.
- Stunkard, A., 1960. A Method of Studying Physical Activity in Man. *Am. J. Clin. Nutr.* 8.
- Swan, M., 2012. Sensor Mania! The Internet of Things, Wearable Computing, Objective Metrics, and the Quantified Self 2.0. *J. Sens. Actuator Networks* 1, 217–253.
- Swingler, R.J., Compston, D.A., 1992. The morbidity of multiple sclerosis. *Q. J. Med.* 83, 325–337.

- Sylos Labini, F., Meli, A., Ivanenko, Y.P., Tufarelli, D., 2012. Recurrence quantification analysis of gait in normal and hypovestibular subjects. *Gait Posture* 35, 48–55.
- Taborri, J., Palermo, E., Rossi, S., Cappa, P., 2016. Gait Partitioning Methods : A Systematic Review. *Sensors* 40–42.
- Taborri, J., Scalona, E., Palermo, E., Rossi, S., Cappa, P., 2015. Validation of Inter-Subject Training for Hidden Markov Models Applied to Gait Phase Detection in Children with Cerebral Palsy. *Sensors (Basel)*. 15, 24514–29.
- Taghian, F., Rahnema, N., Esfarjani, F., Sharifi, G.R., 2012. Does aerobic exercise effect on the levels of interleukin-6, TNF- α and plasma CRP in the elderly women? *Gazz. Med. Ital. Arch. Sci. Med.* 171, 767–773.
- Takacs, J., Pollock, C.L., Guenther, J.R., Bahar, M., Napier, C., Hunt, M.A., 2014. Validation of the Fitbit One activity monitor device during treadmill walking. *J. Sci. Med. Sport* 17, 496–500.
- Takeda, R., Tadano, S., Todoh, M., Morikawa, M., Nakayasu, M., Yoshinari, S., 2009. Gait analysis using gravitational acceleration measured by wearable sensors. *J. Biomech.* 42, 223–233.
- Tao, W., Liu, T., Zheng, R., Feng, H., 2012. Gait analysis using wearable sensors. *Sensors (Basel)*. 12, 2255–83.
- Taylor, D., Stretton, C.M., Mudge, S., Garrett, N., 2006. Does clinic-measured gait speed differ from gait speed measured in the community in people with stroke? *Clin. Rehabil.* 20, 438–444.
- The NPD Group, 2016. Year-Over-Year Wearables Spending Doubles [WWW Document]. URL https://www.npd.com/wps/portal/npd/us/news/press-releases/2016/year-over-year-wearables-spending-doubles-according-to-npd/?utm_source=twitter&utm_medium=social&utm_content=Oktopost-twitter-profile&utm_campaign=Oktopost-Press+Releases (accessed 5.12.16).
- Tigbe, W., Lean, M., Granat, M., 2007. The objective assessment of free-living physical activity in determining cardiovascular risk factors. In: *Proceedings of the 15th European Congress on Obesity (EASO)*.
- Tinetti, M.E., 1986. Performance-oriented assessment of mobility problems in elderly patients. *J. Am. Geriatr. Soc.* 34, 119–126.
- Tong, K., Granat, M.H., 1999. A practical gait analysis system using gyroscopes. *Med. Eng. Phys.* 21, 87–94.
- Toosizadeh, N., Mohler, J., Lei, H., Parvaneh, S., Sherman, S., Najafi, B., 2015. Motor Performance Assessment in Parkinson’s Disease: Association between Objective In-Clinic, Objective In-Home, and Subjective/Semi-Objective Measures. *PLoS One* 10, e0124763.
- Troiano, R.P., Berrigan, D., Dodd, K.W., Mâsse, L.C., Tilert, T., Mcdowell, M., 2008. Physical activity in the United States measured by accelerometer. *Med. Sci. Sports Exerc.* 40, 181–188.
- Trojaniello, D., Cereatti, A., Della Croce, U., 2014a. Accuracy, sensitivity and robustness of five different methods for the estimation of gait temporal parameters using a single inertial sensor mounted on the lower trunk. *Gait Posture* 40, 487–492.

- Trojaniello, D., Cereatti, A., Paolini, G., Ravaschio, A., Croce, U. Della, 2013. Temporal gait parameters determination from shank-worn MIMU signals recorded during healthy and pathological gait. In: XXIV Congress of the International Society of Biomechanics. pp. 1–2.
- Trojaniello, D., Cereatti, A., Pelosin, E., Avanzino, L., Mirelman, A., Hausdorff, J.M., Della Croce, U., 2014b. Estimation of step-by-step spatio-temporal parameters of normal and impaired gait using shank-mounted magneto-inertial sensors : application to elderly , hemiparetic , parkinsonian and choreic gait. *J. Neuroeng. Rehabil.* 11, 152.
- Trojaniello, D., Ravaschio, A., Hausdorff, J.M., Cereatti, A., 2015. Comparative assessment of different methods for the estimation of gait temporal parameters using a single inertial sensor: application to elderly, post-stroke, Parkinson’s disease and Huntington’s disease subjects. *Gait Posture* 42, 310–316.
- Troped, P.J., Oliveira, M.S., Matthews, C.E., Cromley, E.K., Melly, S.J., Craig, B.A., 2008. Prediction of activity mode with global positioning system and accelerometer data. *Med. Sci. Sports Exerc.* 40, 972–978.
- Trost, S.G., Mciver, K.L., Pate, R.R., 2005. Conducting accelerometer-based activity assessments in field-based research. *Med. Sci. Sports Exerc.* 37, 531–543.
- Tudor-Locke, C., Camhi, S.M., Leonardi, C., Johnson, W.D., Katzmarzyk, P.T., Earnest, C.P., Church, T.S., 2011a. Patterns of adult stepping cadence in the 2005-2006 NHANES. *Prev. Med. (Baltim).* 53, 178–181.
- Tudor-Locke, C., Craig, C.L., Brown, W.J., Clemes, S.A., De Cocker, K., Giles-Corti, B., Hatano, Y., Inoue, S., Matsudo, S.M., Mutrie, N., Oppert, J.-M., Rowe, D.A., Schmidt, M.D., Schofield, G.M., Spence, J.C., Teixeira, P.J., Tully, M.A., Blair, S.N., 2011b. How many steps/day are enough? for adults. *Int. J. Behav. Nutr. Phys. Act.*
- Turcot, K., Aissaoui, R., Boivin, K., Pelletier, M., Hagemester, N., De Guise, J.A., 2008. New accelerometric method to discriminate between asymptomatic subjects and patients with medial knee osteoarthritis during 3-D gait. *IEEE Trans. Biomed. Eng.* 55, 1415–1422.
- Ulas, T., Buyukhatipoglu, H., Eren, M.A., Dal, M.S., Torun, A., Aydogan, T., Demir, M.E., Turan, M.N., 2012. Evaluation of sleeping energy expenditure using the SenseWear Armband in patients with overt and subclinical hypothyroidism. *Clin. Investig. Med. Médecine Clin. Exp.* 35, E126-31.
- Urry, S., 1999. Plantar pressure-measurement sensors. *Meas. Sci. Technol* 10, 16–32.
- van Hees, V.T., Gorzelniak, L., Dean León, E.C., Eder, M., Pias, M., Taherian, S., Ekelund, U., Renström, F., Franks, P.W., Horsch, A., Brage, S., 2013. Separating movement and gravity components in an acceleration signal and implications for the assessment of human daily physical activity. *PLoS One* 8, e61691.
- van Hees, V.T., van Lummel, R.C., Westerterp, K.R., 2009. Estimating activity-related energy expenditure under sedentary conditions using a tri-axial seismic accelerometer. *Obesity (Silver Spring)*. 17, 1287–92.
- Van Remoortel, H., Raste, Y., Louvaris, Z., Giavedoni, S., Burtin, C., Langer, D., Wilson, F., Rabinovich, R., Vogiatzis, I., Hopkinson, N.S., Troosters, T., 2012. Validity of six activity monitors in chronic obstructive pulmonary disease: a comparison with indirect calorimetry. *PLoS One* 7, e39198.

- Veltink, P., Slycke, P., Hemssems, J., Buschman, R., Bultstra, G., Hermens, H., 2003. Three dimensional inertial sensing of foot movements for automatic tuning of a two-channel implantable drop-foot stimulator. *Med. Eng. Phys.* 25, 21–28.
- Venkata, A., DeDios, A., ZuWallack, R., Lahiri, B., 2012. Are depressive symptoms related to physical inactivity in chronic obstructive pulmonary disease? *J. Cardiopulm. Rehabil. Prev.* 32, 405–9.
- Voloshin, A., Wosk, J., Brull, M., 1981. Force wave transmission through the human locomotor system. *J. Biomech. Eng.* 103, 48–50.
- Wang, J.-H., Ding, J.-J., Chen, Y., Chen, H.-H., 2012. Real time accelerometer-based gait recognition using adaptive windowed wavelet transforms. In: 2012 IEEE Asia Pacific Conference on Circuits and Systems. IEEE, pp. 591–594.
- Warburton, D., Jeklin, A., Bredin, S., 2013. The validity of the Tractivity motion sensor during walking. *Heal. Fit. J. Canada* 6, 114–122.
- Warburton, D.E.R., Nicol, C.W., Bredin, S.S.D., 2006. Health benefits of physical activity: the evidence. *CMAJ* 174, 801–809.
- Watanabe, K., Hokari, M., 2006. Kinematical analysis and measurement of sports form. *IEEE Trans. Syst. Man, Cybern. Part A Systems Humans* 36, 549–557.
- Weir, J.B.D. V., 1949. New methods for calculating metabolic rate with special reference to protein metabolism. *J. Physiol.* 109, 1–9.
- Welk, G.J., McClain, J., Ainsworth, B.E., 2012. Protocols for evaluating equivalency of accelerometry-based activity monitors. *Med. Sci. Sports Exerc.* 44, S39-49.
- Westerterp, K.R., 2013. Physical activity and physical activity induced energy expenditure in humans: measurement, determinants, and effects. *Front. Physiol.* 4, 90.
- Whittle, M.W., 2007. *An Introduction to Gait Analysis*, Library.
- Wijndaele, K., Westgate, K., Stephens, S.K., Blair, S.N., Bull, F.C., Chastin, S.F.M., Dunstan, D.W., Ekelund, U., Esliger, D.W., Freedson, P.S., Granat, M.H., Matthews, C.E., Owen, N., Rowlands, A. V., Sherar, L.B., Tremblay, M.S., Troiano, R.P., Brage, S., Healy, G.N., 2015. Utilization and Harmonization of Adult Accelerometry Data: Review and Expert Consensus. *Med. Sci. Sports Exerc.*
- Willemsen, A.T.M., Frigo, C., Boom, H.B.K., 1991. Lower extremity angle measurement with accelerometers - error and sensitivity analysis. *IEEE Trans. Biomed. Eng.* 38, 1186–1193.
- Willemsen, A.T.M., van Alste, J.A., Boom, H.B.K., 1990. Real-time gait assessment utilizing a new way of accelerometry. *J. Biomech.* 23, 859–863.
- Winter, D.A., 1995. Human balance and posture control during standing and walking. *Gait Posture.*
- Wolfson, L., Whipple, R., Amerman, P., Tobin, J.N., 1990. Gait assessment in the elderly: a gait abnormality rating scale and its relation to falls. *J. Gerontol.* 45, M12–M19.
- Wong, T.C., Webster, J.G., Montoye, H.J., Washburn, R., 1981. Portable accelerometer device for measuring human energy expenditure. *IEEE Trans. Biomed. Eng.* 28, 467–471.

- World Health Organization, 2006. WHO | International Classification of Functioning, Disability and Health (ICF).
- World Health Organization, 2016. Health topics: physical activity [WWW Document]. URL http://www.who.int/topics/physical_activity/en/ (accessed 5.6.16).
- Wosk, J., Voloshin, A., 1981. Wave attenuation in skeletons of young healthy persons. *J. Biomech.* 14.
- Wu, G., 1995. A Review of Body Segmental Displacement, Velocity and Acceleration in Human Gait. In: Craik, R.L., Oatis, C.A. (Eds.), *Gait Analysis Theory and Application*. St Louis, pp. 205–222.
- Yack, H.J., Berger, R.C., 1993. Dynamic stability in the elderly: identifying a possible measure. *J. Gerontol.* 48, M225–M230.
- Yakeu, G., Butcher, L., Isa, S., Webb, R., Roberts, A.W., Thomas, A.W., Backx, K., James, P.E., Morris, K., 2010. Low-intensity exercise enhances expression of markers of alternative activation in circulating leukocytes: Roles of PPAR?? and Th2 cytokines. *Atherosclerosis* 212, 668–673.
- Yang, C.-C., Hsu, Y.-L., 2010. A review of accelerometry-based wearable motion detectors for physical activity monitoring. *Sensors (Basel)*. 10, 7772–88.
- Yang, C.-C., Hsu, Y.-L., Lu, J.-M., Shih, K.-S., Chan, L., 2011. Real-time gait cycle parameters recognition using a wearable motion detector. In: *Proceedings 2011 International Conference on System Science and Engineering*. IEEE, pp. 498–502.
- Yang, S., Zhang, J.T., Novak, A.C., Brouwer, B., Li, Q., 2013. Estimation of spatio-temporal parameters for post-stroke hemiparetic gait using inertial sensors. *Gait Posture* 37, 354–358.
- Yates, T., Davies, M., Brady, E., Webb, D., Gorely, T., Bull, F., Talbot, D., Sattar, N., Khunti, K., 2008. Walking and inflammatory markers in individuals screened for type 2 diabetes. *Prev. Med. (Baltim)*. 47, 417–421.
- Yates, T., Davies, M.J., Gorely, T., Talbot, D., Bull, F., Sattar, N., Khunti, K., 2010. The effect of increased ambulatory activity on markers of chronic low-grade inflammation: evidence from the PREPARE programme randomized controlled trial. *Diabet. Med.* 27, 1256–63.
- Ying, H., Silex, C., Schnitzer, a, Leonhardt, S., Schiek, M., 2007. Automatic Step Detection in the Accelerometer Signal. 4th Int. Work. Wearable Implant. Body Sens. Networks (BSN 2007) 13, 80–85.
- Zhang, J., Chaaban, J., 2013. The economic cost of physical inactivity in China. *Prev. Med. (Baltim)*. 56, 75–78.
- Zheng, R., Liu, T., Inoue, Y., Shibata, K., Liu, K., 2008. Kinetics Analysis of Ankle, Knee and Hip Joints Using a Wearable Sensor System. *J. Biomech. Sci. Eng.* 3, 343–355.
- Zijlstra, W., 2004. Assessment of spatio-temporal parameters during unconstrained walking. *Eur. J. Appl. Physiol.* 92, 39–44.
- Zijlstra, W., Hof, A., 2003. Assessment of spatio-temporal gait parameters from trunk accelerations during human walking. *Gait Posture* 18, 1–10.
- Zijlstra, W., Hof, A.L., 1997. Displacement of the pelvis during human walking:

experimental data and model predictions. *Gait Posture* 6, 249–262.

Zok, M., Mazzà, C., Della Croce, U., 2004. Total body centre of mass displacement estimated using ground reactions during transitory motor tasks: Application to step ascent. *Med. Eng. Phys.* 26, 791–798.

Zwibel, H.L., 2009. Contribution of impaired mobility and general symptoms to the burden of multiple sclerosis. *Adv. Ther.*