

# in fragility

portfolio of original compositions with written commentary

**OLIVER WILLIAM MARSHALL THURLEY**

SUBMITTED IN ACCORDANCE WITH THE  
REQUIREMENTS FOR THE DEGREE OF  
DOCTOR OF PHILOSOPHY

THE UNIVERSITY OF LEEDS  
SCHOOL OF MUSIC  
AUGUST 2016



The candidate confirms that the work submitted is his own and that appropriate credit has been given where reference has been made to the work of others. This copy has been supplied on the understanding that it is copyright material and that no quotation from the thesis may be published without proper acknowledgement.

© The University of Leeds and Oliver William Marshall Thurley

The right of Oliver William Marshall Thurley to be identified as author of this work has been asserted in accordance with the Copyright, Designs and Patents Act 1988

This project has been made possible by the Arts and Humanities Research Council.

Approximate word count: 23,000

## ACKNOWLEDGMENTS

This project could never have been completed without the following people, and for that I owe my thanks: my supervisors, Ewan Stefani and Mic Spencer; Martin Iddon, who acted as a mentor; Jakob Ullmann and Klaus Lang for their continued inspiration and willingness to answer all my questions; John Mowitt, for allowing me to sneak into his classes; James Mooney, Scott Mc Laughlin and all my colleagues in the School of Music, particularly Joanne Armitage and Daniel Wilson for their camaraderie and motivation.

I owe my deepest gratitude to the musicians who kindly lent their valuable time, patience and expertise to the development and performance of the works in this portfolio: Alice Dawkins, Hannah Packman, Katherine Lambeth and Claudia Chapman; LSTwo Ensemble; Ellen Fallowfield; Stefanie Mirwald and Janez Uršej; Seongmin Ji and Ensemble iiiiii; Barbara Konrad; Ensemble Nickel—Yaron Deutsch, Patrick Stadler, Antoine François and Brian Archinal; Rei Nakamura; Meitar Ensemble; Dario Calderone and Heather Roche. I am also indebted to the various institutions who have supported, trusted and commissioned my work. My thanks to all those involved at the impuls academy, Gaudeamus Muziekweek, Ulysses Network, the Bliss Trust, i<sup>N</sup> internationalcontemporarymusicfestival, Tzlil Meudcan festival, and CePRA.

Finally, my love and thanks to my family—Annette, Ross and my brother James; to my friends, Andy, Asa, Lav, and particularly to Elspeth for her love and patience. All of whom never wavered in their support and for that I am eternally grateful.

## ABSTRACT

This project documents the development of my recent compositional practice, a selection of which is presented in the accompanying portfolio. Through this commentary, the work is discussed in relation to a central theme: the figure of musical fragility, and its significance to my recent practice and surrounding musical thinking. Fragility is presented as a nebulous aesthetic concept, and a lens through which to examine elements of instability, vulnerability and tension between limits as they occur in various forms throughout my music. The compositions included in this portfolio therefore each exhibit some form of fragility as a moment of tension between that which is held delicately in cohesion, and the point at which it collapses into noise or silence. The compositions broadly operate within the context of instrumental contemporary classical music and the music of John Cage, Iannis Xenakis and late-period Luigi Nono, with a specific focus on stasis and quietness as found in minimal and drone-based musics. The music of Jakob Ullmann is also examined both as a proponent of features I deem to be fragile, and as an influence upon my compositional development. The research methodology for this project follows a reflexive framework: the composition of a work raises questions or problems which are then used to shape the next work, assessing its subsequent outcomes and so on. Particular attention is given to discussion of the development of my various notational practices, both in its technical relation to fragility, but also as a compositional process. This commentary does not attempt to say emphatically what fragility *is*, but rather, follow what fragility *is doing* and how it manifests throughout my recent compositions. The three most prominent themes I have identified are used as a means to navigate the discussion in each chapter: fragility in performance, fragility of form, and fragility as quietness.

**KEYWORDS:** *fragile, quiet, noise, silence, instability, stasis, disorientation, contemporary composition, practice-led research*

---

*To be read as written: with overwhelming anxiety and self-doubt.*

---

# CONTENTS

ACKNOWLEDGMENTS.....	ii
ABSTRACT.....	iii
CONTENTS .....	iv
LIST OF FIGURES.....	v
prologue .....	vi
<b>IN FRAGILITY</b>	
THE FIGURE OF FRAGILITY .....	3
TOWARDS FRAGILITY.....	4
A BRIEF INTRODUCTION TO THE CORE COMPOSITIONS.....	5
METHODOLOGY OF RESEARCH.....	7
FORM.....	7
INSTABILITY.....	9
OVERCOMING THE INSTRUMENT: FRAGILITY IN THE MUSIC OF JAKOB ULLMANN.....	11
TORTUOUS POSITIONS AS A DESTABILISING FORCE.....	14
FRAGILE DEVIATIONS: FRACTAL NOISE AS A PARAMETRIC CONTROL MECHANISM.....	15
LIMINAL BREAKING POINTS.....	19
IN TIME.....	25
SLOW WAVES.....	25
NON - LINEAR STRUCTURES IN THE NETWORK SCORES.....	26
DISPERSED STRUCTURES OF <i>HYMNS TO SING AT THE APOCALYPSE</i> .....	32
THE ATTENUATED SOLO.....	34
MATHEMATICAL FORM AS PITCH BEHAVIOUR.....	37
MASKS AND SLICES: CONSTRAINT AND THE ORGANISATION OF PITCH.....	40
RHYTHM, OVERWRITTEN.....	42
PLURAL TEMPORALITIES OF ROCK CLIMBING.....	44
TRACE, PALIMPSEST, ERASURE.....	46
INTERPOLATIONS AND BIFURCATIONS OF <i>IF SOME THING BLACK</i> .....	48
ARRHYTHMIA IN <i>FALLING AS RAIN AND THEN RISING</i> .....	51
IN DISQUIET.....	53
PIANISS(ISS(ISS))IMO.....	53
PARADOX OF QUIETNESS.....	55
AUDITORY IMAGINATION.....	56
INTERLUDE: KAFKA'S BURROW.....	57
UNHEARD SOUNDS.....	58
DWELLING WITHIN THE AMPLIFIED MUSIC OF LA MONTE YOUNG AND JOHN CAGE.....	59
AMPLIFICATION OF THE PORTFOLIO WORKS.....	61
FRAGILITY IN REPRISE.....	65
epilogue.....	67
BIBLIOGRAPHY.....	68
INDEX OF COMPOSITIONS.....	72
APPENDICES.....	73

---

## LIST OF FIGURES

Figures 1a–c: Diagram comparing fractal noise to random distribution on a circle.....	16
Figures 2a–d: Perlin noise demonstrations .....	18
Figure 3: Excerpt from <i>yet another example of the porousness of certain borders</i> (b.9).....	19
Figure 4: Excerpt from <i>yet another example of the porousness of certain borders</i> (b.10).....	21
Figure 5: Graph notation from <i>Network for string quartet</i> .....	28
Figure 6: Musical notation from <i>Network for string quartet</i> .....	28
Figure 7: Diagram of durations between event nodes.....	29
Figure 8: Structure outline for <i>Hymns to Sing at the Apocalypse</i> .....	33
Figure 9: Excerpt from the end of the bass solo in <i>Hymns to Sing at the Apocalypse</i> .....	36
Figure 10: Hiroshi Sugimoto, <i>Mathematical Form: Surface 0010</i> (2004), Gelatin silver print. ....	39
Figure 11: Basic spiral geometry plot for <i>Orbit</i> .....	39
Figure 12: Demonstrative chart of pitch masking bars 1–24, <i>whose veil remains inscrutable</i> .....	41
Figure 13: Fragment from <i>with the very same twist to their faces (under erasure)</i> score .....	48
Figure 14: Structural schematic for <i>if some thing black</i> .....	50
Figure 15: Multiple simultaneous layers of material in <i>if some thing black</i> (p.21).....	51
Figure 16: Multiple rhythmically obscured layers in <i>falling as rain and then rising</i> (p.6).....	52
Figure 17: Waveform outline of <i>Burrow</i> .....	59
Figure 18: Ensemble Nikel stage positioning during setup .....	62

## prologue

‘And Lo, for the Earth was empty of form, and void.

‘And Darkness was all over the Face of the Deep.

‘And We said:

‘Look at that fucker *Dance*.’

—Madame Psychosis



---

**IN FRAGILITY**



introduction

## THE FIGURE OF FRAGILITY

Musical fragility (factuality, discretion) resides in the inarticulateness of a sense always both extended—offered—and withheld.

—Jean-Luc Nancy, *The Sense of the World*

The works presented as part of this project represent the focal point of my recent compositional practice: to explore the concept of fragility in music. Recent trends across art, music and philosophy have concerned themselves with the aesthetics of noise and post-Cagean ‘silence’ at great length, however, the subject of musical fragility is one rarely discussed. Even within the burgeoning field of so-called ‘Sound Studies’ the concept of fragility—both the aesthetic and physical embodiment of which may be thought of as occupying the interstice noise and silence—remains to be properly addressed. Over the course of this portfolio commentary, the notion of musical fragility features as a central figure, around which to organise and focus various themes which have arisen within my recent compositional practice and surrounding musical thinking. In turn, this project functions as a resonance chamber within which to explore the figure of fragility in detail. Given the apparent ineffability of fragility as a musical concept, however, it becomes difficult to speak of in direct concrete terms. As such, the framework for this discussion

will often rely upon poetic rather than literal or technical terminology as a means to tease out a more lucid understanding of this loosely defined term.<sup>1</sup>

Alongside the central aesthetic interest in musical fragility, this portfolio is also concerned with the exploration and development of original notational systems as a method to effectively communicate these fragile compositional concepts, and the performative and perceptive limits of quietness in music—both as a means to enact and further investigate the figure of musical fragility. The compositions presented in this portfolio represent a recent considered attempt to move away from the hyper-minimal and electronically focused aesthetic context of some of my previous work. Instead, gravitating towards acoustic instrumentation, and collaborating with instrumental performers, I have begun adapting and drawing influence from the sound-worlds and notational practices of post-war experimentalists such as John Cage, Iannis Xenakis, late-period Luigi Nono, and Jakob Ullmann.

## TOWARDS FRAGILITY

In order to better orient this discussion, an initial definition of the figure of fragility will provide a hypothesis against which to assess elements of the compositions presented throughout this commentary and portfolio. Even if a concrete definition is not my concern, it is useful to consider fragility—in the word's more general meaning—in order to clarify this discussion from its beginning. Let us first consider fragility as a quality of vulnerability, prone to disruption of some sort, be it marginally impaired, broken or completely destroyed. Fragility might, therefore, be considered a state: a condition (or perhaps symptom) of the unstable construction of a thing. In a state of fragility, events are susceptible to disruption from their 'intended' goal.<sup>2</sup> Consequently, a fragile sound may be a state of instability in which its means of production, functionality or perception are somehow precarious: frangible and vulnerable to disruption or at risk of collapse. This formation of fragility will be the focus of chapter 1.

The next aspect to consider is how a fragile music might be composed, or how one might bring about this state of precariousness. With regards to technical matters of composition, this is relatively easy to answer: a system is organised whereby some small

---

<sup>1</sup> As a result, the portfolio compositions are not intended to methodically explore hypotheses relating to fragility in an overt or didactic form (i.e. as found in the music of Alvin Lucier and James Tenney).

<sup>2</sup> Of course, this notion of fragility as any sort of fracturing raises issues of the aesthetics of failure, the basis of which assumes a number of relative norms. As eldritch Priest argues in *Boring Formless Nonsense*, such judgements are always made 'subject to perpetual revision' and based upon a certain level of 'assumed functionality.' (New York: Bloomsbury Academic, 2013), 7. If one enters into the infinitely spiralling *succeeding-at-intending-to-fail* paradox, it quickly becomes clear that one is arguing in semantic circles around these judgement values and aesthetics. It should therefore be noted that any implied failure when dealing with fragility is not to say that an event has failed *per se*, but rather that it has been positioned in such a way that it is vulnerable and open to the sometimes rare, sometime inescapable indeterminate influence of factors outside its immediately apparent role: it fails according to traditional normative standards of musical success.

external force is able to undermine it, or, where a system is positioned or organised precariously such that it will collapse, losing cohesion or control under its own weight (for instance, by the nature of its indeterminate/unstable behaviour). In a musical scenario, this might involve the overpressure bowing of a string or the under-blowing of a brass instrument. In both cases the resulting behaviour of each instrument would be chaotic and difficult to predict: unstable, fragile. This model serves well for considerations of the physical production of sound and the performers relationship to their instrument but is less obvious regarding matters of form. Chapter 2 asks the question: how can musical form destabilise or near collapse? Here, one must consider the compositional methods which can manifest or simulate temporal disorientation, or a break from traditional linear musical forms and structures.

It is worth noting at this point that I do not consider musical fragility to be a solely technical feature, a characteristic found only in notation and instrumental technique, but rather a wider aesthetic view, one which encompasses the composition, performance, and perception of the music. Indeed, neither is *musical fragility* limited only to ‘music’ and, in a post-Cagean sense, could be applied to broader sonic, political or ecological concerns, although this falls outside the scope of this project. We might still, however, consider musical fragility more broadly as existing between limits in a moment of tension—or ‘the inarticulateness of a sense’—caught between two opposed forces: that which is ‘offered’, as Nancy claimed in this introduction’s epigraph, and that which is ‘withheld’.<sup>3</sup> As instability, musical fragility manifests at the moment of tension between the stability of a note (offered and held in cohesion), and at the point that it collapses into noise or silence (withheld). Fragility, as an act of listening (the focus of chapter 3) is also caught between such points: offered as audible whilst withheld towards the inaudible. Fragility is, in a sense, a ‘half-heard’ sound.

Ultimately, the focus of this commentary is not to rigidly define what musical fragility *is*, but rather to trace what fragility *is doing* and how it manifests throughout my recent compositions. Throughout this thesis, I will therefore attempt to present the compositions in a method that facilitates a foregrounding of the role and significance of musical fragility. At each stage of the commentary, I will develop upon this initial conceptual idea of fragility in order to readdress its significance in my own music.

## **A BRIEF INTRODUCTION TO THE CORE COMPOSITIONS**

By way of orienting this commentary, the following is a very brief chronological outline of some of the compositions central to the portfolio. Whilst additional works will appear

---

<sup>3</sup> Jean-Luc Nancy, “Music”, *The Sense of the World*. (Minneapolis, MN: University of Minnesota Press, 1997), 86.

throughout the project, the pieces mentioned here are central to this commentary and deserve some discussion of context before moving forward. More detailed explanations of the portfolio pieces will be provided throughout the commentary as and when the works are discussed.<sup>4</sup>

The earliest composition of the portfolio, *Network for String Quartet* (2013), comprises a non-linear, graph-based score system. Performers navigate through an interconnected system of nodes, each representing sound events where the spatial relation of the network nodes determine the sequence and duration of an event.

*yet another example of the porousness of certain borders* (2014), for solo contrabass, was written for Dario Calderone.<sup>5</sup> Here, delicate and often seemingly static gestures are destabilised (and occasionally undermined) by a constantly fluctuating dynamic control, notated in the score as a complex envelope waveform.

*whose veil remains inscrutable* (2014) was composed at the same time as *yet another example of the porousness of certain borders*. Written for Ensemble Nickel—tenor saxophone, electric guitar, percussion and piano—the piece constructs a delicate membrane which is held together by intricate tensions in the rhythmic material.<sup>6</sup> Constant dilations and contractions of various complex rhythmic elements—played with ascetic restraint and focus—binds the performance into a disorienting and uneasy interstice of flux and stasis.

*Hymns to Sing at the Apocalypse* (2015) is a small chamber concerto for bass flute, bass clarinet, violin, violoncello and solo contrabass.<sup>7</sup> The piece experiments with a fragmented form by isolating the bass from the ensemble and allowing various parts to loop independently. In the second half of the piece, the bass soloist interprets a number of elaborate parametric graphic systems to create a solo of tremors and restrained gestures.

Finally, *if some thing black* (2015) is a solo work of ‘interpolations and bifurcations’ for bass clarinet, commissioned by Heather Roche.<sup>8</sup> Here, the composition exhibits a more

---

<sup>4</sup> A list of portfolio compositions is located in Appendix I. A number of supplementary compositions, included as examples of progenitors, developments or tangents from the central portfolio compositions, can be found in Appendix VII.

<sup>5</sup> Commissioned by the Impuls academy (Graz, Austria) and later in a revised version for Gaudeamus Muziekweek 2015 (Utrecht, Netherlands). Premiered in February 2015 by Dario Calderone.

<sup>6</sup> Ensemble Nickel were ensemble in residence at the Impuls academy (Graz, Austria), 2015. Premiered in February 2015. The piece has subsequently been recorded for Nickel’s forthcoming album.

<sup>7</sup> Commissioned by the i<sup>N</sup> internationalcontemporarymusicfestival 2015 (Seoul, South Korea). Premiered in October 2015 by Ensemble iiiiii.

<sup>8</sup> Commissioned by Heather Roche as part of her crowd-funded 2015 composition competition. Premiered in London, February 9th 2016.

extensive fragility of form, juxtaposing a range of complex notational styles which the performer must orient, assemble and navigate.

## **METHODOLOGY OF RESEARCH**

As noted, my intention with this project is not to write the corpus of musical fragility or develop an exhaustive stylistic or aesthetic framework for analysis, but instead, to explore the concept as a more nebulous term which prompts a wider discourse along a number of interconnected themes. To this end, the research methodology for this project follows an iteratively reflexive framework: the composition of a work raises questions or problems which are then used to shape the proceeding work, assessing its subsequent outcomes and so on. Whilst a chronological discussion of the works in this thesis would perhaps prove the most obvious method of framing the research process, I have instead opted for a more thematic arrangement in order to discuss these issues more effectively. The commentary is therefore built around the central theme of the research—to develop an understanding of a compositional approach to fragility—assessed from a number of perspectives, each focusing upon a different element or strand. The benefit of this structure is a more holistic overview of the project as a whole, with the ability to make observations as the discussion requires, rather than be constrained to a chronological narrative. The result is a series of threads which delicately draw together the various features of my practice-led research through a common theme.

## **FORM**

Over the course of this commentary, I identify three key areas which contribute to a sense of musical fragility fundamental to my compositional thinking and practice. Using these themes as a means to navigate the discussion, chapter 1 focuses upon fragility as manifested in performance—which I term ‘timbral instability’—as a central feature in my recent works. It introduces German composer Jakob Ullmann as a case study to discuss the act of overcoming the resistance of an instrument during performance, and the instability of sound through its production. Compositional concepts such as parametric control, the use of fractal noise to destabilise data, and the physical instrumental constraints of extreme quietness are examined in order to address the fragility of my compositional material.

Chapter 2 concerns itself with fragility of form: fragility as an effect of temporal disorientation, and the various approaches to time, structure and duration, presented as fragile elements throughout the portfolio. In my series of network-based scores, the structural time of a performance is not merely presented as the linear ‘clock-time’ duration of a piece, but also non-linear structures. The morphology of pitch organisation in the portfolio is considered in relation to the development of ‘tendency masking’ techniques. Finally, my compositional approach to rhythmic layering and erasure are discussed in a move that assesses the score as a form of palimpsest, and how this may

destabilise or obfuscate a performer's interpretation of the music to create a sense of temporal disorientation.

Finally, in chapter 3, the overall veiled sound-world of the music is addressed and, having explored the performative issues and compositional material of the works, the discussion turns toward the prominent quietness of the portfolio. Here, fragility manifests through quietness, unstable between the limits of audible and inaudible—quietness breeds disquiet. By discussing the listener's paradox of quietness and quietness under amplification, I examine how the search for a fragile listening experience shaped the development of these compositions as well as a move towards an original conception of musical fragility



one

## INSTABILITY

To look for the half-light, paint in half-tones, half-say, with a lowered voice: in all these forms of allusion and of continence, as quasi-ascetic will shows through, the will to arrest oneself in mid-flight on the way to exaggeration. *En sourdine*: muted.

—Vladimir Jankélévitch, *Music and the Ineffable*

In this chapter, fragility is examined as a compositional device that manifests itself during performance: composing specific obstacles which confront the performer, destabilising the music. As noted in the introduction, this type of fragility takes on the form of a tension or instability wherein a specific action or sound is rendered vulnerable to disruption or collapse. Before any further discussion, I would like to begin with two short examples of possible instances of fragility within my own work.

In *whose veil remains inscrutable*, a rhythmically focused composition for a quartet of tenor saxophone, electric guitar, percussion and piano, the percussion part takes on an atypically precarious role as the most delicate and exposed player of the piece. For the majority of the piece, the percussionist is equipped with two small glass test tubes which are struck, scraped and blown. When struck, the tubes produce a short, piercing onomatopoeic ‘clinking’ sound. For the blown-tube technique, air is blown across and into the open end of the tube producing a delicate and hollow whistle tone. This technique uses a lot of air, requiring the performer to breath regularly, a condition at odds with the task of maintaining a continuous tone on a rudimentary instrument. The sounds produced are thus inconsistent: pitch is unpredictable and fluctuates depending upon the

breath pressure and angle of incidence for air entering the instrument. This, combined with the performer's other complex tasks (performing other actions simultaneously whilst counting complex and irrational rhythms) requires great focus and does not lend itself to producing a 'clean' and even tone. The score's simplistic instruction to maintain a steady tone is thus much harder to achieve than it would initially seem. The sound tremors; shaken by the imperfections in the breathing, the tone shifts unsteadily and ultimately cannot help but break apart, faltering as the performer takes breaths. The performer is not at fault, or rather, they have done nothing wrong.

In *Burrow* and *translucent spaces\_courtyard*, electronic sine waves feature as a key voice in the destabilisation of the music. Sinusoidal waves are—mathematically speaking—pure, and present a clear point of contrast to the imperfections of tones produced by humans or acoustic instruments. However, when two or more sine waves, whose frequencies are in close proximity, sound, their phase discrepancies cause interferences, manifesting as audible amplitude beatings at a frequency equal to the difference of the two waves. Both *Burrow* and *translucent spaces\_courtyard* exploit this phenomenon, interfering not only with other sine waves, but also the timbral and harmonic properties of the accompanying acoustic instrument of each piece (sustained acoustic guitar and harmonium respectively). There is no actual (physical) fluctuation in the stability of the sine tones, they remain continuous and unbroken; however, it is their interference with other close frequencies which creates a psychoacoustic effect of fragile sounds that appear to destabilise and disrupt an otherwise 'pure' timbre.

Referring back to the initial conceptions of musical fragility from the introduction, we see that compositionally, both situations in the above examples have been organised into a precarious formulation which will to some degree collapse under its own weight or action. These examples demonstrate two very simple ways in which a tone might be destabilised: either by the performer, whose actions directly cause the sound to physically falter, or from the interference of various sonic elements which disturb the perceived timbre of a sound. What may be viewed as sonic imperfections are, in both cases, reframed to become a key aspect and focal point of the works' sound-worlds. The fragility is exposed so that it may be closer examined, rather than simply masked. In *whose veil remains inscrutable*, the faltering and hollow whistles draw attention to the shaking breath of the performer and the unsteady, fluctuating pitch. Conversely, in *Burrow* and *translucent spaces\_courtyard*, the resultant acoustic interferences expose an internal and unpredictable sound-world. Complex, periodic beatings create their own unstable textures that seem to undermine the timbrally pure character of the sine tones. The term 'timbral instability', then, might be used to refer to a sound that is rendered fragile and whose cohesion is compromised in some way through its performance. To further assess how fragility manifests in performance, the performer's relationship to their instrument

and compositional context must be examined to better understand how this timbral instability may be further exploited.

## **OVERCOMING THE INSTRUMENT: FRAGILITY IN THE MUSIC OF JAKOB ULLMANN**

The compositions in this portfolio have been written with the explicit intention that they may collapse in some manner. For the performers of this fragile music, one of the foremost struggles is not with the difficulty or complexity of the music, but rather from the resistance of the instrument itself.<sup>9</sup> A simple example may be found in brass instruments, where under-blowing creates a point of tension in the instrument which sets off a number of reactions resulting in an unpredictable or unstable outcome (i.e. split tones). Similar vulnerabilities can of course be found in any instrument, and exploited in order to produce equally fragile results. In the double bass solo, *yet another example of the porousness of certain borders*, the performer must perform a number of harmonics and multiphonics amongst long sustained tones and slow glissandi. Given the quietness of the performance, many of these harmonics fail to sound clearly or collapse just as soon as they begin to sound. Of course, this scenario—like that of the under-blowing brass player—creates a point of tension between the performer and their instrument: they are attempting to carry out a specific action while the instrument resists due to the limitations of the system (in this case, principally due to the quietness which compounds the inherent instability of the multiphonic). Quietness, as a condition of performance, therefore raises a number of issues for the performer and their instrument. In *yet another example of the porousness of certain borders*, simply locating specific harmonics and multiphonics at such low volume can be problematic, but the delicate and unstable pressure of the bow on the strings creates an additional point of tension: the instrument becomes a point of resistance for the performer.

The work of German composer Jakob Ullmann exemplifies this relationship of ‘resistance and overcoming’ between instrument and performer, and as such has been a significant influence upon my compositional thinking as well as a provocative musicological case study for fragility and its relation to the performer.<sup>10</sup> One of the most interesting aspects for me in studying Ullmann’s music is the tension of performances as musicians struggle with their instruments under exhaustingly ascetic conditions. Frank Hilberg notes that:

---

<sup>9</sup> I have been fortunate enough to have collaborated with some of the very best performers while developing these pieces, and as such matters of ‘difficulty’ have rarely been insurmountable.

<sup>10</sup> I have written elsewhere on Ullmann and the role of fragility within his music, and some of the present considerations repeat elements of those discussions. See Oliver Thurley, “Disappearing Sounds: Fragility in the Music of Jakob Ullmann”, *Tempo* 69, no. 274 (October 2015): 5-21; also Thurley, “Rebuilding Babel: On Fragility and the Palimpsest in Jakob Ullmann’s *voice, books and FIRE*”, forthcoming.

Although the actions of the instrumentalists are apparently reduced to a minimum, they require utmost virtuosity in their execution. This virtuosity of restraint, though less conspicuous than conventional forms of virtuosity, is no less backbreaking.<sup>11</sup>

Hilberg confronts the typical image of the virtuoso performer as one performing death-defying, complex passages with theatrical ferocity, instead proposing a new ‘virtuosity of restraint’ wherein the notion of a sparse performance provides its own unique set of challenges. In stripping away and restricting their actions, this ascetic virtuoso is left completely exposed to Ullmann’s extreme sparsity—there is nowhere within the music for them to hide—and the gravity of their actions becomes magnified. As I have noted elsewhere, in his attenuation of activity, which often involves long sustained notes with very limited pitch movement, Ullmann composes at the ‘microscopic level,’ retuning a performer’s attention—and effort—to the smallest of details and tremors.<sup>12</sup>

In *Disappearing Musics* (1989–91), written for ‘6 players (more or less)’, Ullmann separates the score parts into distinct notational styles, each one adopting a different method of creating a timbrally fragile music.<sup>13</sup> The score material includes three distinct parts for winds, strings and two pianos, employing various elements of Ullmann’s signature traditional/graphic hybrid notational style. Whilst all are characteristically quiet and restrained, each of these parts presents the performer with a problematic scenario which they must attempt to navigate. The part for wind instruments employs an elaborate three-dimensional parametric chart system regulating the performer’s breathing (inhaling/exhaling) and the intended timbre of the instrument, all in constant flux according to parametric plots.<sup>14</sup> Pitch is then notated in a separate system as a continuous glissando.<sup>15</sup> The notation for strings is presented in two separate sections: one, a linear series of units, each one specifying a series of bow actions, whilst the second presents a set of thirteen pitch groups as double-, triple- and even quadruple-stops. Finally, the two piano parts (one prepared, one normal, both to be played by a single player) consist of sets of rapid rhythmic gestures to be played extremely fast and, of course, extremely quietly, catching the performer in a fragile tension between these directions. The use of Ullmann’s obscure notational systems could be seen as an attempt to compose a music

---

<sup>11</sup> Frank Hilberg, compact disc liner notes in *Jakob Ullmann: Komposition Für Streichquartett / Komposition Für Violine / Disappearing Musics*, trans. J. Bradford Robinson (Wergo, WER 6532-2, 1996), 21.

<sup>12</sup> Thurley, “Disappearing Sounds”, 11. This notion of ‘microscopic’ notation that will return in chapter 2 when discussing the notation of *Hymns to sing at the Apocalypse*.

<sup>13</sup> Jakob Ullmann, *Disappearing Musics* score (1989–91).

<sup>14</sup> This particular notational style would go on to influence elements of the notation for *Hymns to sing at the Apocalypse* and *if some thing black*.

<sup>15</sup> Ullmann’s glissando systems often bear a striking resemblance to Iannis Xenakis’ UPIC compositions, for instance *Mycenae-Alpha* (1978). Ullmann has spoken to me in conversation of the influence of composers such as Xenakis and—most importantly for Ullmann—John Cage on his early compositional thinking. Email correspondences with the author, 2013–2014.

which may only be realised in performance. In *Disappearing Musics*, each of the parts includes some element of instrumental de-coupling and an overabundance or material, however this could also be viewed as an attempt to reframe the performer's relationship to their instrument: approaching the instrument from a new perspective. In his notational style, Ullmann presupposes the limitations of the instrument and presents his music in a manner that requires the performer to re-evaluate their approach: destabilising the performer's practiced—and deeply ingrained—traditional technique.

This type of instrumental destabilising is characteristic of much of Ullmann's compositional style. In his undermining of certain performance techniques, Ullmann transforms his performer's awareness of their instruments: if the instrument is no longer able to carry out its intended purpose, then it effectively ceases to function as a tool or prosthetic extension to the musician's body. Instead, it becomes metaphorically broken, debilitating the performer. As I noted in my article on Ullmann's work: 'the destabilisation of the instrument's regular functionality renders it fragile, and it becomes precarious: the performer must take extra care to overcome the resistance of the instrument.'<sup>16</sup> Ullmann appears to locate and exploit vulnerable pressure-points in the performer-instrument relationship, creating fragile musical systems which the performer must attempt to overcome, pushing beyond the system's carefully arranged limitations.

A clear example of such exploitation of the instrument can be found in the oboe da caccia part of Ullmann's *Horos Metéoros: dramatisches fragment mit Aischylos und Euripides* (2008–09), where he purposefully writes beyond the stable range of the instrument.<sup>17</sup> The oboe part is fragile and difficult to control as the pitch is constantly at the brink of collapse. In order to contend with the parts, oboist Molly McDolan had to make a number of modifications to her playing technique in order to coerce the desired pitches from her instrument at such extremely quiet dynamics. This required McDolan to use tape to partially cover fingering holes, biting down onto the reed, changing reeds and seeking alternate fingerings that allow certain glissandi and overtones to sound.<sup>18</sup> McDolan's resultant tones are fragile, difficult to control and faltering with the strain to achieve relatively muted results. Ullmann effectively reframes McDolan's 'relationship to [her] instrument, rendering it an obstacle with which to contend.'<sup>19</sup>

To a degree, this obstacle is present in all music. Aden Evens asserts that music 'lives perpetually under the threat of its own death, in the face of its imminent dissolution.'<sup>20</sup>

---

<sup>16</sup> Thurley, "Disappearing Sounds", 14.

<sup>17</sup> Ibid., 14–15.

<sup>18</sup> Michael Kunkel, "Ankunft Basel, Badischer Bahnhof", in *Dreizehn 13 – Basels Badischer Bahnhof in Geschichte, Architektur und Musik*, (Saarbrücken: Pfau, 2012), 151.

<sup>19</sup> Thurley, "Disappearing Sounds", 15.

<sup>20</sup> Aden Evens, *Sound Ideas*, (Minneapolis, MN: University of Minnesota Press, 2005), 141.

Fragile music, therefore, is interested in explicitly teasing out these moments of ‘imminent dissolution.’ Developing Martin Heidegger’s conception of Dasein’s being-towards-death as a way to experiences one’s ‘ownmost possibility’, Evens notes that it is the precariousness of musical performance which is perpetually ‘being-towards death’:

Music is not a succession of static elements but a threatened inertia gathered into a fragile cohesion and held together only for an instant by the noise from which it is drawn before immediately falling back into that noise. Immersed in the music, entwining her own life with that of the music, the musician also confronts the imminent death of the music, and in so doing, discovers in each instant its ownmost possibility.<sup>21</sup>

Evens’ comment here refers to all music as this ‘threatened inertia’, requiring the constant struggle of the musician to hold together a cohesion that is constantly disintegrating. In explicitly composing fragile music, the possibility (or opportunity) for failure is drawn into focus, requiring an even greater effort from the performer to keep sound afloat above its collapse into noise.

While Evens contends that it is the performer who most directly experiences the fragility of this musical cohesion and is ‘bound up with its fate’, (principally through an awareness of and resistance from their instrument), the listener is also present in this being-towards-death of the music and able to feel this ‘threatened inertia’ of a performance as it balances precariously at the edge of noise.<sup>22</sup> Similar to Ullmann’s music, the fleeting tremors and fluctuations of the test tubes in *whose veil remains inscrutable* or the double bass struggling to sustain its multiphonics in *yet another example of the porousness of certain borders* make this musical ‘being-towards-death’ seem almost palpable. It is this possibility (or threat) of a collapse into noise which allows fragility as timbral instability to function with such liminal and precarious cohesion.

### **TORTUOUS POSITIONS AS A DESTABILISING FORCE**

Drawing strong influence from the work of Ullmann, a number of my compositions make use of difficult playing positions as a means to undermine and restrict the performer’s movements, limiting their ability to maintain a ‘clean’ tone. Ullmann uses similar techniques, particularly in his works for strings such as *A Catalogue of Sounds* (1995–), and, as with the oboe part of *Horos Meteoros* examined above, this amounts to a torturing of both the performer and sound produced.<sup>23</sup> Throughout *A Catalogue of Sounds*, Ullmann employs sustained triple-stopped passages, mixing artificial harmonics and open strings with normal stopped notes. In such quiet music, the performer must take care in their

---

<sup>21</sup> Ibid., 142.

<sup>22</sup> Ibid.

<sup>23</sup> cf. Thurley, “Disappearing Sounds”, 15. and Hilberg, liner notes to *Jakob Ullmann* compact disc, 21.

bow position in order to play evenly across all strings without resorting to overpressure, while the left-hand positions tire the player's musculature quickly. The sonic result is an unclear shaking sound as the performer battles against cramping to hold position and prevent the sound from collapsing. There is certainly an analogy to be made here with so-called 'stress positions' employed in forms of coercive interrogation.

This technique has been adapted in *yet another example of the porousness of certain borders* to incorporate difficult fingering positions into shifting behaviours sometimes incorporating large intervals or awkward positions. Here the intention was to not only destabilise the performer's techniques, but to actively interrupt it. In an effort to extrapolate and pay homage to a particular technique from Xenakis' bass solo *Theraps* (1976), *yet another example of the porousness of certain borders* features two opposing pitch layers; long glissandi moving independently of each other and incorporating double-stops with large awkward stretches in places.<sup>24</sup> Whilst I acknowledge their presence, the intention here is not one of difficulty, the assertion of power relations, or the theatricality of a grimacing performer. Rather, these physically gruelling intervals and double-stopped hand positions are a means to force the performer into a position where muscular limitations are pushed beyond the point of control, causing tones to audibly shake and tremor. It is here, in the moment where a performer's control is tested and destabilised, that musical fragility becomes audible in performance and, for the performer, a palpable point of tension.

## **FRAGILE DEVIATIONS: FRACTAL NOISE AS A PARAMETRIC CONTROL MECHANISM**

Like Ullmann's work, a number of the compositions in this portfolio incorporate some form of parametric notation as a method to variably control a performer's actions. The technique in itself is nothing new and similar examples of parameter-based notation can be found in the work and sketches of Cage, Xenakis, Sylvano Bussotti and James Tenney to name but a few. In my own application of the technique—partly inspired by an interest of algorithmic architecture, morphogenic design and falling somewhere between forms of generative art and data visualisation—I have developed a system to constrain parametric plot variables algorithmically. By implementing a form of fractal Perlin noise as a parameter modulation, elements of noise, small fluctuations, randomness or instability may be added to disrupt an otherwise static or unchanging value.<sup>25</sup> A simple

---

<sup>24</sup> This theme was initially explored in *Mathematical Forms 001: Orbit*, a duo for viola and contrabass. See chapter 2.

<sup>25</sup> Perlin Noise—named after its creator Ken Perlin—is a specific fractal noise algorithm designed in 1983 for the modelling and texturing of pseudo-natural phenomena in computer graphics. The algorithm was originally conceived during Perlin's work on the film *Tron* (Disney, 1981), and has become a standard visual effect in computer graphics. The most significant early application of the effect was its use of Perlin noise is found in *Star Trek II: Wrath of Khan* (Paramount Pictures, 1982) as

example can demonstrate this visually: consider a circle (Figure 1a), then the same circle drawn in two rotations, this time with a small fractal deviation ( $\pm$ ) to the radius (Figure 1b). Figure 1c was generated in two rotations using a completely random distribution applied to the radius (constrained to  $\pm 20\text{px}$  to limit dispersion). In all cases, the circle form is still clear—it remains a closed loop—however, in the latter two, there is an imperfection, or degree of fluctuation to its form. The difference between the fractal noise and the randomly distributed radii is clear: in the former there is a smooth, self-similar flow between values, while the totally random distribution exhibits no predictable behaviour from point to point.



Figures 1a-c. (left to right), a) regular circle with uniform radius; b) circle drawn with two layers of fractal noise deviation applied to radius; c) circle drawn using random deviation applied to radius.

In the development of the hybrid notational styles employed throughout the portfolio, fractal noise has been adopted within a number of my compositions at various pre-compositional levels in order to destabilise and add delicate deviations to variable parameters. The earliest experiments in applying noise in this method can be seen in the small ensemble pieces *Vermilion Sands*, *Envelop* for eight voices, and in *face of the deep* for four violas.<sup>26</sup> In *Vermilion Sands*, the noise values are used to regulate a number of parameters across all instruments; from bow pressure or position, to pitch glissandos. In both *Envelop* and *face of the deep*, the data controls volume and is thus visualised as an amplitude-over-time waveform.<sup>27</sup> After an offset limit, any noise value which returned as negative was eliminated, whilst all positive noise values were mirrored across the central horizontal axis, generating the symmetrical waveform. This allows the length of waveforms to vary, whilst also providing tapered start and end points, thus accurately

---

a tool for creating the ‘Genesis’ device’s effect, which could terraform and create life. Ken Perlin, “Noise and Turbulence”, <http://mrl.nyu.edu/~perlin/doc/oscar.html> last accessed: 28 June 2015.

<sup>26</sup> Similar charts can be found in *so much vapour aloft* and the contrabass solo in *Hymns to sing at the Apocalypse*, however these are not created using fractal noise algorithms since more extreme gestural behaviours were required. See chapter 2.

<sup>27</sup> These waveforms were created in the Processing programming language, using the ‘noise ()’ function implementation of Perlin noise. <https://processing.org/>



enveloping the wave.<sup>28</sup> Figures 2a–d provide an generalised example of the procedure for transforming two-dimensional noise data into waveforms.<sup>29</sup>

For the purposes of musical application, I have found the use of fractal noise algorithms to be of more use when attempting to add fluctuation to smoothly transitioning states. The ‘flow’ noted in the examples above can be transposed onto musical parameters such as pitch or timbre control with more subtlety, gradually unfolding over time, rather than instantly jumping from one random value to another. Aesthetically, I am not particularly concerned with incorporating noise as an absolute disruptor of communication into my compositions as encountered in Noise or Glitch music, however, its attenuated function as a means to subtly destabilise musical control cannot be overlooked. This has been an important consideration in maintaining a delicately fluctuating set of values whilst maintaining a constant average, an element of semi-stasis which, structurally, is key to my work.

In its implementation in *Vermilion Sands*, *Envelop* and *face of the deep*, fractal noise is generated within a two-dimensional array wherein lines of influence run vertically as well as horizontally. This is most clearly demonstrated in Figures 2a–d which show the development of data sets into the dynamic waveform notation found in *Envelop* and *face of the deep*. As seen in the circle example above (Figure 1), the use of a fractal noise algorithm allows for a smooth stream of interpolating values, creating a self-similar yet still dynamically varying behaviour. Musically, the use of a two-dimensional array in the generation of noise is significant as it enables a semi-random fluctuation of variables over time, whilst maintaining a level of uniformity—or perhaps influence—between members of an ensemble. The two-dimensions of an array may therefore loosely be thought of as time (*x*-axis, horizontal) and voice/instrument (*y*-axis, vertical), and unfold together over time.<sup>30</sup>

---

<sup>28</sup> The only technical exception to this enveloping was at page start and end points. In these cases, ‘fades’ were added artificially, or left un-tapered to create more abrupt start or stop points.

<sup>29</sup> Note that this sequence of examples bypasses the ‘negative offset’ (i.e. -127–127) used to create silences in *Envelop* and *face of the deep*, instead returning only positive values (0–255).

<sup>30</sup> Further experiments with implementing fractal noise as a notational tool made efforts to develop a three-dimensional system. See Appendix III.

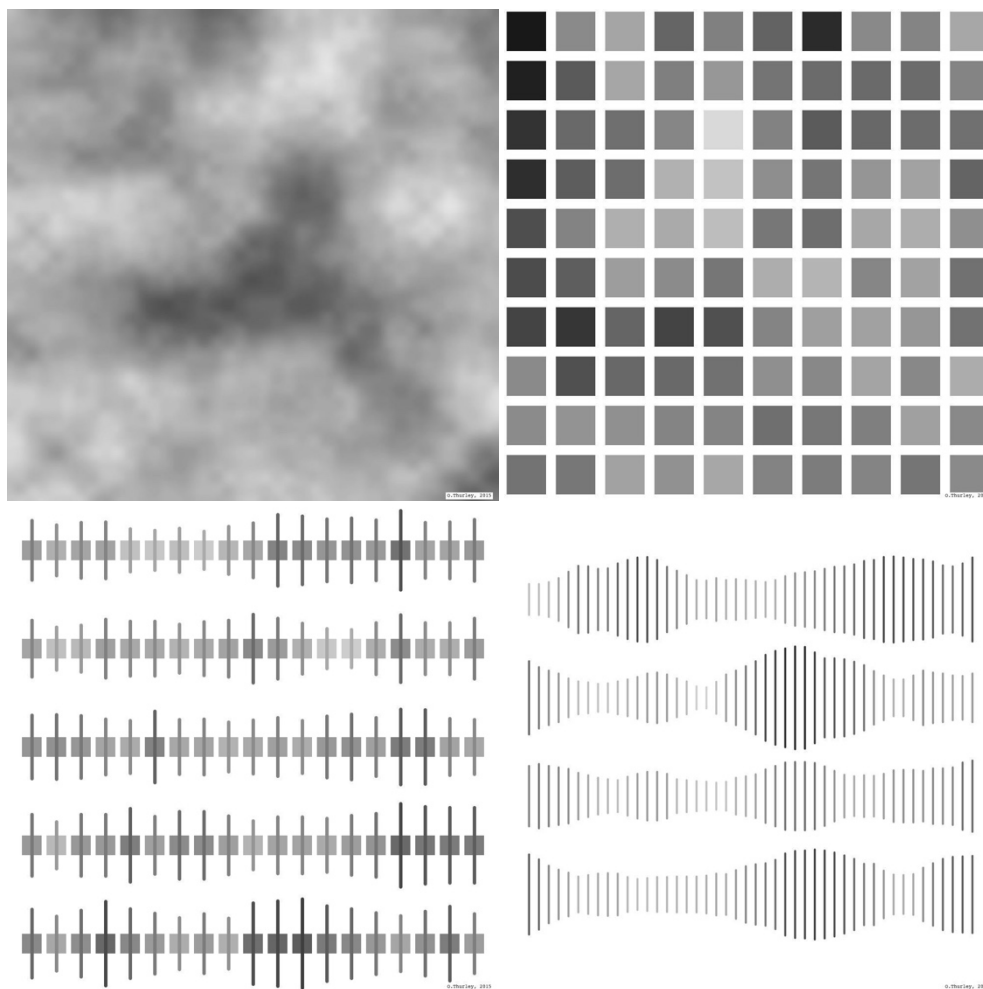

Figures 2a-d: (top L-R, beneath L-R), a) Two-dimensional Perlin noise used at fine resolution generating smoke/cloud effect; b) lowered resolution rendered as two-dimensional gridded array; c) array values expressed as a vertical line, darker shaded boxes producing longer lines (N.B. values are still two-dimensionally related); d) vertical lines generating waveform visualisation used in final dynamic notation.

One of the most distinctive notational elements of the contrabass solo, *yet another example of the porousness of certain borders*, is the use of a continuous visual waveform displayed below the main staff (Figure 3). The waveform may be thought of as a continuous, more turbulent parametric alternative to traditional hairpin dynamic markings, allowing very flexible dynamic behaviours during performance. In *Envelop* and *face of the deep*, these waveforms appear as the sole durational parameter for a sustained tone, in *yet another example of the porousness of certain borders* however, the waveform system is used as a supplement to the traditional staff-system notation which continues to communicate pitch and rhythmic information. The inclusion of this dynamic waveform as an additional system in *yet another example of the porousness of certain borders* provides a constantly fluctuating dynamic indication, operating independently of other features such as pitch and rhythm, thereby undermining the stability of the main system.

The constant shifting of dynamics deliberately hinders the performer's control, never allowing them to settle into the performance as their playing technique becomes continuously destabilised by these fluctuations and tremors. In a sense, the waveform dynamics have an effect of erasure over the piece.<sup>31</sup> As the waveforms fade out and then back in, notes which are otherwise notated as single, sustained tones become divided, or even partially effaced. While the music's quietness will be discussed more fully in chapter 3, this extreme softness of course affects the timbre and stability of events, as the very minimal bow pressure will have adverse effects on the behaviour of the instrument. The performer must decouple the dynamics of *yet another example of the porousness of certain borders* from its pitch, rhythm and bowing structures.

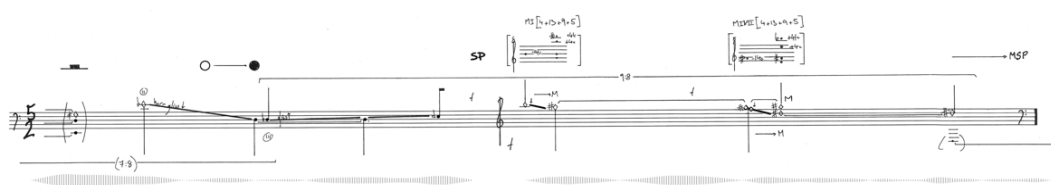

Figure 3: Excerpt from *yet another example of the porousness of certain borders* (b.9) showing waveform dynamic markings below the staff.

### LIMINAL BREAKING POINTS

The continual dynamic swells and tremors which occur throughout *yet another example of the porousness of certain borders* have a particularly strong destabilising effect for one of the most delicate techniques in the piece: the double-stop harmonics and string multiphonics. For these multiphonics to sound clearly depends upon a number of variables and, as such, is incredibly vulnerable to disruption and the agency of the performer.<sup>32</sup> Not only is the positioning of the left hand critical, but bow pressure, movement and position are of equal importance. Altering any one of these variables can easily cause the multiphonic to lose its cohesion, collapsing and leaving only a prominent harmonic or simply muted string noise sounding. It is this type of precarious state that *yet another example of the porousness of certain borders* is principally concerned with: once again presenting the instrument or action as a form of resistance, drawing awareness to the fragility of the performance.

The use of waveform dynamics in *yet another example of the porousness of certain borders* allows a further exploration of the liminal space surrounding the multiphonic's breaking

<sup>31</sup> This notion of erasure will be considered more fully in chapter 2 as part of the discussion of the palimpsest.

<sup>32</sup> The multiphonic elements of this piece were developed using research and consultation with Ellen Fallowfield and her Cello Map project with Thomas Resch. <http://www.cellomap.com> last accessed: 11 June 2016. See Appendix IV for further information on the technical aspects of string multiphonics in the portfolio.

points, rather than simply attempt to play these multiphonics perfectly. It is, of course, possible that at no point in a given multiphonic's notated duration will any or all of the harmonic partials sound. In fact, it is more likely that as the bow moves and pressure fluctuates, that different partials will emerge or disappear, or even none at all; instead producing a finely granulated noise as the bow hair sounds on a muted string. The performer is left seeking the full multiphonic. Here, it is the act of searching itself—the microscopic adjustments, the slight shifts in timbre—that is of importance, rather than the utopia of these largely theoretical multiphonics. The actions instructed by the score are not necessarily to the benefit of the multiphonic, they simply operate concurrently and indifferently to it. The fragility of the multiphonics is thus almost experienced as an indeterminate event, reliant on the agency of the performer. At points, the various parameters may align, allowing the multiphonic to sound clearly, whilst at other times, only partial elements may sound. The score presents a space in which the performer searches for the multiphonic, and, as actions and events shift, so does the perspective with which they approach the sound. Whilst most of the time the multiphonics are only encountered in fractured pieces, occasionally a performer may be able to catch a glimpse of the full multiphonic before the perspective changes again, collapsing the multiphonic.

While workshopping the sketches of *so much vapour aloft*, cellist Ellen Fallowfield noted the critical importance that bow placement can have on the timbre of string multiphonics. As a string is divided into overtones, the number of nodes and anti-nodes also increases relative to the partial number. The bow placement in relation to these nodes and anti-nodes is similar to the effect of bowing *sul ponticello* and *sul tasto*, however when it comes to sounding a number of overtones in a multiphonic, the bow's point of contact in relation to these nodes and anti-nodes can easily choke the multiphonic. As such, a performer has to carefully consider their bow position when playing multiphonics as this can immediately preclude a multiphonic from sounding. It is for this reason that I have not notated bow positions when dealing with multiphonics, instead leaving them to the discretion of the performer. Fallowfield and Resch note other limitations encountered with string multiphonics:

The scope for varying bow pressure, bow speed and point of contact in multiphonics is limited compared to normal playing, and even compared to performing harmonics. In general, these factors control the loudness and noisiness of a multiphonic. However, they also influence which harmonics take part in a multiphonic and can block high/low components. Therefore, when trying to change the loudness or colour of a multiphonic, it is very easy to 'break up' the multiphonic.<sup>33</sup>

---

<sup>33</sup> Ellen Fallowfield and Thomas Resch, "Multiphonics", *Cello Map*, <http://www.cellomap.com/index/the-string/multiphonics-and-other-multiple-sounds.html> last accessed: 11 June, 2016.

Of course, to an extent it is this ‘breaking up’ of the multiphonic that I am most interested in, and the constant shifting of bow pressure through the dynamic waveform notation ensures this. Similarly, the multiphonic can be easily destabilised by the attempt to carry out other actions simultaneously, such as double-stopped open strings or even double-stopped multiphonics. Fallowfield and Resch note that double-stopped multiphonics are ‘problematic’ due to the bow position and speed requirements being specific to each multiphonic, and thus a bow position for one string’s multiphonic may choke a multiphonic on an adjacent string.<sup>34</sup> In *yet another example of the porousness of certain borders*, I have attempted to exploit this particular vulnerability, calling for the performer to move from a single frail multiphonic on the A-string before introducing a parallel double-stopped multiphonic on the E-string (Figure 4). At first, both multiphonics are located at the same neck position to bring out the fifth, eleventh and sixth overtones. This in itself is difficult though not impossible, however after a short period of sustain, the A-string multiphonic shifts up to attempt a multiphonic of the sixth, thirteenth and seventh overtones while the lower multiphonic remains fixed. In attempting to sound two multiphonics simultaneously in different positions, both multiphonics become completely compromised. In their fragile state the multiphonics fail to operate as a cohesive sounding event, and rather as a fragile space of possible and fragmented sounds. These unstable, fragile multiphonics immolate themselves, collapsing either into one of their constituent partials or into noise.

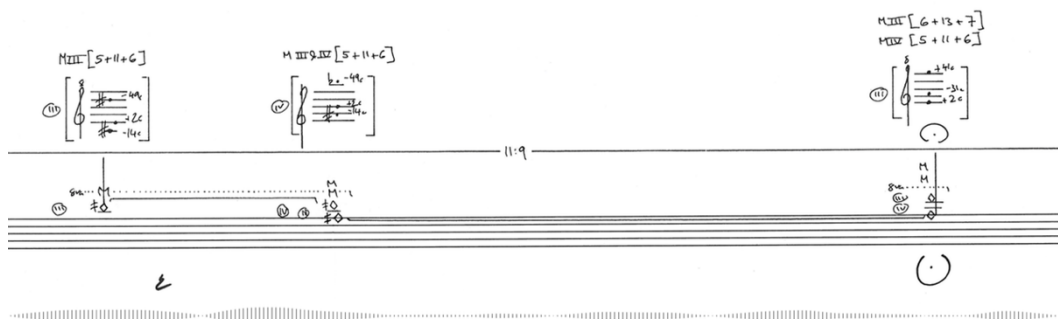

Figure 4: Excerpt from *yet another example of the porousness of certain borders* (b.10) showing a move between double-stopped multiphonics with sounding pitches in the bracketed systems.

By this point it will come as little surprise that the late-period works of Luigi Nono have also provided a good deal of influence within my exploration of musical fragility. The

<sup>34</sup> Ellen Fallowfield and Thomas Resch, “Further Examples of Multiphonics”, *Cello Map*, <http://www.cellomap.com/index/the-string/multiphonics-and-other-multiple-sounds/further-examples-of-multiphonics.html> last accessed: 11 June, 2016.

freedom with which Nono approached quietness in his search for a ‘mobile sound’ (*suono mobile*) in many ways validated my own exploration of the depth of similarly small sounds:

Different techniques of emission and interference of the breath, and a relative control of its articulation, its perception and of the modulation of the micro-intervals, of the large range of intensities and the quality of the voice [...] And the new techniques: exact multiphonics, and not random to different clusters of harmonics obtained with the lips, by a strong, medium and weak pressure on the reed of the clarinet, to new relationships between the dynamic *pppppp* and the registers unobtainable until now in the tuba...<sup>35</sup>

This type of delicate instrumental interference and instability becomes a key concept in Nono’s later works and their mutating sounds find resonance in this current discussion of fragility. Foreshadowing a discussion from chapter 3, these delicate and labyrinthine sounds draw the listener into the music through their subtle fluctuations which seem *outside* the typical sound-world of the instrument. Like Nono’s *suono mobile*, *suono ombra*, *suono non statico*, *Eolien*, *Tibet* and other vaguely mysterious performance directions, the *arco mobile* technique is a sonically rich technique, albeit notationally ambiguous.<sup>36</sup> Allegedly derived from Nono’s close collaborations with contrabassist Stefano Scodanibbio—the manuscript for Nono’s ‘tragedy of listening’, *Prometeo* (1981–85), features the note ‘*arco mobile (à la Stefano Scodanibbio)*’—the *arco mobile* technique remains little-known, and somewhat cryptic outside Nono’s circle, surviving through oral tradition rather than rigorous notational documentation.<sup>37</sup>

My own introduction to the *arco mobile* technique came by chance through a conversation with contrabassist Dario Calderone, for whom *yet another example of the porousness of certain borders* was written. In the first draft of the score, I had written instructions for a slowly transforming sound, in which gradual movement of the bow and slight shifts in pressure would slowly pull out different harmonics. This was a difficult technique to describe in a score, and the best verbal description I could find was ‘wandering’ or ‘wayfaring’ harmonics. The link between this sound to the inscription from the Toledo monastery that followed Nono throughout his life and career—‘*Caminantes, No hay caminos, hay que caminar*’ (Travellers, there are no paths but you must walk)—is clear.<sup>38</sup>

---

<sup>35</sup> Luigi Nono, “Vers *Prometeo*, fragments de journaux”, *Écrits*, ed. Laurent Feneyrou (Paris: Christian Bourgois, 1993), 521, quoted in Gerard Pape, “Luigi Nono and His Fellow Travellers”, *Contemporary Music Review* 18, no. 1 (January 1999): 62.

<sup>36</sup> Veniero Rizzardi, “Notation, Oral Tradition and Performance Practice in the Works with Tape and Live Electronics by Luigi Nono”, *Contemporary Music Review* 18, no. 1 (January 1999): 47–56.

<sup>37</sup> Luigi Nono, *Prometeo, tragedia dell’ascolto: Isola Prima* manuscript score (Milan: Ricordi, 1985), 1. <http://www.stefanoscodanibbio.com/contributions.htm> last accessed: 11 June 2016.

<sup>38</sup> Interestingly, Hans Peter Haller—collaborator and designer of the Halaphon spatialisation system—notes that Nono occasionally translated *caminar* (walk) as ‘search’, alluding to his own desire for exploration. Hans Peter Haller, “Nono in the Studio — Nono in Concert — Nono and the Interpreters”, *Contemporary Music Review* 18, no. 2 (January 1999): 18.

After going to lengths explaining the sound I was after, Dario Calderone pointed out that this was essentially Nono's *arco mobile* technique, albeit with a more specifically harmonic focus.<sup>39</sup> In my own work, I am less aesthetically interested in the 'search' as a means to answering specific questions, but instead preferring the simple action as its own goal. That is to say, that in these sustained periods, I am avoiding the stillness that is often assumed as being a necessary part of slow, quiet music. As already noted, locating specific harmonic overtones or clearly isolating tones of a multiphonic is not a primary concern (although of course, they may well be fragile and unstable), so much as the act of simply wandering and observing the changes.

---

<sup>39</sup> In preparation for the performance of a revised *yet another example of the porousness of certain borders* at Gaudeamus Muziekweek 2015, Calderone discovered that performing with a violin bow allowed greater finesse when attempting the piece's multiphonics, as well as capturing a more delicate overall sound.





two

## IN TIME

What, then, is time? I know well enough what it is, provided that nobody asks me; but if I am asked what it is and try to explain, I am baffled.

—Saint Augustine

### SLOW WAVES

eldritch Priest notes that in the recent history of contemporary music, composers have begun to take a more phenomenological approach towards time:

Expressed in Steve Reich's noted essay on music as a gradual process, in Feldman's interest in the sublime effects of scale, and in Brian Eno's development of open or generative musical systems, duration began to resemble Henri Bergson's notion of *durée*, the lived experiences of dilations and contractions that give time its qualitative character.<sup>40</sup>

While the compositions of this portfolio are not concerned with the forms of structurally extended duration as explored by the composers Priest notes, they are nonetheless preoccupied with these qualitative 'dilations and contractions' of time. Throughout this portfolio, the fragility of time manifests as a temporal disorientation: a dilation and contraction of duration, an overlaying of rhythmic layers and an effacement of form.

---

<sup>40</sup> eldritch Priest, *Boring Formless Nonsense*, 62.

In this search for temporal disorientation a number of compositional methods can be highlighted as being temporally focused. Perhaps the clearest and most immediate example appears in the aesthetic concerns with slowness and the dilation or ‘slowing down’ of time. Across the portfolio, comparisons might be drawn between the near-static long-form drones of *yet another example of the porousness of certain borders* or *Hymns to Sing at the Apocalypse* and the stasis of Eliane Radigue or the tape loops of Danielle Baquet-Long. Even within the most rhythmically dense works such as *whose veil remains inscrutable or if some thing black*, one does not have to look far to find the sticky Promethazine-and-Codeine fingerprints of DJ Screw’s (or even Graham Lambkin’s) anaesthetised rhythms and disoriented voices.

One might compare this type of soporific disorientation with the compositional techniques of Morton Feldman, who used the listener’s own memory against them, invoking the sublime and disorientating temporal perceptions of his work through subtle variations on *nearly* returned phrases. In *Triadic Memories* (1981) slowly repeating chords shift their number of repeats causing both audience and composer alike to ‘forget the reiterated chord before it’, allowing the composer to reconstruct a section and rearrange the number of repeats without discernible pattern. Here, Feldman refers to the technique as ‘a conscious attempt at “formalising” a *disorientation of memory*.’<sup>41</sup> An urge to recognise pattern and find form in this music becomes the listener’s own undoing; expecting a section to have some symmetrical relationship to the sections preceding it, and those that follow. Instead, when Feldman shifts a bar-line or subtly morphs the returning material in his attempt to ‘alienate memory’ in his *String Quartet No.2* (1983), he is purposefully making it harder for the listener to orient themselves temporally within the piece.<sup>42</sup> Throughout the works of this portfolio there remains the clear intent to disorientate and alienate memory, however, in the search for a temporal fragility, Feldman’s protracted scale and *near*-symmetry are replaced by quiet monotony and stumbling, bloated rhythms.

## **NON-LINEAR STRUCTURES IN THE NETWORK SCORES**

The *Network* series of scores explore a spatiotemporal relationship between the static score object and its performance by creating a notation system in which spatial arrangements allow for scalable durations and non-linear structures. Observing a number of simple rules, performers play through the system, in a sense similar to so-called ‘game

---

<sup>41</sup> Morton Feldman, “Crippled Symmetry”, *Give My Regards to Eighth Street: Collected Writings of Morton Feldman*, ed. B. H. Friedman (Cambridge, MA: Exact Change, 2000), 137. Italics added.

<sup>42</sup> Morton Feldman quoted in Michael Whitticker, “Morton Feldman: Conversation without Cage, 25 July 1984”, *Morton Feldman says: selected interviews and lectures 1964-1987*, ed. Chris Villars. (London: Hyphen Press, 2006), 186.

pieces' of composers such as John Zorn.<sup>43</sup> The portfolio includes two versions, one for string quartet and another for between two and four pianos (one of which is prepared).<sup>44</sup> Both pieces employ elements of graphic score systems, which resemble graph diagrams found in network theory—a visual representation of the relationship between elements of a set.<sup>45</sup>

In the first *Network* piece, for string quartet, the score is separated into two elements for each part: a network graph, and a page of musical actions. On the graph, nodes (shown as numerated circles) are linked to other nodes via edges (straight lines). In the context of the score this corresponds to a potential route from one node to another. Where each node represents a musical activity (Figures 5 and 6), linked nodes are events which may follow each other in performance. The edges' length between these nodes represents the time period that separates these events, and the duration they are scaled to (Figure 7).<sup>46</sup> Performers therefore observe this time-space parallel, navigating the space of the score in order to realise the duration and structure of musical events. The *Network* scores operate in a similar lineage to works such as Morton Feldman's *Intermission 6* (1953) and Stockhausen's *Klavierstück XI* (1956) which explored a similar 'modularity' and polyvalence. Unlike the freedom afforded by Feldman's mobile forms—inspired by the mobile sculptures of Alexander Calder—and the complex systems of Stockhausen's piece, the *Network* scores determine their own structure based upon the Markovian 'rules' of performance.

---

<sup>43</sup> See Zorn's 'sport pieces' *Lacrosse* (1977), *Hockey* (1978), *Fencing* (1978), *Archery* (1979) etc. Also *Xu Feng* (1985), *Hu Die* (1987), *Bézique* (1989) and, most famously, *Cobra* (1984).

<sup>44</sup> The network score for four pianos makes a number of small changes to the string quartet version, the most notable of which is the combination of musical events and structural graph on a single page. Each player therefore only requires a single page to play from, thus requiring less cross-referencing during performance. In the string quartet version durations of events tended to be sustained for the length of graph edges; for the piano version however, these edges are rests, allowing struck tones to gradually fade away through the sustain pedal. *Network for four pianos* is therefore a piece based upon decay as opposed to sustain as was the case in *Network for string quartet*.

<sup>45</sup> It should be noted that the resemblance to network graphs is largely visual. In network theory, the diagram is a purely abstract representation of the relationships between elements and no significant meaning is given to the spatial arrangement.

<sup>46</sup> One could think of 'time' here as a direct link to 'space'. The space that separates these nodes on the page translates directly to the time, duration, or temporal space which separates the musical events that the nodes represent.

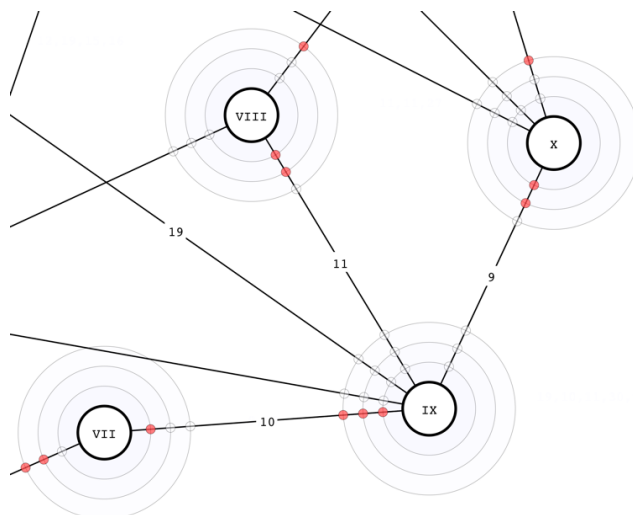

Figure 5: Graph notation from *Network for string quartet*.

Figure 6: Musical notation from *Network for string quartet*.

Although the score specifies the durations of each edge relative to an arbitrary scale (in the string quartet version, this scales as 150 pixels  $\approx$  twelve seconds, giving an average edge duration of approximately thirty-three seconds), the entire piece can be thought of as proportional. All durations are relative to one another, and simply scaled to a common factor.<sup>47</sup> As such, this technique of composing with the spatial arrangement of graphs works as a method to govern the temporal relationship of events at any time-scale. For instance, at a smaller time-scale (i.e. an edge of 150 pixels  $\approx$  two second duration) such a tool could be used to generate arborescent melody lines as demonstrated in the version for four pianos, or, at a larger scale (where each node contains its own sub-structures) such a tool could govern other, to use Curtis Roads' terminology, 'mesostructural' or even the 'macro time scales' of a composition.<sup>48</sup>

<sup>47</sup> During the first rehearsals, these durations were all half as long. They were easily scaled up to manipulate time and slow the performance.

<sup>48</sup> Curtis Roads, *Microsound*, (Cambridge, MA: MIT Press, 2004), 11–15. Graphs also appear as a model to govern macroform in Michael Winter's composition *Small World* (2008).

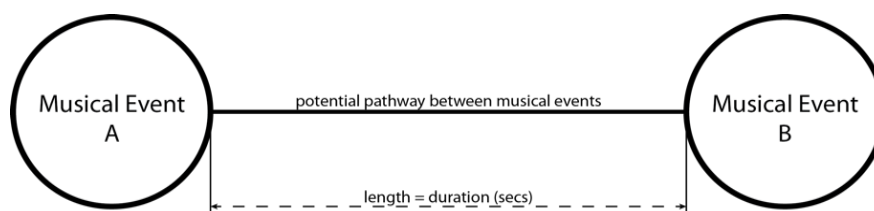

Figure 7: Diagram of durations between event nodes.

Each performer plays according to a unique temporal structure produced by their individual score. The piece audibly moves in and out of moments of cohesion where musical events drift in and out of synchronicity, yet these are chance occurrences and fleeting. In this sense the piece is in a state of perpetual motion across the network map. The sounding elements of the gamut set are simultaneously moving towards and away from each other temporally, whilst the overall static quality of the piece is underpinned by the gamut's quiet sonorities and extended durations.<sup>49</sup> It is the non-linear modular format of the score which therefore allows a complex structure to emerge. James Saunders, in his study of modularity in music, notes:

With temporal modularity there are also two principal interface methods: linear and simultaneous. Modules might be placed so as to follow each other or to occur at the same time, and combinations of these two methods of placement have the potential to create a rich network of inter-relations.<sup>50</sup>

In the case of the *Network* pieces, whilst each part remains non-linear ('linear' by Saunders definition, although the specific sequence of action is not predetermined), it is the simultaneous performance by the quartet members which forms this 'rich network of inter-relations.' In an analogy to bird flocking algorithms ('boids'), each part follows its own simple rules: separation, alignment, cohesion to its nearest neighbours; to create an overall system complex of behaviours.<sup>51</sup> For the *Network* pieces, by providing only individual performer parts rather than attempt to work from a single 'full' score, the resultant performance can be thought of as an emergent system whereby very simple operations or rules at a low level create complex results at higher-level organisation.<sup>52</sup>

<sup>49</sup> An animated version of the network score system was developed as part of an involvement with the 'Digital Score' project conference (Goldsmiths, University of London, 22 April 2013), although it was never developed further. An early proof-of-concept animation video can be seen at: <https://vimeo.com/60938778> last accessed: 19 July 2015. Additional developments are detailed in Appendix III.

<sup>50</sup> James Saunders, "Modular Music", *Perspectives of New Music* 46, no. 1 (Winter 2008): 159.

<sup>51</sup> Daniel Shiffman, "Autonomous Agents", *The Nature of Code*, (2012) <http://natureofcode.com/book/chapter-6-autonomous-agents/>

<sup>52</sup> Matt Pearson, *Generative Art*, (Shelter Island, NY: Manning, 2011), 107.

*Network for string quartet* uses a Markovian branching pathway system along the network to achieve a complex non-linear structure in each performer's part. Each graph's nodes are connected to at least two others and, as a result, have the potential to move along as many paths. Rather than permit the performer to choose their own path, a stochastic weighting system—which I term 'volta' markings—determines the path to follow based upon a set of probabilities. For each performance, the score's compiler script (acting as meta-score) can be executed to create a unique set of stochastic paths (signalled visually by the volta markings), according to these probabilities. The result is a precisely notated score, yet indeterminate until the performance begins through use of statistical variation across multiple performances.<sup>53</sup> This use of stochastic score generation derives from and elaborates Xenakis' comment that, through the use of computational calculation, elements of a composition may differ in each performance and yet fall within stochastic limits to build up a 'statistically identical' body of performances.<sup>54</sup>

The piano version, however, foregoes the volta system of guiding pathways through the score. Since the score was handwritten and could not be procedurally generated for each performance, a volta system would have amounted to merely creating a closed performance environment. The removal of the volta paths instead allows the score to remain fixed, whilst opening up for performances by allowing performers to choose their own path during performance. Also open to interpretation, graph edges in the piano version also include interruptive actions (notated in square brackets), which indicate the action—often a small percussive element or single note—may be played at any point within that duration. The fourth piano part also features two sets of sub-networks, smaller nested networks which serve as non-linear melodic elements. The fourth piano part also is written for an optionally prepared piano as a means to vary the overall timbre of the piece. The preparations focus mainly upon producing artificial harmonics through the use of putty, with some additional paperclip and adhesive tape.<sup>55</sup>

Despite the non-linearity of its structure, *Network for string quartet* presents the string quartet through an incredibly static harmonic field for its entire durations. The pitches of each musical event in the network form partial frequencies of the harmonic scale from

---

<sup>53</sup> Early rehearsals of the piece revealed an interesting structural matter I had not previously considered. Upon generation of a score, the arrangement of volta pathways may 'lock-out' certain nodes, meaning that depending on where the performers start, some musical events can never be reached (that is, no pathways point to them). Unfortunately, due to the indeterminate nature of the score generation—and the performer's free choice in initial node—this cannot be avoided without redesigning the stochastic algorithm to include a number of complex checks. As such, the lock-out is accepted to be an idiosyncrasy of the performance: some musical events will never occur during a specific performance.

<sup>54</sup> Iannis Xenakis, *Formalized Music*, ed. Sharon Kanach, rev. ed. (Stuyvesant, NY: Pendragon Press, 1992), 37.

<sup>55</sup> More information on the harmonics of this preparation part can be found in Appendix IV.

the cello's low C<sub>2</sub>-string (65.41 Hz). Not all frequencies are covered by each instrument, and they are often displaced from their original octave. This functions to create points of dissonance and perceived instability within the spectra creating holes in the spectrum while reinforcing other areas. This scheme of mapping instruments to a single harmonic spectra is no doubt reminiscent of basic 'spectral' approaches to music, but particular influence comes from James Tenney's *QUINTEX V: SPECTRA For Harry Partch* (1972) which uses scordatura to tune a string quartet plus double bass to the harmonic spectrum of a low F<sub>1</sub>, and covering 105 partials through natural harmonic options.<sup>56</sup> Tenney's final work, *Arbor Vitae* (2006) for string quartet, also uses a complex arborescent algorithm to generate glacial sequences of branching partials across multiple latticed spectra.<sup>57</sup> In the notation of the pitch material, microtones which were approximated rather than calculated to the precise cent-deviation or strict harmonic ratios as found in the scores of Tenney or Ben Johnston respectively. This deliberately imperfect spectra used in *Network for string quartet* offers an unstable and uneasy organisation of pitch around a single spectrum, creating subtle imperfections and points of tension.

With each node in the network map representing a musical event, each instrument's part is somewhat minimal. Each member of the quartet is restricted to twelve discrete sonorities, totalling forty-eight across the whole composition (although this is somewhat more limited if one takes into account shared pitch-classes, or the resultant locking-out of certain nodes created by the volta paths). Enough events to provide sufficient variance, but not too large so as to become unwieldy and difficult to navigate in the score. This use of limited musical actions can be traced to John Cage's use of the 'gamut' in a number of his works, particularly in the *String Quartet in Four Parts* (1950)—a piece that acted as an important musical inspiration to the production of this composition. Structurally, *Network for string quartet* also draws from another of Cage's string quartets, one of the so-called number pieces, *FOUR* (1989), where similar discrete musical actions are played within defined time brackets.<sup>58</sup> Whilst in *FOUR*, each discrete action is performed in order (reading down the score's pages), *Network for string quartet* takes an alternative approach to the arrangement of these musical events, by changing their order based on the path of connectivity, and Markovian-influenced structures. Where Cage adds variation (and a limited degree of indeterminacy) by instructing performers to exchange

---

<sup>56</sup> See Robert A. Wannamaker, "The Spectral Music of James Tenney" *Contemporary Music Review* 27, no. 1 (February 2008): 98. See also Larry Polansky, "The Early Works of James Tenney", in *Soundings 13: The Music of James Tenney*, ed. Peter Garland (Santa Fe, NM: Soundings Press, 1984), 214–18.

<sup>57</sup> Michael Winter, "On James Tenney's *Arbor Vitae* for String Quartet", *Contemporary Music Review* 27, no. 1 (February 2008): 131–50.

<sup>58</sup> A similar technique is employed by Witold Lutosławski in the opening to *Symphony No.3* (1983), in which the orchestra plays a 'collective temporal *ad libitum*'. Mark Delaere, "Tempo, Metre, Rhythm. Time in Twentieth-Century Music", in *Unfolding Time*, ed. Darla Crispin, (Leuven: Leuven University Press, 2009), 38.

score parts during the performance, variation within the *Network* pieces is built into the core of the system through the statistically derived repeats and inherent non-linearity.

Whilst not static in the same sense as the long-form drone works of Eliane Radigue, Phill Niblock or La Monte Young, the *Network* pieces offer a sense of harmonic stasis in their organisation of pitch. Throughout the meandering, aimless form of the piece, there remains a single unchanging pitch schema, limiting the harmonic and melodic motion of a given performance. In compositions such as this—which Jonathan Kramer might refer to as being ‘vertical’ music—there is no clear *telos* for the music and its sense of pitch movement.<sup>59</sup> In the case of the network piece for string quartet, the harmonic content of the networks are limited to a single spectrum and thus everything that occurs within the piece unfolds without changing the overall tonality of the piece. For Tenney, the pitch structure might be considered ‘ergodic’: a term borrowed from thermodynamics to indicate music which is ‘*statistically homogeneous* at some hierarchical level of formal perception.’<sup>60</sup> Following the *Network for string quartet*, I began to explore other compositional approaches to pitch material, searching for some level of structural pitch variation, while retaining a degree of relative stasis. In later works such as *Hymns to Sing at the Apocalypse*, there becomes a clear preference for small, attenuated pitch movements. Here, microtonality is not adopted as a dogmatic tuning system or conceptual idealism, but rather as an effort to attenuate and minimise pitch motion. The focus is not on microtonal formalism *per se*, but rather a move towards microscopic tonality.

### **DISPERSED STRUCTURES OF HYMNS TO SING AT THE APOCALYPSE**

*Hymns to sing at the apocalypse* is a small chamber concerto for bass flute, bass clarinet, violin, violoncello and solo contrabass.<sup>61</sup> Structurally, the piece is an attempt to further explore elements of modularity and non-linearity initially used in pieces such as the *Network* scores. Taking elements of a traditionally notated ensemble piece, the piece experiments with possible ways in which fragmented or non-linear elements can be incorporated into a structurally coherent ensemble piece.

Throughout the first movement (section X) the bass—treated as a soloist throughout the piece—is isolated from the ensemble and plays a continuous low F# while the ensemble

---

<sup>59</sup> Jonathan D. Kramer, “New Temporalities in New Music”, *Critical Inquiry* 7, no.3 (Spring, 1981): 551.

<sup>60</sup> James Tenney, “John Cage and the Theory of Harmony”, in *SOUNDINGS* 13, 64. Italics in the original.

<sup>61</sup> The work was commissioned by the *internationalcontemporarymusicfestival* in Seoul, South Korea, however, due to logistical issues, I did not get the chance to work with the ensemble in rehearsals. As the ensemble was unknown to me, I decided to act cautiously and avoid some of the more complex elements of my works such as *whose veil remains inscrutable*, instead focusing on more structural experiments.



follows a simple *tutti* structure. The second ( $\Psi$ , ensemble) and third ( $\Omega$ , bass solo) movements are played simultaneously with all parts moving independently. The ensemble members each split off, acting individually and looping their way through fragmentary phrases, each lasting a proportional duration. For its ‘solo’ part, the bass interprets a number of parametric graphic systems which seek to destabilise the instrument. As Figure 8 shows, *Hymns to Sing at the Apocalypse* features four distinct temporalities across the two sections.<sup>62</sup> Section  $X$  is the most straightforward, making use of traditional mensural rhythms and durations. This section, however, is destabilised by the foregrounding solo bass which plays a continuous low  $F\#$  *outside* the time of the rest of the ensemble. The bass counters the rhythmic structures of the ensemble, remaining isolated and static. This is the logical extreme of the temporal pushing and pulling of time as seen in the layered rhythms of *whose veil remains inscrutable* or *with the very same twist to their faces* (discussed at the end of this chapter). Rather than time sticking and slipping, in *Hymns to Sing at the Apocalypse* the bass part is figuratively frozen whilst the rest of the ensemble moves as standard.<sup>63</sup>

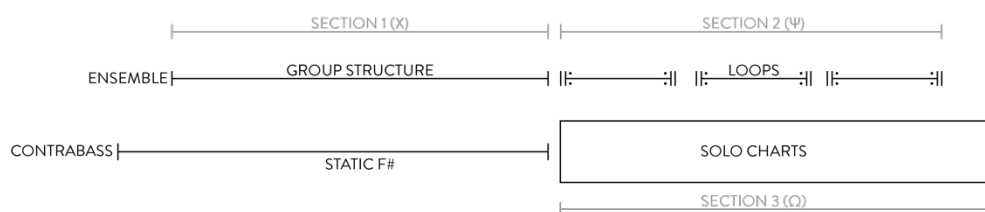

Figure 8: Structure outline for *Hymns to Sing at the Apocalypse*. The bass’s  $F\#$  drone begins before the ensemble, as a kind of *fermata-anacrusis*.

In section  $\Psi$ , the ensemble disperses and, while individual parts harmonically relate to one another, they are free from any unifying meter. Here, the temporality of the section is governed by a kind of economics of labour: a musical cell’s duration is directly determined by the relative duration of an action. For instance, a basic cell might include a single bow stroke or breath. The duration of this part is thus equal to the longest (slowest) possible bow stroke or breath that one can perform. Each cell is encapsulated in repeat bars and must be repeated before the performer can move to the next cell. As the number of repeats and duration of each cell are not uniform, the notion of any

<sup>62</sup> Section  $\Omega$  in reality, is more part of the second section than it is its own, however naming it such highlights its autonomy from the group structure and drone of section  $X$ , and the recursive temporality of section  $\Psi$ .

<sup>63</sup> Being frozen in time, only to awaken at a later time is a standard trope of much science fiction. The temporalities of other such recurrent science fiction themes have played an large influence in much of my compositional process. *Escapement* for instance is structurally modelled on a 1956 J. G. Ballard short story of the same name. In it, the protagonist becomes caught in a gradually shortening loop of time—experiencing a monotonous fragment of his life until the loop closes in on itself.

ensemble or mensural organisation becomes blurred here, temporally overlapping and recursively looping as the cells move out of phase with each other.<sup>64</sup> As noted in chapter 1, the physical effort required by these laborious tasks should not be underestimated. As a player repeats these parts—which are unstable by the nature of their actions—small changes will obviously occur, from the subtle tremors and fluctuations of pitch, to the deterioration of sustained tones as the performer becomes fatigued. Though relatively brief in its implementation here, the logical conclusions of this difference through repetition might be seen in the late works of Morton Feldman, or in the 840 repetitions of Eric Satie’s *Vexations* (1893) where the performer’s stamina and concentration brings about variations and inconsistencies in their interpretation. Alternatively, at a less confrontational extreme, is Bryn Harrison’s *a leaf falls on loneliness* (2007), wherein a single page of music is repeated 27 times. Though the number of repeats are perhaps more manageable than those of Satie, here alterations arise from the rhythmic complexity of the notation, as tuplets must be counted relative to other offset or divergent rhythms. Harrison notes that:

whilst the piece becomes more known on one level as time goes on (due to the highly repetitive nature of the music), it also becomes subjected to more scrutiny by the listener as more and more of the details become audibly noticeable. I would like to think that, by offering various points of focus upon the same event over a prolonged period of time, the piece allows for the possibility of opening up a variety of implicit interpretations and, as a result, offers a degree of multi-dimensionality and a reflective space for the listener.<sup>65</sup>

The variations being considered here are minute however, and certainly not enough to deem the outcome structurally indeterminate (as seen in the *Network* scores). Although it is unlikely that any differences within the short repetitions of any one instrument in *Hymns to Sing at the Apocalypse* will be picked up by the listener, the emergent behaviour of the ensemble members—each operating autonomously yet repeating—no doubt presents the listener with an interesting tension and similar ‘degree of multi-dimensionality’.

## THE ATTENUATED SOLO

In the second half (section  $\Omega$ ) of *Hymns to Sing at the Apocalypse*, the bass tentatively rises to the surface for its solo movement. Of course, the term ‘solo’ is something of a misnomer here as the ensemble continues to play, with each instrumentalist splintering off to play simultaneous, independent solos. However, following the protracted drone of

---

<sup>64</sup> This concept was later developed into a complex nesting of repeat marks in *if some thing black and falling as rain and then rising*, both discussed towards the end of this chapter.

<sup>65</sup> Bryn Harrison, “Scanning the Temporal Surface: Aspects of Time, Memory and Repetition in my recent music”, *Divergence Press* 1 (March 2013): 61.

the contrabass' first movement, even the faintest action of the performer can be viewed as a significant shift. For such discrete events to function as a solo, one must consider the overall attenuation of expression throughout the piece as a whole. Far from calling attention to itself, the bass appears only as a thin sonic protrusion, a veil tracing the surface of the ensemble's repetitive actions. Nevertheless, I wish to address section  $\Omega$  as an attenuated 'bass solo' in which the bass does, in some sense, act as the focal point of *Hymns to Sing at the Apocalypse*.

The solo section comprises a number of discrete notational systems, which the soloist selects from in advance and plays through. The relatively constrained actions of the material (often small gestures of less than a semitone) are offset by the temporal flexibility of the systems: the soloist is free to choose as many or as few systems to play, altering their duration and speed. There is no preferred number or order that the systems should be navigated in, and system durations are scaled relative to the number to be played. Hypothetically, then, a performer could attempt to play all systems (relatively quickly), or spend the entire duration of the solo playing a single system, stretched out accordingly. The degree of choice afforded to the performer here serves to add a sense of freedom to the solo's structure, further underpinning its autonomy from the ensemble. Whilst the remainder of the ensemble becomes stuck in their recursive temporal eddies and sink into the background, the contrabass has broken free of its former stasis, becoming unthreaded and moving freely, fragile in its new precariousness. The solo section, moving fluidly, operates in a foreign temporality, independent and running parallel to the ensemble, just as it had remained isolated and frozen in section  $X$ .

The notational systems of the section make use of hyper-precision as a means to 'zoom-in' on the soloist's actions. Here, notation functions again as a microscope—or perhaps, a stethoscope—with which to focus in upon the sound itself, encountering the music and technical execution from a new sonic perspective. The resolution (or fidelity), at which elements of the solo's notation operate begin to resemble microsound composition, not necessarily in its concern for the microscopic time scale (i.e. granular sounds), but rather, through the precision and closeness at which the performer must focus. The use of parametric charts to control musical parameters ensures a certain level of clarity in the notation, allowing state changes to occur relative to certain specified variables, for instance: an elaborate glissandi occurring between two defined pitches. The resolution of the traditional stave is therefore readjusted, providing a new, enlarged space within which to explore the limits of motion, constrained within a (smaller) interval.

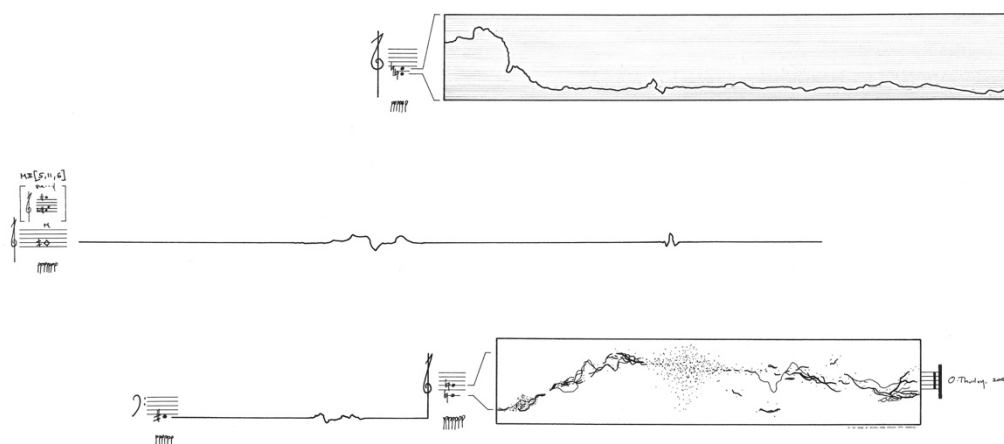

Figure 9: Excerpt from the end of the bass solo in *Hymns to Sing at the Apocalypse*.

Figure 9 shows a number of the various notational systems employed in the bass solo of *Hymns to Sing at the Apocalypse*. Stylistically, the influence of both Ullmann and Xenakis is clear, yet while the gestures are more extreme than any of the previously composed parametric notations in the portfolio, the scale at which they operate is limited. The largest of these intervals occurs in the final line of the piece (bottom of Figure 9) spanning a fifth from C to G natural. Here the graphic curve is dense and populated with a number of overlapping lines suggesting multiple simultaneous tones; midway through the cell, the line explodes into a cloud of points. No explicit guide is given to the performer with regards to how this section should be performed, instead leaving them to freely interpret it. This abstraction and juxtaposition of notational styles is developed even further in the bass clarinet solo *if some thing black*.

In practice, the precision and continuously branching arborescent fluctuations of these parametric notations call for a constant realignment of technique as the limit points of their control shifts. Whilst from a structural or macroscopic view it may seem that this music is static, from this new, closer, perspective, one realises that the music is—through this dynamic and constantly fluctuating notation—in fact in a state of constant motion: struggling to retain its cohesion beneath its *almost*-still surface. Occasionally, melodic fragments may emerge, yet mostly the stasis remains; the solo is ascetic and bound—uncomfortably—between narrow constraints.<sup>66</sup> Given that the whole piece is so

<sup>66</sup> There are a number of anecdotal references to various apocalypse mythologies concealed throughout the score to *Hymns to Sing at the Apocalypse*. One more oblique reference can be found in the bass solo, in the system at the top of page 3 in which the melody to the hymn *Nearer, My God, To Thee*. Allegedly, this is the hymn prepared by CNN’s CEO, Ted Turner, as a doomsday sign-off to be broadcast at the end of the world. There is also some speculation that this was the final song played by the ship’s band on the Titanic, although this conflicts with stories that the tune was “Autumn”, as referenced in Gavin Bryars’ *The Sinking of the Titanic*.

restrained, once the bass breaks free of the ensemble and its own stasis, it seems to float to the surface of perception, finally appearing and figuratively hovering over the piece.

In the solo of *Hymns to Sing at the Apocalypse*, it is worth noting that for many of the parametric systems the plotted pathways are not smooth glissandi as found in the conceptual form of *Mathematical Forms 001: Orbit* (discussed later in the chapter). Instead, they are hesitant in their movements: trembling and in a constant state of flux.<sup>67</sup> Composing at this lower—microscopic—level, the solo’s notational systems are able to control even the smallest tremors in sound, which, at any other notational scale would seem inconsequential (or, at the very least, an irrational and unforgiving request). Even where actions may not afford an audible result, they engage the performer both temporally and timbrally at this microscopic level, forcing them to consider the smallest, most delicate fluctuations of sound as a direct outcome of their performance (see chapter 1). Whilst notated gestures remain almost infinitesimal, bringing about relatively little reward for such an exhausting performance, the microscopic detail of the score can still reframe the performer’s interface between notation and their instrument. Through this microscopically ascetic solo, the performer is drawn deeper inside the music.

### **MATHEMATICAL FORM AS PITCH BEHAVIOUR**

In considering the portfolio’s approach to time, it is perhaps also worth discussing the composition’s structural approaches to pitch. For the most part, my compositional concerns regarding pitch are not harmonically focused, but structural and melodic, focusing on small intervals unfolding over time. At the beginning of this project, inspired by the virtual pitch structures of Xenakis—for instance, the now iconic hyperbolic paraboloid glissandi of *Metastasis* (1953–54) and its subsequent influence on the architecture of the Philips pavilion—I became interested in the use of mathematical surfaces as a means to create tensile textures and geometric pitch behaviours. Using Hiroshi Sugimoto’s *Conceptual Forms* (2004) series as its influence, *Mathematical Forms 001: Orbit* (hereafter, *Orbit*) was the first work in the portfolio to explore the use of geometric form as a means of pitch organisation. The mathematical forms of the ‘sculptural renderings of trigonometric functions’ in Sugimoto’s photographs are geometrically simpler than the those employed by Xenakis and better suited to simple application by a smaller instrumentation.<sup>68</sup> In *Orbit*, written for viola and contrabass, a

---

<sup>67</sup> In the initial pre-compositional stages, a fractal noise algorithm was used to generate these charts, as seen in similar functions of earlier pieces. However, the final version makes use of ‘free-hand’ plots as a mean to make more unpredictable gestural movements sporadically. The problem of self-similar algorithms is, of course, that they maintain an average over time, which can often preclude any anomalous events. In the solo, I wanted to include some of these behaviours as a means to occasionally perforate the fragile surface of the solo. Moving freely, this allows the solo to move chaotically, wandering ‘off-course’ over time and further contrasting the locked loops of the ensemble.

<sup>68</sup> Hiroshi Sugimoto, “Conceptual Forms, 2004”, *Hiroshi Sugimoto* (Ostfildern: Htje Cantz, 2010), 273.

simple spiral function mimics the sculptural subject of Sugimoto's *Mathematical Form: Surface 0010* (2004) (Figure 10):

$$\begin{aligned} \text{radius} &= \theta * \text{time} \\ x &= \text{radius} * \sin(\theta) \\ y &= \text{radius} * \cos(\theta) \end{aligned}$$

Here, the  $x$ -axis is used to determine relative pitch movement, slowly orbiting a central pitch (i.e.  $\text{o.o=C}$ ), while the  $y$ -axis denotes bow position (*molto sul ponticello* ↔ *molto sul tasto*) (Figure 11). The curves of each instrument are plotted as polar opposites, essentially mirroring each other across the central pitch axis, so that together the duo trace the outline of the spiral's virtual surface.<sup>69</sup> In compositional sketches for other mathematical forms, axes could theoretically be used as trajectories for more complex behaviours such as deviation from a focal point/pitch, or control of other musical parameters such as bow position/movement as seen in *Orbit*.<sup>70</sup> In this sense, the basic parametric control takes influence from James Tenney's ninth postal-piece score, *Cellogram* (1971) which employs Tenney's 'parametric profiles' to perceptually model a sound within so-called 'attribute space'.<sup>71</sup>

---

<sup>69</sup> The models in Sugimoto's *Conceptual Forms* were in fact originally created in the nineteenth century and used teaching aids for visualising complex trigonometric functions and geometry. Now nearly two-hundred years old, the small plaster models have become chipped and partially eroded by time. The physical cracks and imperfections of these ideal mathematical concepts renders them imperfect, breaking and destabilising the continuity of the trigonometric functions the models represent. In *Orbit*, the sonification of these same mathematical functions becomes similarly eroded. The acoustic instruments used in performance render the pure abstract geometric forms fragile through the subtle instabilities and imperfections of the performance.

<sup>70</sup> A secondary version was created electronically using the Dini's surface form, although never completed due to problems with the instrumentation. This sketch could only be realised with an electronic sine wave rendering.

<sup>71</sup> James Tenney, *META † HODOS and META Meta † Hodos*, (Oakland, CA: Frog Peak Music, 1988), 33–35.



Figure 10: Hiroshi Sugimoto, *Mathematical Form: Surface 0010* (2004), Gelatin silver print.

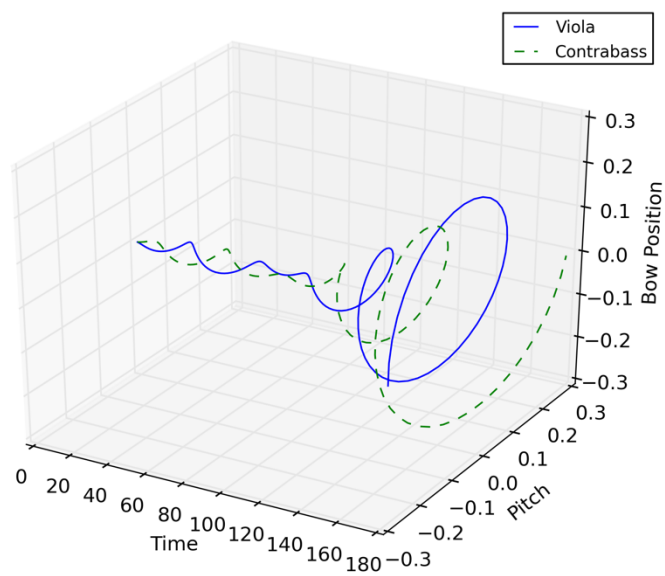

Figure 11: Basic spiral geometry plot for *Orbit*.

## MASKS AND SLICES: CONSTRAINT AND THE ORGANISATION OF PITCH

While the experimentation with geometric modelling in *Orbit* was conceptually interesting, it provided only simple linear melodic lines within pitch space—basic glissandi motions. Developing upon this scheme, a system of constraining pitches between dynamic boundaries was explored in order to enable more harmonic flexion. Inspired by Gottfried M. Koenig’s ‘tendency masking’ techniques, a system of expanding and contracting pitch ‘masks’ allow the procedural generation of sets of available pitches, developing over time.<sup>72</sup> Some iteration of this system has been used in organisation of pitch material in the majority of my recent compositions to varying degrees.

One of the earliest uses of this tendency masking technique in the portfolio is found in *Envelop* for eight voices. *Envelop* employs Messiaen’s third mode of limited transposition—a symmetrical scale which is transposable four times—as its core pitch set within which the tendency masking technique may manoeuvre. Cycling through the scale, ‘slices’ of varying widths are used as masks of available pitches for each page of the score:

FULL PITCH SET:	{E, F#, G, Ab, Bb, B, C, D, Eb, E'}	
slice t:	[Ab, Bb, B, C]	width = 4
slice t+1:	[Bb, B, C, D, Eb, E]	width = 6
slice t+2:	[B, C, D, Eb, E, F#, G, Ab]	width = 8

As Donald Street notes, ‘the attraction of the modes of limited transposition is in the tonal ambiguity which results from their symmetry, for, as Messiaen points out, a tonality can be emphasised or left unsettled.’<sup>73</sup> It was the nature of this ‘tonal ambiguity’ in particular that attracted me to the application of a mode of limited transposition in the the pitch masks for *Envelop*. By only employing the scale in these fragmented slices per page, I was able to maintain a constant level of ambiguity and equality even when only using a few notes. As the slices shift, expand and contract, the harmonic content remains in a sort of unsettled suspended animation where no preference is given to any tonal centre of the available notes.<sup>74</sup>

---

<sup>72</sup> According to Robert Rowe, a tendency mask is ‘a set of dynamic boundary points between which elements will be selected at random.’ Robert Rowe, *Machine Musicianship*, (Cambridge, MA: MIT Press, 2004), 208.

<sup>73</sup> Donald Street, “The Modes of Limited Transposition”, *The Musical Times* 117, no. 1604 (October 1976): 819.

<sup>74</sup> The mode (amongst others) is also employed to similar effect in both Howard Skempton’s string quartet, *Tendrils* (2004), and in Bryn Harrison’s *Vessels* (2013) for solo piano. Bryn Harrison, “Repetitions in extended time: recursive structures and musical temporality”, in *Overcoming Form: Reflections on Immersive Listening*, eds. Richard Glover and Bryn Harrison, (Huddersfield: University of Huddersfield Press, 2013), 41–60. Both pieces explore the simultaneously arborescent and aimless qualities inherent in these symmetrical modes and were both influential on the composition of *Envelop*. The cyclical use of symmetrical pitch materials (including Messiaen’s modes of limited



The use of a fragmented mode of limited transposition as material for pitch slices drew my attention towards further exploration of masking limited bandwidth of pitches during the composition of *with the very same twist to their faces* and *whose veil remains inscrutable*. Drawing upon the heavy chromaticism used in my earlier work, the tendency mask system was employed once again, this time applied to an evenly tempered chromatic scale. The use of highly constrained slices of chromaticism ensure a number of very close interval to always be possible. The minor second interval therefore becomes a central building block in the compositions, and the gradual development of a central plot will not necessitate larger intervallic leaps which might break continuity or sense of stasis. As previously seen in *Envelop*, the masking system retains its shifting slice width, while the limit points are centred around a focal plot. However, for both *with the very same twist to their faces* and *whose veil remains inscrutable*, this locus was made dynamic, shifting over time (see Figure 12).

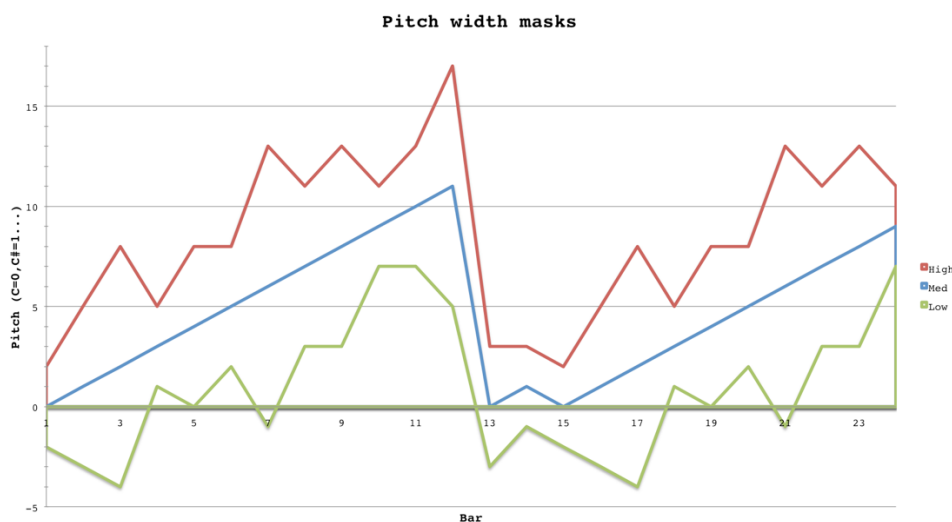

Figure 12: Demonstrative chart of pitch masking bars 1-24, *whose veil remains inscrutable*. Red and green plots mark the respective high and low limit points of the mask widths.

In the implementation of this technique for *with the very same twist to their faces* and *whose veil remains inscrutable*, the masks were layered to match the multiple parallel rhythmic layers of the score. The computational nature of technique allowed the process to be recursively repeated with subtle differences at each layer (once again, minor deviations a result of random and self-similar noise). For instance, *whose veil remains inscrutable* comprises multiple independent layers for each instrument. While they each follow similar trajectories, small discrepancies in their behaviour (i.e. changing direction after a certain number of iterations, or varying mask widths slightly) allow for subtle development and variation to the process throughout the piece. Despite the static nature

---

transposition) is also central to much of Harrison's work. See Bryn Harrison, "Cyclical Structures and the Organisation of Time", (PhD thesis, University of Huddersfield, 2007), 11-12.

of much of the work in this portfolio, the use of these shifting pitch masks allows a constantly evolving form to emerge; obscuring and effacing clear tonal centres and with it, a clear sense of melodic *telos*. The effect is such that, while on the surface level the music appears still, below the surface the music is always in flux and never settles. To this end, the function of pitch in my work is not harmonic, but intervallic and disorienting: the emergent outcome of layering these discrete interval processes.

### **RHYTHM, OVERWRITTEN**

Whilst the same cyclical pitch masking system of *whose veil remains inscrutable* was used in *with the very same twist to their faces*, at the pre-compositional stage, the initial rhythmic layers deliberately contained too much information, making the material far denser than required for the final piece. These layers were then subjected to a subtractive process as a means to sculpt ‘melodic’ phrases from an incredibly dense source material. Despite this filtering process, *with the very same twist to their faces* consciously attempts to retain certain quasi-paradoxical elements of its multiple layers as discrete temporal strata. The final score presents plural temporalities, with layers moving at different speeds, interweaving yet remaining separate.<sup>75</sup>

For the majority of *with the very same twist to their faces*, layers interact—or rather, interfere—with each other, each causing the performer to break off from one layer to play another. This can be heard most clearly in the baritone saxophone part: as a monophonic instrument, the player is more constrained than the accordionist in how much of the material presented is actually performable. This forces the performers to constantly interrupt themselves, decoupling between various rhythmic layers as these branches shift and intertwine. I have adopted this technique of rhythmic interruption from Brian Ferneyhough, who uses it extensively throughout the works *Mnemosyne* (1986) and *Trittico per G.S.* (1989). However, where Ferneyhough explicitly marks out where interruptions take place (using a horizontal line to denote the duration of the initial note and a vertical line connecting to the interrupting note at the point of cut-off), I have chosen to leave such interruptions unmarked. In his Darmstadt lecture from 1988, Ferneyhough notes that in *Mnemosyne*, ‘how the layers interact in detail is left to the performer to determine, since it is he who assigns relative hierarchical values to the intersecting or colliding linear tendencies.’<sup>76</sup> However, in his separation of layers across multiple systems and notation of specific interruption points, Ferneyhough, to some

---

<sup>75</sup> The only significant moments of temporal cohesion occur during the sparse ‘frozen’ pauses which subdivide the piece; a brief Sisyphian resetting of time.

<sup>76</sup> Brian Ferneyhough, “The Tactility of Time (Darmstadt Lecture 1988)”, *Perspectives of New Music* 31, no. 1 (Winter 1993): 27.

extent, precludes the performer's freedom to interpret the autonomy of each layer. Whilst attempting to eschew these 'relative hierarchical values', he notes that in *Mnemosyne*:

What happens is that each of the three lines has its own typical materials in any given section; hence, there is always a particular priority pattern characteristic of the lines among themselves—one is always dominant, the others accompanimental, interjectional, or otherwise subordinate.<sup>77</sup>

Rather than treating all layers as equal, Ferneyhough draws the performer's attention along an explicit line of interruption, towards a separate layer on an adjacent staff within the system. This, of course, creates a dominant layer as focus is drawn *away* from one layer and *towards* another. Whilst my decision to compress all layers onto a single system and leave interruptions unmarked may not solve the problem of dominance and hierarchy any more than Ferneyhough—of course, the currently occupied temporal layer will always be dominant—it homogenises rather than separates the data, blurring the clear distinction between layers. In *with the very same twist to their faces*, and later *if some thing black and falling as rain and then rising*, the intention is that rather than plot a path between rhythmic layers *for* the performer, they are allowed to make decisions themselves without the influence of separated layers. This pseudo-palimpsestic blurring of layers allows numerous possible pathways and intersections to occur through these plural temporalities. This method of temporal navigation of divergent pathways through the piece further highlights the temporal (dis)orientation of the work as layers do not assert their dominance over others, but simply come and go, constantly trapped between differing layers of time.

Juxtaposing the rhythmic rigidity of these prescriptively complex notation methods, a number of my works incorporate fermatas as a device to create an illusion of 'hanging time'. Although this might constitute an implied hierarchy of rhythmic layers, the intention is that these arise from a lower level, emerging as an alternative time scale, and offering an escape from the trapping between temporal layers. The fermatas that occur between systems—tacit rest points—are clear and require no further explanation. However, where arising within a musical system, these fermatas seem incongruent with the precision of more complex rhythmic schema and require greater consideration. The technique is once again inspired by Nono's later works, particularly *Das atemde Klarsein* (1980–83) for bass flute, small choir and live electronics. Here, Nono employs fermatas with approximate durations within metered bars, skewing the typical rhythmic duration of notes. Peter Ivan Edwards speculates that Nono employs the use of fermatas (their length ranging from two to seventeen-seconds), principally as a 'another form of moving

---

<sup>77</sup> *Ibid.*

into the interior of a sound world.<sup>78</sup> Whilst Nono's combination of notated rhythm and fermatas initially seems irrational, or convoluted at best, Edwards concludes that such 'active motion versus suspension, is one more method to create the sense of fragility and involution of sound objects.'<sup>79</sup> The technique is a delicate temporal blurring, one in which rhythm's duration becomes distorted, whilst the sense of attack—the relative placement of events—is not. These fermatas mark a rift in the temporal schema of the piece, pointing outside itself and towards an alternate notion of duration: not mensural, but personal to the performer. A post-modern conception of time. In these brief moments of cessation from the score's complex rhythmic notation, the temporality of the score is overwritten by a new (and contrastingly undefined) scale of time.

### PLURAL TEMPORALITIES OF ROCK CLIMBING

For Russell West-Pavlov, postmodern time is 'a temporal logic in which the suppressed aporia of absolute or universal time begin to re-emerge, often manifesting themselves in spatial form.'<sup>80</sup> The effect of this postmodern notion of time with its 'immanent intertwined temporalities' implies a need to become 'attentive in the present moment [...] to the interconnections between the various temporal strands which make up existence, and whose dynamic becoming is time itself.'<sup>81</sup> It is the complexity of this postmodern time, which points us towards a more immediate experience of time—'a plurality of interacting temporal flows'—than that proliferated by abstracted 'clock-time'.<sup>82</sup> By way of gauging what the 'overlapping and interactions' of postmodern time might appear like, West-Pavlov turns to Sanford Kwinter's discussion of contemporary free-soloist rock climbing as 'a conception of the temporal interactions between multiple human and non-human actants'.<sup>83</sup> West-Pavlov argues that in the dispensing of traditional climbing apparatus, free-soloist climbers 'rely entirely upon the interaction of their own balance/weight with the contours and texture of the cliff face', and in doing so become 'reciprocally interconnected' at varying timescales.<sup>84</sup> For Kwinter, this is a result of 'the morphogenetic principle of the climbers' space' becoming 'no longer susceptible to forms imposed from outside (the "assisted" ascent)'.<sup>85</sup> Kwinter continues:

---

<sup>78</sup> Peter Ivan Edwards, "Object, Space, and Fragility in Luigi Nono's *Das atemde Klarsein*", *Perspectives of New Music* 46, no. 1 (Winter 2008): 240.

<sup>79</sup> *Ibid.*

<sup>80</sup> Russel West-Pavlov, *Temporalities* (London: Routledge, 2013), 137.

<sup>81</sup> *Ibid.*, 133–34.

<sup>82</sup> *Ibid.*, 157.

<sup>83</sup> *Ibid.*, 154–55.

<sup>84</sup> *Ibid.*

<sup>85</sup> Sanford Kwinter, *Architectures of Time: Toward a Theory of the Event in Modernist Culture* (Cambridge, MA: MIT Press, 2002), 29.

The free-soloist must flow up the mountain, flow or ‘tack’ against the downward gradient of gravity—but also must become hypersensitive tamer and channellers of the gravitational sink, masters at storing it in their muscles or making it flow through certain parts of their pelvis, thighs, palms, and only at certain times; they must know how to accelerate the flow into a quick transfer that could make the difference between triumph and disaster, to mix and remix dynamic and static elements in endless variation.<sup>86</sup>

West-Pavlov notes that Kwinter’s description of the climber’s body reframes the way we might typically think of gravity as a grounding ‘derivative of inertia,’ instead imagining it as ‘a positive flow of energy’ which the climber must channel, ‘setting up a body-gravity dynamic.’<sup>87</sup> The body, then, for Kwinter: ‘must be broken apart into a veritable multiplicity of quasi-autonomous flows’ in order to interface with the intractable complexity presented by the rock face. ‘Every square centimetre represents its own interdependent dynamical system continually cross-referencing with the others, but locally in relation to its own “micro-site-specificity”.’<sup>88</sup> It would be unreasonable, then, to assume that a climber could assert complete control over the emergent complexities, the ‘interweaving forces and flows’ of the rock face. Instead they must attempt to interface with the plural temporalities entwined in this space:

the climber’s task is less to “master” in the macho, form-imposing sense than to forge a morphogenetic figure *in time*, to insert himself into a seamless, streaming space and to subsist in it by tapping or tracking the flows—indeed to stream and to become soft and fluid himself, which means momentarily to recover real time, and to engage the universe’s wild and free unfolding through the morphogenetic capacities of the singularity.<sup>89</sup>

West-Pavlov concludes: ‘in this conception of immanent plural temporalities, every entity becomes dynamic, flowing at a greater or lesser speed. Any situation is the sum total of the interactions between these multiple temporal flows.’<sup>90</sup> Musically, it is clear that these various temporalities operate contemporaneously when one considers a system of unified time structures in music. As Aden Evens reminds us, ‘music is constructed from airwaves, vibrations of the air that determine sound’s pitch and timbre, but it also involves crucially the vibrations of rhythm and of form.’<sup>91</sup> These scales of time—waves, rhythms, forms—all materially intertwine, operating in complex polyrhythms, each

---

<sup>86</sup> *Ibid.*

<sup>87</sup> West-Pavlov, *Temporalities*, 155.

<sup>88</sup> Kwinter, *Architectures of Time*, 30–31

<sup>89</sup> *Ibid.*, 31.

<sup>90</sup> West-Pavlov, *Temporalities*, 156.

<sup>91</sup> Aden Evens, *Sound Ideas*, 31.

‘flowing at a greater or lesser speed’ to produce what we commonly consider music.<sup>92</sup> Music, then, might be thought of as not dissimilar to the rock face with its plural temporalities and ‘interweaving forces and flows’.<sup>93</sup> Kwinter’s free-soloist climber who must track these flows, by comparison, becomes a musician who must orient themselves within this plurality of time. Like the rock face, the terrain of these fragile sounds are intractably complex. It is not a case of virtuosic attempts to master the technique, perfecting and smoothing out irregularities of previously unstable sounds.<sup>94</sup> Instead, the performer must tentatively navigate these temporal aporias and anomalous disruptions as they occur: flowing with emerging forces rather than attempting to assert dominance over the sound. Again, we return to Frank Hilberg’s ‘virtuosity of restraint’.<sup>95</sup>

The duo for baritone saxophone and accordion, *with the very same twist to their faces*, offers a view of these plural temporalities as they occur within my work through its layering of complex rhythms. The multiple temporal (rhythmic) layers of the piece overlap and become entwined with other temporal layers, or—for the sake of geological continuity—strata; constantly overlapping and shifting against any semblance of regular pulse. The piece functions, like the palimpsest: *through* these strata, as ‘immanent plural temporalities,’ with each one flowing dynamically at different speeds—pushing or pulling against the abstract mensural time and tempo.<sup>96</sup>

### TRACE, PALIMPSEST, ERASURE

Returning momentarily to West-Pavlov’s comment that ‘any situation is the sum total of the interactions between these multiple temporal flows’, it is possible to visually draw these interactions towards the surface through the image of the palimpsest.<sup>97</sup> The palimpsest is a document or manuscript (historically a sheet of parchment or papyrus) where the text has been partially effaced by superimposed layers of later writing.<sup>98</sup> Often, the document still bears traces of these older, overwritten layers, which remain partially visible *through* the more recent layers. These compounded traces can lead to obscured or altered readings of the document, where previous traces of writing influence the context

---

<sup>92</sup> West-Pavlov, *Temporalities*, 156.

<sup>93</sup> Kwinter, *Architectures of Time*, 31.

<sup>94</sup> Here, one might consider the music of Brian Ferneyhough and subsequent composers of the ‘New Complexity’, in which the theatre of struggle begins to collapse when the technical difficulty—the reliance upon virtuosity—becomes normalised.

<sup>95</sup> Hilberg, liner notes to *Jakob Ullmann* compact disc, 21.

<sup>96</sup> West-Pavlov, *Temporalities*, 156.

<sup>97</sup> *Ibid.*

<sup>98</sup> The notion of the palimpsest is one I have used elsewhere in my discussion of Jakob Ullmann’s *voice, books and FIRE* project. This section reuses my definition of ‘palimpsest’, shifting focus from its relationship with Ullmann’s work to that of my own. See Thurley, ‘Rebuilding Babel: On Fragility and the Palimpsest in Jakob Ullmann’s *voice, books and FIRE*’, forthcoming.

of later writing. For Max Silverman, ‘the palimpsest captures most completely the superimposition and productive interaction of different inscriptions and the spatialisation of time central to the work of memory’.<sup>99</sup> Conceptually then, the palimpsest offers a view of memory which is cumulative, allowing the past to be read through—and indeed influence—other traces; in effect collapsing the history of multiple temporal traces, each a discrete tool of memory, onto a single page.

In a number of the compositions of this portfolio, the image of the palimpsest emerges and provides a valuable concept with which to approach the music. Perhaps the palimpsest can be found most clearly within the rhythmic aspects of the compositional process: within these multiple layers which overwrite each other; shifting between layers and erasing others, all the while remaining open to alternative readings between these cumulative layers. The hanging fermata pauses, as noted above, also offer a kind of palimpsestic overwriting as rhythmic traces are erased and skewed by this new inscription. Here the ‘productive interaction’ of these layers occurs at the moment the fermata intersects—and effaces—the rhythmic coherence of its immediate surroundings: briefly overwriting and pausing time. The palimpsestic composition of these pieces draws the fragility of musical time to the surface, exploiting the way time may be broken apart by the interruptions and tensions arising from these multiple layers.<sup>100</sup>

To further explore this notion of the palimpsest and erasure within the compositional process of this portfolio, an alternate version of *with the very same twist to their faces* was created as a proof-of-concept. *with the very same twist to their faces (under erasure)* takes the score material of its progenitor, subjecting it to a parasitic algorithm which erases sections of the page.<sup>101</sup> These partially erased pages were then overlaid with others, made partially transparent so as to mimic the palimpsest, allowing multiple layered pages to be read through each other (Figure 13).<sup>102</sup> Of course, this process extrapolates the pre-compositional process in which complex material is filtered out to form the final layers. Whereas the pre-compositional process deals abstractly with conceptual data sets of pitches, rhythms and structural detail, this algorithmic erasure operates on the actual score, removing the concrete visual elements that a performer requires to make sense of the score (clefs, staff, accidentals, beams, dynamics, etc.) Like the palimpsest, this

---

<sup>99</sup> Max Silverman, *The Palimpsestic Memory: The Holocaust and Colonialism in French and Francophone Fiction and Film* (New York: Berghahn, 2013), 4.

<sup>100</sup> One can also trace this palimpsestic image through a number of the compositions’ approach to pitch as each discrete rhythmic layer employs its own cyclical pitch structure. As the layers bind together the pitch contours take on a more cohesive form and the material of individual pitch layers become, to a degree, lost.

<sup>101</sup> The version’s title suffix references the ‘*sous rature*’ (under erasure) strategic philosophical technique originated by Martin Heidegger and subsequently developed and used frequently by Jacques Derrida.

<sup>102</sup> This algorithm, once again, employs fractal noise mechanisms as discussed in chapter 1.

approach to erasure obscures the available information and thus transforms our ability to interpret the score.

Though this version has not been realised in performance, it provides an interesting thought experiment for the compositional and interpretative process. How would one read or interpret this disorienting notation? Occasionally pitches remain visible, though their duration or temporal placement is obscured. Similarly, where fragmented rhythms appear, they may lack any pitch material, or be interrupted by other information from layers. One might imagine a performance in which only those notes whose pitch and rhythm is clear and unimpeded by effacement are played. This would certainly be a more reductive interpretation than the original, as opposed to a reading which tries to interpret every single mark on the page as some inflected musical action. Although only a proof of concept in *with the very same twist to their faces (under erasure)*, the issues raised by a notation of fragmented and partial traces was later developed for the composition of *falling as rain and then rising*.

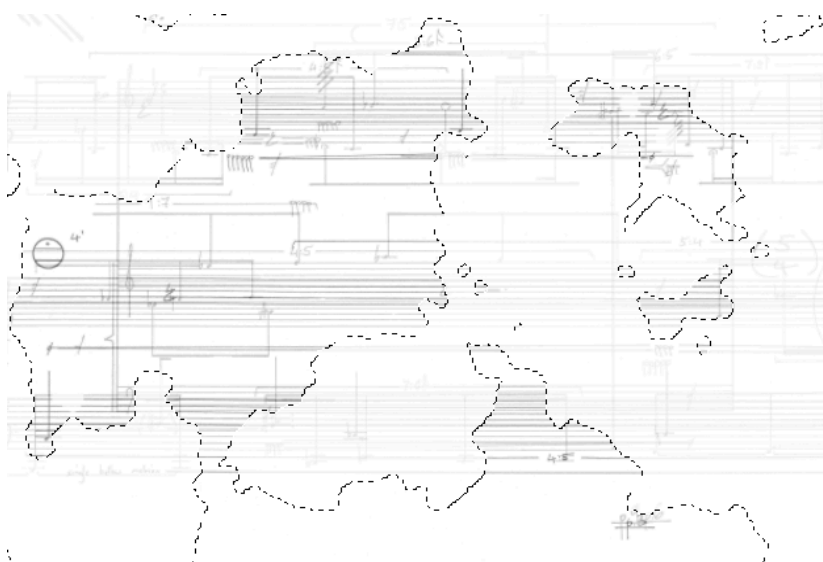

Figure 13: Fragment from the *with the very same twist to their faces (under erasure)* score. Dotted lines show the areas erased by algorithm, partially erased pages are then overlaid with slight transparency to create palimpsest notation.

### **INTERPOLATIONS AND BIFURCATIONS OF IF SOME THING BLACK**

The solo bass clarinet piece *if some thing black* adopts elements of the dispersed and fragmented structural models of pieces such as *Hymns to Sing at the Apocalypse* and the *Network* pieces, and develops them into a system which requires the performer to assemble and navigate their own path through the score. The score material is divided into three main sections (i, ii, iii), a set of ‘interpolations’, and an epilogue. Of the interpolations, five pages are harmonic network systems and seven pages feature ‘parameter cubes’ which interface with eight transparent pages. These alternative notations form points of juxtaposition within a framework which is already



discontinuous with itself given the quasi-modular nature of the score. The notational systems create both visual and audible ruptures, breaking up and punctuating the main sections. The network systems each focus on a sustained root, guiding the player through various harmonic overtones. The layout of the network pages are similar to those found in the *Network* scores, but with the added complication of an additional linear timeline—representing the sustained root note—which passes along the bottom of the page. This notation juxtaposes linear and non-linear structures on the same page, prompting the performer to try and reconcile the two. The parameter cubes function as nested repeat bars within a three-dimensional parameter space. Here, simple glissando lines (given by the transparencies) guide the performer through a complex system of overlapping repeats (in effect creating ‘splice-points’ within an otherwise smooth glissando).<sup>103</sup>

Provided with the full set of materials, the performer must assemble their own version of the score, choosing the order and amount of material they wish to work with. In assembling their own score, the performer must follow three rules:

- ‘Sections are played sequentially (i→ii→iii→epilogue), although pages within sections may be played in any order.’
- ‘Each section ends with intersecting network or parameter cube pages.’
- ‘Ghost fragments may be included at the performer’s discretion by reinserting previously played pages back into the score to be re-read later.’<sup>104</sup>

The result is a score that retains its notational detail, but can structurally change from performance to performance through the performer’s assembly (Figure 14). The macro structure remains the same (section i→interpolation→section ii→etc.) but the lower-level elements (the order of pages, which form or direction the interpolation will take) are open and subject to change. Here, a fragility of form begins to appear. The form of *if some thing black*, despite its stable macroscopic structure, is fragile and porous to the agency of the performer.

---

<sup>103</sup> This technique was greatly influenced by Cassandra Miller’s violin solo *For Mira* (2012).

<sup>104</sup> ‘Ghost’ fragments are elements from previously played pages which reappear within the performance. Performance notes to *if some thing black* (2015), v.

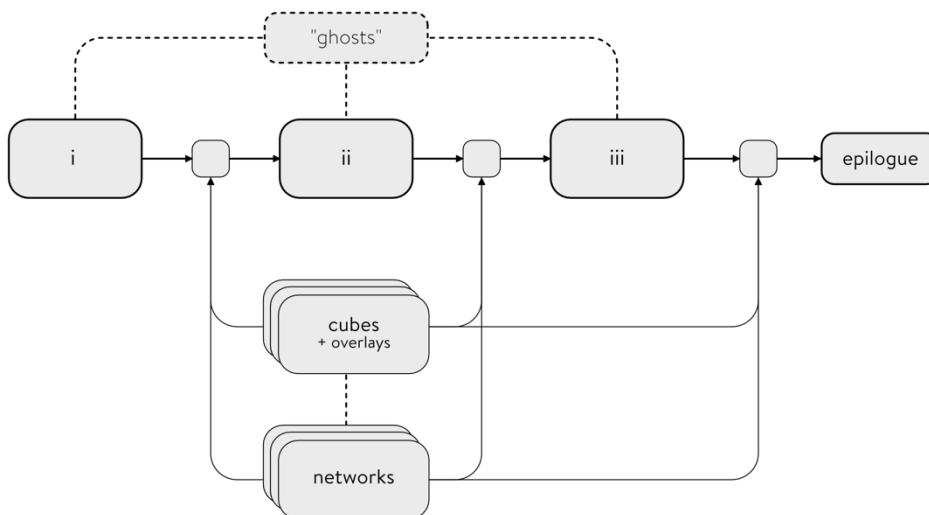

Figure 14: Structural schematic for *if some thing black*.

Looking closer at the fragile form of *if some thing black*, the performer's intervention comes into greater focus. In addition to the piece's adaptable macroscopic structure, the microscopic level confronts the performer with a surfeit of complex notation opening up a new layer in its fragility of form. Throughout the score, multiple rhythmic layers operate independently of each other, often overlapping to form polyphonic textures largely impossible on a single instrument (Figure 15). While *with the very same twist to their faces* employed multiple rhythmic layers, in an effort to explore plural temporalities, here the effect is amplified, with layers abstracted to their own systems, running concurrently with other systems and moving at different speeds. Compounded by the often complicated notational style, the performer must attempt to negotiate a path through these layers, choosing which elements to incorporate and which to omit. Despite the apparent complexity of its prescriptive notation then, the score is atomistic, and open to a number of interpretations.

By choosing to notate in these discrete systems, rather than a fixed or consolidated view, the score's manifold layers remain open as traces of possible paths, regardless of whether they are followed by the performer or not. The performer is free to make their own interpretation of the specific interaction between these systems; treating them as isolated threads, interpolating them together, or attempting to fuse their traces into something else entirely. This method of palimpsestic notation obstinately refuses to be tied down to a single interpretation. Instead, it affords a level openness (and paradox) without sacrificing detail or need for focussed precision.

Figure 15: Multiple simultaneous layers of material in *if some thing black* (p.21).

### ARRHYTHMIA IN *FALLING AS RAIN AND THEN RISING*

Following *if some thing black*'s openness and multi-layered polyvalence, *falling as rain and then rising* attempts to retain these qualities in its notation whilst simplifying the rhythmic complexities significantly. In this short trio for clarinet, violin and cello, many complex rhythmic behaviours were blurred and obscured before being 'flattened' on the score: their metric information stripped and then fused into illogical arrhythmic strings (Figure 16).<sup>105</sup> By removing the information necessary to decode these rhythms, a tension forms among the players. The trio attempt to follow the score with its various points of synchronisation between players; however, without the necessary ciphers (i.e. note-lengths, tuplet values, etc.) they lack a common point of orientation. *falling as rain and then rising* is based on this unstable foundation, its form is fragile and liable to collapse—to fall apart—if the trio become too disorientated. The focus here is therefore less about rhythmic accuracy (as found in the taxing *whose veil remains inscrutable*, meticulously navigated by Ensemble Nikel), but rather precision relative to the other players. A natural ebb and flow emerges amongst the players as they attempt to consolidate the score's paradox with the actions of others. Of course, in leaving the intersection of layers open to interpretations, a performer may choose to omit certain notes in favour of moving to a new layer or remaining in another. This would create a new level of complexity in the ensemble dynamic as other performers attempt to orient themselves with notes that have already been palimpsestically effaced.

<sup>105</sup> See Appendix V for structural sketches of these strings. The notational technique used for Section III of *falling as rain and then rising* draws inspiration from Martin Iddon's *Ptelea* (2014) for solo bass clarinet. The multiple lines within a single voice might also be deemed similar to the technique employed by J. S. Bach in his Sonatas and Partitas for solo violin (BWV 1001–1006, 1720).

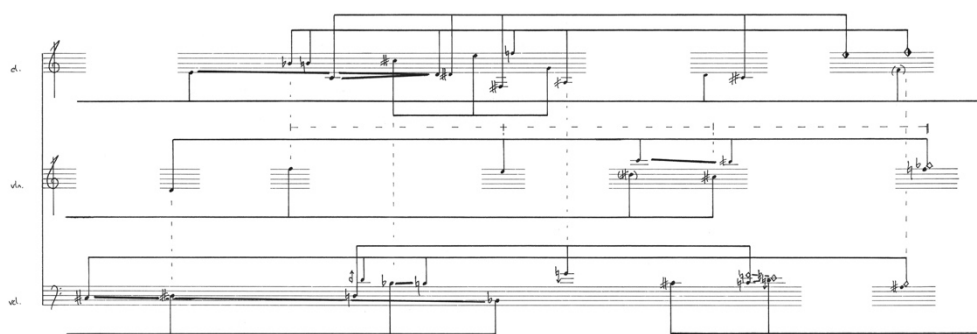

Figure 16: Multiple rhythmically obscured layers in *falling as rain and then rising* (p.6)

At the premiere of *falling as rain and then rising*, a practical issue with my compositional and notational approach became apparent. In my conceptual effort to allow open interpretation of the piece's multiple layers, the erasure of rhythmic information, combined with a lack of timbral variation (a concerted effort to remain restrained and sparse; everything is played *sempre ppppppppp*, without articulation or phrasing), flattened the layers to the point that they became indistinguishable. This resulted in any sense of temporal fragility and tension in the performance being lost as I had provided no clear means to articulate the layers as independent and conflicting. Instead the performers had little choice but to play the various layers as if they were simply a single linear voice in time-space notation. The issue arises from an all too theoretical consideration of the temporal complexities of this compositional feature: in my own narrow speculative and abstract approach, my concerns became isolated from wider, more practical, musical considerations. This was an important and stark reminder (if a bruise to my ego), that careful consideration of the performer's relationship to the score, physicality and timbre play an invaluable role in the fragile tensions of time and form in performance. For *falling as rain and then rising*, a solution to this loss of temporal fragility would require some means to distinguish the layers in order to reinforce their differences. This may involve the addition of timbral variations (bow position, speed, articulation, etc.), or experimenting with explicitly highlighting the layers as separate voices in the score (for example, 'Hauptstimme' and 'Nebenstimme' as seen in Schoenberg's music), to preserve a degree of tension and precision for the performers and avoid a recourse to flattening the notation into a single simplified layer.

three

## IN DISQUIET

To be listening is always to be on the edge of meaning, or in an edgy meaning of extremity and as if the sound were precisely nothing else than this edge, this fringe, this margin.

—Jean-Luc Nancy, *Listening*

I must have slept for a long time. I was only wakened when I had reached the last light sleep which dissolves of itself, and it must have been very light, for it was an almost inaudible whistling noise that wakened me.

—Franz Kafka, *The Burrow*

### PIANISS(ISS(ISS))IMO

Undoubtedly, the influence of a post-Cagean embrace of ‘silence’ can be felt resonating deeply throughout the quietness of my work, however it should be noted that although extremely quiet, silence is rarely incorporated explicitly into the work. Whilst composers such as Antoine Beuger, Jürg Frey, Eva-Maria Houben, Michael Pisaro and others associated with the Wandelweiser group have taken up the mantle of embracing post-Cagean silence, employing it through the use of extended pauses and tacet sections in the music, I have rarely made much emphasis on its use as a compositional tool.<sup>106</sup> Instead, silence is

---

<sup>106</sup> Hyper-quietness as an explicit musical aesthetic or style has received relatively little focused attention in the same manner as other extreme styles such as ‘Noise’ music. Whilst the Wandelweiser group have garnered some academic interest, this dialogue focuses on the role of silence and tends to remain exclusive to a small social group (Beuger, Frey, etc.) rather than the nature of the music.

treated as an implicit phenomenon throughout the portfolio; the proximity to this horizon point is constantly alluded to by the extreme quietness of performances. For the listener, silence never feels far away, and where it does emerge, its presence is subtle. In operating so close to the brink of inaudibility, the music is always close to disappearing into a perceptual abyss.

Whilst the dynamic levels throughout a number of my scores may at first appear exorbitantly ambitious in their direction (hairpin crescendos between *ppppppp*–*pppppp* are not uncommon), they are not without purpose: there exists a gradient of possibility in which a performer may control their dynamic. This of course shifts depending on the instrument, though for the most part, the upper limit would be around *fff*–*ffff*. Up to that point, all dynamics are possible, although not necessarily equally controllable. By limiting dynamic range to a small bandwidth at the lower end of this gradient, it is my intention to restrict control around an unstable range of possibility. The entire range of action is reduced or attenuated to the immediate range surrounding the as-soft-as-possible. Constantly operating at the brink of collapsing into silence, it is expected that even a simple sustained tone at the quietest of levels will occasionally falter and fall silent before crossing back into the realm of the audible (as discussed in chapter 1).

The extremity of the dynamics (the sheer number of *p*'s) additionally serves as a constant reminder to the performer that they are aiming for an *almost* unattainable level of quietness: they become markers for an *idealised* level of quietness rather than a practical performance direction. In this sense, the dynamic markings are relative, suggestive of an atmosphere of quietness which presides over the majority of my work. By composing at *ppppppp*, I constantly remind the performer that they can always strive to be quieter and that there is always some degree of amplitude as long as they are in motion, or until they reach the lowest possible limit: folding into silence, *al niente* ( $\emptyset$ ). As noted in chapter 1, the waveform dynamics of *yet another example of the porousness of certain borders* act as an effacing force within the music, intermittently erasing the score's material and destabilising the performer's control. In *Hymns to Sing at the Apocalypse*, the bass' microscopic gestures are threatened by the quietness of the performance and indistinguishable from the subconscious tremors of the performer as they struggle with

---

Nicholas Melia, and James Saunders. "Introduction: What Is Wandelweiser?" *Contemporary Music Review* 30, no. 6 (December 2011): 445–48. Michael Pisaro offers a personal account of the group's formation in his blog essay "Wandelweiser". (23 September 2009) <http://erstwords.blogspot.co.uk/2009/09/wandelweiser.html> last accessed: 21 June 2016. Given this limited attention, a wider and more inclusive study of quietness in music is therefore required. This would, for instance, accommodate the work of contemporary 'instrumental' composers such as Jakob Ullmann, but also look further afield to other musical styles such as so-called 'lowercase' or 'microsound' artists Bernhard Günter and Richard Chartier, or branches of EAI (and the closely related Onkyo music movement in Japan) such as AMM, Otomo Yoshihide, Bonnie Jones, Annette Krebs, Taku Sugimoto and Sachiko M. All of these artists could be said to explore the theme of hyper-quietness—and to an extent musical fragility—although, unfortunately, such a broad study is outside the range of this commentary.

the instrument at such low volume. It is important, then, to remember the disparity that exists between the clarity and precision of the score, and the sounding result, which is rather more out of focus and unpredictable. These are therefore approached as a dynamic marking of intention, rather than of actual—or (un)heard—amplitude.

### PARADOX OF QUIETNESS

In composing quiet music, it is my intention to draw, not only the performers, but also the audience into this delicate sound-world, creating a tense environment in which one must strain to listen. In my study of Ullmann's work, I noted that a 'paradox of quietness' is central to the fragile experience of such quiet music.<sup>107</sup> In order to immerse oneself in quiet music, an audience must focus intently, listening attentively so as not to 'miss' the music and its delicate changes or tremors. In a state of heightened aural awareness, these tiny sounds become seemingly magnified; as in states of 'deep' or 'reduced' listening, subtle details become amplified through concentrated listening.<sup>108</sup> While these disturbances provide brief moments to draw one's attention, quiet music can evade even the most focussed listener: concentration or no, quiet music presents a challenge for listening.

Here, then, lies the paradox: quiet music, with its fragile instabilities and shifting sounds presents a delicate and rich sound-world which draws its listener inwards so that they may examine the music closely and immerse themselves within it. However, it is precisely this quietness (which causes this fragile sound-world), that makes it difficult for the performer to control and for the listener to hear. The music retreats from observation, pushing them away, and yet in doing so, continues to beckon to the listener from just out of reach.

For both performer and audience alike, it is also my intention that the disorientating temporalities of the music compounds this paradox of quietness: it also evades the listener's focus, avoiding intimate inspection as clear, rhythmic pattern and veiled by its quietness so as to draw them inwards. Zattra, Burleigh and Sallis note a similar deliberate effort of avoidance in Nono's work, through both his *suono mobile* technique as well as visual performative aspects, which obfuscate the listener's comprehension of *A Pierre*. *Dell'azzurro silenzio, inquietum* (1985):

Neither the source of the sound nor the structure of the work should be rendered obvious to the listeners. [...] The point is not to confound or confuse the listener, but rather to stimulate active participation in apprehension of

---

<sup>107</sup> Thurley, "Disappearing Sounds", 18.

<sup>108</sup> The performance of quiet music seems to also affect a peculiar confrontational tension in its audience in which their own efforts to be quiet and listen without distraction resonates with this sense of inquiet in the music.

the aesthetic object, i.e. the listener should be actively attempting to find his or her way through the proposed labyrinth.<sup>109</sup>

Resonating with the paradox of quietness, Nono's labyrinth draws us back to Nancy's conception of musical fragility ('the inarticulateness of a sense always both extended—offered—and withheld') encountered at the beginning of this commentary.<sup>110</sup> Nono, like Ullmann, offers these wonderfully complex yet fragile sounds, but withholds them from clear focus by placing them at the brink of silence. In doing so, the listener is pulled into this labyrinthine search for the source and structure of the music: '*Caminantes, No hay caminos, hay que caminar*'.

### AUDITORY IMAGINATION

The quietness of this delicate music does not force itself into one's focus through intense amplitude like Noise music. Instead, it allows one to 'retire into' one's own 'thinking self', which is to say: quiet music allows its audience distance and a chance to lose themselves in their own listening.<sup>111</sup> In his phenomenological study, *Listening and Voice*, Don Ihde notes the importance of a phenomenon he terms 'auditory imagination' in our listening experience:

There is, in auditory imagination, the possibility of a synthesis of imagined and perceived sound [...] But in this case the auditory "hallucination" is not a matter of hearing one thing as something else but a matter of a doubled sound, a synthesised harmonic echo.<sup>112</sup>

The 'harmonic echo' here forms a 'polyphony of auditory experience' as the listener blurs the sound that is heard (as it physically occurs in the performance space), and their own perception of it, shaded by their imagination.<sup>113</sup> For instance, if an audience member focuses upon a specific instrument or sound, bringing it to the forefront of their attention, that sound becomes existentially closer in their perceptual mix. Whilst this mix must remain largely isomorphic to actual heard sounds, certain areas will resonate alongside the listener's focus—or imagination. Again we encounter the idea of some inconspicuous sound coming under the microscope and revealing new facets. However, the music now faces an unstable grounding: occupying the interstitial space between how it is heard (Barthes and Havas make the distinction that 'hearing is a physiological

---

<sup>109</sup> Laura Zattra, Ian Burleigh, and Friedemann Sallis, "Studying Luigi Nono's *A Pierre. Dell'azzurro silenzio, inquietum* (1985) as a Performance Event", *Contemporary Music Review* 30, no. 5 (October 2011): 433.

<sup>110</sup> Nancy, *The Sense of the World*, 86.

<sup>111</sup> Don Ihde, *Listening and Voice: Phenomenologies of Sound* (Albany, NY: SUNY, 2012), 132.

<sup>112</sup> *Ibid.*

<sup>113</sup> *Ibid.*



phenomenon'), and how it is listened to ('a psychological act'), and whether this is augmented through imagination or not.<sup>114</sup> In quiet music, this auditory imagination becomes a particularly potent phenomenon: listening without hearing. Through the retreat (retraction, restriction) of clarity for the listener, this retraced 'harmonic echo' becomes largely unavoidable within the labyrinthine sound-world of fragile, mutating sounds. The synthesis between 'imagined and perceived sound' becomes further skewed by the listener's strain to hear. For the audience then, there is some bifurcation between what is occurring through the composition, its performance, and finally their listening.



### INTERLUDE: KAFKA'S BURROW

In one of Franz Kafka's final unfinished short stories, *The Burrow*, an unseen and neurotic creature details its sanctuary: a burrow—an echo-chamber of elaborate tunnels. The narrator's animosity for the outside world turns to fear as a faint sound, possibly a hallucination, permeates the burrow's silence, signalling the impending danger of an approaching 'beast':

Had the whistling grown fainter? No, it had grown louder. I listen at ten places chosen at random and clearly notice the deception; the whistling is just the same as ever, nothing has altered. Over there, there are no changes, there one is calm and not worried about time; but here every instant frets and gnaws at the listener. I go once more the long road to the Castle Keep, all my surroundings seem filled with agitation, seem to be looking at me, and then look away again so as not to disturb me, yet cannot refrain the very next moment from trying to read the saving solution from my expression. I shake my head, I have not yet found any solution.<sup>115</sup>

In Kafka's paranoid narrator, we encounter the act of listening for the 'alert'—sound as warning signal for predator and prey, an encroachment of territory.<sup>116</sup> As the faint sound burrows itself into the narrator's mind, even in its slightness, the sound becomes all-consuming—a disturbing obsession. Just as with the paradox of quietness, it is precisely the sound's near inaudibility which drives the listener's obsession and its sense of disquiet. Kafka's narrator is drawn into the alert, deciphering its indices, and yet, when attempting to locate the sound's source, is evaded: the sound retreats. As the sound is just out of perceptual reach, so too is the possible danger of its source: it is an unseen and imagined fear, which, of course, psychologically, makes it all the more imposing. Are those

---

<sup>114</sup> Roland Barthes and Roland Havas. "Listening." In *The Responsibility of Forms*, translated by Richard Howard (New York: Hill & Wang, 1985), 245.

<sup>115</sup> Franz Kafka, "The Burrow", translated by Willa and Edwin Muir, in *The Complete Short Stories*, ed. Nahum N Glatzer (London: Vintage, 2005), 357.

<sup>116</sup> Barthes and Havas, "Listening", 245.

sounds—be they the boring of a ‘beast’, or the shimmering overtones of a multiphonic—real or imagined, or a synthesis of both?



### UNHEARD SOUNDS

Taking its title from Kafka’s story, *Burrow*, the only electroacoustic work in the portfolio, examines the fragility of listening to quiet music in a rather more insidious manner. The frequency range of the composition contains material below 20 Hz, and continues well up to 25,000 Hz.<sup>117</sup> In composing at the brink of and beyond the range of human hearing, *Burrow* is a hybrid of faint and feint sound: sound continues all the way through a performance, it is always received, but not necessarily at a frequency that can be perceived. It evades listening, this time not through quietness and avoidance, but rather subterfuge, outmanoeuvring our audible limits. The effect is, at first, unnerving: the very lowest and highest frequencies cannot be heard, though in certain conditions they can be felt as somatic vibrations or creeping at the back of the neck. The anxiety of these unheard frequencies is resolved by a return to a central (audible) drone: an electromagnetically sustained layering of acoustic guitars, which contain a great wealth of sonic data (shifting microtonal interference and complex beating patterns, overtones, difference tones, etc.). However, it is at the brink between the limits of audibility where *Burrow* exhibits a fragility of audition. As frequencies move beyond a listener’s audible limit, they seemingly disappear. Given that audience members will each have a slightly different range of hearing, *Burrow* will appear to contain a greater or lesser periods of silence or bandwidth (although as Figure 17 shows, no silence exists at all). Like quietness, at the limit of audible frequency, these sounds are fragile, not in their production (as encountered in chapter 1), but in their perception—again, caught between the heard and unheard. As with Kafka’s tunnelling narrator and the labyrinthine sound-world of Nono’s *A Pierre. Dell’azzurro silenzio, inquietum*, the lack of audible clarity provided by these infra/ultrasonic frequencies prompt the listener to strain to hear that which appears just beyond reach.

---

<sup>117</sup> The general frequency range of human hearing is 20–20,000 Hz, although in actuality, the average upper limit for most people is closer to 18,000 Hz.

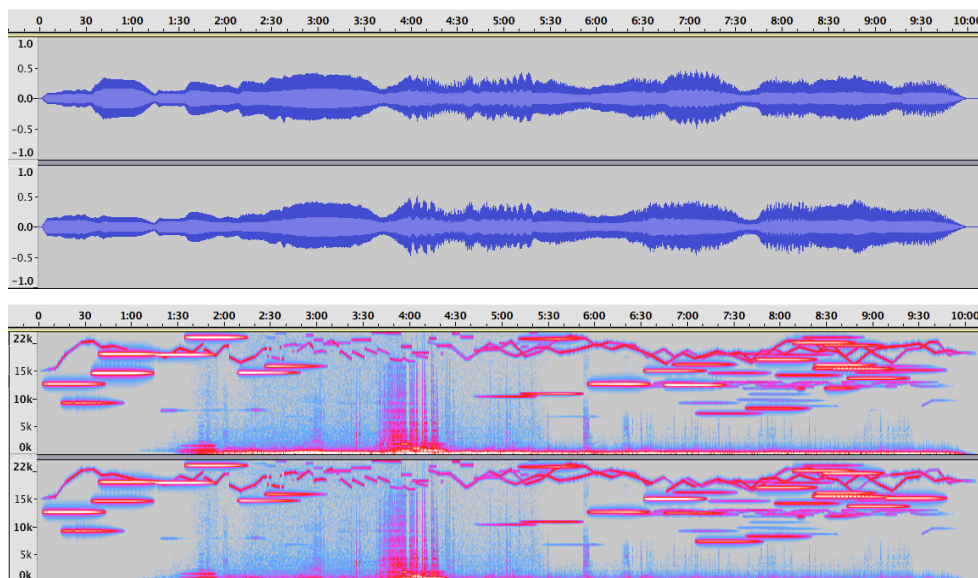

Figure 17: Above, waveform outline of *Burrow*. Below, spectrogram (linear frequency scale, 0–22kHz).

In *if some thing black*, the score periodically makes reference to instruments other than the bass clarinet, not as actions for the performer to realise, but as simultaneous, unheard supplementary parts. Of course, these were not necessarily written with the intention that a string trio would join the performance for a single chord, or that a bass drum would periodically perforate the performance. Instead they were added as a personal, private supplement to the piece for the performer. Here, in addition to the many possible arrangements of its modular framework, an element of the piece remains isolated to the page as a private communication with the performer—something that only they will ever ‘hear’ in the performance.

## DWELLING WITHIN THE AMPLIFIED MUSIC OF LA MONTE YOUNG AND JOHN CAGE

Douglas Kahn notes that in the music of La Monte Young and the Theatre of Eternal Music, the technique of extended durations and harmonic stasis ‘became an occasion for listening inside the sounds, in the sense of one’s envelopment within the sound and in the sense of the attention paid to “microscopic” subtleties of the sounds that had hitherto gone unheard.’<sup>118</sup> However, Young’s stasis is not the only factor to allow such envelopment and intense focus. Kahn also notes the importance of enormous volume levels in Young’s music as a means to allow the audience to ‘dwell inside the sounds, feel the ubiquity, and discern the subtleties’ of the Theatre of Eternal Music.<sup>119</sup> For Young, Cale, MacLise,

<sup>118</sup> Douglas Kahn, *Noise, Water, Meat: A History of Sound in the Arts* (Cambridge, MA: MIT Press, 1999), 230.

<sup>119</sup> *Ibid.*, 231.

Zazeela, Conrad and other members of the so-called 'Dream Syndicate', amplification offers a sense of expansiveness, and with it, the ability to 'hear *inside* musical sounds and establish a common space of auditive being for both the musicians and the audience.'<sup>120</sup>

Kahn also observes that whilst both Young and John Cage explored the amplification of smaller sounds in works such as *o'oo" (4' 33" No. 2)* (1962), Cage was not interested in amplification 'as a means to divulge the contents or become immersed in its environment,' but rather, as a means to simply 'establish their presence'.<sup>121</sup>

Kahn asserts that 'loud sounds did not need Cage to detect or emancipate them because they were the rulers of their own presence and reigned over their own space.'<sup>122</sup> Listening within the space of these loud sounds then, they are experienced passively, taking over and becoming their own sonic environments. In loudness, sound becomes on the one hand a co-habitant to be endured, or, on other, the environment itself: like Young's eternal drone, allowing one inside, but through its force of presence and ubiquity, unable to be shut out. Quieter sounds however do not by definition assert themselves in this way. They must be sought out, examined closely and placed under the audible microscope of amplification to reveal their secrets.

Branden Josef further details the differences between Cage and Young's amplified space:

Whereas Cage sought to place the listener into a nonhierarchical field with which he or she could interact as a disinterested equal, Young reinscribed a dialectical relation between subject (the listener) and object (the environmental, nearly overwhelming, sound). [...] Furthermore, in so amplifying the sound, both literally and figuratively, Young exacerbated this interaction to such a degree as to make the inherent power relationship palpable. (In doing so, he may in fact merely have desublimated a dialectic inherent in Cage's work.) Markedly different from the situation in *Composition 1960 #3*, where the audience was free to do whatever they wanted, in work from *2 Sounds* up to the *Theatre of Eternal Music*, Young's listener and sound were engaged in a type of struggle, the phenomenological particularities of hearing in "one's own terms" fighting, in some sense, for autonomy against the nearly overwhelming pressure exerted by the sound.<sup>123</sup>

I would argue that while I am more interested in Cage's attempt to draw out and examine quieter sounds, my own use of quietness has more in common with Young's subject/object relation than with Cage's egalitarian sound-world. In quiet, un-amplified music, it is certainly possible to imagine a similar power relation between audience and

---

<sup>120</sup> Ibid.

<sup>121</sup> Ibid.

<sup>122</sup> Ibid., 234.

<sup>123</sup> Branden W Josef, *Beyond the Dream Syndicate: Tony Conrad and the Arts after Cage* (New York, Zone Books, 2008), 116-17.

music which is not oppressive in its volume, but rather in its retreat.<sup>124</sup> In works such as the original version of *yet another example of the porousness of certain borders*, the listener must, through determined listening, force themselves into the attenuated sound-world of the performance in order to uncover any of the music's subcutaneous detail. Returning to the paradox of quietness, the tension created between musical environment and listener remains palpable: an interaction not dissimilar to Young's 'overwhelming pressure exerted by the sound.' At the point at which one approaches the music from a disinterested perspective, unwilling to immerse themselves within the 'object', then the music will undoubtedly fail.<sup>125</sup> Here, listener and sound engage in a struggle—not for autonomy as in Josef's assertion of Young's music—but for clarity.

### AMPLIFICATION OF THE PORTFOLIO WORKS

Whilst the compositions discussed here are quiet by design, it is worth briefly considering an alternate, amplified, state of listening. To increase the gain and push these pieces beyond their intended dynamic range (either in live performance, or through playback of a recording), fundamentally alters the function of the music's quietness. As noted, the role of quietness in my work is constantly bound between a restriction upon the production of sound, and a distancing of the listener through attenuation. Instead of the music existing as a temporary cohesion amongst noise, defying collapse; the fragility of sound is bolstered by amplification and to a degree stabilised by the fact that it no longer risks disappearing from the listener's auditory horizon. Where the precarious state of the music's very audibility is lost—that is to say, an instability of hearing—so too is the sense of fragility in the listening experience. It is at this point, however, that a new fragility reveals itself to the listener: through amplification, the tremors and fluctuations are made more explicit in amplifying the work and in doing so, become something altogether new. They become articulate gestures, exaggerated and pronounced rather than subtle inflections of a vulnerability in sound.

There are two instances of works included in the portfolio where amplification of acoustic instruments has been necessary which are worth briefly mentioning at this point.<sup>126</sup> The first, the premiere performance of *whose veil remains inscrutable*, took place in a large hall with heavy acoustic dampening.<sup>127</sup> The unusual acoustic of the room meant

---

<sup>124</sup> Of course the nature of the performance environment plays a vital role here: for better or worse, the much maligned proscenium staging of the traditional concert hall—with its imposed etiquettes and bourgeois rituals—certainly bolsters such power relations. As n+1 wryly observed: 'Don't worry, we weren't feeling or thinking anything about what we heard—we were only sitting here, trying not to cough.' "The Intellectual Situation", *n+1: Nineteen*, eds. Carla Blumenkranz, Keith Gessen, and Nikil Saval (Spring 2014), 8.

<sup>125</sup> Certainly, Young's use of protracted duration and stasis acts to affirm this sense of immersion.

<sup>126</sup> Not including the technical requirements of electronic works.

<sup>127</sup> The György-Ligeti-saal in the MUMUTH building (Graz, Austria) is a large hall with elaborate acoustic control and artificial reverberation system.

that very little sound travelled naturally, requiring even performances of a moderate volume to be amplified. For the performance of *whose veil remains inscrutable*, this required not only amplification for the audience, but a reconfiguring of monitoring and performer positioning so that they could hear each other on such a large stage (Figure 18). This instance of amplification was merely a practical exercise ensuring that the piece could be heard by the 450 audience members, and was—as far as possible—faithful to the essential quality of the piece.



Figure 18: Ensemble Nickel during setup at MUMUTH (Graz, Austria); dispersed across a large stage (L-R: Rei Nakamura—piano, Patrick Stadler—tenor saxophone, Yaron Deutsch—electric guitar, Brian Archinal—percussion).

The second example of amplifying acoustic instruments during performance is less transparent and serves more to accentuate certain elements of the piece. *yet another example of the porousness of certain borders* is one of the quietest pieces in the entire portfolio, and during its premiere encountered similar difficulties to *whose veil remains inscrutable*. Due to the size of the hall, the piece had to be amplified to some degree so that it could be heard at all. The level was kept relatively low, and speakers were located behind the performer so that the amplification was mainly a reinforcement of the acoustic sound rather than an extreme manipulation of the sound. An interesting feature of this setup was the use of the performer's small condenser microphone positioned on the double bass bridge which did to some extent warp the sonic perspective of the piece. Of course, the positioning of this single microphone created a focal point around its immediate vicinity: sounds produced close to the microphone (*sul ponticello* passages and bowing on the tailpiece) became overly pronounced in the loudspeaker/performer mix, whilst other relatively distant sounds were not amplified at all. An entirely new perspective of the music was therefore created. In this quiet fragile music, the

technological affordances of the microphone and loudspeaker bear a striking similarity to the revealing capabilities of the camera in the early days of film, outlined by Benjamin:

By close-ups of the things around us, by focusing on hidden details of familiar objects, by exploring commonplace milieus under the ingenious guidance of the camera, the film, on the one hand, extends our comprehension of the necessities which rule our lives; on the other hand, it manages to assure us of an immense and unexpected field of action. Our taverns and our metropolitan streets, our offices and furnished rooms, our railroad stations and our factories appeared to have us locked up hopelessly. Then came film and burst this prison-world asunder by the dynamite of the tenth of a second, so that now, in the midst of its far-flung ruins and debris, we calmly and adventurously go travelling. With the close-up, space expands; with slow motion, movement is extended. The enlargement of the snapshot does not simply render more precise what in any case was visible, though unclear: it reveals entirely new structural formations of the subject. So, too, slow motion not only presents familiar qualities of movement but reveals in them entirely unknown one 'which, far from looking like retarded rapid movements, give the effect of singularly gliding, floating, supernatural motions.'<sup>128</sup>

These amplified sounds reveal new and interesting timbres which shift subtly as well as sounds not normally heard such as the delicate grain of the bow hair against the strings: 'entirely new structural formations of the subject.' These extremely quiet and subtle sounds could only be revealed through amplification. To adapt Benjamin's comment: even if one has a general knowledge of the way a bowed string sounds, one knows nothing of the minute grain of bow hair under the microscope of amplification.<sup>129</sup> This was the initial inspiration for a later reworking of the piece, commissioned by Gaudeamus Muziekweek 2015, which, while still quiet, employed more prominent amplification, and even feedback to create direct interaction between performance and amplification. In a proposed revision not yet realised, localisation of performance techniques will be further explored by creating a spatially diffused loudspeaker performance, revealing a variety of sounds and shifting timbres through close amplification.

Amplification, despite its affordances, does however present a problem for musical fragility within quiet music which should not be discounted. As noted, although it acts as a valuable prosthesis able to reveal hidden sonic details which may otherwise lay beyond the reach of the listener, amplification of quiet music may also retreat the function of fragility for the listener. In offering a magnified sound, amplification normalises the listening environment, removing the need to focus intently on the sound and thus

---

<sup>128</sup> Walter Benjamin, "The Work of Art in the Age of Mechanical Reproduction", *Illuminations*. ed. Hannah Arendt, trans. Harry Zorn (London: Pimlico, 1999), 229–30. Benjamin quotes Rudolf Arnheim, *Film als Kunst* (Berlin, 1932) at the end of this passage.

<sup>129</sup> 'Even if one has a general knowledge of the way people walk, one knows nothing of a person's posture during the fractional second of a stride.' Walter Benjamin, "The Work of Art in the Age of Mechanical Reproduction", 230.

nullifying the listener's struggle to hear. Where sound is no longer withheld, the listener is no longer prompted to actively explore the fragile sound-world. The sounds may indeed be clearer, but they are stripped of their sense of mystery and unknowableness. In amplification, fragility becomes stabilised: this is an unavoidable consequence of course, but not necessarily a negative one, simply an alternative. Given the determinism of the scores, the performer's actions are not significantly changed by the amplification, only the perspective offered to the listener: everything simply becomes audible.<sup>130</sup> Sounds may no longer disintegrate or disappear into inaudibility, but relative disintegration of these fragile sounds still occurs; if not into silence, then into noise.

Given the significance of quietness and the conditions of listening in this portfolio, some final consideration should be given to the form of listening in which these pieces will most likely be heard, the recordings. Though it may seem obvious, the recordings of my work afford a listener alternative perspectives of the compositions, allowing one to become immersed in the music in a way that may not otherwise be possible. While I would contend that an 'ideal' listening experience would perhaps entail very quiet playback (a mimetic listening environment as close to the original performance as possible), recordings of course afford curious listeners a choice to listen how they wish. This is a separate and more personalised perspective of the music not available in normal live performance.<sup>131</sup> By exploring these recordings, one is able to experience the interior of the music with a new level of intimacy, unveiling the fracture of string harmonics, the delicate fluctuations of pitch, and the breathing of wind players with hyper-real precision and clarity.<sup>132</sup>

---

<sup>130</sup> Of course, this will change (and smooth over) some techniques, including the search for hard-to-find multiphonics as noted in chapter 1.

<sup>131</sup> Although I believe that the live performance environment should be tightly controlled, I have no interest in specifying how one should listen to recordings of my work, and am far more interested in the prospect of a listener exploring the sound from various positions: loud, quiet, headphones or spatialised; each offer a unique and no less valid sound-world.

<sup>132</sup> While these minute details are valuable, John Mowitt notes that 'electronically reproduced art has radicalized noise by seeking to eliminate it.' "The Sound of Music in the Era of its Electronic Reproducibility", in *The Sound Studies Reader*, ed. Jonathan Sterne (New York: Routledge, 2012), 221. In listening to the recordings—especially that of extremely quiet music—noise becomes emphasised as an unwanted artefact of the performance, perhaps more-so than in the actual performance.



conclusion

## FRAGILITY IN REPRISE

Throughout the course of this commentary I have traced the theme of fragility through a portfolio of original compositions in order to indicate its fundamental role in both my compositional practice and thinking. Though the nature of musical fragility in and of itself is an unwieldy and difficult concept to define, it should be clear by now that it is the central thread which ties together and underpins this portfolio. In this attempt to unpack the notion of fragility in music, three main types of fragility have been encountered: fragility in performance, fragility of form, and fragility as quietness.

In chapter 1, fragility was examined as an effect which manifests during performance as an obstacle for performers to overcome. Compositionally, the use of fractal noise algorithms feature in a number of pieces as a means to add pseudo-random self-similar data to a given parameter, allowing a number of compositional techniques to be built upon deliberately fragile foundations, ensuring they will break in some manner and forcing the performer to overcome this instability during a performance. Compositions such as *yet another example of the porousness of certain borders* are rendered fragile through intensive attempts to control de-facto unstable instrumental devices such as string multiphonics, physically gruelling posture, or the constant flux of dynamic variation in microscopic detail.

Chapter 2 discussed fragility of form within the portfolio, exploring the various approaches to time and pitch as fragile objects. The *Network* series of scores represents the most extreme case of temporal disorientation, with the sequential form of each composition becoming completely determined by the performer's action of reading the score. In exploring the palimpsestic concept of layering and erasure, works such as *with*

*the very same twist to their faces* and *falling as rain and then rising* explore the pluralities of dilating and contracting qualitative time in their densely layered and often contradicting temporal schemata. Compositions such as *Hymns to Sing at the Apocalypse* and *if some thing black* retain more explicit structural devices, albeit abstracted through the use of looping, overlaying, interpolating and bifurcating of material to create fragile, disorienting forms.

Finally, fragility in chapter 3 was explored as a function of extreme quietness in performance. Separating quietness from the much discussed topic of silence, quietness offers a fragile listening experience which ultimately shapes the perception of the work. In the music's quietness, the audience is prompted to focus their attention on a music which appears to evade such close listening. By employing amplification as a tool for detailed listening alternatives, a new wealth of sonic material is revealed, albeit at the expense of a fragile and quiet listening experience.

Fragility ultimately represents a vast aesthetic area which requires further dedicated consideration. The principles and concepts outlined in this portfolio are, of course, not exhaustive and will no doubt provide a wealth of material for future exploration and development in my compositional practice.

---

## epilogue

It'll get so quiet when this record ends.  
You can hear the first hour of the world.

—Jason Molina, *The Big Game Is Every Night*

---

## BIBLIOGRAPHY

Barthes, Roland, and Roland Havas. "Listening." In *The Responsibility of Forms*, translated by Richard Howard, 245–60, New York: Hill & Wang, 1985.

Benjamin, Walter. "The Work of Art in the Age of Mechanical Reproduction." In *Illuminations*. Edited by Hannah Arendt, Translated by Harry Zorn, London: Pimlico, 1999.

"The Intellectual Situation." Edited by Carla Blumenkranz, Keith Gessen, and Nikil Saval. *n+1, Nineteen: Real Estate*, 2014.

*Unfolding Time: Studies in Temporality in Twentieth Century Music*. Edited by Darla Crispin, Leuven: Leuven University Press, 2009.

Delaere, Mark. "Tempo, Metre, Rhythm. Time in Twentieth-Century Music." In *Unfolding Time: Studies in Temporality in Twentieth Century Music*, edited by Darla Crispin, Leuven: Leuven University Press, 2009.

Edwards, Peter Ivan. "Object, Space, and Fragility in Luigi Nono's *Das atemde Klarsein*." *Perspectives of New Music* 46, no. 1 (2008): 225–43. doi:10.2307/25652381.

Evens, Aden. *Sound Ideas: Music, Machines, and Experience*, Minneapolis, MN: University of Minnesota Press, 2005.

Fallowfield, Ellen, and Thomas Resch. "Further Examples of Multiphonics." *Cello Map*. Accessed June 19, 2016. <http://www.cellomap.com/index/the-string/multiphonics-and-other-multiple-sounds/further-examples-of-multiphonics.html>

———. "Multiphonics." *Cello Map*. Accessed June 19, 2016. <http://www.cellomap.com/index/the-string/multiphonics-and-other-multiple-sounds.html>

Feldman, Morton. "Crippled Symmetry." In *Give My Regards to Eighth Street*, edited by Bernard Harper Friedman, Exact Change, 2000.

- Ferneyhough, Brian. "The Tactility of Time (Darmstadt Lecture 1988)." *Perspectives of New Music* 31, no. 1 (1993): 1–12.
- Soundings 13: The Music of James Tenney*. Edited by Peter Garland, Santa Fe, NM: Soundings Press, 1984.
- Overcoming Form: Reflections on Immersive Listening*. Edited by Richard Glover and Bryn Harrison, Huddersfield: University of Huddersfield Press, 2013.
- Haller, Hans Peter. "Nono in the Studio — Nono in Concert — Nono and the Interpreters." *Contemporary Music Review* 18, no. 2 (January 1999): 11–18. doi:10.1080/07494469900640171.
- Harrison, Bryn. "Cyclical Structures and the Organisation of Time," University of Huddersfield, 2007.
- . "Repetitions in Extended Time: Recursive Structures and Musical Temporality." In *Overcoming Form: Reflections on Immersive Listening*, edited by Richard Glover and Bryn Harrison, Huddersfield: University of Huddersfield Press, 2013.
- . "Scanning the Temporal Surface." *Divergence Press, CeReNeM Journal* 3 (March 2013): 59–71.
- Frank Hilberg. *Jakob Ullmann: Komposition Für Streichquartett / Komposition Für Violine / Disappearing Musics*. Translated by J Bradford Robinson, Wergo, WER 6532-2, 1996. Compact Disc, Liner Notes.
- Ihde, Don. *Listening and Voice: Phenomenologies of Sound*. Second Edition. Albany, NY: SUNY Press, 2012.
- Jankélévitch, Vladimir. *Music and the Ineffable*. Translated by Carolyn Abbate, Princeton, NJ: Princeton University Press, 2003.
- Josel, Seth F, and Ming Tsao. *The Techniques of Guitar Playing*, Kassel: Bärenreiter, 2014.
- Joseph, Branden W. *Beyond the Dream Syndicate: Tony Conrad and the Arts After Cage*, New York: Zone Books, 2008.
- Kafka, Franz. "The Burrow." In *The Complete Stories*, translated by Willa Muir and Edwin Muir, 325–59, Schocken, 1971.
- Kahn, Douglas. *Noise, Water, Meat: A History of Sound in the Arts*, Cambridge, MA: MIT Press, 1999.
- Kramer, Jonathan D. "New Temporalities in Music." *Critical Inquiry* 7, no. 3 (1981): 539–56.
- Dreizehn 13: Basels Badischer Bahnhof in Geschichte, Architektur Und Musik*. Edited by Michael Kunkel, Saarbrücken: PFAU, 2012.
- Kwinter, Sanford. *Architectures of Time: Toward a Theory of the Event in Modernist Culture*, Cambridge, MA: MIT Press, 2002.
- Levine, Carin, and Christina Mitropoulos-Bott. *The Techniques of Flute Playing*, Kassel: Bärenreiter, 2002.
- Melia, Nicholas, and James Saunders. "Introduction: What Is Wandelweiser?" *Contemporary Music Review* 30, no. 6 (December 2011): 445–48. doi:10.1080/07494467.2011.676893.
- Mowitt, John. *Sounds: The Ambient Humanities*, Oakland, CA: University of California Press, 2015.

Oliver Thurley

Nancy, Jean-Luc. *Listening*. Translated by Charlotte Mandell, New York: Fordham University Press, 2007.

———. *The Sense of the World*. Translated by Jeffrey S Librett, Minneapolis, MN: University of Minnesota Press, 1997.

Pape, Gerard. “Luigi Nono and His Fellow Travellers.” *Contemporary Music Review* 18, no. 1 (January 1999): 57–65. doi:10.1080/07494469900640071.

Pearson, Matt. *Generative Art*, Shelter Island, NY: Manning Publications Company, 2011.

Pisaro, Michael. “Wandelweiser.” 23 September, 2009. <http://erstwords.blogspot.co.uk/2009/09/wandelweiser.html>

Polansky, Larry. “The Early Works of James Tenney.” In *Soundings 13: The Music of James Tenney*, edited by Peter Garland, Santa Fe, NM: Soundings Press, 1984.

Priest, eldritch. *Boring Formless Nonsense*, New York: Bloomsbury Academic, 2013.

Rizzardi, Veniero. “Notation, Oral Tradition and Performance Practice in the Works with Tape and Live Electronics by Luigi Nono.” *Contemporary Music Review* 18, no. 1 (January 1999): 47–56. doi:10.1080/07494469900640061.

Roads, Curtis. *Microsound*, Cambridge, MA: MIT Press, 2004.

Rowe, Robert. *Machine Musicianship*, Cambridge, MA: MIT Press, 2004.

Saunders, James. “Modular Music.” *Perspectives of New Music* 46, no. 1 (2008): 152–93.

Shiffman, Daniel. *The Nature of Code*, 2012. <http://natureofcode.com/book/>

Silverman, Max. *Palimpsestic Memory: The Holocaust and Colonialism in French and Francophone Fiction and Film*, New York: Berghahn Books, 2013.

Street, Donald. “The Modes of Limited Transposition.” *The Musical Times* 117, no. 1604 (October 1976): 819–23.

Sugimoto, Hiroshi. “Conceptual Forms, 2004.” In *Hiroshi Sugimoto*, Ostfildern: Htje Cantz, 2012.

Tenney, James. “John Cage and the Theory of Harmony.” In *Soundings 13: The Music of James Tenney*, edited by Peter Garland, Santa Fe, NM: Soundings Press, 1984.

———. *META † HODOS and META Meta † Hodos*, Oakland, CA: Frog Peak Music, 1988.

Thurley, Oliver. “Disappearing Sounds: Fragility in the Music of Jakob Ullmann.” *Tempo* 69, no. 274 (October 2015): 5–21. doi:10.1017/S0040298215000339.

———. “Rebuilding Babel: On Fragility and the Palimpsest in Jakob Ullmann’s *voice, books and FIRE*,” forthcoming.

Wannamaker, Robert A. “The Spectral Music of James Tenney.” *Contemporary Music Review* 27, no. 1 (February 2008): 91–130. doi:10.1080/07494460701671558.

Wallace, David Foster. *Brief Interviews with Hideous Men*, London: Abacus, 2013.

———. *Oblivion: Stories*, London: Abacus, 2014.

———. *Infinite Jest*, London: Abacus, 2013.

Weiss, Marcus, and Giorgio Netti. *The Techniques of Saxophone Playing*, Kassel: Bärenreiter, 2010.

West-Pavlov, Russell. *Temporalities*, London: Routledge, 2013.

Whiticker, Michael. "Morton Feldman: Conversation Without Cage, 25 July 1984." In *Morton Feldman Says: Selected Interviews and Lectures 1964–1987*, edited by Chris Villars, London: Hyphen Press, 2006.

Winter, Michael. "On James Tenney's *Arbor Vitae* for String Quartet." *Contemporary Music Review* 27, no. 1 (February 2008): 131–50. doi:10.1080/07494460701671566.

Xenakis, Iannis. *Formalized Music*. Edited by Sharon Kanach. Revised Edition. Stuyvesant, NY: Pendragon Press, 1992.

Zattra, Laura, Ian Burleigh, and Friedemann Sallis. "Studying Luigi Nono's *A Pierre. Dell'Azzurro Silenzio, Inquietum* (1985) as a Performance Event." *Contemporary Music Review* 30, no. 5 (October 2011): 411–39. doi:10.1080/07494467.2011.665579.

---

## INDEX OF COMPOSITIONS

*Burrow*, v, 10, 53, 57, 58, 59, 69, 77, 95

*Envelop*, 16, 17, 18, 40, 41

*Escapement*, 33

*face of the deep*, 16, 17, 18, 95

*falling as rain and then rising*, v, 34, 43, 48, 51, 52, 66, 82, 86, 95

*Hymns to Sing at the Apocalypse*, v, 6, 26, 32, 33, 34, 36, 37, 48, 54, 66, 76, 77

*if some thing black*, v, 6, 12, 26, 34, 36, 48, 49, 50, 51, 59, 66, 76, 77, 82, 84

*a technical diagram for the abstraction of Ockeghem's missa pro defunctis*, 77, 93, 95

*Mathematical Forms 001 Orbit*, v, 15, 37, 38, 39, 40

*Network*

*for four pianos*, 27, 28, 76, 81

*for string quartet*, 27, 30, 31, 32, 76, 77

*now did one now did one now did one*, 95

*so much vapour aloft*, 16, 20, 95

*translucent spaces*, 10, 89, 92, 93

*Vermilion Sands*, 95

*whose veil remains inscrutable*, v, 6, 9, 10, 14, 26, 32, 33, 41, 42, 51, 61, 62, 76, 77, 88

*with the very same twist to their faces*, v, 33, 41, 42, 43, 46, 47, 48, 50, 66, 76, 77, 87, 95

*(under erasure)*, v, 47, 48, 95

*yet another example of the porousness of certain borders*, v, 6, 11, 14, 15, 18, 19, 21, 22, 23, 26, 54, 61, 62, 65, 76, 77, 82



---

# APPENDICES

I: PORTFOLIO COMPOSITIONS

II: RECORDINGS

III: FURTHER NOTATIONAL EXPERIMENTS WITH FRACTAL NOISE

IV: SPECULATIVE CARTOGRAPHIES OF STRING MULTIPHONICS

V: STRUCTURAL SKETCHES

VI: TRANSLUCENT SPACES

VII: SUPPLEMENTARY COMPOSITIONS

---

## APPENDIX I: PORTFOLIO COMPOSITIONS

List of compositions included in the portfolio:

- *network for string quartet* (2013)
- *network for four pianos* (two–four pianos, 2014)
- *with the very same twist to their faces* (baritone saxophone and accordion, 2014)
- *whose veil remains inscrutable* (tenor saxophone, electric guitar, piano and percussion, 2014)
- *yet another example of the porousness of certain borders* (double bass, 2014)
- *hymns to sing at the apocalypse* (double bass and small chamber ensemble, 2015)
- *if some thing black* (bass clarinet, 2015)

---

## APPENDIX II: RECORDINGS

### DISC I

1. *yet another example of the porousness of certain borders* (2014/15)<sup>1</sup> \_\_\_\_\_ 10:59
2. *hymns to sing at the apocalypse* (2015)<sup>2</sup> \_\_\_\_\_ 11:08
3. *with the very same twist to their faces* (2014)<sup>3</sup> \_\_\_\_\_ 09:09
4. *whose veil remains inscrutable* (2014)<sup>4</sup> \_\_\_\_\_ 11:41
5. *burrow* (2014)<sup>5</sup> \_\_\_\_\_ 10:02
6. *network for string quartet* (2013)<sup>6</sup> \_\_\_\_\_ 20:36

### DISC II (DVD)

1. *a technical diagram for the abstraction of ockeghem's missa pro defunctis: kyrie, side elevation* (2015)<sup>7</sup> \_\_\_\_\_ 00:00–08:12
2. *if some thing black* (2015)<sup>8</sup> \_\_\_\_\_ 09:11

---

<sup>1</sup> Performed by Dario Calderone (double bass), Gaudeamus Muziekweek, Utrecht, Netherlands; 11 September 2015.

<sup>2</sup> Performed by Ensemble iiiiii, i<sup>N</sup> festival, Seoul, South Korea; 12 October 2015. World Premiere.

<sup>3</sup> Performed by Stefanie Mirwald (accordion) and Janez Uršej (baritone saxophone), impuls festival, Graz, Austria; 21 February 2015. World Premiere.

<sup>4</sup> Performed by Ensemble Nickel (Yaron Deutsch—electric guitar, Patrick Stadler—tenor saxophone, Antoine François—piano and Brian Archinal—percussion), unmixed demo studio version. Recorded by Benoit Piccand, Bern, Switzerland; December 2015.

<sup>5</sup> Electroacoustic, stereo version.

<sup>6</sup> Performed by Alice Dawkins (violin), Hannah Packman (violin), Katherine Lambeth (viola) and Claudia Chapman (cello), Studio recording, Leeds; May 2013.

<sup>7</sup> *a technical diagram* is the first performance of this video (00:00–08:12), the second part (08:13–16:42) is Lang's *viola harmonium*. (2014). Performed by Klaus Lang (harmonium) and Barbara Konrad (viola d'amore), Ilkley Moor; 26 November 2016. Filmed by Ollie Jenkins, produced by Elspeth Mitchell, sound by Oliver Thurley.

<sup>8</sup> Performed by Heather Roche (bass clarinet), University of Leeds, UK; 11 February 2016.

---

## APPENDIX III: FURTHER NOTATIONAL EXPERIMENTS WITH FRACTAL NOISE

During the experimentations with Perlin noise systems, an attempt at creating a form of tactile notation which also made use of this scheme was attempted, although never continued. Figure 1 shows the 3D-printed ‘sculpture’ of a terrain map that was to be used as a similar notational guide as the mathematical forms examined previously. Here, the physical complexities of this model would have been interpreted with a basic musical parameter (i.e. pitch vs. amplitude or timbre) and ‘read’ as the performer physically moved around the space of this notational map. An experimental effort to explore a non-visual form of notation, the project never came to fruition due to impracticalities of a performer having to read—or rather, touch—the sculpture whilst playing.

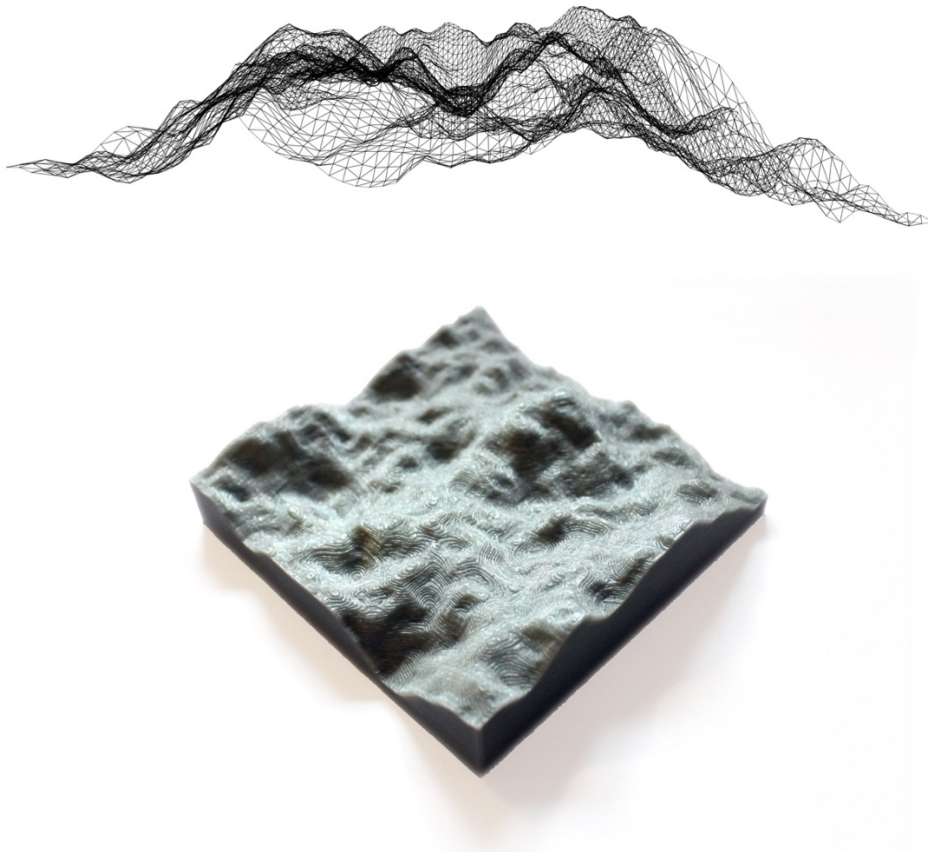

Figure 1: *Above*, fractal noise mesh for 3D terrain. *Below*, 3D-printed model of fractal noise terrain.

In its spatial, non-linear form, the system drew influence from the network score pieces, and in turn inspired further experiments attempting to modify the network scores to exhibit similar terrain variables (Figure 2).

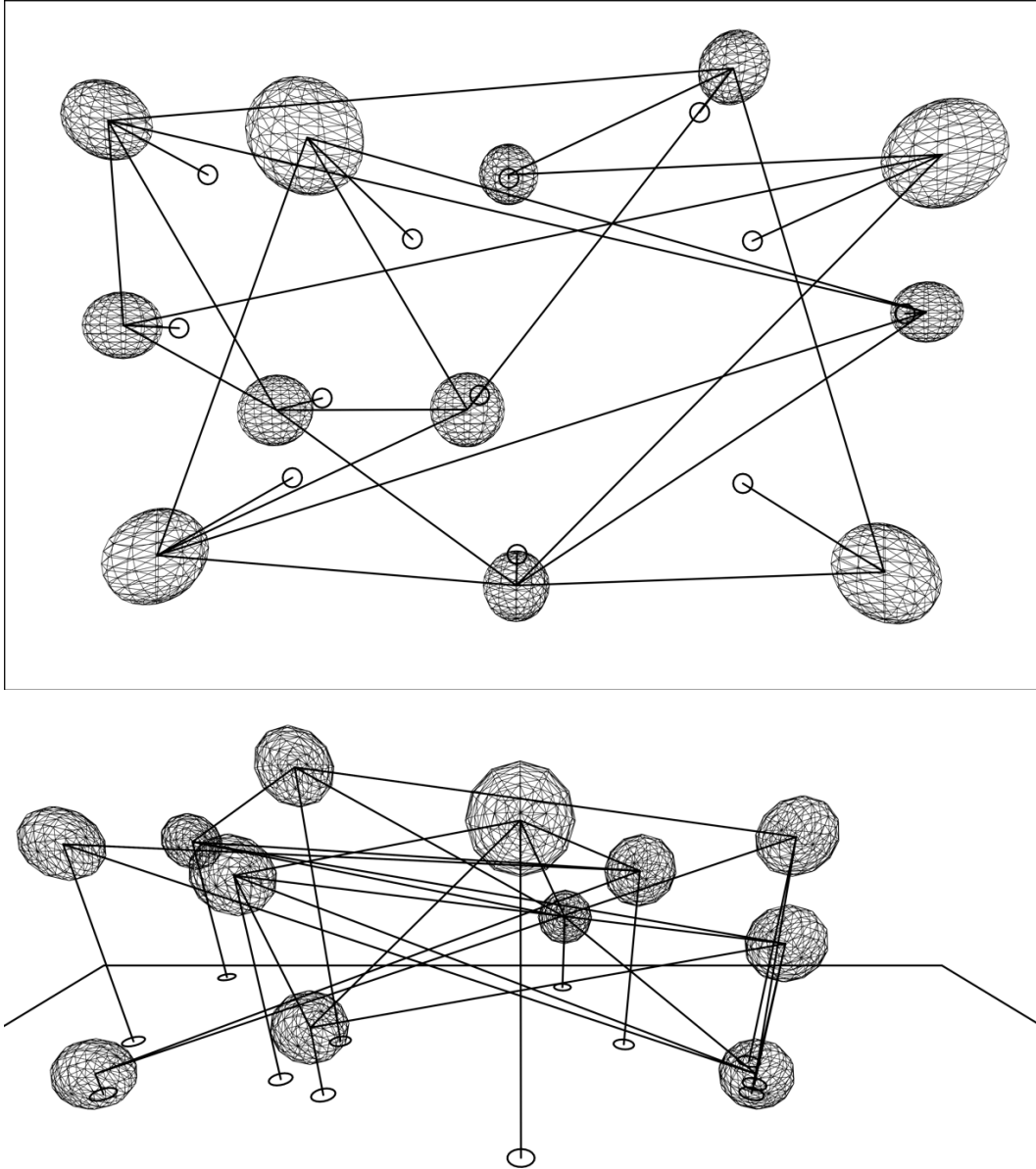

Figure 2: Modification of network score system to implement 3D fractal noise.

---

## APPENDIX IV: SPECULATIVE CARTOGRAPHIES OF STRING MULTIPHONICS

A number of recent pedagogical writings have focused upon the meticulous cataloguing of multiphonic techniques for a variety of wind instruments, however discussion of multiphonics for stringed instruments has—despite being, according to the simple physics, far easier to comprehend—been overlooked and fallen into the realm of mystery and spoken of only in hushed tones.<sup>1</sup> In their Cello Map project, Ellen Fallowfield and Thomas Resch have laid out a simple framework for understanding string multiphonics, and directly applying them for use on the cello.<sup>2</sup> I have taken this framework and produced a simple computer script which maps out string harmonics and positions for  $n$ -tuned strings. This has become a useful tool in a number of my recent compositions for plotting multiphonics across a number of various string instruments.<sup>3</sup> The flexibility of the tool also allows me to quickly and easily calculate pitch values for alternatively tuned instruments—an initial draft of *yet another example of the porousness of borders* was to gradual change the tuning over the course of the performance, so this feature was incredibly useful despite not being implemented in the final version of the piece. Of course, the nature of these mappings are purely theoretical, any number of variables can mean that some harmonic or multiphonic clusters will not sound. The script produces a map of a given string, plotting harmonic nodes in red and ‘traditional’ equally-tempered note positions in blue, as a point of reference. The results of these maps cannot be followed blindly then, and each multiphonic needs to be checked, however, this mapping system has saved a huge amount of time when it comes to locating possible nodal locations and clusters. Figure 3 shows the map from a low E-natural of a double bass as an example.

---

<sup>1</sup> Carin Levine and Christina Mitropoulos-Bott, *The Techniques of Flute Playing*, (Kassel: Bärenreiter, 2002), Marcus Weiss and Giorgio Netti, *The Techniques of Saxophone Playing*, (Kassel: Bärenreiter, 2010), Seth F Josel and Ming Tsao, *The Techniques of Guitar Playing*, (Kassel: Bärenreiter, 2014), and Heather Roche’s online resources for clarinet, <https://heatherroche.net> have all been used extensively in writing this portfolio’s compositions.

<sup>2</sup> Ellen Fallowfield and Thomas Resch, ‘Multiphonics’, *Cello Map*, <http://www.cellomap.com/index/the-string/multiphonics-and-other-multiple-sounds.html> last accessed: 11 June 2016

<sup>3</sup> I have created a number of similar compositional tools over the course of this project, including: pitch system generators for sieve sets; spectrum calculators; pitch value converters; networked performance clocks and OpenCV motion-tracking systems. A number of these tools are stored are open-source and in an online GitHub repository: <https://github.com/owmty>

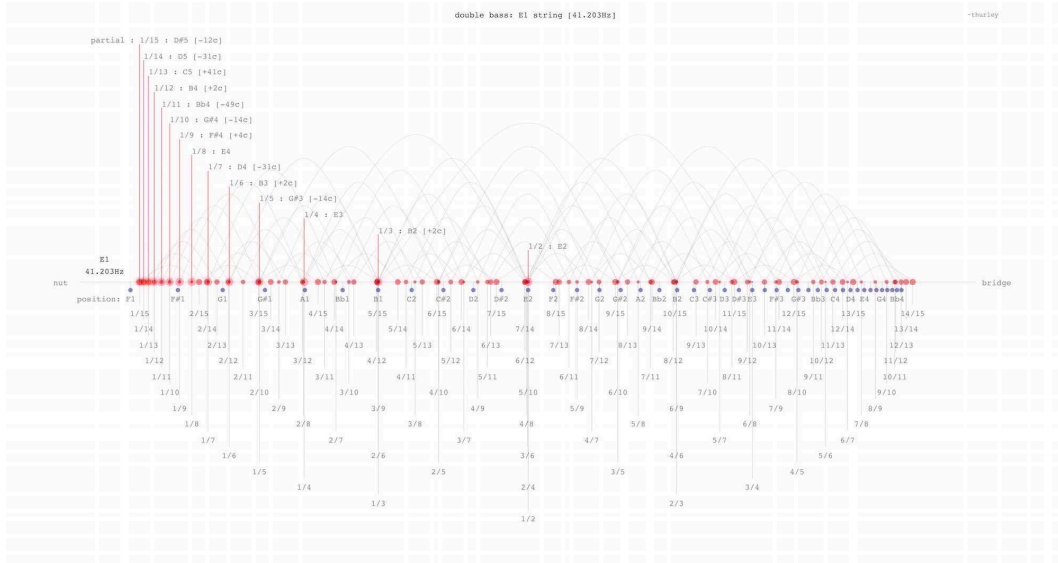

Figure 3: Harmonic map of a low E-string of a double bass.

During the development of *Network for four pianos*, I required a similar mapping of string harmonics for the prepared piano parts (Figure 4). Again, a simple matter of string lengths and harmonic ratios, I created a spreadsheet to calculate the location, and sounding pitches of harmonics for each piano string.

**piano harmonics calculator**  
-owmtxy, 2014

String No.	Note	Oct.	MIDI no.	Freq. (Hz)	No. of Strings	String Length (mm)	Partial No.	Partial Freq. (Hz)	Sounding difference (semitones)	Sounding note	Sounding Oct.	Approx. Node position (mm from stop)
Calibrate parameters to your piano →						Set	Set*	Set	← Choose partial to locate on string			
1	A#0	21	27.5	27.5	1	1	1	27.5	0	A#0	0	0
2	A#0	22	29.14	29.14	1	2	2	58.28	12	A#1	0	0
3	B0	23	30.87	30.87	1	3	3	92.61	19.02	F#2	0	0
4	C1	24	32.71	32.71	1	4	4	130.84	24	C2	0	0
5	C#1	25	34.66	34.66	1	5	5	173.3	27.86	F3	0	0
6	D1	26	36.72	36.72	1	6	6	220.32	31.02	A3	0	0
7	D#1	27	38.9	38.9	1	7	7	272.3	33.69	C#3	0	0
8	E1	28	41.21	41.21	1	11	11	453.31	41.51	A#4	0	0
9	F1	29	43.66	43.66	1	9	9	392.94	38.04	G4	0	0
10	F#1	30	46.26	46.26	1	10	10	462.6	39.86	A#4	0	0
11	G1	31	49.01	49.01	2	2	2	98.02	12	G2	0	0
12	G#1	32	51.92	51.92	2	2	2	103.84	12	G#2	0	0
13	A1	33	55.01	55.01	2	2	2	110.02	12	A2	0	0
14	A#1	34	58.28	58.28	2	2	2	116.56	12	A#2	0	0
15	B1	35	61.75	61.75	2	2	2	123.5	12	B2	0	0
16	C2	36	65.42	65.42	2	1	1	65.42	0	C1	0	0
17	C#2	37	69.31	69.31	2	2	2	138.62	12	C#2	0	0
18	D2	38	73.43	73.43	2	3	3	220.29	19.02	A3	0	0
19	D#2	39	77.8	77.8	2	1688	4	311.2	24	D#4	422	422
20	E2	40	82.43	82.43	2	1646	5	412.15	27.86	G#4	329	329
21	F2	41	87.33	87.33	2	1596	3	261.99	19.02	C3	532	532
22	F#2	42	92.52	92.52	2	1542	5	462.6	27.86	A#4	308	308
23	G2	43	98.02	98.02	2	1487	6	588.12	31.02	D4	248	248
24	G#2	44	103.85	103.85	2	1431	7	726.95	33.69	F#5	204	204
25	A2	45	110.03	110.03	2	1375	8	880.24	36	A5	172	172
26	A#2	46	116.57	116.57	2	1321	9	1049.13	38.04	C5	147	147
27	B2	47	123.5	123.5	3	1266	10	1235	39.86	D#6	127	127
28	C3	48	130.84	130.84	3	1183	2	261.68	12	C3	592	592
29	C#3	49	138.62	138.62	3	1117	2	277.24	12	C#3	559	559
30	D3	50	146.86	146.86	3	1054	2	293.72	12	D3	527	527
31	D#3	51	155.59	155.59	3	997	2	311.18	12	D#4	499	499
32	E3	52	164.84	164.84	3	942	2	329.68	12	E4	471	471
33	F3	53	174.64	174.64	3	891	2	349.28	12	F4	446	446
34	F#3	54	185.02	185.02	3	843	2	370.04	12	F#4	422	422
35	G3	55	196.02	196.02	3	797	2	392.04	12	G4	399	399
36	G#3	56	207.68	207.68	3	756	2	415.36	12	G#4	378	378
37	A3	57	220.03	220.03	3	716	2	440.06	12	A4	358	358
38	A#3	58	233.11	233.11	3	680	2	466.22	12	A#4	340	340
39	B3	59	246.97	246.97	3	644	2	493.94	12	B4	322	322

Figure 4: Interactive harmonic map for prepared piano.

## APPENDIX V: STRUCTURAL SKETCHES

The following are scans of various sketch materials demonstrating various stages of the temporal frameworks for *yet another example of the porousness of certain borders, if something black, falling as rain and then rising, with the very same twist to their faces and whose veil remains inscrutable.*

### YET ANOTHER EXAMPLE OF THE POROUSNESS OF CERTAIN BORDERS

The image shows a handwritten musical score sketch for a piece titled "yet another example of the porousness of certain borders". The score is written on ten staves, each with a circled letter on the left: L, K, Γ, Δ, E, Z, H, and Θ. Above the staves, there is a handwritten note: "yet water except of the porousness of color borders". The score includes various musical notations such as notes, rests, and beams. Above the staves, there are several horizontal lines with numbers and arrows indicating time intervals or measures. These numbers include 6:7, 5:6, 4:5, 3:4, 2:1, 1:1, 1:2, 2:3, 3:4, 4:5, 5:6, 6:7, 7:8, 8:9, 9:10, 10:11, 11:12, 12:13, 13:14, 14:15, 15:16, 16:17, 17:18, 18:19, 19:20, 20:21, 21:22, 22:23, 23:24, 24:25, 25:26, 26:27, 27:28, 28:29, 29:30, 30:31, 31:32, 32:33, 33:34, 34:35, 35:36, 36:37, 37:38, 38:39, 39:40, 40:41, 41:42, 42:43, 43:44, 44:45, 45:46, 46:47, 47:48, 48:49, 49:50, 50:51, 51:52, 52:53, 53:54, 54:55, 55:56, 56:57, 57:58, 58:59, 59:60, 60:61, 61:62, 62:63, 63:64, 64:65, 65:66, 66:67, 67:68, 68:69, 69:70, 70:71, 71:72, 72:73, 73:74, 74:75, 75:76, 76:77, 77:78, 78:79, 79:80, 80:81, 81:82, 82:83, 83:84, 84:85, 85:86, 86:87, 87:88, 88:89, 89:90, 90:91, 91:92, 92:93, 93:94, 94:95, 95:96, 96:97, 97:98, 98:99, 99:100. The score is divided into two systems by a vertical bar line. The notation is dense and includes many slurs and ties, suggesting a complex rhythmic structure.

Figure 5: Structural sketch for *yet another example of the porousness of certain borders*.



IF SOME THING BLACK

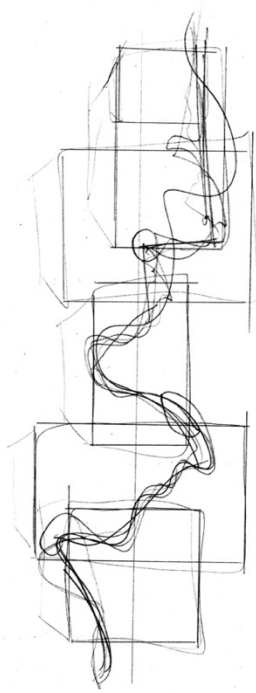
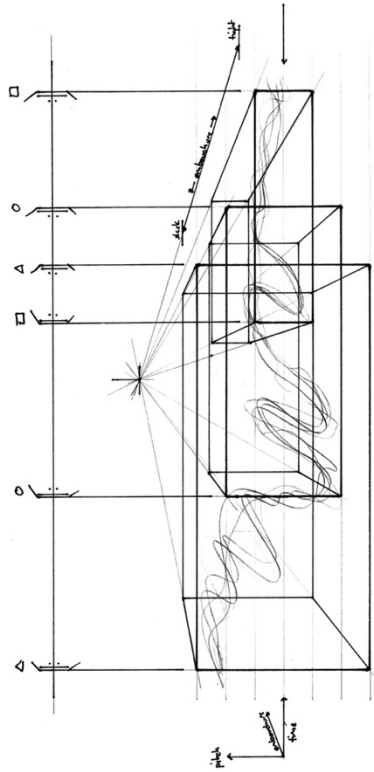

B

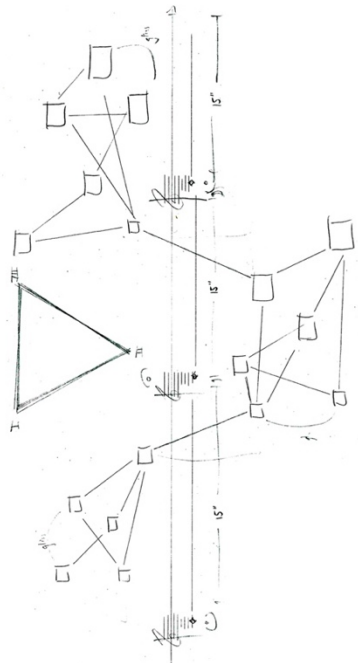
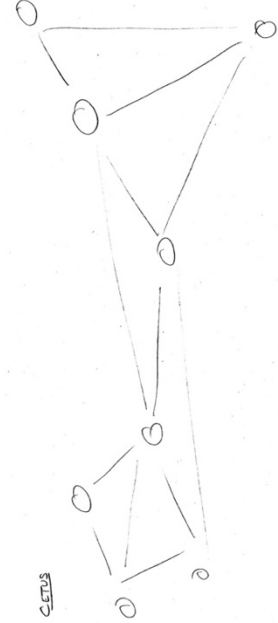
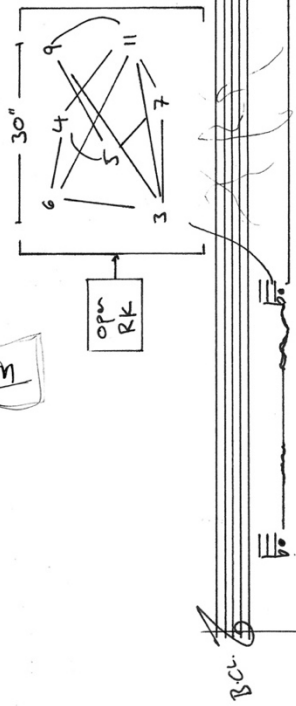

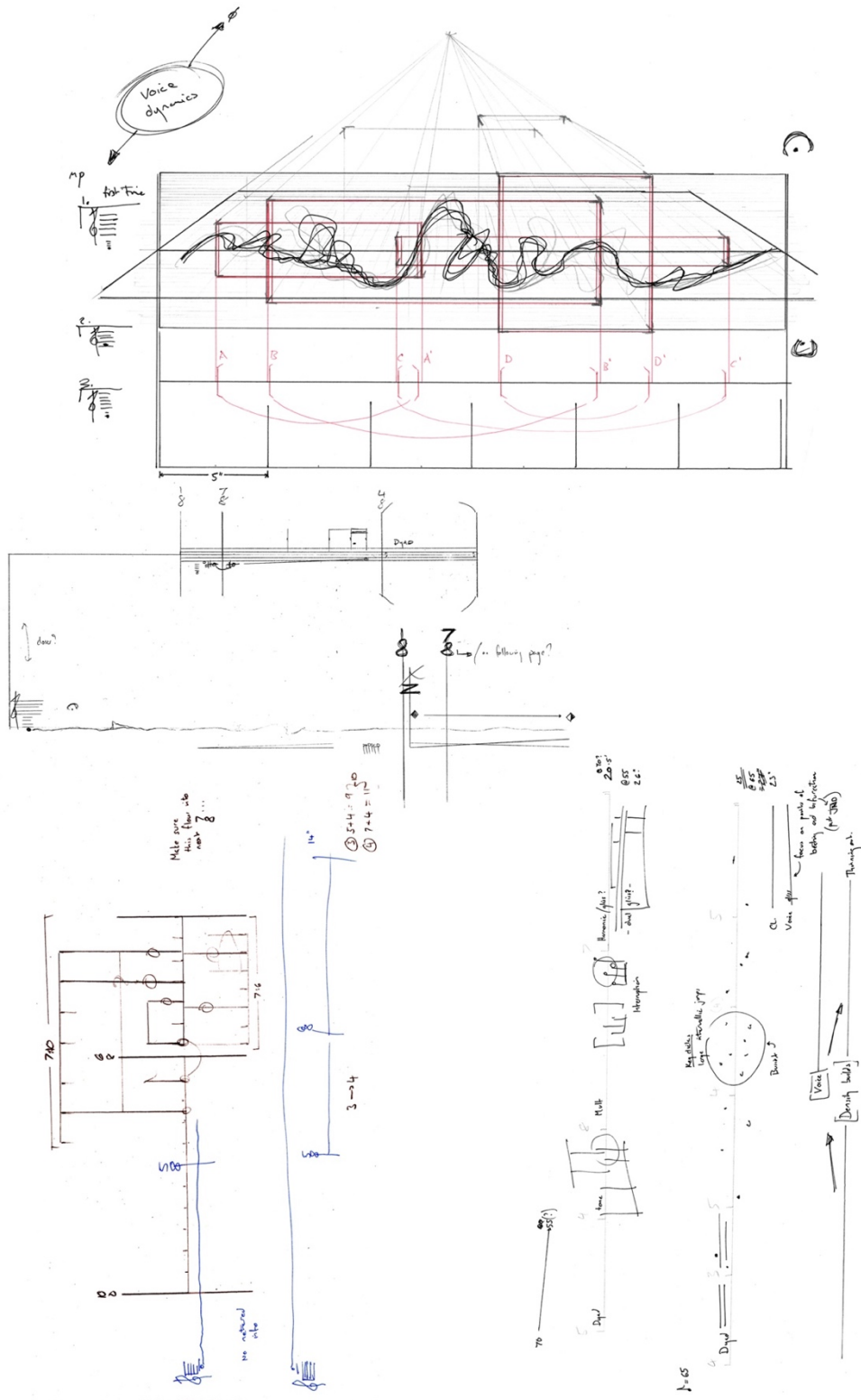

Figure 5: Structural sketches for *if some thing black*.



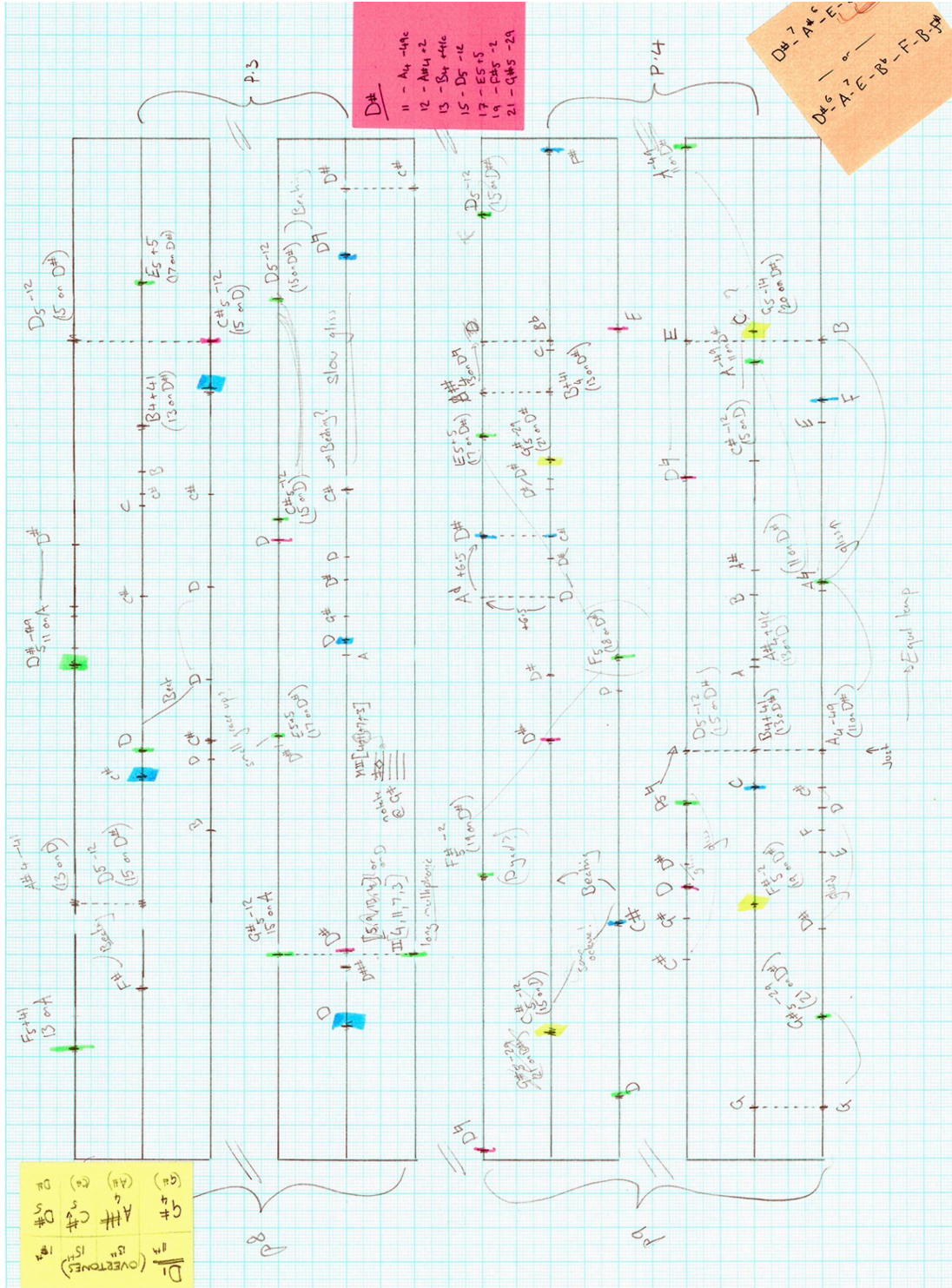

Figure 6: Structural sketches for *falling as rain and then rising*. Above, rhythmic framework of temporal contractions and dilations. Below, interval motions mapped onto filtered rhythms.

WITH THE VERY SAME TWIST TO THEIR FACES

with the very same twist to their faces - [intro, sustained section] - [end, sustained section]

START END

**No VIBRATO!**

**Baritone Saxophone**

**Accordion**

Duration equals a single, long breath. Hold evenly, and for as long as possible.

Duration determined by a single motion of the diaphragm. Slow as possible.

Shut up air hole: hand filters and bleeds through.

Breathless as slow as possible. Pitch should fall, inconsistently.

[429] A C

Match duration (and dynamic) to accordion. Circular breathing required. Pitcher unstable.

**=ERASED**

If I had less eyes, I would delete this bar.

Baritone Saxophone

Accordion

SEND HELP.

July 26<sup>th</sup> Adding multiple layers (to later strip/bleed out) - (more material can it be stored down to c. 7:40?)

(full gully on road as soon as sound breaks, only back to make)

by then we'll be all down beyond the hill too.

Figure 5: Notational and structural sketches for *with the very same twist to their faces*.

**WHOSE VEIL REMAINS INSCRUTABLE**

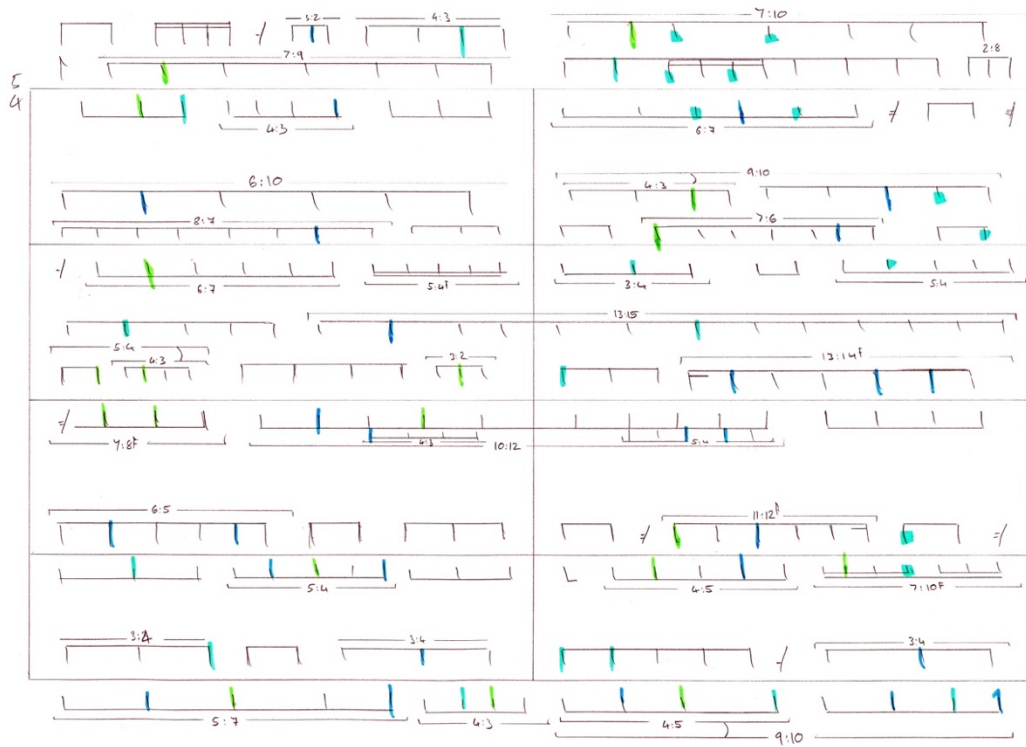

Figure 7: Structural impulse sketch for *whose veil remains inscrutable*.

---

## APPENDIX VI: TRANSLUCENT SPACES

### 22 FEBRUARY, 2015. GRAZ, AUSTRIA.

In early 2015, I took part in a two-week workshop project with Austrian composer Klaus Lang, focusing upon the incorporation of space into the compositional process. Whilst site-specific by nature, the workshop was principally concerned with an attempt to redefine ‘musical spaces’ in relation to ‘the borderline of concert, installation and performance’ environments.<sup>1</sup> In composing for this workshop participants were ‘to work with what can be found at a specific site on spot, not to intrude and impose, and only carefully and gently interfere with what these sites unfold themselves, and to open up to new sounds that are already at least potentially existing at specific sites.’<sup>2</sup> Whilst I have written site-specific works in the past, this particular project was of interest due to its focus on this mutual interference: that the music should be a part of the space as much as the space is part of the music. This provided an interesting opportunity to explore a potentially delicate liminal point between these two elements.

My own composition for the project took place in a small courtyard in Graz, part of the University’s church music department. The courtyard had a small tunnel access, and a staircase leading up three floors, each with balconies overlooking the courtyard. *translucent spaces\_courtyard* was written for Klaus Lang playing harmonium placed at the tunnel entrance to the courtyard, with a fixed sine-wave accompaniment. The sine-wave part was played from a small portable speaker placed in one of the archways of the courtyard.<sup>3</sup> During performance the sine-waves resonated throughout the courtyard, blending with the harmonium and combining at moments of harmonic consonance and rupturing to create spatial psychoacoustic beat frequencies as the sine-waves deviate microtonally towards dissonance. Whilst not an explicitly multi-spatial performance in the same sense as Rebecca Saunders’ *Chroma* (2003–), audience members were free to move about the courtyard, listening from different levels and perspectives, and experiencing different auditory ‘mixes’ of the harmonium/sine wave/environmental soundscape. Minutes before to the performance began, it started to rain.<sup>4</sup> A truly

---

<sup>1</sup> Impuls academy programme, <http://www.impuls.cc/en/academy-2015/special-programs.html#c2563> last accessed: 30 June 2015

<sup>2</sup> Ibid.

<sup>3</sup> Due to the portable loudspeaker’s limited bandwidth, only frequencies above 5,000Hz were played in order to maintain a clean signal.

<sup>4</sup> As a personal aside, the scene of the performance bore a striking resemblance to the films of Andrei Tarkovsky—another important aesthetic influence upon me. In a final moment of poetic significance, at the end of the performance, the rain destroyed the only copy of the work’s score—as no recording was made of the performance, this serves to underpin the ephemeral nature of the performance at *that time in that space*.

serendipitous moment, the sound of the rain falling into pools in the courtyard and dripping from the roofs created a gentle interference in the soundscape of the performance space, just as the performance resonated throughout the courtyard. For the listener, then, *translucent spaces\_courtyard* became not only an immersive experience, but permeable: one in which the musical ‘composition’ and the natural soundscape became inextricably fused.









Figure 8: Photographs of *translucent spaces\_courtyard* performance. Klaus Lang (Harmonium), Church Music courtyard, Graz, Austria. Photographs by the author.

**26 NOVEMBER, 2015. ILKLEY MOOR, UK.<sup>1</sup>**

In late 2015, Lang and I once again convened to organise an outdoor performance; this time in Yorkshire on the Ilkley Moor.<sup>2</sup> For the occasion, I wrote a small piece based upon my earlier network scores, whilst—in homage to Lang’s working methods—incorporating pitch material from the fifteenth century (a recurrent stylistic theme in Lang’s music). *a technical diagram for the abstraction of Ockeghem’s missa pro defunctis: kyrie, side elevation* for viola d’amore and harmonium distributes fragments from Ockeghem’s Kyrie across the score, allowing the performers to move across branching pathways between discrete fragments. Unlike the *translucent spaces\_courtyard* performance, the flat and windy moors did not allow for such a rich and immersive experience, but rather an even more ephemeral one: strong winds carrying fragments of fragments of the Kyrie out and across the moors. The effect of hearing this music floating out across this relatively remote location gave the performance a surreal quality and a discontinuity between landscape and soundscape.

---

<sup>1</sup> Full video available at: <https://vimeo.com/othurley/viola-harmonium> This short film was made possible with financial support from CePRA (University of Leeds), Ollie Jenkins (cameras and editing), and Elspeth Mitchell (producer).

<sup>2</sup> At the time, Lang was conducting his own project, ‘*viola. harmonium.*’ with Barbara Konrad, performing fragments of a large scale work of the same name at various remote locations around Europe.



Figure 9: *viola. harmonium. on Ilkley Moor* (2015) performance for short film. Klaus Lang (harmonium) and Barbara Konrad (viola d'amore), Ilkley Moor, West Yorkshire, UK. *Above*, still from video by Ollie Jenkins; *below*, photo by Elspeth Mitchell.

---

## APPENDIX VII: SUPPLEMENTARY COMPOSITIONS

The following compositions are included as supplementary to the main portfolio works. They are included as examples of progenitors, developments or tangents from the central portfolio compositions:

- *falling as rain and then rising* (clarinet, violin and cello, 2016)
- *a technical diagram for the abstraction of Ockeghem's missa pro defunctis: kyrie, side elevation* (viola d'amore and harmonium, 2015)
- *so much vapour aloft* (sketches for cello, 2015)
- *with the very same twist to their faces (under erasure)* (instrumentation indeterminable, 2014)
- *now did one now did one now did one* (contrabass clarinet, 2014)
- *face of the deep* (viola quartet, 2014)
- *envelop* (eight voices, 2014)
- *burrow* (electroacoustic, 2014)
- *mathematical forms 001: orbit* (viola and contrabass, 2013)
- *vermillion sands* (flute, violin, cello and percussion, 2013)