

**TOWARDS SUSTAINABLE RESIDENTIAL BUILDINGS
IN THE KINGDOM OF SAUDI ARABIA**

**A thesis submitted to the University of Sheffield for the degree of
Doctor of Philosophy
in the School of Architecture**

Hanan M. Taleb

September 2011

LIST OF CONTENTS

| | |
|--|-----------|
| List of Contents | 2 |
| LIST OF FIGURES | 6 |
| List of Tables | 9 |
| LIST OF ABBREVIATIONS | 10 |
| Abstract | 11 |
| Acknowledgements | 12 |
| | |
| <u>Chapter 1</u> INTRODUCTION | 13 |
| 1.1. Research Background..... | 13 |
| 1.2. Problem Statement..... | 14 |
| 1.3. Scope of the Research..... | 14 |
| 1.4. Research Aims and Objectives..... | 15 |
| 1.5. Thesis Layout..... | 16 |
| | |
| <u>Chapter 2</u> AN OUTLINE OF SUSTAINABLE ARCHITECTURE | 19 |
| 2.1 Chapter Overview..... | 19 |
| 2.2 The Need for Considering Sustainability in Architecture..... | 19 |
| 2.2.1 Environmental Concerns..... | 19 |
| 2.2.2 Energy Considerations..... | 24 |
| 2.2.3 Other Factors..... | 26 |
| 2.3 The Concept of Sustainable Architecture..... | 27 |
| 2.4 Application of Sustainable Architecture around the World..... | 37 |
| 2.5 A Glance into the Status of Sustainable Architecture in the Middle East..... | 62 |

| | | |
|-------------------------|---|------------|
| <u>Chapter 3</u> | THE KINGDOM OF SAUDI ARABIA: AN OVERVIEW | 68 |
| 3.1 | Chapter Overview..... | 68 |
| 3.2 | Introducing Saudi Arabia..... | 68 |
| 3.3 | Topography and Landscape of Saudi Arabia..... | 70 |
| 3.4 | Climate of Saudi Arabia..... | 72 |
| 3.5 | Traditional Architecture of Saudi Arabia..... | 76 |
| 3.5.1 | Tents..... | 76 |
| 3.5.2 | Traditional Architecture of Najd..... | 78 |
| 3.5.3 | Traditional Architecture of Hijaz..... | 83 |
| 3.5.4 | Traditional Architecture of the Eastern Region..... | 89 |
| 3.5.5 | Traditional Architecture of Asir..... | 90 |
| 3.5.6 | Traditional Architecture of the Northern Region..... | 93 |
| 3.6 | Contemporary Architecture of Saudi Arabia..... | 97 |
| 3.6.1 | Transformation towards Contemporary Architecture..... | 98 |
| 3.6.2 | Main Types of Modern Housing..... | 101 |
| 3.6.3 | Main Types of Modern Construction Materials..... | 104 |
| 3.6.4 | Concerns Associated with Saudi Contemporary Architecture..... | 105 |
| 3.7 | Sustainable Architecture in Saudi Arabia..... | 108 |
| 3.7.1 | Drivers and Barriers Concerning the Application of Sustainable Architecture in Saudi Arabia..... | 108 |
| 3.7.2 | An Overview of Sustainability Initiatives in Saudi Arabia..... | 111 |
| | | |
| <u>Chapter 4</u> | RESEARCH METHODOLOGY | 116 |
| 4.1 | Chapter Overview..... | 116 |
| 4.2 | Methodological Approach..... | 116 |
| 4.3 | Research Design..... | 118 |
| 4.3.1 | Simulation..... | 122 |
| 4.3.2 | Interviews..... | 124 |
| 4.4 | Research Ethics..... | 127 |

| | | |
|-------------------------|--|------------|
| <u>Chapter 5</u> | BASE CASE: ENERGY AND WATER CONSUMPTION WITHIN TYPICAL SAUDI HOUSES | 129 |
| 5.1 | Chapter Overview..... | 129 |
| 5.2 | An Introduction to the Case Studies..... | 129 |
| 5.2.1 | Case 1: The Apartment Complex..... | 129 |
| 5.2.2 | Case 2: The Villa..... | 132 |
| 5.3 | An Overview of the Jeddah Climate..... | 138 |
| 5.4 | Energy Consumption within the Case Study Buildings..... | 142 |
| 5.5 | Water Consumption within the Case Study Buildings..... | 151 |
| | | |
| <u>Chapter 6</u> | EFFICIENT CASE: MAKING SAUDI HOUSES MORE ENERGY AND WATER EFFICIENT | 155 |
| 6.1 | Chapter Overview..... | 155 |
| 6.2 | Evaluation of Suggested Energy Conservation Measures..... | 155 |
| 6.2.1 | Improved Thermal Insulation..... | 157 |
| 6.2.2 | More Efficient Glazing and Shading Arrangements..... | 162 |
| 6.2.3 | Improved HVAC Strategy..... | 165 |
| 6.2.4 | Energy-Efficient Lighting Equipment..... | 167 |
| 6.2.5 | Improved Water Heating Equipment and Strategy..... | 168 |
| 6.2.6 | Green Roofing..... | 169 |
| 6.3 | Energy Consumption after adopting all the Proposed Energy Conservation Measures..... | 171 |
| 6.4 | Evaluation of the Suggested Water Conservation | 177 |
| 6.5 | Rendering the Case Study Buildings More Sustainable..... | 179 |
| | | |
| <u>Chapter 7</u> | PLACING THE CASE STUDY BUILDINGS IN A DIFFERENT CLIMATIC CONTEXT: DESIGN IMPLICATIONS | 181 |
| 7.1 | Chapter Overview..... | 181 |
| 7.2 | An Overview of the Riyadh Climate..... | 181 |
| 7.3 | Climate-Responsive Recommendations for Building Design in Riyadh City..... | 184 |
| 7.4 | Energy Consumption within the ‘Base’ Case Study Buildings..... | 187 |
| 7.5 | Applying Passive Thermal Strategies to the Case Study Buildings..... | 190 |
| 7.5.1 | Building Orientation..... | 190 |

LIST OF FIGURES

| | |
|---|----|
| 2.1. The Greenhouse Effect..... | 20 |
| 2.2. The Relationship between Global Temperatures and Atmospheric Carbon Dioxide Concentrations Derived from the Vostok Ice Core from Antarctica..... | 21 |
| 2.3. Anticipated Impacts of Climate Change..... | 22 |
| 2.4. Global Oil and Natural Gas Production; Past, Current and Future..... | 24 |
| 2.5. What Makes a Building Sustainable..... | 31 |
| 2.6. Geographical Locations of the Sustainable Residential Buildings Selected..... | 38 |
| 2.7. Bariloche Ecohouse: Picture and Cross Section..... | 40 |
| 2.8. BowZED Tower Hamlets: Picture and Cross Section..... | 42 |
| 2.9. Gelsenkirchen Solar Housing Estates: Picture and Site Plan..... | 44 |
| 2.10. Vineyard Residence: Picture and Plan..... | 45 |
| 2.11. Soft and Hairy House: Picture and Plan..... | 47 |
| 2.12. Zero Energy Houses: Picture and Construction Section..... | 48 |
| 2.13. Lengau Lodge: Picture and Main Floor Plan..... | 50 |
| 2.14. Great (Bamboo) Wall: Picture and Plan..... | 52 |
| 2.15. Howard House: Picture and Combined Elevation, Plan and Section..... | 54 |
| 2.16. Robbs Run Residence: Picture and Site Plan..... | 56 |
| 2.17. Farm House: Picture and Site Plan..... | 58 |
| 2.18. Lindavista House: Picture and Plans..... | 60 |
| 2.19. Meir House..... | 63 |
| 2.20. The Green City at Euro University in Bahrain..... | 64 |
| 2.21. The Bahrain World Trade Centre..... | 65 |
| 2.22. 100% Renewable Energy Burj Al Taqa Skyscraper..... | 66 |
| 3.1. Administrative Provinces of Saudi Arabia..... | 69 |
| 3.2. General Topographical Map of the Arabian Peninsula..... | 70 |
| 3.3. Climatic Zones of Saudi Arabia..... | 72 |
| 3.4. A Bedouin Tent..... | 77 |
| 3.5. Hajj Tents..... | 77 |
| 3.6. The Locations of Traditional Architectural Examples selected in Saudi Arabia..... | 78 |
| 3.7. Typical Courtyard Houses in Najd..... | 79 |
| 3.8. A Thermal System of a Courtyard House in Najd..... | 80 |
| 3.9. A typical Najdi House in section in Riyadh..... | 81 |
| 3.10. A Roof Overlooking the Courtyard..... | 82 |
| 3.11. The Entrance of Qasr Al-Qishla in Ha'il..... | 83 |
| 3.12. A View to Old Jeddah..... | 84 |
| 3.13. Al Shafi'ay House in Old Jeddah..... | 85 |
| 3.14. A Traditional House in Yanbu..... | 86 |
| 3.15. Sketches of Different Makkah Traditional Houses..... | 87 |
| 3.16. Typical Medina Traditional House..... | 88 |
| 3.17. House of Al-Baikawat in Al-Taif..... | 89 |
| 3.18. An Example of Traditional Buildings in Al-Hufuf..... | 89 |
| 3.19. A Traditional House in Al-Qatif Before Demolition..... | 90 |

| | |
|---|-----|
| 3.20. Traditional Houses in Abha..... | 91 |
| 3.21. Typical Plans for Tower Houses in Asir..... | 92 |
| 3.22. The Old Emirates Castle in Najran..... | 93 |
| 3.23. A Traditional House in Tabuk..... | 94 |
| 3.24. Qasr Marid in Al Jawf..... | 95 |
| 3.25. Nasif House in Jeddah..... | 96 |
| 3.26. Masmak Palace in Riyadh..... | 97 |
| 3.27. The Kingdom Tower in Riyadh..... | 99 |
| 3.28. Al-Faisaliah Tower in Riyadh..... | 100 |
| 3.29. A Typical Apartment Complex in Saudi Arabia..... | 101 |
| 3.30. A Typical Villa in Saudi Arabia..... | 102 |
| 3.31. An Example of a Subdivision of Villas..... | 102 |
| 3.32. A High-rise Residential Building in Jeddah..... | 103 |
| 3.33. A Royal Palace in Jeddah..... | 104 |
| 3.34. A Residential Building under Construction in Saudi Arabia..... | 105 |
| 3.35. Electricity Consumption by Sector in Saudi Arabia..... | 109 |
| 4.1. The Research Process..... | 121 |
| 4.2. Backgrounds of the Interviewees..... | 125 |
| 5.1. An Aerial View of Case 1 and its Urban Context..... | 129 |
| 5.2. Floor Plans of Case 1..... | 130 |
| 5.3. Elevations of Case 1..... | 131 |
| 5.4. 3D Model View of Case 1..... | 131 |
| 5.5. An Aerial View of Case 2 and its Urban Context..... | 132 |
| 5.6. Floor Plans of Case 2..... | 133 |
| 5.7. Elevations of Case 2..... | 134 |
| 5.8. 3D Model View of Case 2..... | 134 |
| 5.9. Temperature and Solar Radiation Levels in Jeddah..... | 139 |
| 5.10. Wind Velocity Range in Jeddah..... | 140 |
| 5.11. Dry Bulb Vs. Relative Humidity in Jeddah..... | 140 |
| 5.12. Dry Bulb Vs. Dew Point in Jeddah..... | 141 |
| 5.13. Temperatures and Heat Balances of the Base Case 1 on 15 July..... | 144 |
| 5.14. Temperatures and Heat Balances of the Base Case 2 on 15 July..... | 145 |
| 5.15. Monthly Comfort Conditions vs. Energy Consumption of the Base Case 1..... | 147 |
| 5.16. Monthly Comfort Conditions vs. Energy Consumption of the Base Case 2..... | 148 |
| 5.17. Calibration of the Simulation Results for Base Case Study 1..... | 149 |
| 5.18. Calibration of the Simulation Results for Base Case Study 2..... | 150 |
| 6.1. Cross-sections of the External Walls in the Base and Efficient Case Buildings..... | 158 |
| 6.2. Cross-sections of the Roofs in the Base and Efficient Case Buildings..... | 159 |
| 6.3. Shading Devices Fitted around the Windows of the Case Study Buildings..... | 164 |
| 6.4. Monthly Comfort Condition vs. Energy Consumption..... | 166 |
| 6.5. Comparing Potential Savings of the Adopted Energy Conservation Measures..... | 170 |
| 6.6. Heat Balances of the Base and Efficient Case 1 on 15 July..... | 173 |
| 6.7. Heat Balances of the Base and Efficient Case 2 on 15 July..... | 174 |
| 6.8. Monthly Comfort Conditions vs. Energy Consumption of the Efficient Case 1..... | 175 |

| | |
|---|-----|
| 6.9. Monthly Comfort Conditions vs. Energy Consumption of the Efficient Case 2..... | 176 |
| 6.10. Potential CO ₂ Emission Reductions for the Case Study Buildings..... | 179 |
| 7.1. Temperature and Solar Radiation Levels in Riyadh..... | 182 |
| 7.2. Wind Velocity Range in Riyadh..... | 182 |
| 7.3. Dry Bulb Vs. Relative Humidity in Riyadh..... | 183 |
| 7.4. Dry Bulb Vs. Dew Point in Riyadh..... | 184 |
| 7.5. An Illustrative Example for the Process of Evaporative Cooling in Riyadh..... | 185 |
| 7.6. Varying surface to volume ratio with different building types..... | 187 |
| 7.7. Monthly Comfort Conditions vs. Energy Consumption of the Base Case 1..... | 188 |
| 7.8. Monthly Comfort Conditions vs. Energy Consumption of the Base Case 2..... | 189 |
| 7.9. Experimenting Different Orientations..... | 191 |
| 7.10. Cross-sections of the External Walls in the Base and Efficient Case Buildings..... | 196 |
| 7.11. Cross-sections of the Roofs in the Base and Efficient Case Buildings..... | 197 |
| 7.12. Method for Approximating Bridging Effects in DesignBuilder Simulations..... | 199 |
| 7.13. Building Design Strategies for Riyadh's Climate..... | 200 |
| 7.14. Position of Aphelion and Perihelion Relative to the Earth's Orbit around the Sun..... | 202 |
| 7.15. The Earth's Revolution around the Sun..... | 203 |
| 7.16. Variations in Solar Altitude at Solar Noon for 50° N from the Southern Side of the Horizon..... | 204 |
| 7.17. Variations in Solar Altitude at Solar Noon for the Equator from the Northern Side of the Horizon..... | 204 |
| 7.18. Relationship of Maximum Sun Height to Latitude for the Equinox (Left) and June Solstice (Right)..... | 205 |
| 7.19. The Altitude and Azimuth of the Sun..... | 206 |
| 7.20. Determining the Altitude and Azimuth of the Sun for Riyadh City on the 3 rd of September at 9AM..... | 207 |
| 7.21. Horizontal and Vertical Shadow Angles..... | 209 |
| 7.22. The Average Cost of Shading Materials in Saudi Arabia..... | 212 |
| 7.23. Comparing Potential Savings of the Adopted Climate-Responsive Energy Conservation Measures..... | 216 |
| 7.24. Monthly Comfort Conditions vs. Energy Consumption of the Efficient Case 1..... | 217 |
| 7.25. Monthly Comfort Conditions vs. Energy Consumption of the Efficient Case 2..... | 218 |

LIST OF TABLES

| | |
|--|-----|
| 2.1. Sustainable Building Rating Systems around the World..... | 32 |
| 2.2. Examples of Constraints, Priorities and Complexities in Sustainability..... | 34 |
| 3.1. Characteristics of the Different Climatic Zones of Saudi Arabia..... | 73 |
| 3.2. Monthly Mean Total of Rainfall in Five Different Saudi Cities..... | 74 |
| 3.3. Average Minimum and Maximum Temperatures in Five Different Saudi Cities..... | 75 |
| 3.4. Previous Postgraduate Research, Conducted in the UK, in Relation to Sustainable Architecture in Saudi Arabia..... | 112 |
| 5.1. Detailed Description of the Case Study Buildings..... | 135 |
| 5.2. Specification of Case 1's Building Materials and Their Thermal Properties..... | 136 |
| 5.3. Specification of Case 2's Building Materials and Their Thermal Properties..... | 137 |
| 5.4. Assumed Input Data for Water Consumption Analysis..... | 151 |
| 5.5. Water Consumption of Activities not considered by the BRE Code Water Calculator..... | 153 |
| 6.1. Thermal Conductivities of Different Insulation Materials..... | 160 |
| 6.2. Maximum U-values (W/m ² K) in Australia, China, India and the USA..... | 161 |
| 6.3. The Potential Effect of Improving Thermal Insulation..... | 162 |
| 6.4. Different Types of Window Glazing Compared..... | 163 |
| 6.5. The Potential Effect of Improving Glazing and Fitting Shading Devices in terms of Electricity Use and CO ₂ Reductions..... | 165 |
| 6.6. The Potential Effect of Improving HVAC Strategy..... | 167 |
| 6.7. The Potential Effect of Fitting Energy-efficient Lighting in terms of Electricity Use and CO ₂ Reductions..... | 168 |
| 6.8. The Potential Effect of Improving Water Heating Equipment in terms of Electricity Use and CO ₂ Reductions..... | 168 |
| 6.9. Characteristics of the Green Roof..... | 169 |
| 6.10. The Potential Effect of Installing Green Roofs in terms of Electricity Use and CO ₂ Reductions..... | 170 |
| 6.11. The Potential Savings after incorporating all Suggested Energy Conservation Measures..... | 171 |
| 6.12. The Potential Savings after Incorporating Suggested Water Conservation Measures..... | 177 |
| 7.1. Estimated Annual Solar Gains for Different Orientations in Riyadh..... | 191 |
| 7.2. Thermal Mass-Related Properties of Different Materials..... | 193 |
| 7.3. Simple U-value Calculation Example for a Typical Building's Roof..... | 194 |
| 7.4. Estimated Annual Reduction of Total Solar Gain for Different Types of Internal Shading Devices and Orientations in Riyadh..... | 210 |
| 7.5. The Potential Reduction of Direct Solar Radiation for Different Types Shading Devices: Results of Two Studies Compared..... | 213 |
| 7.6. Recommended Climate-Responsive Energy Conservation Measures for Riyadh's Buildings..... | 215 |
| 8.1. Detailed Background Information about the Interviewees..... | 219 |
| 8.2. Barriers to Sustainable Residential Buildings in Saudi Arabia..... | 233 |

LIST OF ABBREVIATIONS

| | |
|-----------------------|---|
| 3D | Three-Dimensional |
| AC | Air Conditioning |
| AC/h | Air Changes per Hour |
| AIA | American Institute of Architects |
| ASHRAE | American Society of Heating, Refrigerating and Air-conditioning Engineers |
| ASPO | Association for the Study of Peak Oil |
| BESTest | Building Energy Simulation TEST |
| BREEAM | Building Research Establishment's Environmental Assessment Method |
| CAD | Computer-Aided Design |
| <i>cf</i> | Latin <i>confer</i> , meaning 'compare' |
| CFCs | Chlorofluorocarbons |
| CIA | Central Intelligence Agency |
| CIBSE | Chartered Institution of Building Services Engineers |
| CFL | Compact Fluorescent Light |
| CO₂ | Carbon Dioxide |
| DEFRA | Department for the Environment, Food and Rural Affairs |
| GCC | Gulf Cooperation Council |
| GUI | Graphical User Interface |
| HVAC | Heating, Ventilation, Air Conditioning |
| IEA | International Energy Agency |
| IPD | Integrated Project Delivery |
| IPPC | Intergovernmental Panel on Climate Change |
| kWh | kilowatt hour |
| LCD | Litres per Capita, per Day |
| LEDs | Light-Emitting Diodes |
| LEED | Leadership in Energy and Environmental Design |
| MW | Megawatt |
| ppm | parts per million |
| SBS | Sick Building Syndrome |
| SHGC | Solar Heat Gain Coefficient |
| UK | United Kingdom |
| UNDP | United Nations Development Programme |
| USA | United States of America |
| VOC | Volatile Organic Compound |
| W | Watt |
| WHO | World Health Organisation |
| ZED | Zero Energy Development |

ABSTRACT

Towards Sustainable Residential Buildings in the Kingdom of Saudi Arabia

Hanan M. Taleb, September 2011

School of Architecture – The University of Sheffield

Residential buildings are not only a major energy consumer, but also have considerable ecological impact. Quite often, architects can constitute a large part of the problem of tackling climate change. It is notable, however, that architects around the world have recently been encouraged to embrace the principles of sustainable design, which essentially aims to promote a suite of sustainable architectural practices such as those centred on enhancing household energy and water efficiency. Nonetheless, there seems to be a comparatively limited interest in pursuing the sustainability agenda among architects in the Middle East. In addition, there has been a corresponding dearth of academic research on this topic in spite of its apparent importance. This thesis considers the case of Saudi Arabia, and analyses the energy and water consumption of its current residential buildings in the context of two different climatic settings in the country, with the ultimate aim of establishing guidelines towards achieving sustainable architectural practices within the Saudi residential sector.

An extensive literature review has been conducted in order to establish a broad understanding of existing sustainable architectural practices around the world. Using available literature, the thesis also examines both the current status of sustainability within the Saudi building sector, and the need for sustainable residential buildings in Saudi Arabia. Current energy and water consumption within two typical Saudi houses (an apartment complex and villa) were analysed using simulation software packages. Next, a number of design-orientated energy and water conservation measures were suggested, and their saving potential assessed. In addition, especially as for this Ph.D. research, fourteen highly-informed Saudi stakeholders were interviewed in order to both validate the simulation results and to engage in in-depth discussions on ways of making residential buildings within Saudi Arabia more sustainable. Ultimately, a number of barriers that currently impede a transition towards a sustainable residential sector in Saudi Arabia have been identified. The thesis goes further and provides a number of design and non-design related strategies that have the potential to change the status quo with regard to the limited application of sustainable architectural principles within Saudi residential buildings.

ACKNOWLEDGEMENTS

I am deeply indebted to Professor Steve Sharples, whose help, advice, guidance and much-appreciated supervision was invaluable. Thanks are also extended to Professor Flora Samuel for supervising the late stages of this research. Last, but certainly not least, I would like to thank my husband Dr. Yasser Al-Saleh for his support, patience and encouragement whilst conducting this research.

Chapter 1

Introduction

1.1 Research Background

With the rapid growth of evidence that the phenomenon of climate change is caused by greenhouse gas emissions, it has become necessary to take immediate action to avoid dangerous consequences for future generations. Buildings are a major consumer of energy; and as such their potential impact on the environment is considerable. The concept of ‘Sustainable Architecture’ – which essentially aims to promote a suite of sustainable building practices – is increasingly recognised around the world as being amongst the most effective means to minimise the negative impacts associated with buildings through enhanced efficiency and sensible use of energy, water, materials and development space.

In a world that has become extremely concerned with diminishing natural resources and degraded ecosystems, a number of sustainability assessment tools have been developed that provide a pathway towards achieving sustainable buildings. Examples of such tools include BREEAM (Building Research Establishment’s Environmental Assessment Method) in the United Kingdom (UK) and LEED (Leadership in Energy and Environmental Design) in the United States of America (USA). It appears that oil-rich and developing Middle-Eastern countries, including Saudi Arabia, lag behind these leading countries in a sustainable context. Saudi Arabia is currently experiencing vigorous infrastructural growth especially with respect to residential buildings. Unfortunately, however, not only have no sustainability assessment tools been developed for this country, additionally the issue of sustainability is not being taken into consideration in Saudi building designs. In this regard, the author believes that sustainability should no longer be seen as a luxury; and should be actively pursued in a rapidly-developing country like Saudi Arabia with a sense of urgency.

This is believed to be an imperative step towards attaining sustainable development, the underlying aim of which is to meet the needs of the present without adversely affecting the ability of future generations to meet their own needs (World Commission for Environment and Development, 1987).

1.2 Problem Statement

In Saudi Arabia, a country experiencing rapid population growth and increased urbanisation, residential applications constitute more than half of the country's energy demands (Al-Ajlan et al., 2006). However, it is noted that the notion of sustainable buildings has not yet received sufficient consideration in this country for a number of reasons. These include having abundant oil reserves as well as heavily subsidised electricity prices and a general lack of awareness with regard to the environment in Saudi Arabia (Al-Saleh, 2010). Therefore, the underlying premise of this research is that serious measures must be taken in order to enhance the sustainability status of residential buildings in Saudi Arabia.

1.3 Scope of the Research

Despite its apparent focus upon environmentally-conscious design techniques, the concept of defining sustainable architecture remains controversial. However, whilst most scholars argue the need to consider a wide range of aspects such as economic and social issues, much focus often appears to be placed upon making efficient use of energy and water, as well as the incorporation of renewable energy technologies in buildings (e.g. see Edwards and Turrent, 2000). For instance, it is noted that not only are energy-related improvements awarded the most credits in BREEAM assessments, but also in all of the different LEED rating systems, a category named 'Energy and Atmosphere' contains the most credits

available (BREEAM, 2010; US Green Building Council, 2009). Moreover, since most of the water used in Saudi Arabia is produced in desalination plants, water is usually considered as part of the Saudi energy sector (Al-Saleh, 2009). It is true that the subject of sustainable buildings within Saudi Arabia is under-researched, but it would not be an exaggeration to suggest that an attempt to adequately cover all aspects concerning sustainable architecture would probably require more space than this thesis allows. Consequently, whilst recognising the need to consider all design factors relating to sustainable buildings, it was decided to devote the attention of this thesis to energy and water-related issues only, whilst taking into account the climatic context of Saudi Arabia. Furthermore, it is anticipated that the outcomes of this research will be useful not only for Saudi designers and architects, but also for many other stakeholders in the public and private sectors, such as ministries, municipalities, universities, research centres and investors. Nonetheless, whilst this research focuses on the residential buildings of Saudi Arabia, it could be argued that many of the research outcomes are relevant to other countries, especially those with similar climatic, social and economic conditions to Saudi Arabia.

1.4 Research Aim and Objectives

The aim of this research is to assess the energy and water consumption of current residential buildings in Saudi Arabia in order to establish guidelines towards achieving sustainable architectural practices in the country. In order to fulfil this overall aim, the following objectives will need to be addressed:

- To review recent literature in order to establish a broad understanding of existing sustainable architectural practices around the world.

- To conduct a literature review in order to both assess current sustainability status within the Saudi building sector, and examine the need for sustainable residential buildings in Saudi Arabia.
- To assess energy and water consumption within typical Saudi houses using energy use simulation software and water consumption calculating tools. The energy consumption analysis will be carried out in two cities in Saudi Arabia in order to examine how climate informs built and why different energy conservation strategies might be suitable for the two different climates.
- To suggest design-based modifications that could contribute towards achieving energy and water-efficient residential buildings in Saudi Arabia. The utility of these suggestions are then to be discussed and verified with relevant stakeholders and practising professionals in the country.
- To provide a set of recommendations that aims to make residential buildings within Saudi Arabia more sustainable.

1.5 Thesis Layout

Having briefly introduced the research context and proposed the aim of this research and its related objectives, the remainder of this thesis is comprised of the following chapters:

Chapter 2 presents a literature-based introduction to the concept of sustainable architecture, with a brief account of its main principles and the driving factors behind the promotion of sustainable building practices. The current global status of sustainable residential buildings is then critically reviewed through examining a number of exemplar

projects located in various climatic settings. The chapter concludes by reviewing the rather modest sustainability-orientated initiatives in the building sector of the Middle East region.

Chapter 3 aims to examine the case of Saudi Arabia through an extensive review of relevant literature. As part of this examination, geographic and climatic features, as well as prevailing architectural practises are thoroughly assessed. In addition, not only does this chapter argue the need for considering sustainable architectural practices in Saudi residential buildings, it also acknowledges potential barriers that could impede a successful sustainability-orientated endeavour in the Saudi Arabian residential sector. The chapter concludes with an overview of the sustainability status of the country.

Chapter 4 discusses, in detail, and justifies the methodology adopted in this research. The methodological approach as well as a detailed account of the various research methods, and the simulation software package selected, is included in this discussion.

Chapter 5 introduces the case study buildings that have been selected as typical Saudi houses. Following this, the chapter provides a detailed simulation-based analysis of energy and water consumption within these typical houses currently located in Jeddah City.

Chapter 6 suggests a number of design-related measures and principles that could enhance the sustainability status of residential buildings in Jeddah City. Next, the potential energy and water savings that could result from incorporating these measures in the case study buildings are evaluated using the simulation software package.

Chapter 7 explores potential sustainable design implications when placing the two case study buildings in the climatic context of the Saudi capital city of Riyadh. A number of climate-responsive energy conservation strategies for building designs in Riyadh City are applied to the case study buildings, and their potential energy savings are estimated using the simulation software package.

Chapter 8 presents feedback received, on the simulation findings and suggested sustainability measures and, from informed architectural professionals and relevant stakeholders in Saudi Arabia. The chapter also provides an account of the findings that have emerged from the in-depth discussions, with these stakeholders, about ways of making residential buildings within Saudi Arabia more sustainable.

Chapter 8 reiterates the research aims and objectives that were set out in the first chapter. Research findings emerging from both the analysis of Saudi houses and consultation with experts are then discussed. The thesis concludes by stating the limitations of the study as well as suggestions of possibilities for future research.

Chapter 2

An Outline of Sustainable Architecture

2.1 Chapter Overview

This chapter comprises four sections. The first section highlights some of the reasons behind the necessity of considering sustainability in the field of architecture. The concept of sustainable architecture, along with its definitions and underlying principles, will then be discussed in further detail. The third section presents several exemplar projects of sustainable residential buildings from around the world, whilst the fourth section provides an overview of the sustainability status of Middle Eastern architecture.

2.2 The Need for Considering Sustainability in Architecture

A review of the literature reveals that the main drivers behind promoting sustainable building practices are as follows:

2.2.1 Environmental Concerns

Climate change has, without doubt, become the overriding environmental issue of today and is one of the highest-profile global issues. The existence of greenhouse gases (i.e. heat-trapping gases including carbon dioxide 'CO₂') in the atmosphere is vital in order to keep the earth's surface warm enough to make life on earth possible. Figure 2.1 illustrates the concept of the greenhouse effect.

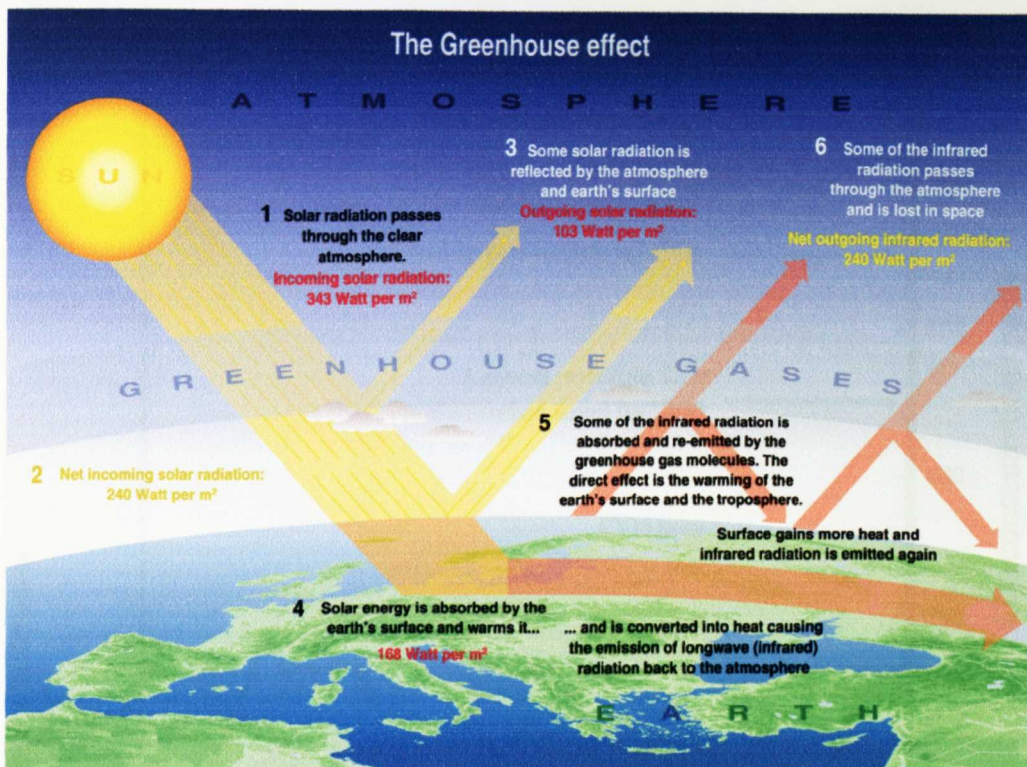


Figure 2.1: The Greenhouse Effect (Source: Climate Change Connection, 2010)

Nevertheless, the concern is not that there is a greenhouse effect, but rather that human activities are actually causing an enhancement of that effect. More specifically, it is argued that burning fossil fuels has caused concentrations of greenhouse gases to increase; with the consequence that the earth's temperature is climbing above past levels. The Intergovernmental Panel on Climate Change (IPCC) affirms that "Warming of the climate system is unequivocal, as is now evident from observations of increases in global average air and ocean temperatures, widespread melting of snow and ice, and rising global mean sea level" (IPCC, 2007). Figure 2.2 illustrates the close relationship that there has been over the years between global concentrations of carbon dioxide and global temperatures. The current carbon dioxide concentration is estimated at around 370 ppm; and Figure 2.2 shows the likely rises during the 21st Century under various projections of its growth.

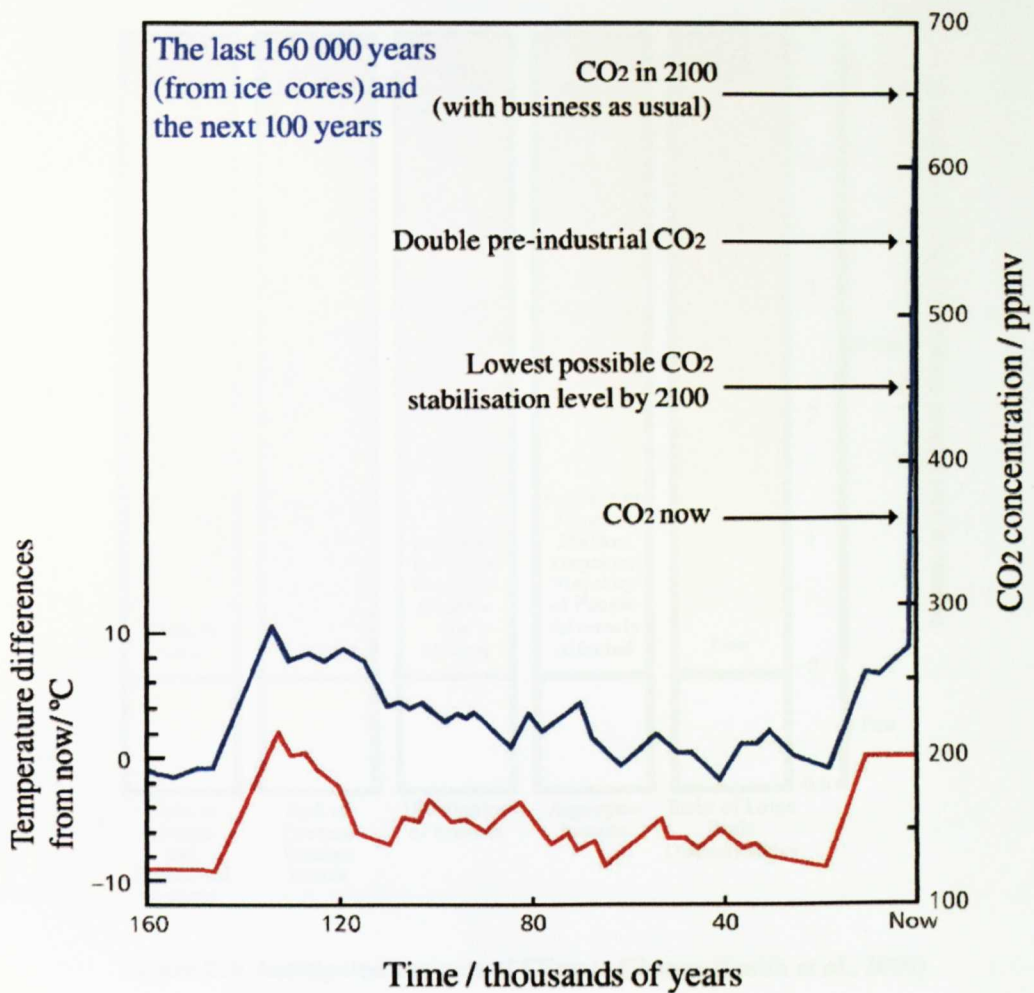


Figure 2.2: The Relationship between Global Temperatures and Atmospheric Carbon Dioxide Concentrations Derived from the Vostok Ice Core from Antarctica
(Source: Houghton, 2004)

Recent climate models indicate that if no actions are taken today to reduce CO₂ emissions, there are risks of irreversible and serious climate change. Forecasts for the year 2100 predict potential rises in the global temperatures by at least 2° Celsius for the most conservative scenarios; with a probable chance of temperatures rises above 2° Celsius in other scenarios (Stern, 2006). Depending on how high global temperatures get (from 1990), Figure 2.3 shows some of the potential consequences of climate change.

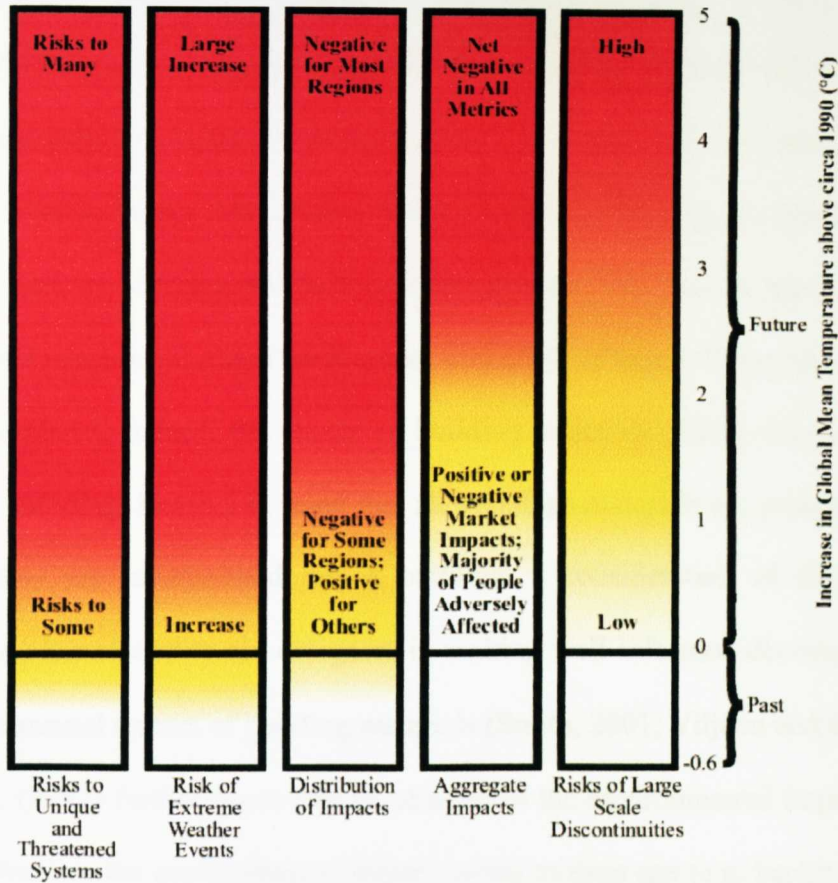


Figure 2.3: Anticipated Impacts of Climate Change (Smith et al., 2009)

In order to control greenhouse gas concentrations, everyone (including architects and builders) has a responsibility and should act now both collectively and individually to address climate change. There seems to be a never-ending debate on whether or not climate change is caused by human activities. Nevertheless, the seriousness of the situation necessitates immediate and urgent actions (Paltridge, 2009). In this regard, it is believed that buildings, which are major energy consumers, are particularly relevant when discussing ways to curb greenhouse gas emissions. Williamson et al. (2003) point out several aspects that need to be addressed, either explicitly or implicitly, during the design of a building to deal with climate change. More specifically, care must be taken to reduce both greenhouse gas emissions that result from the operation of the building, and those that

resulted during the manufacture, transport and putting in place of the materials of construction. Moreover, it should be recognised that the more we deplete our raw materials and natural resources, the more we erase the base of support for our current and future natural and economic health (McLennan, 2004). Douglas (2002) argues that the extensive use of timber and wood-based products in buildings has been one of the key causes of depletion of that rainforests, which are home of two thirds of all the living animal and plant species on the planet. Indeed, the choice of building materials affects the environmental impact of any building. Bearing in mind that all buildings materials are processed in some way before they are incorporated into a building, a consideration of the Life Cycle Analysis (LCA) has started to aid designers in making well-informed decisions about the overall environmental impact of building materials (Smith, 2001; Viljoen and Bohn, 2007). Woolley et al. (1997) further argue that in addition to the environmental impact owing to materials production, the environmental impact owing to their use (e.g. health hazards and potential for reusing/recycling) also needs careful consideration. Despite these concerns, it is estimated that around 50% of both natural materials resources and global waste productions are in fact building-related (Anink et al., 1996).

Before concluding this section on environmental concerns, one needs to acknowledge the fact that the world is evidently facing an escalating scarcity of water. According to the United Nations Development Programme (2006), almost two in three people in the world lack access to clean water; as demand for water has been dramatically increasing whilst supply is decreasing around the world. It also concludes that for individuals and for households, access to clean water is one of the foundations for progress in human development and health. It is, therefore, time to reconsider a variety of sustainable actions and strategies to minimise water consumption when designing buildings. For instance,

since toilets account for 30%-40% of indoor household water consumption (Chiras, 2004), using low-flush toilets (and low-flow showerheads) is very important to preserve water.

2.2.2 Energy Considerations

There seems to be an ongoing discussion on how soon a peak in global oil production will be reached; after which will begin an irreversible decline towards ultimate depletion. Appreciably, as oil production begins to decline, oil prices are expected to soar. The idea of 'Peak Oil' was initially introduced by Hubbert (1949) who successfully predicted that oil production of the American fields would peak around 1970. Many oil experts believe that the decline in global oil and natural gas production has already begun; hence today's high prices of petrol, electricity and home heating (Campbell, 2005; Deffeyes, 2005). Figure 2.4, provided by The Association for the Study of Peak Oil, projects a slippery downward slope from around the year 2009. Other energy experts maintain that global oil production will peak and then begin to decline soon because – as is the case with other fossil fuels (such as natural gas and coal) – oil is a non-renewable source of energy (Chiras, 2004).

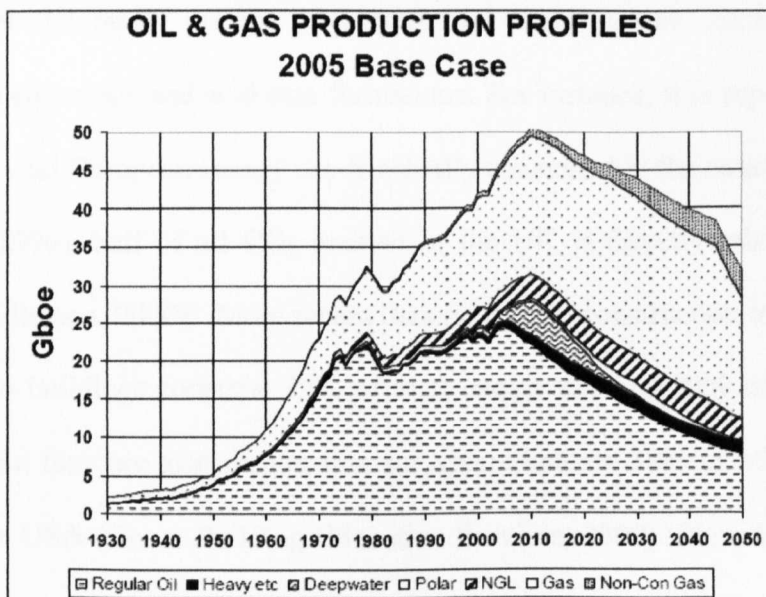


Figure 2.4: Global Oil and Natural Gas Production; Past, Current and Future (Source: ASPO, 2006)

Moreover, Hart (2003) notes that all forecasts for global energy use anticipate significant future increases; which are largely attributed to population growth, industrialisation and an increase in living standards. Bearing in mind that energy use in China and India is expected to more than double by 2030 (IEA, 2007); it is believed that the developing countries, particularly Asian ones, will be the largest future energy consumers. Apparently, such increased energy demands will have significant consequences for global supply security. It was estimated that in 2008 approximately 1.5 billion people (i.e. 22% of the world's population) lacked access to electricity (IEA, 2009). The vast majority of the generated electricity around the world is heavily reliant on burning fossil fuels (i.e. coal, oil, natural gas). These unsustainable energy sources not only increase atmospheric CO₂ concentration; but also produce other pollutants which react in the atmosphere with water, oxygen and other chemicals to form various acidic compounds (Douglas, 2002). Therefore, improvements in energy efficiency and the encouragement of the use of renewable energy sources are vital requirements (Alternative Energy Institute, 2005; United Nations, 2005).

Such concerns are particularly relevant for designers and architects because buildings are clearly amongst the major energy consumers and hence major contributors of both greenhouse gas emissions and acid rain formations. For instance, it is reported that whilst at least 40% of total European energy use is actually consumed in the construction industry (Anink et al., 1996), half of all CO₂ emitted in the UK is directly related to buildings (Graves and Phillipson, 2000). More recent data on the US construction industry indicates that not only do buildings consume 39% of total energy use and 72% of total electricity consumption, but they are also responsible for approximately 38% of all CO₂ emissions generated in the USA (Green Building Education Services, 2009). Considering worldwide final energy use, recent data affirms that the building sector accounts for 40%. It is

interesting to note here that energy efficiency in buildings is not something that has to wait for technological advancements. In other words, much of the potential for energy efficiency in buildings can be achieved through using technologies (including efficient household appliances) currently available on the market. It could, therefore, be argued that the strategic focus of the building sector in climate change mitigation cannot be underestimated (Dalhammar et al., 2009).

2.2.3 Other Factors

In addition to the previously mentioned ecological and energy-related issues, there are other pressing concerns that need to be addressed when designing buildings. For example, it appears that the problem of Sick Building Syndrome (SBS) - usually caused by flaws in heating, ventilation, air conditioning (HVAC) systems - has been severely underestimated (Bain and Baldry, 1995). According to the World Health Organisation (WHO), up to 30% of new and re-modelled buildings around the world suffer from SBS symptoms, which include headaches, dizziness, fatigue, and difficulties in concentration as well as eye, nose and throat irritation (Spengler et al., 2001). Moreover, as a result of modernising and urbanism, people in today's society apparently suffer from loneliness and a severe lack of common spaces where all residents can meet and socialise (Christain, 2007). It is no exaggeration to claim that sustainable architecture, which will be introduced in the next section, has the potential to address almost all of the above mentioned concerns in addition to improving the residents' quality of life and buildings' reparability, without compromising the aesthetic quality of the architect's work (Broadbent and Brebbia, 2006; Kibert, 2005; Low, 2005). Other drivers for sustainability include international regulations and agreements such as the Kyoto targets for reducing greenhouse gas emissions. Arising from the first Earth Summit was a concept called Local Agenda 21; with the number 21

referring to the 21st Century. It is often argued that this programme, which is run by the United Nations and related to sustainable development, is an idea that has not yet been fully exploited (Pitts, 2004).

2.3 The Concept of Sustainable Architecture

When we hear the verb “to sustain,” what first comes to mind is the meaning “to keep alive”. Hence sustainability seems to have been commonly understood as being mankind’s strong desire to survive and continue to exist through time; i.e. ‘being made to last’. According to the Oxford English Dictionary, one of the meanings of the verb “to sustain” is to keep something going over time or continuously; and the term “sustainability” refers to avoiding the depletion of natural resources in the industrial or development fields (Soanes, 2008). Based on probably the most quoted definition, sustainability is defined as meeting “the needs of present without compromising the ability of future generations to meet their own needs” (World Commission on Environment and Development, 1987: 8). It is noted, however, that this definition has attracted criticism on the part of several scholars, such as Brandon and Lombardi (2005), who argued that it is difficult, even today, to determine people’s needs. Hence, an attempt to forecast what they might be in the future is an almost impossible task. Edwards (1996) assures us that the concept of sustainability has evolved over time to an extent that “much of what the term conveys today is probably different from what it conveyed a decade ago” (pg.1). As Beatley and Manning (1997) put it “There is a general sense that sustainability is a good thing (and that being unsustainable is a bad thing), but will we know it when we see it?” (pg.3). Generally speaking, the definition provided by the World Commission on Environment and Development, despite its inadequacies, is most often considered as the most appropriate.

On the other hand, architecture has traditionally been associated with buildings that meet essential needs; the most basic of which is shelter (Moffett et al., 2004). It could be argued that the notion of sustainability is not something new in the field of architecture. Gibson et al. (2005) believe that sustainability is ancient, yet as a recent concept it was gradually neglected over the last few hundred years as a dominant concern due to technological progress and economic development. It has, however, become apparent from the literature review that there is no single agreed definition for the concept of sustainable architecture. Quite often, scholars have tended to demonstrate what sustainable architecture embodies as opposed to trying to define it. To some, sustainable buildings are narrowly misunderstood as being focused on just utilising renewable energy technologies. To others, sustainable architecture is considered to be nothing but a fashionable concept. On the other hand, some take a spiritual view and others regard the notion of sustainable design as a philosophical approach as opposed to a stylistic endeavour (e.g. see Glass, 2002; McLennan, 2004; Moore, 2001; Sustainable Buildings Industry Council, 2007).

Generally speaking, a broad indicator of sustainability is the 'triple bottom line', which was first coined by Elkington (1994) and later developed by several other scholars. The triple bottom line essentially refers to three aspects: economics, environmental and social responsibility. In effect, achieving sustainability requires striking a balance between environmental protection, social progress and economic growth (Glass, 2002). Thinking within the context of buildings, architectural professionals need to accept the fact that as the economic status of a society improves, demand for architectural resources (e.g. land, buildings, energy, etc.) will increase. The underlying goal of sustainable design is to find design solutions that achieve a compromise between economic, environmental and social aspects (Kim and Rigdon, 1998). For example, one could rightly argue it is better to use

brighter, compact fluorescent light bulbs (CFLs) or light-emitting diodes (LEDs) instead of cheap conventional incandescent bulbs (which tend to be less energy efficient than CFLs and LEDs). Installing incandescent light bulbs may maximise the upfront profits for the building, but it would not contribute towards satisfying the triple bottom line of sustainability. In other words, despite the high capital costs of CFLs, they require less energy and do not need to be replaced as often as incandescent bulbs do. Moreover, the lower energy requirement will allow the local utility company to burn less fossil fuel, and thus generate less pollution (i.e. an environmental advantage). In terms of social aspects, not only do brighter light bulbs foster visual comfort which improves living and work environments, but the reduced pollution also creates more breathable and healthier air in the surrounding communities (Green Building Education Services, 2009).

Another example is 'green roofing' which essentially refers to the partial or complete covering of the roof of a building with vegetation and a growing medium, planted over a waterproof membrane (Werthmann, 2007). Benefits of green roofing include the reduction of the building's energy consumption through improving the roof's thermal insulation, decreasing the heat island effect¹, delaying and reducing the volume of storm water runoff, increasing the lifespan of roofing membranes, mitigating air and noise pollution, improving aesthetic values, enhancing biodiversity and providing habitats for plants, insects and birds; all of which contribute to the ultimate goal of achieving sustainable development. On the other hand, the main disadvantage of green roofs appears to be their high initial cost – and high maintenance requirements for some types – but it is widely acknowledged around the world that carefully designed green roofs will eventually pay for

¹ The process of urbanisation has resulted in population concentrations in cities. Structures in urban areas tend to trap heat, resulting in higher local temperatures in a process called the 'heat island effect'. This causes urban air in metropolitan areas to be around 1-6 °C warmer than in surrounding rural regions. Mitigation of such a phenomenon can usually be achieved through the use of green roofing as well as light-coloured surfaces, which reflect more sunlight and absorb less heat, in urban areas (Silver, 2008).

themselves within a relatively short period of time (Getter and Rowe, 2006). The concept of green roofing has recently been proposed in the United Arab Emirates (UAE), which is a neighbouring country to Saudi Arabia, as a means of energy conservation in its residential sector (Dubai Municipality, 2010). In response to some protests from homeowners concerning cost-related factors, the Director General of the Dubai Municipality argued that not only would green roofing keep household energy costs down over the long run, but it should also be noted that the average house – which typically has air conditioning units running round the clock – produces 10 to 20 gallons of water per day, which could be used for irrigating the plants. According to some preliminary studies, the capital cost of installing a green roof for an average UAE house is estimated to be around US\$800, which is seen as a small upfront cost when bearing in mind all the benefits associated with green roofing (Al-Lawati, 2009). The attractiveness of green roofing can be easily justified if the triple bottom line is universally adopted as a means to make design decisions.

Yet, it is often argued that the pluralism of sustainable architecture (s) constitutes a perceived obstacle for anyone wishing to standardise a set of best practices (Guy and More, 2005). Cook and Golton (1994) thus argued that the concept of sustainable architecture is socially constructed and should be treated in a “relative” rather than an “absolute” sense. Whilst there are no consistent sets of principles that define the ‘concept’ – or probably better the ‘discourse’ (Moore, 2006) – of sustainable architecture, it might be worthwhile to review some of the previous attempts to explain what this concept entails for building design. In terms of sustainable building design, Kim and Rigdon (1998) proposed a conceptual framework that is comprised of three main principles. Firstly, ‘Economy of Resources’ focuses on conservation of the energy, water and materials needed to construct

a building. Secondly, 'Lifecycle Design' – i.e. a 'cradle-to-grave' approach – emphasises the need to consider the pre-building, building and post-building phases of a building project. The third principle, 'Humane Design', is much more in line with the guidelines provided by Beer (1990) including the need for designs that promote human comforts whilst minimising the impact of a building on a local ecosystem, urban design and site planning. In another notable endeavour, the Department for the Environment, Food and Rural Affairs 'DEFRA' (2006) put forward a set of key features that explain what makes a building sustainable (see Figure 2.5).

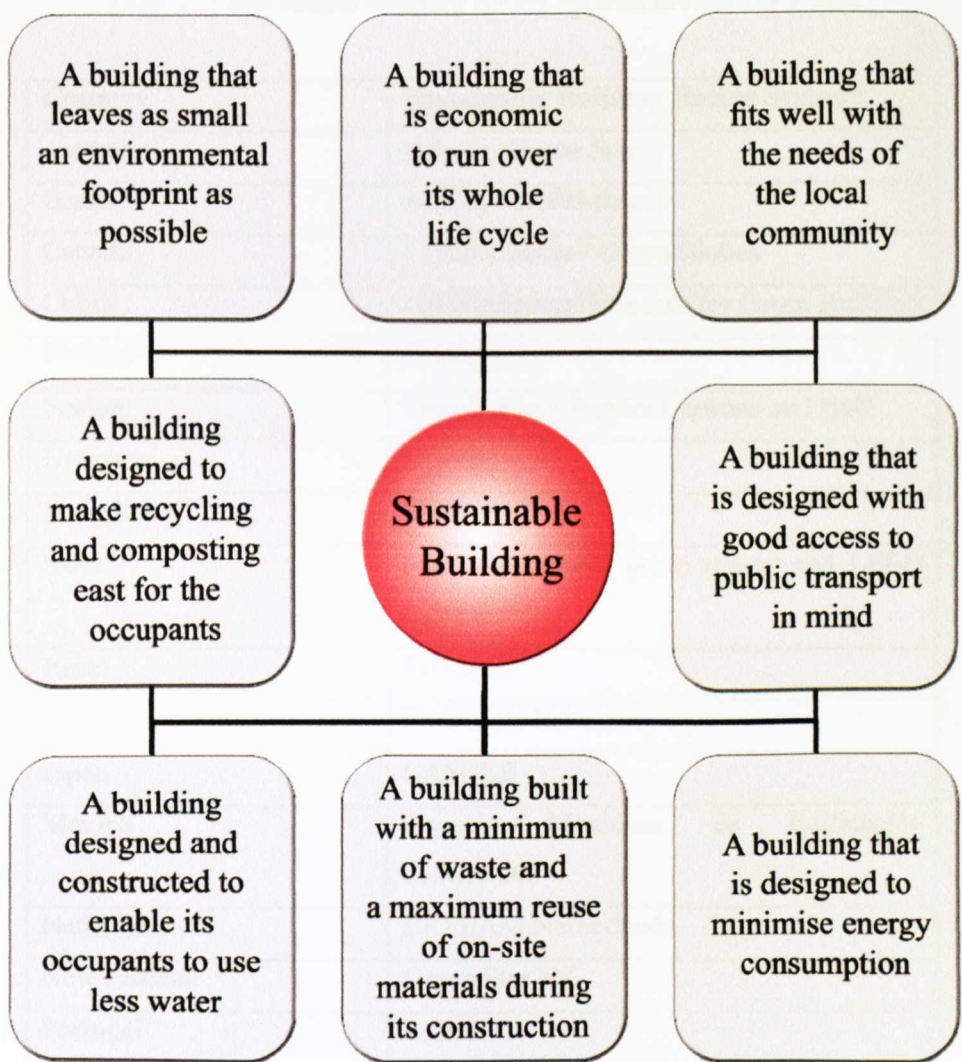


Figure 2.5: What Makes a Building Sustainable (Based on DEFRA, 2009)

A number of sustainable building rating systems, (sometimes referred to as sustainability assessment tools), have been developed around the world. Whilst BREEAM (in the UK) and LEED (in the USA) seems to be the most well-known and perhaps most comprehensive and widely used assessment tools, Table 2.1 lists a number of rating systems currently in place around the world. In effect, such national sustainable building rating systems aim to define ‘sustainable building’ by establishing a set of measurement standards for environmentally sustainable design, construction and operation of buildings and neighbourhoods.

Table 2.1: Sustainable Building Rating Systems around the World

| Country | Sustainable Building Rating Systems |
|----------------|---|
| Australia | Nabers / Green Star |
| Brazil | AQUA / LEED Brasil |
| Canada | LEED Canada / Green Globes |
| China | GB Evaluation Standard for Green Building |
| Finland | PromisE |
| France | Care & Bio, Chantier Carbone and HQE |
| Germany | DGNB |
| Hong Kong | HKBEAM |
| India | GRIHA (national green rating) and LEED India |
| Israel | SI-5281 |
| Italy | Protocollo Itaca |
| Japan | CASBEE |
| Mexico | Consejo Mexicano de Edificación Sustentable |
| Netherlands | BREEAM Netherlands |
| New Zealand | Green Star NZ |
| Portugal | LiderA |
| Singapore | Green Mark and Construction Quality Assessment System (CONQUAS à) |

| | |
|---------------------|---------------------------------|
| South Africa | Green Star SA |
| South Korea | Greening Building System |
| Spain | VERDE |
| Switzerland | Minergie |
| Taiwan | EEWH |
| UAE | Estidama |
| UK | BREEAM |
| USA | LEED / Green Globes |

Flynn (2001) and Ward (2004) suggest that the key to achieving a sustainable building is to consider its potential at a very early stage of the project (preferably at the pre-design stage). More specifically, it is argued that the architect should engage with the client, right at the beginning of the design discussion, to explore energy and environment-related issues related to the building project. At that juncture, key sustainability issues can be addressed in the project more simply; and perhaps in the most cost-effective way. As a matter of fact, one of the main aims of the LEED rating system is to promote integrated and whole-building design practices, as opposed to the traditional way of viewing planning, the design process and building systems as separate elements. In the conventional building process, specialists usually work in isolation, focusing on their specific area of project expertise and interact together only when absolutely necessary. LEED, however, encourages collaboration among key stakeholders and design professionals from project conception to completion (US Green Building Council, 2009). This is commonly referred to as integrated project delivery (IPD), and it has been defined by the American Institute of Architects (AIA) as "...[A] project delivery approach that integrates people, systems, business structures and practices into a process that collaboratively harnesses the talents and insights of all participants to optimize project results, increase value to the owner, reduce waste, and maximize efficiency through all phases of design, fabrication, and construction" (pg. 1). Principles of IPD include early goal definition; intensified planning; open

communication; appropriate technology; organisation and leadership; mutual respect and trust; mutual benefit and reward; collaborative innovation and decision making; early involvement of key participants (AIA, 2007). Nevertheless, a lack of commitment to the sustainability agenda is usually reported, and is often that this is mainly due to a lack of familiarity with the underlying principles of sustainable architecture amongst architects (Ibrahim and Abbas, 2001; Steele, 1997). Apparently, there seem to be a considerable number of constraints, priorities and complexities associated with the application of the concept of sustainable buildings that need careful consideration (see Table 2.2).

Table 2.2: Examples of Constraints, Priorities and Complexities in Sustainability

(Source: Yang et al., 2005)

| Constraints | Potential priorities | Typical complexities |
|-----------------------------|---|---|
| Resources Depletion | <ul style="list-style-type: none"> • Reduction of energy consumption during construction and use • Conservation of water resources • Deployment of alternative materials | <ul style="list-style-type: none"> • Lack of awareness and sharing of knowledge and experiences among professionals and tradespeople • Incompatible methods of procurement and construction • Inefficiency in process modelling |
| Financial Targets | <ul style="list-style-type: none"> • Lean construction • Target setting, information sharing and benchmarking • Technological innovation | <ul style="list-style-type: none"> • Dependency on multi-level coordination, and government incentives • The conservative nature of the construction business • Inability to assess and handle risks • Input/Benefit analysis |
| Environmental Damage | <ul style="list-style-type: none"> • Design for minimum waste • Reduction in construction | <ul style="list-style-type: none"> • Deficiency in comprehending natural systems and phenomena • Inability of design tools |

| | | |
|--|---|---|
| | <p>waste and usage waste</p> <ul style="list-style-type: none"> • Minimisation of pollution through efficient operation • Maintenance and improvement of biodiversity | <ul style="list-style-type: none"> • Consumer habits • Legislation and governance • General public awareness |
| Social Context and Political Stance | <ul style="list-style-type: none"> • Respect for people and nature • Health and safety principles • Legislation and codes • Implementation and incentives • Education of professionals and community | <ul style="list-style-type: none"> • Lack of competence in managing the process of changing attitudes of people and institutions • Lack of appropriate education channels • Inability to establish “best practice” |

Finally, it should be mentioned that an inconsistency of using terminologies related to sustainable issues has been the cause for a considerable degree of confusion. For instance green, bio-climatic, ecological, low energy and self-sustaining are just a few of the terminologies that have been applied to buildings. The term ‘green architecture’ has long been associated with designing environmentally-friendly buildings (Wines, 2000); ‘bio-climatic architecture’ refers to the ability of building designs to adapt to local climatic conditions (Edwards, 1998); whilst the term ‘ecological architecture’ is mainly concerned with the harmonisation of buildings and nature (Broadbent and Brebbia, 2006; Steele, 2005). Many scholars argue that sustainable buildings relate to the notion of climate-responsive design, which essentially places an emphasis upon natural energy sources and systems with the aim of achieving building comfort through interactions between the dynamic conditions of the building’s environment. For example, it is often argued that the placement of a window in a sustainable building is of the greatest importance as it could

provide effective natural light, comfort cooling and ventilation (Hyde, 2000). For the purpose of this research – and as has already been tentatively adopted by a number of scholars (e.g. Johnson, 1993; Maiellaro, 2001; Zacharirah et al., 2002) – it is assumed that since there is not a great deal of difference between these somewhat overlapping terms, the term ‘sustainable architecture’ will encompass almost all of the above concepts.

Having introduced the notion of sustainable building, it appears that the broad premise of the sustainable design of buildings is to use as little energy as possible in both construction and use; whilst causing the least possible interruption to the environment (Thomas, 2006). In fact, this observation is also evident in most of the sustainable building assessment tools (mentioned earlier in Table 2.1). For example, energy-related improvements are awarded the most possible credits within BREEAM sustainability assessment schemes. Similarly, within the LEED credit rating systems, a category named ‘Energy and Atmosphere’ contains the most credits available. Nonetheless, all of the highlighted sustainable design principles should be applied holistically to the building as a whole, and over its lifetime, whilst taking into account a range of climatic, energy, environmental, social and economic issues.

To conclude this section, it is important to recognise that various attempts have been made to characterise the essence of sustainable architecture, yet they slightly differ depending on the authors’ background, perspectives, interests and scope of their studies. For instance, Foster et al. (2007) thoroughly argued, from an interior designer’s point of view, for the need to ‘green’ residential interiors in order to enhance comfort and ensure greater durability, less maintenance and lower utility bills. For the purpose of this thesis, and given the practical limitations associated with this academic undertaking, it was decided to make

the main focus on issues related to household energy and water (all of which is currently produced in Saudi Arabia through desalination as part of the power sector). However, other relevant aspects related to sustainable building will be touched upon throughout the thesis. With the absence of a universal set of principles for the concept of sustainable architecture, the subject might better be further illuminated by reviewing a range of residential buildings which are regarded as being sustainable buildings.

2.4 Application of Sustainable Architecture around the World

One of the most exciting aspects of today's movement towards sustainable architecture is the large diversity of exemplary projects that are emerging. It is also apparent that case studies are the most common methods used in previous studies for exploring the application of sustainable architecture (e.g. Heaton, 1995; Steele, 1997; Vale and Vale, 1991). Therefore, an intensive review of the literature was conducted to select a number of sustainable residential buildings in order to explore a wide range of issues that could make a building potentially sustainable. Ultimately, twelve building projects were selected which will be examined over the next few pages. The criteria for project selection included an emphasis on residential buildings in order to match the theme of this research. Furthermore, care was taken to not consider more than one project from any single country in order to provide an overview of sustainable projects in different parts – hence featuring different climatic features – of the world. Figure 2.6 illustrates the locations of the selected projects.

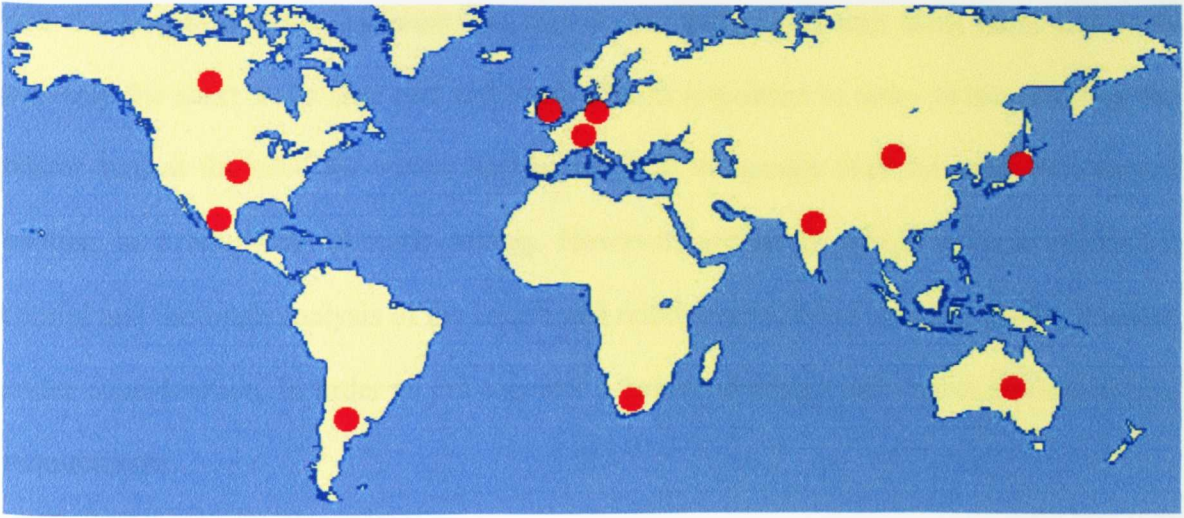


Figure 2.6: Geographical Locations of the Sustainable Residential Buildings Selected

In addition to discussing different sustainable features for each project, special care will be taken to highlight how the residential building has been designed in response to its climatic characteristics. Some locations, although belonging to the same climatic zone, have distinctive climate features that need to be addressed in sustainable building design. The following review starts by presenting the broad design guidelines that are usually recommended for a given climatic zone, and then discusses in more detail the location, climatic characteristics and design features of the individual case studies that are located in that climatic zone. It should be mentioned, however, that the longitude and latitude provided are for the centre of the project's city/town and not necessarily for the project itself. This information has been obtained from Google Earth, whilst climate-related information has been obtained from the Met Office (2011).

2.4.1 Case Studies in a Temperate Climate

The temperate climate zone is characterised by warm summers and cool winters. Therefore, the design of the building should provide a balanced response to such composite climatic conditions. It is, however, usually recommended that the building should be orientated

with the long axis in the east-west direction so that the longest wall faces north and south and only the short walls face east and west. This is important in order to benefit from the winter sun, as the need for winter heating tends to be greater than the need for summer cooling in a temperate climatic setting. However, architects should always conduct a careful and thorough analysis of the length and relative severity of seasons, for the location under consideration, in order to put together a balanced design that meets the conflicting requirements.

General design guidelines for a temperate climate include making use of shading arrangements, which in turn should be designed in a way they admit the heat of the sun when the winter sun is low on the horizon. In addition, it is recommended to have good insulation in order to both reduce the need for heating and enhance occupant comfort by keeping the indoor temperature more consistent. Internal heat storage capacity is also required to soak up heat during the day and re-radiate it at night. In addition, a house plan which allows cross-ventilation is advantageous, so that the house can be cooled down by opening windows during summer's nights. In this regard, a careful consideration of the windows' orientation, size and type is necessary. Moderately-sized and glazed openings could provide acceptable conditions for the major part of the year in temperate climatic conditions.

Case Study 1: Bariloche Ecohouse

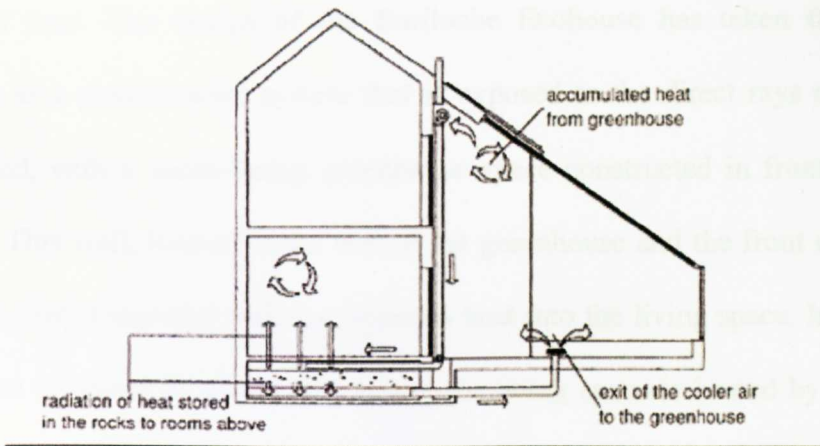


Figure 2.7: Bariloche Ecohouse: Picture and Cross Section (Roaf et al., 2007)

Geographical Location and Climatic Characteristics

This residential project is located in the Argentinean city of Bariloche (Longitude: $62^{\circ}14'$ W and Latitude: $35^{\circ}30'$ S). This area enjoys temperate mountain-type weather, although it belongs to the continental cold climatic zone with a dry season. In this area, day and night temperatures tend to be quite variable, independent of the season of the year. Precipitation occurs the whole year round in Bariloche, especially over the May-August period, during which precipitation totals over 150mm whereas the rest of the year accounts for less than 50mm. The strongest winds in Bariloche come from the west, especially in springtime and during the months of October and November. Summers are dry with temperatures reaching

32° Celsius during the day and dropping to 18° Celsius at night. Winters are usually humid and snowy, with temperatures averaging between 2 and 10° Celsius. Both spring and autumn are characterised by cold nights and day temperatures of between 5 and 20° Celsius.

Climate-Responsive Design Features of the Case Study

In such relatively cold, yet temperate, climatic conditions, it is often recommended to employ passive solar systems on the south-facing part of the house in order to trap solar radiation and heat. The design of the Bariloche Ecohouse has taken this point into consideration as a passive solar system that is exposed to the direct rays of the sun has been employed, with a south-facing greenhouse space constructed in front of a thermal storage wall. This wall, located at the rear of the greenhouse and the front of the primary structure, is a vented masonry wall that releases heat into the living space. In other words, the greenhouse is heated by direct gain whilst the living space is heated by indirect gain. The heat is then transferred, via pipes, to a rock-bed system, under the main living space using temperature-controlled fans. These rocks retain heat during the day and release it during cold nights in Bariloche. Cool air drops to the bottom of the rock-bed and is sent back to the sunspace (i.e. greenhouse) to create air movement in the house.

The orientation of this house was wisely chosen as it is situated along an east-west axis, thus maximising solar capture through south-facing glazing. This orientation is also advantageous for summer cooling purposes since it minimises exposure to morning and afternoon summer sunlight. The house also uses sun-shading devices to prevent the sunspace from heating-up during the summer. In addition, house openings have been designed and carefully allocated with the objective of maximising the admittance of heat

into the building and minimising heat loss. The latter objective has also been partly achieved by using thermal insulation materials in the construction of this house.

As a final note, bearing in mind the mountainous location, measures must be taken in order to provide shelter against wind. Besides the orientation-related considerations, wind-resistant doors and windows can be used to both protect against extreme wind loads and reduce the incidence of flying objects due to strong winds. There seems to be no published information about any design measures employed in this project to protect against wind coming from the west, but the trees planted around the house could act as a barrier.

Case Study 2: BowZED Tower Hamlets

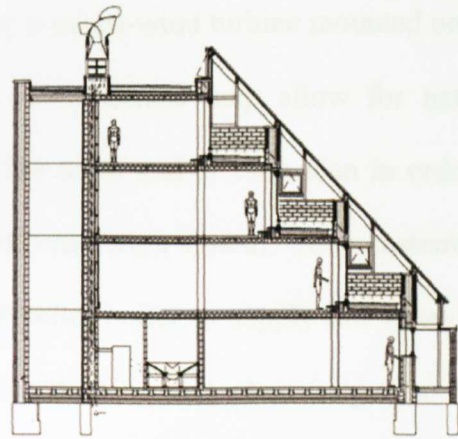


Figure 2.8: BowZED Tower Hamlets: Picture and Cross Section (Turrent, 2007)

Geographical Location and Climatic Characteristics

This residential project is located in London (Longitude: $0^{\circ}07'34.45''$ W and Latitude: $51^{\circ}30'00.55''$ N). London is situated in south-eastern England on the River Thames, and its overall climate is temperate – meaning that the city rarely sees extremely high or low temperatures. Generally speaking, the temperature does not get much lower than 0° Celsius

in winter and not much higher than 32° Celsius in the hottest summers. Winters in London are chilly, but rarely below freezing, whilst both spring and autumn are characterised by mild days and cool evenings. Rainfall is fairly regular throughout the year, but is most often in the form of drizzle. Overall rainfall is highest in November (64mm) and August (59mm), and is lowest in March and April (37mm each).

Climate-Responsive Design Features of the Case Study

The initial challenge that faced the architect of this project was how to provide solar access for a building, located in a north-south street, whose main elevations face east and west. This challenge was, however, overcome by stepping the southern elevation of the building to provide every floor with a south-facing glazed wall and a terrace. South-facing photovoltaic (PV) panels are sized to provide 50% of the household electrical demand, whilst the other half of the energy demand is met by a micro-wind turbine mounted on the stair tower. The building form, orientation and sunlit terrace help allow for natural ventilation. Kitchens and bathrooms are placed at the north end of each plan in order to facilitate connection to a wind-assisted passive stack ventilation system. Other sustainable features of the building include the use of a wood pellet boiler to supply hot water and back-up heating and rainwater harvesting for toilet flushing and plant irrigation. This project incorporates the use of super-insulated thermally massive masonry with precast concrete floor planks. External walls have a thickness of 0.5m and achieve a low U-value of 0.1 W/m²K. Bearing in mind that the U-value measures the rate of heat transfer through a building element, achieving U-values is considered to be a good insulation property. The windows are triple-glazed, with low-emissivity glass in order to reduce heat loss. The construction meets zero energy development (ZED) standards, which aim to achieve a 'zero heating requirement' in buildings.

Case Study 3: Gelsenkirchen Solar Housing Estates



Figure 2.9: Gelsenkirchen Solar Housing Estates: Picture and Site Plan

(Hastings and Wall, 2007)

Geographical Location and Climatic Characteristics

This residential compound project is located in Gelsenkirchen, Germany (Longitude: $7^{\circ}05'34.91''$ E and Latitude: $51^{\circ}30'41.52''$ N). In Germany, the climate varies considerably from east to west, with the western part being the most temperate area. Gelsenkirchen is situated in the north west of Germany and its temperate climate is affected by warm western winds from the North Sea, resulting in warm summers and drizzly winters. In general, Gelsenkirchen has a temperate climate with coldish winters and moderately warm summers, with an average yearly temperature of 9.6° Celsius and approximately 77cm of rainfall. The dominant winds come from the south and southeast, with velocities in the range of 3-4 m/s. Calm winds are evident about 35% of the time around the year, but more frequently at night and in the winter.

Climate-Responsive Design Features of the Case Study

The Gelsenkirchen Solar Housing Estates project features the attached houses theme. In the southern part of the compound, thirty-eight houses were built, twenty-two of which have a wooden structure. The northern part consists of thirty-three large houses that are orientated southwards. All of these houses make use of both active and passive solar energy use. PV elements are mounted not only on the roofs but are additionally integrated to act as sunshades for the south-facing windows in order to prevent summer-time overheating. Not only are the external walls of these houses efficiently insulated, but outside shutters are also installed for the purpose of controlling the amount of sunshine (and heat) coming inside the house during the summer. As a result of these energy-efficiency measures, household energy requirements have been cut by more than half when compared to a typical German house. Additionally, the pitched roof (shown in Figure 2.9) serves as wind protection and also sheds rain. Last, but certainly not least, the structure containing the houses enjoys a central ventilation system with efficient fans so that fresh air is admitted through an off-centre special opening in the façade.

Case Study 4: Vineyard Residence

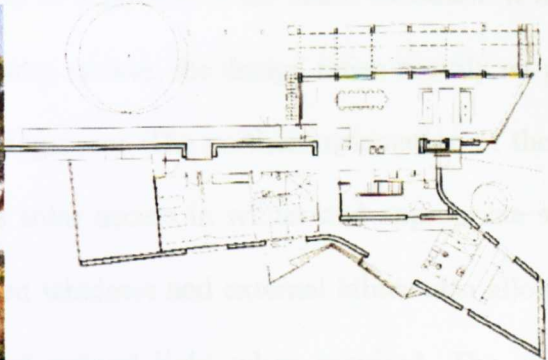
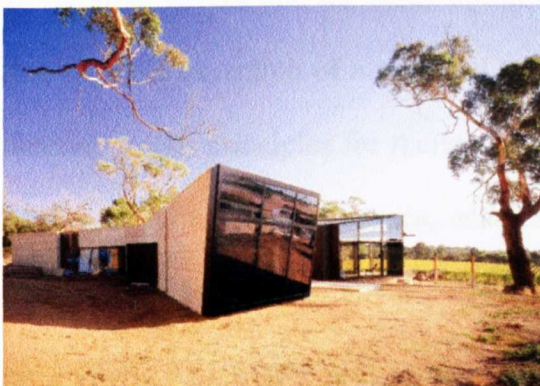


Figure 2.10: Vineyard Residence: Picture and Plan (Minke, 2006)

Geographical Location and Climatic Characteristics

This residential project is located on the Mornington Peninsula, south-east of Melbourne, Australia (Longitude: 144°50'18.83" E and Latitude: 38°24'01.57" S). This area enjoys a temperate climate with four distinct seasons, i.e. warm summers and cool winters, whilst spring and autumn is generally mild. The summer season (December to February) has an average temperature of 25.5° Celsius, but occasional heat waves can produce temperatures that exceed 40° Celsius. The average temperature during the winter (June to August) is around 14° Celsius, although it can fall below 4° Celsius. The wettest months of the year are usually October to December, but rain is fairly well spread throughout the year. Melbourne, which is only sixty miles away from the Mornington Peninsula, is known for having 'four seasons in one day'.

Climate-Responsive Design Features of the Case Study

This contemporary house is situated in a large vineyard and is built of rammed earth and exposed timbers, in an area where timber is considered a sustainable and renewable resource. The main bedroom, with its walls angling outwards, gives the impression of continuing into the landscape and hence creates visual harmony with the surrounding environment. The living area of this house extends out to the north terrace, the kitchen to an informal terrace and the study opens up to a garden on the south elevation. It is noted that with the exception of a gas-fired heating system, the design relies heavily on passive thermal design principles for thermal management. The northern orientation of the living area, with its continuous terrace, ensures solar access in winter and appropriate shading from the sun in summer. The use of glazed windows and external blinds also allows both the control of sunlight and enjoyment of natural light when required. The carefully-designed layout also facilitates cross-natural ventilation throughout the house especially in the summer.

Case Study 5: Soft and Hairy House

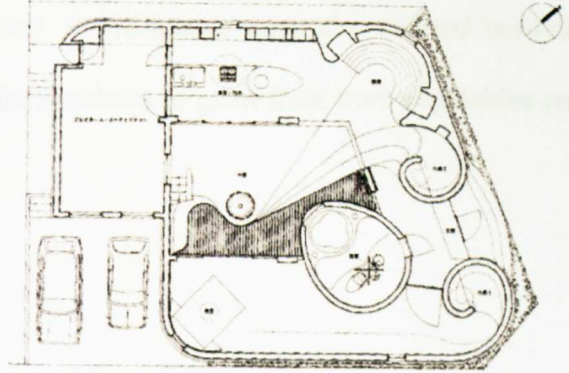


Figure 2.11: Soft and Hairy House: Picture and Plan (Wines, 2000)

Geographical Location and Climatic Characteristics

The residential project is located in Tsukuba, Japan (Longitude: $140^{\circ}05'52.62''$ E and Latitude: $36^{\circ}05'13.02''$ N). Tsukuba has a temperate climate with warm summers and cool winters. The hottest month is August, with an average day temperature of 28° Celsius and around 20° Celsius during the night. On the other hand, the coldest month is January, during which the day temperature is 8° Celsius on average, but goes down to around 0° Celsius at night. The number of snow days is approximately five days per year – mostly during January and February. There are about 190 rainy days a year, with the heaviest experienced in the months of April (78mm), July (73mm) and October (79mm).

Climate-Responsive Design Features of the Case Study

No detailed information seems to have been published in the literature about this particular project. However, it appears that careful consideration was placed to effectively utilising

natural light, partly by building the house so it folds around an inner courtyard in a way that also promotes excellent natural ventilation. Nonetheless, the most distinctive feature of this project is the employment of an extensive roof garden that resembles the wild and tangled original site. The vegetation (i.e. green roof) is beneficial in terms of improving both aesthetic values and the roof's thermal insulation (and hence control of interior temperature with minimal energy consumption). Some spaces were also created between the walls in order to provide the opportunity for residents to grow their own vegetables and herbs.

Case Study 6: Zero Energy Houses

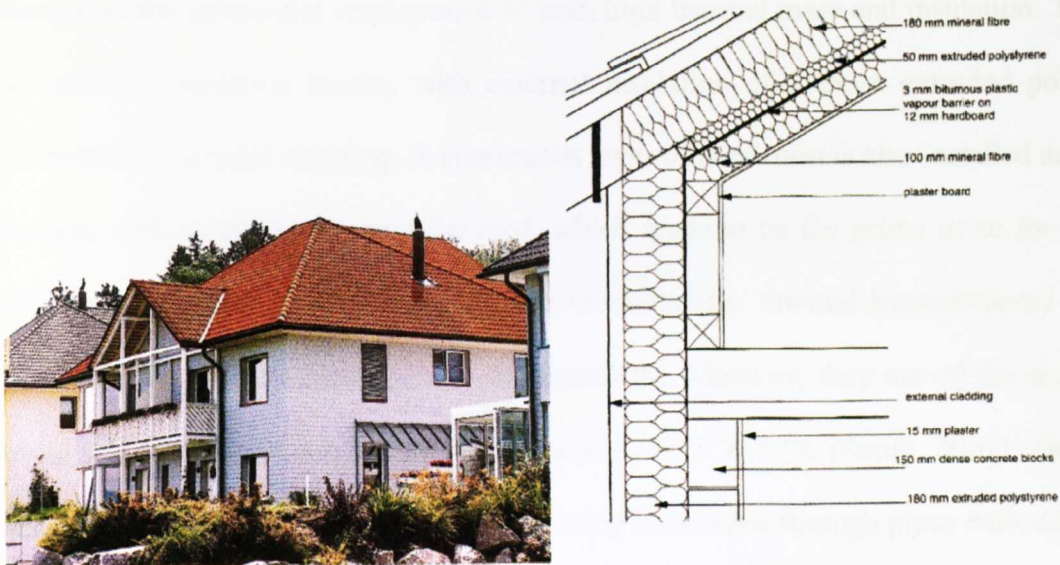


Figure 2.12: Zero Energy Houses: Picture and Construction Section (Smith and Pitts, 1997)

Geographical Location and Climatic Characteristics

This residential project is located in Wädenswil, Switzerland (Longitude: 8°40'16.81" E and Latitude: 47°13'42.68" N). Wädenswil, which is a municipality in the district of Horgen in the canton of Zurich, enjoys a temperate climate that rarely features severe

weather extremes. July tends to be hottest month, with an average day temperature of 22° Celsius and an average night temperature of around 13° Celsius. January is the coldest winter month during which the average recorded temperature ranges between -3 and 2° Celsius. The average temperatures during the spring and autumn range from 8 to 19° Celsius. Wädenswil has an average of 142 days of rain (totalling to 1,353 mm of precipitation) per year. The wettest month is usually August, during which it receives an average of 157mm of precipitation. However, the month with the most rainy days is May, with an average of around 14mm.

Climate-Responsive Design Features of the Case Study

The most distinctive feature of this case study, which is comprised of ten semi-detached houses, is the substantial employment of both high thermal mass and insulation. The walls are made of concrete blocks, with external insulation of 180mm extruded polystyrene protected by external cladding. A continuous layer of insulation is also installed around the houses, with an emphasis upon the roof, which tends to be the prime route for potential heat loss. As a result, the houses achieve U-values (i.e. thermal transmittance) of about 0.15 W/m²K for the opaque fabric. As regards the windows, they are of the argon-filled triple glazing type, which achieved a U-value of 0.85 W/m²K (Smith, 2001). The houses also have a solar heating system with heat being distributed through pipes embedded in the concrete floors. This is supplemented by a long-term heat storage facility and a propane-fuelled back-up heating unit.

Case Study 7: Lengau Lodge

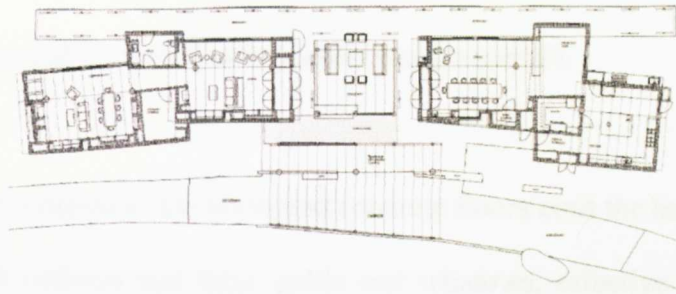


Figure 2.13: Lengau Lodge: Picture and Main Floor Plan (Trulove, 2006)

Geographical Location and Climatic Characteristics

This lodge consists of nine buildings located in Welgevonden, South Africa (Longitude: 27°51'47.16" E and Latitude: 27°13'22.87" S). The climate in this area is warm and temperate and characterised by three distinct seasons. The first (from May to July) is the dry season with an average temperature of 12° Celsius. The second (from August to October) witnesses temperatures starting to rise (up to an average of around 17° Celsius) and is considered a relatively dry climate, although occasional thunderstorms sometimes develop. The third (from November to April) spans the summer season, which is wet and humid, with an average temperature of 23° Celsius. Annual rainfall is estimated to be around 600 millimetres.

Climate-Responsive Design Features of the Case Study

This case study sits on a private South African wildlife reserve. Since this region suffers from periodic droughts, employing water conservation measures becomes a critical issue. In addition, the house is remotely located which means that all sewage and water reticulation has to be dealt with on site. All grey water, and even black water, produced at the lodge travels through a series of filters and is then used for irrigation purposes and to fill up a watering hole that attracts lions and rhinos among other wildlife. An arrangement is also made in order to collect rainwater and funnel it into landscape areas which contain native and drought-resistant plants. With regard to the construction materials, an emphasis has been placed on locally sourced and manufactured materials.

The buildings are orientated to the north and concrete floors emit the heat they store during the day. With high ceilings and large gable end windows, effective cross-ventilation is created. Large shutters are used for the gable windows in order to cut out sunlight if required, whilst still allowing the transmission of air. The masonry base and wood roof are separated by glazed windows which allow natural light to penetrate well into the rooms whereas the concrete floors are heated in the winter. This project also makes extensive use of natural grass around the house which works as a highly effective insulator. In addition, grass is planted on the roof of the north side verandas in order to shade and insulate the sunny side of the buildings.

2.4.2 Case Studies in a Cold Climate

Given a prevailing cold climate, care must be taken to both protect against cold winds and maximise solar gain. Here, site planning and orientation are of great importance because walls exposed to the sun and protected from cold winds can create warm pockets.

According to the Energy and Resources Institute (2004), it is usually recommended to orient buildings in cold climates with their long axes running in an east-west direction or to incline the axes 15-25° towards the south in order to ensure greater north and south exposure. Furthermore, an inadequate building layout can increase air speed causing excessive infiltration in winter and will probably lead to difficulties in utilising wind for natural ventilation. During the summer season, an effort should be made to make use of natural ventilation, where possible, in order to reduce total reliance upon air conditioning. Windows should be insulated (to reduce heat loss in winter and solar gain in summer), shade protected and fitted with shutters which can be used in winter whilst allowing for natural ventilation in summer. In general, both passive and active solar strategies are recommended for this climatic setting. Last, but certainly not least, it is recommended that construction materials with high thermal inertia are used, such as stones or bricks, to store internal heat gains and reduce indoor temperature fluctuations in comparison to outside temperature extremes.

Case Study 8: Great (Bamboo) Wall

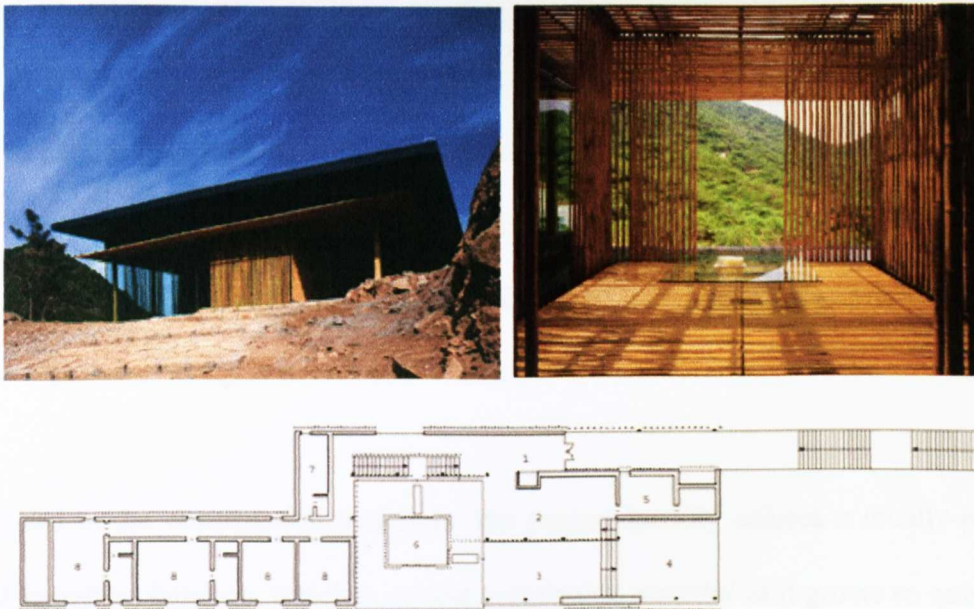


Figure 2.14: Great (Bamboo) Wall: Picture and Plan (Stang and Hawthorne, 2007)

Geographical Location and Climatic Characteristics

This residential project is located in a new development, north of Beijing, named the Commune situated by the Great Wall in China (Longitude: 116°02'48.82" E and Latitude: 40°20'14.01" N). Beijing has a climate of cold and dry winters, especially in January, with an average temperature of -4.6° Celsius. The cold and dry winters are largely due to the Siberian air masses that move southward across the Mongolian Plateau. Winter is the longest season in Beijing (it begins towards the end of October) whilst summer is the shortest (lasting from June to August). The latter is characterised by a hot and humid climate, with an average relative humidity of 78% and average temperatures of around 28° Celsius in July. The wind has significant seasonable variations, with prevailing northwesterly winds in winter and a prevailing southeasterly wind in the summer.

Climate-Responsive Design Features of the Case Study

This project does not make use of sun shutters, but double-glazed glass was used in the east and south elevations as a passive strategy to trap solar heat and transfer it to internal spaces. This would, in turn, reduce heat loss and subsequently heating loads in winters. Here, it is worth mentioning that the site and orientation of this building have been wisely chosen to ensure maximum sun exposure throughout the year. The house is located on a sloping site that is shielded from winter winds by the surrounding rocks. In addition, the long south eastern elevation helps in maximising solar gain for space and water heating in winter, whilst minimising solar access in summer.

With regard to the construction materials, the project heavily utilises a locally-produced material known as bamboo, which is a most sustainable material as it grows so quickly that stocks can be replenished in an efficient manner. Bamboo works as a shading element in

the summer and allows light and wind to pass through. In addition, it is a flexible material that offers a variety of space partitioning methods. It has been used to enclose the stairwell and living spaces in an elegant fashion. The kitchen and dining room both have a bamboo-clad ceiling as well. Glass was used to obtain natural light and solar access during winter, which is the longest season at this location. Marble was used for the floors and the exteriors were partly made of concrete. Both of these materials have a high thermal mass (i.e. thermal inertia) property – i.e. a high capacity to store heat. Such materials store heat during the day and release it during the night when the temperature falls. In other words, they provide better indoor comfort through reducing the impact of outdoor temperature changes.

Case Study 9: Howard House

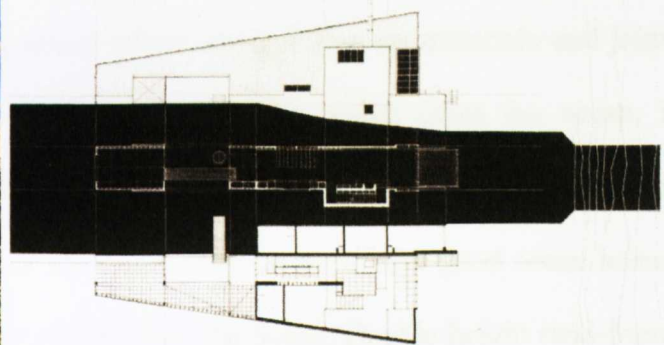
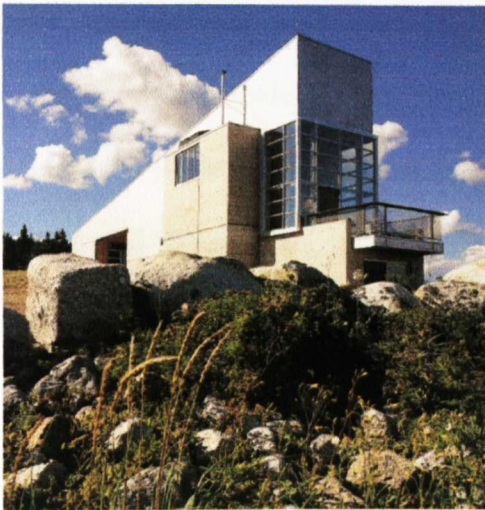


Figure 2.15: Howard House: Picture and Combined Elevation, Plan and Section

(Stang and Hawthorne, 2005)

Geographical Location and Climatic Characteristics

This residential project is located in the Canadian province of Nova Scotia (Longitude: 63°44'15.53" W and Latitude: 44°30'24.54" N). Despite the fact that the province is

surrounded by water, its climate is closer to a continental than a maritime climate, but with temperature extremes being moderated by the ocean. However, winter is still often characterised by heavy ice build-up, with an average winter temperature of around -15° Celsius. The lowest temperature ever recorded at this area was -41° Celsius. January is usually the coldest month, whilst the warmest is July. During the summer, the average temperature is estimated to be around 14° Celsius. Since Nova Scotia is situated in the Atlantic Ocean, it is additionally prone to occasional tropical storms and hurricanes, especially in the summer and autumn, with annual rainfall of about 120 centimetres.

Climate-Responsive Design Features of the Case Study

The building is constructed with locally available materials with forms that respond to the complex climate of the site. For instance, the lack of overhangs reflects the constantly fluctuating temperatures in the area. The designer of the Howard House explained that with a rather unpredictable freeze-thaw cycle, overhangs could create leaks. The frequent freezing, expanding and then thawing action could wreak havoc on materials and joints (Stang and Hawthorne, 2005). The lengthy western side, which faces the ocean, is protected against prevailing winds with a concrete casement, whilst sturdy steel trusses help the rest of the house to manage the wind load. This house enjoys good ocean breeze ventilation, with glass walls that admits sunlight into the house. Double-height steel-frame windows are fitted in order to maximise solar gain in this rather cold climatic setting. The house also makes use of a variety of sustainable design features including passive solar collection, passive venting, in-floor radiant heating and carefully placed thermal massing throughout the building.

2.4.3 Case Studies in a Humid Subtropical Climate

This climate is considered to be one of the most difficult climates in which to achieve energy-efficient buildings, mainly due to the need for mechanical cooling during the hot summer months. Air conditioning is needed not only to deal with the high temperatures, but also to reduce the amount of moisture in the air and to prevent mildew and other inconveniences brought about by humidity. Nonetheless, the building needs to be designed in order to take an advantage of the comfortable temperatures offered by spring and autumns, during which windows should be opened and natural air circulation should take place (Mamontoff, 2009). Therefore, in this type of location, large openings are suggested in order to ensure cross-ventilation and air movement. It is also recommended that the longest dimension of the building be perpendicular to the direction of airflow to facilitate natural ventilation. In addition to the need for adequate shading on the southern side, shading devices on all other sides should be large enough to cut off diffused radiation, which in turn is prominent in this type of climate (Energy and Resources Institute, 2004).

Case Study 10: Robbs Run Residence



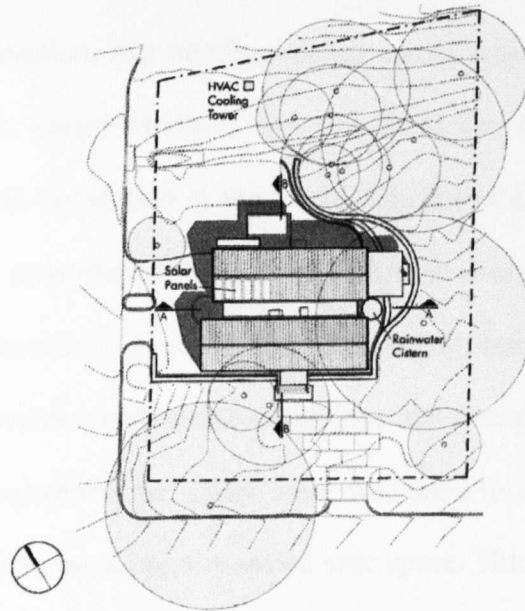


Figure 2.16: Robbs Run Residence: Picture and Site Plan (Trulove, 2006)

Geographical Location and Climatic Characteristics

This residential project is located in Austin – Texas, USA (Longitude: 97°44'42.75" W and Latitude: 30°16'07.45" N). Austin is alternately influenced by a continental regime, with southern and western winds, and a maritime regime with southeasterly winds from the Gulf of Mexico. Generally speaking, Austin has a humid subtropical climate, which features hot (humid) summers and mild (relatively dry) winters. The coldest month of the year is January, while the peak of summer is in July and August, during which the average temperature is 35° Celsius. Temperature variations between day and night tend to be moderate throughout the year. In addition, this location experiences sunshine for more than 200 days a year, with around 90 days below 7.2° Celsius, and about 850mm of rain per year (mostly in the spring).

Climate-Responsive Design Features of the Case Study

To start with, it should be noted that not only native plants with a low irrigation need were utilised for landscaping, but that also rain water harvesting technology was employed here.

The latter consists of a 4,500 litres gallon rainwater collection cistern. In order to address the hot climate of the location, this building makes use of a high-efficiency water-cooled air-conditioning system. Large windows are also fitted for the purpose of promoting natural ventilation and air circulation in the house. The use of natural light is achieved by dividing the compactly proportioned floor plan with a narrow glass slot along its central circulation spine. Furthermore, good insulation measures have been employed in this building in order to provide comfortable conditions for occupants throughout the year. More specifically, high-performance spray foam was used to insulate the entire exterior and envelopes of the house, including the sealed attic space. This building also made use of recycled construction materials from a pre-existing house. For example, stones were used to build the fireplace and the remaining walls, and 75% of the interior furniture was made from volatile organic compound (VOC)-free compressed wheat board.

Case Study 11: Farm House

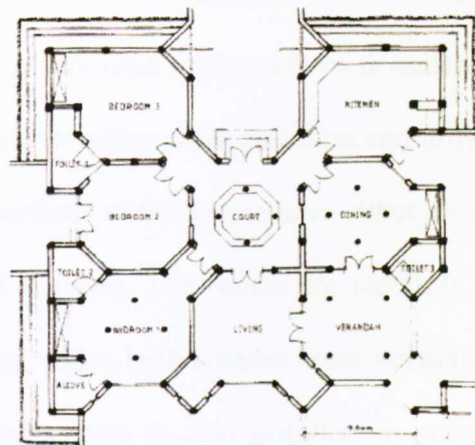


Figure 2.17: Farm House: Picture and Site Plan (Minke, 2006)

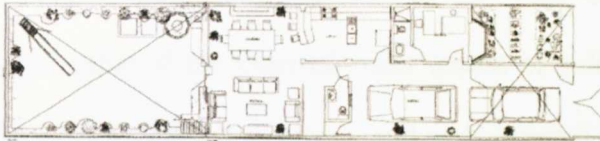
Geographical Location and Climatic Characteristics

This residential project is located in Wazirpur, India (Longitude: 28°41'42.98" N and Latitude: 77°09'42.67" E). The climate in Wazirpur is a monsoon-influenced humid subtropical climate with high variations between summer and winter in terms of both temperature and precipitation. In general, it has relatively dry winters and a prolonged spell of hot and humid summers. However, unlike a typical humid subtropical climate, this area features dust storms – similar to those experienced in a desert climate. The summer starts in early April, runs until September and peaks in May-June with an average temperature of around 32° Celsius. The winter is shorter than the summer and is characterised by foggy and chilly conditions. Winter starts in November and peaks in January with an average temperature of about 12° Celsius. Due to the area's proximity to the Himalayas, some cold waves can result in temperatures dropping below freezing. With regard to the monsoon period, that starts in late June and continues until September, with about 791mm of rain.

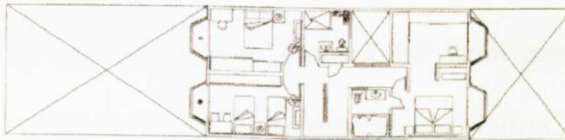
Climate-Responsive Design Features of the Case Study

This house has a single storey, which is mainly set into the earth towards the north of a nearby lake. Whilst the southern side of this house is exposed to the winter sun, it is shaded against summer sun by overhangs and louvers. With regard to the construction materials, the walls are made of sustainable and vernacular material (i.e. mud bricks) with good thermal mass properties. Light coloured stone roofs were built above the rooms not only to provide an air cavity, but also to reflect solar radiation and provide shade for the thin roof below. In fact, all external surfaces of this house have either air cavities or summer shading devices (i.e. overhangs and louvers). The rooms are carefully arranged around a central patio containing a small pool, which both enables cross ventilation and cools the rooms by evaporation. An earth tunnel system is also installed in order to provide an additional cooling system during hot and humid summers.

Case Study 12: Lindavista House



Ground Floor Plan



First Floor Plan

Figure 2.18: Lindavista House: Picture and Plans (Roaf et al., 2006)

Geographical Location and Climatic Characteristics

This residential project is located in Mexico City, Mexico (Longitude: $99^{\circ}00'30.31''$ W and Latitude: $19^{\circ}22'49.11''$ S). The city is surrounded by mountains and volcanoes with elevations of over 5,000 metres. Due to its tropical location and high elevation (over 2 kilometres above sea level), this city enjoys a subtropical 'highland' climate, which is characterised by a relatively mild climate all year. The average annual temperature only varies between 12 and 16° Celsius with the coldest months usually being January and February, which can witness temperatures as low as -5° Celsius. Afternoon rains come

usually during the summer months (i.e. June to September), whilst the driest months tend to be between October and May. The city receives approximately 820 millimetres of annual rainfall, mainly during the summer season when winds bring in tropical moisture from the sea.

Climate-Responsive Design Features of the Case Study

The orientation of this house is carefully selected in order to utilise daylight. Not only were energy-efficient lighting fixtures used, but also PV panels were installed in order to supplement artificial lighting. Proper insulation materials for external walls and roofs are used in order to reduce the loading and heating load for the building. According to Roaf et al. (2007), the reported U-value of the external walls (made of solid brick and plaster) is $1.8 \text{ W/m}^2\text{K}$, whilst the roof (made of concrete and polystyrene) has a U-value of $1.1 \text{ W/m}^2\text{K}$. Various measures have been taken in order to ensure proper natural ventilation in the house. For example, the openings are located 30° from prevailing winds, which has been proven to be the optimum position for better air circulation. In addition, the doors are fitted with operable louvers in order to control air movement through the house. These louvers are usually closed during the winter in order to reduce undesirable heat losses, whereas the building surfaces act essentially as 'heat sinks', providing comfortable temperatures the following day. Finally, bearing in mind the level of water scarcity in this region, a number of water-saving fixtures and measures have been employed in this house. For example, rain water (i.e. grey water) is collected, stored and used for various non-drinking purposes such as irrigation. Used water from kitchen and bathrooms (i.e. black water) is also recycled to the water closet tank.

Given the fact that the Kingdom of Saudi Arabia is a large country and that its climate differs significantly from one region to another, there is limited potential to draw specific lessons that could be applied to all Saudi dwellings. However, bearing in mind the prevailing hot and arid climate of the country, useful strategies include good thermal insulation in walls and roofs, natural ventilation, careful orientation of the building whilst making use of window glazing, shading arrangements, an energy-efficient HVAC system, solar-powered water heaters, green roofing and energy-efficient equipment and water-conservation measures. Before concluding this chapter, and moving on to examine the case of Saudi Arabia in more detail in the next chapter, the following section will highlight the rather limited application of sustainable architecture in the Middle East region.

2.5 A Glance into the Status of Sustainable Architecture in the Middle East

Asfour (2007) acknowledged the Egyptian, Hassan Fathy (1900-1989), as being the first architect in modern Middle Eastern history to have advocated sustainable standards in architecture. Fathy designed a large number of projects, both in and outside Egypt. One of his most known published works on this subject is a book named *Natural Energy and Vernacular Architecture* (Fathy, 1986). However, when searching for real-life applications of sustainable architecture in the Middle East, there is an obvious dearth. Reporting on some of the obstacles that impede the use of sustainable architecture in the Arab region, the League of Arab States (2005) referred to a lack of public awareness with regard to the necessity for environmental protection, as well as of the use of equipment and technology to achieve such protection. Another problem reported is apparent poor coordination between researchers and those working in the construction industry on issues particularly related to the sensible use of energy and building materials. Therefore, there is an urgent need to develop human resources in the field of sustainable building and construction

through the launch of public awareness campaigns, as well as through the incorporation of the subject of ‘sustainability’ into the curriculum at all academic levels, including university education and vocational training. In addition, given the ever-increasing demand on building materials and on energy use in particular, it is time to seriously consider developing and applying the use of sustainability tools into building projects, given that these are quite absent in the Middle East. As previously shown in Table 2.1, Israel & UAE are the only Middle Eastern countries that have developed their own sustainable building rating systems.

One example from the few sustainable residential buildings in the Middle East is that of Isaac Meir (see Figure 2.19). Among the sustainable features of the Meir House is the application of thermal mass, solar water heating, summer cooling and stack ventilation (Roaf et al., 2007).



Figure 2.19: Meir House (Source: Roaf et al., 2007)

At the centre of the Middle East region, there exists the Gulf Cooperation Council (GCC), comprised of the Kingdom of Saudi Arabia, the Kingdom of Bahrain, and also the states of Kuwait, Oman, Qatar and the UAE. Al-Hathloul (2004) noted that, over the last thirty

years or so, the oil-rich GCC countries have experienced an unprecedented construction boom that has led to a swift expansion in the size of cities as well as energy consumption per capita that currently exceeds most parts of the world. For instance, the work of AboulNaga and Elsheshtawy (2001), which examined the buildings of the UAE, reported that energy use per area in domestic buildings is relatively high when compared with comparable examples in Europe. Looking into the case of Bahrain, Alnaser and Flanagan (2007) maintained that the vast majority of Bahraini buildings currently lack sustainable measures. Although mainly focusing on the potential use of renewable energy sources in the GCC, other studies (e.g. Doukas et al., 2006; Patlitzianas et al., 2006) have therefore called for the need to formulate strategic policies on the rational use of energy in order to ensure the sustainability of future buildings and architecture.

Nevertheless, there seem to be a few emerging examples in the GCC countries that aim to apply the concept of sustainable building to some degree. For instance, the Kingdom of Bahrain has recently pioneered efforts in the region to integrate renewable energy technologies in buildings. For example, the US\$211m Green City Project is to be built at the Euro University in Bahrain, which aims to use solar photovoltaics to power some 10-20% of the campus (Alnaser and Flanagan, 2007).



Figure 2.20: The Green City at Euro University in Bahrain (Source: Egbert, 2005)

Another promising project is that of the Bahrain World Trade Centre, regarded as the first large-scale project to adopt an emphasis on balanced energy utilisation by including wind energy as a core source of power for the building. In this project, which was completed in 2008, three large wind turbines are strategically positioned at three different heights, in order to provide 11-15% of the towers' total electricity consumption (Bahrain World Trade Centre, 2010).

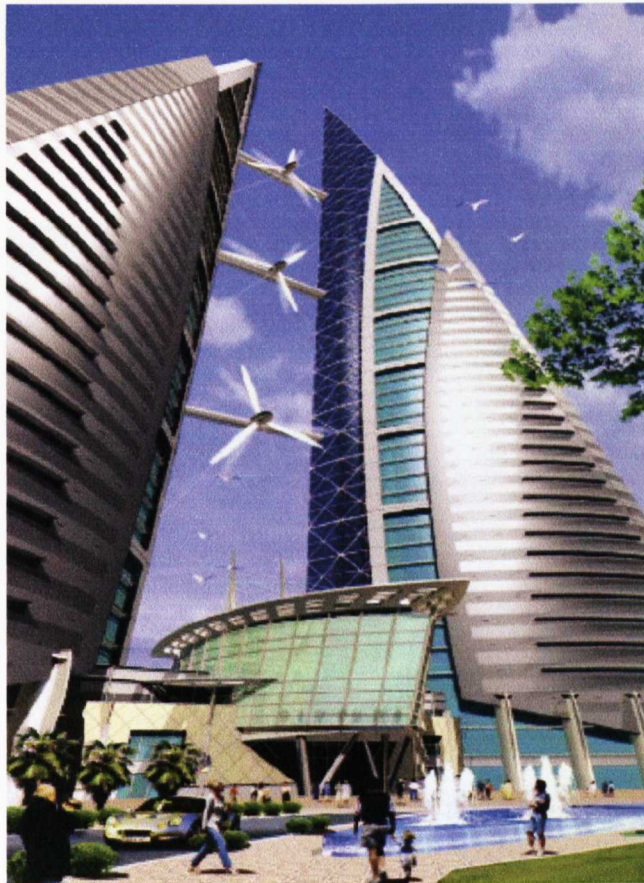


Figure 2.21: The Bahrain World Trade Centre

(Source: Bahrain World Trade Centre, 2010)

More recently, plans have been announced to construct a skyscraper – named ‘Burj Al Taqa’ which is an Arabic translation of ‘Energy Tower’ – in Dubai that will be the world’s

first skyscraper to generate 100% of its energy needs from wind and solar power. The energy will come from a 60-metre diameter roof-mounted wind turbine and 15,000 m² of photovoltaic solar panels. Another 17,000 m² of solar panels will be located on a nearby artificial island, visible from the tower. Excess electricity will be used to extract hydrogen from sea water, through electrolysis, in order to generate electricity at night via hydrogen-fuelled fuel cells (Renewable Energy UK, 2007). In this iconic building, natural light will be reflected in a cone shape throughout the building from mirrors on the roof, whilst the cylindrical shape of the building is designed to minimise exposure of the surface to the sun (Design Build Network, 2010).



Figure 2.22: 100% Renewable Energy Burj Al Taqa Skyscraper (Source: Iyer, 2007)

Apart from the obvious emphasis on renewables, whether these mega projects will truly incorporate other sustainable features is yet to be demonstrated. A review of the LEED projects directory indicates that a number of projects in the GCC region have recently been registered, but only fourteen projects (thirteen in Dubai and one in Saudi Arabia) have actually earned LEED Certification to date (US Green Building Council, 2010). Having discussed the status of sustainable buildings in the Middle East region with special reference to the GCC countries, the next chapter examines in more detail the case of Saudi Arabia.

Chapter 3

The Kingdom of Saudi Arabia: an Overview

3.1 Chapter Overview

The aim of this chapter is to examine, in detail, the case of Saudi Arabia through an extensive literature review. Brief background information is first given about the country including its significance and geographical location. Next, topographic features, climatic conditions and both traditional and contemporary architectural practices in Saudi Arabia are thoroughly assessed. Towards the end of this chapter, an effort is made to (i) justify the need for sustainable architectural practices within the Saudi residential sector; (ii) highlight potential barriers that may impede the realisation of sustainable houses in Saudi Arabia; (iii) review relevant sustainability-driven initiatives in the country.

3.2 Introducing Saudi Arabia

Saudi Arabia is a land of rapid economic, development and social change. The current population is 28.7 million (CIA, 2010), with a population growth rate of 4.1% per annum (UNDP, 2006). To begin with, it is worth highlighting that the Kingdom of Saudi Arabia holds a significant place among the countries of the world for at least two reasons. Firstly, Saudi Arabia holds around a quarter of the world's proven oil reserves. Oil was initially discovered in abundance in the country during the 1930s. Since then, Saudi Arabia has been a key oil exporter to the world. However, despite ongoing economic diversification, its economy is still heavily tied to oil sales (BP Amoco, 2008; Cordesman, 2003; Energy Information Administration, 2010; Facey, 1994). Secondly, Saudi Arabia has an undeniable religious significance for many Muslims around the world as the home of the two most holy mosques in Islam (Dew, 2003). For these reasons, Saudi Arabia is

considered by many to be a key country in the Middle East region with imperative political and economic roles.

Saudi Arabia is a vast country, with an estimated total land area of around 2,150,000 km²; i.e. approximately 830,120 square mile (CIA, 2010). It is located within the latitudes 16° N to 32° N. It occupies a central and strategic position in the Arabian Peninsula as it is bordered to the north by Jordan, Iraq and Kuwait and to the South by Yemen and Oman. To the west lies the Red Sea and on the east it is bounded by the Persian Gulf, Bahrain, Qatar and the UAE. The country is divided into thirteen provinces (see Figure 3.1).



Figure 3.1: Administrative Provinces of Saudi Arabia (Adapted from: Maps of World, 2009)

3.3 Topography and Landscape of Saudi Arabia

The vast land area of Saudi Arabia is characterised by varied topographical features (Figure 3.2). Generally speaking, however, it is a desert area with few green spots and no permanent bodies of water or main rivers. Its main topographical constituents are highlighted next:

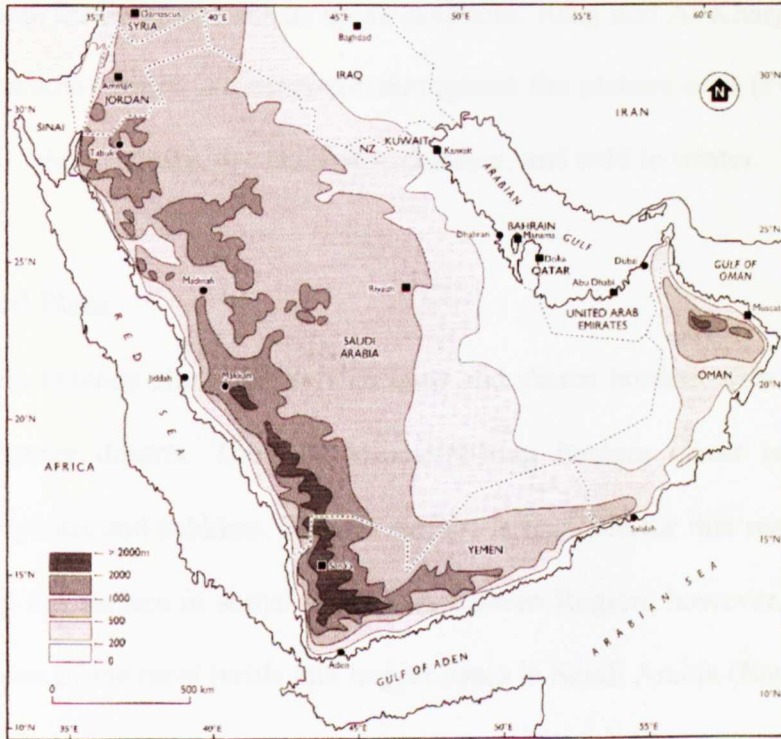


Figure 3.2: General Topographical Map of the Arabian Peninsula (Source: Vincent, 2008)

Sarawat Mountains and Tihamah

The Sarawat Mountains, or Sarat, form the longest strip of high country in Saudi Arabia. This mountainous chain extends parallel to the Red Sea coast, from Jordan in the north to Yemen in the South. The northern and central part of the Red Sea coast is known as Al-Hijaz, and the southern part as Asir. To the west of the Sarawat Mountains there exists a 1,100 kilometre-long coastal plain, known as Tihamah, which rises gradually from the sea to the mountains. Some parts of Sarat Al-Hijaz rise to around 2,000 metres, whilst Sarat Asir can reach heights above 3,300 metres (Peterson, 1993).

Najd Plateau

The Najd Plateau lies in the heart of the Arabian Peninsula, to the east of the Sarawat Mountains. It is also bounded by the Nefoud, Dahna and Empty Quarter deserts. Besides containing the Saudi capital city of Riyadh, this region includes the Tuwaig mountainous chain as well as the mountains of Jabal Shammar, Aja and Salma. In addition to the existence of some fertile lands such as those in Qasim, Aflaj and Al-Kharj, there are large salt marshes (sabkha) which are scattered throughout the plateau area (Federal Research Division, 2004). Najd is dusty, dry and hot in summer, and cold in winter.

Eastern Coastal Plain

This sandy plain extends along the Persian Gulf and shares borders with both the Dahna and Empty Quarter deserts. The 610 kilometre-long Eastern Coast is very irregular merging sandy plains and sabkhas. Its land surface is unstable for this reason, with water rising almost to the surface in some areas. This Eastern Region, however, houses the Al-Ahsa which is one of the most fertile and largest oases in Saudi Arabia (Barth, 2000).

The Empty Quarter

This large desert occupies approximately 650,000 km² of land surface (i.e. more than the combined area of France, Belgium and the Netherlands). The vast majority of this area is waterless and extremely uninhabited except for a few wandering Bedouin tribes at some of the outskirts of the desert (Cuddihy, 2001). The eastern region of the Empty Quarter has now been opened up by oil companies with a massive oilfield developed near the border with UAE (Vincent, 2008).

3.4 Climate of Saudi Arabia

The climate of Saudi Arabia can differ significantly from one part of the country to another. Since the Kingdom of Saudi Arabia is situated between sixteen and thirty two degrees of latitude north, it falls within the tropical zone. Hot temperatures are predominant in the long hot summer, whilst low temperatures are experienced during the short and cool winter. The month of March marks the start of summer and October or November sees the beginning of winter. The number of hours of sunshine that the country receives is very large; ranging from twelve to thirteen hours in summer to six to eight hours in winter (Al-Ansari et al., 1985). However, given the various topographic features of Saudi Arabia, the weather tends to differ in different areas of the Kingdom, whilst rainfall is – generally speaking – limited, uneven and unreliable.

A notable attempt to identify the different climatic zones of Saudi Arabia was undertaken by Al-Jerash in 1985. According to his classification, Saudi Arabia can be divided into six different zones: (A) Central; (B) Tihama; (C) Gulf coast; (D) Highlands; (E) South-West Highlands; and (F) Western slopes. These climatic zones are shown in Figure 3.3, whilst Table 3.1 illustrates some characteristics of each zone.

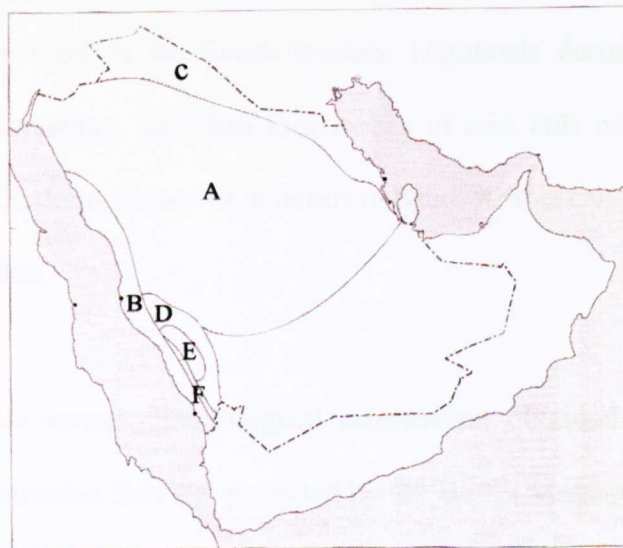


Figure 3.3: Climatic Zones of Saudi Arabia (Source: Al-Jerash, 1985)

Table 3.1: Characteristics of the Different Climatic Zones of Saudi Arabia

(Source: Al-Jerash, 1985)

| | Central | Tihama | Gulf Coast | Highlands | South- West Highlands | Western Slopes |
|-------------------------------|----------------|---------------|-------------------|------------------|--------------------------------------|---------------------------|
| | (A) | (B) | (C) | (D) | (E) | (F) |
| Average Annual Temp (°C) | 24 | 30 | 23 | 17 | 17 | 30 |
| Average January Temp (°C) | 13 | 24 | 12 | 15 | 11 | 26 |
| Average July Temp (°C) | 33 | 32 | 32 | 26 | 22 | 34 |
| Average Annual Rainfall (mm) | 95 | 110 | 91 | 210 | 539 | 352 |
| Average January Rainfall (mm) | 13 | 20 | 17 | 14 | 97 | 19 |
| Average July Rainfall (mm) | 0.4 | 8 | 0.1 | 15 | 27 | 56 |

With regard to rainfall, Saudi Arabia is considered to be one of the driest countries in the world. Whilst some parts of the country receive scant amounts of rain in winter and spring, rainfall is more significant in the South-Western Highlands during the summer. Janin (1995) noted that on average, less than four inches of rain falls on major cities such as Riyadh, Jeddah and Dhahran. However, a desert in Saudi Arabia can go without any rain at all for 10 years at a time.

With the aid of more recent climatological information obtained from datasets called 'World Weather Information Service' provided by the World Meteorological Organisation, Table 3.2 and Table 3.3 present total monthly rainfall and average temperature data for five

different Saudi cities (namely Riyadh, Jeddah, Dhahran, Khamis Mushait and Tabuk) that exhibit different topographic and climatic conditions. The population estimate of these cities (7.7, 3.6, 0.1, 1.8 and 0.4 millions respectively) indicates a comparative concentration in Riyadh and Jeddah, which are the two largest cities in Saudi Arabia. According to recent data, the current urban population of the country represents 82% of total population, with an annual growth rate of 2.5% (CIA, 2010). It is worth noting here that the Saudi capital city of Riyadh lies in the central part of the Kingdom (on the Najd Plateau), Jeddah is on the Western Coast (in the Hijaz region), Dhahran is on the Eastern Coast, Khamis Mushait is located in the South (part of the Asir region) and Tabuk is in the Northern Region. The traditional architectural features of these five regions will be examined later in this chapter. Table 3.2 below compares the mean total rainfall within the cities indicated above.

Table 3.2: Monthly Mean Total of Rainfall in Five Different Saudi Cities
(Source: World Weather Information Service, 2010)

| Month | Riyadh | Jeddah | Dhahran | Khamis Mushait | Tabuk |
|---------------------|-------------|-------------|--------------|----------------|-------------|
| | (mm) | (mm) | (mm) | (mm) | (mm) |
| January | 12.3 | 9.8 | 17.7 | 8.2 | 4.6 |
| February | 5.8 | 3.3 | 15.2 | 9.1 | 1.3 |
| March | 30.2 | 2.9 | 35.3 | 33.8 | 4.4 |
| April | 23.3 | 1.4 | 3.0 | 36.0 | 3.1 |
| May | 6.2 | 0.3 | 1.2 | 31.4 | 1.6 |
| June | 0.0 | 0.0 | 0.0 | 12.6 | 0.0 |
| July | 0.0 | 0.0 | 0.0 | 22.9 | 0.1 |
| August | 0.3 | 0.6 | 0.0 | 27.5 | 1.0 |
| September | 0.0 | 0.0 | 0.0 | 3.8 | 0.1 |
| October | 2.3 | 1.3 | 0.3 | 5.0 | 7.3 |
| November | 7.4 | 25.7 | 18.6 | 6.3 | 5.2 |
| December | 11.2 | 11.5 | 15.7 | 2.0 | 6.3 |
| Annual Total | 99.0 | 56.8 | 107.5 | 198.6 | 35.0 |

With regard to temperatures, Saudi Arabia is one of the few places in the world where temperatures above 48° C. are not unusual during the summer. However, given the higher altitudes in the south, temperatures are comparatively low and this results in a pleasant summer in the southern region. Frost and some freezing takes place some winters in the mountainous Asir region and the northern city of Tabuk. Such temperature variations are evident in Table 3.3.

Table 3.3: Average Minimum and Maximum Temperatures in Five Different Saudi Cities

(Source: World Weather Information Service, 2010)

| Month | Riyadh | | Jeddah | | Dhahran | | Khamis Mushait | | Tabuk | |
|-----------|--------|------|--------|------|---------|------|-------------------|------|-------|------|
| | ° C | | ° C | | ° C | | ° C | | ° C | |
| | MIN | MAX | MIN | MAX | MIN | MAX | MIN | MAX | MIN | MAX |
| January | 8.9 | 20.3 | 18.2 | 28.7 | 10.2 | 20.8 | 7.7 | 21.1 | 4.1 | 17.9 |
| February | 10.7 | 22.7 | 17.4 | 28.9 | 11.5 | 22.3 | 9.6 | 21.8 | 5.4 | 19.9 |
| March | 14.6 | 26.7 | 19.0 | 31.1 | 14.7 | 25.6 | 11.6 | 23.8 | 9.0 | 23.9 |
| April | 19.9 | 32.9 | 21.7 | 34.6 | 19.7 | 32.4 | 13.1 | 26.1 | 14.1 | 30.2 |
| May | 25.5 | 38.9 | 24.0 | 36.8 | 24.6 | 38.7 | 15.3 | 29.5 | 18.3 | 34.4 |
| June | 27.5 | 42.2 | 24.4 | 37.8 | 27.5 | 41.7 | 16.8 | 31.7 | 21.2 | 37.7 |
| July | 28.9 | 43.4 | 26.1 | 39.0 | 28.9 | 43.3 | 17.5 | 31.7 | 23.1 | 38.8 |
| August | 28.6 | 43.1 | 26.7 | 38.3 | 28.7 | 42.4 | 17.3 | 31.5 | 23.0 | 38.8 |
| September | 25.6 | 40.3 | 26.1 | 37.4 | 25.6 | 40.3 | 15.3 | 30.1 | 20.5 | 37.0 |
| October | 20.9 | 34.8 | 32.8 | 36.4 | 22.0 | 35.6 | 11.9 | 26.6 | 16.0 | 31.8 |
| November | 15.3 | 27.6 | 21.9 | 33.0 | 17.1 | 28.9 | 9.7 | 24.7 | 10.5 | 25.0 |
| December | 10.5 | 22.0 | 19.9 | 30.5 | 12.4 | 23.2 | 7.8 | 22.3 | 5.6 | 19.7 |

With regard to humidity, there seems to be no supporting climatic data in the literature available for the five Saudi cities selected. It is noted, however, that humidity is high on the western coast and mountains all year round; and it – generally speaking – decreases as we go inland. Moreover, there are winds that come from the north, in Arabic called *Shamal*,

that are famous for the sand storms they bring from the northern deserts. This wind comes alive in February and March, frequently whipping up sand-storms in its path. Occasionally, it can blow for a few days reducing visibility and causing discomfort before being cleansed by a rain storm (Rashid and Shaheen, 1995).

Having briefly introduced the geographical location and topographic features of Saudi Arabia as well as its mean climatic characteristics, the next two main sections will examine traditional and contemporary architectural practices in the country.

3.5 Traditional Architecture of Saudi Arabia

Although Saudi Arabia is a young nation (formally founded in September 1932), the Arabian Peninsula has an ancient history. There is a unique culture and tradition for every aspect of its people's lives. The traditional architecture of Saudi Arabia has been influenced by its cultural heritage, history, environment and climatic conditions.

3.5.1 Tents

In the Arab region, the tent is the traditional form of accommodation that has been used by tribal and nomadic people – commonly referred to as 'Bedouins' who raise camels and sheep, and are always on the move in search of water for their flocks and herds. The tent is the simplest dwelling in Saudi Arabia, and was common in some parts of the country even as recently as in the 1980s (Editors of Life-Time Books, 1985). Historically, tents were mostly made of black goats' hair, but nowadays different fabrics are used in their manufacture. It should be mentioned here that tents are climatically suited for the Arabian environment, as they protect people from the desert sun, dust and wind, whilst reducing the glare of sunlight and protecting them from cold (Drew, 1979). Figure 3.4 shows a simple type of Bedouin tent.



Figure 3.4: A Bedouin Tent (Source: Nizwa, 2006)

Nowadays, Hajj tents (Figure 3.5) are erected in order to provide temporary accommodation for pilgrims from all over the world during the Hajj period. They can be distinguished from Bedouin tents by their white colour. Hajj tents protect people from harsh sunlight and provide shade and insulation. Tents, in general, are simple forms of accommodation in a desert environment that provide the basic needs of shelter and privacy. However, they do not perform well in the rain nor can they cope with hazardous situations such as fires.

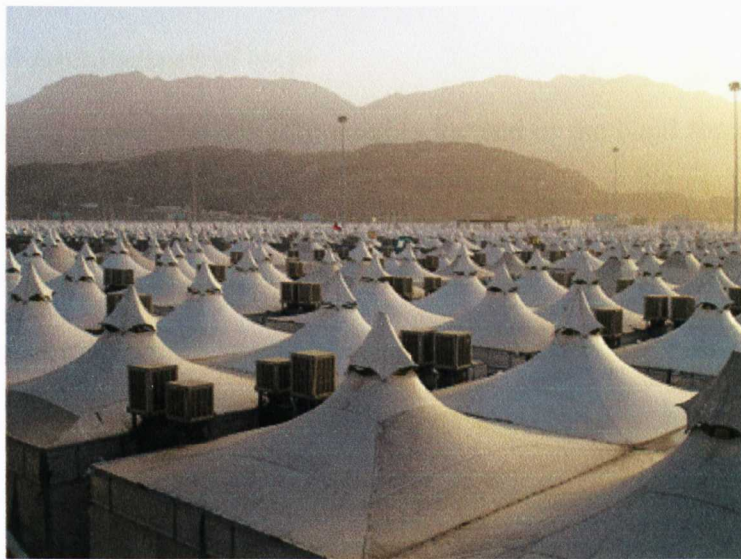


Figure 3.5: Hajj Tents (Source: Author)

In order to provide an overview of traditional architecture in Saudi Arabia, the following sub-sections present architectural examples from five regions; namely the central 'Najd' region, western 'Hijaz' region, eastern region, southern 'Asir' region and the northern region. Figure 3.6 exhibits a map illustrating the cities where these examples are located.



Figure 3.6: The Locations of Traditional Architectural Examples selected in Saudi Arabia

3.5.2 Traditional Architecture of Najd

Riyadh is the capital city of the Kingdom and is located in the Najd region. As previously mentioned Najd lies in the centre of the country and has a hot-dry climate. Traditional buildings in Najd use a number of local materials and building methods that aim to moderate such a hot climate. These include mud brick walls which help to maintain both a coolness of the inner rooms in the summer and warmth in the winter. It is worth mentioning here that mud and wood were available in abundance in Riyadh in the past, and were mostly locally obtained (Facey, 1997). Size was the main difference between palaces

and humble Najdi houses. Most traditional houses in Riyadh were characterised by a flat open space, with the separation of genders achieved by two individual entrances at opposite sides of the house. In addition, the houses were characterised by a courtyard in the centre of the house, acting as a ventilation shaft which provides both natural air and natural lighting. This also provides a safe play area for the family, especially for children under the supervision of their parents (Figure 3.7). Sometimes, a pool is found in the middle of the courtyard. The water from this pool evaporates and eases the hot weather by providing natural cooling. Figure 3.8 exemplifies the thermal system of a courtyard house in the Najdi architectural style.

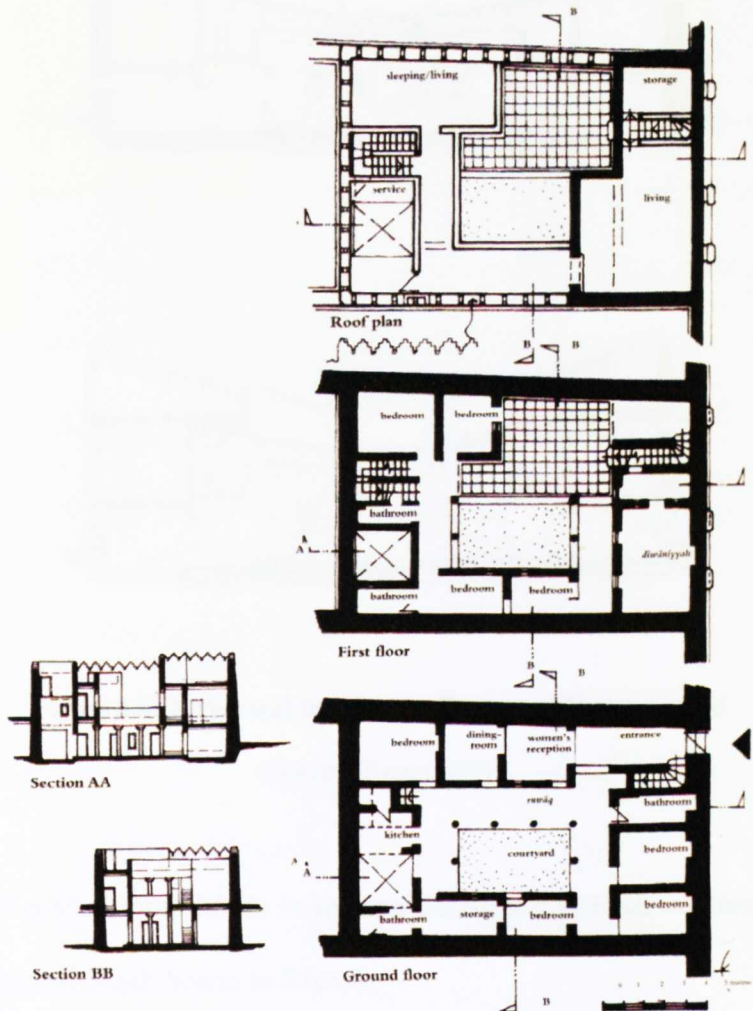


Figure 3.7: Typical Courtyard Houses in Najd (Source: Facey, 1997)

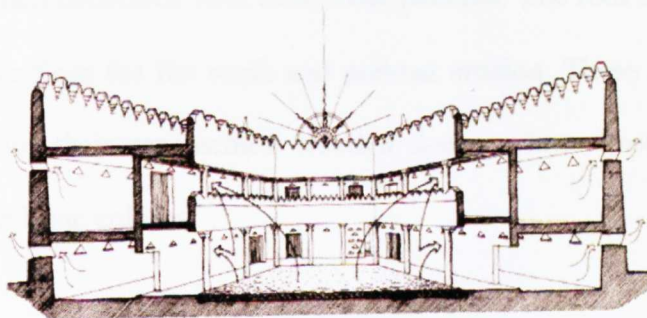
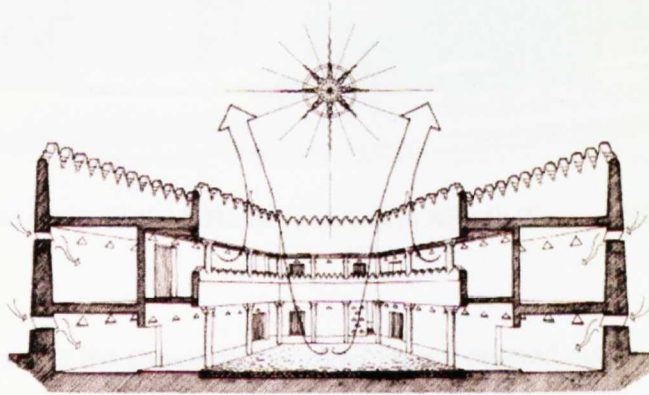
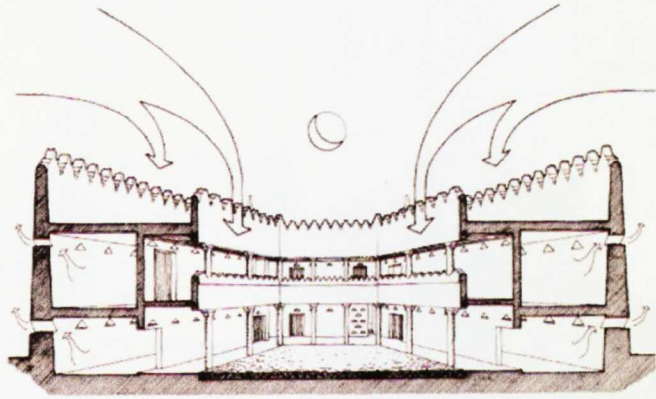


Figure 3.8: A Thermal System of a Courtyard House in Najd

(Source: Facey, 1997)

Figure 3.9 shows a traditional house in section during the process of demolition. It shows the design of a typical Najdi house in Riyadh.



Figure 3.9: A typical Najdi House in section in Riyadh (Source: King, 2005)

The photo also shows that the rooms in the upper storey opened out onto an interior terrace supported by columns of stone or palm tree trunks while the interior walls were stuccoed with unfired mud, often decorated with traditional patterns. The roof has metal drain pipes to carry off rainwater from the flat roofs and prevent erosion. These traditional houses in Najd were famous for their ornamented wooden doors, whose geometric designs were sometimes painted in basic colours.

Burayda is located to the north of Riyadh and is the capital of the Al-Qasim province in Najd. The traditional houses there were also characterised by the typical courtyard style found in Riyadh. Some of the walls were stone-built, and others have their building materials concealed by plaster. The roof and crenellations overlooking the courtyard of the house are shown in Figure 3.10.



Figure 3.10: A Roof Overlooking the Courtyard (Source: King, 1998)

Ha'il is an oasis and agricultural city in the north of the Najd region. Most of the traditional houses there have been demolished. Qasr Al-Qishla, built in 1943, is a surviving traditional palace in Ha'il. The main purpose of this castle/palace as a military base, but it was then subsequently turned into a prison for a period of time, and it is now a tourist attraction. This castle has eight watch-towers, with two main gates, the eastern and western gates. It has two floors of clay structure and is covered in mud plaster. The only ornament on the exterior is a single triangular motif and the walls have a row of crenellations along the top which have recently been painted white (see Figure 3.11).

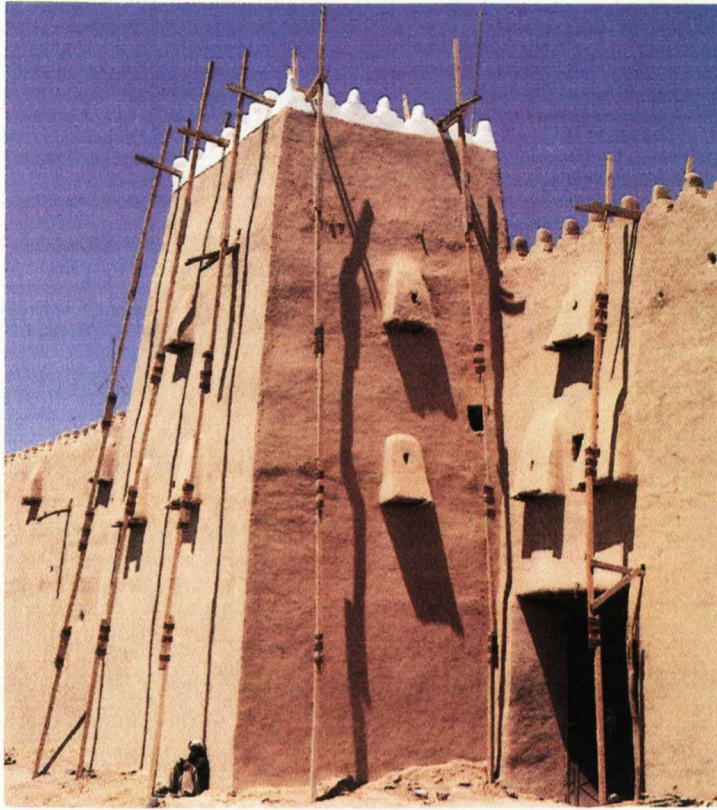


Figure 3.11: The Entrance of Qasr Al-Qishla in Ha'il (Source: King, 1998)

3.5.3 Traditional Architecture of Hijaz

Hijaz is in the western part of the Kingdom and contains a number of major cities including Jeddah, Yanbu, Makkah, Medina and Al-Taif. Traditional Hijazi houses usually consist of two to five stories made of coral rock or stone and reinforced by horizontal timbers. The traditional architecture of Hijaz reflects the influence of the Ottoman Empire, which controlled this region through much of its history. Thick layers of lime plaster are used in stuccoing both inside and out in Hijazi houses for the dual purposes of decoration and insulation. The main distinctive feature of the traditional Hijazi houses is *Roshan* - enclosed wooden balconies or windows that are decorated with ornamental carvings that sometimes extend over several stories. Al-Murahhem (2008) explains that 'Roshan' is an old term that has historically been used to describe a wooden projected window, which consists of horizontal and vertical wooden slats. She further notes that the word 'Roshan'

has now been replaced by many local terms around the Islamic world. For example, it is known as 'Mashrabiyyah' in Egypt and in some parts of Northern Africa.

Jeddah is a city located on the Red Sea and is of the utmost importance, being the commercial capital of Saudi Arabia. It is known as an enchanting old city, with a long history of being a crossroads for the meeting and interaction of people (including traders and pilgrims) from all over the world. Not only is Jeddah home to people of many diverse backgrounds, it is also the principal gateway to the holy cities of Makkah and Medina. Old Jeddah (shown in Figure 3.12) is a central point for the expansion of the city. Most of these old houses are now abandoned, demolished or, in some cases occupied by poor foreign workers.

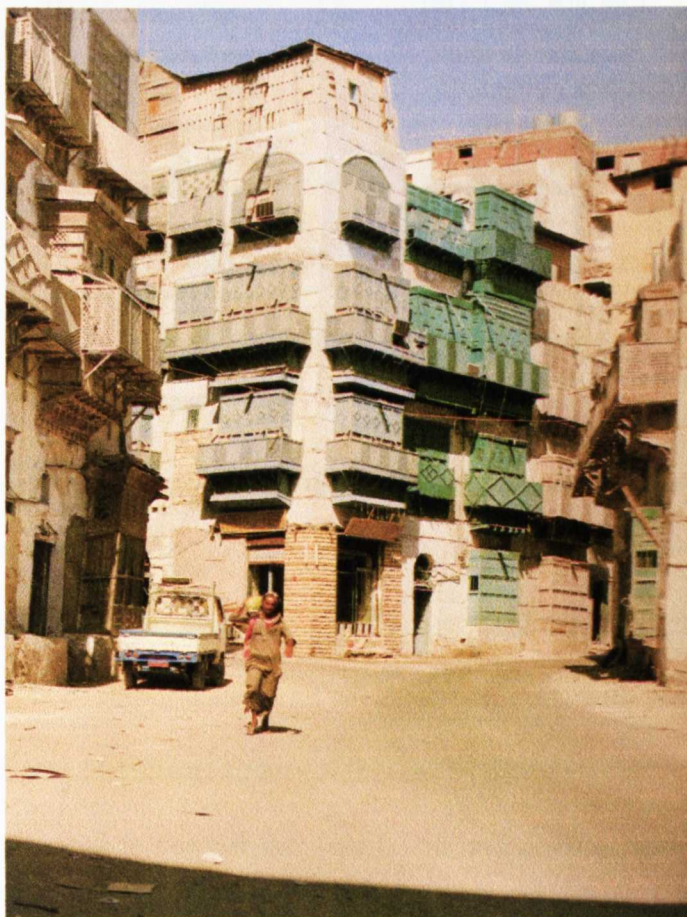


Figure 3.12: A View to Old Jeddah (Source: Buchan, 1991)

The house windows used to be orientated towards the north and west where they can obtain natural ventilation from the northern wind and western sea breezes. Most of the houses were built close to each other, creating narrow spaces and intimate neighbourhoods. The basic materials used for traditional houses in Jeddah are coral limestone and stone with mud mortar. Blocks of coral limestone were used to construct the walls. The external walls were reinforced by horizontal wooden beams called *Akalil*, placed equally at every five to six courses of coral stone. The floors used to be constructed of wooden beams on palm trunks. The Al Shafi'ay house (Figure 3.13) is a typical example of a Jeddah house.

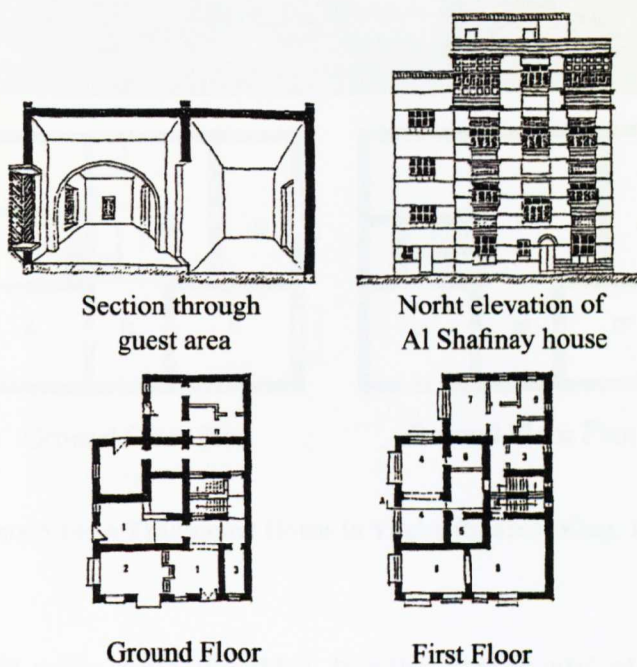


Figure 3.13: Al Shafi'ay House in Old Jeddah (Source: Al-Harbi, 1989)

Yanbu is a major port on the Red Sea and its history dates back at least 2,500 years. Nowadays, this city is of importance as an oil-exporting port, with petrochemical and oil-refinery facilities. Some traditional houses still stand in the town centre but they are largely neglected. *Roshan* is used to control the ventilation and natural light. Coral stones were used for building as well as mud bricks. Figure 3.14 shows an example of a traditional house in Yanbu.

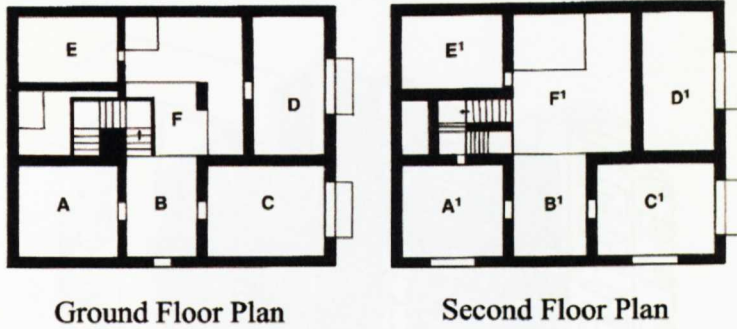


Figure 3.14: A Traditional House in Yanbu (Source: King, 1998)

Makkah is located 45 miles south of Jeddah. It is the ‘capital city’ of Islam because of the Grand Mosque, which is the focal centre of the city. Many houses are concentrated around the Mosque and along the roads and paths that lead to it. Whenever the Grand Mosque is undertaking expansion, many nearby houses are subject to demolition. Most traditional houses have already been demolished and replaced by high rise buildings, which are mostly luxury hotels for the pilgrims who come for Hajj every year. The surviving traditional houses are typically five to seven stories high (as shown in Figure 3.15) with wooden latticework on their facades and coloured brickwork around the terraces of the

upper stories. Stone, brick and wood were the three types of materials that were used to build the traditional houses of Makkah. Two kinds of woods were used: (i) locally produced palm and other trees for the ceiling or for reinforcing the stone walls; (ii) imported hardwood from Java or India for the doors and windows. The main factor determining the use of space in these houses is privacy. For instance, the ground or entrance floor is reserved for men. They enter through a doorway and steps into an entrance hall called a *dihliz*. One never risks meeting an unveiled woman there because the upper floors belong to the women, and a visitor cannot go upstairs without a guide (Uluengin and Uluengin, 1993).

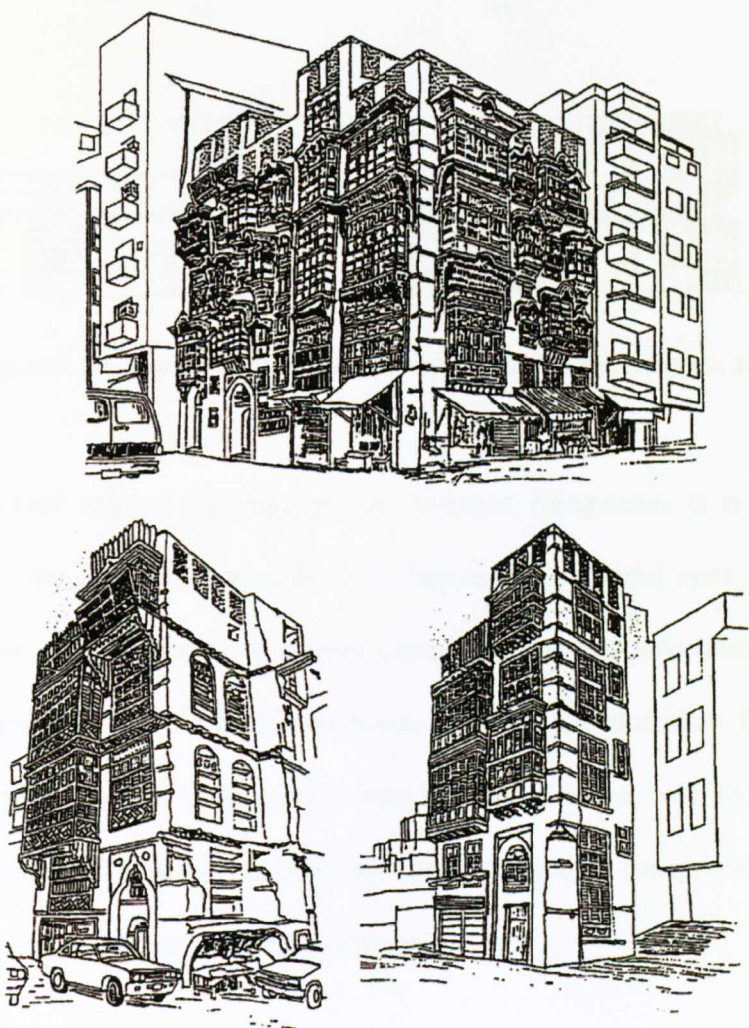


Figure 3.15: Sketches of Different Makkah Traditional Houses (Source: Fadan, 1983)

Medina is the second holiest city in Islam, and the burial place of Prophet Mohammed (peace be upon Him). Similarly to Makkah, the Prophet Mosque is the focal centre of the city and residential houses around it are packed into narrow winding streets which lead directly to the mosque. The typical traditional house of Medina (Figure 3.16) is an introverted house, with a front stairs and a rear lightwell, creating a reversed arrangement.

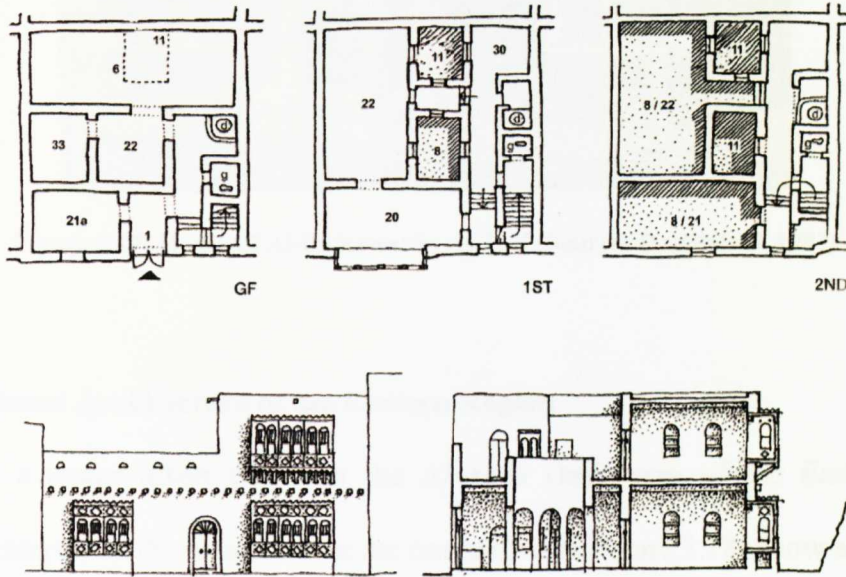


Figure 3.16: Typical Medina Traditional House (Source: Ragette, 2003)

The city of **Al-Taif** lies on the edge of the Al-Hijaz Mountains. It is one of the most historic cities in the Arabian Peninsula. It is famous as a tourist spot, especially in the summer, because it is blessed with a mild climate and green surroundings. Figure 3.17 shows a photograph of the Al-Baikawat house built by the Sharifian family during the Ottoman era. This house has three stories with wooden *Roshan*, with Ottoman ornaments representing the typical fine Hijazi building. The entrance is comprised of a number of columns and arches with some painted motifs on the top.



Figure 3.17: House of Al-Baikawat in Al-Taif (Source: Daghistani, 1981)

3.5.4 Traditional Architecture of the Eastern Region

Al-Hufuf is a major urban centre in the Al-Ahsa Oasis area of the Eastern Region. Surviving examples in the area (such as the one shown in Figure 3.18) show a similarity to both Najdi houses and those of the Persian Gulf coast, in terms of the arch forms, plaster decorations and woodwork.



Figure 3.18: An Example of Traditional Buildings in Al-Hufuf (Source: King, 1998)

Al-Qatif is a coastal oasis located in the eastern region of the Kingdom. Traditional houses there are characterised by typical close-knit settlements with shaded areas of narrow pathways. Some of the houses contain courtyards, and most of them have wind catchers. Thick mud walls and wooden framed mud roofs were used in order to increase the quality of the insulation. Some houses have terraces which occupants enjoy during the day, perhaps sleeping on them if the weather was suitable. Wooden shutters and palms (as shown Figure 3.19) were used for shade and for privacy.

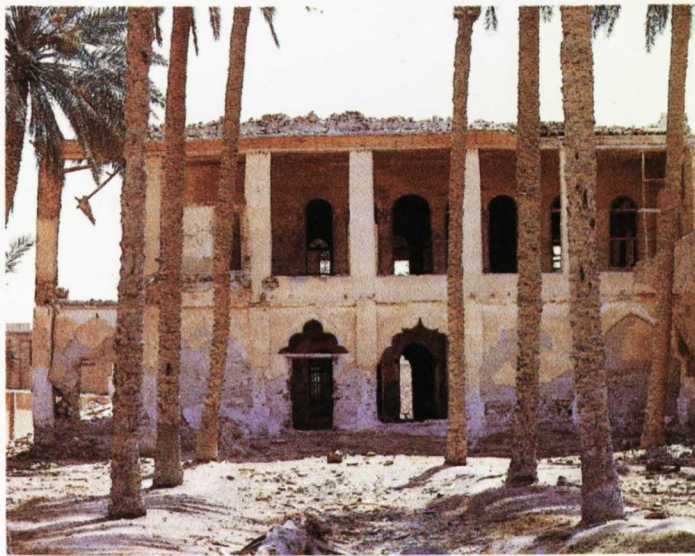


Figure 3.19: A Traditional House in Al-Qatif Before Demolition (Source: King, 1998)

3.5.5 Traditional Architecture of Asir

Asir stretches from the Southeast of Hijaz to the border with Yemen. Among the traditional building materials used for houses in Asir were stone, mud bricks and wood. Stone gathered from nearby hills was the basic local material used for building houses on the mountains, together with mud bricks because they help to store heat during the winter. Wood was used for the manufacture of doors, roof beams and for decorations. Tamarisk and palm trees were available locally. These houses could be found in the villages and towns on the escarpment ridges that descend to the Tihama Coastal Plain where the traditional architecture resembles coastal Hijaz.

Abha is the capital of Asir and a tourist city. Some of its traditional houses (Figure 3.20) are painted in bright colours with geometric designs and floral motifs – both on the outside and inside rooftops and on door and window frames as well.

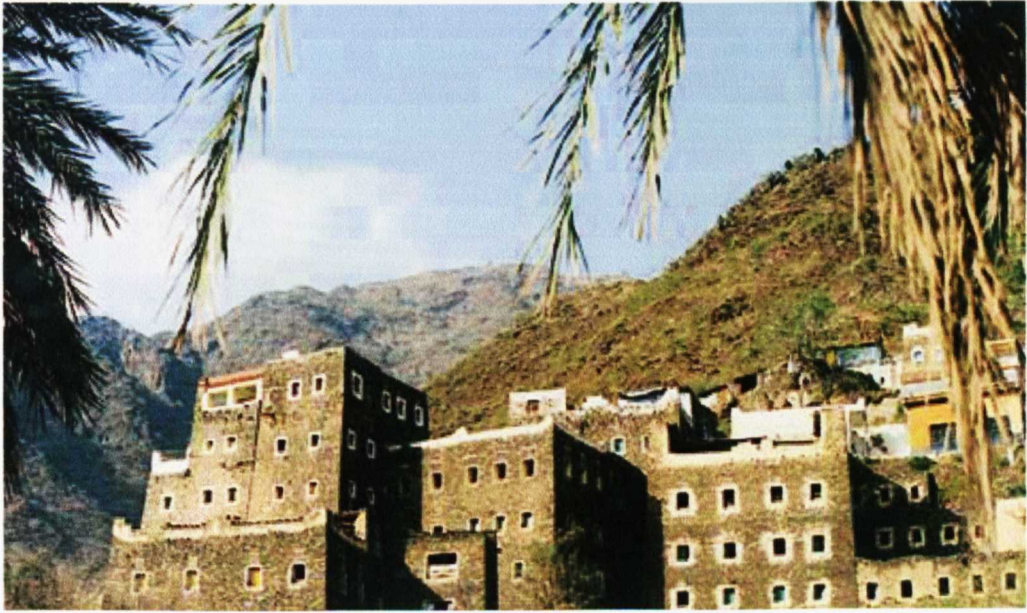


Figure 3.20: Traditional Houses in Abha (Source: Royal Embassy of Saudi Arabia, 1997)

Al-Baha is in the southwest of Saudi Arabia. It has traditional houses of two to four stories with high square towers called *husns*, in English ‘tower houses’ (Figure 3.21), which are massive structures that could be used to store grain, to afford protection against rain and for defence purposes. These constructions are usually 9x9x12 metres with high-ceilinged three storeys blocks. Stone is the main construction material for the ground floor, whilst cast mud with projection slates is used for constructing the upper floors (Ragette, 2003). These slates, which serve the purpose of protecting the walls from rain, are inserted into the mud walls so that the rain does not fall on the walls.

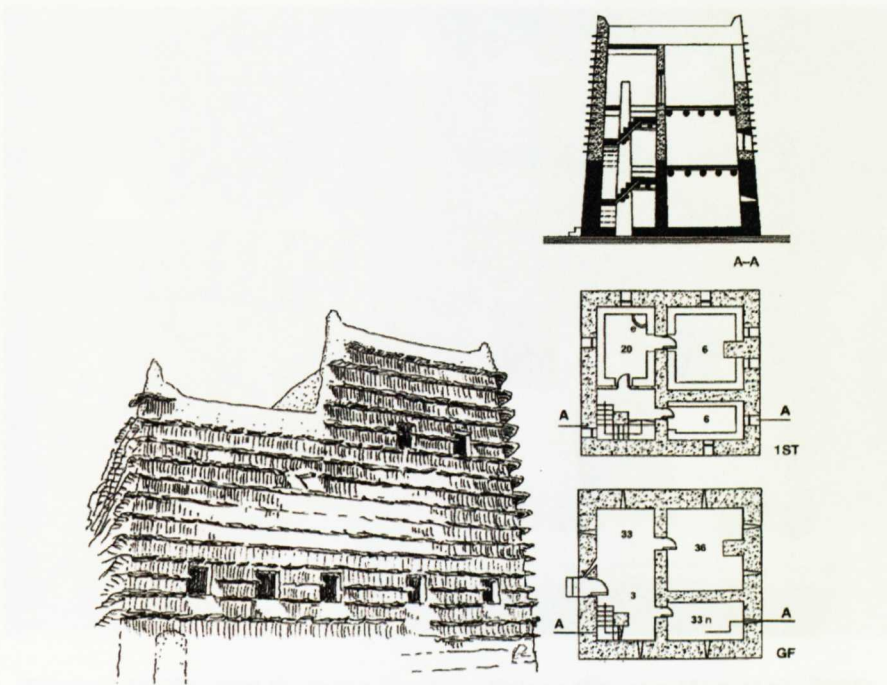


Figure 3.21: Typical Plans for Tower Houses in Asir (Source: Ragette, 2003)

Najran is a city in the south of Asir near the frontier with Yemen, famous for its archaeological importance. Traditional houses there are characterised by four to five stories and are usually called *Castle houses*, most which were abandoned after the city came under Saudi rule. The most famous is called “Qasr Al-Amarah” (Figure 3.22), which translates into ‘Emirates Castle’ in English. This building, which used to be the governor’s residence, represents the traditional architecture of that time. It is constructed of mud courses, each of which overlaps with the previous one in order to bear the weight and provide stability and protection against earthquakes. This particular example, Emirates Castle, has interior courtyards and around sixty rooms. The exterior window frames and entranceways are all highlighted with white gypsum to add decoration and retard erosion (Long, 2005).



Figure 3.22: The Old Emirates Castle in Najran (Source: Ham et al., 2004)

3.5.6 Traditional Architecture of the Northern Region

Tabuk is a city located in the north west of Saudi Arabia, which retains a few historical sites and archaeological monuments. Tabuk has an historic importance because it was a station along the pilgrim's road from Syria to Hijaz. The old centre of Tabuk still stands in the city, but it has been completely abandoned. The Municipality of Tabuk has a plan to restore most of the houses in order to prevent them from vanishing. Figure 3.23 shows one of the old houses in Tabuk. The ground floor has a row of windows while the second floor has *Roshan*, which reflects the typical Hijaz style. There is a roof terrace and drainpipes that cast rainwater off the roofs into the street. The materials used were mud and mud bricks with wood. The main elevation is orientated towards the sun in order to make use of sunlight and provide warmth to the house, as Tabuk city usually experiences harsh cold winter.



Figure 3.23: A Traditional House in Tabuk (Sketched by the Author)

Al Jawf is a city in the north of Saudi Arabia. In ancient times, buildings in the Al Jawf area were constructed out of cut stones. Qasr Marid (shown in Figure 3.24) is the most impressive site in the ancient capital, Dumat Al-Jandal. It is a stone fortress that had many restorations throughout its history, illustrating a shift from stone masonry in ancient times to mud bricks (Long, 2005).



Figure 3.24: Qasr Marid in Al Jawf (Source: Author)

In short, this section – which reviewed a range of traditional buildings in different regions within Saudi Arabia – has presented a suite of traditional houses which the people of the country managed to build and adapt according to their needs, climate and locally available resources. These houses belong to a period when architecture reflected the sparse conditions in which people lived. They relate to an era when the climate could not be eased by air-conditioning, and builders were generally limited by their cultural context and local materials. It is a pity to see such traditional houses being demolished, as they represent a real national treasure and should be preserved. It is apparent – as will be discussed in the next section – that Saudi Arabia has changed dramatically as a result of the economic transformation following the discovery of oil in the 1930s. One should recognise, nevertheless, that whilst a sudden economic boom can bring benefits and opportunities to a country; it may also bring out difficulties and challenges. If such apparent wealth in oil-rich Saudi Arabia is used unwisely or improperly, it may create untold harm for the future, especially if it erodes the country's identity and traditions (Daghistani, 1981). Whilst such views do not seem to prevail within Saudi society in general, which has already neglected

and lost a large number of its traditional buildings, it is fair to acknowledge some of the recent – yet limited – attempts to preserve such an important architectural heritage. For instance, Jeddah Municipality has recently identified 537 historic structures for preservation (Long, 2005). One of these is the Nasif House, formally a private residence, now restored and turned into a local museum (see Figure 3.25).



Figure 3.25: Nasif House in Jeddah (Source: Buchan, 1991)

Another notable restoration endeavour is that of Al Masmak Palace in Riyadh, which was the residence of King Abd al-Aziz Al Saud when he began his rule (see Figure 3.26). It has recently been renovated and transformed into a public museum and is now a home for many Saudi traditional festivals.

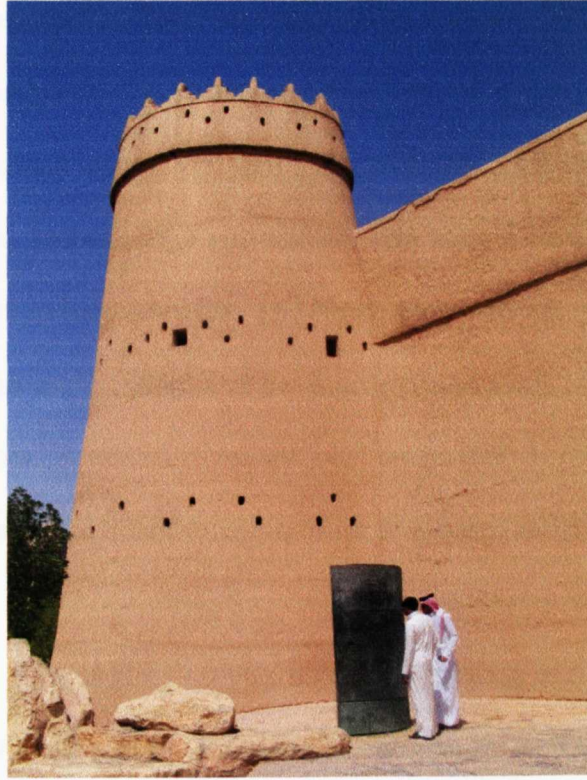


Figure 3.26: Masmak Palace in Riyadh (Source: Author)

Having reviewed traditional houses in Saudi Arabia, Section 3.6 will provide a general overview of Saudi current contemporary architectural practice that began with the discovery of oil and still is in the process of development.

3.6 Contemporary Architecture of Saudi Arabia

The aim here is to highlight the modernisation and advances that have been experienced within the Saudi residential sector since the discovery of oil. This is still very much a work in progress. This section begins by pointing out the main factors that facilitated such a transformation towards contemporary architecture, before discussing the main types of houses and construction materials currently prevailing in the country. To conclude this section, some of the areas of concerns associated with Saudi contemporary architectural practice will also be underlined.

3.6.1 Transformation towards Contemporary Architecture

Aba Alkhail (1989) suggested that economic development in the history of Saudi Arabia could be classified into four stages. The first stage was before the oil discovery, which took place in the 1930s. The second stage was the one that soon followed the discovery of oil, and lasted for more than three decades. The third stage was the period of the economic boom (of the 1970s and early 1980s) and the fourth period starts after the economic boom and continues until now. A literature review was conducted in order to investigate what factors actually facilitated the transformation towards modern architecture in Saudi Arabia.

A number of scholars, such as King (1998), noted that because of a rise in oil prices due to the oil crises of the 1970s, a rapid – and particularly intense – rate of architectural change has reached every part of the Kingdom. Saudi Arabia has also become an attractive destination for a large number of firms from all parts of the world. A large number of foreign architects, engineers and building professionals were invited to create a modern built environment in Saudi Arabia. This involved, in most cases, importing modern designs, building techniques and construction materials that had been developed and engineered abroad. Saudi citizens, in general, were keen on getting rid of the traditional way of life that reminded them of poverty, and on experiencing a sense of new modern living standards that reflects wealth and prosperity. Elsheshtawy (2008) also asserts that most social and economic development in Saudi Arabia has been as a direct result of oil wealth, due to which the country has experienced rapid advances and modernisation in transportation and construction. During this process of modernisation, a large number of traditional buildings, including mosques, have been demolished. Such an observation was also made by Shihabi (2004), who mentioned that most traditional houses were demolished in order to give way to modern ones. He further argued that Saudi people have experienced

major changes in terms of lifestyle that are influenced by a number of internal and external factors. Whilst the quality of construction materials and methods are more advanced than those which were in use during the pre-oil era, the speed of growth in major cities – e.g. Riyadh and Jeddah – has been such that expediency has often taken precedence over quality. On the other hand, Ham et al. (2004) noted that stunning new buildings have provided “...a much-needed counterpoint to the functionality of sprawling Saudi cities” (pg. 59). The most stylish expressions of this new aesthetic Saudi architecture are the Kingdom Tower (Figure 3.27) and Al-Faisaliah Tower (Figure 3.28). The first tower is a mixed-use building constructed in 2002, whilst the latter is an office-block tower constructed in 2000.

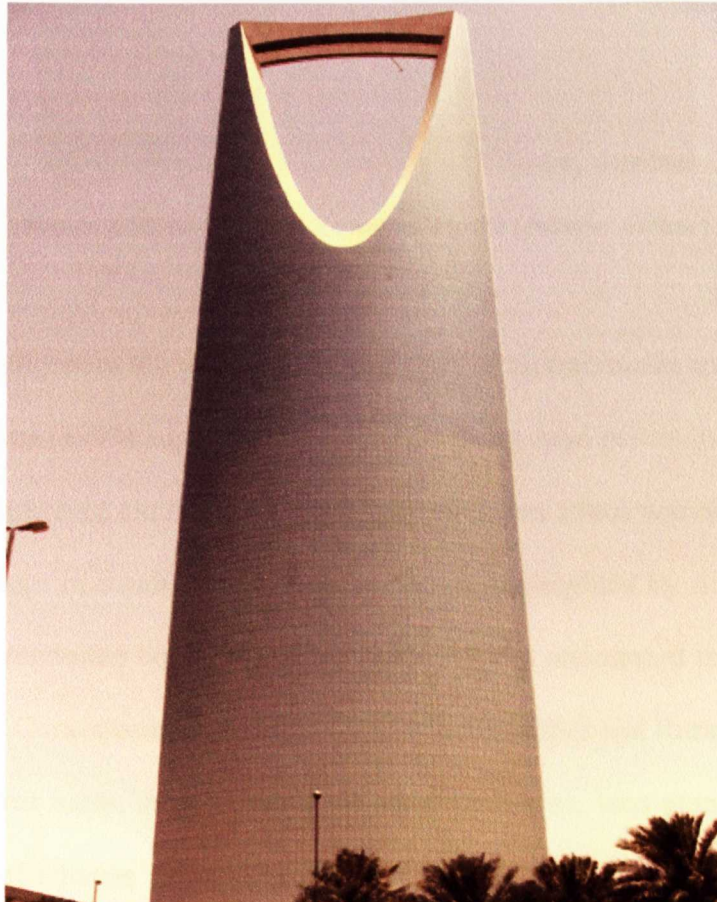


Figure 3.27: The Kingdom Tower in Riyadh (Source: Author)



Figure 3.28: Al-Faisaliah Tower in Riyadh (Source: Author)

Returning to the subject of the rushed departure away from traditional architecture in Saudi Arabia, Kultermann (1999) suggested that sharply rising land prices in cities contributed towards the demolition of old houses. Hence, the 1970s and 1980s witnessed a huge loss of architectural heritage in Saudi Arabia. Another factor, highlighted by Alafghani (1991), is that – during the economic boom – the Saudi Government announced the goal of ‘a home for every citizen’. Consequently, the Ministry of Municipalities and Rural Affairs started to provide interest-free loans, subsidies and, on some occasions, land grants which helped a large proportion of citizens to construct their own houses. Such factors have collectively led to the emergence of different types of modern houses, which will be described in the following sub-section.

3.6.2 Main Types of Modern Housing

There are three main types of modern Saudi houses: apartment complex, villa and subdivision (Talib, 1984). An **apartment complex**, known as *Emarah* in Arabic, represents a type of residence for the middle class of Saudi society, who cannot afford to build their own independent house. Apartment complexes – which are found in many districts of Saudi cities – aim to shelter many families within a limited space and volume. They are typically between two and five storeys. The ground floors can be used for commercial purposes by converting them into shops which could be rented as retail for different functions including groceries, bakeries, barber shops or laundries. Figure 3.29 shows a typical apartment complex in Saudi Arabia.



Figure 3.29: A Typical Apartment Complex in Saudi Arabia (Source: Author)

A **villa** is another modern type of housing found Saudi Arabia. Despite the foreign origin of the word ‘villa’, it is used by Arab nationals including Saudis. The villa is characterised by a courtyard and fence which protect the boundaries of the villa. The Saudi villa, which does not usually exceed two storeys, houses one family. On some occasions, a villa will be divided into two separate parts in order to house two families. A large proportion of villas

in Saudi Arabia tend to be large and luxurious (essentially small palaces) whose designs are largely varied. Figure 3.30 is a photograph of a typical Saudi villa.



Figure 3.30: A Typical Villa in Saudi Arabia (Source: Author)

A **subdivision** (loosely referred to a ‘compound’) is a repetition of apartment complexes or villas that forms a community, with its own facilities, amenities and open spaces. Figure 3.31 illustrates an example of a villa compound (i.e. subdivision of villas).



Figure 3.31: An Example of a Subdivision of Villas (Source: Author)

Another type of modern housing that has recently appeared in Saudi Arabia is the high-rise residential building (sometimes called ‘tower blocks’ or ‘blocks of flats’). Figure 3.32 shows a recent residential project with sea views in the city of Jeddah. It is apparent that high-rise residential buildings are advantageous in areas experiencing high population density, as they can accommodate a large number of inhabitants per unit of area of land they occupy. Such a benefit is, however, often overshadowed by the Saudi buildings’ suboptimal performance in terms of energy efficiency and/or safety features.



Figure 3.32: A High-rise Residential Building in Jeddah (Source: Author)

Finally, it should be acknowledged that traditional architectural features are not always absent in new Saudi buildings. For instance, Figure 3.33 – which exhibits a royal palace in Jeddah – demonstrates the incorporation of distinctive Arabic architectural character into the design of a contemporary dwelling.

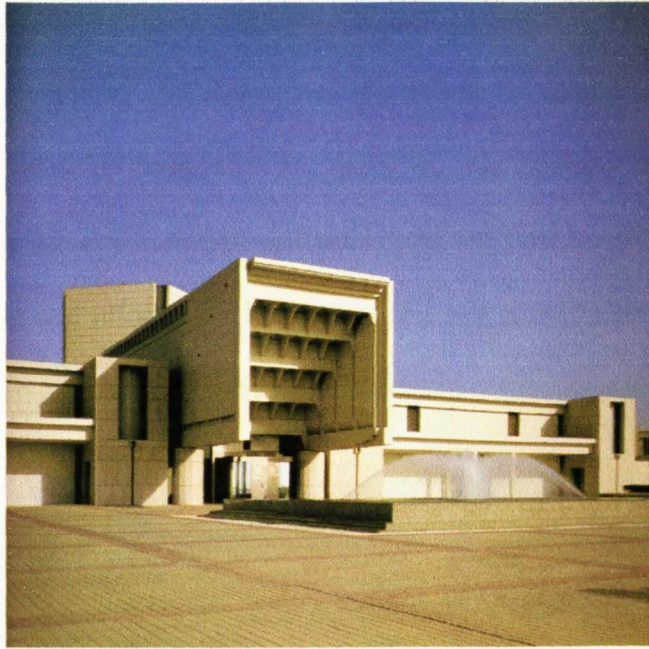


Figure 3.33: A Royal Palace in Jeddah (Source: Buchan, 1991)

Having reviewed different types of residential houses, it is also worthwhile to provide here an overview of the construction materials that are currently in use in Saudi Arabia.

3.6.3 Main Types of Modern Construction Materials

As mentioned earlier, the move towards contemporary architecture in Saudi Arabia has led to an increased reliance on imported modern designs, technologies and building materials. The transformation away from mud to modern materials was rapid and impressive. There is no doubt that traditional construction materials and methods could not bridge the gap between traditional and contemporary architectural trends in Saudi Arabia, nor could they be reinterpreted to cope with the challenges of a modern city (Shihabi, 2004). Among the materials introduced to modern construction is reinforced concrete which is used for utilising slabs, floors and concert blocks for exterior and interior walls. The exterior is usually plastered or faced with brick, stone or marble. Metals and cast iron are used for structuring and support. A number of local factories have been established around the

country in order to produce cement and stone as well as finishing materials. Wood is still sometimes used for windows and doors, but aluminium is used more often for frames. Glass is also used widely, especially for building the façades of some commercial buildings. Among the interior materials utilised is gypsum board, which is sometimes used for creating partitions and interior walls. Figure 3.34 is a photograph of a building that is still under construction, illustrating various construction materials used for building.



Figure 3.34: A Residential Building under Construction in Saudi Arabia (Source: Author)

Having provided an overview of different types of Saudi houses and the materials that contribute to their construction, the next sub-section will point out a number of issues of concern with regard to modern residential buildings.

3.6.4 Concerns Associated with Saudi Contemporary Architecture

Although it is almost impossible to comprehensively cover all issues of concern, an attempt is made here to highlight those which are believed to be the major ones. Alafghani

(1991) pointed out some problems, such as invasion of privacy, that have arisen as a result of the contemporary architectural movement in Saudi Arabia. For instance, it is argued that recent building regulations allowed apartment complexes to have more storeys than they used to have, without placing any restrictions on the number of windows and balconies on elevations. The privacy of low-rise buildings has, therefore, been invaded by these high-rise buildings. Moreover, due to the harsh climatic conditions in Saudi Arabia, contemporary buildings rely heavily on the use of air-conditioning (mechanical cooling). Among the issues that have been experienced with the excessive use of air-conditioning are acoustic and health-related concerns as well as an increased demand for electricity. Another design-related fault identified in the literature is the extensive use of glass as a material for building façades, as people started to complain about the glare caused by the harsh sun. Although reflective glass can be used, it still cannot bear the intensity of the sun's heat. Consequently, the building gains heat through the glass which leads to a greater use of air-conditioning. The cleaning requirements for a glass façade can also be prohibitive (Al-Jadeed, 1994).

Furthermore, the design of contemporary Saudi houses has encouraged the use of large quantities of water, with bathrooms that are designed to be as large as living rooms by western standards. Artificially cheap water, due to governmental subsidies, has given new Saudi generations a sense that water is something natural in such an arid country. In essence, they have not experienced the rough life of older generations who used to be much more sensible in terms of water use. In addition, according to Bahammam (1998), the size of contemporary Saudi houses is a pressing issue worth considering. New building developments are spacious and take more land. Villas are the preference of many people, and their size exceeds the average size of a house in many other countries. Counter to such

prevailing preferences, and bearing in mind the rapid increase of population, it is becoming more difficult to obtain large sized houses. Moreover, not only have government subsidies reduced since the 1970s, but also the price of construction materials is continuously rising. Hence, it is becoming increasingly challenging for an average Saudi citizen to buy or build a decent house.

Another critical issue is an improper building code which has long been considered as one of the major problems that Saudi Architecture faces. Al-Jadeed (1994) believed that many developing countries, including Saudi Arabia, simply adopted the building codes and regulations of those in developed countries without an attempt to adapt them to their local context, e.g. through taking into account climate and locally available materials. A new entity named the 'Saudi Building Code National Committee' was founded by Royal Decree dated 11th June 2000 in order to develop a new building code; an endeavour that will be discussed later in this chapter (Saudi Building Code National Committee, 2007). Scholars, including Rovers (2003), pointed out that the planners of major cities – such as Riyadh and Jeddah – realised that copying western styles was not always suitable to the local climate, nor did it corresponded with people's needs and habits. Other researchers believe that Saudi architecture has already lost its identity and characteristics. In this regard, Al-Angari (1997) drew on the example of the city of Riyadh. He stated that the city has experienced extensive growth and architects, urban planners, engineers and contractors from all over the world have participated in the process of its modernisation. Unfortunately, however, these endeavours have produced an incoherent entity, which does not relate to either local society or the indigenous character of the Najd region. It took decision makers a long time to realise such a problem and subsequently gain awareness with regard to the need to address the issue of lack of a unified architectural identity across the city. Last, but

certainly not the least, some scholars have agreed that the suboptimal quality of urban planning in Saudi Arabia is behind the lack of co-ordination between old and new urban patterns; thus creating a conflict between traditional and modern designs (Saleh, 1998). According to Alafghani (1991), urban planning of some Saudi cities is poor and unorganised due to the fact that the expansion of the urban cities was so rapid. In effect, even though current Saudi architecture looks modern and gives an impression of prosperity and wealth, it is associated with many problems that should be addressed. One of these problems which have not been appropriately addressed is the lack of emphasis upon sustainable architecture practices.

3.7 Sustainable Architecture in Saudi Arabia

Using available literature, this section starts by highlighting the need for – as well as potential challenges that may presently impede – considering sustainability in the residential sector in Saudi Arabia. Following this, an overview is provided with regard to sustainability initiatives that have already been embarked upon in the country.

3.7.1 Drivers and Barriers Concerning the Application of Sustainable Architecture in Saudi Arabia

Whilst the need for considering sustainability in architecture has been thoroughly discussed in Chapter 2 (Section 2.2), it is unfortunate to witness that application of sustainable architecture is almost absent in current Saudi buildings, which continue to depend heavily on air conditioning which consumes massive amounts of electricity. As a result of poorly designed buildings in the GCC countries, which include Saudi Arabia, nearly 80% of household electricity is used for air conditioning and refrigeration purposes (Akbari et al., 1996). In Saudi Arabia, as a result of a rapid population growth, a high level

of economic growth and increased urbanisation, not only is the residential sector booming, but it also constitutes more than half of the country's energy demand (Al-Shehri, 2008). Hence, the focus of this thesis upon residential buildings can be justified.

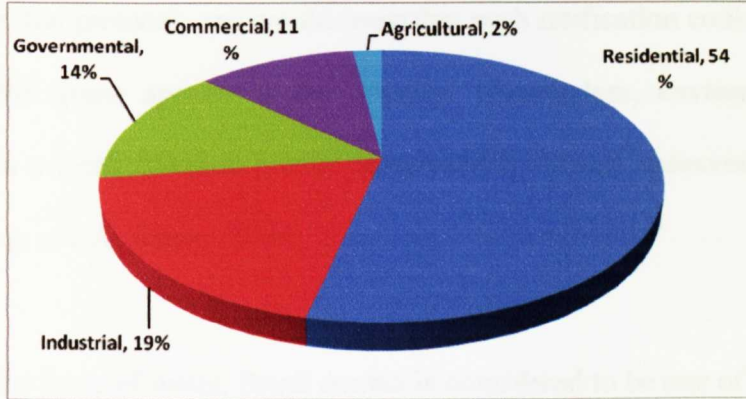


Figure 3.35: Electricity Consumption by Sector in Saudi Arabia (Al-Shehri, 2008)

Moreover, it is noted that the design of modern houses in Saudi Arabia is no longer based on vernacular architecture, whose principles somewhat coincide with that of sustainable architecture. Generally speaking, vernacular architecture tends to emphasise the utilisation of local building resources, as well as the use of passive and low-energy strategies that could lead to reducing the need for both air conditioning and lighting requirements (Al-Ismaily and Probert, 1997). In fact, due to a rapid increase in demand for electricity (averaging around 7% per annum), Saudi Arabia has become the fastest growing consumer of energy in the Middle East (Energy Information Administration, 2009). What is also disappointing is the fact that electricity generation (and most water production) is entirely dependent upon the unsustainable practice of burning fossil fuels, which not only causes climate change, but also has major environmental impacts on air, water and land (Alnatheer, 2006). In addition, despite the abundant availability of renewable energy sources, the use of sustainable energy technologies, such as solar PV is exceptionally rare

in an oil-rich Saudi Arabia (Al-Saleh, 2009). It is regrettable to note that although Saudi Arabia ratified the Kyoto Protocol in 2005 (Planet Ark, 2005), there has been a comparatively limited application of environmentally-friendly technologies and solutions. Whilst Saudi Arabia, as a developing country, has no obligation to cut its greenhouse emissions under that protocol, one would hope that such ratification could lead to a certain embracing of the green agenda in the country. Nonetheless, environmental concerns continue to form a weak driver to pursue sustainability-related endeavours in present-day Saudi Arabia (e.g. see Al-Saleh, 2010).

With regard to the issue of water, Saudi Arabia is considered to be one of the driest regions in the world that is facing serious challenges relating to rapid growth in water demand. It has no permanent rivers or lakes and the country depends heavily on desalination plants to bring water supplies to a population scattered across a very large Kingdom. The government has been tackling the issue of increasing water demand, which is manifest in the domestic sector, by the development of 33 desalination plants, thereby making Saudi Arabia the world's largest producer of desalinated water (Vincent, 2008). In spite of the limited availability of natural water resources in Saudi Arabia its water tariffs – due to high subsidies provided by the government – are set at approximately US\$0.03/m³, compared with over US\$6/m³ in many wet regions around the world (Gasson, 2008). Such an artificially low price for water, as well as for electricity, provides no incentive for water and energy conservation; hence the design of Saudi houses tends to lay stress on a luxurious style of living without paying attention to principles of sustainability. For instance, when compared to the rest of the world, Saudi houses tend to be relatively large residences with air conditioning units running continuously. Therefore, there is a pressing need to improve the efficiency of energy use and water consumption in Saudi buildings

through the application of sustainable architectural principles. Recent studies indicate that having abundant oil reserves, heavily subsidised electricity and water prices creates a lack of awareness with regard to environmental concerns as well as a shortage of regulations and policies in terms of sustainable construction implementation. These factors are believed to be amongst the most significant barriers to a flourishing sustainable architecture movement in Saudi Arabia (Al-Yami and Price, 2006). Other worldwide potential barriers that are sometimes quoted in the literature, and are expected to be of more significance to the case of Saudi Arabia, include lack of awareness (across all levels) with regard to the potential benefits of sustainable architecture. That is fuelled by a mere focus upon initial costs as opposed to lifecycle costs and benefits (Landman, 1999; Pitts, 2004).

3.7.2 An Overview of Sustainability Initiatives in Saudi Arabia

Among recent initiatives was the organisation of a conference entitled ‘Technology and Sustainability in the Built Environment’ over the period of 3-6 January 2010. This conference – at which the author of this thesis participated with a paper to present the findings of this research (Taleb, 2010) – was the first gathering of its kind in Saudi Arabia about the subject of sustainable architecture. Another related initiative was a publication, in Arabic, entitled ‘The Manual of Affordable Houses’ which came as a result of a study embarked upon by the Riyadh Development Authority (Bahammam, 2004). Whilst the focus of this study was on raising awareness with regard to the factors of reducing costs associated with building, there was a tentative reference to some factors related to sustainable architecture such as: the need for achieving harmony with nature, proper insulation and the shading of buildings, harnessing natural ventilation and natural light and green roofing as well as a few energy and water conservation measures. Nevertheless, it is unfortunate that not only have the recommendations of this broad study not been translated

into action, but also the study lacked details and goals. Moreover, up until the writing of this thesis, there has been no attempt to review and/or update the findings of this study. Visits were conducted to various libraries belonging to a number of major UK universities in order to search for previous academic work on the subject of sustainable residential buildings in Saudi Arabia. Whilst no postgraduate theses were found that have examined this subject per se, Table 3.4 lists the theses that are of some relevance to the subject. Given the rapid technological advancements with regard to energy conservation in buildings, it is reasonable to suggest that some of the findings of the few theses about this particular subject – shown below – could now be somewhat outdated.

**Table 3.4: Previous Postgraduate Research, Conducted in the UK,
in Relation to Sustainable Architecture in Saudi Arabia**

| Source | Thesis Title | Degree | University |
|-------------------|--|---------|-------------------------|
| Abideen (1996) | Aspects of passive cooling and the potential saving in energy, money and atmospheric pollutants emissions in existing air conditioned mosques in Saudi Arabia. | Ph.D. | University of Edinburgh |
| Al-Buijan (1987) | Computer modelling of buildings for energy conscious design in eastern province of Saudi Arabia. | M.Phil. | University of Leicester |
| Al-Jammaz (2006) | An approach for the assessment of sustainability of construction materials. | Ph.D. | University of Newcastle |
| Al-Maayouf (2005) | The Impact of Envelope Design on the Energy Performance for Modern Houses Application in Hot, Arid Regions with Special Reference to Riyadh, Saudi Arabia. | Ph.D. | University of Cardiff |
| Al-Naimi (1989) | The potential for energy conservation in residential buildings in Dammam region, Saudi Arabia. | Ph.D. | University of Newcastle |
| Al-Shihri | Sustainable development and strategic | Ph.D. | University of |

| | | | |
|-----------------------|---|--------|----------------------------|
| (2001) | environmental assessment in the context of the Saudi Arabian planning process: The case of Al-Qatif oasis and its settlements. | | Newcastle |
| Al-Solaiman (2003) | The Integration of the Passive Cooling System into Multi User Building with Reference to Riyadh, Saudi Arabia. | Ph.D. | University of Nottingham |
| Al-Yami (2008) | An Integrated Approach to Value Management and Sustainable Construction During Strategic Briefing in Saudi Construction Projects. | Ph.D. | University of Loughborough |
| Monawar (2001) | A study of Energy conservation in the existing apartment building in Makkah Region, Saudi Arabia. | Ph.D. | University of Newcastle |
| Taleb (2007) | The potential use of solar photovoltaic technology in the buildings of Arabian gulf countries. | M.Arch | University of Sheffield |
| Waheeb (2005) | Impact of shading devices on indoor sunlight distribution and building energy performance, with reference to Saudi Arabia. | Ph.D. | University of Nottingham |

Some of the developments and initiatives recently taken by the government are indeed steps in the right direction. The most notable achievement is the award of the LEED Platinum Certificate to King Abdullah University of Science and Technology (KAUST), which opened in September 2009. The award came in recognition of the campus design's emphasis upon sustainable site planning, sustainable building materials, water conservation, energy efficiency and renewables, natural ventilation and lighting as well as coral reef and mangrove protection. This makes KAUST the first LEED-Certified project in Saudi Arabian history (KAUST, 2010). Moreover, although progress in the field of wastewater treatment across the country has thus far been very slow, it is expected to receive more attention following the recent establishment of a National Water Company with the aim of overseeing a range of aspects within the state-controlled Saudi water sector (Fallatah, 2008). In addition, according to Alzahrani et al. (2007), there have been a small number of campaigns intended to increase people's awareness of the problem of water scarcity and

the importance of its conservation in Saudi Arabia. Additionally, the government has recently started implementing a number of campaigns to increase people's awareness with regard to the importance of electricity conservation (Saudi Ministry of Water and Electricity, 2009).

To conclude this chapter, it is important to mention that there are no regulations, or compulsory building codes, that currently incorporate the principles of sustainable architecture in Saudi Arabia. It has been argued by many scholars (e.g. Chwieduk, 2003) that setting a coherent set of these codes and standards is one of the most important and cost-effective ways to promote the widespread use of sustainable practices, especially with regard to reducing household energy and water consumption. Following the energy crises of the 1970s, such building codes have been widely adopted in developed nations, and more recently in the developing countries of Argentina, China and Taiwan. It appears, however, that the sustainable building regulations in some of the countries of the European Union are amongst the most stringent. A review of such national codes and building regulations, which is beyond the scope of this thesis, is plentiful in the literature (e.g. see Balaras et al., 2005). The first comprehensive Saudi building code was published in 2007, and has thirteen main requirements: architectural; loading and forces; testing and inspection; soil and foundations; concrete structures; masonry structures; steel structures; electrical; mechanical; energy conservation; sanitary; fire protection; existing buildings requirements. In essence, this code is "...[A] set of legal, administrative and technical regulations and requirements that specify the minimum standards of construction for building in order to ensure public safety and health" (pg. 1). It should be noted, however, that most of the requirements in this code have, admittedly, been borrowed from the international codes of the USA, Canada and Australia as well from Europe and the Arab

world. For example, the ‘Saudi Building Code Architectural Requirements’ were developed based on chapters of the International Building Code, published by the International Code Council. Whilst it is promising to see that ‘energy conservation’ was considered as one of the main requirements of this initiative, the code is not planned to be fully implemented anytime before the year 2020 (Saudi Building Code National Committee, 2007). Since the efforts highlighted in this section are – at best – modest when compared to other world standards, efforts should be made by Saudi architectural professionals to minimise a building’s water and energy consumption through the active, serious and urgent implementation of sustainable architectural practices in order to address future energy and environmental challenges. This study contributes to such tentative, yet promising, moves towards sustainable housing in the country. The next chapter discusses in detail the methodology design of this research.

Chapter 4

Research Methodology

4.1 Chapter Overview

This chapter highlights the methodological approach adopted for this research. There follows a detailed description of the design of the research and the methods employed, along with an account of the ethical aspects.

4.2 Methodological Approach

Research methodology literature – traditionally articulated within the realm of social science – often distinguishes between quantitative and qualitative research. Broadly speaking, the quantitative approach seeks to quantify structured data with the aim of testing causal hypotheses in order to establish objective and measurable laws, whilst qualitative enquiries underscore the importance of exploring subjective venues in order to understand a specific phenomenon (Flick, 2006; Thomas, 2003). As will be discussed in the next section, computerised energy simulation tools were the main data collection methods used in this research project. Nonetheless, given that this research is not really concerned with verifying and/or refuting causal hypotheses, it might be wrong to assume that it is based on the quantitative approach per se. In other words, in spite of its heavy reliance on computer-based simulation, the methodological approach adopted is chiefly qualitative in nature. Denzin and Lincoln (1994), in their comprehensive three-volume handbook on qualitative research, explain that “Qualitative research is multi method in focus, involving an interpretive, naturalistic approach to its subject matter. This means that qualitative researchers study things in their natural settings, attempting to make sense of, or interpret phenomena in terms of the meanings people bring to them. Qualitative research involves the studied use and collection of a variety of empirical materials – case study, personal

experience, introspective, life story, interview, observational, historical, interactional and visual texts” (pg. 2). In effect, the underlying goal of qualitative research is to obtain a holistic overview of the context under consideration (Miles and Huberman, 1994). Moreover, Mason (2002) argues that qualitative research allows for an in-depth examination of under-researched subjects and contexts that suffer from a dearth of published literature. Since the topic of sustainable architecture in Saudi Arabia has not been adequately addressed in published literature, adopting a qualitative approach to the research has been deemed to be most appropriate in this instance.

Another important element in the design of any research is deciding upon a clear research strategy. The research strategy – defined here as the broad plan of how researchers go about addressing their research objectives (Ghauri and Grønhaug, 2005) – adopted for the present research is that of case study. Robson (2002) defines a case study as “...[A] strategy for doing research which involves an empirical investigation of a particular contemporary phenomenon within its real life context using multiple sources of evidence” (pg. 178). Whilst adopting a case study approach can yield a rich understanding of the context of the research and the processes to be studied (Morris & Wood, 1991; Yin, 2009), it is often criticised for its lack of generalisability (Stake, 1995). Quite often, multiple data collection methods are employed in case study research (Saunders et al., 2007; Yin, 2009). For the purpose of this research project, two typical houses in Saudi Arabia were selected as case buildings. The next stage was to study energy and water consumption within these two buildings using various methods. A further review of the literature on research methodology revealed a tendency to categorise research strategies in terms of the purpose of the enquiry. More specifically, research strategy is sometimes classified as being explorative, descriptive or explanative. Morrell (2010) explains that exploratory studies

involve gathering information and seeking new insights into a relatively under-researched problem or context. Descriptive research involves providing an in-depth examination of a problem, context or situation, whereas explanatory research seeks to identify and explain causal relationships between variables or events. Bearing in mind that these broad strategies are not entirely discrete entities, a combination of explorative and – to a certain extent – descriptive strategy seems appropriate for addressing the aim of the present research and its related objectives.

Having highlighted in this section the overall approaches adopted in this research along with its strategy, it is next necessary to discuss and justify in further detail the ‘tactics’ employed, i.e. finer detail on the data collection methods used.

4.3 Research Design

The most recent reports on the number and types of Saudi houses, including those provided by the Ministry of Economy and Planning (2005, 2007) and Central Department of Statistics and Information (2008), suggest that at least three quarters of the Saudi population currently live in apartments and villas, whilst the remaining quarter lives in either traditional mud houses or tents. For the purpose of this research, two typical residential buildings (an apartment complex and a villa) were selected to act as case studies. The two recently-built residential buildings are located in a relatively new district of the city of Jeddah that has witnessed heavy construction activity in recent years. Energy use within the two houses was analysed using DesignBuilder version 2.2, which is based on the state-of-the-art building performance simulation software entitled EnergyPlus, originally developed by the US Department of Energy. DesignBuilder is a commercially available software package that provides dynamic and comprehensive energy simulation for

buildings. Three-dimensional (3D) DesignBuilder models for the two case studies were first developed based on drawings of the buildings, and then after conducting site visits and undertaking intensive discussions with the occupants and with the owners who oversaw the construction of the buildings themselves. Since gas is not used within the two houses, household electricity consumption alone was analysed on daily, weekly, monthly and yearly bases. In addition, the DesignBuilder simulation software provided an estimation of CO₂ emissions. This was calculated based on the type and amount of fuel used to generate electricity at the building level. At a later stage, household energy consumption, and its associated CO₂ production levels, was assessed again using DesignBuilder in order to examine potential improvements following both the application of a range of design-based energy efficiency measures, and the use of solar PV technology. In other words, DesignBuilder was used to calculate energy use and potential savings in the case study buildings before and after applying various energy savings measures and strategies. In addition, DesignBuilder was used to assess the potential savings made by each of the adopted energy conservation measures or strategies within the selected case studies in Jeddah City. This analysis has also been conducted when placing the case study buildings in the context of a different climatic setting in Saudi Arabia, i.e. of the capital city of Riyadh. Throughout the thesis, the term 'Base Case' refers to the original state of each building. The term 'Efficient Case' refers to the state of each building after incorporating energy efficiency measures.

Since DesignBuilder does not provide an assessment of water consumption, a search was conducted to select a suitable means to analyse water use in the case studies. Rather than carrying out this assessment manually, it was decided to largely base such an analysis on an adapted version of the BRE (the trade name of Building Research Establishment

Limited) Code Water Calculator, which is used as part of the BREEAM 'Code for Sustainable Homes' assessment methodology. What further enhanced the attractiveness of this particular calculator, besides its reputability and relevance, is the fact that after undertaking necessary training and examinations in the UK, the author became a licensed assessor for the BRE Code for Sustainable Homes, and therefore formally qualified to use this software-based calculator. Based on the number and type of fittings and appliances installed in a house, this calculator estimates the average water consumption per capita, using typical usage patterns for each user. Bearing in mind the limitations associated with data availability and method of analysis, the calculated figures for water consumption were then validated with findings from published literature. A number of water saving measures were then suggested in order to reduce household water consumption rates. Next, the software was run again (to establish the efficient case) in order to estimate water saving potential following application of the measures suggested.

The energy and water simulation results for the apartment complex and the villa (for both the base and efficient cases) were then presented to a number of informed stakeholders who were interviewed in order to both obtain feedback on the simulation exercise and to discuss the prospects for sustainable residential buildings within the Kingdom of Saudi Arabia. Finally, a set of recommendations – that have potential for making Saudi residential buildings more sustainable – were drawn from the whole research project. A simplified schematic for the research process is provided in Figure 4.1.

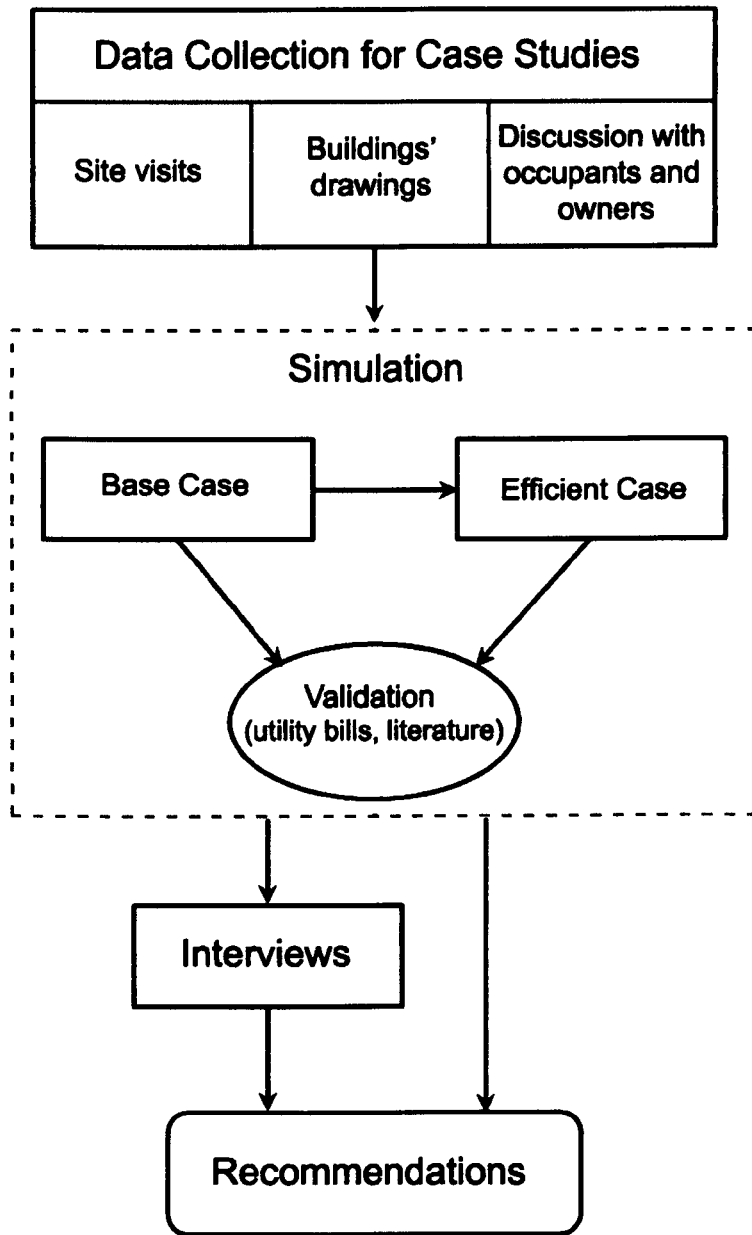


Figure 4.1: The Research Process

In this research, a combination of data collection methods was used. The use of a variety of evidence is often referred to as ‘data triangulation’, which is recommended in order to boost the validity of the research and protect it against researcher bias, as no single research method is totally reliable and without its limitations (Denzin, 2009; Flick, 2006).

In order to determine the accuracy of the information collected, extensive field notes were taken and data obtained from primary sources were confirmed with data obtained from secondary ones. Such a triangulation is regarded by many scholars (e.g. Remenyi et al., 1998; Yin, 2009) as an important feature of exemplary case study work. Given the key roles of both simulation and interviews in terms of addressing the set research objectives, the following sub-sections will discuss these research methods in more detail.

4.3.1 Simulation

Despite the fact that simulation and modelling tools are frequently used for building energy analysis, their principles are not always clearly understood. It might therefore be beneficial to highlight here the nature of simulation and the basic principles of energy modelling. According to Matko et al. (1992), simulation and modelling are inseparable procedures used to analyse the complex behaviour of real processes. Whilst modelling is the process of producing a model (i.e. a representation of the construction and working of some system of interest), simulation is the operation of that model. It should also be borne in mind that the simulation of a building is by no means an exact science, as there are many subjective judgements needed in terms of what inputs and methods should be incorporated. As vividly put by Neelamkavil (1987), “[modelling] is more than an art, but not a fully developed science. Human judgement, experience and computer programming skill still play an important role in the formulation and solution of problems by this method” (pg. i). Therefore, Heinrich (1998) assures us that there will almost always be controversies about which algorithms and solution techniques should be used to analyse the energy consumption of a building. With regard to building energy simulation, software developers usually handle the modelling of system dynamics which form the basis of the simulation

software (i.e. the tool), whilst building designers use this software to build their models and to carry out energy simulation and analysis for the building under consideration.

Among the reported drawbacks of simulation are the complex and time-consuming nature of the process (Clarke, 2001; Maria, 1997). Moreover, much of the success of modelling obviously relies on the experience, skill and integrity of the software user. Therefore, proficiency in modelling techniques and skills play an important role in the quality and adequacy of the results obtained from the simulation models. Hui (2003) further explains that in the past (and still with some recent simulation software), the user interface is the weakest part of any building energy simulation exercise. It is true that the issues associated with user friendliness have been partly addressed with the increasing popularity of the Windows-based graphical user interface (GUI). However, there remain plentiful opportunities for an unwary or misinformed user to make significant mistakes when performing the simulation. In this regard, in addition to her previous experience and knowledge of energy modelling, the author undertook an intensive 4-day course in London (over the period 26-29 January 2009) on the energy simulation software used for this research, namely DesignBuilder.

The DesignBuilder software is based on a state-of-the-art building performance simulation software package entitled EnergyPlus. A DesignBuilder simulation is based on 'real' hourly weather data, and takes into consideration both solar gain through windows and heat conduction and convection between zones of different temperature (Chowdhury et al., 2008; DesignBuilder Software, 2009). The accuracy of the DesignBuilder software has been validated using the BESTest (Building Energy Simulation TEST) procedure, originally developed by the International Energy Agency. The BESTest is a comparative

set of tests regarded by the US Department of Energy and the international community as being a reputable basis for evaluating the capabilities of building energy simulation programs (Radhi, 2010).

4.3.2 Interviews

The underlying assumption with regard to conducting interviews is that knowledge can be generated through engaging on purposeful conversation with other individuals (Patton, 1990). Generally speaking, interviews can be fully structured, semi-structured or unstructured (Robson, 2002; Thiétart et al., 1999). For the purpose of this research, semi-structured interviews seemed attractive in that they ensure a focused approach yet offer flexibility to modify the questions in order to target new ideas raised by the interviewee. Bearing in mind the diverse backgrounds of the interviewees, the semi-structured approach also seemed beneficial in that questions would be posed to interviewees with different knowledge of the subject, some of whom might seek further explanation and clarification. The criterion for selecting the interviewees was that each person should have an interest in, or knowledge of, the subject of sustainable buildings in Saudi Arabia. In other words, a judgmental sampling strategy (i.e. non-representative; non-probability sampling) was used. According to Saunders et al. (2007), such a strategy is usually recommended for explorative and/or qualitative studies, especially when there are a limited number of people involved in the area being researched. Some thirty highly-informed individuals were invited to participate, resulting in fourteen semi-structured interviews ultimately being conducted over the period 3rd January to 27th February 2010. Figure 4.2 shows the background of the fourteen interviewees – all of whom were male Saudi nationals of which detailed background information will be provided in Chapter 8.

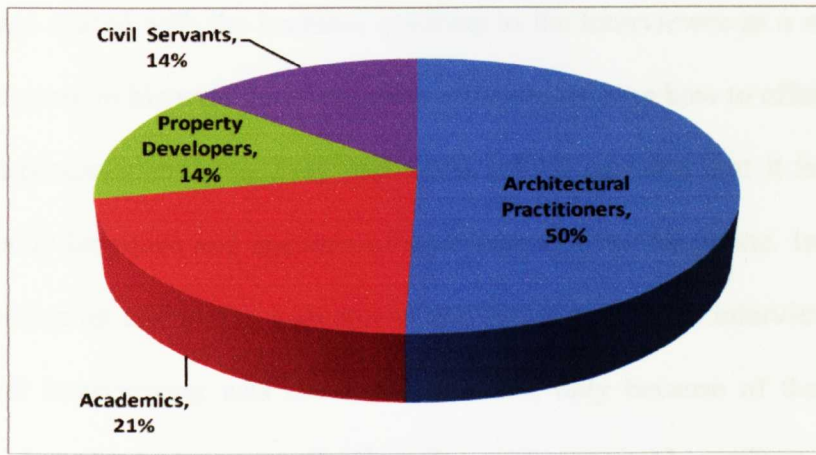


Figure 4.2: Backgrounds of the Interviewees

An apparent scarcity of Saudi practitioners with an interest in sustainability was the most significant issue experienced in terms of conducting the interviews, followed by a lack of punctuality from the interviewees. On a few occasions, the interviews had to be re-scheduled at the last minute. The likelihood of such events has already been acknowledged in research methodology literature (see Bailey, 1978), but their incidence seems to be more pronounced in a developing country like Saudi Arabia. Moreover, it should be mentioned here that gaining access to the overwhelmingly male-dominated construction industry was not as easy as initially anticipated. Being a female researcher, it was hard to approach – let alone conduct – interviews with male research participants. A very few Saudi female designers were identified, but they admitted their ignorance with regard to the subject of sustainable architecture. Ultimately, only five interviews were conducted on a face-to-face basis, with the remaining nine being conducted by telephone. The five interviewees who agreed to conduct their interviews in person, were open-minded professionals who had received their education abroad. In spite of this, they demanded the physical presence of the author's husband to act as a '*mahram*' during the interviews². Even the phone

² According to Islam, women should not travel or meet other men without the presence of a *mahram* – an Arabic word that refers to an unmarriageable male relative (e.g. a father, a brother or a son if they have reached puberty). A husband is not forbidden in marriage, but is classified as *mahram* as an exception.

interviews were started with the husband speaking to the interviewee as a way of granting permission to speak to his wife. In a book devoted to explaining how to effectively conduct phone and in-person interviews, Frey and Oishi (1995) mention that it is impossible to observe the body language and gestures of interviewees over the phone. Instead, the tone of voice served as an alternative indicator of the legitimacy of the interviewees' answers. Indeed, E-mail interviewing was not considered, not only because of the potential low response rate, but also because usually E-mails are an unsuitable medium for conducting semi-structured interviews (Ghauri and Grønhaug, 2005).

Bearing in mind that no interviewee was willing to participate in an interview lasting for more than an hour, semi-structured interview questions were formulated and are provided in Appendix A. The simulation results for both the 'Base Case' and 'Efficient Case' were circulated to the interviewees long before the start of the actual interview. The aims of the interviews were twofold; (i) to validate the simulation results; (ii) to engage in in-depth discussions on ways of making residential buildings within Saudi Arabia more sustainable. In other words, the interviews were to contribute to addressing the fourth and fifth research objectives, previously set out in Chapter 1 (Section 1.4). A pilot test was conducted before embarking upon the actual interviews not only to examine the level of clarity, but also to confirm the suitability of the interview questions for addressing the abovementioned aims. To that end, two independent researchers were invited to comment on an earlier draft of the interview questions. Despite the fact that an Arabic version of the questions was prepared, all of the interviewees were more than comfortable to conduct the interview in English. In addition, the interviewees did not mind the researcher tape recording the actual interview or taking notes during the interviews, the length of which ranged between thirty-five minutes and an hour. With respect to data analysis, given the small number of interviews,

the use of any sophisticated analysis software was deemed unnecessary. Hence, the interviews were analysed manually through identifying the similarities and differences with regard to the responses of the participants. In this regard, Hart (2005) affirms that adopting such a qualitative approach to data analysis could be beneficial in terms of relating the individual responses to the “big picture” set by the research objectives.

4.4 Research Ethics

Discussing the prospects for sustainable buildings in Saudi Arabia involved criticising some current practice and regulations set by the Saudi Government – a potentially sensitive subject in a country like Saudi Arabia. In fact, such an issue was pointed out by some of the interviewees before carrying out the actual interviews. In this regard, Renzetti and Lee (1993), who wrote a book about researching sensitive topics, suggest that the anonymity of the research participants must be ensured. Therefore, at the start of each interview, assurances were given that identities would not be revealed in the thesis, in order to obtain the confidence of interviewees and to increase the chance of them expressing their views more candidly. Moreover, as mentioned earlier, care was taken to respect the fact that Saudi Arabia is a country that strictly follows the teachings of Islam and which requires the presence of a male escort (*mahram*) during women’s travel and/or interaction with males.

Care was also exercised to address a number of ethical factors that might limit the validity of the research process (i.e. data collection and analysis). Validity can be defined here as the extent to which the responses reported truly represent the reality of the subject being investigated (Mason, 2005). For instance, bearing in mind the author’s interest in the subject of sustainable architecture, it was important to take into account the issue of reflexivity, which essentially refers to an awareness of the background and perspective of

the researcher. Gorat and Wang (2003) further explain that it involves self-understanding and moral questioning on the part of the researcher in order to address any potential bias that could invalidate the interpretation of the research results. Considering the validity of the simulation exercise, factors such as fabrication, fraudulent materials and omissions are blatantly unethical. Among the factors that may affect the validity of the responses of the interviewees are poorly-framed, complicated or leading questions. The latter are those questions that subtly prompt the respondent to answer in a particular way. In order to limit the possibility that an interviewee might provide the type of answers that he thinks the interviewer might want to hear, the interviewees were encouraged to answer freely, and they were assured that no specific answer would be seen as being right or wrong.

Having explained and justified the methodology adopted in this research, the next chapter presents the two case study buildings and analyses their current energy and water consumption.

Chapter 5

Base Case: Energy and Water Consumption within Typical Saudi Houses

5.1 Chapter Overview

This chapter starts by introducing the two case study buildings that have been selected as typical Saudi houses. Since these residential buildings are located in Jeddah City, an overview of Jeddah's climate is also provided. Following this, the results of detailed analyses with regard to the energy and water consumption of the two houses are presented.

5.2 An Introduction to the Case Studies

Two typical residential buildings (a villa and an apartment complex) were selected to act as case studies for this research. Throughout the thesis, the apartment complex will be referred to as 'Case 1', whilst the villa will be referred to as 'Case 2'. Below is a brief introduction to both buildings.

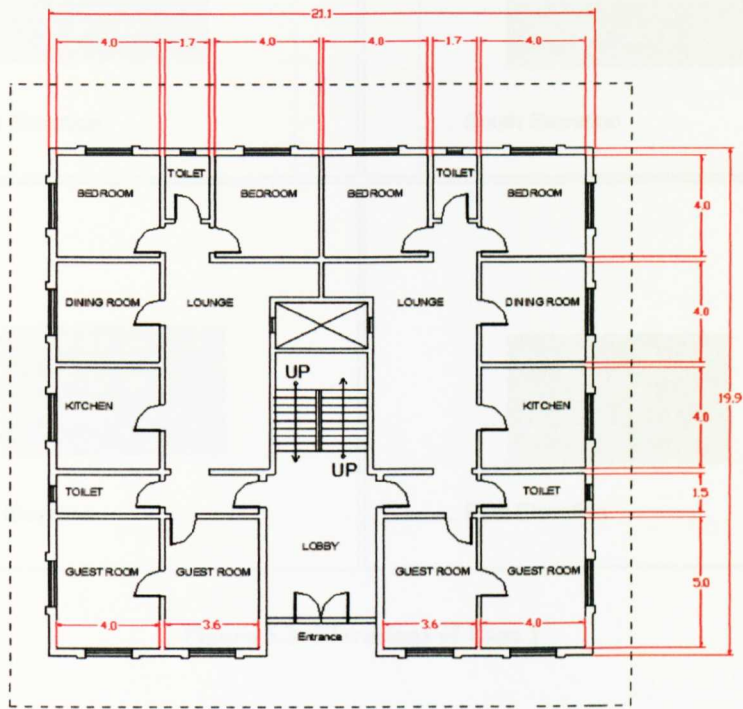
5.2.1 Case 1: The Apartment Complex

The two recently-built residential buildings that have been chosen are located in relatively new districts of Jeddah City. Figure 5.1 illustrates an aerial view of Case 1 within its urban context.

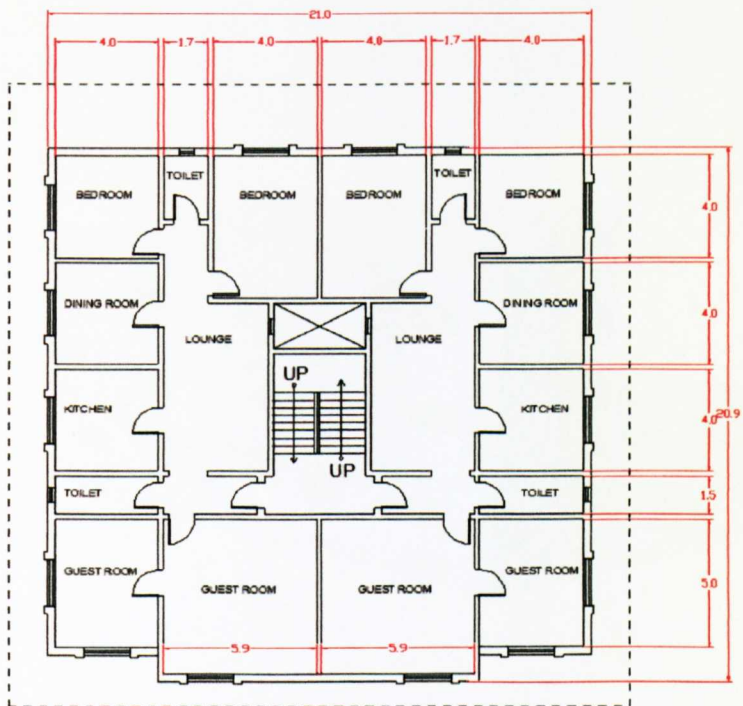


Figure 5.1: An Aerial View of Case 1 and its Urban Context (Source: Google Earth)

The apartment complex selected for this study is only five years old. It comprises three storeys and six apartments. Figures 5.2, 5.3 and 5.4 demonstrate floor plans, elevations and 3D models for Case 1 respectively.



Ground Floor



First and Second Floors

Figure 5.2: Floor Plans of Case 1

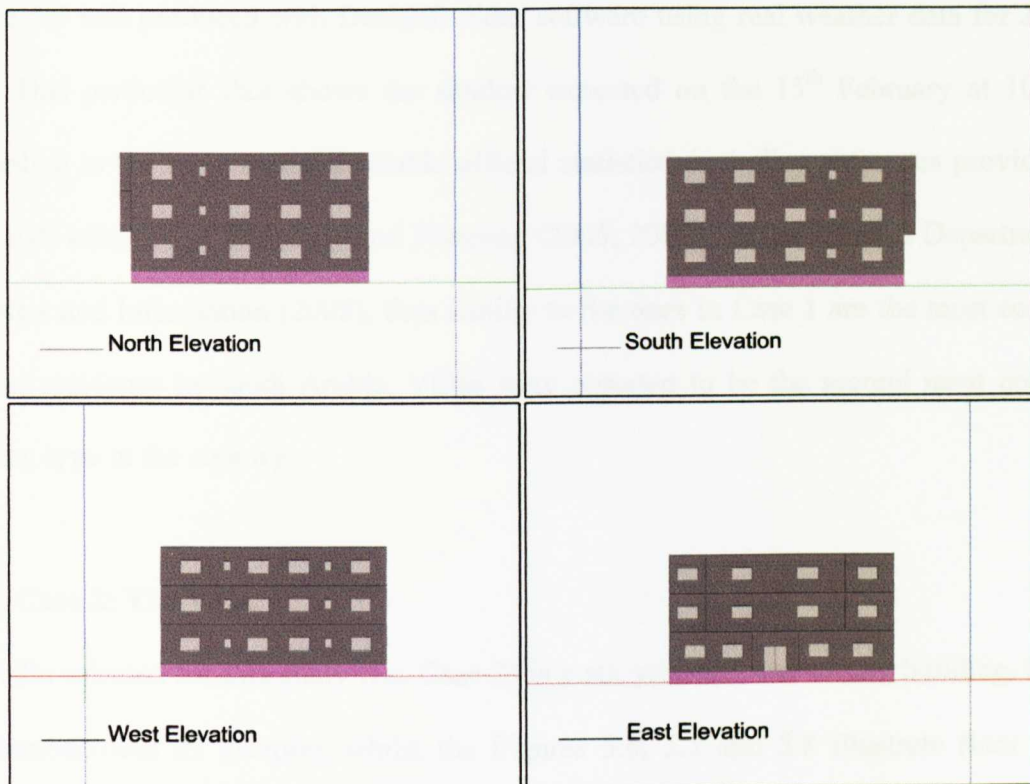


Figure 5.3: Elevations of Case 1

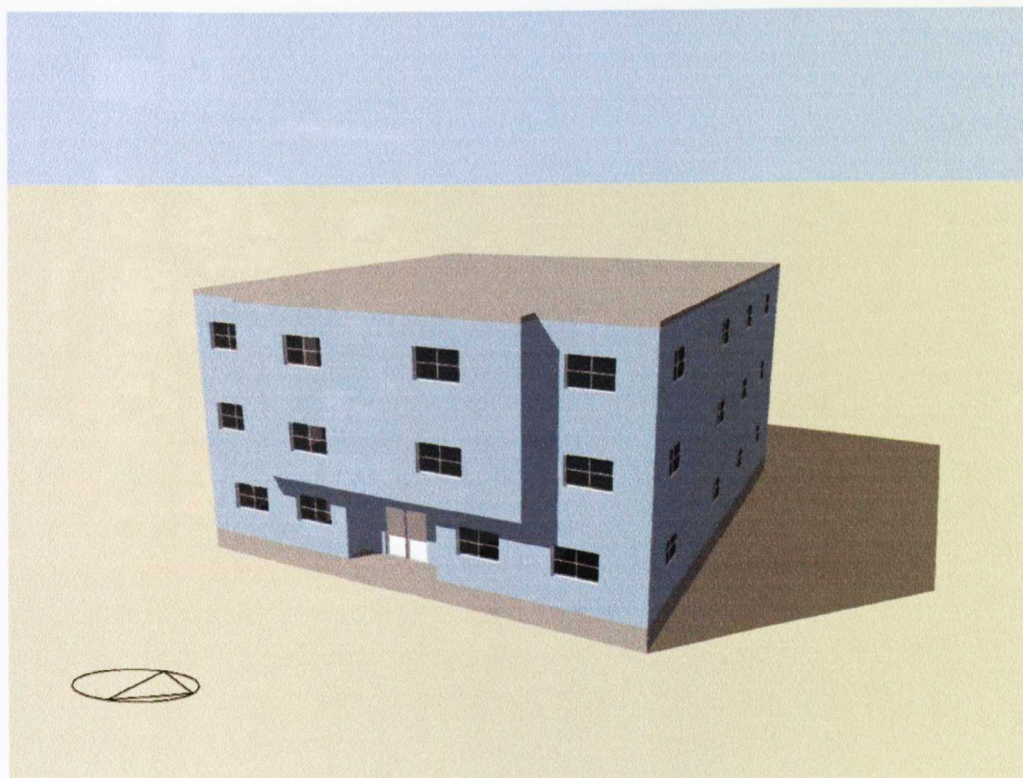


Figure 5.4: 3D Model View of Case 1 (This shot taken on the 15th February at 10 AM)

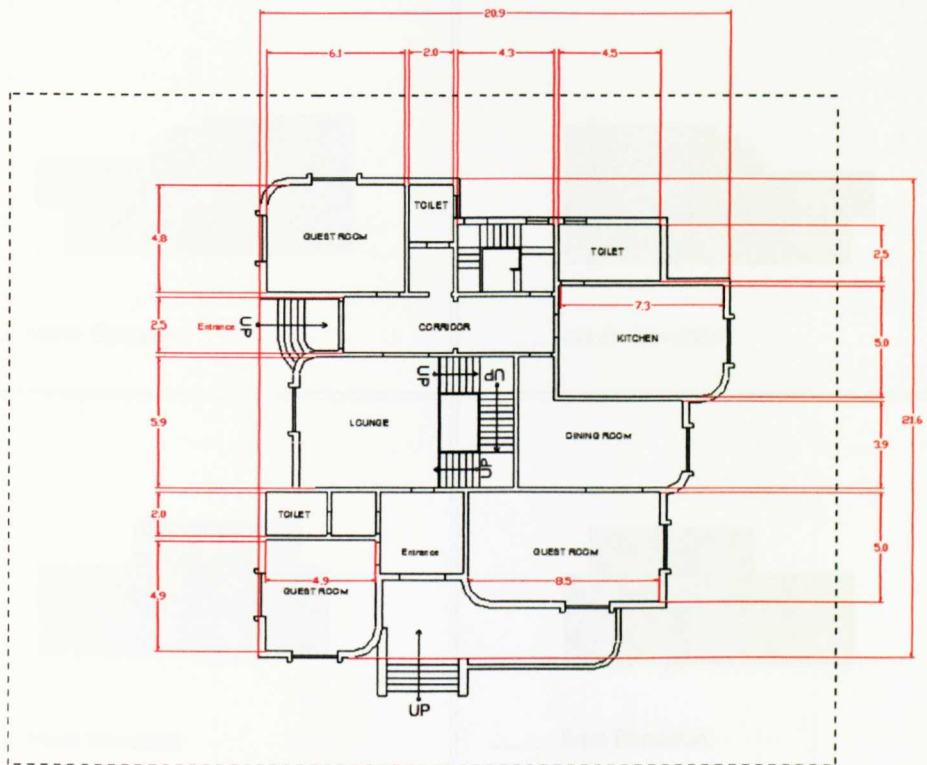
Figure 5.4 was produced with DesignBuilder software using real weather data for Jeddah City. This particular shot shows the shadow expected on the 15th February at 10 AM. According to the most recent available official statistics, including estimates provided by the Saudi Ministry of Economy and Planning (2005, 2007) and the Central Department of Statistics and Information (2008), flats similar to the ones in Case 1 are the most common type of residence in Saudi Arabia. Villas were reported to be the second most common housing type in the country.

5.2.2 Case 2: The Villa

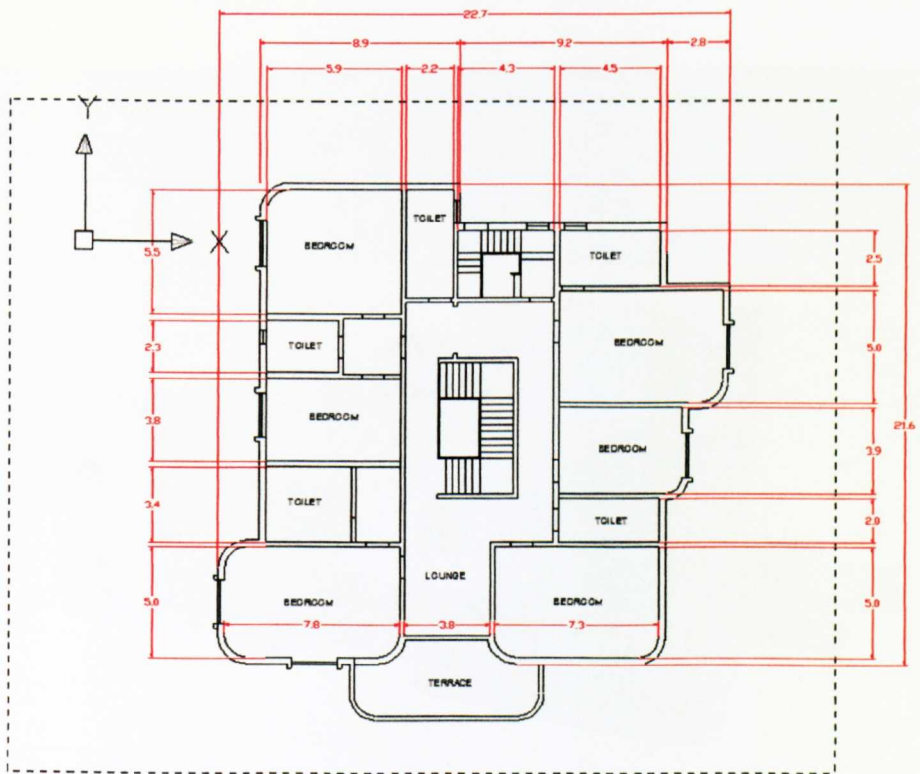
The villa selected for this study (i.e. Case 2) is a six year old, two-storey building. Figure 5.5 demonstrates its location, whilst the Figures 5.6, 5.7 and 5.8 illustrate floor plans, elevations and a 3D model respectively.



Figure 5.5: An Aerial View of Case 2 and its Urban Context (Source: Google Earth)



Ground Floor



First Floor

Figure 5.6: Floor Plans of Case 2

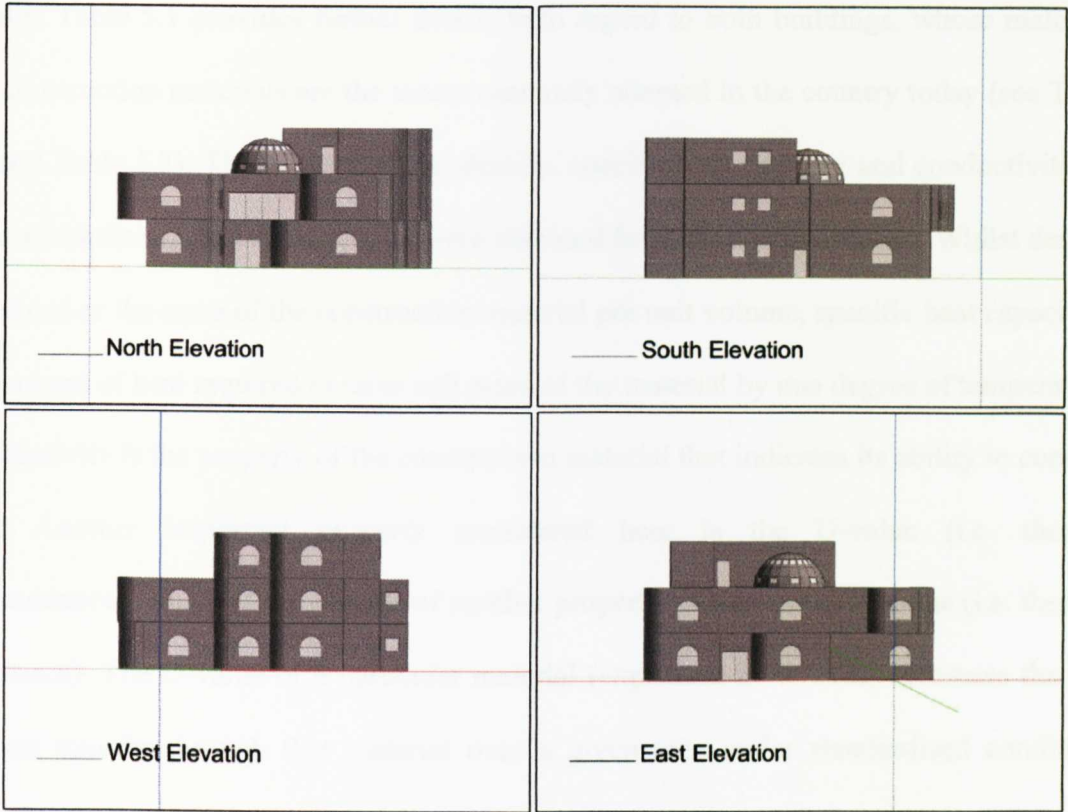


Figure 5.7: Elevations of Case 2

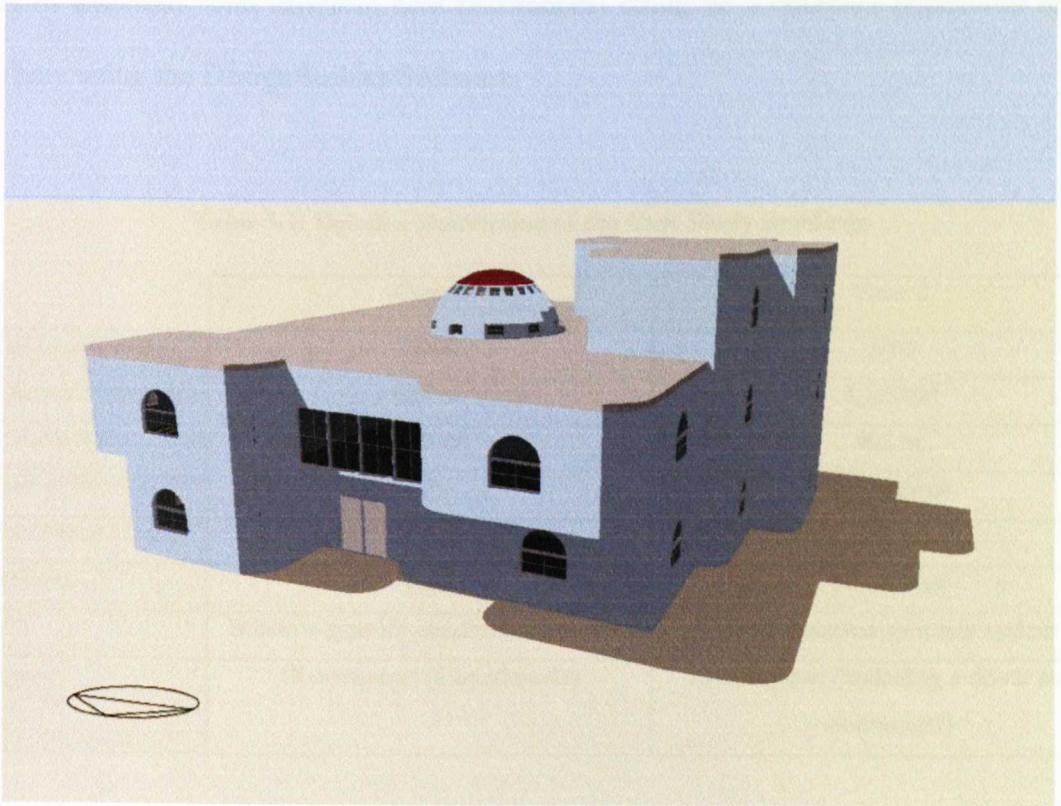


Figure 5.8: 3D Model View of Case 2 (This shot taken on the 15th July at 10 AM)

Finally, Table 5.1 provides further details with regard to both buildings, whose materials and construction materials are the most commonly adopted in the country today (see Table 5.2 and Table 5.3). The properties (i.e. density, specific heat capacity and conductivity) of the construction materials employed were obtained from the DesignBuilder. Whilst density is defined as the mass of the construction material per unit volume, specific heat capacity is the amount of heat required to raise unit mass of the material by one degree of temperature. Conductivity is the property of the construction material that indicates its ability to conduct heat. Another important property considered here is the U-value (i.e. thermal transmittance), which is the inverse of another property known as the R-value (i.e. thermal resistance). The U-value of a particular material (expressed in W/m^2K) measures the rate of heat transfer through that material over a given area under standardised conditions (usually at a temperature of 24° Celsius, 50% humidity with no winds). Calculating the U-value of a construction element (e.g. floors or roofs which essentially consist of several layers of materials with different heat resistances) could be a complex endeavour and is done here using the DesignBuilder Software.

Table 5.1: Detailed Description of the Case Study Buildings

| | Case 1 | Case 2 |
|------------------------------|-------------------------------------|---|
| Year of Completion | 2006 | 2005 |
| Total Land Area | 625 m ² | 1,122 m ² |
| Floor Built Area | 420 m ² | 462 m ² |
| Number of Stories | 3 | 2 + annexe |
| Floor to Floor Height | 3.4 m | 3.6 m |
| Orientation | East | North-East |
| HVAC | Window-type air-conditioning system | Wall-mounted split unit system |
| Occupancy | 18 occupants (6 apartments) | 13 occupants (including a driver and a housemaid) |

Table 5.2: Specification of Case 1's Building Materials and Their Thermal Properties

A) Ground Floor, including earth layer (U-Value = 2.02 W/m²K)

| Material | | | | |
|------------------------------|-------------------------------------|--------------------------------|-------------------------|------------------------------|
| Name | Density kg/m³ | Specific Heat J/kgK | Thickness Mm | Conductivity W/mK |
| Ceramic Tiles | 2300 | 840 | 25 | 1.3 |
| Mortar | 2800 | 896 | 25 | 0.88 |
| Sandstone | 2200 | 712 | 100 | 1.83 |
| Reinforced Concrete | 2300 | 1000 | 100 | 2.3 |
| Asphalt Insulation | 2100 | 1000 | 5 | 0.7 |
| Concrete High Density | 2400 | 1000 | 50 | 2.0 |
| Base-course Stone | 2000 | 1000 | 150 | 1.40 |
| Earth | 1460 | 880 | 2000 | 1.28 |

B) External Walls from outside to inside (U-Value = 0.58 W/m²K)

| Material | | | | |
|------------------------|-------------------------------------|--------------------------------|-------------------------|------------------------------|
| Name | Density kg/m³ | Specific Heat J/kgK | Thickness Mm | Conductivity W/mK |
| Marble | 2800 | 1000 | 40 | 3.5 |
| Mortar | 2800 | 896 | 20 | 0.88 |
| Concrete Blocks | 600 | 1000 | 50 | 0.19 |
| Air Gap | - | - | 50 | - |
| Concrete Blocks | 600 | 1000 | 200 | 0.19 |

C) Internal Partitions (U-Value = 1.92 W/m²K)

| Material | | | | |
|------------------------|-------------------------------------|--------------------------------|-------------------------|------------------------------|
| Name | Density kg/m³ | Specific Heat J/kgK | Thickness Mm | Conductivity W/mK |
| Plaster (Light) | 600 | 1000 | 25 | 0.16 |
| Concrete Blocks | 600 | 1000 | 100 | 0.19 |
| Plaster (Light) | 600 | 1000 | 25 | 0.16 |

D) Intermediate Floors (U-Value = 1.15 W/m²K)

| Material | | | | |
|----------------------------|-------------------------------------|--------------------------------|-------------------------|------------------------------|
| Name | Density kg/m³ | Specific Heat J/kgK | Thickness Mm | Conductivity W/mK |
| Ceramic Tiles | 2300 | 840 | 30 | 1.3 |
| Mortar | 2800 | 896 | 25 | 0.88 |
| Sand Stone | 2200 | 712 | 50 | 1.83 |
| Reinforced Concrete | 2300 | 1000 | 120 | 2.3 |
| Concrete Blocks | 900 | 1000 | 250 | 0.25 |
| Plaster (Dense) | 1300 | 1000 | 20 | 0.5 |

E) Roof (U-Value = 1.16 W/m²K)

| Material | | | | |
|----------------------|------------------------------|------------------------|-----------------|----------------------|
| Name | Density kg/m ³ | Specific Heat J/kgK | Thickness Mm | Conductivity W/mK |
| Ceramic Tiles | 2300 | 840 | 20 | 1.3 |
| Mortar | 2800 | 896 | 10 | 0.88 |
| Sand Stone | 2200 | 712 | 50 | 1.83 |
| Foam Slag Insulation | 1040 | 960 | 20 | 0.25 |
| Asphalt Insulation | 2100 | 1000 | 5 | 0.7 |
| Reinforced Concrete | 2300 | 1000 | 150 | 2.3 |
| Concrete Blocks | 600 | 1000 | 200 | 0.19 |
| Plaster (Dense) | 1300 | 1000 | 20 | 0.5 |

Table 5.3: Specification of Case 2's Building Materials and Their Thermal Properties

A) Ground Floor, including earth layer (U-Value = 1.84 W/m²K)

| Material | | | | |
|-----------------------|------------------------------|------------------------|-----------------|----------------------|
| Name | Density kg/m ³ | Specific Heat J/kgK | Thickness mm | Conductivity W/mK |
| Ceramic Tiles | 2300 | 840 | 25 | 1.3 |
| Mortar | 2800 | 896 | 25 | 0.88 |
| Sandstone | 2200 | 712 | 130 | 1.83 |
| Reinforced Concrete | 2300 | 1000 | 100 | 2.3 |
| Asphalt Insulation | 2100 | 1000 | 5 | 0.7 |
| Concrete High Density | 2400 | 1000 | 70 | 2.0 |
| Base-course Stone | 2000 | 1000 | 180 | 1.40 |
| Earth | 1460 | 880 | 2000 | 1.28 |

B) External Walls from outside to inside (U-Value = 0.57 W/m²K)

| Material | | | | |
|----------------------|------------------------------|------------------------|-----------------|----------------------|
| Name | Density kg/m ³ | Specific Heat J/kgK | Thickness mm | Conductivity W/mK |
| Marble | 2800 | 1000 | 45 | 3.5 |
| Mortar | 2800 | 896 | 25 | 0.88 |
| Concrete Blocks | 600 | 1000 | 50 | 0.19 |
| Foam Slag Insulation | 1040 | 960 | 50 | 0.25 |
| Concrete Blocks | 600 | 1000 | 200 | 0.19 |

C) Internal Partitions (U-Value = 3.50 W/m²K)

| Material | | | | |
|-----------------|------------------------------|------------------------|-----------------|----------------------|
| Name | Density kg/m ³ | Specific Heat J/kgK | Thickness mm | Conductivity W/mK |
| Plaster (Light) | 600 | 1000 | 25 | 0.16 |
| Concrete Blocks | 600 | 1000 | 100 | 0.19 |
| Plaster (Light) | 600 | 1000 | 25 | 0.16 |

D) Intermediate Floors (U-Value = 1.14 W/m²K)

| Material | | | | |
|---------------------|------------------------------|------------------------|-----------------|----------------------|
| Name | Density kg/m ³ | Specific Heat J/kgK | Thickness mm | Conductivity W/mK |
| Marble | 2800 | 1000 | 45 | 3.5 |
| Mortar | 2800 | 896 | 25 | 0.88 |
| Sand Stone | 2200 | 712 | 60 | 1.83 |
| Reinforced Concrete | 2300 | 1000 | 120 | 2.3 |
| Concrete Blocks | 600 | 1000 | 250 | 0.25 |
| Plaster (Dense) | 1300 | 1000 | 25 | 0.5 |

E) Roof (U-Value = 1.0 W/m²K)

| Material | | | | |
|---------------------|------------------------------|------------------------|-----------------|----------------------|
| Name | Density kg/m ³ | Specific Heat J/kgK | Thickness mm | Conductivity W/mK |
| Ceramic Tiles | 2300 | 840 | 20 | 1.3 |
| Mortar | 2800 | 896 | 15 | 0.88 |
| Sand Stone | 2200 | 712 | 50 | 1.83 |
| Foam Insulation | 1040 | 960 | 20 | 0.25 |
| PVC Insulation | 1379 | 1004 | 20 | 0.16 |
| Reinforced Concrete | 2300 | 1000 | 150 | 2.3 |
| Concrete Blocks | 600 | 1000 | 200 | 0.19 |
| Plaster (Dense) | 1300 | 1000 | 20 | 0.5 |

As previously indicated in Chapter 3, Jeddah – which is a diverse and rapidly growing commercial city – is located on the Red Sea (latitude 21.5° N and longitude 39.17° E). The next section provides a detailed overview of the climate of this city.

5.3 An Overview of the Jeddah Climate

When conducting an analysis of the energy use and/or water consumption of a building, it is important to consider the climatic conditions that affect it. The climate in Jeddah during the summer is characterised by fierce heat and high humidity, which tends to be unbearable towards the end of the summer season. During the winter, it maintains its warmth, but with reduced humidity, with some small amounts of rain occasionally falling in November and December (Ham et al., 2004). Further information on temperatures and the rather high solar radiation levels in Jeddah throughout the year are given in Figure 5.9.

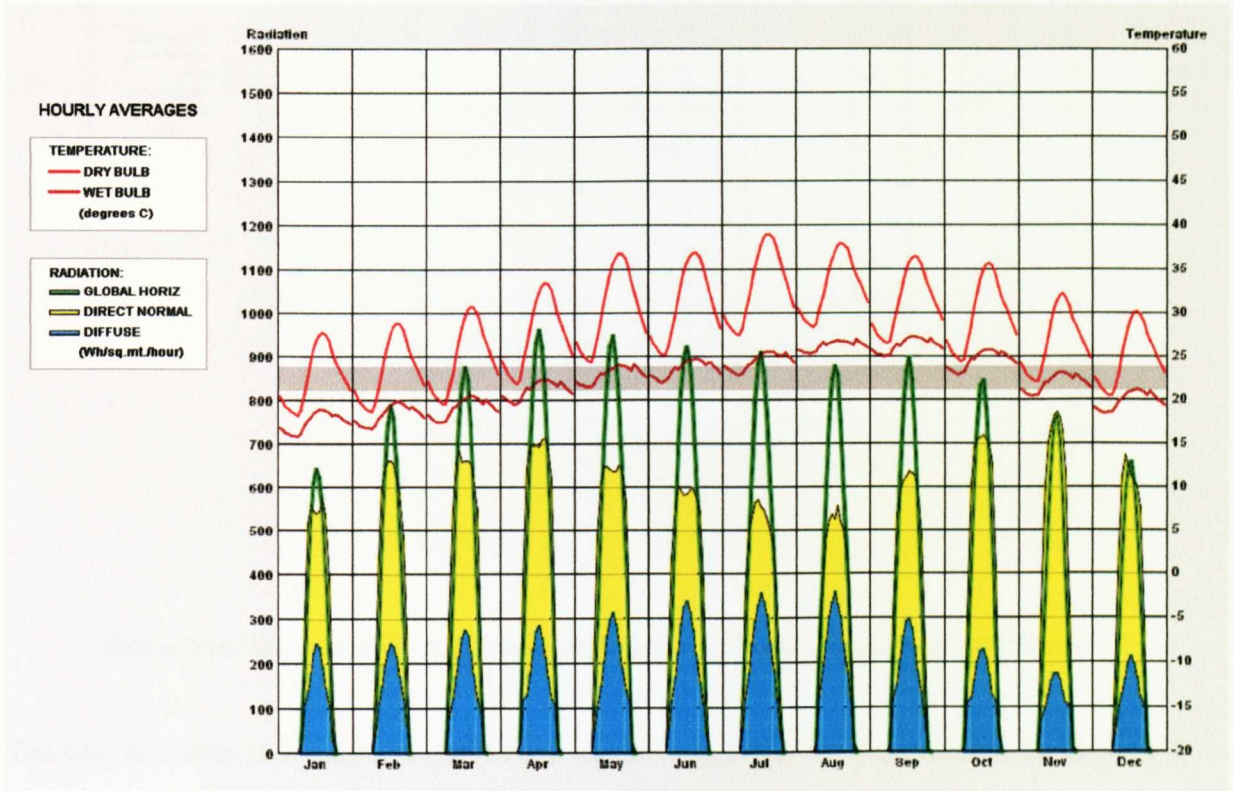


Figure 5.9: Temperature and Solar Radiation Levels in Jeddah
 (Source: Climate Consultant 5 Software)

Figure 5.10 shows wind velocity, measured in metres/second, for each month. The ‘Record High value’ is shown as a small coloured circle. The ‘Average High’ is the average of the highest values from each day of the month or annually and is shown as the top of the coloured bar. The ‘Mean’ or average of all hours is shown as the break in the coloured bar. The ‘Average Low’ is the average of the lowest values from each day of the month or annually and is shown as the bottom of the coloured bar. The ‘Record Low’ value is shown as a small coloured circle.

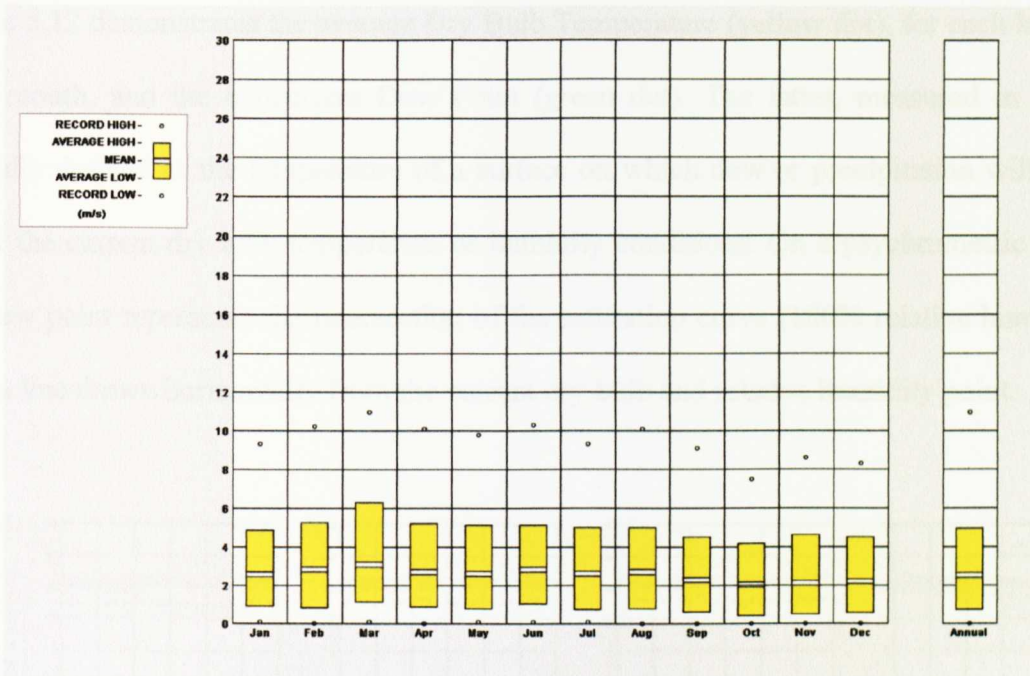


Figure 5.10: Wind Velocity Range in Jeddah (Source: Climate Consultant 5 Software)

The twelve charts, in Figure 5.11, illustrate the average Dry Bulb Temperature (yellow dot), for each hour of each month, and the concurrent Relative Humidity (green dot). The latter, measured as a percentage, is the ratio of the amount of moisture in the air compared to the total amount it could hold at the same Dry Bulb Temperature.

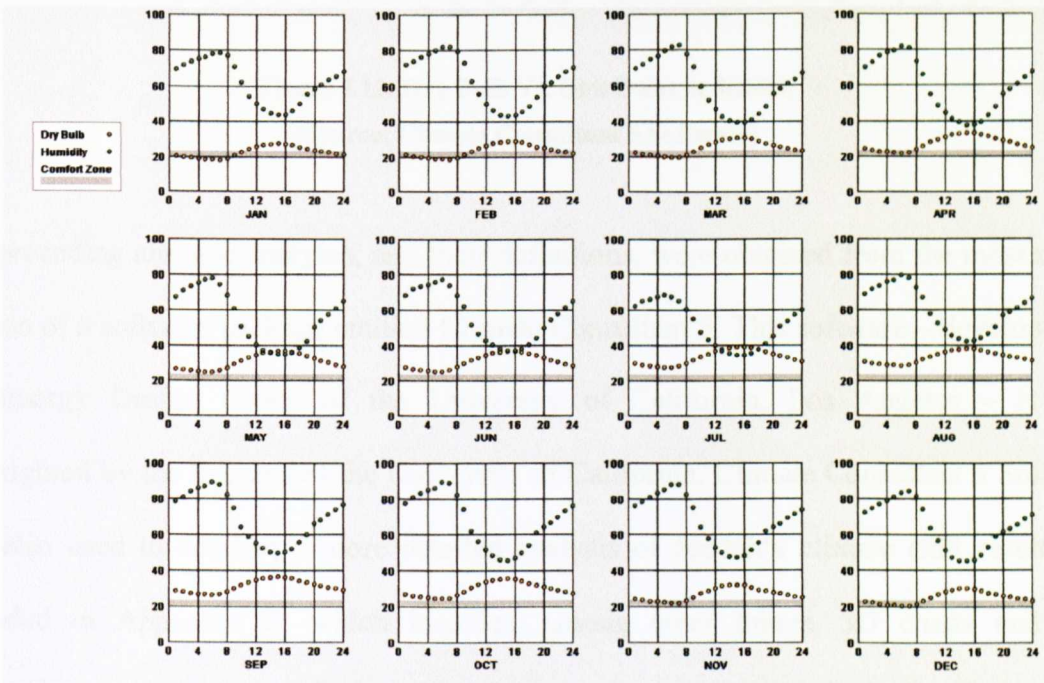


Figure 5.11: Dry Bulb Vs. Relative Humidity in Jeddah (Source: Climate Consultant 5 Software)

Figure 5.12 demonstrates the average Dry Bulb Temperature (yellow dot), for each hour of each month, and the concurrent Dew Point (green dot). The latter, measured in °C, is typically defined as the temperature of a surface on which dew or precipitation will form under the current dry bulb temperature or humidity conditions. On a psychrometric chart, the dew point represents the intersection of the saturation curve (100% relative humidity) with a line drawn horizontally from the current dry bulb and relative humidity point.

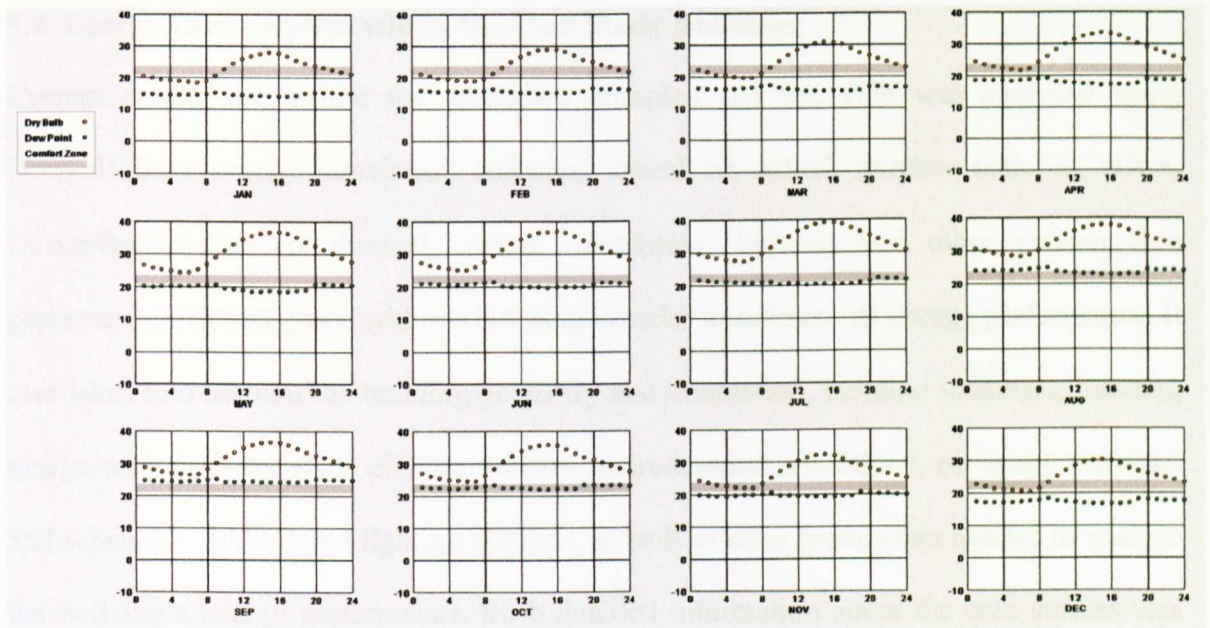


Figure 5.12: Dry Bulb Vs. Dew Point in Jeddah
 (Source: Climate Consultant 5 Software)

The preceding climatic analyses, and their definitions, were obtained from the most recent version of a software package entitled Climate Consultant 5. This software – developed by the Energy Design Group of the University of California, Los Angeles – is now copyrighted by the Regents of the University of California. Climate Consultant 5 Software was also used to conduct a more detailed analysis of Jeddah’s climate (full results are provided in Appendix B, which includes, among other things, 3D charts and data concerning temperatures, radiation, illumination, sky cover and wind). Wasilowski and

Reinhart (2009) argue that bearing in mind the significant influence of weather conditions on building performance, it is essential to use reliable climate data for energy modelling. For the purpose of this thesis, a DesignBuilder simulation was conducted using EnergyPlus built-in hourly weather data for Jeddah City. Having introduced both the case studies and the climate conditions prevailing in the city under consideration, it is now the time to analyse energy and water consumption in the case study buildings.

5.4 Energy Consumption within the Case Study Buildings

Current energy use within the apartment complex and the villa was analysed using DesignBuilder energy simulation software, based on actual weather data. In effect, DesignBuilder models thermal, visual, ventilation, lighting and other consumption processes which take place within a building in order to estimate its energy performance. It also takes into account the building geometry and orientation, building materials, building design and characteristics, climate, indoor environmental conditions, occupant activities and schedules, HVAC and lighting systems, as well as other parameters needed to analyse the building's energy performance. Such detailed information about the case studies was obtained through site visits and intensive discussions with the occupants and with the owners, who oversaw the construction of the houses themselves. Generally speaking, only minor differences were found in terms of human-related factors in each case study. For instance, whilst the number of occupants (and hence occupancy density) varies in houses, the time spent at home (and hence lighting and HVAC schedules) was very similar. DesignBuilder was also used to estimate CO₂ consumption within each building. This was calculated in terms of the type and amount of fuel used to generate electricity at the building level. In essence, CO₂ emissions were calculated by the software by multiplying fuel consumption by a CO₂ conversion factor. No recent conversion factors for Saudi

Arabia seem to be available in the literature. According to DesignBuilder, however, the CO₂ conversion factor in Saudi Arabia is estimated to be 0.685 kgCO₂/kWh.

DesignBuilder provides two further options for design calculations: 'heating design' and 'cooling design'. The first calculation option allows the modeller to determine the size of heating equipment needed for the coldest winter day, whilst the latter examines the capacity of mechanical cooling equipment needed to meet the hottest summer conditions likely to be encountered at the building's site location. Given that no heating equipment is likely to be used in Jeddah's winter season, the 'heating design' calculations are not an applicable design option. Instead, 'cooling design' calculations were carried out by DesignBuilder for both buildings. Such calculations are traditionally carried out using periodic steady-state methods such as the admittance and response factor methods provided by the Chartered Institution of Building Services Engineers (CIBSE) and the American Society of Heating, Refrigerating and Air-conditioning Engineers (ASHRAE). DesignBuilder now carries out the same calculations effectively using the EnergyPlus dynamic thermal simulation engine.

The calculation results for the 'cooling design' simulation at the building level on one of the hottest summer days of the year in Jeddah (i.e. 15th July) were plotted as a graph for Case 1 in Figure 5.13, and Case 2 in Figure 5.14. These graphs show temperatures (in °C) at the top, with all actual heat balances, i.e. heat gain and losses (in kW) at the bottom. The temperatures shown are the outside temperature (in dark blue), air temperature (blue), radiant temperature (red) and finally (in green) the 'operative or comfort temperature', which is the average of the last two. Whilst the temperatures shown are averaged from across the whole building, the heat balance (i.e. gains and losses) is totalled across the

whole building, depending upon its structure and climatic conditions. For instance, the graphs show direct solar gain through windows (in yellow) being highest during the late afternoon, and relatively low at noon time when the sun is in an almost perpendicular position directly above the building.

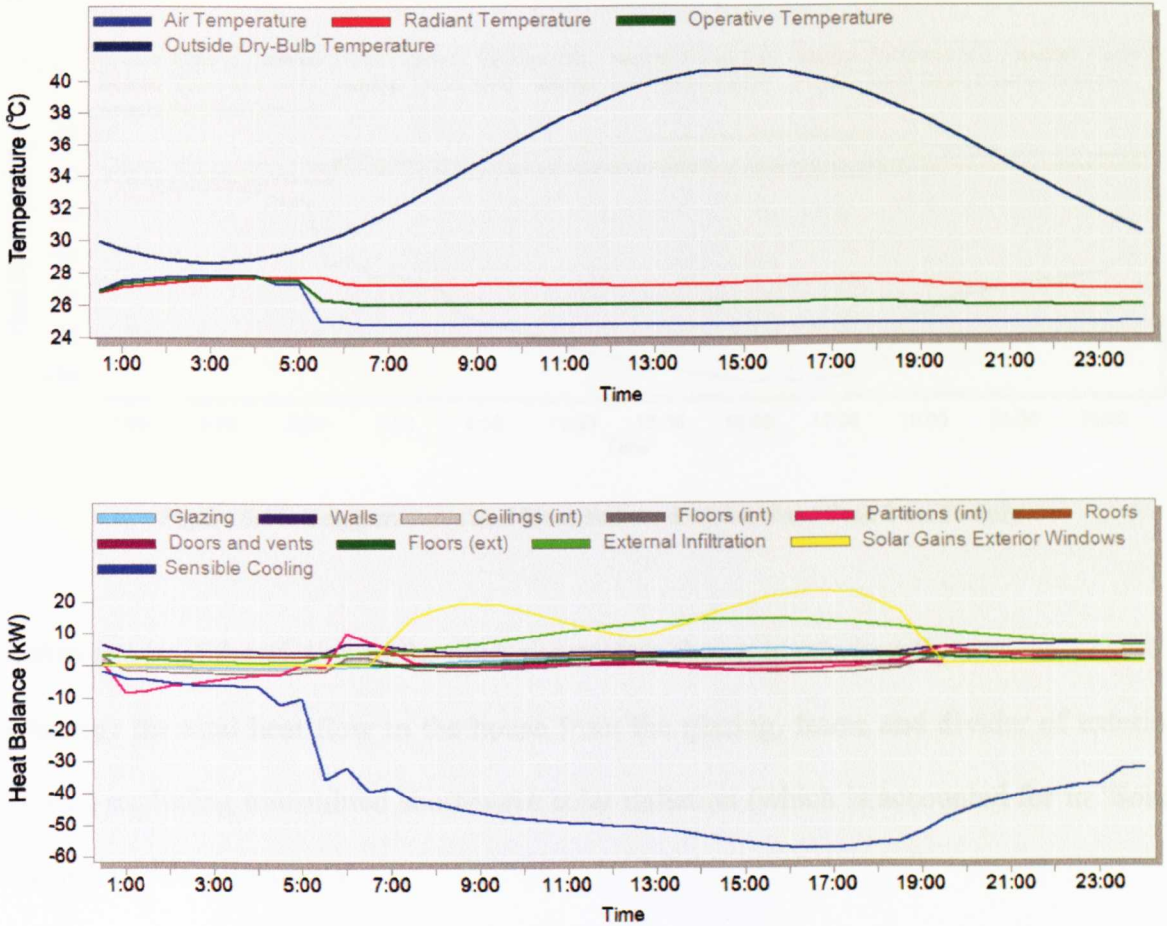


Figure 5.13: Temperatures and Heat Balances of the Base Case 1 on 15 July

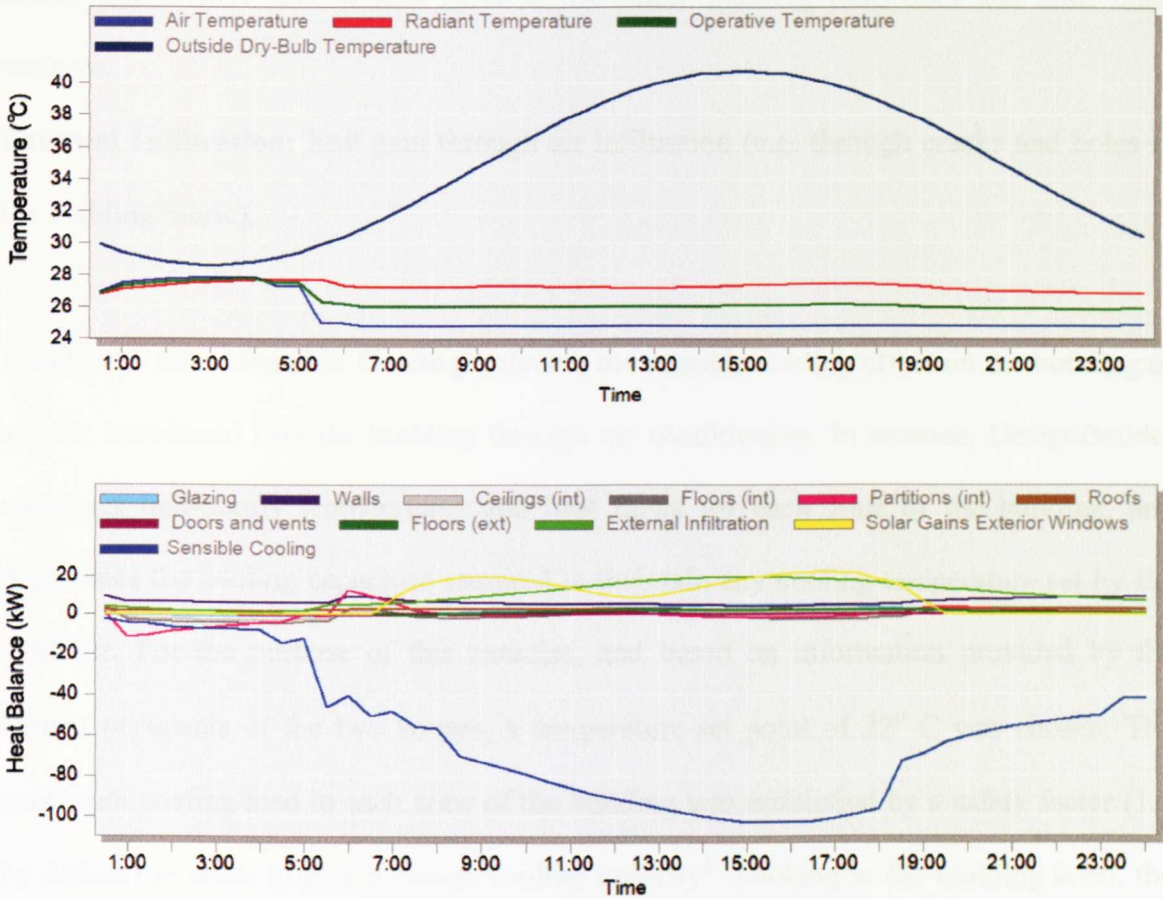


Figure 5.14: Temperatures and Heat Balances of the Base Case 2 on 15 July

Below is a brief description of the other parameters shown in previous figures:

Glazing: the total heat flow to the house from the glazing, frame and divider of exterior glazing excluding transmitted short-wave solar radiation (which is accounted for in ‘Solar Gains Exterior Windows’).

Walls: sum of heat gains to the whole building from external wall inner surfaces.

Ceilings: sum of heat gains to the whole building from ceiling inner surfaces.

Floors (int): sum of heat gains to the whole building from internal floor inner surfaces.

Floors (ext): sum of heat gains to the whole building from external floor inner surfaces.

Partitions: sum of heat gains to the whole building from internal partition inner surface.

Roofs: sum of heat gains to the whole building from external roof inner surfaces.

Doors and Vents: sum of heat gains to the whole building from door and zone inner surfaces.

External Infiltration: heat gain through air infiltration (e.g. through cracks and holes in the building fabric).

Finally, the term '**Sensible Cooling**' refers to the sensible cooling effect on the building of any air introduced into the building through air conditioning. In essence, DesignBuilder calculates half-hourly temperatures and heat flows for each zone of the building, and determines the cooling capacities required to maintain any cooling temperature set by the modeller. For the purpose of this exercise, and based on information provided by the current occupants of the two houses, a temperature set point of 22° C was chosen. The maximum cooling load in each zone of the building was multiplied by a safety factor (1.3 by default) in order to give a design cooling capacity³. Looking at the building level, the total design cooling requirement for Case 1 and Case 2 was estimated at 88.24 MW and 151.37 MW, respectively. Besides looking at the hottest summer day, energy use within the two buildings was also examined using longer timeframes, e.g. weeks, months and seasons. Figure 5.15 and Figure 5.16 illustrate the monthly energy consumption of Case 1 and Case 2 respectively, in relation to comfort conditions (measured in terms of temperature and humidity readings).

³ The safety factor is a 'cooling design margin' used to multiply the cooling loads calculated, in order to give a recommended maximum cooling equipment capacity. This multiplier accounts for any additional cooling required to cool the building down in a reasonably short pre-cool period, and allows the modeller to be confident that comfort conditions will be maintained in all but the most extreme summer conditions (DesignBuilder Software, 2009).

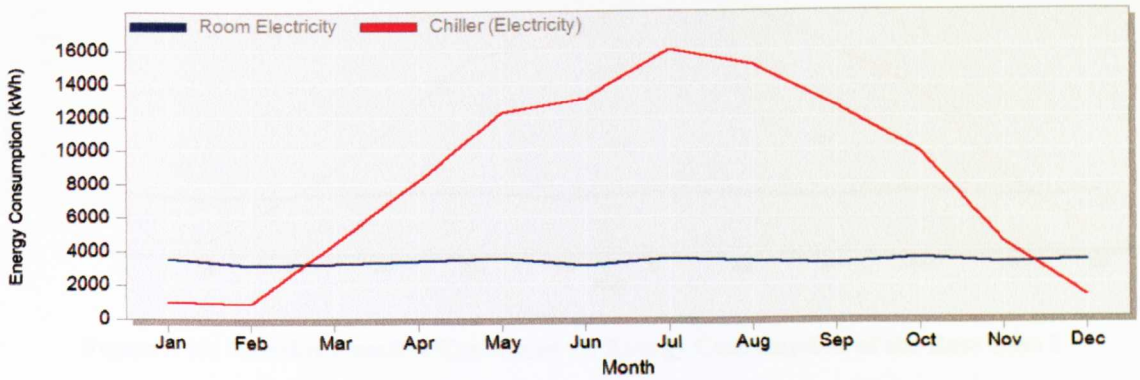
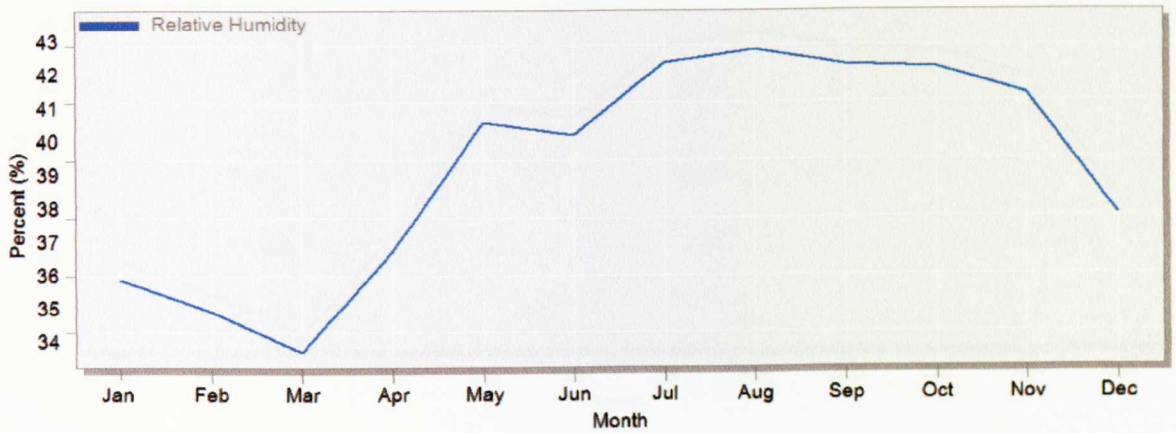
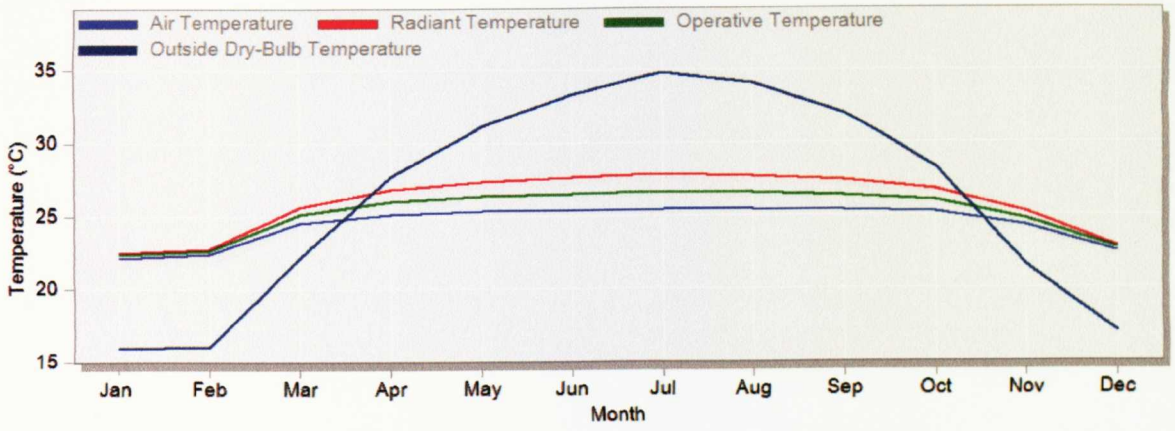


Figure 5.15: Monthly Comfort Conditions vs. Energy Consumption of the Base Case 1

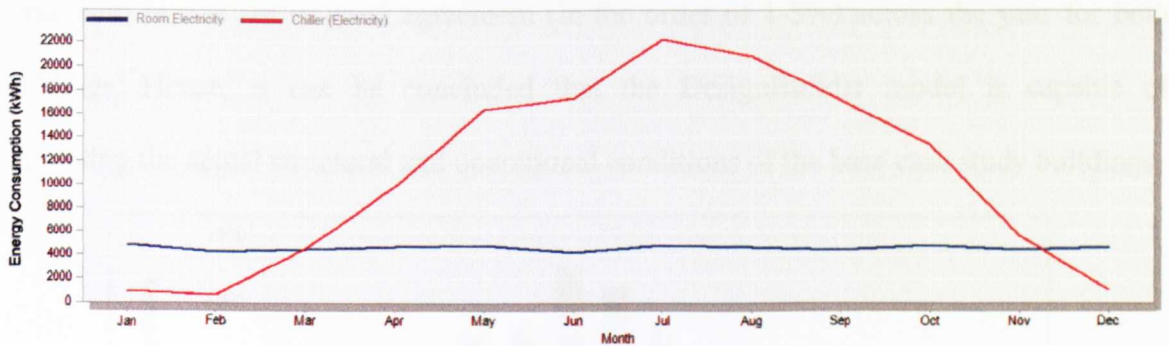
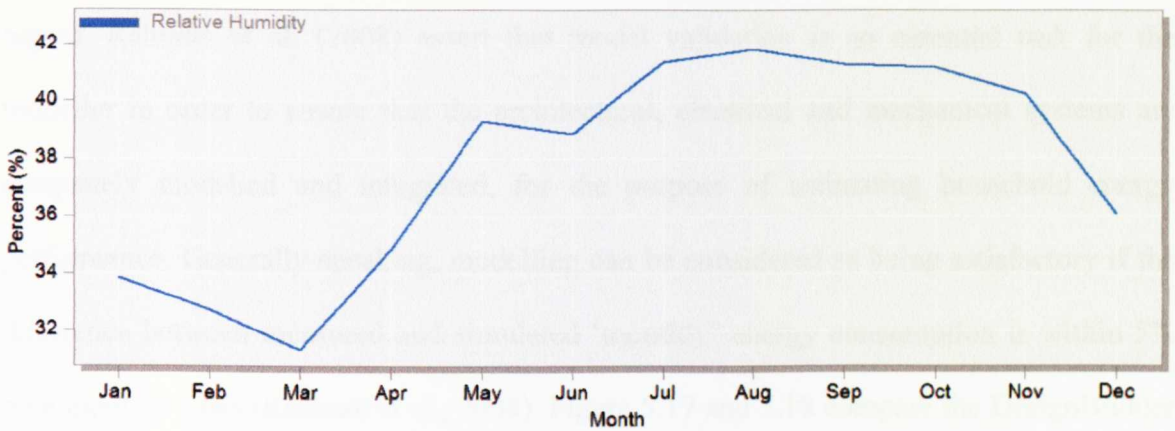
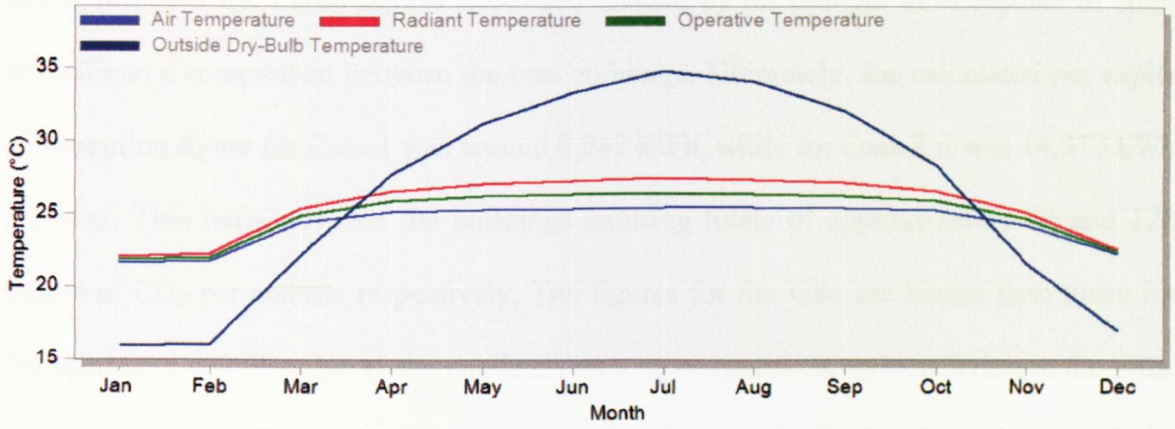


Figure 5.16: Monthly Comfort Conditions vs. Energy Consumption of the Base Case 2

Next, total energy use within the buildings was simulated for a whole year, using EnergyPlus real climatic data. Looking at the building level, the annual energy consumption figures for Case 1 and Case 2 were calculated to be 144.9 MWh and 186.9

MWh, respectively. These figures were then divided by the number of occupants in order to facilitate a comparison between the two buildings. Ultimately, the calculated per capita consumption figure for Case 1 was around 8,047 kWh, while for Case 2 it was 14,377 kWh per year. This translates into the buildings emitting totals of approximately 99 and 128 tonnes of CO₂ per annum, respectively. The figures for the villa are higher than those for the apartment complex due to the emphasis on a more luxurious style of living at the villa. In order to validate the accuracy of the DesignBuilder models that had been developed, the simulation results were compared with readings obtained from actual utility bills. In this regard, Rahman et al. (2008) assert that model validation is an essential task for the modeller in order to ensure that the architectural, electrical and mechanical systems are adequately modelled and integrated, for the purpose of estimating household energy performance. Generally speaking, modelling can be considered as being satisfactory if the difference between measured and simulated ‘monthly’ energy consumption is within 5% on a monthly basis (Rahman et al., 2008). Figure 5.17 and 5.18 compare the DesignBuilder simulation results and actual utility bills for the year 2008, and demonstrates that the simulation results are in good agreement (in the order of 1-5%) across the year for both buildings. Hence, it can be concluded that the DesignBuilder model is capable of simulating the actual structural and operational conditions of the base case study buildings.

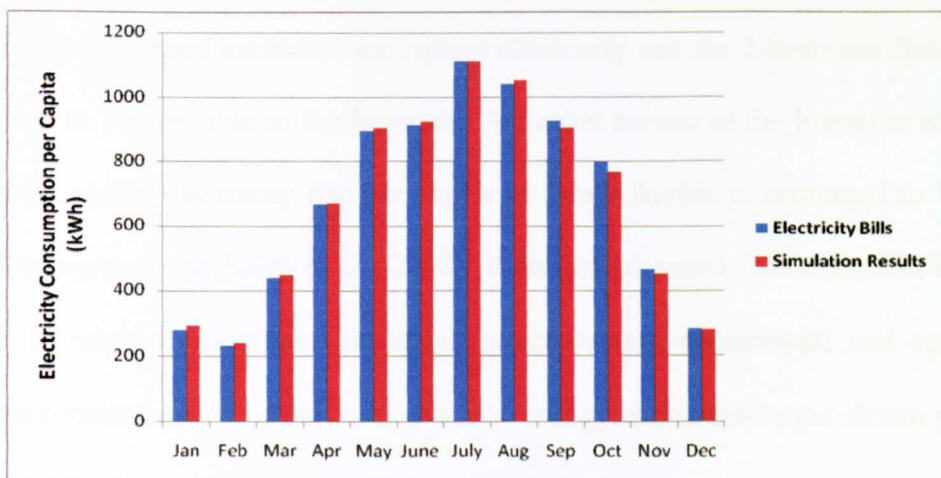


Figure 5.17: Calibration of the Simulation Results for Base Case Study 1

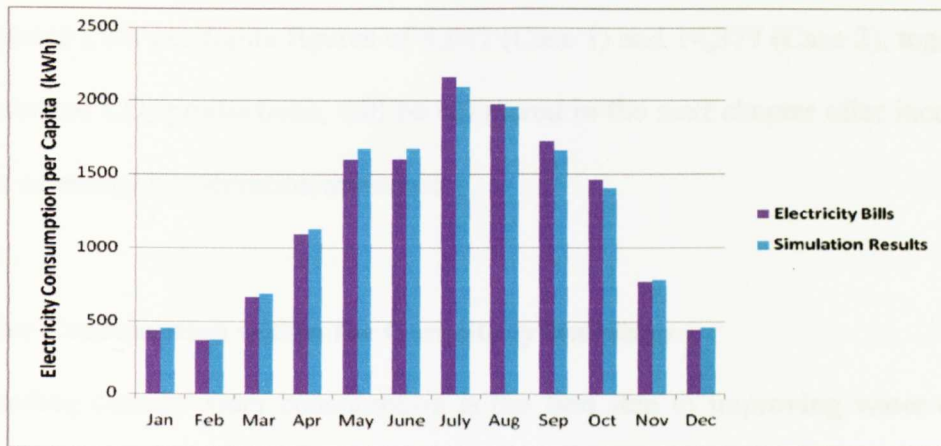


Figure 5.18: Calibration of the Simulation Results for Base Case Study 2

Considering Case 1, annual electricity consumption per flat was obtained by dividing the annual consumption for the building by six, the number of flats in the building. Hence, the average annual per capita figure for each flat is estimated at around 24,141 kWh, which seems exceptionally high when compared with other parts of the world with similar climatic conditions. An attempt was therefore made to validate such a high calculated electricity use rate. Eventually, not only did it show reasonable agreement with readings obtained from actual utility bills, but the estimate seemed to be a conservative one when bearing in mind that typical household electricity consumption for a Saudi flat was reported to be 20,000 kWh per year more than a decade ago (Al-Ajlan et al., 1998). No more recently published estimates for typical electricity use for 2-bedroom flats in Saudi Arabia seem to be available in the literature. A further review of the literature reveals that the ‘overall’ annual electricity use per capita in Saudi Arabia is estimated to be around 6,200 kWh/cap/year (Al-Saleh et al., 2008). It should be noted, however, that due to the existence of other applications (industrial, governmental, commercial and agricultural) which also constitute parts of the country’s total energy consumption (as shown previously in Figure 3.35), the country’s ‘overall’ per capita electricity consumption is expected to be

less than the abovementioned calculated ‘residential’ figures. For the purpose of this thesis, the calculated kWh per capita figures of 8,047 (Case 1) and 14,377 (Case 2), together with their associated CO₂ productions, will be compared in the next chapter after incorporating a number of energy conservation measures.

5.5 Water Consumption within the Case Study Buildings

Understanding current water consumption is the first step to improving water efficiency within a building. As explained in Chapter 4 (Section 4.3), the estimation of water use in the case study buildings was largely based on an adapted version of the BRE Code Water Calculator, which determines average water consumption per capita, depending on the number and type of fittings and appliances installed in a house. Table 5.4 contains the input figures which were assumed for the purpose of this exercise. These assumptions were based on real specifications, not all of which were readily available from the occupants. On some occasions, photographs were taken of the fittings and appliances, which were then shown to an appliance provider or salesman in order to identify the particular model, allowing the specifications to be obtained in that manner.

Table 5.4: Assumed Input Data for Water Consumption Analysis

| Item | Specification | Case 1 | Case 2 |
|--------------------------|----------------------|------------------|------------------|
| Basin taps (dual) | Flow rate | 10 Litres/min | 11 Litres/min |
| Fixed-flush cistern | Capacity | 8 Litres | 9 Litres |
| Bidet | Consumption | 2.64 Litres/use | 2.64 Litres/use |
| Shower | Flow rate | 18 Litres/min | 20.5 Litres/min |
| Bath | Capacity to overflow | 225 Litres | 320 Litres |
| Kitchen sink taps (dual) | Flow rate | 15 Litres/min | 16 Litres/min |
| Washing machine | Consumption | 151 Litres/cycle | 151 Litres/cycle |
| Dishwasher | Consumption | N/A | 20 Litres/cycle |

These assumptions for the number, type, flow rates and consumption figures for each item were entered into the BRE Code Water Calculator. A rule set by this water use simulation software is that only 2/3 of the actual flow rates for the taps of both hand basin and kitchen should be entered. The outputs from this software are provided as litres per capita, per day (LCD), and hence figures for water consumption per capita will be expressed throughout the thesis in terms of LCD. Having run the water calculator, the water consumption per capita figures for Case 1 and Case 2 were estimated to be 449 and 504 LCD, respectively. However, when considering the living style within a typical house in Saudi Arabia, it is noted that there are additional water-consuming activities that are not taken into account by the BRE Code Water Calculator. These include ablutions, toilet cleaning, car washing, irrigation, courtyard cleaning and water used to top up swimming pools. Therefore, real-life experiments were conducted in order to estimate the amount of water consumed in each of these activities within both houses (see Table 5.5 for the results of these experiments). By adding the sum of water used during these activities to the water consumption figures obtained from the BRE Code Water Calculator, it is estimated that the 'total' water consumption per capita within Case 1 and Case 2 is 497 and 565 LCD respectively. It should be mentioned here that whilst there are twelve toilets in Case 1, only eight exist in Case 2. Nonetheless, the toilets, courtyards and gardens in Case 2 (the Villa) are larger than those in Case 1 (the apartment complex). Therefore, the amount of water consumed during toilet cleaning, irrigation and courtyard cleaning is relatively larger in Case 2. In addition, the 18 occupants who live Case 1 own six cars (one car for each apartment), whilst the 13 occupants of Case 2 own four cars in total. As a final note, the swimming pool (in Case 2) has a capacity of 42 m³ (42,000L of water), with an estimated water consumption figure of around 360 Litres/week in order to compensate any loss due to evaporation (and water that leaves the pool on bodies).

Table 5.5: Water Consumption of Activities not considered by the BRE Code Water Calculator

| Activity | Case 1 | Case 2 |
|--------------------------------------|------------------------------------|------------------------------------|
| Ablutions | 26 LCD | 28 LCD |
| Toilet cleaning | 21 L/toilet per day (14 LCD) | 29 L/toilet per day (16 LCD) |
| Car washing | 126 L/car per week (6 LCD) | 159 L/car per week (7 LCD) |
| Irrigation/courtyard cleaning | 252 L/building per week (2 LCD) | 540 L/building per week (6 LCD) |
| Swimming pool – make-up water | N/A | 360 L/week (4 LCD) |
| TOTAL | 48 LCD | 61 LCD |

In short, having modelled and assessed water consumption for the two case studies, the average daily amount of water consumed within the residential buildings is estimated as being 497 LCD (Case 1) and 565 LCD (Case 2). Bearing in mind the simplifications adopted when conducting this analysis, an attempt was made to validate these calculated estimates. To do this, water utility bills for the year 2008 were collected and scrutinised, whilst also bearing in mind the number of times that private water trucks had to be procured over the whole year. According to these empirical findings, the consumption rate over the 2008 year averaged around 560 LCD (Case 1) and 596 LCD (Case 2). This translates into being 63 and 31 LCD respectively higher than the calculated consumption rates. These findings seem logical given that the calculated figures did not take into account any potential losses in the system due to leaks. According to Al-Saleh (2010), the amount of water loss due to faulty maintenance in the country's water networks ranges from 22% to 30%, which is very high compared with a typical international standard of 10%. Further attempts were also made to compare the calculated per capita figures with published estimates in the literature. For instance, it was found that the calculated figures

were higher than the anticipated rate of 435 LCD that was forecast a couple of decades ago by Abdulrazzak and Khan (1990). However, given that they are comparable to recently reported rates within other GCC countries (e.g. Alshawaf, 2008; Darwish et al., 2008; Sorenson, 2007), it could be suggested that the calculated consumption rates represent typical Saudi household water consumption rates. Such rates would indeed place them among the highest users in the world, bearing in mind that the European average is approximately 200 LCD, whereas in many places in Africa it is much lower than 20 LCD (UNDP, 2006).

Having analysed energy and water consumption for the 'base case' study buildings, the next chapter considers the 'efficient case' by looking into ways that could make the buildings more energy and water efficient.

Chapter 6

Efficient Case: Making Saudi Houses More Energy and Water Efficient

6.1 Chapter Overview

This chapter will suggest a number of design-related measures and strategies that could enhance energy and water efficiency within the case study buildings under consideration that are located in Jeddah City. In addition, potential energy and water savings that could result from incorporating these recommended measures, both individually and collectively, are evaluated in detail.

6.2 Evaluation of Suggested Energy Conservation Measures

Electrical energy conservation and renewable energy technologies are usually considered as the most vital pillars of sustainable energy policy. In the context of buildings, the term ‘energy conservation measures’ essentially refers to any installation and/or modification of an existing building, with the ultimate aim of reducing its energy consumption. Among the many factors that affect the energy consumption of a given building are the building type, climatic conditions, building materials, lighting systems, installations for HVAC and cooling and energy consumption profiles (Balara et al., 2000). Building envelopes (walls, floors, roofs, windows and doors) also make a vital impact on the energy used within the building. Therefore, amongst the most frequently recommended energy conservation measures is the improvement of the energy performance of the building envelope, which may entail the addition of thermal insulation, the proper placement of windows and the use of more energy-efficient windows (Kreith and Goswami, 2007). For instance, insulating a home in a hot region would allow the building to use less cooling energy to achieve the same temperature. Similarly, installing fluorescent lights – instead of incandescent lights – helps by achieving higher levels of illumination from a lower energy input (Energy

Efficiency and Renewable Energy, 2009). Many of these energy conservation measures may require additional upfront costs, but often pay for themselves quickly through energy savings. CFLs, for example, use two-thirds less energy and tend to last some six to ten times longer than conventional incandescent lights (Environmental and Energy Study Institute, 2006).

Nonetheless, it should be recognised that whilst improving household energy efficiency is usually considered a measure of progress towards achieving sustainable architecture, there are still some controversial issues that are occasionally associated with it. For instance, it has recently been argued that energy efficiency may result in a 'rebound effect', which essentially refers to possible increases in consumption caused by the introduction of more efficient technologies (Hanley et al., 2009). Nonetheless, it is generally accepted that, given the negligible impact of this rarely-occurring phenomenon, enhancing energy efficiency results in economic and environmental benefits, and should therefore be encouraged and pursued at all levels (Linares and Labandeira, 2009).

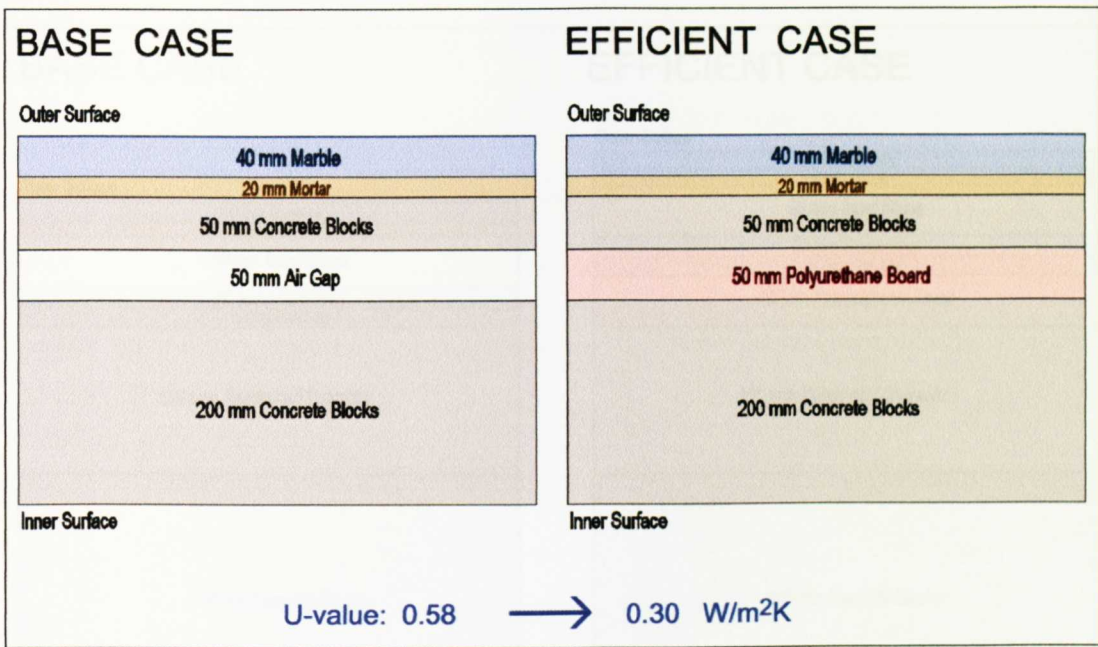
If the case study building studies were still at the design stage, a number of measures could have been taken in order to enhance energy efficiency and hence reduce household electricity consumption. Some of the available options include: insulating external walls and the roofs of the house; using glazed windows and fitting shading devices (e.g. windows with side fins, overhangs or a combination of both); changing the HVAC strategy; fitting green roofing and using energy-efficient equipment including water heaters and lighting fittings. For example, fluorescent lights instead of less-efficient incandescent lamps could be used. A range of other energy-efficient practices do indeed exist around the world, such as the use of free cooling to reduce the electric load of air conditioning (AC)

systems, as well as the fitting of lighting controls in order to adjust the lighting according to daylight luminance. Certainly, re-running the DesignBuilder simulations with such modifications shows a significant improvement in terms of energy efficiency. Below is a brief description of each energy conservation measure suggested, followed by an evaluation of its energy saving potential.

6.2.1 Improved Thermal Insulation

When considering the structure of the external walls of Cases 1 and 2 (described previously in Table 5.2 and Table 5.3), it is noted that some kind of thermal insulation had already been employed. More specifically, an ‘air gap’ was found in Case 1, whilst ‘Foam Slag’ insulation was used in Case 2. If the case study buildings were still at the design stage, one could recommend using alternative insulation materials with better insulation properties. For instance, it could be suggested that replacing the air gap and foam slag insulation with 50mm ‘polyurethane’ insulation could achieve significant reductions in terms of the U-value (i.e. thermal transmittance) of the external walls. It should be noted here that since the U-value measures the rate of heat transfer through a building element, reducing the U-values should lead to energy savings through lower solar cooling loads. Figure 6.1 illustrates the modification suggested, along with the calculated U-values of the external walls before and after applying polyurethane insulation materials.

A) CASE 1: The Apartment Complex



B) CASE 2: The Villa

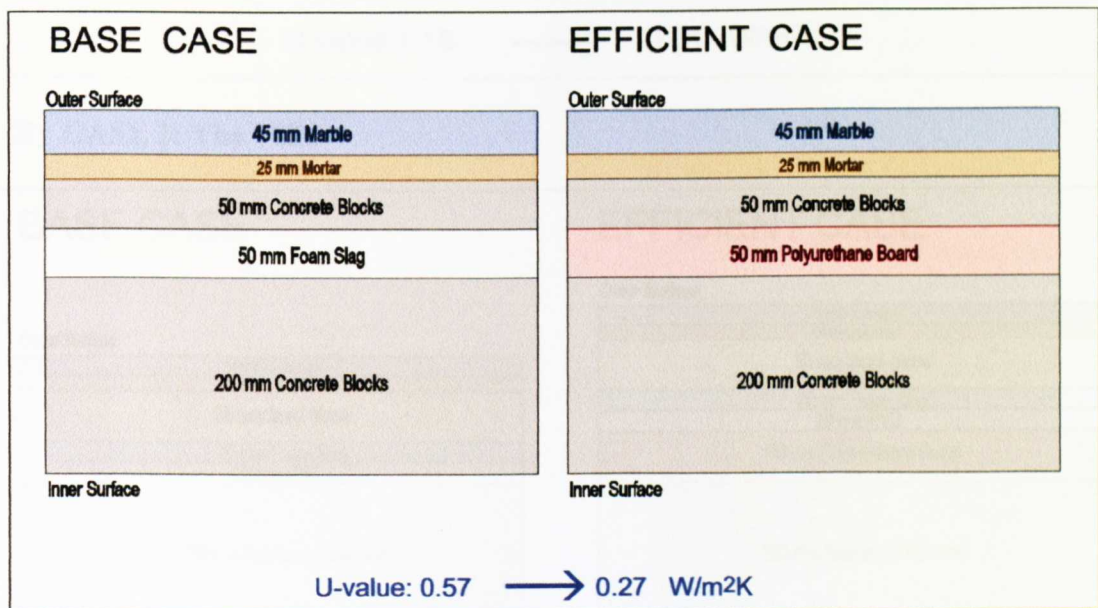
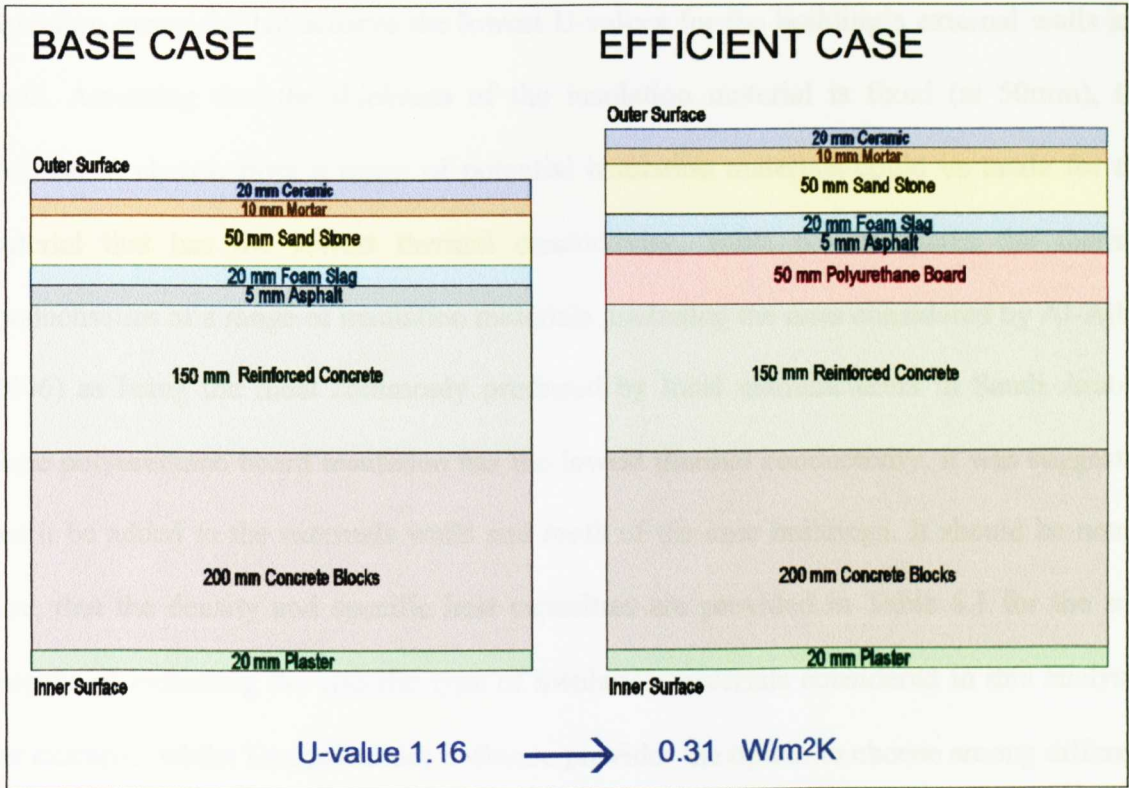


Figure 6.1: Cross-sections of the External Walls in the Base and Efficient Case Buildings

With regard to the roofing, it is recommended that an additional layer of 50mm of polyurethane insulation should be added between the asphalt insulation and the reinforced concrete that made up the roof of Case 1. A similar polyurethane layer could be added in Case 2's roof construction, between the PVC insulation and the reinforced concrete (see Figure 6.2).

A) CASE 1: The Apartment Complex



B) CASE 2: The Villa

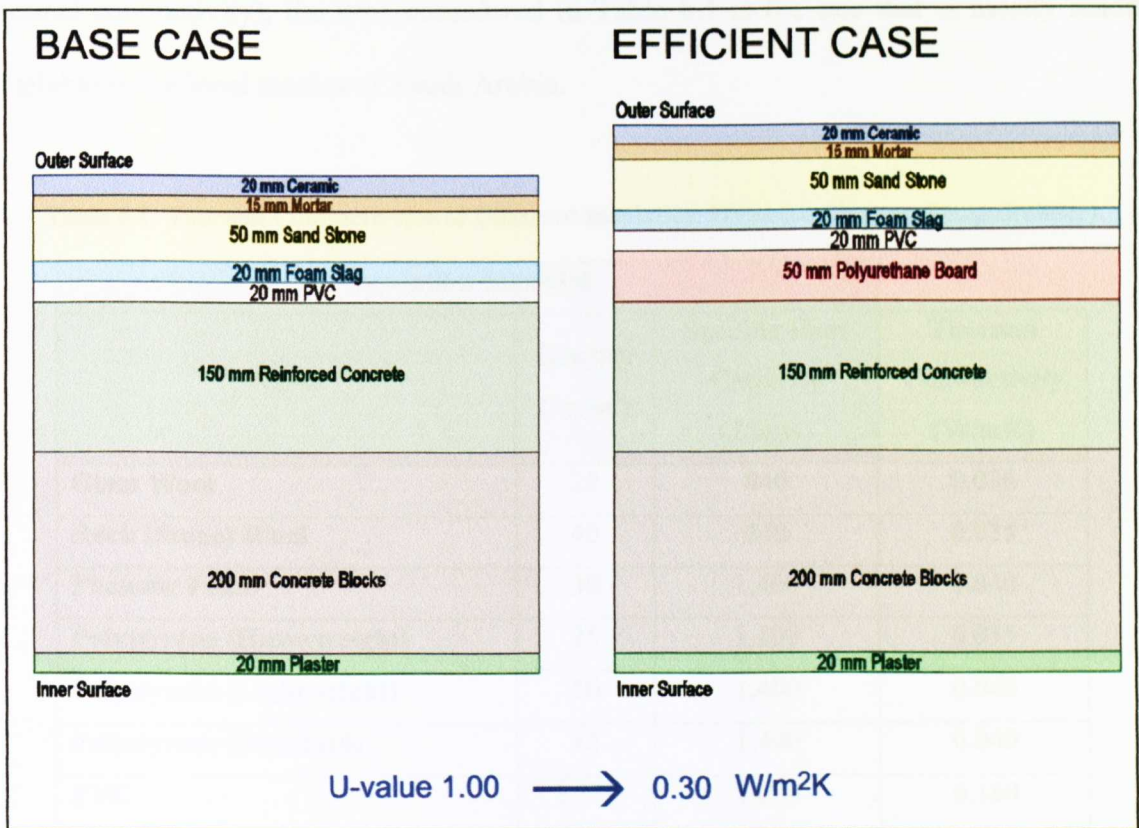


Figure 6.2: Cross-sections of the Roofs in the Base and Efficient Case Buildings

In order to enhance the energy efficiency of a building, it is usually suggested to choose insulation materials that achieve the lowest U-values for the building’s external walls and roofs. Assuming that the thickness of the insulation material is fixed (at 50mm), the decision to choose from a range of potential insulation materials could be made for the material that has the lowest thermal conductivity. Table 6.1 compares the thermal conductivities of a range of insulation materials, including the ones considered by Al-Ajlan (2006) as being the most commonly produced by local manufacturers in Saudi Arabia. Since polyurethane board insulation has the lowest thermal conductivity, it was suggested that it be added to the external walls and roofs of the case buildings. It should be noted, here, that the density and specific heat capacities are provided in Table 6.1 for the sole purpose of indicating the specific type of insulation materials considered in this analysis. For example, whilst DesignBuilder Software provides the option to choose among different types of polyurethane insulations (each with different density, specific heat capacity and thermal conductivity), the type considered in Table 6.1 is the one that is mostly readily available in the local market of Saudi Arabia.

Table 6.1: Thermal Conductivities of Different Insulation Materials (Source: DesignBuilder)

| Insulation Material | | | |
|----------------------------------|---------------------------------------|---|--|
| Name | Density (kg/m³) | Specific Heat Capacity (J/kgK) | Thermal Conductivity (W/mK) |
| Glass Wool | 20 | 840 | 0.036 |
| Rock (Stone) Wool | 40 | 840 | 0.038 |
| Phenolic Foam | 30 | 1,400 | 0.040 |
| Polystyrene (Heavyweight) | 25 | 1,400 | 0.035 |
| Polystyrene (Lightweight) | 10 | 1,400 | 0.046 |
| Polystyrene (Standard) | 15 | 1,400 | 0.040 |
| PVC | 1,379 | 1,004 | 0.160 |
| Polyurethane Board | 35 | 1,590 | 0.028 |

Apparently, whilst the use of any of these insulation materials could have achieved better thermal insulation than that provided by the materials originally used in the ‘base’ case studies, it is clear that polyurethane has the best insulation properties. In addition, if polyurethane was used as suggested above, the ‘efficient’ case studies would comply with the U-value requirements for building energy efficiency in Australia, China, India and the USA. Table 6.2 provides a snapshot of the maximum limits for the U-factors of the roofs and external walls in these countries, most of which were exceeded in the ‘base’ case study buildings.

Table 6.2: Maximum U-values (W/m²K) in Australia, China, India and the USA

(Source: Bureau of Energy Efficiency, 2009)

| Building Element | Australia (Darwin) | China (Hainan) | India (New Delhi) | USA (Miami) |
|-------------------------|---------------------------|-----------------------|--------------------------|--------------------|
| External wall | 0.56 | 1.5 | 0.44 | 0.64 |
| Roof | 0.31 | 0.9 | 0.41 | 0.36 |

It is worth mentioning, here, that another important property for improving energy efficiency is thermal inertia (or thermal mass). As mentioned earlier in Chapter 2, this property represents the capacity of a material to store heat. High thermal inertia walls, whilst not necessarily having good insulation properties, have the ability to provide better indoor comfort through delaying and reducing the impact of outdoor temperature changes on air-conditioned indoor environments. In other words, walls that are constructed from materials with high thermal inertia will delay heat entering the building by storing it during the day and releasing it during the night when the temperature falls. It is widely accepted that the use of high thermal inertia walls, with excellent thermal insulation in buildings, will usually result in a reduction of energy requirements in terms of both cooling and heating (Aste et al., 2009).

Using real climatic data for Jeddah City, DesignBuilder was used to estimate possible savings in terms of household energy consumption and associated CO₂ emission levels (see Table 6.3) as a result of potential thermal insulation improvements. Considerable savings are achievable after incorporating the use of polyurethane board in the external walls and roofs of each case building.

**Table 6.3: The Potential Effect of Improving Thermal Insulation
in terms of Electricity Use and CO₂ Reductions**

| | | Before | After | Reduction (%) |
|--------|--|--------|--------|---------------|
| Case 1 | Electricity consumption (kWh/cap/year) | 8,047 | 7,442 | 7.5 |
| | CO₂ emissions (kg/cap/year) | 5,512 | 5,098 | |
| Case 2 | Electricity consumption (kWh/cap/year) | 14,377 | 13,834 | 3.8 |
| | CO₂ emissions (kg/cap/year) | 9,848 | 9,476 | |

6.2.2 More Efficient Glazing and Shading Arrangements

There is no doubt that using energy-efficient windows (those with low rates of heat loss or low U-values) is beneficial in terms of both reducing energy consumption and improving indoor comfort levels. Therefore, the buildings' original single-glazed windows were changed to triple-glazed windows. Table 6.4 compares between different types of glazing, and shows that the chosen triple glazing is the best available option. It should be noted here that total Solar Heat Gain Coefficient (SHGC) is also an important property to consider in hot climates, because the lower a window's SHGC, the less solar heat it transmits.

Table 6.4: Different Types of Window Glazing Compared

| Properties | Single Glazing | Double Glazing (i) | Double Glazing (ii) | Triple Glazing |
|--|-----------------------|---------------------------|----------------------------|-----------------------|
| Colour | Clear | Clear | Bronze | Clear |
| Number of Layers | 1 | 2 | 2 | 3 |
| Structure | 3mm | 3mm-6 mm Air | 3mm-13 mm Air | 3mm-13 mm Air |
| Total Solar Transmission (SHGC) | 0.858 | 0.758 | 0.616 | 0.468 |
| Direct Solar Transmission | 0.837 | 0.705 | 0.542 | 0.358 |
| Light Transmission | 0.898 | 0.812 | 0.618 | 0.661 |
| U-Value (W/m²K) | 6.257 | 3.226 | 2.761 | 0.993 |

In addition, egg-crate shading devices (made of steel overhangs and side fins with 0.5m projection) were fitted around windows in order to prevent the houses from overheating (see Figure 6.3). Table 6.5 demonstrates the potential effect of incorporating these changes. Such significant improvements did not come as a total surprise, given the cheap and very energy-inefficient windows that were originally fitted in the selected case study buildings. Furthermore, it is anticipated that such efficiency improvements (which essentially translate into lower electricity bills) would offset the high initial cost of the proposed type of glazing.

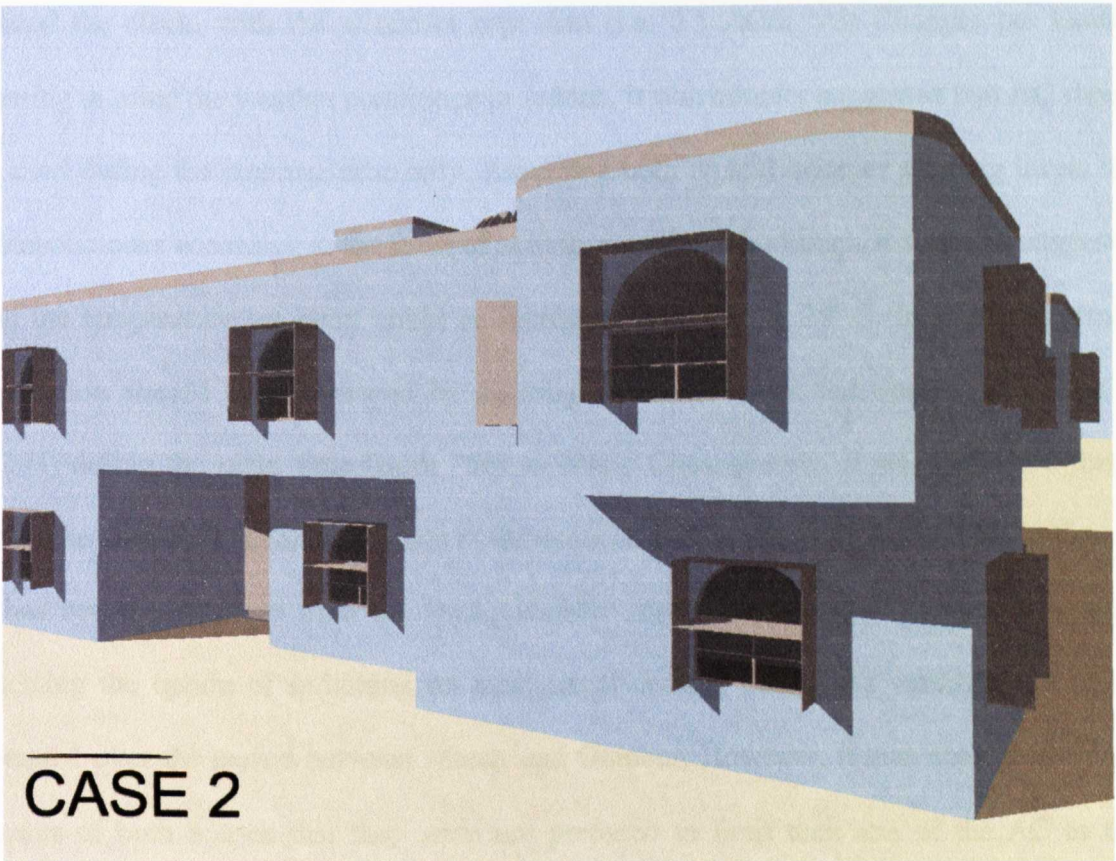
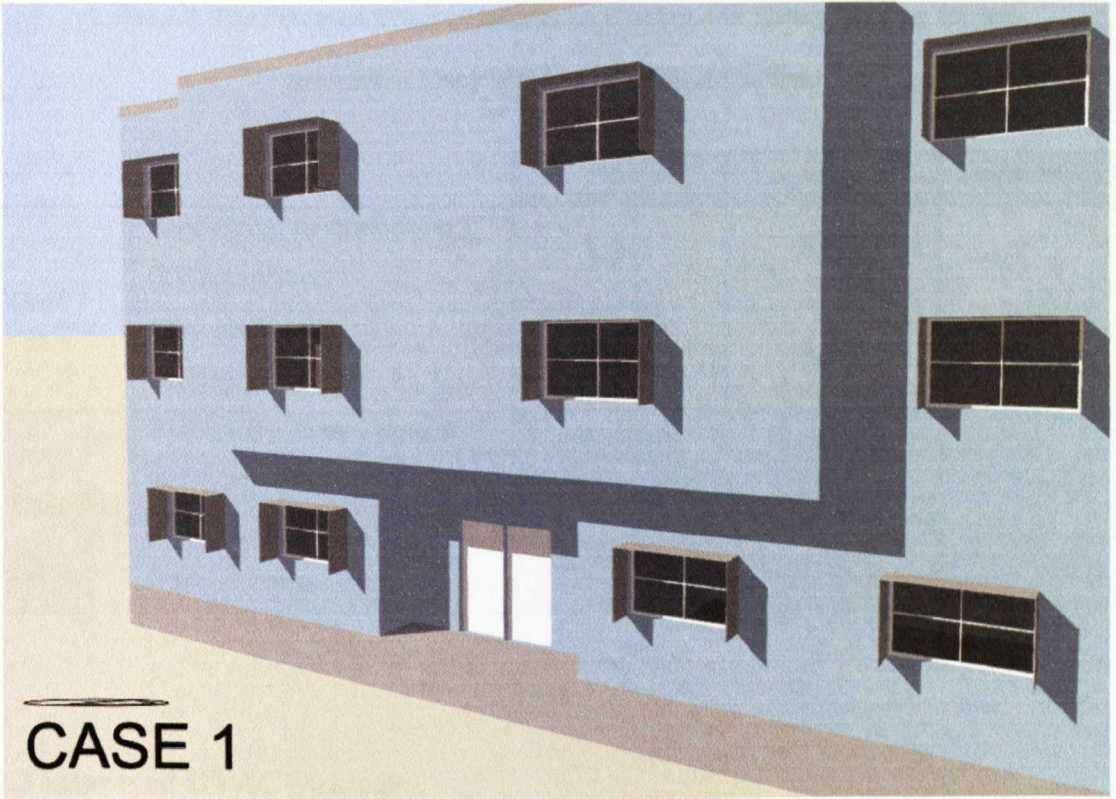


Figure 6.3: Shading Devices Fitted around the Windows of the Case Study Buildings

Table 6.5: The Potential Effect of Improving Glazing and Fitting Shading Devices**in terms of Electricity Use and CO₂ Reductions**

| | | Before | After | Reduction (%) |
|--------|--|---------------|--------------|----------------------|
| Case 1 | Electricity consumption (kWh/cap/year) | 8,047 | 6,622 | 17.7 |
| | CO₂ emissions (kg/cap/year) | 5,512 | 4,536 | |
| Case 2 | Electricity consumption (kWh/cap/year) | 14,377 | 12,409 | 13.7 |
| | CO₂ emissions (kg/cap/year) | 9,848 | 8,500 | |

6.2.3 Improved HVAC Strategy

When considering the base case, AC units installed in the buildings were run almost around the clock, with the windows kept shut (i.e. 0.5 AC/h ‘Air Changes per Hour’). Bearing in mind the weather conditions in Jeddah, it was initially suggested that AC should be used during the summer-time only. Assuming both typical summer clothing levels and metabolic rates according to the level of activity within the buildings, it was also suggested that the temperature set point could be increased from 22° to 24° C. In addition, natural ventilation should be encouraged by shutting down AC units and opening windows (6 AC/H) during the night time (from 18hr to 24hr). Consequently, it was estimated that it would be possible to achieve savings in the order of 14.7% in Case 1, and 11.3% in Case 2. It has become apparent from the DesignBuilder simulation models, however, that when selecting the option of switching on mechanical cooling during the summer, the AC is operated over the period between March and October. However, it was suggested by the tenants of both houses that they were not prepared to limit their use of the AC to this period, as it is needed almost all year round, with the exception perhaps of only a few

warm nights during the winter. The expected thermal comfort conditions that could result from the abovementioned modifications were examined using the DesignBuilder Software (e.g. see Figure 6.4 for Case 1), which further confirmed potentially high indoor temperatures, and therefore unbearable conditions in terms of comfort (*cf.* Figure 5.15 for the Base Case).

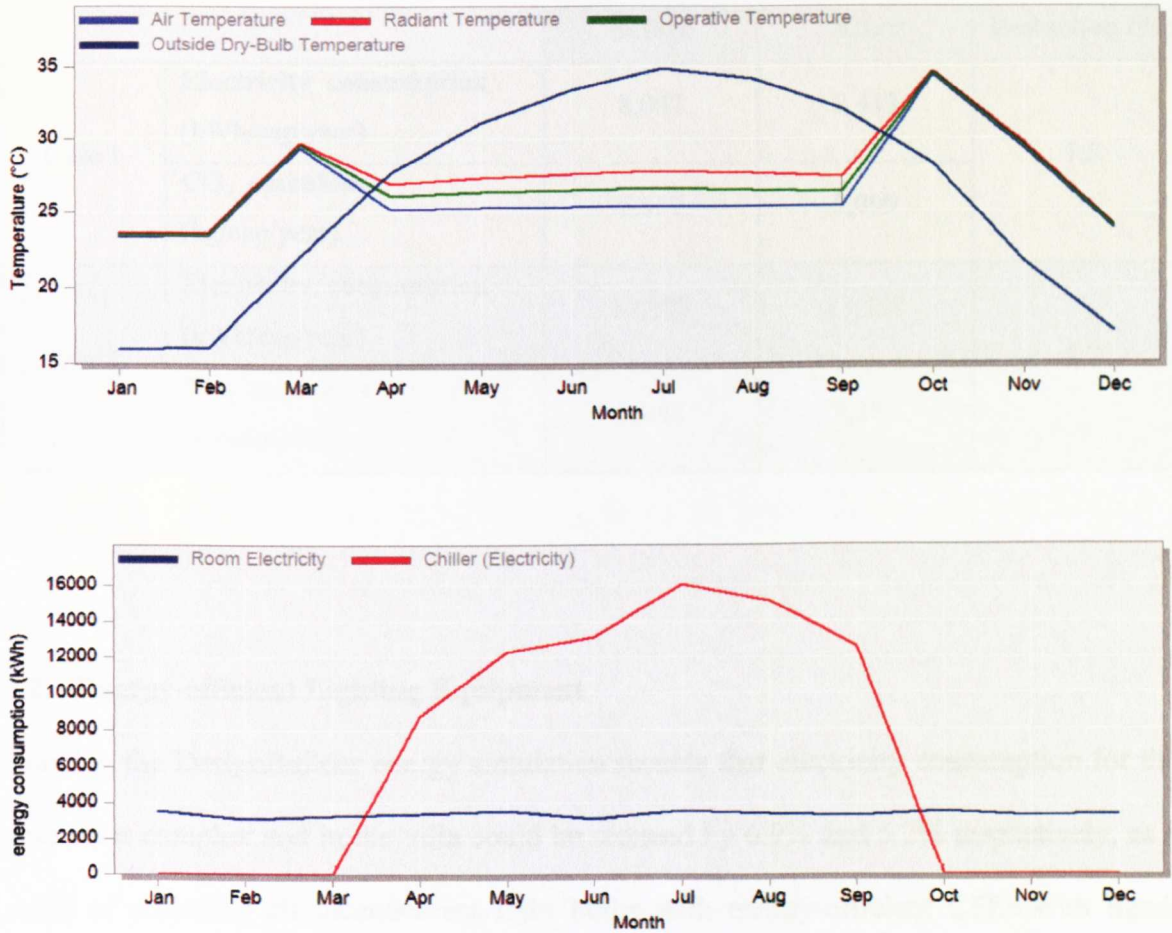


Figure 6.4: Monthly Comfort Condition vs. Energy Consumption when Changing the HVAC Strategy in Case 1

Alternatively, it was decided to keep the AC units running all year, whilst increasing the temperature set point to 25° C. Moreover, at night, the AC could be shut down and windows opened in order to promote natural ventilation. As a result of such modifications,

which were acceptable to vast majority of the tenants, electricity consumption was reduced without jeopardising the thermal comfort of the inhabitants too much (see Table 6.6). It should be recognised however, that whilst such modifications do not involve additional costs, other possible actions (such as changing the type of AC units) may well do.

**Table 6.6: The Potential Effect of Improving HVAC Strategy
in terms of Electricity Use and CO₂ Reductions**

| | | Before | After | Reduction (%) |
|--------|--|---------------|--------------|----------------------|
| Case 1 | Electricity consumption (kWh/cap/year) | 8,047 | 7,443 | 7.5 |
| | CO₂ emissions (kg/cap/year) | 5,512 | 5,099 | |
| Case 2 | Electricity consumption (kWh/cap/year) | 14,377 | 13,558 | 5.7 |
| | CO₂ emissions (kg/cap/year) | 9,848 | 9,287 | |

6.2.4 Energy-efficient Lighting Equipment

Running the DesignBuilder energy simulation reveals that electricity consumption for the apartment complex and in the villa could be reduced by 6.9% and 5.2% respectively, as a result of replacing all incandescent light bulbs with energy-efficient CFLs with linear daylighting control. The ‘linear’ control is likely to achieve higher energy savings than other dimming types such as ‘stepped’ daylighting control. Whereas stepped controls switch lighting on and off according to the availability of natural daylight in discrete steps, linear controls provide precisely controlled illumination by dimming the lights.

Table 6.7: The Potential Effect of Fitting Energy-efficient Lighting in terms of Electricity Use and CO₂ Reductions

| | | Before | After | Reduction (%) |
|--------|--|--------|--------|---------------|
| Case 1 | Electricity consumption (kWh/cap/year) | 8,047 | 7,489 | 6.9 |
| | CO₂ emissions (kg/cap/year) | 5,512 | 5,130 | |
| Case 2 | Electricity consumption (kWh/cap/year) | 14,377 | 13,624 | 5.2 |
| | CO₂ emissions (kg/cap/year) | 9,848 | 9,332 | |

6.2.5 Improved Water Heating Equipment and Strategy

With regard to the water heating in place in each of the buildings, three sensible modifications have been suggested: restricting the operation to when it is most needed (during the night time only); lowering the water delivery temperature from 85° to 65° C; and changing the current low-standard stand-alone water heaters to best-practise ones. Table 6.8 shows that an annual energy saving of up to 3.1% in Case 1 and 2.3% in Case 2 could be achieved by implementing these small modifications. It should be remembered here that since these potential energy saving levels have been estimated for two buildings only, higher or lower saving potentials could be achieved in other houses across Saudi Arabia.

Table 6.8: The Potential Effect of Improving Water Heating Equipment and Strategy in terms of Electricity Use and CO₂ Reductions

| | | Before | After | Reduction (%) |
|--------|--|--------|--------|---------------|
| Case 1 | Electricity consumption (kWh/cap/year) | 8,047 | 7,798 | 3.1 |
| | CO₂ emissions (kg/cap/year) | 5,512 | 5,342 | |
| Case 2 | Electricity consumption (kWh/cap/year) | 14,377 | 14,046 | 2.3 |
| | CO₂ emissions (kg/cap/year) | 9,848 | 9,622 | |

6.2.6 Green Roofing

Within the DesignBuilder models, a layer of vegetated roof was added to the outer surface of the roofs of both case buildings. The thermal properties of the green roof selected are listed in Table 6.9. It should be noted here that the leaf area index represents the projected leaf area per unit area of soil surface. Moreover, leaf reflectivity is defined here as the fraction of incident solar radiation (i.e. visible spectrum as well as infrared and ultraviolet wavelengths) that is reflected by the individual leaf surfaces. According to DesignBuilder, green roofs should have a leaf reflectivity of between 0.1 and 0.4. Another important property is leaf emissivity, which is defined as the ratio of thermal radiation emitted from leaf surfaces to that emitted by an ideal black body at the same temperature. The US Green Building Council (2009) suggests that green roofs should have a thermal emissivity value of at least 0.9 on a scale of 0 (no emittance) to 1 (maximum emittance physically possible). Generally speaking, it is usually desired to have a green roof that has a high leaf emissivity so it can radiate absorbed heat quickly and stay cool at night.

Table 6.9: Characteristics of the Green Roof

| Property | Value |
|------------------------|-------------------------|
| Density | 1,000 kg/m ³ |
| Specific heat capacity | 1,000 J/kgK |
| Height of plant | 0.10 metre |
| Leaf area index | 5.00 |
| Leaf reflectivity | 0.22 |
| Leaf emissivity | 0.95 |

As a result of planting an area of 350 m² (which represents about 60% of the free area of the roofs in Cases 1 and 2; after deducting the area of the annexe and dome in the latter), it is estimated that both electricity bills and CO₂ emissions could be reduced by 4.5% and 3.6% respectively.

Table 6.10: The Potential Effect of Installing Green Roofs

in terms of Electricity Use and CO₂ Reductions

| | | Before | After | Reduction (%) |
|--------|--|--------|--------|---------------|
| Case 1 | Electricity consumption (kWh/cap/year) | 8,047 | 7,685 | 4.5 |
| | CO₂ emissions (kg/cap/year) | 5,512 | 5,264 | |
| Case 2 | Electricity consumption (kWh/cap/year) | 14,377 | 13,859 | 3.6 |
| | CO₂ emissions (kg/cap/year) | 9,848 | 9,493 | |

Figure 6.5 summarises the above findings and compares the potential savings for each of the adopted energy conservation measures.

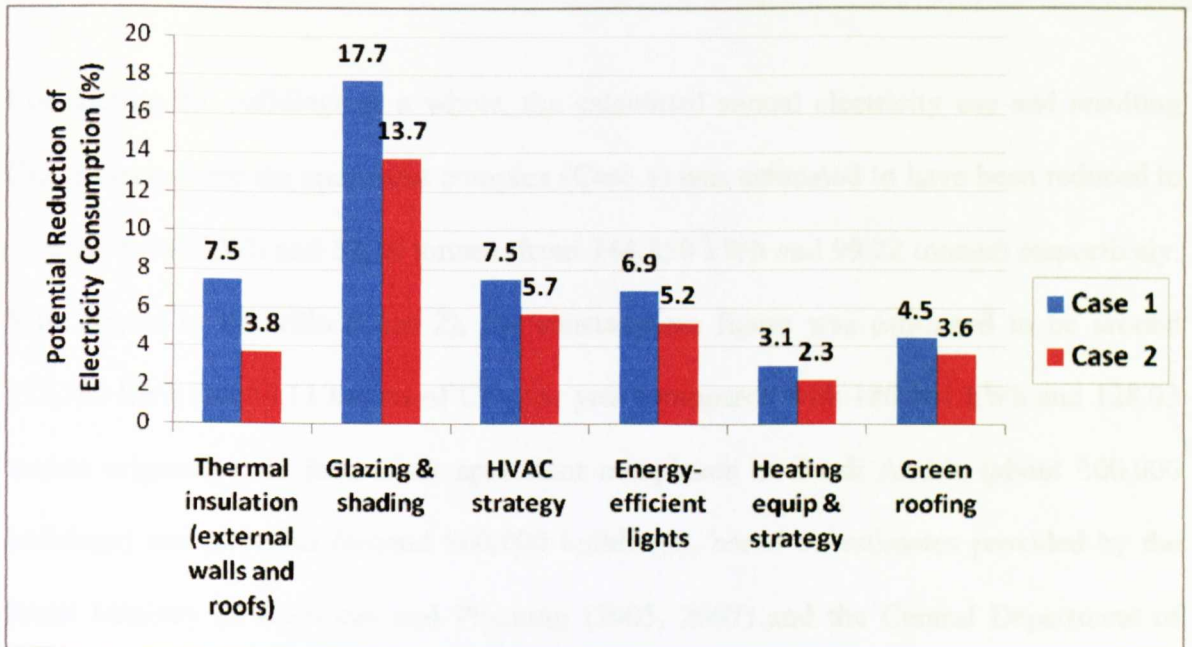


Figure 6.5: Comparing Potential Savings of the Adopted Energy Conservation Measures

6.3 Energy Consumption after adopting all the Proposed Energy Conservation Measures

Having made all of the abovementioned changes to the DesignBuilder models' input data, Table 6.11 demonstrates energy simulation results concerning potential efficiency improvements as a result of incorporating such modifications in each of the buildings under consideration – using real climatic data for Jeddah City.

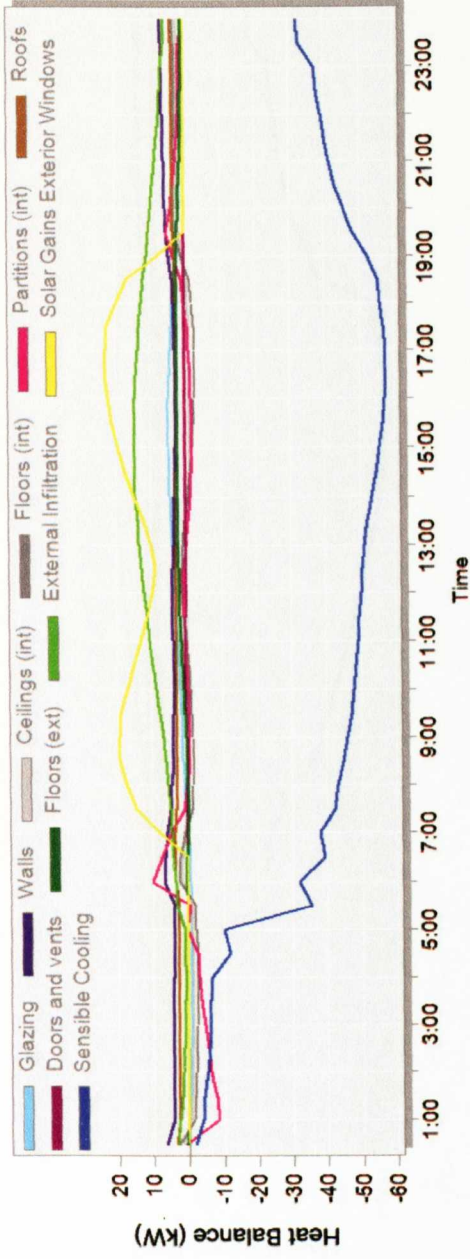
Table 6.11: The Potential Savings after incorporating all Suggested Energy Conservation Measures

| | | Base Case | Efficient Case | Reduction (%) |
|--------|--|------------------|-----------------------|----------------------|
| Case 1 | Electricity consumption (kWh/cap/year) | 8,047 | 4,247 | 47.2 |
| | CO₂ emissions (kg/cap/year) | 5,512 | 2,909 | |
| Case 2 | Electricity consumption (kWh/cap/year) | 14,377 | 9,445 | 34.3 |
| | CO₂ emissions (kg/cap/year) | 9,848 | 6,470 | |

Considering the buildings as a whole, the calculated annual electricity use and resulting CO₂ emissions for the apartment complex (Case 1) was estimated to have been reduced to around 76,446 kWh and 52.36 tonnes (from 144,850 kWh and 99.22 tonnes) respectively. With regard to the villa (Case 2), the consumption figure was estimated to be around 122,785 kWh and 84.11 tonnes of CO₂ per year (compared with 186,901 kWh and 128.03 tonnes originally). In fact, if all apartment complexes in Saudi Arabia (about 300,000 buildings) and all villas (around 800,000 buildings), based on estimates provided by the Saudi Ministry of Economy and Planning (2005, 2007) and the Central Department of Statistics and Information (2008), had managed to achieve such an attainable level of energy savings, at least 83 million tonnes of CO₂ could be saved per annum within the Saudi residential sector.

Figure 6.6 and Figure 6.7 show the energy ‘cooling design’ simulation results for the 15th July in order to compare the potential improvements as a result of such modifications. It should be noted that, since the thermal comfort conditions were kept almost the same as in the initial energy analysis, the reduction in electrical consumption was merely due to the modifications mentioned above. Obviously, solar gain has been reduced when compared to the original design. This is largely attributable to fitting shading devices on the windows which are, in turn, of the triple-glazing type. Moreover, it is estimated that the total design cooling requirement for Case 1 and Case 2 was reduced to 55.89 MW and 99.83 MW, respectively (compared to 88.24 MW and 151.37 tonnes originally).

Base Case:



Efficient Case:

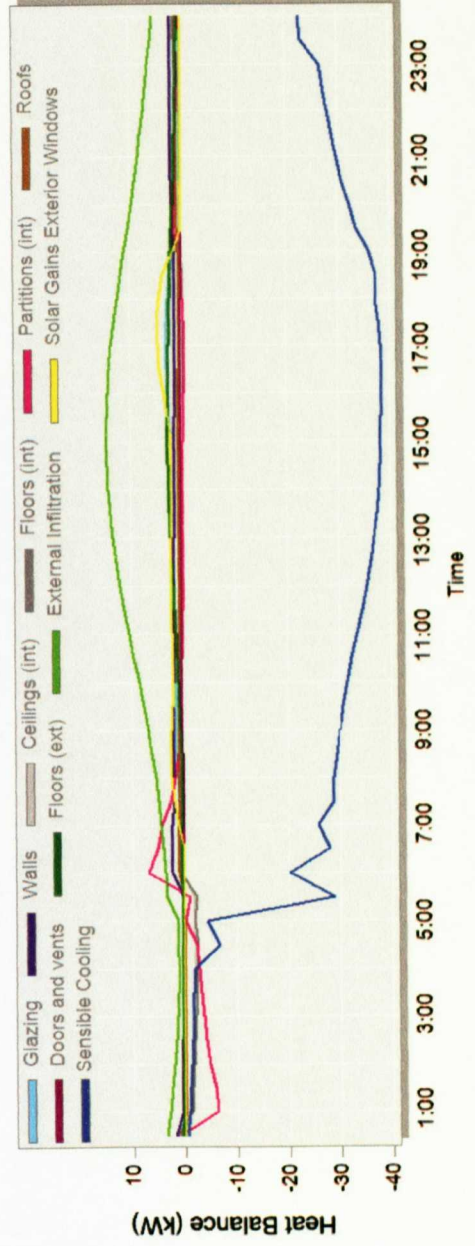
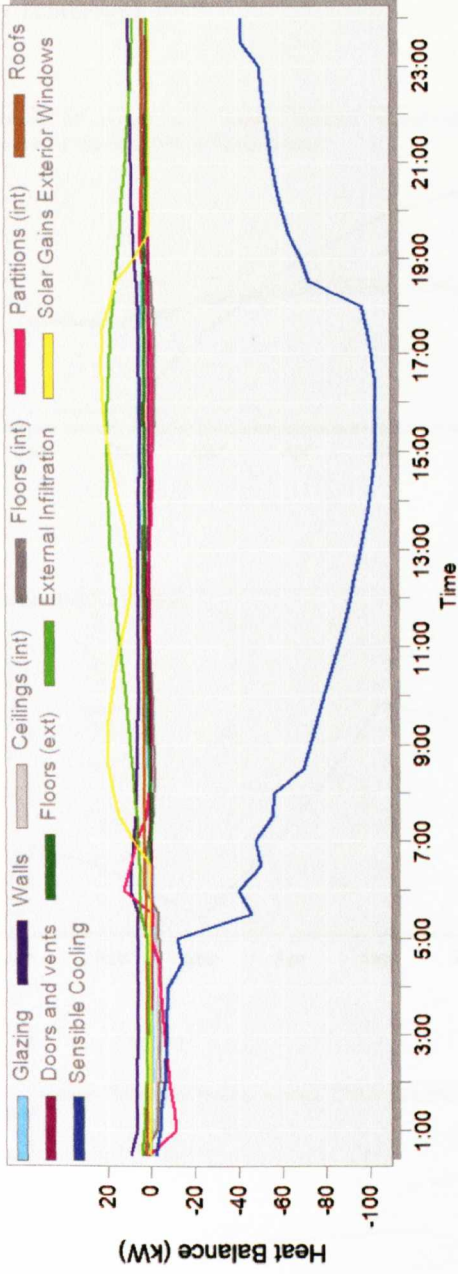


Figure 6.6: Heat Balances of the Base and Efficient Case 1 on 15 July (i.e. before and after incorporating all Suggested Energy Conservation Measures)

Base Case:



Efficient Case:

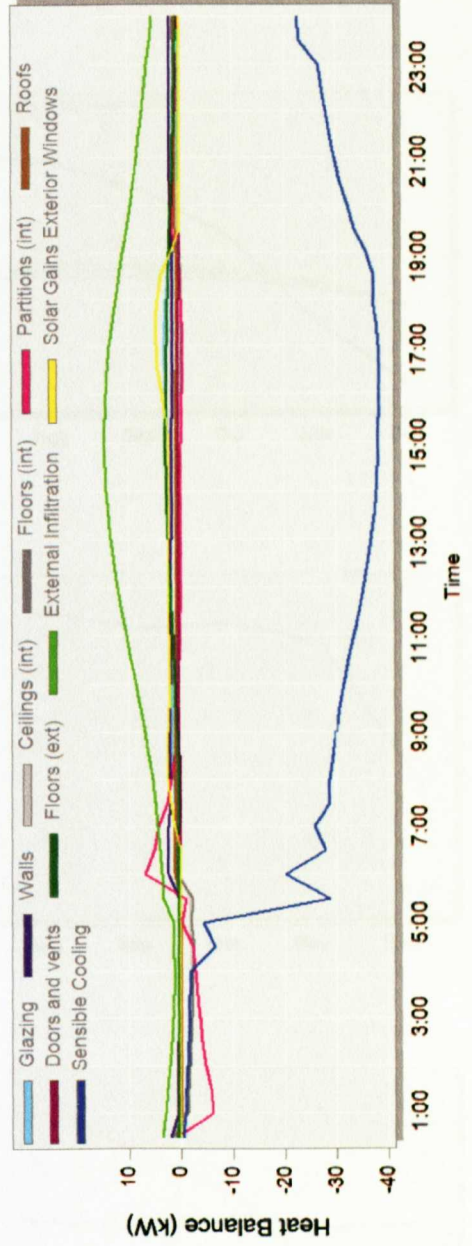


Figure 6.7: Heat Balances of the Base and Efficient Case 2 on 15 July (i.e. before and after incorporating all Suggested Energy Conservation Measures)

In addition to looking at the hottest summer day, energy use within the two buildings was also examined using the longer timeframes of weeks, months and seasons. Figure 6.8 and Figure 6.9 illustrate the monthly energy consumption of the 'efficient' Cases 1 and 2 respectively, in relation to comfort conditions (measured in terms of temperature and humidity readings).

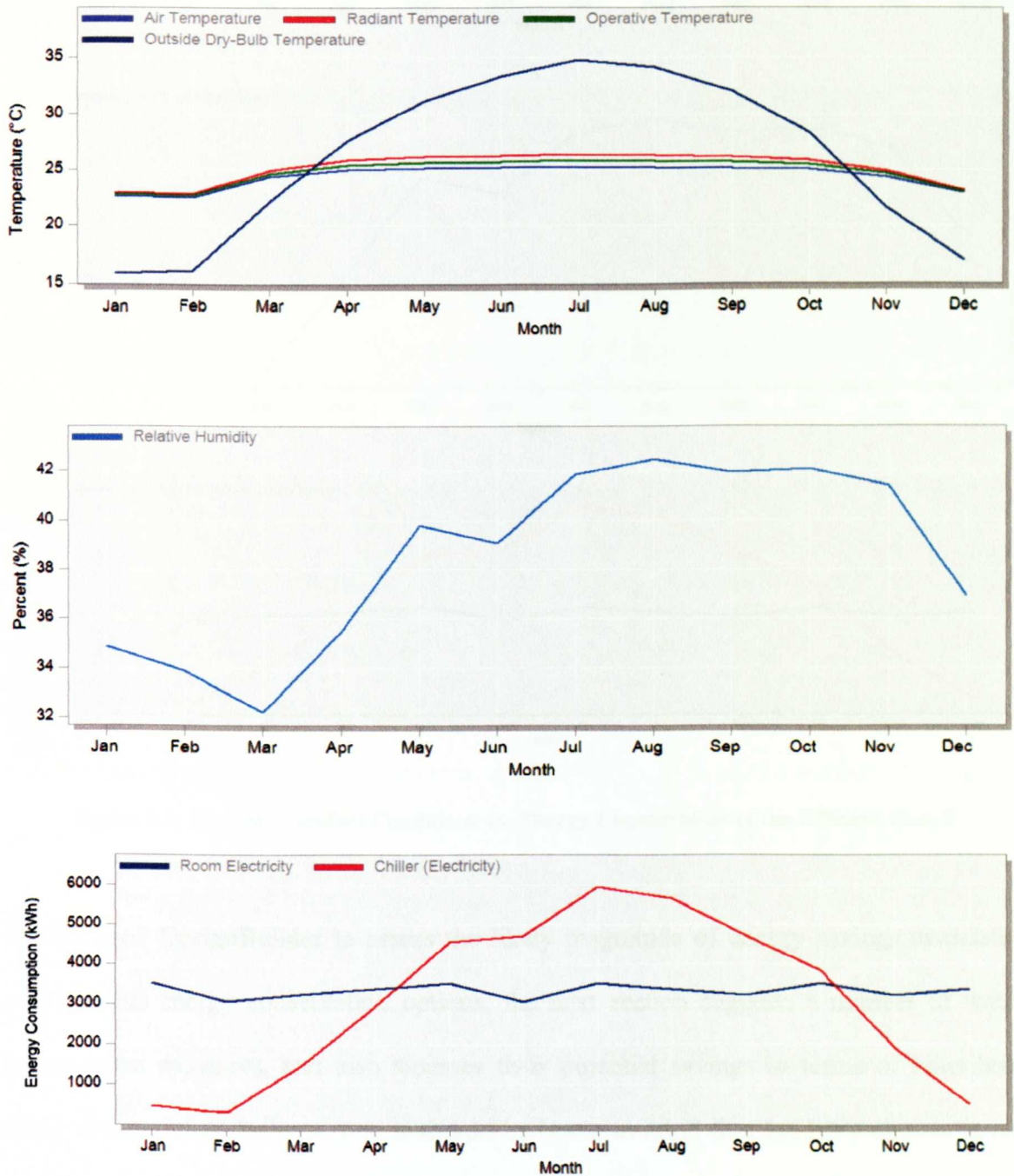


Figure 6.8: Monthly Comfort Conditions vs. Energy Consumption of the Efficient Case 1

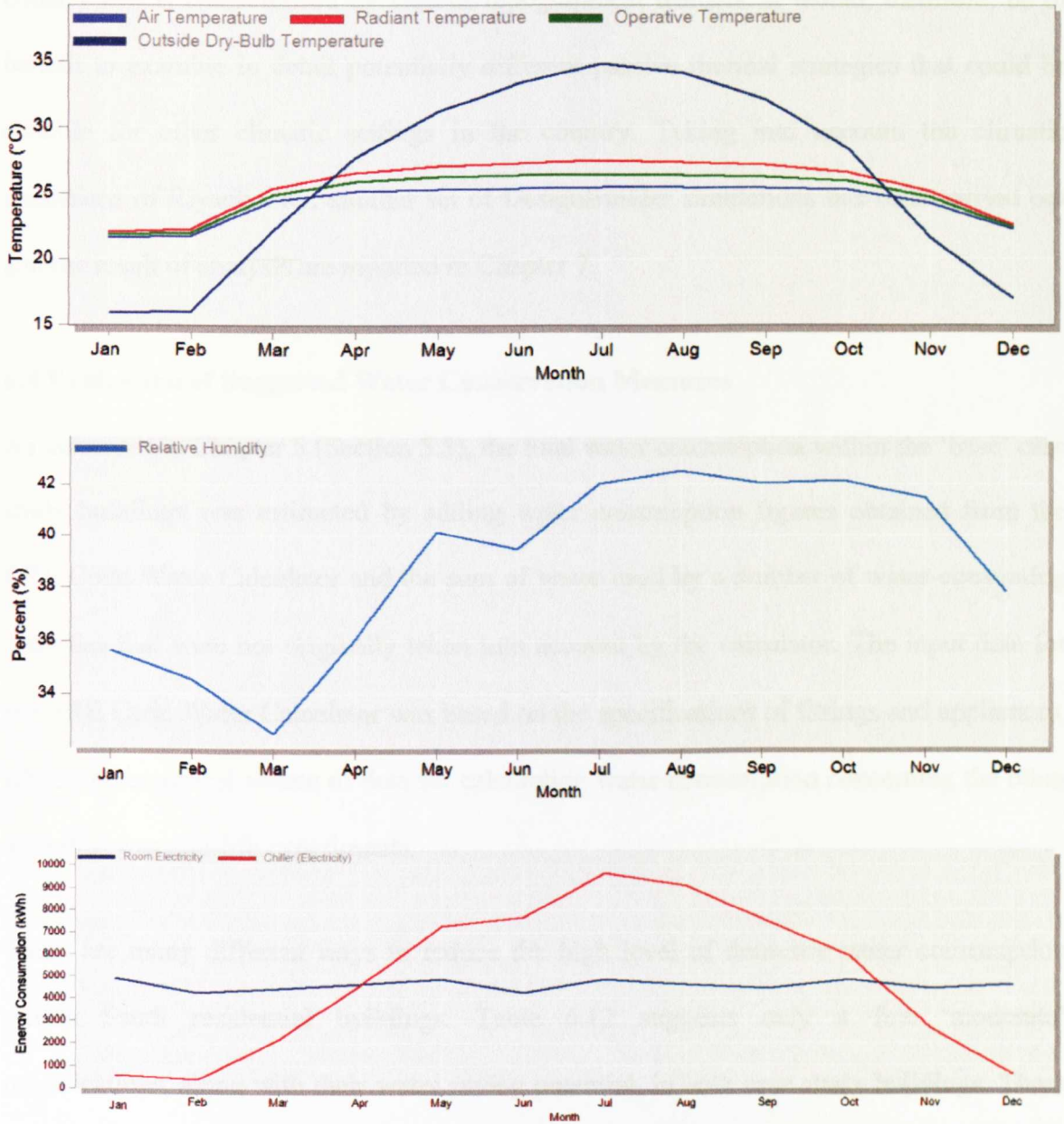


Figure 6.9: Monthly Comfort Conditions vs. Energy Consumption of the Efficient Case 2

Having used DesignBuilder to assess the likely magnitude of energy savings associated with various energy conservation options, the next section suggests a number of water conservation measures, and also assesses their potential savings in terms of household water consumption. Prior to that, it should be borne in mind that Jeddah's climate is not representative of that for the whole Kingdom of Saudi Arabia, which in turn is a large

country that is characterised by various topographical features. It would, therefore, be of benefit to examine in detail potentially different passive thermal strategies that could be suitable for other climatic settings in the country. Taking into account the climatic conditions of Riyadh City, another set of DesignBuilder simulations has been carried out and the result of analysis are reported in Chapter 7.

6.4 Evaluation of Suggested Water Conservation Measures

As discussed in Chapter 5 (Section 5.5), the total water consumption within the ‘base’ case study buildings was estimated by adding water consumption figures obtained from the BRE Code Water Calculator and the sum of water used by a number of water-consuming activities that were not originally taken into account by the calculator. The input data for the BRE Code Water Calculator was based on the specifications of fittings and appliances, whilst the empirical source of data for calculating water consumption concerning the other activities was real-life experiments.

There are many different ways to reduce the high level of domestic water consumption within Saudi residential buildings. Table 6.12 suggests only a few ‘moderate’ modifications, along with their water saving potential, in both case study buildings. These potential water savings were estimated using the BRE Code Water Calculator. It should be noted here that many of the water-efficient items listed below, with perhaps the exception of the grey water system, are considered as being quite normal practice in developed countries.

Table 6.12: The Potential Savings after Incorporating Suggested Water Conservation Measures

| Modification | Potential Savings (in LCD) | |
|---|----------------------------|--------|
| | Case 1 | Case 2 |
| Low-flow tap aerators in the kitchen (9 Litres/min) | 63.5 | 74.1 |

| | | |
|---|--------------|--------------|
| Low-flow tap aerators in the bathroom (6 Litres/min) | 42.3 | 52.92 |
| Low-flow showerheads (9 Litres/min) | 27.0 | 43.5 |
| Dual-flush (6/4 Litres) cisterns | 16.0 | 20.8 |
| Efficient washing machines (49 Litres/min) | 34.7 | 34.7 |
| Efficient dishwasher (13 Litres/cycle) | - | 2.1 |
| A grey water system, which collects 90% of the wash hand basin, and shower waste in order to supply the toilet cisterns (and perhaps to water the green roof) | 39.1 | 39.1 |
| Total Savings | 223.6 | 267.2 |

There is a range of additional ways to further reduce water consumption, some of which require the sensible use of water. Examples of sensible behavioural changes include reducing shower times and turning off taps when brushing teeth or shaving. Moreover, instead of using a running hose to wash a car, a trigger hose or even a bucket with a sponge should be used. The occupants of the houses admitted that they never thought about these approaches or, rather, never felt the need to think about ways to conserve domestic water. It is important to recognise here that the rational use of water and other natural resources is embedded within Islamic principles, which are largely followed and respected by the Saudi population (e.g. see Faruqui et al., 2000). Finally, examples of design-related improvements that could be applied are the use of drip irrigation (drops of water are delivered to the plants root zone); covering the villa's swimming pool in order to reduce the water evaporation rate; and fitting shading devices in order to reduce water requirement of plants. Bearing in mind that it is often difficult to change water consumption habits, it is conservatively estimated – following discussions with the tenants of both houses – that it could be possible to achieve water savings of at least 10 LCD, if such additional conservation measures are taken into account. Ultimately, the water consumption per capita figure for the efficient Cases 1 and 2 are estimated to be 263.4 and 287.8 LCD,

respectively (compared to 497 and 565 LCD originally). This magnitude of savings means that approximately 1,534,752 and 1,315,314 litres could be saved a year from Cases 1 and 2, respectively. If all apartment complexes and villas in Saudi Arabia managed to achieve such an attainable level of water savings, at least 1.5 million, million (i.e. 10^{12}) litres of water could be saved per annum within the Saudi residential sector.

6.5 Rendering the Case Study Buildings More Sustainable

To conclude this chapter, it is worth remembering that the incorporation of renewable energy technologies is often considered an essential element of sustainable buildings. Therefore, a final suggestion that could be made for the case study buildings is the utilisation of renewable energy. Given the high level of solar irradiation in Jeddah, as well as available free space area on the roof of the buildings, it is estimated that installing solar PV panels could easily supply around 10% of the household electricity requirements. Consequently, the amount of household CO₂ emissions of Cases 1 and 2 could be further reduced by over five and eight tonnes per year, respectively (see Figure 6.10). Looking at the sectoral level, using solar PV technology to supply 10% of household electricity requirements would reduce CO₂ emissions by over eight million tonnes in Saudi Arabia.

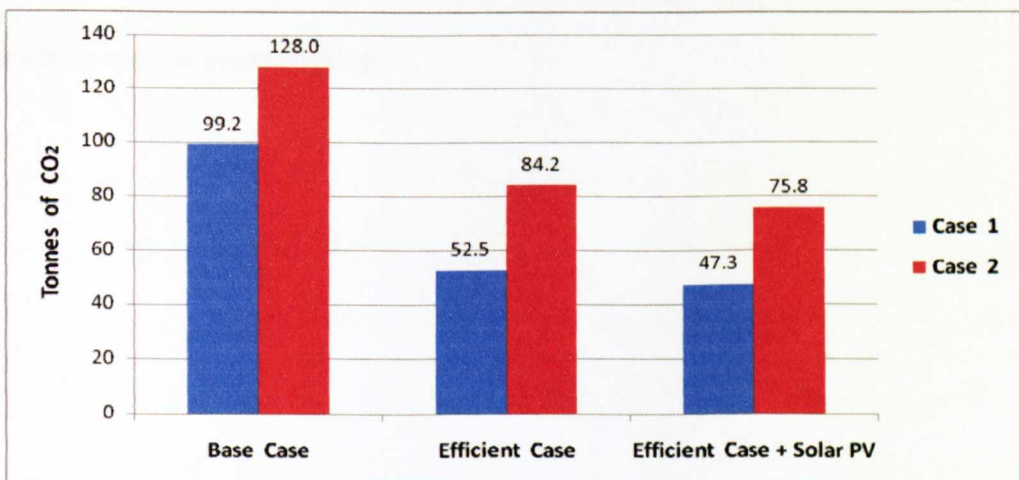


Figure 6.10: Potential CO₂ Emission Reductions for the Case Study Buildings

For the purpose of this analysis, it was assumed that solar PV panels would provide 10% of household electricity requirements. This conservative figure, which could be higher if there is willingness and the financial capability to invest more, can be achieved by fitting just eight PV modules on the building's roof. This estimate is based on the following assumptions that have been adopted from a recent scholarly paper (Kabir et al., 2009): inverter efficiency 60%, battery efficiency 80%, and that the area of a typical PV module with an output of 75W is 0.8 m^2 ($1\text{m} \times 0.8\text{m}$). The validity of these assumptions has also been confirmed through contacting several Saudi firms that import, install and maintain solar energy systems in the country. If average solar irradiance in Saudi Arabia exceeds $6 \text{ kWh/m}^2/\text{day}$ (International Network for Sustainable Energy, 2010), then the 'annual averaged' output of each module was calculated to be around 216W ($75 \times 0.6 \times 0.8 \times 6$). The potential power generation of the eight PV modules was estimated to be 1.73kW (no. of modules \times 'annual averaged' output of each module in kW), which would be the equivalent of 15,155kWh per annum ($1.73\text{kW} \times 365 \text{ days} \times 24 \text{ hours}$). The latter figure represents 10.5% of the calculated figure for annual electricity consumption of base Case 1. Bearing in mind that the eight PV modules will only occupy 6.4 m^2 ($8 \times 0.8\text{m}^2$), this would leave approximately 98.9% of the roof space of both Cases 1 and 2 for other activities and/or purposes for the tenants, which may include the possibility of installing additional PV panels as well as green roofing.

Chapter 7

Placing the Case Study Buildings in a Different Saudi Climatic Context: Design Implications

7.1 Chapter Overview

Given the significant influence of climate on built form and energy performance, this chapter explores potential different passive thermal strategies when the two case study buildings are placed in a different climatic setting in Saudi Arabia. Whilst the preceding analysis has been carried out in the climatic context of Jeddah (in the Hijaz region), this chapter discusses the sustainable design implications of placing the two case study buildings in the Saudi capital city of Riyadh (in the Najd Plateau). This chapter starts by providing an overview of Riyadh's climate, and then discusses passive thermal strategies that are appropriate for this climatic setting and compares them with those most suitable for Jeddah City. Next, energy simulation models are generated when the two 'base' case study buildings are placed in Riyadh City. After that, a number of climate-responsive strategies for building designs in Riyadh City are applied to the case study buildings, and their potential energy savings are estimated.

7.2 An Overview of the Riyadh Climate

The climate in Riyadh is characterised by fierce, dry and very hot summers, whilst winter is usually mild with cold and windy nights. The overall climate is hot arid, receiving very little rain (Ham et al., 2004). Further information on temperatures and the rather high solar radiation levels in Riyadh throughout the year are given in Figure 7.1, whilst Figure 7.2 shows wind velocity measured in metres/second for each month. The terms that appear in these figures have already been explained in Chapter 5 (Section 5.3). Unlike Jeddah, winds in Riyadh tend to be hot and dry and sometimes carry dust and sand.

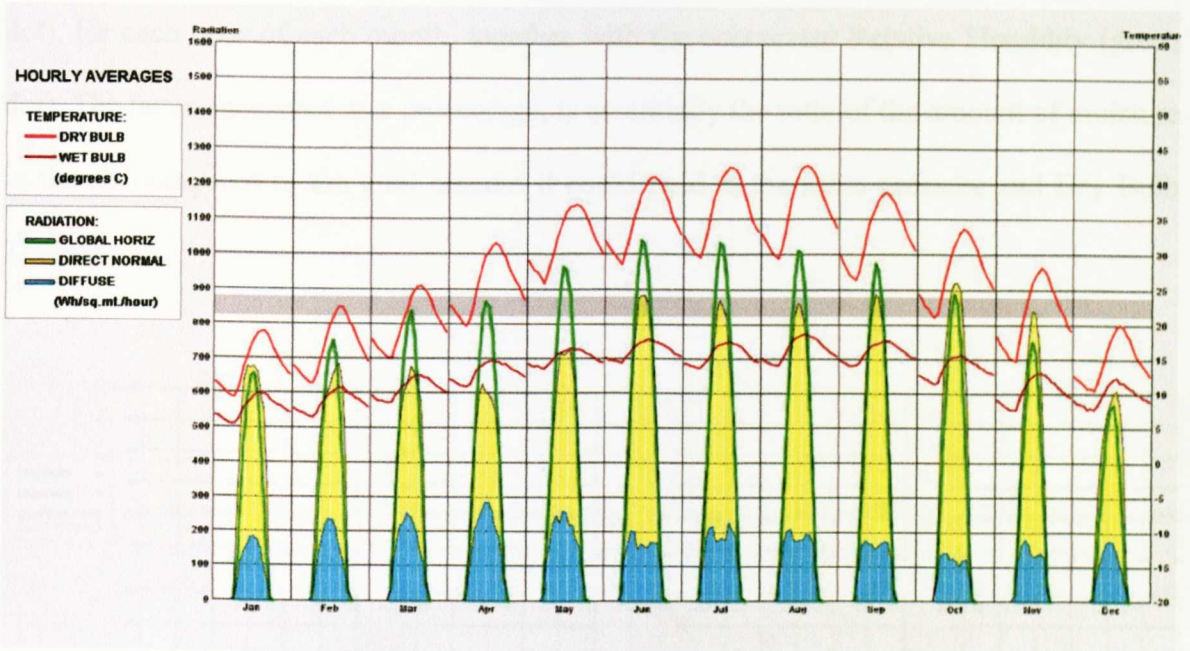


Figure 7.1: Temperature and Solar Radiation Levels in Riyadh
 (Source: Climate Consultant 5 Software)

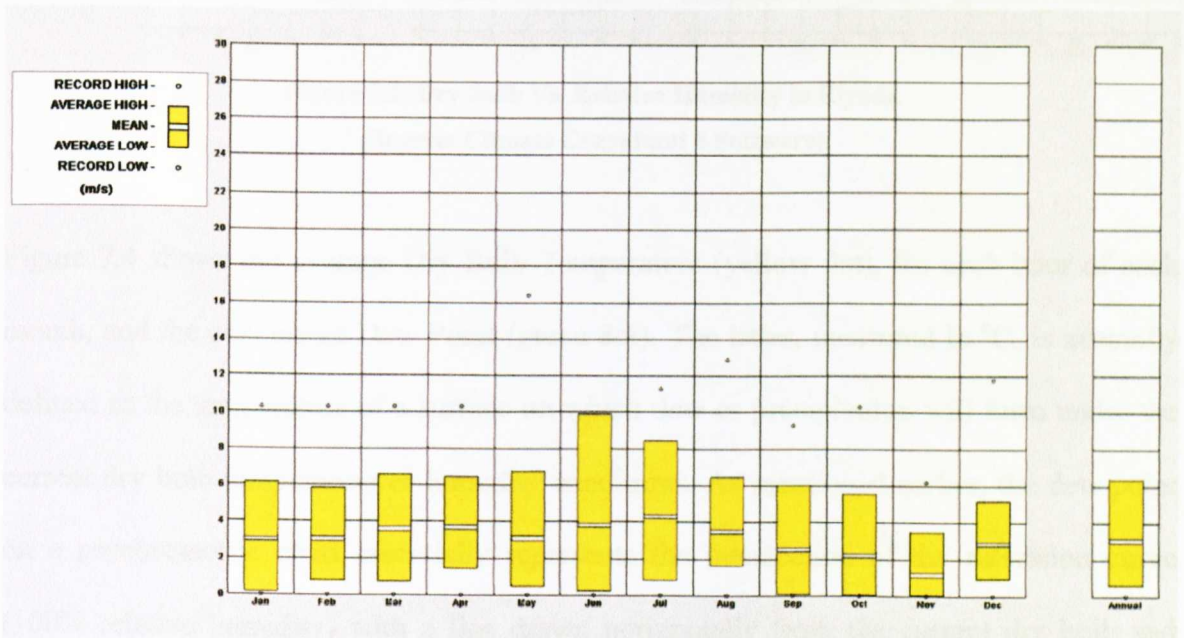


Figure 7.2: Wind Velocity Range in Riyadh
 (Source: Climate Consultant 5 Software)

The twelve charts in Figure 7.3 demonstrate the average Dry Bulb Temperature (yellow dot), for each hour of each month, together with the concurrent Relative Humidity (green dot). The latter, measured as a percentage, is essentially the ratio of the amount of moisture in the air compared to the total amount it could hold at the same pressure and Dry Bulb Temperature.

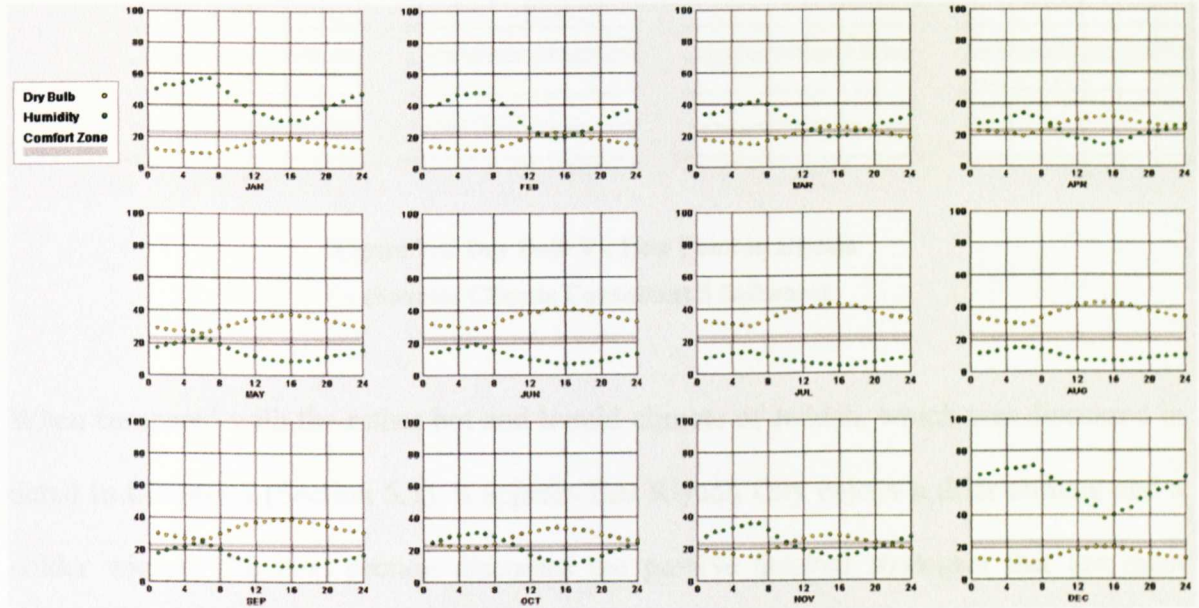


Figure 7.3: Dry Bulb Vs. Relative Humidity in Riyadh
 (Source: Climate Consultant 5 Software)

Figure 7.4 shows the average Dry Bulb Temperature (yellow dot), for each hour of each month, and the concurrent Dew Point (green dot). The latter, measured in °C, is normally defined as the temperature of a surface on which dew or precipitation will form under the current dry bulb temperature or humidity conditions. As mentioned earlier, the dew point on a psychrometric chart essentially represents the intersection of the saturation curve (100% relative humidity) with a line drawn horizontally from the current dry bulb and relative humidity point.

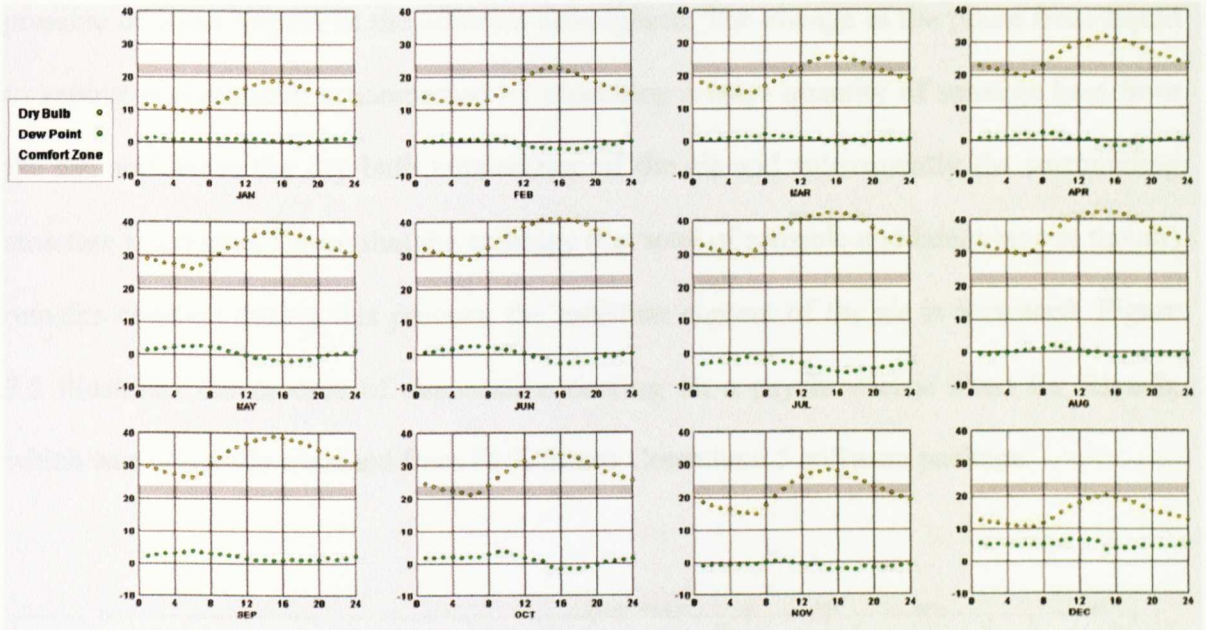


Figure 7.4: Dry Bulb Vs. Dew Point in Riyadh
 (Source: Climate Consultant 5 Software)

When compared with the rather hot and humid climate of Jeddah, which was discussed in detail in Chapter 5 (Section 5.3), it appears that Riyadh City enjoys a drier climate and a colder winter. The next section discusses the passive thermal strategies that are most suitable for this kind of climate.

7.3 Climate-Responsive Recommendations for Building Designs in Riyadh City

Among the relevant passive thermal strategies that have already been mentioned when discussing the traditional architectural features of Najd in Chapter 3 (Section 3.5.2) is courtyard design. Courtyards are typically found in the centre of traditional Najdi houses where they act as a ventilation shaft which also provides both natural lighting and shading. Vegetation and water features, such as pools and fountains, are also often used in the central outdoor areas in order to provide evaporative cooling (sometimes referred to as adiabatic cooling). The Energy and Resources Institute (2004) explains that such evaporation takes place when the vapour pressure of the water is higher than the partial

pressure of water vapour in the adjacent atmosphere. The change in the phase from liquid to vapour is essentially accompanied by absorbing a large quantity of sensible heat from the air, and hence the dry bulb temperature of the air and subsequently the surrounding structure is lowered. Given that the enthalpy (i.e. total of sensible and latent heat in the air) remains constant during this process, the moisture content of the air is increased. Figure 7.5 illustrates the process of evaporative cooling on a psychrometric chart for Riyadh, which was originally obtained from the Climate Consultant 5 software package.

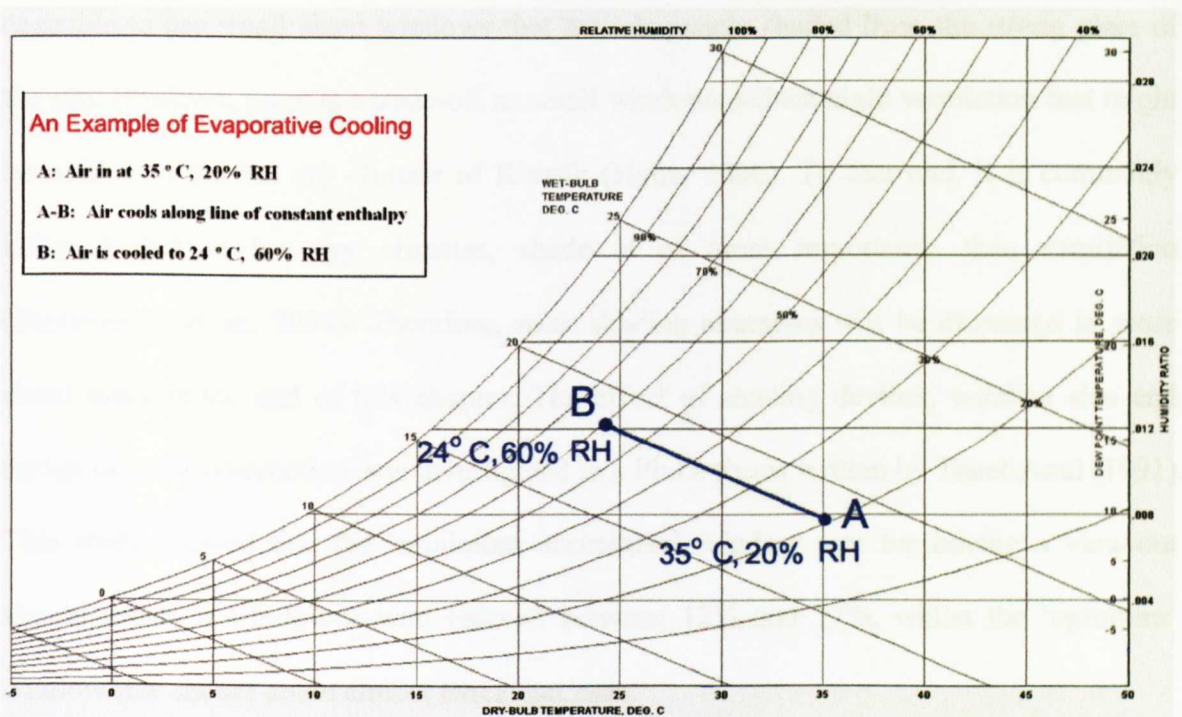


Figure 7.5: An Illustrative Example for the Process of Evaporative Cooling in Riyadh

Another distinguishing feature of houses in Najd is that they are normally built close together so that they can shade each other from intense solar radiation. On the other hand, Hijzai houses (such as those found in the rather hot and humid Jeddah City) are usually detached and spread out in order to allow air movement between them and provide natural ventilation. This notable difference in layout design is consistent with the

recommendations provided by Konya (1980) with regard to buildings in hot dry locations and those found in hot humid climates. Generally speaking, cross ventilation is needed more in the hot humid climate, whilst ventilation in the hot dry climate is only advisable at night-time and should be as low as possible during the daytime, during which dust storms are sometimes present. It is worth mentioning here that although vegetation could hinder natural ventilation, it is useful in terms of both providing shade and filtering dust from air. Large windows should also be orientated towards the north, and – if possible – no windows should be placed on either the eastern or western side of the building. In addition, it is desirable to use small sized windows that are adequately shaded from the strong glare of the sun. However, there is a trade-off as small windows reduce night ventilation that might be needed in the hot dry climate of Riyadh (Hyde, 2000). To that end, it is commonly believed that in hot dry climates, shade is of more importance than ventilation (Santamouris et al., 2004). Therefore, solar shading strategies will be discussed in more detail towards the end of this chapter. The effect of shading devices, window size and design on view obstruction was investigated in a Ph.D. thesis written by Tabet-Aoul (1991). This study showed that the ‘minimum acceptable’ window size for having a view-out should satisfy a window-to-wall ratio of between 12% and 17%, whilst the ‘optimum’ window size should attain almost twice that ratio.

A design recommendation that is appropriate for both humid and dry hot climates is the use of light colours, such as white, for facades in order to reflect solar radiation. Another important design parameter that affects indoor thermal comfort and energy conservation is the building envelope design. For example, for this type of hot dry climate, it is recommended to employ thick walls that are constructed from materials with a high thermal mass in order to delay the effect of temperature variations from outside the wall to

the wall's interior. Last, but certainly not least, it is usually recommended in hot dry climates to make the building as compact as possible. The reason is that a compact building (i.e. one of a cubic form) gains less heat during the day and loses less heat at night, when compared with more linear forms of building. The compactness of the building is usually measured in terms of the surface area/volume ratio. As shown in Figure 7.6, a compact building is one that has a low surface area/volume ratio.

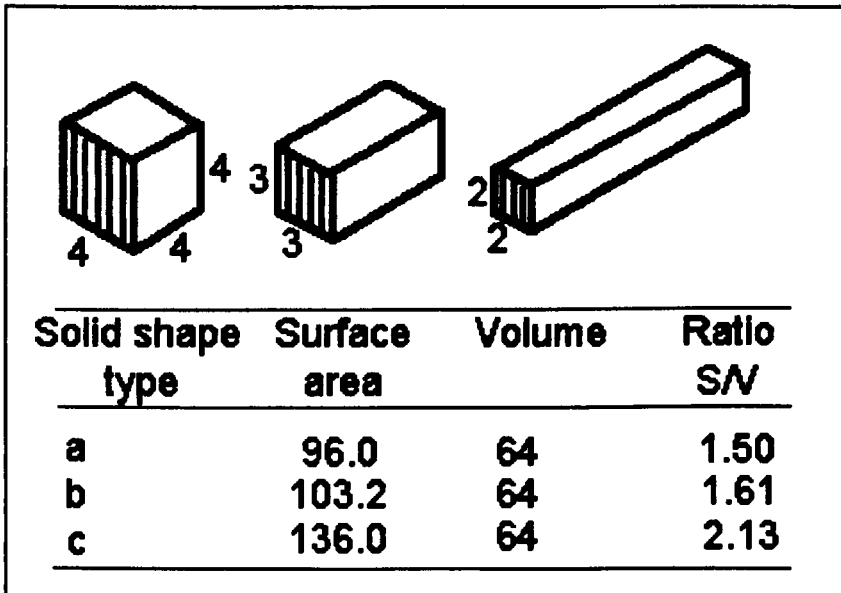


Figure 7.6: Varying surface to volume ratio with different building types
(Energy and Resources Institute, 2004)

7.4 Energy Consumption within the 'Base' Case Study Buildings

Based on actual weather data for Riyadh City, energy use within the apartment complex (Case 1) and the villa (Case 2) was analysed using DesignBuilder. Figure 7.7 and Figure 7.8 show the estimated monthly energy consumption of Case 1 and Case 2 respectively, in relation to comfort conditions (measured in terms of temperature and humidity readings).

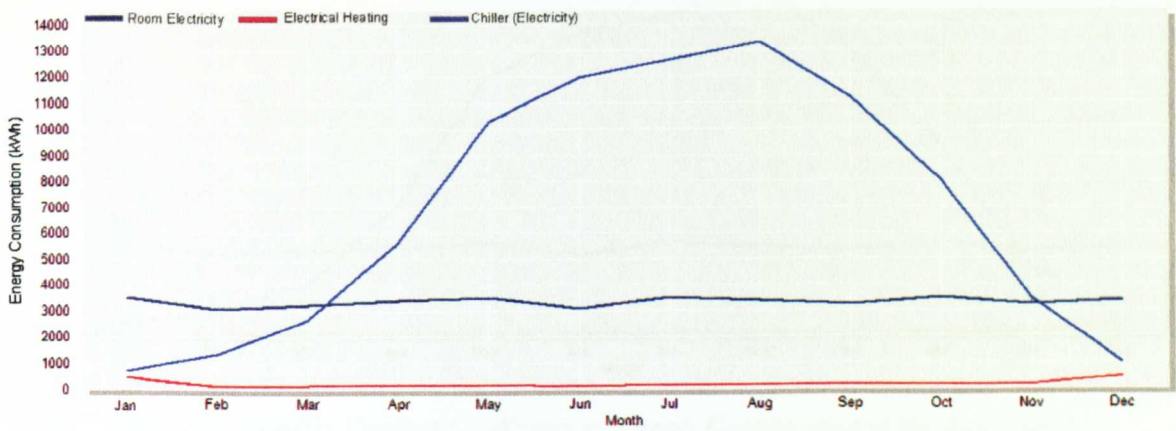
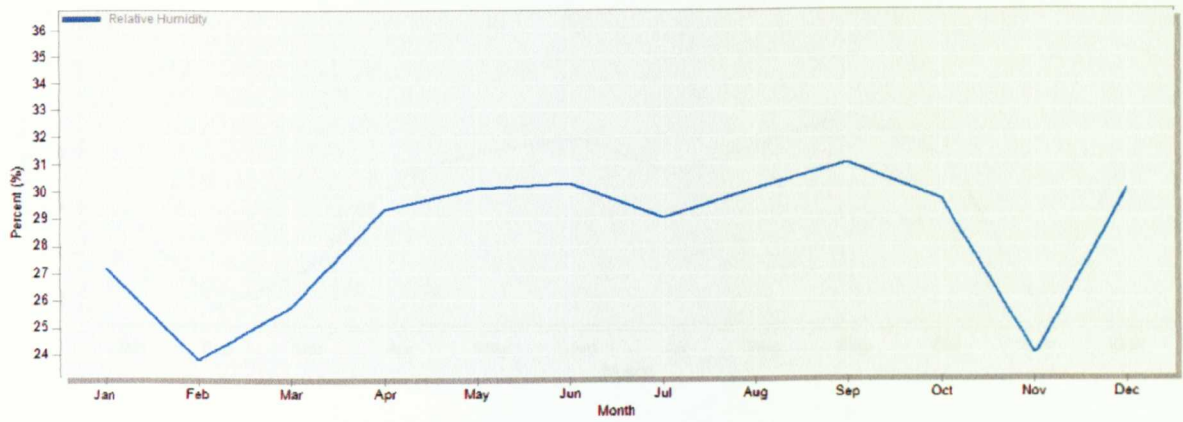
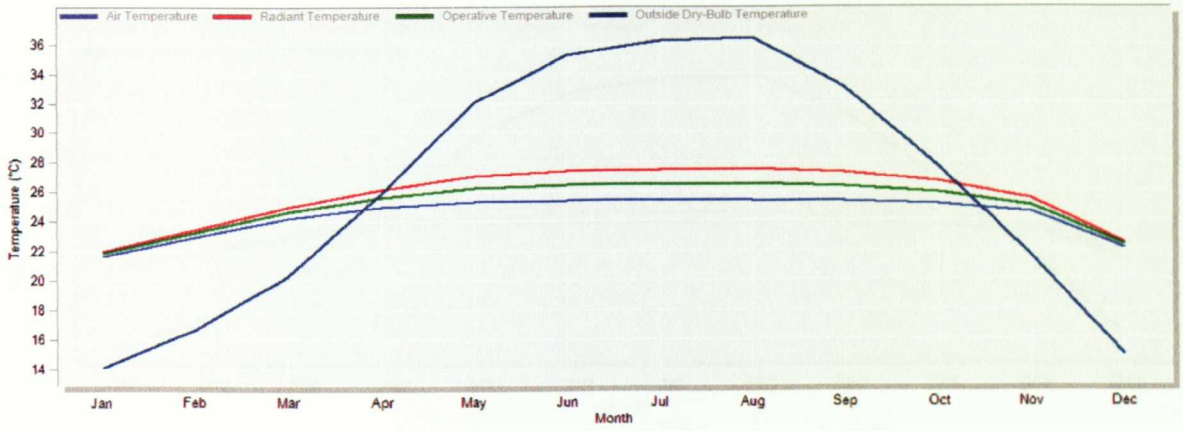


Figure 7.7: Monthly Comfort Conditions vs. Energy Consumption of the Base Case 1

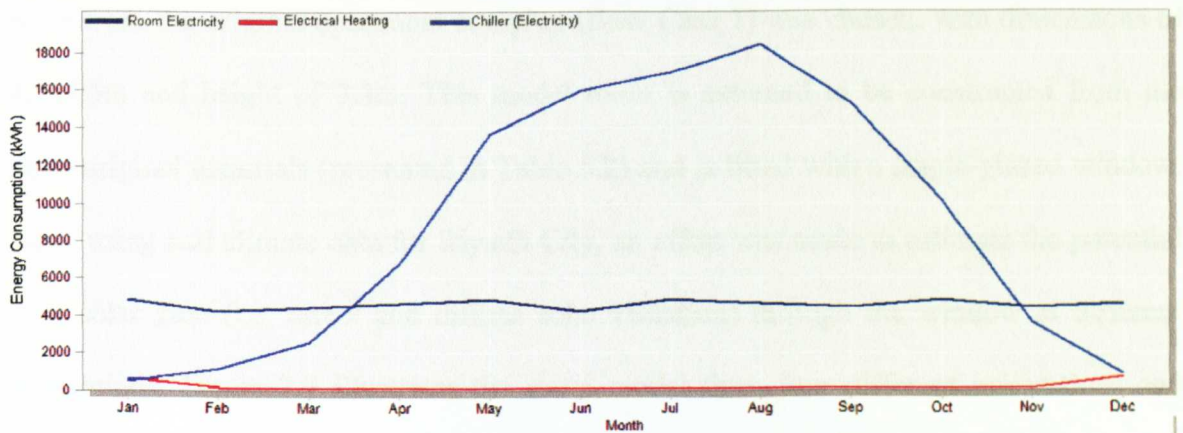
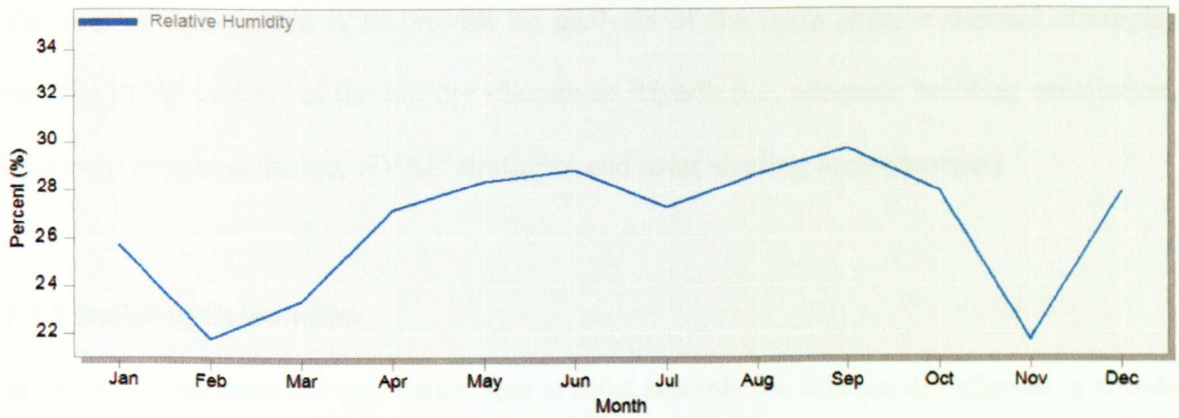
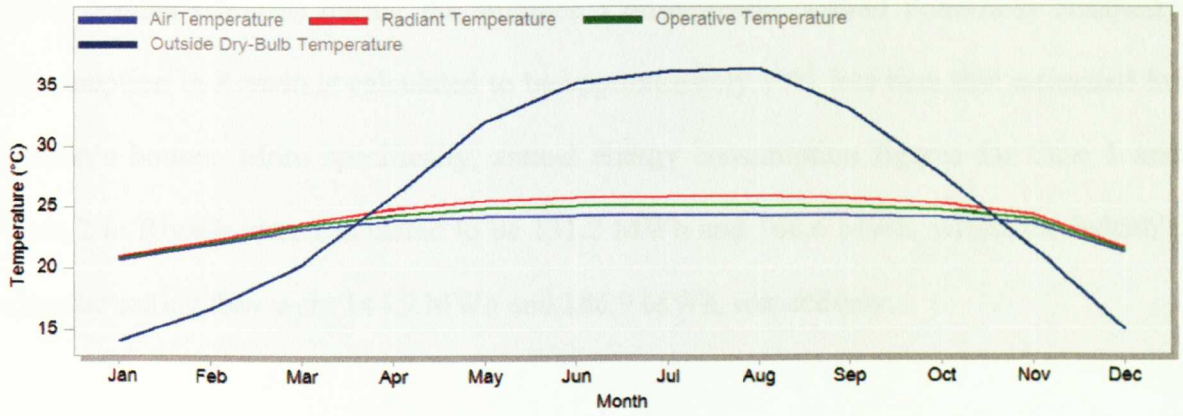


Figure 7.8: Monthly Comfort Conditions vs. Energy Consumption of the Base Case 2

It is interesting to note here that, unlike the case of Jeddah, electrical heating was needed to warm the two houses during the relatively cold winter nights in Riyadh. However, it appears that the energy required to heat Riyadh's houses is less than that needed to cool

down Jeddah's houses during the summer. Consequently, annual household electricity consumption in Riyadh is calculated to be approximately 10% less than that estimated for Jeddah's houses. More specifically, annual energy consumption figures for Case 1 and Case 2 in Riyadh were calculated to be 131.2 MWh and 168.6 MWh, whilst for Jeddah's climatic setting they were 144.9 MWh and 186.9 MWh, respectively.

7.5 Applying Passive Thermal Strategies to the Case Study Buildings

The aim of this section is to provide an analysis of the main passive thermal strategies suitable in the context of the hot dry climate of Riyadh (i.e. adequate building orientation, improved envelope design, HVAC strategies and solar shading arrangements).

7.5.1 Building Orientation

In order to determine the orientation that is most suitable for this hot dry climate, a simple DesignBuilder simulation-based experiment was conducted. More specifically, a single room from the original apartment complex (Base Case 1) was chosen, with dimensions of 4.5x4.5m and height of 3.4m. This model room is assumed to be constructed from the same original materials (presented in Table 5.2) and is fitted with a single-glazed window. Next, using real climate data for Riyadh City, an effort was made to estimate the potential total solar gain (i.e. direct and diffuse solar radiation) through the window at different orientations. Figure 7.9 illustrates the room model from four different orientations and Table 7.1 shows that a northern orientation achieves the least solar gain during throughout the year in Riyadh.

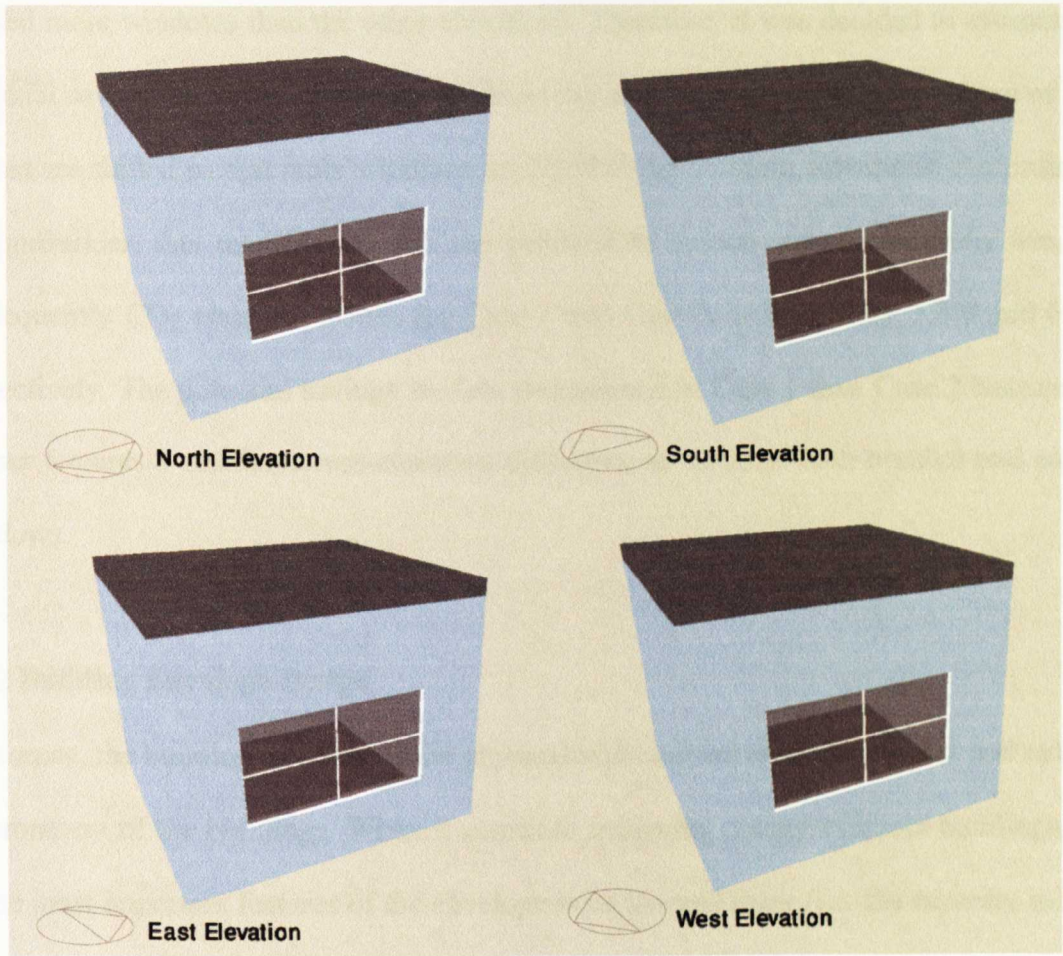


Figure 7.9: Experimenting Different Orientations

Table 7.1: Estimated Annual Solar Gains for Different Orientations in Riyadh (Source: DesignBuilder)

| Orientation | Annual Solar Gain through Exterior Windows (kWh) |
|--------------------|---|
| North | 1408.33 |
| South | 3405.62 |
| East | 3204.71 |
| West | 3259.59 |

Having carried out this simulation, and consistent with the literature-based recommendation provided in Section 7.3, one should aim to place as many of the building's windows as possible in the northern elevation. It was, however, found that the western elevations of the two case buildings (as shown in Figures 5.3 and 5.7) currently

housed more windows than the other elevations. Therefore, it was decided to estimate the potential savings in terms of household electricity consumption if the orientations of both houses are shifted so that more windows are fitted to the northern elevations. According to DesignBuilder, this modification has the potential to reduce annual electricity use, and subsequently CO₂ emission levels, for Case 1 and Case 2 in Riyadh by 3.0% and 6.6%, respectively. The potential savings are less pronounced in Case 1 than Case 2 because the former features a smaller across-elevation difference in terms of both number and area of windows.

7.5.2 Building Envelope Design

In essence, the building envelope is the physical separator between the interior and exterior environment of the buildings. When it comes to achieving energy-efficient buildings, one of the most important features of the envelope is its thermal mass (i.e. the capacity to store heat). This property essentially describes how the mass of the building provides inertia against temperature fluctuations. When adequately used, in combination with other passive solar design strategies, thermal mass could play a major role in reducing energy use within Saudi buildings (Al-Maayouf, 2005). As shown in Tables 5.2 and 5.3, it was found that the structure of the external walls and roofs of the two 'base' case study buildings employed the use of 'light' concrete blocks. Whilst concrete blocks provide relatively good thermal mass potential, there do exist other materials with potentially higher thermal inertia (see Table 7.2). Bearing in mind that the ideal materials for thermal mass are those materials that have both high density and high specific heat capacity (Smith, 2001), it is clear that 'heavy' concrete blocks achieve the highest thermal inertia.

Table 7.2: Thermal Mass-Related Properties of Different Materials (Source: DesignBuilder)

| Material | Density (kg/m³) | Specific Heat Capacity (J/kgK) |
|-------------------------|---------------------------------------|---|
| Concrete Block (Light) | 600 | 1000 |
| Concrete Block (Medium) | 1400 | 1000 |
| Concrete Block (Heavy) | 2300 | 1000 |
| Alluvial Clay | 1960 | 840 |
| Sedimentary Rock | 1500 | 1000 |

According to DesignBuilder, replacing the ‘light’ concrete blocks – originally used in the external walls and roofs of the two case buildings – with ‘heavy’ concrete blocks could achieve reductions in annual household electricity consumption level to the order of 1.7% and 0.8%, respectively. Borrowing from the recommendations provided earlier in Chapter 6, other possible improvements to the building envelope design include: (i) replacing the original single-glazed windows with triple glazing; (ii) replacing the original air gap and foam slag insulation in the external walls with 50mm polyurethane insulation; (iii) adding a 50mm layer of polyurethane insulation to the roof the buildings. As a result of incorporating all of these improvements to the envelope design of Case 1 and Case 2, it is estimated that it would be possible to reduce annual electricity use – and hence CO₂ emission levels – by 17.6% and 11.3%, respectively. However, one has to be aware of the limitations associated with the simple nature of these recommendations. For example, bearing in mind that thicknesses other than the proposed 50mm polyurethane insulation have not been considered here, thicker layers of thermal insulation could achieve better improvements in terms of building energy performance.

In addition to the potential savings in terms of household electricity consumption, it is of relevance here to report on the potential improvements in terms of U-values (i.e. thermal transmittance). As explained in Chapter 5 (Section 5.2), the U-value of a particular material (expressed in W/m^2K) is the inverse of its R-value. The latter is obtained by dividing the thickness of the material (in metres) by its conductivity (W/mK). Table 7.3 illustrates an example of a simplified manual U-value calculation for a typical building's roof in Saudi Arabia.

Table 7.3: Simple U-value Calculation Example for a Typical Building's Roof in Saudi Arabia

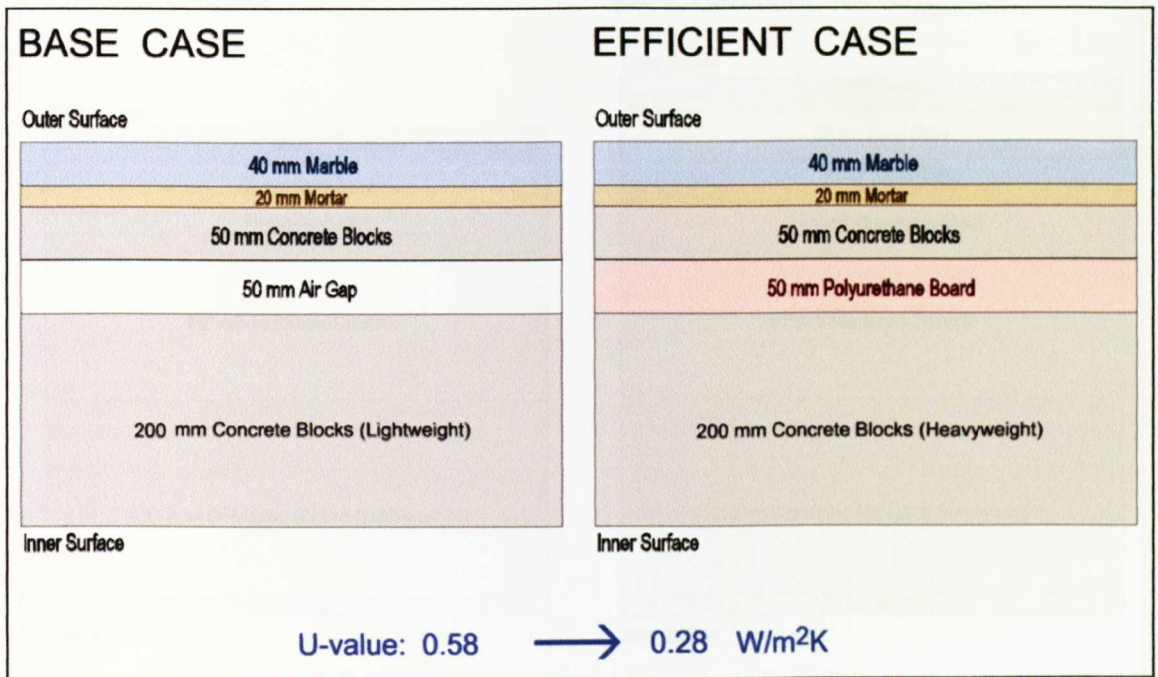
| Material | Thickness (mm) | Conductivity (W/mK) | Resistance 'R' (m²K/W) |
|----------------------|---------------------------|--------------------------------|--|
| Ceramic Tiles | 20 | 1.3 | 0.015 |
| Mortar | 10 | 0.88 | 0.011 |
| Sand Stone | 50 | 1.83 | 0.027 |
| Foam Slag Insulation | 20 | 0.25 | 0.080 |
| Asphalt Insulation | 5 | 0.7 | 0.007 |
| Reinforced Concrete | 150 | 2.3 | 0.065 |
| Concrete Blocks | 200 | 0.19 | 1.053 |
| Plaster (Dense) | 20 | 0.5 | 0.040 |
| Total R-value | | | 1.298 |
| U-value | | | $\frac{1}{1.298} = 0.77$ |

It should be noted, however, that not only does this manual calculation assume that all constituent materials are sufficiently homogenous, but it also does not include the thermal resistances due to the external and internal surface layers of the roof under consideration. When calculating the U-value, it is important to take into account the effect of thermal bridges, i.e. junctions where insulation is not continuous through which heat is transferred

at a substantially higher rate than through the surrounding envelope area. In other words, thermal bridging happens when a highly conductive (or poorly insulating material) spans the gap between the interior and exterior environment of a building, bypassing its insulation and subsequently causing thermal loss from the building. For this reason, calculating the exact U-values of a construction element (e.g. floors or roofs which essentially consist of several layers of materials) tends to be a complex undertaking and is usually done with the aid of computerised software. Examples of software packages available to calculate the U-values include those developed by BRE (201), Celotex (2010) and the Concrete Block Association (2009). The methodology adopted in such U-value calculation tools are based on the BS EN ISO 6946 procedures as well as the conventions and guidelines provided by various reputable bodies such as the ASHRAE, BRE and the CIBSE.

For the purpose of this thesis, and to ensure consistency of this work, calculation of the U-value was carried out here using DesignBuilder. The latter, which in turn is an interface for the powerful EnergyPlus Software, is compliant with the requirements set out by both the CIBSE and BRE amongst other accreditation schemes (DesignBuilder Software, 2010). According to DesignBuilder, Figure 7.10 and 7.11 illustrate the calculated U-values of the external walls and roofs before and after applying the abovementioned modifications.

A) CASE 1: The Apartment Complex



B) CASE 2: The Villa

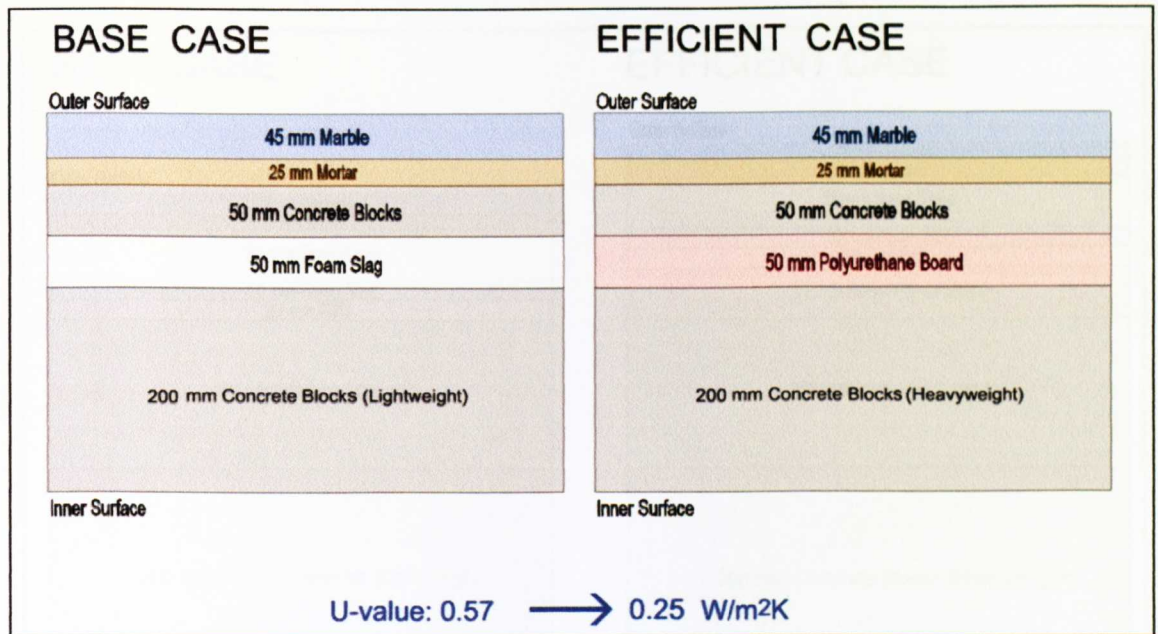
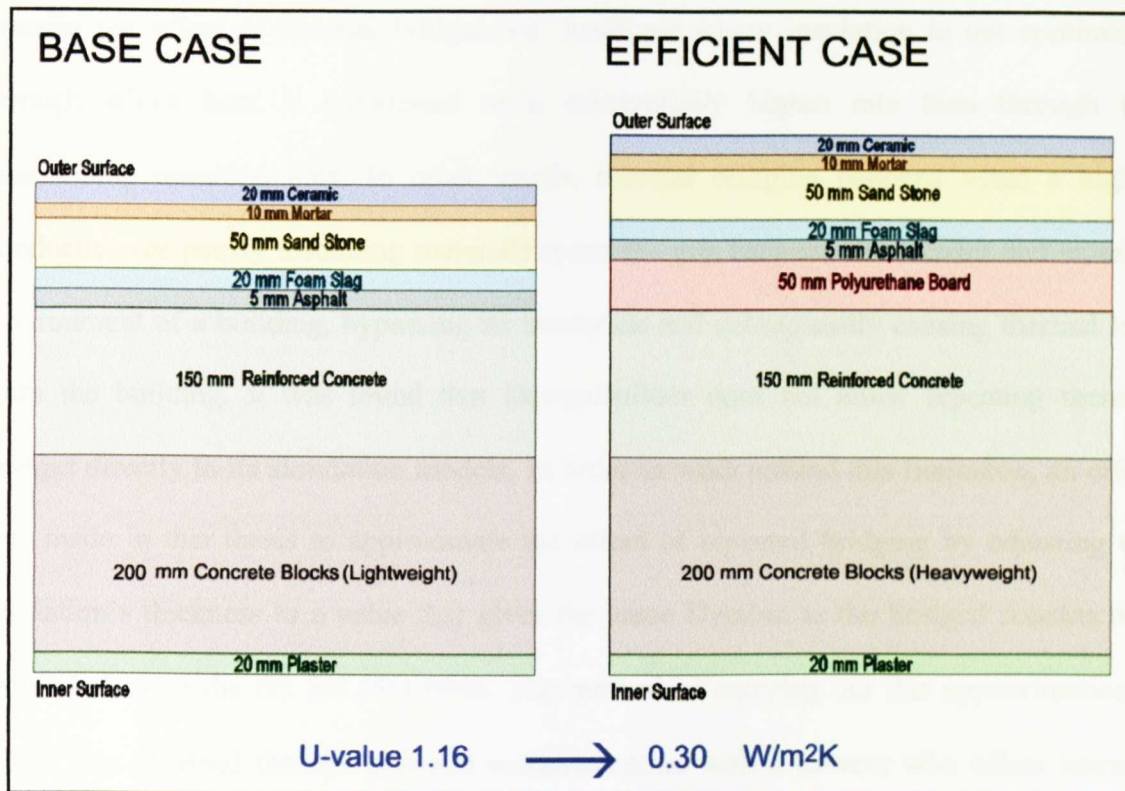


Figure 7.10: Cross-sections of the External Walls in the Base and Efficient Case Buildings

A) CASE 1: The Apartment Complex



B) CASE 2: The Villa

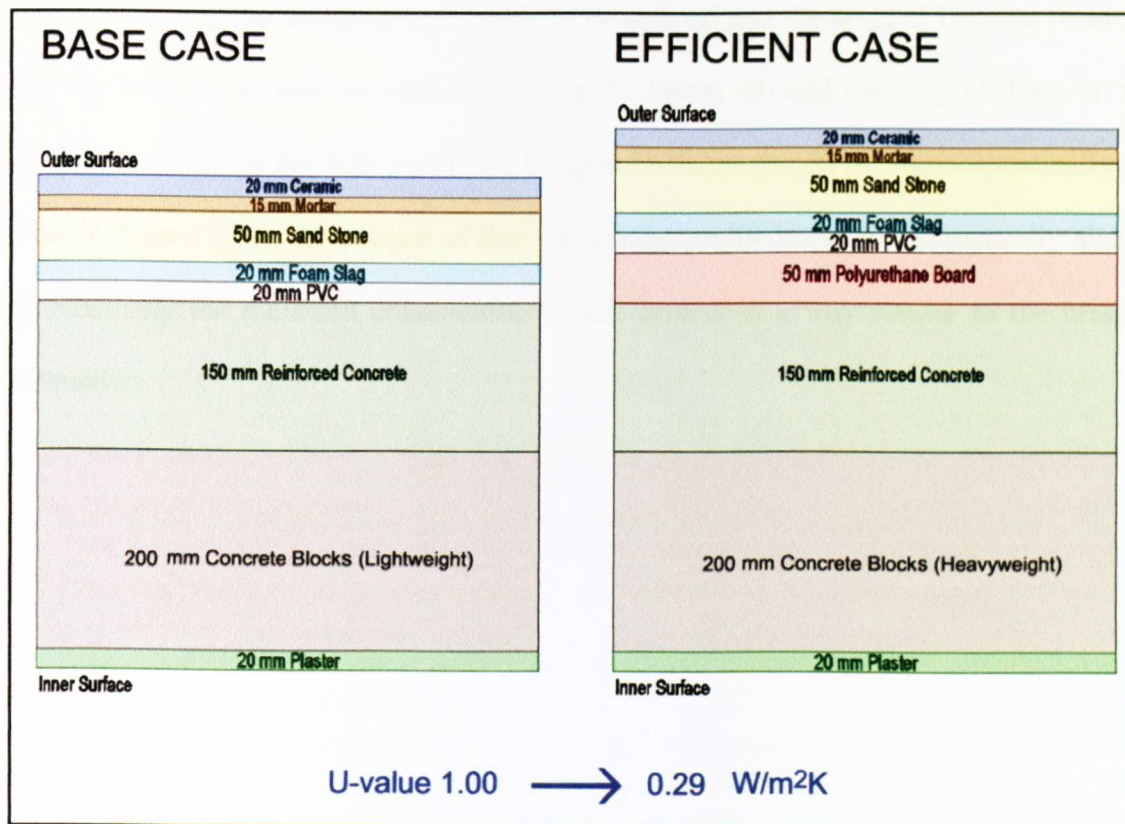


Figure 7.11: Cross-sections of the Roofs in the Base and Efficient Case Buildings

It should be noted here that when calculating the U-value, it is important to take into account the effect of thermal bridges, i.e. junctions where insulation is not continuous through which heat is transferred at a substantially higher rate than through the surrounding envelope area. In other words, thermal bridging happens when a highly conductive (or poorly insulating material) spans the gap between the interior and exterior environment of a building, bypassing its insulation and subsequently causing thermal loss from the building. It was found that DesignBuilder does not allow repeating thermal bridges directly in its simulation models. In order to work around this limitation, an effort was made in this thesis to approximate the effect of repeated bridging by adjusting the insulation's thickness to a value that gives the same U-value as the bridged construction calculated using the BS EN ISO 6946. The method of carrying out this approximation – which was obtained through personal communication with a lecturer who offers training courses on using DesignBuilder – is as follows. Firstly, the structure of the building element, including the bridging data, needs to be defined and the bridged U-value recorded. Next, the bridging should be switched off on the layers tab and then, by clicking on the 'Set U-Value' link on the Info panel, the bridged U-Value should be inserted manually (as shown in Figure 7.12). As a result of this, the insulation thickness is automatically altered and eventually the modified construction would behave in a way similar to the bridged construction.

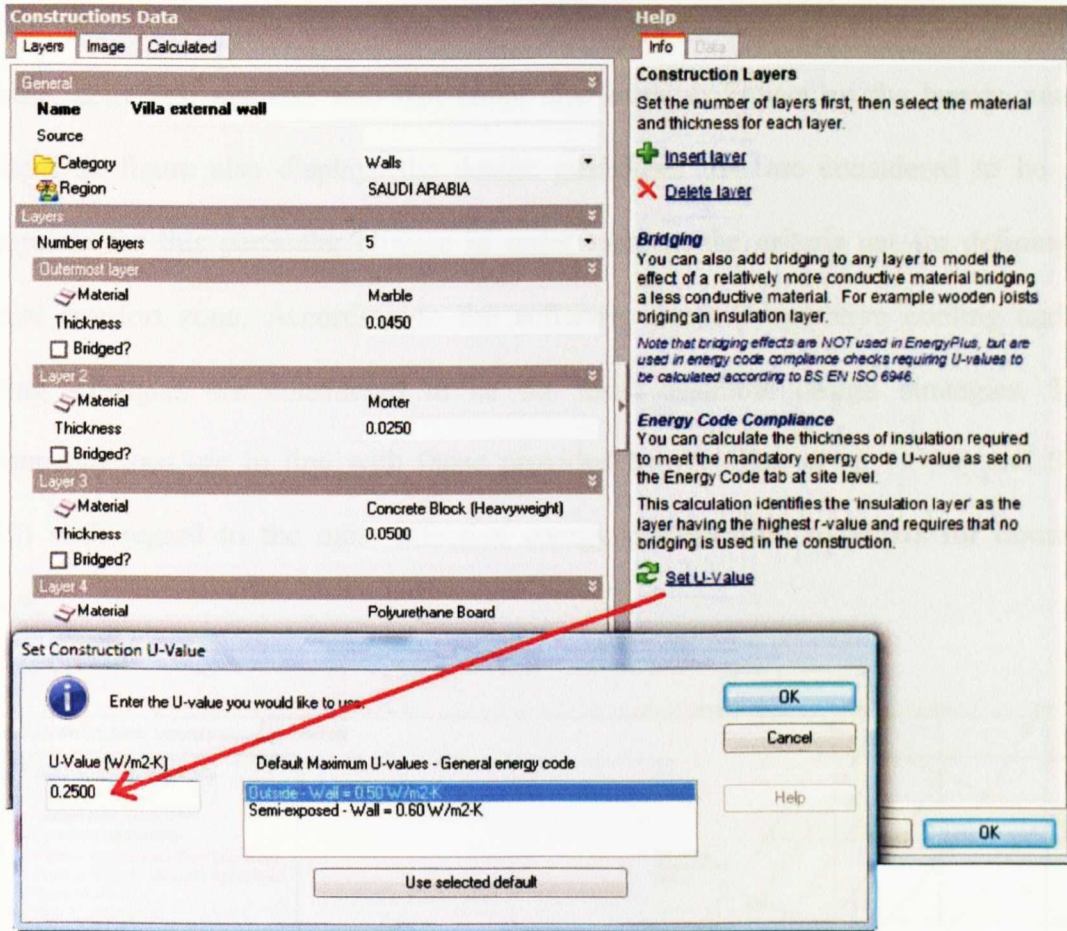


Figure 7.12: Method for Approximating Bridging Effects in DesignBuilder Simulations

7.5.3 HVAC Strategy

In Chapter 6, methods of determining the HVAC strategy that is most suitable for the climate of Jeddah were based on extensive discussions with the current tenants of the case study buildings. Bearing in mind that their opinions do not represent the view of the whole Saudi population, an effort was made to determine the HVAC strategy for the hot dry climate of Riyadh whilst taking into consideration Riyadh's psychrometric chart. Figure 7.13 illustrates the thermal comfort zone for the climate of Riyadh on the psychrometric chart (also known as bioclimatic chart) provided by Climate Consultant 5 Software. It should be noted here that the criteria for setting this zone is defined in terms of two environmental factors (i.e. dry bulb temperature between 21° and 24°C, and a maximum

relative humidity of 80%), but it does not take into account many physiological factors (e.g. clothing, activities, age and sex) that could also have an impact on the human comfort levels. This figure also displays the design guidelines that are considered to be most appropriate for this particular climate in order to meet the criteria set for defining the thermal comfort zone. According to the software, direct evaporative cooling and sun shading strategies are considered to be the most desirable design strategies. These recommendations are in line with those provided by Al-Ajlan et al. (1998) and Saeed (1989) with regard to the most effective energy conservation measures for houses in Riyadh.

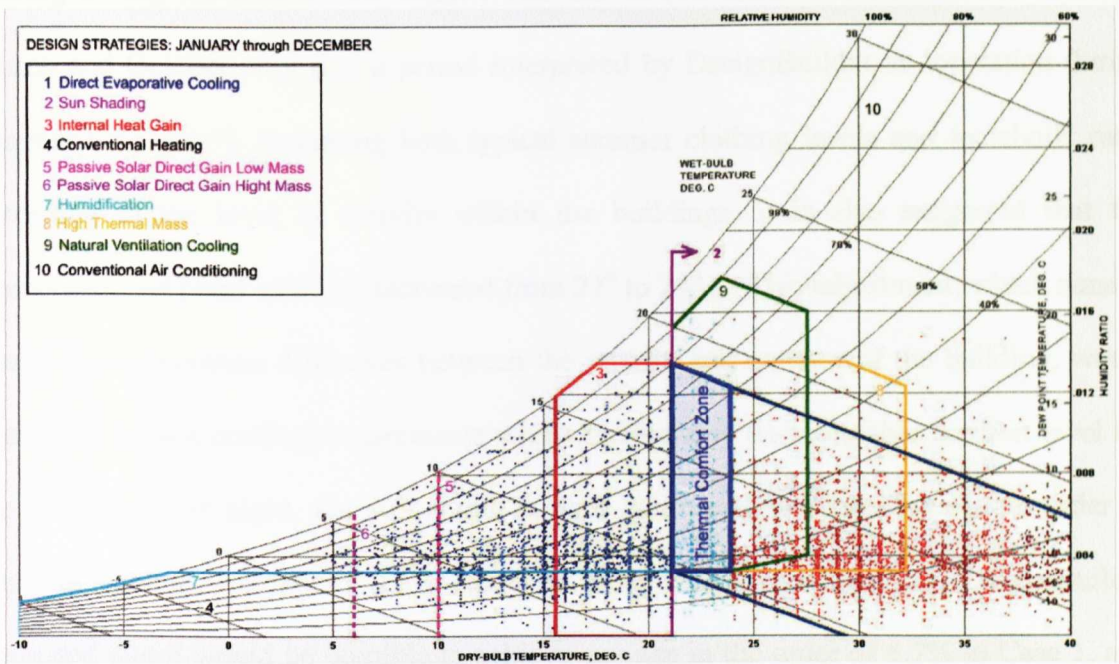


Figure 7.13: Building Design Strategies for Riyadh's Climate

It is interesting to note here that evaporative cooling could, theoretically speaking, provide almost all of the required cooling capacity and hence could eliminate the need for conventional AC systems. The need for AC could be further reduced by using ceiling fans inside Riyadh's residential buildings. The principles of natural evaporative cooling could be incorporated into the building through the provision of down draught towers. Despite

the fact that this technology has been successfully demonstrated in some parts of the world, it might be impractical to utilise within the buildings of Riyadh due to both installation complexity and water requirements. In addition, it is important to constantly monitor the quality of the water in order to prevent any potential build-up of scale and to reduce potential microbiological-related risks such as legionella disease (Kang and Strand, 2009). Given the lack of awareness of such technologies and the additional costs involved, it is reasonable to suggest improving the strategies of conventional HVAC systems that are readily available in the local markets of Saudi Arabia. More specifically, and bearing in mind the weather conditions in Riyadh, it is suggested to continue making use of electrical heating during the cool winter nights. The use of AC should be restricted to between March and October only (i.e. a period interpreted by DesignBuilder as 'operation during summer-time only'). Assuming both typical summer clothing levels and metabolic rates according to the level of activity within the buildings, it is also suggested that the temperature set point could be increased from 22° to 24° C. This adjustment, which aims to lessen the temperature difference between the interior and exterior of the building, would eventually reduce cooling requirements whilst maintaining an acceptable comfort level for the occupants. At night, the AC could be shut down and windows opened in order to promote natural ventilation. As a result of these minor modifications, DesignBuilder estimated that it would be possible to achieve savings in the order of 6.7% in Case 1, and 5.2% in Case 2.

7.5.4 Solar Shading Strategies

Before making any recommendations on the solar shading strategies that are most appropriate for houses in Riyadh, it is important first of all to establish a basic understanding with regard to the subjects of solar geometry, solar charts and the solar shading design principle.

7.5.4.1 Solar Geometry

There are two main earth movements: (i) 'Earth Rotation' in which the earth spin on its axis; and (ii) 'Earth Revolution' where the earth orbits sun. Whilst rotation on its own axis takes twenty-four hours (i.e. a period referred to as a 'mean solar day'), an orbit cycle around the sun takes 365 days to complete. It is important to note here that the earth's orbit around the sun is not circular, but rather oval or elliptical. Such an elliptical orbit results in a variation in the distance from the sun to the earth at different times of the year. Consequently, the amount of solar radiation intercepted by the earth tends to vary annually by approximately 6%. Figure 7.14 illustrates the positions in the earth's revolution that are closest and farthest from the sun. With a distance of 147.3 million km, 'Perihelion', which takes places on January 3, is the point closest to the sun. The farthest is on July 4, known as Aphelion, with a distance of 152.1 million km from the sun (Pidwirny, 2006).

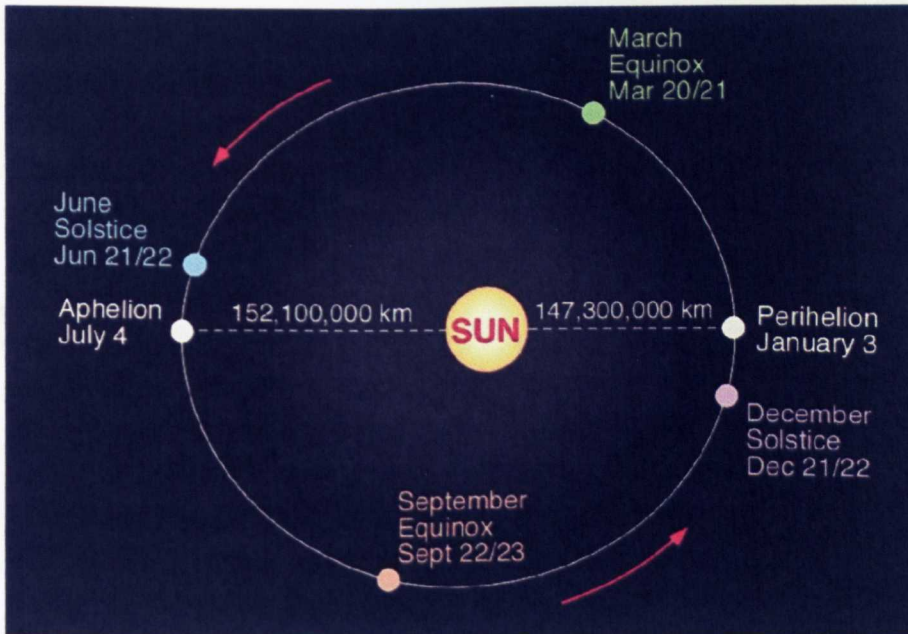


Figure 7.14: Position of Aphelion and Perihelion Relative to the Earth's Orbit around the Sun

(Pidwirny, 2006)

According to Pidwirny (2006), another important aspect to note here is that the earth's axis is not at right angles to its orbit plane (known as ecliptic), but rather it is inclined at an angle of 23.5° from the perpendicular. Figure 7.15 shows the movement of the earth around the sun on four important dates, namely the December solstice, March equinox, June solstice and September equinox. During the solstices, the sun appears to stand still in declination before it starts moving in the opposite direction either towards or away from the sun. On the December solstice (December 21), the earth is positioned so that the South Pole is leaning 23.5° towards the sun. Consequently, all locations south of the equator have day lengths that exceed twelve hours, whilst all locations above the equator have day lengths that are less than twelve hours. The March equinox takes place a quarter of year later, (i.e. around March 21), during which the equator faces the sun directly whilst the poles are not tilted towards or away from the sun. The same declination angle of zero occurs on about September 22 (September equinox). During both equinox days, the day lengths are exactly twelve hours regardless of latitude (Seeds and Backman, 2007).

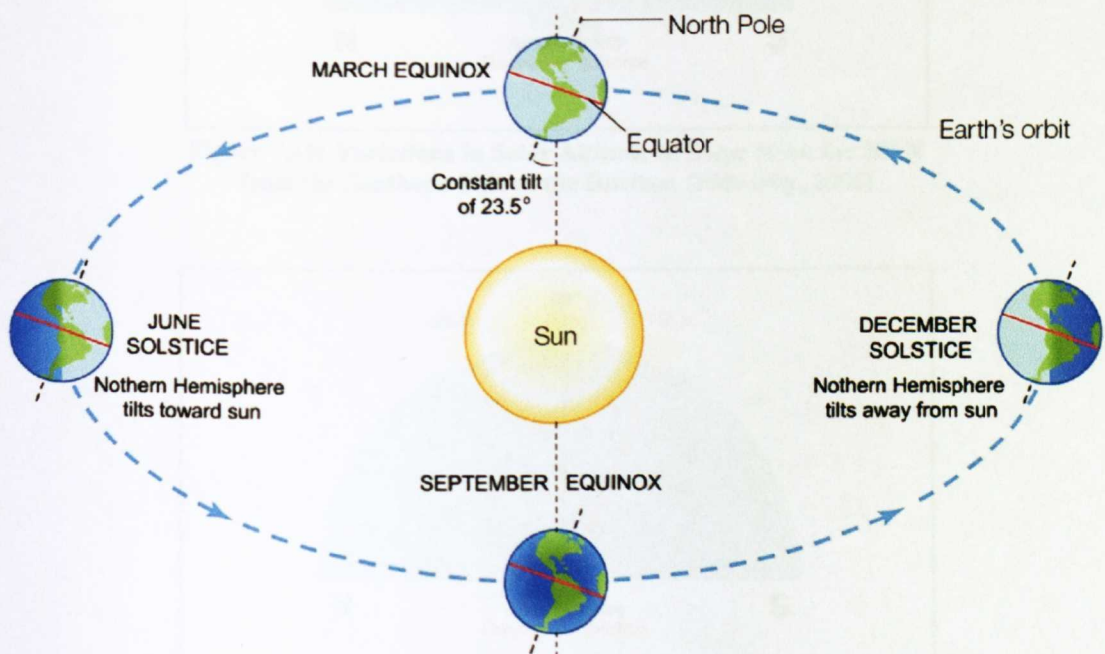


Figure 7.15: The Earth's Revolution around the Sun (Adapted from: Encyclopaedia Britannica (2010))

Another important notion to bear in mind is the solar altitude, which can be defined as the height of the sun from the horizon – measured from either the southern or northern point along the horizon. Over a one-year period, the total variation in maximum solar altitude for any location on earth is 47° (i.e. double the earth's tilt). Such a variation is due to the abovementioned annual changes in the Earth's relative position to the sun. Figure 7.16 shows that at 50° N, the maximum solar altitude – measured from the southern end of the horizon – changes from 63.5° on the June solstice to 16.5° on the December solstice. At the equator, the maximum solar altitude varies from 66.5° above the northern end of the horizon during the June solstice, to directly overhead on the September equinox, and then down to 66.5° above the southern end of the horizon (i.e. 113.5° above the northern end of the horizon) during the December solstice (Figure 7.17).

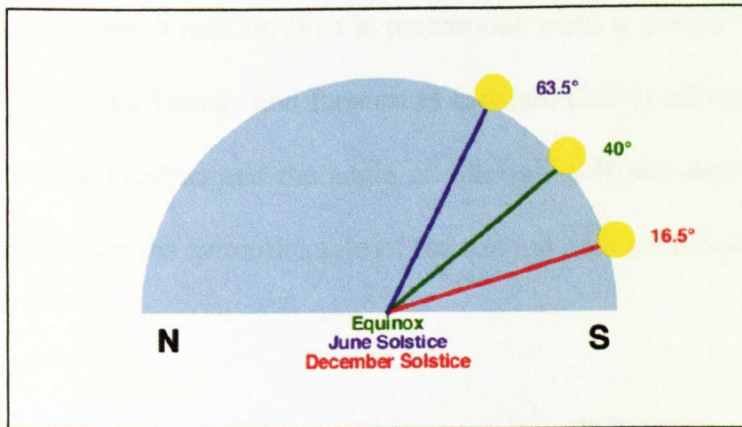


Figure 7.16: Variations in Solar Altitude at Solar Noon for 50° N from the Southern Side of the Horizon (Pidwirny, 2006)

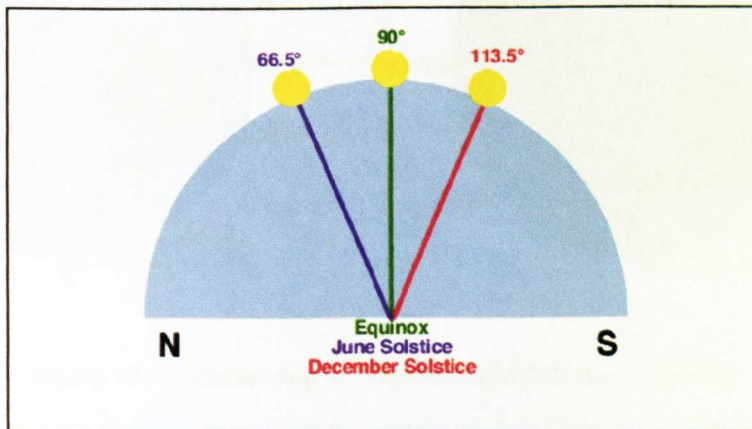


Figure 7.17: Variations in Solar Altitude at Solar Noon for the Equator from the Northern Side of the Horizon (Pidwirny, 2006)

The location on the earth where the sun is directly overhead at solar noon is termed the 'subsolar point'. During the two equinox days, this point becomes located over the equator, which in turn is lined up with the ecliptic plane. The December solstice occurs when the subsolar point is over the Tropic of Capricorn, whilst the June solstice occurs when the subsolar point is over the Tropic of Cancer. Figure 7.18 illustrates such a relationship, between the maximum sun heights and latitude, for both the Equinox and June Solstice. The values indicated in red are the maximum sun heights (i.e. solar altitude), whilst the values in black colour relate to Earth's latitude. As a rule of thumb, for every 1° of latitude we move away from the location where the sun is directly overhead, the solar altitude drops by 1° (Pidwirny, 2006). Given that the amount of annual solar energy variation received on the earth depends on the latter's position and tilt on the orbit around the sun, knowledge of such sun-earth relationships is paramount when it comes to designing solar controls for buildings. The Energy and Resources Institute (2004) affirms that besides the latitude of the building location and the angle of solar altitude, the design of the shading device largely depends on the azimuth angle of the sun – a notion that will be explained in the next section.

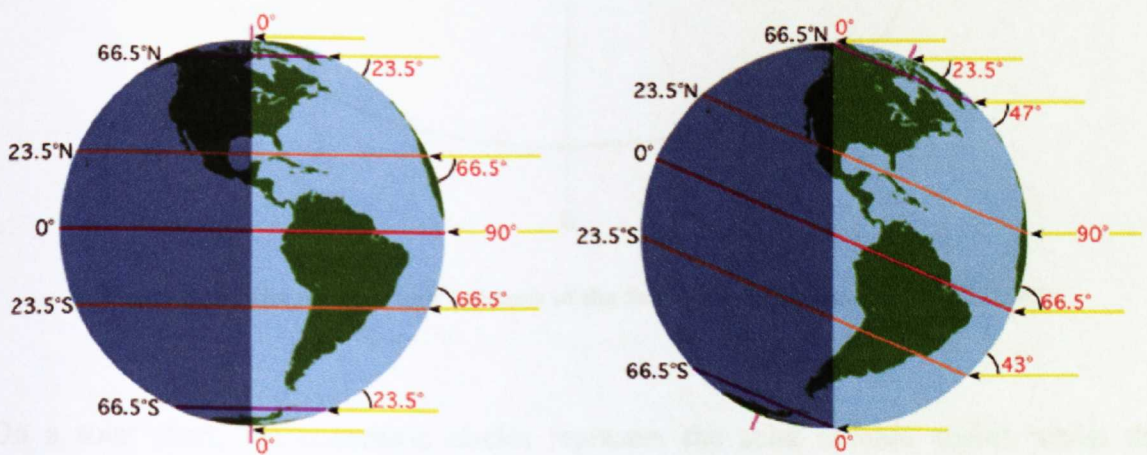


Figure 7.18: Relationship of Maximum Sun Height to Latitude for the Equinox (Left) and June Solstice (Right) (Pidwirny, 2006)

7.5.4.2 Solar Charts

Solar charts (sometimes referred to as 'sun path diagrams') are widely used to determine the position of the sun in the sky in terms of two angles, namely the solar altitude angle and the azimuth angle. Whilst the solar altitude is the height of the sun measured between the horizontal plane and the line connecting the sun to the observer, the solar azimuth angle is the horizontal angle measured at the horizontal plane between the north and the vertical plane including the sun. In other words, altitude is the vertical angle in the sky, whilst azimuth is the horizontal direction from which it comes (see Figure 7.19). Altitude angles vary from 0° (i.e. right on the horizon) to 90° (i.e. directly overhead), whereas the azimuth is usually measured clockwise from north so that due north is 0° (or 360°), east 90° , south 180° , west 270° (Roaf et al., 2007).

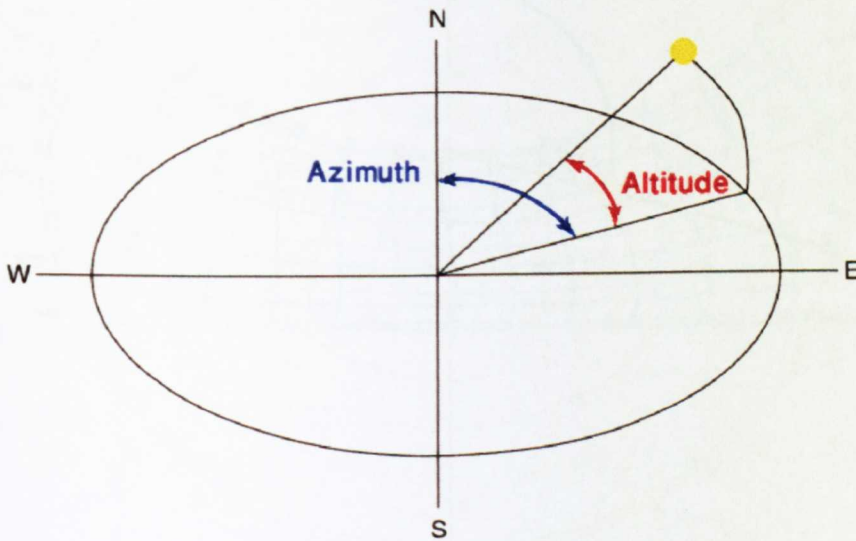


Figure 7.19: The Altitude and Azimuth of the Sun (Adapted from: Roaf et al., 2007)

On a solar chart, the concentric circles represent the solar altitude angles whilst the azimuth angles are represented by the lines radiating from the centre of the chart. An example is given in Figure 7.20 to illustrate the method of determining sun's position (in

terms of altitude and azimuth angles) for Riyadh City at a certain date and a particular time (say 3rd September at 9h). The solar chart of Riyadh was obtained from a commercially available 3D environmental design software package, named EcoTect, and the selected date line (3rd September) was located in the chart. Next, the intersection between that date line and the selected time line (9h) was found. An altitude of 45° is read off from the concentric circles. In addition, an azimuth of 105° is read off by laying a straight edge from the centre of the chart through the marked time point to the perimeter scale.

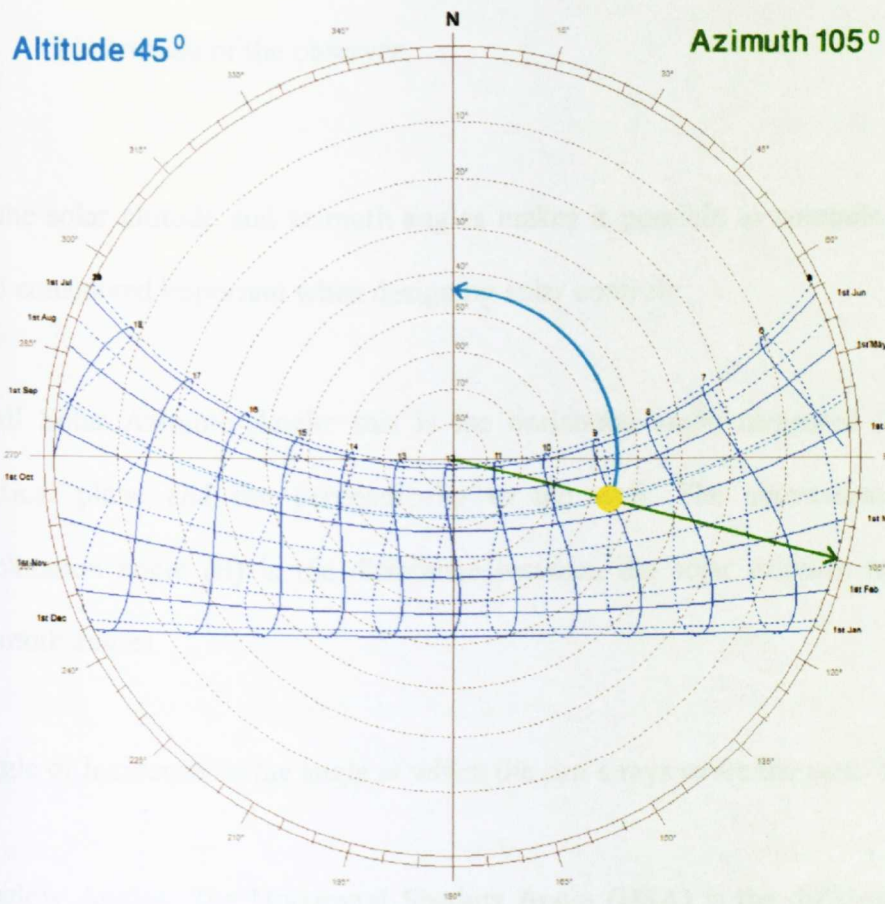


Figure 7.20: Determining the Altitude and Azimuth of the Sun for Riyadh City on the 3rd of September at 9AM (Adapted from: EcoTect Software)

According to Iqbal (1983), the solar altitude (α) and azimuth angle (ψ) can be calculated using the following equations:

$$\text{Solar Altitude } (\alpha) = \sin^{-1} \{ \sin (\delta) \sin (\phi) + \cos (\delta) \cos (\phi) \cos (\omega) \}$$

$$\text{Solar Azimuth } (\psi) = \cos^{-1} \left\{ \frac{\sin(\alpha) \sin(\phi) - \sin(\delta)}{\cos(\alpha) \cos(\phi)} \right\}$$

Where: **(δ)** solar declination angle: the angle between the sun-earth line and the equatorial plane.

(ω) hour angle: the angular distance that the earth has rotated in a day.

(ϕ) latitude of the observer.

Knowing the solar altitude and azimuth angles makes it possible to compute three other angles also considered important when designing solar controls:

- **Wall Solar Azimuth Angle:** this is the horizontal angle measured between the vertical plane and the perpendicular to the wall. The abovementioned solar declination angle (δ) is the difference between the solar azimuth and the wall azimuth angles.
- **Angle of Incidence:** is the angle at which the sun's rays strike the earth's surface.
- **Shadow Angles:** The Horizontal Shadow Angle (HSA) is the difference between the wall azimuth and the solar azimuth, whilst the Vertical Shadow Angle (VSA) is the angle between the direction of the sun, resolved in the plane of the elevation, and the horizontal plane (CLEAR, 2010).

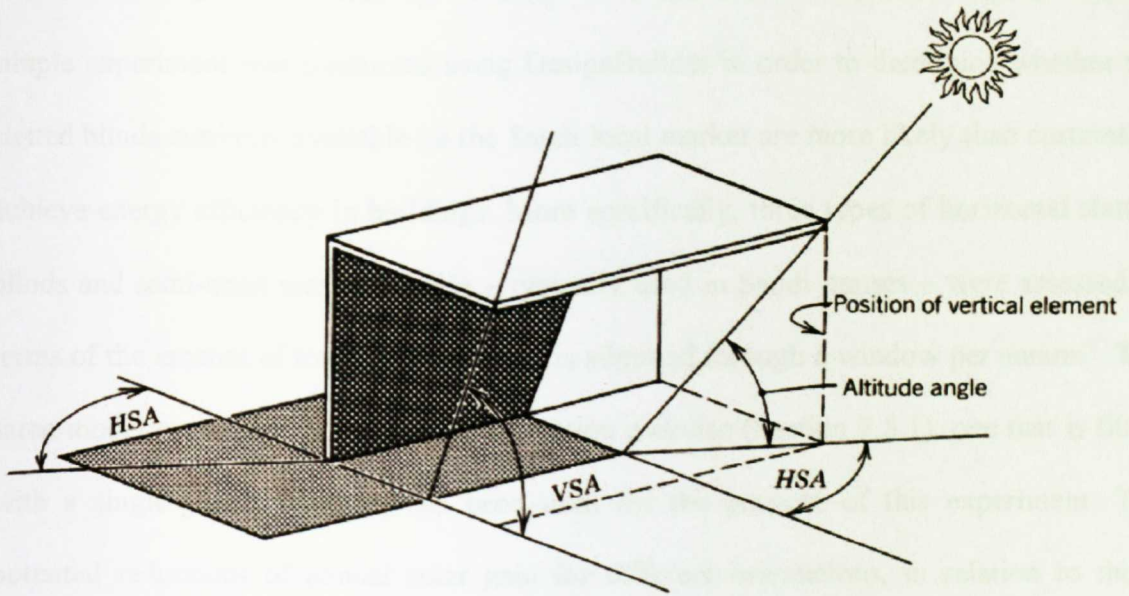


Figure 7.21: Horizontal and Vertical Shadow Angles (Grondzik et al., 2010)

7.5.4.3 Solar Shading Design Considerations

Kachadorian (2006) mentions that the underlying aims of solar controls such as shading devices are twofold: (i) To reduce solar heat gain in overheating periods (i.e. natural cooling); (ii) To maximise solar heat gain in underheating periods (i.e. natural heating). In general, there are two types of shading devices: external and internal shading. Examples of the latter include curtains, venetian blinds and vertical louvres – which are common features of residential buildings. Joudah (1992) conducted doctoral research with the aim of investigating the effect of such internal shading devices on the cooling loads, energy consumption and thermal comfort of the occupants of Riyadh's buildings. According to his research findings, slatted blinds are more efficient than curtains in terms of reducing both the solar heat gain factor and transmission coefficient of double-glazed fenestration. Strictly speaking, by using typical blinds available to him in the early 1990s, the solar heat gain factor could be reduced by 34% and the transmission coefficient of double-glazed

fenestration could be reduced by 11% (*cf.* 29% and 8% for curtains, respectively). A simple experiment was conducted using DesignBuilder in order to determine whether the slatted blinds currently available on the Saudi local market are more likely than curtains to achieve energy efficiency in buildings. More specifically, three types of horizontal slatted blinds and semi-open weave curtains – typically used in Saudi houses – were assessed in terms of the amount of total solar gain that is admitted through a window per annum⁴. The same model room used earlier in the orientation exercise (Section 7.5.1), one that is fitted with a single-glazed window, has been used for the purpose of this experiment. The potential reductions of annual solar gain for different orientations, in relation to those reported in Table 7.1, are shown in Table 7.4.

Table 7.4: Estimated Annual Reduction of Total Solar Gain for Different Types of Internal Shading Devices and Orientations in Riyadh (Source: DesignBuilder)

| Type of Internal Shading Device | | Estimated Annual Reduction of Total Solar Gain through Exterior Windows | | | |
|---------------------------------|-------------------|---|-------------------|------------------|------------------|
| Name | Solar Reflectance | North Orientation | South Orientation | East Orientation | West Orientation |
| Blind 1 | 0.02 | 53.5% | 63.8% | 57.5% | 63.3% |
| Blind 2 | 0.05 | 49.9% | 60.4% | 54.3% | 59.7% |
| Blind 3 | 0.08 | 19.9% | 27.8% | 23.8% | 25.6% |
| Curtain 1 | 0.05 | 19.9% | 20.8% | 19.0% | 20.7% |
| Curtain 2 | 0.15 | 19.3% | 20.0% | 18.3% | 20.0% |
| Curtain 3 | 0.25 | 18.6% | 19.4% | 17.7% | 19.3% |

⁴ This parameter used to be called ‘Transmitted solar gains’ in earlier versions of the DesignBuilder software. For windows with a blind, this transmitted radiation consists of beam, diffuse short-wave radiation that passes between the slats and diffuse radiation from beam-to-diffuse reflections from the slats.

Clearly, these results vary according to the properties of the particular samples of the internal shading devices operating under the conditions of the study. Different results are likely to be obtained for different variables such as fabric type and geometric configurations. Based on the results shown in Table 7.4, it appears that – on all orientations – blinds are more likely to admit less solar heat gain than curtains. This finding is in agreement with the thesis of the abovementioned Joudah. It should be noted, however, that although internal shading devices offers glare control (and consequently can improve visual acuity and comfort), they are thermally ineffective and, on their own, are unlikely to reduce cooling loads. CLEAR (2010) explains that if radiation strikes the glazing with no interference, it penetrates into the internal space and heats up the blinds/curtains, which in turn heats up the room by both long-wave radiation and conduction (i.e. airflow around them). The situation becomes even worse if the colour of the blinds and/or curtains is not white. This is why one should not depend on internal shading only for neutralising the effects of heating by radiation. It is, therefore, usually preferable to combine the use of internal shading devices with energy-efficient glazed windows (i.e. those with low rates of heat loss or low U-value) and external shading devices.

External shading will reduce the amount of direct radiation that strikes the glazing, thereby influencing the temperature of the internal space of the building. It should be noted, however, that since direct radiation could represent a small proportion of the radiation striking the glazing, heating needs to be prevented by installing a cover (e.g. shutter or front curtain) in front of the glazing. The effectiveness of external shading depends on the type of shading and its placement relative to the glass. When solar radiation strikes the external shading device, one part is reflected outwards from its surface whilst another part could be reflected onto the glazing (depending on the geometry of the external shading

element) and the remainder is absorbed by the shading device itself. The latter can result in the heating up of the shading element and consequently a certain flow of heat is created from the shading element by both conduction and radiation. That is why it is usually recommended to use shading devices that are made of a non-reflective material, with minimal heat capacity (CLEAR, 2010).

Another relevant parameter to consider when selecting the material for the shading device is its cost. An effort was made by Waheeb (2005) to estimate the average cost of shading material in Saudi Arabia through consulting three local contractors (see Figure 7.22). Apparently, wall and block shading are the cheapest and the easiest to design and construct. Wall shading is essentially an extension of the wall, whilst blocks are one of the most common materials in Saudi Arabia. In addition, both materials possess effective thermal properties. Steel is the third cheapest material, but it was not recommended because constructing steel shading requires highly-skilled labourers and special expertise, which Saudi Arabia seems to lack.

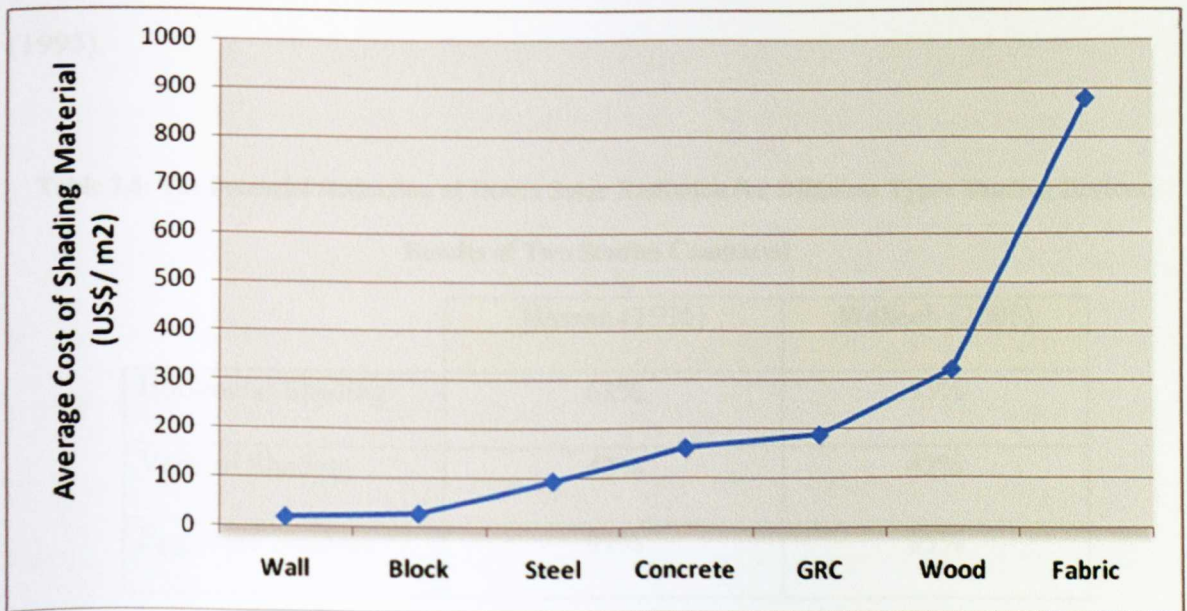


Figure 7.22: The Average Cost of Shading Materials in Saudi Arabia (Source: Waheeb, 2005)

There are three main types of external shading devices: horizontal overhangs, vertical fins and an egg-crate type (i.e. a frame made of a horizontal projection and vertical fins). Hassan (1995) conducted a doctoral research in order to examine the shading effectiveness of these types in terms of reducing the diffuse and reflected components of solar gains, as well as the direct components. The study was conducted in the context of the hot humid climate of Malaysia, which is somewhat comparable to that of Jeddah. Among the findings of the study were that horizontal shading devices are more effective in the case of high sun positions, whilst vertical devices are most suited for cases when the sun is low. Egg-crate shading devices are usually effective in both sun positions and for all window orientations. The second best performing type on most window orientations is the horizontal device. In another piece of research dedicated to examining the impact of shading on both indoor sunlight distribution and building energy performance in Saudi Arabia, Waheeb (2005) suggested that vertical shading is not recommended due its negligible effect on solar penetration during the Saudi summer, resulting in potentially high cooling loads. In addition, egg-crate shading seems to be capable of reducing a comparatively large amount of direct solar radiation. Table 7.5 compares the results of this study with that of Hassan (1995).

Table 7.5: The Potential Reduction of Direct Solar Radiation for Different Types Shading Devices:

Results of Two Studies Compared

| | Hassan (1995) | Waheeb (2005) |
|--------------------|---------------|---------------|
| Horizontal Shading | 63% | 45% |
| Vertical Shading | 42% | 42% |
| Egg-crate Shading | 91% | 95% |

Whilst there is general agreement between the results of these studies, the only difference was evident in the case of horizontal shading. Waheeb (2005) attributed this slight discrepancy to the environmental conditions being dissimilar in the two studies. Moreover, the cooling loads required for both horizontal and egg-crate shading devices and for different window sizes, were examined in Riyadh City. It was found that, for various window-to-wall ratios, egg-crate shading achieves lower cooling loads than horizontal shading. This finding validates an earlier decision, made in Chapter 6, to recommend egg-crate shading devices. However, according to Waheeb (2005), the difference in cooling loads between horizontal and egg-crate shading is not large enough to justify the higher cost of the latter. Other reasons provided to suggest that horizontal shading devices are the most preferable for buildings in Saudi Arabia include: (i) They are effective in most window orientations, especially those with a southern orientation – such as in Riyadh City which, as was shown in Table 7.1, receives the highest solar gain throughout the year; (ii) They are most effective for high sun at lower altitudes which makes them suitable for buildings in Saudi Arabia; (iii) Their design is simple and can be constructed from different materials; (iv) Daylighting studies indicate that horizontal overhangs allows desirable levels of daylight into the buildings; (v) The view-out function of the window is not disturbed by horizontal shading; (vi) When compared to other types of shading, horizontal overhangs cause less disturbance to air movement and achieve a relatively higher ventilation rate. Moreover, as a part of this research, an effort was made to examine the optimal shading device dimensions that could keep the window shaded for the whole year in Riyadh. Based on experiments conducted using the EcoTect and SunCast software packages, whilst taking into account Riyadh solar charts and optimal HSA and VSA considerations, it was suggested that an overhang of about 4m in width has the ability to completely block the sun's radiation throughout the year. However, since some sunlight

might be needed to penetrate in the relatively cool winter months in Riyadh, not to mention the impracticality of fitting 4m overhangs, it was recommended to use horizontal overhangs of about 1m in width.

As a result of fitting both internal and external shading devices suitable for Riyadh’s latitude (i.e. 1m overhangs) on the ‘original’ case study buildings in Riyadh, DesignBuilder estimated potential savings of annual electricity, and subsequently CO₂ emission levels, for Case 1 and Case 2 to be 16.9% and 11.5% respectively. To sum up, Table 7.6 lists all the suggested climate-responsive energy conservation measures for the buildings in Riyadh City, and Figure 7.23 indicates the potential electricity savings of each for both case study buildings. The total potential electricity savings, after incorporating all of these modifications in Case 1 and Case 2, are estimated to be around 44.2% and 34.6%, respectively. It is interesting to note here that such a magnitude of savings is almost equal to that estimated earlier for Jeddah City in Chapter 6 (i.e. 47.2% and 34.3%). However, it should be noted that a direct comparison between these figures is misleading, not only due to the different climatic contexts, but also because Riyadh’s figure does not account for potential additional savings as a result of using energy-efficient lighting equipment, solar water heaters or green roofing – all of which were considered in the Jeddah case.

Table 7.6: Recommended Climate-Responsive Energy Conservation Measures for Riyadh’s Buildings

| | |
|--|--|
| Improved Building Orientation | <ul style="list-style-type: none"> • Orientate the buildings so that more windows are fitted in the northern elevation. |
| Improved Building Envelope Design | <ul style="list-style-type: none"> • Improve thermal mass by replacing ‘light concrete blocks with ‘heavy’ ones. • Replace original single-glazed windows with triple glazing. • Replace the original air gap and foam slag insulation in the |

| | |
|-----------------------------------|--|
| | <p>external walls with 50mm polyurethane insulation.</p> <ul style="list-style-type: none"> • Add a 50mm layer of polyurethane insulation to the buildings' roofs. |
| Improved HVAC Strategy | <ul style="list-style-type: none"> • Limit the use of AC to between March and October only. • Increase the temperature set point from 22° to 24° C. • During night time, AC to be shut down and windows opened in order to promote natural ventilation. |
| Solar Shading Arrangements | <ul style="list-style-type: none"> • Use both types of shading devices: internal (blinds with low solar reflectance) and external (1m horizontal overhangs). |

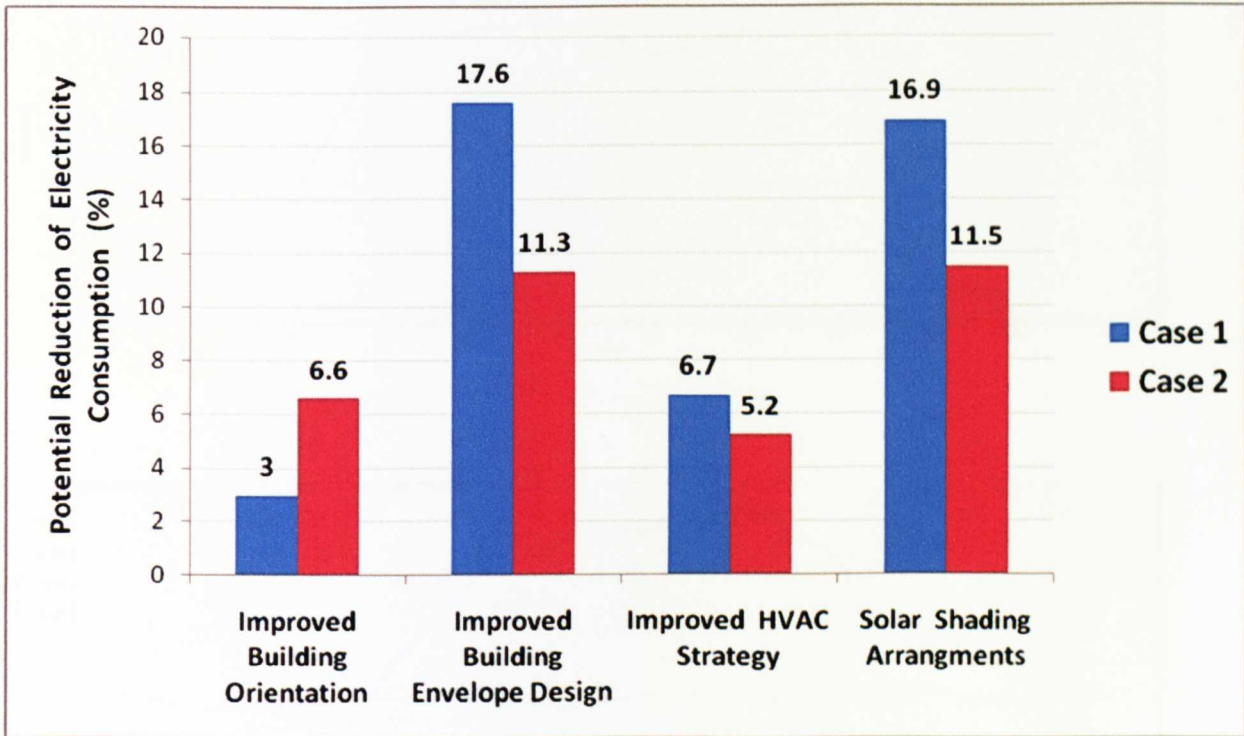


Figure 7.23: Comparing Potential Savings of the Adopted Climate-Responsive Energy Conservation Measures

To conclude this chapter, Figure 7.24 and Figure 7.25 illustrate the monthly energy consumption of the 'efficient' Cases 1 and 2 respectively, in relation to comfort conditions (measured in terms of temperature and humidity readings).

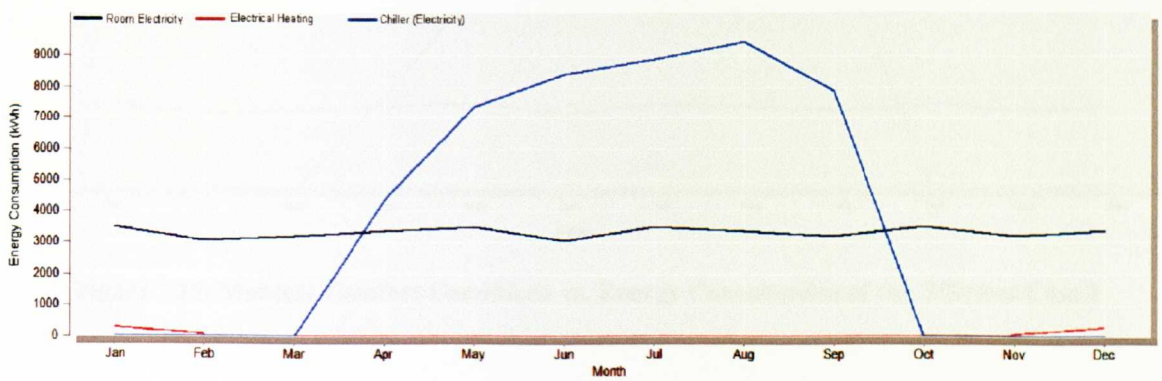
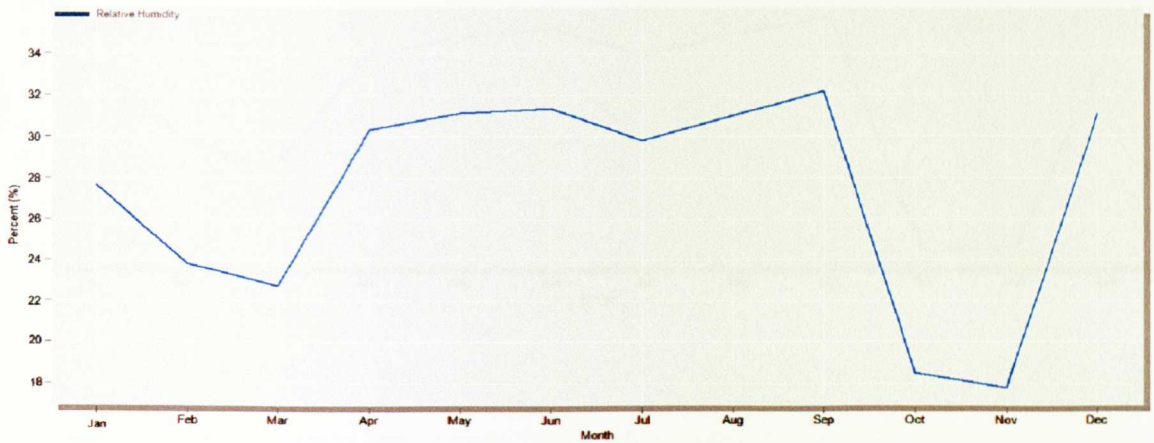
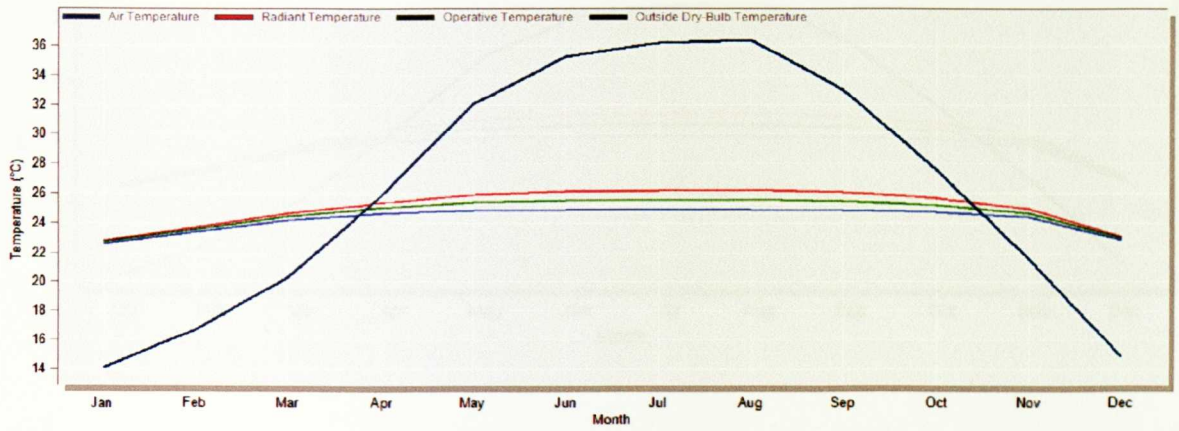


Figure 7.24: Monthly Comfort Conditions vs. Energy Consumption of the Efficient Case 1

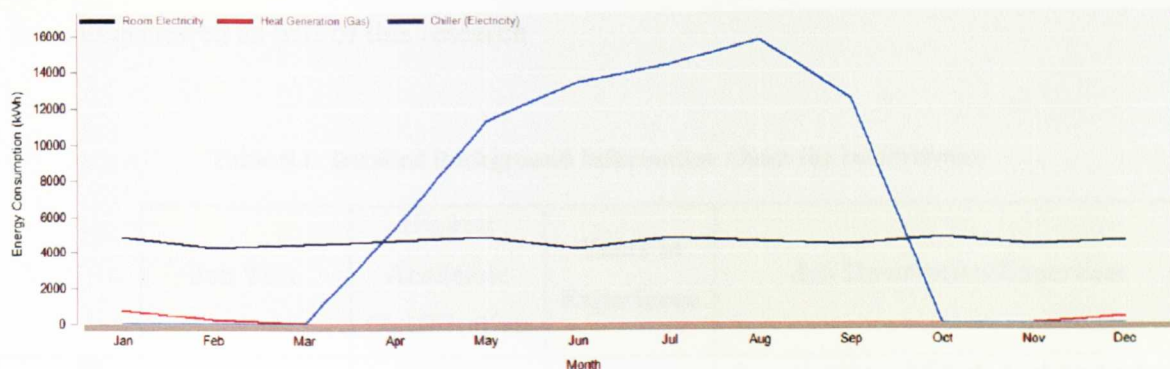
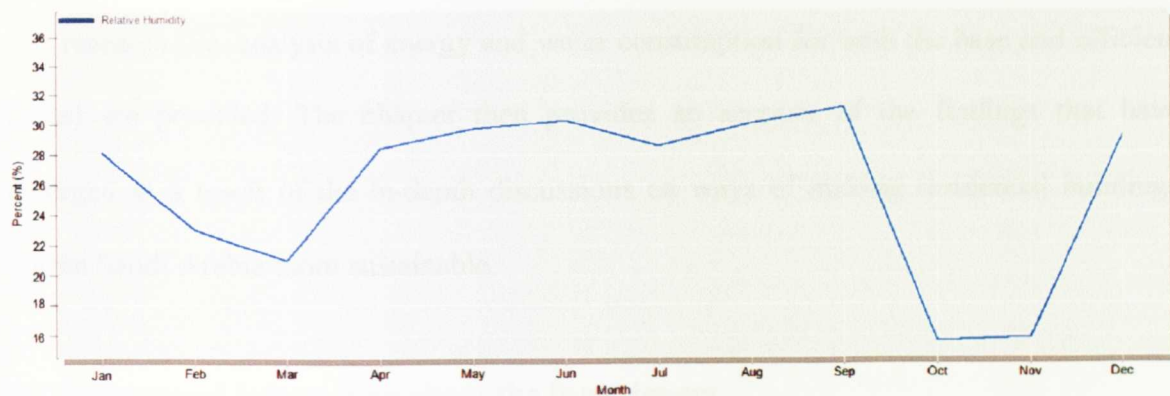
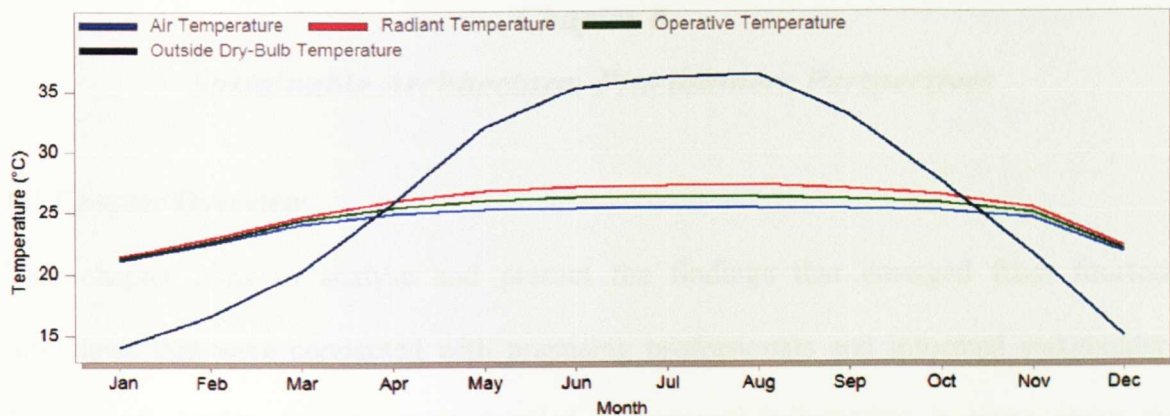


Figure 7.25: Monthly Comfort Conditions vs. Energy Consumption of the Efficient Case 2

Whilst Chapters 5, 6 and 7 have addressed the first phase of this research project (the analysis of energy and water consumption for both the base and efficient cases), the next chapter reports on the second phase, which entailed conducting fourteen interviews with practising architectural professionals and informed stakeholders in Saudi Arabia.

Chapter 8

Sustainable Architecture: Practitioners Perspectives

8.1 Chapter Overview

This chapter aims to analyse and present the findings that emerged from fourteen interviews that were conducted with practising professionals and informed stakeholders from Saudi Arabia. Firstly, some detailed background information is given about the interviewees. Secondly, their feedback and comments on the results of the first phase of this research (i.e. analysis of energy and water consumption for both the base and efficient cases) are provided. The chapter then provides an account of the findings that have emerged as a result of the in-depth discussions on ways of making residential buildings within Saudi Arabia more sustainable.

8.2 Background Information about the Interviewees

Table 8.1 provides detailed background information about the fourteen stakeholders that were interviewed as part of this research.

Table 8.1: Detailed Background Information about the Interviewees

| | | Job Title | Highest Academic Qualification | Years of Experience | Job Description/Expertises |
|-----------------------------|---|---------------------|--------------------------------|---------------------|--|
| Architectural Practitioners | A | Senior Architect | Bachelor's Degree | 15 | An experienced Saudi Architect who currently oversees major commercial and housing projects from inception to completion. He has previously worked for house developers, multi-disciplinary companies and local authorities in Saudi Arabia. |
| | B | Architect (Retired) | Doctoral Degree | 25 | A retired Architect, who was self-employed for ten years in Jeddah City. |

| | | | | |
|----------|----------------------------|-------------------|---|---|
| | | | | <p>Prior to retirement, he worked for two large architectural firms, specialising in a variety of projects. He retired as an Architect five years ago, and has recently completed a Ph.D. in business studies.</p> |
| C | Architect | Bachelor's Degree | 3 | <p>A young Architect who works for a small architectural office in the city of Riyadh. He completed his undergraduate studies on energy-conscious building design in Germany.</p> |
| D | Architect (CAD Technician) | Diploma | 8 | <p>A relatively experienced CAD (Computer-Aided Design) Technician who works for a large construction firm in Jeddah. His expertise includes 2D design (surface modelling), 3D design (solid modelling) as well as building energy simulation (e.g. EnergyPlus, DesignBuilder, eQUEST).</p> |
| E | Architectural Technician | Bachelor's Degree | 5 | <p>An Architectural Technician who works closely with architects and other building professionals, providing architectural design services and solutions on construction projects. He has recently been certified as a LEED Green Associate.</p> |
| F | Interior Architect | Master's Degree | 2 | <p>Current job responsibilities include designing and creating indoor spaces for houses, hotels and retail stores. After obtaining his Bachelor's degree from Saudi Arabia, he completed his postgraduate studies in the use of</p> |

| | | | | | |
|--------|----------|---|-------------------|------------------------------------|--|
| D e | G | Landscape Architect | Bachelor's Degree | 5 | energy-efficient lighting in Australia. A Landscape Architect who works on both small residential projects and large public ones. He has recently written a number of articles in local newspapers to advocate the importance of electricity and water conservation in Saudi Arabia. |
| | H | Professor at King Fahd University in Dhahran | Doctoral Degree | 12 | A university Professor who received his undergraduate and postgraduate education in the USA. Teaching and research interests include energy conservation and maintenance management. |
| | I | Professor at King Saud University in Riyadh | Doctoral Degree | 15 | A Saudi Professor who played a key role in organising the first-of-its kind Saudi conference on Technology and Sustainability in the Built Environment, which took place in Riyadh over the period 3-6 January 2010. He has also participated in the development of the new Saudi building code. |
| | J | Associate Professor at King Abdul-Aziz University in Jeddah | Doctoral Degree | 6 | After completing his tertiary architectural education in the UK, he joined the Faculty of Environmental Designs in King Abdul-Aziz University. His research interests include sustainable design and building insulation materials. |
| K | CEO of a | Master's | 20 | CEO of a major contracting firm in | |

| | | | | | |
|----------------|---|--|-------------------|----|---|
| | | Contracting Company | Degree | | Jeddah, which is currently carrying out a multi-million US dollars worth suite of projects (residential and otherwise) in the country. He has a strong passion for environmental sustainability, and is a big fan of sustainable homes. |
| | L | Senior Manager at a Real Estate Development Company | Master's Degree | 11 | Senior Manager at an international real estate company in Riyadh that provides – among other services – feasibility studies, environmental assessments, design consultation, operation and maintenance and property management in a range of sectors (including residential). He has recently received extensive training on LEED assessment tools. |
| Civil Servants | M | Project Manager for Jeddah Municipality | Bachelor's Degree | 10 | A Project Manager in charge of executing projects for the Jeddah Municipality. He has also worked on setting and implementing local building regulations. He is currently enrolled on a distance-learning Masters course in 'Energy and Sustainable Building Design' provided by a UK university. |
| | N | Senior Inspector at the Ministry of Public Works and Housing | Bachelor's Degree | 15 | He supervises the construction and maintenance of public sector projects, and has a strong personal passion for renewable energy technologies, including the installation of a solar heater at his own house. |

8.3 Feedback on the Simulation Exercise

As mentioned earlier, the simulation results for both the 'Base Case' and 'Efficient Case' were circulated to the interviewees long before the start of the actual interview. Generally speaking, the vast majority of the interviewees were not surprised with the simulation findings. In other words, they were expecting the base case to be inefficient and they were to some extent aware of the significant saving potential in terms of household electricity and water use in Saudi Arabia. Nonetheless, a few of the more elderly interviewees (namely A, B and K) expressed their astonishment with regard to the capabilities of today's modelling software packages. In the words of Interviewee B, "I am very impressed with the capabilities of the modelling software you used in your analysis, especially when it comes to calculating CO₂ emissions...Until recently, doing energy, emissions and water analysis was only possible manually". On the other hand, Interviewee D – who currently works as a CAD Technician – mentioned that it is true that DesignBuilder provides an effective and user-friendly graphical interface for the powerful EnergyPlus software, but it does not utilise its full potential. For example, it has been recently announced that the forthcoming version of EnergyPlus will be able to perform simulation of both water consumption and integration of PV modules within a building. Whilst such an analytical enhancement would have been useful for the purpose of this research, it is not expected to be incorporated in DesignBuilder anytime soon. In spite of this, DesignBuilder remains to be recognised and highly recommended by the US Department of Energy (2010) as a most reputable GUI for EnergyPlus.

Interviewee E – who works as a University Professor – acknowledged the fact that when using DesignBuilder, as is the case with any modelling software, it is inevitable to make many assumptions and hence there is an unavoidable element of simplification. He also

agreed on the need to validate the simulation results using utility bills and literature. He went further to suggest that the validity of the research findings would have been enhanced by increasing the number of case study buildings. Nonetheless, due to access constraints associated with this research project, it was decided to place the same two case buildings in the context of a significantly different climate in Saudi Arabia and then examine how climate informs built form in these two different regions. A few research participants hoped that this research could provide a foundation for future research endeavours that investigate ways of making Saudi houses more sustainable.

During the interviews, an attempt was made to obtain some feedback on the modifications suggested in terms of enhancing energy and water efficiency. Broadly speaking, all the interviewed stakeholders agreed on the utility of the conservation measures suggested. With regard to the use of efficient lighting equipment, they affirmed that energy-efficient fluorescent bulbs consume less power compared to incandescent bulbs, last much longer, emit less heat and keep room temperatures down. Interviewee F, however, pointed out that fluorescent lamps, when compared to incandescent ones, are usually bulkier and more complicated to dispose of. Interviewee C, moreover, indicated that fluorescent lighting is not widely accepted among the Saudi general public, who not only prefer to use incandescent lights, but also regard using them as an essential element of a modern and luxurious style of living. The author of the thesis, who is also from Saudi Arabia, agrees that the latter observation is truthful, despite the fact that none of the tenants of the case study buildings have actually raised this matter to the author. Two of the interviewed academics (i.e. H and J) believed that such a negative attitude is largely due to a lack of awareness among the public with regard to the potential benefits of, let alone the need for, energy saving measures. Interviewee F, who has his expertise in efficient lighting, went

further and warned that most of the light fittings – and other electrical equipment for that matter – available in the domestic Saudi market are energy inefficient. He mentioned during his interview that “most of the light bulbs sold here are of such a low quality and they do not match international standards”. Moreover, he criticised a sole emphasis on changing light bulbs to efficient ones, whilst overlooking the utilisation of natural light. He argued that “Daylight, like any other natural resource, is free... Natural lighting should be encouraged for health and economic reasons... Unfortunately, the provision of daylight is rarely considered by architects when designing Saudi dwellings”.

Some fruitful discussions were also held about the need to improve the HVAC strategy within the houses of Saudi Arabia. As previously mentioned in Chapter 6 (Section 6.2.3) that after consulting the tenants of the two case study buildings in Jeddah City, the three modifications suggested were: (i) to switch off the AC units during the winter season; (ii) to increase the thermostat set point; and (iii) to encourage natural ventilation by opening windows. A number of the stakeholders interviewed thought it might be possible to go further, beyond the desire of the tenants, and limit the use of AC units to summer daytimes only. Nonetheless, they agreed that such an action would not be popular amongst the public who are currently indulged with very cheap electricity prices. According to Interviewee L, “If electricity prices were high enough, what defines being an acceptable comfort state would be different from what is now.” With regard to natural ventilation, a couple of the interviewees advocated opening windows not only to reduce the need for mechanical cooling, but also for health reasons in order to maintain acceptable indoor air quality in the building. On the other hand, twelve interviewees were not very much in favour of the idea of natural ventilation even in Jeddah City. One reason cited was that given the hot and humid weather of Jeddah, natural ventilation may create hot draughts or

discomfort to the tenants. Nonetheless, the most reported concern was invasion of privacy. Bearing in mind that Saudi people prefer to keep their windows closed for culturally-motivated privacy reasons, it is fair to suggest that natural ventilation is not likely to be widely accepted by the general public.

An important energy conservation measure for buildings in Saudi Arabia is solar shading. It was suggested that the use of window overhangs (that are designed for the latitude of the location), or even operable sunshades (that can extend in summer and retract in winter), can significantly reduce the need for AC. Other conservation measures suggested were glazing and insulation enhancements to the construction of external walls and roofs. Apparently, not all the modifications suggested in Chapters 6 and 7 can be easily implemented in existing buildings. For example, the addition of insulation materials into the cavities of walls is not usually applicable for existing buildings. It would also be difficult to make sustainable an existing residential building, which – for example – has already been built with many large bathrooms. Interviewee A further adds that during the pre-design stage, where there are the most opportunities to achieve sustainability, architects need to carefully consider the size, shape and orientation of the windows in order to manage heat gain during the day. In addition, whilst the triple-glazed windows and polyurethane board (i.e. the insulation material selected to carry out the simulation for the efficient case) have good insulation properties and hence can achieve outstanding energy savings, Interviewee J was convinced that their relatively high price would be a deterrent to their widespread application. Therefore, it is reasonable to suggest that the average citizen is likely to choose other insulation materials (such as the ones considered in Table 6.1), which would still provide a tremendous improvement to the base case.

It is noted, however, that green roofing was both the most controversial and the least familiar energy measure amongst the research participants. For example, four interviewees admitted that although they heard about green roofing, they felt that they did not personally know enough about this particular energy conservation measure. Moreover, Interviewee B expressed some scepticism with regard to the feasibility of green roofing by arguing that one of the main purposes of promoting green roofing in other countries is to catch rainwater and reduce the storm water runoff. Not only rain is scarce in Saudi Arabia, but we should be concerned with cutting down household water consumption, as opposed to increasing it. In addition, besides the high maintenance requirement of the green roofs, he doubted that planting would be suitable in the hot weather and harsh environment of Saudi Arabia. On the other hand, Interviewees I and L applauded the green roofing initiatives recently launched in the neighbouring country of the UAE, which shares similar climatic conditions. Moreover, Interviewee I made available to the author of this thesis a manual about green roofing that was recently published by the Dubai Municipality (2010), which suggests a range of suitable plants for different types of green roof systems. Finally, one of the most constructive technical remarks about green roofing was made by Interviewee E who mentioned that it is important to consider the weight of the green roof before installing it on an existing building. Therefore, one needs to consult an inforemd civil engineer to assess the structural strength of the existing building in order to ensure that it can accommodate the additional weight of a green roof retrofit.

Looking at the water consumption analysis, the vast majority of the interviewees agreed that advocating water conservation within Saudi houses is likely to be harder than achieving energy efficiency. During the interviews, there was a common belief that in light of the fact that water is provided almost for free, it would be difficult to change habits and

behaviours towards preserving water in the Kingdom. As a matter of fact, four of the stakeholders interviewed (namely G, H, L and M) thought that actual water consumption per capita exceeds the figures of 497 and 565 LCD calculated for Case 1 and Case 2, respectively. More specifically, they pointed out that the consumption figures assumed for ablutions and various cleaning activities are on the conservative side. As argued by Interviewee H, “Water is abused all the time in our country... Cars are washed daily, courtyards are hosed down day and night, water is left running as dishes are washed, etc.” Whilst some acknowledged the simple nature of water consumption analysis, the research participants – as a whole – agreed on the suitability of all of the conservation devices suggested to reduce water use and/or waste. However, there was some scepticism on the part of Interviewees F and J with regard to the economic viability of installing grey water systems in existing buildings. In addition, they mentioned that such systems are not available in the domestic market. Nonetheless, stakeholders E, I and M assured in their interviews that not only did several grey water system suppliers and installers exist in the country, but also a few more are expected to establish their business soon in the major cities of Riyadh and Jeddah.

It has to be acknowledged here that with the slight exception of vegetated roofing, all the interviewed stakeholders showed a high level of knowledge with regard to various energy and water conservation measures. This should not come as a surprise when bearing in mind that they were specifically handpicked owing to their interest and/or knowledge of the subject. Conducting interviews with such highly-informed individuals revealed further measures that could facilitate the move towards a sustainable residential sector in Saudi Arabia. These aspects will be discussed in the next section.

8.4 Other Sustainable Design Measures

In addition to the energy conservation measures suggested in Chapters 6 and 7, some of the interviewees suggested other possible design-related modifications. For example, as mentioned in the previous section, there was a reference to some of passive solar design techniques, e.g. daylighting and controlling heat gain through changing the size, shape and orientation of the windows. Interviewee B suggested that a critical issue is the proper orientation of the building, as the orientation to the sun and prevailing winds affects the building's lighting and cooling requirements. Moreover, Interviewee L mentioned that HVAC systems have air filters for the purposes of both cleaning impurities from the air and protecting the HVAC equipment from dust. Not only do these air filters need to be replaced on a regular basis, but choosing the suitable filter is also an important aspect. For example, if filters have a low resistance to air passing through them, the HVAC system will use less energy to move the air, whilst providing better air quality for the occupants. Furthermore, when discussing potential sustainable design measures, Interviewee E rightfully argued that green roofing is not the only way available to reduce the heat island effect. Other methods include painting roofs and exteriors with bright colours, and using landscape materials with high solar reflectance.

Interestingly enough, two interviewees (namely C and E) mentioned that some tentative initiatives are under way to introduce energy labelling in the Kingdom. Electrical appliances will, therefore, have to have labels indicating how energy efficient they are compared to similar products. In addition, Interviewee K showed a strong passion for the concept of 'intelligent homes', which allows the occupants to control virtually all aspects of the house functions and environment from climate to lighting and household appliances from any location. He highlighted the fact that the increased automation of appliances

could help to improve the energy efficiency of the house, as energy use can be adjusted according to occupancy, time of the day, temperature and light levels. He stated that, for instance, “It will be possible to set the AC to an energy saving mode when the house is unoccupied, and automatically restore the normal setting when the occupants are about to return” Finally, there was frequent mention during the interviews of renewable energy technologies other than solar PV panels. For example, it was recommended by Interviewees G and N to install solar-powered water heaters (i.e. solar thermal systems) and perhaps geothermal heat pumps for residential buildings in Saudi Arabia.

With regard to water conservation measures, examples of urgently needed steps include fixing leaking water fixtures, minimising the number and size of bathrooms in houses, installing vacuum toilets, taking showers as opposed to baths, using washing machines and dishwaters with full loads and using a bucket and sponge (as opposed to a running hosepipe) when washing the cars. In terms of landscaping, Interviewee I recommended the selection of native plants, as they tend to survive when water restrictions are implemented. The vast majority of the research participants also perceived drip irrigation as the most water efficient form of irrigation because it does not create surface runoff water. Moreover, Interviewee K mentioned that in an intelligent home, irrigation could be scheduled in advance. Interviewee G, who works as a Landscape Architect, added that as a general rule, watering should be conducted during the coolest part of the day (generally in the morning), and should be avoided on windy days. Finally, Interviewee A mentioned that he once saw a man who collects water drippings from his house’s wind-type AC units and used that to water his garden. In essence, when humidity in the air is high, the AC unit condenses the water vapour into liquid water that can be used for irrigation purposes. This is a nice idea that could be implemented by all Saudi houses that use this type of AC systems.

In addition to these energy and water efficiency measures, the following are other general, yet relevant, design guidelines which could also contribute towards achieving sustainability within the residential sector in Saudi Arabia:

- Prior to building the house, an effort should be made to select a location within a dense development with good community connectivity in order to reduce urban sprawl and make use of existing infrastructures. In addition, architects should be encouraged to make the most efficient use of land by trying to accommodate more floor space within a smaller building footprint.
- Architects also need to consider the ecological damage of the buildings during their lifecycle. An effort should be made to restore some of the ecological value of the site, for example through planting native trees, which could also block solar radiation and provide cooling benefits.
- Secure and suitable storage spaces should be allocated for bikes, and tenants need to be encouraged to use them for short journeys instead of an utter reliance on private cars.
- Household waste recycling schemes and infrastructures, which currently do not exist in the country, should be promoted. In addition, there is a need for public awareness programmes on the benefits of conserving natural resources and the importance of recycling.
- During construction of the houses, an effort should be made to only use local, recycled and responsibly sourced construction materials. Arguing the need for exploring advanced procurement strategies for green building products, Interviewee J adds that “A balance should be struck between local manufacturing, available resources and low carbon transport solutions”.

- The amount of household waste sent to landfill could be reduced through providing the occupants with the means necessary to compost their organic waste.
- The use of chlorofluorocarbons (CFCs), which has a high negative impact on both the ozone and climate change, should be banned as a refrigerant in HVAC systems.
- In addition, the use of insulation containing asbestos or ozone-depleting materials, or those emitting VOCs, should be prohibited.
- The house should provide a reduced energy means of drying clothes, e.g. the use of a clothes line instead of drying machines.
- The house should provide adequate sound insulation in order to both reduce the likelihood of noise complaints from neighbours, and to prevent street noise from reaching the occupants. In order to enhance the occupants' quality of life, it is also recommended that an outdoor space is provided for their use.
- Shield fixtures for outdoor lights should be installed in order to avoid creating outdoor light pollution.

In response to a request to classify the current status of Saudi houses in terms of sustainability, all of the stakeholders interviewed agreed on that the status was deprived. Looking at the Saudi residential sector as a whole, the remainder of this chapter reports on the interviewees' points of view with regard to the barriers that currently impede a transition towards sustainable residential buildings. The chapter then concludes by providing recommendations (i.e. non-design related strategies) that could have the potential to overcome these barriers.

8.5 Barriers Hindering the Move towards Sustainable Residential Buildings

A large number of non-technical barriers emerged in the interviews. Broadly speaking, they can be grouped into four categories: political, economic, social and educational (see Table 8.2). Approximately 85% of the interviewees stated that the main economic-related barriers are cheap prices of electricity and water, which are currently heavily subsidised by the government. Eleven interviewees emphasised the lack of supportive government-led incentives for sustainable buildings, which could well be perceived as being a significant political barrier. Such a lack of enthusiasm towards energy and water conservation appears to be largely due to the fact that Saudi Arabia has the largest oil reserves in the world. As pointed out by Interviewee L, “Yes, Saudi Arabia does not have much in the way of natural water resources, but it has the world’s largest water desalination capacity so we can produce large amounts of fresh water by burning fossil fuels”.

When asked who has the major role in terms of promoting sustainability within the residential sector, all of the interviewees emphasised the role of the government and its regulations. This should not come as a surprise given the tight control of the monarchy on all aspects relating to the running of the Kingdom. A few interviewees pointed out recent efforts which are underway to privatise the electricity and water sectors, which are currently almost entirely controlled by the authorities. Nonetheless, it appears that, as vigorously argued by two of the academics interviewed (namely I and J), even if attaining sustainable buildings becomes high on the political agenda, one would still expect significant social-related obstacles. In this regard, the lack of awareness with regard to the importance of energy and water conservation, as well as to the potential benefits of sustainable houses, were often claimed to be the main social barriers. It is, therefore, perhaps not surprising that – as confirmed by Interviewees E and G – the subject of

sustainability does not currently receive adequate attention in the local media. More disappointingly perhaps is that Saudi architects do not seem to be sufficiently informed with regard to sustainable design principles. This point was raised by approximately half of the stakeholders interviewed, some of whom asserted that the subject of sustainable design does not currently receive adequate attention in architectural education curriculums, not to mention the lack of professional training opportunities. Such a situation is not particularly unique to the Saudi context, as it has been reported elsewhere that a lack of commitment to the sustainability agenda is often due to a lack of familiarity with sustainable architecture among architects (e.g. see Ibarahim and Abbas, 2001; Steele, 1997).

Table 8.2: Barriers to Sustainable Residential Buildings in Saudi Arabia

| | N ^a |
|--|----------------|
| Political Barriers | |
| Heavy consumer subsidies on energy and water prices. | 12 |
| Lack of supportive government-led incentives for sustainable buildings. | 11 |
| Almost an absence of sustainable design principles in current building regulations and codes. | 5 |
| Tight control by the authorities on most aspects relating to the running of the country. For example, the role of the private sector within the power and water sectors is kept minimal. | 4 |
| Economic Barriers | |
| Cheap energy and water prices. | 12 |
| High capital costs of sustainable buildings. | 10 |
| Lack of sustainability-orientated investors and property developers. | 3 |
| The country has a rapidly growing population, which faces many challenges, such as escalating rates of unemployment. | 2 |
| Social Barriers | |
| Lack of awareness with regard to the need of achieving household energy and water efficiency. | 13 |
| Lack of awareness with regard to the potential long-term benefits of sustainable buildings. | 6 |

| | |
|---|---|
| Emphasis is usually on reducing cost, as opposed to enhancing quality, of construction. | 4 |
| A strong change resistance mentality (i.e. absence of entrepreneurial spirit) among the Saudi public. | 3 |
| A widespread belief that oil in Saudi Arabia will last forever, and that energy and water prices will always remain low. | 1 |
| Educational Barriers | |
| The subject of sustainable design does not currently receive adequate attention in formal educational curriculums for architecture. | 5 |
| Lack of professional training opportunities on sustainable architectural principles. | 3 |
| The subject of sustainability is not adequately covered in local media. | 2 |
| Lack of innovation-orientated academic research on sustainable architecture. | 1 |

^a N is the number of interviewees who identified this barrier

8.6 Potential Enablers to Overcome the Barriers

Towards the end of each interview, the respondents were asked to suggest ways to overcome the various barriers that they had identified. Listed in a random order, below is a list of the non-technical recommendations, which have not been acknowledged yet in this chapter:

- The government needs to implement building regulations, compulsory codes and standards that promote energy and water efficiency in buildings. It also needs to impose strict legally-binding plumbing codes and penalties for wasting household water. Such codes and regulations need to be specifically developed for Saudi Arabia, as opposed to being borrowed from other leading countries.
- The government should remove the consumer price subsidies on water and conventional fossil-based electricity. On the other hand, it should encourage the use of water-efficient and energy-efficient household appliances, whose prices could be subsidised by the government.

- **The Saudi power and water markets need to be privatised and restructured in order to encourage more realistic pricing.**
- **The government should introduce and enforce sustainability assessment systems, which are tailor-made to assess Saudi houses in a two-stage process (i.e. the design stage and post-construction).**
- **The government should provide financial incentives, such as capital-investment subsidies or rebates, to encourage the construction of sustainable houses. In order to promote the use of renewable energy technologies, suggested financial incentives include net metering and feed-in tariffs.**
- **In addition, necessary resources should be allocated to stimulate and enhance awareness – e.g. through media campaigns and innovative demonstration projects as well as by organising conferences and seminars – with regard to sustainable architecture among architects, engineers and the general public.**
- **Sustainable design principles should be incorporated into the formal teaching curriculum for architects, who should also be incentivised to both attend relevant professional courses and attain professional qualifications on sustainable building.**
- **There is a need for establishing a non-profit entity, such as the US Green Building Council in the USA, which promotes sustainability in how Saudi buildings are designed, built and operated. The aims of this organisation should include the provision of professional education and certifications to green buildings, as well as**

leading and working closely with key industry and research organisations and relevant governmental entities in order to develop best sustainable design practices in the country.

- Saudi schools and universities should help by supporting the development of entrepreneurial mindsets among the student population from an early age.
- Competitions should be held and awards given to individuals and organisations that make innovative efforts in the field of sustainable building.
- There is an apparent need for intensive electricity and water rationing schemes. Conservation campaigns should not only be directed at Saudi nationals but also with messages that inform and teach domestic help such as drivers and housemaids the need and importance of conservation. Bearing in mind the strong religious character of the Saudi government and its population, it is further suggested that these programmes need to make reference to Islamic teachings and principles, which – for example – explicitly encourage thriftiness in water use.
- It might be worthwhile revisiting some of the principles of vernacular architecture, which tend to stress utilising locally available construction materials, in addition to applying passive and low-energy strategies.
- In addition, there is a need to make use of technological solutions in order to change behavioural patterns. For example, energy and water meters should be installed

in houses in order to provide real-time information to residents on their usage levels, allowing them to make personal adjustments in order to save energy and money.

- It is the responsibility of the house owner to provide his/her tenants with a user guide, which covers information relevant to the operation and environmental performance of the house. This manual could also enable occupants to understand and operate their house efficiently and make the best use of local facilities.
- The Saudi public and private sectors could benefit from the experiences of other leading countries in the field of sustainable building. In this regard, it is suggested that making collaborative and international joint-venture agreements is of the utmost importance in order to exchange information and experiences with regard to the design, construction, operation and maintenance of sustainable residential projects. As a start, communication links could be created and expanded with other successful examples of sustainable architecture in the region.
- At the project level, it would be beneficial to explore opportunities for sustainability with a collaborative, multi-disciplinary design team as early as possible, e.g. through holding a sustainable design charrette to kick-off the residential construction project.

Chapter 9

Conclusions

9.1 Chapter Overview

This chapter presents overall conclusions drawn from the research conducted. The first section reflects on the research approach, and provides brief remarks on the aims and objectives of this research, as well as the methodology selected. The second section highlights key research findings from the previous chapters, and discusses ways of making residential buildings within Saudi Arabia more sustainable. The thesis concludes by stating the limitations of this study as well as suggestions of possibilities for future research.

9.2 The Research Approach

This PhD research argues the need for considering sustainable architectural practices within the residential buildings of Saudi Arabia. Based on available data and information, the author of this thesis has attempted to investigate a potential transition towards sustainable houses in the Kingdom. Since it was impracticable to adequately cover all aspects relating to sustainable architecture, it was decided – as is the norm – to place an emphasis upon certain areas, namely the energy and water-related aspects of the buildings. Thus, the broad aim of this research was to assess the energy and water consumption of existing Saudi houses in order to establish guidelines towards achieving sustainable architectural practices in the Saudi residential sector. The thesis started by introducing the notion of sustainable architecture and its potential attractiveness. In order to address the first research objective, the current global status of its application was examined through a critical review of previously-published literature. The second objective was mainly concerned with examining the current status of sustainability within the Saudi residential sector using relevant literature. Not only did this literature review indicate the near absence

of applications of sustainable architecture in Saudi Arabia, it also confirmed that this subject is substantially under-researched.

In order to address the third objective of this research investigation, two typical, real, houses (an apartment complex and a villa) in Saudi Arabia were selected to act as case study buildings. Simulation models of these buildings were first constructed, and then their energy and water consumption was assessed using simulation software packages. More specifically, energy use within the two houses was analysed using DesignBuilder version 2.2, which provides a Windows-based GUI for the state-of-the-art building performance simulation software entitled EnergyPlus. On the other hand, simplified water consumption analysis was largely based on an adapted version of the BRE Code Water Calculator, which is used as part of the BREEAM 'Code for Sustainable Homes' assessment methodology in the UK. The energy and water simulation results were then validated using both actual utility bills and published data from the literature.

In order to address the fourth research objective, a number of energy and water efficiency measures (i.e. design-based modifications) were suggested, and the likely magnitude of savings associated with these modifications was then assessed using the simulation software. The energy consumption analysis within these houses was carried out in the cities of Jeddah and Riyadh in order to examine how climate informs built and why different energy conservation strategies might be suitable for the two different climates. In order to validate the utility of the conservation measures suggested, and the whole simulation exercise, fourteen in-depth interviews were conducted with highly-informed Saudi stakeholders. Not only were the simulation results validated by the interviewees, but they also provided solid background material to elicit the stakeholders' informed views regarding ways of making Saudi houses more sustainable. In essence, these interviewees

have contributed towards the achievement of a fifth research objective, which was concerned with providing a set of recommendations that aims to make residential buildings within Saudi Arabia more sustainable.

For these reasons, the author believes that the objectives set forth in order to fulfil the aims of this research have been met, and that the research methods applied were adequate within the time allocated to complete this type of academic investigation. During the Ph.D. course, the author was also fortunate to attend professional courses on DesignBuilder software, LEED Green Associate and BREEAM 'Code for Sustainable Homes Assessor Training'. In fact, not only has this investigate journey been very educational, intellectually stimulating and enjoyable, it has also resulted in the publication of a few Ph.D. and non-Ph.D. related papers. Excluding ones that are forthcoming, the published PhD-related output thus far includes two peer-reviewed conference papers (Taleb, 2010; Taleb and Sharples, 2010a) and a journal paper in Applied Energy (Taleb and Sharples, 2010b). The following section summarises the key findings of this research.

9.3 Research Findings

It has become apparent that the global move towards sustainable architecture is – generally speaking – driven by environmental and energy-related considerations, as well as health, social and well-being factors. Given the fact that residential buildings are a major energy consumer and hence a major contributor of both greenhouse gas emissions, there is an apparent need for considering sustainable architectural principles, which include – among many other things – achieving household energy and water efficiency. One would hope that achieving significant reductions in terms of energy and water consumption could offset some of the rapid growth of global population and associated energy demand. In addition, the deployment of sustainable buildings should be seen as an important part of

lessening global warming. In spite of the compelling case for sustainable buildings, it was disappointing to find out that they almost cease to exist within the Middle East in general, and within Saudi Arabia in particular.

Given the rapid increase of population as well as economic growth and increased urbanisation in Saudi Arabia, growth rates in electricity use and water consumption are among the biggest in the world. More disappointing perhaps is the fact that electricity generation (and most water production) is entirely dependent upon burning fossil fuels, with an almost complete absence of utilising renewable energy sources. With regard to water, Saudi Arabia – which is considered as one of the driest countries in the world – depends heavily on desalination plants to bring water supplies across a very large Kingdom. In spite of this, there are no regulations, or compulsory building codes, that currently promote water and/or energy efficiency. Looking at the design of Saudi residential buildings, the emphasis tends to be on building spacious houses that are not only heavily dependent on air conditioning, but also aim to attain a luxurious style of living without paying any attention to the principles of sustainability. Therefore, this thesis argues that there is an urgent need to improve the efficiency of energy use and water consumption in Saudi buildings through the application of sustainable architectural practices.

The empirical findings, comprising the results both from the simulation exercise and the interviews, have confirmed the literature-based findings concerning the poor sustainability performance of Saudi houses. According to the simulation results for the case study buildings currently located at Jeddah City, the per capita electricity consumption figure for the apartment complex was around 8,047 kWh, while for villa it was 14,377 kWh per year. Moreover, the water consumption figure was calculated to be 497 LCD and 565 LCD,

respectively. Such consumption rates are very high when compared to others internationally, especially when bearing in mind the fact that the production of both electricity and water in Saudi Arabia relies on burning fossil fuels. Hence, the associated environmental damage is high. As a part of the simulation phase, a number of design-related modifications were also suggested, including the enhancement of thermal insulation in external walls and the roofs of the house; using glazed windows and fitting horizontal shading devices; improving the HVAC strategy; fitting green roofing; and using energy-efficient equipment including water heaters and lighting fittings, e.g. fluorescent lights instead of the less-efficient incandescent lamps. This analysis was also conducted in the context of Riyadh's climate in order to find out how climate informs built. For instance, whilst natural ventilation was considered to be important in the hot humid climate of Jeddah City, shading and evaporative cooling were considered to be effective measures in the hot dry climate of Riyadh.

With regard to water conservation measures, besides changing behavioural habits, suggestions included the use of efficient water fittings (e.g. taps, showerheads, dual-flush cisterns) and equipment (efficient washing machines, dishwashers and grey water systems). Despite the existence of other energy and water conservation fittings on the market, re-running the energy and water simulations with such a few modifications have showed a significant saving potential. In other words, the simulation exercise revealed that the case study buildings – which are typical existing Saudi houses – have several design-related faults that promote increased energy and water consumption. Last, but certainly not least, architects should make use of zero-carbon energy technologies such as solar PV and/or wind turbines if feasible. This indeed should not underplay the possibility of other, and perhaps lower-cost, energy saving options such as the fitting of solar-based AC and

domestic water heating solutions, the utilisation of wasted heat from air conditioning for domestic heating (or preheating the mains water supply), as well as the use of free cooling (if compatible with the type of AC system employed).

One of the research findings revealed is that there is a need to use sufficient thermal mass and adequate insulation in the houses' walls and roofs. An emphasis should be placed upon selecting materials with good thermal insulation properties, which lead to both low U-values and high thermal inertia for the construction. For example, it was estimated that the addition of 50mm of polyurethane insulation to the walls and roofs of the case study buildings in Jeddah can achieve household energy saving of around 7.5% and 3.8%, respectively. Bearing in mind the simple nature of such a suggested modification, it should be noted that thicker layer of thermal insulation could achieve better improvements in terms of building energy performance. To that end, a balance should always be struck between the design practicality and potential life-cycle costs and benefits in order to achieve an optimum energy performance. Another design-related recommendation is the use of appropriate internal and external (horizontal) shading systems in order to shade residential buildings and their gardens from excessive solar radiation. It should be recognised that effective design and positioning of solar shading devices are not only important to reduce undesirable solar gain, but also to utilise natural light for indoor illumination. Saudi architects should make an effort to place windows in such a way as to maximise the utilisation of natural light and thereby lessen the need for electric light during the day. The orientation of the building to the sun and prevailing winds also affects the building's lighting and cooling requirements.

During the interviews phase, the simulation results were discussed with the stakeholders interviewed. Not only did they agree on the utility of the energy and water conservation measures suggested, but they also provided a suite of other measures that included and went beyond energy and water-related issues. Moreover, during the interviews, in-depth discussions took place on the barriers that currently impede a transition towards sustainable residential buildings in Saudi Arabia. Among the main barriers reported were the cheap prices of electricity and water on one hand, and the absence of financial incentives for sustainable buildings on the other. Nonetheless, the most reported barrier was the severe lack of public awareness with regard to the need for household energy and water efficiency. There was also a frequent reference to the high capital costs of sustainable buildings, in addition to a lack of awareness with regard to the potential long-term benefits of these buildings. In essence, the emphasis tends to be placed on reducing initial costs, as opposed to considering lifecycle costs or the quality of construction. Moreover, it has pointed out that the subject of sustainability does not currently receive adequate attention in the local media and educational curriculums, including those for students studying at Saudi universities to become architects. Another identified barrier is the almost complete absence of sustainable design principles in current building regulations and codes, not to mention improper enforcement of the latter.

As much as the research has identified barriers, it has also provided a range of strategies to overcome them. There is an apparent need to take serious action to change the current situation, which scores poorly in terms of sustainability. Such corrective actions are indeed not the sole responsibility of one party (e.g. architects who need to consider the abovementioned design-related aspects whilst bearing in mind the environmental impact of their buildings), but rather should come as a result of collaborative efforts across all levels

in the country. However, when considering the Kingdom of Saudi Arabia, one cannot overemphasise the role of the government in terms of taking appropriate strategic action to stimulate the production of sustainable architecture. At the moment, energy and water conservation as well as the use of renewable energy is not economically viable in Saudi Arabia. However, their viability could be significantly boosted if the Saudi Government decides to lift the heavy subsidies on fossil-fuel electricity generation. Given the fact that it is very difficult to change habits and induce attitudes, the government needs to not only provide incentives for sustainable buildings, but also impose regulations and punishments for non-compliance (i.e. to follow the carrot and stick principle). It is true that a transition towards sustainability in Saudi Arabia cannot happen overnight. Nonetheless, given the financial muscle of this oil-rich country, not to mention its untapped solar resources, it is better suited than other developing countries to achieve a quick transition towards a sustainable residential sector. Saudi Arabia does not need to construct a few token residential buildings scattered here and there, but rather needs to develop sustainable communities all across the country. This will require the developing of supportive infrastructure (e.g. recycling facilities) and the proper maintenance of the existing ones, e.g. the rate of leaks in the country's water networks is among the highest in the world. The fate of such a grand transition appears to be almost entirely dependent on a strong political buy-in and an enhanced awareness with regard to the importance of sustainability across all levels. For instance, before installing a PV system in a house in order to meet a part of their current energy usage, the occupants need to learn how to reduce their household energy consumption first so that fewer PV modules are required. Ongoing energy and water efficiency changes the way people live, and the Saudi public needs to be aware of this fact.

9.4 Further Research

Despite the fact that the case study buildings selected for this research were real and typical houses in Saudi Arabia, one cannot generalise the findings of the energy and water simulation to all houses in the Kingdom, let alone to countries with similar climatic, social and/or economic conditions. Due to time constraints and access difficulties, this thesis has examined the current energy use and potential savings within two Saudi residential buildings placed in two climatic settings in Saudi Arabia. In order to enhance the generalisability of the research findings, it is recommended that further research is carried out with similar modelling and analysis on a larger number of houses in different regions within Saudi Arabia. Such a simulation could be carried out using DesignBuilder, possibly in conjunction with other reputable software packages. Moreover, it should be noted that an emphasis was placed in this thesis upon analysing energy and water-related issues, as opposed to an attempt to cover all aspects (e.g. economic and social factors) related to sustainability. This PhD research project could pave the way for other research endeavours that address all aspects associated with this important, yet under-researched, topic. Finally, it should be mentioned that a number of recommendations – which were not energy and water-related – have been provided by the research participants. It could, therefore, be of interest, to take these recommendations on board and investigate their potential impacts on Saudi houses.

REFERENCES

- Aba Alkhail, I. (1989). *Architecture in the Gulf*. Albenaa Magazine, Vol. 8, no. 47, p. 26.
- Abdulrazzak, M. and Khan, M. (1990). *Domestic water conservation potential in Saudi Arabia*. Environmental Management, Vol. 14, no.2, pp. 167-178.
- AboulNaga, M.M. and Elsheshtawy, Y.H. (2001). *Environmental sustainability assessment of buildings in hot climates: the case of the UAE*. Renewable Energy, Vol. 24, no. 3-4, pp. 553-563.
- Akbari, H., Morsy, M.G. and Al-Baharna, N.S. (1996). *Electricity saving potentials in the residential sector of Bahrain*. Energy and Environment Division, Lawrence Berkeley National Laboratory Publication, LBL-38677, UC-000, 1996. pp. 1.11-1.20.
- Alafghani, A. S. (1991). *The Saudi house in the past, present and future: a study of change*. Unpublished Ph.D. thesis: University of Glasgow.
- Al-Ajlan, S.A. (2006). *Measurements of thermal properties of insulation materials by using transient plane source technique*. Applied Thermal Engineering, Vol. 26, no 1, pp. 2184-2191.
- Al-Ajlan, S.A., Al-Ibrahim, A.M., Abdulkhaleq, M. and Alghamdi, F. (2006). *Developing sustainable energy policies for electrical energy conservation in Saudi Arabia*. Energy Policy, Vol.34, no.13, pp.1556-1565.
- Al-Ajlan, S., Smiai, M. and Elani, U. (1998). *Effective tools toward electrical conservation in Saudi Arabia*. Energy Conservation and Management, Vol. 39, no.13, pp. 1337-1349.
- Al-Angari, A. (1997). *The revival of architectural identity: the city of Riyadh*. Unpublished Ph.D. thesis: University of Edinburgh.
- Al-Ansari, J., Bakhsh, H. and Madni, I. (1985). *Wind energy atlas for the Kingdom of Saudi Arabia*. Riyadh: King Abdulaziz City for Science and Technology.
- Al-Buijan, K.y. (1987). *Computer modelling of buildings for energy conscious design in eastern province of Saudi Arabia*. Unpublished M.Phil. thesis: University of Leicester.
- Al-Harbi, T. H. (1989). *The development of housing in Jeddah change in built from the traditional to the modern*. Unpublished Ph.D. thesis: University of Newcastle Upon Tyne.
- Al-Hathloul, S. (2004). *Planning in the Middle East: moving toward the future*. Habitat International, Vol. 28, no. 4, pp. 641-643.
- Al-Hathloul, S. and Edadan, N. (1995). *Urban development in Saudi Arabia: challenges and opportunities*. Riyadh: Dar Al Sahan.
- Al-Ismaily, H.A. and Probert, S.D. *Energy overview of the Sultanate of Oman*. Applied Energy, Vol. 57, no. 4, pp. 287-325.

- Al-Jadeed, M.A.I. (1994). *Building with earth: traditional architecture and new technology with special reference to Saudi Arabia*. Unpublished Ph.D. thesis: University of Wales.
- Al-Jammaz, K.M. (2006). *An approach for the assessment of sustainability of construction materials*. Unpublished Ph.D. thesis: University of Newcastle.
- Al-Jerash, M.A. (1985). *Climatic subdivisions in Saudi Arabia: an application of principal component analysis*. *Climatology*, Vol. 5, no. 3, pp. 307-323.
- Al-Lawati, A. (2009). *Green roofing will help keep buildings cooler*. Gulf News Website. Available from: <http://gulfnews.com/news/gulf/uae/environment/green-roofing-will-help-keep-buildings-cooler-1.538569> [accessed 2 January 2010].
- Al-Maayouf, M. (2005). *The impact of envelope design on the energy performance for modern houses application in hot, arid regions with special reference to Riyadh, Saudi Arabia*. Unpublished Ph.D. thesis: University of Cardiff.
- Al-Murahhem, F. (2008). *Behind a Roshan: visualizing the Roshan as an architectural element in traditional domestic interiors*. Unpublished Ph.D. thesis: University of Brighton.
- Al-Naimi, I.M. (1989). *The potential for energy conservation in residential buildings in Dammam region, Saudi Arabia*. Unpublished Ph.D. thesis: University of Newcastle.
- Alnaser, N.W. and Flanagan, R. (2007). *The need of sustainable building construction in the Kingdom of Bahrain*. *Building and Environment*, Vol. 42, no. 1, pp. 495-506.
- Alnatheer, O. (2006). *Environmental benefits of energy efficiency and renewable energy in Saudi Arabia's electric sector*. *Energy Policy*, Vol. 34, no. 1, pp. 2-10.
- Al-Saleh, Y.M. (2009). *Renewable energy scenarios for major oil-producing nations: the case of Saudi Arabia*. *Futures*, Vol. 41, no. 9, pp. 650-662.
- Al-Saleh, Y.M. (2010). *An examination of the prospects of sustainable energy within major oil-producing countries using an innovation systems approach*. Unpublished Ph.D. thesis: University of Manchester.
- Al-Saleh, Y.M., Upham, P. and Malik, K. (2008). *Renewable energy scenarios for the Kingdom of Saudi Arabia*. Tyndall Centre for Climate Change Research Working Paper 125, October 2008.
- Alshawaf, M. (2008). *Evaluating the economic and environmental impacts of water subsidies in Kuwait*. Unpublished M.Sc. Thesis: Louisiana State University.
- Al-Shehri, A.M. (2008). *Electricity industry in Saudi Arabia: an overview*. In Saudi Water and Power Forum, Jeddah, 1-4 November 2008.
- Al-Shihri, F.S. (2001). *Sustainable development and strategic environmental assessment in the context of the Saudi Arabian planning process: the case of Al-Qatif Oasis and its settlements*. Unpublished Ph.D. thesis: University of Newcastle.

Al-Solaiman, M.M. (2003). *The integration of the passive cooling system into Multi-user building with reference to Riyadh, Saudi Arabia*. Unpublished Ph.D. thesis: University of Nottingham.

Alternative Energy Institute (2005). *Powering our future: an energy sourcebook for sustainable living*. Lincoln: iUniverse Inc.

Al-Yami, A.M. (2008). *An integrated approach to value management and sustainable construction during strategic briefing in Saudi construction projects*. Unpublished Ph.D. thesis: University of Loughborough.

Al-Yami, A.M. and Price, A.D.F. (2006). *An overview of sustainability in Saudi Arabia*. In The Joint International Conference on Construction, Culture, Innovation and Management. Dubai, 26-29 November 2006.

Alzahrani, K., Elsahfie, I. and Muneer, S (2007). *Factors affecting adoption of water conservation practices in the household sector in Riyadh, Saudi Arabia*. In World Water Week. Stockholm, August 2007.

American Institute of Architects (2007). *Integrated project delivery: a guide*. Chicago: American Institute of Architects.

Anink, D., Boonstra, C. and Mak, J. (1996). *Handbook of sustainable building: an environmental preference method for selection of materials for use in construction and refurbishment*. London: James & James (Science Publishers) Ltd.

Asfour, K. (2007). *Polemics in Arab architecture: theory versus practice*. International Journal of Architectural Research, Vol. 1, no. 1, pp. 53-69.

Aste, N., Angelotti, A. and Buzzetti, M. (2009). *The influence of the external thermal inertia on the energy performance of well insulated buildings*. Energy and Buildings, Vol. 41, no. 11, pp. 1181-1187.

Bahammam, A.S., Alhosin, M.A., Edrees, M.E., Bahammam, O.S., Blous, E.M. and Hassan, N.M. (2004). *The manual of affordable houses*. Riyadh: Ar-Riyadh Development Authority (ADA).

Bahammam, A. (1998). *Factors that affect the size of contemporary dwelling in Saudi Arabia*. Habitat International, Vol. 22, no. 4, pp. 557-570.

Bahrain World Trade Centre (2010). *About BWTC* [WWW]. BWTC Website. Available from: <http://www.bahrainwtc.com/realestate.htm> [accessed 2 April 2010].

Bain, P. and Baldry, C. (1995). *Sickness and control in the office: the sick building syndrome*. New Technology, Work and Employment, Vol. 10, no. 1, pp. 19-31.

Balara, C.A., Droutsas, K., Argiriou, A. and Asimakopoulos, D.N. (2000). *Potential for energy conservation in apartment buildings*. Energy and Buildings, Vol. 31, no. 2, pp. 143-154.

- Balaras, C.A., Dascalaki, E. and Kontoyiannidis, S. (2005). *Heating energy consumption and resulting environmental impact of European apartment buildings*. Energy and Buildings, Vol. 37, no. 5, pp. 429-442.
- Bailey, K.D. (1978). *Methods of social research*. London: Collier Macmillan Publishers.
- Barth, H-J. (2002). *The sabkhat of Saudi Arabia: an introduction*. In *Sabkha ecosystems*, Barth, H-J. and Böer, B. (Eds.). Dordrecht: Kluwer Academic Publishers.
- Beatley, T. and Manning, K. (1997). *The ecology of place: planning for environment, economy and community*. Washington DC: Island Press.
- Beer, A.R. (1990). *Environmental planning for site development*. London: E&FN Spon.
- BP Amoco (2008). *Statistical review of world energy* [WWW]. BP Amoco Website. Available from: <http://www.bp.com/productlanding.do?categoryId=6929&contentId=7044622> [accessed 25 February 2010].
- Brandon, P.S. and Lombardi, P. (2005). *Evaluating sustainable development in the built environment*. Oxford: Blackwell Science Ltd.
- BRE (2010). *U-value calculator*. The BRE Website. Available from: <http://projects.bre.co.uk/uvalues/> [accessed 2 November 2010].
- BREEAM (2010). *BREEAM assessor manuals* [WWW]. BREEAM Website. Available from: <http://www.breeam.org/manualpage.jsp?id=28> [accessed 20 March 2010].
- Broadbent, G. and Brebbia, C.A. (Eds.). (2006). *Eco-architecture: harmonisation between architecture and nature*. Billerica: WIT Press.
- Buchan, J. (1991). *Jeddah old and new*. London: Stacey International.
- Bureau of Energy Efficiency (2009). *Energy conservation building code: user guide*. New Delhi: Bureau of Energy Efficiency.
- Campbell, C. (2005). *Oil crisis*. Brentwood: Multi-Science Publishing Company Ltd.
- Celotex (2010). *U-Value calculator*. The Celotex Website. Available from: <http://www.celotex.co.uk/Other-Resources/U-value-Calculator> [accessed 2 November 2010].
- Central Department of Statistics and Information (2008). *Annual statistical yearbook*. Riyadh: Central Department of Statistics and Information.
- Central Intelligence Agency (2010). *The world factbook: Saudi Arabia* [WWW]. CIA Website. Available from: <https://www.cia.gov/library/publications/the-world-factbook/geos/sa.html> [accessed 17 April 2010].
- Chiras, D.D. (2004). *Environmental science: creating a sustainable future*. 6th Edition, London: Jones & Bartlett Pub.

- Christain, D.L. (2007). *Finding community: how to join an ecovillage or intentional community*. Gabriola Island: New Society Publishers.
- Chowdhury, A.A., Rasul, M.G. and Khan, M.M.K. (2008). *Thermal-comfort analysis and simulation for various low-energy cooling-technologies applied to an office building in a subtropical climate*. *Applied Energy*, Vol. 85, no.6, pp. 449–462.
- Chwieduk, D. (2003). *Towards sustainable-energy buildings*. *Applied Energy*, Vol. 76, no. 1, pp. 211-217.
- Clarke, J.A. (2001). *Energy simulation in building design*. 2nd edition, Oxford: Butterworth-Heinemann.
- Climate Change Connection (2010). *Greenhouse effect* [WWW]. Climate Change Connection Website. Available from: <http://www.climatechangeconnection.org/Science/Greenhouseeffect.htm> [accessed 20 March 2010].
- Comfortable Low Energy ARchitecture 'CLEAR' (2010). *Sun path diagrams* [WWW]. CLEAR Website. Available from: http://new-learn.info/learn/packages/clear/thermal/climate/sun/angle_incidence.html [accessed 20 December 2010].
- Concrete Block Association (2009). *CBA U-Value calculator*. The CBA Website. Available from: http://www.cba-blocks.org.uk/tech/tech_uvalue.html [accessed 2 November 2010].
- Cook, S.J. and Golton, B.L. (1994). *Sustainable development concepts and practice in the built environment; a UK perspective*. In *Sustainable Construction*, CIB TG 16; 6-9 November, pp. 677-685.
- Cordesman, A.H. (2003). *Saudi Arabia enters the 21st Century*. London: Praeger Publishers.
- Cuddihy, K. (2001). *An A to Z of places and things Saudi*. London: Stacey International.
- Daghistani, A. I. (1981). *Al-Taif: a city in transition*. Riyadh: Saudi Arabian Ministry of Information.
- Dalhammar, C., Peck, P., Tojo, N, Mundaca, L. and Neij, L. (2009). *Advancing technology transfer for climate change mitigation: considerations for technology orientated agreements promoting energy efficiency and carbon capture and storage*. Lund: The International Institute for Industrial Environmental Economics at Lund University.
- Darwish, M., Al-Awadhi, F. and Darwish, A. (2008). *Energy and water in Kuwait Part I: a sustainability overview*. *Desalination*, Vol. 225, no.1-3, pp. 341-355.
- Deffeyes, K.F. (2005). *Beyond oil: the view from Hubbert's Peak*. New York: Hill and Wang.
- Denzin, N.K. (2009). *The research act*. Piscataway: Transaction Publishers.

- Denzin, N.K. and Lincoln, Y.S. (1994). *Handbook of qualitative research*. London: Sage Publications Ltd.
- Department for the Environment, Food and Rural Affairs (2009). *Better buildings* [WWW]. DEFRA Website. Available from: <http://www.defra.gov.uk/environment/energy/betterbuildings.htm> [accessed November 2009].
- DesignBuilder Software (2009). *User manual* [WWW]. DesignBuilder Website. Available from: <http://www.designbuilder.co.uk/> [accessed 23 June 2010].
- DesignBuilder Software (2010). *Accreditation schemes*. [WWW]. DesignBuilder Website. Available from: <http://www.designbuilder.co.uk/content/view/84/121/> [accessed 28 December 2010].
- Dew, P. (2003). *Saudi Arabia: restructuring for growth*. London: Euromoney Books.
- Douglas, J. (2002). *Building adaptation*. Oxford: Butterworth-Heinemann.
- Doukas, H., Patlitziyas, K.D., Kagiannas, A.G., Psarras, J. (2006). *Renewable energy sources and rationale use of energy development in the countries of GCC: myth or reality?*. *Renewable Energy*, Vol. 31, no. 6, pp. 755-770.
- Drew, P. (1979). *Tensile architecture*. Boulder: Westview Press.
- Dubai Municipality (2010). *Green roof manual*. Dubai: Dubai Municipality.
- Editors of life-time books (1985). *Arabian peninsula*. Amsterdam: Time-Life Books.
- Edwards, B. (1996). *Towards sustainable architecture: European directives and building design*. Oxford: Butterworth-Heinemann.
- Edwards, B. (1998). *Sustainable architecture*. 2nd edition, Oxford: Butterworth-Heinemann.
- Edwards, B. (2005). *Rough guide to sustainability*. 2nd Edition, London: RIBA Enterprises Ltd.
- Edwards, B. and Turrent, D. (Eds) (2000). *Sustainable housing: principles and practice*. London: E&FN Spon.
- Egbert, C. (2005). *Bahrain set to build multi million dollar Green City* [WWW]. *Construction Week Magazine*, 11 June 2005. Available from: http://www.itp.net/business/news/details.php?id=16056&srh=green%20city&tbl=itp_news [accessed 28 January 2007].
- Elkington, J. (1994). *Towards the sustainable corporation: win-win-win business strategies for sustainable development*. *California Management Review*, Vol. 36, no. 2, pp. 90-100.
- Elsheshtawy, Y. (2008). *The evolving Arab city: traditional, modernity & urban development*. Abingdon: Routledge.

Encyclopaedia Britannica (2010). *Seasonal configuration of earth and sun* [WWW]. Encyclopaedia Britannica Online. Available from: <http://www.britannica.com/EBchecked/media/112844/Earths-orbit-around-the-Sun-with-the-positions-of-solstices> [accessed 23 December 2010].

Energy and Resources Institute (2004). *Sustainable building design manual*. New Delhi: The Energy and Resources Institute.

Energy Efficiency and Renewable Energy (2009). *Energy savers* [WWW]. Energy Efficiency and Renewable Energy Website. Available from: http://www.energysavers.gov/your_home/lighting_daylighting/index.cfm/mytopic=12030 [accessed 6 December 2009].

Energy Information Administration (2009). *Saudi Arabia: electricity overview* [WWW]. Energy Information Administration Website. Available from: http://www.eia.doe.gov/cabs/Saudi_Arabia/Background.html [accessed 6 January 2010].

Energy Information Administration (2010). *Country analysis brief: Saudi Arabia* [WWW]. Energy Information Administration Website. Available from: http://www.eia.doe.gov/emeu/cabs/Saudi_Arabia/Oil.html [accessed 22 March 2010].

Environmental and Energy Study Institute (2006). *Energy-efficient buildings: using whole building design to reduce energy consumption in homes and offices*. Washington DC: Environmental and Energy Study Institute.

Facey, W. (1994). *The story of the Eastern Province of Saudi Arabia*. London: Stacey International.

Facey, W. (1997). *Back to earth: Adobe building in Saudi Arabia*. Riyadh: Al-Turath

Fadan, Y. (1983). *Traditional houses of Makkah: the influence o socio-cultural themes upon Arab-Muslim dwellings*. In *Islamic architecture and urbanism*, College of Architecture and Planning. Dammam: King Faisal University.

Fallatah, M. (2008). *Business opportunities in water and wastewater sector in Saudi Arabia*. In Saudi Water and Power Forum. Jeddah, November 2008.

Faruqi, N., Asit, B. and Bino, M. (2000). *Water management in Islam*. Tokyo: United Nations University Press.

Fathy, H. (1986). *Natural energy and vernacular architecture*. Chicago: University of Chicago Press.

Federal Research Division (2004). *Saudi Arabia: a country study*. Kila: Kessinger Publishing Co.

Flick, U. (2006). *An introduction to qualitative research*. 3rd edition, London: Sage Publications Ltd.

Flynn, L. (2001). *Sustainability takes root*. Building Design & Construction, Vol. 42, no. 4, pg. 26.

- Foster, K., Stelmack, A. and Hindman, D. (2007). *Sustainable residential interiors*. Hoboken: John Wiley & Sons.
- Frey, J.H. and Oishi, S.M. (1995). *How to conduct interviews by telephone and in person*. London: Sage Publications Ltd.
- Gasson, C. (2008). *Tariff policy: a global perspective*. In Saudi Water and Power Forum, Jeddah, 1-4 November 2008.
- Getter, K. and Rowe, D. (2006). *The role of extensive green roofs in sustainable development*. Hortscience, Vol. 41, no. 5, pp. 1276-1285.
- Ghauri, R. and Grønhaug, K. (2005). *Research methods in business studies: a practical guide*. 3rd edition, London: Pearson Education Ltd.
- Gibson, R. B., Hassan, S., Holtz, S., Tansey, J., and Whitelaw, G. (2005). *Sustainability assessment: criteria, process and applications*. London: Earthscan
- Glass, J. (2002). *Encyclopaedia of architectural technology*. Chichester: John Wiley & Sons.
- Gorat, L. and Wang, D. (2002). *Architectural research methods*. New York: John Wiley & Sons, Inc.
- Graves, H.M. and Phillipson, M.C. (2000). *Potential implications of climate change in the built environment*. London: BRE & Construction Communications.
- Green Building Education Services (2009). *LEED Green Associate Study Guide*. Lewisville: Green Building Education Services.
- Grondizk, W.T., Kwok, A.G., Stein, B. and Reynolds, J.S. (2010). *Mechanical and electrical equipment*. 11th edition, Chichester: John Wiley & Sons.
- Guy, S. and More, S.A. (Eds.). (2005). *Sustainable architectures: cultures and natures in Europe and North America*. London: Spon Press.
- Ham, A., Shams, M. B. and Madden, A. (2004). *Saudi Arabia*. London: Lonely Planet Publications.
- Hanley, N., McGregor, P.G., Swales, J.K. and Turner, K. (2009). *Do increases in energy efficiency improve environmental quality and sustainability?*. Ecological Economics, Vol. 68, no. 3, pp. 692-709.
- Hart, C. (2005). *Doing your Masters dissertation*. London: Sage Publications Ltd.
- Hart, D. (2003). *Alternative energy sources: an assessment*. In *The future of oil as a source of energy*, Al-Suwaidi, J.S. (Ed.). Abu Dhabi, The Emirates Centre for Strategic Studies and Research.

- Hassan, K.A. (1995). *The application of solar shading devices for buildings in hot humid climates: with special reference to Malaysia*. Unpublished Ph.D. thesis: University of Wales Institute.
- Hastings, R. and Wall, M. (2007). *Sustainable solar housing. Vol.2. Exemplary buildings and technologies*. London: Earthscan
- Heaton, C. (1995). *Case studies of sustainable architecture in Utah*. Provo: Brigham Young University.
- Heinrich, M. (1998). *The performance and scalability of distributed shared memory cache coherence protocols*. Unpublished Ph.D. thesis: Stanford University.
- Houghton, J. (2004). *Global warming: the complete briefing*. 3rd Edition, Cambridge: Cambridge University Press.
- Hubbert, M.K. (1949). *Energy from fossil fuels*. Science, Vol. 109, no. 2023, pp. 103-109.
- Hui, S.C.M. (2003). *Effective use of building energy simulation for enhancing building energy codes*. In Eighth International IBPSA Conference, Eindhoven, 11-14 August 2003.
- Hyde, R. (2000). *Climate responsive design: a study of buildings in moderate and hot humid climates*. London: E&FN Spon.
- Ibrahim, B. and Abbas, M.Y. (2001). *Perception of local architects on sustainable architecture*. Kuala Lumpur: Universiti Teknologi MARA.
- International Energy Agency (2009). *Access to electricity* [WWW]. International Energy Agency Website. Available from: <http://www.iea.org/weo/electricity.asp> [accessed 3 February 2010].
- International Energy Agency (2007). *World energy outlook 2007: China and India insights*. Paris: International Energy Agency.
- International Network for Sustainable Energy (2010). World solar energy map. International Network for Sustainable Energy Website. Available from: <http://www.inforse.dk/europe/dieret/Solar/asolarirrad.gif> [accessed 2 July 2010].
- IPCC (2007). *The physical science basis: summary for policy makers* [WWW]. IPCC Website. Available from: <http://www.ipcc.ch/pdf/assessment-report/ar4/wg1/ar4-wg1-spm.pdf> [accessed 2 February 2008].
- Iqbal, M. (1983). *An introduction to solar radiation*. Toronto: Academic Press.
- Iyer, S. (2007). *Burj Al-Taqa: yet another feather in the cap for Middle East* [WWW]. EcoFriend Website. Available from: <http://www.ecofriend.org/entry/burj-al-taqa-yet-another-feather-in-the-cap-for-middle-east/> [accessed 2 February 2010].
- Janin, H. (1995). *Saudi Arabia*. Singapore: Times Editions Pte Ltd.

- Johnson, S. (1993). *Greener buildings: environmental impact of property*. London: Macmillan Press Ltd.
- Kabir, M.H., Endlicher, W. and Jagermeyr, J. (2009). *Calculation of bright roof-tops for solar PV applications in Dhaka Megacity Bangladesh*. *Renewable Energy*, Vol. 35, no. 8, pp. 1760–1764.
- Kachadorian, J. (2006). *The passive solar house: the complete guide to heating and cooling your home*. Vermont: Chelsea Green Publishing Company.
- Kang, D. and Strand, R.K. (2009). *Simulation of passive down-draught evaporative cooling systems in EnergyPlus*. In Eleventh International IBPSA Conference: Building Simulation. Glasgow, 27-30 July 2009.
- Kibert, C.J. (2005). *Sustainable construction: green building design and delivery*. Chichester: John Wiley & Sons.
- Kim, J. and Rigdon, B. (1998). *Introduction to sustainable design* [WWW]. National Pollution Prevention Centre for Higher Education. Available from: <http://www.umich.edu/~nppcpub/resources/compendia/ARCHpdfs/ARCHdesIntro.pdf> [accessed 5 February 2010].
- King, G. (1998). *The traditional architecture of Saudi Arabia*. London: I. B. Tauris Publishers.
- King Abdullah University of Science and Technology (2010). *Sustainable development* [WWW]. KAUST website. Available from: <http://www.kaust.edu.sa/about/sustainable/sustainable.html> [accessed 17 April 2010].
- Konya, A. (1980). *Design primer for hot climate*. Oxford: Architectural Press.
- Kreith, F. and Goswami, D.Y. (2007). *Handbook of energy efficiency and renewable energy*. Boca Raton: CRC Press.
- Kultermann, U. (1999). *Contemporary Architecture in the Arab states: a renaissance of a region*. New York: McGraw-Hill
- Landman, M. (1999). *Breaking through the barriers to sustainable building*. Unpublished Ph.D. thesis: Tufts University.
- League of Arab States (2005). *Sustainable building and construction in the Arab region*. Cairo: League of Arab States.
- Linares, P. and Labandeira, X. (2009). *Energy efficiency: economics and policy*. Madrid: FEDEA.
- Long, D. E. (2005). *Culture and costumes of Saudi Arabia*. Westport: Greenwood Press.
- Low, N. (2005). *Green city: sustainable homes*. Sydney: University of New South Wales Press.

- Maiellaro, N. (Ed.). (2001). *Towards sustainable building*. Boston: Kluwer Press.
- Mamontoff, A. (2009). *Incorporating solar technology to design in humid subtropical climates*. Unpublished M.Arch thesis: University of South Florida.
- Maps of World (2009). *Saudi Arabia political map* [WWW]. Maps of World Website. Available from: <http://www.mapsofworld.com/saudi-arabia/saudi-arabia-political-map.html> [accessed 26 March 2010].
- Maria, A. (1997). *Introduction to modelling and simulation*. In 1997 Winter Simulation Conference. Atlanta, 7-10 December 1997.
- Mason, J. (2002). *Qualitative researching*. 2nd edition, London: Sage Publications Ltd.
- Matko, K., Zupancic, B. and Matko, D. (1992). *Simulation and modelling of a continuous system: a case study approach*. London: Pearson Education Ltd.
- McLennan, J.F. (2004). *The philosophy of sustainable design*. Kansas City: Ecotone LLC.
- Met Office (2011). *World weather* [WWW]. The Met Office Website. Available from: <http://www.metoffice.gov.uk/weather/world/> [accessed 6 February 2011].
- Miles, M.B. and Huberman, A.M. (1994). *Qualitative data analysis: an expanded sourcebook*. 2nd edition, London: Sage Publications Ltd.
- Minke, G. (2006). *Building with earth: design and technology of a sustainable architecture*. Basel: Birkhäuser-Publishers for Architecture.
- Moffett, M., Fazio, M.W. and Wodehouse, L. (2004). *A world history of architecture*. New York: McGraw Hill.
- Monawar, A.H. (2001). *A study of energy conservation in the existing apartment building in Makkah Region, Saudi Arabia*. Unpublished Ph.D. thesis: University of Newcastle.
- Moore, S.A. (2001). *Technology and place: sustainable architecture and Blueprint firm*. Austin: University of Texas Press.
- Moore, S.A. (2006). *Useful theory: on sustainable architecture and philosophy* [WWW]. The University of Texas at Austin School of Architecture Website. Available from: http://soa.utexas.edu/faculty/moore/presentations/presentation_unt.pdf [accessed 12 February 2007].
- Morrell, K. (2010). *Choosing a dissertation topic* [WWW]. Dr Kevin Morrell Personal Website. Available from: http://www.kevinmorrell.org.uk/choosing_a_topic.htm [accessed 13 June 2010].
- Morris, T. and Wood, S. (1991). *Testing the survey method: continuity and change in British industrial relations*. Work Employment and Society, Vol. 5, no. 2, pp. 259-282.

- Neelamkavil, F. (1987). *Computer simulation and modelling*. Chichester: John Wiley & Sons.
- Nizwa (2006). *Dhofar's unsullied traditions* [WWW]. Nizwa Website. Available from: <http://www.nizwa.net/heritage/dhofartrad/dhofar.html> [accessed 9 April 2008].
- Paltridge, G.W. (2009). *The climate caper*. Ballan: Connor Court Publishing Ltd.
- Patlitzianas, K.D., Doukas, H. and Psarras, J. (2006). *Enhancing renewable energy in the Arab States of the Gulf: constraints and efforts*. Research Policy, Vol. 34, no. 18, pp. 3719-3726.
- Peterson, J. (1993). *Historical dictionary of Saudi Arabia*. Lanham: Scarecrow Press.
- Pidwirny, M. (2006). *Earth-sun geometry* [WWW]. Fundamentals of Physical Geography, 2nd Edition. <http://www.physicalgeography.net/fundamentals/6a.html> [accessed 15 December 2010].
- Pitts, A. (2004). *Planning and design strategies for sustainability and profit*. Oxford: Architectural Press
- Planet Ark (2005). *Saudi government approves Kyoto climate protocol* [WWW]. Planet Ark Website. Available from: <http://www.planetark.com/dailynewsstory.cfm/newsid/28658/story.htm> [accessed 6 January 2010].
- Radhi, H. (2010). *On the optimal selection of wall cladding system to reduce direct and indirect CO₂ emissions*. Energy, Vol. 35, no. 3, pp. 1412–1424.
- Ragette, F. (2003). *Traditional domestic architecture of the Arab region*. Kornwestheim: Edition Axel Menges.
- Rahman, M.M., Rasul, M.G. and Khan, M.M.K. (2008). *Energy conservation measures in an institutional building by dynamic simulation using DesignBuilder*. In 3rd International Conference on Energy and Environment. Cambridge: 23-25 February 2008.
- Rashid, N. I., and Shaheen, E. I. (1995). *Saudi Arabia: all you need to know*. Missouri: International Institute of Technology, Inc.
- Remenyi, D., Williams, B., Money, A. and Swartz, E. (1998). *Doing research in business and management: an introduction to process and method*. London: Sage Publications Ltd.
- Renewable Energy UK (2007). *Wind and solar powered Dubai skyscraper* [WWW]. Renewable Energy UK Website. Available from: <http://www.reuk.co.uk/Wind-and-Solar-Powered-Dubai-Skyscraper.htm> [accessed 2 April 2010].
- Renzetti, C.M. and Lee, R.M. (1993). *Researching sensitive topics*. London: Sage Publications Ltd.
- Roaf, S., Fuentes, M. and Thomas, S. (2007). *Ecohouse: a design guide*. 3rd edition, Oxford: Architectural Press.

- Robson, C. (2002). *Real world research*. 2nd edition, Oxford: Blackwell Science Ltd.
- Rovers, R. (2003). *The role of policies in promoting sustainable practices*. UNEP Industry and Environment, Vol. 26, no. 2-3, pp 29-32.
- Royal Embassy of Saudi Arabia (1997). *The unspoiled beauty of Asir*. Saudi Arabia, Vol. 14, no. 2, pp. 1-4.
- Saeed, S.A. (1989). *Climate and socioeconomic influence on house design: with special reference to the hot-dry regions of Saudi Arabia and Sudan*. King Saud University Architecture and Planning, Vol. 1, no. 1, pp. 37-55.
- Saleh, M.A.E. (1998). *Place Identity: The visual image of Saudi Arabian cities*. Habitat International, Vol. 22, no. 2, pp. 149-164.
- Santamouris, M., Adnot, J., Alvarez, S., Klitsikas, N., Orphelin, M., Lopes, C. and Sanchez, F. (2004). *Cooling the cities*. Paris: Mines ParisTech.
- Saudi Building Code National Committee (2007). *Saudi Building Code*. Riyadh: Saudi Building Code National Committee.
- Saudi Ministry of Economy and Planning (2005). *Estimating the demand for housing in the Kingdom of Saudi Arabia over the period 2005-2025*. Riyadh: Saudi Ministry of Economy and Planning.
- Saudi Ministry of Economy and Planning (2007). *Population and housing characteristics in the Kingdom of Saudi Arabia: demographic survey 1428H*. Riyadh: Saudi Ministry of Economy and Planning.
- Saudi Ministry of Water and Electricity (2009). *The national campaign for electric consumption guidance* [WWW]. Tarshdeed Website. Available from: <http://www.tarshdeed.gov.sa/> [accessed 30 March 2010].
- Saunders, M., Lewis, P. and Thornhill, A. (2007). *Research methods for business students*. 4th edition, London: Pearson Education Ltd.
- Shihabi, B. (2004). *Architecture in Saudi Arabia*. In *Architecture re-introduced: new projects in societies in change*, Abed, J. (Ed). Geneva: The Aga Khan Award for Architecture.
- Siani, B.S. (1980). *Building in hot dry climates*. Chichester: John Wiley & Sons.
- Silver, J. (2008). *Global warming and climate change demystified: a self-teaching guide*. New York: McGraw Hill.
- Smith, J.B., Schneider, S.H., et al., (2009). *Assessing dangerous climate change through an update of the Intergovernmental Panel on Climate Change (IPCC) 'reasons for concern'*. Proceedings of the National Academy of Sciences, Vol. 106, no. 11, pp. 4133-4137.

- Smith, P. (2001). *Architecture in a climate of change: a guide to sustainable design*. Oxford: Architectural Press.
- Smith, P. and Pitts, A. C. (1997). *Energy: building for the Third Millennium*. London: B.T. Batsford Ltd
- Soanes, C. (2008). *Compact Oxford English dictionary of current English*. 3rd Edition, Oxford: Oxford University Press.
- Sorenson, D. (2007). *An introduction to the Middle East*. Boulder: Westview Press.
- Stake, R.E. (1995). *The art of case study research*. London: Sage Publications Ltd.
- Stang, A. and Hawthorne, C. (2005). *The green house: new directions in sustainable architecture*. New York: Princeton Architectural Press.
- Stern, N. (2006). *The economics of climate change: the Stern Review*. Cambridge: Cambridge University Press.
- Steele, J. (1997). *Sustainable architecture: principles, paradigms and case studies*. New York: McGraw Hill.
- Steele, J. (2005). *Ecological architecture: a critical history*. New York: Thames & Hudson, Inc.
- Sustainable Buildings Industry Council (2007). *Green building guidelines: meeting the demand for low-energy, resource-efficient homes*. 5th Edition, Washington DC: Sustainable Buildings Industry Council.
- Spengler, J.D., Samet, J.M. and McCarthy, J.F. (2001). *Indoor air quality handbook*. London: McGraw-Hill Education.
- Tabet-Aoul, K. (1991). *The interaction of view, window design and shading devices*. Unpublished Ph.D. thesis: University of Sheffield.
- Taleb, H.M. (2007). *The potential use of solar photovoltaic technology in the buildings of Arabian gulf countries*. Unpublished M.Arch thesis: University of Sheffield.
- Taleb, H.M. (2010). *Towards sustainable buildings in the Kingdom of Saudi Arabia*. In Technology and Sustainability in the Built Environment. Riyadh, 3-6 January 2010.
- Taleb, H.M. and Sharples, S. (2010a). *Applying energy conservation measures within residential buildings of Saudi Arabia: a scoping study of two case buildings*. In International Conference on Applied Energy. Singapore, 21-23 April 2010.
- Taleb, H.M. and Sharples, S. (2010b). *Developing sustainable residential buildings in Saudi Arabia: a case study*. Applied Energy, Vol. 88, no. 1, pp. 383-391.
- Talib, K. (1984). *Shelter in Saudi Arabia*. New York: St. Martin's Press.

- Thomas, R. (1996). *Environmental design: an introduction for architects and engineers*. 3rd Edition, Oxon: Taylor and Francis.
- Thomas, R. (2006). *The Millennium Centre; Dagenham*. In *Environmental design: an introduction for architects and engineers*, Thomas, R. and Max Fordham LLP. London: E & FN Spon.
- Thomas, R.M. (2003). *Blending qualitative and quantitative research methods in theses and dissertations*. Thousand Oaks: Corwin Press, Inc.
- The Association for the Study of Peak Oil (2006). *The general depletion picture* [WWW]. Newsletter no. 61; 6 January 2006. Available from: <http://www.aspo-ireland.org/contentFiles/newsletterPDFs/newsletter61.pdf> [accessed 9 February 2008].
- Trulove, J.G. (2006). *New sustainable homes*. New York: Collins Design and HarpersCollins Publishers.
- Turrent, D. (2007). *Sustainable architecture*. London: RIBA Publishing.
- Uluengin, B. and Uluengin, N. (1993). *Homes of old Makkah*. Saudi Aramco World, July/August, Vol. 44, no. 4, pp. 20-29.
- United Nations (2005). *End-use energy efficiency and promotion of a sustainable energy future*. New York: United Nations Publications.
- United Nations Development Programme 'UNDP' (2006). *Human development report: beyond scarcity: power, poverty and the global water crisis*. Basingstoke: Palgrave Macmillan.
- United Nations Development Programme 'UNDP' (2006). *Human development report: beyond scarcity: power, poverty and the global water crisis*. Basingstoke: Palgrave Macmillan.
- US Department of Energy (2010). *EnergyPlus interfaces* [WWW]. US Department of Energy Website. Available from: http://apps1.eere.energy.gov/buildings/energyplus/ep_interfaces.cfm#designbuilder [accessed 8 April 2010].
- US Green Building Council (2009). *Green building and LEED core concepts guide*. Washington DC: US Green Building Council.
- US Green Building Council (2010). *LEED projects and case studies directory* [WWW]. US Green Building Council Website. Available from: <http://www.usgbc.org/LEED/Project/CertifiedProjectList.aspx?CMSPageID=247> [accessed 21 March 2010].
- Vale, B. and Vale, R. (1991). *Towards a green architecture: six practical case studies*. London: RIBA Publications Ltd.
- Viljoen, A. and Bohn, K. (2007). *The environmental impact of building materials*. In *Ecohouse: a design guide*, Roaf, S. (Ed.). Oxford: Butterworth-Heinemann.

- Vincent, P. (2008). *Saudi Arabia: an environmental overview*. London: Taylor & Francis
- Waheeb, S.A. (2005). *Impact of shading devices on indoor sunlight distribution and building energy performance, with reference to Saudi Arabia*. Unpublished Ph.D. thesis: University of Nottingham.
- Wasilowski, H. and Reinhart, C. (2009). *Modelling an existing building in DesignBuilder: custom versus default inputs*. In Building Simulation Conference. Glasgow: 27-30 July 2009.
- Werthmann, C. (2007). *Green roof: a case study*. New York: Princeton Architectural Press.
- Williamson, T., Radford, A. and Bennetts, H. (2003). *Understanding sustainable architecture*. London: Spon Press.
- Wines, J. (2000). *Green architecture*. Cologne: Taschen.
- Woolley, T., Kimmins, S., Harrison, P. and Harrison, R. (1997). *The green building handbook*. London: E&FN Spon.
- World Commission on Environment and Development (1987). *Our common future*. Oxford: Oxford University Press.
- World Weather Information Service (2010). *Saudi Arabia* [WWW]. World Weather Information Service Website. Available from: <http://worldweather.wmo.int/079/m079.htm> [accessed 20 January 2010].
- Yang, J., Brandon, P.S. and Sidwell, A.C. (2005). *Smart and sustainable built environments*. Oxford: Blackwell Publishing.
- Yin, R.K. (2009). *Case study research: design and methods*. 4th edition, London: Sage Publications Ltd.
- Zacharirah, J.L., Kennedy, C. and Pressnail, K. (2002). *What makes a building green?* International Journal of Environmental Technology and Management, Vol. 2, no. 1, pp. 38-53.

Appendix A: Interview Guide

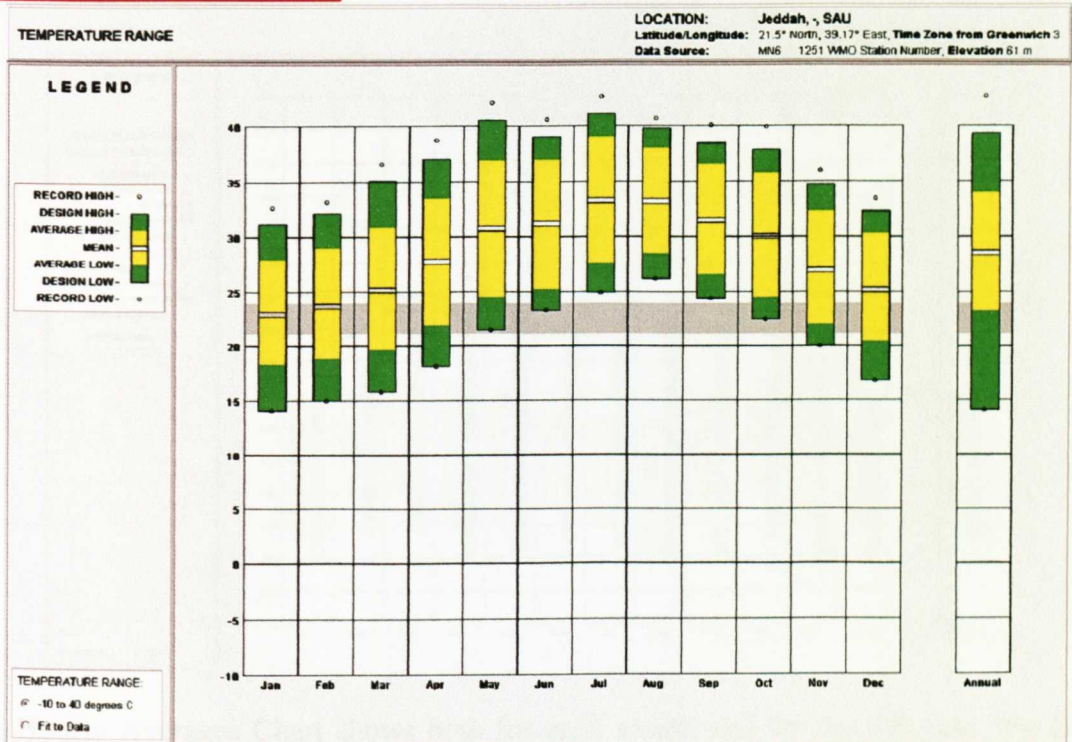
This Appendix shows broad guidelines, as opposed to precise questions to be put to the interviewees. Each interview question could be adapted depending on how each interviewee responds.

1. Could you please introduce yourself (education, work experience and expertise)?
2. What do you think of the simulation results of the two case studies?
3. How feasible do you think the modifications suggested are in terms of enhancing energy and water efficiency? What is the likelihood of their acceptance among the general public in Saudi Arabia?
4. Can you suggest any further measures to enhance household energy and water efficiency in the country?
5. How would you classify the current status of Saudi houses in terms of sustainability? Why?
6. What do you think are the barriers that currently impede movement towards sustainable residential buildings?
7. Who do you think has the major role in terms of promoting sustainable design practices in the Saudi residential sector? Why?
8. Can government regulations help in terms of making houses more sustainable in Saudi Arabia? Why?
9. What strategies would you recommend in order to make residential buildings in Saudi Arabia more sustainable?
10. Do you have any comments on any of the previous questions and/or the simulation exercise?

Appendix B: Jeddah Climatic Data

This appendix shows the results of a detailed climatic analysis of Jeddah City using Climate Consultant 5 Software.

1) Temperature Range



This is the simplest of all the charts and shows the Dry Bulb temperature ranges enclosing the Record High and Low Temperature (round dots), the Design High and Low Temperatures (top and bottom of green bars), Average High and Low Temperatures (top and bottom of yellow bars), and Mean or Average Temperature (open slot). These values are calculated for each month and for the full year by Climate Consultant. Below is a brief description of the terms used.

- **Record High or Low Temperature**

These are the highest and lowest Dry Bulb Temperatures in each month or over the full year.

- **Design High or Low Temperature**

The Annual Design Temperatures are used to calculate the required size of the heating and cooling equipment. Design Temperatures are also shown for each month using the same percentage of hours in that month.

- **Average High and Low Temperature**

These are the average of the highest or lowest dry bulb temperatures for each day during the month, or annually.

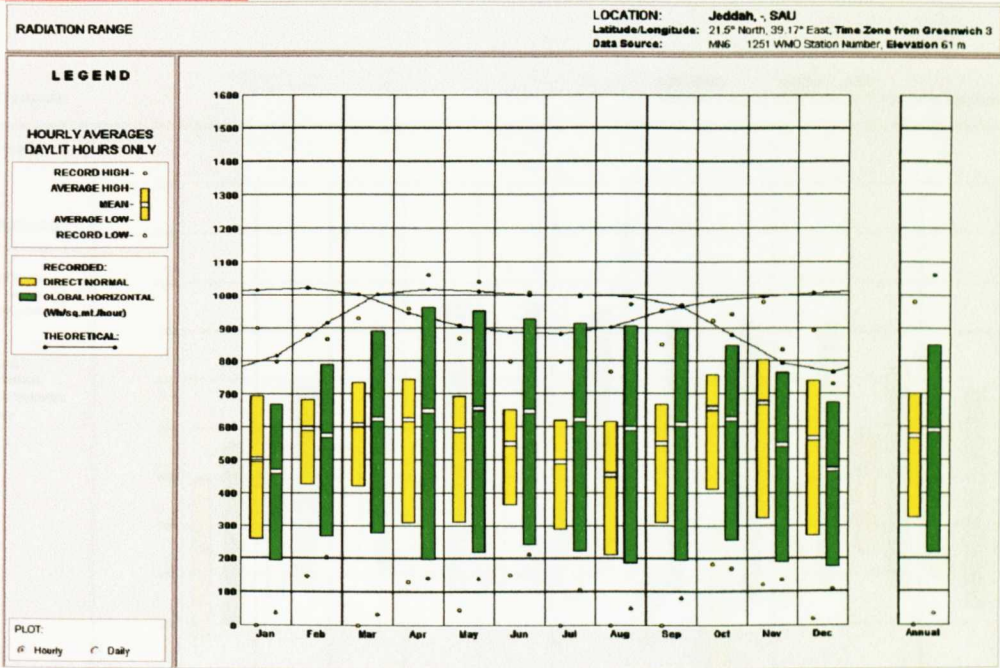
- **Mean or Average Temperature**

This is the average of all Dry Bulb temperatures in that particular month or annually.

- **Dry Bulb Temperature**

Dry Bulb Temperature is the sensible temperature typically measured by a thermometer with a dry bulb. The units are either in degrees C or F.

2) Radiation Range



The Hourly Averages Chart shows both for each month and for the full year, the Direct Normal Solar Radiation (yellow) and Global (Total) Horizontal Solar Radiation (green) for all daylight hours. Using ASHRAE formulas Climate Consultant calculates the Theoretical maximum hour during each month for both Direct Normal and global Radiation and displays it as the solid black line. The Record (or Peak) highest hour of radiation is shown as a small coloured circle. The Average High is the average of the highest value from each day of the month or annually and is shown as the top of the coloured bar. The Mean or average of all the daylight hours is shown as the break in the coloured bar. The Average Low value is the average of all the lowest values of the month during daylight hours, and the Record Low value will represent the lowest radiation during that month between sunrise and sunset.

The Daily Total Averages chart shows this same data but averaged for the full day in each month, for the hours between sunrise and sunset.

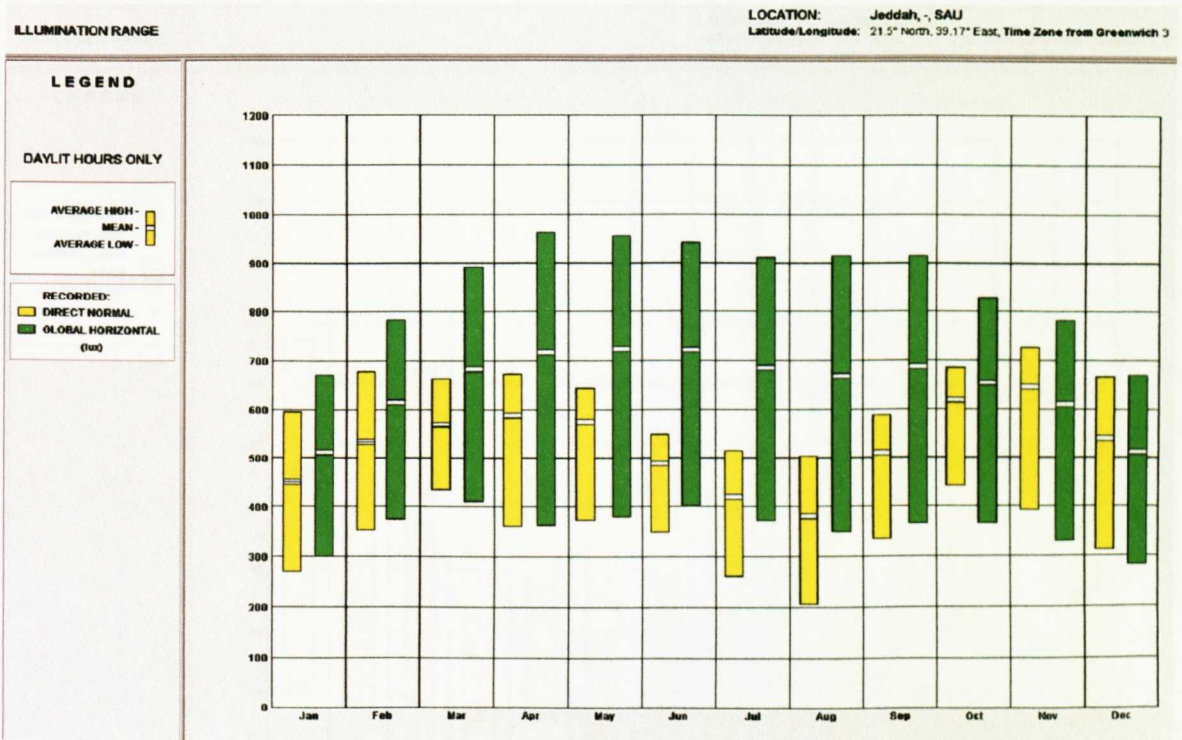
- Direct Normal

The yellow bars show the amount of solar radiation measured as if the sensor was pointed directly toward (or normal to) the sun. It should be noted here that the theoretical maximum value for the Direct Normal Solar Radiation peaks in February when the earth's orbit brings us closest to the sun. This is sometimes called Beam Radiation.

- Global Horizontal

The green bars show the amount of solar radiation that is recorded falling on a horizontal surface. In theory, it is composed of all the diffuse radiation from the total sky vault plus the direct radiation from the sun times the cosine of the angle of incidence. It should be noted here that the Global Horizontal Radiation peaks in summer because that is when the sun is highest in the sky and is thus more perpendicular to a horizontal surface. This is sometimes also called Total Horizontal Radiation.

3) Illumination Range



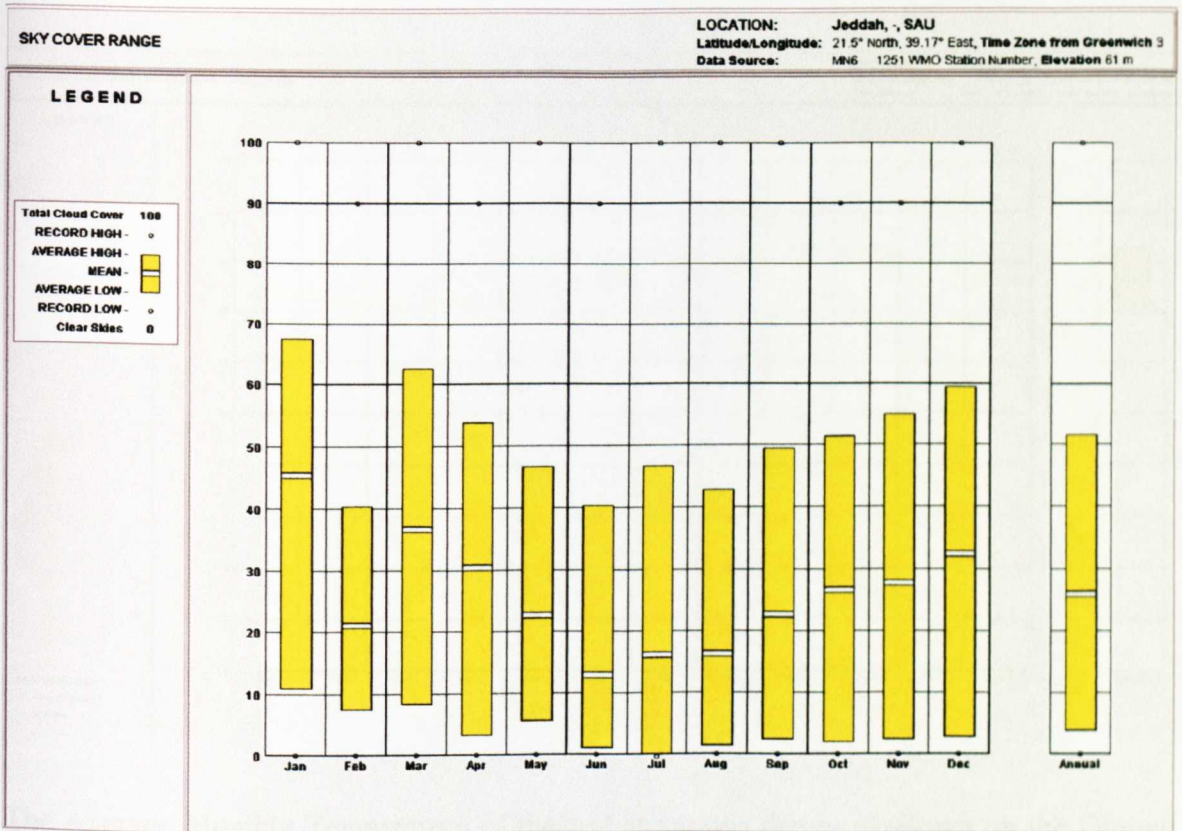
- Direct Normal Illumination

Direct Normal Illumination is defined as the visible light from the sun that is measured by a narrow angle meter pointed directly at the sun and that excludes the surrounding sky. The units are in lux (also called lumens per square metre).

- Global Horizontal Illumination

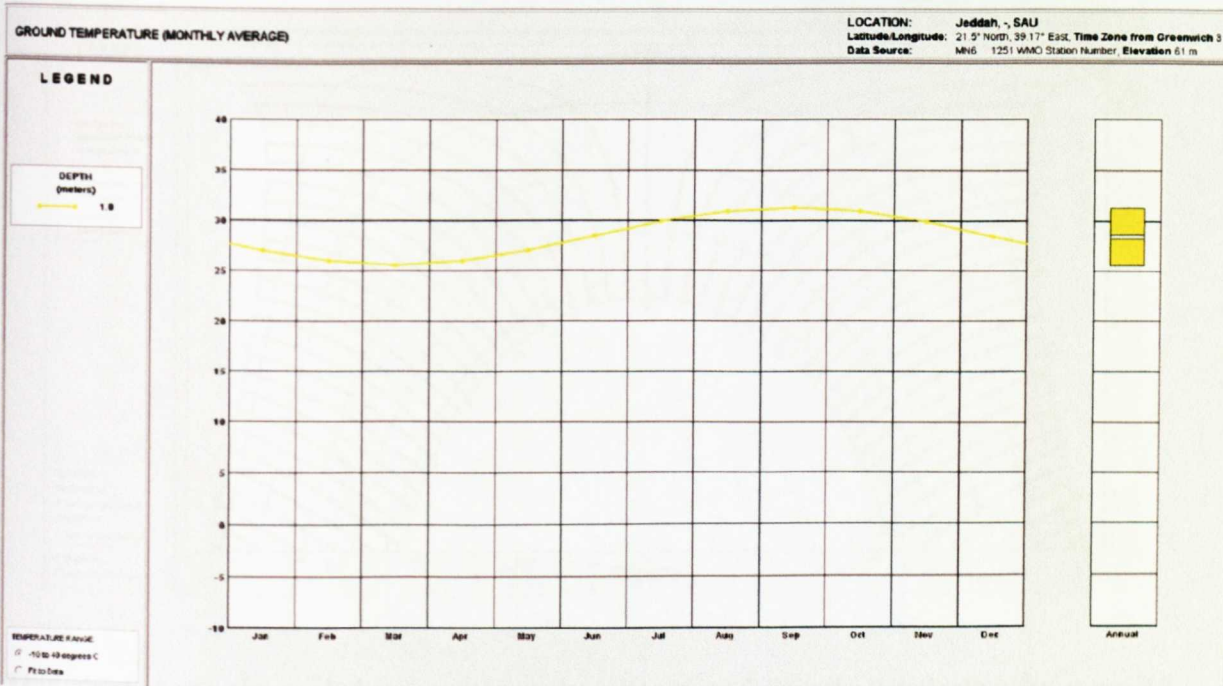
Global Horizontal Illumination is defined as the total visible light that falls on a horizontal surface from the entire sky vault plus Direct Normal Illumination from the sun. The units are in lux (also called lumens per square metre).

4) Sky Cover Range



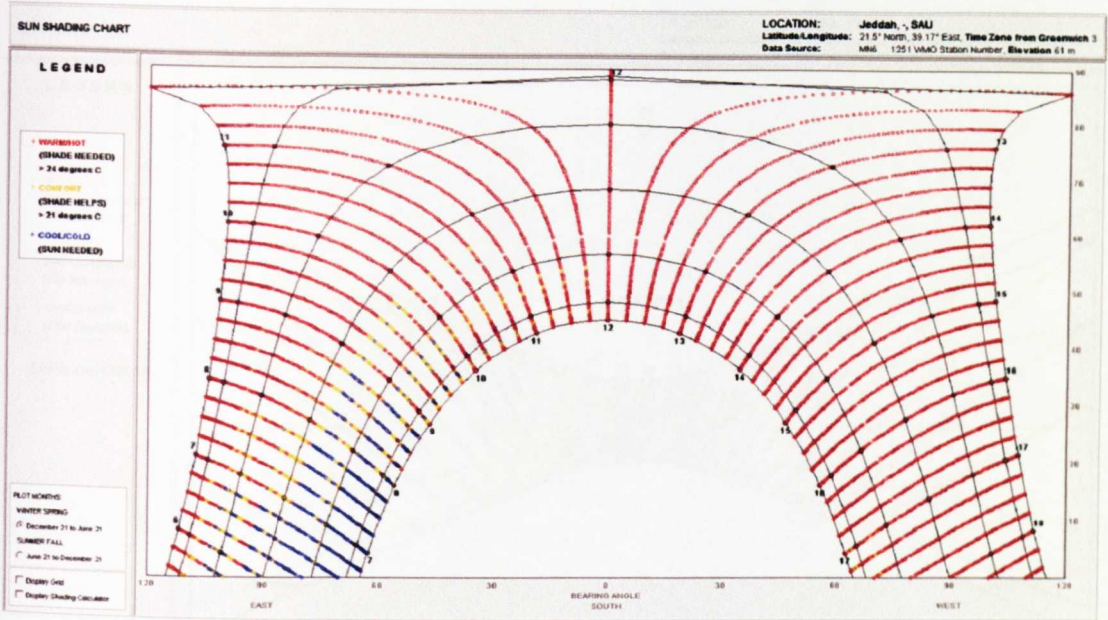
This chart shows Sky Cover for each month and for the full year. Clear sky is 0% Sky Cover and completely obscured is 100% Sky Cover. This corresponds to the amount of the sky dome in tenths covered by clouds or obscuring phenomena at the hour indicated. This parameter is shown in Climate Consultant as a percentage, with the Record highest amount in is shown as a small coloured circle. The Average High is the average of the highest value from each day of the month or annually and is shown as the top of the coloured bar. The Mean or average is shown as the break in the coloured bar. The Average Low is the average of the lowest values from each day of the month or annually and is shown as the bottom of the coloured bar. The Record Low value is shows as the small coloured circle.

5) Ground Temperature (Monthly Average)



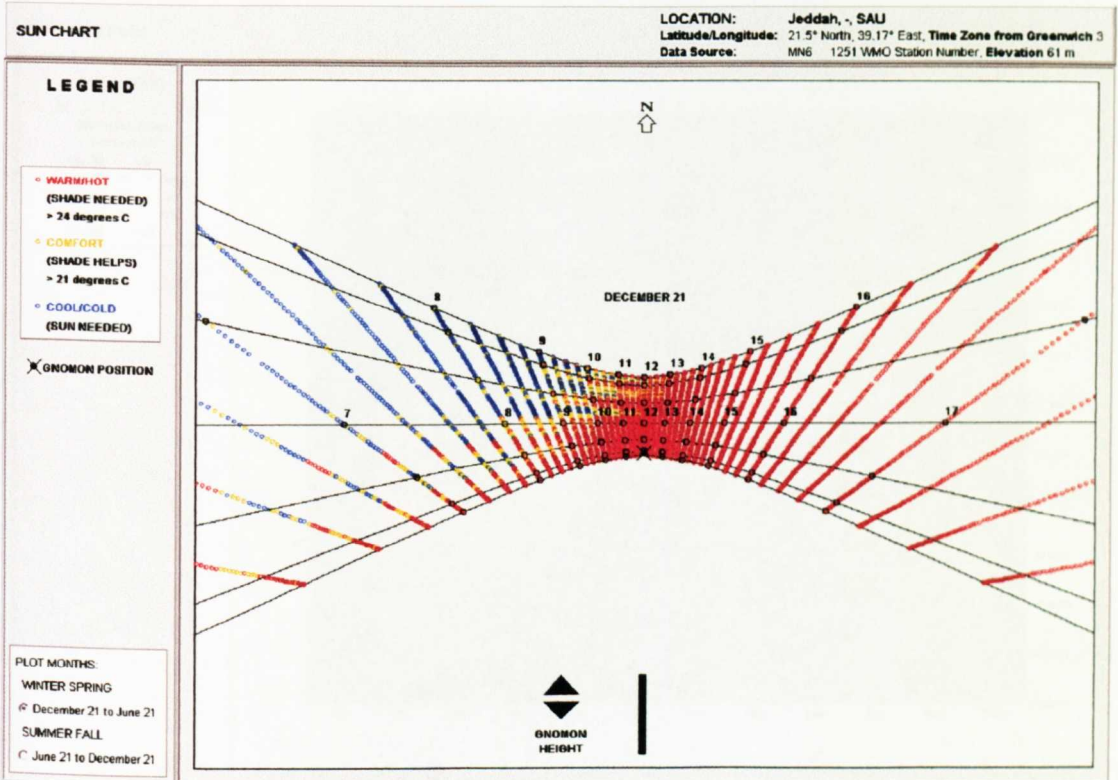
The Average Monthly Temperature of the soil at various depths is shown on the Ground Temperature chart. The top and the bottom of the bar charts on the right show the highest monthly temperature and lowest monthly temperature, while the average monthly temperature is shown in the centre of each bar. Depth is given in feet (or metres) and the temperatures are in degrees F (or degrees C).

6) Sun Shading Chart



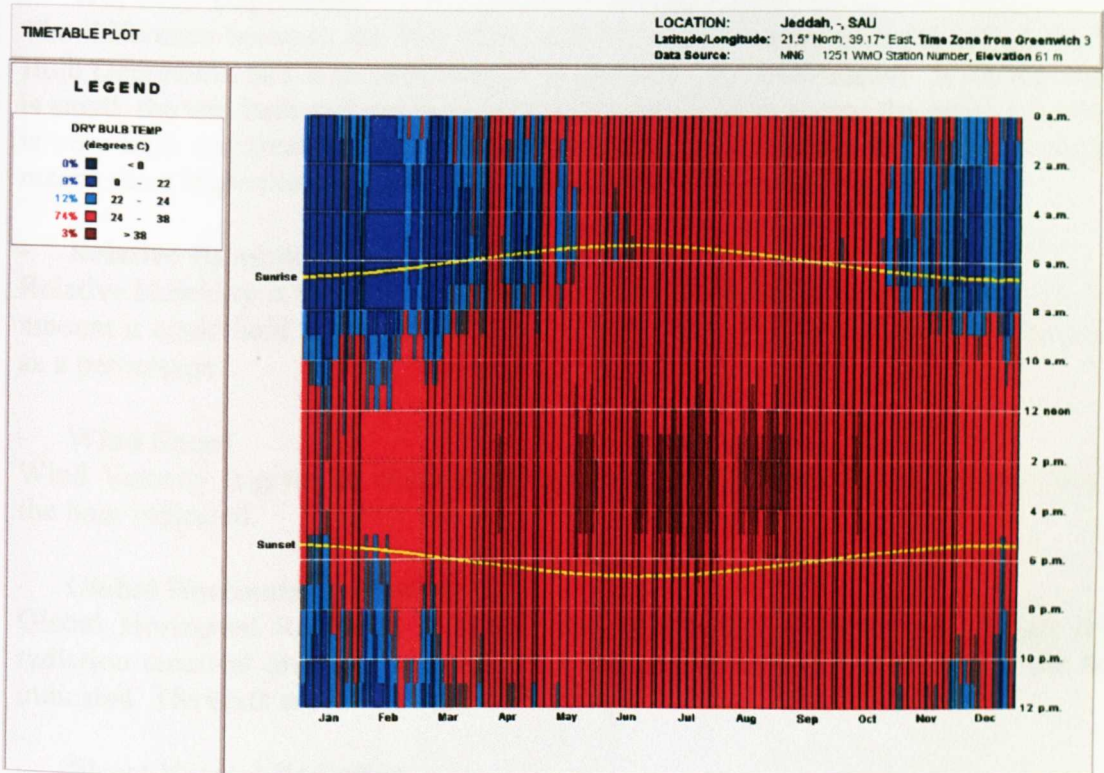
This chart shows the sun's bearing (along the bottom) and altitude (vertically) for every 15 minutes during the year in coloured dots. Yellow dots indicate comfort conditions when the dry bulb temperature is within the comfort zone. Red dots indicate overheat conditions when the dry bulb temperature is above the top of the comfort range. Blue dots indicate underheat conditions when dry bulb temperatures are below the bottom of the comfort zone. Ideally for passive heating the windows should be fully exposed wherever there are blue dots, and to prevent overheating windows should be fully shaded wherever there are red or yellow dots.

7) Sun Chart



This chart is like a flagpole sundial. The gnomon is like a pin or flagpole mounted vertically on the x shown as Gnomon Position. It shows in plane view the shadow cast by the gnomon for every 15 minutes during the year in coloured dots. The Yellow dots indicate comfort conditions when the dry bulb temperature is within the comfort zone. Red dots indicate overheat conditions when the dry bulb temperature is above the top of the comfort range. Blue dots indicate underheat conditions when dry bulb temperatures are below the bottom of the comfort zone. Ideally for passive heating the windows should be fully exposed wherever there are blue dots, and to prevent overheating windows should be fully shaded wherever there are red or yellow dots.

8) Timetable Plot



- Dry Bulb Temperature

Dry Bulb Temperature is the sensible temperature typically measured by a thermometer with a dry bulb. The units are either in degrees C or F.

- Wet Bulb Temperature

This represents the temperature measured by a thermometer that has a wet wick surrounding the bulb. On the Psychrometric chart this line runs diagonally, starting at the point where a dry bulb temperature of the same value intersects the saturation line, or the point of 100% Relative Humidity. To read the Wet Bulb temperature off any point on the Psychrometric chart, run up this diagonal line to the saturation curve and

read the dry bulb temperature at that point. Notice that as water is evaporated into the air, the Wet Bulb remains the same while the dry bulb temperature falls.

- **Wet Bulb Depression**

The difference between the Wet Bulb and Dry Bulb Temperatures is called the Wet Bulb Depression and is an indication of the potential for evaporation. If the depression is small, the wet bulb and dry bulb are almost equal which means the relative humidity is very high and there is little potential for evaporation. If the depression is large, it means there is greater potential for things like evaporative cooling.

- **Relative Humidity**

Relative Humidity is the ratio of the amount of moisture in the air compared to the total amount it could hold at the same dry bulb temperature. Relative Humidity is measured as a percentage.

- **Wind Speed**

Wind Velocity is given in either miles per hour (mph) or metres per second (mps) at the hour indicated.

- **Global Horizontal Radiation**

Global Horizontal Radiation is defined as the amount of direct and diffuse solar radiation received on a horizontal surface during the 60 minutes preceding the hour indicated. The units are in Wh/m.sq or Btuh/sq.ft.

- **Direct Normal Radiation**

Direct Normal Radiation (also called Beam Radiation) is defined as the amount of solar radiation received within a 5.7° field of view centred on the sun during the 60 minutes preceding the hour indicated. The units are in Wh/m.sq or Btuh/sq.ft.

- **Global Horizontal Illumination**

Global Horizontal Illumination is defined as the total visible light that falls on a horizontal surface from the entire sky vault plus Direct Normal Illumination from the sun. The units are in footcandles (also called lumens per square foot) or in lux. (also called lumens per square metre).

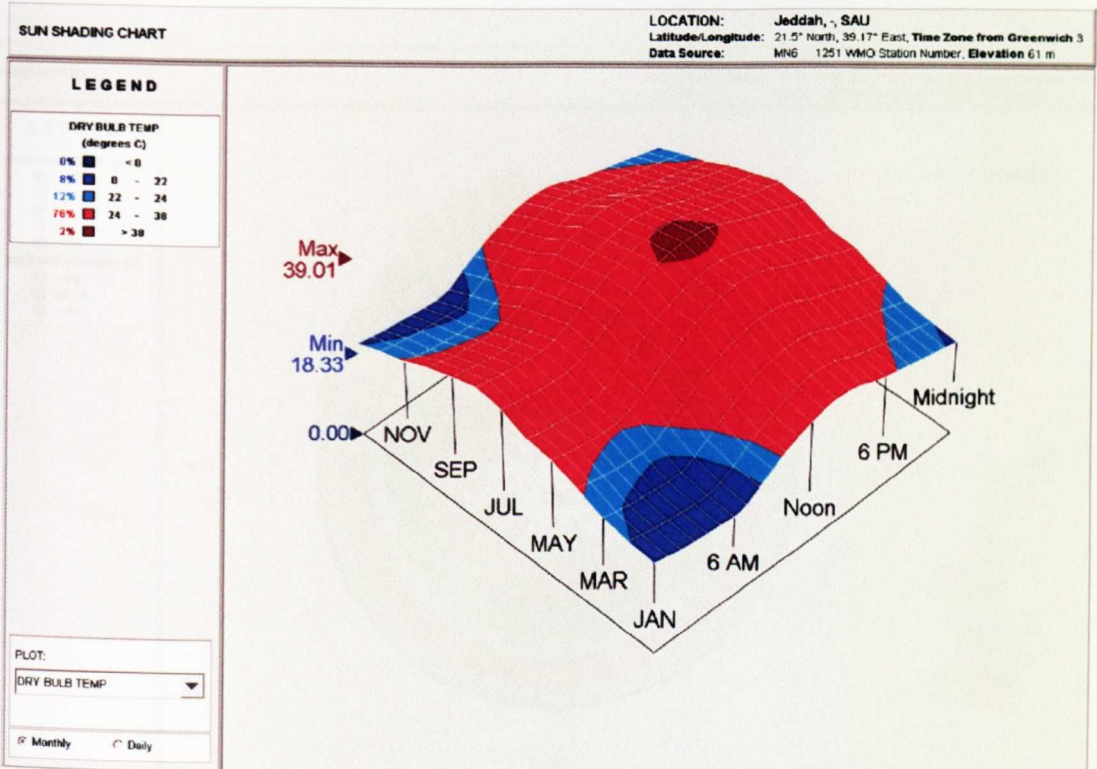
- **Direct Normal Illumination**

Direct Normal Illumination is defined as the visible light from the sun that is measured by a narrow angle metre pointed directly at the sun and that excludes the surrounding sky. The units are in footcandles (also called lumens per square foot) or in lux (also called lumens per square metre).

- **Total Sky Cover**

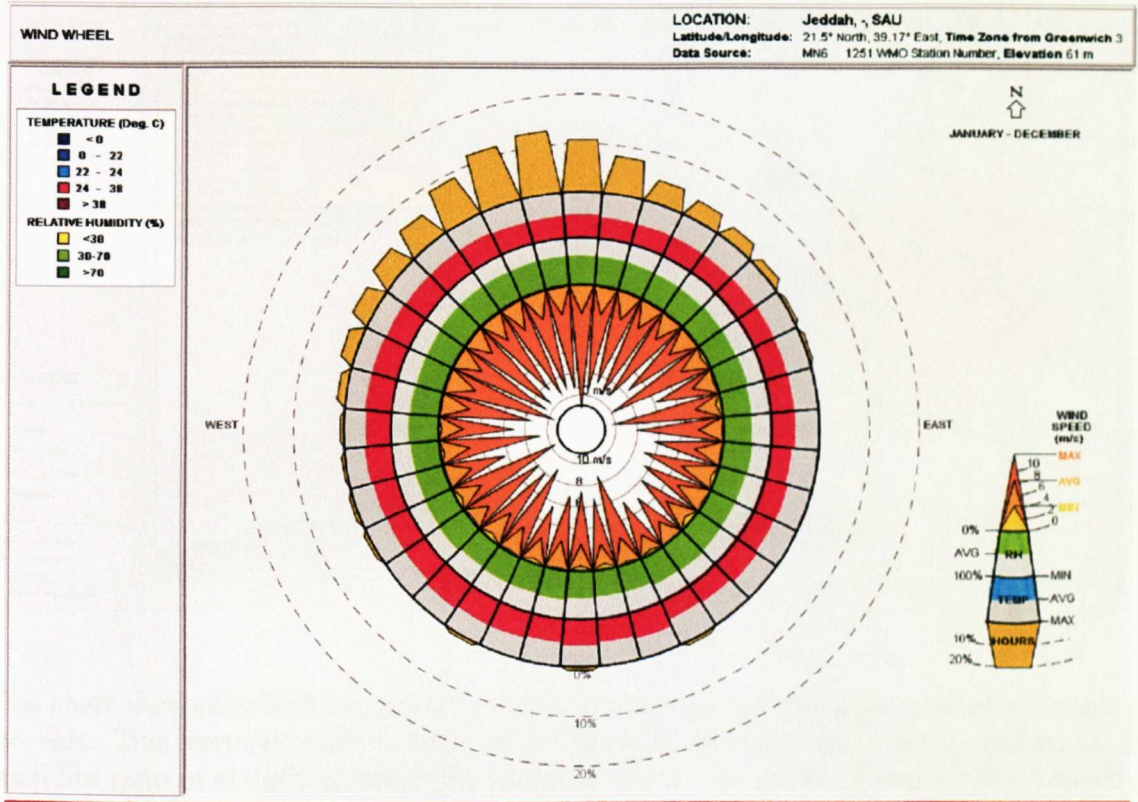
Sky cover is defined as the amount of the sky dome in tenths covered by clouds or obscuring phenomena at the hour indicated. The units used in Climate Consultant are between 0 and 100%.

9) 3D Charts



This plot is the same as the Timetable Plot, except in three dimensions. It shows the months of the year along the bottom, and the hours of the day along the side. Eight different variables can be plotted by selecting from the box in the lower left: Dry Bulb Temperature, Wet Bulb Temperature, Depression (difference between Dry Bulb and Wet Bulb Temperatures), Relative Humidity, Wind Speed, Total Horizontal Radiation, Direct Normal Radiation, and Sky Cover. The units for each variable are shown in the upper left, divided into five different ranges in colours from blue to red, and the percentages of hours that fall in each range are also shown.

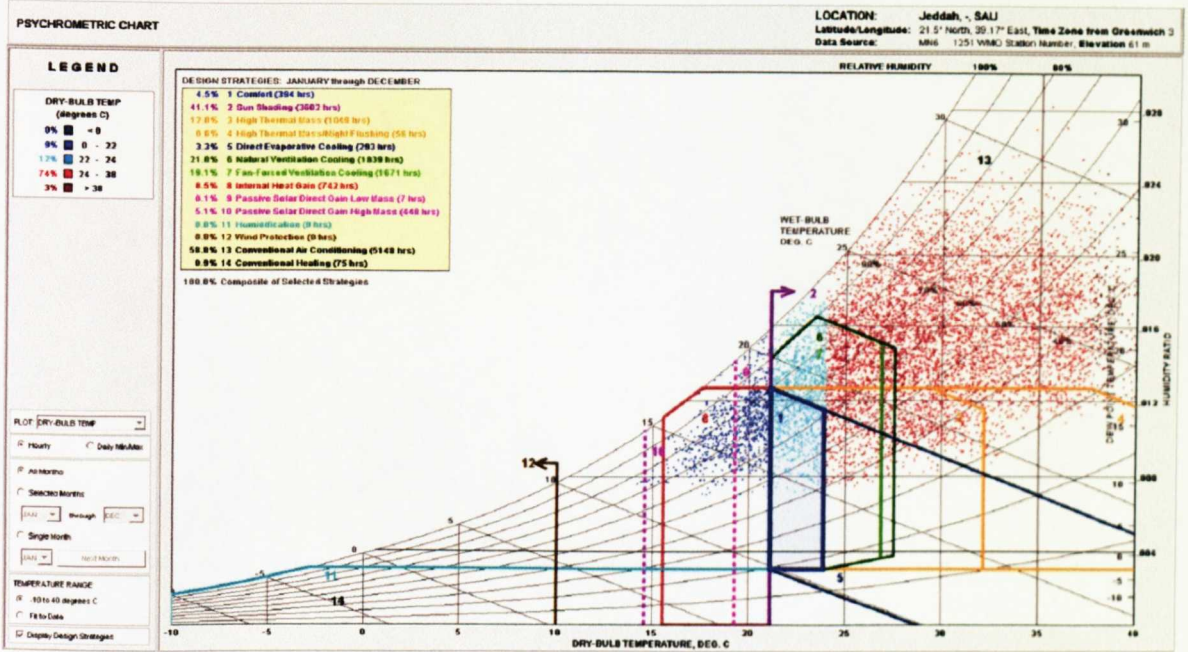
10) Wind Wheel



The Wind Wheel displays for each wind direction the Wind Velocity and Frequency of Occurrence along with concurrent Dry Bulb Temperature and Relative Humidity. The outer ring shows the percentage of hours when the wind comes from each direction. On the next ring the height and colour of the bars shows the average temperature of the wind coming from that direction (light blue is in the comfort zone, blue is cool or cold, and red is warm or hot). The next smaller ring shows average humidity (light green is comfortable, yellow is dry, and green is humid). The innermost circle shows the wind velocities that come from each direction; the tallest brown triangle is the maximum velocity for that period, medium brown is the average velocity, and the smallest light brown triangle is the minimum velocity. Hours when there is zero wind speed do not appear on this chart. The graphic key to all this information is summarized in the icon in the lower right labelled Wind Speed, RH, Temp, and Hours.

With regard to temperatures, the average Dry Bulb Temperature of the wind coming from each direction over the period selected is shown in colour on the second ring. The height of the bar is proportional to the temperature. The colour of the bar is indicated on the upper left panel, with light blue indicating the comfort range as defined on the Criteria screen. Medium blue is the range from the bottom of the comfort range to freezing, and dark blue represents temperature below freezing.

11) Psychrometric Chart



This chart shows dry bulb temperature across the bottom and moisture content of the air up the side. This vertical scale is also called absolute humidity and can be shown as the humidity ratio in pounds of water per pound of dry air (or grams of water per kilogram of dry air), or as the vapour pressure. The curved line on the left is the saturation line (100% Relative Humidity line) which represents the fact that at lower temperatures air can hold less moisture than at higher temperatures. It should be noted here that some dots may represent more than one hour, for example when a given temperature and humidity occurs more than once in any month. Notice also that a given hour's dot might meet the criteria for more than one strategy zone, in which case it is counted in the Percentage of Hours for both zones, which is why the percentages add up to more than 100%. The colour of each dot can represent any one of four variables: Dry Bulb Temperature, Total Horizontal Radiation, Sky Cover, and Wind Speed. The units for each variable are indicated in the upper left and are divided into five different ranges in colours from blue to red. The percentages of hours that fall in each range are also shown.