

**BIOGRAPHIES OF PEOPLE AND PLACE:  
THE HAREWOOD ESTATE, 1698-1813**

**NO. 2 OF 2 VOLUMES:  
FIGURES & APPENDICES**

**TIMUR GURAN TATLIOGLU**

**PHD**

**UNIVERSITY OF YORK**

**DEPARTMENT OF ARCHAEOLOGY**

**JULY 2010**

---

 FIGURES

1.1 LOCATION MAP OF THE HAREWOOD ESTATE.....	5
1.2 MAP OF THE MODERN HAREWOOD ESTATE.....	6
3.1 SCHEMATIC MAP OF THE MEDIEVAL TOWNSHIPS SURROUNDING HAREWOOD .....	7
3.2 1698 ESTATE MAP.....	8
3.3 FIELD SURVEY, NORTH PARK .....	8
3.4 THE SOUTH VIEW FROM THE TERRACE OF HAREWOOD HOUSE .....	9
3.5 GAWTHORPE HALL, 1727.....	9
3.6 AERIAL PHOTOGRAPH, LOFTHOUSE .....	10
3.7 SKETCH, HAREWOOD CASTLE.....	11
3.8 1698 ESTATE MAP .....	12
3.9 TENANCY PATTERNS OF 1738, HAREWOOD ESTATE .....	12
4.1 MAIN TRAVEL ROUTES NEAR HAREWOOD HOUSE.....	13
4.2 STABLES, HAREWOOD HOUSE, 1755-59. ....	13
4.3 NORTHERN FAÇADE, HAREWOOD HOUSE .....	14
4.4 1698 ESTATE MAP SHOWING MAIN AREAS OF LANDSCAPE DEVELOPMENT .....	14
4.5 1ST EDITION ORDNANCE SURVEY (1851).....	15
4.6 ‘COTTAGE-IN-THE-WALLS’, HARROGATE ROAD.....	15
4.7 ARRANGEMENT, ‘COTTAGE-IN-THE-WALLS’ .....	16
4.8 THE AVENUE, HAREWOOD.....	16
4.9 HAREWOOD ESTATE C. 1781.....	17
4.10 WESTERN ELEVATION, BARN, HOLLIN HALL.....	18
4.11 1930S SALES PARTICULARS, ARBOUR HILL FARM, HORNBY CASTLE, NORTH YORKSHIRE..	18
4.12 MODEL FARMHOUSE, NEW LAYS FARM.....	19
4.13 PLAN OF FAIRNLEY FARM, CAMBO .....	19
4.14 SOUTH ELEVATION, STOCKTON GRANGE FARMHOUSE .....	20
4.15 WEST ELEVATION, CARR HOUSE .....	20
4.16 EAST ELEVATION, BARN, STOCKTON FARM.....	21
4.17 FALSE VOUSSOIRS, STABLES, LOFTHOUSE GRANGE FARM.....	21
4.18 MOULDED KNEELERS, STABLES FARM .....	22
5.1 THE EAST KESWICK ENCLOSURE MAP, 1801 .....	22
5.2 THE PLANNED ALLOTMENTS, HAREWOOD VILLAGE .....	23
5.3 1796 ESTATE MAP.....	24
5.4 HOLLIN HALL FARM PLAN, KENT, CLARIDGE AND PEARCE SURVEY, 1796.....	25
5.5 HAREWOOD MILL,.....	26
5.6 WESTERN ELEVATION, BARN, STABLES FARM .....	26
5.7 BARN, LOFTHOUSE GRANGE.....	27
5.8 STAIRS LEADING TO THE FIRST FLOOR, STABLES, STOCKTON FARM.....	27
5.9 KNEELER, STOCKTON FARM .....	28
5.10 DESIGN FOR ‘T’-SHAPED FARMHOUSE, HAREWOOD ESTATE ARCHIVE.....	28
5.11 1813 ESTATE MAP SHOWING THE EXTENT OF THE HAREWOOD PARKLAND.....	29
5.12 THOMAS GIRTIN, <i>HAREWOOD HOUSE FROM THE SOUTH-EAST</i> , 1801.....	30
5.13 1ST EDITION ORDNANCE SURVEY MAP, 1851 .....	30
5.14 J. M. W. TURNER, <i>HAREWOOD CASTLE FROM THE SOUTH EAST</i> , C. 1798. ....	31
5.15 1ST EDITION ORDNANCE SURVEY MAP, 1851 .....	31
5.16 ‘GARRETT’S DESIGN OF A GATE’ FOUND IN THE HAREWOOD ESTATE PAPERS .....	32
6.1 JOINERS WORKSHOP, STANK .....	32
6.2 SOUTH ELEVATION, JOINERS WORKSHOP .....	33
6.3 C.1698 HAREWOOD ESTATE MAP, STANK.....	33

6.4 GROUND FLOOR PLAN, JOINERS' WORKSHOP .....	34
6.5 SOUTH ELEVATION, JOINERS' WORKSHOP .....	34
6.6 WEST ELEVATION, JOINERS' WORKSHOP .....	35
6.7 TWO FORMS OF WINDOW INCLUDED ON THE SOUTH ELEVATION OF THE WORKSHOP .....	35
6.8 MAIN WORKSHOP ROOM, JOINERS' WORKSHOP .....	36
6.9 WALL NICHES IN THE EASTERN WALL OF THE MAIN WORKSHOP ROOM .....	36
6.9 OFFICE IN THE WEST OF THE WORKSHOP .....	37
7.1 STABLES FAMILY'S HOLDINGS NEAR STANK .....	37
7.2 MEASURED SURVEY, STABLES FARMHOUSE .....	38
7.3 REAR ELEVATION, STABLES FARMHOUSE .....	39
7.4 SANDYGATE FARM, KENT, CLARIDGE AND PEARCE, 1796 .....	39
7.5 PLAN OF STABLES FARM, 1979 .....	40
7.6 BARN, STABLES FARM .....	41
7.7 BLOCKED ARCHWAYS, STABLES FARM .....	41
7.8 STABLES, STABLES FARM .....	42
7.9 CELLAR, LOFTHOUSE GRANGE FARMHOUSE .....	42
8.1 WEST ELEVATION, ALL SAINTS' CHURCH, HAREWOOD .....	43
8.2 HAREWOOD ESTATE C. 1775 .....	43
8.3 MOVEMENTS OF SAMUEL POPPLEWELL .....	44
8.4 MOVEMENTS OF EDWIN LASCELLES .....	45
8.5 MOVEMENTS OF WILLIAM STABLES .....	46
8.7 GENERIC MOVEMENTS OF THE ESTATE JOINERS .....	47
8.7 THE PRINCIPAL AND BASEMENT FLOORS OF HAREWOOD HOUSE, AS PUBLISHED IN <i>VITRUVIUS BRITANNICUS</i> (1771) .....	48
8.8 GAMMA MAP, BASEMENT STOREY, HAREWOOD HOUSE .....	49
8.9 LAYOUT OF ALL SAINTS' CHURCH, HAREWOOD, C.1775 .....	50
8.10 THE NAVE OF ALL SAINT'S CHURCH, HAREWOOD .....	50

## APPENDICES

APPENDIX A: .....	51
HAREWOOD ESTATE SURVEYS .....	51
1738 ESTATE SURVEY (WYAS WYL/250/3/13B SURVEYS): TENANTS/SIZE OF FARMS	51
1758 ESTATE SURVEY (WYAS WYL/250/3/16 SURVEYS): TENANTS/SIZE OF FARMS	53
1796 ESTATE SURVEY (WYAS WYL/250/3/KENT, CLARIDGE & PEARCE SURVEYS):	
TENANTS/SIZE OF FARMS .....	55
APPENDIX B: .....	57
HAREWOOD ESTATE FARMSTEAD SURVEYS .....	57
<b>Farm Name &amp; Situation:</b> Carr House Farm .....	58
<b>Farm Name &amp; Situation:</b> Harewood Mill Farm .....	61
<b>Farm Name &amp; Situation:</b> High Lofthouse Farm .....	65
<b>Farm Name &amp; Situation:</b> Hollin Hall .....	68
<b>Farm Name &amp; Situation:</b> Lofthouse Grange Farm .....	72
<b>Farm Name &amp; Situation:</b> New Laithe Farm .....	75
<b>Farm Name &amp; Situation:</b> Stables Farm .....	79
<b>Farm Name &amp; Situation:</b> Stockton Farm .....	83
<b>Farm Name &amp; Situation:</b> Stockton Grange Farm .....	86
APPENDIX C: .....	89
BUILDING MATERIALS, ARCHITECTURAL FORM AND ORNAMENT OF FARMHOUSES AND BARNs,	
HAREWOOD ESTATE, 1700-1850 .....	89

---

APPENDIX D:.....	92
HAREWOOD ESTATE CASHBOOKS ACCOUNTS , 1764-1810 .....	92

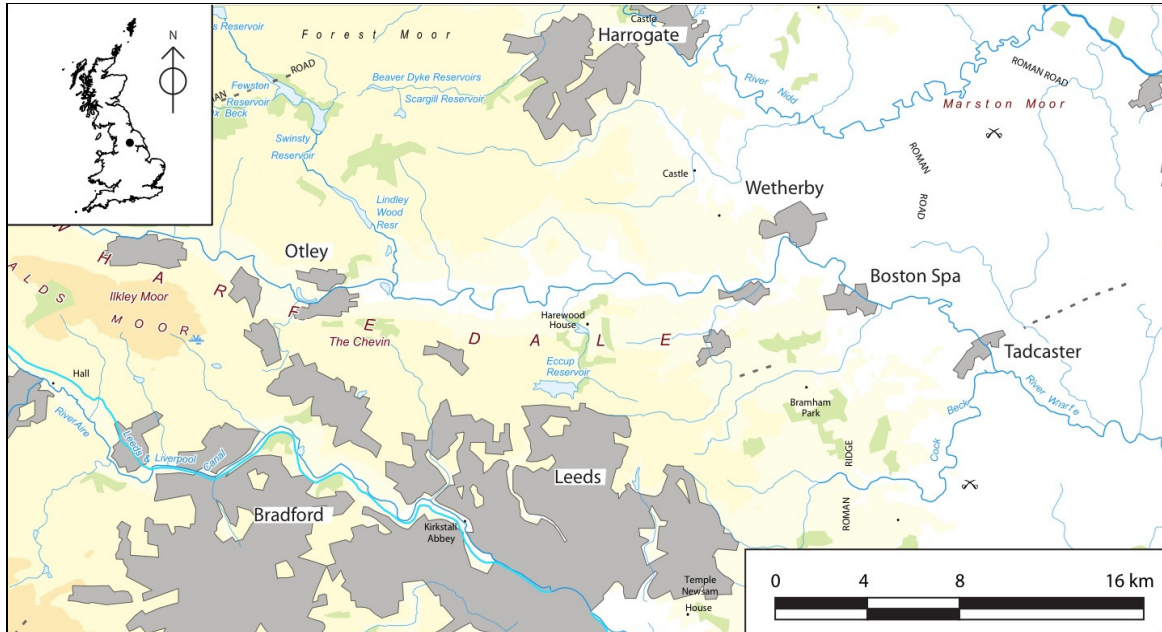

1.1 Location map of the Harewood Estate in relation neighbouring settlements and cities. Harrogate and Leeds lie to the north and south of Harewood respectively, while Tadcaster and Otley are either side. The land to east is lower lying and forms part of the Magnesium Limestone Belt. Closer to Leeds, the underlying geology becomes coalfields while the undulating landscape near Harewood is largely derived from the Millstone Grit (Crown Copyright/database Right 2009. An Ordnance Survey/EDINA supplied service).

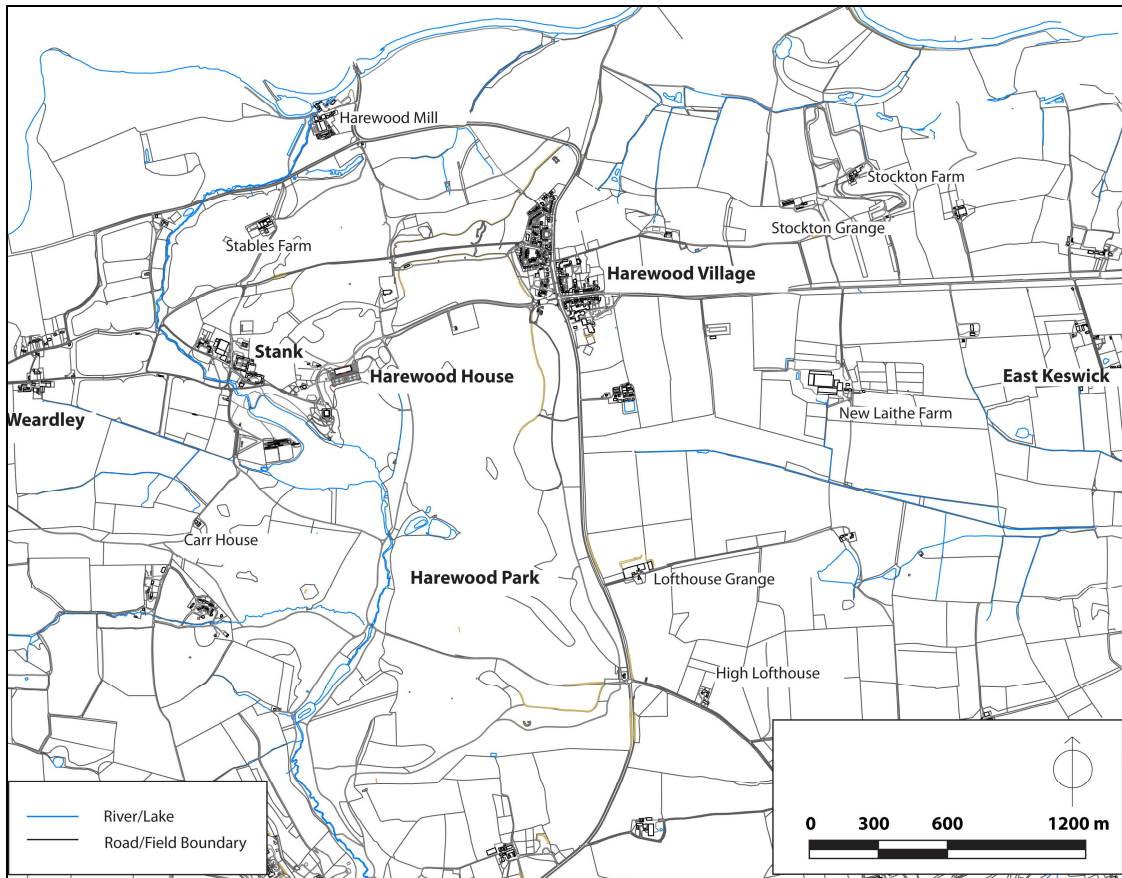

1.2 Map of the modern Harewood Estate highlighting the key places within the local landscape. Surveys have been carried out as a part of this research at each of the farmsteads, while the parkland has been the subject of topographic and geophysical survey. The Hollin Hall Plateau lies to the south of New Laithe Farm, while North Park is located to the southeast of Stables Farm (Crown Copyright/database Right 2009. An Ordnance Survey/EDINA supplied service)

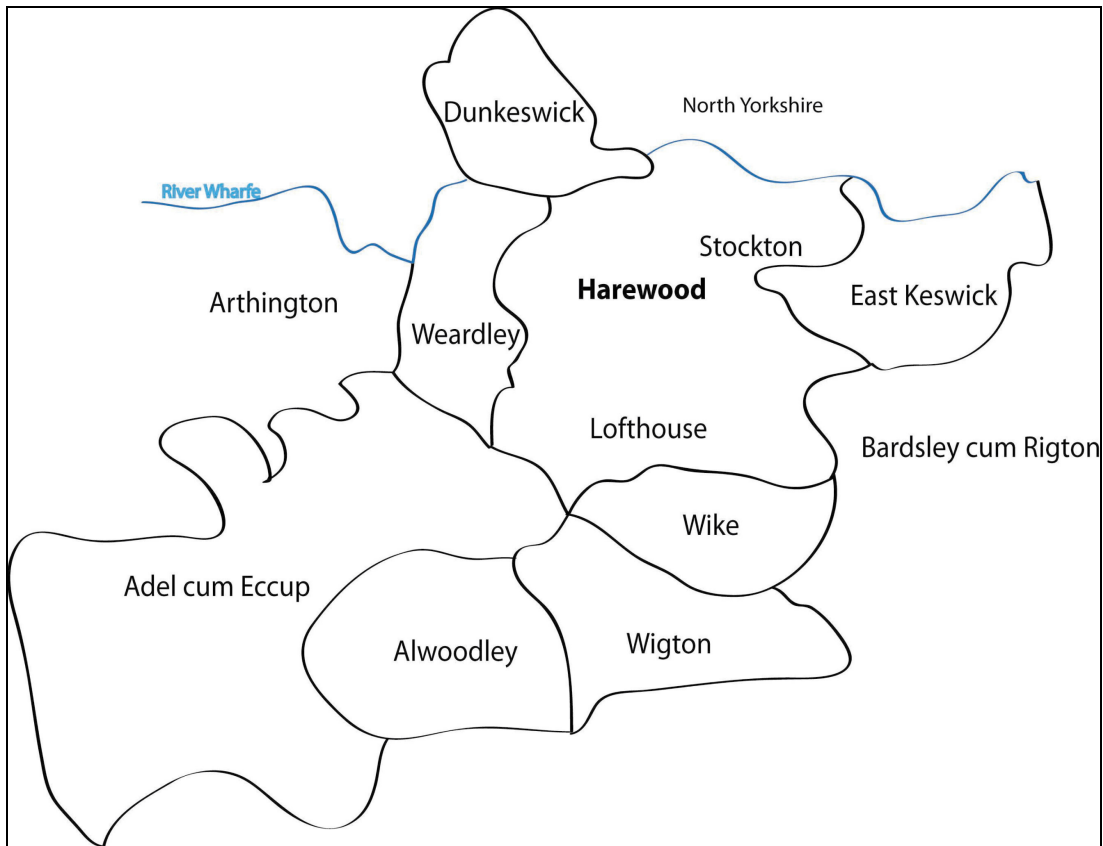

3.1 Scheme map of the medieval townships surrounding Harewood. The township boundaries noted in the image are modern, however these have been subject to change, hence the fluid nature of the drawing.

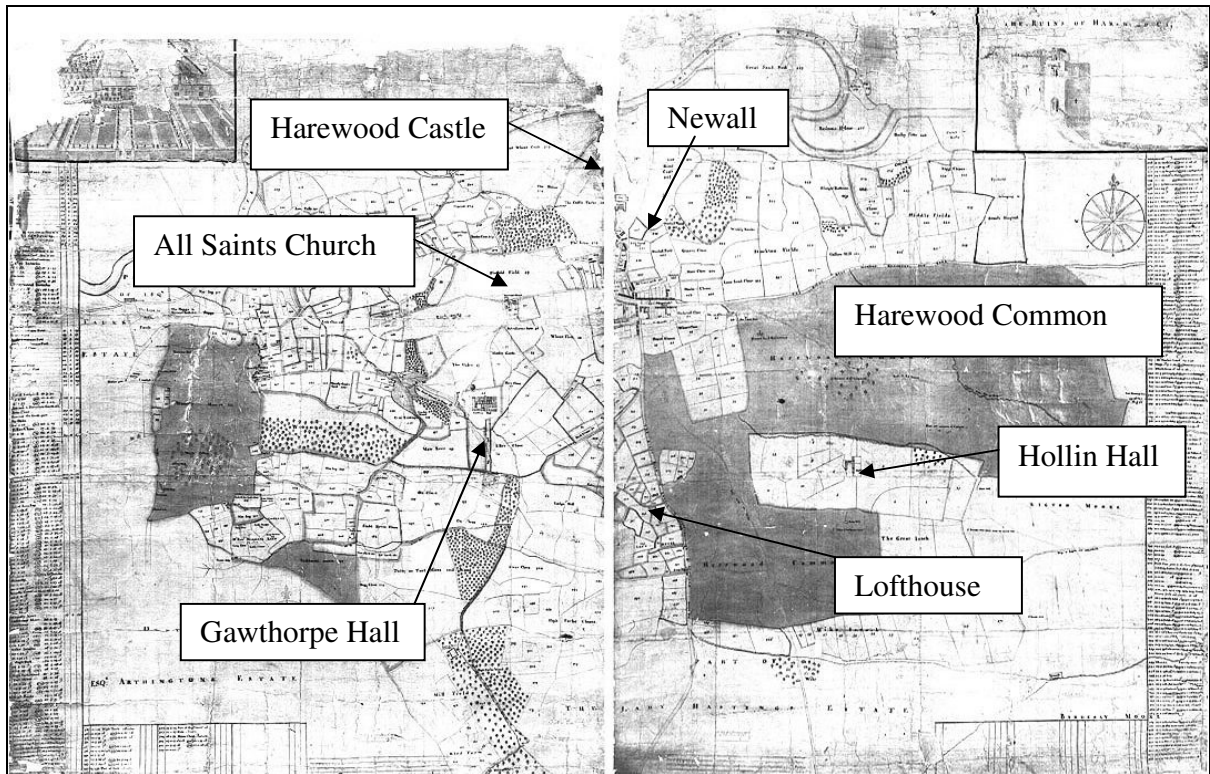

3.2 1698 Estate Map showing Harewood Common in the east of the image, Gawthorpe Hall at the centre, and the different areas of agriculture (WYAS WYL/250/3/33 Estate Maps). (Reproduced by the kind permission of the Earl and Countess of Harewood and Trustees of the Harewood House Trust)

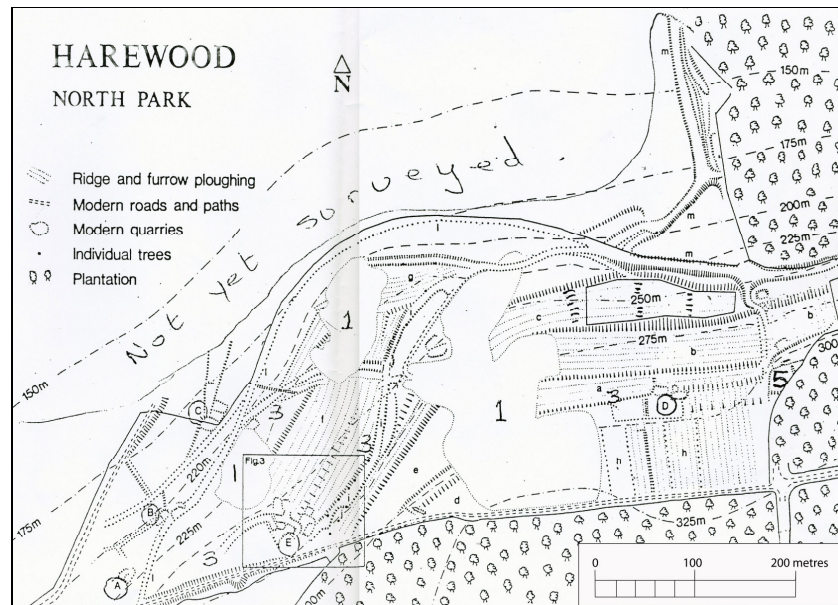

3.3 Field Survey of the North Park undertaken by Steve Moorhouse (1985) indicating medieval field systems in the form of ridge and furrow and lynchets.





3.4 The south-facing view from the terrace of Harewood House showing the site of Gawthorpe Hall. The hall is likely to have been situated in the plateau indicated by the area cast in shadow. On the horizon are the Sugar Hills, while the adjacent parkland was mainly laid out in the late-eighteenth century.

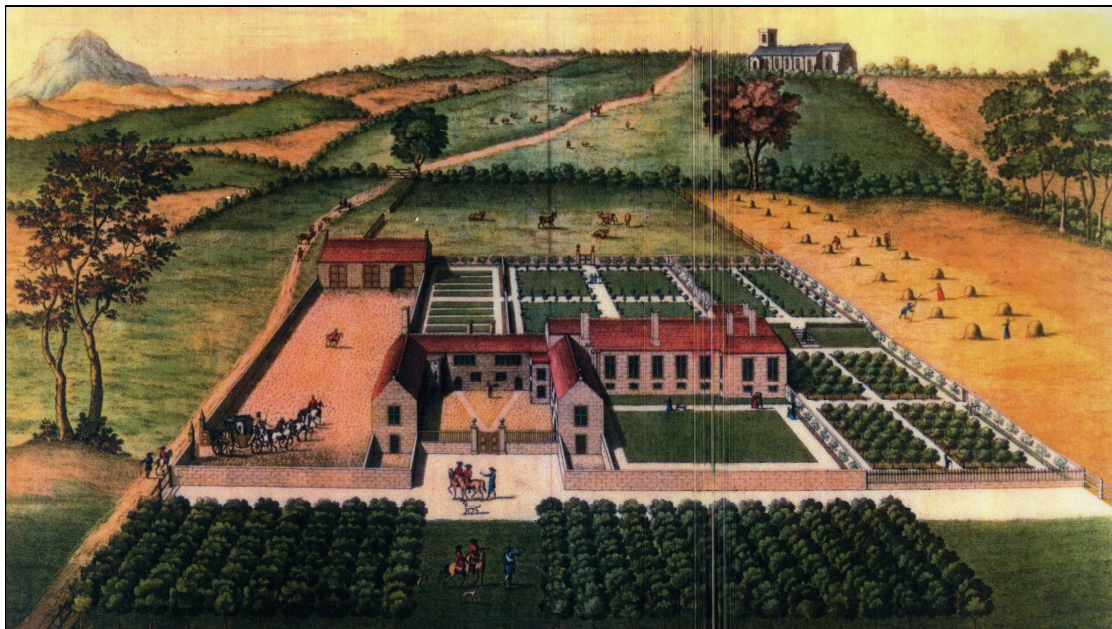

3.5 Gawthorpe Hall from the south by Anthony Van der Hagen (1727)



3.6 Aerial photograph of Lofthouse showing the post-medieval ridge and furrow, as well as the area cleared for the 1970s pipeline. The wallside plantation is visible in the right of the photograph. 21<sup>st</sup> October 1983 (WY114-16, WYHER 44.34.23.33)

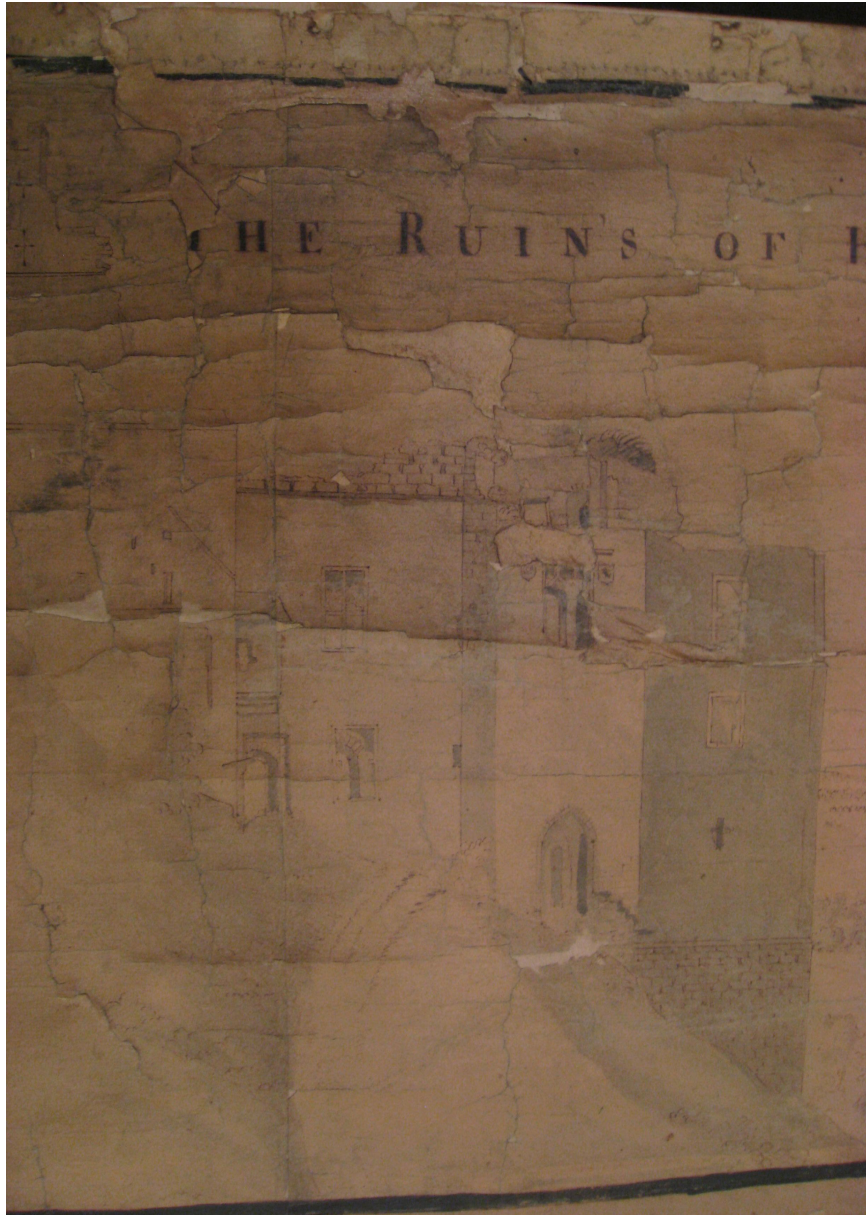

3.7 Sketch of Harewood Castle on the 1698 estate map illustrating the ruins and the Wharfe Valley to the far right of the image (WYAS WYL/250/3/33 Estate Maps).

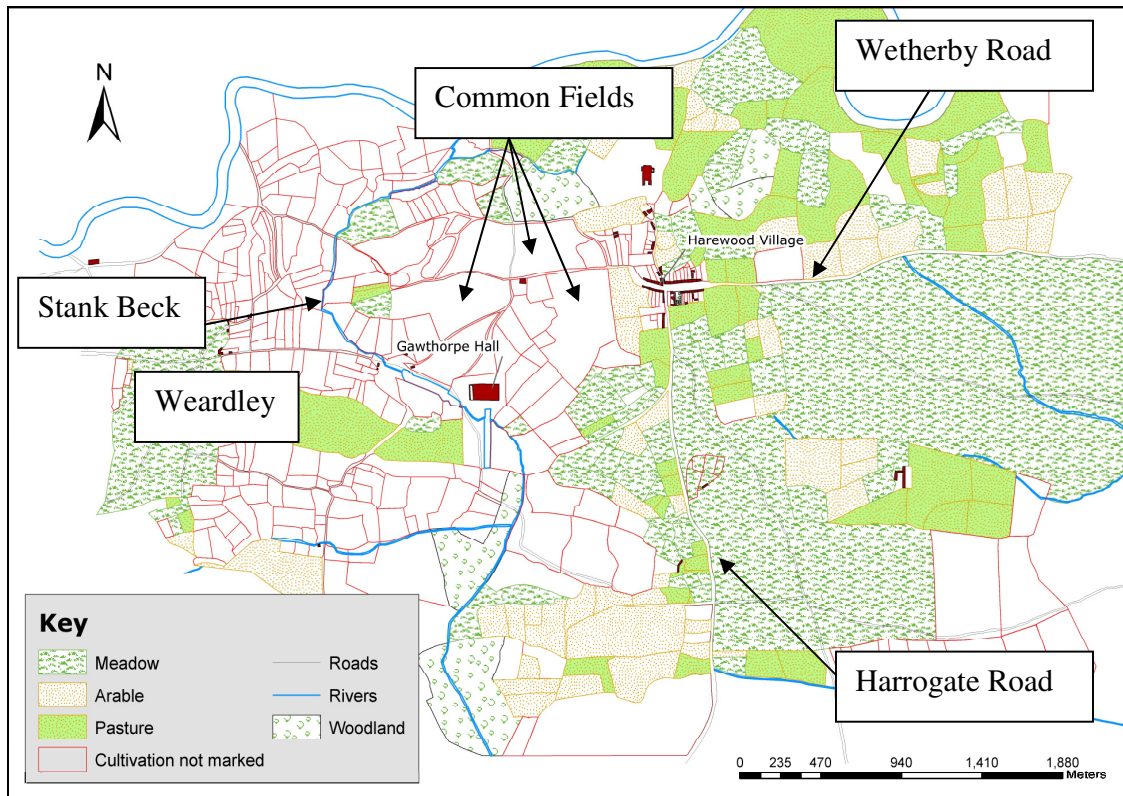

3.8 Digitised copy of the 1698 estate map showing the cultivation patterns in 1738, as well as the position of the common fields (Pinfold Field, Wheat Field, & Little Field).



3.9 Tenancy patterns of 1738 showing how the Pike family's holdings (in grey) were spread across the estate close to Harewood village, near the church, adjacent to Weardley and in the east near East Keswick.

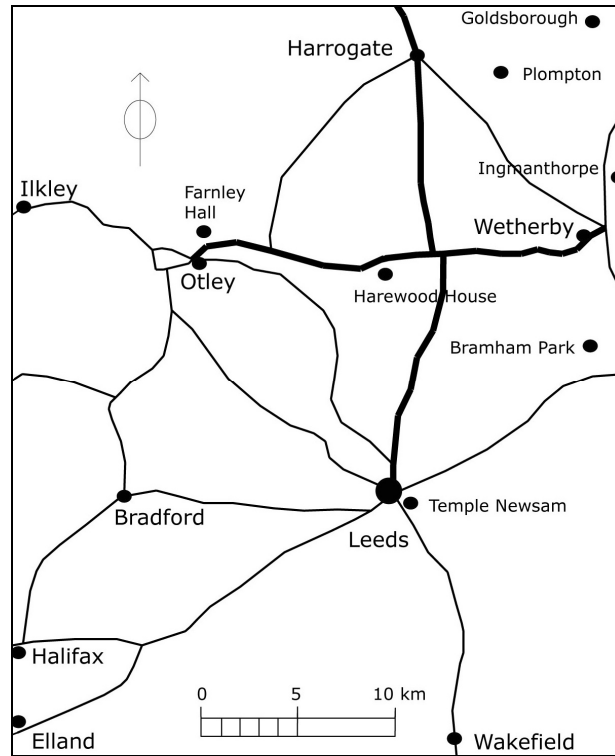

4.1 The main travel routes near Harewood House accompanied by local towns, cities and a selection of the main country houses in the West Yorkshire. The thicker lines denote the turnpike roads between Leeds and Harrogate, and Otley and Tadcaster.



4.2 The classically designed stables at Harewood built between 1755-59.



4.3 The northern façade of Harewood House designed by John Carr of York. Carr's central nine-bay section includes giant Corinthian pilasters supporting a pediment incised with the Lascelles' coat of arms.

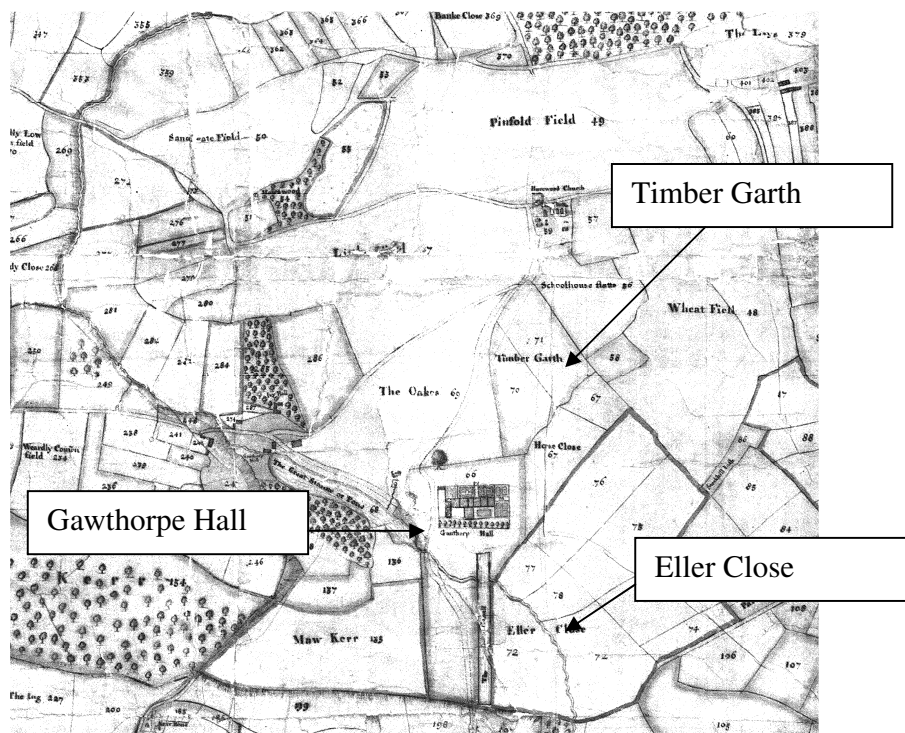

4.4 The 1698 estate map showing where the main areas of landscape development took place from the late-1750s. (Reproduced by the kind permission of the Earl and Countess of Harewood and Trustees of the Harewood House Trust)

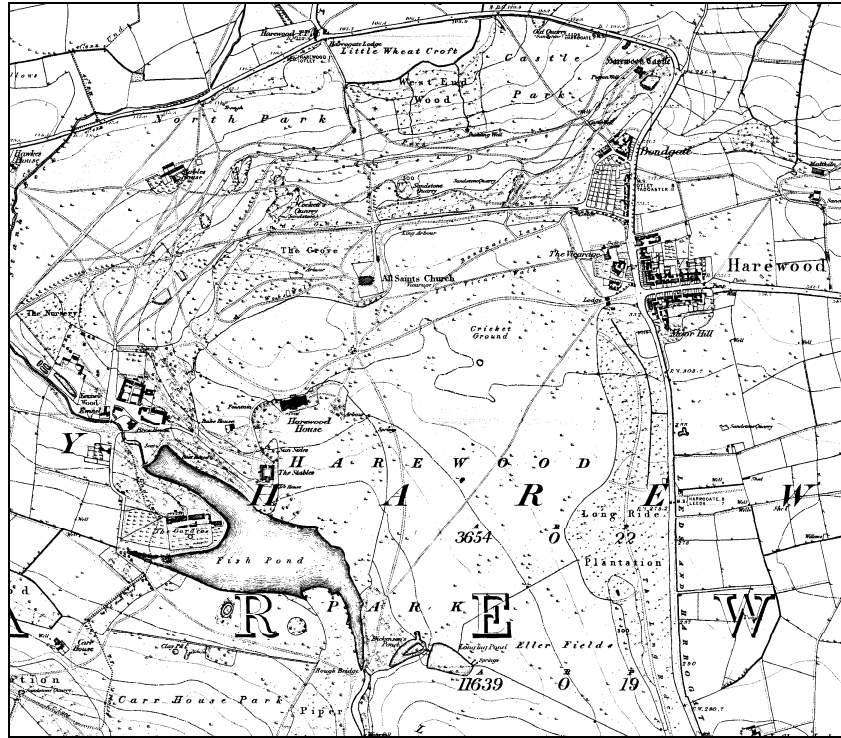

4.5 The 1st Edition Ordnance Survey (1851) illustrating the extent of the designed landscape by the mid-nineteenth century. The kitchen gardens were located to the west of the 'Fish Pond' close to the service buildings in Stank and the main house. (Crown Copyright/database Right 2009. An Ordnance Survey/EDINA supplied service)



4.6 The seventeenth-century 'Cottage-in-the-Walls' located on Harrogate Road.

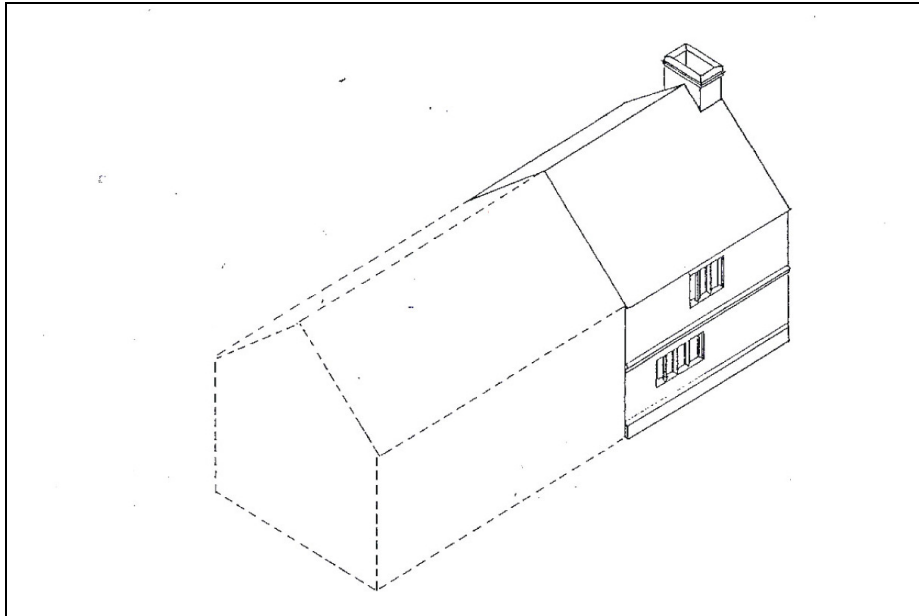

4.7 The likely arrangement of the original 'Cottage-in-the-Walls' and its likely position within an eighteenth-century terrace (Ward 1998).



4.8 The Avenue, Harewood, showing the ribbon factory part of the new village designed by John Carr of York.





4.9 The Harewood Estate c. 1781. By the mid-1760s much of Harewood Common had been enclosed leading to several new farms in the area. By this period the main approach from Harewood village to Harewood House was via Robert Adam's Lodge. Additionally, the designed landscape and parkland had been extended to the south of the new house.



4.10 Part of the western elevation of the barn at Hollin Hall. The rest of the elevation shows signs of rebuilding, raising of the roofline with insertion and filling of doorways.

ARBOUR HILL FARM (LOT 77).

**LOT 77.**  
(Coloured Pink on Plan No. 1).

**A Well-placed Mixed Stock Raising Farm**

situated in the Parish of Hornby, and known as

**Arbour Hill Farm**

**THE HOUSE,**  
which is constructed of stone with tiled roof, enjoys an exceptionally fine position, situated as it is on an eminence overlooking Hornby Castle with its Park-like Meadows in front, nicely studded with Trees.

The accommodation comprises:—  
ENTRANCE HALL, SITTING ROOM with Fireplace and window overlooking the Castle, DINING ROOM with Fireplace, KITCHEN with Range, back KITCHEN with Copper, Fireplace and Glazed Sink with soft water laid on. Upstairs are 3 LARGE BEDROOMS and one BEDROOM on the second floor, situated over the Kitchen and with a separate staircase are 2 MEN'S ROOMS. Outside are Coal House and E.C.

**THE LAND,**  
which is for the most part good GRAZING PASTURE, extends to an area of about

**230a. 3r. 1p.**

as shown in the following:—

SCHEDULE.

No. on Plan.	Description.	Ordnance Area.
<b>Hornby Parish.</b>		
7	Arable ... ..	18-024
8	Grass ... ..	3-372
9	Roadway ... ..	4-01
10	Arable ... ..	15-570
11	Do. ... ..	9-548
19	Grass ... ..	17-314
20	Honestead ... ..	4-06
20a	Orchard ... ..	6-59
21	Grass ... ..	5-319
22	Woodland ... ..	33-731
24	Grass (Parkland) ... ..	40-057
35	Do. do. ... ..	22-772
36	Do. do. ... ..	12-683
38	Grass ... ..	7-033
41	Renforth Oak ... ..	4-585
42	Arable ... ..	9-651
43	Do. ... ..	21-583
<b>Patrick Brompton Parish.</b>		
Pt. 127	Roadway ... .. (est.)	7-47
Total Acres (est.)		230-755

51

4.11 1930s sales particulars for Arbour Hill Farm, Hornby Castle Estate, North Yorkshire. The farm was built in a similar style and design as High Lofthouse by John Carr of York (NMR EST01/SC01305).

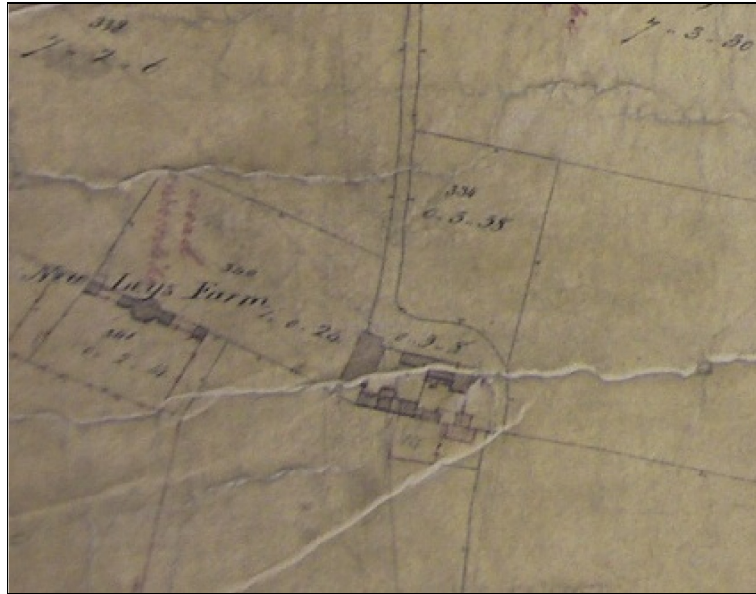

4.12 The model farmhouse at New Lays Farm with central section flanked by pavilions, located to the west of the farmstead. The image is a section of the 1813 Harewood Estate map (WYAS WYL 250/3/49 estate maps). (Reproduced by the kind permission of the Earl and Countess of Harewood and Trustees of the Harewood House Trust)

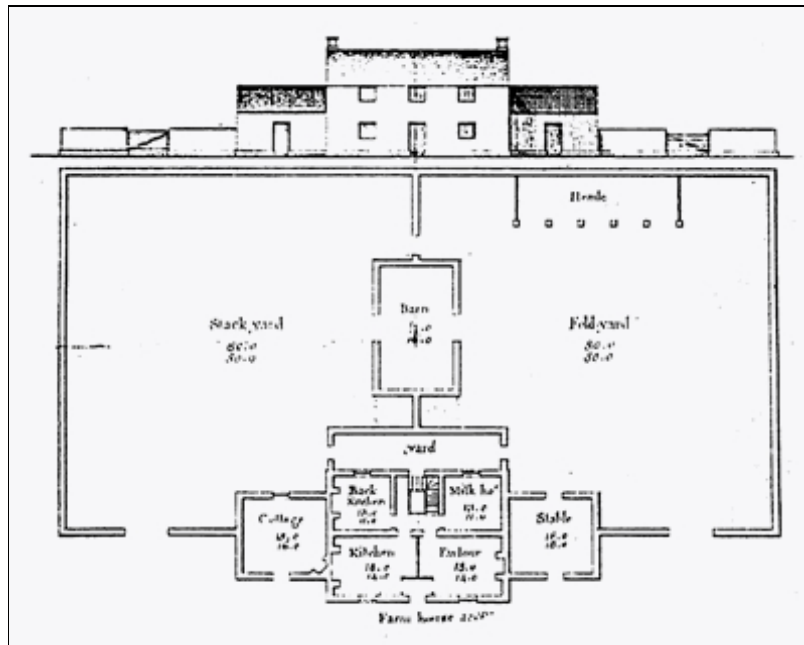

4.13 Design for Fairley Farm, Cambo by Daniel Garrett 1764 (© The National Trust)



4.14 Front elevation of Stockton Grange farmhouse. The awkward proportions of the elevation may suggest that local craftsmen were only beginning to work with classical designs when the building was constructed in the 1760s.



4.15 The west elevation of Carr House, one of the few farmhouses on the Harewood Estate of the period 1755-71 where mullioned windows continued to be used.



4.16 The east elevation of the barn at Stockton Farm showing entrances to mistalls at one end of the building. Multiple entrances and their fills suggest that the building was altered to accommodate new practices and agricultural methods.



4.17 False voussoirs in the lintels of the stables at Lofthouse Grange Farm. This arrangement did not become a part of the local vernacular architecture until the final quarter of the eighteenth century.



4.18 Cyma-recta mouldings on the moulded kneelers at Stables Farm. This type is also found at Stables House and the accompanying barn.

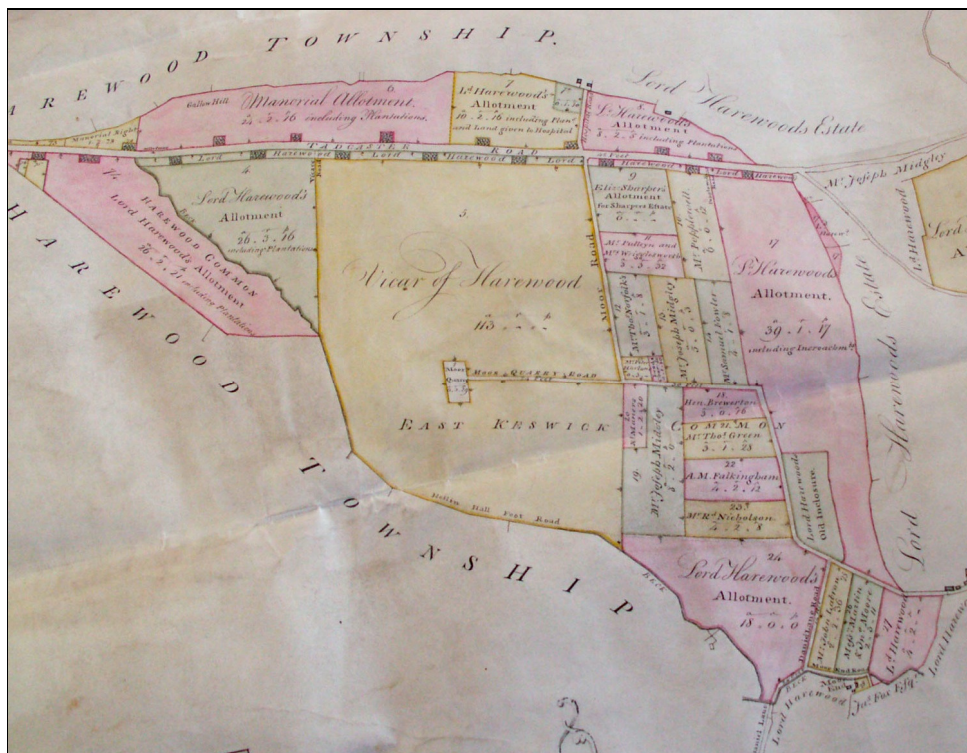

5.1 The East Keswick enclosure map drawn by Jonathan Teal (1801). East Keswick Common is represented as a coloured block bounded by the Harewood township to the north and west, Keswick Beck to the south and Lord Harewood's estate to the east. (WYAS WYL 779). (Reproduced by the kind permission of the Earl and Countess of Harewood and Trustees of the Harewood House Trust).



5.2 The planned allotments marked in red at Bondgate in the north of Harewood village (1813). The red ink indicates planned alterations to the Harewood Estate in c. 1814. (WYAS WYL 250/3/49 Estate Maps). (WYAS WYL 250/3/49 estate maps). (Reproduced by the kind permission of the Earl and Countess of Harewood and Trustees of the Harewood House Trust)

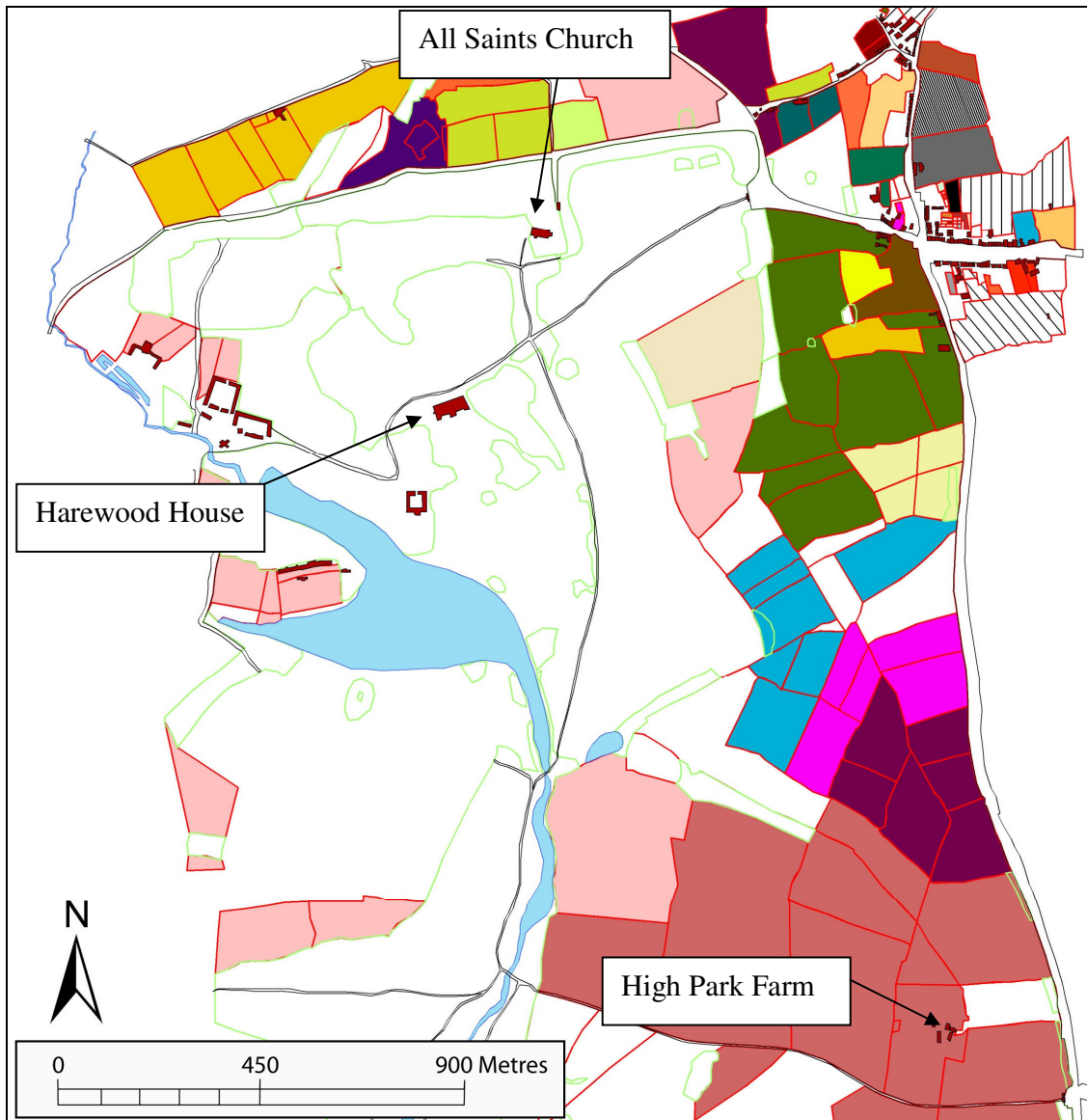

5.3 Digitised image of the 1796 Estate map (WYAS WYL 250/3/44 Estate Maps).showing the organisation of fields according to tenant. Each colour denotes a different farm in the area west of the Leeds to Harrogate Road.



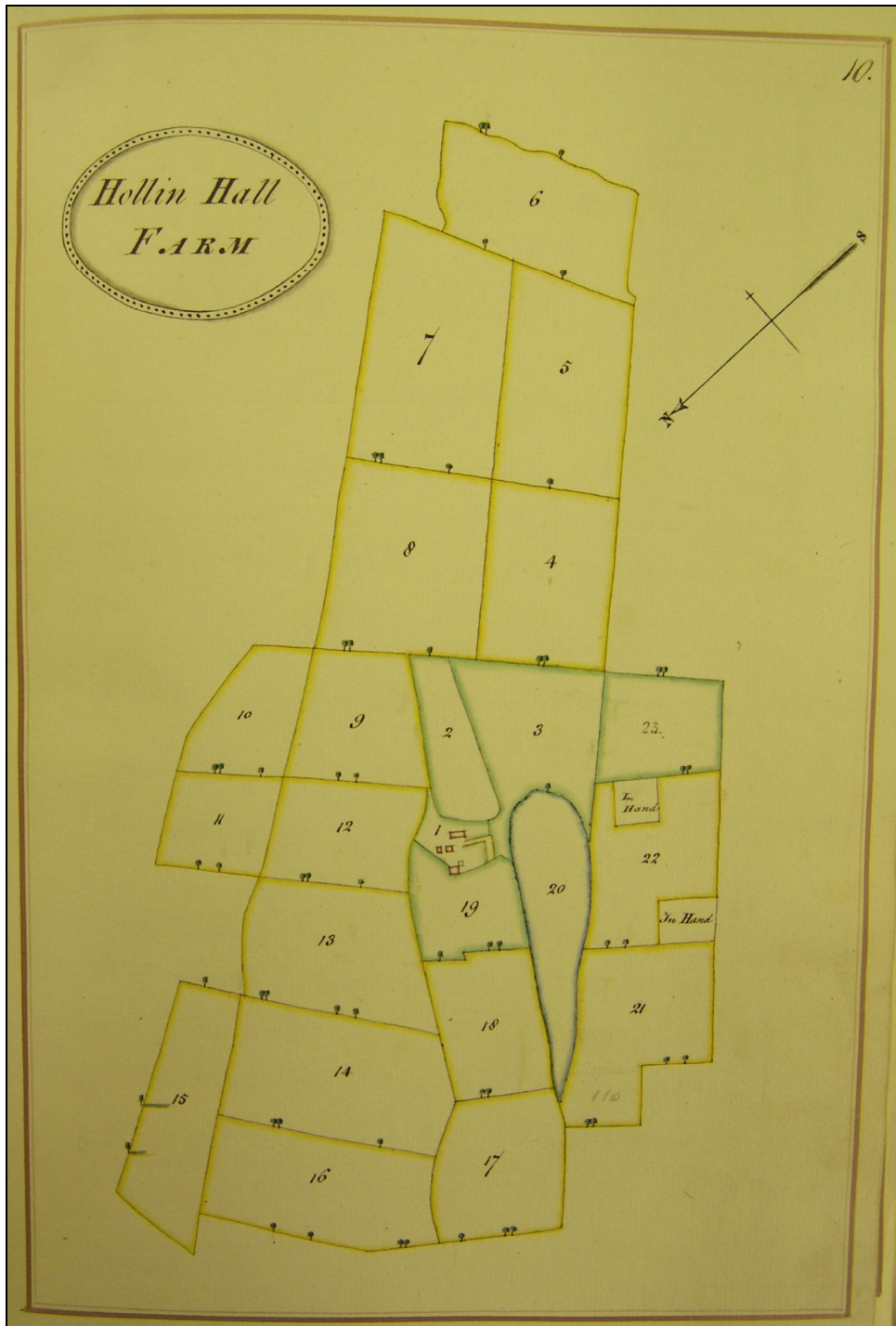

5.4 Photograph of Hollin Hall Farm plan drawn up as a part of the Kent, Claridge and Pearce Survey. Three volumes detail the Lascelles holdings in 1796 in the West and North Ridings. (Reproduced by the kind permission of the Earl and Countess of Harewood and Trustees of the Harewood House Trust)



5.5 Harewood Mill, rebuilt in the 1780s by John Muschamp at a cost of nearly £250.



5.6 The western elevation of the barn at Stables Farm. To the right of the image a wall bracket is visible and is likely to be evidence of a granary. The bracket would have been used to hoist grain to the first floor.



5.7 The reused barn at Lofthouse Grange that was altered during the eighteenth century. In the left of the image are insertions for nineteenth-century machinery showing that the building has been subjected to several building phases.



5.8 An image of the stairs leading to the first floor of the stables and cowhouses at Stockton Farm. The window on the left contains a lintel carved with false voussoirs. This became the common window arrangement in farm buildings in the late-eighteenth century.



5.9 A simplified kneeler at Stockton Farm dating to the late-eighteenth century. The moulding had simplified considerably from the cyma-recta found at Stables Farm built in the 1760s.

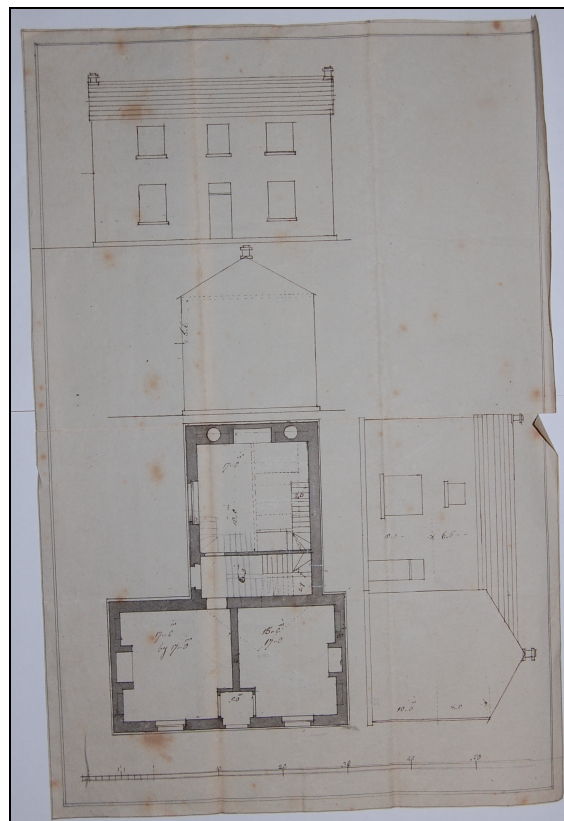

5.10 A design for a 'T'-shaped farmhouse in the Harewood Estate archive. This design was a prominent feature of early-nineteenth century farmhouses in Harewood. (Reproduced by the kind permission of the Earl and Countess of Harewood and Trustees of the Harewood House Trust)

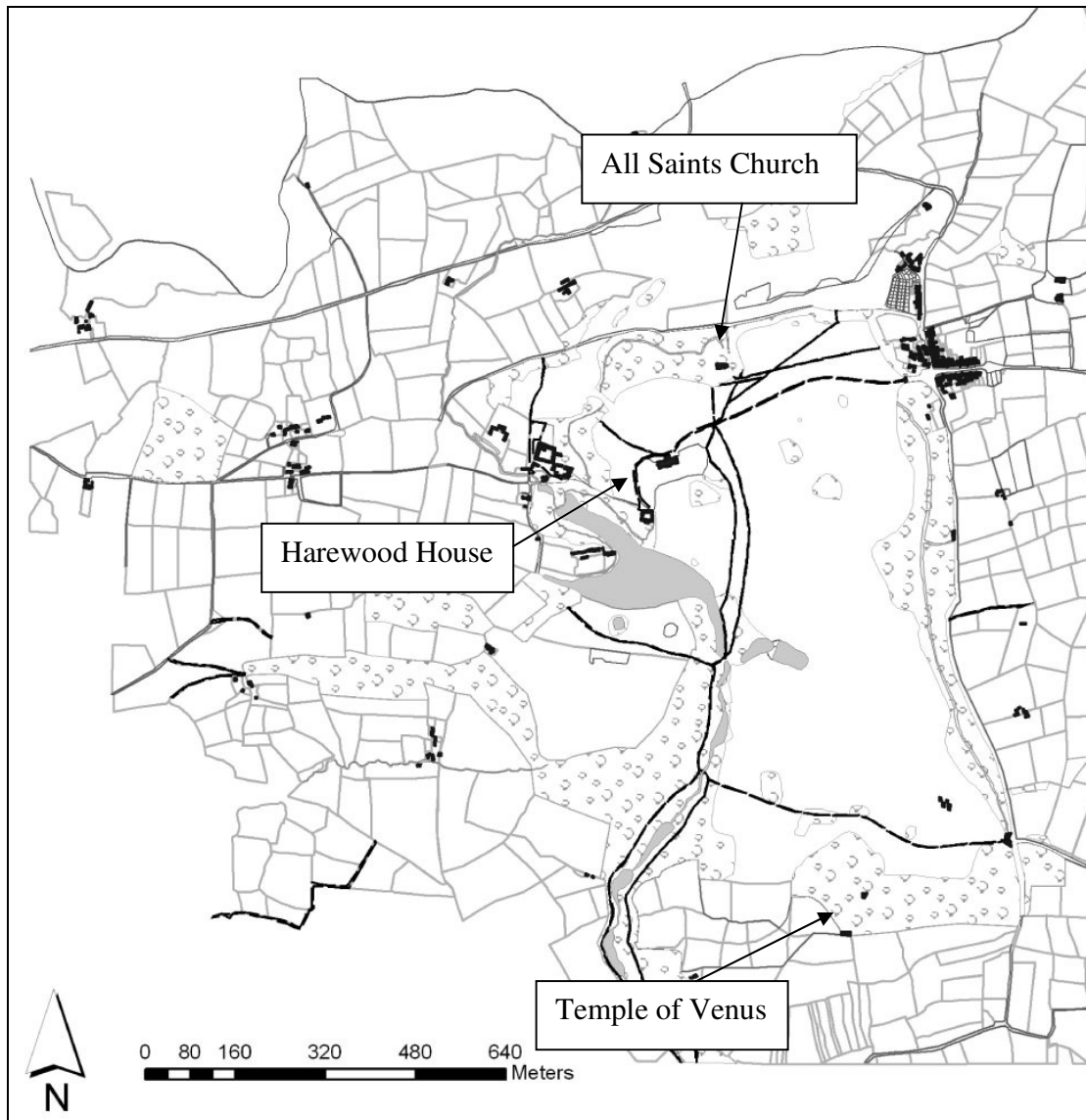

5.11 Digitised image of the 1813 estate map showing the extent of the Harewood parkland towards Lofthouse. (Reproduced by the kind permission of the Earl and Countess of Harewood and Trustees of the Harewood House Trust)



5.12 Thomas Girtin, Harewood House from the South-East, 1801 (Reproduced by the kind permission of the Earl and Countess of Harewood and Trustees of the Harewood House Trust)

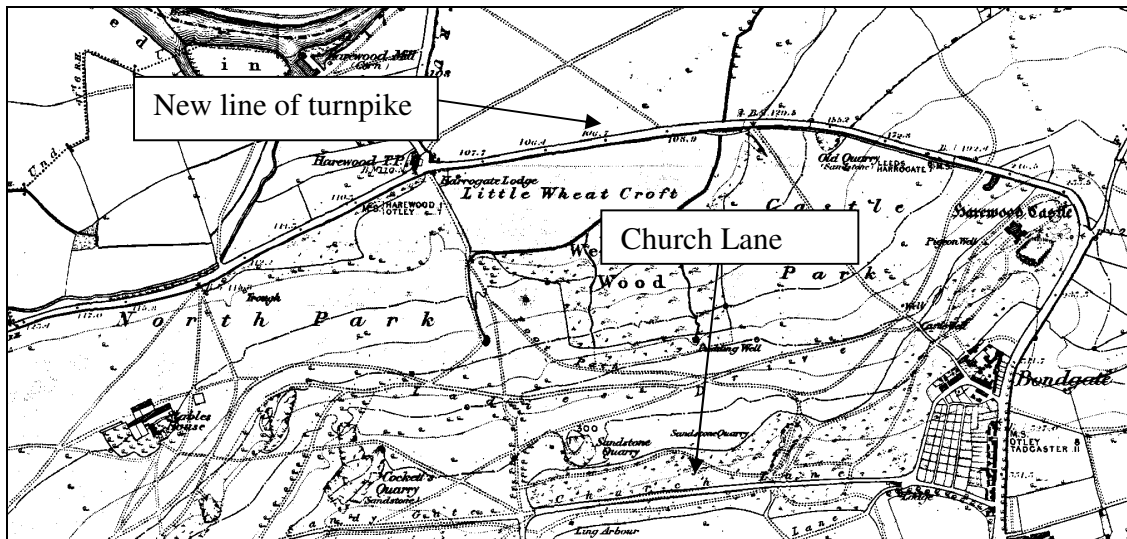

5.13 The 1st Edition Ordnance Survey Map showing the rerouting of the Otley-Tadcaster turnpike away from Church Lane and around Harewood Castle.



5.14 J. M. W. Turner, Harewood Castle from the South East, c. 1798. The livestock in the middle distance reveal that the land surrounding the castle may have been used for pasture, and in turn, as a part of Samuel Popplewell's (jnr) farm. (Reproduced by the kind permission of the Earl and Countess of Harewood and Trustees of the Harewood House Trust)

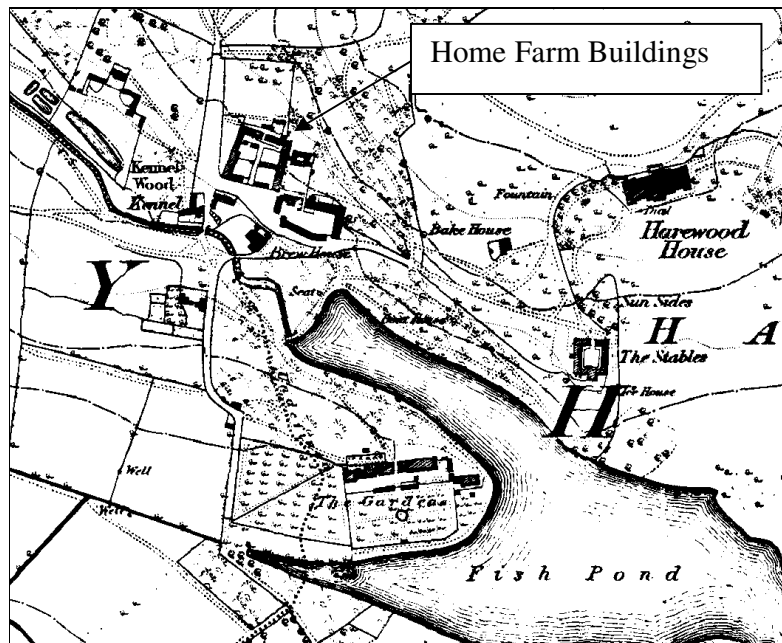

5.15 1st Edition Ordnance Survey Map showing the extent of the main service buildings close to Harewood House. The Home Farm is located among the estate offices and workshops.

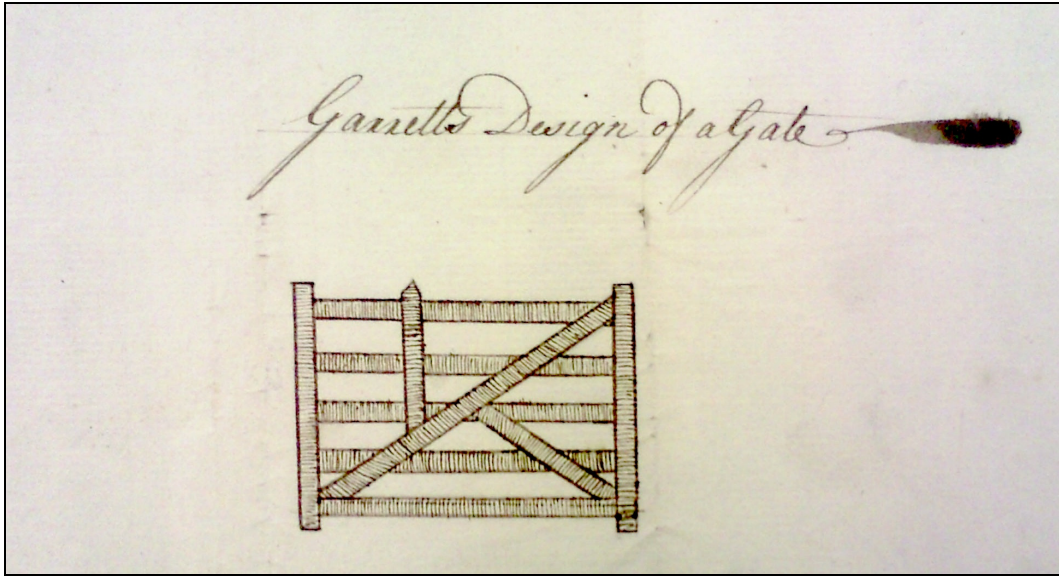

5.16 'Garrett's design of a gate' found in the Harewood Estate papers and taken from Daniel Garrett's *Designs of Farmhouses* (1747). (Reproduced by the kind permission of the Earl and Countess of Harewood and Trustees of the Harewood House Trust)

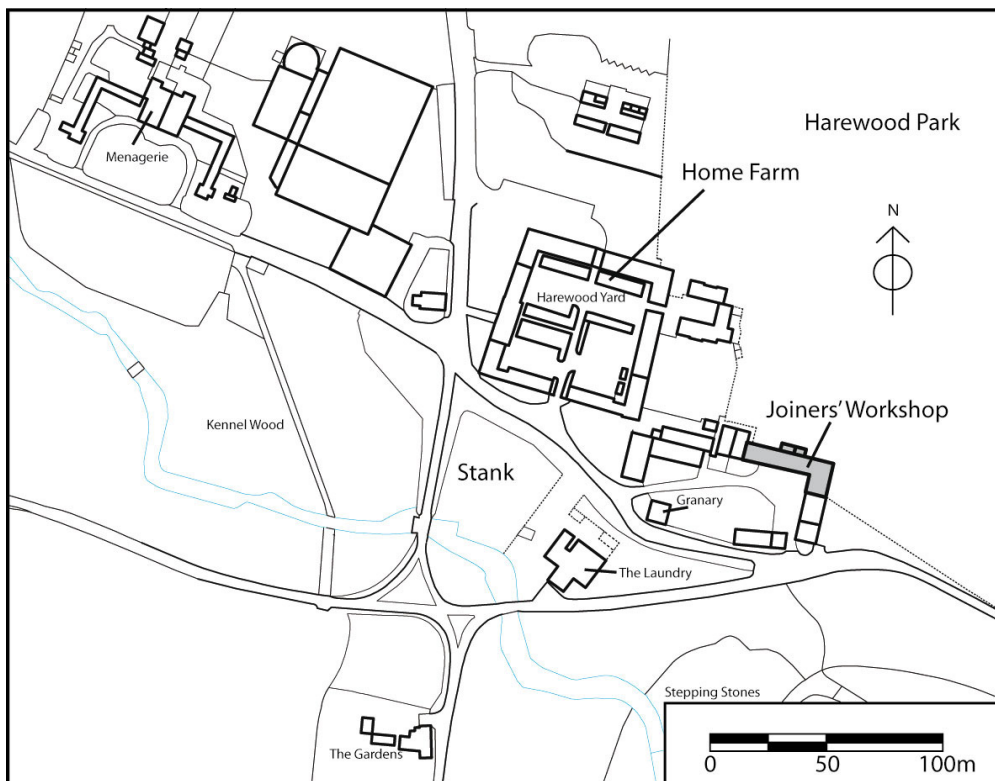

6.1 The Joiners Workshop in Stank (Crown Copyright/database right 2009. An Ordnance Survey/EDINA supplied service)





6.2 South Elevation of the Joiners Workshop (Lane 2008, reproduced courtesy of Scott Wilson Ltd)

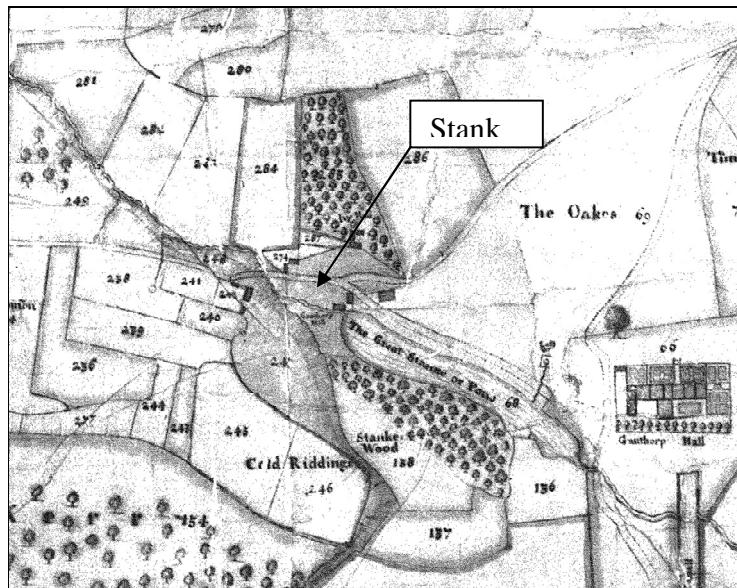

6.3 c.1698 Harewood Estate Map showing Stank, the hamlet to the north-west of 'The Great Stanke', developed in the 18<sup>th</sup> century into the estate yard (Reproduced by the kind permission of the Earl and Countess of Harewood and Trustees of the Harewood House Trust)

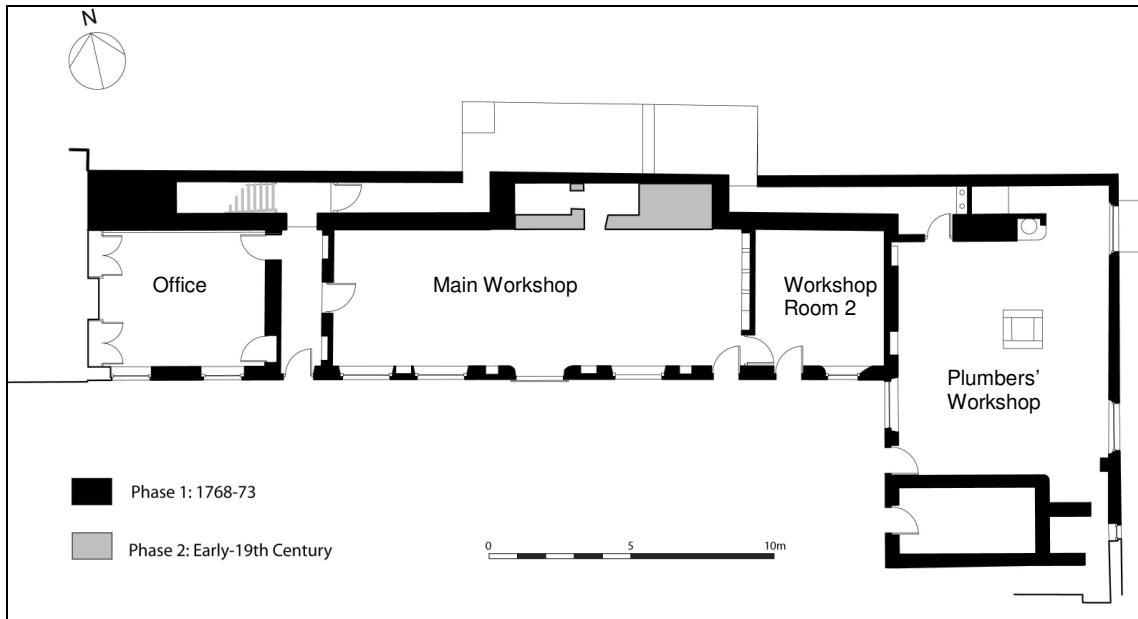

6.4 Ground Floor Plan, Joiners' Workshop (after Lane 2008, reproduced courtesy of Scott Wilson Ltd)

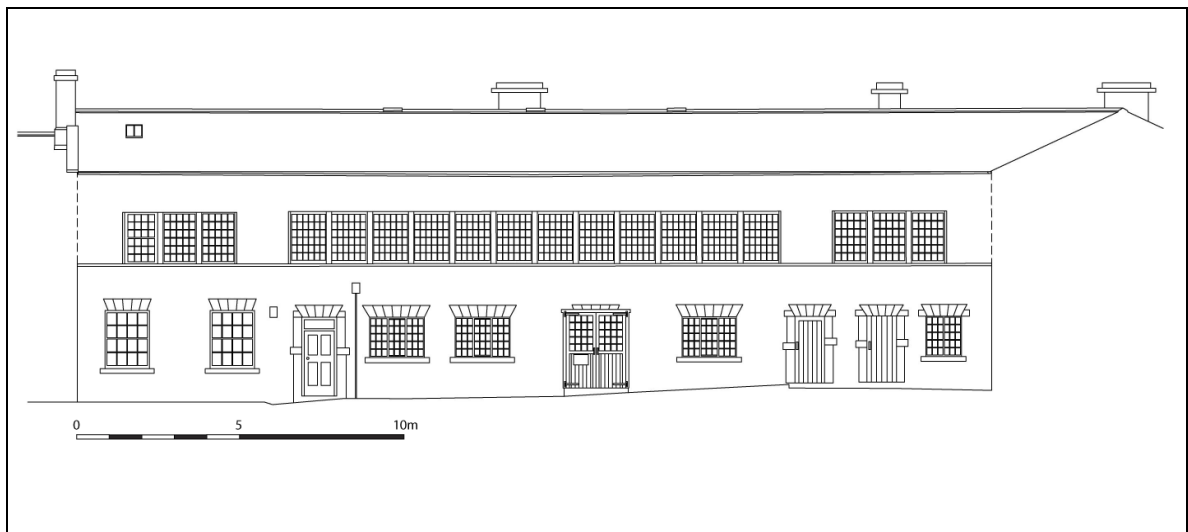

6.5 South Elevation, Joiners' Workshop (after Lane 2008, reproduced courtesy of Scott Wilson Ltd)

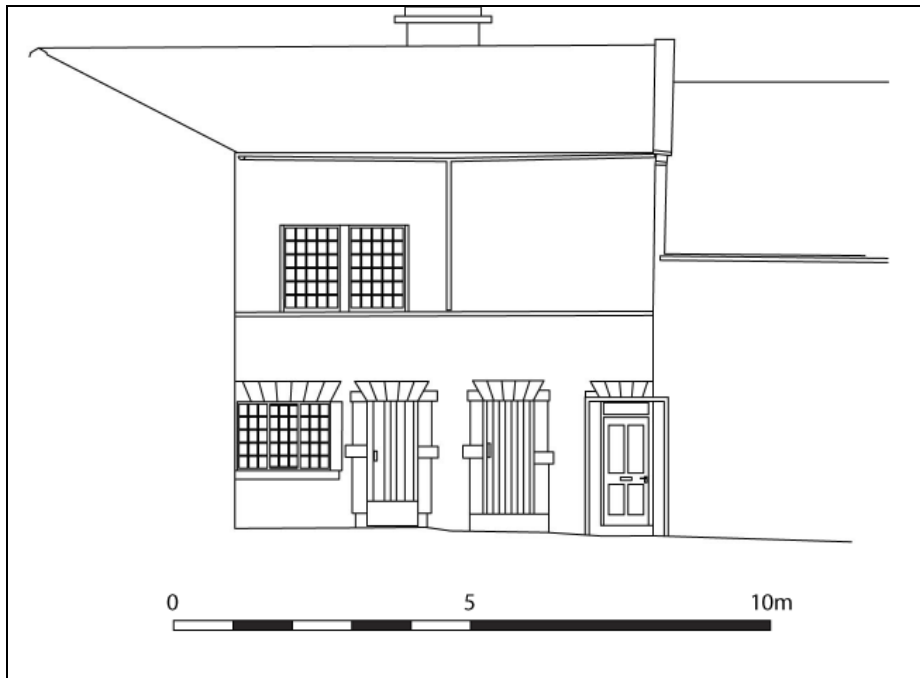

6.6 West Elevation, Joiners' Workshop (after Lane 2008, reproduced courtesy of Scott Wilson Ltd)

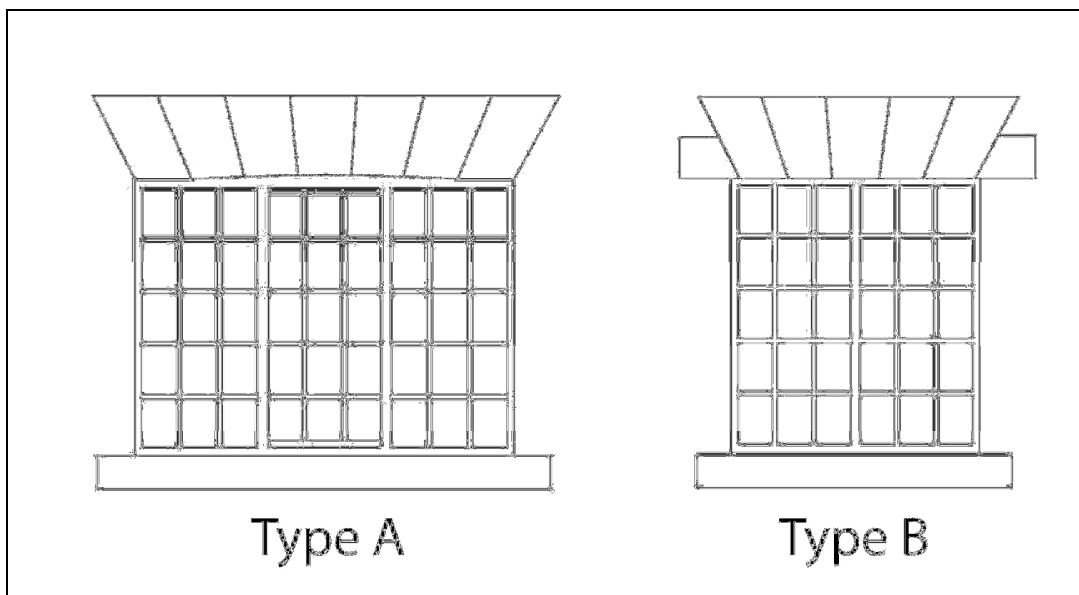

6.7 Two forms of window included on the south elevation of the workshop. Type A: Yorkshire sliding sash; Type B: casement window.



6.8 Main workshop room, Joiners' Workshop (Lane 2008, reproduced courtesy of Scott Wilson Ltd)



6.9 Wall niches in the eastern wall of the main workshop room (Lane 2008, reproduced courtesy of Scott Wilson Ltd)



6.9 Office in the west of the workshop, facing south. It is unlikely that the desk is original (Lane 2008, reproduced courtesy of Scott Wilson Ltd)

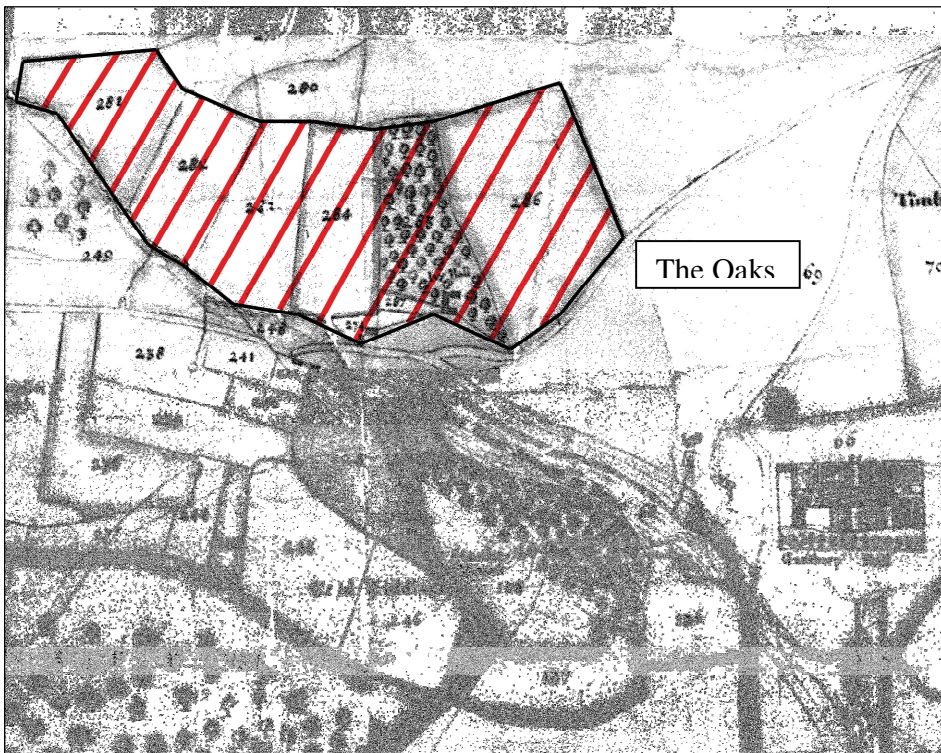

7.1 The Stables family's land holdings near Stank.

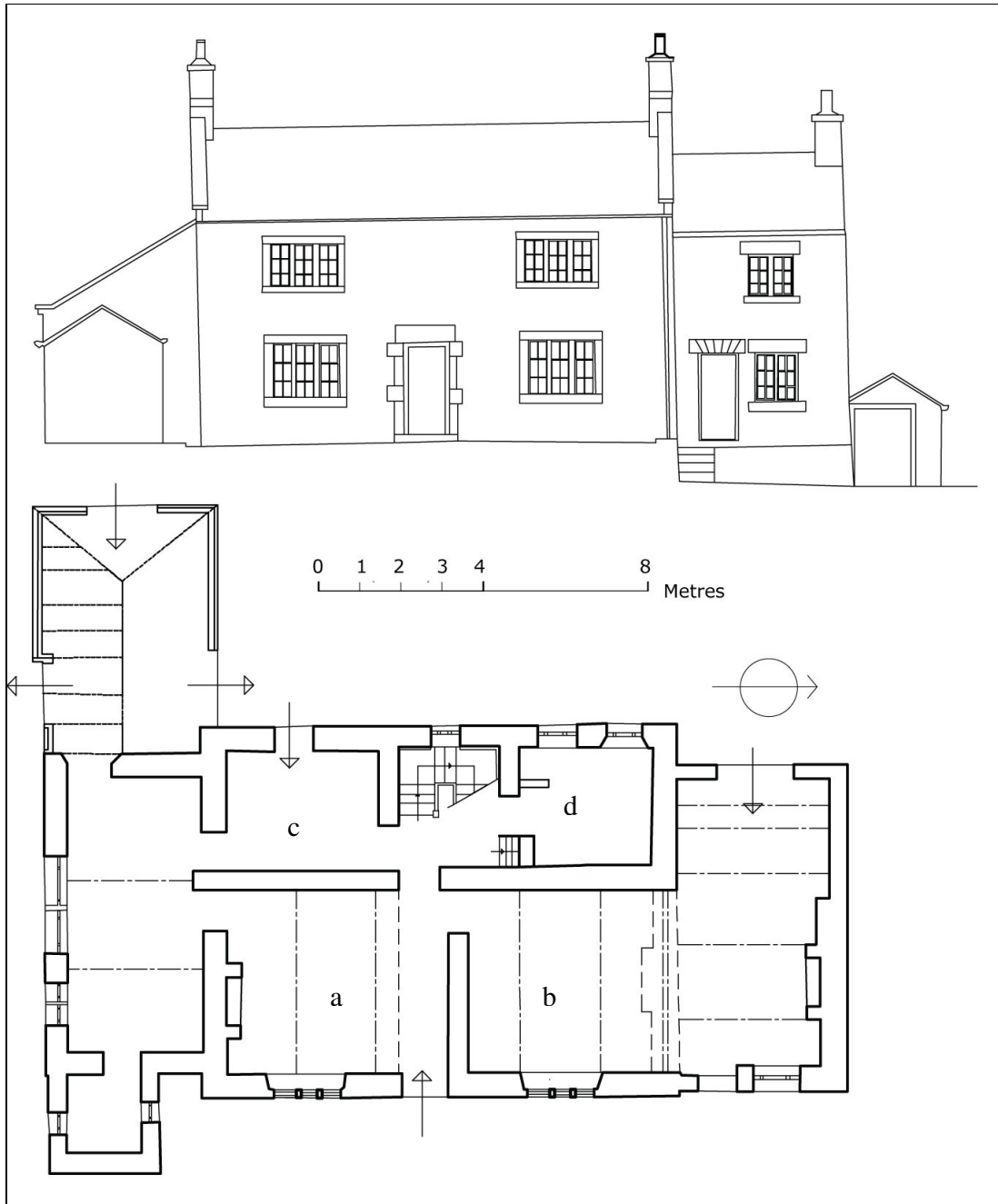

7.2 Measured survey of Stables Farmhouse. Extensions are visible on either side of the building.  
(a) Parlour (b) 'Best' Parlour (c) Kitchen (d) Dairy



7.3 The rear elevation of Stables Farmhouse with a symmetrical layout. The doorway to the right has been extended from a former fenestration, while those on the ground floor in the left of the elevation have been inserted in the twenty-first century. A moulded kneeler is visible on the gable end.



7.4 Sandygate Farm depicted by Kent, Claridge and Pearce in their estate survey of 1796. The Farmstead is visible at the centre of the image, and by this period, was 'L'-shaped (WYAS WYL/250/3/Surveys Kent, Claridge & Pearce). (Reproduced by the kind permission of the Earl and Countess of Harewood and Trustees of the Harewood House Trust)

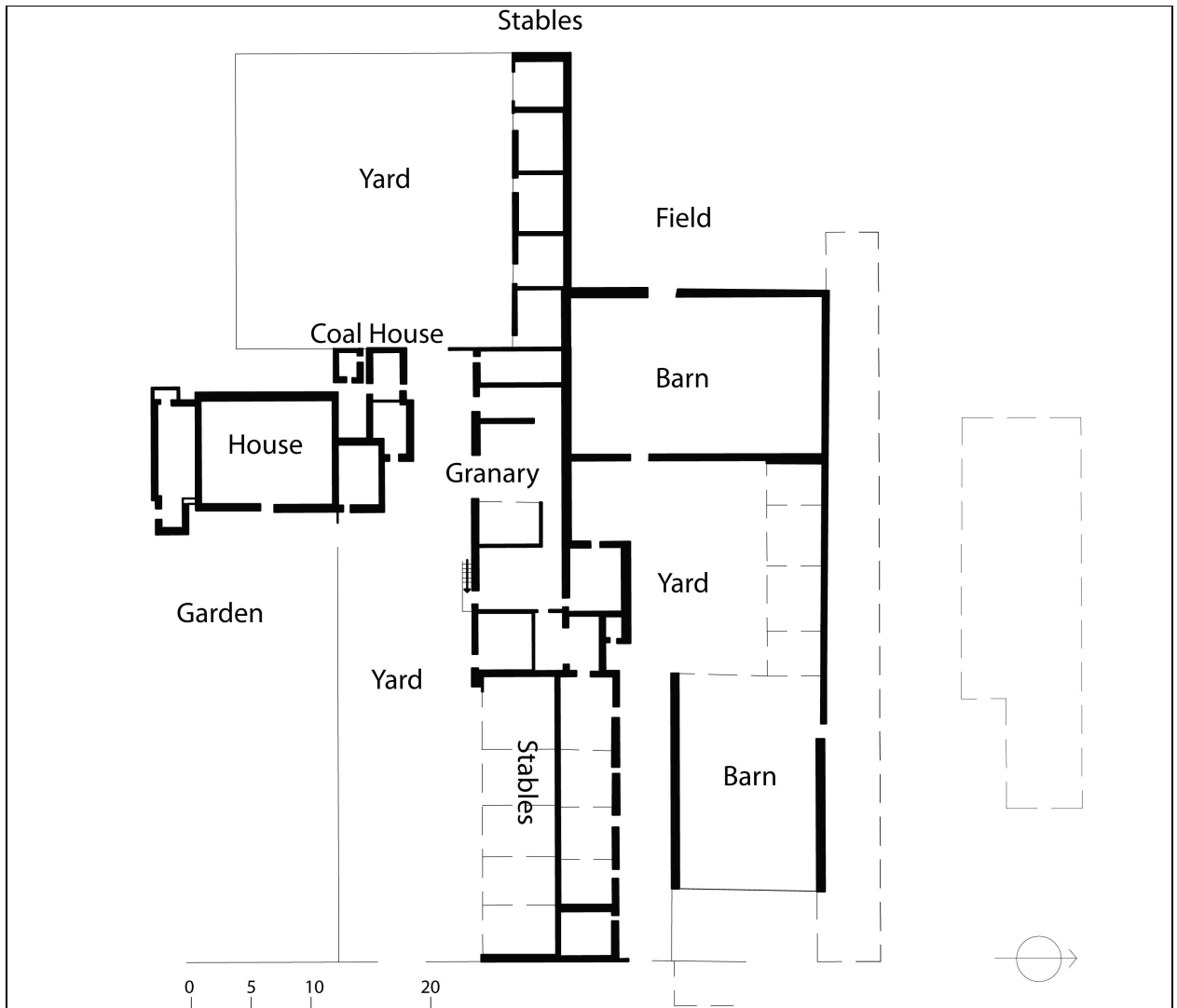

7.5 A plan of Stables Farm drawn in 1979. By 1814, and through a series of alterations the farmstead took the form of a linear plan rather than the L-shape recorded by Kent, Claridge and Pearce. The building noted as the ‘Granary’ is the original barn.





7.6 The barn at Stables Farm viewed from the north. Ventilation slits above the arched doorways indicate the existence of a threshing floor.



7.7 Blocked archways located in the western end of the barn at Stables Farm. Formerly provided access to another room in the western end of the building. A row of mortices above the arches indicate the addition of a new floor, possibly used a grain store.



7.8 The stables at Stables Farm built in the early-nineteenth century but repointed and altered in the early twenty-first century.



7.9 Cellar at Lofthouse Grange farmhouse, similar to that at Sandygate. Hooks in the ceiling indicate where meat and other types of foodstuff were hung and stored during the winter months.



8.1 The west elevation of All Saints' church, Harewood. It is clear from surviving drawings that Robert Adam supplied a scheme to Gothicise the building between 1765-71. In 1793, the east gable was modified with new battlements, pinnacles and a quatrefoil window, while the roof was recast in Westmoreland slate. This may have been the work of John Carr of York, although this matter remains largely unresolved (Butler 1986, 91).

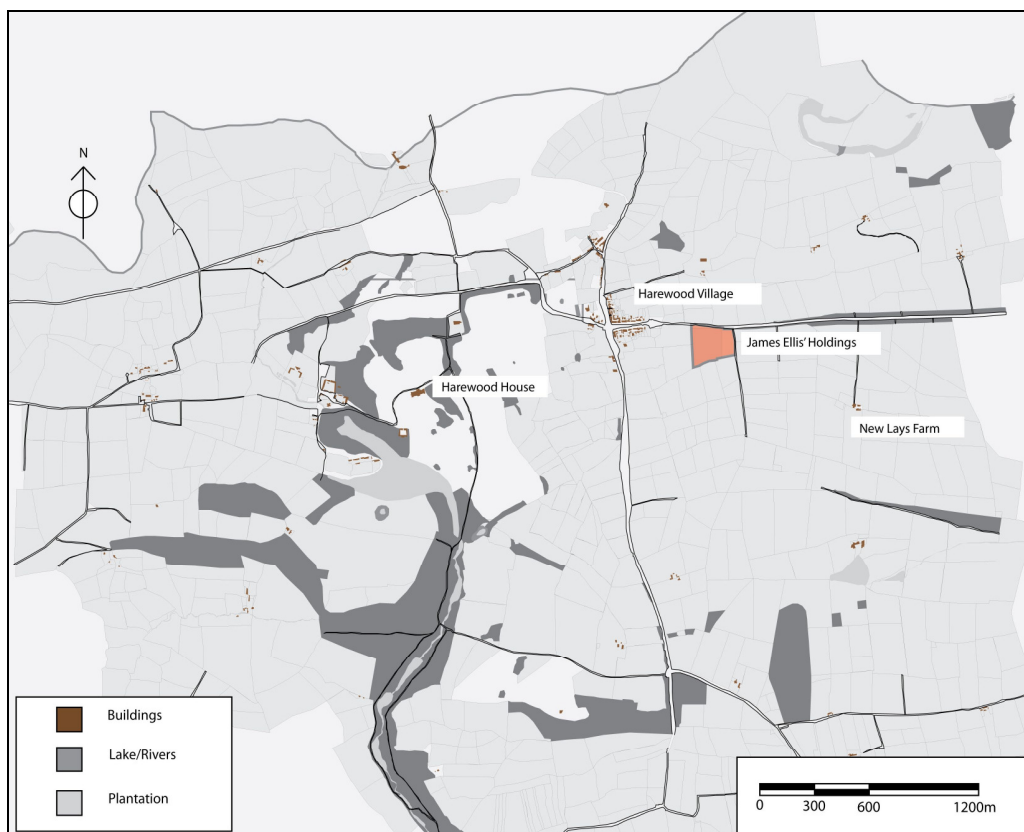

8.2 The Harewood Estate c. 1775. The area marked in red indicates James Ellis' holdings to the south of Harewood Avenue.

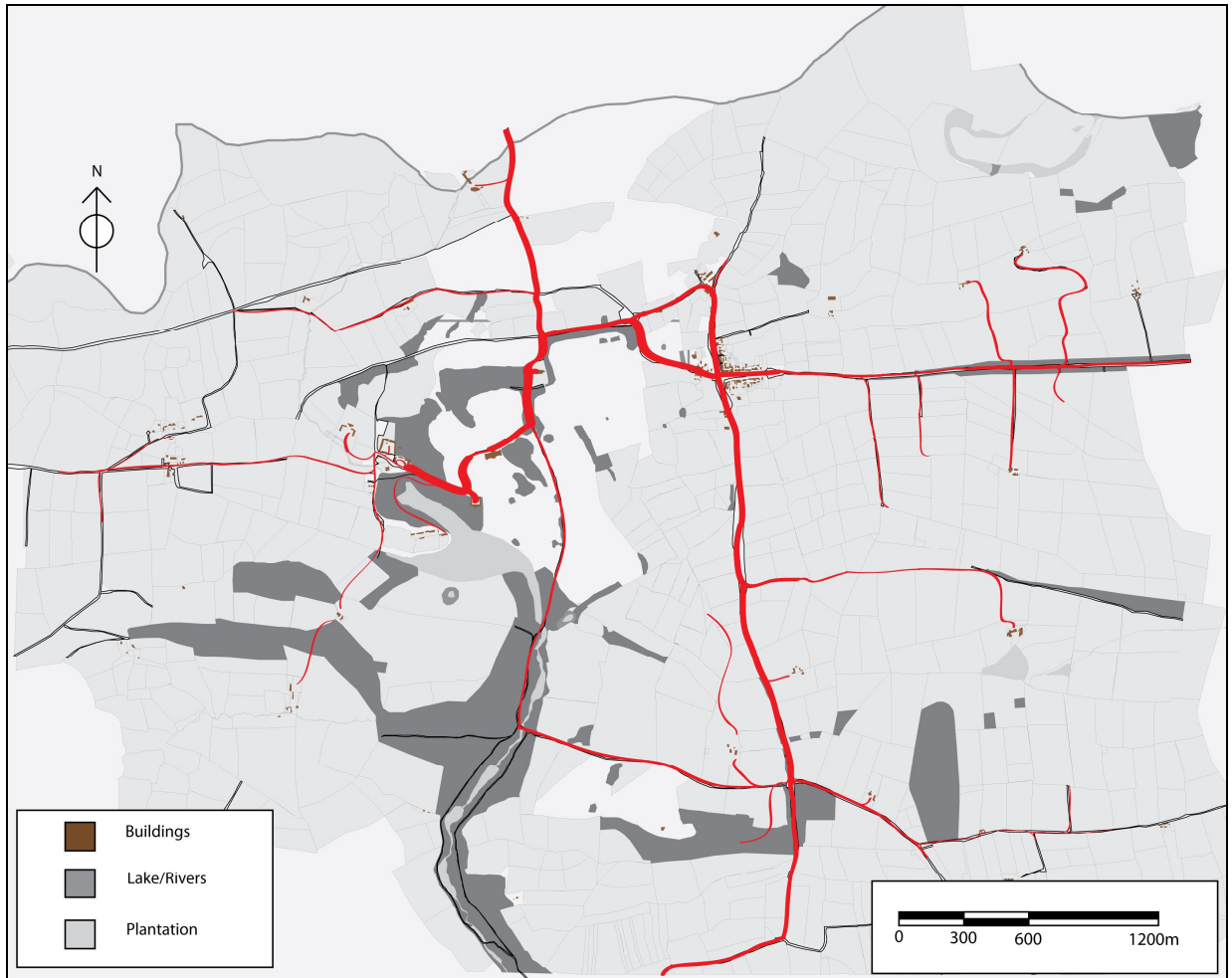

8.3 The movements of Samuel Popplewell overlaid on the Harewood landscape c. 1775. The red line denotes those journeys made regularly during the steward's lifetime, with the thicker areas indicating where journeys were made more often. (Source: Steward's Correspondence, WYAS HAR/SC1-7)

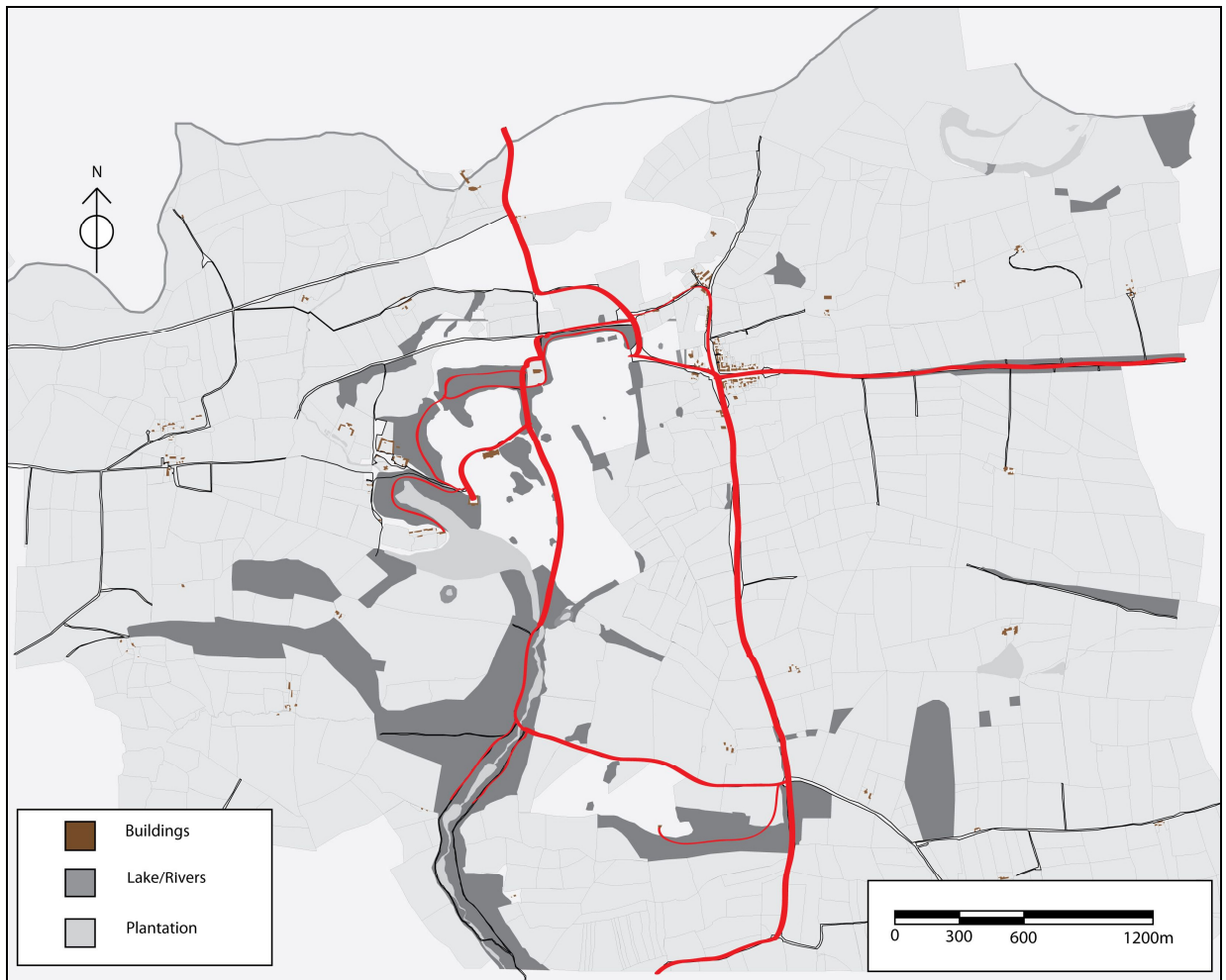

8.4 The movements of Edwin Lascelles. (Source: Steward's Correspondence, WYAS HAR/SC1-7)

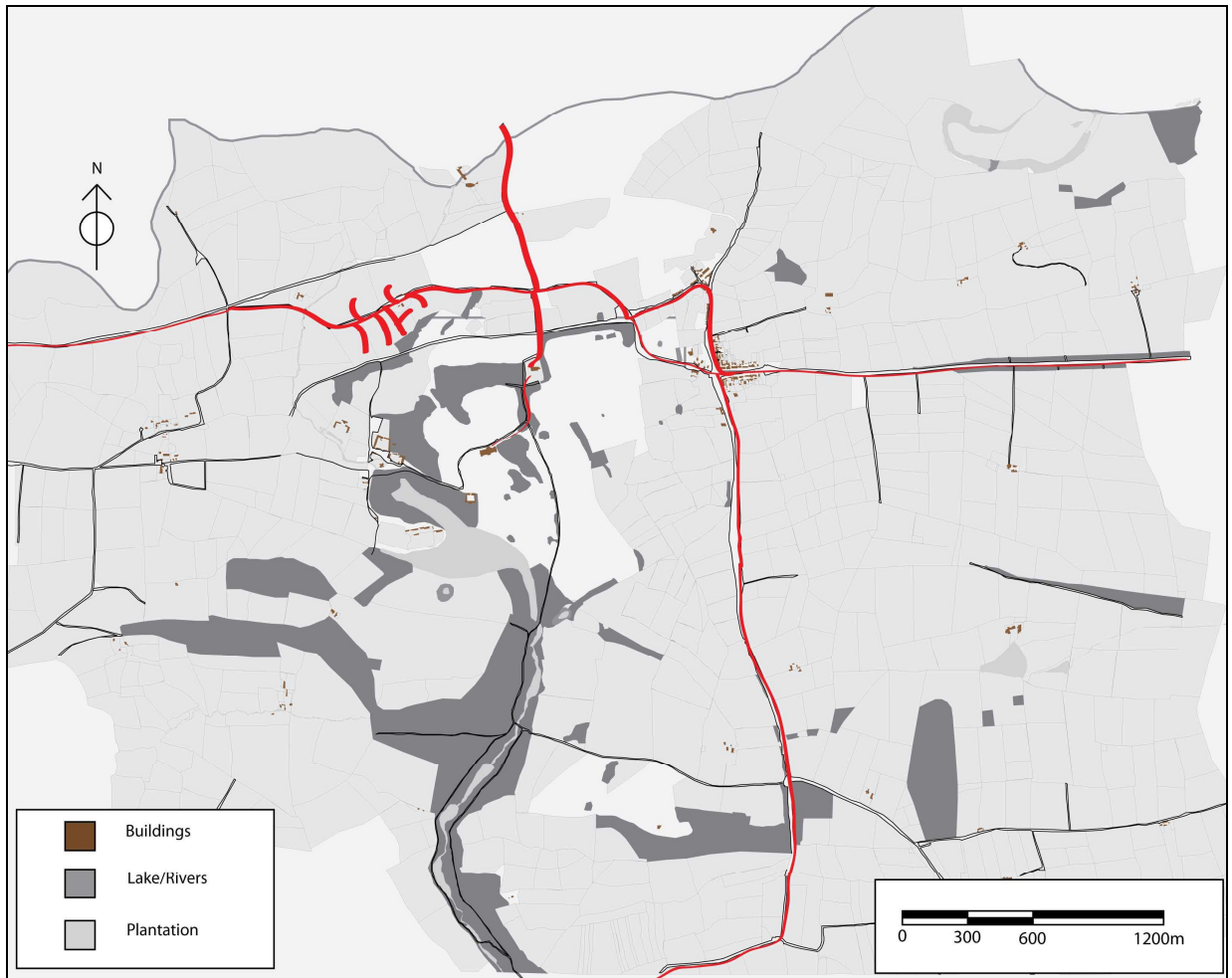

8.5 The movements of William Stables (Source: Stables 1855)

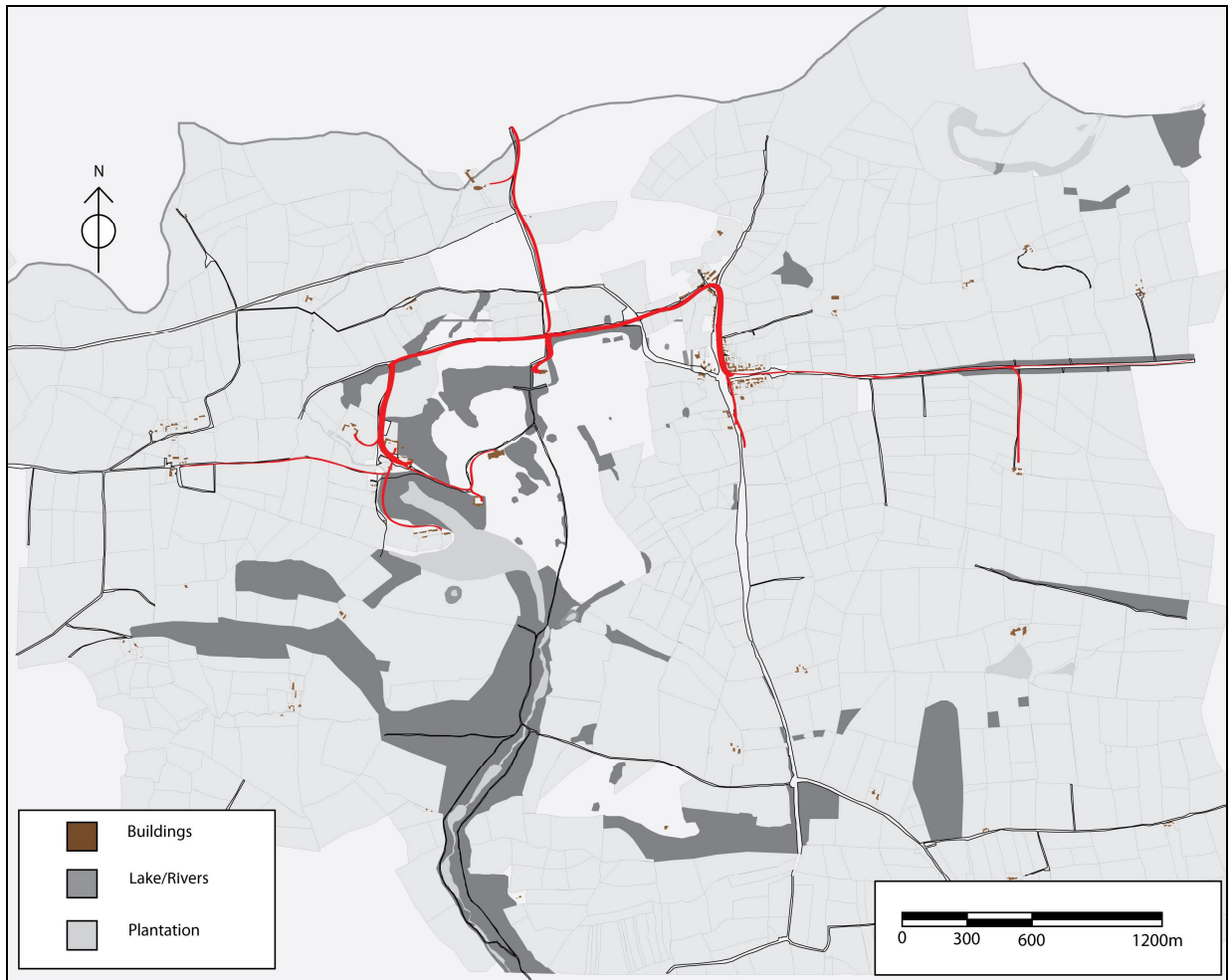

The generic movements of the estate joiners (Source: Harewood Estate Archive, WYAS WYL 250/1-4)

Harewood House, John Carr c. 1758

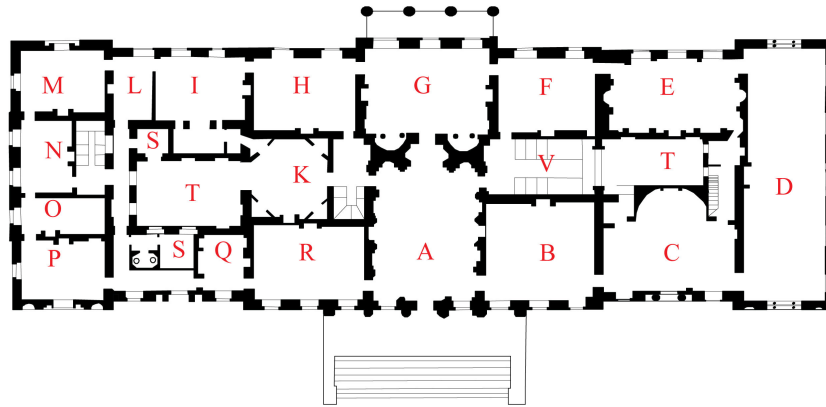

Principal Floor

- |                               |                         |
|-------------------------------|-------------------------|
| A - Hall                      | L - Anti Room           |
| B - Music Room                | M - Bed Room            |
| C - Gallery                   | N - Dressing Room       |
| D - South Dining Room         | O - Ditto               |
| E - Dining Room               | P - Bed Room            |
| F - Drawing Room              | Q - Wardrobe            |
| G - Salon                     | R - Library             |
| H - Gentleman's Dressing Room | SS - Servant's Bed Room |
| I - Bed Room                  | T - Open Courts         |
| K - Lady's Dressing Room      | V - Best Stairs         |

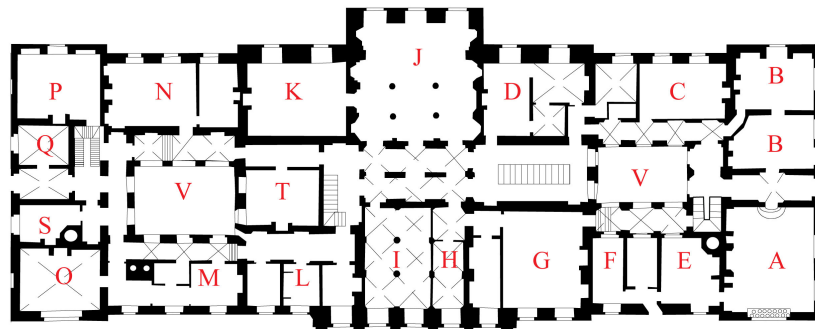

Basement Floor

- |                                |                   |
|--------------------------------|-------------------|
| A - Kitchen                    | L - Dressing Room |
| B - House Keeper's Room        | M - Dairy         |
| C - Steward's Room             | N - Billiard Room |
| D - Buttery                    | O - Wood House    |
| E - Back Kitchen and Bakehouse | P - Laundry       |
| F - Larder                     | Q - Room          |
| G - Servant's Hall             | S - Bakehouse     |
| H - Boot Room                  | T - Tenant's Room |
| I - Small Beer Cellar          | V - Court         |
| J - Servant's Hall             |                   |
| K - Coffee Room                |                   |

8.7 The Principal and Basement floors of Harewood House, as published in *Vitruvius Britannicus* (1771)



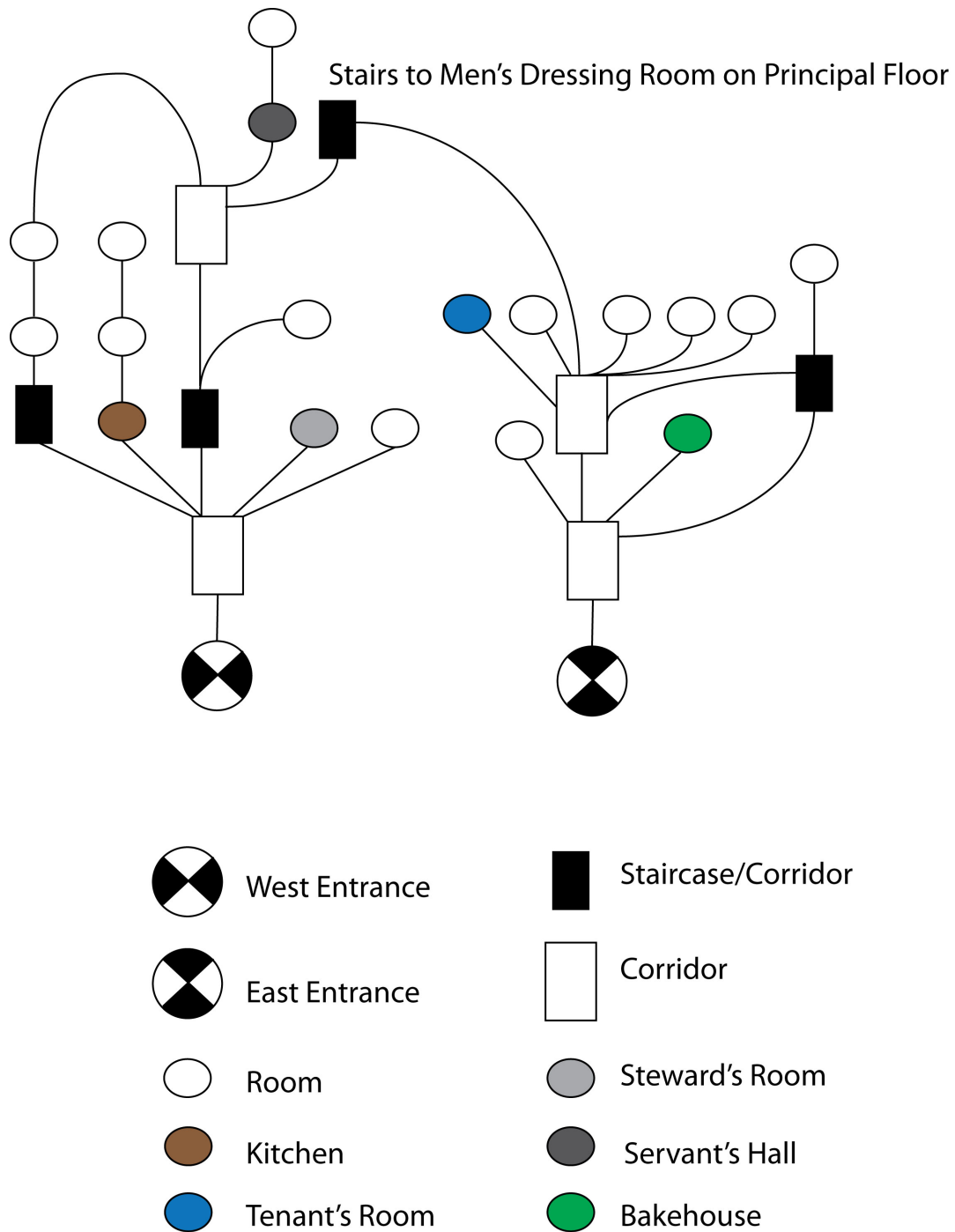

8.8 A gamma map showing access from both entrances in the basement storey of Harewood House. The map is directly related to the basement floor plan shown in Fig. 8.7. The position of the Steward's room provided Samuel Popplewell with unrestricted movement through the floor, i.e. he did not have to enter any other rooms when walking to either entrance or the Men's Dressing Room on the ground floor. The gamma map therefore provides an illustration of the spatial relationship between Samuel Popplewell and the layout of Harewood House .

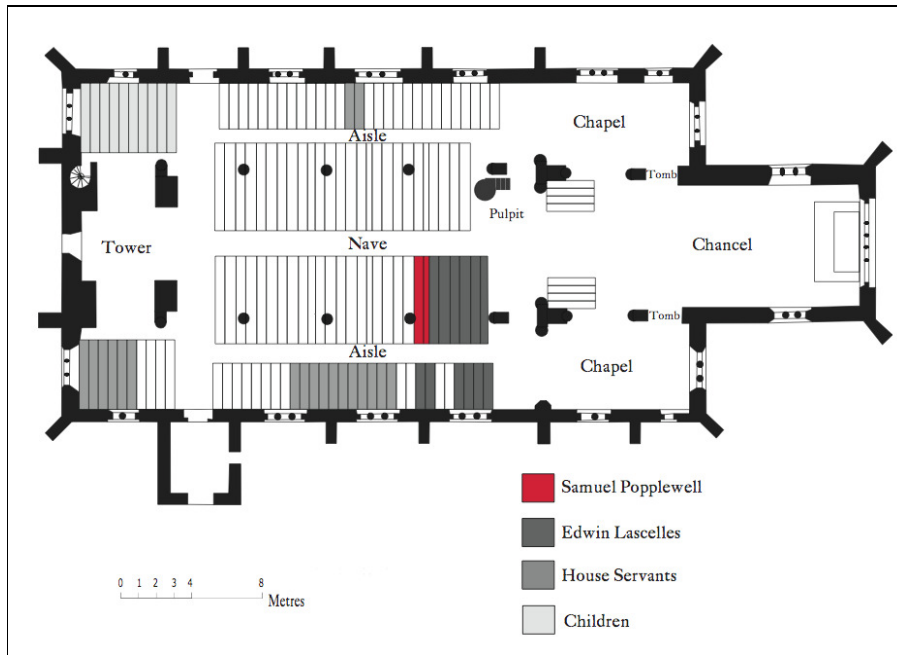

8.9 Layout of All Saints' Church, Harewood, c.1775. The plan is taken from a mid-nineteenth century plan (WYAS WYL 250/4) and has been adjusted according to the description provided by the Parish Registers and the pew layout.

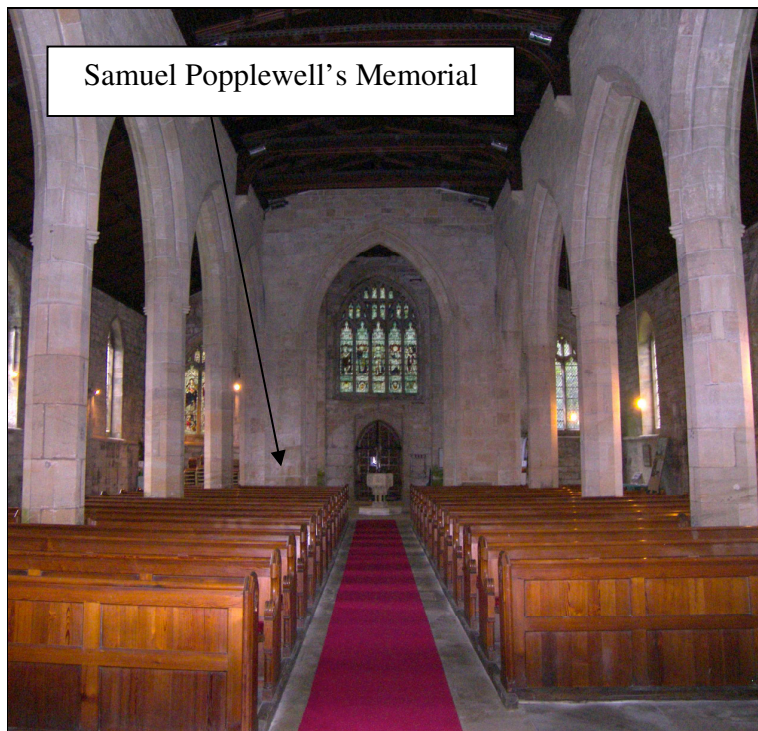

8.10 The nave of All Saint's Church, Harewood, facing west. Samuel Popplewell's memorial brass was positioned below the tower at the rear of the church.

## APPENDIX A:

## HAREWOOD ESTATE SURVEYS

1738 ESTATE SURVEY (WYAS WYL/250/3/13B SURVEYS): TENANTS/SIZE OF FARMS

<b>Name</b>	<b>Acres</b>	<b>Rods</b>	<b>Perches</b>	<b>Rent</b>
Daniel Wiggan, Benjamin Holmes, William Wright	347	1	29	62.4.13
George and William Smith	231	0	39	58.9.8
John Kitchingman	225	3	16	171.5.6
James Ellis	218	2	6	161.10.13
John Hunter	167	3	38	4.10.0
James Tidswell	143	2	35	55.0.2
Christopher Pike	114	2	33	35.3.18
Richard Turner	79	0	6	79.0.0
Thomas Mallory	79	2	34	9.10.0
John Watson	77	3	17	29.5.6
Richard Savage	65	1	17	41.4.18
John Stables	62	0	38	7.12.0
Richard Savage	50	2	22	34.4.18
Henry Whitaker	43	3	35	1.2.6
Mr Samuel Midgeley	38	2	38	19.10.0
Redman, Holmes and Milham rented to Dunkeswick	37	0	28	N/A
Mr Samuel Midgley	30	0	31	6.6.0
Gregory Clayton	30	2	19	28.4.0
Widow Craven	26	3	21	40.6.0
William Scott	19	1	9	19.10.0
Samuel Rainton	19	2	31	15.16.9
Robert Bickerdike	13	0	39	94.9.3
John Cooper	13	1	7	57.13.9
Thomas Harrison	13	2	10	14.10.0
John Lee	12	2	3	15.8.0
William Kemp	11	0	30	5.10.0
Richard Lockett	10	0	13	7.8.0
Thomas Smith	10	1	26	4.10.0
George Brown	10	1	36	15.8.0
Thomas Ellis	9	0	5	None
James Norfolk	9	1	16	
Robert and Christopher Robinson	8	0	29	16.0.0
John Gill	8	3	22	21.17.6

---

<b>Name</b>	<b>Acres</b>	<b>Rods</b>	<b>Perches</b>	<b>Rent</b>
James Watson	4	3	36	4.6.0
Mary Bateman	3	1	30	4.6.0
Robert Dickinson	4	1	0	2.3.17
Mary Hawke	3	2	30	7.5.0
Anthony Hunter	2	0	0	1.0.0
John Barber	2	1	21	7.0.0
Elizabeth Royston	1	2	10	3.4.0

## 1758 ESTATE SURVEY (WYAS WYL/250/3/16 SURVEYS): TENANTS/SIZE OF FARMS

<b>Name</b>	<b>Acres</b>	<b>Rods</b>	<b>Perches</b>
James Ellis	379	1	2
John Bickerdike	193	0	0
James Wright	169	0	3
John Hunter	167	3	1
Home Farm	163	3	3
Mr Kitchingman	138	2	2
Charles Pike	113	1	3
Widow Smith	108	2	3
Mr Lascelles	87	0	0
John Wright	85	4	14
Wiggan and Wright	83	3	1
Anthony Shearwin	82	3	1
Matthew Bickerdike	78	3	1
Mr Midgley	76	3	2
Thomas Smith	75	3	2
Thomas Bradley	65	1	3
Robert Wiggan	62	1	0
John Hill	50	1	2
John Craven	47	1	3
Mr Stables	42	2	2
William Wiggan	40	3	3
Abraham Barrett	37	1	3
William Thompson	37	3	1
Charles thompson	35	3	2
Robert Bickedike	34	0	2
Thomas Harrison	32	2	3
John Wilkinson	31	1	2
John Watson	30	1	0
William Scott	29	0	2
Richard Craven	28	3	2
James Watson	27	2	0
William Kemp	27	0	1
John Cooper	26	2	0
George Renton	22	3	1
Samuel Smith	22	3	2
Widow Stead	21	2	0
Thomas Ely	19	2	0
Waite and Mallory	19	1	11
Richard Hargreaves	18	0	0

<b>Name</b>	<b>Acres</b>	<b>Rods</b>	<b>Perches</b>
Widow Clayton	18	1	0
Thomas Lee	17	1	3
Robert Cockets	15	1	2
John Holmes	14	2	10
William Carr	13	3	0
William Norfolk	13	2	3
Thomas Bickerdike	11	1	2
John Jackson	10	3	3
Joshua Craven	7	3	0
Mary Craven	5	4	21
George Wright	4	1	1
John Thompson	4	4	19
Mary Hawke	3	7	33
William Baldwinson	3	0	1
James Norfolk	2	2	34
John Dobson	2	2	1
William Craven	2	1	8
Ann Lee	1	2	20
Daniel Jackson	1	2	36
John Lee	1	2	28
Elizabeth Parker	0	0	8
John Birdsall	0	0	36
John Richardson	0	0	37
Mr Clark	0	2	28
Mr Hollins	0	0	38
Mrs Wilkinson	0	0	29
Thomas Liverseige	0	0	17
Thomas Reeds	0	0	12
Widow Craven	0	1	2
William Carr and Mrs Stavely and	0	1	3
Thomas Harrison			

---

 1796 ESTATE SURVEY (WYAS WYL/250/3/KENT, CLARIDGE & PEARCE SURVEYS):  
 TENANTS/SIZE OF FARMS

<b>Name</b>	<b>Acres</b>	<b>Rods</b>	<b>Perches</b>
Land In Hand	760	3	17
Thomas Shiers	219	0	11
Lancelot Dickenson	209	0	4
Samuel and William Popplewell	173	0	9
John Bickerdike	140	0	27
Sarah Collett	128	2	32
Samuel Popplewell	126	1	11
Abraham Barrett	111	3	26
Robert Bickerdike	109	3	22
Benjamin Smith	108	2	18
John Greeves	96	2	39
William Kirby	90	3	24
Peter Scott	89	0	33
Daniel Wiggan	83	1	24
George Craven	80	3	3
Joseph Smith	74	0	6
William Stables	67	1	31
Thomas Parker	57	3	8
Matthew Bickerdike	57	2	35
William Kemp	48	2	9
Charles pike	44	1	1
Widow Lister	33	1	11
John Parkinson	23	0	24
George Jackson	22	3	7
Joseph Hanson	21	1	8
Richard Hargrave	16	3	17
Widow Norfolk	14	0	30
Jonathan Renton	14	2	10
Leonard Horseman	12	2	20
John Muschamp	12	0	34
John Briggs	12	2	4
Hannah Waterworth	12	1	37
Richard Snow	11	3	30
Samuel Ellison	10	0	16
Thomas Webster	9	0	8
Robert Cockett	9	3	17
John Clayton	9	2	30
William Jackson	8	1	3

---

<b>Name</b>	<b>Acres</b>	<b>Rods</b>	<b>Perches</b>
Susannah Taylor	8	0	38
William Fleming	5	2	20
Rev. Mr Tattersall	5	2	20
John Wright	4	2	7
John Birdsall	4	2	6
Thomas Baldwinson	3	1	0
john Thompson	3	2	8
Jeffery Ibbetson	3	3	3
Robert Thompson	2	1	32
Robert Chapman	2	1	25
Mary Walker	2	2	3
John Wood	2	2	22
John Heaton	2	0	2
William Thompson Snr	1	2	3
William Lee	1	2	38
Samuel Middleham	1	3	8
Beamsley Hospital	0	0	0



APPENDIX B:

HAREWOOD ESTATE FARMSTEAD SURVEYS

## Harewood Farmstead Survey Sheet *Updated Sept 2009*

**Farm Name & Situation:** Carr House Farm

**Date Visited:** 02/10/2009

**Access:**.....(Partial (limited)/**Medium**/Full)

**Ordnance Survey Grid Reference:** SE 30465 43889

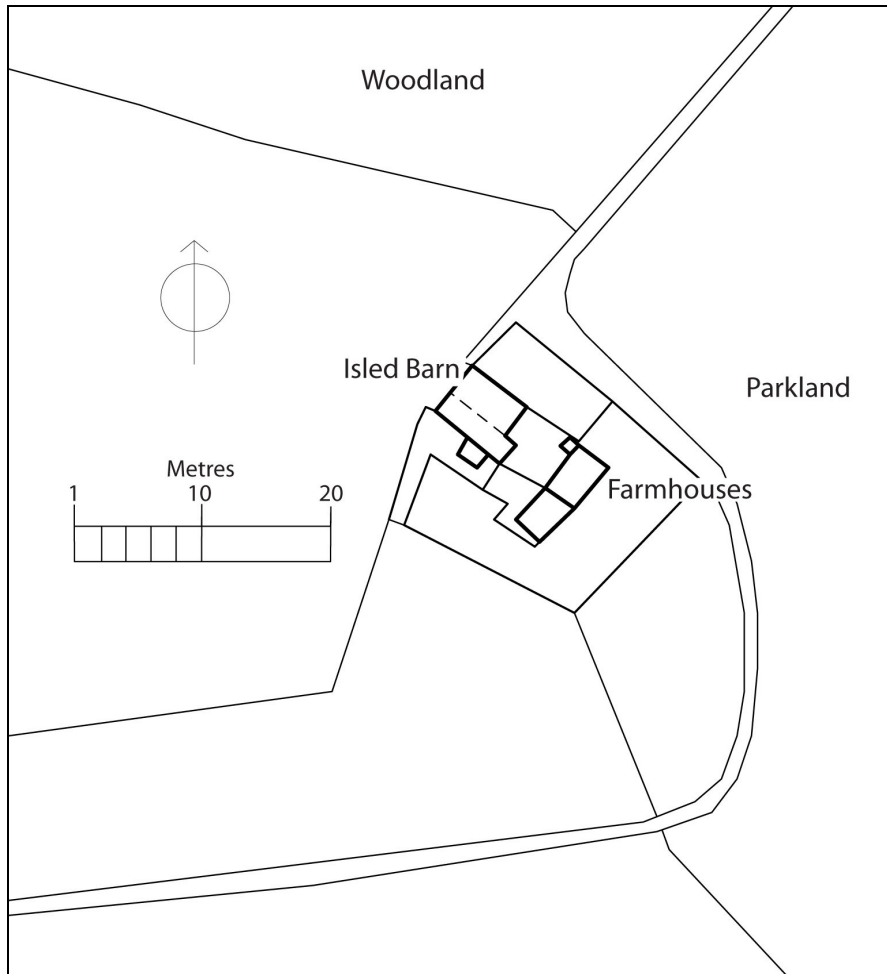

- 1. Date of Building/Farmstead** Pre-1750  
 (Please circle) **1751-1796**  
 1796-1813  
 1813-1900  
 Post 1900

- 2. Survival of farmstead as a whole: Partially (less than 25%)**  
 (Please circle) Partial Loss (25-50%)  
 Significant Loss (50-75%)  
 Major Loss (More than 50%)

**Significance of the farmstead:** **Rare survival on estate**  
 (Please circle) Representative for the period and areas  
 Unrepresentative for the period and area

**3. Fittings and fixtures:** **Rare original features, e.g.:**.....  
**(E.g. doors, windows, surfaces, fittings)**  
 Typical original features, e.g.....  
 Partial survival of original features, e.g.....  
 All original features removed, e.g.....

**4. Farmstead Type:** Dispersed (e.g. no focal area)  
**Loose Courtyard Plan (e.g. piecemeal development around courtyard)**  
 Regular Courtyard Plan (e.g. careful plan in E, U or L shape)  
 Linear (e.g. buildings attached in line)  
 Parallel (e.g. buildings lie opposite main house)

**5. Farmstead House:** *Date/Period:* mid-18<sup>th</sup> Century

*Form (e.g. T-Shaped, double pile, etc):* Double Pile

*Description & Features (E.g. Rooms, size, style, features, building materials)*

To the south-east of the barn, across the yard are two farmhouses. The 1st, to the south, was built of coursed punch-dressed sandstone, quoins, in a double-pile plan on 2 storeys, with a stone slate roof with stacks to ridge on the gable ends. The front has 3 bays with 3-light flat faced mullioned windows with post-and-lintel surrounds on each floor, flanking a central doorway with a stone lintel and tie-stone jambs. Above the doorway is a small single light window also with a post-and-lintel surround. The rear elevation also has 3 bays. On the ground floor are 2 windows close to the left and right-hand returns with replaced monolithic lintels and projecting sills. Above, but positioned close to the centre of the elevation are 2 further windows of the same configuration as those below. At the centre is a stair window also with a replaced monolithic lintel.

The 2nd farmhouse, abutting the gable end of the 1st, probably dates to the late-18th century and is built of punch-dressed sandstone with a pitched stone slate roof with stacks to ridge, 1 on the northern gable end and the other above the 4th bay of the west elevation. This facade has 4 bays with lean-tos in the 1st and 3rd bays. In the 2nd and 4th are 6-pane sash windows above one another on both floors with projecting sills and lintels carved with false voussoirs. The left-hand return (gable end) has 2 windows, 1 off-centre with a 6-pane sash with the same, but central, above, both with large replaced monolithic lintels. The rear has 4 bays. The 1st contains a doorway with replaced monolithic lintel on the ground floor with a 9-pane sash window above. The 2nd and 3rd bays contain 9-pane sash windows with projecting sills and large monolithic stone lintels, on the ground and 1st floor respectively. To the right is a double door with a 9-pane sash window above. Those windows in the 3rd and 4th bays also feature false voussoirs.

**6. Other Buildings:****Building 1** *Name/Description:* Barn

*Description (e.g. Main Purpose, No. of Storeys, buildings materials, roof, distinguishing features)*

Carr House Barn is built of hammer-dressed sandstone with a stone slate roof, quoins and contains a single-aisle of 4 bays dating it to the mid-18th century. The south elevation contains a cart entry in the 2nd bay, which has composite jambs and a flat-arch with margin-dressed skewbacks, voussoirs and a keystone. To the right is a later outshut with a lean-to, stone slate roof. The rear elevation contains a central cart entry of the same configuration to the south, but has been filled and includes an doorway and window to right with projecting sill. Above is a short lateral stack. The left-hand return has a central doorway with composite jambs and flat-arched lintel with voussoirs. To the right at a lower level is a mistal doorway, leading to the aisle, which has a punch-dressed quoined lintel.

The interior contains a central threshing floor accessed from the south cart entry. This is also indicated by the inclusion of ventilation slits in the south elevation. To the north the aisle has been compartmentalised with the 1st 2 bays separated by stone walls either side of the cart entry. Bays 3 and 4 are open and have post on tall dressed padstones with wall ties and straight braces to the arcade-plate and tie-beam. The barn has a fish-bone king-post roof with 2 purlins morticed and pegged through each principal rafter. The roof also contains the original rafters.

**Sources Consulted:**

English Heritage, 'Carr House Barn', Listed Buildings Online (13/02/1986)

Michaelmore, D. J. H, 1974, 'A Preliminary typology for Pennine Aisled Barns with King-Post' in *Brigantian* 3, pp. 15-17

**Farm Name & Situation:** Harewood Mill Farm  
**Date Visited:** 02/10/2009  
**Access:**.....(**Partial** (limited)/Medium/Full)  
**Ordnance Survey Grid Reference:** SE 31092 45862

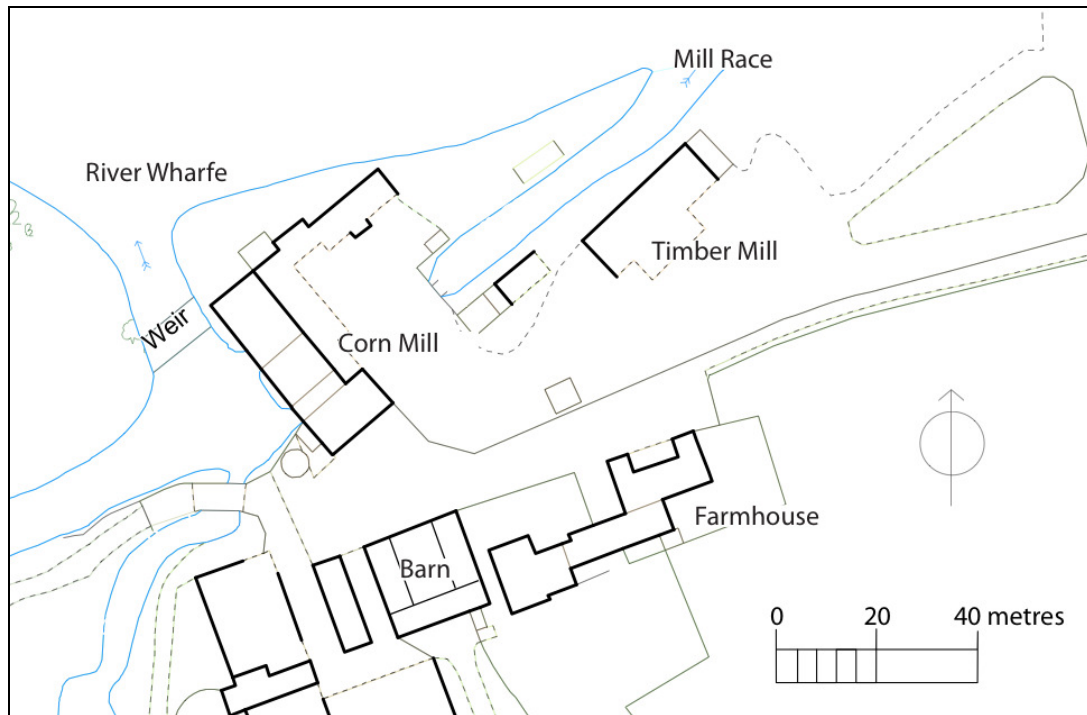

**1. Date of Building/Farmstead** Pre-1750  
 (Please circle) **1751-1796**  
 1796-1813  
 1813-1900  
 Post 1900

**2. Survival of farmstead as a whole: Partially (less than 25%)**  
 (Please circle) Partial Loss (25-50%)  
 Significant Loss (50-75%)  
 Major Loss (More than 50%)

**Significance of the farmstead:** Rare survival on estate  
 (Please circle) **Representative for the period and areas**  
 Unrepresentative for the period and area

**3. Fittings and fixtures:** **Rare original features, e.g.:**.....  
**(E.g. doors, windows, surfaces, fittings)**  
 Typical original features, e.g.....  
 Partial survival of original features, e.g.....  
 All original features removed, e.g.....

- 4. Farmstead Type:** Dispersed (e.g. no focal area)  
 Loose Courtyard Plan (e.g. piecemeal development around courtyard)  
 Regular Courtyard Plan (e.g. careful plan in E, U or L shape)  
**Linear (e.g. buildings attached in line)**  
 Parallel (e.g. buildings lie opposite main house)

**5. Farmstead House:** *Date/Period:* 18/19<sup>th</sup> Century

*Form (e.g. T-Shaped, double pile, etc):* Various Phases

*Description & Features (E.g. Rooms, size, style, features, building materials)*

The farmhouse is Grade II listed and is built in the south-east of the complex. It was constructed using hammer-dressed stone with a welsh blue slate roof, with 2 storeys and a pitched roof with oversailing eaves, most of which dates to the early-19th century. The garden front is of 3 bays with the 3rd bay seemingly earlier than the rest of the building. The rear entry has windows with small paned Gothic glazed sashes. The 1st 2 bays have windows with double chamfered surrounds. The north elevation is of 3 bays with the 2nd and 3rd breaking forward featuring 2 sets of windows on the ground and 1st floors with double-chamfered surrounds and hoodmould. The inner return has a Tudor-arched doorway with moulded surround and spandrels. The left-hand return has a similar doorway with a stair-window above, while the right-hand return has a doorway with a stop-chamfered surround.

**6. Other Buildings:**

**Building 1** *Name/Description:* Barn

*Description (e.g. Main Purpose, No. of Storeys, buildings materials, roof, distinguishing features)*

To the west of the house is a barn, likely to have originally dated to the mid-18th century, but was later extended to the north. The original range was orientated on an east-west alignment and was built of punch-dressed sandstone with coped gables with corbelled kneelers (simple cavetto mouldings like Harewood Mill. In the west gable elevation there is a square window under the apex with a lintel carved with false voussoirs, screwbacks and a projecting sill. The roof would have originally been slated but appears to have been replaced with corrugated iron presumably at the same time as the rest of the barn. At some stage during the 19th century the barn was extended northwards, perpendicular to the original range, possibly with a central cart-entry providing access to the larger barn space. This cannot be verified, however, as access was severely limited at the time of survey. The extension, built originally of punch-dressed sandstone, consisted of a central bay flanked on either side by single aisles likely to have been used to house livestock. This is indicated on the west elevation by a series of doorways similar in character to those in the large barn at New Laithe Farm though a 19th century double door was inserted on the southern end. The north elevation, meanwhile, has 5 bays with the 1st and 5th forming aisles. The central section has largely been replaced by wooden boarding although stone does survive to approximately 1.5m in some areas. This elevation

also reveals that the aisles are likely to have been a later addition, once again in similarity to New Laithe.

**Building 2** *Name/Description: Stable*

*Description (e.g. Main Purpose, No. of Storeys, buildings materials, roof, distinguishing features)*

To the west, in line with the barn, are a set of stables built of punch-dressed sandstone and a stone slate roof to 1 storey. They incorporate 9 filled bays all separated by stone pillars, but with windows and doorways. Much of the original facade has been altered by the refurbishment of the building as offices for the farm and estate.

**Building 3** *Name/Description: Corn Mill*

*Description (e.g. Main Purpose, No. of Storeys, buildings materials, roof, distinguishing features)*

Harewood Mill was built as a part of the improvement of the Harewood Estate during the 2nd half of the 18th century by the Lascelles family. While the period 1758-85 was largely characterised by large-scale agricultural improvements, the decade between 1787-96 appears to have been when buildings such as mills were rebuilt (WYAS WYL 250/3/250). This may have been in response to favorable economic conditions, i.e. high grain prices leading to investment in agrarian farming, and the resulting demand for fully functional and efficient milling equipment.

Between 1787-94 Harewood Mill was rebuilt in piecemeal while the adjacent farm, Harewood Mill Farm, was occupied by Norfolk family. It was overseen by John Muschamp, the estate mason, who was also responsible for many estate buildings such as Harewood House, the Estate offices and the archway (SE 32098 44949) in Harewood village. In total the structure cost nearly £250 including various craftsmen's work. It was built of hammer-dressed gritstone with a welsh blue slate roof to 3 storeys and a loft. The south facade is of 3 bays with a plinth and 6-panel doors that flank a central bay that has "18+66" under a window. The fenestrations have flat arches with voussoirs and projecting sills. The left and right-hand returns have coped gables with kneelers featuring simple cavetto mouldings similar to the barn at Harewood Mill Farm. The right-hand return has an off-centre doorway with a window to the right, both with lintels carved with false voussoirs and screwbacks. The 1st floor has windows flanking a central take-in doorway, with another above and a 3rd providing access to the loft. To the left at 1st-floor level is a window of similar configuration to that on the south elevation, while another window is placed to the right and is tall. Projecting to the north is a 2 storey range of 4 bays. At ground level, facing east, is a lean-to with a corrugated iron roof. The 1st bay contains a doorway leading to the wheelhouse, and in turn, through an arched entry, to the millrace. The wheelhouse contains the original cast-iron undershot water wheel (stationary) with wooden brackets and intact gearing by Porteus (Leeds). Set above the wheel is a semi-circular arch lending support to a timbered floor above. Each floor has appropriate gearing and grindstone chambers and wooden cog wheels.

The ceilings have square cut pine spine beams and joists with wide floorboards. Set in the south-west corner is a half-turn closed-string staircase with a moulded hand rail and stick balusters. It appears that the mill was last used around 1974.

The survey of the farmstead also included the mill, although access to the interior was restricted owing to the Harewood Estate suggesting that the building had been condemned (09/2009). The listed building description, dating to 1986, included the mill wheel and it seems that it has remained in-situ into the present (12/2009). As such the wheel remains as a rare survival of its kind.

**Sources Consulted:**

WYAS WYL 250/3/250: West Yorkshire Archive Service, Leeds; Harewood Estate Archive, Steward's Cashbooks

WYAS WYL/250/3/33: West Yorkshire Archive Service, Leeds; Harewood Estate Archive, c.1698 Estate Map

English Heritage, 'The Old Corn Mill', Listed Buildings Online (22/07/1986)

English Heritage, 'Mill Farmhouse, Harrogate Road', Listed Buildings Online (22/07/1986)

PRH: Parish Registers of Harewood, Co. York - Burials, 1614-1813



**Farm Name & Situation:** High Lofthouse Farm  
**Date Visited:** N/A, Photographic Record from WYHER  
**Access:**.....(**Partial** (limited)/Medium/Full)  
**Ordnance Survey Grid Reference:** SE3289343074

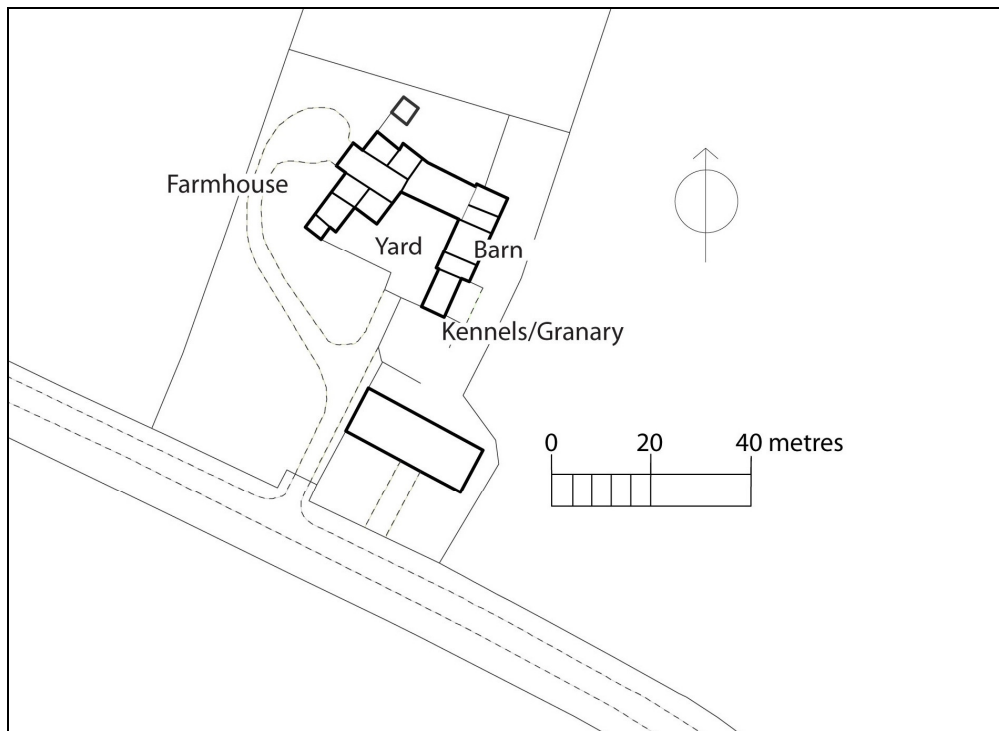

**1. Date of Building/Farmstead** Pre-1750  
 (Please circle) **1751-1796**  
 1796-1813  
 1813-1900  
 Post 1900

**2. Survival of farmstead as a whole: Partially (less than 25%)**  
 (Please circle) Partial Loss (25-50%)  
 Significant Loss (50-75%)  
 Major Loss (More than 50%)

**Significance of the farmstead: Rare survival on estate**  
 (Please circle) Representative for the period and areas  
 Unrepresentative for the period and area

**3. Fittings and fixtures:** Rare original features, e.g.:.....  
 (E.g. doors, windows, surfaces, fittings)  
**Typical original features, e.g.....**  
 Partial survival of original features, e.g.....  
 All original features removed, e.g.....

- 4. Farmstead Type:** Dispersed (e.g. no focal area)  
 Loose Courtyard Plan (e.g. piecemeal development around courtyard)  
**Regular Courtyard Plan (e.g. careful plan in E, U or L shape)**  
 Linear (e.g. buildings attached in line)  
 Parallel (e.g. buildings lie opposite main house)

**5. Farmstead House:** *Date/Period:* c.1764

*Form (e.g. T-Shaped, double pile, etc):* 2:3:2

*Description & Features (E.g. Rooms, size, style, features, building materials)*

This is a farmhouse with flanking pavilions and link walls. It was built between 1758-65, probably by John Carr for Edwin Lascelles, 1st Earl of Harewood. It is constructed of punch-dressed stone and has stone-slate roofs. It is designed with a symmetrical composition - a central 3-bay house with windows on 1st and 2nd floors with flat-faced mullions, flanked on either side by 2-storey projections. This central house is linked by walls on either side to 1-storey and 1-bay pavilions. The pavilions each have small blind window with plain-stone surround with small oculus (partly blocked) above and pyramidal roofs. The walls to the pavilions had lean-to roofs, one of which now has been altered into a garage, while the other is gone.

Inside, the kitchen, to the rear, has stop-chamfered soft wood spine-beam and floor joists. The central room has fireplace with monolithic jambs and basket-arched lintel. The house and farm like that at New Laithe, was designed to be an eye-catcher along the formal approaches to Harewood House. Lofthouse was positioned on the ridge off Wike Lane, visible to those approaching from London and among the new intakes on Harewood Common, enclosed between 1738-c.1765: "Lofthouse Farm facing the gate was built in a style to emulate the house" (Robinson 1979).

(Text edited from English Heritage's LBO description)

In April 2003 the barn, attached to the south-east wing of the farmhouse was photographed by the property's owner (Denney 2002). No written report was made detailing any features of archaeological interest.

**6. Other Buildings:**

**Building 1** *Name/Description:* Barn

*Description (e.g. Main Purpose, No. of Storeys, buildings materials, roof, distinguishing features)*

The barn appears to have been the 1st building constructed among the agricultural structures and was built of roughly cut coursed punch-dressed stone, in 3 bays with quoins and a pitched stone slate roof. At either end of the front elevation in the 1st and 3 bays, are doorways with composite jambs and monolithic lintels. these formerly led to mistals on either side of the interior barn space. In the centre is a

large cart-entry with composite jambs, now inhabited by sliding doors. This leads into a central space, possible for cart storage or for use as a threshing floor, although a lack of ventilation slits within the building fabric and the prominence of pastoral farming in the area may indicate that the barn was initially designed for livestock housing and storage. Either side of this central space are areas for livestock, more recently used as stables. In the north wall a series of three arches, approximately 1m high have been filled. These appear to be original and may have been used either for troughs or access points for livestock to the stables in the north. Similar examples of three arches can be found in barns on the Harrewood Estate at Stockton Grange, Stockton Farm and Stables Farm. Above the mistal/stables are two hay lofts occupying the 1st floor possibly added when the stables to the south were constructed. They are separated by the central cart-space continuing to roof level, which features a fish-bone king-post roof with one purlin. The rear elevation mirrors the front.

### **Building 2** Name/Description: Kennels

*Description (e.g. Main Purpose, No. of Storeys, buildings materials, roof, distinguishing features)*

Abutting the barn to the south is a 2-storey building, probably stables with granary above, built of coursed punch-dressed stone with stone slate roof. The front has windows above one another on both floors with sills and lintels cut with false voussoirs. At ground floor, these flank a central doorway with lintel cut with false voussoirs. The right hand return has steps leading to 1st floor doorway to granary floor, which in turn, provides access to the southern hayloft in the barn via an inserted doorway between the two structures. The roof is a fish-bone king-post. The interior of the ground floor shows signs of divisions formerly used for stabling. The building was more recently used as kennels.

### **Sources Consulted:**

Robinson, J. M., 1979, "In Pursuit of Excellence", *Country Life*, June 28, pp. 2113-2115

English Heritage. 'Lofthouse Farmhouse, Harewood'. *Listed Buildings Online* (date listed 22/07/1986)

Denney. 2003.. 'Lofthouse Farm: Barn at Wike Lane' (Photographs)

Denney. 2002. 'Lofthouse Farm, Wike Lane: Existing Plans and Elevations'

WYAS WYL 250/3/Kent, Claridge & Pearce: West Yorkshire Archive Service, Leeds, Harewood Estate Archive, Estate Surveys, Kent, Claridge and Pearce 1796

WYAS WYL/250/3/49: West Yorkshire Archive Service, Leeds, Harewood Estate Archive, Estate Maps, c.1813.

**Farm Name & Situation:** Hollin Hall  
**Date Visited:** 02/10/09  
**Access:**.....(**Partial** (limited)/Medium/Full)  
**Ordnance Survey Grid Reference:** SE 33554 43822

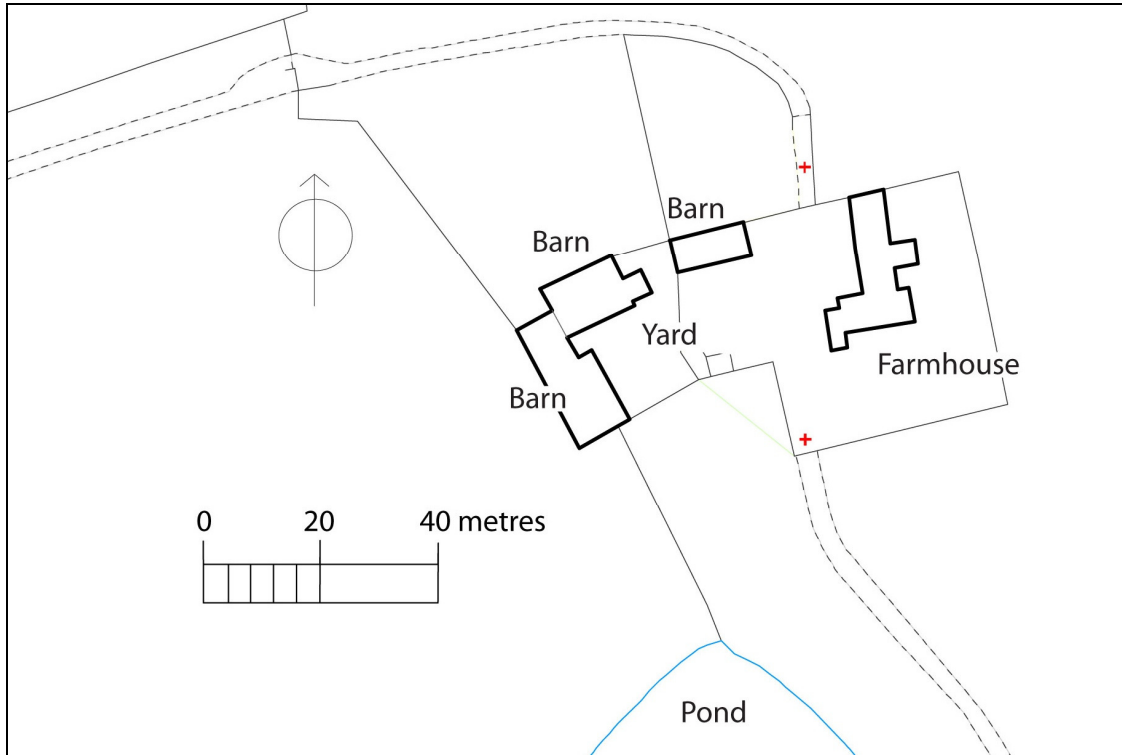

**1. Date of Building/Farmstead**                      Pre-1750  
 (Please circle)    1751-1796  
    **1796-1813**  
    1813-1900  
    Post 1900

**2. Survival of farmstead as a whole:**    Partially (less than 25%)  
 (Please circle)    **Partial Loss (25-50%)**  
    Significant Loss (50-75%)  
    Major Loss (More than 50%)

**Significance of the farmstead:**    Rare survival on estate  
 (Please circle)    **Representative for the period and areas**  
    Unrepresentative for the period and area

**3. Fittings and fixtures:**                      Rare original features, e.g.:.....  
    (E.g. doors, windows, surfaces, fittings)  
    **Typical original features, e.g.**.....  
    Partial survival of original features, e.g.....  
    All original features removed, e.g.....

**4. Farmstead Type:** Dispersed (e.g. no focal area)

**Loose Courtyard Plan (e.g. piecemeal development around courtyard)**

Regular Courtyard Plan (e.g. careful plan in E, U or L shape)

Linear (e.g. buildings attached in line)

Parallel (e.g. buildings lie opposite main house)

**5. Farmstead House:** *Date/Period:* 1813-51

*Form (e.g. T-Shaped, double pile, etc):* T-shaped typical of Harewood Estate

*Description & Features (E.g. Rooms, size, style, features, building materials)*

The farmhouse, located to the south-east of the present site, is likely to date to the early-19th century. Its form, as a double-pile, T-shaped building with kitchen at the rear, is very similar to those found at Stockton Farm, New Laithe and Lofthouse Grange and are clearly marked on the c.1813 Harewood Estate map (WYAS WYL/250/3/49) suggesting that they date to this period. Although the basic form is still discernable, a number of modern additions have masked the early-19th century structure.

**6. Other Buildings:**

**Building 1** *Name/Description:* Barn

*Description (e.g. Main Purpose, No. of Storeys, buildings materials, roof, distinguishing features)*

The earliest structure, a barn, lies to the west, and was evidently built in the early-to-mid 18th century with later additions. It is built of rubble brought to courses with areas of punch-dressed sandstone denoting a later phase of construction. The earliest part of the barn is to the north, and is indicated on the western elevation by rubble masonry. The elevation contains 6 bays to 1 storey, with the 1st 2 bays including ventilation slits commonly associated with threshing floors. In the 3rd bay is an original door with composite jambs and a stone lintel. To the right are two inserted windows within an area of disturbed stone courses, possibly formerly an area for a doorway or window. Above this area it appears that the barn was raised, likely to be when the final bay, or southern part of the barn, was added. This is indicated by the use of coursed punch-dressed sandstone, with a raising of approximately 4 courses, as well as a straight joint between the 5th and 6th bays. The doorway in the final bay has a stone lintel and composite jambs.

The southern half of the barn is divided by an internal division created by a stone wall, likely to have built in parallel with the extension (approximately the late-18th century). To the north is a single aisle, formerly supported by arcade posts, but owing to probable instability, have been replaced by 2 brick pillars. The north elevation contains a large inserted double doorway that leads into the barn space. The room, complete with a stone flagged floor, may represent an area for cart storage or livestock housing. To the north, accessed internally via a doorway in the

west of the dividing wall, the original barn space provides evidence of a change of use. The north elevation contains an original cart entry with a cantilevered segmental arch, suggesting the space was used for cart storage. In the south and north walls ventilation slits indicate the former existence of a threshing floor, while stone corbels at first floor level in the gable end suggest that a shallow hay loft had formerly been in use. A modern, 20th century structure was inserted in the west of the room, and forms an office space accessed via a lean-to extension to the left of the cart-entry. In both gable ends (north and south) there are small square windows near the apex.

### **Building 2** Name/Description: Barn

*Description (e.g. Main Purpose, No. of Storeys, buildings materials, roof, distinguishing features)*

The 2nd structure, dating to the mid-19th century was built perpendicular to the barn abutting its north-eastern elevation. It may have been used as a barn or stables with an accommodation floor above. It is built of punch-dressed stone with a pitched roof, coped gables with quoins and corbelled kneelers that feature a simplified ovolo moulding. The south elevation is of 5 bays with windows in the ground and 1st floor, all with stone lintels and flush sills. To the east is a 1 bay extension, built on 1 storey, likely to date to the mid-to-late-19th century. It includes a doorway and window both with stone lintels cut with false voussoirs and screwbacks.

The north elevation has 3 bays, although the 1st contains a double-door, likely to be a 20th-century insertion, opened to provide access for tall farm machinery. The 1st floor has been removed in order to accommodation storage space and is indicated by a limewash to the ground floor as well as the existence of 2nd storey windows. In the west wall, at 1st floor, the remains of a brick lined chimney can be seen, suggesting that this level may have provided accommodation for farm workers. In the southwest corner there is an inserted doorway that provides access to the original barn. The roof contains king-post trusses with 2 purlins of 4 bays, but all have been replaced.

### **Other History:**

The site of Hollin Hall dates to the medieval period when a hall is said to have been built in the area. By the late-17th century the farm, known as Hollin Hall, was located within Harewood Common and occupied a space of 143 acres with the fields being of a recent date owing to their well-proportioned, rectangular shape reminiscent of enclosures for that period (WYAS WYL 250/3/33). By 1758, and following a 15-year tenancy by a farmer, John Bickerdike, the farm had increased in size to 193 acres with the rent doubling from £30 to £60 (WYAS WYL 250/3/247). Between the end of Bickerdike's lease and the start of the new tenancy (1764-5), several improvements were made to the farm including substantial draining of the surrounding land and the building of two ponds (SE 33552, 43645; SE 33778, 43652), part of an audacious scheme to provide water for Harewood House ( WYAS HAR SC 3 &4). In 1765 the rent was increased to £120 per annum, over double the former rent (WYAS WYL/250/3/247). While favourable economic conditions (Chambers & Mingay 1966) and a rise in agricultural prices may have led to the rental increase, it is more likely that the investments in fixed capital such as barns and farm buildings by the Estate would have been more influential in this instance.

The modern form represents a partial loss of the original farmstead plan largely owing to recent developments of the farmhouse and the area to the west, between the house and barns. This was formerly used as a yard, creating a loose courtyard plan (e.g. piecemeal development around a courtyard). The layout has been disrupted in the last decade owing to modern development of the farmhouse and associated gardens.

**Sources Consulted:**

WYAS WYL 250/3/33: West Yorkshire Archive Service, Leeds: Harewood Estate Papers, Estate Maps - c.1698

WYAS WYL 250/3/247: West Yorkshire Archive Service, Leeds: Harewood Estate Papers, Estate Accounts

WYAS HAR SC 3 &4: West Yorkshire Archive Service, Leeds: Harewood Estate Papers, Stewards' Correspondence

WYAS WYL/250/3/49: West Yorkshire Archive Service, Leeds: Harewood Estate Papers, Estate Maps - c.1813

Chambers, J. D. & Mingay, G. E., 1966, *The Agricultural Revolution: 1750-1880*, BT Batsford: London

**Farm Name & Situation:** Lofthouse Grange Farm  
**Date Visited:** 11/09/09  
**Access:**.....(Partial (limited)/**Medium**/Full)  
**Ordnance Survey Grid Reference:** SE 32570 43670

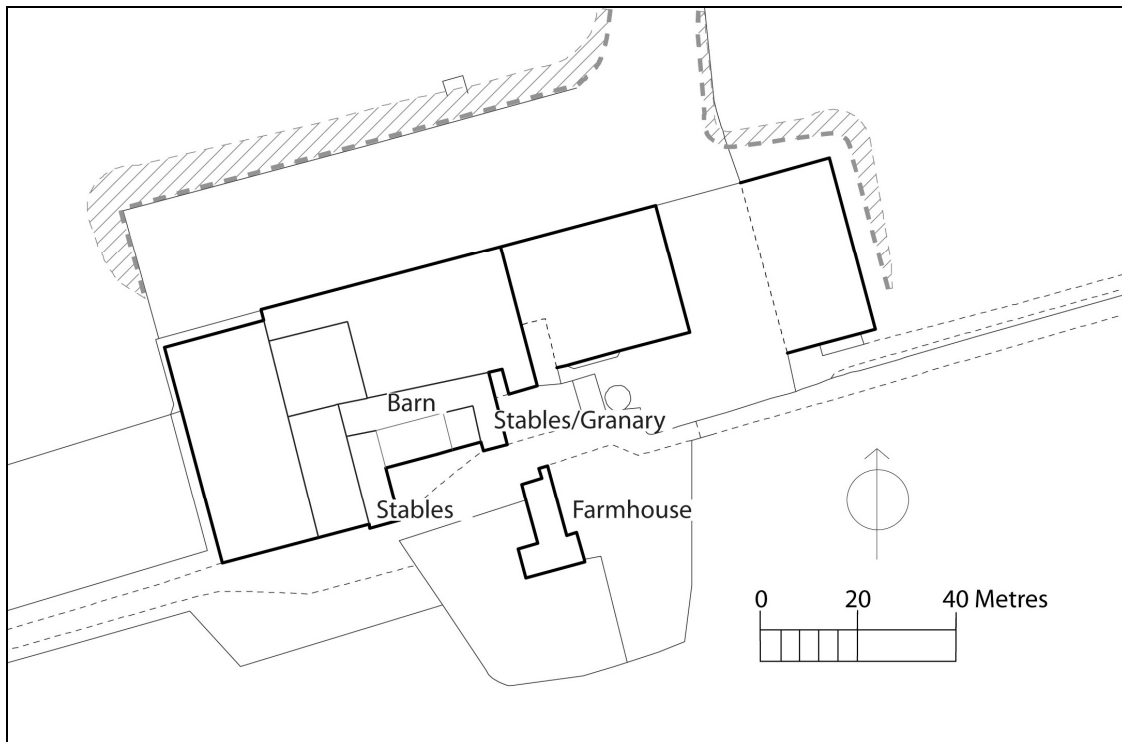

**1. Date of Building/Farmstead** (Please circle)      Pre-1750  
 1751-1796  
 1796-1813  
**1813-1900**  
 Post 1900

**2. Survival of farmstead as a whole:** (Please circle)      Partially (less than 25%)  
**Partial Loss (25-50%)**  
 Significant Loss (50-75%)  
 Major Loss (More than 50%)

**Significance of the farmstead:** (Please circle)      Rare survival on estate  
**Representative for the period and areas**  
 Unrepresentative for the period and area

**3. Fittings and fixtures:**      **Rare original features, e.g.:**.....  
 (E.g. doors, windows, surfaces, fittings)  
**Typical original features, e.g.**.....  
 Partial survival of original features, e.g.....  
 All original features removed, e.g.....



**4. Farmstead Type:** Dispersed (e.g. no focal area)

**Loose Courtyard Plan (e.g. piecemeal development around courtyard)**

Regular Courtyard Plan (e.g. careful plan in E, U or L shape)

Linear (e.g. buildings attached in line)

Parallel (e.g. buildings lie opposite main house)

**5. Farmstead House:** *Date/Period:* 1813-51

*Form (e.g. T-Shaped, double pile, etc):* T-shaped typical of Harewood Estate

*Description & Features (E.g. Rooms, size, style, features, building materials)*

The farmhouse, located to the south of the historic buildings, is built of punch-dressed sandstone, with a stone slate roof and stacks to ridge at gable ends with quoins and coped corbelled kneelers with cavetto mouldings. It is typical of a double-pile Georgian exterior with the southern elevation consisting of 3 bays and 2 storeys with a central doorway flanked on either side by windows on both floors cut with false voussoirs and projecting sills. To the rear of the house is a projecting service end creating a T-shape, similar to the farmhouses at New Laithe and Stockton Farm. The west elevation consists of 2 bays with windows on both floors in the 1st bay, with lintels cut with false voussoirs and projecting sills. The 2nd bay, closer to the returning wall of the main range, has a doorway at ground level, again with a lintel cut with false voussoirs, and a smaller window above with the same details as those on the rest of the elevation. An extension to the north had been added to the range and is of 2 bays. A doorway at ground level, with steps leading up in the 1st bay has monolithic jambs and lintel cut with false voussoirs. To its left are 2 windows on 1st and 2nd storeys, both with projecting sills and lintels cut with false voussoirs. Further lean-to additions to the east and north of the building are more recent, but are also built of dressed sandstone.

**6. Other Buildings:**

**Building 1** *Name/Description:* Barn

*Description (e.g. Main Purpose, No. of Storeys, buildings materials, roof, distinguishing features)*

The earliest building on the farmstead is the barn, likely to have been built in the final quarter of the 18th century. It is built of punch-dressed sandstone with a stone slate roof and corbelled kneelers in the gable ends with cyma recta mouldings. On either side of the main elevations are large cart-entries with composite jambs and cantilevered segmental arches. A double doorway has been inserted into the west gable end and has a timber beam lintel. On the same elevation, below the gable ridge, is a small box window of a post-and-lintel composition; this is also repeated in the eastern elevation but has been blocked. Below, on the east elevation is an inserted doorway to the right and an inserted window to its left (Both have monolithic stone lintels). The north elevation has evidence of 19th century mechanisation where an inserted square hole provided access for a an axel from a horse-wheel that was situated outside on the north side of the barn. An alternative

interpretation shown in Hartley & Ingilby (1972), reveals how these small windows may have been used to allow communication from the barn to the person managing the horses outside. The roof is of a fish-bone queen-post configuration.

**Building 2** *Name/Description: Stables & Granary*

*Description (e.g. Main Purpose, No. of Storeys, buildings materials, roof, distinguishing features)*

Adjoining the barn, to the south-west are stables with a granary on the 1st floor now occupied by a modern workshop. The structure abuts the southern elevation of the barn. The eastern elevation was of 3 bays with windows at ground floor (with stone lintels cut with false voussoirs) either side of an entrance now filled to include a 3rd window. Above is another window of similar ilk to the others on the elevation. The rear has a central staircase leading up into the building with rooms either side formerly used as a granary. Both rooms are open to the roof with fish-bone king-posts, and have original plank doors.

**Building 3** *Name/Description: Stables*

Perpendicular to the barn, at its south-west corner is a range of stables running southwards. It is built of punch-dressed sandstone, with a stone slate roof and has 1 storey and 6 bays consisting of stable doors in the 1st, 2nd and 4th bays and windows in the remaining. Each opening has stone lintels cut with false voussoirs. The interior has had the internal divisions removed and the walls have been lime washed. An inserted, open double door with wooden beam lintel to the north provides access to the adjacent barn, and the roof has been replaced with king-post trusses. The north elevation reveals that a wall in line with the elevation was extended eastwards, joining to the adjacent barn. Within this extension is an inserted doorway with a monolithic stone lintel.

**Sources Consulted:**

Hartley, M., & Ingilby, J., 1972, *Life in the Moorlands of North-East Yorkshire*, London: J. M. Dent & Sons Ltd

WYAS WYL 250/3/247: West Yorkshire Archive Service, Leeds, Harewood Estate Archive, Estate Accounts

**Farm Name & Situation:** New Laithe Farm  
**Date Visited:** 01/09/08  
**Access:**.....(Partial (limited)/**Medium**/Full)  
**Ordnance Survey Grid Reference:** SE 33589 44530

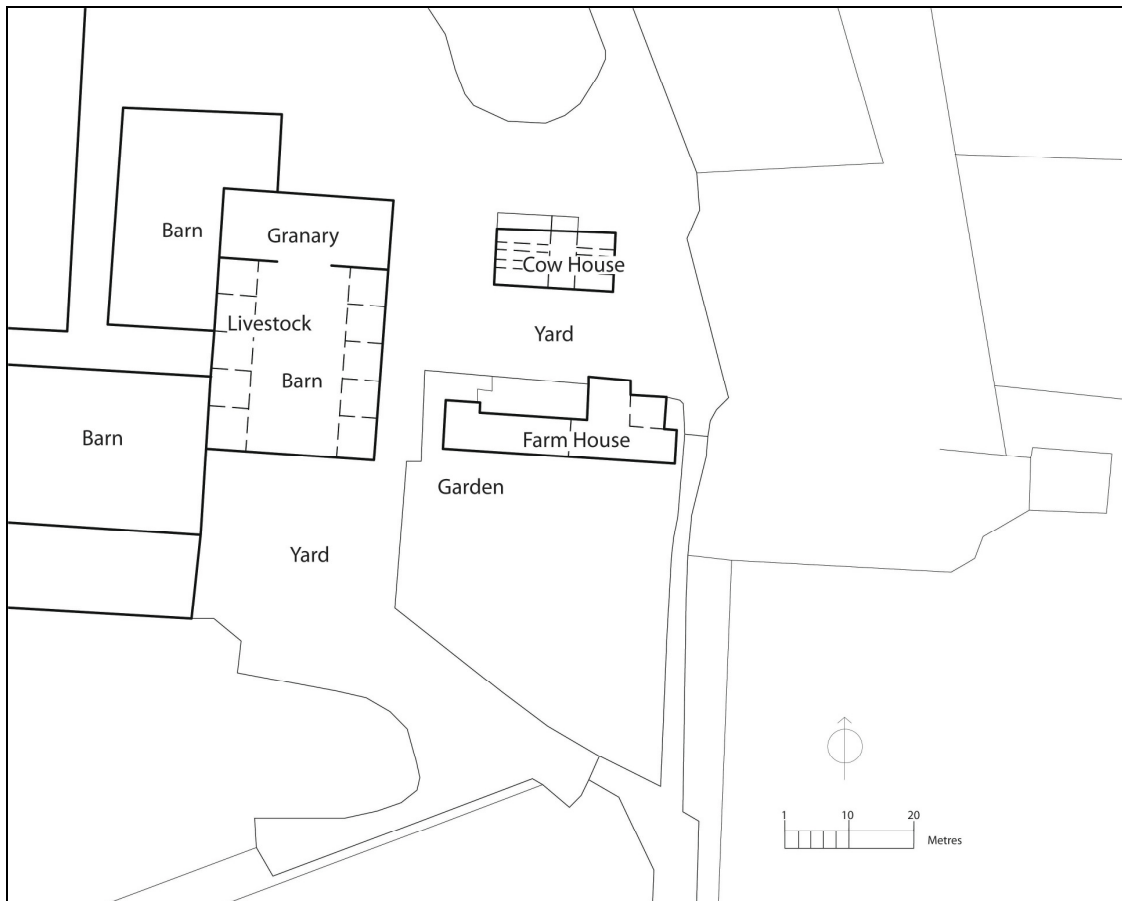

**1. Date of Building/Farmstead** Pre-1750  
(Please circle) **1751-1796**  
1796-1813  
1813-1900  
Post 1900

**2. Survival of farmstead as a whole:** Partially (less than 25%)  
(Please circle) **Partial Loss (25-50%)**  
Significant Loss (50-75%)  
Major Loss (More than 50%)

**Significance of the farmstead:** Rare survival on estate  
(Please circle) Representative for the period and areas  
**Unrepresentative for the period and area**

**3. Fittings and fixtures:****Rare original features, e.g.:**.....

(E.g. doors, windows, surfaces, fittings)

**Typical original features, e.g.**.....

Partial survival of original features, e.g. ....

All original features removed, e.g. ....

**4. Farmstead Type:** Dispersed (e.g. no focal area)**Loose Courtyard Plan (e.g. piecemeal development around courtyard)**

Regular Courtyard Plan (e.g. careful plan in E, U or L shape)

Linear (e.g. buildings attached in line)

Parallel (e.g. buildings lie opposite main house)

**5. Farmstead House:** *Date/Period:* 1813-51*Form (e.g. T-Shaped, double pile, etc):* T-shaped typical of Harewood Estate*Description & Features (E.g. Rooms, size, style, features, building materials)*

The present farmhouse lies to the south of the farmstead and is made of punch-dressed sandstone with quoins, a stone slate roof, stacks to ridge at the gabled ends and is a T-shape, dating the house to the early 19th century. A number of extensions have altered this original form including a long addition to the west, and another, smaller one, to the east. The original southern façade was of 2 storeys and 3 bays with hung-sash windows with lintels and sills at both ground and 1st floor either side of a central doorway. The interior had a double pile plan with 2 cells, a parlour and best parlour, with a service room or kitchen to the rear. This provided easier access to the barn placed to the north. 1st floor rooms and a cellar were also included.

**6. Other Buildings:****Building 1** *Name/Description:* Barn*Description (e.g. Main Purpose, No. of Storeys, buildings materials, roof, distinguishing features)*

Surviving from this initial phase of development is a barn built to the north of the present farmhouse, of punch-dressed stone with a stone slate roof. At the centre of the front elevation, which is of 8 bays, is a large cart-entry with a segmental arch and composite jambs. At a later date part of the entry was filled with coursed sandstone leaving a doorway. This may have taken place in parallel to the insertion of 2 windows at 1st floor level in the 3rd and 5th bays and a doorway in the 7th with external steps leading up. The addition may have been linked to the formation of a granary, a development seen at other sites on the Harewood Estate including Stables Farm. At the rear, a lean-to was added abutting the barn with cart sheds to the right.

**Building 2** *Name/Description: Barn & Granary*

*Description (e.g. Main Purpose, No. of Storeys, buildings materials, roof, distinguishing features)*

Another significant building is a barn with an extension dating to the late-18th and early 19th centuries, positioned to the north-west of the farmhouse. The structure is built of punch-dressed stone, with a stone slate roof, and is principally of 2 phases, the 1st being the barn on an east/west orientation, and then a large extension running perpendicular. The north elevation is of 6 bays and 2 storeys with access to the interior provided by a large inserted, central cart-entry, as well as doorways on the 1st floor in the 1st and 5th bays. Windows are also present in the 2nd, 4th and 6th bays; all have curved lintels carved with false voussoirs and composite jambs. The interior shows signs of mortices indicating the former existence of a hay loft, while above is an oak fish-bone king-post roof. To the south of the barn is a large extension accessed via an enlarged cart-entry. An aisled threshing floor/storage area with brick arches is flanked on either side by 8 bays of livestock housing running perpendicular to the original barn. These are now separated by a concrete wall approximately 1m high. The east and west elevations are faced with punch-dressed sandstone and contain stable doors with accompanying windows, all with monolithic lintels and sills. The south elevation, a gable end, is built in 3 bays with a large central cart-entry at ground floor, 2 filled windows with curved lintels and false voussoirs at 1st floor, 2 similar windows but blind on the 2nd floor, and a central oculus below the gable. The initial extension is likely to date to the early-19th century while the addition of the brick aisles and livestock housing is probably later.

**Building 3** *Name/Description: Farmhouse (Demolished)*

*Description (e.g. Main Purpose, No. of Storeys, buildings materials, roof, distinguishing features)*

To the west of the main group of buildings was an ornamental farmhouse with an octagon roof flanked on either side by pavilions (WYAS WYL/HAR ACC/386). This was a very similar arrangement to those built by John Carr at High Lofthouse, Harewood, as well as Arbour Hill and the Street Farm on the Hornby Estate, North Yorkshire, suggesting that Carr may have been responsible. The house would have been one of the few ornamental farms built on the estate during the period, with New Lays and Lofthouse facing one another across the newly enclosed common. Although the farmhouse was visible on the 1813 Harewood Estate map (WYAS WYL/250/3/49) it appears to have been demolished by 1851.

**Sources Consulted:**

WYAS WYL 250/3/247: West Yorkshire Archive Service, Leeds, Harewood Estate Archive, Estate Accounts

WYAS WYL/250/3/33: West Yorkshire Archive Service, Leeds, Harewood Estate Archive, Estate Maps

WYAS WYL/HAR ACC/386: West Yorkshire Archive Service, Leeds, Harewood Estate Archive, Additional Documents

**Farm Name & Situation:** Stables Farm

**Date Visited:** 17/03/2009

**Access:**.....(Partial (limited)/Medium/**Full**)

**Ordnance Survey Grid Reference:** SE 30800 45310

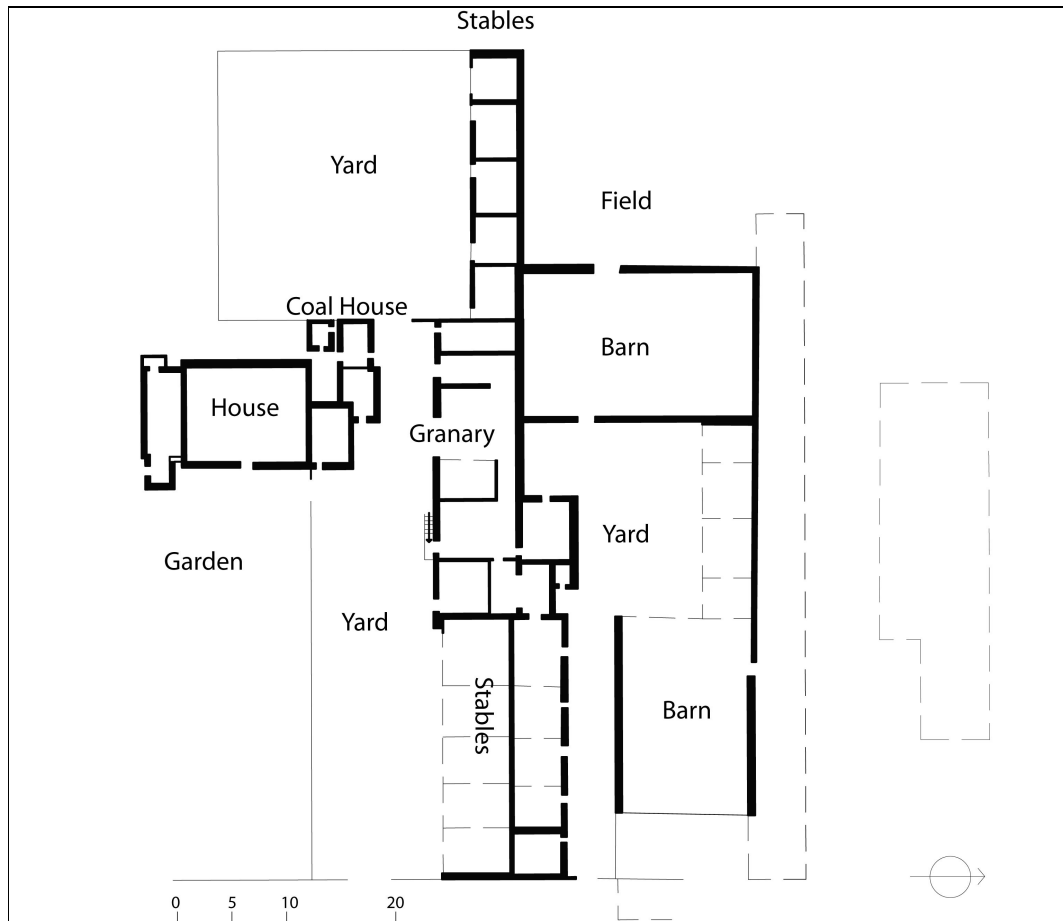

**1. Date of Building/Farmstead** Pre-1750  
 (Please circle) **1751-1796**  
 1796-1813  
 1813-1900  
 Post 1900

**2. Survival of farmstead as a whole: Partially (less than 25%)**  
 (Please circle) Partial Loss (25-50%)  
 Significant Loss (50-75%)  
 Major Loss (More than 50%)

**Significance of the farmstead: Rare survival on estate**  
 (Please circle) Representative for the period and areas  
 Unrepresentative for the period and area

- 3. Fittings and fixtures:**      **Rare original features, e.g.:**.....  
**(E.g. doors, windows, surfaces, fittings)**  
 Typical original features, e.g.....  
 Partial survival of original features, e.g.....  
 All original features removed, e.g.....

- 4. Farmstead Type:** Dispersed (e.g. no focal area)  
 Loose Courtyard Plan (e.g. piecemeal development around courtyard)  
 Regular Courtyard Plan (e.g. careful plan in E, U or L shape)  
**Linear (e.g. buildings attached in line)**  
 Parallel (e.g. buildings lie opposite main house)

- 5. Farmstead House:** *Date/Period:* mid-18<sup>th</sup> Century

*Form (e.g. T-Shaped, double pile, etc):* Double Pile

*Description & Features (E.g. Rooms, size, style, features, building materials)*

Begun in 1759, Stables Farmhouse was the 1st of the new set of houses and farm buildings built as a part of the 'improved' agricultural landscape planned by Edwin Lascelles (1713-95). It was built of punch-dressed sandstone with a stone slate roof and gable stacks to ridge. The front elevation is of 3 bays and storeys with 2 sets of 3-light flat-faced mullioned windows with plain surrounds flanking a central door with composite jambs and a chamfered surround. This double-pile plan was altered in the 19th century when a single-cell outshut was added to the right. This lower bay has a doorway with monolithic lintels dressed with false voussoirs, and a window on the ground and 1st floors with also with monolithic lintels. In the 1990s this room was extended westwards. During the 19th century an addition was also made to the south when an extension was added with a lean-to roof and coping. All the gable ends have corbelled kneelers with cyma recta mouldings.

The rear elevation was originally of 3 bays, with windows either side of a tall stair window. The bottom right window has recently (2009) been enlarged to include a doorway with tie-stone jambs and a stone lintel. To the left, 2 square post-and-lintel windows have replaced that on the ground floor. The lean-to outshut to the right includes a Tudor-arched doorway with a hollow chamfered surround possibly dating to the 16th century and may be from Harewood Castle.

The interior is typical of the mid-18th century, and features a central entry double pile plan with a parlour and living room at the front, and a dairy/pantry, kitchen, and access to the cellar at the rear. The form is remarkably similar to Daniel Garrett's design for Fairley Farm, Cambo, Northumberland, as well as others found in his *Designs for Farmhouses* (1747). By the 1750s such plans had become popular among fashionable landowners following the publication and distribution of Garrett's book and may well have been a direct influence on Edwin Lascelles' designs.

- 6. Other Buildings:**  
**Building 1** *Name/Description:* Barn



*Description (e.g. Main Purpose, No. of Storeys, buildings materials, roof, distinguishing features)*

North of the farmhouse is a barn of 6 bays, the last 2 of which are later additions, built of punch-dressed sandstone, a stone slate roof, quoins with 2 storeys. The south elevation consists of a tall segmental-arched cart-entry with composite jambs that was formerly flanked by mistal doorways, with that to the right now altered. The 1st bay contains an original doorway with stone lintel, likely to have provided access to a mistal or storage area with the barn. Above is an inserted doorway with large composite jambs and a massive stone lintel, accessed via external stone steps adjoining the south elevation. Above the door is an iron pulley bracket indicating that the 1st floor may have been used as a granary with the bracket used to hoist bags of grain. Immediately at the foot of the stairs is an inserted doorway with composite jambs and a shouldered chamfered lintel featuring lateral masons' marks. The doorway formerly provided access into a small internal area of the barn, the divisions of which are no longer visible. The 4th, 5th and 6th bays have recently been altered when establishing a domestic dwelling into the eastern half of the barn. An inserted doorway has been placed at 1st floor level in the 5th bay with external stairs providing access. To the left and right are 3-light flat-faced mullion windows. In the 6th bay at ground floor level a small window and doorway have been inserted in place of a double door. Both gable ends have coped corbelled kneelers with cyma recta mouldings. The western gable includes 2 square, post-and-lintel windows, 1 of which is filled. The north elevation also contains a central cart-entry, but a 20th century barn now hides much of facade to the right. That to the left has been altered presumably when the barn was converted to a dwelling. A straight joint between the 2nd and 3rd bays indicate the original extent of the barn.

Internally, the space to the right has been divided by a stone wall, leaving only the central, former threshing area and that to the left being accessible. The space is characterised by the presence of ventilation slits in both the north and south elevations that are normally associated with threshing floors. In the west wall are 3 arches approximately 1.5m high, with those to the left and right having been filled. These are similar in character to those found in barns at Stockton Grange and Lofthouse Farm. The central arch contains a wooden doorway that formerly provided access to the room behind (accessed via the doorway in the 1st bay of the south elevation). This is likely to have been a mistal or storage area for grain prior to the addition of the 1st floor granary. The insertion of this floor is evidenced by the insertion of approximately 18 mortice joints above the arches.

### **Building 2** *Name/Description: Stable*

*Description (e.g. Main Purpose, No. of Storeys, buildings materials, roof, distinguishing features)*

To the west, in line with the barn, are a set of stables built of punch-dressed sandstone and a stone slate roof to 1 storey. They incorporate 9 filled bays all separated by stone pillars, but with windows and doorways. Much of the original facade has been altered by the refurbishment of the building as offices for the farm and estate.

**Building 3** *Name/Description: Cart Sheds*

*Description (e.g. Main Purpose, No. of Storeys, buildings materials, roof, distinguishing features)*

North of the barn are cart sheds built around 1814. 4 bays survive of a long structure built of punch-dressed sandstone to 1 storey with stone pillars (similar to stables). The structure has been truncated by 20th century barns to the east and west. At some stage the south elevation has been weather-boarded and converted to stables. The only other occurrence of weather-boarding on the Harewood Estate can be found at the Joiners' Workshop.

**Sources Consulted:**

English Heritage, 'Stables Farmhouse', Listed Buildings Online (22/07/1986)

Garrett, D., 1749, Designs of Farmhouses, etc, for the Counties of Yorkshire, Northumberland, Cumberland, Westmoreland and the Bishoprick of Durham

**Farm Name & Situation:** Stockton Farm  
**Date Visited:** 21/08/2009  
**Access:**.....(Partial (limited)/Medium/**Full**)  
**Ordnance Survey Grid Reference:** SE 33610 45560

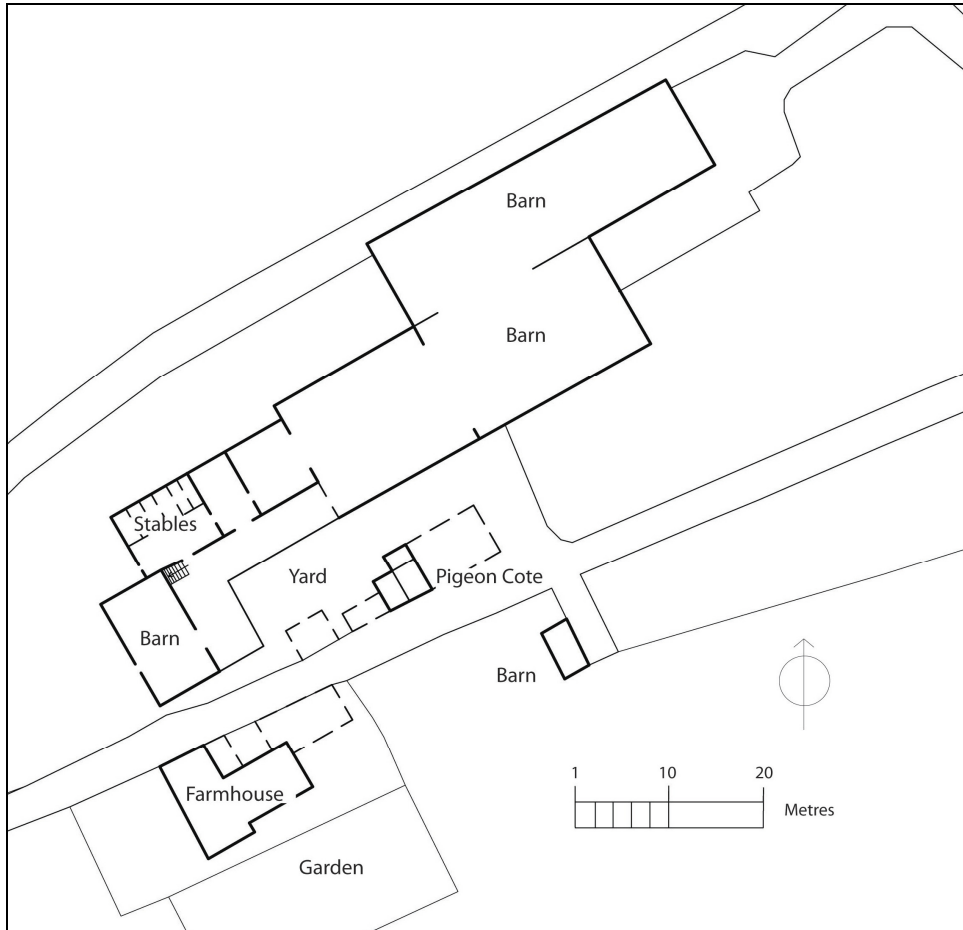

**1. Date of Building/Farmstead** Pre-1750  
 (Please circle) **1751-1796**  
 1796-1813  
 1813-1900  
 Post 1900

**2. Survival of farmstead as a whole: Partially (less than 25%)**  
 (Please circle) Partial Loss (25-50%)  
 Significant Loss (50-75%)  
 Major Loss (More than 50%)

**Significance of the farmstead:** Rare survival on estate  
 (Please circle) **Representative for the period and areas**  
 Unrepresentative for the period and area

- 3. Fittings and fixtures:** Rare original features, e.g.:.....  
(E.g. doors, windows, surfaces, fittings)  
**Typical original features, e.g.....**  
Partial survival of original features, e.g.....  
All original features removed, e.g.....

- 4. Farmstead Type:** Dispersed (e.g. no focal area)  
Loose Courtyard Plan (e.g. piecemeal development around courtyard)  
**Regular Courtyard Plan (e.g. careful plan in E, U or L shape)**  
Linear (e.g. buildings attached in line)  
Parallel (e.g. buildings lie opposite main house)

- 5. Farmstead House: Date/Period:** 1813-51

*Form (e.g. T-Shaped, double pile, etc):* T-shaped typical of Harewood Estate

*Description & Features (E.g. Rooms, size, style, features, building materials)*

The farmhouse, dating to the early-19th century is built of punch-dressed sandstone, with stone slate roof with stacks to ridge at gable ends with quoins and coped corbelled kneelers with cavetto mouldings. The front elevation has 3 bays and 2 storeys with a central doorway flanked on either side by windows on both floors with lintels cut with false voussoirs but with the main window having been replaced by modern fittings. The north-gable has a window below floor level indicated by its lintel, also cut with false voussoirs, at foot height. To the rear of the house, a projecting service end helps to form a T-shape. This is consistent with other farmhouses on estate dating to this period such as that at New Laithe and Lofthouse Grange. A 20th-century extension to the north-east conceals a former doorway that would have led to the fold yard in the north. To the rear of the house is a more recent stable built of punch-dressed sandstone and stone slate roof to 1 storey. It has a central stack to ridge, with doorways and windows (all with monolithic jambs and lintels) on the south elevation.

## **6. Other Buildings:**

**Building 1** *Name/Description:* Barn

*Description (e.g. Main Purpose, No. of Storeys, buildings materials, roof, distinguishing features)*

The earliest structure on the farmstead is the barn to the north of the farmhouse, now separated by a road. It is built of roughly-dressed sandstone, a stone-slate roof with quoins. With 1 storey, it has large central cart-entries on both the west and east elevations, both with composite jambs and cantilevered segmental arches. The east elevation has a blocked mistal doorway to the right, with tie-stone jambs and wooden lintel. Immediately to its left is a smaller, again blocked, arched entrance, possibly used as a trough or entry point for animals. Ventilation slits are visible in all elevations, suggesting that the interior central space would have been used as a

---

threshing floor, possibly with livestock housing either side. In the north elevation is an external stone buttress, while a stack has been added centrally above the gable.

**Building 2** *Name/Description: Stable*

*Description (e.g. Main Purpose, No. of Storeys, buildings materials, roof, distinguishing features)*

Perpendicular to the barn, and joined at its north-east corner, is a former stable with livestock housing. It is built of punch-dressed sandstone, with quoins, and a stone slate roof. The south elevation is of 6 bays, but has been whitewashed concealing windows in the 1st, 4th and 6th bays. Doorways in the 2nd, 3rd and 5th bays lead to smaller rooms, formerly used for livestock housing. The gable end to the east shows signs of an small extension to the north, which is presumably when a large central cart-entry with tie-stone jambs was inserted. Above, there is another, smaller, inserted doorway with tie-stone jambs with lintels cut with false voussoirs. This presumably provided access to a 1st floor granary.

An extension to the building took place to the west and is of 3 bays. A doorway in the 3rd bay at ground floor level, with tie-stone jambs and lintels cut with false voussoirs, leads to a former 1-cell stable with evidence of partitions remaining in the concrete floor. Access to the original range was provided through a doorway in the east elevation, while another, filled, is in the north elevation. An external staircase on the south facade provided access to a doorway at 1st floor level in the 1st bay. A window to the right has a monolithic lintel with herringbone masons marks. The doorway itself contains an original plank door with lock, and leads down a corridor, recently built with offices to the left, eastwards to a loft or granary built above the original building with replaced Queen-Post roof trusses with 1 purlin. The east gable end contains the inserted doorway mentioned above.

**Building 3** *Name/Description: Dovecote*

*Description (e.g. Main Purpose, No. of Storeys, buildings materials, roof, distinguishing features)*

Helping to form the courtyard is a dovecote arrangement to the south of the stables. It is built of dressed sandstone with stone slate roof and is flanked on both sides by outshuts. The south elevation is of 1 bay with a central doorway with composite jambs and stone lintel. A doorway above has monolithic lintel, while another, smaller below the gable, has a sill and lintel. The gables are coped with corbelled kneelers, and are flanked either side by outshuts also with pitched stone slate roofs. The addition in the east forms cart-sheds accessed via the fold yard in the north.

**Sources Consulted:**

WYAS WYL 250/3/247: West Yorkshire Archive Service, Leeds, Harewood Estate Archive, Estate Accounts

**Farm Name & Situation:** Stockton Grange Farm  
**Date Visited:** 11/09/2009  
**Access:**.....(Partial (limited)/Medium/**Full**)  
**Ordnance Survey Grid Reference:** SE 33346 45408

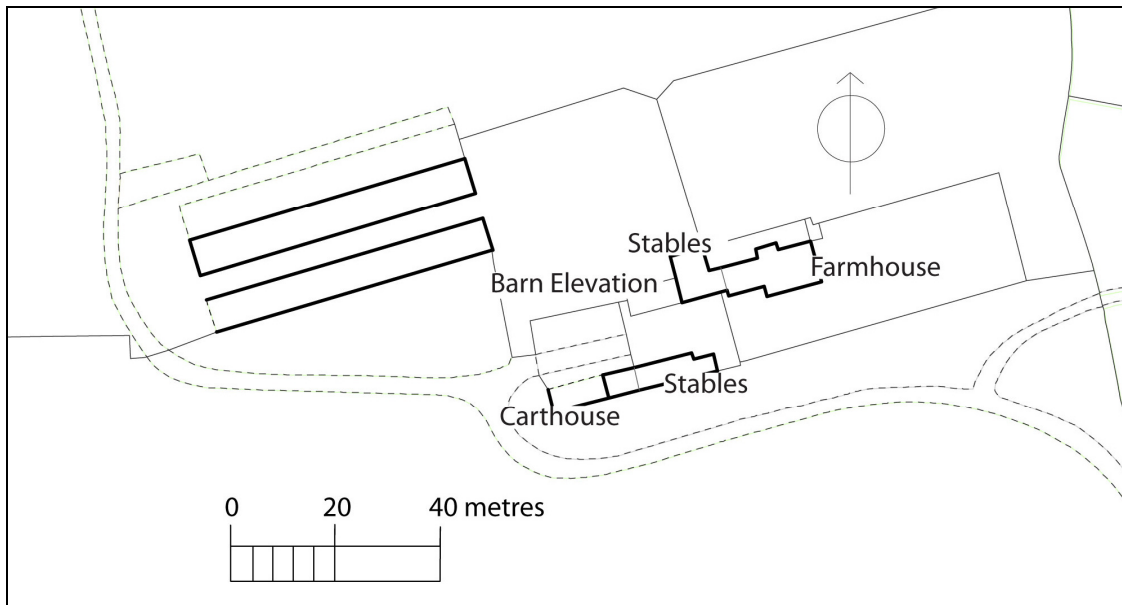

**1. Date of Building/Farmstead**  
 (Please circle)

- Pre-1750
- 1751-1796
- 1796-1813**
- 1813-1900
- Post 1900

**2. Survival of farmstead as a whole:**  
 (Please circle)

- Partially (less than 25%)**
- Partial Loss (25-50%)
- Significant Loss (50-75%)
- Major Loss (More than 50%)

**Significance of the farmstead:**  
 (Please circle)

- Rare survival on estate
- Representative for the period and areas**
- Unrepresentative for the period and area

**3. Fittings and fixtures:**

- Rare original features,**  
**e.g.:.....**  
**(E.g. doors, windows, surfaces,**  
**fittings)**
- Typical** original features,  
 e.g.....
- Partial survival of original features, e.g.....
- All original features removed, e.g.....

**4. Farmstead Type:**

Dispersed (e.g. no focal area)

**Loose Courtyard Plan (e.g. piecemeal development around courtyard)**

Regular Courtyard Plan (e.g. careful plan in E, U or L shape)

Linear (e.g. buildings attached in line)

Parallel (e.g. buildings lie opposite main house)

**5. Farmstead House: Date/Period:** late-18<sup>th</sup> Century*Form (e.g. T-Shaped, double pile, etc):* Double Pile*Description & Features (E.g. Rooms, size, style, features, building materials)*

Stockton Grange Farmhouse was built in the late-18th century and was extended in the early-19th century. It was built of hammer-dressed stone with a stone slate roof with stacks to ridge on the gable ends. The south elevation was built in 2 storeys with quoins and 3 bays with an extension of a bay to the left. The 1st and 3rd bays contain wide 28-pane sash windows with post-and-lintel surrounds below 21-pane sashes. These flank a central doorway with large composite jambs and massive stone lintel. Above is a blind square window with post-and-lintel surround. Either side are coped gables with corbelled kneelers. The extension to the left has 30-pane sash windows on the ground floor and a 24-pane sashes above, both with projecting sills and lintels cut with false voussoirs. The gable end has corbelled kneelers with cyma recta mouldings (similar to the original range) and a stack to ridge. The rear has 3 bays. In 1 and 3 are 2 16-pane sashes above one another with projecting sills, monolithic jambs and a lintels cut with false voussoirs. These flank a central window with large monolithic lintel and flush sill. Above is a more recent dormer, likely to date to the late-19th, early-20th century.

The interior was built to a central lobby double depth plan with two rooms either side and a central staircase. Either side of the lobby entrance were the two main rooms heated by hearths and fireplaces. Both rooms have fitted cupboards, which indicate that these spaces were used as parlours. At the rear of the house is a central corridor linking 3 rooms, 1 a modern water closet; that in the far east provides original access to a cellar below via a trapdoor. The extension to the west forms a kitchen with a large central hearth in the west wall. In the north-east of the room is a trapdoor leading down to the cellar. The cellar itself is built under the north part of the house and is made of two rooms with light provided by 12-pane windows. These include original stone worktops that show signs of wear. These are also accompanied by hooks and nails in the ceiling formerly used to hang foodstuffs and for general storage. Between the rooms is an original doorway with a plank door.

**6. Other Buildings:****Building 1** *Name/Description:* Stables*Description (e.g. Main Purpose, No. of Storeys, buildings materials, roof, distinguishing features)*

To the west of the Stockton Grange Farmhouse, abutting the structure, are stables built of punch-dressed sandstone with a stone slate roof of 3 bays and 2 storeys. The 1st floor contains 2 windows with projecting sills and lintels cut with false voussoirs in both the 1st and 3rd bays. Below, in that to the left, is an inserted window with a large lintel and projecting sill. The 2nd bay contains a stable door with a lintel cut with false voussoirs. To the right is another doorway of the same configuration of the 1st. Access to the 2nd storey is provided at the rear. At ground level the interior is split into 2 rooms. To the left is a space containing a crucible at the centre of the floor space and hooks in the ceiling. The room on the right also features hooks in the ceiling, but also contains a fireplace in the west wall and a doorway providing access to the north. To the left of the stables range was formerly a two bay extension. This is indicated by the western elevation where mortices for roof beams are visible and a door on the 1st floor are visible. A single wall, the south elevation, survives only on the ground floor and contains 2 doorways. North of the range was another extension. This is indicated by a 2 bay lean-to extension abutting the stables to the south. Again, 1 elevation remains projecting north with a doorway and window.

**Building 2** *Name/Description: Stable*

*Description (e.g. Main Purpose, No. of Storeys, buildings materials, roof, distinguishing features)*

Across the yard, to the south, are another set of stables built of punch-dressed ashlar sandstone with a stone slate roof, all likely to have been built in the 19th century. The structure is of 5 bays with the 1st 2 set back, and stable doors with post-and-lintel surrounds in bays 2, 3 and 5. Late-19th century windows are visible in bays 1 and 4.

**Building 3** *Name/Description: Barn & Cart Sheds*

*Description (e.g. Main Purpose, No. of Storeys, buildings materials, roof, distinguishing features)*

To the west of the stables, separated by the east elevation of a former barn, are cart sheds in 4 bays. These are built of sandstone with a stone slate roof. The barn elevation is the only surviving evidence of the structure and was built in a north-south orientation. It has a central cart entry with composite jambs and a cantilevered segmental arch. To the right is a square window, while on the other side are 2 small blocked arched entrances approximately 1m in height. These are similar to those found in the barns at Lofthouse Farm, Stockton and Stables Farm. These can be interpreted as either entrances for animals or as feeding troughs such as those seen at Lofthouse. Either way, the evidence suggests that the central cart-entry provided access to a threshing floor/cart storage flanked on either side by mistals.

**Sources Consulted:**

English Heritage, 'Stockton Grange Farmhouse', Listed Buildings Online (22/07/1986)



## APPENDIX C:

BUILDING MATERIALS, ARCHITECTURAL FORM AND ORNAMENT OF  
FARMHOUSES AND BARNs, HAREWOOD ESTATE, 1700-1850

## FARMHOUSES

<b>Year</b>	<b>Frequency</b>
1700-1750	0
1751-1800	7
1801-1850	4
Total	11

**Farmstead Type**

<i>Dispersed</i>	<i>Loose Courtyard</i>	<i>Regular Courtyard</i>	<i>Linear</i>
0	6	2	2

**Walling Technique**

<i>Ashlar</i>	<i>Rubble brought to courses</i>	<i>Squared rubble brought to courses</i>
11	0	0

**Plan**

<i>Asymmetrical</i>	<i>Rectangular/Double-Pile</i>	<i>T-Plan</i>
2	6	3

**Bays of Front Elevation**

3	4	5
11	0	0

---

**Classical Ornament**

---

<i>False-Voussoir</i>	<i>Entrance Stair</i>	<i>Windows/Door Mouldings</i>	<i>Moulded Kneelers</i>	<i>Central Pediment</i>
9	2	2	7	1

**Local Vernacular Features in Doors and/or Windows**

---

<i>Mullioned Windows</i>	<i>Tie-Stone Jambs</i>	<i>Composite Jambs</i>	<i>Plain Jambs</i>	<i>Plain Lintels</i>
2	1	2	8	3

## BARNs

<b>Year</b>	<b>Frequency</b>	<b>Adaptation(s)</b>
1700-1750	2	0
1751-1800	7	2
1801-1850	0	5
1851-1900	0	2

**Walling Technique**

---

<i>Dressed Stone</i>	<i>Rubble brought to courses</i>	<i>Squared rubble brought to courses</i>
2	1	6

**Classical Ornament**

---

<i>False-Voussoir</i>	<i>Windows/Door Mouldings</i>	<i>Moulded Kneelers</i>
4	0	4

**Local Vernacular  
Features in Doors  
and/or Windows**

<i>Mullioned Windows</i>	<i>Aisle(s)</i>	<i>Tie-Stone Jambs</i>	<i>Composite Jambs</i>	<i>Plain Jambs</i>	<i>Plain Lintels</i>
1	3	0	5	5	7

**King Post  
Roof  
Structure**

<i>1 Purlin</i>	<i>2 Purlins</i>	<i>3 Purlins</i>
1	4	0

**Additional  
Functions**

<i>Threshing Floor/Ventil ation Slits</i>	<i>Granary</i>	<i>Hay Loft</i>	<i>Mistall(s)</i>
6	6	4	7

## APPENDIX D:

## HAREWOOD ESTATE CASHBOOKS ACCOUNTS , 1764-1810

<b>Year</b>	<b>Expenditure on Harewood House (£)</b>	<b>Expenditure On Stables (£)</b>	<b>Total Expenditure (£)</b>	<b>Rental Income (£)</b>	<b>Rent % of Total Income</b>	<b>Total Income (£)</b>
1764	2187	n/a	6583	4849	68.83	7045
1765	1722	n/a	5461	4752	65.55	7249
1766	3509	n/a	8544	6425	72.07	8915
1767	4016	n/a	8810	4641	51.00	9100
1768	3702	n/a	6939	4675	58.25	8026
1769	3080	n/a	6636	5466	71.64	7630
1770	2380	n/a	6563	5335	68.97	7735
1771	2056	n/a	6991	5891	70.14	8399
1772	1405	n/a	6882	6294	72.47	8685
1773	688	51	7508	6545	72.72	9000
1774	517	n/a	8055	7316	75.52	9687
1775	n/a	n/a	9534	7222	71.68	10075
1776	n/a	n/a	6846	5192	65.86	7883
1777	n/a	n/a	7212	6810	70.17	9705
1778	n/a	n/a	7840	8199	75.30	10889
1779	n/a	n/a	8061	8004	75.29	10631
1780	n/a	n/a	10028	8983	76.98	11670
1781	n/a	n/a	8007	7402	74.12	9987
1782	n/a	n/a	8535	9987	96.87	10310
1783	n/a	n/a	10062	10112	94.55	10695
1784	n/a	n/a	10640	8537	90.62	9421
1785	n/a	n/a	10053	9210	95.30	9664
1786	n/a	n/a	11307	9518	87.20	10915
1787	n/a	n/a	11141	9567	86.29	11087
1788	n/a	n/a	11368	9406	78.86	11928
1789	1395	118	13226	13570	91.19	14881
1790	1534	n/a	14990	14068	89.75	15675
1791	1668	n/a	12886	13140	98.10	13394
1792	1738	n/a	13956	13504	98.11	13764
1793	1671	n/a	12818	13473	98.42	13689
1794	2000	n/a	14635	14235	94.81	15015
1795	2366	n/a	17108	14007	81.87	17108
1796	2643	n/a	16958	13278	89.43	14848
1797	3020	n/a	21478	15240	80.48	18936
1798	n/a	n/a	22389	21067	97.19	21676
1799	2002	n/a	18287	18331	97.18	18862
1800	2931	n/a	20946	20934	97.10	21560
1801	2818	n/a	23401	26114	98.44	26528
1802	2575	n/a	29204	29148	98.91	29468

---

<b>Year</b>	<b>Expenditure on Harewood House (£)</b>	<b>Expenditure On Stables (£)</b>	<b>Total Expenditure (£)</b>	<b>Rental Income (£)</b>	<b>Rent % of Total Income</b>	<b>Total Income (£)</b>
<i>1803</i>	3015	n/a	24932	25701	98.97	25968
<i>1804</i>	3406	n/a	24579	26856	99.01	27125
<i>1805</i>	3171	n/a	26781	28179	98.98	28468
<i>1806</i>	3773	n/a	27010	27762	98.32	28235
<i>1807</i>	3781	n/a	26546	27754	98.85	28078
<i>1808</i>	3328	n/a	27181	29981	96.00	31230
<i>1809</i>	3885	n/a	31769	32293	95.42	33842
<i>1810</i>	3644	n/a	31447	31106	90.61	34330

---

*Source:* Harewood Estate Archives, Steward's Cashbooks