



The  
University  
Of  
Sheffield.

**Modelling of existing high-rise apartment buildings  
for energy-efficient refurbishment in South Korea**

**By:**

Hyunju Jang

A thesis submitted in partial fulfilment of the requirements for the degree of  
Doctor of Philosophy

The University of Sheffield  
Faculty of Social Sciences  
School of Architecture

January 2016



## Abstract

Since the 1960s, the construction of high-rise apartment buildings has been prolific across Asia. These buildings, nowadays, are required to reduce excessive energy consumption in order to mitigate carbon emissions. Various measures of refurbishment strategies have focused on measuring energy saving. A building energy model, one of the more dominant measurement methods, needs to be advanced for more reliable and achievable results. However, the current approaches for existing apartments in the context of South Korea is unsatisfactory due to influential factors, being disregarded in the process.

This study aims to develop a building energy model of existing apartment buildings for energy-efficient refurbishment in South Korea by integrating the influencing factors that cause variation in actual energy consumption. The developed building energy model implemented to evaluate refurbishment strategies of reducing energy consumption with respect to future climate change.

The overall results can be summarised as follows: firstly, the prioritisation of the physical characteristics affecting energy consumption provides one determinant building feature, construction years, and two subsidiary features, heating methods and unit sizes, to classify existing buildings. Secondly, the 90% probability of occupants' behaviours, inferred from actual consumption, is set with 17 – 20°C set temperatures and 3 – 8 hours of operation for heating. Electricity consumption is derived from 3 – 6 hours of operation with several influential appliances. Thirdly, variation among the middle floors requires the building energy model specified with individual units. Moreover, a numerical model of individual heating controls showed 18 – 22°C set-point temperatures in apartment units with different locations with 7 – 8 hours of heating. Lastly, the refurbishment strategies based on the thermal regulations in 2011 efficiently reduce energy consumption. However, further improvement of increasing insulation is not efficient. Climate projection for a heating dominant climate would have a limited impact on the total energy consumption, with only 600 kWh/year in 2050.



# Acknowledgements

My immense gratitude goes to Professor Jian Kang for the academic advice, support and willingness. You have been an ever present beacon of encouragement. Thank you for keeping your calendar free and be available all the times when I needed your guidance.

I am grateful to Dr. Lucy Jones, for the guidance in the beginning of this study and continuous support. My sincere thanks to Professor Jae-dol Kim for helping me collect essential data and carry out this study. I greatly appreciate the detailed and constructive comments and suggestions given by Professor Steve Sharples and Dr Chengzi Peng. I also sincerely appreciate Supakchai Ponglertsakul for the mathematical support, and Kate Orgill for the English support.

I am grateful to my parents for their encouragement at every step of this journey. My sincere thanks to Chomchon Fusinpaiboon, for unfailing support. I also appreciate my dear friends, Jisoo Hong, Aunwaya Kaewpitak, Liyuen Gu, Minkyu Kim, Sujung Lee and Sebastian Diaz-Gasca.



# Content

|   |            |
|---|------------|
| <b>Abstract.....</b>  | <b>i</b>   |
| <b>Acknowledgements .....</b>   | <b>iii</b> |
| <b>Content.....</b>   | <b>v</b>   |
| <b>List of Abbreviations .....</b>  | <b>x</b>   |
| <b>List of Figures.....</b>   | <b>xii</b> |
| <b>List of Tables .....</b>   | <b>xv</b>  |
| <b>1 Introduction.....</b>  | <b>1</b>   |
| 1.1 Background of the research.....   | 2          |
| 1.1.1 Green House Gas emissions and energy use in existing buildings .....                          | 2          |
| 1.1.2 Assessment methods of energy performance in buildings .....                                   | 3          |
| 1.1.3 Main challenges of quantifying energy performance in buildings.....                           | 5          |
| 1.1.4 High-rise apartment buildings and refurbishment measures in South Korea.....                  | 6          |
| 1.2 Research questions arising from the gap.....  | 8          |
| 1.3 Aims and objectives .....   | 10         |
| 1.4 Structure of the thesis.....  | 11         |
| <b>2 Literature review.....</b>   | <b>15</b>  |
| 2.1 Energy-efficient refurbishment of existing buildings .....                                      | 16         |
| 2.1.1 Overview of energy-efficient refurbishment.....   | 16         |
| 2.1.2 Assessment schemes of energy performance for existing buildings.....                          | 19         |
| 2.1.3 Energy quantification methods measuring energy efficiency and energy saving in buildings..... | 21         |
| 2.1.4 Challenges of energy-efficient refurbishment for existing buildings.....                      | 26         |
| 2.1.1 Performance gap and advanced modelling methods .....  | 29         |
| 2.1.1.1 Uncertainty in occupant behaviour .....   | 30         |
| 2.1.1.2 Uncertainty in physical conditions in buildings .....                                       | 31         |
| 2.1.1.3 Decision making under uncertainties .....   | 33         |
| 2.2 Existing high-rise apartment buildings in South Korea .....                                     | 35         |

|          |   |           |
|----------|---|-----------|
| 2.2.1    | Climate conditions in South Korea .....   | 35        |
| 2.2.2    | Profile of buildings in South Korea .....   | 39        |
| 2.2.3    | High-rise apartment buildings in South Korea.....   | 41        |
| 2.2.3.1  | Development of high-rise apartment buildings.....   | 41        |
| 2.2.3.2  | Transformation of building characteristics of high-rise apartment buildings .....   | 44        |
| 2.2.3.3  | Energy systems in high-rise apartment buildings .....   | 52        |
| 2.2.4    | Building performance assessment schemes in South Korea .....  | 54        |
| 2.2.1    | Refurbishment measure quantifying energy performance in existing buildings in South Korea.....                                      | 58        |
| 2.2.2    | Limitations of measuring building energy performance .....  | 59        |
| 2.3      | Summary .....   | 61        |
| <b>3</b> | <b>Methodology .....</b>  | <b>65</b> |
| 3.1      | Research design.....  | 66        |
| 3.1.1    | Overall strategy .....  | 66        |
| 3.1.2    | Sampling .....  | 71        |
| 3.1.3    | Data collection .....   | 73        |
| 3.1.4    | Building simulation.....  | 76        |
| 3.2      | Data analysis .....   | 77        |
| 3.2.1    | Frequency inference .....   | 78        |
| 3.2.2    | Bayesian inference .....  | 80        |
| 3.3      | Summary .....   | 82        |
| <b>4</b> | <b>Classification of existing apartment buildings with respect to effective building features affecting energy consumption.....</b> | <b>85</b> |
| 4.1      | Background .....  | 86        |
| 4.2      | Methodology .....   | 89        |
| 4.2.1    | Evaluation of energy consumption in existing apartment buildings .....  | 89        |
| 4.2.2    | Identification of building features affecting energy consumption .....  | 89        |
| 4.2.3    | Quantification of effects by building features.....   | 93        |
| 4.2.3.1  | Sampling .....  | 94        |
| 4.3      | Results.....  | 96        |



|          |   |            |
|----------|---|------------|
| 4.3.1    | Energy consumption in old apartment buildings.....  | 96         |
| 4.3.2    | Building features affecting to energy consumption .....   | 100        |
| 4.3.3    | Quantification of effects of building features on energy consumption .....  | 103        |
| 4.3.3.1  | Results of multiple regression analysis .....   | 103        |
| 4.3.3.2  | Results of factor analysis .....  | 107        |
| 4.4      | Discussion .....  | 109        |
| 4.5      | Summary .....   | 111        |
| <b>5</b> | <b>Integration of variation arising from occupants' behaviours consuming heating and electricity into a building energy model of existing apartment buildings..</b> | <b>113</b> |
| 5.1      | Background .....  | 114        |
| 5.2      | Methodology .....   | 116        |
| 5.2.1    | Evaluating variation in actual energy consumption in apartment buildings .....  | 117        |
| 5.2.1.1  | Sampling .....  | 117        |
| 5.2.1.2  | Normality tests .....   | 118        |
| 5.2.2    | Integrating occupant behaviour reflecting actual energy consumption into building energy models .....   | 119        |
| 5.2.2.1  | Building energy models of occupant behaviours controlling heating and electricity .....   | 119        |
| 5.2.2.2  | Optimisation of model estimation reflecting variation in the actual energy consumption .....  | 122        |
| 5.2.3    | Generalisation of probability of occupant behaviours consuming heating and electricity.....   | 124        |
| 5.2.4    | Evaluating estimated energy consumption of probabilistic models.....  | 125        |
| 5.3      | Results.....  | 126        |
| 5.3.1    | Variation in actual energy consumption in apartment buildings.....  | 126        |
| 5.3.2    | Probability of standardised conditions regarding variation in actual energy consumption.....  | 127        |
| 5.3.2.1  | Optimisation of the estimated energy consumption in building energy models .....  | 127        |
| 5.3.2.2  | Probability of energy consumption with Gaussian Process Classification .....  | 135        |
| 5.3.3    | Evaluation of estimating energy consumption with the probability of the standardised conditions .....   | 139        |

|          |  |            |
|----------|--|------------|
| 5.4      | Summary .....  | 141        |
| <b>6</b> | <b>Developing a building energy model corresponding to variation in individual apartment units in existing apartment buildings .....</b> | <b>143</b> |
| 6.1      | Background .....   | 144        |
| 6.2      | Methodology .....  | 147        |
| 6.2.1    | Measuring heating energy consumption in apartment units with different locations .....   | 147        |
| 6.2.2    | Estimating heating energy consumption with a building energy model of high-rise apartment buildings .....                                | 148        |
| 6.2.3    | Creating a new model of unit-specific heating energy consumption .....   | 151        |
| 6.3      | Results .....  | 153        |
| 6.3.1    | Heating energy consumption in individual apartment units .....   | 154        |
| 6.3.2    | Influence of variables in heating controls on the unit-specific heating energy consumption in the building energy model .....            | 155        |
| 6.3.3    | Polynomial models integrating heating controls and interaction between floors....  | 157        |
| 6.3.3.1  | Polynomial models of heating controls .....  | 159        |
| 6.3.3.2  | Polynomial models of interaction between floors .....  | 162        |
| 6.3.4    | New model estimations of heating controls determining real energy consumption  | 168        |
| 6.4      | Summary .....  | 172        |
| <b>7</b> | <b>Implementation of the building energy model developed for refurbishment measures under future climate change.....</b>                 | <b>175</b> |
| 7.1      | Background .....   | 176        |
| 7.2      | Methods.....   | 179        |
| 7.2.1    | Identifying relationships between climate factors and heating energy consumption .....   | 179        |
| 7.2.2    | Analysing impacts of refurbishment strategies on heating energy consumption and overheating hours .....                                  | 183        |
| 7.2.3    | Evaluating change in impact of refurbishment strategies under future climate change .....  | 185        |
| 7.3      | Results.....   | 187        |
| 7.3.1    | Relationships between climate factors and heating energy consumption .....   | 187        |

|          |   |            |
|----------|---|------------|
| 7.3.2    | Causality of variables in building envelope with heating energy consumption.....                            | 191        |
| 7.3.3    | Change in heating energy consumption and overheating hours with the holistic refurbishment strategies ..... | 194        |
| 7.3.4    | Impact of refurbishment strategies under future climate change scenarios .....                              | 197        |
| 7.4      | Summary .....   | 204        |
| <b>8</b> | <b>Conclusions and future works.....</b>  | <b>206</b> |
| 8.1      | Contributions of the thesis .....   | 207        |
| 8.2      | Future works .....  | 210        |
|          | <b>References.....</b>  | <b>212</b> |
|          | <b>Appendix A.....</b>  | <b>235</b> |
|          | <b>Appendix B.....</b>  | <b>243</b> |
|          | <b>Appendix C.....</b>  | <b>245</b> |
|          | <b>Appendix D.....</b>  | <b>246</b> |

## List of Abbreviations

|                   |  |
|-------------------|--|
| ANOVA             | Analysis of Variance                                   |
| AMIS              | Apartment Management Information System                |
| BMS               | Building Management System                             |
| CCWorldWeatherGen | Climate Change World Weather File Generator            |
| CV RMSE           | Coefficient of Variation of Root-Mean-Square Deviation |
| ECMs              | Energy Conservation Measures                           |
| GBCC              | Korea Green Building Certificate Criteria              |
| GHG               | Greenhouse Gas   |
| HDDs              | Heating Degree Days                                    |
| IPCC              | International Panel on Climate Change                  |
| IWEC2             | International Weather for Energy Calculations 2.0      |
| KAB               | Korea Appraisal Board                                  |
| KDHC              | Korea District Heating Corporation                     |
| KEPC              | Korea Electric Power Corporation                       |
| KHMA              | Korea Housing Management Association                   |
| KMA               | Korea Meteorological Administration                    |
| KMO               | Kaiser-Meyer-Olkin measure of sampling adequacy        |
| LHS               | Latin Hyper-cube Sampling                              |
| MCMC              | Markov Chain Monte Carlo                               |
| MLIT              | Ministry of Land Infrastructure and Transport          |
| nested EP         | nested Expectation Propagation                         |
| PCA               | Principle Component Analysis                           |
| PDF               | Probability Density Function                           |
| PHPP              | Passive House Planning Package                         |
| Q – Q             | Quantile – Quantile                                    |
| RCPs              | Representative Concentration Pathways                  |

|        |   |
|--------|---|
| RMSD   | Root-Mean-Square Deviation                            |
| SE     | Squared Exponential                                   |
| SRC    | Standardised Regression Coefficient                   |
| SRES   | Special Report on Emissions Scenarios                 |
| UNFCCC | United Nations Framework Convention on Climate Change |
| VIF    | Variance Inflation Factor                             |

# List of Figures

|  |     |
|--|-----|
| Figure 1.1. Diagram showing overall structure of this study .....  | 13  |
| Figure 2.1 Proportions of housing by construction years .....  | 17  |
| Figure 2.2 Procedure of refurbishment .....  | 19  |
| Figure 2.3 Classification of energy quantification methods .....   | 26  |
| Figure 2.4 Six challenges for energy-efficient refurbishment measures.....   | 28  |
| Figure 2.5 Climate classifications and regions of South Korea divided by building thermal regulations.....                           | 36  |
| Figure 2.6 Climate data of South Korea (1981 - 2010).....  | 38  |
| Figure 2.7 Profile of buildings in South Korea .....   | 40  |
| Figure 2.8 Proportion of residential buildings in South Korea .....  | 40  |
| Figure 2.9 Proportion of energy use in residential buildings .....   | 40  |
| Figure 2.10. Timeline of apartment constructions in South Korea .....  | 42  |
| Figure 2.11 Apartment buildings in apartment districts in South Korea.....   | 43  |
| Figure 2.12 Three different scales of apartments in South Korea.....   | 44  |
| Figure 2.13 Three types of apartment clusters .....  | 45  |
| Figure 2.14 Two types of apartment buildings .....   | 46  |
| Figure 2.15 Two types of apartment units .....   | 47  |
| Figure 2.16 Image of apartment buildings with two types.....   | 47  |
| Figure 2.17 Sections of underfloor heating applied in apartment buildings .....  | 52  |
| Figure 2.18 Underfloor hot-water heating, applied to apartment buildings in South Korea..  | 53  |
| Figure 2.19 Diagram of heating, applied to apartment buildings in South Korea .....  | 54  |
| Figure 3.1 Diagram of classifying existing apartment buildings with building features .....  | 67  |
| Figure 3.2 Diagram of creating a new standardised condition of occupants' behaviours adjusted for existing apartment buildings ..... | 68  |
| Figure 3.3 Diagram of dealing with uncertainties derived from individual apartment units .   | 69  |
| Figure 3.4. Diagram of the overall strategy of the research.....   | 70  |
| Figure 3.5. Apartment districts in Seoul .....   | 72  |
| Figure 3.6. Screenshot of monthly expenditure of one of apartments in AMIS .....   | 75  |
| Figure 3.7. Example of architectural drawings of existing apartment buildings .....  | 76  |
| Figure 4.1. Changes of building features in apartment construction of South Korea since the 1970s.....                               | 90  |
| Figure 4.2. Total average energy consumptions of the sampled apartment buildings .....   | 97  |
| Figure 4.3. Energy consumption of apartment buildings by construction years.....   | 99  |
| Figure 4.4. Monthly Energy consumption in 2011 and 2012 .....  | 101 |

|  |     |
|--|-----|
| Figure 4.5. Energy consumptions of old apartment buildings .....   | 105 |
| Figure 4.6. Regression curves of building features with energy consumption .....   | 107 |
| Figure 5.1. Description of the apartment units.....  | 120 |
| Figure 5.2. Results of normality tests of actual energy consumption .....  | 129 |
| Figure 5.3. Optimisation of model estimations in comparison to the variation in actual energy consumption .....  | 132 |
| Figure 5.4. Changes in R-squared values and F-ratios of the building energy models.....  | 133 |
| Figure 5.5. Results of Gaussian Process Classification for heating consumption .....   | 137 |
| Figure 5.6. Results of Gaussian Process Classification for electricity consumption .....   | 138 |
| Figure 5.7. Estimated energy consumption with the probability of the standardised conditions .....   | 140 |
| Figure 6.1. Description of the building energy model .....   | 150 |
| Figure 6.2. Comparison between the targeted heating energy consumption and the estimation of the simplified energy model for the 15 apartment units on different floors .....                          | 155 |
| Figure 6.3 R-squared values of polynomial models: heating controls in apartment units (solid line with solid dots) and heating set temperatures between two floors (dotted line with empty dots) ..... | 157 |
| Figure 6.4. Results of correlation coefficients analysis .....   | 158 |
| Figure 6.5. Goodness of fit for heating controls of 15 apartment units .....   | 160 |
| Figure 6.6. Estimation of heating set-point temperatures by heating hours in heating consumption.....  | 161 |
| Figure 6.7. R-squared values and sum of squared errors of polynomial models .....  | 163 |
| Figure 6.8. Sensitivity analysis of polynomial models with 7 hours heating.....  | 166 |
| Figure 6.9. Sensitivity analysis of polynomial models with 8 hours heating.....  | 167 |
| Figure 6.10. Estimation of heating set-point temperatures in apartment units .....   | 168 |
| Figure 6.11. Comparison of calculated heating energy consumption with targeted heating energy consumption .....  | 170 |
| Figure 6.12. Comparison of calculated heating energy consumption with targeted heating energy consumption with the measured standard deviation .....   | 171 |
| Figure 7.1. Monthly climate conditions in Seoul .....  | 182 |
| Figure 7.2. Current trends of national carbon emissions and energy consumption in households in South Korea .....  | 186 |
| Figure 7.3. Change in mean temperature in Seoul under different climate projections (historical, RCP4.5, SRES_A2 and RCP8.5 scenarios) .....   | 187 |
| Figure 7.4. Relationships between climate factors and heating energy consumption.....  | 190 |
| Figure 7.5. Impact of variables in building envelope on heating energy consumption .....   | 193 |
| Figure 7.6. Impact of holistic refurbishment strategies.....   | 195 |

|   |     |
|---|-----|
| Figure 7.7. Impact of refurbishment strategies .....  | 196 |
| Figure 7.8. Change in total energy consumption in individual apartment units depending on the holistic refurbishment strategies ..... | 196 |
| Figure 7.9. Change in heating energy consumption under future climate change .....  | 200 |
| Figure 7.10. Change in overheating hours under future climate change.....   | 200 |
| Figure 7.11. Impact of future climate change on the unit-specific heating energy consumption.....                                     | 202 |
| Figure 7.12. Impact of future climate change on overheating hours in individual units.....  | 203 |
| Figure 7.13. Change in total energy consumption with three refurbishment strategies under the future climate change .....             | 204 |



## List of Tables

|   |     |
|---|-----|
| Table 2.1 Legislation of insulation for building in the 1980.....   | 49  |
| Table 2.2 Legislation of insulation for building in the 1984.....   | 49  |
| Table 2.3 Legislation of insulation for building in the 1987.....   | 49  |
| Table 2.4 Legislation of the insulation for central region in the 2001 .....  | 50  |
| Table 2.5. Proportional rates of heating energy consumption in apartment units.....   | 52  |
| Table 2.6 Summary of building energy assessment methods in South Korea .....  | 57  |
| Table 2.7 Input data of building conditions in existing literature .....  | 63  |
| Table 4.1. Change in designs of building features in apartment construction in South Korea<br>in pre-2001 .....                                     | 93  |
| Table 4.2. The result of multiple regression analysis.....  | 103 |
| Table 4.3. Pattern matrix in factor analysis .....  | 108 |
| Table 5.1. Profile of thermal properties in the building energy models.....   | 121 |
| Table 5.2. Prior distributions of uncertain parameters in building energy models .....  | 122 |
| Table 5.3. Result of multivariate regression analysis .....   | 134 |
| Table 6.1. Binary linear model of 15 apartment units.....   | 161 |
| Table 6.2. Binary quadratic models of 15 apartment units .....  | 162 |
| Table 6.3. Binary linear models of 15 apartment units with 7 and 8 heating hours.....   | 164 |
| Table 6.4. Binary quadratic models (degree 2x1) with 7 and 8 heating hours.....   | 164 |
| Table 6.5. Binary quadratic models (degree 1x2) with 7 and 8 heating hours.....   | 165 |
| Table 6.6. Correlation coefficients of targeted and estimated energy consumption with input<br>heating set-point temperature on the top floor ..... | 171 |
| Table 7.1. Collinearity statistics of climate factors.....  | 180 |
| Table 7.2. Thermal conditions of the building envelopes with the building regulation.....   | 184 |



# Chapter 1

---

## Introduction

## 1.1 Background of the research

### 1.1.1 *Green House Gas emissions and energy use in existing buildings*

Global warming has been an international challenge as a result of the increase of Greenhouse Gas (GHG) emissions. Global mean temperature increased up to 0.8°C between 1880 and 2010 (Hansen *et al.*, 2010), and extreme weather events have taken place in many countries (e.g. United States Environmental Protection Agency, 2016; Korea Meteorological Administration, 2012). Human activities giving rise to GHG emissions commonly come from fossil fuel combustion that is one of the significant contributors increasing GHG emissions (Pachauri *et al.*, 2014). Since the first climate change assessment report from Intergovernmental Panel on Climate Change (IPCC) in 1990, the international treaty, named the United Nations Framework Convention on Climate Change (UNFCCC), was negotiated to stabilise GHG emissions in 1992. Further agreement was also made in the Kyoto Protocol, establishing national GHG inventories of the emissions from industrialised countries in 1997. Developing countries were also encouraged to produce the inventories, whereas developed countries had to submit the inventories to UNFCCC.

Many countries have paid significant attention to the diverse driving sectors. Policies and regulations have been enhanced to suppress GHG emissions in the driving sectors including buildings. For example, the European Union (EU) has cooperated to achieve 21% lower GHG emissions than the 2005 level of the emissions by 2020, and 43% lower by 2030 under the EU emissions trading system, limiting an allowance of the emissions but with the availability to purchase an allowance (Woerdman, 2015). South Korea, ranked 8<sup>th</sup> in the largest carbon emission country (Oliver *et al.*, 2012), has established a law, 'Framework act on Law Carbon Green Growth', enhancing levels of regulation in the sectors consuming fossil fuels, such as agriculture, transportation, industry and buildings (Jones and Yoo, 2012). However, the national GHG emissions of South Korea has been growing in all

sectors since 2000 (Oliver *et al.*, 2012), despite the mitigation policies enacted. Additional efforts have been addressed to achieve an actual reduction in the GHG emissions.

About 50% of the indirect GHG emissions, due to economic sectors, is comprised of energy use in buildings, according to the IPCC assessment (Pachauri *et al.*, 2014). Buildings are required to consume less and less energy while preserving a comfortable indoor environment. Thermal conditions of buildings have been intensified through policies and regulations to restrict excessive energy consumption. As a result, new buildings have been designed to be energy-efficient. Moreover, existing buildings that have already been built before this energy reduction scheme have been highly regarded to be refurbished. Both academic and industrial fields have explored the actual potent of reducing energy consumption inherent in buildings. Both fields have shown their focus on developing construction technologies in reducing building energy consumption and provided the quantification of ‘pre-’ and ‘post-’ levels of energy use in buildings.

### ***1.1.2 Assessment methods of energy performance in buildings***

As mentioned in the previous section, improving thermal conditions in existing buildings has been considered as one of the potential strategies in reducing GHG emissions. In order to succeed in the reduction, the energy performance of existing buildings has to be accurately assessed. Thus, refurbishment strategies are able to determine inefficient parts of buildings that need to be improved. Moreover, the accurate diagnosis helps to select appropriate refurbishment technologies.

According to Ma *et al.* (2012), energy-efficient refurbishments require six key elements: (1) policies and regulations, (2) client recourses and expectations; (3) retrofit technologies; (4) building-specific information; (5) human factors; (6) uncertainties. Policies and regulations provide the minimum requirements of building conditions for a comfortable indoor environment. The purpose and direction of refurbishments are determined by clients. The applicable retrofit technologies need to be accurately evaluated in comparison with the

original conditions. In order to identify the original energy performance of buildings, the specific building information needs to be surveyed. Moreover, how the buildings are operated and maintained also have to be identified. Finally, the possible errors causing uncertainties should be taken into consideration. Consequently, understanding the original conditions of buildings is crucial to implement energy-efficient refurbishments. Based on the accurate understanding of the 'pre' refurbishment conditions, the most efficient refurbishment strategies can be made. In order to achieve this, appropriate assessment methods for measuring energy performance in buildings are essentially needed.

The current assessment methods for building energy performance are differentiated by the purpose of analysis: energy classification and performance diagnosis (Wang *et al.*, 2012). Energy classification has been applied to provide levels of energy performance or GHG emissions in buildings, whilst performance diagnosis evaluates insufficient building performance for actual improvement. These assessments have been applied through four types: (1) building environment assessment schemes; (2) energy certifications; (3) whole-building benchmarking models; (4) hierarchical assessment and diagnosis tools (Wang *et al.*, 2012).

As reviewed in Chapter 2, each application takes different methods for quantifying building energy performance. The energy quantification methods can be categorised by three types: calculation-based, measurement-based and hybrid methods (Wang *et al.*, 2012). The calculation-based methods estimate energy performance by creating calculation models with input data of building conditions. The methods are specified by the dynamic simulation and steady-state method depending on how to consider dynamic effects of buildings. The measurement-based methods are expected to reduce discrepancies in the calculation-based methods by using actual energy use data from energy bills and monitored records. The hybrid methods are the integrated approaches of combining the calculation-based and the measurement-based methods. The calculation-based methods take the leading position in

analysing building performance, while the measured data is used to calibrate the calculation models (Wang *et al.*, 2012).

In short, building energy performance needs to be accurately measured in order to create efficient refurbishment strategies. The diverse applications of assessing energy performance buildings have been used to implement the assessments. This also determines how to quantify building energy performance (specifically reviewed in Chapter 2, Literature review).

### ***1.1.3 Main challenges of quantifying energy performance in buildings***

To determine the success or failure of refurbishment projects, two foundations have to be ensured. The first foundation is whether the original conditions of building energy performance are accurately diagnosed. The second one is whether the anticipated energy saving through refurbishment strategies can be achieved in real situations.

Six challenges for energy-efficient refurbishment have been reported by Stafford *et al.* (2011). Firstly, inflexible frameworks of refurbishment struggle to encapsulate complexity and diversity in individual buildings. Thus, refurbishment strategies may not be tailored for an individual or a specific group of buildings. Secondly, actual energy consumption can be different from the estimated energy consumption, which is called ‘The performance gap’. It is problematic because overestimation brings about over-sized HVAC systems and vice versa. Thirdly, the factors encompassing building envelopes are interacting a complex way, which requires to be considered holistically. The fourth challenge is how to integrate renewable technologies with the improvement of the building envelopes. The fifth challenge is how to deal with the uncertain occupant’s related issues, including occupancy, day-to-day behaviour, building services and maintenance. Lastly, continuous monitoring and feedback are important for further improvement. It has been revealed that the six challenges are derived from the complex and diverse building conditions, and the limitations of the current framework in assessing refurbishment.

In particular, existing literature has mentioned the performance gap that the predicted energy performance has easily over- or under-estimated compared to actual achievement in real situations. The performance gap causes high levels of uncertainties in the prediction of energy performance. This can result in unreliable refurbishment strategies. There have been continuous attempts to improve the energy quantification methods in order to reduce the discrepancy derived from the performance gap. Many previous studies suggest a probabilistic approach for the possible distribution of building factors in quantifying building energy performance, rather than a deterministic approach. Moreover, assessment methodologies have been more systematic and sophisticated with regard to actual energy use. Despite these efforts, there is no perfect and solid process quantifying energy performance in buildings. It is still an ongoing process.

#### ***1.1.4 High-rise apartment buildings and refurbishment measures in South Korea***

Refurbishing existing buildings has also been an important issue in many Asian countries, including China, Japan, Hong Kong, Singapore and South Korea (Yuen, 2011). Particularly, high-rise apartment buildings in South Korea have made up the dominant proportion not only in dwellings but also in buildings. 63% of high-rise apartment buildings were built before buildings were energy-efficient (Statistics Korea, 2000; Statistics Korea, 2010b), which implies that these old apartment buildings can be easily vulnerable in sustaining a comfortable indoor environment than new buildings.

The physical characteristics of apartment buildings can be described by three different scales: clusters, buildings and units. An apartment unit is an individual space for each household living in the same building. An apartment building is a group of the apartment units, while an apartment cluster is a group of the apartment buildings. Throughout reviewing the development of high-rise apartment buildings (Chapter 2), the physical characteristics of old apartment buildings have been transformed. Chronologically, apartment buildings in the 1960s were in the process of development, so that there were various attempts to increase



the number of floors from five to higher. In the 1970s and 1980s, a great number of apartment buildings had been constructed in a short period under the governmental-led projects. To this reason, the shape of apartments has been much unified without considering diversities. Despite this, the shape of buildings has been transfigured for social and economic profits. The general number of floors has been increased up to 15 from five. The width of buildings has been shortened. In the 1990s, the massive constructions were continued by similar trends of building characteristics from the previous decade. Since the 2000s, a new type of apartment buildings, 'Tower type' has appeared. This type increases the limit of apartment floors from 25 to more than 40 – 50.

Fundamentally, the transformation of high-rise apartment buildings was intended to bring about higher economic profit and reflect social requirements. Recently, not only new but also existing buildings have to be more energy-efficient. Thus, energy use in old high-rise apartment buildings has to be assessed in order to choose the most appropriate design strategies or refurbishment strategies. There are five types of building performance assessment methods in South Korea: Green Building Certificate Criteria (GBCC), Building Energy Efficient Rating System (BEERS), Housing Performance Rating Disclosure System (HPRDS), Energy Saving Design Standards (ESDS) and The Environmental-Friendly Housing Certification (EFHC). As compared in Section 2.2.4, four of the five assessment methods, apart from BERS, take the Energy Performance Indicator (EPI), which evaluates building energy performance by designated criteria with different credits. For example, GBCC requires credits higher than 60 to certify buildings as energy-efficient (MLIT, 2013). This system with EPI is easy for assessing building performance without complicated calculations. However, it is difficult to diagnose detailed energy performance in order to improve specific parts of buildings. Unlike the four assessments, BEERS takes the calculation-based methods, specifically, the steady-state method. The quantification is followed by the international standards, ISO 13790 (ISO, 2008) and DIN V 18599-2 (DIN,

2007). This method can easily calculate energy use in buildings, but the result, neglect the possible impacts of unexplained factors and data error.

As reviewed in Section 2.2.1 and 2.2.2, the current five assessment methods have limited interpretations in quantifying energy performance. To this reason, the performance gap is problematic with the current approach. Although hybrid methods integrating different measurement methods have been implemented to cover drawbacks and limitations of each quantification method, this kind of attempt is difficult to find in the case of South Korea.

## **1.2 Research questions arising from the gap**

Decision-making in refurbishment fundamentally requires appropriate assessment methods for building energy performance. Thus, the original building conditions can be scrutinised and compared to determine efficient refurbishment strategies for specific buildings. However, the current assessment methods show their limitations in coping with the complexity and diversity of buildings. This could result in significant discrepancies between the estimated energy saving and actual achievement in real situations. To this reason, existing literature, related to refurbishment measures, has focused on reducing the performance gap by improving the energy quantification methods. The methodologies have been more systematic and sophisticated to integrate uncertainties arising from various building factors affecting energy consumption.

In the scope of the assessment methods in South Korea, the limitations are in the line with the global point of view, which can be specified by three aspects. Firstly, the current assessment methods using EPI and the steady-state methods (simplified calculation methods) are not specific enough to be tailored for the group of old existing high-rise apartment buildings. Moreover, the methods are not flexible enough to take the diversities of buildings, derived from the transformation of building characteristics. As reviewed, old existing high-rise apartment buildings in South Korea have been transformed with the changes in public preference and economic profit. Moreover, the main targets of occupants have been replaced

from the working class to the new middle class. Unless dealing with these diversities, the calculated energy saving can contain a high level of uncertainty, which is hardly reliable.

Secondly, the current energy quantification methods are dominated by the calculated-based methods (dynamic simulations with idealised conditions and steady-state calculations). A single apartment building, as a group of apartment units having diverse households, is complicated in terms of these factors that would contain significant uncertainties. The dynamic simulation with the idealised building conditions has widely been chosen to evaluate energy saving in refurbishment technologies. However, it is highly limited to reflect realistic building conditions actually occupied. Despite this, no attempt to integrate more than two quantification methods has been made in assessing building energy performance. In order to reduce discrepancy between the predicted and actual energy consumption, the importance of dealing with uncertainties, arising from physical characteristics and occupant-related factors, has been addressed. Moreover, the methodologies of quantification, in the global view, have been more systematic and sophisticated. In this regard, the various attempts need to be explored in the context of South Korea.

Thirdly, the current assessment methods (whole-building calculations) have not taken into account variation arising from apartment units. Individual apartment units are placed in different locations in buildings that can be exposed to the different outdoor environment. However, the conventional quantification methods have regarded an apartment building with many individual units as one single building containing a large number of residents. Therefore, the interaction through the interconnected floors as well as occupants' operations living in different apartment units have been disregarded, even though their impacts on energy consumption are obvious.

By reviewing the current literature, it has been revealed that the current energy quantification methods need to be improved in order to deal with the complexities and

diversities in existing apartment buildings by integrating them, based on actual energy use.

Three research questions can be identified, as below:

- How can the energy quantification methods take into account the diversities of building characteristics in old high-rise apartment buildings?
- How do the energy quantification methods integrate the uncertainties derived from a group of occupants' behaviours living in high-rise apartment buildings?
- How can the energy quantification methods take variation arising from individual apartment units in different locations?

### **1.3 Aims and objectives**

This study aims to create a new methodology developing a building energy quantification model of existing high-rise apartment buildings in South Korea to be used for refurbishment measure. The study, specifically, develops a framework of building energy modelling for the existing apartment buildings by integrating variations in the actual energy consumption, derived from the physical characteristics, occupants' behaviours and individual units with different locations. The main objectives can be stated as follows:

- 1) Classify the physical characteristics of existing high-rise apartment buildings, dealing with variation in building features affecting energy consumption (Chapter 4)
- 2) Integrate variation arising from occupants' behaviours consuming heating and electricity into a building energy model of existing high-rise apartment buildings (Chapter 5)
- 3) Develop a building energy model with corresponding variation in the unit-specific heating energy consumption arising from the locations of apartment units and individual heating controls in each unit (Chapter 6)
- 4) Implement the building energy model developed to evaluate refurbishment strategies under climate change (Chapter 7)

## 1.4 Structure of the thesis

The structure of the thesis consists of eight chapters including this introduction chapter, as described in Figure 1.1.

Chapter 2, *'Literature review'*, interprets the energy-efficient refurbishment, the current assessment methods for quantifying building energy performance and the challenges of the assessment methods. The chapter is divided into two parts. The first part reviews existing literature about the energy-efficient refurbishment and the assessment methods with a global point of view, while the second part scopes down the focus to the context of existing buildings in South Korea.

Chapter 3, *'Methodology'*, states the specific problem that this study is tackling through the whole process. It also provides a thorough description of overall strategy, and the necessary data and tools used for calculation. At the same time, the essential methods of analysing data are also demonstrated with the specific applications of each method in this study.

Chapter 4, *'Classifying existing apartment buildings with respect to efficient building features affecting energy consumption'*, determines a definition of existing high-rise apartment buildings that need to be refurbished. By prioritising the efficient building features transformed from the 1970s to 1990s in terms of the impacts on energy consumption, the existing apartment buildings are classified not only for building energy models used for simulations but also for energy-efficient refurbishment.

Chapter 5, *'Integrating variation arising from occupants' behaviours consuming heating and electricity into a building energy model of existing high-rise apartment buildings'*, questions the conventional building energy model, which is mainly applicable for reducing the energy demand of buildings under the standardised conditions, rather than reflecting actual energy consumption. This chapter accounts for variation in actual energy consumption caused by occupants' behaviours. By integrating a stochastic data of

occupants' behaviours consuming heating and electricity, interred from actual energy consumption, a probabilistic model of the new generalised occupants' behaviours consuming heating and electricity has been established to be used for a building energy model of these apartment buildings.

Chapter 6, *'Developing a building energy model of existing high-rise apartment buildings corresponding to variation in individual apartment units'*, scopes down the main scale of the study from existing apartment buildings to individual apartment units, and identifies variation in energy consumption arising from individual units according to two aspects. The first aspect is the different physical characteristics of apartment units in different locations, whilst the second aspect is independent heating controls by occupants in each unit. These two aspects have been integrated into a building energy model of existing apartment buildings to correspond to actual data. Furthermore, the dataset of the individual heating controls for each unit is provided.

Chapter 7, *'Implementing the building energy model developed for refurbishment measure under climate change impacts'*, conducts the building energy models to examine building thermal regulations revised from 1987 to the present as refurbishment strategies for the existing apartment buildings under future climate change. The thermal regulations have been intensified by increasing the thickness of insulation and U-values of windows. By using the building energy model developed through the previous chapters, the effectiveness of these regulations is evaluated for refurbishing existing apartment buildings. Climate change impacts are also included with a long-term perspective.

Chapter 8, *'Conclusions and Future work'*, summarises the main findings in this thesis. Limitations and future works are also indicated.

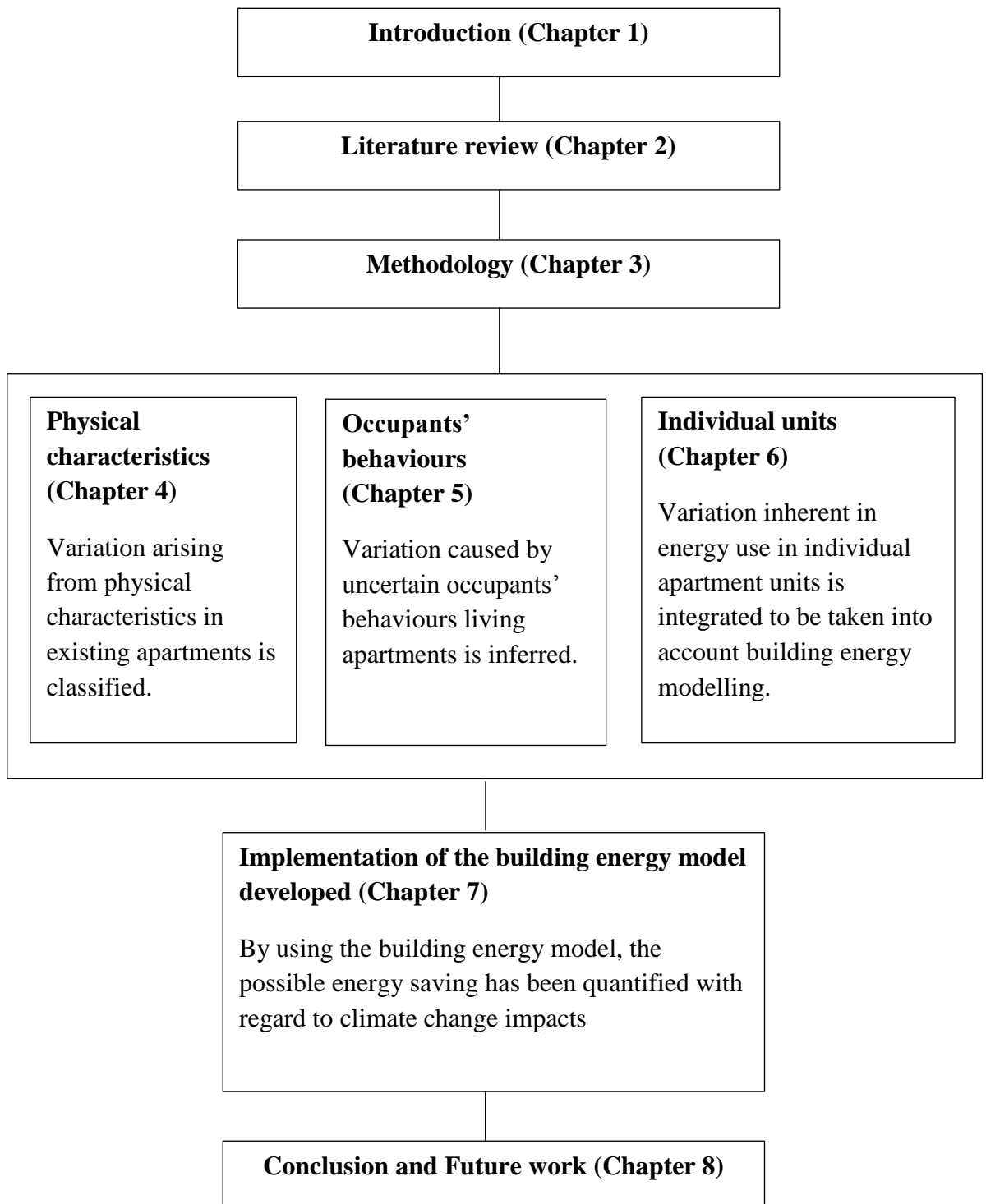

Figure 1.1. Diagram showing overall structure of this study





## **Chapter 2**

---

### **Literature review**

This chapter aims to review existing literature in order to explain energy-efficient refurbishment and the current assessment methods for quantifying energy performance in buildings. This literature review is comprised of two parts. The first part, Section 2.1, discusses about a global overview of energy-efficient refurbishment, while the second part, Section 2.2, scopes down the topic to the context of South Korea. In the first part, the general concept of energy-efficient refurbishment is interpreted in Section 2.1.1. Section 2.1.2 and 2.1.3 take a look at the current assessment methods of energy performance quantification methods, which have been applied to refurbishment projects. Section 2.1.4 scrutinises challenges and limitations of the current methods of quantifying energy performance in existing buildings. Section 2.1.5 discusses advanced methods dealing with the challenges, especially ‘Performance gap’, in refurbishment measures. In the second part, Section 2.1.1 – 2.1.3 provide an overview of built environment in South Korea including climate conditions, a profile of buildings and high-rise apartment buildings. Section 2.2.4 and 2.2.5 examine the building energy performance assessment methods and their applications to refurbishment measures in South Korea. Section 2.2.6 identifies the limitations of the current approaches and their relation to the global point of view. Lastly, Section 2.3 summarises the chapter and restates the research gap that needs to be investigated.

## **2.1 Energy-efficient refurbishment of existing buildings**

### ***2.1.1 Overview of energy-efficient refurbishment***

Many countries have included not only designing new buildings with energy-efficient technologies, but also improving the thermal conditions of existing buildings. 70% of UK buildings in 2010 will remain in 2050 (Stafford *et al.*, 2011). This significant proportion of existing buildings have insufficient thermal conditions (Dowson *et al.*, 2012), which have resulted in increasing energy use for heating. As shown in Figure 2.1, some European countries, such as Netherlands, Sweden, Germany, France and Denmark, also have more

than 50% of housing stock constructed before the 1970s (Baek and Park, 2012), which are considered for refurbishment in order to reduce energy consumption as well as fundamentally reduce GHG emissions.

As existing buildings were built before buildings became energy-efficient, existing buildings can be more vulnerable to sustainability. Compared to European countries, residential buildings in South Korea are relatively new (Figure 2.1). This is because the development of housing followed the great economic growth in the 1960s. Other Asian countries such as Singapore, Hong Kong and China also have shown a similar history of residential buildings (Yuen, 2011). Although the newer construction years of existing buildings in South Korea identified, it does not guarantee the quality of energy-efficiency in the buildings. In fact, under the current Building Act in South Korea (Enforcement Degree of the Housing Act, 2009), apartment buildings constructed over fifteen years ago can be refurbished, and those buildings over forty years ago can be even demolished if needed. A significant number of existing apartment buildings constructed during the great economic growth have already been in a stage of refurbishment (Kim, 2010).

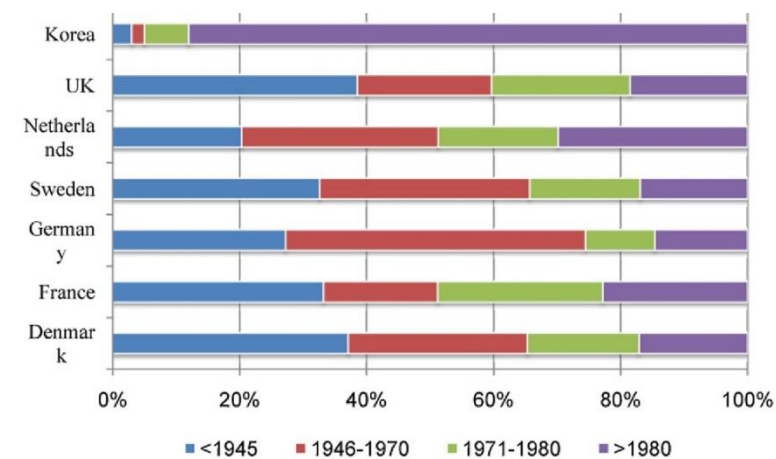

Source: Europe: Housing Statistics in the European Union 2004; Korea: 2005 Population & Housing Census (as for the data of Korea, <1959, 1960-1970, 1971-1980, >1980)

**Figure 2.1 Proportions of housing by construction years (Baek and Park, 2012)**

A concept of refurbishment is generally accepted as an improvement in building conditions by replacing deteriorated and inefficient parts of buildings. The success and failure of refurbishment can be determined by the quality of their achievement in terms of cost-effectiveness technologies, satisfactory services and acceptable indoor comfort (Ma *et al.*, 2012). Moreover, energy-efficient refurbishment is expected to provide improved thermal conditions of buildings with less financial investment, compared to a new build. Ma *et al.* (2012) divided the procedure of refurbishment into five steps: (1) project set-up and pre-retrofit survey; (2) energy auditing and performance assessment; (3) identification of retrofit options; (4) site implementation and commissioning; (5) validation and verification (Figure 2.2). Firstly, refurbishment needs to be well-planned with achievable targets of energy saving, and building conditions have to be surveyed to identify actual operations and occupant impacts on energy use. Secondly, energy audit data and building factors affecting energy consumption have to be recognised by assessing building performance. The information through assessments can provide potential retrofit opportunities and energy saving (Ma *et al.*, 2012). Thirdly, possible alternatives in reducing energy consumption need to be compared by using appropriate energy performance quantification methods. Fourthly, the selected refurbishment options are required to be implemented on-site. Finally, energy saving can be confirmed through a validation and verification.

Six key elements affecting building refurbishment have been defined (Ma *et al.*, 2012): (1) policies and regulations, which are minimum requirements for energy efficiency in existing buildings; (2) client resources and expectations, which determine a purpose and direction for refurbishment; (3) retrofit technologies that use Energy Conservation Measures (ECMs) as indicators representing energy efficiency and sustainability; (4) building-specific information that includes geographic locations, building types, ages, occupant schedules, utility rates, building fabric and service systems; (5) human factors, which include not only occupant behaviours but also building management and maintenance; (6) uncertainties,

arising from variation in building characteristics, and a selection of measuring models (building performance simulations).

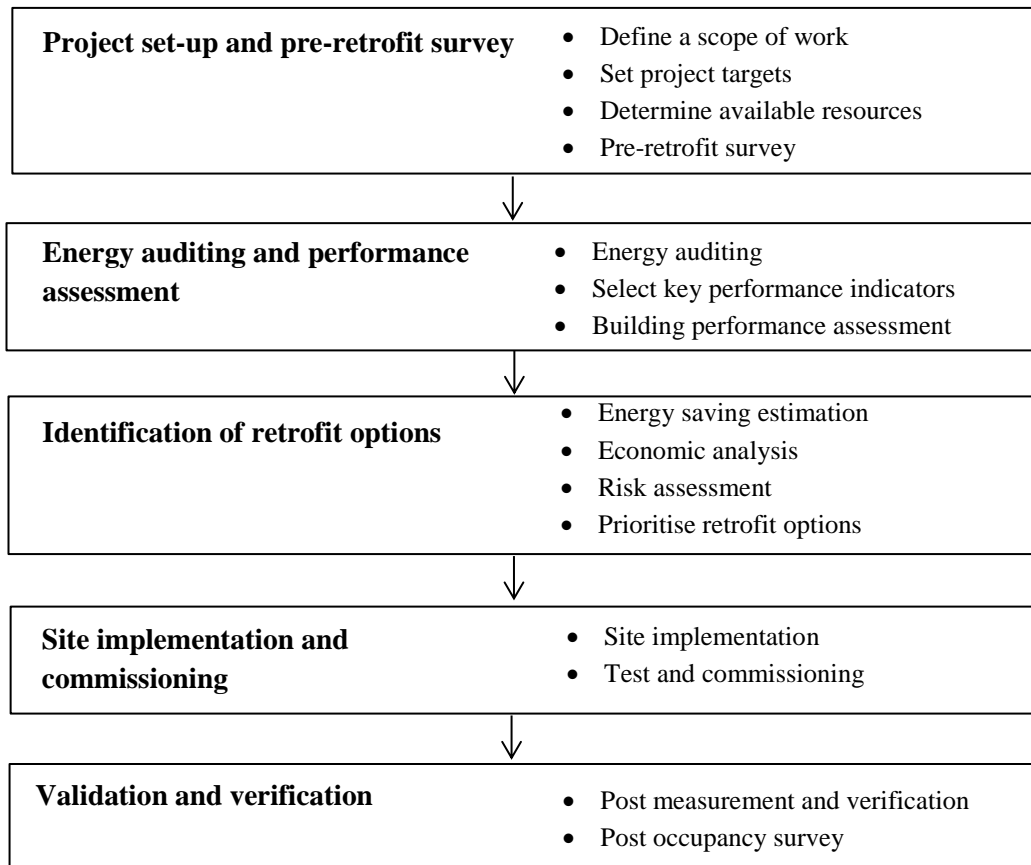

Figure 2.2 Procedure of refurbishment (Ma et al., 2012)

### 2.1.2 *Assessment schemes of energy performance for existing buildings*

The previous section addressed the potential contribution of existing buildings to mitigate GHG emissions by refurbishing their inefficient building conditions, no matter how old existing buildings are in different countries. Besides, the procedure and key elements of refurbishment imply that adequate assessments of building energy performance are required to provide the correct understanding of building conditions. Then, the result could help to choose the most appropriate and efficient refurbishment strategies.

“How to measure energy performance in buildings?” has been a crucial question in determining the quality of energy performance in existing buildings. This is because capricious building conditions effect on energy use that could result in an unreliable understanding of building energy performance. The unreliable understanding could end up with inefficient refurbishment strategies. Therefore, there is a need for accurate methods of quantifying both the energy performance of buildings as well as the amount of energy saving through refurbishment technologies. For policy-makers and the public, the results can help to determine policies and regulations in refurbishing the existing conditions of buildings (Summerfield *et al.*, 2010).

Building energy performance assessment has been used to quantify levels of energy use in building, and support decisions for additional improvement. The main objectives of assessment are found by two purposes: energy classification and performance diagnosis (Wang *et al.*, 2012). The energy classification provides levels of energy efficiency or carbon emissions for buildings (energy benchmarking, rating systems, labelling and certificates), whereas energy performance diagnosis detects faults and causes of poor performance in buildings. The former is mainly used for encouraging public participations, but the latter is intended to improve insufficient energy performance in buildings (Wang *et al.*, 2012).

Wang *et al.* (2012) defined four applications of the energy performance assessments: (1) building environment assessment schemes; (2) energy certification; (3) whole-building benchmarking models; (4) hierarchical assessment and diagnosis tools. Firstly, building environment assessment schemes evaluate the effectiveness of energy use in diverse factors including water, waste, material and site. They evaluate the general environment impacts of building conditions and encourage public awareness about that issue. There are several assessment schemes in different countries such as LEED (Leadership in Energy and Environmental Design) in USA (US Green Building Council, 2004), BREEAM (Building Research Establishment Environmental Assessment Method) in the UK (Baldwin *et al.*,

1990) and Green Star in Australia (Australia Green Building Council, 2012). Secondly, energy certification methods have been developed by EPBD (Energy Performance of buildings Directive) in Europe and ASHRAE's programs in USA (Wang *et al.*, 2012). The EPBD assessment methods provide general calculation methods for building energy performance (minimum performance requirement for new and existing buildings, certifications for rating and displaying the energy performance in buildings). Thirdly, whole-building benchmarking models represent overall energy efficiency in buildings in comparison to energy use in other buildings having similar floor areas (Chung 2011). Lastly, hierarchical assessments and diagnosis tools specifically detect energy performance in buildings with a detailed energy audit in existing buildings.

In short, the energy performance assessments have been implemented to classify building energy performance, and to diagnose poor energy performance in existing buildings. Both purposes have been applied to assess building energy performance by quantifying the quality of energy performance. Depending on each assessment, there are the different designated methods and criteria, measuring energy efficiency and energy saving. Therefore, selecting an appropriate assessment with a clear target can be an important issue.

### ***2.1.3 Energy quantification methods measuring energy efficiency and energy saving in buildings***

As reviewed in Section 2.1.2, energy performance assessments are intended to measure the efficiency of building energy performance by using the specific criteria and quantification methods. There are three types of quantification methods that have been applied to assess building energy performance (Figure 2.3): calculation-based, measurement-based and hybrid methods (Wang *et al.*, 2012). Firstly, **calculation-based methods** create calculation models to measure output (energy consumption) by using input data of building conditions. The methods are classified by dynamic simulations and steady-state methods depending on how to consider dynamic effects of buildings.

- **Dynamic simulation**

Most dynamic simulation uses a forward modelling approach that typical inputs (weather conditions, building description, system description and component description) are used to be analysed by a simulation engine performing for mathematical simulation algorithms.

As an example of application, a whole-building benchmarking method creates one customised building by simulation, which is an identical to a studied building, as a self-reference building (Wang *et al.*, 2012). The simulation models are used to compare the minimised conditions of energy use with the actual energy consumption so that the decision of possibility of energy saving use could be compared. This method has been widely adapted in various countries for a judgement, and has used to assess building performance of both new and existing buildings (Wang *et al.*, 2012). This method benefits for cases that do not have many reference buildings and sufficient energy use data (Chung, 2011).

- **Steady-state method (simplified building energy calculation)**

**Forward modelling approach:** heating and cooling demands are calculated by correlation factors which determine to what extent heat gains and losses are useful (Wang *et al.*, 2012). Heating energy use is calculated by the amount of heating demand divided by System Coefficient of Performance (SCop), whereas cooling energy use is by the amount of cooling demand divided by System Energy Efficiency Ratio (SEER) of HVAC systems (Wang *et al.*, 2012). The application of them is shown in an international standard (ISO 13790:2008), Energy performance of buildings – calculation of energy use for space heating and cooling.

$$E_{Heating} = \frac{Q_{NH}}{SCop}$$

$$E_{Cooling} = \frac{Q_{NC}}{SEER}$$



where  $Q_{NH}$  and  $Q_{NC}$  are the monthly energy demand for heating and cooling, respectively.

**Inverse modelling approach:** this approach for whole-building energy consumption is regressed against several important influencing parameters. Linear, change-point linear and multiple regressions are commonly accepted to correlate energy use in buildings. A number of different regression models can be created for a particular building, and then choose the best-fitted model can be finally selected by  $R^2$  and CV (RMSE). The commonly used model is as below:

$$E = C + \beta_1 V_1 + \beta_2 V_2 + \dots + \beta_n V_n$$

where  $E$  is the estimated energy consumption.  $C$  is a constant in energy units.  $\beta_n$  is the regression coefficient of independent variables,  $V_n$ .

This method is built based on the robustness of associations between independent variables (building factors) and dependent variables (energy use). Regression models attempt to find the most-fitted regression line that represents the average levels of dependent variables, energy use in this case. Building energy benchmark models with the regression modelling method often used Energy Use Intensity (EUI) representing a typical rate of energy use in a certain type of buildings (Sharp, 1996). The EUI is expressed by energy use with floor area (Btu/ft<sup>2</sup>/year or kWh/m<sup>2</sup>/year). Therefore, the floor area has been considered as a main determinant to identify similarities in buildings in comparing energy consumption. Summerfield *et al.* (2010) created two different regression models of calculating the benchmark performance of residential buildings, based on the UK national data of domestic energy consumption and building characteristics such as physical conditions, occupant characters, heating systems and economic factors. Additionally, the models were used to estimate the possible reduction of these

building by energy refurbishment, the amount of energy saving were provided as evidence to be used for policies' decision making.

The limitations of measuring energy saving through the calculation-based methods are clear. Summerfield *et al.* (2010) stated that their regression models of residential benchmarks using national data are highly limited due to many uncertain social and technological factors. Moreover, the method does not take into account unexplained factors and data errors, which could result in inaccurate estimation. In terms of the dynamic simulation, as mentioned by Chung (2011), energy use calculated by building simulations with idealised conditions could not provide a realistic amount of energy saving that can be achieved in real situations.

Secondly, **measurement-based methods** are collecting actual building energy consumption records from energy bills to detailed monitoring data, which are able to cover discrepancies in calculation-based methods (Wang *et al.*, 2012).

- **Energy bill-based method**

Energy bill is a good quality of data representing an amount of energy use and easily accessible (Swan and Ugursal, 2009). The original bill data provides an acceptable level of accuracy, but limited for diagnosis; thus, it needs to be disaggregated into end-use forms to be used for more in-depth investigation (Wang *et al.*, 2012). The disaggregation is adopted by two types of algorithms, according to Yan *et al.* (2012). The first type, 'estimation algorithm', sums an individual calculation of each facilities at bottom level, while the second type, 'disaggregation algorithm', decomposes the total energy consumption into related factors such as seasonal and non-seasonal consumption factors (Yan *et al.*, 2012).

- **Monitoring-based method**

Although the energy bill data is transformed to end-use forms, the data does not represent sufficient details of building energy performance. Instead, monitored

data, such as end-use sub-metering data and BMS (Building Management System) data, can provide more accurate and precise energy use information (Wang *et al.*, 2012).

Thirdly, **hybrid methods** combine both calculation-based and measurement-based methods. The calculation-based methods have taken a leading position, while the measurement-based methods have been used to reduce discrepancies between estimation derived from calculations and actually used consumption (Wang *et al.*, 2012). Two types of methods are allocated in this category: calibrated simulation and dynamic inverse models.

- **Calibrated simulation**

Calibration is a process of revising initial inputs assumed for predicted energy use to be matched to actual consumption (Wang *et al.*, 2012). The procedure of calibration are comprised of three parts (Pedrini *et al.*, 2002): (1) the initial model estimation, based on building design and documentation, compares with actually measured consumption; (2) the second model estimation, based on wall-through and audit, is compared to the actual consumption; (3) the final model can be developed by comparing end-use energy measurements (monitoring).

- **Dynamic inverse model**

Dynamic inverse models can capture more detailed effects of building energy factors with differential equations. However, it requires the site measurement to acquire detailed training data in order to be used in models so that the process is greatly complex (Wang *et al.*, 2012).

It has been found that the methods of quantifying energy use in buildings are diverse. Therefore, the purpose of measuring energy use in buildings needs to be clearly stated in order to select the most appropriate methods for buildings concerned. However, it has also been revealed that each method requires either precise data or complex processes to bring about adequate results of estimating energy use. In this reason, limitations and problematic

aspects of each method that could result in inaccuracy in assessing building conditions.

Therefore, precise implementation can be required in the quantifying process.

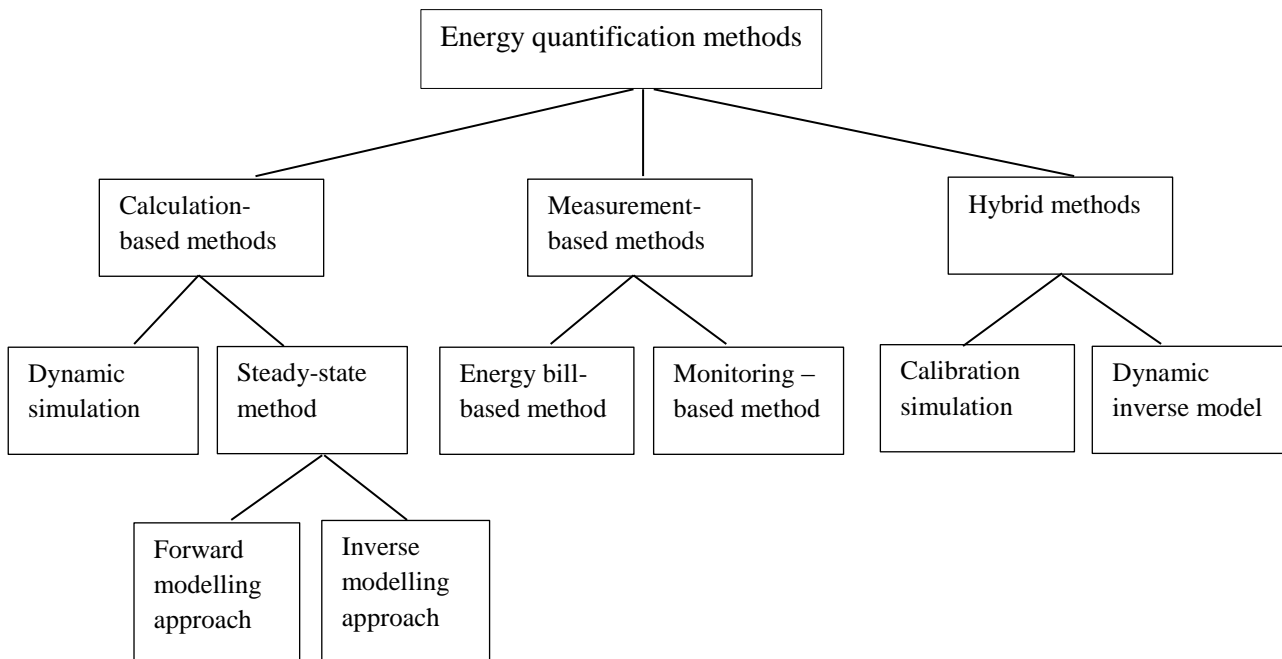

**Figure 2.3 Classification of energy quantification methods (Wang et al., 2012)**

#### 2.1.4 *Challenges of energy-efficient refurbishment for existing buildings*

It has been found that there are two important aspects of assessing energy use in existing buildings. One is that building energy performance in original conditions needs to be adequately assessed. Another aspect is that the possible amount of energy that could be saved, compared to original conditions, needs to be accurately measured for successful refurbishment. The previous section implied that energy quantification methods contain limitations and problematic aspects, related to data collection and complex process, which could bring about inaccurate estimations. These have been challenged in the real application of refurbishing existing buildings.

Stafford *et al.* (2011) claimed six challenges in refurbishment measures (Figure 2.4). Firstly, fixed frameworks for refurbishment could be inflexible to encapsulate the complexity and diversity of existing buildings. Thus, refurbishment strategies may not be tailored for specific cases or groups of buildings. Multiple disciplines including technological, social and financial aspects need to be carefully considered in determining refurbishment. Secondly, actual energy performance can easily be different from the expected performance in real cases. The performance gap, derived from in design and construction stages, is often found, but the design process rarely regards allowances for possible errors in real situations. Thirdly, interactions of factors encompassing building envelopes are complex. The factors including the thermal transmission of elements on building envelopes, such as walls, floors, roofs and windows, air-tightness, thermal bridge and bypass mechanisms, complicatedly interact and affect thermal conditions of buildings. If the factors are considered individually or separately, the result can easily go wrong in terms of total building energy performance. In this respect, holistic consideration is essentially required. Fourthly, appropriate renewable technologies need to be integrated with the process of improving thermal conditions of building envelopes. However, the report (Stafford *et al.*, 2011) claimed that the relationships between building envelopes and renewable technologies are often complex. Moreover, economics of installing renewable technologies have to be carefully taken into account. Fifthly, it is complex to encompass uncertain occupants' related issues such as occupancy, day-to-day behaviour and interaction of building services and technologies. As these issues are highly uncertain, they remain as one of difficult challenges to achieve. Finally, continuous monitoring and feedback needs to be implemented for further improvement.

In short, the report (Stafford *et al.*, 2011) pointed out that there are many obstacles, derived from the complexities and diversities in buildings. The obstacles can result in a significant level of performance gap in real situations. There have been intensive efforts in developing methods of assessing energy saving in refurbishment. The details are followed in the next chapter.

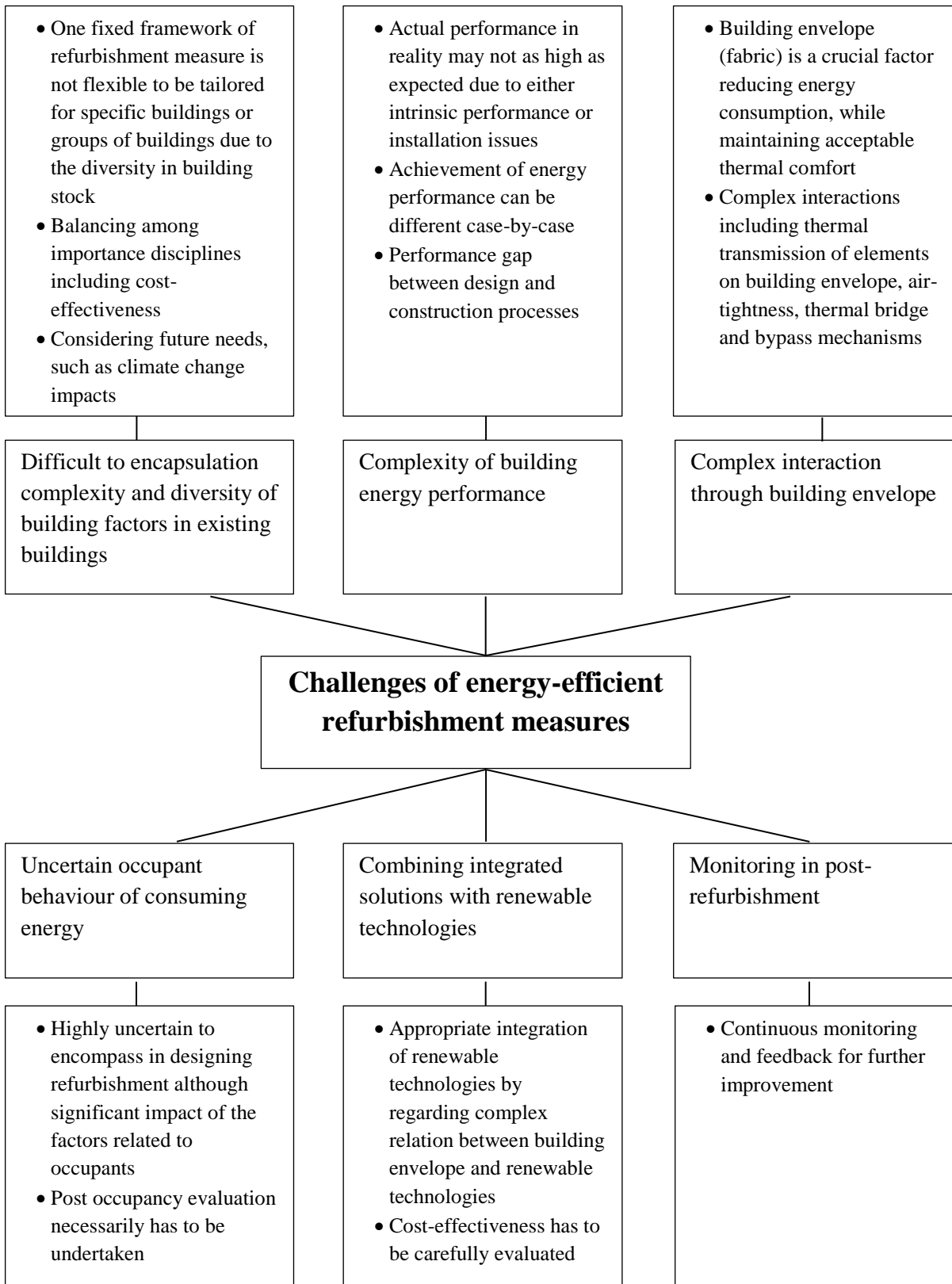

Figure 2.4 Six challenges for energy-efficient refurbishment measures (Stafford *et al.*, 2011)

### 2.1.1 *Performance gap and advanced modelling methods*

The previous three sections, Section 2.1.2, 2.1.3 and 2.1.4, identified building energy performance assessments, energy-saving quantification methods and the current challenges in refurbishment. By reviewing existing literature, the adequate prediction in designing refurbishment strategies have been problematic due to the intrinsic complexities and diversities. This section reviews the performance gap, caused by variation in uncertain occupant behaviour (Section 2.1.5.1) and physical characteristics (Section 2.1.5.2), and advanced methods of refurbishment measures (Section 2.1.5.3).

The performance gap has been defined when the designed energy performance is not the same as realised one when buildings are actually in use (Bell *et al.*, 2010). The causes of the performance gap are derived from many aspects (building components, materials, occupant behaviour patterns or poor workmanship) (Bell *et al.*, 2010). There have been efforts to reduce the performance gap and improve the prediction of building energy models to be similar to real situations.

In assessing building energy performance, uncertainty and sensitivity analyses have been essentially undertaken (e.g. Hyun *et al.*, 2008; Silva and Ghisi, 2014). Uncertainty analysis takes a probabilistic approach that regards values of independent variables (input factors) with distributions of possible values, whereas sensitivity analysis evaluates the effectiveness of parameters that generate variation in energy consumption (Silva and Ghisi, 2014). Silva and Ghisi (2014) conducted both analyses with various building factors, categorised by physical conditions of building and parameters related to occupant behaviour. With the different types of units, the building factors were differently defined by probability density functions. The results have shown that levels of uncertainty are higher with occupant related parameters than physical conditions.

### 2.1.1.1 Uncertainty in occupant behaviour

Occupants' behaviours, as the main agents of controlling energy consumption (Steemers and Yun, 2009), are difficult to be defined due to significant uncertainty (Gunay *et al.*, 2013). As the uncertainties can also be adaptive by social factors, it is far more complicated to be formulated for building simulations. For example, Sunikka-Blank and Galvin (2012) identified 'rebound effect' that economic status constrains actual energy consumption not as much as it is expected. Conversely, energy consumption in a refurbished house can often be increased after a short period of reduction, as described in (Galvin, 2014b).

The impact of uncertain occupants' behaviour on energy consumption have been assessed, and attempted to be integrated into building energy models. At the early stage, possible ranges of various occupants' behaviours consuming energy were measured by minimum, mean and maximum values (e.g. Hyun *et al.*, 2008), or distributions of variables (e.g. Silva and Ghisi, 2014). The ranges were input to measure their probable fluctuation in energy consumption. Significant impact of uncertainties arising from occupants' behaviour has been identified through uncertainty analysis.

The recent methods of integrating occupants' behaviours into building energy models can be categorised as three approaches. Firstly, occupants' behaviours in buildings were specifically measured by higher resolution data. Richardson *et al.* (2008) used surveyed data with ten-minute intervals to measure precise occupancy. Stoppel and Leite (2014) improved occupancy in modelling, based on interview data in a specific occupant group. Secondly, occupants' characteristics were classified by several representative groups. For example, Bourgeois *et al.* (2006) created occupant characteristics as passive and active behaviour groups, converting indoor environments. Tanimoto *et al.* (2008) specified occupants living in apartments with eight types: working male and female, housewife, elementary school child, junior high school student, college student, senior male and female. These groups were differently modelled by their characteristic of living styles. Thirdly, specific activities



resulting energy consumption were formulated for building simulations. Daily profiles of occupants' activities were mostly investigated in relation to consuming energy. Various activities such as washing, cooking, and cleaning were used to produce electricity-demand schedules for housing in the UK (Richardson *et al.*, 2010). Tanimoto *et al.* (2008) combined these activities with types of occupants, and created about 10,000 samples in calculating peak energy demand.

In summary, significant uncertainties have been identified by occupants' behaviours. These uncertainties have been approached with higher quality of data and more elaborate techniques to integrate into building simulations. Therefore, the building energy model of high-rise apartment buildings, despite targeting unspecified occupants, cannot easily disregard this aspect due to the great number of occupants living in the same buildings. The process may be complicated. However, it should be considered for the accuracy of the building energy model.

#### **2.1.1.2 Uncertainty in physical conditions in buildings**

Physical characteristics of buildings determine energy requirements in buildings (Pacheco *et al.*, 2012). However, measuring building energy performance can easily contain uncertainty to tailor individual cases in the fixed frameworks with limited interpretation of physical characteristics, which could enlarge the performance gap. BektasErci and Aksoy (2011) defined six parameters of physical characteristics in buildings affecting energy consumption by shape, transparent surfaces, orientation, thermal properties of materials and distance between buildings. Another criteria of parameters included orientation, shape, envelope system, passive heating and cooling mechanisms, and shading and glazing (Pacheco *et al.*, 2012).

- **Shape of buildings**

Building shape determines the total amount of building surfaces exposed to the outside, which receive solar radiation and transfer heat energy (Pacheco *et al.*,

2012). Therefore, a ratio between outer surface and total volume was required to be reduced (Ourghi *et al.*, 2007). Florides *et al.* (2002) quantified the percentage between building length and depth causing the most energy efficient ratio between both parameters; elongated shape resulted in more energy demand than square shape.

- **Orientation and shading**

Building orientation also effects on the level of direct solar radiation reaching to building façade (Pacheco *et al.*, 2012). The solar radiation influences on indoor thermal conditions as well as energy demands in buildings. South-facing including 20 – 30° from south (in northern hemisphere) angles has been commonly regarded as the best orientation to maximise solar gain (Littlefair, 2001). Aksoy and Inalli (2006) combined building orientations with shapes to find the most efficient combinations of them to reduce heating energy demands in buildings. The authors concluded that buildings should avoid 60° from the west to the east with square-shape, and 80° or 40° with rectangular-shape.

- **Envelope conditions**

The building envelope contains the outer parts of buildings including foundation, roof, walls, doors and windows, which creates indoor environments in buildings (Pacheco *et al.*, 2012). By suppressing heat transfer through the building envelope, energy-efficient building requires less energy for heating. For this reason, existing literature has focused on improving the thermal resistance of the building envelope.

Insulating building envelope is one of common approaches in reducing U-values, which indicate coefficients of heat transfer. Diverse parameters related to insulations have been investigated: thickness (Çomaklı and Yüksel, 2003), locations (Ozel, 2014) and materials (Soubdhan *et al.*, 2005). Çomaklı and Yüksel (2003) found that increasing the thickness of thermal insulation reduced fuel costs for heating.

However, the reduction of fuel costs became a nearly zero after increasing the thickness of insulation over 300 mm. Thus, the optimum thickness can be about 100 mm with respect to total costs. Ozel (2014) found that the locations of insulation affect time reaching peak temperatures in indoor environment, and reduce temperature fluctuation. However, it did not reduce heat loss through building envelope. Sadineni *et al.* (2011) mentioned a holistic approach can be more efficient to reduce energy demands in buildings than partially insulating.

Glazing types of windows need to be carefully chosen by regarding energy saving and daylighting aspects concurrently (Hee *et al.*, 2015). Tahmasebi *et al.* (2011) found that double-glazed window was beneficial to gain more solar radiation in comparison to triple-glazed window, but triple-glazed window showed lower U-values, which meant more energy-efficient. However, triple-glazed window could also reduce cooling energy demand in tropical climates (Sadzadehrafiei S, 2012). Types of filling in multiple-glazing could also positively reduce total energy consumption (Gao *et al.*, 2016).

### **2.1.1.3 Decision making under uncertainties**

The previous two sections pointed out that uncertainties arise from the variations in occupant behaviour and building physical characteristics. The building energy performance assessment methods, as their limitations of reflecting realities, cannot be perfect in evaluating energy efficiency in buildings that aggravate the enlarged performance gap. Furthermore, it gives rise to difficulty in comparing energy efficiency among different strategies and in choosing the most efficient option. In order to alleviate the discrepancies and difficulties, there have been continuous attempts to take the uncertainties into account with a framework of assessing building energy use for refurbishment measure.

Heo *et al.* (2011) attempted to infer probabilistic values of physical characteristics in buildings, in order to improve building energy models evaluating retrofit projects. The

authors applied Bayesian Inference to calibrate the initial physical conditions of building energy models, based on the measured data of energy consumption. As a result, the calibrated model estimation became more similar to the measured data.

Booth *et al.* (2012) developed a framework of handling uncertainty in housing stock models by using Bayesian calibration. The authors precisely defined the uncertainty in housing stock as “first-order” (aleatory) and “second-order” (epistemic) uncertainties; the aleatory uncertainty is arising from variabilities of a single individual or a group of the similar buildings, while the epistemic uncertainty is derived from variation in input parameters of models (Booth *et al.*, 2012). The framework was structured by three stages: clustering, Bayesian calibration and Monte Carlo analysis. Clustering sub-divided housing stock into smaller groups in accordance with similarities such as ages, types and heating systems. The authors insisted that clustering housing stock is not a part of the calibration process, but informative for decision makers applying refurbishment to a set of similar housings with specific types and conditions. Bayesian calibration adjusts average values of uncertain factors in each cluster to be similar to the measured values. This stage copes with the second-order uncertainty arising from the lack of knowledge about the true values of input parameters. Monte Carlo analysis lastly conducts a probabilistic sensitive analysis for the first-order uncertainties from the probabilistic distribution, derived from Bayesian calibration.

Booth and Choudhary (2013) improved the decision making framework from the previous work coping with uncertainty in housing stock models (Booth *et al.*, 2012). The structure of framework became more sophisticated from three to five stages: (1) cluster housing stock into building classes; (2) Bayesian regression analysis estimating annual energy demand of each building class; (3) Bayesian calibration of uncertain parameters in building energy models; (4) probabilistic sensitivity analysis using Monte Carlo simulation; (5) calculate energy saving by using the calibrated building energy models.

## 2.2 Existing high-rise apartment buildings in South Korea

### 2.2.1 *Climate conditions in South Korea*

Although climate conditions are not exact building factors, they are underlying factors determining the forms of buildings (Bougdah and Sharples, 2009). Geographical locations, categorised by the characteristics of climate conditions, are an important consideration in designing the built environment. This is because building technologies differently respond to thermal environments in buildings located in different climate zones, as shown in (Waide *et al.*, 2006). Furthermore, climate factors can be differently dealt with reducing energy consumption depending on geographical locations. For example, how to maximise solar gain can be a major goal of building design in cold climates, while how to prevent solar gain can be a design concept in tropical climates (Mingotti *et al.*, 2013).

South Korea is a protruded peninsula located in the Eurasian Continent. The climate conditions can be simply described as temperate conditions with the mean temperatures between 6.6 – 16.6 °C (Korea Meteorological Administration (KMA), 2009). According to the Köppen climate classification (Kottek *et al.*, 2006), the climate condition in South Korea is classified as humid continental and humid subtropical climate zones that have hot and humid summers, and cold and dry winters (Figure 2.5 (left)). Based on this, building regulations divide the country into three regions: central, southern regions and Jeju Island (Figure 2.5 (right)).

Figure 2.6 describes the historical climate conditions of the three regions (central, southern and Jeju Island) in South Korea from 1981 to 2010 (KMA, 2010). Although the mean temperatures imply temperate climate conditions, the monthly change in the mean dry-bulb temperature is considerably large (Figure 2.6-(a)). The temperature change in the southern region and Jeju Island is around -7.6 °C and -1.4 °C in winter, respectively, while the temperature in summer becomes 33 – 34 °C for both regions. More significant change is found in the central region, the temperature change in the central region radically rises to

35°C in summer, but decreases down to -14 °C in winter. Because of the huge range of temperature changes, buildings in South Korea need to have both heating and cooling facilities.

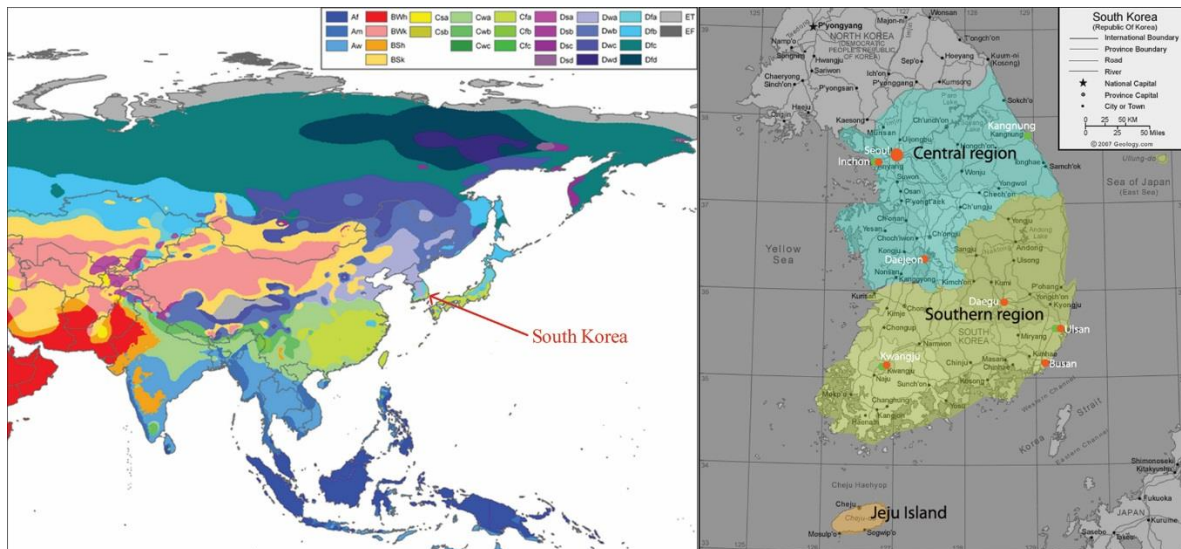

**Figure 2.5 Climate classifications and regions of South Korea divided by building thermal regulations** (Source: [https://commons.wikimedia.org/wiki/File:Asia\\_Koppen\\_Map.png](https://commons.wikimedia.org/wiki/File:Asia_Koppen_Map.png), <http://geology.com/world/south-korea-satellite-image.shtml>)

Relative humidity, overall, changed between 50 and 80% depending on seasons (Figure 2.6-(b)). In general, the highest level of relative humidity is found in summer (July and August) that is caused by a short monsoon. The most significant change in relative humidity is in the southern region. The level of relative humidity in the southern region drops down to 50% in winter while the highest level of relative humidity, 80%, is found in summer. However, the relative humidity in Jeju Island is relatively stable, with above 60%, as it is an island enclosed by the sea.

The seasonal change in precipitation is dramatically different, as shown in (Figure 2.6-(c)). The annual precipitation mostly occurred in summer (July and August). The amount of rainfall in this period is often 200 times higher than the amount in winter. Besides, the wide variation is identified for the thirty-years of records (1981 – 2010). For example, the average

precipitation in July in the central region is about 400mm, but it can be increased up to nearly 590mm depending on years.

The change in mean wind velocity is different by three regions (Figure 2.6-(d)). The central region indicates the least mean wind speed with about 2m/s, than the other two regions with about 4m/s. The reason of difference could be because of wind from the sea.

The sun is one of the most important sustainable energy resources (Bougdah and Sharples, 2009). Buildings can obtain heat from the sun, which can reduce supplementary heating by fossil fuels. However, an excessive amount of heat gain results in an uncomfortable indoor environment that require supplementary cooling from air-conditioners. Sunshine hours, which is the duration of sunshine in months, varies among the three regions in South Korea from 70 hours to 220 hours (Figure 2.6-(e)). The central and southern regions show consistent sunshine hours between 170 and 220 hours. However, the sunshine hours in Jeju Island has the least duration starting from 70 hours.

Global solar radiation is the total amount of solar energy including direct, diffuse and reflected solar radiation on the surface of the earth (Bougdah and Sharples, 2009). The trend of global solar radiation is generally increased from spring (approximately, 300 MJ/m<sup>2</sup>) to summer (about 600 MJ/m<sup>2</sup>). Then, the level of radiation is decreased from autumn (about 500 MJ/m<sup>2</sup>) to winter (approximately, 200 MJ/m<sup>2</sup>). The difference among the three regions is that the change of global solar radiation in the southern region and Jeju Island is greater than the change in the central region.

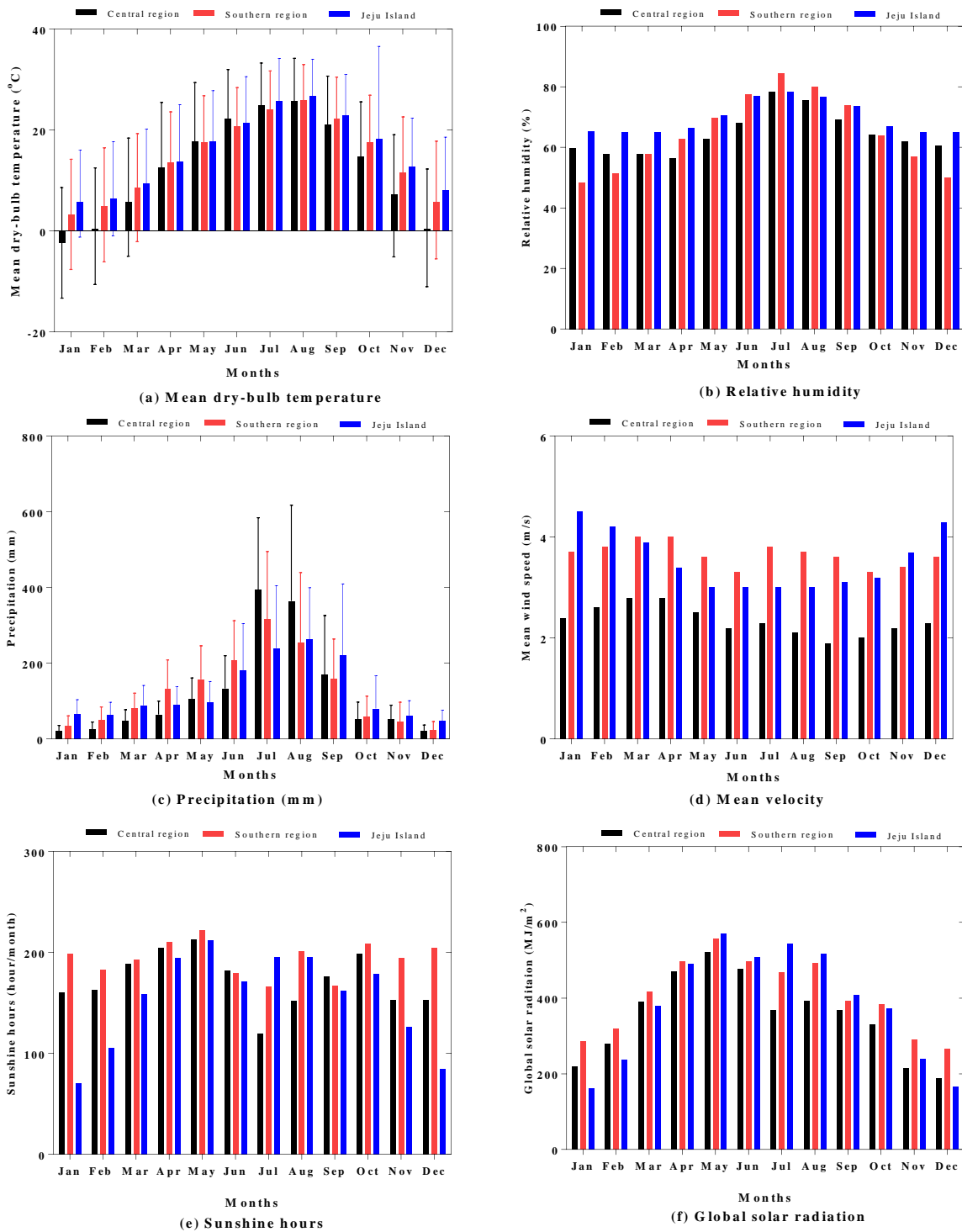

**Figure 2.6** Climate data of South Korea (1981 - 2010): (a) mean dry-bulb temperature, (b) relative humidity, (c) precipitation, (d) mean velocity, (e) sunshine hours and (f) global solar radiation



### 2.2.2 *Profile of buildings in South Korea*

The great number of building construction had been undertaken in accordance with the great economic growth (Chung, 2007). Figure 2.7 depicts the profile of buildings in South Korea. 66% of buildings in South Korea have been used for the residential purpose (Statistics Korea, 2013). The second largest proportion is commercial buildings with 17%, followed by industrial and educational buildings with 4% and 3%, respectively. In the residential buildings (Figure 2.8), the most dominant housing type in the 1970s (above 90%), which was detached housing, had been dramatically replaced by apartment buildings. The proportion of apartment buildings in housing was less than 10% in 1975, but it had been rapidly increased during the 1980 – 1990s. Finally, the type has become the most dominant housing type in South Korea with 58% (Statistics Korea, 2010b). 63% of apartment buildings were constructed before 2001 (Statistics Korea, 2000; Statistics Korea, 2010b) when the higher levels of energy-efficient scheme were applied to buildings, as depicted in Figure 2.10.

Three main purposes of energy consumption in residential buildings have been identified (Korea Energy Economics Institute (KEEI) (2011)). Heating is the most significant purpose of consuming energy in buildings. Although the proportion of heating in energy use has been gradually decreased from 1990 to 2008 (Figure 2.9), it has still dominated the energy consumption in buildings with about 50%. The second and third dominant purposes of energy use are for Domestic Hot Water (DHW) and electricity with approximately 25% and 20%, respectively.

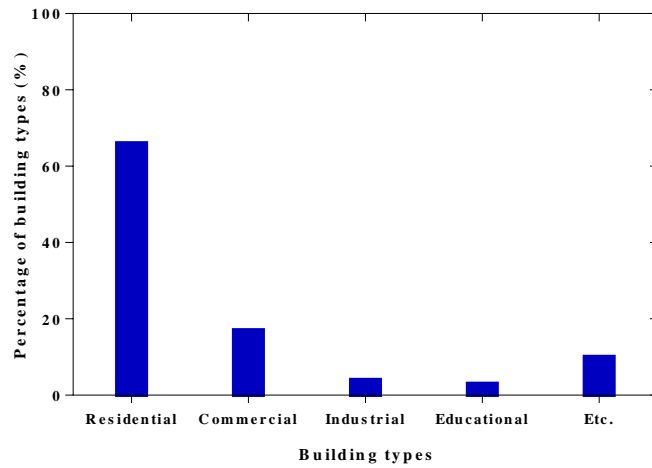

Figure 2.7 Profile of buildings in South Korea (Statistics Korea, 2013)

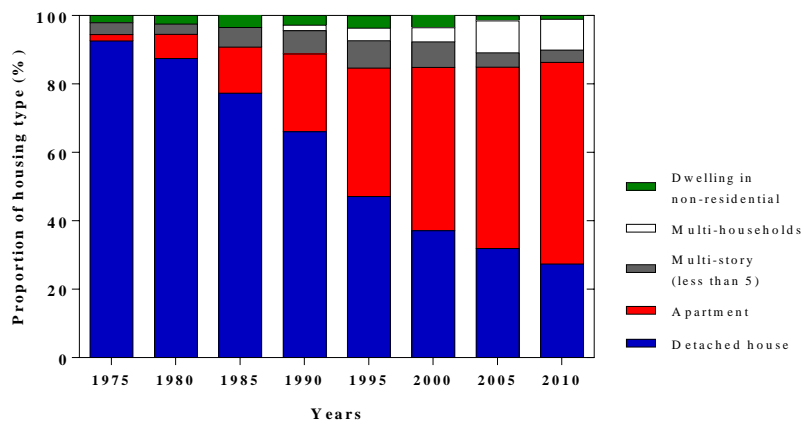

Figure 2.8 Proportion of residential buildings in South Korea (Statistics Korea, 2010b)

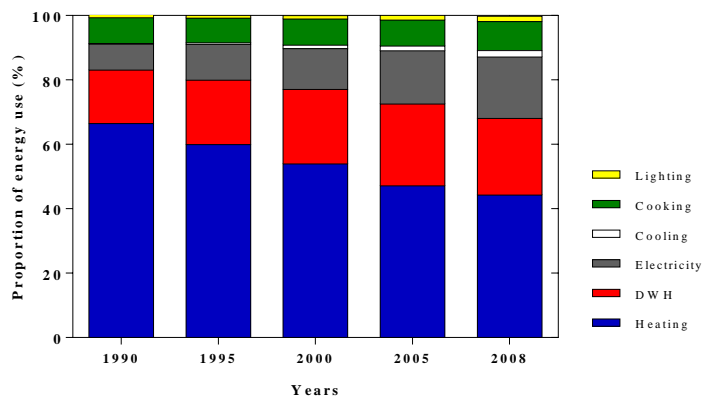

Figure 2.9 Proportion of energy use in residential buildings (KEEI, 2011)

### 2.2.3 *High-rise apartment buildings in South Korea*

#### 2.2.3.1 **Development of high-rise apartment buildings**

Apartment buildings were chosen to accommodate the rapidly increasing urban population during great economic growth since the 1980s (Jeon, 2010). As shown in Figure 2.10, the number of apartment constructions greatly increased in the last forty years. Figure 2.11 depicts one of the representative apartment districts in South Korea. In terms of this, Gelézeau (2007) described the shapes of apartment buildings in Seoul as featureless and significantly unified appearance. She pointed out that the massive apartment constructions brought about the radical changes in the urban form of the city, Seoul. Jeon (2010) interpreted that these physical characteristics of apartment buildings are for economic profit and social preference being similar to majorities of the South Korean society. Like their descriptions, apartments have not only been influencing the urban features, but also influenced by the social and economic aspects. This section briefly summarises the development of high-rise apartment buildings.

The stages of apartment construction can be chronologically divided into four: introduction (1960s), proliferation (1970s – 1980s), maturation (1990s) and multiplication (2000s). As construction techniques were not well developed, there was trial and error in the 1960s. For example, the first apartment cluster, ‘Mapo apartment’, was initially planned to have ten-story buildings, but was finally erected with six-story buildings, due to safety reasons and the lack of public awareness in terms of high-rise buildings (Jeon, 2010). However, the attempts in increasing the height of apartment buildings was continued so that the overall number of floors increased from 5 – 6 to 12 – 15 in the late-1970s.

The apartment construction in the 1970s – 1980s can be described as mass production. Based on the trial and error in the 1960s, South Korean Governments politically encouraged a massive number of apartment constructions. Urban planning was implemented based on the mass production (Jeon, 2010). Besides, a building regulation, which only permitted

apartment buildings in residential areas, was established in 1976, and was empowered until 1993 (Zhang, 1994). Enormous scales of apartment constructions were begun as government-led projects in the 1980s, called the ‘Five millions housing project’ in 1980 and the ‘Two millions housing project’ in 1989 (Jeon, 2010). These projects brought about the great conversion of land topography, and rapidly transformed the areas.

In the 1990s, the enormous number of apartment constructions continued (shown in Figure 2.10). The type of building structure changed from the non-bearing wall structure to the bearing wall structures in order to shorten the construction period. Thus, the number of floors was increased up to 25, which was the limitation of the bearing wall structures (Son, 2004). Since the 2000s, a new type of apartment buildings, a tower type (Figure 2.14-(right)), has been introduced. As this type increases the height of buildings from 25 floors to 40 – 50 floors, it has been replacing the main design of apartment buildings.

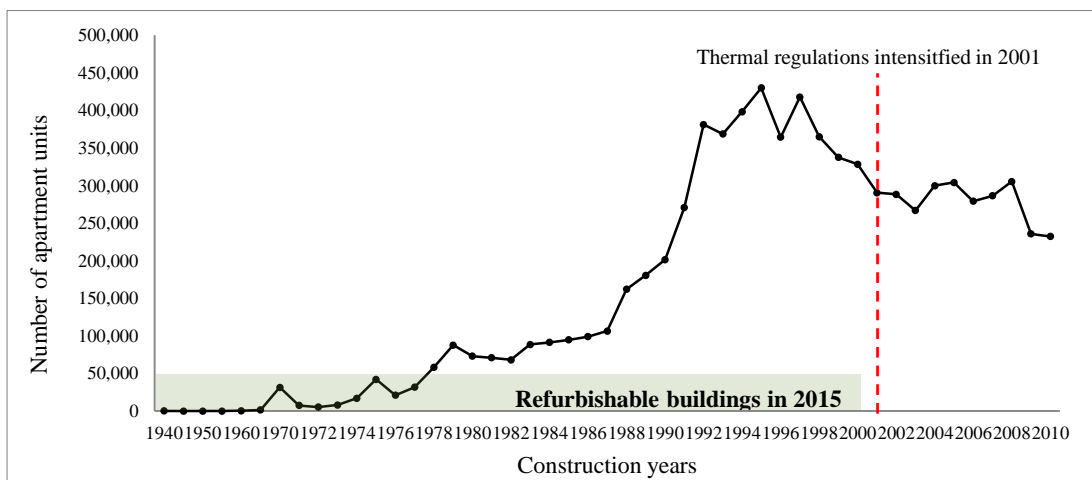

**Figure 2.10. Timeline of apartment constructions in South Korea (Source: Statistics Korea, 2010a)**

The main target of residents living in apartment buildings in the initial stage of apartment constructions was for the working classes. However, the target of the massive constructions has been shifted to “new middle class” grown by the great economic growth in South Korea (Zhang, 1994; Chung, 2007). Living in apartments for them became the rise of social status

(Gelézeau, 2007). Therefore, apartment buildings have been required to be more luxurious, convenient with advanced technologies and even more private. Zchang (1994) classified distinctive characteristics of apartment buildings built from the 1960s to the 1970s that unit designs have also been prevalently investigated with time-specific, as also shown in (Bae *et al.*, 2001; Lee, 2006; Kim and Yoon, 2010). These previous studies confirm that the physical characteristic of apartment buildings in South Korea have been also interconnected with the economic and social aspects.



**Figure 2.11 Apartment buildings in apartment districts in South Korea (Source: [http://economyplus.chosun.com/special/special\\_view.php?boardName=C01&num=6793](http://economyplus.chosun.com/special/special_view.php?boardName=C01&num=6793) )**

Recently, energy efficient schemes have been an important issue for apartment buildings in accordance with the intensifying of building thermal regulations since 2001. Apartment buildings constructed after 2001 have been forced to be energy-efficient under the intensified thermal regulations. However, apartment buildings constructed before 2001, despite the significant proportion of housing in South Korea, have not responded to the

requirement of the intensified thermal regulations. Excessive energy consumption in these old apartment buildings has been pointed out (Kim, 2010). However, the main focus of existing literature investigating energy-efficiency in buildings has been given to buildings which are forced to be energy-efficient by the regulations rather than buildings which need to reduce energy consumption in real situations.

### 2.2.3.2 Transformation of building characteristics of high-rise apartment buildings

#### *Apartment clusters, buildings and units*

The characteristics of apartment buildings in South Korea can be interpreted by three different scales: apartment clusters, buildings and units. Figure 2.11 describes the three different scales of high-rise apartment buildings in South Korea. An apartment unit is a living space allocated to each household. The apartment building is a group of apartment units in the same buildings. The group of apartment buildings, under the same management with a near distance, is called clusters.

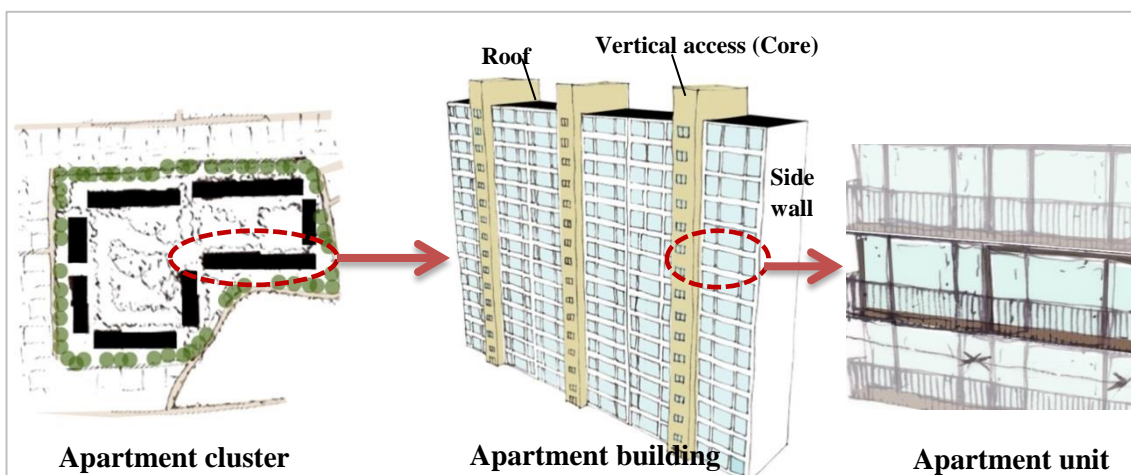

Figure 2.12 Three different scales of apartments in South Korea

The cluster can be categorised by three types of building layout: linear, square and grid types (Figure 2.13). The initial cluster type was the linear type that buildings are located alongside horizontal lines on site. Square and grid types are the cluster types that buildings are used to enclose one large and several small square-shape open spaces, respectively, to increase the floor area ratio (Jeon, 2010).

How to layout apartment buildings in sites has been important for buildings in the clusters to acquire enough solar radiation. Traditionally, residential buildings including apartment buildings were preferred to face south (Jeon, 2010). Empirical studies, such as (Lee and Lim, 2000; Park *et al.*, 2011), also identified the least amount of energy consumption in apartment buildings with the linear-type cluster for south-facing. Existing literature often compared the types of building layouts in apartment clusters, and the impact of building layouts on shading and solar gain. Yoon *et al.* (2006) measured the shaded areas on a building facade by surrounding apartment buildings in the same block. Buildings with the square-type cluster showed the greatest amount of shaded area. Park *et al.* (2007) analysed solar radiations on building façade with the three cluster types. The authors found out that building with a linear layout resulted in the most equalised distribution of solar radiation, whilst the square-type cluster was the lowest levels.

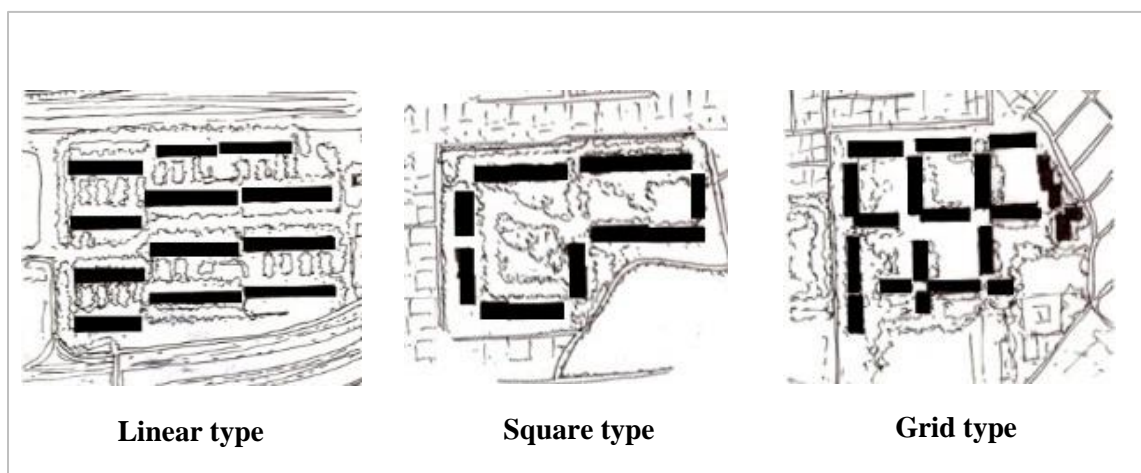

Figure 2.13 Three types of apartment clusters



Apartment buildings consist of multiple apartment units, occupied by individual households. The shape of apartment buildings has been determined by unit designs and layouts of units on floors. Previous studies, such as (Park *et al.*, 2011; Kim *et al.*, 2013e), categorised the shape of buildings by a flat-type and tower-type (Figure 2.14), which used the totally different methods of unit layouts and the systems of building envelopes. The flat-type is considered as a traditional style, while the tower-type has been constructed since the 2000s. Existing literature tends to compare these two types. According to Park *et al.* (2011), apartment buildings with the flat-type consumed less energy for electricity than the tower-type although the tower-type is relatively newer conditions. The result can be interpreted by the disparities of solar radiation on building façade (Kim *et al.*, 2013e). The tower-type is subdivided into several shapes such as L-shape, cross-shape and two-wing shape (e.g. Kim *et al.*, 2013e; Roh, 2014).



**Figure 2.14 Two types of apartment buildings: flat type (left) and tower type (right)**  
(Source: <http://blog.naver.com/PostView.nhn?blogId=sugar7777&logNo=90086687153>  
<http://news.joins.com/article/6409693>)

The flat type of apartment buildings is divided by the type of vertical accesses: corridors and stairs (Figure 2.14 and 2.15). As depicted in Figure 2.15, the corridor type is for residents to enter their apartment units through the corridor from a lift all, while the stair type let residents directly access to individual units from a lift hall. The buildings with the corridor



type can often have a longer width than the stair type, while multiple vertical assesses can increase the width of building with the stair type (Figure 2.16).



**Figure 2.15 Two types of apartment units: corridor type (left) and stair type (right)**  
(Source: <http://land.naver.com/> )



**Figure 2.16 Image of apartment buildings with two types: corridor type (left) and stari type (right)** (Source: <http://news.naver.com/main/read.nhn?mode=LSD&mid=sec&sid1=101&oid=015&aid=0002204036> , [http://www.hdapt.com/g4/bbs/board.php?bo\\_table=tb\\_apt\\_5&wr\\_id=66&top\\_menu=6&top\\_sub=3](http://www.hdapt.com/g4/bbs/board.php?bo_table=tb_apt_5&wr_id=66&top_menu=6&top_sub=3))

Another important aspect of apartment buildings is the thermal conditions of building envelopes. Since the first building thermal regulations have been established, apartment buildings should be more insulated to prevent heat loss through building envelopes. The first regulations, established in 1980, simply suggested the thickness of insulations for nine

materials and the additional conduction resistance level (Table 2.1). The first revision (Table 2.2), which was implemented in 1984, specified the parts of apartment buildings that need to be insulated (External walls, ground floors, roofs and side walls). Depending on the parts, the thickness of insulation became different from 30mm to 70mm for three insulating materials (glass, polystyrene form and rock wool). The second revision (Table 2.3), enacted in 1987, divided the regions in South Korea into three groups (central region, southern region and Jeju Island). Moreover, the building parts were more precisely divided. The roof and side walls required thicker insulation than other parts. The thermal regulations became much more specified and intensified in 2001 (Table 2.4). The most significant conversion of the regulation is the one in 2001. The parts of buildings, which were not directly exposed to the outside, also needed to be insulated. Moreover, the thicker insulation was required if the parts of buildings enclosed the heated areas. The recently revised regulations have also been implemented based on the conversion in 2001.

Improving the thermal conditions of the building envelopes in high-rise apartment buildings has also been intensively continued in many previous studies dealing with buildings in South Korea. The external insulation was recommended to prevent heat loss through the ends of internal insulation (Song, 2014). Heating demands were significantly reduced by increasing the thickness of insulation, while time-lag impeding heat loss through external walls was not efficient with this (Choi and Cho, 2012). The increase of window-to-wall ratio from 37% to 64% brought about higher energy consumption in apartment buildings (Kim *et al.*, 2013c). Other aspects of windows were investigated: glazing types (Lee *et al.*, 2012), glazing systems (Cheong *et al.*, 2009) and window frames (Yoon *et al.*, 2008b). Moreover, types of balcony area, enclosing living spaces heated from the outside, also brought about up to 19% difference in energy consumption (Yoon *et al.*, 2007).

**Table 2.1 Legislation of insulation for building in the 1980 (Kim *et al*, 2009b)**

| Materials           | Thickness (mm)                                     |
|---------------------|--|
| Glass               | 50   |
| Polystyrene foam    | 50   |
| Polyurethane foam   | 50   |
| Rock wool           | 60   |
| Asbestos            | 60   |
| Calcium silicate    | 60   |
| Magnesium carbonate | 70   |
| Cork                | 70   |
| Perlite             | 100  |
| Others              | Resistance of heat conduction more than 1.6°C/kcal |

**Table 2.2 Legislation of insulation for building in the 1984 (Kim *et al*, 2009b)**

| Parts and locations of materials                   |                              | Glass, polystyrene form, rock wool (mm) | Others with resistance of heat conduction (°C/kcal) |
|--|------------------------------|---|---|
| External walls, ground floors and roof (top floor) | Central and southern regions | Thicker than 50 mm                      | Higher than 1.6                                     |
|  | Jeju Island                  | Thicker than 30 mm                      | Higher than 1.0                                     |
| Side walls   | Central and southern regions | Thicker than 70 mm                      | Higher than 2.2                                     |
|  | Jeju Island                  | Thicker than 40 mm                      | Higher than 1.2                                     |

**Table 2.3 Legislation of insulation for building in the 1987 (Kim *et al*, 2009b)**

| Parts and locations of materials |                  | Glass, polystyrene form, rock wool (mm) | Others with resistance of heat conduction (°C/kcal) |
|----------------------------------|------------------|---|---|
| External walls and ground floors | Central regions  | Thicker than 50 mm                      | Higher than 1.6                                     |
|                                  | Southern regions | Thicker than 40 mm                      | Higher than 1.25                                    |
|                                  | Jeju Island      | Thicker than 30 mm                      | Higher than 1.0                                     |
| Roofs                            | Central regions  | Thicker than 80 mm                      | Higher than 2.5                                     |
|                                  | Southern regions | Thicker than 60 mm                      | Higher than 1.9                                     |
|                                  | Jeju Island      | Thicker than 40 mm                      | Higher than 1.25                                    |
| Side walls                       | Central regions  | Thicker than 70 mm                      | Higher than 2.2                                     |
|                                  | Southern regions | Thicker than 50 mm                      | Higher than 1.6                                     |
|                                  | Jeju Island      | Thicker than 40 mm                      | Higher than 1.25                                    |

**Table 2.4 Legislation of the insulation for central region in the 2001 (Kim *et al.*, 2009)**

| Thickness of insulation depending on types of materials |                                 |            | Thickness of insulation (mm) |              |               |               |
|---|---------------------------------|------------|------------------------------|--------------|---------------|---------------|
|   |                                 |            | A                            | B            | C             | D             |
| Thermal resistance level ( $W/m^2K$ )                   |                                 |            | ~<br>0.34                    | 0.35~<br>0.4 | 0.41~<br>0.46 | 0.47~<br>0.51 |
| External walls of living room                           | Directly exposed to the outside |            | 65                           | 75           | 85            | 100           |
|   | Indirectly exposed              |            | 45                           | 50           | 55            | 65            |
| Ground floors   | Directly exposed to the outside | Heated     | 90                           | 105          | 120           | 135           |
|   |                                 | Non-heated | 75                           | 90           | 100           | 115           |
|   | Indirectly exposed              | Heated     | 55                           | 65           | 75            | 80            |
|   |                                 | Non-heated | 50                           | 55           | 65            | 70            |
| Roofs   | Directly exposed to the outside |            | 110                          | 125          | 145           | 165           |
|   | Indirectly exposed              |            | 75                           | 85           | 100           | 110           |
| Side walls  |                                 |            | 90                           | 105          | 120           | 135           |
| Shared floors   | Heated                          |            | 30                           | 35           | 45            | 50            |
|   | Non-heated                      |            | 20                           | 25           | 25            | 30            |

Apartment units can be considered as independent housing occupied by different households. The diversity among apartment units in the same buildings can be identified by four characteristics. Firstly, the thermal conditions of surfaces in apartment units are different by the locations of apartment units (Kang *et al.*, 1995; Yoon *et al.*, 2009). As apartment units on the ground, top floors and the side of buildings have more surfaces directly exposed to the outside, these units can be less energy-efficient than other units in the middle of buildings (Yoo *et al.*, 2007). Thus, energy consumption could be varied by the unit locations. Second, external environment is different in individual units with different locations. Solar radiation and sunshine duration can be increased in accordance with higher floors (Kim *et al.*, 2013e). Moreover, the different levels of natural ventilation rates and their uncertainties were found by the unit locations (Hyun *et al.*, 2008). Thirdly, there is thermal interaction through sharing slabs between apartment units on the different vertical locations. The slabs are equipped with an under-floor heating system; heated water is circulated through pipe lines buried in the slabs. Two apartment units share one slab as a floor for the unit on an upper floor and a ceiling for the unit on a lower floor although the heating system is controlled by the unit on an upper floor. Hence, heat can be transferred to both floors

through the shared slabs, which affect to change indoor temperatures in other apartment units (Choi *et al.*, 2007a). Lastly, individual units have been independently controlled by occupants. Depending on how each household control the heating system, energy consumption in each unit can be significantly varied. However, independent energy controls of apartment units have not been paid much attention in existing literature. This can be easily found that all energy models were set by the standardised conditions, even though the detailed values could be slightly different depending on which guidelines were chosen. However, empirical data, reported in (Kang *et al.*, 1995; Kim and Lee, 2005; Kim *et al.*, 2011), showed that energy consumption in individual apartment units was varied by not only physical conditions but also individual controls in each unit. Unfortunately, these empirical studies analysing building energy consumption only focused on verifying theoretical findings related to the physical building conditions. Therefore, variation in energy consumption arising from individual units has been dismissed in the analysis of these studies.

For example, Kang *et al.*(1995) provided the proportional rates of heating energy consumption depending on the unit locations for fifteen-story apartment buildings, as shown in Table 2.5. As can be expected, apartment units on the ground and top floors consumed higher heating energy than the other floors. Slight higher consumption also can occur in the units on the side of apartment buildings than the units on the middle of buildings. However, these two statements did not always correspond to this data. Many of the middle floors showed higher energy consumption than the west side of apartment buildings as well as lower floors. This showed the clear impact of the unit locations as well as the variation in individual controls in each apartment unit.

**Table 2.5. Proportional rates of heating energy consumption in apartment units (Source: Kang et al., 1995)**

| Locations          |                        | Horizontal locations |        |       |
|--------------------|------------------------|----------------------|--------|-------|
|                    |                        | West                 | Middle | East  |
| Vertical locations | Top floor              | 1.564                | 1.608  | 1.744 |
|                    | 13 <sup>th</sup> floor | 1.000                | 1.000  | 1.000 |
|                    | 12 <sup>th</sup> floor | 1.098                | 1.113  | 1.149 |
|                    | 11 <sup>th</sup> floor | 1.116                | 1.173  | 1.196 |
|                    | 10 <sup>th</sup> floor | 1.033                | 1.170  | 1.200 |
|                    | 9 <sup>th</sup> floor  | 1.133                | 1.244  | 1.211 |
|                    | 8 <sup>th</sup> floor  | 1.441                | 1.353  | 1.429 |
|                    | 7 <sup>th</sup> floor  | 1.159                | 1.352  | 1.139 |
|                    | 6 <sup>th</sup> floor  | 1.091                | 1.390  | 1.332 |
|                    | 5 <sup>th</sup> floor  | 1.581                | 1.363  | 1.404 |
|                    | 4 <sup>th</sup> floor  | 1.318                | 1.425  | 1.478 |
|                    | 3 <sup>rd</sup> floor  | 1.392                | 1.466  | 1.479 |
|                    | 2 <sup>nd</sup> floor  | 1.391                | 1.584  | 1.560 |
|                    | 1 <sup>st</sup> floor  | 1.498                | 1.605  | 1.504 |
|                    | Ground floor           | 1.667                | 1.995  | 1.839 |

### 2.2.3.3 Energy systems in high-rise apartment buildings

Because of the climate conditions (Section 2.2.1), buildings in South Korea require both heating and cooling to preserve a comfortable indoor environment. An underfloor heating system is installed in apartment buildings in South Korea. The floors are warmed by the heated water circulating through pipelines in the concrete slabs (floors), as described in Figure 2.17.

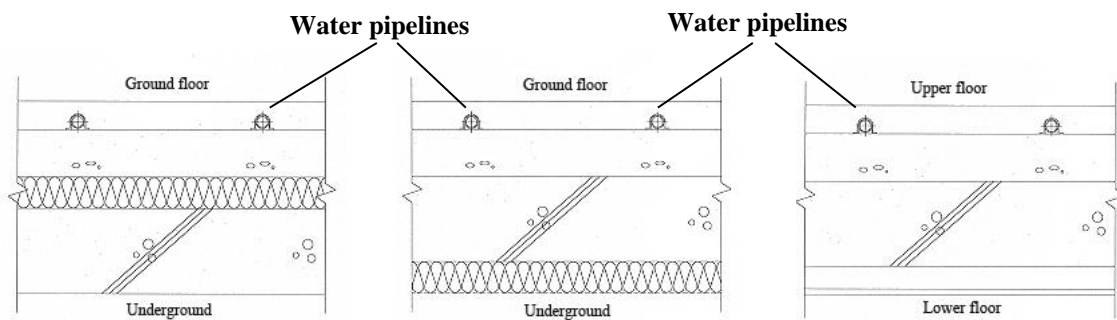

**Figure 2.17 Sections of underfloor heating applied in apartment buildings (Song, 1994)**



**Figure 2.18 Underfloor hot-water heating, applied to apartment buildings in South Korea**

(Source:

<http://www.oknusu.co.kr/technote7/board.php?board=freeborad&page=4&sort=hit&command=body&no=85>,  
<http://blog.daum.net/blog/photoList.do?blogid=0IjvL>,  
[http://www.bomicorp.co.kr/xe/view.php?id=sigong\\_3&page=2&sn1=&divpage=1&sn=off&ss=on&sc=on&select\\_arrange=headnum&desc=asc&no=29](http://www.bomicorp.co.kr/xe/view.php?id=sigong_3&page=2&sn1=&divpage=1&sn=off&ss=on&sc=on&select_arrange=headnum&desc=asc&no=29) )

Heating systems used in apartment buildings can be categorised as three types depending on heat resources and distribution methods: central and individual gas heating and district heating (Lee *et al.*, 2004). The central and individual gas heating methods use natural gas as the main energy resource. The difference between them is that the central gas heating is operated by a main engineering room, while the individual gas heating warms up water through an individual boiler equipped in individual apartment units. The district heating takes district heat from thermal power stations. The flow chart of supplying heated water in the heating systems (individual gas heating) is provided in Figure 2.19.

Although the climate conditions require cooling in buildings, cooling systems were not initially installed in apartment buildings. Traditionally, electric fans have been used as a cooling device. However, the demand of air-conditioning has increased throughout South Korea, and residents purchase air-conditioners individually. Nowadays, new apartment buildings are equipped with air-conditioners like heating systems. To this reason, the penetration rate of air-conditioners has been rapidly increased and reached more than 70% households in South Korea (KEPC, 2013). Depending on models of air-conditioners, the specification can be diverse.

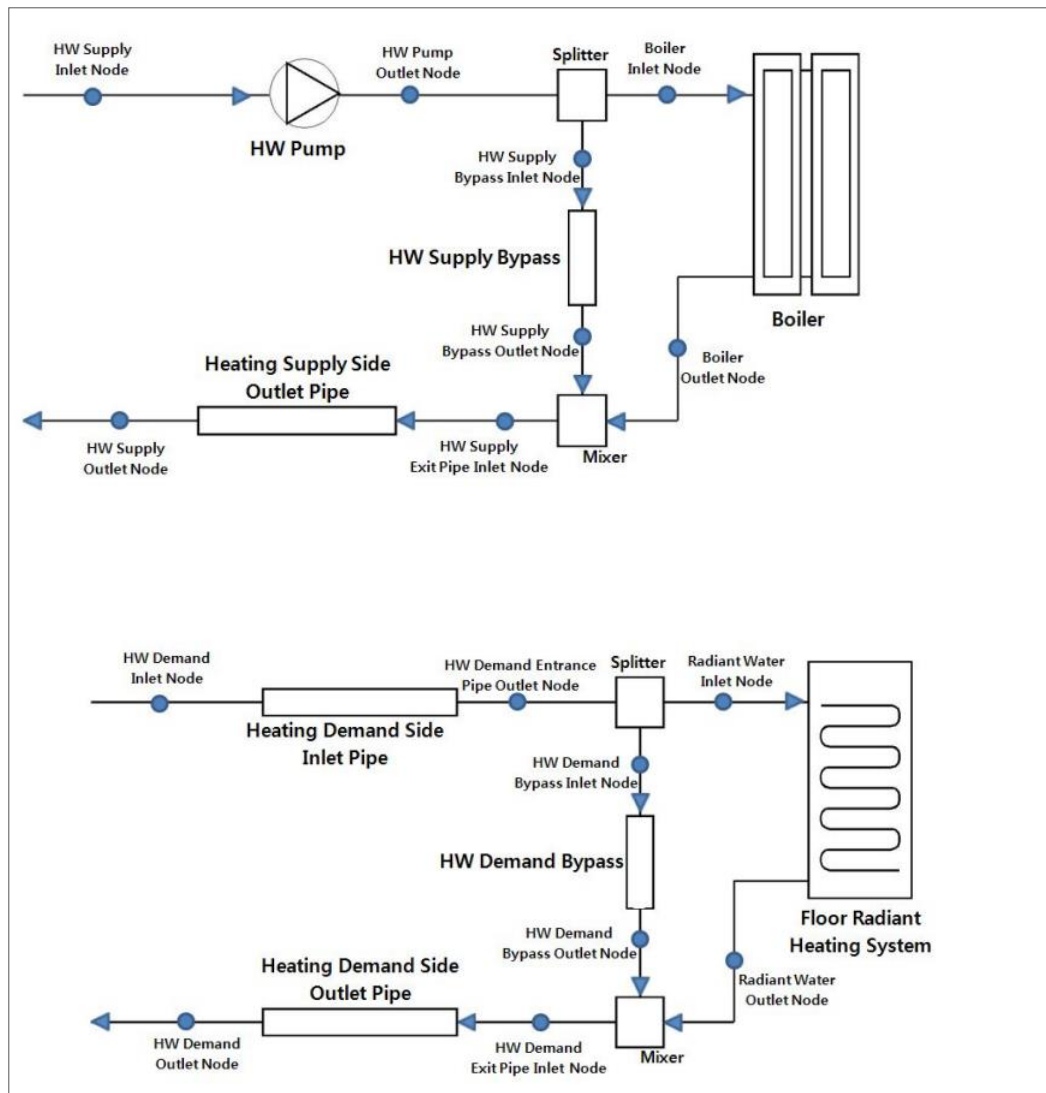

**Figure 2.19** Diagram of heating, applied to apartment buildings in South Korea (Individual gas heating) (Lee, 2009)

#### 2.2.4 *Building performance assessment schemes in South Korea*

As reviewed in Section 2.1.2, building energy performance in buildings has been evaluated through various assessment methods depending on the specific purposes of the assessments. Five types of building performance assessment methods have been used for buildings in South Korea: Green Building Certification Criteria (GBCC), Building Energy Efficient Rating System (BEERS), Housing Performance Rating Disclosure System (HPRDS),



Energy Saving Design Standards (ESDS) and The Environmental-Friendly Housing Certification (EFHC) (Shin, 2008; Park, 2012), as summarised in Table 2.6.

For all types of buildings, two assessment methods, GBCC and BEERS, have been applied to evaluate building energy performance. The other three methods are specified only for apartment buildings. GBCC was established to reduce GHG emissions by certifying environmental impacts of buildings, while BEERS has been enacted to certify energy-saving technologies that have been adopted by the relevant regulations (Park, 2012). GBCC has a wider range of consideration impacting on GHG emissions so that it is more like the building environment assessment schemes such as LEED and BREEAM. On the contrary, BEERS is focused on evaluating energy efficiency in buildings by quantifying energy performance with international standards, ISO 13790 (ISO, 2008) and DIN V 18599-2 (DIN, 2007).

Three types of the assessment methods, HPRDS, ESDS and EFHC, have been authorised for evaluating apartment buildings. HPRDS is used to classify the performance of housing in terms of noise, structure, environment, living environment, fire (Shin, 2008). Apartment clusters with more than 1000 households compulsorily need to indicate the levels of HPGS (Park, 2012). ESDS guides how apartments have to be designed in order to be energy-efficient (MLIT, 2015b). EFHC was enacted to reduce GHG emissions as well as energy consumption from housing (Shin, 2008). They measure the expected rates of total energy saving.

Apart from BEERS, the quantification methods of the four assessment methods are using Energy Performance Indicator (EPI). EPI sets the best performance of energy use in buildings is 100, and evaluates the energy performance of buildings concerned through the specified criteria having credits (Kang, 2010). Each criterion has different credits. For example, GBCC requires higher than 60 from 100 credits. HPRDS certifies housing with higher than 90 credits for the first grade. The planned technologies acquiring credits in each

criterion are expected to be performed in actual performance. Instead, BEERS takes the quantifying methods from ISO 13790 and DIN V 18599-2 (Park, 2012). If the expected energy saving is outweighed than 40%, the first grade can be given.

In the cases of South Korea, the limitations of the assessment methods, which were identified with the global point of view (Section 2.1.4 and 2.1.5), are also found. The four assessment methods using EPI, except for BEERS, classify energy performance in accordance with the designated criteria rather than scrutinise the quality of building performance. Thus, it does not provide a precise diagnosis of insufficient energy performance. BEERS actually quantifies building energy performance, based on the calculation-based methods. However, this simplified calculations have neglected the possible impacts of unexplained factors and data error (Summerfield *et al.*, 2010), as identified in Section 2.1.3.

**Table 2.6 Summary of building energy assessment methods in South Korea**

|                                     | Green Building Certification Criterion (GBCC)   | Building Energy Efficient Rating System (BEERS)  | Housing Performance Rating Disclosure System (HPRDS)  | Energy Saving Design Standards (ESDS)   | The Environmental-Friendly Housing Certification (EFHC)   |
|-------------------------------------|---|--|---|---|---|
| Outline (Shin, 2008; Park, 2012)    | A certification system for GHG emissions from a buildings   | A certification system for new apartments that apply energy-efficient building technologies, which are adopted by the relevant regulations | A indicator classifying performance of housing, intended to provide accurate information of housing and to improve the general performance of housing | A standard of energy efficient design limiting an amount of energy consumption in buildings | A housing standard providing construction and performance limitations to reduce energy consumption as well as GHG emissions |
| Regulations related (Park, 2012)    | Building Act, Article 65  | Building Act, Article 66   | Housing Act, Article 21   | Building Act, Article 66  | Housing Construction Standards, Article 64  |
| Methods of evaluation (Park, 2012)  | EPI   | ISO 13790 and DIN V 18599-2  | EPI   | EPI   | EPI   |
| Supervising department (Park, 2012) | Ministry of Land, Transport and Maritime Affairs, and Ministry of Environment   | Ministry of Land, Transport and Maritime Affairs, and Ministry of Knowledge Economy  | Ministry of Land, Transport and Maritime Affairs  | Ministry of Land, Transport and Maritime Affairs  | Ministry of Land, Transport and Maritime Affairs  |
| Assessment criteria (Shin, 2008)    | Land use, transportation, energy, material and resource, water use, environmental impact, maintenance, ecological impact and indoor environment | Total energy saving, total energy demand and carbon emissions  | Noise, structure, environment, living environment, fire   | EPI in architectural design, engineering, electricity                                       | Rates of total energy saving, qualities of insulation, energy-saving facilities   |
| Targets (Park, 2012)                | Apartment, office, multi-flex, school, accommodation, commercial  | All buildings  | Apartment with more than 1000 households  | Apartment, other buildings with larger than 500m <sup>2</sup> floor area                    | Apartment   |
| Application (Park, 2012)            | Compulsory for governmental facilities, but recommended for others  | Recommended  | Compulsory  | Compulsory  | Compulsory  |

### 2.2.5 *Refurbishment measure quantifying energy performance in existing buildings in South Korea*

The initial focus of refurbishment with existing apartment buildings in South Korea was to answer whether the economic profit of refurbishing existing apartments outweigh the profit of building new apartments. Therefore, previous studies mostly compared the economic profit of both approaches, such as (Lee *et al.*, 2007; Kang *et al.*, 2010; Kim *et al.*, 2013a).

With the growing attention to energy-efficiency, three methods have been used in existing literature treating refurbishment in the context of South Korea. The most dominant quantification method is using simplified energy calculation models (steady-state methods). This can be comprehended that economic aspect is still one of significant factors in determining refurbishment. Therefore, the quantified energy saving with energy-efficient technologies is expected to be converted to the possible economic profit. As the types of energy calculation models used in existing literature, the packages of calculating energy consumption, based on ISO 13790 (ISO, 2008) and DIN V 18599-2 (DIN, 2007), were often used. Alternatively, Passive House Planning Package (PHPP) is used in (Seo *et al.*, 2011). The second method is using engineering methods with archetypes. This is because this method has been commonly used to assess energy saving technologies. The last method is creating create mathematical models to calculate energy consumption with regard to influential parameters.

The dynamic simulation, another method of the calculation-based methods, has also been widely used to evaluate an amount of energy saving in applying energy-efficient building technologies. While the calibrated simulation, mentioned in Section 2.1.3, revises initial inputs based on actual energy use, the dynamic simulation creates a self-reference building with idealised conditions of building factors. The difference between them is that the dynamic simulation is expected to be achieved in a real building, whereas the calibrated simulation modifies the inputs to adjust the prediction to be similar to the actual consumption. Therefore, the input factors, except for building forms, have been inferred

from the national and international guidance of creating building simulation models, such as BEERS, ESDS and ASHRAE fundamental handbook (Table 2.7). This approach can be comprehended by a trend of constructing apartment buildings in South Korea, which targets unspecified occupants with supplying in large number. However, this focus has been criticised due to the high disparities of their estimation, compared to real consumption.

### ***2.2.6 Limitations of measuring building energy performance***

In the decision-making process of refurbishment, two aspects have to be ensured by reviewing existing literature, described in Section 2.1.4 and 2.1.5. The first aspect is accurately measuring the amount of energy saving from the original conditions. The second aspect is reducing the performance gap between the predicted energy consumption with the assessment methods and the actual achievement in real situations. The clear limitations, derived from the complexities and diversities of buildings, have been recognised in quantifying energy performance in buildings, especially in building simulation models. The review of energy performance assessment methods in South Korea also implied the similar limitations, as shown in Section 2.2.4 and 2.2.5. This section interprets the specific limitations of the measurement methods used for buildings in South Korea.

By reviewing existing literature, the limitations can be interpreted by three aspects. Firstly, the deterministic approach has only been considered to quantify energy performance in buildings. Thus, the complexities and diversities in buildings have been neglected in the quantification process. As identified in Section 2.1.4, one of main challenges of energy-efficient refurbishment is the inflexible frameworks encapsulating diverse building conditions in the fixed one. This could limit to give rise to the true building conditions of existing buildings into the calculation process. The building characteristics of existing apartment buildings in South Korea have been transformed. Moreover, uncertainties in occupant-related factors have been disregarded in the quantification methods. As shown in Table 2.7, the input values of occupant-related factors have been fixed by the national and

international guidance. Global attention has been given to the attempts dealing with uncertainty arising from the complex and diverse buildings conditions, including physical characteristics and occupant behaviour. This attempt also needs to be implemented for existing apartment buildings in South Korea.

Secondly, the dominant quantification methods were only chosen from the calculated-based methods, dynamic simulation and steady-state method (simplified building energy calculation). No hybrid method integrating more than two quantification methods have been applied to supplement limitations of applying one method. A failure of the idealised conditions in the dynamic simulation, especially identifying occupant behaviour, has been argued by disparities between estimated consumption and actual use, called the performance gap (Galvin, 2014a). Sunikka-Blank and Galvin (2012) also pointed out that actual energy consumption can be easily different from the estimated consumption because of occupants' adapting behaviours. For this reason, building energy models can often overestimate energy consumption than actual energy use (Ingle *et al.*, 2014). Many previous studies have attempted to clarify uncertain factors causing the disparities of the model estimations, and explore solutions to control the uncertainties.

Thirdly, the building energy models of apartment buildings are fragmented by either a single building or a group of representative units. Apartment units are independent thermal zones in buildings as they have been individually controlled by diverse households. However, previous building energy models radically simplified these aspects. Most of simplification of the modelling focused on a single building with disregard variation in individuals. Empirical studies showed how this simplification can misread the energy modelling into high levels of discrepancy, as shown in (Yao and Steemers, 2005; Richardson *et al.*, 2008; Widén *et al.*, 2009; Richardson *et al.*, 2010). This aspect needs to be improved in the conventional modelling for high-rise apartment buildings.

In summary, the limitations of assessing building energy performance have been identified in the context of South Korea. The first aspect is the inflexibility of reflecting variation in the transformed building features. Secondly, less attention has been paid to reflect realities with uncertain factors in apartment buildings, especially occupants' behaviours. The variation in self-contained individual apartment units is the last aspect.

### **2.3 Summary**

How to make a decision in refurbishment can be re-defined as how to measure energy-saving in refurbishment strategies and how to estimate the measured energy-saving accurately to be achieved in real situations. The six challenges, defined in Section 2.1.4, represent the crucial difficulty in successful refurbishment due to the intrinsic complexities and diversities of building factors encompassing buildings concerned. The assessment methods of quantifying energy performance in buildings and energy-saving in refurbishment strategies have been improved and sophisticated. However, the performance gap, caused by the disparity between the predicted and measured energy consumption, has still been problematic in this field. Uncertainty and sensitivity analyses under the current assessment methods, especially with building simulation models, have shown how much the predicted energy consumption can be different from the achieved value in realities. This has been the serious obstacle of making a decision for refurbishment strategies. Some studies have been focused on integrating the uncertainties into the process of predicting energy consumption. A probabilistic approach with the distribution of building factors helps making a decision finding the most probable values to be used for evaluating refurbishment strategies, while alleviating the performance gap arising from the uncertainties.

In the context of South Korea, the assessment methods have shown the clear limitations in the line with the global point of view. The deterministic approach has only been used to quantify building energy performance. Therefore, the complexities and diversities derived from the transformation of building characteristics and occupant-related factors have not

been regarded in the quantification. Moreover, the applied methods have been dominated by the calculation-based methods, which have limitations to take unexplained factors and data errors into consideration. Hybrid methods by combining the calculation-based methods with actual consumption data need to be attempted. Lastly, the variation arising from the individual apartment units has also need to be contained.

Energy-efficient refurbishment has shown its potentiality contributing to reduce GHG emissions. However, the actual achievement can be followed, once the reliable process of the refurbishment is consolidated. Existing literature pointed out the challenges of the current assessment methods treating the performance gap in refurbishment measures. This issue is still an ongoing process.



Table 2.7 Input data of building conditions in existing literature

| Authors                   | Set-point temperature |         | Schedules     |               | Internal gain                                  |                      |                       |                            | Ventilation      |                    | Cooling system | Guideline                   |
|---------------------------|-----------------------|---------|---------------|---------------|--|----------------------|-----------------------|----------------------------|------------------|--------------------|----------------|-----------------------------|
|                           | Heating               | Cooling | Heating       | Cooling       | Equipment                                      | Lighting             | Occupant              | No. occupant               | Conditioned area | Unconditioned area |                |                             |
| Kim <i>et al.</i> (2013)  | 20 °C                 | -       | -             | -             | 2.98 W/m <sup>2</sup>                          | -                    | 1.27 W/m <sup>2</sup> | 0.03 person/m <sup>2</sup> | 0.7 ACH          | 2.0 ACH            | -              | BERS                        |
| Roh (2012)                | 20 °C                 | 26 °C   | -             | -             | 7.53 W/m <sup>2</sup>                          | -                    | 73.3 W/m <sup>2</sup> | -                          | -                | -                  | EER 2.5        | BERS, ESDS                  |
| Roh <i>et al.</i> (2011)  | 20 °C                 | 26 °C   | -             | -             | 3.76 W/m <sup>2</sup>                          | -                    | 1.72 W/m <sup>2</sup> | 0.04person/m <sup>2</sup>  | 0.7 ACH          | 2.0 ACH            | -              | BERS, ESDS                  |
| Yoon <i>et al.</i> (2009) | 20 °C                 | 27 °C   | 30/09 – 18/05 | 30/06 – 31/08 | 463 W  | -                    | -                     | -                          | 0.7 ACH          | 2.0 ACH            | -              | BERS                        |
| Yoo <i>et al.</i> (2002)  | 20 °C                 | 28 °C   | Oct -Mar      | Jul-Aug       | -  | -                    | -                     | 4 people                   | 1.5 ACH          | 0.5 ACH            | -              | -                           |
| Park (2009)               | 20 °C                 | 26 °C   | -             | -             | 14 W/m <sup>2</sup>                            | 4 W/m <sup>2</sup>   | 65 W/m <sup>2</sup>   | 0.04person/m <sup>2</sup>  | 0.1 ACH          | 0.1 ACH            | COP 3.14       | ISO 7730                    |
| Son <i>et al.</i> (2010)  | 24 °C                 | 26 °C   | -             | -             | 314 W  | 68 W                 | 70W                   | 4 people                   | 0.4 ACH          | 2.0 ACH            | -              | -                           |
| Park and Park (2012)      | 20 °C                 | 26 °C   | -             | -             | -  | -                    | -                     | -                          | 0.7 ACH          | -                  | -              | BERS                        |
| Song (2008)               | 30 °C (floor)         | 26 °C   | -             | -             | -  | -                    | -                     | 4 people                   | 0.5 ACH          | -                  | -              | BERS, ESDS                  |
| Choi and Cho (2012)       | 18 °C                 | 26 °C   | -             | -             | -  | 3.4 W/m <sup>2</sup> | -                     | 0.03person/m <sup>2</sup>  | -                | -                  | -              | -                           |
| Suh and Kim (2011)        | -                     | -       | -             | -             | 7.01 W/m <sup>2</sup>                          | 5.4 W/m <sup>2</sup> | 131W/person           | 4 people                   | -                | -                  | -              | ASHRAE 90.1                 |
| Yoon <i>et al.</i> (2007) | 24 °C                 | 26 °C   | -             | -             | 65 W   | -                    | -                     | 3 people                   | -                | -                  | -              | -                           |
| Kim <i>et al.</i> (2006)  | 20 °C                 | 26 °C   | -             | -             | 12 W/m <sup>2</sup>                            | 4 W/m <sup>2</sup>   | 22.4W/person          | -                          | -                | -                  | -              | -                           |
| Lee (2009)                | 24 °C                 | 26 °C   | -             | -             | 314 W  | 68 W                 | 70 W                  | 4 people                   | 0.5 ACH          | 1 ACH              | COP4.11        | ASHRAE fundamental handbook |
| Park <i>et al.</i> (2013) | 20 °C                 | -       | -             | -             | 7.53 W/m <sup>2</sup><br>8.07 W/m <sup>2</sup> | -                    | 65 W                  | -                          | 0.7 ACH          | 2.0 ACH            | -              | ASHRAE 90.1                 |
| Lim <i>et al.</i> (2014)  | 20 °C                 | 26 °C   | -             | -             | -  | -                    | -                     | -                          | 0.7 ACH          | 5 ACH              | COP2.5         | ASHRAE 90.1                 |
| Jo <i>et al.</i> (2009)   | 24 °C                 | 26 °C   | 01/11 – 31/03 | 11/06 – 10/09 | 267 W  | 80 W                 | 70 W                  | 4 people                   | 0.82 ACH         | -                  | -              | ASHRAE 90.1                 |



## **Chapter 3**

---

### **Methodology**

This research intends to develop a building energy model of existing high-rise apartment buildings by integrating influential factors causing variation in actual energy consumption, which have been disregarded and anticipated to raise the significant levels of uncertainties in the conventional building energy models for high-rise apartment buildings in South Korea. The methodology of this research was guided by a quantitative analysis, which is used when theories or hypotheses are tested, based on valid measures from empirical evidence (Campbell *et al.*, 1966; Newman and Benz, 1998). This chapter presents the methodology of this research. Section 3.1 describes how the methodology is designed to improve the identified limitations of the conventional building energy models. Section 3.2 interprets how the collected and calculated data are analysed. Section 3.3 summarises the strategy of this research.

### **3.1 Research design**

#### **3.1.1 Overall strategy**

This study focuses on the limitations of the conventional building energy models, which were identified from the literature review, as depicted in Figure 3.4. The methodology of this study is designed in four strategies. Firstly, this study attempts to identify the physical characteristics of existing apartment buildings in relation to actual energy consumption (Chapter 4). By quantifying the significance of the physical characteristics in changing energy consumption, existing apartment buildings can be classified. Figure 3.1 depicts the concept of classifying existing apartment buildings with regard to the effective building features affecting on energy consumption. Through this stage, existing apartment buildings can be set by similar conditions, which similar refurbishment strategies can be applied. As measurement methods, two types of statistical analysis are chosen: multiple linear regression analysis and exploratory factor analysis. Multiple linear regression analysis has been applied to account for the relationship between energy consumption and the building features of existing apartment buildings. Exploratory factor analysis is intended to identify an

underlying structure among the building features. By prioritising the effective building features in the classification, the building energy model is able to control the variation arising from the physical characteristics of existing apartment buildings.

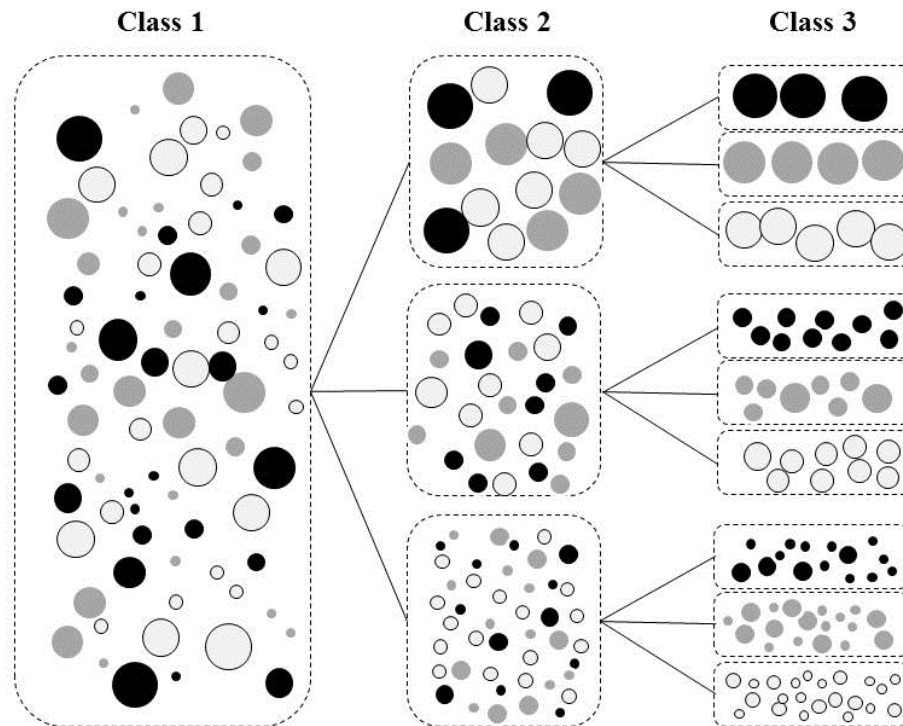

**Figure 3.1 Diagram of classifying existing apartment buildings with effective building features**

Secondly, this study plans to create a new standardised condition of occupants' behaviours consuming heating and electricity, which is adapted for existing high-rise apartment buildings (Chapter 5). Figure 3.2 interprets how occupants' behaviours can be adapted for existing apartment buildings. With a probabilistic approach, how occupants generally consume heating and electricity has been inferred from actual energy consumption. Gaussian Process Classification is used to deal with the sets of possible random behaviours of controlling heating and electricity to functions. The prior distribution, which is identified by a national survey of occupants' consumption behaviours, has been modified by actual energy consumption in existing apartment buildings, according to Bayesian inference. The outcome

is expected to control the variation caused by occupants' behaviours in the building energy model for existing apartment buildings.

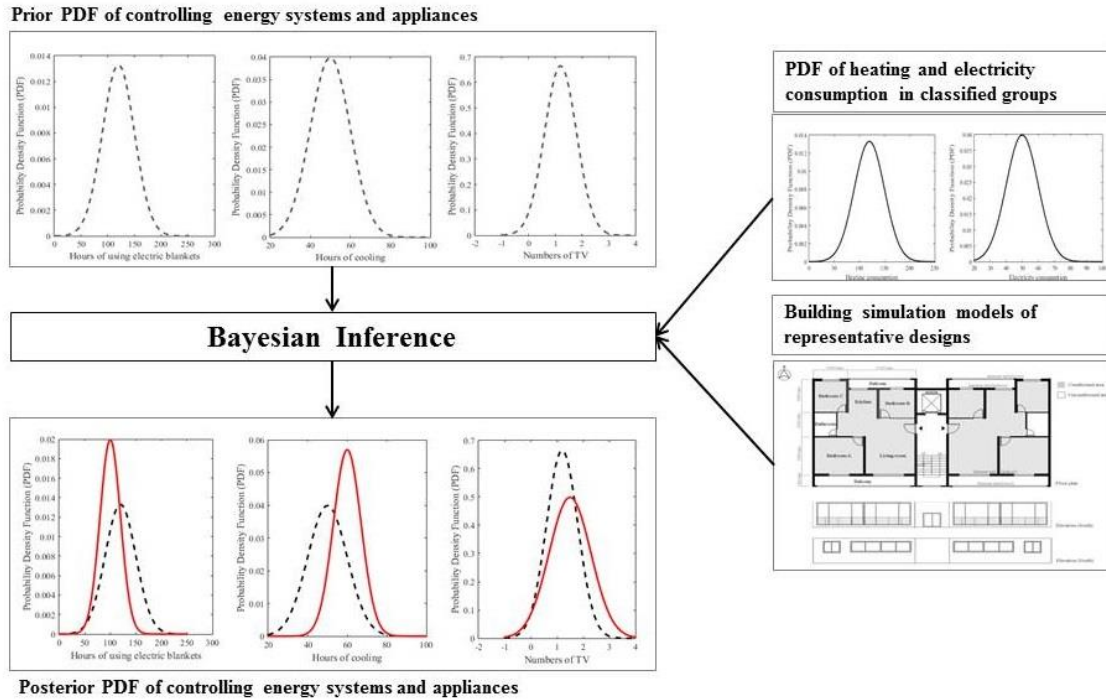

**Figure 3.2 Diagram of creating a new standardised condition of occupants' behaviours adjusted for existing apartment buildings**

Thirdly, this study combines the fragmented modelling approaches to cope with the variation in individual apartment units (Chapter 6). Figure 3.3 describes the process of dealing with uncertainties derived from the variation in individual units. The building energy model has been firstly specified with individual units regarding the locations of apartment units. Then, a numerical model of the individual heating controls and the interaction between floors is integrated to improve the previous building energy model estimation. A polynomial regression model has been applied to create the numerical model, and has sought the dataset of heating controls in each apartment units determining actual unit-specific heating consumption. As a result, the energy model is expected to be more accurate in calculating

energy use not only for a whole building, but also individual units. Moreover, the dataset of heating controls in each apartment unit can be provided.

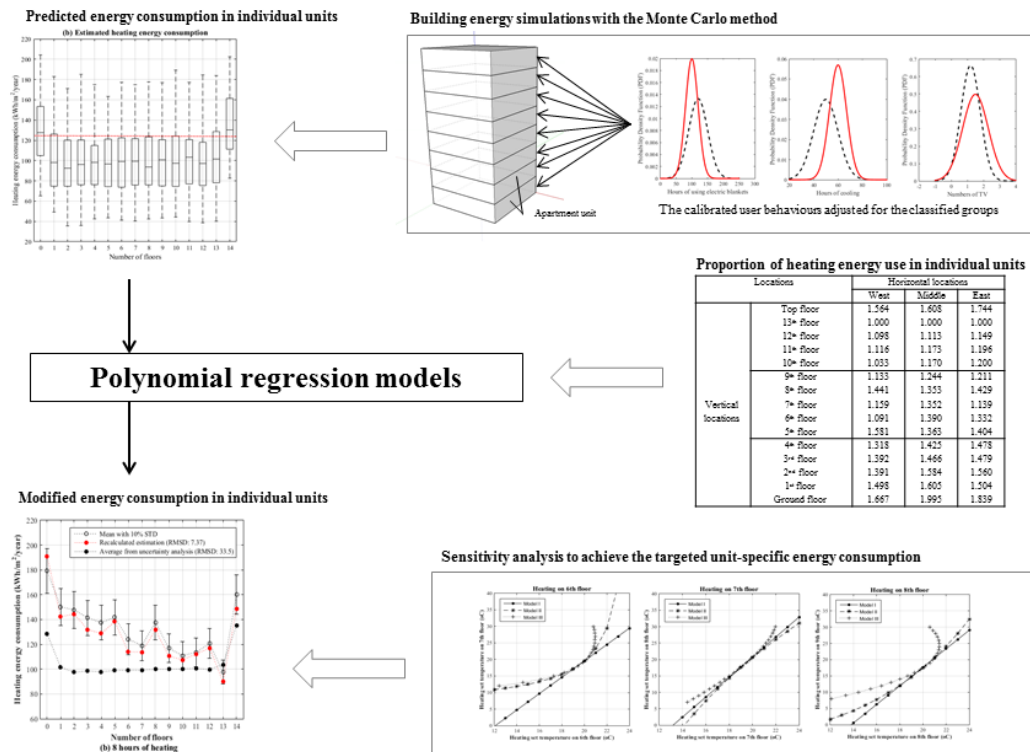

Figure 3.3 Diagram of dealing with uncertainties derived from individual apartment units

Lastly, the building energy model developed through the previous three strategies is used to implement refurbishment measures for existing apartment buildings (Chapter 7). Climate uncertainty is added to consider refurbishment with a long term perspective. The four revisions of the building thermal regulations from 1987 to the present have been assessed as refurbishment strategies. Building simulation with the present and future climate conditions has been used to calculate changes in energy consumption. The outcome is expected to provide an assessment of the intensified thermal regulations and a comprehensive selection of the efficient heating refurbishment strategy for existing apartment buildings.

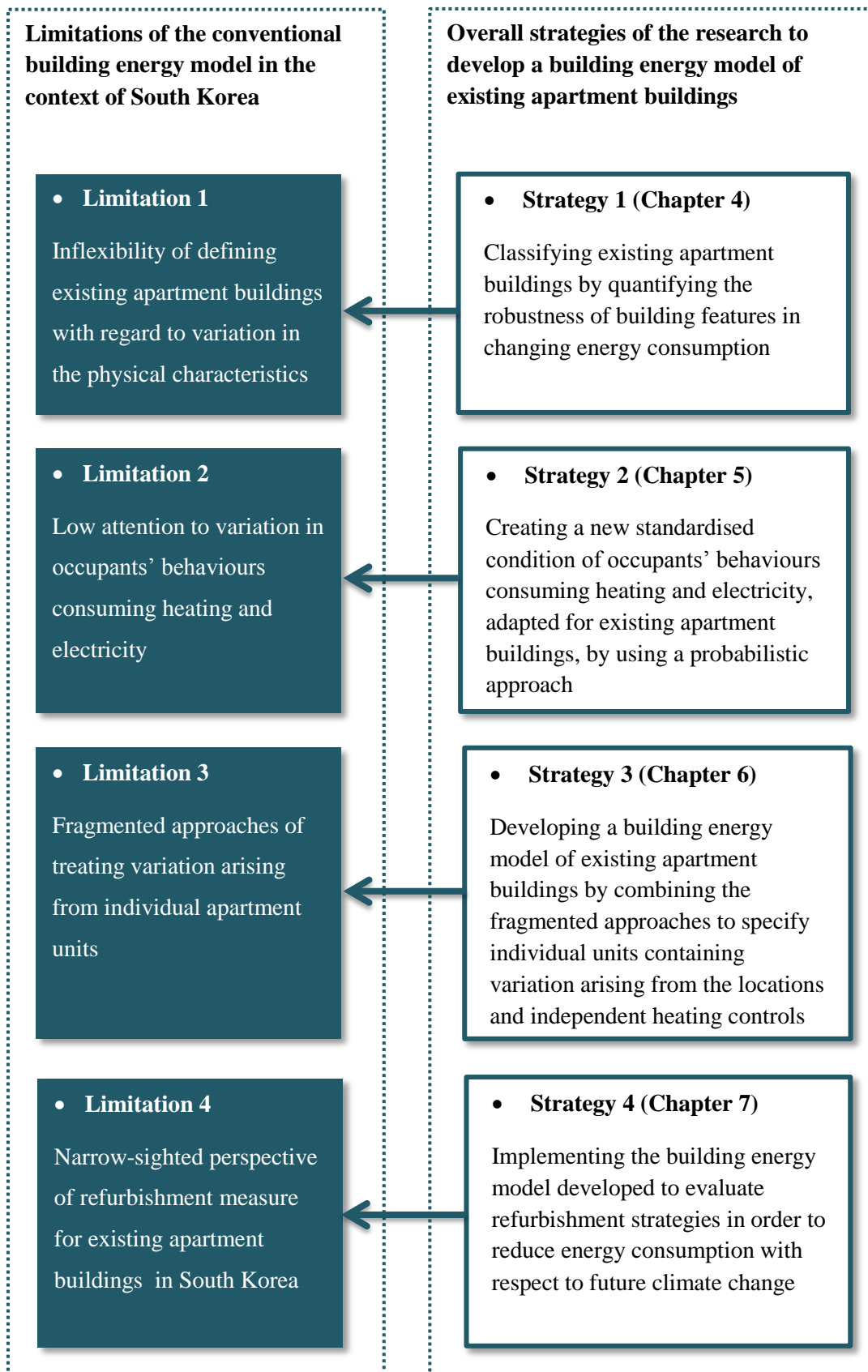

Figure 3.4. Diagram of the overall strategy of the research



### 3.1.2 *Sampling*

In this study, the definition of old existing apartment buildings was chosen by apartment buildings that are allowed to be refurbished under the current law and their urgent requirement to reduce energy consumption. Under the Enforcement Decree of the Housing Act 2009, apartment buildings built for over fifteen years ago can be freely refurbished to improve their conditions. This condition limits existing high-rise apartment buildings built before 2005. According to Kim (2010), apartment buildings which were constructed after 2001 relatively consumed less energy for heating compared to buildings built before. This is because thermal regulations were significantly reinforced with energy-efficient scheme since 2001. By regarding both conditions, apartment buildings constructed before 2001 were initially defined as old existing apartment buildings in this study.

Although the initial definition of old existing apartment buildings was identified, specific sampling was carried out to have a realistic scope of the research. Sampling can be a useful technique to conduct a research with a large population because of the three reasons: cost, utility and accessibility (Barnett and Barnett, 1991). Samples should not be distorted by other sources, which is called ‘fair representation’ of the population (Barnett and Barnett, 1991). Four or five sampling units were designed in Chapter 4 and 5. Concurrently, the first sampling unit was the construction year of apartment buildings. In Chapter 4, this unit limits apartment buildings constructed before 2001, as initially designated. However, this sampling unit also represents the thermal conditions of existing apartment buildings, because of the thermal regulations revised three times until 2001. Therefore, the construction years, divided by the revisions of the thermal regulations, could categorise existing apartment buildings with the specific conditions of building envelopes.

The second sampling unit was the locations of apartment buildings. This unit is intended to minimise the possible distortion, caused by geographical locations including climate

impacts. 16 apartment districts were selected, which were only allowed apartment constructions in Seoul (Zhang, 1994), as depicted in Figure 3.5.

The third unit was the number of floors of apartment buildings. Utility was the reason why the number of floors was limited to more than ten floors (Chapter 4). Existing apartment buildings with more than ten floors are highly expected to be refurbished due to a low possibility to get permission for demolition. Besides, the range (ten to fifteen floors) is the most typical height for existing apartment buildings (Statistics Korea, 2010a). However, this sampling unit was also used to eliminate the possible distortion by external environment in building simulation (Chapter 5). The last unit was the availability of data. Monthly energy bill records were collected from Apartment Management Information System (AMIS). Some missing data was found in the process of collecting data. These were not counted in the sampling. Specific sampling process is provided in each chapter (Chapter 4 and 5).

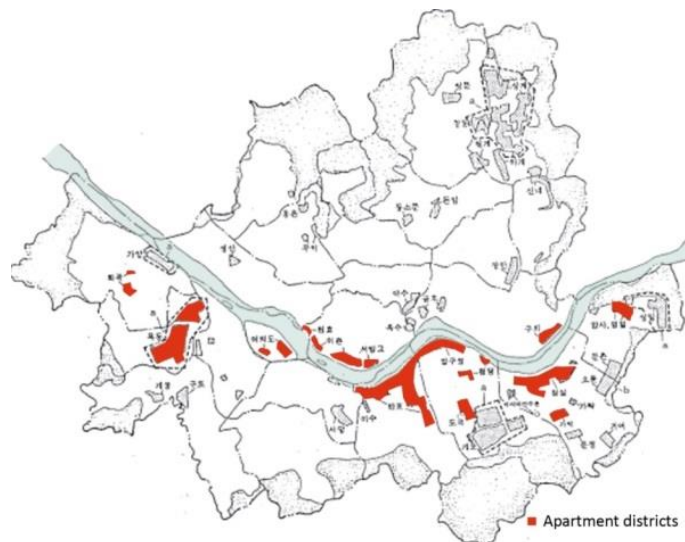

**Figure 3.5. Apartment districts in Seoul (Source: Zhang, 1994)**

### 3.1.3 *Data collection*

Three types of data were collected in this research: energy bills, the national survey of behaviours using domestic appliances in households and architectural drawings. Energy bills were converted to energy consumption, and used for various purposes in this study such as a dependent variable in statistical modelling and a source of calibrating an energy model. The survey data provides the specific consumption behaviours of electric appliances in households, accounting for stochastic occupants' behaviours. Architectural drawings were additionally acquired to assure the physical conditions of apartment buildings to be used for modelling.

- **Energy bills**

Actual energy consumption in high-rise apartment buildings is an important material to conduct this research. The consumption data was extracted from a monthly expenditure of apartment buildings, provided from AMIS. The AMIS, organised by the MLIT, was managed by (Korea Housing Management Association (KHMA), 2013), but the management has been shifted to (Korea Appraisal Board (KAB), 2014) since 2014. All apartment buildings in South Korea are required to open the monthly expenditures on the website, as shown in Figure 3.6. The expenditures are specified by its purpose including heating, electricity and domestic hot water. Therefore, the monthly bills consumed for energy consumption factors (heating, electricity and domestic hot water) were collected for this study. The collected energy bills in the currency of South Korea (Won/m<sup>2</sup>) was converted to energy unit (kWh/m<sup>2</sup>) by the rates tables, provided from the suppliers (Seoul City Gas, 2014; Korea Electric Power Corporation (KEPC), 2014; Korea District Heating Corporation (KDHC), 2015).

In Chapter 4 – 7, the applied energy consumption is slightly different. In Chapter 4, the energy consumption data used for analyses is the energy bills that were consumed in apartment buildings from 2011 to 2012. Therefore, the consumption data includes the energy

bills consumed for public and private purposes. The data from the 16 apartment districts were used. However, Chapter 5 and 6 specifies the interest to occupants' behaviours controlling heating and electricity and unit-specific heating controls, respectively. Chapter 7 also uses the building energy model calculating unit-specific energy consumption. Thus, the energy consumption is measured from the energy bills spent for a private purpose in only four apartment districts from 16 in 2014, not 2011 – 2012. Therefore, the consumption values can be different because of these reasons: the purposes of consumption, years (climate conditions) and apartment districts. Specific data collection is illustrated in each chapter (Chapter 4 – 5).

- **Survey on the behaviours of using electric appliances in households**

Occupants' behaviours of using domestic appliances were surveyed by (KEPC, 2013). This survey indicated the detailed profiles of domestic appliances and the distribution of usage. 500 households from 4,000 samples designated to represent the proportion of housing in South Korea were investigated for one week. Thus, the data helped to draw a whole picture of the distribution of occupants' behaviours controlling electric devices with the quantified data (Appendix B), which is applicable for energy simulation. This data were the key material to identify the prior distribution of occupants' behaviours in Chapter 5.

- **Site survey (Architectural drawings)**

Although building regulations and literature review provide sufficient evidence to generalise the typical designs of existing high-rise apartment buildings, a short site survey was undertaken to collect architectural drawings. The main purpose of this was to cover the construction details of those apartment buildings. The apartment blocks were chosen by their representativeness among existing apartment buildings, used in this study. However, there was a significant limitation of collecting architectural drawings. Only three apartment blocks were available. Their architectural drawings were copied by taking pictures, due to them only preserved as a printed version (Figure 3.7).

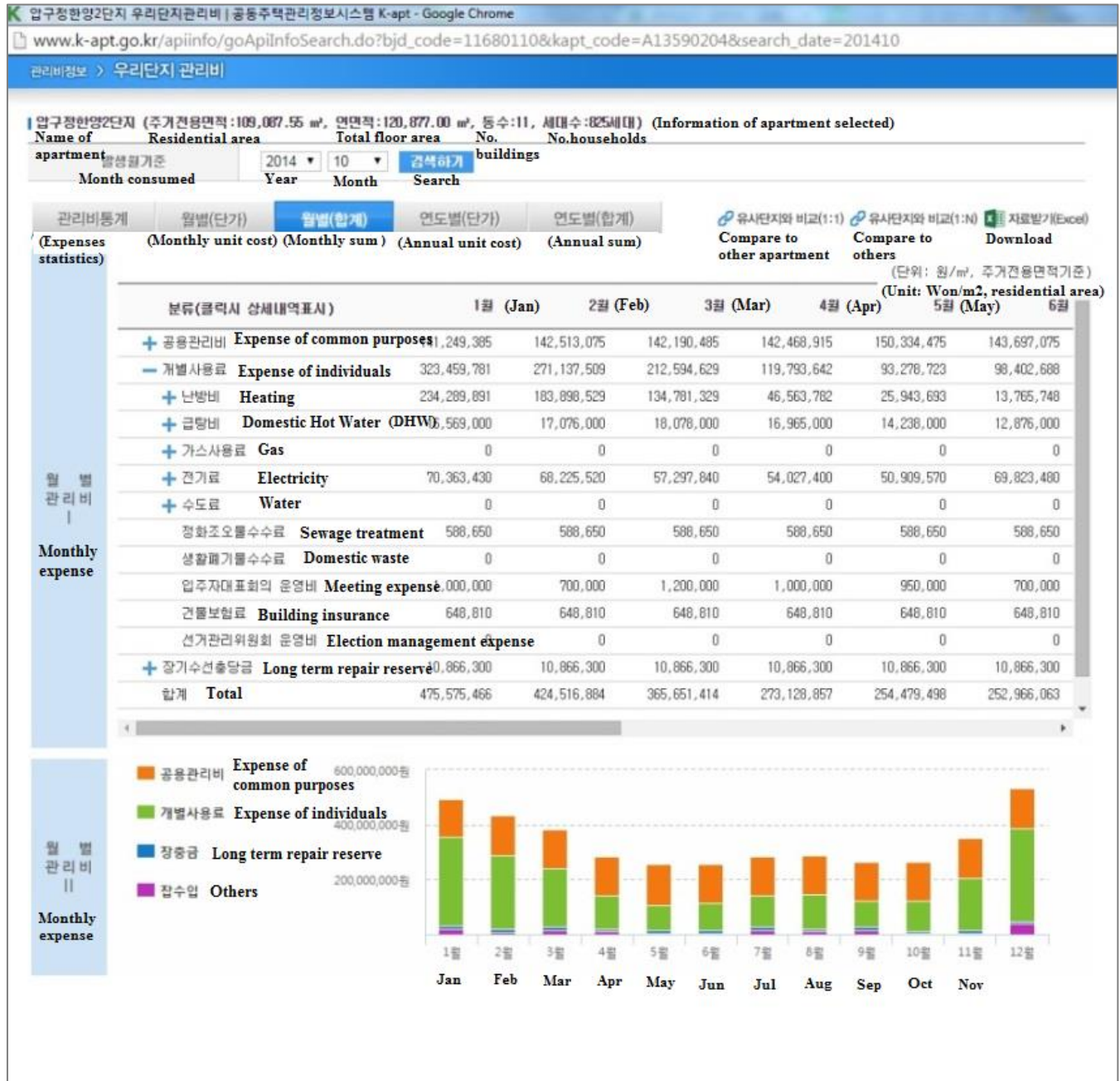

Figure 3.6. Screenshot of monthly expenditure of one of apartments in AMIS (Source: KAB, 2014)

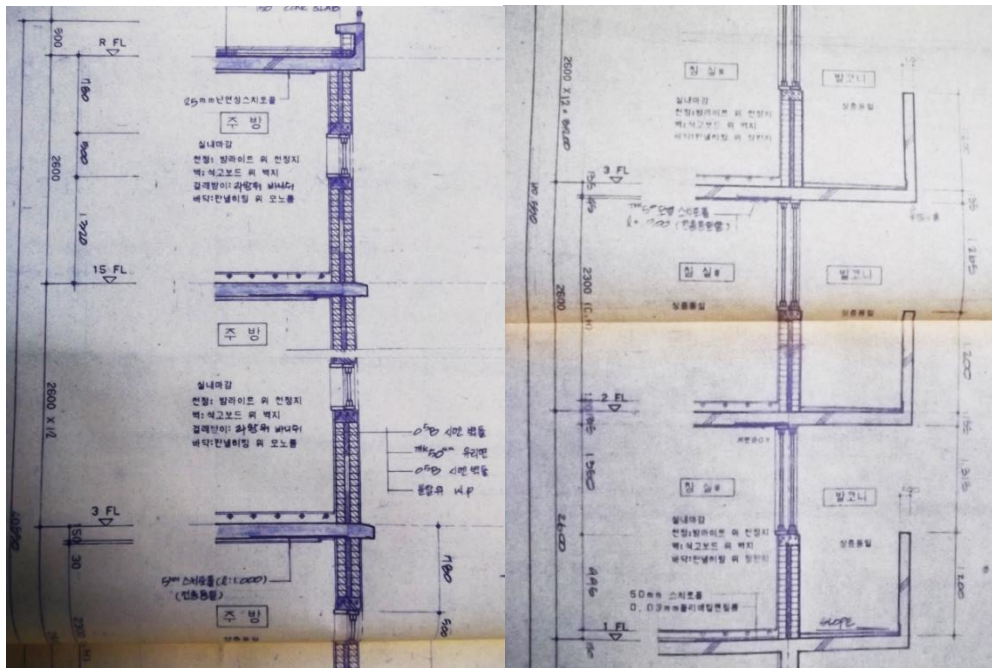

Figure 3.7. Example of architectural drawings of existing apartment buildings  
(Source: Apartment managers at site survey)

### 3.1.4 Building simulation

Building simulation is one of the most powerful analytic tools, based on numerical methods of calculating building performance (Hensen and Lamberts, 2012). The method has been commonly used in analysing buildings as the wide ranges of building conditions can be simulated. The aim of this study, developing a building energy model of high-rise apartment building, necessarily requires this tool to calculate energy use in these buildings.

For a main tool of building simulation, several simulation programs such as EnergyPlus, IES<VE> and eQUEST were compared. As shown in (Crawley *et al.*, 2008), EnergyPlus and IES<VE> provide the wider range of tasks analysing building performance. Between them, EnergyPlus was chosen for this research. The first reason is the popularity of the software analysing buildings in South Korea. While reviewing existing literature, most of previous studies with buildings in South Korea took this software as the analytic tool. Besides, the software was already evaluated with a building in South Korea, which is

conducted by (Seo, 2001). According to the author, EnergyPlus sensitively responded to windows in relation to cooling loads, compared to other programs such as BLAST, DOE-2 and TRANSYS. However, analysing energy consumption showed about 2 – 3% errors in comparison to a real value although it requires a calibration process. The second reason is the compatibility of the software. EnergyPlus is a core engine analysing building performance. Thus, it does not provide a function visualising building models. However, its high level of compatibility allows visualising models with other modelling tools. For example, Openstudio (Guglielmetti *et al.*, 2011) with Sketch-up and DesignBuilder (Tindale, 2005) integrate modelling and analysing into the one format by using EnergyPlus. Moreover, BEopt (Christensen *et al.*, 2006) provides cost-effective analysis with building simulation using EnergyPlus.

## **3.2 Data analysis**

Energy consumption data either collected or calculated were analysed by statistical methods. The statistical approaches verify hypotheses and infer relationships of interests from observed samples. The procedure of statistical methods can be, therefore, similar from inductive inference (Romeijn, 2014). Bandyopadhyaya and Forster (2011) defined four paradigms of statistical inference: Classical statistics (also called frequency inference), Bayesian, Likelihood and Akaikean paradigms.

Classical statistics (frequentist statistics) stands on inductive inference to confirm questions and hypotheses (Mayo and Spanos, 2011). According to the author, the observed data generates functions verifying parameters, but the functions inevitably include errors due to the limitation of the observed data. In Bayesian statistical methods, the observed data incorporates to modulate prior probability assignment, called a posterior probability distribution (Romeijn, 2014). The difference between the two paradigms is that classical procedure focuses on improving a probability of inferences by selecting or deselecting

parameters, while Bayesian methods optimise the prior probability with respect to the observed data.

### 3.2.1 *Frequency inference*

As mentioned above, the importance of frequency inference is to secure the reliability of inference, which is measured by significant tests and confidence-interval estimation (Mayo and Spanos, 2011). The author described the three components of significant tests: a null hypothesis; the test statistic; the significance level ( $\rho$ -value). A null hypothesis is a premise that no valid relationship between variables. If the null hypothesis is rejected, a valid relationship can be measured. The test statistics reflect the goodness of data in accordance with the null hypothesis. The significance level indicates the probability of results when the null hypothesis is true. This inference approach has been leadingly used in this research. Therefore, the significance of inference was necessarily undertaken to improve the reliability of analysis.

- **Significant tests**

Analysis of Variance (ANOVA) tests can be used to evaluate the fit of a regression model (Field, 2009). The tests describe how well-fit regression model is with the five types of information: sum of squares, degree of freedom, mean square, F-ratio and  $\rho$ -value. Sum of squares means total variation explained. Mean squares are the sum of squares divided by degree of freedom. F-ratio is calculated by the model mean squares (explained in the model) divided by the residual mean squares (unexplained in the model). Therefore, F-ratio needs to be no less than 1 (Field, 2009).  $\rho$ -values represent how significant variables are to interpret the regression model if the null hypothesis is true. Thus, lower  $\rho$ -value means that the variables give significant impacts on a regression model.



- **Regression analysis**

Regression analysis is a tool quantifying relationships between dependent and independent variables (Kleinbaum *et al.*, 2013). However, it does not represent causalities of them. In this study, dependent variables are mostly actual energy consumption, while independent variables can be varied depending on the specific focus of each chapter. The identified relationships in a regression model provide the robustness of independent variables in changing energy consumption. The results can also be used to filter ineffective variables.

In Chapter 4, various building features, as independent variables, have been evaluated by multiple linear regression analysis to assess the strength of building features in changing actual energy consumption. In Chapter 5, this analysis also has been applied to measure the significance of associations between occupants' behaviours and energy consumption in a building energy model. Based on the result, only influential variables have been taken into account to further stages.

Polynomial regression model, which is a type of multiple regression analysis, has been applied to Chapter 6 and 7. This regression model considers only one or two independent variables. Although multiple linear regression model measures linear relationships between dependent and independent variables, polynomial regression allows various orders and degrees of models, which can be more flexible to fit observed data to statistical models. Chapter 6, considering the heating controls of individual apartment units, has created binary linear and quadratic models with different degrees to account for heating energy consumption in the apartment units. In Chapter 7, associations between climate factors and energy consumption have been analysed with polynomial regression to avoid high levels of multicollinearity, which indicates associations among independent variables (Field, 2009).

- **Exploratory factor analysis**

Exploratory factor analysis seeks an underlying specific factor structure (Johnson and Wichern, 1992). The analysis is often confused with Principle Component Analysis (PCA). Field (2009) clarified the difference between them is that factor analysis is only capable of estimating the underlying structure with various assumptions, while PCA establishes linear components within the data. The output values of this analysis are affected by the types of rotating method, which needs to be carefully chosen. If independent variables are not correlated, orthogonal rotation can be more appropriate. Otherwise, oblique rotation, which allows correlations among variables, can be applicable (Field, 2009). Kaiser-Meyer-Olkin measure of sampling adequacy (KMO) and Bartlett's test of sphericity evaluates the accuracy of results (Kaiser and rice, 1974). KMO measures the sum of partial correlations, which is recommended to be higher than 0.5, Bartlett's test requires significantly high values which means correlations between variables are significantly different from zero (Field, 2009). This analysis has been applied in Chapter 4 to identify intrinsic structures from all independent variables, building features, in relation to actual energy consumption.

### 3.2.2 *Bayesian inference*

Frequency inference deals with parameters either choosing or eliminating in an inferring process, whereas Bayesian inference concludes a posterior probability of distribution, which is updated by a prior probability of distribution and observed data (Gelman *et al.*, 2014). As shown in Equation (3-1) below, Bayes' theorem yields the posterior density,  $p(\boldsymbol{\theta} | \mathbf{y})$ , from the joint probability density function,  $p(\boldsymbol{\theta}, \mathbf{y})$ , and the probability of observed values,  $p(\mathbf{y})$ . Prior distribution,  $p(\boldsymbol{\theta})$ , and the distribution of sampling,  $p(\mathbf{y} | \boldsymbol{\theta})$ , consists of the joint probability density function (Gelman *et al.*, 2014). The sampling distribution,  $p(\mathbf{y} | \boldsymbol{\theta})$ , needs to be processed in a stochastic process. For example, Gaussian processes, which are one of the stochastic processes, compute likelihoods of observations given model parameters,  $p(\mathbf{y} | \boldsymbol{\theta})$  (Heo *et al.*, 2012). This has been applied to update occupants'

behaviours consuming heating and electricity for existing apartment buildings, based on the observed actual energy consumption and sampling cases with building simulation.

$$p(\boldsymbol{\theta} | \mathbf{y}) = \frac{p(\boldsymbol{\theta}, \mathbf{y})}{p(\mathbf{y})} = \frac{p(\boldsymbol{\theta})p(\mathbf{y}|\boldsymbol{\theta})}{p(\mathbf{y})} \quad (3-1)$$

- **Stochastic process**

Doob (1953) described the definition of stochastic processes as a collection of random variables,  $\{\mathbf{X}(\mathbf{t}), \mathbf{t} \in \mathbf{T}\}$ . In other words, the processes can be interpreted as mathematical models of random phenomena arising through a process in a manner of the probability law (Parzen, 1999). Particularly, the wider application of Gaussian processes was addressed by (Parzen, 1999).

Gaussian processes specify the properties of functions that take the prior distributions and observed data; thus, uncertainties can be reduced by the combination of the prior distributions and the observed data (Rasmussen and Williams, 2006). As the process is not a parametric model, specifying the prior distributions of functions including covariance functions is important (Rasmussen and Williams, 2006). The process deals with two forms of problems, regression and classification. Simply, regression problems target real values while classes in problems are assigned to the classification. According to Rasmussen and Williams (2006), Gaussian likelihood in regression models, results in a posterior distributions over functions, which is analytical. For classification models with discrete class labels, Gaussian likelihood is inappropriate. Different methods of approximate inference, such as probit likelihood, can be treated (Rasmussen and Williams, 2006).

In Chapter 5, occupants' behaviours of consuming heating and electricity have been identified by the surveyed data. However, their distribution is not specified for types of housing, particularly old existing high-rise apartment buildings, which have shown excessive energy consumption. Therefore, Chapter 5 takes the occupants' behaviours of

controlling heating and electric devices as a collection of random variables. Their distribution of usage is used as a prior distribution. As outcome, the occupants' behaviours are optimised for old existing apartment buildings.

- **Normality tests**

The distributions of samples can be bell-shape, normally distributed, when the number of samples is large enough, according to the central limit theorem (Sheldon, 2002). The collected energy consumption, used in Chapter 5, is required to be normally distributed. Three types of normality tests have been applied in this research. Firstly, Kolmogorov-Smirnov and Shapiro-Wilk tests compare the distribution of collected samples with the normal distribution with the same mean and standard deviation (Field, 2009). If the result is not significant, samples can be considered as normally distributed. Secondly, quantile – quantile plot (Q – Q plot) visualises how similar the distribution of samples is from the normal distribution by plotting the observed quantile with the estimated quantile (Field, 2009). Finally, skewness and kurtosis indicate the pile-up data from zero (normal distribution). If both values are nearly zero, it means that samples are normally distributed.  $\pm 1.96$  limits were applied to determine the acceptable range as a normal distribution.

### **3.3 Summary**

The overall strategies, as illustrated in Figure 3.4, are integrating the quantified variation arising from the influential factors, specified for existing apartment buildings by statistical inference, in order to enhance a building energy model for these buildings. To achieve the four objectives of this study, the specific methods can be summarised as follows:

- Quantifying the robustness of building features in changing energy consumption through multiple linear regression and exploratory factor analysis in order to classify existing apartment buildings

- Modifying the stochastic data of occupants' behaviours with regard to actual energy consumption in order to be adjusted for existing apartment buildings, according to Bayesian inference.
- Combining the fragmented modelling approaches in order to develop the building energy model for integrating variation arising from individual apartment units.
- Evaluating refurbishment strategies for existing apartment buildings with the building energy model developed.



### **Classification of existing apartment buildings with respect to effective building features affecting energy consumption**

This chapter sets out with the aim of classifying existing apartment buildings by quantifying the robustness of building features in changing energy consumption. The classification is undertaken by quantifying impacts of the transformation of buildings features on actual energy consumption, collected from existing apartment buildings constructed in the 1970s – 1990s. The outline of this chapter consists of five sections. Section 4.1 provides a background of existing apartment buildings in relation to energy-efficient refurbishment, and the research gap that the current literature cannot cover variation related to the physical characteristics of existing apartment buildings. Section 4.2 explains a methodology of quantifying the robustness of building features in changing energy consumption. Section 4.3 illustrates the effective building features and the significance of the building features in energy consumption. Section 4.4 compares the results with other cases in different countries. Lastly, the overall contribution of this work is summarised in Section 4.5.

## **4.1 Background**

In Asian countries that experienced dramatic economic growth, such as Japan, Hong Kong, Singapore and South Korea (Chang, 2006), high-rise apartment building became one of the most dominant types of housing (Yuen, 2011; Yuen *et al.*, 2006). The refurbishment of those buildings is a common issue after more than 40 years of extensive construction of apartment buildings. This issue can be also extended to some countries such as China and Malaysia that have experienced the economic growth in recent years.

In South Korea, ranked 8<sup>th</sup> for GHG emissions (Olivier *et al.*, 2012), the Government has attempted to reduce carbon emissions of the country by enhancing building regulations and policies. Apartment buildings were required to be energy-efficient since 2001 (Kim, 2010). In 2009, a new law, ‘Framework Act on Law Carbon Green Growth’, required higher levels of energy efficiency in buildings (Jones and Yoo, 2012). Despite these attempts, energy consumption in residential buildings has not declined (Huh, 2013), and carbon emissions in South Korea have also not reduced (Olivier *et al.*, 2012). Several studies such as (Jo *et al.*, 2010; Kim 2010) have criticised this unwanted outcome. Particularly, Kim (2010) claims



ineffective energy reduction in residential buildings was due to energy consumption in existing apartment buildings, which were excluded in the energy-efficient scheme. In the building stock of South Korea, the largest proportion of all building types is residential buildings, which amounts for 67.1% (Statistics Korea, 2013). 58% of the residential building stock is apartment buildings (Statistics Korea, 2010b), which is the most dominant proportion. 63% of apartment buildings were constructed before 2001 (Statistics Korea, 2000; Statistics Korea, 2010b) when the higher levels of energy-efficient scheme were applied to buildings. In this aspect, the old apartment buildings constructed over 20 years ago, which occupies the largest proportion in the building stock of South Korea, were not counted to be energy-efficient.

There has been a controversial debate amongst policy makers, building developers and residents in South Korea during the last decade as to whether old existing apartment buildings should be demolished or refurbished. However, policy makers have proposed to refurbish old apartment buildings to contribute reducing carbon emissions rather than demolish those buildings. As a result, building regulations have been altered in recent years to encourage refurbishment and reduce demolition of old existing apartment buildings. The South Korean Government, for example, has permitted developers to increase the number of floors on top of apartment buildings in case of refurbishment (MLIT, 2010). This policy can represent the governmental intention to vitalise refurbishment.

Despite the governmental efforts, there are limits in current and recent literature in terms of creating effective strategies of refurbishment for old high-rise apartment buildings to reduce energy consumption. Firstly, great attention has been paid to economic profit rather than reducing energy consumption or carbon emissions. The concept of refurbishment in existing literature such as (Son *et al.*, 2005; Lee *et al.*, 2007) was identified by maximising economic profit, and the strategies of refurbishment were focused on cost-effectiveness. Therefore, the strategies would not necessarily be beneficial to reduce energy consumption. Secondly, existing literature, engaging with energy efficient technologies, does not cover old existing

apartment buildings that need to be refurbished (e.g. Kim *et al.*, 2006a; Kim *et al.*, 2009a; Jang *et al.*, 2010; Ki *et al.*, 2013). It relies on the ‘Standard housing’ model which draws the thermal condition of buildings from simplified indices (MLIT, 2013), assuming that building features affecting energy consumption in all apartment buildings are the same. However, the building features in old apartment buildings were changed by different design preferences in different periods and contexts. The existing literature does not take into account the transformation of building features in old apartment buildings that have been constructed in different periods and contexts (Zhang 1994; Choi, 1997; Bae *et al.*, 2001; Hong, 2003; Jeon, 2010; Kim and Yoon, 2010; Park, 2012). This chapter argues that the transformation of building features affects energy consumption and needs to be taken into account when classifying the physical characteristics of existing apartment buildings as well as creating refurbishment strategies.

This chapter, therefore, focuses on identifying existing high-rise apartment buildings in South Korea which need to be refurbished to reduce energy consumption. Furthermore, the efficient building features and their effect on energy consumption for both building energy modelling and refurbishment will be identified to classify these existing buildings. Five questions will be answered:

- What are the levels of energy consumption in old existing apartment buildings? Do these levels of consumption need to be reduced?
- Which features in existing apartment buildings have affected the energy consumption?
- Which building features should be prioritised in refurbishment strategies in order to reduce energy consumption? How can these existing buildings be classified for the building energy models to deal with the variation in the physical conditions of these buildings?

## 4.2 Methodology

The methodology is designed to analyse the impact of building features in old existing apartment buildings on actual energy consumption. The results will help to prioritise which building features can most effectively reduce energy consumption and thus guide not only to classify existing apartment buildings for building energy models but also to create refurbishment strategies. The method is threefold: evaluating energy consumption in old apartment buildings; identifying effective building features on energy consumption; ranking the effects of building features to energy consumption.

### 4.2.1 *Evaluation of energy consumption in existing apartment buildings*

Energy consumption in existing apartment buildings was evaluated to determine the necessity of refurbishment to reduce energy consumption. The consumption in old existing apartment buildings was, therefore, compared to the consumption in apartment buildings which were certified as energy-efficient. To conduct this, old apartment buildings are defined by those which were constructed before 2001, a year when building regulations for the thermal conditions of apartment buildings was much intensified and building energy rating system was just established. Permission has already been given for some of these buildings to be refurbished, others will be available to be refurbished in 2015 by a building regulation in South Korea (Enforcement Decree of the Housing Act 2009). In contrast, the comparison group of apartment buildings were certified as energy-efficient in an energy rating system set by (Korea Land and Housing Corporation (KLHC), 2013). The three values of energy consumption in the both groups were compared: total end-use energy consumption; space heating and electricity consumption by construction years; monthly energy consumption for space heating and electricity. The result is shown in Section 4.3.1.

### 4.2.2 *Identification of building features affecting energy consumption*

Building features in old apartment buildings were identified by reviewing previous literature and surveying existing apartment buildings. To prioritise building features in refurbishment,

this chapter was, particularly, focused on the transformation of building features rather than characteristics which are commonly found in all buildings. It is difficult to precisely divide time periods of each feature. Instead, this chapter used the dominant designs since the 1980s, as described in Figure 4.1. Three distinctive trends are identified in the transformation of building features in old apartment buildings constructed before 2001.

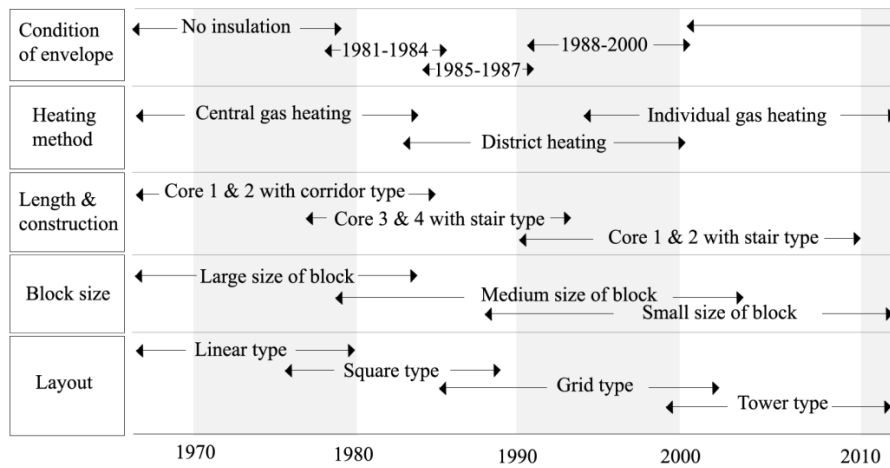

**Figure 4.1. Changes of building features in apartment construction of South Korea since the 1970s**

First of all, the main purpose in the early stage of apartment construction was to accommodate a rapidly increased urban population and building features were chosen accordingly whilst building features in the late stage were transformed to acquire higher levels of privacy in each apartment building (Jeon, 2010). For example, between the mid-1970s and 1980s, large volume apartment clusters of more than twenty buildings were constructed as governmental-led projects (Gelézeau, 2007). During the 1990s, the size of apartment clusters was reduced when the government handed over apartment construction to private developers (Gelézeau, 2007). Total cluster areas were also changed with the transformations of the size of apartment clusters, but it was differently evolved as the higher requirements for public space with service facilities (Lim, 2008). Moreover, apartment

buildings constructed in the early stage were designed with longer lengths and smaller sized units. A maximum of eight to ten apartment units were placed on each floor; thus small unit sizes of less than 60m<sup>2</sup> (70m<sup>2</sup> including communal space) were constructed in the 1980s (Kim and Yoon, 2010). Since privacy has become a sensitive issue, buildings with a stair type whereby only two units share one vertical access points (called a ‘core’) are preferred (Jeon, 2010).

Second, economic profit has also been a significant factor to transform the building features in existing apartment buildings. For instance, three types of building layout can be identified (Choi, 1997; Lee *et al.*, 2005; Park *et al.*, 2007): the linear type where buildings are long and thin in plan and located parallel to one another; the square type where buildings are square in plan; and the grid type where buildings are located on a grid. According to Jeon (2010), the linear type was the typical design type in the early stage of apartment construction in South Korea, but the design was changed to square and grid type to accommodate more buildings. The sizes of building units were also enlarged; thus the most dominant unit size became about 85 - 100m<sup>2</sup> (about 100 - 120m<sup>2</sup> including communal space) (Kim and Yoon, 2010).

Third, some building features were transformed by stringent policies and the development of technologies. The thermal conditions of envelopes in existing apartment buildings have been determined by a building regulation (Kim *et al.*, 2009b). The regulation determining the thermal conductivity of materials and the thickness of insulations required was firstly established in 1980. Since 1980, there have been two significant revisions to the regulations in 1984 and 1987, and in 2001, a significant improvement was made. Therefore, buildings constructed before 1980 have no thermal insulation in their envelopes which created a poor thermal environment for residents. The second revision, implemented in 1987, required all apartment buildings to be equipped with double glazing. Despite the dramatic increase in apartment construction in the 1990s (Statistics Korea, 2010a), there was no revision of the regulation to improve the thermal conditions of buildings until 2001. Also, three different heating methods were found in old apartment buildings: central gas heating, district heating

and individual gas heating (Noh, 1998; Ha, 2007). Central gas heating was mostly used in buildings constructed in the early stage. Since the district heating was introduced in 1985 (Kang *et al.*, 1995), apartment buildings constructed in Seoul have been connected to the district heating system. Since the national construction of gas supply lines into the cities, individual gas boilers have become the dominant type of heating.

Table 4.1 indicates how designs of building features were transformed until 2000. As mentioned above, the three main reasons of the transformation of building features were categorised specific variables of building features. With the changes in public preference, four building features have been transformed: sizes of clusters, total cluster area, types of buildings access, lengths of buildings. The sizes of clusters were measured by the number of buildings in clusters. The large cluster meant more than 20 apartment buildings in clusters. The medium and small contains 6 – 15 apartment buildings and less than 5 buildings in cluster, respectively. The lengths of buildings were indicated by the number of vertical access points (core) from one to maximum six, as described in Figure 2.6. The second reason was to increase economic profit, which included two variables: types of building layouts and sizes of apartment units. The three types of clusters were input. The changes of averaged sizes of apartment units from 41.05 to 181.82 m<sup>2</sup> were analysed. The last reason is due to the improvement of building policies and technologies. The thermal conditions of building envelopes were measured by the construction years, which were divided by the revisions of building thermal regulations: before 1980, 1981 – 1984, 1985 – 1987 and after 1988. Moreover, the three types of heating system methods were input. Depending on the types of data measured, the input data was either categorical (CA) or continuous (CO). This transformation of those building features was examined as to whether they affect actual energy consumption or not; thus effective building features on energy consumption were identified. The result is described in Section 4.3.2.

**Table 4.1. Change in designs of building features in apartment construction in South Korea in pre-2001**

| Category                            | Variables<br>(CA: categorical, CO: continuous)                              | Data range  |
|-------------------------------------|---|---|
| Changes in public preference        | Sizes of clusters - CA<br>(No. of apartment buildings in clusters)          | Large ( $\geq 20$ ), Medium (6-15),<br>Small ( $\leq 5$ )           |
|                                     | Total cluster area- CO  | 12,562 – 515,906m <sup>2</sup>                                      |
|                                     | Types of building access - CA   | Corridor type, Stair type   |
|                                     | Widths of buildings – CA<br>(No. of vertical access points)                 | 1- 6  |
|                                     | Economic profit   | Types of building layouts - CA<br>Sizes of building units - CO      |
| Developed policies and technologies | Thermal conditions of building envelopes (insulation and fenestration) – CA | Buildings constructed before 1980, 1981-1984, 1985-1987, after 1988 |
|                                     | Heating system methods – CA   | Central gas, District, Individual gas heating                       |

#### 4.2.3 *Quantification of effects by building features*

This section is intended to quantify these relations to energy consumption separated into space heating and electricity. Two types of statistical analyses were conducted, which are multiple regression and factor analyses. Multiple regression analysis is one of popular techniques to measure the capability of statistical models to interpret a dependent variable through correlated independent variables, and determine influential independent variables in statistical models (Everitt and Dunn, 2001). The multiple regression analysis was applied to interpret a dependent variable (energy consumption for space heating and electricity) by using independent variables (building features in existing apartment buildings). The values of R-squared demonstrate how efficient this statistical model accounts for energy consumption in old apartment buildings. The standardised regression coefficient (SRC) was used to measure the influences of independent variables (cluster sizes, building lengths, construction types, total cluster area, building layouts, building unit sizes, the conditions of building envelopes and heating methods). The multiple regression models were assessed by

power analysis to examine the power of the samples used in this chapter; f-test was conducted by SPSS version 21.0.

Exploratory factor analysis was, therefore, intended to identify an underlying structure between observed variables consisted of the building features in this chapter; thus the results can be used to specify efficient targets for refurbishment. The principle axis factoring method was performed by Oblimin rotation (delta 0.4) with Kaiser Normalisation (Everitt and Dunn, 2001). The criterion used to indicate an adequacy of factor analysis in the sample was followed by a Bartlett's test of Sphericity of significance, and a Kaiser-Meyer-Olkin measure of sampling adequacy (Kaiser and Rice, 1974). In order to identify robust variables, the variables with the low loadings ( $< 0.3$ ) and cross-loadings were eliminated. SPSS version 21.0 was used in all statistical analyses and the results of analyses are shown in Section 4.3.3.

#### **4.2.3.1 Sampling**

- **Old existing apartment buildings constructed in pre-2001**

A total of 189 apartment clusters (171,054 households) were selected as samples. The samples occupy 3.5% of the population size, 4,988,441 households (Statistics Korea, 2000; Statistic Korea, 2010a) in apartment buildings constructed between 1976 and 2000 in South Korea. The sampling frame was designed with four sampling units: 1) construction years; 2) regions; 3) the number of floors; 4) the availability of data on energy consumption. Firstly, apartment buildings which were built between 1976 and 2000 were only considered, because apartment buildings constructed after 2001 are regarded less urgent to be refurbished with an intensified building regulation, and constructed before 1976 are highly regarded to be demolished as low-rise buildings to rebuild high-rise buildings. Second, sixteen apartment districts in Seoul were selected. The districts were established as part of an enormous housing construction projects between the 1980s and 1990s, leading to the dramatic increase of apartment building construction. 60% of apartment buildings constructed before 2000 in



Seoul were built in these districts (Statistics Korea, 2010a). Therefore, buildings in these districts have been used to identify dominant characteristics built in that period. Moreover, these districts in Seoul are in the same climate zone, and the same thermal building regulations are applied to the buildings in Seoul and the central regions of South Korea; thus there would not be significantly different climate impacts in these districts. However, these possible impacts were taken into account in this chapter as building features related to building clusters. Third, only apartment buildings with more than ten floors were considered. This is because refurbishment would be inevitable for the buildings which have more than ten floors. As they were densely constructed, it is difficult to acquire permissions to demolish them in order to build super high-rise buildings under the current building regulations (Kim 2002; MLIT, 2010). Lastly, the availability of data on energy consumption limited the samples. 15.2% of apartment buildings which did not fill their energy bill records between 2011 and 2012 in AMIS were not counted in this chapter.

Energy consumption bills between 2011 and 2012 were collected from AMIS. This system is organised by MLIT and managed by KHMA. A policy has been implemented under which all apartment buildings in South Korea should input their expenses into this system. The system displays the expenditure of apartment buildings. However, there were some missing data on the energy bills of some apartment buildings in the system. These apartment buildings were excluded in the samples. The collected data from energy bills were converted from Won/m<sup>2</sup> to kWh/m<sup>2</sup>. The conversion rates refer to those of the KEPC (2014) for electricity and Seoul City Gas (2014) for gas.

- **A comparison group of apartment buildings**

A total of 34 apartment clusters (13,551 households) were built between 2008 and 2010 in one district. The samples occupy 1.8% of the population size, 740,214 households (Statistics Korea 2010b) in apartment buildings constructed between 2008 and 2010 in South Korea. Five sampling units were used: 1) construction years; 2) regions; 3) the number of floors; 4) energy-efficient certificates; 5) the availability of data on energy consumption. Firstly,

buildings built after 2001 were selected to compare energy consumption in old apartment buildings because those buildings are relatively regarded as energy-efficient. Secondly, as climate conditions can have a significant impact on energy use in buildings, a district in close proximity to the districts in Seoul were selected for the analysis of old apartment buildings was selected to minimise variation between the old and new samples. Thirdly, the same number of floors, more than ten floors, was also applied. Fourth, the certified apartment buildings as energy-efficient in this district were only used in this chapter as mentioned in Section 4.3.1. Lastly, the availability of data limited to choose the samples like old apartment buildings. The certified buildings which did not fill their energy bill records between 2011 and 2012 in AMIS were not counted. Energy bill data was collected by the same method used for old apartment buildings.

### **4.3 Results**

The results are illustrated by three parts to answer the five questions to identify the energy consumption in old existing apartment buildings and the effective building features, as mentioned in Section 4.1.. The first part (Section 4.3.1) describes energy consumption in old existing apartment buildings built in before 2001 by comparing the consumption in the group of apartment buildings built between 2008 and 2010. The second part (Section 4.3.2) indicates building features affecting energy consumption in old apartment buildings. The last part (Section 4.3.3) quantifies the effects of building features to energy consumption.

#### **4.3.1 *Energy consumption in old apartment buildings***

Figure 4.2 shows a comparison of the total energy consumption divided by total floor area of two groups of apartment buildings, which are 234.2 kWh/m<sup>2</sup>/year and 190.0 kWh/m<sup>2</sup>/year, respectively. Both numbers are much higher than the 1<sup>st</sup> grade in energy rating systems set by Korea Green Building Certificate Criteria (GBCC) in South Korea (60.0 kWh/m<sup>2</sup>/year) (MLIT, 2013) and Passivhaus (120.0 kWh/m<sup>2</sup>/year) (Passivhaus Trust, 2015). As a long term plan, South Korean Governments have planned to reduce energy consumption in all

buildings in order to be energy-efficient as equivalent to the Passivehaus (Yoo, 2015). This result shows that the energy consumption of both groups of apartment buildings needs to be reduced to satisfy these energy rating systems. Despite excessive energy consumption, detailed consumption (separated by use) indicates different tendencies. Old apartment buildings consumed 109.6 kWh/m<sup>2</sup>/year for space heating whilst apartment buildings built between 2008 and 2010 only consumed 66.0 kWh/m<sup>2</sup>/year. Conversely, energy consumption of electricity and water heating did not have significant reductions in this period.

These tendencies are also shown in Figure 4.3. The average energy consumed for space heating in old buildings has reduced by their construction years. 100% of old apartment buildings constructed before 1980 consumed more energy for space heating than the average of 108.8 kWh/m<sup>2</sup>/year, compared to 53% of old apartment buildings constructed in the 1980s. Only 20% of buildings in the 1990s and none of buildings constructed between 2008 and 2010 consumed above average energy for heating, these results suggest that apartment buildings built before 2001 have been able to decrease energy consumption efficiently regarding space heating.

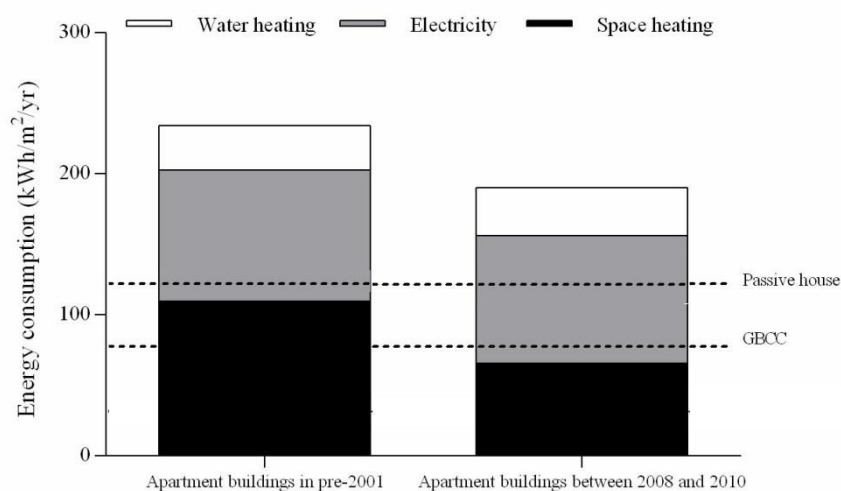
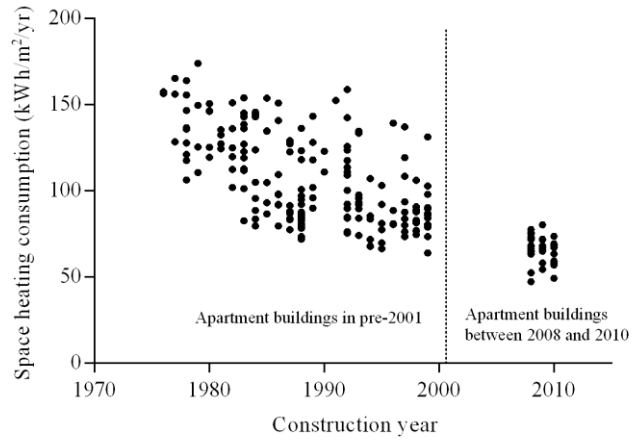

**Figure 4.2. Total average energy consumptions of the sampled apartment buildings (1767 buildings for apartment buildings in pre-2001 and 319 buildings for the buildings between 2008 and 2010) in 2011 and 2012**

Energy consumption for electricity was not reduced in this period; 92.2 kWh/m<sup>2</sup>/year of electricity was continuously consumed by apartment buildings in both groups. This can be explained by the everyday use of domestic appliances such as refrigerators, televisions and computers. However, Figure 4.4 demonstrates that the summer use of electricity for space cooling in the old apartment building was especially high in August. In each month, there was only 0.05 kWh/m<sup>2</sup>/year difference between apartment buildings in the both groups, except for August when the gap was enlarged to 1.5 kWh/m<sup>2</sup>/year in 2011 and 5.7 kWh/m<sup>2</sup>/year in 2012.

Like electricity consumption, there was no significant reduction in water heating consumption; 32.6 kWh/m<sup>2</sup>/year of water heating was continuously consumed in both groups. However, the old building group demonstrated a higher relative standard deviation with 32.3% while 19.6% was for the new building group. Furthermore, these values are also higher, compared to space heating with 25.2% in old building group and 11.5% in new building group, and electricity with 15.3% and 11.9% in old and new building groups, respectively.

Overall, apartment buildings have been able to decrease energy consumption efficiently regarding space heating and cooling although there were not significant reduction in energy consumption for electricity and water heating. As identified in Section 4.2.2, physical conditions in apartment buildings constructed between 1976 and 2000 have been transformed. This would probably result in the changes of energy consumption in these buildings.



(a) Space heating consumption

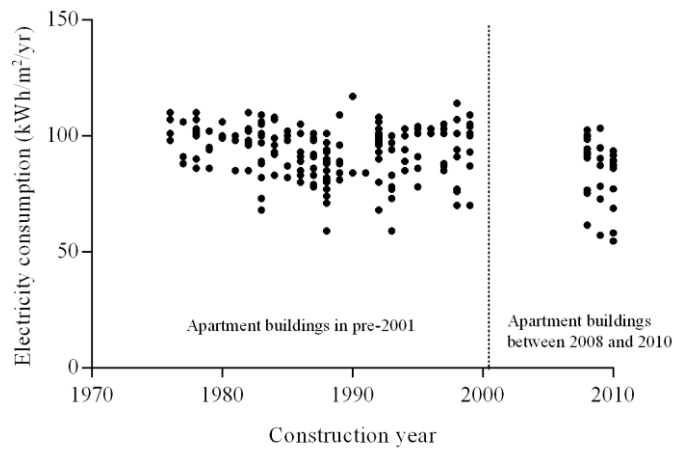

(b) Electricity consumption

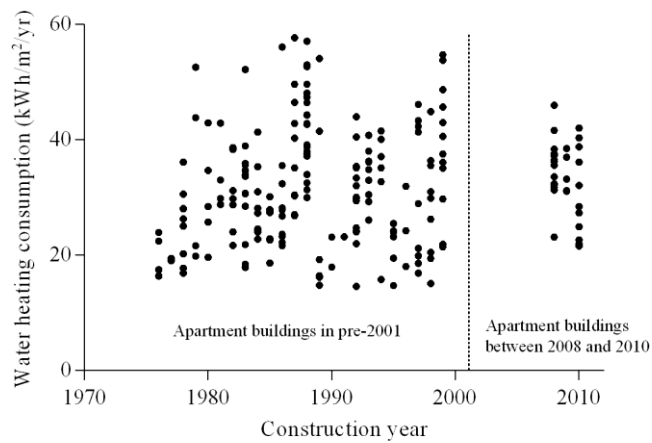

(c) Water heating consumption

**Figure 4.3. Energy consumption of apartment buildings by construction years: (left) space heating, (right) electricity**

However, the effects of occupants could also be important factors to understand energy consumption in these buildings. Interestingly, residents living in apartment buildings in South Korea showed the extremely unified composition of households. 90% of apartment buildings' inhabitants are parents with their offspring, and families with three or four members occupy 80% of households in apartment buildings (Statistics Korea, 2010c). Therefore, the general profiles of occupants such as the number of occupants and types of family may not give meaningful results explaining energy consumption. However, geographical segregations in residential areas caused by socio-economic factors such as the levels of income and education have been identified in South Korea (Choi, 2004). Their effects would also be useful to identify the continuous energy consumption in electricity and water heating, and the large variations in water heating (Korea Energy Economics Institute (KEEI), 2011). However, this chapter focused on the physical features of apartment buildings, which were described in Section 4.2.2, to create the efficient strategies for refurbishment.

#### ***4.3.2 Building features affecting to energy consumption***

It can be seen that six of the eight features (Table 4.2) had an effect on energy consumption for space heating while little difference was found in electricity consumption. This can be explained by two opposing tendencies. As expected, one of these tendencies is that old apartment buildings constructed in the early stage consumed more energy than those constructed in the late stage. Three features, the conditions of building envelopes, the lengths of buildings and heating methods, accounted for this increasing tendency in energy consumption. This means that the transformations of the three features reduced energy consumption as seen in Figure 4.5.

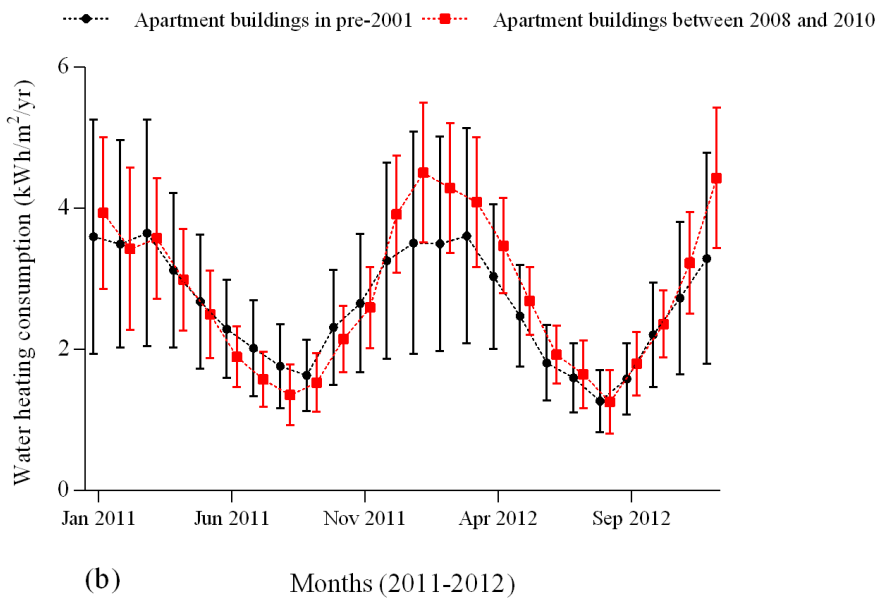
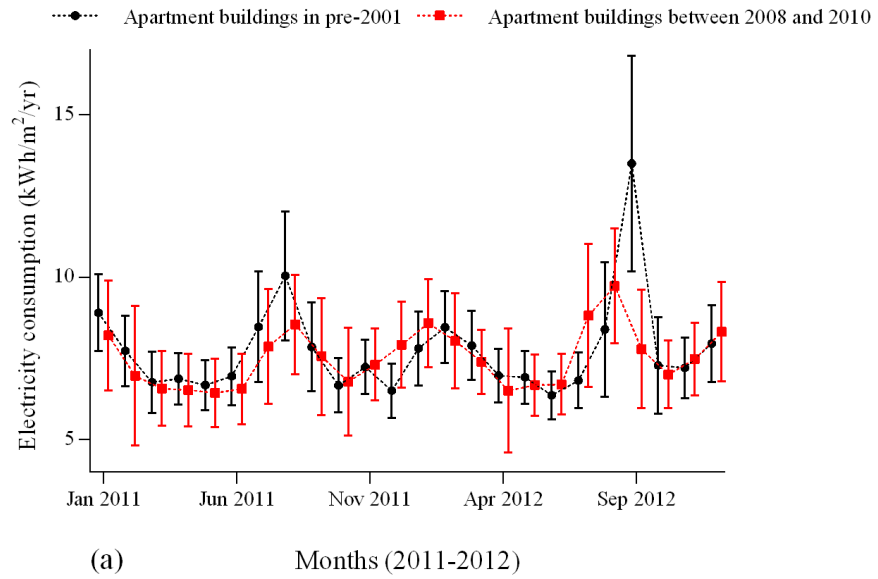

**Figure 4.4. Monthly Energy consumption between for (a) electricity and (b) water heating 2011 and 2012**

First, the most effective reduction was found by improving the condition of building envelopes, which was a maximum 48.7 kWh/m<sup>2</sup>/year (Figure 4.5-(a)). In particular, the largest reduction occurred between buildings constructed before 1980 and those constructed between 1981 and 1984. This is because buildings built before 1980 did not have insulation

on their envelopes while 50 mm internal insulations were applied for those constructed between 1981 and 1984. The second largest reduction was between buildings built between 1981 and 1984 and 1985 and 1987. This was achieved by replacing the type of glazing in windows from 3mm single glazing to double glazing. The result indicates the thermal condition of building reduced energy consumption.

Second, the shorter lengths (that is with fewer vertical access points) the buildings had, the less energy consumed for space heating. Specifically, gradual energy reduction up to 30.2 kWh/m<sup>2</sup>/year was found by decreasing the lengths of buildings. As the heights of buildings were mostly fixed either 12 or 15 stories, the total amount of surface area, which is exposed to heat transfer, was reduced. Consequently, this was beneficial in reducing energy consumption. Third, the changes in heating methods also reduced up to a maximum of 26.2 kWh/m<sup>2</sup>/year of energy consumed for space heating. A large gap was found between buildings with central gas heating, and buildings with district and individual gas heating. 24.3 kWh/m<sup>2</sup>/year was found between central gas heating and district heating, but only 2.0 kWh/m<sup>2</sup>/year was found between district and individual gas heating.

The opposite tendency is that greater energy consumption occurred in buildings constructed in the late stage. This is due to three features, namely the sizes of building units, the sizes of clusters and the types of building layouts (Figure 4.5-(d-f)). Firstly, the sizes of buildings units were increased in response to higher preference for the large sizes of units. This increase in unit sizes caused higher energy consumption in old apartment buildings, which is nearly 30 kWh/m<sup>2</sup>/year more energy consumption for space heating and 20 kWh/m<sup>2</sup>/year for electricity, to maintain a certain level of thermal comfort within the indoor environment. Secondly, old apartment buildings in large apartment clusters consumed less energy than those in small apartment clusters. The amount of energy reduced according to the sizes of clusters, a maximum 12 kWh/m<sup>2</sup>/year for space heating and 9 kWh/m<sup>2</sup>/year for electricity which were not as significant as the reductions for other features. Third, the types of building layout showed increases with 5 kWh/m<sup>2</sup>/year in electricity from linear to grid.



In short, the six building features are identified as being effective in energy consumption. However, the different amount of energy affected by each building feature needs to be evaluated in order to prioritise refurbishment strategies. The results of these evaluations are illustrated in Section 4.3.3.

**Table 4.2. The result of multiple regression analysis**

|  | <b>Independent variables</b>                 | <b>SRC (Standardised Regression Coefficient)</b> | <b>Significance</b> |
|--|--|--|---------------------|
| <b>Space heating consumption (R<sup>2</sup>=0.580)</b> | The thermal conditions of building envelopes | -0.626   | 0.000               |
|  | Heating methods                              | -0.301   | 0.000               |
|  | The lengths of buildings                     | 0.196  | 0.000               |
|  | The sizes of apartment clusters              | -0.129   | 0.008               |
| <b>Electricity consumption (R<sup>2</sup>=0.256)</b>   | The sizes of apartment units                 | 0.300  | 0.000               |
|  | The sizes of apartment clusters              | -0.202   | 0.002               |
|  | The types of building layouts                | 0.203  | 0.004               |
|  | The thermal conditions of building envelopes | -0.203   | 0.008               |

### 4.3.3 *Quantification of effects of building features on energy consumption*

#### 4.3.3.1 **Results of multiple regression analysis**

In order to reject the null hypothesis, the results of f-test in multiple regression models require not being less than 2.42 with 95% critical confidence interval. The f-test results showed 63.88 with the model for space heating and 15.94 with the model for electricity, which means that the sample sizes were large enough to bring about reliable results.

Table 4.2 demonstrates the results of multiple regression analysis. The values of R-squared in these two models are 0.580 for space heating and 0.256 for electricity. The both R-squared are not very good to account for energy consumption; the R-square for electricity is relatively low. This could be the primary data on energy consumption were limited to extract gas consumption for cooking and electricity consumption for the everyday use of domestic appliances, which are highly determined by user behaviour rather than building features. Despite it, both models are statistically significant at 5% level.

The standardised regression coefficients (SRC) of building features specify the effects of building features on energy consumption. The opposite trends of building features, as seen in the previous section, are found by negative and positive values of the standardised coefficients (Figure 4.6 (a-d)). The negative values of coefficients, decreasing energy consumption, are attributed to the transformations of these three features: improving the conditions of building envelopes; changing heating methods from central gas to individual gas heating; reducing the sizes of clusters. On the contrary, the positive values of coefficients, increasing energy consumption, are found by the other three features: shortening the lengths of buildings; reducing the sizes of building units; changing the types of building layouts from linear to grid.

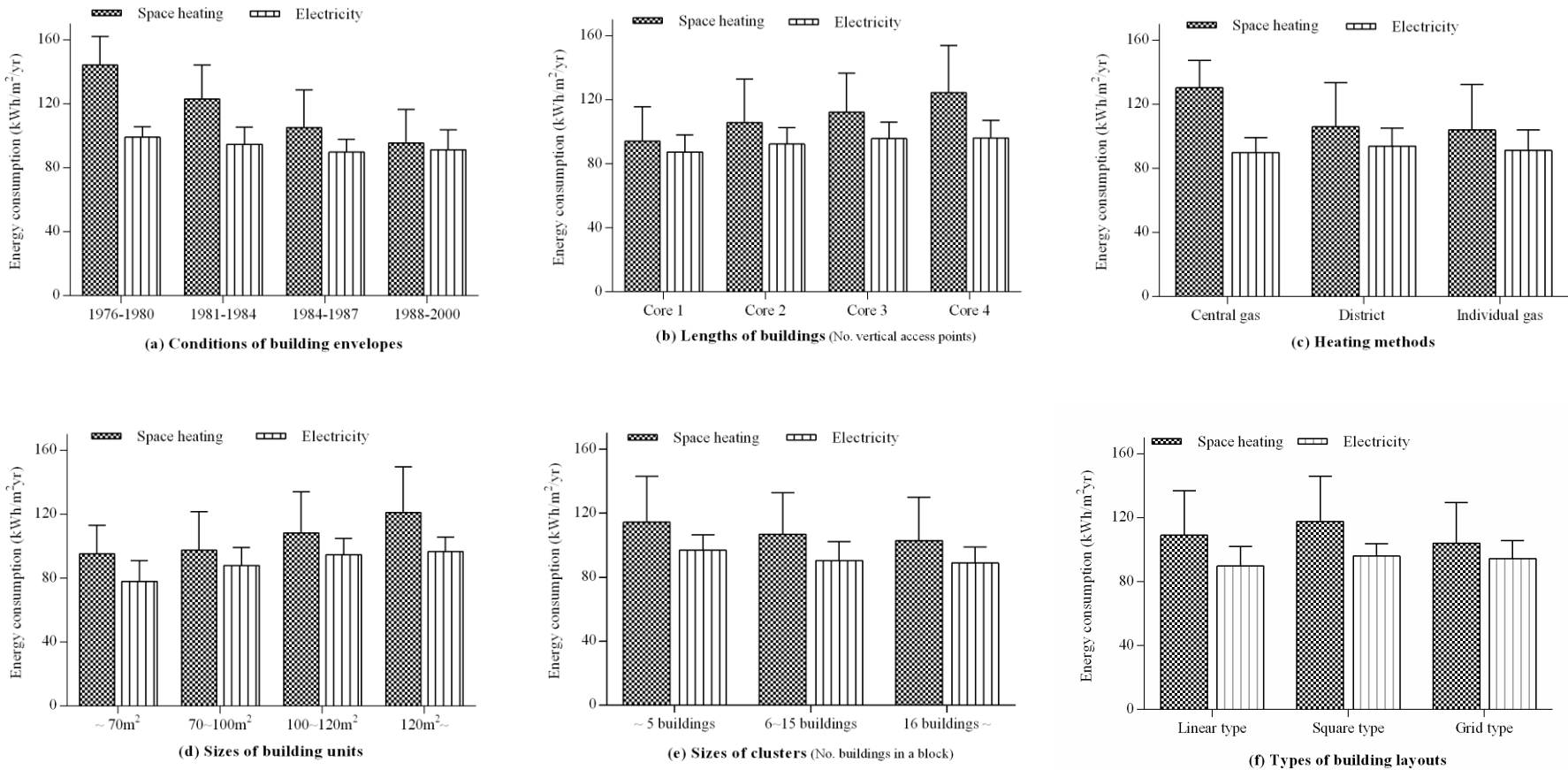
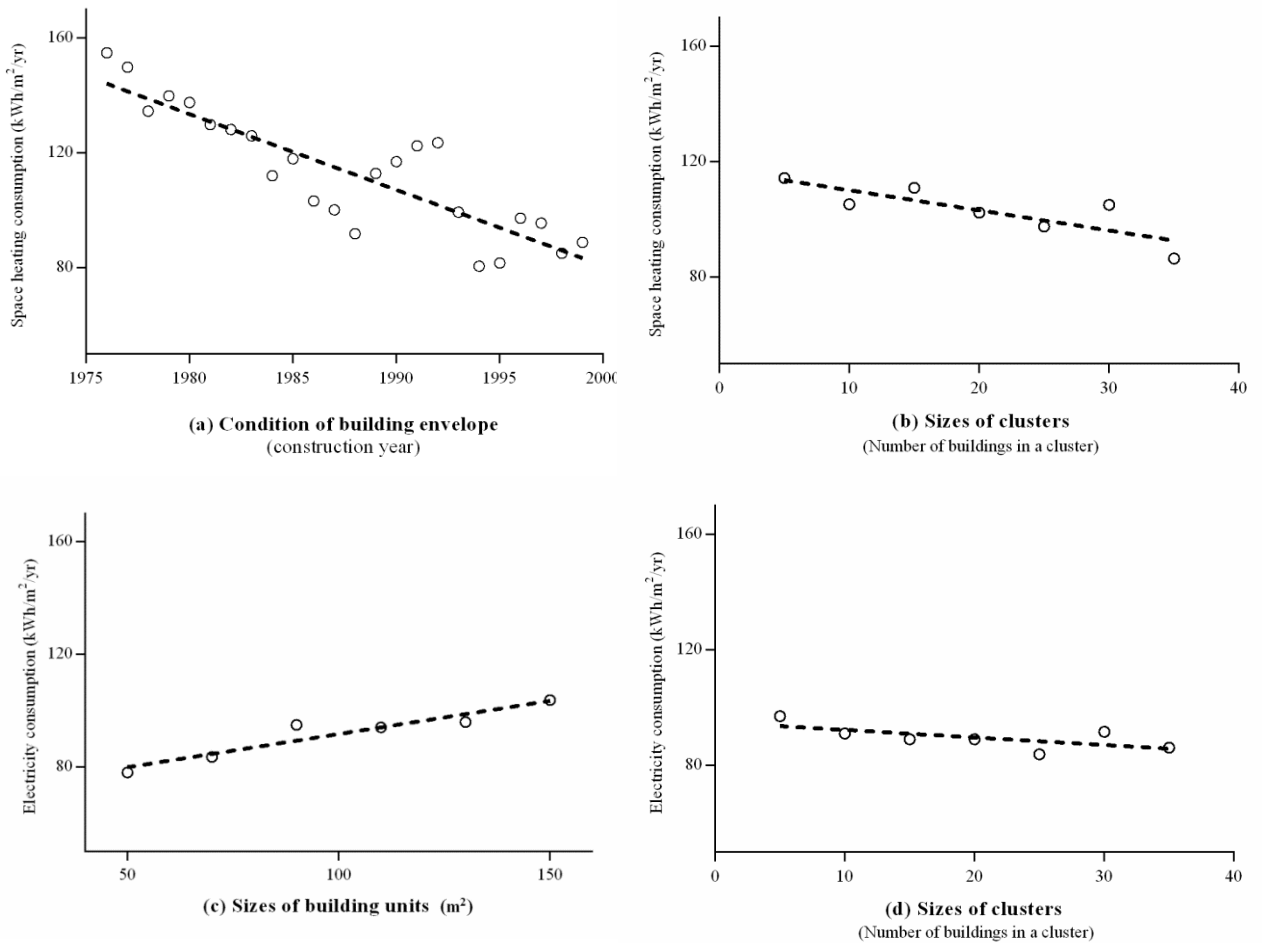

Figure 4.5. Energy consumptions of old apartment buildings by (a) conditions of building envelopes, (b) lengths of buildings, and (c) heating methods , (d) sizes of units, (e) sizes of clusters, and (f) types of building layouts

In space heating, four features were chosen as influential variables: the thermal condition of building envelopes, heating system methods, the lengths of buildings and the sizes of clusters (Table 4.2). Only the feature, the lengths of buildings, is with positive SRC while the other three features are with the negative SRCs. This means that space heating consumption was decreased by these four conditions: reducing the lengths of buildings; improving the conditions of building envelope; changing heating methods from central gas to district or individual gas heating; increasing the sizes of clusters. The former three conditions are typically found in apartment buildings constructed in late stage whilst the large sizes of clusters are identified in the early stage of apartment construction. The effects of the opposite tendencies on space heating are quantified by the values of SRC in Table 4.2. The former three features are relatively the higher values of SRC than the sizes of clusters with SRC 0.129. This interprets the reason why space heating in old apartment buildings could effectively reduce space heating consumption by transforming building features. Specially, improving the thermal conditions of building envelope played a significant role in this tendency with the most robust SRC 0.626 as seen in Table 4.2. This can be a strong criterion to determine a priority for refurbishment.

In electricity, the opposite tendencies are also identified. The sizes of units and the types of layouts show the positive SRC whereas the sizes of clusters and the thermal conditions of building envelopes indicate the negative SRC. In other words, electricity consumption was decreased by reducing the sizes of clusters and improving the thermal conditions of building envelope. However, the consumption was increased by the larger sizes of units and the changes of layout types from linear to grid. These four conditions are found in buildings built in late stage. The most significant feature is the sizes of units with SRC 0.300, but the significance is not as robust as the features affecting space heating. The other three features are approximately the very similar value of SRC with 0.202 or 0.203. These values of SRC reflect that both opposite tendencies have not significant differences each other. This interprets the reason why there was no significant change in electricity consumption in old apartment buildings.



**Figure 4.6. Regression curves of building features with energy consumption: space heating with (a) construction year and (b) sizes of clusters, and electricity with (c) sizes of building units and (d) sizes of clusters**

#### 4.3.3.2 Results of factor analysis

In the factor analysis, Bartlett's test of Sphericity was significant (186.557,  $p=0.000$ ) and Kaiser-Meyer-Olkin was satisfactory (0.616); thus this factor analysis model is acceptable, but not marvellous due to the same reason of the multiple regression analysis. Despite it, 70.8% of the total variance is explained by the eight measured variables, which is statistically effective to account for the variance. Four factors are identified in this factor analysis as seen Table 4.3.

The first factor explains the most significant proportions of the total variance with 25.9%. The measured variables in this factor are associated with building form and fabric such as the sizes of building units, the types of building accesses, the conditions of building envelopes and the lengths of buildings. Apartment buildings in early stage need to be suitable to accommodate population increased in urban area; therefore, the building form was longer length, smaller unit sizes and corridor type, as identified in Figure 4.1. The conditions of building envelopes were similarly improved with these factors. In this reason, the four variables are in the same factor, and they are statistically correlated with overall correlation coefficients ( $R=0.4$ ). The second and third factors account for 18.0% and 15.5% of total variance, respectively. The second factor is comprised by as the types of layouts, the sizes of clusters while the third has total cluster area. Although the three variables are associated with apartment clusters, the difference between them is that the two variables in the second factor is associated with specifically the characteristic of buildings in clusters whilst total cluster area is more likely the sizes of site. However, the variables are statistically correlated with overall correlation coefficients ( $R= 0.3$ ). The last factor contains heating system method accounting for 11.4% of total variance.

**Table 4.3. Pattern matrix in factor analysis**

| Category                            |                                  | Factors  |          |          |          |
|-------------------------------------|----------------------------------|----------|----------|----------|----------|
|                                     |                                  | Factor 1 | Factor 2 | Factor 3 | Factor 4 |
| Structure Matrix                    | Sizes of building units          | 0.663    |          |          |          |
|                                     | Types of building access         | 0.584    |          |          |          |
|                                     | Conditions of building envelopes | -0.584   |          |          |          |
|                                     | Lengths of buildings             | 0.370    |          |          |          |
|                                     | Types of building layouts        |          | 0.675    |          |          |
|                                     | Sizes of clusters                |          | -0.591   |          |          |
|                                     | Total cluster area               |          |          | -0.608   |          |
|                                     | Heating methods                  |          |          |          | -0.342   |
| Total Variance Explained (70.866 %) | % of Variance                    | 25.900   | 18.082   | 15.445   | 11.440   |

## 4.4 Discussion

The results based on empirical data in this chapter demonstrated four distinctive aspects, compared to findings in other countries. Firstly, energy consumption for space heating in old apartment building is not extremely high by regarding the climate zone of Seoul in South Korea (Heating Degree Days (HDDs) 2800-3200) (Cho *et al.*, 2010). Compared to European countries, Denmark (HDDs 3000-3400) (Eurostat, 2014) showed 144.1 kWh/m<sup>2</sup> of heating consumption in apartment buildings (Balaras *et al.*, 2005). United Kingdom (HDDs 2800-3100) and Germany (HDDs 2700-3200) (Eurostat, 2014), which have similar HDDs from South Korea, showed higher energy consumption in dwelling constructed in the 1980s and 1990s: 268.2 kWh/m<sup>2</sup> in detached houses in the UK and 159 kWh/m<sup>2</sup> in Germany; 102.8 kWh/m<sup>2</sup> in post 2002 mid-terrace housing in the UK, and 94 kWh/m<sup>2</sup> in Germany in 1995 (Economidou *et al.*, 2011). In this chapter, apartment buildings indicated 116.7kWh/m<sup>2</sup>/year in the 1980s and 94.4 kWh/m<sup>2</sup>/year in the 1990s although the maximum consumption in the samples was 173.9 kWh/m<sup>2</sup>/year in the 1980s and 158.8 kWh/m<sup>2</sup>/year in the 1990s. The space heating consumption in old apartment buildings in South Korea is not significantly high in the climate zone. However, the consumption needs to be reduced like how European countries have been trying to achieve.

Secondly, the eight building features of apartment buildings in South Korea indicated the significantly higher percentage of the variation explained in energy use which is 70.9% ( $R^2=0.580$  for space heating,  $R^2=0.256$  for electricity). 42% ( $R^2=0.379$  for space heating) of the variation explained was reported in analysing building characteristics with 15,000 houses in Netherlands (Guerra Santin *et al.*, 2009). Sonderegger (1978) reported 54% of total variation was explained by physical building features with 205 houses in USA. Schuler *et al.*, (2000) found relatively low  $R^2$ value, 0.144, with building characteristics in West-German households. Pachauri (2004) found 61.4 % of total explained variance by including socio-economic characteristics in dwelling in India. Consequently, the effects of physical

conditions in old apartment buildings in South Korea are much more significant than buildings in other countries. In other words, the energy consumption of these old apartment buildings in South Korea can be effectively reduced by improving their physical conditions.

Thirdly, the building features affecting energy consumption in old apartment buildings in South Korea are more prominent with higher SRC values although the lists of efficient building features are similar from buildings in other countries. Three building features have been identified in common as efficient factors reducing energy consumption: thermal conditions of building envelope (insulations and the glazing of windows); the volume of areas (heated areas, housing sizes and the number of rooms); construction years (vintages). In West-Germany, construction years and the sizes of housing were found as the relatively effective factors with SRC 0.225 and -0.221 (Schuler *et al.*, 2000). In Netherlands, the sizes of heated area (useful living area), construction years and the insulations of building facades showed relatively higher SRC values, 0.321, -0.082 and 0-0.087 (Guerra Santin *et al.*, 2009). According to Balaras *et al.* (2005), the thermal insulation of the building envelopes and building system in European apartment buildings, such as Denmark, France, Poland and Switzerland, were the main factors influencing space heating. In this chapter, there is a dominant determinant affecting space heating consumption, the thermal conditions of building envelope with SRC -0.626 in space heating. This result clearly showed how the energy-efficient refurbishment should approach.

Fourthly, the effects of building features related to building clusters are important factors. Unlike European countries, apartment buildings in South Korea were built as clusters including more than two buildings that can be up to thirties. Therefore, the relationships among individual buildings are also important factors that must be considered in energy consumption. In this chapter, the features related to building clusters explained 33.4% of total variations in energy use. Moreover, the undeniable contribution of these features was identified in the results of the multiple regression analysis for space heating and electricity although the SRC values were not decisively high.



## 4.5 Summary

This chapter aims to identify old existing apartment buildings in South Korea that need to be refurbished in terms of energy efficiency by regarding the efficient building features on energy consumption. It reveals that old apartment buildings constructed between the 1980s and 1990s are those which need to be urgently refurbished. This is because they showed excessive energy consumption for space heating and cooling, compared with the consumption of apartment buildings built in the 2000s. However, maximum 43.65 kWh/m<sup>2</sup>/year in space heating and 5.70 kWh/m<sup>2</sup>/year in cooling were reduced in those old apartment buildings in terms of construction years. This reduction was attributed to the transformations of building features in the twenty-year period. The eight features in old apartment buildings successfully account for 70.9% of total variance in the factor analysis. The largest proportion, 25.9%, was explained by the factor related to building form and fabric. Multiple regression analysis indicated the three most influential parameters, the thermal conditions of building envelopes with SRC 0.626, heating methods with SRC 0.301 and the sizes of building units with SRC 0.300.

Hence, this chapter suggests how the refurbishment should be done to reduce their energy consumption and how the building energy models should classify those buildings to reduce variation in the physical characteristic. The priority of refurbishment should be given to these three features. Amongst them, the most significant determinant should be the thermal conditions of building envelopes with SRC 0.626. The other two features will be subsidiary conditions in refurbishment strategies. In this respect, the most urgent target for refurbishment should be the buildings constructed before 1980 (with central gas heating and large sizes of building units), and the latest target can be those constructed after 1988 (with individual gas heating and small sizes of building units).

Furthermore, the prioritisation of building features allows classifying the existing apartment buildings. This classification benefits for the building energy models to cope with variation

in energy consumption, caused by the physical characteristics of existing apartment buildings. At least, these existing apartment buildings need to be grouped by their construction years, according to the revisions of thermal regulations. The other two features, heating methods and unit sizes can also be applied for more precise modelling.

Applications of this approach to cases in the other countries may bring about different building features in prioritising old high-rise apartment buildings for energy-efficient refurbishment. Thus, the refurbishment strategies for each country should take specific features and conditions of the apartment buildings into account in order to suggest efficient policies and regulations for refurbishment in each country. In the same way, the building energy models could provide more adaptive and accurate estimation with the specific features and conditions in each context.

**Integration of variation arising from occupants' behaviours consuming heating and electricity into a building energy model of existing apartment buildings**

In Chapter 4, one of the influential factors that this research is focusing, the physical characteristics, was classified by their effectiveness on energy consumption. Thus, the building energy model for existing apartment buildings can take this classification to constrain the impacts of variation in the physical characteristics on energy consumption. This chapter applies two building features from the classification, construction years and heating systems. The initial objective of this chapter is devoted to the second factor, occupants' behaviours, causing variation in actual energy consumption, and aims to create a new probabilistic standardised condition of occupants' behaviours for existing apartment buildings. The national survey of occupants' consumption characteristics is inferred from actual energy consumption to be adjusted for existing apartment buildings. The set of random behaviours of consuming heating and electricity is dealt with by Gaussian Process Classification. This chapter is structured by four sections. Section 5.1 provides a brief background of the conventional building energy model for high-rise apartment buildings, and the importance of human interactions in energy consumption. Section 5.2 describes a methodology of integrating occupants' behaviours and conducting Gaussian Process Classification. Section 5.3 interprets a distribution of actual energy consumption and a probability of the new standardised conditions of occupants' behaviours. The key findings of this chapter are summarised in Section 5.4.

## **5.1 Background**

Apartment building is one of the common types of housing in Asia (Yuen, 2011). Their high capability of accommodating a large number of residents has attracted the fast grown and growing countries, such as China, South Korea, Hong Kong and Singapore (Yuen, 2011). One of the representative countries, South Korea, experienced great economic growth in the 1960s, and the country became rapidly urbanised (Chung, 2007). This urbanisation also resulted in dramatically increased urban population (Chung, 2007). Apartment buildings were introduced to accommodate this increased size of the urban population, particularly for

the working class (Lim, 2011). However, the main target of apartment buildings was gradually transferred from the working class to the new middle class that was rapidly growing during the economic growth in the 1970s and 1980s (Hong and Lett, 1999). This transfer meant that living in apartment buildings became a representative of rising social status (Gelézeau, 2007). For this reason, the proportion of apartment building in housing were extremely raised (Statistics Korea, 2000). Seoul was one of the main centres in this significant transformation. In the 1970s and 1980s, 48% and 26% of national apartment constructions were concentrated in Seoul, respectively (Statistics Korea, 2000). They still comprised about 50% of housing in the city (Kim, 2010).

Improving thermal performance in existing buildings has been discussed in many countries (Ouyang *et al.*, 2011) as carbon emissions have been internationally issued. Especially, refurbishing old existing apartment buildings has been importantly investigated in Asian countries, such as (Yuen *et al.*, 2006; Ouyang *et al.*, 2011). In South Korea, apartment buildings built in the 1970s and 1980s have been pointed out due to their large population, as well as high energy consumption (Kim, 2010), in accordance with the intensified building thermal regulations (Kim *et al.*, 2013b). Existing literature (Kim *et al.*, 2006b; Lee, 2009; Song, 2009; Kim *et al.*, 2010; Son *et al.*, 2010; Roh, 2012) has focused on reducing the energy demand of apartment buildings in standardised conditions defined by Energy performance Index (MLIT, 2013) and Building Energy Efficiency Rating System (MLIT, 2015a). These standards have provided deterministic conditions to identify changes in energy demands of buildings. Thus, they have been used to verify energy efficiency in buildings, and guide buildings to improve their energy performance. However, this approach has been questioned about its achievement in real situations. Many studies pointed out limitations and uncertainties contained in the standard conditions of buildings used in existing literature (Ryan and Sanquist, 2012). One of difficulties in refurbishing existing buildings is the lack of interaction with occupants (Gholami *et al.*, 2013).

Apartment buildings have been evolved to be self-sufficient by occupants despite the unified features of buildings (Gelézeau, 2007). The usage of heating and electricity is individually controlled in each apartment unit, which can be considered as independent thermal zones in these buildings. Therefore, energy consumption in apartment buildings can be significantly different. Besides, some empirical data in existing studies (Kang *et al.*, 1995; Lee *et al.*, 2012), showed various actual energy consumption in apartment buildings despite the similar thermal conditions. However, building energy models with standardised conditions in the existing literature are not flexible to take into account the possible variations in energy consumption. Furthermore, the results would contain a high amount of uncertainty due to random behaviours of energy consumption.

This chapter, therefore, aims to develop a probabilistic model of occupant random behaviour consuming heating and electricity, regarding the variation in actual energy consumption for existing high-rise apartment buildings. Three objectives are designed: to identify the variation in actual energy consumption in old high-rise apartment buildings built between the 1970s and 1980s; to integrate the variation in actual consumption into building energy models; and to identify the possible occupant random behaviours controlling heating and electricity corresponding to the probability of energy consumption.

## **5.2 Methodology**

In order to identify probabilistic occupant random behaviours controlling heating and electricity the procedure was designed in four steps. At first, actual energy consumption in apartment buildings was surveyed, and grouped by two efficient building features, construction years and heating methods. Afterwards, variation in each group was measured. Second, building energy models of random control of heating and electricity were analysed with their uncertainty. Estimated energy consumption of the building energy models was optimised to reflect the distribution of the actual usage. Third, the probability of energy consumption was predicted by Gaussian Process Classification. At the same time, the

possible ranges of occupant random controls were updated. Last, the probabilistic random behaviour was evaluated.

## ***5.2.1 Evaluating variation in actual energy consumption in apartment buildings***

### **5.2.1.1 Sampling**

There are many factors interrelating with energy consumption. Thus, it was important to compare effects from unrelated factors in this chapter. Four sample frames were chosen: 1) locations; 2) physical conditions; 3) heating methods; 4) data availability. Firstly, the locations of apartment buildings were used to eliminate external effects. 16 apartment districts in Seoul were chosen. These districts were mainly developed for apartment constructions under an enforcement decree of the Urban Planning Act since 1976 (Son, 2004). Thus, apartment buildings in these districts were constructed in a similar time frame and near distance, which can minimise the difference in climate effects. Afterwards, these 13 districts were separated by socio-economic factors to avoid the impact of urban segregation in Seoul (Jee, 1988; Rhee, 2005; Yoon 2011). Some districts are in high demand despite the relatively deteriorated conditions of apartment buildings. This is because their locations have been centres of business and commerce (Gelézeau, 2007). For this reason, factors representing the financial status of households, such as tax revenues (Yoon, 2011), the proportion of education levels (Jee, 1988) and housing prices (Rhee, 2005), were regarded. Finally, four districts were chosen from the 16.

Secondly, the physical conditions of apartment buildings need to be constrained to avoid giving impact on energy consumption, according to the findings in the previous chapter. Two of the most influential factors affecting energy consumption, thermal conditions of building envelopes and heating methods were chosen from Chapter 4. Therefore, apartment buildings constructed in the 1970s and 1980s were divided into two groups depending on the thermal conditions of building envelopes, which were filtered by construction years. The

first group, period A, was comprised of apartment buildings constructed before 1980 when a legislation of building thermal regulations was enacted. The revisions in 1984 and 1987 were combined. The second group, period B, contained buildings built between 1981 and 1987 before the building regulation had a professional form. Therefore, the buildings in both periods need to be refurbished to reduce high energy consumption (Kim, 2010) although buildings in period B can be expected to have relatively advanced thermal conditions than buildings in period A.

Thirdly, heating methods were also controlled due to the valid association with heating energy consumption, as found in Chapter 4. In this study, district heating method was only considered, which was mainly applied for many apartment buildings constructed in the four districts.

Lastly, energy bills were collected by apartment management information system (KAB, 2014). The monthly consumption in 2014 was transformed from Won/m<sup>2</sup>/year to kWh/m<sup>2</sup>/year, according to calculation methods by (KDHC, 2015) and (KEPC, 2014). The bills were separated by heating and electricity. This chapter only considered energy bills consumed for individual units. Energy bills used for communal purposes were, therefore, excluded even though they were consumed in buildings. In total 96 apartment clusters (44 blocks in period A and 51 blocks in period B) were chosen in this sample study. They occupy 37.1% and 16.3% of apartment buildings built in both periods A and B in Seoul, respectively.

### **5.2.1.2 Normality tests**

Central limit theorem states that frequencies in empirical populations show bell-shape curves if the number of independent random samples is large enough (Sheldon, 2002). The collected samples were evaluated for this normality. Firstly, Kolmogorov-Smirnov and Shapiro-Wilk tests were conducted to measure the deviations of the samples from the normal distribution with the same mean and standard deviation. If  $p$ -values in both tests are not



significant ( $p > 0.05$ ), the normality of the samples can be accepted (Rose *et al.*, 2014). Secondly, Q – Q plots were drawn to supplement the limitation of the previous normality tests through visual inspection (Field, 2009). Lastly, skewness and kurtosis were measured to identify how far the sample data is different from the normal distribution;  $\pm 1.96$  limits were considered as normally distributed (Field, 2009). SPSS version 22.0 (Field, 2009) was used to conduct these tests. The results of normality tests are illustrated in Section 5.3.1.

### ***5.2.2 Integrating occupant behaviour reflecting actual energy consumption into building energy models***

A probabilistic approach was applied to reflect variation in the actual energy consumption in the building energy models. The building energy models were created by the possible behaviours of controlling heating and electricity. The possible energy consumption in the energy models was compared to the variation in the actual energy consumption. The model estimation was optimised to be as similar as the real consumption.

#### **5.2.2.1 Building energy models of occupant behaviours controlling heating and electricity**

The building energy models consisted of three parts: building form, thermal properties and energy controls. First, building form was fixed by choosing the most typical unit design (Kim and Kim, 1993; Park, 2003; Kim and Yoon, 2010) and building design (fifteen-story and south-facing (Son, 2004; Lim, 2011), as shown in Figure 5.1. This unit design comprised about 80% of apartment buildings built until the 1980s (Kim and Yoon, 2010). The apartment buildings with 15 floors consist of the largest proportion, 31.7% (Statistics Korea, 2010a). The building energy models were created with six units: two units on three floors (ground, middle and top floors). The energy consumption in the two units on the middle floor was multiplied to estimate the total amount of energy consumption from 2<sup>nd</sup> to 14<sup>th</sup> floors by using multiplier in EnergyPlus8.0. Multipliers in EnergyPlus are used for convenience in modelling; Zone multipliers are designed to multiply floor area, zone loads and energy consumed by internal gains (EnergyPlus Documentation, 2010). The multiplied

loads are used to specify the HVAC system size. In this study, the total energy loads of the thirteen floors (from the first to 14th floors) were calculated by using the multipliers in EnergyPlus. Each room was separately modelled as individual thermal zones to be controlled by different schedules as it occurs in real situations.

Second, thermal properties (U-values) for the two periods (before 1980, and between 1981 and 1988) were identified by reviewing the building thermal regulations and existing literature (Seo, 2012; Kim *et al.*, 2013b), and site survey mentioned in Methodology. The specific applications were also verified by the site survey collecting actual architectural drawings in three apartment blocks. The thermal condition in apartment units is divided into two different areas: unconditioned and conditioned areas (Figure 5.1). Unconditioned areas mean the bathroom and two balconies which are directly exposed to the outside without heating facilities, whereas conditioned areas are the main living spaces, which are enclosed by the unconditioned areas to be protected from the outside, apart from the bedroom C. Therefore, thermal protection was focused on the conditioned areas. The profiles of building envelopes are described in Table 5.1.



**Figure 5.1.** Description of the apartment units (*Source of the unit plan: Kim and Yoon, 2010*)

Table 5.1. Profile of thermal properties in the building energy models

| Location                                    | Exposure to the outside | Materials (mm)<br>(In → out, up → down)                          |  | Thickness (mm)<br>(Period A/B) | Thermal conductivity<br>(W/m.K)                                  | Density (kg/m <sup>3</sup> )<br>(Period A/B) | Specific heat (J/kg.K)<br>(Period A/B)   | U-value (W/m <sup>2</sup> K) |          |
|---|-------------------------|--|--|--------------------------------|--|--|--|------------------------------|----------|
|   |                         | Period A<br>(Before 1980)  | Period B<br>(1981 – 1988)  |                                |  |  |  | Period A                     | Period B |
| External wall                               | Direct                  | Mortar<br>Cement<br>brick<br>Cavity<br>Cement<br>brick<br>Mortar | Mortar<br>Cement brick<br>Cavity<br>Cement brick<br>Mortar                           | 18<br>90<br>50<br>90<br>18     | 1.081<br>0.605<br>0.15<br>(m <sup>2</sup> K/W)<br>0.605<br>1.081 | 1950<br>1700<br>-<br>1700<br>1950            | 921<br>1550<br>-<br>1550<br>921          | 2.08                         | 2.08     |
|   | Indirect                | Mortar<br>Cement<br>brick<br>Cavity<br>Cement<br>brick<br>Mortar | Mortar<br>Cement brick<br>Insulation<br>Cement brick<br>Mortar                       | 18<br>90<br>50<br>90<br>18     | 1.081<br>0.605<br>0.033<br>0.605<br>1.081                        | 1950<br>1700<br>- / 50<br>1700<br>1950       | 921<br>1550<br>- / 838<br>1550<br>921    | 2.08                         | 0.50     |
| Side wall                                   | Direct                  | Mortar<br>Cement<br>brick<br>Concrete                            | Mortar<br>Insulation<br>Concrete<br>Mortar   | 18<br>90 / 50<br>200<br>18     | 1.081<br>0.605<br>1.400<br>1.081                                 | 1950<br>1700 /<br>50<br>2240<br>- / 1950     | 921<br>1550 / 838<br>879<br>- / 921      | 3.24                         | 0.59     |
| Roof  | Direct                  | Mortar<br>Concrete<br>Cavity<br>Insulation<br>Plaster<br>board   | Mortar<br>Concrete<br>Cavity<br>Insulation<br>Plaster board                          | 24<br>200<br>220<br>50<br>10   | 1.081<br>1.400<br>0.18<br>(m <sup>2</sup> K/W)<br>0.033<br>0.209 | 1950<br>2240<br>-<br>50<br>940               | 921<br>879<br>-<br>838<br>1130           | 0.52                         | 0.52     |
| Floor between ground and underground floors | Indirect                | Mortar +<br>Gravels<br>(heating<br>tubes)<br>Concrete            | Mortar +<br>Gravels<br>(heating<br>tubes)<br>Concrete<br>Insulation<br>Plaster board | 100<br>200<br>50<br>10         | 1.081<br>1.260<br>1.400<br>0.033<br>0.209                        | 1950<br>1522<br>2240<br>- / 50<br>- / 940    | 921<br>908<br>879<br>- / 838<br>- / 1130 | 4.36                         | 0.55     |
| Window                                      | Direct                  | Single<br>glazing  | Single<br>glazing  | 3                              | 0.900  | -  | -  | 5.89                         | 5.89     |

Some appliances such as TV, refrigerator, and Kimchi refrigerator, also indicated high electricity consumption, but their operations were much unified: always on for refrigerators and 5 hours for TV, according to the national survey (KEPC, 2013). Therefore, they were set in the building energy models, but with consistent values. Two air-conditioners were equipped in the living room and the largest bedroom A. Electric blankets for supplementary heating were applied in the living room and two bedrooms. A computer and rice cooker were placed in the living room including kitchen. Four occupants were in each apartment unit,

which is the most representative type of household living in apartment buildings (Statistics Korea, 2010c). Electric power of appliances was taken from the average values in the national survey (KEPC, 1990; KEPC, 2013): TV (130.6W), refrigerator (40.0W), Kimchi refrigerator (22.6W), computer (263.3W), fluorescent light (55.0W in bed rooms, and 165W in the living room), rice-cooker (1022.9W in cooking, and 143.4 in warming). Ventilation rates were set 0.82ACH for conditioned area and 2.00ACH for unconditioned area (MLIT, 2015b).

**Table 5.2. Prior distributions of uncertain parameters in building energy models**

| Categories  | Input parameters                         | Prior distributions | Optimised distribution |                  | Locations                       | Units                | No. Parameters |
|-------------|--|---------------------|------------------------|------------------|---------------------------------|----------------------|----------------|
|             |  |                     | Period A               | Period B         |                                 |                      |                |
| Heating     | Set-point temperatures                   | 16 – 22             | 16– 20<br>16 – 20      | 15 – 21<br>16–21 | Living room<br>Bed room A – C   | °C(winter)           | 1<br>2,3,4     |
|             | Operating hours                          | 3 – 9               | 3–6<br>-               | 3 – 9<br>-       | Living room<br>Bed room A – C   | Hour/day<br>(winter) | 5<br>6,7,8     |
| Electricity | Air-conditioner (set-point temperatures) | 23 – 29             | -                      |                  | Living room<br>Bed room A       | °C(summer)           | 9<br>10        |
|             | Air-conditioner (operating hours)        | 0 – 7               | 0 – 7                  |                  | Living room<br>Bed room A       | Hour/day<br>(summer) | 11<br>12       |
|             | Rice-cooker (operating hours)            | 10 – 16             | 7 – 16                 |                  | Living room (kitchen)           | Hour/day             | 13             |
|             | Computer (operating hours)               | 1 – 4               | 0.5 – 3.5              |                  | Living room                     | Hour/day             | 14             |
|             | Lighting (operating hours)               | 1 – 7               | 0 – 7                  |                  | Living room<br>Bed rooms        | Hour/day             | 15,16          |
|             | Electric Blanket                         | 60 – 120            | -                      |                  | Living room<br>Bed room A and C | Day/year<br>(winter) | 17,18,19       |

### 5.2.2.2 Optimisation of model estimation reflecting variation in the actual energy consumption

The building energy models defined in the previous section were used to estimate the possible ranges of energy consumption. A great number of possible cases were created due to the uncertain controls of heating and electricity. 200 random samples were chosen by Latin Hyper-cube Sampling (LHS) to conduct the Monte Carlo Method. LHS method is more robust than other sampling methods (Macdonald, 2009), and has been widely applied to the uncertainty analysis in building simulations such as (Hyun *et al.*, 2008; Silva and

Ghisi, 2014). EnergyPlus 8.0 (Crawley *et al.*, 2001) was used to conduct building simulations. Historical weather data of Seoul in 2014, which is provided by White Box Technologies weather data for energy calculations (White Box Technologies, 2014), was applied. Both LHS samplings and simulations were managed by jEPlus (Zhang, 2012). Heating and electricity consumption were separately accumulated. The Probability Density Function (PDF) of the estimated energy consumption was compared to the PDF of the actual energy consumption. The Coefficient of Variation of Root-Mean-Square Deviation (CV RMSE) was used to measure the discrepancy between the model estimation and the actual energy consumption.

The previous occupant random behaviour in building energy models could not be specified for the residents living in the old apartment buildings. This can bring about high amounts of discrepancy, comparing to the actual energy consumption. This discrepancy was optimised in order to reflect the actual energy consumption. The procedure was divided into two parts. Firstly, multivariate regression analysis was conducted to create linear models of energy consumption only with influential parameters of occupants' random controls. Above all, the linearity was examined by the coefficients of determination (R-squared) and F-ratio values (Field, 2009). SRC values were used to determine the influential parameters in the linear models. A stepwise method was applied to create possible linear models automatically. Secondly, the ranges and values of the uncertain parameters were revised for their regenerated random samples to have similar mean and standard deviation of the actual energy consumption. Random sampling was conducted by uniformly distributed pseudorandom integers in MATLAB 2014a (Hunt *et al.*, 2014). The linear models identified above were used to estimate energy consumption of the regenerated samples. The distribution of the re-estimated energy consumption was compared to the actual energy consumption. CV RMSE was used to evaluate the difference between them. The results are shown in Section 5.3.2.1.

### 5.2.3 *Generalisation of probability of occupant behaviours consuming heating and electricity*

Based on the optimised model estimation, this section conducted stochastic processes to identify the probability of energy consumption. Stochastic processes deal with the sets of all possible random parameters (Ross, 2014), and form the generalised probability distributions to functions (Rasmussen and Williams, 2006). In particular, Gaussian Processes easily deal with many random variables that are approximately considered normally distributed, according to the probability theory (Parzen, 1999). The processes follow Bayes theorem (Rasmussen and Williams, 2006) that modifies prior distributions through observed data to achieve target distributions (Kalbfleisch, 2012). This inference has been used to calibrate parameters of building energy models in building simulations, as shown in (Heo *et al.*, 2012). Depending on the types of outputs, either regression or classification is determined in conducting Gaussian processes; regression deals with continuous outputs that deal with real values while classification considers discrete outputs classified by labels (Bernardo *et al.*, 1998).

This chapter focused on classification to predict the probability of heating and electricity in the group of old apartment buildings rather than exact calibration for case-by-case. The process was divided into three steps. Firstly, the optimised random samples were prepared as training data. The energy consumption was subdivided by 25% deviation, which was called 'Medium class'. Heating consumption with 25% deviation was defined between 107 and 138 kWh/m<sup>2</sup>/year in period A and between 87 and 112 kWh/m<sup>2</sup>/year in period B. The electricity consumption between 30.1 and 33.3 kWh/m<sup>2</sup>/year decided the medium class for the both periods.

Secondly, Gaussian Process priors such as covariance functions were formed. Many covariance functions can be applicable. The details of covariance functions were studied by (Neal, 1997). More than that, the suitable values of hyper-parameters defining covariance

functions is more problematic (Neal, 1997; Rasmussen and Williams, 2006). Prior distributions of hyper-parameters are required to be predefined, although the values are optimised during the process. In this chapter, the Squared Exponential (SE) covariance function, which has been the most widely used (Rasmussen and Williams, 2006), was chosen. This covariance function necessarily requires two hyper-parameters: length-scale and magnitude. The inverse of length-scales demonstrates the relevance of inputs in the process, while magnitude indicates the variances of unknown function values (Neal, 2012). Gaussian distribution was applied for the hyper-parameters in this chapter.

Thirdly, Gaussian Process models were structured by multinomial probit models with nested Expectation Propagation (nested EP) algorithm (Riihimäki *et al.*, 2013) to take into account the classes of energy consumption with four to six parameters for heating and electricity consumption. Comparing to Markov Chain Monte Carlo (MCMC), nested EP algorithm also showed consistent results with small inaccuracy (Riihimäki *et al.*, 2013), but much less operating time was required. The calculations were conducted by GP-Stuff (Vanhatalo *et al.*, 2013), run by MATLAB 2014a (Hunt *et al.*, 2014). Contour plots were used to draw the predictive probability. The results are illustrated in Section 5.3.2.2.

#### ***5.2.4 Evaluating estimated energy consumption of probabilistic models***

The previous section identified the probability of energy consumption, and the previous identification of behaviours controlling heating and electricity were modified. The updated random behaviours were evaluated to whether or not the predicted energy consumption reflects the variation in the actual energy consumption with reduced uncertainty. 100 random samples were chosen with different probability: high probability (50 – 90%) and total probability (0 – 90%). Their estimated energy consumption was compared in Section 5.3.3.

## 5.3 Results

The results section is designed in three parts. The first part describes the analysis of variation in actual energy consumption in Section 5.3.1. The second part illustrates the probability of standardised conditions in Section 5.3.2. Specifically, the optimisation of estimated energy consumption regarding the actual energy consumption is interpreted in Section 5.3.2.1, and the results obtained from Gaussian Process Classification are shown in Section 5.3.2.2. Finally, the estimated energy consumption with the probability of standardised conditions is evaluated in Section 5.3.3.

### 5.3.1 *Variation in actual energy consumption in apartment buildings*

The results of normality tests demonstrate the collected samples are normally distributed (Figure 5.2). The  $p$ -values in the Kolmogorov-Smirnov tests are unified with 0.200 in the heating and electricity consumption for both periods. Shapiro-Wilk tests also show the  $p$ -values 0.362 – 0.792, which are not significant. This means that the normality of the samples can be accepted. The Q – Q plots of the samples show slight deviations from the normal distribution at the tails. The deviations are interpreted by kurtosis and skewness. The largest kurtosis is 1.30 in the electricity consumption in period A while the greatest skewness is found in the heating consumption in period A. However, these deviations are within  $\pm 1.96$  limits of kurtosis and skewness. Therefore, the samples can be regarded as normally distributed, which means that the number of samples is large enough to represent their population.

Figure 5.3 gives the overview of energy consumption in old high-rise apartment buildings constructed between the 1970s and 1980s. The average heating energy consumption in apartment buildings constructed before 1980 (Period A) is 123.2 kWh/m<sup>2</sup>/year while the consumption is reduced to 99.66 kWh/m<sup>2</sup>/year in apartment buildings built between 1981 and 1988 (Period B). The comparison of the two average values reveals the significant impacts of thermal conditions of building envelopes on heating consumption. However, the



electricity consumption is similar in both periods, A and B, with 31.77 kWh/m<sup>2</sup>/year and 31.67 kWh/m<sup>2</sup>/year.

The more interesting aspect is the variation in energy consumption in each period (Figure 5.3). Heating consumption is deviated 20.6 kWh/ m<sup>2</sup>/year among buildings in period A while the greater deviation about 30.1 kWh/ m<sup>2</sup>/year is identified in period B. Furthermore, the difference between minimum and maximum values in heating consumption is 98.0 kWh/m<sup>2</sup>/year in period A, and is enlarged to 128.5 kWh/m<sup>2</sup>/year in period B. The relatively lower variation in period A could reveal their desperate necessity of heating due to the low energy-efficient building conditions. The higher variation in period B would result from the diverse preference of controlling heating by occupants. In electricity consumption, the standard deviation for both periods is about 3.5 kWh/m<sup>2</sup>/year, and the minimum and maximum ranges are about 15 – 20 kWh/m<sup>2</sup>/year. In general, the actual energy consumption in apartment buildings is 10 –30% deviation from average values. The difference between minimum and maximum consumption is extended up to 50 – 128%.

### ***5.3.2 Probability of standardised conditions regarding variation in actual energy consumption***

The probabilistic approach integrating the variation into building energy models is illustrated in this section. Firstly, building energy models with the prior distributions are optimised to reflect the variation in the actual energy consumption in Section 5.3.2.1. Secondly, the probability of energy consumption is calculated by Gaussian Process Classification. At the same time, the possible ranges of influential parameters are modified. The results are illustrated in Section 5.3.2.2.

#### **5.3.2.1 Optimisation of the estimated energy consumption in building energy models**

The model estimation with the prior distribution of input parameters (thick dashed lines in Figure 5.3) is dissimilar from the distribution of the actual energy consumption (solid lines

with dots). At first, the average values of the model estimation are greater than the actual values, apart from the heating estimation for period A. The average values of heating consumption in period B is overestimated by about 23 kWh/m<sup>2</sup>/year with the prior distribution, while a nearly 3 kWh/m<sup>2</sup>/year reduction is required in the average value of electricity consumption. Second, the distribution of the estimated heating consumption is far greater than the one of actual consumption: 62% discrepancy in period A (Figure 5.3 (a)) and 51% in period B (Figure 5.3 (b)). This wider distribution of the estimated heating consumption indicates that the ranges of occupants' random controls would be wider than the actual usage, which needs to be narrowed down. On the contrary, the ranges of the parameters for electricity consumption are required to be wider to reduce about 35% discrepancy from the variation in the actual use (Figure 5.3 (c and d)). This opposite trend of estimation, compared to the actual use, implies that different parameters respectively effect on heating and electricity, and their modification needs to be different.

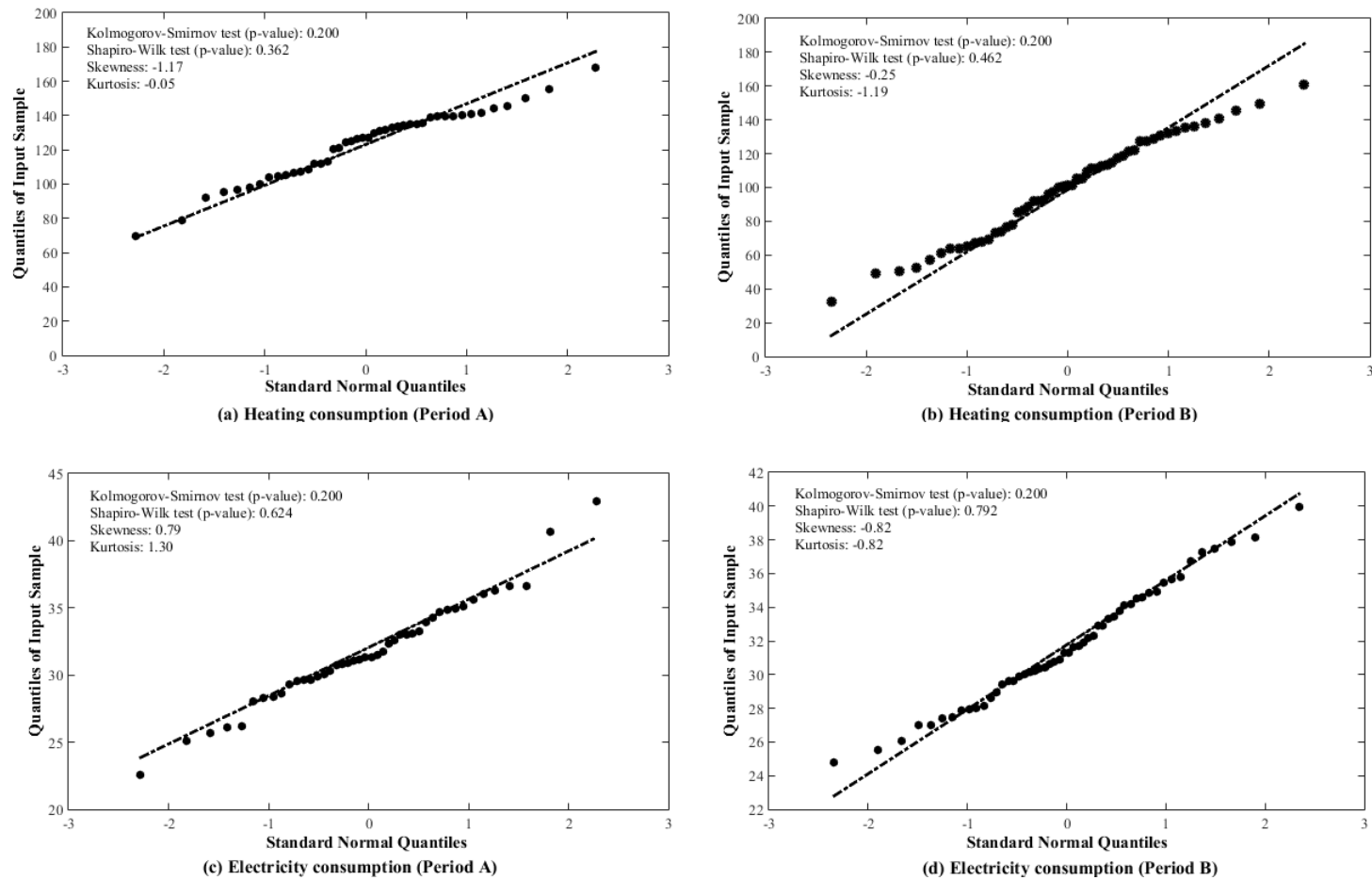

Figure 5.2. Results of normality tests of actual energy consumption

Multivariate regression analysis was used to choose the most rigid linear models with less residual. In the results of R-squared values (Figure 5.4 (a and b)), the highest R-squared values more than 0.7 are generally achieved by increasing the number of parameters. However, the increasing of R-squared values in heating models becomes significantly steady after the fourth model (0.84 and 0.70 for period A and B) while the sixth model (0.94 and 0.78 for period A and B) in electricity models. These models also show higher F-ratios with less numbers of input parameters: 256.2 in period A and 114.6 in period B for heating (degree of freedom: 4), and 554.4 in period A and 112.2 in period B for electricity (degree of freedom: 6) (Figure 5.4 (c and d)). Hence, they are chosen as the most fitted models.

These linear models for heating and electricity consumption are respectively comprised of four and six parameters, as shown in Table 5.3. In the heating models, set-point temperature is the most significant factor, followed by their operating hours. Specifically, the volume of space determines their impacts on heating consumption. Thus, set-point temperature in the living room presents the highest SRC 0.587 and 0.526 in periods A and B. Their operating hours has the second highest SRC, which are 0.504 and 0.469 for period A and B, respectively. The third parameter is set-point temperatures in the bedroom A with SRC of 0.320 and 0.271 for both periods A and B. This is because the bedroom A is the largest bedroom. The fourth parameter is set-point temperatures in the bedroom C with SRC of 0.285 and 0.260 for both periods A and B, which is the bedroom directly exposed to the outside.

Electricity models are structured by operating hours of six parameters that can be categorised by three groups: lighting, appliance used in daily routines and cooling. The most influential factors are the operating hours of lighting in the bedrooms (SRC 0.527 and 0.475 in periods A and B) and living room (SRC 0.475 and 0.433). The operating hours of rice-cookers and computers show the fourth and fifth highest SRC of 0.343 and 0.339 in period A, and 0.336 and 0.329 in period B. In terms of the seasonal devices, cooling hours is the

most influential compared to the other factors, including cooling set-point temperatures. Their impact on electricity consumption is determined by the size of volume. Thus, cooling hours in the living room have SRC 0.459 and 0.383 in periods A and B while cooling operation in the bed room show SRC 0.239 and 0.220 in the two periods, respectively.

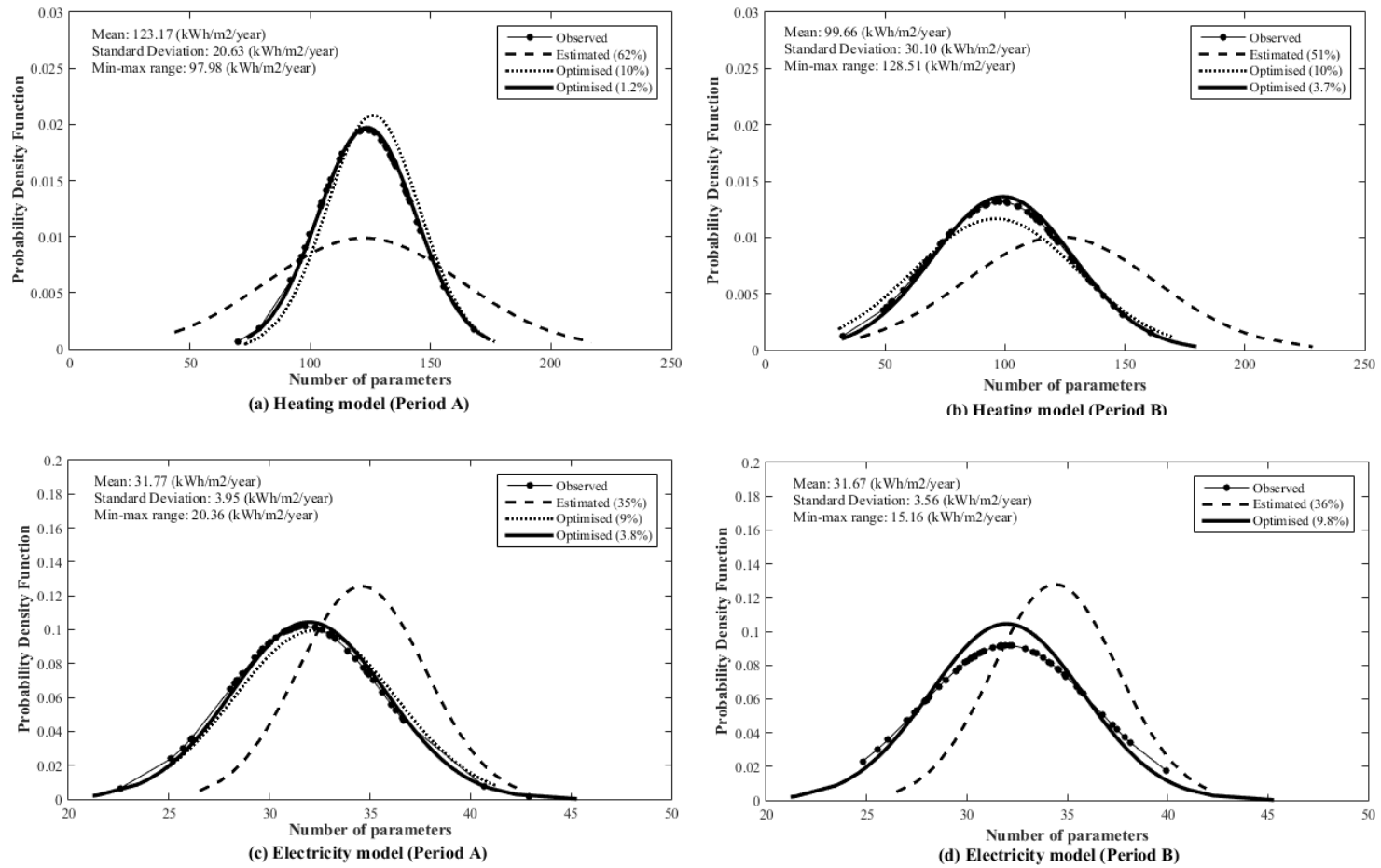

Figure 5.3. Optimisation of model estimations in comparison to the variation in actual energy consumption

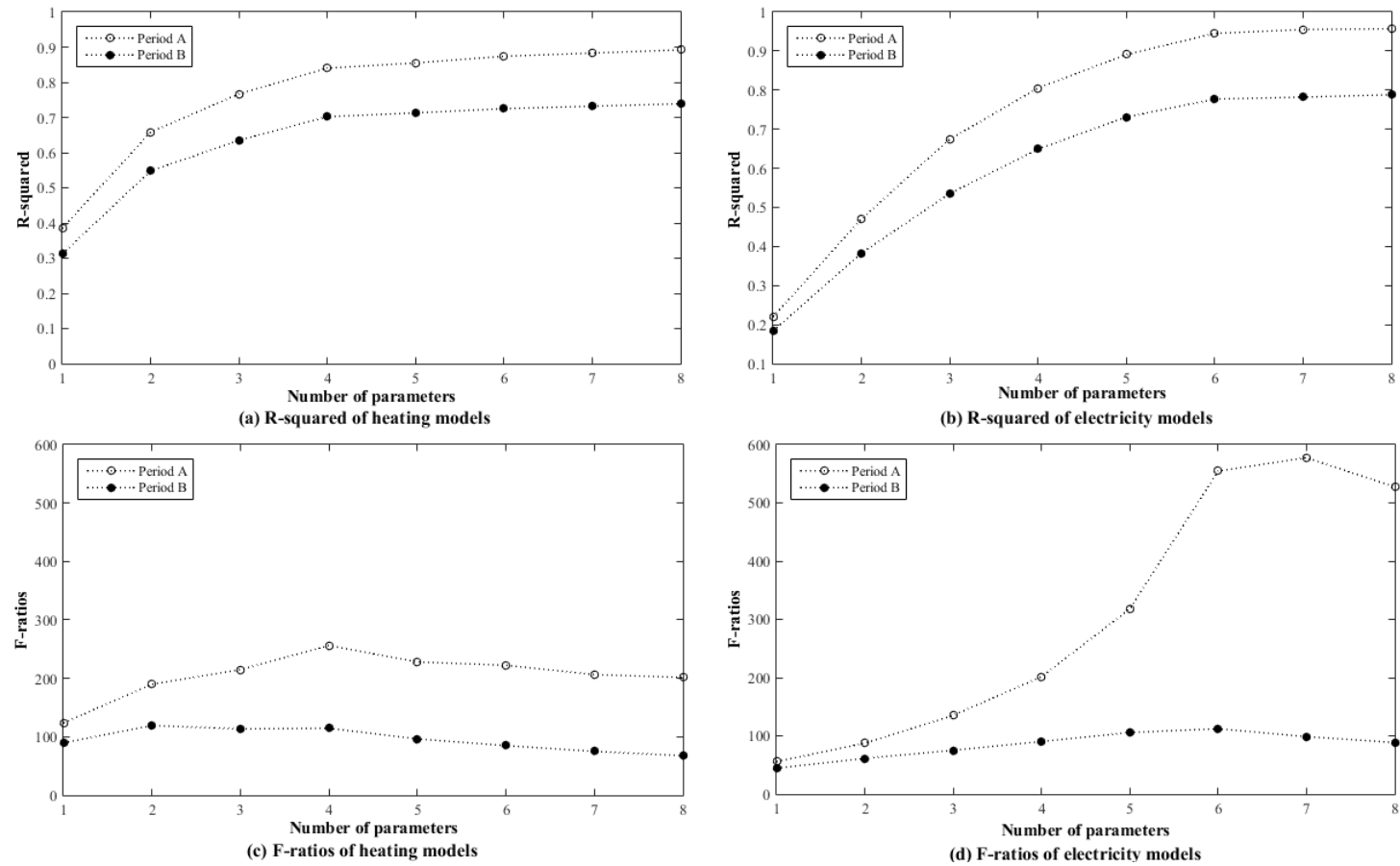

Figure 5.4. Changes in R-squared values and F-ratios of the building energy models

Diverse ranges of the input parameters in the linear models are examined for their estimation to be as close as the distribution of the actual energy consumption. As a result, the discrepancy is significantly declined with the new sets of random samples, as depicted by 'optimised' in Figure 5.3. The lowest discrepancy is achieved: 1.2% of the heating energy model for period A and 3.7% for period B. The modified electricity consumption in period A shows 3.8% of discrepancy. The discrepancy became higher to 9.8% for period B by applying the same set of the modified samples used for period A. In comparison to the previous distribution (Table 5.2), the large discrepancy in annual energy consumption is reduced by little change in daily routines. In the heating models, the range of set-point temperatures is reduced from 16 – 22 °C to 16 – 20 °C, and the operating hours are also reduced from 3 – 9 hours to 3 – 6 hours in the heating models for period A. For period B, the range of set-point temperatures is moved to 15 – 21 °C in the living room, and reduced to 16 – 21 °C in the bedroom A and C. In the electricity model, the possible ranges of operating hours of lighting and rice-cooker are extended by about 1 – 3 hours. The range of computer is moved to 0.5 – 3.5 hours. Overall, the changes in set temperatures are within 2 °C, while operating hours are revised within 3 hours from the previous distributions.

**Table 5.3. Result of multivariate regression analysis**

|                    |                                 | Period A (Before 1980)      |            |                                     | Period B (1981 – 1988)      |            |                                     |
|--------------------|---------------------------------|-----------------------------|------------|-------------------------------------|-----------------------------|------------|-------------------------------------|
|                    |                                 | Unstandardised Coefficients |            | Standardised Coefficients (p-value) | Unstandardised Coefficients |            | Standardised Coefficients (p-value) |
|                    |                                 | B                           | Std. Error |                                     | B                           | Std. Error |                                     |
| <b>Heating</b>     | Set temperatures in living room | -303.777                    | 16.520     | - (0.000)                           | -346.219                    | 26.161     | - (0.000)                           |
|                    | Heating hours in living room    | 10.070                      | 0.500      | 0.587 (0.000)                       | 10.444                      | 0.792      | 0.526 (0.000)                       |
|                    | Set temperatures in bedroomA    | 8.669                       | 0.497      | 0.504 (0.000)                       | 9.347                       | 0.787      | 0.469 (0.000)                       |
|                    | Set temperatures in bedroomC    | 5.470                       | 0.495      | 0.320 (0.000)                       | 5.651                       | 0.784      | 0.285 (0.000)                       |
|                    | Set temperatures in living room | 4.649                       | 0.492      | 0.271 (0.000)                       | 5.157                       | 0.779      | 0.260 (0.000)                       |
| <b>Electricity</b> | (Constant)                      | 15.134                      | 8.036      | - (0.000)                           | 16.546                      | 15.921     | -(0.000)                            |
|                    | Lighting in bedrooms            | 0.835                       | 0.027      | 0.527(0.000)                        | 0.740                       | 0.053      | 0.475 (0.000)                       |
|                    | Lighting in living room         | 0.755                       | 0.027      | 0.475(0.000)                        | 0.676                       | 0.053      | 0.433 (0.000)                       |
|                    | Cooling hours in living room    | 0.729                       | 0.027      | 0.459(0.000)                        | 0.597                       | 0.054      | 0.383(0.000)                        |
|                    | Operating hours of rice-cooker  | 0.544                       | 0.027      | 0.343(0.000)                        | 0.523                       | 0.054      | 0.336(0.000)                        |
|                    | Operating hours of computer     | 1.079                       | 0.055      | 0.339(0.000)                        | 1.028                       | 0.109      | 0.329(0.000)                        |
|                    | Cooling hours in bedroom A      | 0.378                       | 0.027      | 0.239(0.000)                        | 0.343                       | 0.054      | 0.220(0.000)                        |



### 5.3.2.2 Probability of energy consumption with Gaussian Process Classification

Figure 5.5 and 5-6 show that the probability of energy consumption with 25% deviation (medium class) is formed by various combinations of the influential parameters. In other words, the definition of standardised conditions can also be varied by the probability of energy consumption. All parameters linearly effect energy consumption, but they are paired depending on the relevance and the order of coefficient values for the presentation. Pairs of the parameters can be organised in different ways. However, each parameter interacts in inverse proportion in determining the probability of energy consumption. For instance, the operating hours of the living room is reduced, while the set-point temperature is increased. Hence, the distribution taken from the actual consumption can be maintained. At the same time, this interaction allows the standardised conditions flexible in determining the probability of energy consumption. In addition, impacts of the parameters shift the probability of energy consumption. This is shown by the dispersion of contour lines. Thus, wider dispersion reveals that the parameters are not significantly relevant to determine the probability of energy consumption as found in heating set-point temperatures in the bedroom A and C (

Figure 5.5 ( b)) and cooling hours (Figure 5.6 ( c)).

The 90% probability of the medium class (25% deviation) is overall formed by the range of heating set-point temperature from about 17 to 20 °C (

Figure 5.5). Heating operating hours are about 3 – 6 hours for period A, and 5 – 8 hours for period B. This range is lower than the conventional standardised conditions that include 20 or 24 °C set temperatures and its operation controlled by the set temperatures. Furthermore, the possible deterministic value of heating set temperature can be closer to 18 °C by regarding the actual energy consumption rather than 20 °C mostly used in existing literature. The conventional conditions in calculating energy demands are not perfectly out of range, but heating energy consumption can be overestimated.

Interestingly, the probability in heating consumption for period A (

Figure 5.5 (a and b)) is formed by the slightly lower values of set temperatures and operating hours, than the values for period B (

Figure 5.5 (c and d)), despite higher heating consumption of period A. This can be interpreted by realistic compromise, possibly due to the cost of energy. The medium class for period A consumes about 107 – 138 kWh/m<sup>2</sup>/year by the possible setting identified

above. However, the medium class for period B spends less heating energy between 87 and 112 kWh/m<sup>2</sup>/year with the setting above because of their relatively advanced thermal conditions, compared to period A. This reveals that occupants in period A would tactically suppress their heating controls despite the significant heat loss through building envelopes.

Electricity consumption with 90% probability is generally derived from 3 – 6 hours of ranges in operation (Figure 5.6). Specifically, lighting is possibly used from 1 to 5 hours. The rice-cooker can be operated about 9 – 14 hours in warming rice, and the computer is operated for 0.5 – 3.5 hours per day. The air-conditioner can be used for up to 6 hours during summer. The results provide more realistic operations for the appliances with intermittent operations by linking between the actual energy consumption and the national survey about using electrical appliances.

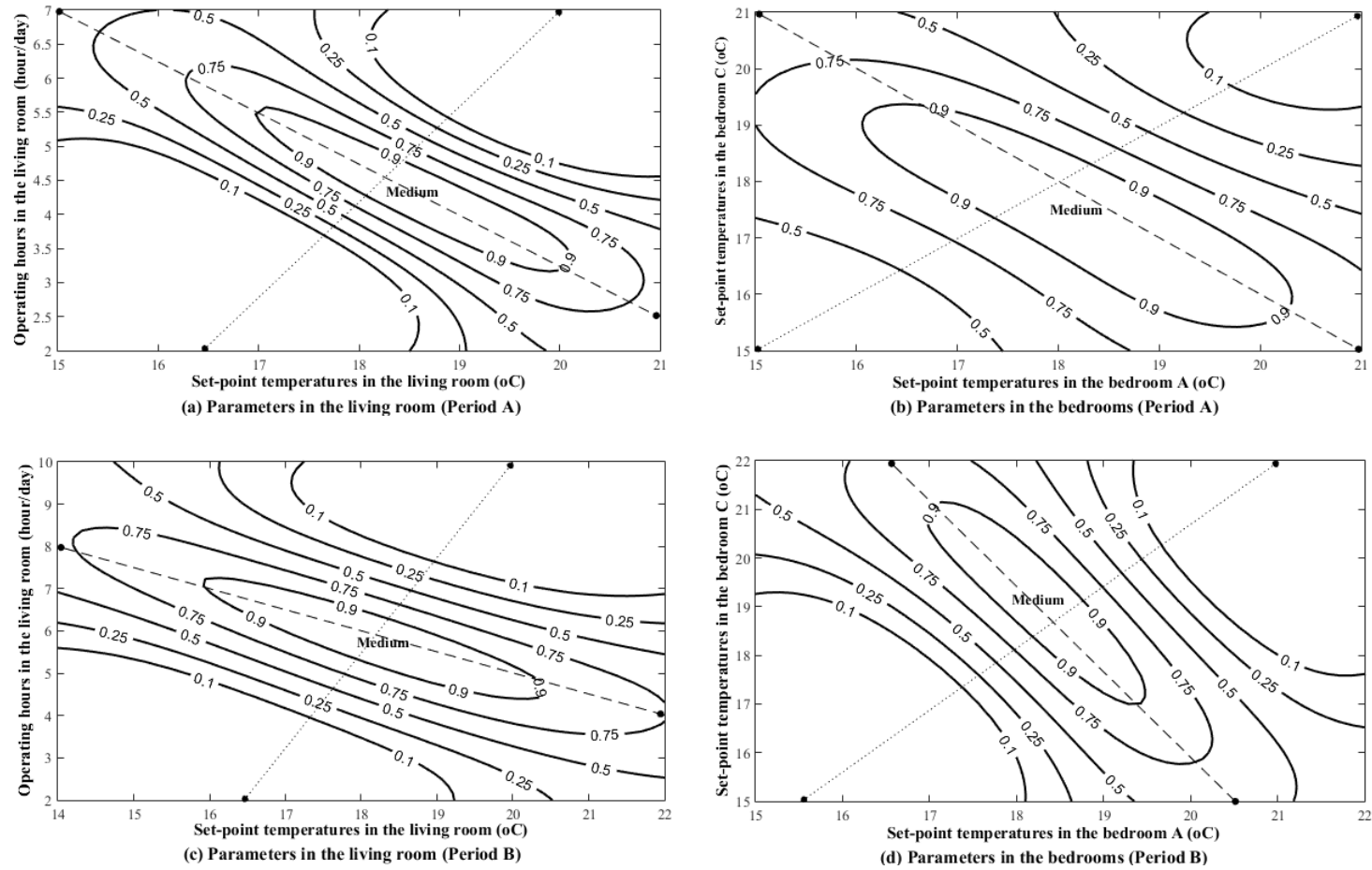

Figure 5.5. Results of Gaussian Process Classification for heating consumption

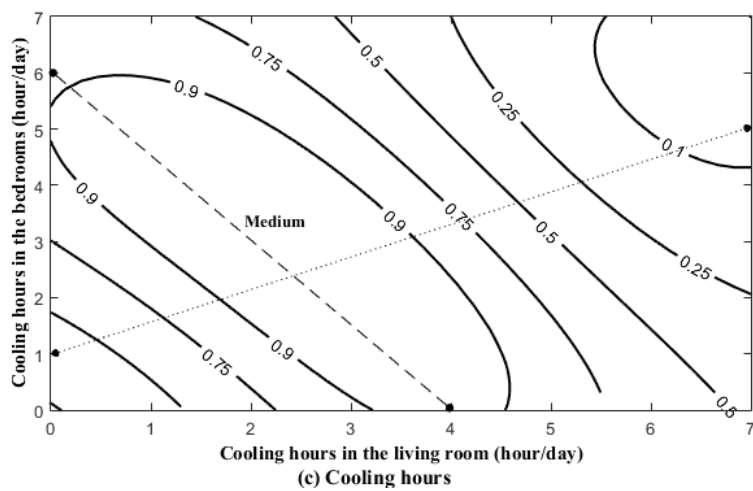
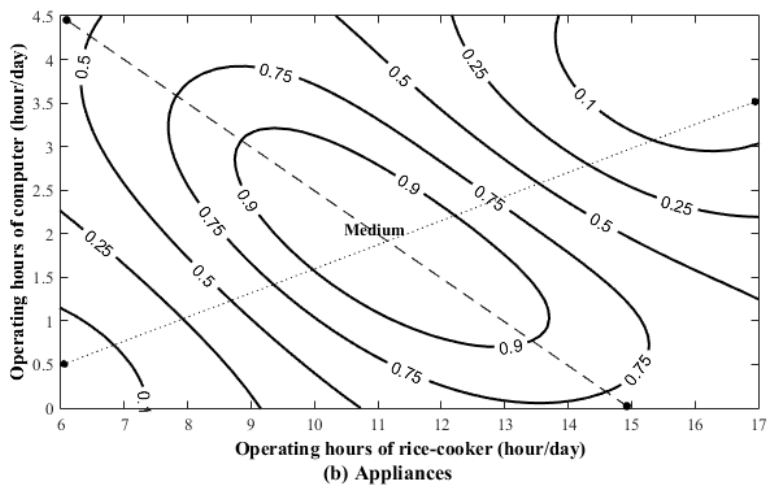
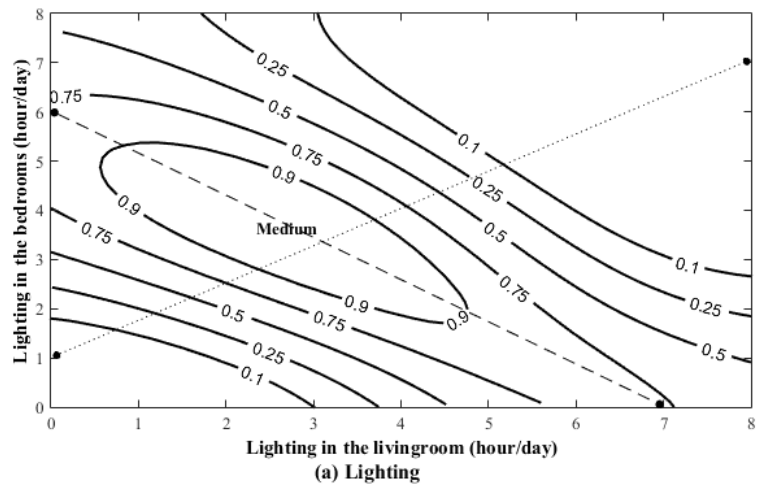
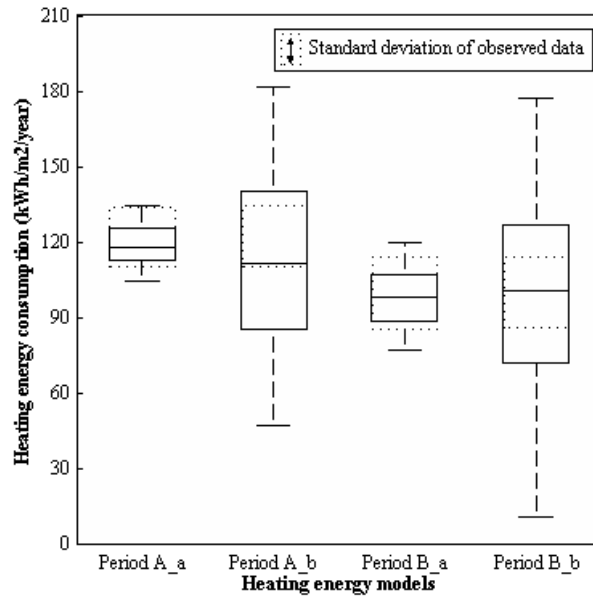

Figure 5.6. Results of Gaussian Process Classification for electricity consumption

### 5.3.3 *Evaluation of estimating energy consumption with the probability of the standardised conditions*

Energy consumption is estimated by 100 random samples with different probability: high (50 – 90%), and total probability (0 – 90%). Figure 5.7 demonstrates the comparison between the two different probabilities. The random samples with high probability (on the long-dashed lines in Figure 5.5 and 5-6) result in a much lower distribution compared to the samples with total probability (on the dotted lines). The estimated heating consumption of the samples with high probability is distributed from 104 kWh/m<sup>2</sup>/year to 136 kWh/m<sup>2</sup>/year for period A (Period A\_a in Figure 5.7), while the estimation for period B is from 76 kWh/m<sup>2</sup>/year to 119 kWh/m<sup>2</sup>/year (Period B\_a). In contrast, the samples chosen with total possibility create much extended distribution, 46 – 195 kWh/m<sup>2</sup>/year heating consumption for period A (Period A\_b) and 23 – 179 kWh/m<sup>2</sup>/year for period B (Period B\_b). In terms of electricity consumption, the samples with high probability estimate electricity consumption between 30 and 32 kWh/m<sup>2</sup>/year for both periods (Period A\_a and Period B\_a). The distribution of estimation is enlarged with total probability from about 24 to 44 kWh/m<sup>2</sup>/year. Depending on the form of the probability, combinations of random samples can be diverse, and their estimation can be different each other. However, the estimation with high probability closely represents the standard deviation identified in the actual energy consumption in each period, while the estimated consumption with total probability reflects the minimum and maximum range of the actual energy consumption.



(a) Estimated heating energy consumption

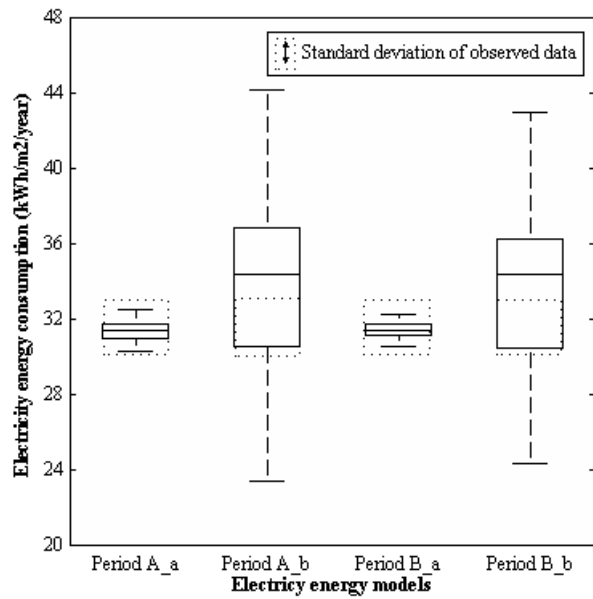

(b) Estimated electricity energy consumption

Figure 5.7. Estimated energy consumption with the probability of the standardised conditions

## 5.4 Summary

This chapter questioned the inflexible conventional modelling which disregards the various occupant random behaviour of controlling energy consumption in apartment buildings. Despite minimising variation caused by building features in the existing apartment buildings, the actual energy consumption still shows 10 – 30% deviation from average values in apartments built in the 1970s – 1980s. Moreover, the range between minimum and maximum values is much greater up to 128%. This variation reveals that deterministic values defining typical conditions in apartment buildings could provide a limited interpretation about energy consumption in these buildings. This chapter attempted to identify the probability of energy consumption in apartment buildings regarding the variation in actual energy consumption.

The probability of energy consumption with 25% deviation was drawn through Gaussian Process Classification. The updated values of input parameters represent the probability of the standardised condition in apartment buildings, according to Bayesian inference. The 90% probability of heating consumption is formed by 17 – 20°C set temperatures and 3 – 8 operating hours. 25% deviation in electricity is derived from 3 – 6 hours of ranges in operation. Compared to the values in conventional modelling, these results imply that conventional modelling may overestimate energy consumption. Overall, sets of parameter in 50 – 90% probability could achieve nearly the standard deviation, 10 – 30%, in real energy use whereas sets of parameters in total probability showed the far greater distribution of estimating energy consumption, nearly about the minimum and maximum ranges. Hence, the standardised conditions in apartment buildings can be varied depending on the probability of energy consumption.

This chapter applies the actual energy consumption and develops the probabilistic models of occupant random behaviour controlling heating and electricity in apartment buildings. It can benefit building energy models for these apartment buildings in South Korea to reduce

uncertainties caused by the variation in actual energy consumption. Furthermore, this approach will be applicable for defining realistic standard conditions in different types of buildings, based on their actual energy consumption.



### **Developing a building energy model corresponding to variation in individual apartment units in existing apartment buildings**

In Chapter 4 and 5, the variation arising from the physical characteristics and occupants' behaviours in existing apartment buildings were investigated. The scale of the main topic in this chapter scopes down from the group of apartment buildings to the group of apartment units. As identified in the literature review, variation in unit-specified energy consumption, due to the locations of apartment units, has been already well-known. However, variation caused by internal factors, especially individual heating controls in each apartment unit and their interaction through the sharing slabs, has not been regarded in the conventional building energy model. Therefore, this chapter combines the fragmented modelling approaches to integrate the variation arising from the unit locations and the internal factors for a building energy model of existing apartment buildings. The chapter consists of four sections. Section 6.1 discusses about a brief background of the conventional building energy model used for high-rise apartment buildings, and the limitation to reflect variation in individual units. Section 6.2 provides a methodology of creating two types of models; one is representing variation in the physical conditions with regard to the unit locations, and another is a numerical model of internal factors, calculating the unit-specific heating energy consumption. Section 6.3 interprets the unit-specific energy consumption and the result of the numerical model of the individual heating controls in units and interaction between floors. The final summary is indicated in Section 6.5.

## **6.1 Background**

Building energy models have been widely used in measuring thermal performance in buildings (Ingle *et al.*, 2014). It also allows the analysis of energy-efficient technologies to determine the most effective solutions in order to improve thermal performance for various types of buildings (Hong *et al.*, 2000). Due to its convenience in analysing building conditions, the approach has been commonly applied for high-rise apartment buildings.

The conventional building energy model, used for high-rise apartment buildings in the context of South Korea, has been approached as either a whole building with simplified thermal envelope or several single units in different locations such as the ground, middle and top floors (Yoo *et al.*, 2007). The whole building approach considers apartment buildings as one single building with the unified controls of building systems. The building energy model with this approach mostly focuses on improving the physical conditions of building envelope. Therefore, the model became radically simplified by only considering the physical conditions of the building envelope exposed to the outside with disregard to internal details, as shown in (Yoo *et al.*, 2007). Another approach deals with several representative units in the same building. These selected units with this approach are separately modelled and considered like a detached house. This approach provides specific energy consumption with a unit scale, but only for the selected units, based on the variation in the physical characteristics. It has been found that the primary consideration of both approaches is the physical conditions. Therefore, it is difficult to provide the comprehensive understanding of variation arising from individual apartment units. The limitations of both approaches can be described by three aspects as below.

Firstly, individual apartment units contain variation in both physical characteristics and independent controls of energy systems. The variation in the physical characteristics is mainly arisen from the vertical locations of apartment units, comprised of ten to fifteen stories in existing apartment buildings, and the horizontal locations depending on the number of units on the same floor. These variations determine the amount of surfaces exposed to the outside and the amount of solar radiation received. However, the whole building approach does not take into account these variations individually. The representative unit approach only considers these variations, but only limits to selected units.

Secondly, apartment units are interlinked by sharing slabs equipped with an under-floor heating system. The heating system, supplying heated water through the pipe lines buried in

the sharing slabs, is mainly controlled by the unit on an upper floor having the sharing slab as a floor, while the slab also effect on the unit on a lower floor having the slab as a ceiling. The interaction to indoor mean temperatures through these slabs among apartment units is identified (Choi *et al.*, 2007a). However, both modelling approaches have a limitation to take this interaction into account the energy calculation.

Lastly, human interaction controlling energy systems is one of important factors in building energy models although it is difficult to clarify (Hoes *et al.*, 2009). Heating controls in each apartment units are independently managed by unspecified occupants. However, both approaches took the standardised condition, and disregarded the possible variation by this aspect.

Building energy models, without considering actual energy consumption, tend to overestimate their outcomes in comparison to real data (Ingle *et al.*, 2014). This disparity can be an obstacle to use model estimations for practical application. In order to reduce the disparity, various building controls in households (Ingle *et al.*, 2014) and actual consumption data (Galvin, 2014b) are essentially required. The empirical study, measuring the proportional rates of heating energy consumption in apartment units, shows significant variation, which represents the necessity to be integrated into a building energy model of high-rise apartment buildings. Moreover, the variation is not thoroughly corresponded with theoretical expectation, which indicates human interaction that needs to be considered.

This chapter, therefore, aims to develop a building energy model of existing high-rise apartment buildings reflecting the variation in heating energy consumption caused by the location of units and individual heating controls, and identify the specific dataset of heating controls of apartment units in different locations. Four questions will be answered:

- What are the levels of heating energy consumption depending on the location of units and individual heating controls? Do building energy models well-reflect the targeted consumption?

- What variables in heating controls of individual apartment units influence heating energy consumption in the building energy model?
- How can those influential variables in individual apartment units be integrated in the energy model for calculating heating energy consumption?
- What are the values of those influential variables in individual apartment units for determining real energy consumption in the building energy model?

## **6.2 Methodology**

The procedure is formed by three steps: (1) measuring heating energy consumption in individual apartment units with different locations; (2) comparing the targeted consumption to the estimated energy consumption of a building energy model, based on the physical characteristics of apartment units in different locations; (3) creating a new model of unit-specific energy consumption integrating relationships with independent heating controls in units and their interactions between floors.

### **6.2.1 *Measuring heating energy consumption in apartment units with different locations***

This section intends to identify variation in heating energy consumption in individual apartment units. The unit-specific consumption data of apartment buildings has been strictly managed as private information, which was not accessible. Moreover, empirical consumption based on one or two buildings can be limited to deliver the generalised information of energy consumption in individual units. Therefore, the average heating energy consumption of existing apartment buildings with similar construction specifications, which was measured in the previous chapter (Chapter 5) was applied to the proportional rates of unit-specific heating energy consumption with different locations, surveyed by (Kang *et al.*, 1995), as presented in Table 2.5. The proportional rates could be applicable in this analysis, because of the similarity of the sampling units: construction periods,

geographical locations and the number of floors. The surveyed proportional rates were measured by apartment buildings constructed in the 1970s – 1990s in Seoul, which satisfy two sampling units used in this chapter. Besides, the proportional rates were also calculated for fifteen-story apartment buildings. Although no information on the number of floors of apartment building was indicated in (Kang *et al.*, 1995), this range (twelve to fifteen floors) can be reasonably assumed as a typical number of apartment floors in the period (Statistics Korea, 2010a). This sampling unit is also applied in this work.

The unit-specific energy consumption was generated by the proportional rates and the average energy consumption value in existing apartment buildings constructed before 1980, 123.2 kWh/m<sup>2</sup>/year (Appendix C). As identified in Section 2.3.3, vertical unit locations need to be carefully regarded in the building energy model. However, horizontal locations in the modelling resulted in much less impact on energy consumption. More significant impact could be assumed by occupants, as shown in the empirical study (Kang *et al.*, 1995). Therefore, the energy consumption in individual units in this study is generated for the vertical locations of apartment units, but the heating consumption among the three units on the same floor was used as variation in calculating mean and standard variation of energy consumption on each floor. These two values, mean and standard variation, generated the possible range of energy consumption in apartment units with different locations by using random number generator in MATLAB R2015a (The MathWorks Inc, 2015). The unit-specific heating energy consumption generated, called ‘Targeted heating energy consumption’, is shown in Section 6.3.1.

### ***6.2.2 Estimating heating energy consumption with a building energy model of high-rise apartment buildings***

High-rise apartment buildings were simplified for more efficient energy simulation. The simplified building energy model was intended to reflect not only the different locations of units but also the internal thermal interactions through the sharing slabs. Therefore, two

aspects were carefully modelled despite the simplification: vertical locations and the sharing slabs with an under-floor heating system. Firstly, the building energy model was built by 15 units on different floors as the same reasons of generating the unit-specific energy consumption in Section 6.2.1. Thus, one unit was placed on each floor of the simplified model for the fifteen-story apartment building; the east side walls are connected to the lift halls, not exposed to the outside, as described in Figure 6.1. Secondly, the sharing slabs, equipped with the under-floor hot water heating, between two apartment units were built to indicate the thermal interaction between floors. Heated water could be circulated through pipe lines buried in the sharing slab. A low temperature radiant system (Zone HVAC: Low Temperature Radiant Variable Flow) in EnergyPlus 8.0 was applied in the building simulation model.

The profiles of the simplified models are identified by four aspects: (1) unit designs; (2) thermal properties; (3) internal gains; (4) heating controls. Firstly, the same unit design (the most common type) in Chapter 5 was used (Figure 6.1). This unit consisted of heated and non-heated zones. Heated zones meant the main living area equipped with the heating system, while non-heated zones included balcony areas where no heating was provided. Thus, the non-heated zones enclosed the heated zones as a transition between indoor and outdoor environments. However, the internal walls dividing rooms were removed in this modelling to reduce the operating time for simulations. The possible difference can be less than 5%, according to (Choi *et al.*, 2007b).

Secondly, thermal properties of the building envelope were input to reflect the typical thermal conditions of apartment buildings constructed before 1980, as modelled in Chapter 5. The profile of thermal properties for apartment buildings was identified (Table 5.1). U-values of building envelopes were input as shown: external walls ( $2.08\text{W/m}^2\text{K}$ ); side walls ( $3.24\text{W/m}^2\text{K}$ ); roof ( $0.52\text{W/m}^2\text{K}$ ); floors ( $4.36\text{W/m}^2\text{K}$ ); windows ( $5.89\text{W/m}^2\text{K}$ ).

Thirdly, the details of occupants, lighting and electric appliances, were taken from the generalised conditions, identified from the actual energy consumption in Chapter 5. The number of occupants was input as four, which is the most common type of residents living in apartments. Lighting levels were identified for one apartment unit with 330.0W (Bedrooms + Livingroom) (KEPC, 1990). For electric equipment, five major appliances were input: TV (130.6W), refrigerator (40.0W), rice-cooker (143.4W – warming and 1022.9W – cooking), computer (263.3W) and Kimchi refrigerator (22.6W) (KEPC, 2013). Their daily schedules for lighting, computer and rice-cooker are taken from the results in Chapter 5. The schedules of refrigerator and Kimchi refrigerator were set 24 hours, whilst 5 hours for TV (KEPC, 2013).

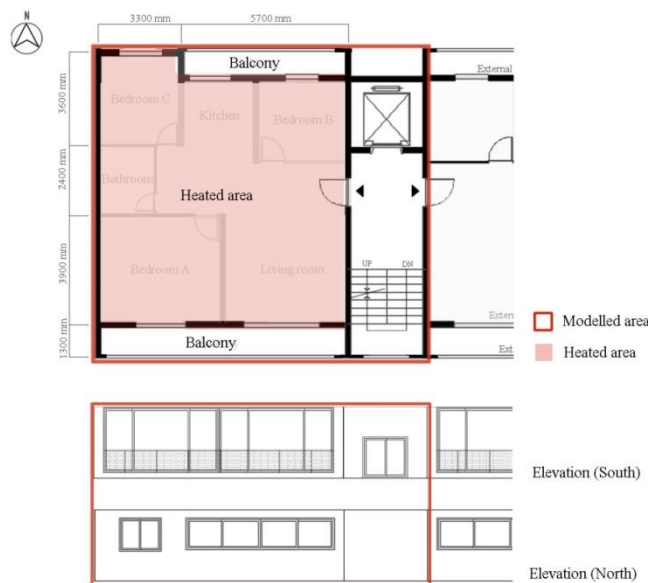

**Figure 6.1. Description of the building energy model (Source of the unit plan: Kim and Yoon, 2010)**

Fourthly, heating controls in apartment units were kept as uncertain factors, although the average controls were generalised in Chapter 5. Two factors, independently controlled in apartment units, were mainly used: heating set-point temperatures and heating hours. 18 – 20°C for heating set-point temperatures was recommended in building regulations (MLIT, 2015b), whereas heating hours have not yet been officially provided. The heating hours in



the conventional building energy models were assumed to be 24 hours, and controlled by zone mean temperatures without considering occupancy. In this chapter, uncertainty analysis was undertaken with the possible range of heating set-point temperatures from 16°C to 22°C, and heating hours from 3 hours per day to 9 hours. In total 30 independent variables (2 variables of heating controls  $\times$  15 apartment units), and 15 dependent variables, heating energy consumption in each unit, were created. 150 random samples of heating controls for individual units were generated by LHS to conduct the Monte Carlo Method, which has been widely used in many studies for uncertainty analysis (Macdonald, 2009). The sampling was managed by jEplus (Zhang, 2012), and actual simulations were conducted by EnergyPlus 8.0 (Crawley *et al.*, 2001). Historical weather file for 2014 generated for building simulations was acquired from (White Box Technologies, 2014).

### ***6.2.3 Creating a new model of unit-specific heating energy consumption***

Polynomial regression was conducted to create the new model of heating energy consumption specified by independent heating controls in individual units and their interaction between floors. This regression model is a type of multiple linear regression, but focuses one variable with curve fitting or two variables with surface fitting to improve predictions of mathematical models (Kleinbaum *et al.*, 2013). Therefore, heating energy consumption in each apartment unit can be modelled by considering two input influential variables, which are heating set-point temperatures and heating hours. Before the polynomial regression modelling, a correlation coefficient analysis was conducted to determine influential variables of heating controls for the unit-specific heating energy consumption in each apartment unit. The correlation coefficient values of independent variables were compared as they interpreted the strength of heating controls with heating energy consumption, and the directions with positive or negative values (Chen and Popovich, 2002). Heating set-point temperatures and heating hours for the 15 apartment units from the 150 samples were input as 30 independent variables. The heating energy consumption in the 15 apartment units were as 15 dependent variables. Pearson's correlation coefficient (Chen and

Popovich, 2002) was applied to measure the linear correlations of heating controls with heating energy consumption in the apartment units on the 15 floors. SPSS version 22.0 (Field, 2009) was used for calculation. The correlation analysis is interpreted in Section 6.3.2.

Based on the correlation coefficient analysis, polynomial models were created by polynomial surface fitting in the Curve Fitting Toolbox in MATLAB R2015a (The MathWorks Inc, 2015). The procedure of polynomial regression minimises the sum of squares of deviation from corresponding points (Kleinbaum *et al.*, 2013). Therefore, the goodness of fit in the polynomial models were measured by the coefficient of determination (R-squared values), representing how much data can be explained by polynomial models, and the sum of squared errors, indicating how much data cannot be fitted into the models.

The polynomial models in this chapter were defined by two conditions: heating controls in apartment units and heating set-point temperatures between floors. Two different orders of polynomial models were applied: binary linear model (Model 1 and I) and binary quadratic polynomial models (Model 2, 3, II and III). For heating controls in apartment units, heating set-point temperatures and heating hours in apartment units where heating was controlled were considered with Model 1 – 3. Due to the model for each apartment unit disconnected with other floors, the possible interaction with other floors was disregarded in these polynomial regression models.

$$f_i = A + B \times x_i + C \times y_i \quad (\text{Model 1}) \quad (6-1)$$

$$f_i = A + B \times x_i + C \times y_i + D \times x_i^2 + E \times x_i \times y_i \quad (\text{Model 2}) \quad (6-2)$$

$$f_i = A + B \times x_i + C \times y_i + D \times x_i \times y_i + E \times y_i^2 \quad (\text{Model 3}) \quad (6-3)$$

$f_i$ : Heating energy consumption (kWh/m<sup>2</sup>/year)

$x_i$ : Heating set-point temperatures in a unit (°C)

$y_i$ : Heating hours in a unit (hour/day)

$A, B, C, D$  and  $E$  : Unknown parameters in polynomial models

The interaction of heating controls between floors, arising from heat transfer on the shared slabs, was considered with Model I – III. Heating set-point temperatures on two floors were comprised of the polynomial model of each floor. Therefore, the models of apartment units are interlinked with each other. For example, heating set-point temperatures on the second floor can be a variable for both models on the ground and second floors. The goodness of fits is evaluated in Section 6.3.3, and the model estimation is examined in Section 6.3.4.

$$f_i = A + B \times x_i + C \times x_{i+1} \quad (\text{Model I}) \quad (6-4)$$

$$f_i = A + B \times x_i + C \times x_{i+1} + D \times x_i^2 + E \times x_i \times x_{i+1} \quad (\text{Model II}) \quad (6-5)$$

$$f_i = A + B \times x_i + C \times x_{i+1} + D \times x_i \times x_{i+1} + E \times x_{i+1}^2 \quad (\text{Model III}) \quad (6-6)$$

$f_i$ : Heating energy consumption (kWh/m<sup>2</sup>/year)

$x_i$ : Heating set-point temperatures in a unit (°C)

$A, B, C, D$  and  $E$ : Unknown parameters in polynomial models

### 6.3 Results

The results are described in four sections to address the four research questions. Section 6.3.1 interprets the measured unit-specific heating energy consumption, and compares this to the estimated consumption with the building energy model, focused on the physical conditions arising from the individual unit locations. Section 6.3.2 analyses the most influential variables of the simplified building energy model, correlated with heating energy consumption in each apartment unit. Section 6.3.3 scrutinises polynomial regression models for the unit-specific heating energy consumption by regarding individual heating controls in each unit. In addition, the sensitivity analysis of the heating controls in each unit in the polynomial models is illustrated. Section 6.3.4 identifies the new dataset of heating controls

in the 15 apartment units for the simplified model, and evaluates the dataset of heating controls in building simulation.

### 6.3.1 *Heating energy consumption in individual apartment units*

The quantified heating energy consumption with different unit locations demonstrates the prominent variation, compared to the average value, 123.2 kWh/m<sup>2</sup>/year, as shown in Figure 6.2 (a). Above all, higher heating energy consumption on the ground and top floors caused by the physical conditions is clearly quantified. Heating energy consumption on the ground and top floors is enlarged to 179.3 kWh/m<sup>2</sup>/year and 160.2 kWh/m<sup>2</sup>/year, respectively. The disparities of these are 45% and 37% (56.1 and 37.6 kWh/m<sup>2</sup>/year), compared to the average value. However, heating energy consumption is decreased in accordance with higher floors from the 1<sup>st</sup> to the 13<sup>th</sup> floors. The total amount of heating energy decreased from the 1<sup>st</sup> to the 13<sup>th</sup> floors is about 50 kWh/m<sup>2</sup>/year, which is as great as the disparity of the ground floor, compared to the average value. Another variation in heating energy consumption on the same floor, generated by variation in the three units on the same floor, is also significant. The average standard deviation of heating consumption in apartment units on the same floors is 9.13 kWh/m<sup>2</sup>/year. The greatest standard deviation is identified on the 12<sup>th</sup> floor with 21.7 kWh/m<sup>2</sup>/year, which is more significant than the ground floor with 16.0 kWh/m<sup>2</sup>/year. The smallest standard deviation is found on the upper (13<sup>th</sup> floor with a nearly zero value) and lower floors (the 11<sup>th</sup> floor with 4.0 kWh/m<sup>2</sup>/year) of the 12<sup>th</sup> floor.

However, the simplified building energy model, focusing on the physical conditions arising from the individual units, shows its limited interpretation of reflecting the identified variation from the measured heating energy consumption, as illustrated in Figure 6.2 (b). Higher energy consumption on the ground and top floors is roughly found although the specific values are different with significant uncertainties. Therefore, a new model

integrating individual heating controls in each apartment units needs to improve the model estimation as well as reduce uncertainties in the building energy model.

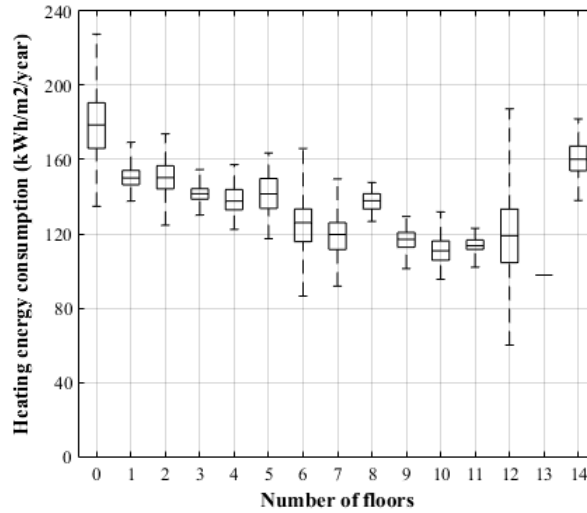

(a) Targeted heating energy consumption

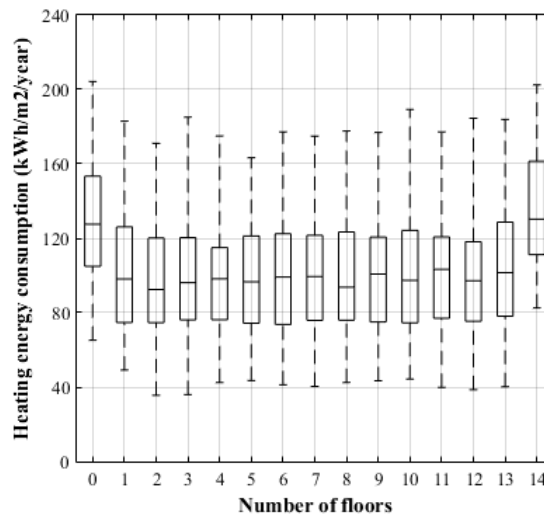

(b) Estimated heating energy consumption

**Figure 6.2.** Comparison between the targeted heating energy consumption and the estimation of the simplified energy model for the 15 apartment units on different floors: (a) Targeted heating energy consumption, (b) Estimated heating energy consumption

### 6.3.2 *Influence of variables in heating controls on the unit-specific heating energy consumption in the building energy model*

How significant the heating controls in apartment units are related to the unit-specific heating energy consumption in the building energy model is identified by correlation

coefficients. As shown in Figure 6.4 (a), both variables, heating set-point temperatures and heating hours in units where the heating is on, are significantly correlated, but the impact of the variables from upper and lower floors also shows their considerable correlation.

As can be expected, heating set-point temperatures and heating hours in apartment units increase heating energy consumption with positive correlation coefficient values. The most significant correlation coefficient value is heating set-point temperatures with the overall correlation coefficients between 0.70 and 0.90, indicating the high dependence of heating energy consumption. The operating hours of heating is followed with moderate correlation coefficients values between 0.25 and 0.50. These results show that heating consumption is mostly determined by heating set-point temperatures, but it also somewhat affected by the number of operating hours in the building energy model.

However, heating energy consumption on the 3<sup>rd</sup> and 5<sup>th</sup> floors shows valid correlation not with heating hours, but with heating set-point temperatures on an upper floor (4<sup>th</sup> and 6<sup>th</sup> floors). The heating controls on upper and lower floors impacts on reducing heating energy consumption in a unit in-between with negative correlation coefficient values. The overall correlation coefficient values of this variable for the 15 apartment units are between -0.20 and -0.30. Apartment units which do not have a valid correlation with heating hours demonstrate greater correlation coefficients with this variable. The interlinked relationships of heating controls between floors through the shared slabs are shown through this correlation.

In summary, heating energy consumption in this building energy model is highly associated with heating set-point temperatures in apartment units. However, operating hours of heating in units and heating temperature controls on an upper floor are also important variables for heating energy consumption, as summarised in Figure 6.4 (b).

### 6.3.3 *Polynomial models integrating heating controls and interaction between floors*

The correlation coefficient analysis indicates two correlated conditions for the unit-specific heating energy consumption. One is heating controls in apartment units where heating is operating, another is heating set-point temperatures between floors. These two conditions are integrated into the polynomial regression models to be used for further predictions (Figure 6.3): heating controls in each apartment unit (dotted line with empty dots) and heating set-point temperatures between floors (solid line with solid dots). The polynomial models of both conditions show high levels of R-squared values between 0.6 and 0.9. The R-squared values of polynomial models with heating controls in apartment units are slightly higher than the models with heating set-point temperatures between floors. However, the difference is not significant enough to disregard one of the conditions. The detailed analyses of both conditions are separately interpreted in Section 6.3.3.1 and 6.3.3.2.

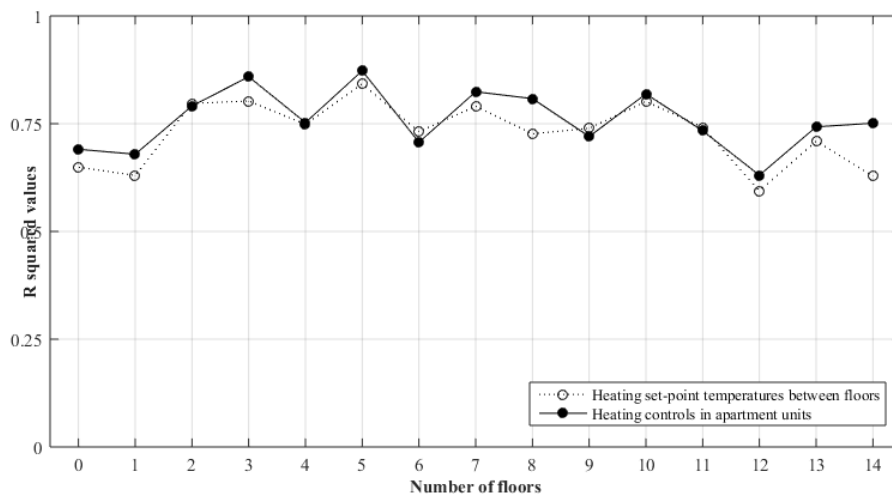

**Figure 6.3 R-squared values of polynomial models: heating controls in apartment units (solid line with solid dots) and heating set temperatures between two floors (dotted line with empty dots)**

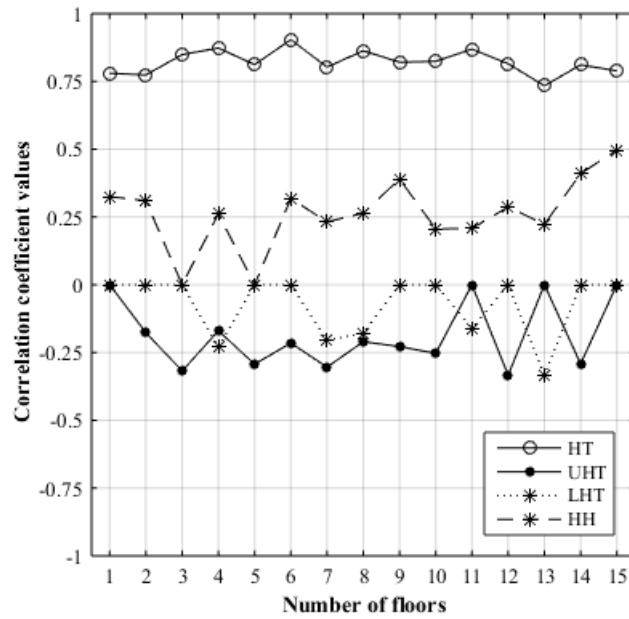

(a) Correlation coefficient analysis by number of floors

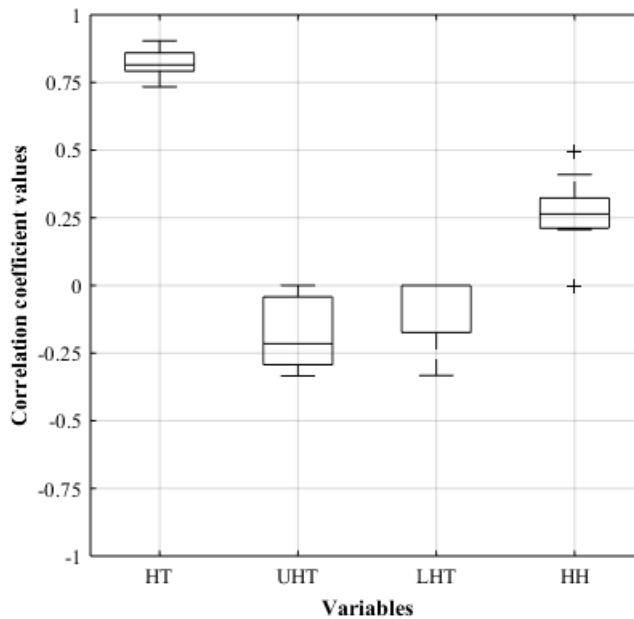

(b) Correlation coefficient analysis by variables

Figure 6.4. Results of correlation coefficients analysis: (a) correlation coefficient values of variables on different floors and (b) correlation coefficient values of variables HT (Heating set-point temperature in apartment units), UHT (Heating set-point temperature in apartment units on an upper floor), LHT (Heating set-point temperature in apartment units on a lower floor), and HH (Heating hours in apartment units)



### 6.3.3.1 Polynomial models of heating controls

This section, firstly, evaluates the goodness of fit in the polynomial models of heating controls in apartment units (Model 1, 2 and 3). Secondly, the sensitivity analysis of the independent variables in the models is interpreted. Different values are determined for the unknown parameters of the models depending on the locations of apartment units (Table 6.1 and 6.2).

The R-squared of polynomial models for the 15 floors are, overall, between 0.6 and 0.9, indicating the robust interpretations of the unit-specific heating energy consumption. The sum of squared errors, which is the reverse trend of R-squared values, is 33,200 in the polynomial models on average. However, the goodness of fit is not significantly different in the different order of polynomial models (Model 1, 2 and 3), as shown in Figure 6.5. The ground, 2<sup>rd</sup>, 8<sup>th</sup> and 11<sup>th</sup> floors show slightly higher R-squared values with Model 3, but the difference is not significant with less than 0.05 R-squared values. Besides, the difference in the sum of squared errors is also small with about 5% on average errors.

The sensitivity analysis is measured on the apportioned uncertainties of two variables, heating set-point temperatures and heating hours in apartment units, when the outcome  $f_i$  is fixed with the targeted heating energy consumption in the polynomial models (Model 1, 2 and 3) (Figure 6.6). Above all, inverse proportion is prominently identified between heating hours and heating set-point temperatures. Average heating set-point temperature is gradually reduced from 22°C to 15°C by increasing heating hours from one to 12 hours. The standard deviation of heating set-point temperatures is also reduced, whilst heating hours are increased from one hour to seven hours of heating. However, the standard deviation is increased again, while heating hours are increased from eight hours to twelve hours. Hence, the least standard deviation is found by seven and eight hours of heating with 0.9°C. The distribution of heating set-point temperatures with these two heating hours is located

between 18°C and 20°C, which are commonly used as standard heating set-point temperatures (MLIT, 2015b).

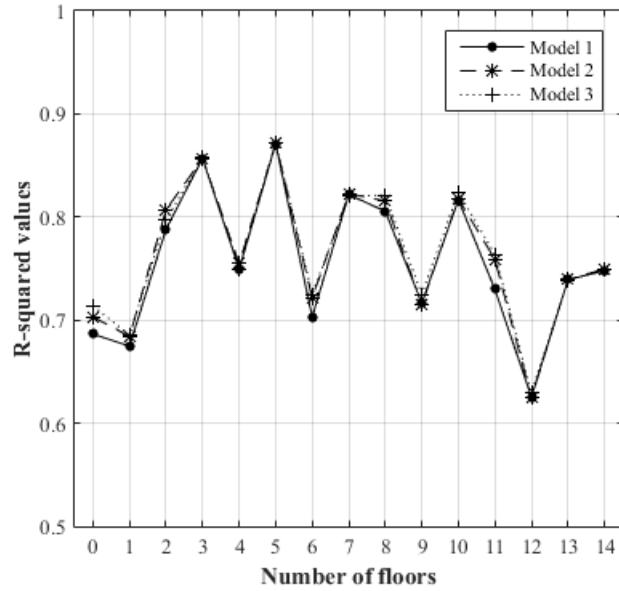

(a) R-squared values of polynomial models

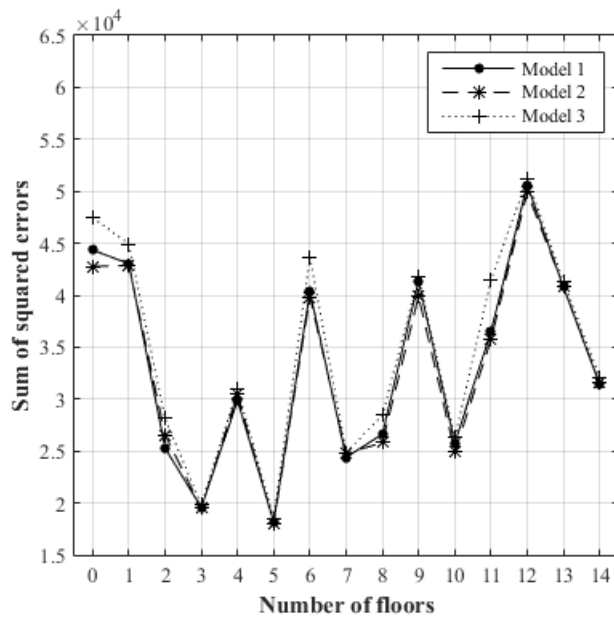

(b) Sum of squared errors of polynomial models

Figure 6.5. Goodness of fit for heating controls of 15 apartment units: (a) R-squared values of 15 units on different floors, (b) Sum of squared errors of 15 models for units on different floors

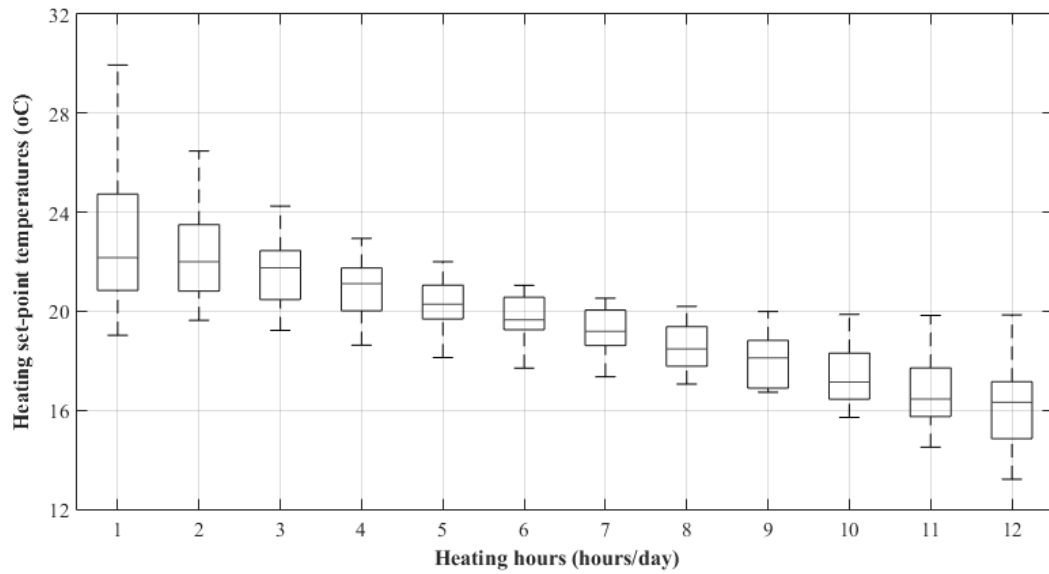

**Figure 6.6. Estimation of heating set-point temperatures by heating hours in heating consumption**

**Table 6.1. Binary linear model of 15 apartment units**

|                | $f_i = A + B \times x_i + C \times y_i$ |       |       |
|----------------|---|-------|-------|
|                | A                                       | B     | C     |
| <b>Unit 1</b>  | -193.9                                  | 15.51 | 7.090 |
| <b>Unit 2</b>  | -204.5                                  | 14.75 | 6.662 |
| <b>Unit 3</b>  | -245.3                                  | 16.86 | 6.202 |
| <b>Unit 4</b>  | -257.5                                  | 17.25 | 7.359 |
| <b>Unit 5</b>  | -229.9                                  | 15.82 | 6.988 |
| <b>Unit 6</b>  | -251.0                                  | 17.38 | 5.711 |
| <b>Unit 7</b>  | -229.9                                  | 16.14 | 6.088 |
| <b>Unit 8</b>  | -246.0                                  | 16.84 | 6.731 |
| <b>Unit 9</b>  | -243.2                                  | 16.13 | 8.941 |
| <b>Unit 10</b> | -227.7                                  | 16.36 | 4.996 |
| <b>Unit 11</b> | -251.9                                  | 17.38 | 6.102 |
| <b>Unit 12</b> | -236.4                                  | 16.46 | 6.526 |
| <b>Unit 13</b> | -208.0                                  | 14.70 | 7.164 |
| <b>Unit 14</b> | -227.6                                  | 15.89 | 7.447 |
| <b>Unit 15</b> | -154.5                                  | 13.42 | 8.318 |

**Table 6.2. Binary quadratic models of 15 apartment units**

|                | $f_i = A + B \times x_i + C \times y_i + D \times x_i^2 + E \times x_i \times y_i$ |        |        |          |        | $f_i = A + B \times x_i + C \times y_i + D \times x_i \times y_i + E \times y^2$ |       |        |        |          |
|----------------|--|--------|--------|----------|--------|--|-------|--------|--------|----------|
|                | A  | B      | C      | D        | E      | A  | B     | C      | D      | E        |
| <b>Unit 1</b>  | -7.184   | 6.396  | -34.3  | -0.05368 | 2.24   | 58.86  | 4.614 | -55.79 | 2.205  | 2.213    |
| <b>Unit 2</b>  | -7.803   | 2.239  | -35.8  | 0.09952  | 1.757  | -55.29   | 5.729 | -19.08 | 1.793  | -0.7388  |
| <b>Unit 3</b>  | 377  | -42.12 | -25.42 | 1.361    | 1.714  | -93.35   | 9.104 | -26    | 1.544  | 0.3867   |
| <b>Unit 4</b>  | -179   | 12.2   | -4.933 | 0.04598  | 0.655  | -180.8   | 13.74 | -9.867 | 0.6729 | 0.459    |
| <b>Unit 5</b>  | 209.9  | -27.46 | .10.24 | 1.046    | 0.9399 | -130.7   | 11.44 | -17.05 | 0.8914 | 0.7514   |
| <b>Unit 6</b>  | -102.4   | 4.209  | -5.523 | 0.2745   | 0.6095 | -171.6   | 14.1  | -14.77 | 0.6675 | 0.816    |
| <b>Unit 7</b>  | 252  | -26.06 | -31.95 | 0.861    | 2.08   | -17.92   | 6.919 | -47.24 | 1.902  | 1.849    |
| <b>Unit 8</b>  | 37.09  | -11.69 | -1.937 | 0.7086   | 0.4736 | -205.9   | 14.69 | -1.508 | 0.4394 | 0.008316 |
| <b>Unit 9</b>  | -78.3  | 6.78   | -22.7  | 0.02074  | 1.719  | -56.6  | 8.034 | -37.4  | 1.642  | 1.608    |
| <b>Unit 10</b> | -198.5   | 17.04  | -9.503 | -0.1226  | 0.7883 | -105.8   | 12.42 | -31.76 | 0.846  | 2.123    |
| <b>Unit 11</b> | -118.9   | 7.501  | -10.51 | 0.1458   | 0.8929 | -122   | 12.52 | -28.38 | 0.9475 | 1.682    |
| <b>Unit 12</b> | 245.8  | -23.76 | -40.07 | 0.7542   | 2.537  | 52.12  | 3.179 | -63.02 | 2.751  | 1.884    |
| <b>Unit 13</b> | 14.16  | -4.816 | -9.602 | 0.4047   | 0.901  | -79.5  | 9.807 | -26.58 | 0.953  | 1.602    |
| <b>Unit 14</b> | -46.61   | 0.5806 | -8.269 | 0.2951   | 0.8525 | -145.5   | 11.13 | -7.579 | 0.9198 | -0.2162  |
| <b>Unit 15</b> | -274.9   | 31.44  | -9.575 | -0.6167  | 0.9599 | -86.88   | 8.912 | -1.886 | 0.9188 | -0.695   |

### 6.3.3.2 Polynomial models of interaction between floors

The unknown parameters of the polynomial models are determined, whilst heating hours are limited to seven and eight hours (Table 6.3, 6.4 and 6.5). The model with seven heating hours shows higher R-squared values of polynomial models with lower values of errors than the models with eight hours of heating (Figure 6.7). Five floors with seven hours of heating have an R-squared value higher than 0.9, but none of floors with 8 hours of heating has R-squared value over 0.9 (Figure 6.7(a)). The difference in the sum of squared error between two models is more outstanding (Figure 6.7(b)). All floors with eight heating hours show the greater sum of squared errors, between 33,000 and 110,000, than the values with seven heating hours only between 11,000 and 53,000.

The three types of polynomial models (Model I - III) with heating set-point temperatures between floors do not indicate significant differences in terms of goodness of fit (Figure 6.7). However, the sensitivities between independent variables can be differently

determined by the types of polynomial models. Figure 6.8 and 6.9 illustrate the sensitivity analysis of heating set-point temperatures between floors with seven and eight hours of heating, respectively. The sensitivities of heating set-point temperatures are linearly overlapped from 18°C to 22°C of heating set-point temperatures in units with the three polynomial models. Specifically, the linearly overlapping parts are identified between 18°C to 20°C with seven hours of heating (Figure 6.8) while the part is shifted to 19°C to 22°C with eight heating hours (Figure 6.9). In this range, about 5°C of heating set-point temperatures on an upper floor is increased in 2°C increases of heating set-point temperatures in apartment units on a lower floor. However, the sensitivities analysis between the 13<sup>th</sup> and top floors shows the greater increase of heating set-point temperatures, with about 10°C.

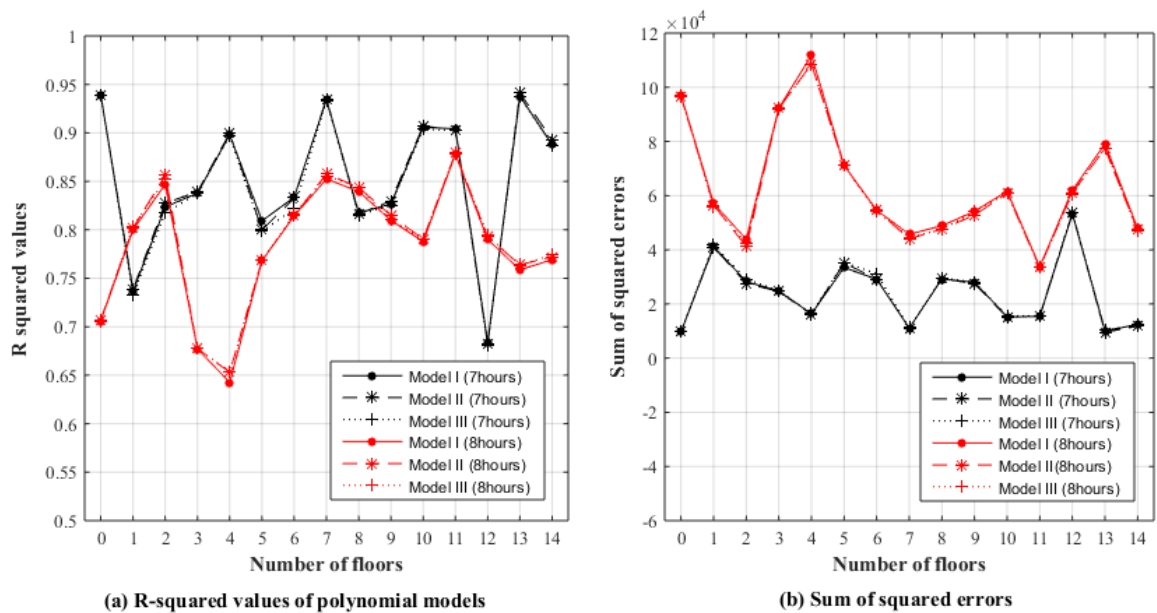

Figure 6.7. R-squared values and sum of squared errors of polynomial models

**Table 6.3. Binary linear models of 15 apartment units with 7 and 8 heating hours**

|                | 7 hours |       |        | 8 hours |       |        |
|----------------|---------|-------|--------|---------|-------|--------|
|                | A       | B     | C      | A       | B     | C      |
| <b>Unit 1</b>  | -97.1   | 20.05 | -7.175 | -38.9   | 18.27 | -8.139 |
| <b>Unit 2</b>  | -131.1  | 17.63 | -4.817 | -113.7  | 20.24 | -8.220 |
| <b>Unit 3</b>  | -112.8  | 18.55 | -6.900 | -150.7  | 20.51 | -6.726 |
| <b>Unit 4</b>  | -124.0  | 18.69 | -6.435 | -136.0  | 18.80 | -5.780 |
| <b>Unit 5</b>  | -145.5  | 19.46 | -6.057 | -91.0   | 17.54 | -6.860 |
| <b>Unit 6</b>  | -124.7  | 18.39 | -6.058 | -99.6   | 19.66 | -8.513 |
| <b>Unit 7</b>  | -100.4  | 18.59 | -7.516 | -133.0  | 2.22  | -7.289 |
| <b>Unit 8</b>  | -146.1  | 20.09 | -6.594 | -96.4   | 19.79 | -8.764 |
| <b>Unit 9</b>  | -119.5  | 18.62 | -6.525 | -167.7  | 21.14 | -6.357 |
| <b>Unit 10</b> | -134.8  | 18.77 | -5.847 | -92.4   | 19.86 | -9.032 |
| <b>Unit 11</b> | -120.9  | 19.35 | -7.145 | -132.0  | 19.79 | -6.866 |
| <b>Unit 12</b> | -165.9  | 19.96 | -5.373 | -116.7  | 20.84 | -8.703 |
| <b>Unit 13</b> | -26.4   | 15.47 | -8.229 | -111.8  | 19.38 | -7.480 |
| <b>Unit 14</b> | -168.7  | 20.37 | -5.634 | -123.4  | 19.39 | -6.988 |
| <b>Unit 15</b> | -94.8   | 16.54 | -3.322 | -69.4   | 16.24 | -3.996 |

**Table 6.4. Binary quadratic models (degree 2x1) of 15 apartment units with 7 and 8 heating hours**

|                | 7 hours |        |         |        |        | 8 hours |        |         |        |        |
|----------------|---------|--------|---------|--------|--------|---------|--------|---------|--------|--------|
|                | A       | B      | C       | D      | E      | A       | B      | C       | D      | E      |
| <b>Unit 1</b>  | -72.4   | 18.44  | -8.163  | 0.016  | 0.052  | 131.6   | -0.35  | -7.760  | 0.498  | -0.015 |
| <b>Unit 2</b>  | 237.7   | -19.77 | -6.724  | 0.929  | 0.109  | 129.8   | -4.16  | -9.556  | 0.610  | 0.064  |
| <b>Unit 3</b>  | 529.3   | -37.01 | -19.540 | 1.129  | 0.671  | -130.1  | 0.70   | 10.640  | 0.978  | -0.916 |
| <b>Unit 4</b>  | 67.2    | -1.25  | -6.772  | 0.517  | 0.016  | -84.7   | 17.25  | -9.653  | -0.061 | 0.205  |
| <b>Unit 5</b>  | -31.8   | 2.30   | -1.054  | 0.584  | -0.265 | 397.1   | -8.88  | -31.910 | 0.043  | 1.314  |
| <b>Unit 6</b>  | -120.8  | 11.96  | -0.213  | 0.325  | -0.308 | -144.5  | 19.62  | -3.803  | 0.122  | -0.245 |
| <b>Unit 7</b>  | 409.1   | -8.17  | -33.590 | 0.018  | 1.351  | -175.9  | 21.58  | -4.128  | 0.047  | -0.168 |
| <b>Unit 8</b>  | -136.1  | 13.36  | -0.987  | 0.329  | -0.301 | 152.0   | -12.04 | -3.319  | 0.985  | -0.295 |
| <b>Unit 9</b>  | 97.2    | -0.12  | -10.660 | 0.385  | 0.215  | 275.0   | -17.84 | -14.560 | 0.806  | 0.443  |
| <b>Unit 10</b> | -338.5  | 44.72  | -10.020 | -0.789 | 0.215  | 116.1   | -9.81  | -1.720  | 0.969  | -0.379 |
| <b>Unit 11</b> | 52.2    | -3.52  | -2.636  | 0.726  | -0.246 | -353.9  | 31.43  | 4.941   | 0.002  | -0.621 |
| <b>Unit 12</b> | -145.2  | 19.73  | -7.241  | -0.043 | 0.097  | -47.5   | 9.42   | -4.714  | 0.403  | -0.208 |
| <b>Unit 13</b> | 27.1    | 16.02  | -14.420 | -0.173 | 0.324  | 98.5    | -5.52  | -5.036  | 0.718  | -0.126 |
| <b>Unit 14</b> | -18.6   | -1.74  | 0.353   | 0.738  | -0.312 | 440.0   | -27.22 | -20.380 | 0.873  | 0.717  |
| <b>Unit 15</b> | 226.7   | -15.25 | -5.440  | 0.785  | 0.101  | 75.6    | -2.73  | -0.527  | 0.591  | -0.183 |

**Table 6.5. Binary quadratic models (degree 1x2) of 15 apartment units with 7 and 8 heating hours**

|                | 7 hours |       |         |        |        | 8 hours |       |         |        |        |
|----------------|---------|-------|---------|--------|--------|---------|-------|---------|--------|--------|
|                | A       | B     | C       | D      | E      | A       | B     | C       | D      | E      |
| <b>Unit 1</b>  | -26.7   | 19.35 | -13.930 | 0.036  | 0.160  | -4.2    | 18.18 | -11.730 | 0.004  | 0.093  |
| <b>Unit 2</b>  | -418.7  | 18.24 | 25.420  | -0.048 | -0.077 | 191.2   | 20.41 | -40.850 | -0.006 | 0.862  |
| <b>Unit 3</b>  | -164.4  | 6.65  | 10.600  | 0.634  | -0.779 | -373.6  | 36.81 | 0.468   | -0.860 | 0.238  |
| <b>Unit 4</b>  | -184.2  | 17.57 | 1.113   | 0.057  | -0.227 | 46.5    | 14.54 | -20.900 | 0.227  | 0.285  |
| <b>Unit 5</b>  | -345.4  | 24.78 | 9.778   | -0.280 | -0.277 | 339.7   | -6.93 | -27.760 | 1.299  | -0.102 |
| <b>Unit 6</b>  | 284.9   | 22.61 | -53.710 | -0.231 | 1.369  | -242.8  | 23.86 | 2.414   | -0.222 | -0.176 |
| <b>Unit 7</b>  | 526.0   | -7.32 | -46.770 | 1.338  | 0.353  | -422.7  | 24.37 | 19.410  | -0.225 | -0.591 |
| <b>Unit 8</b>  | -155.0  | 25.57 | -11.300 | 0.284  | 0.265  | -547.0  | 29.58 | 29.150  | -0.515 | -0.741 |
| <b>Unit 9</b>  | 168.2   | 13.92 | -32.270 | 0.246  | 0.554  | -325.8  | 13.14 | 18.600  | 0.418  | -0.863 |
| <b>Unit 10</b> | -170.6  | 14.17 | 2.615   | 0.243  | -0.344 | -186.0  | 24.51 | -3.844  | -0.246 | -0.013 |
| <b>Unit 11</b> | -401.4  | 24.27 | 17.660  | -0.258 | -0.524 | -360.9  | 31.44 | 5.672   | -0.618 | -0.021 |
| <b>Unit 12</b> | 63.4    | 17.81 | -27.260 | 0.100  | 0.525  | -44.4   | 23.23 | -18.820 | -0.125 | 0.328  |
| <b>Unit 13</b> | 303.5   | 8.63  | -36.540 | 0.370  | 0.561  | -524.4  | 23.49 | 32.090  | -0.214 | -0.934 |
| <b>Unit 14</b> | -332.9  | 26.48 | 5.480   | -0.319 | -0.131 | -223.7  | 9.96  | 13.240  | 0.499  | -0.781 |
| <b>Unit 15</b> | -64.0   | 13.51 | -3.478  | 0.157  | -0.075 | -476.0  | 22.91 | 32.690  | -0.361 | -0.788 |

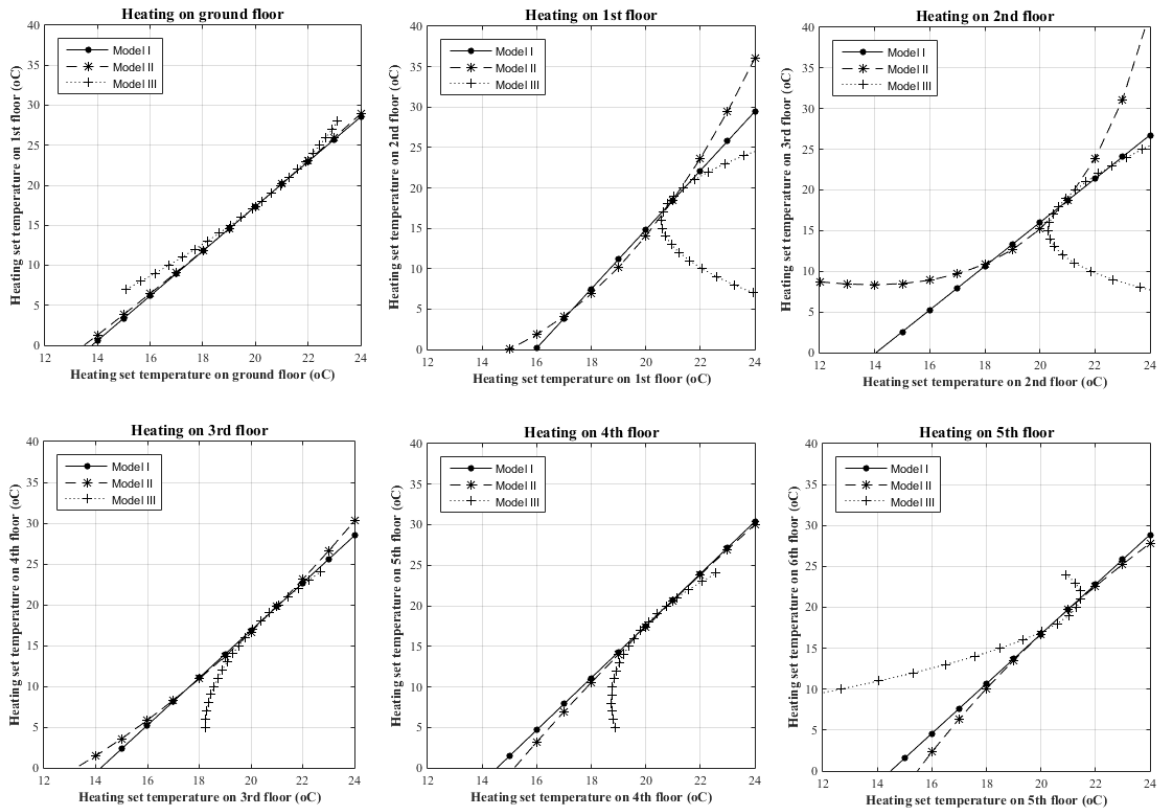

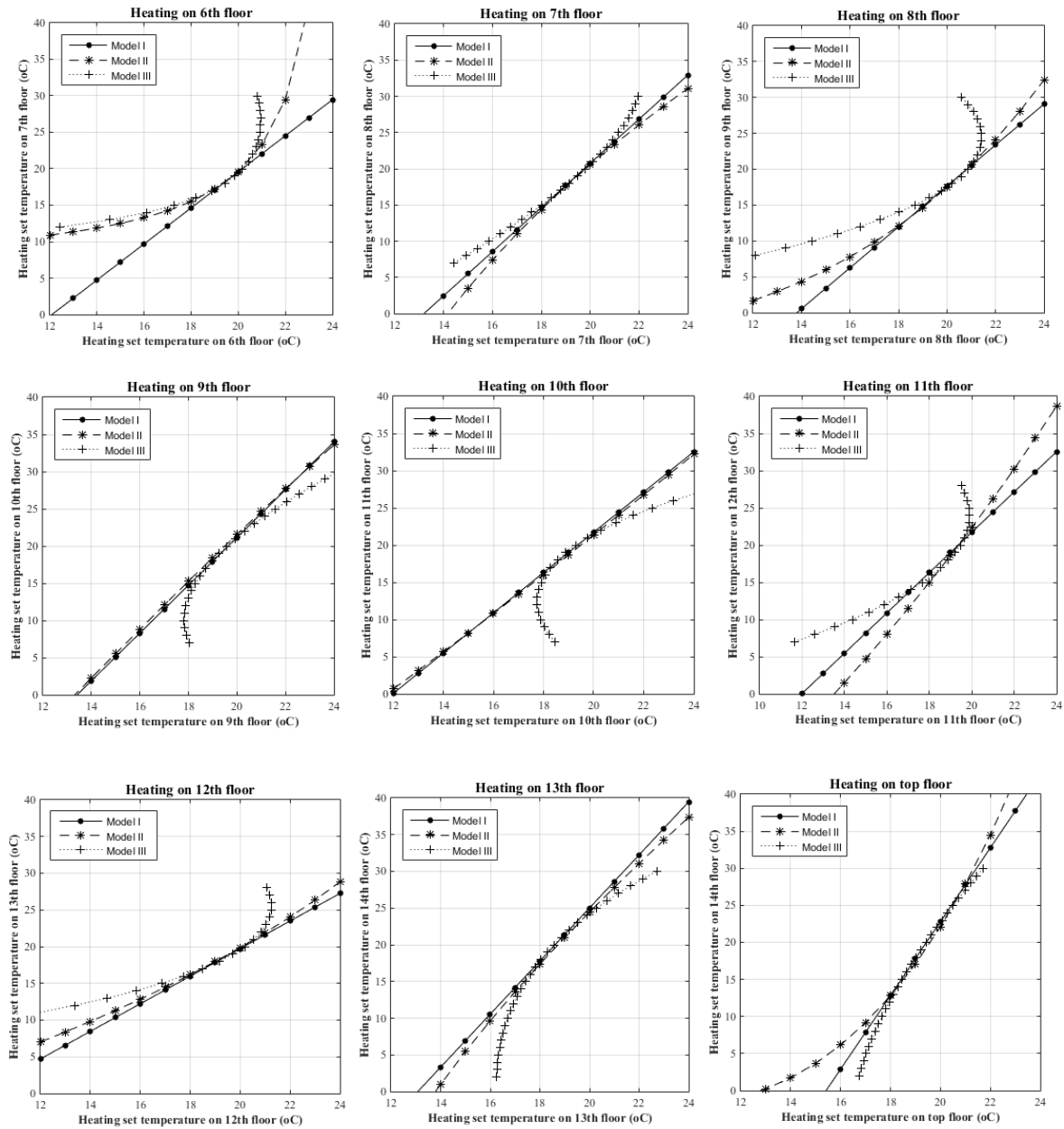
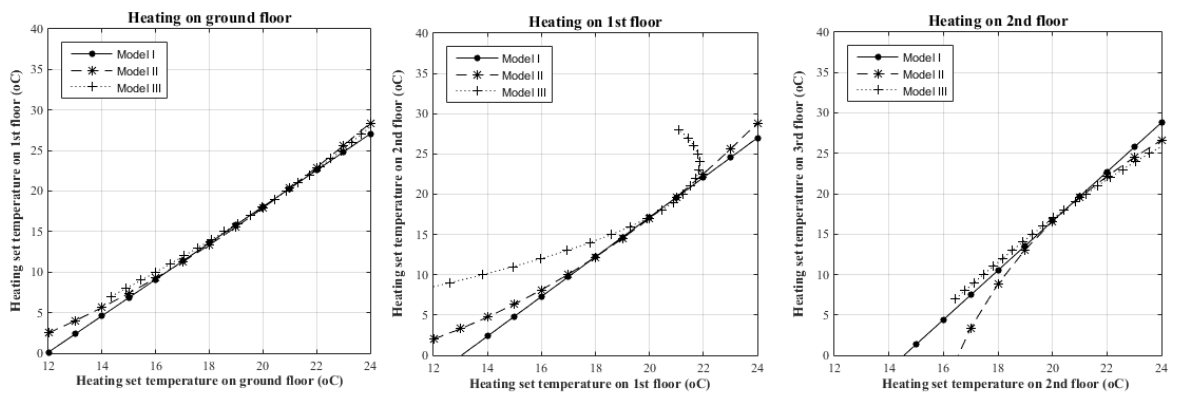

Figure 6.8. Sensitivity analysis of polynomial models with 7 hours heating





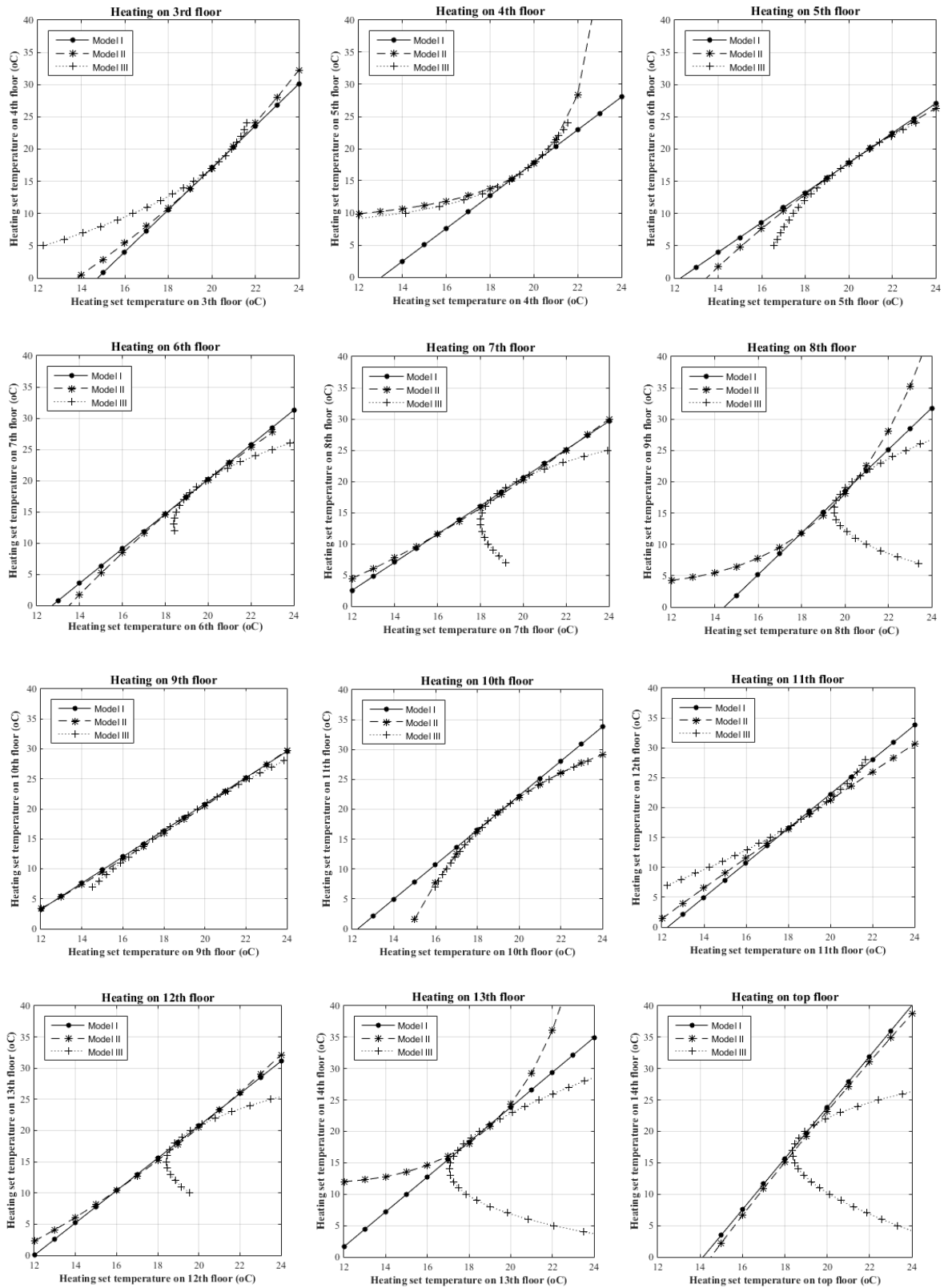
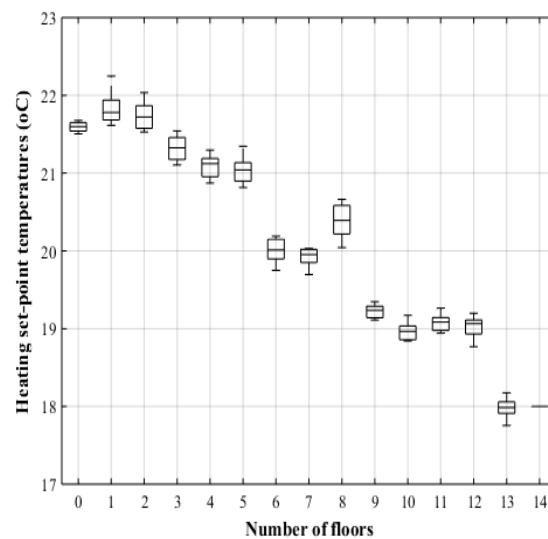

Figure 6.9. Sensitivity analysis of polynomial models with 8 hours heating

### 6.3.4 *New model estimations of heating controls determining real energy consumption*

Figure 6.10 describes the newly estimated heating set-point temperatures for the 15 apartment units with the polynomial models when the initial heating set-point temperatures on the top floors are changed from 18°C to 20°C. Overall, the heating set-point temperatures for all units are distributed between 18°C to 22°C, and gradually reduced in accordance with higher floors. Variation in the set-point temperatures for heating on each floor is identified by the types of models (Model I - III), heating hours (seven and eight hours) and the initial temperatures of the top floors (18°C to 22°C). However, the variation caused by all factors is not less than 0.4°C on each floor.



**Figure 6.10. Estimation of heating set-point temperatures in apartment units**

In comparison to the targeted average heating consumption (Figure 6.11), about 0.5°C change in heating set-point temperatures brings approximately 10 kWh/m<sup>2</sup>/year change in heating energy consumption for the 15 apartment units. Interestingly, heating set-point temperatures on the ground floor are similar to the temperatures on the floors from the 1<sup>st</sup> and 5<sup>th</sup> floors. However, the actual heating energy consumption on the ground floor is about 30 – 50 kWh/m<sup>2</sup>/year higher than the consumption on the 1<sup>st</sup> and 5<sup>th</sup> floors. This suggests

that a greater heat loss has occurred in the unit on the ground floor than on the five upper floors.

The new dataset of heating set-point temperatures is applied to the building energy model in order to re-calculate heating energy consumption for the 15 apartment units, and their outputs are compared to the targeted heating energy consumption. Correlation coefficient analysis is conducted to evaluate the correspondence between the targeted values and the re-estimated energy consumption. In addition, Root-Mean-Square Deviation (RMSD) is also identified to compare the difference between the targeted and the recalculated estimation of heating energy consumption, as shown in Equation 7. All of polynomial models show higher than 0.90 correlation coefficient values, regardless of the initial heating set-point temperatures on the top floor. These re-calculated values interpret high associations with the targeted heating energy consumption. The sets of heating set-point temperatures with 19°C on the top floor show the greatest correlation coefficient values. Binary linear models (Model 1 and I ) indicate a slightly more robust correlation than other models.

$$RMSD = \sqrt{\frac{\sum_{t=1}^n (x_{1,t} - x_{2,t})^2}{n}} \quad (6-7)$$

The recalculated estimation of heating energy consumption is compared with the targeted heating energy consumption with 10% standard deviation (Figure 6.11) and the measured standard deviation (Figure 6.12). The estimated heating energy consumption with the previously simplified model, focused on the physical conditions in units with different locations, is also compared to visualise the improved estimation of heating energy consumption with the new model. The recalculated estimation shows much reduced RMSD values of 5.42 (seven heating hours) and 7.37 (eight heating hours) from RMSD 33.5 (the previous simplified building energy model). Moreover, all of the newly estimated heating energy consumption for the 15 units is within 10% of the standard deviation (Figure 6.11).

With the measured standard deviation (Figure 6.12), the estimated heating energy consumption shows very close values, although some floors, 3<sup>th</sup>, 4<sup>th</sup> and 13<sup>th</sup> floors with seven hours of heating, and 3<sup>th</sup>, 13<sup>th</sup> and top floors with eight hours of heating, are slightly out of range of the measured standard deviations. However, the difference in each floor is less than 5kWh/m<sup>2</sup>/year, which could be acceptable.

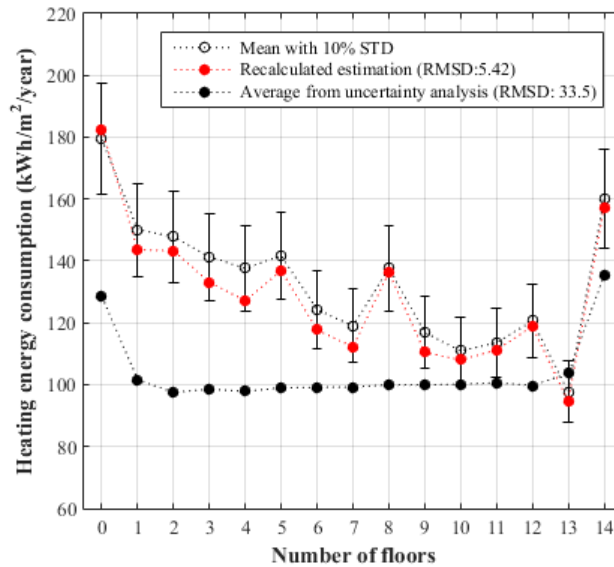

(a) 7 hours of heating

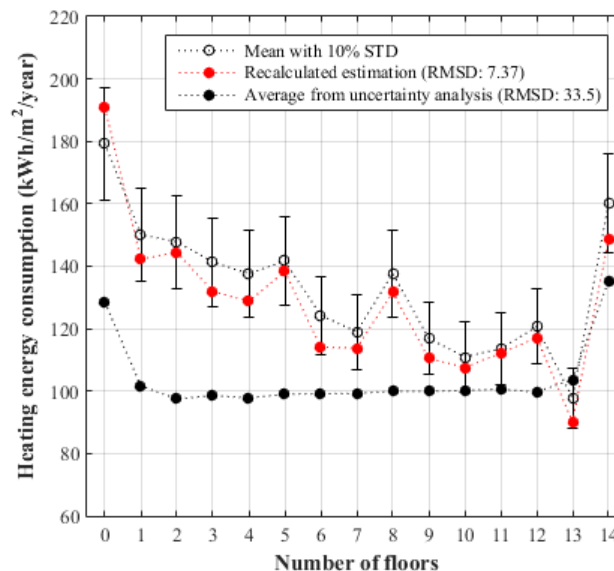

(b) 8 hours of heating

Figure 6.11. Comparison of calculated heating energy consumption with targeted heating energy consumption: (a) 7 hours of heating; (b) 8 hours of heating

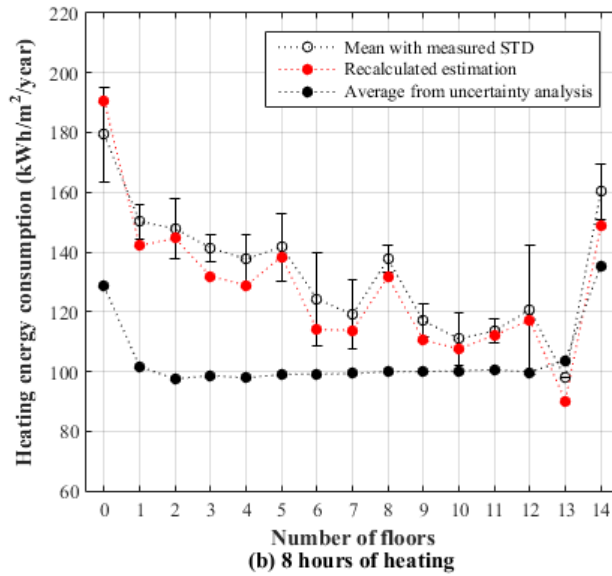
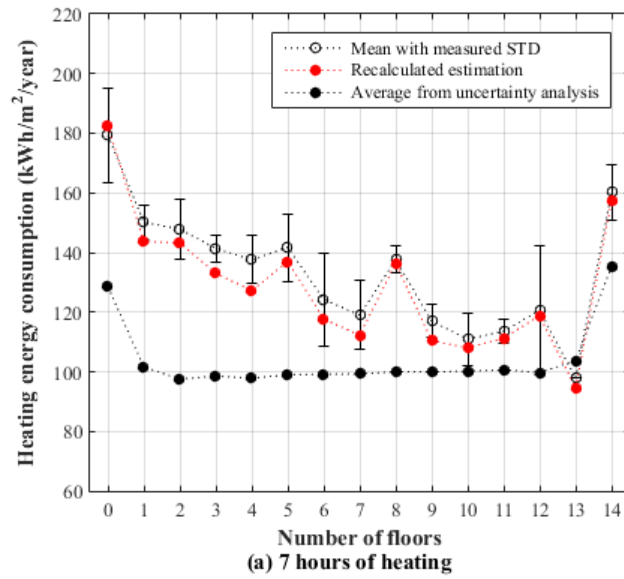

**Figure 6.12.** Comparison of calculated heating energy consumption with targeted heating energy consumption with the measured standard deviation: (a) 7 hours of heating; (b) 8 hours of heating

**Table 6.6.** Correlation coefficients of targeted and estimated energy consumption with input heating set-point temperature on the top floor

|      | 7hours     |            |            | 8hours     |            |            |
|------|------------|------------|------------|------------|------------|------------|
|      | degree 1x1 | degree 2x1 | degree 1x2 | degree 1x1 | degree 2x1 | degree 1x2 |
| 18°C | 0.972      | 0.963      | 0.968      | 0.974      | 0.972      | 0.976      |
| 19°C | 0.990      | 0.979      | 0.988      | 0.983      | 0.978      | 0.982      |
| 20°C | 0.975      | 0.963      | 0.976      | 0.965      | 0.959      | 0.963      |

## 6.4 Summary

In this chapter, a model was established by the individual heating controls of apartment units in different locations. This has been carried out integrating actual data into the existing building energy model, focusing on the physical conditions of individual units, in building simulation, and then developing the new polynomial models with regard to the individual heating controls for further prediction.

The targeted energy consumption, applied to the proportional rates of heating energy consumption depending on the unit locations, quantified 45% and 37% higher heating consumption in units on the ground and top floors. The great variation in energy consumption among the middle floors is also found with about 50 kWh/m<sup>2</sup>/year. However, the building energy model, focused on the physical conditions in the individual units, could not fully explain the variation in the unit-specific energy consumption specified in individual apartment units. The new model was applied to integrate individual heating controls in each unit.

Two conditions which indicated the high correlation with heating energy consumption need to be considered to take into account this unit-specified heating energy consumption for more accurate energy modelling: heating controls in apartment units and heating set-point temperatures between floors. The two types of polynomial models with these two conditions showed higher levels of goodness of fit, with above 0.6 – 0.9 of R-squared values.

Sensitivity analysis determined that the polynomial models of heating controls in apartment units indicated the least standard deviations with seven and eight hours of heating, corresponding to 18 – 20 °C of heating set-point temperatures in apartment units where heating is operating. For the interaction of this controls between floors, the polynomial model of heating set-point temperatures between floors showed heating set-point temperatures distributed between 18°C and 22°C for the 15 apartment units.

The first building energy model in building simulation, regarding the physical conditions of the units in different locations, showed RMSD 33.5. This disparity was significantly reduced to RMSD 5.42 with the dataset identified by the new model integrating the individual heating controls of apartment units, based on the measured data.





**Implementation of the building energy model  
developed for refurbishment measures under  
future climate change**

The previous three chapters focused on developing a building energy model of existing apartment buildings to integrate the variations arising from the three influential factors, physical characteristics, occupants' behaviours and individual units. With the building energy model developed, this chapter evaluates the building thermal regulations from 1987 to the present as energy-efficient refurbishment strategies for existing apartment buildings with respect to future climate change. The four revisions of the thermal regulations have been applied to calculate an amount of energy saving, compared to the baseline conditions in the building energy model. The reduction in heating energy consumption is also evaluated with the increased cooling energy consumption to determine the efficiency of the refurbishment strategies. The chapter consists of four sections. Section 7.1 provides a brief background of the main topic, refurbishment strategies of reducing energy consumption and future climate change in South Korea. Section 7.2 describes methods of evaluating partial and holistic refurbishment strategies in the current and future climate conditions. Section 7.3 presents results of efficiency of refurbishment strategies in the present and future climate conditions. Lastly, Section 7.4 summarises overall findings of this work.

## **7.1 Background**

A new agreement of reducing global carbon emissions has been accepted in 2015. All participating countries, regardless of developed and developing countries, agreed to more actions to mitigate global warming (Harvey, 2015). Some countries, heavily relying on energy resources overseas, have been making great efforts to reduce their dependence upon fossil fuels. Specifically, South Korea, ranked 8<sup>th</sup> in the largest carbon emissions (Olivier *et al.*, 2012), imports 95.5% of energy resources from abroad (KEEI, 2015), and renewable energy is only able to cover less than 1.9% of electricity production (World Bank, 2013). For this reason, South Korean Governments have led the decrease energy consumption in various sectors.

As one of the central strategies, building thermal regulations have been strictly intensified to achieve 25% reduction in carbon emissions in buildings by 2020 (Yoo, 2015). As a long term plan, all buildings in South Korea are expected to be energy-efficient as equivalent to Passivhaus (Passivhaus Trust, 2015). The intensified regulations were focused on reducing U-values of building envelopes since 2001. Moreover, the thickness of thermal insulation and U-values of windows have been annually improved by 25% from 2011 to the present. Furthermore, this improving trend seems to be continued. However, this continuously intensifying trend of thermal conditions is questionable in achieving an unconditional reduction in energy consumption, as identified in the literature review.

Another issue is that climate projections generally estimate warmer winters, which could reduce heating energy consumption, whereas higher cooling consumption can be expected during the summer (Sharples and Lee, 2013). Specifically, mean temperatures in South Korea increased by 1.5°C in the last century, whilst global mean temperature only increased 0.6°C (National Institute of Meteorological Sciences, 2015). 1 – 2°C additional increase of mean temperature is predicted in South Korea up to 2050, according to the climate change reports published by International Panel on Climate Change (IPCC) (cited by Climate Change Information Center, 2015). This change would affect the proportion of heating and cooling in energy consumption. Therefore, increasing thermal insulation, meant to reduce heating energy consumption, could also bring about an overheating risk, as mentioned in (Gupta and Gregg, 2013). For this reason, existing national building regulations focusing on heating, based on historical climate conditions for 20 – 30 years, would be required to take into account future climate projections (Xu *et al.*, 2012).

Despite this, the current building regulations continuously focus on intensifying the increase in the thermal insulation and the decrease in the U-values of windows. In hot summer continental climates, heating is the dominative factor of consuming energy in residential buildings, although cooling consumption has rapidly increased. However, a previous study

(Li *et al.*, 2012) anticipated the significant increase of cooling energy loads compared to the decrease of heating energy loads in buildings in South Korea under climate change scenarios. On the other hand, other studies, such as (Collins *et al.*, 2010; Wang *et al.*, 2010), concluded that reducing heating consumption is still a more efficient strategy in heating dominant climates.

Old high-rise apartment buildings, which consist of the largest proportion of buildings in South Korea (Statistics Korea, 2010b), have been expected to be refurbished in order to reduce their problematic excessive energy consumption (Kim, 2010). The current thermal regulations, reducing heating energy consumption, can be highly considered as a guideline for refurbishment strategies. However, no previous study critically evaluated this application for old high-rise apartment buildings, and the validity under climate projections.

This chapter, therefore, attempts to assess the building thermal regulations, improving thermal conditions in building envelopes, as refurbishment strategies for existing apartment buildings constructed before 1980, and the efficiency of these strategies on reducing energy consumption with regard to future climate change scenarios. Three questions will be answered as below:

- How sensitive are climate factors in effecting actual heating energy consumption in old high-rise apartment buildings? Is future climate change an important issue for refurbishing these buildings?
- How does improving the thermal conditions of the building envelope effect heating energy consumption under the current climate conditions? Do the improved thermal conditions change cooling energy consumption during the summer?
- Will the change in energy consumption with refurbishment strategies be valid under future climate change scenarios?

## 7.2 Methods

The methods are designed in three steps. The first step is identifying relationships between climate factors and actual heating energy consumption, to determine the most sensitive climate factors affecting heating energy consumption and the significance of considering climate projections in refurbishing old existing apartment buildings. The second step is analysing the causality of improving variables in the building envelope with energy consumption, based on the four revisions of the building thermal regulations from 1987 to the present. The last step is measuring change in energy consumption with the holistic refurbishment strategies with the present and future climate conditions.

### 7.2.1 *Identifying relationships between climate factors and heating energy consumption*

This section intends to determine the sensitive climate factors affecting actual heating energy consumption in old existing apartment buildings. This sensitivity helps to answer whether climate projections are important considerations for creating refurbishment strategies. Monthly climate conditions were collected from annual climate reports (2011 – 2014), published by Korea Meteorological Administration (KMA, 2014). Six climate factors, importantly considered in buildings (Bougdah and Sharples, 2009), were chosen: air temperature, relative humidity, precipitation, total horizontal solar radiation, sunshine hours and wind speed.

According to Köppen–Geiger climate classification (Kottek *et al.*, 2006), the central region of South Korea is classified by the hot summer continental climates, with dry and cold winters and hot and humid summers. Seoul, one of the representative cities of the central region, shows 12.5°C as mean temperature (averaged maximum 18.1°C and averaged minimum 7.7°C) (KMA, 2015). However, specific weather conditions in heating and cooling seasons are more severe, as shown in

Figure 7.1. The range of mean temperatures in winter is from  $-5.9^{\circ}\text{C}$  to  $1.5^{\circ}\text{C}$ , while the range is shifted to  $22.4^{\circ}\text{C} - 29.6^{\circ}\text{C}$  in summer. Relative humidity becomes higher, up to about 80% in summer because of the precipitation concentrated in a short monsoon season from late July to early August. Horizontal solar radiation gradually increases from winter to late spring, but reduces from summer to autumn, which is also the same for sunshine hours. However, the short monsoon season brings about a significant drop in both solar radiation and sunshine hours in July (

Figure 7.1 (d – e)).

The averaged conditions of the five climate factors, excluding mean wind speed, for the last thirty years (1981 – 2010) are in between the weather conditions from 2011 to 2014, as described in (

Figure 7.1). Thus, the range of climate conditions from 2011 to 2014 can cover the possible variation in current climate conditions in Seoul. The energy consumption in the four years (2011 – 2014) was applied to identify the relationship between climate factors and heating energy consumption.

**Table 7.1. Collinearity statistics of climate factors**

| Climate factors                  | Collinearity Statistics |                                 |
|----------------------------------|-------------------------|---------------------------------|
|                                  | Tolerance               | Variance Inflation Factor (VIF) |
| Air temperature                  | 0.168                   | 5.966                           |
| Relative Humidity                | 0.217                   | 4.611                           |
| Precipitation                    | 0.396                   | 2.526                           |
| Total horizontal solar radiation | 0.249                   | 4.018                           |
| Sunshine hours                   | 0.348                   | 2.878                           |
| Mean wind speed                  | 0.691                   | 1.447                           |

However, high levels of multicollinearity are found among the six climate factors (Table 7.1). Although the Variance Inflation Factor (VIF) levels are not extremely significant, but high enough to be concerned about their mutual influence (Field, 2009).

Hence, the multiple regression method did not accurately analyse the relationships between climate factors and heating energy consumption. Instead, polynomial regression was used, which analyse the relationship of the dependent variable with only one or two independent variable by minimising the sum of squared errors (Kleinbaum *et al.*, 2013). Monthly average heating energy consumption from 2011 to 2014 in old high-rise apartment buildings, constructed before 1980, was used in the previous chapters (Chapter 4 and 5). The result is interpreted in Section 7.3.1.

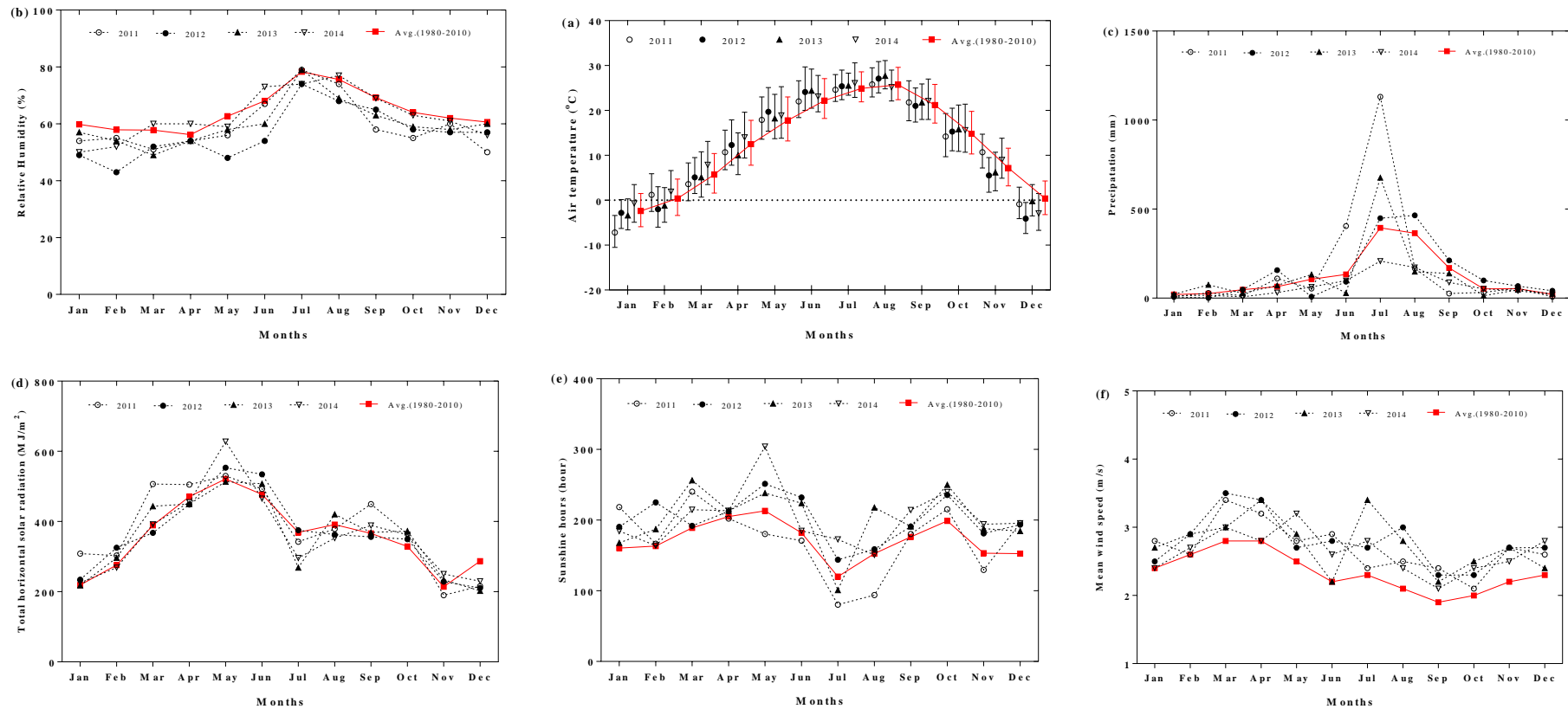

Figure 7.1. Monthly climate conditions in Seoul (2011 – 2014, average from 1981 to 2010): (a) Air temperature, (b) Relative Humidity, (c) Precipitation, (d) Total horizontal solar radiation, (e) Sunshine hours and (f) Mean wind speed (*Source: annual reports 2011 – 2014 (KMA, 2014) and average climate data (1981 – 2010) (KMA, 2015)*)



### ***7.2.2 Analysing impacts of refurbishment strategies on heating energy consumption and overheating hours***

This section is intended to analyse whether or not the continuous improvement of thermal conditions in the building envelope, according to the building thermal regulations, brings about an efficient reduction in heating energy consumption. The assessment was divided into two parts. Firstly, the causality of individual variables in the building envelope on heating energy consumption was evaluated under the current climate conditions. The building envelope of existing apartment buildings was decomposed into the six parts: external walls, internal walls, roof (ceiling on the top floor), floor (floor on the ground floor), side walls, and windows. By improving the thermal conditions of these six parts, change in heating energy consumption was measured. The improvement of thermal conditions was designed by the four revisions of thermal regulations from 1987 and 2015, as illustrated in Table 7.2. Secondly, the causality of holistic refurbishment strategies with energy consumption was evaluated. The full strategies were comprised of the six variables in the building envelope of the thermal regulations. Heating energy consumption was measured by Zone HVAC: Low Temperature Radiant Variable Flow in EnergyPlus 8.0, while cooling energy consumption was assumed by the number of hours with zone mean temperatures higher than 26°C.

The improvement of thermal conditions in the building regulations (1987 – 2015) has been focused on increasing thermal insulation and decreasing the U-values of windows in buildings. Table 7.2 interpreted the change in the building regulation that restricts the thickness of insulation in apartment building envelopes since 1980, which has been applied in this chapter. As the regulation was established in 1980, apartment buildings constructed before were hardly insulated. After the first and second revisions in 1984 and 1987, the envelope of apartment buildings could have 50mm insulation. Since this regulation has been enhanced under the government intent, the parts of apartment buildings that need to be insulated became more precise by separating the building parts in terms of the exposure of the outside. The parts directly exposed to the outside have required thicker insulation than

the parts indirectly exposed to the outside. The thermal conditions of window were measured by U-values that represents the level of effectiveness in protecting heat transfer. The lower U-values indicate the more efficient heat protection as a material for insulation. It has been achieved by developing the glazing type from single and double to triple (Lee *et al.*, 2012). Moreover, the thickness of insulation has annually been increased up to 25% since 2011. Further improvement can be upcoming.

The existing apartment buildings in this chapter were limited to the buildings constructed before 1980. As a baseline model, the building energy model developed in the previous chapter (Chapter 6) was used. Thus, the outcome with the energy model can be specified not only for the whole building but also for individual units. For the improvement of thermal insulation, the thermal conductivity of insulation was fixed at 0.034 W/m·K (MLIT, 2015b). Zone mean temperatures were measured to ensure comfortable indoor conditions, while assessing heating energy consumption. Historical weather data in 2014 (White Box Technologies, 2014), which was used to validate the building energy model, was applied, and EnergyPlus 8.0 (Crawley *et al.*, 2001) was used for calculations. The impact of the decomposed variables in the building envelope on heating consumption is illustrated in Section 7.3.2. The holistic strategies are analysed in Section 7.3.3.

**Table 7.2. Thermal conditions of the building envelopes with the building regulation**

|   | Parts of apartment buildings    | Exposure of the outside | Holistic strategies and the revised years |      |      |      |      | Possibly upcoming (+25%) |
|---|---------------------------------|-------------------------|---|------|------|------|------|--------------------------|
|   |                                 |                         | Before 1980                               | 1987 | 2011 | 2014 | 2015 |                          |
| 1 | External walls (mm)             | Direct exposure         | -   | 50   | 85   | 120  | 155  | 195                      |
| 2 | Internal walls (mm)             | Indirect exposure       | -   | 50   | 60   | 80   | 105  | 130                      |
| 3 | Roof/ ceiling of top floor (mm) | Direct exposure         | 50  | 80   | 160  | 180  | 220  | 275                      |
| 4 | Floor on ground floor (mm)      | Direct exposure         | -   | 50   | 105  | 140  | 175  | 220                      |
| 5 | Side wall (mm)                  | Direct exposure         | -   | 70   | 120  | 120  | 120  | 150                      |
| 6 | Windows (U-value)               | Direct exposure         | 5.9                                       | 5.9  | 2.1  | 1.5  | 1.2  | 1.08                     |
|   |                                 | Indirect exposure       | 5.9                                       | 5.9  | 2.8  | 2.2  | 1.6  | 1.13                     |

### 7.2.3 *Evaluating change in impact of refurbishment strategies under future climate change*

This section was conducted to understand the efficiency of the current thermal regulations in 2015 as a refurbishment strategy to reduce heating energy consumption despite climate change impact that possibly increases cooling energy consumption. A 25% increase and decrease in thermal conditions were added, according to the 25% increasing trend of the thermal regulations since 2011. The 25% decreased conditions are the same as the regulations in 2014. The 25% increased conditions from the regulations in 2015 are illustrated in Table 7.2.

Climate projections for this chapter were chosen by identifying the recent trends of national carbon emissions (Olivier *et al.*, 2012) and energy consumption in households in South Korea (Huh, 2013). For the last twenty years, both national carbon emissions and energy consumption in households have shown increasing trends, except for the noticeable drop in 1998 due to an economic crisis (Figure 7.2). Various attempts such as the improvement of building regulations, have been implemented to reduce carbon emissions and energy consumption in housing since 2001. However, the outcome is still not visible in these indices, as shown in Figure 7.2.

Two types of climate scenarios have been published by IPCC. The Special Report on Emissions Scenarios (SRES) focused on the assumption of driving forces in the future (Nakicenovic and Swart, 2000), while the Representative Concentration Pathways (RCPs) scenarios are based on the possible GHG emissions (van Vuuren *et al.*, 2011). This chapter took one of the SRESs scenarios, A2 scenarios, in analysing energy consumption. This is because the A2 scenarios are set with fragmented and slower technological changes, which predict continuous increasing trends of carbon emissions. As shown in Figure 7.3, the projections of the A2 scenarios are between the RCP 4.5 and 8.5 scenarios; the RCP 4.5 scenarios assume the rise in carbon emissions can be effectively suppressed at the current

levels of carbon emissions, whilst the RCP 8.5 scenarios are based on the continuous rise in carbon emissions.

Typical Reference Year (TRY), acquired from ASHRAE International Weather for Energy Calculations 2.0 (IWEC2) (White Box Technologies, 2015), was used to calculate heating energy consumption under the typical climate conditions in Seoul. This TRY file was converted for future climate files in 2020 and 2050 to be applicable for building simulation, based on the A2 scenarios in SRES scenarios. Climate Change World Weather File Generator (CCWorldWeatherGen) (Jentsch *et al.*, 2013) was used to generate the future climate files. This tool has been applied in other studies to produce future climate data for building simulation such as (Peng and Elwan, 2014). The result is interpreted in Section 7.3.4.

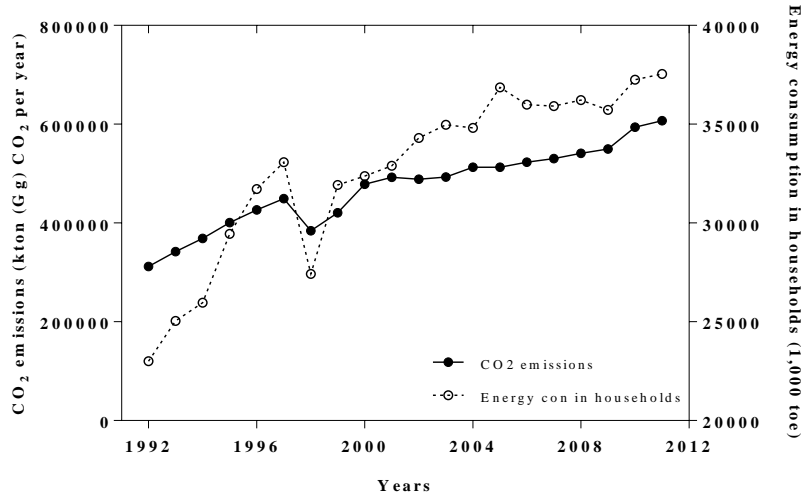

**Figure 7.2. Current trends of national carbon emissions and energy consumption in households in South Korea (Source: Olivier *et al.*, 2012; Huh, 2013))**

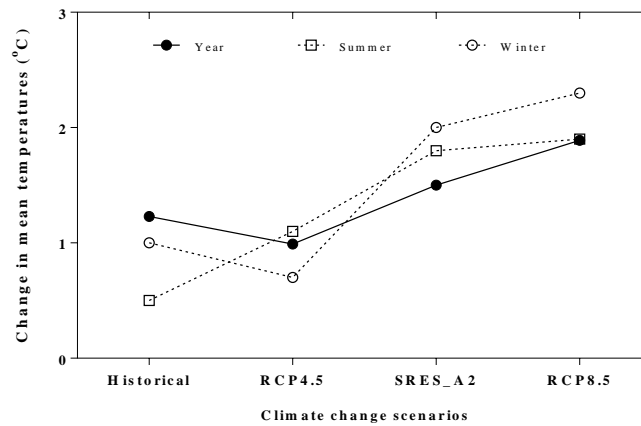

**Figure 7.3.** Change in mean temperature in Seoul under different climate projections (historical, RCP4.5, SRES\_A2 and RCP8.5 scenarios) (Source: *Climate data (1981-2010) published by (KMA, 2012)*)

## 7.3 Results

The results are interpreted by four sections. Section 7.3.1 analyses the relationships between climate factors and heating energy consumption in 2011 – 2014. Section 7.3.2 describes the causality in improving thermal condition of variables in the building envelope and heating energy consumption. Section 7.3.3 illustrates change in heating consumption and overheating hours with the holistic refurbishment strategies under the current climate conditions. The strategies are also evaluated with climate change scenarios, which are described in Section 7.3.4.

### 7.3.1 *Relationships between climate factors and heating energy consumption*

Figure 7.4 illustrates the polynomial regression analysis between climate factors and heating energy consumption. As expected, the change in temperatures is the most determinant factor

corresponding to heating energy consumption in existing high-rise apartment buildings. Heating consumption is rising when the dry-bulb temperature is below 20°C. The actual increasing trend of heating energy consumption is shown by the dry-bulb temperature below 18°C, and the consumption is increased up to 32 kWh/m<sup>2</sup>/year when the dry-bulb temperature reaches below -7°C. The consumption is increased about 0.9 – 1.2 kWh/m<sup>2</sup>/year per 1°C decrease of dry-bulb temperatures when dry-bulb temperature is between -10°C and 10°C.

Relative humidity and total horizontal solar radiation have a moderate relationship with heating energy consumption, shown by R-squared values of 0.39 and 0.46 respectively, as they showed the noticeable change in months. However, precipitation and sunshine hours do not indicate as significant relationships as relative humidity and solar radiation. This is because precipitation is only concentrated in July and August, whilst no significant difference is identified among other months (

Figure 7.4 (c)). Beside, monthly change in sunshine hours is not robust enough, due to the shorter hours in July because of the monsoon (

Figure 7.4 (e)). Monthly change in wind speed indicates the limited interpretation for heating energy consumption. However, this does not mean the two factors are not related to change in heating energy consumption. More elaborate data would be required for more in-depth understanding.

In short, the change in the dry-bulb temperatures demonstrates the sensitive association with heating consumption. In other words, monthly change in heating energy consumption is heavily dependent on outdoor temperatures, which brings about 0.9 – 1.2 kWh/m<sup>2</sup>/year of heating consumption per 1°C change in dry-bulb temperatures between -10°C and 10°C.

Therefore, climate projections, indicating the increase of mean temperature in South Korea, could impact on energy consumption in buildings. Furthermore, the other factors also need to be carefully regarded in building energy consumption, as the change in temperature has the significant levels of multicollinearity with the other five climate factors (Table 7.1).

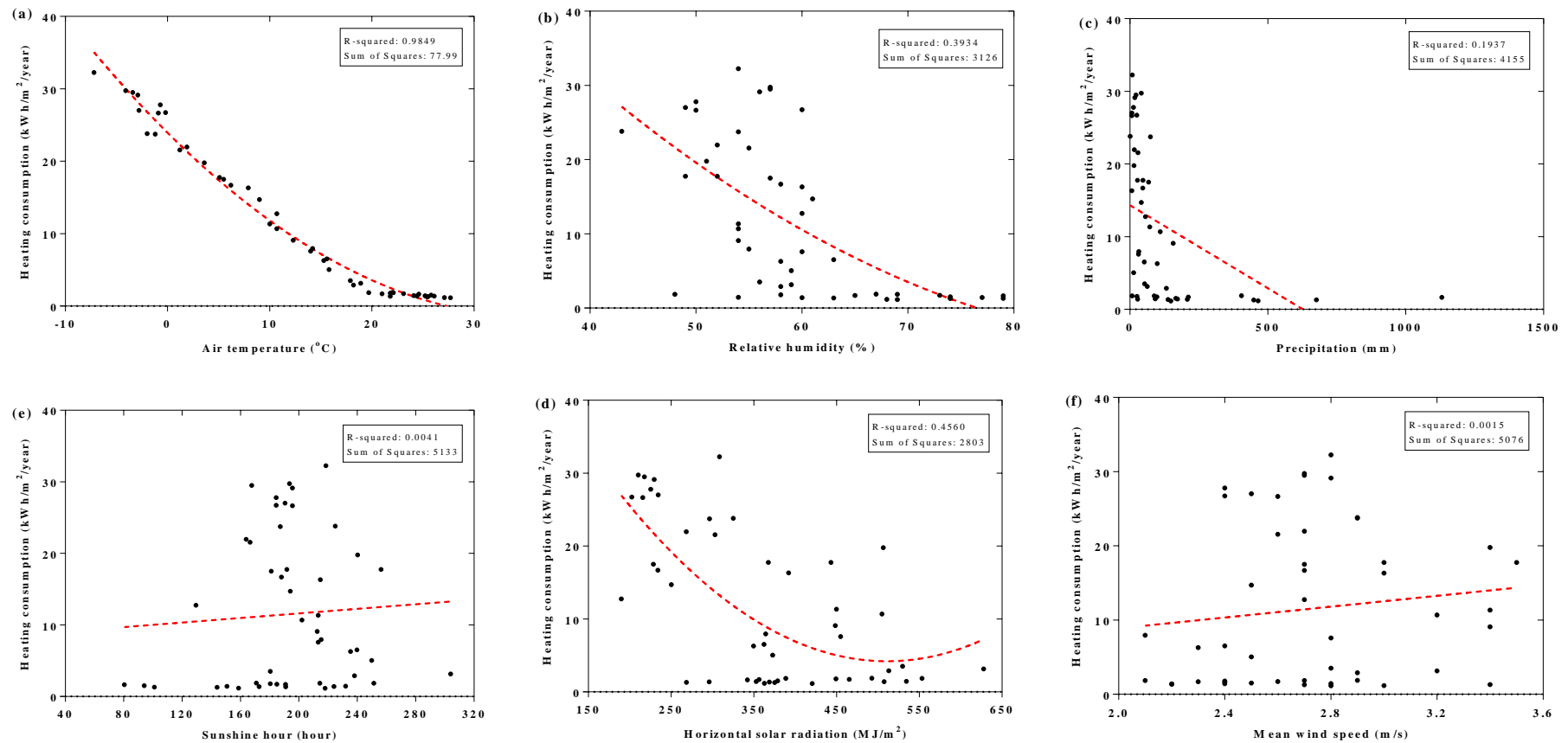

Figure 7.4. Relationships between climate factors and heating energy consumption: (a) Air temperature, (b) Relative humidity, (c) Precipitation, (d) Solar horizontal radiation, (e) Sunshine hours and (f) Mean wind speed



### 7.3.2 *Causality of variables in building envelope with heating energy consumption*

Improving the thermal conditions of the six variables in the building envelope contributes to reduce heating energy consumption under the current climate conditions, as shown in Figure 7.5. The most significant reduction is found with side walls. The heating consumption is significantly decreased from 126 kWh/m<sup>2</sup>/year to 83 kWh/m<sup>2</sup>/year by inserting 70mm insulation, whilst zone mean temperature is increased from 18.5°C to 19.3°C. However, only 3 kWh/m<sup>2</sup>/year of heating energy consumption is dropped by increasing the thickness of insulation from 70 mm to 120 mm.

The second significant variable is improving the U-values of windows. This brings about an average heating energy consumption is reduced from 126 kWh/m<sup>2</sup>/year to 115 kWh/m<sup>2</sup>/year, whilst zone mean temperature is stable at 18.5 – 18.6°C. Specifically, about 7 kWh/m<sup>2</sup>/year of reduction is caused by improving the U-values of windows with 2.1W/m<sup>2</sup>·K (directly exposed to the outside) and 2.8 W/m<sup>2</sup>·K (indirectly exposed to the outside). 3.4 kWh/m<sup>2</sup>/year of further reduction in heating energy consumption is also achieved by strengthening the U-values of windows with 1.2 W/m<sup>2</sup>·K (directly exposed to the outside) and 1.6W/m<sup>2</sup>·K (indirectly exposed to the outside).

The third noticeable reduction is arising from increasing the thickness of insulation on external walls. The average heating energy consumption is reduced from 126 kWh/m<sup>2</sup>/year to 119 kWh/m<sup>2</sup>/year with stable zone mean temperature with 18.6°C. The largest reduction (5.5 kWh/m<sup>2</sup>/year) is found by inserting 50 mm of insulation on external walls. However, the reduced heating consumption is limited to about 2 kWh/m<sup>2</sup>/year when the thermal insulation increased from 85 mm to 155 mm.

Unlike the external walls, no significant effect on the average heating energy consumption is shown by increasing thermal insulation on internal walls. The increase in the thickness of

insulation to 105 mm results in only about 1 kWh/m<sup>2</sup>/year reduction in the average heating energy consumption. The first reason for this ineffective reduction could be the small amount of area of the internal walls, which are mainly comprised of glass doors. The second reason would be that the walls are not directly exposed to the outside.

Improving the insulation on the roof and ground floors does not noticeably reduce the average heating energy consumption. However, it effectively reduced heating energy consumption on the top and ground floors. A significant reduction from 182 kWh/m<sup>2</sup>/year to 106 kWh/m<sup>2</sup>/year is found by inserting 50 mm of insulation on the ground floor. Moreover, about 10 kWh/m<sup>2</sup>/year of heating energy consumption is additionally reduced by increasing the thickness of insulation from 105 mm to 175 mm. Although less significant reduction is shown on the top floor, the heating consumption is also reduced, from 141 kWh/m<sup>2</sup>/year to 134 kWh/m<sup>2</sup>/year.

In summary, the average heating energy consumption is significantly reduced by inserting thermal insulation in the six parts of the building. However, increasing thermal insulation does not always bring about an unconditional reduction in heating energy consumption. The efficiency especially becomes much lower with the regulations revised in 2011 (Table 7.2), apart from the U-values of windows, and the thickness of insulation on the ground floor. Hence, improving thermal conditions in buildings has to be critically designed.

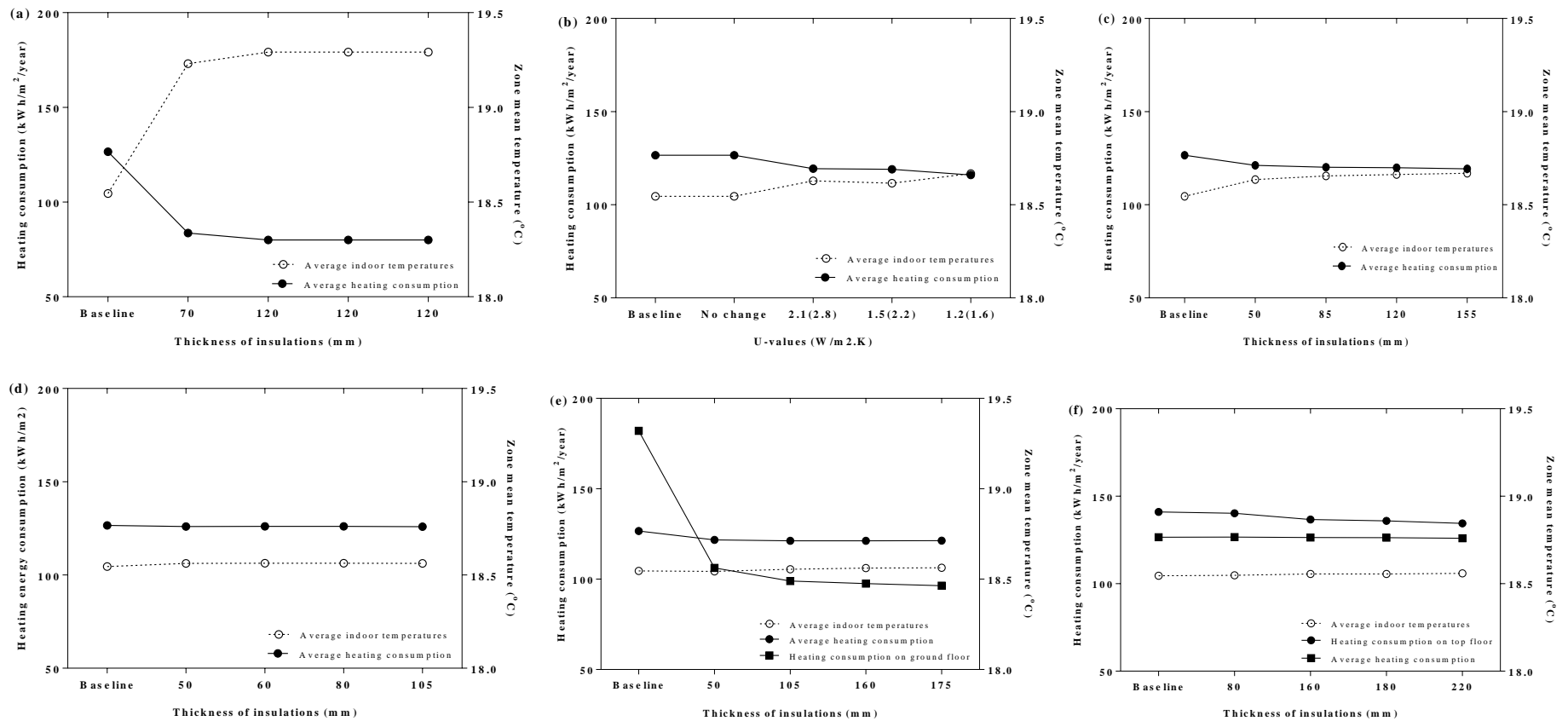

Figure 7.5. Impact of variables in building envelope on heating energy consumption: (a) Side walls, (b) Windows, (c) External walls, (d) Internal walls, (e) Floor on the ground floor and (f) Roof on the top floor

### ***7.3.3 Change in heating energy consumption and overheating hours with the holistic refurbishment strategies***

The holistic refurbishment strategies bring about changes in both heating energy consumption and the number of hours with zone mean temperatures exceeding 26°C (Figure 7.6). However, far little change is shown after the revisions in 2011, as also previously identified in Section 7.3.2.

The most significant reduction in heating energy consumption is shown by inserting the sets of thermal insulation, following by the regulation in 1987. The average heating energy consumption is reduced from 126.6 kWh/m<sup>2</sup>/year to 73.5 kWh/m<sup>2</sup>/year. On the other hand, the improved thermal performance in the building energy model brings about the increase of overheating hours. 232 hours with zone mean temperatures exceeding 26°C are added by this improvement, where cooling is required. With the air-conditioner consuming 1.3 kWh/hour (KEPC, 2013), a total 302 kWh/year of increased electricity consumption can occur, whereas the average heating energy consumption is reduced by 53.1 kWh/m<sup>2</sup>/year (4386 kWh/year). This comparison shows that the reduced heating energy consumption significantly outweighs the increased cooling energy consumption.

The improved building conditions based on the regulations in 2011 result in an average heating energy consumption of 60.2 kWh/m<sup>2</sup>/year. 13.5 kWh/m<sup>2</sup>/year (1098 kWh/year) of the average heating consumption is reduced more from the regulations in 1987, whereas 34 hours of required cooling (44.2 kWh/year) is added. By the improvement in thermal regulations from 2014 to 2015, only 2 kWh/m<sup>2</sup>/year (165.2 kWh/year) of the average heating energy consumption is reduced. Interestingly, this leads to a reduction in overheating hours from 3365 to 3292, resulting in a 96.2 kWh of extra reductions in electricity consumption. In total 261.4 kWh/year energy consumption can be reduced.

Change in heating energy consumption and overheating hours differ in the different locations of apartment units, as shown in Figure 7.7. The most significant reduction in total energy consumption is found in the unit on the ground floor, compared to the other fourteen floors. The heating energy consumption on the ground floor is reduced from 182.0 kWh/m<sup>2</sup>/year to 54.0 kWh/m<sup>2</sup>/year. However, the increased overheating hours are also the most significant on the ground floor, from 2882 hours to 3178 hours per year, which causes only 384.8 kWh/year increased cooling loads.

In heating dominated climates the methods of increasing thermal insulation and the U-values of windows are efficient approaches in reducing heating energy consumption, despite the increase of cooling loads during summer. However, the reduction in total energy consumption is limited, as shown in Figure 7.8. Specifically, there were nearly no change between the regulation in 2014 and 2015.

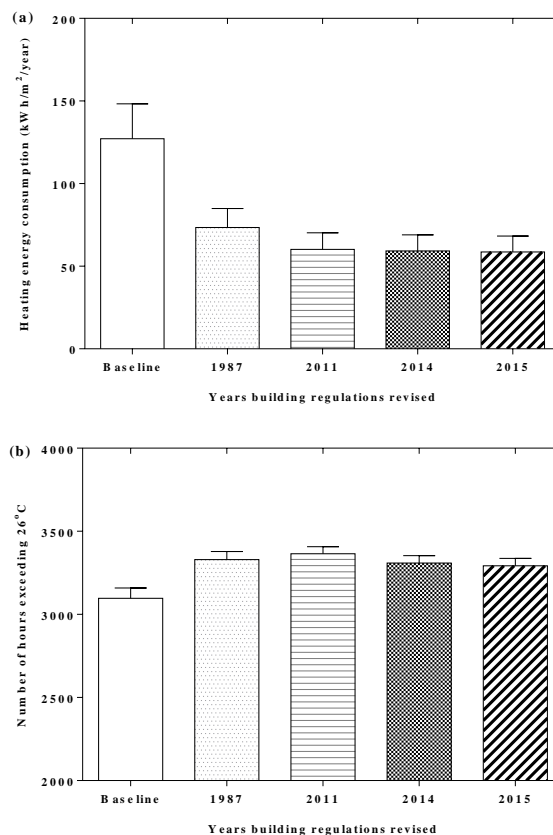

**Figure 7.6. Impact of holistic refurbishment strategies, revised in 1987, 2011, 2014 and 2015: (a) change in averaged heating energy consumption and (b) overheating hours**

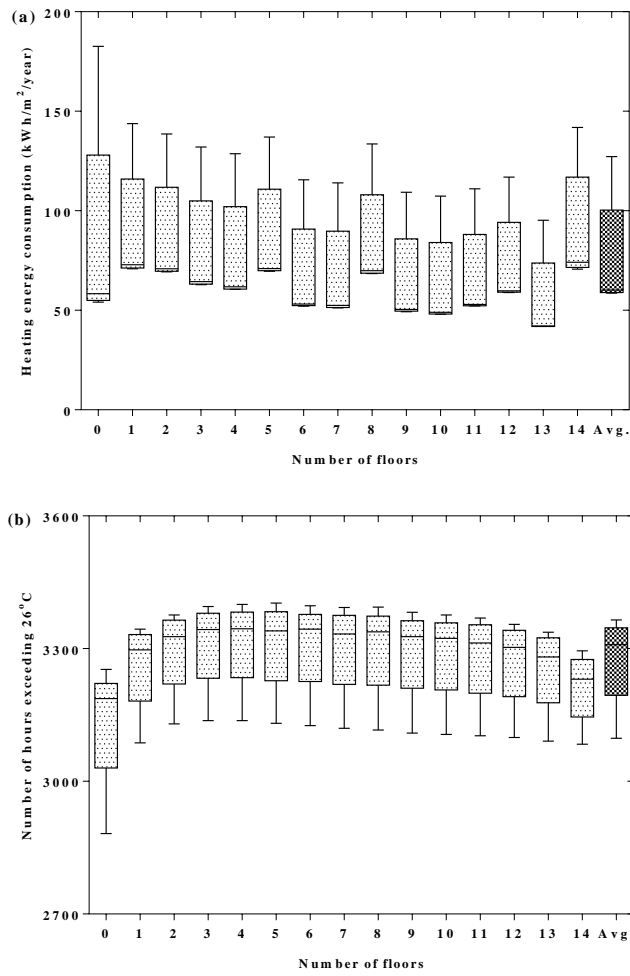

Figure 7.7. Impact of refurbishment strategies: (a) change in the unit-specific heating energy consumption and (b) overheating hours depending on the locations of units

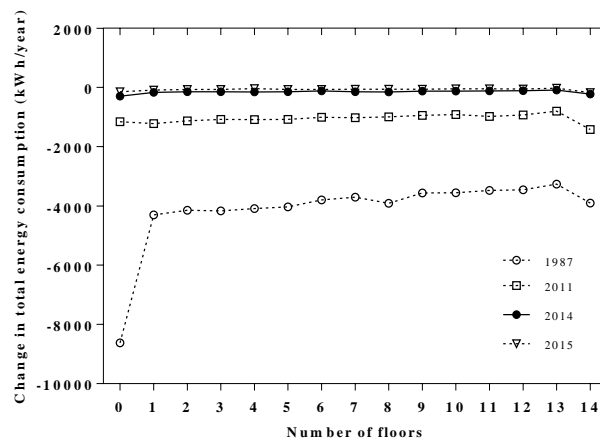

Figure 7.8. Change in total energy consumption in individual apartment units depending on the holistic refurbishment strategies based on the thermal regulations in 1987, 2011, 2014 and 2015

### 7.3.4 *Impact of refurbishment strategies under future climate change scenarios*

Figure 7.9 and 7.10 depict the average heating energy consumption and overheating hours with the three holistic refurbishment strategies under the three different climate conditions: TRY, 2020 and 2050. Figure 7.11 and 7.12 demonstrate how these two factors, heating consumption and overheating hours, are changed in the different locations of apartment units.

- **The current regulations in 2015**

The average heating energy consumption, with the current regulations revised in 2015, is 61.8 kWh/m<sup>2</sup>/year with the TRY, whereas the number of overheating hours is 2747. According to the A2 scenarios, this consumption is reduced to 57.1 kWh/m<sup>2</sup>/year in 2020 and 48.2 kWh/m<sup>2</sup>/year in 2050. The climate scenarios also increase the overheating hours to 3150 in 2020 and 3513 in 2050. In 2020, the increased overheating hours increases cooling energy consumption up to 524 kWh/year. This value slightly outweighs the reduction in heating energy consumption, 4.7 kWh/m<sup>2</sup>/year (389 kWh/year). However, the reduction in heating energy consumption (1123 kWh/year) is slightly higher than the increased cooling consumption (996 kWh/year) in 2050. The total change can be about a 127 kWh/year reduction in total energy consumption.

The heating consumption and overheating hours in individual units are significantly different under the locations of units (Figure 7.11 and 7.12). Specifically, the most significant reduction occurs in the unit on the top floor, with 18 kWh/m<sup>2</sup>/year in 2050, whilst the smallest reduction with 10 kWh/m<sup>2</sup>/year is found on the ground floor. Both floors show the less number of overheating hours, compared to the average value. The top floor has 102 less overheating hours than the average in 2050, whilst the ground floor requires 133 less overheating hours. This change can bring about a 168 kWh/year increase in total energy

consumption on the ground floor, but a 522 kWh/year decrease in consumption on the top floor (Figure 7.13).

Despite the reduction in total energy consumption, the amount of reduced total energy consumption, a maximum of 552 kWh/year on the top floor, may be insignificant with respect to the general energy consumption in these buildings.

- **25% decreased thermal conditions (the regulation in 2014)**

The average heating energy consumption is 62.8 kWh/m<sup>2</sup>/year, whilst the overheating hours is 2757 with the TRY. The average heating energy consumption is reduced to 58.1 kWh/m<sup>2</sup>/year in 2020 and 48.9 kWh/m<sup>2</sup>/year in 2050, whilst the overheating hours can be 3164 and 3529, respectively. As a result, only 144.6 kWh/year reduction in total energy consumption can be expected in 2050 (1148.4 kWh/year decrease in heating energy consumption and 1003.6 kWh/year increase in cooling energy consumption).

The result also show that the 25% decrease in thermal conditions indicate similar results in heating energy consumption and overheating hours, compared to the current regulations revised in 2015. Heating energy consumption with the 25% decrease in thermal conditions is only 1 kWh/m<sup>2</sup>/year higher than the consumption with the thermal conditions in 2015, whilst 10 more overheating hours are found. 1 kWh/m<sup>2</sup>/year higher heating energy consumption can be still continued in 2020, and 14 extra overheating hours are shown. In 2050, 17 more overheating hours are found with the 25% decrease in thermal condition, and 0.7 kWh/m<sup>2</sup>/year higher heating consumption is identified.

The change in unit-specific energy consumption with the 25% decrease in thermal conditions is also nearly similar to the result from the current conditions in 2015. The most significant reduction occurs in the unit on the top floor, with 18 kWh/m<sup>2</sup>/year, whilst the smallest reduction of 10 kWh/m<sup>2</sup>/year is found on the ground floor. This can bring about a 136 kWh/year increase in total energy consumption on the ground floor, but a 557 kWh/year decrease in the consumption on the top floor.

In this respect, the improvement of thermal conditions in 2015 is not efficient in reducing both heating energy consumption and overheating hours with TRY, compared to the result



with the thermal regulation in 2014. Moreover, the inefficient reduction could be continued in 2020 and 2050.

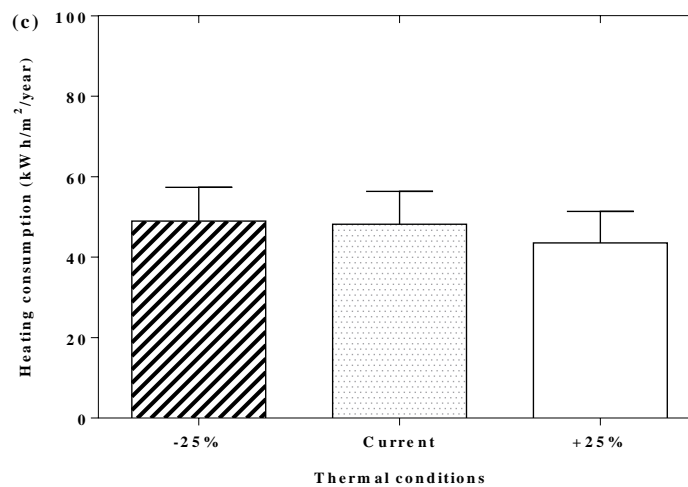
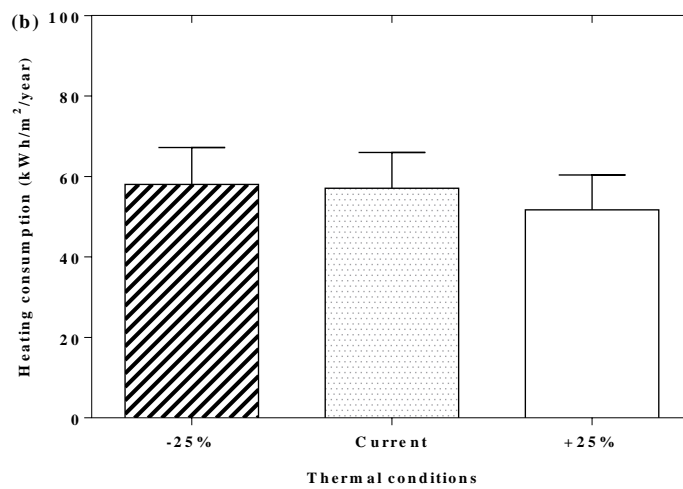
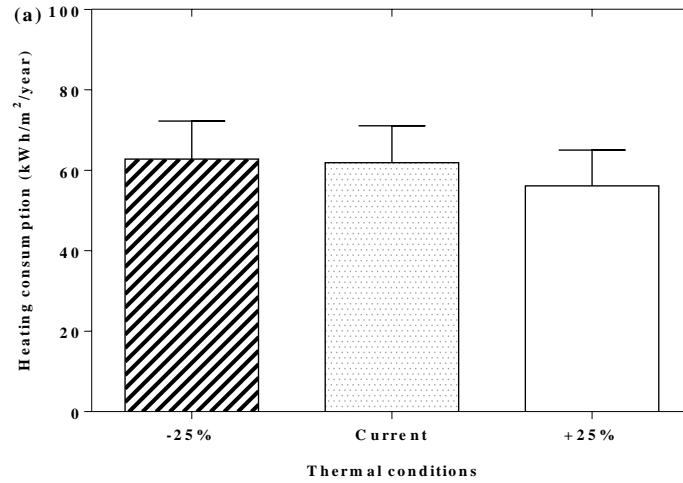

**Figure 7.9. Change in heating energy consumption under future climate change: (a) Typical Reference Year, (b) 2020 and (c) 2050**

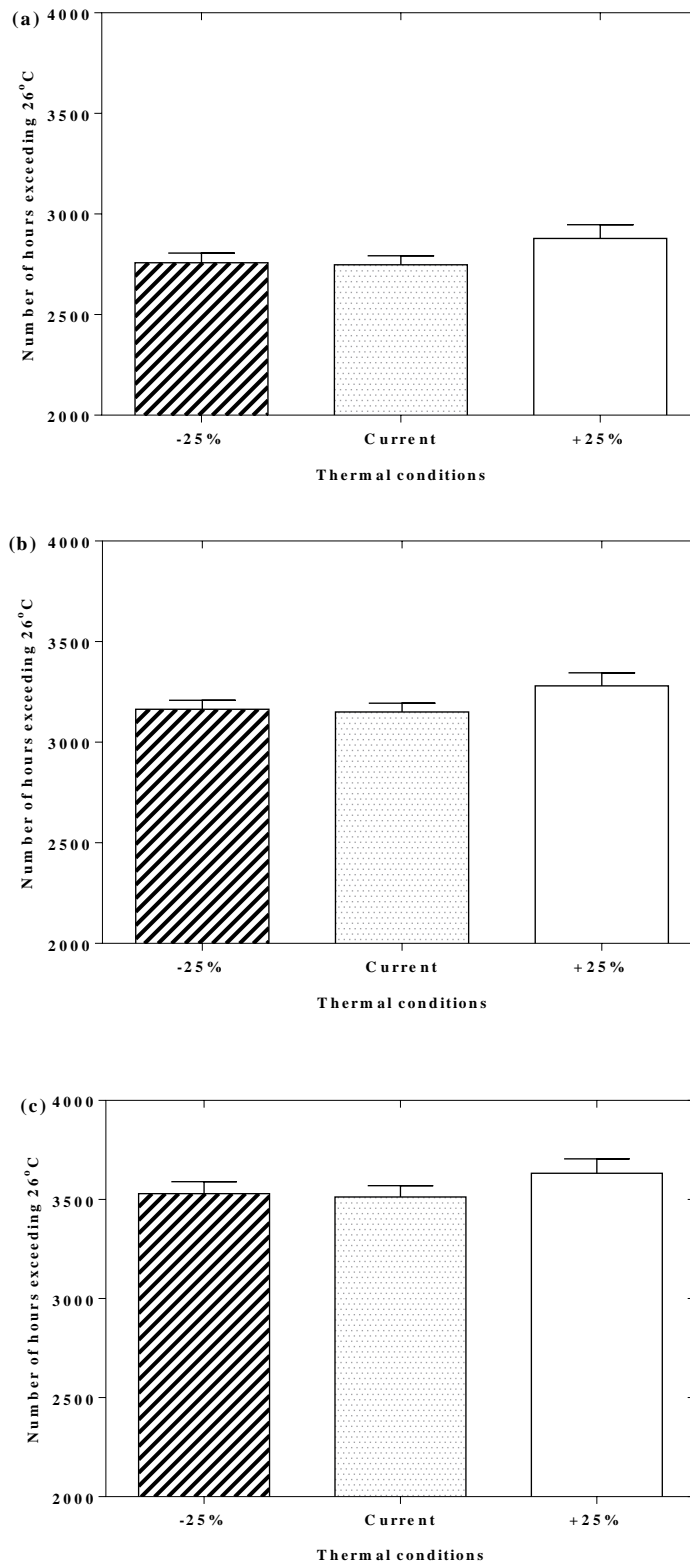

**Figure 7.10. Change in overheating hours under future climate change: (a) Typical Reference Year, (b) 2020 and (c) 2050**

- **25% increased thermal conditions**

The average heating energy consumption with the 25% increase in thermal conditions is 56.1 kWh/m<sup>2</sup>/year with TRY, whilst the number of overheating hours is 2878. The heating energy consumption is reduced to 51.7 kWh/m<sup>2</sup>/year in 2020 and 43.5 kWh/m<sup>2</sup>/year in 2050, whilst the overheating hours becomes 3279 in 2020 and 3633 in 2050. The increased cooling energy consumption is 157.8 kWh/year higher than the reduced heating energy consumption in 2020. However, the reduced heating energy consumption is, reversely, 59.3 kWh/year higher than the increased cooling energy consumption in 2050.

In comparison to the results of the current thermal conditions in 2015, the 25% increase in thermal insulation results in about 5 – 6 kWh/m<sup>2</sup>/year lower heating energy consumption, whereas the number of overheating hours is increased by about 131. However, the difference in heating energy consumption is continued in 2020 and 2050. The difference in overheating hours is reduced to 129 in 2020 and 120 in 2050. Unlike the result of the 25% decrease in thermal conditions, the more prominent change in reducing heating energy consumption and overheating hours is shown.

The reduction in heating consumption on the top floor is 17 kWh/m<sup>2</sup>/year, whilst the reduction on the ground floor is 9 kWh/m<sup>2</sup>/year. The number of overheating hours is gradually reduced from the second floor to the ground floor and from 12<sup>th</sup> floor to the top floor. The top and ground floors indicate 168 and 124 less overheating hours respectively, exceeding 26°C of zone mean temperature higher than the average value. The change can reduce total energy consumption on the top floor up to 401 kWh/year. However, the total energy consumption on the ground floor is increased up to about 193 kWh/year due to the smaller amount of heating energy consumption reduction.

In summary, the total energy consumption with the 25% increase in thermal conditions can still be reduced by climate change impact, but limited. The increased overheating hours brings about more cooling consumption. However, the amount of energy for heating is reduced more than the increased cooling energy.

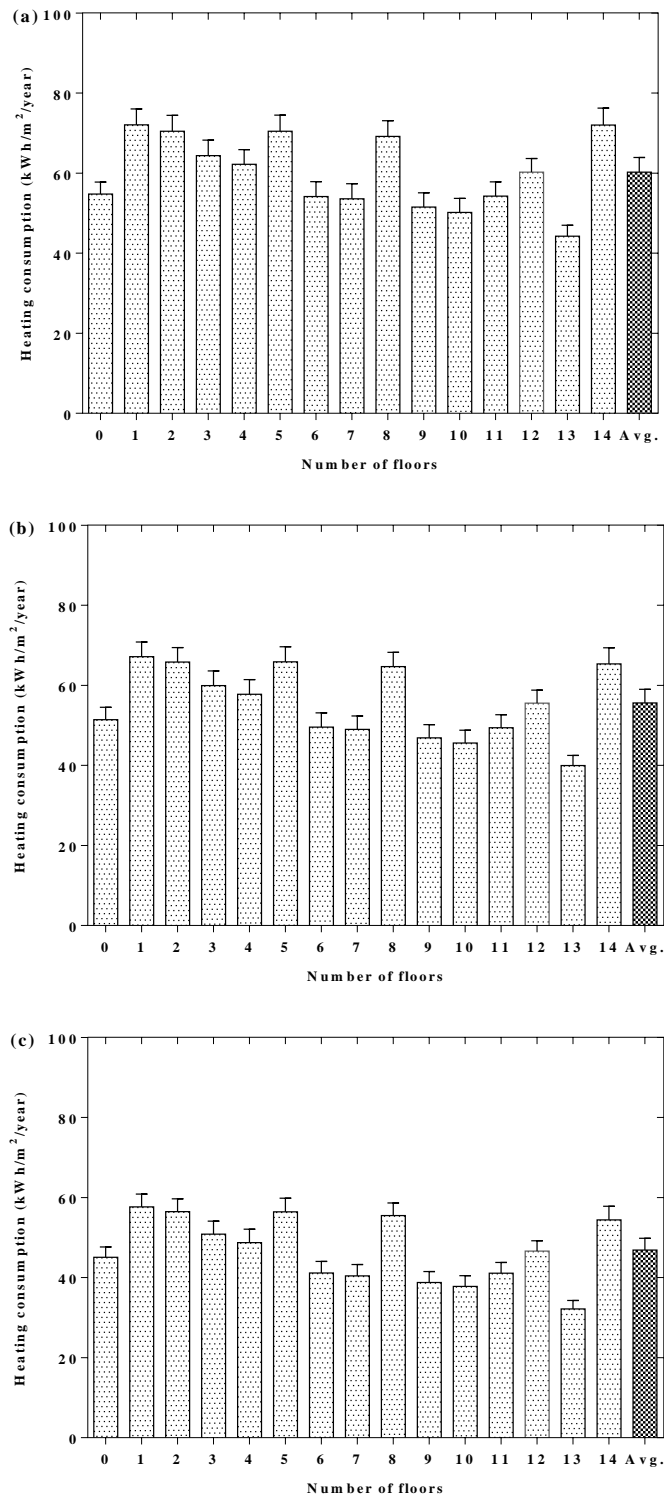

Figure 7.11. Impact of future climate change on the unit-specific heating energy consumption: (a) Typical Reference Year, (b) 2020, (c) 2050

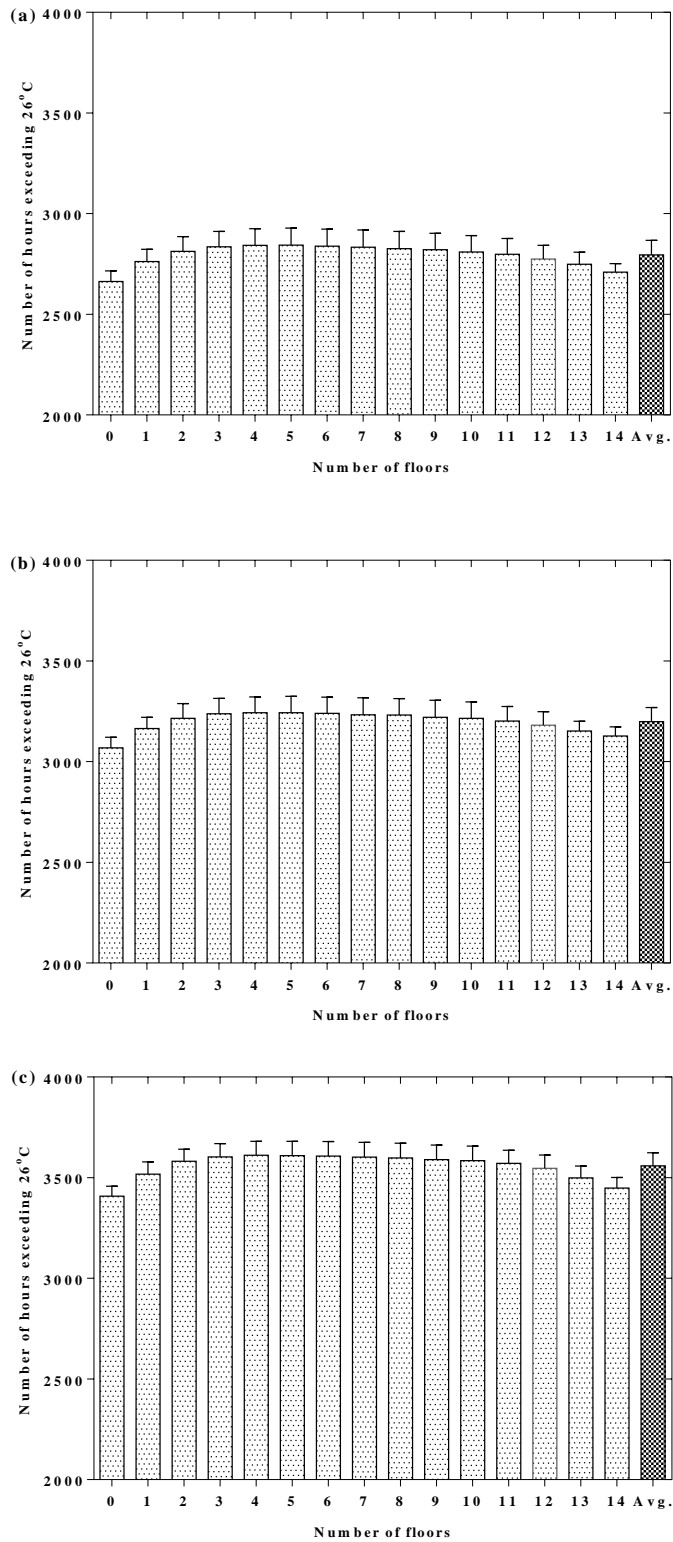
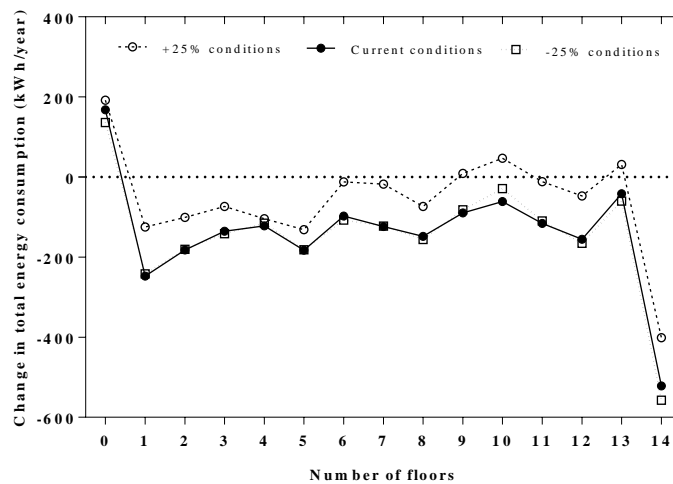

Figure 7.12. Impact of future climate change on overheating hours in individual units: (a) Typical Reference Year, (b) 2020, (c) 2050



**Figure 7.13. Change in total energy consumption with three refurbishment strategies under the future climate change**

## 7.4 Summary

In this chapter, refurbishment strategies, defined by the building thermal regulations in 1987, 2011, 2014, 2015 and the upcoming conditions, were evaluated for existing high-rise apartment buildings with regard to future climate change scenarios. This has been carried out by the building energy model developed for existing apartment buildings to measure the efficiency of reducing heating energy consumption.

The actual heating energy consumption in high-rise apartment buildings sensitively corresponds to the dry-bulb temperature. 0.9 – 1.2 kWh/m<sup>2</sup>/year of heating consumption was changed by 1°C change in dry-bulb temperature between -10°C and 10°C. Thus, climate projections, indicating the increase of mean temperature in South Korea, could impact on energy consumption in buildings.

By upgrading the thermal conditions of the six parts of the building envelope, heating energy consumption was significantly reduced, but the reduction was limited. Inserting thermal insulation always brought about the most significant reduction up to 76 kWh/m<sup>2</sup>/year. Only 1 – 2 kWh/m<sup>2</sup>/year reduction was found by further improvement of the thermal conditions

with the regulations after 2011. Moreover, the holistic approaches also showed the limited reduction in heating energy consumption. Despite the increase of overheating hours, the reduced heating energy consumption outweighed the increased cooling consumption. 4100 kWh/year of the total energy consumption in the baseline model was reduced by inserting thermal insulation, following the regulation in 1987. However, inefficient change in total energy consumption with only 264.1 kWh/year was found between the thermal regulations in 2014 and 2015.

With the climate change scenarios, heating energy consumption can be reduced, whilst cooling energy consumption is expected to be increased. However, the change in total energy consumption is between 50 – 600 kWh/year, which would be insignificant in the average energy consumption in residential buildings in South Korea.

The thermal conditions with the current building regulations in 2015 did not result in an efficient reduction in heating energy consumption, compared to the previous regulations in 2014. Almost, similar results in the heating energy consumption and overheating hours were identified in the TRY, 2020 and 2050. Although 25% increased conditions reduced heating energy consumption, as well as overheating hours with regard to climate change, the difference is limited to the 5 – 6kWh/m<sup>2</sup>/year reduction in heating energy and 131 hours of overheating period with both current and future climate conditions.

Consequently, the climate change effect in South Korea with heating dominant climate conditions is not significant for annual energy consumption in old high-rise apartment buildings. Therefore, refurbishment strategies should focus on reducing heating energy consumption. However, the current approach, improving the thickness of insulation and the window conditions in the building envelope, showed limited effects on reducing heating consumption. Thus, other methods need to be considered.

## **Chapter 8**

---

### **Conclusions and future works**



This thesis set out to explore the building energy models of high-rise apartment buildings, and has integrated the influential factors causing variation in actual energy consumption in existing high-rise apartment buildings in South Korea. The previous literature on this subject, and specifically in the context of South Korea, is unsatisfactory, due to the influential factors disregarded in the conventional building energy models. To provide rigorous estimation of refurbishment strategies, which can be achieved in real situations, conventional building energy models needed to be improved. The conditions of the influential factors were sought and optimised for the building energy model of existing apartment buildings, based on the actual energy consumption, through the process of this thesis. As a result, the efficient building features on energy consumption are used as a guide to classify the existing apartment buildings to treat the variations arising from the physical characteristics. Moreover, the new standardised conditions of occupants' behaviours consuming heating and electricity could provide the adapted data for a building energy model for these buildings. Furthermore, the specified approach of modelling in regard to variation in individual units let the building energy model be more comprehensive. Key findings of each factor are addressed in the following section.

## **8.1 Contributions of the thesis**

Chapter 4 questioned how to define the physical characteristics of existing apartment buildings to control the variation arising from the building features affecting energy consumption. The question was approached by analysing the transformation of the building features in existing apartment buildings and its relation to actual energy consumption. The effectiveness of building features in changing energy consumption were quantified, and applied to classify existing apartment buildings for building energy models as well as refurbishment.

The main contribution of this chapter is the classification of building features affecting energy consumption in old existing high-rise apartment buildings with empirical

verification. It has been revealed in this research that the first priority of the classification should be given to building envelopes. Therefore, construction years, representing the thermal conditions of the building envelopes, have to be the first consideration for the building energy model as well as refurbishment. Heating methods and unit sizes can be followed as subsidiary categories. By using this classification, the building energy model of the existing apartment buildings could control the variation arising from the physical characteristics.

Chapter 5 focused on the variation in actual energy consumption caused by occupants' behaviours in controlling heating and electricity. Energy use in existing apartment buildings built in the 1970s – 1980s was 10 – 30% deviated from, the average, despite the effective building features that were constrained not to impact on energy consumption. Gaussian Process Classification dealt with the sets of occupants' behaviours to functions. Bayesian inference allowed inferring the distribution of occupants' behaviours consuming heating and electricity in South Korean households from actual energy consumption. The inferred results provide the quantified conditions of controlling heating systems and electric devices with their probabilities.

A key contribution of this chapter is a new approach in using the stochastic data of occupants' behaviours consuming energy in building simulation. For apartment buildings which target unspecified ordinary people, the unpredictable occupants' behaviours with high levels of variation need to be treated by probabilistic values, rather than deterministic values. The 90% of probability of heating consumption was drawn by the set-point temperature between 17°C and 20°C, when three to eight hours of the operation in 25% deviation. Electricity consumption with 25% deviation was defined by three to six hours for the several effective appliances. These findings benefit the building energy model in selecting the profile of occupants' behaviours consuming energy only with valid parameters, and reduce the uncertainties in the model estimation.

Chapter 6 looked at the existing apartment buildings at a more precise scale, the individual apartment units. The conventional modelling was fragmented to reflect the real situation of apartment buildings, not only as one large building, but also as single units individually controlled by independent occupants. This study attempted to combine both of these in the building energy model with actual consumption data to reduce the variation arising from individual units. The energy model was, firstly, established with regard to the variation in the physical conditions of apartment units in different locations. Then, the new numerical model was created to integrate individual heating controls in apartment units and the interaction between floors into the first building energy model, and applied to seek the dataset of unit-specific heating controls determining actual heating consumption in each unit.

The contribution of this chapter is encompassing the fragmented approaches of treating individual apartment units in the conventional building energy models. This comprehensive understanding of apartment buildings upgraded the building energy model of apartment buildings to take variation arising from individual units into account. It has been found that two conditions which had a high correlation with heating energy consumption need to be considered to take into account this unit-specified heating energy consumption: heating controls in individual apartment units, consisting of heating set-point temperatures and heating hours, and heating set-point temperatures between floors, concerning the interlinked heat transfer between floors through the sharing slabs in the whole apartment building. It has been revealed that the set-point temperatures were distributed between 18°C and 22°C depending on the unit locations, with seven and eight hours of heating in operation. This dataset of heating controls, which is specified by individual units with the different locations, provided the individual setting of heating in each apartment unit.

Chapter 7 implemented the developed building energy model to evaluate the building thermal regulations from 1987 to the present, as refurbishment strategies for existing apartment buildings. The initial question of this work was whether the refurbishment

strategies, created by the building thermal regulations from 1987 to the present, result in a continuous reduction in energy consumption in the existing apartment buildings under future climate change.

It has been found that the significant reduction in total energy consumption can be achieved with the refurbishment strategies conditioned with the regulations of 1987 and 2011. Efficient energy reduction can be expected with the thermal conditions of these regulations. Under climate change, it has been revealed that South Korea in heating dominant climates would not have a great difference in total energy consumption with only about 50 – 600 kWh/year in 2050. The findings of this chapter suggest that policy on thermal regulations in buildings in South Korea should focus on reducing heating energy consumption rather than considering the possible increase of cooling loads due to climate projection. Despite this, it has been found that the current thermal regulation of 2015, with a 25% improvement from the conditions in 2014, is inefficient.

## **8.2 Future works**

Through the whole process of the research, this study attempted to improve the building energy model for existing high-rise apartment buildings, by treating the uncertain and disregarded factors inferred from the actual energy consumption to reflect real situations. However, there are some still limitations, which could be worthwhile for future work.

Firstly, this study only used buildings in Seoul, South Korea. The influential factors investigated in this study are essential for buildings in different locations. Therefore, the factors can be differently defined in different locations, regarding construction details, climates and occupants, not only with other cities in South Korea, but also other Asian countries that have a large number of these buildings, such as China, Hong Kong and Singapore. For instance, Hong Kong is classified as the sub-tropical climate conditions; thus cooling energy consumption is more important issue than heating. In a previous study (Cheung *et al.*, 2005), the thickness of insulation was experimented with its relation to

cooling energy consumption in high-rise apartment buildings in Hong Kong. In China, due to the wide range of climate conditions, the thermal conditions of buildings are differently determined by regions, as shown in (Ling *et al.*, 2015). These diversities could be compared to provide the broader understanding of high-rise apartment buildings in Asia.

Secondly, the scope of buildings is limited to existing apartment buildings constructed before 2001. However, this scope could be expanded or shifted to other periods. During analysis in Chapter 4, an interesting finding was that high energy consumption is also found in apartment buildings constructed between 2008 and 2010, despite the view that the building conditions are expected to be more energy-efficient. This unexpected higher consumption needs to be interpreted. Moreover, this would provide the different quantifications of the influential factors used for building energy models.

Thirdly, this study only focused on the three influential factors, physical characteristics, occupants' behaviours controlling heating and electricity and individual units. Despite the significance of these three factors in buildings, the focus can be extended to other factors or even more specified with these three. For example, occupants' window opening behaviours controlling ventilation could be another factor that can be extended, as reviewed in (Fabi *et al.*, 2012). This could be determined by buildings in the specific context and comparable with others. These comparative studies could provide a broader range of the understanding of treating these uncertain and disregarded factors in the building energy model of high-rise apartment buildings.

---

## References

References written in Korean are indicated by '(Korean)' at the end of reference.

Aksoy, U. and Inalli, M. (2006). Impacts of some building passive design parameters on heating demand for a cold region. *Building and Environment*, 41(12), pp.1742-1754.

Asadi, E., da Silva, M., Antunes, C. and Dias, L. (2012). Multi-objective optimization for building retrofit strategies: A model and an application. *Energy and Buildings*, 44, pp.81-87.

ASHRAE., (2013). *2013 ASHRAE Handbook - Fundamentals*, Atlanta, USA: ASHRAE.

Australia Green Building Council. (2012). Green Star. Green Building Council of Australia.

Bae, J., Chung, Y. and Yoon, C. (2001). A Study on Characteristics of Apartment Housing Unit Plans. *Journal of The Korean Housing Association*, 12, pp.1-12. (Korean)

Baek, C. and Park, S. (2012). Changes in renovation policies in the era of sustainability. *Energy and Buildings*, 47, pp.485-496.

Balaras, C., Drousa, K., Dascalaki, E. and Kontoyiannidis, S. (2005). Heating energy consumption and resulting environmental impact of European apartment buildings. *Energy and Buildings*, 37(5), pp.429-442.

Baldwin, R., Leach, S., Doggart, J. and Attenborough, M. (1990). Building Research Establishment Environmental Assessment Method. UK BREEAM Version 1/90 for New Office Designs.

Bandyopadhyaya, P.S. and Forster, M. (2011). *Handbook of the Philosophy of Statistics*. Oxford, UK: Elsevier.

Barnett, V. and Barnett, V. (1991). *Sample survey principles and methods*. London: Edward Arnold.

BektasEkici, B. and Aksoy, U. (2011). Prediction of building energy needs in early stage of design by using ANFIS. *Expert Systems with Applications*, 38(5), pp.5352-5358.

Bell, M., Wingfield, J., Miles-Shenton, D. and Seavers, J. (2010). Low carbon housing: lessons from Elm Tree Mews. [online] Available at: <https://www.jrf.org.uk/report/low-carbon-housing-lessons-elm-tree-mews>. [Accessed 10/05 2016]

- 
- Bernardo, J., Berger, J., Dawid, A. and Smith, A. (1998). Regression and classification using Gaussian process priors. *Bayesian Statistics*, 6, 475.
- Bougdah, H. and Sharples, S. (2009). *Environment, technology and sustainability*. London, UK: Taylor & Francis.
- Bourgeois, D., Reinhart, C. and Macdonald, I. (2006). Adding advanced behavioural models in whole building energy simulation: A study on the total energy impact of manual and automated lighting control. *Energy and Buildings*, 38(7), pp.814-823.
- Campbell, D., Stanley, J. and Gage, N. (1966). *Experimental and quasi-experimental designs for research*. Chicago, Ill.: R. McNally.
- Chang, H. (2006). *The East Asian development experience*. Penang, Malaysia: Third World Network.
- Chen, P. and Popovich, P. (2002). *Correlation*. Thousands Oaks, Calif.: Sage Publications.
- Cheong, C., Kim, J., Kim, T., and Leigh, S. (2009). Verification about the Energy Consumption Reduction Performance of Double Window System in Residential Building. *Journal of the Architectural Institute of Korea Planning & Design*, 25, pp.393-401. (Korean)
- Cheung, C., Fuller, R. and Luther, M. (2005). Energy-efficient envelope design for high-rise apartments. *Energy and Buildings*, 37(1), pp.37-48.
- Cho, S., Kim, S., and Choi, C. (2010). Study on the Revision of HDD for 15 Main Cities of Korea. *Journal of Air-Conditioning and Refrigeration Engineering*, 22, pp.436-441. (Korean)
- Choi, E. (2004). Residential Segregation and the Differentiation of Housing Value in Seoul. *Journal of the Korean Association of Regional Geographers*, 10(2), pp.592-605. (Korean)
- Choi, J. and Cho, S. (2012). A Study on Relationship Insulation Thickness and Infiltration Load by Window. *Korean Journal of Air-Conditioning and Refrigeration Engineering*, 24(5), pp.422-427. (Korean)
- Choi, M. (1997). A Study on the Characteristics of the Physical Form and the Spatial Layout of Multi-Family Housing in Taegu. *Journal of the Architectural Institute of Korea*, 13, pp.117-124. (Korean)
- Choi, W., Kim, H., Lee, H. and Suh, S. (2007a). Theoretical Study on the Patterns of Temperature Variation and Thermal Load According to Each Household Heating and

- Cooling in Apartment. *Journal of the Architectural Institute of Korea Planning & Design*, 23, pp.279-288. (Korean)
- Choi, W., Kim, H. and Suh, S. (2007b). A Study on the Simulation Methods for Thermal Performance Analysis in Apartment Housing - Focused on the Modelling Methods Using the TRNSYS. *Journal of the Architectural Institute of Korea Planning & Design*, 23, pp.155-162. (Korean)
- Chow, D., Li, Z. and Darkwa, J. (2013). The effectiveness of retrofitting existing public buildings in face of future climate change in the hot summer cold winter region of China. *Energy and Buildings*, 57, pp.176-186.
- Christensen, C., Anderson, R., Horowitz, S., Courtney, A. and Spencer, J. (2006). *BEopt software for building energy optimization: features and capabilities*, National Renewable Energy Laboratory.
- Chung, Y. (2007). *South Korea in the fast lane*. Oxford: Oxford University Press.
- Climate Change Information Center. (2015). *Climate change Scenarios*. [online] Available at: [http://www.climate.go.kr/home/02\\_information/07\\_5.html](http://www.climate.go.kr/home/02_information/07_5.html) [Accessed 26/01 2016]. (Korean)
- Collins, L., Natarajan, S. and Levermore, G. (2010). Climate change and future energy consumption in UK housing stock. *Building Services Engineering Research and Technology*, 31(1), pp.75-90.
- Çomaklı, K. and Yüksel, B. (2003). Optimum insulation thickness of external walls for energy saving. *Applied Thermal Engineering*, 23(4), pp.473-479.
- Crawley, D., Hand, J., Kummert, M. and Griffith, B. (2008). Contrasting the capabilities of building energy performance simulation programs. *Building and Environment*, 43(4), pp.661-673.
- Crawley, D., Lawrie, L., Winkelmann, F., Buhl, W., Huang, Y., Pedersen, C., Strand, R., Liesen, R., Fisher, D., Witte, M. and Glazer, J. (2001). EnergyPlus: creating a new-generation building energy simulation program. *Energy and Buildings*, 33(4), pp.319-331.
- Doob, J. (1953). *Stochastic processes*. New York: Wiley.



- DIN, V. (2007). 18599-2 (2007-02) Energy efficiency of buildings—calculation of the net, final and primary energy demand for heating, Cooling, Ventilation, Domestic hot water and lighting—Part, 2.
- Economidou, M., Atanasiu, B., Despret, C., Maio, J., Nolte, I. and Rapf, O. (2011). Europe's Buildings under the Microscope. A Country-by-Country Review of the Energy Performance of Buildings. *Buildings Performance Institute Europe (BPIE)*.
- Enforcement Decree of the Housing Act 2009, Article 4-2 (Scope of Extension), Presidential Decree No. 21098, Ministry of Land, Infrastructure and Transport. South Korea. (Korean)
- EnergyPlus Documetation. (2010). *Tips & tricks for using EnergyPlus: insider secrets to using EnergyPlus*, US Department of Energy.
- Eurostat (2014). *Heating degree-days by NUTS 2 regions - monthly data - Eurostat*. [online] Available at: [http://ec.europa.eu/eurostat/en/web/products-datasets/-/NRG\\_ESDGR\\_M](http://ec.europa.eu/eurostat/en/web/products-datasets/-/NRG_ESDGR_M) [Accessed 27/01 2015].
- Everitt, B. and Dunn, G. (2001). *Applied multivariate data analysis*. London: Arnold.
- Fabi, V., Andersen, R., Corgnati, S. and Olesen, B. (2012). Occupants' window opening behaviour: A literature review of factors influencing occupant behaviour and models. *Building and Environment*, 58, pp.188-198.
- Field, A. (2009). *Discovering statistics using SPSS*. Los Angeles, USA: SAGE Publications.
- Florides, G., Tassou, S., Kalogirou, S. and Wrobel, L. (2002). Measures used to lower building energy consumption and their cost effectiveness. *Applied Energy*, 73(3-4), pp.299-328.
- Galvin, R. (2014a). Integrating the rebound effect: accurate predictors for upgrading domestic heating. *Building Research & Information*, 43(6), pp.710-722.
- Galvin, R. (2014b). Why German homeowners are reluctant to retrofit. *Building Research & Information*, 42(4), pp.398-408.
- Gao, T., Ihara, T., Grynning, S., Jelle, B. and Lien, A. (2016). Perspective of aerogel glazings in energy efficient buildings. *Building and Environment*, 95, pp.405-413.
- Gelézeau, V. (2007). *The Republic of Apartments (Apart Gonhwagook)*. Seoul, South Korea: Humanitasbooks. (Korean)

- 
- Gelman, A., Carlin, J.B., Stern, H.S. and Rubin, D.B. (2014). *Bayesian data analysis*. London: Chapman & Hall/CRC.
- Gholami, E., Sharples, S., Shokooch, J.A. and Kochturk, T., 2013, September. Exploiting BIM in Energy Efficient Refurbishment. In *PLEA 2013 29<sup>th</sup> Conference, Sustainable Architecture for a Renewable Future, Munich, Germany*
- Gibb, K. (1996). Housing affordability: key issues and policies. *Strategies for Housing and Social Integration in Cities*, pp.147-192.
- Gorgolewski, M. (1995). Optimising renovation strategies for energy conservation in housing. *Building and Environment*, 30 (4), pp.583-589.
- Gorgolewski, M., Grindley, P. and Probert, S. (1996). Energy-efficient renovation of high-rise housing. *Applied Energy*, 53(4), pp.365-382.
- Guerra Santin, O., Itard, L. and Visscher, H. (2009). The effect of occupancy and building characteristics on energy use for space and water heating in Dutch residential stock. *Energy and Buildings*, 41(11), pp.1223-1232.
- Guglielmetti, R., Macumber, D. and Long, N., 2011, November. OpenStudio: an open source integrated analysis platform. In *Proceedings of the 12th Conference of International Building Performance Simulation Association*.
- Gunay, H., O'Brien, W. and Beausoleil-Morrison, I. (2013). A critical review of observation studies, modeling, and simulation of adaptive occupant behaviors in offices. *Building and Environment*, 70, pp.31-47.
- Gupta, R. and Gregg, M. (2013). Preventing the overheating of English suburban homes in a warming climate. *Building Research & Information*, 41(3), pp.281-300.
- Ha, S. (2007). *Resident's Satisfaction Evaluation of Rental Apartment by Heating Type in Busan - Kyungnam*. Master, Pukyong University. (Korean)
- Harvey, F. (2015). *Paris climate change agreement: the world's greatest diplomatic success*. [online] the Guardian. Available at: <http://www.theguardian.com/environment/2015/dec/13/paris-climate-deal-cop-diplomacy-developing-united-nations> [Accessed 26/01 2016].
- Hee, W., Alghoul, M., Bakhtyar, B., Elayeb, O., Shameri, M., Alrubaih, M. and Sopian, K. (2015). The role of window glazing on daylighting and energy saving in buildings.

---

*Renewable and Sustainable Energy Reviews*, 42, pp.323-343.

Hansen, J., Ruedy, R., Sato, M. and Lo, K. (2010). Global Surface Temperature Change. *Review of Geophysics*, 48(4).

Hensen, J. L. and Lamberts, R. (2012). *Building performance simulation for design and operation*, London, UK: Routledge.

Heo, Y., Choudhary, R. and Augenbroe, G. (2012). Calibration of building energy models for retrofit analysis under uncertainty. *Energy and Buildings*, 47, pp.550-560.

Hoes, P., Hensen, J., Loomans, M., de Vries, B. and Bourgeois, D. (2009). User behavior in whole building simulation. *Energy and Buildings*, 41(3), pp.295-302.

Hong, D. and Lett, D. (1999). In Pursuit of Status: The Making of South Korea's "New" Urban Middle Class. *Contemporary Sociology*, 28(6), p.677.

Hong, J. (2003). *A Study on the Varying Trend for Apartment Unit Plan in Seoul and the Metropolitan Area*. Master, Yonsei University. (Korean)

Hong, T., Chou, S. and Bong, T. (2000). Building simulation: an overview of developments and information sources. *Building and Environment*, 35(4), pp.347-361.

Huh, J. (2013). *2013 Handbook of Energy and Economic Statistics in Korea*. Yongin, South Korea: Korea Energy Management Corporation. (Korean)

Hunt, B., Lipsman, R. and Rosenberg, J. (2014). *A guide to MATLAB: for beginner and experienced users*. Cambridge, UK: Cambridge University Press.

Hyun, S., Park, C. and Augenbroe, G. (2008). Analysis of uncertainty in natural ventilation predictions of high-rise apartment buildings. *Building Services Engineering Research and Technology*, 29(4), pp.311-326.

Ingle, A., Moezzi, M., Lutzenhiser, L. and Diamond, R. (2014). Better home energy audit modelling: incorporating inhabitant behaviours. *Building Research & Information*, 42(4), pp.409-421.

ISO, E. 2008. 13790: Energy performance of buildings—Calculation of energy use for space heating and cooling (EN ISO 13790: 2008). *European Committee for Standardization (CEN), Brussels*.

Jang, C., Han, H., and Lee, J. 2010, April. The Building Energy Rating Evaluation of Middle

- Region Apartment Depending on Window Area Ratio. In *The Spring conference of Korea Institute of Architectural Sustainable Environment and Building Systems*, pp.207-210. (Korean)
- Jang, H., Jones, L. and Kang, J. (2015). Prioritisation of old apartment buildings for energy-efficient refurbishment based on the effects of building features on energy consumption in South Korea. *Energy and Buildings*, 96, pp.319-328.
- Jang, H. and Kang, J. (2016). A stochastic model of integrating occupant random behaviour into energy simulation with respect to actual energy consumption in high-rise apartment buildings. *Energy and Buildings*, (Accepted for publication).
- Jang, H. and Kang, J. (2016). An energy model of high-rise apartment buildings integrating variation in energy consumption depending on individual units. (In preparation to submit *Journal of Building Performance Simulation*).
- Jee, H. (1988). *A Geographical Study of the Change in the School year group and Educational Space in Seoul*. Master, EhwaWomans University. (Korean)
- Jentsch, M., James, P., Bourikas, L. and Bahaj, A. (2013). Transforming existing weather data for worldwide locations to enable energy and building performance simulation under future climates. *Renewable Energy*, 55, pp.514-524.
- Jeon, N. (2010). *Spatial history of housing in South Korea (Hangukjugeogonggansa)*. Paju, South Korea: Dolbaegae. (Korean)
- Jo, H., Jin, S. And Kim, M. (2010). *Energy Reduction Strategy Toward Low-carbon Society 2009*. Seoul: Seoul Development Institute. (Korean)
- Johnson, R. and Wichern, D. (1992). *Applied multivariate statistical analysis*. Englewood Cliffs, N.J.: Prentice-Hall.
- Jones, R. S. and B. Yoo (2012), "*Achieving the "Low Carbon, Green Growth" Vision in Korea*", OECD Economics Department Working Papers, No. 964, OECD Publishing, Paris. DOI: <http://dx.doi.org/10.1787/5k97gkdc52jl-en>
- Kaiser, H. F. and Rice, J. (1974). Little Jiffy, Mark IV. *Educational and psychological measurement*.
- Kalbfleisch, J. (2012). *Probability and Statistical Inference: Volume 1: Probability*. New York, NY: Springer & Business Media.

- Kang, B. (2010). *A Study on the Evaluation System of the Green-building Certifications for Energy Conservation in Apartment Housing*. PhD, Gyeongsang National University. (Korean)
- Kang, H., Won, Y. and Kim, Y. (2010). A Study on the Long-Term Maintenance Costs and Elemental Maintenance Costs for Apartment Buildings. *Journal of the Architectural Institute of Korea Structure & Construction*, 26, 111-118. (Korean)
- Kang, J., Lee, S. and Ahn, T. (1995). A Study on Characteristics of Energy Consumption in Apartment Buildings. *Journal of the Architectural Institute of Korea*, 11, 139-148. (Korean)
- Ki, H., Park, J. and Park, J. 2013, November. An Analysis on the Effects of Applying Interior Insulation and Exterior Insulation in Buildings, In *The Winter Conference of the Society of Air-Conditioning and Refrigerating Engineers of Korea*, pp. 310-313. (Korean)
- Kim, W., Cha, H., Shin, D. And Kim, K. (2013a). Profit/Cost Prediction Model for Economic Feasibility Assessment on Aged-Housing Remodeling Projects. *Journal of the Architectural Institute of Korea Structure & Construction*, 29, pp.85-89. (Korean)
- Kim, C., Ahn, B., Kim, J. and Jang, C. 2009a. April. A Study on the Evaluation of Building Energy Rating considering the Insulation Performance of the Window and Wall in Apartment Houses. In *The Spring Conference of the Society of Air-Conditioning and Refrigerating Engineers of Korea*, pp.291-295. (Korean)
- Kim, D., Chung, K., Kim, Y. And Kim, S. (2013b). A Comparative Study on Heating Energy Consumption for Apartment Based on the Annually Strengthened Criteria of Insulation. *Journal of Energy Engineering*, 22, pp.83-89. (Korean)
- Kim, J. (2013). *A Comparative Study on the Regional Group of City Gas Consumption in Apartment Housing*. Master. Dong-A university. (Korean)
- Kim, J., Chun, J. and Lee, B. (2009b). Study about Change of Insulation Standard in Apartment in Its Effect. *Journal of Architectural Institute of Korea*, 11, pp.125-132. (Korean)
- Kim, J. and Lee, B. (2005). A Study on the Investigation of the Amount of City Gas Use for the Location of a Major Apartment Building and House Holds - With Reference to the City of Jinju, Gyeongnam. *Journal of the Architectural of Korea Planning & Design*, 21, pp. 217-226. (Korean)
- Kim, J., Moon, J. and Lee, B. (2006a). Experimental Study on the Influence of the Insulation

of External Walls in the Basement of Apartment Houses to the Temperature of Basement and the Consumption of Heating City-gas on the First Floor. *Journal of the Architectural Institute of Korea Planning & Design*, 22, pp.241-248. (Korean)

Kim, J., Kim E. and Suh, S. 2006b, June. Prediction on Variation of Building Heating and Cooling Energy Demand according to the Climate Change Impacts on Korea. In *the summer conference of the Society of Air-Conditioning and Refrigerating Engineers of Korea*, pp.789-794. (Korean)

Kim, J., Lee, G., Lee, S., Kim, M. and Min, J. (2013c). An Effect of the Change of Orientation and Window Area Ratio upon Building Energy Requirement in Apartment Housings. *Journal of the Korea Institute of Ecological Architecture and Environment*, 13, pp.21-26. (Korean)

Kim, J., Choi, J. and Um, J. (2011). Comparative Evaluation of Electric Power and LNG Load according to Floor Level of Tower-Type Apartments. *Journal of Korean Society of Environment Impact Assessment*, 20, 10. (Korean)

Kim, M., Park, H. and Song, K. (2013d). Evaluation and Analysis of Building Energy Rating System According to Insulation Performance of Building Envelope in Regional and Building Form of Apartment House. *Korean Journal of Air-Conditioning and Refrigeration Engineering*, 25(2), pp.49-54. (Korean)

Kim, M. and Yoon, C. (2010). A Study on Statistical Characteristics of Space Dimension of 60 and 85m<sup>2</sup> Size Apartment Plan Types in Seoul. *Journal of the Korean Housing Association*, 21, pp.53-65. (Korean)

Kim, M (2010). How to reduce energy consumption in buildings. *Seoul Development Institute Reports*, Seoul: Seoul Development Institute. (Korean)

Kim, M., Jo, H. and Jin, S. (2010). Program Evaluation Methods for Building Energy Saving of Seoul. *Seoul Development Institute Reports*. Seoul: Seoul Development Institute. (Korean)

Kim, S. (2002). Perspectives of apartment buildings in remodeling markets. Seoul: LG Economic Research Institute. (Korean)

Kim, S., Park, D. and Kim, K. (2013e). A Study on Solar Radiation Analysis and Saving Elements of Heating Load according to the Location and Type of Housing in Multi-family Apartments. *Journal of the Korea Institute of Ecological Architecture and Environment*, 13,

pp.47-55. (Korean)

Kim, S. and Kim, S. 1993, October. A Study on the Changes of Apartment Housing Plan in Korea. In *the Autumn conference of the Architectural Institute of Korea*, pp. 113-118. (Korean)

Kleinbaum, D., Kupper, L., Nizam, A. and Rosenberg, E. (2013). *Applied regression analysis and other multivariable methods*. Boston, MA, USA: Cengage Learning.

Korea Appraisal Board (KAB). (2014). *Monthly expenditure of apartment buildings in South Korea*, [online] Apartment Management Information System. Available at: <http://www.k-apt.go.kr/> [Accessed 30/08 2015]. (Korean)

Korea District Heating Corporation (KDHC). (2015). *District Heat Energy Rates Table*. [online] Korea District Heating Corporation. Available at: <https://www.kdhc.co.kr/index.do?sgrp=S10> [Accessed 08/12 2015]. (Korean)

Korea Electric Power Corporation (KEPC). (1990). *Survey on Electricity Consumption Characteristics of Home Appliances*. [online] Korea Statistical Information Service. Available at: [http://kosis.kr/statisticsList/statisticsList\\_01List.jsp?vwcd=MT\\_ZTITLE&parentId=H](http://kosis.kr/statisticsList/statisticsList_01List.jsp?vwcd=MT_ZTITLE&parentId=H) [Accessed 08/12 2015]. (Korean)

Korea Electric Power Corporation (KEPC). (2013). *Survey on Electricity Consumption Characteristics of Home Appliances*. [online] Electric Power Statistics Information System. Available at: [https://epsis.kpx.or.kr/epsis/ekkn/board/n/list.do?bbs\\_id=100232&cd\\_upper=100200&left\\_pos=100232](https://epsis.kpx.or.kr/epsis/ekkn/board/n/list.do?bbs_id=100232&cd_upper=100200&left_pos=100232) [Accessed 08/12 2015]. (Korean)

Korea Electric Power Corporation (KEPC). (2014). *Electric Rates Table* [online]. Korea Electric Power Corporation. Available at: <http://cyber.kepco.co.kr/ckepco/front/jsp/CY/E/E/CYEEHP00201.jsp> [Accessed 20/04 2014]. (Korean)

Korea Housing Management Association (KHMA). (2013). *Certificate results of Green buildings* [online] LH Housing Land Development Institute. Available at: [http://huri.lh.or.kr/ecohouse/sub3\\_07.asp](http://huri.lh.or.kr/ecohouse/sub3_07.asp) [Accessed 25/04 2014]. (Korean)

Korea Meteorological Administration (KMA). (2012). *Climate Change Outlook Report: Seoul, Incheon, Gyeonggi-do*. Seoul: Korea Meteorological Administration. (Korean)

- 
- Korea Meteorological Administration (KMA). (2014). *Annual Climatological Report 2011-2014*. Seoul, South Korea: Korea Meteorological Administration. (Korean)
- Korea Meteorological Administration (KMA). (2015). *Climate data: average year values (1981 - 2010)* [online] Korea Meteorological Administration. Available at: [http://www.kma.go.kr/weather/climate/average\\_30years.jsp?yy\\_st=2011&stn=108&norm=M&x=29&y=12&obs=0&mm=1&dd=11](http://www.kma.go.kr/weather/climate/average_30years.jsp?yy_st=2011&stn=108&norm=M&x=29&y=12&obs=0&mm=1&dd=11) [Accessed 08/12 2015] (Korean)
- Korea Energy Economics Institute (KEEI). (2011). *Energy Consumption Survey*. 1st ed. [ebook] Seoul: Korea Energy Economics Institute. Available at: [http://www.keei.re.kr/keei/download/ECS2011\\_Revised.pdf](http://www.keei.re.kr/keei/download/ECS2011_Revised.pdf) [Accessed 28/01 2015] (Korean)
- Korea Energy Economics Institute (KEEI). (2015). *Dependence of Energy on Overseas Statistics of Energy Demand and Supply*. [online] Korean Statistical Information Service. Available at: [http://kosis.kr/statisticsList/statisticsList\\_01List.jsp?vwcd=MT\\_ZTITLE&parentId=H](http://kosis.kr/statisticsList/statisticsList_01List.jsp?vwcd=MT_ZTITLE&parentId=H) [Accessed 08/12 2015] (Korean)
- Kottek, M., Grieser, J., Beck, C., Rudolf, B. and Rubel, F. (2006). World Map of the Köppen climate classification updated. *Meteorologische Zeitschrift*, 15(3), pp.259-263.
- Lee, B., Chung, D., Lee, S. and Hong, H. (2004). Analysis of Heating Energy in a Korean-Style Apartment Building 2: The Difference according to Heating Type. *Korean Journal of Air-Conditioning and Refrigeration Engineering*, 16, 459-467.
- Lee, J. and Lim, C. (2000). A Study on the effect of heating energy consumption with solar radiation to apartment - concentrated on district heating area in Pusan Haewoondae New town. In *Proceeding of annual conference of the architectural institute of Korea*, pp.529-532. (Korean)
- Lee, J. (2006). *A Study on the Transformation of Apartment Unit Plans after 1990*. Master, Kookmin University. (Korean)
- Lee, J. (2009). *A Study on the Performance Assessment of the Sustainable Building Technologies for Multi-Family Residential Buildings*. Master, Chung Ang University. (Korean)
- Lee, K. and Levermore, G. (2010). Weather data for future climate change for South Korean building design: analysis for trends. *Architectural Science Review*, 53, pp.157-171.



- Lee, K., Kim, K., Kim, K. and Shin, D. (2007). Profitability Influence Factor Analysis by Apartment Remodelling Case Study. *Korea Journal of Construction Engineering and Management*, 8, 133. (Korean)
- Lee, M., Cho, G., Seong, Y., Yeo, M. and Kin, K. 2005, June. A Study of Solar Access Right of Apartment Buildings According to Planning. In *the Autumn Conference of Korean Solar Energy Society*, pp.211-216. (Korean)
- Lee, N., Ahn, B., Jang, C. And Leigh, S. (2012). A Study on Evaluation of the Building Energy Rating depending on the Thermal Performance of Balcony Window with Low-E glazing. *Solar Energy*, 32, pp.58-63. (Korean)
- Li, D., Yang, L. and Lam, J. (2012). Impact of climate change on energy use in the built environment in different climate zones - a review. *Energy*, 42(1), pp.103-112.
- Lim, C. (2011). *Housing in Korea: the History of Transition*, Paju, South Korea: Dolbaegae. (Korean)
- Lim, J., Jung, H. and Yun, G. 2013, November. The forecasts of energy consumption and peak demand for electricity in a building under climate change. In *The Winter conference of the Society of Air-Conditioning and Refrigerating Engineers of Korea*, pp.294-297. (Korean)
- Lim, K. (2008). *A Study on the Evaluation of Residential Environment of the Outdoor Space in Apartment*. PhD, Chosun University. (Korean)
- Ling, J., Li, Q. and Xing, J. (2015). The influence of apartment location on household space heating consumption in multi-apartment buildings. *Energy and Buildings*, 103, pp.185-197.
- Littlefair, P. (2001). Daylight, sunlight and solar gain in the urban environment. *Solar Energy*, 70(3), pp.177-185.
- Ma, Z., Cooper, P., Daly, D. and Ledo, L. (2012). Existing building retrofits: Methodology and state-of-the-art. *Energy and Buildings*, 55, pp. 889-902.
- Macdonald, I.A., 2009, July. Comparison of sampling techniques on the performance of Monte-Carlo based sensitivity analysis. In *Eleventh International IBPSA Conference*. pp. 992-999.
- Mayo, D. and Spanos, A. (2011). *Error and inference*. Cambridge: Cambridge University Press.
- McMullan, R. (1998). *Environmental science in building*. Basingstoke, England: Macmillan.

- Mingotti, N., Chenvidyakarn, T. and Woods, A. (2013). Combined impacts of climate and wall insulation on the energy benefit of an extra layer of glazing in the facade. *Energy and Buildings*, 58, pp.237-249.
- Ministry of Land, Infrastructure and Transport. (2015a). Building Energy Rating System management regulations. *Seoul: Ministry of Land, Infrastructure and Transport*. (Korean)
- Ministry of Land, Infrastructure and Transport. (2015b). Korea Building Energy Saving Design, *Seoul: Ministry of Land, Infrastructure and Transport*. (Korean)
- Ministry of Land, Infrastructure and Transport. (2010). Permission of vertical floor extension in apartment buildings. *Seoul, Ministry of Land, Infrastructure and Transport*. (Korean)
- Ministry of Land, Infrastructure and Transport. (2013). *The Energy-Efficient Certificate Criteria*. [online] Ministry of Land, Infrastructure and Transport. Available at: [http://www.molit.go.kr/USR/law/m\\_46/dtl.jsp?r\\_id=3130](http://www.molit.go.kr/USR/law/m_46/dtl.jsp?r_id=3130) [Accessed 26/01 2015]. (Korean)
- Mohammadpourkarbasi, H. and Sharples, S. (2013). The Eco-Refurbishment of a 19th Century Terraced House: Energy and Cost Performance for Current and Future UK Climates. *Buildings*, 3(1), pp.220-244.
- Moon, C., Kim, S., Seol, W., Kim, J. And Yoon, J. 2001, November. A Study on Maintenance Cost of the Each Heating Type Apartment. In *The Winter conference of the Society of Air-Conditioning and Refrigerating Engineers of Korea*, pp.525-529. (Korean)
- Nakicenovic, N. and Swart, R. (2000). *Special report on emissions scenarios*. Cambridge: Cambridge University Press.
- National Institute of Meteorological Sciences. (2015). *Temperature anomalies*. [online] Climate Change Information Center. Available at: <http://www.climate.go.kr/> Accessed 12/12 2015]. (Korean)
- Neal. R. (1997). Monte Carlo implementation of Gaussian process models for Bayesian regression and classification. *arXiv preprint physics/9701026*.
- Neal, R. (2012). *Bayesian learning for neural networks*. New York: Springer & Business Media.
- Newman, I. and Benz, C. (1998). *Qualitative-quantitative research methodology*. Carbondale, Ill.: Southern Illinois University Press.

- Noh, M. (1998). *A Study on the Comparative Analysis of the Apartment Heating Systems in the Economics*. Master, Konkuk University. (Korean)
- Olivier, J., Janssens-Maenhout, G. and Peters, J. (2012). *Trends in global CO2 emissions*. Luxembourg: Publications Office.
- Ourghi, R., Al-Anzi, A. and Krarti, M. (2007). A simplified analysis method to predict the impact of shape on annual energy use for office buildings. *Energy Conversion and Management*, 48(1), pp.300-305.
- Ouyang, J., Wang, C., Li, H. and Hokao, K. (2011). A methodology for energy-efficient renovation of existing residential buildings in China and case study. *Energy and Buildings*, 43(9), pp.2203-2210.
- Ozel, M. (2014). Effect of insulation location on dynamic heat-transfer characteristics of building external walls and optimization of insulation thickness. *Energy and Buildings*, 72, pp.288-295.
- Pedrini, A., Westphal, F.S. and Lamberts, R. (2002). A methodology for building energy modelling and calibration in warm climates. *Building and Environment*, 37, 903-912.
- Pachauri, S. (2004). An analysis of cross-sectional variations in total household energy requirements in India using micro survey data. *Energy Policy*, 32(15), pp.1723-1735.
- Pachauri, R.K., Allen, M., Barros, V., Broome, J., Cramer, W., Christ, R., Church, J., Clarke, L., Dahe, Q. and Dasgupta, P. (2014). *Climate Change 2014: Synthesis Report. Contribution of Working Groups I, II and III to the Fifth Assessment Report of the Intergovernmental Panel on Climate Change*.
- Pacheco, R., Ordonez, J. & Martinez, G (2012). Energy efficient design of building: A review. *Renewable and Sustainable Energy Reviews*, 16(6), pp.3559-3573.
- Palmer, J. and Cooper, I. (2013). *United Kingdom housing energy fact file 2013*. London: Department of Energy and Climate Change.
- Parekh, A. and Eng, P. (2005). Development of archetypes of building characteristics libraries for simplified energy use evaluation of houses. In *Proceedings of the Ninth International Building Performance Simulation Association Conference (IBPSA)*.
- Park, J., Chin, K. and Yoon, J. (2007). Solar Access Evaluation of Roof and Facade Area of Apartment Building Depending on the 4 Different Types of Building Arrangement. *Journal*

- 
- of Korean Institute of Architectural Sustainable Environment and Building Systems, pp.178-183. (Korean)
- Park, J. (2003). *A Study on the Change of Apartment Unit Plan focusing on the Gangbukgu, Nowongu, Gangnamgu, Gangseogu Apartment Complex in Seoul*. Master, Kwangwoon University. (Korean)
- Park, J. (2012). A Study on Comparing Green Building Rating Systems. *Real Estate FOCUS* (51), 29-42. (Korean)
- Park, N. (2012). *A Study on the Changes in Characteristics of Unit Plan in National Housing Scale Apartment*. Master, Myeongji University. (Korean)
- Park, S., Lee, Y. and Lee, H. (2011). Analysis on Electricity Consumption Characteristics of Apartments based on Architectural Planning Factors - focused on Households with a total area of 132~165m<sup>2</sup> in Seoul. *Journal of the Korea Institute of Ecological Architecture and Environment*, 11, pp. 107-117. (Korean)
- Parzen, E. (1999). *Stochastic processes*. Philadelphia: Society for Industrial and Applied Mathematics.
- Passivhaus Trust (2015). *What is Passivhaus?*. [online] Available at: [http://www.passivhaus.org.uk/what\\_is\\_passivhaus.php](http://www.passivhaus.org.uk/what_is_passivhaus.php) [Accessed 26/01 2015].
- Peng, C. and Elwan, A. (2014). An outdoor-indoor coupled simulation framework for Climate Change-conscious Urban Neighborhood Design. *SIMULATION*, 90(8), pp.874-891.
- Petersdorff, C., Boermans, T., Harnisch, J., Joosen, S. And Wouters, F. (2005). Cost effective climate protection in the building stock of the New EU Member States. *Beyond the EU Energy performance of Buildings Directive*. ECOFYS, Germany.
- Prasanta S. Bandyopadhyay., (2011). *Philosophy of Statistics*. North Holland.
- Raftery, P., Keane, M. and O'Donnell, J. (2011). Calibrating whole building energy models: An evidence-based methodology. *Energy and Buildings*, 43(9), pp.2356-2364.
- Rasmussen, C. and Williams, C. (2006). *Gaussian processes for machine learning*. Cambridge, Mass.: MIT Press.
- Reeves, A., Taylor, S. and Fleming, P. (2010). Modelling the potential to achieve deep carbon emission cuts in existing UK social housing: The case of Peabody. *Energy Policy*, 38(8), pp.4241-4251.

- Rhee, K. (2005). *A Study on Price Comparison of Gangnam and Gangbuk Region Apartment* Master, Kwangwoon University. (Korean)
- Richardson, I., Thomson, M. and Infield, D. (2008). A high-resolution domestic building occupancy model for energy demand simulations. *Energy and Buildings*, 40(8), pp.1560-1566.
- Richardson, I., Thomson, M., Infield, D. and Clifford, C. (2010). Domestic electricity use: A high-resolution energy demand model. *Energy and Buildings*, 42(10), pp.1878-1887.
- Riihimaki, J., Jylanki, P. and Vehtari, A. (2013). Nested expectation propagation for Gaussian process classification. *The Journal of Machine Learning Research*, 14, pp.75-109.
- Roh, E. (2012). *Energy Performance Evaluation of Apartment Building according to Window-to-wall ratio and Energy Performance of Envelope*. Master, Ewha Womans University. (Korean)
- Roh, J. (2014). An Analysis of Heating and Cooling Energy and Effect on Outdoor Air Cooling according to Building Type of Apartment Complex. *Solar Energy*, 34, pp.31-38. (Korean)
- Romeijn, J. (2014). *Philosophy of Statistics*. [online] Plato.stanford.edu. Available at: <http://plato.stanford.edu/entries/statistics/> [Accessed 26/01 2016].
- Rose, S., Spinks, N. and Canhoto, A. (2014). *Management Research: Applying the Principles*, London: Routledge.
- Ross, S. (2007). *Introduction to probability models*. Amsterdam: Academic Press.
- Ryan, E. and Sanquist, T. (2012). Validation of building energy modeling tools under idealized and realistic conditions. *Energy and Buildings*, 47, pp.375-382.
- Sadineni, S., Madala, S. and Boehm, R. (2011). Passive building energy savings: A review of building envelope components. *Renewable and Sustainable Energy Reviews*, 15(8), pp.3617-3631.
- Sadrzadehrafiei, S., Sopian, K. and Lim, C. (2012). Potential energy and emission reduction through application of triple glazing. In *Proceedings the 6th international conference on energy and development – environment – biomedicine (EDEB(12'))*. pp.138-42.
- Schuler, A., Weber, C. and Fahl, U. (2000). Energy consumption for space heating of West-German households: empirical evidence, scenario projections and policy implications.

---

*Energy Policy*, 28(12), pp.877-894.

Seo, J. (2012). *The Passive Renovation Methods and Energy-Saving for Old Apartment Buildings*. Master, Ewha Womans University. (Korean)

Seo, J., LIM, J. and Song, S. (2011). Case Study of Energy-Saving Effect through Renovation of Old Apartment Building. *Journal of Korean Institute of Architectural Sustainable Environment and Building systems*, 59-62. (Korean)

Seo, K. (2001). *Analytical Study on the Effects of Energy Use Factors on the Energy Consumption of a Building*. Ph.D, Korea University, South Korea. (Korean)

Seoul City Hall. (2013). *An aerial view of the transformation of Seoul*. [online] Seoul City Hall. Available at: <http://opengov.seoul.go.kr/paper/85237> [Accessed 08/12 2013]. (Korean)

Seoul City Gas. (2014). *Gas Rates Table* [online] Available at: <http://www.seoulgas.co.kr/> [Accessed 08/12 2015]. (Korean)

Sharp, T. (1996). Energy benchmarking in commercial office buildings. *In Proceedings of the ACEEE*, pp.321-29.

Sharples, S. and Lee, S. (2013). Climate Change and Building Design. In: Mumovic, D. and Santamouris, M. ed., *A Handbook of Sustainable Building Design and Engineering: An integrated Approach to Energy, Health and Operational Performance*, 1st ed. Routledge, pp.263-270.

Sheldon, R. (2002). *A first course in probability*. Upper Saddle River, N.J.: Prentice Hall.

Shin, S. (2008). Current Work and Future Trends for Sustainable Buildings in South Korea. Ministry of Land Infrastructure and Transport. [online] Available at: [http://www.iisbe.org/sbconferences/Korea\\_SB\\_Report\\_SB08.pdf](http://www.iisbe.org/sbconferences/Korea_SB_Report_SB08.pdf) [Accessed 10/05/2016]

Silva, A. and Ghisi, E. (2014). Uncertainty analysis of user behaviour and physical parameters in residential building performance simulation. *Energy and Buildings*, 76, pp.381-391.

Son, B., Jang, M. and Lee, H. (2005). A Method of Economic Analysis for Remodeling of Apartments Using the Life Cycle Costing. *Journal of the Architectural Institute of Korea Structure & Construction*, 21, 73-81. (Korean)

Son, J. (2004). A 70-year history of Apartments in Korea. *Urban Problem*, 39, 109-126. (Korean)

- Son, W., Kang, H., Park, J. and Rhee, E. (2010). Estimation of energy savings contribution rate for design strategies of apartment houses. In *Proceeding of annual conference of the architectural institute of Korea*, pp.453-454. (Korean)
- Sonderegger, R. (1978). Movers and stayers: The resident's contribution to variation across houses in energy consumption for space heating. *Energy and Buildings*, 1(3), pp.313-324.
- Song, S. (2009). *Analysis of Energy Saving Effects of Apartment Housing and Economy Efficiency of Window according to the Thermal Insulation Performance of Windows*. Master, Pusan National University, South Korea. (Korean)
- Song, S. (2014). Internal insulation vs External insulation, Energy saving potentials of externally insulated apartment buildings. *Review of Architecture and Building Science*, 58, 16-20. (Korean)
- Song, Y. (2005). Influence of new town development on the urban heat island-the case of the Bundang area. *Journal of Environmental Sciences*, 17, 641-645. (Korean)
- Soubdhan, T., Feuillard, T. and Bade, F. (2005). Experimental evaluation of insulation material in roofing system under tropical climate. *Solar Energy*, 79 (3), pp.311-320.
- Stafford, A., Gorse, C. and Shao, L. (2011). *The retrofit challenge: Delivering low carbon buildings*. Centre for Low Carbon Futures, Leeds, UK.
- Statistics Korea. (2000). *Housing Census*. Seoul: Korean Statistical Information Service. [online] Available at: [http://kosis.kr/statHtml/statHtml.do?orgId=101&tblId=DT\\_1JU0005&conn\\_path=I2](http://kosis.kr/statHtml/statHtml.do?orgId=101&tblId=DT_1JU0005&conn_path=I2) [Accessed 28/12 2015]. (Korean)
- Statistics Korea. (2010a). *Apartment House Living Condition Statistics*. Seoul: Korean Statistical Information Service. [online] Available at: [http://kosis.kr/statHtml/statHtml.do?orgId=116&tblId=TX\\_116101595&conn\\_path=I2](http://kosis.kr/statHtml/statHtml.do?orgId=116&tblId=TX_116101595&conn_path=I2) [Accessed 28/12 2015]. (Korean)
- Statistics Korea, (2010b). *Housing Census*. Seoul: Korean Statistical Information Service. [online] Available at: [http://kosis.kr/statHtml/statHtml.do?orgId=101&tblId=DT\\_1JU1001&conn\\_path=I2](http://kosis.kr/statHtml/statHtml.do?orgId=101&tblId=DT_1JU1001&conn_path=I2) [Accessed 28/12 2015]. (Korean)
- Statistics Korea. (2010c). *Population Census*. Seoul: Korean Statistical Information Service. [online] Available at:

- [http://kosis.kr/statHtml/statHtml.do?orgId=101&tblId=DT\\_1JC1008&conn\\_path=I2](http://kosis.kr/statHtml/statHtml.do?orgId=101&tblId=DT_1JC1008&conn_path=I2)  
[Accessed 23/12 2015]. (Korean)
- Statistics Korea. (2013). *Statistics of Buildings*. Seoul: Korean Statistical Information Service. [online] Available at:  
[http://kosis.kr/statHtml/statHtml.do?orgId=116&tblId=DT\\_MLTM\\_522&conn\\_path=I2](http://kosis.kr/statHtml/statHtml.do?orgId=116&tblId=DT_MLTM_522&conn_path=I2)  
[Accessed 08/11 2015]. (Korean)
- Stemers, K. and Yun, G. (2009). Household energy consumption: a study of the role of occupants. *Building Research & Information*, 37(5-6), pp.625-637.
- Stoppel, C. and Leite, F. (2014). Integrating probabilistic methods for describing occupant presence with building energy simulation models. *Energy and Buildings*, 68, pp.99-107.
- Summerfield, A., Lowe, R. and Oreszczyn, T. (2010). Two models for benchmarking UK domestic delivered energy. *Building Research & Information*, 38, pp12-24.
- Sunikka-Blank, M. and Galvin, R. (2012). Introducing the profound effect: the gap between performance and actual energy consumption. *Building Research & Information*, 40(3), pp.260-273.
- Swan, L. and Ugursal, V. (2009). Modeling of end-use energy consumption in the residential sector: A review of modeling techniques. *Renewable and Sustainable Energy Reviews*, 13(8), pp.1819-1835.
- Tahmasebi, M., Banihashemi, S. and Hassanabadi, M. (2011). Assessment of the Variation Impacts of Window on Energy Consumption and Carbon Footprint. *Procedia Engineering*, 21, pp.820-828.
- Taleb, H. and Sharples, S. (2011). Developing sustainable residential buildings in Saudi Arabia: A case study. *Applied Energy*, 88(1), pp.383-391.
- Tan, B., Yavuz, Y., Otay, E. and Çamlıbel, E. (2015). Optimal selection of energy efficiency measures for energy sustainability of existing buildings. *Computers & Operations Research*, 66, pp.258-271.
- Tanimoto, J., Hagishima, A. and Sagara, H. (2008). A methodology for peak energy requirement considering actual variation of occupants' behavior schedules. *Building and Environment*, 43(4), pp.610-619.
- Tindale, A. (2005). Designbuilder software. *Stroud, Gloucestershire, Design-Builder*



*Software Ltd.*

The Mathworks Inc. (2015). *Curve Fitting Toolbox User's Guide*. [online] Available at: [http://www.mathworks.com/help/pdf\\_doc/curvefit/curvefit.pdf](http://www.mathworks.com/help/pdf_doc/curvefit/curvefit.pdf) [Accessed 28 Dan. 2015].

Uihlein, A. and Eder, P. (2010). Policy options towards an energy efficient residential building stock in the EU-27. *Energy and Buildings*, 42, 791-798.

United States Environmental Protection Agency. (2016). "Understanding the Link between Climate Change and Extreme Weather". [online] United States Environmental Protection Agency. Available at: <https://www3.epa.gov/climatechange/science/extreme-weather.html> [Accessed 10/05 2016]

US Green Building Council. (2004). Leadership in Energy and Environmental Design (LEED). [online] US Green Building Council (USGBC). Available at: <http://www.usgbc.org/LEED>. [Accessed 10/05 2016]

vanVuuren, D., Edmonds, J., Kainuma, M., Riahi, K., Thomson, A., Hibbard, K., Hurtt, G., Kram, T., Krey, V., Lamarque, J., Masui, T., Meinshausen, M., Nakicenovic, N., Smith, S. and Rose, S. (2011). The representative concentration pathways: an overview. *Climatic Change*, 109(1-2), pp.5-31.

Vanhatalo, J., Rihimäki, J., Hartikainen, J., Jylänki, P., Tolvanen, V. and Vehtari, A. (2013). GPstuff: Bayesian modeling with Gaussian processes. *The Journal of Machine Learning Research*, 14, 1175-1179.

Waide, P., Guertler, P. and Smith, W. (2006). High-rise refurbishment: The energy-efficient upgrade of multi-story residences in the European Union. *International Energy Agency*.

Wan, K. and Yik, F. (2004). Representative building design and internal load patterns for modelling energy use in residential buildings in Hong Kong. *Applied Energy*, 77(1), pp.69-85.

Wang, L., Mathew, P. and Pang, X. (2012). Uncertainties in energy consumption introduced by building operations and weather for a medium-size office building. *Energy and Buildings*, 53, pp.152-158.

Wang, S., Yan, C. And Xiao, F. (2012). Quantitative energy performance assessment methods for existing buildings. *Energy and Buildings*, 55, 873-888

Wang, Q. and Holmberg, S. (2015). A methodology to assess energy-demand savings and

cost effectiveness of retrofitting in existing Swedish residential buildings. *Sustainable Cities and Society*, 14, pp.254-266.

Wang, X., Chen, D. and Ren, Z. (2010). Assessment of climate change impact on residential building heating and cooling energy requirement in Australia. *Building and Environment*, 45(7), pp.1663-1682.

Widen, J., Lundh, M., Vassileva, I., Dahlquist, E., Ellegard, K. and Wackelgard, E. (2009). Constructing load profiles for household electricity and hot water from time-use data—Modelling approach and validation. *Energy and Buildings*, 41(7), pp.753-768.

White Box Technologies, (2014). *Historical Weather Data*. [online] Available at: <http://weather.whiteboxtechnologies.com/> [Accessed 28/12 2014].

White Box Technologies, (2015). *Typical-Year Weather data*. [online] Available at: <http://weather.whiteboxtechnologies.com/> [Accessed 28/12 2014].

Woerdman, E. (2015). ‘The EU Greenhouse Gas Emissions Trading Scheme’ (Chapter 3), in: Woerdman, E., M.M. Roggenkamp and M. Holwerda (eds.), *Essential EU Climate Law*, Cheltenham: Edward Elgar (Forthcoming). ; University of Groningen Faculty of Law Research Paper No. 2015/34. Available at SSRN: <http://ssrn.com/abstract=2654641>. [Accessed 10/05 2016]

World Bank (2013). *Renewable electricity output (% of total electricity output) Data table*. [online] Available at: <http://data.worldbank.org/indicator/EG.ELC.RNEW.ZS> [Accessed 28/01 2016].

Xu, P., Huang, Y., Miller, N., Schlegel, N. and Shen, P. (2012). Impacts of climate change on building heating and cooling energy patterns in California. *Energy*, 44(1), pp.792-804.

Xu, P., Xu, T. and Shen, P. (2013). Energy and behavioral impacts of integrative retrofits for residential buildings: What is at stake for building energy policy reforms in northern China?. *Energy Policy*, 52, pp.667-676.

Yan, C., Wang, S. and Xiao, F. (2012). A simplified energy performance assessment method for existing buildings based on energy bill disaggregation. *Energy and buildings*, 55, 563-574.

Yao, R. and Steemers, K. (2005). A method of formulating energy load profile for domestic buildings in the UK. *Energy and Buildings*, 37(6), pp.663-671.

- Yoon, H., Hwang, C. and Hyun, S. (2013). Climate Change and Building Load Variation by Regional Characteristics. *Journal of the Architectural Institute of Korea Planning & Design*, 29, 345-352. (Korean)
- Yoo, H., Chung, J., Moon, J. and Lee, J. (2007). Proposal of Unit Building Method for Calculating Unit Heating Load of Apartment Houses. *Korean Journal of Air-Conditioning and Refrigeration Engineering*, 19, 68-76. (Korean)
- Yoo, I. (2015). Energy Saving Design Standards of Buildings: new and intensified requirements. *Seoul, Ministry of Land, Infrastructure and Transport*. (Korean)
- Yoon, J., An, Y., Kim, B. and Hwang, S. (2007). A Study on the Energy Performance Evaluation of Window System with the Balcony Types of Apartments. *Solar Energy*, 27, pp.83-90. (Korean)
- Yoon, J., Yeo, S., Park, J., Choi, Y and Lee, S. 2006, September. Overshadowing analysis of apartment building arrangement with winter average shading ratio of window. In *the KSES spring conference South Korea*, pp. 225-230. (Korean)
- Yoon, S., Jang, H. and Kim, Y. (2009). Analysis on the Characteristics of Thermal Load Classified by the Household Location in Apartment House. *Journal of the Architectural Institute of Korea Planning & Design*, 25, 289-296. (Korean)
- Yoon, S., Song, S., Kim, Y. and Yum, S. (2008a). The Analysis on Saving Effect of Heating and Cooling Load According to the Thermal Insulation Specification of Window through Dynamic Heat Load Calculation. *Journal of Korean Institute of Architectural Sustainable Environment and Building Systems*, 2, 21-27. (Korean)
- Yoon, S., Song, S., Kim, Y. and Yum, S. (2008b). Saving Effects according to the Window Performance for an Apartment House and the Estimation of the Window Economical Efficiency. *Journal of the Architectural Institute of Korea Planning & Design*, 24, 321-330. (Korean)
- Yoon, T. (2011). *A Study on the Regional Disparities between the Autonomous Districts (Jachi-Gu) in Seoul Metropolis*. Master, Kyung Won University. (Korean)
- Yuen, B. and Yeh, A. (2010). *High-rise building living in Asian cities*. Dordrecht: Springer.
- Yuen, B., Yeh, A., Appold, S., Earl, G., Ting, J. and Kwee, L. (2006). High-rise living in Singapore public housing. *CURS*, 43(3), pp.583-600.

Yuen, B.(2011). *In the march of high-rise*, in: Yuen, B. and Yeh, A. (Eds.) *High-Rise Living in Asian Cities*, Springer Netherlands, pp. 179-186.

Zhang, S. (1994). *A Study on the Transition of the 60-70's Apartment Houses in Korea*. Ph.D, Seoul National University. (Korean)

Zhang, Y., 2012, April. Use jEPlus as an efficient building design optimisation tool. *In CIBSE ASHRAE Technical Symposium, Imperial College, London*, pp.1-12.

## Appendix A

### Data of building features and energy consumption

| Ref | Layout | Block size             | Total floor area               | Length of Buildings | Envelope  | Average unit sizes          | Heating Method | Construction type | Space heating | Electricity |
|-----|--------|------------------------|--------------------------------|---------------------|-----------|-----------------------------|----------------|-------------------|---------------|-------------|
| 1   | Linear | less than 5 buildings  | More than 13,001m <sup>2</sup> | Core 4              | 1988-2000 | 101-120m <sup>2</sup>       | District       | Mixed             | 100.8245      | 59.5034     |
| 2   | Square | more than 15 buildings | 10,001-13,000m <sup>2</sup>    | Core 4              | 1976-1980 | 71-100m <sup>2</sup>        | Central        | Mixed             | 146.4440      | 100.1017    |
| 3   | Linear | 6-15 buildings         | 10,001-13,000m <sup>2</sup>    | Core 2              | 1985-1987 | 101-120m <sup>2</sup>       | Central        | Mixed             | 134.5834      | 82.9543     |
| 4   | Linear | 6-15 buildings         | 10,001-13,000m <sup>2</sup>    | Core 4              | 1985-1987 | more than 120m <sup>2</sup> | Central        | Stair             | 140.7532      | 83.5659     |
| 5   | grid   | less than 5 buildings  | More than 13,001m <sup>2</sup> | Core 2              | 1988-2000 | 101-120m <sup>2</sup>       | Central        | Mixed             | 103.0646      | 86.8373     |
| 6   | grid   | less than 5 buildings  | More than 13,001m <sup>2</sup> | Core 4              | 1988-2000 | 101-120m <sup>2</sup>       | District       | Stair             | 158.8055      | 96.7405     |
| 7   | grid   | 6-15 buildings         | Less than 10,000m <sup>2</sup> | Core 4              | 1981-1984 | 101-120m <sup>2</sup>       | Individual     | Mixed             | 151.1495      | 97.7749     |
| 8   | Square | 6-15 buildings         | More than 13,001m <sup>2</sup> | Core 3              | 1976-1980 | more than 120m <sup>2</sup> | Individual     | Mixed             | 155.6599      | 110.6973    |
| 9   | grid   | 6-15 buildings         | 10,001-13,000m <sup>2</sup>    | Core 4              | 1976-1980 | more than 120m <sup>2</sup> | Individual     | Mixed             | 163.9712      | 107.3454    |
| 10  | Linear | 6-15 buildings         | More than 13,001m <sup>2</sup> | Core 3              | 1981-1984 | more than 120m <sup>2</sup> | Central        | Mixed             | 124.3461      | 98.1676     |
| 11  | Linear | less than 5 buildings  | More than 13,001m <sup>2</sup> | Core 4              | 1981-1984 | more than 120m <sup>2</sup> | Individual     | Mixed             | 136.0940      | 110.2094    |
| 12  | Square | 6-15 buildings         | More than 13,001m <sup>2</sup> | Core 3              | 1985-1987 | more than 120m <sup>2</sup> | Individual     | Mixed             | 128.6402      | 101.3513    |
| 13  | Linear | more than 15 buildings | 10,001-13,000m <sup>2</sup>    | Core 4              | 1981-1984 | more than 120m <sup>2</sup> | Individual     | Mixed             | 151.0455      | 103.3513    |
| 14  | grid   | more than 15 buildings | More than 13,001m <sup>2</sup> | Core 3              | 1976-1980 | more than 120m <sup>2</sup> | Individual     | Mixed             | 156.5666      | 107.3967    |
| 15  | Linear | 6-15 buildings         | 10,001-13,000m <sup>2</sup>    | Core 3              | 1981-1984 | more than 120m <sup>2</sup> | Central        | Stair             | 145.5362      | 107.2381    |
| 16  | Square | less than 5 buildings  | Less than 10,000m <sup>2</sup> | Core 4              | 1981-1984 | more than 120m <sup>2</sup> | Individual     | Stair             | 153.9995      | 100.8795    |
| 17  | Linear | more than 15 buildings | More than 13,001m <sup>2</sup> | Core 2              | 1976-1980 | 101-120m <sup>2</sup>       | Individual     | Corridor          | 173.8685      | 95.8795     |
| 18  | Linear | 6-15 buildings         | More than 13,001m <sup>2</sup> | Core 4              | 1981-1984 | more than 120m <sup>2</sup> | Individual     | Stair             | 145.0110      | 101.6313    |
| 19  | Square | less than 5 buildings  | 10,001-13,000m <sup>2</sup>    | Core 4              | 1981-1984 | more than 120m <sup>2</sup> | Individual     | Stair             | 138.6358      | 101.2057    |

|    |        |                        |                    |        |           |                 |            |          |          |          |
|----|--------|------------------------|--------------------|--------|-----------|-----------------|------------|----------|----------|----------|
| 20 | Square | 6-15 buildings         | Less than 10,000m2 | Core 3 | 1981-1984 | 101-120m2       | Individual | Stair    | 142.8603 | 99.3223  |
| 21 | Linear | more than 15 buildings | More than 13,001m2 | Core 4 | 1985-1987 | more than 120m2 | Individual | Mixed    | 104.7771 | 98.6639  |
| 22 | Square | 6-15 buildings         | Less than 10,000m2 | Core 4 | 1988-2000 | 101-120m2       | Individual | Mixed    | 118.0085 | 93.8542  |
| 23 | Square | less than 5 buildings  | Less than 10,000m2 | Core 3 | 1985-1987 | 71-100m2        | Individual | Stair    | 79.5575  | 101.6911 |
| 24 | Square | less than 5 buildings  | More than 13,001m2 | Core 3 | 1985-1987 | 101-120m2       | Individual | Mixed    | 150.9976 | 85.3086  |
| 25 | Square | less than 5 buildings  | More than 13,001m2 | Core 2 | 1988-2000 | more than 120m2 | Individual | Stair    | 81.4686  | 114.8413 |
| 26 | grid   | 6-15 buildings         | Less than 10,000m2 | Core 2 | 1988-2000 | 101-120m2       | Individual | Mixed    | 78.8850  | 105.2758 |
| 27 | Square | 6-15 buildings         | More than 13,001m2 | Core 2 | 1988-2000 | more than 120m2 | District   | Mixed    | 69.8231  | 104.0296 |
| 28 | Square | less than 5 buildings  | Less than 10,000m2 | core 1 | 1988-2000 | 101-120m2       | Individual | Corridor | 76.1782  | 93.2339  |
| 29 | Linear | less than 5 buildings  | More than 13,001m2 | core 1 | 1988-2000 | 71-100m2        | District   | Corridor | 63.9580  | 87.1210  |
| 30 | grid   | less than 5 buildings  | Less than 10,000m2 | Core 2 | 1988-2000 | 71-100m2        | Central    | Mixed    | 107.1202 | 94.0579  |
| 31 | Square | 6-15 buildings         | Less than 10,000m2 | Core 3 | 1976-1980 | more than 120m2 | Individual | Mixed    | 150.5591 | 100.1592 |
| 32 | Linear | less than 5 buildings  | 10,001-13,000m2    | Core 4 | 1988-2000 | 101-120m2       | Individual | Stair    | 136.3240 | 101.6168 |
| 33 | Square | 6-15 buildings         | More than 13,001m2 | Core 2 | 1981-1984 | more than 120m2 | Individual | Mixed    | 104.9421 | 108.0573 |
| 34 | grid   | 6-15 buildings         | Less than 10,000m2 | Core 2 | 1988-2000 | 101-120m2       | Individual | Mixed    | 102.7253 | 104.6586 |
| 35 | Square | less than 5 buildings  | Less than 10,000m2 | Core 3 | 1988-2000 | 101-120m2       | Individual | Mixed    | 97.9403  | 109.7018 |
| 36 | grid   | less than 5 buildings  | More than 13,001m2 | Core 3 | 1988-2000 | 101-120m2       | Individual | Mixed    | 86.7140  | 109.3539 |
| 37 | Linear | more than 15 buildings | More than 13,001m2 | core 1 | 1976-1980 | 101-120m2       | Individual | Mixed    | 106.2227 | 103.7738 |
| 38 | Square | more than 15 buildings | Less than 10,000m2 | Core 4 | 1981-1984 | 101-120m2       | Individual | Mixed    | 127.2736 | 100.2994 |
| 39 | Square | more than 15 buildings | More than 13,001m2 | Core 4 | 1985-1987 | more than 120m2 | Individual | Mixed    | 92.0635  | 105.8801 |
| 40 | Square | 6-15 buildings         | Less than 10,000m2 | Core 3 | 1981-1984 | 101-120m2       | Individual | Stair    | 101.2023 | 97.6314  |
| 41 | Square | 6-15 buildings         | 10,001-13,000m2    | Core 3 | 1981-1984 | more than 120m2 | Central    | Mixed    | 144.0756 | 93.2744  |
| 42 | Square | 6-15 buildings         | Less than 10,000m2 | Core 3 | 1985-1987 | more than 120m2 | Individual | Stair    | 86.5900  | 87.5292  |
| 43 | Square | 6-15 buildings         | Less than 10,000m2 | Core 3 | 1981-1984 | more than 120m2 | Individual | Mixed    | 95.5796  | 83.1628  |
| 44 | grid   | 6-15 buildings         | 10,001-13,000m2    | Core 2 | 1985-1987 | 71-100m2        | Individual | Mixed    | 91.8246  | 80.1457  |
| 45 | Square | 6-15 buildings         | 10,001-13,000m2    | Core 4 | 1981-1984 | more than 120m2 | Individual | Mixed    | 82.5782  | 88.8914  |
| 46 | Linear | 6-15 buildings         | Less than 10,000m2 | Core 3 | 1981-1984 | more than 120m2 | Individual | Stair    | 88.5449  | 96.0908  |

|    |        |                        |                    |        |           |                 |            |          |          |          |
|----|--------|------------------------|--------------------|--------|-----------|-----------------|------------|----------|----------|----------|
| 47 | Square | 6-15 buildings         | 10,001-13,000m2    | Core 3 | 1981-1984 | more than 120m2 | Individual | Corridor | 83.5186  | 92.7631  |
| 48 | Linear | 6-15 buildings         | Less than 10,000m2 | Core 3 | 1981-1984 | more than 120m2 | Individual | Corridor | 79.6220  | 99.3635  |
| 49 | grid   | less than 5 buildings  | Less than 10,000m2 | Core 3 | 1988-2000 | 71-100m2        | Individual | Stair    | 122.9608 | 117.6341 |
| 50 | Linear | less than 5 buildings  | More than 13,001m2 | core 1 | 1976-1980 | more than 120m2 | Individual | Corridor | 121.0600 | 101.8403 |
| 51 | Square | less than 5 buildings  | 10,001-13,000m2    | Core 2 | 1976-1980 | more than 120m2 | District   | Mixed    | 125.3474 | 94.9942  |
| 52 | grid   | less than 5 buildings  | More than 13,001m2 | Core 4 | 1981-1984 | more than 120m2 | Individual | Mixed    | 136.0019 | 106.9173 |
| 53 | Square | less than 5 buildings  | 10,001-13,000m2    | core 1 | 1981-1984 | 101-120m2       | Individual | Mixed    | 143.1924 | 89.2784  |
| 54 | Linear | 6-15 buildings         | 10,001-13,000m2    | core 1 | 1976-1980 | 101-120m2       | Individual | Corridor | 119.4338 | 100.9302 |
| 55 | Square | less than 5 buildings  | More than 13,001m2 | Core 4 | 1976-1980 | more than 120m2 | Individual | Mixed    | 146.0584 | 99.5515  |
| 56 | Square | less than 5 buildings  | More than 13,001m2 | Core 2 | 1981-1984 | 101-120m2       | Individual | Corridor | 111.7794 | 82.3829  |
| 57 | Linear | less than 5 buildings  | More than 13,001m2 | Core 2 | 1981-1984 | Less than 70m2  | Individual | Corridor | 122.8221 | 73.4575  |
| 58 | Linear | less than 5 buildings  | More than 13,001m2 | Core 2 | 1981-1984 | 101-120m2       | Individual | Corridor | 112.4233 | 85.8793  |
| 59 | Linear | 6-15 buildings         | 10,001-13,000m2    | Core 2 | 1976-1980 | 101-120m2       | Individual | Mixed    | 117.5721 | 103.2465 |
| 60 | Square | 6-15 buildings         | 10,001-13,000m2    | Core 2 | 1981-1984 | 101-120m2       | District   | Mixed    | 123.7432 | 99.2802  |
| 61 | grid   | less than 5 buildings  | More than 13,001m2 | Core 2 | 1976-1980 | 101-120m2       | Individual | Corridor | 125.2864 | 106.3686 |
| 62 | grid   | less than 5 buildings  | Less than 10,000m2 | Core 2 | 1985-1987 | 71-100m2        | Individual | Mixed    | 127.2685 | 99.2424  |
| 63 | Square | 6-15 buildings         | More than 13,001m2 | core 1 | 1976-1980 | more than 120m2 | Individual | Mixed    | 110.5539 | 102.1668 |
| 64 | Square | more than 15 buildings | More than 13,001m2 | Core 2 | 1981-1984 | 71-100m2        | Individual | Mixed    | 135.3571 | 100.1654 |
| 65 | Linear | 6-15 buildings         | Less than 10,000m2 | Core 2 | 1981-1984 | more than 120m2 | District   | Mixed    | 101.8713 | 96.3444  |
| 66 | Linear | less than 5 buildings  | Less than 10,000m2 | core 1 | 1985-1987 | more than 120m2 | Individual | Mixed    | 93.0931  | 100.5004 |
| 67 | Linear | 6-15 buildings         | 10,001-13,000m2    | Core 2 | 1976-1980 | 101-120m2       | Individual | Mixed    | 136.5092 | 86.0036  |
| 68 | Linear | more than 15 buildings | 10,001-13,000m2    | Core 3 | 1976-1980 | more than 120m2 | Individual | Mixed    | 127.8237 | 100.1812 |
| 69 | Linear | less than 5 buildings  | 10,001-13,000m2    | Core 3 | 1981-1984 | Less than 70m2  | Individual | Corridor | 127.0199 | 68.5705  |
| 70 | grid   | 6-15 buildings         | More than 13,001m2 | Core 2 | 1985-1987 | 101-120m2       | Individual | Corridor | 129.1026 | 83.6651  |
| 71 | grid   | less than 5 buildings  | 10,001-13,000m2    | Core 3 | 1985-1987 | more than 120m2 | Individual | Mixed    | 122.6351 | 86.9338  |
| 72 | grid   | 6-15 buildings         | Less than 10,000m2 | core 1 | 1981-1984 | 101-120m2       | Individual | Mixed    | 142.9152 | 105.8778 |
| 73 | Square | 6-15 buildings         | More than 13,001m2 | Core 3 | 1981-1984 | more than 120m2 | Individual | Mixed    | 119.7452 | 102.2290 |

|     |        |                        |                    |        |           |                 |            |          |          |          |
|-----|--------|------------------------|--------------------|--------|-----------|-----------------|------------|----------|----------|----------|
| 74  | grid   | less than 5 buildings  | More than 13,001m2 | Core 4 | 1988-2000 | 101-120m2       | Central    | Mixed    | 139.2235 | 103.1263 |
| 75  | grid   | less than 5 buildings  | More than 13,001m2 | Core 4 | 1988-2000 | 101-120m2       | District   | Stair    | 92.0987  | 101.6571 |
| 76  | grid   | 6-15 buildings         | Less than 10,000m2 | Core 3 | 1988-2000 | 101-120m2       | Individual | Stair    | 100.2769 | 106.3153 |
| 77  | Square | less than 5 buildings  | 10,001-13,000m2    | Core 3 | 1988-2000 | 101-120m2       | Individual | Stair    | 117.5108 | 96.6932  |
| 78  | grid   | 6-15 buildings         | Less than 10,000m2 | Core 3 | 1988-2000 | 101-120m2       | Individual | Stair    | 101.9208 | 109.6932 |
| 79  | grid   | less than 5 buildings  | More than 13,001m2 | Core 3 | 1988-2000 | 101-120m2       | Individual | Stair    | 92.0604  | 100.3002 |
| 80  | grid   | less than 5 buildings  | 10,001-13,000m2    | Core 4 | 1988-2000 | 101-120m2       | Individual | Stair    | 110.8721 | 103.3998 |
| 81  | grid   | less than 5 buildings  | More than 13,001m2 | core 1 | 1988-2000 | 71-100m2        | Individual | Corridor | 117.8688 | 88.0997  |
| 82  | grid   | 6-15 buildings         | More than 13,001m2 | Core 3 | 1988-2000 | 101-120m2       | Central    | Stair    | 108.4340 | 88.8053  |
| 83  | grid   | 6-15 buildings         | 10,001-13,000m2    | core 1 | 1988-2000 | 101-120m2       | Central    | Mixed    | 93.5665  | 87.1964  |
| 84  | grid   | less than 5 buildings  | 10,001-13,000m2    | core 1 | 1988-2000 | 101-120m2       | Individual | Mixed    | 86.0457  | 90.6834  |
| 85  | grid   | less than 5 buildings  | More than 13,001m2 | Core 3 | 1988-2000 | 101-120m2       | District   | Stair    | 125.7756 | 98.8670  |
| 86  | grid   | less than 5 buildings  | More than 13,001m2 | Core 4 | 1988-2000 | 101-120m2       | Central    | Stair    | 142.3977 | 99.8580  |
| 87  | Linear | more than 15 buildings | Less than 10,000m2 | Core 2 | 1988-2000 | 71-100m2        | Individual | Mixed    | 82.7460  | 89.1805  |
| 88  | Linear | more than 15 buildings | Less than 10,000m2 | Core 2 | 1985-1987 | more than 120m2 | Individual | Mixed    | 79.6300  | 91.1408  |
| 89  | Linear | more than 15 buildings | Less than 10,000m2 | Core 4 | 1985-1987 | 101-120m2       | Individual | Mixed    | 98.0074  | 93.5329  |
| 90  | Square | more than 15 buildings | Less than 10,000m2 | Core 4 | 1985-1987 | more than 120m2 | Individual | Mixed    | 97.7982  | 83.8794  |
| 91  | Square | more than 15 buildings | Less than 10,000m2 | Core 2 | 1985-1987 | 101-120m2       | Individual | Mixed    | 92.0491  | 89.1457  |
| 92  | Square | more than 15 buildings | Less than 10,000m2 | core 1 | 1985-1987 | 101-120m2       | Individual | Mixed    | 83.2686  | 92.1487  |
| 93  | Linear | more than 15 buildings | Less than 10,000m2 | Core 3 | 1985-1987 | more than 120m2 | Individual | Mixed    | 86.8576  | 91.8184  |
| 94  | Linear | more than 15 buildings | Less than 10,000m2 | Core 2 | 1985-1987 | more than 120m2 | Individual | Mixed    | 91.4115  | 79.4292  |
| 95  | Square | more than 15 buildings | Less than 10,000m2 | Core 2 | 1985-1987 | 101-120m2       | Individual | Mixed    | 83.4094  | 83.0564  |
| 96  | Linear | 6-15 buildings         | 10,001-13,000m2    | Core 2 | 1985-1987 | 71-100m2        | Individual | Mixed    | 88.1137  | 83.3815  |
| 97  | grid   | less than 5 buildings  | 10,001-13,000m2    | core 1 | 1988-2000 | 101-120m2       | Individual | Mixed    | 83.7299  | 105.8431 |
| 98  | grid   | less than 5 buildings  | More than 13,001m2 | Core 4 | 1988-2000 | 101-120m2       | Individual | Stair    | 71.6713  | 103.4638 |
| 99  | grid   | less than 5 buildings  | 10,001-13,000m2    | Core 2 | 1988-2000 | 101-120m2       | Individual | Mixed    | 80.0845  | 101.8450 |
| 100 | grid   | less than 5 buildings  | Less than 10,000m2 | core 1 | 1988-2000 | 101-120m2       | Individual | Mixed    | 76.8910  | 107.5737 |



|     |        |                        |                    |        |           |                 |            |          |          |          |
|-----|--------|------------------------|--------------------|--------|-----------|-----------------|------------|----------|----------|----------|
| 101 | grid   | less than 5 buildings  | More than 13,001m2 | core 1 | 1988-2000 | 101-120m2       | Individual | Mixed    | 86.1523  | 101.8592 |
| 102 | Linear | less than 5 buildings  | More than 13,001m2 | Core 2 | 1988-2000 | 101-120m2       | Individual | Stair    | 80.4509  | 101.1550 |
| 103 | grid   | less than 5 buildings  | Less than 10,000m2 | Core 3 | 1988-2000 | 101-120m2       | Individual | Stair    | 67.7048  | 89.9932  |
| 104 | grid   | less than 5 buildings  | Less than 10,000m2 | Core 3 | 1988-2000 | 101-120m2       | Individual | Stair    | 89.7977  | 101.2703 |
| 105 | grid   | 6-15 buildings         | More than 13,001m2 | Core 4 | 1988-2000 | 101-120m2       | Individual | Stair    | 80.9275  | 103.5389 |
| 106 | grid   | less than 5 buildings  | 10,001-13,000m2    | Core 3 | 1988-2000 | 101-120m2       | Individual | Stair    | 109.1350 | 103.0738 |
| 107 | Square | less than 5 buildings  | 10,001-13,000m2    | Core 3 | 1988-2000 | Less than 70m2  | Individual | Corridor | 88.5791  | 103.4214 |
| 108 | grid   | less than 5 buildings  | 10,001-13,000m2    | Core 3 | 1988-2000 | 71-100m2        | Individual | Stair    | 113.5712 | 108.7048 |
| 109 | grid   | 6-15 buildings         | Less than 10,000m2 | Core 4 | 1988-2000 | 101-120m2       | Individual | Stair    | 84.7012  | 100.6639 |
| 110 | grid   | 6-15 buildings         | Less than 10,000m2 | Core 3 | 1988-2000 | more than 120m2 | Individual | Mixed    | 84.3052  | 101.0321 |
| 111 | grid   | 6-15 buildings         | Less than 10,000m2 | core 1 | 1988-2000 | 71-100m2        | Individual | Corridor | 73.4644  | 70.6342  |
| 112 | Linear | more than 15 buildings | Less than 10,000m2 | core 1 | 1988-2000 | 71-100m2        | Individual | Mixed    | 97.1225  | 74.1899  |
| 113 | Square | more than 15 buildings | Less than 10,000m2 | Core 4 | 1988-2000 | 71-100m2        | Individual | Stair    | 96.8844  | 89.6055  |
| 114 | Square | 6-15 buildings         | Less than 10,000m2 | Core 3 | 1976-1980 | more than 120m2 | Central    | Mixed    | 149.5477 | 86.2643  |
| 115 | Linear | less than 5 buildings  | 10,001-13,000m2    | Core 3 | 1981-1984 | more than 120m2 | Central    | Mixed    | 132.3601 | 85.6732  |
| 116 | Square | 6-15 buildings         | 10,001-13,000m2    | Core 2 | 1981-1984 | more than 120m2 | Central    | Mixed    | 124.9839 | 98.4459  |
| 117 | Linear | 6-15 buildings         | 10,001-13,000m2    | Core 3 | 1985-1987 | more than 120m2 | Central    | Mixed    | 134.7491 | 87.4459  |
| 118 | Linear | 6-15 buildings         | More than 13,001m2 | Core 3 | 1981-1984 | more than 120m2 | Individual | Mixed    | 119.1233 | 100.2183 |
| 119 | Linear | 6-15 buildings         | More than 13,001m2 | Core 3 | 1988-2000 | 101-120m2       | Central    | Mixed    | 123.6496 | 68.9029  |
| 120 | grid   | 6-15 buildings         | More than 13,001m2 | Core 3 | 1988-2000 | 101-120m2       | Central    | Mixed    | 95.8047  | 78.8654  |
| 121 | grid   | 6-15 buildings         | 10,001-13,000m2    | Core 4 | 1988-2000 | 101-120m2       | Individual | Mixed    | 97.5768  | 59.1518  |
| 122 | Square | 6-15 buildings         | 10,001-13,000m2    | Core 3 | 1988-2000 | 101-120m2       | Central    | Stair    | 110.8857 | 84.3787  |
| 123 | grid   | less than 5 buildings  | Less than 10,000m2 | Core 2 | 1988-2000 | 71-100m2        | Individual | Mixed    | 106.0177 | 94.7613  |
| 124 | Linear | 6-15 buildings         | Less than 10,000m2 | Core 2 | 1988-2000 | 101-120m2       | Central    | Mixed    | 152.4505 | 84.0332  |
| 125 | Linear | less than 5 buildings  | Less than 10,000m2 | core 1 | 1988-2000 | 101-120m2       | Central    | Stair    | 123.2122 | 88.8186  |
| 126 | Linear | less than 5 buildings  | More than 13,001m2 | Core 4 | 1988-2000 | 101-120m2       | Individual | Stair    | 79.5508  | 94.2017  |
| 127 | Linear | more than 15 buildings | Less than 10,000m2 | core 1 | 1988-2000 | 71-100m2        | Individual | Corridor | 94.9888  | 77.0782  |

|     |        |                        |                    |        |           |                 |            |          |          |          |
|-----|--------|------------------------|--------------------|--------|-----------|-----------------|------------|----------|----------|----------|
| 128 | Linear | more than 15 buildings | Less than 10,000m2 | core 1 | 1988-2000 | 71-100m2        | Individual | Corridor | 78.2379  | 71.0000  |
| 129 | grid   | 6-15 buildings         | 10,001-13,000m2    | core 1 | 1988-2000 | 71-100m2        | Individual | Mixed    | 87.6256  | 79.3559  |
| 130 | Linear | 6-15 buildings         | 10,001-13,000m2    | core 1 | 1988-2000 | 71-100m2        | Individual | Mixed    | 82.8890  | 77.0879  |
| 131 | Linear | 6-15 buildings         | Less than 10,000m2 | core 1 | 1988-2000 | Less than 70m2  | Individual | Mixed    | 76.7221  | 70.5565  |
| 132 | Square | 6-15 buildings         | Less than 10,000m2 | Core 4 | 1988-2000 | 101-120m2       | Individual | Stair    | 90.1844  | 100.4750 |
| 133 | grid   | less than 5 buildings  | Less than 10,000m2 | Core 2 | 1988-2000 | 71-100m2        | Central    | Mixed    | 137.1510 | 101.7536 |
| 134 | grid   | 6-15 buildings         | More than 13,001m2 | Core 3 | 1988-2000 | 101-120m2       | Central    | Mixed    | 131.2898 | 93.7315  |
| 135 | grid   | 6-15 buildings         | More than 13,001m2 | Core 2 | 1988-2000 | 71-100m2        | Central    | Mixed    | 128.1046 | 89.6744  |
| 136 | grid   | less than 5 buildings  | Less than 10,000m2 | core 1 | 1985-1987 | 71-100m2        | Individual | Mixed    | 83.8714  | 98.7981  |
| 137 | grid   | less than 5 buildings  | 10,001-13,000m2    | Core 4 | 1988-2000 | 71-100m2        | Individual | Mixed    | 85.4430  | 97.4595  |
| 138 | grid   | less than 5 buildings  | More than 13,001m2 | Core 2 | 1988-2000 | more than 120m2 | Individual | Corridor | 71.9621  | 82.4085  |
| 139 | Linear | more than 15 buildings | Less than 10,000m2 | Core 2 | 1985-1987 | 71-100m2        | District   | Mixed    | 77.4517  | 78.1032  |
| 140 | Linear | more than 15 buildings | Less than 10,000m2 | core 1 | 1988-2000 | 71-100m2        | Individual | Corridor | 87.4500  | 77.8306  |
| 141 | Linear | more than 15 buildings | Less than 10,000m2 | core 1 | 1988-2000 | 71-100m2        | Individual | Corridor | 88.7285  | 76.5229  |
| 142 | Linear | more than 15 buildings | Less than 10,000m2 | Core 3 | 1988-2000 | 71-100m2        | Individual | Mixed    | 87.5181  | 82.9549  |
| 143 | Linear | more than 15 buildings | Less than 10,000m2 | core 1 | 1988-2000 | 71-100m2        | Individual | Corridor | 92.1277  | 85.2475  |
| 144 | Linear | 6-15 buildings         | 10,001-13,000m2    | Core 2 | 1988-2000 | Less than 70m2  | Individual | Corridor | 79.3868  | 59.1813  |
| 145 | Linear | more than 15 buildings | 10,001-13,000m2    | core 1 | 1988-2000 | 71-100m2        | Individual | Corridor | 80.8158  | 80.0262  |
| 146 | Linear | more than 15 buildings | More than 13,001m2 | core 1 | 1988-2000 | 71-100m2        | Individual | Corridor | 73.3545  | 80.4135  |
| 147 | Linear | more than 15 buildings | Less than 10,000m2 | core 1 | 1988-2000 | 71-100m2        | Individual | Corridor | 84.1944  | 81.3869  |
| 148 | Linear | 6-15 buildings         | Less than 10,000m2 | core 1 | 1988-2000 | Less than 70m2  | Individual | Corridor | 89.8445  | 81.4222  |
| 149 | Square | more than 15 buildings | Less than 10,000m2 | Core 2 | 1988-2000 | 71-100m2        | Individual | Mixed    | 95.9475  | 84.9381  |
| 150 | Linear | less than 5 buildings  | 10,001-13,000m2    | Core 4 | 1976-1980 | 101-120m2       | Individual | Mixed    | 157.4231 | 101.3463 |
| 151 | Linear | 6-15 buildings         | 10,001-13,000m2    | Core 4 | 1976-1980 | more than 120m2 | Individual | Stair    | 135.6901 | 90.8789  |
| 152 | Linear | less than 5 buildings  | More than 13,001m2 | Core 4 | 1976-1980 | 101-120m2       | Individual | Corridor | 142.3645 | 93.7434  |
| 153 | Linear | less than 5 buildings  | 10,001-13,000m2    | Core 2 | 1976-1980 | 71-100m2        | Individual | Corridor | 165.1784 | 88.7676  |
| 154 | Square | 6-15 buildings         | More than 13,001m2 | Core 4 | 1976-1980 | more than 120m2 | Individual | Mixed    | 156.0452 | 91.4188  |

|     |        |                        |                    |        |           |                 |            |          |          |          |
|-----|--------|------------------------|--------------------|--------|-----------|-----------------|------------|----------|----------|----------|
| 155 | Square | 6-15 buildings         | 10,001-13,000m2    | Core 2 | 1976-1980 | more than 120m2 | Individual | Mixed    | 158.9505 | 95.1734  |
| 156 | Square | less than 5 buildings  | 10,001-13,000m2    | Core 4 | 1976-1980 | more than 120m2 | Central    | Stair    | 157.7143 | 100.3576 |
| 157 | Linear | less than 5 buildings  | More than 13,001m2 | Core 4 | 1976-1980 | more than 120m2 | Individual | Stair    | 156.3474 | 110.0230 |
| 158 | Square | less than 5 buildings  | More than 13,001m2 | Core 4 | 1976-1980 | more than 120m2 | Individual | Mixed    | 167.0549 | 98.2054  |
| 159 | Linear | more than 15 buildings | Less than 10,000m2 | core 1 | 1976-1980 | 71-100m2        | Individual | Corridor | 156.3682 | 99.5716  |
| 160 | Square | less than 5 buildings  | 10,001-13,000m2    | Core 4 | 1976-1980 | more than 120m2 | Individual | Stair    | 163.5000 | 93.4361  |
| 161 | Square | less than 5 buildings  | More than 13,001m2 | Core 2 | 1976-1980 | more than 120m2 | Individual | Mixed    | 146.5108 | 102.8396 |
| 162 | Linear | less than 5 buildings  | Less than 10,000m2 | core 1 | 1988-2000 | 71-100m2        | Individual | Corridor | 119.1732 | 85.1189  |
| 163 | Linear | less than 5 buildings  | Less than 10,000m2 | Core 3 | 1976-1980 | more than 120m2 | Individual | Stair    | 128.3441 | 106.4052 |
| 164 | Linear | 6-15 buildings         | 10,001-13,000m2    | Core 3 | 1976-1980 | more than 120m2 | Individual | Mixed    | 145.2396 | 108.3420 |
| 165 | Linear | less than 5 buildings  | 10,001-13,000m2    | Core 2 | 1988-2000 | 101-120m2       | Individual | Mixed    | 66.4319  | 103.5456 |
| 166 | grid   | more than 15 buildings | 10,001-13,000m2    | Core 2 | 1988-2000 | 101-120m2       | Individual | Mixed    | 87.6778  | 91.9506  |
| 167 | Linear | less than 5 buildings  | More than 13,001m2 | Core 3 | 1988-2000 | 101-120m2       | Individual | Stair    | 83.5127  | 85.0411  |
| 168 | Linear | less than 5 buildings  | 10,001-13,000m2    | Core 3 | 1988-2000 | 71-100m2        | Individual | Stair    | 73.4506  | 103.0283 |
| 169 | Linear | 6-15 buildings         | 10,001-13,000m2    | Core 2 | 1988-2000 | 101-120m2       | Individual | Mixed    | 90.7153  | 101.6275 |
| 170 | grid   | 6-15 buildings         | 10,001-13,000m2    | Core 4 | 1985-1987 | more than 120m2 | Central    | Stair    | 153.6998 | 102.7178 |
| 171 | Square | 6-15 buildings         | Less than 10,000m2 | Core 3 | 1988-2000 | 101-120m2       | Central    | Stair    | 143.3137 | 96.6535  |
| 172 | grid   | more than 15 buildings | More than 13,001m2 | Core 3 | 1988-2000 | more than 120m2 | Central    | Corridor | 133.4959 | 83.5196  |
| 173 | Linear | more than 15 buildings | More than 13,001m2 | Core 4 | 1981-1984 | more than 120m2 | Individual | Stair    | 112.7135 | 109.3505 |
| 174 | grid   | 6-15 buildings         | Less than 10,000m2 | Core 4 | 1988-2000 | 71-100m2        | Individual | Mixed    | 74.5615  | 70.5983  |
| 175 | grid   | 6-15 buildings         | Less than 10,000m2 | core 1 | 1988-2000 | Less than 70m2  | Individual | Corridor | 84.0571  | 80.5859  |
| 176 | grid   | 6-15 buildings         | 10,001-13,000m2    | Core 2 | 1988-2000 | more than 120m2 | Individual | Stair    | 84.1309  | 97.6957  |
| 177 | Linear | 6-15 buildings         | Less than 10,000m2 | Core 3 | 1988-2000 | 101-120m2       | Individual | Stair    | 93.2061  | 100.0822 |
| 178 | grid   | 6-15 buildings         | Less than 10,000m2 | core 1 | 1988-2000 | Less than 70m2  | Individual | Corridor | 92.3197  | 90.3108  |
| 179 | Linear | 6-15 buildings         | More than 13,001m2 | Core 3 | 1988-2000 | more than 120m2 | Individual | Stair    | 89.5274  | 94.7778  |
| 180 | grid   | 6-15 buildings         | Less than 10,000m2 | Core 2 | 1988-2000 | 71-100m2        | Individual | Stair    | 89.6285  | 101.8818 |
| 181 | grid   | less than 5 buildings  | 10,001-13,000m2    | Core 2 | 1988-2000 | 71-100m2        | Individual | Mixed    | 76.3110  | 93.5467  |

|     |        |                        |                    |        |           |                 |            |          |          |          |
|-----|--------|------------------------|--------------------|--------|-----------|-----------------|------------|----------|----------|----------|
| 182 | Square | 6-15 buildings         | Less than 10,000m2 | Core 2 | 1988-2000 | 71-100m2        | Individual | Stair    | 80.3614  | 101.3024 |
| 183 | grid   | 6-15 buildings         | Less than 10,000m2 | core 1 | 1988-2000 | 71-100m2        | Individual | Corridor | 81.1147  | 78.2776  |
| 184 | grid   | 6-15 buildings         | 10,001-13,000m2    | Core 2 | 1988-2000 | more than 120m2 | Individual | Stair    | 75.4309  | 97.4701  |
| 185 | grid   | 6-15 buildings         | 10,001-13,000m2    | Core 2 | 1988-2000 | more than 120m2 | Individual | Stair    | 77.3555  | 91.9409  |
| 186 | Square | 6-15 buildings         | Less than 10,000m2 | Core 3 | 1988-2000 | 101-120m2       | Individual | Stair    | 85.4689  | 100.1438 |
| 187 | grid   | 6-15 buildings         | Less than 10,000m2 | core 1 | 1988-2000 | 71-100m2        | Individual | Corridor | 74.1524  | 77.3113  |
| 188 | Linear | 6-15 buildings         | 10,001-13,000m2    | core 1 | 1988-2000 | 101-120m2       | Individual | Corridor | 67.9960  | 85.9527  |
| 189 | grid   | more than 15 buildings | 10,001-13,000m2    | Core 3 | 1985-1987 | more than 120m2 | Central    | Mixed    | 109.3708 | 83.4943  |

## Appendix B

- Stochastic data of usage of electric appliances (KEPC, 1990; KEPC, 2013), used in Chapter 5 ( ■ input items)

| Items                 | Electric power consumption (W) | Penetration rates (%) | Daily usage (min/day) | Annual usage (hour/year) | Annual electric consumption (Wh) | Standard deviation of annual usage |
|-----------------------|--------------------------------|-----------------------|-----------------------|--------------------------|----------------------------------|------------------------------------|
| TV                    | 130.6                          | 123                   | 331                   | 1918                     | 255,520                          | 63.5                               |
| Washing machine       | 242.8                          | 98                    | 72                    | 205                      | 51,555                           | 30.1                               |
| Electric iron         | 1265.5                         | 79                    | 22                    | 36                       | 43,871                           | 25.2                               |
| Computer              | 255.9                          | 62                    | 130                   | 599                      | 155,589                          | 109.1                              |
| Rice-cooker (cooking) | 1036.2                         | 93                    | 66                    | 341                      | 342,407                          | 25.8                               |
| Rice-cooker (warming) | 158.2                          | 93                    | 719                   | 3719                     | 604,011                          | 631.7                              |
| Microwave             | 1040.3                         | 71                    | 12                    | 34                       | 35,753                           | 4.8                                |
| Vacuum cleaner        | 1016.2                         | 82                    | 28                    | 107                      | 109,186                          | 12.3                               |
| Video/DVD             | 18.2                           | 8                     | 65                    | 60                       | 1,064                            | 34.6                               |
| Electric blanket      | 170.00                         | 87                    | 339                   | 576                      | 97,340                           | 98.18                              |
| Air-conditioner       | 1340.3                         | 78                    | 173                   | 156                      | 238,245                          | 18.85                              |
| Refrigerator          | 40                             | 104                   | -                     | -                        | 350,634                          | -                                  |
| Kimchi-refrigerator   | 22.6                           | 86                    | -                     | -                        | 155,275                          | -                                  |

- Stochastic data of occupants' behaviours of consuming electric appliances (KEPC, 2013), used in Chapter 5 (■ input range of schedules)

|                       | Time |      |      |      |      |      |      |      |      |      |      |      |      |      |      |      |      |      |      |      |      |      |      |      |
|-----------------------|------|------|------|------|------|------|------|------|------|------|------|------|------|------|------|------|------|------|------|------|------|------|------|------|
|                       | 0    | 1    | 2    | 3    | 4    | 5    | 6    | 7    | 8    | 9    | 10   | 11   | 12   | 13   | 14   | 15   | 16   | 17   | 18   | 19   | 20   | 21   | 22   | 23   |
| TV                    | 5.4  | 0.9  | 0.2  | 0.2  | 0.3  | 8.5  | 35.2 | 46.0 | 35.9 | 19.4 | 7.3  | 5.1  | 6.2  | 6.5  | 6.9  | 7.7  | 12.6 | 29.5 | 62.8 | 84.1 | 92.6 | 87.6 | 58.9 | 29.2 |
| Washing machine       | 0.0  | 0.0  | 0.0  | 0.0  | 0.0  | 0.7  | 4.9  | 15.3 | 19.6 | 18.6 | 6.4  | 3.5  | 2.5  | 2.3  | 1.9  | 1.3  | 3.0  | 5.3  | 7.0  | 6.7  | 3.8  | 1.5  | 0.4  | 0.1  |
| Air-conditioner       | 5.2  | 1.1  | 0.0  | 0.0  | 0.0  | 0.0  | 3.5  | 2.0  | 0.7  | 0.7  | 0.4  | 4.3  | 7.2  | 7.0  | 5.9  | 6.7  | 7.0  | 12.6 | 20.0 | 32.6 | 32.2 | 22.8 | 16.1 | 10.7 |
| Electric Iron         | 0.0  | 0.0  | 0.1  | 0.0  | 0.1  | 1.5  | 13.9 | 14.2 | 7.0  | 5.4  | 4.2  | 2.0  | 2.9  | 1.8  | 2.2  | 1.9  | 2.9  | 2.9  | 3.9  | 9.2  | 5.3  | 3.6  | 1.2  | 0.0  |
| Computer              | 3.9  | 1.5  | 1.0  | 0.6  | 0.0  | 0.0  | 0.7  | 1.0  | 2.2  | 2.8  | 3.7  | 3.1  | 3.3  | 5.6  | 5.8  | 7.4  | 9.5  | 13.2 | 18.6 | 26.8 | 31.2 | 32.5 | 21.5 | 12.3 |
| Rice-cooker (warming) | 37.0 | 37.1 | 36.9 | 36.9 | 37.9 | 39.5 | 49.0 | 63.9 | 69.4 | 69.1 | 68.8 | 67.8 | 62.1 | 57.7 | 55.5 | 54.6 | 54.2 | 54.2 | 53.5 | 52.1 | 48.0 | 43.1 | 41.0 | 40.0 |
| Rice-cooker (cooking) | 1.8  | 1.8  | 1.8  | 1.8  | 2.5  | 12.4 | 42.8 | 20.5 | 7.2  | 3.4  | 3.1  | 3.5  | 3.2  | 3.0  | 3.0  | 3.4  | 5.2  | 21.1 | 21.8 | 6.6  | 2.5  | 2.5  | 1.9  | 1.9  |
| Microwave             | 0.3  | 0.0  | 0.1  | 0.0  | 0.1  | 1.0  | 14.3 | 18.5 | 4.9  | 2.9  | 1.0  | 3.4  | 3.0  | 0.8  | 1.9  | 1.0  | 2.5  | 11.5 | 15.0 | 9.0  | 2.8  | 2.5  | 0.4  | 0.4  |
| Vacuum cleaner        | 0.0  | 0.1  | 0.0  | 0.0  | 0.3  | 0.1  | 3.5  | 14.2 | 21.6 | 18.9 | 3.5  | 1.9  | 1.7  | 1.5  | 1.9  | 2.1  | 2.6  | 6.0  | 7.0  | 4.0  | 1.5  | 0.6  | 0.0  | 0.0  |
| Fluorescent lights    | 0.0  | 0.0  | 0.0  | 0.0  | 0.0  | 0.2  | 0.8  | 0.7  | 0.1  | 0.0  | 0.0  | 0.0  | 0.0  | 0.0  | 0.0  | 0.0  | 0.0  | 0.1  | 0.3  | 0.8  | 0.7  | 0.6  | 0.6  | 0.6  |
| Hair dryer            | 0.0  | 0.0  | 0.0  | 0.0  | 0.1  | 2.0  | 37.2 | 37.8 | 12.3 | 7.0  | 2.1  | 1.2  | 0.5  | 0.2  | 0.7  | 0.5  | 0.9  | 1.3  | 1.1  | 2.5  | 2.4  | 0.6  | 0.1  | 0.0  |
| Audio                 | 0.0  | 0.0  | 0.0  | 0.0  | 0.0  | 2.2  | 0.0  | 6.7  | 6.7  | 8.9  | 8.9  | 15.6 | 15.6 | 11.1 | 8.9  | 6.7  | 6.7  | 8.9  | 6.7  | 6.7  | 8.9  | 4.4  | 0.0  | 0.0  |
| Refrigerator          | 100  | 100  | 100  | 100  | 100  | 100  | 100  | 100  | 100  | 100  | 100  | 100  | 100  | 100  | 100  | 100  | 100  | 100  | 100  | 100  | 100  | 100  | 100  | 100  |
| Kimchi-Refrigerator   | 100  | 100  | 100  | 100  | 100  | 100  | 100  | 100  | 100  | 100  | 100  | 100  | 100  | 100  | 100  | 100  | 100  | 100  | 100  | 100  | 100  | 100  | 100  | 100  |

## Appendix C

### Heating energy consumption in apartment units applied in Chapter 6

| Locations          |                        | Horizontal locations |         |              |
|--------------------|------------------------|----------------------|---------|--------------|
|                    |                        | West                 | Middle  | East         |
| Vertical locations | Top floor              | 152.930              | 157.233 | 170.532      |
|                    | 13 <sup>th</sup> floor | 97.781               | 97.781  | 97.781       |
|                    | 12 <sup>th</sup> floor | 107.364              | 108.831 | 145.695      |
|                    | 11 <sup>th</sup> floor | 109.124              | 114.698 | 116.947      |
|                    | 10 <sup>th</sup> floor | 101.008              | 114.404 | 117.339      |
|                    | 9 <sup>th</sup> floor  | 110.786              | 121.640 | 118.414      |
|                    | 8 <sup>th</sup> floor  | 140.903              | 132.298 | 139.731      |
|                    | 7 <sup>th</sup> floor  | 113.329              | 132.201 | 111.374      |
|                    | 6 <sup>th</sup> floor  | 106.680              | 135.916 | 130.246      |
|                    | 5 <sup>th</sup> floor  | 154.593              | 133.276 | 137.286      |
|                    | 4 <sup>th</sup> floor  | 128.876              | 139.339 | 144.521      |
|                    | 3 <sup>rd</sup> floor  | 136.112              | 143.382 | 144.619      |
|                    | 2 <sup>nd</sup> floor  | 136.014              | 154.886 | 152.541      |
|                    | 1 <sup>st</sup> floor  | 146.477              | 156.940 | 147.064      |
|                    | Ground floor           | 163.002              | 195.074 | 179.821      |
|                    |                        |                      |         | Ground level |

## Appendix D

### Publications

#### **A stochastic model of integrating occupant behaviour into energy simulation with respect to actual energy consumption in high-rise apartment buildings**

Hyunju JANG & Jian KANG\*

School of Architecture, University of Sheffield, Sheffield S10 2TN, United Kingdom

\* Corresponding author

### Abstract

Apartment buildings have evolved to be self-sufficient for occupants. Thus, energy use is individually controlled in apartment units, which can be considered as independent thermal zones within buildings. However, this has been disregarded in conventional energy modelling which is mainly applicable for reducing energy demands of buildings with standardised conditions, rather than reflecting actual consumption. This approach has been questioned due to the high levels of uncertainty formed with real buildings. In this study, a model considering occupant random behaviour consuming heating and electricity is developed to reflect variations in actual energy consumption in apartments. Moreover, the effects of various parameters of occupant behaviour in relation to the model were examined. In total 96 apartment blocks in Seoul were used as samples. Gaussian Process Classification was applied to modify occupant random behaviours corresponding to the probability of energy consumption. As a result, it has been found that occupants' general heating controls (25% deviation) are between three and eight hours, with 17 – 20 °C set temperatures. Moreover, the operating hours of electric appliances and lighting are also approximated with the probabilities. This methodology could reduce uncertainties in building simulations, and provide a broader application in buildings with similar development stages.

### Keywords

Bayesian inference, Uncertainty, Gaussian Process, Occupant behaviour, Apartment building



---

**2016 Energy and Buildings****Received** 5 October 2015, **Revised** 15 February 2016, **Accepted** 16 March 2016**Available online** 17 March 2016**1. Introduction**

Apartment buildings are one of the most common types of housing in Asia (Yuen, 2011). Their high capacity of accommodating a large number of residents has attracted the fast grown and growing countries, such as China, South Korea, Hong Kong and Singapore (Yuen, 2011). One of the representative countries for a great number of apartment construction, South Korea, experienced great economic growth in the 1960s, and the country became rapidly urbanised (Chung, 2007). This urbanisation also resulted in a dramatically increased urban population (Chung, 2007). Apartment buildings were introduced to accommodate this increased size of the urban population, particularly for the working class (Lim, 2011). However, the main target for apartment buildings was gradually transferred from the working class, to the “new” middle class that rapidly grew during the economic growth in the 1970s and 1980s (Lett, 2001). This transfer meant that living in apartment buildings became a representative of rising social status (Gelézeau, 2007). For this reason, the proportion of housing that were apartment buildings was much greater (Statistics Korea, 2010a). Seoul was one of the main centres in this significant transformation. In the 1970s and 1980s, 48% and 26% of national apartment construction was concentrated in Seoul, respectively (Statistics Korea, 2010a). They still comprised about 50% of housing in the city (Kim, 2010).

Improving thermal performance in existing buildings has been discussed in many countries (Ouyang et al., 2011) as carbon emissions is an international issue. Refurbishing old existing apartment buildings has been importantly investigated in Asian countries, such as (Yuen et al., 2006; Ouyang et al., 2011). In South Korea, apartment buildings built in the 1970s and 1980s have been highlighted due to their large population, as well as high energy consumption (Kim, 2010), in accordance with the intensified building thermal regulations (Kim et al., 2013). Existing literature (Kim et al., 2006; Lee, 2009; Song, 2009; Son et al., 2010; Kim et al., 2010; Roh, 2012) has focused on reducing the energy demand of apartment buildings in standardised conditions defined by the Energy Performance Index (Ministry of Land, Infrastructure and Transport, 2015a) and Building Energy Efficiency Rating System (Ministry of Land, Infrastructure and Transport, 2015b). These standards have provided deterministic conditions to identify changes in the energy demands of buildings. Thus, they have been used to verify energy efficiency in buildings, and guide buildings to improve their energy performance. However, this approach has been questioned in its relation of real

situations. Many studies pointed out the limitations and uncertainties contained in the standard conditions of buildings used in existing literature (Ryan & Sanquist, 2012). One of the difficulties in refurbishing existing buildings is the lack of interaction with the occupants (Gholami et al., 2015).

Apartment buildings have evolved to be self-sufficient for occupants despite the unified features of buildings (Gelézeau, 2007). The usage of heating and electricity is individually controlled in each apartment unit, which can be considered as an independent thermal zone in these buildings. Therefore, energy consumption in apartment buildings can significantly vary. Besides, some empirical data in existing studies (Kang et al., 1995; Lee et al., 2012), showed variation in actual energy consumption in apartment buildings despite the similar thermal conditions. However, energy models with standardised conditions in the existing literature are not flexible enough to take into account the possible variations in energy consumption. Furthermore, the results would contain a high amount of uncertainty due to random behaviours of energy consumption.

Existing field studies have indicated how much energy consumption can vary by occupant energy behaviour. One of the existing studies (Galvin, 2013) divided consumers living in the same apartment buildings by the heating consumption levels, due to the normality of the three distributions in the frequency density: lower than 500 kWh, 501 – 3000 kWh and higher than 3000 kWh. Except for the consumption of space heating, electricity consumption could also vary from 50 to 750 kWh among 100 households, and the consumption for standby was between 0 and 1300 kWh per year (Gram-Hanssen, 2013). The monitored usage of electric appliances, apart from the consumption for space heating and hot water, was differed between 35% and 40% depending on the characteristics of the consumers' behaviours (Sidler et al., 2002).

In order to take these variations caused by occupants' controls into building simulations, energy modelling in existing literature has attempted to integrate the variations with a probabilistic approach, rather than deterministic values. One of the probabilistic approaches is to use stochastic models. The concept of stochastic occupants' behaviours considers human behaviour as not deterministic, but complex and unpredictable actions which are represented by a composition of observable states (Virote & Neves-Silva, 2012). Therefore, the stochastic model of occupants' behaviours takes the probability of actions which brings about energy consumption or a change in indoor environment. Virote & Neves-Silva (2012) used the hidden Markov Chain model to integrate observable motivations of occupant behaviour taking the actions consuming energy. Nicol (2001) considered occupants' behaviours as binary – heating on or off – and applied the probit regression analysis for

modelling the proportion of occupants' actions in relation to outdoor temperatures. The stochastic models refine the ranges of possible consumption behaviours with the quantified probability. Therefore, the models draw uncertain factors with the more distinctive boundaries in building simulations. However, the limitations of stochastic models can be that they do not provide consistent results that can be directly input in building simulations (Virote & Neves-Silva, 2012), even the results are within the probable ranges.

This study, therefore, aims to develop a probabilistic model of occupant random behaviour consuming heating and electricity, regarding the variation in actual energy consumption for old high-rise apartment buildings. Three objectives are designed: to identify the variation in actual energy consumption in old high-rise apartment buildings built between the 1970s and 1980s; to integrate the variation in actual consumption into energy models; and to identify the possible occupant random behaviours controlling heating and electricity corresponding to the probability of energy consumption.

## **2. Methods**

In order to identify probabilistic occupant random behaviours controlling heating and electricity the procedure was designed in four steps. At first, actual energy consumption in apartment buildings was surveyed, and then its variation was measured. Second, energy models of the random control of heating and electricity were analysed with their uncertainty. Estimated energy consumption of the energy models was optimised to reflect the distribution of the actual usage. Third, the probability of energy consumption was predicted by Gaussian Process Classification. At the same time, the possible ranges of occupant random controls were updated. Last, the probabilistic random behaviour was evaluated.

### **2.1 Evaluating variation in actual energy consumption in apartment buildings constructed in the 1970s – 1980s**

#### **2.1.1 Sampling**

There are many factors interrelating with energy consumption. Thus, it was important to control effects from unrelated factors in this study. Three sampling units were chosen: 1) locations; 2) physical conditions; 3) data availability. Firstly, the locations of apartment buildings were used to eliminate external effects. Sixteen apartment districts in Seoul were chosen. These districts were mainly developed for apartment constructions under an enforcement decree of the Urban Planning Act since 1976 (Son, 2004). Thus, apartment buildings in these districts were constructed in a similar time frame and near distance, which can minimise the difference in climate effects. Afterwards, these 16 districts were separated

by socio-economic factors to avoid the impact of urban segregation in Seoul. Existing literature has identified that the disparities of education levels and occupations are highly correlated to the income levels of residents in Seoul (Yoon, 1998; Lee, 2008; Chung, 2015). Yoon (2011) compared the geographical disparities of various indices related to the socio-economic factors: population, fiscal self-reliance ratio, health and welfare, education, prices of housing and land, industrial structure and transportation. Five boroughs representing relatively better living conditions were chosen from a total of 25 boroughs in Seoul by comparing a standard score of the indices. Residents with high level education were densely populated in these five boroughs. The robust correlation between the high-education residents in these five boroughs and their housing types (apartment buildings) has been found (Zhang, 1994). Sixteen apartment districts are affiliated to these five boroughs. Four of the five boroughs (13 apartment districts), all with apartment buildings constructed in the mid – 1970s and 1980s, were chosen for this study. The residents in the four boroughs, especially those who live in high-rise apartment buildings, were called “new” urban middle class (Lett, 2001; Zhang, 1994). Zhang (1994) described the “old” middle class as small business owners and a higher income than the average. In contrast to the “old” middle class, Lett (2001) discovered the seven categories of occupations in the “new” urban middle class in the four boroughs: scholars, government bureaucrats, corporate salary men, business owners, professionals, religious leaders, nouveaux riches. The life styles of the “new” urban middle class are varied (Lett, 2001; Gelézeau, 2007), but people in this class can afford not to be concerned about energy consumption.

Secondly, the physical conditions of apartment buildings need to be constrained to avoid giving impact on energy consumption. Two of the most influential factors affecting energy consumption, thermal conditions of building envelopes (Kim, 2013) and heating methods (Lee et al., 2004; Moon et al., 2001) were chosen. Therefore, apartment buildings constructed in the 1970s and 1980s were divided into two groups depending on the thermal conditions of building envelopes, which were filtered by construction years. The first group, period A, was comprised of apartment buildings constructed before 1980 when a legislation of building thermal regulations was enacted. The second group, period B, contained buildings built between 1981 and 1988 before the building regulation has a professional form. Therefore, the buildings in both periods need to be refurbished to reduce high energy consumption (Kim, 2010), although buildings in period B can be expected to have relatively advanced thermal conditions compared to buildings in period A. The district heating method was considered only, which was mainly applied to many apartment buildings constructed in the four boroughs.

Lastly, energy bills were collected through the Apartment management information system (Korea Appraisal Board, 2015). The monthly consumption in 2014 was transformed from  $\text{Won}/\text{m}^2/\text{year}$  to  $\text{kWh}/\text{m}^2/\text{year}$ , according to calculation methods by the Korea District Heating Corporation (2015) and Korea Electric Power Corporation (2014). The bills were separated by heating and electricity. This study only considered energy bills consumed for individual units. Energy bills used for communal purposes were, therefore, excluded even though they were consumed in buildings. In total 96 apartment blocks (44 blocks in period A and 51 blocks in period B) were chosen in this sample study. They occupy 37.1% and 16.3% of apartment buildings built in both periods A and B in Seoul, respectively.

### **2.1.2 Normality tests**

Central limit theorem states that frequencies in empirical populations show bell-shape curves if the number of independent random samples is large enough (Ross, 2002). The collected samples were evaluated for this normality. Firstly, Kolmogorov-Smirnov and Shapiro-Wilk tests were conducted to measure the deviations of the samples from the normal distribution with the same mean and standard deviation. If  $p$ -values in both tests are not significant ( $p > 0.05$ ), then the normality of the samples can be accepted (Ross et al., 2014). Secondly, Q – Q plots were drawn to supplement the limitation of the previous normality tests through visual inspection (Field, 2009). Lastly, skewness and kurtosis were measured to identify how far the sample data is different from the normal distribution;  $\pm 1.96$  limits were considered as normally distributed (Field, 2009). SPSS (Field, 2009) was used to conduct these tests. The results of normality tests are illustrated in Section 3.1.

## **2.2 Integrating occupant random behaviour reflecting actual energy consumption into energy modelling**

A probabilistic approach was applied to reflect variation in the actual energy consumption in energy models. Energy models were created by the possible behaviours in controlling heating and electricity. The possible energy consumption in the energy models was compared to the variation in the actual energy consumption. The model estimation was optimised to be as similar as possible to the real consumption, which indicates the possible ranges of occupant behaviours determining the variation in the actual consumption.

### **2.2.1 Energy models of occupant random behaviours controlling heating and electricity**

Energy modelling consisted of three parts: building form, thermal properties and energy controls. First, building form was fixed by choosing the most typical unit design (Kim & Kim, 1993; Park, 2003) and building design (fifteen-story and south-facing (Son, 2004; Lim,

2011), as shown in Figure 1. This unit design made up about 80% of apartment buildings built until the 1980s (Kim & Yoon, 2010). The apartment buildings with 15 floors make up the largest proportion, 31.7% (Ministry of Land, Infrastructure and Transport, 2004). Energy models were created with six units: two units on three floors (ground, middle and top floors). The energy consumption in the two units on the middle floor was multiplied to estimate the total amount of energy consumption from the 2nd to 14th floors by using multiplier in EnergyPlus8.0 (EnergyPlus Documentation, 2010). Each room was separately modelled as individual thermal zones to be controlled by different schedules as it occurs in real situations.

Second, thermal properties (U-values) for the two periods (before 1980, and between 1981 and 1988) were identified by reviewing the building thermal regulations and existing literature (Seo, 2012; Kim et al., 2013). The specific applications were also verified by the site survey collecting actual architectural drawings in three apartment blocks. The thermal condition in apartment units is divided into two different areas: unconditioned and conditioned areas (Figure 1). Unconditioned areas mean the bathroom and two balconies, which are directly exposed to the outside without heating facilities, whereas conditioned areas are the main living spaces, which are enclosed by the unconditioned areas to be protected from the outside, apart from the bedroom C. Therefore, thermal protection was focused on the conditioned areas. The profiles of the building envelopes are described in Table 1.



**Figure 1 Description of the apartment units**

**Table 1 Profile of thermal properties in energy models**

| Location                                    | Exposure to the outside | Materials (mm)<br>(In → out, up → down) |                                  | Thickness (mm)<br>(Period A/B) | Thermal conductivity (W/m.K) | Density (kg/m <sup>3</sup> )<br>(Period A/B) | Specific heat (J/kg.K)<br>(Period A/B) | U-value (W/m <sup>2</sup> K) |          |
|---|-------------------------|---|----------------------------------|--------------------------------|------------------------------|--|--|------------------------------|----------|
|   |                         | Period A<br>(Before 1980)               | Period B<br>(1981 – 1988)        |                                |                              |  |  | Period A                     | Period B |
| External wall                               | Direct                  | Mortar                                  | Mortar                           | 18                             | 1.081                        | 1950   | 921                                    | 2.08                         | 2.08     |
|   |                         | Cement brick                            | Cement brick                     | 90                             | 0.605                        | 1700   | 1550                                   |                              |          |
|   |                         | Cavity                                  | Cavity                           | 50                             | 0.15(m <sup>2</sup> K/W)     | -  | -                                      |                              |          |
|   |                         | Cement brick                            | Cement brick                     | 90                             | 0.605                        | 1700   | 1550                                   |                              |          |
|   |                         | Mortar                                  | Mortar                           | 18                             | 1.081                        | 1950   | 921                                    |                              |          |
|   | Indirect                | Mortar                                  | Mortar                           | 18                             | 1.081                        | 1950   | 921                                    | 2.08                         | 0.50     |
|   |                         | Cement brick                            | Cement brick                     | 90                             | 0.605                        | 1700   | 1550                                   |                              |          |
|   |                         | Cavity                                  | Insulation                       | 50                             | 0.033                        | - / 50                                       | - / 838                                |                              |          |
|   |                         | Cement brick                            | Cement brick                     | 90                             | 0.605                        | 1700   | 1550                                   |                              |          |
|   |                         | Mortar                                  | Mortar                           | 18                             | 1.081                        | 1950   | 921                                    |                              |          |
| Side wall                                   | Direct                  | Mortar                                  | Mortar                           | 18                             | 1.081                        | 1950   | 921                                    | 3.24                         | 0.59     |
|   |                         | Cement brick                            | Insulation                       | 90 / 50                        | 0.605                        | 1700 / 50                                    | 1550 / 838                             |                              |          |
|   |                         | Concrete                                | Concrete                         | 200                            | 1.400                        | 2240   | 879                                    |                              |          |
|   |                         |   | Mortar                           | 18                             | 1.081                        | - / 1950                                     | - / 921                                |                              |          |
| Roof  | Direct                  | Mortar                                  | Mortar                           | 24                             | 1.081                        | 1950   | 921                                    | 0.52                         | 0.52     |
|   |                         | Concrete                                | Concrete                         | 200                            | 1.400                        | 2240   | 879                                    |                              |          |
|   |                         | Cavity                                  | Cavity                           | 220                            | 0.18(m <sup>2</sup> K/W)     | -  | -                                      |                              |          |
|   |                         | Insulation                              | Insulation                       | 50                             | 0.033                        | 50   | 838                                    |                              |          |
|   |                         | Plaster board                           | Plaster board                    | 10                             | 0.209                        | 940  | 1130                                   |                              |          |
|   |                         |   |                                  |                                |                              |  |  |                              |          |
| Floor between ground and underground floors | Indirect                | Mortar + Gravels (heating tubes)        | Mortar + Gravels (heating tubes) | 100                            | 1.081                        | 1950   | 921                                    | 4.36                         | 0.55     |
|   |                         |   |                                  |                                | 1.260                        | 1522   | 908                                    |                              |          |
|   |                         | Concrete                                | Concrete                         | 200                            | 1.400                        | 2240   | 879                                    |                              |          |
|   |                         |   | Insulation                       | 50                             | 0.033                        | - / 50                                       | - / 838                                |                              |          |
|   |                         | Plaster board                           | 10                               | 0.209                          | - / 940                      | - / 1130                                     |  |                              |          |
| Window                                      | Direct                  | Single glazing                          | Single glazing                   | 3                              | 0.900                        | -  | -                                      | 5.89                         | 5.89     |

Third, heating and electricity controls were set differently depending on uncertainty. Heating supply in each room is controlled by supplying valves, and the controller manipulates set-point temperatures and operations. Heating controls in this study concentrated on the set-point temperatures and operating hours in each room. The possible range of heating set-point temperatures was set between 16 °C and 22 °C. The operating hours were gradually increased from three to nine hours per day. In terms of electricity controls, the national surveys investigating behaviours of electricity consumption (Korea Electric Power Corporation, 1990; Korea Electric Power Corporation, 2013) were used to identify the possible range of operations in households. Daily routines of using electric appliances in 500 households were collected in this survey. Lighting and four electric appliances showing

variations in their operating hours with higher penetration rates (60%) were chosen: air-conditioner, electric blanket, computer and rice-cooker. Lighting operation was separated by the living room and the bedrooms. The operating hours were increased from 1 to 7 hours per day with maximum 70% fluorescent lights in operation among the 500 households (Korea Electric Power Corporation, 1990). The control of air-conditioners was separated by set-point temperatures and hours. The temperatures were increased from 23°C to 29°C. Overall, operating hours of cooling did not exceed more than 32%, which is relatively lower compared to other appliances. The maximum hours of using an air-conditioner was 7 hours in a day with 10% probability. Rice-cookers showed the highest operating hours, with an average of 3800 per year in consuming electricity for warming rice (Korea Electric Power Corporation, 2013). The maximum operating hours was identified to be 16, with about 40% in operation, and the minimum hours was 10, with about 60% in operation. The computer was mainly used at night. The maximum usage is distributed between 7pm and 11pm with about 30% in operation. The electric blanket was generally used between five to six hours per day, but the number of days used in a year indicated more prominent variations from 60 to 120 days. This variation was taken into account in models. In total 19 input parameters were set with the possible range of values (Table 2).

Some appliances, such as the TV, refrigerator, and Kimchi refrigerator, also indicated high electricity consumption, but their operations were much unified: always on for refrigerators and five hours on for the TV, according to the national survey (Korea Electric Power Corporation, 2013). Therefore, they were set in the energy models, but with consistent values. Two air-conditioners were equipped in the living room and the largest bedroom A. Electric blankets for supplementary heating were applied in the living room and two bedrooms. A computer and rice cooker were placed in the living room, including the kitchen. Four occupants were set in each apartment unit, which is the most representative type of household living in apartment buildings (Statistics Korea, 2010b). Electric power for appliances was taken from the average values in the national survey (Korea Electric Power Corporation, 2013): TV (130.6W), refrigerator (40.0W), kimchi refrigerator (22.6W), computer (263.3W), fluorescent light (55.0W in bed rooms, and 165W in the living room), rice-cooker (1022.9W in cooking, and 143.4 in warming). Ventilation rates were set at 0.82ACH for conditioned area and 2.00ACH for unconditioned area (Ministry of Land, Infrastructure and Transport (2015b)).



**Table 2 Prior distributions of uncertain parameters in building energy models**

| Categories  | Input parameters                         | Prior distributions | Optimised distribution |                  | Locations                     | Units                | No.        |
|-------------|--|---------------------|------------------------|------------------|-------------------------------|----------------------|------------|
|             |  |                     | Period A               | Period B         |                               |                      |            |
| Heating     | Set-point temperatures                   | 16 – 22             | 16– 20<br>16 – 20      | 15 – 21<br>16–21 | Living room<br>Bed room A – C | °C(winter)           | 1<br>2,3,4 |
|             | Operating hours                          | 3 – 9               | 3–6<br>-               | 3 – 9<br>-       | Living room<br>Bed room A – C | Hour/day<br>(winter) | 5<br>6,7,8 |
| Electricity | Air-conditioner (set-point temperatures) | 23 – 29             | -                      |                  | Living room<br>Bed room A     | °C(summer)           | 9<br>10    |
|             | Air-conditioner (operating hours)        | 0 – 7               | 0 – 7                  |                  | Living room<br>Bed room A     | Hour/day<br>(summer) | 11<br>12   |
|             | Rice-cooker (operating hours)            | 10 – 16             | 7 – 16                 |                  | Living room<br>(kitchen)      | Hour/day             | 13         |
|             | Computer (operating hours)               | 1 – 4               | 0.5 – 3.5              |                  | Living room                   | Hour/day             | 14         |
|             | Lighting (operating hours)               | 1 – 7               | 0 – 7                  |                  | Living room<br>Bed rooms      | Hour/day             | 15,16      |
|             | Electric Blanket                         | 60 – 120            | -                      |                  | Living room                   | Day/year<br>(winter) | 17,18,19   |

**2.2.2 Optimisation of model estimation reflecting variation in the actual energy consumption**

The energy models defined in the previous section were used to estimate the possible ranges of energy consumption. A great number of possible cases were created due to the uncertain controls of heating and electricity. 200 random samples were chosen by Latin Hyper-Cube Sampling (LHS) to conduct the Monte Carlo Method. The LHS method is more robust than other sampling methods (Macdonald, 2009), and has been widely applied to the uncertainty analysis in building simulations such as (Hyun et al., 2008; Silva & Ghisi, 2014). EnergyPlus 8.0 (Crawley et al, 2001) was used to conduct building simulations. Historical weather data for Seoul in 2014, which is provided by White Box Technologies weather data for energy calculations (White Box Technologies, 2014), was applied. Both LHS samplings and simulations were managed by jEPlus (Zchang, 2012). Heating and electricity consumption were separately accumulated. The Probability Density Function (PDF) of the estimated energy consumption was compared to the PDF of the actual energy consumption. The Coefficient of Variation of Root-Mean-Square Deviation (CV RMSE) was used to measure the discrepancy between the model estimation and the actual energy consumption.

The previous occupant random behaviour in energy models could not be specified for the residents living in the old apartment buildings. This can bring about high amounts of discrepancy, compared to the actual energy consumption. This discrepancy was optimised in order to reflect the actual energy consumption. The procedure was divided into two parts. Firstly, multivariate regression analysis was conducted to create linear models of energy consumption only with influential parameters of occupants' random controls. Above all, the linearity was examined by the coefficients of determination (R-squared) and F-ratio values (Field, 2009). Standardised Regression Coefficient (SRC) values were used to determine the influential parameters in the linear models. A stepwise method was applied to create possible linear models automatically. Secondly, the ranges and values of the uncertain parameters were revised for their regenerated random samples to have a similar mean and standard deviation of the actual energy consumption. Random sampling was conducted by uniformly distributed pseudorandom integers in MATLAB 2014a (Hunt et al., 2014). The linear models identified above were used to estimate energy consumption of the regenerated samples. The distribution of the re-estimated energy consumption was compared to the actual energy consumption. CV RMSE was used to evaluate the difference between them. The results are shown in Section 3.2.1.

### **2.3 Generalisation of probability of occupant random behaviours consuming heating and electricity**

Based on the optimised model estimation, this section conducted stochastic processes to identify the probability of energy consumption. Stochastic processes deal with the sets of all possible random parameters (Ross, 2014), and form the generalised probability distributions to functions (Rasmussen and Williams, 2006). In particular, Gaussian Processes easily deal with the many random variables that are approximately considered normally distributed, according to the probability theory (Parzen, 1999). The processes follow Bayes theorem (Rasmussen and Williams, 2006) that modifies prior distributions through observed data to achieve target distributions (Kalbfleisch, 2012). This inference has been used to calibrate parameters of energy models in building simulations, as shown in (Heo et al., 2012). Depending on the types of outputs, either regression or classification is determined in conducting Gaussian processes; regression deals with continuous outputs that deal with real values while classification considers discrete outputs classified by labels (Neal, 1998).

This study focused on classification to predict the probability of heating and electricity in the old apartment buildings, rather than exact calibration case-by-case. The process was divided into three steps. Firstly, the optimised random samples were prepared as training data. The energy consumption was subdivided by 25% deviation. Heating consumption with 25%

deviation was defined between 107 and 138 kWh/m<sup>2</sup>/year in period A, and between 87 and 112 kWh/m<sup>2</sup>/year in period B. The electricity consumption between 30.1 and 33.3 kWh/m<sup>2</sup>/year decided the medium class for the both periods.

Secondly, Gaussian Process priors such as covariance functions were formed. Many covariance functions can be applicable. The details of covariance functions were studied by Neal (1997). More than that, the suitable values of hyper-parameters defining covariance functions is more problematic (Rasmussen and Williams, 2006; Neal, 1997). Prior distributions of hyper-parameters are required to be predefined, although the values are optimised during the process. In this study, the Squared Exponential (SE) covariance function, which has been the most widely used (Rasmussen and Williams, 2006), was chosen. This covariance function necessarily requires two hyper-parameters: length-scale and magnitude. The inverse of length-scales demonstrates the relevance of inputs in the process, while magnitude indicates the variances of unknown function values (Neal, 2012). Gaussian distribution was applied for the hyper-parameters in this study.

Thirdly, Gaussian Process models were structured by multinomial probit models with nested Expectation Propagation (nested EP) algorithm (Riihimaki, 2013) to take into account the classes of energy consumption with four to six parameters for heating and electricity consumption. Comparing to MCMC, nested EP algorithm also showed consistent results with small inaccuracy (Riihimaki, 2013), but much less operating time was required. The calculations were conducted by GP-Stuff (Vanhatalo et al., 2013), run by MATLAB 2014a (Hunt et al, 2014). Contour plots were used to draw the predictive probability. The results are illustrated in Section 3.2.2.

## **2.4 Evaluating estimated energy consumption of probabilistic models**

The previous section identified the probability of energy consumption, and the previous identification of behaviours controlling heating and electricity were modified. The updated random behaviours were evaluated to whether or not the predicted energy consumption reflects the variation in the actual energy consumption with reduced uncertainty. 100 random samples were chosen with different probabilities: high probability (50 – 90%) and total probability (0 – 90%). Their estimated energy consumption is compared in Section 3.3.

## **3. Results**

The conventional energy modelling used for high-rise apartment buildings has estimated energy consumption based on the standardised conditions, which are provided from the international or national guidelines. Therefore, the estimation could contain high levels of

uncertainties when it is applied to specific types of buildings and groups of occupants. The methodology in this study was designed to reduce the uncertainties, caused by applying the standardised conditions, by identifying the probability of occupant energy behaviour from the national survey and the variation in actual energy consumption. Thus, the result of the probabilistic model can be adjusted for the specific resident group and the conditions of apartment buildings. This section presents the probabilistic model for the “new” urban middle class living in old apartment buildings constructed in the 1970s and 1980s in Seoul. The section is designed in three parts. The first part describes the analysis of variation in actual energy consumption in Section 3.1. The second part illustrates the probability of standardised conditions in Section 3.2. Specifically, the optimisation of estimated energy consumption regarding the actual energy consumption is interpreted in Section 3.2.1, and the results obtained from Gaussian Process Classification are shown in Section 3.2.2. Finally, the estimated energy consumption with the probability of standardised conditions is evaluated in Section 3.3.

### **3.1 Variation in actual energy consumption in apartment buildings built between the 1970s and 1980s**

The results of normality tests demonstrate that the collected samples are normally distributed (Figure 2). The  $p$ -values in the Kolmogorov-Smirnov tests are unified with 0.200 in the heating and electricity consumption for both periods. Shapiro-Wilk tests also show the  $p$ -values 0.362 – 0.792, which are not significant. This means that the normality of the samples can be accepted. The Q – Q plots of the samples show slight deviations from the normal distribution at the tails. The deviations are interpreted by Kurtosis and Skewness. The largest Kurtosis is 1.30 in the electricity consumption in period A, while the greatest skewness is found in the heating consumption in period A. However, these deviations are within  $\pm 1.96$  limits of Kurtosis and Skewness. Therefore, the samples can be regarded as normally distributed, which means that the number of samples is large enough to represent their population.

Figure 3 gives the overview of energy consumption in old high-rise apartment buildings constructed between the 1970s and 1980s. The average heating energy consumption in apartment buildings constructed before 1980 (Period A) is 123.2 kWh/m<sup>2</sup>/year, while the consumption is reduced to 99.66 kWh/m<sup>2</sup>/year in apartment buildings built between 1981 and 1988 (Period B). The comparison of the two average values reveals the significant impacts of thermal conditions of building envelopes on heating consumption. However, the electricity consumption is similar in both periods, A and B, with 31.77 kWh/m<sup>2</sup>/year and 31.67 kWh/m<sup>2</sup>/year, respectively.

The more interesting aspect is the variation in energy consumption in each period (Figure 3). Heating consumption is deviated 20.6 kWh/m<sup>2</sup>/year among buildings in period A, while a greater deviation about 30.1 kWh/m<sup>2</sup>/year is identified in period B. Furthermore, the difference between minimum and maximum values in heating consumption is 98.0 kWh/m<sup>2</sup>/year in period A, and is enlarged to 128.5 kWh/m<sup>2</sup>/year in period B. The relatively lower variation in period A could reveal their desperate need of heating due to the low energy-efficient building conditions. The higher variation in period B would result from the diverse preference in controlling heating by occupants. In electricity consumption, the standard deviation for both periods is about 3.5 kWh/m<sup>2</sup>/year, and the minimum and maximum ranges are about 15 – 20 kWh/m<sup>2</sup>/year. In general, the actual energy consumption in apartment buildings is 10 –30% deviated from average values. The difference between minimum and maximum consumption is extended up to 50 – 128%.

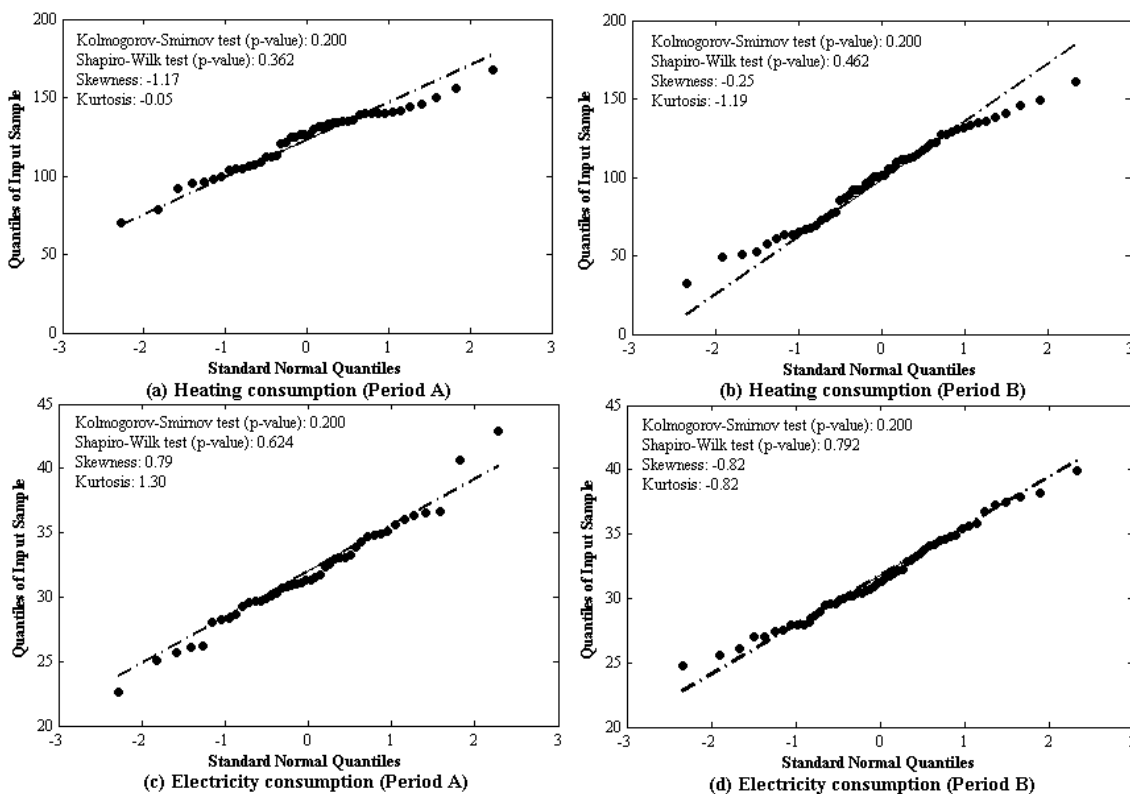

**Figure 2 Results of normality tests of actual energy consumption**

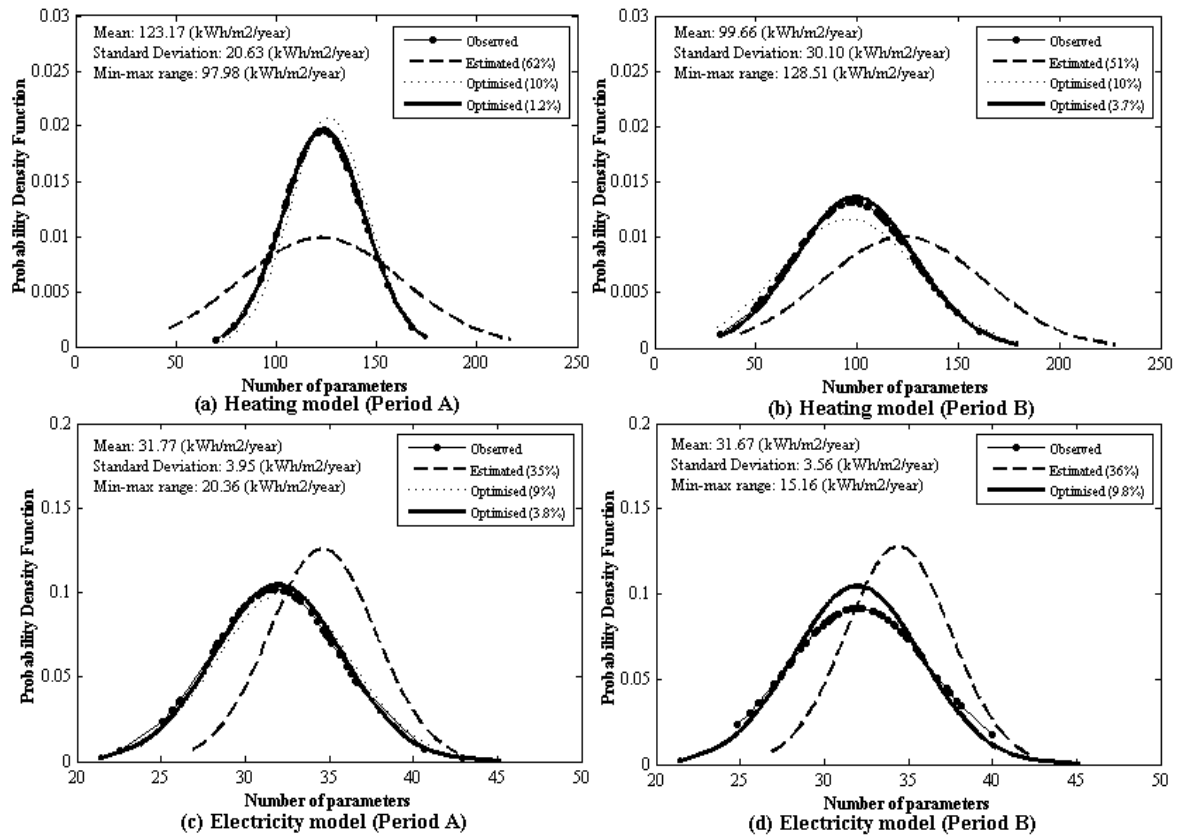

**Figure 3 Optimisation of model estimations in comparison to the variation in actual energy consumption**

### 3.2 Probability of standardised conditions regarding variation in actual energy consumption

The probabilistic approach integrating the variation into energy modelling is illustrated in this section. Firstly, energy models with the prior distributions are optimised to reflect the variation in the actual energy consumption in Section 3.2.1. Secondly, the probability of energy consumption is calculated by Gaussian Process Classification. At the same time, the possible ranges of influential parameters are modified. The results are illustrated in Section 3.2.2.

#### 3.2.1 Optimisation of the estimated energy consumption in energy modelling

The model estimation with the prior distribution of input parameters (thick dashed lines in Figure 3) is dissimilar from the distribution of the actual energy consumption (solid lines with dots). At first, the average values of the model estimation are greater than the actual values, apart from the heating estimation for period A. The average values of heating

consumption in period B is overestimated by about 23 kWh/m<sup>2</sup>/year with the prior distribution, while a nearly 3 kWh/m<sup>2</sup>/year reduction is required in the average value of electricity consumption. Second, the distribution of the estimated heating consumption is far greater than the one of actual consumption: 62% discrepancy in period A (Figure 3 – a) and 51% in period B (Figure 3 – b). This wider distribution of the estimated heating consumption indicates that the ranges of occupants' random controls would be wider than the actual usage, which needs to be narrowed down. On the contrary, the ranges of the parameters for electricity consumption are required to be wider to reduce the about 35% discrepancy from the variation in the actual use (Figure 3 – c and d). This opposite trend of estimation, compared to the actual use, implies that different parameters respectively affect heating and electricity, and their modification needs to be different.

Multivariate regression analysis is used to choose the most rigid linear models with less residual. In the results of the R-squared values (Figure 4 – a and b), the highest R-squared values of more than 0.7 are generally achieved by increasing the number of parameters. However, the increasing of R-squared values in heating models becomes significantly steady after the fourth model (0.84 and 0.70 for period A and B), while the sixth model (0.94 and 0.78 for period A and B) in electricity models. These models also show higher F-ratios with less numbers of input parameters: 256.2 in period A and 114.6 in period B for heating (degree of freedom: 4), and 554.4 in period A and 112.2 in period B for electricity (degree of freedom: 6) (Figure 4 – c and d). Hence, they are chosen as the most fitted models.

These linear models for heating and electricity consumption are respectively comprised of four and six parameters, as shown in Table 3. In the heating models, set-point temperature is the most significant factor, followed by operating hours. Specifically, the volume of space determines their impacts on heating consumption. Thus, set-point temperature in the living room presents the highest SRC of 0.587 and 0.526 in periods A and B. Their operating hours has the second highest SRC, which are 0.504 and 0.469 for period A and B, respectively. The third parameter is set-point temperatures in the bedroom A with SRC of 0.320 and 0.271 for both periods A and B. This is because the bedroom A is the largest bedroom. The fourth parameter is set-point temperatures in the bedroom C with SRC of 0.285 and 0.260 for both periods A and B, which is the bedroom directly exposed to the outside.

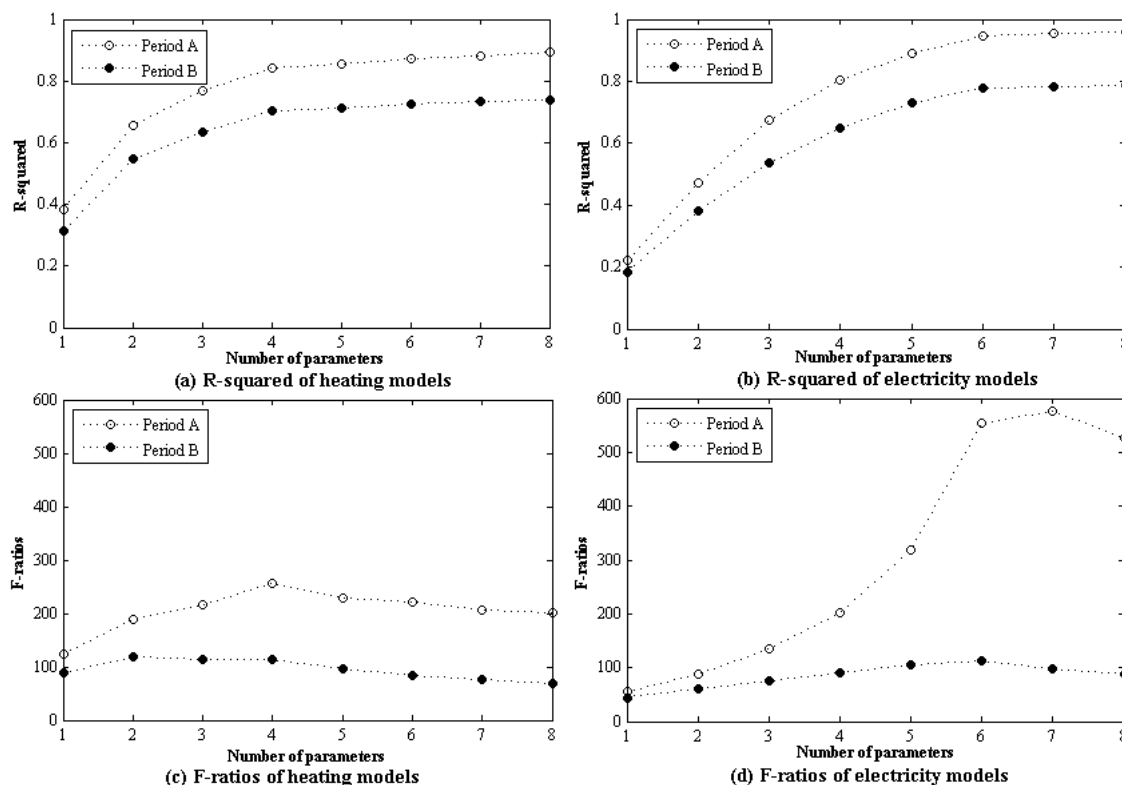

**Figure 4 Changes in the coefficient of determination (R-squared) and F-ratios of energy models**

Electricity models are structured by operating hours of six parameters that can be categorised by three groups: lighting, appliances used in daily routines and cooling. The most influential factors are the operating hours of lighting in the bedrooms (SRC 0.527 and 0.475 in periods A and B) and living room (SRC 0.475 and 0.433). The operating hours of rice-cookers and computers show the fourth and fifth highest SRC of 0.343 and 0.339 in period A, and 0.336 and 0.329 in period B. In terms of the seasonal devices, cooling hours is the most influential compared to the other factors, including cooling set-point temperatures. Their impact on electricity consumption is determined by the size of volume. Thus, cooling hours in the living room have SRC of 0.459 and 0.383 in periods A and B, while cooling operation in the bed room show SRC 0.239 and 0.220 in the two periods, respectively.

Diverse ranges of the input parameters in the linear models are examined for their estimation to be as close as the distribution of the actual energy consumption. As a result, the discrepancy is significantly declined with the new sets of random samples, as depicted by ‘optimised’ in Figure 3. The lowest discrepancy is achieved: 1.2% of the heating energy model for period A and 3.7% for period B. The modified electricity consumption in period A shows 3.8% discrepancy. The discrepancy became higher to 9.8% for period B by applying



the same set of the modified samples used for period A. In comparison to the previous distribution (Table 2), the large discrepancy in annual energy consumption is reduced by little change in daily routines. In the heating models, the range of set-point temperatures is reduced from 16 – 22 °C to 16 – 20 °C, and the operating hours are also reduced from 3 – 9 hours to 3 – 6 hours in the heating models for period A. For period B, the range of set-point temperatures is moved to 15 – 21 °C in the living room, and reduced to 16 – 21 °C in the bedroom A and C. In the electricity model, the possible ranges of operating hours of lighting and rice-cooker are extended by about 1 – 3 hours. The range of the computer is moved to 0.5 – 3.5 hours. Overall, the changes in set temperatures are within 2 °C, while operating hours are revised within 3 hours from the previous distributions.

**Table 3 Result of multivariate regression analysis**

|                    |                                 | Period A (Before 1980)      |            |                                     | Period B (1981 – 1988)      |            |                                     |
|--------------------|---------------------------------|-----------------------------|------------|-------------------------------------|-----------------------------|------------|-------------------------------------|
|                    |                                 | Unstandardised Coefficients |            | Standardised Coefficients (p-value) | Unstandardised Coefficients |            | Standardised Coefficients (p-value) |
|                    |                                 | B                           | Std. Error |                                     | B                           | Std. Error |                                     |
| <b>Heating</b>     | Set temperatures in living room | -303.777                    | 16.520     | (0.000)                             | -346.219                    | 26.161     | -(0.000)                            |
|                    | Heating hours in living room    | 10.070                      | 0.500      | 0.587 (0.000)                       | 10.444                      | 0.792      | 0.526 (0.000)                       |
|                    | Set temperatures in bedroomA    | 8.669                       | 0.497      | 0.504 (0.000)                       | 9.347                       | 0.787      | 0.469 (0.000)                       |
|                    | Set temperatures in bedroomC    | 5.470                       | 0.495      | 0.320 (0.000)                       | 5.651                       | 0.784      | 0.285 (0.000)                       |
|                    | Set temperatures in living room | 4.649                       | 0.492      | 0.271 (0.000)                       | 5.157                       | 0.779      | 0.260 (0.000)                       |
| <b>Electricity</b> | (Constant)                      | 15.134                      | 8.036      | (0.000)                             | 16.546                      | 15.921     | (0.000)                             |
|                    | Lighting in bedrooms            | 0.835                       | 0.027      | 0.527 (0.000)                       | 0.740                       | 0.053      | 0.475 (0.000)                       |
|                    | Lighting in living room         | 0.755                       | 0.027      | 0.475 (0.000)                       | 0.676                       | 0.053      | 0.433 (0.000)                       |
|                    | Cooling hours in living room    | 0.729                       | 0.027      | 0.459 (0.000)                       | 0.597                       | 0.054      | 0.383 (0.000)                       |
|                    | Operating hours of rice-cooker  | 0.544                       | 0.027      | 0.343 (0.000)                       | 0.523                       | 0.054      | 0.336 (0.000)                       |
|                    | Operating hours of computer     | 1.079                       | 0.055      | 0.339 (0.000)                       | 1.028                       | 0.109      | 0.329 (0.000)                       |
|                    | Cooling hours in bedroom A      | 0.378                       | 0.027      | 0.239 (0.000)                       | 0.343                       | 0.054      | 0.220 (0.000)                       |

**3.2.2 Probability of energy consumption with Gaussian Process Classification**

Figures 5 and 6 show that the probability of energy consumption with 25% deviation (medium class) is formed by various combinations of the influential parameters. In other words, the definition of standardised conditions can also be varied by the probability of energy consumption. All parameters linearly effect energy consumption, but they are paired depending on the relevance and the order of coefficient values for the presentation. Pairs of the parameters can be organised in different ways. However, each parameter interacts in an inverse proportion in determining the probability of energy consumption. For instance, the operating hours of the living room is reduced, while the set-point temperature is increased. Hence, the distribution taken from the actual consumption can be maintained. At the same time, this interaction allows the standardised conditions flexible in determining the

probability of energy consumption. In addition, impacts of the parameters shift the probability of energy consumption. This is shown by the dispersion of contour lines. Thus, wider dispersion reveals that the parameters are not significantly relevant to determine the probability of energy consumption as found in heating set-point temperatures in the bedroom A and C (Figure 5 – b) and cooling hours (Figure 6 – c).

The 90% probability of the medium class (25% deviation) is overall formed by the range of heating set-point temperature from about 17 to 20 °C (Figure 5). Heating operating hours are about 3 – 6 hours for period A, and 5 – 8 hours for period B: three hours (19:00 – 22:00), four hours (19:00 – 23:00), five hours (19:00 – 24:00), six hours (18:00 – 24:00), seven hours (18:00 – 01:00) and eight hours (18:00 – 02:00). This range is lower than the conventional standardised conditions that include 20 or 24 °C set temperatures and its operation controlled by the set temperatures. Furthermore, the possible deterministic value of heating set temperature can be closer to 18 °C by regarding the actual energy consumption rather than the 20 °C mostly used in existing literature. The conventional conditions in calculating energy demands are not perfectly out of range, but heating energy consumption can be overestimated.

Interestingly, the probability in heating consumption for period A (Figure 5 – a and b) is formed by the slightly lower values of set temperatures and operating hours, than the values for period B (Figure 5 – c and d), despite higher heating consumption in period A. This can be interpreted by realistic compromise, possibly due to the cost of energy. The medium class for period A consumes about 107 – 138 kWh/m<sup>2</sup>/year by the possible setting identified above. However, the medium class for period B spends less heating energy, between 87 and 112 kWh/m<sup>2</sup>/year with the setting above because of their relatively advanced thermal conditions, compared to period A. This reveals that occupants in period A would tactically suppress their heating controls despite the significant heat loss through building envelopes.

Electricity consumption with 90% probability is generally derived from diverse ranges in operation (Figure 6). Specifically, lighting is possibly used from 1 to 5 hours. The rice-cooker can be operated about 9 – 14 hours in warming rice, and the computer is operated for 0.5 – 3.5 hours per day. The air-conditioner can be used for up to 6 hours during summer. The results provide more realistic operations for the appliances with intermittent operations by linking between the actual energy consumption and the national survey about using electrical appliances.

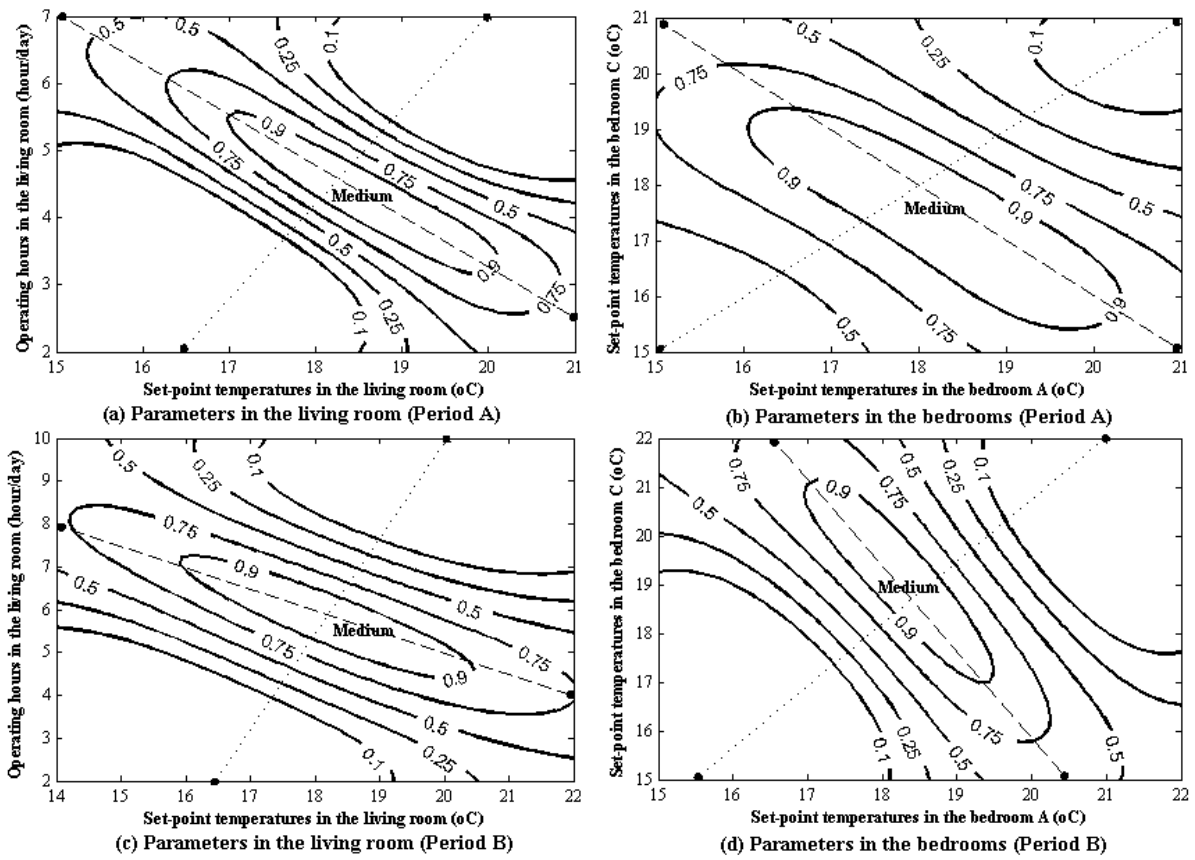

Figure 5 Results of Gaussian Process Classification for heating consumption

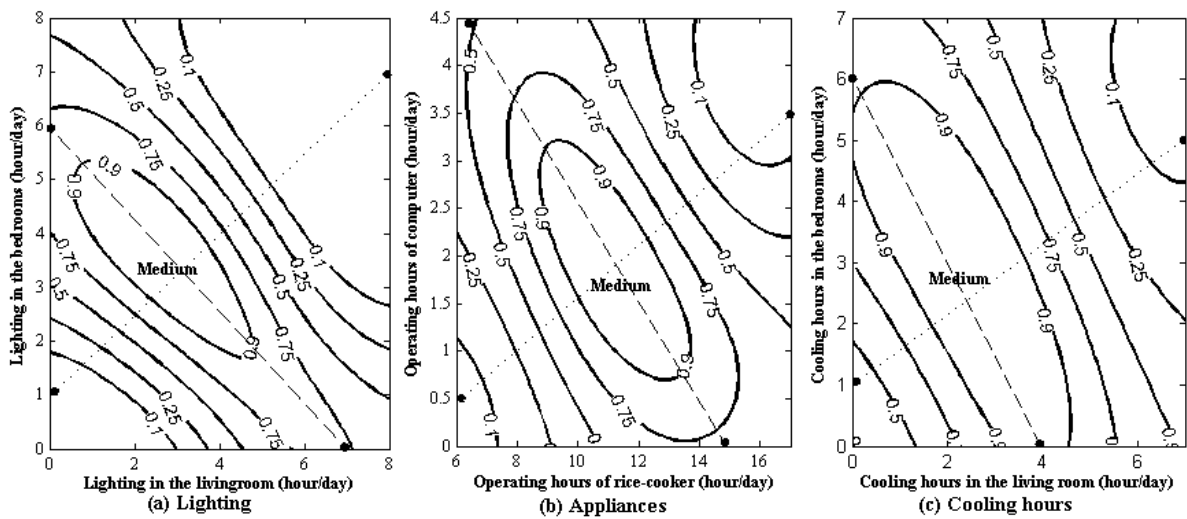

Figure 6 Results of Gaussian Process Classification for electricity consumption

### 3.3 Evaluation of estimating energy consumption with the probability of the standardised conditions

Energy consumption is estimated by 100 random samples with different probability: high (50 – 90%), and total probability (0 – 90%). Figure 7 demonstrates the comparison between the two different probabilities. The random samples with high probability (on the long-dashed lines in Figure 5 and 6) result in a much lower distribution compared to the samples with total probability (on the dotted lines). The estimated heating consumption of the samples with high probability is distributed from 104 kWh/m<sup>2</sup>/year to 136 kWh/m<sup>2</sup>/year for period A (Period A\_a in Figure 7), while the estimation for period B is from 76 kWh/m<sup>2</sup>/year to 119 kWh/m<sup>2</sup>/year (Period B\_a). In contrast, the samples chosen with total possibility create a much extended distribution, 46 – 195 kWh/m<sup>2</sup>/year heating consumption for period A (Period A\_b) and 23 – 179 kWh/m<sup>2</sup>/year for period B (Period B\_b). In terms of electricity consumption, the samples with a high probability estimate electricity consumption between 30 and 32 kWh/m<sup>2</sup>/year for both periods (Period A\_a and Period B\_a). The distribution of estimation is enlarged with total probability from about 24 to 44 kWh/m<sup>2</sup>/year. Depending on the form of the probability, combinations of random samples can be diverse, and their estimation can be different each other. However, the estimation with high probability closely represents the standard deviation identified in the actual energy consumption in each period, while the estimated consumption with total probability reflects the minimum and maximum range of the actual energy consumption.

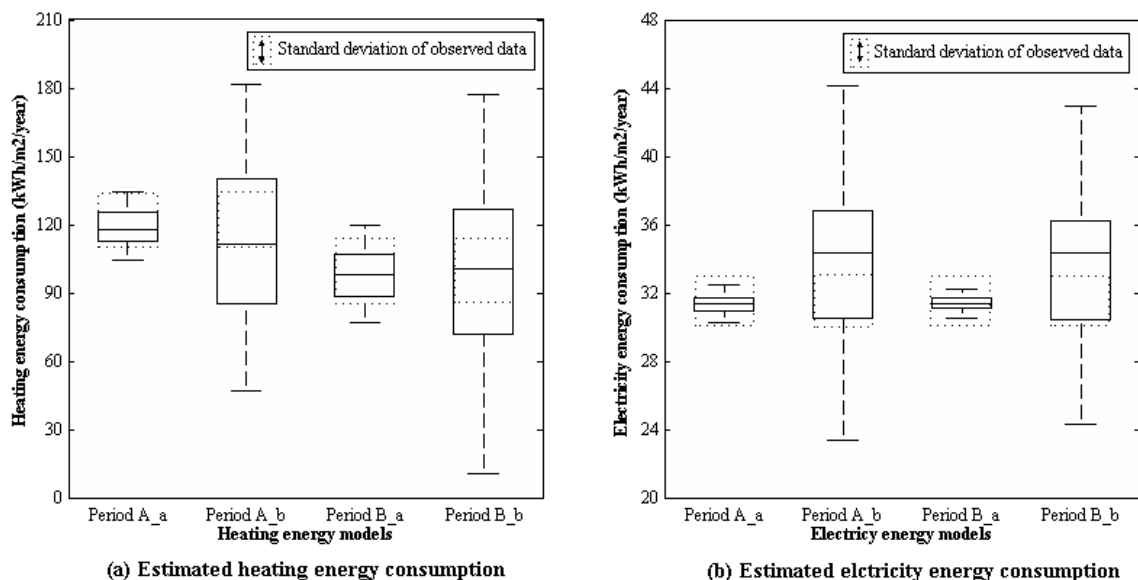

Figure 7 Estimated energy consumption with the probability of the standardised conditions

#### 4. Conclusions

This study questioned the inflexible conventional modelling which disregards the various occupant random behaviour of controlling energy consumption in apartment buildings. The actual energy consumption shows 10 – 30% deviation from average values in apartments built in the 1970s – 1980s. Moreover, the range between minimum and maximum values is much greater, up to 128%. This variation reveals that deterministic values of defining typical conditions in apartment buildings could provide a limited interpretation of energy consumption in these buildings. This study attempted to identify the probability in energy consumption in apartment buildings, regarding the variation in actual energy consumption.

The probability of energy consumption with a 25% deviation was drawn through Gaussian Process Classification. The updated values of input parameters represent the probability of the standardised condition in apartment buildings, according to Bayesian inference. The 90% probability of heating consumption is formed by 17 – 20°C set temperatures and 3 – 8 operating hours. 25% deviation in electricity is derived from 3 – 6 hours of ranges in operation. Compared to the values in conventional modelling, these results imply that conventional modelling may overestimate energy consumption. Overall, sets of parameter in 50 – 90% probability could achieve nearly the standard deviation, 10 – 30%, in real energy use, whereas sets of parameters in total probability showed a far greater distribution of estimating energy consumption, nearly about the minimum and maximum ranges. Hence, the standardised conditions in apartment buildings can be varied depending on the probability of energy consumption.

This paper applies the actual energy consumption and develops the probabilistic models of occupant random behaviour controlling heating and electricity in apartment buildings. How people consume energy is difficult to be determined by a certain value, which is often preferred for building simulations. However, stochastic data provide the probability of occupant energy behaviour for more specified occupants' groups, which reduces uncertainties and discrepancies in the estimation in building simulations. In the case of South Korea, the general characteristic of residents living in apartment buildings is comprised of parents with one or two offspring. By taking socio-economic factors the group of residents became more specific. The deviations in energy consumption of the resident group led to refine most of the possible range of energy behaviours. Moreover, the generalisation process drew the specific operating hours of heating and electric appliances. The result provides the adapted energy controls of the resident group, called “new middle class”, living in old apartment buildings constructed before 1980 and 1981 – 1988, respectively. It is noted that the behaviour model developed in this study is specified for

residents living in apartment buildings in particular districts in Seoul, so that residents in a different context could be difficult, due to the different life styles, such as types of domestic appliances and their usage, although the application for South Korean residents would be applicable, because the original surveyed data are based on South Korean residents. Moreover, the behaviour model only included several influencing factors into the stochastic model. Although these factors were selected by their generalities of usage in households and the high levels of correlation with energy consumption, the impacts of the disregarded appliances and operating hours could contain uncertainties in the model in certain situations.

## References

- Chung, S. (2015). Socio-economic Polarization and Intra-Urban Residential Segregation by Class, *Journal of The Economic Geographical Society of Korea*. 18, 1-16.
- Chung, Y. (2007). *South Korea in the fast lane*, Oxford University Press, Oxford.
- Crawley, D. Lawrie, L. Winkelmann, F. Buhl, W. Huang, Y. and Pedersen C. (2001). EnergyPlus: creating a new-generation building energy simulation program, *Energy and Buildings*. 33, 319-331.
- EnergyPlus Documentation (2010). *Tips & tricks for using EnergyPlus: insider secrets to using EnergyPlus*, US Department of Energy.
- Field, A. (2009). *Discovering statistics using SPSS*, SAGE Publications, Los Angeles.
- Galvin, R. (2013). Targeting ‘behavers’ rather than behaviours: A ‘subject-oriented’ approach for reducing space heating rebound effects in low energy dwellings, *Energy and Buildings*. 67, 596-607.
- Gelézeau, V. (2007). *The Republic of Apartments (Aprt Gonghwagook)*, Humanitas, Seoul.
- Gholami, E., Kiviniemi, A., Kocaturk, T. and Sharples, S. (2015). Exploiting BIM in energy efficient domestic retrofit: evaluation of benefits and barriers, In *Proceeding of the 2nd International Conference on Civil and Building Engineering Informatics*, 2015.
- Gram-Hanssen, K. (2013). New needs for better understanding of household's energy consumption – behaviour, lifestyle or practices?, *Architectural Engineering and Design Management*. 10, 91-107.
- Heo, Y., Choudhary, R. and Augenbroe, G. (2012). Calibration of building energy models for retrofit analysis under uncertainty, *Energy and Buildings*. 47, 550-560.

- Hyun, S. Park, C. and Augenbroe, G. (2008). Analysis of uncertainty in natural ventilation predictions of high-rise apartment buildings, *Building Services Engineering Research and Technology*. 29, 311-326.
- Hunt, B. Lipsman, R. and Rosenberg, J. (2014). *A Guide to MATLAB: for Beginners and Experienced Users*, Cambridge University Press, Cambridge.
- Kalbfleisch, J. (2012). *Probability and Statistical Inference: Volume 1: Probability*, Springer Science & Business Media, New York, NY.
- Kang, J., Lee, S. and Ahn, T. (1995). A Study on Characteristics of Energy Consumption in Apartment Buildings, *Journal of the Architectural Institute of Korea*. 11, 139-148.
- Kim, D., Chung, K., Kim, Y. and Kim, S. (2013). A Comparative Study on Heating Energy Consumption for Apartment Based on the Annually Strengthened Criteria of Insulation, *Journal of Energy Engineering*, 22, 83-89.
- Kim, J., Kim, E. and Suh, S. (2006). Prediction on Variation of Building Heating and Cooling Energy Demand According to the Climate Change Impacts in Korea, In *Proceeding of the Summer Conference of the Society of Air-Conditioning and Refrigerating Engineers of Korea*: 789-794.
- Kim, M. (2010). How to reduce energy consumption in buildings, Seoul Development Institute, Seoul.
- Kim, M., Jo, H. and Jin, S. (2010). Program Evaluation Methods for Building Energy Saving of Seoul, Seoul Development Institute, Seoul.
- Kim, M. and Yoon, J. (2010). A Study on Statistical Characteristics of Space Dimension of 60 m<sup>2</sup> & 85 m<sup>2</sup> Size Apartment Plan Types in Seoul, *Journal of The Korean Housing Association*. 21, 53-65.
- Kim, S. and Kim, S. (1993). A Study on the Changes of Apartment Housing Plan in Korea, *Journal of the Architectural Institute of Korea*. 13, 113-118.
- Korea Appraisal Board (2015). Expenditure of apartment buildings, Apartment Management Information System [online] Available at: <http://www.k-apt.go.kr/> (accessed 11 February 2016).
- Korea District Heating Corporation (2015). District Heat Energy Rates Table [online] Available at: <https://www.kdhc.co.kr/index.do?sgrp=S10> (accessed 11 February 2016).

---

Korea Electric Power Corporation (1990). Survey on Electricity Consumption Characteristics of Home Appliances Korea Electric Power Corporation [online] Available at: [http://kosis.kr/statisticsList/statisticsList\\_01List.jsp?vwcd=MT\\_ZTITLE&parentId=H](http://kosis.kr/statisticsList/statisticsList_01List.jsp?vwcd=MT_ZTITLE&parentId=H) (accessed 11 February 2016).

Korea Electric Power Corporation (2013). Survey on Electricity Consumption Characteristics of Home Appliances, Korea Electric Power Corporation. [online] Available at: [https://epsis.kpx.or.kr/epsis/ekkn/board/n/list.do?bbs\\_id=100232&cd\\_upper=100200&left\\_pos=100232](https://epsis.kpx.or.kr/epsis/ekkn/board/n/list.do?bbs_id=100232&cd_upper=100200&left_pos=100232) (accessed 11 February 2016).

Korea Electric Power Corporation (2014). Electric Rates Table [online] available at: <http://cyber.kepco.co.kr/ckepco/front/jsp/CY/E/E/CYEEHP00201.jsp> (accessed 11 February 2016).

Lee, B., Chung, D., Lee, S. and Hong, H. (2004). Analysis of Heating Energy in a Korean - Style Apartment Building 2: The Difference according to Heating Type, *Korean Journal of Air-Conditioning and Refrigeration Engineering*. 16, 459-467.

Lee, H., Park, S., Bae, S., Lee, B. and Kim, Y. (2012). The Analysis of Energy Consumption Characteristics of the Apartment, In *Proceeding of the Spring Conference of the Korean Solar Energy Society*: 305-310.

Lee, J. (2009). *A Study on the Performance Assessment of the Sustainable Building Technologies for Multi-Family Residential Buildings*, Master, Chung Ang University, South Korea.

Lee, S. (2008). A Spatial Statistical Approach to Residential Differentiation (II): Exploratory Spatial Data Analysis Using a Local Spatial Separation Measure, *Journal of The Korean Geographical Society*. 43, 134-153.

Lett, D. (2001). *In Pursuit of Status: The Making of South Korea's "New" Urban Middle Class*, Harvard University Asia Center, London.

Lim, C. (2011). *Housing in Korea: The History of Transition*, Dolbaegae, Paju.

Macdonald, I. (2009). Comparison of sampling techniques on the performance of Monte Carlo based sensitivity analysis., In *Proceeding of Building Performance Simulation Association (IBPSA) Conference*, Glasgow, 2009: 992-999.



- 
- Ministry of Land, Infrastructure and Transport (2004). *Apartment House Living Condition Statistics*, Ministry of Land, Infrastructure and Transport, 2004.
- Ministry of Land, Infrastructure and Transport (2015a). *Korea Building Energy Saving Design*, Ministry of Land, Infrastructure and Transport, Seoul.
- Ministry of Land, Infrastructure and Transport (2015b). *Building Energy Rating System Management Regulations*, Ministry of Land, Infrastructure and Transport, Seoul.
- Moon, C., Kim, S., Kim, J., Choi, G. and Yoon, J. (2001). A Study on Maintenance Cost of the Each Heating Type Apartment, In *Proceeding of the Spring Conference of Korea Solar Energy Society*: 151-156.
- Neal, R. (1997). Monte Carlo implementation of Gaussian process models for Bayesian regression and classification, *arxiv Preprint Physics/9701026* [online] Available at: <http://arxiv.org/abs/physics/9701026> (accessed 11 February 2016).
- Neal, R. (1998). Regression and Classification Using Gaussian Process Priors, in: Bernardo J., Berger, J., Dawid, A., and Smith A. (Ed.), *Bayesian Statistics 6*, 1st ed.
- Neal, R. (2012). *Bayesian learning for neural networks*, Springer Science & Business Media, New York.
- Nicol, J. (2001). Characterising occupant behaviour in buildings: towards a stochastic model of occupant use of windows, lights, blinds, heaters and fans, In *Proceeding of the Seventh International IBPSA Conference*: 1073-1078.
- Ouyang, J., Wang, C., Li, H. and Hokao, K. (2011). A methodology for energy-efficient renovation of existing residential buildings in China and case study, *Energy and Buildings*. 43, 2203-2210.
- Park, J. (2003). *A Study on the Change of Apartment Unit Plan focusing on the Gangbukgu, Nowongu, Gangnamgu, Gangseogu Apartment Complex in Seoul*, Master, Kwangwoon University, 2003.
- Parzen, E. (1999). *Stochastic processes*, SIAM.
- Rasmussen, C. and Williams, C. (2006). *Gaussian processes for machine learning*, MIT Press, Cambridge, Mass.

- 
- Riihimaki, J., Jylanki, P. and Vehtari, A. (2013). Nested expectation propagation for Gaussian process classification, *The Journal of Machine Learning Research*. 14, 75-109.
- Roh, E. (2012). *Energy Performance Evaluation of Apartment Building according to Window-to-wall Ratio and Energy Performance of Envelope*, Master, Ewha Womans University, South Korea.
- Ross, S. (2002). *A first course in probability*, Prentice Hall, Upper Saddle River, N.J.
- Ross, S. (2014). *Introduction to probability models*, 11th ed., Academic Press, Amsterdam.
- Rose, S. Spinks, N. and Canhoto, A. (2014). *Management Research: Applying the Principles*, London: Routledge.
- Ryan, E. and Sanquist, T. (2012). Validation of building energy modeling tools under idealized and realistic conditions, *Energy and Buildings*. 47, 375-382.
- Seo, J. (2012). *The Passive Renovation Methods and Energy-Saving for Old Apartment Buildings*, Master, Ewha Womans University.
- Sidler, O., Lebot, B. and Pagliano, L. (2002). Electricity Demand in European Households: Major Findings from an Extensive End-Use Metering Project in Four Individual Countries, In *Proceeding of the American Council for an Energy Efficient Economy Summer Study in Building*, ACEEE, Washington DC.
- Silva, A. & Ghisi, E. (2014). Uncertainty analysis of user behaviour and physical parameters in residential building performance simulation, *Energy and Buildings*. 76, 381-391.
- Son, J. (2004). A 70-year history of Apartments in Korea (I), *Urban Problem*. 39, 109-126.
- Son, J. (2004). A 70-year history of Apartments in Korea (II), *Urban Problem*. 39, 106-125.
- Son, W., Kang, H., Park, J. and Rhee, E. (2010). Estimation of Energy Savings Contribution Rate for Design Strategies of Apartment Houses, In *Proceeding of the Annual Conference of Architectural Institute of Korea*: 453-454.
- Song, S. (2009). *Analysis of Energy Saving Effects of Apartment Housing and Economy Efficiency of Window according to the Thermal Insulation Performance of Windows*, Master, Pusan National University, South Korea.

---

Statistics Korea (2010a). Housing Census: Statistics on Population and Housing, Korea Statistical Information Service.

Statistics Korea (2010b). Population Census, Korea Statistical Information Service [online] Available at:  
[http://kosis.kr/statHtml/statHtml.do?orgId=101&tblId=DT\\_1JC1008&conn\\_path=I2](http://kosis.kr/statHtml/statHtml.do?orgId=101&tblId=DT_1JC1008&conn_path=I2)  
(accessed 11 February 2016).

Vanhatalo, J., Riihimäki, J., Hartikainen, J., Jylänki, P., Tolvanen, V. and Vehtari, A. (2013). GPstuff: Bayesian modeling with Gaussian processes, *The Journal of Machine Learning Research*. 14 (2013) 1175-1179.

Virote, J. and Neves-Silva, R. (2012). Stochastic models for building energy prediction based on occupant behavior assessment, *Energy and Buildings*. 53, 183-193.

White Box Technologies (2014), White Box Technologies Weather Data: Historical Weather Data of Seoul in 2014 [online] Available at:  
<http://weather.whiteboxtechnologies.com/> (accessed 11 February 2016).

Yoon, I. (1998). A Case Study of Seoul = Residential Differentiation by Class and Its Social Implications, *The Journal of Seoul Studies*.

Yoon, T. (2011). *A Study on the Regional Disparities between the Autonomous Districts (Jachi-Gu) in Seoul Metropolis*, Master, Kyung Won University.

Yuen, B. (2011). In the March of High-Rise, in: B. Yuen, A. Yeh (Ed.), *High-Rise Living in Asian Cities*, Springer, London.

Yuen, B., Yeh, A., Appold, S., Earl, G., Ting, J. and Kwee, L. (2006). High-rise living in Singapore public housing, *Urban Studies*, 43(3), 583-600.

Zhang, S. (1994). *A Study on the Transition of the 60-70's Apartment Houses in Korea*, Ph.D, Seoul National University.

Zhang, Y. (2012). Use jEPlus as an efficient building design optimisation tool, In *CIBSE ASHRAE Technical Symposium*, CIBSE, London.

---

## **Prioritisation of old apartment buildings for energy-efficient refurbishment based on the effects of building features on energy consumption in South Korea**

**Authors:** Hyunju Jang<sup>1</sup>, Lucy Jones<sup>2</sup> and Jian Kang<sup>2\*</sup>

**Affiliation:** Sheffield School of Architecture, University of Sheffield, Arts Tower, Western Bank, Sheffield S10 2TN, UK

---

### **Abstract**

Since the 1970s the construction of high-rise apartments has been prolific across Asia. More recently, due to changes in legislation, there has been a growing trend towards refurbishment for those old apartments, however this has primarily focused on the economic benefits and rarely taken energy saving and the reduction of carbon emissions into account. Therefore, this study aims to evaluate what features in old apartment buildings need to be taken into account in refurbishment strategies. The method is threefold: evaluating energy consumption in old apartment buildings; identifying effective building features on energy consumption; ranking the effects of building features on energy consumption. The results show that old apartment buildings have consumed excessive energy for space heating and cooling. Maximum 43.65 kWh/m<sup>2</sup>/year in space heating and 5.70 kWh/m<sup>2</sup>/year in cooling were reduced as a result of the transformation of eight building features, accounting for 70.9% of total variance in factor analysis. Three most influential features, which should be used to priorities for refurbishment schemes, have been identified by multiple regression analysis: the conditions of building envelopes, heating methods and the sizes of building units. Therefore, the priority should be given to these three features.

### **Keywords**

Refurbishment, energy efficiency, building features, old high-rise apartment building

---

### **2015 Energy and Buildings**

**Received** 13 August 2014, **Revised** 12 March 2015, **Accepted** 13 March 2015,

**Available online** 21 March 2015

---

<sup>1</sup>[hjang1@shef.ac.uk](mailto:hjang1@shef.ac.uk)

<sup>2</sup>[lucy.jones1@sheffield.ac.uk](mailto:lucy.jones1@sheffield.ac.uk) and \* Corresponding author: [j.kang@sheffield.ac.uk](mailto:j.kang@sheffield.ac.uk), tel) +44 (0)114 222 0325

## 1. Introduction

In Asian countries that experienced dramatic economic growth such as Japan, Hong Kong, Singapore and South Korea [1], high-rise apartment building became one of the most dominant types of housing [2, 3]. The refurbishment of those buildings is a common issue after more than 40 years of extensive construction of apartment buildings. This issue can be also extended to some countries such as China and Malaysia that have experienced the economic growth in recent years.

In South Korea, ranked 8<sup>th</sup> for Green House Gases (GHGs) emissions [4], for instance, the Government has attempted to reduce carbon emissions of the country by enhancing building regulations and policies. Apartment buildings were required to be energy-efficient since 2001 [5]. In 2009, a new law, 'Framework Act on Law Carbon Green Growth', required higher levels of energy efficiency in buildings [6]. Despite these attempts, energy consumption in residential buildings has not declined [7], and carbon emissions in South Korea have also not reduced [4]. Several studies such as [8, 9] have criticised this unwanted outcome. Particularly, Kim [9] claims ineffective energy reduction in residential buildings was due to energy consumption in old apartment buildings, which were excluded in the energy-efficient scheme. In the building stock of South Korea, the largest proportion of all building types is residential buildings, which amounts to 67.1% [10]. 58% of the residential building stock is apartment buildings [11], which is the most dominant proportion. 63% of apartment buildings were constructed before 2001 [11, 12] when the higher levels of energy-efficient scheme were applied to buildings. In this aspect, the old apartment buildings constructed over 20 years ago, which occupies the largest proportion in the building stock of South Korea, were not counted to be energy-efficient.

There has been a controversial debate amongst policy makers, building developers and residents in South Korea during the last decades to whether old apartment buildings should be demolished or refurbished. However, policy makers have proposed to refurbish old apartment buildings to contribute reducing carbon emissions rather than demolish those buildings. As a result, building regulations have been altered in recent years to encourage refurbishment and reduce demolition of old apartment buildings. The South Korean Government, for example, has permitted developers to increase the number of floors on top of apartment buildings in case of refurbishment [13]. This policy can represent the governmental intention to vitalise refurbishment.

Despite the governmental efforts, there are limits in current and recent literature in terms of creating effective strategies of refurbishment for old high-rise apartment buildings to reduce

energy consumption. Firstly, great attention has been paid to economic profit rather than reducing energy consumption or carbon emissions. The concept of refurbishment in existing literature such as [14, 15] was identified by maximising economic profit, and the strategies of refurbishment were focused on cost-effectiveness. Therefore, the strategies would not necessarily be beneficial to reduce energy consumption. Secondly, existing literature, engaging with energy efficient technologies, does not cover old apartment buildings that need to be refurbished [16-20]. It relies on the ‘Standard housing’ model which draws the thermal condition of buildings from simplified indices [21], assuming that building features affecting energy consumption in all apartment buildings are the same. However, the building features in old apartment buildings were changed by different design preferences in different periods and contexts. The existing literature does not take into account the transformation of building features in old apartment buildings that have been constructed in different periods and contexts [22-28]. This study argues that the transformation of building features affects energy consumption and needs to be taken into account when creating refurbishment strategies.

This study, therefore, focuses on identifying old high-rise apartment buildings in South Korea which need to be refurbished to reduce energy consumption. Furthermore, the most efficient strategy of refurbishment will be identified by investigating building features and their effect on energy consumption in those apartment buildings. Three questions will be answered:

- What are the levels of energy consumption in old apartment buildings? Do these levels of consumption need to be reduced?
- Which features in old apartment buildings have affected the energy consumption?
- Which building features should be prioritised in refurbishment strategies in order to reduce energy consumption?

## **2. Methodology**

The methodology is designed to analyse the impact of building features in old apartment buildings on actual energy consumption. The results will help to prioritise which building features can most effectively reduce energy consumption and thus guide the creation of refurbishment strategies. The method is threefold: evaluating energy consumption in old apartment buildings; identifying effective building features on energy consumption; ranking the effects of building features to energy consumption.

### ***2.1 Evaluation of energy consumption in old apartment buildings***

Energy consumption in old apartment buildings was evaluated to determine the necessity of refurbishment to reduce energy consumption. The consumption in old apartment buildings was, therefore, compared to the consumption in apartment buildings which were certified as energy-efficient. To conduct this, old apartment buildings are defined by those which were constructed before 2001, a year when building regulations for the thermal conditions of apartment buildings was much intensified and building energy rating system was just established. Permission has already given for some of these buildings to be refurbished, others will be available to be refurbished in 2015 by a building regulation in South Korea [29]. In contrast, the comparison group of apartment buildings were certified as energy-efficient in an energy rating system set by Korea Land and Housing Corporation in South Korea [30]. The three values of energy consumption in the both groups were compared: total end-use energy consumption; space heating and electricity consumption by construction years; monthly energy consumption for space heating and electricity. The result is shown in Section 3.1.

## ***2.2 Identification of building features affecting energy consumption***

Building features in old apartment buildings were identified by reviewing previous literature and surveying existing old apartment buildings. To prioritise building features in refurbishment, this study was, particularly, focused on the transformation of building features rather than characteristics which are commonly found in all buildings. It is difficult to precisely divide time periods of each feature. Instead, this study used the dominant designs since the 1980s, as described in Figure 1. Three distinctive trends are identified in the transformation of building features in old apartment buildings constructed before 2001.

First of all, the main purpose in the early stage of apartment construction was to accommodate a rapidly increased urban population and building features were chosen accordingly whilst building features in the late stage were transformed to acquire higher levels of privacy in each apartment building [25]. For example, between the mid-1970s and 1980s, large volume apartment clusters of more than twenty buildings were constructed as governmental-led projects [31]. During the 1990s, the size of apartment clusters was reduced when the government handed over apartment construction to private developers [31]. Total cluster areas were also changed with the transformations of the size of apartment clusters, but it was differently evolved as the higher requirements for public space with service facilities [32]. Moreover, apartment buildings constructed in the early stage were designed with longer lengths and smaller sized units. A maximum of eight to ten apartment units were placed on each floor; thus small unit sizes of less than 60m<sup>2</sup> (70m<sup>2</sup> including communal space) were constructed in the 1980s [26]. Since privacy has become a sensitive issue,

buildings with a stair type whereby only two units share one vertical access points (called a ‘core’) are preferred [25].

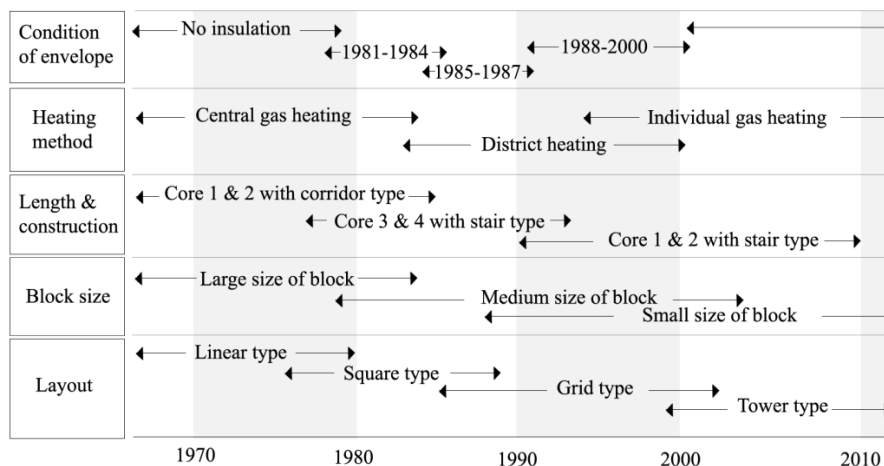

**Figure 1) Changes of building features in apartment construction of South Korea since the 1970s**

Second, economic profit has also been a significant factor to transform the building features in old apartment buildings. For instance, three types of building layout can be identified [23, 33-35]: the linear type where buildings are long and thin in plan and located parallel to one another; the square type where buildings are square in plan; and the grid type where buildings are located on a grid. According to Jeon [25], the linear type was the typical design type in the early stage of apartment construction in South Korea, but the design was changed to square and grid type to accommodate more buildings. The sizes of building units were also enlarged; thus the most dominant unit size became about 85 – 100m<sup>2</sup> (about 100 - 120m<sup>2</sup> including communal space) [26].

Third, some building features were transformed by stringent policies and the development of technologies. The thermal conditions of envelopes in old apartment buildings have been determined by a building regulation [36]. The regulation determining the thermal conductivity of materials and the thickness of insulations required was firstly established in 1980. Since 1980, there have been two significant revisions to the regulations in 1984 and 1987, and in 2001, a significant improvement was made. Therefore, buildings constructed before 1980 have no thermal insulation in their envelope which created a poor thermal environment for residents. The second revision, implemented in 1987, required all apartment buildings to be equipped with double glazing. Despite the dramatic increase in apartment construction in the 1990s [11], there was no revision of the regulation to improve the thermal



conditions of buildings until 2001. Also, three different heating methods were found in old apartment buildings: central gas heating, district heating and individual gas heating [37, 38]. Central gas heating was mostly used in buildings constructed in the early stage. Since the district heating was introduced in 1985 [39], apartment buildings constructed in Seoul have been connected to the district heating system. Since the national construction of gas supply lines into the cities, individual gas boilers have become the dominant type of heating.

Table 1 indicates how designs of building features were transformed until 2000. This transformation of those building features was examined as to whether they affect actual energy consumption or not; thus effective building features on energy consumption were identified. The result is described in Section 3.2.

### ***2.3 Quantification of effects by building features***

This section is intended to quantify these relations to energy consumption separated by space heating and electricity. Two types of statistical analyses were conducted, which are multiple regression and factor analyses. Multiple regression analysis is one of popular techniques to measure the capability of statistical models to interpret a dependent variable through correlated independent variables, and determine influential independent variables in statistical models [40]. The multiple regression analysis was applied to interpret a dependent variable (energy consumption for space heating and electricity) by using independent variables (building features in old apartment buildings). The values of R-squared demonstrate how efficient this statistical model accounts for energy consumption in old apartment buildings. The standardised regression coefficient (SRC) was used to measure the influences of independent variables (cluster sizes, building lengths, construction types, total cluster area, building layouts, building unit sizes, the conditions of building envelopes and heating methods). The multiple regression models were assessed by power analysis to examine the power of the samples used in this study; f-test was conducted by SPSS.

Exploratory factor analysis was, therefore, intended to identify an underlying structure between observed variables consisted of the building features in this study; thus the results can be used to specify efficient targets for refurbishment. The principle axis factoring method was performed by Oblimin rotation (delta 0.4) with Kaiser Normalisation [40]. The criterion used to indicate an adequacy of factor analysis in the sample was followed by a Bartlett's test of Sphericity of significance, and a Kaiser-Meyer-Olkin measure of sampling adequacy [42]. In order to identify robust variables, the variables with the low loadings (< 0.3) and cross-loadings were eliminated. SPSS version 21.0 was used in all statistical analyses and the results of analyses are shown in Section 3.3.

**Table 3 Change in designs of building features in apartment construction in South Korea in pre-2001**

| Category                            | Variables   | Data range  |
|-------------------------------------|---|---|
|                                     | (CA: categorical, CO: continuous)   |   |
| Demands of time periods             | Sizes of clusters - CA<br>(No. of apartment buildings in clusters)          | Large ( $\geq 20$ ), Medium (6-15), Small ( $\leq 5$ )              |
|                                     | Total cluster area – CO   | 12,562 – 515,906m <sup>2</sup>                                      |
|                                     | Types of building access - CA   | Corridor type, Stair type   |
|                                     | Lengths of buildings – CA<br>(No. of vertical access points)                | 1- 6  |
| Economic profit                     | Types of building layouts - CA  | Linear, square and grid types                                       |
|                                     | Sizes of building units - CO  | 41.05 – 181.82m <sup>2</sup>  |
| Developed policies and technologies | Thermal conditions of building envelopes (insulation and fenestration) – CA | Buildings constructed before 1980, 1981-1984, 1985-1987, after 1988 |
|                                     | Heating system methods – CA   | Central gas, District, Individual gas heating                       |

## **2.4 Sampling**

### ***Old apartment buildings constructed in pre-2001***

Total 189 apartment clusters with 1767 buildings (171,054 households) were selected as samples. The samples occupy 3.5% of the population size, 4,988,441 households [11, 12] in apartment buildings constructed between 1976 and 2000 in South Korea. The sampling frame was designed with four sampling units: 1) construction years; 2) regions; 3) the number of floors; 4) the availability of data on energy consumption. Firstly, apartment buildings which were built between 1976 and 2000 were only considered, because apartment buildings constructed after 2001 are regarded less urgent to be refurbished with an intensified building regulation, and constructed before 1976 are highly regarded to be demolished as low-rise buildings to rebuild high-rise buildings. Second, sixteen apartment districts in Seoul were selected. The districts were established as parts of enormous housing construction projects between the 1980s and 1990s, leading the dramatic increase of apartment building construction. 60% of apartment buildings constructed before 2000 in Seoul were built in these districts [43]. Therefore, buildings in these districts have used to identify dominant characteristics built in that period. Moreover, these districts in Seoul are in the same climate zone, and the same thermal building regulations are applied to the

buildings in Seoul and the central regions of South Korea; thus there would not be significantly different climate impacts in these districts. The impacts of microclimate such as heat island effects may give influence in energy consumption [44]. However, these possible impacts were taken into account in this study as building features related to building clusters. Third, apartment buildings with more than ten floors were considered. This is because that refurbishment would be inevitable for the buildings which have more than ten floors. As they were densely constructed, it is difficult to acquire permissions to demolish them in order to build super high-rise buildings under the current building regulations [13, 45]. Lastly, the availability of data on energy consumption limited the samples in this study. 15.2% of apartment buildings which did not fill their energy bill records between 2011 and 2012 in AMIS were not counted in this study.

Energy consumption bills between 2011 and 2012 were collected from ‘Apartment Management Information System (AMIS)’. This system is organized by the Ministry of Land, Infrastructure and Transport (MLIT) and managed by the Korean Housing Management Association (KHMA). A policy has been implemented under which all apartment buildings in South Korea should input their expenses into this system. The system displays the expenditure of each apartment building. However, there were some missing data on the energy bills of some apartment buildings in the system. These apartment buildings were excluded in the samples. The collected data from energy bills were converted from Won/m<sup>2</sup> to kWh/m<sup>2</sup>. The conversion rates refer to those of the Korean Electric Power Corporation [46] for electricity and Seoul City Gas [47] for gas.

#### ***A comparison group of apartment buildings***

Total 34 apartment clusters with 319 buildings (13,551 households) built between 2008 and 2010 in one district. The samples occupy 1.8% of the population size, 740,214 households [11] in apartment buildings constructed between 2008 and 2010 in South Korea. Four sampling units were used: 1) construction years; 2) regions; 3) the number of floors; 4) energy-efficient certificates; 5) the availability of data on energy consumption. Firstly, buildings built after 2001 were selected to compare energy consumption in old apartment buildings because those buildings are relatively regarded as energy-efficient. Secondly, as climate conditions can have a significant impact on energy use in buildings, a district in close proximity to the districts in Seoul selected for the analysis of old apartment buildings was selected to minimise variation between the old and new samples. Thirdly, the same number of floors, more than ten floors, was also applied. Fourth, the certified apartment buildings as energy-efficient in this district were only used in this study as mentioned in Section 2.1. Lastly, the availability of data limited to choose the samples like old apartment

buildings. The certified buildings which did not fill their energy bill records between 2011 and 2012 in AMIS were not counted. Energy bill data was collected by the same method used for old apartment buildings.

### 3. Results

The results are illustrated by three parts to answer the three research questions in this study. The first part (Section 3.1) describes energy consumption in old apartment buildings built before 2001 by comparing the consumption in the group of apartment buildings built between 2008 and 2010. The second part (Section 3.2) indicates building features affecting energy consumption in old apartment buildings. The last part (Section 3.3) quantifies the effects of building features to energy consumption.

#### 3.1 Energy consumption in old apartment buildings

Figure 2 shows a comparison of the total energy consumption of two groups of apartment buildings which are 234.2 kWh/m<sup>2</sup>/year and 190.0 kWh/m<sup>2</sup>/year respectively. Both numbers are much higher than the 1<sup>st</sup> grade in energy rating systems set by Korea Green Building Certificate Criteria (GBCC) in South Korea (60.0 kWh/m<sup>2</sup>/year) [21] and Passive house standard (25.0 kWh/m<sup>2</sup>/year) [48]. This result shows that the energy consumption of both groups of apartment buildings needs to be reduced to satisfy these energy rating systems. Despite excessive energy consumption, detailed consumption (separated by use) indicates different tendencies. Old apartment buildings consumed 109.6 kWh/m<sup>2</sup>/year for space heating whilst apartment buildings built between 2008 and 2010 only consumed 66.0 kWh/m<sup>2</sup>/year. On contrary, energy consumption of electricity and water heating did not have significant reductions in this period.

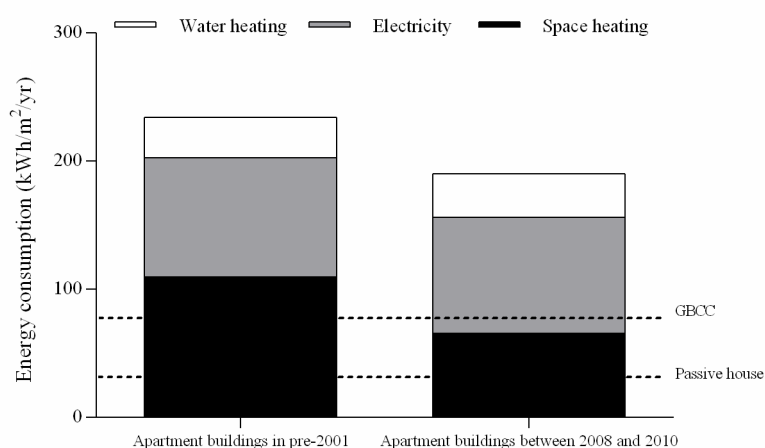

Figure 2) Total energy consumptions of apartment buildings in 2011 and 2012

These tendencies are also shown in Figure 3. The average energy consumed for space heating in old buildings has reduced by their construction years. 100% of old apartment buildings constructed before 1980 consumed more energy for space heating than the average of 108.8 kWh/m<sup>2</sup>/year, compared to 53% of old apartment buildings constructed in the 1980s. Only 20% of buildings in the 1990s and none of buildings constructed between 2008 and 2010 consumed above average energy for heating, these results suggest that apartment buildings built before 2001 have been able to decrease energy consumption efficiently regarding space heating.

Energy consumption for electricity was not reduced in this period 92.2 kWh/m<sup>2</sup>/year of electricity was continuously consumed by apartment buildings in both groups. This can be explained by the everyday use of domestic appliances such as refrigerators, televisions and computers. However, Figure 4 demonstrates that the summer use of electricity for space cooling in the old apartment building was especially high in August. In each month, there was only 0.05 kWh/m<sup>2</sup>/year difference between apartment buildings in the both groups, except for August when the gap was enlarged to 1.5 kWh/m<sup>2</sup>/year in 2011 and 5.7 kWh/m<sup>2</sup>/year in 2012.

Like electricity consumption, there was no significant reduction in water heating consumption; 32.6 kWh/m<sup>2</sup>/year of water heating was continuously consumed in both groups. However, the old building group demonstrated a higher relative standard deviation with 32.3% while 19.6% was for the new building group. Furthermore, these values are also higher, compared to space heating with 25.2% in old building group and 11.5% in new building group, and electricity with 15.3% and 11.9% in old and new building groups, respectively.

Overall, apartment buildings have been able to decrease energy consumption efficiently regarding space heating and cooling although there were not significant reduction in energy consumption for electricity and water heating. As identified in Section 2.2, physical conditions in apartment buildings constructed between 1976 and 2000 have been transformed. This would probably result in the changes of energy consumption in these buildings.

However, the effects of occupants could also be important factors to understand energy consumption in these buildings. Interestingly, residents living in apartment buildings in South Korea showed the extremely unified composition of households. 90% of apartment buildings' inhabitants are parents with their offspring, and families with three or four

members occupy 80% of households in apartment buildings [49]. Therefore, the general profiles of occupants such as the number of occupants and types of family may not give meaningful results explaining energy consumption. However, geographical segregations in residential areas caused by socio-economic factors such as the levels of income and education have been identified in South Korea [50]. Their effects would also be useful to identify the continuous energy consumption in electricity and water heating, and the large variations in water heating.[51]. However, this study focused on the physical features of apartment buildings, which were described in Section 2.2, to create the efficient strategies for refurbishment.

### ***3.2 Building features affecting to energy consumption***

It can be seen that six of the eight features (Table 2) had an effect on energy consumption for space heating while little difference was found in electricity consumption. This can be explained by two opposing tendencies. As expected, one of these tendencies is that old apartment buildings constructed in the early stage consumed more energy than those constructed in the late stage. Three features, the conditions of building envelopes, the lengths of buildings and heating methods, accounted for this increasing tendency in energy consumption. This means that the transformations of the three features reduced energy consumption as seen in Figure 5.

First, the most effective reduction was found by improving the condition of building envelopes, which was a maximum 48.7 kWh/m<sup>2</sup>/year (Figure 5(a)). In particular, the largest reduction occurred between buildings constructed before 1980 and those constructed between 1981 and 1984. This is because buildings built before 1980 did not have insulation on their envelopes while 50mm internal insulations were applied for those constructed between 1981 and 1984. The second largest reduction was between buildings built between 1981 and 1984 and 1985 and 1987. This was achieved by replacing the type of glazing in windows from 3mm single glazing to double glazing. The result indicates the thermal condition of building reduced energy consumption.

Second, the shorter lengths (that is with fewer vertical access points) the buildings had, the less energy consumed for space heating. Specifically, gradual energy reduction up to 30.2 kWh/m<sup>2</sup>/year was found by decreasing the lengths of buildings. As the heights of buildings were mostly fixed either 12 or 15 stories, the total amount of surface area, which is exposed to heat transfer, was reduced. Consequently, this was beneficial in reducing energy consumption. Third, the changes in heating methods also reduced up to a maximum of 26.2 kWh/m<sup>2</sup>/year of energy consumed for space heating. A large gap was found between

buildings with central gas heating, and buildings with district and individual gas heating. 24.3 kWh/m<sup>2</sup>/year was found between central gas heating and district heating, but only 2.0 kWh/m<sup>2</sup>/year was found between district and individual gas heating.

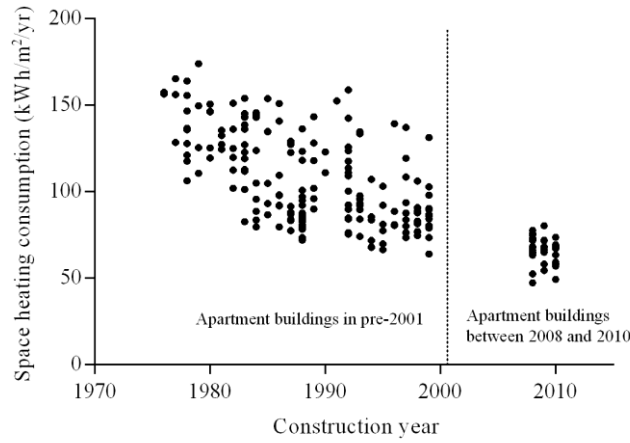

(a) Space heating consumption

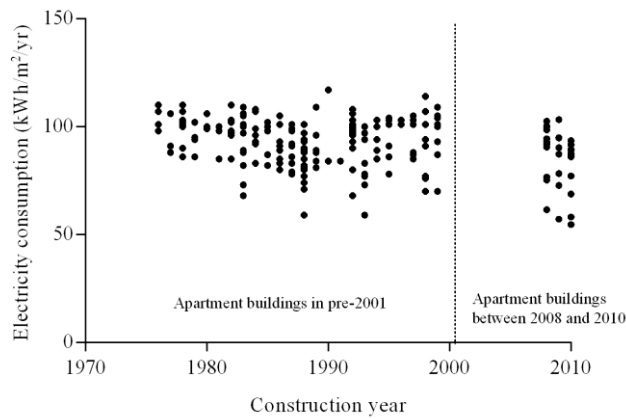

(b) Electricity consumption

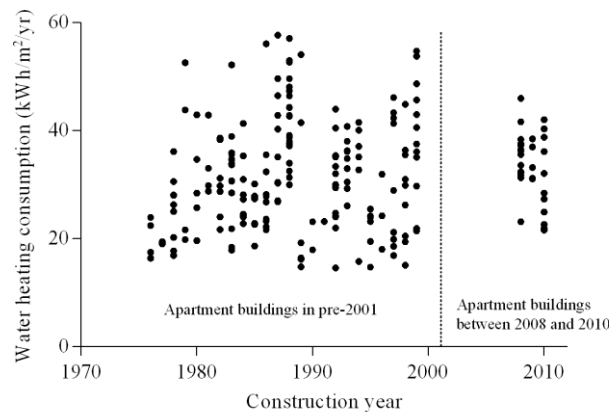

(c) Water heating consumption

**Figure 3) Energy consumption of apartment buildings by construction years: (left) space heating, (right) electricity**

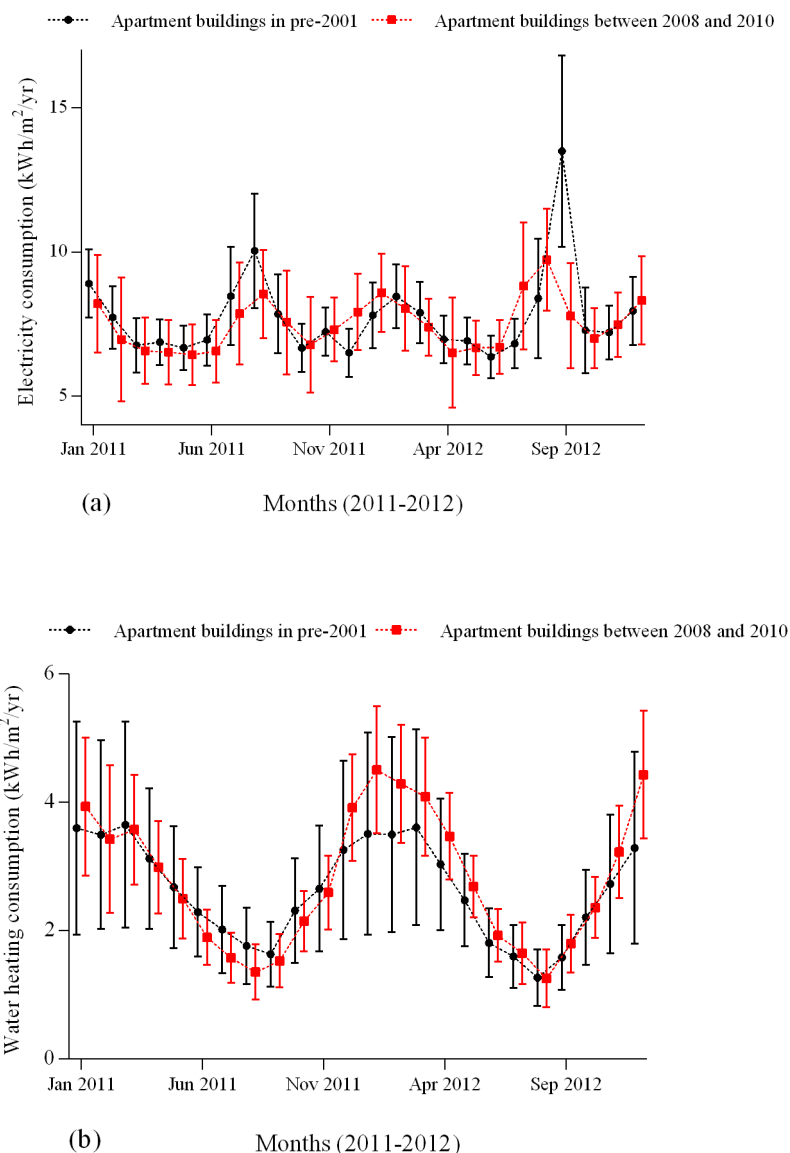

**Figure 4) Monthly Energy consumption between for (a) electricity and (b) water heating 2011 and 2012**

Second, the shorter lengths (that is with fewer vertical access points) the buildings had, the less energy consumed for space heating. Specifically, gradual energy reduction up to 30.2 kWh/m<sup>2</sup>/year was found by decreasing the lengths of buildings. As the heights of buildings were mostly fixed either 12 or 15 stories, the total amount of surface area, which is exposed to heat transfer, was reduced. Consequently, this was beneficial in reducing energy consumption. Third, the changes in heating methods also reduced up to a maximum of 26.2 kWh/m<sup>2</sup>/year of energy consumed for space heating. A large gap was found between buildings with central gas heating, and buildings with district and individual gas heating. 24.3



kWh/m<sup>2</sup>/year was found between central gas heating and district heating, but only 2.0 kWh/m<sup>2</sup>/year was found between district and individual gas heating.

The opposite tendency is that greater energy consumption occurred in buildings constructed in the late stage. This is due to three features, namely the sizes of building units, the sizes of clusters and the types of building layouts (Figure 5 (d-f)). Firstly, the sizes of buildings units were increased in response to higher preference for the large sizes of units. This increase in unit sizes caused higher energy consumption in old apartment buildings, which is nearly 30 kWh/m<sup>2</sup>/year more energy consumption for space heating and 20kWh/m<sup>2</sup>/year for electricity, to maintain a certain level of thermal comfort within the indoor environment. Secondly, old apartment buildings in large apartment clusters consumed less energy than those in small apartment clusters. The amount of energy reduced according to the sizes of clusters, a maximum 12 kWh/m<sup>2</sup>/year for space heating and 9 kWh/m<sup>2</sup>/year for electricity which were not as significant as the reductions for other features. Third, the types of building layout showed increases with 5 kWh/m<sup>2</sup>/year in electricity from linear to grid.

In short, the six building features are identified as being effective in energy consumption. However, the different amount of energy affected by each building feature needs to be evaluated in order to prioritise refurbishment strategies. The results of these evaluations are illustrated in Section3.3.

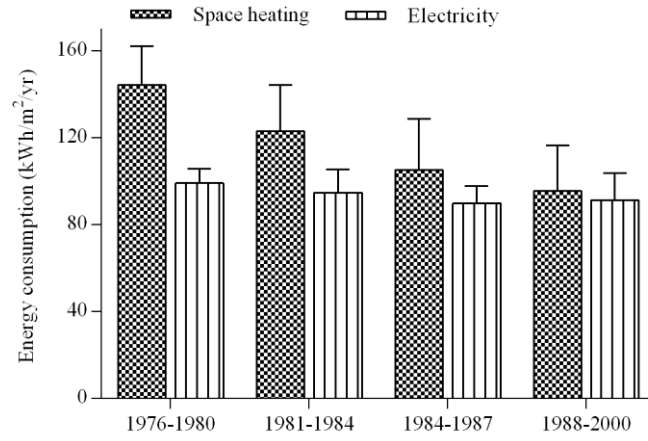

(a) Conditions of building envelopes

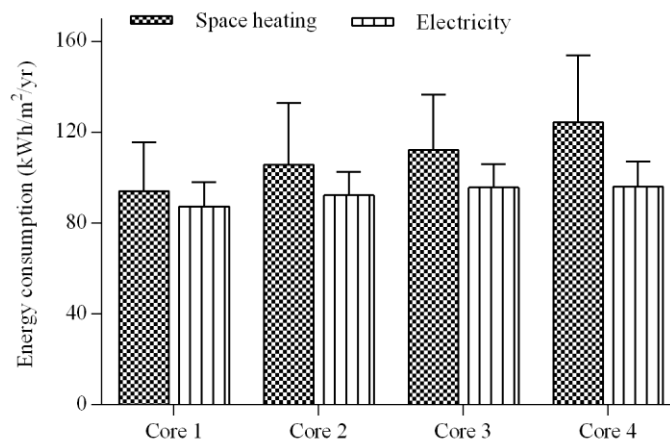

(b) Lengths of buildings (No. vertical access points)

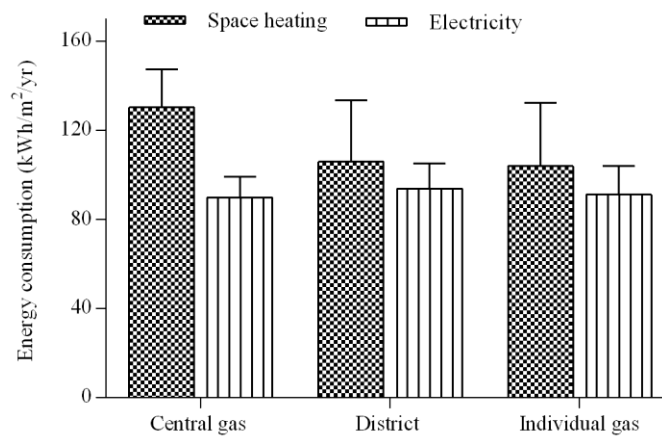

(c) Heating methods

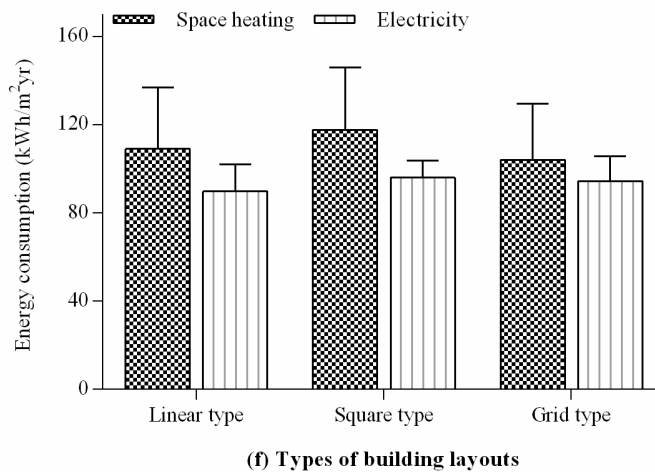
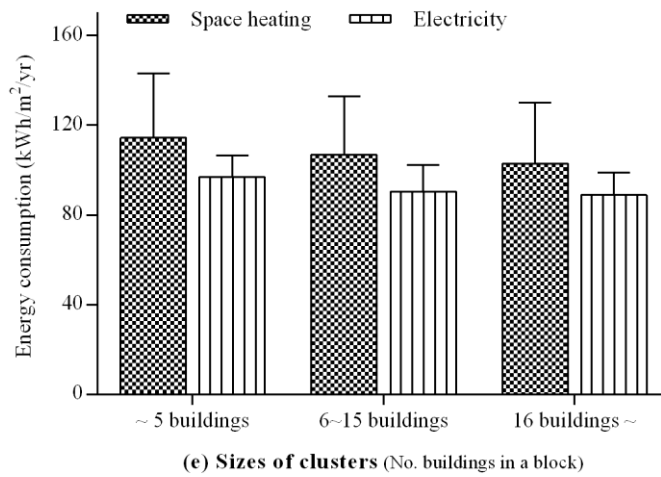
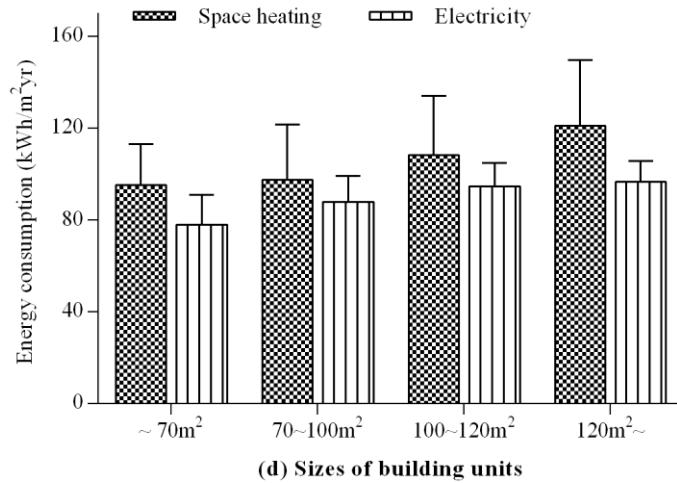

**Figure 5) Energy consumptions of old apartment buildings by (a) conditions of building envelopes, (b) lengths of buildings, and (c) heating methods , (d) sizes of units, (e) sizes of clusters, and (f) types of building layouts**

**3.3 Quantification of effects of building features on energy consumption**

**3.3.1 Results of multiple regression analysis**

In order to reject the null hypothesis, the results of f-test in multiple regression models require not being less than 2.42 with 95% critical confidence interval. The f-test results in this study showed 63.88 with the model for space heating and 15.94 with the model for electricity, which means that the sample sizes were large enough to bring about reliable results.

Table 2 demonstrates the results of multiple regression analysis. The values of R-squared in these two models are 0.580 for space heating and 0.256 for electricity. The both R-squared are not very good to account for energy consumption; the R-square for electricity is relatively low. This could be the primary data on energy consumption were limited to extract gas consumption for cooking and electricity consumption for the everyday use of domestic appliances, which are highly determined by user behaviour rather than building features. Despite it, both models are statistically significant at 5% level.

**Table 4 The result of multiple regression analysis**

| Independent variables                                  |  | SRC    | Significance |
|--|--|--------|--------------|
| <b>Space heating consumption (R<sup>2</sup>=0.580)</b> | The thermal conditions of building envelopes | -0.626 | 0.000        |
|  | Heating methods                              | -0.301 | 0.000        |
|  | The lengths of buildings                     | 0.196  | 0.000        |
|  | The sizes of apartment clusters              | -0.129 | 0.008        |
| <b>Electricity consumption (R<sup>2</sup>=0.256)</b>   | The sizes of apartment units                 | 0.300  | 0.000        |
|  | The sizes of apartment clusters              | -0.202 | 0.002        |
|  | The types of building layouts                | 0.203  | 0.004        |
|  | The thermal conditions of building envelopes | -0.203 | 0.008        |

The standardised regression coefficients (SRC) of building features specify the effects of building features on energy consumption. The opposite trends of building features, as seen in the previous section, are found by negative and positive values of the standardised coefficients (Figure 6 (a-d)). The negative values of coefficients, decreasing energy consumption, are attributed to the transformations of these three features: improving the conditions of building envelopes; changing heating methods from central gas to individual gas heating; reducing the sizes of clusters. On the contrary, the positive values of coefficients, increasing energy consumption, are found by the other three features: shortening the lengths of buildings; reducing the sizes of building units; changing the types of building layouts from linear to grid.

In space heating, four features were chosen as influential variables: the thermal condition of building envelopes, heating system methods, the lengths of buildings and the sizes of clusters (Table 2). Only the feature, the lengths of buildings, is with positive SRC while the other three features are with the negative SRCs. The means that space heating consumption was decreased by these four conditions: reducing the lengths of buildings; improving the conditions of building envelope; changing heating methods from central gas to district or individual gas heating; increasing the sizes of clusters. The former three conditions are typically found in apartment buildings constructed in late stage whilst the large sizes of clusters are identified in the early stage of apartment construction. The effects of the opposite tendencies on space heating are quantified by the values of SRC in Table 2. The former three features are relatively the higher values of SRC than the sizes of clusters with SRC 0.129. This interprets the reason why space heating in old apartment buildings could effectively reduce space heating consumption by transforming building features. Specially, improving the thermal conditions of building envelope played a significant role in this tendency with the most robust SRC 0.626 as seen in Table 2. This can be a strong criterion to determine a priority for refurbishment.

In electricity, the opposite tendencies are also identified. The sizes of units and the types of layouts show the positive SRC whereas the sizes of clusters and the thermal conditions of building envelopes indicate the negative SRC. In other words, electricity consumption was decreased by reducing the sizes of clusters and improving the thermal conditions of building envelope. However, the consumption was increased by the larger sizes of units and the changes of layout types from linear to grid. These four conditions are found in buildings built in late stage. The most significant feature is the sizes of units with SRC 0.300, but the significance is not as robust as the features affecting space heating. The other three features are approximately the very similar value of SRC with 0.202 or 0.203. These values of SRC reflect that both opposite tendencies have not significant differences each other. This interprets the reason why there was no significant change in electricity consumption in old apartment buildings.

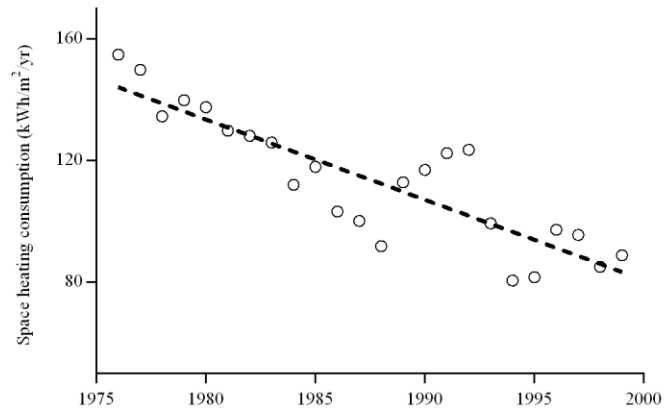

(a) Condition of building envelope  
(construction year)

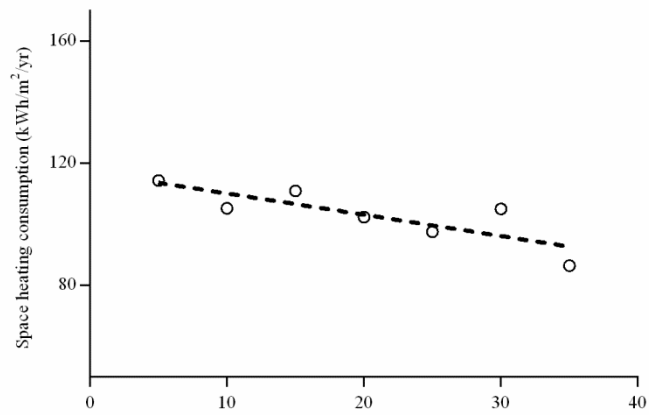

(b) Sizes of clusters  
(Number of buildings in a cluster)

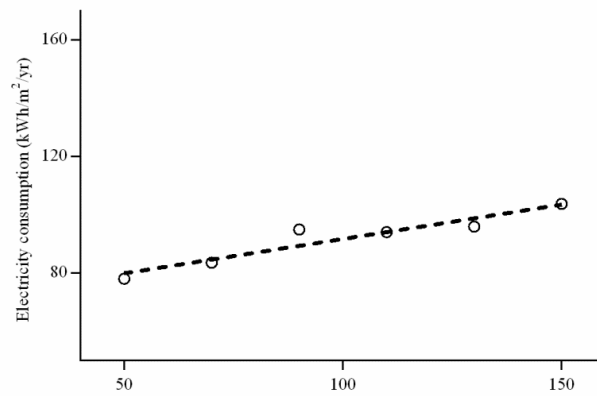

(c) Sizes of building units (m<sup>2</sup>)

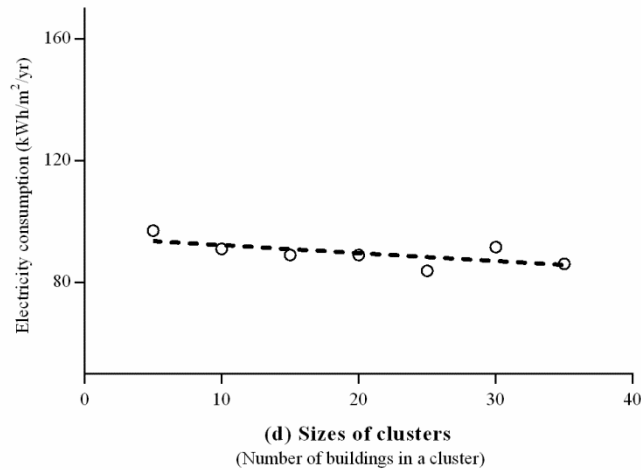

**Figure 6) Regression curves of building features with energy consumption: space heating with (a) construction year and (b) sizes of clusters, and electricity with (c) sizes of building units and (d) sizes of clusters**

### 3.3.2 Results of factor analysis

In the factor analysis, Bartlett's test of Sphericity was significant (186.557,  $p=0.000$ ) and Kaiser-Meyer-Olkin was satisfactory (0.616); thus this factor analysis model is acceptable, but not marvellous due to the same reason of the multiple regression analysis. Despite it, 70.8% of the total variance is explained by the eight measured variables, which is statistically effective to account for the variance. Four factors are identified in this factor analysis as seen Table 3.

The first factor explains the most significant proportions of the total variance with 25.9%. The measured variables in this factor are associated with building form and fabric such as the sizes of building units, the types of building accesses, the conditions of building envelopes and the lengths of buildings. Apartment buildings in early stage need to be suitable to accommodate population increased in urban area; therefore, the building form was longer length, smaller unit sizes and corridor type, as identified in Figure 1. The conditions of building envelopes were similarly improved with these factors. In this reason, the four variables are in the same factor, and they are statistically correlated with overall correlation coefficients ( $R=0.4$ ). The second and third factors account for 18.0% and 15.5% of total variance, respectively. The second factor is comprised by as the types of layouts, the sizes of clusters while the third has total cluster area. Although the three variables are associated with apartment clusters, the difference between them is that the two variables in

the second factor is associated with specifically the characteristic of buildings in clusters whilst total cluster area is more likely the sizes of site. However, the variables are statistically correlated with overall correlation coefficients ( $R= 0.3$ ). The last factor contains heating system method accounting for 11.4% of total variance.

**Table 5 Pattern matrix in factor analysis**

| Category                            |                                  | Factors  |          |          |          |
|-------------------------------------|----------------------------------|----------|----------|----------|----------|
|                                     |                                  | Factor 1 | Factor 2 | Factor 3 | Factor 4 |
| Structure                           | Sizes of building units          | 0.663    |          |          |          |
| Matrix                              | Types of building access         | 0.584    |          |          |          |
|                                     | Conditions of building envelopes | -0.584   |          |          |          |
|                                     | Lengths of buildings             | 0.370    |          |          |          |
|                                     | Types of building layouts        |          | 0.675    |          |          |
|                                     | Sizes of clusters                |          | -0.591   |          |          |
|                                     | Total cluster area               |          |          | -0.608   |          |
|                                     | Heating methods                  |          |          |          | -0.342   |
| Total Variance Explained (70.866 %) | % of Variance                    | 25.900   | 18.082   | 15.445   | 11.440   |

#### 4. Discussion

The results based on empirical data in this study demonstrated four distinctive aspects, compared to findings in other countries. Firstly, energy consumption for space heating in old apartment building is not extremely high by regarding the climate zone of Seoul in South Korea (Heating Degree Days (HDDs) 2800-3200) [52]. Compared to European countries, Denmark (HDDs 3000-3400) [53] showed 144.1 kWh/m<sup>2</sup> of heating consumption in apartment buildings [54]. United Kingdom (HDDs 2800-3100) and Germany (HDDs 2700-3200) [53], which have similar HDDs from South Korea, showed higher energy consumption in dwelling constructed in the 1980s and 1990s: 268.2 kWh/m<sup>2</sup> in detached houses in the UK and 159 kWh/m<sup>2</sup> in Germany; 102.8 kWh/m<sup>2</sup> in post 2002 mid-terrace housing in the UK, and 94 kWh/m<sup>2</sup> in Germany in 1995 [55]. In our study, apartment buildings indicated 116.7 kWh/m<sup>2</sup>/year in the 1980s and 94.4 kWh/m<sup>2</sup>/year in the 1990s although the maximum consumption in the samples was 173.9 kWh/m<sup>2</sup>/year in the 1980s and 158.8 kWh/m<sup>2</sup>/year in



the 1990s. The space heating consumption in old apartment buildings in South Korea is found to be generally higher than the climate zone. However, the consumption needs to be reduced like how European countries have been trying to achieve.

Secondly, the eight building features of apartment buildings in South Korea indicated the significantly higher percentage of the variation explained in energy use which is 70.9% ( $R^2=0.580$  for space heating,  $R^2=0.256$  for electricity). 42% ( $R^2=0.379$  for space heating) of the variation explained was reported in analyzing building characteristics with 15,000 houses in Netherlands [56]. Sonderegger [57] reported 54% of total variation were explained by physical building features with 205 houses in USA. Schuler et al [58] found relatively low  $R^2$  value, 0.144, with building characteristics in West-German households. Pachauri [59] found 61.4 % of total explained variance by including socio-economic characteristics in dwelling in India. Consequently, the effects of physical conditions in old apartment buildings in South Korea are much more significant than buildings in other countries. In other words, the energy consumption of these old apartment buildings in South Korea can be effectively reduced by improving their physical conditions.

Thirdly, the building features affecting energy consumption in old apartment buildings in South Korea are more prominent with higher SRC values although the lists of efficient building features are similar from buildings in other countries. Three building features have been identified in common as efficient factors reducing energy consumption: thermal conditions of building envelope (insulations and the glazing of windows); the volume of areas (heated areas, housing sizes and the number of rooms); construction years (vintages). In West-Germany, construction years and the sizes of housing were found as the relatively effective factors with SRC 0.225 and -0.221 [58]. In Netherlands, the sizes of heated area (useful living area), construction years and the insulations of building facades showed relatively higher SRC values, 0.321, -0.082 and 0-0.087 [56]. According to Balaras et al [54], the thermal insulation of the building envelopes and building system in European apartment buildings, such as Denmark, France, Poland and Switzerland, were the main factors influencing space heating. In our study, there is a dominant determinant affecting space heating consumption, the thermal conditions of building envelope with SRC -0.626 in space heating. This result clearly showed how the building refurbishment for old apartment buildings in South Korea to approach in order to reduce energy consumption efficiently.

Fourthly, the effects of building features related to building clusters are important factors. Unlike European countries, apartment buildings in South Korea were built as clusters including several buildings up to thirties. Therefore, the relations among individual buildings are also important factors that must be considered in energy consumption. In our study, the

features related to building clusters explained 33.4% of total variations in energy use. Moreover, the undeniable contribution of these features was identified in the results of the multiple regression analysis for space heating and electricity although the SRC values were not decisively high.

## 5. Conclusions

This study aims to identify old apartment buildings in South Korea that need to be refurbished in terms of energy efficiency and suggests how the refurbishment should be done to reduce their energy consumption. It reveals that old apartment buildings constructed between the 1980s and 1990s are those which need to be urgently refurbished. This is because they showed excessive energy consumption for space heating and cooling, compared with the consumption of apartment buildings built in the 2000s. However, maximum 43.65 kWh/m<sup>2</sup>/year in space heating and 5.70 kWh/m<sup>2</sup>/year in cooling were reduced in those old apartment buildings in terms of construction years. This reduction was attributed to the transformations of building features in the twenty-year period. The eight features in old apartment buildings successfully account for 70.9% of total variance in the factor analysis. The largest proportion, 25.9%, was explained by the factor related to building form and fabric. Multiple regression analysis indicated the three most influential parameters, the thermal conditions of building envelopes with SRC 0.626, heating methods with SRC 0.301 and the sizes of building units with SRC 0.300.

Hence, this study found that the priority of refurbishment should be given to these three features. Amongst them, the most significant determinant should be the thermal conditions of building envelopes with SRC 0.626. The other two features will be subsidiary conditions in refurbishment strategies. In this respect, the most urgent target for refurbishment should be the buildings constructed before 1980 (with central gas heating and large sizes of building units), and the latest target can be those constructed after 1988 (with individual gas heating and small sizes of building units).

Applications of this approach to cases in the other countries may bring about different building features in prioritising old high-rise apartment buildings for energy-efficient refurbishment. Thus, the refurbishment strategies for each country should take specific features and conditions of the apartment buildings into account in order to suggest efficient policies and regulations for refurbishment in each country.

## 6. References

- [1] H.-J. Chang, *The East Asian development experience: the miracle, the crisis and the future*, Zed Books, 2006.
- [2] B. Yuen, A.G. Yeh, *High-rise living in Asian cities*, Springer, 2011.
- [3] B. Yuen, A. Yeh, S.J. Appold, G. Earl, J. Ting, L.K. Kwee, *High-rise living in Singapore public housing*, *Urban Studies*, 43 (3) (2006) 583-600.
- [4] J.G. Olivier, J.A. Peters, G. Janssens-Maenhout, *Trends in Global CO2 Emissions 2012 Report*, PBL Netherlands Environmental Assessment Agency, 2012.
- [5] J. Kim, *A Review of the Building Energy Efficiency Rating System of South Korea*, *Korean Journal Of Air-Conditioning and Refrigeration Engineering*, 39 (10) (2010) 11-18.
- [6] R. Jones, B. Yoo, *Achieving the " Low Carbon, Green Growth" Vision in Korea*, in, OECD Publishing, 2012.
- [7] J. Huh, *2013 Handbook of Energy and Economic Statistics in Korea*, in, Korea Energy Management Corporation,, Yongin, 2013, pp. 56.
- [8] H. Jo, S. Jin, M. Kim, *Energy Reduction Strategy Toward Low-carbon Society 2009*, in, Seoul Development Institute,, Seoul, 2010.
- [9] M. Kim, *How to reduce energy consumption in buildings*, Seoul Development Institute Reports, 79 (2010) 1-21.
- [10] Ministry of Land Infrastructure and Transport, *Statistics of Buildings*, in: Ministry of Land Infrastructure and Transport (Ed.), Korean Statistical Information Service,, Seoul, 2013.
- [11] Korean Statistical Information Service, *Housing Census 2010*, in, Korean Statistical Information Service,, 2010.
- [12] Korean Statistical Information Service, *Housing Census*, in: Korean Statistical Information Service (Ed.), 2000.
- [13] Ministry of Land Infrastructure and Transport, *Permission of vertical floor extension in apartment buildings*, in: Ministry of Land Infrastructure and Transport (Ed.), Seoul, 2010, pp. 1.
- [14] K.-S. Lee, K.-H. Kim, K.-R. Kim, D.-W. Shin, *Profitability Influence Factor Analysis by Apartment Remodelling Case Study*, *Korea Journal of Construction Engineering and Managment*, 8 (2) (2007) 133.
- [15] B.-S. Son, M.-H. Jang, H.-S. Lee, *A Method of Economic Analysis for Remodeling of Apartments Using the Life Cycle Costing*, *Journal of the Architectural Institute of Korea Structure & Construction*, 21 (7) (2005) 73-81.
- [16] H.Y. Ki, J.H. Park, J.C. Park, *An Analysis on the Effects of Applying Interior Insulation and Exterior Insulation in Buildings*, in: The SAREK Annual Conference The

- Society Of Air-Conditioning And Refrigerating Engineers Of Korea (SAREK), 2013, pp. 310-313.
- [17] C.-Y. Jang, H.-S. Han, J.-S. Lee, The Building Energy Rating Evaluation of Middle Region Apartment Depending on Window Area Ratio, in: The KIAEBS Annual Spring Conference Korea Institute of Architectural Sustainable Environment and Building Systems (KIAEBS), 2010, pp. 207-210.
- [18] J.-G. Kim, J.-W. Moon, B.-H. Lee, Experimental Study on the Influence of the Insulation of External Walls in the Basement of Apartment Houses to the Temperature of Basement and the Consumption of Heating City-gas on the First Floor, Journal of The Architectural Institute of Korea Planning & Design 22 (7) (2006) 241-248.
- [19] N.E. Lee, B.-L. Ahn, C.-Y. Jang, S.-B. Leigh, A Study on Evaluation of the Building Energy Rating depending on the Thermal Performance of Balcony Window with Low-E glazing, Solar Energy, 32 (2) (2012) 58-63.
- [20] C.-H. Kim, B.-L. Ahn, J.-Y. Kim, C.-Y. Jang, A Study on the Evaluation of Building Energy Rating considering the Insulation Performance of the Window and Wall in Apartment Houses, in: The SAREK Annual Conference The Society of Air-Conditioning and Refrigerating Engineers of Korea (SAREK), 2009, pp. 608-613.
- [21] Ministry of Land Infrastructure and Transport, Act on the Energy-Efficient Certificate Criteria, in: Ministry of Land Infrastructure and Transport (Ed.), Seoul, 2013.
- [22] J.-M. Bae, Y.-S. Chung, C.-S. Yoon, A Study on Characteristics of Apartment Housing Unit Plans, Journal of Korean Housing Institute, 12 (2) (2001).
- [23] M.-H. Choi, A Study on the Characteristics of the Physical Form and the Spatial Layout of Multi-Family Housing in Taegu Journal of the Architectural Institute of Korea 13 (2) (1997) 117-124.
- [24] J.W. Hong, A Study on the Varying Trend for Apartment Unit Plan in Seoul and the Metropolitan Area, Architectural Engineering, Yonsei University, 2003.
- [25] N.i. Jeon, Spatial history of housing in South Korea (Hanguk jugeo gonggansa), Dolbaegae, 2010.
- [26] M.-K. Kim, C.-S. Yoon, A Study on Ststistical Characteristics of Space Dimension of 60m<sup>2</sup> and 85m<sup>2</sup> Size Apartment Plan Types in Seoul, Journal of the Korean Housing Association, 21 (1) (2010).
- [27] N.H. Park, A Study on the Changes in Characteristics of Unit Plan in National Housing Scale Apartment, Architecture, Myeongji University, 2012.
- [28] S.S. Zchang, A Study on the Transition of the '60~ 70s' Apartment Houses in Korea, Architecture, Seoul National University, 1994.

- [29] Ministry of Land Infrastructure and Transport, Enforcement Decree of the Building Act, in: Ministry of Land Infrastructure and Transport (Ed.) Presidential Decree No.25339,, South Korea, 2014.
- [30] Green City and Building Centre, Certificate results of Green buildings, in, LH Housing Land Development Institute,, Daejeon.
- [31] V. Gelezeau, The Republic of Apartments (Apart Gonhwagook), Humanitasbooks, Seoul, (2007) 65-66.
- [32] K.-h. Lim, A Study on the Evaluation of Residential Environment of the Outdoor Space in Apartment Architectural Engineering Chosun University, 2008.
- [33] M.-W. Lee, G.-Y. Cho, Y.-B. Seong, M.-S. Yeo, K.-W. Kim, A Study of Solar Access Right of Apartment Buildings According to Planning, in: The KSES Annual Autumn Conference, The Korean Solar Energy Society (KSES), 2005, pp. 211-216.
- [34] J. Yoon, S.-K. Yeo, J. Park, Y. Choi, S.-W. Lee, Overshadowing Analysis of Apartment Building Arrangement with Winter Average Shading Ratio of Window, in: The KSES Annual Autumn Conference, The Korean Solar Energy Society (KSES), 2006, pp. 225-230.
- [35] J.-S. Park, K.-I. Chin, J.-H. Yoon, Solar Access Evaluation of Roof and Facade Area of Apartment Building Depending on the 4 Different Types of Building Arrangement, in: The KIAEBS Annual Autumn Conference Korean Institute of Architectural Sustainable Environment and Building Systems (KIAEBS), 2007, pp. 178-183.
- [36] J.-G. Kim, J.-S. Chun, B.-H. Lee, Study about Change of Insulation Standard in Apartment in Its Effect, Journal of Architectural Institute of Korea, 11 (1) (2009) 125-132.
- [37] M.B. Noh, A Study on the Comparative Analysis of the Apartment Heating Systems in the Economics, Architectural Engineering, Konkuk University, 1998.
- [38] S.J. Ha, Resident's Satisfaction Evaluation of Rental Apartment by Heating Type in Busan-Kyungnam, Refrigeration & Air Conditioning Engineering, Pukyong University, 2007.
- [39] J.S. Kang, T.K. Ahn, S.E. Lee, A Study on Characteristics of Energy Consumption in Apartment Buildings Journal of The Architectural Institute of Korea 11 (7) (1995) 139-148.
- [40] B.S. Everitt, Applied multivariate data analysis.
- [41] F. Faul, E. Erdfelder, A. Buchner, A.-G. Lang, Statistical power analyses using G\* Power 3.1: Tests for correlation and regression analyses, Behavior research methods, 41 (4) (2009) 1149-1160.
- [42] H.F. Kaiser, J. Rice, Little Jiffy, Mark IV, Educational and psychological measurement, (1974).
- [43] Ministry of Land Infrastructure and Transport, Apartment Housing Living Condition Statistics, in: Ministry of Land Infrastructure and Transport (Ed.), Korean Statistical Information Service,, Seoul, 2010.

- [44] Y.-b. Song, Influence of new town development on the urban heat island-the case of the Bundang area, *Journal of Environmental Sciences*, 17 (4) (2005) 641-645.
- [45] S. Kim, Perspectives of partment buildings in remodeling markets in, LG Economic Research Institute, Seoul, 2002.
- [46] Korea Electric Power Corporation, Electric rates table, in, 2014.
- [47] Seoul City Gas, Gas rates table, in, 2014.
- [48] P. Trust, What is Passivhaus?, in, The UK Passive House Organisation.
- [49] Korean National Statistical Office, Composition of households depending on housing types, in: Korean National Statistical Office (Ed.) Population and Housing Census Report, 2010, Korean Statistical Information Service,, Seoul, 2010.
- [50] E. Choi, The Residential Segregation and the Differentiation of Housing Value in Seoul, *Journal of The Korean Association of Regional Geographers*, , (2004).
- [51] Korea Energy Economics Institute, Energy Consumption Survey 2011, in, Korea Energy Economics Institute,, 2011.
- [52] S.-H. Cho, S.-S. Kim, C.-Y. Choi, Study on the Revision of HDD for 15 Main Cities of Korea, *Korean Journal Of Air-Conditioning and Refrigeration Engineering*, 22 (7) (2010) 436-441.
- [53] Eurostat, Heating degree-days by NUTS 2 regions - annual data [nrg\_esdgr\_a], in: Eurostat (Ed.), Eurostat, 2014.
- [54] C.A. Balaras, K. Droutsa, E. Dascalaki, S. Kontoyiannidis, Heating energy consumption and resulting environmental impact of European apartment buildings, *Energy and buildings*, 37 (5) (2005) 429-442.
- [55] M. Economidou, B. Atanasiu, C. Despret, J. Maio, I. Nolte, O. Rapf, Europe's Buildings under the Microscope. A Country-by-Country Review of the Energy Performance of Buildings, Buildings Performance Institute Europe (BPIE), (2011).
- [56] O. Guerra Santin, L. Itard, H. Visscher, The effect of occupancy and building characteristics on energy use for space and water heating in Dutch residential stock, *Energy and buildings*, 41 (11) (2009) 1223-1232.
- [57] R.C. Sonderegger, Movers and stayers: the resident's contribution to variation across houses in energy consumption for space heating, *Energy and buildings*, 1 (3) (1978) 313-324.
- [58] A. Schuler, C. Weber, U. Fahl, Energy consumption for space heating of West-German households: empirical evidence, scenario projections and policy implications, *Energy policy*, 28 (12) (2000) 877-894.
- [59] S. Pachauri, An analysis of cross-sectional variations in total household energy requirements in India using micro survey data, *Energy policy*, 32 (15) (2004) 1723-1735.