

THE OPTICAL CONCERNS OF JAN VAN EYCK'S PAINTING
PRACTICE

STEPHEN JAMES HANLEY

TWO VOLUMES
VOLUME 2

PH.D.

THE UNIVERSITY OF YORK

HISTORY OF ART

AUGUST 2007



Fig 0.1 - Campin Group, *Saint John the Baptist and the Franciscan Master of Arts, Heinrich von Werl* (left wing panel), 1438. 101.0 x 47.0 cm. Museo del Prado, Madrid.



Fig 0.2 - Petrus Christus, *A Goldsmith in his Shop (Saint Eligius?)*, 1449. 99.1 x 85.1 cm. The Metropolitan Museum of Art, New York.

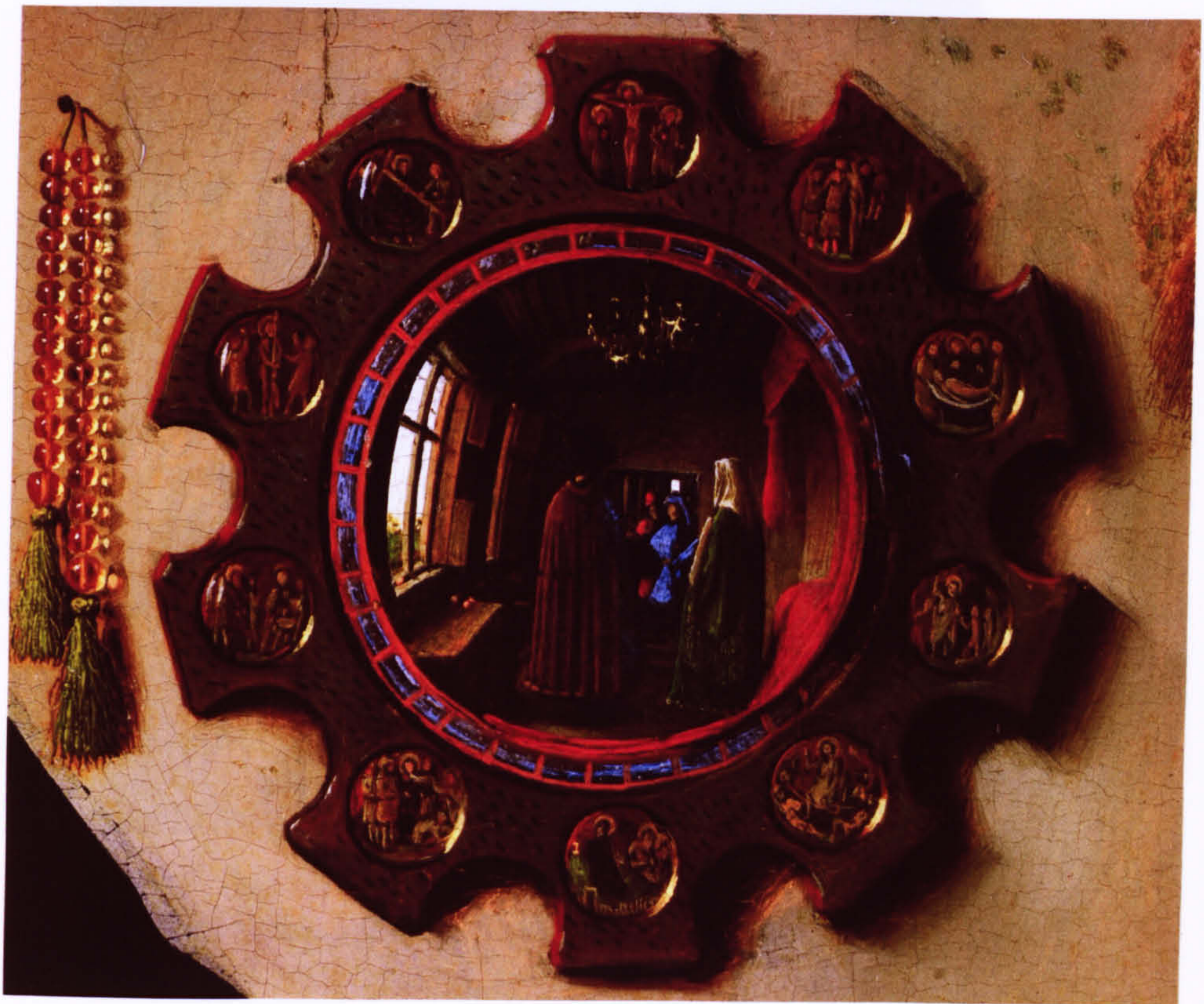

Fig 0.3 - Detail of convex mirror, *Arnolfini Double Portrait*.



Fig 0.4 - North Italian mirror frame, fifteenth century.
Walters Art Gallery, Baltimore.

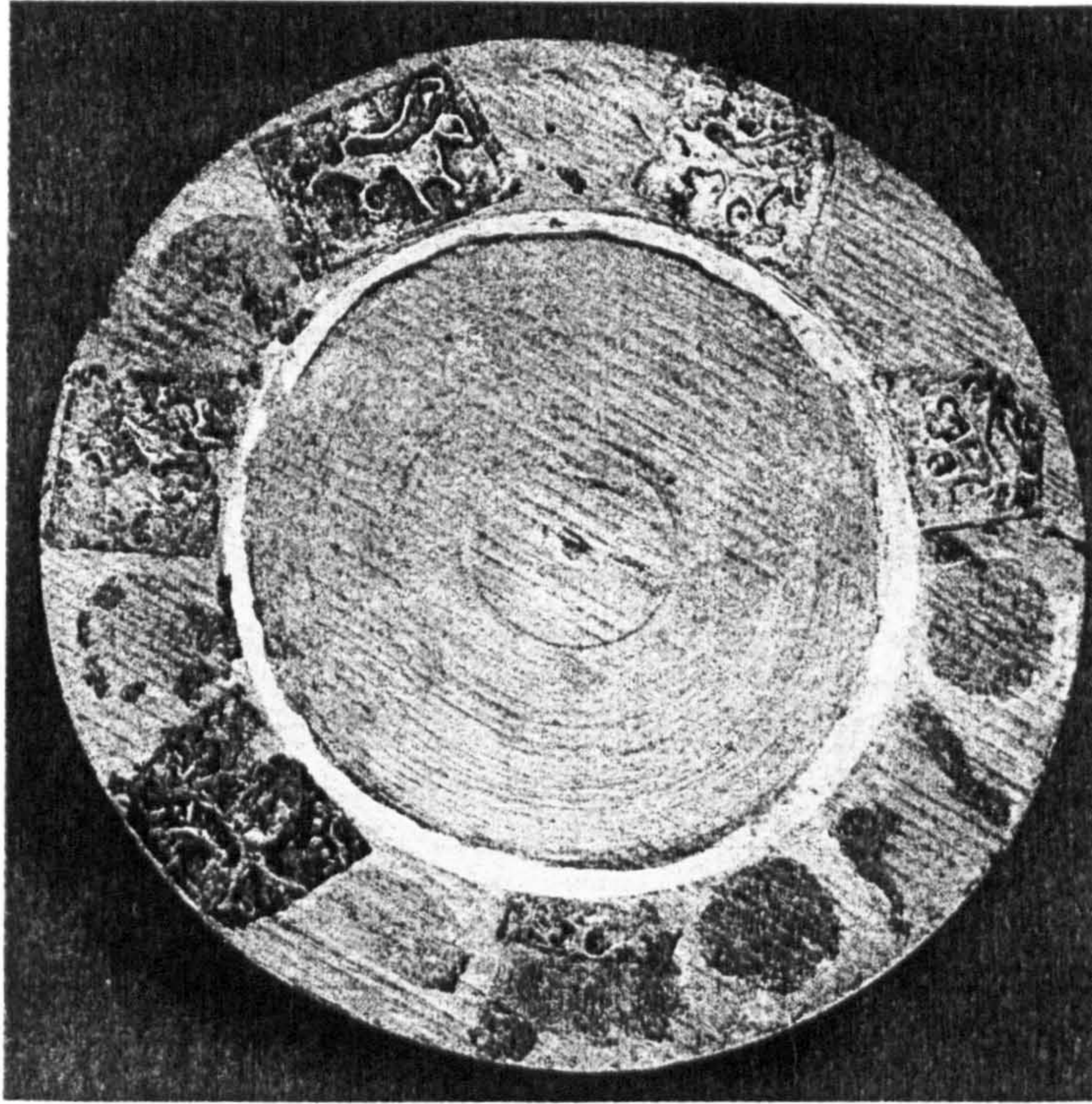

Fig 0.5 - Mirror frame, fourteenth century. Amt für Vor- und Frühgeschichte Lübeck, Schleswig-Holstein.

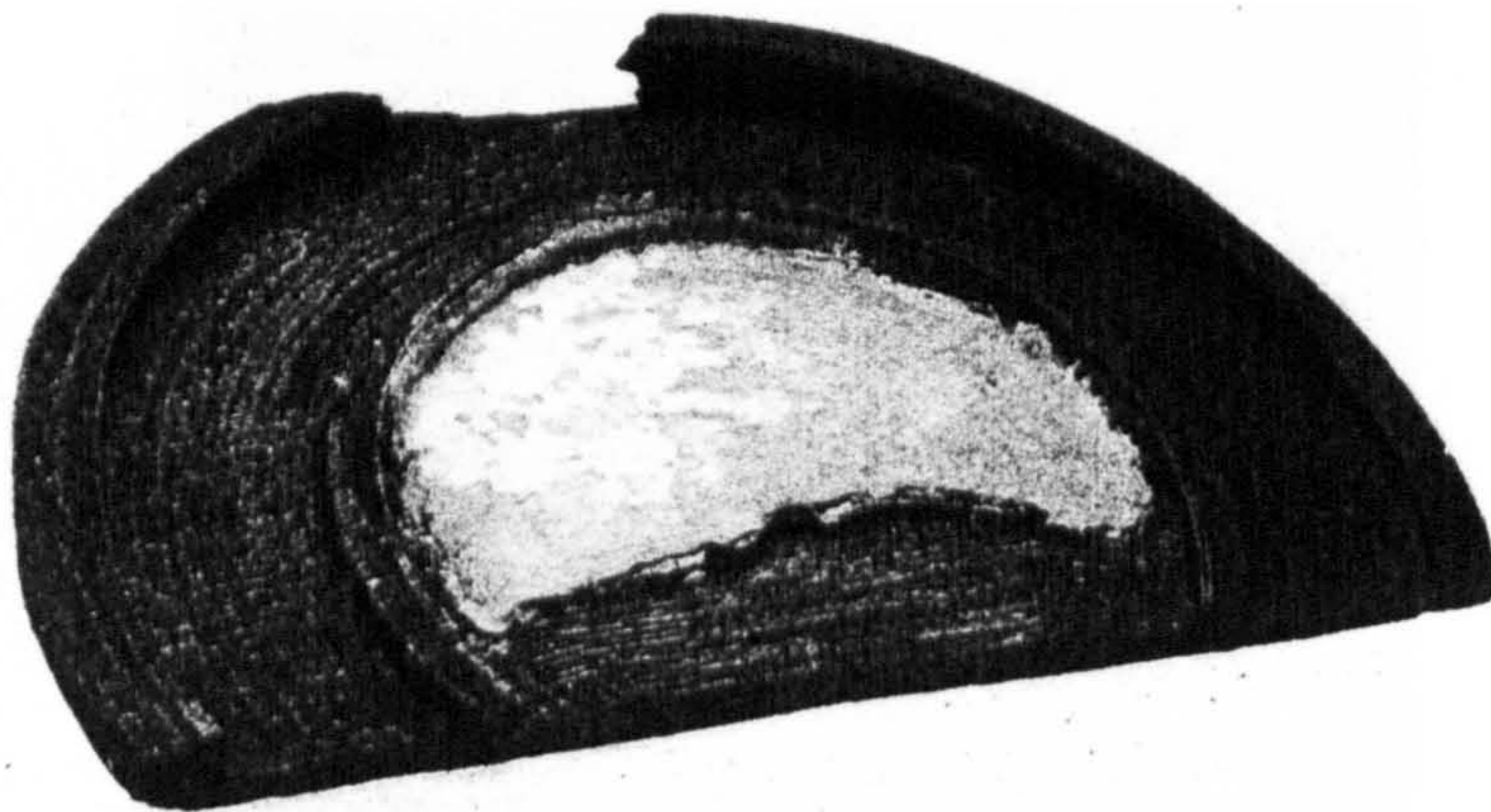

Fig 0.6 - Mirror fragment, fourteenth century. Západočeské Muzeum, Pilsen.



Fig 0.7 - Convex mirror on the *Millennium Clock*, Great Hall, National Museum of Scotland, Edinburgh.



Fig 0.8 - Photograph showing reflections in a modern mirror and a fragment of mirror glass from Gujarat, western India.



Fig 0.9 - Photograph of a modern convex mirror.



Fig 0.10 - Pair of rivet spectacles from Trig Lane, London, c.1440. Museum of London.



Fig 0.11 - Housebook Master, detail of a goldsmith wearing spectacles, *Mercury and his Children*, *The Housebook*, c.1475-85. Collection of the Princes of Waldburg-Wolfegg.



Fig 0.12 - Simon Bening, *Self-Portrait*, 1558. 8.6 x 5.9 cm. Victoria and Albert Museum, London.



Fig 1.1 - Jan van Eyck, *Lucca Madonna*, c.1434-37. 65.5 x 49.5 cm. Städelsches Kunstinstitut, Frankfurt am Main.



Fig 1.2 - Detail of crystal carafe and basin, *Lucca Madonna*.



Fig 1.3 - Jan van Eyck, *Arnolfini Double Portrait*, 1434. 81.8 x 59.7 cm. National Gallery, London.

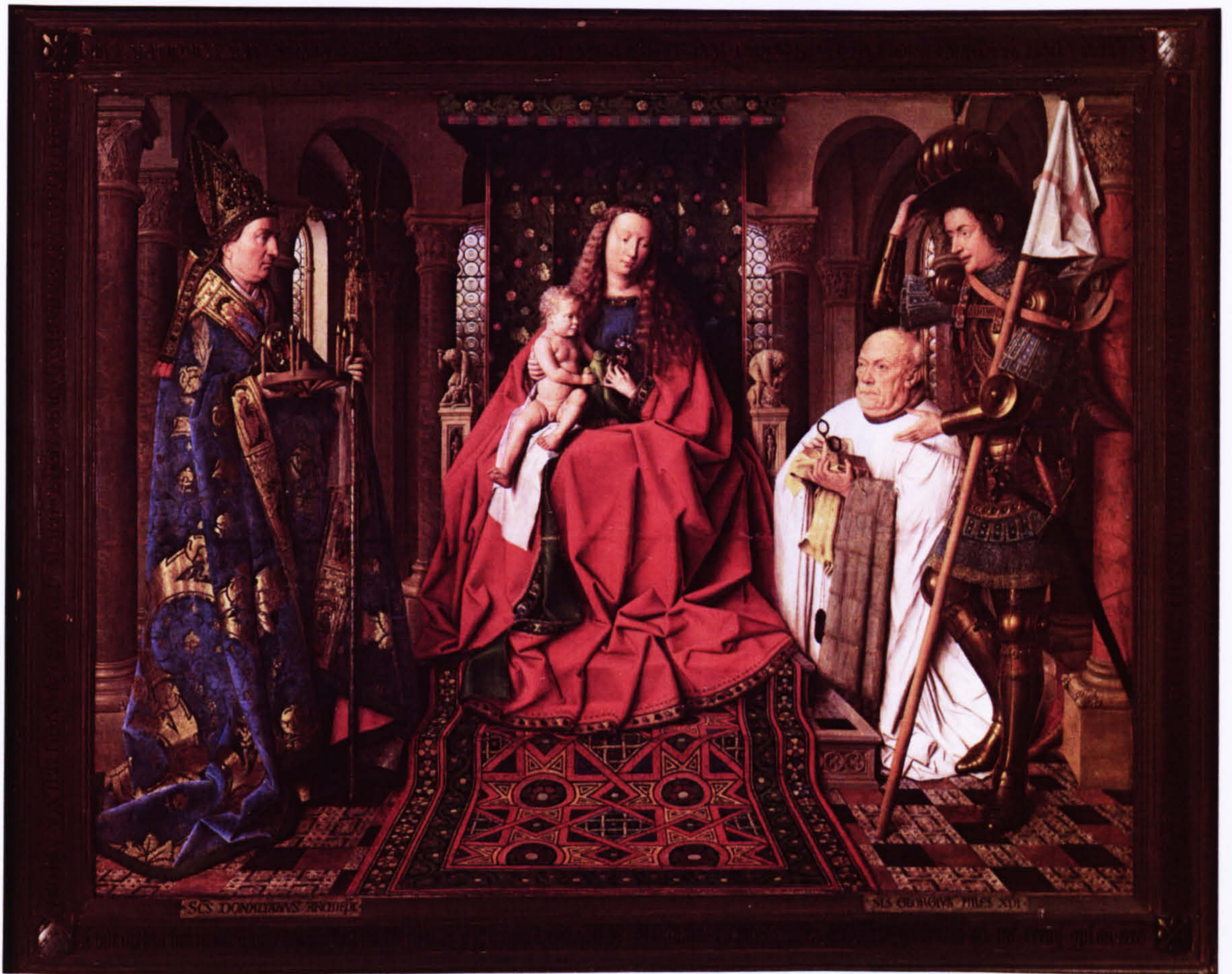

Fig 1.4 - Jan van Eyck, *Virgin and Child with the Canon van der Paele*, 1434-36. 140.8 x 176.5 cm. Groeningemuseum, Bruges.



Fig 1.5 - Detail of van der Paele's spectacles, *van der Paele Virgin*.



Fig 1.6 - Photograph of a patient with temporal arteritis.



Fig 1.7 - Detail of van der Paele's temple, *van der Paele Virgin*.

Fig 1.10 - Claus Sluter and workshop, *Prophet Jeremiah*, "Well of Moses", 1395-1404. Figure approx. 140cm. Chartreuse de Champmol, Dijon.



Fig 1.8 - *Saint Luke*, French, c.1400. Pierpont Morgan Library, New York, ms. 331, fol. 187r.



Fig 1.9 - *Saint Matthew*, French, c.1420. Bibl. Trivulziana, Milan, ms. 445, fol. 15r.

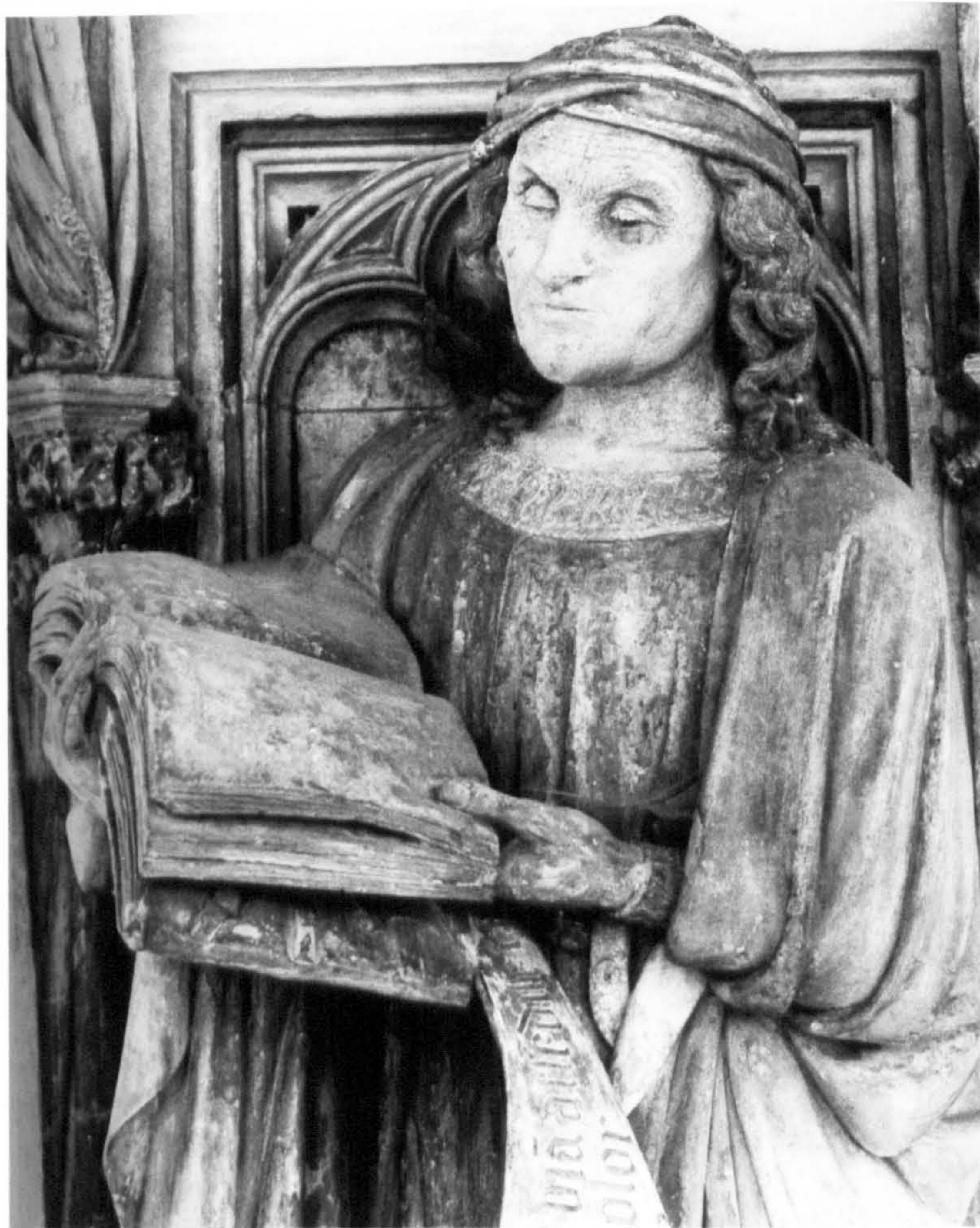

Fig 1.10 - Claus Sluter and workshop, *Prophet Jeremiah*, 'Well of Moses', 1395-1404. Figure approx 180cm. Chartreuse de Champmol, Dijon.



Fig 1.11 - Jan van Eyck, *Virgin in a Church*, c.1426-28.
31.0 x 14.0 cm (painted surface). Staatliche Museen,
Gemäldegalerie, Berlin.

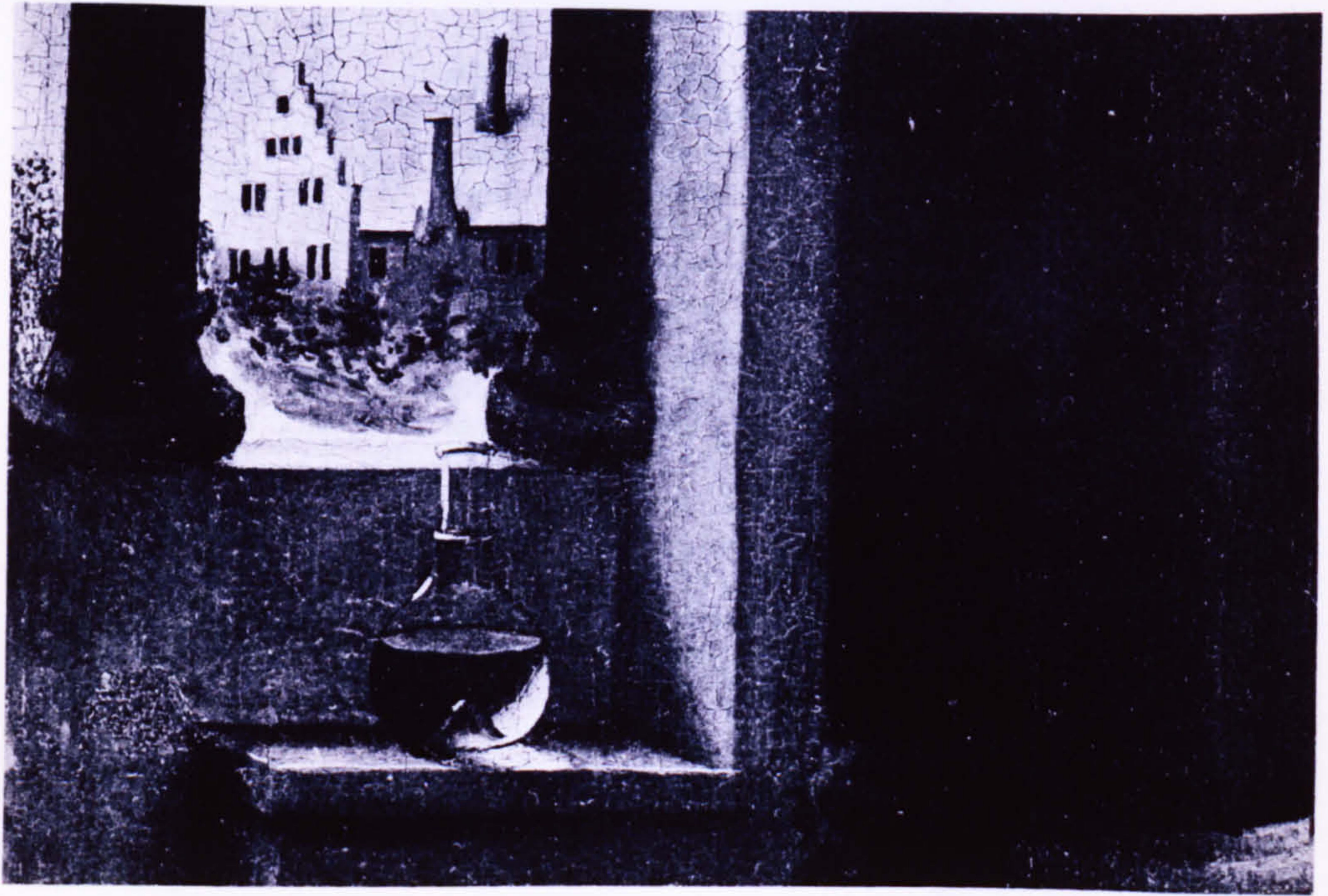

Fig 1.12 - Detail of crystal carafe, *Ghent Altarpiece*.



Fig 1.13 - Heinrich of Constance, *The Visitation*, c.1310.
59.1 x 30.5 cm. The Metropolitan Museum of Art, New York.

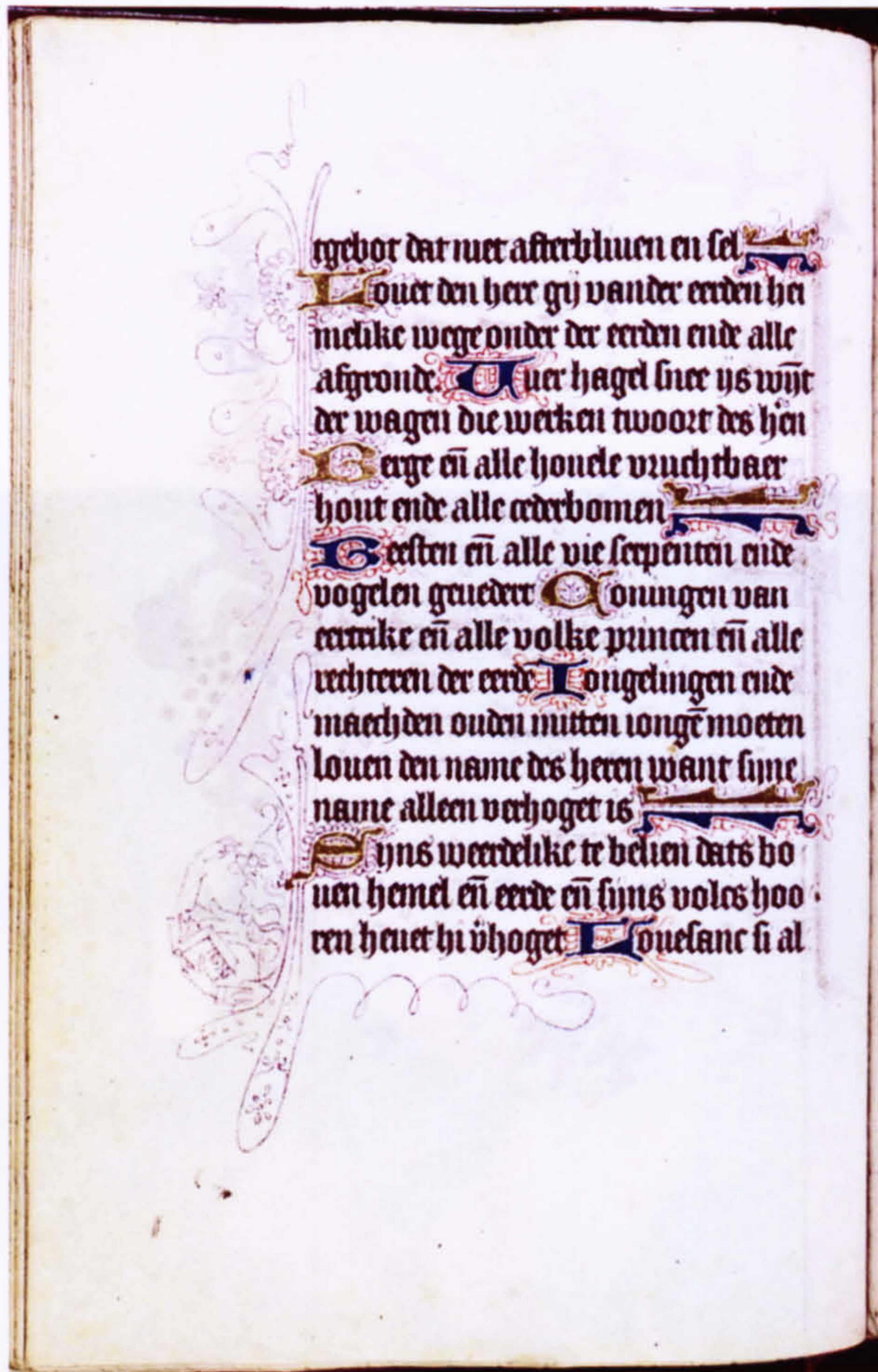

Fig 1.14 - Lieven van Lathem, detail of a scholar with spectacles, Utrecht, c.1460. 18.4 x 12.8 cm. Koninklijke Bibliotheek, The Hague, MMW 10f50, fol. 26v.

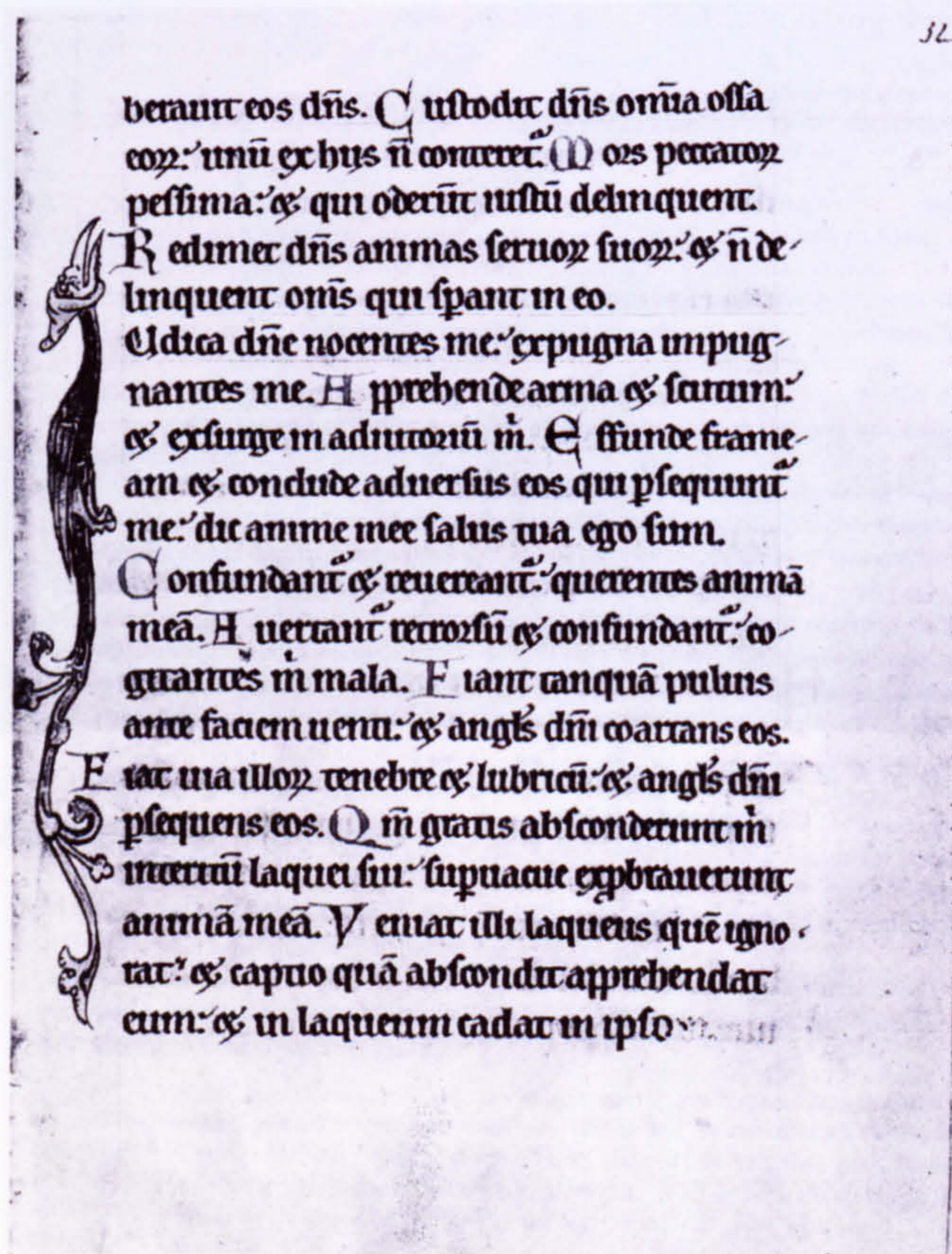

Fig 1.15 - Detail of a bird apparently wearing spectacles, Ghent, c.1250-70, Bibliothèque Royale, Brussels, BR MS5163-4, fol. 32r.



Fig 1.16 - Joos van Cleve, *Holy Family*, c.1513. 42.5 x 31.8 cm.
The Metropolitan Museum of Art, New York.



Fig 1.17 - Joos van Cleve, *Holy Family*, c.1515. 51.8 x 37.1 cm.
The Metropolitan Museum of Art, New York.

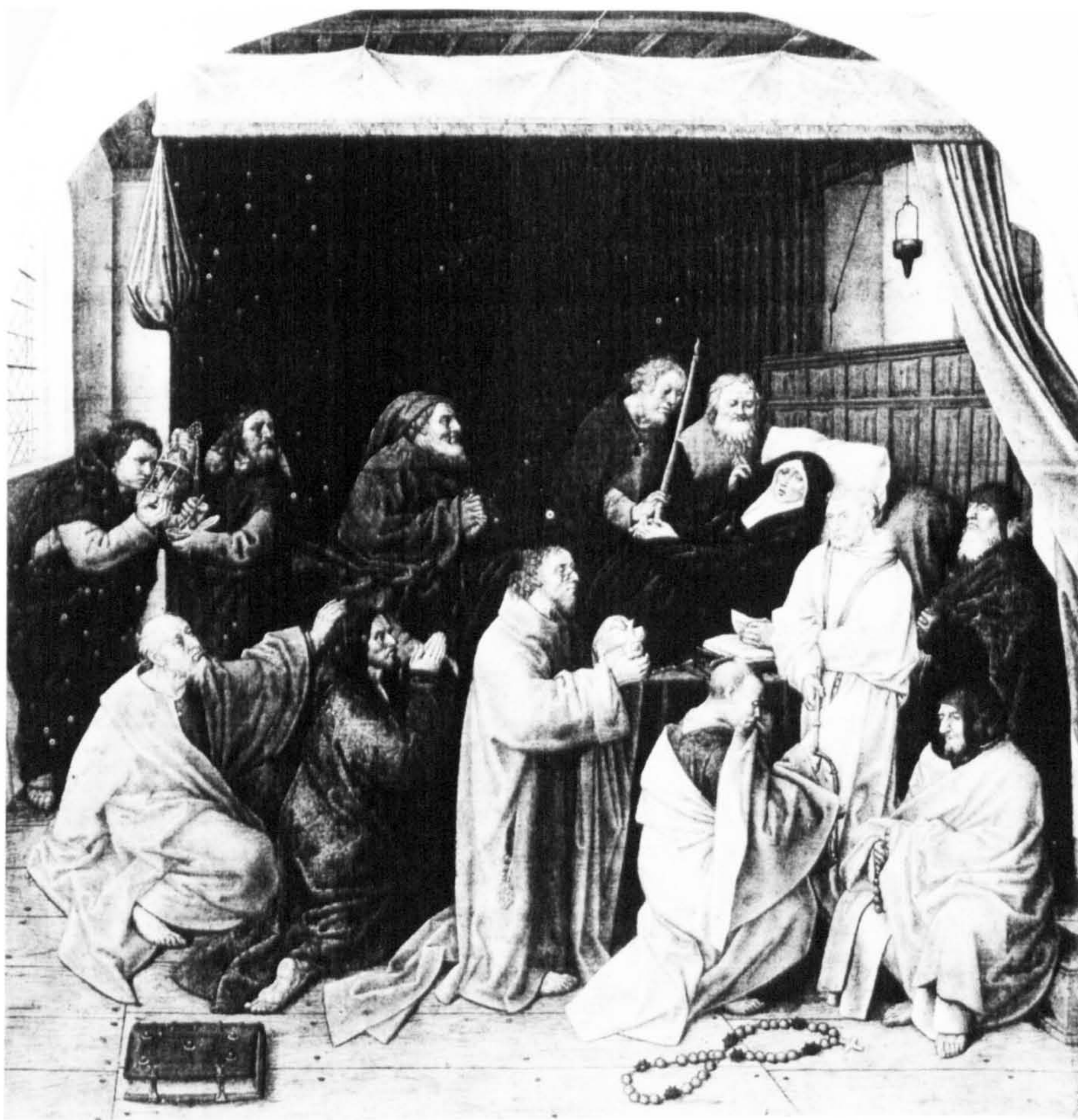

Fig 1.18 - Follower of Hugo van der Goes, *Death of the Virgin*, late fifteenth century. 39.3 x 37.6 cm. Staatliche Museen, Gemäldegalerie, Berlin.

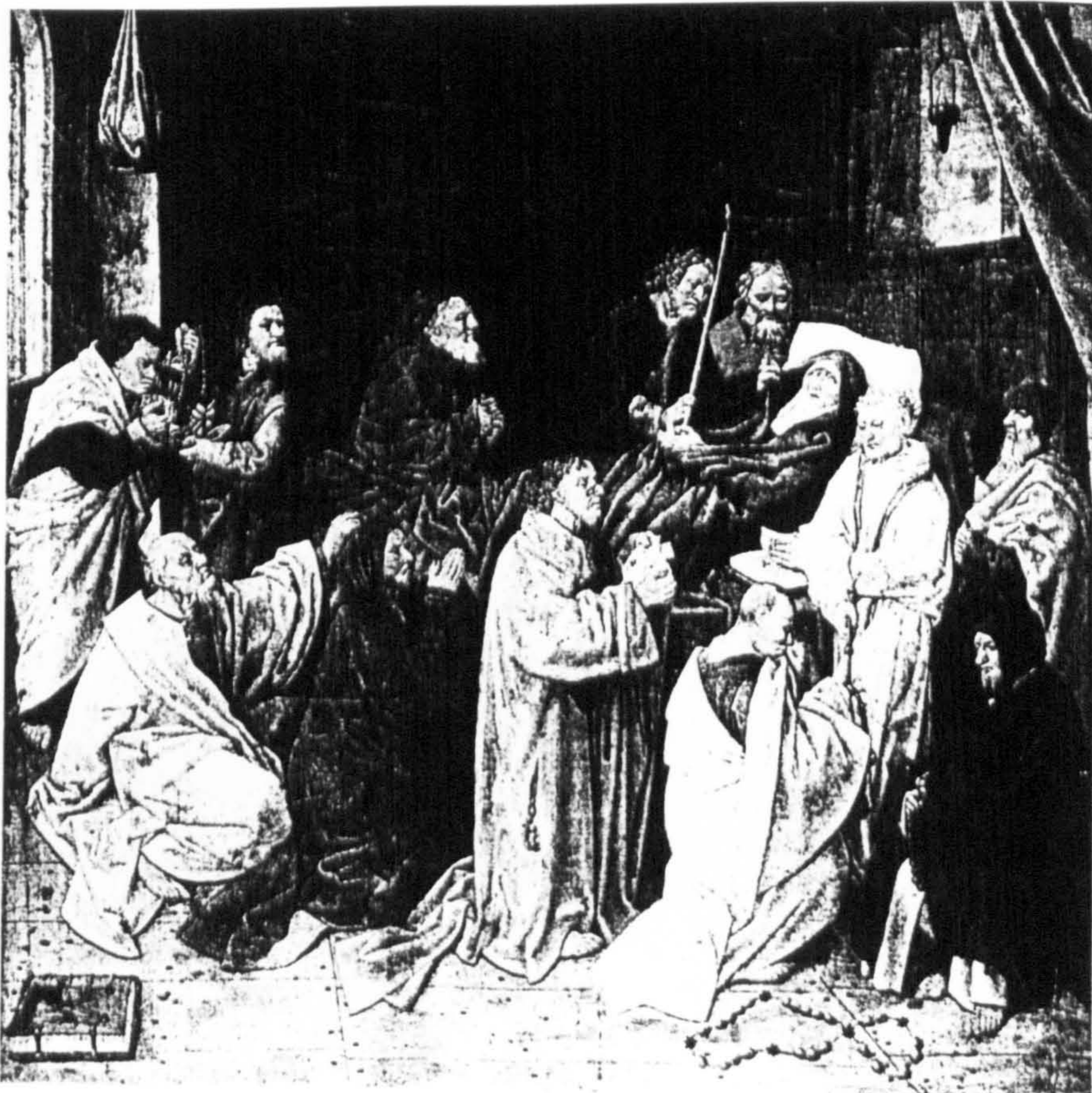

Fig 1.19 - Follower of Hugo van der Goes, *Death of the Virgin*, late fifteenth century. 35.0 x 36.5 cm. Nardoni Galerie, Prague.



Fig 1.20 - Follower of Robert Campin, *Death of the Virgin*, early sixteenth century. 39.4 x 35.6 cm. National Gallery, London.



Fig 1.21 - Bedford Master, *Death and Assumption of the Virgin*, Châteauroux Breviary, c.1412-13. 28.0 x 28.2 cm (page). Châteauroux Bibliothèque Municipale, ms.2, fol. 282v.



Fig 1.22 - Bedford Master, *Death and Coronation of the Virgin*, *The Bedford Hours*, c.1410-15. 26.3 x 18.4 cm (page). British Library, London, Add. 18850. Fol. 89r.



Fig 1.23 - *Death of the Virgin*, Tyrol, c.1370-72.



Fig 1.24



Fig 1.25 - Detail of the Virgin and Christ, *van der Paele Virgin*.

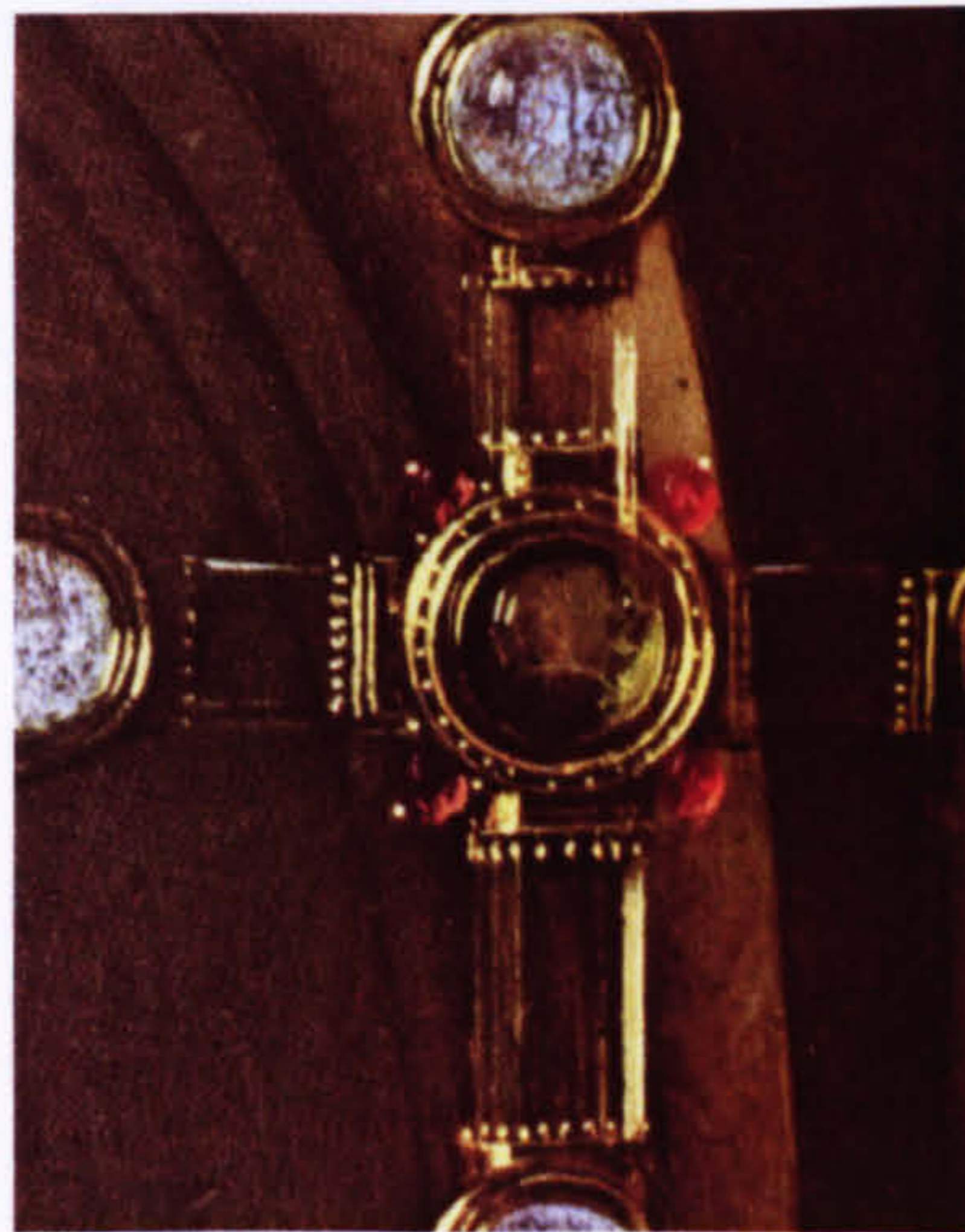

Fig 1.26 - Detail of rock crystal in Donatian's cross, *van der Paele Virgin*.



Fig 1.27 - Detail of Saint George's helmet, *van der Paele Virgin*.



Fig 1.28 - Detail of Saint George's shield, *van der Paele Virgin*.

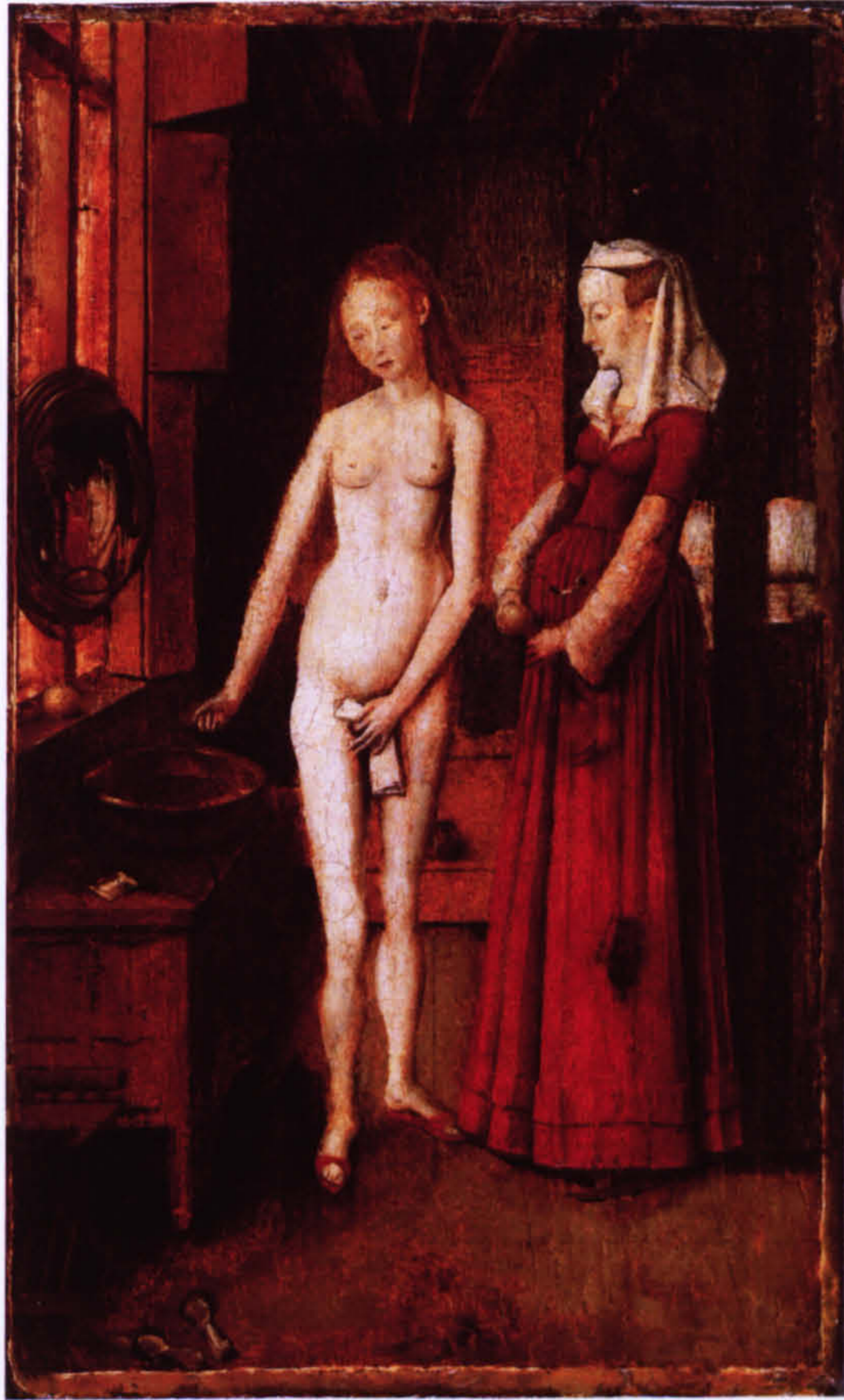

Fig 2.1 - Copy after Jan van Eyck, *Woman at her Toilet*, probably sixteenth century. 27.5 x 16.5 cm. Fogg Art Museum, Harvard University, Cambridge, Mass.



Fig 2.2 - Quinten Massys, *The Banker and his Wife*, 1514.
71.0 x 68.0 cm. Musée du Louvre, Paris.

Fig 2.4 - Colijn de Coox (after Robert Campin?),
Saint Luke Painting the Virgin, ca.1475. 117 x 108cm.
Parish church, Vieux



Fig 2.3 - School of Konrad Witz, *Holy Family with Saint Catherine and Saint Barbara*, c.1440-45. 62.0 x 43.5 cm. Galleria Nazionale, Naples.



Fig 2.4 - Colyn de Coter (after Robert Campin?), *Saint Luke Painting the Virgin*, c.1493. 135 x 108cm. Parish church, Vieure.



Fig 2.5 - Quinten Massys (follower of ?),
Saint Luke Painting the Virgin and Child,
c.1530. 113.7 x 34.9 cm. National Gallery,
London.

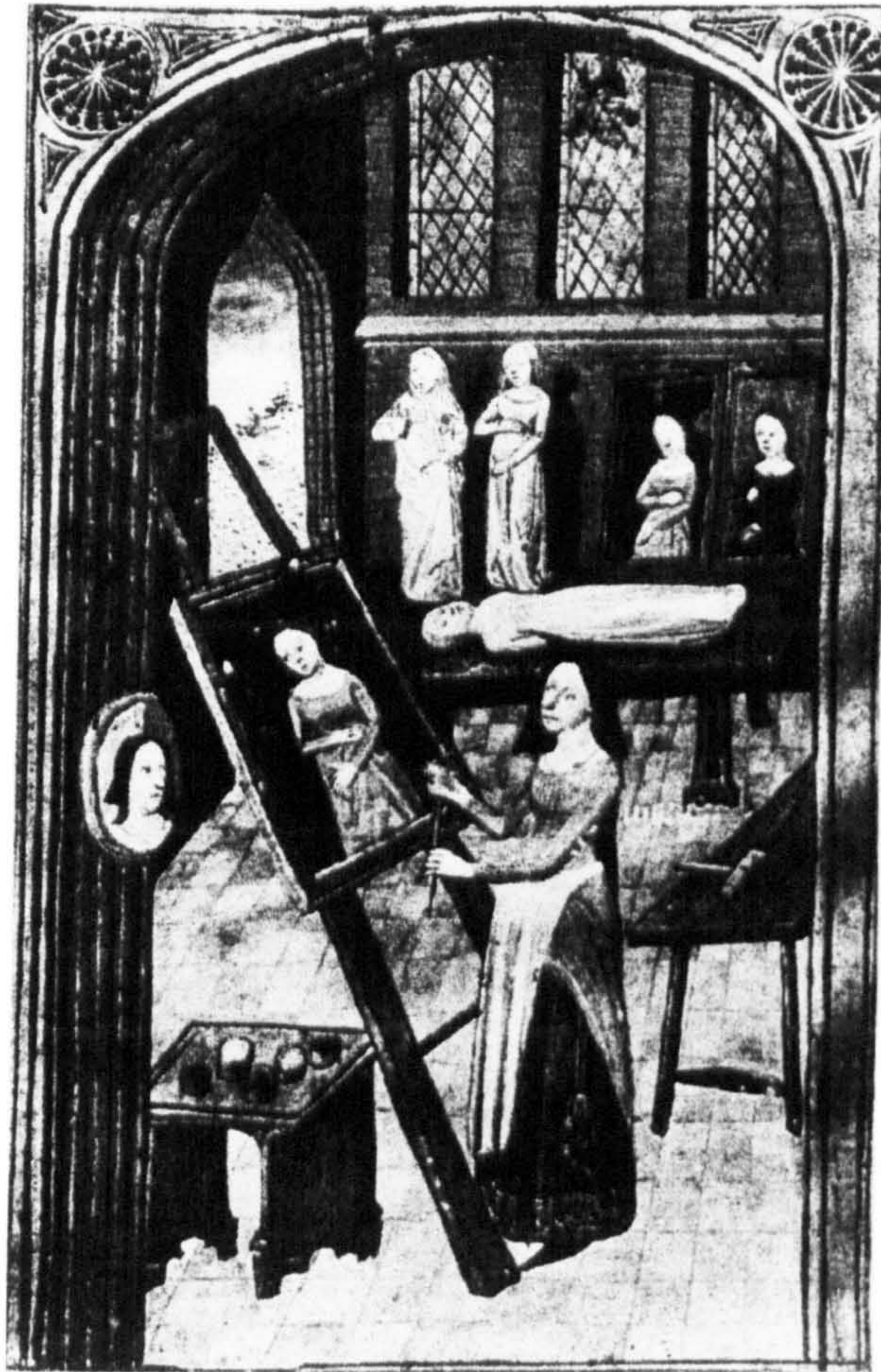
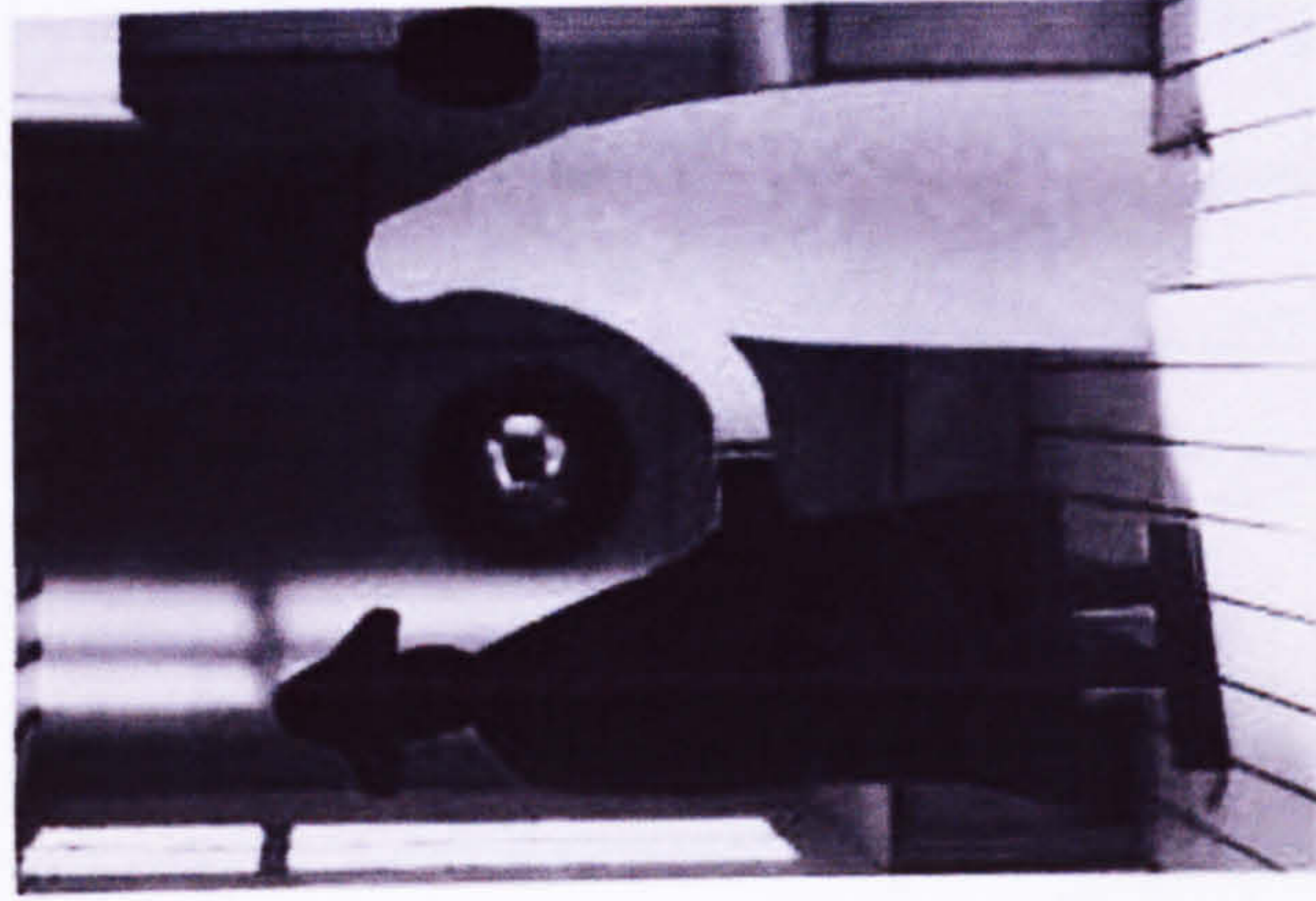
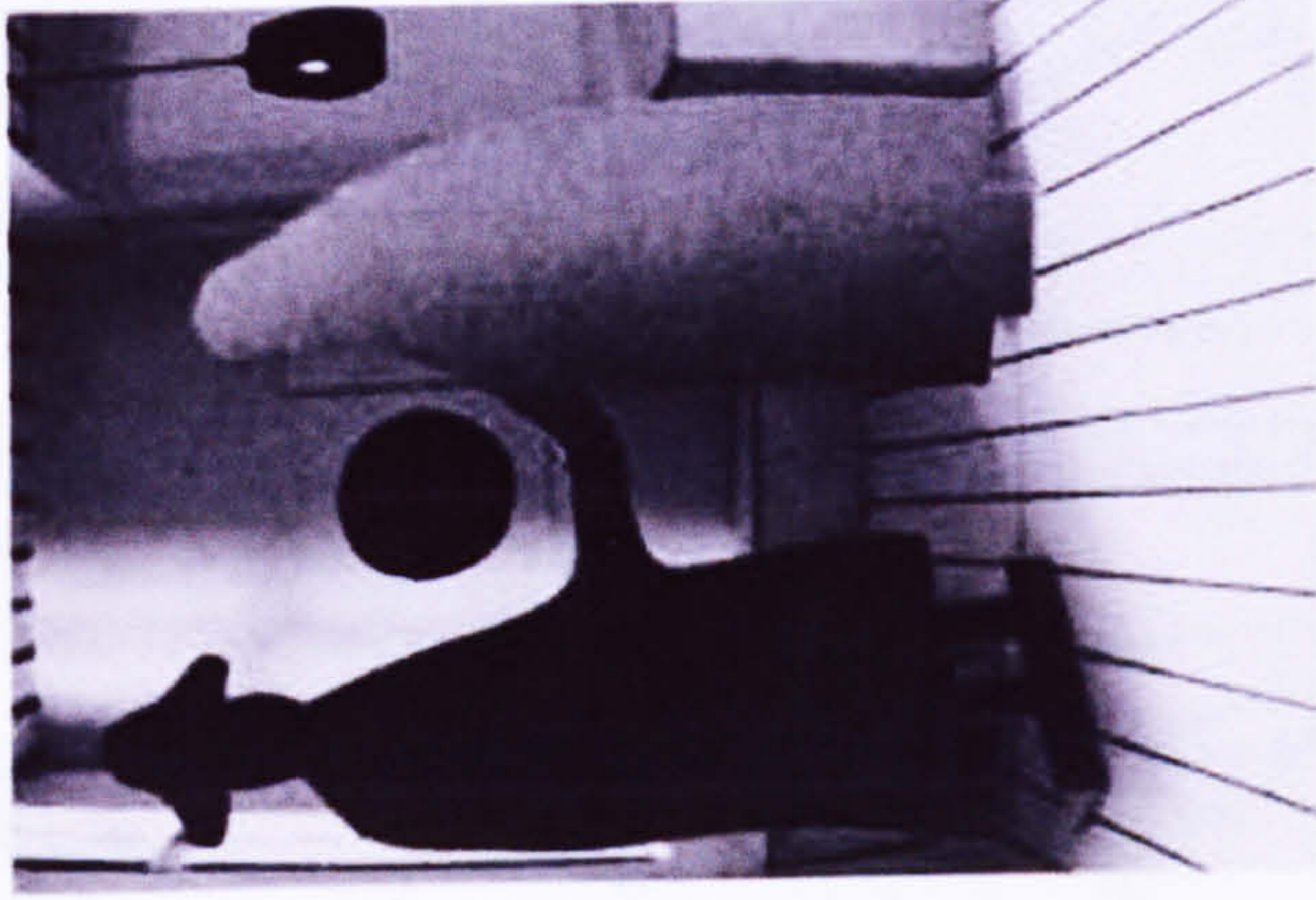

Fig 2.6 - Marica working in her studio,
Boccaccio, *Des Cleres et Nobles Femmes*, c.1475.
Lord Mostyn Sale, Sotheby's, 13.7.1920.

Fig 2.7 - David Carleton's photographs showing his model of the *Arnolfini Double Portrait* reflected in a convex mirror.



2.7 (1)



2.7 (2)



2.7 (3)

Fig 2.8 - Perspective reconstructions by David Carleton of seven Eyckian paintings.

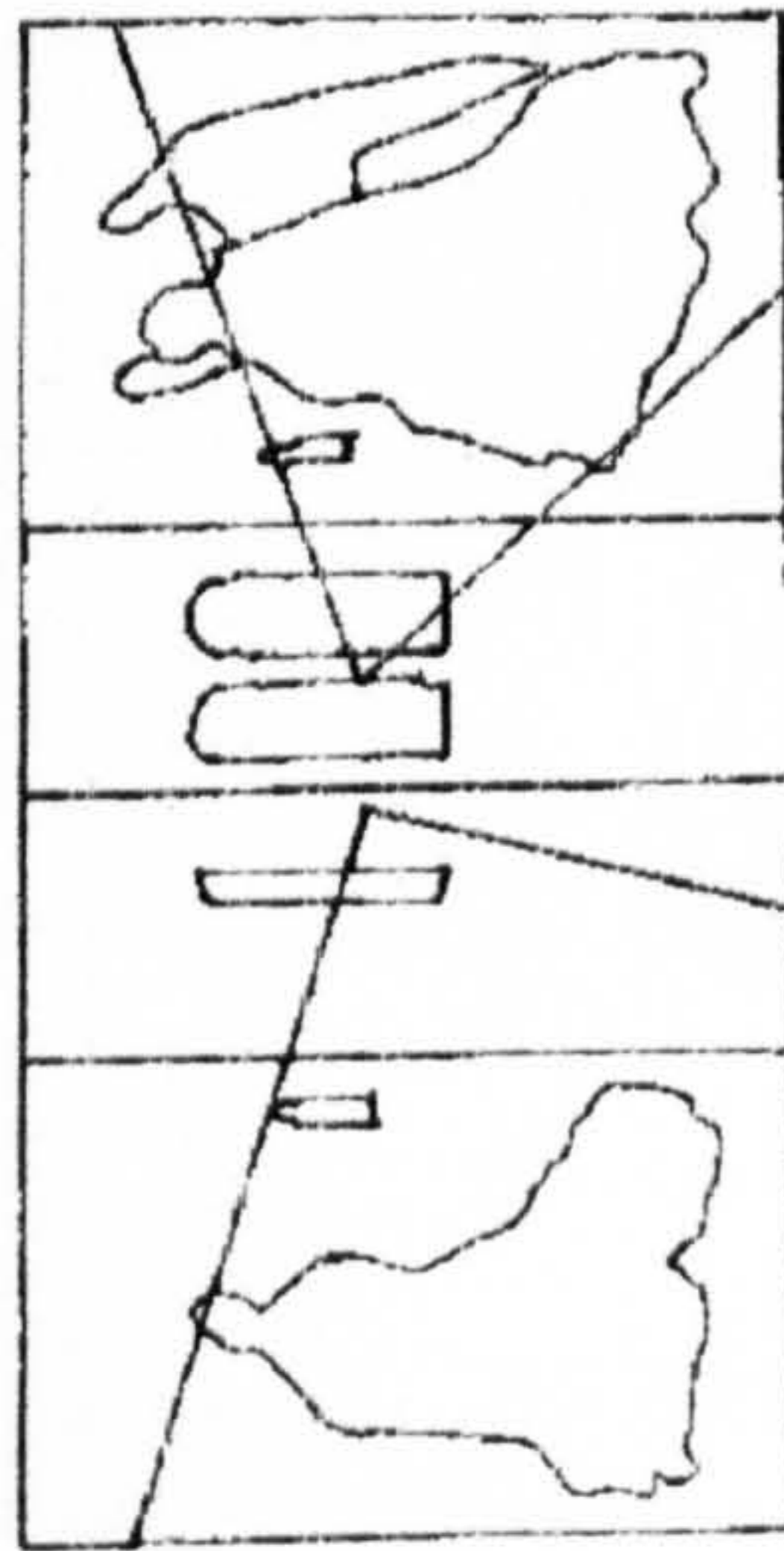

2 Annunciation, Ghent Altarpiece, perspective drawing

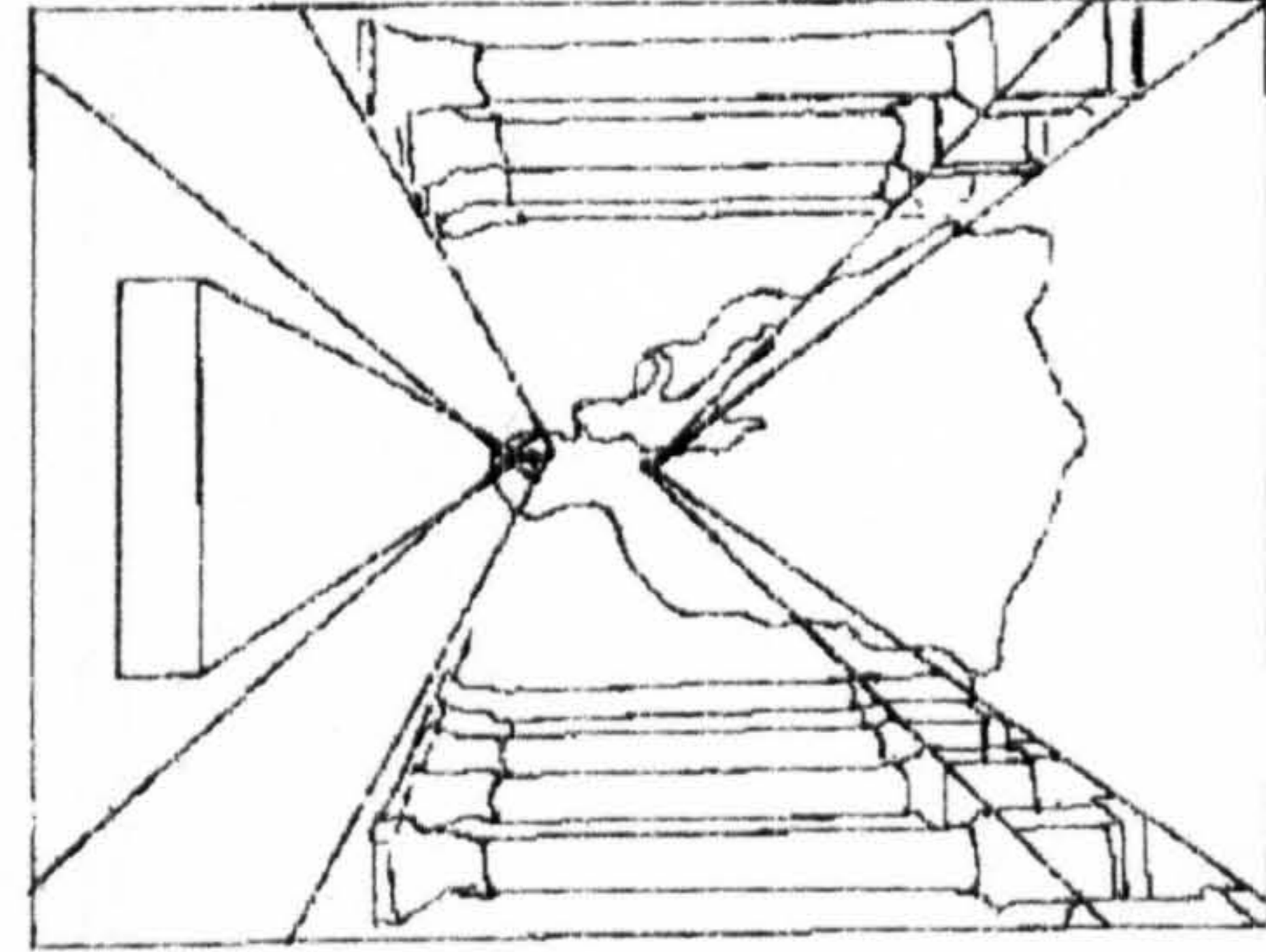

3 Dresden Triptych, perspective drawing

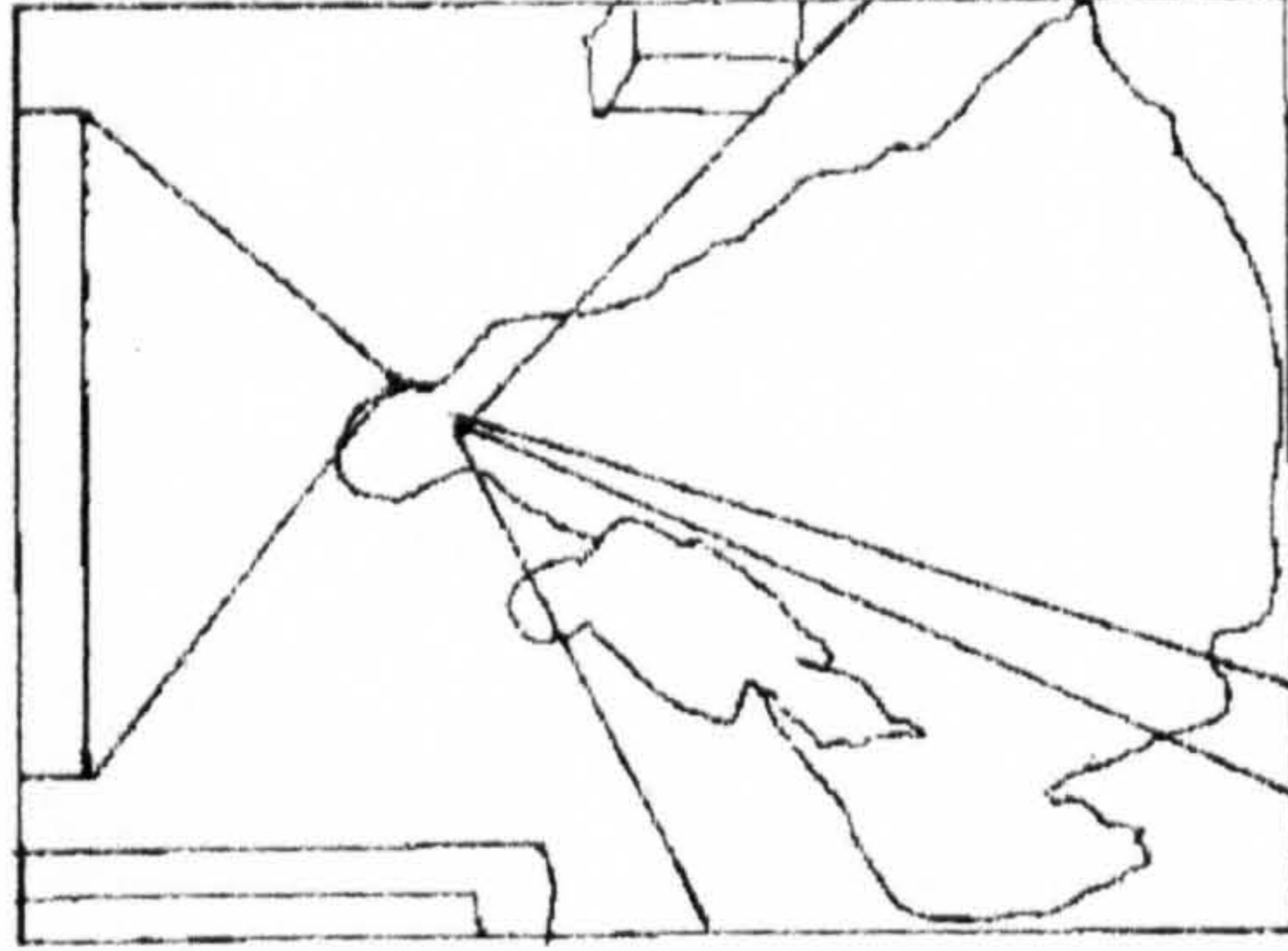

4 Ince Hall Madonna, perspective drawing

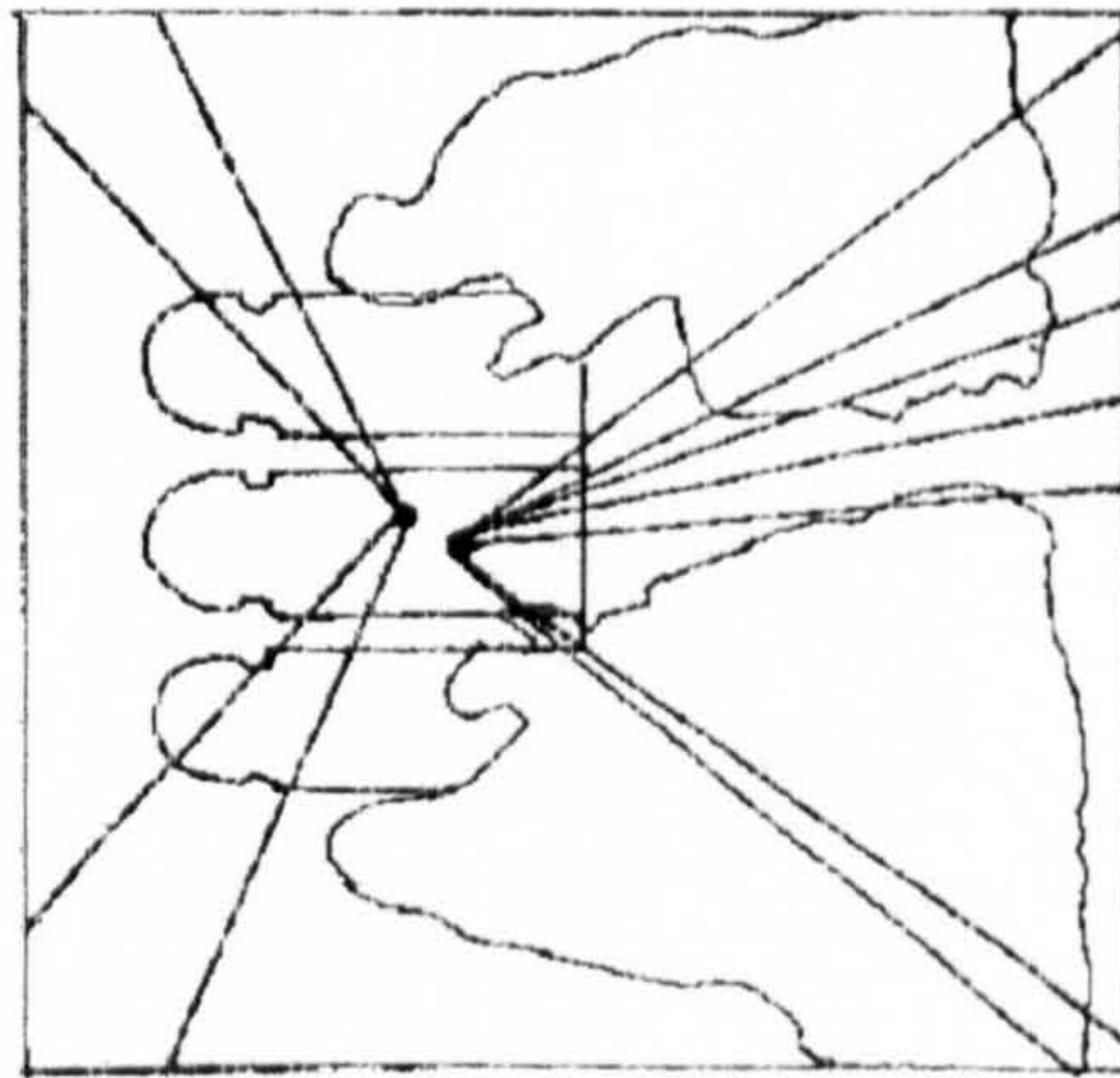

5 Madonna of Chancellor Rolin, perspective drawing

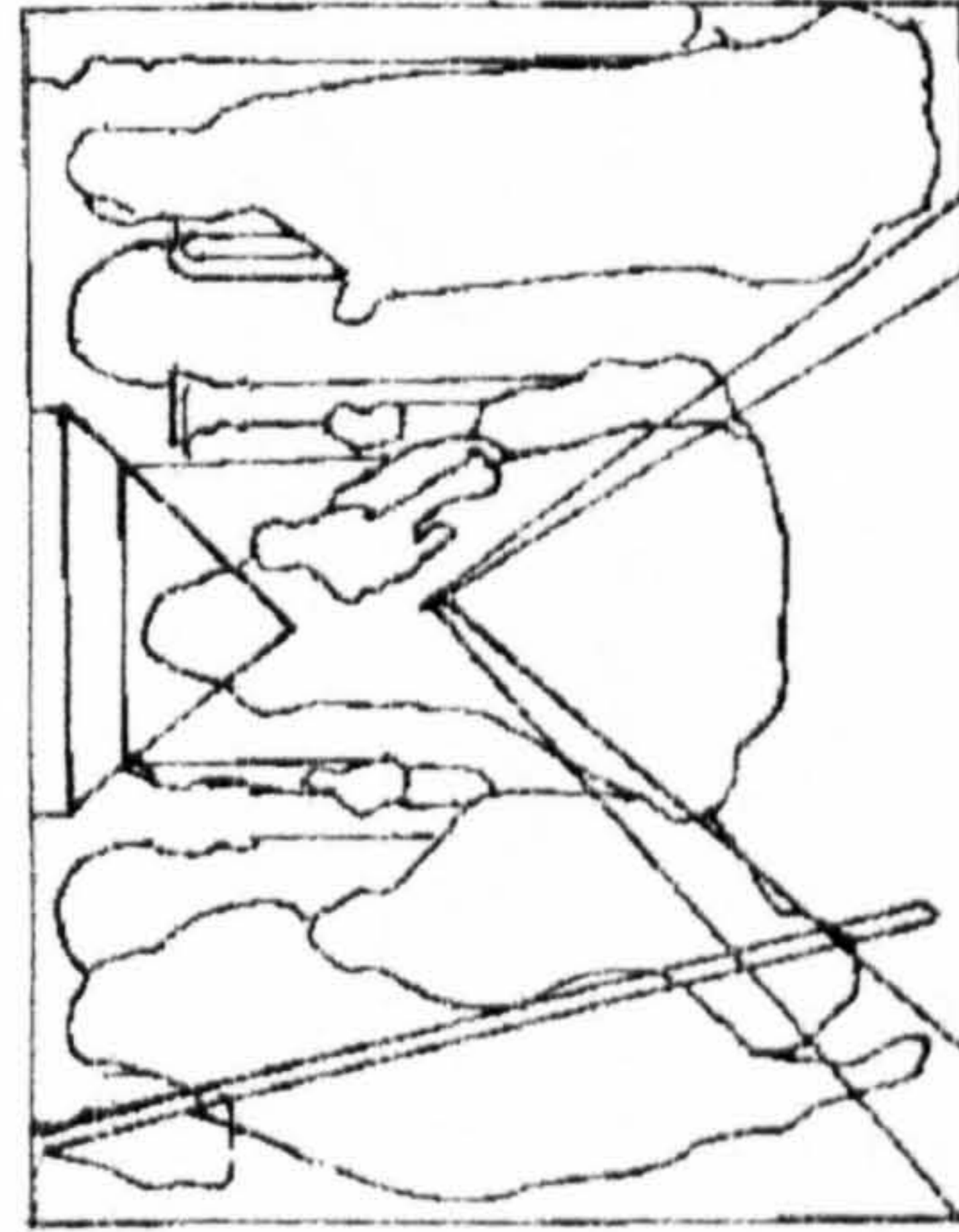

6 Madonna of Canon van der Paele, perspective drawing

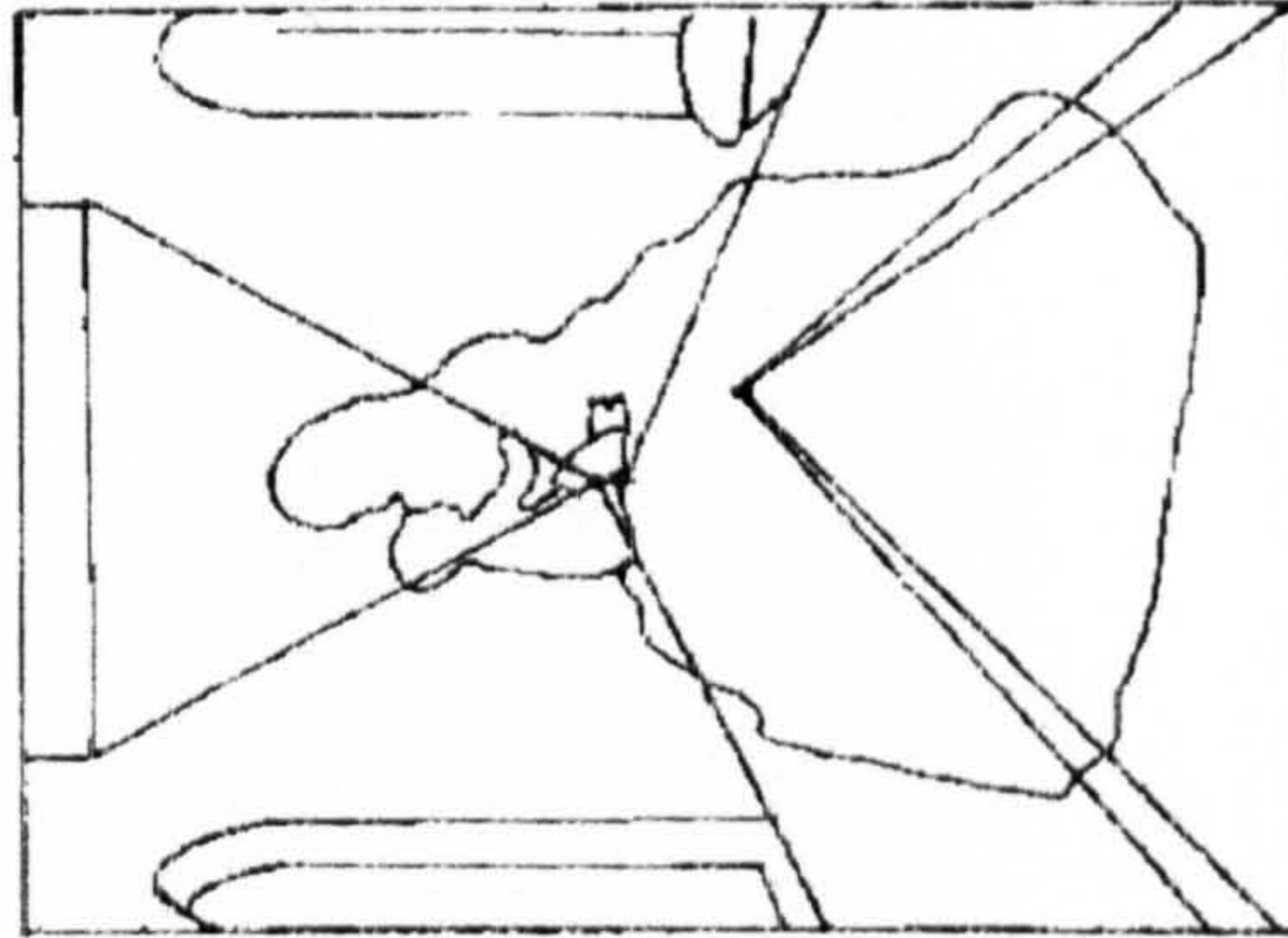

7 Lucca Madonna, perspective drawing

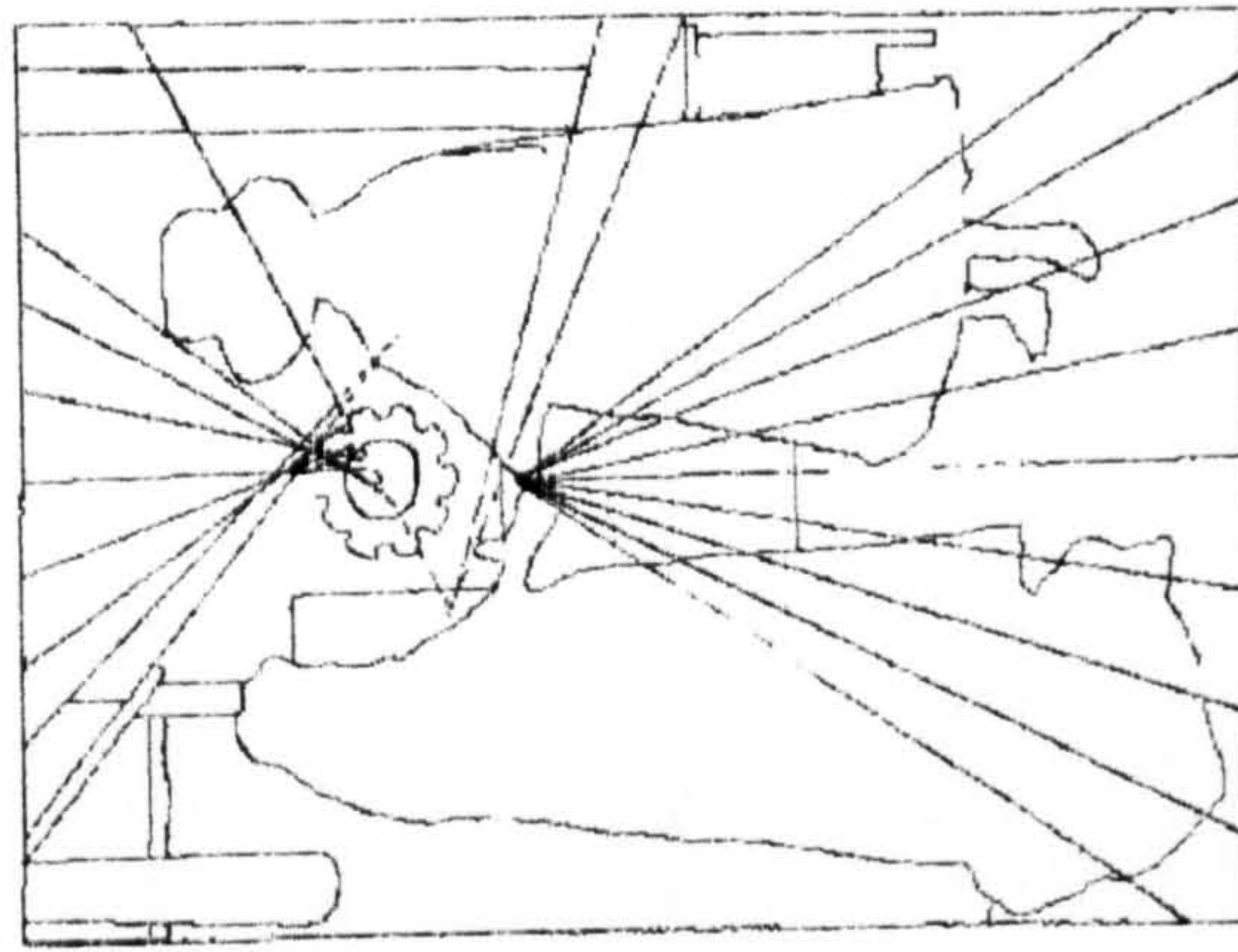

8 Jan van Eyck, Arnolfini Portrait, perspective drawing

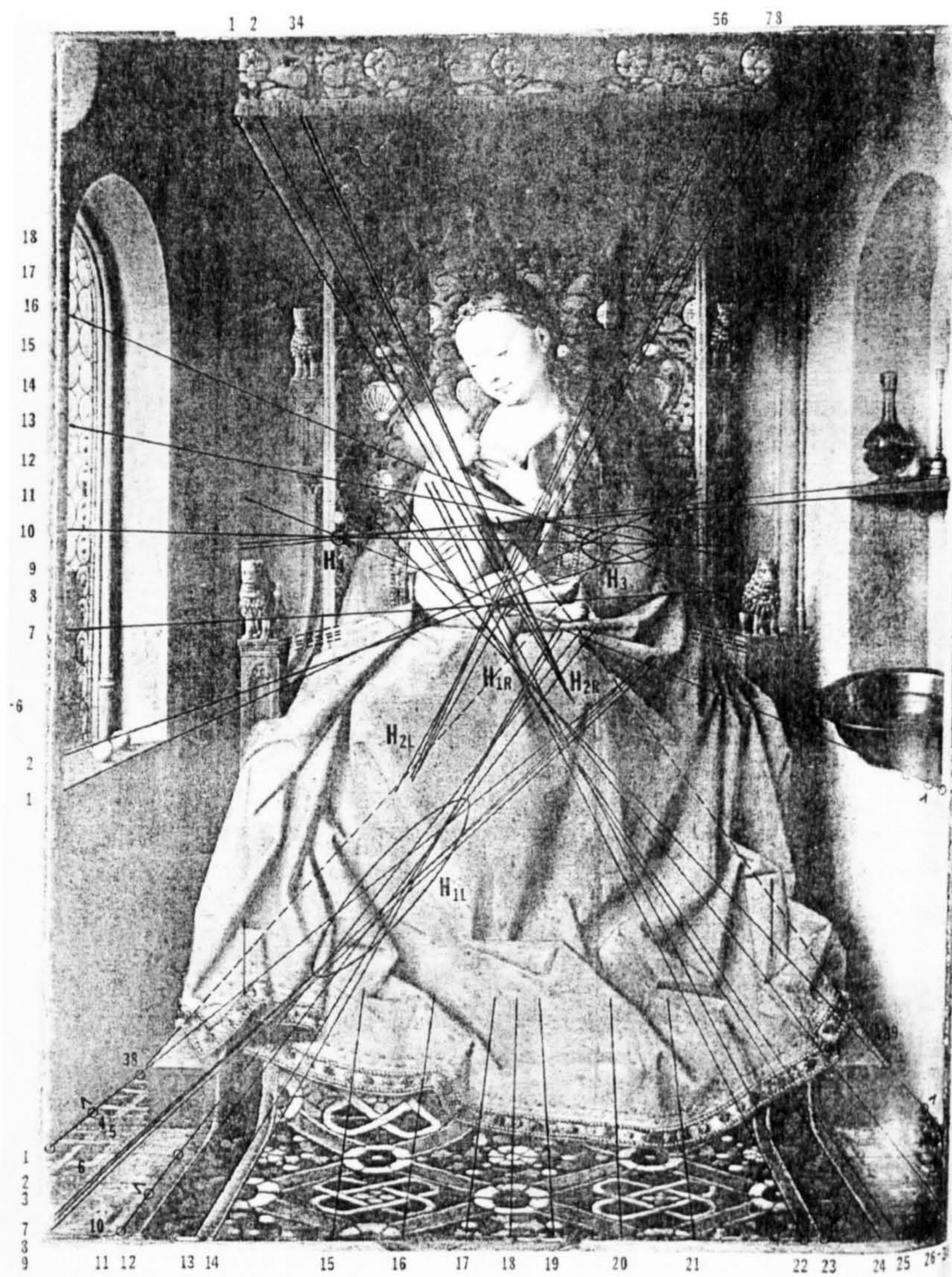

Fig 2.9 - Perspective Reconstruction of Jan van Eyck's *Lucca Madonna* by James Elkins.



Fig 2.10 - Jan van Eyck, *Virgin and Child with the Chancellor Nicolas Rolin*, c.1435-36. 66.0 x 62.0 cm. Musée du Louvre, Paris.

Fig 2.11 - Perspective analysis of the Rolin Virgin.

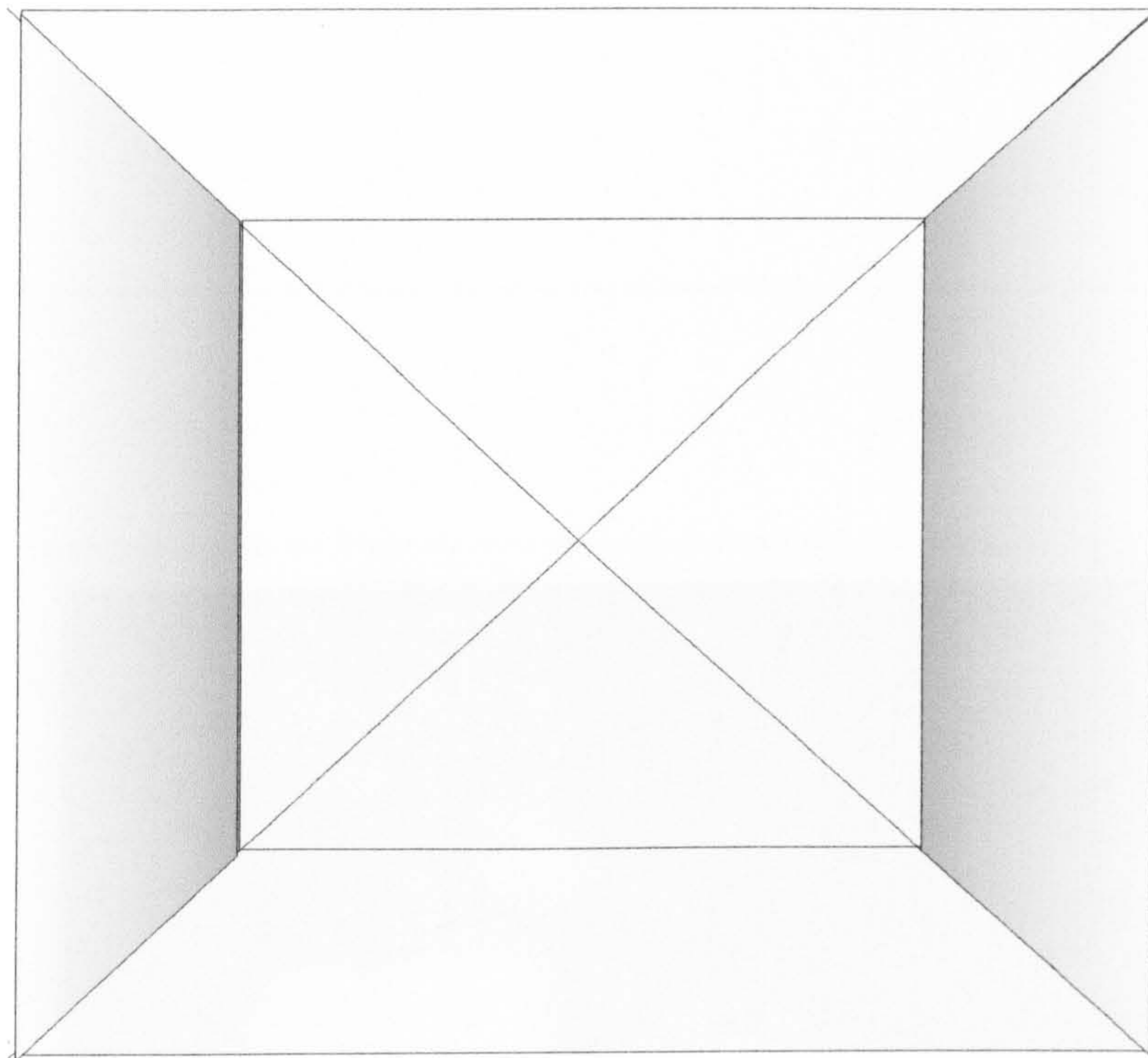

Fig 2.11 - Perspective analysis, *Rolin Virgin*.

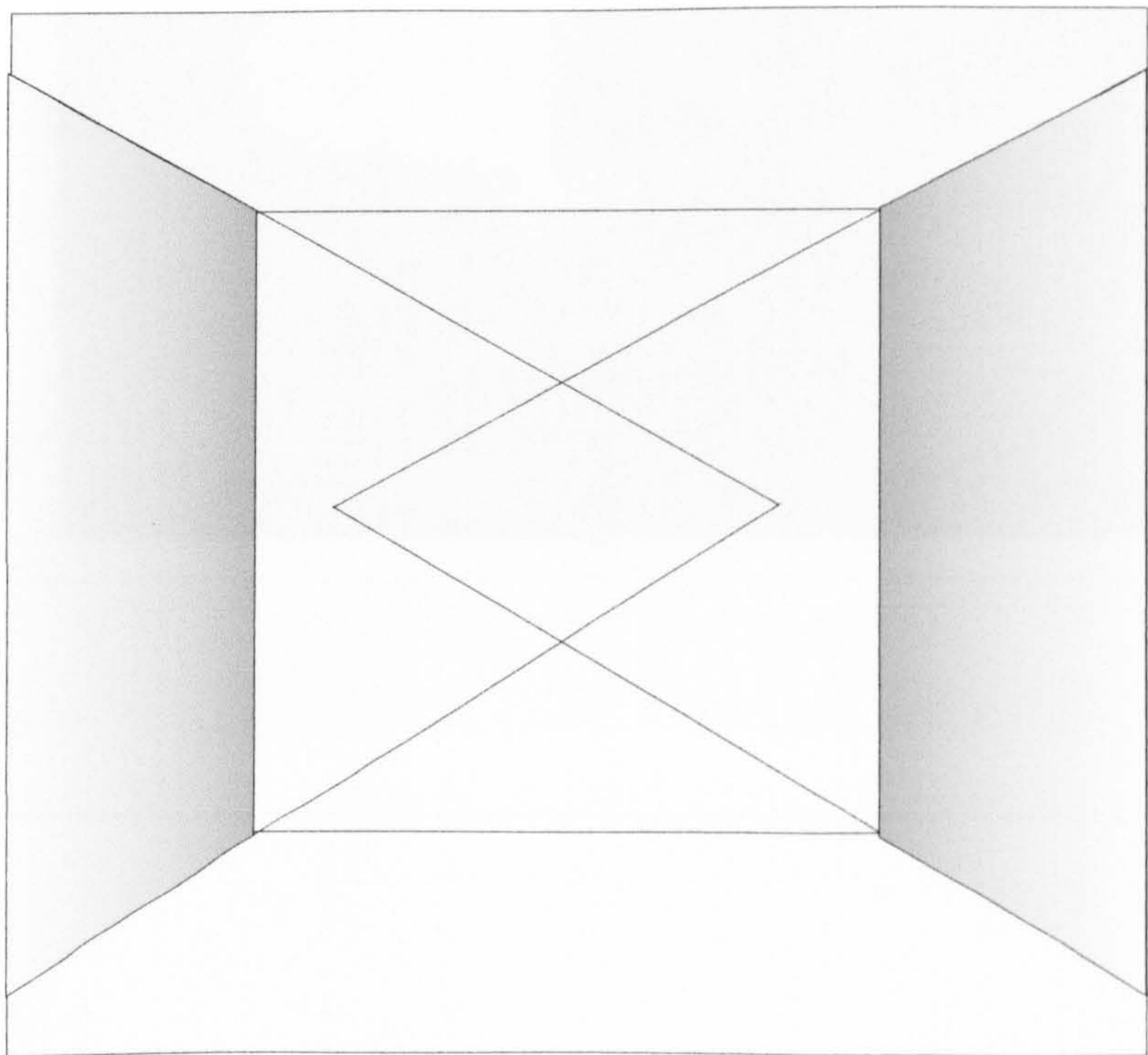

Fig 2.12 - Primary orthogonals of side arcades, *Rolin Virgin*.

Fig 2.13



2.13 (1) - Properties of a single-point construction.



2.13 (2) - Properties of an image with overlapping 'vanishing points'.



Fig 2.14 - 'Correct' position of side columns relative to floor tiles, *Robin Virgin*.

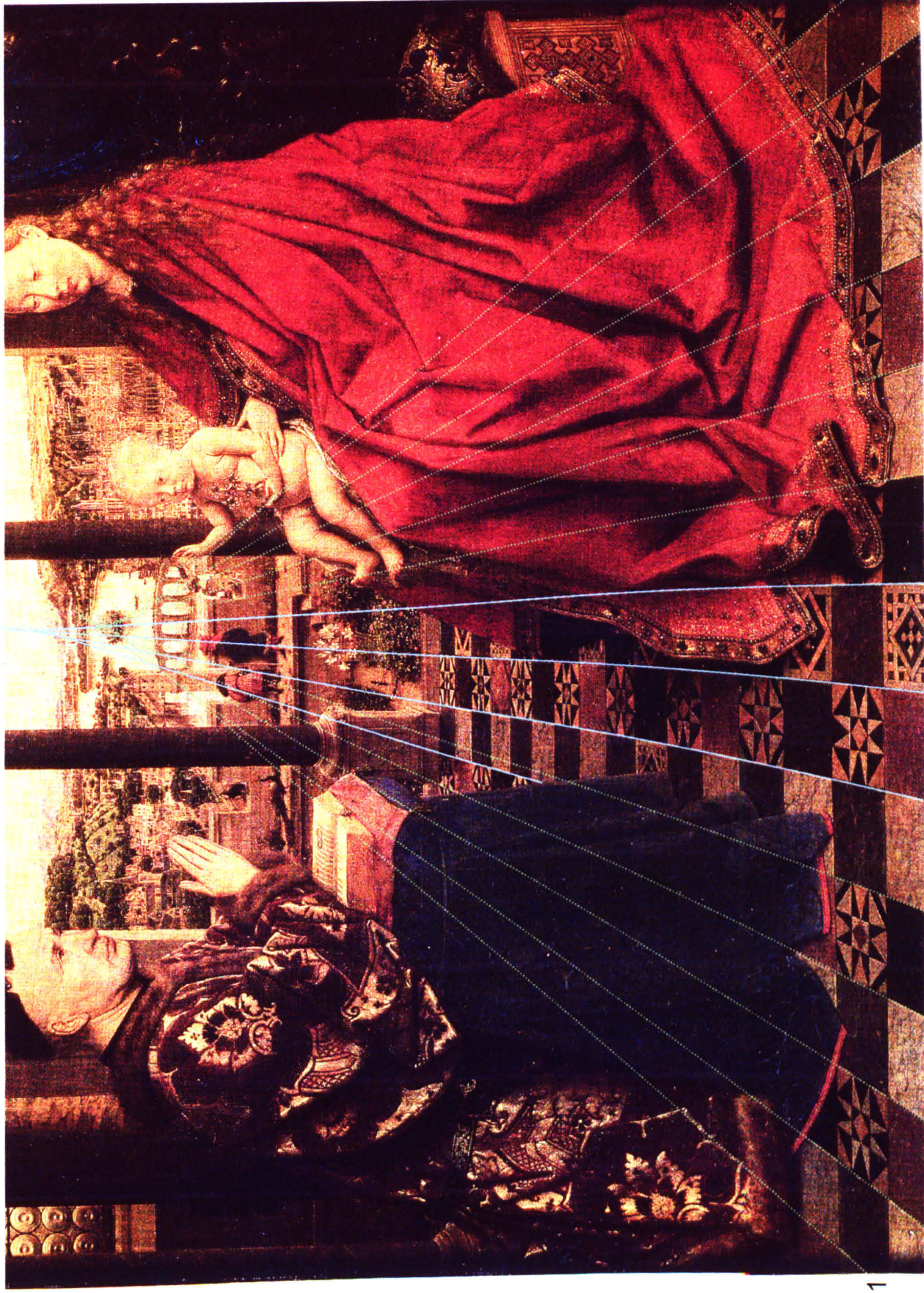

Fig 2.15 - Convergence of orthogonals on back wall, *Rolin Virgin*.



Fig 2.16 - Implied position of edges shared by side walls and floor plane, *Rolin Virgin*.

Fig 2.17 - Convergence of orthogonals on floor plane, *Rolin Virgin*.



F14

F13

F12

F11

F10

F9

F8

F7

F6

F5

F4

F3

F2

F1

Fig 2.18 - Scale model of *Rolin Virgin* photographed with standard and wide-angle lenses.



2.18 (1) - Wide-angle (28mm) lens.

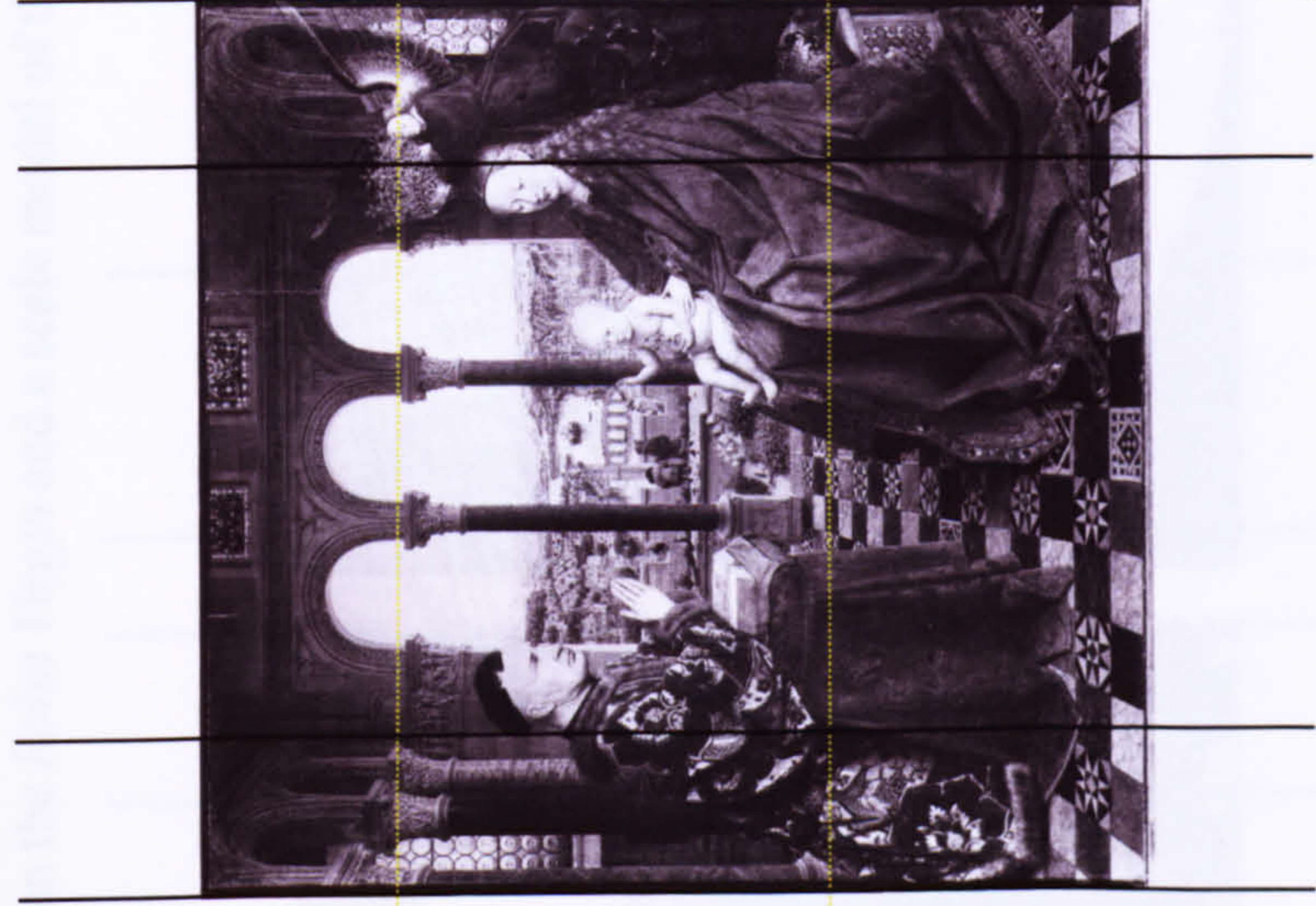

2.18 (2)

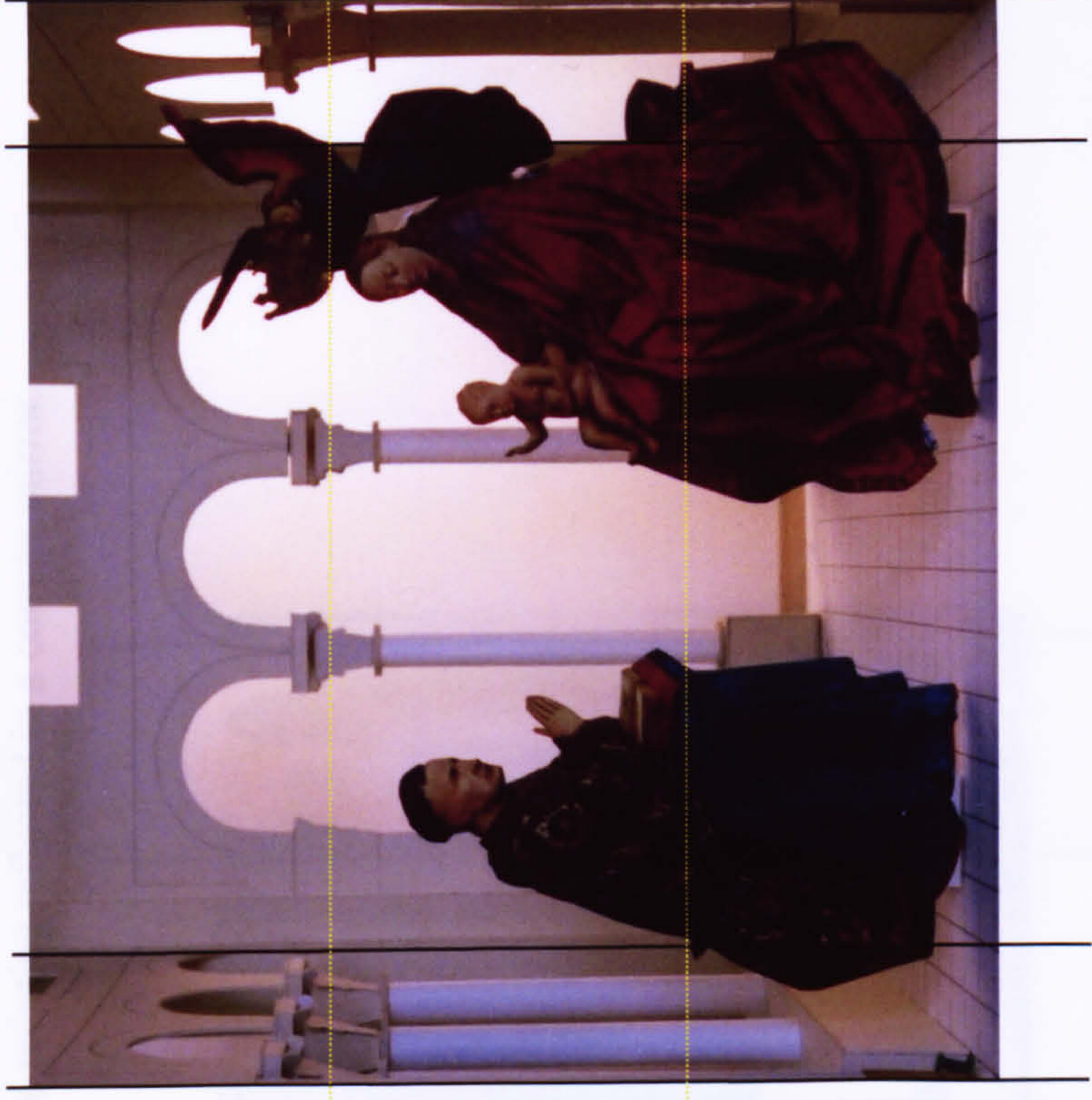

2.18 (3) - Standard (50mm) lens.

Fig 2.19 - Comparison between the *Rolin Virgin* and a scale model of the painting reflected in a convex mirror.

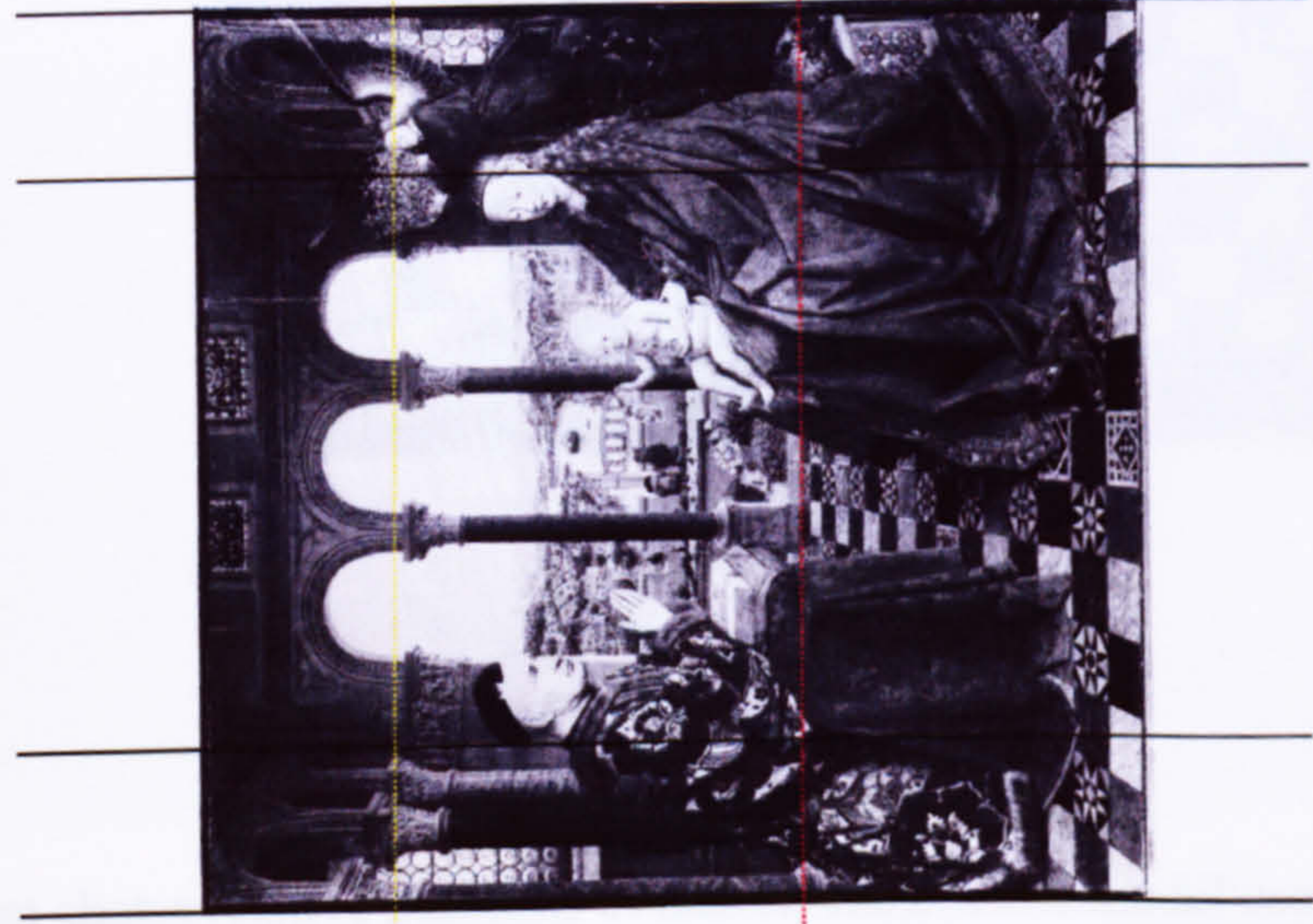

2.19 (1).

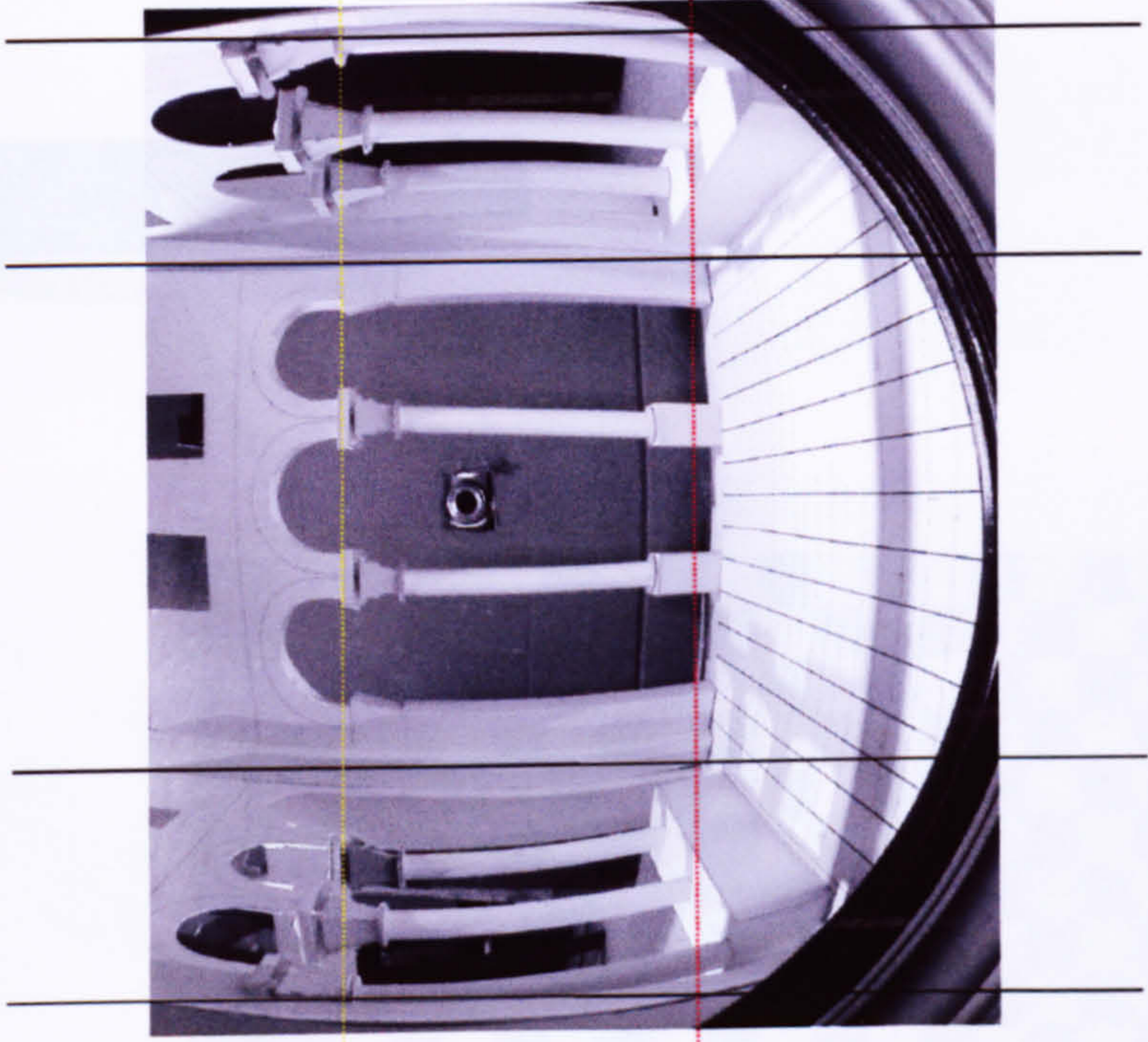

2.19 (2).

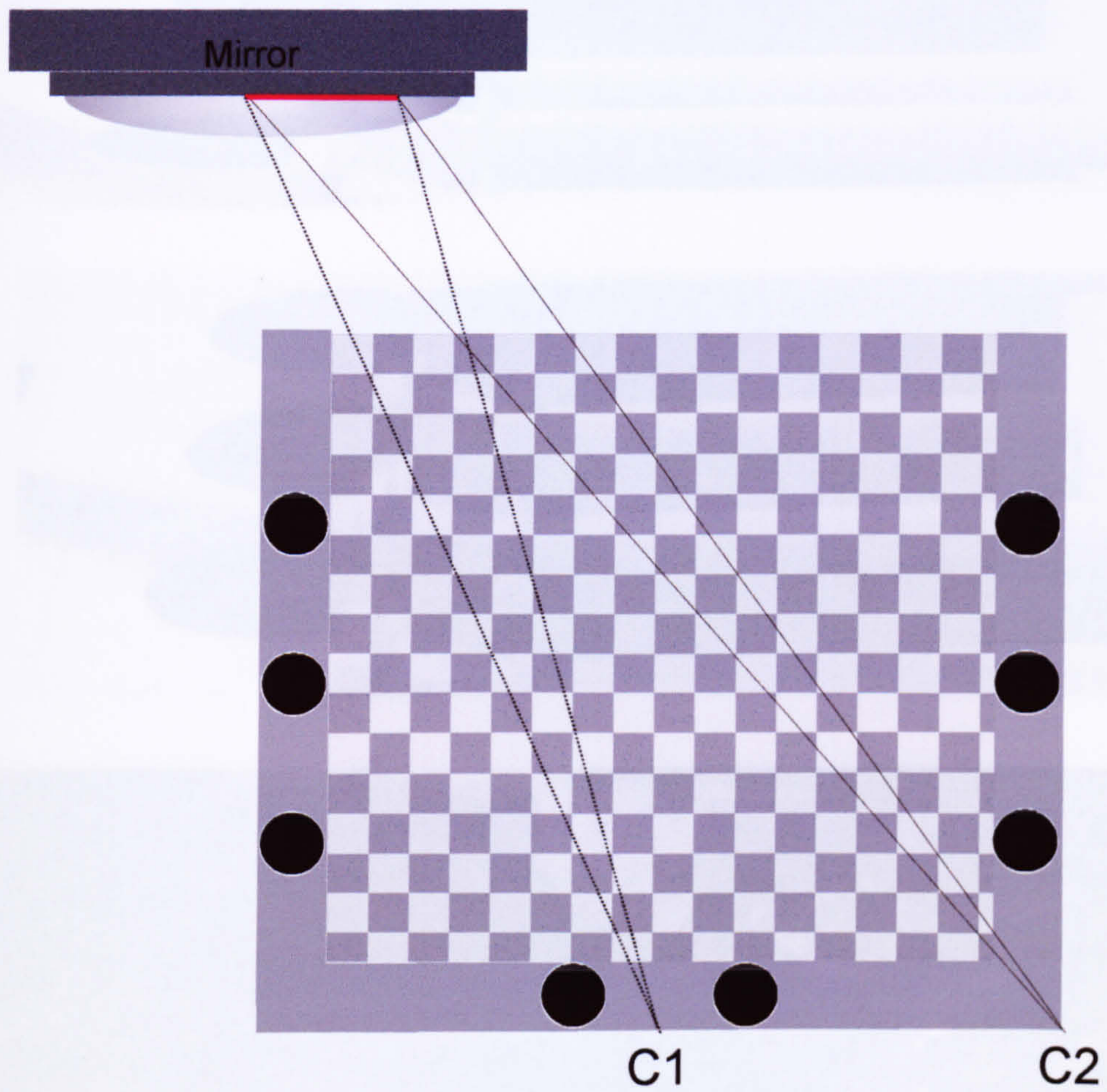
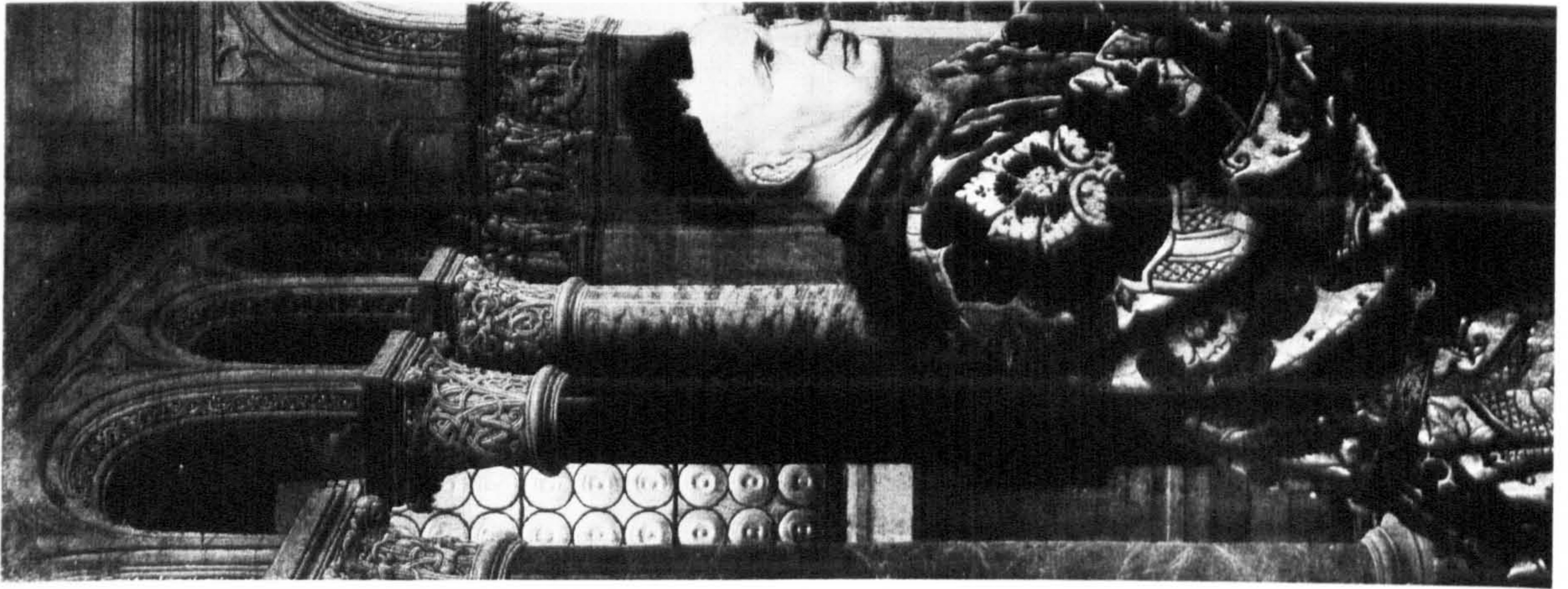
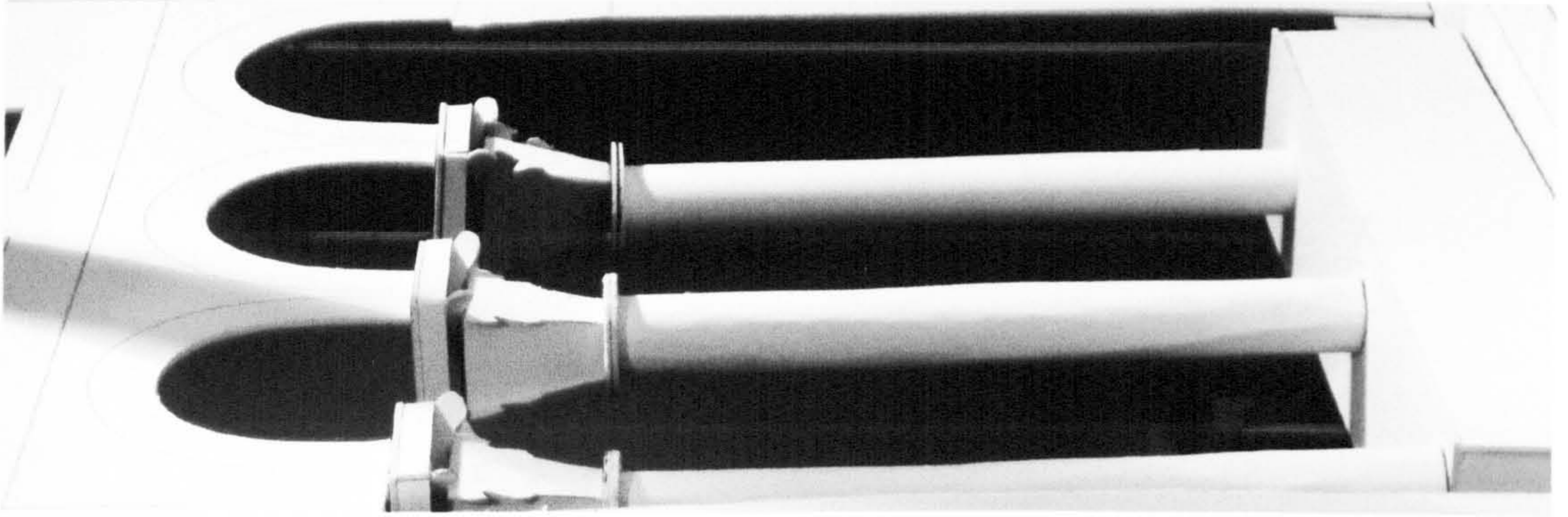

Fig 2.20 - Diagram shows relative positions of mirror, camera and model used in the demonstration.

Fig 2.21



2.21 (1)



2.21 (2) - Plane mirror,
50mm lens point C2

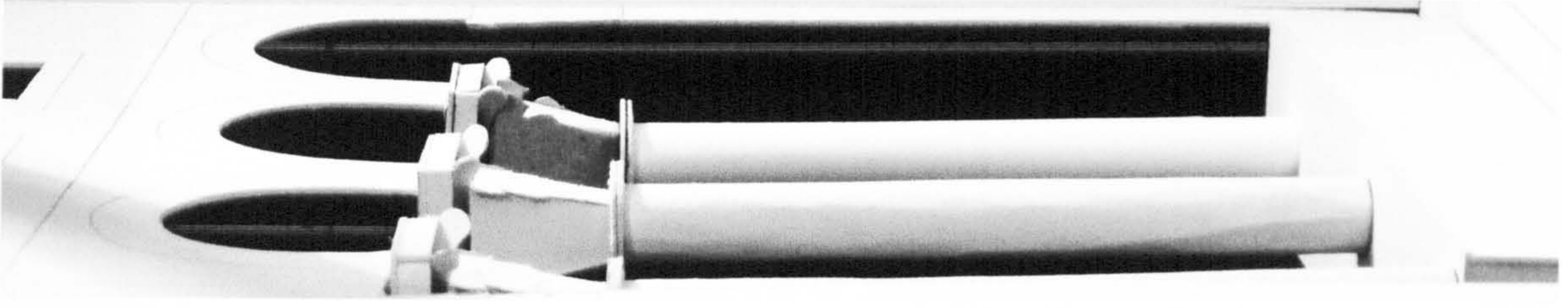

2.21 (3) - Plane mirror,
50mm lens point C1

Fig 2.22

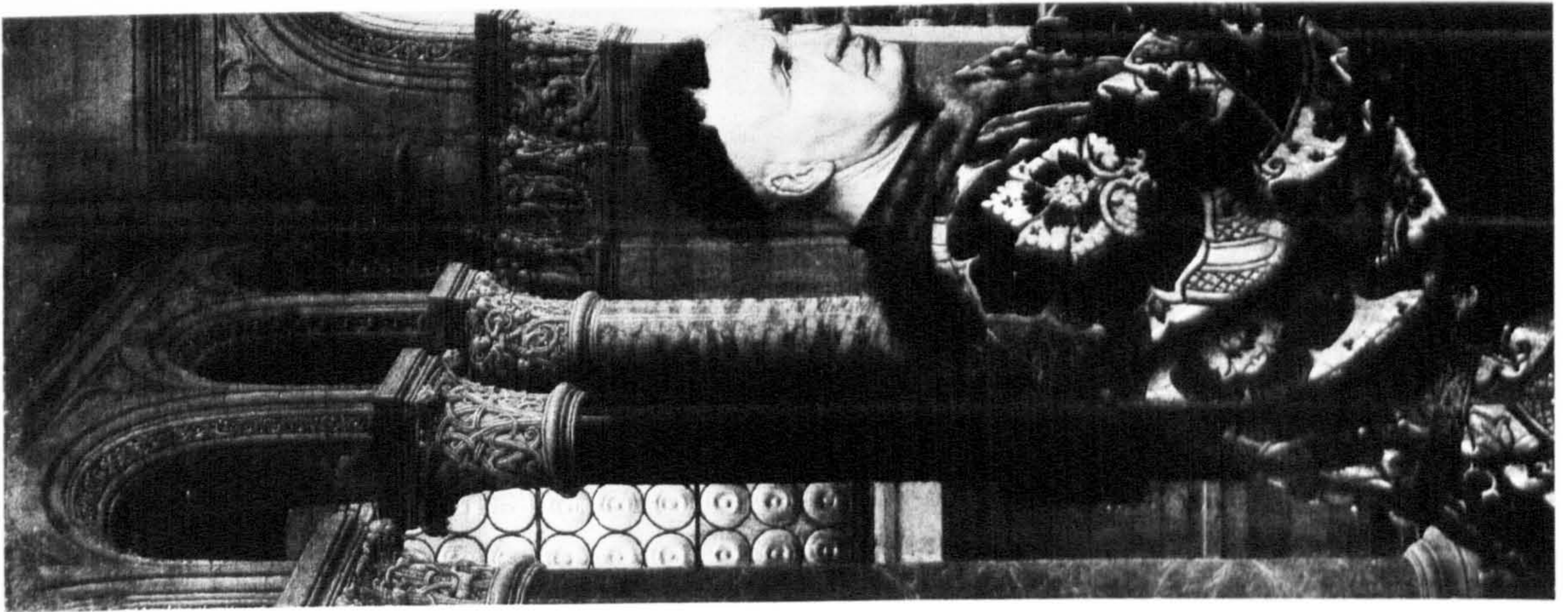

2.22 (1)

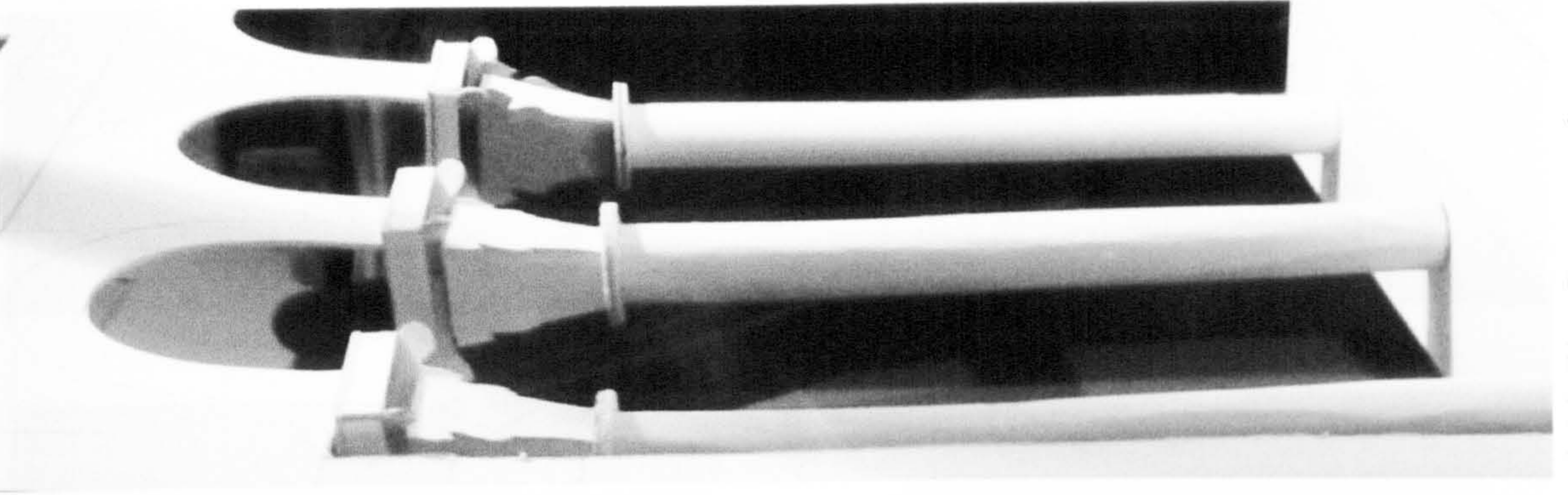

2.22 (2) - Convex mirror,
50mm lens, point C2.

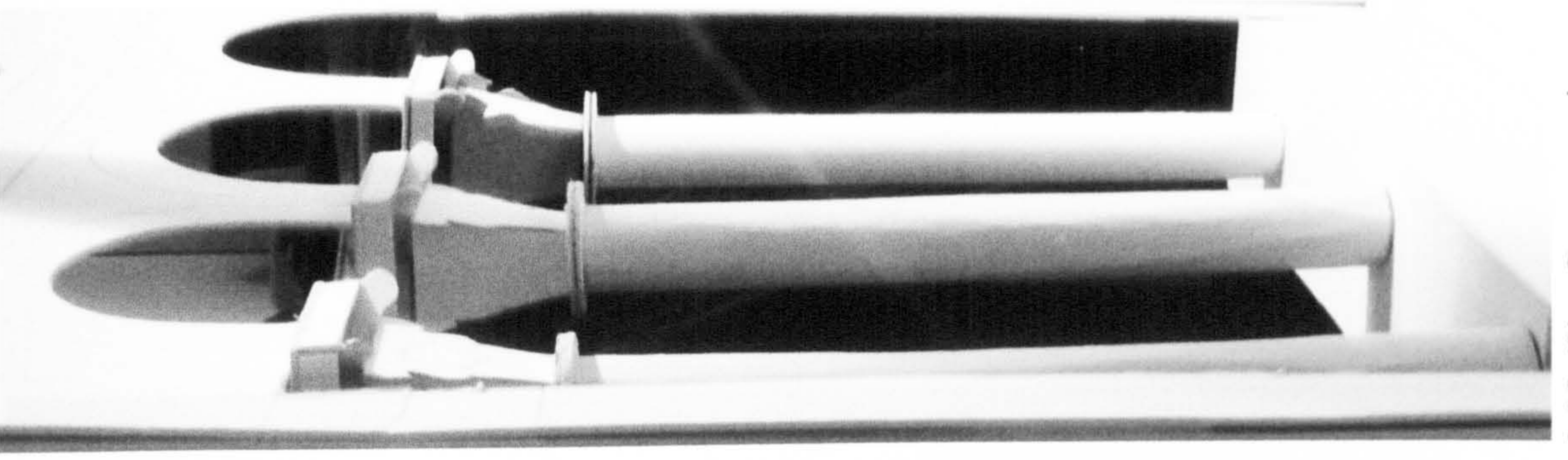

2.22 (3) - Convex mirror,
50mm lens, point C1

Fig 2.23

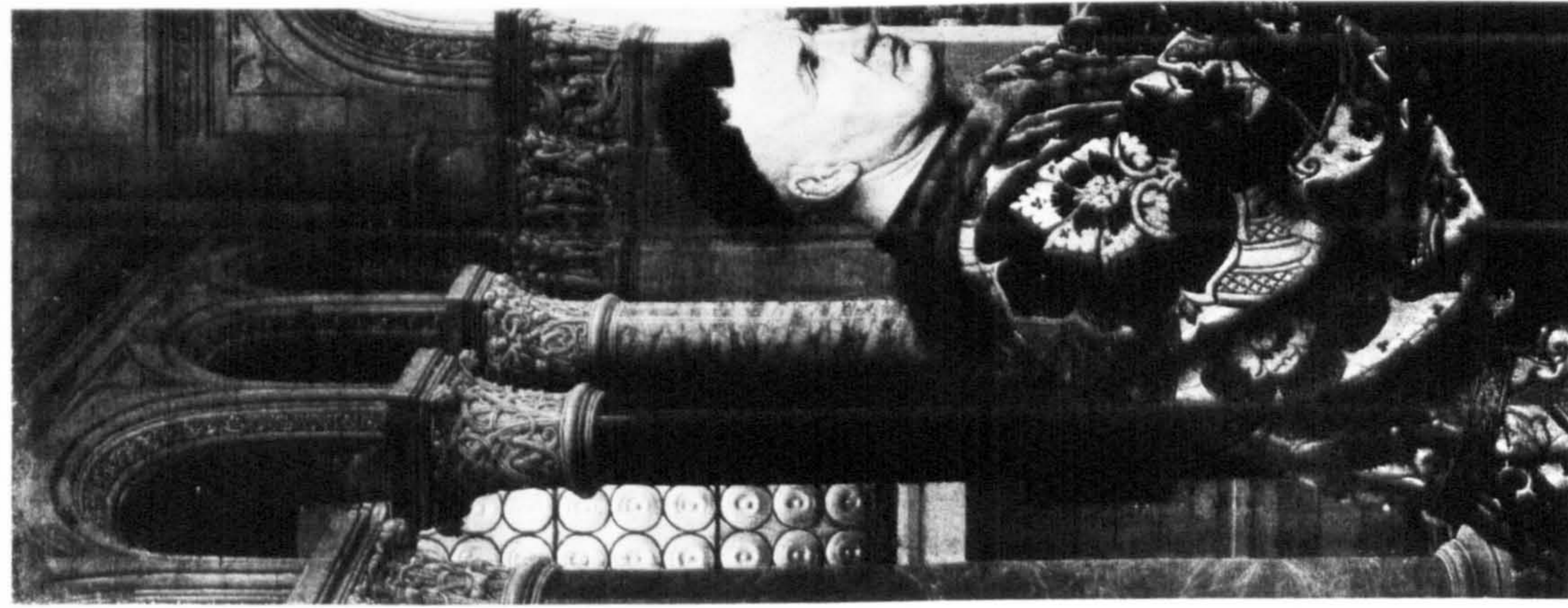

2.23 (1)

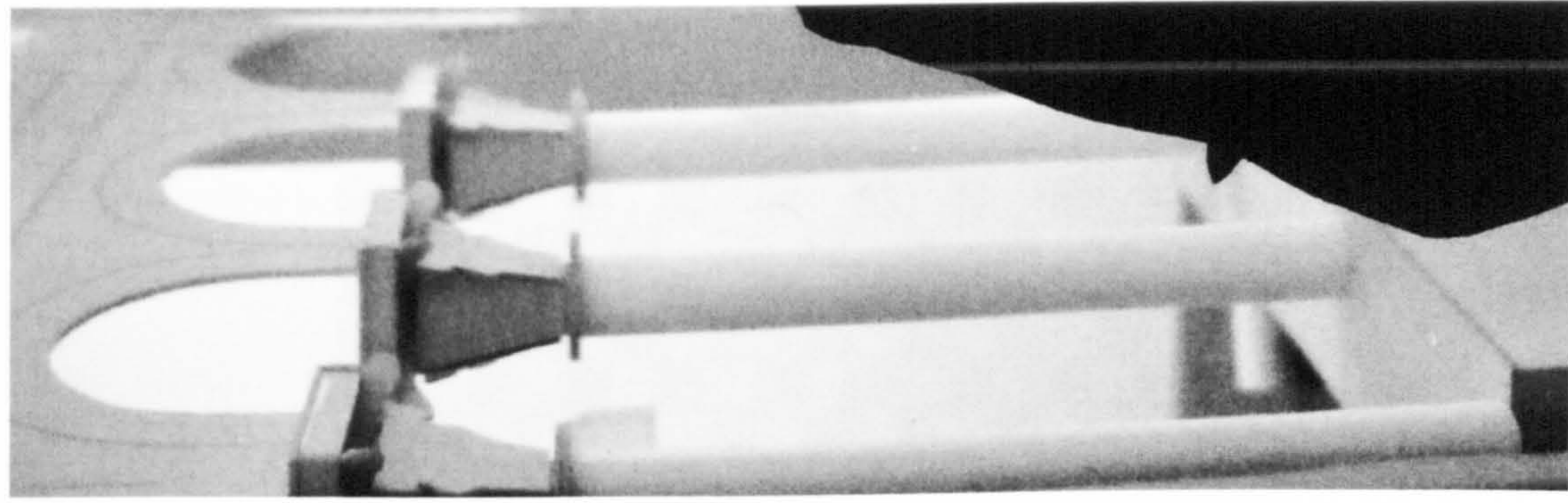

2.23 (2) - 28mm lens,
point C3

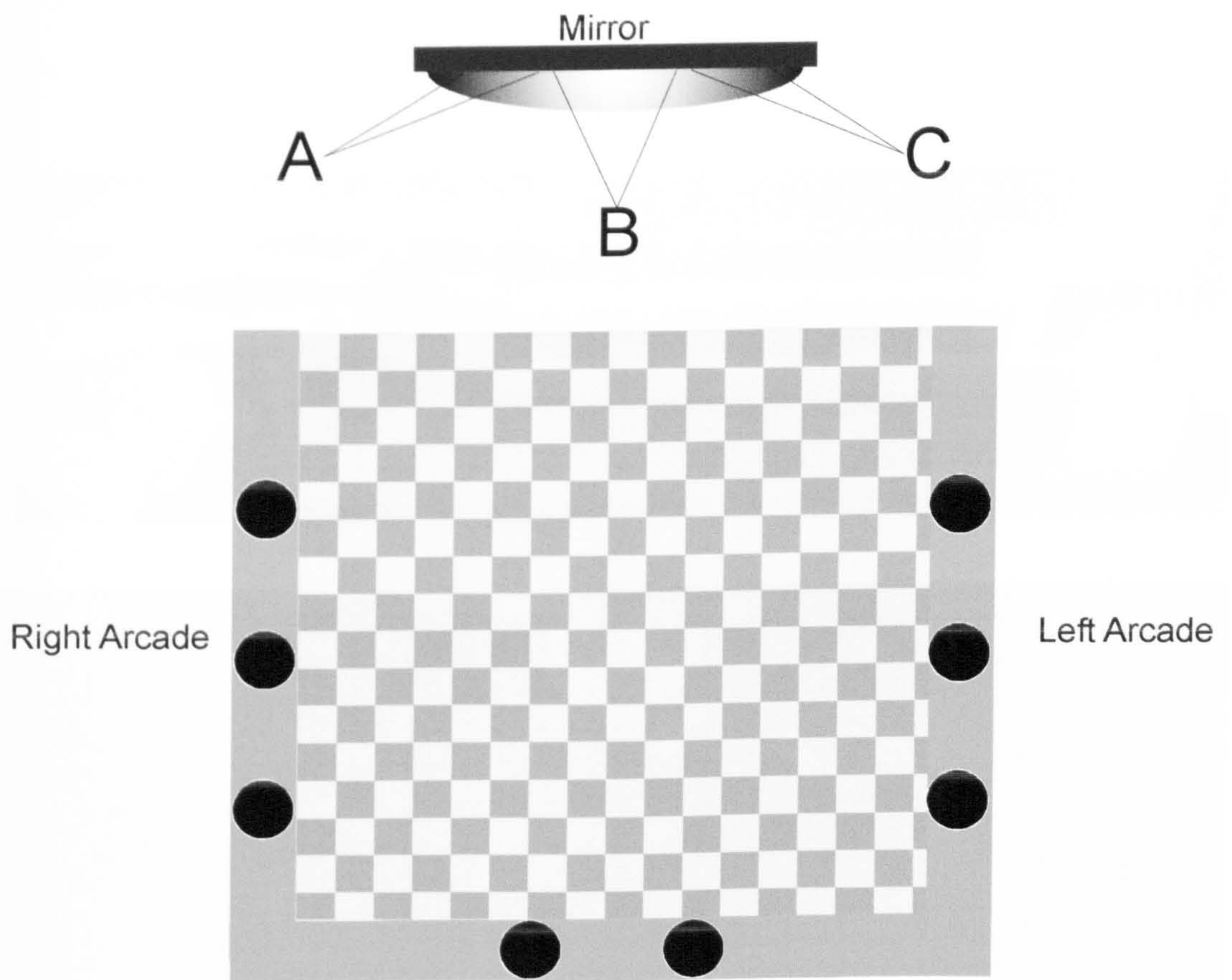
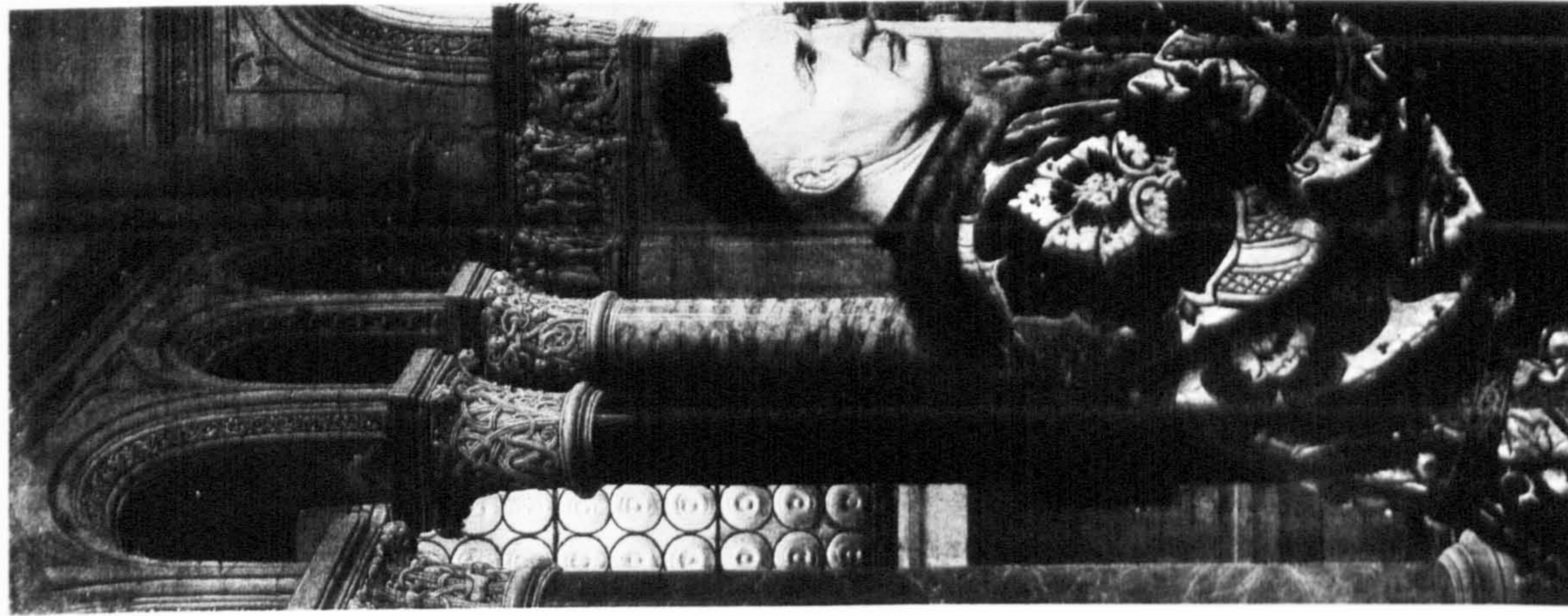
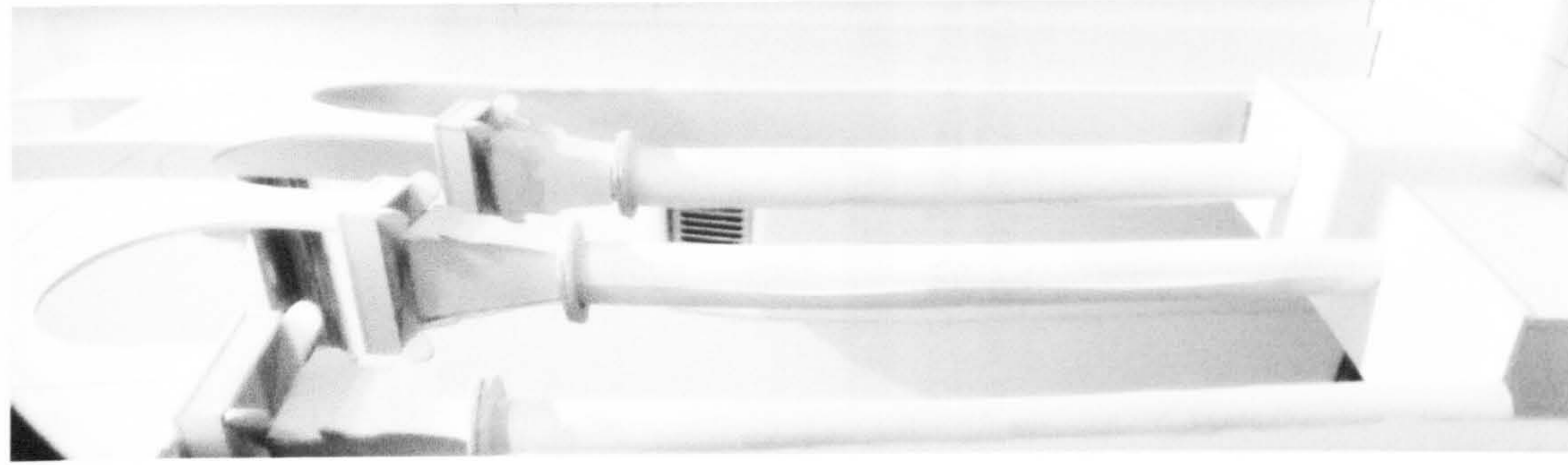

Fig 2.24 - Diagram shows three alternative positions (A, B and C) for viewing the reflection of the model.

Fig 2.25



2.25 (1)



2.25 (2) - Convex mirror, point C

Fig 2.26

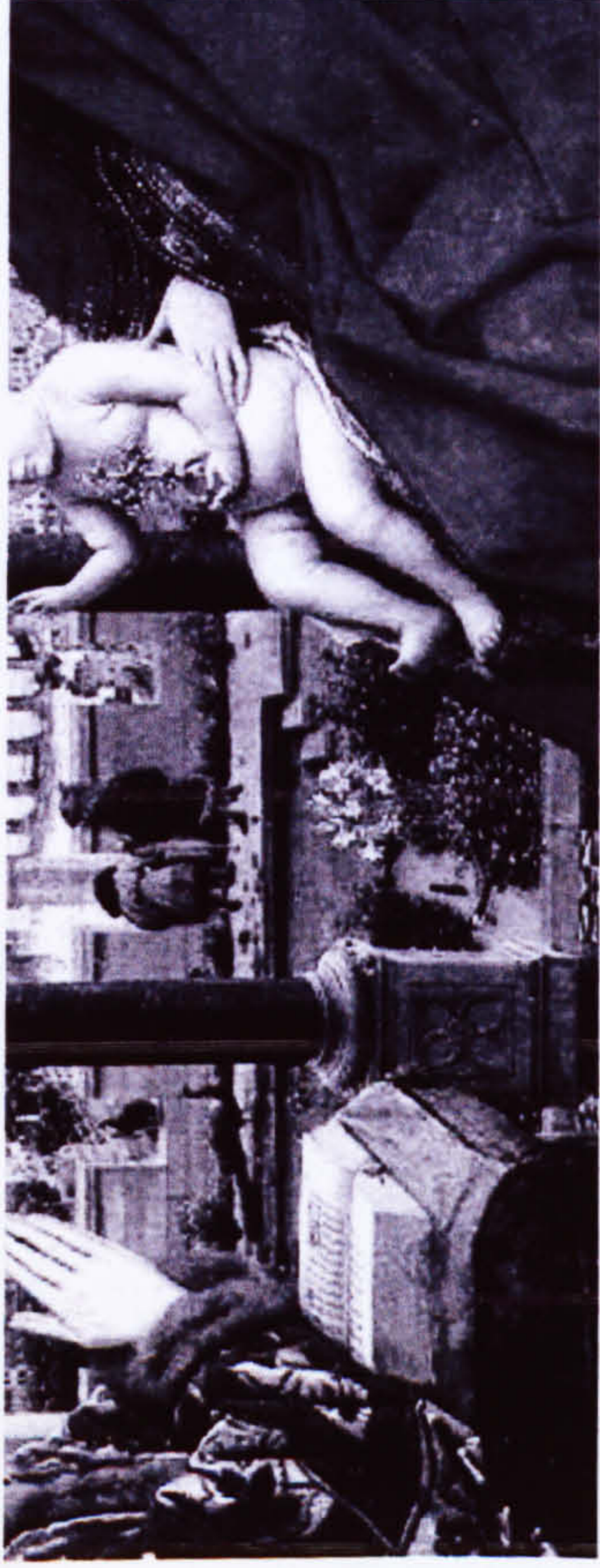

2.26 (1)

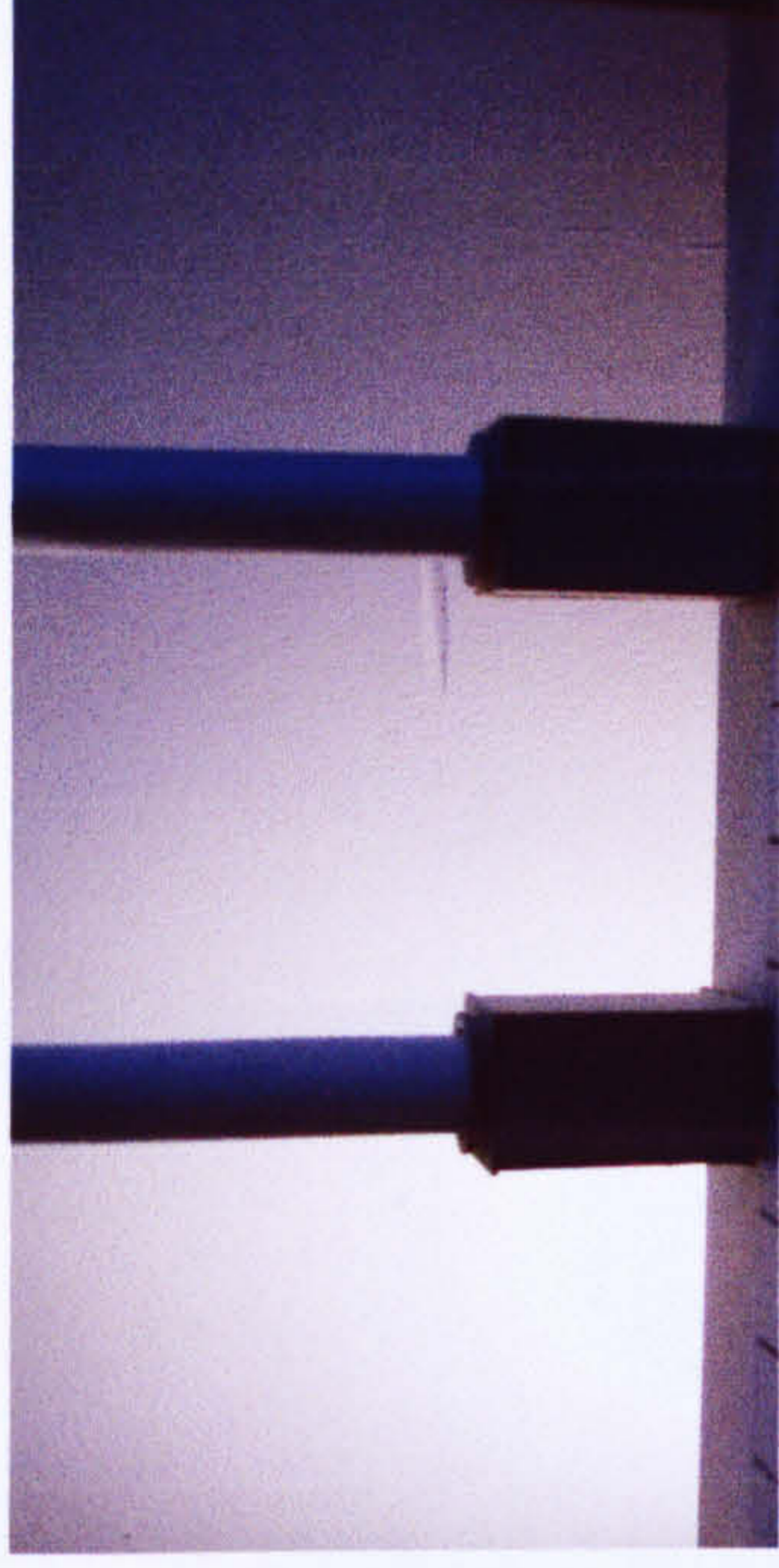

2.26 (2) - Pedestal bases of model taken with a wide-angle (28mm) lens.

Fig 2.27

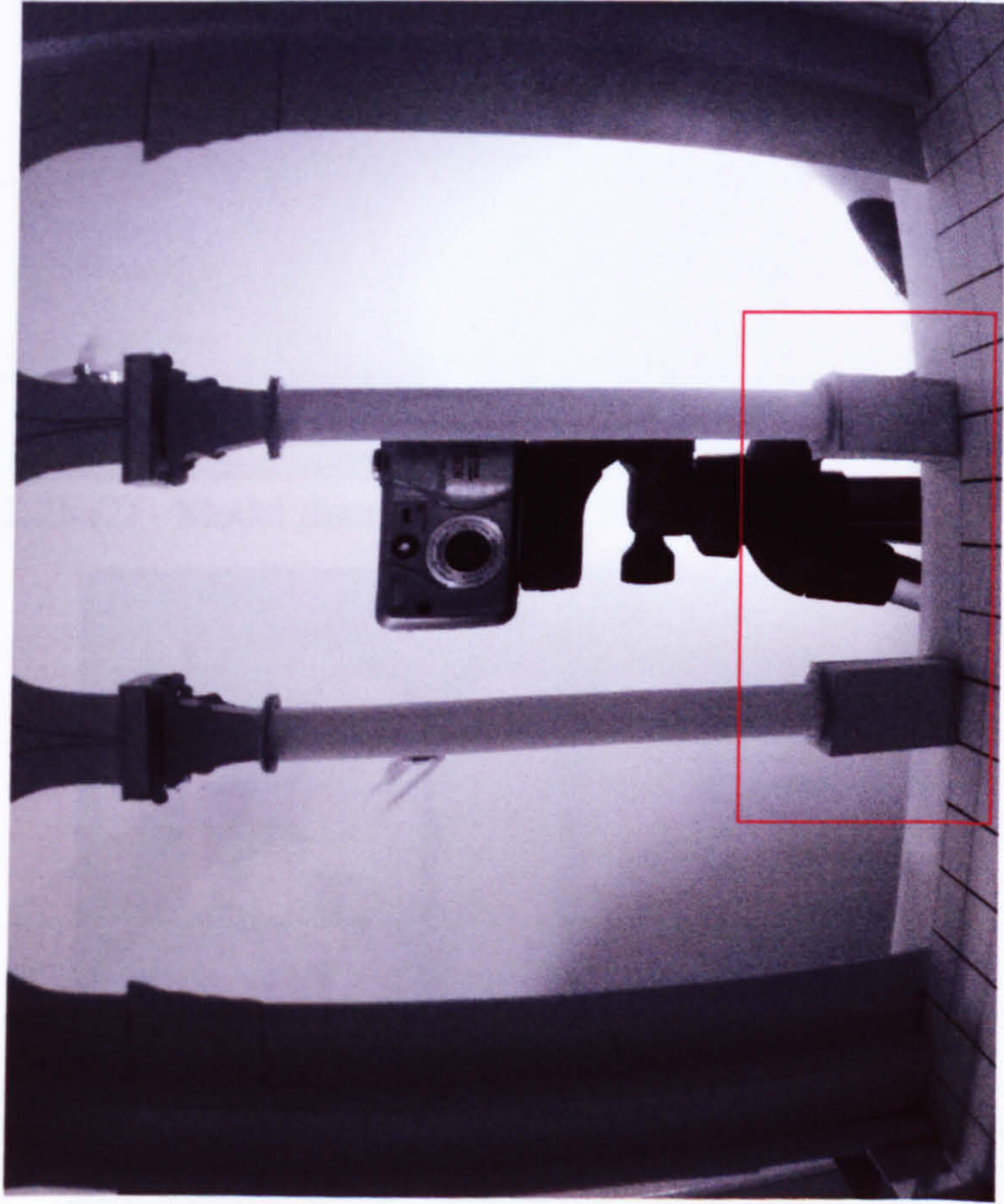

2.27 (1) - Convex mirror

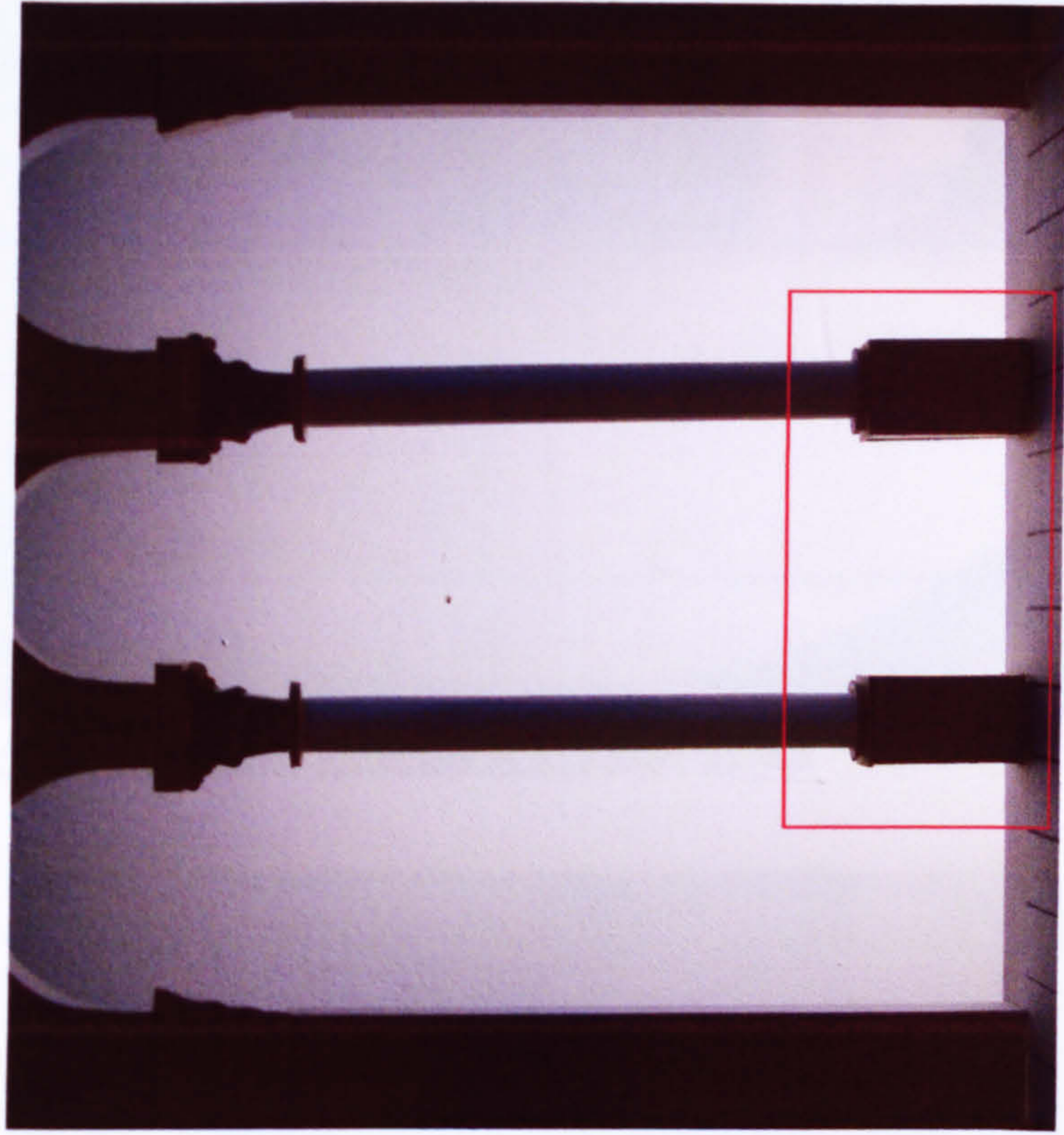

2.27 (2) - 50mm lens

Fig 2.28

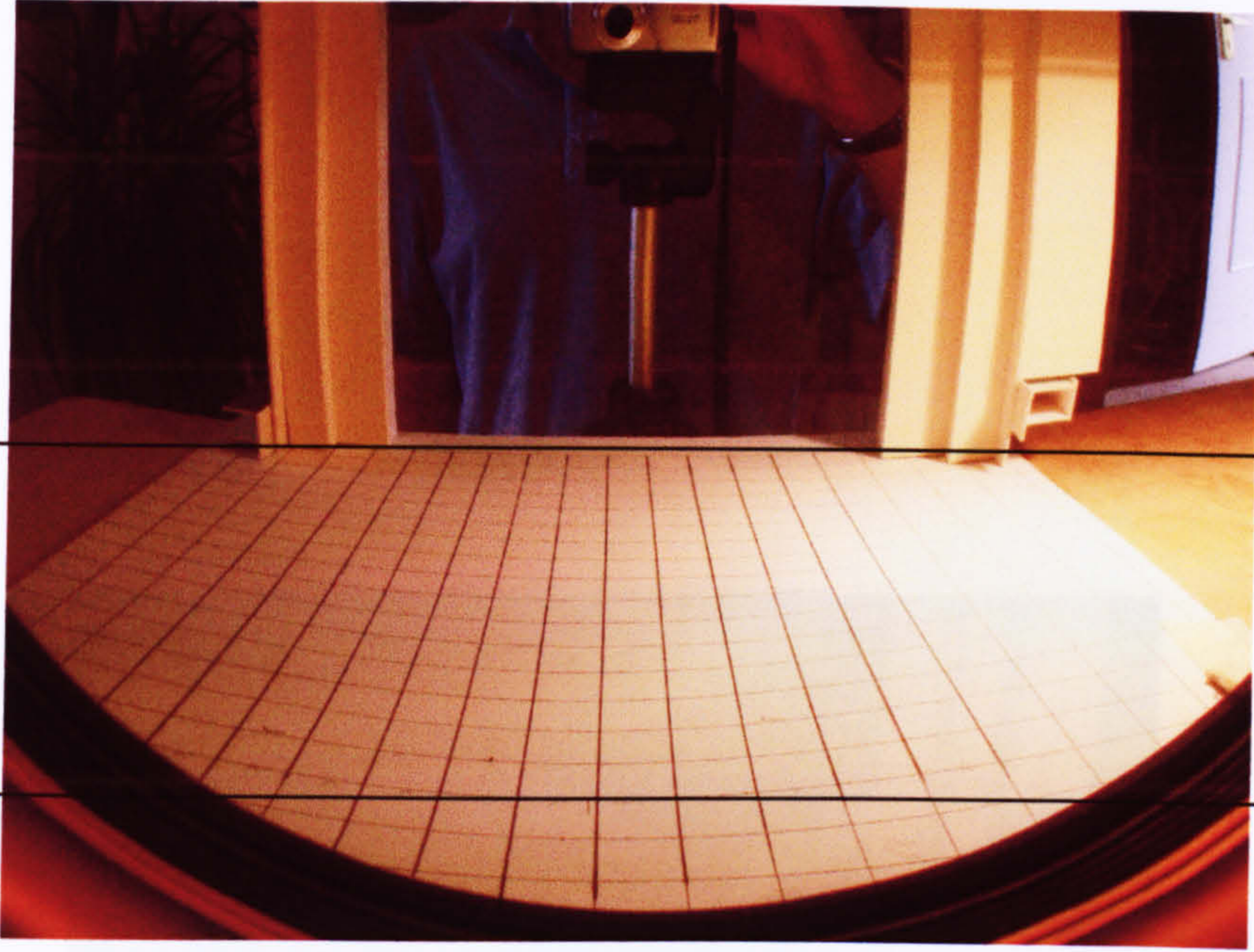

2.28 (1) - Model floor reflected in a convex mirror.

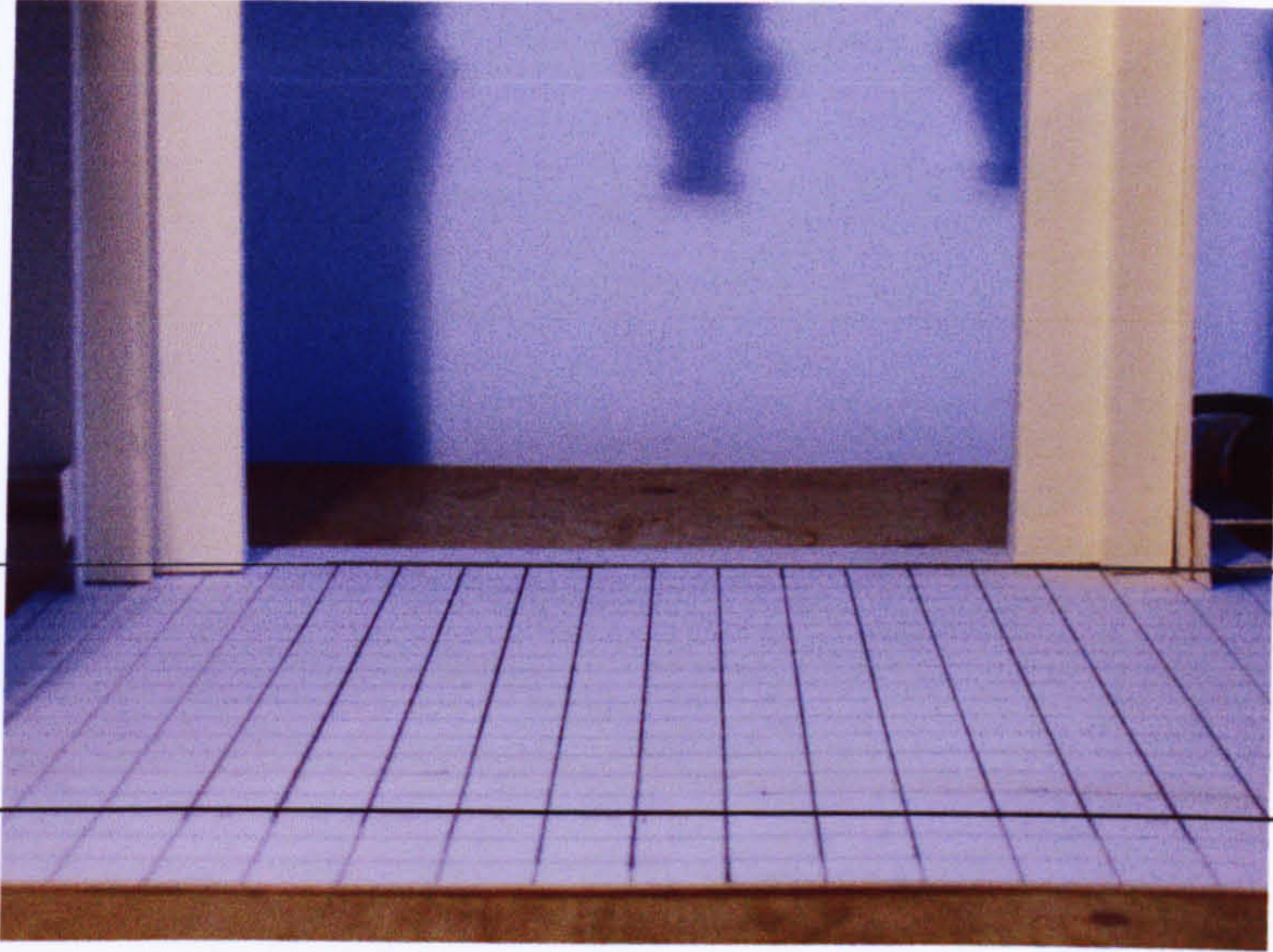

2.28 (2) - Model floor take with a 50mm lens.

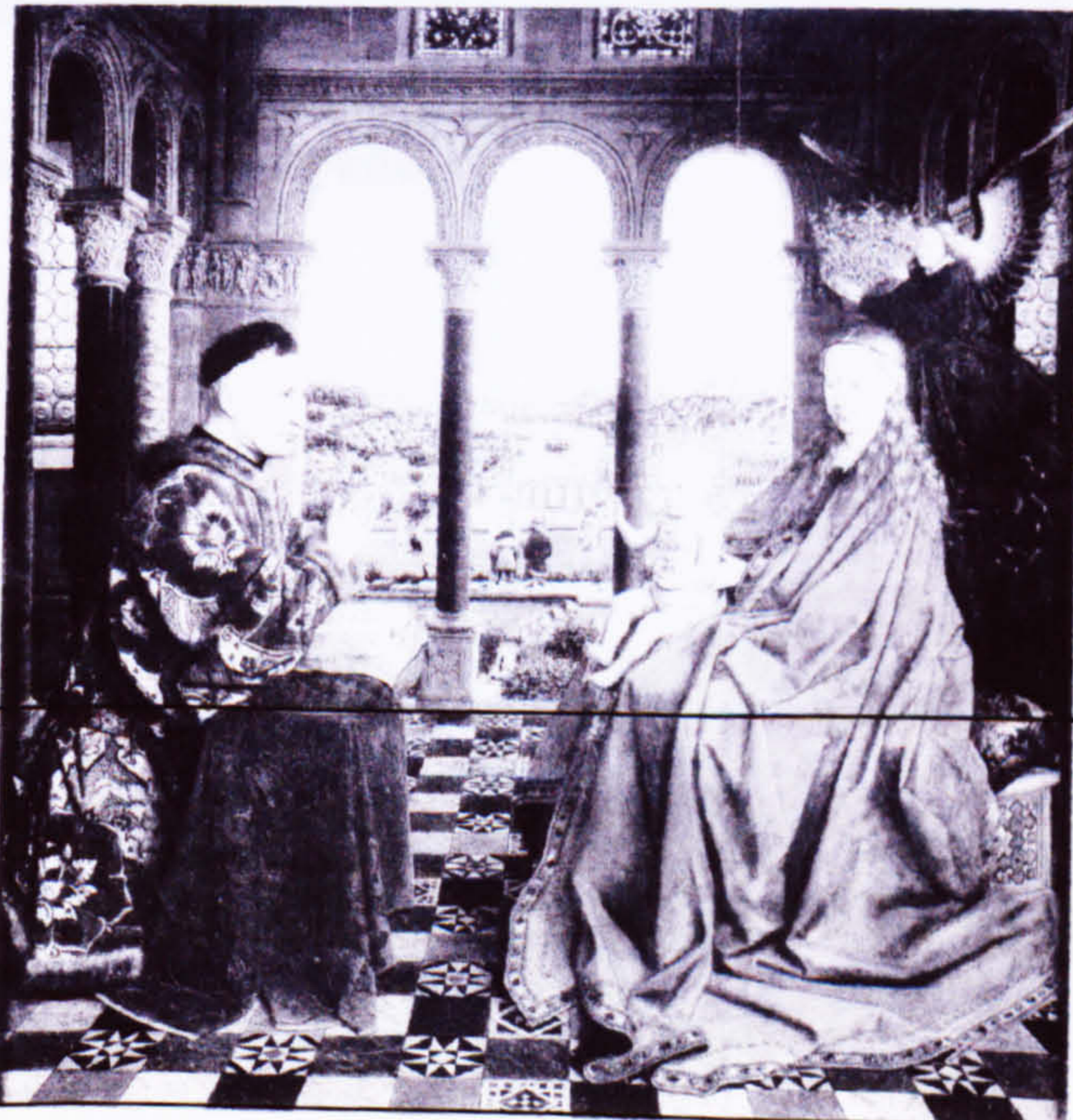

2.28 (3)



Fig 2.29 - Glass tumbler reflected in a convex mirror, showing the 'tipping effect'.



Fig 2.30 - Perspective analysis of the Washington *Annunciation*.



Fig 2.31 - Washington *Annunciation* showing floor orthogonals converging to the same 'vanishing area' as the side plane.

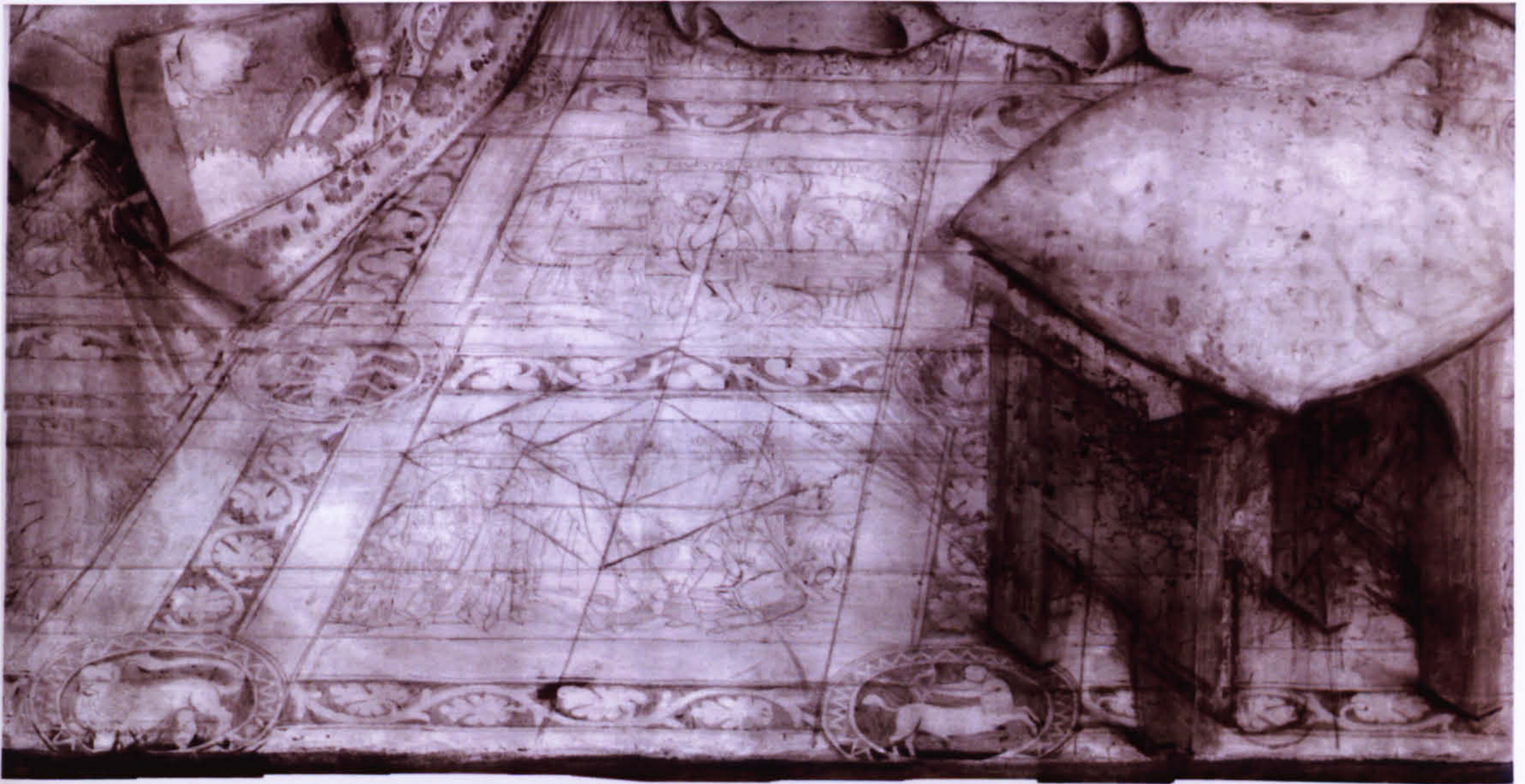

Fig 2.32 - Infra-red reflectogram assembly, Washington *Annunciation*.



Fig 2.33 - Washington *Annunciation*, detail of floor.



Fig 2.34 - Washington *Annunciation*, floor grid.

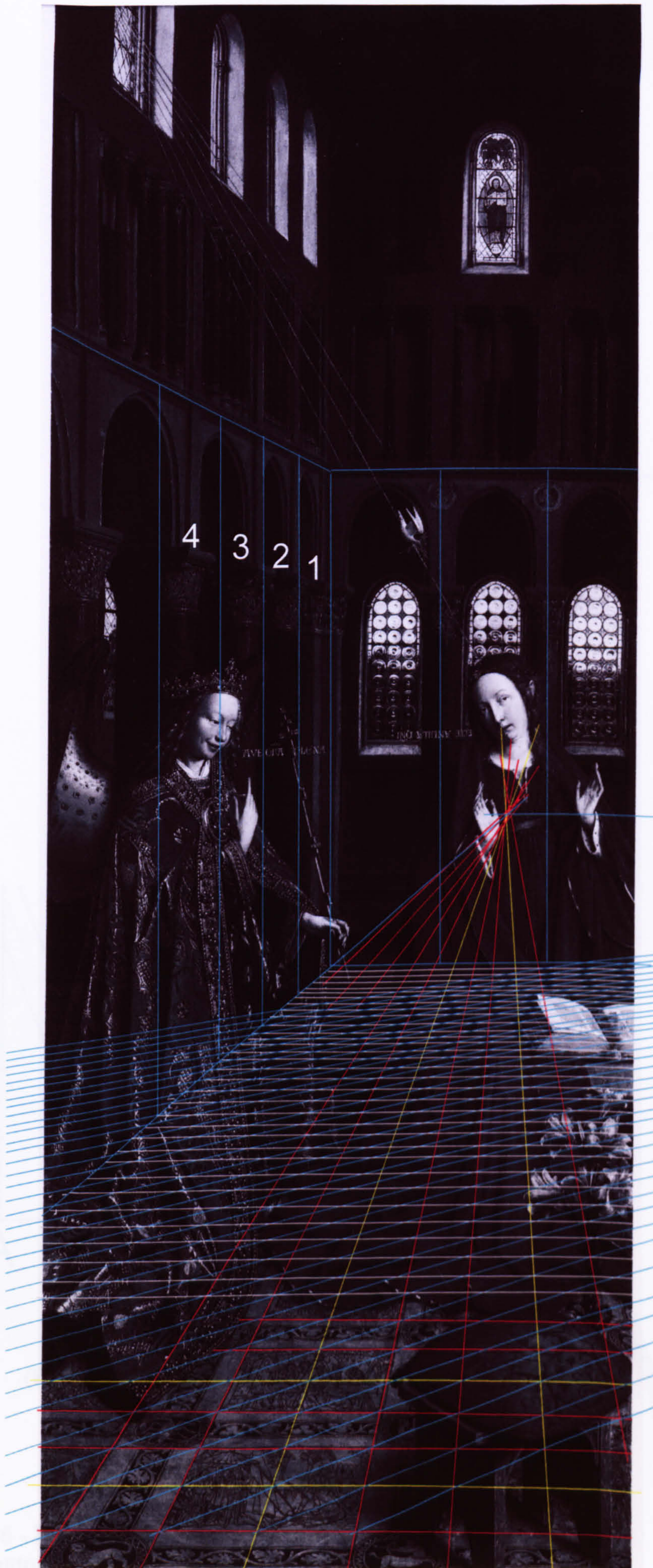

Fig 2.35 - Washington *Annunciation*, showing diminution of floor and arcade bays implied by visible floor grid.

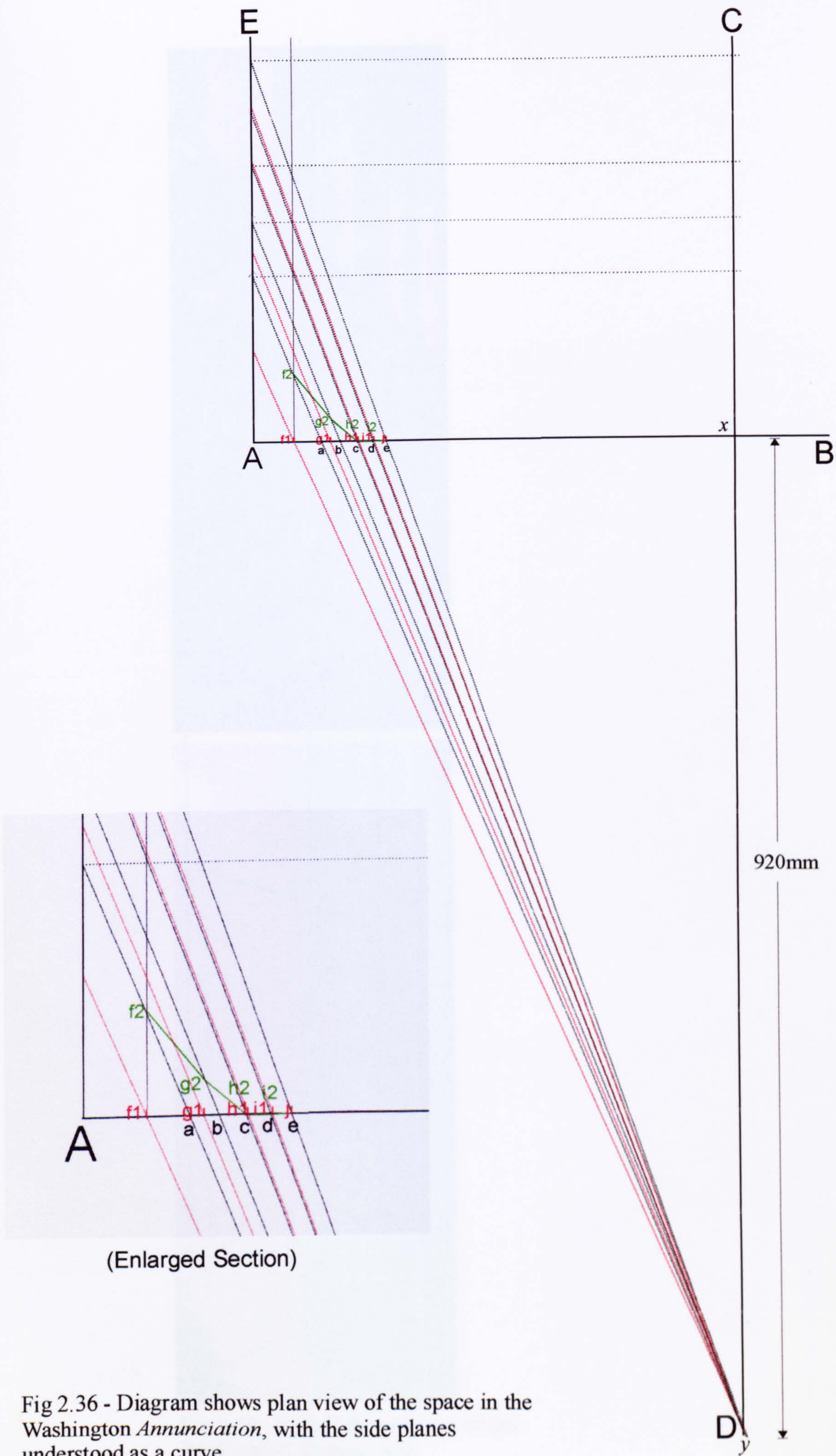

Fig 2.36 - Diagram shows plan view of the space in the Washington *Annunciation*, with the side planes understood as a curve.

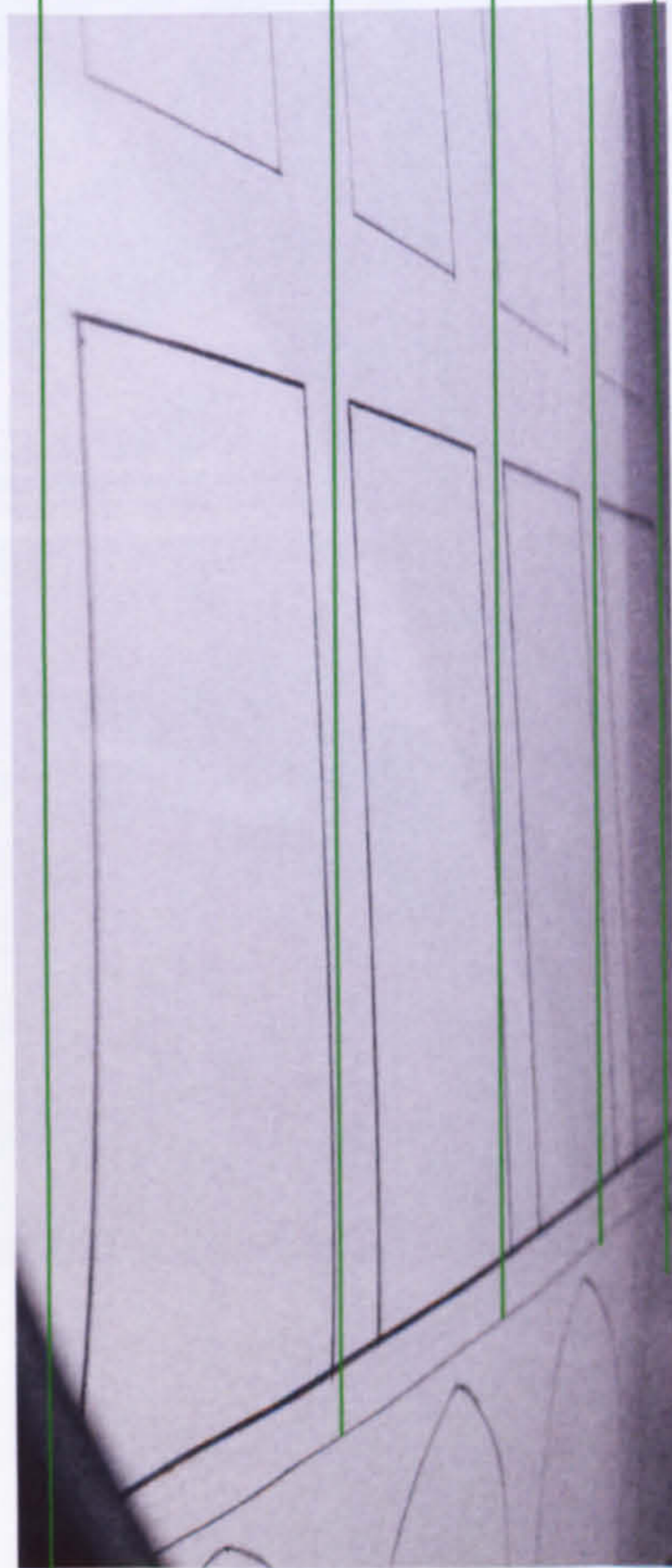
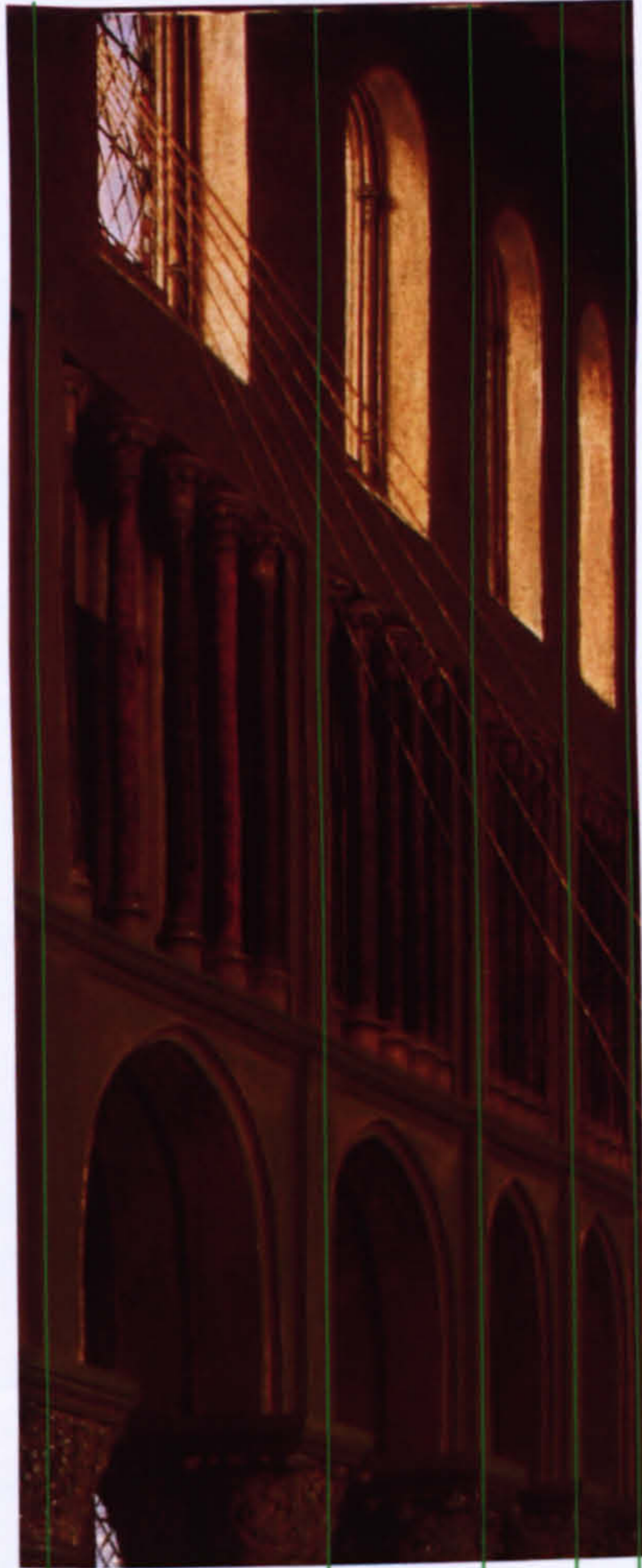

Fig 2.37 - Scaled down image of the
on *Annunciation*
with the model side wall
a convex mirror.



Fig 3.1 - Antwerp-Baltimore Quadriptych, c.1400. (Average 37.8 x 26.3 cm each). Walters Art Museum Baltimore, and Museum Mayer van den Bergh, Antwerp.



Fig 3.2 - Detail of Heddal Frontal.



Fig 3.3 - Detail of Virgin's robe, *Antwerp-Baltimore Quadriptych*.

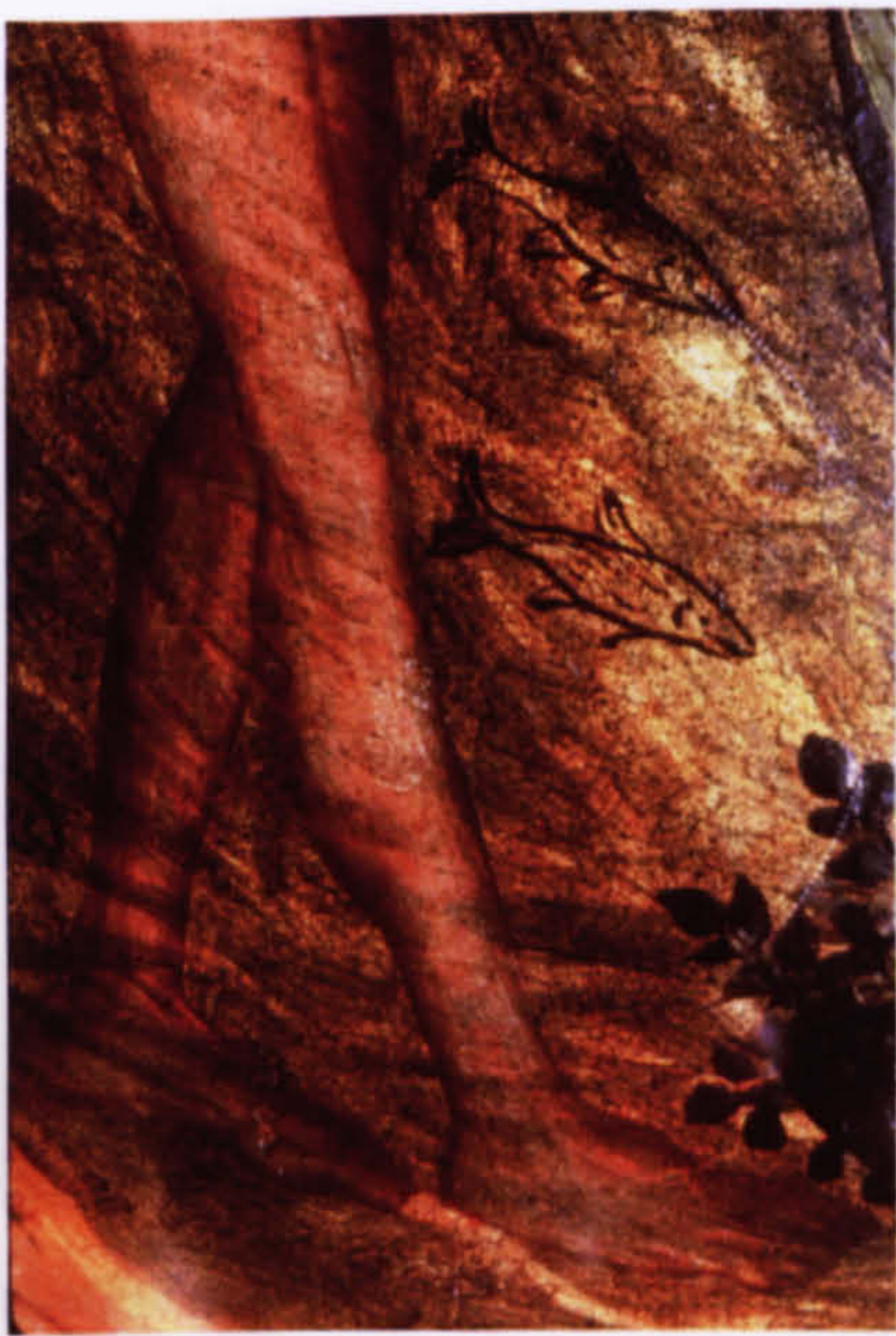

Fig 3.4 - Detail of Christ's feet, *Antwerp-Baltimore Quadriptych*.



Fig 3.5 - Micrograph detail of lecturn, *Antwerp-Baltimore Quadriptych*.



Fig 3.6 - Fragment of the wall paintings formerly in Saint Stephen's chapel, Westminster Palace, scenes from Job and Tobit, c.1352-63. British Museum.



Fig 3.7 - The *Thornham Parva Retable*, c.1330. 110.5 x 390.5 cm. Saint Mary's Church, Thornham Parva, Suffolk.

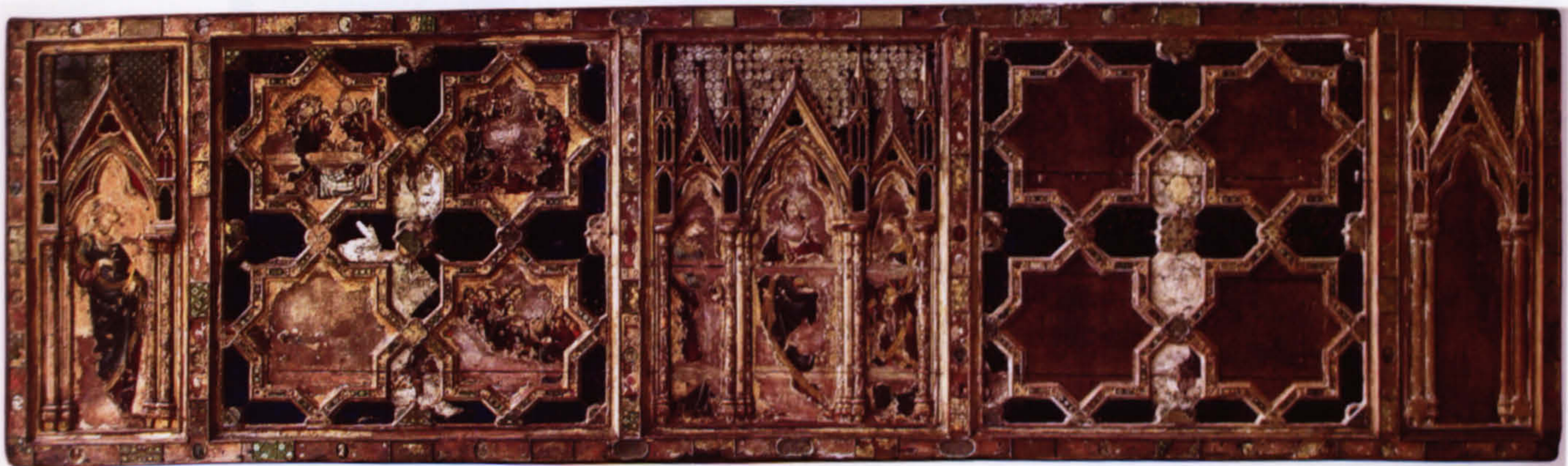

Fig 3.8 - The *Westminster Retable*, c.1270-90. 97.0 x 333 cm. Westminster Abbey.



Fig 3.9 - Frontal from Heddal, Telemark, c.1250. 149.5 x 92.0 cm. Universitetets Kulturhistoriske Museer, Oslo.



Fig 3.10 - Frontal from Kaupanger, Norway, c.1250. 197.5 x 103.5 cm. Bergen Museum.



Fig 3.11 - Seated Virgin from a Coronation of the Virgin altarpiece, Mosan, c.1330-60. 57 x 22 x 11.5 cm. Victoria and Albert Museum, London.



Fig 3.12 - St Edmund, *Thornham Parva Retable*.



Fig 3.13 - St Peter, *Thornham Parva Retable*.



Fig 3.14 - St John the Evangelist, *Thornham Parva Retable*.



Fig 3.15 - Detail of the king's banquet scene, Saint Maurille cycle of wall paintings, c.1270, Angers Cathedral choir.

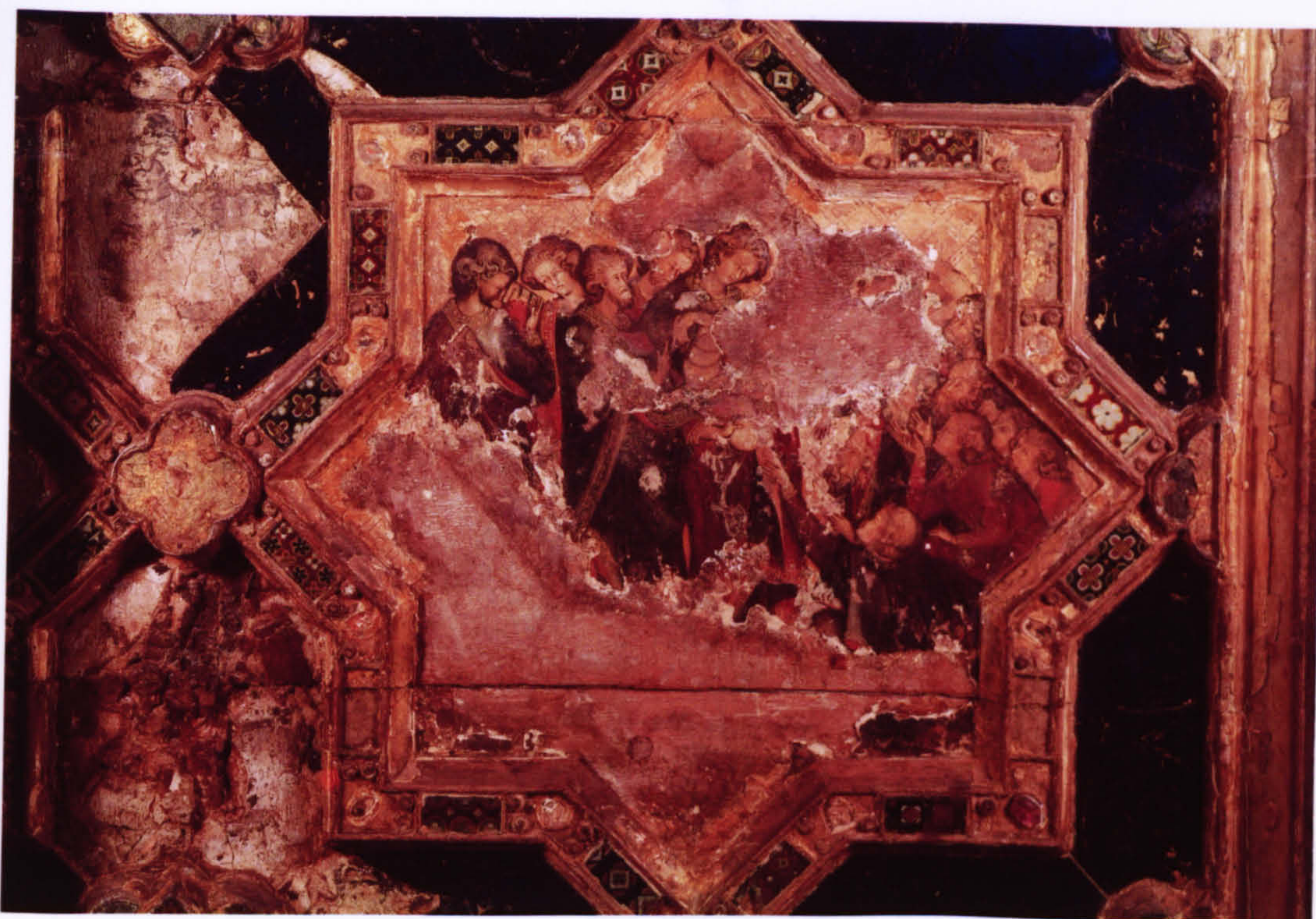

Fig 3.16 - The Feeding of the Five Thousand, *Westminster Retable*.



Fig 3.17 - Saint Peter, *Westminster Retable*.



Fig 3.18 - Tower Retable, Mosan or Southern Netherlands, c.1390-95.
137 x 47.5 x 63 cm. Mayer van den Bergh Museum, Antwerp.



Fig 3.19 - Jean de Touyl (attrib), Reliquary Shrine, Paris, second quarter of the fourteenth century. 25.4 x 40.6 cm (open). The Cloisters, New York.



Fig 3.20 - *Choques Triptych*, Paris, c.1390-1400. 12 x 12.7 x 2.5 cm. Rijksmuseum, Amsterdam.



Fig 3.21 - Detail of the Nativity, Tower Retable.



Fig 3.22 - Jacques de Baerze and Melchior Broederlam, Adoration of the Magi, *Crucifixion Altarpiece*, interior, 1390-99. Musée des Beaux-Arts, Dijon.



Fig 3.23 - Nativity, *Antwerp-Baltimore Quadriptych*.



Fig 3.24 - Saint Christopher, *Antwerp-Baltimore Quadriptych*.

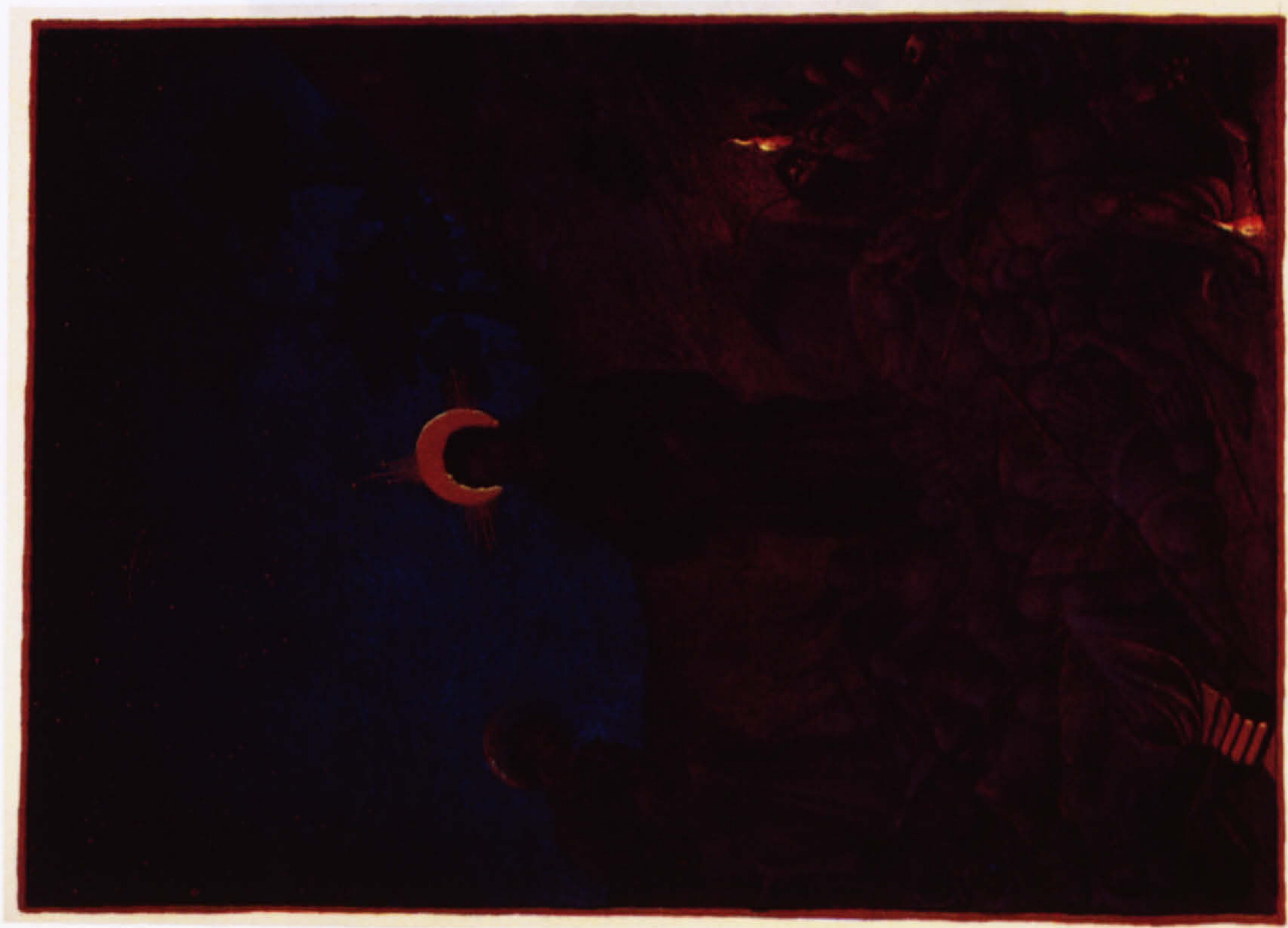

Fig 3.25 - Limbourg Brothers, Christ in Gethsemane, *Très Riches Heures*, c.1411/12-16. 29.0 x 21.0 cm (page). Musée Condé, Chantilly, fol. 142v.



Fig 3.26 - Bouicaut Master, Flight into Egypt, *Bouicaut Hours*, c.1410. 27.5 x 19.0 cm (page). Musée Jacquemart-André, Paris, ms. 2, fol. 90v.



Fig 3.27 - Robert Campin, *The Trinity*, c.1428-32.
147.5 x 57.6 cm. Städelsches Kunstinstitut, Frankfurt
am Main.



Fig 3.28 - Jan (and Hubert?) van Eyck, *Ghent Altarpiece*, interior, completed 1432. Approx 375 x 520 cm. Cathedral of Saint Bavo, Ghent.



Fig 3.29 - *Ghent Altarpiece*, exterior. Approx 375 x 260 cm.



Fig 3.30 - *Norfolk Triptych*, wing panel,
Southern Netherlands, c.1410-15. 33.0 x 13.1 cm.
Boijmans van Beuningen Museum, Rotterdam.



Fig 3.31



Fig 3.32



Fig 3.33 - Robert Campin, *Portrait of a Stout Man*, early 1430s.
29.5 x 18.0 cm. Thyssen-Bornemisza Collection, Madrid.



Fig 3.34 - Robert Campin, *Portrait of a Man*, c.1435.
40.6 x 28.1 cm. National Gallery, London.



Fig 3.35 - Jan van Eyck, *Man with a Ring*, c.1420-25. 22.5 x 16.6 cm. Muzeul national de Arta, Bucharest.



Fig 3.36 - Jan van Eyck, *Jan de Leeuw*, 1436. 33.3 x 27.5 cm. Kunsthistorisches Museum, Vienna.



Fig 3.37 - Robert Campin, *The Entombment, Seilern Triptych*, c.1415.
60 x 48.9 cm. Courtauld Institute, London.



Fig 3.38 - Robert Campin, *The Nativity*, c.1420-25. 84.1 x 69.9 cm.
Musée des Beaux-Arts, Dijon.



Fig 3.39 - Robert Campin, Annunciation, *Mérode Triptych*, c.1425. 64.1 x 63.2 cm (central panel). The Cloisters, New York.



Fig 3.40 - Detail of swaddling cloth, *van der Paele Virgin*.



Fig 3.41 - Detail of Saint Donatian's left hand, *van der Paele Virgin*.

Fig 3.40 - Donatius van Agou, Madonna and Child with Saints
Saint Lucy, Mary Magdalene, c.1440, 200 x 170 cm, Oil on Panel, Florence.

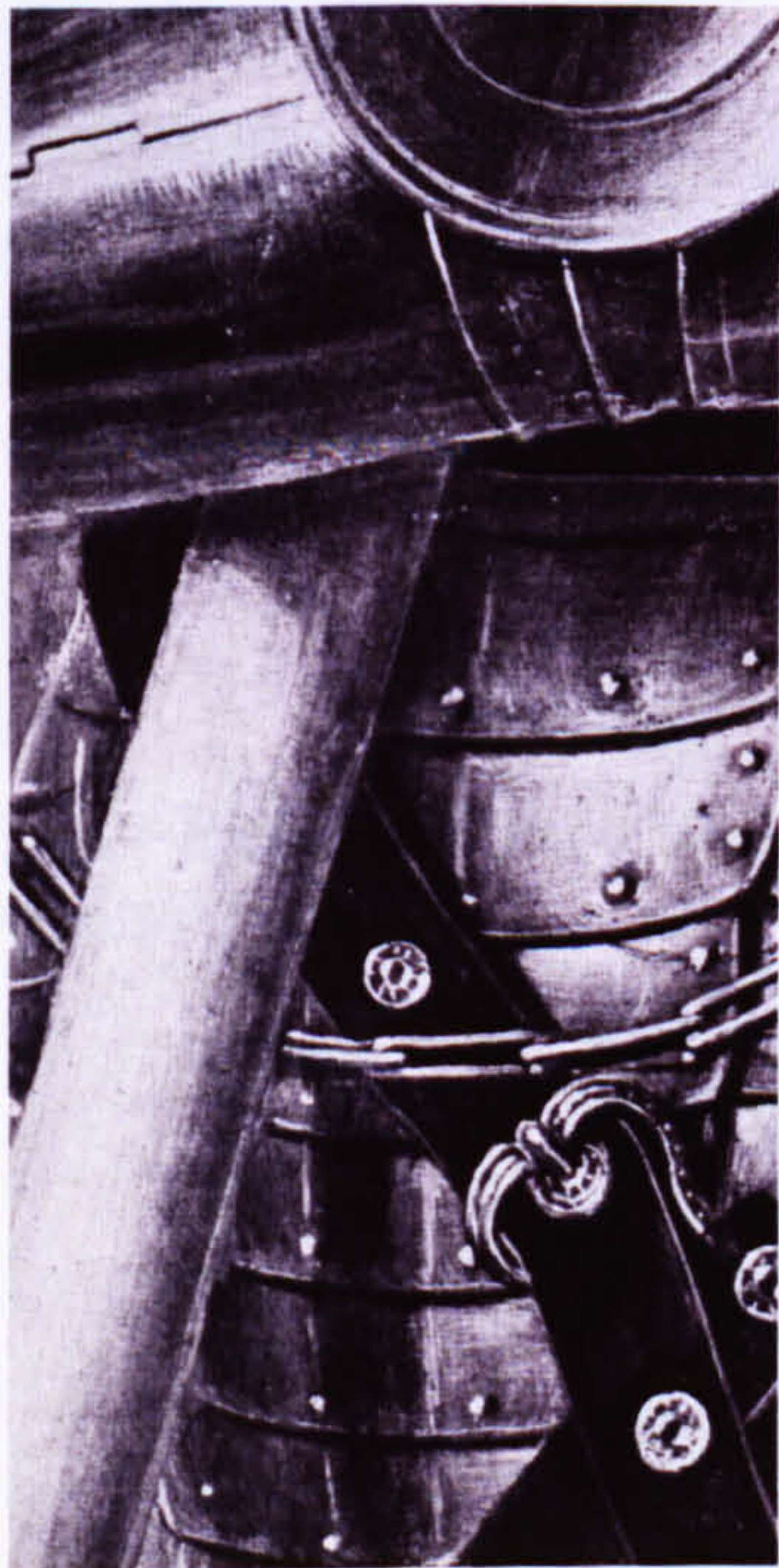

Fig 3.42 - Detail of Saint George's flag-pole, *van der Paele Virgin*.

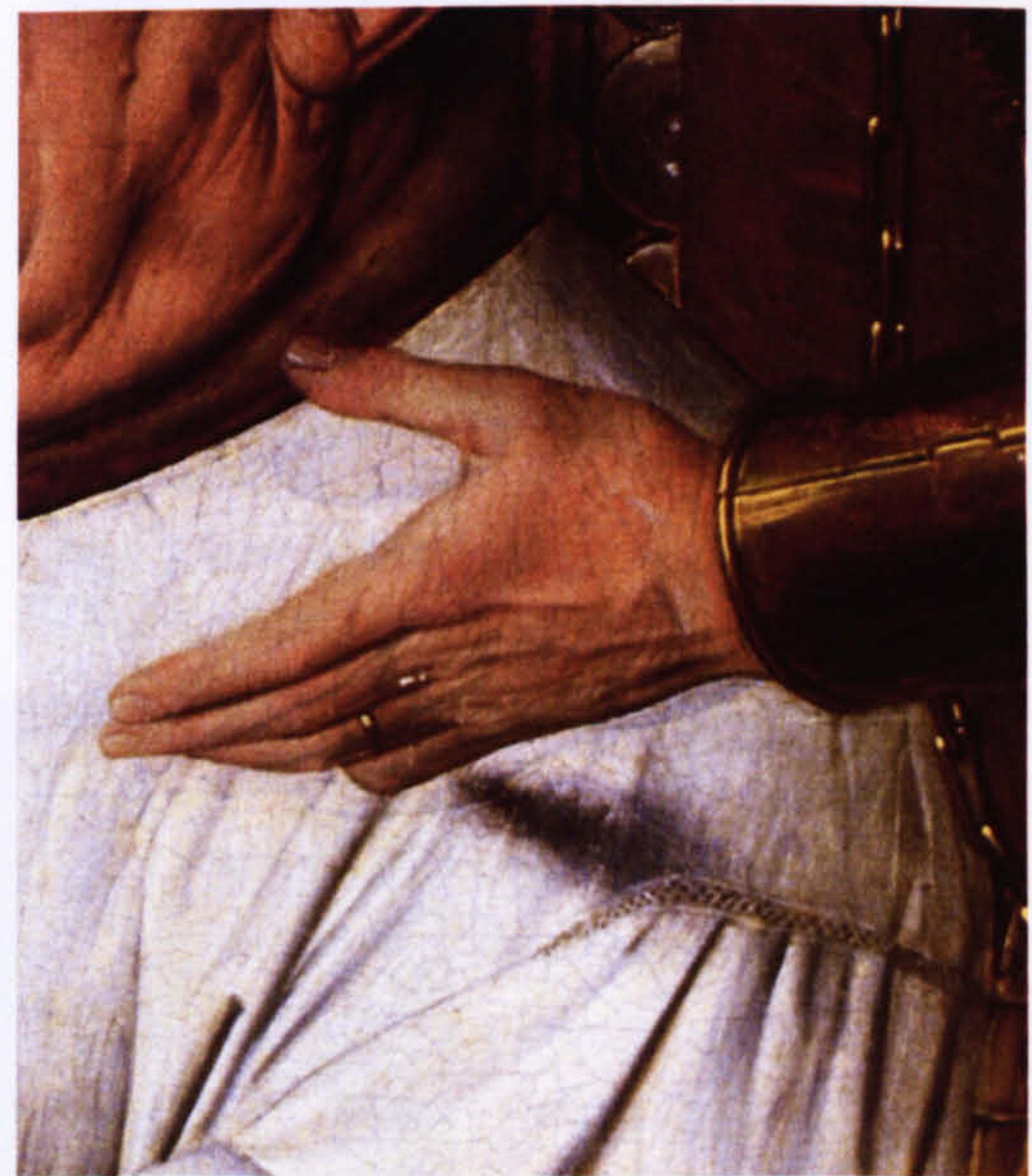

Fig 3.43 - Detail of Saint George's left hand, *van der Paele Virgin*.



Fig 3.44 - Domenico Veneziano, *Madonna and Child with Saints (Saint Lucy Altarpiece)*, c.1445. 209 x 213 cm. Uffizi, Florence.



Fig 3.45 - Detail of Adam's eyes, *Ghent Altarpiece*.



Fig 3.46 - Detail of Eve's eyes, *Ghent Altarpiece*.



Fig 3.47 - Detail of angel's brooch, *Ghent Altarpiece*.



Fig 3.48 - Limbourg Brothers, January, *Très Riches Heures*, c.1411/12-16. 29.0 x 21.0 cm (page). Musée Condé, Chantilly, ms. 65, fol. 2r.



Fig 3.49 - Boucicaut Master, Saint George and the Dragon, *Boucicaut Hours*, c.1410. 27.5 x 19.0 cm (page). Musée Jacquemart-André, Paris, ms. 2, fol. 23v.



Fig 3.50 - Bedford Master, Saint Ursula and her Companions, *Châteauroux Breviary*, c.1412-13. 28.0 x 20.2 cm (page). Bibliothèque Municipale, ms. 2, fol. 376r..



Fig 3.51 - Limbourg Brothers, Saint Jerome Arriving in Constantinople, *The Belles Heures of Jean, Duc de Berry*, c.1405-09. 23.8 x 17.0 cm (page). The Cloisters, New York, Acc. No 54.1.1, fol. 185r.



Fig 3.52 - Boucicaut Master, Ostentation of the Relics, *Châteauroux Breviary*, c.1412-13. 28.0 x 20.2 cm (page). Bibliothèque Municipale, ms. 2, fol. 350r.



Fig 3.53 - Detail of windows, *Châteauroux Breviary*.



Fig 3.54 - Boucicaut Master, Martyrdom of Saint Denis, *Châteauroux Breviary*, c.1412-13. 28.0 x 20.2 cm (page). Bibliothèque Municipale, ms. 2, fol. 364r.



Fig 3.55 - Boucicaut Master, Saint Michael on Mount Gargano, *Châteauroux Breviary*, c.1412-13. 28.0 x 20.2 cm (page). Bibliothèque Municipale, ms. 2, fol. 345v.



Fig 3.56 - Detail of Saint Edmund's crown, *Wilton Diptych*.



Fig 3.57 - Detail of soldier's armour, *Antwerp-Baltimore Quadriptych*.



Fig 3.58 - Detail of soldier, *Seilern Triptych*.



Fig 3.59 - Detail of soldier's breast-plates, *Seilern Triptych*.



Fig 3.60 - Detail of soldier's armoured leg, *Seilern Triptych*.



Fig 3.61 - Detail of floor tiles, *Ghent Altarpiece*.



Fig 3.62 - Detail of the crown,
Rolin Virgin.



Fig 3.63 - Detail of brocade,
Rolin Virgin.



Fig 3.64 - Detail of surplice, *van der Paele Virgin*.



Fig 3.65 - Detail of Saint George's
armour, *van der Paele Virgin*.



Fig 3.66 - Micrograph detail (7.7xM)
of Gabriel's brocade dalmatic,
Washington Annunciation.

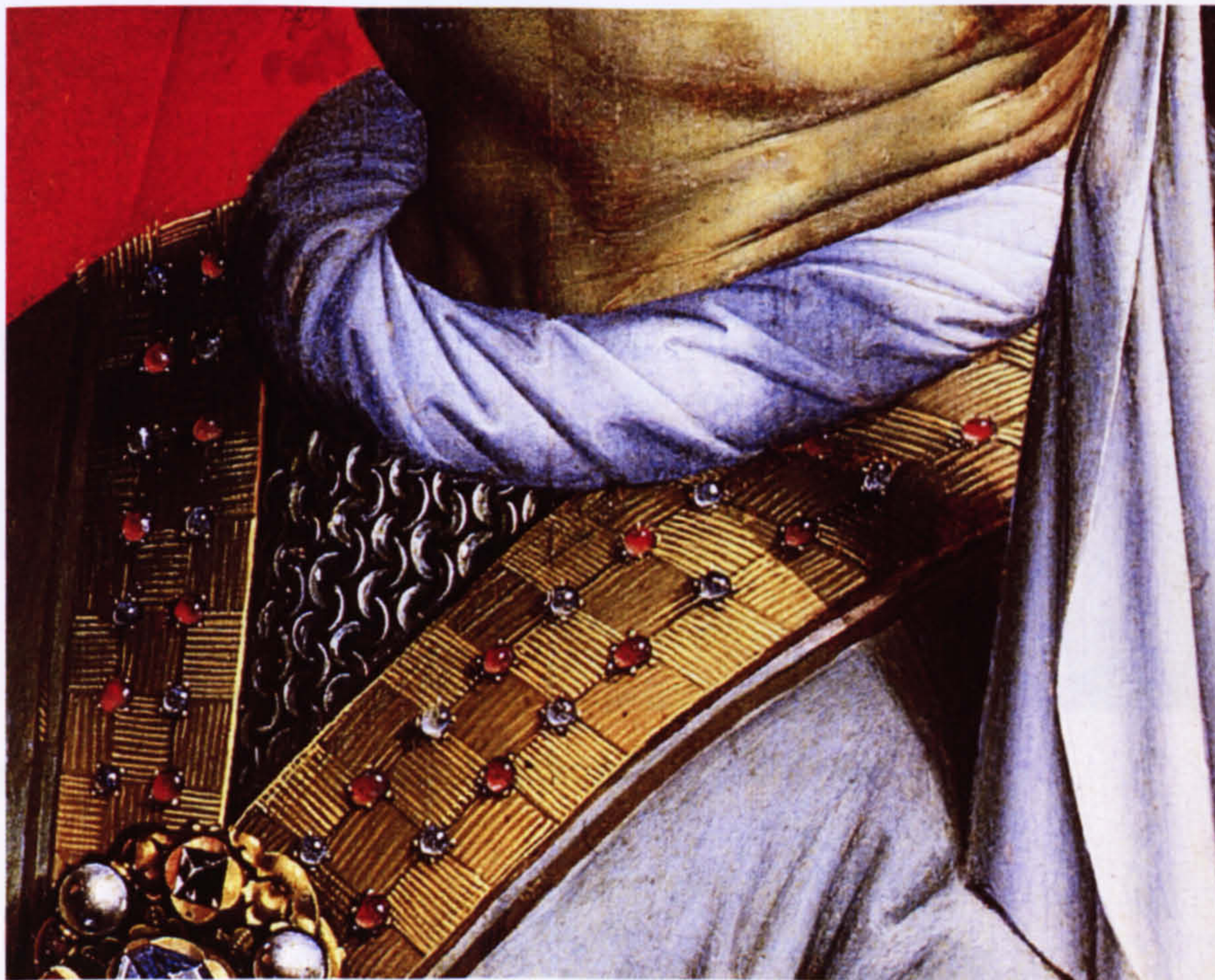

Fig 3.67 - Detail of gemstones, *Thief on the Cross*.



Fig 3.68 - Detail of singing angels, *Ghent Altarpiece*.

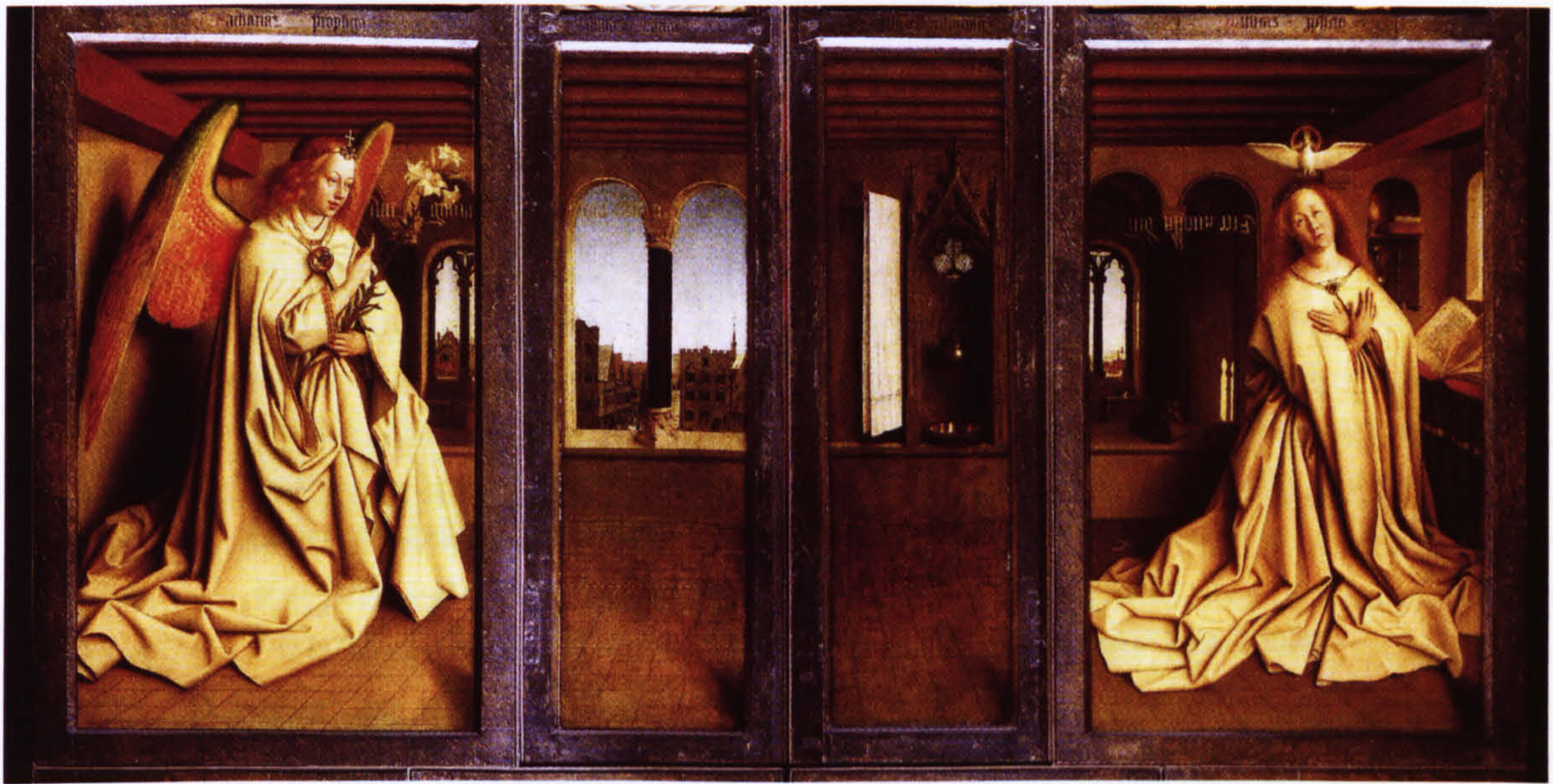

Fig 3.69 - Annunciation scene, *Ghent Altarpiece*.



Fig 3.70 -Robert Campin, *John the Baptist*, c.1428-32.
133.7 x 92.2 cm. Städelsches Kunstinstitut, Frankfurt am Main.

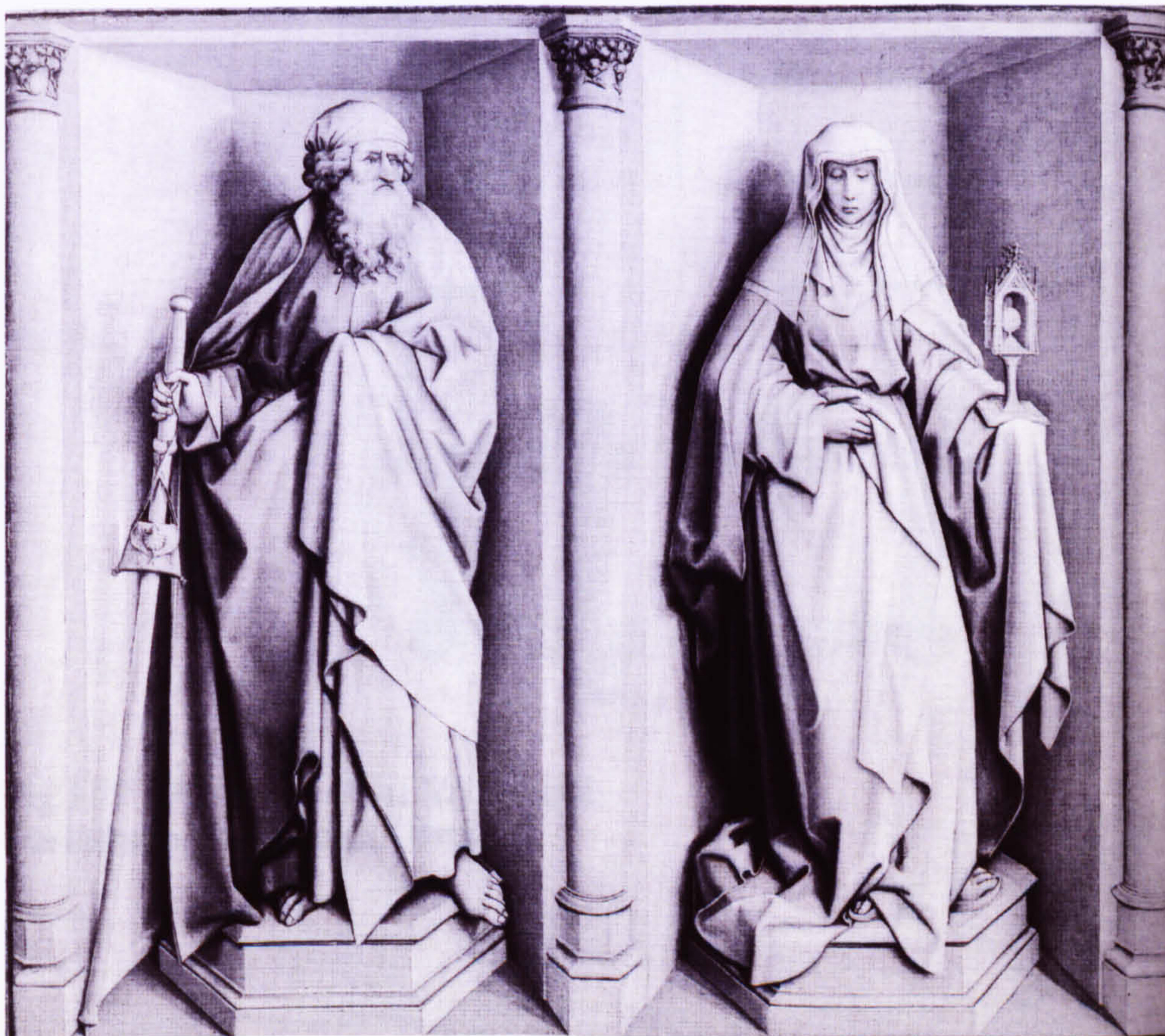

Fig 3.71 - Campin group, *Saint James the Elder and Saint Clare*, c.1435-40.
76.5 x 88.5 cm. Museo del Prado, Madrid.

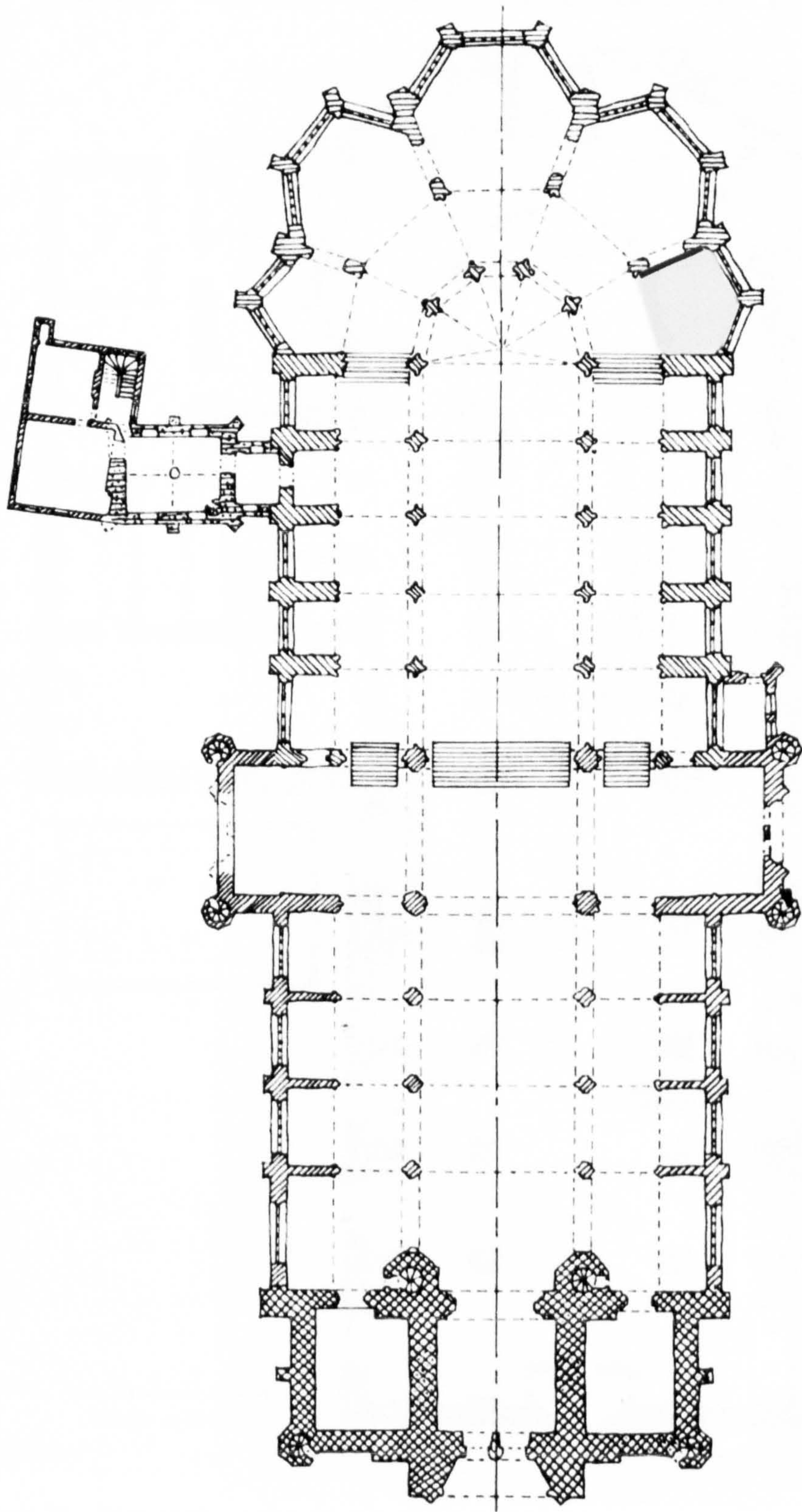
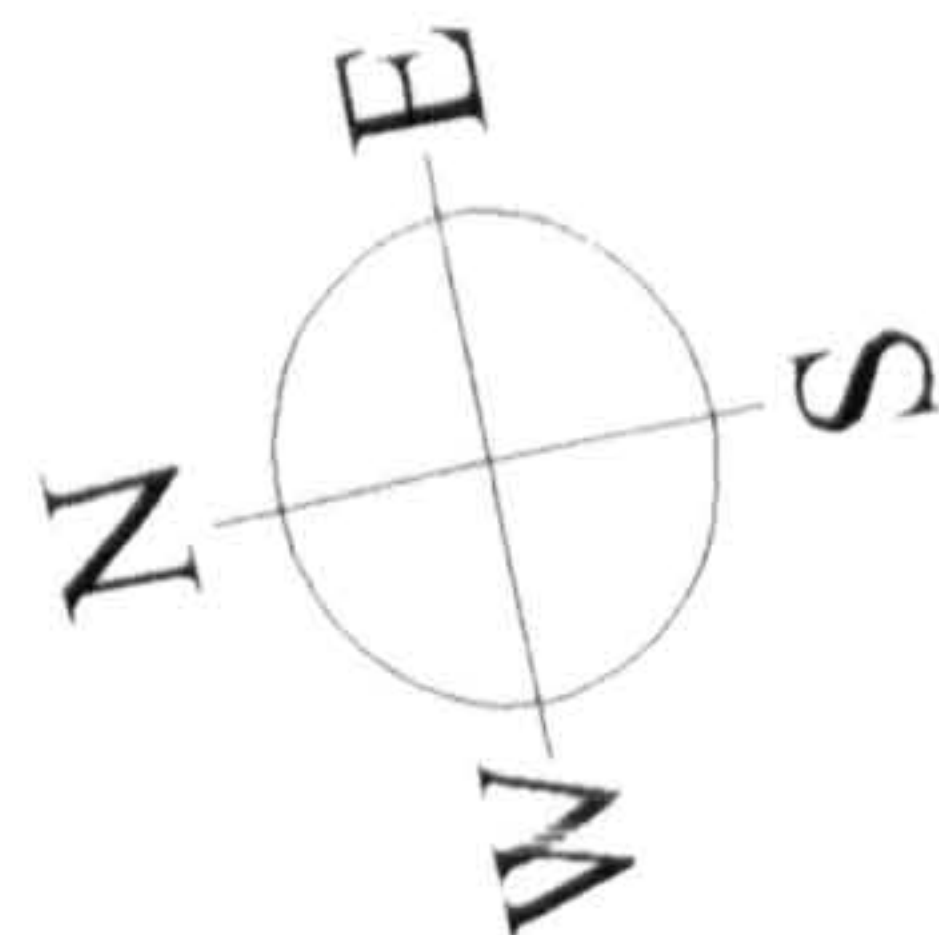

Fig 3.72 - Plan view of the Vijd chapel,
Cathedral of Saint Bavo, Ghent.



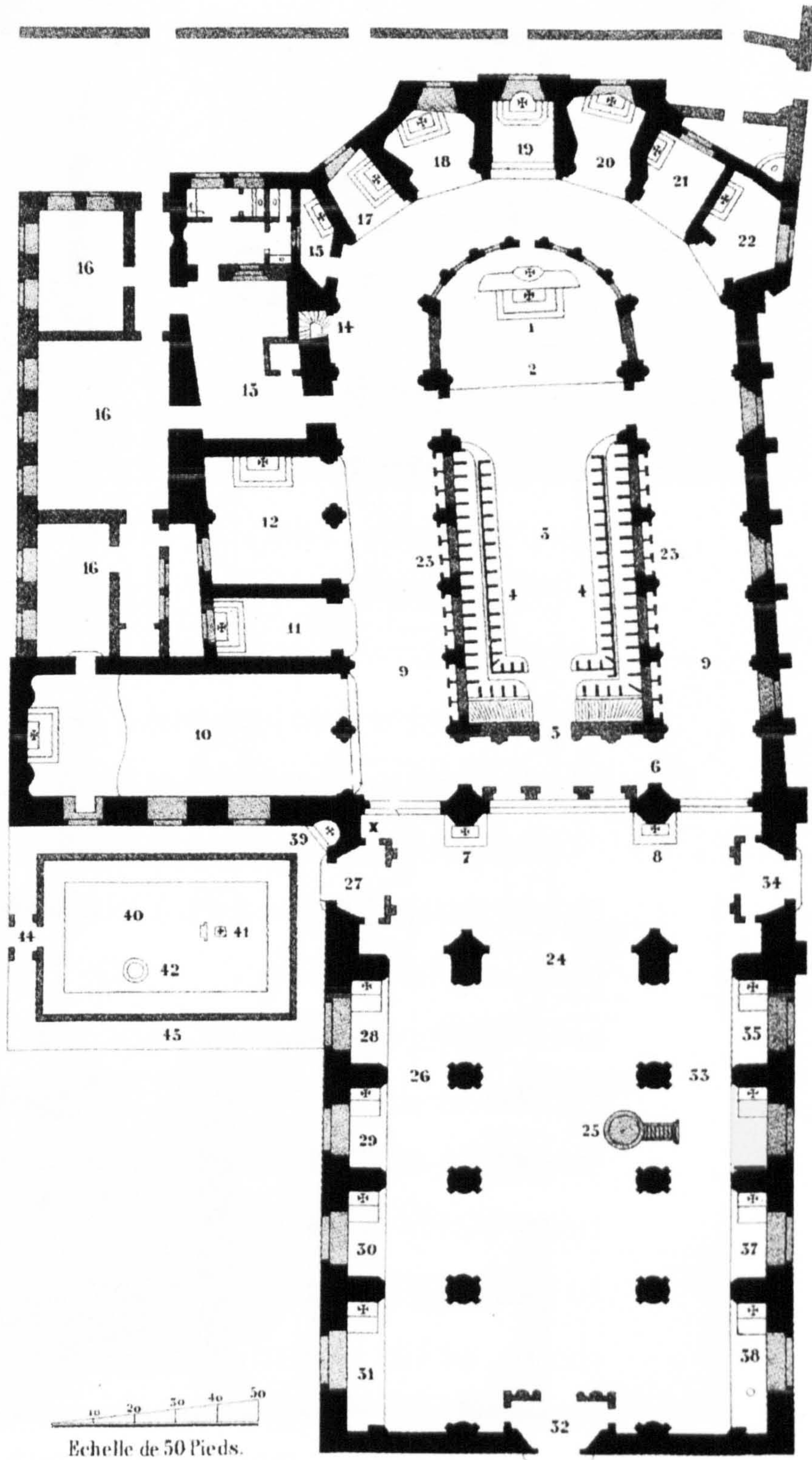
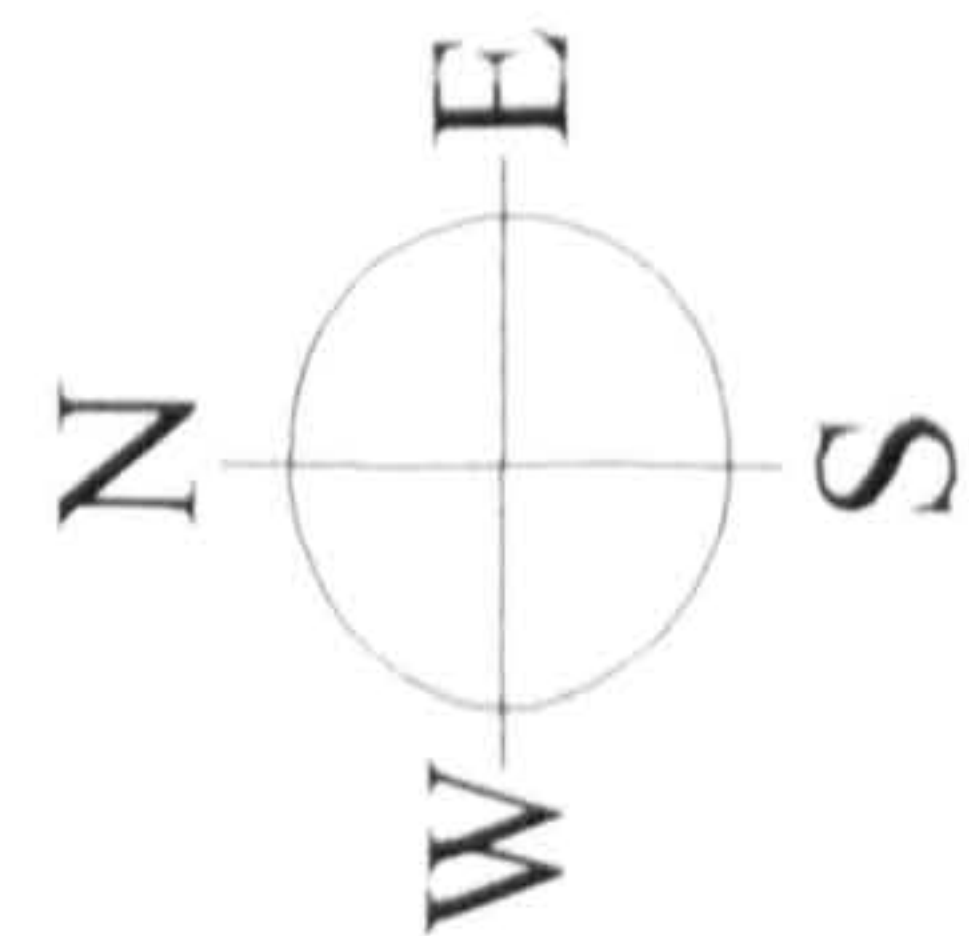

Fig 3.73 - Plan view of the church of Saint Donatian, Bruges (after Gailliard, 1861).



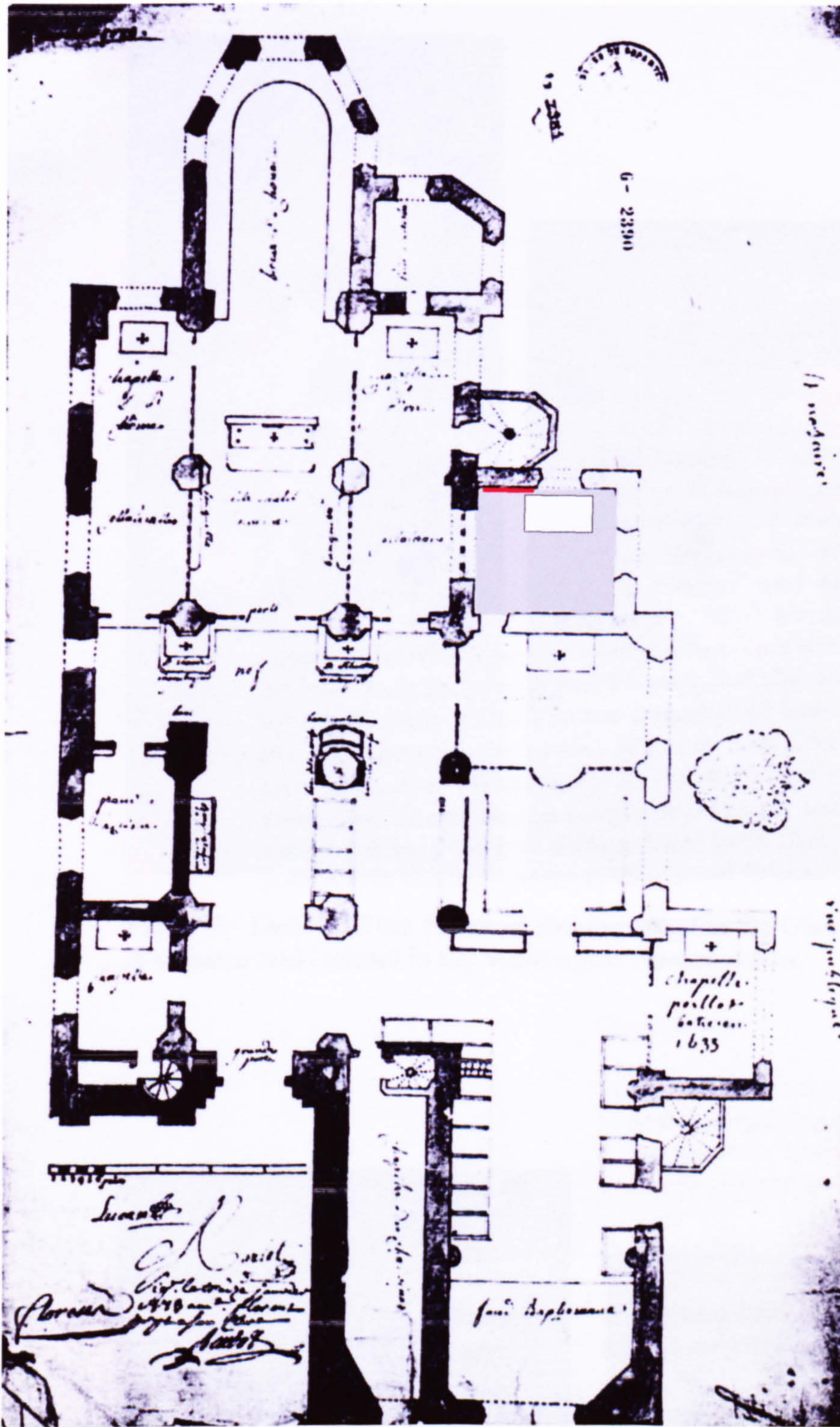
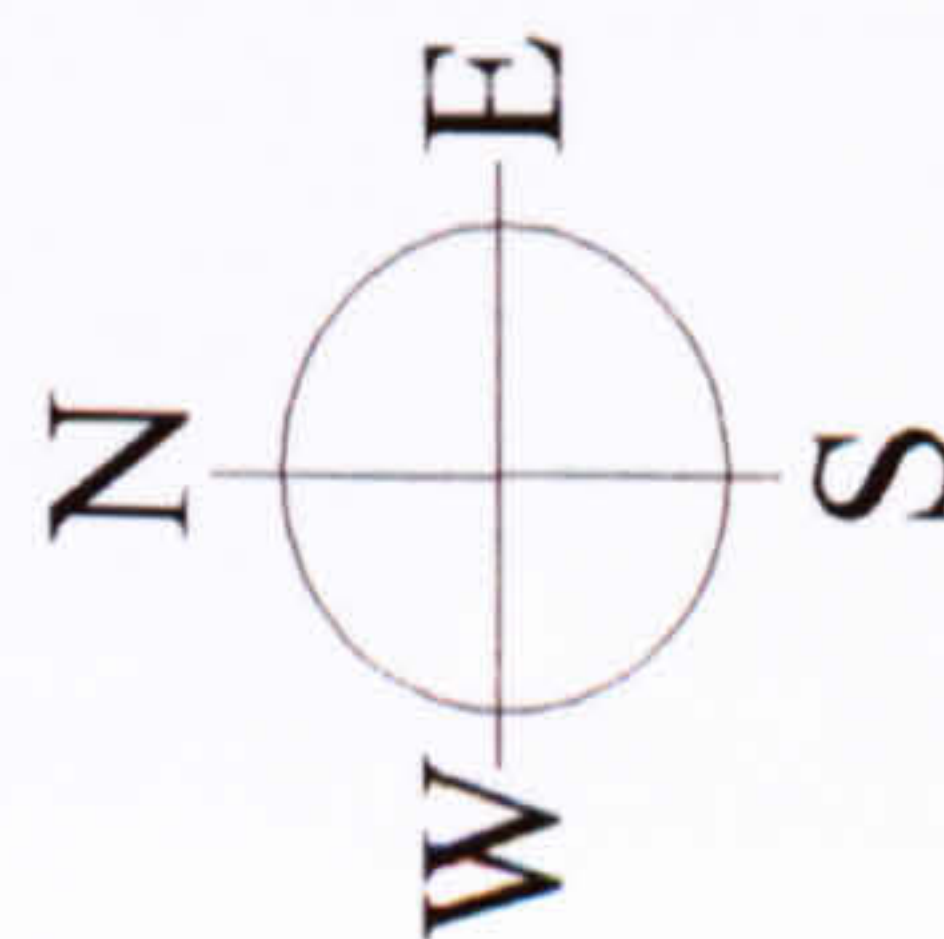

Fig 3.74 - Plan view of the former church of Notre-Dame du Chastel in 1773.



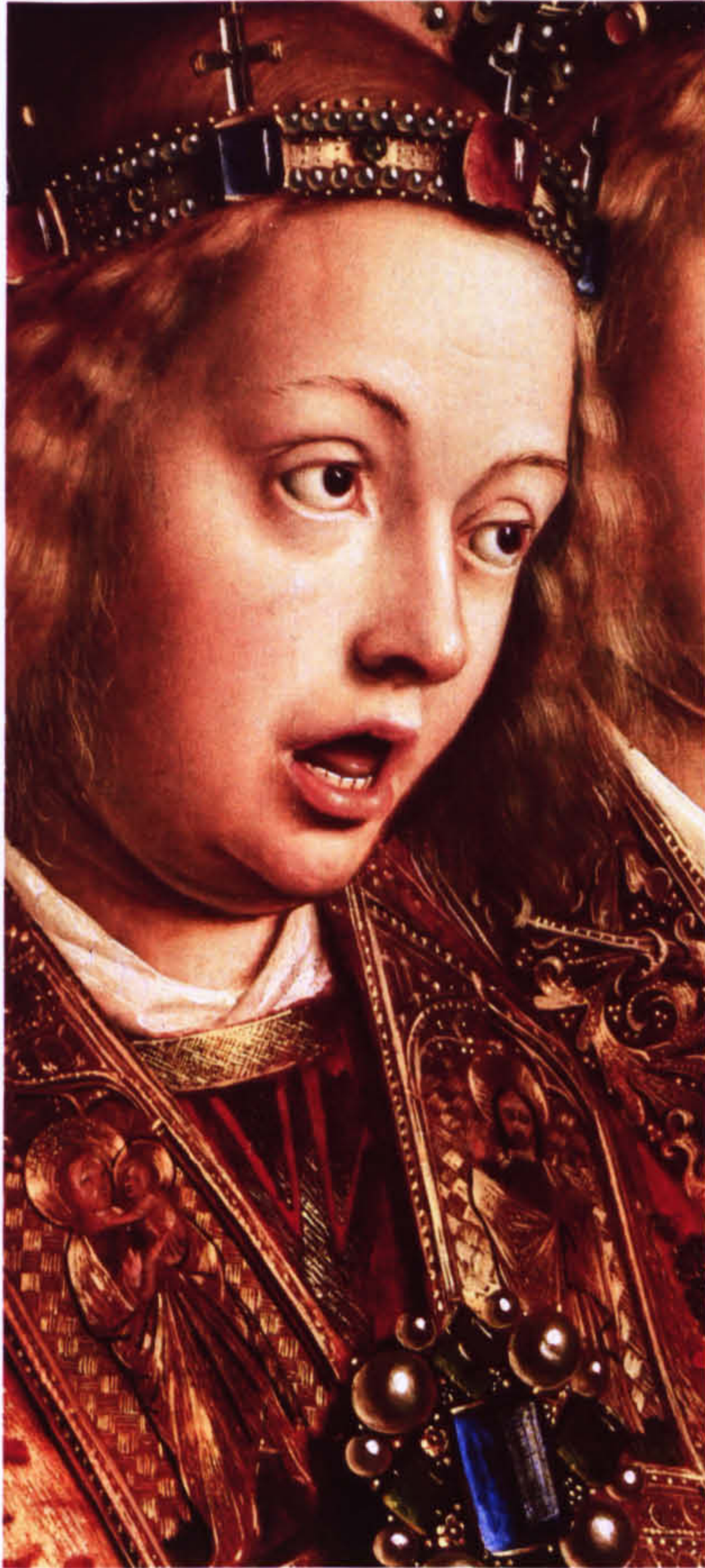

Fig 3.75 - Details of the foremost singing angel in the *Ghent Altarpiece* and Gabriel in the *Washington Annunciation*.



Fig 3.76 - Details of the stools in the *Washington Annunciation* and the *Ghent Altarpiece*.



Fig 3.77 - Jan van Eyck, *Annunciation Diptych*, c.1437-39. 38.8 x 46.4 cm. Thyssen-Bornemisza Collection, Madrid.



Fig 3.78 - Details from the Washington *Annunciation* and the *van der Paele Virgin*.



Fig 3.79 - Melchior Broederlam, wing panels, *Crucifixion Altarpiece*, exterior, 1393-99. 165.5 x 124.9 cm (left) and 165 x 130 cm (right) . Musée des Beaux-Arts, Dijon.



Fig 3.80 - *Calvary of the Tanners*, c.1400. 141 x 70.5 cm. Cathedral of Saint Salvator, Bruges.

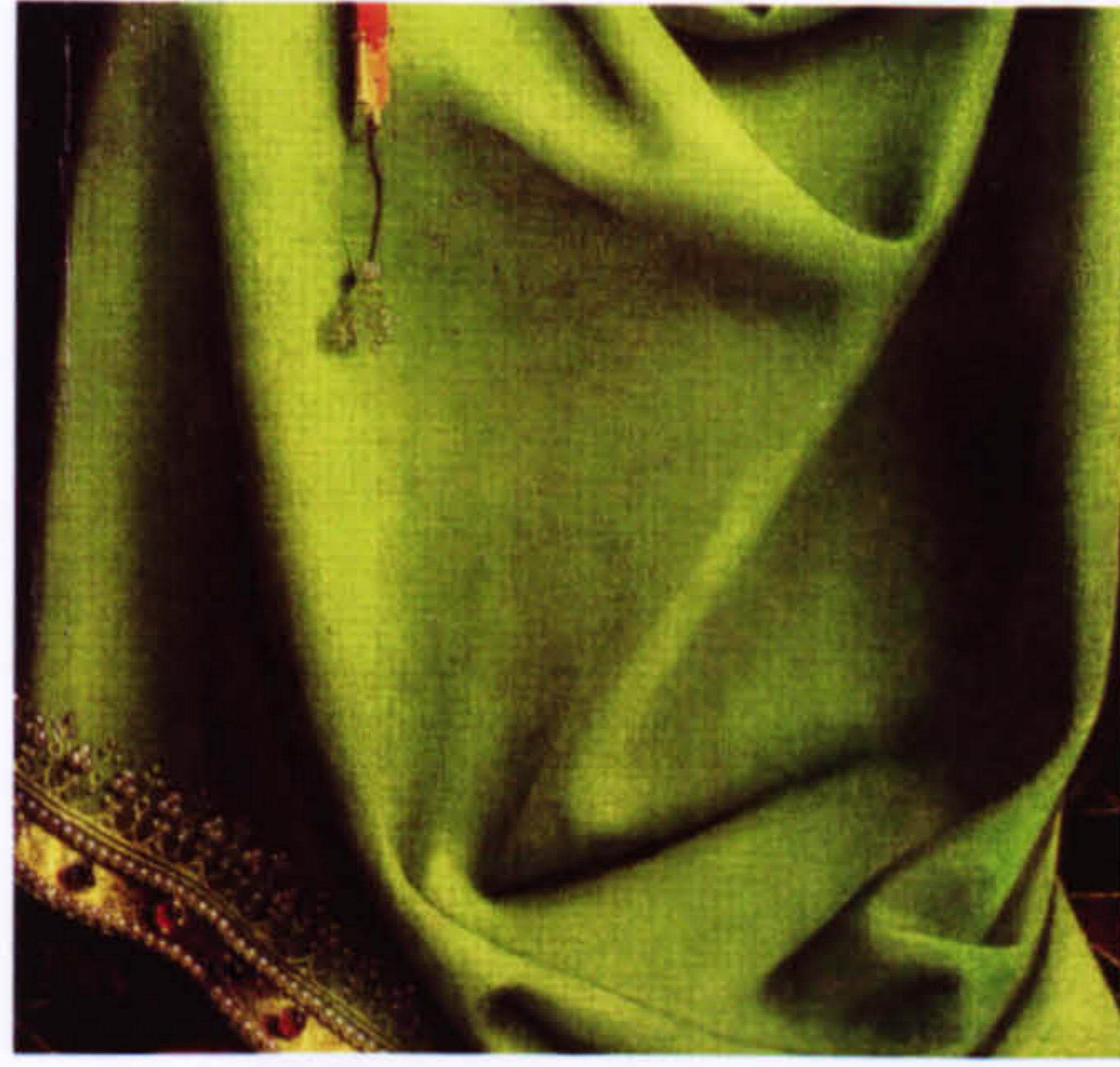
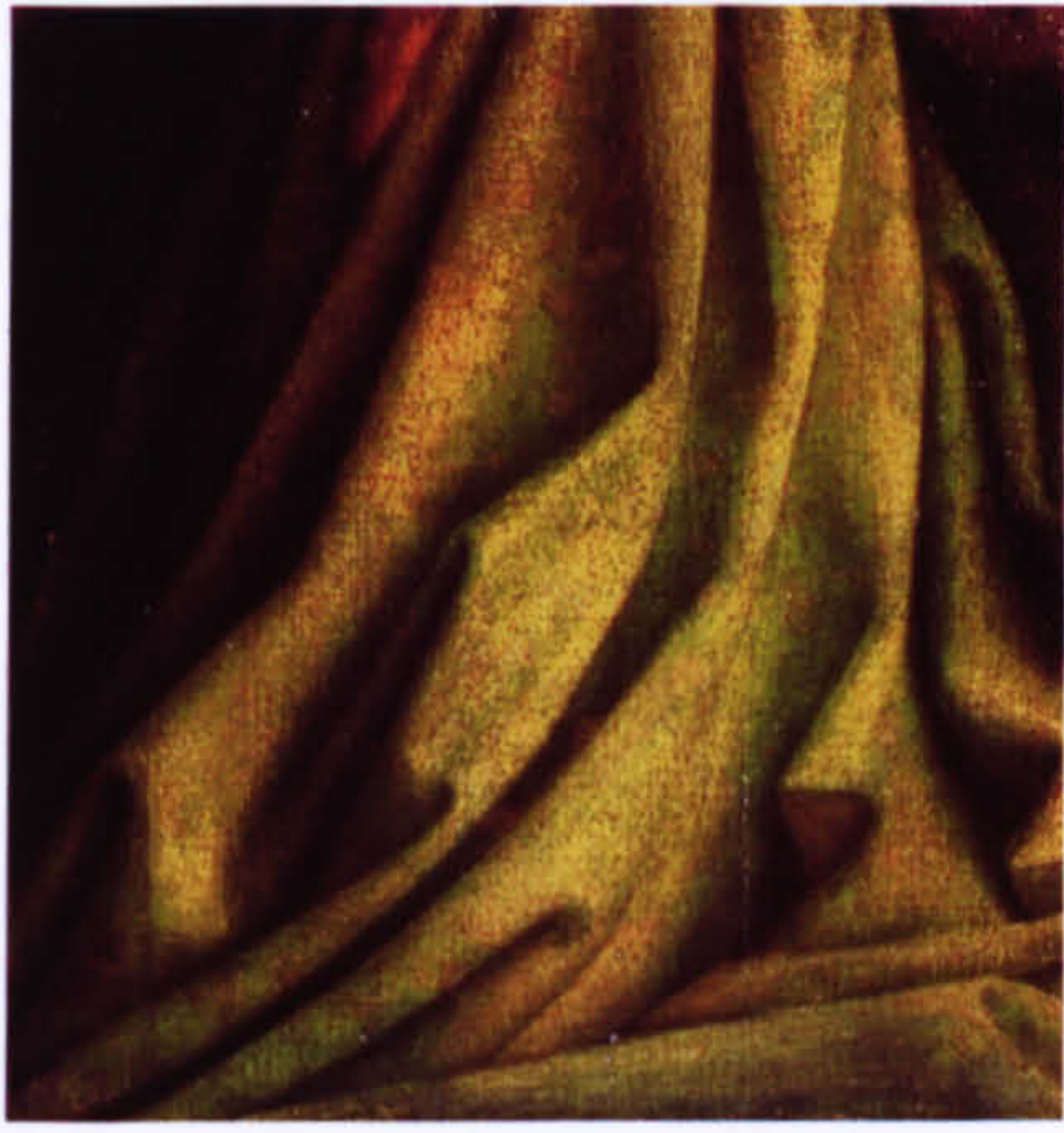

Fig 3.81 - Details of the Cumaean Sibyl (exterior) and John the Baptist (interior), *Ghent Altarpiece*.



Fig 3.82 - Details of the Virgin Mary (exterior) and an angel in the Adoration panel (interior), *Ghent Altarpiece*.



Fig 3.83 - Detail of Christ, *Antwerp-Baltimore Quadriptych*.



Fig 3.84 - Detail of angel's broomcod collar, *Wilton Diptych*.



Fig 3.85 - Detail of servant's robe, *Antwerp-Baltimore Quadriptych*.



Fig 3.86 - Detail of Saint Christopher, *Antwerp-Baltimore Quadriptych*.



Fig 3.87 - Detail of white cloth, *Mérode Triptych*.

Fig 3.80 - Detail of
Christ's leg, *Mérode Triptych*.

Fig 3.91 - Detail of
Mary's head, *Mérode Triptych*.

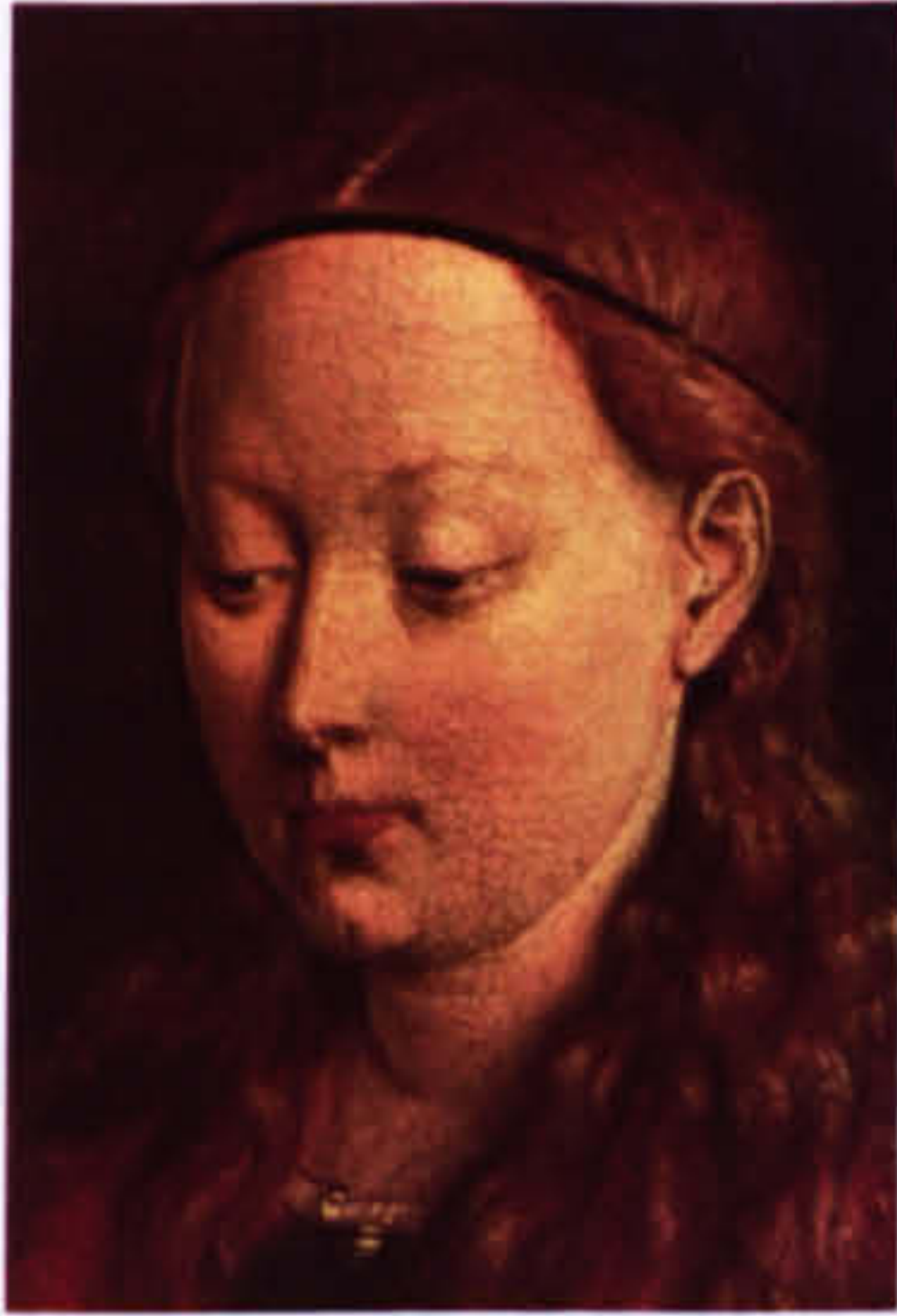

Fig 3.88 - Detail of the Virgin's head, *Rolin Virgin*.



Fig 3.89 - Detail of the angel's head, *Rolin Virgin*.



Fig 3.90 - Detail of Christ's leg, *Rolin Virgin*.



Fig 3.91 - Detail of Rolin's head, *Rolin Virgin*.



Fig 3.92 - Jan van Eyck, silverpoint drawing, *Portrait of an Old Man (Cardinal Nicolò Albergati?)*, c.1435-38. 21.4 x 18.1 cm. Kupferstichkabinett, Dresden.



Fig 3.93 - X-radiographs of the *Lucca Madonna* and the 'Campin group' *Virgin and Child*.



Fig 3.94 - X-radiographs of *Margaret van Eyck* and Rogier van der Weyden's *Portrait of a Lady*.



Fig 3.95 - Detail of the Virgin's robe,
Virgin and Child before a Firescreen.

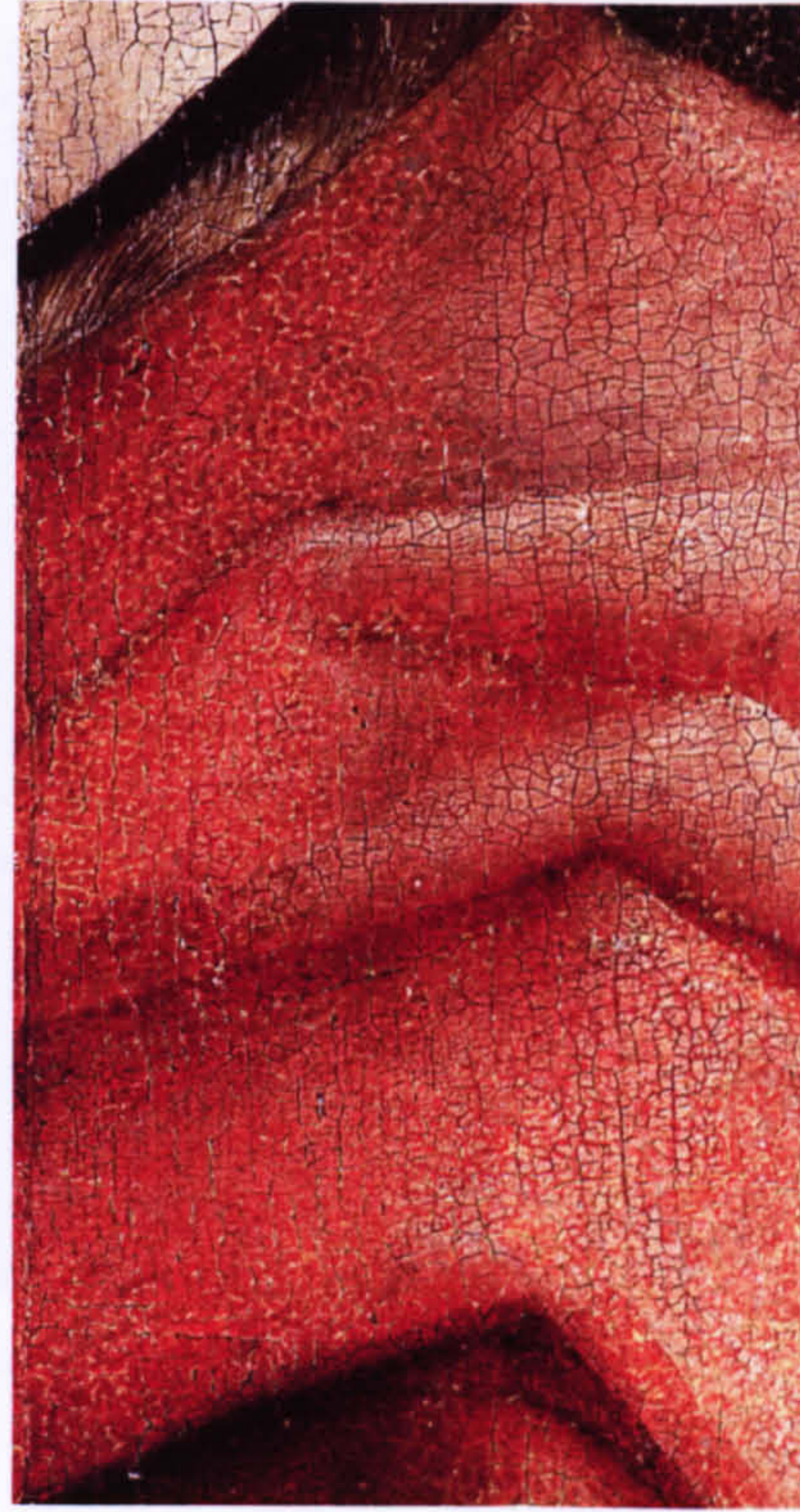

Fig 3.96 - Detail of Saint Luke's red
drapery, *Saint Luke Drawing the Virgin.*



Fig 3.97 - Detail of the Virgin's robe,
Washington Annunciation.



Fig 3.98 - Detail of green dress,
Magdalen Reading.



Fig 3.99 - Detail of the Virgin's robe
and mantle, *Ghent Altarpiece*.



Fig 3.100 - Jan van Eyck, *Washington Annunciation*, c.1434-36. 90.2 x 34.1 cm. National Gallery of Art, Washington D.C.

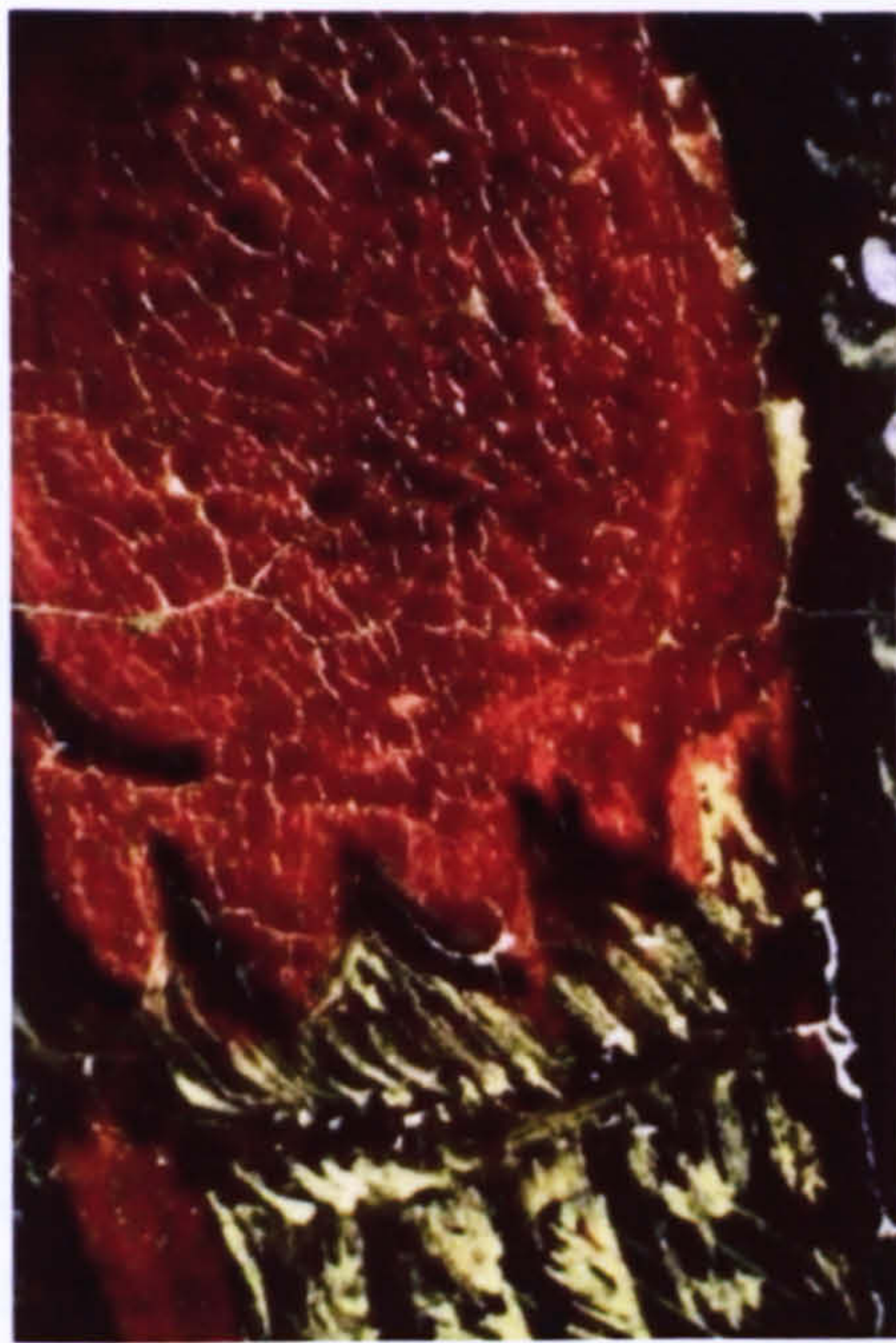

Fig 3.101 - Micrograph detail of Gabriel's cope, Washington *Annunciation*.



Fig 3.102 - Campin group, *Virgin and Child before a Firescreen*, c.1440, National Gallery, London.



Fig 4.1 - Micrograph detail of beads (4xM), *Magdalen Reading*.

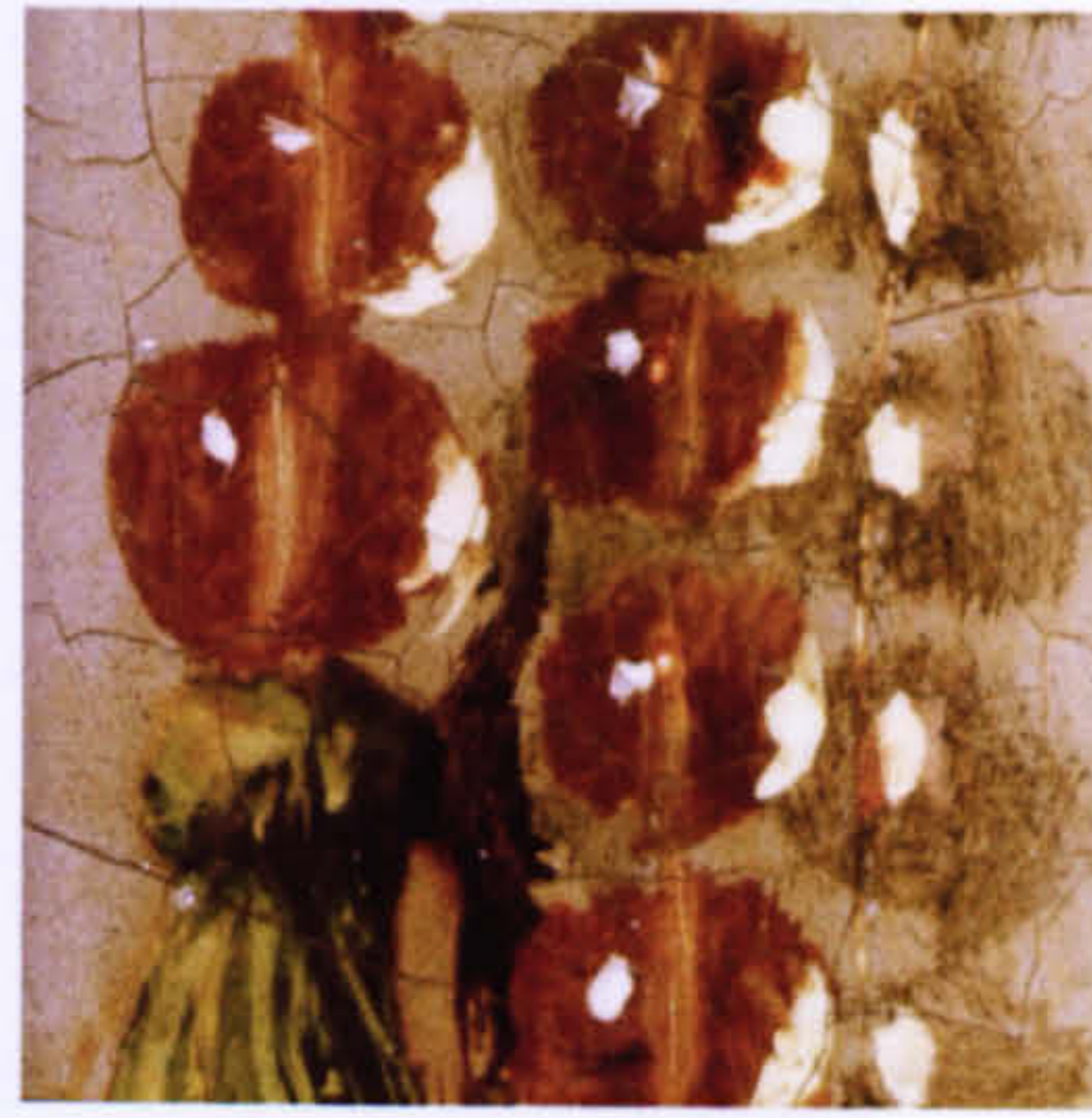

Fig 4.2 - Micrograph detail of beads (4xM), *Arnolfini Double Portrait*.

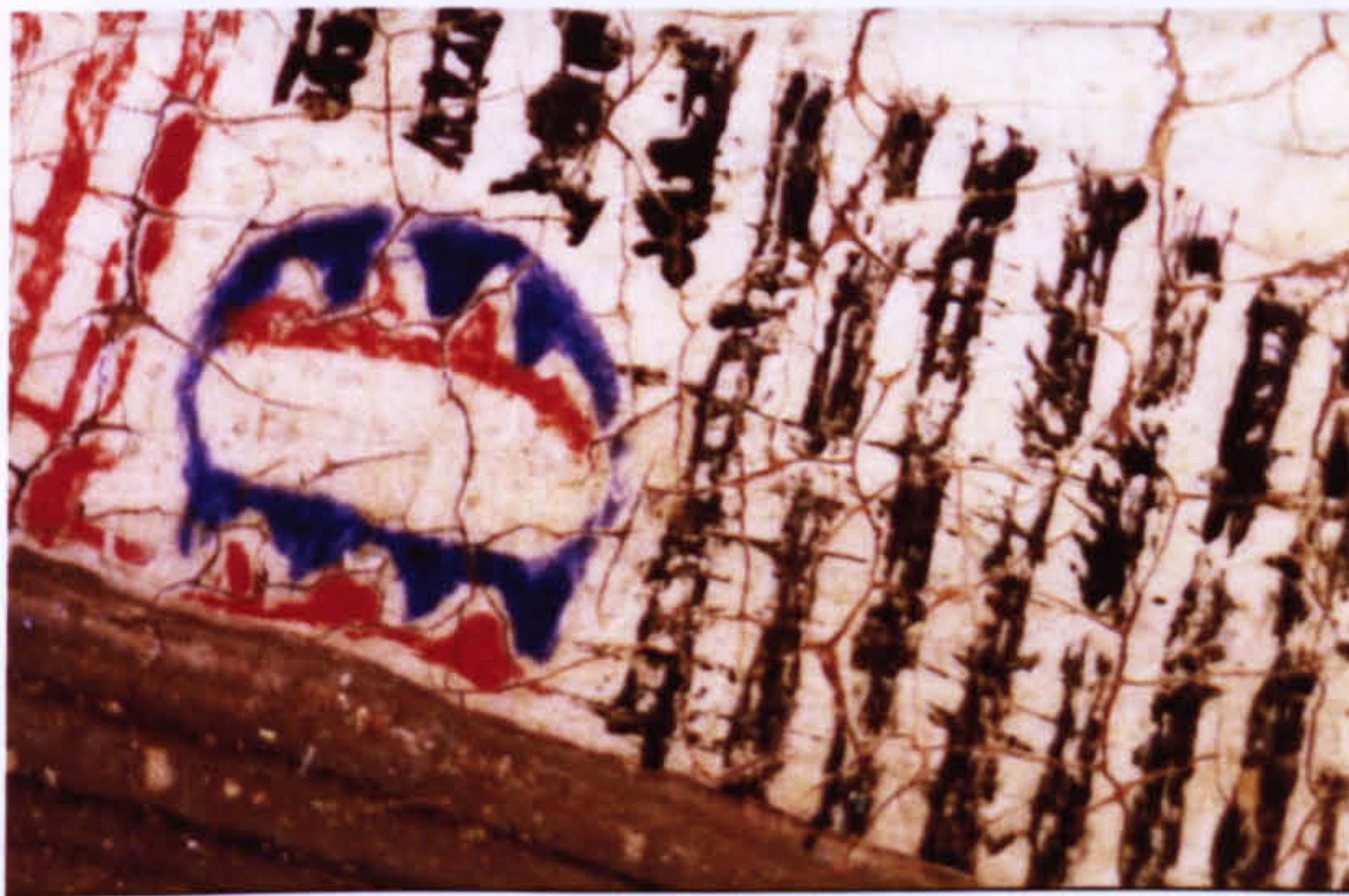

Fig 4.3 - Micrograph detail of book (4xM), *Magdalen Reading*.



Fig 4.4 - Micrograph detail of boot (4xM), *Magdalen Reading*.



Fig 4.5 - Micrograph detail of brush (4xM), *Arnolfini Double Portrait*.



Fig 4.6 - Micrograph detail of shadow cast by the dog (4xM), *Arnolfini Double Portrait*.



Fig 4.7 - Detail of background landscape (2xM), *Turin Saint Francis*.

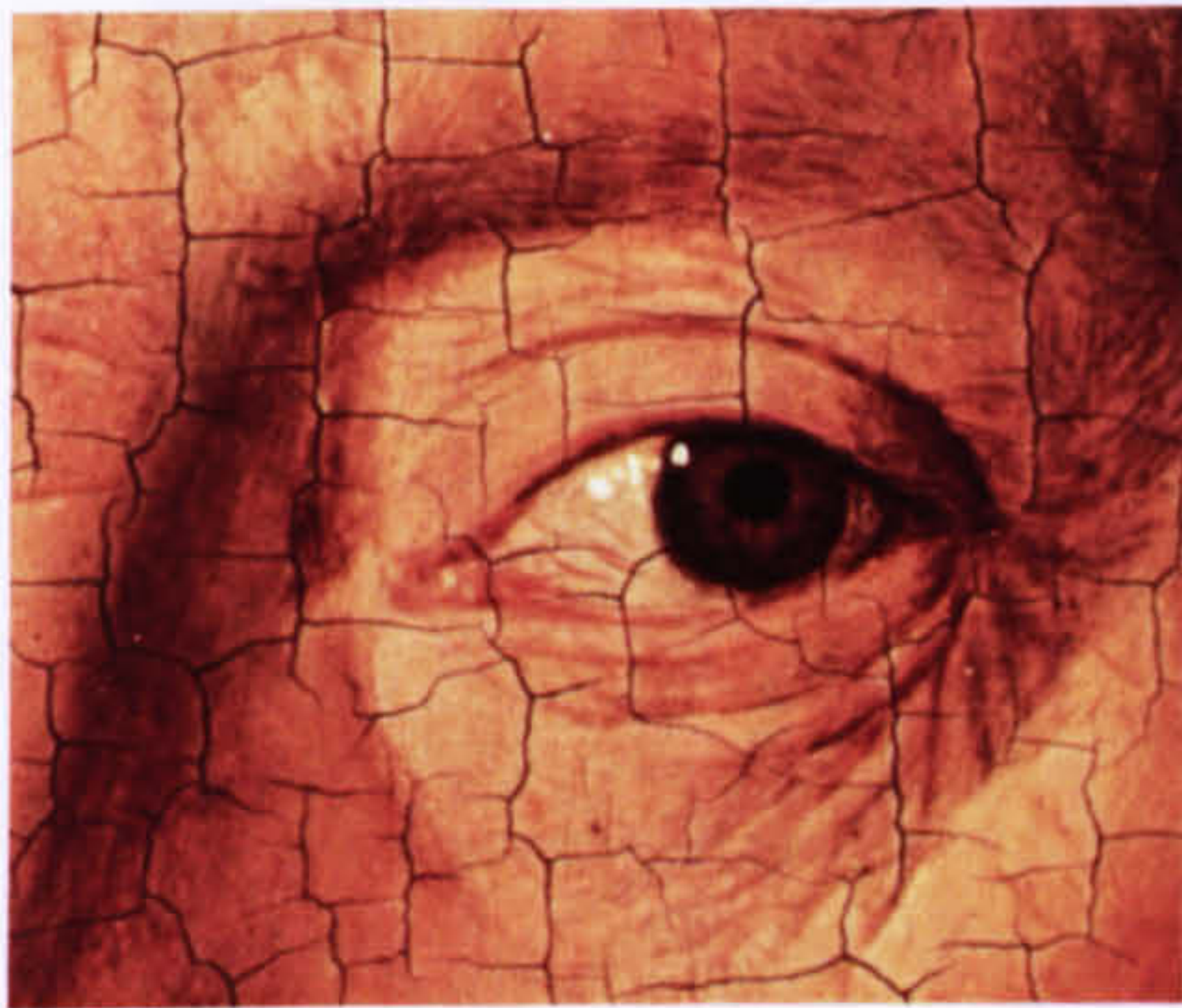

Fig 4.8 - Detail of eye (2xM), *Man with a Red Chaperon*.



Fig 4.9 - Detail of fur trim (2xM), *Arnolfini Double Portrait*.

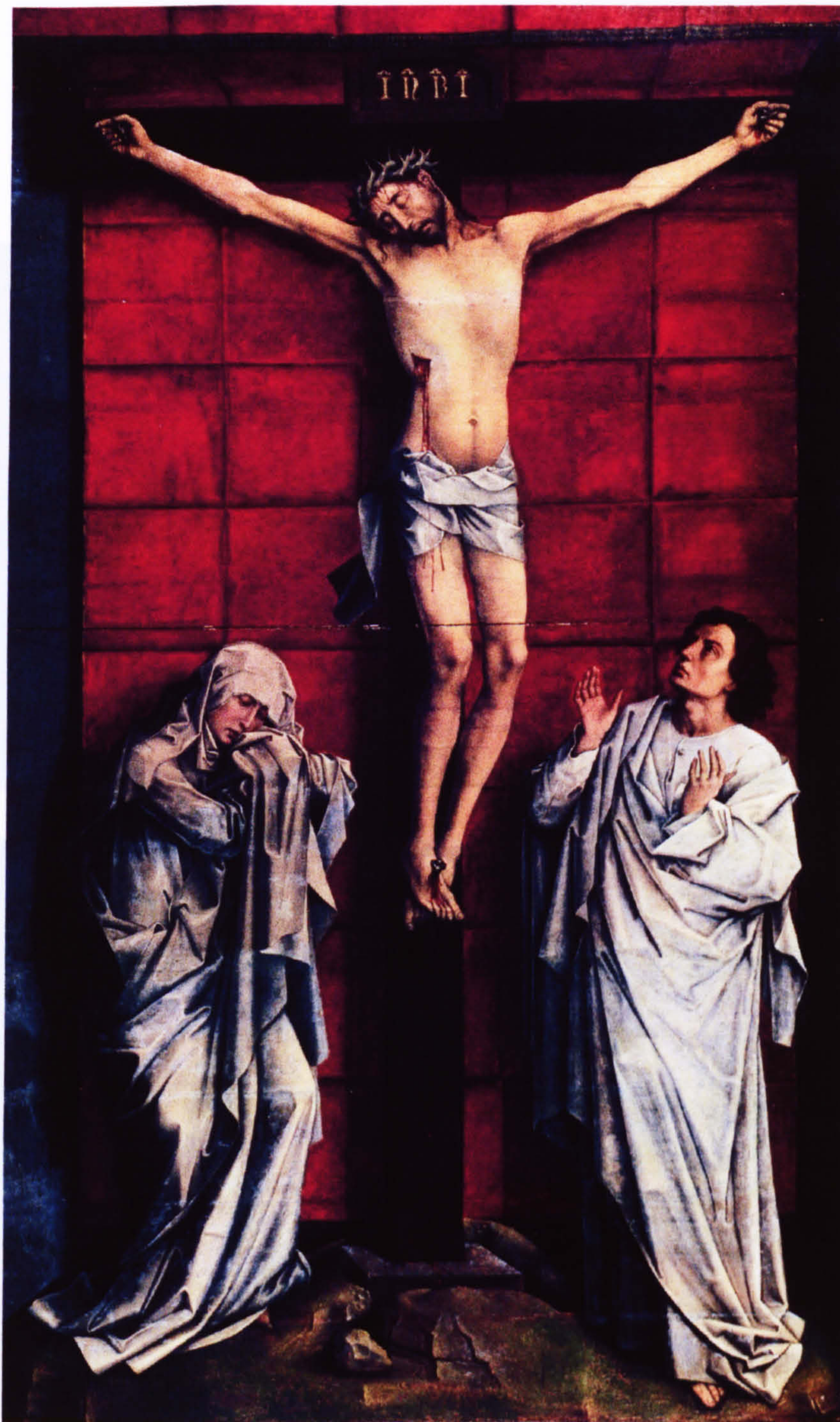

Fig 4.10 - Rogier van der Weyden, *Scheut Crucifixion*, c.1454-55. 325 x 192 cm. Real Monasterio de San Lorenzo, El Escorial.



Fig 4.11 - Rogier van der Weyden, *Crucifixion Diptych*, c.1463-64. 180.3 x 92.6 cm (left) and 180.3 x 92.3 cm (right). Philadelphia Museum of Art.



Fig 4.12 - Rogier van der Weyden, *Polyptych of the Last Judgement*, exterior, c.1443-51. Approx 220 x 273 cm. Musée de l'Hôtel-Dieu, Beaune.



Fig 4.13 - Rogier van der Weyden, *Polyptych of the Last Judgement*, interior, c.1443-51. Approx 220 x 547 cm. Musée de l'Hôtel-Dieu, Beaune.



Fig 4.14 - Detail of the Virgin (1:1), *Last Judgement*.

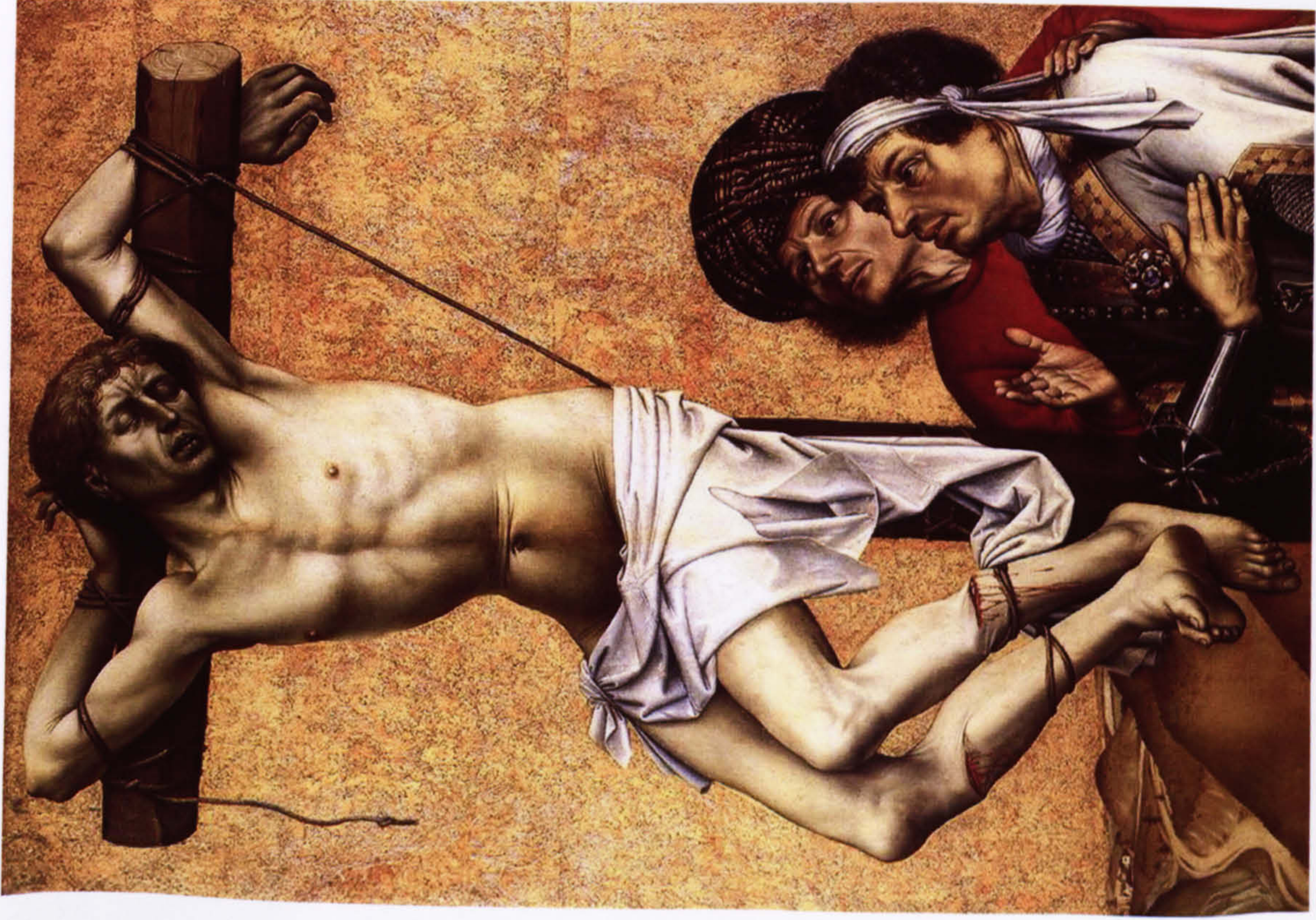

Fig 4.15 - Robert Campin, *Thief on the Cross*, c.1428-32.
133.7 x 92.2 cm. Städtisches Kunstinstitut, Frankfurt am Main.



Fig 4.16 - Detail of landscape (1:1), *Thief on the Cross*.



Fig 4.17 - Detail of townscape, *Ghent Altarpiece*, exterior.



Fig 4.18 - Detail of townscape (1:1), *Ghent Altarpiece*.



Fig 4.19 - Detail of wildflowers (1:1), *Ghent Altarpiece*.



Fig 4.20 - Detail of distant wildflowers (1:1), *Ghent Altarpiece*.

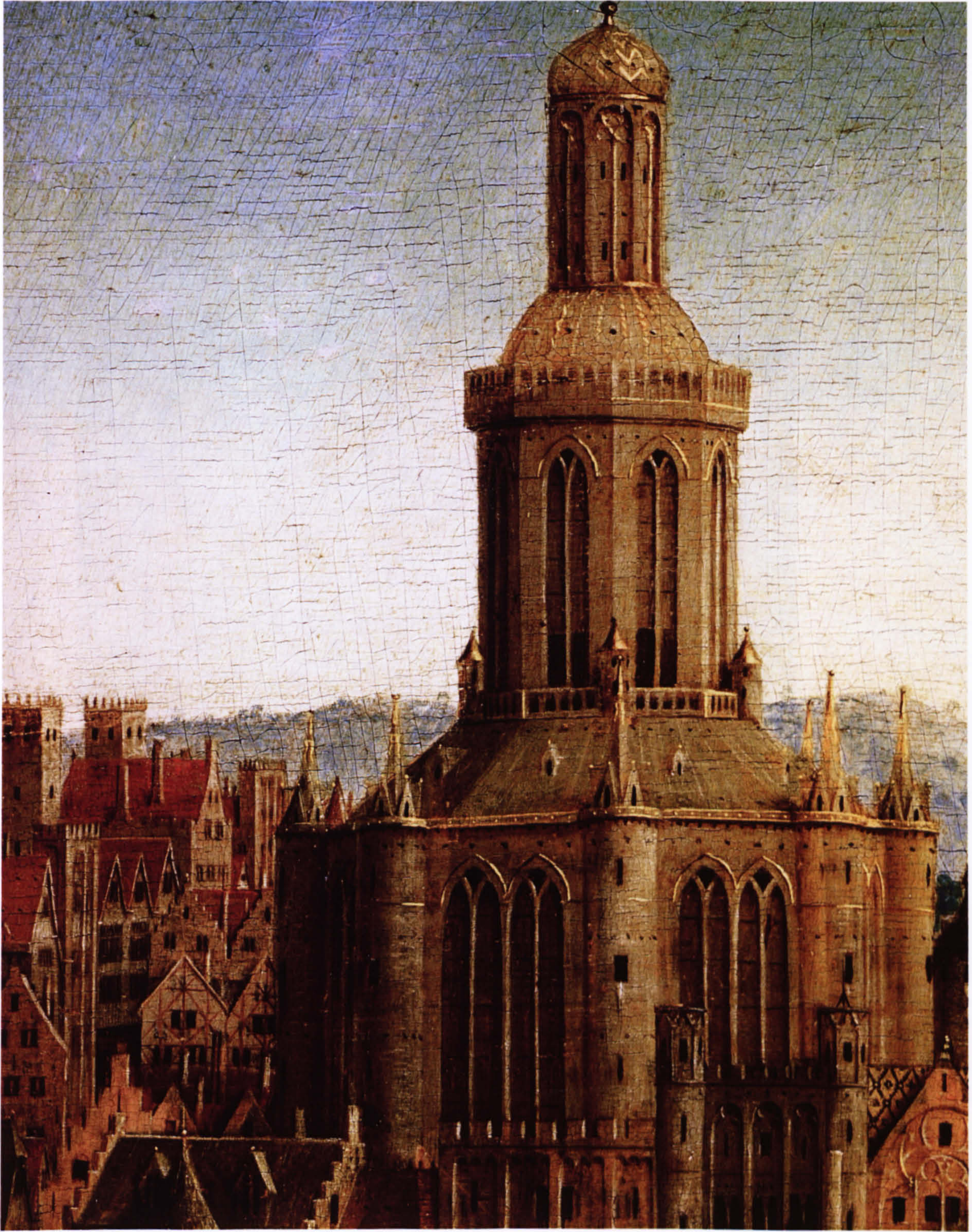

Fig 4.21 - Detail of distant buildings (1:1), *Ghent Altarpiece*.



Fig 4.22 - Detail of plants (1:1), *Last Judgement*.



Fig 4.23 - Detail of hermits (1:1), *Ghent Altarpiece*.

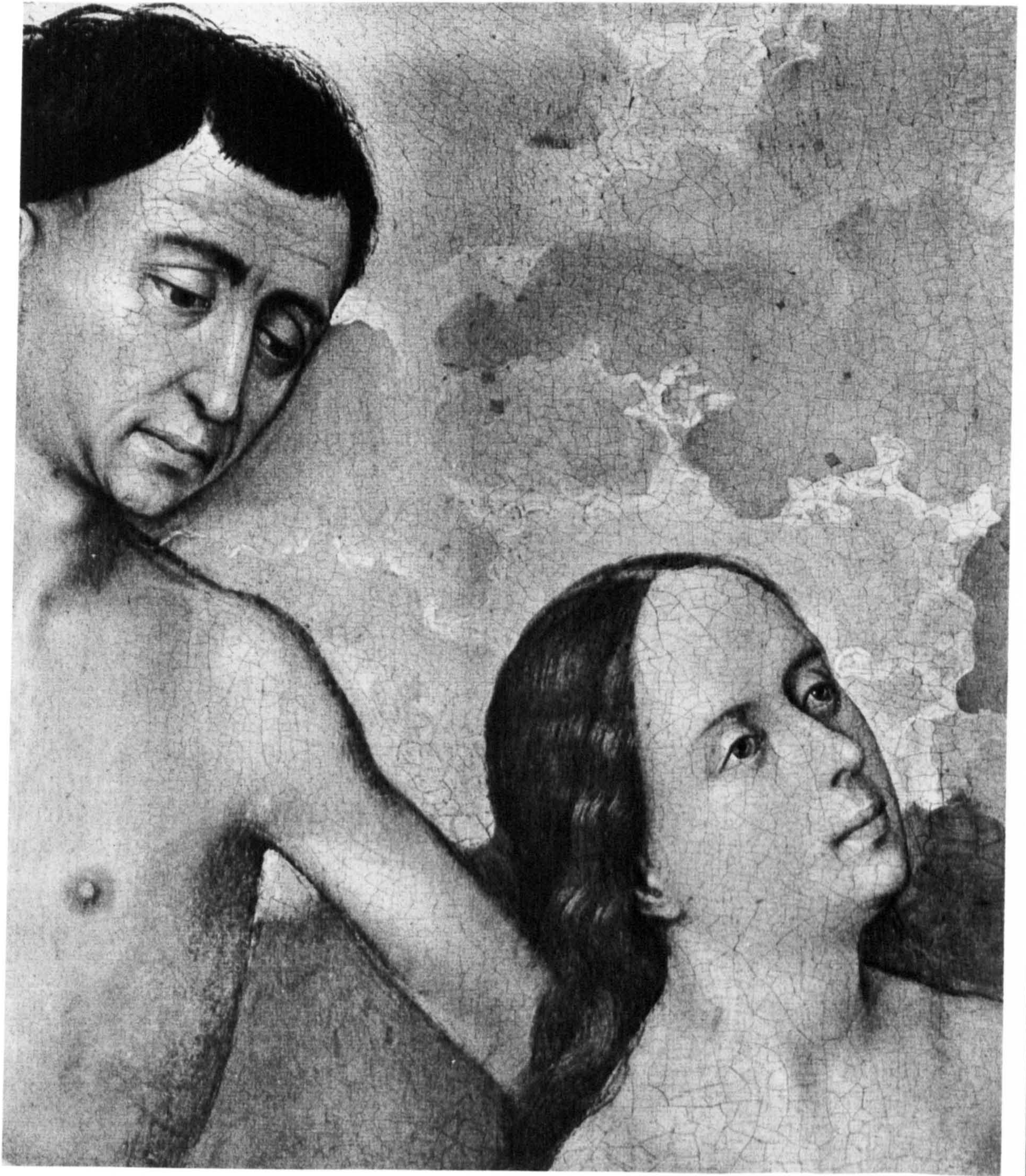

Fig 4.24 - Detail of resurrected souls (1:1), *Last Judgement*.



Fig 4.25 - Detail of the Fountain of Life (1:1), *Ghent Altarpiece*.

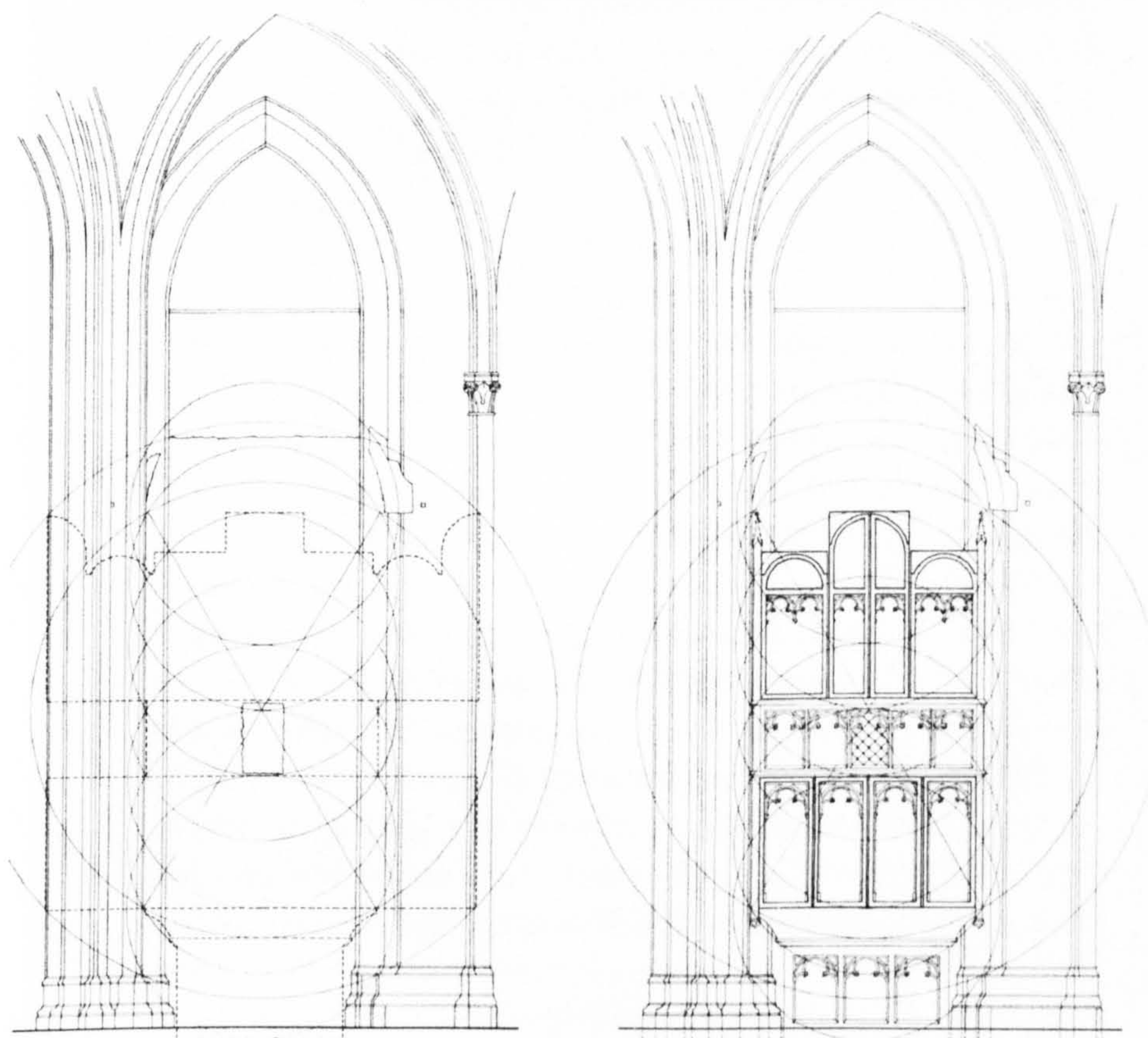

Fig 4.26 - Reconstruction drawing of the Ghent Altarpiece in the Vijd Chapel, as suggested by Dhanens.



Fig 4.27 - Detail of Chancellor Rolin (1:1), *Last Judgement*, exterior.

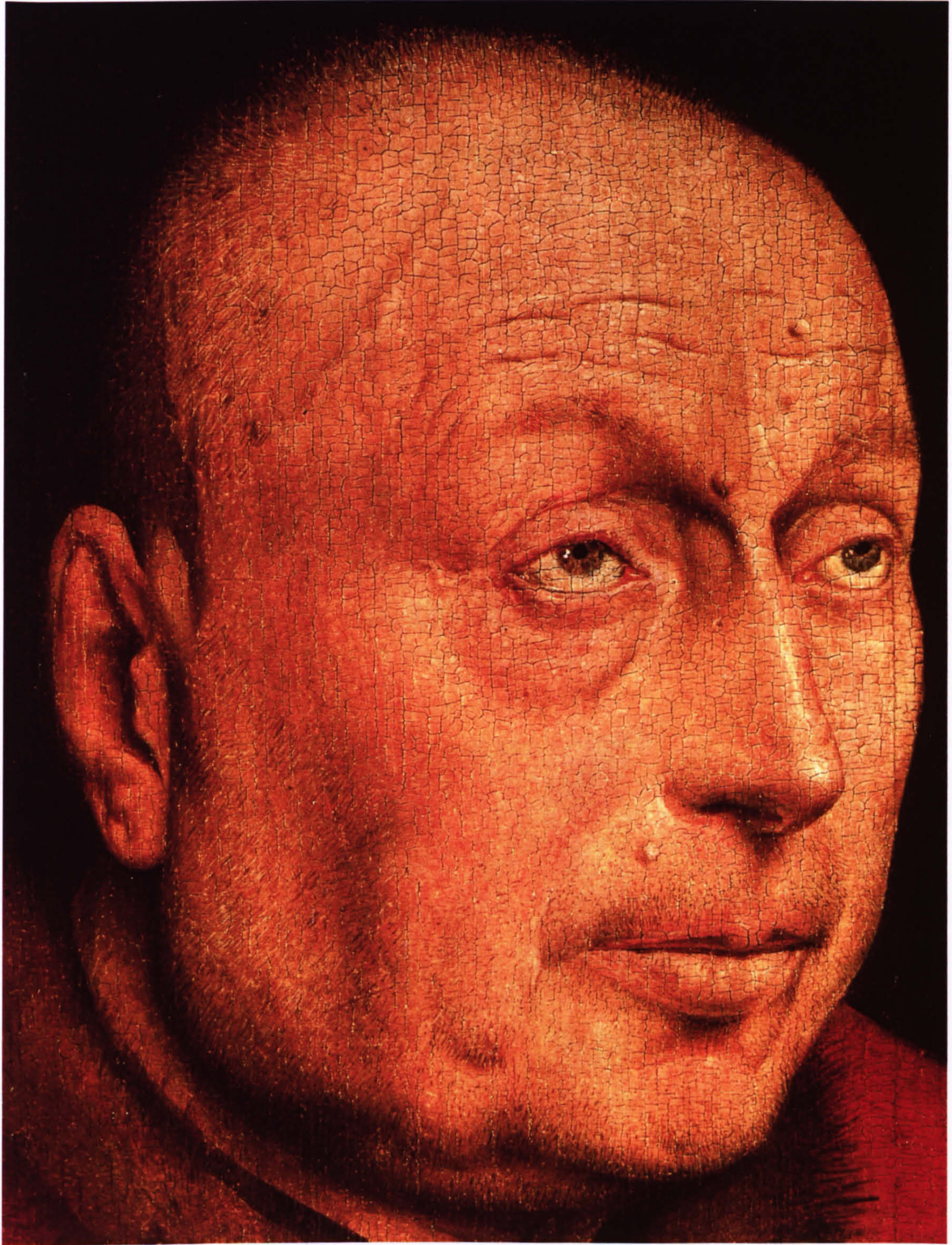

Fig 4.28 - Detail of Jodocus Vijd's head (1:1), *Ghent Altarpiece*, exterior.



Fig 4.29 - Detail of God's brooch (1:1),
Ghent Altarpiece, interior.



Fig 4.30 - Detail of gemstones on the
Virgin's halo (1:1), *Virg*



Fig 4.31 - Detail of Eve's hair (1:1), *Ghent Altarpiece*, interior.

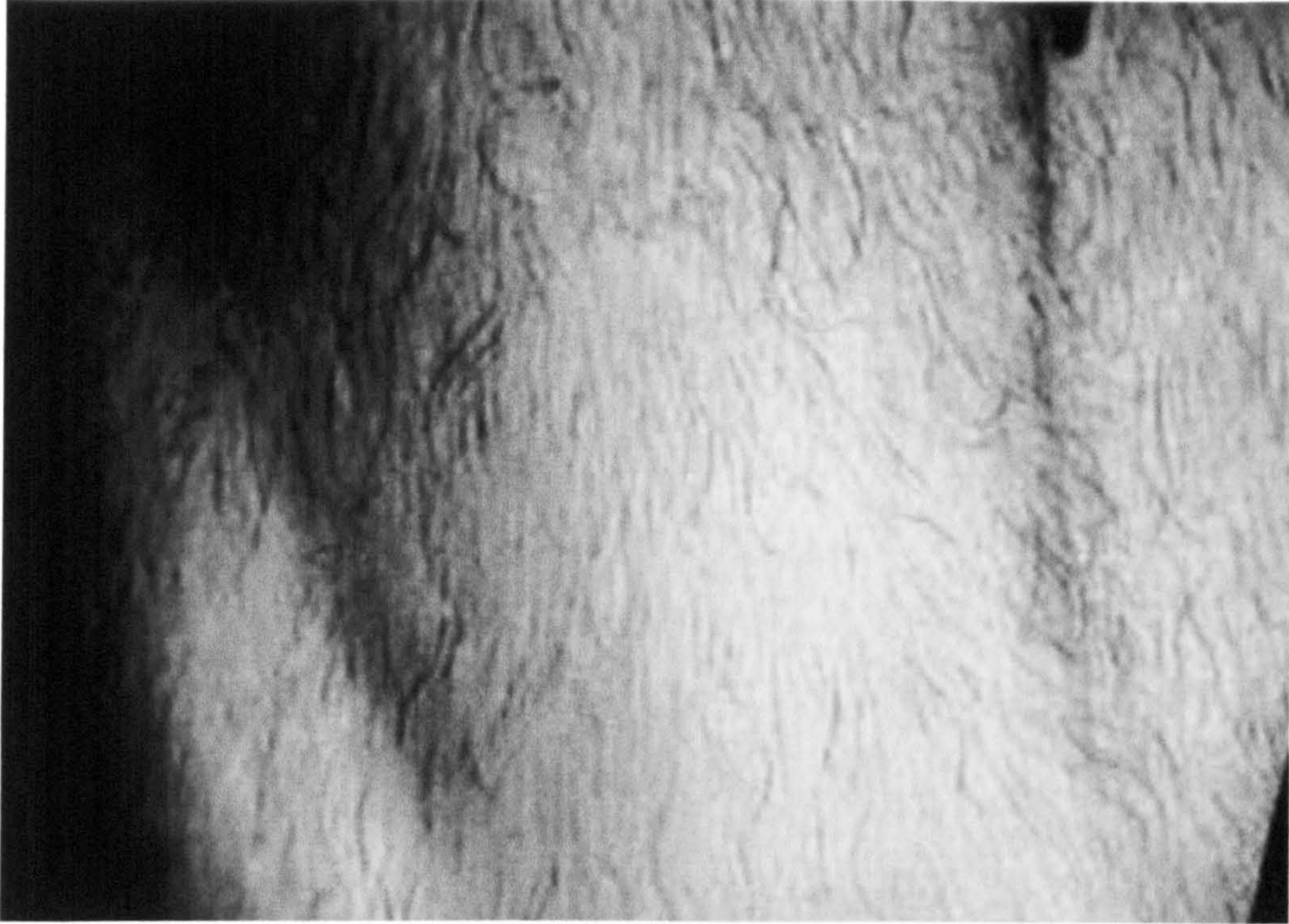

Fig 4.32 - Detail of Adam's leg, *Ghent Altarpiece*, interior.



Fig 4.33 - Detail of van der Paele's head (1:1),
van der Paele Virgin.



Fig 4.34 - Detail of Donatian's cope (1:1), *van der Paele Virgin*.

Fig 4.35 - Detail of
Donatian's cope (1:1),
van der Paele Virgin.



Fig 4.35 - Detail of
Donatian's cross (1:1),
van der Paele Virgin.



Fig 4.37 - Detail of carpet edge (1:1), *van der Paele Virgin*.



Fig 4.36 - Detail of Donatian's morse (1:1), *van der Paele Virgin*.



Fig 4.38 - Rogier van der Weyden, *Descent from the Cross*, c.1430-35. 220.5 x 259.5 cm. Museo del Prado, Madrid.



Fig 4.39 - Detail of Nicodemus's brocade (1:1), *Descent from the Cross*.

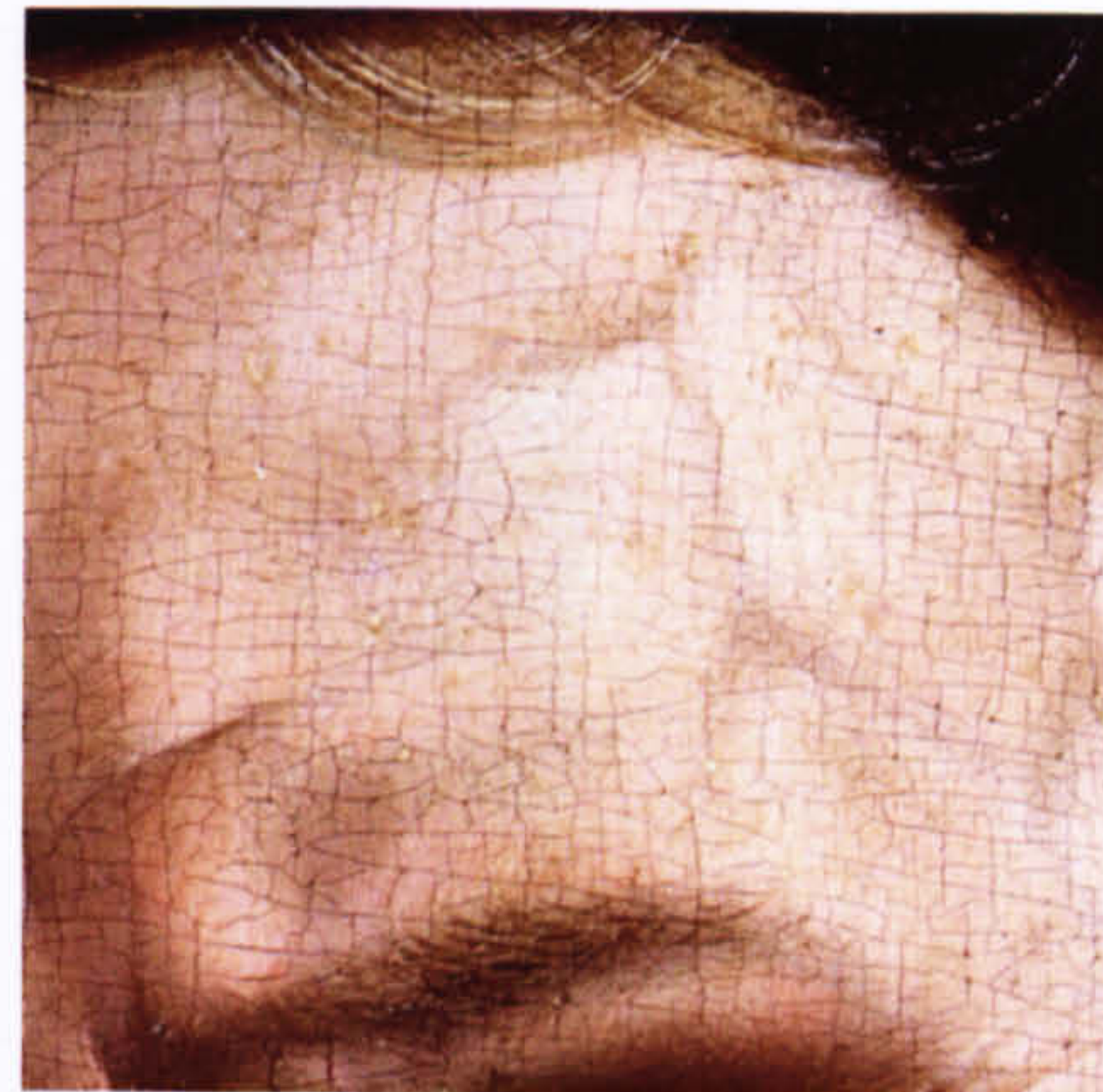

Fig 4.40 - Detail of Nicodemus's hair (1:1), *Descent from the Cross*.

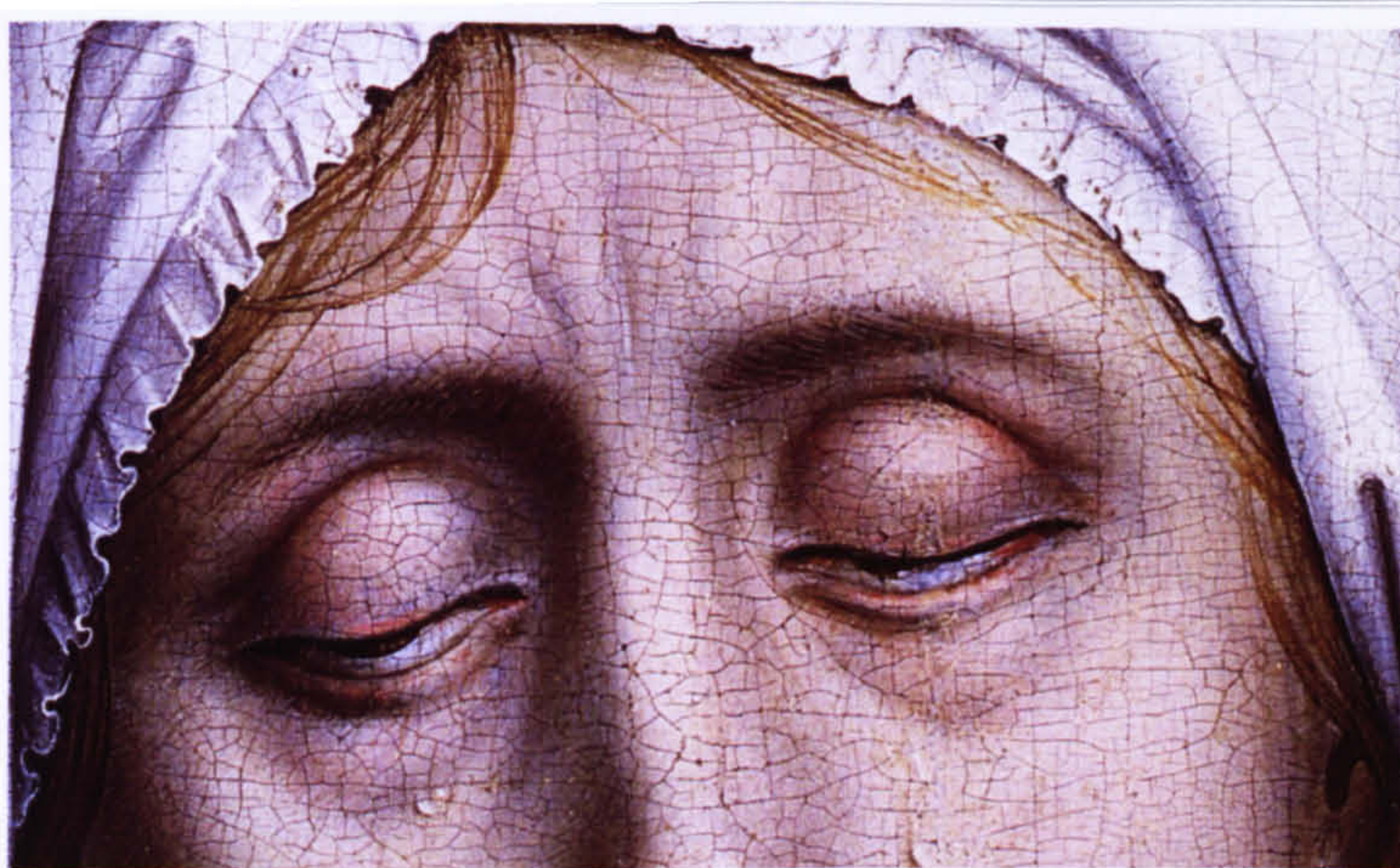

Fig 4.41 - Detail of the Virgin's hair (1:1), *Descent from the Cross*.



Fig 4.42 - Detail of the Virgin's hair (1:1), *van der Paele Virgin*.

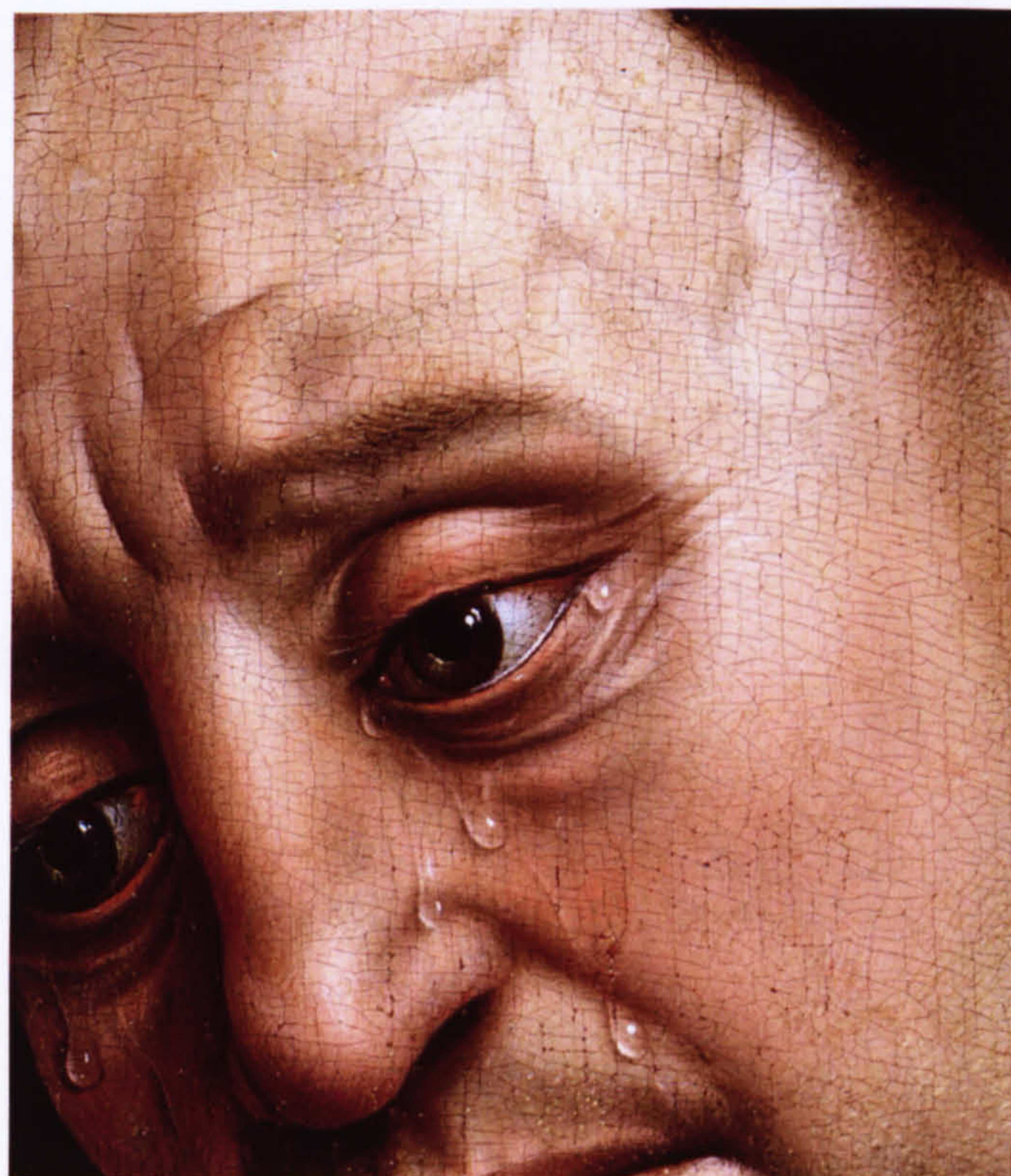

Fig 4.43 - Detail of Nicodemus's face (1:1), *Descent from the Cross*.



Fig 4.44 - Detail of trim on Joseph of Arimathea's clothing (1:1), *Descent from the Cross*.



Fig 4.45 - Rogier van der Weyden, *Saint Luke Drawing the Virgin*, c.1435-36. 137.5 x 110.8 cm. Museum of Fine Arts, Boston.



Fig 4.46 - 1.5xM



Fig 4.47 - 1.5xM



Fig 4.48 - 1.5xM



Fig 4.49 - 1.5xM

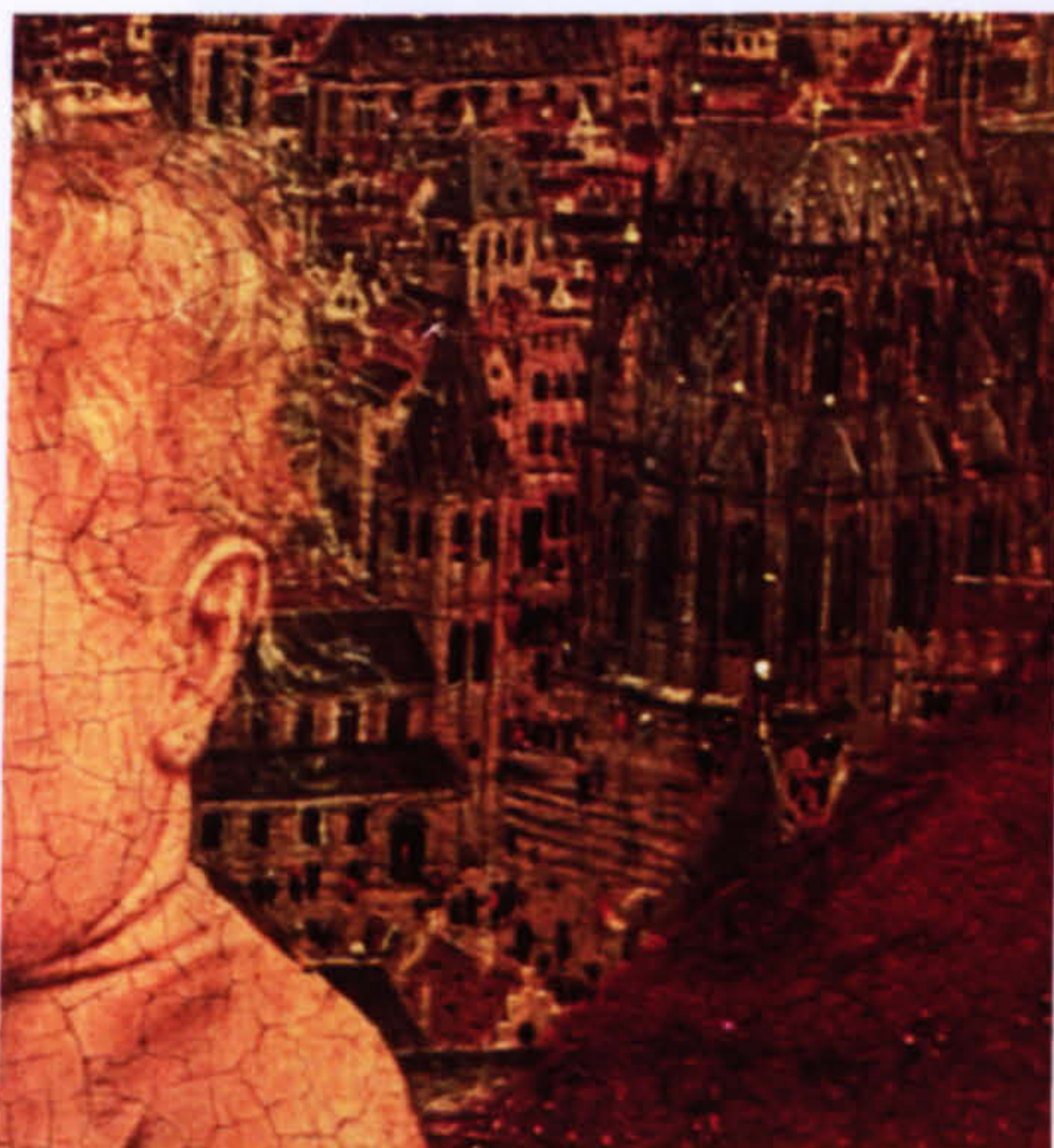

Fig 4.50 - 1.5xM



Fig 4.51 - 1:1.



Fig 4.52 - Detail of Rolin's gown (1.5xM), *Rolin Virgin*.



Fig 4.53 - Detail of Rolin's stubble (1.5xM), *Rolin Virgin*.



Fig 4.54 - Detail of Saint Luke's head (1:1), *Saint Luke*.



Fig 4.55 - Detail of garden (1:1), *Rolin Virgin*.



Fig 4.56 - Detail of garden (1:1), *Saint Luke*.

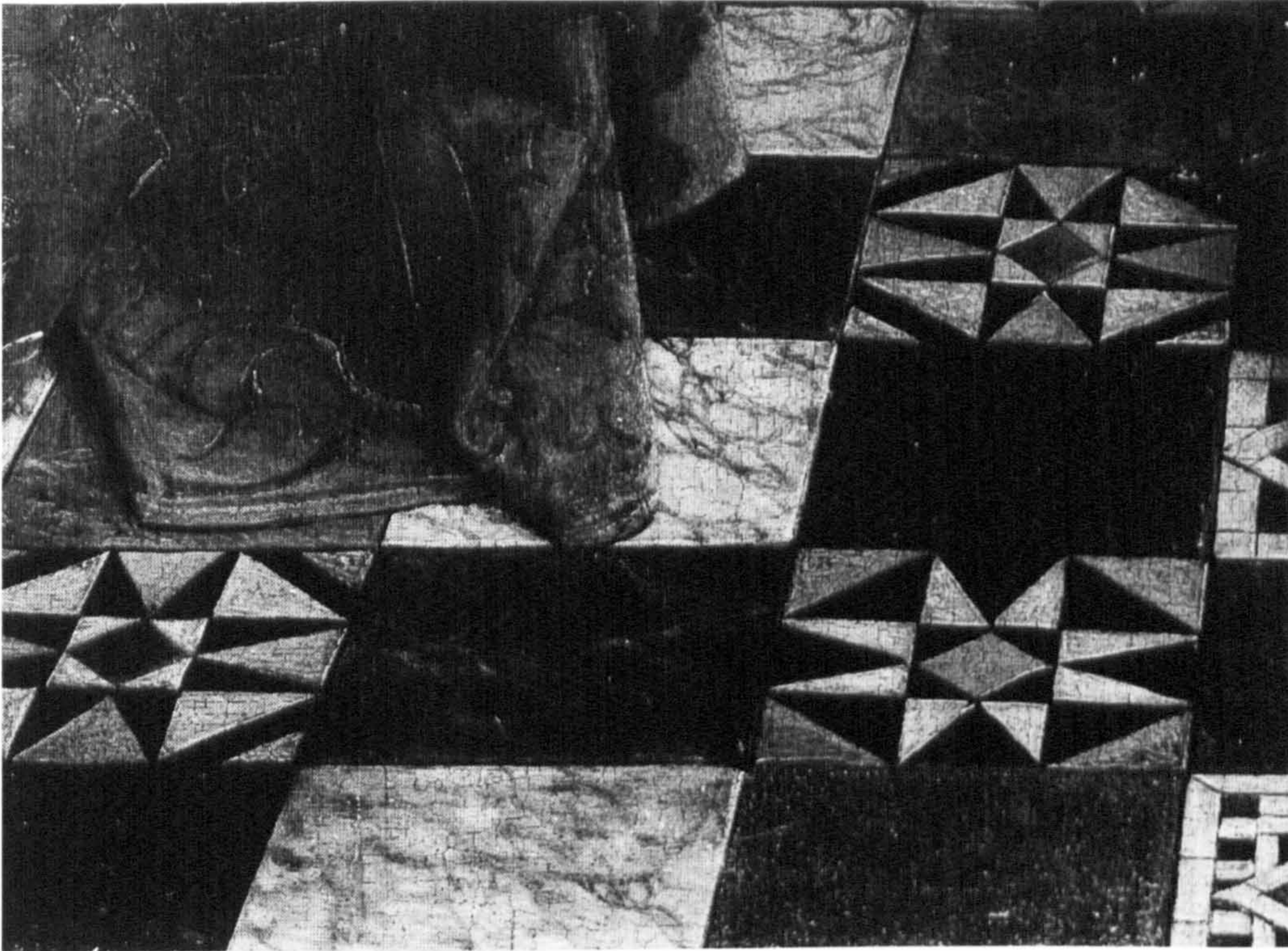

Fig 4.57 - Detail of floor tiles (1:1), *Rolin Virgin*.

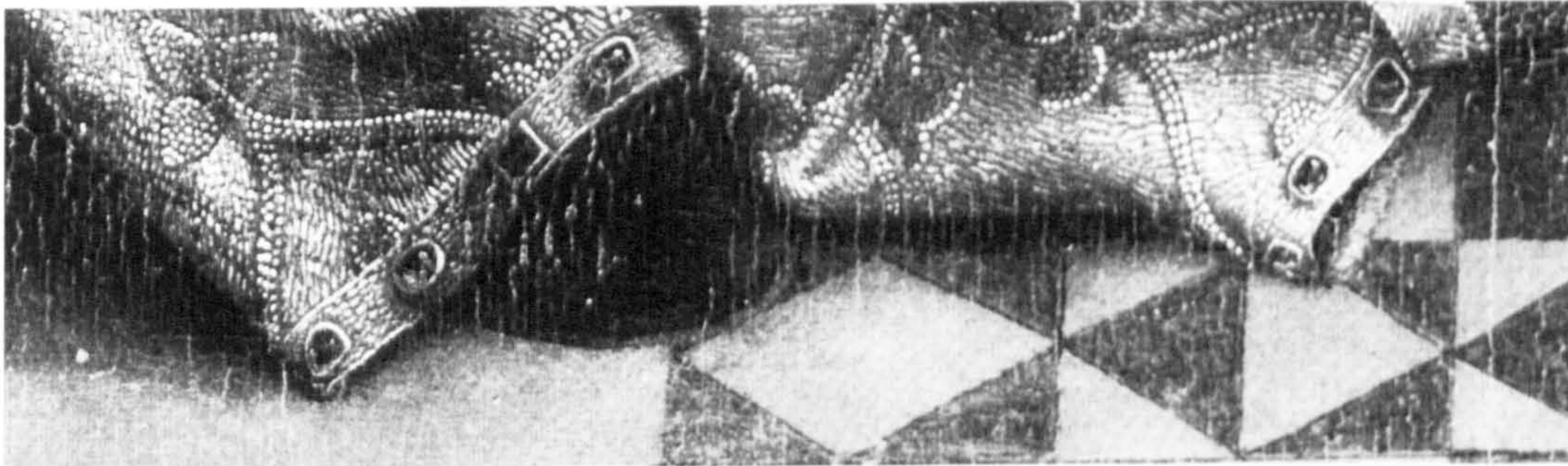

Fig 4.58 - Detail of floor tiles (1:1), *Saint Luke*.



Fig 4.59 - Rogier van der Weyden, *Portrait of a Woman*, c.1432-35. 47.0 x 32.0 cm. Staatliche Museen, Gemäldegalerie, Berlin.



Fig 4.60 - Detail of face (1:1), *Portrait of a Woman*.

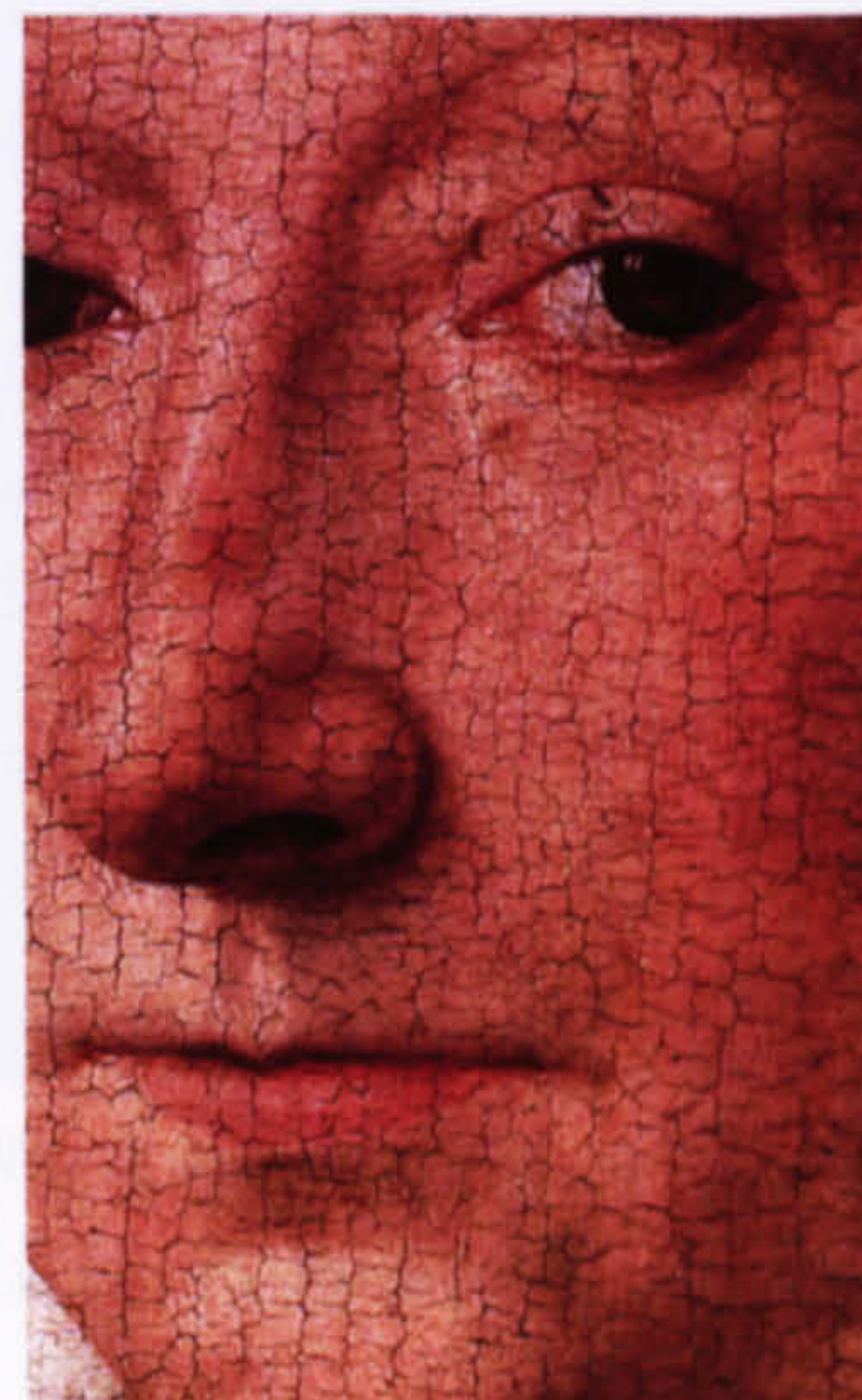

Fig 4.61 - Detail of face (1:1), *Margaret van Eyck*.



Fig 4.62 - Rogier van der Weyden, *Portrait of a Lady*, c.1463-64, National Gallery of Art, Washington D.C.



Fig 4.63 - Detail of hands and buckle (1:1), *Portrait of a Lady*.



Fig 4.64 - Detail of face (1:1), *Portrait of a Lady*.



Fig 4.65 - Detail of face (1:1),
Portrait of a Man.

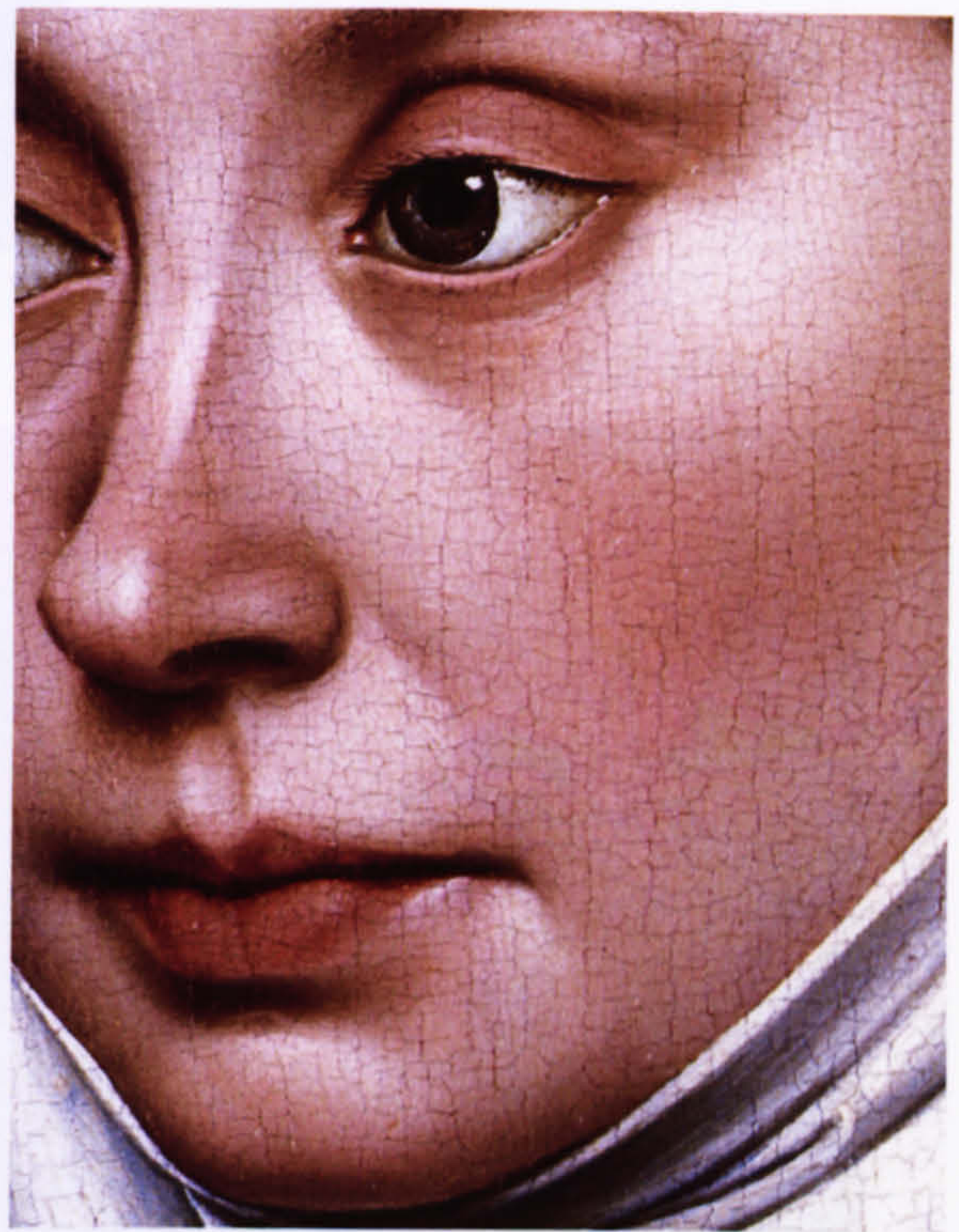

Fig 4.66 - Detail of face (1:1),
Portrait of a Woman.

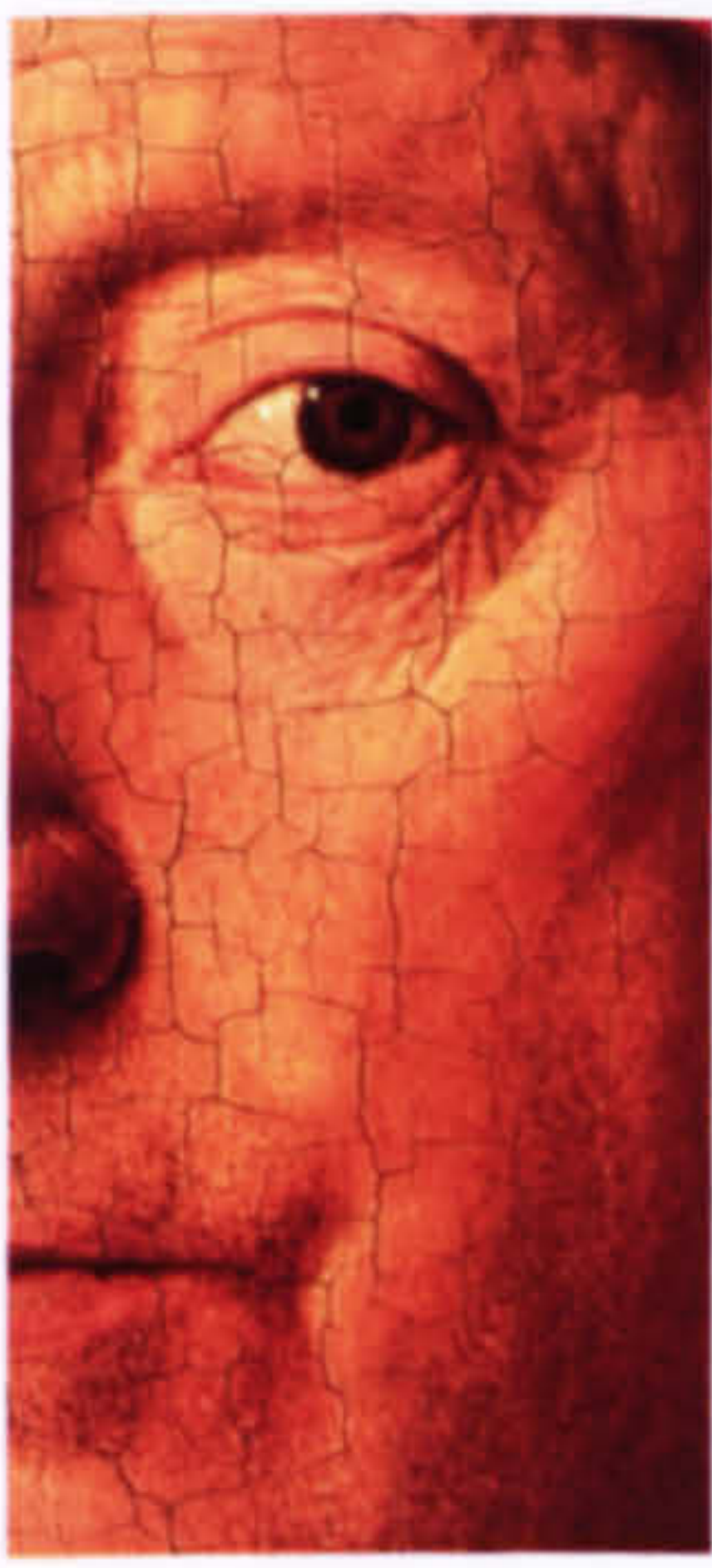

Fig 4.67 - Detail (1:1), *Man in a Red Chaperon*.

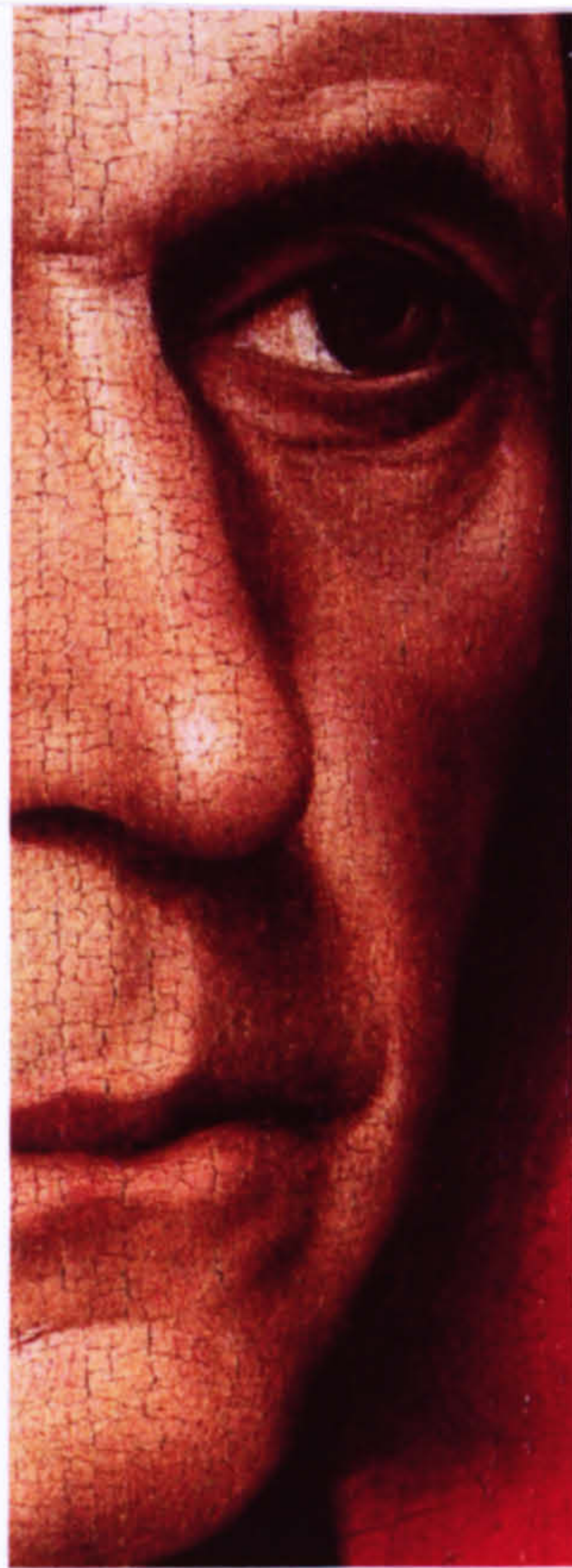

Fig 4.68 - Detail (1:1), *Portrait of a Man*.

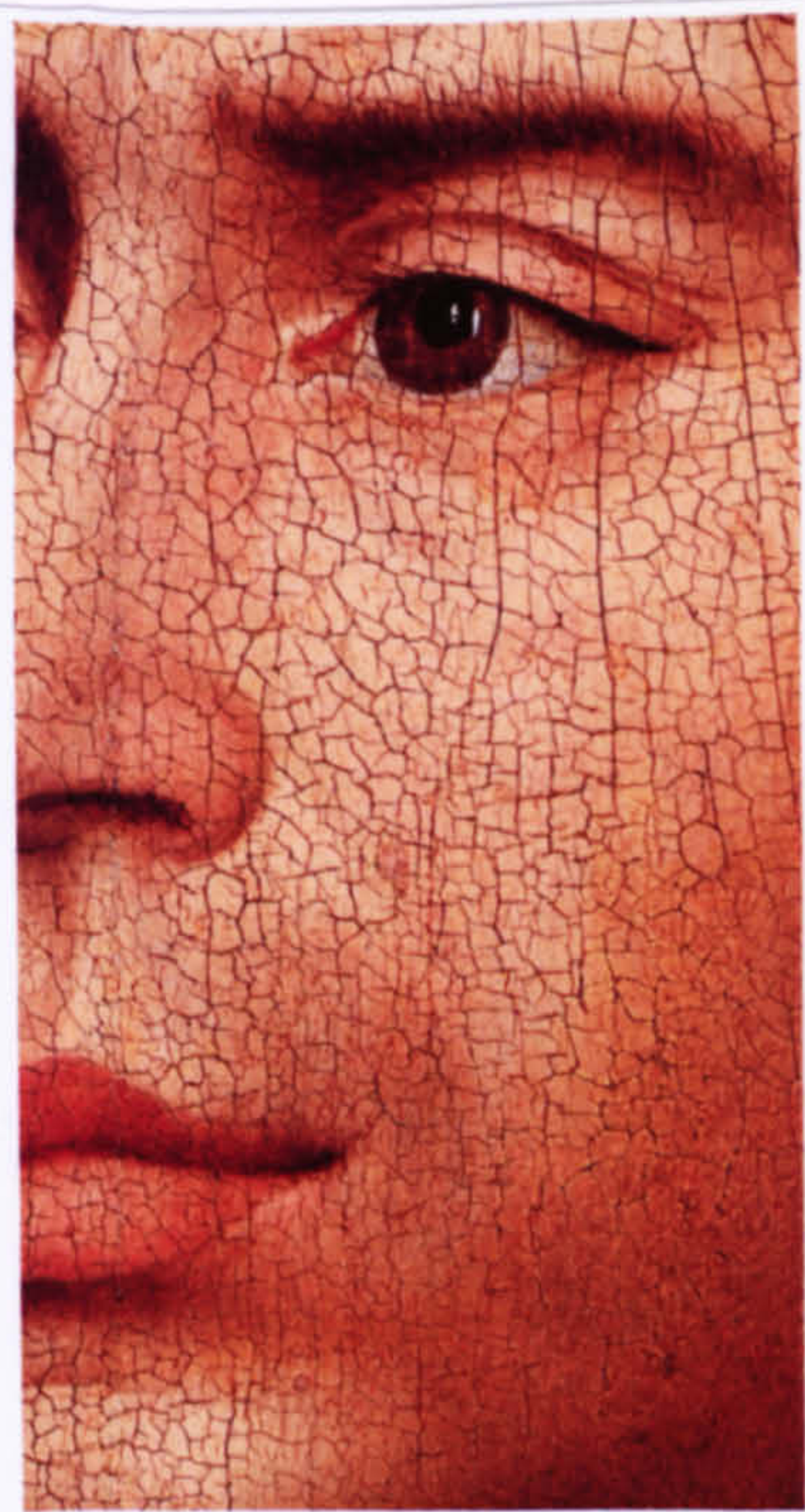

Fig 4.69 - Detail (1:1), *Anthony of Burgundy*.



Fig 4.70 - Detail (2xM), *Anthony of Burgundy*.

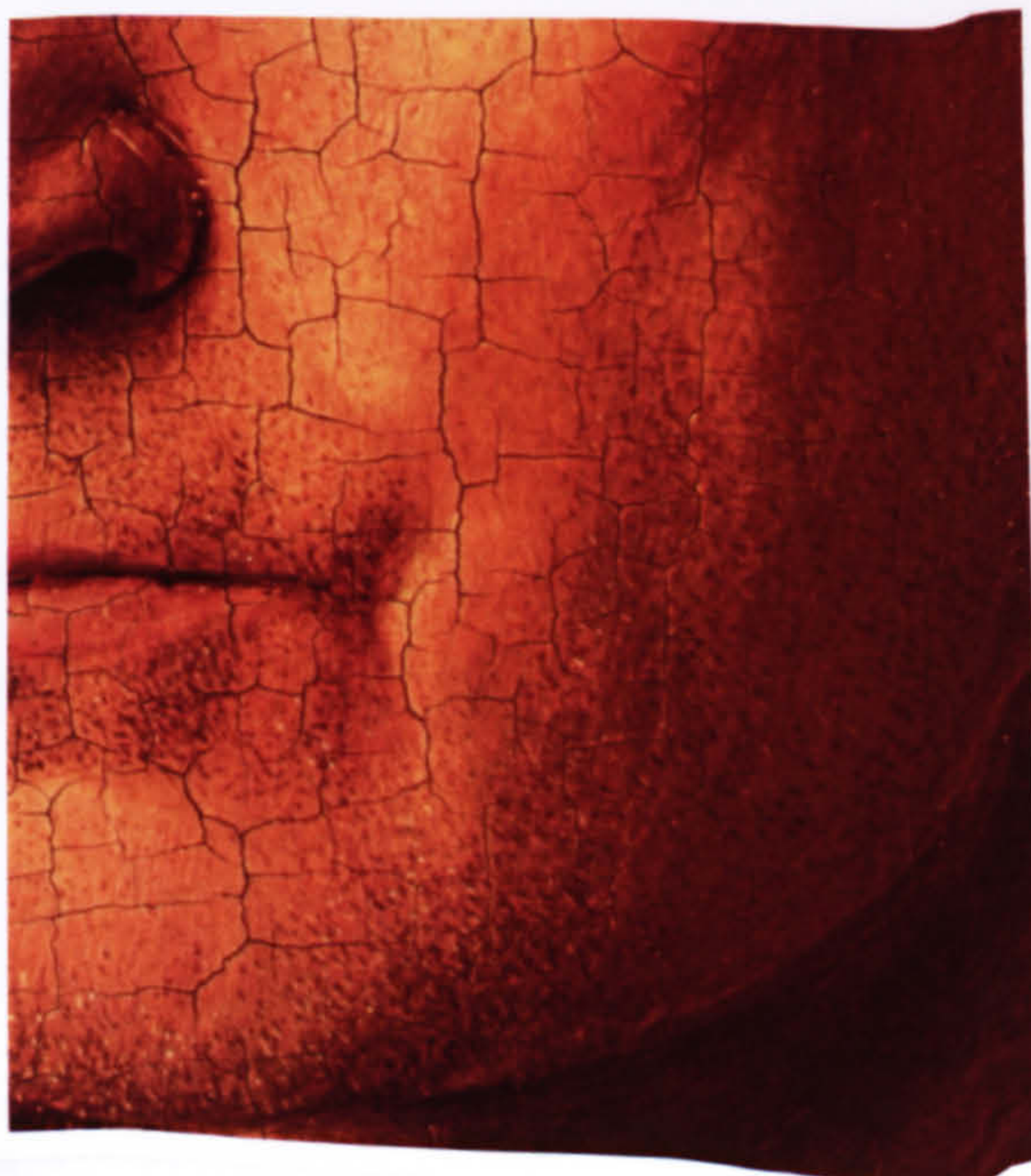

Fig 4.71 - Detail (2xM), *Man in a Red Chaperon*.



Fig 4.72 - Detail of hand (2xM), *Jan de Leeuw*.



Fig 4.73 - Detail of hand (2xM), *Tymotheos*.



Fig 4.74 - Detail of hands (2xM), *Portrait of a Woman*.



Fig 4.75 - Detail of drapery (1:1), *Bladelin Altarpiece*.



Fig 4.76 - Detail of Marriage scene (1:1), *Seven Sacraments Altarpiece*.



Fig 4.77 - Detail (1.4xM),
Saint Catherine.



Fig 4.78 - Detail (1.4xM),
Turin Saint Francis.



Fig 4.79 - Detail (1:1),
Virgin in a Church.



Fig 4.80 - Detail (1:1),
Dresden Triptych.



Fig 4.81 - Detail (2xM),
Dresden Triptych.



Fig 4.82 - Detail (1:1),
Virgin in a Niche.



Fig 4.83 - Detail (2xM),
Virgin Enthroned in a Niche.

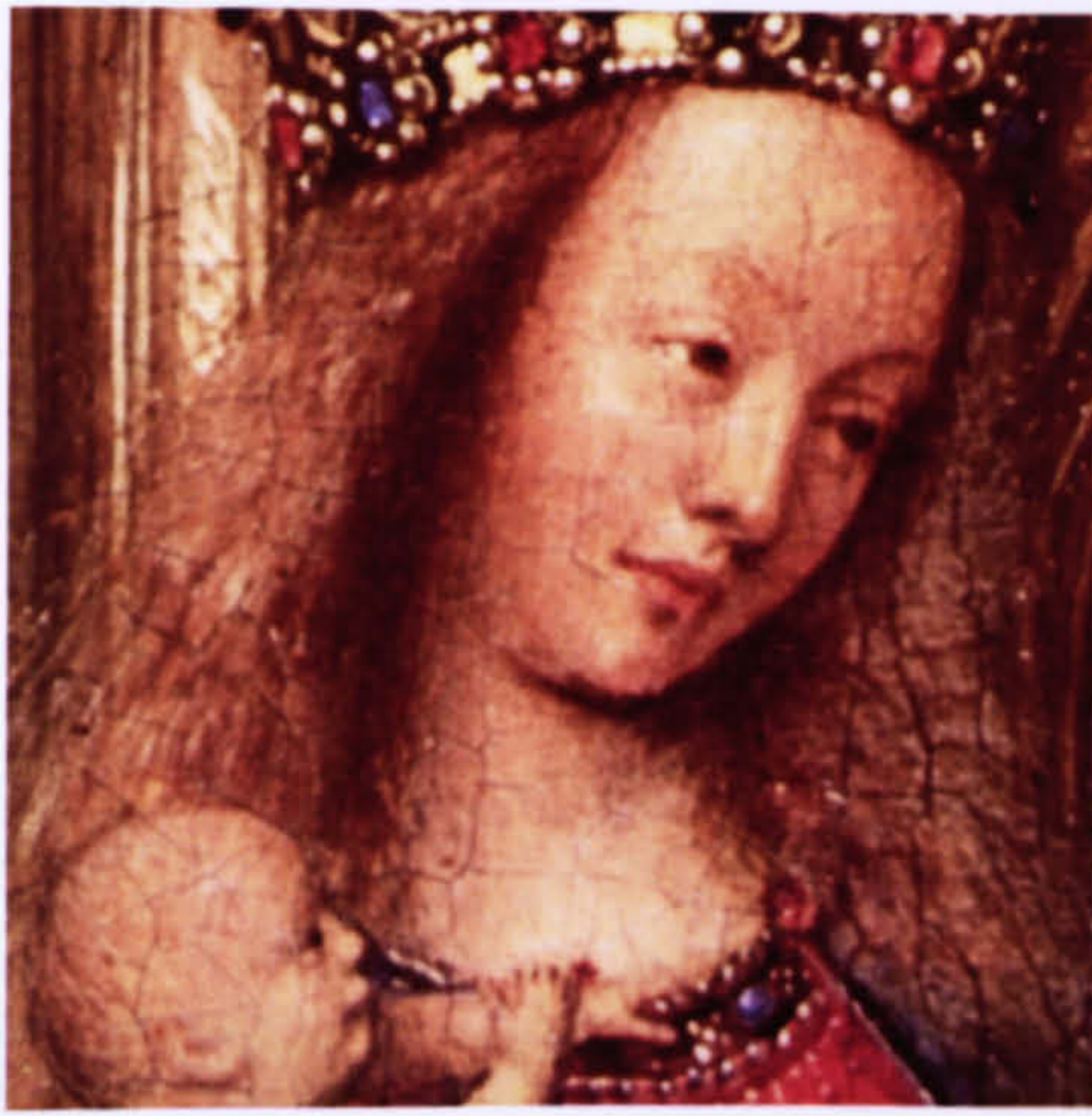

Fig 4.84 - Detail of hair (2xM),
Virgin in a Church.

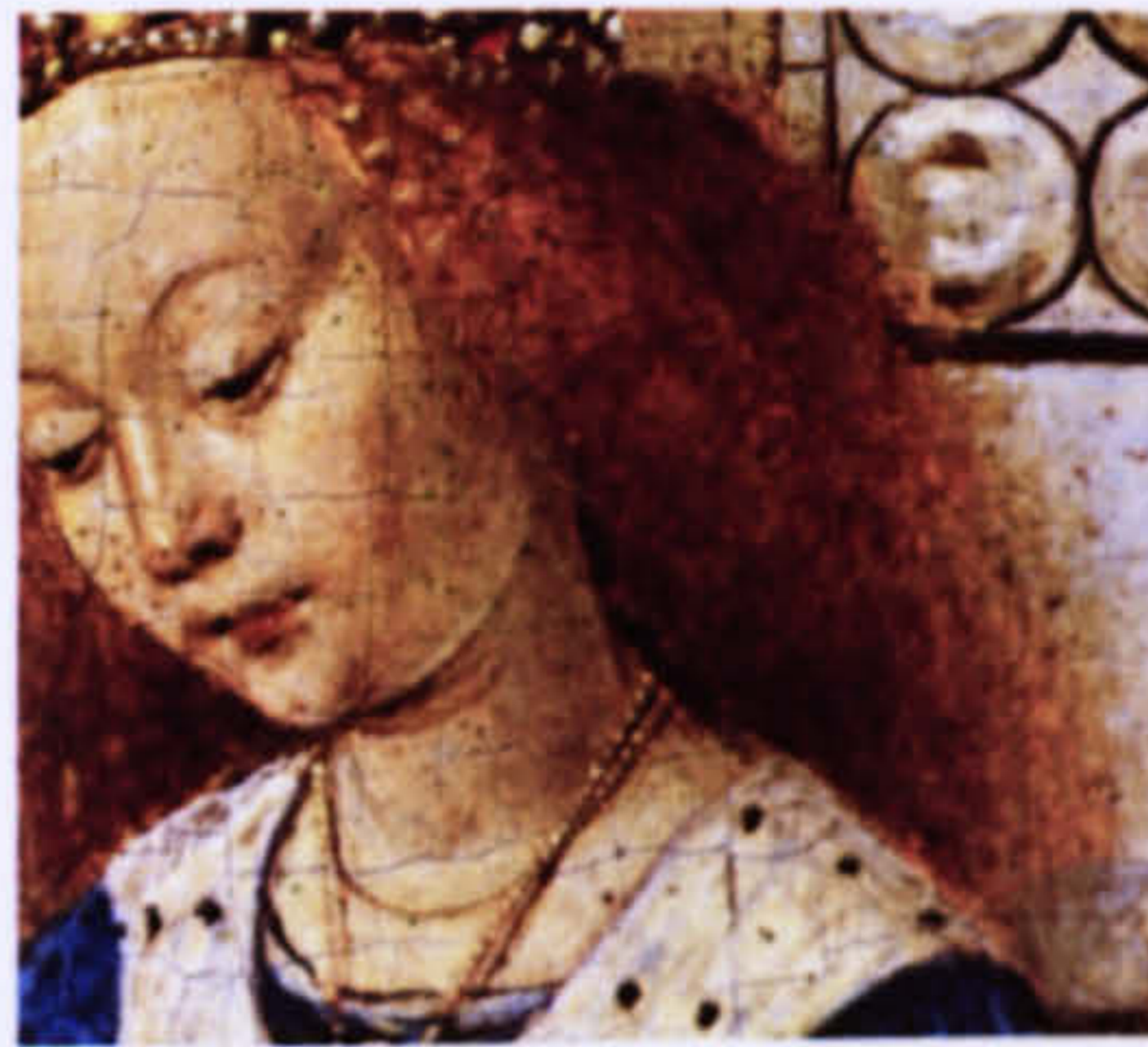

Fig 4.85 - Detail of hair
(2xM), *Dresden Triptych*.

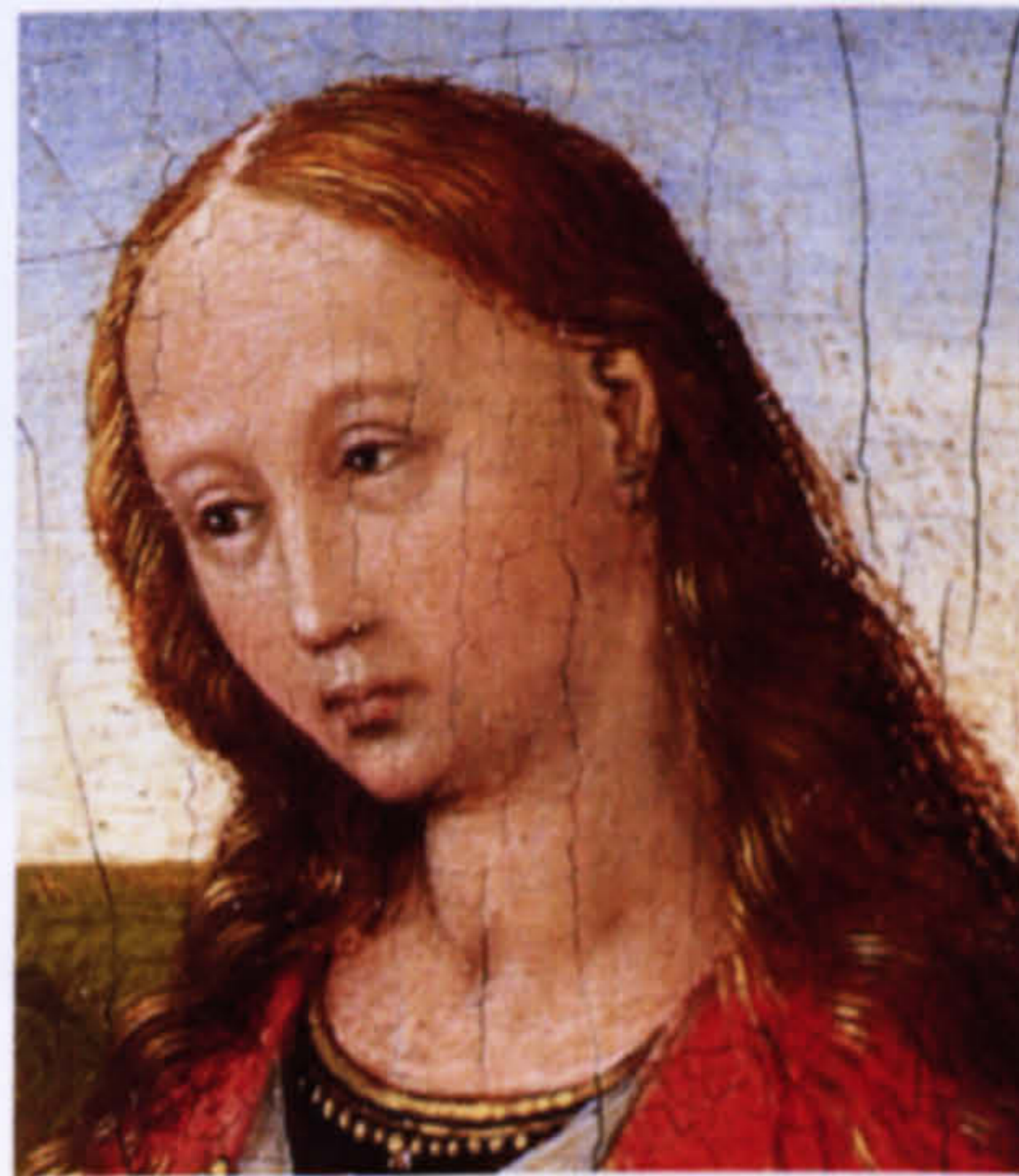

Fig 4.86 - Detail of hair
(2xM), *Saint Catherine*.



Fig 4.87 - Photograph
showing effect of 'depth
of field'.



Fig 4.88 - Jan van Eyck, *Saint Francis Receiving the Stigmata* (1:1), 1430s.
John G. Johnson Collection, Philadelphia Museum of Art.



Fig 4.89 - Jan van Eyck, *Saint Francis Receiving the Stigmata*, 1430s. 29.2 x 33.4 cm. Galleria Sabuda, Turin.

Fig 4.95 - Desch
(G&M), Philadelphia
Saint Francis



Fig 4.90 - Detail (1.7xM), Philadelphia *Saint Francis*.



Fig 4.91 - Detail (2xM), Philadelphia *Saint Francis*.

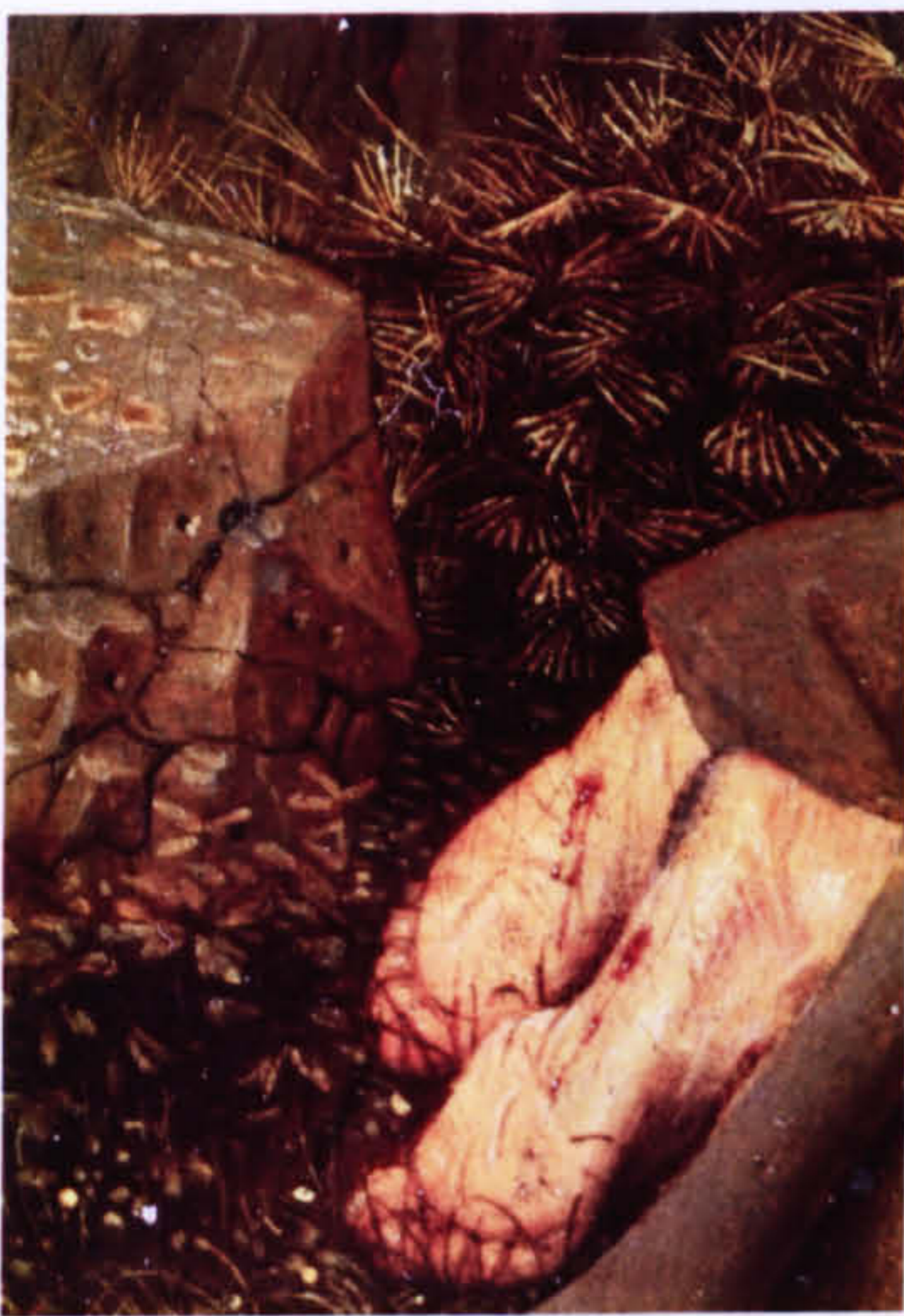

Fig 4.92 - Detail (2xM), Philadelphia *Saint Francis*.



Fig 4.93 - Detail (2xM), Philadelphia *Saint Francis*.



Fig 4.94 - Detail (2xM), Philadelphia *Saint Francis*.



Fig 4.95 - Detail (2xM), Philadelphia *Saint Francis*.



Fig 4.96 - Detail (2xM), Philadelphia *Saint Francis*.



Fig 4.97 - Detail (2xM), Philadelphia *Saint Francis*.



Fig 4.98 - Rogier van der Weyden, *Saint George and the Dragon* (1:1), c.1425-30. National Gallery of Art, Washington D.C.



Fig 4.99 - Detail of figures on a path (2xM), *Saint George*.



Fig 4.100 - Detail of landscape with figures on horseback (2xM), *Saint George*.

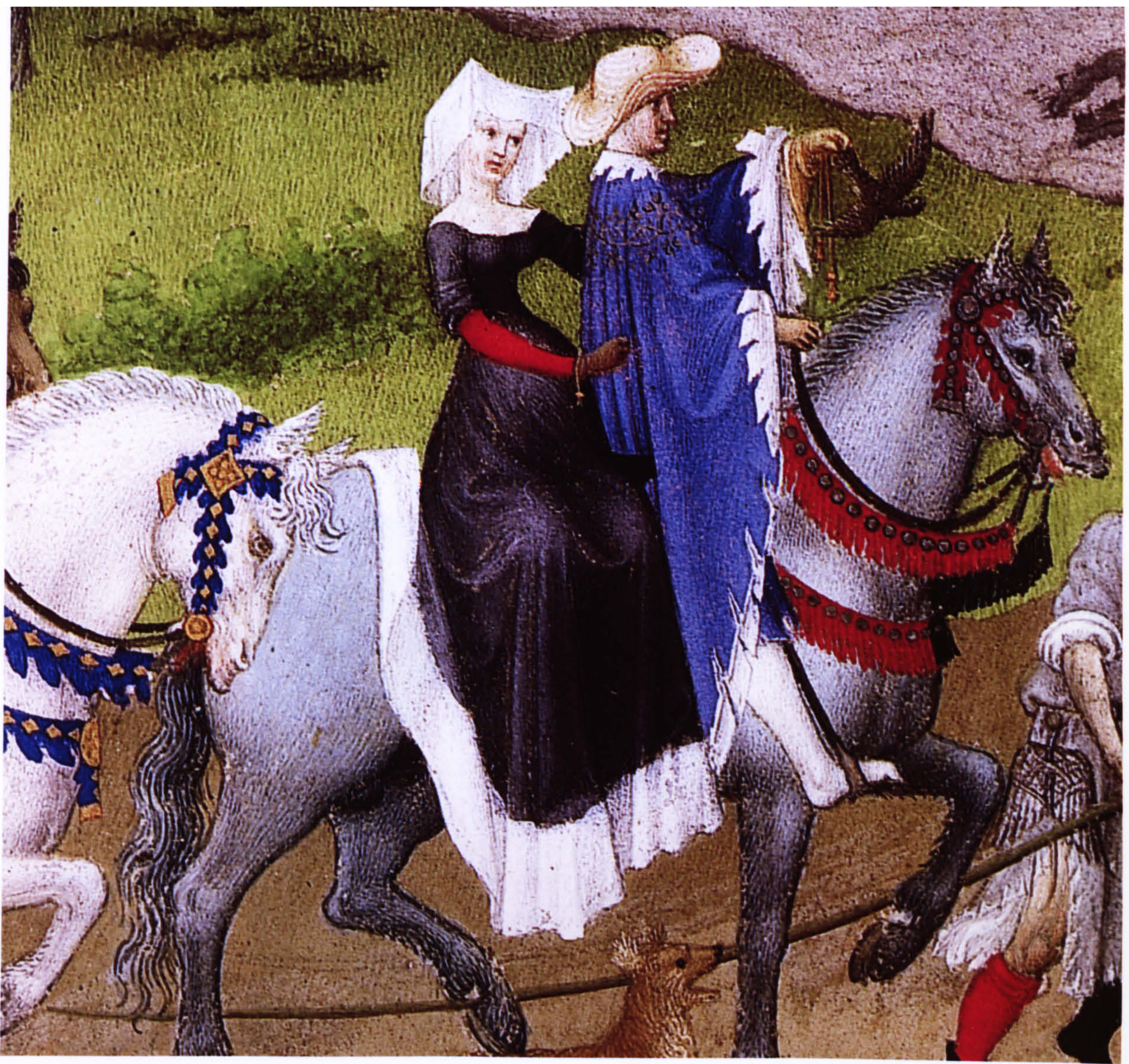

Fig 4.101 - Limbourg Brothers, detail of figures (2xM), August miniature, 1411/12-16, *Très Riches Heures*. Musée Condé, Chantilly, ms. 65, fol. 8v.

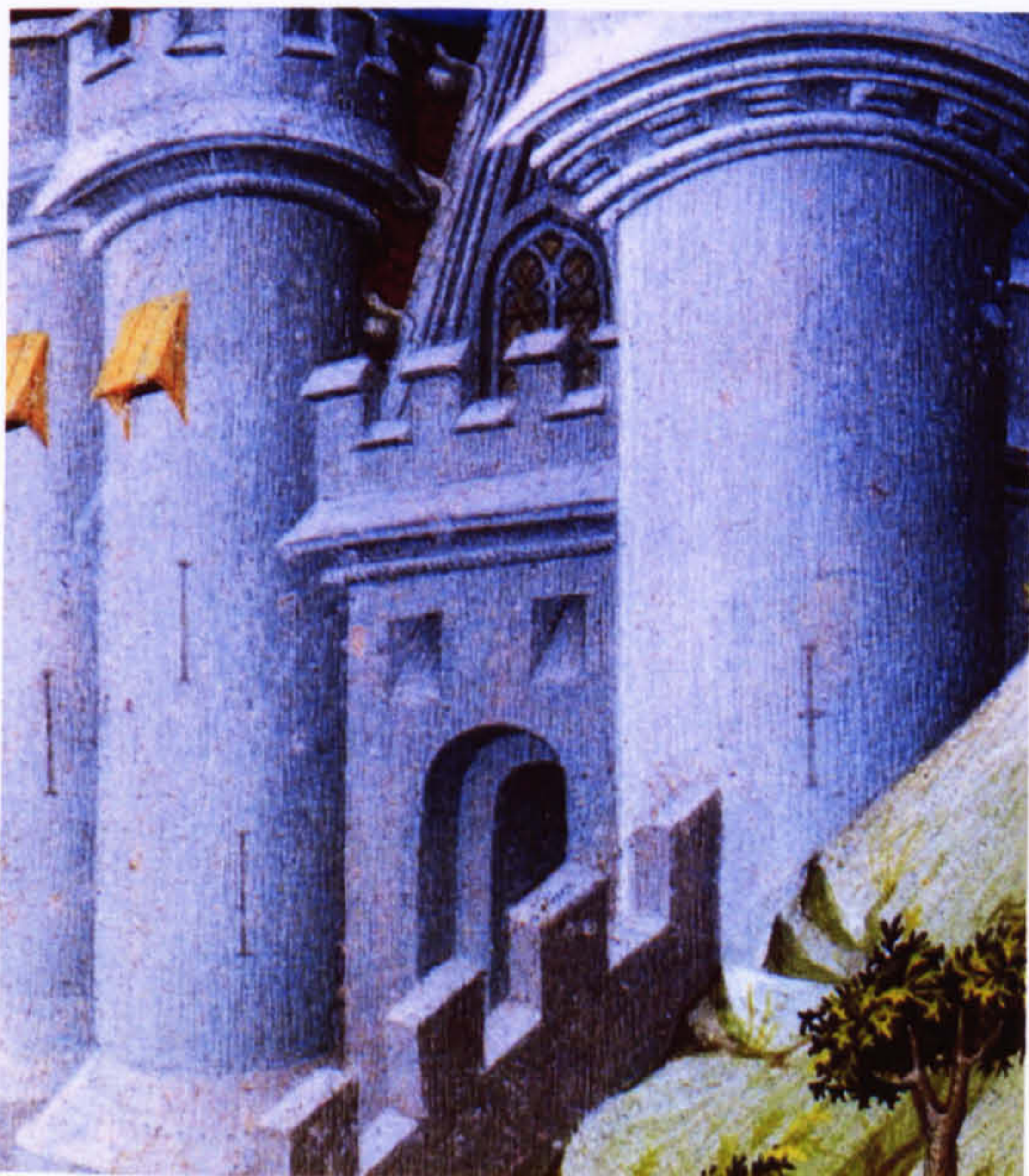

Fig 4.102 - Jacquemart de Hesdin, detail of Flight into Egypt (1.2xM), *Très Belles Heures de Notre-Dame*, c.1403. Bibliothèque Royale de Belgique, Brussels, ms. 11060-61, fol. 106r.



Fig 4.103 - Boucicaut Master, detail of Saint Victor of Marseille (2xM), *Châteauroux Breviary*, c.1412-13. Bibliothèque Municipale, ms. 2, fol. 237r.

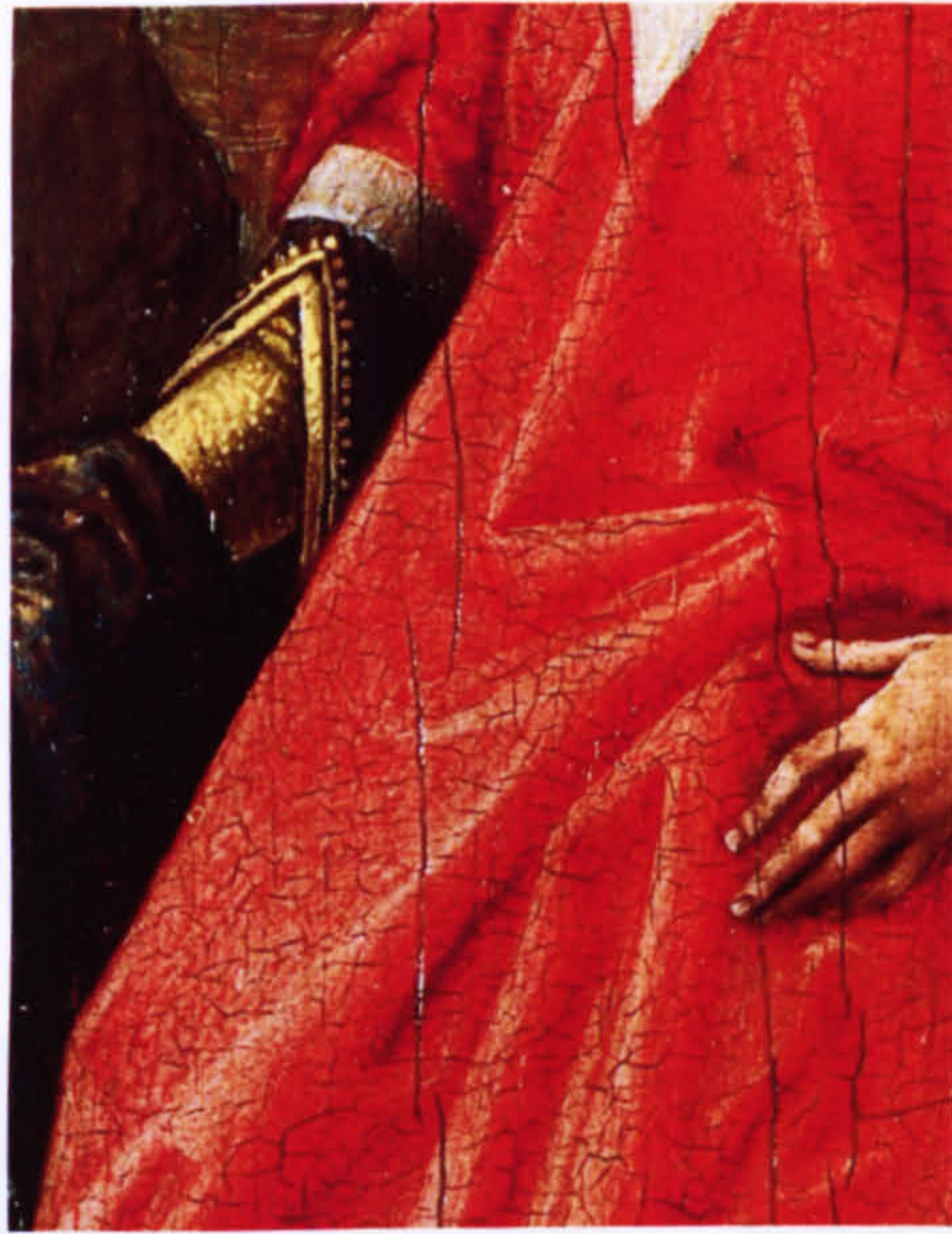

Fig 4.104 - Detail of Saint Catherine's dress (2xM), *Saint Catherine*.



Fig 4.105 - Jan van Eyck, detail from Birth of John the Baptist (1:1), *Turin-Milan Hours*, c.1422-25. Museo Civico d'Arte Antica, Turin, fol. 93v.



Fig 4.106 - Detail from Birth of John the Baptist (1:1), *Turin-Milan Hours*, fol. 93v.



Fig 4.107 - Detail from Birth of John the Baptist (1:1), *Turin-Milan Hours*, fol. 93v.



Fig 4.108 - Detail from Baptism of Christ (1:1), *Turin-Milan Hours*, fol. 93v., bas-de-page.



Fig 4.109 - Detail from Baptism of Christ (1:1), *Turin-Milan Hours*, fol. 93v., bas-de-page.



Fig 4.110 - Detail from Birth of
John the Baptist (2xM),
Turin-Milan Hours, fol. 93v.



Fig 4.111 - Detail from Birth of John the Baptist (2xM), *Turin-Milan Hours*, fol. 93v.



Fig 4.112 - Detail from Birth of John the Baptist (2xM), *Turin-Milan Hours*, fol. 93v.



Fig 4.113 - Detail from Baptism of Christ (2xM),
Turin-Milan Hours, fol. 93v., bas-de-page.



Fig 4.114 - Detail from Baptism of Christ (2xM), *Turin-Milan Hours*, fol. 93v., bas-de-page.

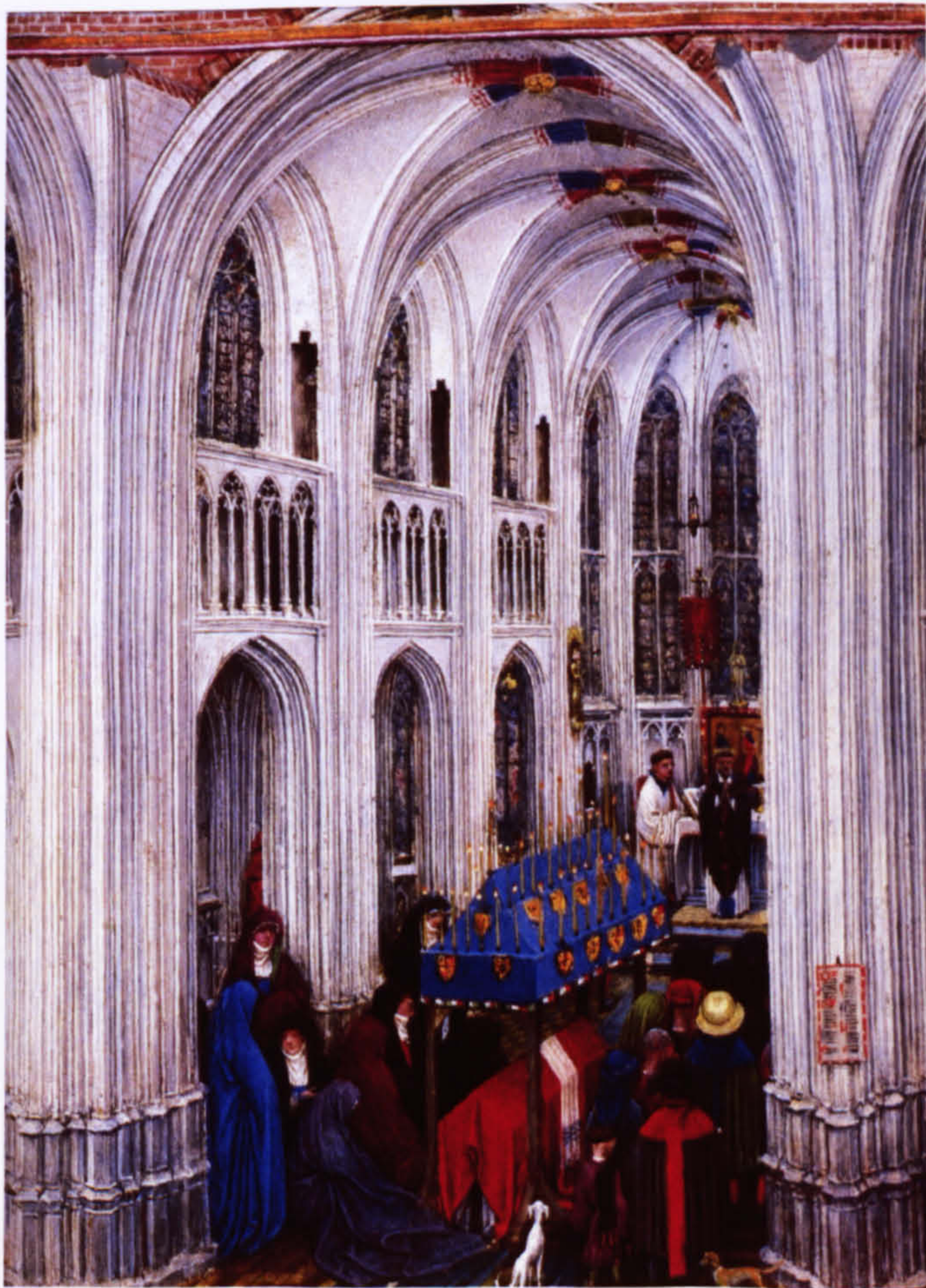

Fig 4.115 - Detail from Funeral Mass (1:1),
Turin-Milan Hours, fol. 116r.



Fig 4.116 - Detail from Funeral Mass (2xM), *Turin-Milan Hours*, fol. 116r.