

**THE EVOLUTION OF THE
BROADWOOD GRAND PIANO**

1785-1998

by

Alastair Laurence

DPhil. University of York

Department of Music

September 1998



Broadwood Grand Piano of 1801 (Finchcocks Collection, Goudhurst, Kent)

Abstract:

The Evolution of the Broadwood Grand Piano, 1785-1998

This dissertation describes the way in which one company's product - the grand piano - evolved over a period of two hundred and thirteen years. The account begins by tracing the origins of the English grand, then proceeds with a description of the earliest surviving models by Broadwood, dating from the late eighteenth century. Next follows an examination of John Broadwood and Sons' piano production methods in London during the early nineteenth century, and the transition from small-scale workshop to large factory is noted. The dissertation then proceeds to record in detail the many small changes to grand design which took place as the nineteenth century progressed, ranging from the extension of the keyboard compass, to the introduction of novel technical features such as the famous Broadwood barless steel frame. The dissertation concludes by charting the survival of the Broadwood grand piano since 1914, and records the numerous difficulties which have faced the long-established company during the present century.

The unique feature of this dissertation is the way in which much of the information it contains has been collected as a result of the writer's own practical involvement in piano making, tuning and restoring over a period of thirty years; he has had the opportunity to examine many different kinds of Broadwood grand from a variety of historical periods. His family have been associated with the 'House of Broadwood' from the time of the earliest surviving Broadwood grand (1787) down to the present day. Although there have been numerous books and studies dealing with the early piano, or the modern piano (as specialised fields of research), this dissertation is perhaps the first of its kind in the way that 'continuity', spanning over two hundred years, is the underlying theme.

Alastair Laurence

Alastair Laurence.

Moss, Norway, September 1998.

'Parliament Place, Westminster.

May 14th 1805

'Dear Daughter,

'You will see by the above bill that we have bespoke you a pianoforte. It is an extremely fine instrument, both in sound and handsome appearance. In both these respects, it greatly surpasses everything of the kind. We had Mr Elwick's assistance. Mr Broadwood says that he has none left either of the satinwood, or of the kind of mahogany of which the case is made. The instrument will take you some time and practice, before you find out all its beauties.

'Mr Broadwood says it will be in tune, when you receive it at Dover. He advises that you should not let any tuner at Dover touch it, as by that means, several of his instruments have been, so far, spoiled that they have been obliged to be sent back to him to London, to be repaired. He says there is a Mr Saffery of Canterbury, and another of the same name at Ramsgate, who are often in different parts of Kent; and are skilful in tuning and managing his instruments. At or near Dover, General Churchill has a pianoforte, which he suffers nobody to tune but Mr Brd's people, for which purpose Mr Brd sends a man to Dover - on purpose; when that man is there, he may be ordered to call and look at yours.

'As there is such a scramble for Mr Broadwood's instruments, I have marked yours at the lower end of the soundboard, as you will see as soon as you open the cover, thus: 'IV'

(Letter from Edward Delaval to his daughter Sarah Gunman. The piano he chose for Sarah, Broadwood grand serial number 2975, is owned by one of his descendants, Antony Jarvis, of Doddington Hall, Lincoln).

LIST OF CONTENTS

- Chapter 1: The origins of the English grand piano, 1740-1780.**
The first English grand piano; Andrew or Americus Backers; Backers, Stodart, Broadwood and Plenius; Robert Stodart. — — — — — 4 - 21
- Chapter 2: The earliest Broadwood grands, 1785-1805.**
The earliest-surviving Broadwood grand, number 69, dated 1787; string speaking lengths; strike points and plucking points; Broadwood's Divided Bridge of 1788; string lengths, 1787-1805; soundboards and bridges; the English 'single lever' grand action; keyboard extension. — — — — — 22 - 64
- Chapter 3: The Transition from Workshop to Factory, 1805-1830.**
Grand piano production methods and techniques in the early nineteenth century; manufacturing costs of a Broadwood grand, 1805; the retirement and death of John Broadwood; JA Stumpff, Thomas Broadwood and Beethoven; the move to Horseferry Road, 1823. — 65 - 82
- Chapter 4: Broadwood grands: changes in Product Range 1825-1865.**
The cottage grand; William Southwell's Patented Grand Action, 1837; the Grand Range 1840-1850; new models from the Mid Century; Grand Stock Levels and Hire Fleet in the Mid Century; Hire Pianos; and the Custom of Hire before Sale. — — — — — 83-104

Chapter 5: Broadwood Grand Pianos at the 1862 International Inventions Exhibition. Broadwood tuning forks in 1862; the Patent Metallic Pin Plate of 1862; after the Exhibition.	<i>105-121</i>
Chapter 6: The Scale Design of Broadwood Grands, 1850-1895. International Manufacturing Competition; the Scale Design of Five Grands Compared; Blüthner's Problems, Steinway's Remedies; London Scale Calculations; the Octave Ratios Compared; Hammer Strike Proportion; Wire Strength, String Tension and Conclusion.	<i>122-161</i>
Chapter 7: The Broadwood 'Barless' Grand Piano, 1888-1914. The Historical Background to the Barless Idea; Henry Fowler Broadwood's 'Original Iron Grand' of 1847; the Barless grand of 1888; the barless overstrung grands of George Rose; comments on the Barless Conception from Writers and Journalists.	<i>162-197</i>
Chapter 8: The Survival of the Broadwood Grand since 1914. The Crisis in Grand Manufacture, 1918-1931; the Challen-Broadwood, 1931-1938; the Carrier-designed Broadwood grands, 1950-1982; the Danemann Broadwood, 1982-1984; the Birmingham Barless, 1997.	<i>198-219</i>
Chapter 9: Conclusion.	<i>220-228</i>

Appendix I: James Broadwood's and John Farey's correspondence about piano tuning, which appeared in the <u>Monthly Magazine</u> , 1811. _____	229-234
Appendix II: The 'Chopin' Broadwood Grand, 1847-1998 Details of movements of this piano, 1847-1922, according to the Broadwood Porters' Books. Notes on the various whereabouts of the Chopin grand from 1922. _____	235-243
Appendix III: Two Years in the Life of Broadwood Concert Grand Number 22021 (1885-1887). _____	244-254
Notes for Chapters 1 to 8. _____	255-287
Notes for Appendix III. _____	288-290
Bibliography _____	291-295
Articles and Pamphlets Consulted _____	296-298
Chronological Checklist of Patents Referred to in the Main Text.	299-300

CHAPTER 1

THE ORIGINS OF THE ENGLISH GRAND PIANO, 1740-1780

The first English grand piano

The grand pianoforte first made its appearance in England sometime during the late 1730s or early to mid 1740s. The advent of the grand in this country did not take the form of an enthusiastic flurry of speculative, experimental manufacturing. Instead, the first grand ever seen apparently remained the one and only grand piano in England for perhaps as long as ten years after its arrival. The unique instrument in question naturally aroused great interest from keyboard players and harpsichord builders, but as far as we know there was no attempt to write music for this solitary phenomenon; and for many years there appeared to be no desire on the part of the well-established London harpsichord makers to emulate its features and go into production with copies of it.

This first grand piano is certainly something of a mystery object. We do not know exactly when it was imported into England; we do not know what it looked like; we do not know how many keys it had; we are totally in the dark when it comes to guessing the precise form of its mechanical action; and we have no idea about its tonal properties. All we know is that the instrument in question was built in Rome by a certain elusive individual, as elusive as the piano itself, called 'Father Wood'. Presumably he was a Roman Catholic priest, and presumably he was an Englishman, who might have combined a vocation in the Vatican with the unusual hobby of piano making. Wood's piano was brought to England by a certain Samuel Crisp, and shortly afterwards it was sold by Crisp to Fulke Greville (a wealthy aristocrat and the member of Parliament for Monmouth) for the sum of one hundred guineas. (1)

It is highly likely that the Rome-built Wood piano was closely modelled on the wing-shaped instruments constructed by the Italian Bartolomeo Cristofori (1655-1732) in Florence. Cristofori's pioneering

piano designs were copied by builders in Spain, Portugal and South Germany, (2) and so we might guess that Wood's piano was similarly modelled on one of Cristofori's creations. We also know that at least one of Cristofori's instruments existed in Rome: it had been given to a certain Cardinal Ottoboni in 1709 by Ferdinando de Medici of Florence. The Cardinal's letter of thanks for this gift still survives in the Florence Archives.(3)

From the point of view of historical evidence about the first grand piano seen and heard in England, we are very lucky to have the written record of Dr Charles Burney (1726-1814). He had the opportunity to regularly play Wood's piano between the years 1746 and 1749, when he was lodging as resident music master at Fulke Greville's country mansion, Wilbury, near Salisbury. Burney wrote down his recollections about the Father Wood piano in his Memoirs:

'The touch was very imperfect, and the mechanism clumsy; so nothing but slow movements could be executed upon it. However in slow pieces, such as the dead march in Saul, Arne's march in Zara, and a very few pathetic strains in Italian operas, it had a magnificent and new effect in the 'Chiar'oscuro' of which, with a little use, it was capable. Experience was necessary to the performer upon it - which by living in the house and trying the effects and discovering by degree the force or delicacy of touch it was capable of, I gained considerable credit in shewing it off.' (4)

As these events must have taken place at least fifteen years before the arrival in London of JC Bach (whose notable public performances on the piano were considered to be the first of their kind), then we must credit Burney with the achievement of being probably the first performing pianist in England, playing his Wood piano to an admiring audience in a slow but nevertheless pioneering pianistic style, rather than in the manner of a harpsichordist. Burney's own experimentation at the piano's keyboard had created new sounds and effects which might have helped to aroused interest from, among others, the Dutch harpsichord maker living in London, Roger Plenius (1696-1774).(5) Plenius had moved from Amsterdam

sometime between the years 1736 and 1741. It is most likely that he would have been able to examine the Wood piano at Wilbury, and meet the young Burney there, at some point in the mid 1740s. According to Burney, Plenius was given permission by Fulke Greville to build a copy of the Wood piano, but it was not to be a carbon copy; the Dutchman was anxious to try to improve the action mechanism, so as to enable better repetition of individual keys, in order that faster pieces could be played on the instrument. Apparently, he was successful in this attempt; but as neither his prototype, nor any other piano by him, appears to survive, we have absolutely no way of knowing exactly what Plenius did to improve things, apart from Burney's assertion that 'the touch was better but the tone very much weaker' than Wood's Rome-built instrument. (6)

As the mid eighteenth century approached, there appeared to be perhaps only two grand pianos in the whole of England: one of these had been made in Rome by an English priest and possessed an expressive tone quality but a sluggish touch; and the second, built by a Dutchman living in London, had a more satisfactory action but a disappointing sound. There was not very much to choose from in the way of grand pianos in mid eighteenth century England. Of course, other English harpsichord builders may have embarked on piano construction at this period; but if they did, then their efforts have gone unrecorded, and their instruments, like those of Wood and Plenius, do not appear to have survived.

There must have been considerable discouragement to further progress, partly because the cultured musical taste of the nation was not yet ready for the 'piano sound'; and partly because of the serious technical difficulties in achieving both a satisfactory touch and an agreeable tone. Experimenting with pianos must have been a costly and time-consuming business, and it is perhaps not surprising that Roger Plenius, who was noted for his innovative design work, was declared bankrupt in July 1756. (7) It was not until the early 1770s that the making of grand pianos was seriously taken up again in England.

Andrew or 'Americus' Backers

The first grand pianos to be successfully made in England on a regular basis were constructed by an individual named Andrew or Americus Backers, a harpsichord builder living and working in the parish of St James', Westminster, London. Backers' piano-making work began in earnest in the year 1770, some five years after the first square pianos began to be made in London by Zumpe and his followers. All of the early square piano makers of London were German immigrants; they worked in and around the Parish of St James', close to Backers' own home and workshop, and so Backers (for some years before he himself began piano making) must have had ample opportunity to assess the little square pianos being constructed by his enterprising neighbours; and he must have been well-aware of the financial rewards which piano making had brought to Zumpe.(8) This must have encouraged Backers to emulate Zumpe. However, being a harpsichord maker and not a clavichord or square piano maker, Backers naturally concerned himself with the logistics of incorporating a hammer mechanism within an existing form of harpsichord case, rather than embarking on a completely new venture with the square type of instrument more familiar to the Anglo-German builders.

Backers had been established in business in Jermyn Street since 1763. Unfortunately, only one of his harpsichords survives: this is a two manual instrument dated 1766, (9) made in the same year that Zumpe almost certainly began his London square piano production. Backers' grand piano making venture commenced in earnest during the winter of 1770-71, as the following advertisement, which appeared in the London daily newspaper, 'The Public Advertiser' on March 1st 1771 (shortly after Backers' prototype instrument was ready for sale) leads us to believe:

'TO THE PUBLIC

'At the Long Room in the Thatched House, St James's Street, on Monday, Tuesday, Friday and Saturday Mornings, may be seen and heard a new invented Instrument of the Size and Shape of a Harpsichord, which answers all the Purposes that have been hitherto wanted in an Instrument

of the Harpsichord Kind. It is played on in the same Manner, but differs in all other Respects, as the Tone and Expressions are far superior to any Musical Instrument yet offered for public Inspection. This instrument is made by Americus Backers, of Jermyn Street, St James', who calls it an Original Forte Piano; and thereby means that it is no Copy, being entirely his own Invention. There are many Things made under the Denomination of Forte Piano, but as this is the real one, Mr Backers takes this Method of informing the Public, that they may form a Judgement how much this is superior to those which have been offered under that Name.

'A fine Harpsichord Player is engaged to play on it from One 'till Two o'Clock; After which Time it will be left at Liberty for any Lady or Gentleman to make Trial thereof. Admittance 2s 6d each.' (10)

The nameboard of the 1772 Backers grand piano in the Russell Collection, Edinburgh (11) is inscribed 'Americus Backers'; and so it is obvious that Backers employed the unusual Christian name 'Americus' in his commercial venture (as the above advertisement also shows) although his real name appeared to have been Andrew, and he is so named in the rate books for Jermyn Street which survive from the 1760s and 70s.(12) James Shudi Broadwood wrote a short anecdote about Backers in the year 1838:

'The Grand Piano may be called an English instrument, it having been invented by Americus Backers, a Dutchman, who resided in Jermyn Street about 1776. He was a maker of Harpsichords, and on his first application of hammers, to gain the jingling music of the Harpsichord, then so much admired, he did not clothe them, but struck the strings with soft wood or cork; he afterwards clothed them slightly with leather. Of late years, as the ears of the musical world have become more sensible to sweetness of tone, the hammers have become more and more clothed, with cloth, leather or other substances, to suit the taste of the maker, or rather that of the musical public. Backers' mechanism, at once simple and effective, has stood the test of competition with those of the most ingenious of the line, and is used by all the makers in England and on the Continent, where it is known by the name of *Mécanique Anglaise*. Backers died of consumption, sometime about 1781, recommending his

invention, of which he was justly proud, with the anxiety of a parent to the care and attention of his friend John Broadwood, who, however, being fully engaged in other objects, did not much affect it, till the success in sale of these instruments by the late Robert Stodart awakened him to a sense of its importance.'(13)

As James Broadwood was only six years of age when Backers died in January 1778 (not 1781 as suggested by Broadwood in the above account), it is unlikely that he would have had strong personal memories of the man he was writing about: rather, his information would have been received by word of mouth from his father, John Broadwood, or from other senior piano workmen's recollections. However, it is highly likely that James Broadwood, as a youth, would have worked as a tuner and repairer of Backers' instruments, and this explains his familiarity with the different types of Backers' hammer heads - some made of 'soft wood or cork', and others 'clothed slightly' with leather. In fact the 1772 Backers grand, surviving in the Russell Collection, does indeed have its hammer heads 'clothed slightly' with a thin strip or pad of soft leather glued along the top of each wooden hammer head. The leather strips may well have been an afterthought.

James Broadwood's account of 1838, although highly interesting, is not accurate, partly because Broadwood may have been entirely unaware of the 'grand' instruments built in Italy by Cristofori a half century before Backers, or the 'grands' constructed at Freiburg, Lower Saxony, by the builder Gottfried Silbermann during the 1730s and 40s. As we have seen from Burney's evidence, Backers was not the inventor of the grand, as James Broadwood asserts. Backers never actually patented his ideas or designs, in spite of claiming to be the 'inventor' of the 'Original Forte Piano' in his advertisement of March 1771. Had Backers been the true inventor of the grand, or the sole originator of the hammer action mechanism associated with it, then it is more than likely that he would have endeavoured to protect the uniqueness of his idea with a patent; but letters patent were never granted. Nevertheless, Backers was the first in England to make, on a regular basis and in a successful way, pianos in the grand form.

It is also likely that James Broadwood was wrong in his statement that Backers was a Dutchman. He was possibly confusing Backers with Roger Plenius, who, as we have already noted, had built at least one grand piano in London sometime before 1756. It now appears possible that Backers was in fact English, but of German parentage. The parish register of St James', Westminster, dutifully records the baptism of 'Andrew Henry, son of Christian Gottlieb Baker [sic] and Elizabeth his wife' on the 25th March 1733.(14) If the infant Andrew Henry 'Baker' (bearing in mind the arbitrary spelling employed by parish clerks of this period) ultimately became Americus Backers the grand piano maker, then it is quite likely that the person we believe may have been Andrew's father, Christian Gottlieb, was a keyboard instrument maker as well, possibly working with one or other of the two main London builders of the period, Kirkman and Shudi, both German-speaking.

At present there appears to be no final proof that Andrew Backers was English, nor even that the person we believe might have been his father, Christian Gottlieb 'Baker' was German. However, it is curious to note that Charles Burney, in his book The Present State of Music in Germany, the Netherlands and United Provinces (London, 1775) states:

'The Germans work much better out of their own country than they do in it, if we may judge by the harpsichords of Kirkman and Shudi; the piano fortes of Backers; and the organs of Snetzler; which far surpass, in goodness, all the keyed instruments that I met with, in my tour through Germany.'

When Burney wrote this account, Backers was still active as a builder in Jermyn Street, and it is highly likely that Charles Burney had met him.

As late as 1860, the London author EF Rimbault (15) stated that Backers was 'a German who had been in the employ of Silbermann of Neuberg.' Rimbault was recording a long-established oral tradition of the Backers family having been German, although he confused 'Neuberg'

with 'Freiburg', home of the Silbermanns. Rimbault confirms Burney's statement that Backers was as much German as English, and gives some new information that Backers had apparently served his apprenticeship in the Freiburg piano workshop during the late 1740s. This time spent abroad may have been the result of the obvious German connection with Christian Gottlieb 'Baker', the person we believe might have been Americus Backers' father. Interestingly, Backers' own daughter was given the name 'Christiana' (16), a further small piece of circumstantial evidence indicating a possible link with 'Christian Gottlieb'.

Whatever the genealogical truth, of much more importance to the piano historian is the fact that the design and construction of Backers' first London grands of the early 1770s owe little to the grand pianos of Silbermann (17); in shape, size, method of construction, and materials used, they are closely related to the building tradition established by the London harpsichord builders, Kirkman and Shudi. This is not surprising, bearing in mind the general assumption that the last of the London harpsichord makers were also the first of the grand piano makers.

The 1772 Americus Backers grand in the Russell Collection, Edinburgh, is probably the only surviving piano by this maker (because the only other known 'Backers' grand, that in the Benton Fletcher Collection at Fenton House, Hampstead, London, is almost certainly a fake).(18) When the 1772 grand piano in Edinburgh is closely examined and carefully compared with the earliest-surviving Stodart and Broadwood grand pianos dating from fifteen or so years later (from the mid to late 1780s), it is very obvious that almost every single stylistic and mechanical design feature found in the Backers piano had been copied by the other two makers. The only significant differences relate to string length design and method of hammer head covering. Although comparatively little is known about Backers and his work (19), and although only one authenticated grand piano of his survives today, there is no doubt that Backers was the constructor of the important prototype on which all other later English grands were based. The design of the action, the layout of the strings, the materials used in the construction, the iron supporting arches across the hammer gap, the una corda keyboard shift, and the

method of attachment of the pedals to the two front legs of the stand, are but six features found on the 1772 Backers which were directly copied by both Broadwood and Stodart. This raises the question of how much collaboration among makers, in the field of research and development, there might have been during the early 1770s.

Backers, Stodart, Broadwood and Plenius

Turning again to James Shudi Broadwood's anecdotes of the year 1838, these were eventually printed in the year 1862 (see chapter 5 dealing with the International Exhibition of 1862), and their editor, Henry Fowler Broadwood (son of James), added the following interesting footnote to his father's original account:

'JS Broadwood does not mention here what he afterwards told me, that his father, John Broadwood, then with his apprentice, Stodart, in the employ of Burkhardt Shudi, used to go of an evening to Jermyn Street, to assist Backers in bringing his mechanism to perfection. This was the case, and hence the dying man [Backers] recommended the farther care of his invention to his friend John Broadwood.'

From this intriguing piece of evidence, it is clear that Backers' experimental work had aroused the interest of two of his fellow tradesmen who lived nearby, and who were curious enough to want to see, on a regular basis, how work on the prototype was progressing; hence the frequent visits, 'of an evening', in their leisure time, of John Broadwood and Robert Stodart to the grand piano maker's workshop in Jermyn Street. We can well imagine the three men's enthusiasm growing as a new kind of musical instrument took shape before their eyes; but what we shall never know is the extent of each man's contribution to the design and evolution of this prototype; nor do we know whether the first Backers grand piano was a completely new conception, or whether it was in fact modelled on the grand piano designed and made by Roger Plenius over fifteen years earlier.

The writer conjectures that Roger Plenius may have played a role in the design of the new Backers instrument. As we noted earlier, Plenius had been declared bankrupt in 1756; but we know that he continued to live in London and remained in the capital for a further eighteen years until his death in 1774.(20) It is hard to believe that an impoverished former piano maker would have spent eighteen years idle, unless he was chronically sick: he needed to work; and he had much knowledge and many skills to give. His mechanical ingenuity was well known: he patented a number of extraordinary 'improvements' to harpsichords in 1741, including:

'A machine of weights and swivels for keeping harpsichords in tune; ivory and tortoiseshell plectra, and regulating screws behind the tongues; metal jack slides, hollow keys' and also 'octave strings kept in tune full as long as the unison strings by means of iron or other metal pegs or screws which are fixed in the body of the harpsichord, and appear through the belly thereof, and to which the said octave strings at the end are fastened to the tops of the said pegs or screws.' (21)

It is probable that Roger Plenius was the only person in England during the 1750s and 60s with sufficient mechanical knowledge and experience to build a grand piano action; and it is only natural that such a prolifically inventive individual should have wished to see his early, unsuccessful prototype piano developed and improved. As a former bankrupt, Plenius would not have had the financial means to continue to develop his own ideas: he must have been content to toil, as a humble harpsichord regulator and finisher, for others. His skills and new ideas would have been admired, but his 'brainstorming' enthusiasm may well have been the object of ridicule from the much more cautious and conservative harpsichord makers, who would have been well aware of his bankruptcy. However, Plenius could have found in Americus Backers an individual who was willing to continue where he had left off. It is easy to imagine Plenius working for Backers as a harpsichord voicer and finisher; and it is also very easy to imagine Roger Plenius, working late in the evenings at Backers' workshop, being the guiding hand behind the new grand piano project and enjoying the company and interest of two much younger men, the evening visitors Stodart and Broadwood.

Therefore, when James Shudi Broadwood wrote his anecdotes in 1838, he may well have been confusing Backers with Plenius, and this would explain the apparent error when Broadwood describes Backers as 'a Dutchman.' It was Plenius who was the Dutchman. There are two further small pieces of circumstantial evidence suggesting involvement by Plenius in the first grand piano of Backers. When Plenius patented his harpsichord improvements in 1741, mention was made in the patent application of two novel features: regulating screws, and 'metal jack slides'. These radically new departures from the usual harpsichord specifications of the time suggest that Plenius must have been adept when it came to the necessary metal-working skills needed to cut the numerous slots in the metal slide through which the jacks passed, and to make and fit the regulating screws. It may be more than coincidence that the surviving eighteenth century grands of Backers, Stodart and Broadwood each have their hammer assemblies held in place within a series of slots cut in solid brass pieces, later known as the 'comb' system. Most of them also have small regulating grubscrews to control the degree of freedom of swing in the hammers.

The second small piece of circumstantial evidence relates to the fact that Backers never actually patented the mechanical features of his 'Original Forte Piano'. If Roger Plenius did make a significant contribution towards the invention of the hammer mechanism of the prototype in Jermyn Street, then he may have effectively prevented Backers from taking the necessary legal steps to patent the design of the piano. Alternatively, it might have been Stodart and Broadwood who, because of their own contributions, prevented the idea from becoming an exclusive Backers patent. Rosamund Harding (22) quotes Pierre Erard's opinion on the origin of the English grand mechanism: Erard stated that the authorship of the invention was uncertain and that even the London makers themselves were in doubt about the matter.



Americus Backers Grand Piano of 1772 (Russell Collection, Edinburgh)

Robert Stodart

The young man who accompanied John Broadwood to Backers' workshop 'of an evening' was destined to become Backers' successor. Robert Stodart was only in his early twenties when, as an apprentice of John Broadwood, he first became acquainted with Backers and his work; but he already had a background of mechanical skills which must have been useful for the development and manufacture of grand piano mechanisms. Stodart was, like John Broadwood, a Scotsman: he was born at Walston in Lanarkshire in 1748. He had been bound apprentice to a mechanical engineer in Dalkeith, and, at the age of about twenty, had gone out to Tobago in the West Indies to install machinery in the sugar plantations there. It is likely that he caught malaria in Tobago, because we next find him spending a season in Greenland, which was at that time a recognised 'cure' for malaria. (23) By the year 1770, Stodart was living in London, learning the art of harpsichord tuning and finishing with Shudi and Broadwood, and at the same time becoming involved with Backers' prototype grand piano. The initial meeting between the two Scotsmen, Broadwood and Stodart, probably occurred because Soho was, in the 1770s, the particular place of residence in London for many Scottish tradesmen and their families. A Scottish chapel had been established in Wells Street, and this would have been the kind of place where the two men could have become acquainted. In addition, Broadwood was in the habit of employing fellow-Scots.

Stodart's mechanically inventive mind became something of a legend in his own family. An interesting anecdote, told by his descendants, concerns his idea for the design of a new 'upright grand' piano action: one Sunday, Stodart was in church listening to a dull sermon and his mind was fully engaged, not on the sermon, but on thoughts about a new piano action and its mechanical problems. Suddenly, he realised that he had a clear mental picture of the action he was planning, and, without waiting a moment longer, he hurried out of church to begin work on the making of a one-note prototype model.(24) At a later date, the design was put into production in London by two of Robert's nephews, William and Matthew Stodart.

We know that Robert Stodart had left the employ of Shudi and Broadwood by the year 1776, because the rate books for Westminster (25) show that he had by then set up in business on his own account in Wardour Street, Soho. From the start, Stodart appears to have concentrated on the production of grand pianos rather than any other kind of keyboard instrument. In 1776, at the age of twenty seven, he must have been fully conversant with all the mechanical details of piano action making, and he must have had sufficient confidence in his own practical abilities as a piano maker to become an independently-established 'master'. In 1776, Backers was still in business, and so Stodart was in effect setting up in competition against him, making an identical product. The fact that Backers was unable to prevent the manufacture of his own 'invention' by another builder once again suggests that he was not the sole inventor of the new product.

It is quite possible that Stodart had been, for some period during the early to mid 1770s (and after the completion of his apprenticeship with Shudi and Broadwood), a specialist freelance maker of grand piano mechanisms, supplying parts for Backers, or alternatively working for Backers in a mechanical capacity in the Jermyn Street workshop. Stodart's specialised training as an engineer would have been of obvious use in the necessary 'mass production' of numerous, small, identical piano action parts. Alternatively, Stodart may have been greatly helped in the setting up of his own business if he was able to 'poach' the assistance of some former skilled employee of Backers with the ability to make piano actions.

In November 1777, Stodart applied for a patent for a 'combined piano and harpsichord.' This was a single manual instrument in which one set of keys could operate, at choice, either a hammer mechanism or a plucking mechanism. The patent specification (26) shows a drawing of an instrument with two pedals attached to the front legs in a manner identical to that found in Backers' grand pianos. When both pedals were in the 'up' position, the instrument was a piano with a hammer mechanism; when the left pedal was pressed down, the hammer mechanism was disengaged and at the same time the harpsichord jacks alone brought into play; and

when the right pedal was depressed, the four foot strings on the harpsichord (strings one octave higher than unison) became available. The idea behind the invention was obviously to produce an instrument for those individuals who, although attracted to the new sounds that the grand piano could produce, nevertheless could not bear to part company with the harpsichord. One major drawback in Stodart's patent was the fact that the newly-designed instrument had neither sustaining pedal nor una corda keyboard shift, two important musical features which Backers' grands possessed. Interestingly, the wording in Stodart's 1777 patent specification describes his invention as 'A new sort of instrument, or grand forte piano.' This is believed to be the first-recorded occurrence of the name 'grand piano' in English terminology. It seems probable that Stodart coined it.

The 1777 Patent specification also shows a detailed cross-section drawing of Stodart's piano and harpsichord mechanism, which is reproduced (as it appears on the original application) on the following page of this present account (Fig.1/1). If this drawing is carefully compared with a drawing of the surviving Backers hammer mechanism found in the 1772 Edinburgh grand (Fig.1/2), this is sufficient proof to show that Stodart was producing what amounted to almost an exact replica. We have already noted that Backers took no steps to prevent Stodart's activities. One of the possible reasons for this we have already mentioned: the fact that Backers had no power to make the design of the grand mechanism exclusively his own. In fact, there had already been successful attempts by other unknown makers, before Stodart commenced business, not only to reproduce the Backers' design, but also to falsely inscribe his name on their pianos' nameboards. (27) This probably accounts for the 'fake' Backers instrument, already mentioned, to be found at Fenton House, London.

A further possible reason for Backers' unwillingness to take steps to halt Stodart's copying and selling what might have been Backers' own ideas was a matter of ill health: at the time that Stodart applied for letters patent on the 21st November 1777, Backers was terminally ill with consumption: he had only a further six weeks to live. The timing of

Stodart's patent application may well have been calculated deliberately.

Backers left no obvious successors to his business. In his will, (28) he made no provision for the continuation of grand piano making in Jermyn Street, although his business appeared to be thriving and the workshop well-stocked with piano parts and materials. Neither Broadwood nor Stodart are mentioned in the text of the will. It is likely that the business, with its tools, designs and materials, was offered for sale by the executor. By far the most likely individual to have made a purchase of the whole was Robert Stodart. During the period 1778 until the mid 1780s, Stodart appeared to have been the only producer of grand pianos in England; and as such he was, in a sense, Backers' successor, being the solitary representative of continuity in grand piano manufacture. It is hard to believe that he was not utilising a large part of the manufacturing equipment and piano components which had once been at Jermyn Street.

The measure of Stodart's business success may be judged from the fact that he permanently retired from work after thirteen years activity. In 1789, at the age of about forty-one, he was able to purchase at auction a country sporting estate in Peeblesshire and return to his native land. The estate, at Kailzie near Traquair, cost Stodart just over eleven thousand pounds. William Chambers, in his 'History of Peeblesshire' (29) stated that members of the local gentry were 'not accustomed to seeing men of mechanical professions becoming landed proprietors.' Stodart handed over his London business to his two nephews, William and Matthew, and from 1792 until his death (many years later in 1831 at the age of about eighty three) Stodart was able to live comfortably on an annuity of £200 per year provided by his London piano-making interests.

It was Robert Stodart's great financial success as a constructor of grand pianos which prompted John Broadwood to take the decision to emulate Stodart and embark on grand manufacture as well.(30) This occurred in the mid 1780s, some eight to ten years after Stodart had

built his first instrument. The earliest-surviving examples of Broadwood's grand handiwork are examined in detail in the following chapter.

CHAPTER 2:

THE EARLIEST BROADWOOD GRANDS, 1785-1805

John Broadwood's 'late' start in grand manufacture, when compared with Backers and Stodart, is easy to account for. On the 2nd January 1769, Broadwood married Barbara Shudi, the youngest daughter of his employer, Burkat Shudi. Shortly after the wedding, plans were made for Broadwood to succeed to the famous Shudi harpsichord-making business, well-established in Great Pulteney Street, Soho; and in the same month that Backers was advertising his first 'original fortepiano' in the 'Public Advertiser' (March 1771, see chapter 1), Broadwood was signing an agreement with his father-in-law concerning the continuity of harpsichord manufacture in Great Pulteney Street. (1) At this date, therefore, Broadwood would have been preoccupied in getting to grips with his new administrative role as Shudi's successor, and would not have had the time or energy to consider piano manufacture.

During the 1770s and 80s, the annual output of Shudi/Broadwood harpsichords was actually increasing rather than diminishing, in spite of the arrival of the square and grand piano in London and the competition for sales which this event must have brought about. Looking back to the three decades, 1740 to 1770, Shudi's business had produced little more than one harpsichord per month, each instrument finished by Shudi himself. Under John Broadwood's ambitious direction, from 1771, output doubled to around two per month; and this level of production was maintained throughout the 1780s.(2) This expansion would also have made demands on Broadwood's available time and energy, and would have helped to distract him from thoughts of grand piano making.

Burkat Shudi's activities, and details of his surviving instruments, have been well documented. (3) He was a German-speaking native of Switzerland who had settled in London many years earlier, in 1718. He had become internationally famous as a builder of harpsichords

by the mid eighteenth century; and Broadwood was lucky enough to have been able to 'prove his worth' to his master: as a fine craftsman, as a dependable employee, as a suitable husband for Barbara Shudi, and as a capable man of business worthy to succeed the elderly Burkat. At the time of the wedding, John Broadwood was thirty-six, and his wife Barbara, twenty. Broadwood had been in the employ of Shudi since 1761, shortly after he had arrived in London as a humble journeyman joiner from Oldhamstocks, Berwickshire, Scotland. In 1769, at the time of his marriage to Barbara, he was in all probability Shudi's foreman.

We do not know to what extent John Broadwood was a 'finisher' of harpsichords, the work usually undertaken by the 'master' harpsichord builder. When he first commenced work for Shudi, and throughout most of the 1760s, his role within the business appeared to be that of a maker of wooden parts: soundboards, bridges, structural framework, and casework, the kind of work we would expect to be undertaken by a skilled joiner.(4) Nevertheless, by the early 1770s Broadwood had learnt how to tune and restring, and part of his work after he took over the Shudi concern from his father-in-law included visits to 'out of town' locations such as Beckenham (Kent) and Wimbledon (Surrey) in order to tune and service harpsichords there. (5) However, as time went on, Broadwood must have become less and less a bench worker, and more and more an office administrator. It is possible that the work of 'harpsichord finisher' was undertaken by his brother-in-law, Burkat Shudi the younger (born 1737), a shadowy figure within the firm who nevertheless remained a junior partner of Broadwood until the early 1790s. All of the surviving harpsichords made in the Great Pulteney Street workshops between the early 1770s and early 1790s (except one, dated 1793) bear the inscription 'Shudi and Broadwood', suggesting that Burkat Shudi the younger was involved in their manufacture. In contrast, all the surviving early pianos of Broadwood, whether grand or square, bear only the Broadwood name (the exceptions being two surviving very early squares, both dated 1780, labelled 'Shudi and Broadwood'). (6) This evidence suggests that the younger Shudi, whilst remaining in partnership with Broadwood to manufacture harpsichords, had very little interest in pianos.

It is possible that the elderly Shudi objected to his son-in-law becoming involved with the early development of the piano; he may not have liked the sound of the earliest squares, and certainly he would have been severely critical of the shoddy workmanship found in Zumpe's instruments. It is perhaps no coincidence, therefore, that John Broadwood's first pianos date from after Shudi's death (August 1773). In fact, Broadwood did not go into regular piano production until after the year 1780, although he had been tuning and repairing pianos since the early 1770s.(7) Instead of building grands in the manner of Backers or his own former employee, Stodart, Broadwood first chose to manufacture square pianos, emulating Zumpe and the other German builders locally resident in Soho. The manufacture of squares took considerably less space than grands, and certainly at this period, because of the expansion of harpsichord production, space was becoming something of a problem at the Pulteney Street premises. Square piano making was considerably less complicated than grand making, and the success of the Soho Germans had shown Broadwood that squares were a 'safe bet' as far as sales were concerned. The market for grands, because of their comparatively high cost, appeared to be much more limited, and therefore grand making could seem to be a risky business. In addition, it is probable that parts for squares could be more easily obtained from among the group of German craftsmen living in Soho, whereas the much more specialised grand parts may have been difficult to find. In fact, it might have been the simple matter of his inability to procure the services of a 'grand action maker' which prevented Broadwood from manufacturing grands during the 1770s, even if he had a strong wish to do so.

However, the chief reason for Broadwood's reluctance to commence grand manufacture appeared to have been the fact that the grand competed directly with the harpsichord for orders. John Broadwood must have felt that he would be damaging his and his junior partner's well-established harpsichord production if he commenced the building of grands. The much cheaper little square pianos were made for a different market. We must always bear in mind the probable influence and opinions of Broadwood's junior partner, Burkat Shudi the younger, who (having been taught harpsichord finishing and voicing by his late father) might

have been determined to maintain Shudi/Broadwood harpsichord production throughout the 1770s and 80s and who might have seen grand piano production as the most serious threat to harpsichord sales.

Whatever the circumstances, Broadwood's square piano-making venture eventually became remarkably successful, in terms of volume of production and profits, without damaging harpsichord sales. During the first few years of production (from around 1780), output was approximately one square piano per week. During the period 1785 to 1790, production increased to roughly three per week; but then there was a dramatic upturn between 1790 and 1795, when the Great Pulteney Street workshop's production reached the remarkable figure of eight squares per week. By the end of the year 1795, an impressive total of 3,000 square instruments had been made by the firm. (8) One of the main reasons for this success (apart from Broadwood's ambition and organising capabilities) lay in the fact that Broadwood himself had introduced a number of significant improvements to the design of the square. The type of square which became available immediately after his patent of 1783 (9) contained the 'brass underdamper' action (which was far superior to the mechanism used by the Soho Germans), had a much better quality of bass register (full and more resonant), and had considerably-improved tuning stability - as a result of the repositioning of the tuning pins to the back of the interior of the case. Broadwood's squares from the early 1780s were probably the best obtainable in London; they were certainly competitively priced; their casework was unpretentious, simple and cheap to manufacture. Even cheaper and more puritan-looking models were made, without pedal. (10)

John Broadwood had become a mass-producer of keyboard instruments. It is remarkable that such a high output had been achieved by the toil of hand labour in modestly-sized work premises; but even at this early date, Broadwood must have used the subdivision of labour in order to speed up production and lower manufacturing costs. A major subdivision of labour had existed throughout the period that Burkat Shudi the elder was manufacturing (into two main trades, harpsichord 'builder' and harpsichord 'finisher'). Under Broadwood, this subdivision was further

increased: the firm now employed key makers, jack makers, action part makers, case makers, polishers, tuners and finishers. When the thirteen-year-old James Shudi Broadwood (John's eldest son) joined the business in 1785, he was given the surprisingly responsible job of 'ordering clerk.' He must have been kept busy ensuring that the firm had sufficient timber, veneer, lacquer, glue, ivory, music wire, tuning pins, screws and nails etc to maintain its monthly production at that date of twelve or so squares and two harpsichords. It was to be a further ten years before James was taken into partnership and the firm renamed 'John Broadwood and Son.' (11)

Before John Broadwood could commence the manufacture of grands in a serious way, he needed to find further manufacturing space. Additional workspace had also become a necessity in order to cope with the growing output of squares; and so on the 1st July 1785 he purchased the lease of premises occupied by a certain Job Jones, a timber merchant, in Bridle Lane, the 'back lane' or service street which ran parallel with Great Pulteney Street. These new premises, described as 'workshops and buildings adjoining northward to a messuage on the east side of Bridle Lane'(12) were conveniently sited very close to Broadwood's existing workshop. Then in 1787, the Broadwood family, who had been using the front part of the premises in Pulteney Street as a dwelling house, moved out, enabling further expansion of workshop space. This removal coincided with the creation of even more workspace in the attics of the house: the roof had been heightened by 1787, and new windows inserted. The carrying of half-built pianos and harpsichords up and down stairs within the old Shudi home at this period must have been tedious and exhausting.

Broadwood's grand production began early in the year 1785, more or less coincidental with the large expansion of manufacturing premises. According to Michael Cole, who has carefully examined the company's journals of that period, the first grand piano was sold on the 12th January 1785 to a certain 'Mr Tyler' of Bath, for the sum of 46 guineas. (13) In the first two years of grand production, the firm was able to achieve an output of at least one grand piano per week, which suggests that around ten employees of Broadwood were engaged in grand manufacture

alone. By the end of 1792, after seven years of production, over 450 Broadwood grands had been constructed, giving a very consistent average weekly output (assuming 50 working weeks in the year) over the seven-year period, of one grand piano.

There was an upsurge in the numbers of grands manufactured during the two years 1793 and 1794: production rose to almost three per week, a level maintained until the end of the century. Between 1800 and the end of the year 1805, there was a further increase in grand output to about five instruments per working week.

The grand pianos produced by Broadwood during the twenty-year period 1785-1805 may be conveniently divided into four distinct types:

1. The earliest kind of Broadwood grand, five-octave models, compass F to F, (in musical terminology, FF to f3) with single bridge, manufactured between 1785 and 1788.

2. Five-octave models, compass also FF to f3, but with divided bridge, (having a separate bass bridge for the brass bass strings) constructed from 1788 until 1796.

3. Five-and-a-half octave models, compass FF to c4, with divided bridge, in regular production from 1792 through to 1808, and then continuing to be made, but in a much more limited way, until around the year 1812.

4. Six octave models, compass either CC to c4, or FF to f4, the earliest surviving dating from 1796, but made in very limited numbers before 1805. (Only six Broadwood grands with a six-octave compass survive from the period 1796-1805. This compares with over sixty surviving instruments from the same period with the much more customary five-and-a-half octave compass). However, from the year 1810, the six-octave compass became standard on all Broadwood grands.

The Earliest Surviving Broadwood grand, number 69, dated 1787.

The earliest surviving grand piano by John Broadwood is in private ownership in Buckinghamshire. Its nameboard is dated 1787, and marked on both the music desk and the lid is the serial number '69'. The instrument has a five-octave compass, F to F, as we would expect at this period, and a single, undivided bridge. Unlike the only surviving Backers grand, the stringing is tricord (three per note) rather than bicord. Broadwood's single lever action is not only a direct copy of the kind of action which had been used by Backers and then Stodart since 1771: it is also the only kind of grand action which was to be found on Broadwood grands during a hundred-and-ten-year period from the instrument which bore serial number 1, (circa 1785), until around the year 1895.

All the notes of the 1787 grand are damped, the pearwood dampers themselves being strongly reminiscent, in dimension, of harpsichord jacks. It is obvious that by 1787, the craftsman whose customary job it was to make pearwood harpsichord jacks for Shudi and Broadwood now had to turn his attention to making an almost identical item, the piano damper stem. The casework of grand number 69 is made from Spanish mahogany, the rim being veneered on an oak core, whilst the lid, trestle stand, music desk, damper rail and propstick, are all constructed from solid mahogany. Three simple oval brass handles, two on the bentside and one on the treble cheek, function as lid catches. The instrument sits on a four-legged trestle stand, attached to which are two large wooden pedals: right: sustaining (damper lift); and left: una corda (keyboard shift).

There are only five known Broadwood grands having the five-octave compass with single mainbridge (numbers 69, 141, 208, 258 and 274), all made before 1790. (14) Nevertheless, most of the features described in the previous paragraph, found on the 1787 model, are also to be found on the vast majority of Broadwood grands made between 1785 and 1805. The only significant differences from grand to grand during this manufacturing period concern keyboard compass: as we have just noted, grands manufactured by the firm between 1785 - 1805 may have a five, a five-and-a-half, or a

six-octave compass. A major change to the appearance of Broadwood grands did not take place until circa 1805, when four hefty turned legs began to be used on the six-octave models in place of the trestle stand.

When grand piano number 69 was first examined for its present owner, the keyboard/action unit was withdrawn from the instrument, and decades of dirt, dust and cobwebs carefully removed from it. After the cleaning had taken place, the signature 'Alex Finlason' [sic] could be clearly seen, inked on the front right-hand-side of the action. This individual, probably Broadwood's first grand action maker, was in fact an ancestor of the writer of this dissertation. He was a Scottish highlander, Alexander Finlayson, who came from the village of Redcastle, near Inverness in Ross-shire, and who had settled in London during the second half of the eighteenth century. It is not known how he found work in the Broadwood workshop in Pulteney Street, nor how he learnt the extremely specialised skill of grand action making. However, his employment by the firm must have been related to the fact that he was Scottish: John Broadwood at this period was in the habit of providing employment for fellow Scots residing in London. In the late 1790s, Alexander Finlayson was joined at Broadwood's by his kinsman, Finlay Finlayson; and Finlay's son, another Alexander Finlayson (1788-1865), almost certainly an action and keyboard maker as well, became one of the company's foremen. This second Alexander Finlayson was succeeded at Broadwood's by his three sons John Finlay Finlayson, (company clerk) Alexander and William Finlayson (both piano tuners); by a son-in-law, Edward Laurence (1808-1885) a piano case maker; and by four grandsons: Alexander Laurence, Alfred Marlborough Laurence, a second John Finlay Finlayson, and a fourth Alexander Finlayson (all piano tuners). This particular family working-connection with Broadwood lasted for the remarkably long span of at least one hundred and fifteen years, and is traceable back to the earliest surviving Broadwood grand of 1787.

String speaking lengths

It is interesting to compare the string speaking lengths found in

the 1787 Broadwood model with the lengths of strings found in a Kirkman harpsichord of 1755 (in the Russell Collection, Edinburgh) and in the only surviving Backers grand of 1772, also in the Russell Collection. They are shown as figure 2/1. At first glance, it would appear that the only thing which the three sets of string lengths have in common is that they more or less double in length at the octave, a common practice found on most makes of harpsichord and early grand. However, it is often a puzzle to discover how keyboard instrument makers arrived at their particular choice of string lengths. In the case of Backers, it is very clear to see from Figure 2/1 that he took as a basis for his new piano measurements the already-existing lengths found in a Kirkman, but applied the lengths to notes one fourth below those found in the harpsichord. Backers had quickly learnt, by trial and experiment, that the treble strings of the harpsichord were too long, thin and weak to respond well to hammer blows; his grands therefore employ a considerably shorter scale design than a harpsichord, but nevertheless one based on measurements which were apparently derived from those he found in an existing Kirkman. The arrowed lines in figure 2/1 show the links to the 1755 Kirkman. Broadwood's and Backers's grands' shorter scales also utilise thicker stringing than a harpsichord in order that the wires should have sufficient rigidity to withstand the hammer blows. At the same time, the shorter, thicker piano strings emit a more powerful tone than harpsichord strings.

The Broadwood of 1787 has remarkably similar string lengths to the 1772 Backers in its top half octave, but then from below c3 the Broadwood's strings become consistently longer: they are between 5% and 7% longer than Backers'. However, in the low bass - the bottom half octave - the Backers strings are in fact longer than those of Broadwood. Both grands are strung, like the harpsichord, mainly with iron wire. In their lowest sixteen notes they are strung in brass instead of iron, a custom derived directly from harpsichord maker's practice. This brass stringing was to cause a number of headaches for John Broadwood in his early days of grand manufacture, as we shall shortly see, and ultimately led to his introduction of the divided bridge some three years after he had commenced grand building.

Fig 2/1 :

SHOWING SPEAKING LENGTHS (in centimetres) OF:

KIRKMAN HARPSICHORD 1755 ('Long' 8'),

THE ONLY-SURVIVING BACKERS GRAND, 1772 (serial number 21),

AND THE EARLIEST-SURVIVING BROADWOOD GRAND, 1787 (serial number 69)

Also showing pluck and strike proportions for notes 'c' and 'f' (in brackets)

Note	Kirkman 1755 (Pluck)	Backers 1772 (Strike)	Broadwood 1787 (Strike)
f3 highest	13.20 (2.75)	10.50 (9.13)	10.30 (10.30)
e	14.00	11.10	10.80
d#	14.70	11.50	11.30
d	15.60	12.00	12.00
c#	16.40	12.70	12.80
c3	17.20 (3.13)	13.30 (11.08)	13.50 (7.94)
b	18.30	13.90	14.20
a#	19.30	14.60	15.10
a	20.40	15.50	16.00
g#	21.60	16.30	16.90
g	22.90	17.40	17.90
f#	24.30	18.40	19.00
f	25.70 (3.84)	19.50 (13.45)	20.10 (8.74)
e	27.30	20.60	21.40
d#	28.90	21.85	22.60
d	30.60	23.10	24.00
c#	32.45	24.50	25.50
c2	34.25 (4.57)	25.85 (14.00)	27.00 (8.71)
b	36.40	27.45	28.70
a#	38.60	29.10	30.40
a	41.05	30.75	32.20
g#	43.70	32.50	34.00
g	46.20	34.40	36.00
f#	49.10	36.45	38.20
f	52.10 (5.85)	38.65 (13.33)	40.50 (9.20)
e	55.20	40.95	43.00

	Kirkman 1755	Backers 1772	Broadwood 1787
d#	58.40	43.50	45.60
d	61.70	46.05	48.20
c#	65.20	48.80	51.20
c1 middle c	69.00 (6.76)	51.80 (12.20)	54.20 (10.03)
b	72.70	54.75	57.40
a#	76.50	58.15	61.00
a	80.40	61.50	65.10
g#	84.50	65.30	69.00
g	89.80	69.15	73.50
f#	93.10	73.40	78.10
f	97.10 (8.30)	77.55 (11.24)	82.90 (10.23)
e	102.00	82.15	88.00
d#	106.40	86.90	93.10
d	110.80	91.65	98.10
c#	115.00	96.50	103.30
c	119.30 (9.12)	101.40 (11.00)	108.50 (10.64)
B	123.50	106.40	113.60
A#	127.80	111.45	118.80
A	132.0	116.50	123.80
G#	137.8	121.30	129.00
G	139.4	126.35	134.00
F#	143.00	131.40	138.90
F	146.50 (9.64)	136.45 (10.54)	143.80 (10.90)
E	150.00	141.35	148.80
D#	153.30	146.25	153.30
D	156.90	151.45	157.20
C#	160.20	156.30	160.00
C	163.50 (9.73)	161.35 (10.28)	162.40 (10.48)
BB	166.80	165.85	164.10
AA#	169.90	168.80	165.60
AA	173.00	170.25	167.00
GG#	175.50	173.00	168.10
GG	177.60	173.25	169.10
FF#	-	-	169.90
FF	179.10 (9.63)	174.10 (9.16)	170.20 (9.25)

Strike Points and Plucking Points

The 'strike' and 'plucking' points of the three instruments may now be compared. They are also shown in figure 2/1. In its high treble, the Kirkman's strings are plucked at roughly one-half their length in order to achieve sufficient uplift of the string by the plectra, and therefore sufficient power. Piano hammers striking at this same point would produce a weak, dull and uninteresting sound. Backers had realised that he needed his treble hammers to strike much closer to the 'nut' (front) bridge than a harpsichord plectrum usually plucked, and in his piano of 1772 one ninth is established as the strike proportion for the highest notes. However, for most of the instrument's compass, the strike points are even closer to the nut bridge, hovering between one fourteenth and one eleventh, giving his instrument a characteristic clear, thin, but somewhat nasal tonal quality.

Broadwood had a different approach: he arranged his hammer strike line so that the strings are struck at about one tenth of their lengths in the high treble. Within an octave downwards, his hammers begin to strike at the eighth, considerably further along the strings than Backers; and then a strike of between one eighth and one ninth is maintained for the top two octaves. Such a strike proportion helps to give Broadwood's instrument a fuller and more rounded tone in its mid treble than Backers'. The middle register of the 1787 Broadwood has its hammers striking at around one tenth of each string's length. In their lower registers, all three instruments have a strike or plucking point close to the ninth. It could be argued that the establishment of the ninth as one of the most used strike measurements in this and later Broadwood grands is derived directly from one of the customary positions of the harpsichord jack, which also has contact with the strings in the region of one ninth for the lowest two octaves.

What is very clear from an examination of both the 1772 Backers and the 1787 Broadwood is that the strike proportion is not very regular, not at all predictable, and not very scientifically worked out: it changes from note to note in what appears to be a random way. This

suggests a level of carelessness on the part of the London grand piano makers at this date. It is highly likely that they did not bother to calculate mathematically the exact hammer-strike position, but instead 'used their ears' to determine what seemed to them to be the best places for the hammer heads to strike. This contrasts very strongly with the early nineteenth-century Paris built grands of Erard (such as the 5½-octave model of 1803 supplied to Beethoven), in which the exact strike position for each hammer in the piano is very precisely mathematically calculated in order to give a graduated strike from one ninth in the bass to one twenty-first in the top treble. (15)

Broadwood's Divided Bridge of 1788

One of the shortcomings of the earliest Broadwood grands - those models with the single, undivided bridge - is the unfortunate tendency of the thinnest brass wires, which serve the notes in the tenor section of the piano, to break rather too readily, either during a tuning pitch-raise, or as a result of any natural changes in room temperature and humidity which might cause the brass wires to be stretched 'sharpwards.' This same problem may also exist in a harpsichord, but it is less serious, as the brass tenor wires in this instrument are strung at a lower tension than in a piano. The chief problem in the single-bridge early grand is that two 'dissimilar metals' are obliged to share the same bridge. Eighteenth-century iron music wire, which may be 20% to 30% stronger than eighteenth century brass wire, (16) obviously has a higher breaking point. To gain the best possible tone from iron, string lengths were chosen so as to ensure that the iron wire was drawn up to some 60%-80% of its breaking tension when the correct pitch had been tuned. However, if an iron wire tensed at more than 70% of its breaking strain was replaced with a brass wire of exactly the same length and thickness, then this same brass wire was likely to break. On the single bridge grand piano of the type that Broadwood began to produce in 1785, the string lengths had to be calculated so that the lowest iron wires were considerably under-tensed, and the highest brass wires dangerously over-tensed, in order that they could share the same mainbridge. The end

result is inferior tone quality in the longest iron strings, then a noticeable 'bump' or tonal change in the transition from iron to brass stringing, (the iron sounding dull, the brass sounding stronger and more sustained). These faults go hand-in-hand with the worrying tendency of the thinnest brass strings to break far too readily.

John Broadwood must have become increasingly irritated by the repeated requests from his customers for replacement brass piano strings. He may have been forced to overstock with brass wire, and he might have been losing money as a result of having to supply numerous 'spares' free of charge. Brass wire, drawn by hand, was certainly not cheap to manufacture in the eighteenth century: sufficient brass wire required to string just the bass section of a grand piano cost around three shillings, the equivalent of the cost of a few days' labour. (17) In 1788, three years after commencing grand manufacture, Broadwood called upon the advice of Dr Edward Whitaker Gray (1748-1806) who was in fact a botanist, and by profession 'Keeper of the Department of Natural History and Antiquities in the British Museum'. (18) Gray was a friend of Broadwood, and a probable customer as well, who must have had a scientific interest in piano string tensions. According to James Shudi Broadwood, commenting fifty years later in 1838, his father John Broadwood

' - - obtained the assistance, amongst others, of Cavallo (well known by his Treatise on Acoustics and other works), who calculated from the monochord, the length and due tensions of the strings, a paper on which he read to the Royal Society - and the valuable services of Dr Gray, late of the British Museum, who, by his experiments, established the due portions in the gravity and vibration of the brass and steel strings, and thereby led to the division of the bridges on the sounding boards of Grand Pianos. (19)

Gray's solution, the divided bridge of 1788, was soon incorporated into every new Broadwood grand, and (as Broadwood did not take the trouble to patent the idea) was later copied by every other English grand maker. The divided bridge caused the highest brass strings to have

shorter lengths than the lowest iron strings, thereby largely eliminating the serious problem which had existed on the single bridge models. Although it was the problem of frequent brass wire breakages which appeared to have been the prime motivation for the introduction of the divided bridge, it was discovered, to the delight of those listening to the earliest examples of Gray's innovation, that there was a remarkable improvement in the quality of bass register tone as a result of the use of two bridges instead of one. The single, 'coathanger-shaped' curved bridge of the type found in the bass section of harpsichords and the earliest grands is the strongest and most rigid 'bar' attached to the soundboard of these instruments; and so it has a strong 'clamping' effect on the small-sized soundboard found in the tail of these models. As a result, the free movement or 'compliance' of the board is severely restricted in this area, and consequently the depth of tone quality of the bass suffers, being rather thin and lacking in volume. The substitution of one bridge with two bridges causes a gap to be formed on the soundboard at the point where the two bridges meet. This gap or 'incision' certainly allows the soundboard to move more freely under the bass strings, with very noticeable improvement in bass tone.

Once the divided bridge had been introduced, there was never a return to the single bridge. The divided bridge is found on all types of Broadwood grand made throughout the nineteenth century. From the early 1820s, copper-wound iron strings began to replace brass strings on the bass bridge (for example, the lowest six notes of the 1823 model shown in chart 2/2 have copper-wound strings); and by the mid century brass strings had been phased out altogether and replaced with copper-wound steel strings, either one per note for the lowest bass, or two per note for the tenor section. The brass wire had always been unsatisfactory from the point of view of strength: in spite of the divided bridge, breakages continued occasionally and could be troublesome. The Broadwood company must have been pleased to have been able to eliminate brass stringing altogether by the mid nineteenth century.

John Broadwood's divided bridge of 1788 is perhaps his most notable contribution to the evolution of the grand. Its great success in helping

to improve the tonal qualities of the grand's bass register may be judged by the fact that the idea was ultimately adopted by every other grand maker throughout Europe; the principle was extended to square and upright pianos as well; and of course, it was the existence of the separate, self-contained bass bridge which many years later resulted in overstringing, introduced by Steinway in 1859, in which a higher, separate bass bridge, repositioned behind the mainbridge, enables the bass strings to cross diagonally above the other strings in the piano.(20)

String Lengths, 1787-1805

Figure 2/2 shows the string lengths found in various examples of Broadwood grand manufactured between 1787 and 1806. In the same figure, these lengths are compared with those found in a grand of somewhat later date, bearing serial number 9356 and made in the year 1823. The earliest example shown, the grand of 1787 previously discussed (serial number 69), is the only one of the seven to have the single bridge; and it will be seen how its iron tenor strings are shorter - and highest brass strings longer - than those found in five of the other six models. After the introduction of the divided bridge, the end of the long treble bridge usually occurred at tenor note 'A', of speaking length around 130cm (4'3½"). This particular measurement for the longest mainbridge string occurs with remarkable consistency throughout most of the samples illustrated, and was chosen because it was the longest feasible length for this string within the case size being made at this period. It will be seen in the examples from 1796 to 1823 that in every case, the first brass tenor string on the separate bass bridge is always shorter than the last iron string on the mainbridge, usually by some 18%.

At first glance, it is quite hard to see, from the seven examples shown in figure 2/2, a level of continuity in Broadwood scale design throughout the period. Each instrument appears to have its own scale pattern, and, frustratingly, there are no two pianos having identical scales. The existence of such a wide range of slightly varying patterns makes it difficult to neatly categorise the different scales found.

Fig 2/2

STRING SPEAKING LENGTHS FOUND IN SEVEN BROADWOOD GRANDS, 1787-1823
(All measurements in centimetres)

Date	1787	1796	1801	1802	1805	1806	1823
Serial No: (69)	(1246)	(2204)	(2443)	(Ringve)	(3451)	(9356)	
f4					5.4		5.8
e					5.65		6.1
d#					5.9		6.4
d					6.15		6.6
c#					6.5		6.9
c4		8.1	7.6	7.1	6.8	7.5	7.25
b		8.4	7.75	7.4	7.2	7.7	7.55
a#		8.7	8.15	7.7	7.55	7.9	7.9
a		9.2	8.45	8.0	8.1	8.3	8.35
g#		9.6	8.75	8.4	8.55	8.6	8.9
g		10.0	9.15	8.8	9.05	9.0	9.35
f#		10.6	9.75	9.3	9.55	9.4	9.85
f3	10.3	11.2	10.25	9.8	10.05	9.9	10.35
e	10.8	11.9	10.9	10.4	10.6	10.4	11.0
d#	11.3	12.5	11.5	11.0	11.35	10.9	11.60
d	12.0	13.3	12.2	11.7	12.0	11.6	12.25
c#	12.8	14.0	12.85	12.4	12.85	12.2	13.15
c3	13.5	14.8	13.65	13.2	13.15	13.1	13.9
b	14.2	15.8	14.45	14.0	14.5	13.9	14.65
a#	15.1	16.7	15.25	14.9	15.5	14.8	15.55
a	16.0	17.6	16.15	15.8	16.5	15.6	16.45
g#	16.9	18.9	17.2	16.8	17.65	16.6	17.45
g	17.9	19.9	18.2	17.9	18.75	17.6	18.5
f#	19.0	20.8	19.3	18.9	19.9	18.7	19.6
f	20.1	21.9	20.4	20.1	21.1	20.0	21.1
e	21.4	23.1	21.7	21.4	22.65	21.2	22.25
d#	22.6	24.5	23.0	22.7	24.1	22.5	23.45
d	24.0	25.9	24.25	24.1	25.5	23.9	24.9
c#	25.5	27.2	25.85	25.6	27.15	25.4	26.3

Fig2/2	1787	1796	1801	1802	1805	1806	1823
c2	27.0	28.6	27.2	27.2	28.85	27.0	27.85
b	28.7	30.1	28.9	28.9	30.75	28.7	29.45
a#	30.4	31.9	30.4	30.6	32.5	30.4	31.25
a	32.2	33.8	32.45	32.4	34.6	32.3	33.05
g#	34.0	35.8	34.45	34.4	36.65	34.3	35.55
g	36.0	37.9	36.55	36.5	38.85	36.4	37.6
f#	38.2	40.0	38.65	38.8	41.15	38.6	39.7
f	40.5	42.4	40.95	41.1	43.15	40.9	42.1
e	43.0	44.9	43.35	43.6	45.85	43.2	44.6
d#	45.6	47.5	46.05	46.3	48.4	45.7	47.15
d	48.2	50.4	48.7	49.0	51.25	48.3	49.95
c#	51.2	53.4	51.55	51.9	54.15	51.2	52.7
c1	54.2	56.3	54.45	55.0	55.95	54.2	55.1
b	57.4	59.4	57.95	58.3	60.15	57.6	58.8
a#	61.0	63.2	61.1	61.7	63.2	61.0	62.1
a	65.1	66.6	64.8	65.5	66.7	64.6	65.65
g#	69.0	70.7	68.9	69.5	70.1	68.5	69.3
g	73.5	74.8	72.85	73.5	73.8	72.6	73.15
f#	78.1	78.9	77.2	78.0	77.55	76.8	78.55
f	82.9	83.5	81.85	82.7	81.15	81.4	83.0
e	88.0	88.2	86.4	87.4	85.5	86.3	88.15
d#	93.1	93.4	91.6	92.7	89.55	91.4	93.6
d	98.1	98.9	97.25	98.1	93.7	96.7	99.05
c#	103.3	104.4	103.85	103.8	b82.05	102.6	104.95
c	108.5	110.8	109.6	110.0	88.15	109.1	111.0
B	113.6	117.3	116.55	116.8	93.85	116.0	117.45
A#	118.8	124.0	123.5	123.8	99.25	123.1	124.2
A	123.8	130.0	130.65	131.2	105.0	130.5	131.0
G#	b129.0	b108.2	b107.75	b109.0	110.55	b107.6	b109.2
G	134.0	113.8	114.05	114.4	116.0	114.0	114.65
F#	138.9	120.2	120.8	119.9	121.55	120.4	119.9
F	143.8	126.2	126.95	125.5	126.95	126.7	125.45
E	148.8	132.2	133.2	131.0	132.25	132.9	130.65
D#	153.3	138.2	139.25	136.8	137.75	138.7	137.85

Fig2/2

	1787	1796	1801	1802	1805	1806	1823
D	157.2	144.2	145.0	142.4	142.65	144.4	142.75
C#	160.0	149.8	150.5	147.9	147.35	149.9	147.9
C	162.4	155.4	155.4	153.3	151.75	155.1	153.05
BB	164.1	160.7	159.55	158.8	155.7	159.4	158.15
AA#	165.6	165.2	163.15	163.8	158.85	163.0	163.2
AA	167.0	168.7	166.2	168.8	161.5	165.9	168.15
GG#	168.1	170.6	168.65	173.8	163.45	168.1	172.75
GG	169.1	172.1	170.45	178.3	164.9	169.8	177.3
FF#	169.9	173.1	171.8	182.5	166.25	171.2	181.0
FF	170.2	173.9	172.95	186.0	167.25	172.3	w184.1
EE				188.8			186.4
DD#				191.1			188.2
DD				192.7			189.55
CC#				194.1			190.7
CCC				195.2			v191.4

Key: b = commencement of brass wire
w = commencement of wound strings

1787: Measurements by Michael Latcham (Holland)

1796/1806: Measurements by John Watson (USA)

1802: Measurements by David Hunt (UK)

1801/1805/1823: Measurements by Alastair Laurence

This fact suggests that this period in the company's grand evolution was one involving many small design changes and many experiments with differing string lengths. In spite of this, we are able to detect three broadly different scale designs in operation: first of all, the instruments of 1787, 1801, 1802, and 1806 have similar though not identical scales. Secondly, the model of 1796 has a rather different scale from the others, with noticeably longer string lengths in its top three octaves; and thirdly, the grand of 1805 found in the Ringve Museum, Trondheim, Norway, (serial number missing) has a quite different scale design from the others, having shorter strings in the treble, longer strings in the middle of the keyboard compass, and considerably shorter iron strings in the tenor; in addition, the 1805 Ringve model has a different change-over point from its iron-strung mainbridge to brass-strung bass bridge (c# to c) when compared with the other divided-bridge instruments. It is likely that the differences found on the Ringve instrument relate to the fact that the compass of this particular piano, an unusual one for Broadwood, spans from F down to F, (6 octaves) whereas most of the other instruments of the similar date span from C down to F (5½ octaves).

The string lengths of the 1823 grand are also included in figure 2/2 to show that there had been very little overall change in Broadwood's grand scale design since 1787; the lengths in the 1823 model are remarkably similar to those found in the 1787 piano. The chief difference between the scale design of the two instruments concerns the thickness of wire used, rather than any significant changes in string lengths. The 1787 piano is strung with wire diameters ranging between approximately 0.4mm and 0.7mm (music wire gauges '6' to '13'), whereas the 1823 model is strung with wire diameters from around 0.6mm to 1.00mm (music wire gauges '10' to '17'). The thicker wire and wider compass found in the 1823 model means that approximately 50% more stringing tension has to be borne by the structure of this instrument when compared with the much earlier model. This rise in tension explains the significant increase in tonal volume when the sound of the 1823 piano is compared with that of 1787. (The increase in volume is also in part due to the heavier hammers found in the 1823 model).

Soundboards and Bridges

Figure 2/3a has two illustrations showing the layout of bridges and the direction of soundboard grain found in two different types of early Broadwood grand. The first illustration shows the features we would see on one of the original five-octave models of 1787: a single bridge; and the spruce planks which comprise the soundboard running parallel with the straight spine at the bass side of the instrument. The second plan, illustrating the layout of a six-octave model of 1805, shows the divided bridge and the different method of laying the soundboard planks, now orientated at a 10-degree angle to the spine. This curious new angle is found only in the six octave models dating from the mid 1790s. All the grands of five or five-and-a-half octave compass have a 'straight' soundboard grain running parallel with the bass spine. After the six-octave compass was established by Broadwood as 'standard' from 1810, all grand soundboards made by the firm had this same 10-degree angle, and the practice was continued through into the late 1820s. (However, after 1827 and throughout the 1830s, there was a radical change in Broadwood's thinking, the planks now crossing the width of the piano in relatively short lengths, from left to right. This new conception in the direction of soundboard plank-laying was, in theory at least, far from ideal. It is not surprising to discover that the well-established . . . ↗ . . . orientation was reintroduced in the early 1850s and was maintained as a feature on all grands made by the firm until the mid 1920s). (21)

Broadwood grand soundboards are, like harpsichord soundboards, of varying thickness depending on which part of the musical compass the soundboard is serving. It is usually impossible to measure the precise changes in thickness within a grand soundboard because the 'end grain' of the spruce planks which comprise the board are hidden under the wooden hitch pin rail; and of course changes in thickness of the soundboard in the middle of its surface area cannot be ascertained unless numerous small holes are drilled through it, obviously an undesirable practice. However, in recent years two early Broadwood grands in the Museum of Fine Arts, Boston, USA - a six-octave model of

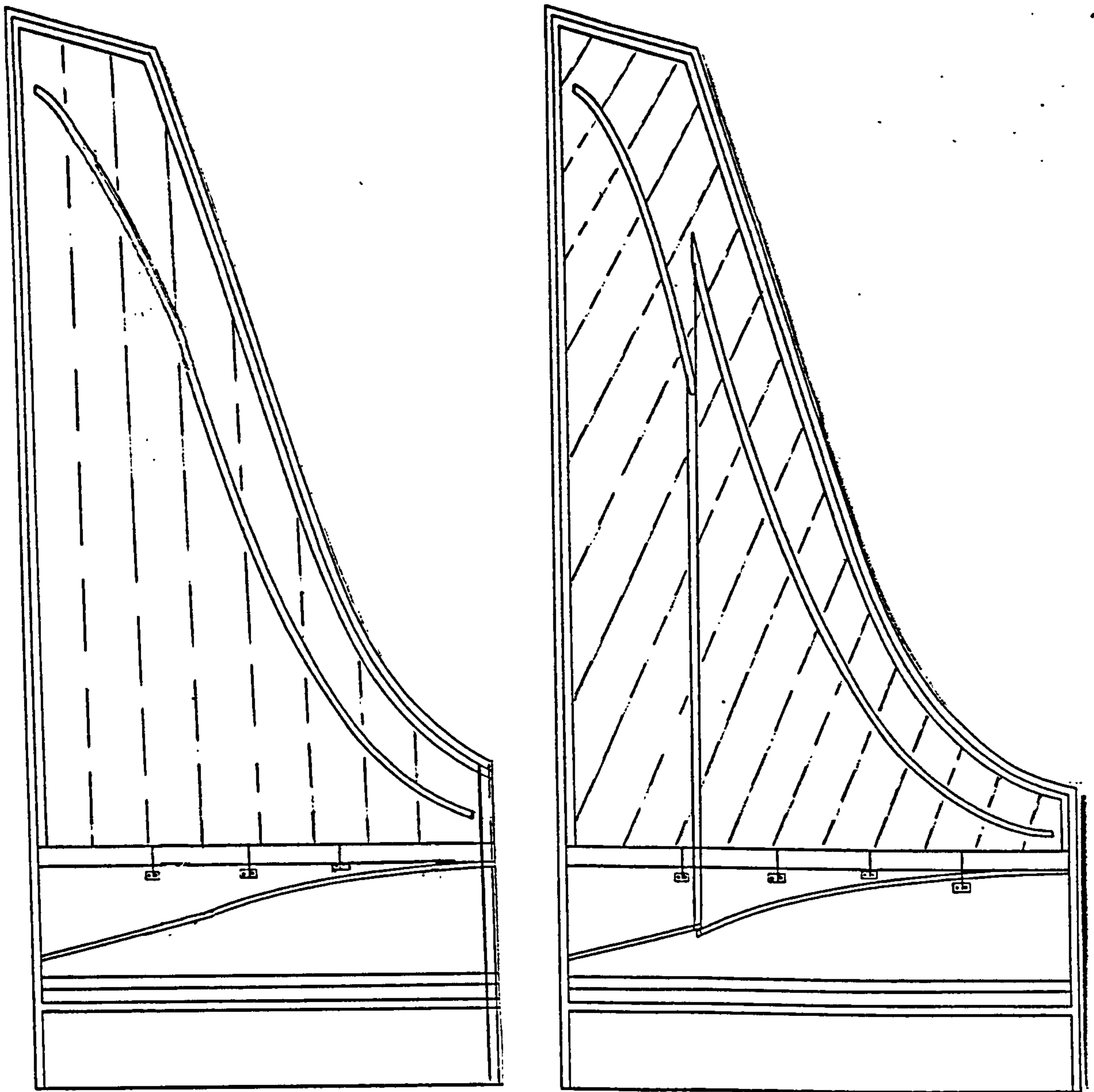

Figure 2/3a: Bridge layout and direction of soundboard grain found in two early Broadwood grands: Left: a five-octave model of 1787; right: a six octave model of 1805. In the six-octave example, the lowest iron string and the highest brass string are shown.

1796 and a five-and-a-half octave model of 1804 - have had their soundboards removed in order for extensive repairs to take place, and their thicknesses were carefully measured by John Koster. (22)

The 1796 instrument has a board mainly of thickness 5.5mm (a little under one quarter of an inch), but in the extreme treble the same board is deliberately 'stiffened up', by slightly increasing its thickness to 6.6mm, presumably in order to help the tonal characteristics of the top treble strings. The 1804 model's soundboard is more complex in its cross-section, which is tapered: the spruce is only 3.5mm thick (slightly over one eighth of an inch) under the bass bridge in the piano's tail; but then this thickness is gradually increased until the board becomes 7mm thick under the high treble strings. Broadwood had obviously discovered, between the years 1796 and 1804, the tonal advantages to be gained by installing a carefully-tapered board into a grand, the thinner planks under the bass bridge helping to produce a more compliant board which helps to produce a 'freer' and more 'boomy' tonal quality in the bass. In contrast, the thickened-up board in the high treble is beneficial to the brilliance and clarity of the grand's highest notes.

Figure 2/3_b shows the barring system of the ribs which lie under the soundboard of the 1804 piano in the Museum of Fine Arts. (23) It is interesting to see how the earliest grand piano makers, just like the last harpsichord makers, were anxious not to have any of their ribs crossing directly underneath the bridges which sit on the other side of the board. The main function of the ribs is to 'stiffen up' the board, to keep it level and rigid, and to help resist the down-pressure from the strings; in the case of the harpsichord and early grand, the triangular cluster of ribs in the bass corner of the board also functions as a 'cut off', reducing the effective size of the soundboard and helping to eliminate any unwanted intrusive ringing noises which may occur when too large a board is employed and when the cloth dampers in the action mechanism cannot adequately control the silencing of the strings.

Figure 2/4 compares the distance between the mainbridge side and

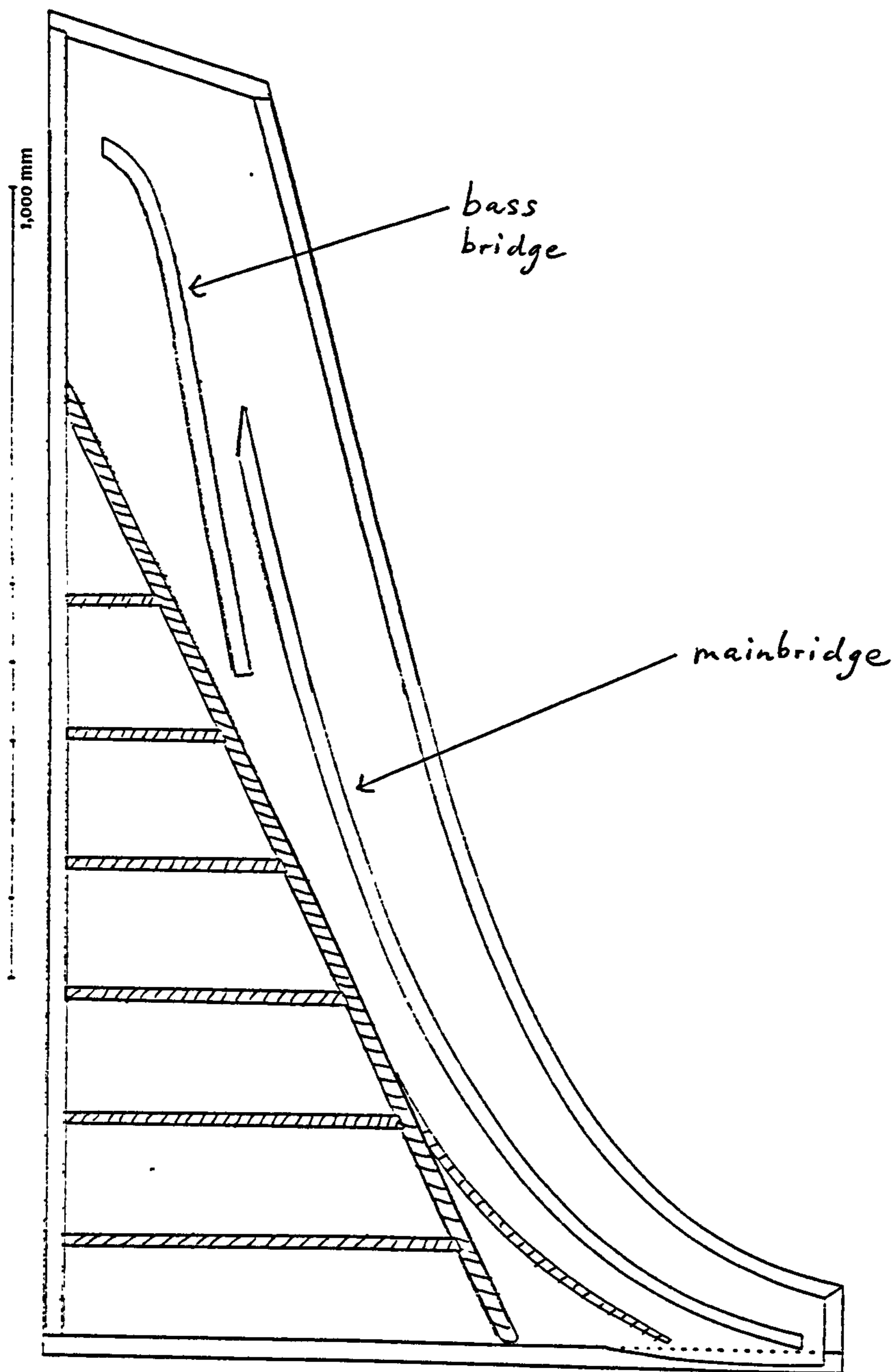

Figure 2/3b: Broadwood grand soundboard, serial number 3027, date 1804, showing position of ribs and bridges. (Museum of Fine Arts, Boston, USA).
Hatched lines = ribs under board.

Fig 2/4: A comparison of the distances between mainbridge side and soundboard edge in English, French and Viennese grands, and an English harpsichord. All measurements, in centimetres, taken from instruments in the Finchcocks Collection, Goudhurst, Kent, 1998.

	Top Note	Next octave down	Next octave down	Next octave down	Bridge end
<u>Harpsichord</u>					
Kirkmann 1756	9.5cm	9.5cm	10cm	11cm	11.5cm
<u>Grand pianos</u>					
Broadwood 1792	7.5cm	8.5cm	9.5cm	10cm	11.5cm
Broadwood 1801	7.5	8	10	10	11
Erard 1801	7	7.5	8	8	8
Stodart 1802	6.5	7.5	10.5	11.5	10
Broadwood 1823	7.5	9	11	12	15
Heilmann 1785	12.5	12.5	11	12	12
Lengerer 1793	10.5	10.5	9	10	10
Rosenberger c1800	12	12	12	10	9.5
Fritz c1815	12.5	11.5	12	11	10
Graf 1826	10	11	12	13	10

soundboard edge (at the bentside) in a number of instruments in the Finchcocks Collection, Goudhurst, Kent, measured by the writer in 1998. It may be seen that in general, the English grands (and a French grand of 1801) have their bridges significantly closer to the edges of their respective soundboards than Viennese instruments. Broadwood grands during the period 1792-1823 have their bridges placed 7.5cm from the soundboard edge at the treble end. In the mid treble of the 1792 and 1801 Broadwood models, the bridges lie between 8 and 10cm from the soundboard's bentside edge; but in the 1823 model, the bridge line in this vicinity is deliberately planned to be a little further away from the edge, between 11 and 12 cm. In comparison with the Broadwood models, most of the Viennese grands have their bridges up to 5cm further away from the bentside edge throughout their top two octaves. The musical result of these differences is a brighter, 'tighter', more incisive sound from the English grands, but with less ability on the part of the player to achieve subtle gradations in tonal expression, because the bridges sit on what are comparatively unyielding parts of the soundboard. The Viennese bridges, sitting further away from their various bentsides, help to give a freer, more singing (but generally less powerful) tonal quality. This treble 'freedom' in the Viennese models is enhanced by the fact that their soundboards' edges are not tightly anchored to their head bars (situated close to the hammer line) as in English grands, but are suspended or 'floated' above the action mechanism. The Viennese soundboards are altogether less rigid in their trebles than the equivalent English boards, and this has quite a bit to do with the particular placement of the mainbridge.

In all the Broadwood grands from the period 1787-1805, the strings, (after passing through the guide pins on the long mainbridge) are anchored at their ends by attachment to stout brass pins inserted into what is known as the hitch-pin rail, a curved beam of walnutwood which sits on top of the soundboard at its bentside edge and which is secured to the inside of the rim of the piano by glue and a multitude of screws. One of the structural weaknesses of the early Broadwood grand concerns this hitch pin rail: under the constant forward pull of the strings, it may be torn away from its junction with the piano's rim, the screws and glue often proving inadequate to resist the constant string tension. This particular problem is worse in the treble part of the hitchrail, where a greater amount of forward pull from

the strings is concentrated in a smaller area.

Any structural failure of the hitchrail in turn causes soundboard cracks to appear, and of course greatly impairs the tuning stability of the instrument. In addition, the hitch pins themselves may become loose in the wood, or alternatively, break when too high a string tension is applied (for example, if the instrument is restrung with wire of too great a thickness). This particular problem was not finally resolved in Broadwood grands until the introduction of the cast-iron hitch plate (with integral iron hitch pins) by James Shudi Broadwood, patented in 1827. (24) The new cast-iron hitch plate of this date replaced the troublesome walnutwood hitchpin rail with its unreliable brass pins. For further details about the evolution of Broadwood's iron supporting structures during the nineteenth century, see chapter 8.

Another structural failing of the early Broadwood grand, and a 'design fault', is the system of iron 'arches' or struts used to span the gap through which the hammers pass to strike the strings. These metal arches, originally three in number, were first introduced by Backers and then later copied by Stodart and Broadwood. Interestingly, they are strongly reminiscent of the wooden arches found in the hammer gap on Cristofori's instruments. Their purpose is of course to resist the string tension; but although they prevent the hammer gap from 'closing up', they are not sufficiently effective to prevent the wooden structure of the instrument - the sides and the base - from undergoing slow plastic deformation under load, the unpleasant twisting and distorting of the wooden casework as a result of the stringing tension.

In Broadwood's early five-octave models, the narrow keyboard compass and generally lower string tensions means that the three metal arches, each of some 3mm thickness, combined with the surrounding wooden case structure, are normally sufficiently strong to resist the stringing load with a minimum of case distortion. However, after the keyboard compass had been extended to five-and-a-half octaves during the 1790s, and in spite of the addition of a fourth metal arch, the problems of case distortion became more serious. The thickness of the arches was increased on the six-octave models (from about 3mm to about 5mm), and the number of arches further increased from four to five, but even this was insufficient to prevent continued 'deformation' of

the grand's wooden structure. The root of the problem lay not so much in the metal arches themselves, but in the structural weakness of the instrument's wooden base, which was made too thin. At its worst, the distortion results in an unsightly upward twist of the treble cheek, making it impossible for the una corda keyboard shift to function without jamming, and disturbing the down-pressure of the treble strings on the mainbridge. It was not until the year 1823 that James Shudi Broadwood began to tackle this serious problem by employing two long iron bars (in place of the arches), placed over the strings in the treble section of the company's grands. These same two bars also helped to keep the hitchrail in place. (25)

The English 'single lever' grand action

As we noted a few pages back when describing the earliest surviving Broadwood grand of 1787, the action of this particular instrument, made by Finlayson, and named the 'English single lever' grand action, was apparently invented by Backers and then copied by Stodart (from 1776) and then Broadwood (from 1785). It is the only kind of mechanism found in Broadwood grands for a period spanning one hundred and ten years, 1785-1895. The fact that the same design of action was employed for such a long period of time suggests that the mechanism must have had considerable merits. Two of its chief virtues immediately spring to mind: a neat, simple design which could be manufactured at a reasonable cost; and a remarkable degree of stability and permanence as far as regulation is concerned. The only significant changes which occurred to the English single-lever grand action between 1785 and 1895 involved the use of larger, heavier hammers and stronger hammer shanks, as the nineteenth century progressed; and the employment of cloth or felt (instead of leather) as a hammer-head covering material, beginning in the late 1820s. The success of the Backers' design may be judged from the fact that it was adopted and copied (in modified form) by the two leading Paris builders, Erard and Pleyel, during the early nineteenth century.

However, when the English grand action is compared with Erard's later 'double escapement' mechanism, (first introduced in the early 1820s and then enthusiastically copied by all the German and American builders)(26) there is

absolutely no question that the French mechanism is superior to the English, from the performer's point of view. If we are to pinpoint the major advantages of the French action over the English, they are as follows:

1. In the Erard action, it is possible to repeat the same note over and over again when the key remains pressed down by the finger, close to the bottom of its touch depth. In comparison, the player of the English action is obliged to let the key return to its point of rest before the same note may be repeated. The French mechanism therefore has much better powers of repetition of the same note, making trills and tremolo passages far easier to execute.
2. The English mechanism, of whatever vintage, is obliged to have a small amount of loose 'play', known as 'lost motion', between its keyboard and its action in order for any kind^{of} repetition of notes to be gained, whereas the Erard system has no 'play' whatsoever, giving a more immediate and positive response to the finger.
3. The Erard action, with its intermediate lever and repetition spring, is able to carry a heavy hammer up to the string with ease (40 to 50 grams finger pressure). In an English action, if a heavy hammer is employed, this invariably means a heavy touch as well (50 grams and above). The early Broadwood grands, with their small and light hammers, have little trouble as far as touch weight is concerned. They are pleasurable and responsive to use because their light hammers can be easily thrown against the strings by the single lever mechanism. However, when hammer heads became larger and heavier (and covered with thick felt) as the nineteenth century progressed, the touch of the Broadwood grand became increasingly unpleasant to use. Its heavy, clumsy and tiring characteristics were the source of constant complaints from concert artists. It is quite remarkable that these complaints appeared to fall on deaf ears as far as the Broadwood company was concerned.
4. The Erard action, because of its unique intermediate lever (an accelerator) throws its hammers against the strings with greater speed than the single-lever English action, and in so doing produces a more powerful and louder tone.

If we have to point out the two main drawbacks of the Erard system, they are as follows:

1. The action is far more complicated than the English, and therefore

significantly more expensive to manufacture.

2. Because of its particular combination of levers, springs and leather pads or 'rollers', the French mechanism has a far greater tendency to go 'out of regulation' within a relatively short period of time when compared with the English action. In particular, the way in which the full weight of each hammer assembly is supported by only a small dome of leather (the 'roller') gives problems: as the instrument is played, the leather roller pad distorts under compression, the correct vertical alignment of the hammer is disturbed, and excessive hammer bounce is the result. Similarly, when the Erard action springs begin to lose their required tension (for example, as a result of a few months of heavy playing) the efficiency of the action repetition is greatly hindered. The early Erard double-escapement grand mechanism requires constant attendance and fussing over if it is to function correctly. Its regulation is never stable; and there is nothing quite as unpleasant as a badly out of regulation Erard action: the touch becomes heavy and sluggish, friction is great, control is lost, and the hammers may bounce or 'roll' a few times against the strings when only one note is desired. It is quite understandable how Broadwood was reluctant to adopt the French action system. The company's own English action, when 'settled in' after a few months' playing, gave years of trouble-free performance. In fact, one of the most remarkable features of early Broadwood grands is the way in which it is possible to find their mechanisms (in unrestored instruments) in tolerable working order almost two hundred years after they were first assembled.

The early Viennese grand action shares many of the same features as the early English mechanism: there has to be a small amount of 'lost motion' within each note of the action assembly in order for the mechanism to 'repeat'; and also each key of the Viennese grand has to return to its position of rest in order for repetition of the same note to take place. However, the touch depth found in early Viennese grands is usually slightly less than contemporary English models (roughly between 4 and 5mm, whereas late eighteenth century London-built instruments have a touch depth of 6 to 8mm). This shallower touch depth aids the fast repetition of the same note, and so in general the early Viennese grands are seen to have slightly better repeating qualities than the English. The hammer assembly found in the

Viennese instruments is a 'first class lever' (viz: fulcrum existing between 'load' and 'effort', whereas the English action is a 'third class lever' (fulcrum at one end, 'effort' between fulcrum and 'load')). As a result of this phenomenon, heavier hammer heads may be employed in the Viennese system without giving an unduly heavy touch. As we have already noted, one of the great faults of the English single-lever mechanism is its noticeable increase in touch weight when a heavier hammer is employed.

The main components of the English single lever grand action (which have already been illustrated in cross-section in the two drawings towards the end of chapter 1) may now be described in detail:

1. The hammer assembly: this unit comprises a) the small leather-covered *walnut* hammer head which strikes the strings and b) a thin cedarwood 'shank' connecting the hammer to its mahogany 'butt', and c) the butt itself, through which the thin pivot rod of silver-plated brass runs. It can be seen from figures 2/5a, 2/5b and 2/5c that the features of the hammer assembly changed very little during the period 1792 to 1823, as far as overall dimensions were concerned. The length of shank remained unchanged, at 10.5cm or $4\frac{1}{4}$ inches, but shank thickness was increased from 3mm to 4mm in order to cope with the heavier hammer heads. Cedarwood was chosen as a shank material because it is very light and elastic, but also very easy to turn and fit (by crushing and then glueing) into the harder *walnut* hammer heads and butts. (Cedarwood also becomes very brittle after a number of years - for example, as a result of drying out - and one of the great bugbears of the early Broadwood grand action is the unfortunate tendency of the cedar material to break under heavy playing. There are very few early Broadwood grands which retain all their original shanks).

The leather hammer coverings comprise under-layers of harder material (such as cowhide sole leather) but then a much softer outer covering of thicker sheepskin or deerskin. When this outer layer became worn and damaged through regular impact with the strings, it was sometimes replaced with a new outer layer. Many surviving early Broadwood grands have had their outer hammer leathers renewed at some period, sometimes, inappropriately, with thin felt in place of leather. It may be seen from the accompanying

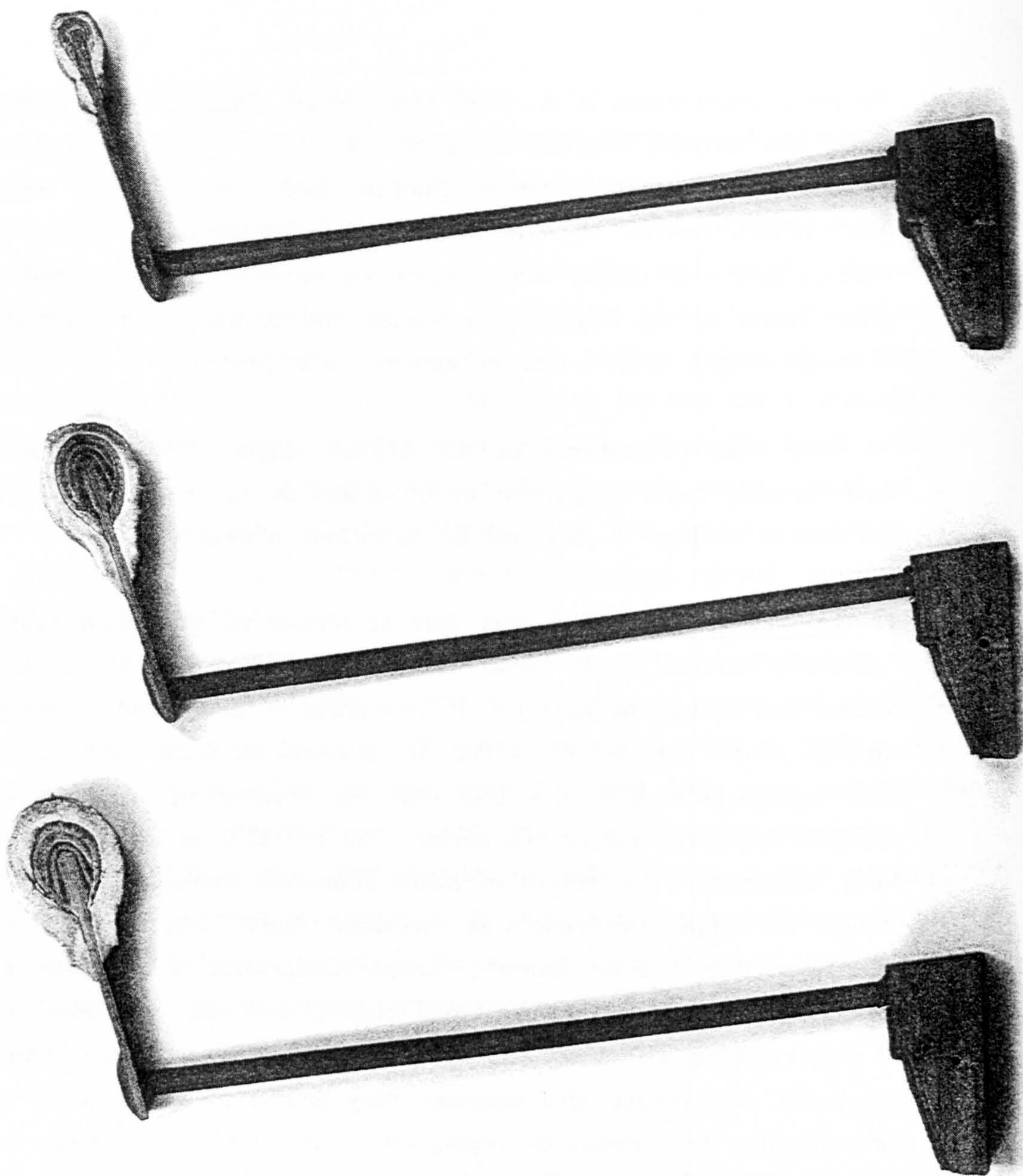

Fig 2/5a: Broadwood hammers, shanks and butts, 1792
(piano serial number 442, Finchcocks Collection)
The three items, top to bottom, are for i) highest
note ii) middle c, and iii) lowest bass note.

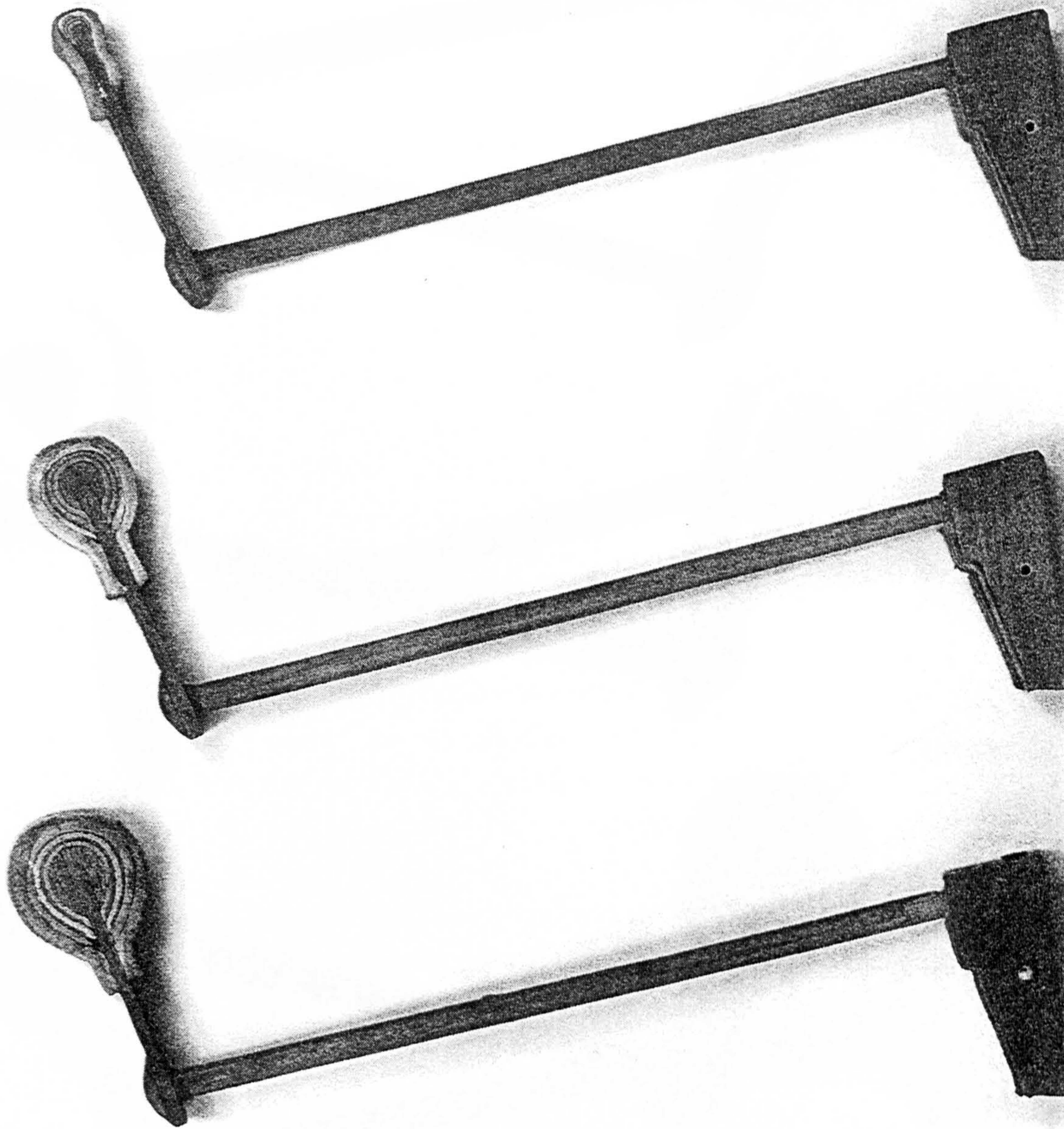

Fig. 2/5b: Broadwood hammers, shanks and butts, 1801
(piano serial number 2204, Finchcocks Collection)
The three items, top to bottom, are for i) highest
note ii) middle c, and iii) lowest bass note.



Fig. 2/5c: Broadwood hammers, shanks and butts, date 1823.
(piano serial number 9356, Finchcocks Collection)
The three items, top to bottom, are for i) highest
note ii) middle c, and iii) lowest bass note.

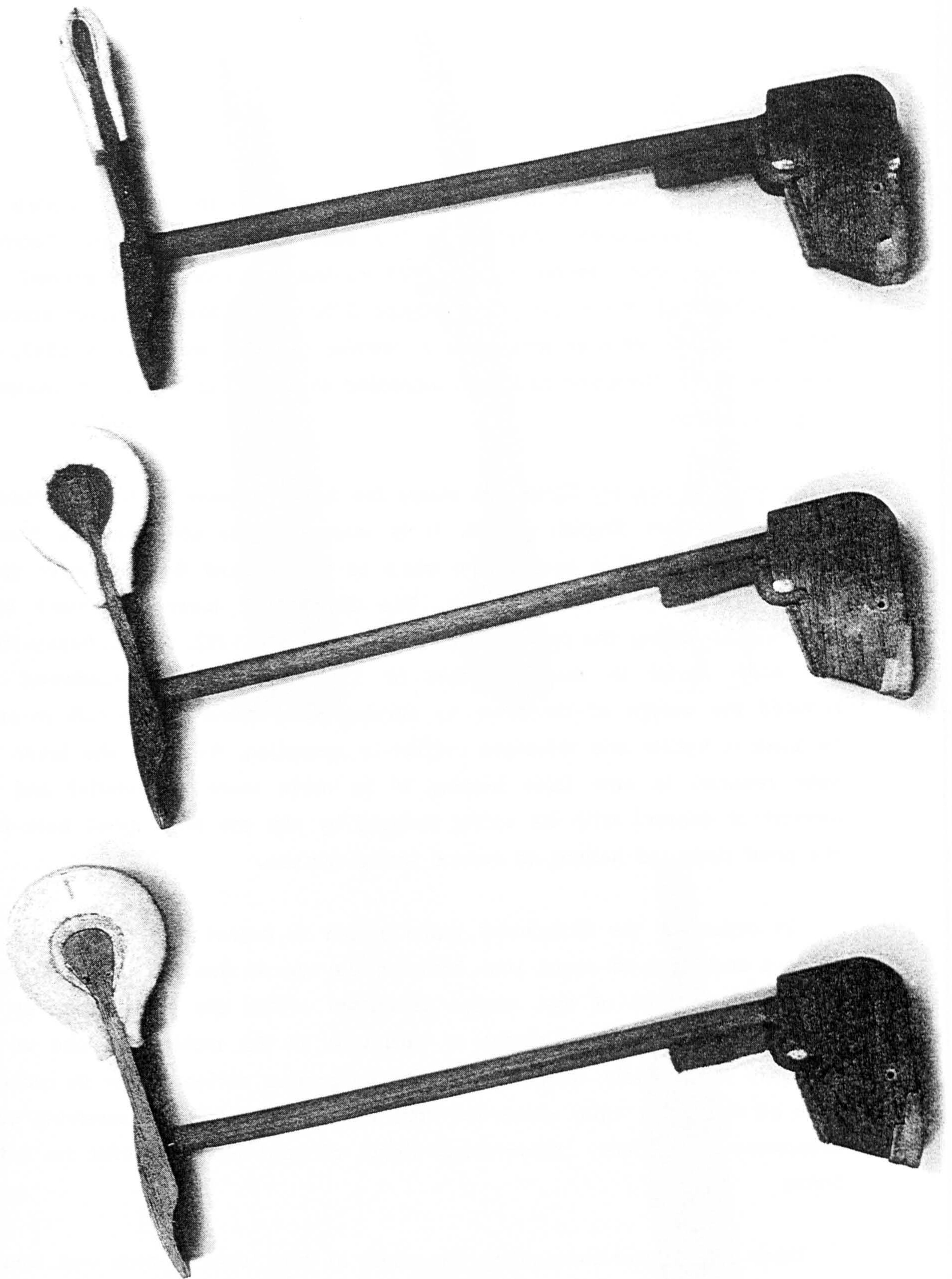

Fig. 2/5d Broadwood hammers, shanks and butts, date 1847
(piano serial number 16368, Finchcocks Collection)
The three items, top to bottom, are for i) highest
note ii) middle c, and iii) lowest bass note.

figures that the shape of the hammer heads found in the earlier models are very much 'pea-shaped', whether in the bass or treble. The later hammers (for example, those found in the 1823 model) are more 'egg shaped' and more pointed at the strike place. Figure 2/5d shows how a thicker piece of felt had largely replaced leather as a hammer-covering material by 1847, and how the shank thickness had been increased to 5mm and slightly increased in length to 11cm.

2.The lever or hopper: figure 2/6 shows the types of lever or hopper found in early single-lever English grands. It is interesting to see how the Stodart grand lever of 1802 is exactly the same as the original Backers lever found in the 1772 piano at Edinburgh. The Broadwood lever underwent some modification during the period under examination. In 1792, it was heavy-looking and much closer in shape to that of Stodart. By 1801, Broadwood had reduced the weight of the lever by carving away some of the bulk in order to make it lighter and therefore swifter in operation. By 1823 the lever had been reduced in size (also helping it to move more efficiently) and the amount of contact with its spring reduced by the use of a small hole near the pivot point, so helping to reduce spring friction.

In order for the Broadwood grand action to repeat correctly, there has to be a small gap of about 1mm between the top of the lever and the butt. This small amount of lost motion is known within the piano trade as the 'card', because two small pieces of card (one at the treble end, one at the bass) are deliberately wedged under the supporting action frame in order to raise all the butts 1mm above the tops of the levers. Every surviving early Broadwood grand has these small pieces of card jammed under its action frame.

There is a legend surrounding the origin of this 'card', which was told to the writer by CH Gilbey (1907-1980) who, as a youth, had worked in Broadwood's grand repair workshop. (27) Gilbey was told by an elderly Broadwood technician that when the original single lever mechanism was being developed (presumably by Backers, Stodart and Broadwood, 1770/71) great problems were met with when it came to achieving repetition, and many hours of fruitless effort were spent trying to improve things. Then one

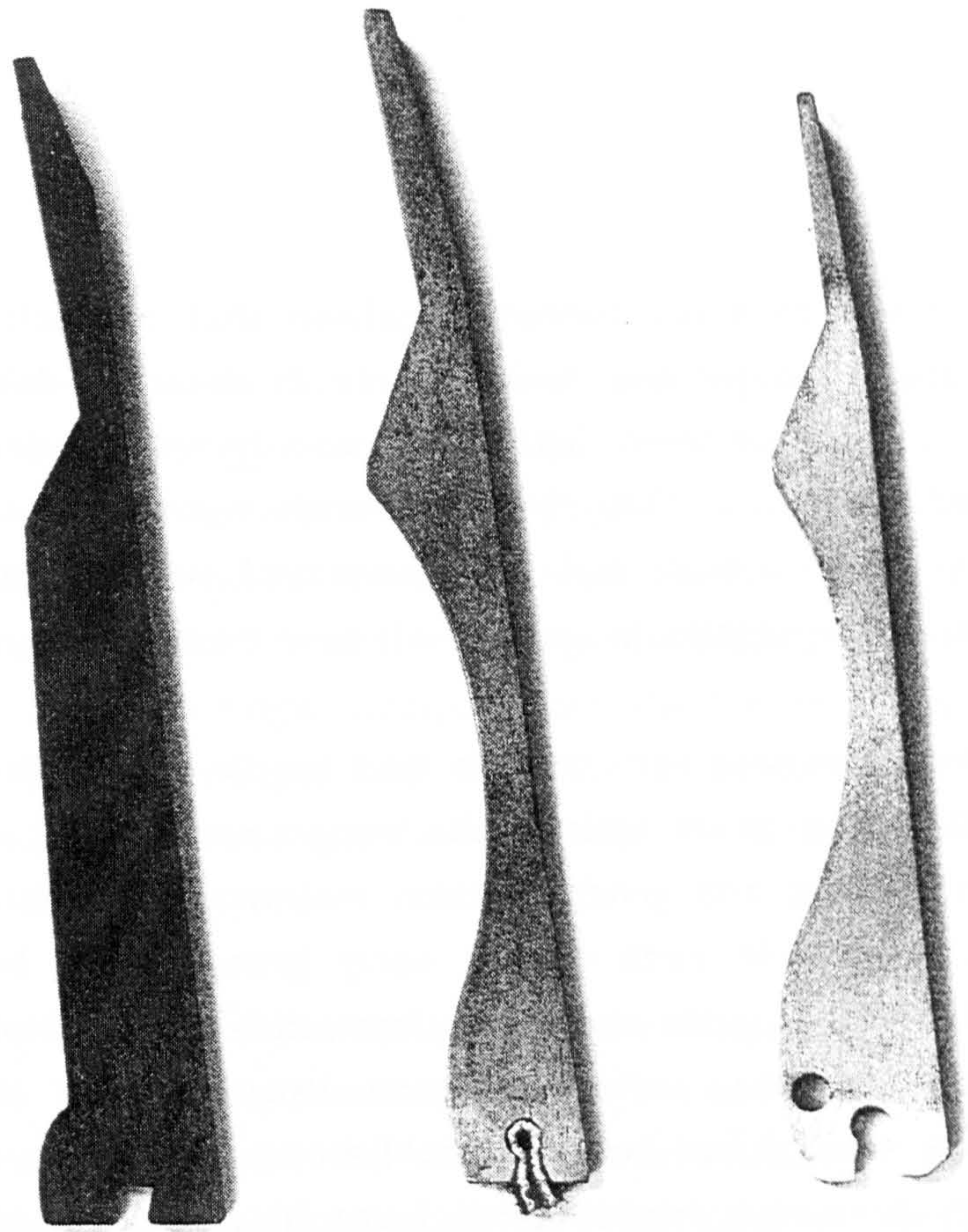

Fig. 2/6: The Evolution of the Broadwood grand lever or 'hopper': Top row, left to right: 1792; 1801; 1823. Compare with Stodart grand lever (1802), right. (Finchcocks Collection)

of the group of three suddenly realised that if small pieces of playing card were jammed under the action frame in order to deliberately force a 1mm gap to appear between lever tops and hammer butts, then the mechanism repeated perfectly. This 'botch' therefore became a feature of the first Backers grand action; and 'card insertion' subsequently became a customary part of the regulating process in all new Broadwood grand actions until 1895.

Broadwood was very anxious that his firm's grands should remain in good regulation; and so to assist piano owners and tuners, a printed sheet, being a guide to tuning and general action maintenance, was stuck to the inside of the nameboard in each of the early grands made between circa 1787 and circa 1794. This guide contains information of great interest. For instance, it confirms that the present-day customary point of hammer 'let off' (3mm from the strings) had become established as the norm as early as the 1780s. The full text of a printed guide found in a piano of 1787 (serial number 208) is given in note (28).

One of the interesting features found in the actions of all the earliest Broadwood grands is the way in which the depth of touch may be increased or diminished by turning three large iron screws situated under the keybed. The screws push small wooden blocks upwards into the key-balance rail, so deepening the touch depth at the front of the keys. This feature is not found in contemporary Viennese grands, and appears to be unique to Broadwood instruments. It seems that John Broadwood wished to give his clients a 'choice' of touch depth. However, a deeper depth of touch (e.g: more than 8mm, following the clockwise turning of the three underlying screws) greatly reduces the repeating capabilities of the action, and also causes the player to 'lose his sharps': the ebony sharp keys disappear under the surface level of the ivory natural keys during playing, an uncomfortable experience.

Another interesting feature found in all Broadwood grand actions during the period 1785-1805 is the small sliding wedge of wood which is fitted into the treble keyblock immediately to the right of the keyboard. When the wedge is pressed downwards into the keyblock, the hammers strike two of the three strings for each note when the left (keyboard shift) pedal is pressed down; and when the same wedge is pulled into the 'up' position, then

the keyboard is moved a little further to the right by the same pedal, so that the hammers now strike one string only (a 'true' una corda). This wedge of wood therefore has a double function: it opens up the special thin, ethereal musical sounds of the 'una corda'; and it serves as a useful tuning aid as well, enabling the piano's temperament and octaves to be first tuned on single strings before the 'unisons' (the other two strings for each note) are brought into play. This particular device continued to be employed in all Broadwood grands throughout the first three decades of the nineteenth century.

3. The dampers: figure 2/7a shows samples of the dampers found in an 1801 Broadwood grand in the Finchcocks Collection. The damper bodies, strongly reminiscent of harpsichord jacks, are made of pearwood, and they move in exactly the same way as harpsichord jacks - through slots in two guide rails. The dampers themselves comprise three layers of white woven flannel cloth, and every one of the sixty eight notes in the piano is damped. All the damper cloths are the same size. Figure 2/7b shows samples of the later style of damper found in Broadwood grands after 1800. In these, the amount of flannel has been generally increased in an attempt to further aid damping, and there is more cloth in the dampers serving the longer bass strings. In the treble, the dampers are 'suspended' on short wires so that they touch parts of the strings (near the hammer strike position) which respond better to the damping process.

When the English grand damper design is compared with the Viennese system from the same period, the Viennese dampers are far more effective in immediately silencing the strings after the hammers have struck, and as a result of this advantage, players of these grands are aware of the 'crisper', dryer and much more controllable character of Viennese tone. In the bass and middle sections of their grands, the Austrian makers employ wedge-shaped dampers, which jam between the two (bicord) strings which comprise each note and therefore function in a very efficient way. The flat English dampers, which ride lightly on the tops of their strings, are far less effective, and there is always a 'halo' of resonance found in the English grands, which to many modern ears is objectionable, but which appeared to be tolerated in the late eighteenth, early nineteenth century. The defective damping of the

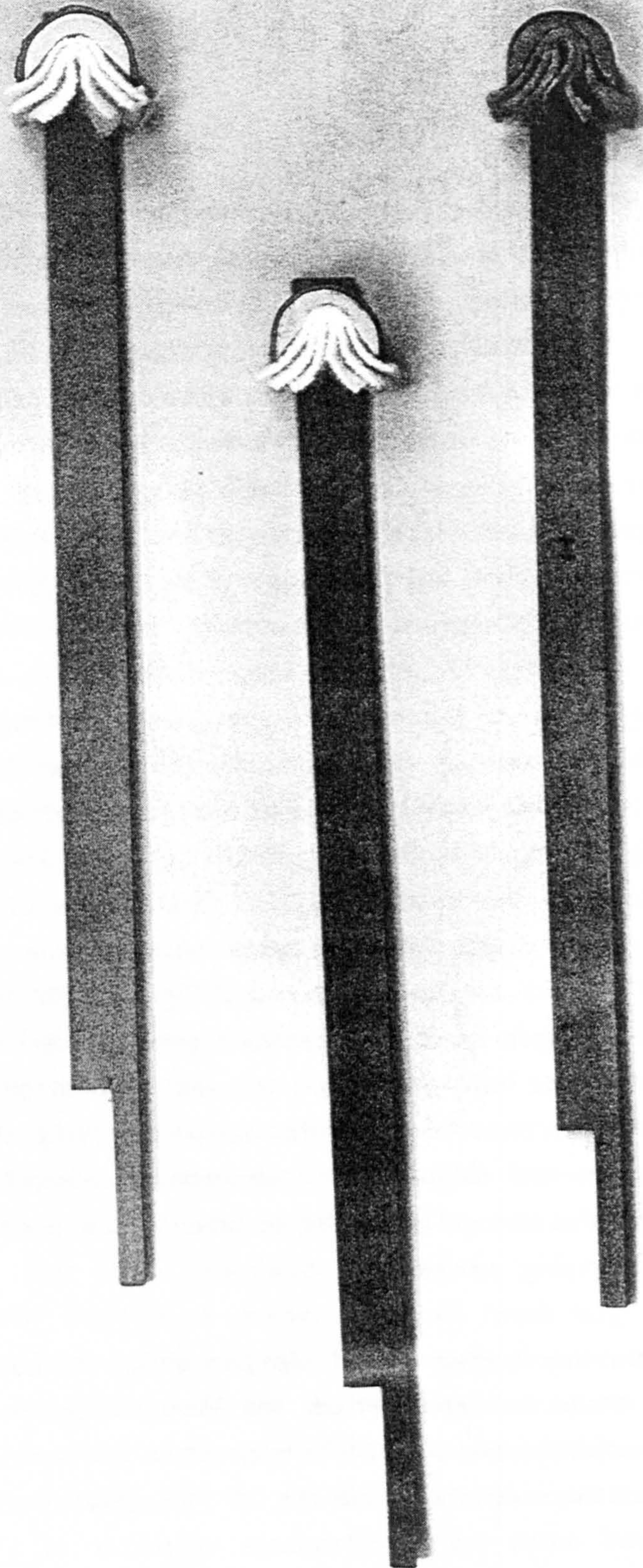

Fig. 2/7a: Broadwood grand dampers
(1801) Finchcocks Collection
Left: high treble
Middle: note c1
Right: lowest bass note

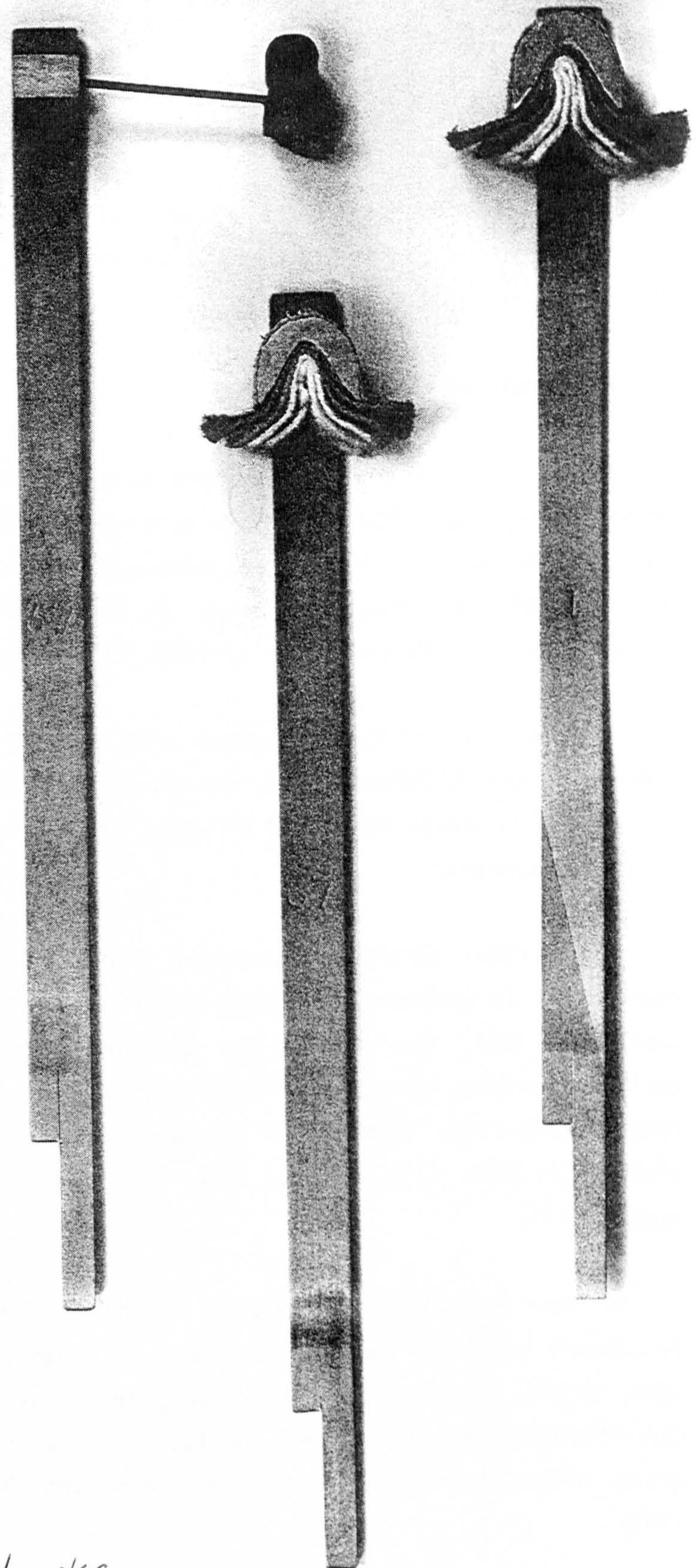

Fig. 2/7b: Broadwood
(1823) Finchcocks
Left: highest treble damper
Middle: note c1
Right: lowest ~~pass~~ bass note

English grand is particularly a problem in the bass section, where the strings are of course longer and therefore harder to 'silence' and control after the hammers have struck.

Keyboard extension

The extensions to the keyboard compass which occurred on Broadwood grands during the 1790s (from five octaves to five and a half, and then from five and a half to six), were apparently first brought about through the influence of the composer Dussek, according to James Shudi Broadwood's, 'Observations and Elucidations' of 1838. (29) Broadwood wrote:

'Dussek came to England about 1792, and, at his request, John Broadwood introduced the additional keys: the novelty of these upper notes so pleased in the several concerts he played at, that they soon became generally introduced in all Pianofortes.'

The earliest surviving Broadwood grand with a five and a half octave compass is an instrument bearing serial number 376, in private ownership in California, USA. The date of the instrument appears to be 1792. (30) The earliest surviving six-octave model (compass CC to c4) is the famous grand dated March 10th 1796, with Sheraton/Wedgwood case design, now in the Museum of Fine Arts, Boston, USA. This particular model's serial number is missing. (31)

In the year 1862, a careful search of the late eighteenth century Broadwood sale/hire ledgers was made in order to discover the precise dates when various famous pianists and composers first used Broadwood instruments. (32) The following list, which concludes our account of the early Broadwood grand, shows the fruits of this interesting search between the years 1789 to 1798:

Potter	17th May 1789
Dussek (JJ)	26th March 1791
Hummel (JN)	13th June 1791

Haydn (Joseph)	6th September 1791
Burney (Dr)	6th February 1792
Wesley (Samuel)	5th October 1792
Clementi (Muzio)	13th October 1792
Cramer (JB)	February 1793
Von Esch	13th June 1794
Bianchi	17th November 1794
Pleyel (Ignace)	30th June 1796
Steibelt (Daniel)	2nd January 1797
Viotti	1st February 1798.

CHAPTER 3:

THE TRANSITION FROM WORKSHOP TO FACTORY, 1805-1830; GRAND PIANO PRODUCTION METHODS AND TECHNIQUES IN THE EARLY NINETEENTH CENTURY.

It was noted in the previous chapter how the earliest Broadwood piano manufacture in Pulteney Street (from the early 1780s) did not supplant harpsichord making. Both pianos and harpsichords were manufactured together for a further fifteen years, until the mid 1790s, when harpsichord making came to a halt, possibly coincidental with the death or retirement of Burkat Shudi the younger. The maintenance of harpsichord output (of approximately two instruments per month throughout the 1780s) whilst at the same time introducing the manufacture of grand and square pianos in considerable numbers, was achieved partly by turning over the whole of the roomy Pulteney Street dwelling house to workshops of one kind or another, and partly by the acquisition of additional manufacturing premises in Bridle Lane, to the rear of Pulteney Street.

We can imagine the two main, spacious, downstairs living rooms of the old Shudi house being turned into 'finishing' workshops (for stringing, voicing, tuning and regulating) and perhaps doubling-up as showrooms or practice rooms housing completed instruments ready for sale. Burney noted that the composer Joseph Haydn, during his visit to London in 1791, actually lodged at a house in Pulteney Street and had 'a room for composing at Shudi and Broadwood's piano shop in the same street'. (1) It would have been practical to have used the newly-modified attics (with raised roof and new windows from 1787) for keyboard manufacture and for the making of other similar small parts, such as pearwood dampers, hammer units, action levers, and wound strings. One of the smaller rooms in the house must have served as an office; and another small room must have functioned as a stock room, containing the necessary quantities of music wire, tuning pins, cloth and leather used in piano manufacture. Yet another room must have been needed simply to store a supplementary stock of finished grands or harpsichords.

The outlying workshops in Bridle Lane were almost certainly used for the assembly of the main 'carcase' of each piano and for the joinery involved in soundboard and casework construction. Bearing in mind the huge amounts of wood shavings and dust which are the chief by-products of the building of pianos, and considering the noise levels associated with the various sawing, hammering and scraping activities of woodworking (and the offensive smell of warm hide glue), it is hard to believe that any of this kind of activity would have been tolerated within the old Shudi house itself; such activities were incompatible with the quiet, clean and concentrated atmosphere needed for tuning, voicing and regulating. We may conjecture, therefore, that piano production was divided into two main departments: construction in Bridle Lane; and 'finishing' in Pulteney Street.

By the end of the year 1805, Broadwood's Soho workshops were turning out approximately five grand pianos per week, plus a further twelve or so square pianos of one kind or another. This level of grand production was gradually increased until around the year 1821. An analysis of the serial numbers found on the surviving, dated, models from the period (2) suggests that the company had achieved an output of approximately six grands per week by the year 1810, rising to seven per week by the year 1820. Between 1821 and 1825, production fell slightly - back to a weekly output of six; and then fell slightly again in the late 1820s, down to the level achieved in 1805. At the busiest period therefore, (1816-1820) Broadwood managed to produce at least one grand piano for every working day of the week (assuming six working days per week).

When the modest size and scale of the company's Soho premises are considered, and when the amount of working space required for grand and square piano manufacture is borne in mind as well, it is remarkable how the limited facilities then available could achieve such a high level of production. On any one working weekday in the early nineteenth century, the jumble of backyard workshops in and around Pulteney Street/Bridle Lane needed to provide sufficient space for perhaps as many as one hundred grand pianos in various stages of manufacture or repair. Working conditions must have been

difficult: overcrowded, cramped, inconvenient, and inefficient. The growing problem of overcrowding was eased in two important ways: first by the use of 'outworkers', individual craftsmen or women who made parts for the pianos in their own homes or in workshops in other parts of London; and secondly, by the company's purchase, in April 1812, of the premises of John Andreas Stumpff, a harp maker, in Henry Street, St Pancras. (3)

The writer estimates (based on his own experience as a keyboard instrument maker) that something like the following workforce must have been required between the years 1816-1820 in order for Broadwood to have achieved an output of six to seven grands per week:

Porters: 2 (for moving timber parts as well as half-completed pianos)

Soundboard makers/markers off: 4

Case and carcass makers: 30

Keyboard makers: 7

Action part makers: 15

Action assemblers/regulators: 7

Stringers: 2

Polishers: 4

Tuners and voicers: 2

Stock and ordering clerk/wages clerk: 2

Estimated total grand-producing workforce: 75

If the numbers of workers required to produce squares is added to this list, then we could expect to have seen something in the region of two hundred piano makers milling in and around the workshops in Pulteney Street, Bridle Lane or Henry Street during every working day of the week during the period 1816-20. However, most of these workers would not have been employed directly by the company; only a group of senior 'core workers', the foremen, were actually on the pay roll of John Broadwood and Sons. The foremen in turn 'hired and fired' the casual workers who made up the bulk of the labour force of the company. During busy periods when sales were brisk, more workers were taken on by the foremen; during slack periods, when orders were low, the same workers were laid off. The workers were

paid by the foremen on a 'piece work' basis, rather than by an hourly arrangement. In other words, they were paid for what they were able to produce, rather than being remunerated for the period of time they actually worked. Such a flexible arrangement was obviously of benefit to the company; but job security must have been precarious for the average Broadwood bench hand in the early nineteenth century; and ill-health (and therefore low productivity) unfortunately went hand in hand with a small weekly wage packet.

The foremen comprised a group of about twenty-five individuals, roughly 12% of the total workforce. Those senior workmen employed by the company early in the year 1807 are named on a piece of paper dated February 4th of that year, found in the Broadwood Papers. (4) Of the twenty-five senior workmen listed, around eight were 'white collar' workers (accounting and wages clerks or warehousemen). The remainder were the skilled manual workers who supervised production in the various departments of manufacture or finishing. The full list of names is shown in note (4). A little information is known about some of the individuals listed. For instance, we know that 'Peppercorn' (John Peppercorn) was the concert tuner (5), that 'Marshall' was the grand action-making supervisor (6), that 'Hopkins' (Thomas Hopkins) was the senior warehouseman, and that 'Forsyth' (James Forsyth), was the senior factory foreman and very much the 'right hand man' of John Broadwood. (7) One of the junior clerks listed on the 4th February 1807 was Daniel Rose (1790-1849). According to a tradition (8), he was the individual whose calligraphy appears on the nameboards of many Broadwood instruments, because one of his jobs was to inscribe the lettering 'John Broadwood and Son Makers to His Majesty and the Princesses' on each piano nameboard. (The title of the firm was changed from John Broadwood and Son to Broadwood and Sons after Thomas Broadwood was taken into partnership on the 1st January 1808).

Daniel Rose's son, Frederick (1828-1904), eventually followed in James Forsyth's footsteps by becoming Broadwood's senior foreman and factory superintendent; and Daniel's grandson, George Rose (born 1857) succeeded his father as works superintendent and was also the designer of the famous range of 'barless' grands, introduced in the closing years of the nineteenth century (see chapter 8). The Rose family's long period of service with the

company therefore spanned three generations and in fact covered a period of just over one hundred years.

Manufacturing costs of a Broadwood grand, 1805

Figure 3/1 shows a highly detailed analysis of the cost of making a Broadwood grand piano in the year 1805. The original (probably in John Broadwood's own handwriting) is on the same sheet of paper as the list of senior workmen (4th February 1807) noted in the previous two paragraphs. It is a matter of great regret that hardly any documentation about manufacturing methods and techniques survives, not only from Broadwood, but from every other piano manufacturer in nineteenth century London. Nevertheless, we are very lucky to have preserved this one isolated item (the only one relating to grand manufacture from this period) which reveals a surprising amount of information about the way in which the construction of grands in Soho was organised in the year 1805.

First of all, from the costing sheet, we are able to see the level of 'outworking' taking place at that date. Those items which were 'bought in' by the company have the word 'complete' written next to them, indicating that Broadwood had no particular knowledge of, or concern about, the material costs involved. It is apparent that the company was buying in finished trestle stands (complete with casters), finished music desks, and finished hammer assemblies. We have no record of the names of the individuals who made these parts. The outworking of the music desks must have saved Broadwood a great deal of time and trouble. As an item, each desk is quite intricate to make, having two sliding candleboards at each side, and a complicated adjustable central section (to hold the music) which may be enlarged or diminished in size according to the size of the music manuscript being used by the performer. The desks found on Broadwood grands are always beautifully made from the finest mahogany, and their attractive design and novel features must have helped to sell the pianos. Because of their relatively compact size, the desks are items which could have been made by a skilled joiner working in a small workshop, or from his own home. The cost of each desk (£1 16s) represented one week's work for a skilled

Fig 3/r: 'Prime Costs of Grand Pianoforte, 1805'

(Source: D Wainwright/Broadwood Papers, Surrey Archives, Woking.)

26 ft Inch Clapd for the Case @ 1/-	£1	6	0
8 ft Inch and half Clapd for Restplank & Rails 1/6		12	0
1 3 inch deal Battons, Panels &c		7	0
1 leaf Inch & half deal Bottm framing & Rails		3	6
2 3 inch deals 3 Artts for long Bottom Name Bd Slip		14	0
30 ft $\frac{3}{4}$ Mahy for Top and Sundries @ 1/6	2	5	0
30 ft Mahy Venr for Panels @ 1/-	1	10	0
10 ft Air wood for Restplank 4d		3	4
8 ft Sattin and Purple Venr for Front @ 1/-		8	0
Making the Case	3	12	6
Brass work & Screws		6	8
The Desk Compleat	1	16	0
The Frame Complete with Casters and Caps	3	3	0
8 ft limetree for Keys @ 6d		4	0
wood for Key frame		4	0
A Sett of Ivory & Cutting		18	0
A sett of Sharps & Making		3	6
Key Pins & Screws Cloath Leather		5	0
Making the Keys	1	5	0
Wood for the Belly, Bridges, Small Pins	1	11	6
Puttg in Belly, Gluing it up, Bracing the Case, inside Mouldings, Making the Bridges	1	8	0
wood for Inside Mouldings, outside do., & Screws		10	6
Marking off		14	9
Outside Mouldings Putting in		10	6
Stringing and Strings	1	1	0
Arches, Rest pins, Iron Movt	1	3	0
Beam, Movt frame, Brass, Brass Screws, Iron Screws, Workmanship	1	10	6
A Sett of Hammers Compleate Silver Centres Included	2	12	6
Checks, levers, lever Springs		4	0
Finishing	3	0	0
Glue, wax, Sand paper, Brads, Taks		10	6
writing the Nameboard		1	0
Socketts and Jacks		8	0
Making the Dampers, Cloath for do. & Leather		4	0
the lower Rack Making, and wood, and leather		3	0
Varnish, wood for the Ruler, and Hooks		7	0
	£35	6	3

man. In 1805, therefore, five craftsmen somewhere in London must have been kept busy feeding Broadwood's regular demand for a weekly supply of music desks.

The trestle stand was also quite a fussy item to make, because the job of trestle stand construction included the making and fitting of the pedals and little brass casters as well. The earliest Broadwood grand trestle stands (1785 to circa 1805) are of plain, simple design, with two large and rather clumsy-looking wooden pedals (damper lift and una corda) mounted at the base of each of the two legs nearest the player. The vertical iron connecting rods between the pedals and action mechanism are cunningly hidden in long holes bored down the length of each of the same two legs. A notable feature of all the grand stands of this period is the way in which the stand itself is not rigidly attached to the body of the piano by locking screws, bolts or other devices; the piano body sits on its own stand and is held in place simply by its own weight, the precise position of the piano body in relation to the stand being guided by four short downward-projecting locating mouldings, attached to the underside of the instrument. It is very important that the stand is placed in exactly the right position underneath the body of the piano, otherwise the foot pedals will not function.

It is easy to see how the stand (as a self-contained unit including pedals) lent itself to outworking. A stand could be bought in and matched up to any grand with a minimum of fuss. What is surprising is the high cost of a trestle stand in 1805 (3 guineas) compared with the cost of a music desk. It is hard to believe that each trestle stand would have taken almost twice as long to build as each desk. Perhaps the extra expense of the four brass casters added a significant amount to the manufacturing cost.

After 1805, there were a number of changes to the style and specification of grand stands. First of all, three pedals, (one pedal lifting the bass dampers, another the treble dampers, and a third being the una corda) began to be seen. Instead of being positioned at the base of the legs, the pedals were mounted on their own wooden 'lyre', close to the natural position of the player's feet. The earliest surviving three-pedalled stand appears to be that found in instrument number 3378, made in 1806. Secondly,

↑ See note (9)

from 1805, four hefty turned legs began to replace the trestle stand on the six-octave instruments, and by about 1814 the turned leg stand had become commonplace on all Broadwood grands. The earliest surviving Broadwood grand with turned legs as opposed to a trestle stand appears to be a six-octave model, serial number 2975, bearing the date 1805. (10) Once again, a turned leg was an item which could be easily 'bought in' from a specialist wood-turner. From about 1810, a further development occurred: the company reverted back to the use of two wooden pedals, mounted on their own lyre, but this time the damper-lift pedal itself consisted of two parts (there was a 'split' down the middle of the pedal) one half raising the bass dampers, the other, the treble. The grand piano presented to Beethoven by Thomas Broadwood in 1817 (serial number 7362) has such a damper lift pedal, and Beethoven must have been intrigued to have observed its function. The split damper lift pedal continued to be used in all Broadwood grands throughout the 1820s.

The other bought-in item on the costing sheet of 1805, the 'Sett of Hammers Complete Silver Centres included' was another component which could be easily made in someone's home. The hammer assembly was perhaps the most tediously labour-intensive item to make in a grand piano at this date. Each walnutwood hammer head had to be individually made by hand, from two pieces of walnut, then covered with carefully selected layers of leather, each leather layer being firmly 'pulled tight' by hand during the gluing process. After glueing, the hammer leathers had to be trimmed with a sharp knife. The work of drilling each hammer butt with a small hole and then bushing each hole with a thin sleeve of boxcloth was highly skilled, tedious and exhausting. The accurate making of the turned cedarwood shanks and the fitting of these shanks into hammer heads and butts required much skill and patience; and the insertion of the long silver centres into the drilled and bushed hammer butts with the correct degree of hammer 'swing' required engineering skills. We can estimate that two skilled artisans, working with nimble fingers for a week, might have been able to manufacture one complete set of hammer assemblies ready for Broadwood's use. Therefore, this particular operation in the manufacturing process must have involved approximately ten individuals in the year 1805, each person probably working from his or her own home rather than using any part of the Pulteney Street premises.

In addition to the three main 'bought in' components (music desks, trestle stands and sets of hammer assemblies) the company was also purchasing smaller ready-made items. It appears from the 1805 list that Broadwood was purchasing all the necessary metal components, such as the curved arches or 'hoops' designed to span the hammer gap on grands, as well as sets of tuning pins, described as 'Rest' [Wrest] pins in the list. Other small items which appeared to have been purchased ready for use are further action components: the levers, the pearwood damper jacks and their sockets, and the hammer 'checks'. These must have been turned out in their thousands by some specialist maker or makers, and produced at a very competitive price. The outworking of all these small components would leave Broadwood with more time and space to concentrate on those aspects of piano manufacture which he and his employees specialised in: carcass, soundboard and case making; marking off and stringing; keyboard making; and action assembly and regulation.

There was one important component which Broadwood did not 'buy in'. This was the grand keyboard; and keyboard making as an activity in Pulteney Street must have gone back to the days of Shudi's harpsichord keys. The work must have been done 'in house'. From the costing sheet of 1805, we can see that each individual component for keyboard making - limewood for the keys themselves, wood for the keyframe, ivory and ebony pieces, pins, cloth and leather, had been very carefully costed, so that Broadwood knew that the total price of a complete keyboard, including raw materials and labour, was just under £3 or roughly 8% of the total manufacturing cost of the whole grand piano. It must have taken one craftsman one week to make a keyboard, and so in 1805 Broadwood must have been employing about five grand keyboard makers. It was usually the custom of each keyboard maker to sign his name in ink on the bottom (lowest note) key, and particular names which often occur at this period (most of them decidedly Scottish) include Bishop, Whitelaw, Finlayson, Wilson and Ranken. We can easily visualise a clan of Scottish keyboard makers hard at work in Broadwood's old attic.

From the 1805 grand costing sheet, we can also form a good idea of the various proportions of manufacturing cost elements. For instance, we discover

that about 63% of the total cost was incurred in labour and outwork, whilst about 37% involved raw materials purchased. The greatest part of the labour cost, understandably, involved making the mechanical components of the piano: time-consuming keyboard construction, action part making, and action assembly and finishing. The making of a grand case (minus its trestle stand and music desk) came to 10% of the total cost of an instrument. This process, undertaken by a team of two or three men rather than one individual, involved the steaming of the oak 'bentside' to form its curved shape, the building-up of the case rim from four heavy oak pieces held together by dovetail joints, the veneering of the rim with cross-banded mahogany, and the making of a three-piece solid mahogany hinged top.

The stringing operation, which cost just one guinea including materials, comprised only 3% of the cost of the instrument. A skilled stringing specialist, doing no other work, could easily string a whole piano in the course of one day. (11) The fact that Broadwood did not bother to separate out the cost of music wire from the labour cost involved in stringing, suggests that the stringer himself may have been self-employed and was expected to provide his own strings as part of the 'service'. 8.5% of an instrument's cost was tied up in the work of 'finishing'. This particular stage of manufacturing included regulation of the action mechanism, tuning (four or five times during the course of finishing), and the final 'voicing' of the hammer leathers to achieve the desired tonal result. The responsibility of these important finishing tasks would have been given to only the most senior and most trusted of Broadwood's employees. They would have been the firm's highest-paid workmen. This explains why 'finishing', although perhaps involving no more than three or four days' work, earned the finishing department the handsome sum of £3 per piano. These workmen must have had incredible pride in their work. (It is recorded that in the year 1809, two journeymen finishers at Broadwood's fought a duel on Primrose Hill, London, as a result of a dispute concerning the tuning of a piano!) (12) Probably the last manufacturing task - the writing of the nameboard - was undertaken by an individual who was given just one shilling for his careful penmanship.

The retirement and death of John Broadwood

John Broadwood formally retired from business on the 4th April 1811, at the age of seventy-nine, handing over responsibility for running the firm to his eldest son James Shudi, aged thirty-nine, and a younger son Thomas, aged twenty-five. Broadwood had spent exactly fifty years of his life involved in the toils and troubles of manufacturing harpsichords and pianos. To commemorate his retirement, he had his portrait painted in oils by John Harrison. A later engraving made from the same portrait (13) clearly shows Broadwood to be tough, strong-willed, powerful personality, and physically of robust constitution. He must have had incredible charm as well - to inspire a loyal and devoted workforce, and to be able to sell his own pianos. His strong hands, which in his earlier days had skilfully pushed the joiner's plane, had now for many years been the hands of numeracy: for Broadwood was also an accomplished financial wizard, and at the time of his retirement he was in all probability one of the wealthiest tradesmen in London. (14)

Although retired, John Broadwood was nevertheless a regular visitor to the firm's premises in Soho after April 1811. Sometime in mid July 1812, he was having a meal with his son Thomas, in the office at Great Pulteney Street, when he suffered a serious stroke, from which he never recovered. He was too ill to be moved home, and he died among his grand pianos in the old Shudi house on the 17th July, aged eighty.

JA Stumpff, Thomas Broadwood, and Beethoven.

As we noted earlier in this chapter, the Broadwood company had bought a small harp factory in Henry Street, St Pancras, from a certain JA Stumpff in April 1812. The purpose of the purchase was obviously to increase piano manufacturing capacity. (It is certain that Broadwood never made harps). As a matter of interest, the purchase from Stumpff included his stock in trade, which suggests that the harp maker was closing down his business. The timber parts for harp making would obviously have been useable in piano construction as well, but there must have been other items in the harp

factory which might have aroused the curiosity of Broadwood; for instance, the machine for making wound harp bass strings could have been adapted for the making of wound bass strings for square pianos; and the tooling for making harp tuning pins could also make piano tuning pins. It is quite possible that Broadwood was already buying from Stumpff small metal components, and so the purchase of his premises and stock in trade might have ensured continuity in supply of those specialist components they were dependant upon.

There was a further possible reason for the purchase of a harp factory: if Broadwood's French competitor Erard had been able to acquire the Stumpff business, this would have helped him develop in London not only harp making, but perhaps piano making as well. By acquiring both the premises and stock in trade of the St Pancras workshop, Broadwood was perhaps trying to block potential future competition from Erard.

Whatever the true circumstances, the two Broadwood brothers, James and Thomas, were soon planning to built pianos or piano parts in Henry Street, St Pancras, and this new development must have taken some of the pressure off the overcrowded workshops in Soho. At a later date (perhaps after the mid nineteenth century) the same premises became the company's repair department, where instruments would be taken in for rebuilding, servicing and repolishing.

As a result of the purchase of the harp factory, Thomas Broadwood became acquainted with John Andreas Stumpff, who was in fact Viennese and who was also a good friend of the composer Beethoven. When the Stumpff family returned to Vienna, Thomas Broadwood kept in touch with them. In 1813, the concert pianist Ferdinand Ries (1784-1838) a pupil of Beethoven, settled in London for eleven years, and soon came into contact with the Broadwood firm, largely because his own brother, Joseph Ries (1791-1882) had found employment as the 'foreign correspondent' for the company. The following year, 1814, the French pianist Frederich Kalkbrenner, another disciple of Beethoven, took up residence in London, which must have further introduced the music of Beethoven to the ears of London concert-goers.

Eventually, in the summer of 1817, Thomas Broadwood decided to pay a visit to Vienna. There he regained contact with the Stumpff family, and

through them, became introduced to Beethoven at a social gathering. Broadwood then made a point of visiting Beethoven's home in order to hear the composer play the piano. (15) On returning to England, he took the bold decision to present, as a gift, a new grand piano to the master, partly out sheer admiration for the composer's genius, but also because he knew that such a move would create very good publicity for his firm. The piano chosen for Beethoven was selected by a small group of the most well-known pianists living in London in 1817: Frederich Kalkbrenner, Ferdinand Ries, JB Cramer, JG Ferrari and Charles Knyvett (the latter being organist at the Chapel Royal), all of whom signed their names on Beethoven's instrument. Their choice, grand piano serial number 7362, was a six-octave grand with a keyboard compass CC up to c4. As most of Beethoven's piano compositions from 1815 extend in the treble register above c4, it is debatable how much Beethoven might have used his Broadwood as a composing or performing instrument, although there is no doubt that he was delighted and honoured to receive the gift, and spoke highly of the piano to his musical friends and acquaintances. (16)

The piano was despatched from London Docks on the 27th December 1817, and first travelled by sea to Trieste in northern Italy, at that time an important transit port for central Europe. From Trieste, the piano was taken the two hundred mile journey to Vienna by horse and cart, reaching the city in the late spring of 1818. On its arrival, the instrument was found to be damaged, and was for a time attended to in the workshops of the Viennese piano maker, Streicher. However, as a matter of interest, it was the former London harp maker, JA Stumpff, who was ultimately given the responsibility of maintaining Beethoven's grand, and after a time he was the only person allowed to tune it. The harp maker evidently had trouble in persuading Beethoven to maintain his grand in good order, as he is quoted as saying (following a visit in 1824):

'What a spectacle offered itself to my view! There was no sound left in the treble and broken strings were mixed up like a thorn bush in a gale.'
(17)

Beethoven's Broadwood has the following Latin inscription on a plaque above its nameboard:

'Hoc instrumentum est Thomae Broadwood (Londini) donum propter ingenium illustrissimi Beethoven.'

After Beethoven's death, his Broadwood was purchased by C Anton Spina, a Viennese music publisher, who in turn presented the instrument to Franz Liszt in 1845. Twenty-nine years later (3rd May 1874), Liszt, in a patriotic mood, wrote to the Hungarian National Museum, Budapest, informing them of his wish to donate the piano to them, although the instrument was not actually installed in the Museum until after Liszt's death in 1887. The instrument has remained in the Museum since then. (18) In 1992, Beethoven's Broadwood was brought back to full working order through the skill of an English restorer, David Winston, shortly after which the piano went on a specially-arranged commemorative concert tour (Vienna, Bonn, Bath, London and Budapest), being played by the concert pianist, Melvyn Tan. (19) Some of the proceeds from the tour, sponsored by Thorn EMI, went towards the Beethoven Fund for Deaf Children.

The move to Horseferry Road, 1823.

The inefficient and cramped manufacturing arrangements, which we have already commented upon in this chapter, were becoming an increasing source of irritation to the Broadwood firm. The additional workspace at St Pancras had helped, but conditions were steadily becoming worse after 1815, largely because Broadwood had embarked upon the construction of upright pianos in addition to grands and squares. The company's earliest upright instruments, the so-called 'upright grands', were very tall models made in small numbers between 1805 and 1813. Although these pianos bore the name 'Broadwood', their construction was in fact farmed out to a certain James Black, an 'outworker' of Percy Steet, Tottenham Court Road. From around the year 1812, the upright grand was quickly phased out (it was very tall, impractical, too clumsy-looking, and quite dangerous as well, because it had an unfortunate tendency to fall over because of its unstable stand) and was replaced by the

cabinet piano, a considerably smaller and better-proportioned design. These 'cabinets' do not appear to have been constructed by Black, but were probably built in the former Stumpff harp factory. Broadwood maintained the manufacture of cabinet uprights for a forty-two year period until they were discontinued in the year 1854. In all, the company managed to produce almost 9,000 cabinet instruments during this period.

In August 1819, the firm began the manufacture of 'cottage' uprights. (20) These were distinguishable from cabinet uprights by their relatively short size; they were never more than 120cm (four feet) high. Obviously their extremely compact design and relatively cheap price made them immediately popular. By the mid 1820s, Broadwood was producing at least five cottage uprights per week, and the demand for these little instruments continued to grow steadily as the century progressed. By 1855, the company was turning out about one thousand cottage uprights per year (or approximately twenty per week). In 1866 the manufacture of squares was discontinued because the demand for these had been largely replaced by a demand for the much more popular 'cottage'. By 1879, cottage upright output was over two thousand per year, or forty per week.

It was the advent of the cottage upright in 1819 which, more than anything else, forced Broadwood to look for a much better long-term solution to the firm's chronic problems related to manufacturing facilities. In the year 1823, the firm leased a large site in Horseferry Road, Westminster, belonging to the Grosvenor Estate. On the site, a purpose-built piano factory was planned and constructed. Within the matter of a year or so, all types of piano making activity were moved here. The choice of site was a good one: it was level and spacious; the factory lay near to timber wharves on the River Thames and other local timber yards; it was conveniently located for good communications to the company's existing offices and showroom in Pulteney Street, Soho, and also for road communications to the south of the River; it was sited near a number of useful 'service' centres, such as stabling for horses and engineering works; and of course the site lay close enough to the homes of thousands of potential new Broadwood customers in Westminster, Kensington, Chelsea, Fulham, Lambeth and Kennington to enable

the speedy delivery of new instruments by horse and cart.

The reason for going into detail at this point about upright pianos is to show that the origins of the Horseferry Road factory had little to do with the demands of grand piano manufacture. In fact, as we have already noted in this chapter, Broadwood's grand piano output declined somewhat after 1821, in spite of the new factory. Output of grands decreased from about seven per week to about six per week during the early 1820s, with a further fall to approximately five per week by 1830. It was not until the 1850s that grand production began to increase significantly, following the introduction of a range of smaller 'cottage' grands (see chapter 4).

One of the features of the new factory was the way in which it did away with the earlier practice of 'outworking'. Now, all parts of the grand, ranging from turned legs to action components, were made 'in house' within the same complex. The new Horseferry Road premises also gave Broadwood the opportunity, for the first time, to arrange piano production in a more orderly and efficient way. We would have expected to see the division of the site into a logical series of production sequences, some related to woodworking, others linked to the fabrication of metal parts, whilst other areas would have concentrated on the assembly and finishing stages of construction. However, it comes something of a surprise when we learn that this was far from the case: the manufacturing pattern on site during the period 1823-1856 was far from logical, far from orderly, and at times, quite chaotic.

The evidence for this fact lies in a visit to the factory made in the early 1840s by the journalist George Dodd, who was compiling information for an article on piano manufacture as part of a series entitled 'Days at the Factories'. (21) Dodd described the Horseferry Road work layout in some detail for his article, from which we can gain a good impression of how disorderly things really were. As a result of Dodd's description, we are able to formulate in outline the production layout of the factory, which, shown schematically, is as follows:

East Range: Square piano case makers; soundboard makers; packing case makers; 'bottom' makers; wood drying stoves.

East Central range: soundboard makers; case makers; keyboard makers; grand piano makers; soundboard makers for grands, cottages and cabinets; cottage and cabinet case makers; fitters up; top makers; veneer cutting room; veneer drying; hammer makers; polishers; stores.

West Central Range: square case makers; square soundboard makers; cabinet pianos - finishers and tuners; regulating and tuning rooms; veneer room; glue room; rosewood store.

West Range: Turner's shop; stringing; action part making.

From Dodd's outline, it appears that Broadwood's production planning at Horseferry Road was remarkably haphazard and inefficient. It was as if the whole production layout on the site had gradually grown in an very random way. Very little care had been taken at the time of planning the layout of the factory in 1823. The chief faults of production at the time of Dodd's visit were: the duplication of the same jobs in different buildings within the same complex, leading to confusion; combined with a very illogical 'flow', compelling too much unnecessary movement of pianos and piano parts from one range of buildings to another during the course of their manufacture. It was not until the radical redesigning of the production layout of the whole site by Frederick Rose, after the disastrous fire of August 1856, that production became orderly and logical: a main 'assembly' building for all models of piano was fed with all necessary components by various 'feeder' workshops.

The plan of Broadwood's Horseferry Road site is shown in figure 3/2, based on the Westminster Ordnance Survey Map of 1867-74. It will be seen how the buildings on the site comprised three main ranges, running north to south, the largest of which was the assembly plant. The intermediate yards were used for timber storage, and the smaller, middle range was the wood-machining mill. Metal parts were fabricated in the range of buildings nearest the 'Westminster Marble Works', whilst actions and keys were made in the long range at the opposite side of the site.

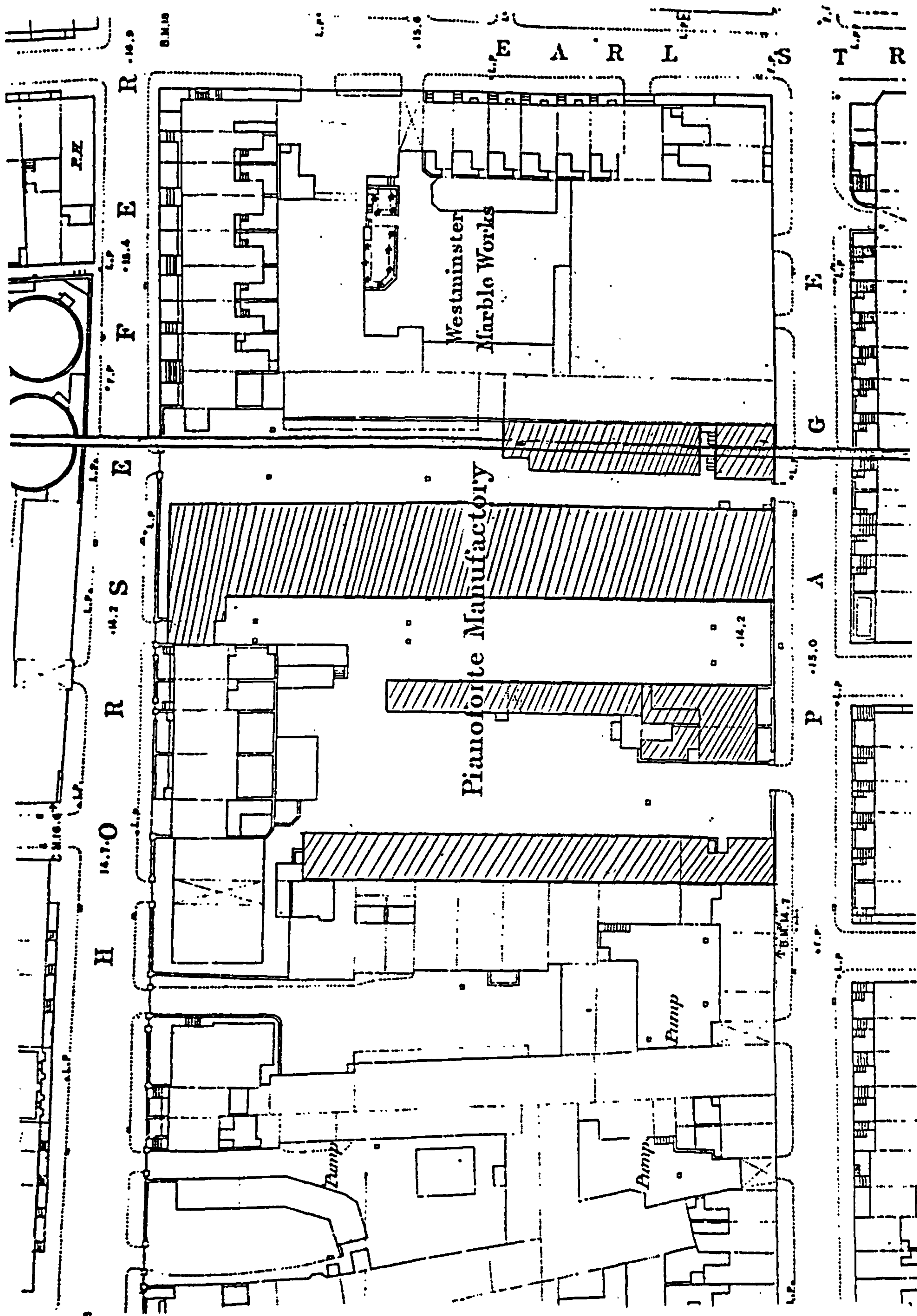

Figure 3/2: Broadwood's factory site, Horseferry Road, Westminster.
 (from the Ordnance Survey Map, 60" to 1 mile, 1867-1874).

CHAPTER 4

BROADWOOD GRANDS: CHANGES IN PRODUCT RANGE, 1825-1865.

THE COTTAGE GRAND (FROM 1834). WILLIAM SOUTHWELL'S PATENTED GRAND ACTION, 1837. STOCK LEVEL IN 1859-1860. HIRE PIANOS AND THE CUSTOM OF HIRE BEFORE SALE.

Shortly after the establishment of the Horseferry Road factory in 1823, Broadwood was offering only two models of grand piano: a plain-cased 'budget' instrument of older design, with a six octave compass of either c to c or f to f; and a wider instrument, which had been available from around the year 1820, of compass six and a half octaves. This wider model was available in three optional case styles: a standard design in mahogany; a more decorative model in mahogany with cross-banded rosewood borders on the case sides and lid; and a third, considerably more expensive, style in a rosewood veneer case with elegant brass ornamentation. (1)

All the grand models, irrespective of keyboard compass or decoration, had a standard length of about 250 centimetres (eight feet). The six octave model, which was to be discontinued in the late 1820s, appeared to have the compass c to c as standard: most of the six-octave Broadwood grands surviving from this period have such a compass. It is possible that the much more rare f to f models were intended primarily for the continental market, where this particular compass was generally in use.

The Cottage Grand

In the year 1834, Broadwood made a major departure from tradition by introducing its range of 'cottage' grands. Also known as 'semi grands' and 'bichorda grands', these instruments were made up to 60 centimetres (2 feet) shorter in length than grands in the main product range. They had only two strings per note in their middle and treble registers instead of the customary three (hence the name 'bichorda'); and the keyboard compass of these new,

smaller models was usually only six octaves instead of the customary six and a half found in the larger models. Here was a serious attempt on the part of Broadwood to introduce a smaller and cheaper instrument, and in doing so the company at this date was clearly responding to competition from its two main London rivals, Collard and Kirkman, both of whom had also recently introduced ranges of smaller, bicord instruments.

The cottage grands, with their gentler tones and more intimate sounds (as a result of the bicord stringing) were a particular favourite of the composer Chopin. He tried them in Broadwood's Pulteney Street showroom in 1848. According to Edith Hipkins, Chopin

'especially liked Broadwood's boudoir cottage pianos of that date, two stringed, but very sweet instruments, and he found pleasure in playing on them.' (2)

Broadwood's cottage grands were given a completely new serial numbers system, as if to emphasise that they were a completely new breed of instrument. Unfortunately, this new numbering system, running parallel with the original numbering system attached to the larger full-size models, has generated much confusion when attempts have been made to establish the age of any particular cottage grand and a number from the 'main' range has been used by mistake. (Matters were made even more confusing in this respect when another range of cottage grands was introduced by the company in 1862, identified by a third numbering system. Then in 1870 a new range of 'boudoir' grands was launched, again with their own numbering system. By 1870, Broadwood was utilising four different grand numbering systems at the same time!).

It is clear from the information found in the Broadwood Number Books (3) that up to the year 1840 the production of cottage, semi or bichorda grands formed just a very small part of Broadwood's annual grand output: apparently only four instruments per year, compared with over 250 units of the larger, standard model. For some inexplicable reason, Broadwood's earliest cottage grands were not popular, or alternatively the company was deliberately producing them in very limited numbers. Perhaps the design and

Fig 4/1: Annual production of Broadwood Cottage Grands, 1840-70,
 compared with annual output of the full-sized grand models.
 Broken line: cottage grands.
 Continuous line: full-sized grands.

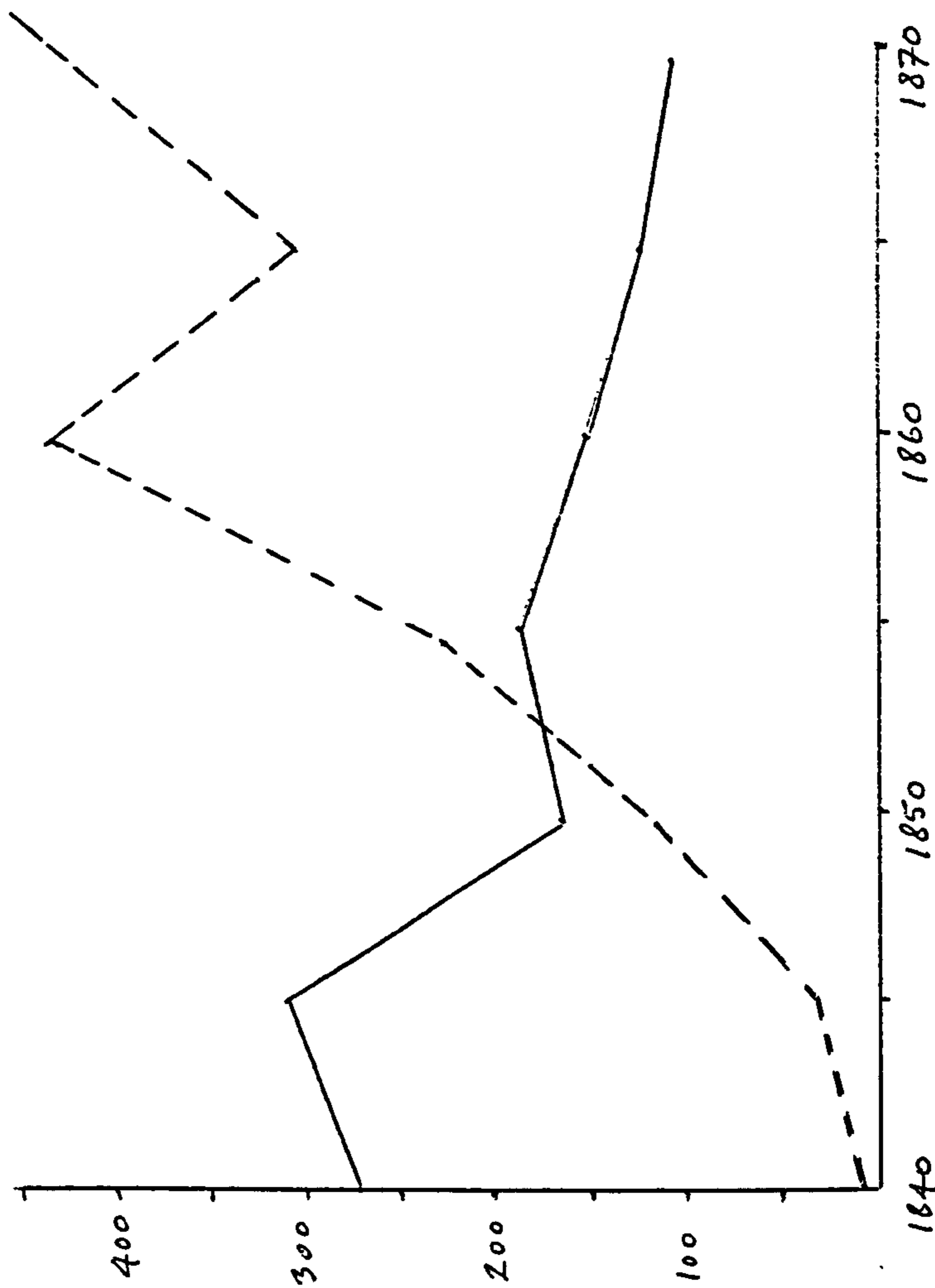

development of the new cottage models took considerable time in the early stages, or perhaps they were disappointing musically.

However, by the year 1850, annual production of cottage grands had risen to about 115, compared with about 150 of the larger models. The ratio of output of the two different types changed dramatically after the mid century: by 1860 approximately 430 cottage grands were being constructed annually at Horseferry Road, whilst production of the bigger models remained at 150. The Broadwood company was clearly responding to a phenomenal increase in the public demand for a cheaper, more modest, more compact grand piano for the home. The accompanying graph (Fig. 4/1) compares the output of cottage models with production of the larger grand pianos during the period 1840-1870.

William Southwell's Patented Grand Action, 1837.

We have already noted the small shortcoming of the English 'single lever' grand action, employed in every kind of Broadwood grand piano from the first ever produced by the firm in 1785 and then in continuous use onwards into the nineteenth century. (see chapter 2, page 49). In spite of the fact that the single lever mechanism was admired for its simplicity of manufacture, its durability, its economical use of materials, its ease of regulation, and perhaps most importantly its permanence in regulation once 'set up,' the action design had a clearly recognisable fault: the performer had to allow a key to return upwards to its point of rest before the same note could be repeated over again, and so repetition of the same note was inevitably impaired.

This is an unfortunate fault which the English single lever grand action shares with the Viennese fortepiano mechanism; but the better action gearing and the generally shallower depth of touch found in the late 18th century and early 19th century Viennese instruments means that this particular defect of repetition is not in any way a serious drawback to good performance, and satisfied the highest standards demanded by the finest pianists of the day. Nor was the shortcoming of the English grand action a serious problem over

a span of forty five years: by the year 1830, Broadwood had manufactured 11,900 grand pianos, a remarkable achievement, which represented an average yearly output of about two hundred and sixty grands, or an average of five grands every week. All 11,900 of these grands had been fitted with exactly the same mechanism over the forty five year period. We have no evidence at all to suggest murmurings of dissatisfaction from among the many thousands of proud Broadwood owners. If there had been customer complaints, then nothing of this nature survives in writing in the Broadwood Archive.

In spite of the situation outlined above, and in spite of the outstanding reputation which the Broadwood company had achieved for its grands by the year 1830, it is quite clear that experiments were underway within the Broadwood workshops during the 1830s in order to try and improve the repeating qualities of the traditional single lever mechanism. It is likely that the motivation for the experiments was not in response to customer complaints, but rather the desire on the part of Broadwood to introduce a new action which could equal the remarkable repeating qualities found in the new, complicated patented grand action made in Paris by Sebastien and Pierre Erard. (4)

The individual behind Broadwood's new experiments was one of the company's senior employees, a certain William Southwell, who was a member of a Dublin family well known as makers of keyboard instruments from the late 18th century. (5) Southwell's name appears in a Broadwood wages book (6) between the years 1846 and 1849, in which it is shown that he received a salary of £156 per year, a sum which was less than half that of the factory foreman, Alexander Russell (£356). Southwell's name disappears from the company's records after 1849, the reason being that he had by this date commenced business as a piano maker on his own account (at 12, St James' Place, Hampstead Road, London).

It was during his time as a Broadwood employee that Southwell devised a new 'improvement' for the single lever grand action, an idea which he patented on August 24th 1837. (7) Immediately afterwards, the exclusive right to use the patent was purchased from Southwell by his employer; and as the patent's date closely coincided with the coronation of the new English queen,

Victoria, those new models incorporating Southwell's patented system were named 'Patent Victoria Repetition Grand.' The firm ordered a large stock of nameplates in readiness for the anticipated production of the new model, with the word 'Patent' engraved boldly above the words 'John Broadwood and Sons.' It was almost as if the wording 'patent' was the first and most essential requirement in order to compete successfully for sales with Erard's similarly patented models.

The main new feature of Southwell's 'improvement' was an additional wire spring and wooden tongue, attached to the top of the hammer butt, the function of which was to forcibly return the lever or 'hopper' as fast as possible back to its starting point under the butt notch. The patent drawing (see Fig. 4/2) shows a downwards-projecting tongue 'b' passing through a slot in the hammer butt, the tongue being pressed against the lever by the spring 'c'. The patent drawing shows a second new spring at 'E', this one aiding the return of the hammer (rather than the lever). Southwell's two new springs therefore functioned to speed the return of both the lever and the hammer to their starting points. These modifications must have resulted in a significant increase in component costs, and must have added considerably to the list of skilled regulating procedures necessary to make each action function correctly.

The new 'Patent Victoria Repetition' system was provided only in the expensive full size models - the cottage grands retained the original, simpler, cheaper, single lever system. Broadwood grands incorporating Southwell's patent were in regular production by the year 1843, and models were still being sold in 1845 (for more details about this, see the following pages of this chapter); but it is clear that by the year 1847 Broadwood had discontinued the use of Southwell's modifications and had reverted back to the much simpler original single lever system dating back to Backers. The lavishly decorated Broadwood concert model of 1847 now in the Finchcocks Museum (8) is entirely without Southwell's system. It may be significant that by 1849 Southwell himself had left the Broadwood company. Reading between the lines, it looks certain that, in the long term, the new patented springs had not been a great success. They would have made the grands expensive to manufacture; and it is clear that the improvement in repetition was not as great as hoped for, nor as good as that found in the Paris grand actions of

F

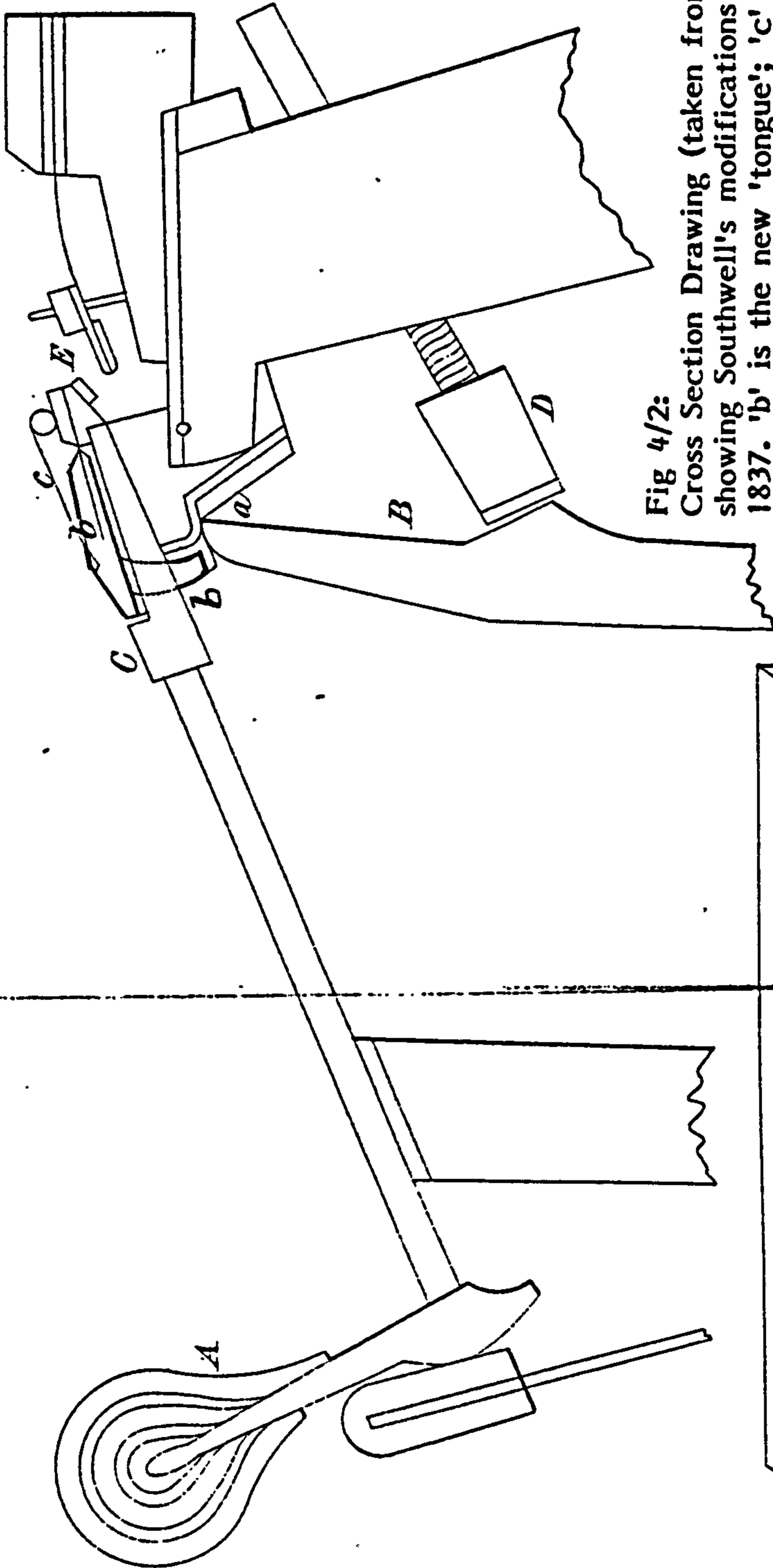

Fig 4/2:

Cross Section Drawing (taken from the original Patent) showing Southwell's modifications to the single lever action, 1837. 'b' is the new 'tongue'; 'c' the new additional spring; and 'E' is the second new spring to aid the hammer's return. This drawing may be compared with the drawings of the original mechanism of Backers shown in Chapter 1, pages 18-19.

Erard.

The Cambridge piano restorer David Hunt has had experience in recent years in restoring one solitary example of a Broadwood grand incorporating Southwell's system. He reports (9) that the mechanism of the instrument he restored works well, but that it is incredibly difficult to regulate in a satisfactory way, and that its stability of regulation (since restoration) has been 'very unreliable.' It is highly likely that it was for these very same reasons that the 'improvements' of Southwell were ultimately discontinued. However, the new nameplates were not discontinued, and full-sized Broadwood grands from the years 1847 and 1848, although entirely without Southwell's system, nevertheless continue to have the word 'Patent' engraved upon their nameboards. It would seem that the company on this occasion was involved in a 'face saving' exercise, being too proud to admit defeat in the face of French competition.

The period 1837-1846 was the only time during a span of one hundred and ten years (1785-1895) that Broadwood attempted to modify or improve in any significant way the single lever grand action. If Southwell's attempt was indeed a costly failure to the company, then this might help to explain the firm's adamant rejection of action experimentation for many years after 1847. Unfortunately, as felt-covered grand piano hammers became larger and heavier as the nineteenth century progressed, then the drawbacks of the single lever action became more and more apparent, and Broadwood grand touch became increasingly heavy, more clumsy to handle, and more tiring to play. It was not until the firm introduced the roller notch double escapement system in 1894, (10) modelled on Erard's Paris system, that a significant improvement to Broadwood grand touch was in evidence.

The grand range, 1840-1850

A company price list dated January 1843 (4) shows the two main types of grand on offer at this date. The cheapest model from the range of cottage grands was one in a plain mahogany case costing 75 guineas. A 'semi grand', also in a plain mahogany case, with 'improved mechanism' cost 85 guineas. Turning to the full-size range, the cheapest of these was one described as having a 'cylinder front' (a curved fall which swings down to cover the keys when the instrument is not in use, an attractive feature which had been first introduced some fifteen years earlier) and cost 122 guineas. Broadwood's best and largest model, the 'Patent Victoria Repetition Grand' was priced at 130 guineas in mahogany or 155 guineas in rosewood. This most expensive grand in rosewood was therefore twice the cost of the cottage grand at the bottom of the range; and the reason for this wide price band lies in that fact that Broadwood was proud of its company policy of providing instruments 'for all pockets'; the company was not just producing highly-priced instruments affordable by only the wealthiest clients.

Another price list of six years later, dated January 1849 (5) shows that the company had now introduced a completely new model: a 'Concert Grand with Elliptical End', costing between £125 and £160 depending on case specification. In this particular instrument, the casework rim at the tail or bass end of the piano was given its own small, curved shape in order to mirror or complement the main curved bentside running down the length of the instrument. As well as being a visually attractive feature, the elliptical end certainly helps to improve the resonance of the bass notes, as there is more 'soundboard area' behind the bass bridge over which the longest strings pass. Broadwood continued to use the elliptical tail until the early years of the present century, when the four-piece case rim was superseded by a continuous one-piece rim. It

is the elliptical end which is a visual feature of the so-called 'Chopin period' Broadwood, and Chopin himself, during his visit to England in 1848, played on three of such concert models from Broadwood's hire fleet.(6)

The elliptical grand is of length 252cm (8'3"). There had been hardly any increase in the length of Broadwood's concert model since the early 1820s, although of course the instrument now sounded much more powerful than those of thirty years earlier. There had also been little development as far as extension of the keyboard compass was concerned: the $6\frac{1}{2}$ -octave compass already in existence during the early to mid 1820s had been increased by a mere two notes by 1849: high treble f#4 and g4.

Other grands on offer in the price list of January 1849 include two much cheaper models: a 'bichorda' grand, and a 'semi grand' (also with bicord stringing) with a shortened compass of f to g (six octaves and one note) instead of the customary $6\frac{1}{2}$ octave compass of this period (c-g). The prices asked for ranged from 85 guineas for the cheapest semi grand in a plain mahogany case; then 100 guineas for another bicord model of larger size and compass. The full-sized concert grands with elliptical ends commenced at 125 guineas in mahogany, or 135 guineas in rosewood. A full-sized model in a Spanish mahogany case and carved legs was priced at 150 guineas; and the top of the range was a special model obtainable in either a maple, satinwood or rosewood veneered case, available at 160 guineas.

The features of the Broadwood grand product range as the mid century approached may be summed up as follows: large concert grands of length around 250 centimetres and compass of $6\frac{1}{2}$ octaves could be had for prices ranging between 125 guineas and 160 guineas depending on case style, decoration, and choice of veneer. These large grands all had the newly-introduced feature, the elliptical tail. The cheaper grands, described as 'cottage', 'semi' or 'bichorda' in the price lists, had a reduced compass, shortened length, a simpler square tail, and bicord stringing, all in order to keep manufacturing costs down and make the instrument much more compact. In the year 1850, cottage grands comprised some two

fifths (40%) of grand output; by 1860, these cheaper models now comprised approximately four-fifths (80%) of grand production, whilst the full-sized concert models accounted for only one fifth.

New models from the Mid Century

From the early 1850s, a number of significant changes were made to Broadwood's grand product range. The changes were the fruits of the design and development work of Henry Fowler Broadwood, now in his early 40s. His father, James Shudi Broadwood, had been the driving force behind the evolution of grand piano design which had taken place within the company between the early 1820s and late 30s. This evolution principally involved the introduction of iron bars and hitch plate, the use of thicker, higher tension stringing, the adoption of felt instead of leather for hammer covering, the introduction of the bicord cottage grand (from 1834); and the general redesigning of casework in keeping with changes in fashion. It would be true to say that the 'Chopin period' Broadwood grand was very much the creation of James Shudi Broadwood, the result of his own choices, tastes and whims being put into practice by a large workforce of skilled men.

By the mid century, however, the James Shudi type of instrument was quickly becoming out-dated, and there was a growing need to modernise the company's fleet of grand pianos. James Shudi Broadwood had had the satisfaction, during his long life, of making his mark on the family's product; he could look back on his career as a piano maker with the satisfaction of having made a significant contribution to the evolution of the Broadwood grand; he died in 1851 aged seventy-eight. Now it was the turn of a representative of the next Broadwood generation to prove his worth, and Henry Fowler's enthusiastic launch into a whole range of new designs shortly after his father's death shows that he was keen to take up the challenge.

From the early 1850s, Henry instigated many changes. First of all, the name 'cottage grand' was generally dropped from price list terminology,

possibly because the name was seen as being too 'down market' and possibly a little insulting to the growing numbers of London middle class who did not wish to live in a cottage but who nevertheless desired a smaller model of grand for their fashionable, respectable terrace houses in Marylebone, Paddington, Chelsea, Bayswater or elsewhere. In response to growing Victorian respectability, the various models of Broadwood grand were now officially and somewhat pompously renamed with grandiose titles such as 'Royal Boudoir Grand', 'Drawing Room Grand', 'Superior Drawing Room Grand', and 'Concert Iron Grand'.

Secondly, as the 1850s progressed, Henry Broadwood decided to discontinue the use of bicord stringing. This was something of a loss, because these bicord instruments have an interesting, charming tone quality all of their own, which today is more appreciated than it was in the later 1850s. The reasons for the phasing out of the bicord models are not hard to see. First of all, there was very little saving in manufacturing costs when the bicord strings were utilised - a saving of perhaps two hours' labour and a few pence of steel wire. Secondly, the top treble octave of the bicord model was always disappointingly thin and weak, lacking power and brilliance. It is likely that this shortcoming was more and more criticised as stronger-toned instruments began to be heard in the 1850s; and thirdly, the thinner gauges of wire (found in the high treble) could give problems when the una corda (left) pedal was brought into use. If the 'una corda' single string was hit in a too-percussive way by the performer, then the force of the hammer blow could result in a broken string. This problem does not occur in tricord (three string) grands of the mid nineteenth century, because the 'una corda' or keyboard shift in fact causes the hammers to strike two strings rather than only one single string.

By the year 1864, the only bicord grand available was a special small 'export' model (model 17) in a solid mahogany case at the budget price of 80 guineas. In the company's price list of the 1st July 1864, (7) this particular model is listed separately from the other grands, being one of a group of instruments described as 'Solid Pianofortes for Extreme Climates'. Clearly the bicord grand was going out of fashion

after the mid century, apart from in those tropical outposts of the British Empire where fashion was of less importance and where an attractively-priced 'solid piano' complete with bicord stringing was still a welcome item.

By far the most important change to the product which took place during the 1850s was the introduction of a completely new range of six sizes of 'iron grand', designed by Henry Broadwood. These models gradually superseded all other models of grand offered. Their main features included a full modern compass of seven octaves (a to a, 85 notes), tricord stringing, a stronger tone, and a newly-developed, simpler yet stronger and more sophisticated wrought-iron barring system to support the string tension. At the same time, and in response to changes in fashion, rosewood veneer casework became standard on all these new models, with mahogany or walnut veneer being seen much less often.

Broadwood's price list of the 1st July 1864 shows the most expensive instrument, the new seven octave 'Iron Concert Grand with diagonal bar', 260cm in length (8'6") to be available at one price only: 250 guineas in a standard rosewood case, or roughly one guinea per centimetre of piano length. This was a very highly-priced item and this particular model was considerably more expensive than any other Broadwood instrument available in 1864 (apart from one-off specials in elaborate decorated cases, built to order). There had been a 40% increase in the price of Broadwood's best concert grand since 1849. The other five models in the new range were as follows:

Superior Drawing Room Grand:	length:256cm(8'5")	price:175 gns
Drawing Room Grand	254cm(8'4")	150 gns
Medium Grand	249cm(8'2")	135gns
Royal Boudoir Grand	229cm(7'6")	120gns
Semi Grand	206cm(6'9")	105gns

All of these instruments were supplied with rosewood veneer cases as standard; the Superior Drawing Room Grand featured 'carved legs and

pedal'; and at the foot of the July 1864 price list, Broadwood noted: 'Most of the above instruments in the finest foreign walnutwood cases kept in stock and made to order in other fancy woods.'

Grand Stock Levels and Hire Fleet in the Mid Century

We would know nothing about the company's stock of finished pianos in the mid nineteenth century were it not for one solitary surviving piece of evidence: a large sheet of paper on which is handwritten a list comparing the numbers of completed instruments held in stock on two days in two successive years: the 3rd October 1859 and the 1st October 1860. (8) This piece of paper lists all kinds of models, including uprights and squares as well as grands. Two locations of piano stock are noted, the first being the Horseferry Road warehouse, where instruments are listed in a column under the heading 'HF'. The second location was the Great Pulteney Street showroom and warehouse, where the same kinds of instruments are listed in a separate column headed 'P St'.

On the 3rd day of October 1859, Broadwood had a total of three hundred and seventy eight grand pianos on the books, the details of which can be seen on the list overleaf (fig.4/2). This grand stock level represented approximately nine month's output of instruments, an uncomfortably high level of stock by today's business standards. It is hard to believe that the company was happy with such a large quantity of unsold grands on the books, with all the capital that was tied up as a result. We should not forget the significance of the calendar date of the list, however: shortly after the 3rd October, the 1859 'Christmas Season' for the trade would have begun, and the stock level would have been reduced dramatically as many pianos of various kinds were ordered either by provincial music shops or by individual purchasers visiting the Great Pulteney Street showroom. A stock list dated the 1st January 1860 might have shown an entirely different picture.

This stockpiling of pianos during the summer months in readiness for a forthcoming Christmas Season was a traditional feature of the London

FIG 4/2: Broadwood's Finished Grand Pianos in Stock, 3rd October 1859

Source: Information extracted from document 2185/JB/24/8, Broadwood Papers, Surrey Archives.

At Horseferry Road factory warehouse:

model 9	Semi grand	rosewood	52
" 9	" "	walnut	5
" 10	Royal Boudoir grand	mahogany	6
" 10	" " "	rosewood	39
" 10	" " "	walnut	8
" 11	Medium grand	mahogany	8
" 11	" "	rosewood	8
" 12	Drawing Room grand	rosewood	8
" 13	Superior Drawing Room grand	rosewood	8
" 13	" " "	" rosewood elegant	8
" 13	" " "	" walnut	8
" 14	Iron Concert grand	rosewood	8
" 17	Tropicalised bicord	mahogany	8

At Great Pulteney Street showroom/warehouse:

Model 9	Semi grand	rosewood	29
" 9	" "	walnut	29
" 10	Royal Boudoir grand	mahogany	4
" 10	" " "	rosewood	24
" 10	" " "	walnut	24
" 11	Medium grand	mahogany	24
" 11	" "	rosewood	5
" 12	Drawing Room grand	rosewood	46
" 13	Superior Drawing Room grand	rosewood	1
" 13	" " "	" rosewood elegant	1
" 13	" " "	" walnut	1
" 14	Iron Concert grand	rosewood	8
" 17	Tropicalised bicord	mahogany	8

TOTAL GRAND STOCK 378

piano industry. Unfortunately, as a result of this phenomenon, with its problematic tying-up of a company's working capital, wages could no longer be paid, and so many of the factory hands were laid off during the summer and autumn. Only the foremen and apprentices would have enjoyed the benefit of permanent employment. Most of the piano factory hands were obliged to seek alternative employment at stock-piling time, either in the housebuilding industry (traditionally a summer occupation) or alternatively in the countryside of Kent, where seasonal hop and fruit picking provided a much-needed wage for a few weeks. This work could be combined with a pleasant country holiday for a piano maker and his family. The customary annual exodus of the London piano makers to the hop gardens of Kent was a phenomenon which continued into the 1920s and 30s of the present century. (9)

The control and supervision of such a large stock of pianos was obviously a responsible and demanding job, and the role of stock clerk an important one within the Broadwood company. The need to keep a very close watch on the movement of pianos (to prevent theft, for example) led to the introduction of the 'Porters' Day Books (10), large bound volumes into which was written on each workday a record of the movement of pianos in and out of the company's warehouses. The clerk whose job it was to compile the information stopped and checked every piano as it was about to enter or leave the company's premises. For every piano checked he needed to know the serial number of the piano, the name and address of the purchaser or hirer, the financial details concerning the instrument's sale or hire, and the name of the firm of porters who were moving the instrument.

Most of these Porter's Day Books from the nineteenth century survive as part of the Broadwood Papers (Surrey Archives, Woking), although sadly some of the earlier ones, dating back to the period 1810-20, have been ruined as a result of past water damage - in some cases the ink has been obliterated by water, and in other cases the water damage has caused clusters of pages to stick together. Nevertheless, the majority of the Books survive intact, and they have proved to be a highly valuable primary source of information, giving many small details about

all types of Broadwood instruments.

The housing of such a large number of grand instruments at both Horseferry Road and Great Pulteney Street must have caused enormous pressure on the available space, and so we must presume that the standard method of grand storage was employed: the action with keyboard attached was first removed from the instrument, for separate storage in a horizontal position on one of a series of shelves. The serial number of the piano was stamped onto the action and keyframe to assist quick and easy reunification with the right piano case, on which the serial number was also stamped (at the bass end of the tuning plank, close to the lowest tuning pin). After the removal of action and keys, the main strung body of the piano was tipped sideways, the legs and pedal lyre removed, and the instrument stored sideways on its straight 'spine' for as long as necessary. The whole purpose of spine storage is to save space. A long row of one hundred or more grands stored in this manner would have presented an impressive and majestic sight. It is undesirable to store a grand piano action on its side, because the hammer shanks and/or flanges can bend or distort under the unwelcome side-weight of the hammer heads (particularly in the bass section, where the heads are large and heavy) and this explains why it was necessary to remove the action and keys for separate, horizontal storage. The same practice is carried out today at Steinway's warehouse in central London, where a concert hire fleet of around twenty instruments each have their action and keys removed prior to spine storage.

From Broadwood's stock list dated the 3rd October 1859 we can also form a very good idea of the most fashionable and popular types of grand case veneer. Obviously, rosewood was by far the most popular veneer available, and of the 378 finished grand pianos in stock, 245 of them (65%) had rosewood cases. Walnut veneer was not particularly popular, as only seventy-five of the grands (20%) had such a case veneer. It is quite possible that the walnut instruments had been made for the continental market, where walnut was much more popular than in England. Broadwood has recently opened a showroom in Paris, where the writer's great-great uncle Alfred Marlborough Laurence (1844-1923) was employed

between 1865 and 1868, and where he had charge of Broadwood's pianos at the Paris Exhibition of 1867. Perhaps most of the walnut grands in Broadwood's stock were destined for the Paris outlet.

What is the most surprising evidence found in the stocklist of the 3rd October 1859 is the obvious unpopularity of mahogany veneer at this date. Only fifty eight of the stock grands (15%) had mahogany casework, most of them being on the 'Medium' model. It is possible that this particular-sized instrument was regarded as being most suitable for 'school' or 'institutional' use, and so many of them were constructed with the cheapest possible case finish. The unpopularity of mahogany in the year 1859 is something of a surprise when we consider how enormously popular mahogany (or mahogany combined with rosewood cross-banding) had been two or three decades earlier. We can presume that recently-improved availability and transportation of tropical hardwoods (for example, as a result of the new steam ships) had reduced the cost of rosewood; and given the choice between mahogany and rosewood, most customers would have recognised that rosewood is considerably more distinguished and exotic-looking than mahogany for case decoration. Having a rosewood-cased grand piano in mid Victorian England was certainly something of a status symbol.

The level of stock at the same period in the following year (1st October 1860) shows a number of significant changes: there had been (perhaps fortunately for Broadwood) an overall reduction in the grand stock level to 273 instruments, a reduction of 105 units; the numbers of semi grands on the books remained more or less the same in both years (131 in 1859, 128 in 1860); but the numbers of the larger instruments in hand (models 11,12,13 and 14) had been drastically reduced. On the 3rd October 1859 there had been eight of each of the large models in store at Horseferry Road. One year later, on the 1st October 1860, only two of each kind were held by the company, suggesting that Broadwood's policy was now to have a minimum stock level of the bigger instruments.

Hire Pianos; and the Custom of Hire before Sale.

Attached to the previously-mentioned stock list is another, smaller piece of paper dated the 1st October 1859 on which is handwritten the words: 'On hire, 272'. Presumably this is a statement of the numbers of pianos (grands, uprights and squares) out on hire at that date. No indication is given as to what proportion of the 272 instruments comprised grands, and so we can only guess that perhaps eighty to one hundred grands were out on hire. Once again, such large numbers of instruments unsold represented a very considerable tying-up of capital on the part of the company, in spite of the regular monthly income which the hiring of 272 instruments would have yielded; but of course no self-respecting mid nineteenth century piano manufacturer in a capital city would consider his business complete without a good choice of pianos for hire at any given time.

There is evidence coming to light to show that Broadwood was engaged in the practice of 'pre-sale hire', a curious custom which is hard to understand today, but which appeared to be perfectly acceptable to the piano-buying public of the mid nineteenth century. When a particular instrument had been completed at Horseferry Road, it might have been hired out immediately on a short-term hire for a few weeks or months, sometimes to a concert pianist or professional music teacher. During this hire period, the instrument would usually have been well 'played in' and occasionally tuned. After some weeks or months, the instrument would have been recalled to the company's warehouse, where the tuning, voicing and mechanical regulation would have been checked over, the casework polish freshened up if necessary, and the instrument cleaned out. Then the instrument would have been offered for sale.

There was a triple attraction for the prospective purchaser of such a piano: to begin with, the instrument was often available at an attractive discount, somewhat less than the current list price. Secondly, in every respect the piano would have been 'as good as new'; and thirdly, after the 'playing in' during the previous hire period, the piano's important tone-producing components, the strings and the hammer

felts, would by now have been in a relatively stable condition, and the mechanical regulation of the action similarly bedded into a dependable, relatively permanent state. In short, the instrument would have been sounding and performing at its best. There is an oft-repeated question in piano trade lore: 'At what age is a piano at its best?' The short answer, which comes as a surprise to many, is: 'after six months' use.'

It is quite possible that such 'ex hire' instruments were sought after by those in the know, particularly if any instrument had been used by a well-known performer and teacher of the day, and particularly if that same performer or teacher had given a personal recommendation of the model he or she had recently hired. Quite a number of examples of this pre-sale hire practice have been unearthed during the past few years as a result of routine searches of the Broadwood Porters' Day Books housed in the Surrey Archives. A selection of the evidence is given in the following five examples:

1. Grand piano number 15614 was found to have been completed at the Horseferry Road factory in the spring of the year 1843. On the 27th May 1843, the instrument was hired out to a certain Mr John Green of 20, Vere Street, Lincolns Inn Fields, London, for a period of about two months. Then the piano was returned to Broadwood's warehouse and on the 15th August of the same year was finally sold to Joseph Travers and Son (presumably a firm of shipping agents) of 19, St Swithin's Lane, London, for export to Valencia in Spain. Interestingly, this piano still survives today in private ownership in Valencia.

2. In similar circumstances, grand piano number 16380, completed on the 3rd June 1845, and described as a 'Patent Repetition grand in Spanishwood' was hired out to Lady Mary Christopher of 97, Eaton Square, London, from the 8th May 1846 for a period of nine weeks, then recalled to the warehouse. Following a period in store, the piano was eventually sold on the 2nd January 1847 to a Mrs Hawkins of Bentham Litcomb, Wantage, for the sum of 145 guineas, which sum appears to have been a discount of five guineas from the then current list price.

3. In the example of grand number 17942, a rosewood instrument, this model was completed at Horseferry Road on the 5th June 1851. It was discovered that on the 24th March 1852 the piano was hired to Lady Francis Pepys of 15, Park Lane, London, until the 13th July of the same year, a period of four months. Number 17942 was then recalled. Shortly afterwards it was purchased by a certain Andrew McCulloch of Sydney, Australia, and exported in a specially-made tin and deal packing case on the ship 'Washington Irving'. McCulloch paid 105 guineas for the instrument, which was a discount of ten guineas from the list price. Today the same piano survives at the Powerhouse Museum, Haymarket, New South Wales, Australia, where it is one of three Broadwood pianos on display.

4. Grand piano number 2723 (one of the cottage grand series with the new numbers) was completed on the 17th December 1857. Described as a 'Bichorda grand in walnutwood', the instrument was hired out to a Mrs Henry King of 8, Lowndes Street, London, from the 30th April 1858 until the 7th July of the same year. Then on the 26th November 1858 the piano was sold to Mr Antony Gibbs, for eventual delivery to the family home, Merry Hill House, Bushey, Hertfordshire. The sale price was 125 guineas, a high price for a cottage grand. There is no evidence to show whether any price discount was given.

5. In the next sample, number 19165, a Concert Iron Grand in rosewood, this instrument appears to have been completed sometime during the first half of the year 1859, and then hired to the Hallé Concerts at Manchester, the period of hire commencing the 30th June 1859. The following month, on the 28th July, presumably at the end of the Concert Season, the same instrument was purchased by a certain S Stern of York House, Oxford Road, Manchester, who was a personal friend of the conductor Charles Hallé. The instrument was sold at its full list price of 250 guineas. We can guess that Mr Stern had seen and heard the instrument at the Hallé concerts, and took a liking to this particular model. He was also no doubt proud to inform friends and relatives who visited York House that his piano was the one which had recently been featured 'at the Hallé'. Today, this concert grand number 19165 forms

part of the Finchcocks Collection at Goudhurst, Kent. The instrument has been tuned on many occasions by the writer since 1990, the last time being for a recording session at Finchcocks in April 1998. (See chapters 5 and 6 for further details about this particular model).

Broadwood's practice of hire before sale continued throughout the nineteenth century and may also be found in the early years of the present century. To close this chapter, we now quote two further interesting examples of pre-sale hire, the first occurring in the mid 1880s, the second in the year 1904:

6. Grand number 10775, one of the semi-grand series, was completed at the factory on the 25th September 1884. On the 14th February 1885 the instrument was hired to 'Professor Joachim' (11), residing at 25 Phillimore Gardens, London. In the following July, Joseph Joachim returned home to Berlin and the piano sent back to Broadwood's. Then on the 12th October 1885 the same grand was purchased for Theodore Waterhouse of 4, Chester Place, London, with a £5 discount from the list price. The piano has remained in the hands of the Waterhouse family (who are delighted to know about the instrument's Joachim connections) down to the present day,

7. Finally, as something of a contrast, we may quote the example of a small 'spinet' grand piano, serial number 47319, which was completed on the 30th April 1904. On the 25th June 1904 the piano was sent for one month's hire to Mrs Patrick Campbell (1865-1940), the famous actress, who was then performing at the Vaudeville Theatre, Strand. On its return from the Vaudeville, the piano was found to be damaged, and repairs were immediately carried out. Shortly afterwards, the instrument was sold to a certain 'Miss Pilkington' (probably a member of the wealthy Pilkington glass-making family) whose address is given in the relevant Broadwood Porters' Book as 'The Mount, St Asaph, North Wales', for the sum of £65.

CHAPTER 5

BROADWOOD GRAND PIANOS AT THE 1862 INTERNATIONAL INVENTIONS EXHIBITION

BROADWOOD TUNING FORKS IN 1862; AND HENRY BROADWOOD'S PATENT METALLIC WREST PIN PLATE OF THE SAME YEAR.

The International Inventions Exhibition, which took place at South Kensington, London, between May and October 1862, was an event which very much involved the Broadwood company. The Exhibition particularly aroused the enthusiasm of the head of the firm, Henry Fowler Broadwood, who saw it as a wonderful opportunity to promote Broadwood's products to a much wider audience than any music shop, piano showroom, or even a concert hall, could achieve. Henry Broadwood was so fascinated by the whole idea of the Exhibition that he reputedly visited South Kensington on a daily basis; it was reported that he could be found, early each morning, trying out and carefully testing the hundreds of pianos there from rival manufacturers based in London, Paris and other European centres. (1)

This was not the first time that Broadwood had participated in such an exhibition; the company had sent four grand pianos to the 1851 'Great' Exhibition in Hyde Park. Unfortunately, very little information about Broadwood's involvement in the 1851 event survives: for instance, the writer has not yet been able to discover the actual serial numbers of the four grands sent to the 'Crystal Palace' in 1851, and there is little or no technical specification surviving about the four instruments displayed. The company's grands at the Great Exhibition appear to have been remembered chiefly for their lavish, highly-decorated, carved and inlaid casework, rather than for any musical qualities or innovative technical features they might have possessed. (2) For Broadwood, *its* display at the 1862 International Inventions Exhibition at South Kensington was a marked contrast to that of 1851, because *the* emphasis was now very much on the theme of the various technical aspects of grand piano design and construction, rather than presenting the grand piano as

a piece of decorative art furniture. This emphasis on technical aspects can be seen from the fact that, of the four Broadwood grand pianos sent to South Kensington, three of them had identical, standard, plain rosewood cases, and none of them were decorated in an artistic fashion as were those of 1851.

Visitors to the Broadwood stand at the Exhibition would have met, not only the 'governor', Mr Henry Fowler Broadwood himself, but also the distinguished piano technician, tuner and concert pianist, AJ Hipkins (1826-1903), a senior Broadwood employee, then aged about thirty six, whose playing and interpretation of the piano works of Chopin was becoming well known in London. It would have been Hipkins' task to supervise the tuning and checking over of the instruments on display early each morning, and then later in the day, as the crowds began to assemble, to demonstrate the Broadwood grands in the best possible manner - by captivating his audience with the music of Chopin.(3) As a much younger man in his early twenties, Hipkins had tuned for Chopin when the composer visited London in 1848, and so he had witnessed first hand and at close quarters the way in which Chopin had used the piano. Hipkins' anecdotes about Chopin must have fascinated Exhibition visitors; they included his memories of how the composer, terminally ill in 1848 with consumption, and practising the piano in Broadwood's Pulteney Street showroom, was so weak that he was unable to climb stairs, and had to be carried up by company employees.(4) Many years after the International Inventions Exhibition, Hipkins as an old man was to write a book dealing with the history and evolution of the piano. (5) His account, whilst being praised for the depth of its scholarship, has also been criticised for the way in which the Broadwood company is favoured in the text. This shortcoming is quite understandable and forgivable, bearing in mind Hipkins' lifelong loyalty and devotion to the firm.

Hipkins' official title within the company was 'sales manager', and as such he had control of the piano showroom in Great Pulteney Street for many years from the mid nineteenth century. His background and skills were ideal for his work: he was an accomplished tuner and voicer; he was a well-spoken scholar and musical antiquarian, with a specialised

knowledge of the harpsichord and clavichord; and of course he was a fine pianist as well, who once had an enviable personal contact with Chopin. One could think of no better person to help promote the Broadwood products at the Exhibition of 1862. However, Hipkins was not a piano maker, nor was he a piano designer; and the blame for the conservatism in the design of the Broadwood grand in the second half of the nineteenth century has mistakenly been laid at his door.(6) The master piano designer at Broadwood's was Henry Fowler Broadwood himself, and Hipkins was very much in his shadow. Henry was the individual who had absolute control of design and manufacturing policy within the firm; it was almost certainly he who drew up the original full-size drawings of the new 'iron grands' introduced in the mid century; it was Henry who calculated such things as string lengths and soundboard dimensions; and it was almost certainly Henry Broadwood who wrote the lengthy and detailed technical text included in a commemorative book published specially for the International Inventions Exhibition of 1862.

The Broadwood company's promotional material for the Exhibition took a number of forms. Of course, there were the finished pianos themselves; on their stand, the company exhibited four large concert grands, three in rosewood cases and a fourth in a special case of coromandel wood (a type of ebony veneer, obtained from the Coromandel Coast at the Bay of Bengal, south east India). No other kinds of piano were shown - only the four concert grands, each instrument having a length of eight feet six inches (260cm). Broadwood was clearly anxious to display only *its* very best instruments, and smaller grands and uprights were excluded. Secondly, the firm mounted a fascinating display showing concert grand pianos and concert grand piano parts at various stages of construction. Included in this particular display was a soundboard, an iron bracing system, a half-finished grand case, and a set of keys with hammer action mechanism attached. Thirdly, Broadwood took the trouble to mount an unusual display of piano designer's 'tools': a geometric diagram showing a 'practical method of finding the lengths of string, with equal tension, for all the intervals of an octave' (7); a monochord for testing wire; and a 'brass scale rule' giving the string lengths and hammer strike measurements for one of the rosewood-cased concert grands

actually on display. These designer's items would certainly have given Henry Broadwood something to talk about at the Exhibition; and his attitude to the subject of design and manufacturing methods was refreshingly open and candid compared with the usual secrecy which many makers attached to this matter. He would have enjoyed explaining at length - to anyone willing to listen - the intricate mysteries of his craft of piano design.

In addition to mounting a display of finished grand pianos, grand piano parts and design equipment, Broadwood also launched into publication with two books, both of which presumably must have been on sale at the company's stand at the Exhibition. The first item, serving partially as a guide book to Broadwood's display, was a publication comprising about sixty pages entitled 'List of Pianofortes and of Various Samples and Models intended to Illustrate the Principles of Their Manufacture, Exhibited by John Broadwood and Sons, London, with an Historical Introduction, Explanatory Remarks and Illustrative Plates and Diagrams.'(8) In spite of its long-winded title, this publication is a very fine piece of work, containing a history of the Broadwood company, a general history of the piano in England from the mid eighteenth century, and a very detailed description of the technical and constructional features found on Broadwood's grands of 1862. At the date of its publication, this book was in all probability the most informative piece of literature about piano making available to the English-speaking world.

At first glance, it would seem that the text for the book must have been provided by Broadwood's servant, AJ Hipkins; but careful comparison of the prose style with Hipkins' own reveals significant differences: the 1862 guide is written in an altogether more self-confident, spontaneous and at times bombastic style, than Hipkins'; furthermore, the technical information provided is far more bluntly stated than Hipkins' own ever was. For example, when dealing with the matter of the grand hammer strike proportion, the 1862 books states: *(on page 43)*:

'The point of the strings where they are struck by the hammers varies from one twelfth to one eighth of the length of the vibrating

International Exhibition,
1862.

LIST OF
PIANOFORTES,

AND OF

VARIOUS SAMPLES AND MODELS,
INTENDED TO ILLUSTRATE THE PRINCIPLES OF
THEIR MANUFACTURE,

EXHIBITED BY
JOHN BROADWOOD AND SONS,
LONDON.

WITH

AN HISTORICAL INTRODUCTION,
EXPLANATORY REMARKS,

AND

ILLUSTRATIVE PLATES AND DIAGRAMS.

LONDON:

PRINTED BY W. S. JOHNSON & CO., 60, ST. MARTIN'S LANE, W.C.

1862.

Title page of Broadwood's publication
for the International Inventions Exhibition, 1862

portion, measured from the front bearing point. In the extreme treble it is about one twelfth, in the middle and the tenor about one eighth, and in the extreme bass about one tenth.'

Hipkins' own reference to hammer strike points, which appears in his 'Description and History of the Pianoforte' (1896) has more the air of the polite, interested observer, than of the practical piano maker:

'According to some authorities, [the strike place] should be the eighth of the vibrating length - - - - but this seems to be authoritative only for the middle and lower divisions of the scale; in the upper, the striking distance has to come into a ninth and very much nearer as the scale shortens and the wrest plank bridge is approached, in order to get a sustained ringing tone. It is a compromise determined by experiment; there is no other way open to the solution of the problem.' (page 39).

A second publication released by Broadwood to coincide with the 1862 Exhibition (and presumably also on sale at the company's stand) was a slender booklet of fourteen pages entitled 'Some Notes made by JS Broadwood, 1838, with Observations and Elucidations by HF Broadwood, 1862.'(9) This booklet deals with the history and development of keyboard instruments in London from the eighteenth century, and with Broadwood's particular role in this development. The editor's (HF Broadwood's) footnotes are written in the same blunt and self-confident style as is the larger 'List of Pianofortes etc' guide book; and it is this fact which leads the writer to believe that both publications had been written and compiled by Henry Fowler Broadwood, rather than by AJ Hipkins.

Tuning forks

Other kinds of promotional items were also to be had on Broadwood's display stand: small, leather-clad presentation cases, each containing three small tuning forks. The items were presumably for sale, and each

obviously intended as a memento and keepsake in connection with the Exhibition. On the lid of each presentation case was embossed in gold-leaf lettering the inscription:

'John Broadwood and Sons
London 1862'

Each of the three blued steel tuning forks bore, in gold stencil, the pitch name to which it was attuned. All three forks were for the note c52 on the piano (c above middle c, or 'c2'). The lowest in pitch was marked 'VOCAL', the middle, 'MEDIUM', and the highest named 'PHILHARMONIC'. These three pitches appear to have been the ones in common use in 1862 for tuning Broadwood grand pianos.

Almost certainly, each Broadwood tuner was issued with a case containing these three forks. This probably explains how one of them belonged to Alexander Laurence (1839-1913), the writer's great-grandfather, who was apprenticed at Broadwood's as a tuner in the mid 1850s and who was still working for the company at the time of the Exhibition in 1862. This little keepsake (belonging to Alexander Laurence) eventually came into the hands of his son Cyril (1885-1970), another piano tuner; and it was Cyril Laurence who in turn gave the case of forks to his grandson (the present writer) around the year 1963, just over one hundred years after they were first used.

As well as being a fascinating historical 'document', this particular case of tuning forks is of course of considerable sentimental value to the writer; and he was glad to have been able to use them for a recording session at Finchcocks, Goudhurst, Kent in April 1998, when an 1859 Broadwood concert grand piano was tuned up to its original, authentic, 'Philharmonic' or 'concert' pitch, using one of Alexander Laurence's forks. At present, the forks are in safe keeping at the writer's home in Norway. Their respective frequencies were recently carefully measured using electronic apparatus, and their corresponding frequencies for 'a' (based on equal temperament) are as follows:

C 'Vocal' pitch: A=434.5 cycles per second
C 'Medium' pitch: A=445 cps
C 'Philharmonic' pitch: A=451.5 cps

It can be seen that the 'Medium' pitch is the closest to present-day standard pitch, A=440cps, but nevertheless a little higher. The 'Philharmonic' or 'concert' pitch of the year 1862 is almost one quarter tone higher than modern pitch; and the level of the 'Vocal' fork in each set corresponds approximately to the pitch A=433cps established in the 1820s by Sir George Smart, conductor of the London Philharmonic Society's concerts, and once also known as 'Philharmonic pitch.'

During the time of the Finchcocks recording session in April 1998, a number of interesting details were noted as the 1859 grand piano's tuning was altered. First of all, the instrument tuned very readily up to what must have been an unaccustomed high level. Not only this, but it could be tuned down again a quarter tone from the high concert pitch to modern standard pitch quite easily. It was as if the instrument had been designed in the first place to be hauled up and down to these different pitches. No doubt the heavily-barred rigid soundboard design helped to reduce the tuning instability normally associated with such pitch raising and lowering. (10) Secondly, the piano stayed very well in tune at the high 'Philharmonic' level because its strings had been tensed tighter and had therefore been made marginally more rigid to withstand the blows from the hammers; and thirdly and of course most importantly, the tonal quality of the instrument changed significantly as the 'Philharmonic' pitch level was reached: it became more sustained and brilliant, more 'pure' and clear-sounding, and less 'coarse.'

There has been considerable concern in recent years to tune early pianos at lower-than-modern pitches in order to help 'authentic' performances; and it is often assumed that it is wise to tune all historic pianos, of whatever age, at a lower pitch, if only for reasons of conservation and safety. The tuning of the 1859 Finchcocks Broadwood grand in April 1998 at a pitch one quarter tone higher than modern pitch is perhaps something of a 'first' (in other words, perhaps the first

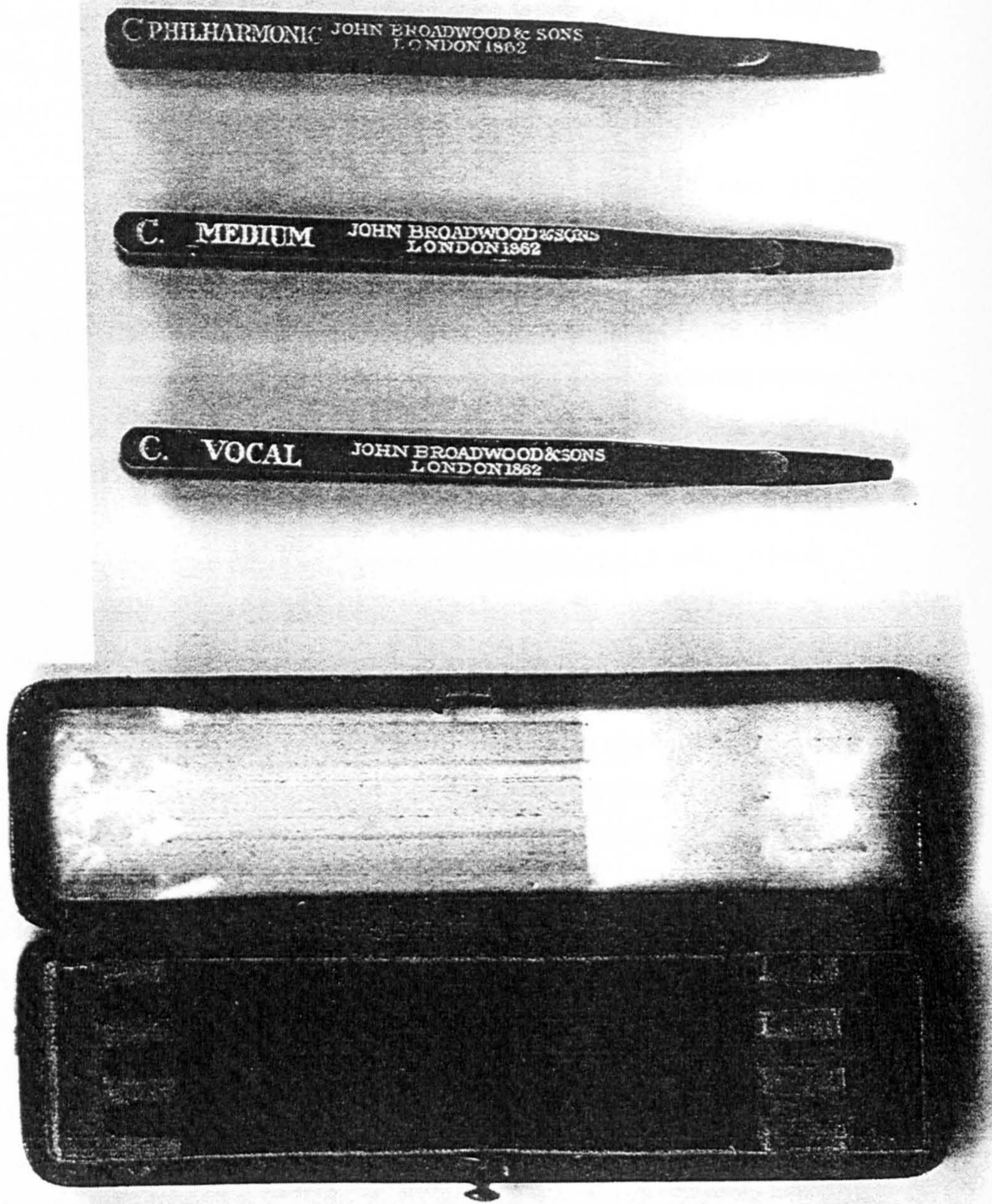

Alexander Laurence's tuning forks, 1862

occasion in modern times that a Victorian grand has been tuned for a recording session or concert at such a high pitch). This is something which might give cause for concern among the custodians of historic keyboard collections. Nevertheless, the original, high 'Philharmonic' pitch is - as shown above - fully 'authentic', and the startling tonal transformation something of an education.

From the point of view of the pianist, the tonal change produces an initial reaction of excitement and surprise, but after some hours of playing, the performer begins to tire of the extreme brilliance, and irritation may set in, followed by a polite request to tune the piano 'down' again to a more accustomed level. This irritation was expressed by foreign pianists visiting London in the mid nineteenth century, who found it hard to tolerate the English concert pitch. Once, during a series of concert engagements in London, Clara Schumann wrote:

'The heaviness and high pitch of the instrument [a Broadwood] is causing me trouble again. For the last few days I have been practicing at Broadwood's. Recently Scharwenka played a Blüthner, a year ago Barth played a Bechstein, which hurt Broadwood considerably. I could not find it in me to do that to Broadwood by bringing a Steinweg [from Brunswick], but oh how happy I would be to have one instead of struggling with this Broadwood.' (11)

The Patent Metallic Pin Plate of 1862

Three of the four finished grands on display at the 1862 International Inventions Exhibition had a new feature which apparently had not been seen before on any piano: they each had their tuning pins secured by a newly-invented system known as the 'metallic wrest pin plate.' Piano number 19451 had an 'iron pin plate, and pins screwed into the plate, but smooth in the wood'; piano number 19499 was also 'with iron pin plate, the wrest pins being screwed throughout'; and piano 19429 had a wrest plank with 'iron covering plate.' (12) These instruments illustrated

what were in effect variations on the same new idea, this being to give the piano tuning pins additional support in order to withstand the forward pull of the tensed strings.

Broadwood had traditionally made *its* grand tuning planks, or wrest planks (the piece of wood which grips the tuning pins), from quarter-sawn solid English oak. This kind of timber serves admirably for lower tension instruments such as harpsichords and clavichords, and was entirely suitable for use in early pianos up to the end of the first quarter of the nineteenth century. Oak is hard, durable and stable, and it has certain 'yielding' qualities which are an advantage when it comes to 'bedding' and 'gripping' the thin, tapered tuning pins found on early keyboard instruments of pre 1830 date. Tuning a piano with an oak wrest plank can be a pleasurable experience, because the tapered pins fit snugly into the wood, and the 'yielding' qualities of the oak timber means that the tuning pins usually turn smoothly in their holes, making fine adjustments easier. However, as string tensions were increased (following the gradual raising of tuning pitch, the use of thicker strings and the introduction of iron bracing systems from the 1820s) it was found that the traditional oak wrest planks gave problems: the additional forward pressure of the tuning pins caused the oak to 'crush'. The timber was simply not hard and dense enough to support the higher tension string load.

This problem was tackled on the European continent and in America by a change of wrest plank material: beech, harder and more rigid than oak, was favoured by the German builders. The customary German tuning plank from around the mid nineteenth century was made from solid quartered beech with a thinner cross-grain capping of about 10 millimetres, also beech, causing the harder 'end grain' of the capping to resist the forward pressure from the tuning pins. In America, the piano makers chose one of the hardest of woods, Canadian rock maple, which was usually laminated in various layers. The traditional New York Steinway tuning plank, for instance, is composed of five cross-grained layers of rock maple.

The crushing problems associated with the use of oak can be seen in Broadwood grands from the 1840s. For instance, in Broadwood grand number 16368, made in 1847 (Finchcocks Collection), the pull of the string tension has caused the tuning pins to pull forwards as the supporting oak slowly 'deforms' under the crushing load from the pins. This problem is more severe in the bass section of the instrument, where the tension of each of the 'single' wound bass strings is more than double that of the tension of each treble string. The crushing force of the low bass tuning pins on the 1847 Broadwood grand has caused large gaps to appear at the sides of the tuning pins, and the enlarged holes assume an 'oval' form. Obviously, the tightness of the tuning pins, and therefore tuning stability, is greatly impaired as a result of this serious problem.

Henry Fowler Broadwood's solution was the metallic pin plate of 1862. He applied for Letters Patent on the 30th April 1862, a day or so before the International Exhibition opened, and so was obviously concerned to protect his firm's unique innovation from being copied. It is highly likely that he had carefully planned the adoption of the metallic plate to coincide with the opening of the Exhibition; and the three grands on display which featured the new 'plates' appeared to be the first of their kind. The provisional specification left with the formal application for Letters Patent states:

'My Invention applies to that part of a pianoforte technically termed the 'wrest plank,' into which are fitted the 'wrest pins' used for drawing up or tuning the strings, the object being to facilitate the tuning of pianofortes and to maintain the tension of the strings. To this end I cover the part of the wrest plank where the wrest pins enter with a metallic plate which I term the 'pin plate' and I use wrest pins formed with a thread upon them after the manner of a screw. Of these wrest pins I use three varieties, namely, either 1, pins with a long thread for screwing both into the metallic pin plate and into the wood beneath it; 2, pins with a shorter thread upon the upper portion for screwing into the pin plate only; or 3, pins with a thread upon the lower portion for screwing into the wood only.

Henry Fowler Broadwood's
Metallic Screw Pin Plate, 1862,
applied to a grand piano. Cross section
drawing as it appears on the original
patent application.

A=underlying wooden wrest plank
B=metallic pin plate
C=threaded tuning pin.

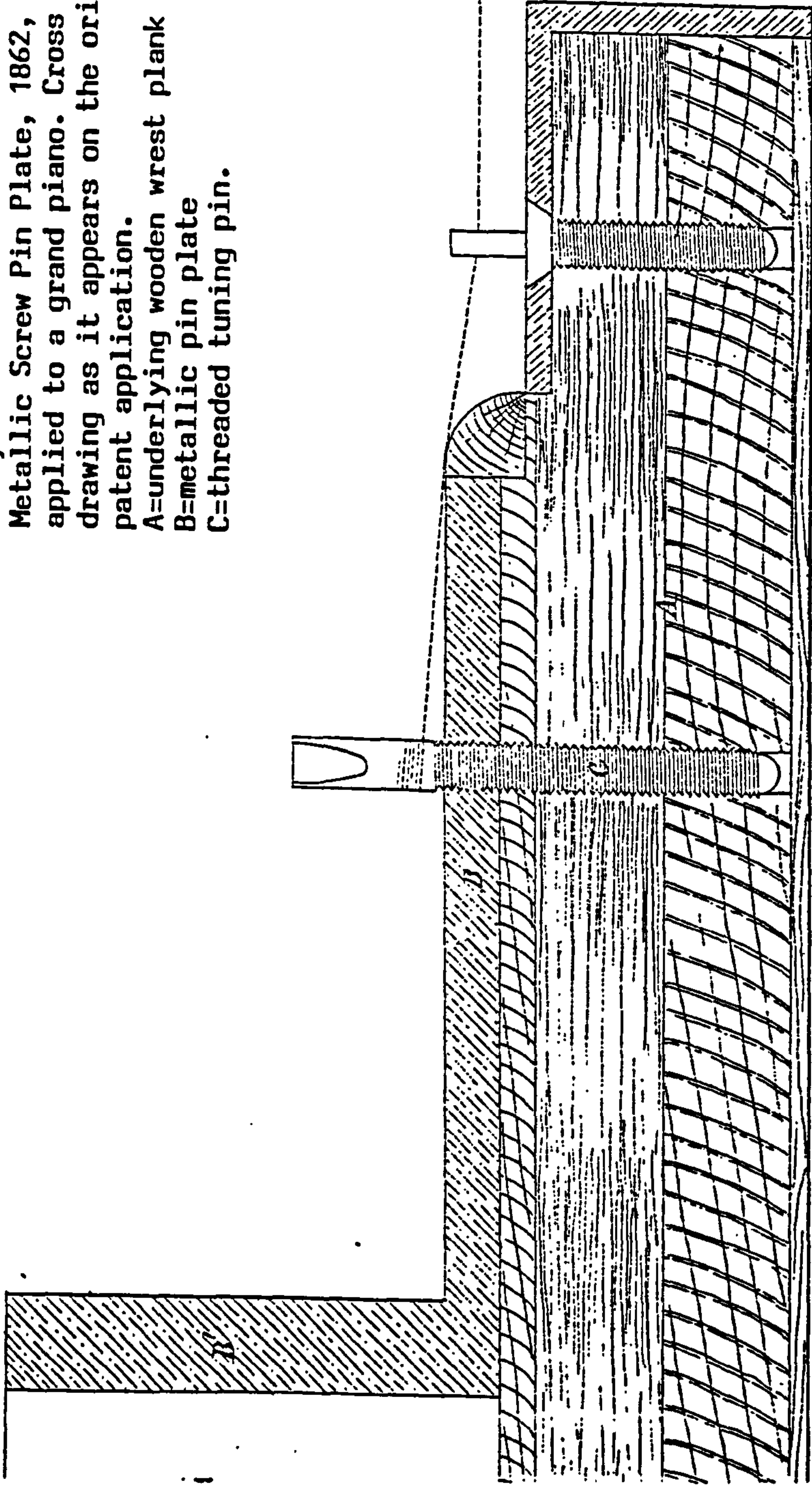

'In applying my Invention to grand pianofortes, I connect the metallic pin plate with a certain bar of the metallic framing attached to the wrest plank, and called the sweep bar, by forming them out of one piece of metal bent into the shape of the letter L. This Invention, besides increasing the facility of tuning the instrument, and the power of its standing in tune, will add much to the strength and durability of the instrument.' (13)

In other words, the newly-patented system worked in the following way: each tuning pin had a 'machine thread' cut into it; the metallic plate which covered the wrest plank was full of holes, and each of these holes had a thread tapped in it to receive the threads from the tuning pins themselves. As each instrument was being strung, the pins were inserted and screwed into place, rather than being hammered directly into the wood in the traditional manner. The tuning pins now pressed forward against the metal plate, and the forward pull of the strings was resisted by this plate, rather than by the wooden tuning plank alone. On grand model 19451 at the Exhibition, the tuning pins were tapped for only part of their length, that which passed through the metallic plate: that part of the tuning pin which was held by the underlying wooden plank was relatively smooth; however, in model number 19499 on display, the whole length of the tuning pin had a screw thread.

How successful was the new system? The Broadwood company wholeheartedly adopted the idea, and, acting under instructions from Henry Broadwood, continued to use the system for a further thirty years, on both grand and upright pianos, until Henry's death in 1893. Shortly afterwards, the idea was quickly withdrawn. It had proved to be an expensive sales 'gimmick' which no other manufacturer had even desired to copy. The job of cutting the screw threads into the metal plates, during the manufacturing process (to receive the newly-designed tuning pins) was laborious, time consuming, and ultimately made the Broadwood grand less profitable to build. The company's financial strength must have been slowly undermined by the cost of installing the new system in every piano made; the pianos stayed in tune no better than instruments built in a cheaper, more conventional manner; and problems could arise when the tapped pins

themselves became 'loose' as a result of the abrasive wear and tear caused by repeated twisting of pins during tunings: in the conventional system, a loose tuning pin can be quickly hammered into the wooden wrest plank a little deeper (one or two millimetres is often sufficient) whereupon its 'grip' improves considerably. However, in Henry Broadwood's metallic thread system, the tuning pin cannot be hammered any further into the plank, as the machined threads prevent this, and so attending to a loose tuning pin becomes a serious problem, with a number of fairly unsatisfactory solutions having been tried. (14)

After the Exhibition

From the Broadwood Porter's Books we are able to discover what happened to the four special display grands after the International Inventions Exhibition closed at the end of October 1862. Initially, all four grands were collected on the 4th of November and returned to Broadwood's warehouse.

The first of the four to be sold was the one most interesting visually, the one in the coromandelwood case (serial number 19502), which was purchased for the sum of £350 by HE Leo of Stanley House, Stanley Grove, Oxford Road, Manchester. The sale had been negotiated through the pianist and conductor Charles Hallé, who received commission for the part he played in helping to find a customer for the instrument. The piano was delivered to Manchester by rail from Camden Town station early in December 1862. It was a very fine Christmas present to the Leo household from the head of the family.

The second grand piano, one of the three in rosewood casework, serial number 19429, was sold to a London music shop, Messrs Cramer, Beale and Wood of Regent Street on the 9th December 1862, the delivery being timed for hopeful Christmas sales. However, the instrument was still at Cramer's at the end of February 1863, and an agreement was reached whereby Broadwood repurchased it. In June 1863 the same piano was hired to the Earl of Dudley, living in Park Lane, London, for an

eleven month period. Then in May 1864 it was returned to Broadwood's warehouse. Finally, on the 10th October of the same year the piano was sold to a certain Richard Potter of Standish House, Stonehouse, Gloucestershire, for the sum of 250 guineas. At present, nothing further is known about this instrument after the 10th October 1864.

The third grand piano from the Exhibition, rosewood model number 19451, remained unsold until April 1863. Then the piano was purchased by another music shop, Keith Prowse and Company of 48, Cheapside, London, for eventual delivery to their customer, James Radcliffe, of Oakwood, Pendlebury, Manchester. Delivery of the instrument was by railway from Camden Town station. There is a further note about this piano twenty years later, in the Porters' Books of the autumn of 1882: still in the hands of the Radcliffe family (now living at Swinnoe Hall, Wetherby, Yorkshire) the grand was returned to Broadwood for 'case repair'. On completion of the necessary work, the instrument was returned to the Radcliffes on the 1st November 1882 by railway from Kings Cross station.

The fourth and last of the four Exhibition grands, serial number 19499 in a rosewood case, remained in store for six months, was hired to the Earl of Dudley for two days only in May 1863, and then similarly hired to Charles Hallé for a fortnight in the following month. Next, the Porters' Books record that on the 30th July 1863 the instrument was purchased by the dealers Messrs A and J Novicow of Odessa, Russia, and exported in a tin and deal packing case on a steamship also named 'Odessa'. The sale price, initially 265 guineas, was reduced to £200 net for a cash payment. In the mid nineteenth century, the city of Odessa, on the Black Sea, was a very affluent place, being the chief Russian grain port and an important industrial centre. The Broadwood grand was no doubt eventually purchased by one of the wealthier members of the Odessa community, perhaps someone with an interest in the shortly-to-be-established University of Odessa (1865).

For Broadwood, the year 1862 had been a busy one. It was also something of a milestone in the company's long history. As a result of the Exhibition, *its* finest instruments had been seen in public by more

people than ever before; there had been public interest in the history of the company and in the way in which its pianos were constructed; and the newly-invented metallic pin plate, if not successful in the longer term, had nevertheless been an important talking point at the Exhibition and showed that Broadwood was at least moving with the times and continuing to develop and experiment in the technical field. The two publications from 1862, compiled and edited by Henry Broadwood, were notable contributions to the literature on the piano, and they are still extremely useful to the piano historian today. The many little cases of souvenir tuning forks made available in 1862 must have found their way into the pockets of enthusiastic amateurs, further helping to promote the Broadwood company. Today, one of these little cases of forks has proved to be valuable historical evidence for establishing authentic pitches for mid nineteenth century English keyboard instruments.

If any one year can be regarded as the date of the 'high water mark' of the company's fortunes, then perhaps 1862 has the strongest claim. The prestige of the Broadwood product was high. The staggering total of almost 125,000 Broadwood pianos had been produced in London since the 1780s. There was a huge number of satisfied, happy, customers. The company was jubilant when it was awarded a Gold Medal at the Exhibition, and the musical jury went on to declare that 'Broadwoods stand, without controversy, at the head of the Pianoforte Makers who exhibit on the present occasion.'(15) As we shall see in the next chapter, the three decades immediately following 1862 were an unfortunate period for the company, when Broadwoods lost much ground, when their designs became 'fossilised' and when they failed to keep up with important developments in piano making which had taken place on the continent and in the United States. The great promotional success following the participation in the 1862 Exhibition was certainly due to the enthusiasm, flair and inventiveness of Henry Fowler Broadwood; but the disappointing period in the company's history after 1862 was almost entirely due to a curious lack of these qualities from the same individual, on whose shoulders alone the fortunes of the company rested.

CHAPTER 6:

THE SCALE DESIGN OF BROADWOOD GRANDS, 1850-1895

International Manufacturing Competition

The Broadwood company had always faced rivalry from other makers from the time they began the manufacture of grands in the mid 1780s. In those early days, Stodart was the main competitor; during the first two decades of the nineteenth century, the firm of Clementi and Company (later known as Collard and Collard) became serious rivals; and other London grand piano makers such as Mott and Kirkman, both of whom had obtained the prestigious Warrant for the supply of pianos to the Royal Household, continued to be significant competitors throughout the 1820s and 30s.

In spite of this competition, (which is regarded as being 'healthy' in the way that it encouraged rival makers to introduce improvements and sometimes new musical features in order to gain sales - such as the gimmicky 'Bridge of Reverberation' of Clementi and Company (1)), John Broadwood and Sons were able to hold their own, not simply because their prices and standards of craftsmanship were the same as those of their competitors, but mainly because their pianos' musical qualities were on a par with those of their rivals.

The Broadwood company appears to have been little troubled by its English or continental competitors throughout the first half of the nineteenth century. As we noted in chapter 4, Henry Fowler Broadwood continued to introduce new grand models during the early to mid 1850s which incorporated the most up-to-date features of piano design, such as the new full seven-octave compass and an improved, stronger, yet simpler iron bracing system to withstand a heavier stringing load. It would certainly be accurate to state that Broadwood's best, largest and most expensive grand model of the 1850s, the 'Iron Concert Grand with

diagonal resistance bar' was regarded as one of the finest concert instruments available at that date. It was to be seen in regular use in the main London and provincial halls, and the model continued to be seen and heard, unaltered in any way as far as its internal design was concerned, until the mid 1890s. As we noted in chapter 4, Broadwood maintained an impressive hire fleet of grands; and a well-travelled body of Broadwood tuners maintained the concert models to an extremely high standard.

During the thirty-year period 1865-1895, however, Broadwood, although continuing to manufacture considerable quantities of all kinds of well-made pianos from concert grands to small cottage uprights, nevertheless slowly began to lose their pre-eminent position in the field of the highest quality concert music and professional performance, a position they still held at the time of the International Inventions Exhibition of 1862 (see chapter 5). It would not be unfair to claim that by the 1880s, most leading concert artists, given the choice, would rather perform in public on a Bechstein concert model than on a Broadwood. This decline in Broadwood's standing was the result of two factors: the emergence of more modern and progressive piano designs from competitors in France and Germany; and the unwillingness of the Broadwood company to alter its scale design in any way whatsoever throughout a period of thirty years, 1864 to 1894. (By 'scale design, we mean the various lengths, and layout, of all the strings in the piano; the thickness of the music wire employed; the tension of the stringing when the piano is tuned up; and the points on the various strings where the hammers strike.)

The new overseas competitors during the 1860s and 70s took the form of three main rivals as far as concert pianos were concerned: Erard of Paris, Blüthner of Leipzig, and Bechstein of Berlin. Although Erard had undoubtedly been a competitor from the early 1800s, and particularly after the introduction of Sebastien Erard's double escapement action of 1821,(2) supplies of Erard instruments in Britain itself appear to have been very restricted throughout the first half of the nineteenth century. The reason for this was that, by comparison with Broadwood,

Erard was a very small company. However, it is surprising not to find more Erard concert pianos in London, bearing in mind that Erard had maintained a London branch to handle the sale of harps and pianos from as early as 1786;(3) but this branch and its associated London workshop may have been much more involved in the tuning, repair and maintenance of a very limited number of Paris-built instruments rather than in the manufacture of completely new instruments.

From the mid nineteenth century, however, Erard greatly expanded its London base: the company opened a new, much larger factory in Warwick Road (from circa 1852) and commenced the assembly of high-quality, often ornate and fashionably-styled, concert grands using components and sub-assemblies shipped in from Paris. The elaborately-decorated, London-built Erard grand in Buckingham Palace dates from this period.(4)

The rivalry from Blüthner and Bechstein became a serious matter for Broadwood after 1870. From 1876 the London-based partnership of Whelpdale and Maxwell began to import Blüthner pianos in large quantities from the Leipzig factory; and the year 1879 marked the establishment of Carl Bechstein's London branch at a prestigious address in Wigmore Street in the West End, where a new concert hall, Bechstein Hall (now known as the Wigmore Hall) was later to be opened (1901). The competition from Steinway at this period was relatively insignificant; the New York company did not open its Hamburg factory - to supply pianos for the European market - until 1880, and Steinway grands did not begin to appear in significant quantities in England until after 1900.

If a prospective piano purchaser of the 1870s had compared two instruments by rival makers (instruments which we are to compare from the point of view of scale design later in this chapter) - a large Broadwood 'Drawing Room' grand (serial number 20820) of 1875 and a Blüthner grand model (serial number 10963) made in 1871 - a number of significant features would have become apparent. The Broadwood piano would have been seen to have had the superior casework, with fine rosewood veneer, hand-carving of the highest order on the three turned legs, and a full-bodied shellac 'French' polish, giving a mirror-like

finish to the case. The Blüthner piano would have looked a little inferior, with simpler casework which looked more mass-produced than the Broadwood's. However, if the lids of the two pianos had been raised, it would have been revealed that the Blüthner possessed a beautifully-finished one-piece cast iron frame, painted a high gloss bronze, and that the frame was specially designed for a new and novel feature, the diagonal crossing of the bass strings over the top of the others. In other words, the Blüthner was overstrung. In contrast, the Broadwood grand when opened would have presented a dull brown frame comprised of numerous bits and pieces bolted together and looking by comparison remarkably crudely engineered. The Broadwood's interior was more reminiscent of railway engineering than of fine art. Moreover, the Broadwood's interior bore a strikingly old-fashioned look, because it was straight strung and its bass strings lay parallel with those in its treble and middle sections.

It is customary to blame Broadwood's refusal or inability to adopt overstringing as the chief cause of the company's failure to maintain its lead in the field of serious concert music during the period after 1865. Cyril Ehrlich writes:

'Broadwood's annual output of some 2500 piano was probably maintained through the 1880s, but by 1890 it had declined precipitously to less than one half of previous levels. At this extraordinary late date not a single overstrung piano had left the Broadwood factory; the first was made in 1897.' (5)

The Broadwood Number Books (6) contradict Ehrlich's statement. They are a highly-accurate record of production, and they show that Broadwood actually maintained a reasonably consistent level of production throughout the period 1850-1900. There was no 'precipitous decline' by the year 1890, as the accompanying chart (Fig 6/1) shows. In fact, it was in all probability the consistent demand for Broadwood's products (particularly from the developing colonies of the British Empire) which was perhaps the greatest deterrent to design modernisation from within the firm, and which lulled the Broadwood partners into the belief that, provided the

Fig 6/1

BROADWOOD PIANO PRODUCTION, HORSEFERRY ROAD, WESTMINSTER, LONDON,
1850-1900

GRANDS, COTTAGE UPRIGHTS, SQUARES AND CABINETS.

SOURCE: THE BROADWOOD NUMBER BOOKS, SURREY ARCHIVES, WOKING.

The figures quoted represent the average output per year during the five year period.

Years	Grands	Cottage ups	Squares (discontinued 1866)	Cabinets (discontinued 1854)	Total annual
1850-54	391	1000	80	32	1503
1855-59	580	1200	94	-	1874
1860-64	412	1220	106		1738
1865-69	538	1240	80		1858
1870-74	404	2104	-		2508
1875-79	586	1516			2102
1880-84	488	1750			2238
1885-89	672	1725			2397
1890-94	420	1320			1740
1895-99	430	1420			1850

order book was healthy, there was no point in wasting time on expensive research and development.

It is true that Broadwood's financial profits were dwindling throughout the 1880s, as Wainwright points out;(7) but this was a problem related to out-dated production methods, inefficient management, and the unavoidable under-pricing and discounting in order to compete with the growing numbers of piano imports, rather than being a consequence of a serious fall-off in numbers of pianos sold, as Ehrlich maintains. If we were to summarise the chief differences between Broadwood's 'output' of pianos and German 'output' in the last quarter of the nineteenth century, we could say that whilst that of the long-established English maker remained reasonably consistent and uniform, German output after National Unification in 1871 expanded remarkably; and so by comparison with German 'industriousness', the English did not appear to be doing so well.

Returning to our comparison of the external and internal physical features of the two rival grands, Blüthner (1871) and Broadwood (1875), we may note one further feature regarding tonal characteristics: overstrung or not, the bass tone quality of the Broadwood is better in every respect than that of the Blüthner. Bearing this in mind, and bearing in mind also one of the main objects of overstringing, which is to improve the tone quality of the bass section, we can well imagine the technical staff at Broadwood's factory saying to each other something along the lines of: 'Why should we adopt overstringing when the overstrung Blüthner bass is less good than our own straight-strung bass?' There was yet another consideration which certainly helped to deter Broadwood from embracing overstringing: the 'tail' of a grand piano becomes noticeably wider and less elegant as a result of it, and the instrument looks decidedly more bulky and therefore less attractive as a piece of furniture. The new fat-tailed German overstrungs must have jarred on the sensibilities of Broadwood's case designers, who had for decades created slim and well-proportioned grands for the elegant drawing rooms of the nobility and gentry. There were good reasons for Broadwood's rejection of overstringing.

The Scale Design of Five Grands Compared

We shall now examine the scalings of five grand pianos in order to discover the way in which different scale designs resulted in distinctive, different and even 'national' piano tones being produced. One of the purposes of our analysis will be to show how the gradual decline and fall from favour of the Broadwood concert grand in professional circles was not the result of the company's failure to adopt overstringing, but was largely the result of the company's clinging on to a very traditional 'short' scale design, which could not be successfully adapted to suit modern steel wire.

The pianos to be examined are: a full-sized Broadwood 'Concert Iron Grand' of 1859 (serial number 19165); another similar Broadwood, a 'Drawing Room Grand' of 1875 (serial number 20820); an Erard concert grand (Paris design, built in London, 1865); and a Blüthner medium-sized overstrung grand of 1871. These particular instruments have been chosen because they represent the two best models that Broadwood could offer, the best model by Broadwood's serious competitor, Erard, and a good example of an instrument from another of Broadwood's main competitors, Blüthner. The measurements obtained from these four pianos will be compared with those found in a fifth grand, a modern Steinway 'D' concert model, built in New York. The Steinway is a useful yardstick against which to consider the other four instruments; and although the New York piano is 'modern', its scale design was nevertheless laid down by Theodore Steinway over one hundred and ten years ago. In this sense, the Steinway scale, perfected during the 1880s, really belongs to the same vintage as the other four grand scales dealt with here. Full background details of each of the grands examined are given in footnote (8).

Figure. 6/2 shows the speaking lengths, in millimetres, of the five grands, and it is the middle string of each tricord note which has been measured. The chart commences with the highest treble note of each piano. For the purposes of this examination, measurements of string lengths below c28 have been excluded, the reason being that the differences in various makers' string lengths below c28 has much more to do with the

Fig 6/2

STRING SPEAKING LENGTHS OF FIVE GRANDS

Note	Broadwood 1859	Broadwood 1875	Erard 1865	Blüthner 1871	Steinway Modern
c88 (c5)					51mm
b87					53
a#86					56
a85	49mm	46mm	56mm	62mm	59mm
g#84	52	49	59	65	61
g83	55	52	62	69	65
f#82	58	55	65	72	68
f81	61	58	68	77	73
e80	65	61	72	81	80
d#79	69	65	75	86	83
d78	73	68	79	90	89
c#77	78	72	83	95	93
c76 (c4)	83	77	87	100	99
b75	80	82	91	105	105
a#74	85	87	96	111	111
a73	90	92	102	117	118
g#72	95	97	107	122	124
g71	101	103	113	129	129
f#70	107	109	119	135	136
f69	114	115	125	142	144
e68	120	121	131	148	152
d#67	127	129	137	156	159

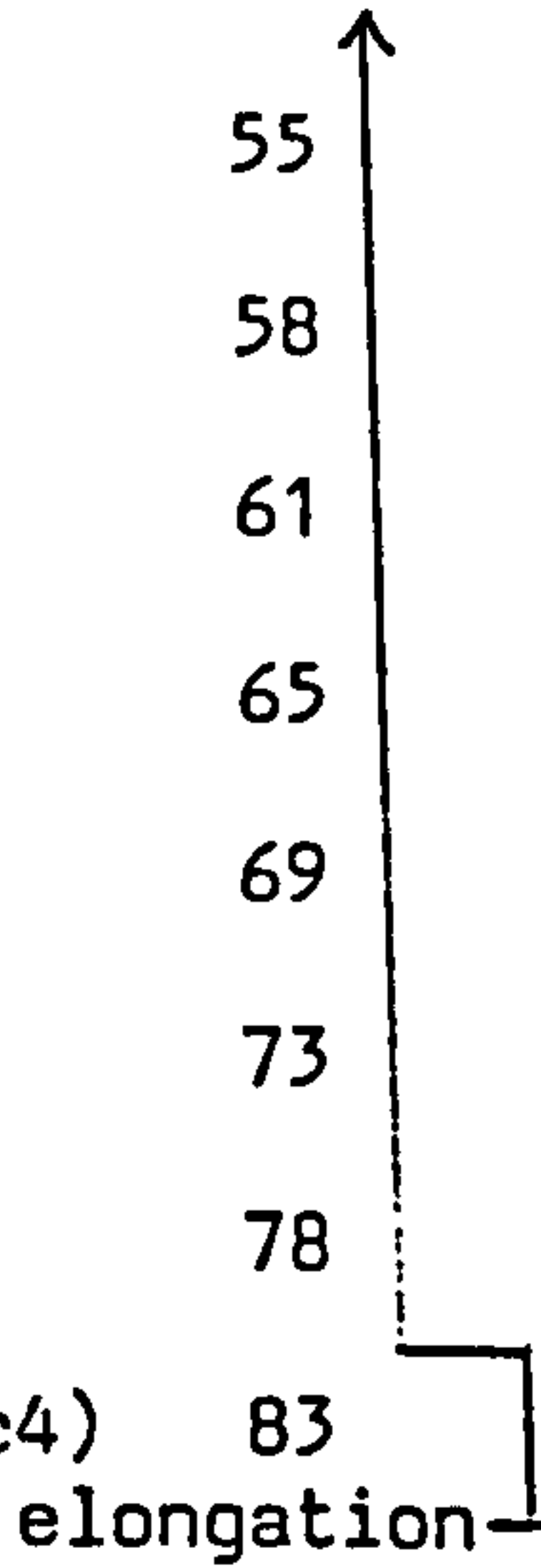

Note	Broadwood 1859	Broadwood 1875	Erard 1865	Blüthner 1871	Steinway Modern
d66	135	136	144	166	168
c#65	144	144	151	175	177
c64 (c3)	153	153	159	184	187
b63	162	163	169	195	197
a#62	172	173	179	206	207
a61	182	182	189	218	219
g#60	193	194	201	230	231
g59	205	205	213	242	242
f#58	216	216	225	256	254
f57	230	230	240	271	266
e56	243	243	254	286	281
d#55	258	257	264	304	294
d54	274	273	286	321	309
c#53	290	289	302	342	292
c52 (c2)	308	306	320	362	310
b51	325	326	339	383	329
a#50	344	345	358	406	349
a49	364	365	378	431	369
g#48	386	386	399	454	391
g47	408	409	420	480	417
f#46	432	433	444	509	443
f45	458	459	470	538	470
e44	484	489	493	572	499
d#43	514	515	518	610	529
d42	544	545	543	650	558
c#41	576	576	572	692	591

foreshortening

Note	Broadwood 1859	Broadwood 1875	Erard 1865	Blüthner 1871	Steinway Modern
c40 (c1)	610	611	603	734	625
b39	625	628	637	781	662
a#38	662	665	673	833	696
a37	701	704	711	877	735
g#36	744	746	753	925	782
g35	787	790	790	973	831
f#34	834	836	850	1018	885
f33	855	858	902	1062	938
e32	906	909	959	1104	997
d#31	960	962	1027	1144	1057
d30	1018	1019	1087	1174	1120
c#29	1077	1079	1149	1202	1182
c28 (c)	1142	1145	1211	1230	1254

No measurements made below c28.

limitations imposed by casework dimensions than with the idiosyncrasies of any particular scale designer. An initial examination of Fig.6/2 will show that the two Broadwood instruments possess what we might call 'short' scales; the Erard could be described as having a 'medium length' scale; and both the Blüthner and Steinway utilise, in the main, 'long' scales. The two Broadwoods have virtually identical scales (apart from in their top octaves), indicating if nothing else that Broadwood had not made any radical change to its large grand design between 1859 and 1875. The slight differences in speaking lengths recorded between the two Broadwood pianos is likely to be caused by very minor errors in measuring the speaking lengths, by structural distortion over a period of time, and possibly by initial errors in manufacturing; but these differences are so small (within three millimetres for each note) that in spite of them it is apparent that the two instruments share exactly the same scale dimensions and were built using identical scale charts.

However, the lengths of the top ten notes of the two Broadwood models are different: it is obvious that the 1859 example had a quirk in the way that note c76 defies scale design logic and actually has a speaking length 3mm longer than the note one semitone below it, b75. From note c76 up to the top of the compass, the 1859 model has strings which are up to 6mm longer than the 1875 instrument. The reason for this deliberate elongation of scale will be explained shortly.

The top treble strings of the 1865 Erard piano are between 15% and 18% longer than those of the 1875 Broadwood, but the Erard's strings in its middle register are very similar in length to those found on the two Broadwood models. The Blüthner has a very long scale, its top treble strings being some 25% longer than the 1875 Broadwood, and throughout the whole of its treble and middle registers down to c28 the Blüthner's strings are at least 15% longer than those equivalents in the Broadwood. This is remarkable, considering that the case of the Blüthner grand is in fact two feet shorter in length than Broadwood's. By comparison, the Steinway may be seen to have decidedly similar speaking lengths to those of the Blüthner in its top two and a half octaves; but then there is a distinct and abrupt foreshortening of the Steinway scale below d54.

The shortness of the 1875 Broadwood's top treble octave strings produce a number of problems for the piano maker. To begin with, the extreme shortness of the highest speaking lengths (only 46mm for top 'a85') means that the builder is compelled to place the bridge, over which the strings pass, right on the edge of the soundboard in the extreme treble. Placing the bridge on such a spot means that it sits on what is very much a 'dead' and unyielding part of the soundboard, and consequently the tonal quality of the highest notes is decidedly impaired. The Broadwood high treble tone is characterised by considerable volume, with a sharp initial 'attack' to the sound; but the degree of sustaining is almost negligible, the sound becoming completely inaudible within the timespace of one second after the hammer blow. The musician's description of such tone is 'wooden', 'dry' or 'bony', because of the marked lack of sustaining power. Of course, the shortness of sustaining power in the high treble is one of the accepted hallmarks of the early piano, with its short, weak, but nevertheless clear high treble. Compared with the Erard's and the Blüthner's, the 1875 Broadwood's high treble is much more reminiscent of the characteristic treble found in an earlier vintage of piano. In other words, the high treble tone of the 1875 Broadwood is comparatively old-fashioned.

The qualities of the Broadwood treble might have been quite acceptable for concert work throughout the 1850s and 60s, particularly where sheer volume was perhaps the only prerequisite for large recital hall pianos; but by the late 1870s and early 1880s, concert goers were becoming much more accustomed to, and more appreciative of, the more silvery, singing and less coarse high treble sounds found in Bechstein's and Blüthner's instruments, with their longer treble scales. It is quite apparent that John Broadwood and Sons were unsatisfied with the lack of sustaining found in their pianos' top trebles, and they endeavoured to make improvements by doing three things: by tinkering with the soundboard; by increasing the down-pressure of the shorter treble strings on the soundboard bridge; and, only in their best concert model, by deliberately elongating the string lengths for the top ten notes.

Broadwood's soundboard in the treble of both the 1859 and 1875 model is 'floated'; in other words, the edge of the board itself does not actually touch the rim along the bentside; only the supporting ribs under the board are actually pocketed into the supporting rim. This evidence is sufficient to show that Broadwood was deliberately attempting to 'free up' the treble soundboard in order to try and produce a more liquid, sustained tone quality (but with very limited success!) The top treble strings on all Broadwood models of grand of this period are made to press down on to the soundboard bridge with a very heavy downbearing, a downbearing which is four times as great as that found on a modern Steinway concert grand. Clearly, Broadwood believed that the strong downpressure would help to maximise whatever potential there was to sustain the tone. The value of this high downbearing is debatable as far as its contribution towards a singing tone is concerned: only the volume would have been increased, not the sustaining power; and in order to withstand the heavy string downpressure on the soundboard, the underlying wooden ribs would have had to be made too deep and too heavy, resulting in a stifling of the effectiveness of the soundboard in this particular area of the piano. The only probable advantage of a heavy string downbearing in the extreme treble is an increase in tuning stability.

The sad fact is that Broadwood's technicians during the 1870s and 1880s must have realised that the fundamental shortcoming of their trebles was a problem of short string length; but they were unable or unwilling to do anything of a fundamental nature to alter things. Only in their best model, the diagonally-barred 'Concert Iron Grand' was an attempt made to improve the high treble tonal qualities by deliberately elongating the scale. This is the explanation of the curious feature found in the scale of the 1859 instrument, where, as we have previously noted, the speaking length of c76 is actually 3 millimetres longer than the note below it, c75, and the remainder of the top treble strings are longer than usual. The result of this 'quirk' is that the top ten notes have a higher string tension than would normally be expected, and therefore, in theory, they should emit greater volume of sound. Furthermore, the longer strings here mean that it is possible (presuming that the 1859 and 1875 pianos have identical hammer strike lines) to

achieve a better strike point for the hammer, relative to the strings' speaking length; and so we find the 1859 model having its highest treble strings struck between one sixteenth and one eighteenth of the speaking lengths. By comparison, the model of 1875 is obliged to have its highest strings struck between one twelfth and one sixteenth of the strings' length. Precise details of these strike variations are shown in Figure 6/3. There is no doubt that striking high treble strings close to one eighteenth of their length gives a more brilliant and penetrating sound than striking the same strings between one twelfth and one sixteenth of their length.

The problems associated with shortness of top treble string length and its inevitable influence on soundboard bridge position are shown in figure 6/4, which illustrates the position of the 1859 Broadwood's treble bridge and compares it with that of the 1865 Erard. As a result of the 15% longer string lengths found in the Erard, it was possible for Erard's builders to place the bridge one centimetre further away from the edge of the soundboard than did Broadwood's builders. Although this appears to be only a small difference, one centimetre change in this part of the grand's soundboard can yield a significant difference in the overall sound quality. The bridge position of the 1875 Broadwood model is also included in the same diagram. It can be seen that this bridge lies even closer to the edge of the board, and must surely sit on part of the rim, a dead area acoustically speaking.

The writer was able to compare the high treble of the 1859 Broadwood grand with that of an 1866 Erard concert grand (but of identical specification to the one examined in this account) during a three-day recording session at Finchcocks, Goudhurst, Kent, in September 1995. (9) Both instruments, tuned by the writer, were heard through speakers in the recording engineer's control room for a period of at least eight hours each day over a three-day period. The microphones for each piano were placed in an identical position relative to each instrument (one close to each bentside, the other about fifteen feet away from each instrument), and so the sound comparison was a very accurate and fair one.

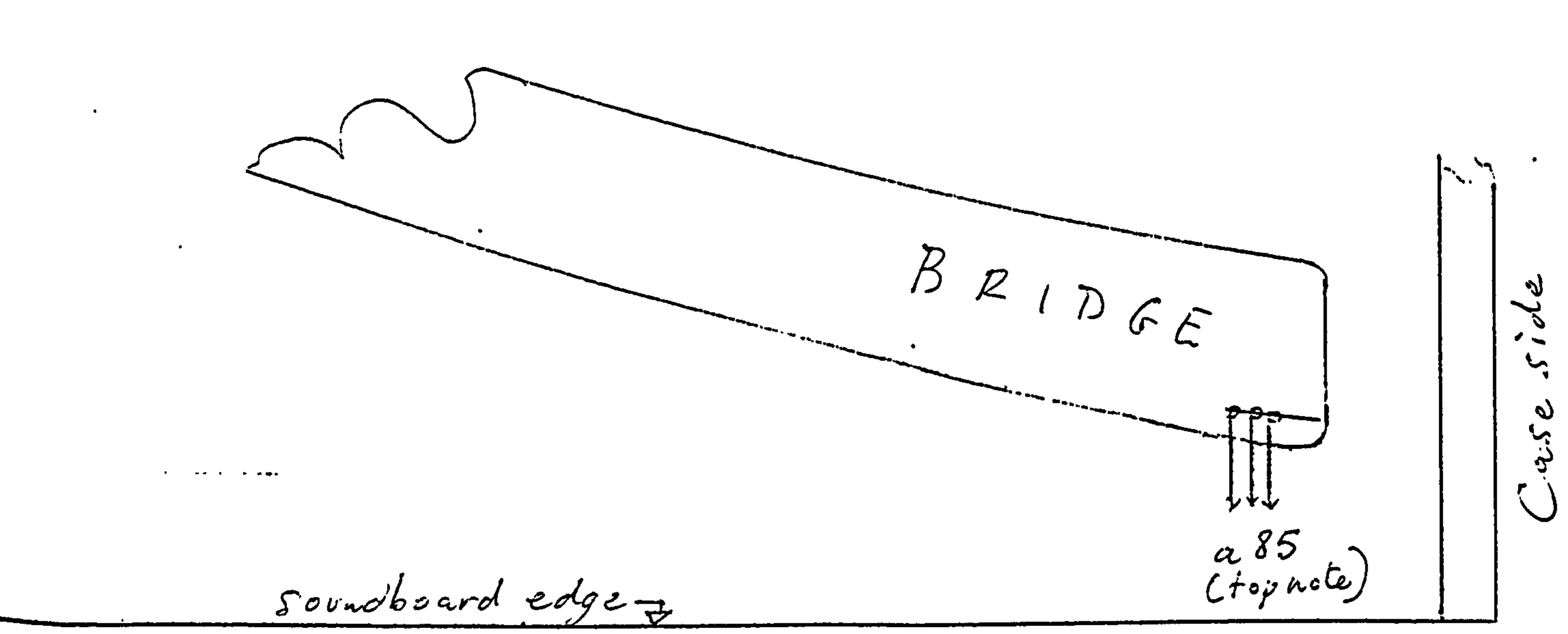
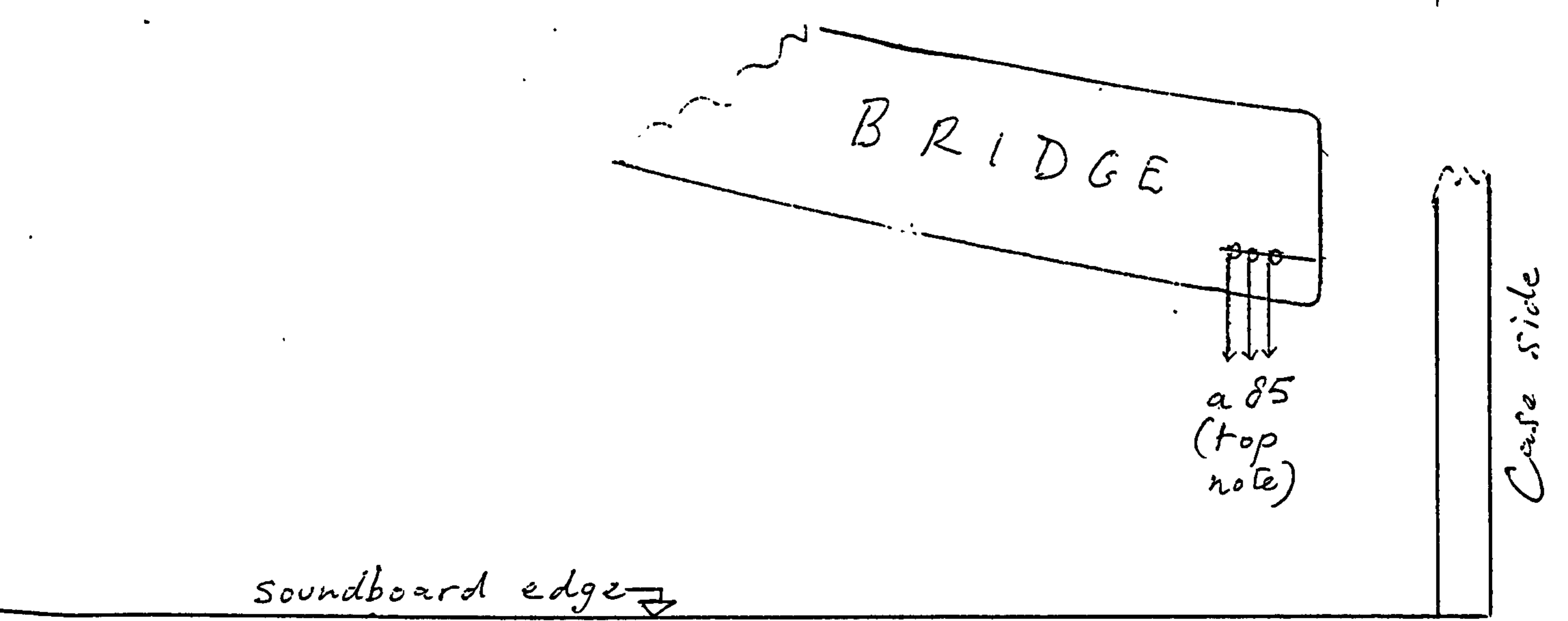
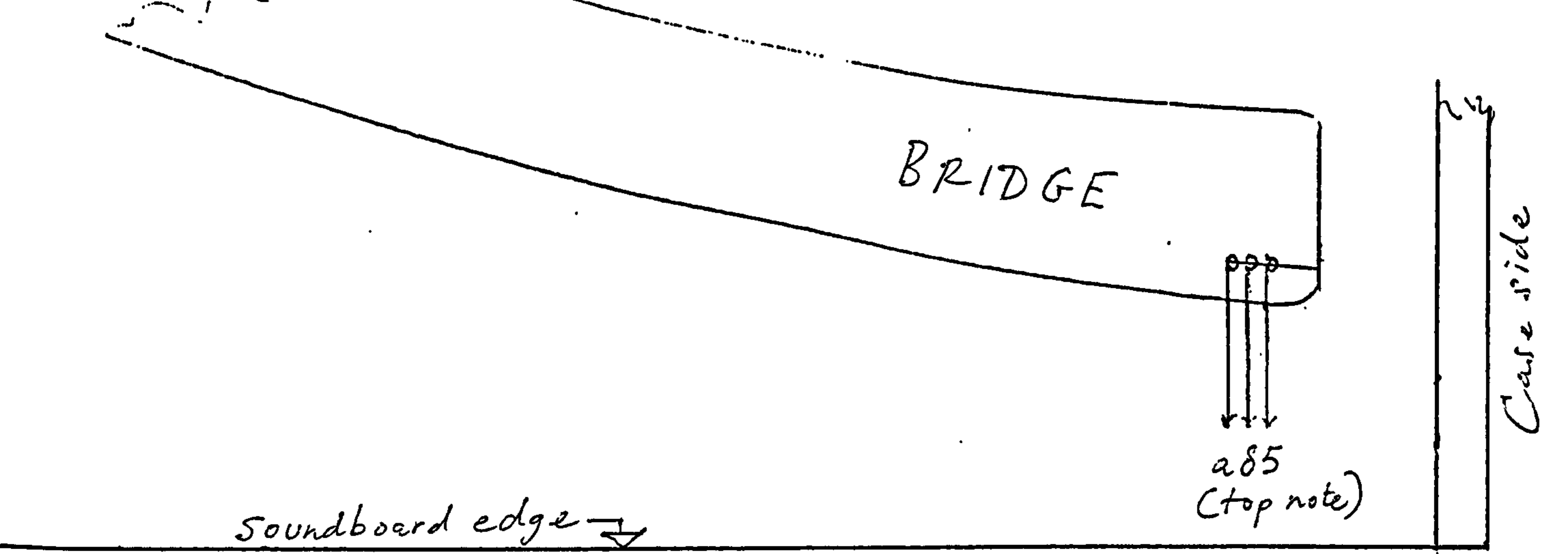

Figure 6/4: Soundboard bridge positions in the high treble:
 Top: Broadwood 1859
 Middle: Erard 1865
 Lower: Broadwood 1875.

Fig 6/3:

BROADWOOD GRANDS, 1859 AND 1875, showing how the scale elongation in the 1859 model enables a better hammer strike proportion to be gained in the top treble octave.

Measurements by the writer, 1994

	1859 Grand	1875 grand
	Hammer strikes at:	Hammer strikes at:
a85	sixteenth	fifteenth
g#	seventeenth	sixteenth
g	eighteenth	fifteenth
f#	seventeenth	fourteenth
f	seventeenth	thirteenth
e	sixteenth	fourteenth
d#	fifteenth	thirteenth
d	fifteenth	twelfth
c#	fifteenth	twelfth
c	<u>Scale elongation begins</u>	twelfth
b	thirteenth	twelfth
a#	thirteenth	eleventh

During the recording, the Broadwood's high treble sound was well-integrated with that of the middle register of the piano, and there was a good 'blend' of tones. The piano had an overall smoothness in its tonal character, with no audible changes in quality from one register to another. The elongation of the scale at note c76 was inaudible. (In other words, there was no 'bump' in the tone whenever passages of melody line crossed over the point of scale elongation). However, the ultimate verdict, as far as the listener was concerned, was that the high treble of the Broadwood sounded generally uninteresting and prosaic, and the performer had difficulty in coaxing either a warm or exciting tone from this region of the 1859 model.

In contrast, the 1866 Erard had a brilliant and exciting high treble, with a much more sustained and singing quality; but its tone was 'screamy' and its highly-penetrating treble sound stuck out in an almost erratic way. In this respect, the Erard lacked the overall smoothness of the Broadwood, and its various registers were much more distinct and pronounced. The greater variety of tonal colour available on the Erard meant that piano pieces sounded much more 'orchestral' in effect. It is easy to see how the Erard piano would have been very attractive to concert artists anxious to 'fill the Albert Hall' with sound, and equally, to concert promoters who wished to thrill their listening customers with all the sparkle that the best pianos could muster.

It is interesting and worthwhile to refer at this point to a letter written by Charles Hallé to Henry Fowler Broadwood in December 1852. Halle had recently had the opportunity to compare an Erard concert grand with one of Broadwood's. Both pianos were used in the same recital:

' - - in the harmony of beauty and richness of tone there is no comparison, yours being far superior. I believe that the public unanimously shared my opinion - - - the tone of the Erard piano, following yours, seemed at first utterly disagreeable. - - - As to the achievement of clarity in very rapid passages, Erard undoubtedly has the advantage; does this happen because the tone is less rich and sonorous than yours,

and is therefore more easily detached? I believe so. I found further that the tone of the Erard is capable of a wider variety of shading - - the character of the various 'nuances' in Erards is rather different, and the effect is definite; in your pianos, the quality of the sound from the pp to the ff remains identically the same, that is to say, that whether you play loud or soft you hear - believe me - that it is always the same instrument, the same sonority. In the Erard pianos, on the other hand, the nature of the sound essentially changes according to the manner of the attack: play pp and it is veiled, ff and it becomes loud and even strident; from this a larger variety of effects is certainly derived.' (10)

It was during the Finchcocks recording of September 1995 that a further problem associated with the short Broadwood treble scale revealed itself: the tuning of the high treble to the degree of accuracy associated with modern concert pianos was very hard to achieve. In the course of tuning the treble of a modern grand it is the usual practice to check the accuracy of octave tuning by utilising what is known as a 'double octave check.' For instance, if a tuner was tuning note 85 to a73, an octave span, he or she would compare a85 with a tuned note a61, two octaves lower, in order to double-check the accuracy of the single-octave tuning, a85 to a73. Any slight error in the single octave tuning would be detectable in the double octave check.

However, in the case of the 1859 Broadwood, if the double octave was apparently in tune, then the single octave sounded out of tune; and vice versa: if the single octave sounded more or less in tune, then the double octave appeared to be not quite in tune. This phenomenon, a frustrating one for the tuner, who has to make difficult aural decisions in high treble tuning, is the result of the strings' unfortunate shortness and stiffness causing excessive 'inharmonicities'. Because of this extreme shortness and stiffness, the strings' harmonic partials do not form in the correct manner, and the wires take on all the characteristics of metal bars or rods. It can be readily understood how distortion of octave tuning can make the piano sound 'sour' in its treble register.

Blüthner's Problems, Steinway's Remedies.

Having previously noted that the strings of the 1871 Blüthner grand under examination are consistently longer than those found in the two Broadwood instruments, and that the top treble speaking lengths of the Blüthner are in fact some 25% longer than those found on the 1875 Broadwood, we now come across another kind of problem: strings which are too long rather than too short. The musical result of comparatively long string lengths in the treble is the production of a weaker sound, with less volume, and lacking in 'guts'; but as some compensation for this, the treble tone gains a sweet, singing and sustained quality. In addition, the overall lower inharmonicity of the treble strings means that accurate and good octave tuning is much easier to achieve, and so the almost 'acidic' distortion of the octave intervals found in the short-scaled instruments is eliminated. It is perhaps no coincidence that the Blüthner is one of the most popular of pianos among tuners, who appreciate the ease with which it can be tuned.

Julius Blüthner, the creator of the 1871 Blüthner grand under examination, was very much aware of the shortcomings of his long treble scale, and ultimately the Blüthner company accepted the fact that their grands, with their gentler treble tones, were more suited to chamber and domestic music making rather than performance in large concert halls. One long-standing problem of the Blüthner design is that the treble register, with its long, thin strings, tends to be overpowered by the bass register during loud playing. It was an attempt to improve his weak treble which led Blüthner to introduce the 'Aliquot Scaling' system, (11) by which an additional sympathetically-vibrating string is placed above each tricord cluster serving the highest forty notes in the piano. The novel idea was hardly a success in musical terms: the improvement to the power of the Blüthner treble as a result of the 'Aliquot' is negligible. However, the visual features of the Aliquot system were so attractive that they became a good selling point in piano showrooms; and so the Blüthner company (probably with some reluctance, because they once tried to remove the system altogether) have retained the system in a simplified form in their four largest grands (models 9,10,11 and 12.)

The New York Steinway piano, with its treble speaking lengths remarkably similar to those of the 1871 Blüthner (suggesting a common source of scale measurement), should in theory suffer from the very same problem which confronted the Leipzig maker: that is, lack of treble power in spite of a very pleasing, singing sustained tone in the high register. Theodore Steinway, working in his family's factory in New York, tackled the problem during the 1870s and 80s by introducing three unique features in all his grand designs: the 'Duplex' scaling of sympathetically-vibrating string lengths (which is far more effective than Blüthner's 'Aliquot'); the capo d'astro bar, a cast-iron bridge structure forming an integral part of the cast-iron frame, and on which the treble strings press; and the 'rim cone', a heavy, cast-iron structure which is screwed on to the interior of the wooden soundboard rim and which is linked, via a heavy bolt, to that part of the cast iron frame which lies in the high treble section. Of these three new features, which did much to establish Steinway's pre-eminence by the 1890s, the contribution of the capo d'astro bar to treble tone volume and power is highly significant: the sound of the high treble strings is actually amplified, radiated and enhanced by the piano's cast iron frame. (12) During the period 1850-95, the Broadwood company made no attempt to improve their grands' top trebles by the use of sympathetic strings in the manner of Blüthner, or by using a cast-iron bar of the type adopted by Steinway.

London Scale Calculations

The speaking length measurements in Fig. 6/2 are given in millimetres; but it has to be borne in mind that Broadwood used English measurements for all scale calculations. The two grands of 1859 and 1875 appear to use as a basis for their string length calculations the very simple measurement of the English foot; and so the speaking length of note c52 (c2 in musical terminology) is almost exactly one foot long (or metric length 305mm) and likewise the length of c40, one octave lower, is exactly two feet. In adhering to this principle of using something as

straightforward as the simple foot measurement for the fundamental basis of scale design, Broadwood appears to have been clinging to some ancient principle, closely related to the theoretical speaking lengths of organ pipes. However, not all Broadwood's London scales were based on exactly a one-foot length: the firm from time to time built pianos of a slightly longer scale length, $c=12\frac{1}{4}$ " , and occasionally even longer scaled instruments using as a basis a 'c' of just over $12\frac{1}{2}$ ".(13) However, the two Broadwood grands being compared in this account both use the foot length as the basis of their scale calculations.

There was no particular practical benefit gained from clinging to such an ancient and time-honoured measurement as the ubiquitous foot. As fig. 6/2 reveals, such a concept results in the 1875 grand, with its half-length octaves, having a six-inch speaking length (153mm) for note c64, a three-inch length (77mm) for c76, and ultimately only a $1\frac{3}{4}$ inch length (46mm) for the top note, a85, giving us the excessively short treble strings that we have been complaining about over the last few pages.

Almost certainly the French and German makers would have used metric measurements and calculations in their scale design, although the writer has no firm evidence at present. The only circumstantial evidence lies in the highly-regarded German treatise on piano design and construction by Siegfried Hansing, (14) written in 1888, in which all the calculations involving length and thickness of music wire use the metric system; and yet oddly enough Hansing's string tensions are calculated in English pounds.

There survives in the Broadwood Papers (Surrey Archives) one solitary piece of evidence which suggests that Broadwood had at least contemplated the possibility of adopting significantly longer string lengths in their pianos during the period in question. Henry Fowler Broadwood wrote a letter dealing with technical matters to the piano maker Andrew Osborne of Chickering and Company, New York, in the year 1867. (15) After discussing such matters as a new action mechanism sample (provided by Osborne), Henry Broadwood goes on to write a few

tantalisingly-brief details about scale design:

'As to the scale of the strings, we adhere to a $24\frac{1}{2}$ inc C - with the Nos of wire given in the book. The longer scale gives no good results unless the thickness of the wire be increased. We used to throw out our backs two or three inches - and doubtless for tone in Bass, it is not a bad thing; but the Instrument loses much in furniture.'

As both the 1859 and 1875 Broadwood grands examined in this account have their scales based on a simple 12-inch c52 (24-inch c40), it is difficult to understand why Henry Broadwood should be writing in 1867 as if $24\frac{1}{2}$ inches were the norm. Nevertheless, his assertion that 'the longer scale gives no good results' suggests that at least the company had done some serious experimentation with longer lengths. The reference to the way in which Broadwood and Sons 'threw out their backs' almost certainly refers to a widening of the grand's tail in order to improve the tone quality of the bass register. Henry Broadwood's objection to this practice stemmed from the fact that tail widening was detrimental to the grand as an item of furniture. Here we have evidence of what is almost certainly the chief reason for Broadwood's rejection of overstringing.

The Octave Ratios Compared

We can now turn to examine one of the most intriguing aspects of scale design: the octave ratios. Practical knowledge about the use of octave ratios in design is almost a lost art; the unwritten nature of ratio knowledge means that there is something of a mystique surrounding its use; and it must be true to say that the vast majority of those piano manufactureres who possessed such specialised knowledge were hardly anxious to share their trade secrets with others. (16) The phrase 'octave ratio' describes the way in which the speaking string length of any one note in the piano compares with and relates to the length of string for the same note either one octave higher or one octave lower. If the string lengths double for an octave (for example c52 = 12 inches;

c40 = 24 inches) then we describe the octave ratio as being 1:2. On the other hand, if the length of the lower octave speaking length is less than twice the length of the upper, then we call this a contracted scale (for example, c52 = 12 inches; c40 = 23½ inches). When utilising a contracted scale in design work, the piano maker can choose a variety of octave ratios, usually ranging between 1:1.80 and 1:1.98. The following list demonstrates the influence of different octave ratios when they are used with note a85, 60mm in length, to determine the length of note a73:

Ratio of 1:1.80:	a73 is 108mm long
" " 1:1.85	" " 111mm "
" " 1:1.875	" " 112mm "
" " 1:1.90	" " 114mm "
" " 1:1.95	" " 117mm "
" " 1:2	" " 120mm "

It may be seen from the above list that the particular choice of octave ratio is the designer's way of controlling the way in which the strings increase in length throughout the compass of any piano. A scale design which uses a ratio of 1:1.80 would obviously result in considerably shorter strings in the middle and tenor sections of the instrument than if a 1:2 ratio were employed. In turn, the string measurements themselves go a long way towards determining the character of tone of any piano. The crucial importance of the choice of octave ratio may thus be fully appreciated.

In addition to determining the overall plan of the strings' layout, the ratios have considerable influence on the final position of the long mainbridge on the soundboard, on which the strings sit and press downwards. A mainbridge which clings to the peripheral bentside region of a soundboard, often found as a result of employing the traditional 1:2 octave ratio, is in theory more likely to result in a harder, less yielding and compliant tone from the instrument than if a contracted scale were to be used. A scale based mainly on the 1:2 ratio (as found in most English harpsichords and early English grands) gives long strings in the tenor section, which on more modern instruments may cause

practical problems when the transition to wound strings is made: there has to be an abrupt change in mainbridge plan at the point of transition, causing a distinct change in tone quality. In contrast, a contracted scale helps to make a smoother link between the longest 'plain' wires of the tenor section and the highest wound strings in the bass. Most importantly, a contracted scale automatically 'pulls' the mainbridge forward into an acoustically better part of the soundboard; and employing a contracted scale means that it is possible to make shorter instruments which are nevertheless musically satisfactory.

There is in fact a 'text book norm' as far as contracted piano scales are concerned. This is the ratio of 1:1.875, which was advocated by Hansing in 1888 and which was agreed upon as being the optimum ratio at the proceedings of the Piano Technicians' Conferences in Chicago and New York, 1916-1919. (17) However, it may be seen from an initial examination of Figure 6/5 that in fact none of the five grand pianos analysed use this ratio exclusively, nor even use one ratio to the exclusion of others. Further examination of Figure 6/5 shows that it is possible to divide the pianos into three main categories: first of all there are the two Broadwood models, which employ primarily the traditional 1:2 ratio throughout their trebles down to c40 and then introduce carefully-planned contraction from here downwards. The next category comprises the Blüthner and Steinway instruments, which have contracted scales of one kind or another averaging around 1:1.875 in their trebles, but then switch to a 1:2 ratio in their middle and tenor sections; and thirdly there is the Erard, which, for want of a better description, has what might be usefully described as a 'wavering contraction' in that the ratios change throughout the instrument's compass in a haphazard fashion. The reason for this particular pattern on the Erard has much to do with the fact that the 'scale' is interrupted along the line of the mainbridge by four intrusive iron bars, which, crossing the mainbridge in four places, disturb the uniform change in string lengths much more than those (fewer) bars found in the two Broadwoods and in the Blüthner model.

(For the purposes of this octave ratio analysis, the top ten notes of

Fig 6/5: The Octave Ratios of Five Grand Pianos, notes a73 down to a25
 (See Fig.6/2 for string speaking lengths of the same pianos)

Note	Broadwood 1859	Broadwood 1875	Erard 1865	Blüthner 1871	Steinway Modern
a73	1:1.83	1:2	1:1.82	1:1.89	1:2
g#72	1.83	1.98	1.81	1.88	2
g71	1.85	2	1.82	1.87	1.98
f#70	1.84	2	1.83	1.87	2
f69	1.87	2	1.84	1.84	1.97
e68	1.85	1.98	1.82	1.83	1.90
d#67	1.84	1.98	1.83	1.81	1.92
d66	1.85	2	1.82	1.84	1.89
c#65	1.85	2	1.82	1.84	1.90
c64	1:1.85	1:2	1:1.83	1:1.84	1:1.89
b63	1:2	2	1.86	1.86	1.88
a#62	2	2	1.86	1.86	1.86
a61	2	2	1.85	1.86	1.86
g#60	2	2	1.88	1.88	1.86
g59	2	1.98	1.88	1.88	1.88
f#58	2	2	1.89	1.90	1.87
f57	2	2	1.92	1.91	1.85
e56	2	2	1.94	1.93	1.85
d#55	2	2	1.93	1.95	1.85
d54	2	2	2	1.93	1.84
c#53	2	2	2	1.95	1.65
c52	1:2	1:2	1:2	1:1.97	1:1.66
b51	2	2	2	1.96	1.67
a#50	2	2	2	1.97	1.69

Note	Broadwood/59	Broadwood/75	Erard	Blüthner	Steinway
a49	1:2	1:2	1:2	1:1.98	1:1.68
g#48	2	2	1.98	1.97	1.69
g47	2	2	1.97	1.98	1.72
f#46	2	2	1.97	2	1.74
f45	2	2	1.96	1.98	1.77
e44	2	2	1.94	2	1.77
d#43	2	2	1.96	2	1.80
d42	2	2	1.90	2	1.81
c#41	2	2	1.89	2	2
c40	1:1.98	1:2	1:1.88	1:2	1:2
b39	1.93	1.93	1.88	2	2
a#38	1.93	1.93	1.88	2	2
a37	1.93	1.93	1.88	2	2
g#36	1.93	1.93	1.89	2	2
g35	1.93	1.93	1.88	2	2
f#34	1.93	1.93	1.91	2	2
f33	1.87	1.87	1.92	1.97	2
e32	1.87	1.87	1.94	1.93	2
d#31	1.87	1.87	1.98	1.87	2
d30	1.87	1.87	2	1.81	2
c#29	1.87	1.87	2	1.74	2
c28	1:1.87	1:1.87	1:2	1:1.68	2
b27	1.85	1.85	2	1.60	2
a#26	1.85	1.85	1.98	-	2
a25	1.85	1.85	1.96	-	2

the 1859 Broadwood should be ignored. As was previously noted, this instrument has the quirky elongated scale which defies conventional scale design logic.)

One important advantage of employing the very traditional 1:2 ratio is that it is possible to maintain an even string tension with fewer changes of wire gauge. In a contracted scale, it is usually necessary to increase the thickness of wire gauge every four to six notes in order to maintain the desired uniform string tension. Bearing in mind that it is sometimes possible for a sharp and attuned ear to hear an audible 'bump' in tone colour and volume at the point of change over of gauge, it is interesting to contrast the stringing schedule (from the top treble downwards) of the 1865 Erard with that of the 1875 Broadwood:

1865 Erard: 4 notes of gauge $12\frac{1}{2}$; 4 of 13; 4 of $13\frac{1}{2}$; 4 of 14; 4 of $14\frac{1}{2}$; 4 of 15; 4 of $15\frac{1}{2}$; 4 of 16; 4 of $16\frac{1}{2}$; 4 of 17; 4 of $17\frac{1}{2}$; 4 of 18; 10 of $18\frac{1}{2}$; 2 of 19; 2 of $19\frac{1}{2}$; and 4 of 20.

1875 Broadwood: 4 notes of gauge 15; 6 of 16; 12 of $16\frac{1}{2}$; 5 of 17; 19 of $17\frac{1}{2}$; 6 of $18\frac{1}{2}$; 6 of $19\frac{1}{2}$; 4 of $20\frac{1}{2}$; 4 of 21; and 2 of $21\frac{1}{2}$.

A comparison may also be made with a later Broadwood concert grand of the same scale design (1885, serial number 22021 - see chapter 7) which according to AJ Hipkins (18) employed the following wire gauges:

1885 Broadwood: 10 notes of gauge $16\frac{1}{2}$; 14 of 17; 22 of $17\frac{1}{2}$; 6 of $18\frac{1}{2}$; 6 of $19\frac{1}{2}$; 4 of $20\frac{1}{2}$; 4 of 21; and 2 of $21\frac{1}{2}$.

It may be observed that by the employment of the 1:2 ratio for its top three octaves, the Broadwood's thicker strung scale is able to use longer runs of the same gauge of wire, whereas the Erard's gauges change much more frequently on a regular four-note basis. The musical result of fewer gauge changes (assuming a reasonably uniform tension throughout the compass) is a smoothness of tone from register to register, with a smaller number of audible 'bumps'. One of the secrets of Broadwood's smooth, homogeneous and uniform tone colour at this period must surely

lie in the employment of the 1:2 ratio. The much more erratic octave ratios found in the Erard, combined with the numerous gauge changes, produces an instrument which by comparison with the Broadwood has a decidedly patchy and multi-faceted tone.

It is worthwhile noting that both the Blüthner's and the Steinway's scale design is contrived to produce the 1:2 octave ratio in the 'scale' area of the piano, the sensitive part of the keyboard compass around note c40 where the tuner lays the foundations, the bearings, and tempers the intervals as necessary to gain equal temperament before proceeding to tune the octaves outwards from the middle of the piano. Below f33, the Blüthner's ratios contract very rapidly in comparison with the other four pianos, the reason being that this instrument is a medium-sized grand of a six and a half foot length, and the rapid contraction in the tenor is very much a necessary compromise as a result of case dimension.

Of the five differing ratio schemes shown in Figure 6/5, that of the Steinway is, curiously enough, the least satisfying from a theoretical point of view, in spite of the fact that the Steinway model 'D' concert piano is regarded by many professional pianists as the most 'satisfying' of modern concert instruments to play on. There is a very noticeable hiatus in the octave ratio scheme between notes d54 and c#53, where the ratio suddenly changes from 1:1.84 to 1:1.65 because of the abrupt foreshortening of the strings (note c#53 is actually shorter in string length than note d54 immediately above it!). Many tuners and technicians who have worked on Steinway concert grands will confirm that this area is tonally very much a 'weak spot', in particular the highest notes of the short-scaled section, c#53, c52, b51 and a#50, which are noticeably weaker (and more 'false' in tone) than those immediately-adjacent notes further up the keyboard compass. Steinway designers must be fully aware of this curious hiatus in their octave ratio scheme. This small digression is made here simply to indicate that any piano scale design might be far from theoretically perfect, and yet be quite acceptable for the highest standard of professional use. We have to be careful, therefore, before criticising scale designs which do not fit nicely into the 'preconceived norm' of Hansing's pedantic 1:1.875 octave ratio.

Grand pianos from the mid nineteenth century onwards which have a scale design based on a contracted ratio appear to have had their string lengths calculated mathematically. In other words, the overall outline of the scale was decided upon, and the lengths and contractions of the speaking lengths for every 'a' or 'c' throughout an instrument's compass laid down as a kind of initial 'framework' around which to develop the scale details. Then the eleven intermediate chromatic string lengths within each octave were worked out precisely, by the use of mathematical tables, and by utilising the principle of a twelfth-root multiple. As a result of the mathematical calculation of the gradual increments in piano string lengths from octave to octave, a neat 'logarithmic' pattern of string length differences emerges.

There appears to be an unwritten general belief from within the piano-making industry that mid nineteenth century Germany was the source of the mathematically-calculated scale; and Hansing's treatise at least confirms that it had become commonplace to utilise mathematics in piano design in Germany by the year 1888. The evidence from Fig. 6/5 however, showing that what is essentially a contracted scale is also to be found in the 1865 Erard, suggests that it was equally as usual to employ scale design mathematics in Paris as in Germany. If we are to detect one major difference between the English and Continental schools of scale design, it is the fact that the London-built pianos of Broadwood and others had most of their speaking lengths worked out geometrically, whereas the Continental pianos, at least by the third quarter of the nineteenth century, appear to have had their speaking lengths calculated mathematically.

The evidence for this intriguing fact is to be found partly in Fig. 6/5, in which only the two Broadwood grands extensively use a 1:2 octave ratio - which was traditionally worked out geometrically; but we have much stronger evidence in the form of a geometric drawing which appeared in the highly-detailed technical and historical book which Broadwood produced for the International Inventions Exhibition of 1862 (see chapter 5). The drawing is entitled 'Diagram shewing a practical method of finding the lengths of Strings for every note in the Octave', and shows a base line, a right-angled triangle, and a series of dotted-

D I A G R A M.

showing a practical method of finding the lengths of Strings, for every note of the Octave, on equal temperament; so that with wire of the same size, the tension on each note shall be the same.

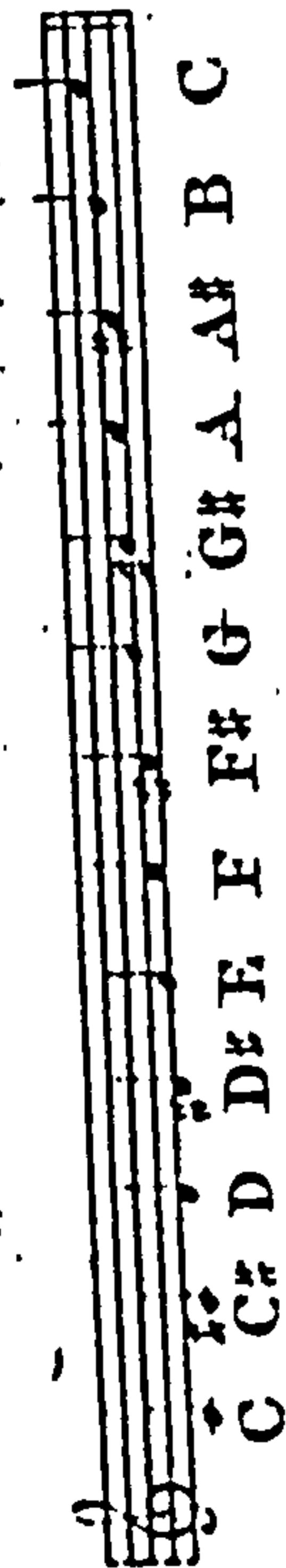

Nº 17 WIRE

Length $24\frac{1}{2}$ gives C
Tension $144\frac{1}{2}$

Phalharmonic Pitch C
546 double vibrations p^r Second



$12\frac{1}{2}$ gives the Octave
Tension $36\frac{1}{2}$

- 1 ... Draw a Base line M.V. of indefinite length.
- 2 ... From M project a line M.P. making an angle of 45° with M.V. and set off upon it the length of string for the Key note of the Octave. In this case the length is $24\frac{1}{2}$ inches, representing middle C.
- 3 ... Bisect this line in Q and draw from Q perpendicular Q.R. upon M.V. and divide it into 12 equal parts.
- 4 ... Take the sum of the three sides of the triangle M.Q.R. and set it off from M along M.V. which will give a point O.
- 5 ... From O as a centre draw radiating lines through the various divisions in Q.R. to the line M.P. and the points where these lines cut the latter will give the particular lengths of string measured from P. of the various notes of the Octave as marked.

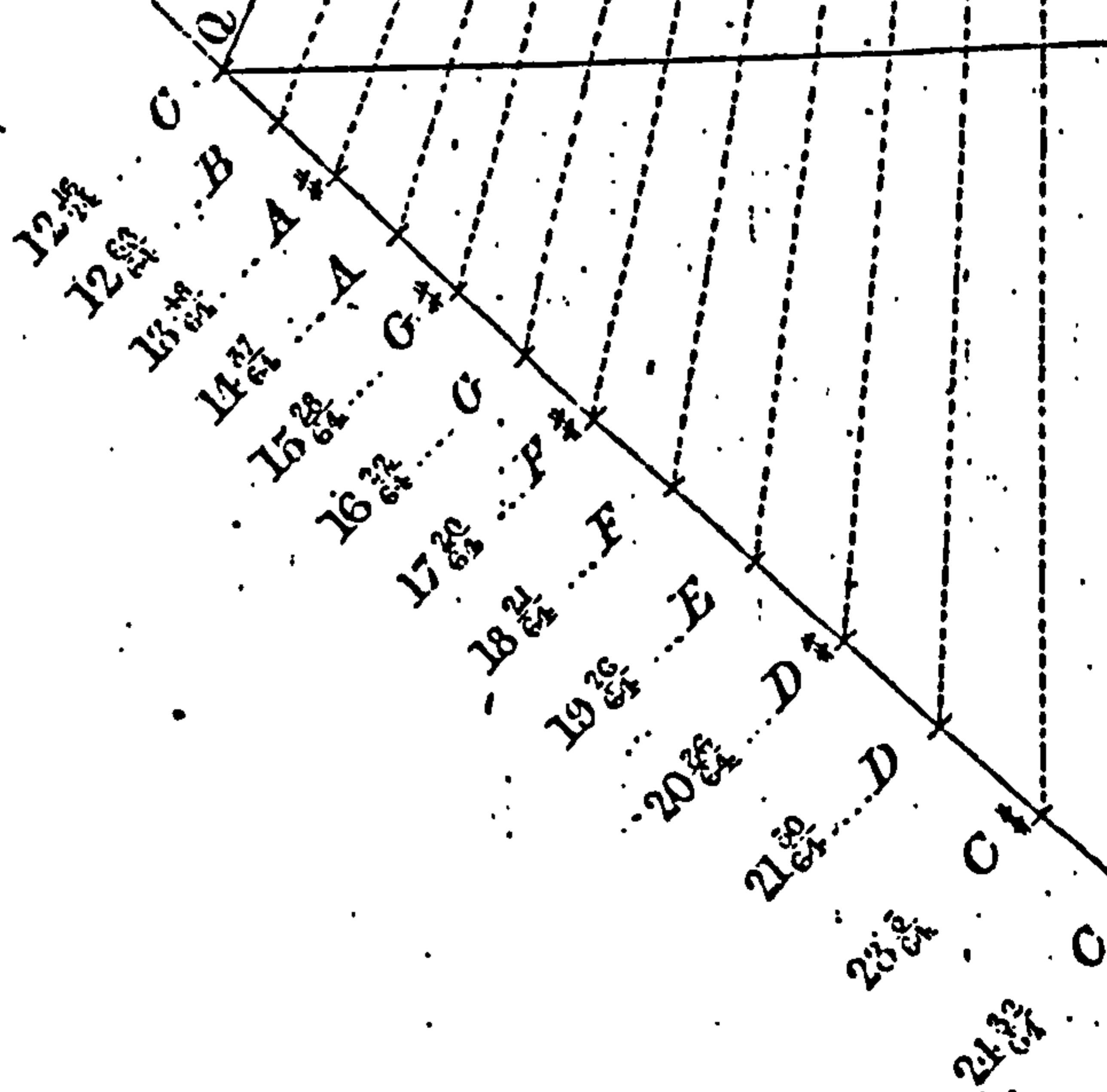

Figure 6/6: Broadwood's scale design geometry, 1862

line intersections which cut through one of the sides of the triangle. The required lengths of the strings, presumably for any octave in the piano, may be 'measured off' from this, or another, full-size geometric drawing. In this sense, the geometric drawing becomes a tool of piano design. It is reproduced (photocopied from the original 1862 publication) as Figure 6/6. Unfortunately we have no idea how far back in Broadwood's design history this particular geometric method dates; but as it can be successfully used to calculate the string lengths for harpsichords (which use the 1:2 octave ratio), there is every reason to believe that the unique geometric drawing, as a design tool, may already have been 'ancient' in 1862, and that the same chart had been used to calculate string lengths, not only for London-built harpsichords of the eighteenth century, but possibly also for Flemish and Italian instruments of the sixteenth century and even earlier.

Hammer Strike Proportion

On a modern grand piano, the customary strike point of the hammer throughout the bass and middle registers is around one eighth of each string's length. This strike proportion had become established as the norm, by repeated trials and experiments, by the third quarter of the nineteenth century. However, it had also been discovered by repeated experiment that a gradual, note by note, alteration to the strike from c52 upwards (in musical terminology, c2 upwards) was desirable in order to achieve sufficient clarity and brilliance in the treble register; (19) and so it is usual to discover an alteration of the strike to one ninth by c52, followed by a gradual change to at least one eleventh by c64, and a further adjustment to at least one thirteenth by c76. In the very high treble, where the precise point of the hammer strike becomes very critical, it was often found desirable to gain a strike of up to one twentieth of each string's length in order to achieve the desired tonal brilliance and clarity.

It is interesting to take the strike measurements of the 1871 Blüthner grand under examination and compare them with the strike

measurements obtained from the 1875 Broadwood. There are a number of notable differences, and they can be seen in detail in Figure 6/7. In its high treble, the Broadwood strike proportion begins at just over one fifteenth of the string's length for the highest note, a85, and then over the span of the next one and a half octaves downwards this strike proportion gradually changes, note by note, so that by e68 a proportion of one eleventh has been reached. In contrast, the Blüthner's high treble strike is no more than one ninth of the speaking length for the highest treble notes, and very soon a strike proportion of one eighth is established by the time that e80, six notes from the top, is reached.

In its central region around middle c40, the Broadwood strike proportion is close to the 'theoretical norm': most of the strings serving notes between c28 and c#41 are struck at approximately one eighth of their length. In the Blüthner, for the same region of the piano, this proportion does not even reach one eighth: the average strike in the section c28 to c#41 is 7.5 (in other words, mid-way between one seventh and one eighth of the strings' lengths) In the two octaves immediately above the middle area (f45 to e68) the Broadwood's proportion ranges between 8.4 and one eleventh, whereas the Blüthner's proportion remains consistently closer to the eighth throughout. The bass section of the Broadwood begins with a proportion of 9.5 for the lowest note, a1, but most of the bass section (the first seventeen or so notes) has a proportion of around one ninth. In the Blüthner, the strike for the bass section is generally much closer to one seventh of the speaking lengths.

These significant differences between the Blüthner and the Broadwood are important factors contributing to the tonal differences of the two grands. The strike differences help to explain why these two makes have such decidedly differing tonal qualities. The typical Blüthner hammer strike, further along the strings and between one seventh and one eighth of each speaking length, must surely contribute towards Blüthner's more rounded, gentler, mellow tone quality. In contrast, the Broadwood's treble and bass strike proportions are significantly nearer the ends of the speaking lengths, and so the piano's tone by comparison tends to be

Fig 6/7:

COMPARISON OF STRIKE PROPORTIONS FOUND ON TWO GRAND PIANOS, BLÜTHNER 1871 AND BROADWOOD 1875.

Explanation/examples: The figures '7' or '8' refer to a hammer strike of one seventh or one eighth of a string's length. '7.5' is therefore a strike proportion midway between one seventh and one eighth. '6.95' is almost one seventh of a string's length; and 8.1 is just over one eighth of a string's length.

Measurements taken by the writer, 1996/97.

	Blüthner 1871	Broadwood 1875
a85	8.98 (ninth)	15.33
g#	8.67	16.33
g	8.52	14.71
f#	8.37	13.62
f	8.19	12.77
e	8.10	13.55
d#	7.96 (eighth)	13.00
d	7.88	12.36
c#	7.92	12.00 (twelfth)
c76	7.69	11.77
b	8.08	11.64
a#	7.93	11.53
a	7.80	11.43
g#	7.63	11.41
g	7.59	11.44
f#	7.94	11.42
f	7.89	11.50
e	7.79	11.00 (eleventh)
d#	7.80	10.71
d	7.55	10.46
c#	7.95	10.28
c64	7.67	10.20
b	7.80	10.19
a#	7.92	9.86
a	7.78	9.84
g#	7.67	9.67
g	7.81	9.29
f#	7.76	9.19
f	7.74	9.20
e	7.73	9.00 (ninth)
d#	7.79	8.86
d	7.83	8.79
c#	7.95	8.74
c52	7.70	8.74
b	7.66	8.68
a#	7.66	8.73
a	7.70	8.69
g#	7.70	8.58

g	7.87	8.52
f#	7.48	8.41
f	7.58	8.42
e	7.63	8.43
d#	7.62	8.37
d	7.65	8.44
c#	7.60	8.11
c40 (middle)	7.57	7.98 (eighth)
b	7.58	7.84
a#	7.64	7.96
a	7.56	7.99
g#	7.52	8.01
g	7.48	7.97
f#	7.48	8.04
f	7.48	8.06
e	7.40	7.67
d#	7.48	8.05
d	7.48	8.08
c#	7.51	8.08
c28	7.55	8.14
b	7.63	8.16
a#	7.81	8.42
a	7.71	8.68
g#	7.67	8.73
g	7.64	8.82
f#	7.60	8.88
f	7.58	9.03 (ninth)
e	7.54	9.04
d#	7.51	9.17
d	7.52	9.12
c#	7.48	8.98
c16	7.45	8.97
b	7.38	8.97
a#	7.36	8.96
a	7.30	8.96
g#	7.28	8.95
g	7.24	8.90
f#	7.16	8.87
f	7.17	8.82
e	7.06 (seventh)	9.67
d#	7.08	9.59
d	7.03	9.56
c#	6.97	9.48
c4	6.95	9.52
b	6.90	9.49
a#	6.85	9.53
a1 (lowest)	6.84.	9.49.

brighter, more penetrating and strident, but less flexible and 'thinner' in quality. One of the problems of the Blüthner - the weak, hollow treble we noted earlier in this chapter - must surely be to some extent the result of the particular strike proportion chosen by Julius Blüthner. It is very surprising that this Leipzig builder appeared to be unaware of the improvements in treble clarity and brilliance which he might have achieved had he moved the hammer strike point on his grands further towards the ends of the speaking string lengths in the treble.

Wire Strength, String Tension, and Conclusion

From the evidence so far gathered in this chapter, we now realise that from a design point of view the English grands of Broadwood were somewhat different from their Continental counterparts during the 1860s and 1870s, principally in the way in which the Broadwood company employed 'short' scales and also in the way that the scales themselves were designed by the use of geometry rather than pure mathematics. Of course there were other important physical differences between grand pianos of Broadwood and similar models by Erard and Blüthner, notably the details of soundboard and case rim design.

We noted that the mid nineteenth century Broadwood had a very uniform, smooth and homogeneous tone, and that there was a good 'fusion' between the piano's treble and its other registers, helped by Broadwood's use of a 1:2 octave ratio which enabled longer runs of the same gauge of piano wire to be employed in the scale design; but we also noted that the short scale resulted in significant drawbacks for the treble, as far as sustaining power, accurate tuning, and ultimately, tone quality, were concerned. The longer treble speaking lengths of the Erard and Blüthner instruments (and also, at a slightly later date, the longer lengths found in the Steinway grand) helped to create a more sustained, singing, treble quality in these makes which became more and more appreciated by pianists and audiences alike as the 1870s and 80s progressed. However, the longer treble strings did create problems of volume and balance in the case of the Blüthner; and we noted how the 1871 Blüthner's bass,

although overstrung, was inferior tonally to that of the straight strung 1875 Broadwood. A comparison of the hammer strike proportions found in the same two pianos revealed that the Broadwood's strings were generally struck nearer the ends of the various speaking lengths of wire, giving a brighter, harder tone, whereas the Blüthner hammers struck further along the wire length, giving a softer, warmer and more rounded tone quality.

The final part of this analysis of Broadwood scale design in the period 1850-1895 deals with the significance of the metallurgy employed in making the steel piano strings and the strength of the various gauges of piano wire.

When Henry Broadwood designed his new range of so-called 'iron grands' in the mid century, he needed to know the strength of his thinnest, and therefore weakest, piano wire; and to this end a string tensioning machine was employed at the Horseferry Road factory to determine the breaking point of the thinnest gauge of wire. (20) It was almost certainly this same machine which was displayed at the International Inventions Exhibition of 1862, where it was described in the published guide as being a 'Monochord, with spring dial and scale, for exhibiting the tension of the string.' Having established the maximum amount of strain that the weakest available piano wire could withstand (in other words, the point at which the particular gauge of thin wire broke), Henry Broadwood's scale calculations then proceeded to establish suitable string lengths which would enable tensions of up to around 80% of the breaking point to be employed. If higher tensions (and therefore longer speaking lengths) were to be used, there was always the risk of the thinner strings breaking, either during a tuner's pitch raise or during heavy playing. Henry Broadwood was particularly proud of the durability, reliability and freedom from string breakage associated with his grand pianos. In his edited notes of his father JS Broadwood's Anecdotes, published in 1862 (21), Henry refers to grand piano number 18192, built in 1852:

'This instrument', he writes, 'the favourite of Hallé, Pauer, Arabella Goddard etc has, from January 1853, to January 1862, been out

to upwards of 400 concerts, is still as fresh as ever, and during the period has lost but one string.'

As Broadwood grand pianos were being mass produced for what was virtually a world market, it was a vital prerequisite that all the pianos should have the utmost reliability, and so it was certainly not in the company's best interests to take risks in employing a higher tension scale and its potential problem of wire breakage. However, we may note that the Broadwood company under the control of Henry Broadwood appeared to put reliability, durability and good engineering before tonal excellence. Quite often, the potential for excellent tone was sacrificed in order to gain maximum durability and reliability; and so we find, for instance, soundboards which are too thick and heavy, actions which are durable but clumsy to play, and strings which for safety's sake are not drawn up in tension to their full tonal potential.

Broadwood was dependent for supplies of piano wire on a once-famous Birmingham firm of wire drawers called Webster and Horsfall, which had introduced in the years 1834 and 1854 great improvements in the strength of its piano wire, which by 1854 was manufactured from a tempered cast steel of excellent quality. (22) The scale lengths of Henry Broadwood's designs were initially determined by the strength of the available wire, and there is no doubt that the range of seven-octave 'iron grands' introduced by the company from the 1850s employed the strongest wire obtainable at that date in the best possible way.

However, during the 1860s and 70s, enormous advances in the manufacture of steel piano wire were made by the Nuremberg firm of Moritz Poehlmann. At the World's Exhibition in Paris, 1867, Poehlmann's gauge 14 piano wire (one of the thinnest gauges usually employed, with a diameter of only 0.825mm) was subjected to a testing machine and broke when a tension of 264 lbs was reached. The wire of Webster and Horsfall, to the dismay of the English observers present (23) was found to break at a tension of 214 lbs, and so the Birmingham wire was seen to have almost 20% less strength than the Nuremberg equivalent. Nine years later, the

Jury at the 1876 World's Exhibition at Philadelphia, USA, found that the breaking point of Poehlmann's gauge 14 piano wire had risen to 287 lbs, 25% stronger than the English wire. By the year 1893, Moritz Poehlmann's gauge 14 was breaking at no less than 335 lbs. There had been a rise of 40% in the strength of piano wire since the 1850s. (24)

The great significance of Poehlmann's work was quickly grasped by the Continental piano manufacturers, particularly those newly-established firms in Germany, who saw Poehlmann's important improvements as being the key to the development of a much more powerful and singing quality of piano tone. It is no exaggeration to claim that the evolution of modern piano tone could not have been possible without the enormous benefits which Poehlmann brought to the industry. Longer string lengths, strung at a higher tension, were the immediate result of Poehlmann's improvements; and this is the explanation for the use of those longer scales we find in the Blüthner and Steinway grands.

However, back in London, Broadwood appeared uninterested in the new improvements to piano wire. One significant event had occurred in 1864 which was to have an impact on the fortunes of the company: in January of that year, Henry Broadwood's uncle, the Reverend John Broadwood, had died, leaving his fine country house and estate at Capel in Surrey to his nephew Henry. From this point, and for the remainder of his life, Henry Broadwood more or less withdrew from active involvement in piano making and became a 'retired' country gentleman. He withdrew from daily personal contact with the firm from April 1864, (25) and from this precise moment we can date the beginnings of outdatedness of the firm's designs, a general stagnation when it came to introducing new ideas, and a profound unwillingness to change anything in any significant way. The Broadwood grand ceased to evolve from April 1864: instead, its design became 'fossilised.' Clearly, Henry Broadwood believed that, under his guidance and inspiration, the grand piano had been brought to the highest level of perfection; and certainly it would be true to say this of his grands designed in the 1850s. It would also be true to say that his instruments were still among the best obtainable at the time of the International Inventions Exhibition of 1862. However, as the 1860s and

70s progressed, Henry inevitably grew increasingly out of touch with the latest Continental developments. Playing his own 1847 grand piano at home in the seclusion and relative isolation of rural Surrey, Henry may well have been ignorant of the improvements brought about by Moritz Poehlmann; and it is even quite possible that he never heard any of the new Blüthner or Bechstein grands which had begun to be available in the English music shops from the mid 1870s. If Henry had heard them, then it is surprising that he did not take up the challenge and modernise his own company's designs; but this was not to be. The strongest resistance to any change certainly came from the direction of Mr Henry Broadwood; and as he was the principal shareholder, and virtually the owner of the company, others partners within the firm, who observed with despair the way in which Broadwood was falling behind, were powerless to change things.

A further problem developed in the 1870s and 80s, which did nothing to further the progress of the Broadwood designs: when the new, much stronger German steel wire was used to string the short-scaled Broadwood grands still in production, it was found that the wire, when brought up to tension, was too far below the higher breaking points associated with the new, improved wire. To illustrate this problem, we may note that Broadwood's 1875 grand has its treble strings brought up no higher than 44% of the breaking strain when Poehlmann's steel wire is used; in contrast, the Erard's strings reach 65% of the breaking strain, and the Blüthner's, 80% with Poehlmann's wire. Here we can see that the longer Continental scales could use the new wire with better results musically: a piano string tensioned up to 80% of its breaking point will always sound much better - more sustained and singing - than a string which remains less than 50% of breaking strain and which sounds relatively dull, coarse-toned and even false as a result.

Henry Broadwood died on the 8th of July 1893 at the age of eighty two; and within a matter of weeks from his death, the technical staff at Horseferry Road works had plunged into the radical rescaling and redesigning of all their pianos, led by the talented scale designer George Daniel Rose, son of the factory manager. It took about five years

to redesign all the company's grands; in fact the old short-scale models of Henry's continued to be available until almost the end of the century. The features of the new range of grands included overstringing, one-piece bronzed cast-iron frames, and the long-overdue longer string lengths. This very active period in Broadwood's design history also saw the introduction of the highly-successful 'barless' grands, to be examined in detail in chapter 7. These new designs 'saved' the company. John Broadwood and Sons regained their confidence in their ability to compete successfully on the concert platform with the best of the grand pianos from the Continent. The company's reputation as the manufacturer of the highest quality musical instruments had been restored, and, as we shall see in chapter 8, the new designs of George Rose were to carry the company forward successfully for at least the next two decades.

Chapter 7: THE BROADWOOD 'BARLESS' GRAND PIANO, 1888-1914.

The Historical Background to the Barless Idea

On the 26th January 1888, Henry JT Broadwood, second son of Henry Fowler Broadwood, applied for letters patent to protect his idea for 'Improvements in Metal Frames for Pianofortes.' (1) Although the Patent specification showed a very novel departure from Broadwood's, or any other maker's, usual design of metal strain-resisting structure, the most significant fact about the details of the Patent is that they represented the culmination of the Broadwood company's long-term ideals as far as metal frame design was concerned.

The 'Improvement' introduced with the Patent soon became known as the 'barless frame'. Very few of these barless pianos were made during the late 1880s. In fact, possibly only one or two prototypes were built. It was to be a further nine years before the Horseferry Road factory went into regular production with grands utilising the patented frames; but by the early years of the present century, the barless conception of Henry JT Broadwood had been adopted wholeheartedly by the company: it was to be seen in every size and type of new Broadwood grand, and the idea was even extended to one of the upright models. The barless frame was a feature which no other piano manufacturer appeared able or willing to emulate (once the Patent had expired); and it soon became well-known as the unique 'hallmark' of a range of fine grand pianos manufactured by John Broadwood and Sons throughout the first quarter of the twentieth century.

In order to understand why the barless frame was introduced in 1888, we need to examine in outline the changes which had occurred to the metal strain resisting structures found in Broadwood grands during the sixty-five-year period before the date of the Patent. As we have already seen in the Chapter 2, entitled 'The Early Broadwood Grand', the system of iron 'hoops', in use from the beginnings of grand manufacture, and which spanned the hammer gap, was generally insufficient to support the

stringing load. The inadequacy of this particular metal supporting system led to distortion - slow plastic deformation under load - of the grand's wooden case, mainly in the treble cheek of the instrument, which as a result of the stringing load could twist upwards by as much as five centimetres 'out of true.' This distortion became a more serious problem after the compass of the instruments were extended from five, to five and a half octaves, during the 1790s. The seven additional tricord notes in the treble (f# up to c) added a further burden of twenty one strings to the already inadequate hoops.

In the early 1820s, Broadwood took steps to reduce this cheek twisting by adding two long wrought-iron bars (in addition to four hoops to be found in the middle and tenor registers) above the stringing in the top treble section of each of their grands. This new feature certainly went a long way towards preventing the wooden supporting structure and casework from distorting; but there was another serious problem associated with the early grand, a problem which was also mentioned in chapter 2: this was the tendency on the part of the wooden hitch rails, glued and screwed to the edge of the casework, and to which the ends of the strings were attached, to be torn away from their foundations as a result of the pull of the strings. This further problem usually resulted in structural damage to the soundboard and of course serious tuning instability as well. The successful remedy came with James Shudi Broadwood's patent of 1827 (2), which, as well as introducing the wide cast-iron hitch plate (which superseded the wooden hitch rails) also featured four new strong wrought-iron bars to replace the traditional hoop system.

The desirability or otherwise of metal framing had always been a matter of debate among piano makers. Some individuals, such as the most illustrious of the Viennese makers, Conrad Graf (1782-1851), refused to allow iron bracings anywhere near their strings and soundboards, although Graf did consent to a single solitary short iron support bar inside the hammer gap between his soundboard and wrestplank, a concession essential if the wooden structure of his instrument was not to deform at this, its weakest point. In contrast, the manufacturing partnership of

William and Matthew Stodart of London was quite content to allow a multitude of tubular bracings to pass over the strings of *its* grands when *it* adopted Thom and Allen's patented 'compensation frame' in 1820. (3)

The need for heavier, stronger and more cumbersome iron bracing systems went hand in hand with, first of all, the desire for louder and more powerful pianos; secondly, with the need for greater tuning stability; thirdly, with the requirement for a wider keyboard compass; and fourthly, with the slow but steady rise in musical pitch during the first half of the nineteenth century - a pitch rise of one semitone over a period of fifty years. In order to create pianos with louder and more powerful musical qualities, it was necessary to use thicker wires, strung at a higher tension; and when it was realised that these thicker, stronger wires, strung at a higher tension, resulted in better tuning stability, there was a general move towards the introduction of iron bracing systems, in spite of the conservatism of some makers such as Graf.

We may gain some idea of the progressive increase in strain on the structure of grand pianos by examining a little of the information contained in Malcolm Rose's and David Law's publication: 'A Handbook of Historical Stringing Practice for Keyboard Instruments'. (4) A Broadwood grand of 1802, for instance, could be expected to have a strain of between 9 and 13 kilograms tension per string throughout the top three treble octaves; by 1822, a Clementi grand had a tension of between 17 kg and 21 kg per string for its top two octaves; fifteen years later, the tension per string found in the top treble octave of a Broadwood grand of 1837 had risen to 32 kilograms; and, according to Broadwood's guide book of the event, one of their grands on display at the International Inventions Exhibition of 1862 commenced with a tension of 48kg per string in the top treble, rising to 70kg per string in the middle register. It is clear to see from these few examples (the tensions of which have been calculated at modern pitch, A=440) that there had been a five-fold increase in treble string load over the sixty-year period 1802-62. Only the introduction of substantial metal bars, struts and

plates had enabled this significant increase in tension to occur.

The steady rise in musical pitch, which contributed to the need for iron bracings, can be confirmed by reference to those surviving Broadwood tuning forks which were examined and tested by Alexander Ellis for inclusion in the appendix to his edition of Helmholtz's 'On the Sensations of Tone' in 1885. (5) The information extracted from this source is shown in Figure 7/1, together with information about Alexander Laurence's Broadwood tuning fork of 1862.

James Shudi Broadwood's patent specification of 1827 shows a detailed drawing of an iron-framed grand with four supporting wrought iron bars placed mainly above the treble strings and attached to the metal hitch plate. The drawing, taken directly from the Patent in question, is shown as Figure 7/2. By the time of the 'Chopin' period grand piano of the mid to late 1840s, the number of supporting bars had been increased to five, although the keyboard compass had been increased by only two notes (high f# and g) during the period 1827-1848. The extra bars were deemed necessary to resist the growing string tension and a historic rise in pitch, rather than being necessary to support extra strings. A drawing of the bracing system of the Chopin grand is shown as Figure 7/3. (See also footnote (6)).

The main criticism expressed against these metal bars was their intrusive presence, which broke up the piano into a number of distinct 'sections', which in turn led to the spoiling of the evenness of tone throughout the registers, and which caused a small but noticeable deterioration in the tone quality of those notes immediately adjacent to each iron bar.

The new metal barring systems were unwelcome but highly necessary. There was a yearning in some circles for a return to the simple, uncluttered elegance of the layout of the earliest grands and last harpsichords, from the late eighteenth century. For example, we may note the very interesting observations from the German concert pianist Sigismond Thalberg, (1812-1871) when he came to write his piano report

Figure 7/1: Evidence of the Rise in Musical Pitch, 1800-1862, found in Broadwood Tuning Forks. Items 1-5 were measured by Alexander Ellis for the appendix to his 1885 edition of Helmholtz's 'On the Sensations of Tone.'

(NB: The transfer of pitches, for the purpose of this comparison, from their original 'c's to 'a's, has been calculated on the basis of equal temperament.)

Date: circa 1800 Pitch 'A': 422.7 cps

Ellis's comments: 'From an old fork c=505.7 belonging to Messrs Broadwood.'

2. Date: 1813 Pitch 'A': 423.3 cps

Ellis's comments: 'Second copy of Peppercorn's fork by which the pianofortes of the Philharmonic Society were originally tuned.' [John Peppercorn was Broadwood's concert tuner at this period.]

3. Date: circa 1820 Pitch 'A': 433 cps

Ellis's comments: 'Fork approved of by Sir George Smart, conductor of the Philharmonic Concerts, in possession of Mr Hipkins, from c=518. It is Broadwood's lowest pitch. Long sold in shops as 'London Philharmonic'.

4. Date: 1846 Pitch 'A': 436 cps

Ellis's comments: 'London Philharmonic from Mr Hipkins' vocal pitch c=518.5.'

5. Date: 1849-54 Pitch 'A': 445.9 cps

Ellis's comments: 'From Broadwood's original medium pitch of c=530.6 fork of the tuner Finlayson.' [Alexander Finlayson, born 1816, lived in a house in Bridle Lane, Soho, adjoining the Broadwood workshops, where he was employed. He died on the 4th September 1854, aged 38, a victim of the Soho cholera epidemic of that autumn. His daughter Jane, aged 7, died from cholera on the same day. The Broadwood workshops closed down for the duration of the epidemic. Alexander Finlayson was survived by

Fig 7/1 continued:

two brothers, John (1813-1886), Broadwood's company clerk, and William (1827-1907), Broadwood's piano tuner to Queen Victoria. Their sister Susannah Mary Finlayson (1812-1897) married Edward James Laurence, a piano maker at Broadwood's. The three Finlayson brothers were uncles to two brothers, Alexander Laurence (born 1839), and Alfred Marlborough Laurence (born 1844), both Broadwood tuners and quite possibly taught to tune by one or other of their uncles.

6. Date: 1862 Pitch 'A': 451.5 cps

Comments: Broadwood's high 'Philharmonic Pitch', from one of three (very slightly rusted) in a small leather case inscribed 'John Broadwood and Sons, London, 1862' formerly belonging to the tuner Alexander Laurence (1839-1913), now in the possession of his great-grandson Alastair Laurence. See chapter 5 of this dissertation for further details.

Mod. drawing is colored.

LOVHORN: Patent Office, Erie, Pa. and WILLIAM STEVENSON.

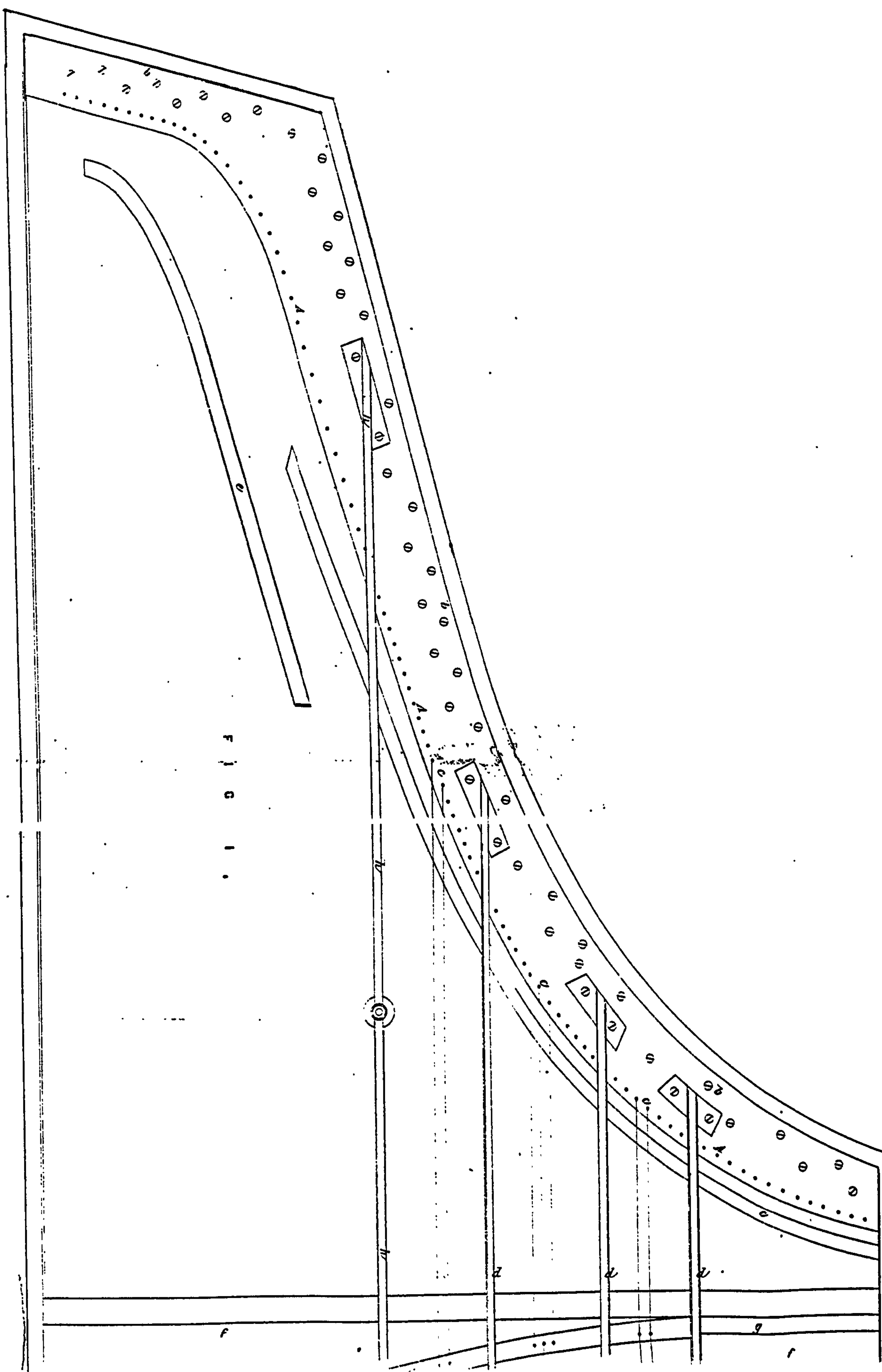
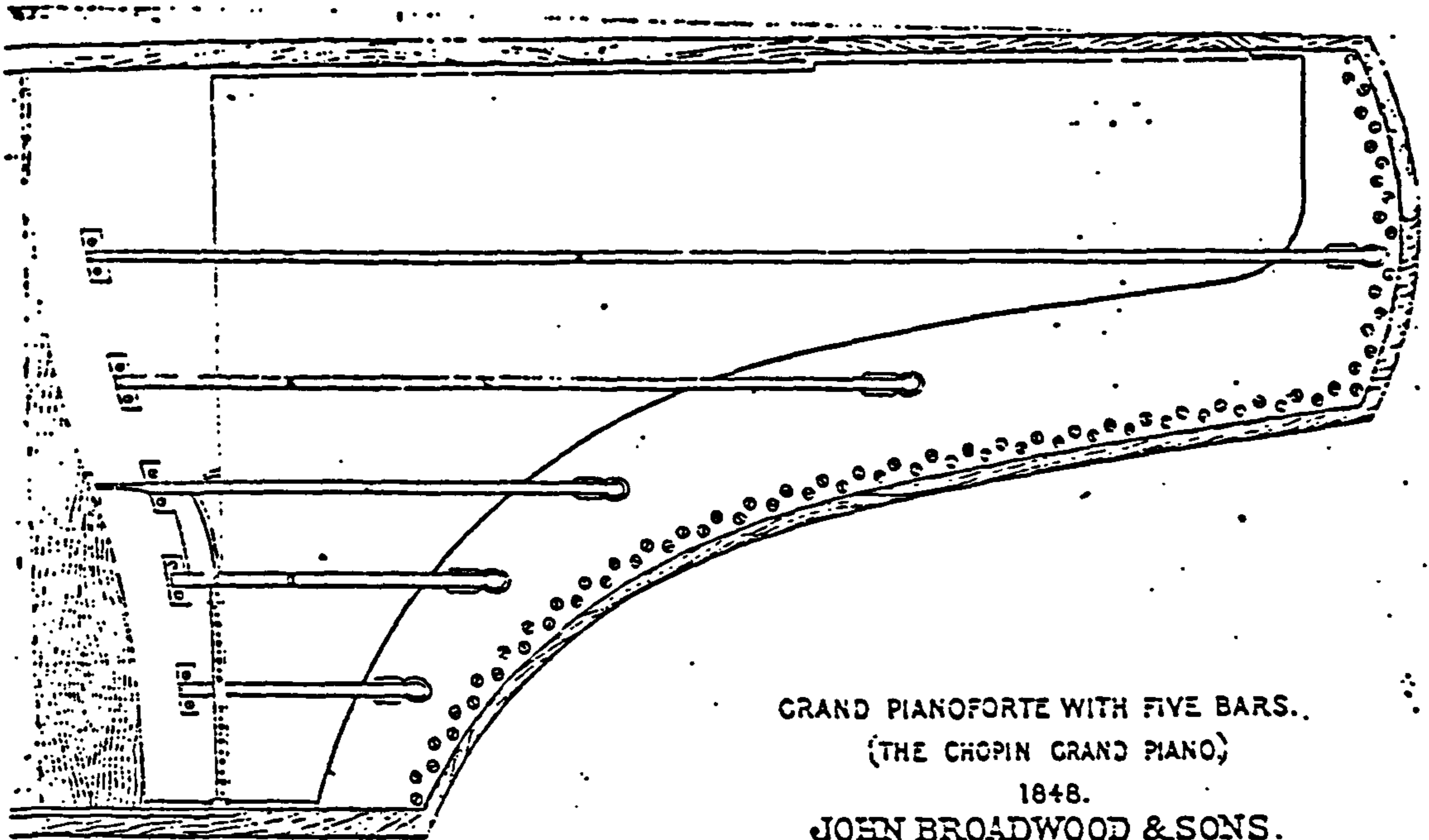
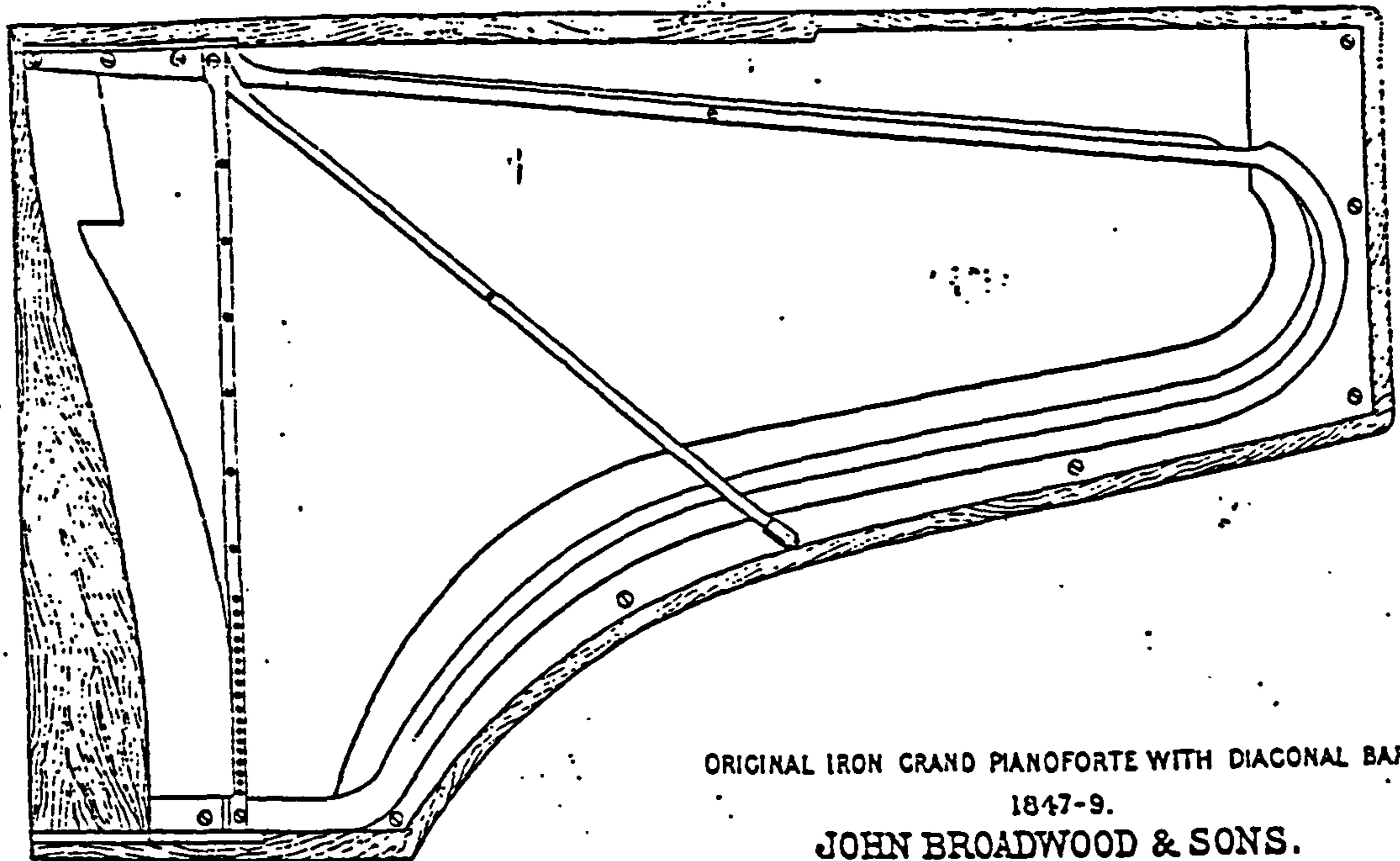

Figure 7/2: Bars and hitchplate of James S Broadwood's patented grand of 1827 (from the original Patent)



GRAND PIANOFORTE WITH FIVE BARS.
 (THE CHOPIN GRAND PIANO)
 1848.
 JOHN BROADWOOD & SONS.



ORIGINAL IRON GRAND PIANOFORTE WITH DIAGONAL BAR.
 1847-9.
 JOHN BROADWOOD & SONS.

Figure 7/3: The 'Chopin' Broadwood grand of 1848; and Henry Fowler Broadwood's 'Original Iron Grand' of 1847/49 (As drawn in 1885).

as a member of the Jury of the 1851 Great Exhibition, where four of Broadwood's iron-barred grands had been on display:

'In all the four [Broadwood] pianofortes, any bending of the wrest planks is obviated by the application of a metal suspension bar, placed over and nearly in line with the studs. The peculiar application of this suspension bar is considered an essential improvement. The tension bars are also new, and entirely peculiar to these instruments, being constructed with flanges on each side to prevent twisting. A section of these bars transversely would present the figure of a cross +.

'- - - Again, there can be no doubt but that simplification of bracing in the construction of pianofortes will eventually enable the public to obtain first-rate instruments at a comparatively moderate price. And it is proper to record that, up to this time, the aim of most makers has been to introduce as much iron or other metal as safety to the quality of tone would bear, and that Messrs Broadwood are now the first to retrace such steps, learning from experience that tensions bars are but make-shifts, and that it is probable that the best mode of constructing a pianoforte would be to strengthen the case by other means, superseding the tension bars altogether.' (7)

It is clear from this report that Thalberg, like Broadwood, regarded the intruding iron bars as something of a necessary evil. Thalberg also confirmed that Broadwood had, by the time of the Great Exhibition, taken important steps to reduce the number of intermediate supporting bars in *its* grands. This is something we shall shortly examine in more detail. However, on the particular matter of the 'evils' of bars, piano makers were labouring under something of a misapprehension: they believed that it was the metallic content of the bars themselves which somehow impaired the tone quality of the nearby strings. This was not usually the case: the impaired tone was largely due to the way in which every iron bar that was introduced disrupted the uniformity of string length, tension, and layout within the stringing scale.

This phenomenon may best be illustrated by reference to Figure 7/4. In example I, two strings lie close together on a grand piano soundboard

SAMPLE I

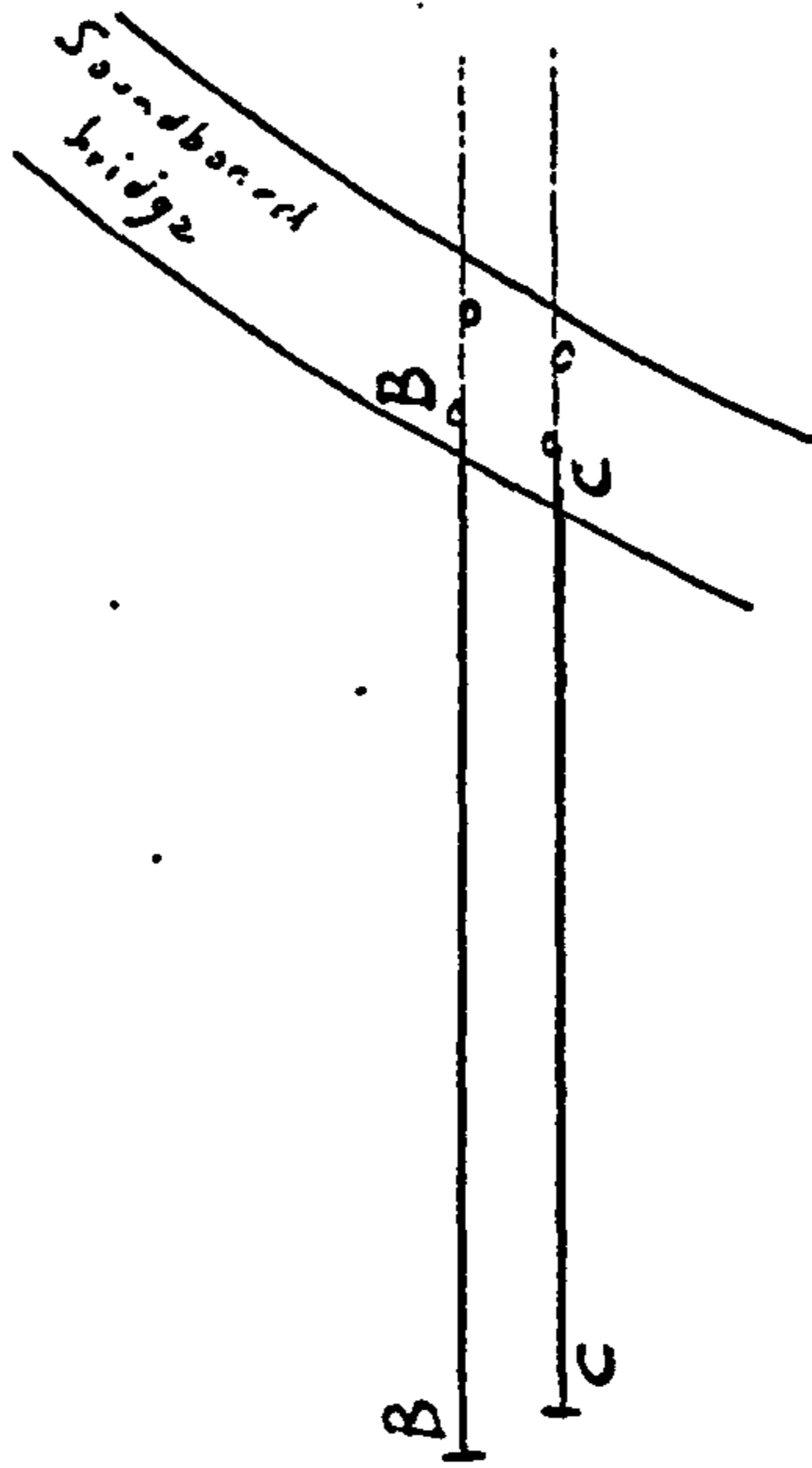

SAMPLE II

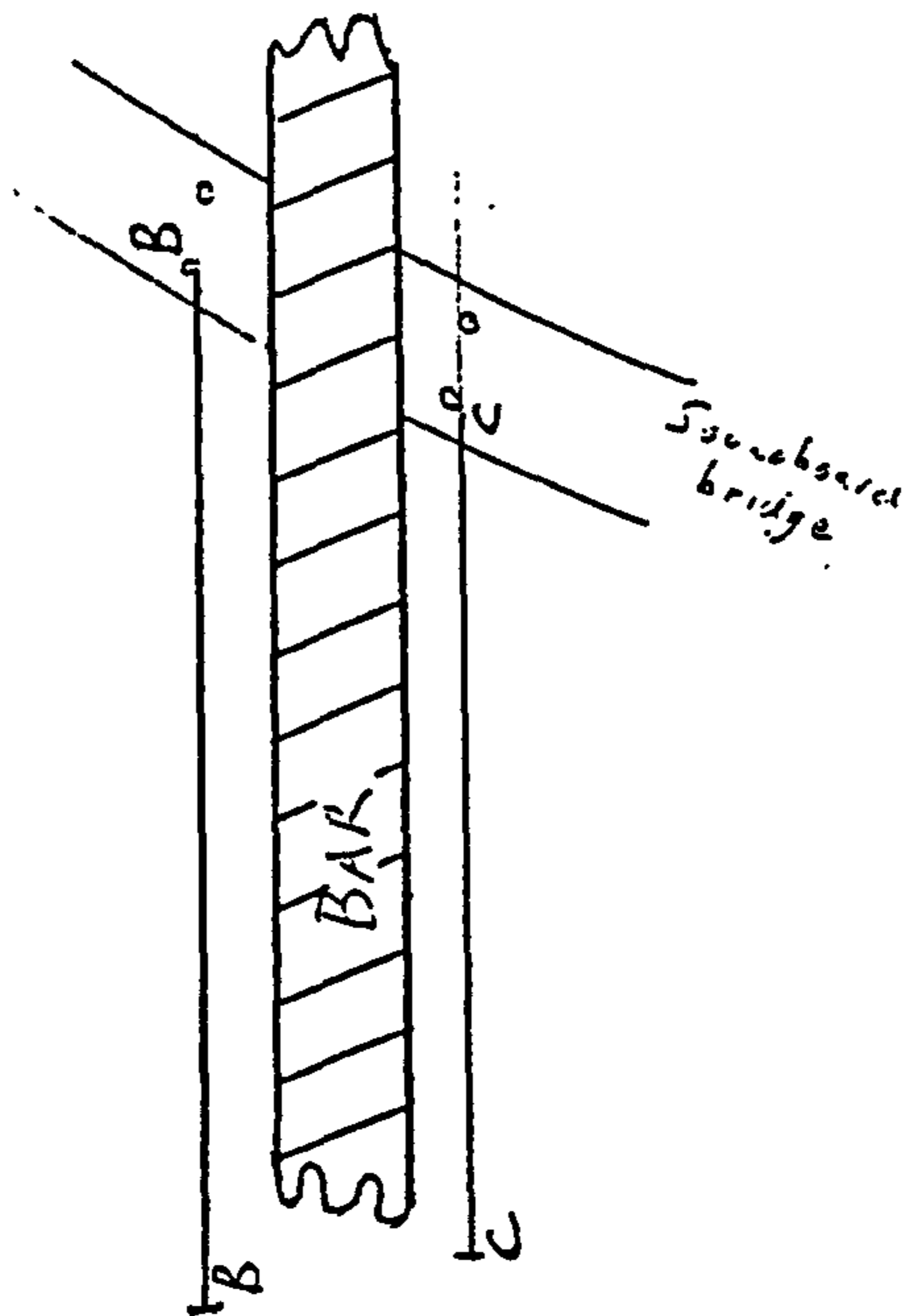

Figure 7/4: Showing the affect on string lengths of two adjacent notes as a result of inserting an iron bar over the bridge. String 'B' becomes noticeably longer.

bridge, the left string sounding the note 'b', the right string sounding a semitone higher 'c'. Both strings are strung with the same gauge of wire, and as a result of their respective lengths, both strings, when pulled up to their correct pitches, share a very similar tension and therefore emit a very similar volume and quality of tone when struck by a piano hammer.

In the case of example II, an iron bar has now been introduced between the two strings. As a result of this, the right-hand string, pitch 'c', remains unaltered, but the left hand string, pitch 'b', has had to be moved further along the soundboard bridge in order to make way for the intruding bar. As a result, the string length of pitch 'b' is considerably longer than it was before. The result of such a large increase, semitonally, in string length, means that the increase in string tension for the string pitch 'b' will probably be as much as 30% above the tension for string 'c', even when both strings are strung with the same gauge of music wire. String 'b', because of its considerably higher tension, will emit a noticeably louder sound, of a different quality, when compared with string 'c', and so a disruption in the smoothness and uniformity of tone will be apparent to the listener, particularly if slow, legato, chromatic passages are being played on the instrument.

There is another acoustic problem associated with the introduction of a metal bar or strut within the stringing layout: the spot on the wooden soundboard bridge over which the bar passes will be devoid of any stringing. This blank and stringless spot varies in width depending on the actual width of the overlying bar, or the angle at which the bar passes over the bridge. It may be as wide as 6 to 8 centimetres on pianos with thicker bars. The musical result of this noticeable hiatus on the bridge is that the transmission of sound along the line of the bridge is impaired, and those strings which lie closest to the 'blank spot' may have noticeably less sustaining power than other adjacent strings. This particular problem was recognised by the early nineteenth century Viennese makers: if there happened to be any kind of break in the uniform progression of strings along the bridge, then the break was

usually filled up with three unstruck 'dummy' strings (tuned up to the same tension as the surrounding strings), thus helping to preserve the uniform and uninterrupted sequence of string pressure along the mainbridge.
(8)

Henry Fowler Broadwood's 'Original Iron Grand' of 1847

As we suggested above, when noting the pianist Thalberg's comments about metal bracings shortly after the Great Exhibition of 1851, the Broadwood company was unhappy with the presence of a multitude of iron bars in their grands, and as early as the period 1846-47 an attempt was made by Henry Fowler Broadwood to begin to eliminate some of the five intervening metal bars found on the 'Chopin' model of this vintage. The result was a fascinating, legendary instrument known as the 'Original Iron Grand,' which never in fact went into regular production. A drawing of the frame design of this instrument is shown in Figure 7/3, taken from a Broadwood promotional booklet of 1885. The same booklet (9) has this interesting information about HF Broadwood's experiment:

'We introduced with this iron framing [viz: the 'Original Iron Grand' of 1847] two novel principles, the rejection of straight resistance bars, and the adoption of a principle which we assert is of the highest and most practical importance, that of a diagonal bar to butt upon the string plate and meet the strain of the tension where, from the harp-like disposition of the scale, it is most concentrated. The result of this complete experiment proved successful in every way. The scale no longer being broken up by the introduction of several straight iron bars, now permitted a perfect tone equality from bass to treble. The gain in nobility and purity of tone was remarkable. That part of the scale which is the equivalent to the cantabile of the violoncello may be said to have been heard for the first time in its due significance and beauty. Had Chopin returned to London in 1849, as it was hoped he would, this instrument would have been placed at his disposal for his performance.'

Such a statement is interesting: in spite of its rather exaggerated

claims as far as improvements in tone were concerned, it shows that Broadwood was preoccupied in the late 1840s with the idea of removing the iron bars as much as possible. It can be seen from the drawing of the 'Original Iron Grand' (Fig. 7/5) that the piano in fact had only one intermediate bar, a light diagonal bracing which crossed above the strings from the bottom bass corner to the middle of the bentside. The surrounding metal hitchplate is shown to be reinforced to compensate for the dramatic reduction in the number of bars.

The Broadwood Porters' Day books (10) provide some interesting background information about this unique instrument: the serial number of the piano was 16927, and it was completed at the Horseferry Road works in February 1847. Henry Fowler Broadwood must have spent much of the previous winter designing it and supervising its production. On the 28th August 1847 the instrument was delivered to the Royal Academy of Music, where it remained, apart from a short period, for a whole year. During this period, the instrument was obviously undergoing trials, and the Broadwood company must have been anxious to learn how the instrument was received by the most eminent London-based pianists and piano teachers, including Cipriani Potter (1792-1871), professor of the piano at the Academy at that time. Then on the 11th November 1848 the Original Iron Grand was hired to Princess Czartoryska, a pupil of Chopin, living at 48, Dover Street. Henry Fowler Broadwood was obviously very keen that Chopin, who was in fact still in London at that date, should try the newly-designed instrument, hence the delivery to Princess Czartoryska; but unfortunately Chopin did not appear to have had the opportunity to use the new instrument.

In March 1849, the same instrument, according to the Porters' Books, was hired to a 'Mr Tellefson' of 39, Brewer Street, London, for approximately four months. This was the young Norwegian concert pianist, Thomas Tellefsen (1823-1874), who was also a pupil and personal friend of Chopin. (11) Then on the 16th July 1849 the piano was transported to Brighton to be hired, again by Princess Czartoryska, for a couple of months. On the 11th May 1850, the Original Iron Grand was moved to Henry Fowler Broadwood's London home, 46, Bryanston Square. From this last

date and for the next forty three years, the instrument became the personal property of Henry Fowler Broadwood. It was occasionally hired out (for example, to the International Inventions Exhibition of 1885) but in general the instrument stayed either at Henry Broadwood's London home, or at his country mansion at Lyne, Surrey. The mystery of why the design of this unique prototype instrument was never put into regular production is to some extent explained by Alfred J Hipkins' information given many years later:

'Henry Fowler Broadwood set himself the problem of still further reducing the iron bars. His aim was to get rid of them altogether, but in this he was not successful. He reduced the number of steel 'arches' or struts fixed between the wrestplank and the belly bar, a wooden transverse bar against which the belly [soundboard] is supported. In 1847-9 he succeeded in making a grand piano with an entire upper framing of iron [the 'Original Iron Grand'] and in this instrument two bars sufficed, neither breaking into the instrument, the one presenting an entirely new feature of a diagonal bar, fixed at the bass corner of the wrestplank and again on the stringing plate, and having its thrust at an angle to the pull of the strings. But in the grand pianos he afterwards made with this diagonal bar, he also used a straight bar towards the treble, of the ordinary type, to avoid any possible sacrifice to durability.' (12)

Henry Broadwood's own comments on his long-held desire to remove intermediate iron bars may be found in the text of his publication launched to coincide with the Broadwood display at the International Inventions Exhibition of 1862:

'In 1849 it became the study of our firm to simplify the metallic bracing, and to reduce the number of bars, with the view to restoring straightness to the keys, of doing away with the imperfection in the mechanism, and of obtaining greater unity of vibration and a more equal tone. This has been so effectually done, that in the short grands, of ordinary construction, two straight bars are now only used, a third being added in the full sized instruments. - - - - The diminution in the

number of bars is compensated by a stronger form of section, and by improved modes of fixing. - - - - For concert instruments, however, we have felt that further improvements were desirable, even at considerable additional outlay; and accordingly, since 1851, we have introduced a class of instrument - - - - termed the 'iron grand.' The chief features of this construction are, that the iron work over the strings form a complete framing, self-supporting and perfect throughout its entire construction; and that the points of abutment in the wrestplank, intermediate between the two ends, have been reduced to a single one, corresponding to one parallel bar in the middle of the scale.' (13)

From the information provided by Hipkins and Henry Broadwood, we conclude that the diagonal bar, the new feature first seen in the Original Iron Grand of 1847, shortly afterwards (from 1851) became a standard feature on Broadwood's best concert instruments, along with one other intermediate bar. However, the Original Iron Grand itself, almost a barless instrument, was, for reasons of safety, never actually put into production. Only one such instrument (number 16927) appears to have been built. This must have been something of a disappointment for Henry Broadwood; and so we can understand how pleased he must have been when his long held ambition apparently came to fruition in 1888 with the arrival of his son's 'Barless' piano.

The Barless Grand of 1888

Turning now to the Patent of 1888, we may examine the details of Henry JT Broadwood's invention. The printed specification shows a drawing of the metal framing of a straight-strung grand piano (reproduced here as Figure 7/5) which is without any intermediate bars at all. The claims made for the invention were as follows: first of all, the metal frame consisted of a single piece of mild steel; secondly, it was claimed that the barless frame possessed 'great lightness and stiffness'; thirdly, the dispensing with struts or bars gave 'greater facility for the arrangement of the action, and a more even tone is produced, it having been found that the tone in the immediate region of the strut is

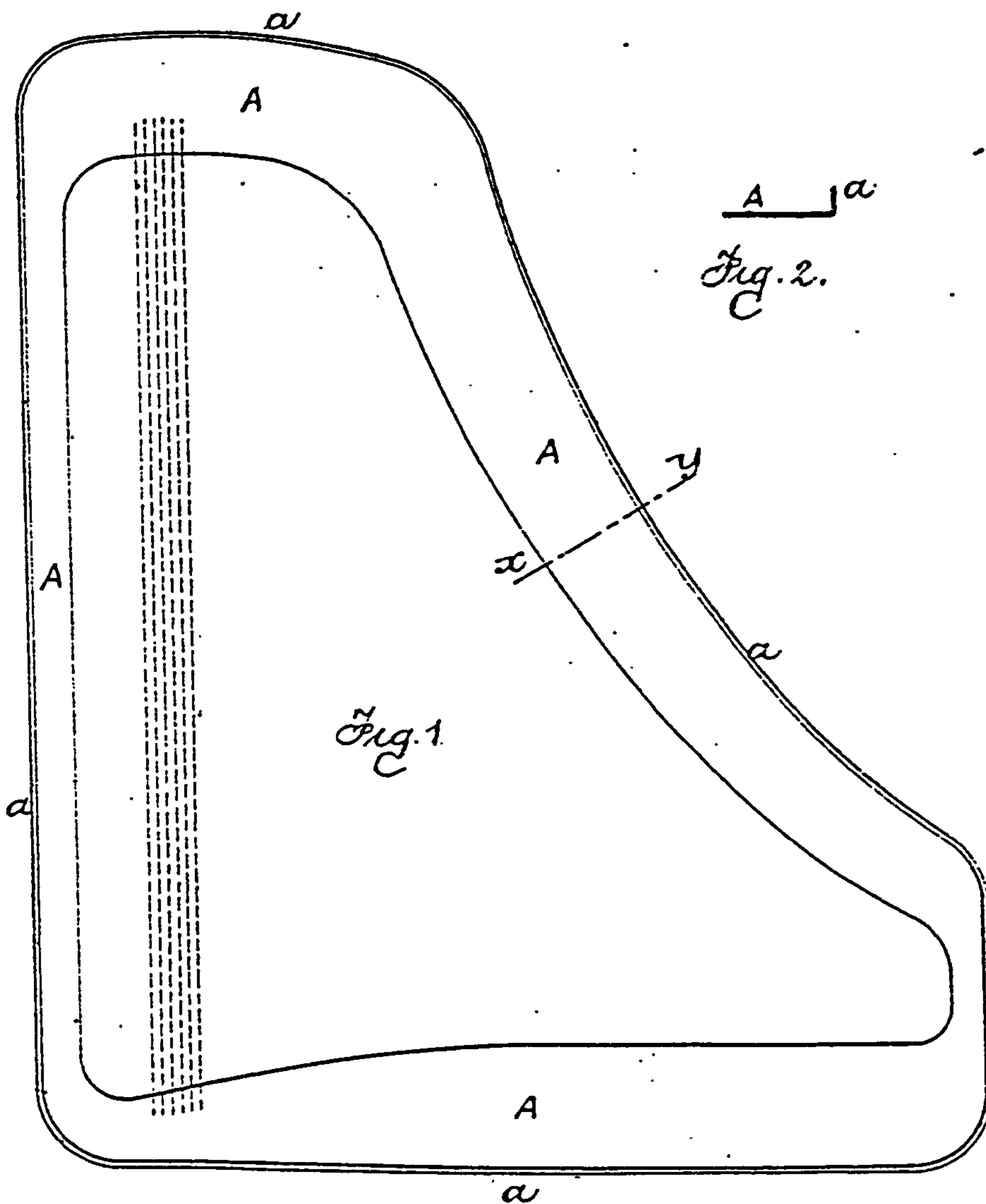

[This Drawing is a reproduction of the Original on a reduced scale.]

LONDON: Printed by DAVIES and SON Ltd.
for Her Majesty's Stationery Office. 1888.

Maib & Sons, Photo-Litho.

Figure 7/5

of slightly different quality from that in other parts of the scale, in consequence of the increased stiffness of the frame at that point.' (14)

Henry JT Broadwood's claims made for the barless idea in 1888 were along very similar lines to those claims made by his father for the simplified iron framing of forty years earlier, particularly as regards the matter of 'even tone'. It may now be understood how the introduction of the barless idea in 1888 was a continuance of, rather than being a radical departure from, Broadwood's long held views on piano frame design. The chief difference between father's and son's invention lay in the fact that the latter was based on the novel use of a single piece of mild steel, whereas the experiments and developments from the late 1840s were based on the use of a number of cast or wrought iron components bolted together to produce the whole supporting frame. The significance of the choice of mild steel in 1888 may be noted: this material, as a malleable metal, has the ability to bear a bending strain as well as a compressive strain. The well-known drawback of cast iron is its great tendency to fracture when put under any kind of tension, although it behaves admirably as a strain-resisting material when under compression alone. The choice of steel in 1888 (or some kind of malleable iron with the characteristics of steel) appeared to be essential in order for the new invention to work; there must have been a slight degree of twisting and bending of the frame (because of the absence of intermediate bars) as the string tension was applied.

In 1986, the National Engineering Laboratory at East Kilbride, Glasgow, undertook a series of tests for the present-day firm of John Broadwood and Sons Ltd in order to ascertain the degree of twisting or bending of a typical barless grand frame as a result of the application of a stringing load. (15) A medium-sized Broadwood grand dating from around the year 1910 (serial number 50803) was chosen for the tests, during which the piano had its strings drawn up to tension, then slackened off, then drawn up again to full tension. The slight bending and twisting of the frame casting which took place as a result of the load application was carefully monitored, using sensitive electronic apparatus, and it was discovered that there was a 'deflection' or

twisting of the frame, corner to corner, of some 2.5 millimetres. It is debatable whether a conventional cast-iron frame casting would have withstood such twisting without fracturing. The need for the use of steel or at least a malleable iron for Broadwood's new design of 1888 may now be understood.

Part of the wording of the Patent is somewhat puzzling. The claim that the 'tone in the immediate region of the strut [in a barred piano] is of a slightly different quality from that in the other part of the scale in consequence of the increased stiffness of the frame at that point' suggests that Broadwood, like other piano makers, may have believed that it was something in the nature and character of the metal which spoiled the tone, rather than, as we have already explained, being a problem related to erratic changes in string length and dumb patches along the wooden mainbridge over which the bars passed. The wording of the Patent leads us to speculate whether Broadwood in fact fully understood the reasons behind the 'problem notes' in the vicinity of its metal bars.

Our misgivings about Broadwood's understanding are further confirmed when we read the earliest promotional literature about the first barless grand pianos manufactured. Dating from around the year 1890, a brochure states the following information about the 'new model 8a Steel Barless Concert Grand':

'All bars and struts being dispensed with, it will be obvious that the utmost freedom of tone is obtained. Experiments show that by these means the carrying quality of sound has been improved; and there is no possibility when the tone is forced in fortissimo playing, of the strings jarring unpleasantly, as can sometimes be heard in concert rooms when, in certain makes of grands, the strings contiguous to the resistance bars are too violently set in vibration.' (16)

Whoever wrote the 'copy' for this promotional leaflet was either not a piano maker, or was a very ill-informed piano maker, or was deliberately attempting to mislead the public. As far as we are aware, there have

never been any instances of strings which lie 'contiguous to the resistance bars' 'jarring unpleasantly' during heavy playing. The wording in Broadwood's brochure implies that the strings themselves, when set into noticeable transverse motion during loud playing, 'foul' or ricochet against any bars which might happen to be in the nearby proximity. This suggestion is complete nonsense.

There is yet more evidence to show Broadwood's apparent lack of understanding of the real drawback of intruding metal bars: the evidence is to be found in the earliest-surviving barless grand pianos themselves: in their mid treble sections, where a bar would normally have been placed, a gap in the stringing, a blank space, is to be found on the wooden soundboard bridge. When the notes at either side of this gap are played and carefully listened to, it is apparent that there is still a 'bump' or change in tone across the gap, as if a metal bar were in fact present. Clearly, Broadwood, in removing the bars, had only partially solved the problems which the new barless design was intended to eliminate. The reason for this deliberate 'gap' will be explained later on in this account.

As we mentioned in the introduction to this section, a few prototype barless grands must have been made in the late 1880s; but then the idea seems to have been quietly dropped by the Broadwood company, and no further production of barless grands took place for some years. The evidence from Broadwood's specification and price list number 71, dated January 1895, (17) shows that eight different straight-strung grands, ranging in size from 6' 3" to 8' 6" in length, were offered. None of these instruments were barless models. By September 1897, the Broadwood grand range as shown in list 74 comprised eight models, two of which were now overstrung instruments, but no barless instruments were advertised. (18) There are obviously important reasons behind Broadwood's decision not to pursue barless manufacture at this period. One reason may have been that the metallurgy originally envisaged - pressed steel frames - proved to be extremely costly, and the new barless instruments, in spite of their novelty value, may have been far too expensive.

The second reason for the lack of barless manufacture lay with the personal circumstances of members of the family who directed the company's activities. In July 1888 (seven months after the Patent application) the elderly Henry Fowler Broadwood, living in retirement in Surrey, suffered a severe head injury which resulted in his confinement to a wheelchair for the remainder of his life. We suspect that it was Henry Fowler who was the encouragement 'behind the scenes' in the move towards barless manufacture, even though the Patent was taken out in his son's name. We know that it was Henry Fowler's long-held ambition to get rid of the bars altogether. However, as a result of Henry's unfortunate accident, the whole project may have been put on ice by other, less enthusiastic, individuals within the company. It is worthwhile noting here the contrast between the personalities of the two Henry Broadwoods: the father, a domineering, confident and vivacious personality; the son, (Henry JT Broadwood) a nervous, shy, stammering and retiring individual. (19)

We have sufficient evidence to show that there was a growing level of disagreement about manufacturing policy at Broadwoods during the early 1890s. There was an urgent need to 're-scale' all the company's instruments with longer string lengths more appropriate for the greatly-improved German steel wire: the characteristic tone of the Broadwood in the 1890s was worryingly old-fashioned; and yet old Henry Broadwood appeared to try to block all change, and his two sons James and Henry, although both active in the company administration, lacked sufficient knowledge to be decisive enough when it came to making important changes in piano design. The main cause of disagreement within the company, as noted by David Wainwright, lay in the matter of whether or not to adopt overstringing - the diagonal crossing of the bass strings over and above the other strings in order that they might make contact, via their own bridge, with an acoustically better part of the soundboard. The elderly Henry was adamantly opposed to its adoption (see chapter 6 about 'Scale Design'), and in spite of the fact that he was confined to a wheelchair, he still had sufficient willpower and, more importantly, financial control, to prevent his two sons from bringing any overstrung proposals to fruition. The younger generation within the Broadwood family were

certainly in awe of their father's piano-making knowledge, and this would have contributed to a severe lack of confidence on their part to instigate new ideas. It needed someone from outside the family, but with sufficient power within the company, and with sufficient piano design knowledge and manufacturing experience, to make the radical changes which were badly needed. These qualities were shortly to be found in George Daniel Rose.

The barless overstrung grands of George Rose

On the 8th July 1893, Henry Fowler Broadwood died at the age of eighty two. The principal obstacle to modernisation within the firm had now disappeared. Within a matter of weeks from old Henry's death, the Horseferry Road factory team, led by an outstanding piano designer and interesting personality, George Daniel Rose (born 1857), embarked on a schedule of radical modernisation of the company's range of grand pianos. George D Rose was the third generation of his family to be closely involved with Broadwood. His grandfather, Daniel Giles Rose (1790-1849), had been a clerk in Broadwood's office and as a young man had witnessed John Broadwood's will in 1811; and his father Frederick Rose (1828-1904), had already been for many years the factory manager and had been responsible for re-planning the whole production layout of the Horseferry Road works after the destructive fire of August 1856. (20) Frederick Rose and his brother George Thomas Rose, an accountant, were both partners and minor shareholders in the Broadwood business. The Rose family's dedication and service to the firm had been outstanding: they were certainly very talented administrators, with financial as well as piano-making skills.

The piano designer George D Rose himself was working for the company by the year 1885, and was aged about thirty six at the time of Henry Fowler Broadwood's death in 1893. He had already gained considerable experience as a result of working in factories in France and Germany, where he would have been involved with instruments of more progressive design than Broadwood's; he must have also played a part in the planning

and development of the patented barless design of 1888. He was described as 'a knowledgeable and charming man, somewhat aloof and, until one got to know him thoroughly and appreciate his gentlemanly qualities, perhaps a little forbidding.' (21) One London timber merchant who supplied Broadwood said of Rose, 'He was somewhat difficult to approach - - - there was an aloofness which was not understood until you had gained his confidence, and then one felt there was a great deal of kindness hidden under an outward icy feeling.' (22) The surviving photographs of George Rose show an individual who appeared to possess determination, self-confidence, hardness, and not a little arrogance, qualities which must have been useful in the working atmosphere of Broadwood's factory in the 1890s when so many radical changes were needed. (23)

Under Rose's direction, the Broadwood grand took many evolutionary steps within a few years. First of all, the range of eight straight strung models, based on Henry Fowler's developments which had taken place forty years earlier in the 1850s, (most of which had bolted-together frames) were withdrawn as quickly as possible. This process took some five years, partly because stocks of parts for these old models had to be used up, and partly because of the 'lead in' time needed to design the new, replacement instruments. There was also a large hire fleet of straight strung grands which, for financial and practical reasons, could not be immediately withdrawn from service; and so, for instance, Broadwood supplied one of *its* old straight-strung concert grands (number 43477) for a concert at St George's Chapel, Windsor Castle, on the 26th October 1896; and similarly, another straight-strung concert grand (number 44306) was hired to the Queen's Hall in August 1897. (24) On the 6th October 1897 the company was obliged to supply a large grand of the old type, number 42337, to the Crystal Palace Company of Croydon for use in the Promenade Concerts there. (24) In spite of their outdatedness, these instruments, as late as the year 1897, still appeared to be acceptable for important professional engagements. The company's straight-strung models continued to be advertised in price lists until the end of 1898, but by the end of the century they were no longer made.

George Rose's designs introduced four new, important features, all

of which appeared at the same time: first of all, the compass of every instrument was extended from a seven, to a seven and one quarter octave range (88 notes, a to c); secondly, each of the new models had cast-iron frames made in one piece instead of the bolted-together system previously used; thirdly, the pianos were totally rescaled with the longer string lengths needed for the best steel wire in the mid 1890s; and fourthly, overstringing replaced straight stringing on all models. We have already noted that production of 'barless' instruments had been put in abeyance at this period, and so the new cast-iron (barred) frames introduced by Rose were of conventional design.

The first model to bear all four of these new features was the 'model 2 overstrung semi-grand,' an instrument 6' 5" (195cm) long, introduced in mid 1895. Of entirely new design, this model soon became very popular and helped to improve the finances of the company. Most of the old range of straight-strung grands had been over 7' 6" in length (230cm) and so the new model 2's particular attraction was its relatively compact size. One of the new semi grands, number 44487, which was finished at the factory on the 21st November 1895, was photographed for promotional purposes. This interesting photograph survives. (25) It is taken from above the piano, and shows the cast iron frame and the newly-introduced overstringing. The 'pioneering' model 2 was soon followed by another new design, the larger model 4 overstrung drawing room grand (7' 6" or 230cm in length), introduced during the second half of 1896, and then by a new overstrung concert grand (model 3, 8' 7" or 260cm long), in production from 1897.

It was clearly the policy of George Rose's development team at the factory to concentrate their time and energies on the establishment of a fleet of modern, up-to-date, conventional overstrung designs, very much modelled along the lines of the Berlin Bechstein. We would not be at all surprised to have found a sample of a Bechstein grand being carefully examined and measured at the Horseferry Road works in the mid 1890s. However, the unique barless idea had not been forgotten. Broadwood must have remembered with both pleasure and regret that its prototype barless grands of a few years earlier, although highly-priced, nevertheless

looked extremely elegant and had been greatly admired. George Rose was also no doubt under some pressure from Henry Broadwood junior to do something about reviving the barless idea, if only as a fulfillment of a long-held Broadwood family and company ambition.

It may have been the attractive appearance of the barless prototypes, rather than any technical or tonal merits they might have possessed, which persuaded the company to seriously consider the reintroduction of the idea. In many respects, the first barless instrument, with its simple, uncluttered layout, was strongly reminiscent of the harpsichord and the early grand piano. It is worthwhile noting that in London during the 1880s there was a significant growth in interest in early keyboard instruments, involving members of the Broadwood circle and including AJ Hipkins (the company's sales manager and a fine harpsichordist), Fuller-Maitland, the music critic (the latter being a brother-in-law of James and Henry Broadwood) and the Austrian pianist, editor and composer, Ernst Pauer (1826-1905). Carl Dolmetsch, writing in 1994, had this to say about early keyboard activity in London at this period:

'Both Hipkins and Fuller-Maitland were performing on the harpsichord in England during the 1880s at a time when my father [Arnold Dolmetsch] was giving his first concerts - - - Arnold Dolmetsch built his first lightly-constructed harpsichord for the Arts and Crafts Exhibition of 1896, London - - - -.'

 (26)

The contribution of Ernst Pauer towards the revival of early keyboard music in England is often overlooked, his activities having been somewhat eclipsed by those of Dolmetsch. Pauer was professor of the piano at the Royal Academy of Music between 1859 and 1864. As early as the year 1861 he had commenced a series of performances of harpsichord music, probably performed on the piano rather than the harpsichord. He had piano-making connections - his mother was a member of the well-known Viennese piano-making family, Streicher; and Pauer was a close friend of Henry Fowler Broadwood, who appears to have been his patron. Ernst Pauer's publication 'Old English Composers for the Virginals and Harpsichord' (1879) is in fact dedicated to Henry Broadwood. The

elaborate title-page dedication states:

'To Henry Fowler Broadwood the first to give me friendly welcome in England, the faithful and sincere friend to those dearest to me, the generous supporter of all I undertook in the interest of musical art, as to one whose house has done a great work in popularising Pianoforte Music by taking a leading part in every improvement in keyboard instruments from the Harpsichord to the Grand Pianoforte, I hereby dedicate this Selection of works of old English composers for the Virginals and Harpsichord, With the kindest feelings of sincere appreciation and grateful friendship. London, 39c Onslow Square, January 1879.' (27)

A copy of Pauer's dedication is illustrated as Figure 7/6. We cannot rule out the possibility that it was the late nineteenth century harpsichord revival which had largely inspired the barless grand piano idea in the first place; and so perhaps it was merely coincidence that Henry Fowler Broadwood was feeling his way towards a barless conception many years earlier in the late 1840s. We must always bear in mind that the prime motivation of the Broadwood company in developing its barless models may have been the fact that they were visually elegant, and therefore eminently saleable, products. The barless frame was also a special feature which went a long way towards making the Broadwood grand a distinctive item in a music shop, particularly when compared with the more conventional-looking pianos of the company's competitors.

A re-introduction of barless instruments began in mid 1897; but these new models were very unlike the originals of the late 1880s: they were not straight strung, but were developed directly from the new conventional overstrung grand models which George Rose had recently introduced. The way in which this was done was quite apparent: once a particular model of new barred overstrung design was 'up and running', then the foundry casting pattern was modified, the intermediate bars (two in number) removed, the sides of the frame design reinforced to compensate for the loss of the intermediate bars, and then a 'barless' frame would be sand cast, using a low carbon malleable iron (as distinct from an ordinary cast iron).



To

HENRY FOWLER BROADWOOD

*the first to give me friendly welcome in England,
the faithful and sincere friend to those dearest to me,
the generous supporter of all I undertook
in the interest of musical art, as to one
whose house has done a great work in popularising*

Pianoforte Music

*by taking so leading part in every improve-
ment in keyed instruments from the
Harpsichord to the Grand Pianoforte,*

*I hereby dedicate
this Selection of works of old English composers,
for the Virginals and Harpsichord,
With the kindest feelings of sincere appreciation
and grateful friendship.*

London, 39, Oldbath Square, January 1879.

E. Pauer.

Figure 7/6: Dedication from 'Old English composers for the Virginals and Harpsichord' edited by E Pauer, 1879-80.

In October 1987, an analysis of the metallurgy of the barless grand frame was undertaken for the writer by Keighley Laboratories Ltd, consulting metallurgists, of Croft House, Keighley West Yorkshire. The composition of the frame was described by them as being:

'a cast mild steel rather than cast iron. The carbon content [very low, 0.17%] is in the order expected in a 'mild steel' and Manganese is unusually low, having apparently been reduced in initial melting. Microstructure and hardness values are as might be expected from this type of steel in cast form. The very uniform fine grain seen in the microstructure suggests that the frame has been given an effective heat treatment after casting - - - -. The chemical composition, with very low Manganese content, is similar to that of 'wrought iron' but the microstructure indicates that the frame has been made as a casting. It is suspected that the heat treatment of the steel frame has been done to give greater stability of dimension so that the instrument will be more readily tuned and stay better in tune - - - -.' (28)

Almost certainly the first of George Rose's barless overstrung grands to be completed was piano number 44716, sold on the 28th July 1897 to the Reverend Montague Alderson of 1, Lothian Villas, Hatfield, Hertfordshire for the sum of 175 guineas. (29) This particular instrument was a barless modification, as described in the previous paragraph, of Broadwood's first barred overstrung design, the model 2 semi grand, and its high price, forty guineas (23% more than the same-sized barred model), a reflection of the high cost of casting the special barless frame. In the written entry of the piano's specification in the porters' book for the 28th July, the words 'steel framed' are strongly underlined, as if to emphasise that this is the first of its kind. There is no further note of barless instruments until over three months later, when on the 8th of November 1897 a second barless semi grand, serial number 44833, was sold to a 'Major Clowes' of 6, Elvaston Place, London, also for 175 guineas. (30)

In spite of this insignificant and modest start (only two barless

grands sold over a six month period in the second half of 1897), the description 'steel barless' soon became a much more familiar entry in the porters' day books of the following year. For a period of approximately six months, the model 2 semi grand was the only piano available with an optional barless frame, but by January 1898 the first barless concert grand had been completed. This prototype was seen at the Horseferry Road works on the 5th of January 1898 by a visiting party comprising members of the Incorporated Society of Musicians. Their commemorative booklet describing the visit noted:

'- - - Here will be seen a new Barless Steel Concert Grand, the first made of this type of pianoforte which has already had great success. The absence of metal rigid bars within the scale results in a remarkable evenness of tone quality throughout the keyboard, and also a decided gain in beauty and purity of tone.' (31)

A photograph of the plan and string layout of this very same prototype concert grand was featured as the frontispiece of the second edition of AJ Hipkins' 'Description and History of the Pianoforte', 1898. (32) The first edition of this same book (1895) had shown a frontispiece photograph of one of the older, straight-strung versions of concert model. In 1899 a third barless option, a modification of the model 4 drawing room grand, became available; and by 1903 a fourth barless instrument, a small 'quarter grand' (5' 7" or 170cm in length) had appeared.

The most important feature of both barred and barless frames made from 1895 is that they were interchangeable: in other words, either type of frame could be fitted into one size of grand. For instance, the pioneering model 2 barred semi grand could become the model 3 barless semi grand overnight, simply by changing over the frame; and similarly, the model 4 drawing room grand could be transformed into the barless model 5 drawing room grand by a frame transplant. The reasons for this desired interchangeability are fairly obvious. In the first place, it would have helped flexibility and organisation in manufacture, so that completed piano cases with soundboards and bridges attached could be

made first, and then the decision whether to add a barred or barless frame could be made at a much later date, dependant on the order book. Secondly, the ability to be able to 'swop over' was a safeguard. The making of the new barless frames was something of a risky buiness; if problems did develop with the new barless castings within a few years of their manufacture (such as the appearance of stress fracture lines), then the faulty pianos could be recalled and their novel barless frames quickly replaced with conventional barred ones.

The interchangeability of Broadwood grand frames may be seen in Figure 7/7. (33) Both frames illustrated fit into the casework of the model quarter grand, first introduced around the year 1899, and Broadwood's smallest grand at this particular date. As we have just noted, by the year 1903 a barless version of exactly the same quarter grand had become available. The need for the interchangeability of frames explains why it was necessary for Broadwood to leave the unwelcome 'gaps' or spaces on the soundboard bridge of the barless models: if the frame at some future date had to be changed over to accomodate a conventional barred version, then these gaps were an essential requirement in order for the bars to fit between the stringing.

The radical changes which had occurred in Broadwood's factory between 1895 and 1901 may now be summarised by comparing the company's specifications and price lists for these two years. (34) In January 1895, eight grands were offered, all of them straight strung, all but one of them with a seven octave compass, and most of them having their iron frames made from various metal components bolted together. Six years later, in September 1901, Broadwood was offering six models of grand piano. All of these were overstrung, with one piece cast frames, and three of them were barless (concert, drawing room and semi grand). Five out of the six had a $7\frac{1}{4}$ octave compass.

By the year 1911, the number of different barless models available had increased to four; and in 1914, shortly before the outbreak of the First World War, the company's grand piano range comprised six models, five of which were now of the barless variety. It is clear that by 1914,

Figure 7/7

BROADWOOD MODEL 4 QUARTER GRAND (4F AND 4C)
Showing interchangeable barred and barless frames
Both versions may fit within the same model 4 grand rim
Both frames share the same 'scale' and string layout.
(Source: Booth and Brookes foundry photographs, 1922 and 1924).

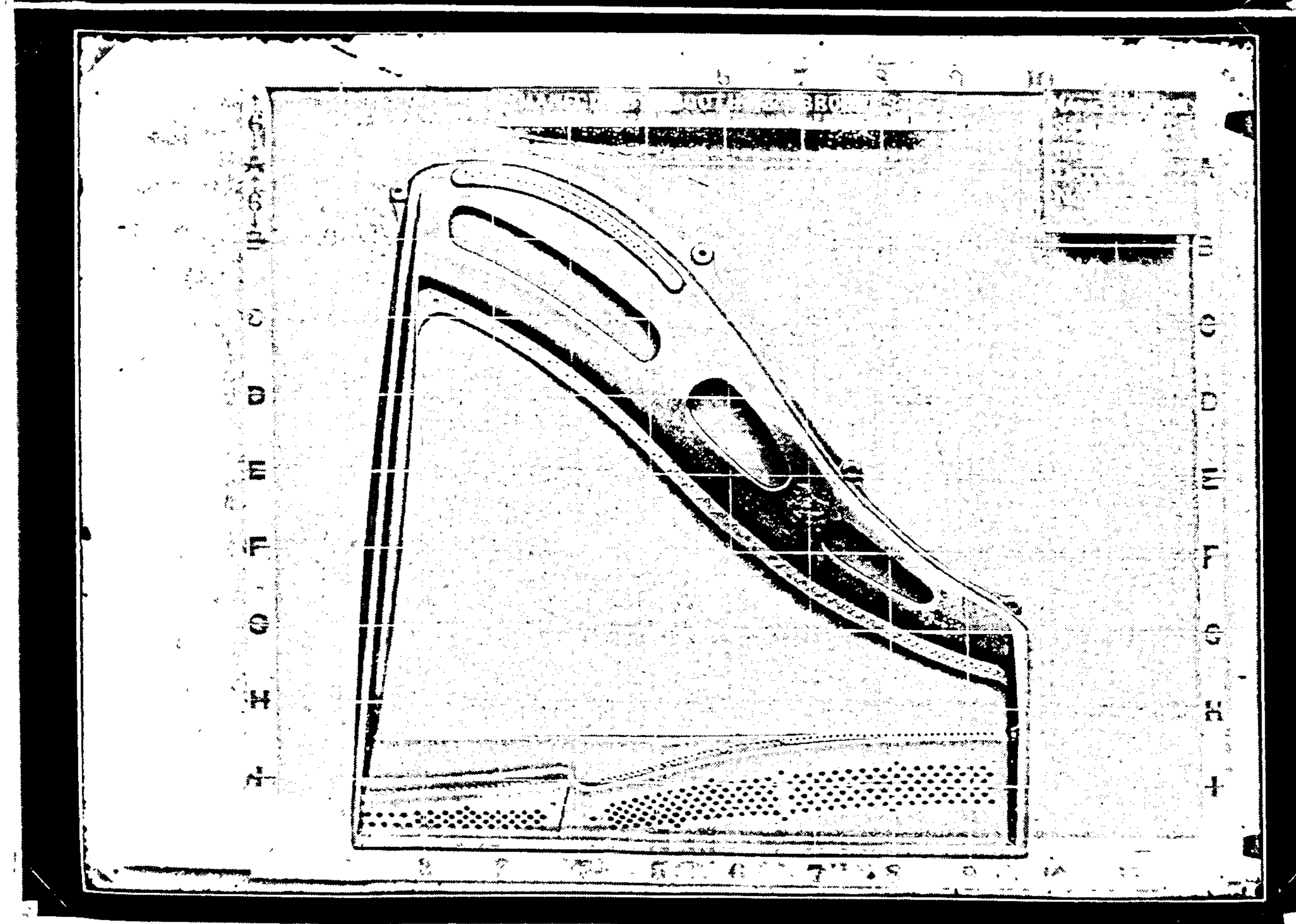
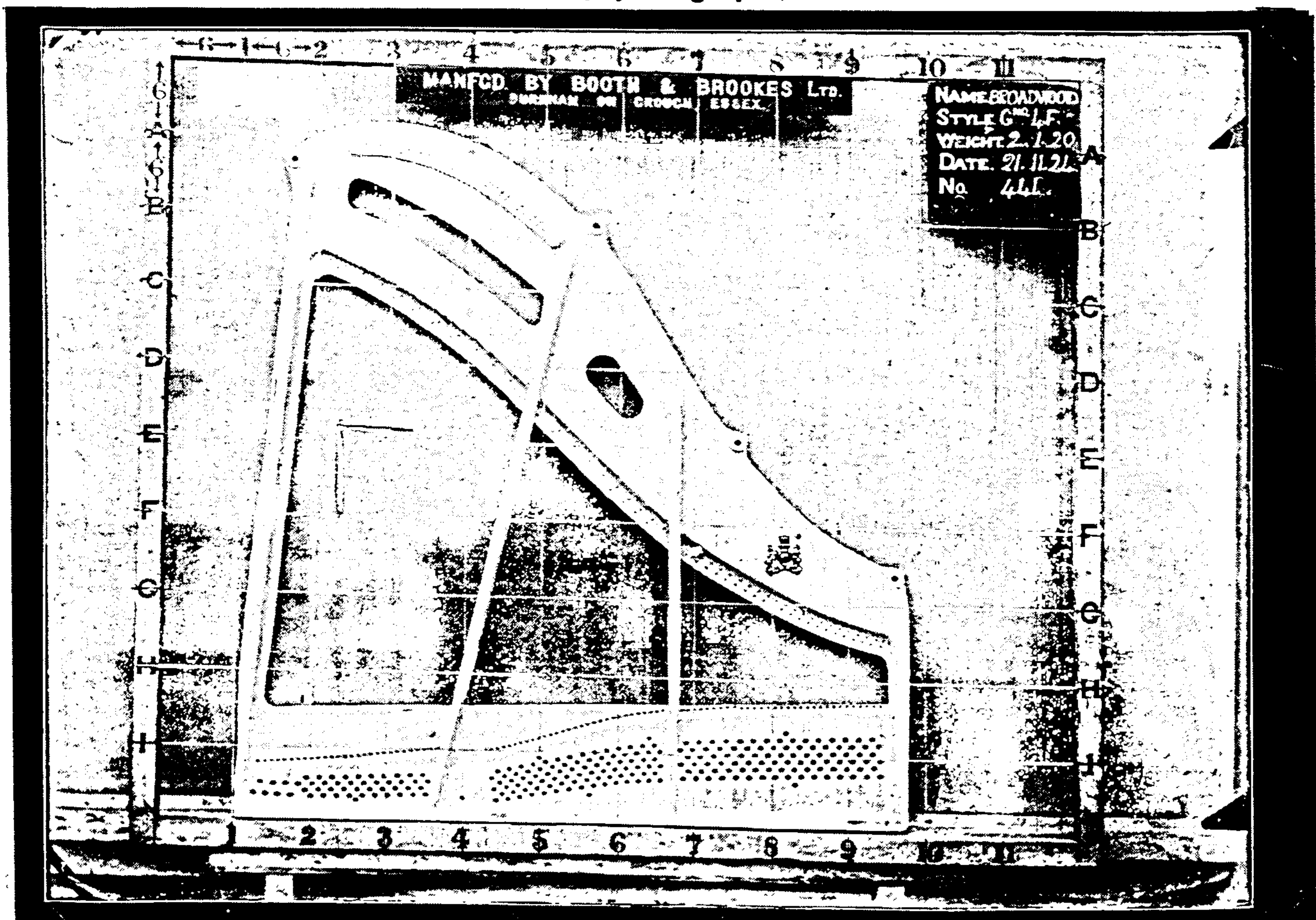

the barless had become the standard feature, rather than the exception, to be found in the range of instruments offered. The company must have been proud of its range of these very distinctive 'thoroughbred' instruments, and it must have been pleased with the way in which George Rose's talented design work in the late 1890s had gone a long way towards restoring and enhancing the company's reputation as the builder of some of the finest grands obtainable at that date.

There was one new introduction of George Rose's which was not so successful. Overstringing and barless frames were obviously the most outstandingly-successful aspects of his design work within the company during the 1890s. However, another new idea which he introduced in late 1896 was discontinued after a very short period. This was the adoption of 'quadracord' stringing (four strings to one note) throughout the treble section of one of the new overstrung grand models. The idea, although perhaps a good selling feature in the piano showroom, was of little or no musical value. Although the instrument is no more difficult to tune than a convention tri-cord model, the contribution of the extra struck string to each note is negligible, there being no perceptible increase in the 'power' of the treble section as a result. The idea necessitated extra manufacturing time and extra materials (more steel wire and more tuning pins) and was ultimately withdrawn within a few months of its introduction. The very rare surviving specimens have become 'collectors' items.'

Comments on the Barless Conception from Writers and Journalists

(See the list of books at the end of this dissertation for further details about the publications quoted below.)

The barless innovations were generally very well received by the 'technical press' and those individuals who chose to write about pianos. Broadwood's own AJ Hipkins was perhaps the first to make comment, in his 'Description and History of the Pianoforte' (1895):

'The latest radical alteration of construction is to be found in Broadwood's barless pianoforte, a patent for which was taken out by Mr Henry John Tschudi Broadwood, January 26th 1888. The metal plate is here of mild or cast steel turned up round the sides to form a continuous flange, so as to meet the strain without requiring bars; going back, in fact, in simplicity of construction to the original pianos of ante 1820, but adequately bearing the modern increase of tension. It is an ideal construction, and the musical instrument thus produced is of singular beauty and equality of tone.'

These comments are interesting, because we learn from them that Hipkins was very much aware that the barless innovation, although 'radical' was nevertheless a 'turning back of the clock' and represented an attempt to restore some of the elegance that was found in the appearance of pre 1820 grands. Hipkins, as a loyal Broadwood employee of almost sixty years, could hardly be expected to give anything but praise to his employer's products.

Quite lengthy comments about Broadwood's barless may be found in William B White's 'Theory and Practice of Piano Building', originally published in New York in 1906. White notes:

'There has appeared an invention which would seem to overcome, in an effective manner, the objections to the multiplication of bracings. The inventor is a member of the celebrated house of Broadwood, and his device is called the 'Barless' or 'open scale' grand pianoforte. By this invention, the barred iron frame is replaced by a plate of mild steel, which is entirely free from bracings, is constructed with a continuous turned-up flange and is bolted in the usual manner into the bottom framing. This flange provides the necessary tensile strength and apparently sustains the tension of the strings in a perfectly satisfactory manner. The advantages presented by a method of construction that avoids the breaking up of the string groups into three or four divisions are obvious and need not be explained in detail.

'It may be stated, however, that the principal and conspicuous advantage presented by this method of construction is found in the fact

that the absence of bars and bracings tends to subdue the metallic and tinkling quality of tone that is so often found to be induced by the presence of heavy masses of cast iron. At the same time, the material employed is so much more elastic than iron that there is no perceptible loss of resonance, nor is the tensile strength lessened to any appreciable degree. No one who has tested the pianofortes thus constructed has failed to be delighted with the singularly beautiful tone-quality and remarkable evenness that is shown throughout the whole compass. It is indeed a most difficult task to overcome the tendency to production of unduly prominent dissonant partials in those parts of the scale where the bracing is especially heavy, particularly in the lower portions, and consequently we must regard with admiration so successful an attempt to do away with these difficulties by removing their cause.'

Some of White's comments, particularly his reference to the 'singularly beautiful tone-quality' appear to be derived straight from the pen of Hipkins, Broadwood's sales manager. We are not sure if White, living in the USA, had actually seen a barless grand. His comment about the presence of the iron bars causing 'unduly prominent dissonant partials' is crass rubbish: the chief cause of such a problem is either a piano which is designed with wires which are too short and too thick, or one in which the piano hammer felt is unduly hard. We have only to recall the typical mellow and velvety qualities of the late nineteenth century Blüthner and Bechstein grands, each with their multitude of heavy iron bars, to realise White's fallacy. (His general ignorance about piano technology is further confirmed when, a couple of paragraphs after dealing with the barless issue, White states that a concert grand is so constructed to bear a total strain 'of not less than 30 tons', when in fact the strain borne by such a piano rarely exceeds nineteen tons.

Alfred Dolge, in his well-written and informative 'Pianos and Their Makers' (published in America, 1911) states:

'John Broadwood and Sons are now making grand and upright pianos with 'barless' steel frame, a notable accomplishment, aiding materially in producing an even scale, and also permitting the soundboard and

strings to vibrate unhampered and unaffected by iron cross bars. Another important effect is that the weight of the piano is reduced in proportion.'

We wonder if Dolge had actually tried to lift up a barless grand before he made his comments. Barless grands are in fact extraordinarily heavy, with a weight of one third more than a conventional grand of the same size. It appears likely that Dolge was noting the written details circularised at the time of the original Patent of 1888, rather than examining any musical instruments. It was the extreme weight and the costly heavy casting which was one of the causes of the downfall of the barless grand after the First World War.

In May 1927, Laurence M Nalder, a London-based piano journalist who must have had access to Broadwood's instruments, published his book 'The Modern Piano' and made a few brief comments about the barless conception:

'No notes on piano frames would be complete without reference to the Broadwood barless frame, which was patented in 1888 by Henry John Tschudi Broadwood. In this frame the plate is of mild or cast steel turned up round the sides to form a continuous flange. The construction meets the modern increase in tension without the aid of bars, and is undoubtedly a realised ideal. - - - - The outstanding advantage of a barless frame is that it permits an even scale. - - - - A frame constructed of cast steel upon these lines is of great comparative lightness and stiffness, and the absence of bars gives a greater facility for the arrangement of the action and keys. The tone of the piano, as a result, possesses a freedom and purity not possible where the depth of the soundboard bridge is reduced to allow room for the frame bars.'

Nalder's notes continue the 'received wisdom' about barless frames, and echo many of the statements previously provided by other writers on the subject, Like Dolge, Nalder was wrong in his assertion about the 'great comparative lightness' of the barless pianos; and his choice of phrase 'freedom and purity of tone' is strongly reminiscent of Hipkins' 'singular beauty and equality of tone', and White's 'singularly beautiful

tone quality and remarkable evenness.'

Perhaps the most interesting comments about the whole idea come from the pen of KS Sorabji, in chapter 27 of his 'Mi Contra Fa: the Immoralisings of a Machiavellian Musician' published in 1947 some twenty or more years after the discontinuation of barless models. The chapter is headed 'Piano design':

'- - - - By far the most important, striking and radical [innovation], was the Broadwood steel barless grand frame; indeed it can hardly be an exaggeration to say that nothing comparable to it has happened since the invention of the all-metal single-piece casting half a century earlier. The conception is as beautiful as it is original. The ordinary metal frame has a number of transverse bars or struts across it, more or less parallel to the strings, to strengthen and to help it to withstand the enormous tension of the strings. The transverse bars have at all times been the bugbear of piano-makers, and all sorts of devices have been tried in order to minimise the tonally deleterious effect of them upon the nearby strings. For, while undoubtedly strengthening the frame, they do introduce two undesirable features, namely a lack of resilience in the frame itself, and the effect upon the tone of the strings immediately adjacent. The barless frame is completely free from transverse strengthening bars; the strings represent an uninterrupted fanlike sweep that is as novel as it is beautiful in appearance; but far more important is that the tone of a barless grand has a freedom and a homogeneity that is unique. I believe that, in the earlier stages, i.e. some forty or so year ago, when the invention was first launched, and metallurgy not as advanced as it is now with high tension alloys, manganese steel, and so on, there were rather frequent breakdowns of the frames under test. This is a state of affairs that cannot any longer be a serious objection, owing to advances in metallurgy and casting. What, however, is so extraordinary and singular, indeed rather disquieting as an indication of the lack of emulative enterprise that seems to have overtaken piano-makers, is that this very remarkable invention, the patent of which must have long expired, has not been developed and adopted by any other maker.'

Sorabji's very readable comments represent something of a fresh approach to writing about the barless, certainly when compared with Hipkins, White and others. His writing appears to show that he had some knowledge about metal casting technology, and he provides us with a tantalising glimpse of what were obviously serious teething problems in the early stages of barless prototypes, information which no other writer appears to have had.

However, Sorabji was inaccurate in a number of details: first of all, he repeats the commonly-held misunderstanding of the way in which the bars spoilt the tone; he refers to the 'lack of resilience' in the conventional frame as being an undesirable feature, when in fact by 1947 it long been the policy of the Steinway company, for instance, to make their frames fit as rigidly and inertly as possible, so as to minimise 'resilience'; and whilst expressing dismay about the way in which the barless idea had not been emulated by other makers, Sorabji overlooked the fact that it had indeed been copied, first by Brinsmead (unsuccessfully) on the firm's uprights during the early 1920s, and, successfully, by Alfred Knight from the 1930s onwards. 'Semi-barless' grands (having only one intermediate bar, but in design very much in the spirit of the barless conception) were also manufactured by the Challen company in association with Broadwood during the mid 1930s. However, it would be true to say that the makers of the highest quality of concert grands - Bechstein, Steinway, and Bosendorfer - do not appear to have had any interest whatsoever in emulating the barless principle.

CHAPTER 8

THE SURVIVAL OF THE BROADWOOD GRAND SINCE 1914

The Broadwood grand product range in 1914 comprised six models, five of which - the barless instruments - are illustrated as figure 9/1 (photocopied from the company's publicity brochure which was available in that year). The largest model, which had achieved considerable fame by the year 1914, was the 'Model 6 Steel Barless Concert Grand', of length 8' 9" (267cm). This was the piano which, after its introduction in 1898, was successor to the barred concert grand. The prototype model had been seen by members of the Incorporated Society of Musicians during their visit to the Broadwood factory in January 1898; it was also the model which had been photographed in plan for the frontispiece of the second edition of AJ Hipkins' 'Description and History of the Pianoforte' published in the same year.

The second largest grand, of length 7' 6" (229cm), was the 'Model 5 Barless Drawing Room Grand', introduced around 1899/1900. Next in the range was Broadwood's original overstrung barless model, the popular 'Model 3 Barless Semi Grand', 6' 7" (201cm) in length. First introduced in 1897, and the company's best-selling grand by the turn of the century, this same model 3 had also been one of Broadwood's most compact instruments by comparison with the grands from the old straight-strung range; but it had, nevertheless, an impressive bass register usually associated with a larger instrument. 'Model 4 Barless Quarter Grand', a smaller instrument first introduced in 1903 and developed from the model 1 barred grand of 1899, was 5' 7" (170cm) in length; and Broadwood's smallest grand model, the 'Barless Baby Grand' of five-foot length (153cm), introduced much later in 1912, was available in either barred or barless form, the barred version, a 'budget' model with an ordinary cast-iron frame, being some 20% cheaper than the barless version.

For the first eleven years of Broadwood's barless grand production, 1897-1908, George Rose was both factory manager and head of the design



MODEL 6 BARLESS CONCERT GRAND
Length 8'9" 7 $\frac{1}{2}$ octaves
Introduced 1898, successor to the
model 3 barred concert grand of 1897.



MODEL 5 BARLESS DRAWING ROOM GRAND
Length 7'6" 7 $\frac{1}{2}$ octaves
Introduced 1899/1900, based on the
model 4 barred drawing room grand of 1896.



MODEL 3 BARLESS SEMI GRAND
Length 6'7" 7 $\frac{1}{2}$ octaves
Introduced 1897. The earliest
barless model in regular production,
based on the model 2 barred grand
of 1895.



MODEL 4 BARLESS QUARTER GRAND
Length 5'7" 7 $\frac{1}{4}$ octaves
Introduced circa 1903 and based
on the model 1 barred grand of 1899.



MODEL 57 BARLESS BABY GRAND
length 5' 7 $\frac{1}{4}$ octaves
Introduced circa 1912 and based
on the model 58 barred baby grand
of circa 1906.

team, and the individual within the company who had absolute control of piano design policy. A careful comparison of the technical and stylistic features found on the many-surviving Broadwood grands from this period show that, in their very individualistic and even idiosyncratic ways, they all bear the signs of having been created and developed from the brain of one individual. For instance, all the barless grand frames use a surprisingly bare minimum of supporting bolts - usually no more than two - to hold the frame in place above the soundboard. This contrasts very strongly with the practice of Steinway, Bechstein and many others, whose cast-iron grand frames are normally held in place by a multitude of screws and bolts - between fifteen and twenty - surrounding the soundboard. Similarly, the soundboard grain on the Steinway and Bechstein models runs parallel with the long mainbridge, whereas the grain of all Broadwood grand soundboards of this period, unlike almost every other manufacturer, crosses diagonally under, and at right-angles to, the line of the long bridge. The bronze colour found on the finish of Steinway, Bechstein, and many other German, French and English frames is a light, silvery shade; in contrast, Broadwood chose a deep, copper-coloured finish which is very unusual and certainly distinctive.

The Broadwood company therefore had its own way of going about things as far as technical design features were concerned, features as individualistic as the barless frame itself; and all these details must have been very much a matter of the personal taste of Rose. Interestingly, when George Rose resigned from the company in June 1908 following a dispute about design and manufacturing policy, he immediately went into partnership with a certain Herbert Marshall and, trading as 'Marshall and Rose', designed and manufactured a range of new grand and upright instruments which bore a striking resemblance, both internally and externally, to contemporary Broadwood models. The personality of George Rose is therefore stamped on his 'Marshall and Rose' products just as much as his earlier Broadwood designs. However, George Rose remained in partnership with Herbert Marshall for only three years. In 1911, at the age of fifty-four, he took the bold decision to emigrate to New South Wales, Australia, where he eventually became a sheep farmer.(1) His was an example of a strangely eventful life in which the first fifty or so

years were remarkably different from the later years.

During the period of grand manufacture between 1897 and the year 1914, there was only one significant change to the design of Broadwood instruments: the replacement of the old style four-piece oak rim with a one-piece laminated continuous rim. This occurred around the year 1905. The new rims were not intended to be a cost-saving exercise (a laminated rim is just as expensive to manufacture as one made from four pieces of solid timber); it was more a response to changes in fashion. The traditional oak rim, comprising two steam-bent pieces and two straight ones, has three 'corners' (two in the tail, and one at the junction of the bentside with treble cheek) . As an item of furniture, the four-piece steam-bent rim looked decidedly old-fashioned and very 'Victorian' by 1905; and many of the German builders, including Bechstein and Blüthner, were following the example of Steinway in building their rims from parallel layers of long, single pieces of wood. This resulted in the side contours of their grands having a smooth, flowing and uninterrupted appearance.

There appears to be no particular acoustic benefit to be derived from the use of a one-piece laminated rim; and it could be argued that the single smooth 'sweep' of the one-piece rim is less interesting and less characterful than a rim comprising four distinct sections, (spine, tail, bentside and treble cheek), one section joining another at a pronounced 'corner.' However, it is certain that the single-piece laminated rim is stronger and more stable than a rim with numerous junctions; and so Broadwood in 1905 must have been happy to adopt the latest changes in fashion with the knowledge that the company's grand products were stronger and more stable than ever before.

The Crisis in Grand Manufacture, 1918-1931.

In spite of starting the new century well with an interesting range of fine, skilfully-designed, modern instruments, Broadwood's period of grand manufacture after 1918 was a tragic one in the company's history,

a tragedy which slowly unfolded and continued until the eventual 'death' of the original company in 1931, when the factory closed, and when there was an end to continuity in grand piano design and evolution following the dismissal of the workforce and the destruction of unique, essential manufacturing equipment. The problems which faced Broadwood immediately after the First World War, during the period 1918 to 1921, were financial ones; then between 1921 and 1925 the problems were more to do with changes in public taste and fashion, when the desire for a grand piano was largely replaced with the desire for a new gramophone, radio, or car, and visits to the cinema replaced home entertainment around the keyboard. A third, equally serious, problem for the company appeared from the mid 1920s: Broadwood's manufacturing policy was formulated by individuals who, whilst possessing admirable technical and engineering skills, appeared unable to distinguish good piano tone from bad, and whose technical innovations - resulting in a marked tonal deterioration in the firm's products - were considered by many within the industry to have 'ruined' the company. (2)

The financial problem which faced the Broadwood company immediately after the First World War was related to a shortage of manufacturing materials and an unprecedented increase in the cost of making the barless cast steel frames. In 1911, Broadwood's medium-sized quality grand, the popular model 3, was priced at 160 guineas retail in a standard rosewood case. This instrument was able to compete in price with the same-sized Bechstein grand, which was available between 110 guineas and 180 guineas depending on case finish. (3) The Broadwood barless concert grand of 1911 retailed at 350 guineas; this was fifty guineas more than the contemporary Bechstein concert model. Customers appeared willing to pay the extra 15% for the privilege of a barless frame, but it is clear that Broadwood in 1911 was having difficulties in competing pricewise with its serious German rival. After 1918, the matter of pricing became a much more serious problem, as figure 8/2 reveals. By the 14th November 1919, the retail price of model 3 had more than doubled - it was now 340 *pounds* retail; and the concert model 6 had been increased in price by 35%. Such a huge increase meant that the larger Broadwood grands (models 3, 5 and 6) were virtually unsaleable:

Figure 8/2: Broadwood Grand Piano Retail Prices, 1911-1923
 (Prices quoted are in guineas unless marked '£')

Sources: Broadwood Papers, (price lists) Surrey Archives; and brochures belonging to Mr Norman Allen of Bramhope, Leeds.

Models	1911	14th Nov	23rd Aug	1923
		1919	1920	
Model 6 Barless Concert Grand	350gns	£473	n/p	?n/p
Model 5 Barless Drawing Room Grand	225	£375	n/p	n/p
Model 3 Barless Semi Grand	160	£340	n/p	n/p
Model 4 Barless Quarter grand	125	£288	£340	£270
Model 4 Iron Barred Quarter Grand	n/p	£273	£325	£240
Model 57 Barless Baby Grand	n/p	£246	£300	£225
Model 58 Iron Barred Baby Grand	100	£219	£280	£200

[Key: n/p = not in production]

they were 'priced out of the market'; and it is not surprising to discover that by the 23rd August the following year, all these larger models had been discontinued.

This was a great tragedy for Broadwood, because it meant that the company was no longer in a position to provide the larger, quality grands sought after by serious professional musicians for concerts and recitals. It must have been a great blow to the pride and self-confidence of the company to see its best and most-admired instruments withdrawn from public sale simply because of over-pricing. By the 23rd August 1920, the smallish model 4 barless 'Quarter Grand', 170cm in length, cost almost as much as the full concert model did some nine years earlier; and the barless baby grand, only five feet in length, now cost some 25% more than the large 7' 6" 'Drawing Room' grand of 1911.

From 1920, the two smallest models (5-foot and 5'7") were by and large the only grands available from Broadwood. They continued to be made and advertised throughout the 1920s, and were offered either as iron-barred or steel barless versions. In April 1923, model 4 barless grand retailed at £270 (considerably less than the £325 of 1920), whilst the barred model 4 was available at £240. The price of the barless baby grand had now been reduced to £225, and its barred twin version, to £200. These reductions in price were achieved because of a significant reduction in raw material costs.(4)

The fall in prices must have encouraged Broadwood to consider a reintroduction of their larger models; but this was done only half-heartedly: a few barless concert grands were made in the period 1922-1925, but it is quite possible that this was a matter of using up 'old stock' frames which may in fact have been made before the First World War and which might have been lying in the company's store waiting for use for some nine or ten years. Sadly, Broadwood's three best grands were never reintroduced in a serious way - in other words, they never went into regular production again after 1920; and those few concert models made during the period 1922-25 do not appear to have been advertised in Broadwood's general retail publicity. The writer has had

the opportunity to spend a day working on one of the last barless concert grands ever made by the company, an instrument bearing the serial number 54604, made in 1925, and very much a 'last fling' for Broadwood as far as concert piano production was concerned. (5) In the writer's opinion, this very fine instrument is equal in every respect to the best concert pianos manufactured in Germany which were also available in 1925 (Bechstein, Steinway, Blüthner etc). It makes it all the more depressing when one reflects on the fact that a company which had such fame, prestige and a long-standing reputation for quality, as Broadwood did in 1920, should within a relatively short period of time lose the will to maintain any presence on the concert platform.

In fact, if we are to detect the most serious underlying problem within the Broadwood company during the early 1920s, this appeared to have been a massive loss of confidence in its own ability to produce a high-quality product acceptable for serious professional use. It is hard to pin-point the source of this unfortunate sense of 'inferiority'; but we can suggest that things were not made any easier by the underlying attitude from the Broadwood directors that the piano, as a successful, saleable object, had a precarious future. Why else would the Broadwood company have attempted to 'diversify' and commence the manufacture of gramophones in the year 1919, something which the leading German piano manufacturers would not have dreamt of doing? (6) During the early 1920s, the company was not trading at a profit, and the introduction of gramophone manufacture was obviously an attempt to maintain 'volume' of output (of 'wooden' items of household furniture) whilst attempting to return to profitability. The company was not only losing its confidence in its ability to produce serious concert pianos; it had begun to lose faith in piano manufacturing as a way of life, and must have doubted whether the industry had any serious future prospects. In contrast, the gramophone industry, rapidly increasing its sales, was seen to have a very promising and glamorous future, like the developing radio and film industries.

Broadwood's ultimate failure in its dabbling in gramophone manufacture, which occurred some five years later,(7) meant that time, money and

expertise had been wasted. The company might have been better advised to have spent its available spare capital on re-launching its tried and tested conventional barred (iron-framed) large overstrung grand models which it had successfully introduced in the late 1890s, followed by a modest amount of regular research and development to ensure that the tonal qualities of these models were on a par with the best instruments available from Broadwood's English or continental competitors. Certainly the barred grands, with their ordinary cast-iron frames, would have been considerably cheaper to manufacture than the company's steel barless specimens.

For most of the 1920s, the Broadwood grand product range comprised only two models, the 'baby' model and the 'quarter grand'. Both sizes of instrument, each less than six feet long, were essentially products for the domestic market. (These models are shown as figures 8/3a, 8/3b and 8/3c). As the 1920s progressed, the Broadwood directors decided that, if the company was to continue as piano manufacturers, then it was to be as the provider of smaller and more modestly-priced instruments for the domestic market, rather than manufacturers of larger expensive grands for professional use. In the year 1927, a third model was added to the grand range, the first completely new model of grand to be introduced by the company since 1912. This was the model '0', an even smaller baby grand of only 4' 6" (137cm) length, designed by the factory manager, Robert Collen.(8) Here was further proof that the company was moving 'down market' and pursuing the policy of manufacturing more compact domestic products at a competitive price.

During the late 1920s, the small grand was becoming increasingly popular. New models of this size and type had recently been introduced by the Chappell, Challen, Monington and Weston, Hopkinson and Aeolian companies, and they were selling well. In particular, Challen's model 16 (in production from the mid 1920s) and Chappell's 'Bijou' model (1926) were popular with piano dealers and music shops. Clearly, Broadwood was responding to the growing public demand for a very small baby grand when they introduced the model '0'. However, the instrument was of indifferent tonal quality, and, because of its extremely short length, possessed a



BY APPOINTMENT
to British Sovereigns from
George II. to George V.



Model No. 57.

JOHN BROADWOOD & SONS, LTD.

Fig 8/3a: Model 57 barless baby grand, length 5ft (153cm)
(from a brochure of 1923).



BY APPOINTMENT
to British Sovereigns from
George II. to George V.



Model No. 58.

JOHN BROADWOOD & SONS, LTD.

Fig 6/3b: Model 58 iron-framed barred baby grand, length 5ft (153cm)
(from a brochure of 1923).



BY APPOINTMENT
to British Sovereigns from
George II. to George V.



Models No. 4F and 4s.

JOHN BROADWOOD & SONS, LTD.

Fig 8/3c: Models 4F and 4s quarter grand, length 5' 7" (170cm)
The 4F has an iron barred frame, the 4s a steel barless
frame. The two models have identical casework.
(from a brochure of 1923).

very disappointing bass register. The model 'O' also featured Robert Collen's new idea of heavy brass studs attached to the long mainbridge in place of the traditional hand-carved bridge with guide pins. The brass studs held the strings in their correct positions on the mainbridge instead of the guide pins. This feature, (a cost-saving measure, as it could be installed by semi-skilled labour and at great speed), certainly further worsened the tonal quality of the model 'O', and led to horrified reactions from those within the industry who were loyal to Broadwood and who remembered the large, fine quality grands the company had produced before the First World War.(9) The new brass studs, because of their weight (one for every note) stifled the resonating capacities of the soundboard and created a high degree of 'falseness' (unwanted pulsating 'beats') in many of the strings, making tuning generally unpleasant and more difficult. A full set of these heavy brass studs added a further burden of approximately 850 grams of unwanted, stifling mass to the soundboard. It is easy to see how they were a serious detriment to the tonal qualities of any piano.

On July 20th 1926, the King and Queen paid an official visit to the Broadwood factory at Old Ford, Hackney. Details of the visit were recorded in a specially-produced commemorative illustrated brochure, entitled, 'Broadwood. The Piano of the Nation for Six Generations'. (10) King George V and Queen Mary toured the factory, met a token number of workmen from the staff of some 750 employees, and witnessed all stages of piano manufacture, including the bending and shaping of the laminated grand rims. During their tour, they were introduced to seventy-five-year-old George Nicholson, the senior 'belly-maker' or constructor of piano soundboards, who had worked for the company for some fifty nine years, since 1867. The commemorative brochure noted:

'Despite his age, he works without glasses, and as, with unerring skill, he picked up a bundle of pieces and turned to his glue pot, the King opened his eyes in astonishment and asked, 'Are you going to stick them together all at once?' 'Yes, Your Majesty,' replied the old man, and proceeded to show how he did it with that simple, unflurried assurance characteristic of the experienced worker in the most unusual

circumstances of his life, and it was indeed an unusual circumstance for him to stand face to face and shake hands with his King.'

The underlying purpose of the Royal visit was obviously a gesture of support for the London piano industry. At the same time, shortly after their visit, the King and Queen placed an order for a new barless baby grand for Buckingham Palace. The instrument, serial number 54315, was destined for the Music Room at the Palace, where it still stands, placed in the large bay window there.(11) The baby grand looks tiny, dwarfed, and insignificant in the imposing, monumental, late baroque decorations of the Music Room. A larger Broadwood grand, such as the concert model, would have looked much more appropriate in this particular setting. The tragedy was that Broadwood, as Royal Warrant holders in 1926, were nevertheless probably unable to supply such a grand. Their horizons were settled on the small domestic compact models which sold much more readily in music shops.

The 'Challen-Broadwood', 1931-1938

The chronic unsatisfactory financial situation which dogged the company throughout the 1920s had become more serious by 1930. Retail sales were diminishing as a result of competition from alternative forms of entertainment - radio, gramophone and cinema; the factory capacity was considerably underused, but overheads remained high; the quality of the Broadwood product had declined noticeably over the previous four or five years, which in turn had a negative affect upon sales; and of course there was the other serious problem of the owners and directors of the company losing faith in the future prospects of their product. One of the senior partners, Leopold Broadwood (1890-1980) (the son of Henry JS Broadwood who had patented the barless grand) became so disillusioned with the piano industry that he left the firm for good in 1928. This act must have further sapped the morale of the ailing company.

It came as no surprise, therefore, when the company was declared

insolvent in the spring of 1931. Alan Rae Smith was appointed Receiver and Manager of the firm in March of that year, and within a very short time piano manufacturing had ceased at the Broadwood factory at Old Ford, Hackney. The measures taken by the Receiver were drastic: the vast majority of the workforce were dismissed; the firm's stock of timber and piano parts was sold at auction; the factory premises were cleared and let as quickly as possible to new tenants; and all the special jigs, tools, patterns, templates and other equipment necessary to manufacture the Broadwood pianos, whether grand or upright, were destroyed. March 1931 was really the 'end of the road' as far as continuity in the manufacture of the original, unique, Broadwood musical instrument was concerned.

A new company, trading as 'John Broadwood and Sons Ltd' was floated, with members of the Broadwood family as shareholders and directors; but its activities were confined to piano retailing, tuning and repairing. A source of new pianos, which the new company could sell, now had to be found. By the month of May 1932, an agreement had been reached with the Challen company of Hendon (Charles H Challen Ltd), manufacturers of medium-priced but well-designed grand and upright instruments. A contract was drawn up whereby the Challen company agreed to manufacture instruments bearing the name 'Broadwood' for a period not exceeding fifteen years. The best Challen models would now have the name 'Broadwood' attached. The instruments would be made and marketed by Challen, and the new Broadwood company would receive a royalty payment for each piano sold. (12)

The Challen grands which bore the Broadwood name were, in general, better-designed and better-sounding instruments than the last grands made in Broadwood's old factory at Hackney; and they were considerably cheaper. The Challen company was lucky to have the services of Leslie Lawrence (1910-1972), a very talented piano designer.(13) During the early 1930s, Lawrence designed a new range of Challen grands which became the 'talk of the trade.' In particular, his 6' 4"(193cm) grand was a good design, and was chosen (in preference to instruments by leading German makers) by the BBC during the early 1930s for use in

broadcasting studios. Many examples of this particular model were sold to retail music shops with the name 'Broadwood' attached. Lawrence also designed, for Broadwood's benefit and for exclusive Broadwood use, two smaller grands featuring what might be described as 'semi-barless' frames. These models (number 24b, dating from 1935, and number 28, dating from 1936) had only one intermediate bar in their cast iron frames. In character, these frames were strongly reminiscent of the original Broadwood versions, and they were finished with the unusual deep copper-coloured bronze traditionally associated with Broadwood castings.

There is no doubt that during the 1930s, the Broadwood name brought great benefit to the Challen company, enabling it to increase production and profits; and similarly, the Challen designs of Lawrence brought great benefit to John Broadwood and Sons, and did something to restore the company's reputation as the provider of good quality, well-designed instruments, a reputation they had been in danger of losing during the late 1920s. A handful of craftsmen from the old Broadwood factory found employment at Challen's Hendon works; but we do not know whether their particular knowledge was of any benefit to the manufacturing company. We cannot overlook the sad fact that the closure of the original Broadwood factory in 1931, the dismissal of the long-established workforce, the loss of unique 'know-how', and the scrapping of the company's tooling, meant the certain end of continuity as far as the evolution of the true Broadwood grand was concerned. The new Challen models, for all their good points, were simply not 'Broadwoods'. They did not sound like a traditional Broadwood, they were not built in the same way, and the grands in appearance were quite different in character from those instruments made at the Hackney factory during the 1920s and before.

The Carrier-designed Broadwood grands, 1950-1982.

After the Second World War, the firm of John Broadwood and Sons was in a position to commence its own manufacture of pianos again. The agreement with Challen had been terminated in 1938, and in 1939, just

before the outbreak of War, a small, modern factory at Brunel Road, Acton, West London, had been leased. The workforce in 1950 and for the next thirty or so years was never more than a dozen men, and so the level of output at Acton was minute by comparison with production during the 1920s and 30s; in fact, in order to keep up with demand, most of the less-expensive Broadwood upright pianos during the period 1950 to 1980 were produced for Broadwood by another, much larger, manufacturer, Kemble and Company.(14) However, steps were taken to reintroduce grand piano manufacture at Brunel Road during the early 1950s. As we noted earlier, the firm had lost all its original designs and manufacturing equipment in 1931, therefore the new factory-manager, Bernard Carrier, was obliged to undertake the difficult and time-consuming task of designing new instruments 'from the drawing board'. He introduced two models of completely new design, a baby grand, and a medium-sized 'boudoir' model. These went into production in a very limited way (perhaps no more than half a dozen instruments per year).

As a result of their very limited production, Bernard Carrier's grands never became very well known within the piano industry. The standard of workmanship was good, and the pianos were always well-regulated and finished. However, there was criticism of the instruments from many quarters; in particular, the thin and weak tone of the baby grand's bass was pointed out, but nothing was done to improve this defect during the thirty years in which the model was made. The members of the Broadwood family who controlled the company at this period had little or no real practical knowledge about pianos design, or even awareness of good piano tone, and they appeared unable or unwilling to take the necessary steps to improve the firm's grands. Bernard Carrier, a strong personality, a good, respected, works manager, and a fine craftsman with great skill and much knowledge, was nevertheless a 'law unto himself' when it came to piano design. He was not an easy person to work with, and this fact was certainly a great obstacle to any improvements in grand design during this period of the company's history. Carrier's best work is found in his uprights, and his model 10F, Broadwood's best upright for over thirty years, was a credit to the company and sold well. (15)

The Danemann Broadwood, 1982-1984.

Production at the Brunel Road works was declining during the late 1970s and early 80s, after the retirement of Carrier. The Broadwood directors decided to vacate their leased premises and try to find an alternative manufacturing base. Two significant events then happened: the company sold its old factory at Hackney (which they had been leasing out since 1931) and as a result realised substantial new capital. Then the well-established north London piano maker, W Danemann and Company Ltd, (established in 1893) came up for sale at the time of Tom Danemann's retirement. Danemann, by now in his late seventies, had managed the factory almost single-handedly after the death of his elder brother Edgar; he was now anxious to retire, and he was happy to sell his business, with its freehold factory, to John Broadwood and Sons Ltd in October 1982.

The most one can write about the period 1982-84 in Broadwood's long history is that it is best forgotten. The Danemann manufacturing company borrowed £250,000 from Islington Borough Council to help 'maintain jobs in the Borough of Islington'; then, as a result of managerial incompetence of the highest order, there followed a period of great confusion and disorganisation. The factory was in serious need of radical reorganisation and modernisation; too many different designs were being made in too small a work space (at one point fifteen different designs of strung back were in production at the same time); 'undisclosed debts' of the Danemann company came to light; unbelievably, there were cash flow problems, and action, keyboard and bass string suppliers simply refused to supply when bills were not paid; for weeks on end, many of the Danemann workforce sat idle, waiting for parts to arrive.(16)

The Broadwood/Danemann fiasco thankfully lasted only twenty months: the Borough of Islington called in the Receiver on the 2nd July 1984, and the Danemann manufacturing company (though not *the* parent company, Broadwood) was finally wound up in the High Court of Justice on the 21st January the following year. The jigs, templates and patterns for the two Bernard Carrier grands, items which still belonged to the Broadwood

company, were personally removed by the writer of this account to his own workshop at Otley, West Yorkshire, in order that they could be put into long-term storage. (In 1984 the writer was a director of a piano-making company known as 'Laurence and Nash Ltd', trading from Otley Mills). About three years after the arrival at Otley of the grand manufacturing equipment, Laurence and Nash Ltd decided to purchase these particular items (with other manufacturing materials and tooling), intending to use them at some future date. Eventually, however, in the summer of 1992, the items were purchased by piano technician Ken Forrest; and at the time of the writing of this chapter (September 1998), they lie half-forgotten and gathering dust, in store at Ken Forrest's workshop, Colne, Lancashire.

The Birmingham Barless, 1997.

Following the disastrous failure of the Danemann venture, the Broadwood company managed to retrieve itself from the unpleasant Islington affair and survive intact as an independent company, pruned down to the barest of essentials: the firm now consisted of one small office at Stony Stratford, Milton Keynes, containing three employees: a general manager and two secretaries. In February 1985, the ruins of the Broadwood business were purchased by Geoffrey Simon, a Birmingham solicitor. During the thirteen years in which Mr Simon has owned the company, production of Broadwood upright instruments has been carried out at two factories: the Bentley Piano Company's premises at Woodchester, near Stroud, Gloucestershire; and, after the closure of the Bentley Piano Company in 1993, the London works of Whelpdale, Maxwell and Codd Ltd, (makers of the Welmar piano) from March 1994. Grand pianos bearing the name 'Broadwood' are no longer made in England: they are imported from Taiwan.

Today, the Broadwood company has only one 'regular' employee, the writer of these words. He works from an office at Moss, Norway, where, acting as a consultant to the company, his main task is to deal with over 150 historical and technical enquiries each year which the company

receives from enthusiastic piano owners from all over the world. Geoffrey Simon has helped to establish a small piano-manufacturing unit to the rear of Ladbroke Pianos Ltd, a shop in the centre of Birmingham. Consisting of four or five Ladbroke workmen who are also engaged in piano repair work, the workshop has produced two or three new barless uprights each year since 1995, models which are based on a prototype designed by the writer of these notes.

Interestingly, in the autumn of 1997, Ladbrookes launched a prototype barless grand piano, built in the Birmingham workshop, which is a close copy of Broadwood's model 4 'quarter grand', originally introduced in 1903. This instrument received its debut at a private function in the concert hall of the Royal College of Music, London, on the 27th November 1997, when approximately three hundred curious guests attended a recital and witnessed the rebirth of 'Broadwood tone'. Shortly afterwards, the same instrument, as a 'creative and innovative product' won a Design Council Millennium Award. On the 26th April 1998 the Birmingham barless received its second public airing, this time at a lunchtime recital at Berrow Court, Edgbaston, Birmingham. Whether Ladbroke's commendable venture leads to further evolution of the Broadwood grand piano remains to be seen.

THE ROYAL COLLEGE OF MUSIC

RECITAL 27TH NOVEMBER 1997

The first public performance of the new Broadwood "Barless" Grand Piano

Introduction
Dr Janet Ritterman

PROGRAMME

Variations on a Theme of Paganini Op 35 - book 1 *Brahms*
Solo piano *Jean-Baptiste Foniupt*

Variations on a Theme by Salieri W0073 *Beethoven*
Fortepiano *David Ward*

Variations in G Major K501 *Mozart*
Fortepiano duet *Mami Shikimori*
Florian Uhlig

Slavonic Dance Op 72 No 2 *Dvorak*
Piano duet *Ruth Gerald*
Yonty Solomon

Ballade in G. Minor Op 23 *Chopin*
Solo piano *George Lazaridis*

CHAPTER 9:

CONCLUSION.

The continued production of grand pianos by John Broadwood and his successors over a period of two hundred years is an example of a remarkable degree of continuity. No other firm of English musical instrument makers shows such continuity, unless of course we include the Whitechapel Bell Foundry, a firm which occupies a medieval bell-founding site in East London, but which has changed ownership on many occasions during its long history.

As far as the histories of English industrial enterprises are concerned, the only parallel to Broadwood's continuity which immediately springs to mind is that of the firm of Wedgwood, manufacturers of pottery near Stoke-on-Trent since the late 18th century. However, there is a significant difference between Wedgwood and Broadwood: the Wedgwood product of today is more or less identical to the pottery manufactured by the same company in the late 18th century; there has been very little change in the product over a period of two hundred years. In contrast, Broadwood's products, although bearing the name 'grand piano', have evolved in a remarkable way over the same period.

The long survival of the Broadwood company can be easily accounted for. To begin with, the Broadwood name had become a household word by the mid nineteenth century, not only in Britain, but throughout the world - as a result of the phenomenal growth of the British Empire. There is ample evidence in the Broadwood Porters' Books to show that the company's Horseferry Road works made pianos which were shipped to all parts of the Empire. Such a firmly-established reputation certainly helped the company to realise 'global' sales for many decades after the mid nineteenth century, and helped to assure the survival of the business. Today, the name 'Broadwood' is still internationally known in piano circles, even though many pianists, piano teachers and tuners may actually not have seen or heard a Broadwood

instrument. The only other old established piano manufacturing firms which share a similar level of world renown may be counted on the fingers of one hand: Steinway, Bechstein, Blüthner, Bosendorfer and Erard.

Broadwood's long survival was further helped by the fact that the company was well capitalised - by the accumulated wealth of various members of the Broadwood family. It was the first two generations of piano manufacturers - John and his sons James and Thomas - who appeared to have been the wealthiest. Thereafter, the family's wealth began to decline; but there were nevertheless still sufficient reserves of family capital to help keep the company afloat during difficult times. A relatively recent example of this phenomenon occurred during the 1950s and 60s, when the small and sometimes ailing family firm was propped up by funding from the personal wealth of Captain Evelyn Broadwood, one of the shareholders.

A third significant detail which helped to ensure the firm's survival was the matter of quality of workmanship and raw materials. Although the tonal and touch qualities of Broadwood grand models are variable, the company maintained a consistently high standard of workmanship, and persevered in using only the finest-obtainable materials, from the very beginnings of grand manufacture until the late nineteen twenties. As a result of these factors, the Broadwood grand piano could be relied upon to be a highly durable household item and a worthwhile 'investment'. Timber was always carefully selected and well seasoned. For many years the company had its own timber wharfe on the north bank of the River Thames. Veneer was always 'thick' cut, helping to ensure casework stability, and only the most interestingly-grained pieces selected for use in casework decoration. Key coverings were of the finest obtainable ivory and ebony. Brass fittings, such as locks, clips, hinges and wheels, were robust and dependable. The action parts were beautifully machined, and all cloth, leather and felt used in action manufacture was the finest Broadwood could obtain. The laquering process by which each piano was finished was so distinguished that it was given a special name within the furniture industry: a 'Piano Finish', the name given to the finest and most luxurious wood finish of all.

Broadwood's maintenance of high standards of workmanship was assured

by a workshop system based upon well-trusted senior foreman and well-trained apprentices. Each foreman, although in charge of only one particular stage of grand piano construction, was nevertheless responsible for quality control. Each foreman was also a kind of 'employer': it was his role to 'hire and fire' those working under him; and if one particular worker was not performing up to the required company standard, then he was soon replaced by another who could. The apprenticeship period of five years ensured that each young worker developed a high level of skill in the particular aspect of piano construction he was engaged in. As an example of this thoroughness of skill development, we can note that a trainee piano tuner was required to spend one year as a stringer before he could proceed to begin to learn the art of tuning.

If Broadwood grands have been criticised from time to time because of their shortcomings as musical instruments, these same grands have never been criticised for shoddy workmanship or poor quality materials. Broadwood grands are noted within the piano industry for their durability: their ability to withstand year-in year-out wear and tear with the minimum of problems. If we are to detect a weakness in some Broadwood models (such as lack of sustaining power, or uninteresting tone, or difficult touch) then this is usually a design fault rather than being the result of inadequate workmanship or faulty materials.

One of the remarkable features of the social aspect of Broadwood's factory system was the way in which the maintenance of quality control was in the hands of a 'clan' of a few inter-related families who made up the 'inner core' of senior workers. The surnames Rose, Murray, Black, Wilkie, Forsyth and Finlayson crop up time and time again throughout the nineteenth century. Most of these families were of Scottish origin, and all of them traced the beginnings of their employment with Broadwood back to the period of John Broadwood himself, when it was the company's policy to choose Scotsmen as workers. Such closely-knit dynasties of inter-related families, all with an interest in maintaining jobs for their offspring, helped to reinforce the 'future prospects' of the company, and so maintained continuity and helped survival.

In chapter 2, page 29, mention was made of the Finlayson family, ancestors of the writer of this dissertation, who came from the village of Redcastle in Ross-shire and who were employed in John Broadwood's Soho workshops by the year 1787. Alexander Finlayson's signature is handwritten on the action of the earliest-surviving Broadwood grand, made in that year. One hundred years later, two Finlayson brothers held positions of responsibility within the company: John Finlay Finlayson (1813-1886) was company wages clerk; and his younger brother William (1827-1907) was piano tuner to Queen Victoria. Their nephew Alfred Marlborough Laurence (1844-1923), who (unusually for a 'worker') spoke fluent French, had responsibility for Broadwood's pianos at the Paris International Exhibition of 1867.

Perhaps the most intriguing family link-up at Broadwood's was that of the Rose, Black and Hipkins families. The accompanying chart (fig 9/1) clearly shows the connections between the three families. The chart also shows that for most of the second half of the nineteenth century the day to day administration of the company's affairs was in the hands of four closely related individuals who were not actually members of the Broadwood family. They were George Thomas Rose, company accountant and a partner on the board; his younger brother Frederick Rose, manager of the Horseferry Road factory and also a partner; their brother-in-law Algernon Black, chief clerk; and another brother-in-law, Alfred James Hipkins, a concert tuner who was also in charge of the sales department in Great Pulteney Street. Hipkins' scholarly and valuable book, A Description and History of the Pianoforte (1896) has been noted on a number of occasions in this dissertation.

The Rose/Black/Hipkins dynasty was carried into the early twentieth century in the shape of George Daniel Rose, designer of the famous barless grands, who succeeded his father as factory manager; and also by Algernon Rose, George's younger brother, in charge of export sales. George D Rose's departure from the company in 1908 as a result of a dispute over manufacturing policy was a severe blow to Broadwood: the firm lost the talents of a loyal and devoted servant whose outstanding abilities as a piano designer had helped to ensure continuity of the Broadwood product into the twentieth century.

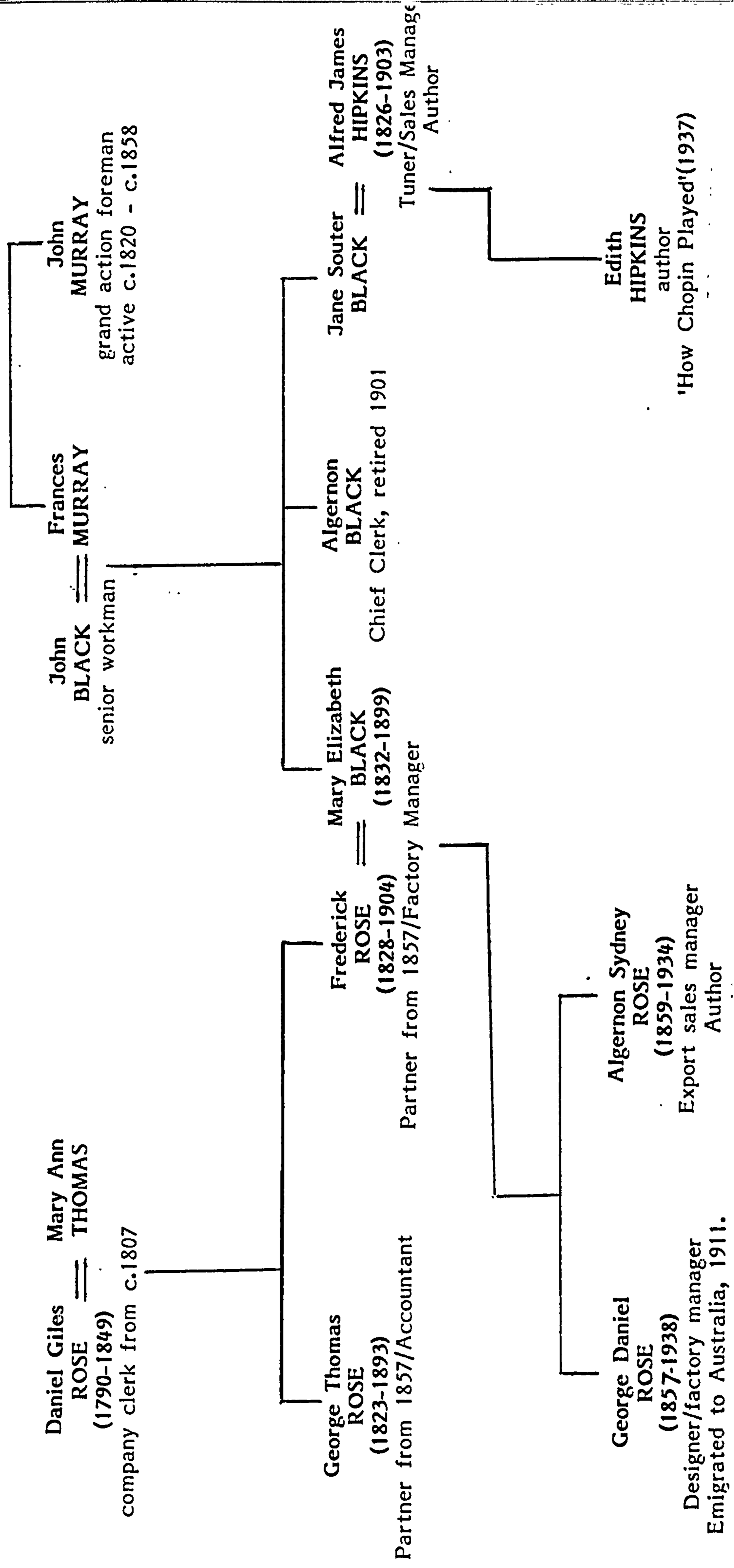

Fig 9/1: Showing the family connections of Broadwood's senior employees.

One question that is often raised by those interested in Broadwood instruments concerns the identification of 'good' or 'indifferent' models, or, alternatively, 'good' or 'indifferent' periods of manufacture. Pianists, piano teachers, tuners, restorers and dealers alike are always curious to know such information. The monetary value of any grand obviously depends on its musical qualities as much as its beauty and interest as an object of furniture.

It is indeed possible to identify historical periods during which the Broadwood was not as good as it was at other times. It is apparent that the varying musical standards which may be found are to a large extent the result of the level of flair, skill and experience of the one individual (usually a member of the Broadwood family) who had the control of the company at the time, and who was also responsible for design policy. The quality and type of grand piano produced at any one time was very much a manifestation of the whims, tastes and opinions of whoever was 'governor' or master piano builder; and if his tastes and opinions were ill-judged or ill-informed, then clearly the end product suffered as a result.

We can trace a pattern of differing musical qualities of piano related to individual members of the Broadwood family. The earliest grands, whose production was supervised by John Broadwood (between 1785 and 1811) are always highly regarded for their musical qualities (touch and tone) and they are continually sought after for use by specialist keyboard performers. The high musical qualities of these instruments are partly the result of John Broadwood's inspiration and technical skills; but they are also the end result of his exposure, on a day to day basis, to the opinions and advice of the greatest pianists of his age, ranging from Clementi and Dussek to Haydn and Cramer. We must not overlook the fact also that John Broadwood had learnt how to create musical sounds from pieces of wood from one of the greatest harpsichord builders of the time, his father-in-law Burkat Shudi; and then we have to consider the probability that other specialist German craftsmen with combined musical and joinery skills were aiding Broadwood in a more or less anonymous capacity within his workshop, perhaps contributing significantly to the evolution of his earliest examples of grand piano.

Turning to John's eldest son, James Shudi Broadwood, the overall

impression one gains when attempting to evaluate his achievements during his time as 'governor' of the company (1811-1851) is that of a disappointing period musically, in spite of enormous technical advances in piano construction. This is surprising, considering that it was James and not his father John who had Shudi's blood in his veins, and that it was James who had both musical skills (he played the piano) and technical skills (he could tune and undertake other manual tasks). The grand pianos made during the earlier part of his reign, from 1812 to circa 1827, still owe a great deal in their scale design and overall conception to his father, John. Perhaps this is why Broadwood grands of the early 1820s are still interesting instruments musically.

However, as the 1830s and 40s progressed, the sound of the Broadwood grand became increasingly 'prosaic' and uninteresting, and the touch became increasingly unwieldy and unresponsive. There are very clear scientific reasons for these disappointments: James had redesigned his soundboards so that they comprised short pieces of wood running across the width of the piano, at right angles to the mainbridge. Such an arrangement, although good for structural strength, was not particularly favourable musically. To make matters worse, James appeared to be incredibly ignorant about the importance of correct strike proportion: his 'Chopin' period grands from the 1840s have strings which are struck mainly between one sixth and one seventh of their lengths throughout the compass, instead of the more customary range of between one ninth and one twelfth (found on Broadwood models made before and after James's time). The musical result of striking strings between one sixth and one seventh of their length is the creation of a bland, 'hollow' and rather uninteresting tone colour, somewhat lacking in definition and incisiveness. The touch of James Broadwood's grands became increasingly heavy as the result of the application of heavy felt hammers to a mechanism - the old English single lever action - which was not altogether appropriate for this modification; and attempts to improve the action's repeating qualities in the late 1830s with Southwell's springs were not a success.

To be fair to James, we must remember that he was working during a very experimental period, during which the grand piano evolved much faster than in his father's time. The arrival of new technical features such as iron bars, iron hitch plates and felt-covered hammers must have de-stabilised

previously-held conceptions about piano design, and perhaps led, if only momentarily, to a lack of clear-headedness in aspects of piano tone creation; and moreover, it was not just the Broadwood grand which suffered a musical decline during James's time: other leading English makers such as Collard and Kirkman produced instruments, designed along the same lines as James Broadwood's, which were just as uninteresting.

With the arrival of Henry Fowler Broadwood, James's son, who was governor between 1851 and 1893, we see first a period of great improvement in the Broadwood product (1851-1862), followed by a long 'stagnant' period (1864-1893) during which the firm's grand designs gradually became more and more old fashioned. Henry's early enthusiasm was the result of his ambition, combined with the urgent need to compete successfully on the concert platform with other leading grand manufacturers, particularly Erard. Henry's new range of 'iron grands' designed in the 1850s were as good as anything else available at that time. After 1864, when Henry wilfully neglected the ancestral factory and lived the life of a country gentleman in Surrey, the Broadwood design became fossilised, and Henry refused to change it, much to the dismay of more progressive personalities within the firm who saw the need for evolutionary change.

Immediately after Henry's death in 1893, we witness the sudden birth of a very productive period in Broadwood's design history when, within a relatively short time, the firm introduced overstringing, barless frames cast from mild steel, Erard-type double escapement actions, and so forth - in short, everything that was needed to haul the product into the twentieth century. The driving force behind such long overdue changes was George Rose, supported and encouraged on the sidelines by the Henry Broadwood (son of Henry Fowler) who had patented the barless idea in 1888. This very fertile design period created a range of fine thoroughbred models which were equal, in every respect, to the finest grands ever made on the continent. We may note in particular the barless concert grand (introduced in 1898), in musical terms perhaps the finest grand piano ever produced in England. Broadwood's high standard was maintained up to the First World War period.

The tragedy of the nineteen twenties may be summarised as a period

during which the company, now under the direction of quite unmusical members of the Broadwood family, completely lost its confidence in its ability to produce high quality concert pianos. A deliberate 'down market' move was made, the large, professional grands were phased out of production, and the firm, whenever it made a grand, chose to build a little model for the cosy modern home. The concert platform was shunned, and so were the early radio and recording studios. At one period in the early 1920s the firm appeared to be more interested in the manufacture of gramophone record players than pianos. Novel technical developments to the piano undertaken by the works manager Collen in the late nineteen twenties damaged rather than enhanced Broadwood's long-standing reputation

The final closure of the Broadwood factory in March 1931 meant the end as far as any 'continuity' in Broadwood grand evolution was concerned, in spite of periods since then during which pianos bearing the Broadwood name, but designed by others, have been constructed by the Challen, Kemble, Danemann, Bentley and Welmar companies. The revival of grand piano making in Broadwood's new Brunel Road factory during the 1950s was a welcome sign, but very few instruments were made, and irritating design faults, which the company appeared unable or unwilling to do anything about, marred the success of the product. The recent (1997) replication of a barless model 4 'quarter grand' of 1903 by the Birmingham firm of Ladbrokees has been an interesting development. The new model has been much praised during its public airings, and it is hoped that more examples will be produced. It is only as a result of Ladbrokees enterprise that the making of Broadwood grand pianos in England has been carried through into the twenty-first century.

APPENDIX I :

James Broadwood's and John Farey's correspondence about piano tuning, which appeared in the 'Monthly Magazine', 1811.

To the editor of the Monthly Magazine

'Sir,

Observing in several of your Numbers, articles on musical subjects, I flatter myself that you may gratify some of your numerous readers by inserting the following observations on, and the best practical method of, tuning keyed stringed instruments.

From whatever tone the tuner begins, it is still the practice, as in the old system of temperament, to end the succession of fifths tuned from notes below in G sharp; and in those tuned from tones above in E flat, whereby the inequalities arising from careless or defective divisions, are thrown into the key of A flat; with this view I prefer tuning from A the second space in the treble cliff [sic] as being less remote from these two finishing fifths, than any other point of departure; the A being tuned to the fork, tone A below an octave, then E above (that octave) a fifth; then B above a fifth; then B below an octave, then F sharp a fifth above, then its octave F sharp below, then C sharp its fifth above, then G sharp its fifth above, then G sharp its octave below. We then take a fresh departure from A, tuning D its fifth below, then G its fifth below, then G its octave above, then C its fifth below, then C its octave above, then F its fifth below, then B flat its fifth below, then B flat its octave above, then E flat its fifth below.

The five fifths tuned from notes below, are to be tuned flatter than the perfect fifth, and the six fifths tuned from tones above, be made sharper than the perfect in proportion. I will endeavour to explain. If the whole be tuned correctly, the G sharp with the D sharp, (which is the same tone on the pianoforte as E flat) will be found to make the same concord, that is, possess the same interval as the other fifths.

There are many amateurs who can draw up two strings to an unison, or produce a good octave, or perfect fifth, yet are unable to appreciate or

make a proper fifth, without which, the temperament necessary to these instruments cannot be formed. This proper fifth is not that given to the violin, or pitched by the voice, which are perfect fifths, but is somewhat a flatter fifth, that is, the interval between A and E on the piano-forte, by rather less than the same interval on the violin, both being understood to be relatively and properly well tuned.

This difference varies according to the temperament intended to be given; but, as the old system of temperament is now deservedly abandoned, and the equal temperament generally adopted, it will be only necessary for me to point out a method of ascertaining the degree of interval required for its proper fifth, which, though not so unexceptionable as I could wish, is perhaps as correct as the nature of the thing will admit, considering the difficulty of conveying on paper the particular distinction of sound we may have in idea; and I offer it the more readily, because in the several little treatises professedly published to make tuning easy, I do not meet with any attempt to give a like guide.

Suppose two strings, B and C in the middle octave of the piano-forte, to be one full semitone from the other; with your hammer lower down, or flatten, C by the smallest possible gradations, until it becomes unison with B; with a tolerably steady hand and a few trials, you will be enabled to enumerate forty gradations of sound, which I call commas. After a little practice having acquired a distinct and clear idea of the quantity meant to be represented by the term comma, nothing more will be required to make the proper fifth, (after having tuned the fifth a perfect, or violin, or singing fifth) than to flatten the said perfect fifth by lowering the string supposed to be tuning, one of the afore defined commas.

Every thing depends on the correctness of this fifth; as, although the unisons and octaves be individually correct, there will be no harmony in the whole, should the temperament be not properly laid.

Those who, after giving this method an attentive trial, are still unable to satisfy themselves in the temperament, may have recourse to a set of twelve forks, correctly tuned, to twelve semitones in the octave, to which the keys in the middle octave are to be tuned unisons; and the notes to the right and left be, as usual, from these tuned octaves. Some gentlemen who have made trial of this mode, have written to me, that

they have succeeded beyond their most sanguine expectations, and find themselves competent to put their instruments in better tune than they could before get done for them in their neighbourhood.

JAMES BROADWOOD

Great Pulteney Street, July 11, 1811.'

To the Editor of the Monthly Magazine

'Sir,

On various occasions since the appearance of the stereotype pamphlet of Earl Stanhope, on tuning, I have been told by professors and teachers of music in the metropolis, that the equal temperament, as laid or tuned by Mr Broadwood, and the tuners in his employ, is alone applicable or in use for modern music, owing to the use of any one key having become as frequent as that of any of the others; without assenting to these assertions, I have constantly enquired of such gentlemen, 'how does it appear that Mr Broadwood does tune an equal temperament?' or, in other words, 'that all the 12 fifths on his instruments are made equal?' but I have always found this question evaded, and am therefore happy to see Mr Broadwood come forward, at page 106, of your last Number, and attempt to explain his method of tuning. As the magnitude of musical intervals and the principles of tuning are capable of exact mathematical treatment, I beg to make a few observations, and put some questions, for the sake of information, on what Mr B has laid down.

By a reference to the article Equal Temperament, in Dr Rees' Cyclopaedia, it will be seen, that the perfect fifth (of the violinist or singer) must be flattened one of a small interval called a schisma (and marked Σ) in order to produce an equal temperament; the perfect octave ($\frac{1}{2}$) being composed of 6 12Σ , (neglecting some extremely minute intervals that it is not necessary here to notice as being, perhaps, quite insensible in practice) the fifth ($\frac{2}{3}$) of 3 58Σ , the major semitone ($\frac{1}{12}$) of 57 Σ , the major comma ($\frac{8}{801}$) of 11 Σ , etc. The equal temperament fifth is therefore 3 57Σ ; 12 of which, or 4 284 is exactly equal to 7 octaves, or $7 \times 612 = 4284$, that must be fallen or

risen, to keep the tuning of 12 fifths within the compass of one octave. Now the full semitone B to C, mentioned by Mr B. should either be the 12th part of the octave or 51Σ , if it be an equal temperament semitone, or 57Σ , if it be a perfect or diatonic semitone; but, instead of which, Mr B., directs his semitone BC to be divided into 40 equal parts! Now is this comma of Mr Broadwood the 480th part of the octave, or is it the 40th part of 57Σ , or 1 and $17/40 \Sigma$, or what other value does Mr B. mean to assign to his comma?

I have only further to remark, that whatever may be Mr B.'s answer, the nature of things and ratios cannot be changed thereby, or any other value than Σ be shewn to be the proper flattening of the fifth (of 358Σ) for an equal temperament, and I pledge myself, in the event of Mr B. assigning any other value than 357Σ to his tempered fifths, to prove by a table of the beats, the only correct mode of tuning, that his is not an equal temperament, but that one or more wolves will be found among his fourths, among his major and minor thirds, and among his major and minor sixths.

JOHN FAREY senr.

Ashbourn, September 6, 1811'

To the editor of the Monthly Magazine

'Sir,

If Mr Farey will peruse again the article on Tuning, in your Magazine of September, he cannot but perceive my object to be, not to advocate the correctness of any system of temperament, but to point out 'the best practical method of tuning keyed stringed instruments'. I gave instructions to produce the interval of a proper fifth in the temperament called the equal temperament, from its being in most general use, and because, of the various systems, it has been pronounced the best deserving that appellation, by Haydn, Mozart, and other masters of harmony. After the pledge given by so renowned a champion in musical controversy as Mr Farey, that he will prove the error of whatever I may advance, it would be temerity in me, were I so inclined, to attempt

enquiring into the relation betwixt his schisma and my comma. But, being still of opinion, in spite of all I have read and heard, that mathematical speculations cannot be of any practical use in directing the tuning-hammer (a mere mechanical operation, guided by the ear, as the brush of the painter is by the eye), I consider useless, to the object in view, my entering upon any.

JAMES BROADWOOD

Great Pulteney Street, Oct. 7'

To the editor of the Monthly Magazine

'Sir,

I am unable to comprehend the distinction which your correspondent Mr James Broadwood makes, at page 321 of your last Number, between his advocating 'the correctness of any system of temperament, and pointing out 'the best practical method of tuning keyed stringed instruments; especially, as he says, just after, that his system (loosely and impracticably as it is defined), of fifths flattened one-fortieth of the semitone from B to C, 'has been pronounced the best', by Haydn, Mozart, and other 'masters of harmony'. But where have they done so, or this system of Mr B. ever before been heard of? I beg to ask. I am equally at a loss to discover where Mr B. inferred that I undertook in your October number to 'prove the error of whatever he may advance' as to the 'proper fifth in the temperament called the equal temperament, since I there pointed out (as I have frequently before done), the schisma (neglecting the almost insensible fraction .0006552 of this small interval Σ) as the truth, which he ought to advance, and to practice also, unless he wishes to persist in imposing on the world a system of twelve tones as 'the equal temperament', which has no pretensions to that character; and assert his instruments when so tuned fit to be used alike in all keys, as has too often, to my knowledge, been asserted by their vendors, masters &c.

Before Mr B. attempts any further reply, let him consider that I am

not now contending with him whether the equal temperament be a good or bad system, the assertion being yet unproved, that as many strains of modern music are set and played in one key as in any other (as I intimated in my first letter), on which account alone, harmony so coarse and imperfect as the isotonic could be tolerated; and still less can that of Mr Broadwood's 'practical method', produced as he directs; where according to a table of the beats transmitted to me in Derbyshire, by a most able theorist and calculator, the Rev. CI Smyth, of Norwich, within a few days of Mr B's new system appearing (at page 106), it appears that the fifths on his notes C#, F#, C#, B^b, and B, beat no less than about 15, 20, 23, 12, and 27 times respectively in one second of time!! in his foundation or first tuned octave, whence those above and below are to be derived.

Before Mr B's bold assertion, that 'mathematical speculations cannot be of any practical use' in tuning, can have any weight, he must prove that he understands the nature and object of these speculations, so far at least as to define accurately what he means, as I have challenged him to do, and had a right to do, after he had volunteered in assigning the quantity of his temperament (though it happens to be 1/40th of an undefined semitone) and had himself brought his method strictly within the province of what he is now pleased to call mathematical speculation; and, to suit his present purpose, wishes to treat, as 'a mere mechanical operation', (mechanical enough, it is true) in the hands of most of the professional tuners of the day, and is ever like to remain while such assertions and reasonings as those I have been commenting on can pass current; but, hoping that the day of such things is now nearly past in all the sciences and liberal arts, I remain &c.

JOHN FAREY senr.

Upper Crown-street, Nov 5, 1811.'

APPENDIX: II

The 'CHOPIN' BROADWOOD GRAND, 1847-1998

A. Details of movements of this piano, 1847-1922, according to the Broadwood Porters' Books, (Surrey Archives):

[The surname/surnames which appear at the end of each date reference are the names of the porters who moved the piano on the date in question.]

Piano number 17047

'Brought in from factory 17th June 1847

'7 December 1847: Taking Grand Pianoforte Patent Repetition Rosewood c to g No. 17047 and case on hire addressed Mr Milson, Bath, delivered at Kings Arms, Holborn Bridge to go by Tanners Rail. Paid 1s. Wren.

'7 March 1848: Received - - - -from Mr C. Milson, Bath. Kings Arms. Paid 26s 6d hire since ['No charges JB' in another hand.]

'23 June 1848: Taking - - - - on hire for one night Mr Chopin Dover St. to Mrs Satoris, 99, Eaton Place and bringing do [ditto] from do [ditto] same day and moving GPF [grand piano forte] in the house. Wicks and Antoni.

'7 July 1848: Taking - - - - on hire Mr Chopin 48 Dover St. to Lord Falmouth 2, St James's Square and bringing do from do same day. Wicks and Antoni.

'23 August 1848: Taking - - - - on hire Monsr Chopin, Dover St, addressed Monsr Chopin care of Messrs Hine and Addison, Manchester, delivered at Chapel St. to go by Pickfords Railway. Wren.

'7 September 1848: Received - - - - Mr Chopin Dover St. from Messrs Hine

and Addison, Manchester, Pickford. Paid 25s 6d hire since.

'3 November 1848: Taking - - - - on hire to Monsr Chopin 4 St James's Place.

'13 November 1848: Taking Grand Pianoforte Patent Repetition Rosewood No. 17284 on hire to Mr Chopin 4 St James Place and bringing GPF No. 17047 from do [ditto]. W Pal and Hatcher.

'16 November 1848: Taking - - - - No. 17047 on hire for one night Mr Chopin 4 St James's Place to Guildhall and bringing do from do the next day. No charge. Child and Hall. [This was a charity performance in aid of Polish refugees.]

'25 November 1848: Taking GPF [grand piano forte] Pat Rep. [Patent repetition] Rosewood c to g No. 17047 and Case on hire. Taking his square PF extra size Rosewood c to g No 59582 tuned and packed in case The Marquess of Abercorn, Chesterfield House, addressed The Most Noble the Marquess of Abercorn, Dale Park, near Arundel, by rail to be left at the Station Arundel till called for. Delivered to New Inn Old Change to go by Heywoods Railway. [This may imply that both pianos went to Dale Park but may imply that 17047 went to Chesterfield House and 59582 to Dale Park].

'6 August 1849': This is a very damp affected entry (barely legible) which seems to involve the return of the Marquess of Abercorn's piano from Chesterfield House or Dale Park.

'21 September 1849: A - - - - Elegant Rosewood (160 Guineas) George Wigg Esqr 22 Mecklenburgh Square delivered to George Wigg Esqr 61 Westbourne Terrace Per Mr C Willing [?] 5 Charlotte T, Pentonville. Con £UD. Cr GPF in the house £CD 3s. Hatcher and Ramsey [?].

'23 March 1885: F.H. Appach esq, Hungerford. Received old - - - from do to wait. We to pay all charges. GWR [Great Western Railway] pd 15s 4d.

'2 May 1885: Taking old Grand Pf (lent by Mr Appach) - - - - to the International Inventions Exhibition, South Kensington.

'10 Nov 1885: - - - - from Inventions Exhibition.

'21 Jan 1886: F.H. Appach esq, Elcot Park, Hungerford. Taking his old Grand - - - - addressed as above to Kintbury Station to Paddington to go by GW Rail. Paid Carriage 15s 10d. Pianoforte thoroughly repaired. ? charge say £10. 11 March 1886. We to bear all expenses of delivery etc. Sending Napier next day to unpack etc. Expenses £1-0-9. Wales.

'22 Jan 1900: Mrs Appach 23 Princes Gardens W (supplied a semi grand) and bringing old Grand Pf No.17047 from do to Credit £20 and say to pay £120 net difference of exchange. This Grand 17047 to be reserved, not sold. Chopin played upon it at his Recitals. Worrall and Witts.

'29 Jan 1904: Orchestrelle Aeolian Hall, New Bond St. Taking Chopin Grand - - - also No.5 Rosewood Grand - - - - No.47735 on hire to Mr Ashton Jonson's lectures until March 13th. Wells and Hibberd.

'23 March 1904: Bringing - - - -from do. Sturdy and Smith.

'7 Dec 1904: [no entry seen for this date in day book but possibly hire to Price and Sons].

'23 Jan 1909: Price and Sons, Bath. Received Chopin Grand - - - from do. per GWR.

'26 April 1921: Lent as part of 'fifteen old instruments' to Rushworth and Dreaper [a music shop], Liverpool.

'27 Jan 1922: Returned by them.

'10 Feb 1922: Lent as one of 'sixteen old instruments' to Harrods.

'18 Feb 1922: Returned by them.

B: Notes on the various whereabouts of the Chopin grand from 1922:

After the 18th February 1922, there are no further entries in Broadwood's Porters' Day Books concerning removals of the Chopin grand. The piano in question now appears to have remained generally in one place: at the address of the company's showroom and office in the West End of London, wherever this address happened to be.

When Broadwood vacated the Conduit Street showroom in 1924, the Chopin piano was moved, along with other 'antique instruments', to a new, smaller, showroom at 158 New Bond Street. Shortly after this removal, the company produced a printed catalogue entitled 'The Broadwood Collection of Antique Instruments; forerunners of the Modern Pianoforte, on view at the Broadwood Galleries, 158 New Bond St London W.' The catalogue is illustrated with many clear but crudely-drawn illustrations, one of which, on page 14, shows the 1848 grand. The brief accompanying text states:

'Made in 1848 by John Broadwood and Sons and used by Chopin when in London. It marks a great advance during the previous forty years, and shows that the Pianoforte had become an instrument of really great musical capabilities. This piano is still in good condition and has a charming tone.'

The title page and two other illustrated pages of the same catalogue are shown at the end of this appendix.

Following the receivership of the Broadwood company in March 1931, and the radical reorganisation of the firm, a new showroom was opened at 9, Hanover Street, London W1, the following year. The Chopin Broadwood was moved into its new home and became a familiar sight on display in the shop throughout most of the 1930s. There appears to be no record of

what happened to the instrument during World War II. Possibly the piano was removed to the relative safety of rural Surrey, and perhaps stored at Captain Evelyn Broadwood's home, Lyne, near Capel, Surrey.

However, the piano had been returned to Hanover Street by the end of 1946, because on the 25th November of that year the pianist Malcuzyński was photographed seated at the instrument in Broadwood's showroom (ref: Broadwood Papers, Surrey Archives, 2185/JB/98/4/6.) A few years later, the instrument was photographed again, this time for an illustration to be included in GA Briggs' book, 'Pianos, Pianists and Sonics', published in 1951. It is likely that the instrument continued to be used for promotional purposes during the early 1950s; for example, during the British Industries Fairs of 1947-52. Throughout the 1960s and continuing on until the early 1970s, Chopin's piano remained quietly on display at Hanover Street. It was 'quiet' because of a general lack of interest in using the instrument and a lack of interest in keeping it in good playing order. The condition of the instrument slowly deteriorated throughout the 1960s, a serious problem being the structural condition of the tuning plank. By the early 1970s the instrument, now unfit for general display and lacking the 'charming tone' it still had in the mid 1920s, was moved into storage at Finchcocks Piano Museum, Goudhurst, Kent.

Between 1977 and 1979, Chopin's grand spent a considerable time in Bristol, being restored by Tony Chappell. There were two attempts at restoration: unfortunately, after the first restoration the tuning plank failed, and ultimately a new plank had to be installed. It was shortly after this extensive restoration work had taken place that the piano was recorded by Kenneth van Barthold ('Chopin', ARGO ZK59.)

At the time of the restructuring of the Broadwood company in the early 1980s, ownership of the Chopin grand passed from the company, John Broadwood and Sons Ltd, to a private registered charity, the Broadwood Trust, which had been set up by some of the descendants of the Broadwood family. The Trust in turn donated the grand on permanent loan to the Royal Academy of Music in 1989. However, after a few years it was clear

that the Academy showed little interest in the instrument, and its storage conditions within the Academy's premises were not ideal. Therefore in 1992 an agreement was reached between the Broadwood Trust, the Royal Academy and the Alec Cobbe foundation, whereby the grand was transferred, also on permanent loan, to become part of the Cobbe Collection housed at Hatchlands Park, East Clandon, Guildford, Surrey. In 1995, further restoration work was undertaken on the piano, this time by David Hunt, who restrung the instrument with wire of more authentic metallurgy and undertook various casework repairs.

Today, Chopin's piano may be seen at Hatchlands Park (a National Trust property), along with another important and interesting Broadwood, Elgar's square piano, made in 1844. This year, 1998, the piano was recorded yet again, on this occasion by Peter Katin, in order to commemorate the instrument's one hundred and fiftieth anniversary.

The **BROADWOOD**
Collection of Antique
Instruments; forerunners
of the Modern Pianoforte

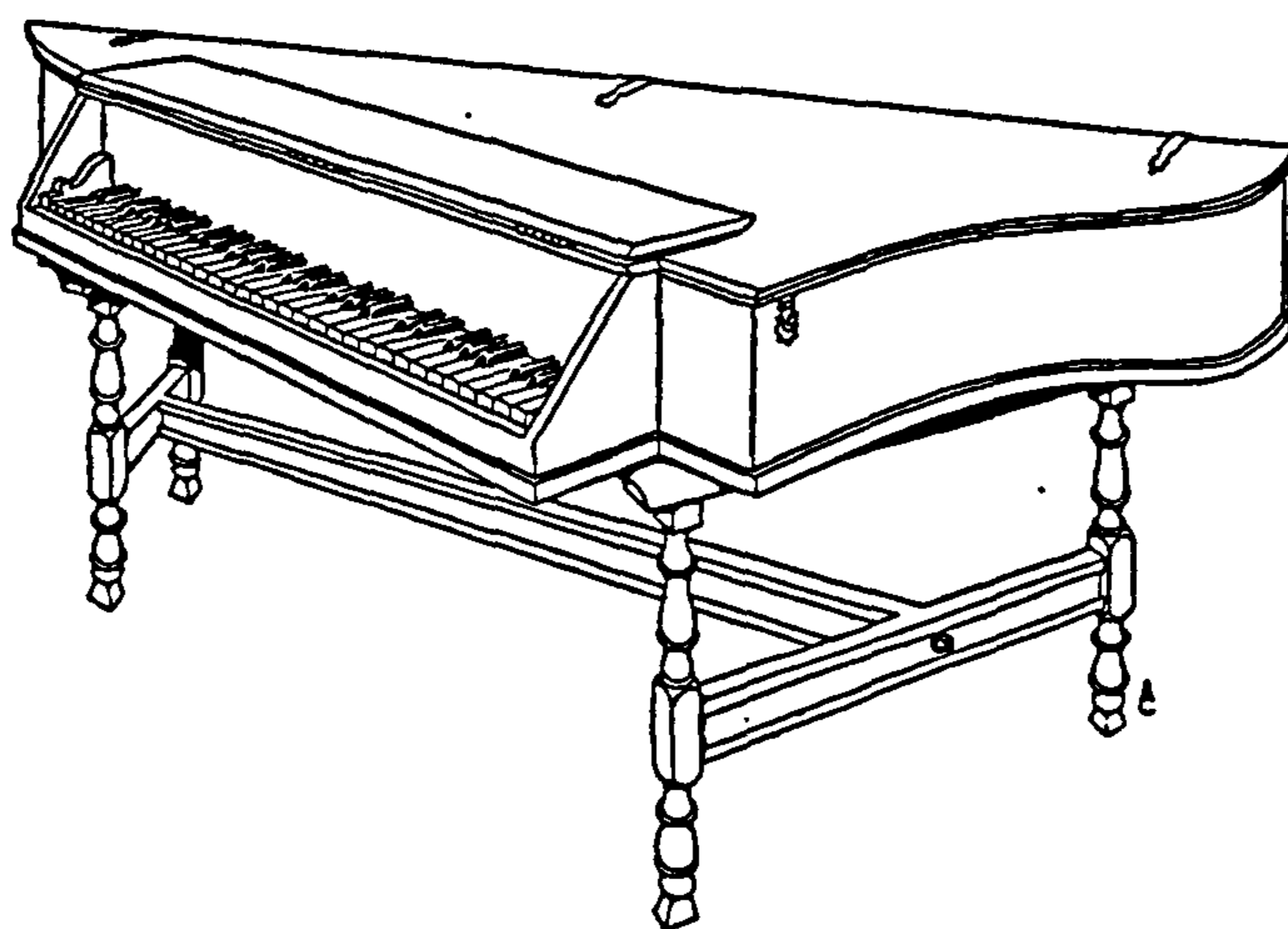

on view at the
BROADWOOD GALLERIES
John Broadwood & Sons Limited
158, New Bond St.
LONDON. W.

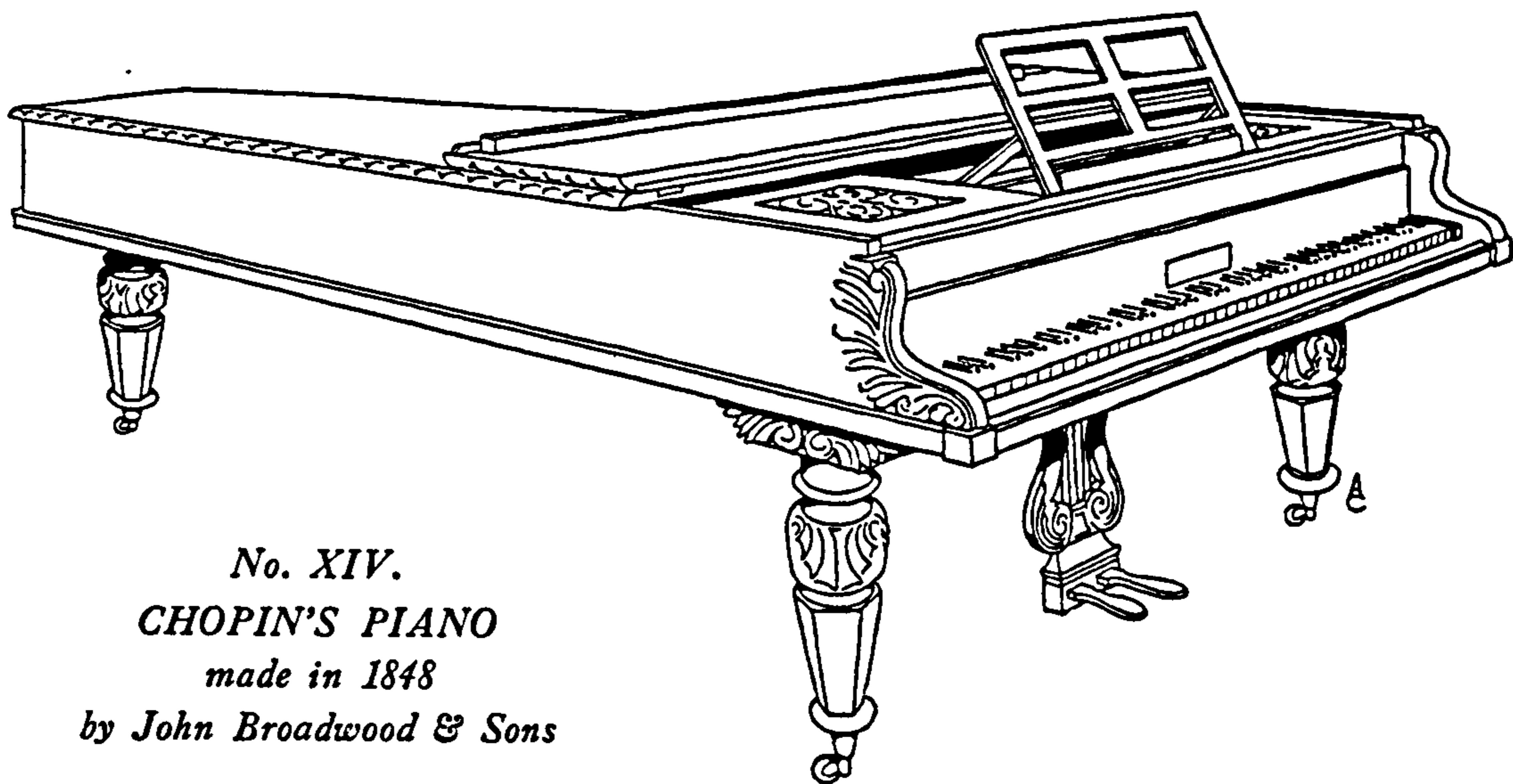

No. XIV.
CHOPIN'S PIANO
made in 1848
by John Broadwood & Sons

square pianofortes. The damper is actuated in a primitive manner, and leather and vellum hinges are used throughout.

The Hawkins action, on the other hand, bears a great resemblance to the modern mechanism, though for half a century it was entirely forgotten.

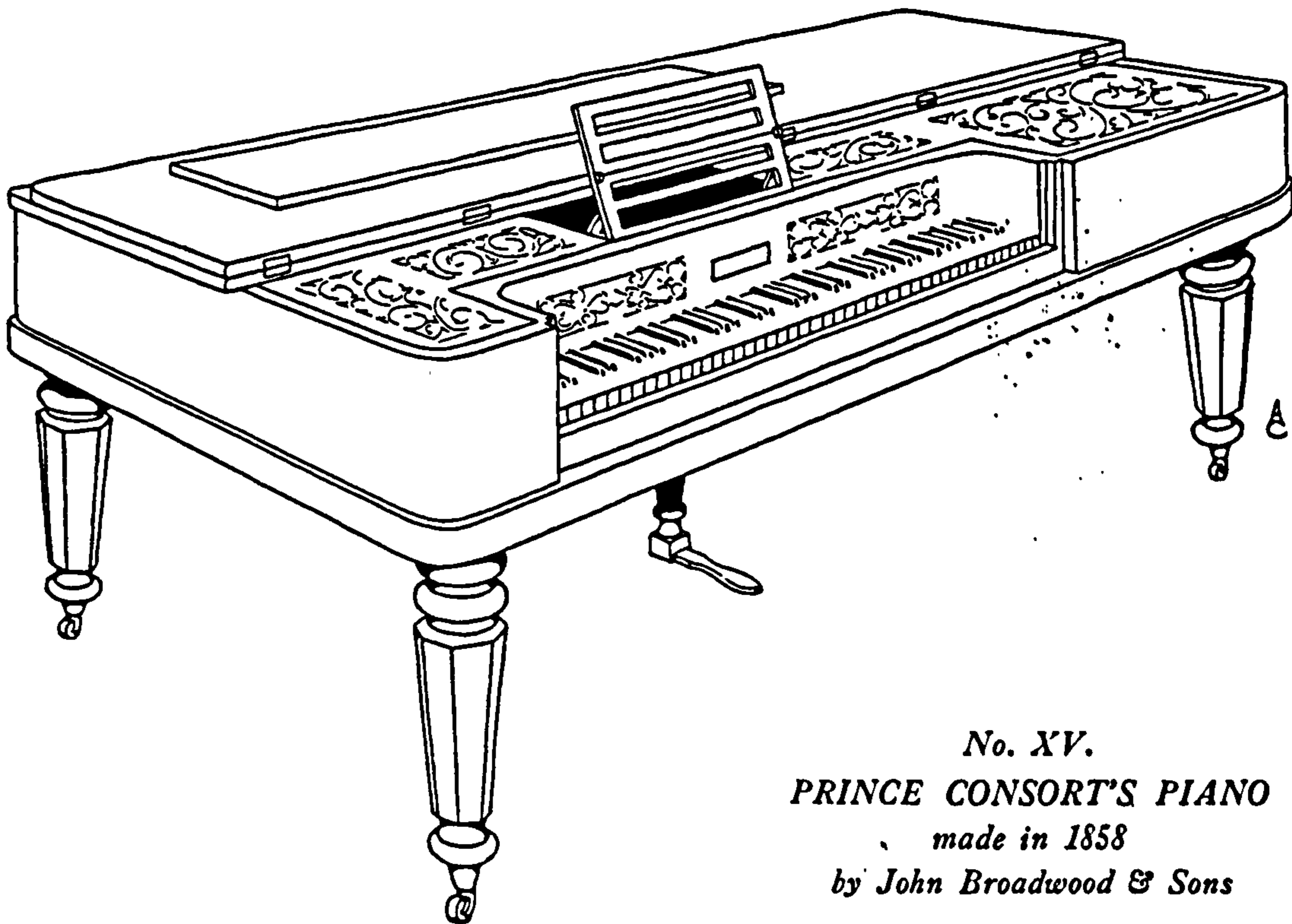

No. XV.
PRINCE CONSORT'S PIANO
made in 1858
by John Broadwood & Sons

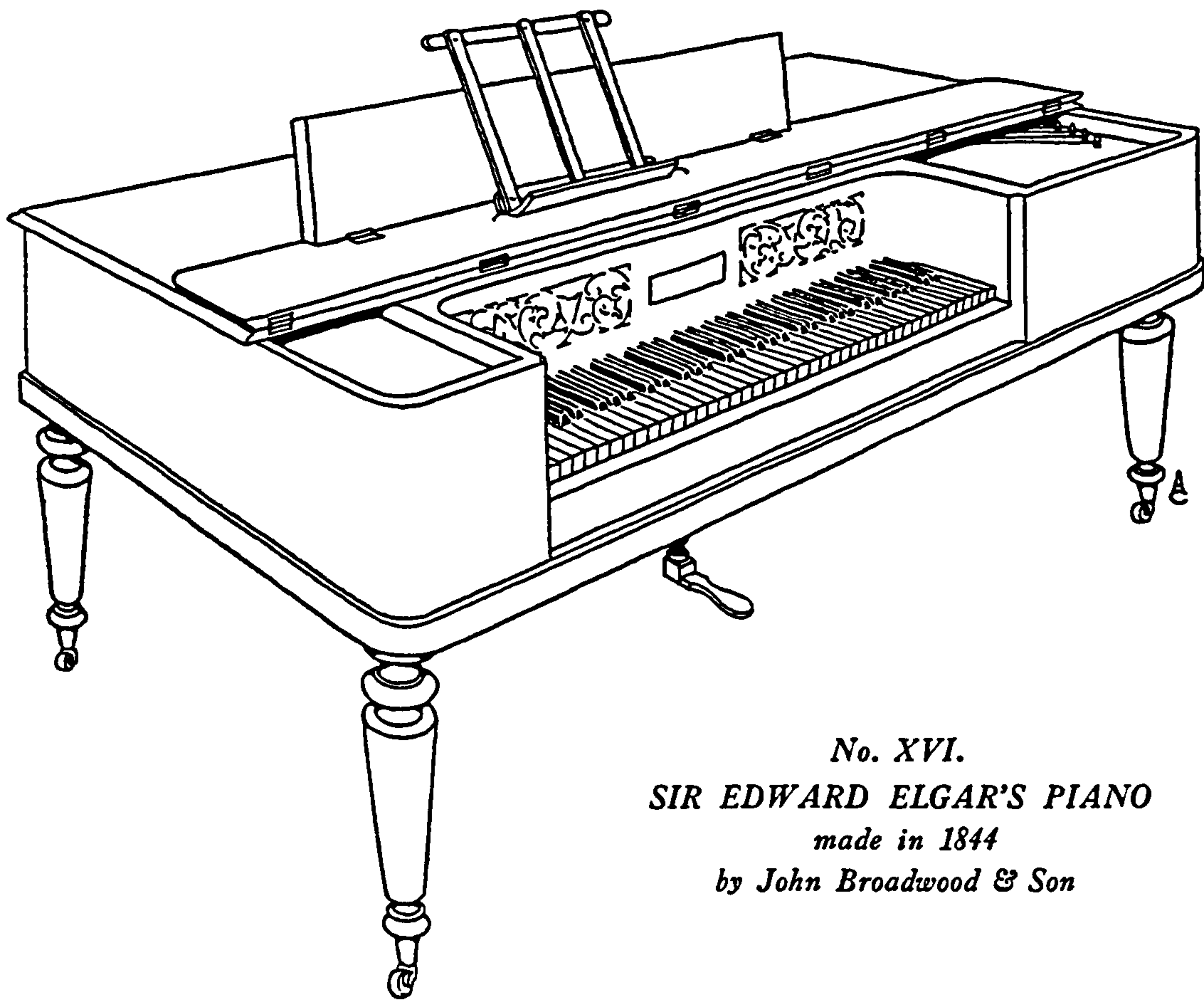

No. XVI.
SIR EDWARD ELGAR'S PIANO
made in 1844
by John Broadwood & Son

No. XIV. Made in 1848 by John Broadwood & Sons, and used by Chopin when in London. It marks a great advance during the previous forty years, and shows that the Pianoforte had become an instrument of really great musical capabilities. This piano is still in good condition and has a charming tone.

No. XV. A Square Pianoforte, made in 1858 for the Prince Consort. It remained in his apartments at Buckingham Palace until the death of Queen Victoria, in 1901. This type is now altogether replaced by the much more convenient Upright Pianoforte.

No. XVI. Sir Edward Elgar's piano: autographed "*Clarice and Edward*

Elgar: Caractacus 1898; Sea Pictures '99; Gerontius 1900; Mr. Rabbit." This piano was used by the famous composer while at work upon these compositions.

No. XVII. A Pianoforte made in 1800 by John Isaac Hawkins, who invented the modern Upright Pianoforte. It is probably the first and perhaps the only one made under his patents.

The disposition of the keyboard in relation to the strings, the complete iron frame, the independent sounding-board, mechanical tuning-pins, equal tension scaling, and the mechanism upon modern lines, with metal supports, together present an astonishing example of inventions completely carried out half a century before their general adoption. The keyboard is arranged to fold up, as

APPENDIX III:

TWO YEARS IN THE LIFE OF BROADWOOD CONCERT GRAND NUMBER 22021 (1885-1887)

During the first few days of the year 1885, a new instrument was nearing completion at Broadwood's Horseferry Road factory, Westminster. It was one of the company's large concert grands, eight feet six inches in length (260cm) and of keyboard compass seven octaves. It appears almost certain that the instrument in question was built with the intention that it should become a hire piano, because it was clad in a case of solid oak instead of the much more customary rosewood veneer. Oak had been chosen because of its hardness and durability, an appropriate case material for any instrument which is likely to receive more than usual wear and tear as a result of constant removal from one concert venue to another. The piano was given the serial number 22021, and received its finishing touches - the final tuning, regulation and voicing - on the 15th January 1885. (1)

The first two years in the life of this particular instrument are certainly of interest to the piano historian. The piano was displayed at the International Inventions Exhibition, London, between May and October 1885; then afterwards, for a period of one year, served as a travelling hire piano, being taken to important recitals in Nottingham, Windsor, Brighton, Birmingham and Oxford as well as various concert locations within London during the period of its service. The artists who performed on the instrument included Liszt, Clara Schumann, Pachmann, Hallé and Fanny Davies. Then in January 1887 the Broadwood company sold the piano to a well-known Dublin music shop, Cramer Wood and Company, and the instrument was transported across the Irish Sea to its new owners. It is highly likely that the concert grand in question continued to be used as a hire instrument in Dublin, although evidence for this is not forthcoming, and any further information about the piano's history after January 1887 remains undiscovered. Nevertheless, the events surrounding the first two

years of the piano's life are of sufficient interest and importance to justify closer examination.

It is not known whether grand number 22021 was specially earmarked, during the course of its manufacture, for display at the forthcoming International Inventions Exhibition, or whether it just happened to be a spare instrument conveniently in stock at that date. Although it was Broadwood's largest and best grand model, there was nothing very special in its design, construction or decoration which would mark it out as being an instrument of particular distinction suitable for display. In almost every way it was very much an instrument of standard specification, apart from the unusual choice of solid oak as a case material. Its internal features, such as the single lever action, the metallic screw pin plate, the straight-stringing and the underdampers, were to be found in every type and size of Broadwood grand at this date. However, it is quite possible that this instrument was recognised as being the 'best of a batch' tonally, and this would explain not only why it was selected for the Exhibition, but also why it was later chosen for use by some of the finest concert artists performing in England during the 1880s.

On the 2nd May 1885, concert grand piano 22021 was removed from the Broadwood warehouse, where it had remained in store since its manufacture, along with another concert grand (serial number 22047, in an ebonised case) and both instruments were transported by horse and wagon to the Central Gallery of the International Inventions Exhibition. The commemorative brochure which Broadwood had printed specially for the Exhibition (2) states that instrument number 22021 was a 'Concert Iron Grand in Solid Oak Case, as sent for Pianists to Public Concerts and Recitals throughout the United Kingdom.' It is more than likely that, from time to time during the course of the Exhibition, the tonal qualities of the grand were demonstrated to the visiting general public by Broadwood's sales manager AJ Hipkins, a fine pianist who was noted for his interpretation of the piano works of Chopin. As we noted in chapter 5, dealing with the Exhibition of 1862, Hipkins, as one of Broadwood's concert tuners, had been able to closely observe Chopin's playing in London in the year 1848.

Shortly after the end of the Exhibition, the oak concert grand was recalled to Broadwood's warehouse (on the 22nd October), remaining there for some weeks. It was obvious that the instrument had not been sold as a result of its public display during the previous months. It was not until the 14th January 1886 that the instrument appeared in public again; on this occasion it was taken to St Pancras Railway Station to be transported by passenger train to Nottingham for an evening recital by the virtuoso pianist Vladimir de Pachmann.(3) Perhaps Pachmann was travelling to Nottingham on the same train as the piano. The following month, on the 5th February, the same piano was delivered by rail to Windsor Station, from where it was collected for an evening concert by Sir Charles Hallé.(4) It is likely that the concert was a royal event which took place at Windsor Castle. The next day, the piano was returned to London and then five days later transported by rail to Brighton for another Pachmann recital.

Following its use in Brighton by Pachmann, concert grand 22021 was returned to the company's warehouse, remaining there until the 26th March. On that day, the instrument was taken out of store and moved by horse and wagon to a private house, number 42, Hyde Park Gate, London, where a recital by the illustrious Clara Schumann was to take place that evening. No further details of this private recital have so far been unearthed. It was around this time that the Broadwood company received a request from the Royal Academy of Music to supply a suitable concert instrument, for one morning only, for a very important event which was to take place on Saturday the 6th April: this was to be a visit to the Academy (then situated in Tenterden Street, near Oxford Street) by the pianist/composer Franz Liszt. The Broadwood Porters' Day Book for the 6th April 1886 briefly records:

'RA of Music. Taking No 15 Grand Pf Oak No 22021 on hire for morning concert and bringing back the same day.'

Possibly as a result of a curious oversight, there is no writing at all in the relevant Porters' Day Book to indicate the fact that the

building ring again and again with a tempest of cheering, which the illustrious master acknowledges with many a stately bow. What a striking figure he looks with his clerical attire, his fine head with its long snow-white hair, and his expressive face lit up with a smile of pleasure at the homage paid him.

A little girl, the youngest student of the Academy, now approaches and presents him with a choice floral harp. Graciously thanking her, he bends down and kisses her tenderly on the cheek. To see old age thus saluting youth is a beautiful sight.

At length the inauguration of the scholarship begins. The blind and aged Principal, rising to his feet, is led to the front of the platform, where he delivers to the guest an address of welcome in eloquent and felicitous language, subsequently speaking in laudatory terms of the efforts of Mr Walter Bache in raising £1,100 to establish a Liszt scholarship. The inaugural ceremony over, the assembly settles down to enjoy a programme of music. Among the items are Liszt's 'Goethe March', played in honour of the composer, Macfarren's 'Overture to St John the Baptist', and a movement from Mackenzie's Violin Concerto conducted by the composer and played by Miss Winifred Robinson, a student.

The programme ended, and the conductors and student-performers presented to Liszt, there follows a never-to-be-forgotten scene - one of the most memorable in the long and distinguished history of the Academy. The audience, prompted by the hope of hearing the great pianist play, bursts into loud and prolonged applause. Liszt for a time is perplexed at this sustained demonstration, till suddenly, its significance dawning upon him, he rises to his feet and with a self-condemnatory gesture moves with the leisured tread of age towards the platform amid a storm of cheering, supported by his friend Bache. Mounting the steps he approaches the piano, and is no sooner seated than from all parts of the hall amid seething excitement, shower upon shower of flowers fall upon him. The floral rain at length spent, and the keyboard cleared, Liszt, amid a sudden hush - 'a silence that might be felt' - begins softly to preludise. Presently the improvisation subtly and dreamily loses itself in his 'Chant Polonaise'. Not a sound disturbs the music, and the audience, over whom the Great Wizard has cast his spell, sits scarcely daring to move or breathe for fear of losing a single note. What artistry;

what delicate arabesques; what wonderful tone-shading! But words are inadequate to describe such a performance.

The playing at an end and the spell lifted, the great audience rises in a frenzy of rapture and makes the hall ring again and again with its wild cheering, which does not subside until Liszt with a smile allows his fingers to sweep the keys again, playing his 'Cantique d'Amour' with a tenderness of touch and expression possible to him alone. Scarcely have the concluding notes languished into silence when again uproar reigns - - - -.'

Two days after the memorable occasion at the Academy, the oak concert grand which Liszt had used was transported to the Grosvenor Gallery in New Bond Street, where a large platform had been erected a few days earlier specially to receive the piano. On the same evening (the 8th April), Liszt performed at a 'brilliant reception' in the Gallery, sponsored by his pupil and great admirer, Walter Bache. The composer Alexander Campbell Mackenzie was there, and he

'had the satisfaction of seeing Joachim shaking hands with his now aged former chief at Weimar, after many years of separation and dissent. - - -the moment was a memorable one for those who deplored a cleavage as unnecessary as useless. 'Das Judenthum in der Musik' was, more than once, responsible for such mischief. An audience of the elite of our profession (Hallé, Piatti, Manns and many others) listened to a programme of special interest, to which the honoured guest, 'forgetting his decision not to play in public, added performances of several items with unexpected vigour.' (7)

It was during the evening reception held at the Grosvenor Gallery that Liszt provided the Broadwood company with a written testimonial giving his opinion about the oak concert grand piano number 22021 which he had just used. Liszt is known to have been very generous and kind as far as the provision of testimonials was concerned. He was too polite a person not to provide one when asked, and it is quite possible that Broadwood's tuner 'on call' for the evening had approached Liszt in his dressing room, asked him if the piano was 'satisfactory' and then

building ring again and again with a tempest of cheering, which the illustrious master acknowledges with many a stately bow. What a striking figure he looks with his clerical attire, his fine head with its long snow-white hair, and his expressive face lit up with a smile of pleasure at the homage paid him.

A little girl, the youngest student of the Academy, now approaches and presents him with a choice floral harp. Graciously thanking her, he bends down and kisses her tenderly on the cheek. To see old age thus saluting youth is a beautiful sight.

At length the inauguration of the scholarship begins. The blind and aged Principal, rising to his feet, is led to the front of the platform, where he delivers to the guest an address of welcome in eloquent and felicitous language, subsequently speaking in laudatory terms of the efforts of Mr Walter Bache in raising £1,100 to establish a Liszt scholarship. The inaugural ceremony over, the assembly settles down to enjoy a programme of music. Among the items are Liszt's 'Goethe March', played in honour of the composer, Macfarren's 'Overture to St John the Baptist', and a movement from Mackenzie's Violin Concerto conducted by the composer and played by Miss Winifred Robinson, a student.

The programme ended, and the conductors and student-performers presented to Liszt, there follows a never-to-be-forgotten scene - one of the most memorable in the long and distinguished history of the Academy. The audience, prompted by the hope of hearing the great pianist play, bursts into loud and prolonged applause. Liszt for a time is perplexed at this sustained demonstration, till suddenly, its significance dawning upon him, he rises to his feet and with a self-condemnatory gesture moves with the leisured tread of age towards the platform amid a storm of cheering, supported by his friend Bache. Mounting the steps he approaches the piano, and is no sooner seated than from all parts of the hall amid seething excitement, shower upon shower of flowers fall upon him. The floral rain at length spent, and the keyboard cleared, Liszt, amid a sudden hush - 'a silence that might be felt' - begins softly to preludise. Presently the improvisation subtly and dreamily loses itself in his 'Chant Polonaise'. Not a sound disturbs the music, and the audience, over whom the Great Wizard has cast his spell, sits scarcely daring to move or breath for fear of losing a single note. What artistry;

what delicate arabesques; what wonderful tone-shading! But words are inadequate to describe such a performance.

The playing at an end and the spell lifted, the great audience rises in a frenzy of rapture and makes the hall ring again and again with its wild cheering, which does not subside until Liszt with a smile allows his fingers to sweep the keys again, playing his 'Cantique d'Amour' with a tenderness of touch and expression possible to him alone. Scarcely have the concluding notes languished into silence when again uproar reigns - - - -.'

Two days after the memorable occasion at the Academy, the oak concert grand which Liszt had used was transported to the Grosvenor Gallery in New Bond Street, where a large platform had been erected a few days earlier specially to receive the piano. On the same evening (the 8th April), Liszt performed at a 'brilliant reception' in the Gallery, sponsored by his pupil and great admirer, Walter Bache. The composer Alexander Campbell Mackenzie was there, and he

'had the satisfaction of seeing Joachim shaking hands with his now aged former chief at Weimar, after many years of separation and dissent. - - -the moment was a memorable one for those who deplored a cleavage as unnecessary as useless. 'Das Judenthum in der Musik' was, more than once, responsible for such mischief. An audience of the elite of our profession (Hallé, Piatti, Manns and many others) listened to a programme of special interest, to which the honoured guest, forgetting his decision not to play in public, added performances of several items with unexpected vigour.' (7)

It was during the evening reception held at the Grosvenor Gallery that Liszt provided the Broadwood company with a written testimonial giving his opinion about the oak concert grand piano number 22021 which he had just used. Liszt is known to have been very generous and kind as far as the provision of testimonials was concerned. He was too polite a person not to provide one when asked, and it is quite possible that Broadwood's tuner 'on call' for the evening had approached Liszt in his dressing room, asked him if the piano was 'satisfactory' and then

presented him with a small card on which to jot down some comments about the piano. Liszt was pleased to oblige and quickly wrote down the following few words of German:

'Diesen vortrefflichen Broadwood Flugel mit Vernugen gespielt im Concert, Grosvenor Gallery, 8th April 86. F. Liszt.'

(Translation: 'At this concert, Grosvenor Gallery, 8th April 86, I played with pleasure on this outstanding Broadwood grand pianoforte.')

It is obvious that the Broadwood company was highly delighted with this testimonial, because they had it specially framed behind glass, with an accompanying written explanation, and it proudly hung in Broadwood's general office for many decades after the event - perhaps for as long as ninety years. In the early 1990s, the framed testimonial was loaned to a piano shop in Birmingham, where it was kept in the safe. Unfortunately, the shop was burgled one night, the safe broken into, and the framed item smashed to pieces by the intruders (8). Luckily, however, the original small card on which Liszt's testimonial was handwritten remained intact and unharmed, and the precious object was reframed (mounted with a photograph of the elderly Liszt) by the writer of this account in 1996.

The day after the Grosvenor Gallery reception, Broadwood's oak concert grand was collected and returned to the warehouse, the company making no hire charge. Then ten or so days later, on the 20th April, number 22021 was hauled out of store again, in order to be transported to Birmingham for a recital held on that evening in her native town by the young Fanny Davies.(9) It is highly likely that Miss Davies knew that the piano she was performing on had recently been played by Liszt, because Walter Macfarren, piano professor at the Academy (younger brother of Sir George Macfarren, the Principal) was present in Birmingham on this occasion. He had witnessed the same instrument being used by Liszt at the Academy in London a few days earlier.

The Macfarren brothers were on particularly good terms with the partners of the Broadwood company. It is worthwhile noting that in March

1893, on the occasion of Sir George Macfarren's eightieth birthday, a 'great reception' was held in Broadwood's showroom in Great Pulteney Street to inaugurate a room there bearing the name of 'The Macfarren Room', on the walls of which were hung portraits of the Macfarren family and their pupils.(10) Like members of the Broadwood family, the Macfarrens were of Scottish origin. It is certain that the Macfarren brothers and the Broadwood partners were linked in a commercial sense, and the creation of the Macfarren Room was as much a token of appreciation on the part of the Broadwood company for the role the two brothers had played in furthering Broadwood business, as it was a tribute to their skills as pianists and composers. Walter Macfarren had regarded George Thomas Rose, a partner of the company, as a 'dear kind friend.'(11) We may suggest that the supply of oak concert grand number 22021 to both the Academy and the Grosvenor Gallery for Liszt's use had been brought about by the influence and 'good offices' of the Macfarrens; and it is also quite possible that the testimonial from Liszt might actually have been procured for Broadwood's benefit by one or other of the brothers.

In spite of the fact that the concert grand in question had been used and favoured by Liszt, which must have made number 22021 the 'flagship' of Broadwood's concert hire fleet, there was surprisingly little demand for this piano from concert artists during the remainder of the year 1886. On the 13th May it was transported by rail to Oxford for a third Pachmann recital; and then on the 19th June hired for a private function at the home of the Countess of Wilton, 20, Upper Grosvenor Street, London. Following this last event, the oak concert grand appears to have been withdrawn from service as a hire piano. We are not certain of the reasons. It is hard to understand why such a piano, with its illustrious Liszt connections, should not have been sought after by other concert artists, or even piano teachers, during the remainder of that year. We can suggest that the most likely reason for the piano's non-use lay in the fact that the instrument had been reserved for display in Broadwood's showroom during the period up to Christmas 1886. It would be difficult to think of a better item to display during the 'piano selling season' leading up to Christmas that year. What could be a better way to promote the Broadwood product than

to proudly show an instrument which Liszt had recently used in London, along with the newly-framed testimonial from the Master?

However, this may not be the whole truth of the matter. It is also quite possible that there was absolutely no call for 22021 from concert artists throughout the remainder of 1886, and so the piano could have been lying on its spine, in store, half-forgotten, for many weeks. During the mid 1880s, more and more concert artists, given the choice, would have preferred to use the Bechstein grand for recital work. The reason for this lay partly in the superior action mechanism of the new Bechstein (the Berlin company employed a modified Erard system of double escapement roller action, which gave superior repetition and tone control when compared with Broadwood's single lever action of that date.) In addition, the Bechstein grand, although possessing no more volume than the Broadwood concert grand, nevertheless has a decidedly greater 'singing' quality in its mid to high treble.

We can gain a very good idea of the current opinion of Bechstein from an advert which appeared in 'The Scotsman' on the 15th September 1893. It quoted a conversation which had apparently occurred between Queen Victoria and a certain Italian concert pianist: 'After the concert, her Majesty conversed cordially with Signor Buonamici, and asked him what instrument he preferred. Signor Buonamici replied that he preferred the Bechstein piano, and her Majesty said that she held the same opinion.' (12) In the following year, 1894, Sir Charles Hallé (who had used, as we have just noted, the oak concert grand 22021 at Windsor in February 1886) wrote in a concert programme: 'I corroborate with pleasure Liszt's, Rubinstein's and Bulow's expressions of admiration for the Bechstein Pianos. I have now so frequently preferred to use the excellent Grands for my concerts that I cannot help acknowledging gratefully their splendid qualities. Their beautiful singing tone in the greatest forte as well as in the most delicate pianissimo is always noble, and capable of the most refined expression.' (13) George Bernard Shaw, writing in 'The Dramatic Review' of the 25th July 1885 stated: 'The old-fashioned English piano is not ----likely to maintain itself on the concert platform against the much richer and more powerful instruments

made on the American system.'

Whatever the reasons for the absence of 22021 from the concert platform, by the early days of the following year Broadwood had decided to dispose of the piano. It was sold on the 21st January 1887 to a music shop, Messrs Cramer Wood and Company of Dublin, who paid the cash sum of £186 13s, (14) a very large discount from the official price list of 250 guineas. Not only was this a discounted 'trade' price; there would have been a further reduction in the final selling price because the piano was not new, but was 'ex hire.' There is unfortunately no further information forthcoming about the subsequent history of oak concert grand number 22021 after it had travelled via the London and North Western Railway to the docks at Holyhead for shipment to Dublin. We can guess that its original function as a concert hire piano must have been continued by the Dublin firm, who would have appreciated the hard-wearing qualities of its oak casework. We do not even know for sure if the purchasers, Cramer Wood, were aware that the piano had been played in London by Liszt. It seems highly likely.

The first two years in the life of Broadwood's oak grand pianoforte 22021 are clearly of great interest. Although the piano was hired out for concert use on only eight separate occasions, its display at the International Inventions Exhibition of 1885 and its subsequent use the following year by Clara Schumann and Franz Liszt marks out the instrument as one of historical importance during this period. Its use for functions of great importance musically indicates that this model of concert grand, for all its obsolete and old-fashioned design features (such as straight stringing and the single-lever action) was still acceptable for the highest standards of concert performance. It is a pity that all trace of the piano is lost after the 21st January 1887; perhaps the instrument will be rediscovered some day, and its former importance during the years 1885-86 finally recognised.

NOTES FOR CHAPTER 1:

'THE ORIGINS OF THE ENGLISH GRAND PIANO, 1740-1780.'

(1) Information from Slave Klima, ed. (1988): The Memoirs of Dr Charles Burney. Lincoln, Nebr., USA: Bowers and Grant.

(2) For further information about Cristofori's influence, see Pollens, Stewart (1995): The Early Pianoforte, chapters 3-5. Cambridge: The University Press; and also Cole, Michael (1998): The Pianoforte in the Classical Era, chapter 1. Oxford: Clarendon Press.

(3) Archivio di Stato di Firenze, Archivio Medicea 5878. Source quoted by Pollens, Stewart (1995): The Early Pianoforte, page 53.

(4) from The Memoirs of Dr Charles Burney. See note (1).

(5) For further biographical information about Plenius, see Boalch, Donald (1995): Makers of the Harpsichord and Clavichord 1440-1840, third edition, ed. Charles Mould, pages 147-148. Oxford: Clarendon Press.

(6) See notes (1) and (4).

(7) See Boalch (1995) page 148.

(8) Sometime between 1778 and 1782 Zumpe had realised sufficient capital to retire from piano making. He invested his piano-making earnings in house and property development. At the time of his death in December 1790, he was the owner of six substantial dwelling houses, four of them in Queen Charlotte Row, and a fifth in the Edgware Road. See Cole, Warwick (1998), page 67.

(9) The instrument, which presently forms part of the collection of Lord Hylton, is signed 'Americus Backers Londini fecit 1766.' Described in Boalch (1995), page 226.

- (10) The newspaper advertisement was discovered by Warwick Cole. He refers to it in his article (1987) 'Americus Backers, Original Forte Piano Maker.' Harpsichord and Fortepiano magazine, volume 4.
- (11) The instrument is described and illustrated in Newman, Sidney and Williams, Peter (1969): The Russell Collection and other Early Keyboard Instruments in St Cecilia's Hall, Edinburgh. Edinburgh: The University Press.
- (12) The eighteenth-century Rate Books for the parish of St James's, Westminster, can be found in the Westminster Archives, 10 St Anne's Street, London SW1.
- (13) From Broadwood, JS: Some Notes made by JS Broadwood, 1838, with Observations and Elucidations by HF Broadwood, 1862, pages 10-12. London: printed by WS Johnson and Company.
- (14) The Parish registers of St James's, Westminster, can be seen on microfilm at Westminster Archives. See note (12).
- (15) Rimbault, EF (1860): The Pianoforte, page 131. London: R Cocks and Company.
- (16) See note (10).
- (17) See note (2).
- (18) See Cole, Warwick (1987): 'Americus Backers Original Forte Piano Maker.' Harpsichord and Fortepiano Magazine, volume 4, pages 79-85. Cole comes to the conclusion, after comparing the Russell Collection Backers with the Fenton House 'Backers', that the latter is not in fact made by Backers.
- (19) Michael Cole and his son Warwick are the only individuals to have investigated the life and piano-making career of Backers in any detail. A transcript of the last will of Backers (1778) and a very interesting inventory of his workshop dated the 5th October 1779 may be found in Cole, Michael (1998): The Pianoforte in the Classical Era, appendix III, pages 371-376.

(20) The Register of St Mary-le-Strand, London, records the burial of 'Rutgerius Plenius' on the 9th January 1774.

(21) British Patents, number 581, 30th December 1741. See also the chronological checklist of British patents which is to be found at the end of this dissertation, pages

(22) See Harding, Rosamund EM (1933): The Pianoforte: Its History Traced to the Great Exhibition of 1851, page 58. Cambridge: the University Press.

(23) Information found in a pamphlet, JJK Rhodes (n.d.): Robert Stodart: a Late 18th Century Piano Maker. Typescript. Edinburgh: The Russell Collection, St Cecilia's Hall, University of Edinburgh. Rhodes appeared to have been in touch with descendants of Robert Stodart in order to gather information for his article.

(24) Further information obtained from the source quoted in note (23) above.

(25) Westminster Rate Books, Westminster Archives. See note (12).

(26) British Patents, number 1172, November 21st 1777.

(27) Backers placed an advertisement in the Morning Post of the 14th April 1774, the following transcript of which helps to explain the kind of difficulties which the maker was experiencing as a result of the fraudulent activities of some of his competitors:

'Americus Backers of Jermyn-street, St James's, original Forte Piano maker, takes the liberty of acquainting the Nobility and Gentry, that there are vended in several music shops in London, Forte Piano's, having his name affixed to them as maker, which were not made by him; this being an imposition on the public, and very detrimental to his character, he inserts it as a caution, assuring the Nobility and Gentry that he never made Forte Piano's for public sale at any music shop whatsoever, and any that are to be sold at those places with his name affixed to them, are counterfeits. He

hereby offers a reward of Twenty Pounds on conviction, to any person who will discover those fraudulent makers that have forged his name, as a sanction to promote the sale of their own imperfect work.'

(28) Transcribed in Cole, Michael (1998): The Pianoforte in the Classical Era, appendix III.

(29) Chambers, William: History of Peeblesshire. This source quoted by JJK Rhodes in his typescript pamphlet Robert Stodart. (see note (23)). Further details of Chamber's book have not been recorded.

(30) The source of this information is Broadwood, JS (1838): Notes etc. See note (13).

NOTES FOR CHAPTER 2:

THE EARLIEST BROADWOOD GRANDS, 1785-1805.

(1) 7th March 1771: An agreement between Burkat Shudi and John Broadwood concerning a)royalties on harpsichord sales and b)leasehold premises in Great Pulteney Street, Westminster. Surrey County Archives, Woking, reference 2185/JB/1/1.

(2) See: Boalch, Donald (1995) Makers of the Harpsichord and Clavichord 1440-1840, pages 173-177, third edition, ed. Charles Mould. Oxford: Clarendon Press.

(3) See (2) above and also Dale, William (1913): Tschudi the Harpsichord Maker. London: Constable.

(4) An affidavit published in the Daily Advertiser, January 1767, concerning a dispute between one, Joshua Shudi, and his uncle Burkat Shudi, includes the statement:

'And these deponents, Andrew Clark and John Broadwood, further say, that they deny that the said Joshua Shudi did begin and end the Harpsichords which the said Burkat Shudi sold to his Prussian Majesty or any of them. And these deponents can the better depose, as aforesaid, for that the greatest part of the work of the said Harpsichords was done by the deponents, Andrew Clark and John Broadwood, under the direction of their said master Burkat Shudi; and particularly this deponent, John Broadwood, perfectly remembers his having glewed up the sounding boards of all the said Harpsichords, and his having assisted his said master Burkat Shudi, in putting the soundboard (after this deponent had wrought and finished the same under the immediate direction of this deponent's said master Burkat Shudi) into the first of the said Harpsichords sold to his Prussian Majesty.'

(5) See: Wainwright, David (1982): Broadwood by Appointment, chapter 2. London: Quiller Press.

- (6) See: Clinkscale, Martha Novak (1993): Makers of the Piano, 1700-1820, page 264. Oxford: The University Press.
- (7) See: The Broadwood Journals, now in the Bodleian Library, Oxford, reference: Eng. Misc. b107; and also Cole, Michael (1998): The Pianoforte in the Classical Era. Oxford: Clarendon Press.
- (8) Outline details of serial numbers/dates for Broadwood squares and grands from this period are preserved in the present office of John Broadwood and Sons Ltd, 154, Clapham Park Road, London SW4. The information was in all probability gathered during the late nineteenth century by the author AJ Hipkins, who was also the company's sales manager.
- (9) British Patents number 1379, July 17th 1783.
- (10) Of forty-three surviving early Broadwood squares made before 1800, listed by Clinkscale (see note (6)), only two have a pedal. It appears that the provision of a pedal was the exception rather than the rule in late eighteenth century Broadwood squares.
- (11) James Shudi Broadwood was taken into partnership in 1795, when he was aged twenty-three. From this date, the firm was styled 'John Broadwood and Son.' After the 1st January 1808, when Thomas Broadwood, a younger brother of James, was taken into partnership at the age of twenty-two, the firm became known as 'John Broadwood and Sons.'
- (12) Broadwood Papers, Surrey County Archives, Woking. Reference 2185/JB/16/5.
- (13) See: Cole, Michael (1998): The Pianoforte in the Classical Era, page 133. Oxford: Clarendon Press.
- (14) Hunt, David P (compiler, 1998): International Register of Surviving Grand

Pianos manufactured by John Broadwood and Sons. Typescript, privately distributed by the compiler, 26 Station Road, Willingham, Cambridge.

(15) See the article: Winter, Robert S. (1988): 'Striking It Rich: The Significance of Striking Points in the Evolution of the Romantic Piano,' in Journal of Musicology 6, number 3, pages 267-292. Los Angeles, USA: University of California.

(16) Details of the relative strengths of eighteenth century iron and brass wire are found in: Goodaway, Martha and Odell, Jay Scott: [n.d.] 'The metallurgy of 17th and 18th century music wire' in Howard Schott (ed.) The Historical Harpsichord, volume 2, chapter 1. Stuyvesant, New York, USA: Pendragon Press.

(17) See: Harding, Rosamund EM (1933): The Pianoforte: Its History traced to the Great Exhibition of 1851, pages 368-369. Cambridge: The University Press.

(18) Information from 'Gray, Edward Whitaker (1748-1806)' in Dictionary of National Biography.

(19) From: Broadwood JS (1838): Some Notes made by JS Broadwood in 1838 with Observations and Elucidations by HF Broadwood, 1862. London: printed by WS Johnson and Company.

(20) Patented by Henry Steinway junior, December 20th 1859. US Patent number 26,532. See: Hoover, Cynthia Adams (1981): 'The Steinways and Their Pianos in the Nineteenth Century.' Journal of the American Musical Instrument Society volume 7, pages 8-9. [n.p].

(21) Throughout the period circa 1850 to circa 1925, Broadwood's grand soundboard makers maintained this particular 10 degree angle of plank orientation described. This idea was very much out of step with the general practice on the Continent and in America, where the vast majority of piano makers from the mid nineteenth century chose to run their grand soundboard planks parallel with the line of the long mainbridge.

(22) Koster, John (1994): Keyboard Musical Instruments in the Museum of Fine Arts, Boston, pages 161-180 and 196-232. Boston, USA: The Museum of Fine Arts.

(23) This drawing is taken from the above publication (22).

(24) British Patents, number 5485, April 9th 1827.

(25) Broadwood grand piano serial number 9248 (Musikk Instrument Akademiet, Moss, Norway) first sold on the 8th November 1822, does not have the two long iron bars in the treble; but grand number 9356 (Finchcocks Collection, Goudhurst, Kent, England), sold in early 1823, does.

(26) The original Erard action in various modified forms (e.g: the Hertz version, the Schwander version, the Steinway version) had become universally adopted by the vast majority of Continental and American grand piano makers by the 1880s.

(27) Charles H Gilbey (1907-1980) was a lecturer in piano tuning and technology at the London College of Furniture during the 1960s and early 1970s. He had spent a lifetime working in the London piano industry. Broadwood's repair workshop appears to have been the same premises (in Henry Street, St Pancras) which the company had originally purchased in 1812 from the harp maker JA Stumpf.

(28) 'Directions for Tuning and Keeping the Grand Piano Forte in Order: (printed sheet glued to the inside of the nameboard in a Broadwood grand of 1787, serial number 208):

'First, draw up the small Piece of Wood which is fixed upon the Block, on the treble side of the Keys, and putting down the left Pedal, the Hammers will strike on one Unison, which tune as you do the Harpsichord; then turn down the said Piece of Wood, and putting down again the left Pedal, the Hammers will strike on two Unisons, which tune; and lastly, by letting the pedal go, you may tune the third Unison to the other

two.

'As for the hammers, they ought to have just Freedom enough to fall easy; for if they have too much Freedom, they will rattle; if too little, they will stick. These may be regulated by gently turning with a Pair of Pliers, or a Tool made for the Purpose, the little Screw with the square Head, which goes into the Head of each Hammer; or by drawing out of Keys, which is done by unscrewing the two Screws that pass through the Bottom of the Piano Forte into the Blocks on each side of the Keys, and then turning with a Screw-driver the said little Screws. But great Care must be taken, that the Hammers do not suffer in taking the Keys out, or in putting them in again.

'As the Hammers ought to rise within half a quarter of an Inch of the String before they fall down, to regulate them in this Respect, there is a long Pin to every Key, like those that the Strings are tuned by, which by screwing in, with a Tuning-hammer, makes the Hammer fall sooner; and, by unscrewing, makes the Hammer rise nearer the String.

'But if it should be required to raise or lower all the Hammers, it may be done at once by the smallest turn of the two Pins of the same length, fixed in plates on each side of the Keys.

'NB: If the Hammers rise too near the String, they knock; and if they fall too soon, they speak too soft.'

(29) See: Broadwood JS, (1838): Some Notes etc, pages 13 and 14. See also note (19)).

(30) According to David Hunt's International Register (see note (14)) grand number 376 is in the ownership of 'B Dahl, California, USA.'

(31) The instrument is described in detail and illustrated in Koster, John (1994): Keyboard Instruments etc., pages 161-180. See note (22).

(32) The full list, which covers the period 1789 to 1860, was printed in Broadwood's Guide to its exhibits at the International Inventions Exhibition of 1862. For details of the Exhibition, see chapter 5.

NOTES FOR CHAPTER 3:

THE TRANSITION FROM WORKSHOP TO FACTORY, 1805-1830.

(1) Scholes, PA (1948): The Great Dr Burney. Oxford: University Press.

(2) Information from a) Hunt, David (compiler, 1998): The International Register of Surviving Broadwood Grands, typescript, distributed privately by the compiler; and b) Outline details of serial numbers/dates, contained in a checklist of early Broadwood grand production, now in the office of John Broadwood and Sons Ltd, 154, Clapham Park Road, London SW4.

(3) Broadwood Papers, Surrey County Archives, Woking. Ref: 2185/JB/16/20.

(4) Broadwood Papers, Surrey County Archives, ref: JB/3081.

The names of the workmen listed are as follows: Pain, Simpson, Savery, Thorp, Webster, Bredford, Benyon, Meggett, Peppercorn, Rose, Clark, Lockyear, Gratten, Garnett, Hopkins Mr., Forsyth, Barling Jr., Bartram, Marshall, Hammerton, Lowe, Mathias, Mulcaster, Barling Senr., Edwards.

(5) John Peppercorn is mentioned on pages 496, 497 and 549 of Helmholtz, Hermann (1885): On the Sensations of Tone, second English edition, ed. Alexander J Ellis. London: Longmans and Company.

(6) The surname 'Marshall' is often found inked on the actions of Broadwood grands during this period. According to typescript notes supplied to the writer by the late David Wainwright, author of Broadwood by Appointment, Thomas Hopkins joined the Broadwood firm in 1780, and was a senior workman in the years 1814-1826. A 'Mrs Hopkins', possibly his widow, was living in a company house in Horseferry Road in the 1840s. Unfortunately, Wainwright did not give the source of his typescript notes when this information was supplied.

(7) James Forsyth is named in John Broadwood's will, dated 17th November 1811. Under the terms of the will, Forsyth was bequeathed the sum of £500

'as an acknowledgement of his diligent attention to business.' He was the only Broadwood company employee to have been left a legacy in the will, unless the 'Thomas Hopkins', Broadwood's nephew who was left £2000 in the same will, was the one and the same as the 'Mr Hopkins' who is included in the list of senior workmen named in note (4) or the 'Thomas Hopkins' named in Wainwright's typescript (see note (6)).

(8) The writer remembers hearing about this tradition in the early 1970s, but at present he cannot remember the source of this information.

(9) Broadwood grand number 3378, compass $5\frac{1}{2}$ octaves, date 1806, in private ownership, UK. Sold at Christies, 1st July 1991. The name 'Marshall' is inked on the action.

(10) Broadwood grand number 2975 is a six octave model, restored by the writer in the mid 1970s. It was originally purchased by Edward Delaval for his daughter in the year 1805, and is now in the ownership of Delaval's descendant, Anthony Jarvis of Doddington Hall, Lincolnshire. See the transcription of Delaval's letter about this particular grand piano which appears at the beginning of this dissertation, immediately after the list of contents.

(11) According to CH Gilbey (1907-1980), a lecturer in piano tuning and technology at the London College of Furniture during the 1960s and early 1970s, it was the practice of the Broadwood stringers working on piece work to prepare the long twisted 'eyes' on the ends of every length of wire during the evenings at home; then throughout the following day, they would string a piano in the Broadwood company's factory, in Horseferry Road, using the wires they had prepared at home. This information was confirmed by evidence found during the cleaning-out of a cellar in a terrace house near the site of the former Broadwood factory (date not known, but the source of information was also CH Gilbey), when many hundreds of rusted, broken, piano string eyes were discovered lying on the floor. The stringer who lived in the house had obviously been using his cellar as a workshop for stringing preparation.

(12) See: Cooper, Anthony (1978): 'Old Chalk Farm Tavern.' Camden History Review, 6, pages 2-5. London: Camden History Society.

(13) A framed engraving of John Broadwood is in the writer's own collection at Moss, Norway.

(14) After John Broadwood's death, his personal wealth (exclusive of business) was calculated as being £106,364. In modern terms, he was a millionaire.

(15) Information from Eszter Fontana, curator of Musical Instruments at the Hungarian National Museum, Budapest.

(16) Source: see note (15) above.

(17) Source: The Musical Times, 15th December 1892.

(18) See note (15).

(19) A commemorative brochure, The Beethoven Broadwood Fortepiano Tour was printed in 1992. The concerts took place during May and June, 1992.

(20) The first cottage upright left the Broadwood works on the 11th August 1819, according to AJ Hipkins. See: Wainwright, David (1982): Broadwood by Appointment, page 330. London: Quiller Press.

(21) Dodd, George (1843): 'A Day at a Piano Factory' in Dodd, George: Days at the Factories. London: Charles Knight and Company.

NOTES FOR CHAPTER 4:

BROADWOOD GRANDS: CHANGES IN PRODUCT RANGE, 1825-1865. ETC.

(1) Broadwood's price list of July 1825. Broadwood Papers Ref: 2185/JB/133. Surrey County Archives, Woking.

(2) Hipkins, Edith (1937): How Chopin Played. London: JM Dent.

(3) Broadwood Number Books, part of the Broadwood Papers housed in the Surrey County Archives.

(4) A Patent for Sebastien Erard's double escapement action was lodged in England by his nephew, Pierre Erard, on the 22nd December 1821. (English Patents no. 4631).

(5) For further information about the interesting Southwell family, see: Cobbe, Alex (1997): 'Beethoven, Haydn and an Irish Genius: William Southwell of Dublin.' Irish Arts Review, Yearbook 1997, volume 13, pages 71-76. Dublin: Irish Arts Review Ltd.

Also see: de Valera, Terry (1983): 'Two Eighteenth Century Instrument Makers'. A paper read to the Old Dublin Society, 26th January 1983. Dublin: The Old Dublin Society. (No further details. Photocopy of the Paper supplied to the writer by David Hunt, Willingham, Cambridge).

(6) Broadwood Papers, Ref:2185/JB/24/16.

(7) British Patents Number 7424, August 24th 1837.

(8) The piano, serial number 16368, has a case of amboynawood veneer, lavishly decorated with carved and gilt limewood floral motifs. The original sale in 1847 was to the Reverend Henry Prince of Bridgewater, Somerset, founder of the 'Agapemonite' movement. The nameboard of the piano reads:

'Patent
Repetition Grand Pianoforte
John Broadwood and Sons
Manufacturers to Her Majesty
33, Great Pulteney Street Golden Square
London.'

(9) Verbal communication to the writer, February 2000.

(10) Broadwood's new grand action of 1894 was designed by George Daniel Rose, son of the factory manager Frederick Rose, and head of Broadwood's research team at that date. A patent was applied for (English Patents 20504) but for some reason was not granted, probably because the action's features were too similar to those already found in the Erard action being manufactured in Paris (from 1821), and also in London (from 1852).

(11) Broadwood's Price List, January 1843. A copy was seen and photocopied by the writer at Broadwood's former General Office, Milton Keynes, 1991.

(12) Broadwood's Price List, January 1849. Broadwood Papers, Ref: 2185/JP/138.

(13) The three elliptical grands supplied by Broadwood to Chopin during his British tour of 1848 were: number 17093 (sent to the composer's lodgings at 48, Dover Street, where it remained throughout his English visit); number 17047 (sent to Manchester, and also played by Chopin at the Guildhall, London); and number 17001 (used by Chopin in Edinburgh and Glasgow). According to the booklet International Inventions Exhibition, 1885: List of John Broadwood and Sons' Exhibits, pages 12-13, (probably written by AJ Hipkins, Broadwood's sales manager):

'All these instruments [viz: 17093, 17047 and 17001] were chosen by Chopin himself in our warehouse, and on such visits he was accompanied by his friends and pupils, Miss Stirling and M. Tellefsen.'

The history of Chopin Broadwood grand number 17047 is dealt with in some details in appendix II which appears at the end of this dissertation.

(14) Broadwood Price List, 1st July 1864. Broadwood Papers, Ref: 2185/JB/139.

(15) Broadwood Papers, Ref: 2185/JB/24/8.

(16) Information about the 'exodus' of piano trade workers to rural Kent was given to the writer by the late Ernest Chalkley, piano action finisher and regulator, apprenticed with Chappell and Company, Chalk Farm, London in the 1930s and later senior action-finishing foreman with W Danemann and Company, Islington, London from the late 1960s until 1984.

(17) The Porters' Day Books, Broadwood Papers Ref: JB/3081.

(18) Joseph Joachim, Austro-Hungarian violinist, composer, conductor and teacher, born Bratislava 1831, died Berlin 1907. His visits to England became an annual event after 1862.

NOTES FOR CHAPTER 5:

BROADWOOD GRAND PIANOS AT THE 1862 INTERNATIONAL INVENTIONS EXHIBITION; BROADWOOD TUNING FORKS; HENRY BROADWOOD'S METALLIC WREST PIN PLATE.

- (1) Information from an obituary which appeared in Music Trades Review, 15th July 1893, shortly after Henry Fowler Broadwood's death.
- (2) See: Mactaggart, Peter and Ann, eds. (1986): Musical Instruments at the Great Exhibition, pages 21, 94-99. Welwyn, Herts: Mac and Me Ltd.
- (3) In her brief account, How Chopin Played, Edith Hipkins, daughter of Alfred James Hipkins, wrote: 'He [viz: her father AJ Hipkins] gave over forty Chopin recitals at the Great Exhibition of 1851 to crowds so dense that he was rarely seen.' There is every reason to believe that Hipkins, as Broadwood's sales manager, would have given similar recitals throughout the 1862 Exhibition. See Hipkins, Edith (1937): How Chopin Played. London: JM Dent.
- (4) This information also from Hipkins, Edith (1937). See note (3).
- (5) Hipkins, Alfred James (1896): A Description and History of the Pianoforte. London: Novello and Company.
- (6) Ehrlich, Cyril (1976): The Piano: A History, page 146. London: JM Dent.
- (7) See: International Exhibition 1862. List of Pianofortes and of Various Samples and Models intended to illustrate the Principles of their Manufacture, exhibited by John Broadwood and Sons, London. With an historical introduction, explanatory remarks and illustrative plates and diagrams. London: Printed by WS Johnson and Company.
- (8) See note (7).

(9) Some Notes made by JS Broadwood in 1838, with Observations and Elucidations by HF Broadwood, 1862. Printed by WS Johnson and Co, London, 1862.

(10) The problems of tuning instability as a result of the raising and lowering of pitch level is demonstrated in the following (printed) letter, which was sent out to all its regular tuning customers by the piano-making firm C Bechstein from its London branch, 40 Wigmore Street, in the late 19th century. (The letter forms part of the writer's collection):

'To reduce your Pianoforte to Continental Pitch [presumably a reduction from the English 'Philharmonic' pitch to 'Continental' pitch, which is A=435, a drop of over a quarter tone] will have the effect upon the Instrument of unsettling the strings, and altering the tension of the Iron Frame; and, as this is a very great change in the instrument, it must be done gradually.

'The Piano should be carefully tuned at least three times, allowing an interval of two days between each tuning, thus lowering the pitch by degrees.

'After the first and second tuning, the instrument may not remain in tune; and even after the third, it may go out of tune again and require a fourth tuning, before it stands absolutely. These visits are charged for separately, at the rate of the annual contract tunings.

Believe me,

Yours truly,

C BECHSTEIN.'

This letter suggests that Bechstein's were unhappy with the practice of raising and lowering pitch, and, reading between the lines, it looks as though their charge for pitch alteration (three or four extra tunings at the normal rate) was intended as some kind of discouragement to those customers of theirs who wished to have the high English 'Philharmonic' pitch. The Bechstein piano, with its thin, delicate soundboard, its

comparatively gentle string downbearing pressure on the soundboard, and its wide domed felt 'pressure pad' between the tuning pins and brass studs, does not respond at all well to the tuner's attempts to lower or raise its pitch level. The tuner certainly finds it something of a challenge to 'stabilise' a Bechstein during a pitch alteration. In contrast, pitch changing on a Broadwood grand of the mid nineteenth century is comparatively easy: it can be accomplished by one tuning and within a couple of hours; and once the pitch change has taken place, the instrument remains stable at the new pitch level. This is largely the result of the heavier, thicker and more rigid soundboard found on the Broadwood grand, combined with a higher string downbearing pressure on to the board.

(11) This letter from Clara Schumann is quoted in Piano Forte: A Social History of the Piano by Dieter Hilderbrandt, page 144. Hutchinson, London, 1985. (However, the date of the letter is not given).

(12) See footnote 7.

(13) *British Patents*, number 1283. 30th April 1862.

(14) Various remedies have been suggested when it comes to attempting to solve the irritating problem of loose machine thread tuning pins found in those pianos having the Broadwood patented system. The looseness is usually found in the bass section, where the string tension is highest, and appears to be the result of long-term 'wear and tear' (viz: numerous tunings over many years). Suggestions range from packing the tuning pin threaded holes with either tinfoil, or piano action bushing cloth, or thread, or thin card; or impregnating the underlying, wooden, section of the wrestplank with a specially-formulated resin fluid to increase the grip of the wood on the pins. Yet another suggestion is to remove the original tuning pins altogether, drill out the original machine threads which are cut into the pin plate, and fit the piano with new, conventional, tuning pins.

(15) At the 1851 Great Exhibition, the highest award, the Council or 'Gold' Medal, had been awarded to Erard of Paris for 'peculiar mechanical action applied to the pianoforte and harp.' However, at the 1862 International Exhibition, it was Broadwood who received the highest award, the Gold Medal, for the company's improvements in piano design. See: Mactaggart, Peter and Ann, eds. (1986): Musical Instruments etc., pages 98 and 104.

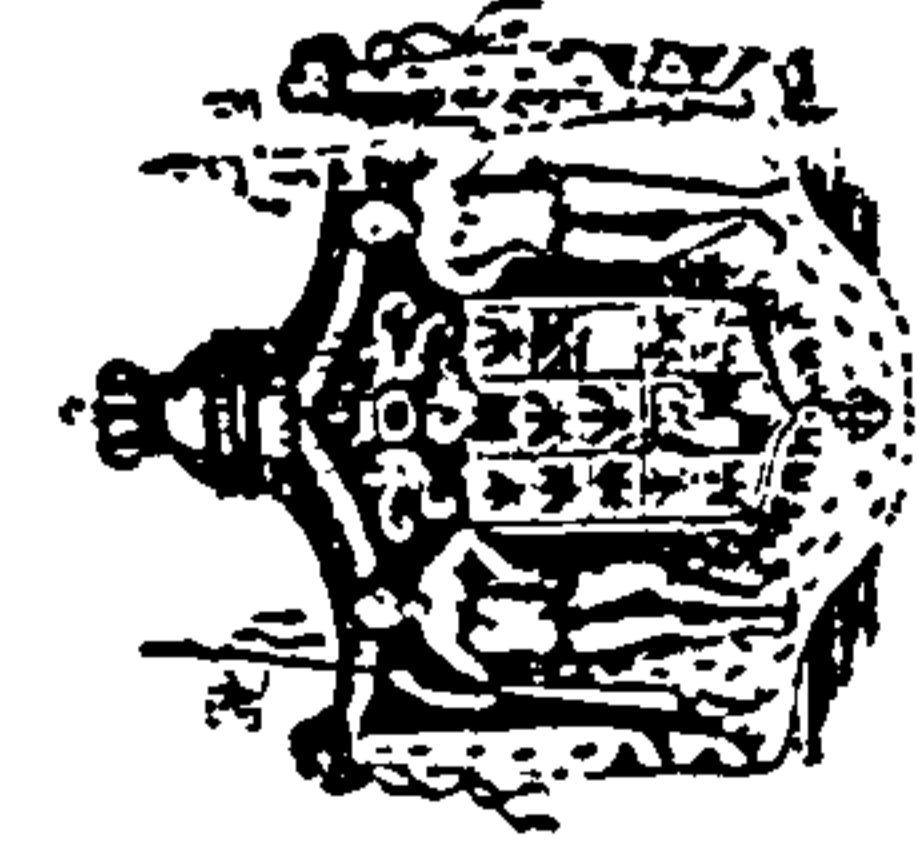

C. BECHSTEIN.

PIANOFORTE MANUFACTURER

BY SPECIAL APPOINTMENT TO

HER MAJESTY THE QUEEN,

HIS MAJESTY THE EMPEROR OF GERMANY, KING OF PRUSSIA,

HER MAJESTY THE EMPRESS QUEEN FREDERICK OF GERMANY,



H.R.H. PRINCESS LOUISE MARCHIONESS OF LORNE, H.R.H. THE DUKE OF EDINBURGH.

H.R.H. THE PRINCE FREDERICK CHARLES OF PRUSSIA.

TELEGRAM ADDRESS:
"BECHSTEIN, LONDON."

London,

40, WIGMORE STREET, W.

AS

After the first and second tuning, the instrument may not remain in tune; and even after the third, it may go out of tune again, and require a fourth tuning, before it stands in tune absolutely. These visits are charged for separately, at the rate of the annual contract tunings.

Believe me,

Yours Truly,

C. BECHSTEIN.

DEAR

To reduce your Pianoforte to Continental

Pitch will have the effect upon the Instrument of

unsettling the strings, and altering the tension of

the Iron Frame; and, as this is a very great change

in the instrument, it must be done gradually.

The Piano should be carefully tuned at least three

times, allowing an interval of two days between

each tuning, thus lowering the pitch by degrees.

NOTES FOR CHAPTER 6:

THE SCALE DESIGN OF BROADWOOD GRANDS, 1850-1895.

(1) The 'Bridge of Reverberation' was patented by William F Collard, a partner of Clementi and Company, on the 8th March 1821. (English Patents number 4542). The Patent specification refers to a third bridge in addition to the usual two, 'to allow that part of the strings which is normally listed, or damped, to sympathise and vibrate in unison with the lengths between the ordinary bridges.'

(2) A Patent for Sebastien Erard's double escapement action was lodged in England by his nephew, Pierre Erard, on the 22nd December 1821. (English Patents number 4631).

(3) See the extensive list of names and addresses of nineteenth century London piano manufacturers in Harding, Rosamund EM (1933): The Pianoforte: Its History Traced to the Great Exhibition of 1851, appendix G, pages 385-409. Cambridge: The University Press.

(4) The Buckingham Palace Erard grand has been standing in the White Drawing Room there for over one hundred years. The special elaborate casework is described in an article, by Crowdy, Wallace L. (1894): 'A True Tale of Two Cities.' Ludgate Hill Magazine, 1894, pages 55-63, as follows:

'The Vernis Martin decorations on the case [of the Erard piano], which are of the most exquisite description, have been twice transferred; that is to say, they were originally upon a harpsichord belonging to Anne of Austria, from which they were removed to a grand pianoforte of Messrs S and P Erard's early manufacture, and thence subsequently to the case of the grand now standing in the White Drawing Room at Buckingham Palace. It is needless to say that the operation of transferring the decorations just mentioned is an exceedingly delicate one indeed, and could only be accomplished by the most expert and skilled workmen - indeed the operation is a work of art in itself, and as such was recognised by her Most Gracious Majesty herself, who summoned the heads of Messrs Erard's house to

Buckingham Palace and, in the presence of the late lamented Prince Consort, personally expressed her great appreciation of the skill displayed in carrying out the work.'

[This same Erard grand piano, serial number 3985, has been regularly tuned and maintained in the White Drawing Room at Buckingham Palace by the writer of this dissertation since 1991].

(5) Ehrlich, Cyril (1976): The Piano: A History, page 146. London: JM Dent and Sons Ltd.

(6) Piano production number books of John Broadwood and Sons, Broadwood Archives, Surrey Record Office, Woking, Surrey.

(7) Wainwright, David (1982): Broadwood by Appointment, pages 244-245. London: Quiller Press.

(8) Details of the five grands analysed in Chapter 6:

1. A Broadwood 'Concert Iron Grand', large concert model, straight strung with diagonal bracing bar, 7 octaves, serial number 19165, made in the year 1859, now forming part of the Finchcocks Collection of Early Keyboard Instruments at Goudhurst, Kent. Measured up by the writer, August 1994. Tuned by the writer on many occasions for recording sessions at Finchcocks, the last being April 1998. This same instrument is discussed in chapter 4 under the heading 'Hire Pianos; and the custom of Hire before Sale.'

2. A Broadwood 'Drawing Room' Grand, large concert model, straight strung with two parallel iron bars, 7 octaves, serial number 20820, made in 1875, now forming part of the collection of the Scottish National Trust at the House of Dun, Montrose, Scotland. Measured up by the writer, July 1994. Restored by the writer, 1995.

3. An Erard (Paris design, London built) eight foot concert grand, straight strung, 7 octaves, made in the year 1865. Measurements provided by Odd Aanstad of Huser, Asmaloy, Norway, 1994. An identical Erard concert grand, made one year later (1866) and forming part of the Finchcocks

Collection, has been tuned, regulated and played by the writer on numerous occasions since 1989. Played by the writer for two recent CD recordings, Laurence Let Loose (1997) and Time Remembered (1999).

4. A Blüthner (Leipzig) boudoir grand, overstrung, 7 octaves, serial number 10693, made in 1871, now part of the collection of historical keyboard instruments at Musikk Instrument Akademiet, Moss, Norway. Measured up and restored by the writer with students from the Akademiet, 1996-7.

5. A modern Steinway full-size concert grand (New York), model 'D', overstrung, $7\frac{1}{4}$ octaves. Serial number not recorded. Measured up by Dr Al Sanderson of Carlisle, Massachusetts, USA. Hundreds of virtually identical concert pianos are in regular use in concert halls and recording studios throughout the world.

(9) The recording, entitled Home Sweet Home: Nineteenth Century Music Party, featured two Broadwood grands (1823, 1859), an Erard grand (1866), a Conrad Graf grand (1826) and a Clementi upright (circa 1823). Produced by Soundalive Music Ltd of Hampton Wick, Surrey.

(10) This letter quoted in Wainwright, David (1982): Broadwood by Appointment, pages 170-171. Unfortunately, the author does not reveal his source. If the letter forms part of the Broadwood Papers housed in Surrey County Archives, then it has not been discovered by the present writer during his searches.

(11) A description of the 'Aliquot Scaling' is contained in a leaflet produced by Blüthner and Co Ltd, 17-23, Wigmore Street, London, circa 1930. The leaflet contains two diagrams showing cross sections of a grand piano: one of the treble, and one of the middle register. The position of the sympathetic strings is indicated.

(12) The 'capo d'astro' bar was patented by Steinway and Sons on the 30th November 1875, and has ultimately been copied by most modern manufacturers, including Yamaha and Bosendorfer. However, a forerunner of the capo d'astro is to be found in the treble sections of the 1865 and 1866 Erard grand pianos mentioned in note (8), and so the 'idea' is not really Steinway's. In the Erard model, however, the bar does not form an integral part of a

cast-iron frame, but instead is attached to the wooden tuning plank by a series of long screws. Therefore, the contribution of Erard's 'capo' bar to the power of treble tone is more limited. Its chief value appears to be that of improving the tuning stability.

(13) See the '24½ inch Scale' and the 'Long Scale' stringing charts included as an appendix to John Broadwood and Sons guide produced for the 1862 International Inventions Exhibition, London. (see chapter 5.)

(14) Hansing, Siegfried (1888, revised edition in English, 1909): Das Pianoforte und seinen akustischen Anagen. New York. Publisher's name not recorded.

(15) The original letter cannot be traced at present. A typescript copy of it was given to the writer by the late David Wainwright, who explained that it had been his intention to include it in the appendices to his book, Broadwood by Appointment. However, because of financial restrictions, the letter was not included in the eventual publication of 1982.

(16) Practical knowledge about the use of octave ratios in piano scale design is almost a lost art. Forty or so years ago, there was a small group of elderly London-based piano designers (Ernest Gowland, John Challen, Sidney Hurren, Clarence Lyon, Alfred Knight and Leslie Lawrence) who had learnt the use of octave ratios by word of mouth: their skills were obtained from a largely unwritten source of common knowledge. Today, all these designers are long dead; and as far as the writer is aware, he is the only surviving English piano designer who is able to use the ratios in design work.

(17) [n.a.] (1916, 1917, 1918, and 1919): Piano Tone Building. Piano Technicians' conferences in Chicago and New York. [n.p]: The Acoustic Department, American Steel and Wire Company. The highly-detailed information, recorded as it was discussed during the Proceedings, is of great value to the present-day piano designer.

(18) International Inventions Exhibition, 1885. List of John Broadwood and Sons' Exhibits (in the Central Gallery). Author's name not given, but the booklet was almost certainly written by Alfred James Hipkins, Broadwood's

sales manager.

(19) Furey, John (1929): The Building of the Piano. London: Musical Opinion. In chapter 1 there is a very good account of the customary method of modifying the hammer strike proportion in the treble section of the instrument. John Furey had worked as a practical piano maker and designer since circa 1880, and at the time of his death he was factory manager of John Spencer and Company of Regent's Park, London, makers of well-designed, medium-priced instruments.

(20) According to the late CH Gilbey (see note (27) for chapter 2), a string tensioning machine of the type used by Broadwood was to be found in each of the factories of the best London makers. A string tensioning machine was designed by Samuel Wolfenden (author and publisher, 1916) of Treatise on the Art of Pianoforte Construction. Sometime during the 1920s, the machine was installed in the Piano Department of the Northern Polytechnic, Holloway Road, London, (where Wolfenden was a part-time lecturer) and was for many years used by the students of piano technology there for testing the strength of steel piano wire.

(21) Broadwood, JS (1838): Some Notes made by JS Broadwood in 1838 with Observations and Elucidations by HF Broadwood, 1862, page 13. London: printed by WS Johnson and Co.

(22) Hipkins, Alfred James (1896): A Description and History of the Pianoforte, pages 10-13. London: Novello and Co.

(23) One of these observers was Alfred Marlborough Laurence (1844-1923) great-great uncle of the writer, who had charge of the Broadwood pianos on display at the 1867 Paris Exhibition.

(24) see: Dolge, Alfred (1911): Pianos and Their Makers, pages 123-126. Corvina, California: Corvina Publishing Company.

(25) The removal date to the house called 'Lyne' at Capel, Surrey, was the 29th April 1864, according to the Diary kept by Henry Fowler Broadwood's

daughter, Bertha, then aged 18. Shortly afterwards (within a matter of weeks) the writer's great-grandfather, Alexander Laurence (1839-1913), left the Broadwood company. He had been on very good terms with Henry Fowler and had been favoured by him. However, after Henry's permanent departure for Surrey in the spring of 1864, life became very difficult for Alexander because of the jealousy of his fellow workers, who became hostile and uncooperative. A heated, quarrelsome period, followed almost certainly by a violent physical assault in the Horseferry Road factory, forced Alexander to resign from the firm. He left to establish his own piano factory in Leicester, which later became known as 'Alex Laurence and Sons.' The date of the establishment of this firm was 1864, the same year that Henry Fowler Broadwood departed from the Horsferry Road works. [Sources of information: Diary of Bertha Broadwood, Surrey County Archives, Woking; and CG Laurence (1885-1970), the writer's grandfather].

NOTES FOR CHAPTER 7:

THE BROADWOOD 'BARLESS' GRAND PIANO, 1888-1914.

- (1) British Patents, 26th January 1888, number 1231.
- (2) British Patents, 9th April 1827, number 5485.
- (3) British Patents, 15th January 1820, number 4431. James Thom and William Allen were employees of William and Matthew Stodart.
- (4) Rose, Malcolm, and Law, David (1991): A Handbook of Historical Stringing Practice for Keyboard Instruments. Lewes: M Rose and D Law.
- (5) Helmholtz, Hermann LF (1862; second English edition by Ellis, Alexander J, 1885): On the Sensations of Tone. London: Longmans and Co.
- (6) The line drawings of the 'Chopin' grand of 1848 and the 'Original Iron Grand' of 1847-49 are photocopied from the booklet International Inventions Exhibition 1885. List of John Broadwood and Sons' Exhibits (in the Central Gallery). London: John Broadwood and Sons.
- (7) Mactaggart, Peter and Ann, eds. (1986): Musical Instruments in the 1851 Exhibition, page 98. Welwyn: Mac and Me Ltd.
- (8) Three Viennese grands in the Finchcocks Collection, Goudhurst, Kent, which have unstruck 'dummy' strings lying on their bridges are: Fritz, circa 1815; Conrad Graf, circa 1820; and Conrad Graf, 1826.
- (9) International Inventions Exhibition, 1885, pages 10-11. See note (6).
- (10) Broadwood Porters' Day Books, Surrey Archives, Woking. Reference 2185/JB/42.
- (11) See his biographical entry in (1980): The New Grove Dictionary of Music and Musicians. London: Macmillan.

(12) Hipkins, Alfred James (1896): A Description and History of the Pianoforte, pages 17-18. London: Novello and Co.

(13) Broadwood, John and Sons (1862): International Exhibition 1862. List of Pianofortes and of Various Samples and Models, Intended to Illustrate the Principles of Their Manufacture, pages 31-32. London: printed by WS Johnson and Co.

(14) See note (1).

(15) Department of Trade and Industry, National Engineering Laboratory, East Kilbride, Glasgow (September 1986): Feasibility Study into the use of Fibre Reinforced Plastics in the Construction of Piano Frames. Glasgow: NEL, commissioned by John Broadwood and Sons Ltd.

(16) Promotional literature, John Broadwood and Sons, circa 1890. Section entitled The No. 8a Barless Steel Concert Grand (3 pages).

(17) Cuttings Book (mainly price lists) 1831-1920, Broadwood Papers, ref. 2185/JB. Surrey County Archives, Woking.

(18) See note (17).

(19) Wainwright, David (1982): Broadwood by Appointment, page 197. London: Quiller Press.

(20) The fire began in the early evening of the 12th August 1856, and could not be contained because of the failure of the water system. Most of the factory buildings and their contents (pianos, materials and workmen's tools) had been destroyed by mid evening. In the winter of 1856/57, Frederick Rose drew up plans for the rebuilding of the firm's premises and the reorganisation of production on the same site. See chapter 3 of this dissertation for further details.

(21) Information supplied to the writer by William Mallinson and Sons Ltd, timber merchants, London.

(22) Bamberger, Louis [n.d. circa 1930]: Memories of Sixty Years in the Timber and Pianoforte Trades, pages 228-229. London: Sampson Low, Marston and Co Ltd.

(23) Photographic portraits belonging to Bernard Davies of Eastbourne, Sussex, great-great nephew of George D Rose.

(24) Information from the Broadwood Porters' Day Books Nos 112 and 114, 1896 and 1897. Surrey County Archives, ref: 2185/JB.

(25) The photograph of piano 44487 is part of the Broadwood Papers, Surrey County Archives, ref: 2185/JB/108. The relevant Porters' Book discloses the following information about the same piano:

'Finished 21st November 1895.

13th February 1896: RD Cleasby Esq. 9 Portman Square [purchaser]

A short Gd Pf Rosewood Overstrung 7 $\frac{1}{4}$ oct.

125 guineas

Per Messrs Heins and Co. Hereford.

[Porters:] Drew and Appleby.'

(26) Early Music Today, January/February 1994.

(27) Biographical information about Pauer is to be found in Hipkins, AJ (1980): The New Grove Dictionary of Music and Musicians. London: Macmillan.

(28) Keighley Laboratories Ltd, Consulting Metallurgists, Croft House, Keighley, West Yorkshire. [n.a.] (26th October 1987): Material Identification and Quality Checks on Piano Frame Casting.

(29) and (30) Broadwood Porters' Day Books Nos 112 and 114, 1896-97. Surrey County Archives, ref: 2185/JB.

(31) [n.a.] Souvenir of the Incorporated Society of Musicians' Conference, London, (January 1898): How the Modern Pianoforte is Made: the Visit to John Broadwood and Sons Pianoforte Manufactory, page 41. London: John Broadwood and Sons.

(32) See note (12).

(33) The two photographs are of inferior quality because they are produced from glass negatives in poor condition, dated 1922 and 1924. The negatives were formerly in the office of Booth and Brookes Ltd, ironfounders, Burnham-on-Crouch, Essex, (who made cast frames for Broadwood from the early 1900s). The two negatives, with approximately another thousand similar ones showing frames supplied to London piano manufactureres, 1920-1939, were given to the writer by Patrick Booth, former director of Booth and Brookes, shortly after the closure of the Burnham Ironfoundry in January 1981.

(34) See note (17).

NOTES FOR CHAPTER 8:

THE SURVIVAL OF THE BROADWOOD GRAND SINCE 1914.

(1). Information received from Mr Bernard Davies of Bournemouth, a great-great-nephew of George Rose.

(2). During his teenage years, (in the 1960s) the writer of this dissertation spoke to many elderly individuals within the piano industry (e.g. piano tuners), all of whom criticised the Broadwood product of the late 1920s. The writer's father's cousin, Leslie Victor Laurence (1897-1976), who was in business as a piano dealer in the town of Leicester during the late 1920s, stated that Broadwood's design innovations of that period 'ruined the [Broadwood] company.'

(3). Price Lists of new Broadwood instruments, 1831-1920, contained in the Broadwood Papers at Surrey Record Office, Woking, Surrey. Reference: 3081. Bechstein prices obtained from an illustrated brochure (early 20th century) from the writer's collection.

(4). Broadwood brochures/ price lists from the year 1923 belonging to Mr Norman Allen of Bramhope, Leeds.

(5). Broadwood barless concert grand, serial number 54604, made in 1925. This piano belongs to Ladbroke Pianos of Birmingham, and is currently on loan to the Foreign Office, London. The piano was examined, tuned, voiced and regulated by the writer in Ladbroke's workshop, 1994/5.

(6). See pages 289-291 of 'Broadwood by Appointment' by David Wainwright, Quiller Press, London, 1982.

(7). Broadwood withdrew from gramophone manufacture circa 1924, when electrically-operated gramophones began to replace wind-up 'acoustic' machines. The company was unable to compete in price with the new electrical machines being designed in the USA and manufactured in large quantities under licence in the UK.

(8). Robert Henry Collen (or 'Reg' Collen as he was familiarly known) was trained as a marine engineer. He joined the Broadwood company circa 1901, probably as works engineer, and had become factory director by 1915. His engineering skills were beyond dispute. He had a deep technical knowledge about player-piano systems; but his awareness of how to create good piano tone appeared to be very limited. His patent of 1927 (British Patents number 267,195, granted March 17th 1927) was for a new system of upright piano manufacture, in which the outer casework, made as a separate item, could be attached to an inner self-contained 'playing unit' of frame/soundboard/keys/action etc. The idea in theory helped to speed up production, but (because of the elaborate, heavy cast-iron frame required) was no cheaper to produce than a conventionally-made upright. In musical terms, Collen's various ideas/designs were not a success, and contributed to a general deterioration in the quality of Broadwood tone during late 1920s.

(9). See note (2). Collen's brass studs were highly disliked by tuners, who complained bitterly about the problems they caused. In some cases, the treble sections of Broadwood pianos were declared to be 'untuneable' because of the large number of unwanted 'pulsating' false-sounding strings.

(10). The lavishly-produced commemorative booklet 'Broadwood. The Piano of the Nation for Six Generations', written by journalist Rudolph de Cordova, gives a fascinating account of the Royal visit of July 20th 1926. Its pages include eight specially-mounted high-quality photographs showing the King and Queen witnessing various stages of piano construction. (Copy in the writer's collection).

(11). Barless baby grand piano, serial number 54315, presently standing in the Music Room at Buckingham Palace, has been regularly tuned and serviced by the writer since August 1991. In May 1993 the piano was restrung and fitted with new hammers.

(12). Correspondence/drafts re: agreement with Challen, are to be found

in the Broadwood Papers, Surrey Archives, Working ref: 2185/JB/11.

(13). Leslie Lawrence (1910-1972) studied piano design with Sydney Hurren at the Northern Polytechnic, Holloway Road, London, during the 1920s. From the early 1930s Leslie Lawrence and his elder brother Albert (a tuner and toner) managed the Challen factory at Hendon. Leslie designed a total of nine grands for Challen, ranging in size from a 12-foot concert model to a 4-foot miniature baby grand. In 1938 Lawrence left the company to take a post as works manager with Martyn Aircraft in Cheltenham, but he rejoined the Challen company in 1950.

(14). The smallest Broadwood upright, the model '65', a 'budget' instrument, was built for Broadwood by Kemble and Company Ltd of Carysfort Road, Stoke Newington, London, throughout the 1960s. After the Kemble company (later known as Kemble-Yamaha) moved to Bletchley, Milton Keynes, in 1965, Broadwood upright production was continued in the factory there until 1991.

(15) The model 10F dates from 1950, and was in production until 1984. A last batch of some 20 sets of parts for the model 10F (dating from 1984) was given to the former piano workshop at Leeds College of Music in order that the students there could learn piano construction. After the closure of this same piano workshop in 1997, the remaining parts were shipped to Moss, Norway, where they are presently being used by the writer of this dissertation to teach Norwegian students the art of piano construction.

(16) Information received from former Danemann employees and also from David Martin, technical director of Herrburger Brooks Ltd (piano action manufacturers, Long Eaton, Nottinghamshire).

NOTES FOR APPENDIX III:

TWO YEARS IN THE LIFE OF BROADWOOD CONCERT GRAND NUMBER 22021, (1885-1887).

(1) Date of completion of manufacture obtained from the Broadwood Number Books, Surrey County Archives, Woking.

(2) International Inventions Exhibition 1885. List of John Broadwood and Sons' Exhibits (in the Central Gallery), page 3. This 44-page brochure, published by Broadwood, was almost certainly written by Alfred James Hipkins, the company's sales manager.

(3) Vladimir de Pachmann (1848-1933), Ukranian concert pianist, noted for his playing of Chopin.

(4) Sir Charled Hallé (born Westphalia 1819, died Manchester 1895) concert pianist and conductor, knighted 1888, founder of the Halle Concerts, Manchester.

(6) Information from the Minutes Book of the Royal Academy of Music, 1885-86. (Royal Academy of Music Library).

(7) from: Mackenzie, Alexander Campbell (1927): A Musician's Narrative, page 148. London: Cassell and Co.

(8) The original framed version of the Liszt Testimonial contained the following additional wording (within the same frame):

'Liszt during his visit to London in 1886 played upon the following Broadwood Concert Grand Pianofortes:

No 22021 at the Royal Academy of Music, April 6th.

No 22021 at Mr Walter Bache's Reception, Grosvenor Gallery, April 8th.

No 22156 at the Baroness Burdett Coutt's Reception,

April 13th.

No 21519 belonging to Mr Henry Littleton, on the occasion of a special Musical evening held at his residence, Westwood House, Sydenham, April 15th.

and also upon the following 'Broadwood' instruments:

No 22132 (Short Iron Grand) at the Princess Gluca's during the afternoon of the 15th April.

No 62441 (Oblique Cottage) at the Lady Walter Scott's during the afternoon of the 8th April.'

(9) Miss Fanny Davies (1861-1934), English concert pianist. Her London debut had taken place the previous October 17th (1885), at the Crystal Palace, where she had performed Beethoven's Fourth Piano Concerto.

(10) Sir George Macfarren (1813-1887), English composer, became Principal of the Royal Academy of Music in 1875, was knighted in 1883, and was described by the composer Wagner (1855) as a 'pompous, melancholy Scotsman.' His younger brother Walter Macfarren (1826-1905) was professor of piano at the Royal Academy of Music from 1846 until 1903. Among his pupils were Tobias Matthay, Stewart Macpherson and Henry Wood. Source of this information: articles in (1980) The New Grove Dictionary of Music and Musicians, ed. Stanley Sadie. London: Macmillan. 1980.

(11) Information from: Macfarren, Walter (1905): Memories: an autobiography, pages 230-231. London: Walter Scott Publishing Co.

(12) From The Scotsman, 15th September 1893.

(13) This testimonial quoted in Wainwright, David (1982): Broadwood by Appointment, page 233. The source of the testimonial is not given in Wainwright's account.

(14) Information from the Broadwood Porters' Books, Surrey County Archives,

Woking. Ref: 3081. The entry for the 21st January 1887 reads:

'Messrs Cramer, Wood and Co., Dublin.
No 22021. 250 Guineas and Case to go
by L and NWR via Holyhead.'

('£186 13s' is entered in the accompanying
cash column).

BIBLIOGRAPHY

Bamberger, Louis (circa 1930): Memories of Sixty Years in the Timber and Pianoforte Trades. London: Sampson Low, Marston and Co Ltd.

Boalch, Donald (1995): Makers of the Harpsichord and Clavichord, 1440-1840. Third edition, edited by Charles Mould. Oxford: Clarendon Press.

Broadwood, JS (1838): Some Notes made by JS Broadwood in 1838 with Observations and Elucidations by HF Broadwood, 1862.
London: printed by WS Johnson and Co.

Broadwood, John and Sons (1862): International Exhibition 1862. List of pianofortes and of various samples and models, intended to illustrate the principles of their manufacture, with historical introduction etc. London: printed by WS Johnson and Co.

Broadwood, John and Sons (1885): International Inventions Exhibition, 1885. List of John Broadwood and Sons' Exhibits. London: 1885

Broadwood, John and Sons (1898): How the Modern Piano is Made. Souvenir book of the Incorporated Society of Musicians' Conference and visit to Broadwood's Horseferry Road factory, London, January 1898.
London: printed by Waterlow and Sons Ltd.

Broadwood, John and Sons (circa 1903): Album of Artistic Pianofortes. (photographs and descriptions of new models).

Broadwood, John and Sons (circa 1905): Catalogue of Latest Models

Brinsmead, Edgar (1889): The History of the Pianoforte.
London: Simpkin, Marshall and Co.

Clinkscale, Martha Novak (1993): Makers of the Piano, 1700-1820.
Oxford: University Press.

Cole, Michael (1998): The Pianoforte in the Classical Era.
Oxford: Clarendon Press.

Colt, CF (1981): The Early Piano. London: Stainer and Bell.

Dolge, Alfred (1911): Pianos and their Makers.
Corvina, California: Corvina Publishing Company.

Dow, William (compiler, 1990): The Finchcocks Collection.
Goudhurst, Kent: Finchcocks Museum.

Ehrlich, Cyril (1976): The Piano, A History. London: JM Dent.

Furey, J (1929): The Building of the Piano. London: Musical Opinion.

Hansing, Siegfried (1888; revised edition in English, 1909): Das Pianoforte und seinen akustischen Anagen.

Revised edition: New York. Publisher's name not recorded.

Harding, Rosamund EM (1933): The Pianoforte. Its History traced to the Great Exhibition of 1851. Cambridge: University Press.

Hildebrandt, Dieter (1988): Piano Forte: a Social History of the Piano. London: Hutchinson.

Hipkins, AJ (1896): A Description and History of the Pianoforte. London: Novello and Company.

Hipkins, Edith (1937): How Chopin Played. London: JM Dent.

Hubbard, Frank (1972): Three Centuries of Harpsichord Making. Massachusetts: Harvard University Press

Koster, John (1994): Keyboard Musical Instruments in the Museum of Fine Arts, Boston. Boston: Museum of Fine Arts.

Mactaggart, Peter and Ann (editors, 1986): Musical Instruments in the 1851 Exhibition, London. Welwyn: Mac and Me Ltd.

Nalder, Laurence M (1927, reprinted 1977): The Modern Piano. Old Woking: The Gresham Press.

National Engineering Laboratory, Glasgow (1986): Feasibility Study into the use of fibre reinforced plastics in the construction of piano frames.
Glasgow: The National Engineering Laboratory.

Newman, Sidney and Williams, Peter (1968): The Russell Collection and other Early Keyboard Instruments in St Cecilia's Hall, Edinburgh.
Edinburgh: The University Press.

[n.a.] (1916, 1917, 1918, and 1919) Piano Tone Building.
Piano Technician's conferences in Chicago and New York. [n.p.]: The Acoustic Department, American Steel and Wire Company.

[n.a.] (1996) Pierce Piano Atlas.
Albuquerque, New Mexico: Larry E Ashley.

Pollens, Stewart (1995): The Early Pianoforte.
Cambridge: The University Press.

Rimbault, EF (1860): The Pianoforte. London: R Cocks and Co.

Rose, Malcolm; and Law, David (1991): A Handbook of Historical Stringing Practice for Keyboard Instruments. Lewes: M Rose and D Law.

Steinway, Theodore E (1953, revised 1961): People and Pianos.
New York: Steinway and Sons.

Wainwright, David (1975): The Pianomakers. London: Hutchinson.

Wainwright, David (1982): Broadwood by Appointment.
London: Quiller Press.

White, William B (1906): Theory and Practice of Piano Construction.
New York: EL Bill.

Wolfenden, Samuel (1916): A Treatise on the Art of Pianoforte Construction
[n.p.] Published by the author.

Wolfenden, Samuel (1927): Supplement to A Treatise on the Art of Pianoforte
Construction. London: King and Jarrett.

ARTICLES AND PAMPHLETS CONSULTED

Cavallo, Tiberius (1788): 'Of the temperament of those musical instruments in which the Tones, Keys or Frets are fixed, as in the Harpsichord, Organ, Guitar etc.' Philosophical Transactions, volume 78.

Cole, Warwick (1986): 'Americus Backers, Preliminary Thoughts' (Author's unpublished typescript, seen in the office of the Russell Collection, St Cecilia's Hall, Edinburgh University).

Cole, Warwick (1987): 'Americus Backers, Original Fortepiano Maker.' Harpsichord and Fortepiano Magazine, volume 4.

Crowdy, Wallace L (1894): 'A True Tale of Two Cities.' Ludgate magazine.

Dodd, George (1843): 'A Day at a Pianoforte Factory.' In George Dodd's Days at the Factories. London: Charles Knight and Company.

[n.a] (1951): 'Pianoforte Frame Castings: production at the Mildmay Ironworks of Booth and Brookes Ltd.' Foundry Trade Journal, February 22nd 1951.

Hipkins, Alfred James (1879 to 1889): 'Pianoforte.' In Groves Dictionary of Music and Musicians, first edition.

Hipkins, Alfred James (1884): 'Observations on the Harmonics of a String

struck at One Eighth of its Length.' Proceedings of the Royal Society,
volume 37.

Hoover, Cynthia Adams (1981): 'The Steinways and their Pianos in the
Nineteenth Century.' Journal of the American Musical Instrument Society,
volume 7.

Hunt, David (1998): 'International Register of Surviving Grand Pianos
manufactured by John Broadwood and Sons, 1787-1837.' (Unpublished typescript
received from the compiler, February 1998). Willingham, Cambridge.

Koster, John (1995): 'The Divided Bridge, Due Tension, and Rational Strike
Point: Towards Cavallo's 'Great Object' of Scientific Design in Early English
Grand Pianos.' (Unpublished typescript received from the author, January
1995). South Dakota, USA: The Shrine to Music Museum, Vermillion.

Laurence, Alastair (1982-84): 'Aspects of Piano Construction.' Piano Tuner's
Quarterly, volume 28 number 3; volume 29 numbers 1 and 3; and volume 30,
number 2.

Lenehan, Michael (1982): 'Building a Steinway.' Reprint from Atlantic
Monthly. New York: Steinway and Sons.

Melville, Derek (1971): 'Beethoven's Pianos.' In Arnold and Fortune (eds), The
Beethoven Companion. London: Faber and Faber.

O'Brien, Grant (1981): 'Some Principles of Eighteenth Century Harpsichord
Strings and their Application.' The Organ Yearbook.

Oliver, JL (1975): 'Piano Manufacture.' Geography, volume 60, part 4.

Parsons, FEL (1981-82): 'Vibrational Characteristics of the Piano Soundboard.' Piano Tuner's Quarterly, volume 27 number 2; and volume 28 numbers 1 and 2.

Pollens, Stewart (1984): 'The Pianos of Bartolemeo Cristofori.' Journal of the American Musical Instrument Society, number 10.

Pollens, Stewart (1986): 'Gottfried Silbermann's Pianos.' The Organ Yearbook, volume 17.

Rhodes, JJK [n.d.]: 'Robert Stodart, a late 18th Century Piano Maker.' (Typescript booklet). Edinburgh: The Russell Collection, St Cecilia's Hall, University of Edinburgh.

Winter, Robert S (1988): 'Striking It Rich.' Journal of Musicology, 6 number 3. (USA).

CHRONOLOGICAL CHECKLIST OF PATENTS REFERRED TO IN THE MAIN TEXT

Words within inverted commas are the original Patent Office 'key words' by which the patent was identified.

Information within brackets [] has been added by the present writer to further aid identification/clarification.

Plenius, Roger, of South Audley Street, London: (date December 30th 1741): 'A machine of weights and swivels for keeping harpsichords in tune; ivory and tortoiseshell plectra, and regulating screws behind the tongues; metal jack slides.' etc. British patents No 581.

Stodart, Robert, of Wardour Street, Soho, Middlesex: (date November 21st 1777): 'A new sort of instrument, or grand forte piano, with an octave swell, and to produce various tones together or separate, and which instrument will be more durable, and produce finer and more variable tones, than any yet made.' [Combined piano and harpsichord using one manual, controlled by 2 pedals]. British Patents No 1172.

Broadwood, John, of Great Pulteney Street, Golden Square, Middlesex: (date July 17th 1783): 'New constructed piano forte, which is far superior to any instrument of the kind heretofore discovered.'

[Improvements in square piano design; brass underdampers; and tuning pins moved to the back of the case interior]. British Patents No 1379.

Broadwood, James Shudi, of Great Pulteney Street, Golden Square, Middlesex: (date April 9th 1827): 'Certain improvement in the grand pianofortes.' [Introduction of the cast iron hitch plate and wrought iron bars to resist the string tension in a grand piano]. British Patents No 5485.

Southwell, William, of 5, Winchester Row, New Road, Middlesex: (date August 24th 1837): 'A certain improvement in pianofortes.' [Introduction of additional springs into the English single lever grand action in order to improve repetition]. British patents No 7424.

Broadwood, Henry Fowler, of Great Pulteney Street, Middlesex: (date April 30th 1862): 'Improvements in the construction of pianofortes.' [Metallic pin plate and screwed tuning pins]. British patents No 1283.

Broadwood, Henry John Tschudi, of 33, Great Pulteney Street, London W.: (date 26th January 1888): 'Improvements in metal frames for pianofortes.' [the steel barless grand piano frame]. British patents No 1231.

Collen, Robert Henry, of 'Blackwater', Woodhouse Grove, East Ham, Essex: (date March 17th 1927): 'Improvements in pianofortes.' [a new system of upright piano construction in which the wooden casework was made completely independently of the strung back and action mechanism]. British patents No 267,195.