

The University of York
DEPARTMENT OF ARCHAEOLOGY
Incorporating
Institute of Advanced Architectural Studies
Centre for Conservation

**CONSERVATION AND SEISMIC STRENGTHENING OF
ARCHITECTURAL HERITAGE**
BYZANTINE CHURCHES
OF THE NINTH TILL THE FOURTEENTH CENTURIES IN MACEDONIA

Dissertation submitted for DPhil Degree

by

Lazar Sumanov

York 1999

На мојата сопруга Бранислава,
на моите деца Ирена и Дејан,
на мојата мајка Слободанка
и на мојот татко, мајстор Георги,
столарот од Скопје

To my wife Branislava, to
my children Irena and Dejan,
to my mother Slobodanka and
my father, master Georgi,
carpenter from Skopje

**CONSERVATION AND SEISMIC STRENGTHENING
OF ARCHITECTURAL HERITAGE**

**BYZANTINE CHURCHES
OF THE NINTH TILL THE FOURTEENTH CENTURIES IN MACEDONIA**

CONTENTS	I
ABSTRACTS	VI
DECLARATION & ACKNOWLEDGEMENT	VII
<u>CHAPTER ONE</u>	1
CONSERVATION AND SEISMIC STRENGTHENING OF ARCHITECTURAL HERITAGE - BYZANTINE CHURCHES OF THE NINTH TILL THE FOURTEENTH CENTURIES IN MACEDONIA	1
1.1 Introduction	1
1.2 Definition the problem	2
1.3 Scope of the study and thesis	5
1.4 Objectives	7
1.5 Research methodology	9
1.6 Structure of the study	10
Figures	12
<u>CHAPTER TWO</u>	13
PROTECTION AND CONSERVATION OF ARCHITECTURAL HERITAGE IN SEISMIC REGIONS	13
Introduction	13
2.1. General recommendations for protection and conservation of the cultural heritage in earthquake - prone regions - α multi - disciplinary process	13
<u>2.1.1 Pre - earthquake or preventive actions - phase (A)</u>	14
<u>2.1.2 Immediately after an earthquake strikes - phase (B)</u>	17
<u>2.1.3 Post - earthquake long - term - phase (C)</u>	17
2.2 Causes of damage	20
<u>2.2.1 Natural</u>	20
<u>2.2.2 Man - made</u>	22

2.3	Earthquakes - nature and characteristics	23
	<u>2.3.1 Nature</u>	23
	<u>2.3.2 Magnitude, intensity, hazard, risk and vulnerability</u>	24
2.4	Earthquake effect, response and degree of damage of the architectural heritage	29
	<u>2.4.1 Earthquake effect</u>	29
	<u>2.4.2 Response</u>	30
	<u>2.4.3 Resistance</u>	30
	<u>2.4.4 Damage</u>	31
	Notes	34
	Tables	37
	Figures	40

CHAPTER THREE

	THE NATURE AND CULTURAL HERITAGE OF THE REPUBLIC OF MACEDONIA	48
3.1	Geographical, geological and climatic characteristics	48
	<u>3.1.1 Geographical and geological characteristics</u>	48
	<u>3.1.2 Climatic characteristics</u>	49
3.2	Historical background	52
	<u>3.2.1 Pre - history</u>	52
	<u>3.2.2 The ancient Macedonian State</u>	53
	<u>3.2.3 Macedonia under the rule of the Roman Empire</u>	53
	<u>3.2.4. Macedonia in the period of the Late Roman and Early Byzantine Rule and the settlement of the Slavs</u>	54
	<u>3.2.5 From the Samuel's Empire until the Balkan Uprisings</u>	55
	<u>3.2.6. The Republic of Macedonia, an independent democratic state of the Macedonian people and the minorities that live in it</u>	57
3.3	Cultural heritage protection policy in the Republic of Macedonia	59
	<u>3.3.1 Legislation and institutional organisation</u>	59
	<u>3.3.2 Conservation and restoration activities</u>	60
	<u>3.3.3 Legislative treatment of cultural heritage before and after disaster (with a special emphasis on earthquakes)</u>	62
3.4	Architectural heritage	66
	<u>3.4.1 Basic information</u>	66
	<u>3.4.2 Typology and chronology</u>	67
	<u>3.4.3 Materials, structural elements and systems</u>	73

<u>3.4.4 Traditional structural seismic elements</u>	80
3.5 Church architecture	85
<u>3.5.1 Development and general characteristics</u>	85
<u>3.5.2 Chronology and typology</u>	86
<u>3.5.3 Building interior and exterior characteristics</u>	88
Notes	91
Tables	92
Figures	95
 CHAPTER FOUR	
BYZANTINE CHURCHES OF NINTH - FOURTEENTH CENTURIES IN MACEDONIA - DATA ANALYSIS	144
4.1 Architectural typology and chronology	144
4.2 Structural elements, systems and materials	151
<u>4.2.1 Materials, structural elements and systems</u>	151
<u>4.2.2 Materials</u>	151
4.3 Characteristics of building interior and exterior	154
<u>4.3.1 Interior</u>	154
<u>4.3.2 Exterior</u>	155
<u>4.3.3 Relationship between interior and exterior</u>	157
4.4 Environmental conditions and location of the buildings	159
4.5 State - of - the art	161
<u>4.5.1 Existing conservation treatment</u>	161
4.6 Comparative analysis of Byzantine church architecture in Macedonia and neighbouring countries	164
4.7 'Learning Tools'	168
<u>4.7.1 Damage caused by earthquakes in the recent past and treatment of this problem in Macedonia and beyond, in the Balkan region</u>	168
<u>4.7.2 International meetings and recommendations on the subject</u>	178
Notes	181
Figures	183
 CHAPTER FIVE	
STUDY OF SEISMIC STRENGTHENING AND CONSERVATION	244
5.1 Selection criteria, selection and characteristics of	244

structural systems of selected churches	
<u>5.1.1 Selection criteria</u>	244
<u>5.1.2 Selection</u>	246
<u>5.1.3 Characteristics of structural systems of selected churches</u>	247
5.2 Seismic parameters	249
<u>5.2.1 Main characteristics of investigated area</u>	249
<u>5.2.2 Earthquake intensity of the sites</u>	249
<u>5.2.3 Seismic model of the sites</u>	250
<u>5.2.4 Local seismological characteristics</u>	251
<u>5.2.5 Seismic hazards for the sites of selected structures</u>	253
5.3 Dynamic characteristics of the selected structures	254
<u>5.3.1 Ambient vibration test</u>	254
<u>5.3.2 The church St. Nikita, v. Banjani</u>	255
<u>5.3.3 The church St. Bogorodica, v. Matejce</u>	256
<u>5.3.4 St. Nikola Church v. Psaca</u>	256
<u>5.3.5 St. Bogorodica Zaumska, v. Trpejca</u>	257
5.4 Methodology for conservation, repair and strengthening	259
<u>5.4.1 Conservation, repair and strengthening criteria</u>	259
<u>5.4.2 Definition of safety criteria</u>	262
<u>5.4.3 Selection of prototype church structure</u>	267
5.5 Possible and appropriate methods and techniques for conservation, repair and strengthening for selected structures	272
5.6 Economical aspects of proposed methods and techniques	278
5.7 Concept for repair and strengthening of the monument selected as a prototype structure	280
5.8 Preparation of the St. Nikita church model - v. Banjani for experimental investigation	284
<u>5.8.1 Architectural and structural characteristics</u>	284
5.9 Experimental investigation of the church model	287
<u>5.9.1 Study and design of the church model</u>	287
<u>5.9.2 Shaking table test of non - strengthened church model</u>	296
<u>5.9.3 Shaking table test of the damaged and strengthened church model</u>	298
Notes	309
Tables	311
Figures	318

CHAPTER SIX

VERIFICATION AND IMPLEMENTATION OF METHODOLOGY FOR SEISMIC STRENGTHENING OF BYZANTINE CHURCHES IN MACEDONIA	375
6.1. Revision of safety criteria	375
6.2. Recommended methods and details for repair and strengthening in accordance with developed and experimentally verified methodology	378
<u>6.2.1 Horizontal tie courses in perimeter walls</u>	380
<u>6.2.2 Vertical tie courses in perimeter walls</u>	380
<u>6.2.3 Details of strengthening of the drum and dome structures</u>	381
<u>6.2.4 Injection, grouting and repair</u>	
6.3 Implementation on representative Byzantine monuments	382
Notes	389
Tables	390
Figures	391

CHAPTER SEVEN

CONCLUSIONS AND RECOMMENDATIONS	414
7.1. Conclusions	414
7.2. Recommendations	415
<u>7.2.1 Recommendations indirectly affecting the Byzantine churches and entire building heritage in the Republic of Macedonia</u>	416
<u>7.2.2 Recommendations directly affecting the Byzantine churches and the structures from the <i>corpus</i> of immovable heritage in the Republic of Macedonia</u>	417
<u>7.2.3 Recommendations at wider regional level</u>	418
Abbreviations	419
Bibliography & References	421
Appendix A - List of Figures	425
Appendix B - List of Tables	441
Appendix 1 - Glossary	444
Appendix 2 - Chapter two	450
Appendix 3 - Chapter three	457
Appendix 4 - Chapter four	485
Appendix 5 - Chapter five	509

ABSTRACT

It is an irrefutable fact that we are living 'between two earthquakes.'

Conservation and restoration of architectural heritage is a complex and scientifically based process. If ^Ait is situated in regions susceptible to one of the most destructive natural factors - earthquakes - this process becomes even more complex and requires an adequate approach.

This dissertation is aimed at proving that maximum protection of architectural monuments can be achieved by maximum respect of their structure and traditional construction techniques, as well as satisfying modern requirements for their seismic stability.

For adequate and appropriate treatment of the Byzantine churches (more than 60) dating from the ninth - fourteenth century ^w in Macedonia, one of the most seismically active territories in the Mediterranean region and Europe, a methodology for conservation, restoration, repair and strengthening has been developed based on ample theoretical and experimental investigations.

After the accomplishment of the investigations for selection of the church prototype (St. Nikita, v. Banjani), a model of this church was constructed to a scale of 1 : 2.75 for the purpose of verification of the methodology. It is first time in the world such a realistic model of the Byzantine church was built. This model was tested in its original state and also after being strengthened by application of the developed repair and strengthening methodology.

On the basis of the results achieved, implementation of the developed methodology on Byzantine churches in Macedonia was proposed.

The obtained results served for drawing the conclusion that it is possible to increase the seismic resistance capacity of these structures by using traditional building materials (like lime mortar and lime - based mixtures) and techniques, without changing the existing structural system. Based on these results, recommendations were made for application of the methodology on Byzantine churches in the Balkan region and for further investigations (investigations of lime mortars and lime-based mixtures).

The results should also be used for providing better protection, building standards and regulations related to architectural heritage in seismically prone regions.

DECLARATION & ACKNOWLEDGMENT

This dissertation is entirely my own work except where otherwise stated.

I would like to express my gratitude to my advisors - Mr. Peter Burman and Mr. Poul Beckmann for accepting to be my advisors and particularly for their useful suggestions and patience.

Gratitude is also accorded to the Getty Conservation Institute for their financial support of the conducted research and experimental activities.

I am also indebted to the Ministry of Culture of the Republic of Macedonia and the British Council Office from Belgrade for their financial support given for my travels, stay and tuition.

I would like to be grateful ^{by thank} Mr. Jovan Ristov - director of the Republic Institute for the Protection of Cultural Monuments, where I am employed, for given support and understanding shown.

Gratitude is extended also to Prof. Dr. Predrag Gavrilovic and Dr. William S. Ginell for their useful suggestions.

I would also like to thank Mr. Keith Parker (for English language suggestions) and Mrs. Jan Powell from the IOAAS Library in York for being so kind and helpful while I was studying in their library too.

I am also indebted to my parents Slobodanka and Gorgi, my wife Branislava and my children Irena and Dejan for the understanding shown for my frequent absence from home, their love and support.

CHAPTER ONE

CONSERVATION AND SEISMIC STRENGTHENING OF ARCHITECTURAL HERITAGE - BYZANTINE CHURCHES OF THE NINTH TILL THE FOURTEENTH CENTURIES IN MACEDONIA

1.1 Introduction

All that is created by mother nature or man is doomed to decay or be destroyed. Throughout the history of Earth and mankind *nature* and *man* have been both supreme creators and also the most destructive factors that have *almost always* acted toward damaging or completely destroying their own creations either deliberately or out of ignorance. The most valuables - the cultural heritage - has unfortunately not been spared from these activities. However, society has recently begun to change its attitude in the sense of better and more adequate treatment of its possessions with the purpose of handing them over to future generations in an even better state than that in which they had been handed down by previous generations.

Irrespective of the level of its social, economic, cultural and technological development, each society with its "professional and scientific consciousness and elite" has the 'sacred duty' of *slowing down*, to the best possible extent, "the process of complete disappearance" of historical buildings, monuments and archaeological sites. The obligation is to provide them with a greater resistance to future long - term or instantaneous damaging man-made or/and natural factors by promoting activities for their protection, conservation and restoration.

Amongst all severe natural phenomena, earthquakes are one of the most destructive natural factors, being different from the other kinds of disasters for their capacity to destroy cultural heritage almost instantaneously, without warning, or cause extensive and often irreparable damage.

In 1987 Bernard Feilden wrote "Even with our present level of technology, we can do nothing to reduce either the frequency or the intensity of earthquakes. The only thing *we can do is take precaution to mitigate potential devastation*" (*Between Two Earthquakes, 1987*).

Let the investigation of the way of decreasing the effect of earthquakes upon valuable architectural heritage (as are the Byzantine churches of Macedonia and beyond) be accepted as the author's personal contribution.

This study should be conceived as an efforts to fulfil this 'sacred duty' and the

author's adherence to *mitigation of potential devastation*. The subjects of the study are existing structures of the highest historical, architectural, structural and artistic worth - the Byzantine churches assigned to the 9th - 14th centuries and located in one of the most seismically active regions in Europe, the territory of the Republic of Macedonia.

The results obtained provide the possibility of defining verified methods and techniques for seismic strengthening and conservation of cultural monuments in a way that enables their greater resistance to ground excitations and rehabilitates the main characteristics of traditional materials that have passed the 'test of time' and are compatible with the original construction techniques. In defining the methods and techniques, new technological achievements in improving the physical - chemical and mechanical characteristics of currently used materials (lime mortars and lime-based mixtures) as well as achievements in earthquake engineering adapted for application on cultural monuments are deployed.

Generally, the theme involved in this scientific research study is the relation between *cultural heritage and earthquakes*, i.e., the 'appropriate and adequate' treatment of architectural heritage located in earthquake-prone areas. It should not only be understood as a small contribution - a little piece of stone in the mosaic called 'the new philosophy of structural treatment of monuments' and 'disaster preparedness' but also as a 'shield' or a recommendation in the hands of the administration and charge institutions and professionals to prevent 'a man - made seismic repair and strengthening disaster.'

1.2 Definition of the problem

This study is concerned with conservation and seismic strengthening of monuments in seismically active regions.

Earthquakes are one of the most destructive natural ~~damaging~~ factors that have inflicted damage or destroyed historic monuments in the past and will still threaten to occur. Notable among the many earthquakes that have occurred during the past thirty years are those in **Japan**, Okushiri (1993) and Kobe (1995); **Philippines**, Luzon (1990); **USA**, San Francisco (1989), Los Angeles (1995); **Mexico**, Mexico City (1985); **Iran**, Manjil (1990); **Yemen**, Dhamar (1982); **Armenia**, Leninakan (1988); **Italy**, Friuli (1976) , Basilicata and Campania (1980), the **Balkan region /Turkey**, Erzurum (1983) and Erzincan (1992); **Romania**, Bucharest (1997), Vrancea (1990); **Greece**, Thessaloniki (1978), Corinth (1981, Kalamata (1986); **Bosnia and Herzegovina**, Banja Luka (1967); **Croatia**, Dubrovnik (1979); **Yugoslavia**, Montenegro (1979); **Macedonia**, Skopje (1963),

Debar (1967), Gevgelija (1991), Bitola (1994). These earthquakes caused huge losses of human lives and damage or total destruction of constructed urban and rural sites and infrastructure.

Within the wide range of damaging natural factors, earthquakes have the characteristic of acting for a short period of time, measured by several tens of seconds and their effect is "cumulative" which means that they represent, in fact, "a natural but destructive test" of all the activities that have so far been taken on the existing immovable cultural heritage. If these activities comply with adequate principles and recommendations, damages to cultural heritage are not so extensive: otherwise, the consequences are of a catastrophic nature.

All over the Balkan Region, particularly in Macedonia, Yugoslavia (Montenegro area), Greece, Slovenia, Romania, Croatia (Dubrovnik area), extensive conservation-restoration, repair and/or strengthening works have been carried out on damaged architectural heritage after earthquakes on the basis of short-term or long-term plans but unfortunately mainly by using new principles, regulations and standards and methods for new structures, constructing new reinforced-concrete structures and structural elements that collide with the modern principles and recommendations for treatment of buildings located in earthquake-prone regions.

These new principles and methods should be regarded as 'inappropriate' regulations and standards for architectural heritage.

The repair and/or strengthening of historical monuments is highly dependent on the earthquake conditions to which they were exposed in their past history, the expected ground motion to which they will frequently be exposed in future. Due to these reasons, it will be important that repair and/or strengthening (as part of the conservation and restoration of historical monuments located in seismically active regions) be planned, based on detailed studies. These are: expected seismic hazard, the local soil conditions and the dynamic behaviour of the soil media under earthquake loading, the dynamic properties of the structural systems, the strength and deformability characteristics of the structural elements and their materials and the dynamic response of the structural systems under expected ground motions.

If, in addition, one considers other influential factors like the fact that most of the historical monuments are constructed of brittle materials with large cross-sections of structural elements and heavy structural systems as well as the limited possibilities for improvement of the ductility of structural elements, it is recognised that their earthquake response is mostly limited to the elastic range of structural behaviour. Hence, it is concluded that the above mentioned factors are of a fundamental

importance in determination of the earthquake response of historical monuments as well as that seismic analysis of this type of structures cannot be performed using seismic design codes for modern buildings and structures.

Determination of criteria and methods and techniques for strengthening and conservation of historical monuments should be based on detailed studies of relevant influencing factors, with due consideration of the economic effects of alternative solutions for repair and strengthening.

In general, seismic design criteria and dynamic response analysis of monuments, as well as adequate repair and strengthening methods and techniques, should be developed primarily in order to achieve the economically justified and technically consistent seismic safety of buildings, providing them with sufficient bearing and deformability capacity and enabling an acceptable level of damage to their structural systems under future earthquakes.

People, particularly those living in seismically active regions, live '*between two earthquakes*' have a responsibility to undertake adequate preventive measures based on scientific investigations for the purpose of proper treatment, conservation, repair and strengthening of cultural and particularly architectural heritage, in full compliance with the modern principles and recommendations. In this way, the realistic assumptions that future ground motion would induce only predicted, allowable and repairable damage will become a reality. This would enable a continuous survival of the cultural and architectural heritage.

We should also consider the fact that in the countries of the Balkan region and particularly in my country, the Republic of Macedonia, which is one of the most seismically active regions in the Mediterranean and Europe, there are short-term and long-term plans for conservation works to be done on cultural heritage. We can completely define the problem that due to non-existence of verified methods and techniques for seismic strengthening of the architectural heritage it is necessary to investigate, develop and recommend such methods and techniques for conservation, repair and/or strengthening of architectural heritage. It would be the comply to completely with the existing principles and recommendations for proper treatment of the architectural heritage in seismically active regions (Eurocode 8, 1996) that suggest '*minimum intervention - maximum protection and resistance.*' Their implementation would form a '*shield*', based on the results of scientific-analytical and experimental investigations and the defined and verified methods and techniques that would prevent the occurrence of '*man - made planned disasters*' caused by application of

inappropriate methods and techniques of repair and strengthening of architectural monuments after an natural disaster occurred.

1.3. Scope of study and thesis

To solve the defined existing problem of the non - existence of scientifically verified methods and techniques for seismic strengthening and conservation of the architectural heritage - especially with regard to monuments located in seismically active regions - aiming at the preservation and protection of the authenticity and the integrity of the original structural systems, by the use of appropriate materials both traditional and new that will be compatible with the original ones.

For the purpose of developing a methodology and new methods and techniques for seismic strengthening and conservation of the architectural heritage, it was necessary to select existing structures - monuments from the wide range of monuments of the Macedonian cultural heritage - as a subject of this research study that will satisfy the following requirements:

- to have multiple cultural, architectural, historic and scientific value;
- to be authentic and original;
- to be complex (from many aspects) and to have been exposed to damaging natural and man-made factors for a long period of time;
- to have undergone certain conservation, restoration, repair and strengthening works in the past;
- to be undergoing conservation, restoration works or to be planned for conservation and restoration works;
- to be located on seismically active ground (like the territory of Macedonia) and subject to additional damage under future earthquakes;
- to have suffered damage due to past earthquakes without experiencing collapse;
- to be similar or have identical architectural and structural characteristics to those of other monuments existing all over the Balkan peninsula because of possible application of the developed and defined methods and techniques, i.e., because of the possibility for comparison with the already performed or planned activities.

From the total corpus of immovable architectural heritage in Macedonia, the most valuable existing architectural monuments, the Byzantine churches dating from the ninth to the fourteenth century, mostly satisfy the above requirements.

However, the final decision to select these monuments as a subject of this research study is also due to the following:

- Byzantine churches from the mentioned period of time are the most valuable architectural collection (there exist more than 50 buildings attributed to this period) of the whole cultural heritage of Macedonia;
- They are characterised by an original and reproduced architectural concept, functional-spatial solutions, structural concepts, moulding and polychromatic finishing of the exterior;
- They have an extraordinarily rich gallery of samples of Byzantine mural paintings that are among the most outstanding works of medieval Byzantine art.

Having all this in mind the question arises how to improve the safety of these buildings, provide them with a better resistance to future turbulence caused by nature and protect them against 'man-made post disaster disasters' or 'catastrophe of reconstruction' as is written by S. Barakat in his doctoral dissertation in 1993.

How will we direct our efforts in the first place? Do we dare ignore qualities proved through the test of time? Are we allowed not to respect the tradition and the application of materials that have proved their value through centuries and were applied through hundreds and hundreds of years? Do we dare ignore the scientific achievements in the technology of new materials and their application particularly in the field of earthquake engineering?

Having in mind these questions and having previous personal knowledge gained through investigation and design of conservation-restoration works to cultural monuments, as well as general knowledge of activities taken for such monuments which were more harmful than the natural factor itself, we can formulate the main postulates of the hypothesis that:

- *Conservation and the seismic strengthening of architectural structural heritage qualified as 'Monuments' located in seismically active regions are highly dependent on the earthquake conditions to which they have been exposed in their past history and the ground motion to which they are expected to be frequently exposed in future, as well as the material and methods used for their construction. Due to these reasons, it will be of importance that repair and/or seismic strengthening, as part of conservation and restoration of historical monuments located in seismically active regions, be planned based on detailed theoretical and experimental studies of the expected seismic hazard, local soil conditions, dynamic behaviour of soil media under earthquake loading, dynamic properties of structural systems, strength and deformability characteristics of the structural elements and their materials, as well as dynamic response of structural systems under expected ground motions.*

A desirable level of seismic safety of an architectural monument that would enable it to sustain the strongest future earthquake with 'allowable and repairable damage' and will prevent human casualty, can be achieved by:

- maximum respect for its original architectural and structural characteristics;
- improvement of its original structural characteristics without their alteration;
- rehabilitation of the usage of traditional construction materials that were used for the construction of the building;
- application of a limited range of 'appropriate' new materials and techniques with maximum reversible characteristics that will contribute to improvement of the original characteristics and "good interaction" with the existing materials. ;
- re - establishment of the horizontal connection of the perimetric structural bearing walls both in longitudinal and transverse direction by non-destructive utilisation of the already existing openings of the originally installed (and now completely destroyed) horizontal belts, application of new materials and formation of horizontal belts with enlarged cross-section at the level of the formerly existing original horizontal wooden belts.

1.4. Objectives

The main objective of this study is to develop and define a methodology and recommend new practical and effective methods and techniques for the solution of the problem of conservation and seismic strengthening of Byzantine churches from the ninth -fourteenth centuries in Macedonia on the basis of theoretical-analytical and experimental investigations.

Hence, it will contribute to creation of realistic, new 'applicable and practical' possibilities for better and high quality treatment of these monuments based on scientific grounds. These - practical and effective - methods and techniques should not be treated as a 'universally applicable solution' but only as a possible way/mode of treatment. They should be also accepted as a contribution to scientific proof, i.e., 'rehabilitation' of the good - original quality of the traditional structural systems and elements, traditional seismic elements (horizontal wooden belts) and construction materials used for these buildings.

This research study should also be conceived as a contribution to the establishment of the new philosophy of technical treatment of cultural monuments located in seismically active regions which is in full compliance with the recommendations given in some international meetings, codes and charters related to

the subject: (Skopje 1985, 1988); INDNR (1990); Eurocode 8 (1996) and others. At the same time, it would represent their practical verification.

A wider aspiration of this study is that it should be a contribution to the establishment of a National Programme of Natural Disaster Preparedness, i.e., preparation of a short and long-term priority list of activities for protection of cultural monuments and a programme for regular maintenance of the cultural heritage as well as a definition of technical standards for treatment of the architectural heritage that will be capable of being implemented (with some minor modifications) in the neighbouring countries in the Balkan region.

Having all this in mind the following objectives are proposed to provide a framework for further investigations:

- 1) To develop a theoretical understanding of the earthquake as a violent natural phenomenon, together with its influence on structures and society. This means investigation of:
 - Theoretical background of the study of earthquakes;
 - Earthquake effects manifested by damage to structural systems and structural elements of buildings, particularly in this context monuments;
 - Relationship between earthquakes and cultural heritage as well as protection of cultural heritage as a sphere of activities; attitude of those directly and indirectly involved in this sphere of activities and their activities; similarities and differences between natural and man-made violent disasters.
 - Earthquake effect and design of physical and urban plans (at national, regional and local level) in which protection also carries a certain weight.
2. To establish a framework of better knowledge of existing structures and monuments and built-in materials as well as new building materials and technology.
 - Obtaining of scientifically verified characteristics of the original (existing) materials and structural elements and systems via theoretical-analytical and experimental studies;
 - Familiarisation with the achievements from applied methodologies and results from similar activities taken in the home-country and abroad through study of existing literature and publications.
3. To examine, in detail, the numerous activities and case studies of repair and seismic strengthening of cultural monuments after natural disasters in the home country and the wider region.

- The first example is Skopje and the activities taken after the earthquake of 1963 as the first activities of this type in the region, with a particular emphasis on the treatment of structural systems and elements of monuments, social attitude, physical and urban planning and support provided by the international community.
- The second example is the earthquake of 1978 in Greece (Thessaloniki region) and the activities taken for structural repair and seismic strengthening of damaged structures after detailed studies.
- The third example is Dubrovnik (Croatia) after the earthquake of 1979 that struck the region of Montenegro (Yugoslavia) - the littoral part and most of the hinterland of these countries - both in respect to structural repair and definition of legislative provisions for protection of the town as a World Cultural Heritage Site (UNESCO 1972).

1.5. Research methodology

In the preparation, development and realisation of this dissertation, two main research methods have been employed: (1) theoretical/analytical and (2) experimental.

1. Within the framework of the theoretical/analytical research, several activities are distinguished such as (1) laboratory and field study of documentation and the present state of the buildings pertaining to the Byzantine period in Macedonia, (2) detailed study of literature related to the theme of the study, i.e., study of theoretically and experimentally obtained results from already performed investigations and activities related to this subject, (3) review and active participation in international and national meetings and seminars dedicated to the problem and (4) familiarisation with and interpretation of the international recommendations and conclusions related to the physical treatment of the buildings for the purpose of (a) improvement of the author's knowledge related the theme and (b) not to 'discover the already discovered.'
2. The experimental study was performed for the purpose of : (1) definition of the physical and mechanical characteristics of the built-in materials, (2) definition of the dynamic characteristics of the existing structures, (3) determination of the physical-chemical and mechanical characteristics of the new materials and structural elements used for construction of the model of the selected building, (4) determination of the physical-chemical and mechanical properties of materials used for repair and strengthening and (5) dynamic shaking table testing of the non-strengthened and strengthened model.

The obtained results proved and verified the theoretically set theses that maximum protection of the considered buildings could be provided by (a) maximal respect for the built-in original structural characteristics of the architectural monuments and (b) traditional structural techniques through moderate usage of new materials and technologies as well as (c) compliance with the modern and recommended requirements for their seismic stability and resistance and (d) the principle of providing maximum protection by minimum intervention.

1.6. Structure of the study

This research study starts with definition of the problem that currently exists and has to be solved for the purpose of better treatment and preservation of the abundant cultural architectural heritage located in seismically active regions - the problem of the non - existence of scientifically verified methods and techniques for adequate seismic strengthening and conservation of buildings pertaining to this heritage. To set the hypotheses and establish their proof by development and definition of methodology, methods and techniques, the Byzantine churches dating from the ninth - fourteenth centuries in Macedonia were selected as subject of detail study since they corresponded, to the maximum extent, to the set requirements and the fact that identical or similar buildings also exist in the wider Balkan region (Chapter 1).

To gradually bring up the solution of the problem, the state - of - the - art of protection and conservation of cultural heritage in seismic prone regions was investigated with a special emphasis on the effect of damaging factors (man-made or natural), particularly the pattern and the extent of damage to the structural and non-structural elements of monuments in the Balkan region caused by earthquakes (Chapter 2).

Presented in Chapter 3 are the natural, historic and cultural characteristics of Republic of Macedonia as well as the characteristics of the whole cultural heritage located in this territory. Selected as the subject of the study are the most valuable buildings from the abundant construction fund - the Byzantine churches.

Through determination of the state-of-the-art of the Byzantine churches we proceed to Chapter 4. This chapter displays a comparative analysis of the existing knowledge and experience in the treatment of cultural heritage in the home country and the neighbouring countries, particularly after inflicted damages, which are 'the learning tools' of the author. It also contains a review, interpretation and discussions

about international recommendations related to the subject. The chapter ends with analysis of the structural systems and structural elements and materials used for construction as well as a study on the historic occurrence of earthquakes and the present state of the buildings.

Chapter 5 starts with the establishment of criteria and selection of characteristic types of structures for detailed theoretical and experimental investigations. The **St. Nikita church (in the village of Banjani) constructed in 1307** is selected as the prototype church for the construction of a model to a scale of 1 : 2.75, definition of appropriate methods and techniques for conservation, repair and strengthening and their theoretically based application on the model. The non-strengthened model is experimentally tested on a shaking table. After applying the method of repair and strengthening, the model is finally tested on the seismic shaking table which is the first attempt of this kind in the world to test a model of a **Byzantine church with characteristics that are very similar to the characteristics of the church - prototype / archetype.**

Chapter 6 provides an explanation to the verification of the established hypothesis on the basis of the experimentally obtained results. Proposed further is the implementation of the verified methods and techniques for seismic strengthening and conservation in Byzantine monuments in Macedonia.

In **Chapter 7** are given the conclusions and a set of recommendations for the improvement of treatment of cultural monuments and the support to be given to professional institutions and experts by state and legislative authorities. Emphasis is put on definition of a priority list of activities as well as suggestions for further studies on subjects initiated during the realisation of this research study.

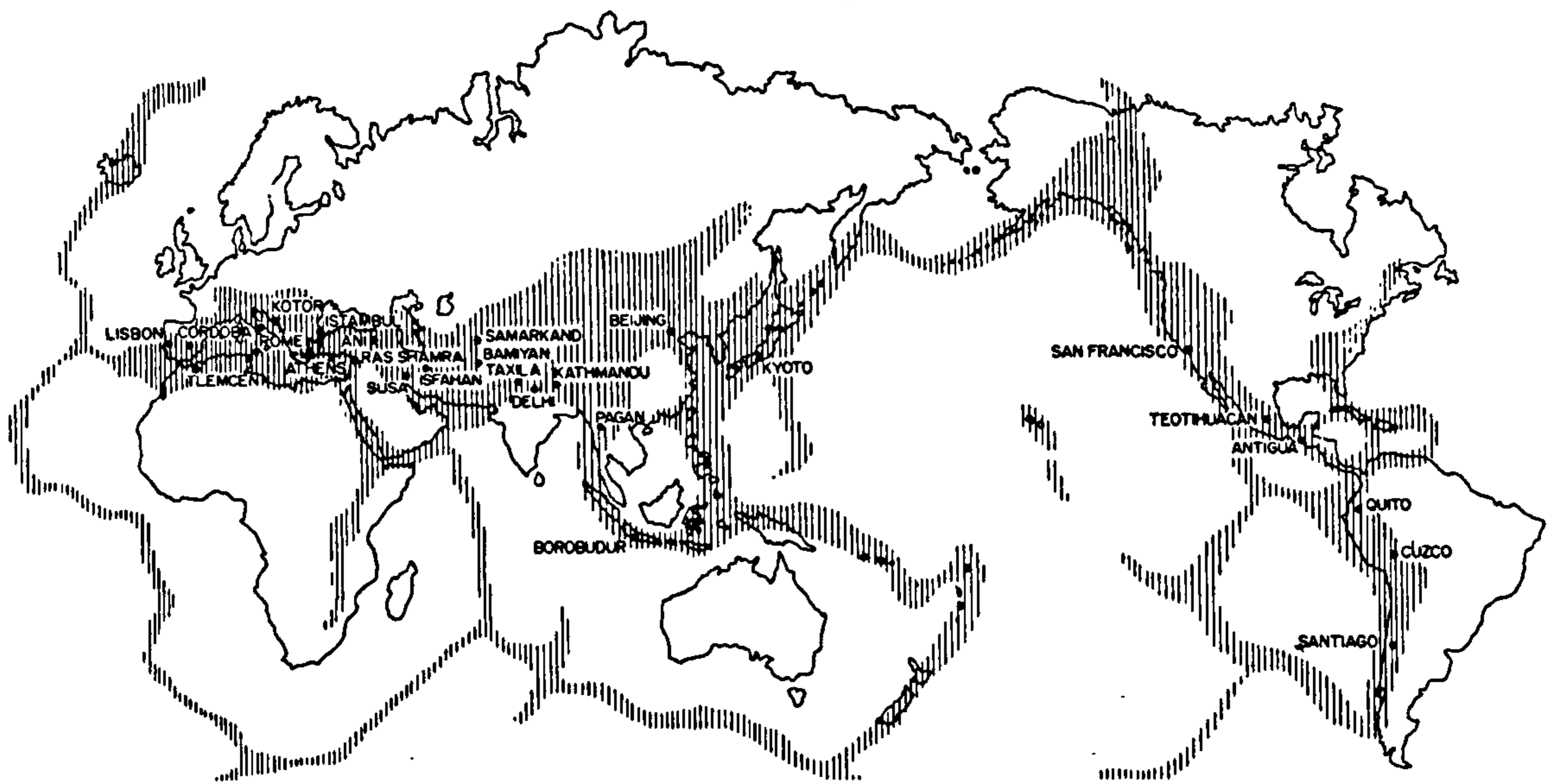

Fig. 1.1 *World earthquake zones, historic cities and monuments*
(Pichard, P. 1984: 35)

CHAPTER TWO

PROTECTION AND CONSERVATION OF ARCHITECTURAL HERITAGE IN SEISMIC REGIONS

Introduction

The investigations, and analysis of practice in this field, carried out by the author prove that protection and conservation of architectural heritage in earthquake-prone areas is a synchronised and multi-disciplinary activity of all those involved.

All these activities could be divided into three successive and mutually dependent phases: (1) the first and, according to author's opinion, the most important as the pre-earthquake or preventive actions phase, (2) the second phase which involves activities immediately after the occurrence of an earthquake, and (3) the third phase which involves activities in the post-earthquake period. Sir Bernard Feilden defined these phases as follows: (1) before an earthquake, (2) when the disaster strikes and (3) after the disaster: long-term.

The nature of the earthquake as a natural phenomenon and its direct effect upon structural systems and elements of architectural heritage, as well as the activities of the administrative and professional-scientific institutions in charge of carried out measures for protection, that is the subject of this chapter.

2.1. The protection and conservation of the cultural heritage in earthquake-prone regions - a multi-disciplinary process

The protection, conservation and restoration of the cultural heritage have their background development in the past two or three hundred years. However, these activities have intensified since the Second World War at both national and international levels.¹

At national level, the designated governmental service has the task of (a) carried out an inventory of the cultural heritage; (b) evaluating and defining the protection regime; (c) conserving, maintaining and presenting this heritage and (d) integrating cultural heritage into all existing and development of environmental / physical and urban plans in accordance with the regulations and criteria of international recommendations.

This is a process that has already been designed and realised to a lesser or greater extent and quality in countries world - wide depending on their economic and political conditions as well as level of development of both their science and culture.

Barclays G. Jones (1984) comments on this as follows: ' Those who hold the cultural heritage in trust must confront the necessity to develop policies related to natural hazards. The first step is to acknowledge that such hazards exist, and there is responsibility to be aware of them and to take actions to mitigate their impacts. It then follows that one must determine the hazards one is subject to and the levels of risk from them. This requires achieving some degree of understanding of the nature of the hazard and the kinds of damage or destruction it can cause.' ² Although this was said in 1984, very little has been carried out since then.

To design an adequate response to natural disasters, we should think in terms of three main phases:

- (1) Pre - earthquake or preventive actions - Phase (A)
- (2) Immediately after an earthquake strikes - Phase (B)
- (3) Post - earthquake long term - Phase (C)

These are the phases of a designed process: a multi - disciplinary process involving theoretical (indirect) and physical - technical - technological (direct) treatment of the architectural heritage by direct and indirect participants (administration and decision - making institutions, as well as the professional and scientific responsible institutions at national and international levels, with the support of the national and international community. *(Table 2.1)*

What are the characteristics of all these phases and what are their merging points? Can there be strict boundaries between the phases or is this a flexible flow of activities? Does the realisation of the planned activities increase the possibility for greater dynamic resistance and stability of the heritage, i.e., the quality of its protection?

A certain works that will guarantee this, has already been carried out.

2.1.1 Pre - earthquake or preventive actions - phase (A)

Considering the fact that we live between two earthquakes, this phase is the most important one and never ends. The main actions that should be taken in this phase are:

- A.1 programmed tasks by the leaders of both administrative and professional - scientific institutions (indirect treatment - theoretical activities), and
- A.2 direct treatment by carried out physical - technical measures.

A.1 Tasks to be realised by the administrative and professional - scientific institutions: (indirect treatment)

In designing this phase, author assumes that a certain and major part of the activities have already been carried out or is in the final realisation. Proposed measures and activities should be accepted as amendment and improvement or as completely new.

- A.1.a Legislative provisions - amendments of existing codes: for the protection of cultural monuments, environmental planning, regulations and building standards and those which indirectly treat it.
- A.1.b Based on legislation or guideline regulations on the level of completeness of the architectural and photo - documentation must be completed and should be stored in two different places.³
- A.1.c Elaboration of different geological, sismological, climatic studies.⁴ (*See app.2,section 2.1*)
- A.1.d For the best possible realisation of those activities, society and the professional - scientific institutions should provide: (1) advanced training of professional and scientific staff, of use of traditional and maintain workmanship skills.
- A.1.e Establishment of the regular Plan of inspection and monitoring⁵ of the cultural heritage. Establishment of national Maintenance Programme.⁶ By author's opinion as an important elements of disaster preparedness.

An important preventive activity of the administrative and professional - scientific institutions is the preparation of a General Emergency Plan of Actions - GEPA⁷ which would be activated after a disaster). It is very important to establish a contact between the disaster relief agencies / institutions and charge cultural heritage

institutions.⁸ Particular importance should be given to profiling of the teams (composed of specialists).

A.2 Tasks of the professional - scientific institutions related to direct physical treatment of cultural monuments

In this phase, assuming that the above - stated actions have been carried out, the professional - scientific institutions should direct their efforts in two broad directions: (1) theoretical preparation in the sense of complete determination of the characteristics of the structural systems and structural elements of the existing architectural heritage and the materials they are made of; and (2) development and definition of a methodology for finding new methods and techniques for seismic strengthening, repair and conservation to be applied to the above structural systems and elements.⁹

- The basis for all actions in the future is: complete definition of its original and existing characteristics of structural system, structural elements and materials. In this way a data bank containing the physical - chemical, bearing and deformability characteristics of each monument obtained from analytical and experimental investigations¹⁰ would be created. This activity is very well defined by P. Beckmann (1995). It is called Structural Appraisal.¹¹
- The next successive¹² activity is development and defining of new appropriate methods and techniques for repair, seismic strengthening and conservation of architectural heritage that respects, to the maximum extent, the parameters indicated in section 1.3. To carry out these activities, the total up - to - date knowledge in this field should be used.
- The application of the above - defined new methods and techniques (verified by experimental studies, if possible) on structures indicated in the priority list should be a permanent process which should be carried out in this 'preventive phase.'¹³

The realisation of above - stated - actions, enables us to conclude that heritage and society will be in position for adequate resistance to future earthquake events. It is important to convince the society that the statements such as 'this will not happen here and now while I am alive' B. Feilden (1987) should be changed to 'that is possible.'

2.1.2 Immediately after an earthquake strikes - phase (B)

If society and the institutions involved in these activities have carried out the planned tasks, or most of them, we may hope that the cultural heritage will successfully pass the 'natural destructive test' and its consequences would be the same or similar to those assumed both in respect to loss of human lives or damages of the heritage.

This phase of activities is the shortest but, no less important, than the others. After the occurrence of a natural catastrophe, General Emergency Plan of Actions is activated in two directions: (1) rescue and treatment of affected population; (2) direct and indirect treatment of cultural heritage.¹⁴

B.1 Rescue and treatment of population

Providing first aid to the injured and their evacuation to safer locations as well as safe disposal of the dead. If necessary, a part or the whole population is evacuated from the affected area with provision minimum of living conditions.¹⁵

B.2 Direct and indirect treatment of cultural heritage

After eliminating all the consequences affecting the population, the affected cultural heritage is then treated. The phases of its treatment are strictly defined and they should be carried out in the shortest possible period of time. The following actions, implied also their possible order of performance. Temporary protection of the monuments; Clearing of debris;¹⁶⁻¹⁸ Providing temporary safety for the structure;¹⁹ Post-disaster inspection;²⁰⁻²² Priority list of activities. (See app. 2, section 2.2)

2.1.3. Post-earthquake long term - phase (C)

After the accomplishment of the activities of phases A and B, the longest phase take place. Should be noted that sometimes this phase passes into phase A due to long lasting of its realisation.

There are several reasons why. First of all, it is due to real factors and situations

related both to the amount of financial resources available and the endeavours of the institutions, the teams and the groups carrying out and controlling the planned activities.²³

This is a phase, which in some ways, carries on and will continue into the future. It is difficult to fix the boundary between the end of phase C and beginning of phase A. This is certainly not the same everywhere and depends on overall conditions at local and national levels.²⁴

The duration of this phase and the quality of its realisation depend on several essential factors. These, it is suggested, are the following:

- Damage level of the heritage;
- Level of national and local development;
- Level of preventive activities taken by the community and professional institutions;
- Level of training and knowledge of national experts to manage the newly created situation, after the occurrence of a catastrophe;
- Readiness of the international community to assist in the domain of know how and by financial participation.

In this phase, and according to importance, the following activities should be carried out:

- Collection / preparation of a 'data bank' of damage.²⁵
- Comparison between the actual and predicted damage which will be the basis for verification or correction of the analytical parameters;
- Evaluation of existing seismic hazards, risk and vulnerability studies for the architectural heritage and their possible correction on the basis of actual damage;
- Providing of information on all analysis and knowledge gained in the post - earthquake period at national, regional and international levels as well as at professional and scientific levels;
- Publication of all collected information as soon as possible;

- **Analysis of the reliability of the designed strengthening (increasing of resistance) and correction of the criteria and principles designed for repair and strengthening, on the basis of damage suffered, if necessary;**
- **Organisation of panels of experts and courses for complete treatment of the architectural heritage in seismic regions, at national, regional and international levels;**
- **Correction of the plans for inspection and regular maintenance;**
- **Final design of repair and strengthening projects based on all previous information and corrections;**
- **Establishment of a priority list for further long - term activities.**

This process of three phases - A, B and C - involves an extraordinarily large scope for all those who directly or indirectly deal with the protection, conservation and restoration of the architectural cultural heritage.

This task should be realised immediately (especially Phase - A) through the financial assistance of the state and the national government as well as the scientific and professional institutions at national and local levels. If all activities envisaged to be in the above phases A, B and C are realised, the cultural heritage should be able to withstand future disaster (earthquakes) and suffer only repairable damage.

2. Causes of damage

All buildings, including those having architectural, aesthetic, structural and other values have always been, and still are, exposed to a wide range of causes of damage.

These are products of the nature and man. Their action, can be direct or indirect, short - or long - term factors. Unfortunately some of them, that can even be more disastrous than the others, are produced by man.

2.2.1. Natural

There is a wide variety of these factors. Their effect upon cultural heritage can be direct or indirect, instantaneous, long - lasting or sometimes cyclic. They occur as external primary factors that induce secondary and tertiary consequences.

Since the subject of this doctoral dissertation is the churches from the Byzantine period in Macedonia and, beyond in the Mediterranean region, we will focus on only to those natural factors that are characteristic for this region. (*Table 2.1*)

1. *External natural factors*

The sun. The dominant factor in this group of factors is the sun, whose effect on the structures is long - term and cyclic.²⁶

Climate.²⁷ Climate factors are cyclic and with long term effect. Diurnal fluctuation of temperature and humidity (day v. night); Seasonal fluctuation of temperature and humidity (summer v. winter); rain and snow, ice and frost, the underground water and the moisture in the soil.

When speaking about these factors should be noted the Byzantine churches have been exposed for more than 700-800 years without large damage. It should be respected.

Biological and botanical factors. Influence of this factors could be decreased by men activities. Damaging biological factors are most frequently animals by their excreta and urine, birds droppings, insects, trees and the plants by infiltration of their roots and attack by fungi, algae and lichens.

Natural disaster factors. From the wide spectrum of natural disaster factors such as: earthquakes, tsunami, tidal waves, floods, avalanches, volcanic eruptions, fires, exceptional winds, there are only a few that are relevant for the region considered. These are, first and foremost, earthquakes, floods and fires.

2. Internal natural factors

Humidity. The main internal natural factor which is a direct product of many others - natural and man-made - is humidity. It is a long-term acting decaying factor that, very subtly, makes use of all the weak points of human activity or, better to say, inactivity.²⁸

2.2.2 Man-made factors

The main difference between natural and man-made causes of damage is that the latter one could be totally eliminated. However, although this is truth, it sometimes happens that their effects can be even more disastrous than those of the natural damaging factors.²⁹

Wars as a planned factor have caused enormous loss of human lives and destruction of building stock.³⁰

A new 'man-made' damaging factor is born. It is so called 'planned destruction of cultural heritage via physical and urban planning.'³¹ The author of this dissertation is very agree that it is very damaging factor. The same error may occur in planning of repair, reconstruction and revitalisation of populated areas that have suffered severe damages due to earthquakes.

Sometimes, absurd situations arise. These are situations where the existence of great financial resources for the conservation and restoration of cultural heritage become a real threat for the preservation of the cultural monument from the following reasons:

- A great fund of financial resources, with an inadequate fund of knowledge and expertise, may lead to 'unaware planned' destruction and degradation of the cultural heritage. Here we can quote the words of Sir Bernard M. Feilden who says that 'a great mistake and damage to the cultural monument cannot be made by a little amount of money.'³²

Man-made damaging factors are: Neglect, war³⁴, environmental pollution, planning and traffic schemes, vandalism and others. (See app.2, section: 2.3)

To summarise briefly, we may say that the types, number and intensity of damaging factors vary widely which aggravates the problem of adequate treatment of heritage and makes it a priority task in all short - and long - term development plans.

2.3. Earthquakes - nature and characteristics

In the previous section the wide range of damaging factors affecting architectural heritage and man by different intensity and duration was considered. Among these the most destructive natural factors is - an earthquake.

For this region, they will always be at the top of the list of destructive factors.

An earthquake is a test of the original construction and effects of subsequent damage, caused by man and nature.

It is certainly to be regarded as a main destructive factor whose existence and action cannot be avoided, but could and would be mitigated.

Presented in the subsequent text will be the main data on the nature and the characteristics of this phenomenon.

2.3.1 Nature

'Tales of destruction of ancient cities, like Troy in Greek mythology and Taxila in Ancient Pakistan, have been attributed to the power of earthquakes. They were instruments of the Greek God Poseidon, the spiritual wriggling of the subterranean catfish Namazu in Japanese mythology, and the punishment of sinners in the Christian belief.' (Coburn et al.1992: 1)

We were witnesses of enormous losses in Macedonia and the wider region caused by earthquakes in the recent past. These have included the Skopje (Macedonia) earthquake of 1963, the Friuli (Italy) earthquake of 1976, the 1977 earthquake in Romania, the Thessaloniki (Greece) earthquake of 1978, the Montenegro earthquake of 1979 and so forth.

According to a widely accepted theory, it is assumed that the surface of the earth consists of a number of independent tectonic plates floating on a softer inner layer. These plates are in continuous motion relative to each other because of currents in the internal liquid core of the earth . The areas of contact between these plates are particularly important. These are the zones where earthquake have occurred and will occur, with high probability, in the future. (Feilden 1987: 1;Coburn et al. 1992:12)

An earthquake is a natural phenomenon during which strong vibration occurs in the ground due to the release of enormous energy within a short period of time causing sudden disturbance in the earth's crust. Therefore, an earthquake is characterised by location (longitude, latitude and depth), time (the starting moment and duration) and energy. These vibrations of the earth's crust are transferred to the

foundations of structures and hence to the superstructures themselves, contributing to a response by the building.

The location of an earthquake in the core of the earth is called the focus or hypocentre. It is the place from which the effects propagate in all directions. The most important for us are those that come up to the earth's surface.

The vertical projection from the focus on the earth's surface is the epicentre. It is always given as a point on the earth's surface with its geographical location given in terms of latitude and longitude. (*Figure 2.2*) (*See app.2, section: 2.4*)

2.3.2 Magnitude, intensity, hazard, risk and vulnerability

Magnitude

When an earthquake occurs, an enormous amount of accumulated energy is released. The accelerometers and seismographs,³⁵ that are placed at different locations record accelerations and displacement of the constructions.

If the earthquake is shallow, the greatest damage will occur immediately above the place of its origin. However, if it occurs at great depth, the affected area will be greater, but the intensity will be lower due to its attenuation in the earth's mass through which the waves travel.

According to the magnitude, the earthquakes have the following characteristics: (*Coburn et al. 1992:21*)

Magnitude less than 4.5³⁶

Below about magnitude 4.5, it is extremely rare for an earthquake to cause damage to the buildings. A shallow earthquake of magnitude 4.5 can be felt for 50 to 100 km from the epicentre.

Magnitude 4.5 to 5.5 - local earthquakes³⁷

Earthquakes of magnitude 4.5 to 5.5 may cause damage weaker buildings. Earthquakes with magnitude of 5.5 may be felt 100 to 200 km away.

Magnitude 6.0 to 7.0 - large magnitude events³⁸

If they occur close to the surface they may cause intensities at their centre of VIII, IX or even X causing very heavy damage or destruction if there are towns or villages close to their epicentre. A magnitude of 7.0 earthquake at shallow depth may be felt at a distance of 500 km from the epicentre.

Magnitude 7.0 to 8.9 - great earthquakes³⁹

Great earthquakes are the massive energy releases caused by long lengths of linear faults rupturing in one break. If they occur at shallow depths they cause slightly stronger epicentre intensities than large magnitude earthquakes but their great

destructive potential is due to the very large areas that are affected by strong intensities.

Intensity

The term 'intensity' is used to denote the severity of earthquake damage at the particular place. Seismic scales currently in use are constructed from either the engineering or the perceptual standpoint and the one most convenient for a particular purpose is the one used. However, the relation between the two aspects is now fairly well understood.

With the increase of the epicentre distance, the severity of an earthquake normally decreases.

Earthquake intensity is assigned through field observation effects and it is a useful quantitative information of direct utility for engineering purposes.

In order to permit, a systematic assessment of intensities through the observations of earthquake effects, it is necessary to have intensity scales that will allow us to trace the variation of intensity at various localities due to a single earthquake or variation of intensity at a single place due to different earthquakes.

(See app. 2, section:2.5)

The description of the damage to buildings induced by earthquakes is subdivided into three scales (MSK - 64) in contrast to the other scales: first, according to the types of buildings; second according to the degree of damage to buildings; and third, according to the number of buildings damaged by an earthquake.

The division of the buildings according to types was made by consideration of their different stability against seismic actions. The buildings are arranged in an ascending order and in accordance with their security against quakes in three groups: A, B and C.

Damages to buildings are classified into five categories: *slight damage, moderate damage, considerable damage, destruction and collapse*. The designation of each category characterises its contents.⁴⁰ Only the damage of structures similar to the Byzantine churches will be discussed. *(See app. 2, section: 2.6)*

Structures subject of this dissertation could be included under B in the list of non-seismic buildings (Ordinary brick buildings, buildings of large blocks and , structures, constructed in non-dressed stone). Classification of considerable damage and, destruction and collapse will be discussed.

Grade 3: *Heavy damage:* Large and deep cracks in walls; falling of chimneys.

Grade 4: *Destruction:* Gaps in walls; parts of buildings may collapse; separate parts of the building lose their cohesion; inner walls and filled-in walls of the frame collapse.

Grade 5: *Total damage:* total collapse of buildings.

Intensity VII. Damage to buildings

- b) in many buildings of type B the damage is of grade 2.

Intensity VIII. Destruction of buildings

- b) Many buildings of type B suffer damage of grade 3.

Intensity IX. General damage to building.

- b) Many buildings of type B show damage of grade 4; Sculptures and columns fall.

Intensity X. General destruction of buildings

- b) Many buildings of type B show damage of grade 5;

Intensity XI. Catastrophe

- b) Severe damage even to well-built buildings, bridges, dams and railway lines; highways become useless; underground pipes destroyed.

Intensity XII. Landscape changes

- b) Practically, all structures above and below ground are greatly damaged or destroyed.

(See app. 2, section: 2.6)

Since there is a certain number of intensity scales used in the world, their comparative presentation is given in *Table 2.2*

We will focus only on those data that are relevant for the region in which are located the Byzantine churches which are the subject of this doctoral dissertation.

The Mediterranean and the Balkan region experienced a large number of strong earthquakes in the considered period of 1900 - 1990. The earthquakes that affected this region prior to 1900 will be considered in the subsequent chapters dealing with site seismicity. (*Table 2.3*)

The data on earthquakes that occurred in the past have been systematised by many specialised organisations and institutions. There are data on the time of occurrence, the magnitude and intensity, the peak ground acceleration values, the losses, the GNP's in the year of occurrence of these earthquakes and the loss as percentage of GNP. (*Table 2.4*)

Hazard

Hazard is defined as the probability that a disastrous event of an earthquake of a given intensity will occur in a particular place and within a specific period of time.

The parameters considered in expressing the characteristics of soil are: ground motion vibration such as MSK or modified Mercalli Intensity scales, or in terms of peak ground acceleration or some other parameter derived from the measured characteristics of motion. (*Coburn et al. 1992: 255*)

The hazard can be expressed as an average rate of occurrence of the specific type of event, or on a probabilistic basis.

To establish a definition for the return period, the annual recurrence rates are used as a basis. The inverse of an annual recurrence rate is a return period.⁴¹

Since it is impossible to define all the hazard rates simply, they are graphically presented. The hazard can be presented cumulatively or separately as a relation between the annual probability and the size of the event.

Risk

By the end of the eighties, at an experts meeting organised by the United Nations Office of the Co - ordinator of Disaster Relief (UNDRO) in 1979⁴², the term 'seismic risk' was related to expected loss of a certain element at risk over a certain future time period.

This term may refer to both built environment (structures, group of buildings and the like) and human population and their economic activities.

According to the type of elements for which it is computed or defined, the risk can be expressed by various parameters like expected economic loss, number of deaths or injured, level of constructed heritage.

It is expressed in terms of expected losses, such as: 12 000 lives lost over a twenty years period, 61, 500 houses experiencing moderate damage or heavy damage within twenty years, or possible values expressed in percentage.⁴³

Vulnerability

According to a number of authors, vulnerability is defined as a rate of loss of some element at risk representing the effect of a given hazard rate. It represents a ratio between the expected and the maximum possible loss. It is represented graphically on a scale from 0 to 1 or from 0 to 100%.

This definition can be used to express a number of elements in terms of number of deaths and injured, cost of repair or level of physical damage to the structures.

The vulnerability of the structures with given parameters can be presented graphically.

The total vulnerability of the element situated in the zone at risk is the synthesis of the individual vulnerabilities for each degree of seismic effect. It should be noted however that due to the negligible vulnerability for the seismic intensity range from I to VI, it is not taken into account when defining the vulnerability for seismic intensity of VI to XII degrees. (*Fig. 2.3*)

2.4. Earthquake effect, response and degree of damage of the architectural heritage

2.4.1. Earthquake effect

As stated in section 2.3 earthquakes have and will always affect our planet. Therefore, the main objective of the society and charge organisations for cultural heritage should be understanding their characteristics, i.e., the mode and degree of effect upon the building heritage.

It can be direct or indirect. Direct effect is manifested through transmission of vibrations as horizontal and vertical motions of the earth's crust accompanied by rocking, twisting and distortion of the ground. These motions directly affect the structural elements and whole structures.

The forces induced in the structural system give rise to complex stresses and strains. Traditional buildings may not have had design calculations against seismic effects carried out, but experience would have led to the adoption of 'anti - seismic features', e.g. timber tie beams in the masonry, such as we find in Byzantine churches.⁴⁴

Vibrations almost always contribute to occurrence of soil settlement, sliding and liquefaction that directly affect (as secondary phenomena) the structural systems.

Since item 2.1. contains the explanation of the nature of the earthquake and its characteristics, only the main points and elements will be discussed generally in the subsequent text.

Peak Ground Acceleration (PGA)

The energy released during the earthquake travels in all directions in the form of waves. Some of these waves reach the surface of the earth upon which the considered structures are located.⁴⁵ The peak ground acceleration (PGA) is the maximum value of acceleration reached at any instant during the ground motion.

(Fig. 2.4)

The duration⁴⁶ of the earthquake excitation can range from a few seconds to several minutes.

The frequency of excitation represents a number of forward and backward ground motions within a second.

2.4.2 Response

How do structures behave? Does this depend only on the earthquake characteristics or its transformation upon structures? Which are the elements of a structure that affect the quality of its behaviour?

The answers to these questions will be given later, in the form of general explanations.

The so called inertia forces are activated in accordance with the acceleration of the structure and its mass. Through the foundations, these forces are transferred from the ground to the superstructure.

Deformations of structural elements occur contributing further to a change of forces distribution. Therefore, in accordance with many calculations and observations that have been performed so far, it may generally be concluded that the small and massive structures are relatively more rigid than those that are taller and lighter. These differences contribute to the different behaviour of the various observed structures.

The natural frequency is an element by which are determined the dynamic characteristics of the structures. The natural frequency of higher ⁴⁷ structures is usually lower than that of the lower ones.

A very important element is the relation between the ground vibrations and the vibrations of the structure. If ground vibrations are much less intense than those of the structure, the deformations of the structure will be very light and will not endanger the structure.

However, with the increasing of the intensity of ground vibrations, deformation of the structure is increased. The situation becomes particularly dangerous when the ground vibrations are 'in tune' with the building, i.e. the frequency of the ground vibrations is equal to the natural frequency of the building. This is called resonance.⁴⁸

It is therefore particularly important that ground vibration and the vibration of the structure are not in resonance.⁴⁹ (*Fig. 2.5*)

2.4.3 Resistance

Since Byzantine churches are considered in this dissertation, further focus will be on the general elements of their resistance to earthquakes.

These are single - storey structures with a rectangular plan and with four massive perimeter walls and pairs of free standing piers (rarely columns), covered by

vaults, pendentives and domes, there are certain elements of behaviour which are special to those buildings.

Here, the explanations given by colleagues (*Coburn et al. 1992:223*) can be cited:

'The effect of horizontal shaking parallel to two of the walls will be to set up horizontal inertia forces on each wall in proportion to their mass: the forces on the walls in the plane of shaking (the in - plane walls) will be along their length, while those on the perpendicular walls (the out - of - plane walls) will be at right angles to them'

According to the laws of mechanics, static and dynamics, the walls positioned out - of - plane are stressed to bend due to the action of the out - of - plane forces, while the walls which are in the direction of action of the in - plane shear forces can sustain them well and suffer lesser damage. (*Fig. 2.6*)

The knowledge gained during author's researches and in the period of performance of the investigations allowed him to conclude that the structural elements and the systems of the churches of Byzantine style and period do possess a certain resistance against dynamic motions of the earth's crust.

The fact that there exist more than fifty structures of this type on the territory of Macedonia that have sustained all past earthquakes suffering certain damage but not total collapsed, confirms the thesis that there is a certain quality that should be confirmed and affirmed. By this, several goals are achieved:

- Affirmation of the built - in structural characteristics by which the authenticity of a structure is preserved to the best possible extent;
- planning of minimum, adequate and appropriate conservation works in full compliance with international recommendations;
- saving of time, labour and financial resources with achieving of maximum effects at the same time.

The good characteristics of the structural systems and elements of the observed buildings are mainly due to the quality of the materials and workmanship used.

2.4.4 Damage

The final effect of the earthquake action is damage of the structure. This refers to the whole structure - from its foundation to the roof. The type and level of damage

depend on many factors:

1. External / natural

- Structure and characteristics of the soil upon which the building is located (with all its geological characteristics);
- State of the ground;
- Earthquake type (total energy release, direction of the waves that reach the structure, relative ground displacements and ground accelerations);
- Distance between the site and the epicentre.

2. Internal / built - in

- Type of constituent materials;
- Physical and / or chemical properties of the constituent materials;
- Technology of construction and walling pattern;
- Type of structural systems and elements used;
- Characteristics arising from the plan, the built - in materials and structural elements and the defined cross - sections: the mass, the stiffness, the period of vibration (all of which affect the loading), the damping capacity or the ability to absorb the energy, the stability margins, the structural geometry, the structural continuities and the distribution of mass and resistance;
- Dynamic characteristics of the structure;
- The state of the materials, the structural elements and the structure as a whole;
- Whether the structure is used for its original function or its function is modified.

3. Man - made

- Level of regular and preventive maintenance of the structure;
- Type and level of repair and strengthening done to the structure in the past.

All these factors cumulatively define the damage level.

Damage pattern

In this part of the dissertation author will focus only on damages to structures that are the same or similar to Byzantine churches, i.e., structures that are characterised by the same or similar materials, structural systems and elements and technology of construction.

As pointed out before, under dynamic loads, the structure generally suffers the least damage to its foundation and the greatest damage to the top of the building. This was concluded based on observation of damages inflicted by earthquakes from the far and recent past.

Since the observed structures have massive perimeter walls (*Figure 2.7*) with two or more than two pairs of free standing piers or columns, covered by vaults that are dominantly of a barrel type, with one or several domes (usually five), author will discuss the type of damage suffered by structures of this type.

If the pattern damage of massive walls and vaults (*presented in Fig. 2.7*) and the classical pattern of damage presented in *Figure 2.8* are carefully examined, it is clear that the deterioration of the connection of the wall corners gives rise to a decrease in their ability to sustain the action of forces that are in - plane of the action of earthquake excitation.

Due to loss of stability and verticality of the perimeter walls (in this case out -of - plane), there is an increase in the vault span and occurrence of the first cracks. If the increase in this span exceeds the set limits, the cracks are widened which further leads to total collapse of the vault. This is proved by the fact that the original fresco - paintings are partially preserved or do not exist at all on those places in the vaults of many churches from the Byzantine period. This happens in the dome which are particularly vulnerable. (*Fig. 2.9 -10*)

Such an increased vulnerability is due to the fact that the damages first result from primary dynamic loads to which are added the effects of the damages to the lower bearing elements (pendentives, arches and vaults). (*Fig. 2.11-12*)

More details on damages to churches from this period are given in Chapter 4.

Chapter two - Notes

- 1** Immediately after the Second World War, conceiving properly the importance of the cultural heritage, the international community established international professional organisations who contributed to the great advance in this activity such as UNESCO, ICCROM, and NGO's such as ICOM, ICOMOS and others.
- 2** Very useful reading.
- 3** These saved copies give the possibility of reconstruction, restoration and conservation of the monument.
- 4** This activity is particularly important since it represents one of the bases for further activities in defining short - and long - term programmes and plans for conservation and restoration of cultural monuments.
- 5** Without such a Plan, there is no possibility of everyday contact with the cultural heritage particularly when dealing with structures that are seldom used or are situated out from the settlements.
- 6** Author consider that this Programme cannot be regarded separately from the Plan of Inspection since they represent parts of the whole.
- 7** It represents the framework within which the activities are to be realised by those in charge. Should be good to involve army or police.
- 8** This activity does not have the force of a 'tradition' since so far there has not been a case of its activation after an actual earthquake.
- 9** The study carried out by the author should be treated as a contribution to the recommended theses for increasing the quality of inactivates on cultural monuments in seismically active regions.
- 10** To obtain relevant data, laboratory and "in situ" tests will be performed.
- 11** The author says: 'Structural appraisal is a process that usually encompasses the following: document search, inspection, measurements and recording and structural analysis. Sometimes it includes testing of materials and occasionally load testing of entire structures is involved.'
- 12** When this term is used, it must be clear that the order of realisation of activities could hardly be programmed in details wherefore it could be treated as a "flexible" order of realisation of activities.
- 13** Theoretically established and experimentally verified methods and techniques will be applied in the phase of conservation works.
- 14** In this study, the main point emphasised by the author was definition of activities, particularly those of the experts in charge of cultural heritage.
- 15** Author in urgent help action saved two human lives (in the morning of the Skopje earthquake - 26 July 1963).
- 16** The members of the expert team should be architect, civil engineer, art historians, archaeologists and painters - conservators have the task to save and provide safety of structures against further damage.
- 17** The examples of activities in clearing the debris after the earthquakes in Skopje, Montenegro and Dubrovnik have showed that a great number of highly valuable fragments have been lost forever because of "ignorance".
- 18** This "shock syndrome" had a catastrophic effect in the demolishing, with full awareness, of two important and highly valuable cultural monuments in Skopje without enabling their repair and reconstruction (the building of the Army Club and the building of the National Theatre).

- ¹⁹ Care should be taken to perform this activity by using materials with good quality, because of the fact that this 'temporary' action could be lasting for ever. (Montenegro experience)
- ²⁰ According to the scale of the catastrophe and the first insight into the level of damage and the number of affected cultural heritage, the established Emergency Headquarters for the cultural heritage organises workshops and short courses for training of experts that will constitute the teams for inspection. Such teams have been well organised by IZIIS (Montenegro 1979, Gevgelija 1991 and Bitola 1994, Macedonia).
- ²¹ It is of an extraordinary importance to prepare complete graphic and photo - documentation based on a previously established methodology, which represents a mighty tool for thorough and accurate evaluation of damage.
- ²² In accordance with the level of damage and the size of affected area, refresher courses must be organised for experts that will carry out the planned tasks.
- ²³ Author emphasise this as experience from the activities in this phase (C) after the Skopje earthquake of 1963 when the main activities were carried out in the course of a period of 7-8 years after the catastrophe, in accordance with the sources available in the fund for renovation of Skopje.
- ²⁴ This refers to the states after the catastrophic earthquake in Skopje (1963) and the catastrophic Montenegro (1979) earthquake that struck the Dubrovnik area (in former Yugoslavia).
- ²⁵ When talking about this activity it should be noted that the author has, for a long time, been professionally occupied with importance of documentation on cultural monuments in seismically active regions.
- ²⁶ The sun as a highly damaging factor affecting structures cannot be eliminated. However, its effect can be decreased by certain technical measures to be undertaken on the exterior of the structures, particularly on facades with fresco - paintings.
- ²⁷ These factors induce particularly heavy damage. Being inevitable, they should be investigated carefully and adequate measures should be taken to decrease, to the best possible extent, their effect upon structures.
- ²⁸ People in my country say that a house or a flat that smells of stale air is badly maintained or not maintained at all by its owner.
- ²⁹ It is again confirmed that man is the greatest creator and builder in nature, but in some cases he is also the greatest destructive factor in the same natural environment.
- ³⁰ During the long civil wars in Lebanon, Cambodia, Afghanistan and particularly the war in Croatia and Bosnia and Herzegovina when human lives were considered worthless, some people went to such an extreme in demolishing cultural monuments that they filmed video tapes to keep evidence of their own crimes (the demolishing of the Old Bridge on the Neretva river in Mostar was ordered by a commander of the Croatian army).
- ³¹ In our country, there are examples of situations when, in elaborating urban plans, certain factors in towns have led to the sacrifice, in full awareness, of cultural monuments because of some inexplicable and purely subjective reasons (Kriva Palanka, Tetovo, Debar, Kicevo, Ohrid).
- ³² For these reasons, it is of particular importance that permanent advanced training of professional staff be carried out at national level in order that they might respond adequately to the set tasks.
- ³³ In 1991, a war broke out in former Yugoslavia (first in Slovenia and then in Croatia and Bosnia and Herzegovina). To prevent its expansion over other countries in the region, the UN Security Council, at the request of the Government of the Republic of Macedonia, decided to send a mission for prevention against breaking out of war - the first in the history of UN referred as UNPREDEP. This mission is active since 1994.

- 34 Prevention was one of the activities to which author have been devoted since the day of employment in the Institute (1971). 'PREVENTION' - 'how simple it sounds' - say those who unfortunately are the ones who have to be the most devoted ones.
- 35 Very sensitive instruments (can record as low as 2: the equivalent of a brick being dropped from the table to the ground).
- 36 Magnitude 4,5 represents an energy release of about 10^8 kilojoules and is the equivalent of about 10 tons of TNT being exploded underground.
- 37 Magnitude 5.5 represents an energy release of around 10^9 kilojoules and is equivalent of about 1000 tons of TNT being exploded underground.
- 38 *d* Magnitude 6.0 represents an energy release of the order of 10^{10} kilojoules and is the equivalent of exploding about 6000 tons of TNT underground. A magnitude of 6.3 is generally taken as being about equivalent to an atomic bomb being exploded underground.
- 39 A magnitude of 8.0 earthquake realise around 10^{13} kilojoule energy, equivalent to more than 400 atomic bombs being exploded underground, or almost as much as a hydrogen bomb.
- 40 In respect to the number of the damaged buildings the scale gives a subdivisions as follows: *most, many, single*; in addition to that relation in percentage for orientation.
- 41 Examples of hazards defined in terms of earthquake source are:
there is an annual probability of 0.08 of an earthquake with magnitude exceeding 7.0 in region E.
- 42 UNDRO (1979), Fourier d'Alba (1982)
- 43 The term *specific risk* is used to refer to risks or loss estimation of either type which are expressed as a proportion of percentage of the maximum possible loss. (Coburn et al. 1992:255)
- 44 Buildings designed only for anticipated gravity and wind loading may well be unable to withstand these forces; and the consequences of such overload can cause significant damage or collapse of the building. (Coburn et al. 1992:218)
- 45 These vertical and horizontal motions are recorded by means of modern apparatus, i.e., strong motion instruments that record the acceleration values in one vertical and two horizontal directions.
- 46 Duration of earthquake shaking is a measure of the length of time during which the acceleration peaks exceeded a certain amplitude.
- 47 A structure consisting of 10 storeys sways backward and forward in one cycle within a period of 1 second, i.e., its natural period is one second. For a building consisting of two storeys, it will take about one fifth of a second, i.e., its natural period is 0.2 seconds. (Cobra, A. Spence, R. - 1992: 221).
- 48 The resonance increases the effect of the vibration, so that the deformations of the structure reach its ultimate values that is much higher than those of the ground.
- 49 The effect of a particular ground motion on a range of buildings is shown by the response spectrum. Fig. 2.5 shows that buildings behave differently in zones that are near and distant from the epicentres. For example, the earthquake that struck Mexico City in 1985 inflicted much more damage to high buildings (15 to 20 storeys) than to lower and old buildings from the reason that the ground motion oscillation of the lake was of the value of 2 seconds.

Table 2.1 General schedule of a 'A possible outline for both to increase the strengthening and to keep the value of cultural property'

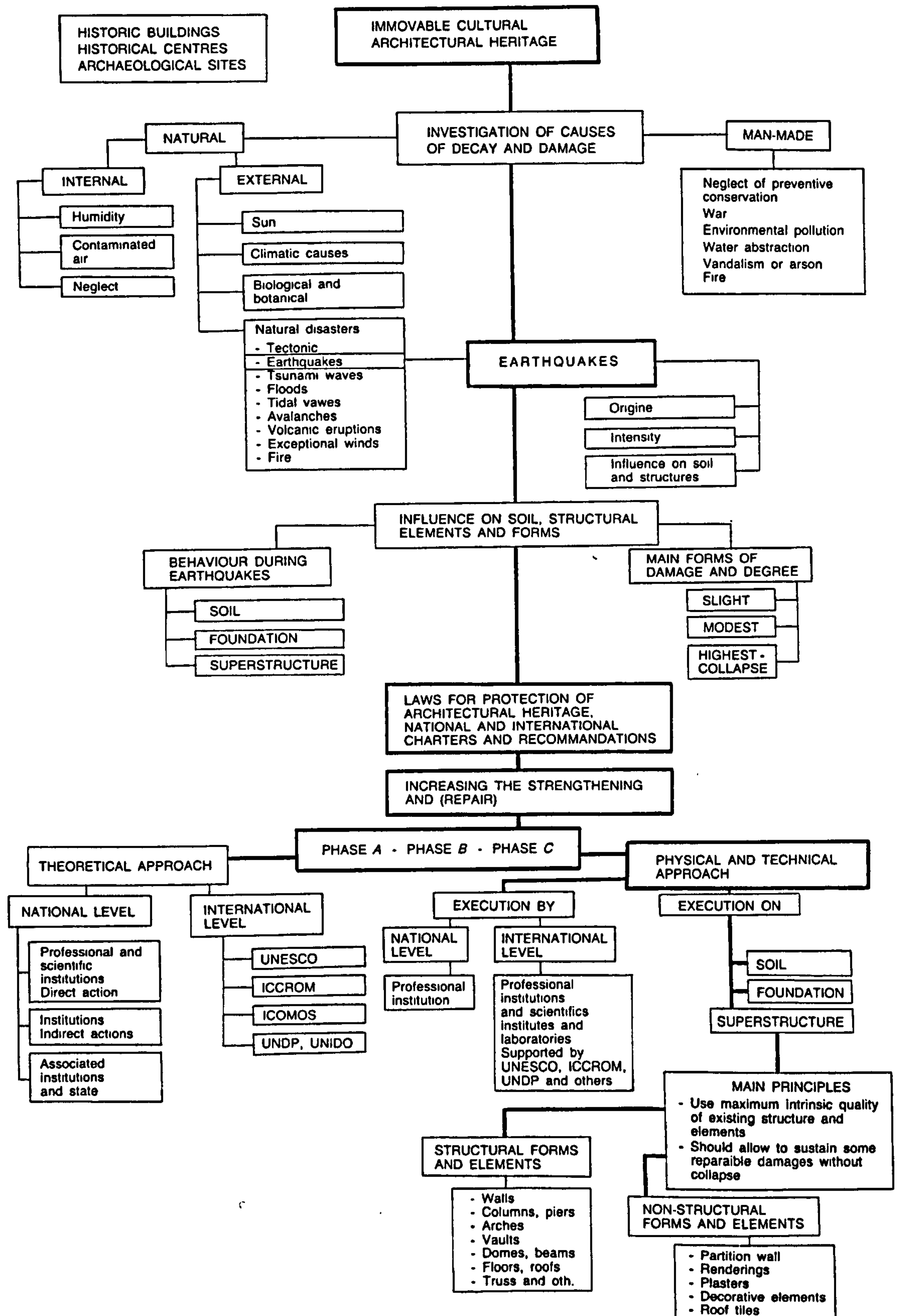

Table 2.2 *Converting table for seismic scales of intensity*

Seismic scale MSK 1981	Scale of the Institute of the Phys. of the Earth-USSR, 1952	American Modified Mercalli Scale (MM) 1931	Japanese scale	Rossi-Forel Scale 1873	Mercalli- Cancani- Sieberg Scale (MCS) 1917
I	1	I	0	I	I
II	2	II	1	II	II
III	3	III	2	III	III
IV	4	IV	2,3	IV	IV
V	5	V	3	V-VI	V
VI	6	VI	4	VII	VI
VII	7	VII	4,5	VIII	VII
VIII	8	VIII	5	IX	VIII
IX	9	IX	6	X	IX
X	10	X	6	X	X
XI	11	XI	7	X	XI
XII	12	XII	7	X	XII

Source: Z. Milutinovic (1985)

Table 2.3 *The Mediterranean's earthquake countries: their loss of life in this century*

Earthquake ranking	No. of lethal earthquakes 1900-1990	Total fatalities	No. of quakes >1000 killed	No. of quakes >10 000 killed	No. of quakes >100 000 killed	Average return period (years)
Italy	43	127 902	6	2		2
Turkey	110	73 967	14	1		1
Romania	4	2 580	2			23
Yugoslavia	18	2 509	1			5
Greece	43	1 150				2
Albania	14	568				7
Bulgaria	6	420				15
Cyprus	2	40				50

Source: Martin Centre Database of destructive earthquakes 1900-1990 (Coburn et al.: 1992)

Table 2.4 *Economic losses inflicted by recent major earthquakes.*

Country	Earthquake	Year	Loss (\$bn)	GNP that year (\$bn)	Loss (%GNP)
Nicaragua	Managua	1972	2.0	5.0	40.0
Guatemala	Guatemala City	1976	1.1	6.1	18.0
China	Tangsang	1976	6.0	400.0	1.5
Romania	Bucharest	1977	0.8	26.7	3.0
Yugoslavia	Montenegro	1979	2.2	22.0 *	10.0 *
Italy	Campagna	1980	45.0	661.8	6.8
Mexico	Mexico City	1985	5.0	166.7	3.0
Greece	Kalamata	1986	0.8	40.0	2.0
El Salvador	San Salvador	1986	1.5	4.8	31.0
USSR	Armenia	1988	17.0	566.7	3.0
USA	Loma Prieta	1989	8.0	4,705.8 **	0.2 **
Iran	Manjil	1990	7.2	100.0	7.2
Philippines	Luzon	1990	1.5	55.1	2.7

Source: Martin Centre earthquake database

Note: GNP's and Loss percentage for Montenegro and Loma Prieta** refer to the whole Yugoslavia and the whole of the USA, respectively.*

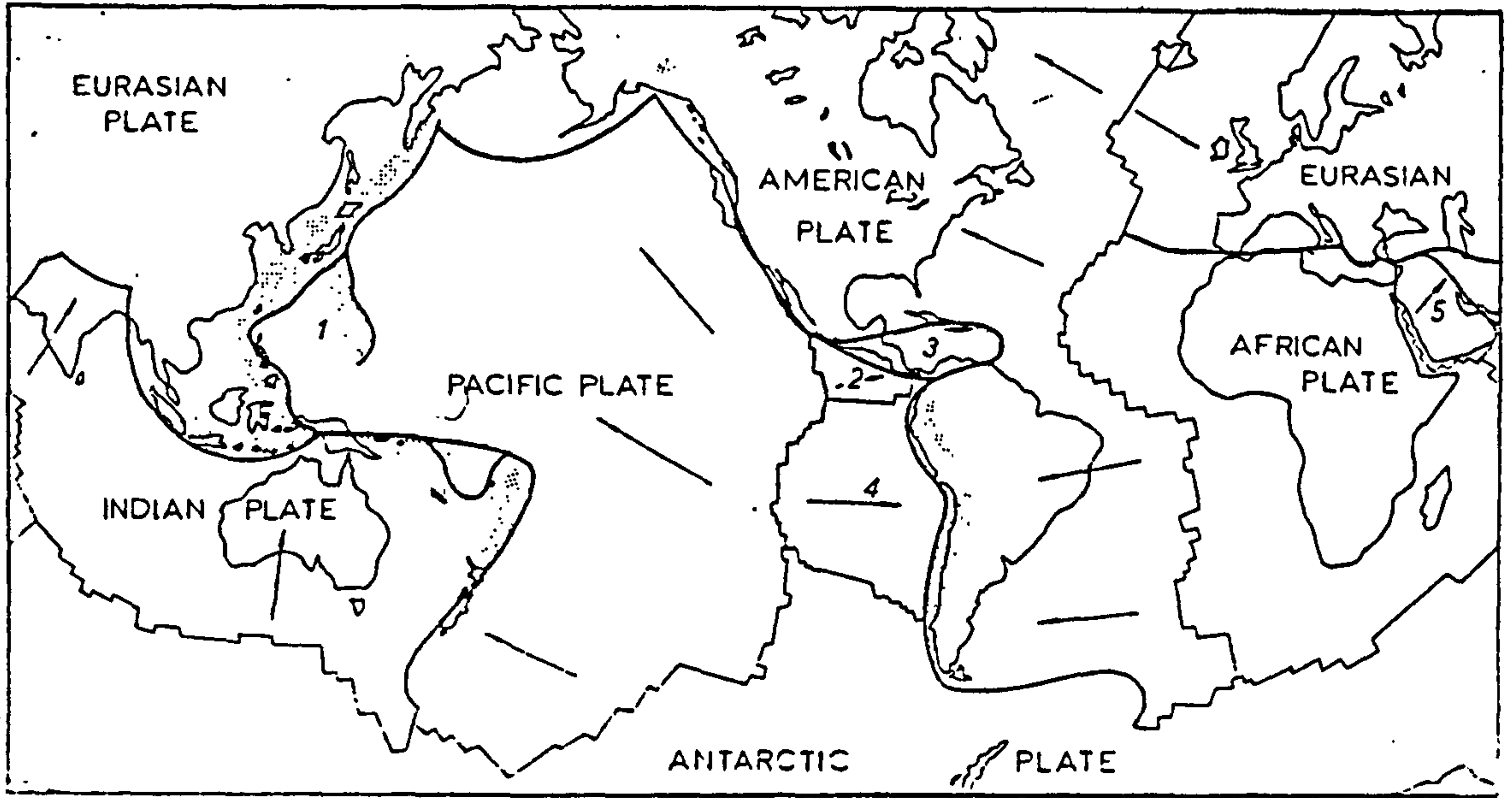

Figure 2.1 *The Earth's plates*
 Source: Bowman, I. (1985:39)

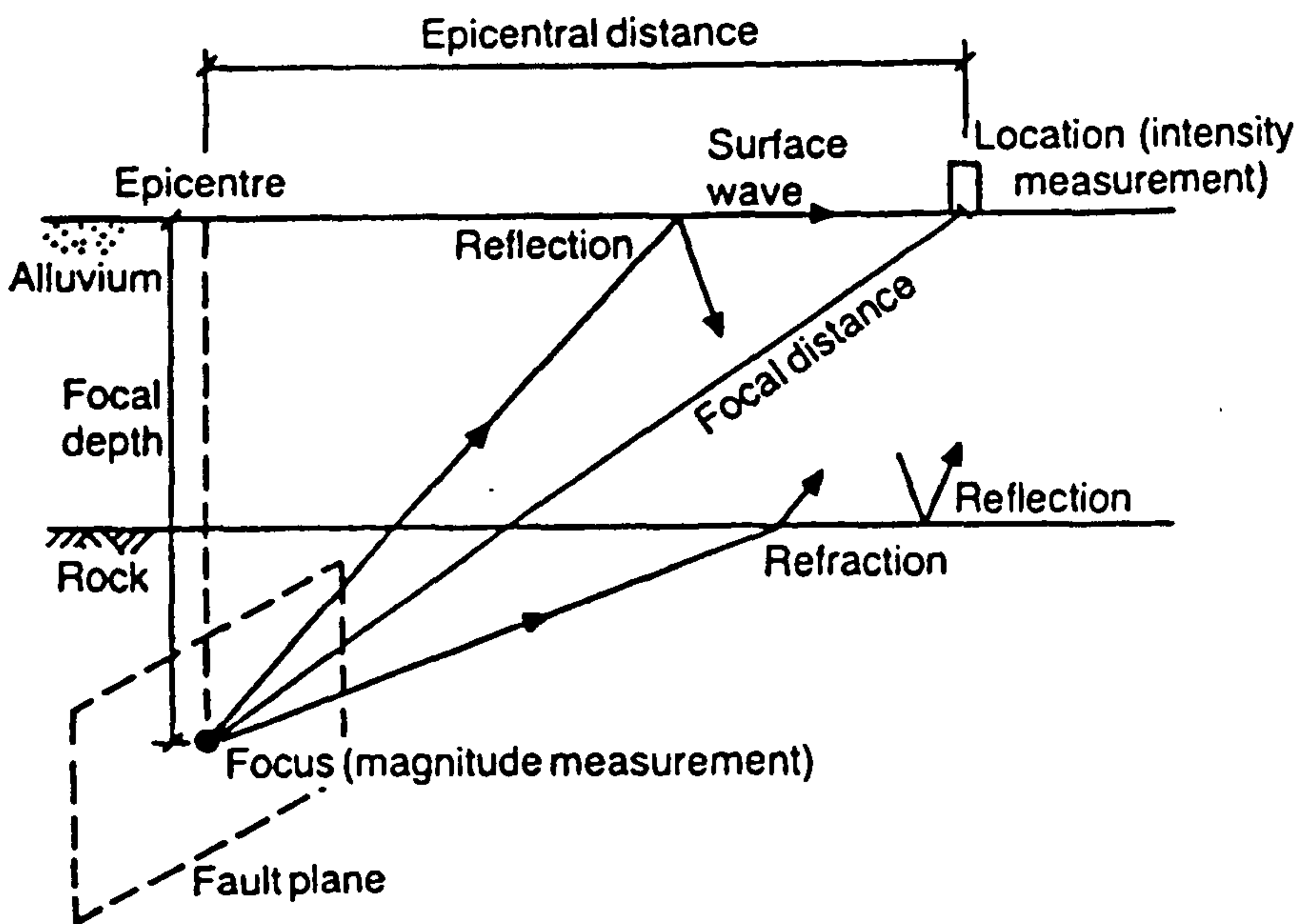

Figure 2.2 *Earthquake transmission .*
 Source: Key (1988 and 1995: 8)

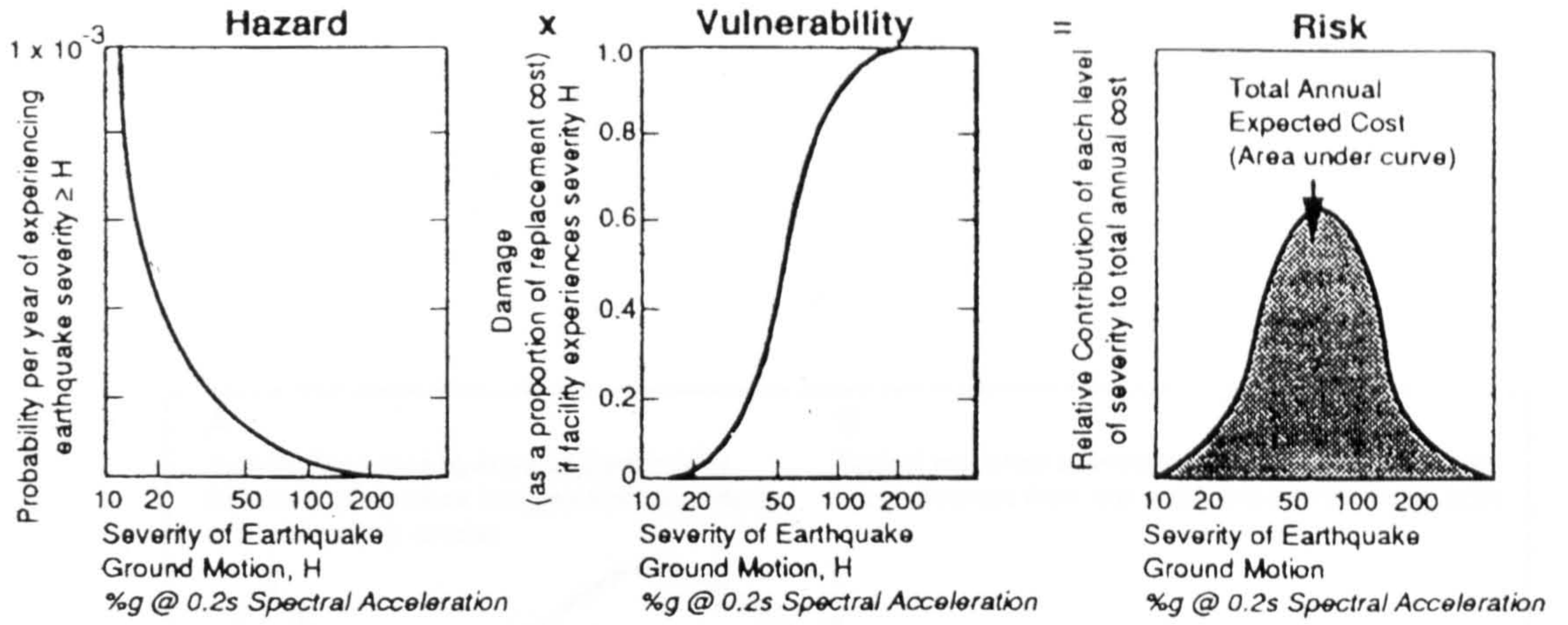

Figure 2.3 Risk is a product of hazard and vulnerability: typical curve shape
 Source: Coburne et al. (1992:258)

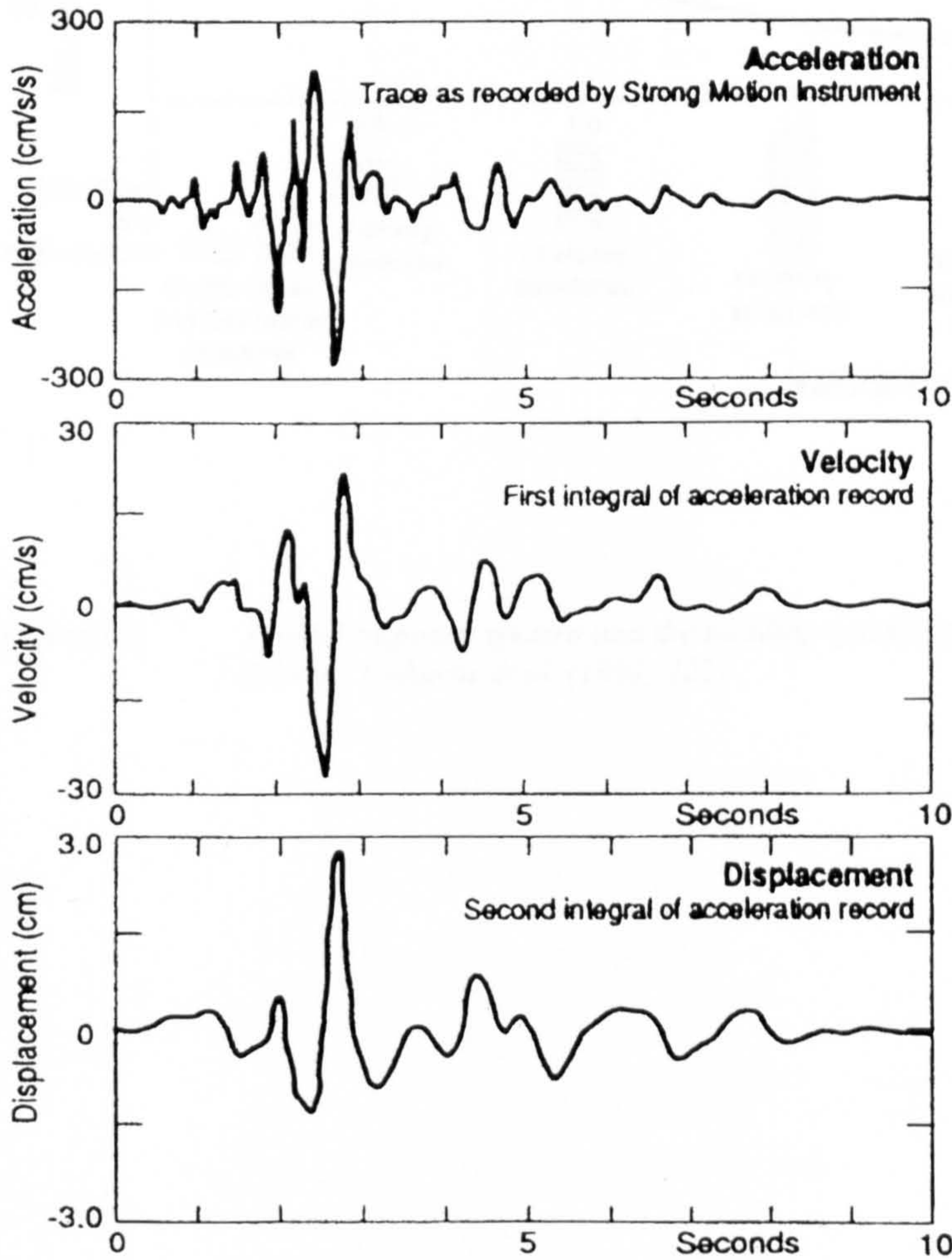

Figure 2.4 A typical earthquake strong motion record
 Source: Coburne et al. (1992: 219)

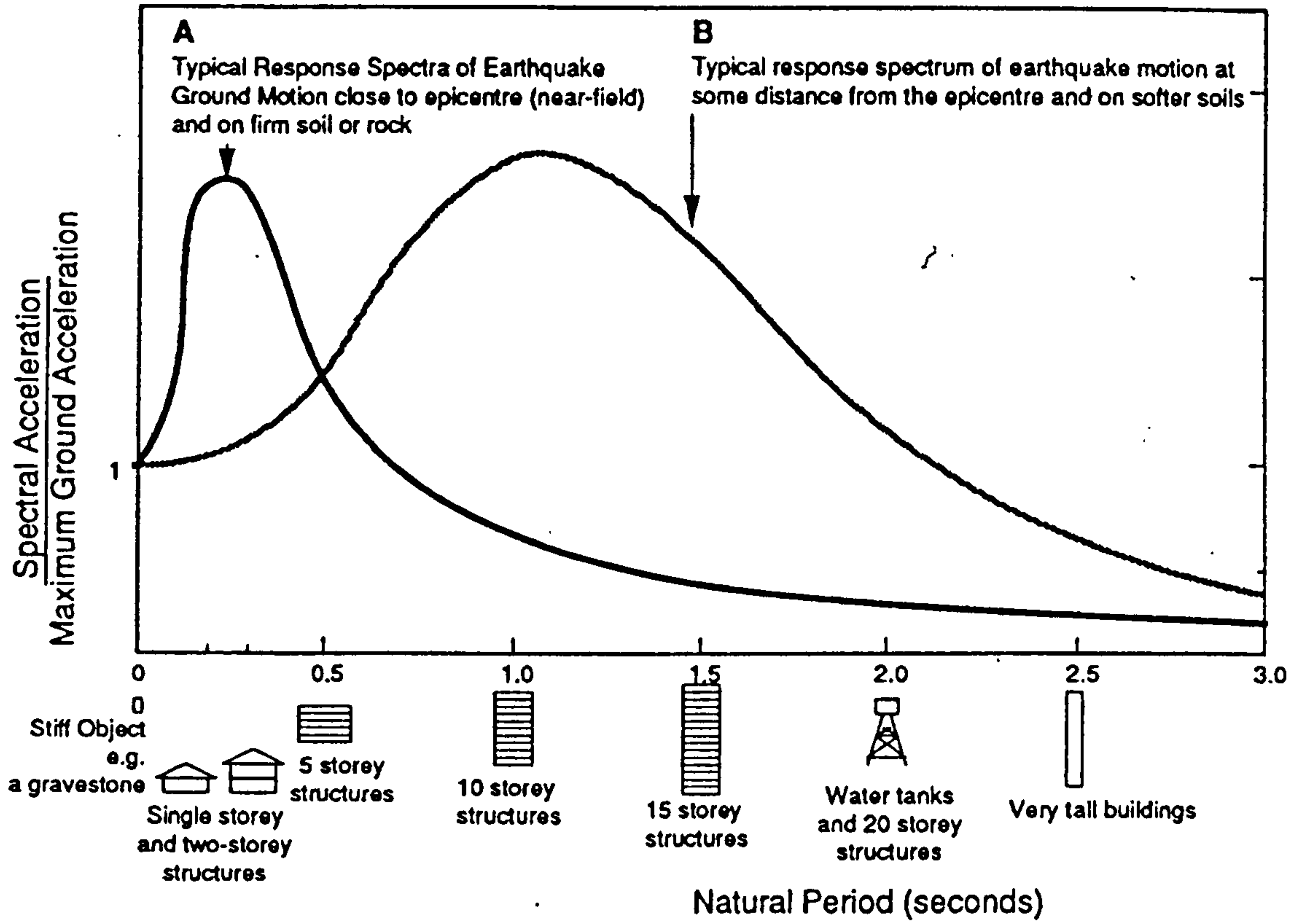
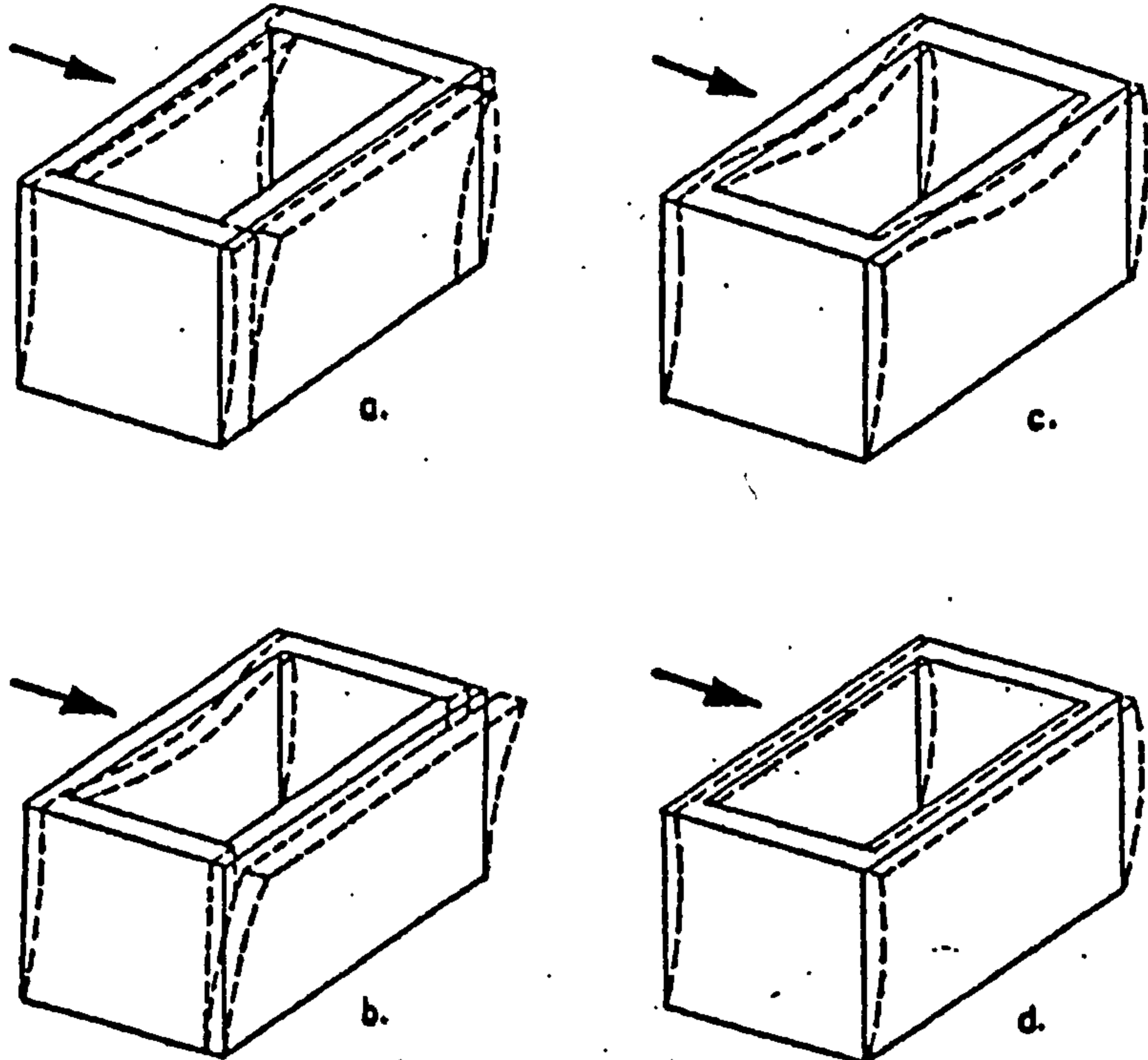
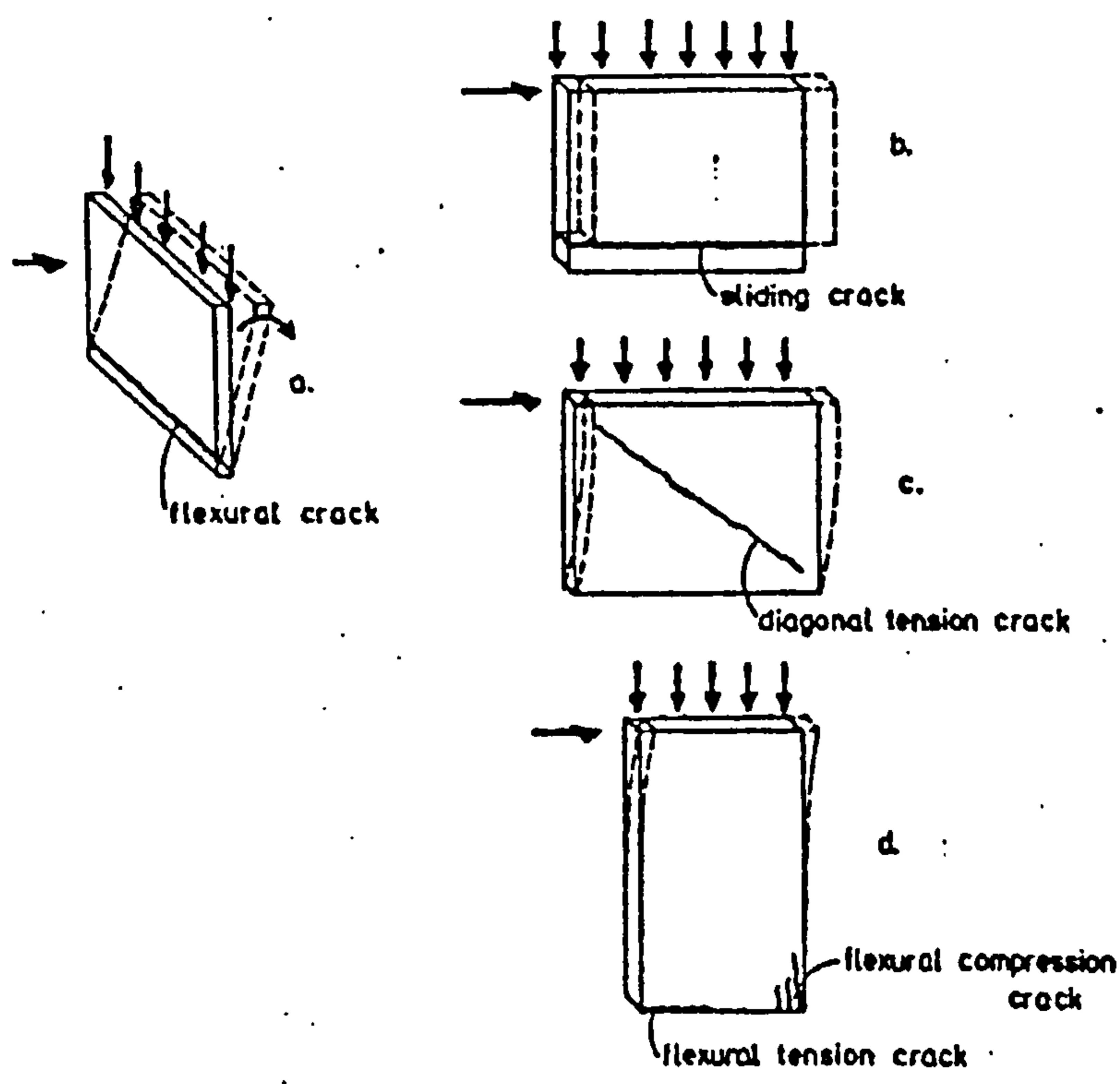

Figure 2.5 Typical response spectra and the building types they affect
 Source: Coburne et al. (1992; 222)



- Vibrations of masonry building during earthquake ground motion:

- a. and b.: structural walls are not tied together;
- c.: structural walls are tied together by means of tie-beams;
- d.: structural walls are tied together by means of rigid floor slab.



- Failure mechanisms of a free standing structural wall

Figure 2.6 Damage pattern
Source: Volume 1 (1992)

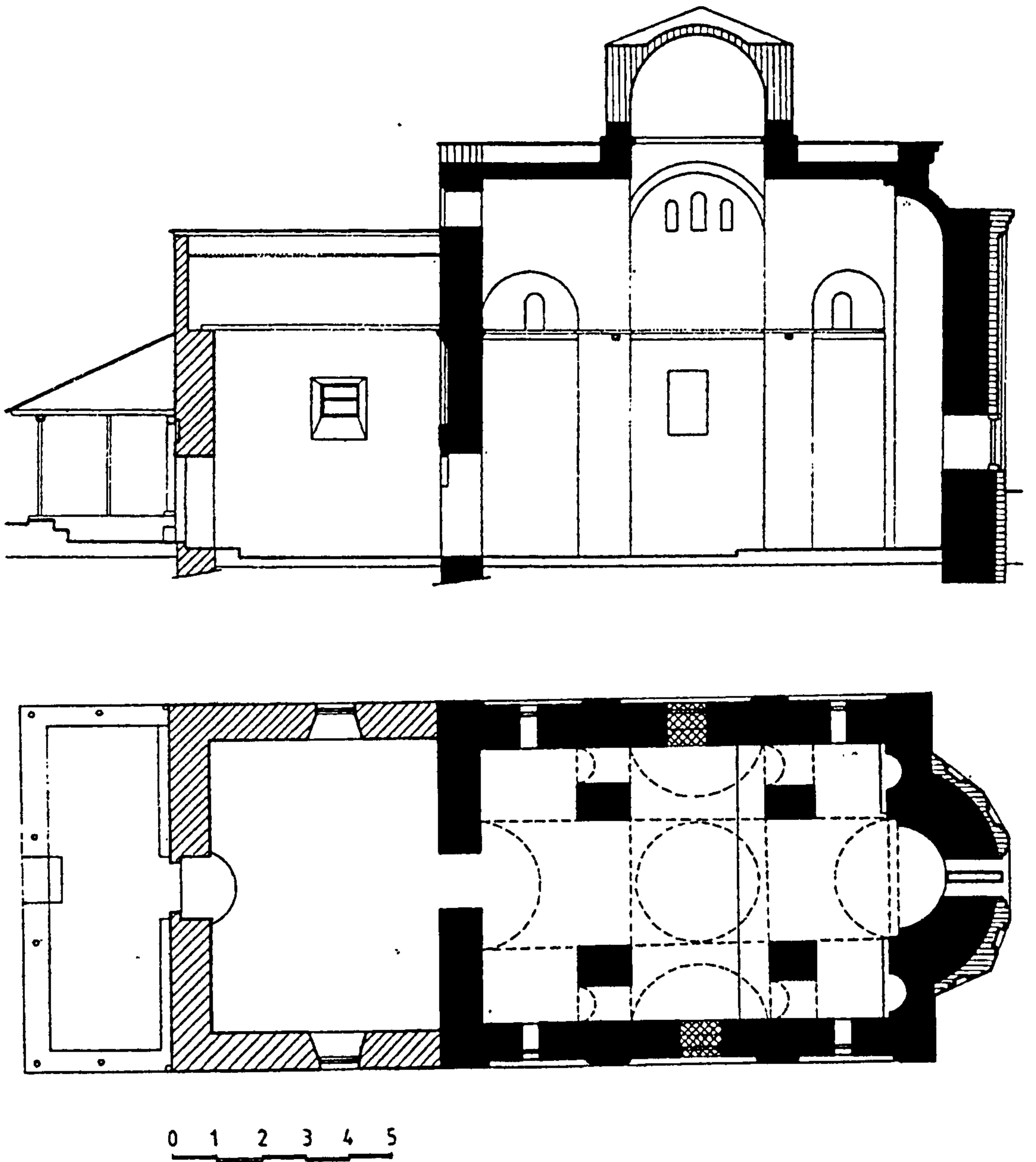

Figure 2.7 Plan of typical Byzantine church (St Stefan, v. Konce - 14th century

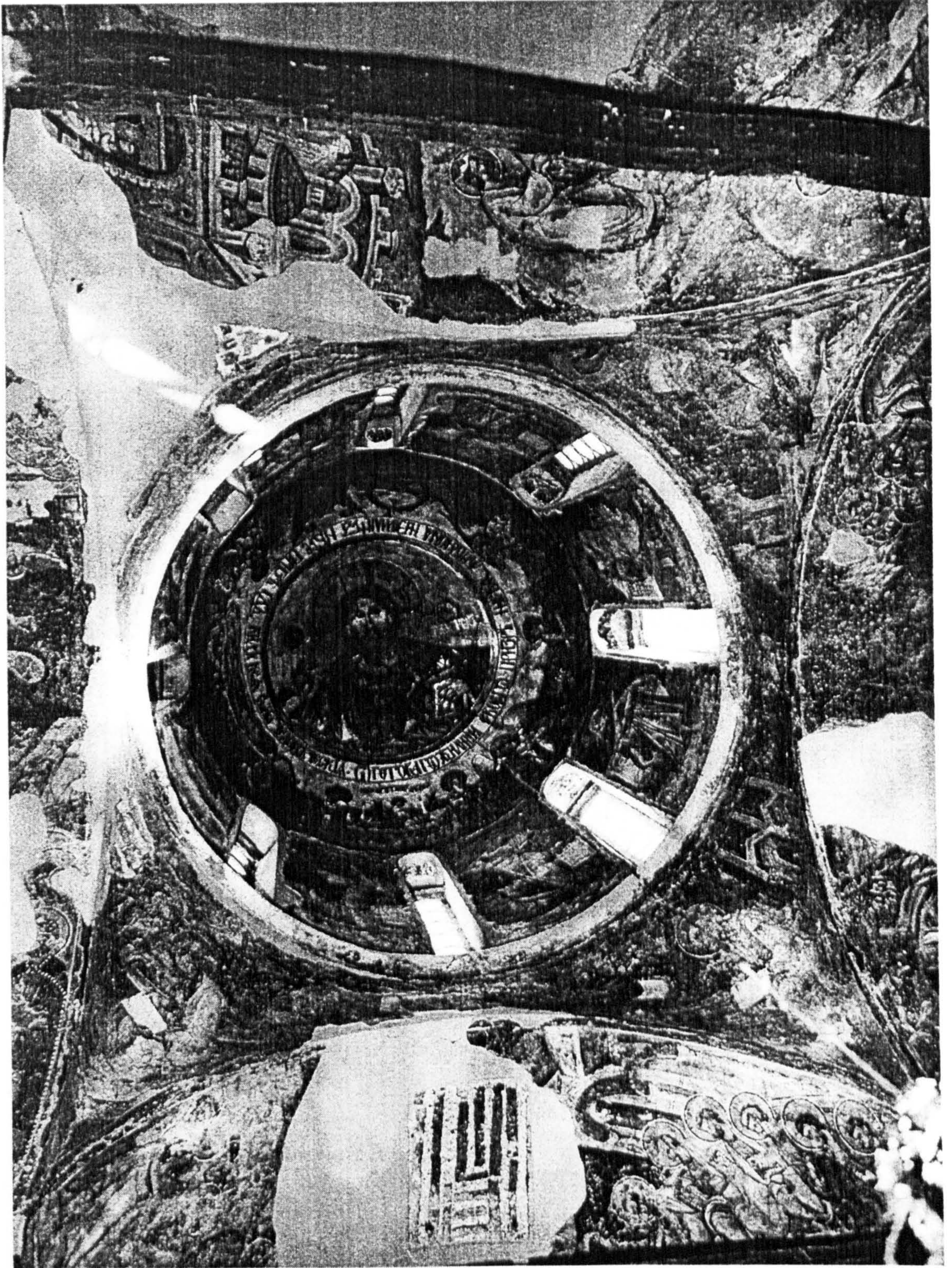

Figure 2.8 Typical damage of Byzantine church, dome and vaults
(St. Nikita, v. Banjani - 14th century)

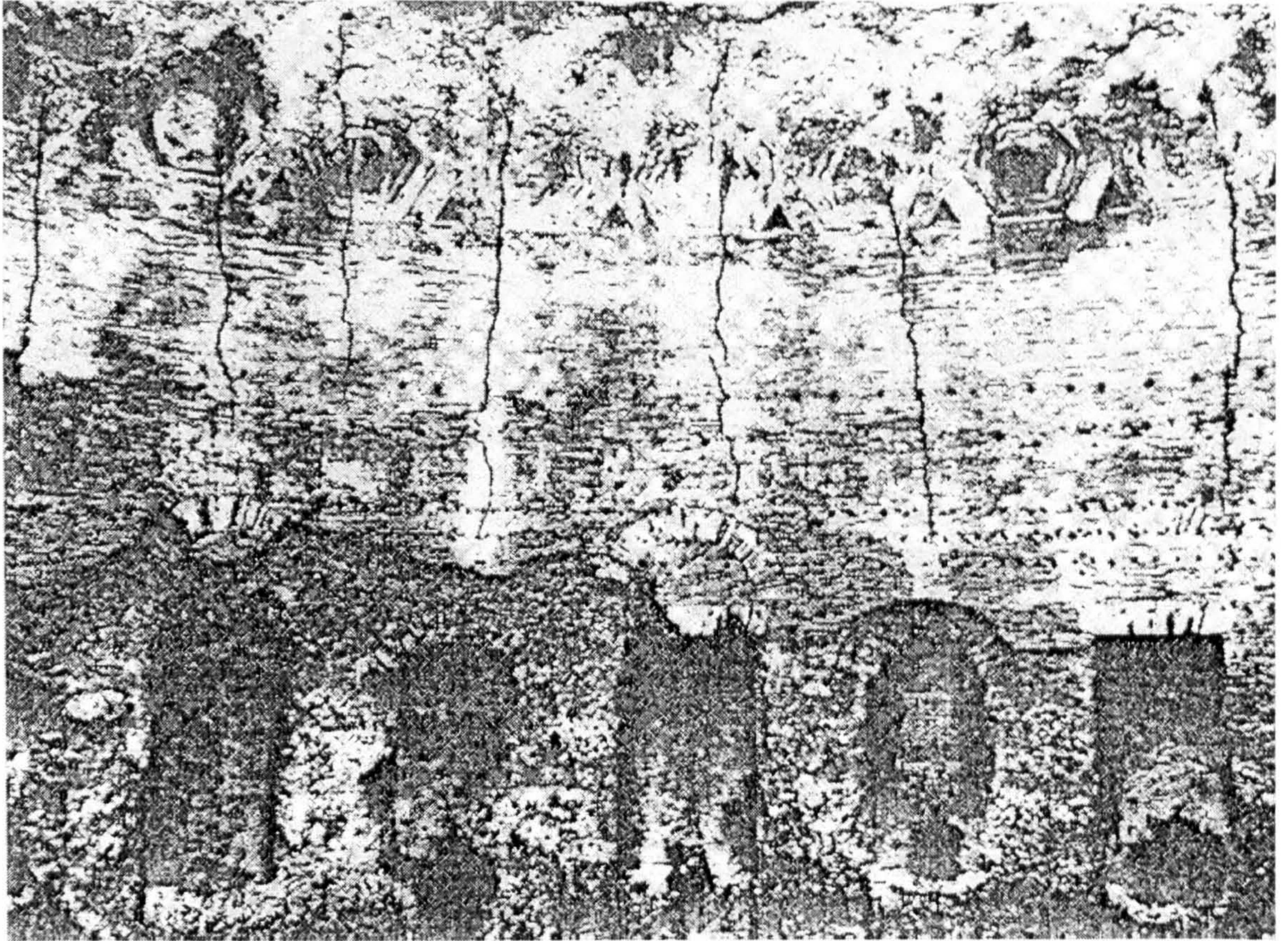

Figure 2.9 *Damage of Baths of Trajan, Rome*
Source: UNDP / UNIDO (1984: 45)

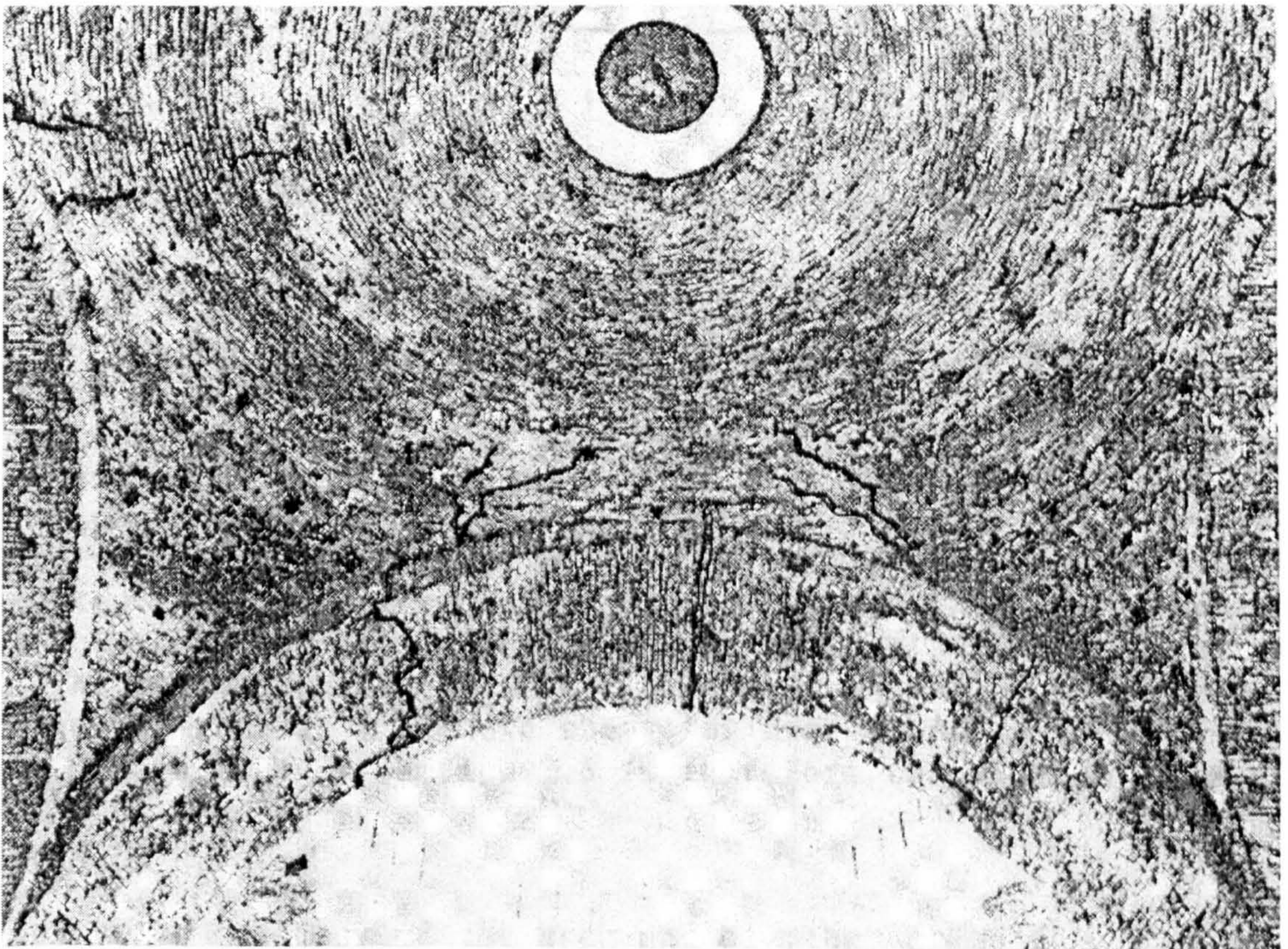

Figure 2.10 *Damage of western dome and pendentives (St. Irene, Istanbul)*
Source: UNDP / UNIDO (1984: 45)

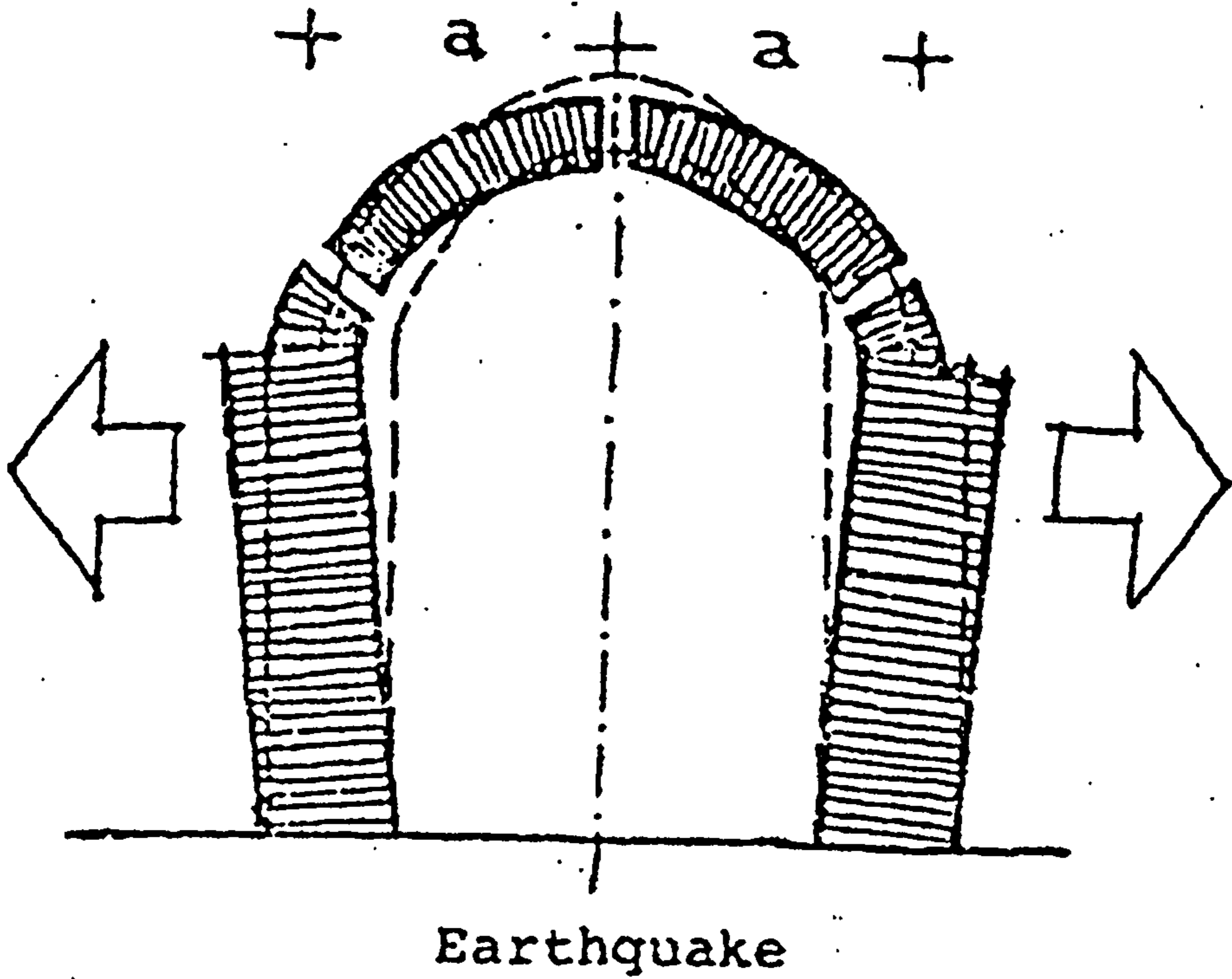

Figure 2.11 Typical damage of perimetral walls and vaults
 Source: Budva - Petrovac seminar (1982)

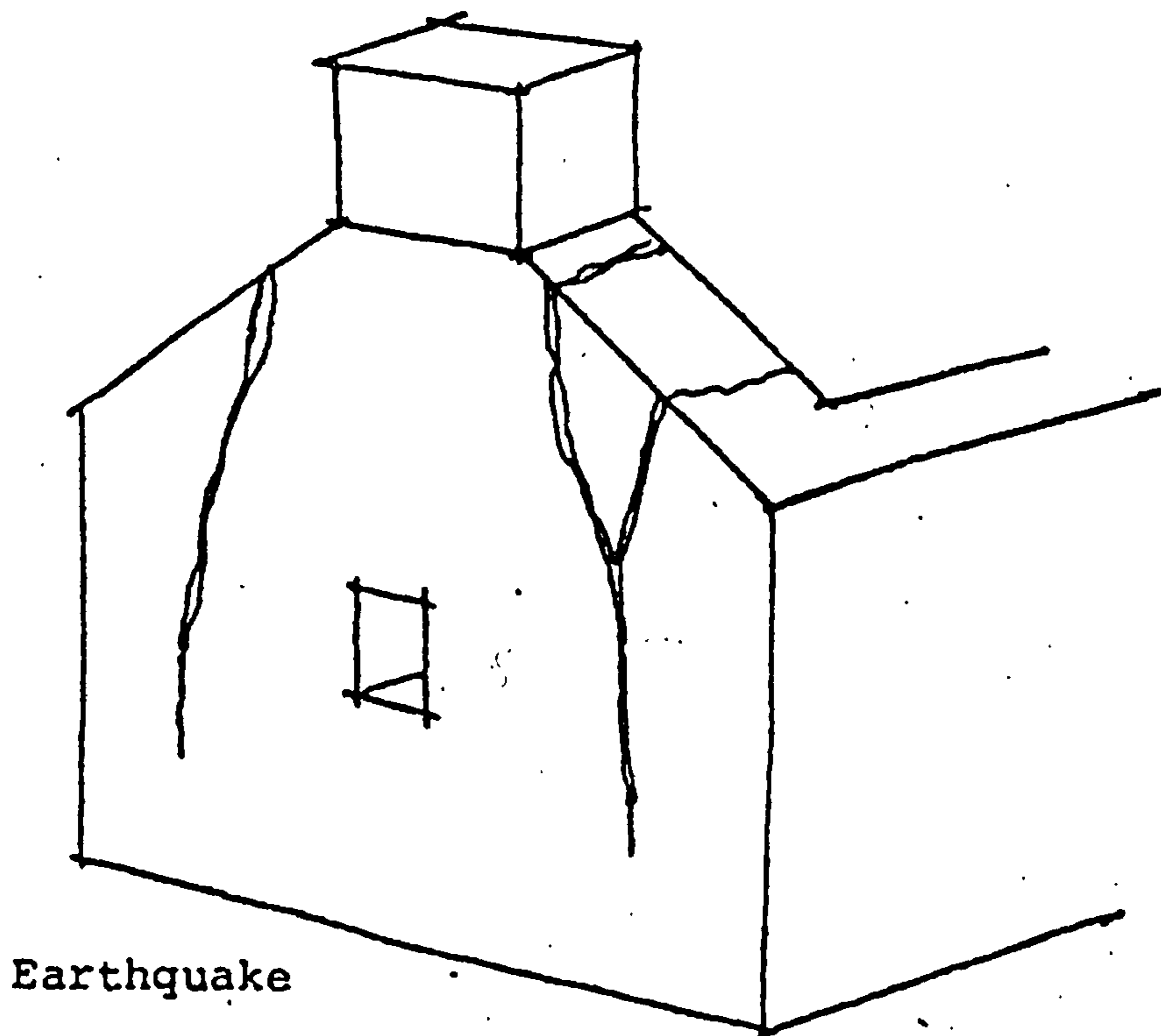

Figure 2.12 Typical damage of out - of - plane walls
 Source: Budva - Petrovac seminar (1982)

CHAPTER THREE

THE NATURE AND CULTURAL HERITAGE OF THE REPUBLIC OF MACEDONIA

3.1 Geographical, geological and climatic characteristics

3.1.1 Geographical and geological characteristics

The Republic of Macedonia is situated in the very heart of the Balkan Peninsula and covers an area of 25,411 km² which is only a part of the vast territory that borne the name of Macedonia¹ in the past.

The geographic position of the Republic of Macedonia is very favourable since it is located between 40° and 42° north latitude and 20° and 23° east longitude.

(Fig. 3.1) It is a cross - road of very important natural communication lines. These communication lines have enabled a natural flow and migration of people from time immemorial.

The Vardar and Struma river valleys open this territory toward the south, i.e., the Aegean Sea whereby a natural link with the Mediterranean basin is created. To the North, through the low Kumanovo - Preshevo watershed, the Republic of Macedonia is connected with the Juzna Morava river valley (present - day Yugoslavia) and hence with Central Europe. To the west, there is another natural connection with the northern part of Europe. This connection is made possible through the Kachanik gorge and the Ibar river valley (both in Yugoslavia). *(See app. 3, section: 3.1)*

In the past, this territory abounded in water, lakes and rivers² wherefore it was called 'a country with a thousand lakes.' However, due to geotectonic activities, this expression is now only partially suitable. Fortunately, due to the intensive tectonic settlement, the waters of the Prespa and Ohrid lakes remained captured by the surrounding high mountains. These lakes presently represent natural resources³ of an extraordinary value. This activity that has still not ended is the reason for occurrence of catastrophic earthquakes.

Wood, as a local construction material, played an extraordinarily important role in the development and preservation of the construction tradition in this territory.

The limestone was of a great significance for the production of lime mixtures and lime mortars. The builders in Macedonia and beyond in this region, raised the production and incorporation of lime mortar mixtures to the highest level of quality.

This is proved by the existence of seven to eight centuries old structures that have been preserved thoroughly or with negligible damage.

This short review of the natural characteristics and resources shows that there were natural possibilities for use of high quality construction materials in the past. This and the skill of builders enabled the creation of architectonic masterpieces that have resisted all kinds of damaging phenomenon.

3.1.2 Climatic characteristics

Climatic parameters

The natural environment of the territory is formed not only by the geographic - geological characteristics but also by the climate too.

The weather and the climate more or less affect the global human activities and have a significant influence upon everyday life. Their interactive effect forms the total natural appearance of the observed territory – in this case – the Republic of Macedonia.

The atmospheric conditions and changes that take place are expressed as parameters of meteorological elements and phenomena.

The most significant meteorological elements and phenomenon, which characterise the weather and mark the climate, are: temperature and air humidity, rain and snow falls, wind and sun radiation, clouds, etc. (See app. 3, section: 3.2)

The relief and the geographical location of Macedonia enable a diverse climate. Since the larger mountains are located in the North - Northwest part of the country, it is naturally protected against the penetration of cold air masses from North. In these parts, the climate is continental – mountainous.

Rainfalls

Precipitation and air as elements creating the climate of a certain area have a particularly great effect upon elements incorporated in the structures: stones, bricks, tiles, timber and lime mortar.

From this aspect, a complete knowledge of these climatic characteristics is of a particular importance for treating these structures adequately. These are natural characteristics that cannot be changed but must be considered in taking activities on buildings pertaining to the cultural heritage.

From the climatic viewpoint, Macedonia has two main pluviometric regimes, as previously mentioned – the Mediterranean and the continental one - which are manifested, in certain regions, as a transition between the two.

The following elements form the characteristics of precipitation:

- Geographic location;
- Altitude;
- Minimum average monthly rainfall;
- Maximum average monthly rainfall;
- Average annual rainfalls;
- Snow percentage included in the average annual rainfalls.

(See app. 3, section 3.2)

Air Characteristics

An important element that participates in the formation of climatic characteristics is the air with all its attributes.

The characteristics of the air are formed by the following elements:

- Geographic location;
- Altitude;
- The lowest average monthly temperature;
- The highest average monthly temperature;
- Annual air temperature range in C°;
- Absolute air temperature – minimum;
- Absolute air temperature – maximum;
- Average duration of frosty periods per year (in days);
- Actual number of frosty days (per year).

Since most of the considered buildings (churches from the Byzantine period) are located in the regions of Skopje, Prilep and Ohrid, it is interesting to present the main characteristics of these sites: the geographic location, the altitude, the characteristics of the air and the intensity of precipitation. *(Table 3.1)*

Author consider that these data should be amended by data on the average monthly and annual temperatures of air and rainfalls. *(Table 3.2)*

These could be used as an important element in making certain conclusions during further investigations. The characteristics of climate in different zones in the Republic of Macedonia are graphically presented in Figure 3.2. *(Characteristics of the Skopje, Prilep and Ohrid regions are presented in app. 3, section 3.3)*

The half of the Republic of Macedonia is influenced by the Mediterranean climate – naturally given element that affected and will affect the considered structures.

The greatest variations in air temperature are found in the Skopje region, although the difference between the daily and the night maximum and minimum temperature is not so pronounced. As to the annual range, it is very wide. Table 3.1 shows that the difference between the measured lowest and highest temperature is 65 C°.

This is the air temperature, but we must, however, emphasise that the temperature to which the south, south - east and south - west facades of the churches are particularly exposed is even higher which increases the intensity of the damaging effect of the sun upon the built -in materials.

Precipitation is also a damaging factor affecting the structures. It increases the moisture in soil that penetrates into the structures through their foundations. Also, the greatest quantities of rainfalls (*Table 3.2*) are in the months characterised by the greatest number of frosty days on the average. This factor contributes considerably to the mechanical damage to particularly weaker materials such as the bricks and the lime mortar.

Despite all this, the state of the structures today makes us believe that they possess certain characteristics of high resistance against natural damaging factors, which are given and cannot be eliminated.

3.2 Historical background

In this chapter is presented a brief, summary of the history of the country and its nearest neighbourhood.

Emphasis will be given to the period between the sixth and the fourteenth century, i.e., from the time of settlement of the Slavic tribes on the Balkans up to the end of the Byzantine Empire at the end of the fourteenth and the beginning of the fifteenth century. This is the period when the buildings, which are the subject of this dissertation, were constructed.

3.2.1 Pre - history

Thanks to its extraordinarily favourable geographical position, Macedonia has had a particularly important place in the thorough continuing development particularly in the cultural developments of the Balkans since the early phases of pre - historic time.

The earliest traces of human existence originate from the early Stone Age, the Palaeolithic period. The real beginning of prehistory, however, is considered to be about 6,000 BC, when the first settlements were founded along the Bregalnica river, Ovce Pole plain, Vardar river and Pelagonia plain. (*See app. 3, section: 3.4*)

The Neolithic Age

The Neolithic period, or the late Stone Age, covers around 1,000 years. By some archaeologists, this period in Macedonia is divided into a number of stylistic groups and periods. (*See app. 3, section: 3.5*)

The Bronze Age

The Neolithic evolution in Macedonia terminated during the last centuries of the third millennium BC. This is the time of the advance of the Iron Age and its first phase - the Bronze Age. This age is characterised by greater organisation of the society and location of settlements in carefully selected locations. Characteristic is the location Skopsko Kale (Skopje fortress) located in the centre of present Skopje. (*See app. 3, section: 3.6*)

The Iron Age

From the cultural - historic viewpoint, this age is characterised by a greater and more refined use of iron. It is divided in four phases: The first from 1,300 to 1,200 BC; the second from the 700 BC; the third from the sixth till the fourth centuries BC and the fourth is covered by Hellenistic influence.⁴ (See app. 3, section: 3.7)

3.2.2 The ancient Macedonian State

The ancient Macedonian state was formed on the territory known as Macedonia by many decades of symbiosis of different cultures. Its founder is considered to be king Perdicca (707 – 645 BC). Its establishment was a long process starting with its coming down to the south. (Fig. 3.3) The advance toward the south was terminated in the beginning of the fifth century. During its existence, it had three capitals: Ajga, Edessa (present Voden) and Pella. The greatest expansion of this state was at the time of king Philip II (359 - 336). (See app. 3, section: 3.8)

His successor was his son Alexander of Macedon, who ruled the country from 336 – 323 BC and overshadowed his father. He was disciple of the Greek philosopher – Aristotle in the period 343 - 340 BC.

Here, we should point out that Alexander of Macedon took some activities as the first 'restorer.' Namely, he ordered the reconstruction of the destroyed temple of god Marduk as a token of his gratitude for being proclaimed king by the Babylonian pagan priests. In his campaign toward the east, he entered India. He died at the age of 33 years. (See app. 3, section: 3.9)

3.2.3 Macedonia under the rule of the Roman Empire

The territory of the Macedonian state became a target of the Roman Empire that started its expansion toward East. The first (215 - 205 BC) and the second (200 - 193 BC), so called Macedonian wars, marked the beginning of the end of the Macedonian state which ceased to exist after the third (171 - 167 BC) Macedonian war when it was ruled by the last Macedonian king - Perseus.

Macedonia was a very important cross - road for the Roman Empire. The Vardar river course was a connection with the Northern borders of the Empire, Via Egnatia connected the Adriatic coast with the Dardanelles and the road known as the Diagonal Way ran from Heraclea (Bitola) to Serdica (Sofia) via Stobi.

During this period, the Roman Empire did not renovate the existing old Paeonian and Macedonian towns. New towns were established like Scupi (Skopje), Lyhnidos, Heraclea, Styberra, while some thirty other towns were deprived of this privilege. (*See app. 3, section: 3.10*)

3.2.4. Macedonia in the period of the Late Roman and Early Byzantine Rule and the settlement of the Slavs

The territory of Macedonia under the Roman rule, represented an area settled by different ethnic groups that gradually became loyal Roman citizens, who accepted the pagan Roman religion. However, this was also the period of the birth of Christianity, as a religion from the East, being different from the then existing ones. Some scholars said that it is a religion that canonised morality and ethics of man. Born in Palestine, in the hearth of Hebraic Judaism, Christianity separated itself from Judaism during the first century AD.

The history of Macedonia is inseparable from the development of Christianity in the Roman, and later in the Byzantine Empire. At the Ecumenical Council of Nicea, the early Christian Church was divided into Aryans and Catholics. (*See app. 3, section 3.11*)

In the first half of the sixth century, there were invasions by the north - east tribes - the Bulgars, the Avars and the Slavs.

Two different worlds came into contact: the world of the citizens of the Byzantine Empire and the world of the Slavs. Although these worlds were very different, they complemented each other through Christianity and advanced further.

This was particularly manifested at the end of the ninth century AD when the territory of Macedonia and the Slavs 'sclavenes' fell, first, under the Bulgarian rule and then under the rule of Byzantium.

The communications, initiated with violence on both sides, were gradually transformed into a search for common interests in establishing links in the creative field of culturalisation, to use the language of socio - anthropologists.

A transformation took place when two cultures recognised the characteristics of each other. Which is the factor that so radically changed the first, destructive trend of relations?

The answer is - Christianity, as a common denominator. Crucial for the Slav population was the language - the Slav language, the language of their fathers and grand, grand fathers.

Why? Because Christianity came with a language - the known mother tongue and all the hindrances were eliminated at the start. Thanks to the intermingling of historic circumstances and the brothers Cyril and Methodius, through their invention and design of the 'Glagolitic' later 'Cyrillic' alphabet the religion and then all the other spheres of life and particularly culture, became constituent part of own existence.

3.2.5 From the Samuel's Empire until the Balkan Uprisings

Religion and the church were and remained the most important driving forces of development and survival for the Slavs and later the Macedonian Slavs through their whole history after settling these areas.

The brothers Cyril and Methodius, the founders of the Glagolitic alphabet (later called Cyrillic, in honour of its creator - Cyril) are eminent persons that mark the Middle Age in Europe. (*See app. 3, section: 3. 12*)

Their work and the alphabet created on the basis of the old Slavic language - the language of the Macedonian Slavic tribes settled around Thessaloniki, enabled fast and accelerated spreading of Christianity among the peoples in South, Central and East Europe.

'Preaching without an alphabet and books is like writing upon water' - said Cyril, so called also 'Teacher and Philosopher.'

In Macedonia the main christianisation took place in the second half of the ninth century when Slav population was converted to Christianity. (*See app. 3, section: 3.13*)

Samuel's State

In Macedonia, the Bogomil movement was particularly influential in the creation of favourable circumstances for a liberation uprising for an independent state organised by local leaders: David, Moses, Aaron and Samuel (969 - 1014) - sons of Prince Nikola, did not miss this opportunity, and Samuel took full advantage of it and established a state, which bore his name.

The first capital of the state was Prespa, but later it became Ohrid. According to John Scilitza, Samuel established a great empire, thus uniting the territories between the Danube and the Balkan mountains. Thessaly, Epirus and part of Albania, including Dyrrachium, and finally, Rashka and Zeta (Montenegro today) were simply annexed to the already existing state.

However, the Byzantine emperor Basil II, a great military leader, did not rest until he defeated Samuel's army in the well known battle on Belasitsa mountain in 1014. From this point the fall of Samuel's Kingdom started very quickly.

After this victory Basil ordered that the eyes of Samuel's captured soldiers be put out. It is said that there were more than 15,000. All of them had been blinded, but at the head of every hundred of these wretches, one was left with a single eye to show the way to the others.

After this terrible defeat, Samuel, who was so shaken by the sight of his soldiers, died two days later. His empire continued to exist until 1018 when Basil II captured finally Ohrid, which marked the end of the Samuel's Macedonian Empire - the last in the long history of the Macedonian people.

The Ohrid Patriarchate

It should be noted that Basil II did not want to abolish Samuel's Patriarchate. He recognised its autonomy although he put it in the lower rank of Archbishopric. Through this Patriarchate, he wisely controlled the church authorities and hence the complete religious life of the Macedonian Slavs and the Slavs in the other regions.

'Even though we have become owners of this land, we have maintained intact its rights which we have defined with our chrystobulls and signs' is what Basil II said in 1020 on the autonomy of the Ohrid Archbishopric. According to chrystobulls, gold-sealed decrees, the jurisdiction of the Archbishopric reached as far as Epirus, Larissa and the Metropolitanate of Thessaloniki in the south and Bulgaria.

The ethnographic structure of the Ohrid church was predominantly Macedonian. Its seat in Ohrid was on the south-western border of this expansive judicial district.⁵ (See app. 3, section: 3.14)

Macedonia under the rule of Ottoman Empire

Establishing their rule, the new masters, with different religious directions, also brought about a new lifestyle. Life was hard, especially in the beginning, since all new rulers - always and everywhere, including this one - then and there, try to forcefully graft their policy and establish their government on the territory. The changes in the system, the administrative division, the overall instability, the restriction of bondage severed the connections between certain regions of the conquered Balkans. Macedonia shared the same destiny. (See app. 3, section: 3.15)

Macedonia in the beginning of the Twentieth century

In the beginning of the twentieth century, when the Ottoman Empire was going through its last days, the Macedonian people who were settled in the central part of the Balkans in a single ethnic territorial unit, became again a plunder for the newly formed states of the Bulgarians, the Serbs and the Greeks.

Although the first Macedonian Republic in the Balkans - the Krusevo Republic (August 1903) created after the Ilinden uprising, lasted only 10 days, the Macedonian people showed that they are capable of establishing their own state - a state of the Macedonian people and minorities that shall live in it with equal rights.

After the Balkan wars waged between the allies (Serbia, Bulgaria and Greece) and the Turkish Empire, the territory of the Macedonian people was divided among the victors.

So, the Macedonian people continued to live under a new yoke, within the frames of the Kingdom of Serbs, Croats and Slovenians. Before and after the Second World War, in the National Liberation War of the Yugoslav peoples, the German, Italian and the Bulgarian occupiers were defeated and the Federal People's Republic of Yugoslavia was established.

Within this state, the Macedonian people established their own Republic with equal rights as the other five. The republic was proclaimed at the Second Session of ASNOM⁷ on 2 August, 1944.

On 8 September 1992, after forty eight years spent in a federation, the Macedonian people and the minorities came out, by a Referendum, for independence and separation from the Yugoslav federation. A democratic state of the Macedonian people and the minorities was established.

3.2.6. The Republic of Macedonia, an independent democratic state of the Macedonian people and the minorities that live in it

In the Constitution of the Republic of Macedonia is written that it is a democratic, pluralistic country that will aim to make permanent advance in all domains of life, develop friendly relations with its neighbours and endeavour to integrate itself into the new architecture of Europe, as a community of states having equal rights.

The territory of Macedonia is somewhat bigger than 25, 000 square kilometres. It has over two million citizens. With its parliament elected according to the principles

of democracy, its government, army and other institutions, it is a modern European country.

The ideologist of the Macedonian renaissance - Goce Delcev said:

'I understand the World only as a Competition of Peoples in Cultural Development.'

3.3 Cultural heritage protection policy in the Republic of Macedonia

3.3.1 Legislation and institutional organisation

Considering the importance of the national cultural heritage and being aware of the responsibility, adequate steps were taken in the course of the National Liberation War (1941 - 1945) and immediately after it.

The first activity was the establishment of a National Museum in 1944. After the liberation, a Commission for Restitution was established in 1947. As a task was action of identifying and listing the monuments that had been taken out of the country during the war. In the same year, a State Commission for protection of cultural monuments was established.

In 1948, the first Code for protection of cultural monuments and Natural Rarities was approved and a Central Institute for protection of cultural monuments and natural rarities was established in 1949.

Today, the 1973 Code is still effective. It represents the third version of the first one.⁸ This code, like the previous ones, contains the legislative norms for thorough and high quality protection.

Presented in the subsequent text are some more important provisions of the above stated code.

I. General provisions

Article 2: 'Under this Code, considered as cultural monuments are immovable and movable objects that, according to their artistic, scientific and other values and importance for the history and culture in general, and particularly for history and the culture of the Macedonian people, the minorities and ethnic groups...., scientific -research, cultural - artistic and educational functions, are put under special protection by the community.'

Article 4: '..... Protection of cultural monuments is carried out, according to the provisions of this Code, by the institutes for protection of cultural monuments and the state authorities, the museums, the galleries, independent museum and gallery collections, archives, libraries, etc., institutions that perform conservation and restoration of cultural monuments.....'

Article 6: 'Damage or destruction of cultural monuments is forbidden. None can take any actions on monuments or in their near surroundings, without permission by competent institutes.'

- ' Article 11: 'Cultural monuments are available to the public according to the provisions of this Code. The scientific and professional documentation on cultural monuments kept at the institutions is also available to the public.'

By the same Code further obligations are prescribed: Rights and obligations of the owners of the cultural monuments; Registration and public designation of cultural monuments and other legislative measures; Organisation of institutional protection of cultural monuments⁹; Penalty provisions, and others. (*See app. 3, section: 3.16*)

Existing seven institutions carry out the total protection activities in the state. In these institutes are employed more than two hundred experts of different profiles like art historians, architects, archaeologists, ethnologists, chemical engineers, painters, conservators and others. Part of the expert staff have attended advanced training in international institutions like ICCROM, the Getty Conservation Institute, the University of York, the Institute of Grabar in Russia, the Institute of Technology in Trondheim, Norway, etc.

It should be noted, however, that the number of the professional staff is not adequate to the great number of cultural monuments, both registered and identified.

According to the latest statistic a data (*Table 3.3*), there are more than 1,100 registered and over 6,600 identified immovable cultural monuments. (*See app. 3, section: 3.17*)

3.3.2 Conservation and restoration activities

Fifty years passes since the establishment of the Service for Protection of Cultural Monuments. This is a period through which, the experts from Macedonia, have succeeded in giving their best by maximum efforts. The results have been adequate to the investments by the state that has always, within the framework of its possibilities, supported these activities.

We may conclude that the achieved results and renown are due to several facts. According to our opinion, the most important of these is that the protection of the cultural - historic heritage has been and always will be an activity of particular importance for the state.

a) *Beginnings*

As we mention in section 3.3.1, the beginning was during the end of the Second World War. Certain preventive - repair works on structures were carried out. Noteworthy among the first activities were those taken for the Daut - pasha bath in Skopje in 1948/49 and church of the Holy Wisdom (St. Sophia) in Ohrid (1951). (See app. 3, section: 3.18)

Under the supervision of Prof. Boris Cipan and according to his own project, a very important conservation work was carried out at that time. Namely, because of the disturbed stability of the south wall of the church St. Sophia, Ohrid and its critical inclination, the whole wall mass was brought back to its original position by a special approach. Namely, steel cables have been used for that activities. (Fig. 3.4)

This operation is considered as one of the most important operations at that time since it was done by preserving, to the best possible extent, the authenticity of the structure. This work was recorded in the history of conservation practice in Macedonia and round the world.

b) *Continuous development*

After these pioneering works, there were a number of activities. First was the drawing up of a complete inventory of building heritage in urban and rural settlements as well as inventory of sacral structures (churches) located over the whole of Macedonia. The inventory of icons, iconostases, woodcarving and church furniture (filed were over 23,000 icons dating from the twelfth till the nineteenth century) especially important activity. (See app.3, section: 3.19)

Particularly intensive conservation - restoration works were carried out in Skopje and its surroundings after the catastrophic earthquake of 26th July 1963.

A large number of cultural monuments, particularly Islamic ones, were then damaged or totally ruined. The earthquake also inflicted damage to the church of St. Pantelejmon in the village of Gorno Nerezi dating from the twelfth century. The conservation - reconstruction works carried out for this church were a pioneering work on repair and strengthening of a structure located in a seismically active region. These works and the works for reconstruction of the damaged structures in the town will be presented in more detail in Chapter 4. (See app. 3, section: 3.20)

According to the author's opinion, the first important factor is the inadequate evaluation and recompense for the service of the experts in these institutions. When we

say this, we also consider the colleagues - the craftsmen - artisans - whose number rapidly declines for the same reason.

Due to the limited financial resources, technical equipment available for these activities is only modest. However this handicap is solved by the great, unexplainable, enthusiasm of our colleagues - experts, who sometimes succeed in achieving the impossible. (See app. 3, section: 3.21)

Still, at this moment also, it should be emphasised that the Venice Charter dictated the conditions of treating cultural heritage until the end of the eighties. In fact, the individual monument was of an extraordinary importance. It must be confessed that it is this position (estimation of only the individual monument) that very negatively affected the remaining existing *corpus* of cultural monuments ranked as having low values.

In consequence, this *corpus* of good, if not outstanding, old buildings of lower values was subjected to deliberate planned removal, through new general and detailed urban plans of urban, and later, rural entities. According to author's opinion, this approach resulted in catastrophic consequences regarding the built urban and rural milieus from the past.

No war neither ravage of time can do what was done in this territory by planners in a 'planned' way.

Therefore, at this point also, we wish to underline the fact that the cultural heritage of Macedonia acquired its due place with the preparation of the Physical Plan of the Republic of Macedonia (1997).¹⁰

It fills us with hope that more important and major results in this field should be expected.

3.3.3 Legislative treatment of cultural heritage before and after disaster (with a special emphasis on earthquakes)

In the still effective Code for Protection of Cultural Monuments, there is not a single word on treating cultural monuments before and after catastrophic events.

Hints of this, but very generally and not directly relevant to cultural monuments, are found in some articles of the Code on Modification and Amendment of the Code for the System of the Physical and Urban Planning (1985 and 1990).

Presented below are some of the provisions:

I. General provisions

Article 9: 'The physical and urban plans involve arrangement and preparation of space for waging of wars and protection against war destruction, natural disasters and other hazards.'

II. Physical planning and populated areas

Article 17: 'Physical plans contain particularly: arrangement of areas of particular purposes; protection of air and cultural heritage; measures for protection and improvement of human environment, measures for defence and relief operations in case of wars, natural disasters.....'

Article 36: 'In case of natural disasters (earthquakes, floods, land slides and the like) inducing larger scale of material losses , the municipality can prescribe a shortened procedure for elaboration and effectuation of plans

III. Effectuation of plans

Article 49: 'Apart from the general conditions, the solution for the location contains also ... seismic protection'

In addition to this Code, the cultural monuments, as part of the total building *corpus* of the state, are also indirectly treated in the Code for construction of investment structures (1990 - 1991).

Presented below are some of the provisions from this Code.

I. Main provisions

Article 8: 'Considered as construction of a structure, according to this Law,.... is construction of a superstructure or enlargement of an existing structure....'

Article 9: 'Considered as reconstruction of a structure... is performance of works of repair, adaptation and the like by which the structural system is modified....'

II. Documentation and technical control of the documentation

Article 15: 'The technical documentation is elaborated according to the

conditions defined by the decision on.... natural and cultural heritage..... and seismic protection....'

If we consider the attitude stated in Article 8 of this Code, regarding the definition of reconstruction, i.e., repair and adaptation by which the structural system is modified, we can indirectly associate this article with Article 16 and its provisions which are as follows:

Article 16: 'For the elaboration of technical documentation on structures in regions prone to earthquakes with intensity of VII, VIII and IX degrees MKS, the parameters defined in the seismic zoning map of the Republic of Macedonia and the detailed seismic zoning maps (microzoning maps) of the considered area are applied...'

The 1963 earthquake meant beginning of definition of regulations for construction of structures on the territory of former Yugoslavia. Accordingly, these standards started to be applied in Macedonia.

The Book of Regulations from 1981 with modified versions from 1982, 1983, 1988 and 1990, entitled Book of regulations on technical norms for construction of high rise buildings in seismically active areas is effective.

Although the provisions of this Book of Regulations are not directly applicable for structures pertaining to cultural heritage, they still were one of the reasons for the elaboration of this dissertation. (*See app. 3, section: 3.22*)

It was as early as author's advanced training at ICCROM ARC 86 in Rome (1986) which investigations were focused on the relation between the cultural heritage and earthquakes. This determination is still main preoccupation, with an endeavour to achieve certain results that will increase the level of protection of cultural monuments against future earthquake effects.

However, a lot of time and effort by individual experts and the state, as a whole, are still needed to achieve adequate treatment of the cultural heritage of Macedonia from the aspect of permanent exposure to the earthquake hazard.

As an expert who has been involved in protection of the cultural monuments of Macedonia for more than 27 years, author supported idea that protection should be realised in phases as stated in item 2.1. Here, we would like to point out that the greatest attention should be paid to the first phase. Why?

According to the considerations presented in: 'Draft-thesis for the model for preventive seismic protection of the world cultural - historic building heritage of Ohrid and Ohrid Region' (*Sumanov 1998: 47- 58*) it may be briefly said that the model (adapted for the whole state) could represent an acceptable basis for development of an adequate system for protection of cultural heritage in seismically active regions.

We consider that some of the main activities planned in this phase have already been realised by joint efforts of the author and other experts at national and international level, being thoroughly supported by domestic and foreign institutions and foundations.

When we mention those things, we are thinking of the following events, which should be taken in account:

- The international seminar entitled '1st International Seminar on modern principles in conservation and restoration of urban and rural cultural heritage in seismic - prone regions'¹¹ organised in 1988;

- Realisation of the research project on Byzantine churches in Macedonia;

- Realisation of the research project financed by UNESCO entitled 'Development of a methodology in order to create Data bank for structures in seismic prone regions' (1994/95)¹² and

- The recently organised Regional workshop entitled 'Integrating cultural heritage into national disaster planning, mitigation and relief' (1997)¹³ in which activities the author took an active part as principal investigator, lecturer and president of the organising committees, respectively.

We hope that the theoretical and the experimental results from these activities would contribute to the future establishment of a 'National Plan for Protection against Catastrophes' in which appropriate treatment will be given to the cultural heritage.

3.4 Architectural heritage

3.4.1 Basic information

If we want to talk about the characteristics of the architectural heritage on the territory of Macedonia, we should refer once again to the historical background previously given in sections 3.2.1 - 3.2.5.

In this section, we will discuss only building heritage matters. From the very first beginning in the prehistory (8.000 years BC) till the Roman period in Macedonia a building tradition exist. Although sometimes prevailed over by local tradition and sometimes by imported values, construction in Macedonia has always had its own unique characteristics, determined by the ethos - the people - that has lived and created in this territory. (*See app. 3, section 3.23*)

Roman Period

During the Roman expansion toward East, Macedonia had an extraordinarily important role.

During the Roman reign in Macedonia, the location of the towns was changed. During the pre - Roman period, the towns were located on uplifted terrain. During the Roman rule, they were located and founded on flat locations - depressions. This is confirmed by the remains of the towns of Stobi, Scupi and others.

Stone (marble - limestone), bricks and lime mortar were the main elements for architectural creation and construction.

During the golden age of the Roman Empire, elements of high architectonic values were produced in Macedonia. More about the representative cities of this period as Stobi (*Fig. 3.5 and 3.64*), Scupi (Skopje today), Heraclea Lyncestis and Lychnidos (Ohrid today) (*Fig. 3.65*), (*See app. 3, section: 3.24*).

More details on the influence of Christianity upon the construction activities on Macedonian soil will be presented in the Chapter four.

Byzantine period

For the Balkans, the importance of the Byzantine state, its life and its mainstay - Christianity - is that the vital impulse entered the network of veins, which nourished the layers of cultural stratification.

The countries of the west are also becoming increasingly aware of their indebtedness to the Byzantine Empire. Due to its remarkable mastery in leading the people, it possessed sufficient power and fame to unite the 'non - barbaric' world and write history, both political and cultural, long before the flourishing of the west.

It was indeed the Byzantine Empire which bridged the gap between Antiquity and the modern world, between the Roman Empire and the western renaissance.

For some scholars this 'cultural era' lasted until the fall of Constantinople under the Turkish rule in 1453.

According to some scholars, 230 basilicas were located in Macedonia in this period. (*See app. 3, section: 3.25*)

At the end of the ninth century and further until the fall of Byzantium under the Turkish rule, extensive construction activities were carried out in Macedonia, particularly for the Christianity. This was the period when, irrespective of the ruler, architectural building works of permanent and recognised value were created. More about this period will be in Chapter four.

Ottoman Empire - the post Byzantine period

In the history of Macedonia, the date of 1395 is the date of Macedonia's fall under the rule of the Ottoman Empire.

The achievements of Islamic architecture in Macedonia from the fifteenth and the sixteenth centuries - religious (mosques, masjids, tombs, dervish lodges) and secular (caravanserais, baths, covered market places and schools) bear the features of the Ottoman school. Byzantine influence, as well as the influence of the local mastery in building 'tempered' through the centuries, are also visible in the principle local Oriental architecture. (*Fig. 3.7-10*) (*See app. 3, section: 3.26*)

Continuing the construction tradition in these areas, the Macedonian builders created magnificent, for Macedonian conditions, secular architectural, functional buildings, which inspired even Le Corbisier in the beginning of the twentieth century.

The construction activities have never stopped. They have continuously been carried out until nowadays. The Macedonian craftsmen, stone cutters, etc. are well known for their skills not only in the narrow region but also beyond, in Europe.

3.4.2 Typology and chronology

Very shortly, in this section of the thesis, typology and chronology of the whole

existing architectural heritage in Macedonia will be discussed.

The period of the beginning of the Roman rule in Macedonia will be considered of the beginning of typological determination of the heritage. Chronologically speaking, this is the end of the millennium before Christ and the beginning of the new Era.

Sometimes, particularly in the nineteenth century, certain types of structures were revived (especially sacral), but in a certain, narrow segment, which is due to the late arrival of the renaissance in Macedonian architecture.

The detail typological and other determination of the sacral Christian architecture in Macedonia will be discussed subsequently in the section 3.5. (*See app. 3, section: 3.27*)

A Definition of typology

To define the type of a structure, several elements are taken into account. These are the following:

- Function / purpose of the structure;
- Plan;
- Structural elements and systems;
- Materials used for construction.

The first two elements, which are basic, will be mainly considered for determination of types of structures in this segment will be mainly the first two elements, which are basic. The second two elements, that are of the second level of importance, are the elements of expression and presentation of the original concept of the structure.

The function of the structure, which is the main element for determination of typology, plays an important role in determination of architectural heritage types in Macedonia.

In accordance with the latest investigations carried out in the study for the cultural heritage included in the physical plan of the Republic of Macedonia (*Sumanov et al. 1997*), a new general classification scheme was designed. According to this scheme, the total architectural (immovable) heritage has been classified into 5 main categories, conditionally speaking. (*Fig. 3.6*)

Since the subject of this thesis are single structures - Byzantine churches, more details will be given in ^{the} section of ^{the} single architectural ^A cultural monuments (category 5 -

architectural monument - in the classification scheme) while for the others, only general notes will be given.

A.1 Sacral architecture

The Christian, Jewish and Islamic sacral architecture are included in this section.

In the domain of the Christian sacral architecture, which will be discussed in the next section 3.5, there has been continuity starting from the middle of the fourth century until now.

In the domain of Jewish sacral architecture in Macedonia, there is ^a material evidence that a Synagogue existed in Stobi (third / fourth century AD) .

The Islamic architecture in Macedonia dates from the end of the fourteenth century, with the conquering of Serbia by the Ottomans (Macedonia was under Serbian rule). Islamic architecture in Macedonia reached its peak during the fifteenth and the sixteenth century. Its conception and plans are part of the Turkish school.

Islamic architecture

- *Mosques*

The simplicity of the functional solutions in mosque architecture is aesthetically presented in the contrast between the outside silhouette, expressed in the composition of the heavy cube - shaped mass with a dome and a high minaret. (*Fig. 3.7-3.10*) (*See app. 3, section: 3.28*)

- *Monastery Complex*

In Macedonia, there exist two monastic complexes of the Dervish order - Rifat Shrine in Skopje and Arabati Baba Shrine in Tetovo.

The shrine in Tetovo is still in use. The buildings are surrounded by a beautiful park. They are functionally clustered in separate units, like a pavilion, with harmonious proportions. Worthy ^{of} mention are Ashi Ane, Ibadet Ane, Dervish Ane, etc.

A.2 Tomb (grave) architecture

Within the frames of sacral architecture, the architectural elements of burial of the dead believers are usually situated within the sacral complexes or in the vicinity. This is the case in both Christian and Islamic sacral architecture. In this part are included: *Christian tombs, Islamic tombs. (Fig. 3.10) (See app. 3, section: 3.29)*

A.3 Fortification architecture

This architecture refers to fortresses, fortification walls, fortification towers and fortified residential towers.

The earliest remains of fortification architecture in Macedonia are found in Stobi, Heraclea, Bargala and Lychnidos bearing traces of the early Byzantine tradition.

Notable structures pertaining to this type of architecture exist in Ohrid, Skopje and Stip. *(Fig. 3.11) (See app. 3, section: 3.30)*

A.4 Economic architecture

To satisfy their needs, the authorities of the past and present designed and constructed and still design and construct structures of economic function that are used for various needs.

These structures can be classified as follows:

- Structures for communication (bridges); *(Fig. 3.13).*
- Water supply structures; *(Fig. 3.12)*
- Production and trade structures; *(Fig. 3.14)*
- Structures for providing information (clock-towers). *(Fig. 3.15)*

More about above mentioned groups in App. 3, section 3.31.

A.5 Secular architecture

Structures of the secular architecture were used by citizens for various needs (living spaces, recreation and other activities).

These are classified into the following categories:

- Residential architecture - individual housing;
- Residential architecture - collective housing;

- Architecture for satisfying of living needs (baths).

A.5.a Residential architecture - individual housing

The end of the millennium before Christ and the beginning of the new one, mean development and strengthening of the Roman Empire. This is a period of intensive construction of residential structures and public structures of different type and purpose.

Through the whole historic period, up to the twentieth century, individual residential structures have been royal residences, palaces, residential structures of landowners, beys and pashas, structures of the new Turkish and Christian clientele in the cities.

- *Palaces, residences, houses*

Noteworthy among the palaces - residences of eminent citizens from the late Roman and the early Christian period in Macedonia are those in Stobi. These are the following:

The House of Peristeri (Stobi, fourth - fifth century AD)

The house of Peristeri is a residential family building. It is a rectangular structure with a patio around which are situated the residential premises (rooms) in the south part of the structure. A big fountain¹⁴ is situated in the central part, to the west.

The Theodosius Palace (Stobi, fourth - fifth century AD)

The building is L - shaped, with exits onto three city streets. The hall had columns on the northern and the western sides. On the eastern side of the hall, there is a pool with eight marble pedestals. (Fig. 3.16)

Unfortunately, there are no important remains of construction activity related to structures for individual or family residence from the time of the Byzantine - medieval period and the Islamic rule.

This period is also marked by intensified activities on construction of residential structures for the needs of the rising Macedonian middle class. Samples of this

residential architecture (*Fig. 3.17 - 22*) are found in the towns of Skopje, Bitola, Ohrid, Prilep, Strumica, Veles, Stip, etc.

- *Residential structure - collective housing*

This type of structure was particularly constructed at the time of the Roman expansion over the territory of Macedonia. Namely, barracks were constructed for collective usage by the army.

As good soldiers, but even better builders, the Roman architects achieved, in this case also, a functional division and proper functional location of certain premises - separate premises for living of people (soldiers), horses, economic part, stores, etc.

This type of structure intended for collective residence, temporary or permanent, have been developed and have existed, to a lesser or larger extent, on the territory of Macedonia, from the midst of the medieval period.

These have existed in the form of monastic Christian complexes - the known monastic 'konaci' (temporary lodgement) that still have the original function (*Fig. 3.23 - 24*) and then, with the domination of the Islamic rule and culture, in the form of structures intended for temporary stay of travellers, merchants, promoters of prosperity. (*See app. 3, section: 3.32*)

The well known 'caravan sarai' or the so called 'an' (inns, taverns) still exist in Macedonia, but unfortunately none has preserved its original function, particularly in Skopje ¹⁵ (*Fig. 3.25*)

- *Baths*

In the Roman Empire, the utilisation of water related to the maintenance of body hygiene was at a very high level. The best examples of Roman *thermae* on the territory of Macedonia are found in Stobi, Heraclea Lyncaestis, Scupi, and Banja BANSKO near Strumica.

During the Turkish rule in Macedonia, the public baths were considered very important for the towns. Very often, almost without exception, it is a constituent element of the so called 'Turkish architectural trio.' Namely, this architectonic complex involved also the mosque and the 'caravan sarai' (or the inn). (*See app. 3, section: 3.33*)

3.4.3 Materials, structural elements and systems

Since pre - historic times, man has had the need to be active, construct and create an environment for himself and his continuing activities.

To materialise the idea of the architectonic plan of any of the above mentioned types of buildings (3.4.2), builders had to use adequate natural or processed construction materials. It is characteristic that mainly local construction materials were used in Macedonia.

A. Building materials

Based on investigations done by the author himself, written and material data, the following building materials have been used on the territory of Macedonia:

- earth (natural and processed);
- stone (natural and dressed);
- sand (river, lacustrine or from mines);
- wood (natural or processed);
- lime;
- lime mortars and lime admixtures;
- bricks, tiles;
- glass
- lead

A.1 Form and mode of use

• *Earth*

The earth, as the oldest and most abundant construction material, in these areas has been used since time immemorial. It has been used for: Earthen floors, masonry mortar, rendering mortar, material for sun - baked bricks.

In some of the west parts of the Republic of Macedonia, earth as a construction material, in its natural and processed form (sun - baked brick), is used for construction of residential rural structures. (*Fig. 3.26*) (*See app. 3, section 3.34*)

• *Stone*

Like earth, stone also represents an archaic construction material. It has been used from times immemorial in its natural form and dressed form. The investigations

have shown that it has been widely used in both forms, but certainly more in the last one.

The most widely found types of stones used as construction material in Macedonia are: limestone, different kinds of marble, different kinds of tuff, volcanic rocks, sandstone and sediment rocks, rarely granites and basalt.

Stone in its natural form was used for: masonry walls, as a component of wall core, like infill material.

In its dressed form has been used for: bearing and non - bearing masonry walls and elements, carving stone elements.

When talking about dressed stone, the art of dressing and incorporation of stones in structures is transferred from generation to generation in some villages in west and east Macedonia even today. There are many known families of builders that cherish this tradition. *(Fig. 3.27)(See app. 3, section 3.35)*

- *Sand*

Sand of different origin is in use (river and lacustrine sands and sand from mines). It is of particular importance to note that, in the course of time, the masters applied sand of granulometric composition suitable for different needs. For the preparation of masonry mortar, river sands or sands from mines are used. The preparation of types of mortar for plastering requires the use of river or lacustrine sands.

- *Wood*

The use of wood in construction activities has been important. It has been used in its natural form and processed form for the construction of:

- structural elements;
- non - structural elements;
- construction of horizontal wooden belts;
- floor, ceiling and roof structures;
- wooden bridges and piles;
- timber frame structures;
- floors and ceilings
- fences
- casings, window jambs, doors, windows and furniture.

Woods of different mechanical, chemical and aesthetic properties are used in accordance with the purpose. The most commonly used types of wood are: oak, fir, pine, beech, chestnut, walnut. (*Fig. 3.28*)

- *Lime and lime admixtures*

It may be said that the whole construction strategy and philosophy is based on this good and high quality product of man.

The characteristics of the natural material and men's skill to make full use of its properties have contributed to the availability of a cultural heritage whose age is measured by millennia.

This is the main binding material used for many purposes:

- construction;
- plastering;
- covering of horizontal and vertical masonry areas;
- preparation of bearing and fresco layers for wall painting;
- cyclic lime wash of masonry areas (This is particularly important for protection of highly vulnerable bearing wall elements made of earth / sun - baked bricks. (*More details on this construction material are given in Chapter 5*).

- *Bricks and tiles*

This product of man has a long history. It has always been well processed and incorporated, with high quality and long durability. This is evident on all the sacral structures, particularly the Byzantine churches. This material is produced for different purposes and with different proportions, according to the needs of the architectonic and structural concept of the structure.

It has been used in different dimensions, but almost always with a thickness of 3 - 5 cm for construction of: walls, columns (piers), arches, vaults, pendentives, domes and other non - bearing partition elements. (*Fig. 3.29*) (*More details on their mechanical characteristics are given in Chapter 5*)

The tiles are used for covering of the oblique and rounded roof areas, in different forms and proportions.

Glass

Glass was used in the Middle Ages to close the window areas and the openings of the windows. Unfortunately, it is found only in traces or as archaeological data.

Lead

In the past, the lead was used for covering highly valued structures like churches, mosques, covered markets, baths, etc. This was due to its durability and easy processing.

B. Structural elements

The varied architectonic heritage that exists in this territory is characterised by a number of structural elements that are incorporated into structural systems defining the architectural plan.

B.1 Columns

The column as a structural element is constructed either as monolithic or composite element. This element was mainly used as a bearing element in churches (in the Byzantine and particularly in the post - Byzantine period) and mosques (at the porches). The columns were exclusively constructed of stone (granite, limestone, marble) with a cylindrical (*Fig. 3.30*) or a square cross - section. (*See app. 3, section 3.36*)

B.2 Piers

The difference between the columns and the piers is that the latter are always composite, exclusively with a square or rectangular cross - section and formed by the use of stones, bricks and lime mortar. In the churches, these are most frequently plastered and covered with fresco - paintings. They are used as independent bearing elements of arches and vaults (central part of the churches) or bearing elements of arcades in three - nave or five - nave basilicas and doorways. (*Fig. 3.31*)

B.3 Posts, lintels and beams

The timber post is used as a bearing vertical element, which, along with the horizontal element (lintel), forms the timber frame structure, or is used as an individual element in the doorway structures or different kinds of porches.

These elements usually have a square or a rectangular cross - section. Often, due to decorative - sculptural reasons, the form is changeable along its length. Usually

the change of the cross - section takes place in the midst of the post, exclusively in the posts which are in the doorways or the porches. (*Fig. 3.32*)

The horizontal beam or lintel, together with the vertical parts, make up the basic timber frame structure. This may be strengthened by adding diagonal beams as braces between horizontal and vertical elements. (*Fig. 3.33*)

B.4 Walls

The wall is a composite, vertical, structural bearing element. It is composed of components without a binding material (dry masonry), or ingredients always connected by lime mortar, or earth mortar, with or without additives, and infill parts as are: natural or dressed stone; baked or sun - baked brick, natural or processed wood.

This bearing structural element has the role of transferring all the loads of the structure, along as short as possible way, to the foundation, and through it, to the soil.

The wall, as a structural element, has been used in Macedonia the ancient times, irrespective of the material of which it was constructed (earth, wood, stone, brick and mortar).

Wall structures which have mainly been constructed in Macedonia can generally be classified as follows:

- Timber - frame structural bearing walls with different kinds of infill: (a) timber frames with wattle - work (*Fig. 3.34*) or (b) timber laths (*Fig. 3.35*) plastered on both sides by earth or lime mortar; (c) timber shuttering (*Fig. 3.36*); (d) sun - baked bricks or stone in earth mortar (*Fig. 3.37*); (e) baked brick or stone in earth or lime mortar (*Fig. 3.38*) (*See app. 3, section 3.37*)

B.5 Arches

The arch as a structural element is mainly found in structures of sacral character in both Christian and Islamic architecture. As a structural element, it is also found in stone or brick masonry (mainly baked).

This element is constructed from bricks or dressed stones in lime mortar and it usually has a semi - circular form in the Christian structures / churches. In Islamic structures, it is usually pointed (equilateral or lancet).

It is an element that forms the window jambs (*Fig. 3.39*) and the lintels, the arcades of the naves (*Fig. 3.31*) and the porches in the sacral structures (the churches, the mosques (*Fig. 3.40*), and secular structures (residential buildings, baths, inns).

B.6 Vaults

The vaults which are simply an arch extended in the direction of its axis are most frequently in a semi - circular form (barrel vaults). The most common type of vault found in Macedonia is the semi - circular one. Cross or groined vaults are present in a few examples. The vaults are constructed of bricks or dressed stones in lime mortar.

Vaults are used for spanning of naves in basilica - like structures, cross arms in cross - in - square plans, doorways of churches and mosques, bridges and the like.

B.7 Domes, semi - domes, pendentives and squinches

The dome represents a hemispherical structural element - an arch rotated about a vertical axis through its crown. It is constructed of bricks or dressed stones in lime mortar.

In Macedonia, it is constructed upon a circular base (upon a formed drum of a circular or polygonal form in churches, mosques, turbehs, baths), square or polygonal compartment or bay.

In porches of the churches and mosques in particular, it is constructed on square or polygonal bases by means of pendentives (*Fig. 3.41*) or squinches. (*Fig. 3.42*) These elements are particularly used in construction of domes of mosques and baths.

Semi - domes are most frequently used as a structural element for covering of apse areas and they always have the form of a hemisphere. (*Fig. 3.43*)

B.8 Ties and buttresses

Ties and buttresses have been used as structural elements aimed at preventing the disruptive tendency of the arches and other arch - like forms.

The ties are either made of wood or iron. They are horizontal structural elements placed between the arches or the vaults, at places where they rest on the bearing elements. Often, at some supports, particularly in churches of greater height, they are placed at more than one level. (*Fig. 3.41*)

Buttresses have also been used in Macedonia as supporting elements of masonry structures. They are most frequently constructed of masonry and are used as elements for improvement of the stability of the bearing structures. (*Fig. 3.44*)

C. Structural systems

The above stated structural elements (under B) that are found in historic structures in Macedonia have enabled formation of structural systems that define the different kinds of architectonic plans and forms.

C.1 Arcades

The arcades as a structural system (*Fig. 3.40*) represent rows of arches supported by columns or piers used to replace the horizontal lintels in solving certain spans. These are most commonly used in churches (basilica - like forms) and doorways or porches of churches and mosques.

C.2 Halls with open non - thrusting timber roofs

It is certain that all the basilica - like structures dating from the Roman and the Early Christian period in Macedonia were once covered with timber roof structures. Unfortunately, none has been preserved to date.

From the Byzantine period in Macedonia, there is only one structure (the church of St. Georgi in the village of Kurbinovo - twelfth century) that has been preserved with its timber couple roof upon a single - nave area. This system of covering the structures was very frequently used in sacral structures in the post - Byzantine period.

C.3 Vaulted and domed structures.

Barrel or groined vaults are elements that were most frequently used for vaulting of single or multi - nave basilicas and their doorways. These elements were also used for vaulting the cross arms in centrally formed churches from the Byzantine period in Macedonia.

At their crossing, which is square plan, there is a transition by means of pendentives, between the ends of the vaults from a square to a circular form on which a drum of a circular form (from the inside) and polygonal form (from the outside) is constructed.

The dome, which was most frequently of a hemispherical form, was constructed upon this vertical masonry structure. This spherical structure is also frequently used to cover the apse area by a semi - dome.

These structural systems can also be found in burial chambers (turbehs), Turkish baths, inns, bridges and aqueducts. They were not used in residential buildings.

C.4 Other structural systems

Apart from the above stated, there are also other types of structural systems used for construction of towers, minarets and residential buildings that complete the architectural heritage of Macedonia.

The architectural heritage of Macedonia represents a wide variety of construction activities - a symbiosis of huge experience and tradition reflecting the influences of the cultures that existed on this soil.

The Byzantine churches stand apart for being well - built and particularly for their structural simplicity reaching to perfection and their capability to survive, with repairable damage, through all kinds of disturbances in the past.

3.4.4 Traditional structural seismic elements

When discussing the materials used for the construction of structural elements and systems of the construction heritage in Macedonia, the wide use of wood was mentioned. It has been used, inter alia, also for construction of a simple traditional structural element - the horizontal wooden belt.

This structural element is composed of two or more parallel beams, placed horizontally in the wall mass, being connected by smaller timber elements perpendicularly to their length, . This element is always at the same level of the perimeter and inner walls, constructed of sun - baked bricks, bricks, stones or combination of stones and bricks in earth or lime mortar.

They are always at a certain vertical distance ranging between one and one and a half metres.

This is certainly an invention by unknown builders that knew how to observe their creations and 'record' all the characteristics, defects and irregularities during their structure's life.

Why were these structural elements used?

a) All the buildings, which contain this element, represent masonry, composite structural elements having cross - section ranging from 0.6 m to 2 metres.

When talking about Macedonia and the Balkan territory, these creations are the walls constructed of bricks (sun - baked or baked), stone and a bonding mortar admixtures made of earth or lime.

b) This bonding element - the mortar - which is absent in dry masonry and timber structures, is obtained by mixing of the necessary components with a certain quantity of water. In this way a plastic admixture is obtained which is easy for incorporation but is characterised by slow hardening - by evaporation of water from earth mortar, or chemical reaction of the lime paste in contact with air.

c) It was very rarely that these walls rested on sound foundation wall elements. Weak foundations contributed to non - uniform settlement of the superstructure sometimes even during the construction.

d) In the course of construction, due to the large size of the wall cross - section, its height gave rise to its great weight, The results was a large deformation of the wall profile due to the increase of load upon the lower layers in the case of constructing masonry upwards uninterruptedly. This was because of the fact that the bonding material, particularly in the lower layers did not reach the necessary hardness to sustain the permanently increasing loads.

e) The Byzantine wall was not able to replicate the compactness and monolithism of the Roman wall, although, in principle, it had the same morphology. Both have two faces and a core in - between, but, it is exactly the core that makes them different. While the Roman wall acquired monolithic properties by the use of pozzolana and represented a compact and stable wall mass, the Byzantine wall with a lower quality of mortar, could never acquire such a compactness and hardness.

To overcome the problems stated under d), the method of building could be changed. The construction of walls was carried out in layers - rows, always in the same direction, from right to left or from left to right, depending on whether the principal master - builders (masons) were left - or right - handed.

After finishing a row, the next was started from the beginning of the previous one in order to prolong the time for hardening of lime mortar (or mud mortar) of previous row.

According to empirical knowledge and depending on the thickness of the walls, at height of 1 - 1.5 m, there is a horizontal layer, almost without exception in all Byzantine churches in Macedonia, composed of a single or a number of horizontal rows of bricks connecting the wall faces. Upon these, horizontal wooden belts composed of two, three or four beams are placed at the same height on all the perimeter walls, depending on the thickness of the wall.

According to the author's opinion, building process stop for a certain time to allow hardening of the binding material up to the level of being able to sustain new loads without unfavourable deformations.

According to Evan's, this element was used in architectonic creations in Knossos, Crete (*Fig. 3.45*) in the second millennium BC. Its use can be traced further from the beginning of the early Christian era until nowadays.

This element has been used in architectonic creations of any type, no matter whether sacral or secular. Based on the author's own investigations done in the territory of Macedonia and the Balkans, there is an evidence for the use of these elements.

In the three - nave basilica in Nicea, Turkey dating from the fifth century AD, this element is used in the wall mass between the naves. It is composed of three beams. (*Fig. 3.46*) The element used in the columns between the central and the side naves is composed of two beams.

In Constantinople, the masonry of the ramparts contains a wooden belt with four parallel beams at the level of one meter, while in the upper rows, there are three beams. (*Fig. 3.47*) The thickness of the wall is 160 cm, while the vertical distance between the rows is about 120 cm. The proportions of the beams range between 15 - 18 cm / 18 - 12 cm.

As to the continuity of usage of this element, another example can be mentioned. Namely, it is the Isar fortress in Stip dating from the early medieval times. These are details of horizontal wooden belts in the first and the second defensive wall. (*Fig. 3.48 - 50*)

This is a system of three beams connected by massive vertical timber elements. Vertically, the distance is from 78 to 110 cm (*Fig. 3.49*) which is certainly because of the great thickness of the wall which is about two metres.

In Byzantine structures - churches - this element is used without exception.

Noteworthy are the details of the church of St. Atanasie in Prilep. (*Fig. 3.51-52*)

This continuity of use of this element was not disrupted even after the fall of Macedonia under the Ottoman rule. Namely, the walls of the Islamic sacral and secular

structures have the same characteristics of the Byzantine wall with two faces. They are different only in respect to their outline and finishing of the openings (the doors and the windows).

This element is still inside the wall mass and consists of two or three beams. There are numerous examples in Skopje notable among which are the remains of Dukandzik mosque (*Fig. 3.53*) and the ruined Turkish bath next to the Kursumli an (inn) complex. (*Fig. 3.54*)

The same element is also used in the construction of individual residential structures both in towns and rural settlements. In Macedonia, on each structure composed of massive bearing walls, irrespective of the material used (sun - baked bricks or stone), this element is used, but now it is visible on the wall face. The horizontal beams are found in the wall plane, both on the facade and the interior.

This is the case with the structures from the nineteenth and the twentieth century. It must be pointed out that this element is still used now, at the end of the twentieth century, in the construction of individual rural structures of sun - baked bricks (in the villages in the western part of Macedonia).

Further example of this construction method may be taken from the traditional building heritage of Macedonia - a few examples out of many.

In the case of the building in the village of Maloviste, Bitola, the horizontal belts, in the masonry made of stone and lime mortar, are situated at approximately the same vertical distance, have well sustained the ravages of time. (*Fig. 3.55*)

The same holds for the structure in the village of Kicinica - Mavrovo, the difference being that the vertical distance is somewhat shorter than that in the previous structure. (*Fig. 3.56*) In both cases, these horizontal belts are used in a stone wall mass in lime mortar.

There are another two examples where this element is used in both a stone wall mass and a wall of sun - baked bricks in mud mortar in the same structure. In both cases, the lower zone of masonry is constructed of stones in lime mortar.

This principle, without exception, is recognisable over the whole territory of Macedonia, irrespective of the function of the structures (residential, public, economic). This contributes, to having always a sound and dry basis as a foundation particularly in walls of sun - baked bricks. This is a particularly important preventive element against moistening.

This is the case with the structure in the village of Gornjani, Skopje (*Fig. 5.57*) and the structure in the village of Cucer, Skopje. (*Fig. 5.58*)

In the structure situated in the village of Konjari, Debar, these elements are used in the wall mass constructed of sun - baked bricks in mud mortar, from the foundation up to the roof structure. Unfortunately, due to migration, the abandoned structure, without regular maintenance, is in a poor state. We are afraid that only the picture of this structure will remain as an evidence of its existence after a few years. (*Fig. 3.59*)

During the author's investigations in the town of Struga with walls of stone in lime mortar as bearing elements at the basement level and a high ground floor, while the walls at the storey are constructed of sun - baked bricks in mud mortar.

The thing that makes this structure unique is that a reinforced concrete structure is used instead of timber floor and ceiling structure. Instead of a timber horizontal belt, a reinforced concrete belt course is constructed. (*Fig. 3.60*)

The explanation given by the owner was that he felt safer in this structure. While he was staying in Skopje after the catastrophic earthquake of 1963, he observed that all structures had reinforced concrete belt courses instead of timber ones. So he thought that the structure would be safer if a reinforced concrete belt course is incorporated into it. By this, the owner made a terrible mistake. He did not increase the safety of the structure but just the contrary. This will lead to severe damage under each future earthquake. This will be an expensive and perhaps fatal experience for the owner.

What particularly makes us happy is the fact that the tradition of use of this timber structural element use continues in Macedonia. Examples of this are found in structures in the village of Dzepiste (*Fig. 3.61*), village of Ljubanci (*Fig. 3.62*) and the village of Otisani (*Fig. 3.26*) where another tradition is also still active. Namely, it is the construction of residential rural structures by using sun - baked bricks in mud mortar as the main construction element.

Following the example of the structure in Struga, presented are elements of horizontal belts (now reinforced concrete) of newly constructed structures in Skopje. (*Fig. 3.63*) This element has an identical position in the wall, at the height of the window base, to that in the previously presented examples.

Summarising the results from this brief study of use of this traditional construction and structural element, it may be said that there is a continuity that should not be disrupted. The usage of this element should be continued, if possible. This study rehabilitates the use of such elements and confirms their good structural characteristics.

3.5. Church architecture

3.5.1. Development and general characteristics

A. Development

The position of Macedonia in the Balkan peninsula is already mentioned in the previous sections.

When talking about church architecture, which is the subject of this section, its origins are traced back to the early days of Christianity, the end of the third and the beginning of the fourth century, when the territory of Macedonia was under the rule of the Roman Empire.

Christianity, as a new idea, had its special meaning in the period of Early Byzantine Empire. More about that was said in section 3.2.4. (*See app. 3, section: 3.38*)

The church architecture in Macedonia has had an undisrupted continuity up to date.

In the beginning, the Slavic tribes were very destructive because of their low magic - ritual consciousness at the time of their settlement in the Balkan (Macedonia) area. They built their adobe and timber structures in the destroyed towns. Since the material used for construction of these structures was liable to fast dilapidation, none of these structures has been preserved up to date. We know about them from written sources.

B. General characteristics

As stated under A due to the still unfavourable conditions, this construction activity which arose from the needs of the new religion, was manifested by adaptation of the civil Roman architecture.

There was a great need for baptising the autochthonous population through the whole empire. Hence, larger structures were needed to accommodate the believers and future believers.

These activities were particularly intensive in towns (whose origins date back to the end of the first millennium BC) such as Scupi, Stobi, Heraclea Lyncestis, Styberra and many towns in the east part of the country.

After the mass conversion of the Macedonian Slavs, there was the need of construction of large churches that were able to respond to the newly created conditions (conversion).

The monastic complexes in Ohrid were the places for spreading of the Christian religion in Slavs communities. This was the beginning of an uninterrupted tradition of construction of Macedonian Christian monastic complexes. These have preserved their original function - the sacral one - up to the present days. During the Ottoman rule, they were centres of preservation of Christian faith and literacy. (*See app. 3, section 3.39*)

3.5.2 Chronology and typology

If, according to chronology, the church architecture in Macedonia starts in the third - the fourth century AD, this does not mean that the church structures in Macedonia typologically always correspond to the chronological parameters.

The origins, we repeat once again, represent, in fact, adaptation of already existing architectonic structures. However, in the course of time, these adapted structures, although with imposing proportions, could not respond to the increased needs for space, which particularly refers to the functioning of the space in accordance with the programme of the church mass.

This imposed the need of an adequate spatial organisation by which each function had to be allocated an adequate space. The basilica structure (three or five aisles), with and without a transept, proved to provide the most appropriate planned organisation.

The first building had different names: *Dominicum, Ecclesia, Convectulum, Oratorio*. The word 'basilica', appeared for the first time in Christianity in Africa, in the middle of the fourth century. Soon afterwards, the word 'basilica' was used to denote any Christian building, regardless its size and shape. The Christian basilica developed following the Ancient Roman basilica and taking some elements from the Egyptian temples.

This was the three - nave (three - aisles) or five - nave basilica with or without a transept, with and without a narthex.

The most important among these (three - nave) structures are: the Episcopal Basilica - Stobi (*Fig. 3.64*), St. Erasmus - Ohrid (*Fig. 3.65*), Bargala, the Early Christian basilica (*Fig. 3.66*) (five - nave), the Cathedral Church - Kale, Krupiste (*Fig. 3.67*), etc.

In the period of the restoration of iconoclasm (726-843), the Byzantine Empire was searching for a type of church which would embody the essence of theocentricity:

a cross - in - square. The solution was found in the central edifice - the cross -in -square with a cupola, and it was complemented by the complex iconography of the space. This resulted in an equilibrium achieved between the construction or mass (the architecture) and theology (the dogma).

St. Clement of Ohrid - Macedonian Slav, decided on the restoration of an older trefoil building, suitable for a school and a monastery. (*Fig. 3.68*) The edifice created was a model which was intended to be followed. And so it was. Soon, St. Naum erected the same kind of a shrine of a compact type, covered with a cupola, where the conches were closer to the square in the middle. (*Fig. 3.69*)

This continuity went on from the end of the ninth until the fourteenth century. It will be presented in Chapter four.

In the fourteenth century the construction activities regarding building of churches stop out almost completely. Later, with the proper evaluation of the new rule and preservation of the autonomy of the Ohrid archiepiscopacy, the building of individual and monastic church structures revived.

These structures are of modest proportions and low height. They are mainly single - nave vaulted structures with a cupola occasionally. This trend was preserved until the beginning of the nineteenth century.

In the period after the First World War church building activities were of a lesser intensity.

After the proclamation of independence of the Republic of Macedonia in 1991, these activities became an important task of the Macedonian Orthodox church, within the limits of its financial possibilities.

From the fourth century until today, the following main types of churches have been built in Macedonia:

- Basilicas having a cupola or without a cupola; (*Fig. 3.70 and 4.1d*)
- Trefoil and tetrafoil church plan;
- Central type of churches - cross - in - square with one or five cupolas;
- Single nave structures.

This continuity went on from the end of the ninth until the fourteenth century. It shall be presented in Chapter four. (*See app. 3, section 3.40*)

In the beginning of the nineteenth century the most frequently constructed churches were of a basilica -type with one, three or five naves and the cross -in - square type as a reflection of the 'Macedonian architectural renaissance.'

3.5.3 Building interior and exterior characteristics

A Interior

The main characteristic of the interior of church structures in Macedonia are the wall paintings. These are a constituent part of each church, regardless of the type and the time period in which it was constructed.

The interior, always, without exception, is plastered and decorated with mural paintings presenting scenes from the Bible and painted according to the church rules. All the walls, the columns, the vaults and the domes are covered with fresco - paintings.

According to a number of authors, the gallery of fresco - paintings dating from the ninth until the fourteenth century is one of the most impressive collections of paintings from the Byzantine world, in existence. (*Fig. 3.71-73*)

The fresco technique was in use until the middle of the Ottoman rule in Macedonia (sixteenth - seventeenth century). After this period, the secco technique was frequently in use.

The separation of the area accessible only for the clergy (the altar area) from that used by the believers was made by a screen or iconostasis constructed of marble elements (columns, capitals, beams and panels). (*Fig. 3.74*)

This was done, as a rule, until the middle of the thirteenth century when the marble was replaced by shallow and deep carved wood, examples of which (dating from the nineteenth century) represent master pieces of wood carving in Macedonia and beyond in the Balkans. (*Fig. 3.75-76*)

The iconostasis has a double function. First, it separates two areas and second, it bears icons - paintings mainly done on wood, with the portrait of Jesus Pantocrator, Holy Mary and other saints. According to their values, the Macedonian icons can be classified among the best examples of fresco-paintings in the whole Christian world. (*Fig. 3.77-78*)

The church floors from the first period are, as a rule, covered with mosaics, which is typical for the Roman structures. World renewed are the mosaics in the sacral structures in Stobi and Heraclea Lyncestis. (*Fig. 3.79-80*)

However, this technique was abandoned in the course of time. The last sample dating from the twelfth century has been preserved in fragments in the church of St. Bogorodica in the village of Veljusa.

Marble, stone slabs and bricks were then used for flooring; some have been preserved to date.

The church furniture in the interior consists of the royal throne, the bishop's throne and the ambo mainly made of wood with deep carving.

Data on the materials used and the structural characteristics of these structures are given in section 3.4.3 since these are characteristic for each type of churches. More detailed results are presented in the next chapter, under items 4.3 and 4.4.

B Exterior

In the period of sixteen centuries, the exterior has also been paid a great attention as it is the first thing seen by the visitor. It has not only a functional and structural role, but reflects the 'soul' of the principal architects and builders.

The exterior of the upper zones of the structures prior to the tenth century can only be assumed based on the remains in the lower zones that are now archaeological localities.

Until the middle of the eighteenth century, the exterior of the church structures was not plastered and is characterised by a polychromatic walling pattern (recognisable for the whole Byzantine period) carried out by the use of the three main elements: the stone, brick and lime mortar, in accordance with the architectonic plan. The exterior of the Byzantine churches is presented in more details in Chapter 4.2.

However, it must be said that the exterior of a structure is not a reliable element for dating of the structure for the simple reason that the walling pattern, characteristic for one period, may be thoroughly replicated in another, without any alterations. Therefore, a much more important and reliable element for dating of these historic structures are the samples of wall painting and the characteristics of the artistic expression.

Later, the church facades were plastered with lime mortar. One of the possible reasons was poverty of the founders, the Macedonian Orthodox church that did not have enough resources for procurement and incorporation of dressed stone and bricks. These elements were only used for shaping of the openings (doors and windows) and the structural elements such as the vaults and the domes.

The covering of the structures was also changed. In the beginning, the basilicas were covered by timber roof structures. Later, vaulted and dome structures were constructed. Tiles were used for covering roofs and they were in different dimensions and forms. Later, there were examples of covering by lead sheet, which practice was abandoned in the beginning of the fifteenth century because lead became a very

expensive strategic material. Tiles began to be used again upon timber or massive roof structures, depending on the main structural concept of the structure.

This brief review of the chronology, typology and characteristics of the interior and exterior shows that the churches constructed on the soil of Macedonia were of a quality that was very close to those of the main centres of Orthodoxy - Constantinople and Thessaloniki, with a certain local interpretation. Their similarities and difference will be presented in the section dedicated to comparative analysis of part of this construction heritage and that in the neighbouring countries - Chapter 4.5.

Chapter three - Notes

- ¹ Mountains to the north present Bulgaria and the Bistritsa river (Present Bulgaria) and the coast of the Aegean Sea (present Greece) up to the mouth of Mesta river to the south. Recently folded mountains like Korab, Jablanica, Gramos and Pind (present Greece) enclose this territory, to the west, while to the east, it is enclosed by the Mesta river and the west parts of Rhodope (present Bulgaria). Within these boundaries, it is an area of a total of 67, 741.2 km². The present territory of Republic of Macedonia represents only 37,51% of this total territory.
- ² In the past, Macedonia was known as a land of a thousand lakes.
- ³ Due to its high natural values, great age and unique flora and fauna, the Ohrid lake was registered in the UNESCO List of World Natural Heritage in 1979. In 1980, the valuable cultural heritage of Ohrid and the Ohrid region were registered as world valuable natural and cultural heritage in the same UNESCO list.
- ⁴ Antoljak 1969
- ⁵ Michael from Devol, adding to the Chronicle of John Scylitsa in 1118 wrote "... it was founded on the judicial system of the Emperor Justinian, in Justiniana Prima...".
- ⁶ The Republic of Macedonia, The Republic of Slovenia, The Republic of Montenegro, The Republic of Serbia, The Republic of Bosnia and Herzegovina and the Republic of Croatia constituted the Federal People's Republic of Yugoslavia.
- ⁷ Antifascist Assembly of the National Liberation of Macedonia
- ⁸ The elaboration of the first Code for Culture of the Republic of Macedonia is adopted (1998). —
- ⁹ In 1999, the Republic Institute for Protection of Cultural Monuments will celebrate its 50th anniversary.
- ¹⁰ The author participated as principal investigator of the team composed of experts from the Republic Institute for Protection of Cultural Monuments (1997).
- ¹¹ The seminar was organized by ICCROM, RZZSK and IZIIS and was held in Skopje in the period 17 - 22 September 1988.
- ¹² It was proposed that the model of the Data Bank developed within the framework of this project be evaluated within a regional workshop proposed and accepted by the Macedonian National Commission for UNESCO and submitted for the UNESCO competition in 1998/99. Principal investigator of the project - Lazar Sumanov.
- ¹³ One of the conclusions at the Workshop was that the Macedonian National Committee of ICOMOS take the role of a Coordination Centre for Central and East Europe for implementation of including of the cultural heritage in national disaster preparedness plans.
- ¹⁴ It is exactly this architectural element - the fountain, that will gave the possibility of converting the residential structure into another with a sacral function.
- ¹⁵ These are structures that exist, in a physical sense, with a new function. Most of these existing in Skopje are now turned into trading centres, administrative-education structures.

Chapter three - Tables

Table 3.1 Climatic characteristics of Skopje, Prilep and Ohrid regions

Regions and objects	N lat	E lon	Alt m	Air parameters							Rainfalls parameters			
				5	6	7	8	9	10	11	12	13	14	15
1	2	3	4	C ⁰	C ⁰	C ⁰	C ⁰	C ⁰	in days	per year	mm	mm	mm	%
SKOPJE	41°54' 42°6'	21°14' 21°28'		-0.1° Jan.	41.2° Jul.	24.1°	-23.9° Feb. 1932	41.2 Jul. 1934	169	86.1	27.1 Aug.	89.9 Nov.	502.3	25
St. Nikita, Banjani			580											
St. Nikola, Ljuboten			650											
St. Nikola, Radisani			380											
St. Spas, Kuceviste			600											
St. Andreja, Matka			317											
St. Panteley G. Nerezi			650											
St. Bogoro. Susica			400											
St. Dimit. Susica			400											
OHRID	41°6' 41°7'	20°47' 20°48'	710- 730	1.8° Jan.	21.8° Jul.	19.9°	-17.2° Jan. 1964	36.2° Jun. 1946	137	62.5	20.7 Aug.	89.9 Nov.	667.9	15
PRILEP	41°20' 41°31'	20°14' 21°44'		-0.3° Jan.	22.2° Jun.	22.8°	-23.8° Dec. 1941	39.8° Aug. 1931	206	82	26.8 Jul.	59.9 Nov.	553.6	18
St. Bogorodica			776											
St. Nikola			650											
St. Dimitrija			640											
St. Atanasie			650											
Sv. Spas			930											

Source: Lazarevski (1971)

Legend

1. Region and object
2. North latitude
3. East longitude
4. Altitude

Air parameters

5. The lowest average monthly temperature
6. The highest average monthly temperature
7. Annual air temperature range in C°.
8. Absolute minimum
9. Absolute maximum
10. Average duration of frosty periods per year (in days)
11. Actual number of frosty days (per year)

Rainfall parameters

12. Minimum average monthly rainfall
13. Maximum average monthly rainfall
14. Average annual rainfall
15. Snow percentage included in the average annual rainfall

Table 3.2 Average monthly and yearly air temperature and rainfalls at Skopje, Prilep and Ohrid region. (1931-1960 period)

<u>AIR TEMPERATURE C°</u>												
I	II	III	IV	V	VI	VII	VIII	IX	X	XI	XII	year
SKOPJE												
-0.1	2.4	6.8	12.5	17.4	21.4	24.0	23.4	18.9	12.5	7.4	2.0	12.4
PRILEP												
-0.3	1.7	5.4	10.0	15.7	19.7	22.5	22.2	17.9	12.1	7.0	2.0	11.4
OHRID												
1.8	2.8	5.8	10.2	14.7	18.8	21.7	21.4	17.5	12.6	7.9	3.9	11.6
<u>RAINFALLS mm</u>												
I	II	III	IV	V	VI	VII	VIII	IX	X	XI	XII	year
SKOPJE												
39.4	32.5	35.4	39.4	51.9	50.4	30.6	27.1	34.4	58.3	51.9	50.9	502.3
PRILEP												
40.4	37.0	36.9	47.8	62.1	51.3	26.8	30.8	44.7	66.0	59.9	49.9	553.6
OHRID												
69.9	70.0	53.5	45.0	54.8	31.4	20.9	20.7	49.0	88.7	89.9	73.3	667.9

Source: Lazarevski (1971)

Table 3.3 *Listed and identified monuments in Macedonia*

Number	Sort of monuments	Listed	Evident
1	2	3	4
1.	Archaeological sites	100	4114
2.	Churches and monasteries	150	907
3.	Rural vernacular architecture	80	209
4.	Urban vernacular architecture	356	343
5.	Monuments and commemorative obj.	91	886
6.	Historic centres	11	10
7.	Fortresses	6	50
8.	Graveyards	11	10
9.	Granaries	1	1
10.	Economic facilities	186	33
11.	Aqueduct	1	-
12.	Fountains	7	-
13.	Mosques	31	10
14.	Turbeh	5	3
15.	Islamic shrine/grave	6	5
16.	Graves	1	1
17.	Turkish baths	19	3
18.	Turkish temporary lodgement - An	4	3
19.	Covered market place	3	2
20.	Towers	11	3
21.	Clock towers	12	3
22.	Bridges	9	5
23.	Islamic fountains	6	1
	Total:	1107	6602

Source: INDOK Centre at the Republic Institute for the protection of Cultural Monuments 1997

REPUBLIC OF MACEDONIA



Figure 3.1 The Republic of Macedonia

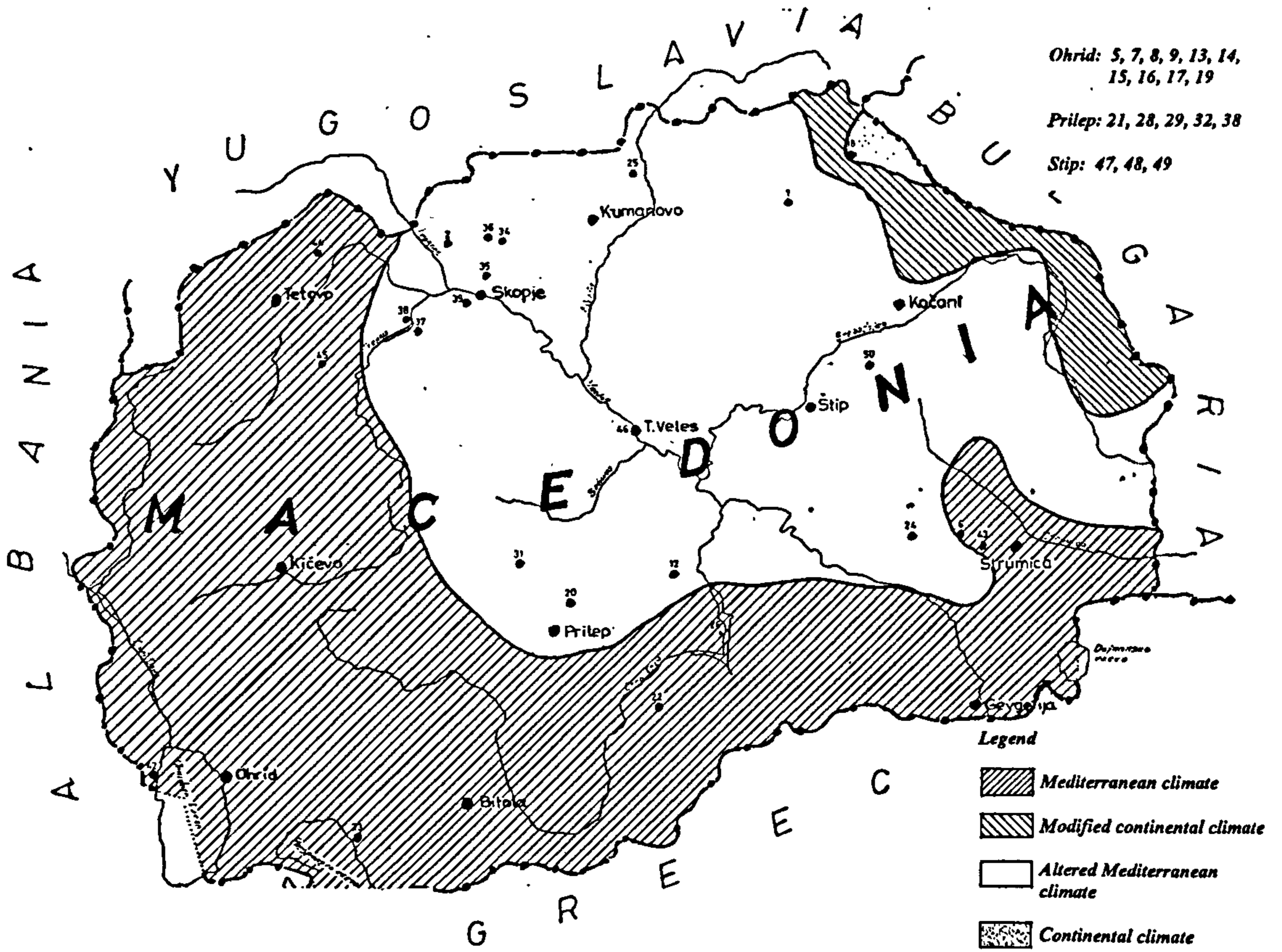

Figure 3.2 *Climate map of the Republic of Macedonia*
 Source: According the text of Lazarevski, A. 1971



Figure 3.3 Map of Ancient Macedonia
 Source: Archive of Republic of Macedonia

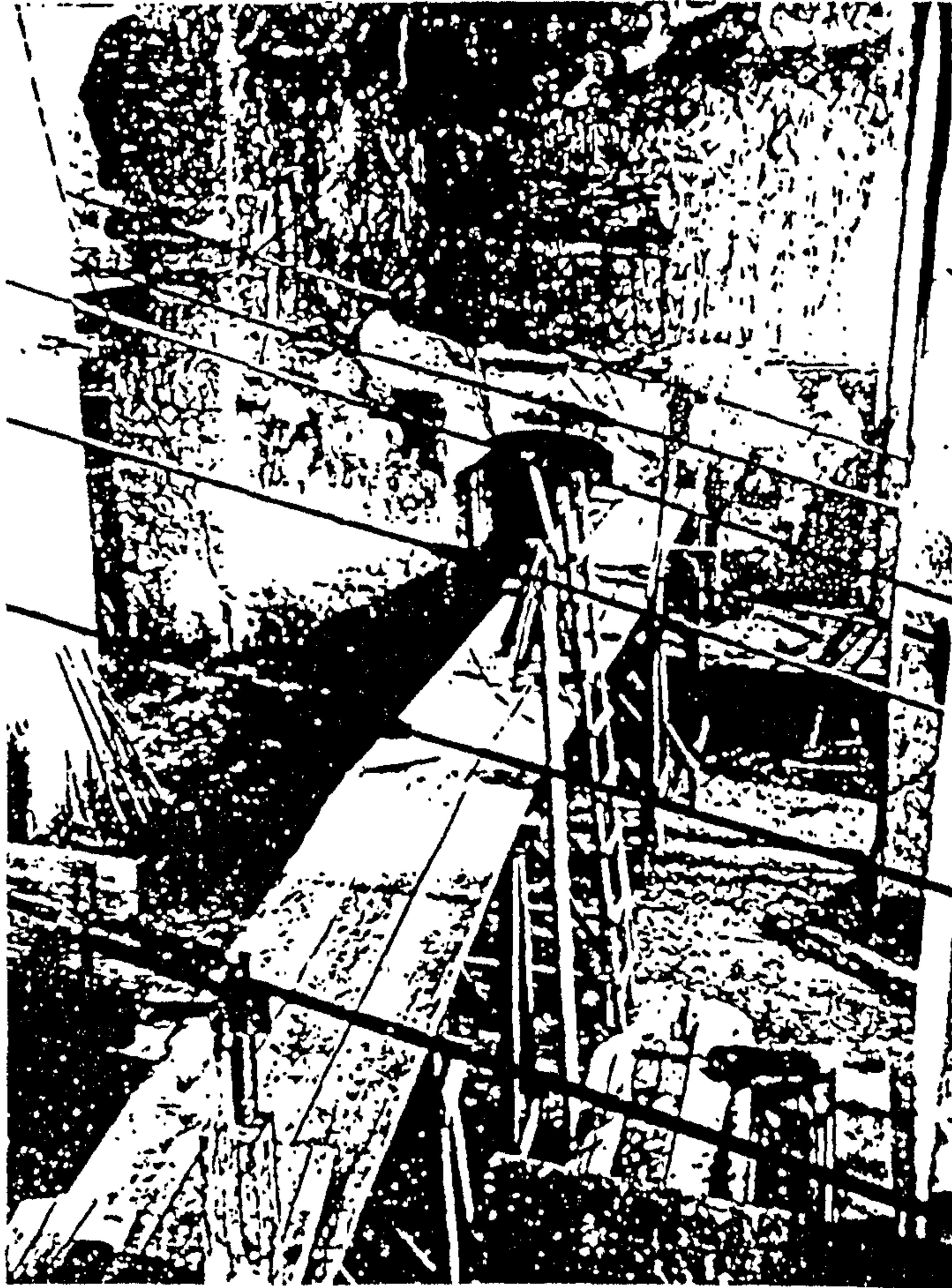
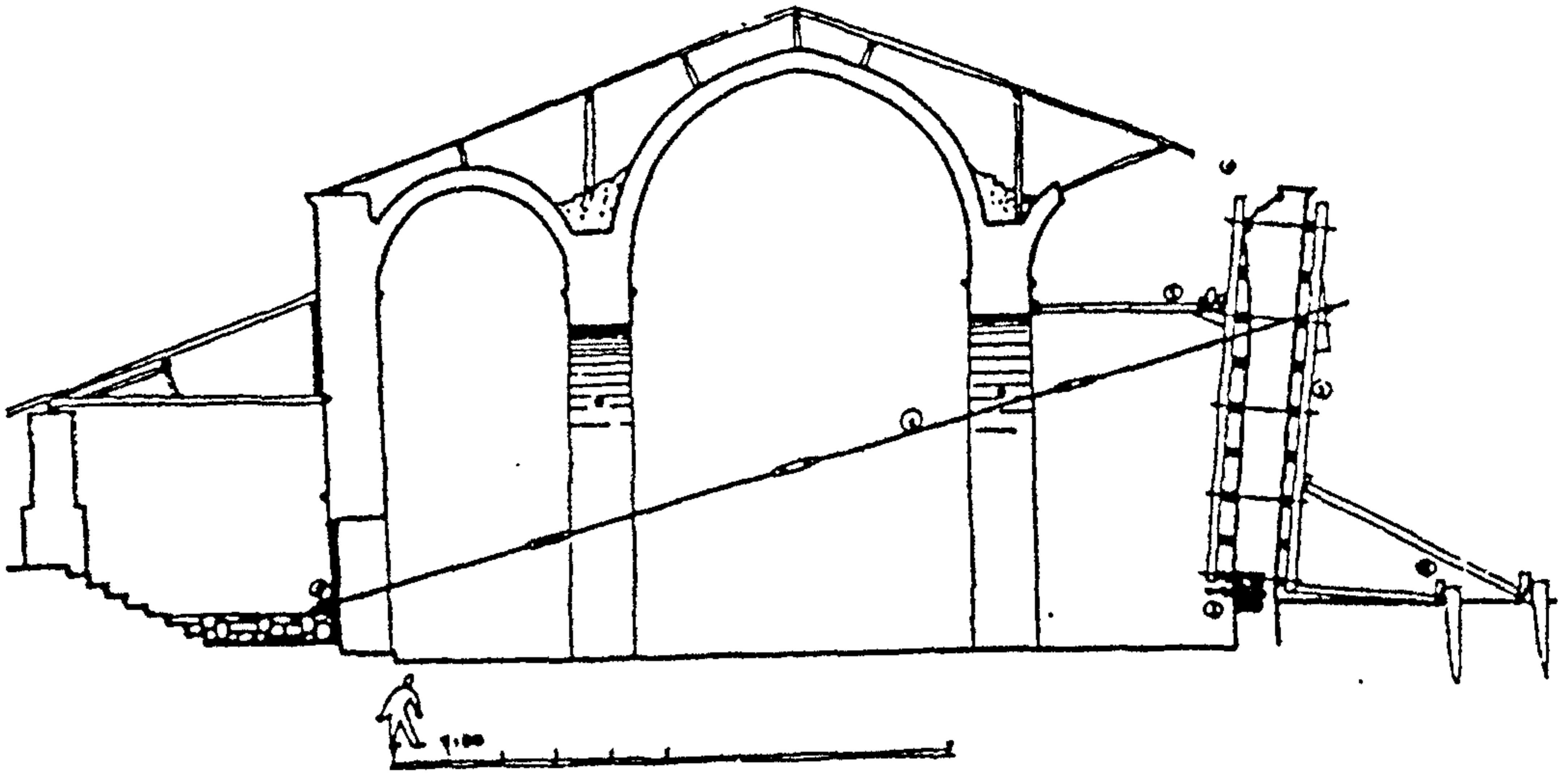

Figure 3.4 *St. Sophia, Ohrid. Wall conservation*
Source: Cipan, B. 1952

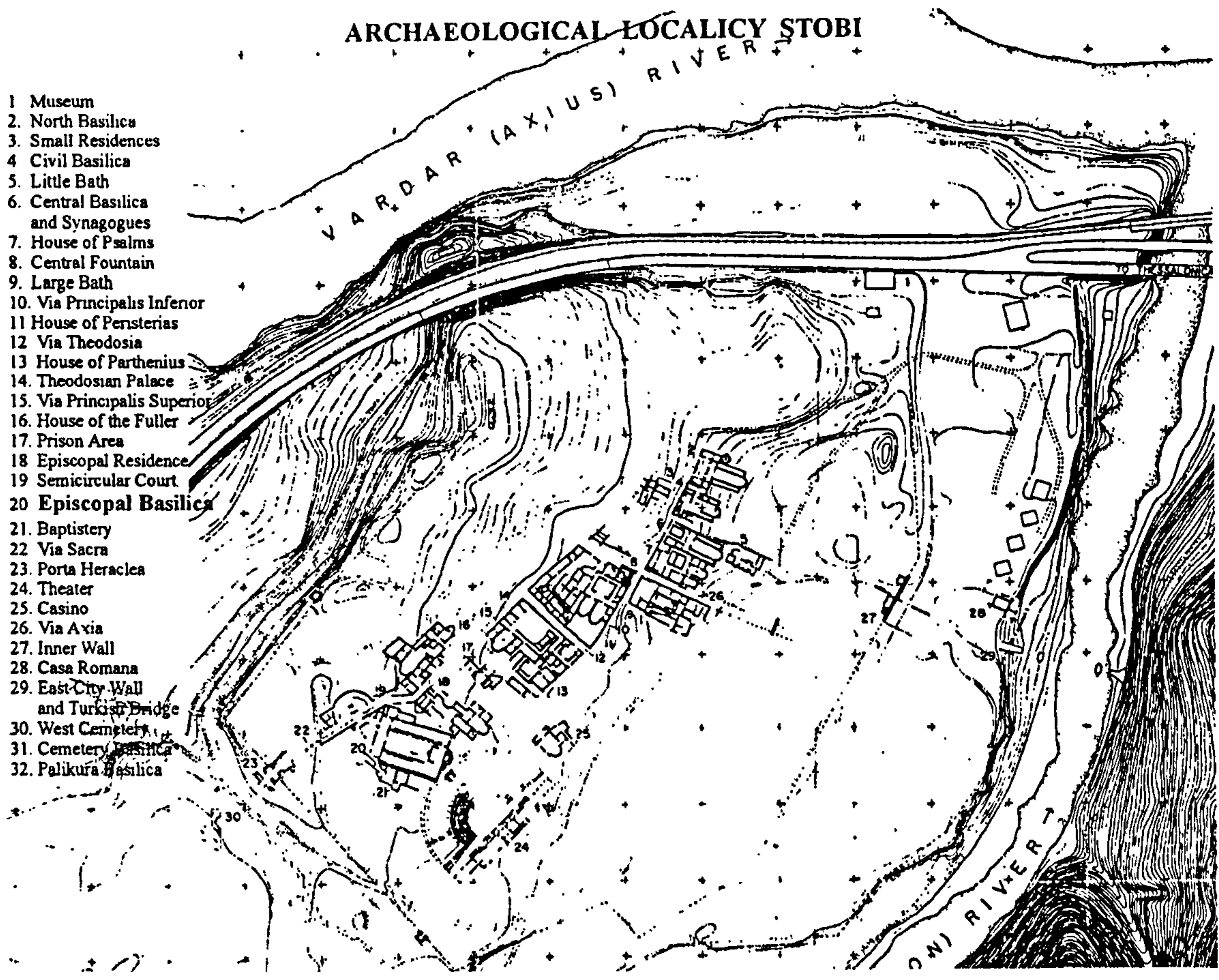

Figure 3.5 *Stobi, Map of the Site*
 Source: Stobi documentation centre

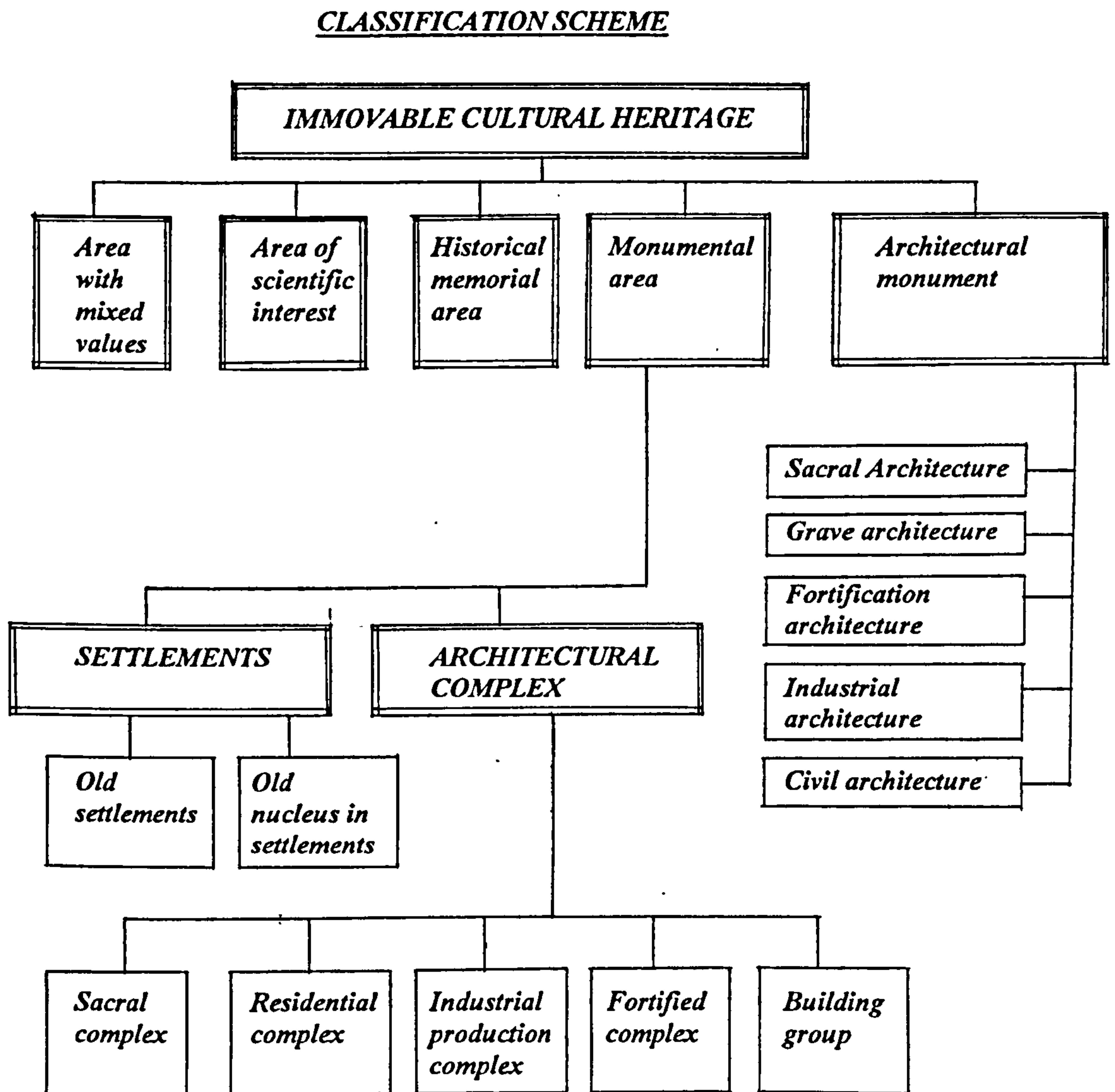

Figure 3.6 *Classification*

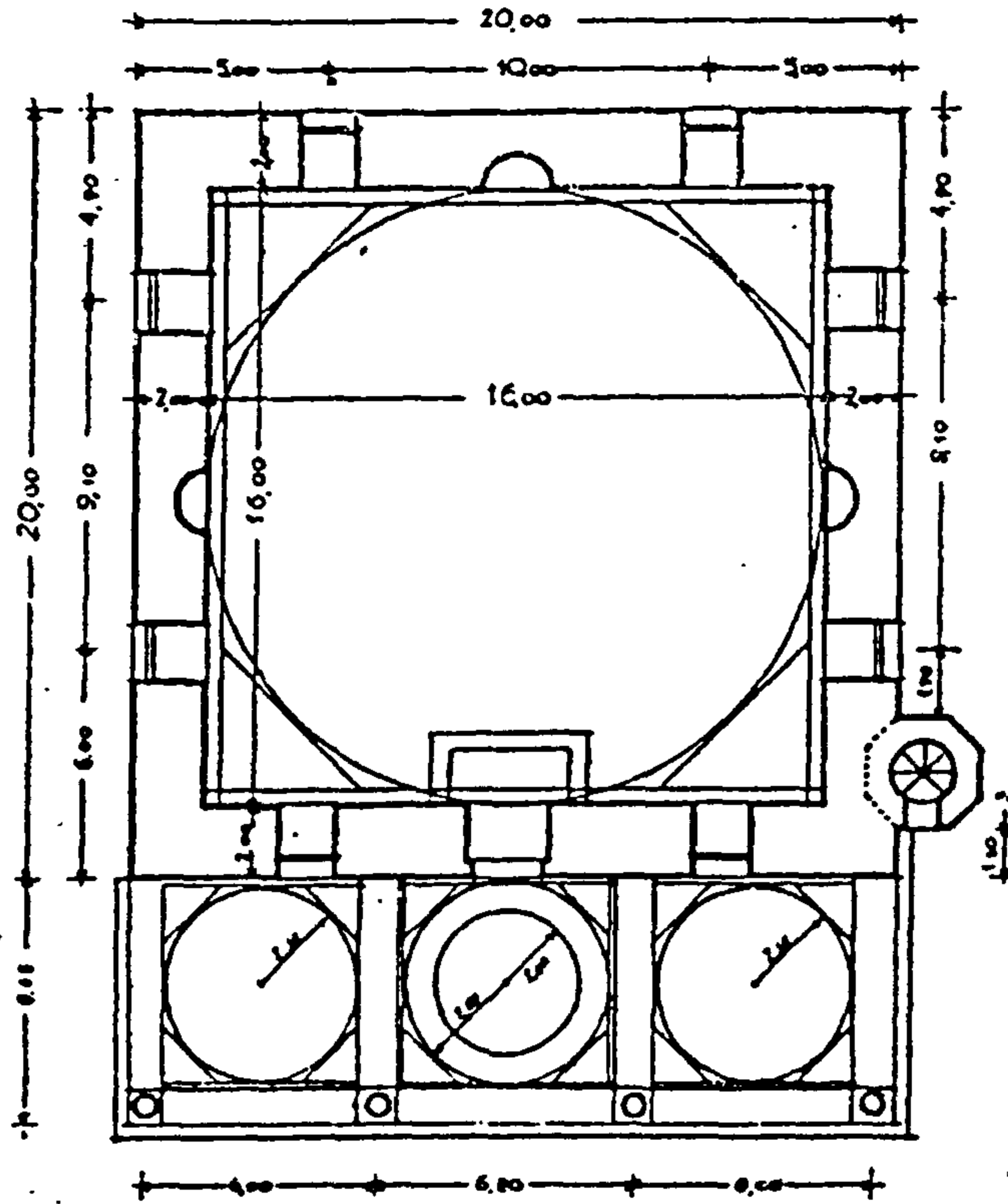

Figure 3.7 *Mustafa Pasha Mosque, Skopje. Plan.*
Source: Archive of Macedonia

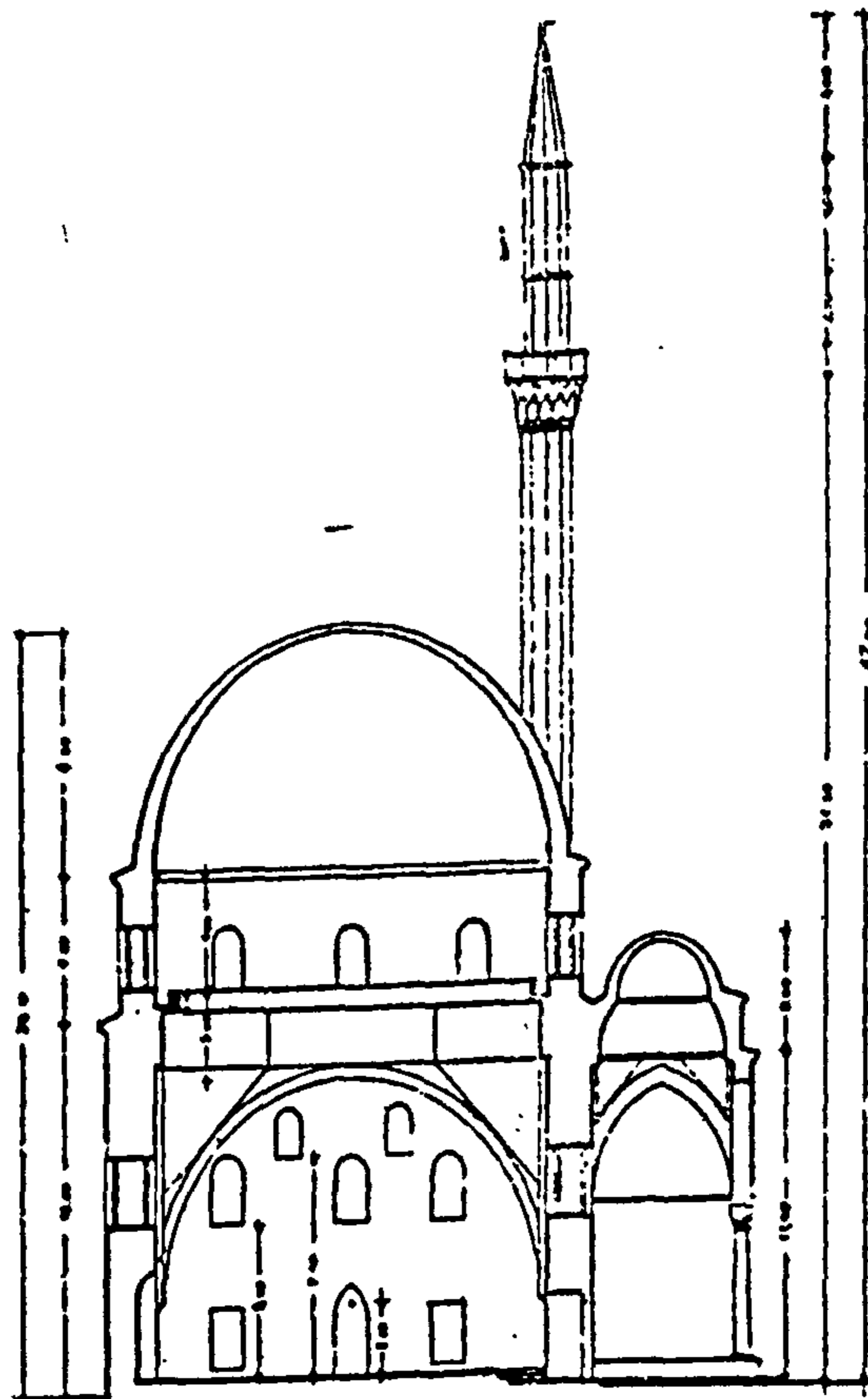

Figure 3.8 *Mustafa Pasha Mosque, Skopje*
Cross - section
Source: Archive of Macedonia

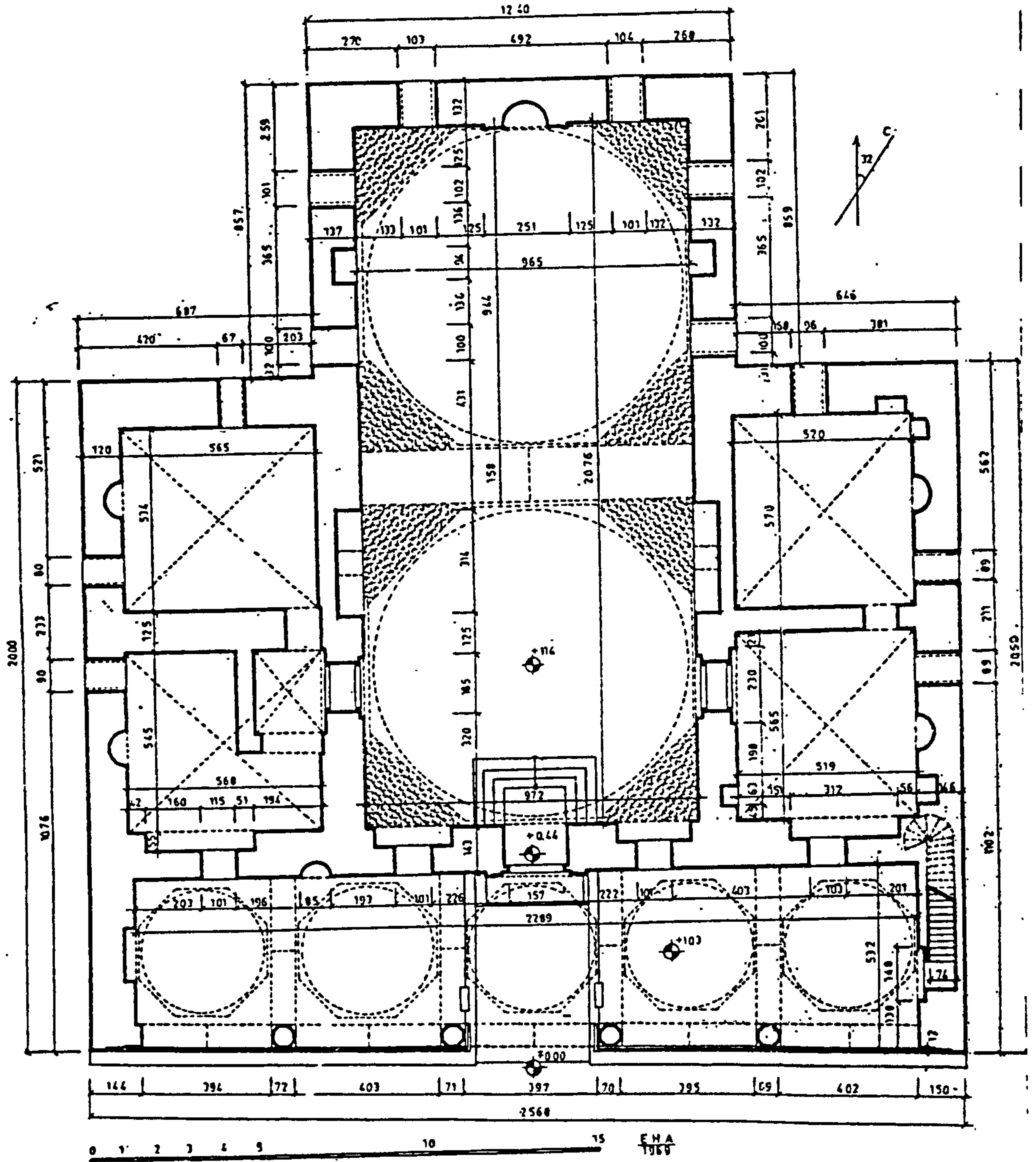

Figure 3.9 Isa Bey Mosque, Skopje

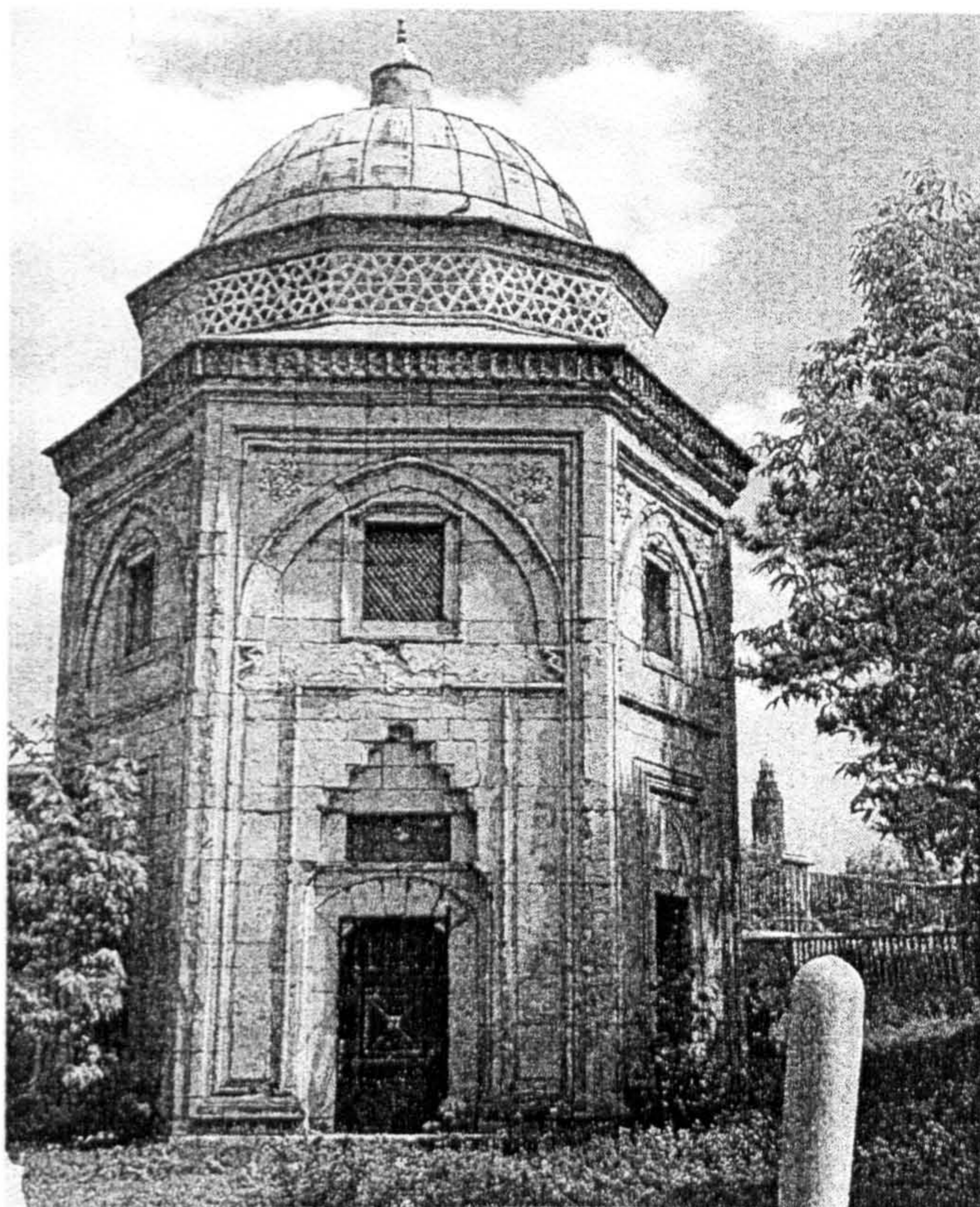

Figure 3.10 Turbeh in the yard of Aladja Mosque, Skopje

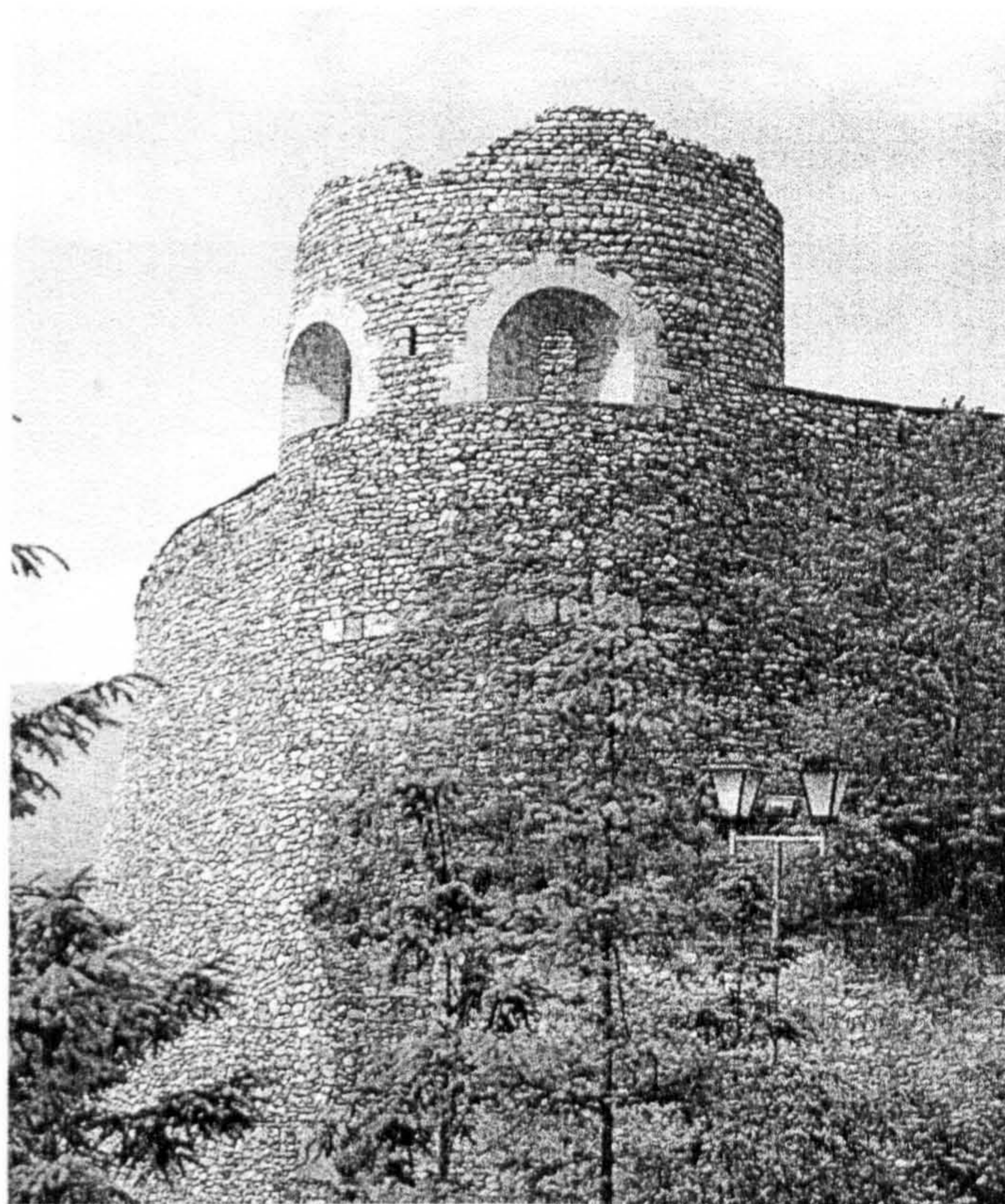

Figure 3.11 Kale Fortress, Skopje

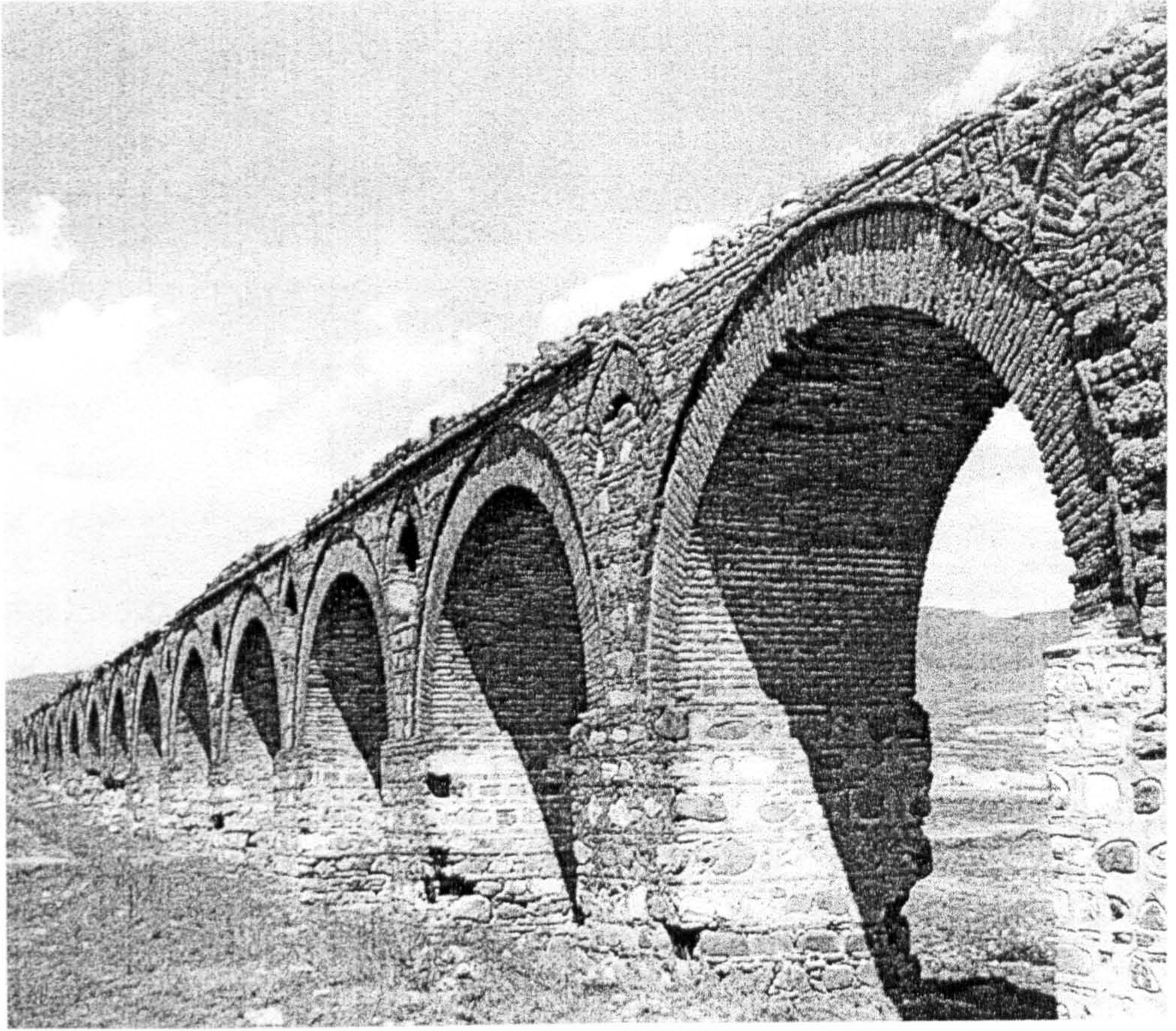

Figure 3.12 The Aqueduct, near Skopje

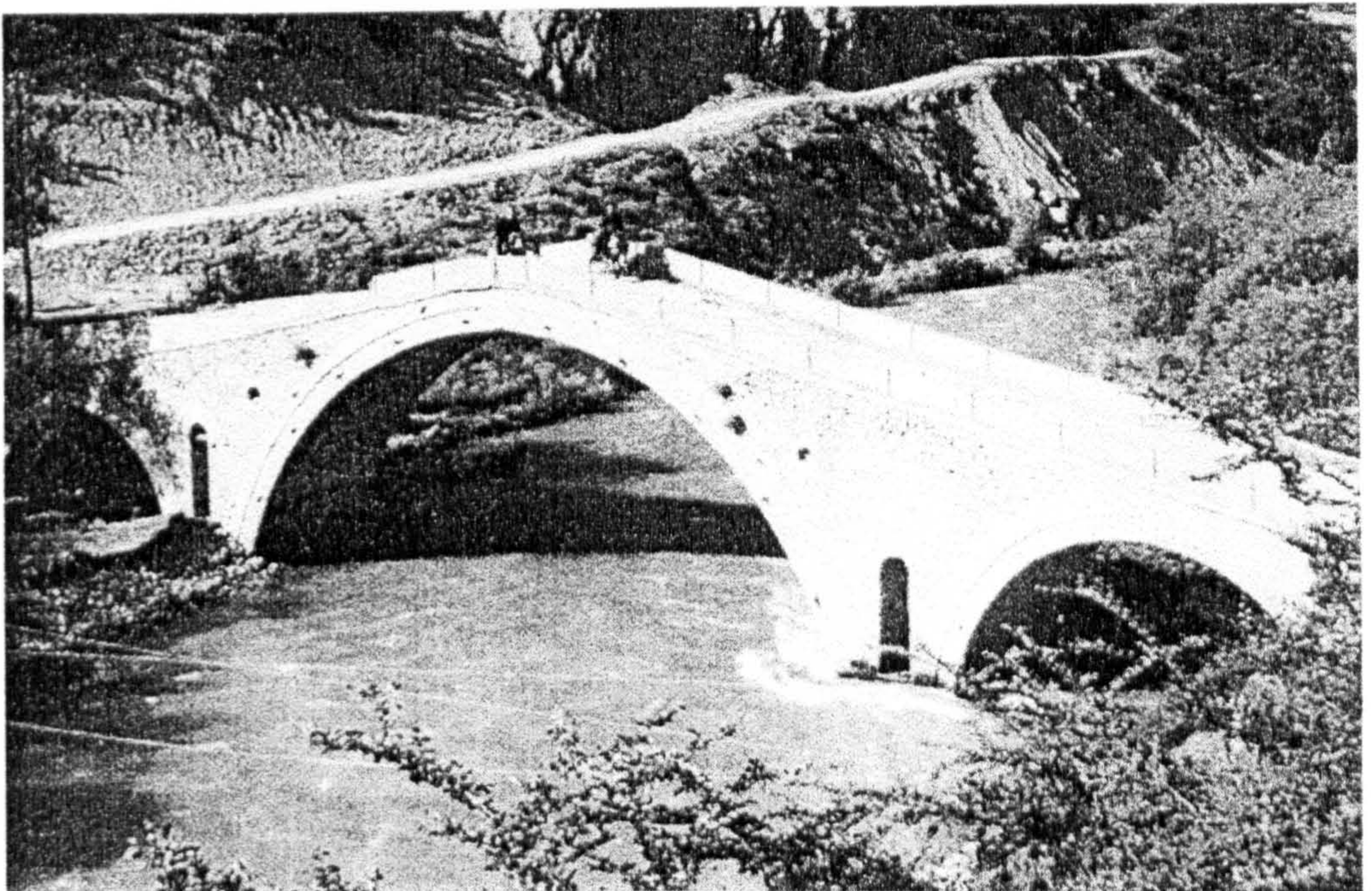

Figure 3.13 Gorenicki Bridge, River Radika near Debar

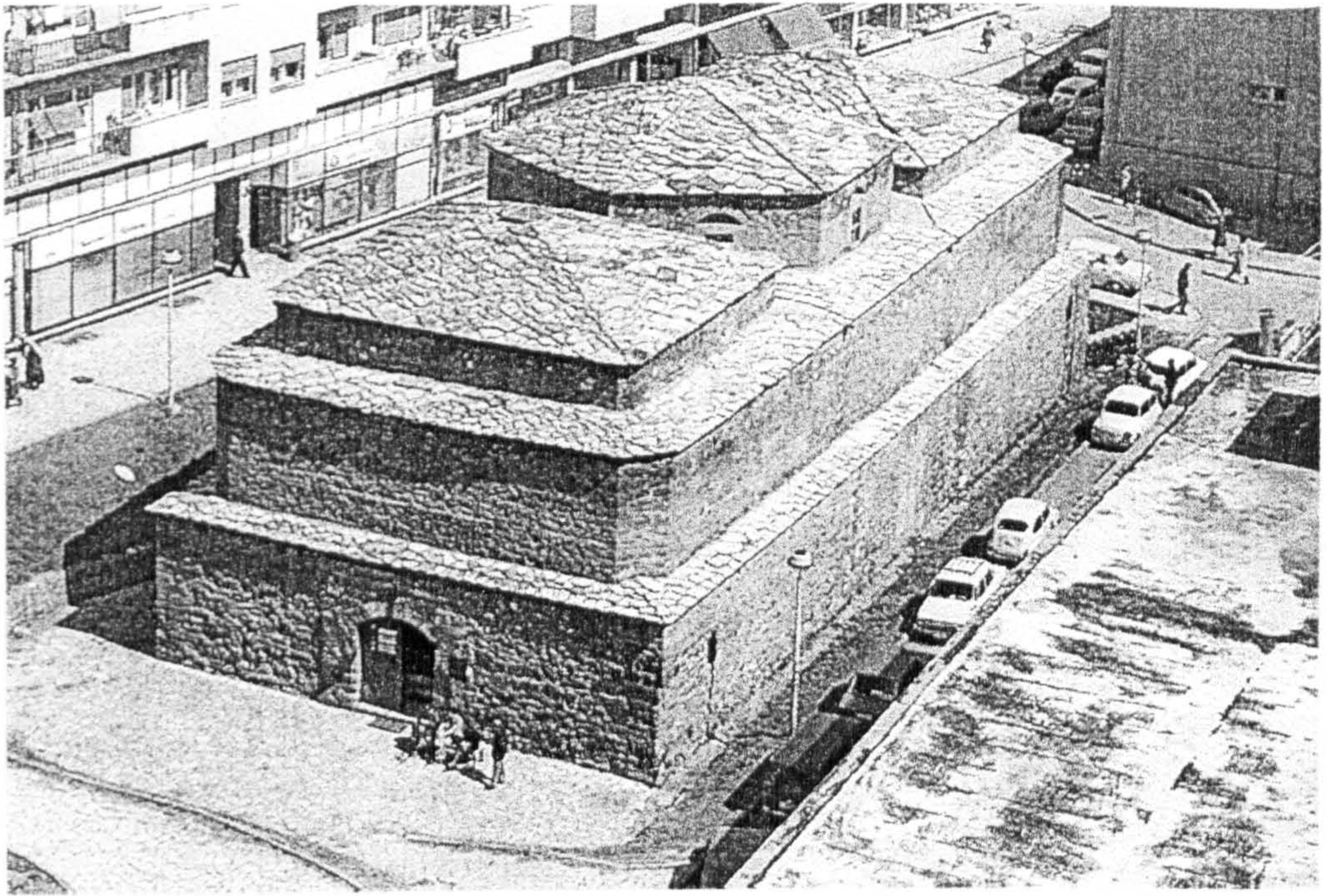

Figure 3.14 Bezisten, Covered Market, Stip

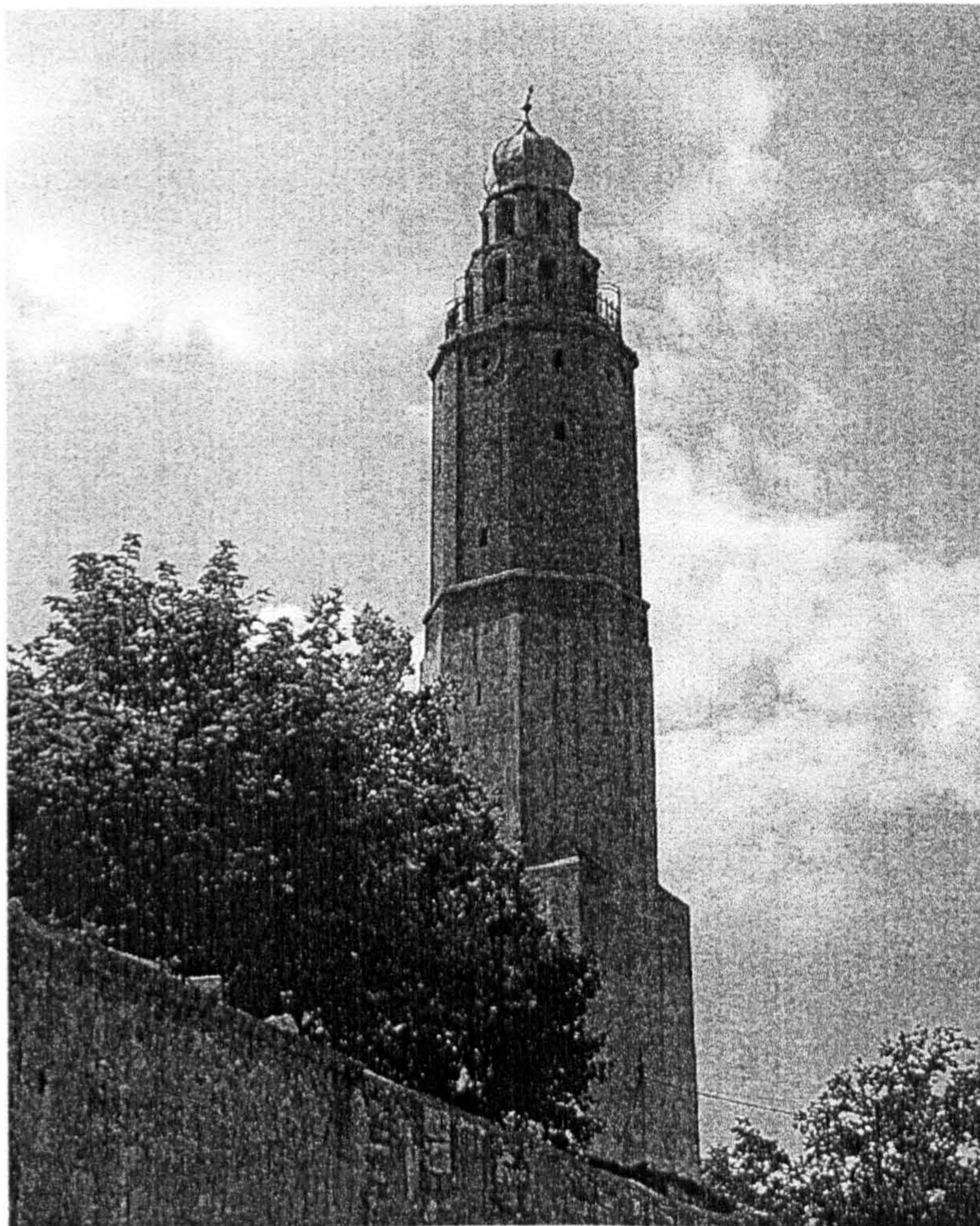

Figure 3.15 Clock Tower, Skopje

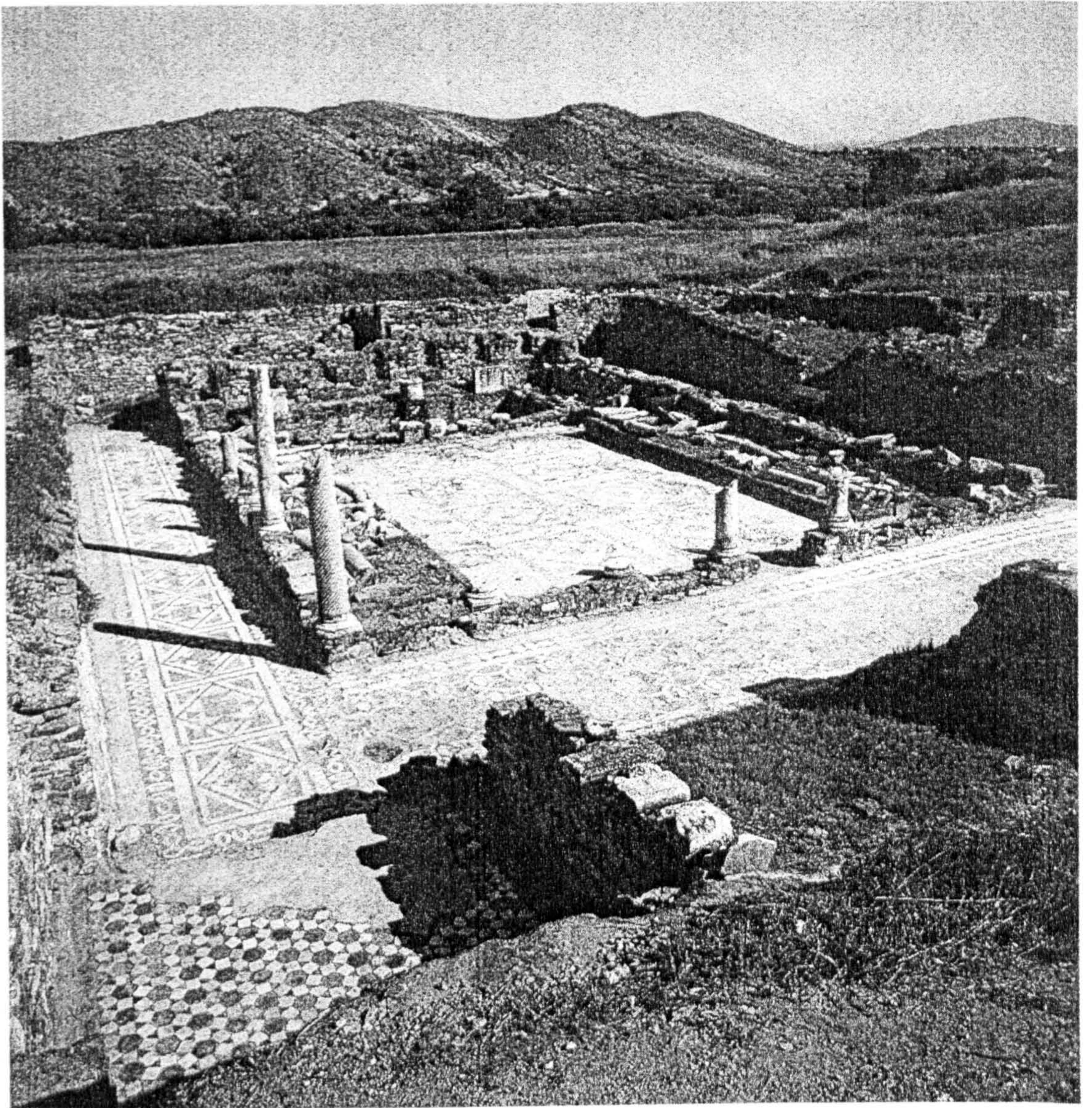

Figure 3.16 Theodosius Palace, Stobi

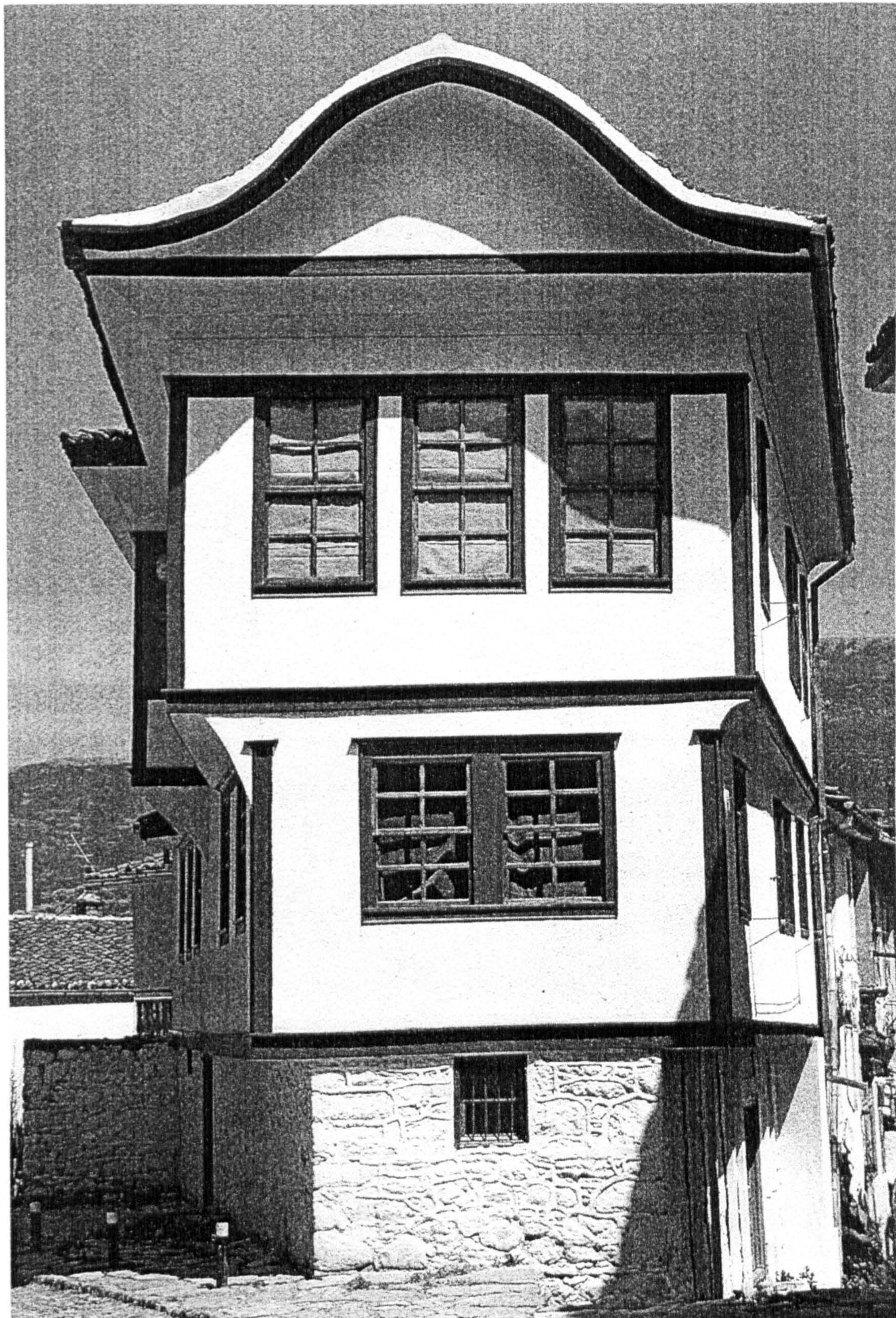

Figure 3.17 House in Ohrid

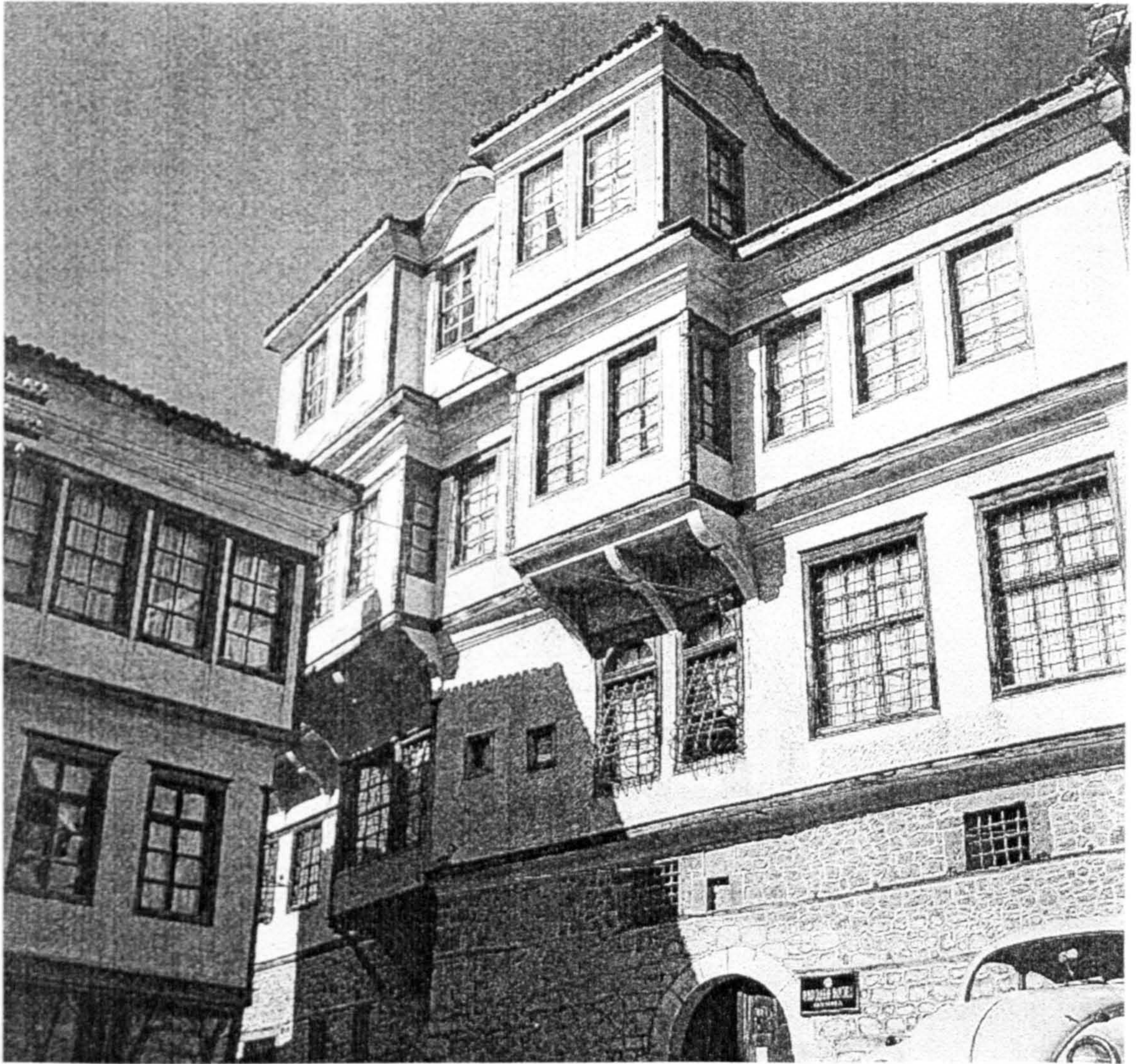

Figure 3.18 Robev's House, Ohrid



Figure 3.19 *Martinovski House, Krusevo*



Figure 3.20 Street in Veles Town



Figure 3.21 Adobe House in village Cucer near Skopje



Figure 3.22 Rural House, Krkornica village

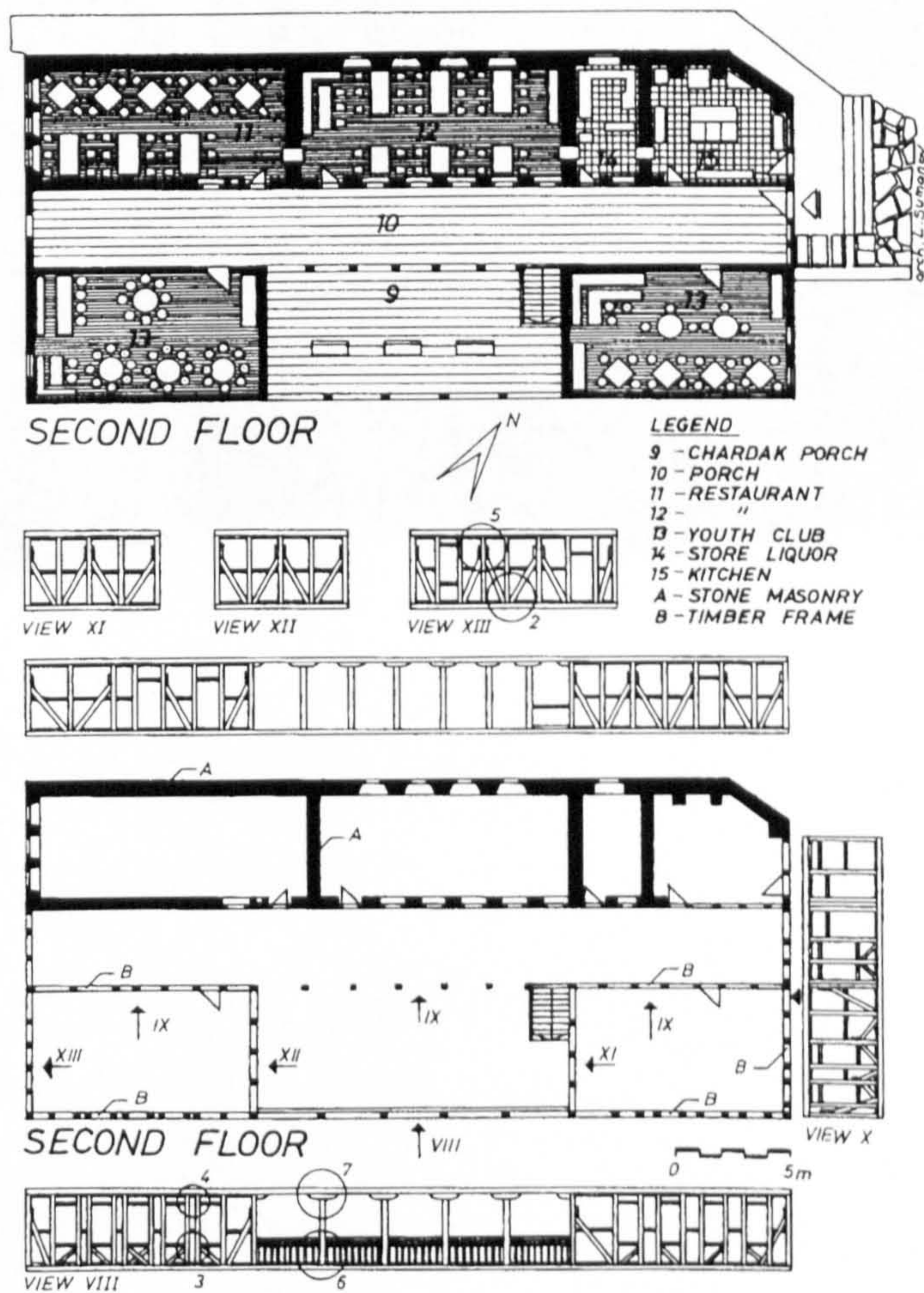
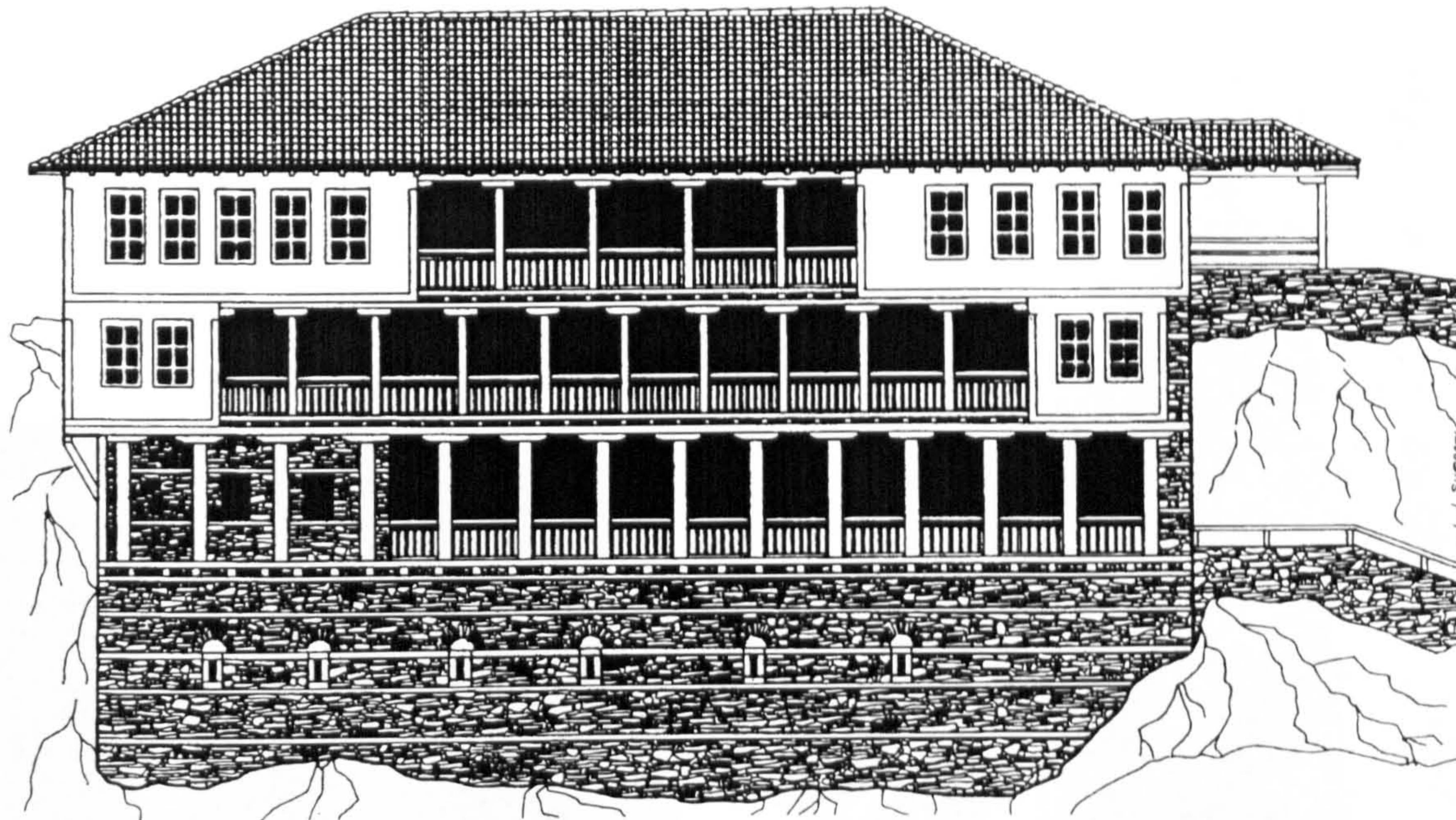
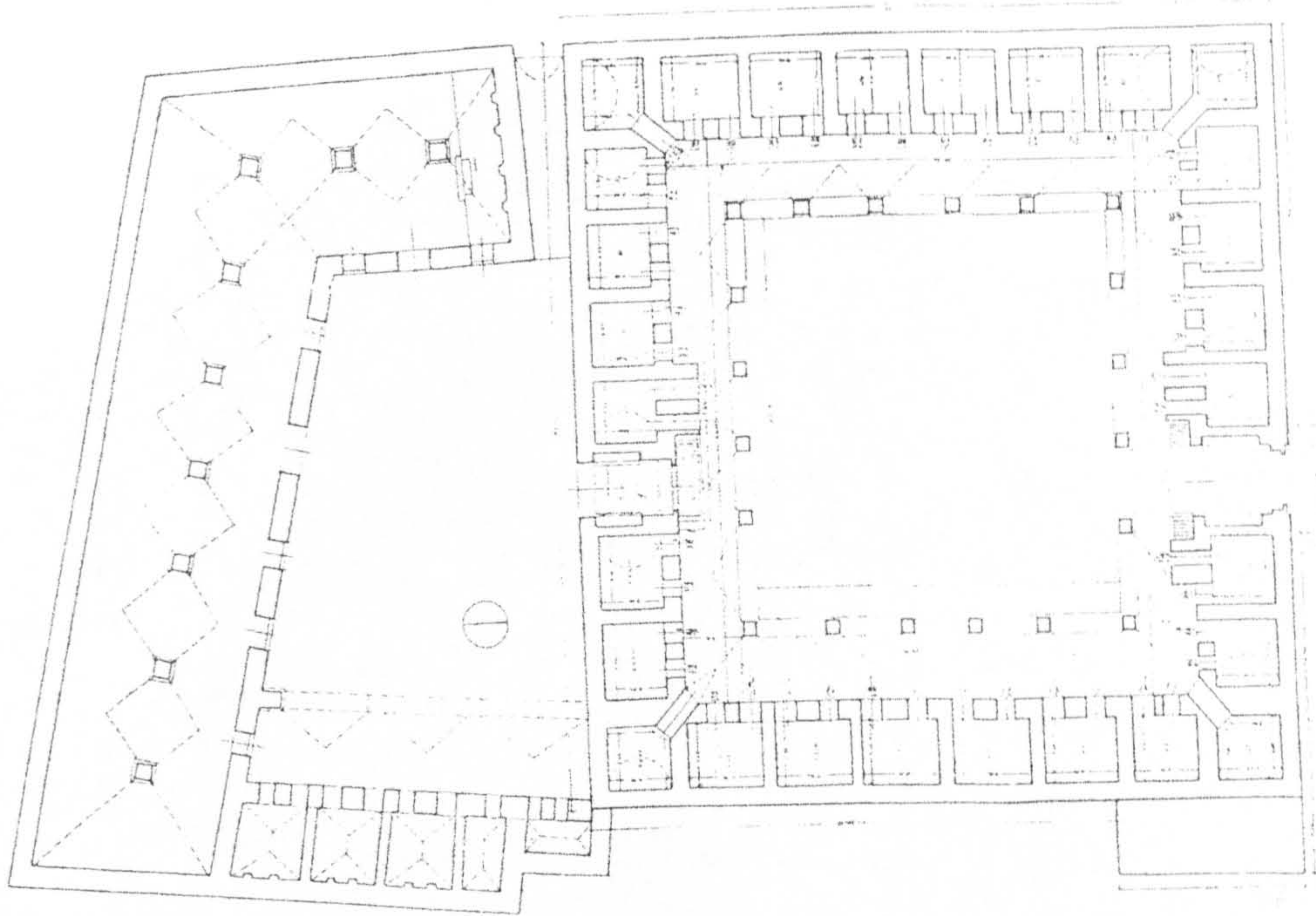

Figure 3.23 St. Joakim Osogovski Monastery - Inn, near Kriva Palanka
 a) South facade; b) Second floor



Figure 3.24 *St. Jovan Bigorski Monastery - Inn, v. Rostusa*



a)



b)

Figure 3.25 *Kursumli An - Caravan Saraj, Skopje*
 a) Ground Floor; b) South facade



Figure 3.26 Rural house in village Djepiste, Debar

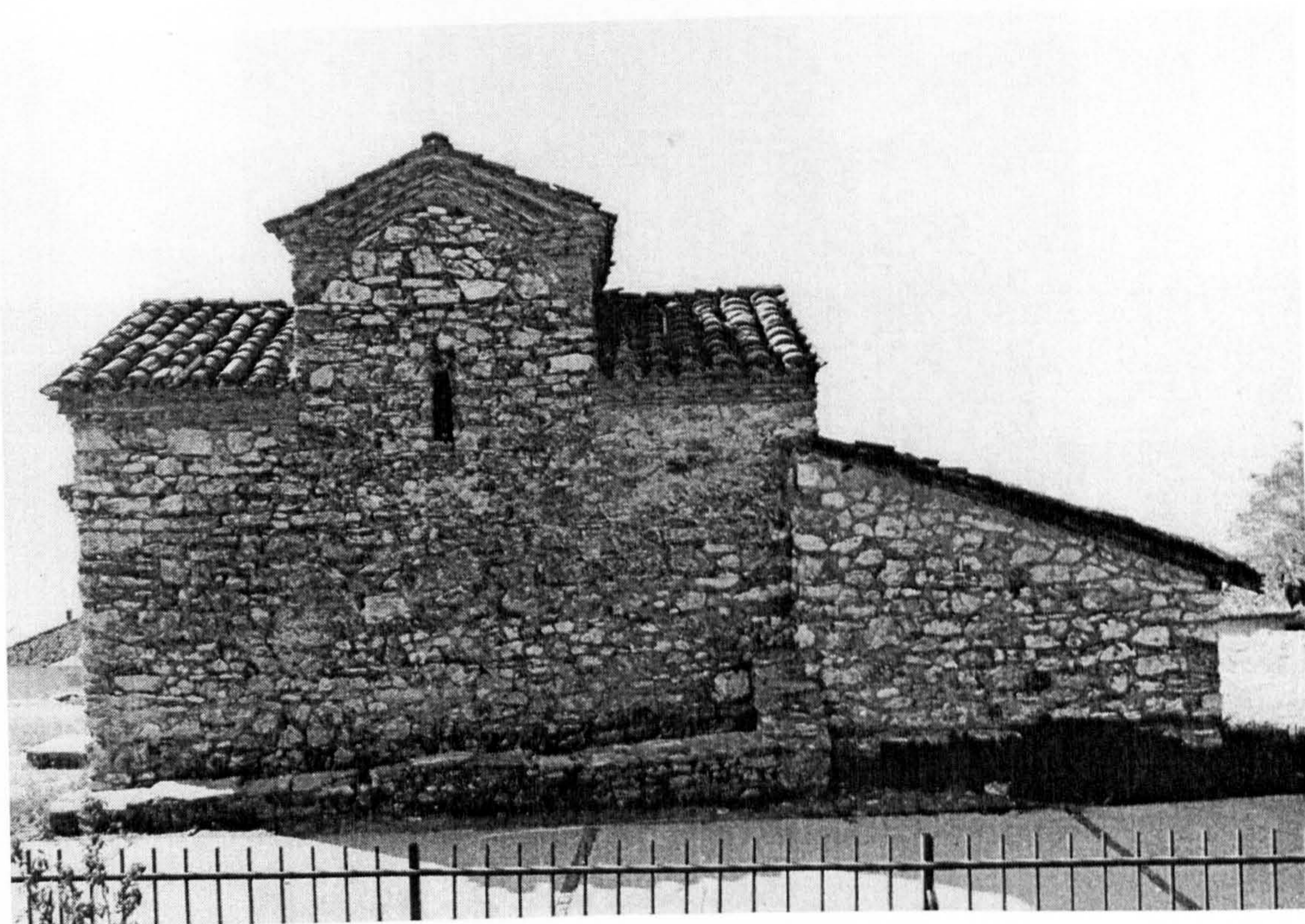

Figure 3.27 St. Elena and Konstantine, Ohrid



Figure 3.28 Rural house in village Zeleznec, Demir Hisar region



Figure 3.29 St. Jovan Kaneo, Ohrid



*Figure 3.30 St. Georgi, v. Gorni Kozjak near Stip, Tribelium
Source: INDOK Centre, RZZSK-Skopje*

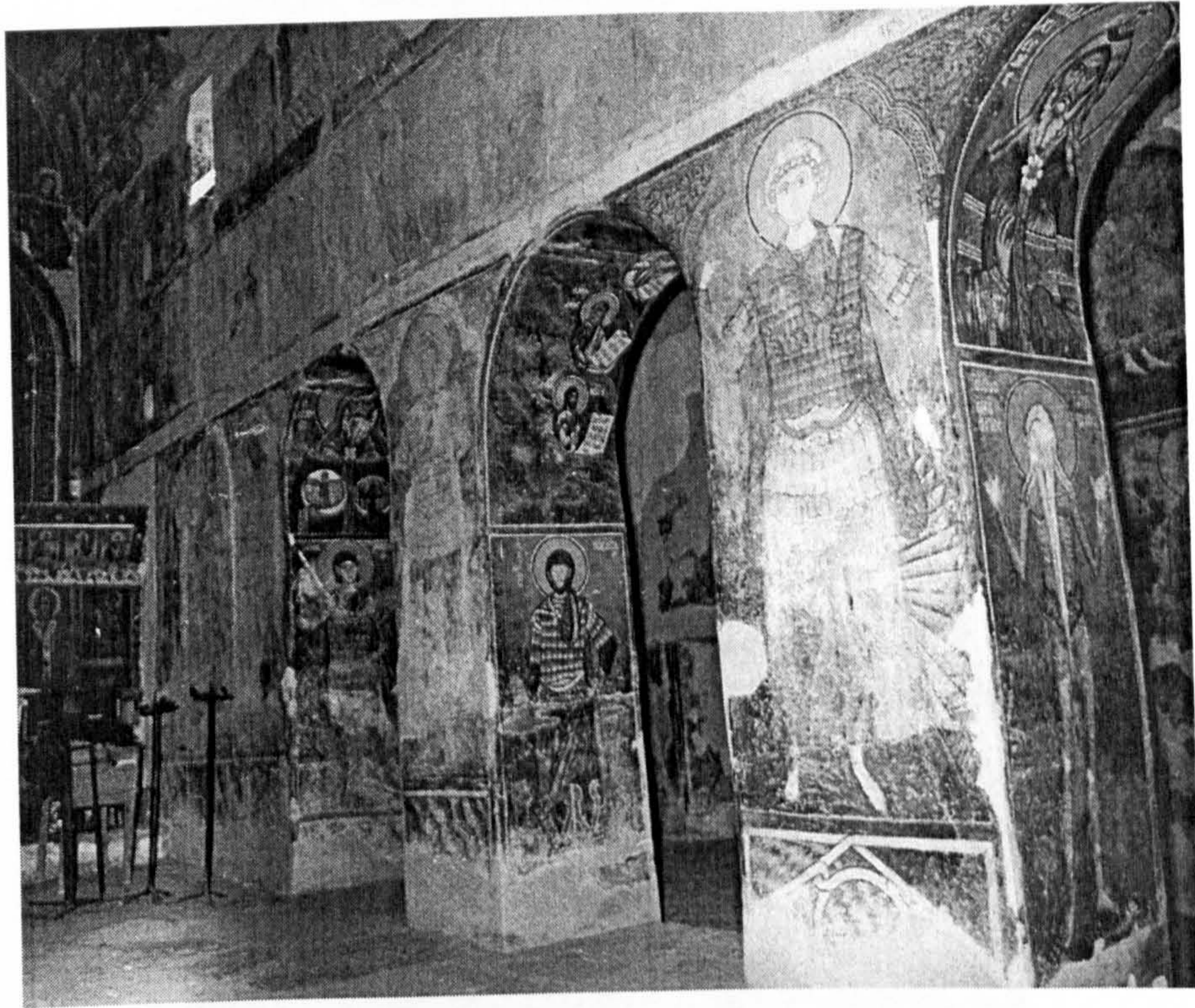

*Figure 3.31 St. Nikola, v. Manastirec, Prilep region - Piers
Source: INDOK Centre, RZZSK-Skopje*

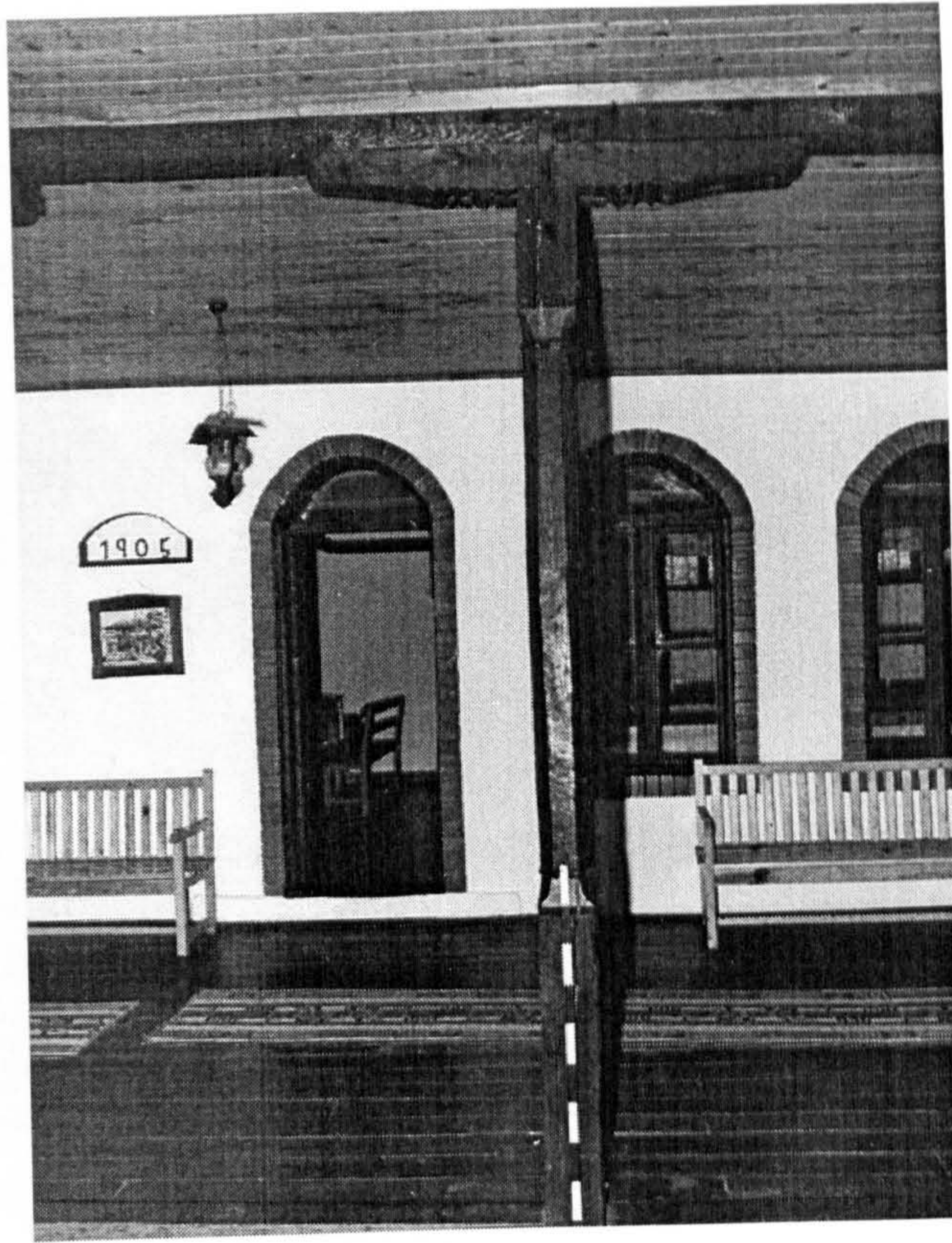

Figure 3.32 Inn, St. Joakim Osogovski Monastery - Wooden post

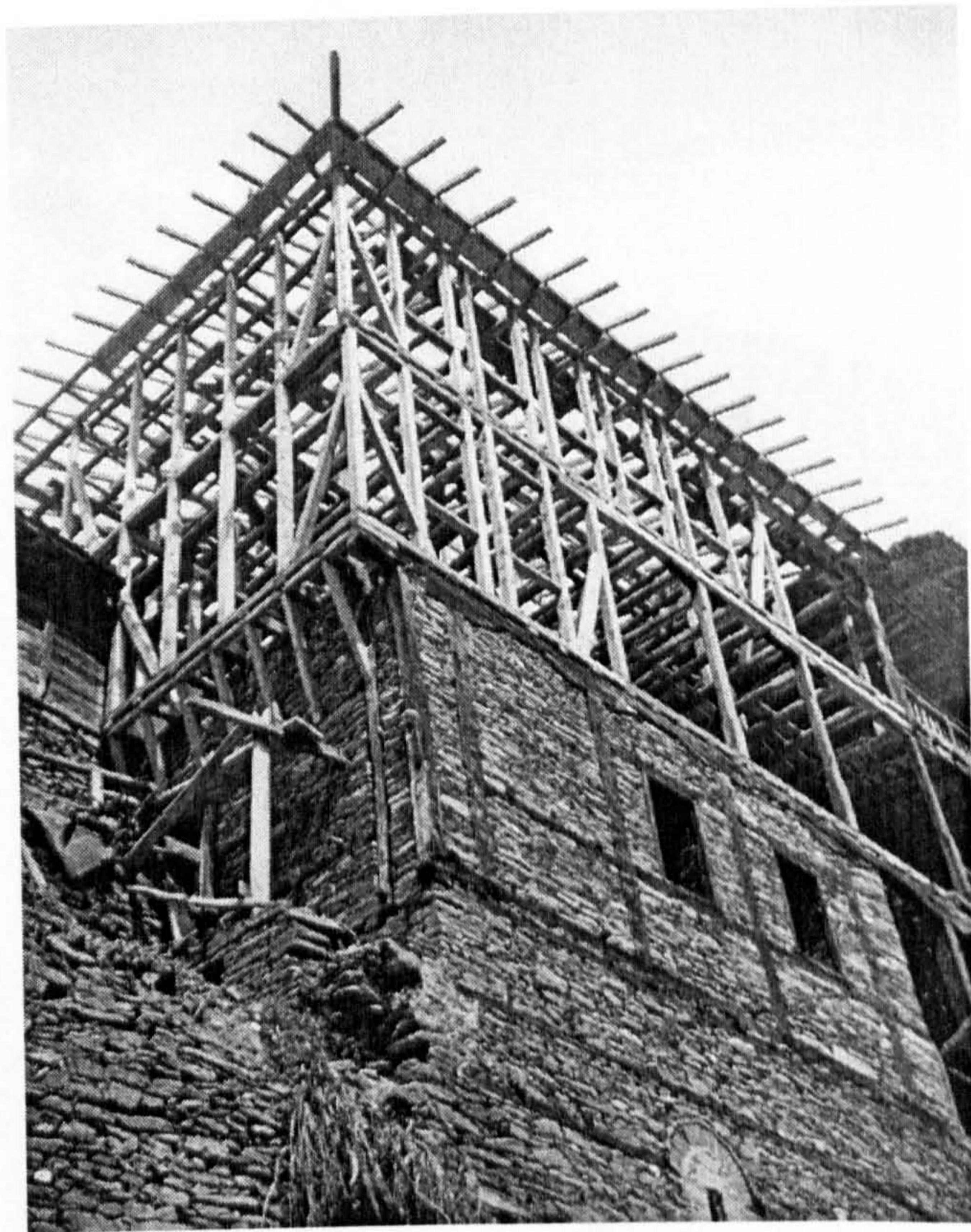

Figure 3.33 Inn, St. Joakim Osogovski Monastery - Timber frame structure



Figure 3.34 Rural store for straw - village Zeleznec, Demir Hisar



Figure 3.35 Rural house - village Gari, Rostusa



Figure 3.36 Rural house - village Galicnik, Mavrovo

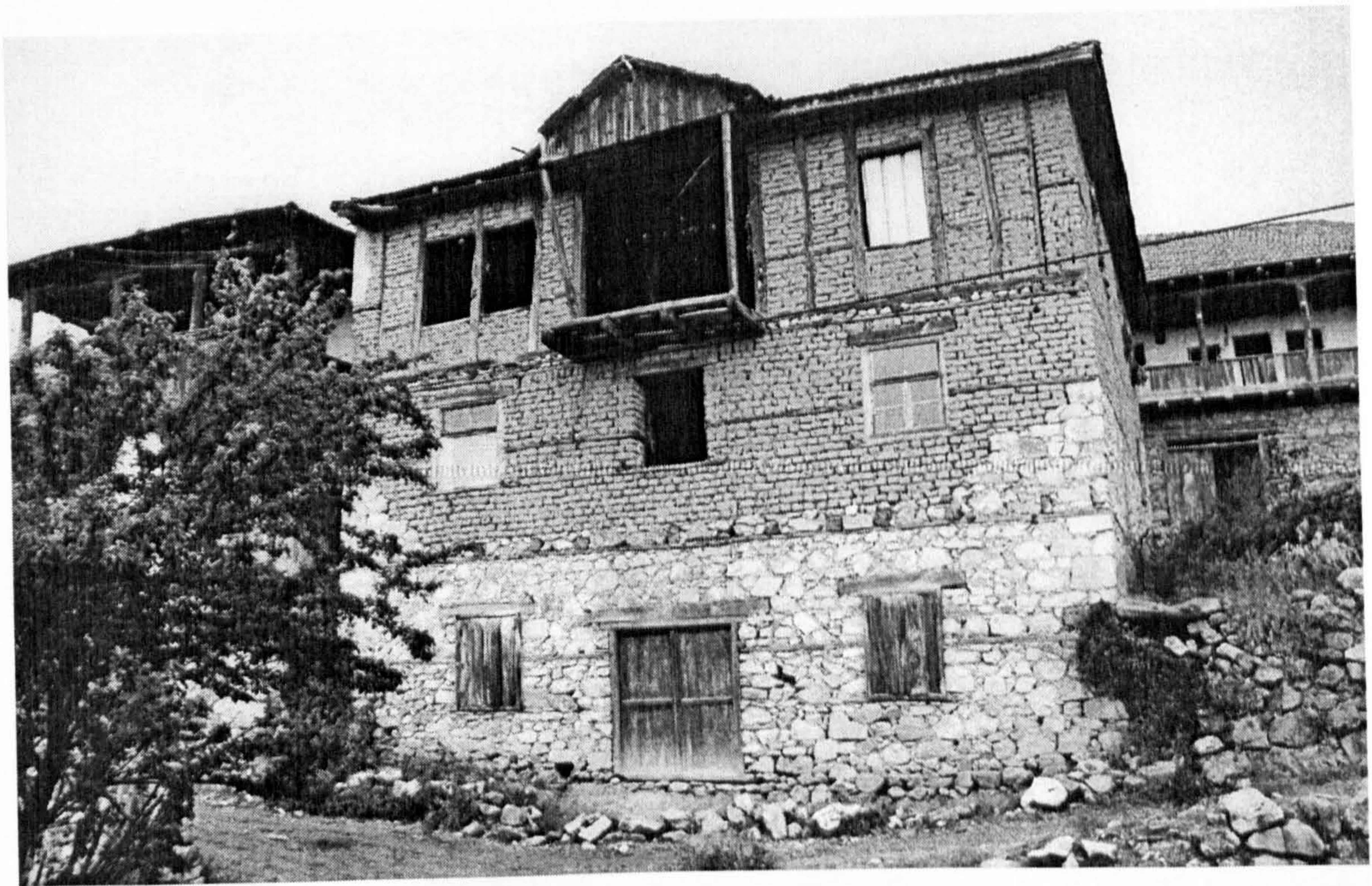

Figure 3.37 Rural house, village Cucer, Skopje



Figure 3.38 Rural house - village Brodec, Mavrovo

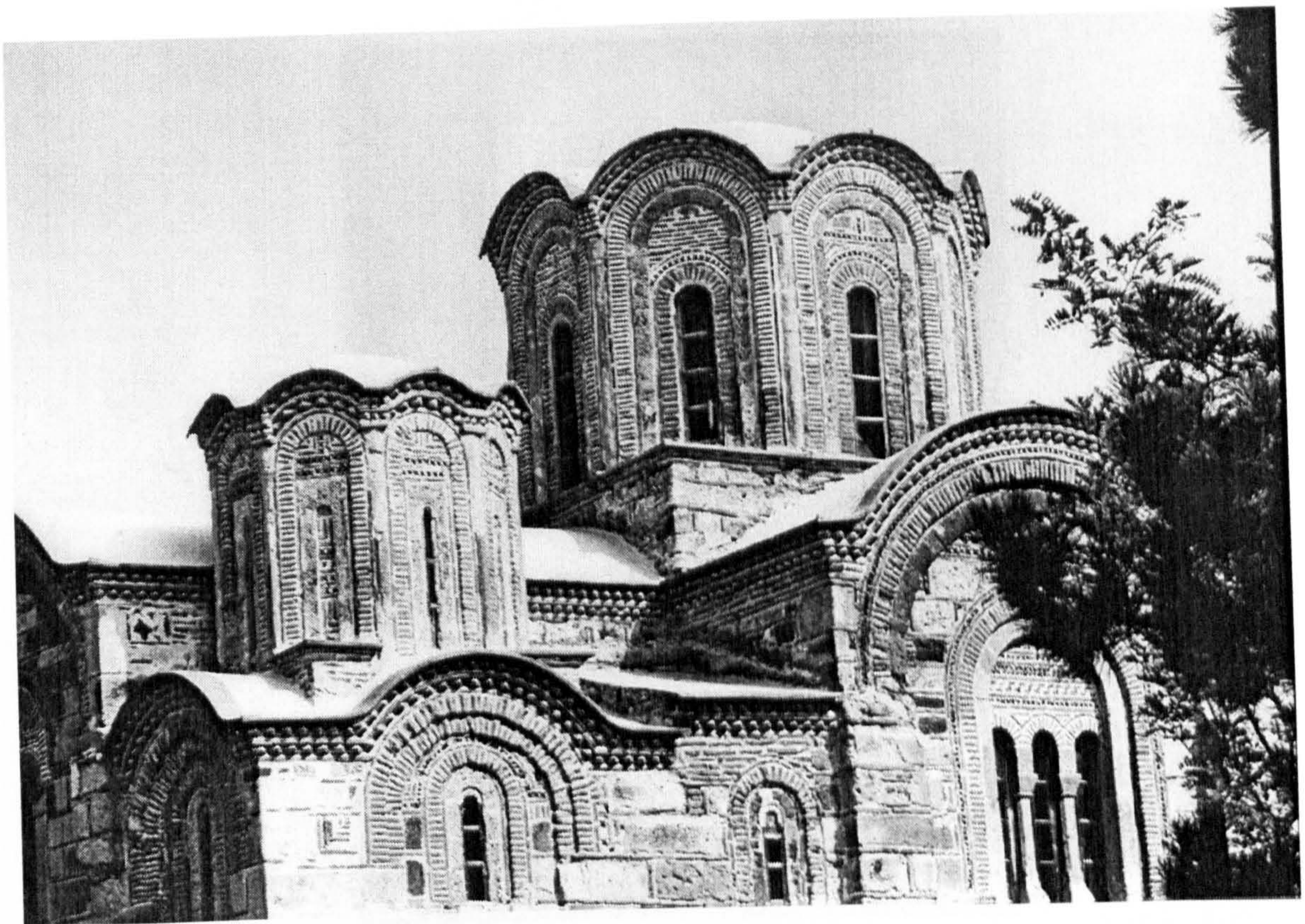

Figure 3.39 St. Georgi, v. Staro Nagoricane

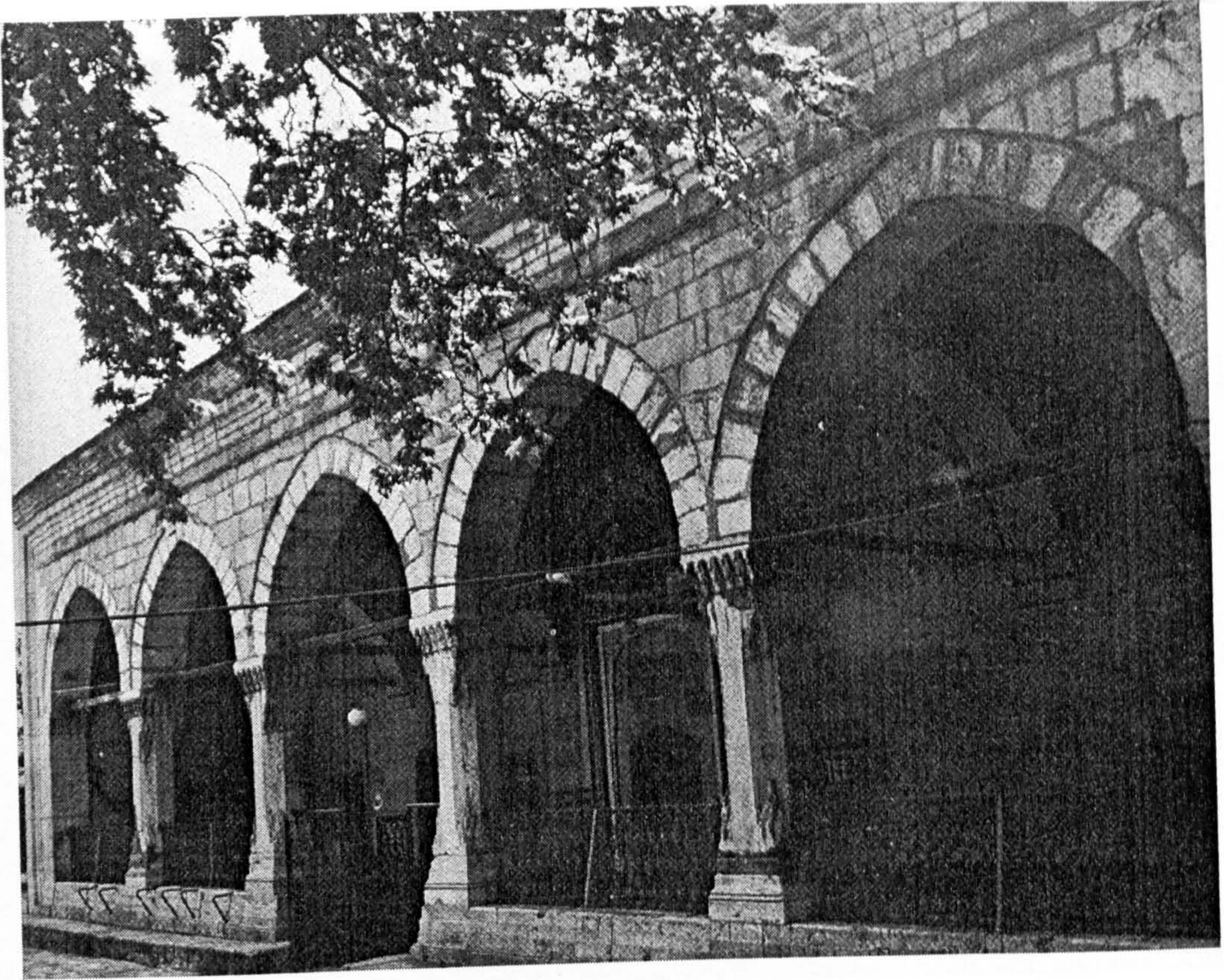

Figure 3.40 *Isa Bey Mosque, Skopje - arches*
 Source: INDOK Centre, Skopje Institute

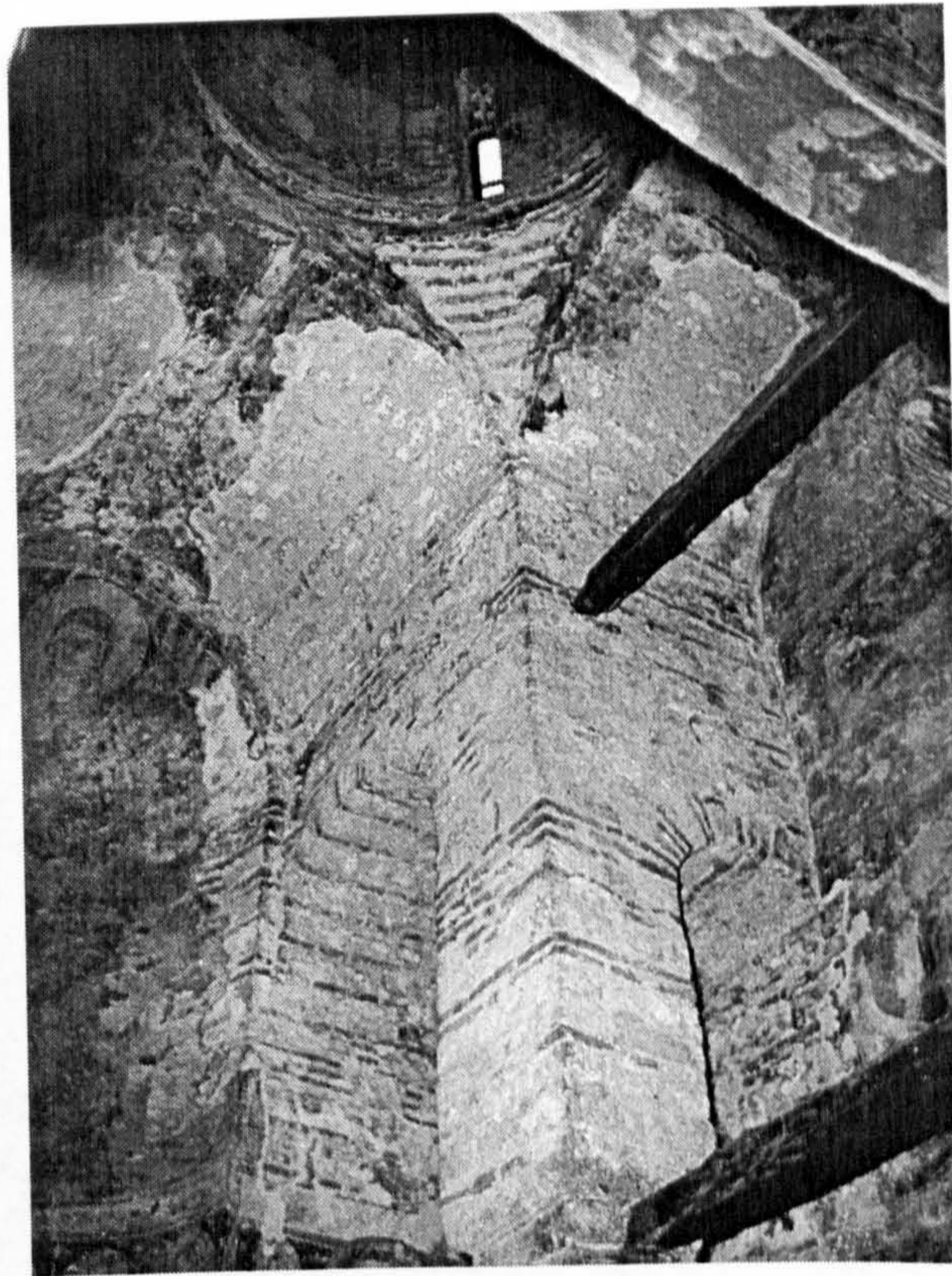

Figure 3.41 *St. Bogorodica Zaum, v. Trpejca, Ohrid - Ties, pier, vaults, pendentive, drum and dome*
 Source: INDOK Centre, RZZSK-Skopje

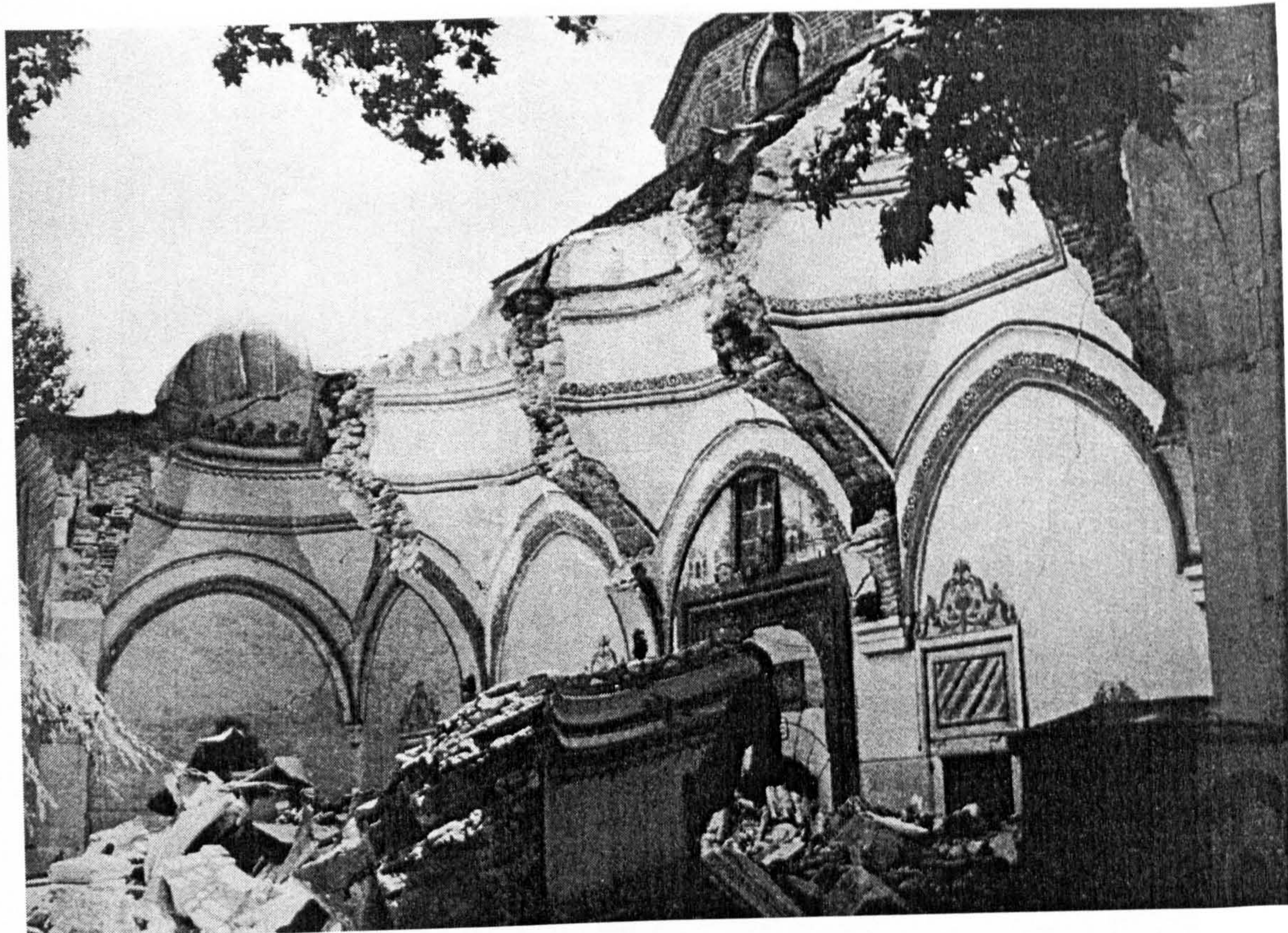

Figure 3.42 *Isa Bey Mosque, Skopje - Squines*
 Source: INDOK Centre, Skopje Institute

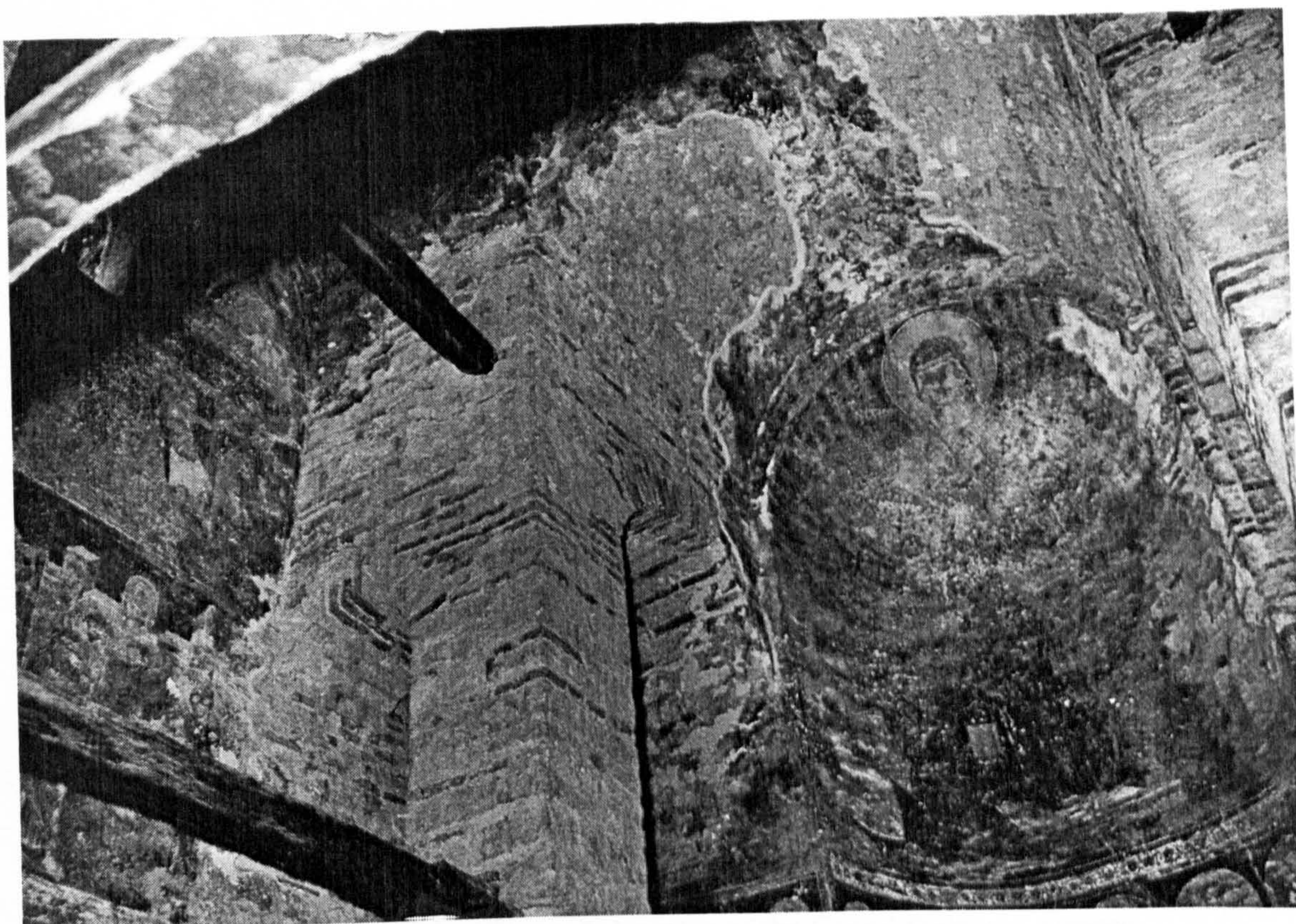

Figure 3.43 *St. Bogorodica Zaum, v. Trpejca, Ohrid - Semidome*
 Source: INDOK Centre, RZZSK-Skopje



Figure 3.44 *St. Kliment Mal, Ohrid - Buttresses*

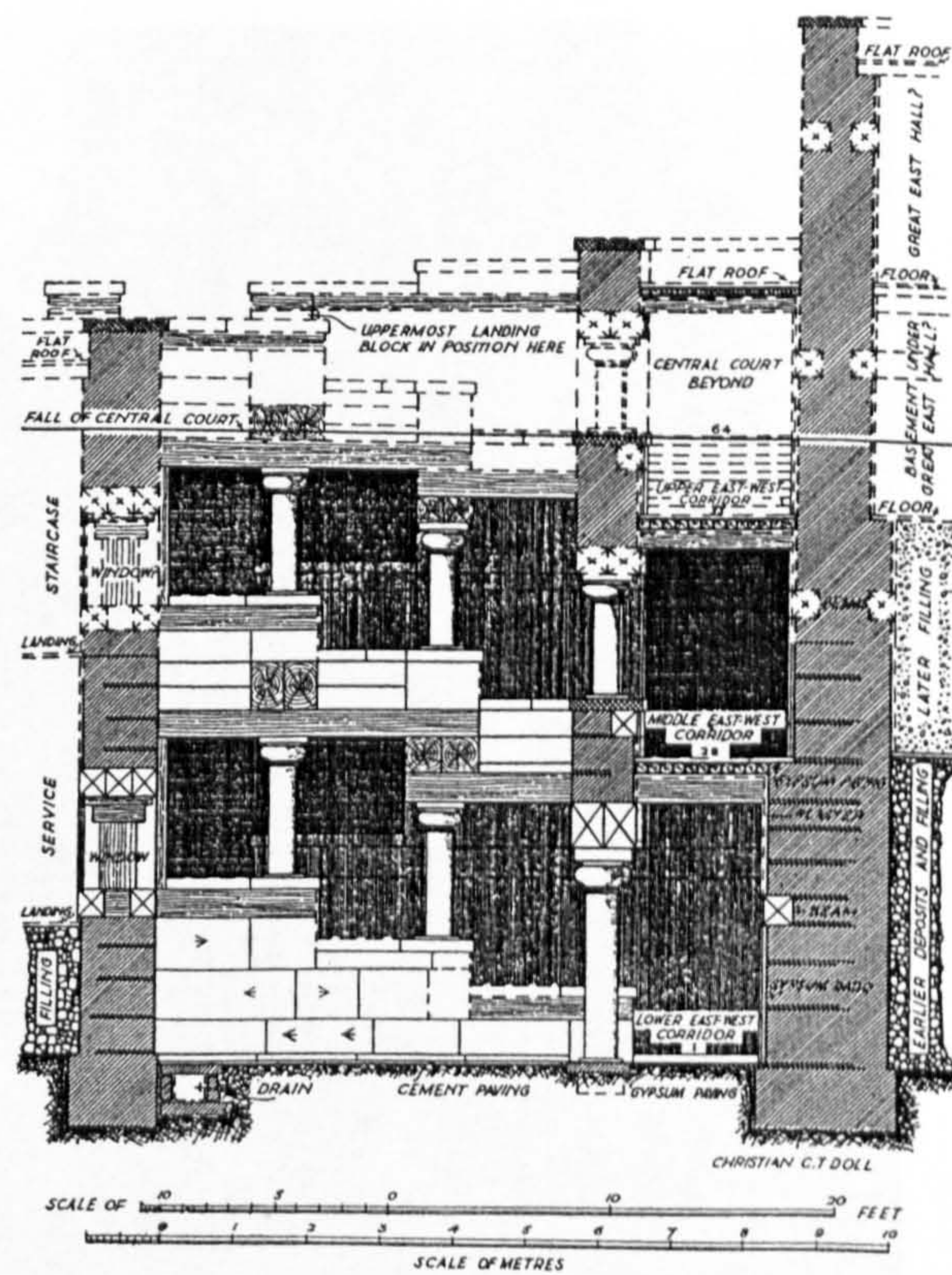

Figure 3.45 *Reconstructed elevation of the Grand Staircase, Knossos*
 Source: Evans, *The Palace of Minos, I*, fig. 247)

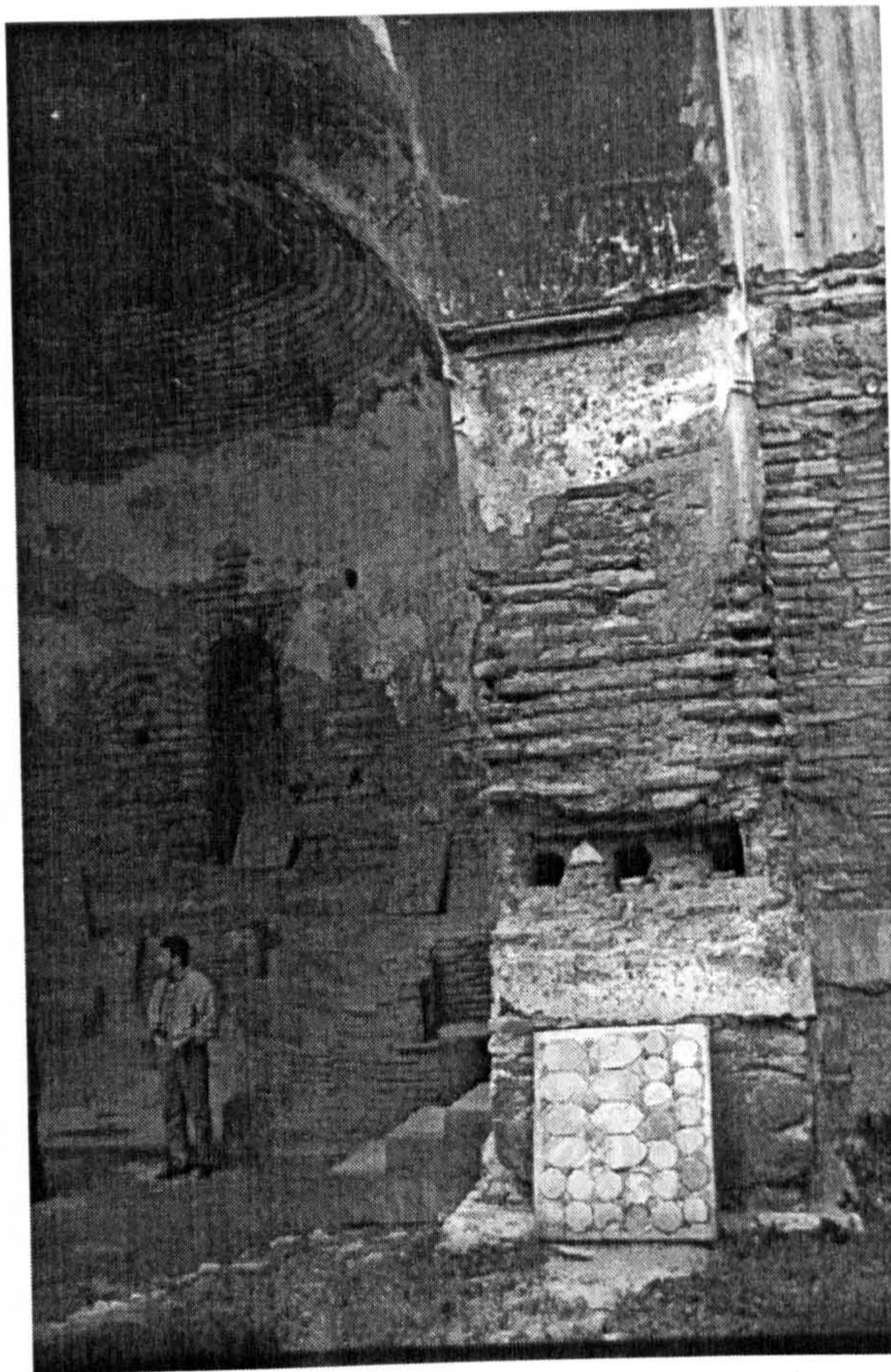

Figure 3.46 Basilica, Nicea (Iznik-Turkey), wall between the nave and the southern aisle

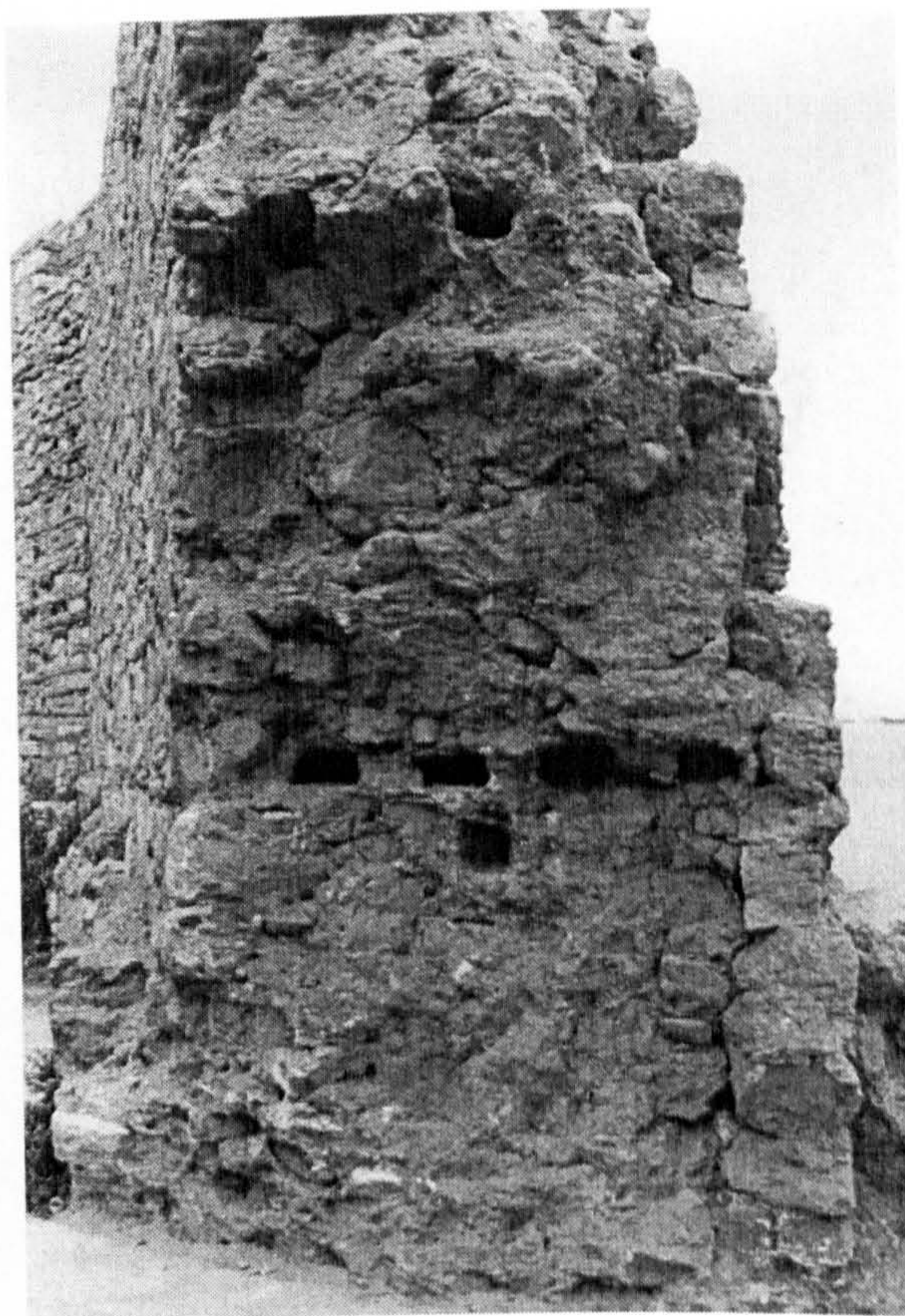

Figure 3.47 City wall near the see, Istanbul



Figure 3.48

Fortress walls, Isar -Stip

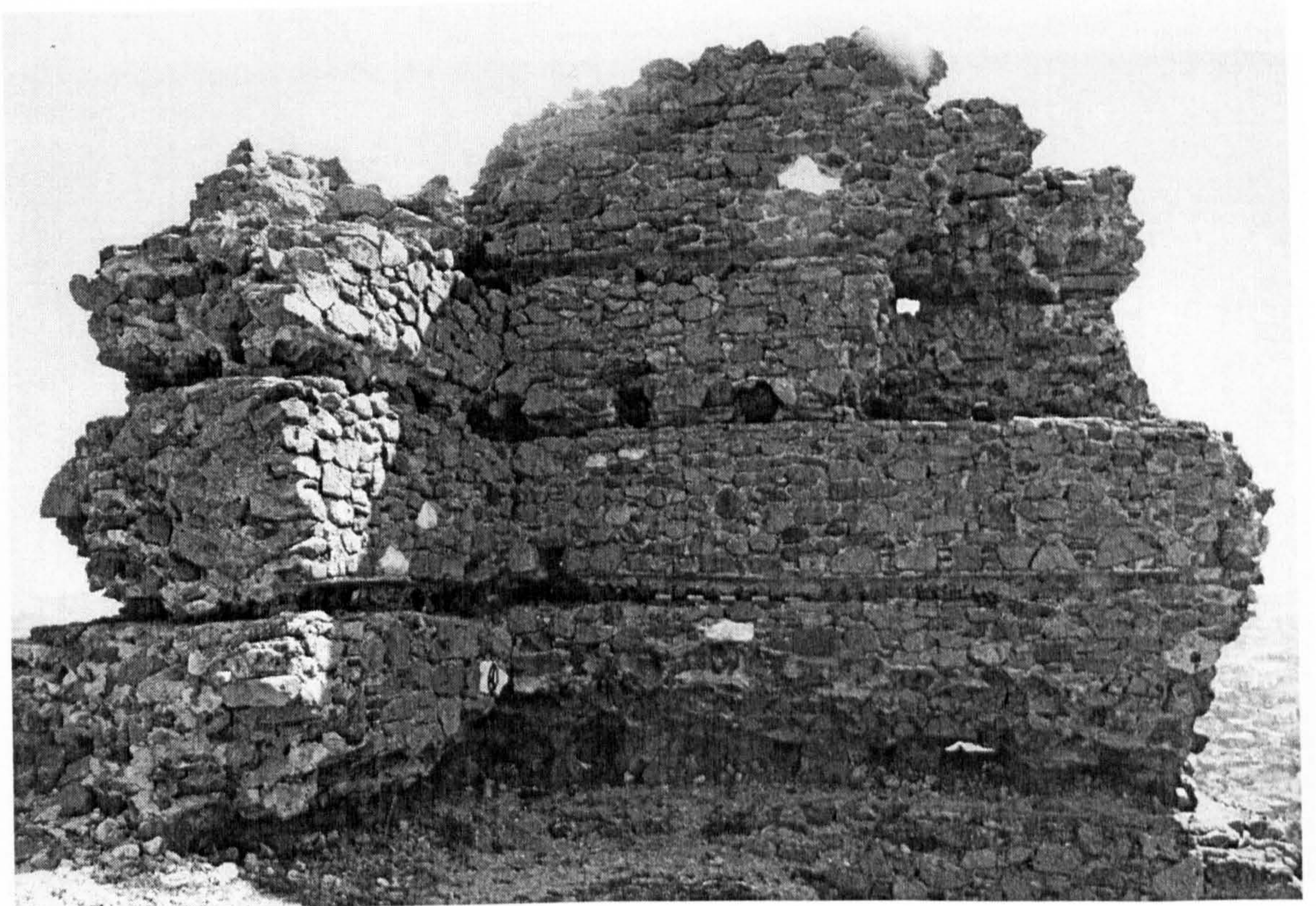

Figure 3.49

Fortress walls, Isar -Stip

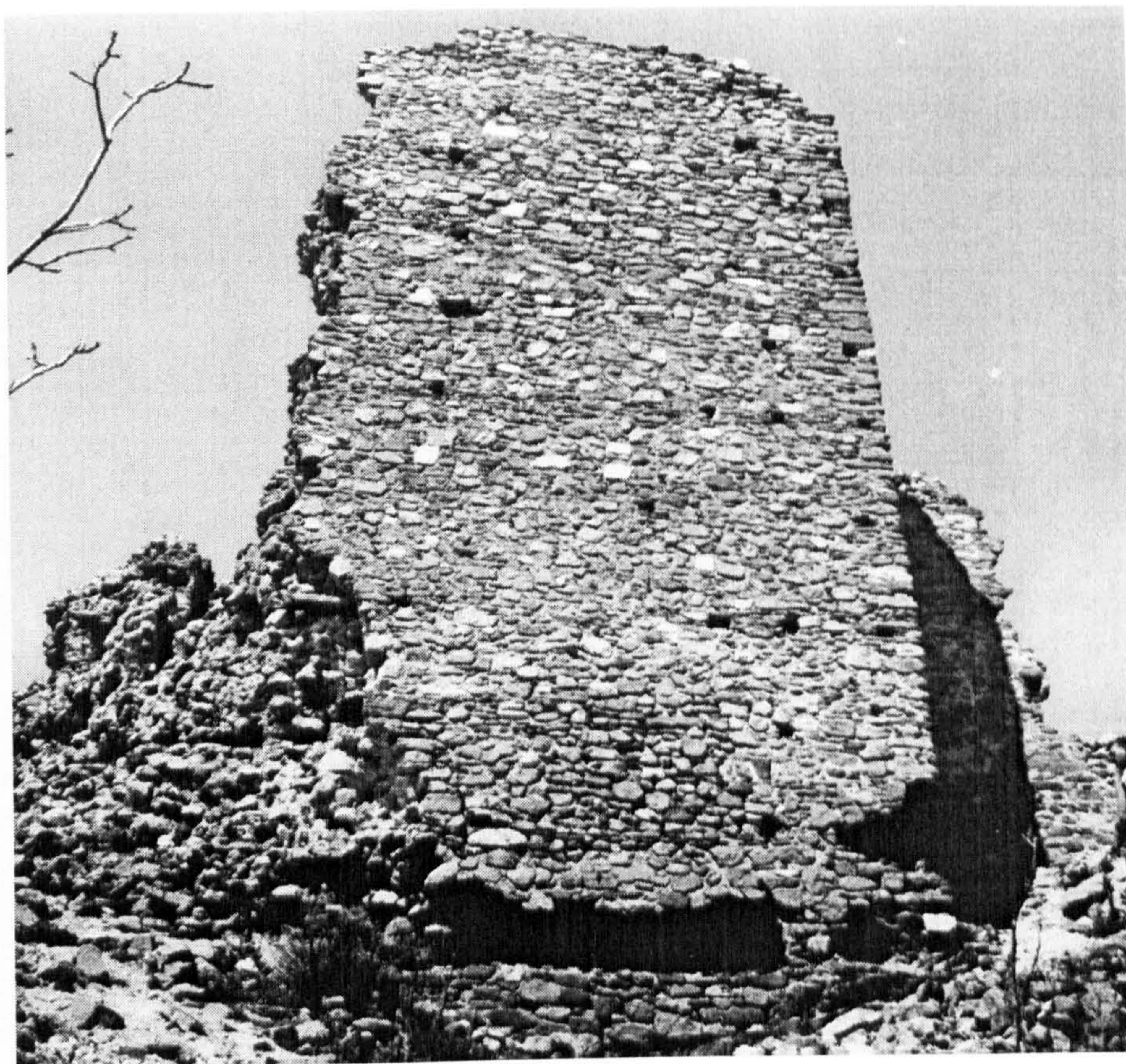

Figure 3.50

Fortress walls, Isar -Stip



Figure 3.51 *St. Atanasie, Varos-Prilep, Southern facade*

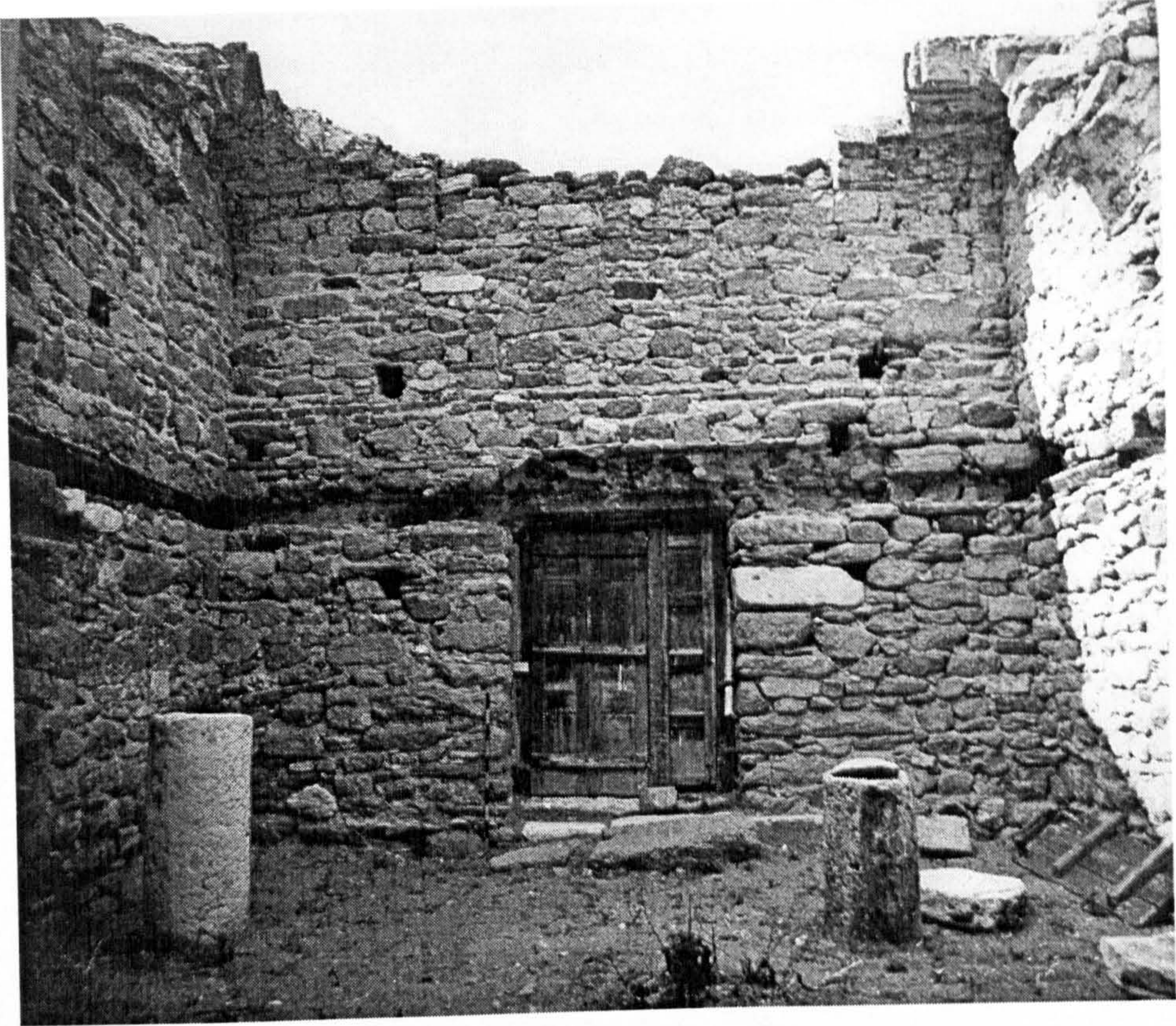

Figure 3.52 St. Atanasie, Varos-Prilep, Interior



Figure 3.53 Dukandjic Mosque, Skopje



Figure 3.54 Turkish bath, near the Kursumli Caravanserai, Skopje

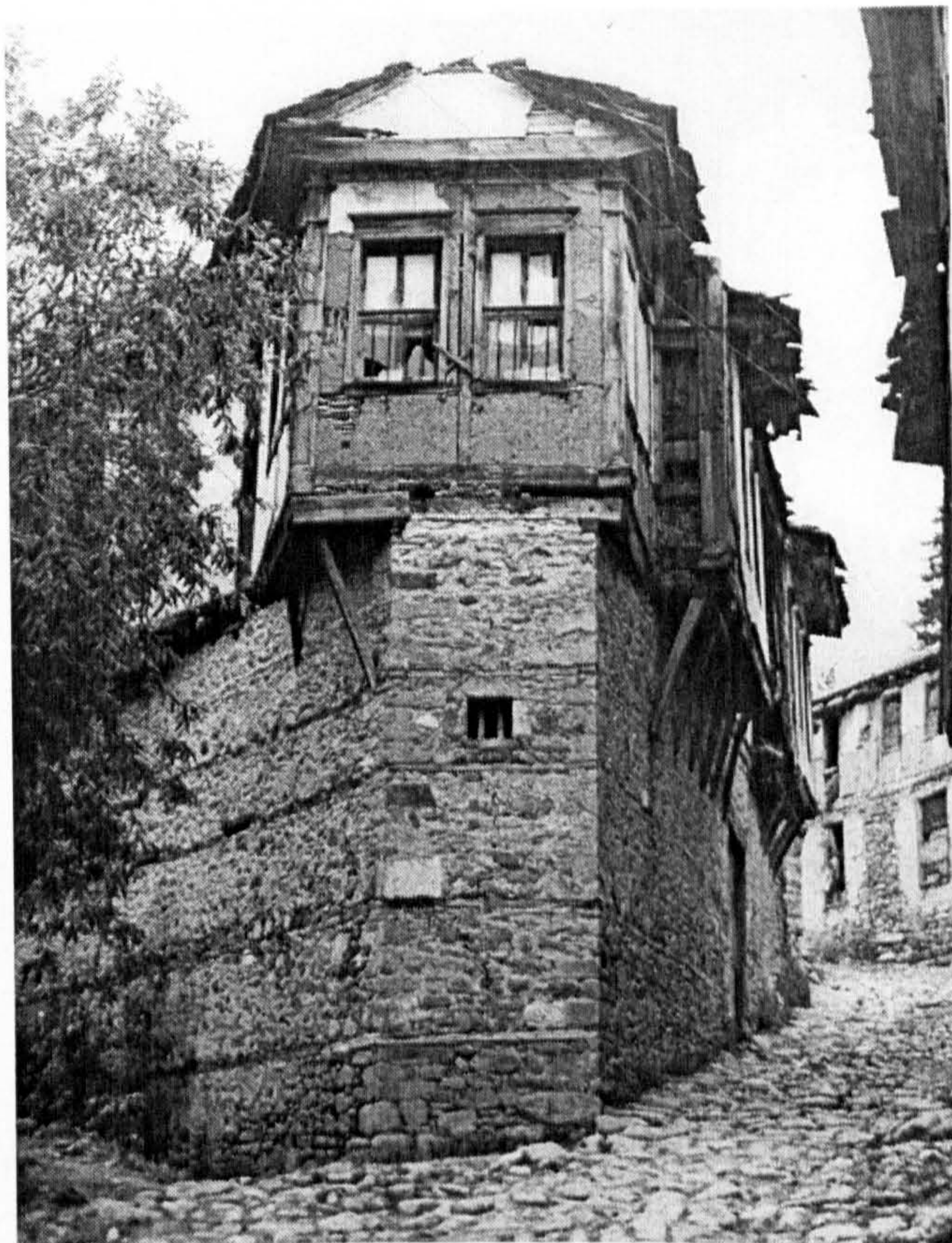

Figure 3.55 Rural dwelling, v. Maloviste-Bitola Region



Figure 3.56 Rural dwelling, v. Kicinica-Mavrovo region



Figure 3.57 Rural dwelling, v. Gornjani - Skopje region



Figure 3.58 Rural dwelling, v. Cucer-Skopje region



Figure 3.59 Rural dwelling, v. Konjari - Debar region



Figure 3.60 Dwelling, Struga

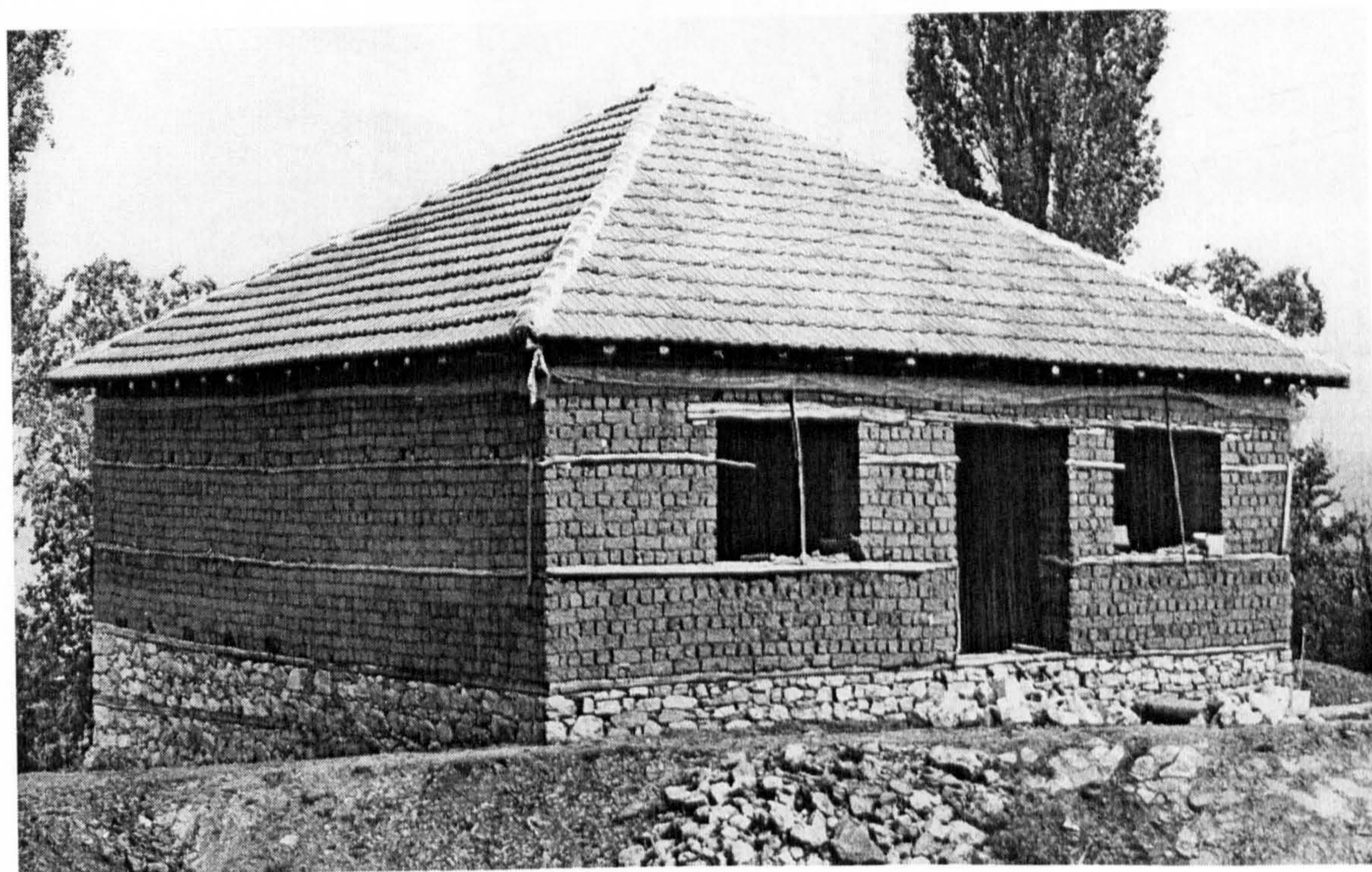

Figure 3.61 Rural dwelling, v. Djepiste, Debar region

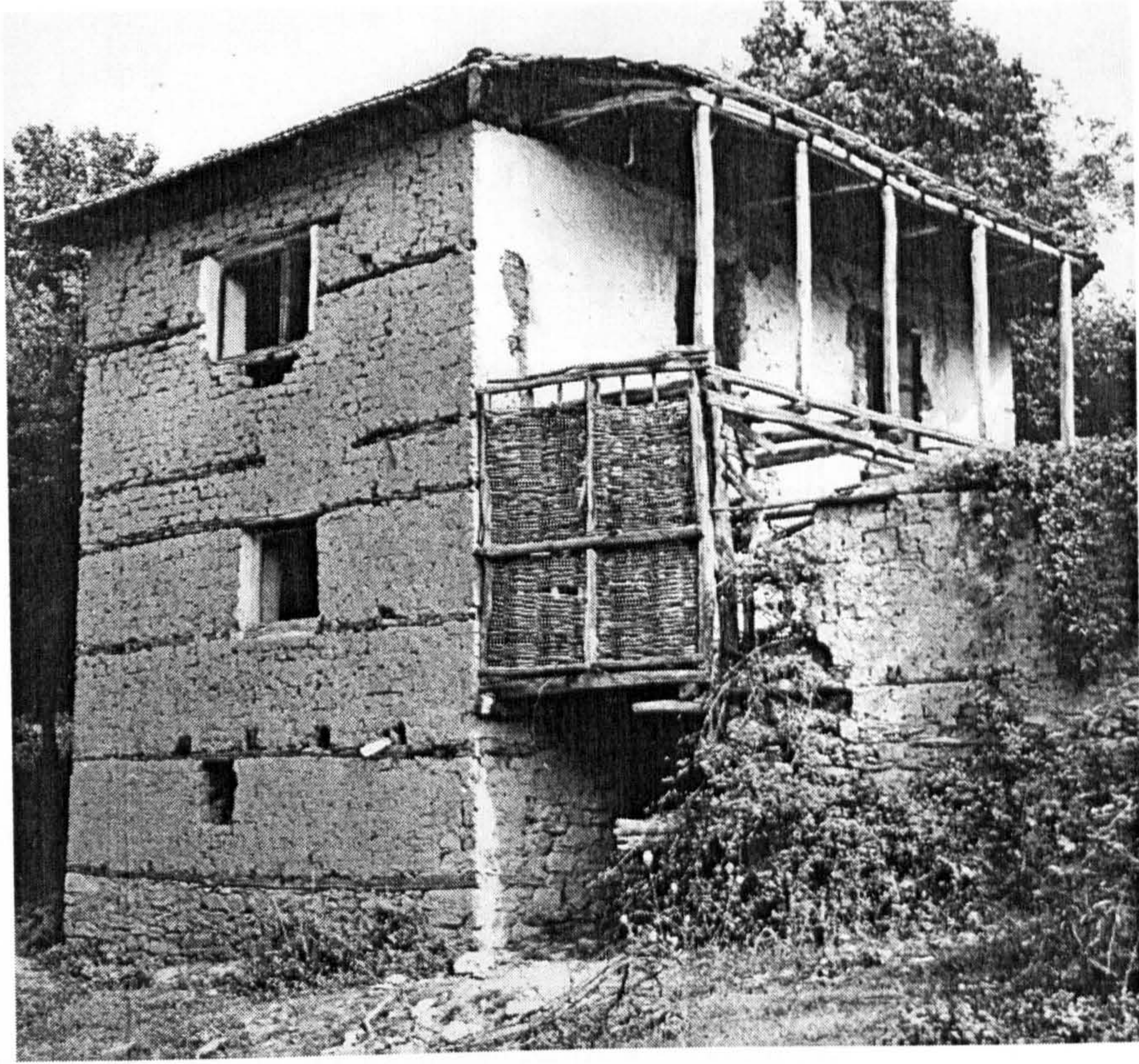

Figure 3.62 Rural dwelling, v. Ljubanci - Skopje region

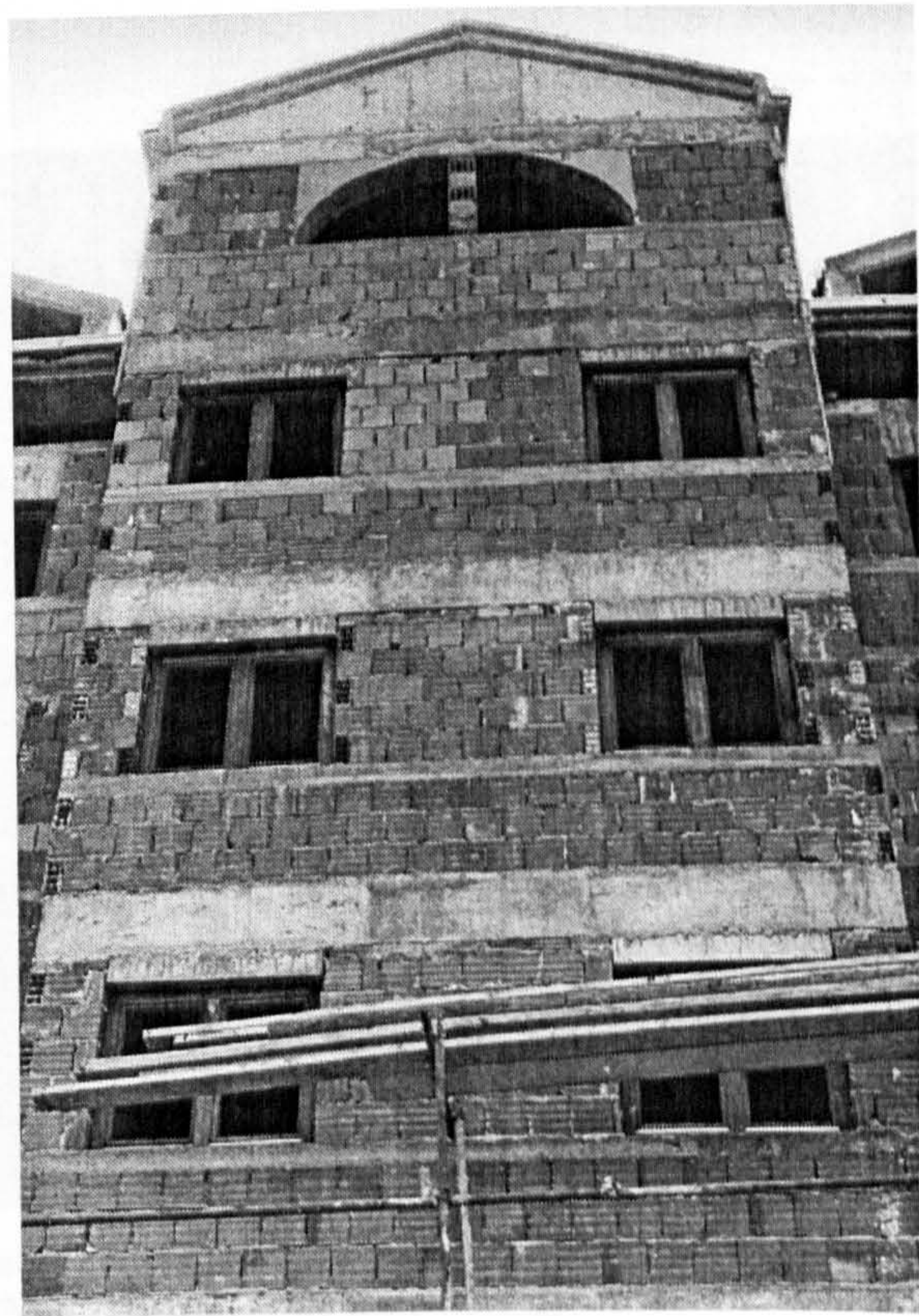

Figure 3.63 New dwelling building 1996, Skopje

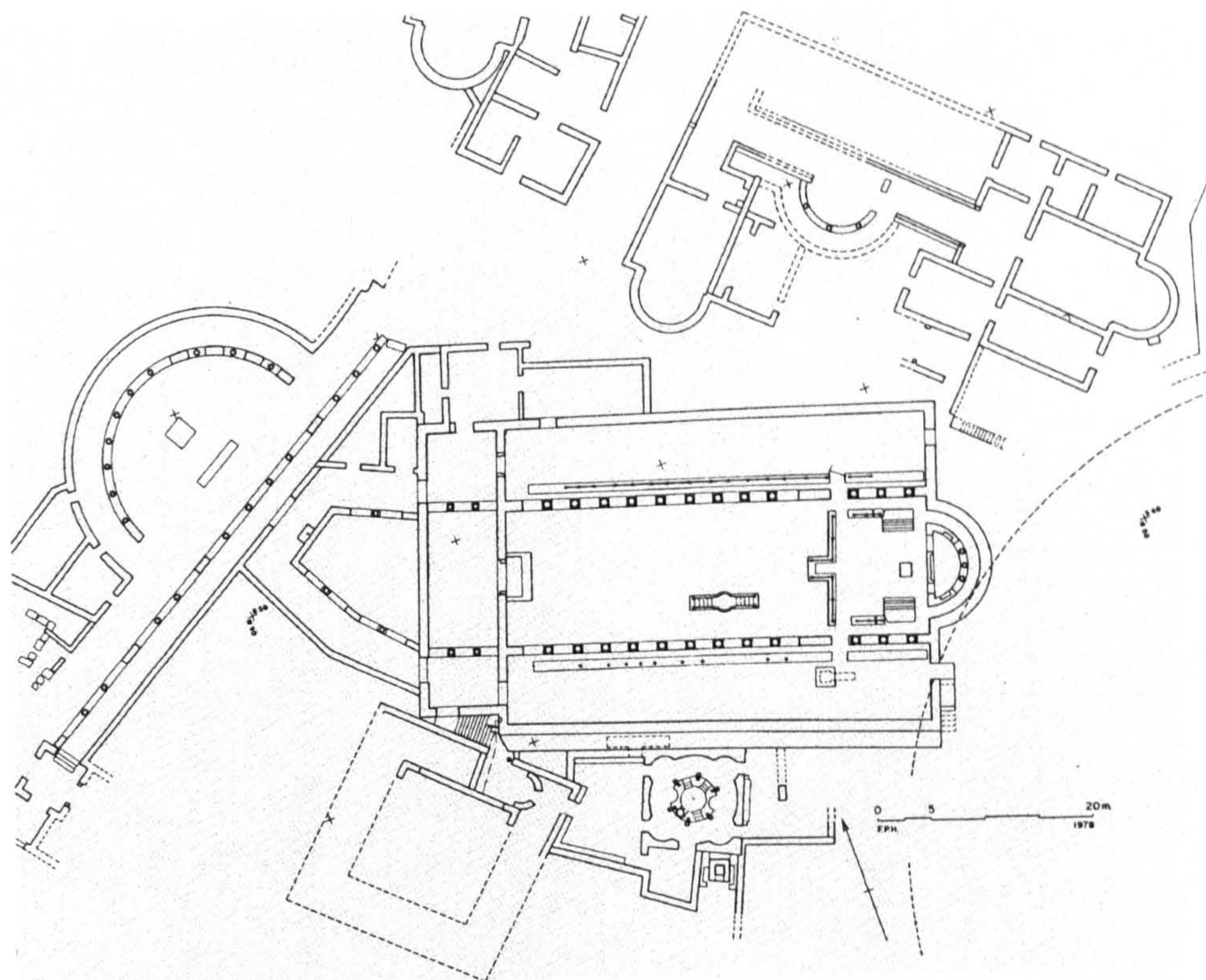

Figure 3.64 *Stobi, the Episcopal basilica - around 525*
 Source: Hamans, F. / Aleksova, B. 1989

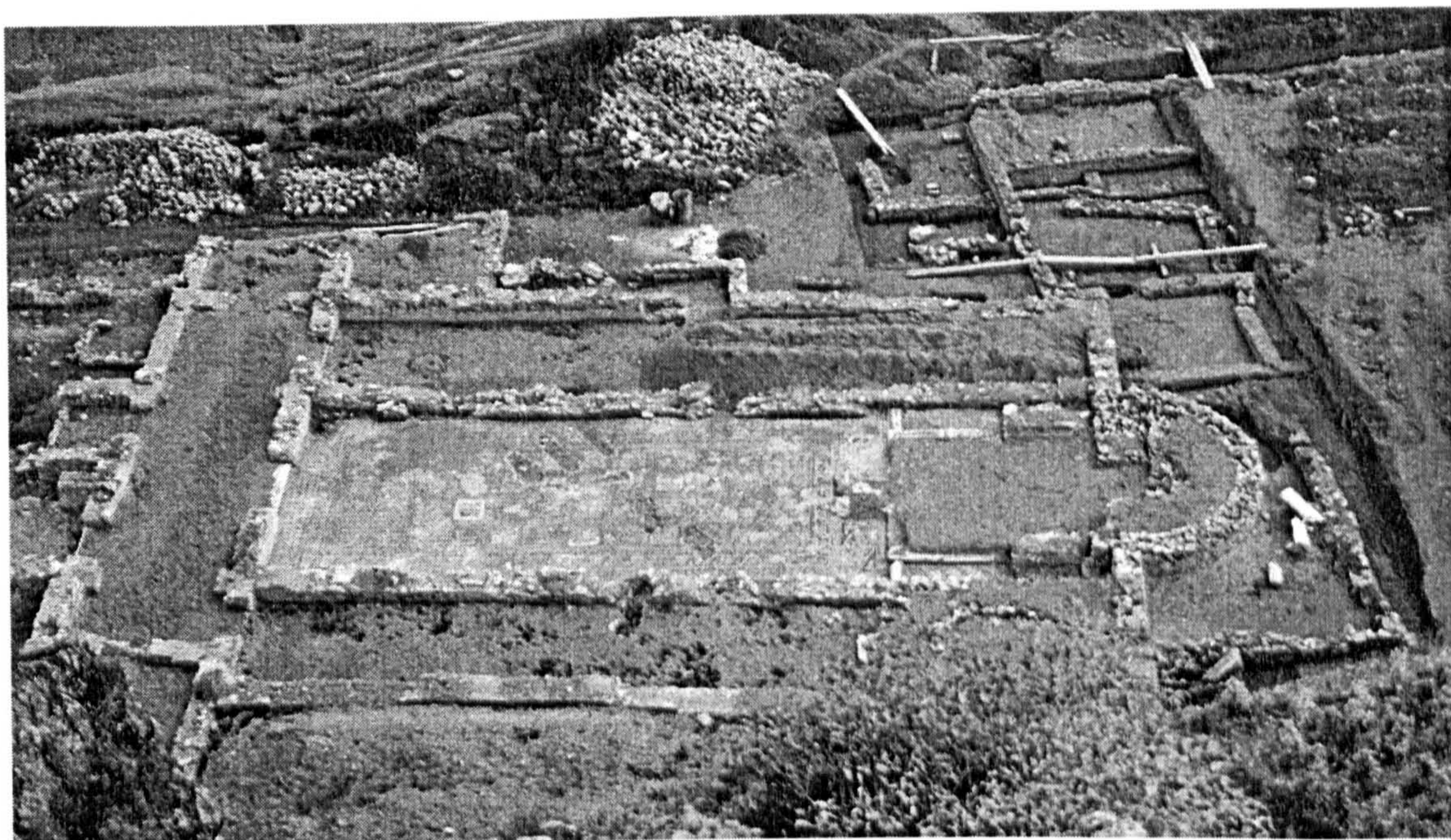

Figure 3.65 *St. Erasmus, Ohrid. An early Christian basilica.*
 Source: INDOK Centre, RZZSK-Skopje

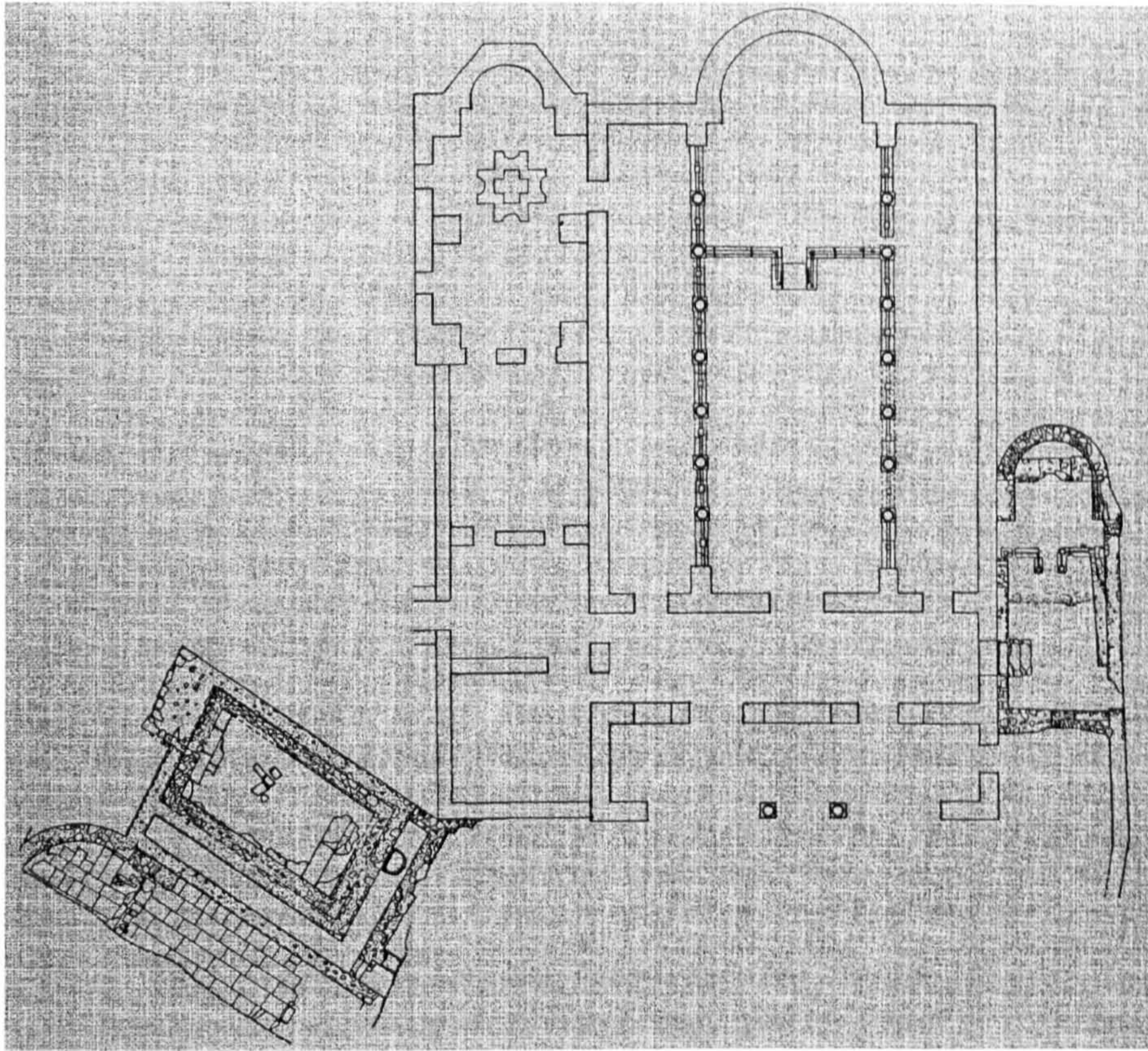

Figure 3.66 *Basilica, Archaeological site - Bargala, v. Gorni Kozjak - Stip region*
 Source: INDOK Centre, RZZSK-Skopje

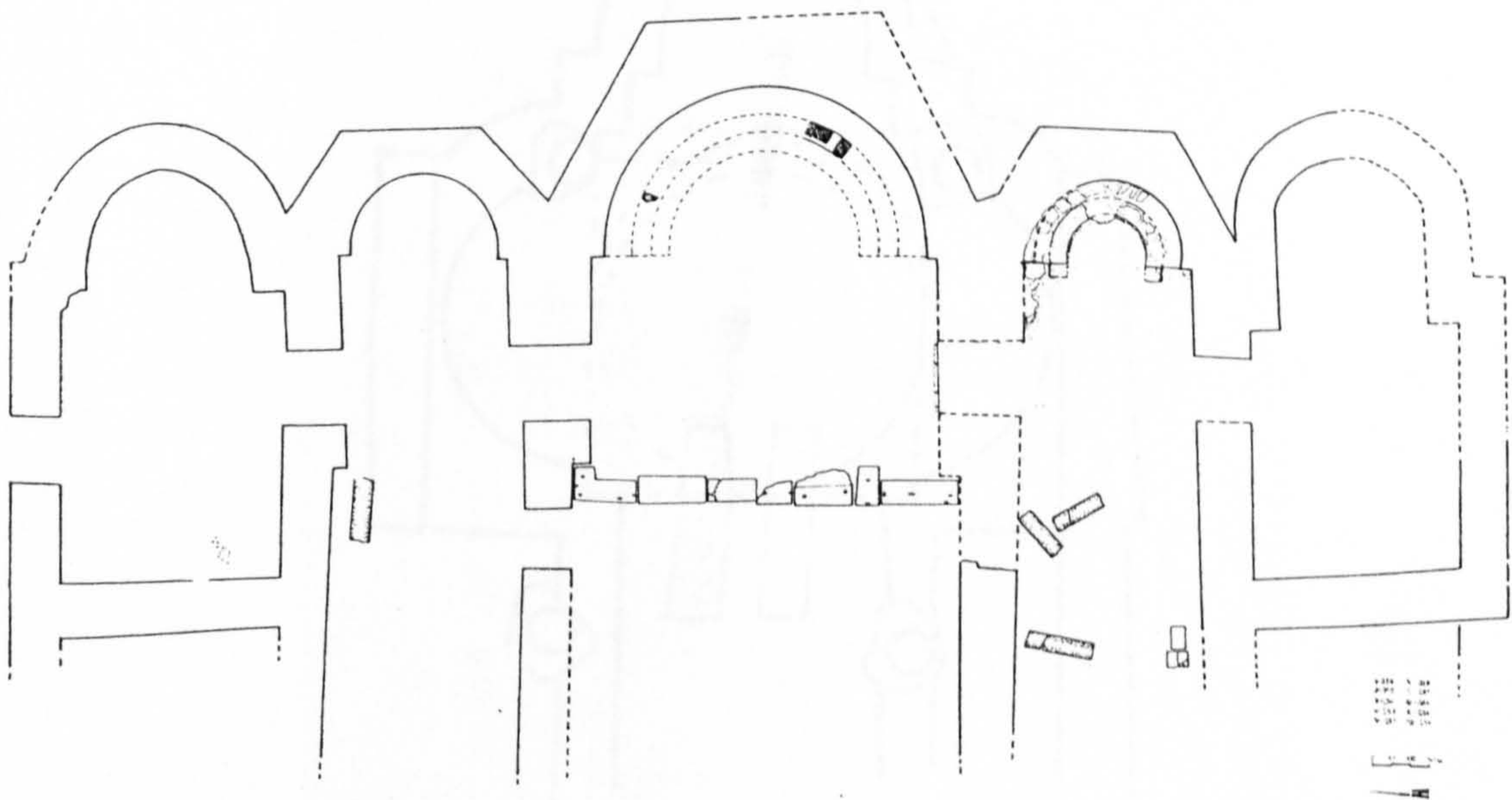
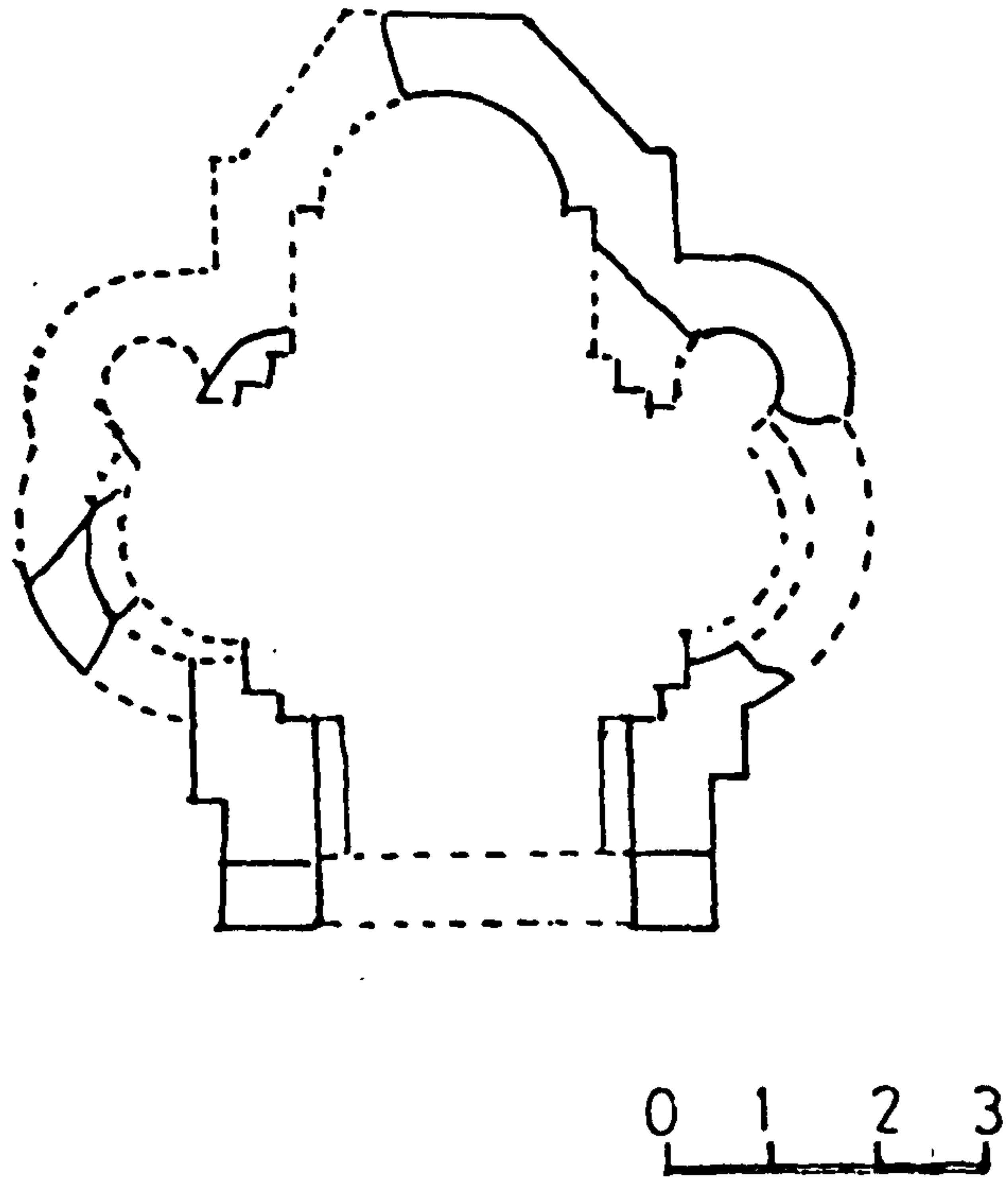
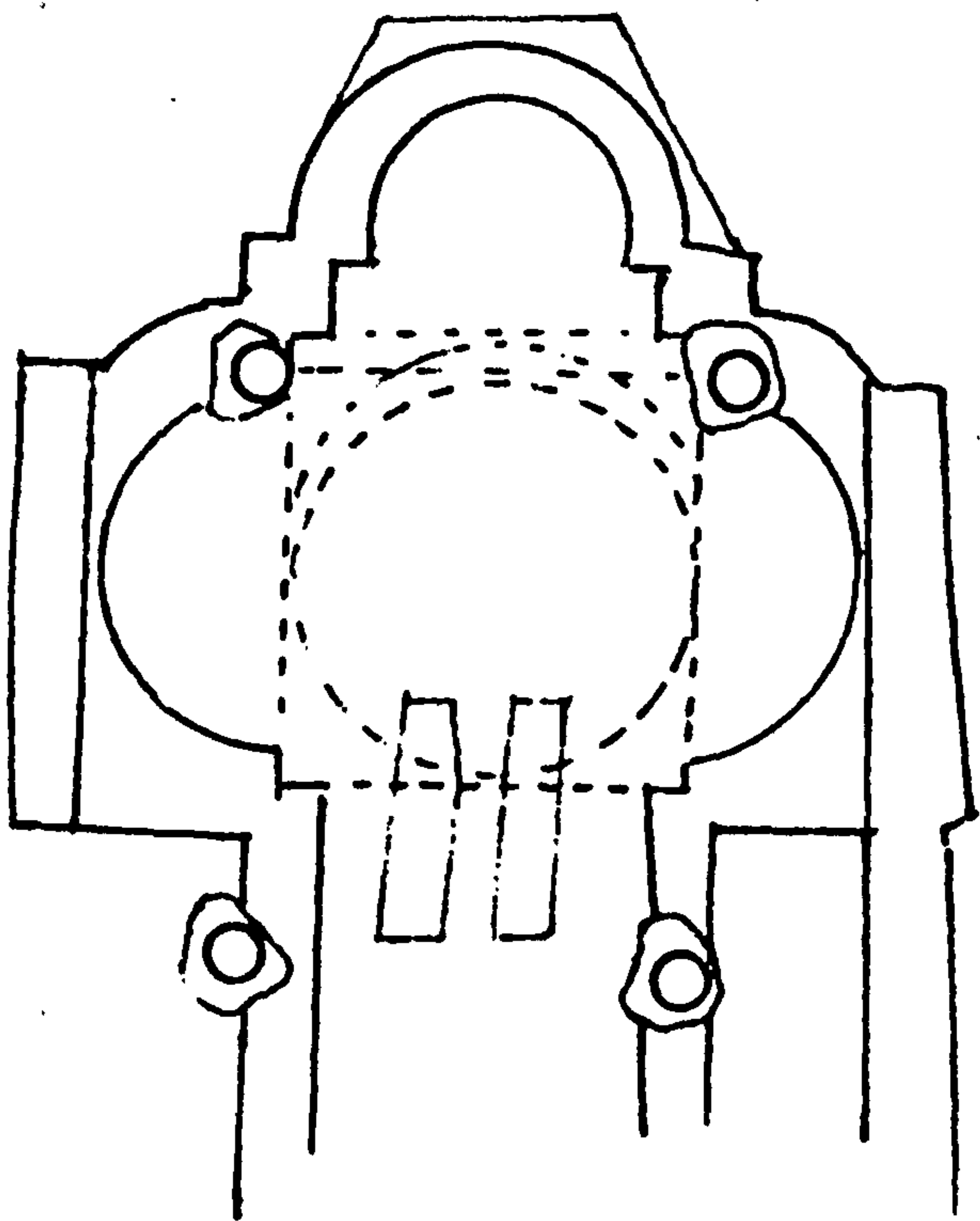

Figure 3.67 *Cathedral church, v. Krupiste-Stip region*
 Source: Aleksova, B. (1989: 277)



*Figure 3.68 St. Kliment, Ohrid. 9th-10th century
Source: INDOK centre, Ohrid Institute*



*Figure 3.69 St. Naum, v. Ljubanista-Ohrid Lake
Source: INDOK centre, Ohrid Institute*

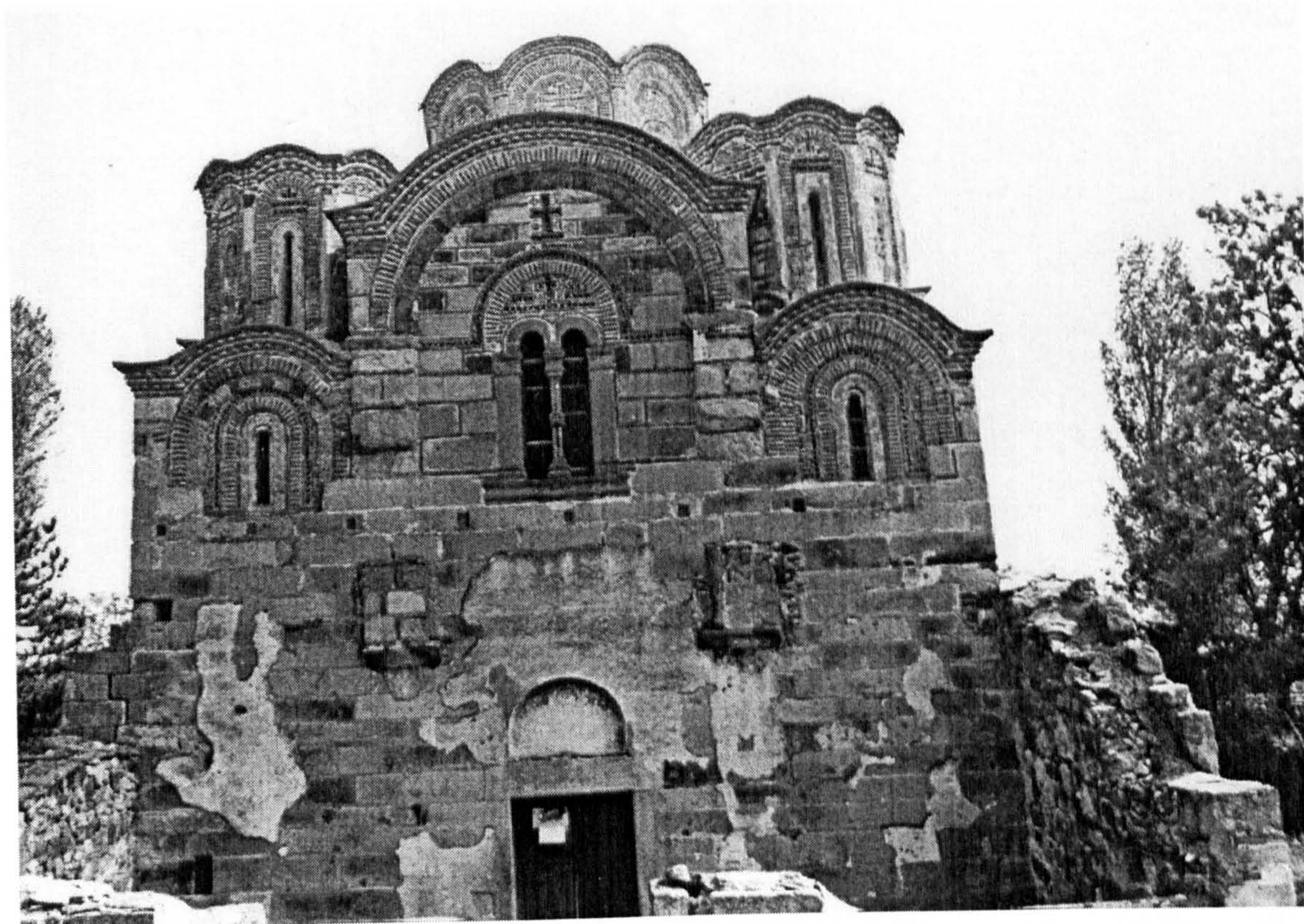

Figure 3.70 St. Georgi, v. Staro Nagoricane - Western facade

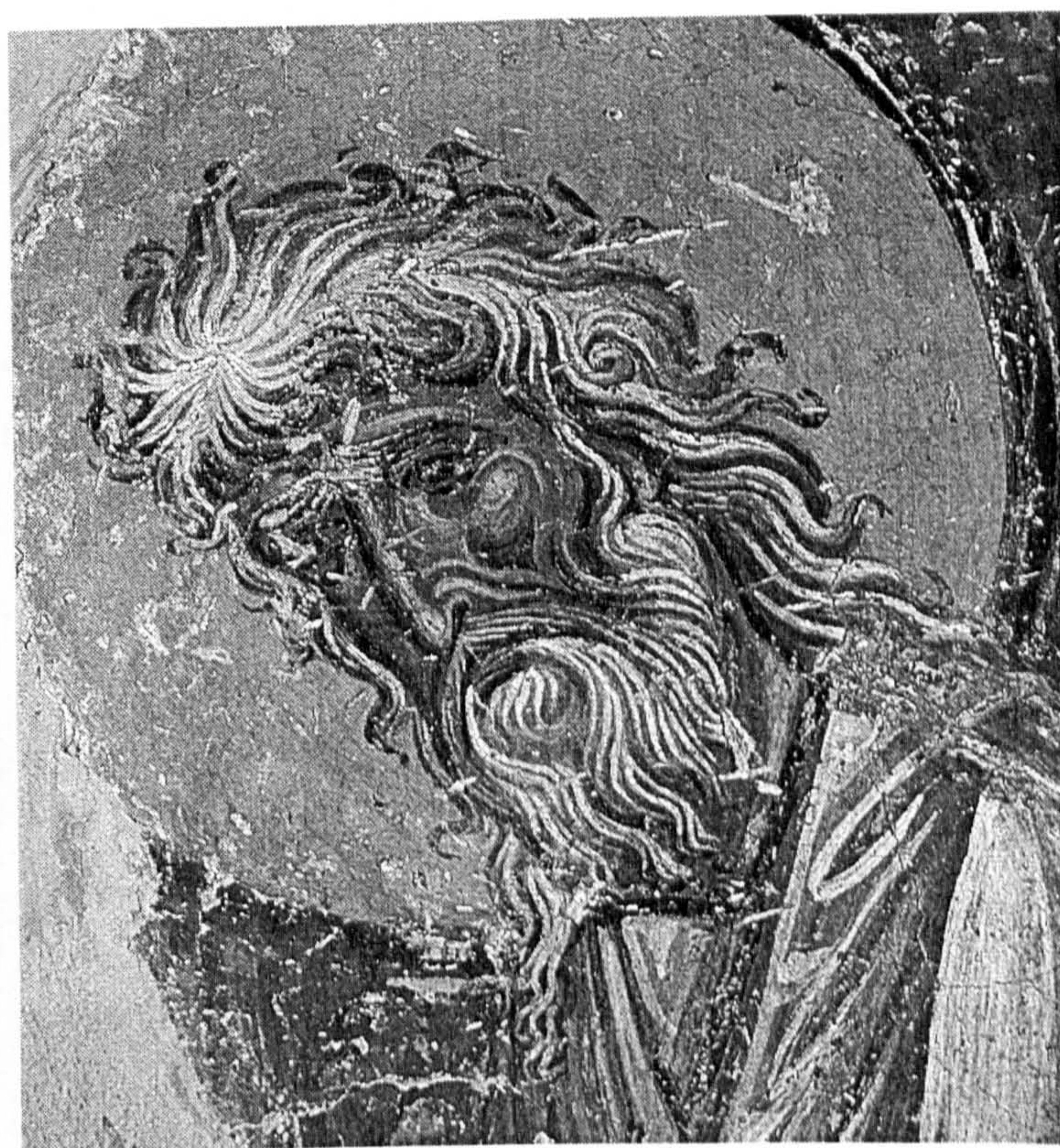
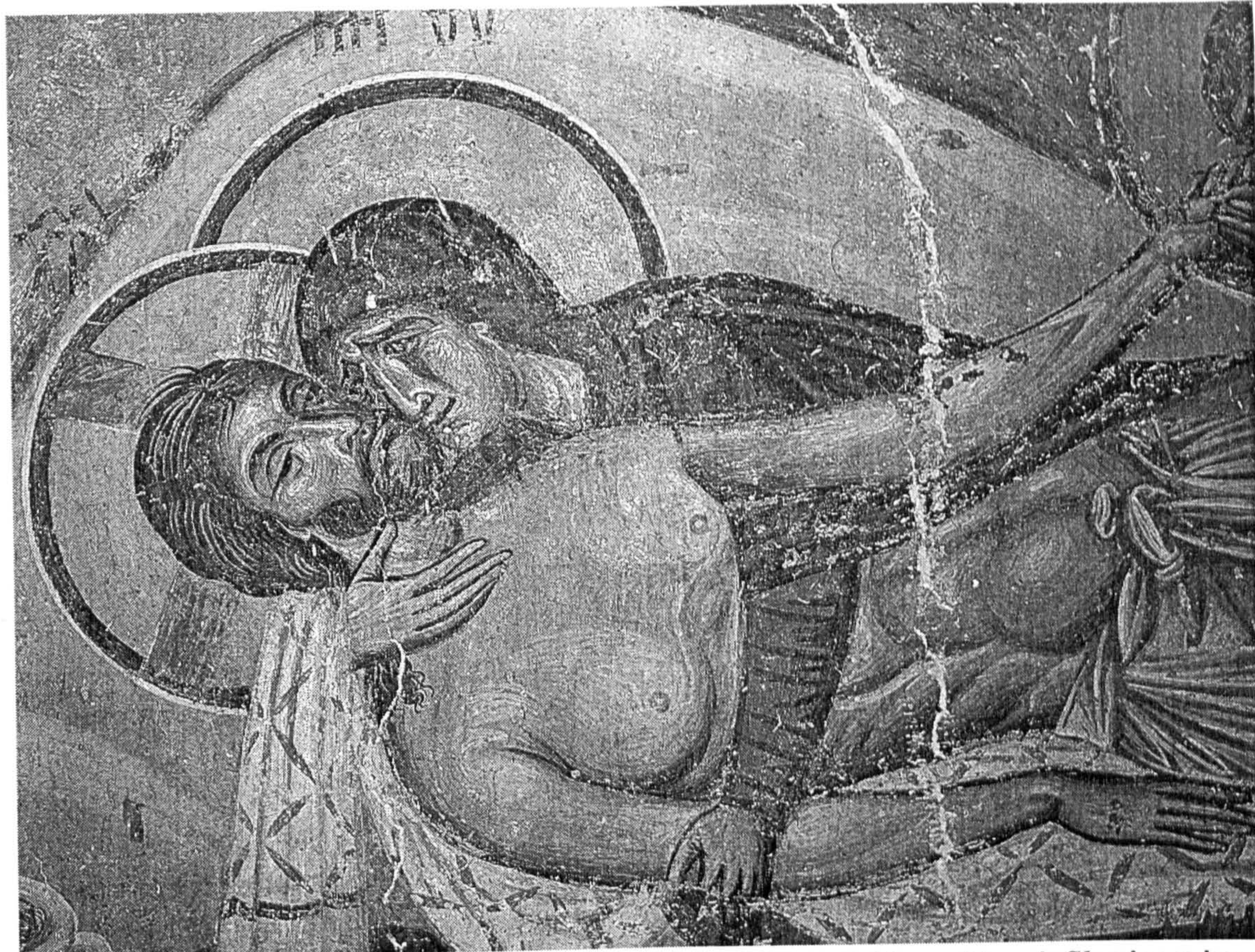

Figure 3.71 The face of St. Simeon the receiver of God, Fresco-St. Panteleimon v. Gorno Nerezi
 Source: INDOK centre, RZZSK - Skopje



*Figure 3.72 The lamentation of the Christ. St. Panteleimon, v. Gorno Nerezi -Skopje region
Source: INDOK centre, Skopje Institute*

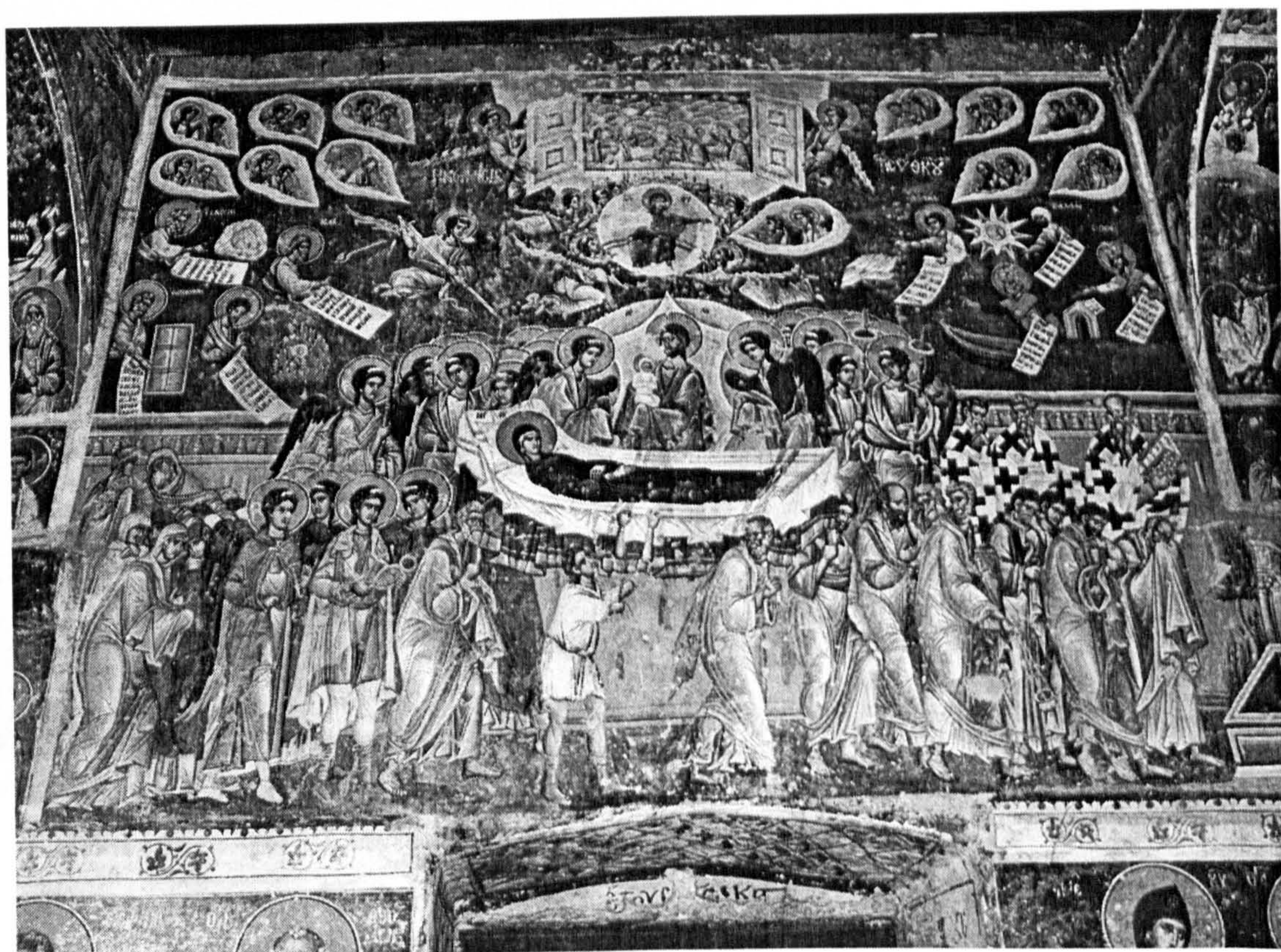

Figure 3.73 Fresco. Western wall. St. Georgi, v. Staro Nagoricane



Figure 3.74 Iconostasis. St. Panteleimon, v. Gorno Nerezi -Skopje region
Source: INDOK centre, Skopje Institute

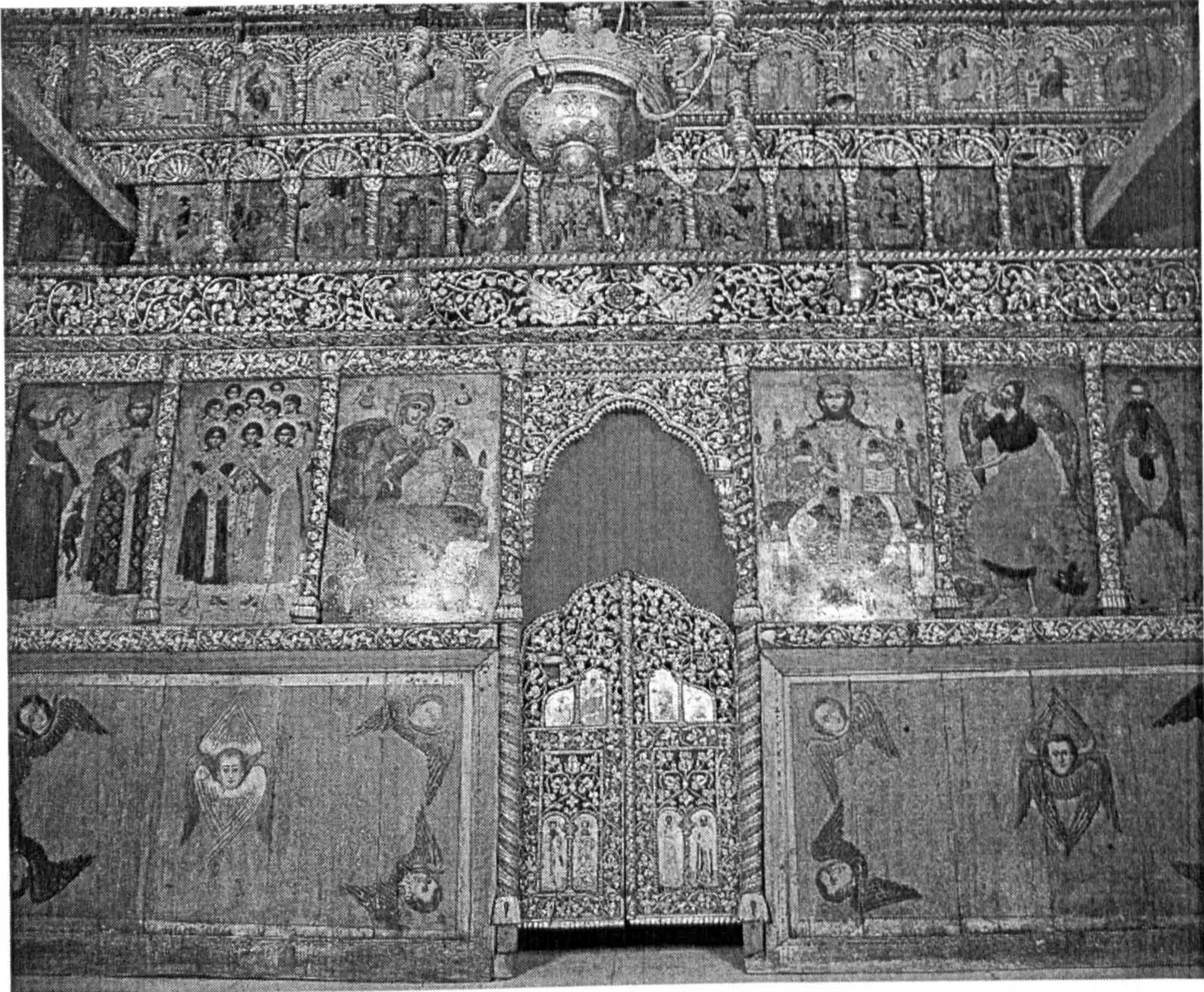

Figure 3.75 *Iconostasis. St. Naum, v. Ljubanista-Ohrid Lake. 1711*
 Source: INDOK centre. RZZSK - Skopje



Figure 3.76 *Portrait of the wood-carvers. Iconostasis. St. Jovan Bigorski Monastery church, v. Rostusa*
 Source: INDOK centre. RZZSK - Skopje



Figure 3.77 **Icon of St. Matthew the Evangelist. Ohrid icon gallery. (1295)**
 Source: INDOK centre. RZZSK - Skopje

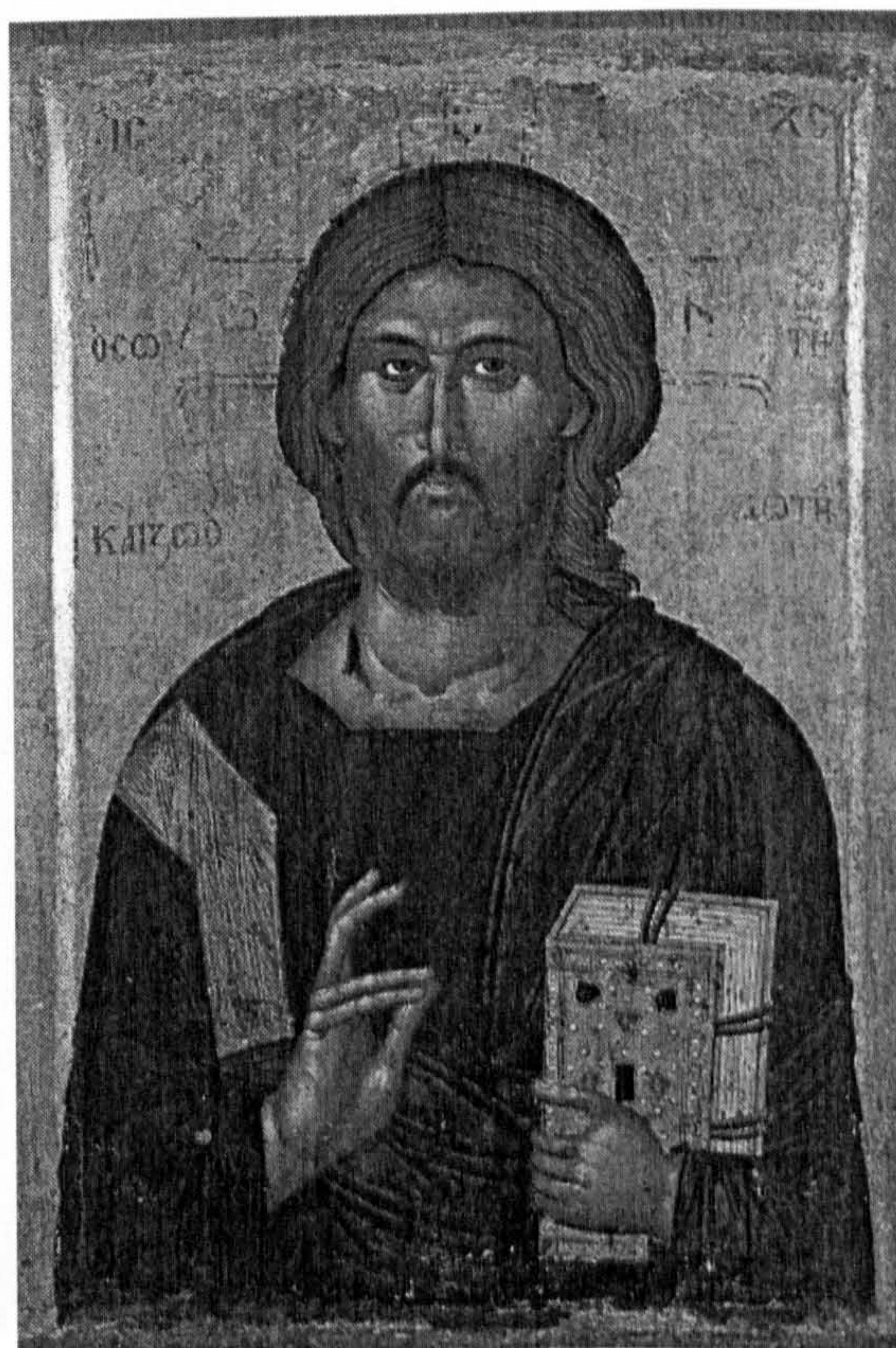

Figure 3.78 **Icon of Christ the Saviour and Giver of Life. (1394) St. Spas, v. Zrze-Prilep region.**
 Source: INDOK centre. RZZSK-Skopje



Figure 3.79 Mosaics at the baptistery. The episcopal basilica - Stobi
 Source: INDOK centre. RZZSK - Skopje



Figure 3.80 Mosaics at large basilica. Heraclea Lyncestis, Bitola
 Source: INDOK centre. RZZSK - Skopje

CHAPTER FOUR

BYZANTINE CHURCHES OF NINTH - FOURTEENTH CENTURIES IN MACEDONIA - DATA ANALYSIS

4.1 Architectural typology and chronology

As stated in the previous chapter , section 3.5, the subject of this chapter will be the Byzantine churches from the ninth to fourteenth centuries.

What are the precise reasons for selecting this period for detailed study? There are several reasons, which will be given below.

First of all, this period was the time when there was mass conversion of Macedonian Slavs to Christianity. This was the period of the formation of the Ohrid archiepiscopacy which, according to some historic sources dates back to the twelfth century and represents continuation of *Justiniana Prima*.

The architectural, aesthetic and structural characteristics of these structures are little different from those in the major centres of the Empire. As to wall paintings, these have the same high values. They represent part of the *corpus* of valuable fresco - paintings from the same period which exist in Yugoslavia (Serbia), Bulgaria, Turkey, Greece, Asia Minor, Cyprus and Albania.

Much more details on these reasons are presented in Chapter one, where the reasons for selecting the Byzantine churches from this period in Macedonia was discussed.

Analysing the conceptual development of churches as sacral structures and according to the principal architectural concept they can be divided into four main types (this is the same division mentioned in Chapter three, section 3.5):

- Churches as basilicas with or without a cupola and transept;
- churches of triconchal and tetraconchal conceptual solutions;
- churches as single or five dome cross -in - square structures;
- churches as single nave buildings.

Churches as basilicas with or without a cupola and transept

Following the chronology of the development of the church architecture , it may be said that the basilicas were the predominant structures from the beginning of this

period till the tenth century. (Fig. 4.1)

Usually they are three - aisle structures with coupled roofs, with the exception of St. Sophia in Ohrid (Fig. 4.1b), St. Bogorodica, v. Drenovo (Fig. 4.1c) and St. Nikola, v. Manastir (Fig. 4.1a) which are all vaulted nave and aisle structures.

The apses are either semi - circular or polygonal from the outside.

Churches of triconchal and tetraconchal conceptual solutions

The conchal churches with a dome (triconchal and tetraconchal) were characteristic for the middle of this period. (Fig. 4.2)

With the exception of the west arm of the cross, all other (east, north and south) are semi - circular conches from the inside and polygonal from the outside. (See app. 4, section 3.1)

Churches as single or five dome cross - in - square structures

The single or five (quincunx) dome cross - in - square churches are among the biggest groups of buildings. (Fig. 4.3A - B)

The main concept of these churches is the inscribed cross in a rectangular space, with a square area being formed at the cross - section of the cross - arms with or without a narthex. Over the main area of the church a naos rising over this square area is a dome (always semi - circular) resting on four free - standing piers (mainly square or rectangular) via pendentives and drum (without exception circular inside and polygonal outside). Sometimes, the circular structure of the drum and the dome is supported by pilasters (corner pilasters which represent, in fact, wall areas in St. Panteleimon, v. Gorno Nerezi (Fig. 4.3Bh) and St. Georgi, v. Gorni Kozjak. The apse is semi - circular from the inside and polygonal from the outside.

These churches are most frequently constructed without a narthex, i.e., there are only an altar and naos areas. The size of the altar area depends, more or less, on the size of the church. The *prothesis* and the *diaconicon* are constructed either as separate areas as in St. Georgi, v. Staro Nagoricane (Fig. 4.1d), St. Bogorodica, v. Matejce (Fig. 4.3Bg) or as two semi - circular niches in the east wall. In some cases, the niches are constructed as semi-circular blind niches from the outside as in St. Spas, v. Kuceviste (Fig. 4.3Bc) and St. Dimitrija, v. Susica. (See app. 4, section 4.2)

Churches as single nave buildings

The single nave churches (*Fig. 4.4*) were constructed mainly between the thirteenth and the fourteenth century, exception is the St. Georgi, v. Kurbinovo (twelfth century).

A lot of Byzantine churches belong to this group. These are smaller, rectangular structures covered with barrel vaults or timber coupled roofs and most frequently have an apse which is semi - circular from the inside and octagonal from the outside.

This was a general characteristic of the main type of Byzantine churches in Macedonia.

Chronological development of the church buildings

In this section we will underline some of important characteristics which are already mentioned in section 3.5.

The basilicas had a predominant role in the period of the Early Christianity. (*Fig. 3.64-65*)

There was a need for smaller structures that would provide enough space for a maximum of 120 persons (one quarter for clergy and three quarters for believers), without separation of the sexes. (*Fig. 3.68*)

However, with the formation of the first medieval state under king Samuel (967 - 1014), the basilica form of structure again became one of the predominant architectonic plans, but with a somewhat altered function. In this period, it represented a cathedral church. (St. Sophia, Ohrid, for example). (*See app. 4, section 4.3*)

Chronologically speaking, two other important basilica structures of the classical type (three naves without a dome) were built in the same century. This is the St. Nikola in the village of Manastir built in 1095. (*Fig. 4.1a*)

It is possible that, in the beginning, the old part of St. Georgi in v. Staro Nagoricane (*Fig. 4.1d and 4.14*) was a basilica as well. (*See app. 4, section 4.4*)

In the eleventh century, there began construction of cross - like dome churches in Macedonia. At first, these were modifications of the classical basilica type (St. Sophia, Ohrid). This is particularly true when looking at the architectural plan of the church of St. Bogorodica in the village of Drenovo, Kavadarci region (*Fig. 4.1c*). Based on the author's own considerations, this church originates from the beginning of the eleventh century.

The church was originally crudely built with an abundant incorporation of marble columns and capitals from Stobi near by. The church is, at the same time, a basilica with three vaulted aisles and compactly cruciform plan in the central aisle with a cupola. It had a narthex with a dome, probably without a drum. Its resemblance to the much older St. Sophia in Thessaloniki is indisputable.

If we carefully analyse the plan of the church complex of St. Leontie, v. Vodoca, near Strumica (*Fig. 4.5*), the latest one (the western church), according to its appearance, was a pre - variant of a fully formed cross - in - square structure with a cupola.

In the same region, in Veljusa village, a former bishop of Strumica, Manuel, originally from Asia Minor, restored the church of St. Bogorodica Eleusa in 1080 (*Fig. 4.2d*). The domed church with four conches, marble floor mosaic, and a carved marble iconostasis, decoration in the interior and exterior beauty were all according to traditional models in the capital of orthodoxy.

In the twelfth century, the development of a central type of a structure continued and buildings with a developed cross - like plan (in a square or a rectangular space) were constructed.

The church of St. Panteleimon, v. Gorno Nerezi, near Skopje, was built in 1164 by Alexis Porphyrogenetus, the grandson of Emperor Alexis I Comnenus. (*Fig. 4.3Ba and 4.8*) From the architectural point of view, it is in the form of a developed cross - in - square with four domed compartments in the corners, which are separated off by walls broken by entrances to the arms of the cross.

In the thirteenth century, the development of the architectural plan continues with two characteristic types of plans: fully developed cross -in - square single domed structures and vaulted single - aisle structures. The first type became dominant in the fourteenth century until the fall of this territory under the Ottoman rule, while the latter was dominant in the whole period from the fifteenth century until the beginning of the twentieth century, with some exceptions.

As a main representative of the first group the church of St. Bogorodica Perivlepta in Ohrid (*Fig. 4.3Ba and 4.6*), which from the fifteenth century started to be called St. Clement's church, was built in 1295 as a fully developed cross - in - square, with a cross - vaulted narthex. The stepped and harmonious upper construction today surmounts the structure of the later porch: the highest point is the central dome, and the ridge of the longitudinal and transverse arms of the cross is levelled with the cubiform base of the dome, while the roof of the rectangular body of the naos and the narthex is lower.

The church of St. Nikola in Varos, Prilep (*Fig. 4.4d and 4.43*) should be taken as a prototype of the second group. It is a remarkably high vaulted single - nave building.

The final phase of this period (the fourteenth century) is marked by a flourishing of the cross - like form with a single dome or, rarely, five domes.

The majority of the churches are in the form of a cross - in - square. The most common are the single - domed.

There are many representatives of this model. Noteworthy among these are: St. Nikita (*Fig. 4.3Aa*) and St. Nikola, v. Ljuboten (*Fig. 4.3Ag*) near Skopje; St. Archangel Michael, v. Lesново (*Fig. 4.3Bb*); St. Stefan, v. Konce (*Fig. 4.3Ad*); St. Nikola, v. Psaca; St. Bogorodica Zaumska, v. Trpejca (*Fig. 4.3Ac*) by the Ohrid Lake and also others.

The king Milutin, ruler of Serbia, ordered, for example, the adaptation of the basilica form of the church of St. Georgi in v. Staro Nagoricane (*Fig. 4.1d and Fig. 62-63*).

A very similar architectonic plan was constructed for the church of St. Bogorodica, v. Matejce (*Fig. 4.3Bg*) where there is also an elongated plan of the cross - in - square with five domes. The four domes at the corners of this structure which are far from the central dome do not present lateral support but are more decorative. To the east, the structure ends with three apses representing a reminiscence of eleventh century basilica churches.

However, when speaking about the characteristics of the structures dating from the fourteenth century, it is necessary to present the example of the *exonarthex* of St. Sophia in Ohrid (*Fig. 4.7*), which is the leading architectural creation of the period. It was known as Gregory's Gallery after its founder, Archbishop Gregory I, and so called because of the row of triple - arched openings along the upper floor. The ceramic inscription on the facade indicates that it was built in 1313-14. Scholars say that the building resembles the Byzantine palaces, of which very little is preserved: the famous Chalce in Ravenna, for instance.

Noteworthy in this "gallery" of architectural types of church structures in Macedonia are also the following three structures that, according to their specific concept, are different from the basic type.

The first is the church of St. Atanasie, v. Lesok (*Fig. 4.3Be*). It has a developed cross - shape freely placed in space. (*See app. 4, section 4.6*)

The second structure is the monastic church of St. Arhangel Michail in the village Kuceviste (*Fig. 4.3Bc*) near Skopje. It has the shape of a developed trefoil with a transept and a very high drum raised over the cubic base.

The third structure is the church of St. Andreja, v. Matka by Treska river

(Fig. 4.2c) representing a central plan – a trefoil with a dome and a narthex which was built in a later period. From its basic plan, this church is reminiscent of the church of St. Bogorodica Eleusa in the village of Veljusa.

This review of the chronological and typological development of Byzantine church architecture in Macedonia from the ninth to the fourteenth centuries shows that there exists a *corpus* of more than fifty structures classified into several main categories.

These are shown as follows:

• Basilicas - in total (Figure 4.1)	4
• Triconchs and tetraconchs - in total (Figure 4.2)	4
• One or five dome cross - in - square (quincunx) - in total (Figure 4.3A - B)	25
• Single nave - in total (Figure 4.4)	27

For detailed information see appendix 4, section 4.6.

If we summarise the number of churches according to types of structure, it is clear that a very small number (only eight structures or 14 percent of the total number (60) belong to the first two types – the basilicas and the central triconchs and tetraconchs. Most of the churches belong to the last two types – single or five domed cross - in - square and single nave structures (86 percent of the total number).

Chronologically, the buildings are classified as follows:

- Four buildings which pertain mainly to the central - conch type of structures¹ date from the ninth and the tenth century;
- Five buildings of mainly basilica and central / conchal type² date from the eleventh century;
- Four buildings³ of which two belong to the central/conch type and two to the single aisle structural type date from the twelfth century;
- Three buildings of which two belong to the cross - in - square type and one to the single aisle structural type⁴ date from the thirteenth century.
- Most of the Byzantine churches, i.e., more than forty⁵ are cross - in -square with one or five domes and single aisle buildings dating from the fourteenth century.

(For notes 1-5 see app. 4, section 4.7)

Although the territory of Macedonia is small, its position is very important in the Balkan region and it is near the greatest Byzantine churches. The above - stated facts

illustrate clearly that there was abundant construction activity in the course of six centuries. This arouses great delight both for the diversity of types and the great number of these structures, and particularly also for the high values of the wall paintings, which will be discussed in more detail when speaking about interiors.

4.2 Materials, structural elements and systems

4.2.1 Materials

In turning the design into reality through structural elements and systems, the Macedonian builder was very rational. Namely, he used local construction materials both natural (dressed or non - dressed) as well as ceramic products (*Fig. 4.10-11*) for different needs but also produced from a local material. The main building materials used in Byzantine churches in Macedonia are in full explained in section 3.4.3. (*See app. 4, section: 4.13*) More details on all the characteristics of materials (chemical - physical and mechanical) will be given in Chapter five.

4.2.2 Structural elements and systems

If the architectonic plan is the 'soul' of a structure, ^ethan its 'body' is represented by the structural elements and the structural system. Such is the case with the Byzantine buildings in Macedonia.

Although there are different types of structures according to the architectonic plan, these have almost the same structural elements that, according to the needs, form adequate structural systems. General data on this are given in 3.4.3 - 4. Presented further will be some principal characteristics of the Byzantine churches.

According to typology, they are divided into four main groups and they all have similarities and peculiarities.

Churches as basilicas with or without a cupola and transept (Fig. 4.1)

The main structural elements of these structures are the massive perimeter walls, masonry columns / piers, arches, barrel vaults, pendentives, semidomes and the domes.

The main, perimeter walls, have massive cross - sections, which, from the engineering point of view, are capable of sustaining the compressive stresses occurring in the structure as the result from the gravity loads. Their proportions, at cross - section, range between ninety to a hundred and thirty centimetres. (*See app. 4, section: 3.8*)

Churches of triconchal and tetraconchal conceptual solutions (Fig. 4.2)

In this type of structures, almost all the mentioned structural masonry and timber elements are used, with the exception of the columns / piers. What has been said previously in section 3.4.3-4 for the masonry elements in the first group holds also for those of the second group.

Although these are smaller than the previous ones according to their proportions and outline, they are constructed by a skilful hand and at a very good technical level. (See app. 4, section: 4.9)

Churches as single or five dome cross-in-square structures (Fig. 4.3A-B)

The single dome cross - in - square design represents the classical Byzantine construction form not only in Macedonia but also beyond in this part of Europe. From structural aspects, all the characteristic elements of the structural system of the previous two types of structures are also present in this type of structures.

The principal structural system of this type of structures is formed by massive perimeter walls, a pair (or more) of symmetrically placed masonry piers with a square or a rectangular cross - section, arches, barrel and groined vaults, pendentives, dome, semi - domes as well as timber horizontal belts and ties. (St. Nikita, v. Banjani (Fig. 4.3Aa), St. Bogorodica Zaumska⁶ (Fig. 4.3Ac), St. Stefan, v. Konce (Fig. 4.3Ad). An exception from this rule are the churches of St. Archangel Michail, v. Lesново (Fig. 4.3Bb) where there is a dome over the later built narthex and a blind dome in the narthex of the church of St. Dimitrija, v. Susica (Fig. 4.3Bd).

From the total fund of structures of this type, only three have the same concept but with five domes (one central and four at the corners) that represent a developed form of the basic single - dome model.

In the case of the single - dome structural system, the corner areas between the cross arms which are always lower than the previous ones, are vaulted by barrel vaults, as are the areas between the piers and the north, west and south walls.

The five - dome system is found in two variants of the same system. In the first variant, the corner dome structures are immediately next to the central dome and, from structural point of view, they have a greater effect upon the stability of the structure. (Fig. 4.3Bh)

In the second variant, the corner domes are situated at a certain distance from the central one for the purpose of satisfying the outline proportions of the rectangular

area. The additional space between the central area and the corners is vaulted, as a rule, by groined vaults, as is the case with the churches of St. Georgi, v. Staro Nagoricane (*Fig. 4.1d*) and St. Bogorodica, v. Matejce. (*Fig. 4.3Bg*) (*See app. 4, section: 4.10*)

In the case of the Byzantine churches, the dome is always in the form of a hemisphere and is placed on the masonry structure of the tambour, which always has a circular form from the inside and an octagonal form⁷ on the facade (irrespective whether it is central or corner) with the following exceptions: the central tambour of the church of St. Bogorodica, v. Matejce and the reconstructed drum and cupola of the Eastern church in the monastic complex of St. Leontie, v. Vodoca are dodecangular, while the corner tambours of the church of St. Panteleimon, v. Gorno Nerezi (*Fig. 4.8*) have a square form. (*See app. 4, section: 4.11*)

Churches as single nave buildings (Fig. 4.4)

The structures belonging to the last typological group are represented by the simplest architectonic plan and structural system. These are the single - nave structures whose number is the same as that of structures from the previous group.

The principal structural system is represented by the massive perimeter walls. The covering of this rectangular area is done in several ways: by a couple flat roofs, by barrel vaults, by barrel vaults and one dome and system of vaults crossed in different levels. (*See app. 4, section: 4.12*)

4.3 Characteristics of the building interior and exterior

4.3.1 Interior

Each defined space that serves a certain purpose, which in this case is the religious rituals, is subjected to certain regularities that must satisfy the requirements.

If the architectural plan and the structural system define the required and expected functional area, the finishing of its interior makes complete the physical presentation of an idea. The interior of the Byzantine church structures in Macedonia is an element which demand attention. Along with the architectural and structural expression, it represents an essential element for the subject of this dissertation. With its form, the structure enables the basic function for which it is built, performance of the church service, i.e., contact with the believer through the teachings of Christ and faith in Christ. The interior is the place where there is faith is made through presentation of pictures and its own expression.

The 'gallery' of Byzantine fine arts in Macedonia, as a constituent part of each sacral creation, is mentioned here only as an element of respect and as an element for other investigations. Many scholars have recognised the values of the interiors of the Byzantine churches in Macedonia. Among these is the renowned Byzantologist Gabriel Millet, who, in 1916, having realised the distinctiveness of Macedonian paintings – which he called a painting treasury of Pan - Byzantine significance – introduced the term 'Macedonian school' (*Fig. 4.15-18*).

From the architectonic aspect, the one - dimensional forms of the interior are: the floor, wall, vault and dome areas and the spatial forms are the iconostasis and the church furniture. These represent the contents of the interior of each structure, almost without exception.

If we analyse carefully the vertical wall areas of the structures, we may conclude that they represent flat, continuous walls along both horizontal and vertical line. One exception to this rule is represented by the church of St. Bogorodica, v. Matejce (*Fig. 4.3Bg*) where the flat surface of the walls is disrupted by shallow pilasters on the south and north walls.

These compact flat areas are often perforated by openings – monoforia such as the monoforia of the church of St. Sophia, Ohrid (*Fig. 4.12*), biforia – as is the one on the apse of the church of St. Jovan Kaneo, Ohrid (*Fig. 4.13*), or triforia – as are those on the church of St. Georgi, v. Staro Nagoricane (*Fig. 4.14*), usually in the upper zones of

the walls, with the exception of the apse wall structure where these openings are mainly in the lower zone. *(See app. 4, section 4.14)*

A constituent and important part of the church that, in the beginning, represented only an architectural element (a screen separating two different areas according to function), is the iconsostasis.

Up to the middle of the thirteenth century, it was constructed mainly of marble elements *(Fig. 3.74)*. Gradually, stone was replaced by wood. Then icons began to be placed on it starting in the fourteenth century. In the nineteenth century, masterpieces of woodcarving were created in this area *(Fig. 3.75)*. *(See app. 4, section: 4.15)*

The oldest icons in Macedonia date back to the eleventh century. From the period of up to the beginning of the twentieth century, over 23,000 icons that have some value have been inventoried. The most valuable, however, are those from the eleventh to the fourteenth century. The Ohrid gallery of medieval icons contains some of most important and most renowned such as those originating from Sinai, Mount Athos, Moscow. *(Fig. 4.19-20)* *(See app. 4, section: 4.15)*

4.3.2 Exterior

As already mentioned when talking about the characteristics and the morphology of the wall of Byzantine architecture, it has two faces and a core. One of the faces, the inner one, is always covered with lime plaster and covered with fresco - paintings for this reason little attention was paid to the vertical surface itself.

The other face, that of the facade, apart from having important structural characteristics, also represents an element of the first contact with the visitor or believer.

For the purpose of presenting beauty and function, the builder – the architect - paid particular attention to its finishing. He used natural elements such as stone⁸, an artificial construction element – brick⁹, and other ceramic elements. Using lime mortar, he created moulded and decorative facades that not only expose the structural composition but represent well - designed ornaments and polychromy.

The main characteristic of these facades is that they are never plastered externally (the only exception is St. Bogorodica Eleusa, v. Veljusa) where the facade is plastered and the original walling pattern is outlined on it – a rarity in Macedonia. *(Fig. 4.21)*

One of the two basic elements for the construction of the facade, brick is more

extensively used than the other. It is used not only in combination with stone, but also exclusively for the ornaments and construction of parts of the walls.

It is not only incorporated into the wall mass in a horizontal position, which is the most common position that corresponds to its proportions and structural characteristics, but is incorporated vertically, diagonally or frontal.

If we look carefully at the east facade of the church of St. Sophia in Ohrid (*Fig. 4.12*), we can see that large sections of the upper zones of the three apses are constructed only of horizontal rows of bricks separated, in a vertical direction, by an expansion joint made of mortar having the same thickness as the brick itself.¹⁰ This system of construction of a facade wall is applied particularly in construction of the drums of the central (*Fig. 4.22-24*) or corner domes (*Fig. 4.8*).

This system of construction was abandoned and there began to be developed the second form of a facade wall that became characteristic not only of the Byzantine churches but also of the structures pertaining to Islamic architecture built later. It is the well-known 'clausonai' *opus*. (*Fig. 4.25-31*) (*See app. 4, section: 4.16*)

The combination of bricks of standard and special proportions and forms with well-dressed stone was used for the construction of the drum of the central dome of several structures. The best examples are the churches of St. Andrea, v. Matka (*Fig. 4.32-33*), St. Dimitrija, v. Susica (*Fig. 4.34-35*) and St. Bogorodica, Osogovski monastery. (*Fig. 4.36*)

Brick as a construction element, used in the construction of Byzantine churches, has also a decorative purpose. Namely, apart from its horizontal and vertical placement on the facade, it can be placed diagonally or with one of its sides. This enables its use for decoration, i.e., imitation of certain forms (from the flora and fauna) as are the meanders, herringbone, chess field and other decorative-relief forms. This group includes also the dented single-row, double- or triple-row horizontal and circular cornices used as endings of the roof, i.e., the dome areas.

The most representative samples of decorative use of bricks are found on the facades of the church of St. Bogorodica Perivlepta, Ohrid (*Fig. 4.37*), St. Dimitrija, Varos (*Fig. 3.38*) and especially on the southern and the northern facade of the church of St. Bogorodica Zaumska, v. Trpejca (*Fig. 4.39-40*). Included in this gallery of decoratively finished facades are also the single-nave dome church of St. Nikola Poloski (*Fig. 4.41-42*) and the church of St. Nikola, Varos. (*Fig. 4.43*)

This plastic-relief and colourful finishing of the facades becomes particularly expressive when used to form the shallow blind niches placed in a cascade manner

that are very impressive for the illuminated and shadowed areas obtained with the rotation of the sun. (Fig. 44-46) (See app. 4, section: 4.17)

A rarity, the only one on the soil of Macedonia, is the finishing of the gable parts of the sides of the tambour of the church of St. Jovan Kaneo, Ohrid. Instead of ending with one, two or more arches upon which there is single or double dentilled cornice, the tambour of this structure ends with a triangular tympanum of dressed stone as a cornice (Fig. 4.47). This is the unique example not only in Macedonia but even beyond, in the Balkan region. According to the author's view, this is an influence from the Armenian architecture where this mode of ending of the sides of the tambour is very common.

By way of conclusion, it might be said the finishing of the facades, although not achieving the universal values of the wall paintings inside the structures, still strives to approach them, with a lesser or greater success. It represents a characteristic mark of architectural expression at the time of Byzantine culture in Macedonia.

It may be said that they, along with the architectural concept and spatial form of the structures, define the values worthy of respect.

4.3.3 Relationship between interior and exterior

During the realisation of the architectonic plan, the builder materialises the idea by means of the structural elements and the system. The additional things done are the finishing of all the spatial and surface elements both in the interior and exterior of the structure.

The spatial concept of the interior is also expressed on the exterior. For example, the cross which is formed by the columns (four or more than four) has its own spatial representation. The vaulted cross arms have greater height than the areas between them. Their intersection is surmounted by the drum on a square base. At first the drum was placed at a low height, but later it was raised higher and higher. This is to emphasise the vertical conceptual presentation of the cross.

If there are simple flat surface forms inside the structure, the builder (the architect) presents the structural concept through the masses of the perimeter walls and in a way that, first of all, satisfies the structural needs and then contributes to relief in expression. If we analyse the classical plan of a single - dome cross - in - square church, we will see that, in the direction of the east - west axis, it is divided into three parts – bays (the first from the east wall to the first pair of columns, the second between the columns and the third between the columns and the west perimeter wall).

This division is also characteristic for the facade, i.e., the plan is very frequently copied in vertical projection. If we carefully analyse the relations between the plans and the facades of the buildings: St. Nikita, v. Banjani (*Fig. 4.3Aa and 4.22*), St. Stefan, v. Konce (*Fig. 4.3Ad and 4.23*) and St. Archangel Mihail, Stip (*Fig. 4.48-49*), the cross is defined and presented spatially by the higher height of the cross - arm in respect to that of the area between the arms. But it is not only the cross - arm, but also the position of the piers, i.e., the division of the inner space into bays is presented by construction of shallow pilasters whose proportions and position correspond to those of the piers in the interior. These are used to form shallow niches by single or double encirclement, ending with a single or double decoratively executed arch.

Such a construction of pilasters with the position of the structural elements in the interior (piers) has, first of all, a structural role. This means, in fact, thickening of the cross - section of the wall by which a greater stability of the wall structure is provided. But in this case, this structural need contributes to the aesthetic, decorative expression on the facade wall. The secondary relief of the structure is represented not only by the openings but also by the decorative finishing of the facade at one or several levels. If one also adds the polychromatic inventiveness in separation of certain parts of these vertical elements, a harmonic image of function and aesthetic presentation is obtained.

If we analyse the plan and the south facade of the church of St. Bogorodica, v. Matejce (*Fig. 4.3Bg and 4.50*), we may conclude that this happens also in the case of structures with more than three bays, as is the case with the classical type of Byzantine single - dome cross - in - square church.

There is a correlation between the plan in horizontal projection and its reflection along both a vertical line and in space, which is one of the noblest achievements of the native builder from this period and region.

4.4 Environmental conditions and location of the buildings

Each structure from the existing *corpus* of the Byzantine churches on the territory of the Republic of Macedonia is generally situated in different conditions.

These conditions depend on many natural factors including geological, geographic and climatic ones.

Man - made factors also influence the characteristics of the environment. At this point, emphasis should be put on the level of development of society with all its attributes, i.e., elements that define it in a given period. (*See app. 4, section 4.18*)

Natural location of the structures.

If we carefully analyse the maps of Macedonia presenting its natural characteristics (soil and climate) (*Fig. 3.2 and 5.7-10*) and the physical location of the structures, we may conclude that:

- All structures from this period are situated in an area susceptible to earthquakes with an intensity greater than six degrees MCS and a minimal return period of fifty years (which is a very unfavourable circumstance);
- Most of them are located in a territory of Mediterranean climatic characteristics (which may be considered as an element of lesser effect regarding mechanical damage to structures than the damage inflicted by ice), while the remaining churches are located in a territory of modified Mediterranean climate.
- The altitude at which the churches are situated ranges between 250 m (St. Leontie, v. Vodoca) and 850 m (St. Bogorodica, v. Matejce and St. Ilija, v. Gmncari) which critically affects the level of damage.

If we analyse the locations of the structures in respect to the living environment, three different locations are generally defined: urban, rural settlement and locations which are at a distance of more than 5 km from the previous two. The situation is as follows:

- 23 structures¹² are within five urban settlements;
- 19 structures¹³ are located in nineteen rural settlements
- 17 structures are located in the vicinity, but outside populated areas¹⁴

(*See app. 4, section: 4.19*)

Based on the analysis, it may generally be concluded that the location of the structures and their surrounding plays an important role as to the extent of our engagement (the engagement of the owners, professional services, local and national authorities). This is particularly important in the phase of preparation of the National Plan for Protection of Cultural Heritage Against Catastrophes and the creation of the List of Regular Inspection and Monitoring at communal, regional and state level. The information could be used in development of a strategy for elaboration of a National Programme of Cultural Tourism, that has lately been given much attention in the Republic of Macedonia.

4.5 State - of - the art

The structures from the Byzantine period, as part of the total cultural heritage of Macedonia, have so far been treated with particular attention. This *corpus* comprising sixty structures is today completely owned by the Macedonian Orthodox Church.

According to the provisions of the presently valid Code for Protection of Cultural Monuments, all activities taking place now and in the future are subjected to the consent of a professional institution, the Republic Institute for the Protection of Cultural Monuments.

All structures, with one exception, are functional in their original form.

4.5.1 Existing conservation treatment

Since its foundation in 1949, the Institute for Protection of Cultural Monuments has been involved intensively in conservation - restoration activities in addition to all other activities in the sphere of protection.¹⁹

The investigations have shown that, within a period of almost fifty years, each structure has undergone more or less extensive conservation - restoration works.

In the following analysis, emphasis will be put on more extensive works carried out on the structures.

Basilicas

All the four structures belonging to this group have, for the last fifty years, have been subjected to intensive works. We will emphasise again the extent of the work at St. Sophia, Ohrid treatment. (Fig. 51-52) Ample conservation works were done both to the interior and the facade and the roof of the churches of St. Nikola, v. Manastir and St. Georgi, v. Staro Nagoricane. Recently, a lead cover was placed on the latter. It should be noted that ample repair works are being currently carried out for the church of St. Bogorodica in the village of Drenovo.²⁰ (Fig. 4.53-54)

Triconch and tetraconch churches

Extensive conservation works were done for the church of St. Bogorodica Eleusa, v. Veljusa (Fig. 4.55) involving removal of the later constructed porches on the

north, the west and the south facades as well as complete conservation of the interior (the frescos and the floor with the mosaic) and thorough conservation of the facades.

In the case of the church of St. Andrea, v. Matka (Fig. 4.32), a complete conservation procedure was carried out and a lead foil was incorporated into the foundation to prevent permanent penetration of moisture²¹. However, the author is of the opinion that the physical cutting of the wall will certainly have negative consequences during future dynamic motion of the soil.

One or five dome cross - in - square structures

Both minor and extensive conservation - restoration and reconstruction works were carried out for twenty five structures. The only structure that has not undergone any intervention is the church of St. Atanasie, Varos. (Fig. 3.51)

Minor works, such as interventions on facades and roofs as well as periodical maintenance have been carried out on several structures.²²

More extensive conservation - restoration works including removal of porches, enlargements of roof areas and domes have been done for the following churches:

St. Jovan Kaneo, Ohrid (Fig.4.13 and 4.57). The conservation activities undertaken for this structure involved removal of the porches surrounding the structure on the north, the west and south facades, restoration of the walls in the upper zones of the structure as well as restoration of the cross arms;

St. Nikola, v. Psaca (Fig. 4.58-59). Works similar to those done for the previous structure were also performed here, the difference being in a more radical but non - defined reconstruction of the cross arms in the part including the narthex and the dome;

St. Stefan, v. Konce²³ (Fig. 4.60-61). After the detailed in - situ research that confirmed the existence of elements of the original cross arms with triple dentilled cornices, ornaments and openings in the tambour as well as elements of medieval glass from the *oculus* of the monoforia, restoration of the cornices on both the structure and the cross arms of the cross and the tambour was performed. Restoration of the drum and dome as well as finishing of the facade were carried out.

St. Panteleimon, v. Gorno Nerezi (Fig. 4.62-63). This structure was damaged during the Skopje earthquake of 1963. The activities for repair and conservation taken for this structure are presented in section 4.7.1 dedicated to earthquake damages.

St. Nikita, v. Banjani (Fig. 4.64-65). Extensive works were done for this structure. These consisted of removal of the later formed coupled roofs and the enlargement of

the dome and presentation of the original wavy form of the cornices on the sides of the tambour. The strengthening which was carried out is explained in more details in 4.7.1.

The most extensive conservation - restoration - reconstruction works were done on the following structures:

St. Leontie, v. Vodoca (*Fig. 4.66-69*). Large reconstruction works were carried out involving construction of reinforced - concrete structures (belt courses, columns, vaults and domes) and completing of the two churches with the later constructed narthex. In the opinion of the author, this reconstruction was not in compliance with the conservation principles since it was done according to assumptions, not actual sources of information.

St. Bogorodica, v. Matejce. (*Fig. 4.70-71*) As for the previous structures, ample conservation - restoration - reconstruction works were done also for this structure including incorporation of reinforced concrete structures and completing of the structure giving it the assumed original appearance. More details on this structure are presented in Chapter five.

Single nave structures

This group encompasses most of the structures considered. These have also undergone interventions of different extents. Out of this group, more extensive works were done for the following: St. Nikola, Varos (*Fig. 4.43*), St. Nikola, v. Radisani, St. Spas, Stip (*Fig. 4.71*), St. Nikola, v. Sisevo. (*Fig. 4.72*)

Based on these data, it can be concluded that much has been done for the past fifty years despite the small amount of allocated financial resources. Hence, it may be expected with a great certainty that, under improved financial conditions, these activities could be more much intensive in future.

These activities affected the selection of the structures for detailed investigation (a total number of four), and the selection of the prototype for dynamic tests and the application of a method for its strengthening (the subject of Chapter 5).

4.6 Comparative analysis of Byzantine church architecture in Macedonia and neighbouring countries

As has already been mentioned, the development and characteristics of Byzantine architecture in Macedonia is generally closely connected with the level of cultural, political and social development of the Byzantine empire. This influence was different depending on the kind of affiliation of this territory with the Byzantine Empire or other states.

All that has been created on this territory can therefore not be considered to be based only on local conditions irrespective from the general situation.

Accordingly, certain examples found in Macedonia may have similarities with examples in neighbouring countries (Serbia, Bulgaria, Greece, Turkey) and vice versa. Some structures can even be compared to some existing in the countries in the Near East (Syria).

As has already have been said, structures from the Byzantine period in Macedonia, are divided into four categories: basilica structures, triconch - and tetraconch structures, one - or five - domed cross - in - square structures and single - nave structures.

In this analysis, only the structures belonging to the first three groups will be analysed.

Structures with basilica plan

There are four structures in Macedonia pertaining to this type. Two are purely basilica structures and the other two are somewhat different from the classical basilica concept. The latter represent, in fact, a modification of existing older structures.

The analysis of the structures dating from the beginning of the fourteenth century, i.e., the churches of St. Georgi, v. Staro Nagoricane and St. Bogorodica Ljeviska, Prizren (Serbia) (*Fig. 4.74b*). points to both similarities and peculiarities. The one in Prizren (1307) is chronologically older. It is assumed that both adaptations were done by the same masters who applied a similar concept.

The enlargement and adaptation of both structures were ordered by king Milutin. Both were founded on older structures representing the classical type of a three - nave basilica. The three - nave area was transformed into a structure with an inscribed cross, with a central dome and four smaller corner domes. (*See app. 4, section: 4.20*)

The second structure of this group is the church of St. Bogorodica, v. Drenovo (*Fig. 4.75*). As we see it, this structure represents a shortened three - nave basilica with a dome in the central nave and two aisles on the north and south side. Its central cross - like area surmounted by a dome (with a diameter of 3.2 metres) is connected with the side area through two openings divided by cylindrical stone columns (forming a kind of a biforium). (See app. 4, section: 4.21)

Considered as a whole, its plan could be compared to the plans of the churches of The Assumption of the Virgin, in Nicea (Iznik - Turkey) (*Fig. 4.75b*) originating from the sixth century, St. Mary Deaconess (Kalender Mosque) (*Fig. 4.75c*) in Istanbul dating from the sixth century, and the church of St. Sophia in Thessaloniki (*Fig. 4.75d*) also dating from the seventh century.

If we compare all these four plans, we may conclude that the plan of the church in Drenovo is the closest in form to that of the church / mosque in Istanbul. Namely, if the first pair of side areas south and north from the central area of the church (mosque) in Istanbul are connected as a mass, the original plan of the church in Drenovo is obtained. Similarities are found in concept and placement of the central and the side apses and their communication in the altar area. However, each of the churches has its own peculiarities in addition to the above similarities. (See app. 4, section: 4.22)

Many authors frequently compare the 'basilica' in Drenovo with that in Thessaloniki (St. Sophia). According to the author's opinion, there are less similarities in this case than with the plan of the church of the Assumption of the Virgin in Iznik (Nicea), with the exception of the corner domes.

If we search for similarities as to the central area of the church in Drenovo, we consider that it is a modification of the cross - like church in Resafa (Syria) dating back to the sixth century²⁶ (*Fig. 4.75e*). Namely, if the corner domes are removed and the full mass of the masonry column supporting the central dome is formed, the basic concept of the central part of the church in Drenovo is obtained.

Triconchal and tetraconchal plan

The second type of structure in Macedonia dating from the Byzantine period includes the churches with tri - and tetra - conchal architectonic plan.

These were mainly structures used exclusively as monastic churches. Their architectonic plan fully satisfied the functional needs of their users. In the side conches, there are acoustic areas for singers whose chants are very important for the

celebration of the liturgy. According to their functional characteristics, these churches in the Balkan region are also referred to as 'monastic churches.'

If we compare the four churches of this type existing in the territory of Macedonia with those in the neighbouring countries, we can find some similarities with those in Greece, Bulgaria, Serbia and Rumania (we may observe that, in this territory, there exist about twenty structures dating from the period between the ninth and the fourteenth century).

The three structures St. Panteleimon (Ohrid), St. Andrea v. Matka and St. Bogorodica Eleusa, v. Veljusa (*Fig. 4.2b-c-d*) have a tri - or tetra - conchal plan recognisable from the outside, while the fourth structure, i.e., the church of St. Archangel Mihail - St. Naum, v. Ljubanista (*Fig. 4.2a*) is situated in a rectangular area and its basic plan is not recognisable from the outside as is the case with the above mentioned three churches.

If we search for similarities or identity with churches in the Balkans, we may conclude that the conchal type of a structure situated within the framework of a rectangular area (St. Naum) can be found only in the plan of the church in the village of Kulata (Petric region, Bulgaria) (*Fig. 4.76a*) where the side conches merge with the mass of the perimeter walls, the difference being that the church in Macedonia is formed by a later adaptation of a triconchal plan. (*See app. 4, section: 2.23*)

If we search for some more developed form of conchal churches than that of the older structures in Macedonia (as is the plan of St. Bogorodica Eleusa from the 11th century) we may find this in the plans of the churches in Kalenic (Serbia) (*Fig. 4.76b*) and the church in Kozi, Romania. (*Fig. 4.76c*)

One - or five - dome cross - in - square structures

This group and the group of single - nave (with or without a dome) structures represent the majority of Byzantine structures in Macedonia dating from the period between the ninth and the fourteenth centuries.

The first represent the classics of Byzantine architecture from this period not only for their architectural and structural concept but also for the finishing of the exterior.

The main concept is repeated with slighter or larger deviations, but each structure still preserves its main local characteristic.

Since the number of similar structures is great, the author would like to discuss, in this part of the analysis, examples in Macedonia that are different from those in the neighbouring countries. .

First is the church of St. Panteleimon, v. Nerezi (*Fig. 4.77a*). Its plan bears traces of cross - like churches from the fifth century. This architectonic plan had been preserved until the twelfth century when the church was constructed. If we search for an analogy , such an architectonic plan is found in the Sulidje Mosque in Thessaloniki (*Fig. 4.77b*). There are the following similarities between these two structures: both structures have an inscribed cross with a central dome and four corner domes upon formed square areas at plan. The central dome rests on masonry elements that form the square areas between the cross arms. (*See app. 4, section 4.24*)

However, there is something that makes the structure in Gorno Nerezi different from the other structures and unique in the Balkans. That is the appearance and the structure of the tambours of the small corner domes. If we carefully examine *Fig. 4.8*, we can see that these are smaller than the central dome structure that dominates with its proportions.

It is the square form of the smaller tambours that makes them unique. This characteristic cannot be found either in Istanbul or in Thessaloniki or beyond in the Balkans. A prototype of this form can be found in old structures in Syria, the difference being in the finishing of the facade. The facades of the structures in Syria are constructed of well dressed stone, while in this structure, the facade is constructed only of bricks and lime mortar.

All the structures of this group in Macedonia have common characteristics particularly regarding the polychromatic and relief finishing of the facades, which are always plastered.

The investigations have shown that it is difficult to find forms of structures that are completely identical not only among structures in different countries but also structures that are very close one to another. This leads to the conclusion that, in the course of six centuries, the builders created architectonic forms that were similar but in no way identical, particularly regarding the finishing of the facades, the first grade and the second grade outline and relief of the structures, constructing long - lasting structures to remind us of the past and to be respected.

4.7 'Learning Tools'

4.7.1 Damage caused by earthquakes in the recent past and treatment of this problem in Macedonia and beyond, in the Balkan region

Among the wide range of damaging factors, natural or man - made, to which the cultural heritage have been and will be exposed, the most destructive, expected and unpredictable factor is - earthquake.

This damaging factor is permanently threatening the territory of Macedonia, the Balkans and beyond, the Mediterranean region. Each person or group of individuals, experts and professionals, and the state entities, put much effort in mitigating the consequences of all those damaging factors.

How? When? To what extent and with what success? How should they treat the cultural building heritage?

A response should be given to all these questions. It will enable not only elaboration of improved methods but also finding out what to be eliminated, modified or made better for the purpose of adequate treatment of this heritage at present and future time.

These 'tools' are elements by which it will be more possible to propose methods and methodologies, which, we do hope, will contribute to, an appropriate and improved, treatment of existing cultural heritage.

Let us analyse recent events. For example, the day of July 26th, 1963 (Skopje earthquake). This date is the key stone upon which an update and adequate treatment of the building *corpus* (in which the cultural heritage of Macedonia has its own place) is developed.

This is not a subjective choice. (See app. 4, section: 4.25)

As to the *corpus* of Byzantine structures, a few were seriously damaged: the church of St. Panteleimon, v. Gorno Nerezi and the church of St. Nikola, v. Radisani.

Islamic architectonic structures (sacral and secular) located strictly in the town area were badly damaged. What was the level of damage? Which structural elements have been damaged and to what extent? What were the activities carried out for repair and strengthening of the damaged structures?

Based on the investigations, it was proved that the vaults and domes have been most severely damaged structural elements as well as the combination of columns and arches (porches and galleries).

This is of importance to know, because the vaults and domes are the principal spatial structural elements of the Byzantine structures too.

However, damages were also inflicted to single, tall structures, such as are the minarets, the towers and the unique clock - tower in the city.

During the author's investigations, attention was particularly focused on repair and strengthening actions on ruined and damaged structures and to their principal bearing elements (walls of stone, brick and lime mortar; piers and columns, as well as to the arches, vaults and domes).

Levels of repair, strengthening, restoration and reconstruction actions have been carried out depending on the level of damage and the function of the structures. During this process, preserving the plan, volume and function was of primary importance. Special attention was to be paid to the conservation of the authentic structure of the building by using traditional material and technology. However, due to lack of previous experience, some of those employed were not appropriate.

However, what was carried out can not be changed, but a lesson can be learned.

How were the above mentioned interventions realised? Injection, rebuilding and reinforcement have been practised. (*See app. 4, section 4.26*)

As strengthening elements steel bracing elements were used for connection of horizontal floor structures with vertical walls preventing their separation. (Applied on Kursumli Caravan Sarai)

Reinforced concrete panels, walls and columns were used in the repair of the superstructure and the foundation elements. (*See app. 4, section 4.27*)

Particularly important strengthening and increase of structural resistance were carried out in the foundation zone. For example, the church of St. Panteleimon (v. Gorno Nerezi) was strengthened after being damaged by the earthquake of 1963 and suffering deformations induced by settlement and sliding. (*Fig. 4.79*)

A reinforced - concrete ring at the level of the foundation, in all perimeter walls, has been used as a strengthening element (foundation of the Sultan Murat's Mosque in Skopje).

According to the data, it is clear that two ways of incorporation of reinforced - concrete belt courses and columns into the existing wall mass were employed. (*Fig. 4.78a-b*)

The Montenegro earthquake or some such reference proved that the stronger method - the reinforced concrete skeleton system - contributed much more to the severe

damage of structure than did older and more flexible one. Hence, instead of contributing to the better resistance of the structure, it became a factor of damage.

For strengthening of the roofs of the damaged churches, reinforced concrete belts were incorporated into the wall mass of the base of the drum (*Fig. 4.80a*), i.e., cylindrical reinforced concrete rings were constructed for strengthening of the structure supporting the dome (*Fig. 4.80b*) This approach is, however, considered unacceptable. During the conservation of the church of St. Bogorodica, v. Matejce, the same flaws were repeated. A completely new system of reinforced concrete vaults was constructed, but now, upon the existing system of masonry structures (*Fig. 4.81*). It is surprising that this intervention on the church of St. Bogorodica was done many years after the Skopje 1963 earthquake. (*See app. 4, section: 4.28*)

As can be seen from these examples, it is clear that, due to insufficient knowledge and non - existence of international recommendations for proper and acceptable treatment of repair and strengthening of cultural monuments, the interventions which were carried out, as seen today, could be qualified as an inappropriate and non - acceptable approach. These were the characteristics of some interventions carried out in Macedonia. In the subsequent text characteristics of approaches adopted in the neighbouring countries will be presented.

Montenegro and Croatia (Dubrovnik)

On April 15, 1979, a strong earthquake inflicting severe damage struck Montenegro and part of Croatia. The earthquake inflicted heavy damage to structures pertaining to cultural heritage. As a consequence, the most valuable cultural heritage of Montenegro, particularly that of the City of Kotor, was damaged. See app. 4, section: 4.29)

The earthquake was the reason for establishment, inter alia, a new institution for protection and conservation of cultural monuments in the City of Kotor. The main objective of this institution was repair and conservation of the damaged structures of Kotor and its surroundings.²⁹

Since the earthquake in Montenegro and Croatia took place sixteen years after the Skopje earthquake and three years after the Friuli (Italy) earthquake, certain activities were executed in a better way. If we consider the example of Kotor, which contains, in fact, all the relevant characteristics of activities undertaken in Montenegro, we will see that there is a certain advance in the sense of a more adequate treatment than those after the Skopje earthquake. (*See app.4, section: 4.30*)

According to the existing documentation, experts from the Institute in Kotor endeavoured to avoid introducing vertical concrete pillars in the corners of buildings. This was as a result of investigation of more than 1000 structures which proved that these parts were carried out with the best quality materials. Hence, the introduction of these elements could have damaged other parts of the buildings.³⁰

What was the material and procedure applied in repair, strengthening and conservation of cultural monuments?

Strengthening of foundations by concrete structures (reinforced and non-reinforced) was done by using reinforced concrete belt courses incorporated into the wall mass. In the attics of the structures, these were anchored into the wall mass by metal anchors sealed with epoxy resins or cement milk (if there were no frescoes).

Cement emulsion was used for injection, i.e., repair of smaller or larger cracks in the wall mass. (*See app.4, section 4.31*)

Noteworthy is the fact that the colleagues from Montenegro had very good co-operation with other colleagues from other republics of former Yugoslavia. Co-operation also was established with ICCROM and UNESCO. A mission was sent to Montenegro.³¹

This mission was important also because its objective was not only to give an answer to some specific problems but to intercede for a certain acceptable methodology.

Within the framework of the mission, particular importance was given to some significant remarks and recommendations related to two structures taken as case studies: the Maritime Museum of Kotor and the Monastery of Praskavica.³²

To that effect, some of the directions given in the report 'Principles of Structural Intervention to Historic Buildings in Earthquake Zones' (*Feilden 1982:20-21*) are quoted below:

'Analyse the values in the building. These must be respected'

'Analyse the structural system' This should not be changed'

'Decide how the structural system is working'

'Having understood the building in its totality....'

'Is a new use proposed? / Does this impose structural requirements? Is it sympathetic to the building and its value?'

'Review the advantages and disadvantages of at least two probable courses of action in the light of the theory of conservation...'

With references to the project for the repair and strengthening of the Maritime Museum offered by P. Beckmann (1982: 28-36), author would like to put an emphasis on his remarks, particularly:

- a) 'The corners of the buildings have, thanks to their materials and manner of construction, great inherent strength. This should be recognised and utilised.... and nothing could be done which would significantly disturb the integrity of the corners.'
- c) 'In the case of the Maritime Museum building, the generous amount of cross-tying of external walls has clearly contributed greatly the capacity of the structure to resist seismic forces.' (See app. 4, section: 4.32)

Croatia (Dubrovnik)

The Montenegro earthquake also struck the town of Dubrovnik in the Republic of Croatia which was part of former Yugoslavia. The earthquake with an intensity of 9 - 10° that took place in Montenegro was manifested with an intensity of 7° MCS on the territory of Dubrovnik and its surroundings. It inflicted heavy damage to structures of high cultural and architectonic values.³² However, it should be noted that, for the last 320 years, the town has been struck by eleven catastrophic earthquakes. Particularly destructive was the one of 1667 and there have been another 200 earthquakes with an intensity of 6 - 8 degrees on the Mercali Modified Scale.

According to knowledge that has been gained so far, the activities taken for repair of the structures in Dubrovnik were much better organised and with much better results. (See app. 4, section: 4.33)

Due to the problems that arose the Code for Renovation of the Endangered Complete Corpus of Cultural Monuments of Dubrovnik was adopted in 1986. Why is this Code so important?

First of all, all the activities have to be in compliance with the legislative provisions and the defined methods. The compliance with this code was to assure, by renovation, (as stated in Article 4 of the same law) 'preservation of the authenticity, urban - architectural, historic, artistic and aesthetic values of these structures and accordingly their structural adaptation and adaptation for different purposes.' This Code gives some directions, noteworthy among which are the directions related to the restoration of the cultural monument *corpus*. Many directives are included, but we will comment only on those which deal with repair and strengthening matter. (See app. 4, section: 4.34)

The Code, which contains 72 articles, shows an advance on what had been achieved in Kotor, and an even greater advance on work in Skopje. However, the theoretical assumptions were not always consistently applied. To prove this thesis, we would like to take, as an example, one of the most important cultural monuments in Dubrovnik - the Duke's Palace. The repair activities report carried out on Dubrovnik historic buildings entitled 'Renovation of Dubrovnik 1979 - 1989' provides information according to which there were great disputes between conservators and structural engineers, who elaborated the project for structural repair of this building. A particularly important moment was the selection of a high safety coefficient because of the change of function of the structure - for public use - which means increased numbers of visitors.

We consider that it is exactly at this point that problems arise and non - appropriate methods for structural repair are proposed.

There were extensive interventions as to foundation, the floor and wall structures by incorporation of a completely new reinforced - concrete system and elements that are 'irreversible.' If we carefully analyse *Figure 4.82*, we will see that it represents a system of a skeleton structure with reinforced concrete belt courses and slabs. Presented in the subsequent *Figure 4.83* is repair of walls carried out by incorporation of reinforced concrete columns of large proportions that are then hidden into the wall mass. However, what is presented in *Figure 4.84* is the 'culmination' of an inadequate, completely irreversible method - gunning of an original wall mass, which seems to be very inadequate in relation to the original stone moulding of the openings.

We consider that these enormous works would have never been done if a lower safety coefficient had been adopted in the beginning.

A conclusion could be drawn that although there were reasonable assumptions about the quality and the adequate approach in repair of cultural monuments in Dubrovnik, these were not sufficiently respected, perhaps because of the discordance with the realistic possibilities for re - use of the structures and modification of their purpose. It is exactly the new function that contributes to the drastic attack on the old structure that cannot satisfy the new safety parameters particularly for structures of public character.

Slovenia and Italy

We will focus on some of the positive and negative results of earthquake in these countries, especially on the earthquake of 1976 (with intensity of 9 - 10°MCS) that

struck the north - east part of Italy and the north - west part of Slovenia. The earthquake occurred in the spring of that year. In the autumn (September) of the same year, a new earthquake of almost the same intensity hit the area which was a real surprise.

Noteworthy is the example of a damaged structure of not very so high monumental value but representing part of an attractive group of buildings, where steel ties were incorporated at the level of the cornice below the roof, along the whole length of the perimeter walls for the purpose of repair and strengthening. These were provided with steel plates on the facade. They took over the role of horizontal belt courses, but were much more flexible than the reinforced - concrete ones.

This structure was tested in a natural way. Namely, the work performed on this structure completely satisfied the parameters of preventing new damage under the earthquake of the same intensity that took place in the autumn of the same year. It was really a 'lucky' circumstance that the method and the works have been tested by a real earthquake.

So, there was incorporation of a new flexible structure at the cornice level by which synchronous behaviour of the perimeter walls was made possible whereby satisfactory results were achieved with greater resistance to dynamic excitation. This is a positive example that should be kept in mind.

The second case that we would like to comment on is the personal experience gathered after the Irpinia (Italy) earthquake of 1987. As lecturer at one seminar which was held in Ravello, author visited the town of Calitri which was engaged in large repair and strengthening activities.

While exchanging opinions with the authorities of the town, we raised the question about the strategy of maintenance of the complete *corpus* of monuments (individual monuments or historic sites). We were astonished by their unofficial answer. In effect, they said that no attention was paid at all to this crucial activity in earthquake - prone regions. The reason was odd, even morbid. Namely, we have been told that if they invested in maintenance, the damage due to earthquake would be lower. According to some legislative provisions, if the damage was below a certain defined percentage, it would be considered due to local natural disaster, in which case, the aid provided by the state would be lower. If the damage exceeded the defined percentage, the state would be involved and it would be considered due to a national catastrophe.

As a result, the budget intended for repair could be much higher and there could be the possibility of more profitable working for the local and regional construction firms dealing with repair.

This means a conscientiously decreased investment for the purpose of a 'greater profit' from a catastrophe. Is not this a striking example of a 'man - made planned disaster' arising with selfishness and profit - seeking.

Albania

According to certain knowledge and information obtained from experts, little has been done in this country in the sense of prevention of catastrophes. However, after the earthquakes that struck this country, certain activities for repair and reconstruction were undertaken by professional institutions. (See app. 4, section: 4.35)

An interesting example is the case of taking preventive measure to prevent widening of cracks which occurred in the drum and the dome of the church of Mborsk (14th century) near Korca after the earthquake of 1988. Such a prevention was executed by reversible elements of steel profiles that represent, in fact, a temporary ring. After the incorporation of the prevention elements, the cracks were injected. It seems that this measure is quite an acceptable method. (Fig. 4.85-87) (See app.4, section: 3.36)

Greece

Greece is a country that has been often stricken by strong and disastrous earthquakes.

For us, the treatment of the Byzantine structures from the sixth till fifteenth centuries, which are representing an important *corpus* of the cultural heritage of Greece, is of a particular importance.

The 1978 earthquake (15 years after the Skopje earthquake) inflicted heavy damage to the churches from the Byzantine period. Repair of these churches is still going on today, twenty years after the earthquake. We emphasise this fact since it supports the opinion of Sir Bernard Feilden that each temporary preventive measure may be long-lasting and should be adequate to those parameters.

A team of experts from the institutions for protection of cultural monuments³⁴ was established at once. (See app. 4, section: 4.37)

What did the natural test show? It pointed out certain defects of materials, structural elements and systems, including effects from enlargements, partitions, repair and conservation carried out in the past.³⁵

However, it also showed that although of a high intensity, this earthquake did not inflict total collapse of any of the structures, but only repairable damage. This is a very important fact that should be taken into account in designing the new method for repair and strengthening of Byzantine churches. (*See app. 4, section: 4.38*)

If the *Figure 4.88* is carefully examined, the following can be concluded:

All the vaults in the naos, the narthex and the paracleses on the north and the south side (added later), suffered characteristic cracks due to separation of the perimeter walls that support these structural elements.

In her presentation of a case study (Theoharidou 1980) provided data on characteristic damages to the arches, the drum and the vault of the Byzantine structure that coincide with those.

Damage occurred to the wall mass of the Rotunda in Thessaloniki, particularly in the weaker area of the springs. There occurred vertical cracks at the level of the dome base, both on the facade and in the interior. (*Fig. 4.89*) (*See app. 4, section 4.39*)

As to the 1986 earthquake that struck the town of Calamata, the damages to the church of Holy Apostles represent a characteristic example. The structure is composed of an older part (the east one) constructed in the twelfth century and its west part constructed in the sixteenth century. Constructed on the more recent structure was a reinforced concrete dome that rested on the perimeter walls via the drum and the four pilasters.

What happened during the earthquake?

Both parts of the building were damaged but differently. (*Fig. 4.90*) The dome of the recent part completely collapsed, which was also the case with the west vault from the arm of the cross. It caused the partial collapse of two perimeter walls (the west and the south one). The other walls also suffered damage in the sense of opening of old cracks and occurrence of new ones - characteristic diagonal cracks.

The older part suffered certain damage, but there were no elements of collapse. There were cracks in the base of the dome, through the barrel vaults and disintegration of the wall mass as well (*Vogiatzis et al. 1989*)

These data are given extraordinary importance from the aspect of the effect of:

- maintenance of the structures;
- modifications and enlargements carried out in the past;
- type of materials and structural elements used for repair and conservation in the past.

which could be used as a real and practical experiment.

Which were the characteristic activities taken to overcome the consequences?

The answers to this question may be classified into two main domains:

research - theory and application - realisation.

The first group involved extensive research works carried out for the purpose of obtaining information for:

- level and type of damage to the foundation and superstructure zone;
- static and dynamic characteristics of the structures with all the necessary parameters;
- chemical - physical and mechanical characteristics of the existing incorporated materials (by means of theoretical and experimental methods)

In accordance with the results obtained, proposals were made for overcoming the consequences (prevention and projects for realisation).

First of all, we would like to focus on the preventive measures that were taken immediately after gaining complete knowledge of the state of affected structures. Various materials were used for that purpose. A good example of a prevention activity is the one taken for the Rotunda and St. Panteleimon in Thessaloniki. (*Fig. 4.91-2*)

The surface cracks and expansion joints of low quality were repaired as follows: the damaged and low quality lime mortar (sometimes mud mortar) was removed and the cleaned expansion joints and cracks were filled with hydraulic lime mortar. This increased the compactness of one face of the wall - the facade. This method could not be applied in the interior because of existence of frescos.

Grouting with injection mixtures of different types and characteristics was done for many structures (Rotunda, St. Panteleimon, St. Sophia in Thessaloniki and Holy Apostles in Calamata (*Fig. 4.93*).

The permanent strengthening of the cornice, the tambour and the base of the dome of the Rotunda in Thessaloniki (*Fig. 4.94*) by means of special steel ties could be mentioned as a quite adequate approach with high reversibility characteristics.³⁵

According to available data, it is clear that reinforced concrete structures were also proposed and used as structural elements of repair and strengthening (*Fig. 4.95*). However, their application was restricted to individual cases.

Still, we could mention, as a particular case, the church of Christ the Saviour's Chapel in Thessaloniki (*Fig. 4.96*). Based on data available, it is a surprising fact that a church from the Byzantine period, was constructed by use of mud mortar as a bonding material. This is really a rare case in Byzantium in the fourteenth century. (Theoharidou 1980)

The interest in this structure is increased since in the eighties, the same author (K. Theoharidou) offered several variant solutions for repair and strengthening that

nevertheless remained as proposals only. In her text published in 1986, she points out that detailed repair works on the facade part of the walls were done by incorporation of lime mortar in place of the existing mud mortar. Also, certain ruined parts of the walls were reconstructed on the basis of existing documentation.

In her considerations, she offered three variant solutions.

Variant A involves incorporation of reinforced concrete structure of arches, reinforced concrete frames at the level of the tambour base, RC columns into the wall mass of the tambour as well as a RC ring beam at the level of the dome base (*Fig. 4.97*).

Proposed as variant B is also a RC structure at the level of the arches, the tambour base and the dome. However, instead of RC columns in the tambour, vertical steel rods connecting the ring beams at the top and the base of the drum are proposed (*Fig. 4.97*).

Variant C involves irreversible injection of the arches and semi-domes and formation of rigid concrete joints at the level of the tambour base and the springing level of the dome and their horizontal and vertical connection with the steel rods (*Fig. 4.98 a-b*).

The author himself considers proper and recommends the last variant which was proposed but not realised.

Of course, the problem was defined and more or less acceptable and adequate methods for repair and strengthening were proposed.

All the presented examples of repair and strengthening of damaged monuments in the Balkan countries, represent a valuable experience, which will contribute to definition of a proper and adequate treatment of the Byzantine churches in Macedonia.

4.7.2 International meetings and recommendations on the subject

It could be said that the initiative for an organised approach of cultural heritage in seismically - active regions treatment, first of all, was undoubtedly the 1963 Skopje earthquake.

It seems that, in the period after, a series of destructive earthquakes have taken place, particularly in the Mediterranean and the Balkan region.³⁶ Effects to repair that damage and overcome to consequences have been intensified in all the countries concerned. This happened at national level, by continuous using their own resources and assistance of the international GO's and NGO's relevant to the problem.

If the Skopje earthquake was the initiative, the Friuli and Montenegro earthquakes of 1976 and 1979 were incentives for greater involvement of the International community in solving this problem.

Given the lack of previous experience and practice international collaboration for repair and elimination of the consequences two compatible main directions are proposed.

The first is theoretical - preparatory and the second executive, i.e., direct contact and treatment of monuments. Basically, it is an interactive action of both directions, in accordance with the determination that it is a new, broadly based, multidisciplinary activity.

In the first, main and fundamental thing is finding out and defining the general principles for an adequate and acceptable treatment. In addition to the establishment of this 'philosophy', steps are being taken toward advanced training of professional and scientific staff involved.

In this domain, we could focus on some conclusions and recommendations which we consider relevant to the problem.

Namely, at the international meeting held in Skopje in 1983³⁷, some more important activities were recommended to be ratified by countries - members of UNESCO. (*See app. 4, section: 4.40*)

In the meantime, there were important meetings in Cetinje, Montenegro (1984) during which the state of Montenegro after the 1979 earthquake were discussed on the occasion of the fifth anniversary. (*Author participate with two papers*)

In accordance with the decisions of the International Community via UNESCO and specialised governmental and international organisations, the first 'International Course on Preventive Measures for the Protection of Cultural Property in Earthquake - Prone Regions' organised by ICCROM and IZIIS (Skopje)³⁸ and financially supported by UNESCO was held in Skopje from 24th June - 5th July 1985.³⁹ (*See app. 4, section 4.42*)

The next year, in co - operation with ICCROM, the International Workshop was held in Mexico City (25th August - 12th September 1986).

(*See app. 4, section: 4.43*)

As a realisation of the author's idea presented during his advanced training in ICCROM (1986) an International seminar was organised in the period of 17 - 22 October 1988 in Skopje. It was 'The 1st International Seminar on Modern Principles in Conservation and Restoration of Urban and Rural Cultural Heritage in Seismic Prone Regions'⁴⁰ was organised by RZZSK⁴¹, IZIIS and ICCROM with the financial support

given by UNESCO. More than 100 lecturers and participants from 26 countries participated. As a result 'Recommendations - Skopje 1988' were adopted. (*See app. 4, section: 4.44*)

In 1989, conceiving the problem of occurrence of natural catastrophes at the widest international level, UN proclaimed the International Decade for Natural Disaster Reduction - IDNDR for the period 1990 - 2000. (*See app. 4, section: 4.45*)

Early in that decade, in 1991, an important meeting was held in Udine, Italy, for the fifteenth anniversary of the 1976 earthquake.⁴²

To build on important information from these meetings, the author, as a principal investigator, a research project was carried out within the framework of UNESCO Participation Programme 1994 / 95 entitled 'Development of a Methodology in Order to Create a Data Bank for Structures of Cultural Heritage in Seismic Prone Regions', which was accepted and financially supported by UNESCO.

Integration of cultural heritage in the national disaster preparedness plans has so far been not done in a large number of countries. To illustrate the slowness in planning and taking action, we must state the fact that a Regional Workshop entitled 'Integrating Cultural Heritage into National Disaster Preparedness Planning, Mitigation and Relief' took place in Skopje and Ohrid (Macedonia) in the period 13 - 17 1997, fourteen years after 1983 meeting.⁴³

At this meeting, the following theoretical - preparatory activities were recognised: estimation on the basis of scientific studies of natural hazards where cultural heritage exists; preparation of complete inventory; assessment of the vulnerability of cultural property (particularly immovable property) to hazards.

The very recent decisions in EUROCODE 8: Design Provisions for Earthquake Resistance of Structures passed by CEN (European Committee for Standardisation) in 1996 (explained in more details in Chapter 5) represent a factor in favour of the increasing standardisation of the efforts in structural strengthening of structures by which their resistance is increased and their vulnerability decreased. Their application is recommended along with maximum respect for the original structural elements and systems.

Instead of a conclusion, it may be said that there is a sufficient number of high quality recommendations that should be respected, verified (if possible) on the basis of experimental studies and applied in practice.

Chapter four - Notes

1-5 See appendix 4, section 4.7

6. A sole example in Macedonia where there are monolith marble columns with a circular "in situ" cross section instead of masonry columns.

7 The exception are St. Leontie, v. Vodoca (Fig. 5.13) and St. Georgi, v. Gorni Kozjak (Fig. 4.9)

8 Plain stone is always used, not dressed.

9 The brick is always well baked and of different proportions, according to the needs.

10 This form of a facade expression reminds ^{one} very much of the structures in Constantinople and Salonika where the facades have this appearance – the use of bricks only.

11 If the structure has more than two pairs of columns, the number of bays is greater.

12 Debar has 1; Ohrid 12; Prilep 5; Veles 2 and Stip 3 churches.

13 19 different villages around Macedonia.

14 17 churches from populated areas.

15 It must be pointed out that the everyday use of the structure for the function for which it is constructed contributes to regular ventilation (decrease of the adverse effect of moisture) and cleaning of the structure.

16 These factors may contribute to permanent disturbance of the integrity of the cultural monument by causing permanent and irreparable damage.

17 Because of problems within the Macedonian Orthodox Church, it is not possible that each church has its own head living in the village.

18 There are only traces of the church of St. Panteleimon in Ohrid.

19 Activities such as inventorying, evaluation and registration, inspection, maintenance and presentation.

20 These works are being done according to a project prepared by the author of this dissertation

21 The structure is located at a distance of about ten metres from the new artificial lake, which represents a permanent source of moisture.

22 St. Panteleimon, Ohrid; St. Nikola, v. Ljuboten (Fig. 4.3Ag); St. Bogorodica Treskavec, v. Dabniste (Fig. 4.56), St. Dimitrija, Varos (Fig. 4.26); St. Atanasie, v. Lesok (4.3Be); St. Petka, Debar.

23 This project was elaborated by the author of this dissertation. Also, the complete conservation-restoration works were done under the supervision of the author in the period 1976-83.

24 On all these vaults, there are traces of pendentives from the old structure.

25 It is disputable whether this dome was hidden in the roof, without being placed on a tambour, or it was placed on an octagonal tambour of smaller proportions than the central one.

26 This fact makes us conclude that there may have been porches on the north, the south and the west side in the initial phase.

27 The characteristics of this earthquake will be discussed in more detail in Chapter 5

- ²⁸ The catastrophic earthquake of an intensity exceeding 9 degrees MCS and with a magnitude of 6.3 on the Richter scale destroyed the Montenegrin seashore and the wide region of the hinterland.
- ²⁹ The Institute for Protection of Cultural Monuments in Kotor was established in June 1980.
- ³⁰ Introducing of these elements in the corners of the buildings damaged by the Skopje earthquake was thought to have had harmful results.
- ³¹ Members from the ICCROM team: : Mr. Jukka Jokilehto as a co-ordinator and Sir Bernard M. Feilden, Mr. Poul Beckmann and Mr. Patrick Faulkner from UK, Mr. Ipolito Massari and Mr. Carlo Cesari from Italy.
- ³² The town is in the UNESCO List of World Natural and Cultural Heritage.
- ³³ According to available data: 1071 structures registered as cultural monuments were damaged. Damaged were also 33 fortification structures, 106 sacral structures and other structures of lower monumental values (over 1000).
- ³⁴ 9th Ephorate of Byzantine Antiquities, Greece
- ³⁵ "International Symposium of Thessalonika entitled "Restoration of Byzantine and Post-Byzantine Monuments", 11-13 December 1985 and International Technical Conference entitled "Structural Conservation of Stone Masonry", Athens, 31 October - 3 November 1989.
- ³⁶ Debar, Macedonia 1967; Banja Luka, Bosnia and Hercegovina - 1967; Friuli - Italy 1976; Bucharest- Romania 1977; Thessaloniki - Greece 1978; Montenegro - Yugoslavia 1979; Calamata - Greece 1980; Irpinia and Basilicata - Italy 1980; Gevgelija - Macedonia 1990; Bitola - Macedonia 1994 and many other earthquakes in Italy, Yugoslavia, Greece, Turkey and Albania.
- ³⁷ International Meeting on Technical and Legal Aspects of the Preservation of the Cultural Heritage Against Disaster and other Major Calamities", Skopje, Macedonia, 31st January - 2nd February 1983, non-published paper. The meeting was organised in co-operation with UNESCO. The author participated in this meeting.
- ³⁸ Institute of Earthquake Engineering and Engineering Seismology, University "St. Cyril and Methodius", Skopje, Republic of Macedonia.
- ³⁹ The author participated in this course with two presentations.
- ⁴⁰ Among the invited experts, there were Sir. B. Feilden, J. Jokilehto and P. Beckmann. The author was Chairman of the Organising Committee and presented three papers.
- ⁴¹ Republic Institute for Protection of Cultural Monuments. The author has been employed by this Institute since 1971.
- ⁴² The author participated with presentation of two papers in both meetings.
- ⁴³ This Regional Workshop was organised by the Macedonian National Committee of ICOMOS , PRDU from the University of York, US ICOMOS with the financial support by the Getty Trust Programme. Author was a President of the Organising Committee and present two papers.
- Ced

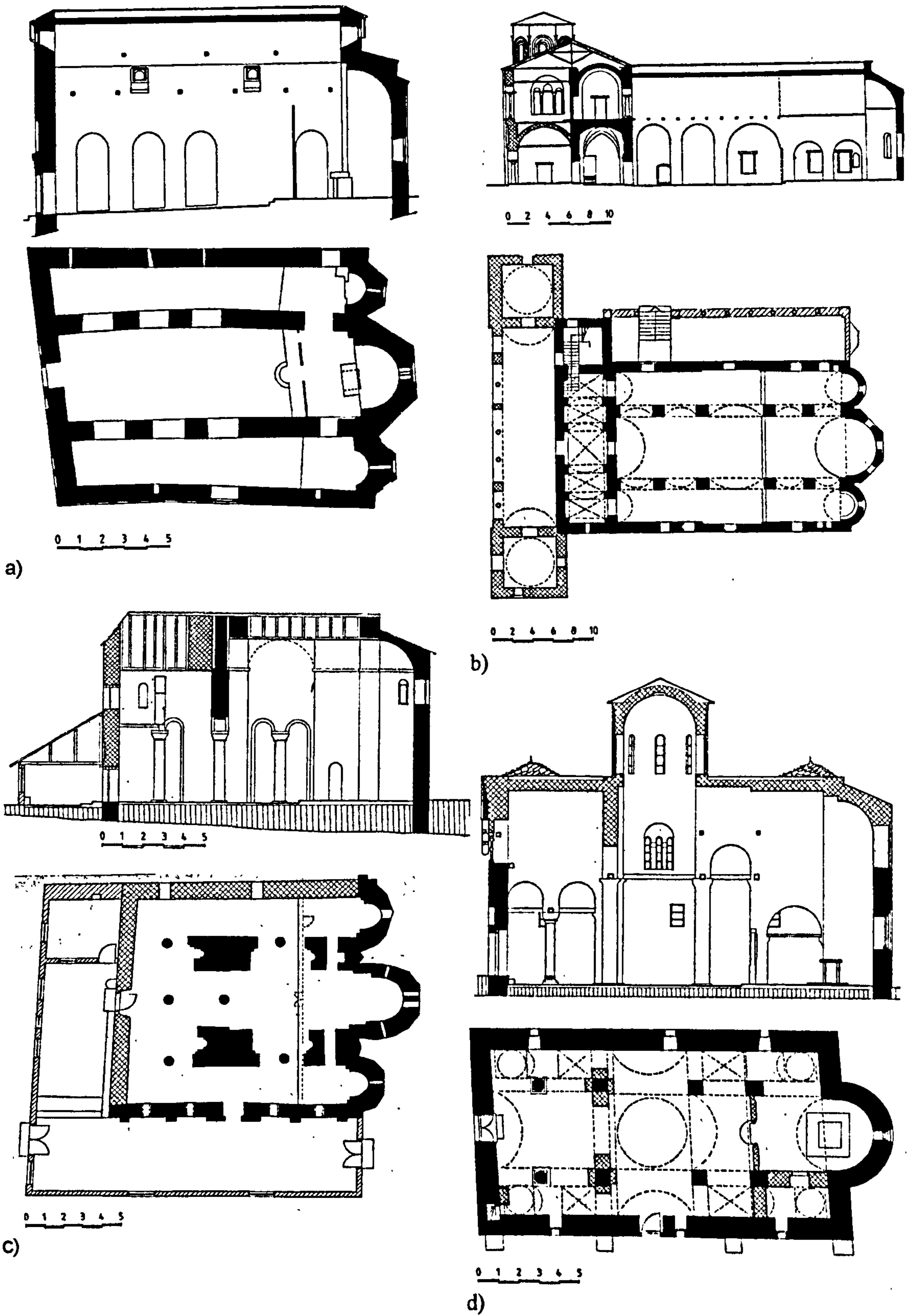

Figure 4.1 Churches as basilica with or without a cupola and transept
 a) *St. Nikola, v. Manastir*;
 b) *St. Sophia, Ohrid*;
 c) *St. Bogorodica, v. Drenovo*;
 d) *St. Georgi, v. Staro Nagoricane*

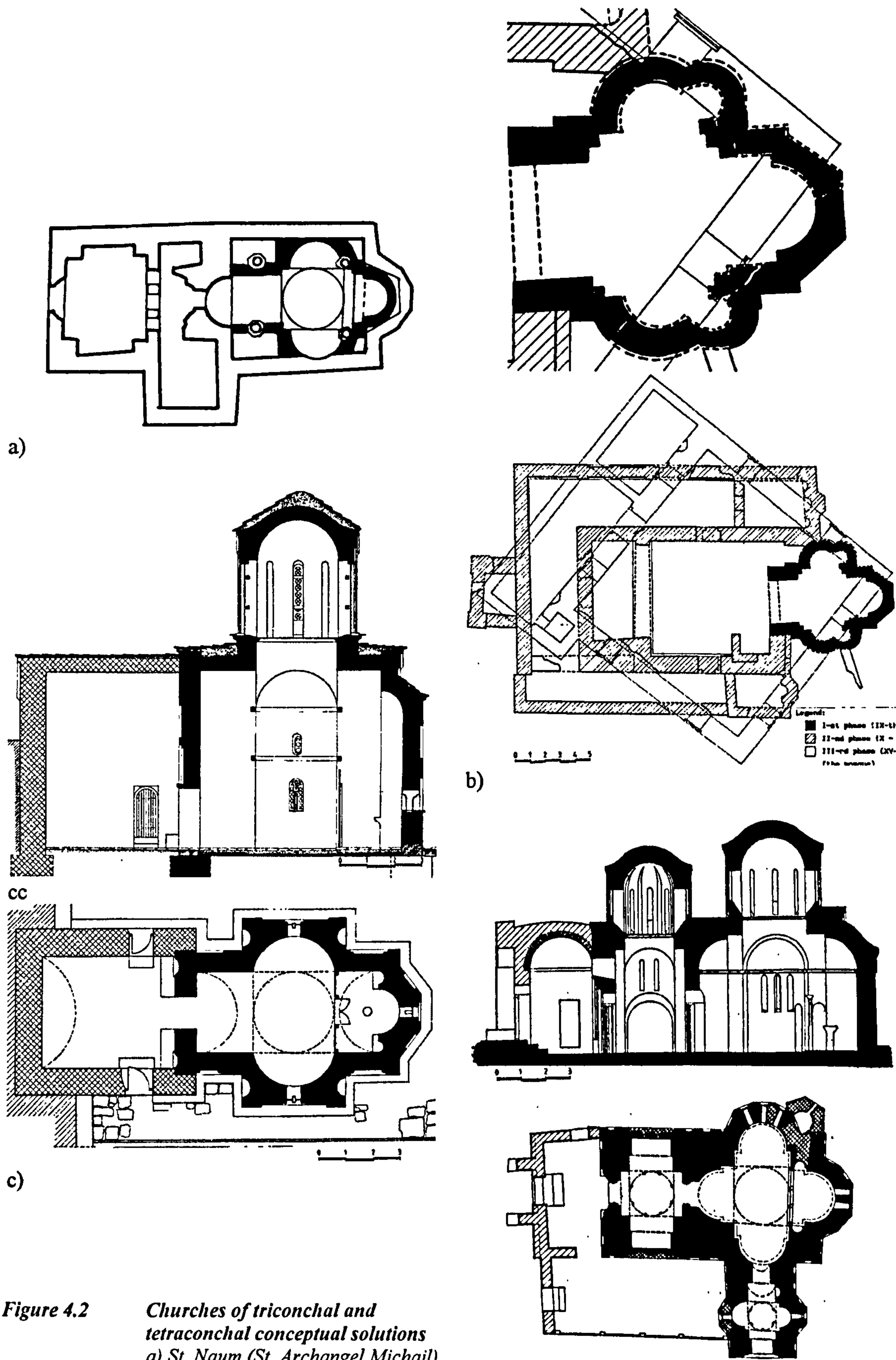
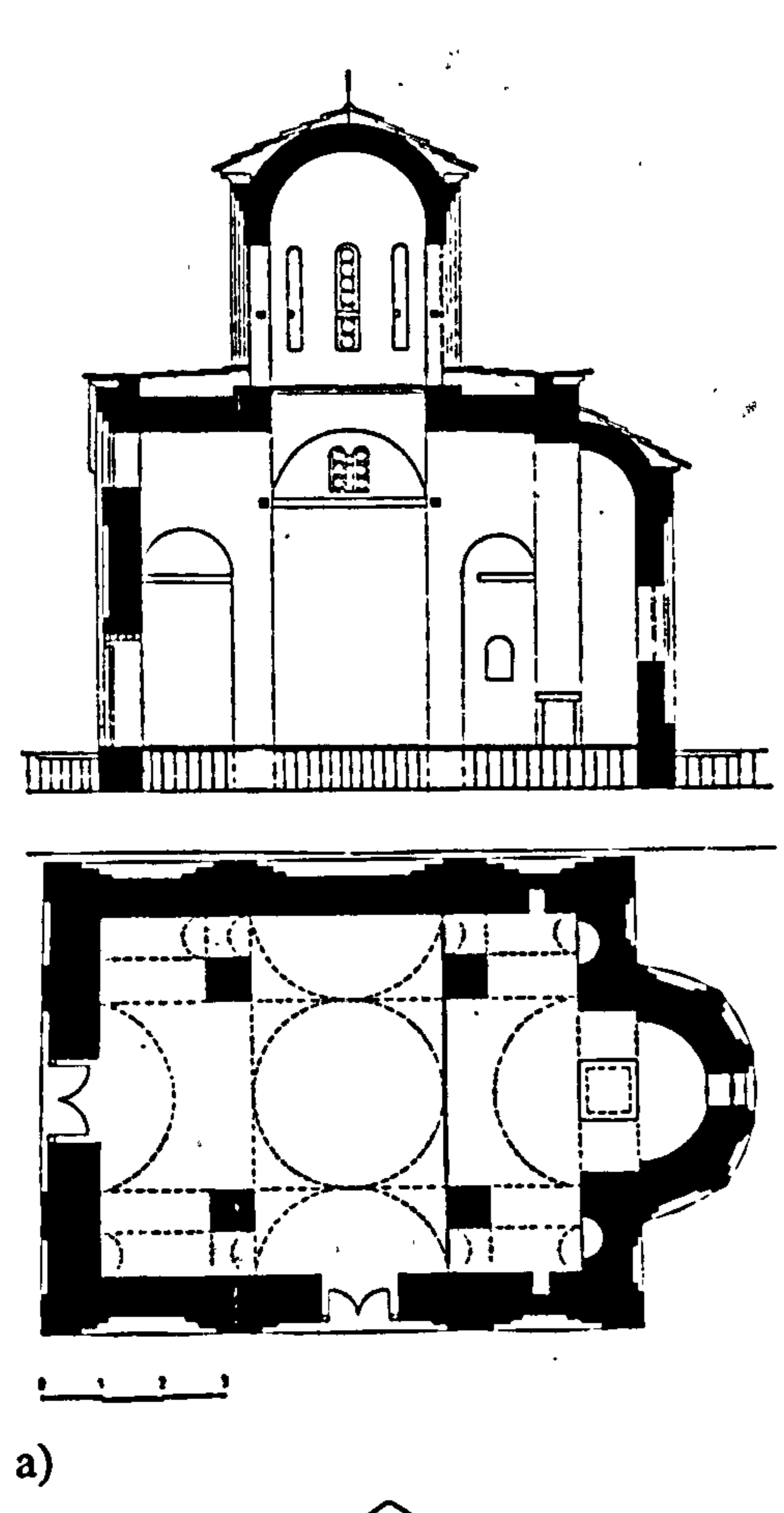
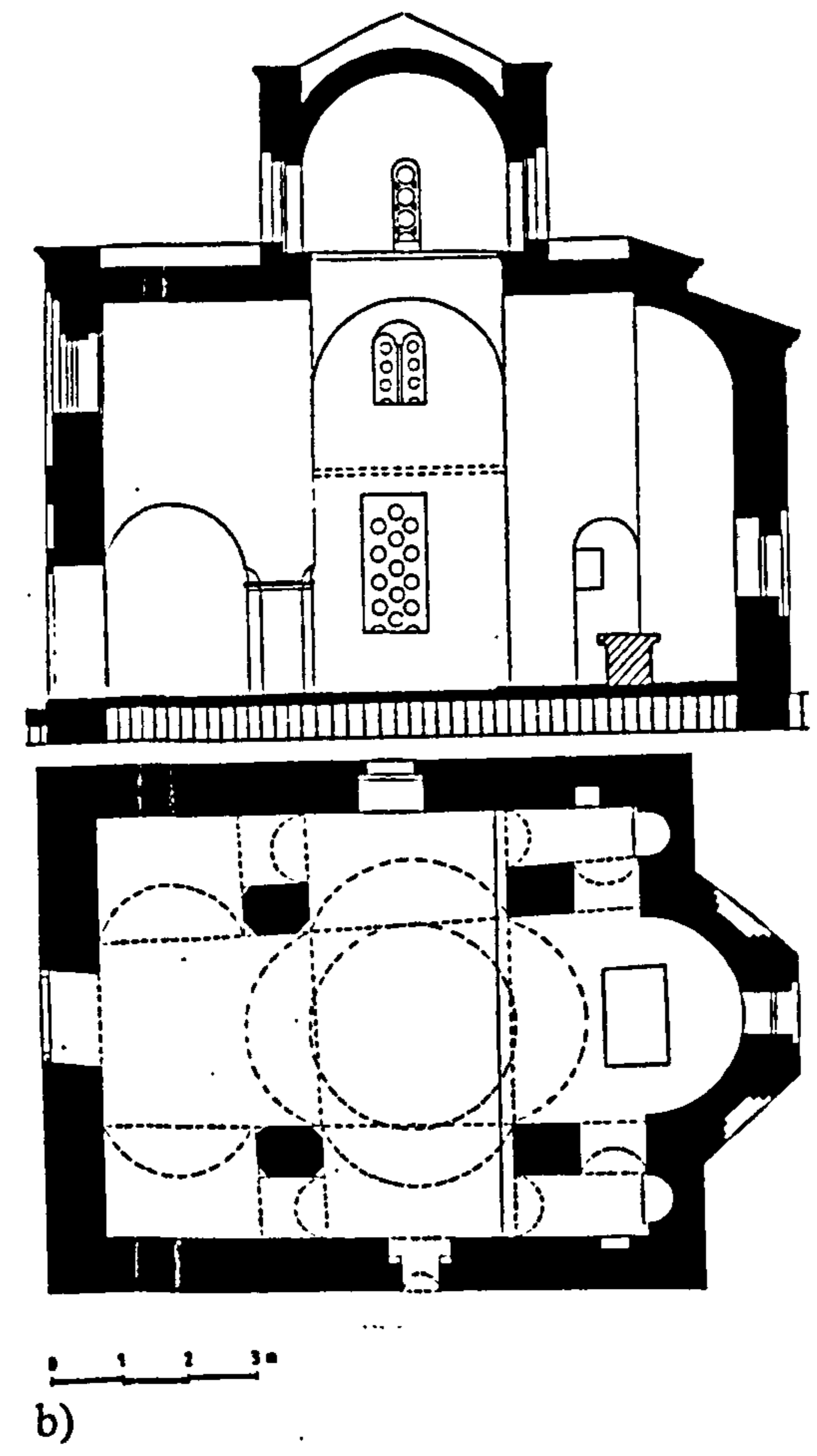

Figure 4.2

Churches of triconchal and tetraconchal conceptual solutions
 a) St. Naum (St. Archangel Michail), v. Ljubaniste-Ohrid Lake;
 b) St. Panteleimon, Ohrid;
 c) St. Andrea, v. Matka;
 d) St. Bogorodica Eleusa, v. Veljusa



a)



b)

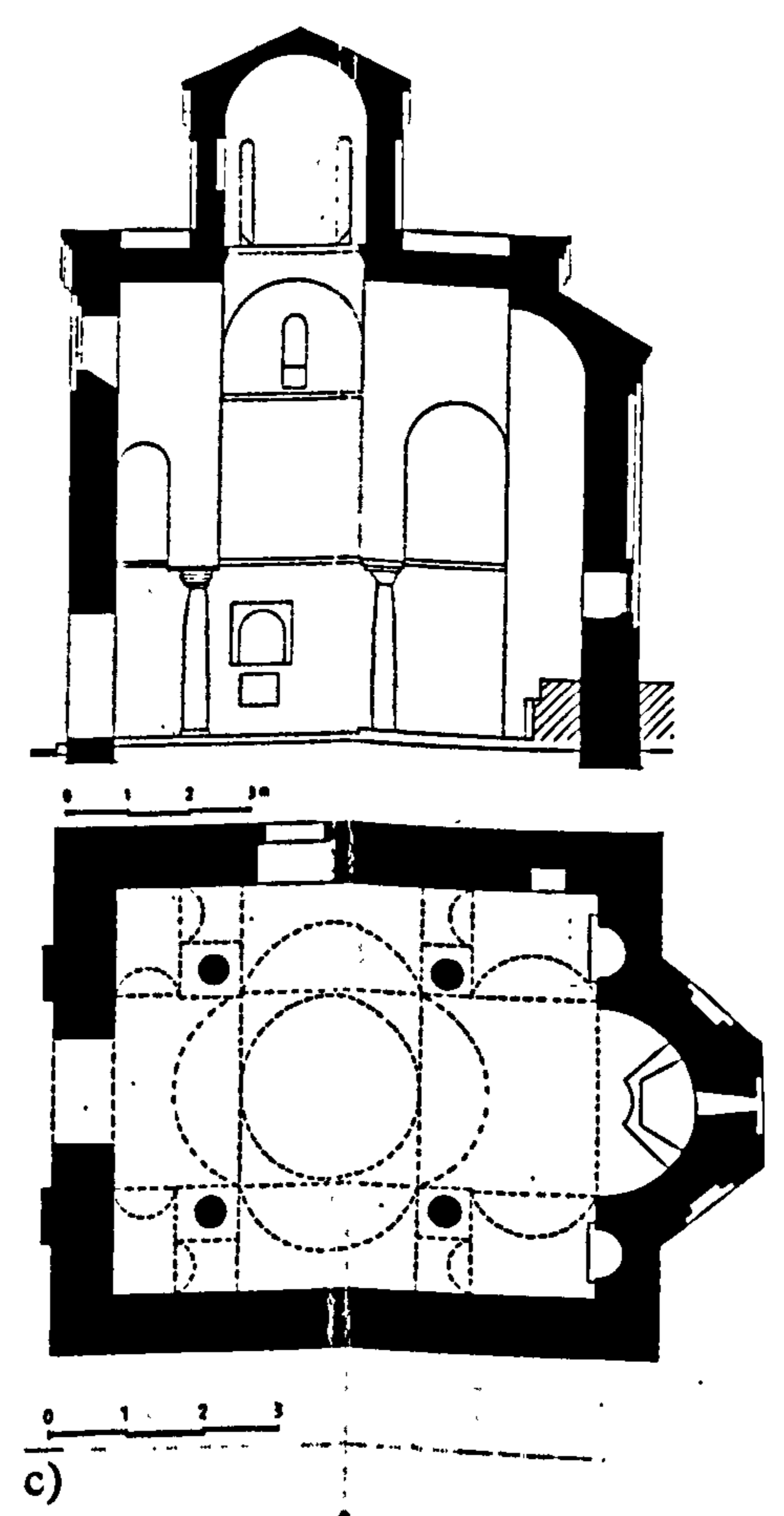

c)

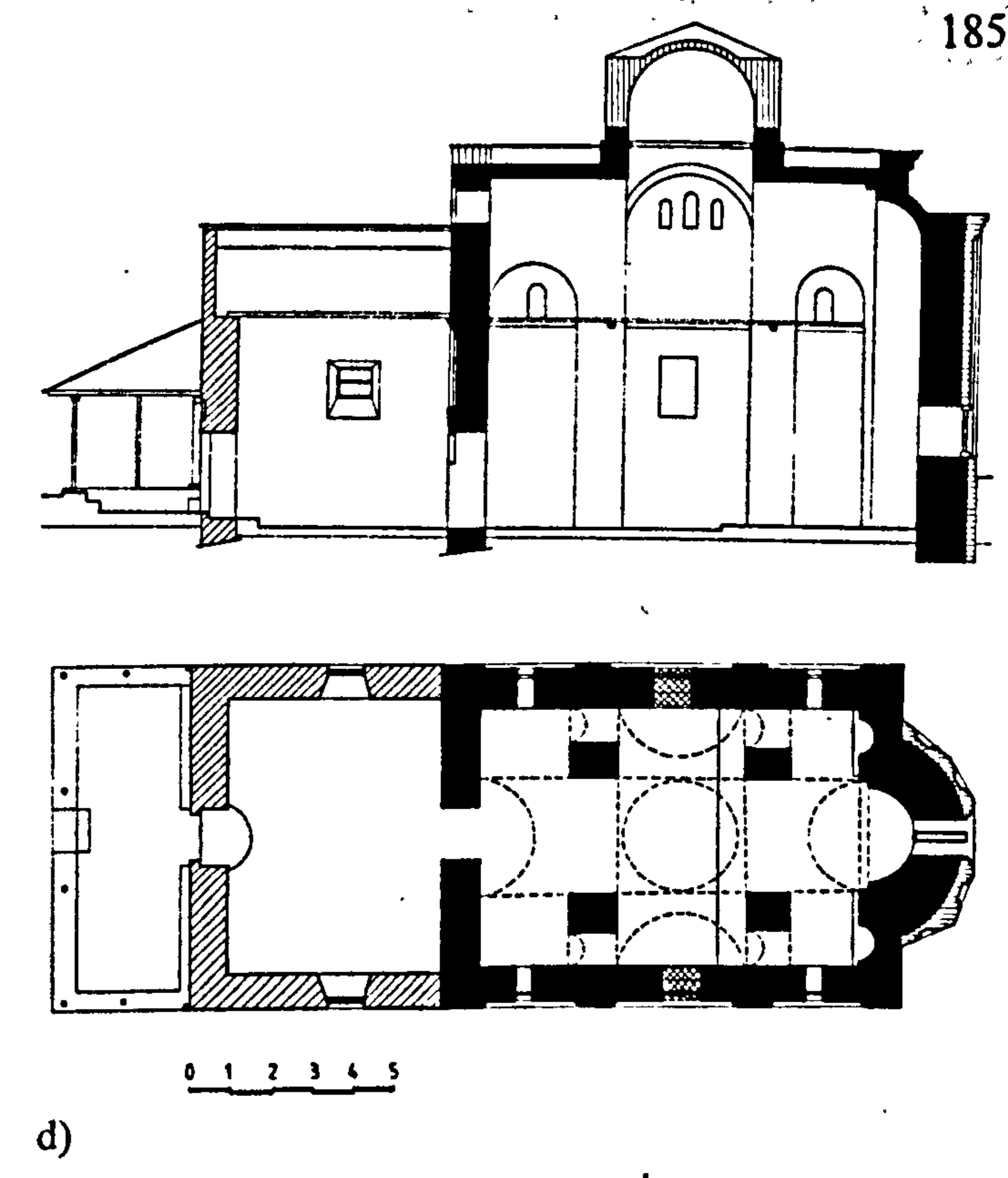

d)

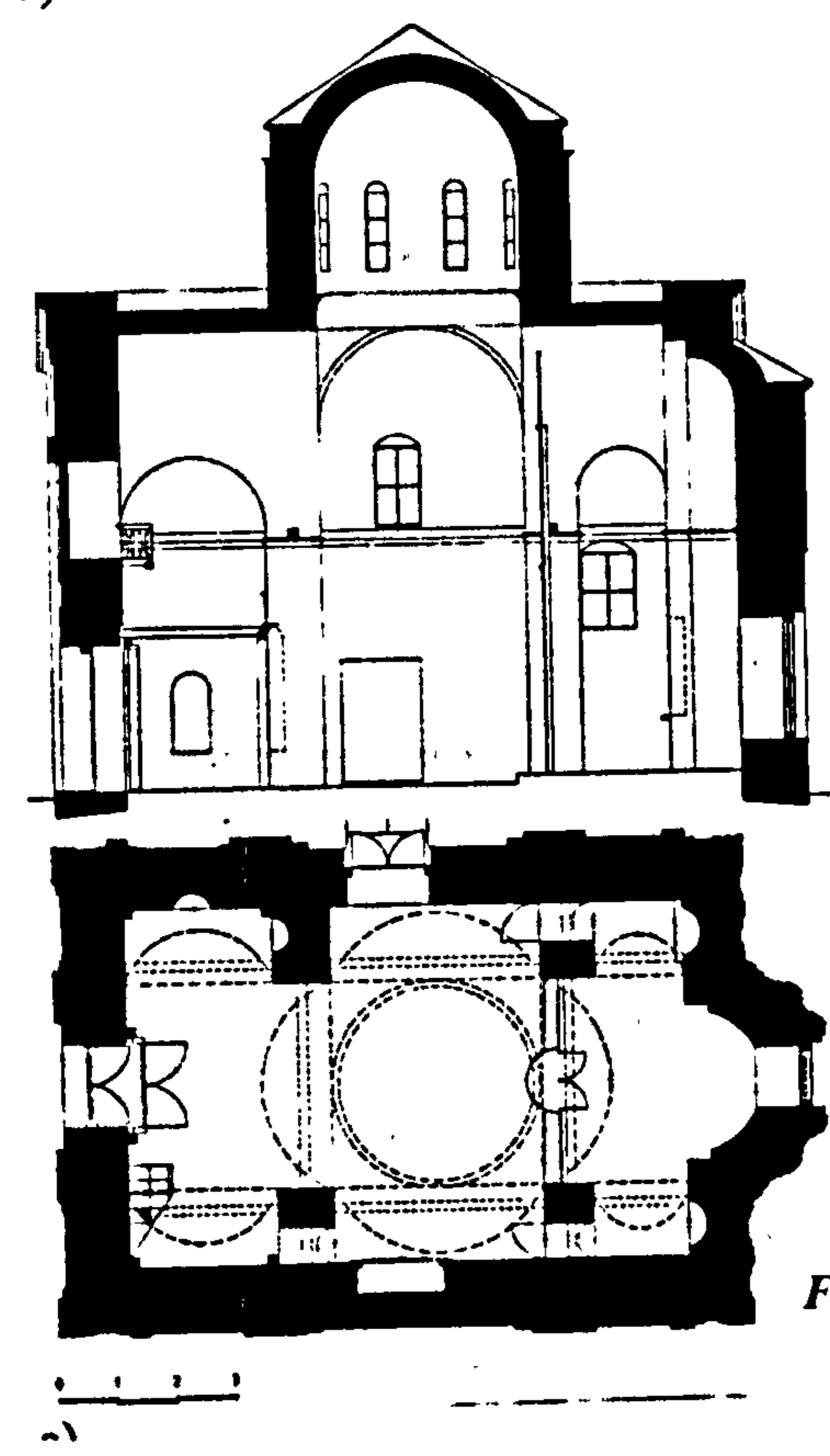
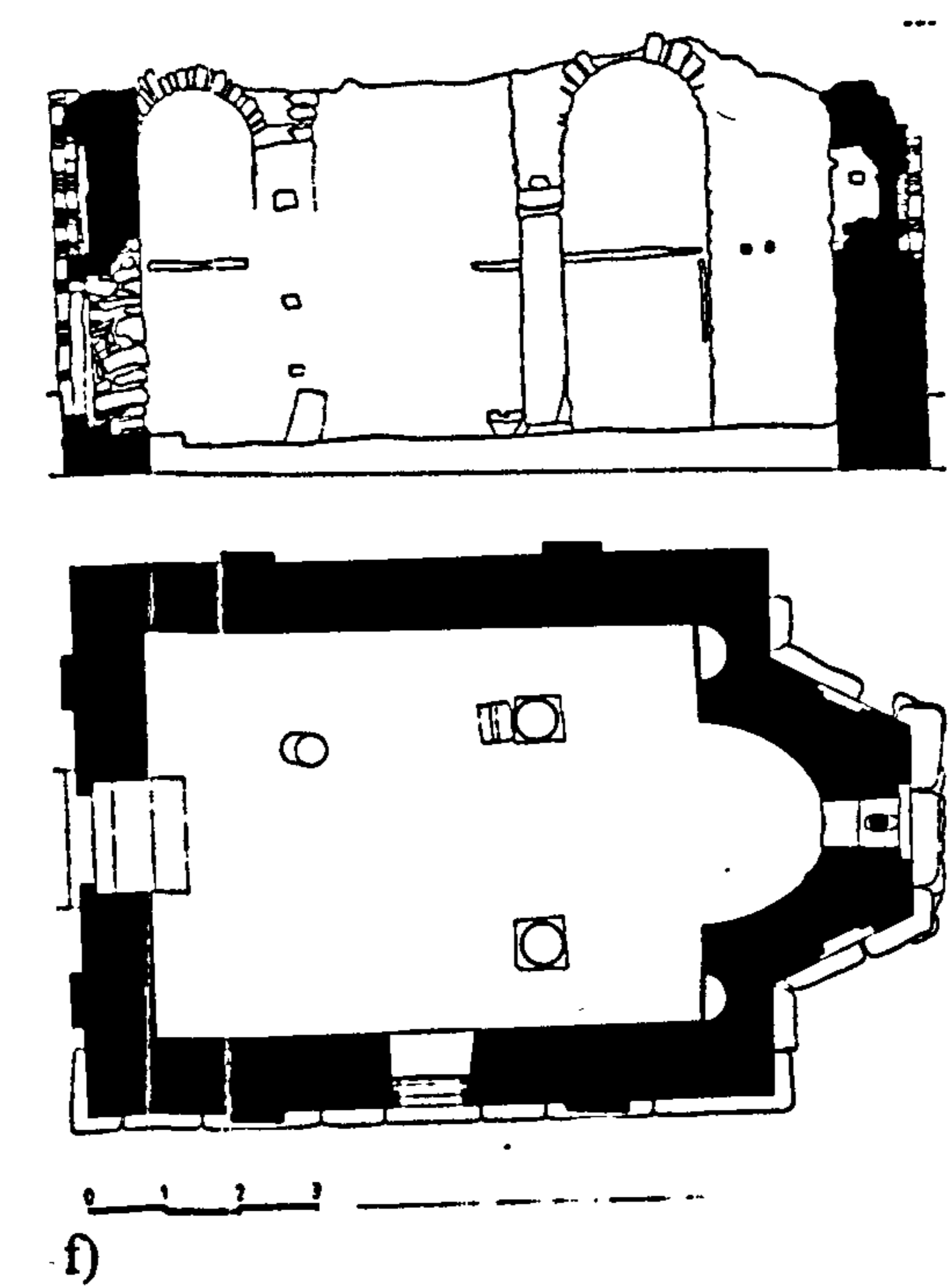
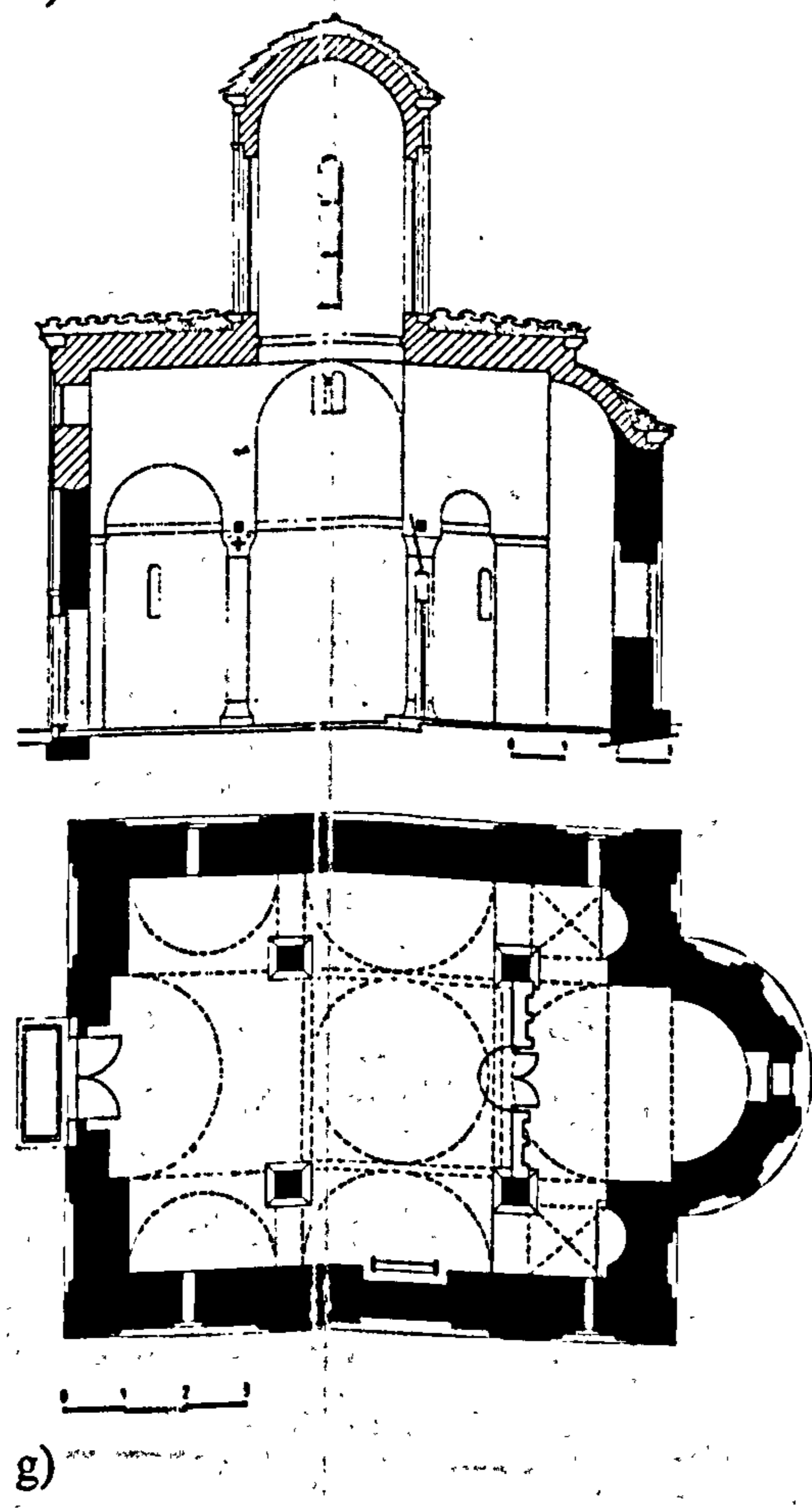

Figure 4.3A



f)



g)

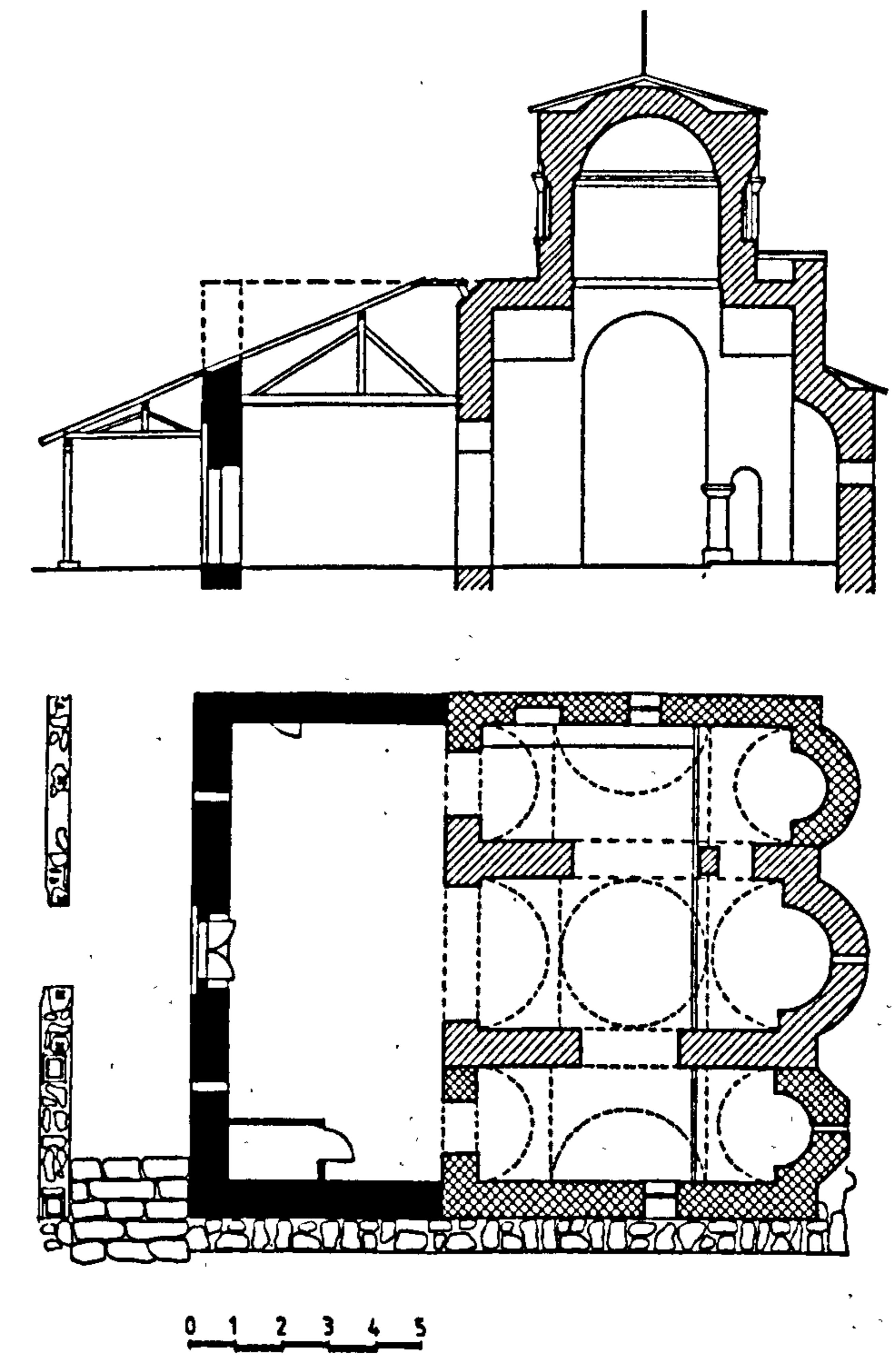

h)

Churches as single or five dome cross-in-square structures
 a) St. Nikita, v. Banjani;
 b) St. Jovan Kaneo, Ohrid;
 c) St. Bogorodica Zaum, v. Trpejca;
 d) St. Stefan, v. Konce;
 e) St. Archangel Mihail, Stip;
 f) St. Atanasie, Varos-Prilep;
 g) St. Nikola, v. Ljuboten;
 h) St. Dimitrija, Varos-Prilep

Figure 4.3A



Figure 4.3B Churches as single or five dome cross-in-square structures
 a) St. Bogorodica Perivlepta, Ohrid;
 b) St. Archangel Mihail, v. Lesnovo;
 c) St. Spas, v. Kuceviste; d) St. Dimitrija v. Susica; e) St. Atanasie, v. Lesok;
 f) St. Bogorodica, v. Gorno Varoviste;
 g) St. Bogorodica, v. Matejce;
 h) St. Panteleimon, v. Gorno Nerezi

Figure 4.3B



Figure 4.4 Churches as single nave building
 a) St. Dimitrija, Ohrid;
 b) St. Kliment Mal, Ohrid;
 c) St. Nikola Bolnicki, Ohrid;
 d) St. Nikola, Varos-Prilep
 e) St. Georgi, v. Kurbinovo;
 f) St. Bogorodica Bolnicka, Ohrid;
 g) St. Elena and Konstantin, Ohrid;
 h) St. Georgi Poloski, v. Begniste

Figure 4.4

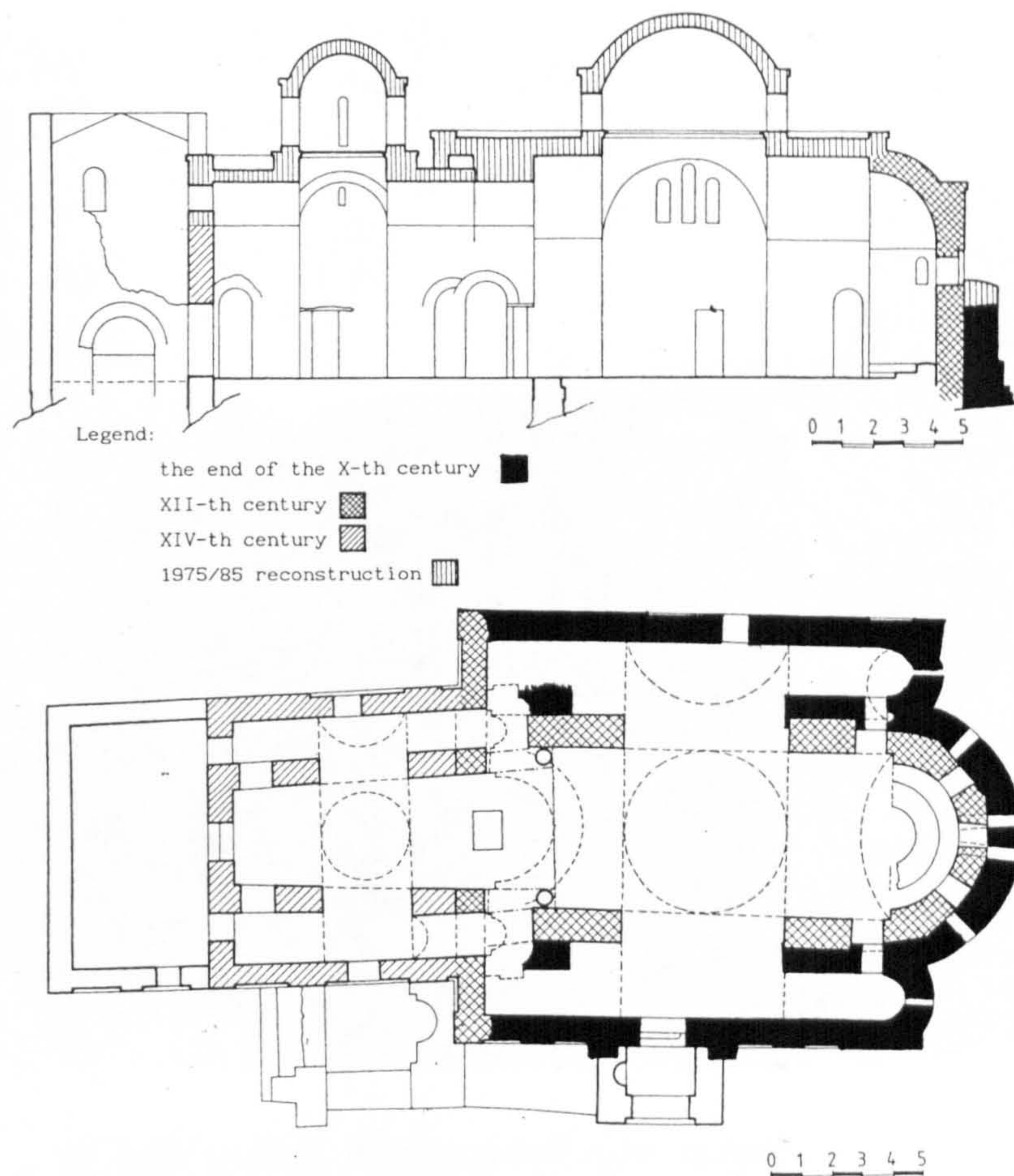

Figure 4.5 Church complex, St. Leontie, v. Vodoca



Figure 4.6 St. Bogorodica Perivlepta, Ohrid. South facade



Figure 4.7 St. Sophia, Ohrid. Western facade of the exonarthex



Figure 4.8 St. Panteleimon, v. Gorno Nerezi. Southern facade



Figure 4.9 St. Georgi, v. Gorni Kozjak. Southern facade

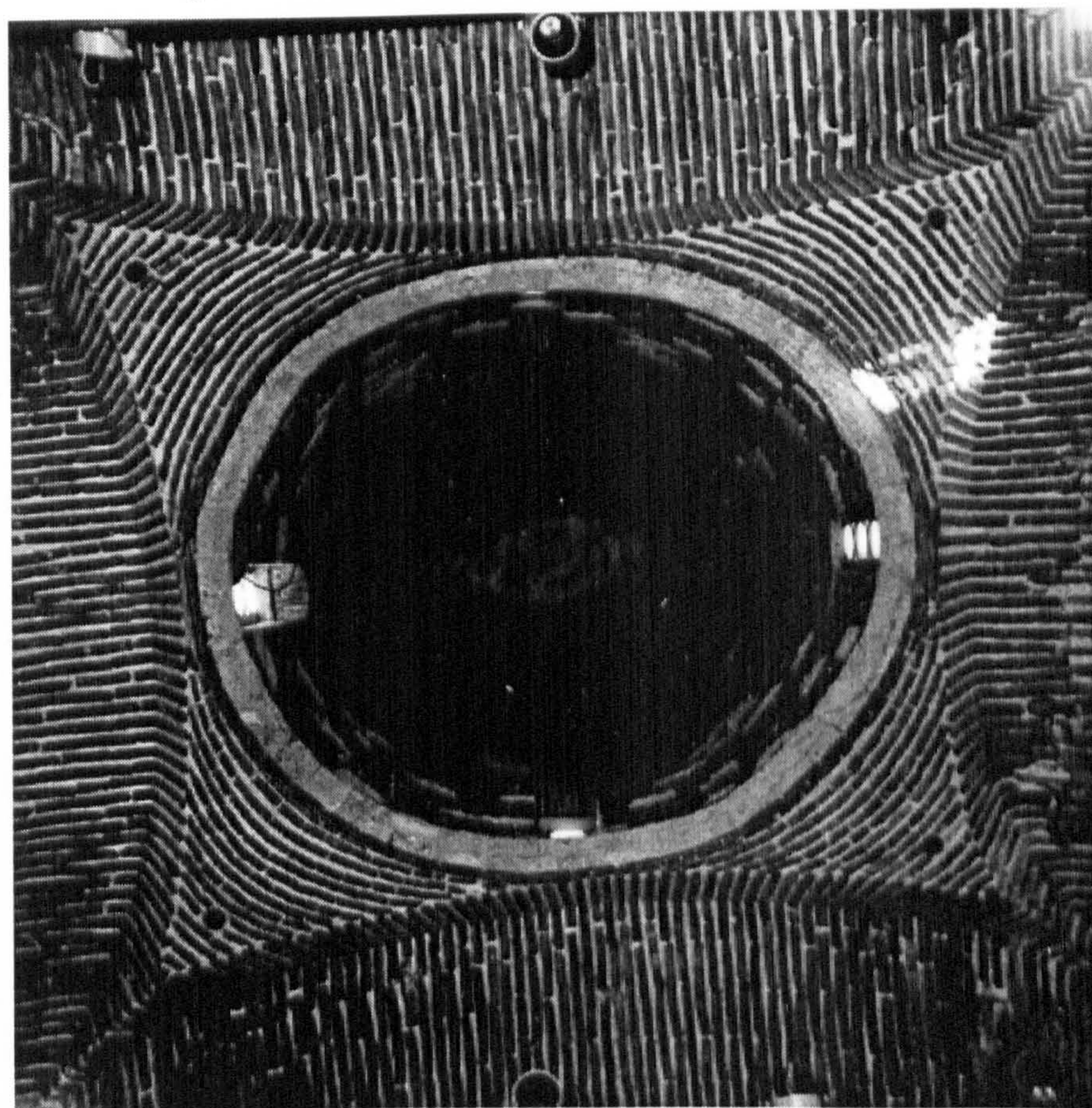

Figure 4.10 St. Leontie, v. Vodoca, Detail of vaults, pendentives and dome

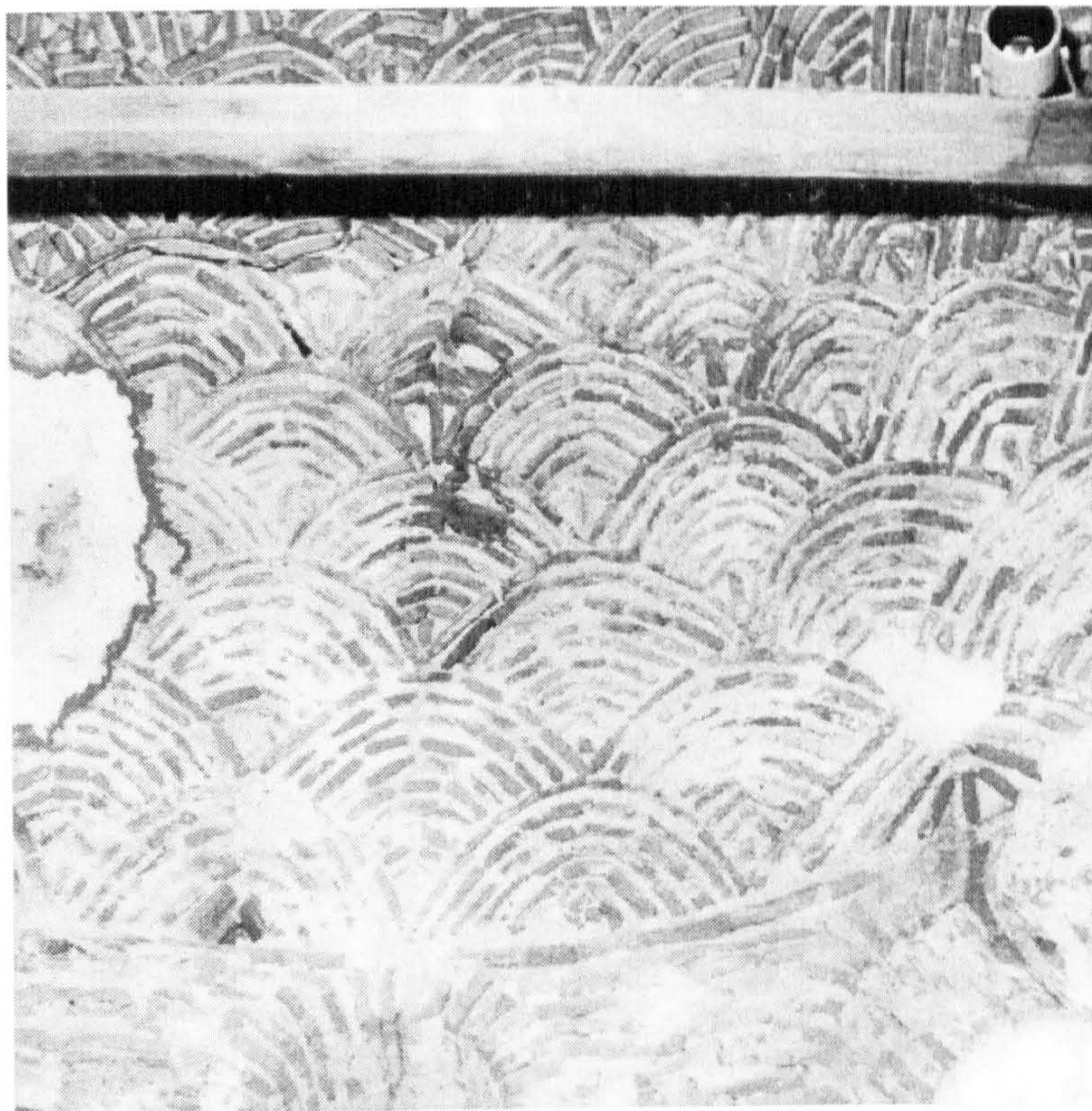

Figure 4.11 St. Leontie, v. Vodoca. Detail of apse semi-dome structure



Figure 4.12 St. Sophia, Ohrid. Eastern facade - monophora



Figure 4.13 St. Jovan Kaneo, Ohrid. Eastern facade - biphora



Figure 4.14 *St. Georgi, v. Staro Nagoricane. Northern facade - trephora*



Figure 4.15 *Pieta. Fresco painting. St. Panteleimon, v. Gorno Nerezi, 1164*



Figure 4.16 *Angel. Fresco painting. St. Georgi, v. Kurbinovo, 1191*



Figure 4.17 *Dormition. Fresco painting. St. Bogorodica Perivlepta, Ohrid, 1295*



Figure 4.18 *The communion of the Apostles. Fresco painting.*



Figure 4.19 *The Holy Virgin. Icon. (1108-1120) Ohrid Icon Gallery*



Figure 4.20 *St. Matthew. Icon, 1295. Ohrid Icon Gallery*

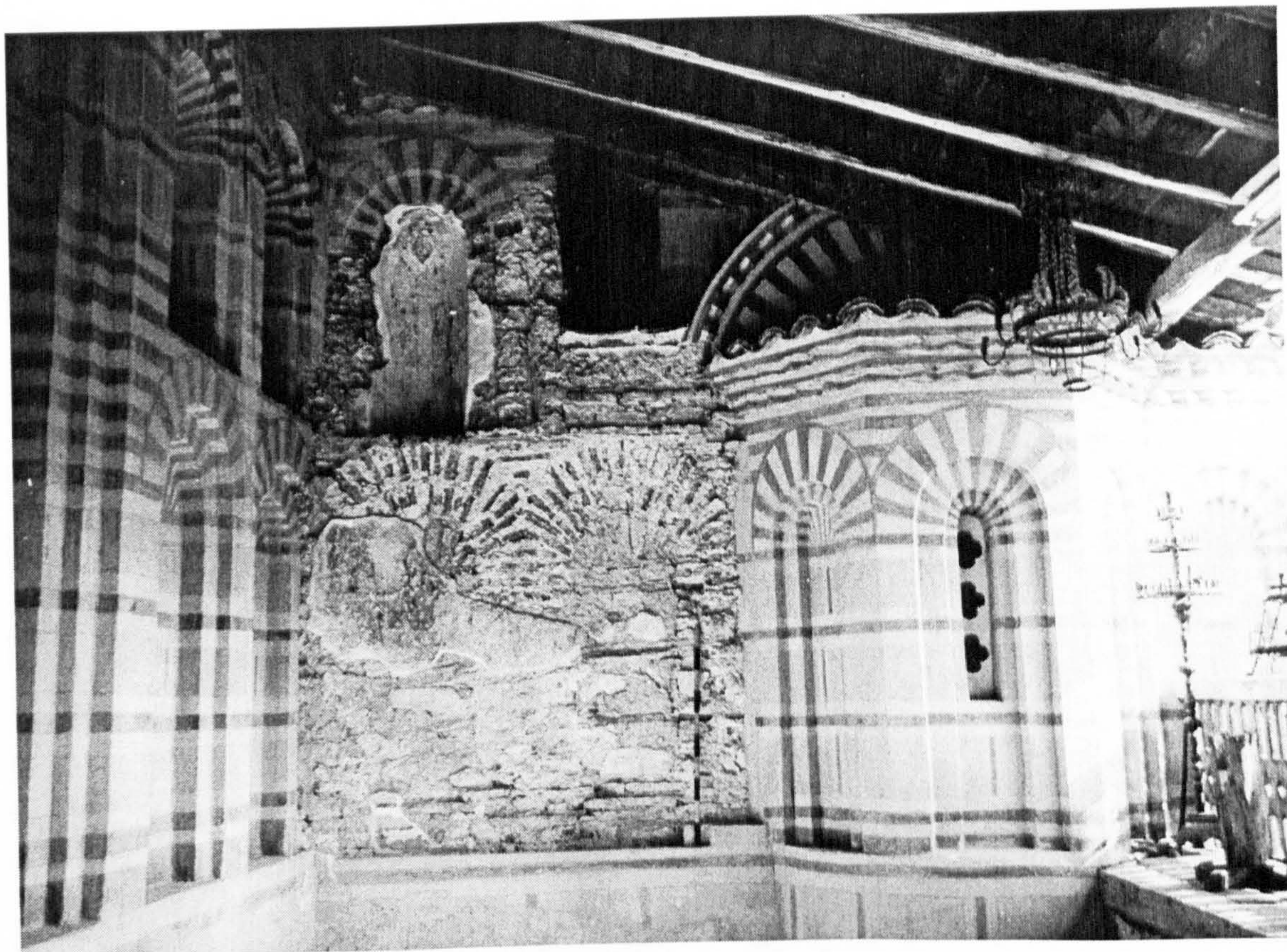

Figure 4.21 *St. Bogorodica Eleusa, v. Veljusa*



Figure 4.22 *St. Nikita, v. Banjani. Eastern and Northern facade*

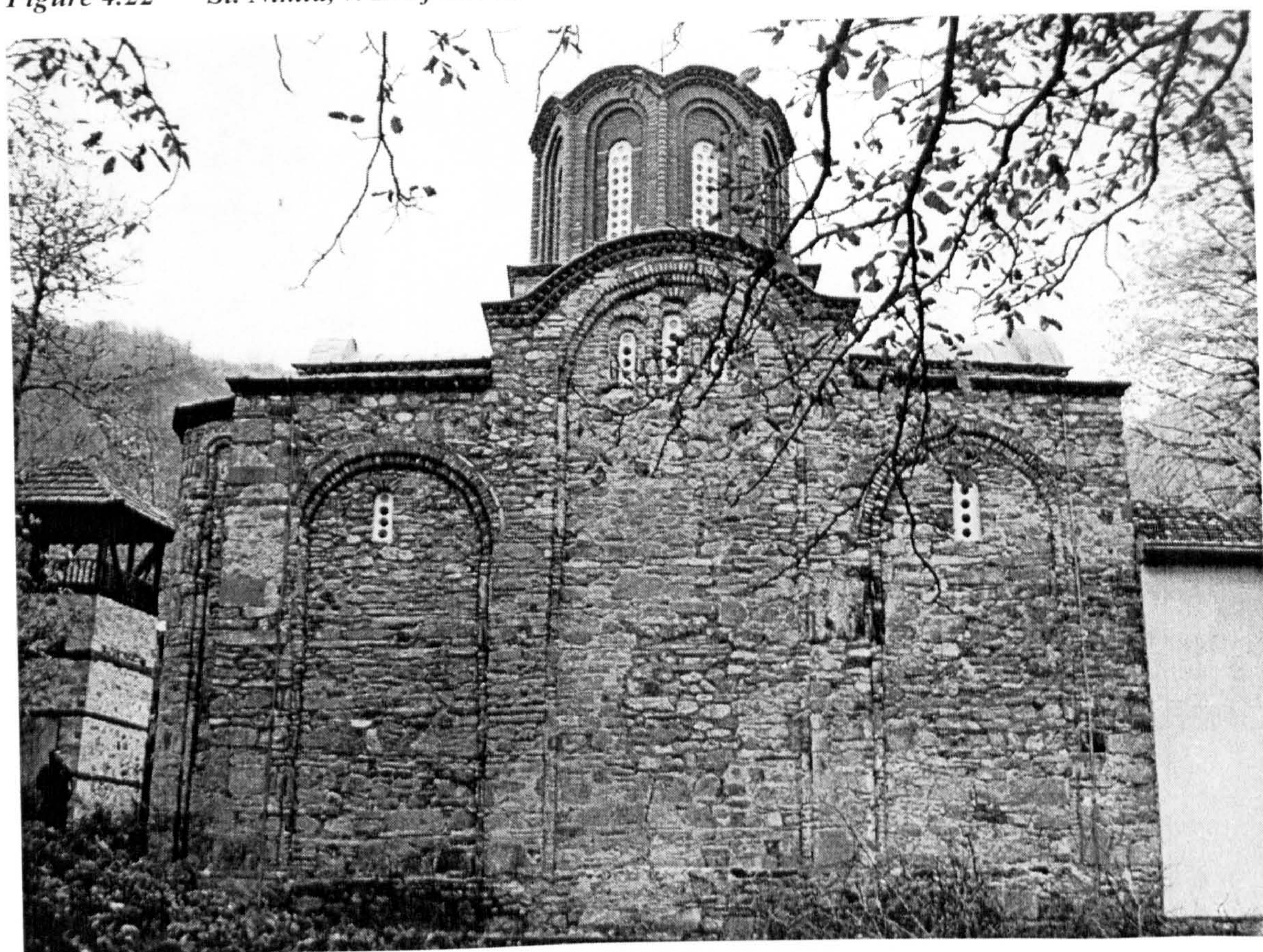

Figure 4.23 *St. Stefan, v. Konce. Northern facade*



Figure 4.24 *St. Archangel Michail, Stip. Southern and Eastern facade*

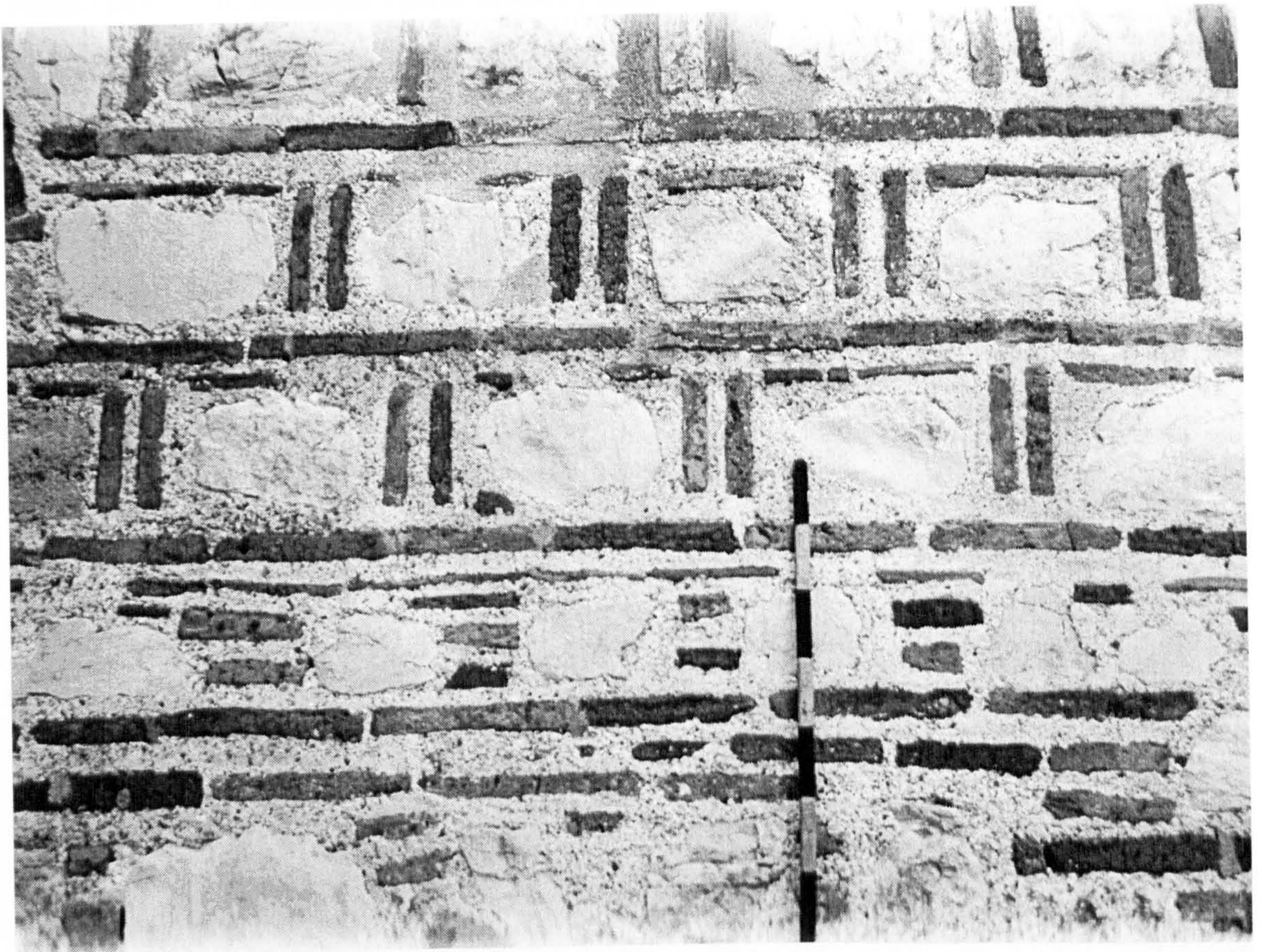

Figure 4.25 *St. Bogorodica Zaum, v. Trpejca. Detail of the facade opus*



Figure 4.26 *St. Dimitrija, Varos. Eastern facade*



Figure 4.27 *St. Leontie, v. Vodoca. Eastern facade*



Figure 4.28 *St. Nikola, v. Psaca. Eastern facade*

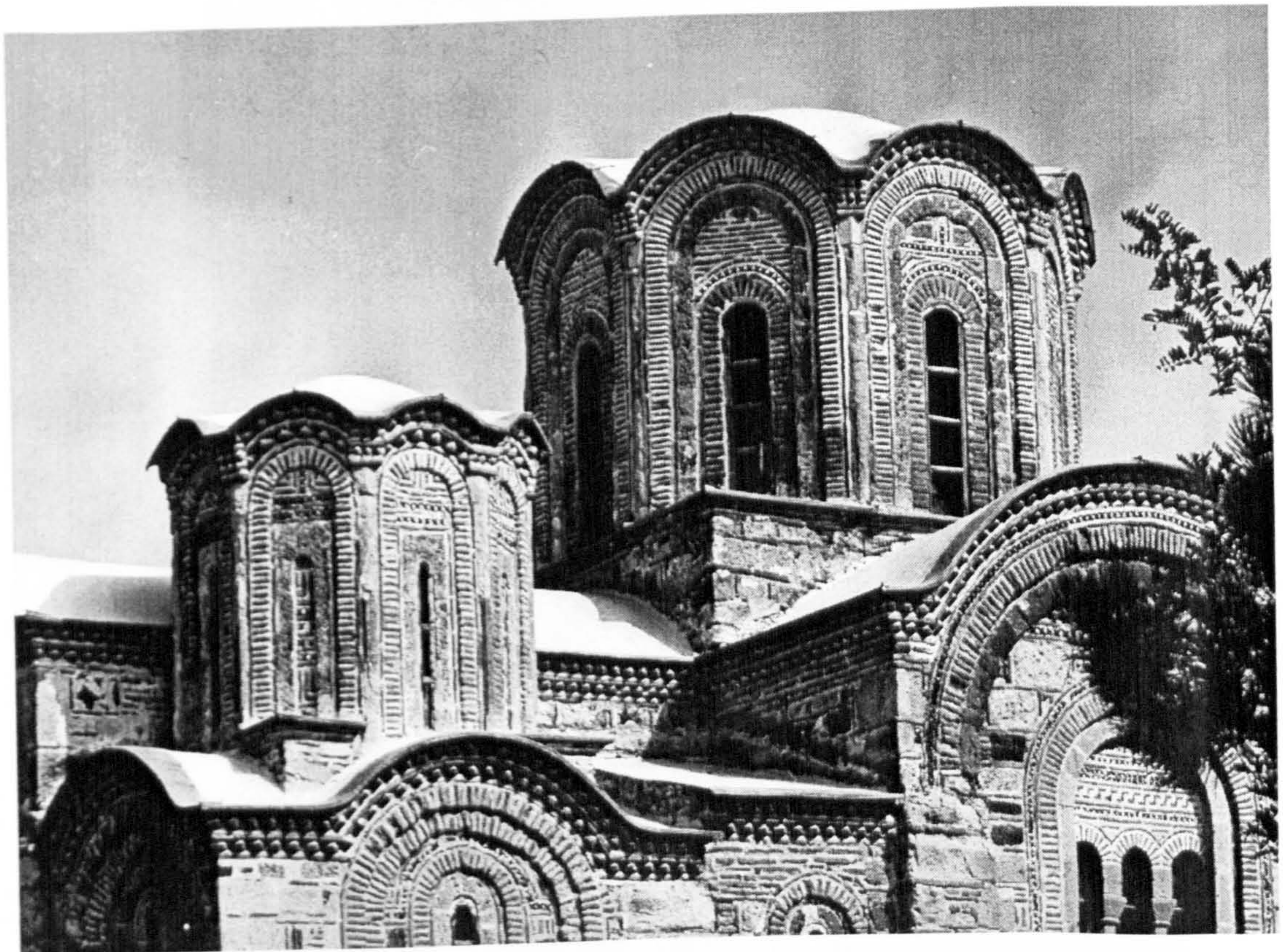

Figure 4.29 *St. Georgi, v. Staro Nagoricane. Southern facade*



Figure 4.30 St. Archangel Mihail, v. Lesnovo. Western facade

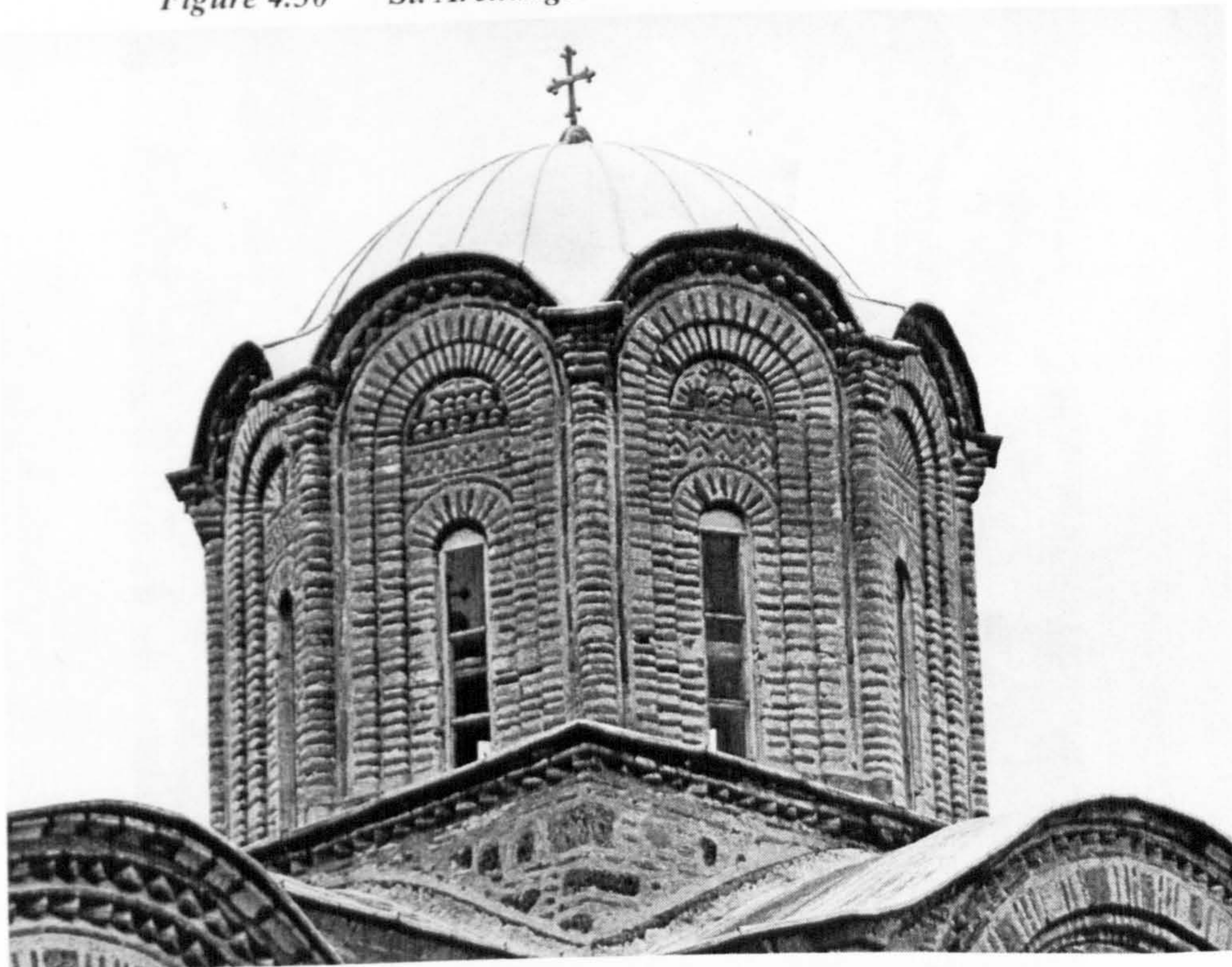

Figure 4.31 St. Archangel Mihail, v. Lesnovo. Central dome

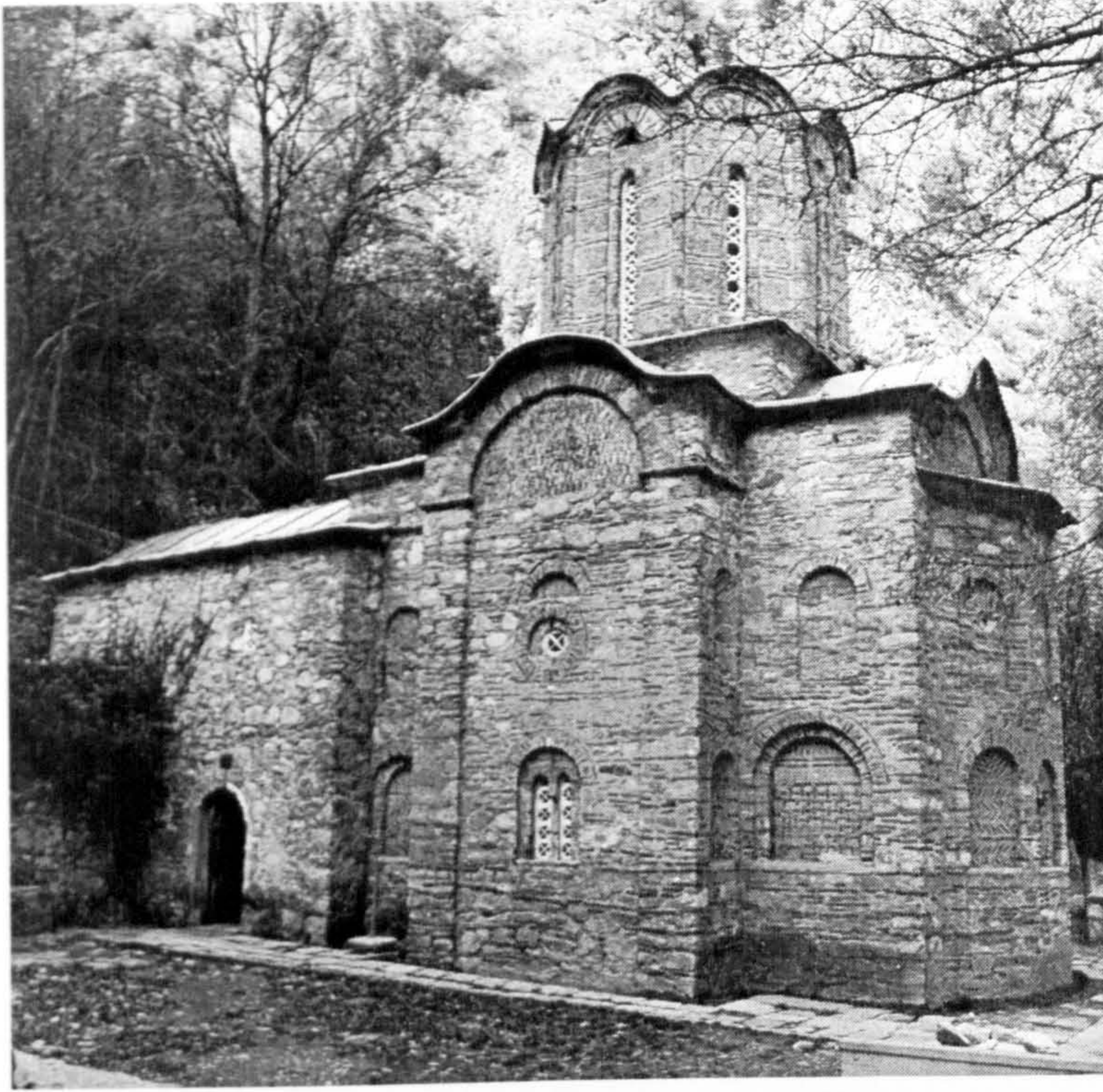

Figure 4.32 St. Andrea, v. Matka. Southern and Eastern facade

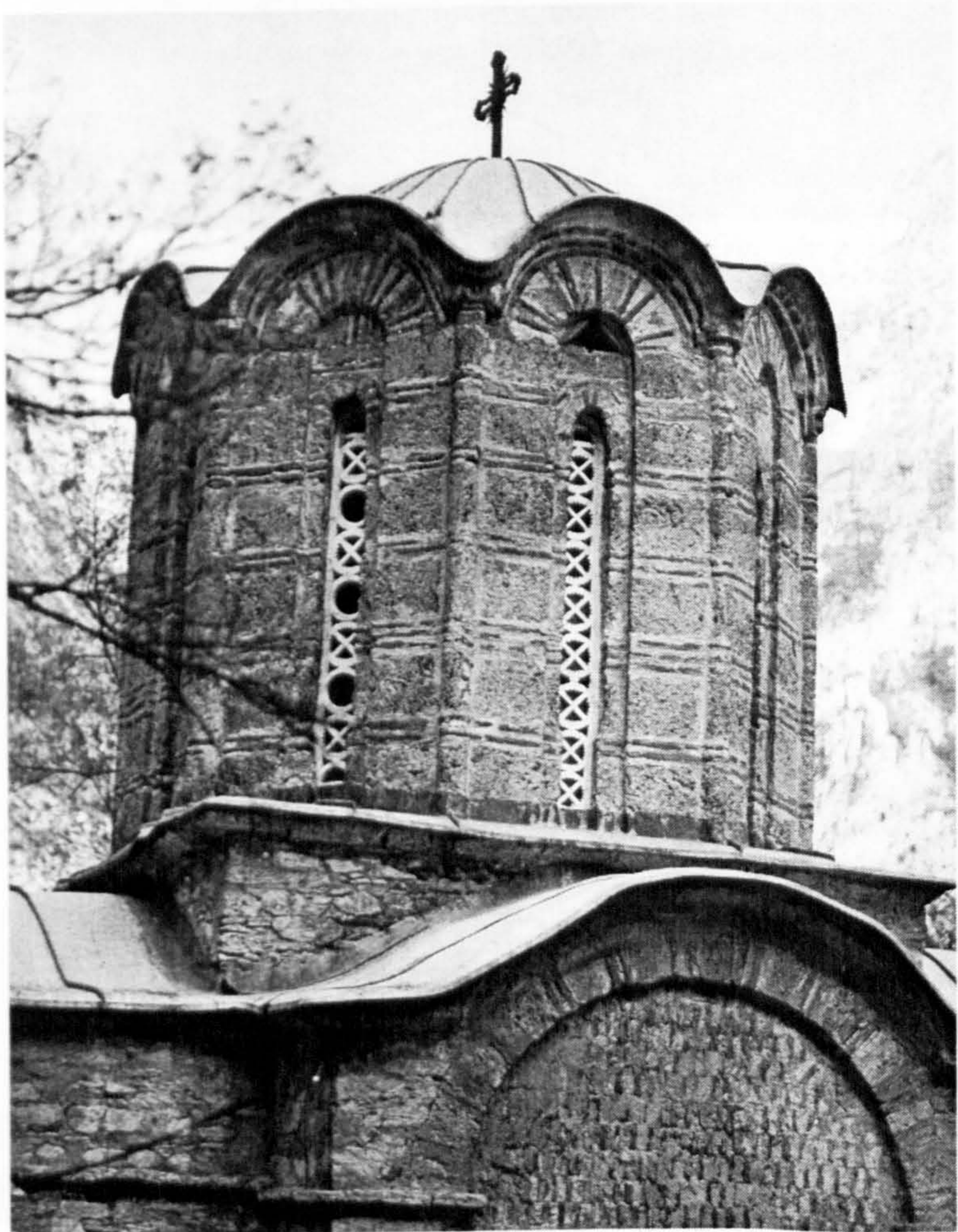

Figure 4.33 St. Andrea, v. Matka. Detail-central dome



Figure 4.34 *St. Dimitrija, v. Susica. Eastern facade*

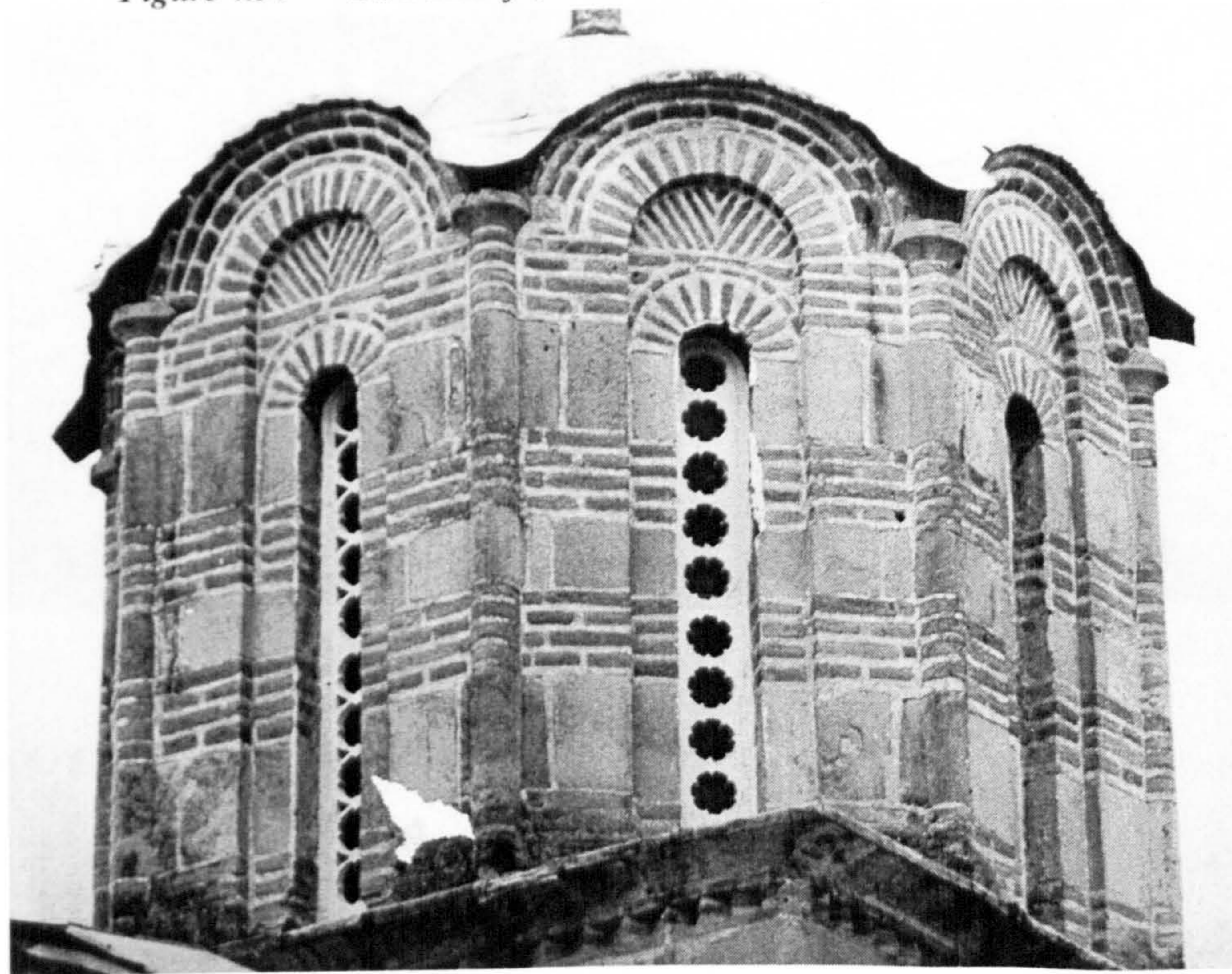

Figure 4.35 *St. Dimitrija, v. Susica. Detail of the drum*



Figure 4.36 St. Bogorodica, Osogovski Monastery



Figure 4.37 St. Bogorodica Perivlepta, Ohrid. Eastern facade

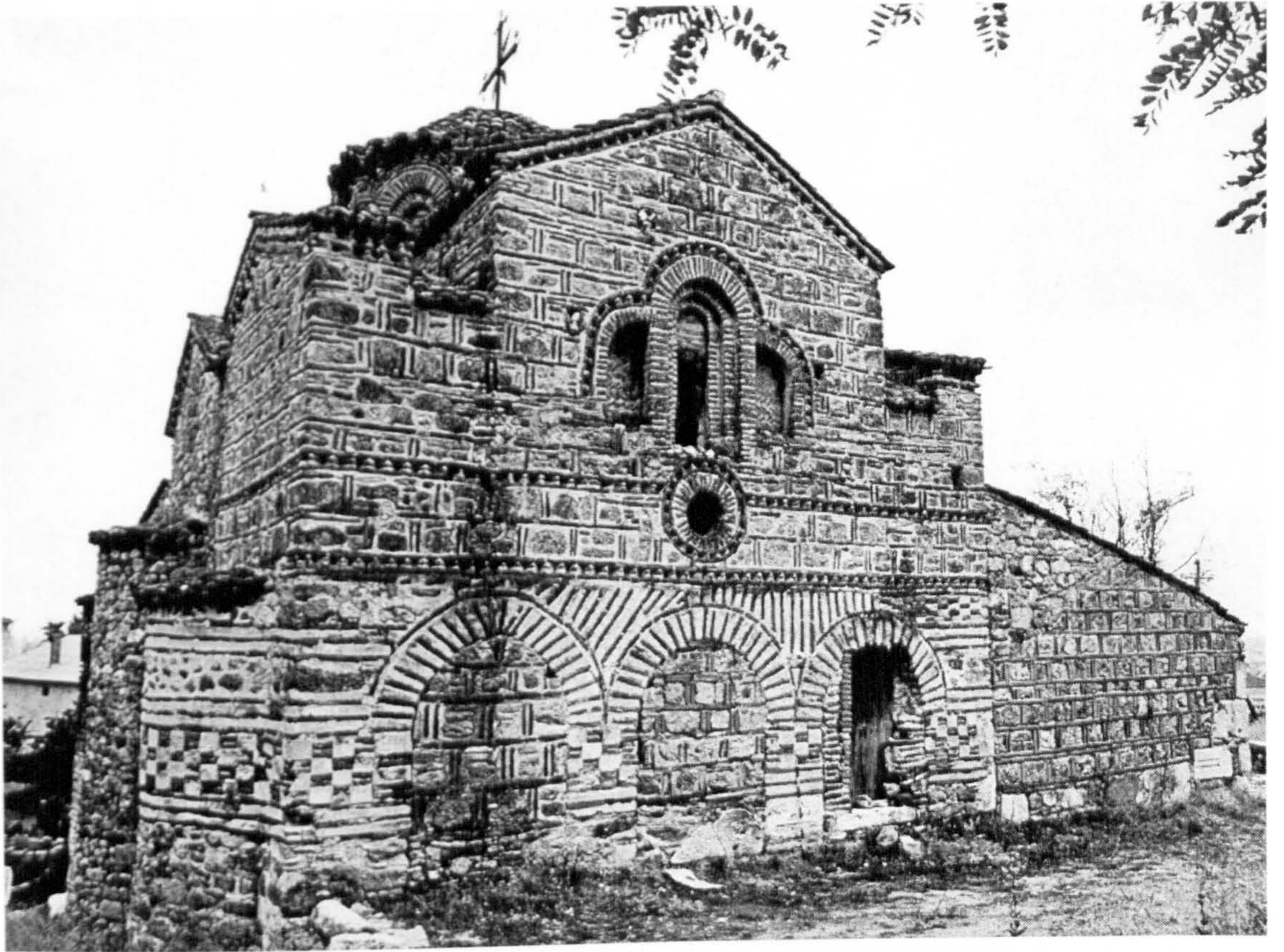

Figure 4.38 St. Dimitrija, Varos. Northern facade

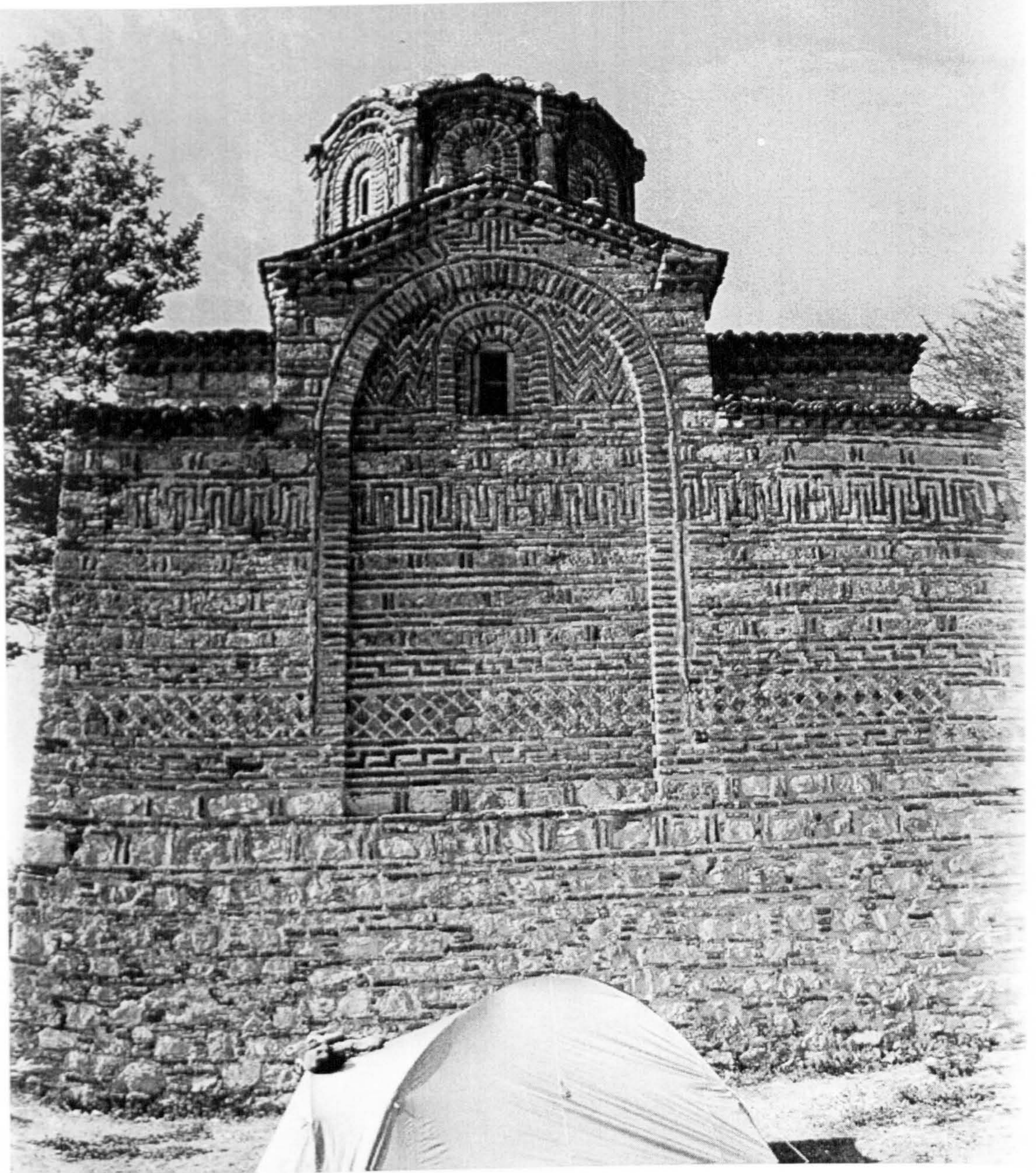

Figure 4.39 *St. Bogorodica Zaum. Southern facade*



Figure 4.40 St. Bogorodica Zaum. Northern facade

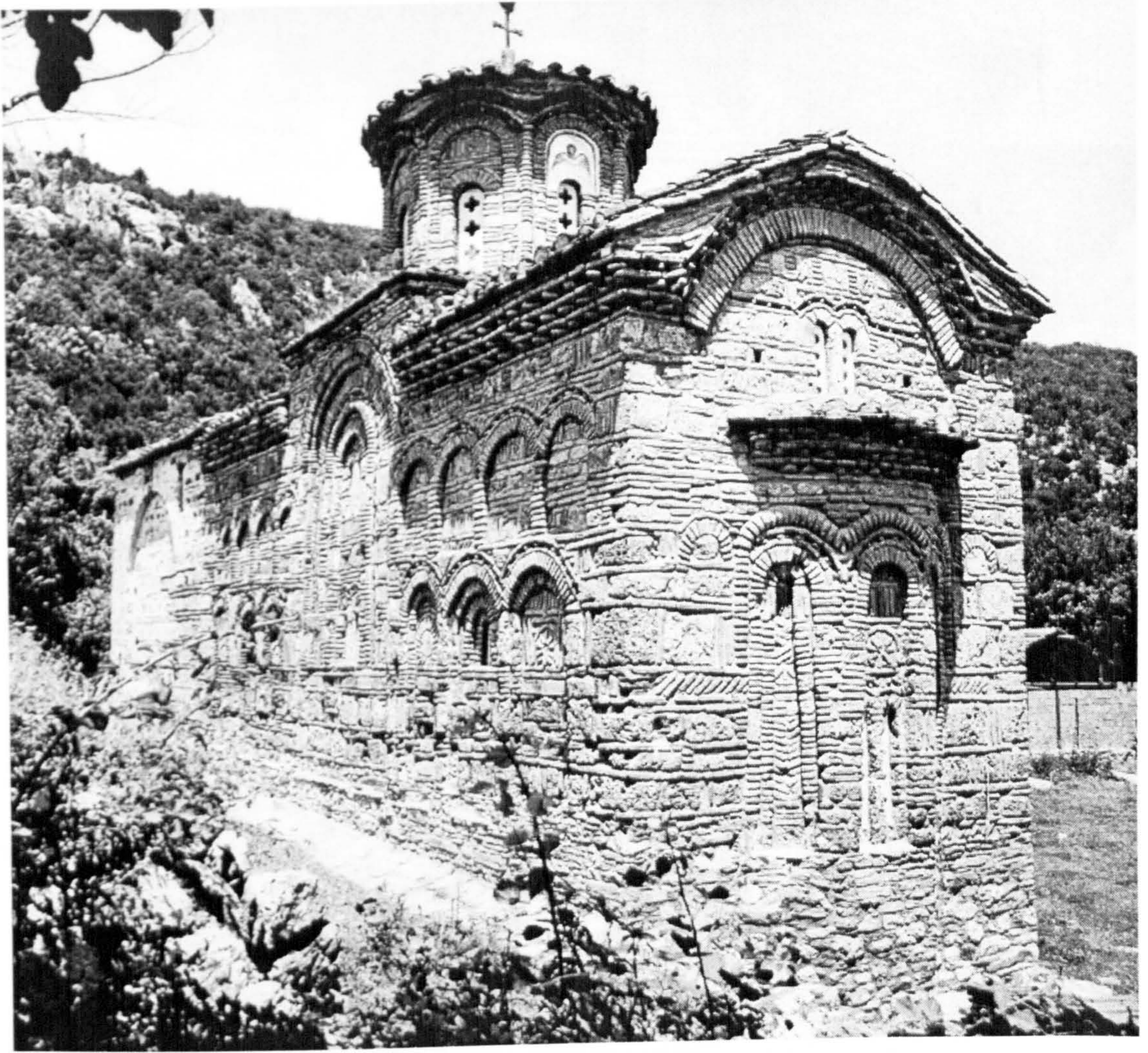

Figure 4.41 St. Georgi Poloski. Southern and Eastern facade



Figure 4.42 St. Georgi Poloski. Eastern facade

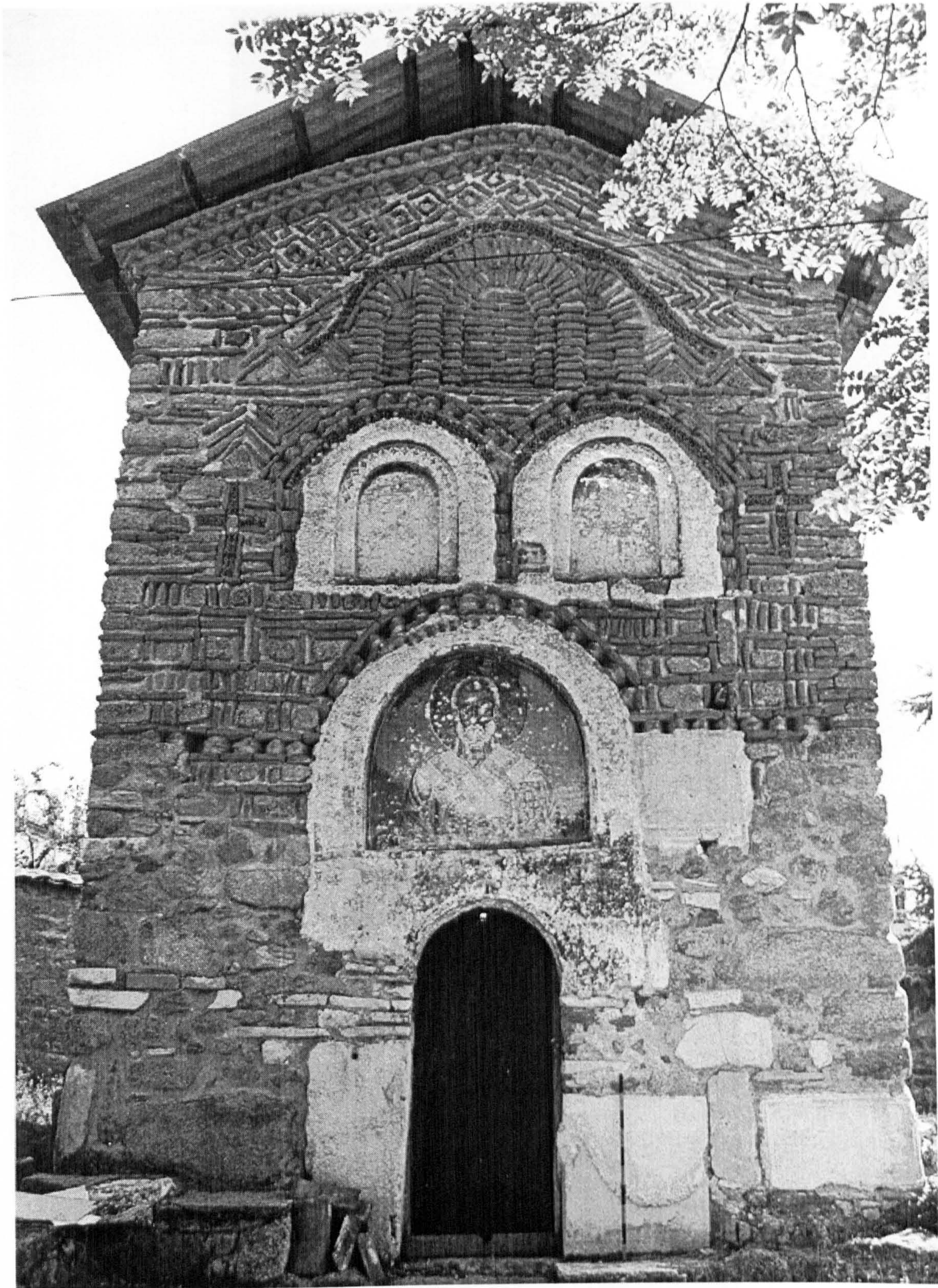

Figure 4.43 St. Nikola, Varos. Western facade

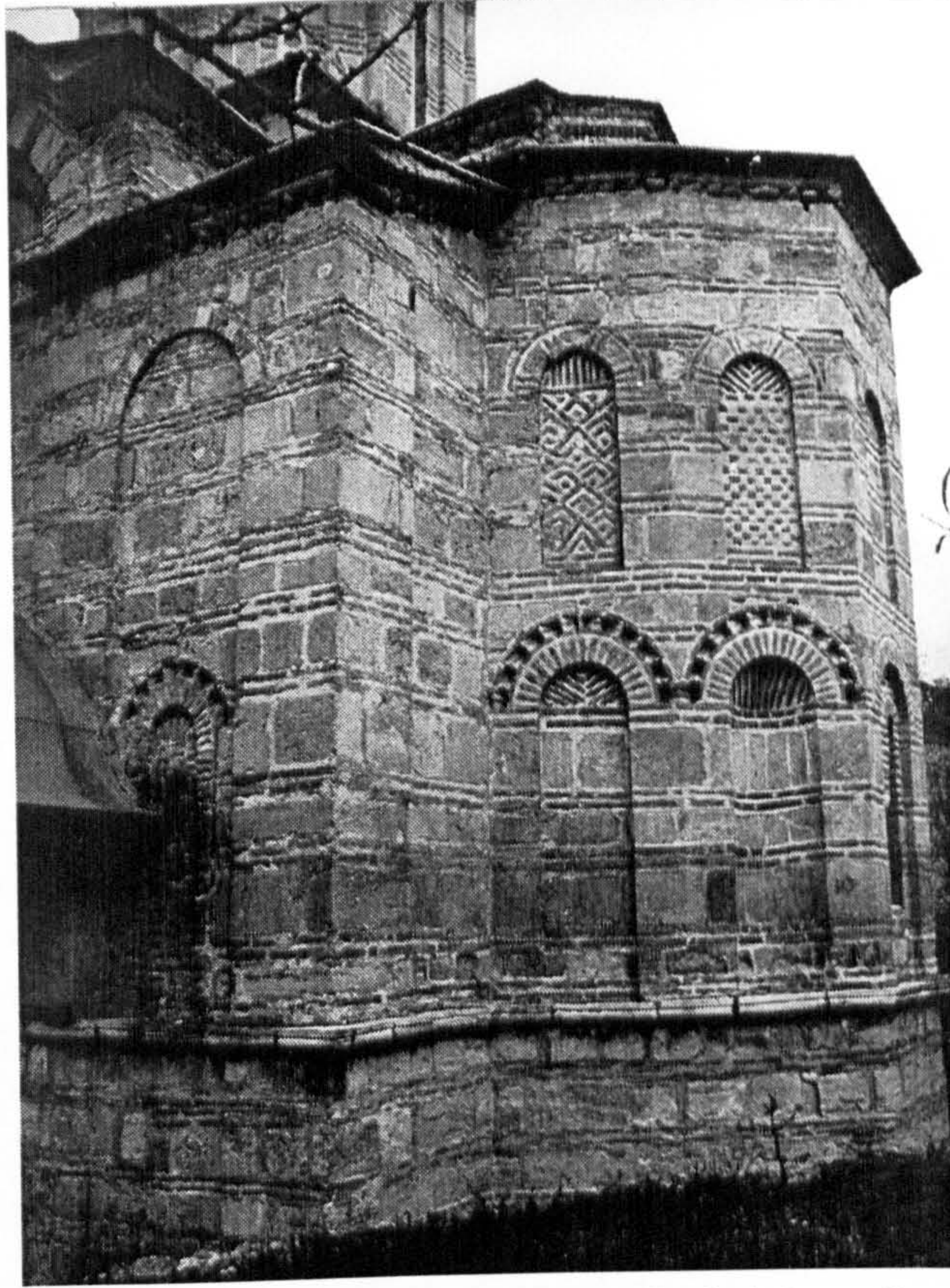

Figure 4.44 *St. Dimitrija, v. Susica. Blind niches - Eastern facade*

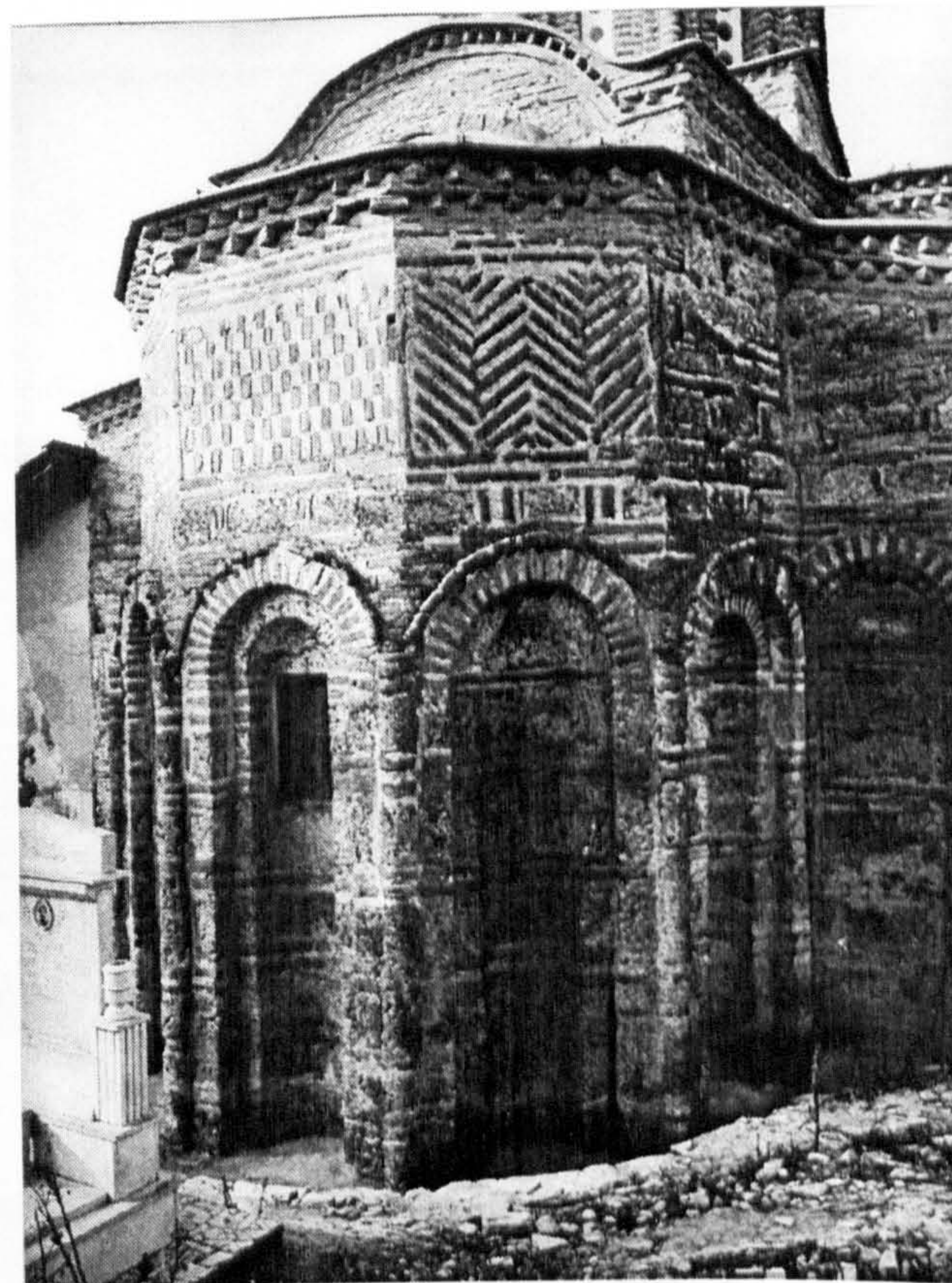

Figure 4.45 *St. Spas, v. Kuceviste. Blind niches on Eastern facade*



Figure 4.46 *St. Bogorodica, v. Matejce. Eastern facade*

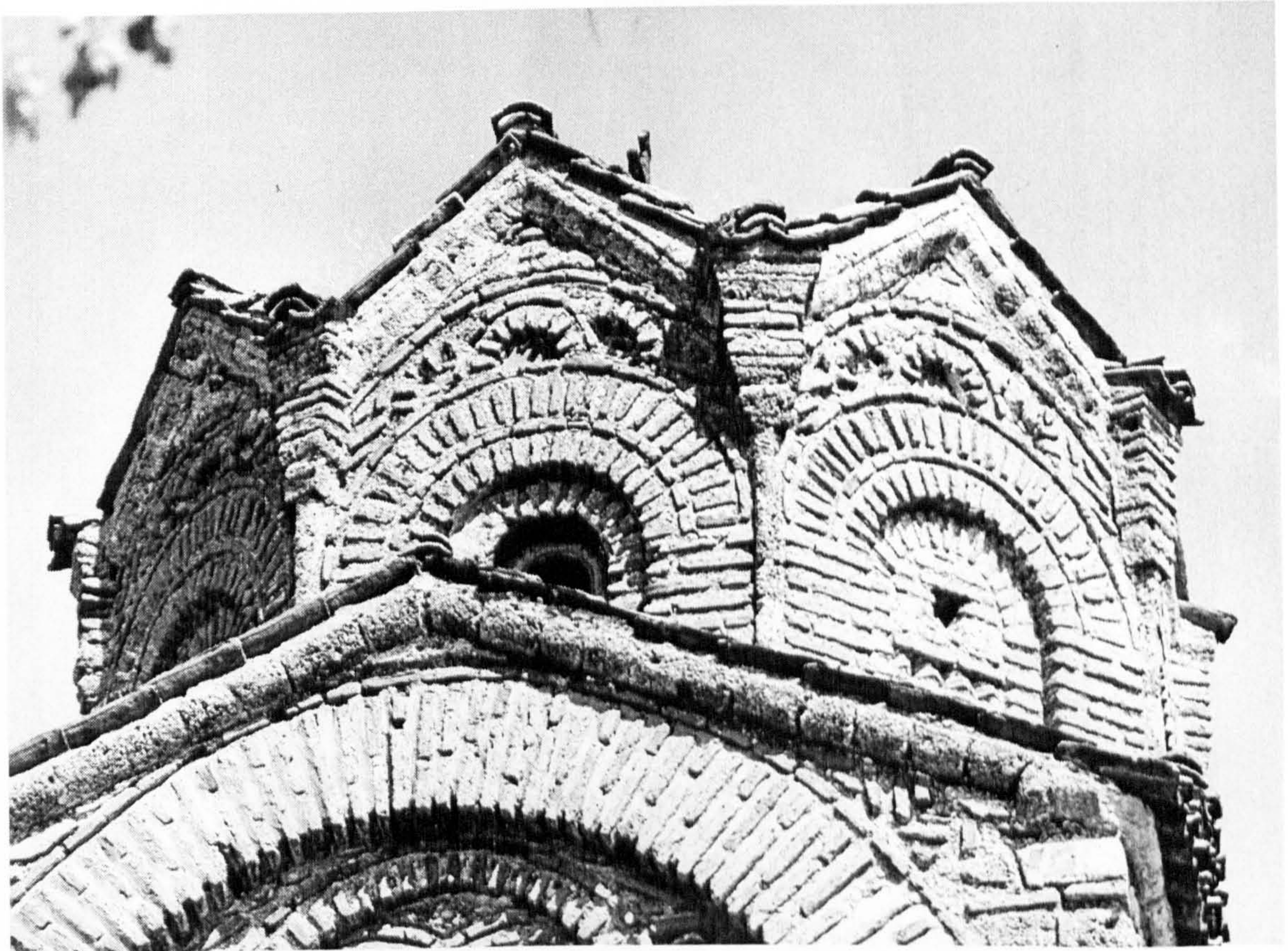

Figure 4.47 *St. Jovan Kaneo, Ohrid. Detail of drum*



Figure 4.48 *St. Archangel Mihail, Stip. Northern facade*



Figure 4.49 *St. Archangel Mihail, Stip. Northern facade*



Figure 4.50 St. Bogorodica, v. Matejce. Southern facade

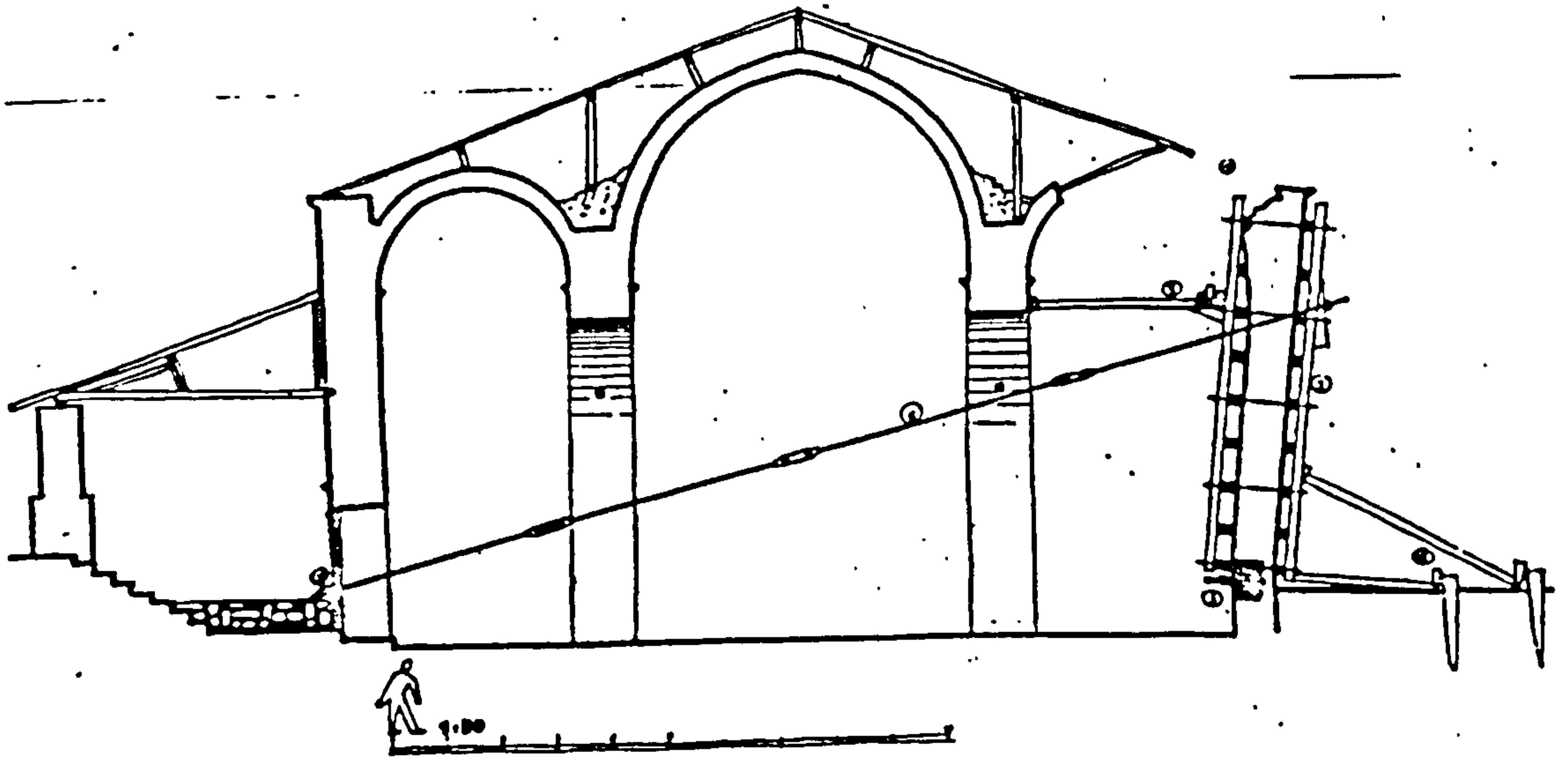

Figure 4.51 St. Sophia, Ohrid. Intervention on South wall

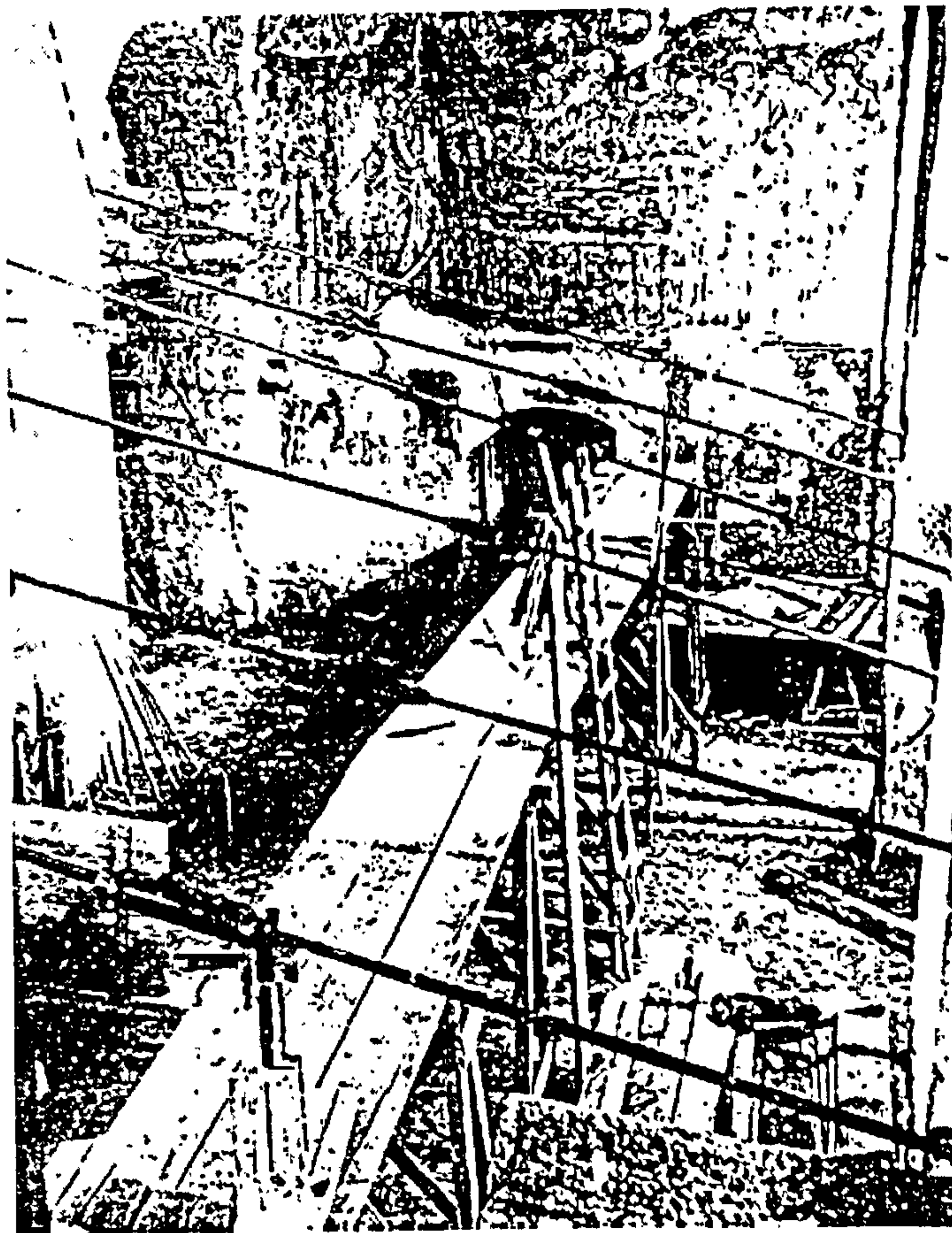

Figure 4.52 St. Sophia, Ohrid. Intervention on South wall.

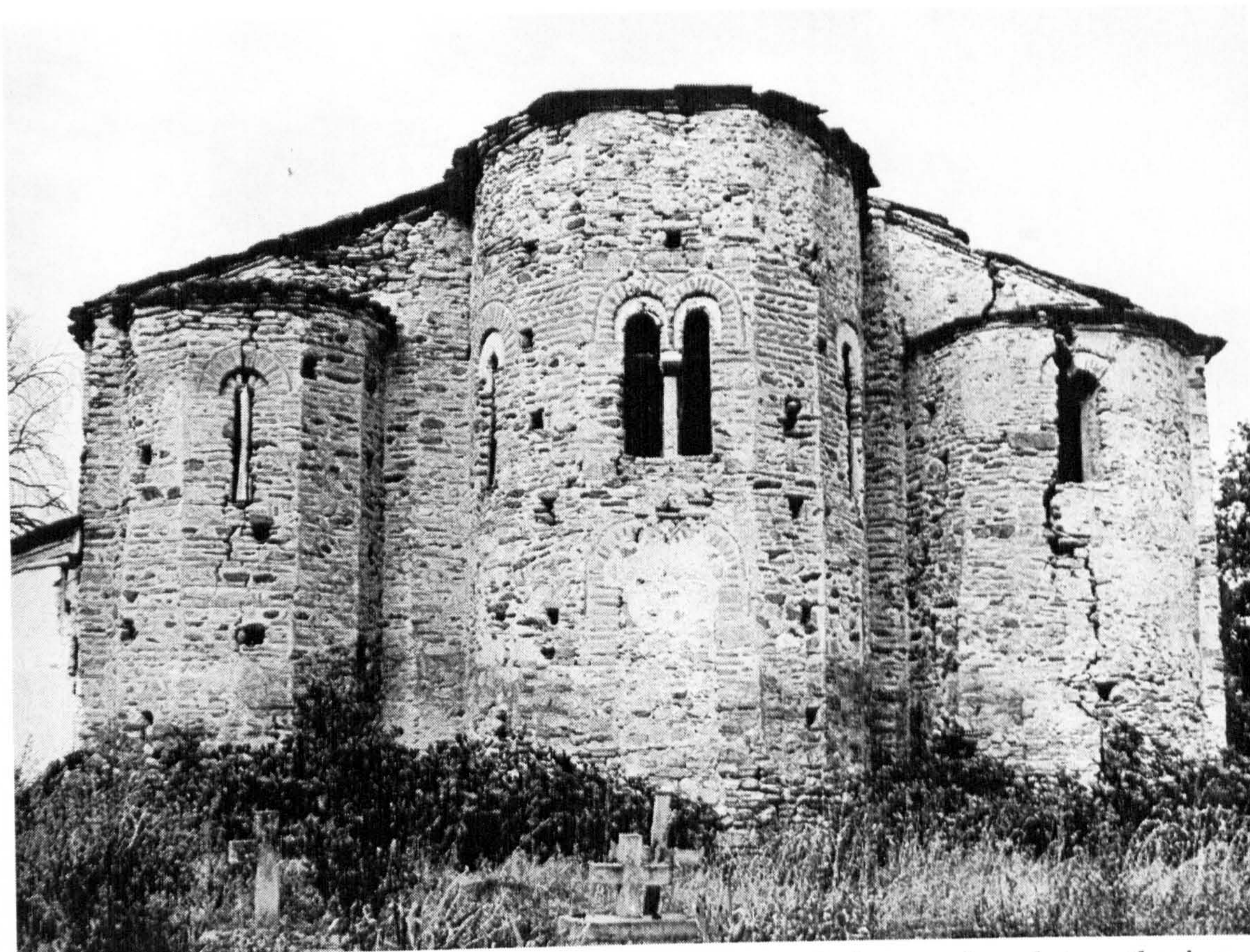

Figure 4.53 St. Bogorodica, v. Drenovo. Eastern facade - before repair and strengthening

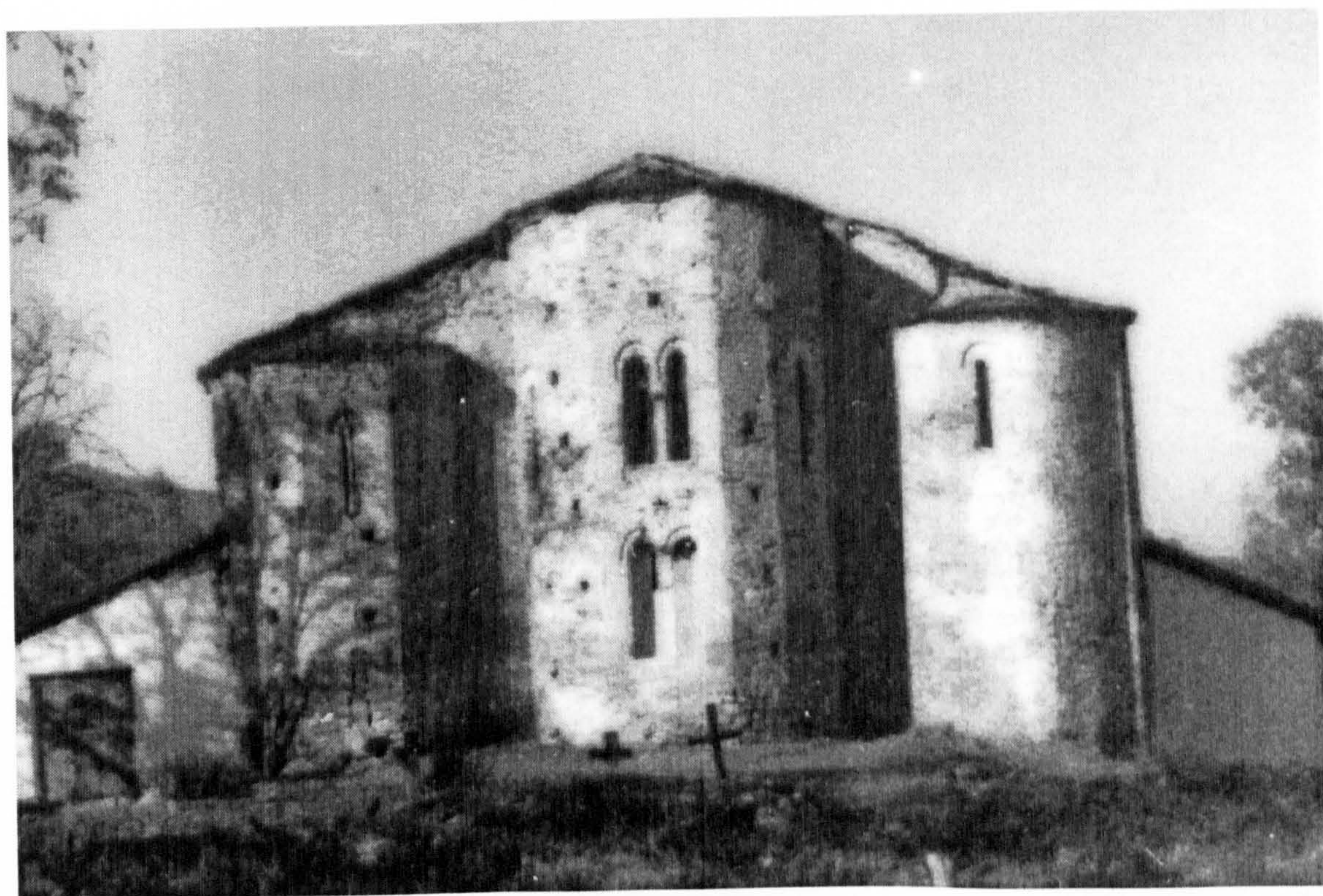

Figure 4.54 St. Bogorodica, v. Drenovo. After partial intervention



Figure 4.55 *St. Bogorodica Eleusa, v. Veljusa*



Figure 4.56 *St. Bogorodica Treskavec, v. Dabniste*



Figure 4.57 St. Jovan Kaneo, Ohrid. Before the restoration

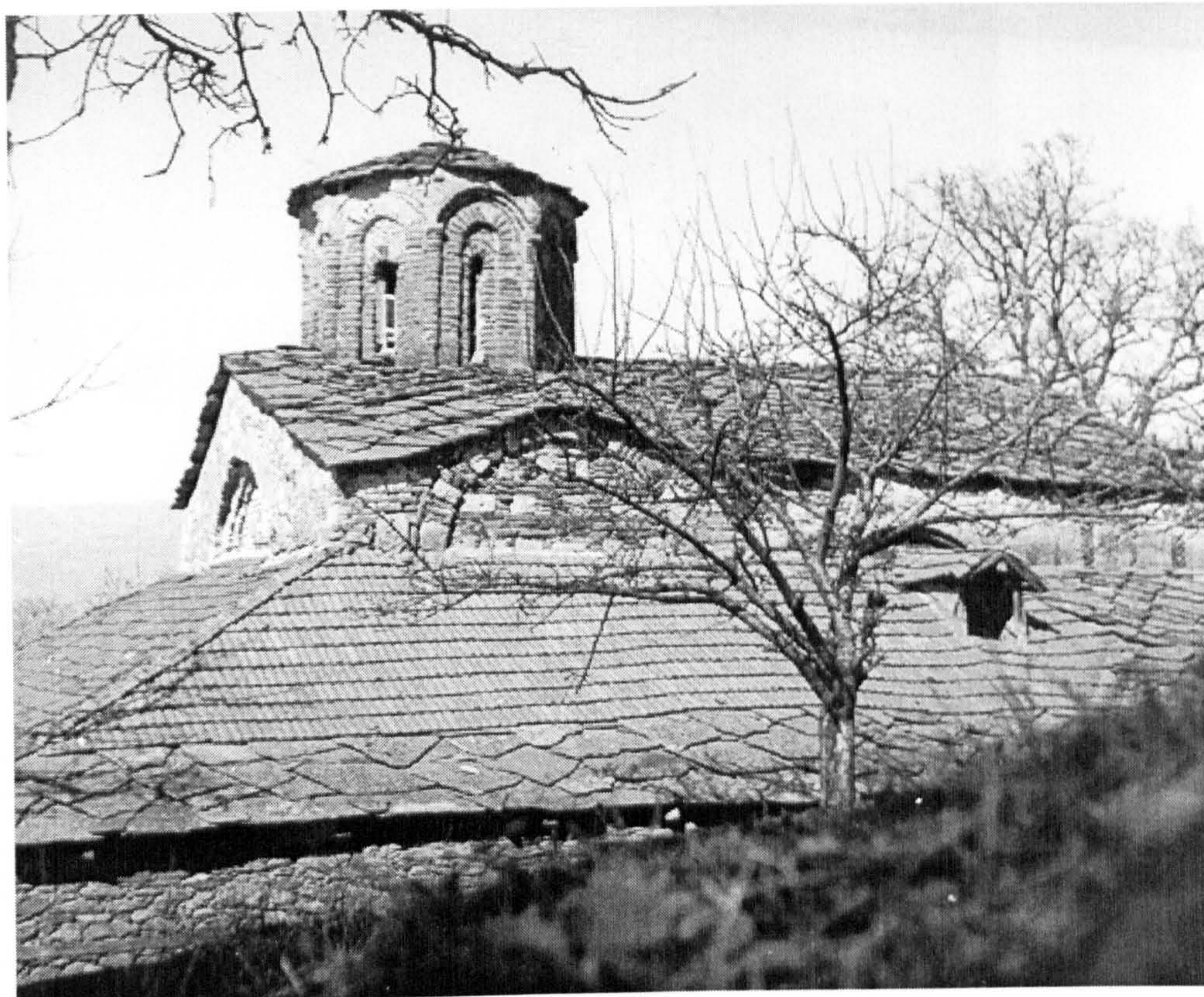

Figure 4.58 St. Nikola, v. Psaca. Before restoration

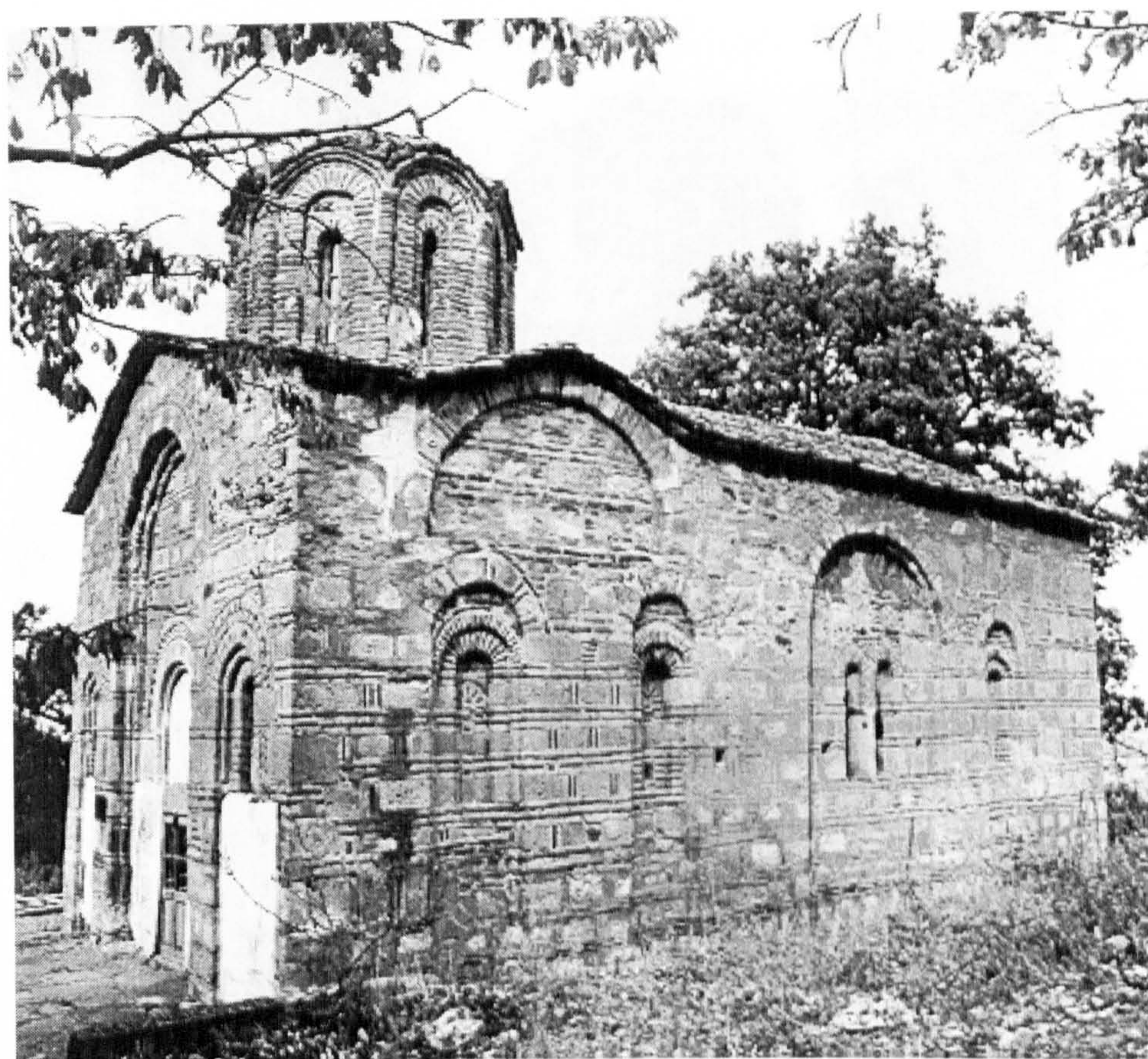

Figure 4.59 St. Nikola, v. Psaca. After restoration



Figure 4.60 St. Stefan, v. Konce. Before restoration and reconstruction



Figure 4.61 St. Stefan, v. Konce. After restoration and reconstruction

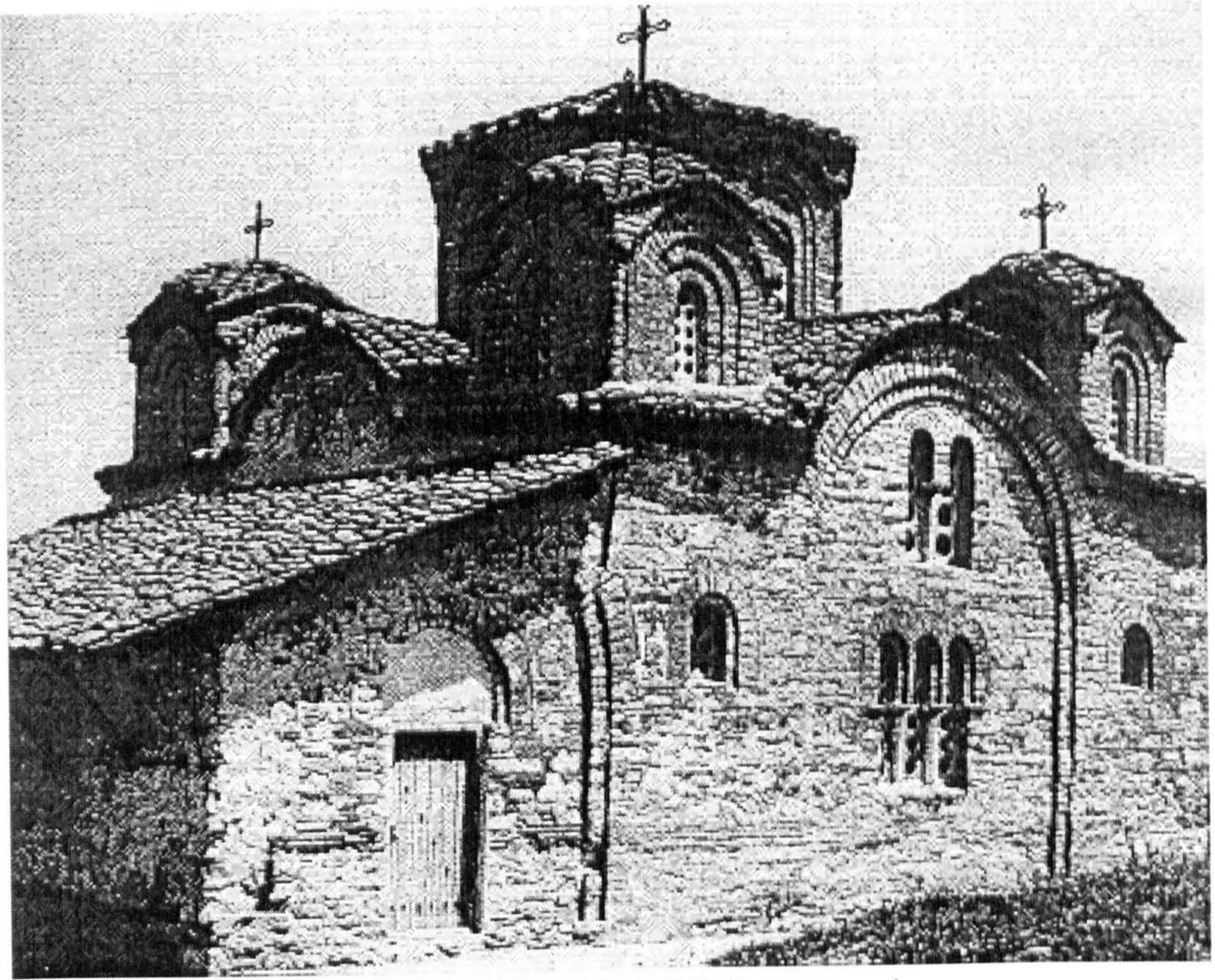

Figure 4.62 St. Panteleimon, v. Gorno Nerezi. Before restoration

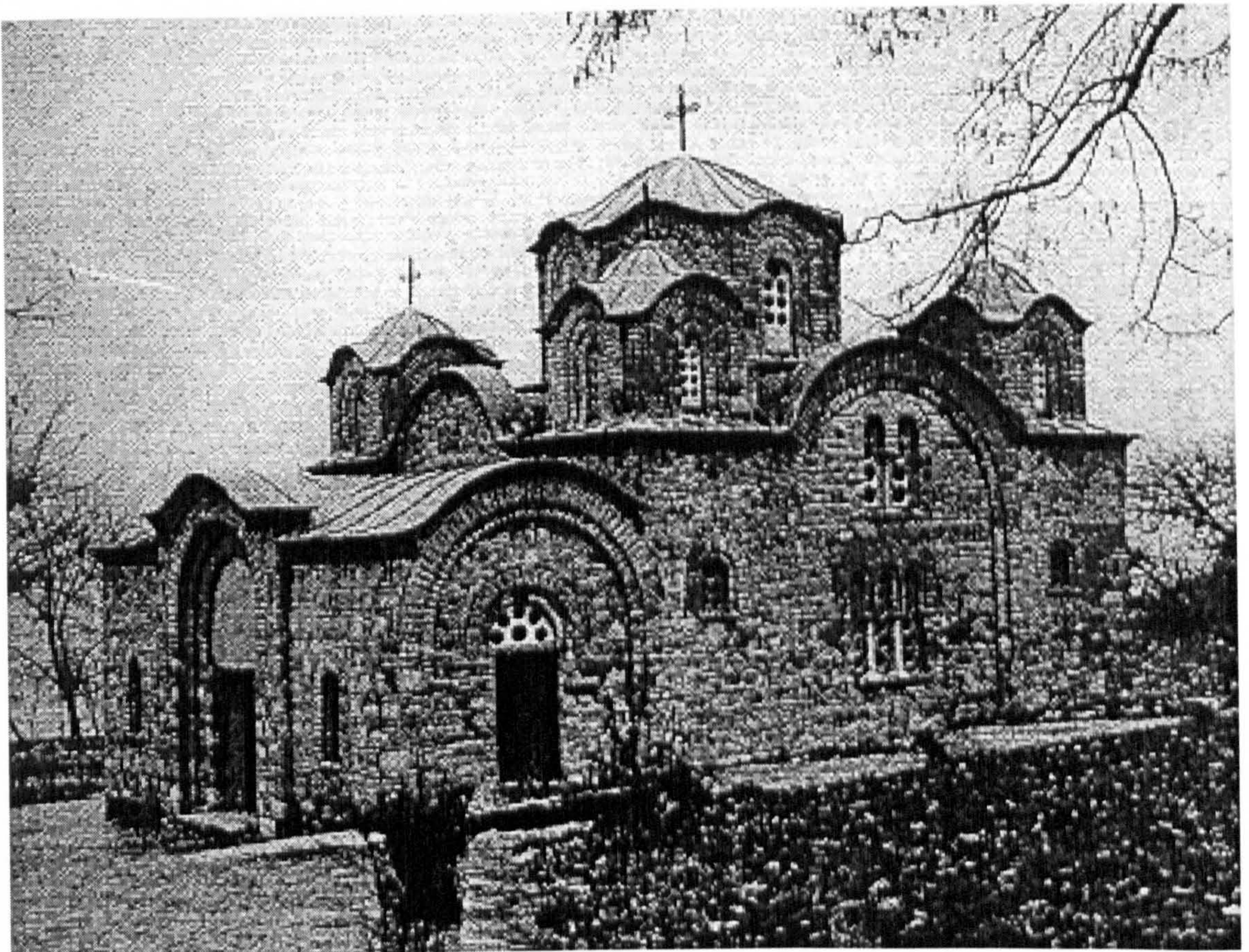

Figure 4.63 St. Panteleimon, v. Gorno Nerezi. After restoration



Figure 4.64 *St. Nikita, v. Banjani. Before restoration*



Figure 4.65 *St. Nikita, v. Banjani. After restoration*



Figure 4.66 St. Leontie, v. Vodoca. North facade - before reconstruction



Figure 4.67 St. Leontie, v. Vodoca. North facade - after reconstruction



Figure 4.68 *St. Leontie, v. Vodoca. East facade - before reconstruction*



Figure 4.69 *St. Leontie, v. Vodoca. East facade - after reconstruction*

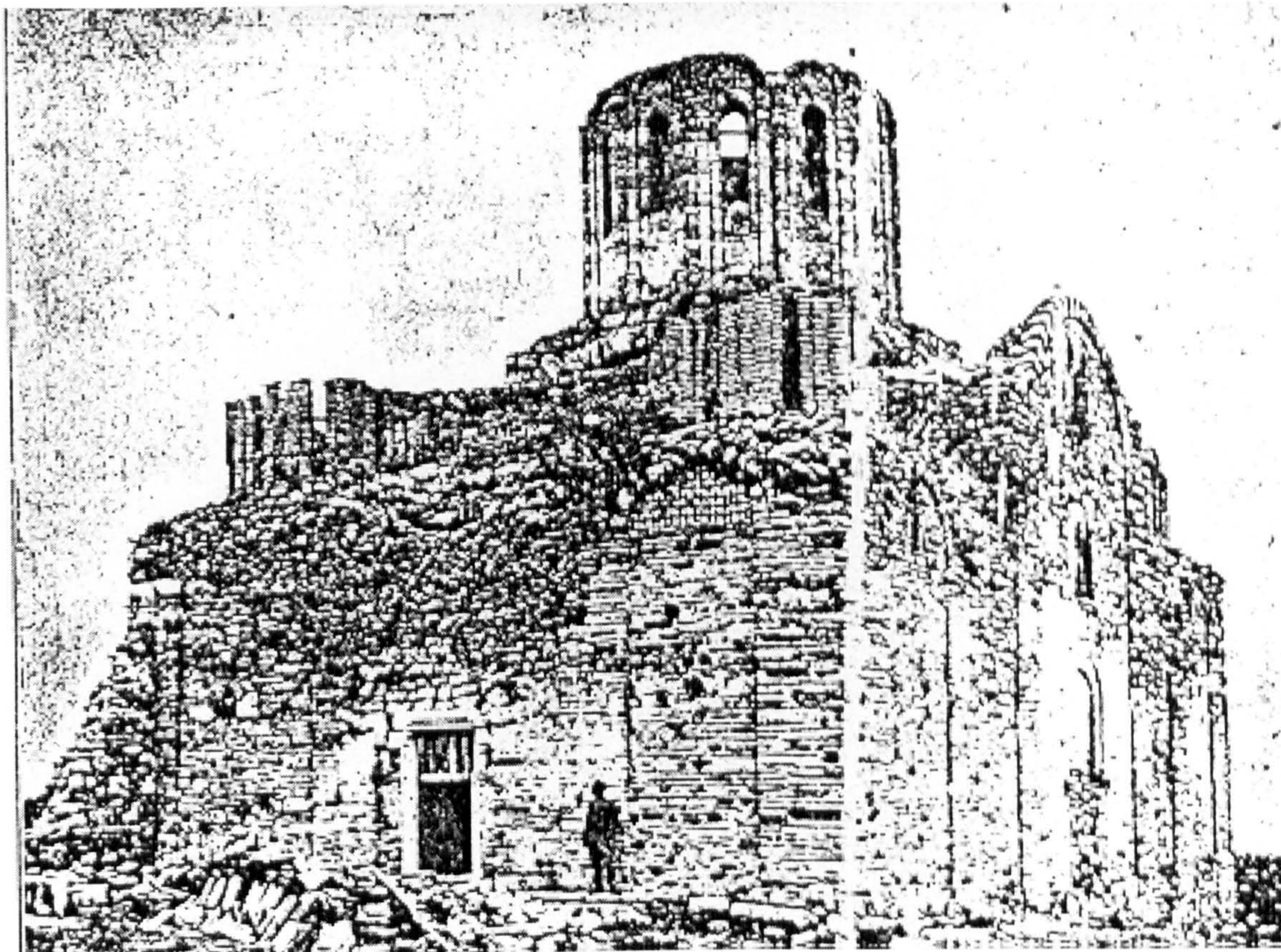

Figure 4.70 St. Bogorodica, v. Matejce. Western and Southern facades - before reconstruction



Figure 4.71 St. Bogorodica, v. Matejce. Western and Southern facade - after reconstruction

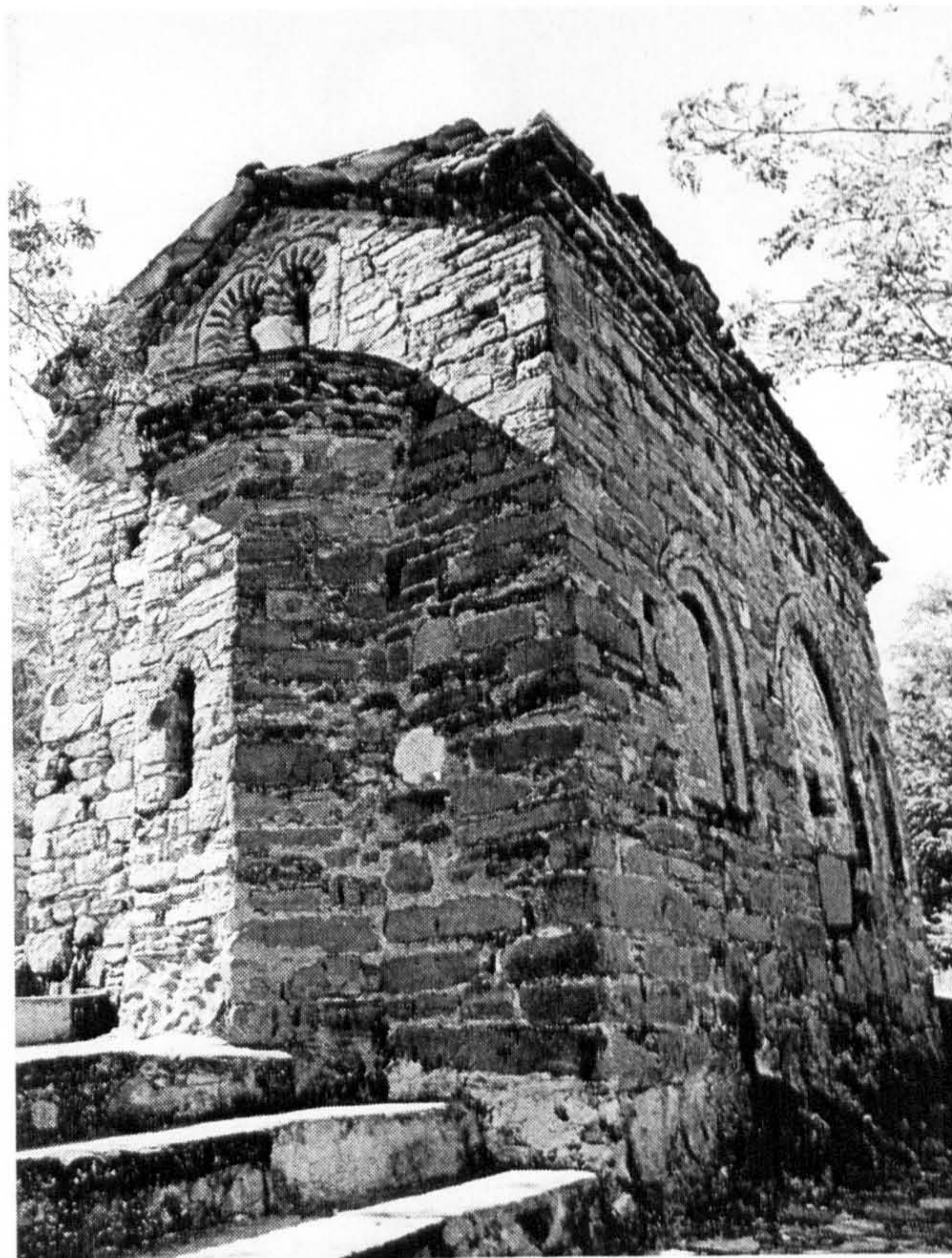

Figure 4.72 St. Spas, Stip



Figure 4.73 St. Nikola, v. Sisevo

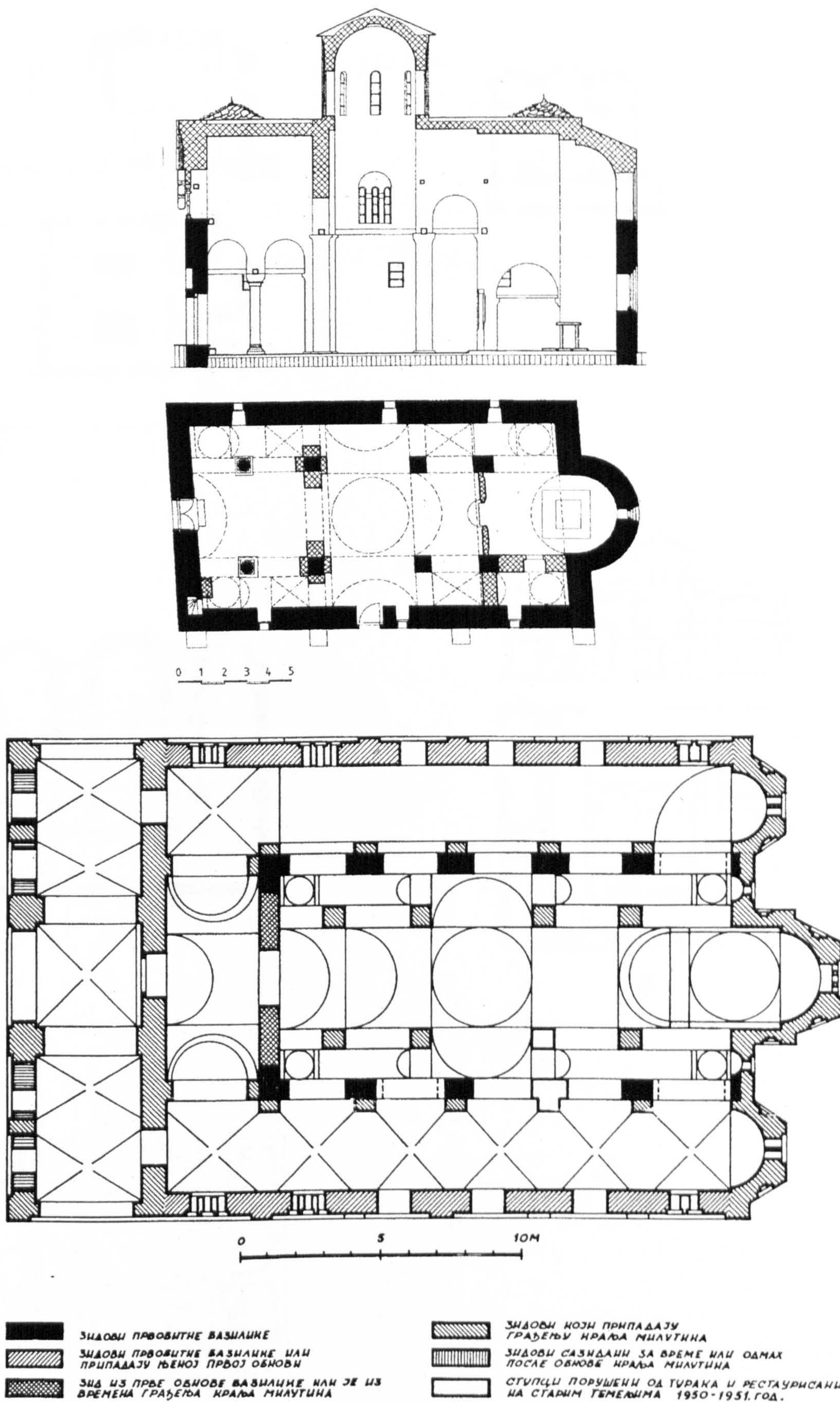
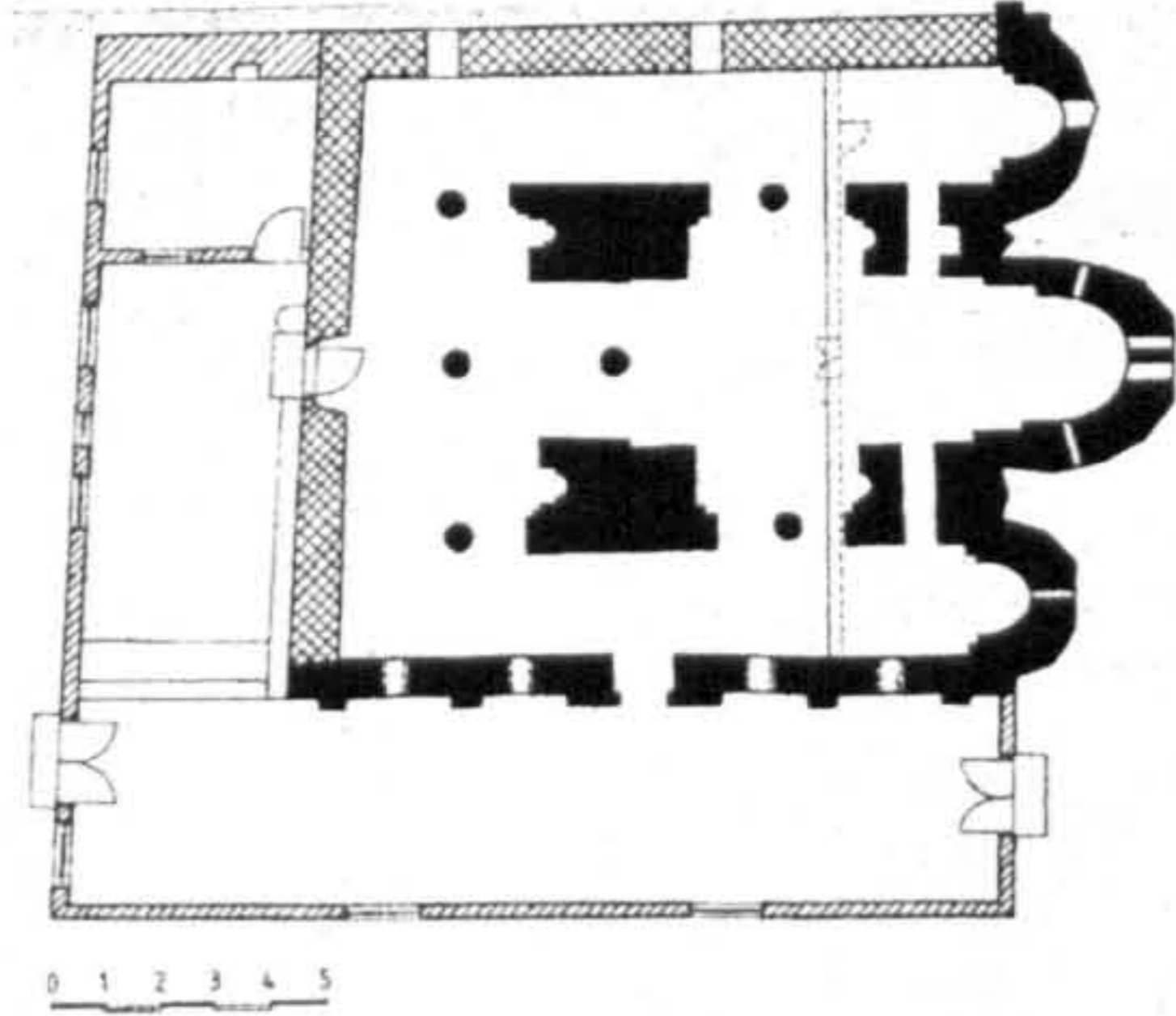
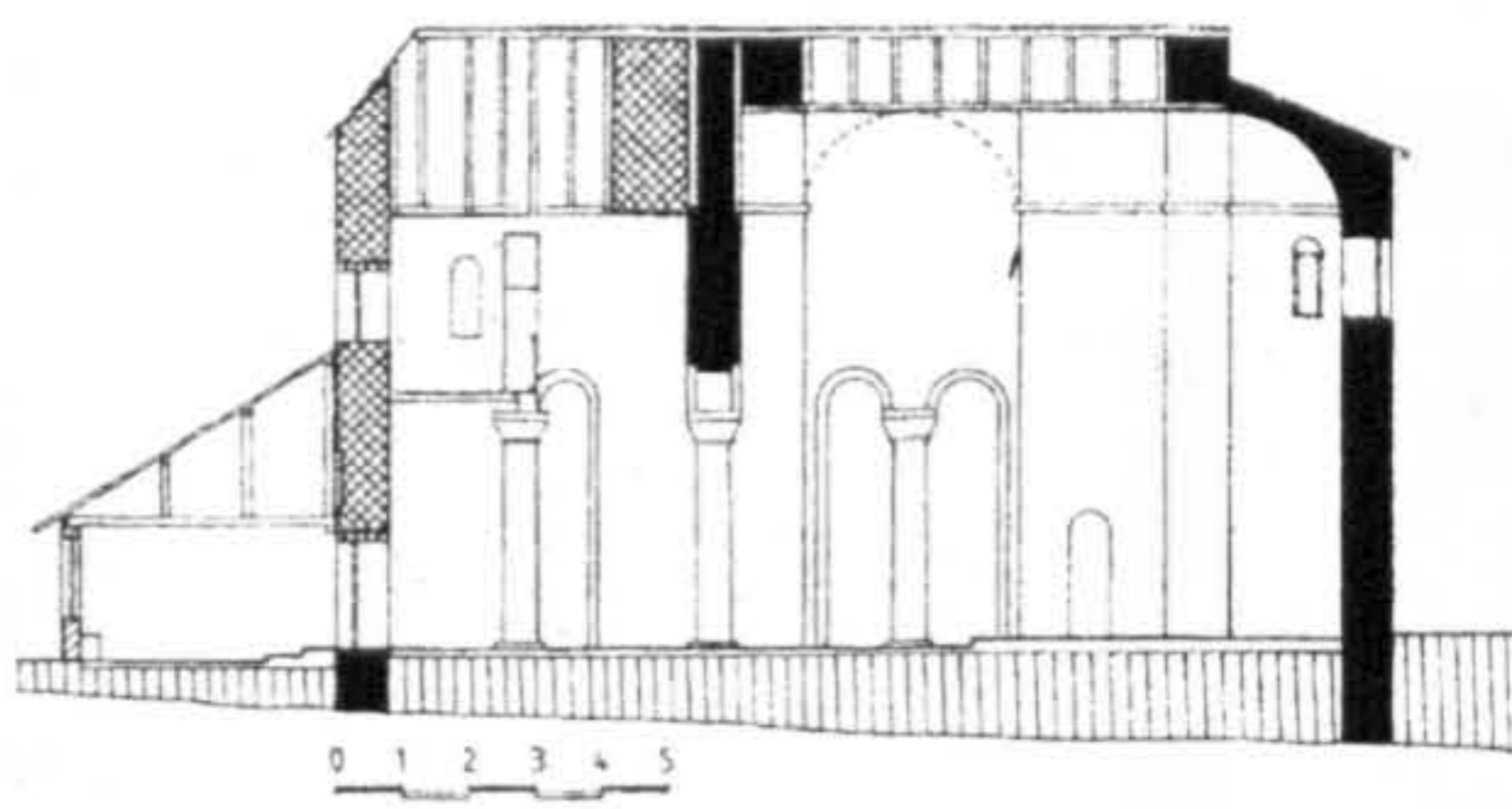
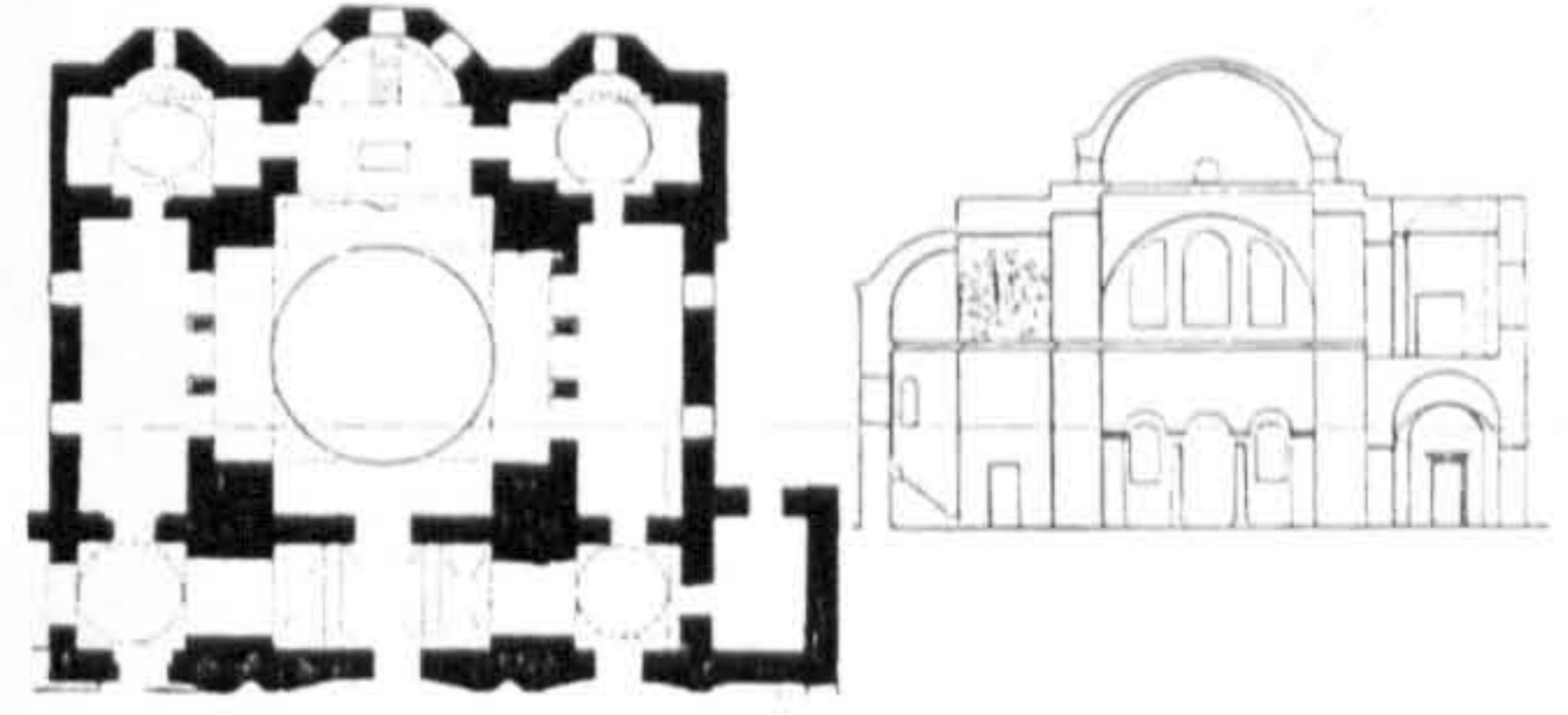

Figure 4.74 a) St. Georgi, v. Staro Nagoricane; b) St. Bogorodica Ljeviska, Prizren (Serbia)



a)



b)

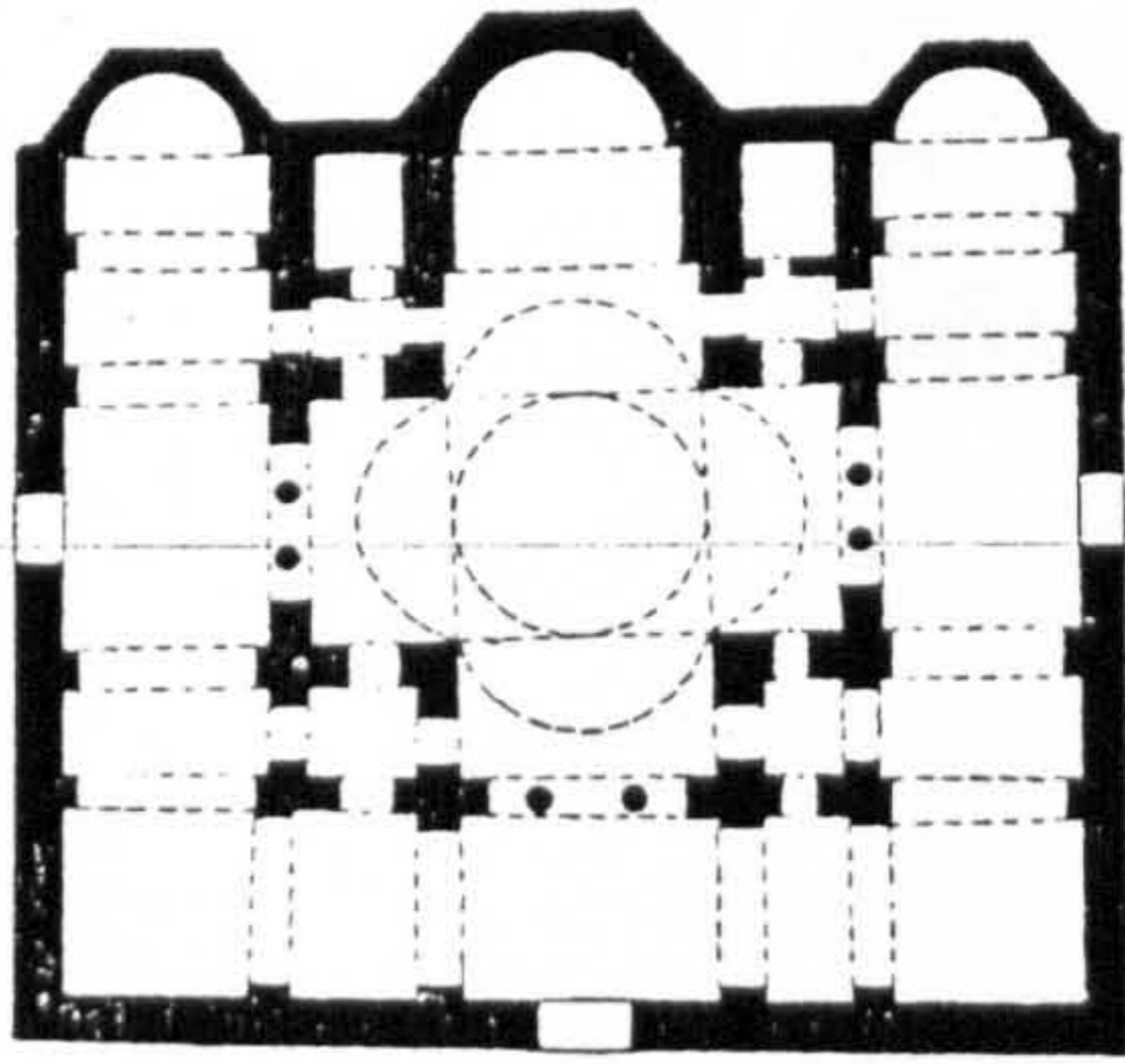

c)

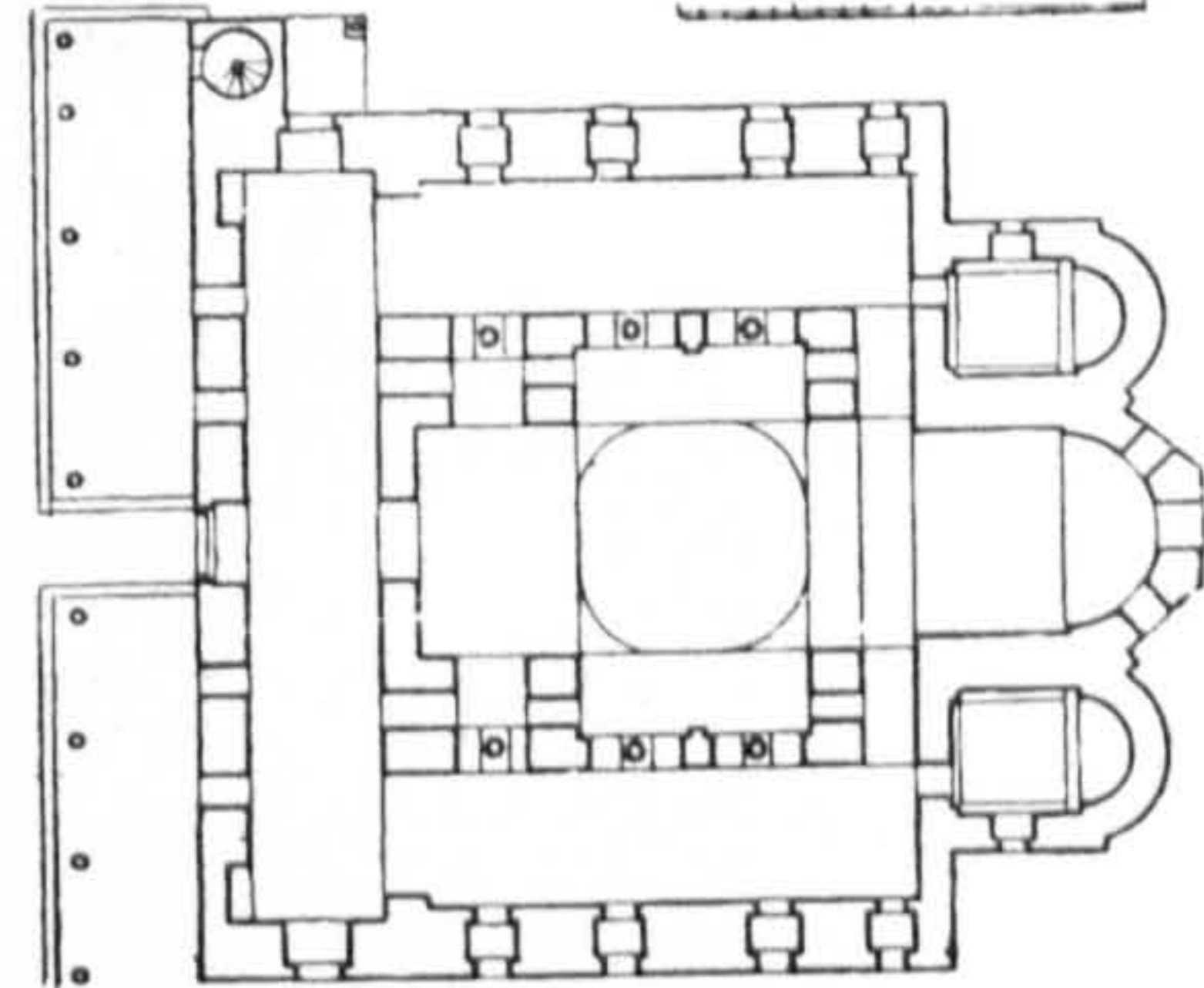

d)

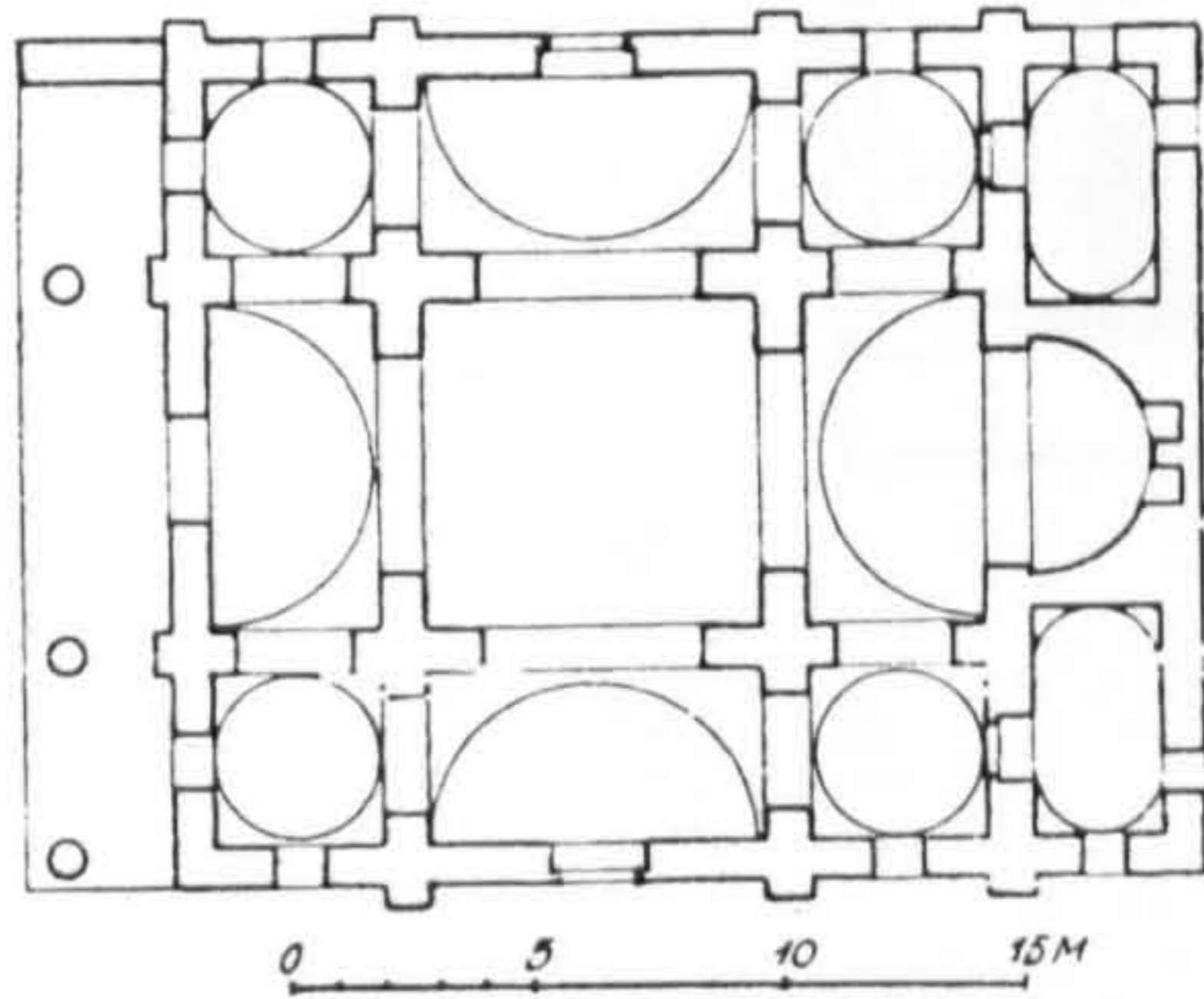

e)

Figure 4.75 a) *St. Bogorodica, v. Drenovo*; b) *St. Bogorodica (Nicea - Iznik), Turkey*;
 c) *St. Mary Deaconess (Kalender Mosque), Istanbul*; d) *St. Sophia, Thessaoiniki*
 e) *Church in Resafa, Syria*

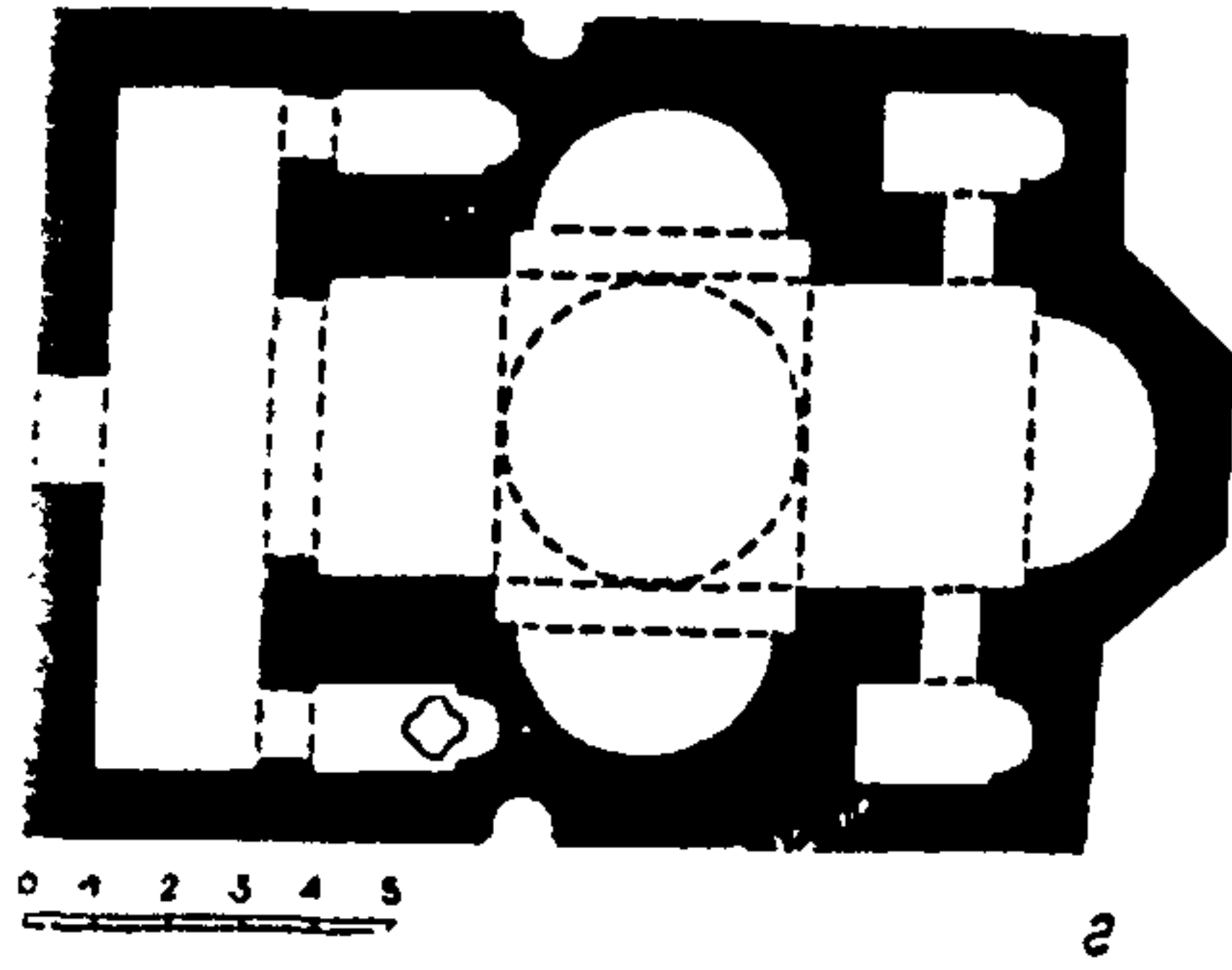

a)

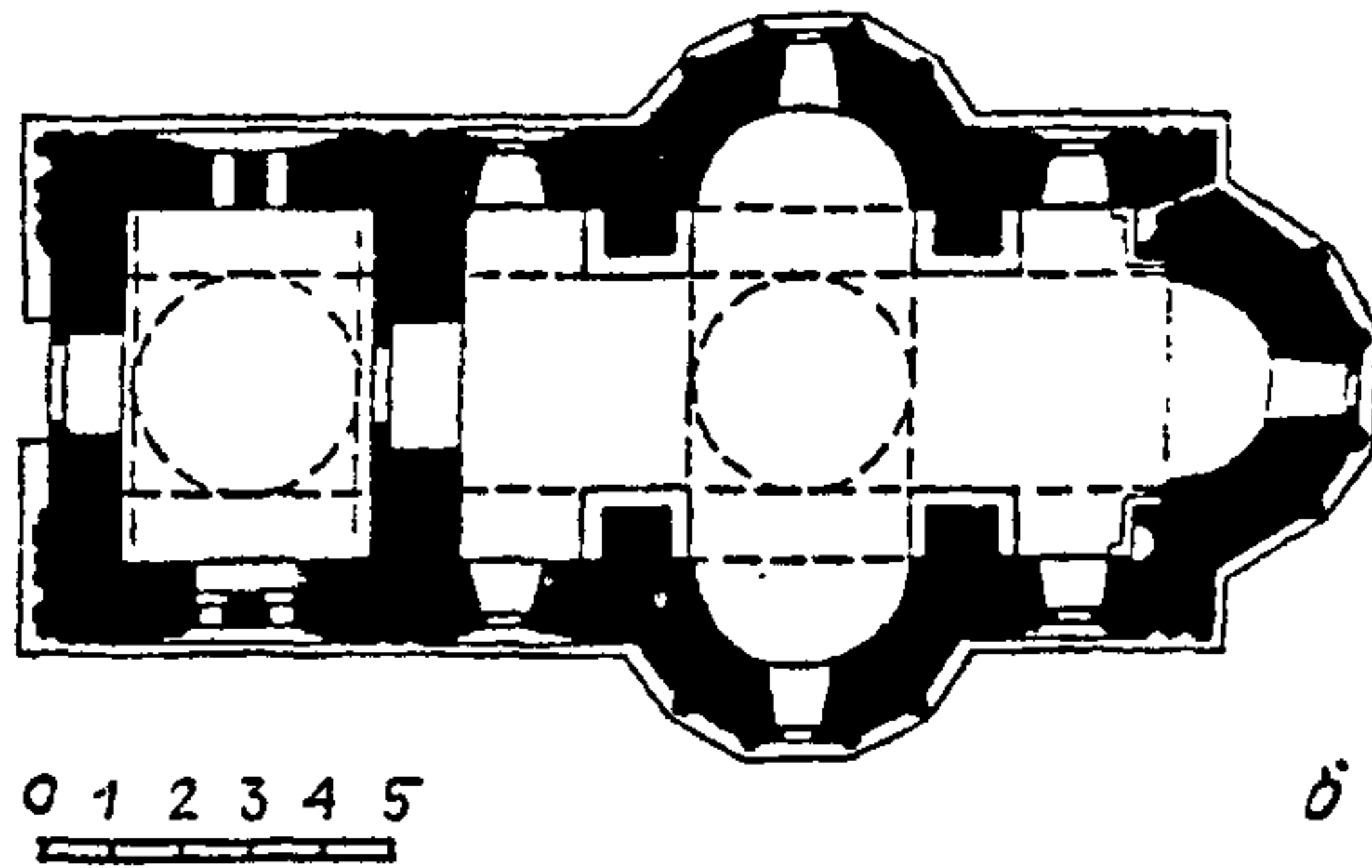

b)

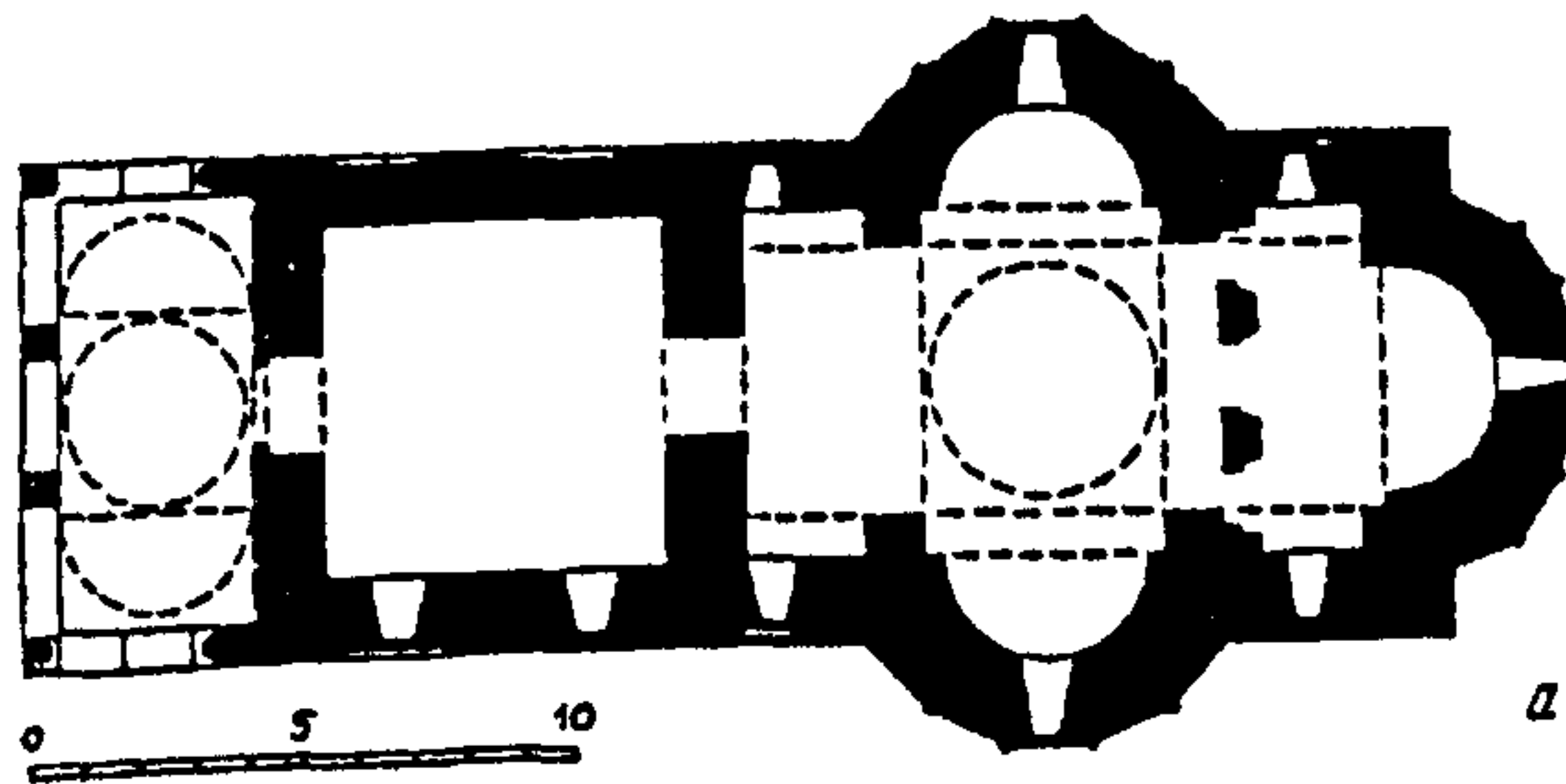

c)

Figure 4.76 a) Church in v. Kulata, Petricko region, Bulgaria; b) Kalenic (Serbia);
c) Kozia, Romania

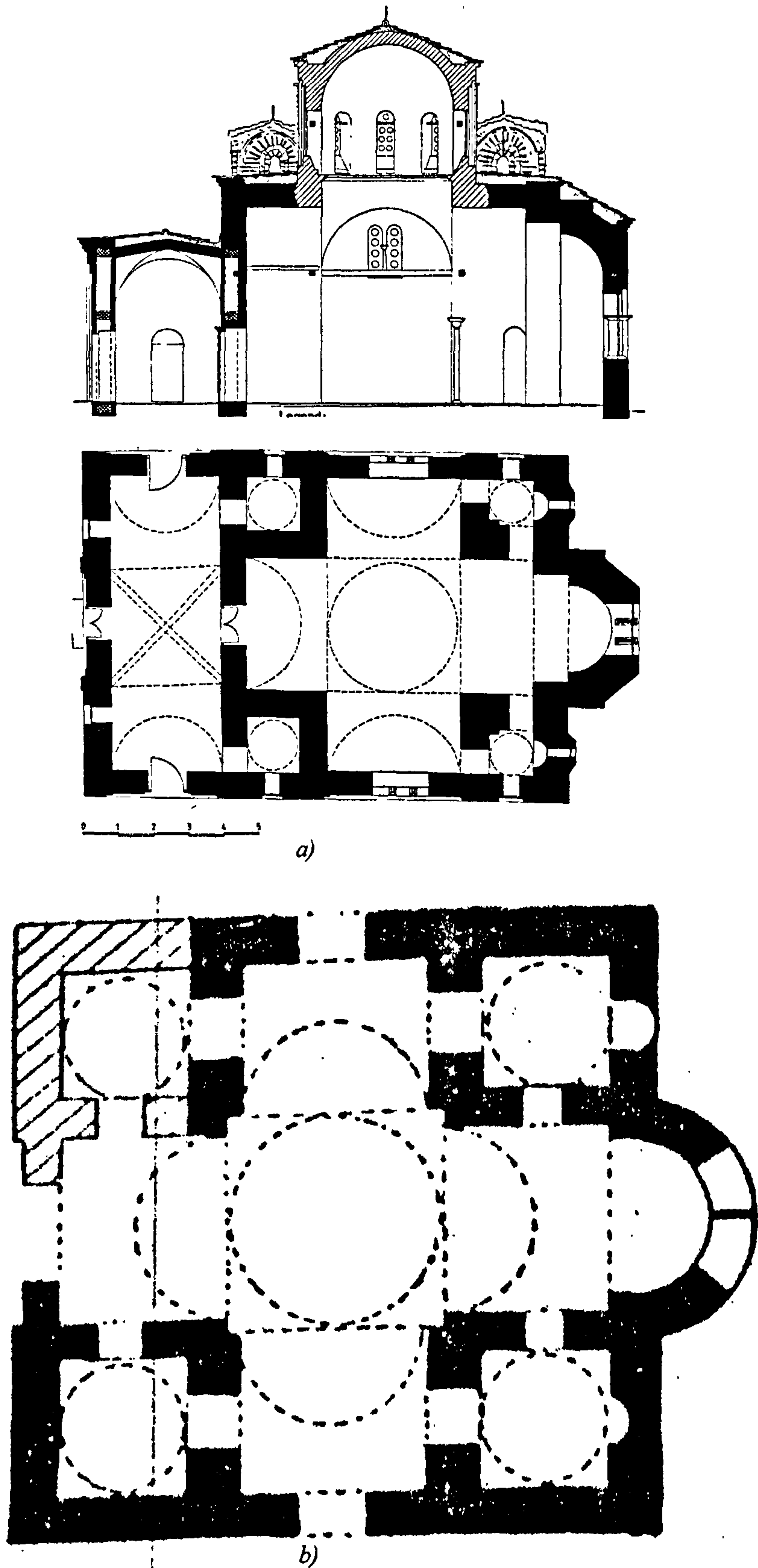

Figure 4.77 a) St. Panteleimon, v. Gorno Nerezi; b) Sulidje Mosque, Thessaloniki

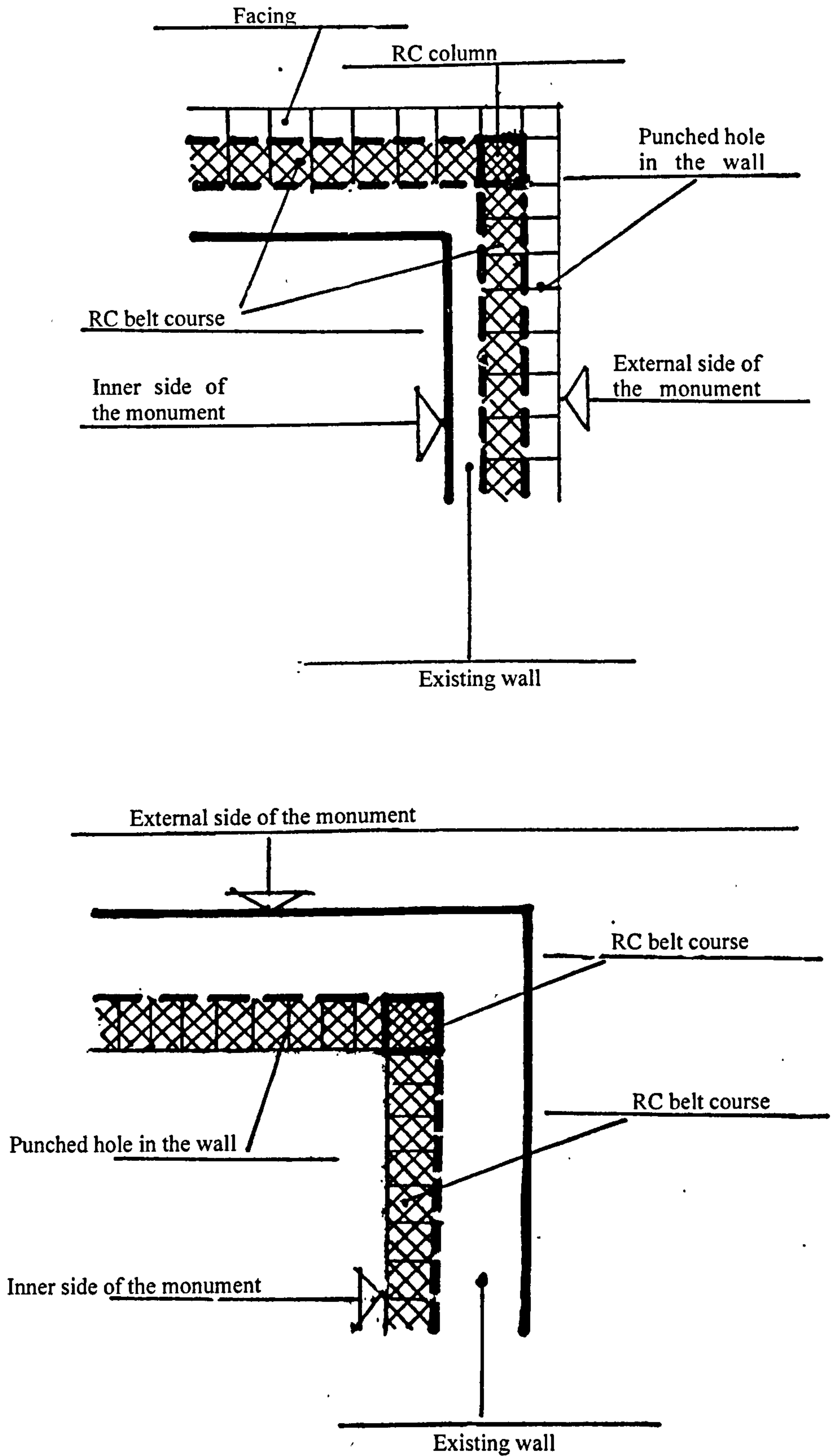

Fig. 4.78

Details

a) Incorporation of horizontal and vertical reinforced concrete belts by cutting the existing wall from the facade

b) The same is done by cutting the wall from the inside.

Source: Nicota 1983: 196

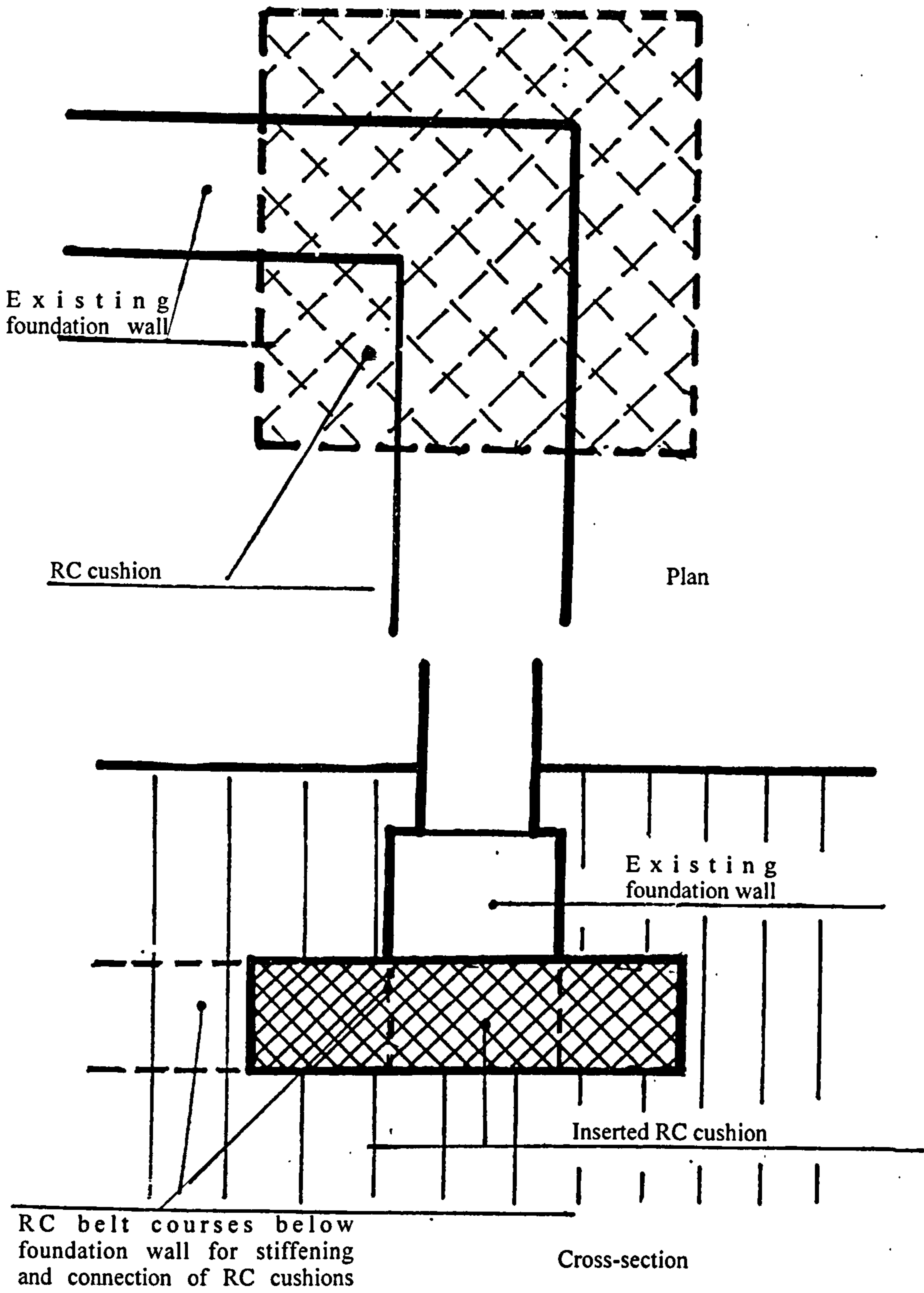

Fig. 4.79 *Reinforcement of the foundation*
 Source: Nicota 1983: 198

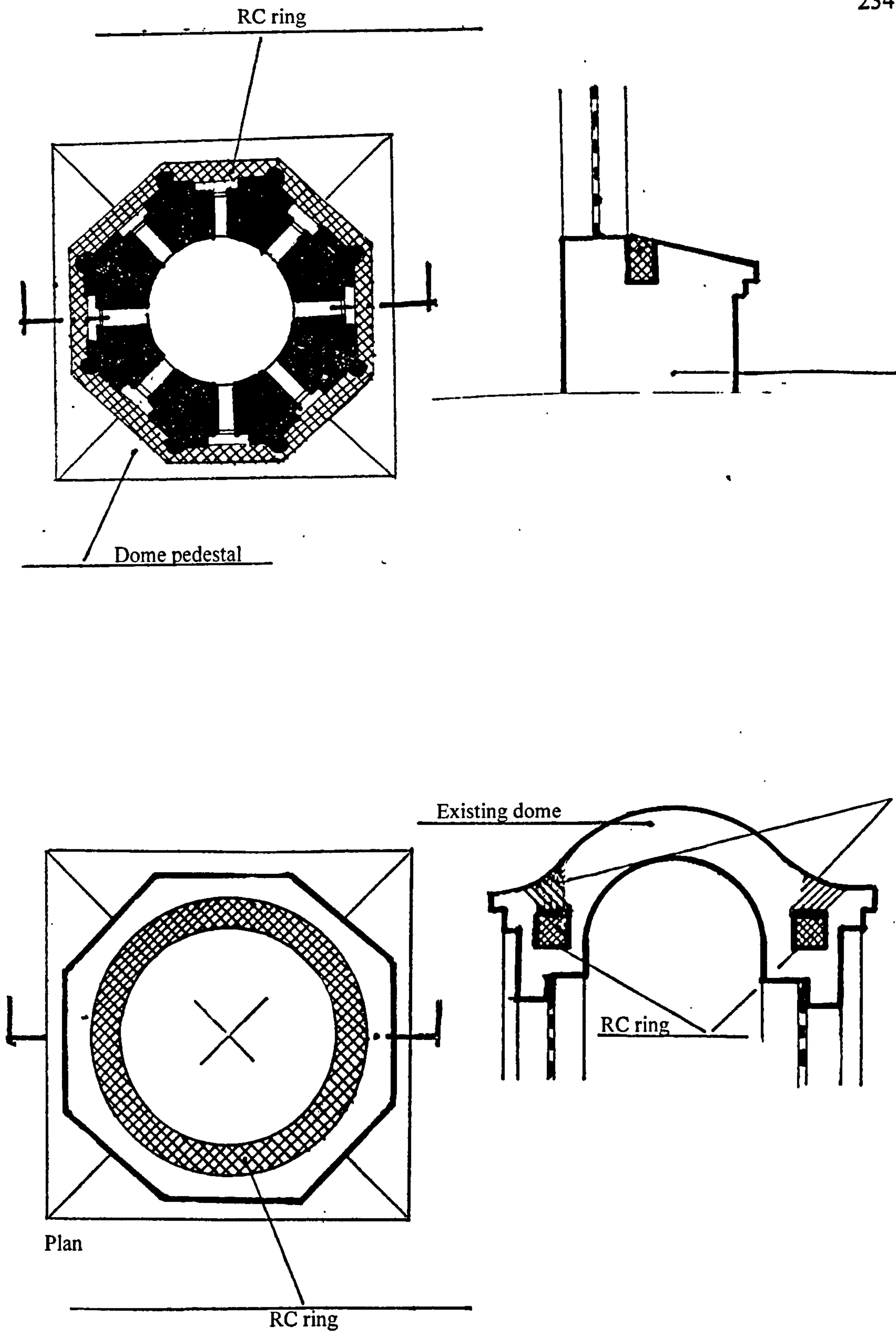
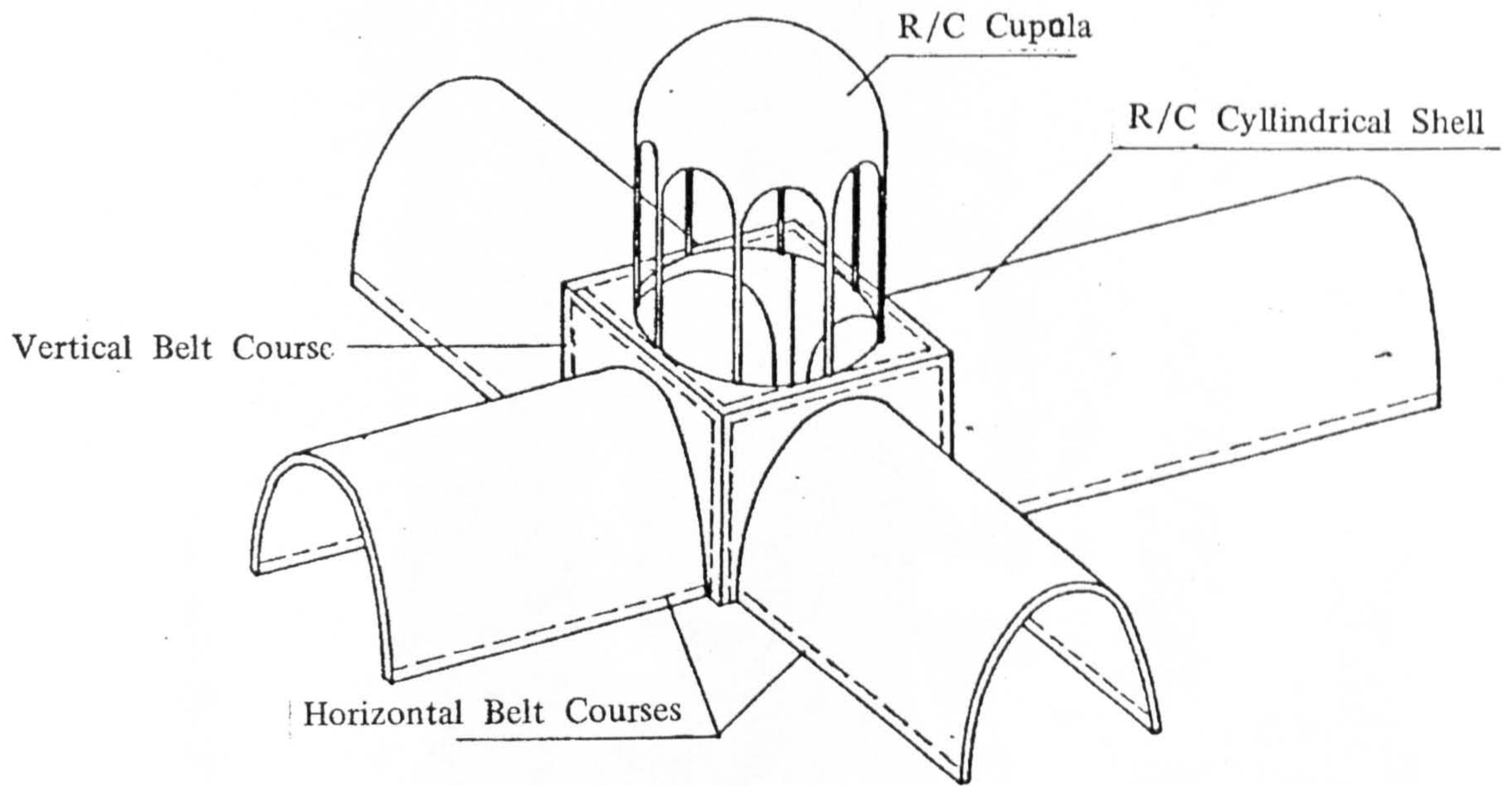

Fig. 4.80

Details

- a) Reinforcement of a drum base element by insertion of a reinforced concrete belt.
- b) Reinforcement of the cupola by insertion of a circular reinforced concrete belt

Source: Nicota 1983: 200



*Figure 4.81 St. Bogorodica, v. Matejce. New reinforcement concrete belts, vaults an dome.
Source: Djurovski et. al 1988:351*

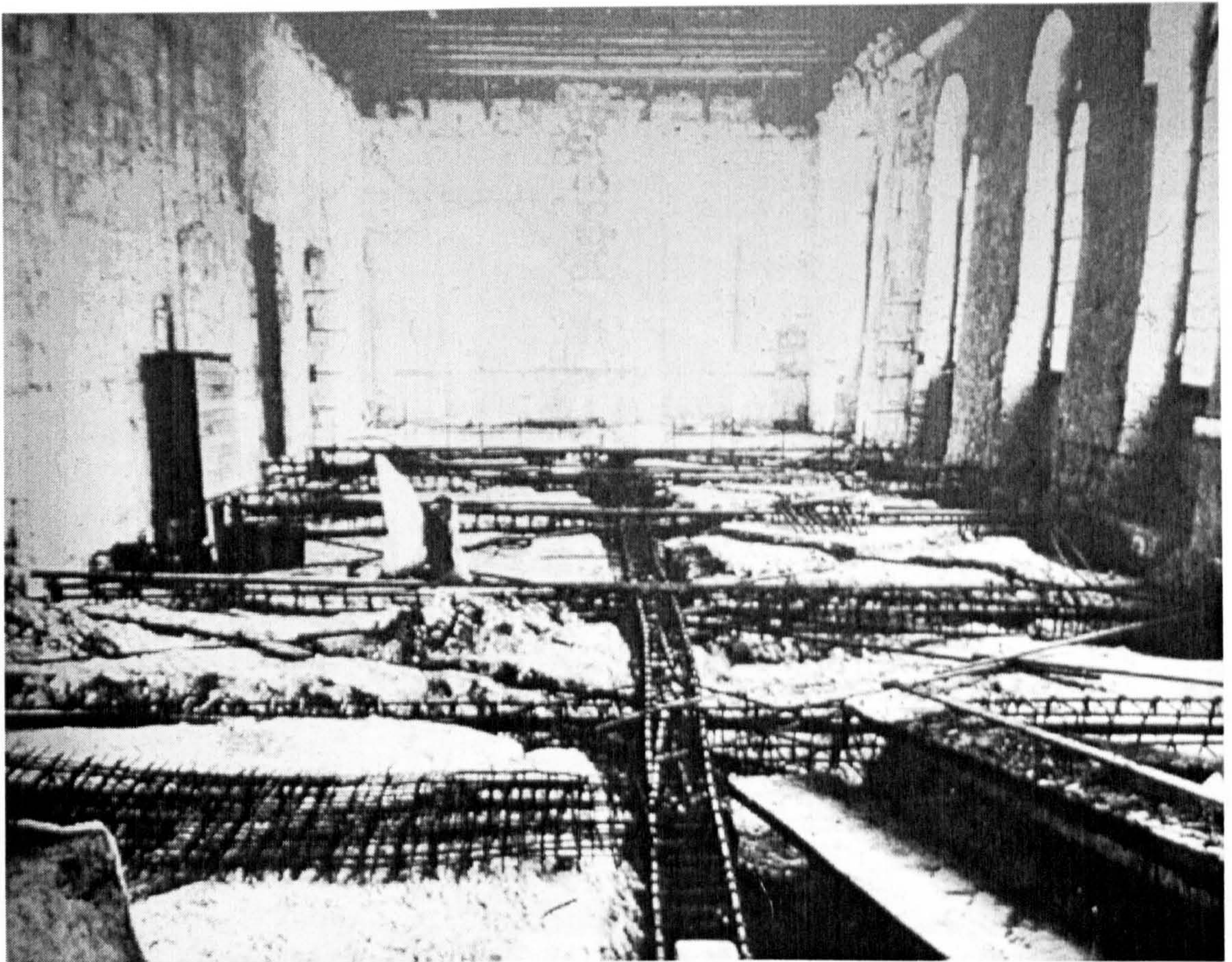

*Figure 4.82 Ducal palace, Dubrovnik.. New reinforced concrete floor structure.
Source: Exhibition in Skopje by Dubrovnik Institute 1988*

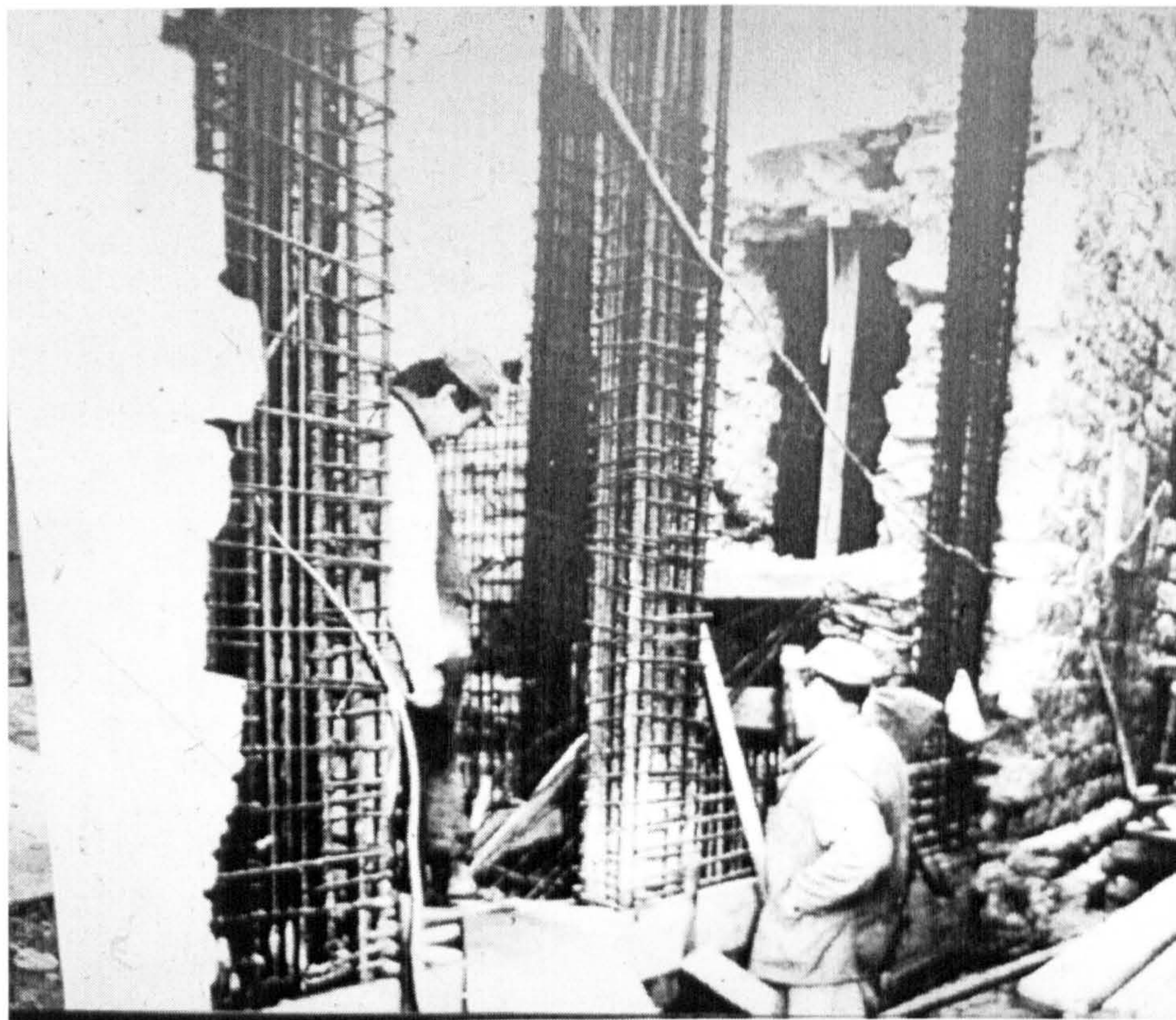

*Figure 4.83 Ducal palace, Dubrovnik.. New reinforce concrete columns.
Source: Exhibition in Skopje by Dubrovnik Institute 1988*

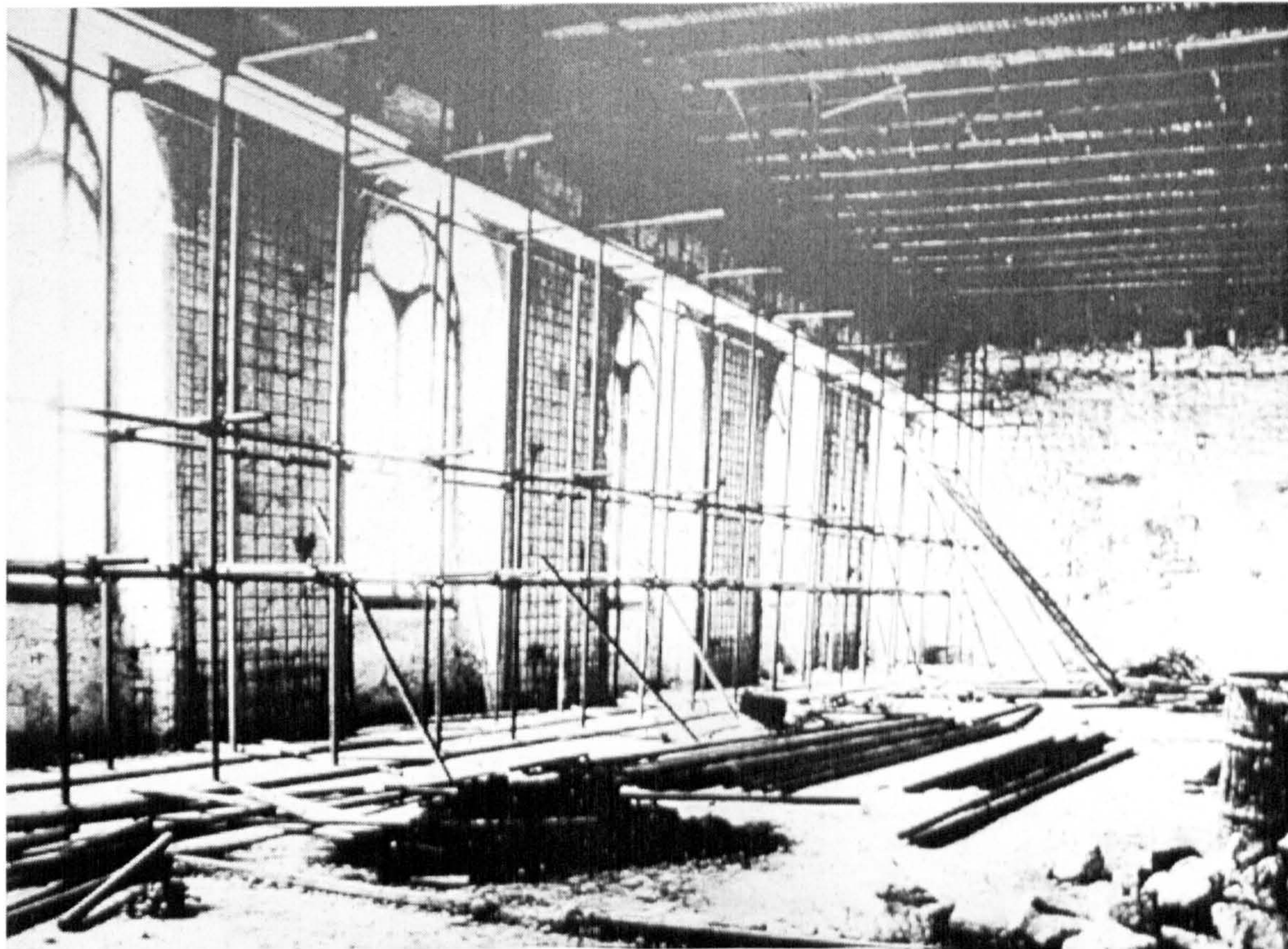

*Figure 4.84 Ducal palace, Dubrovnik.. Reinforcement with reinforce concrete layer of original stone masonry.
Source: Exhibition in Skopje by Dubrovnik Institute 1988*

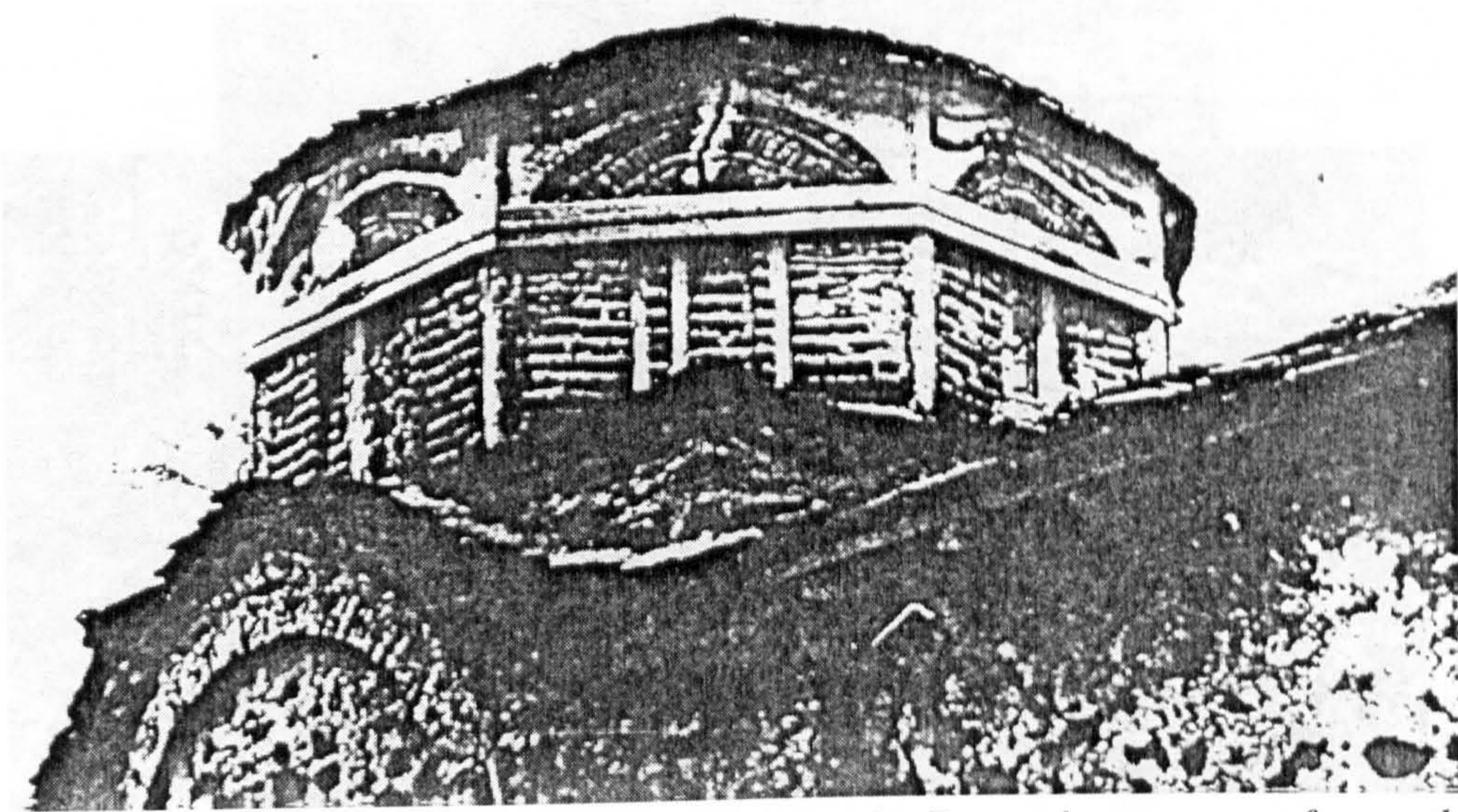

Figure 4.85 St. Christ, v. Mborje near Korca, Albania. Preventive measure after earthquake
Source: Stylla 1988: 150

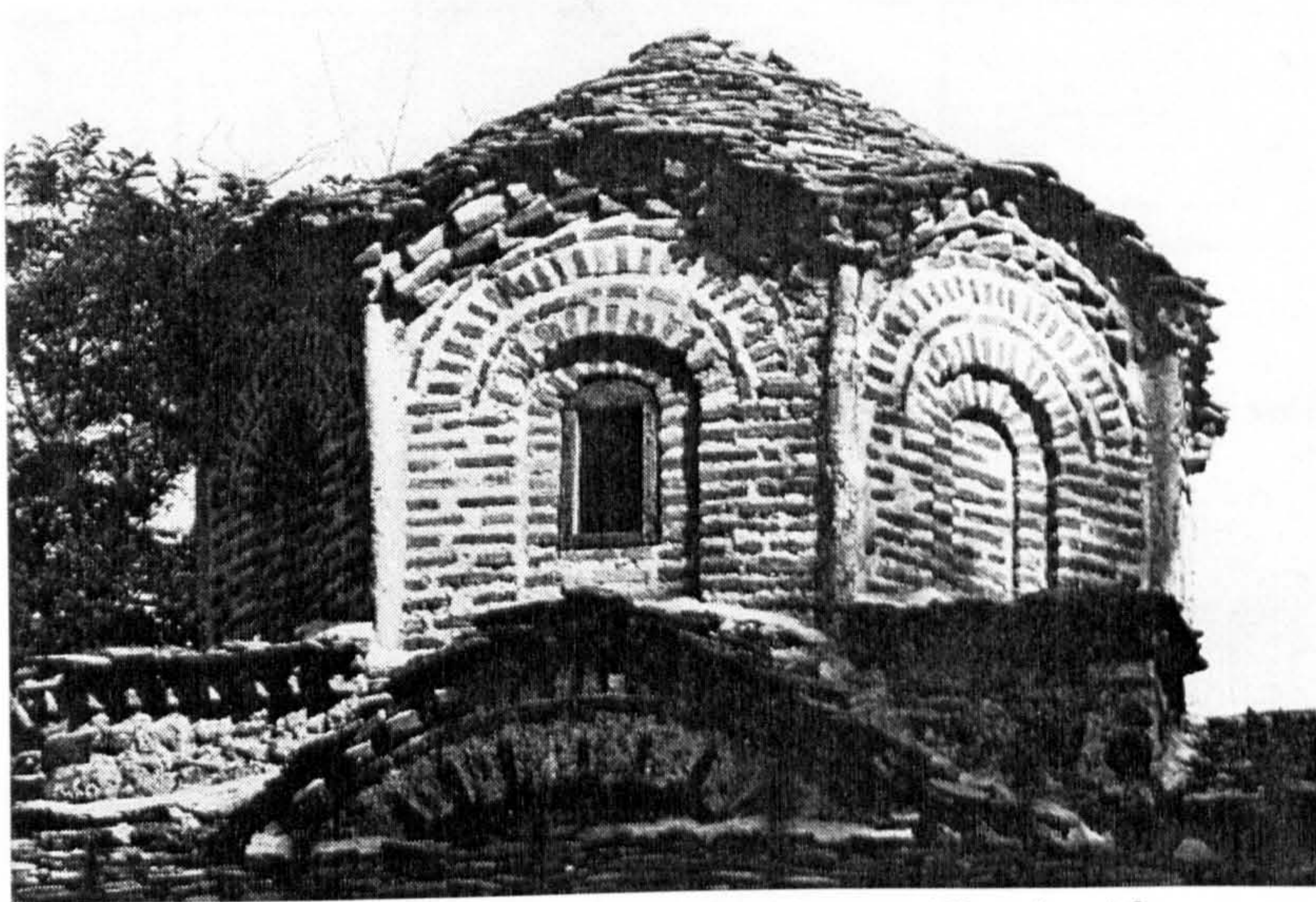

Figure 4.86 St. Christ, v. Mborje near Korca, Albania. After restoration



Figure 4.87 St. Christ, v. Mborje near Korca, Albania. North facade after restoration.

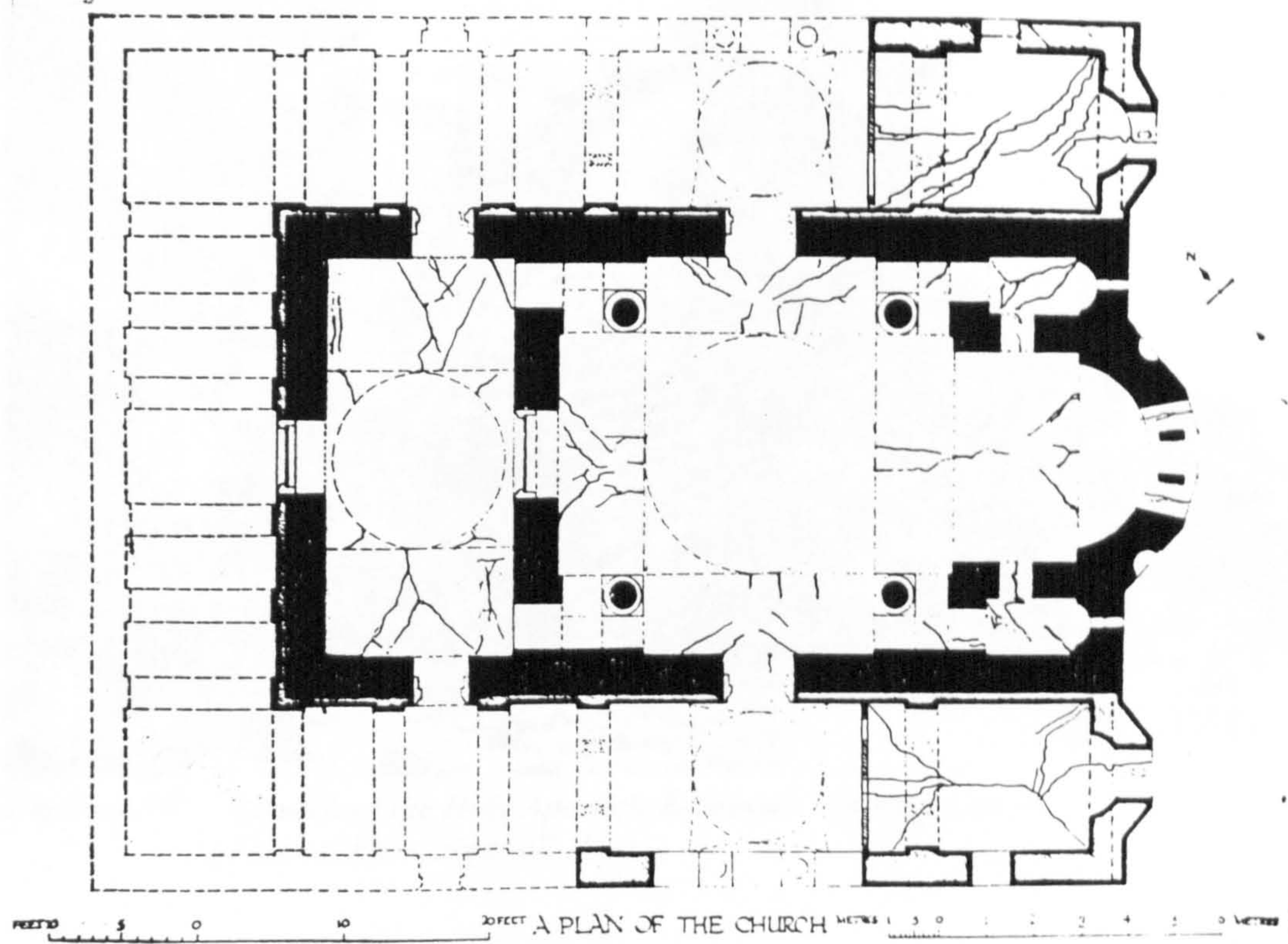

Figure 4.88 St. Panteleimon, Thessaloniki. Damage pattern of the vaults.
Source: T. Theoharidou 1980

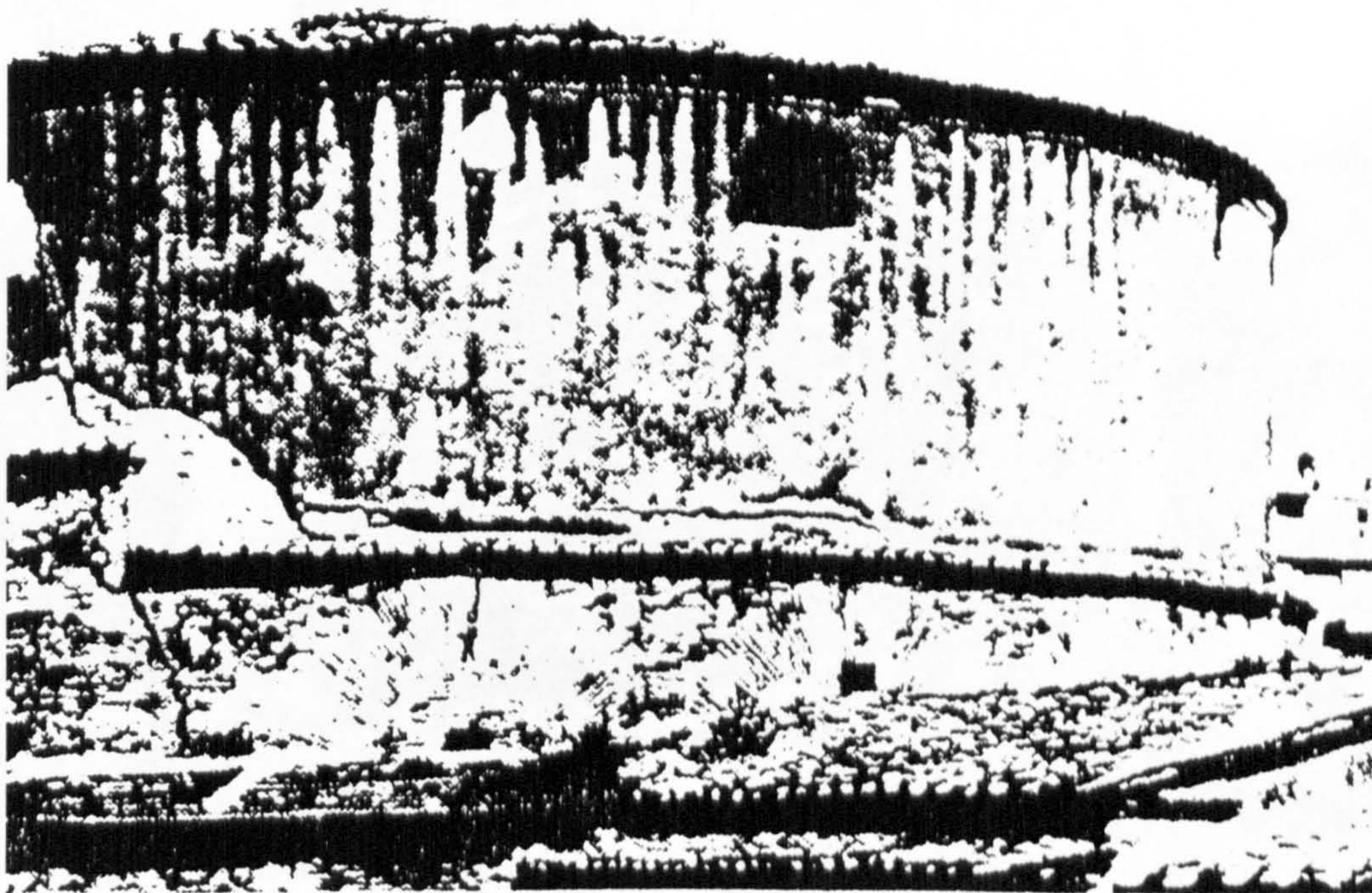

Figure 4.89 Rotunda, Thessaloniki. Cracking of the dome base from the Southeast.
Source: Penelis et. al-1986



Figure 4.90 Church of the Holy Apostles, Kalamata. Damage pattern.
Source: Voziatzis et.al 1990

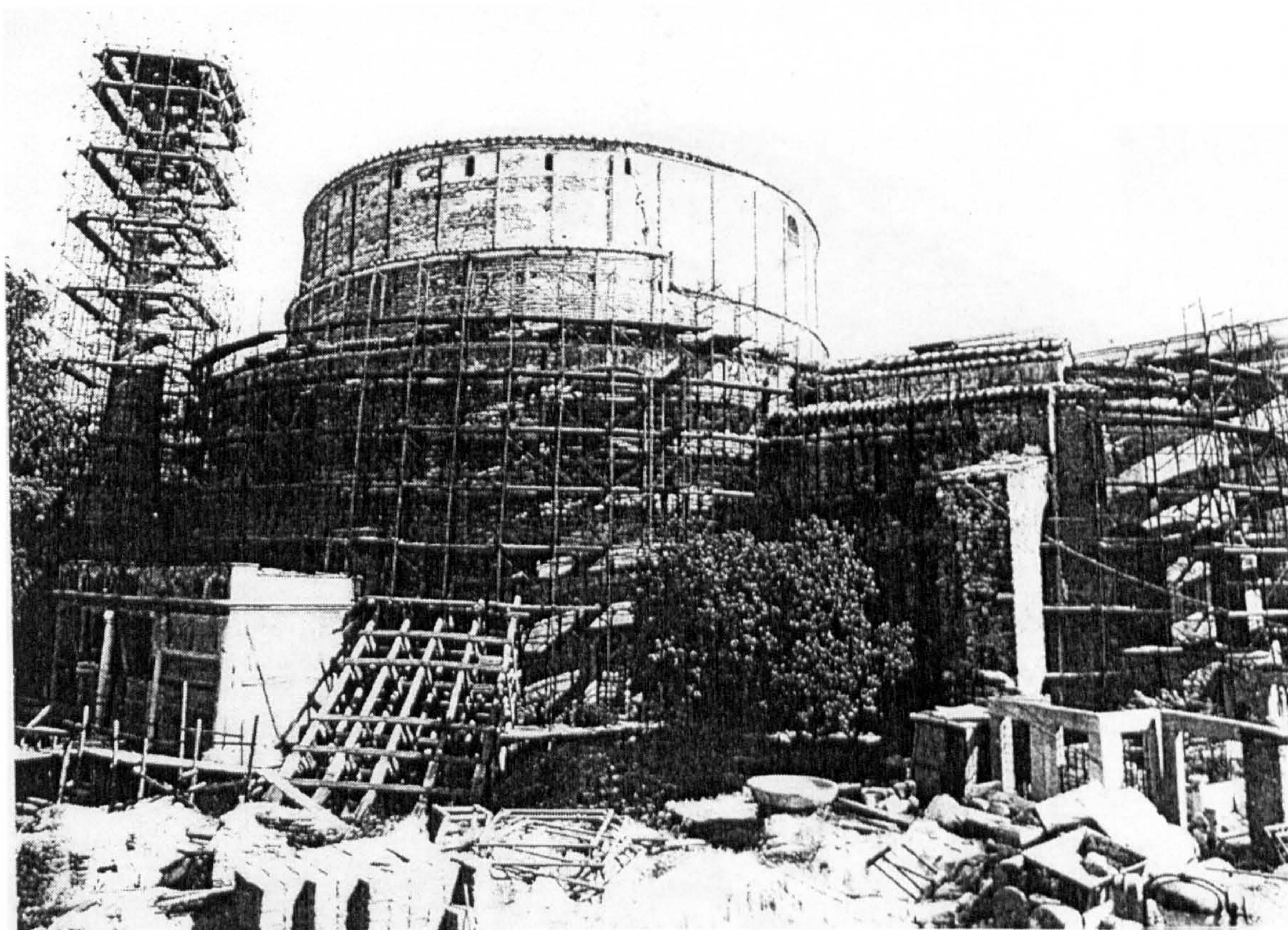

Figure 4.91 Rotunda, Thessaloniki. Temporary supporting of damaged structure.
Source: Penelis et al. 1985



Figure 4.92 St. Panteleimon, Thessaloniki. Temporary supporting of Northern wall.

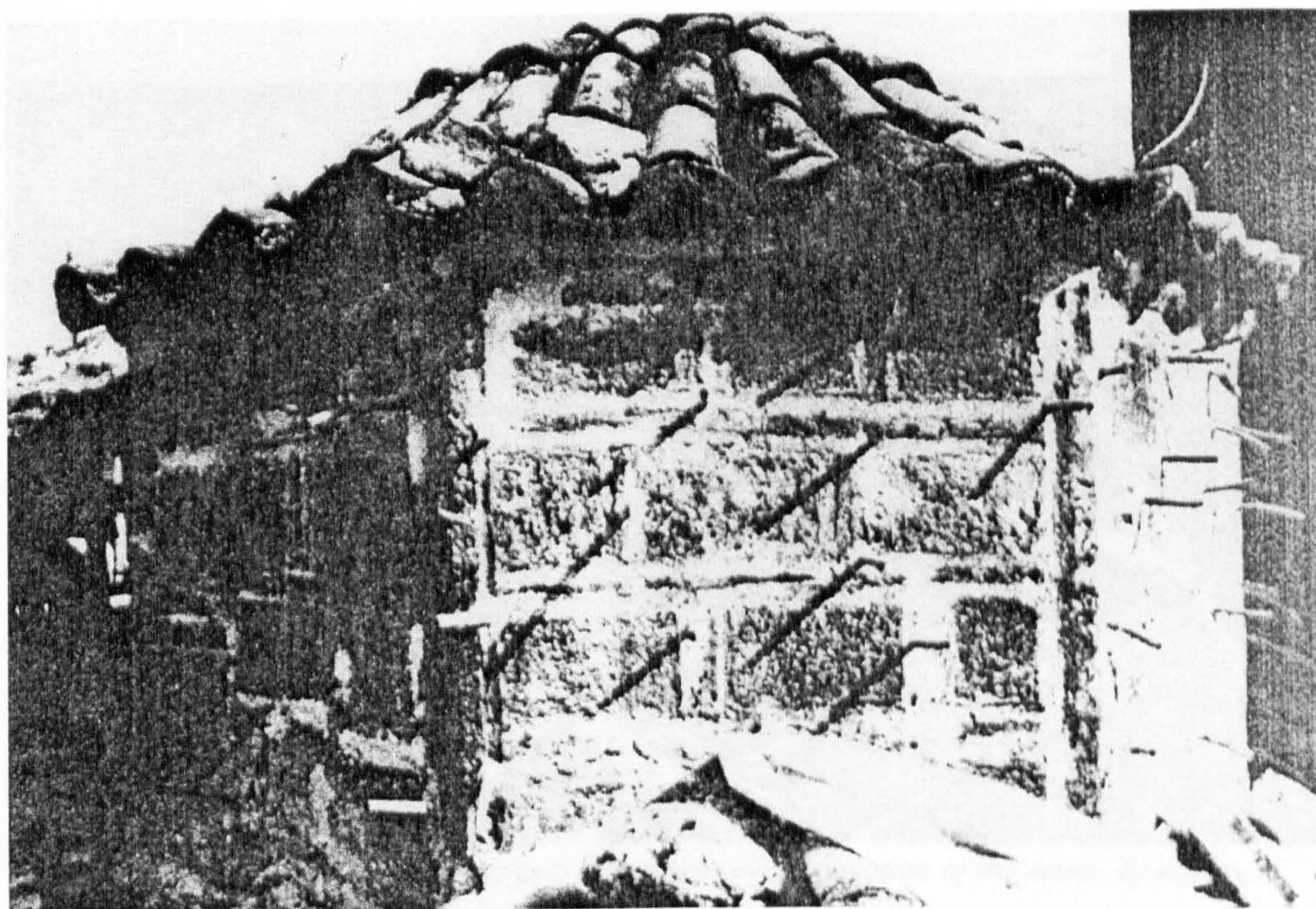

Figure 4.93 Holy Apostles, Kalamata. Grouting of the drum wall of Byzantine part of the church

Source: Voziatzis et.all 1990

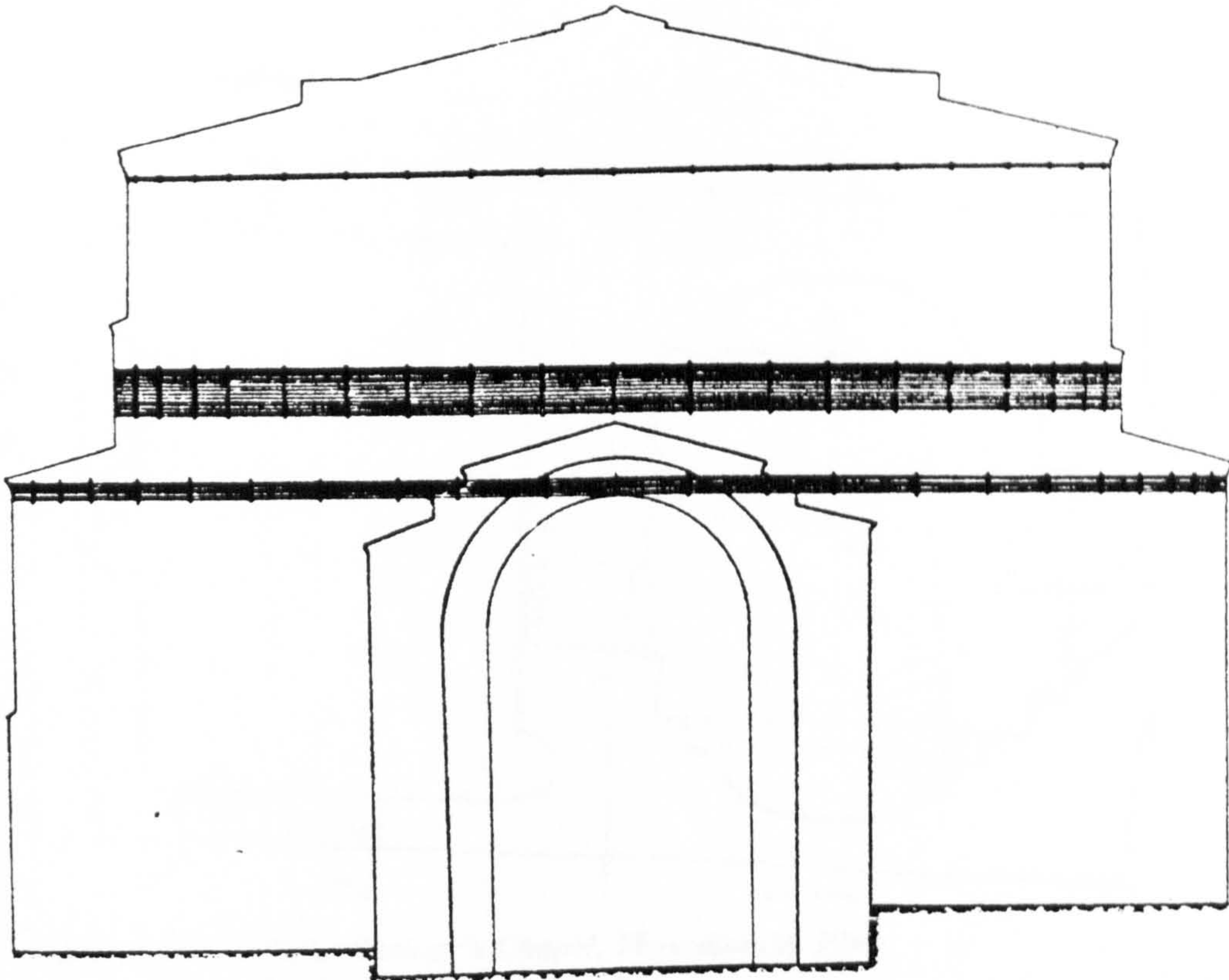

Figure 4.94 Rotunda, Thessaloniki. Permanent prestressed tie rings.
 Source: Penelis et al. 1985

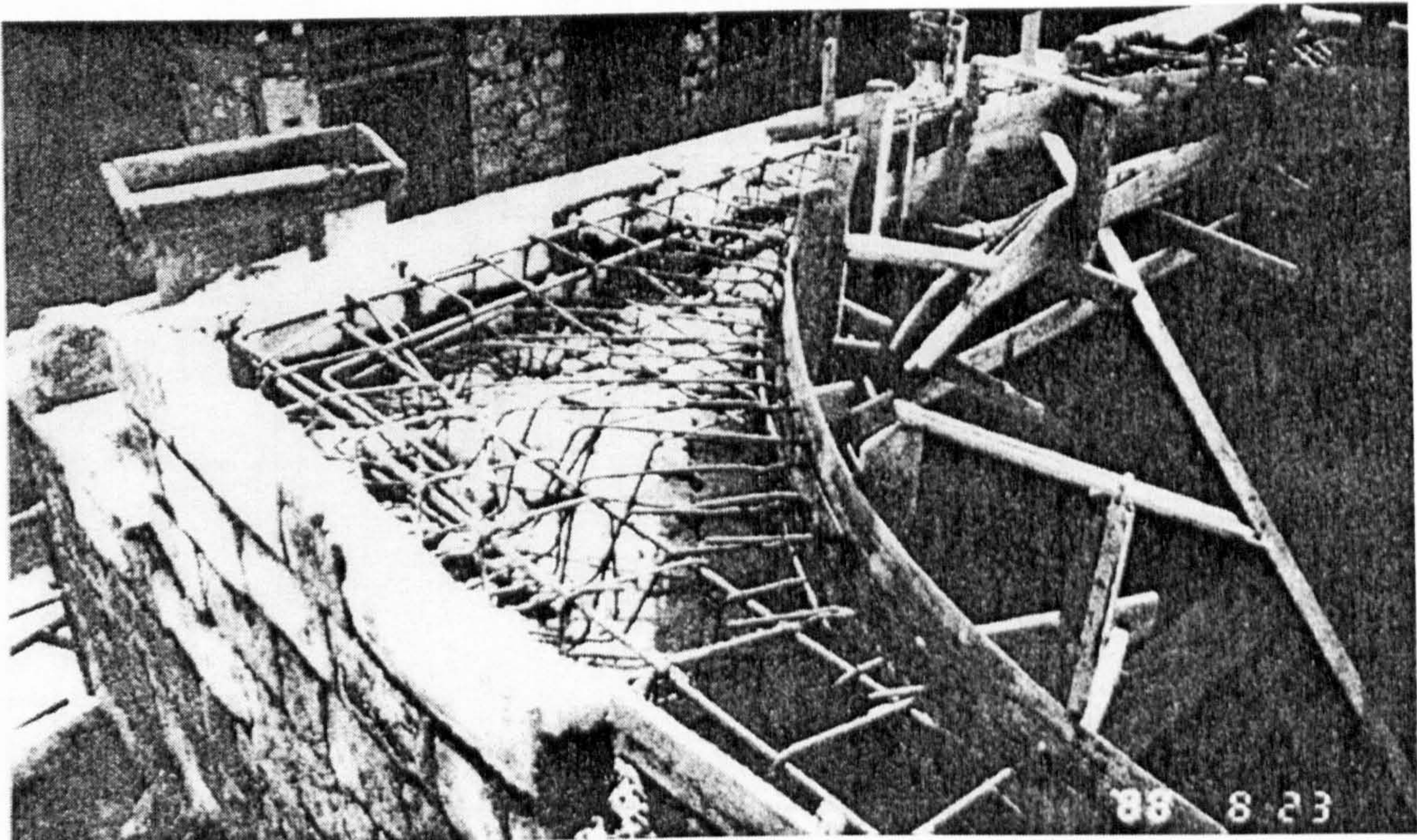

Figure 4.95 Holy apostles, Kalamata. Newer part-reconstruction of the dome. Reinforced concrete beam on pendentives
 Source: Voziatzis et.al 1990

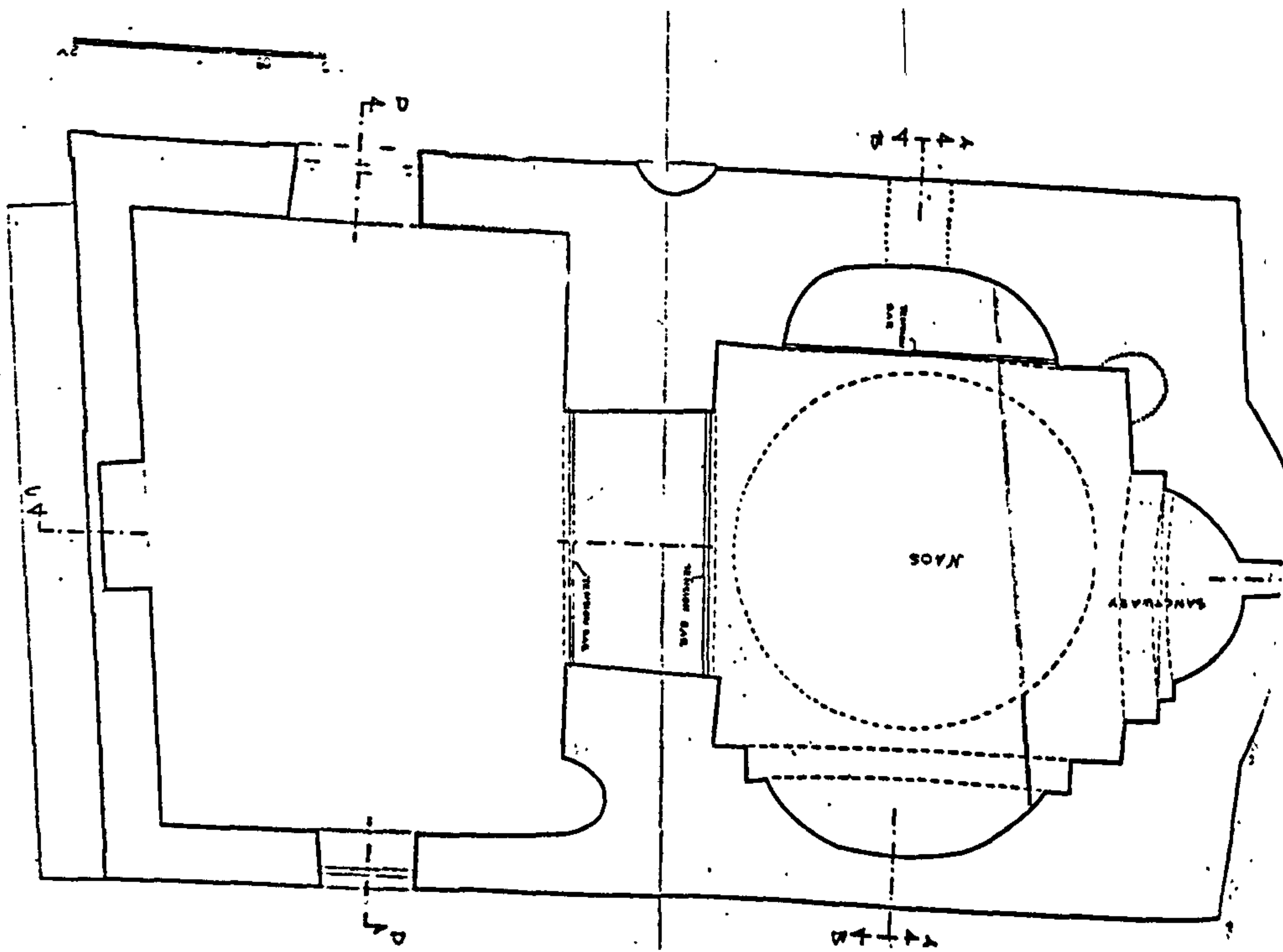

Figure 4.96 *Christ Saviour's Chapel, Thessaloniki. Plan*
 Source: K. Theoharidou 1980

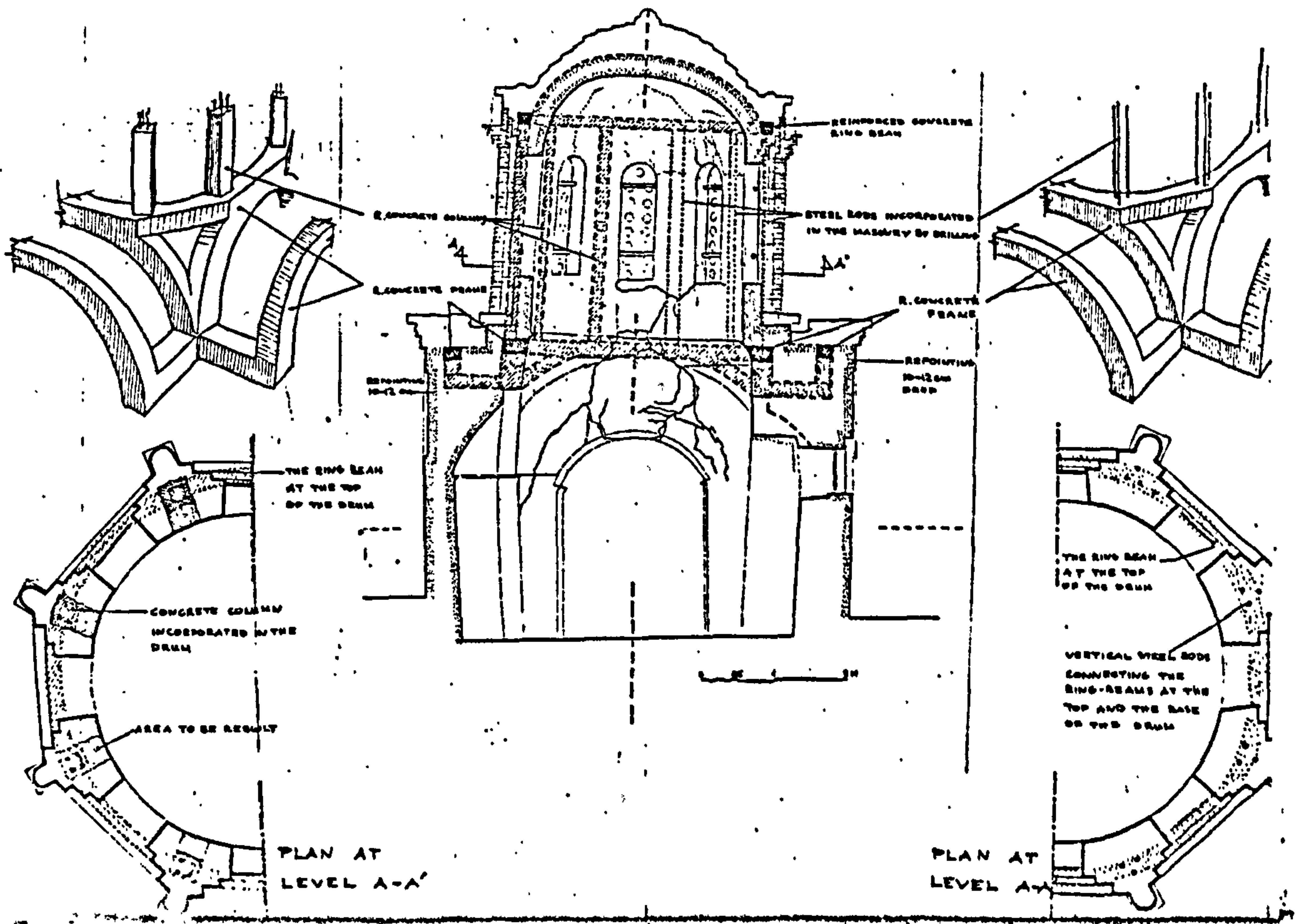

Figure 4.97 *Christ Saviour's Chapel, Thessaloniki. Proposal A (Reinforced concrete frame) and B (Reinforced concrete ring-beam with vertical steel rods)*
 Source: K. Theoharidou 1980

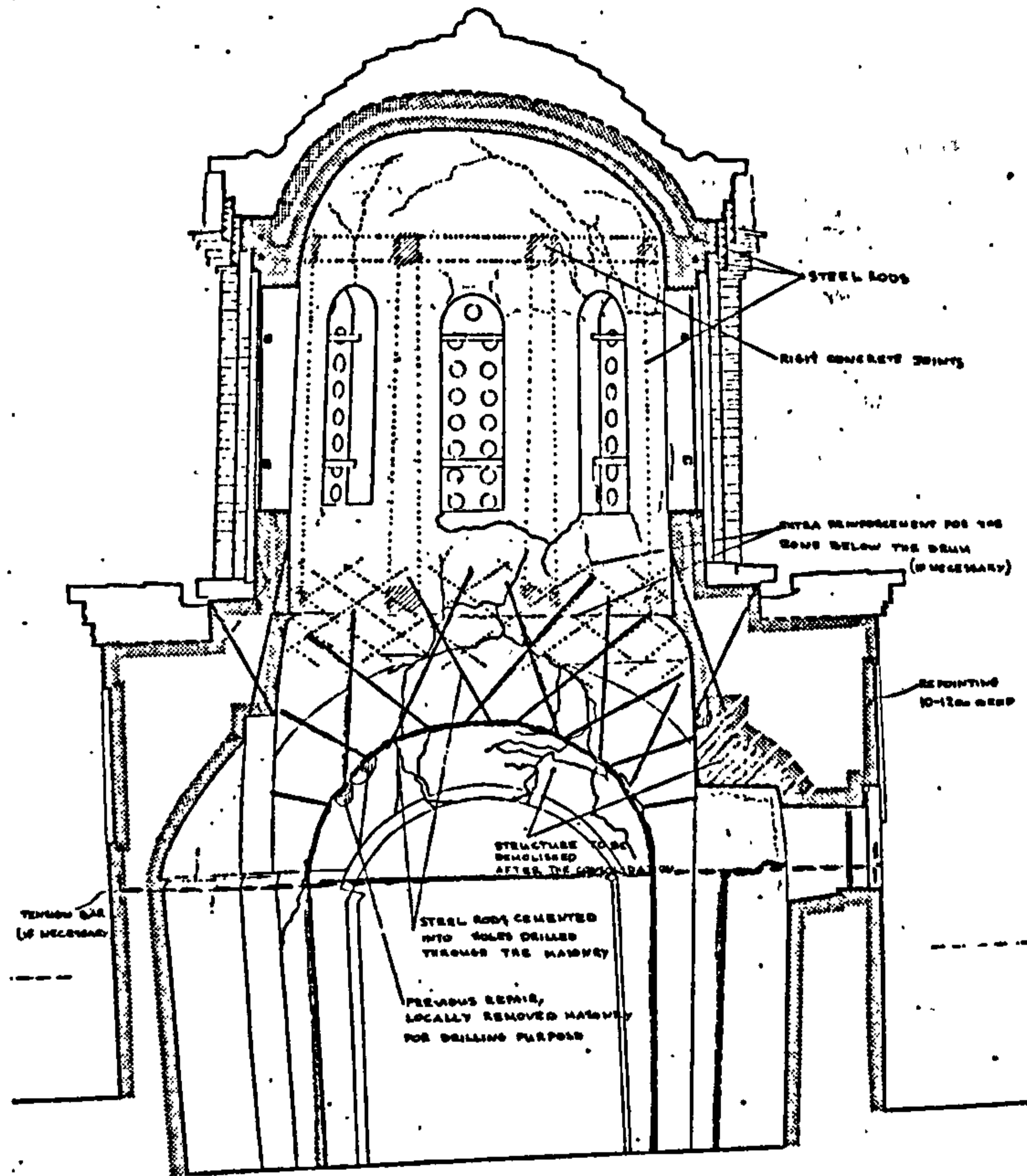

Figure 4.98 Christ Saviour's Chapel, Thessaloniki. Proposal C (Consolidation of the main arch)
 Source: K. Theoharidou 1980

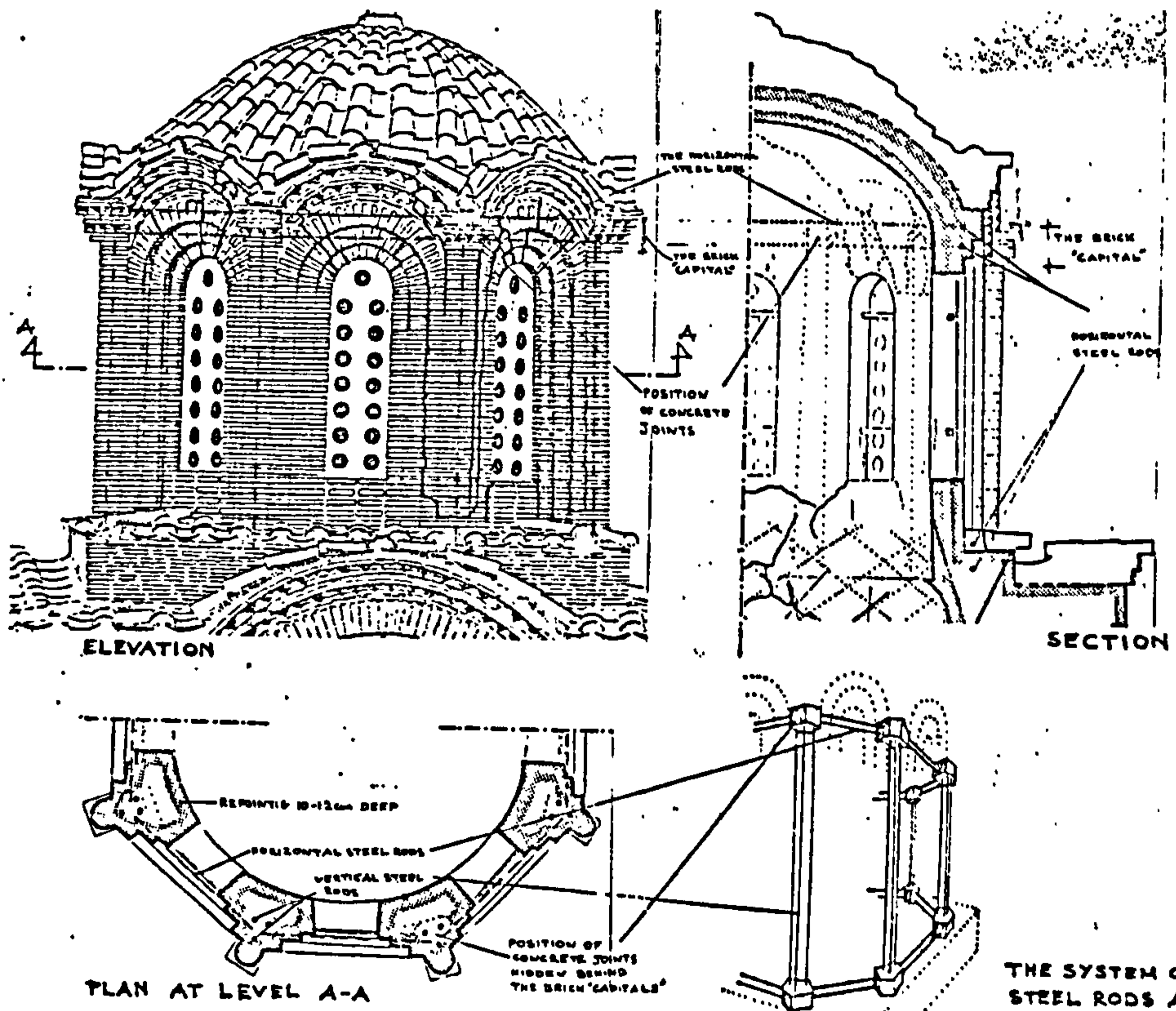

Figure 4.99 Christ Saviour's Chapel, Thessaloniki. Proposal C (Consolidation of the Drum and dome)
 Source: K. Theoharidou 1980

CHAPTER FIVE

STUDY OF SEISMIC STRENGTHENING AND CONSERVATION

5.1 Selection criteria, selection and characteristics of structural systems of selected churches

5.1.1 Selection criteria

From the whole *corpus* of churches (more than fifty) which are the subject of the investigation, four were selected for detailed investigation. These four were selected in accordance with the following criteria:

- Building typology (architecture - structural system);
- historic - artistic characteristics;
- present state of the buildings, damage level and causes of damage;
- the scope and applied methods for conservation, restoration, reconstruction, strengthening and presentation;
- number of existing buildings by type;
- authenticity.

Building typology

As stated before in section 4.1 when defining the typology of the Byzantine churches in Macedonia, the whole *corpus* of buildings from this period has been divided into four main groups:

- Basilicas; (Fig. 4.1)
- triconchs and tetraconchs; (Fig. 4.2)
- single and five - dome (quincunx) churches with cross - in - square; (Fig. 4.3.A-B)
- single - nave churches. (Fig. 4.4)

Historic - artistic characteristics

Their characteristics and value were presented previously in the sections 4.1; 4.3.1 and 4.3.2. We would like underlined again their great value and importance as

the most valuable cultural heritage in the Republic of Macedonia.

Present state of the buildings, damage level and causes of damage

Extensive information has already been presented in section 4.5.

In this section we would like to mention, as a summary of the author's investigation, some information about the direct treatment of structures. The field and laboratory investigation of those structures showed that, conservation works were carried out for almost every structure in varying amounts.

Very frequently, conservation works were performed for the lower zones of the buildings at the point of contacts between the foundation and surrounding terrain. This is basically an appropriate approach but during the realisation of these works and the use of new materials, some errors contributed to increase the level of capillary moisture in the walls.

For example, in the zone of the drainage channels, the wall was first of all covered with cement emulsion from the outside and covered with one or two layers of hot bitumen coating.¹

In the phase of conservation of the monuments, cement mortar was used as well as reinforced - concrete belt courses, vaults, columns and domes which are elements that have an adverse effect to built - in structural elements and materials from several aspects:

- Cement mortar and concrete, have a very unfavourable effect upon the original bonding element - lime mortar. It is stronger and more rigid than the original material. It is also impermeable to water, when icing and freezing can produce mechanical damage of lime mortar, stones and bricks;
- The reinforced - concrete elements incorporated into original structure contribute to greater level of interaction between the original and new structural system. Two systems with different strength and deformation are obtained which might have damaging effects upon the structure under certain conditions (earthquakes). Especially unfavourable is incorporation of new masonry parts into the original corner masonry, in horizontal and vertical directions, as already has been stated in the section 4.7.

- Use of iron ties instead of stainless steel or non - ferrous (stainless) ones induced corrosion and damage. These corroded and the rust expansion caused to the masonry and discoloration of areas covered with mural paintings.

Repair and strengthening material, to be used in the future, should be therefore tested for suitability .

Number of existing buildings by type

As already stated in section 4.1, there are four basilicas, four triconchs and tetraconchs, twenty five one - or five - dome cross - in - square churches as well as twenty seven single - nave structures.

Authenticity

It is very difficult to find a structure that has been preserved without any changes to its original forms. The extent to which structures have preserved their authenticity varies from structure to structure. The most authentic are: St. Bogorodica Zaumska (Fig. 4.39-40), St. Georgi, v. Recica, St. Bogorodica Perivlepta (Fig. 4.37), St. Archangel Mihail, v. Lesново (Fig. 4.30-31), St. Dimitrija, v. Susica (Fig. 4.34-35). Some buildings of this group have undergone major reconstruction such as the church of St. Leontie, v. Vodoca (Fig. 4.66-69), St. Nikola, v. Radisani, St. Nikola, v. Ljuboten and St. Bogorodica, v. Matejce. (Fig. 4.70-71)

There are examples too having reconstruction of the roof zones: St. Nikita, v. Banjani and St. Panteleimon, v. Gorno Nerezi.

The authenticity of their interior (with its mural paintings) is preserved with the highest level. Here attention must be drawn to the non - existence of original mural paintings in the vaults and dome areas. These are the areas most often damaged by earthquakes. Usually, those areas are never painted again.

5.1.2 Selection

On the basis of the presented criteria, listed in section 5.1, four churches have been selected. There are: the church of *St. Nikita, v. Banjani* (Fig. 5.1a and 5.2a), the church of *St. Bogorodica, v. Matejce* (Fig. 5.1b and 5.2b), the church of *St. Bogorodica Zaumska* (Fig. 5.1c - 5.2c) and the church of *St. Nikola, v. Psaca* (Fig. 5.1d and 5.2.d).

They are selected on the ground that they are all one dome cross - in - square type or its quincunx modification and they date from the same period -the fourteenth century. There is a real possibility for multiplication of the results from the same kind of experiments.

The extent of authenticity of these churches decreases starting with the church of St. Bogorodica Zaumska, through those of St. Nikita and St. Nikola. The same is also true of the gradation of conservation works. The least conservation work has been carried out to the church of St. Bogorodica Zaumska, while the most extensive works were executed to the church of St. Nikola.

The church of St. Bogorodica in the village of Matejce has been selected both because it belongs to the type of churches with developed cross and five domes and mostly because of extensive reconstruction in 1926. During the eighties of this century it was strengthened by reinforced - concrete beams and columns, vaults and dome which were inserted into the already reconstructed church.

Another important factor for selection is that most of the churches that exist in the territory of the Balkan region belong to this type and period. This provides extraordinary possibilities for wider implementation and comparison with the works that have already been carried out.

These four structures were planned to be subjected to detailed field and laboratory study and were the basis for selection of a prototype for experimental investigation and definition of the new methods for conservation and strengthening.

5.1.3 Characteristics of structural systems of selected structures

Some characteristics of structural elements considering of the selected structures already has been presented in Chapter four (*section 4.2.1*).

From the structural point of view the dome and the vaulted roof areas of the selected one dome cross - in - square structures rest on the massive perimeter facade walls and the two rows of symmetrically placed columns or piers via the drum, pendentives and arches.

It is immediately obvious that the structural system of the selected structures practically consist of piers / columns, walls and vaults with massive cross - sections which are capable of sustaining the compressive stress occurring in the structure as a result of the gravity loads.

As in all sacral Byzantine structures in Macedonia and the Balkan region, these structures also contain horizontal timber belts on a certain vertical span in the core of

the perimeter walls. This was discussed generally in section 3.4.4. (*Fig. 5.3a-b and 5.4a*)
(*See app. 5, section: 5.1*)

The vaulted elements of these structures are constructed with a great precision and exact proportions. These elements are dependably stable under gravity and lateral effects and are almost, without exception, of an undisturbed geometry with which they contribute to the thorough compactness and stability of the structure, especially under secondary effects.

All the selected structures are based on stone masonry foundation in lime mortar, which are the usually employed structural elements as a base of all Byzantine buildings in Macedonia.

5.2 Seismic parameters

5.2.1 Main characteristics of investigated area

The territory of the Republic of Macedonia as a part of the Mediterranean seismic region is characterised by intensive neotectonic processes, which have been permanently developing till now. These processes resulted as a seismic activity, which has been increasingly recorded during this century. Within this period, the territory of Macedonia experienced over three thousand earthquakes many of which with destructive features. (*Hadjievski 1976*)

Investigations of the seismic characteristics of Macedonia cover its entire territory as well as the border belt of the neighbouring countries. The concentration of past earthquake epicentres shows that there are many seismic zones the distribution of which points to the complex seismic characteristics of this area.

The epicentre map of the territory of the Republic of Macedonia is shown in Figure 5.5. (*Hadjievski 1976*)

On the basis of the performed investigations it was found that the territory of the Republic of Macedonia is characterised by the following three seismic zones which are included among the most active zones of the Balkan region : (*Hadjievski 1976*)

- **Drim seismic zone**, covers the west border between Macedonia and Albania from Peshkopea (Albania) and Debar (Macedonia) and via Ohrid (Macedonia) and Podgradec to Korca (both in Albania)
- **Vardar seismic zone**, stretching from Serbia (Yugoslavia) to Greece through the central part of Macedonia, from Urosevac and Kacanik (both in Yugoslavia), via Skopje, Veles and Valandovo to Thessaloniki (Greece).
- **Struma seismic zone**, covers the east border part between Macedonia and Bulgaria, from Kustendil (Bulgaria) via Pehcevo and Kresna to Sandanski (both in Bulgaria).

(*See app. 5, section: 5.2*)

5.2.2 Earthquake intensity of the sites

The sites of the church *St. Nikita* in the village of Banjani and the church

St. Bogorodica, in the village of Matejce are located close to the Skopje, on the slope of the Skopska Crna Gora hill, within the epicentral zone of Skopje - Kacanik origin. The site of the church of *St. Nikola* in the village of Psaca is close to the city of Kratovo and is affected by earthquakes from the Skopje and Pehcevo - Kresna source zones while the site of the church *St. Bogorodica Zaumska* in the village of Trpejca is on the coast of Ohrid Lake, within the epicentral zone of the Ohrid origin.

There are no historical records of the earthquakes for the period of construction of these churches till 1900, except for the devastating earthquake of 1555 which struck the Skopje area.

However, on the basis of the conditions and age of the mural paintings on the drum, dome and pendentives dating from the later period in St. Nikita, v. Banjani without signs of earlier mural paintings, it is possible to conclude that these parts were rebuilt and repainted in some later period.

However, there is a detailed catalogue for all stronger earthquakes which affected or were felt on the territory of Macedonia in the period from 1900 till now. (*Shebalin et al. 1974*) (Tables 5.1) (See app. 5, section: 5.3)

From the Table 5.1 it is evident that in this century alone from 1900 to 1990, the churches were tested several times. They were subjected to seismic effects with intensities higher than 6 (MCS) degrees and they were exposed to destructive earthquakes of 7 - 8 degrees three or four times, and even to as strong as 9 degrees, which points out to the high seismic risk level, which these churches have been exposed to.

5.2.3 Seismic model of the sites

Investigation of the seismic characteristics of Macedonia started in the beginning of this century while intensive detailed investigations have been introduced since the Skopje earthquake of 1963. Accordingly, the seismic zones mentioned under 5.2.1 with certain seismic sources (epicentral zones) in Table 5.1 having definite seismic characteristic were determined. The defined seismic sources are shown on the epicentral map in Figure 5.5. (*Stojkovic et al. 1992*)

Table 5.2 shows more significant sources with data on the strongest past earthquakes that exhibited destructive effects.

The stated foci have a dominant seismic effect upon the terrain wherefore they are considered to be a distinctive mark of seismic hazards and risk for the territory of

Macedonia. The seismic model for analysis of the seismic hazard on the territory of Macedonia includes all seismic foci presented in Figure 5.6. (*Stojkovic et al. 1992*)

Investigations carried out showed that Skopje - Kacanik seismic focus affecting the structures of St. Nikita and St. Bogorodica, v. Matejce, the occurred M_{max} is 6.1 and the stated M_{max} (possible) is 6.5 with hypocentral depth of 10-13 km. (*See app. 5, section: 5.4*)

The earthquake intensity is decreased with the increase in hypocentral distance of the selected structure due to radial dissipation of the released seismic energy.

5.2.4 Local seismological characteristics

Definition of the seismic - geological characteristics of the terrain of the considered sites is of a particular importance since they influence significantly the amplitude and frequency modification of the main seismic effect making it of a local character. Surface soil layers that filtrate or amplify the seismic waves have their own structural and physical - mechanical characteristics. In accordance with these characteristics, they select waves in compliance with their frequencies, enabling, to the best possible extent, the passing through and the amplification of waves which have the same periods as the natural periods of the surface soil layers. (*Table 5.3*) (*Stojkovic et al. 1992: 13*)

Definition of the seismogeological characteristics of the sites of the selected churches has been performed on the basis of data on the geological characteristics of the terrain and data from geophysical surveys performed for the considered sites. (*Stojkovic et al. 1992: 13-53*)(*See app. 5, section 5.5*)

The church of St. Nikita, V. Banjani

The church is located in the village of Banjani, 11 km from Skopje, at an altitude of 700 metres. From the geological view point, the terrain upon which it is situated represents a composite entity consisting of layers of Palaeozoic, biolite and muscovite shells stretching Northwest - Southeast at an angle of 33°. The thickness of the layers ranges from 10 to 12 metres.

Since the church is located at the highest level of the terrain, the thickness of the alluvial - diluvial layers increases toward the slopes, but there are no signs of instability.

From the structural - tectonic point of view, no fault structures have been detected on the site itself. The closest faults are at a distance of 500 metres to the east and west.

The church of St. Bogorodica, v. Matejce

The church of St. Bogorodica is situated in the vicinity of the village of Matejce, at a distance of about four kilometres from the village and thirteen kilometres from Kumanovo, at an altitude of about 950 metres. (See app. 5, section 5.6)

From the stability aspect, the church is constructed on a slightly inclined slope with no signs of instability of the terrain. As to the structural tectonic aspect, no fault structures have been detected near the church.

The church of St. Nikola, v. Psaca

The church St. Nikola, v. Psaca is situated in the village of Psaca, about twelve kilometres Southwest of Kriva Palanka, at an altitude of 650 metres.

The terrain is composed of Palaeozoic rocks. Due to presence of a fault zone in the near surroundings, the shells are disintegrated and argillaceous up to a depth of about twenty five metres. (See app. 5, section: 5.7)

From the structural - tectonic point of view, the church is in the vicinity (fifty metres) of an east-west oriented zone that intersects a north - south oriented fault at a distance of 200 metres to the west.

The church of St. Bogorodica Zaumska, v. Trpejca

The church St. Bogorodica is located on the coast of Ohrid Lake, about one kilometre south of the village of Trpejca and about eighteen kilometres from Ohrid, at an altitude of 700 metres. (See app. 5, section: 5.8)

A fault zone has been detected at a distance of eight to fifteen metres from the church to the Ohrid lake coast.

Representative geotechnical model of the sites

The geotechnical models of the sites of the selected churches have been

defined on the basis of the results of the geological and geophysical seismic survey performed for the sites.

It was concluded that amplifactory media are the surface quaternary layers and the surface disintegrated and loose parts of the basic hard rocks with seismic velocity of $V_c < 700$ m / s. Due to the relatively low thickness of the disintegrated and loose rock media and the high coefficient of seismic impedance regarding the more compact underlying rock, the disintegrated and loose rock media with $V_s = 1,000$ m / s. were also, adopted as amplifactory media for the needs of the parameter analysis .

For the geotechnical models the compact hard rock mass media were adopted; these are the main masses of the investigated sites characterised by $V_s > 1,500$ m / s. (Stojkovic et.al. 1992: 24)

5.2.5 Seismic hazards for the sites of selected structures

According to Stojkovic et al. (1992: 54) 'On the basis of the presented spatial, time and energy characteristics of the seismicity of the terrain (Fig. 5.5 and Table 5.2), the defined seismic attenuation (expressions 3.2 and 3.3) and Poisson's law of distribution of probability of earthquake occurrence, defined were the maximum accelerations at the surface of the considered α_{cc} and the corresponding earthquake intensities (I) that are expected within certain return periods spanning between *twenty five to ten thousand years.*' (Table 5.4)

In the Table 5.5 will be used information for α_{cc} and (I) and return periods of fifty, two hundred and five hundred years. Last one is accepted because it is fundamental for Macedonian standards of new construction from the seismic aspects.

The notation 'local foci' involves all seismic foci within a radius of up to forty kilometres around the site, while the notation 'adjacent foci' includes the seismic foci which are at a distance of over forty kilometres from the site. The notation 'all foci' stands for the joint influence of all the local and adjacent foci.

From the presented information we can conclude that the site of St. Nikita church, v. Banjani, St. Bogorodica church, v. Matejce and St. Bogorodica Zaumska church, v. Trpejca are exposed to earthquakes originating from local and adjacent foci, those of local origin being predominantly expressed. However, the site of St, Nikola church is exposed only to the effect of adjacent earthquakes originating mainly from the Pehcevo - Kresna focus, the maximum magnitude of which is 7.9 degrees according to the Richter scale. (Fig. 5.7-10)

5.3 Dynamic characteristics of the selected structures

5.3.1 Ambient vibration test

Dynamic response of a structure subjected to a strong earthquake motion depends on many parameters of which the most important are: the frequency content of the earthquake, the dynamic characteristics of soil deposits and the dynamic properties of the structure itself. If the predominant earthquake frequency is close to the natural frequencies of soil layers and the structure, the soil structure system will vibrate more intensively.

The estimation of the seismic resistance and stability of a structural system is based on criteria whose formulation is a complex and sensitive problem. There are many obtained parameters, one of these being a mathematical model which provides a realistic definition of the structure as well as the physical properties of the connection of its elements.

For mathematical model formulation the following structural characteristics have to be known:

- masses
- natural frequencies
- mode shape of vibration
- damping characteristics

Determination of masses should be done in analytical way, but the other parameters may be defined only in an experimental way, applying model testing or full scale testing of structure.

The two prevailing methods for full scale testing of structures are:

- the forced vibration method
- the ambient vibration method

The latter was applied for testing of the selected church structures: St. Nikita, v. Banjani; St. Nikola v. Psaca; St. Bogorodica, v. Trpejca and St. Bogorodica, v. Matejce. (*Krstevska et al. 1992*)

Procedure

Recently, simultaneously with the full - scale forced vibration studies of

structures or even independently, a testing method has been used based on wind or other microtremor effects.

The ambient vibration method for definition of the dynamic characteristics of structures is a relatively simple method which requires equipment easy to be transported and such a test can be conducted even if the structure is in use. These theoretical needs could be successfully fulfilled if the wind as an existing force is assumed. The mode shape of the building could be defined by the ambient vibration method.

Response of the structure in time is registered with highly sensitive sensors, connected through signal conditioners with a tape recorder, or Fourier analyser sensors are placed at selected points on the structure according to the programme of testing. (*Fig. 5.11a-d*)(*See app. 5, section: 5.9*)

5.3.2 The church St. Nikita, v. Banjani

Briefly, some repeated general information. The principal structural system consists of massive perimeter walls, piers, vaults and dome. At the ground level, the walls have a cross - section of 85 cm.

Experimental results

To be sure that seismometers are ready the first test was for their dynamic calibration. It was carried out at point T1, level I for the E - W direction and point T2 for the N - S direction. The Fourier amplitude spectra for translation vibration in both orthogonal directions obtained from this test are shown in (*Fig. 5.12a-b*).

Tests for defining the resonant frequencies of the church for those directions and for torsion were also carried out at level I, by locating two seismometers at points at this level.

A few tests for obtaining the vertical mode shapes of vibration of the structure were performed placing two seismometers along the height of the structure, while the reference one was permanently at the reference point at level I. Tests for obtaining the horizontal profiles during translation vibrations were also carried out at several points at the same level. (*Figure 5.12a*) The Fourier spectra obtained from the tests for definition of mode shapes are presented in (*Fig. 5.12b*) for translation in the E - W and N - S direction. There are spectra of vertical components obtained by measurements at the level of the ground floor for both E - W and N - S directions , respectively. (*Fig. 5.13*)

(See app. 5, section: 5.10)

Using the determined amplitudes for each level and normalising them in respect to the reference amplitude, the vertical mode shapes of the transitional vibrations were obtained. Figure 5.13 shows the natural frequencies, damping coefficient and mode shapes of vibration for the church.

Analysing the mode shapes of vibration it could be said that the shear effect prevails in the lower part of the structure for the E - W direction, while in the upper part, where the dome starts, the effect of bending is more expressed. The explanation of this is the greater flexibility of the dome structure in respect to the basic structure of the church, which has a larger dimension in this direction. For the N - S direction, there is no pronounced difference in the mode shape of vibration along the height of the structure, i.e. the shape of deformation during vibration in this direction is of the shear type. *(Krstevska et.al. 1992)*

5.3.3 The church St. Bogorodica, v. Matejce

This is one of the biggest churches of the Byzantine period in Macedonia. The outline proportions of the building are 23 x 14.5 meters and the height of the dome is 20 meters. The walls have a thickness of 80 cm. *(See app. 5, section: 5.11)*

Experimental results

By the same procedure as mentioned for the church of St. the following values have been obtained: $f = 4.4$ Hz for translation in E - W direction, $f = 3.4$ Hz for translation in N-S direction and $f = 5.8$ Hz for torsion. The damping coefficients are 2.7 per cent, 4.9 per cent and 1.5 per cent for E - W, N - S and torsion, respectively.

(Fig. 5.14) (Krstevska et al. 1992: 23-24)

5.3.4 St. Nikola Church v. Psaca

The church is located above the village of Psaca, on the slopes of the Lisec mountain. The structural system of the church as a whole consists of massive perimeter walls constructed of roughly polished stone, dressed stones and bricks in lime mortar.

(See app. 5, section: 5.12)

Experimental results

Tests were carried out according to the standard procedure to obtain the vertical and horizontal mode shapes of vibration of the structure.

Natural frequencies of the St. Nikola church are as follows: $f = 5.4\text{Hz}$ for the E - W direction, $f = 4.0\text{ Hz}$ for N - S direction and 6.4Hz for torsion. The corresponding damping coefficients are 6.5, 8.3 and 5.2 percent, respectively.

(Fig. 5.15)

In table 5.6 the dynamic characteristics of the church are presented. As can be seen, the vertical mode shapes of translation vibrations are regular, with bending effect prevailing in the E - W direction at the part where the dome starts. The reason for this effect is the greater flexibility of the dome structure in respect to the main structure of the church. Because the length of the church is larger in the E - W direction, the rigidity (i.e. natural frequency) is higher than that in the N - S direction. The stiffness distribution is more regular for the N-S direction, as obvious from the continuation of the mode shape along the height of the church.

Soil structure interaction is not negligible. *(Krstevska; et al. 1992: 40-41)*

5.3.5 St. Bogorodica Zaumska Church, v. Trpejca

The church is situated on the coast of the Ohrid Lake on a small plateau in front of the steep rock terrain, south of the village of Trpejca. *(See app. 5, section: 5.13)*

Experimental results

By standard procedure and investigation the following values have been obtained:

The natural frequencies of the church of St. Bogorodica, v. Trpejca, are clearly selected: $f = 6.0\text{Hz}$ for the E - W direction, $f = 4.6\text{Hz}$ for the N - S direction and 8.2Hz for torsion. Damping coefficients are 1.5 per cent, 2.2 per cent and 2.5 per cent, respectively. *(Fig. 5.16)*

The Mode shape of vibration in the N - S direction is quite regular with shear effect prevailing in vibration, while for the E - W direction a slight discontinuation is noticeable in the vertical mode shape at the level of the tambour. Little soil - structure

interaction, is observed, considering the good soil on which the church is built.

(Krstevska et al. 1992: 54-55)

In the Table 5.6 are general information for natural frequencies and damping coefficient for all selected structures.

5.4 Methodology for conservation, repair and strengthening

5.4.1 Conservation, repair and strengthening criteria

What are the criteria that have to be satisfied for a proper treatment of Byzantine monuments in Macedonia, being at the same time, in full compliance with the many recommendations given in the past (referring to treatment of cultural monuments in seismic regions)?

Conservation, repair and strengthening of cultural monuments is a complex, a multi - disciplinary and continuous process. On one hand, there are the monuments with all their attributes, while on the other, there is the society and the professional institutions with the obligation to protect them. The bases of these activities are found in the valid codes for protection of cultural monuments as well as international recommendations and conventions.

These can be divided into two main categories as follows:

- legislative - administrative treatment (as an indirect approach)
- technical - operative treatment (as a direct approach)

Legislative - administrative treatment (as an indirect approach)

General information already has been presented in Chapter three (3.3.1 section).

Mainly, the code for protection of cultural monuments is based on the assumptions of the Venice Charter (1964). It is therefore almost completely dedicated to protection and treatment of individual cultural monuments and much less to the protection of ambient / vernacular cultural heritage.

The latest knowledge on the need for preparedness and planned protection against natural and man - made damaging factors makes this code obsolete and requires its improvement and adaptation to the new conditions. This need is even more stressed by international recommendations related to natural catastrophes (earthquakes) and architectural heritage.

Parameters of paramount importance are the following:

- In the decision defining a structure as a cultural monument in accordance with the present law on protection of cultural monuments², a detailed protection regime³

should be incorporated as a basis for its present and future treatment.

- In accordance with the Book of Regulations regarding the creation of Files on Immovable Cultural monuments (*Sumanov 1979*)⁴, the file on each cultural monument should contain all relevant information (stored in five main funds: descriptive fund, technical documentation fund, photo - documentation fund, audio - documentation fund and fund of materials).⁵
- The Byzantine cultural monuments and all other cultural monuments situated in the territory of the Republic of Macedonia should be listed in a priority list for urgent and regular activities (inspection and regular maintenance). (*Sumanov 1988*)⁶ This list should represent the basis for a proper and economically justified treatment.
- All the cultural monuments, particularly those of the highest value, should be incorporated in national plans for protection against catastrophes (natural and man - made). (*Sumanov 1997*)⁷
- The conservation works, repair and strengthening, i.e., each direct treatment of immovable architectural heritage in seismically active regions should be done in compliance with the prescribed technical norms and standards (that have still not been designed nor established) in the legislation of the Republic of Macedonia.⁸
- Definition of the legislative obligation for elaboration of complete architectural and photo - documentation on each cultural monument and their storing in three different buildings (safe against total destruction, if possible).
- Due to the multi - phase and multi - disciplinary utilisation of the documentation on cultural monuments (for different purposes), a minimum amount of information it should be defined that should be sufficient for planning and carrying out different activities. (*Sumanov 1994-6*)⁹
- Location of cultural monuments of Republic of Macedonia in macroseismic maps of Macedonia for characteristic return periods of 50, 100, 200 and 500 years.¹⁰

Technical - operative treatment (as a direct approach)

For the last fifty years of this century, the large number of natural catastrophes (earthquakes) that have occurred in different parts of the world (some of these that were of a stronger intensity inflicting heavier damages struck the Republic of Macedonia) accelerated the process of investigation and definition of methods for proper and adequate physical treatment of cultural monuments.

As a contribution to that, and as preparatory phase in Macedonia some important activities have been carried out.

It is important to note that all these activities have been performed in close and permanent co - operation with UNESCO, ICCROM, RZZSK, UNDP and other scientific and professional regional and international organisations. Noteworthy is the importance of the meetings held in Skopje that contributed to the theoretical - experimental improvement of the treatment of cultural monuments and definition of methods for conservation, repair and strengthening. (See app. 5, section: 5.14)¹¹⁻¹⁴

These permanent activities were disrupted by the events that led to the disintegration of former Yugoslavia and the establishment of five new independent countries. However, fortunately for the author, Macedonia was able to continue the activities in this field. The author has been involved in this activities very frequently.

While defining the treatment of cultural monuments, several basic criteria should be planned as direct interventions:

- In each intervention, attention should be paid to the history, aesthetic and physical integrity of the building. To satisfy these criteria each building should be analysed beforehand from the archaeological and historical view point in order to collect information about any element of cultural and historical importance. From structural and architectural elements such as architectural shape, material and technology applied for construction of the building, a decision will be made on the selection of corresponding conservation, repair and strengthening methods.
- Intervention should be minimised.
- Maximum respect of the intrinsic characteristics of built - in materials and structural elements that will contribute to the fulfilment of the preceding item.

In the latest document in this field, among which EUROCODE 8 should be

quoted, there are some recommendations that should be incorporated and accepted in designing of the physical treatment of the structure. They are as follows:¹⁵

- a) effectiveness
- b) compatibility
- c) durability
- d) reversibility

This must be taken into account when defining the appropriate methods for conservation, restoration and strengthening of Byzantine churches in Macedonia.

5.4.2 Definition of safety criteria

Definition of safety criteria for structures represents a continuation and a result from investigations obtained on the basis of analytical and experimental processes for defining of their seismic stability in the light of their main characteristics and artistic - historic values.

To define the seismic safety criteria of structures that are the subject of our interest we must establish general criteria for conservation, repair and strengthening of cultural monuments.

The first and main determination is safety of people in the role of owners, users and visitors of the architectural heritage. This is one of the main bases for determination of all the levels of safety criteria for a structure. It should be noted that the churches are in the private ownership of the Macedonian Orthodox Church, but at the same time, they represent public buildings.

While defining the safety criteria, we have to know that certain factors do exist, are given and these are unchangeable. These are: the use of construction material, adequate structures and structural systems and their proportions, local soil and climatic conditions, tradition, social development level and economic trends, function and importance of the building.

The recommendations for physical treatment of the structures that result from empirical and experimental experience acquired, at national and international level, are also of particular importance for definition of the safety criteria.

In this domain, when talking about interventions on historic structures and cultural monuments, the following definitions of these structures are given in Eurocode8: Design Provisions for Earthquake Resistance of Structures:

- a) 'A monument is a structure having an important "cultural value" so high that is necessary to guarantee its preservation, generally with its architectural, type and material characters.'
- b) 'A historical building is a building of an urban area which has a "cultural value" as a whole (Historical urban area), while the single building is not a monument. That means that the preservation concerns the general character of the construction techniques typical in the whole area.' (*Eurocode 8 1996: 52*)

The author thinks that the preservation of the exterior architecture of the building, as far as practicable, is also important and it will be added to the previous statement under b.

For us, the definition under a) is of a particular importance. Further, on page 53 of the same publication, an emphasis is given to the importance of the values of artistic elements that have to be taken into account in defining the level of seismic safety of the structure, although they are not of a structural interest.

In item F.4.2 - Criteria for Structural Intervention - Paragraph 3 of the same document, importance is given to the occupancy rate of historical buildings. The author considers that such an element has not always been applied for example in the definition of the change of function of the Duke's Palace in Dubrovnik from a residential to mainly public function (on which definition of the safety factors in designing of the works depends).

In the same material, on page 54, item F.4. - Preservation and Safety Levels, there is the following definition:

'(1) A "Monument" level corresponds to a situation in which the maximum probable earthquake (during an assigned time of reference, considerably longer than for ordinary buildings) is expected to produce repairable damages only and no "fatal" artistic damages.'

The author considers that definition of the safety coefficient of a structure represents a multi - disciplinary process in which equal importance is given to several factors:

Function

'Function' means the original and the present purpose of the structure e.g. for a

church the use for religious needs. Basically, all the buildings that are subject of this investigation have still their original function - holding of religious rituals. So, in respect to man as a user, irrespective of whether he is an official person or a believer, the purpose of the building is the same as that in the past. The number of users is changeable in the course of the day, week, month and year, in accordance with the Orthodox calendar.¹⁶

Construction materials

Basically this factor is given and unchangeable. Generally speaking, it provides an insight into relatively close, almost identical characteristics according to type (stone, brick, ceramics, timber, lime mortar) and mode of use (in natural or dressed form), i.e., area of use (foundations, walls, openings, columns, arches, vaults, ties and domes). Greater difference is observed in the level of damage and the present states that are in function of natural and man - made damaging factors. However, it must be emphasised that, in defining the necessary safety, particular attention should be paid to lime mortar as the main bonding material that, compared to other materials, has the lowest strength and deformability characteristics.

Quality of construction / workmanship

The technology employed plays an important role in formation of the structural and non - structural elements of the structure. It is also given and unchangeable with a variable degree of quality of performance, in accordance with the importance of the structure, i.e., the financial power of the founders, which was, sometimes, a crucial factor for the building's quality. Although, there is a period of six centuries of usage of a technology of construction, no great differences were found regarding its characteristics, which is not the case with the quality.

Structural systems and elements

By use of construction materials and workmanship in accordance with the needs of a space for a particular purpose, structural and non - structural elements defining the integral structure were obtained. Their characteristics thoroughly comply with the characteristics of the Byzantine architecture at that time. Although all elements of the structural system have almost equal importance in defining the safety

level of the considered structure, the author personally thinks that these important elements should be considered:

- The earthquake effect upon the structure depends on the mass and the stiffness of the elements and the whole structural system. In the case under consideration the mass is given and unchangeable and the existing stiffness, which is dependent on the original quality of materials, workmanship and the subsequent maintenance, is unchangeable without intervention.
- Structural continuity that enables adequate transferring of loads from the superstructure to the foundations of the buildings, i.e., adequate behaviour under dynamic loads (earthquakes, winds, explosions, etc.).

The author's investigations carried out in this domain, particularly to interventions in Skopje, after the catastrophic earthquake of July 26 1963 and Dubrovnik and Kotor (Croatia and Montenegro) after the catastrophic earthquake of April 15, 1979¹⁷, enabled him to make an analogy between the criteria and methods of conservation, repair and strengthening applied after the Skopje earthquake and those after the Montenegro earthquake for the purpose of defining both the basic approaches and treatment.

These could be defined in two general directions, as follows:

Hard or aggressive treatment

The basis of this treatment is the assumption that the main emphasis in repair and strengthening of structures should be put on its 'structural' or 'physical' restoration. Some authors call this treatment 'technicolastic.' (Maroevic 1988:10)

This treatment was extensively applied in Skopje, but also in Kotor and particularly Dubrovnik which surprises the author because of the fact that the repair and strengthening works in these two cities - Kotor and Dubrovnik - were carried out in the period of 1979 - 89 when certain and theoretical and experimental experience already existed and the Venice Charter had already been drafted, which was not the case for Skopje. One reason was probably an unthinking application of the calculation criteria in the structural code of practice for new constructions.

*Modest or conservative treatment*¹⁸

One of the main supporters of this treatment is Sir Bernard M. Feilden. The basis of this treatment is adequate preventive maintenance of historic buildings for the purpose of improving the capacity of the structure to resist earthquakes. It is a sophisticated implementation of a treatment on the weakest structural elements improving their properties by which they are made capable of sustaining the given seismic hazard. The presupposition is that the structural systems within one building should not be mixed if they have not similar behaviour and if introduction of the new components is carried out with large destruction of the existing fabric. The author's activities in the past, present and in future, have always endeavoured, and will endeavour to stick to this basic idea.

In accordance with the empirical and experimental experience acquired through the activities of an active approach to conservation, repair and strengthening of structures located in seismically active regions and their adequate behaviour under dynamic, i.e., seismic loads, three criteria for the physical behaviour of the structure under seismic excitation have generally been defined:

- Under slight earthquakes, the dynamic structural behaviour should not induce damage either to structural or non - structural elements of the building;
- under stronger earthquakes serious damage to the principal structure is not allowed while slight deformations of the non - structural members are allowable;
- maximum expected earthquakes should not affect the stability of the main structure. Larger deformation of structural and non structural elements are allowable if the elements and the entire structure are not damaged beyond physical repair.

The author gives the greatest importance to the third choice since it enables a maximum respect of built - in materials and structural elements. He supports this standpoint by the fact that these structures have survived through centuries without collapse and being damaged and reconstructed despite the long period of exposure to damaging factors (natural or man - made).

No less importance is given to the following criteria:

- The historic features of the building should be preserved which means that any new structural elements which may be necessary should be visually completely separated from the original structure;
- interventions should be minimised.

The degree of resistance required for a historic building should not be set so high, that measures necessary to achieve that level of resistance, destroy the character and authenticity of the building. Adequate resistance can be achieved by using the same building material and technology as those of existing historical structures.

5.4.3 Selection of prototype church structure

Based on detailed studies of the selected structures (4) (see under 5.1.2 - 3) and the obtained results, criteria for selection of a structure as a 'prototype / archetype' for carrying out experimental research and verification of the methods of conservation and seismic strengthening of Byzantine churches in Macedonia have been established.

According to the author of this dissertation, the following factors were of particular importance and relevance for the proper selection of the prototype church:

Site seismicity characteristics of the location

If we carefully examine Table 5.5, the highest values of maximum ground acceleration and intensity for a return period of 200 years are ascribed to the site of St. Bogorodica Zaumska church ($\alpha_{cc} = 0.268$ and $I = 8.25$). Then follow the sites of the church of St. Bogorodica in v. Matejce ($\alpha_{cc} = 0.233$ and $I = 8.05$), the St. Nikita church, v. Banjani ($\alpha_{cc} = 0.198$ and $I = 7.82$) and finally the church of St. Nikola, v. Psaca ($\alpha_{cc} = 0.191$ and $I = 7.76$).

For a return period of 500 years, the highest values were obtained for the site of St. Bogorodica Zaumska church ($\alpha_{cc} = 0.320$ and $I = 8.51$), then, the church of St. Bogorodica in Matejce ($\alpha_{cc} = 0.293$ and $I = 8.38$), the church of St. Nikita in Banjani ($\alpha_{cc} = 0.292$ and $I = 8.38$) and the church of St. Nikola, Psaca ($\alpha_{cc} = 0.204$ and $I = 7.86$).

If only these data had been taken into account, the church of St. Bogorodica Zaumska would have been selected as a prototype since the highest values of maximum ground accelerations and intensity are expected on its site.

Building typology (architectural - structural system)

It was in the phase of establishing the general criteria for selection of the four structures for detailed study that the criterion - type of architectural plan - such as cross - in - square building was established. The churches of St. Nikita (*Fig. 5.1a and 5.2a*) and St. Bogorodica Zaumska (*Fig. 5.1c and 5.2c*) have a classical plan - single dome and cross - in - square.

In the case of St. Nikola church (*Fig. 5.1d and 5.2d*) there is a small modification of the main plan because, to the west, the naos turns into a 'quasi - narthex' with a single dome. The church of St. Bogorodica in the village of Matejce (*Fig. 5.1b and 5.2b*) also has a classical plan - a cross - in - square with five domes. This structure was selected because of new reinforced concrete structures (horizontal and vertical belt courses, vaults and domes), used in the restoration works.

The classical architectural plan - one dome cross - in - square - was crucial for final decision in selecting the prototype / archetype structure. The prototype structure had to have these characteristics. These were found in St. Nikita church in the village of Banjani and the church of St. Bogorodica Zaumska in the village of Trpejca.

At this point, it should be emphasised that the St. Nikita structure is much closer to the classical model of a single dome structure with an inscribed cross than the church of St. Bogorodica Zaumska. In the St. Nikita church, the symmetry and the length of the cross arms, on plan, and in the direction of the two axes, are almost of the same dimensions, i.e., the east and the west ones have almost the same lengths as those on the north - south axis which are somewhat shorter. In the case of the St. Bogorodica Zaumska church, this symmetry deviates in the east - west direction, the east arm of the spatial cross being somewhat longer than that to the west.

The scope and level of applied methods for conservation, restoration, reconstruction, strengthening and presentation

The investigations of the existing documentation and field studies carried out by the author pointed to the fact that reconstruction works on all the four selected structures have been carried out in the course of time.

The most extensive works, in the sense of reconstruction of destroyed structural parts, were carried out for the church of St. Bogorodica in the village of Matejce. (*Fig. 4.81*) (*See app. 5, section: 5.15*)

The author considers that inappropriate strengthening with reinforced -

concrete structural elements was done during the reconstruction and strengthening works. (Fig. 4.70-71)

The church of St. Nikola in the village of Psaca underwent less extensive works, mainly in the upper parts. The conservation works done for the church are not thoroughly acceptable. (See app. 5, section 5.16) A particularly negative effect has been exerted by the cement mortar used for the construction of the drainage channels and pointing of the facade wall (done by pure cement mortar). The positive thing is that the central dome was not reconstructed. According to the concept of the architectural plan, this dome surely existed in the first phase of the church.¹⁹ (Fig. 4.58-59)

A relatively smaller scope of activities that could disturb the authenticity of the structure were carried out on the St. Nikita church in the village of Banjani. In the course of the seventies, the enlargements on the central vaults and the dome area have been removed and the 'assumed' original forms of the vaults, the tambour and the dome were presented. No disturbance of the structural integrity has been observed which is of a particular importance.

The least works were done on St. Bogorodica Zaumska church. These consist of removal of the enlargements over the vaults and the dome and their bringing into the assumed original form. However, this has been done by using of cement mortar that will surely negatively affect the main - original lime mortar. (Fig. 4.39-40)

If the intensity of the works carried out and its greater or lesser compatibility had been taken into account, the church of St. Bogorodica Zaumska would have been selected as a prototype church for the experimental investigations.

Historic - artistique value

As previously mentioned, one of the criteria, for selection of the Byzantine churches dating from the ninth to the fourteenth century in Macedonia, for detailed investigation and establishment of methods for their conservation and seismic strengthening, was the existence in them of an extraordinary gallery of Byzantine mural paintings.

In all those churches - St. Nikita, St. Bogorodica Zaumska, St. Bogorodica, v. Matejce and St. Nikola - exist master pieces of medieval mural paintings. The history and value of these paintings have been fully investigated by many Macedonian scholars as well as from abroad.

A comparison of the decoration of these churches (see appendix one) led the author to the conclusion that the most important are anthological master pieces of the

well known fresco - painters from the end of thirteenth and the beginning of the fourteenth century - Michael and Eutichios in the church of St. Nikita. (Fig. 5.17a-c) They are the authors of the fresco - paintings in two other churches: St. Bogorodica Perivlepta - Ohrid and St. Georgi in the village of Staro Nagoricane. (Fig. 5.17d) (See app. 5, section 5.16)

Structural characteristics

When the structural characteristics of the architectural plan of the buildings are considered, both St. Bogorodica Zaumska church and St. Nikita church have almost identical concepts.

Both structures have almost identical principal structural elements (materials used, proportions and workmanship) which are: walls of stone and bricks in lime mortar (perimeter walls, drum), vaults, pendentives and a dome constructed of bricks in lime mortar as well as usage of timber ties and horizontal timber belts.

However, some differences regarding the shape and proportions of some of the main structural elements have been detected.

Namely, the main difference lies in the construction of the free standing piers in the naos of the church. In the church of St. Nikita, they represent almost square piers on plan, constructed of stone, bricks and lime mortar without formation of capitals, whereas in the church of St. Bogorodica Zaumska they are monolith columns with $\phi 40$ cm constructed of marble with mounted marble capitals (Fig. 5.18a-b) which is a very rare example of Byzantine architecture in Macedonia. The use of monolith columns is noticeable only in the church of St. Dimitrija in Markov Manastir - village of Susica, with a polygonal cross - section, and in the columns of the tribelium of the St. Georgi church in the village of Gorni Kozjak.

Some difference is spotted also in the vaulting of the areas over the prothesis and the diaconicon. In the church of St. Nikita, this is achieved by an arch and a vault in north-south direction, whereas in the church of St. Bogorodica Zaumska, these areas are vaulted by transverse vaults in east-west direction.

The drum that bears the dome in the church of St. Nikita is higher than that in the church of St. Bogorodica Zaumska - 3.5m and 2.60 m respectively, and according to its concept and appearance it is closer to the characteristics of the drum from the fourteenth century.²⁰ It is exactly these characteristics, particularly the first one - the vertical free standing piers that were crucial for the final selection of the prototype church. (See app. 5, section 5.17)

Final selection of the prototype structure

Based on the presented and applied criteria, the St. Nikita church was selected as a prototype church.

5.5 Possible and appropriate methods and techniques for conservation, repair and strengthening for selected structures

While selecting adequate methods of conservation, repair and strengthening of Byzantine churches, the main goal was, first of all, that they be in compliance with the criteria defined and adopted in 5.4.1 and 5.4.2.

Based on the historic artistic values, the physical - mechanical properties, the dynamic characteristics of the buildings and the defined seismic risk, vulnerability and soil characteristics at the sites, certain methods are applied as appropriate methods since they:

- Respect, to the maximum possible extent, the original architectonic characteristics, the original types of construction materials and technology of their incorporation, which means that materials and technology that are compatible with the original ones are applied;
- support, to the best possible extent, the main original structural system and structural elements and increase their deformability and dynamic characteristics increasing their strength and improving their ductile behaviour;
- satisfy the principle of minimum intervention - maximum improvement of the main necessary mechanical characteristics;
- enable complete reversibility with minimum damage to the original structure;
- satisfy the durability criterion (because of utilisation of materials and workmanship that have been in use for a longer period).

The above stated criteria point to a limited choice of 'appropriate methods.' If we add the impossibility of applying the recommendations and regulations contained in the national Code of Practice relevant for new structures, there is very little choice left.

The adopted and recommended methods should be applied in the process of conservation in a non - urgent situation such as today, in accordance with - the National List of Priority Tasks - in the domain of protection and conservation of cultural

monuments. However, once the earthquake occurs, there is a great probability that the order in the Priority List be changed depending on the site and the level of damage.

In accordance with the investigations and results of characteristics and damage level sustained in the past and the possible failure mechanism (*Fig. 2.6*) as well as the obtained results for seismic stability in present conditions, the main elements of strengthening of the structural system and the structural elements are obtained.

Integrity of the structural system

The analysis of damaged massive structures (it is evident that the perimeter walls of all the Byzantine churches have these characteristics) have shown that one of the initial types of failure is separation of the walls at the corners (*Fig. 2.6*) and disturbance of the structural integrity due to weakness of the upper part (the roof) of the structure which is unable to withstand tensile forces.

It is exactly this type of damage, disintegration, i.e., outward inclination of the main perimeter walls of the principal structure and drum that contributes to damage and collapse of the vaults and dome elements. This is the most frequent damage pattern of all Byzantine churches in Macedonia.

These two evident, and important, factors, point out the need of increasing the capability of the existing structural system. This will be achieved by a strengthening concept which will enable the structure to preserve its integrity and behave as an entity.

In this zone of perimeter walls of the selected, and all other buildings of Byzantine type in Macedonia, horizontal timber belt courses are placed at all the places where the vault structures of the naos, i.e., the dome rest on drum walls. The upper zone of the perimeter walls of the naos and the tambour is characterised by the highest vulnerability wherefore interventions and strengthening should be focused on this zone. (*Fig. 5.3a-b*)

Wall should have sufficient resistance to shear forces, moments and a ductile capacity as well. The walls of these buildings are composite. Built of stone, bricks and lime mortar. Lime mortar is the most vulnerable due to its relatively low strength regarding its resistance to shear forces.

In general, apart from depending on the geometrical characteristics, moment resistance of walls depends also on the capacity of withstanding tensile forces.

As these forces increase during dynamic ground excitation, increasingly severe damage will occur in the lime mortar. This means that the resistance of the masonry as a composite element, needs to be increased.

This type of a structural element behaves rigidly with dominant shear effects, which, mostly depends on the tensile capacity of masonry. The load bearing capacity of masonry in traditional construction is increased and empirically tested by inserting of horizontal timber belt courses at different levels.

This is the case with all the Byzantine churches in Macedonia. We have to repeat again that the horizontal timber belt courses are located at the same level at all perimeter walls and are spatially connected, where the vaults join the walls by timber ties. These ties connected free - standing piers or columns of the naos too. By use of these structural elements integral behaviour of whole structural system under dynamic loads is increased.

Byzantine wall structure is a composite element. It is constructed of stones and bricks with two faces and the core in between. The core is a mixture of crushed stones, bricks and lime mortar which is a dominant component. Those two faces have been connected by regularly inserted brick layers at certain vertical distances. (*Fig. 5.4a-b*)

Those two faces are worked differently but both have certain compactness and strength.

On the facades, this has been achieved by pointing of the joints with high quality special pointing mortar, with much better characteristics and higher resistance than the masonry one. During investigations, some damage to jointing elements have been detected but these have never been very serious. These damages were always heavier on the south, and on the west facade than those on the north and the east facade.²¹

The internal face of the walls are covered by two or more layers of lime fresco - mortar, either original from the time of construction or from the repairs done later.

In our case the roof areas (flat or oval) are exposed to the damage due to dynamic loads. Here, it should be pointed out that the connections of the structural elements at the roof level are zones of penetration of atmospheric water.

According to the above stated and for the purpose of satisfying all those parameters, the author proposes several methods of repair and strengthening. Economic aspects are included too.

1. Main and crucial strengthening should be carried out in the upper zone of the vertical bearing perimeter walls by formation of a kind of a horizontal belt course that as a factor for the integral behaviour of the principal structural system. They should be connected spatially and perpendicularly through the piers or columns.

This should be carried out also at the level of base of the dome at the drum walls.

To increase this integrity, the same horizontal belt courses should be anticipated also at the level of door lintels of the naos, at the base and in the middle of the drum.

How to achieve that? At least two ways could be proposed:

- 1.a The first possibility represents a very complicated and expensive task involving restoration of the horizontal timber belt courses in place of the thoroughly damaged original ones. This would involve removal of old timber which is destructive to the masonry. The new timbers would not be 'bedded - in' , as the old once were, by having masonry built on top of them, and will therefore not be so effective as the original ones. This is a very delicate task too because the whole interior area is covered with fresco - paintings. Particularly difficult is the perpendicular connection of the parallel beams of the timber belt. If this mechanical connection between them is not provided, they will act individually and will not play the role for which they are intended. This method could be qualified as 'hard and rigid.'

So far, we have no information of the application of such a method on this type of monument.

Between the timber elements and the mortar only mechanical contact exists. During dynamic effects the friction factor is very low and insufficient to enable homogeneous behaviour of the composite wall.

- 1.b The second possible and appropriate method for strengthening of this important zone of the structural system could be defined as follows:

The holes of the formerly existing timber belt courses are used for insertion of a new composite element consisting of a combination of lime mortar and special steel ties that are anchored at the ends. For the purpose of increasing the profile of the new structural element, the surrounding of these elements is systematically injected with a mixture of lime mortar with additives that increase the adhesion of the newly incorporated material with the original one. Variant A.(Fig. 5.19a-d)

To increase the efficiency of this new structural element, prestressing of ties is anticipated. This energy is activated only in the phase of dynamic loads.

Anticipated is also 'spatial' connection with the opposite perimeter wall through the vertical individual columns or piers in the naos and also by steel ties anchored into the wall mass in the same way (according to the adopted variant).

When applying this variant, there are two modes of anchoring of the steel ties at the ends, i.e., anchorage into the masonry body or visible anchorage onto the facade. Both modes have their advantages and disadvantages.

1.b.1 If anchoring is performed into the masonry body, the original masonry will have to be destroyed to a certain extent. Although this is a lower scope of destruction, it is still a 'destruction' in principle. Although this mode of anchoring enables reversibility, repeated destruction of the already treated masonry elements is expected in removing the intervention in future.

1.b.2 Anchoring upon the facade surface is much easier, with very small, almost negligible destructive elements and is far more economical. The possible application of this subvariant enables satisfying of the principle of 'sincerity' in intervention. This mode also enables maximum reversibility, with very small damages to the original.

According to some authors, this method (both the above variants) is possible in zones of low seismicity and in the case of small and compact structures. However, we can say that this is a 'conservative' method of maximum 'cautiousness' which is the basis of my thesis.

This variant makes it possible to increase the resistance of the existing buildings with maximum application of the criteria. Applying this method, a repairable damage, but not collapse of the building is anticipated, which is also the basis of the thesis. It must be pointed out, once again, that all products of man or nature are doomed to decline for ever and it is our duty to decelerate this process to the highest possible extent. We do not have the right to reproduce the syndrome 'The Portrait of Dorian Gray', i.e., adorn our product with the attribute 'immortal.' This is the basis of the John Ruskin's philosophy and his slogan 'monuments have the right to die.'

2. The next method of strengthening of Byzantine churches is somewhat 'more hard', i.e., it means an extension of variant A) that was previously described.

Namely, a new element referred to as 'a vertical belt course' is anticipated for certain locations in the perimeter walls, i.e., at the corners and in plane with the columns in the naos to increase the seismic stability and resistance of the structure to tensile forces induced by the overturning moment.

This element could also be used in the drum body.

As in the previous case, there are two subvariants of applying this method:

- 2.a To anticipate vertical installations only at the four corners of the perimeter walls, i.e., only at the four "so called columns" of the drum integrated with the horizontal seismic strengthening elements. Variant B. (*Fig. 5.20a-d*)
- 2.b To anticipate vertical strengthening not only at the corners but also at the plane of the columns in the naos. The intervention on the tambour is the same as in subvariant 2.a. Variant C. (*Fig. 5.21a-d*)

This approach to be applied on the drum masonry results from the fact that this part of the structure behaves differently during dynamic loads which is, first of all, due to the type of structure and its geometry.

While applying any method or subvariant of a method, there arises the problem of interaction between the new and the existing material. This mainly refers to the connection of the new mixture of lime mortar with the existing one and with the masonry elements. The problem to be solved is the adhesion between the lime-based admixture and the steel elements of the ties used for establishment of the composite strengthening element - either horizontal or vertical.

3. Lately, a new method called 'seismic isolation' has been investigated and applied. The basis of this method is enabling of a decreased transfer of dynamic loads to the superstructure of the building by incorporation of a special installation, the so called 'isolator - dampers' below its foundation.²²

Although, at first, this method may seem quite expensive, the author personally thinks that possibility for its application may arise in future, particularly from the reason that most of the Byzantine churches have proportions ranging from 7 x 9 to 10 - 11 x 12-14 m. However, the application of this method will also depend on the historic - cultural and aesthetic values of the building.

The advantage of this method is that the intervention on the superstructure of the building in the sense of strengthening is very small. However its defect is that it is much more expensive than the other methods.

5.6 Economical aspects of proposed methods and techniques

The decision on application of one of the possible appropriate methods will depend not only on the natural factors and recommended processes and treatment, but also on the cost of each method.

This criterion is important in principle, no matter whether a 'rich' or 'poor' society, or a society undergoing transition (as is the present situation with the Republic of Macedonia) is in question.

The author considers that the expenses of application of any method can be divided into two main groups:

- a) Inevitable expenses that must be anticipated as realistic and inevitable (with a very low possibility of decreasing them);
- b) Expenses that are variable and depend on our decision which of the methods or techniques will be applied and realised.

It is logical that the cheapest variant does not mean the most effective variant. The design architect conservators and engineer should have this in mind in making a decision as to which method to use. They should have to make a comparative analysis of the financial structure of the different variants.

If the proposed methods are analysed, it may be concluded that their cost is increased in accordance with the order of their presentation which is due to the increased scope of activities, both direct and indirect.

When applying of each of these methods, the design experts should have to anticipate also the preventive measures for protection of the valuable fresco - paintings against both physical and chemical damage.

The larger the scope of the works is, the higher are the expenses related to prevention of damage both in the sense of usage of an increased amount of materials and consuming of time.

Factors that participate to establish of the variable financial value of direct works are the following:

1. Materials and technology applied. Experimental investigations;
2. Transport of materials and people;
3. Preventive protection of structural, non - structural elements and surfaces in both the interior and on the facade;
4. Preparation of locations for application of the method on the structure;
5. Realisation of the method;
6. Involvement of experts and professional team, time (man/hours);

7. Supervision of works;
8. Factor of usage of construction equipment (amortisation value)

5.7 Concept for repair and strengthening of the monument selected as a prototype structure

The defined mechanical and dynamic characteristics of structural materials and the defined seismic parameters were the basis for detailed analysis of the seismic stability of the structure for the purpose of evaluating its bearing and deformability capacity under different seismic excitations.

Taking into account the strength characteristics of masonry obtained by experimental investigations (mortar: compressive strength $f_c = 1,000 \text{ kPa}$ and tensile strength $f_t = 60 \text{ kPa}$) given in 5.8 and applying the methods of strengthening presented in 5.5, the bearing capacity of masonry was obtained and expressed via the shear base capacity coefficient for the first cracks and the ultimate state. These are $C_{bc} = 0.17$ and $C_{bc} = 0.21$. The coefficient is a quotient of the ultimate seismic force and the dead weight of the building.

Taken as a basis for experimental analytical and experimental investigation were: data on earthquakes, the location of the structures, distant epicentres (2) and local epicentres (1). The characteristics of El Centro and Petrovac earthquakes were considered for the distant epicentres, whereas those of the Breginj earthquake were considered for the local epicentres.

The following results have been obtained; (Gayrilović et al. 1992)

- For the El Centro earthquake, the first cracks appeared, i.e., the structure ceased to behave in elastic range at $\alpha_{\max} = 0.14 \text{ g}$, while failure of the structure took place at $\alpha_{\max} = 0.20 \text{ g}$ ($\alpha_{\max} = \text{peak ground acceleration}$);
- For the Petrovac earthquake, the structure ceased to behave in elastic range at $\alpha_{\max} = 0.12 \text{ g}$, while failure took place at $\alpha_{\max} = 0.20 \text{ g}$.

By further analyses, the following ductility values have been obtained. (Table 5.7)

- for $\alpha_{\max} = 0.12 - 0.14 \text{ g}$ (corresponding to an earthquake with a return period of 100 years) the building will suffer damages to the secondary elements and minimum deformation of its bearing structural elements;

- for $a_{\max} = 0.20$ g, (corresponding to an earthquake with a return period of 200 years) failure of some parts of the structure like the dome, the tambour, the cornices and the lintels and heavy damage to the bearing structural walls take place, the building being still repairable as a whole.
- for $a_{\max} = 0.36$ g, (corresponding to an earthquake with a return period of 1,000 years) which corresponds to the maximum expected earthquake in this area, total failure of the building takes place.

Based on all relevant information, a method was defined to increase the strength of the structure and improve its ductile properties.

Previous analyses of damages have shown that the dominant role is played by the shear effects related to the tensile strength of masonry. In the past, the bearing characteristics of the structure were increased by incorporation of horizontal and transverse timber beams at different levels (the dome level, the ends of the vaults, over the openings and the foundation level). However, these timber ties lost their characteristics and function in the course of time because of decay.

So, this is the moment when a decision is to be made on the method to be used for improving the strength characteristics of the structure.

By using the empty holes where formerly existing timber elements formerly existed, author decided to revive the original function of the horizontal timber belt courses, but this time by applying a new 'composite' element consisting of two components – steel ties and an infilling of a lime mortar mixture with additives that will improve the contact with the existing masonry structure .

This method is particularly suitable for this type of a relatively small and compact church structure. By restarting the role of horizontal connection of perimeter walls in both the orthogonal directions, the possibility for simultaneous behaviour of all the bearing walls would be increased. It should also be noted that, at the state of occurrence of cracks, i.e., exhaustion of the bearing capacity of masonry, the steel ties are activated enabling further vibration of the structure. Systematic injection of the zone around these horizontal elements is planned.

The author considers that this be enough to achieve the first level of strengthening of the structure if seismic parameters for a return period of 200 years are employed.

If we consider earthquakes of a longer return period, new elements with extraordinary reversibility characteristics (as were the previous ones) should be anticipated.

To increase additionally the moment resistance and ductility capacity of the structure in this case, incorporation of vertical 'elements' at the corners, i.e., the ends of the walls should be anticipated. If we decide on an even higher level of increasing the characteristics of the structure, these vertical elements should be incorporated into the wall mass, at the plane of the free standing piers in the naos.

To increase the moment of the walls and hence increase their bearing capacity, certain prestressed force is to be applied in the vertical steel bars which will uniformly be distributed along the height of the wall. Now a dilemma arises as to whether it is right to include this new element since it involves destructive activities (although on a smaller portion of the wall mass – drilling). The infilling will have the same characteristics as those of the horizontal elements.

The drum and dome as constituent parts of the structure are placed on the masonry base of the roof of the main structure. To strengthen this part, it is anticipated to restart the function of the horizontal timber belt courses in the foundation of the drum, in its middle part and in the zone of support of the dome structure (incorporated into the walls of the tambour).

Since dynamic loads affect greatly the drum structure, it is anticipated to increase its characteristics by applying the same vertical elements in the masonry the so called 'piers.'

While applying the method, particular attention should be paid to the characteristics of injection mixtures that have to be compatible with the existing ones and even somewhat stronger, but to a certain limit because of the danger of turning the new elements into factors of destruction of the original masonry.

They also must not exert any damaging effect upon the existing wall painting layers.

To increase the shear capacity of existing masonry, special admixtures should be developed and systematically injected into the masonry.

These are the basic theoretical assumptions of strengthening the existing structure. When analysis of the seismic stability of the structure with the applied strengthening elements was carried out, the strengthened structure behaved in compliance with the previously defined main seismic safety criteria. From these analyses, the following characteristics were obtained:

- The building suffers no damage under the expected earthquake acceleration of $\alpha = 0.20 \text{ g}$.
- Deformations of secondary elements and minimum cracks in the bearing walls of the building occur under expected earthquake intensity of $\alpha = 0.29 \text{ g}$.
- Under maximum expected earthquakes of $\alpha_{\max} = 0.36 \text{ g}$, the building will suffer extensive damage to the main structural elements (drum, dome, lintels) and non-structural elements (cornices) and the bearing structural walls. However its bearing capacity will not be thoroughly exhausted.

To verify the applied strengthening elements, the model of the St. Nikita church taken as a prototype / archetype church was constructed and tested.

5.8 Preparation of the St. Nikita church model for experimental investigation

5.8.1 Architectural and structural characteristics

Although some of the main characteristics of the structure have already been mentioned, the author will briefly present the already known architectural, structural and physical - chemical attributes that were the basis for construction of the model of the church and its testing on a seismic shaking table.

Architectural concept and characteristics

The church of St. Nikita is a representative of the classical type of monastery Byzantine churches. It represents a rectangular space with inscribed cross - in - square and four free - standing rectangular masonry piers supporting the dome. (Fig. 5.1a)

The central part of the church is formed by two rows of rectangular piers in which space it is possible to enter from two sides - west (main) entrance and south (additional) entrance. Remains of the latter one and traces of wall paintings on the south facade bear evidence about the existence of a former opened porch.

Its architectural and structural characteristics have already been described in section 5.3.2. (See app. 5, section: 5.17).

Physical - chemical characteristics of the built - in materials

For the experimental verification of the thesis ample investigations for actual physical - chemical properties of the incorporated construction materials were carried out. The results were used for construction of an adequate 'true replica' model of the prototype structure.

a) Stone (Fig. 5.22b)

Used for the construction of the church was local stone in several variants: undressed, semi - dressed and dressed. It is mainly limestone taken from a mine. The mine is in the vicinity and is still in use. This limestone has been used mainly for the construction of the inner face of the wall and the core infilling. Undressed or semi - dressed stone has been used only for the external side of the face, while the remaining part has an irregular shape. (See app. 5, section 5.18)

b) Brick (Fig. 5.22c)

For finishing of all the structural elements like walls, vaults, arches and the dome, brick of different sizes was used. For the production of bricks, a known technology was used and a stable product was obtained. It withstood harmful effects throughout ages (damage due to natural disasters, technical or weather damage) so that the structure is preserved in relatively good condition. (See app. 5, section: 5.19)

c) Mortar (Fig. 5.22a)

In the construction of the building, lime mortar was used for forming different structural elements. It was used as a fresco - painting layers as well as a pointing material for finishing the joints on the facade.

The composition of the mortar for all ages of use was almost the same but a difference is noticed in the size of stone or brick particles. For the fresco - painting needs, the size of the components is smaller than that used for the masonry structure.

c.1) Mortar for building and filling of joints

Based on chemical - quantitative analysis and chemical qualitative and microscopic investigations, the following results have been obtained, presented in Table 5.8. (Staniseva: Volume 10) (See app. 5, section: 5.20)

The table clearly shows that the binder - filler ratio of sample no. 1 is 1 : 2, while for sample no. 2 it is 1 : 3. Used as a filler is fine river gravel with the following grain size and percentage of presence in the two samples: (Institute "Makedonija" -Volume 10)

- grain size of 0.1 - 0.4 cm 65 %
- grain size of 0.4 - 0.8 cm 15-20 %
- grain size of 0.8 - 1.6 cm 15-20 %

c.2 Mortar for fresco paintings

After the investigations performed on samples of the fresco - mortar from the fourteenth century taken from the church, results have been obtained on its content. (Table 5.8) (See app. 5, section: 5.21)

From the results of physical - chemical analysis of fresco mortars it can be concluded that fresco mortars are rich in lime binder, that is, they have a small quantity of filler. (*See app. 5, section: 5.22*)

d) Wood

For the construction of both the horizontal timber belt courses incorporated into the masonry body and timber ties, oak of well known characteristics was used. The physical - chemical characteristics of this material were not investigated since it was mostly damaged and destroyed.

Mechanical characteristics of the built - in materials

The mechanical characteristics of the built - in materials are important since they affect the quality of the static and deformability characteristics of the structural system and the structural elements.

These were investigated by standard methods at the Institute for Testing of Materials in Skopje. The values obtained are given in Table 5.9.

5.9 Experimental investigation of the church model

It may freely be said that it is an exciting challenge for investigators to define theses about a new method, particularly when the idea is to re - establish an old method with a new composite element as a contribution of new time and its philosophy of conservation and restoration which is in function of maximum respect of 'authenticity.'

In this case, the challenge was not only in the fact whether the thesis will be proved by satisfying results from experimental tests but also in the fact that it is for the first time in the world that the appropriateness of a proposed method is tested on an experimental model of a structure pertaining to Byzantine architecture to such a large scale of approximately 1 : 3.

Another factor of excitation and pleasure was the decision of the sponsor to finance thoroughly these investigations, particularly the experimental tests. This was done by The Getty Conservation Institute from Marina del Rey, Los Angeles, USA through The Getty Grant Programme.

When the sponsor decided to provide a full financial support to this project, emphasis was put on its importance as the first of this kind. It can be understood as a 'pilot project' because of the fact that the same or similar structures pertaining to the same style and time exist in the whole Balkan peninsula and in part of the Mediterranean. This gives the possibility to treat the achieved results as elements for comparison with results from other similar or identical experiments to be carried out in the neighbouring countries in future. Their implementation will be a great pleasure too.

5.9.1 Study and design of the church model

In accordance with the basic principles of analysis of a model and selection of scaling factors, a dimensional system represents a set of physical quantities that are used for solving problems related to physics.

All the quantities in the system can be expressed by means of a certain number of 'main' units. We will repeat that a dimensional system in which all the quantities (displacements, velocities, accelerations, forces) are derived from three main quantities: length L, time T and mass M, can be used for addressing problems related to dynamics.

Using standard procedure, all the physical quantities included in the dynamic analysis results are presented in Table 5.10.

Table 5.10 clearly points out of structures are solved by means of the MLT dimensional system.

A. Basic principles of model analysis and selection of scaling factors

According to the standard procedure, the model used for testing of the dynamic behaviour of churches under earthquake effects has been designed in compliance with the basic principles of analysis of the model. The scale of the model parameters has been selected on the basis of the following criteria: (*Gavrilovic / Sumanov -Volume 10*)

- k1 - Proportions of the seismic shaking table (4.5 x 4.5 m);
- k2 - Total allowable height of the model (10 m);
- k3 - Total weight of the model (400 kN);
- k4 - Realistic simulation of non - linear behaviour;
- k5 - Realistic simulation of failure mechanism.

A.1 Geometrical scale

The geometrical scale of the model is determined considering the first three criteria. For an assumed scale of $l_r = 1 : 2.75$, the following proportions of the model have been obtained: (*Fig. 5.23a-b*)

$$b_m = \frac{11.4}{2.75} = 4.15 \text{ m} \quad \text{- length of the model;}$$

$$d_m = \frac{7.7}{2.75} = 2.80 \text{ m} \quad \text{- width of the model;}$$

$$H_m = \frac{12.4}{2.75} = 4.5 \text{ m} \quad \text{- height of the model}$$

$$G_m = \frac{4,670}{2.75^3} = 210 \text{ kN} \quad \text{- weight of the model}$$

The main information regarding the design and the construction of the model is as follows:

Density

Because of the decision under k4 and due to the specific behaviour of masonry as a non - homogeneous material, the model had to be constructed of natural materials (stone, brick, lime mortar). Hence the scale of the density of material is defined as $\rho_r = 1$.

Stress

Because of the need to satisfy also the condition under k5 – failure mechanism, the required additional normal stresses are provided by application of a corresponding prestressed force in the vertical reinforcement placed at the ends of the walls and in - between. During the construction of the model, this area was left empty in order to prevent the interaction between the installed force and the model during the dynamic tests.

Modulus of elasticity

Because of satisfying the conditions under k5 for realistic simulation of damages and the fact that the same natural materials have been used for the construction of the model, the same values were easily obtained for both E_m (model) and E_p (original).

Mass

For the purpose of the geometrical and density scale, the mass of the model had to be $2.75^2 = 7.56$ times smaller than the mass of the original.

Frequency

The frequency notation is given a significant importance in dynamics of structures. The natural frequencies are the main dynamic characteristic of the

structures. Their relation with the frequency content of excitation has a significant effect upon the dynamic response, inducing either amplification or attenuation of the seismic effect (resonance is the ultimate case of this phenomenon).

$$f_r = \sqrt{\sigma_r / \rho_r / l_r} = \left[\frac{1}{2.75} \right]^{-1} = 2.75$$

Because the natural frequency of the original is $f_r = 4.8$ Hz the natural frequency of the model will be $f_m = 13.2$ Hz. ($4.8 \times 2.75 = 13.2$)

Using the ambient vibration technique for testing of the model in laboratory conditions, the value of $f_m = 11.0$ was obtained. This deviation is due to the impossibility of using materials that have thoroughly the same characteristics as those of the original.

Time

Time is a very important quantity in dynamic analysis. All the terms of the equations of motion represent, in fact, a function of time. The time scaling is inversely proportional to the frequency scale which, in the considered case, means that the whole time has to be reduced, i.e., the scale of the impute excitations is reduced by 2.20 times.

B. Experimental investigation of model elements and material

B.1 Materials

Evidently, in the considered case, it is easy to provide the designed scales of some of the characteristics of the model (geometry, time, acceleration) either during its construction or by proper selection of excitation.

The selected natural materials satisfy the necessary scaling parameters.

For the needs of the model, natural materials of the same (tuff and bricks) or almost the same (lime mortar) characteristics as those of the original ones, were provided.

Based on the experimental tests, the physical - chemical and mechanical characteristics of materials to be incorporated in the model were obtained.

(Table 5.11)

The comparison between these results and the results obtained for the incorporated materials in the original (*Table 5.9*) does not point to any significant difference in the designed scale of tuff stone and bricks.

When testing samples of mortar from the prototype, unexpectedly high strength characteristics were obtained. Therefore, during the design of the mechanical characteristics of lime mortar to be used for the construction of the model, these values have been lower than those of the original.

B.2 Wall elements

To build the model, apart from the tests on materials and their mechanical characteristics, it was necessary to define, through quasi - static tests, the mechanical properties of the model masonry (bearing capacity, failure mechanism and other parameters), i.e., the characteristics of the structural elements. For this purpose, three wall fragments were built using the same material, technology and proportions as those to be used for the model. These fragments were tested in the IZIIS laboratory in Skopje.

Two of the elements were subjected to axial compression test while the third element was subjected to shear compression test. One of the two elements (axial compression) collapsed, while the other suffered damage and was later used as an element for application of strengthening.

The results obtained for the first element (WAC - 1) (*Fig. 5.24*) are given below.

This element was exposed to cyclic loading and unloading by which the characteristics of the failure mechanism, total axial shortening of the wall and side deformation were obtained. More important results are the following:

- Occurrence of the first cracks (point 45) - at $\sigma_o = 270 \text{ Kpa}$
140 KN
- Maximum normal stress: $\sigma_o \text{ max} = \frac{\text{—————}}{0.243 \text{ m}^2} = 567 \text{ Kpa}$

For the second element (WAC - 2) that was exposed to axial compression with continued, gradual increase of force up to complete failure, the following results were obtained: (*Fig. 5.25*)

- Occurrence of the first crack (point 82) at $\sigma_o = 257 \text{ Kpa}$;

136

- Maximum normal stress at failure (compress. strength): $\sigma_o \max f_c = \frac{136}{0.243} = 560 \text{ KPa}$

 σ

- Initial modulus of elasticity: $E_o = \frac{\sigma}{D \ 1/1} = 650,000 \text{ KPa}$

If damages to both wall elements are analysed, it may be concluded that, under axial loads, the walls suffer cracks in the centre of the cross section as well as total separation of both faces (WAC - 2). (Fig. 5.25)

The third element (WSC - 3), was subjected to continued force at an angle of forty five degree in respect to the horizontal position of the expansion joints of the wall up to the total failure of the sample. (Fig. 5.26)

The following results were obtained:

- Maximum normal stress at failure: $\sigma_o \max = 53 \text{ KPa}$;
- Tensile strength: $f^t = 35 \text{ KPa}$;
- Initial sliding modulus: $G = 165,000 \text{ KPa}$.

All these results have been used as main input parameters for analysis of the model not only from the aspect of application of seismic effects on the shaking table (on the non-strengthened and the strengthened model) but also for interpretation of the behaviour of the model.

C. Construction of the church model at scale 1 : 2.75 (Table 5.12)

C.1 Design of the model

The results obtained from the previous analyses and experiments enabled us to define all the data necessary for the construction of the model to a scale suitable for its testing on the seismic shaking table.

In accordance with the designed geometrical scale, all the necessary data on the base and the model itself in three dimensions have been defined. Summarised in Table 5.12 are all the characteristics of the model to be used for further analyses and comparisons with those of the original.

The detailed analysis of the main characteristics points clearly to the fact that an ideal similarity between the model and the prototype has been achieved. The only difference was the great difference in the total weight of the model and the prototype. The problem was solved by incorporation of a certain prestressed force in the vertical strengthening (discussed under 5.7). (*Fig. 5.27*)

So, realistic conditions were created for interpretation of the results obtained by dynamic testing of the model and its response in respect to the original.

C.2 Construction of the model

Based on the obtained results and satisfying the set parameters, the construction of the model of St. Nikita church to a scale of 1 : 2.75 started. All the structural elements were constructed with special care. (All activities were carried out under the by leadership of the author and members of his Institutional staff).

a) Main principles

During construction, the following main principles and criteria were considered:

- Each material to be used for construction of the model should have identical or almost identical physical - chemical and mechanical - strength characteristics as those of the original;
- Materials used for the building of the model should be prepared manually, as was the material used for the original. This mainly refers to the preparation of stone and lime mortar;
- A workmanship similar to that used for the original should be carried out in the sense of simulation of the facade and interior masonry, i.e., formation of a characteristic Byzantine wall with two faces in lime mortar. All the structural elements (arches, vaults, pendentives and the dome) were constructed by using the old technology;

b) Materials used

b.1 Stone

Two types of stone were used for construction:

- Natural lime stone (CaCO_3) from the quarry in the near surroundings of the monastery complex - village of Banjani. Its chemical and mechanical

characteristics are the same or similar to those of the original. The proportions of the individual elements do not exceed 12 - 15 cm.

- Natural tuff stone which represents in fact limestone (CaCO_3) taken from the mines in the vicinity of the village of Veljusa in Strumica district, Southern Macedonia. The stone has the same chemical - physical and mechanical characteristics as those of the original. Most of it was manually dressed.

b.2 Brick

Bricks with designed proportions of 12 x 12 x 3 cm have been used for the construction of the walls, the arches, the vaults, the pendentives and the dome. They have been produced in special moulds, prepared only for this occasion. The physical - chemical structure of these bricks is similar to that of the original, while their strength characteristics are approximately the same as those of the prototype.

b.3 Lime mortar

The lime mortar was prepared in the traditional way and burnt by using charcoal from the surroundings of Valandovo, city in South - West of Macedonia. The quicklime was slaked in a pit with water, and lime ^eputty was obtained. This lime putty was left in the pit for over a year.

For the preparation of mortar for construction, pointing and plastering, a lime putty was used with admixed river sand aggregate with a granulation and a chemical structure scaled 1 : 2.5 (binder-filler) and a grain size distribution of sixty five per cent of size 0-4 mm, 15 - 20 per cent of the size 4 - 8 mm and 15 - 20 per cent of the size 8 - 16 mm. The water used was from the regular supply system. This was the lime mortar for masonry construction.

The same components were used for the preparation of mortar for pointing, the presence of large sand grains (8 - 16 mm) being drastically reduced.

For the preparation of the plastering mortar (two layers of fresco mortar), the same ingredients were used to a scale of 4 : 1 (binder - filler) with admixture of chopped oakum for reinforcing of mortar.

b.4 Wood

Fir wood was used for the construction of the spatial ties. This different wood was used to achieve a strength similar to the present reduced strength of the original oak ties.

b.5 Steel

The repair method involved the use of a steel plate with a thickness of 0.4 cm for the anchors and reinforcement of $r=10, 14$ and 16 mm produced in Macedonia with a bearing capacity $= \sigma^Y = 400$ Mpa; $\sigma^u = 500$ Mpa.

c) Construction

The model was constructed in the Dynamic Testing Laboratory of the Institute of Earthquake Engineering and Engineering Seismology - IZIS by the artisans and experts of the RZZSK, Skopje.

The Model was constructed manually, in accordance with the planned schedule. It was erected on a bearing platform (foundation) located at a distance of 10 meters from the shaking table, due to pressure of time. The shaking table was frequently used and had to be available for use. Time of building and setting of the model was almost more than six months. (*Fig. 5.27a-f*)

After that it was moved by rolling to the shaking table.

From the technical point of view, the connection between the perimeter walls and the piers on one hand and the reinforced concrete platform (foundation) on the other was provided by stone anchors incorporated in the concrete mass of the platform, protruding for 3 - 4 cm from its surface. These anchors are built - in the foundation of the walls and the piers to prevent sliding of the model from the concrete platform during the test. (*Fig. 5.28*)

With the construction of the structural elements of the model, the wall areas and masonry were successfully simulated and corresponded to those of the prototype having a thickness of 26 - 33 cm. Horizontal voids in the masonry of the model correspond to rotted timber wall ties.

The arches, the vaults, the pendentives, the dome, the blind niches, the pilasters and other architectural elements were also simulated which especially refers to the order and the continuity of construction. The mortar was prepared manually.

Vertical steel reinforcement was incorporated during construction, leaving horizontal and vertical empty space for the application of the strengthening method after the performance of the test and the occurrence of damage.

The arches, the vaults and the dome were constructed with a thickness of 12 cm which is the length of the designed brick. (*Fig. 5.29 - 33*)

After the construction of the model, the facades were pointed with lime mortar with a thickness of 1.5 - 2.0 cm. Half of the church interior (the part of the E - W axis) was plastered with two layer of fresco mortar (the first layer having a thickness of 1.5 cm and the second, i.e., the finishing layer with a thickness of about 0.5 cm). (Fig. 5.34.)

5.9.2 Shaking table test of the non - strengthened church model

In general, the experimental tests on the non - strengthened church model performed in the Dynamic Testing Laboratory of IZIS in Skopje were aimed at:

- Evaluation of the vulnerability of this and similar structures, i.e., damage that will be inflicted under different earthquake intensities; and,
- Selection of the most appropriate procedure for their strengthening and repair of damages after occurred earthquakes.

According to the standard procedure and for the purpose of achieving the above goals, a programme of the following activities was adopted:

- Experimental testing under earthquake excitations performed by gradual increase in intensity for the purpose of monitoring the progressive development of cracks;
- Modification of dynamic characteristics;
- Definition of behaviour and the failure mechanism; and,
- Determination of the proportionality limit i.e., the occurrence of the first cracks.

Particular importance is given to the behaviour of the model that simulates the present state of the original and the determination of the main characteristics of its dynamic behaviour in the elastic range.

The results of the conducted ambient, forced and random vibration tests are the following:

- damping of the model is $\beta = 2.2$ per cent
- frequency of the model ranges between 9.4 Hz and 11.2 Hz in the considered direction which corresponds to the frequency of the prototype scaled 2.0 and 2.3 times.

The model was subjected to the effect of three characteristic earthquakes (El Centro, 1940, Petrovac N-S, 1979 and Breginj, 1976).

This time histories were selected from the aspect of both seismic hazards and structural response, i.e., two main types of earthquakes: local (Breginj) earthquake and distant (El Centro and Petrovac) earthquakes were simulated.

The application was carried out gradually for all the three scaled time histories. The results showed that the model reached the elasticity limit at $\alpha_{\max}(\text{PGA}) = 0.17 \text{ g}$ (El Centro earthquake).

The first cracks occurred during the next step of application of the Petrovac earthquake with $\alpha_{\max}(\text{PGA}) = 0.20 \text{ g}$.

The drum suffered larger cracks and some material fell off its arches. Small cracks occurred in the bearing walls, particularly on the east and west walls that are placed in the in - plane direction of the earthquake excitation. (*See Fig. 5.27 - direction of the shaking table movement*) These manifestations observed on the model lead to the conclusion that a state of non - linear behaviour of the model started at this excitation level, i.e., conditions for occurrence of more severe damage under the next earthquake excitation levels were created. Damages to the tambour were visible. Under the applied earthquake excitation, the cracks in the main structural system (the perimeter walls and the vaults) opened and closed.

The next step was to subject the model to the time history of the El Centro earthquake with $\alpha_{\max} = 0.43 \text{ g}$ that induced severe damage to the structure (*Fig. 5.35-37*)

By analysis of the damage received (type and level), it may be concluded that the damage mechanism developed due to the loss of structural integrity and occurrence of cracks in the vaults which, in fact, represents the 'first phase' of behaviour of the model. There was also extension of the main damage to the perimeter walls (the east and the west perimeter wall) where the first cracks had been observed at the point when the model started to behave in the non-linear range.

The stretching direction of cracks presented in Figures 5.35-37 confirms the above stated facts about the type of failure with characteristic cracks of gap between 0.5 - 2.5 cm.

Considerable local damage occurred in the altar manifested by separation of the apse and large diagonal cracks running from the window to the cornices. Shear cracks and failure have not been observed in the lower parts of the bearing walls.

On the south and the north perimeter wall, there are damages around the door lintel, the cornices and the non - structural elements, whereas the walls themselves suffered only slight or negligible damage.

The observed damage, dynamic effects and occurrence of large cracks (El Centro with $\alpha_{max} = 0.43g$) lead to the conclusion that the structure behaved as a rigid body (a type of a box system) in the elastic range.

At the occurrence of the first cracks, separation of the bearing walls and increase of loads in the walls parallel to the direction of excitation took place resulting in an increase in the number and intensity of cracks in these walls.

Notable was the unexpectedly extensive damage to the drum i.e., the dome, in accordance with the excitation level, which was due to the separation of some piers of drum 'piers' from the base and disintegration of the arches and the dome. This can be concluded on the basis of the diminution of the natural frequency value (stiffness deterioration) from 11.2 Hz to 6.6 Hz.

5.9.3 Shaking table test of the damaged and strengthened church model

A. Concept and criteria

After testing of the model by which the present state of the original was simulated and observation of expected and actual damage, the model was repaired and strengthened. The repair and strengthening of the model were designed on the basis of the general principles and criteria presented in 5.7. These were the following:

A.1 In accomplishing repair and strengthening, maximum respect should be given to the original material, structural system and elements as well as maximum use of its intrinsic qualities. It is an obligation to avoid any destructive activities on the original material of the monument.

A.2 Any material used for this purpose should have identical or very similar physical, chemical, mechanical and deformability characteristics to those of the original building and establish a exact interaction behaviour. These material^s should have slightly higher strength characteristics, especially the binder, in order to resist the possible dynamic effects without additional damage to the original binding material (lime mortar).

A.3 To use the existing elements (the timber horizontal belts) of the original structure, to the best possible extent however taking into account the fact that in this case the timber belts are almost totally decayed. The existing holes are used for inserting of new strengthening elements without any destruction.

A.4 All the materials, elements and systems which are in use should have a reversible capacity so that any intervention should not necessary be the final one.

A.5 Adopting the above presented criteria and principles, and defining such safety criteria as allowed definite reparable damage to the bearing structural elements, and more severe damage to the non - structural elements, will make it possible to repair and strengthen the building successfully to withstand future stronger dynamic loads.

Repair of damage and installation of strengthening elements by previous testing of characteristics (that also had to be in accordance with the anticipated criteria) started based on the above elements.

B. Strengthening elements

B.1 Horizontal belt courses

The horizontal belt courses were incorporated into the body of the perimeter walls at three levels and into the body of the drum base formed upon the spatial vaults and pendentives.

These levels were: 0.74, 1.74 and 2.60 m from the level of the model base. The decayed timber belt courses were represented by space, each 4 h 4 cm in cross section. In each of spaces was placed a 10 mm dia reinforcing bar, terminating in a plate of 20 x 20 cm, 10 mm thick . These spaces were filled with special lime mortar based admixture. This was pre - tensioned with a force of 10 kN (1 tonne) (corresponding to a stress of 125 N/mm^2 . For experimental needs, these plates were installed on the facade itself, whereas in an actual structure, they will be incorporated into the wall mass and will be made invisible. (*Fig. 5. 38-40*)

The role of these elements incorporated in the designed space is to form a section with the corresponding masonry which will increase the resistance to the expected tensile forces, caused by the dynamic loads. This installation will increase the

synchronous performance of the perimeter walls. The horizontal belt course at the tie level, is of special importance which means to increase the strength of the bearing walls and prevents inclination of the vertical direction and collapse of the building.

For experimental needs, a semicircular element was installed on the apse by anchorage to the wall mass, at the position of the existing horizontal belt. It was visible on the facade. However, when applied in an actual structure, it is planned to be incorporated into the wall mass. (*Fig. 5.41*)

On the drum, in the zone of the existing horizontal belt course, a metal belt which was visible on the facade was installed. It had the role of a horizontal belt course and, in actual structures, it will be incorporated into the wall core. This belt will prevent the displacement and the cracks in the vertical walls (piers) of the drum. (*Fig. 5.41*)

B.2 Vertical belt courses

Vertical installations, in the perimeter walls and in the walls of the drum, consist of steel ties of 10 mm dia reinforcing bar and lime mortar mixture based filling. The steel reinforcing bars were anchored in a steel plate of 10 x10 cm, and 10 mm thick. Vertical wall elements will be pre - tensioned with a force of 15 kN (1,5 tonne) and drum vertical elements will be pre - tensioned with a force of 10 kN (1 tonne). This was aimed at increasing of axial pressure and tensile stresses.

C. Materials

To complete the composite strengthening element, a special admixture based on lime compounds was injected in the holes. It was anticipated to prepare two kinds of mixtures that were different in respect to the proportions of the aggregate and the filler - binder ratio.

For the purpose of satisfying basic characteristics of grouts with lime used as a binder, it is necessary to incorporate some additives that will improve the fluidity of the grouts and provide their necessary strength. The following additives were used for this purpose:

- An additive for accelerating the hardening process;
- An additive for plasticizing of the admixture.

Slaked lime was used as a binder, whereas the filler itself (taken from the Banjani mine) represents, in fact, a carbonate filler with the following characteristics:

- moisture content: 0.2 per cent;
- volume mass: 1.0 - 1.2 gr/cm;
- volume mass without voids: 2.7 gr/cm

From the mineralogical - petrographic aspect, the following minerals are present:

- calcite 97 - 98 per cent;
- admixtures; 2 - 3 per cent.

Used as admixtures were: dolomite, quartz and ferric hydroxide - limonite which is submicroscopically dispersed into small irregular grains which give rise to the ochre to red colour of the calcite. The filler does not contain organic admixtures.

The following additives were used for the injection admixtures:

- microsiliates -used as accelerators;
- additive - K (casein) and additive 10 used as plasticizers.

This was done to achieve efficiency in using the injection mixtures for the vertical and horizontal elements which characteristics are presented in Table 5.13. (*See app. 5, section: 5: 23*)

It should be noted that after the accomplishment of the experiment, additional investigations were carried out to invent as good as possible admixtures for repair and injection based on lime mortar and lime compounds to protect the original to the maximum extent. These admixtures were paid the greatest attention since, lime mortar and lime - based admixtures are the weakest elements in repair and strengthening.

C.1 Grouts for filling the space around the horizontal and vertical belt courses

They should have following characteristics:

- Good fluidity and slippage ability in order that they may be injected easily under injection pressure of less than 0.5 bars.
- Fast reaching of the necessary compressive strength of 2.0 - 3.0 Mpa. This is needed because the time taken using the premises of the Dynamic Testing Laboratory in IZIS, is very expensive.
- Good adhesion between the stainless steel tie and the existing materials (mortar, stone, brick) is needed. It should be higher than 0.20 Mpa.
- They should not induce crystallisation of salts upon the walls.
- They should not induce corrosion of steel ties.

C.2 The grouts used for injection of cracks should have the following characteristics:

- Good fluidity and slippage ability so that they could enable filling of cracks under low injection pressure (0.6 - 0.8 bars).
- They should be compatible with the existing materials and should not induce occurrence of salts upon the surface nor incomplete filling of gaps in the walls.
- They should not induce chemical or physical damage to fresco paintings.

C.3 Laboratory methods for testing of the grouts

All components used for the preparation of the grouts were dosed in respect to weight and the mixing was performed by usage of a dissolving mixer. The trial samples were proportioned 4 x 4 x 14 cm. and the moulds were made of steel. At their bottom, two filtering paper sheets were placed to simulate the porous structure of the wall. Considering that the grouts were of a very fluid consistency, the trial samples suffered extensive shrinkage and cracks. They were released from the moulds after 10 - 20 days.

Testing was performed by applying the standard procedure to achieve the strength characteristics using the following types of presses:

- Michaelson's press - for the bending force - β_s ;
- Hydraulic press of up to 0.4 kN - for the compressive force - β_p ;
- Shear method - press up to 4.0 kN - for the adhesion force (brick/mortar).

The fluidity of the grouts was tested in compliance with the Swiss regulations for grouts.

C.4 Results from performed test of admixtures (Table 5.14)

If we look at Table 5.14 we may conclude the following:

Comparing combinations If 1 to If 2 made with the same plasticizing additive (applied in the same quantity) and variable inorganic additives, it may be concluded that the best results regarding strength are obtained by using microsilica (If1), the microsilica - filler ratio being 1 : 1.

Trial If2 was performed by using microtufa - filler ratio of 1 : 1. In this case, the strength is lower because a larger quantity of water was used as required for this type of additive.

Although the grouts have a very fluid consistency in respect to mortars for building, it may be observed that they reach the necessary strength in the same time period. (See app. 5, section: 5.24)

C.5 Results from experimental tests of wall elements (Gavrilovic et.al. 1992)

After the performed tests of wall elements with the same characteristics (physical - chemical and mechanical) and the model, the repair grouts were injected under gravity pressure.

Prior to using them, the admixtures were tested on elements proportioned 4 x 4 x 16 cm. In these tests, mixture 'Grout If3' with a filler - lime ratio of 1 : 1 and W/L - 0.05 was used. As a plasticiser in two percent 'additive -10' was used. Ten percent of micro silica was also added to the whole mixture. These were used for elements ETA-1 and ETA-3.

Testing was carried out after 15 days and the following mechanical characteristics were obtained:

$$\begin{aligned} \text{If3- } \gamma &= 1606 \text{ gr/cm}^3 \\ \beta_s &= 1.95 \text{ Mpa} \end{aligned}$$

$$\beta_p = 4.5 \text{ Mpa}$$

For the wall element ETA-2 was used a mixture with additive - K used as a plasticizer. The amount of plasticizer was two-per cent, whereas that of used microsilica was ten per cent. The filler-binder ratio was 1 : 1. The same mixture was prepared with $W/K = 0.36$. After 15 days, it had the following characteristics:

$$I_{k2} \quad \gamma = 1242 \text{ gr/cm}^3$$

$$\beta_s = 0.275 \text{ Mpa}$$

$$\beta_p = 1.3 \text{ Mpa}$$

After injection of the three wall elements with the above mentioned mixtures and a period of 15 days, tests were performed and the following results were obtained:

Wall element ETA 1 R (Repaired - WAC 1, non - strengthened wall element)

1. The obtained results point to considerably higher axial stresses than those recorded for the non-repaired element:

- - Occurrence of the first cracks took place at $\sigma_{o,max} = 182 \text{ kPa}$.
- - Maximum stress $\sigma_{o,max} = P_{max}/f = 167\text{kN}/0.243 \text{ m}^2 = 685 \text{ kPa}$

If these results are compared to those obtained for the non - strengthened element, an improvement of almost 100 per cent can be noticed.

Wall element ETA 2 R (Repaired 2 non - strengthened wall element)

It should be noted that better characteristics were obtained also for this element. Regarding the compressive strength, this improvement amounted to about seventy per cent.

Wall element ETA 3 R (Repaired WSC non - strengthened wall element)

This element was subjected to shear compression test. The following results were obtained:

- - $\sigma_{o,max} = \hat{\tau}_{max} = 55 \text{ kPa}$

- - Tensile strength $F_t = 34 \text{ kPa}$

The comparison of the results from the experiments on the non - strengthened and the strengthened wall elements, are presented at Table 5.15, show improvement of the shear and tensile resistance achieved by injection of admixtures which contributes to the stabilisation of the wall mass, which is one of the main goals of the thesis.

(Fig. 5.42a)

D. Repair and strengthening of damaged model

After the performed experiments and for the purpose of defining the elements of repair and strengthening, the repair and strengthening of the damaged model was started.

The model was prepared for treatment by removal of debris from damaged parts. Particular attention was paid to removal of dust (dry treatment - because of the danger of damaging the frescoes in reality) both from the cracks in the walls and the bearing elements as well as from the voids where the horizontal and vertical strengthening elements had to be installed.

All the cracks were sealed on the surface with a fast - setting mortar . On the vaults and the dome cracks were superficially closed with a binding mixtures with past - setting admixtures with sufficient strength to prevent the flowing out of the injected mixture.

The injection started at the position of the first horizontal belt, then the second and the third. (Fig. 5.43a)

For injection of the voids in the horizontal and vertical strengthening elements, the injection compression ranged between 1.2 to 1.6 atmospheres, whereas for the injection of the cracks, a force of 0.6 to 1.2 atm. was applied. The whole process lasted four working days. (Fig. 5.44a-d)

E. Shaking table test results

After completing the repair and strengthening process, the activities for definition of the dynamic characteristics of the repaired model started by applying the available equipment for ambient, forced and random vibration.

For the repaired model, a frequency of $f = 10.8 - 11.1$ Hz and $\sigma = 1.8$ per cent were obtained.

From the comparison of the results obtained for the repaired and the non-strengthened model, it could be concluded that the repair and strengthening of damaged model slightly increased the model stiffness, however, the main dynamic model remained unchanged.

The structural response of the strengthened model tested under El Centro earthquake with $\alpha_{\max} = 0.17$ g and Petrovac with $\alpha_{\max} = 0.20$ g, points to a significantly different behaviour in respect to crack occurrence and maximum ground acceleration and displacement values.

Under gradual increase of the acceleration level of up to 0.40 g (Petrovac), 0.33 g (El Centro) and 0.37 g (Breginj) it is concluded from the behaviour of the repaired model that the non-linear state starts after this level. Compared to the effects of the same time histories of earthquakes applied on the non-strengthened model, it is concluded that the level of elasticity or linearity limit is increased by about hundred per cent.

In order to obtain the stages of non-linear behaviour and estimate the damage level for higher expected earthquake effects, the following tests were carried out applying the El Centro earthquake with a gradual amplitude increase of $\alpha_{\max} = 0.49$ g. However cracks in bearing walls, drum arches and damage to the dome occurred. (Fig. 5.45-47)

For this acceleration level, the damage level could be characterised by some damage to non-structural elements and in the upper part of the structure. Small cracks in the bearing walls, were noticed, but stability of the complete building was preserved.

The next step was to expose the model to the increasing acceleration of the Breginj earthquake with $\alpha_{\max} = 0.75$ g. However the failure mechanism and damage were not qualitatively changed and opening of these cracks took place. In fact, this acceleration level corresponds to the maximum expected earthquake for which the repair of the building was designed.

Comparison of the levels of maximum applied effects on the original model which is $\alpha_{\max} = 0.43$ g and the strengthened model with $\alpha_{\max} = 0.75$ g shows that the damage of the repaired model is considerably smaller under almost a double excitation.

It is also concluded that there is a significant difference in the type of failure in the load carrying walls of the structure. Namely, there is no separation and vertical

cracks in the wall and the vaults, which points to the significant role of horizontal belts (ties), i.e., the type of failure is transformed into a higher level of a "box system", and in the final stage, it is characterised by occurrence of diagonal shear cracks.

In order to collect data about higher damage level of the damaged model, the El Centro earthquake was applied with $\alpha_{\max} = 0.54$ g. For this level, as expected there was concentration of large cracks in the west wall. The overall stability of the building was not affected and the experienced damage level was not beyond repair.

Considering the fact that these accelerations correspond to the maximum credible earthquake with a return period of 1,000 years, the involved protection level of the building justifies the basic concept of seismic strengthening of this type of building.

E Comparative analyses of original and damaged original strengthened model of the church

If the results on the dynamic characteristics of both the models (the original and the strengthened one) are analysed, it may be concluded that, in the case of the strengthened model, there is a slight increase in stiffness.

If we talk about the structural response of the original and the strengthened model, it is evident that under the same acceleration level ($\alpha_{\max} = 0.20$ g), the first crack occurred in the original model was not observed in the strengthened one.

Under an increased acceleration level ($\alpha_{\max} = 0.43$ g), large cracks occur in the original model which is the maximum possible loading for this model. At this acceleration level, the strengthened model starts to behave in plastic deformation stage - first cracks.

When the strengthened model was tested under the maximum expected earthquake (Breginj $\alpha_{\max} = 0.75$), it still had a sufficient capacity to sustain damage that could lead to collapse of the structure. At this point, noteworthy is the way the horizontal and the additional vertical strengthening elements begin to have effect.

While making this comparison, it must be emphasised that high amplification values of acceleration were obtained for the main structure (main vaults) in both the original and the strengthened model. Due to damage to this zone, an even higher amplification takes place in the dome but still ^{it did} not collapse. (Fig. 49-50)

Based on the experimental results obtained for the original (EXIST) and strengthened (STR) model, the shear force - relative deformation relationship was obtained for the two characteristic levels (the principle structure - level 1 and the drum

structure - the top) under different intensities of El Centro and Petrovac earthquakes.

(Fig. 5.51-52)

These diagrams showing the stiffness degradation of the model structure provide an insight into the ranges of its dynamic response. Two ranges of dynamic response are distinguished for the model (EXIST), i.e., elastic and non-linear range, while in the case of the model (STR), three ranges are evident: elastic, non-linear and ultimate range with evident stiffness degradation and occurrence of large non-linear deformations.

The relationships between the value of the input and output displacement are shown on Figures 5.53-56. It is evident that for the same input acceleration the dynamic behaviour of the original model is more intensive and that bearing and deformability capacity of strengthened model (STR) is higher than in the original model (EXIST).

Applying modelling by concentrated masses which assumes concentration of the distributed structural characteristics at two characteristics levels (top and level 1), a non-linear dynamic analysis was performed by applying a corresponding hysteretic model, *(Fig. 5.57)* which considers the stiffness degradation also after reaching the ultimate deformations in reversible loading. Its main characteristics are:

1. Including of the post-ultimate range U - M which enables analysis of elements (structures) that have suffered considerable damage but not failure.
2. Including of the M - F range which enables modelling of the states close to failure where there is an increase in deformations without an increase in force.
3. Including of S point which takes into account the variation in stiffness under reversible load, i.e., enables modelling of the effects of sliding and loss of adhesion.

Modelling by using this hysteretic model can be characterised by successful description of the behaviour of the church model in all characteristic phases: the elastic (no cracks); the non-linear (occurrence of cracks) and the range of large deformations, sliding and failure. *(Fig. 5.57)*

Chapter five - Notes

- ¹ Both the cement and the bitumen are impermeable and do not allow side moistening of the wall but at the same time these materials do not allow also evaporation of the capillary moisture from the wall whereby it increases after conservation works.
- ² Article 3 of this code states the objectives of protection of cultural monuments.
- ³ For each structure it is prescribed.
- ⁴ This paragraph is based on the Instructions that for each cultural monument, there must be a complete file containing all relevant elements. Its author is the author of this dissertation, who was nominated (in 1977) as the first head of the then existing Bureau of Documentation which is now called - the INDOK Centre.
- ⁵ This fifth *corpus* represents the base for keeping samples of materials originating from the monument that were subjected to different experimental-research tests.
- ⁶ One of the main endeavours of the author of this dissertation is establishment of a List of Priority Tasks.
- ⁷ Knowing the importance of this, the author, as a President of the Macedonian National Committee of ICOMOS, in co-operation with Dr. Sultan Barakat - Director of PRDU, IOAAS, the University of York, with co-operation of the Macedonian National Committee of IDNDR and US / ICOMOS National Committee with the financial support of the Getty Grant programme, the Ministry of Culture of the Republic of Macedonia and Open Society Institute - Macedonia organised a Regional Workshop on "Integrating Cultural Heritage into National Disaster Planning, Mitigation and Relief" in September 1997. The workshop was attended by ICOMOS and IDNDR representatives from 23 countries of Central and Southeast Europe as well as observers from seven neighbouring countries (a total of thirty countries, or ¾ of the number of European states).
- ⁸ The results of this doctoral dissertation should contribute to definition of the basic parameters and criteria for treatment of an immovable cultural monument in the period of its conservation, repair and strengthening.
- ⁹ The author proposed a Programme for a research project entitled: "Development of a Methodology in Order to Create a Data Bank for Structures of Cultural Heritage in Seismic Prone Regions" that was financially supported by the Ministry of Culture of the Republic of Macedonia and UNESCO. At the Regional Workshop which will be held in 1999, the Model of Contact Identification Card - CIC and its possible application as a unified proposal for the countries in the Balkan and Mediterranean region will be evaluated.
- ¹⁰ Macroseismic maps of Macedonia, have been elaborated based on the Book of Regulations on the Technical Norms for Construction of High - Risk in the Republic of Macedonia. In it was no word about treatment of buildings belonging to cultural heritage.
- ¹¹ The author of this dissertation was delegated as RZZSK representative.
- ¹² The Course was organised by the Institute of Earthquake Engineering and Engineering Seismology - IZIIS, University "St. Cyril and Methodius" and ICCROM, with full financial support of UNESCO. At the end of the Course, Recommendations - Skopje 85 were adopted. The Proceedings of the Course were also published. Author was a participant with two presentations.
- ¹³ It was organised by (ANIACAP), Rome - Italy, (IZIIS), University "St. Cyril and Methodius", Skopje - Macedonia, (CTC), Algiers, Algeria and UNESCO - Paris. The Proceedings of the Conference were published. The author participated as representative of his institution.
- ¹⁴ It was organised by IZIIS - Skopje, RZZSK - Skopje and ICCROM - Rome and was fully financially supported by UNESCO. (17-22 October 1988). The author of this dissertation actively participated in the seminar by presentation of three papers. He was Chairman of the Seminar Organising Committee. The Proceedings of the Seminar were published.

¹⁵ The document contains definitions of the following criteria: **a) Effectiveness:** The intervention should be effective, and its effectiveness should be demonstrated by qualitative and quantitative proofs; **b) Compatibility:** The intervention should be compatible with the original structure and its materials from the chemical, mechanical, technological and architectural point of view; **c) Durability:** The intervention should be carried out using materials and techniques the durability of which has been demonstrated to be comparable to that of the other materials of the building. A less durable intervention is accepted if a periodic replacement is foreseen; **d) Reversibility:** The intervention should be as reversible as possible, so that it can be removed if a different decision is made in the future.

¹⁶ The maximum number of visitors - believers is during the feast of the saint once each year.

¹⁷ There is a certain reason why the elements of the methods, structures and materials used for repair of damaged structures in Skopje, Dubrovnik and Kotor have been taken for definition of these two basic treatments.

¹⁸ Definition supported mostly by B. M. Feilden. The basis of this attitude represents adequate preventive preservation of historic buildings for improvement of their earthquake resistance capacity. The presupposition is that structural system within one building should not be mixed .

¹⁹ In the course of 1990-91, the author of this dissertation was head of the team for elaboration of a project for conservation and presentation of the church.

²⁰ From the architectural aspects and the aspect of the silhouette of the building, the height and the appearance of the drum underwent some changes. In the beginning, it was lower and more massive, becoming elongated in the course of time.

²¹ This difference was noticed during the long years of author's experience with Byzantine churches. It could be explained this by the fact that the south and the west facade are always much more exposed to sun rays than the north and the east one. Hence the amplitude of the temperature variations is more pronounced.

²² After the Skopje earthquake of 1963, in the period of construction of new buildings, this system was applied in two important public buildings: the primary school "Pestaloci" and the new railway station with the track zone of the station. Planning of activities for testing of the bearing characteristics and the state of installation incorporated into the primary school "Pestaloci" is underway.

Chapter five - Tables**Table 5.1** *Review of intensities of earthquake effect at the sites of the selected churches in the period 1900-1990*

Church location	Earthquake date	M	h (km)	I ₀ (MCS)	I ₁₀₀ (MCS)	Rep (km)	Epicentral zone
St. Nikita village Banjani Skopje	1555	-	-	8-9	7-8	5-10	Skopje
	04.04.1904	7.1	30	9-10	6	140	Pehcevo
	04.04.1904	7.8	40	10	7	147	Kresna
	24.10.1905	5.0	19	6-7	6	35	Kumanovo
	09.04.1920	4.6	14	6	6	18	Kumanovo
	10.08.1921	5.7	20	8-9	7.75	21	Kacanik
	07.11.1921	4.4	8	6	6	2	Skopje
	12.03.1960	5.7	6	8	6	45	Tetovo
	26.03.1963	6.1	13	8-9	7-8	12	Skopje
St. Bogorodica village Matejce Kumanovo	1555	-	-	8-9	7	5-10	Skopje
	04.04.1904	7.1	30	9-10	6	124	Pehcevo
	04.04.1904	7.8	40	10	7	132	Kresna
	24.10.1905	5.0	19	6-7	6	20	Kumanovo
	09.04.1920	4.6	14	6	6	3	Kumanovo
	10.08.1921	5.7	20	8-9	7	25	Kacanik
	07.11.1921	4.4	8	6	6	13	Skopje
	12.03.1960	5.7	6	8	6	60	Tetovo
	26.07.1963	6.1	13	8-9	7	18	Skopje
St. Nikola village Psaca Kriva Palanka	1555	-	-	8-9	6	55	Skopje
	04.04.1904	7.1	30	10	7	75	Pehcevo
	04.04.1904	7.8	40	10	8	83	Kresna
	24.10.1905	5.0	19	6-7	6	27	Kumanovo
	08.10.1906	6.4	19	8	6	83	Kresna
	26.07.1963	6.1	13	8-9	6	70	Skopje
St. Bogorodica Zaumska village Trpejca Ohrid	04.04.1904	7.8	40	10	6	215	Kresna
	28.09.1906	6.0	20	8	8	8	Ohrid
	18.02.1911	6.7	15	9	9	6	Ohrid
	13.02.1912	6.0	16	8-9	7-8	23	Ohrid
	28.01.1931	5.8	12	9	6-7	40	Korca
	15.03.1958	5.3	16	7	6	35	Prespa
	26.05.1960	6.4	13	8-9	7	40	Korca
	17.09.1962	4.4	9	6	6	17	Ohrid
	09.12.1964	4.5	11	7	6-7	18	Ohrid
	30.11.1967	6.6	17	9	7	59	Debar

Source: Stojkovic et al. Volume 7 (1992: 6)

Table 5.2 *Review of more significant sources and the strongest past earthquakes related to these sources*

Seismic sources	Data	Time (GMT)	Coordinates	M	H km	I (MCS)
Skopje	26.07.1963	04h50m	42.0 21.4	6.1	13	8-9
Tetovo	12.03.1960	11h54m	41.9 21.9	5.7	6	8
Debar	30.11.1967	07h23m	41.4 20.4	6.6	17	9
Ohrid	18.02.1911	21h35m	40.9 20.8	6.7	15	9
Valandovo	08.03.1931	01h50m	41.3 22.5	6.7	16	10
Pehcevo-Kresna	04.04.1904	10h25m	41.8 23.1	7.8	40	10
Titov Veles	14.09.1922	16h37m	41.7 21.4	5.5	15	7-8
Kicevo - Krusevo	21.10.1988	02h18m	41.3 21.0	4.4	9	6-7
Bitola - Florina	14.09.1920	02h09m	41.0 21.4	5.3	18	7
Mrezica - Edesa	09.07.1955	23h53m	40.9 22.1	5.1	6	7-8

Source: Stojkovic et al. Volume 7 (1992: 7)

Table 5.3 *Selected information about the dynamic physical-mechanical characteristic of the geotechnical media*

Geotechnical medium (Lithological structure)	Thickness h(m)	Vp (m/s)	Vs (m/s)	(kN/m ³)
St. Nikita				
• Alluvial clay with detritus	2.5	470	175	17
• Palaeozoic biotite muscovite shells (disintegrated and argillaceous)	10.0	1,550	640	21.5
• Palaeozoic biotite muscovite shells (compacted)	Seismic subsoil	3,450	1,530	26.0
St. Bogorodica, v. Matejce				
• Surface loose layer-diluvial clay and detritus	3.0	425	190	17.0
• Diluvial clay with detritus	12.0-15.0	765	365	19.0
• Palaeozoic sericite phylite shells (disintegrated)				
North side	17.0	1,100	560	20.5
South side	28.0	2,200	2,030	23.0
• Palaeozoic sericite phylite shells (compact)	seismic subsoil	3,750	1,890	26.5
St. Nikola				
• Surface loose layer-diluvial clay with detritus	2.0	510	195	16.5
• Diluvial clay with detritus	8.0	1,040	400	18.5
• Palaeozoic shells, disintegrated and argillaceous	25.0	1,460	560	20.0
• Paleozoic shells (compact)	seismic subsoil	4,080	1,960	26.5
St. Bogorodica Zahumska				
• Lacustrine and marshy sands and gravel	2.0	375	125	16.0
• Triassic limestone, disintegrated with clay in the cracks	7.0	1,750	455	20.0
• Triassic massive limestone (compact)	seismic subsoil	4,350	2,400	27.0

Sources: Stojkovic et al. Volume 7 (1992: 17, 19, 21, 23)

Table 5.4 Maximum ground accelerations (a_{cc}) and seismic intensities (I) for the St. Nikita church, v. Banjani

Seismic influence exerted by:		Return period of t_p (years)						
		25	50	100	200	500	1,000	10,000
Local foci R < 40 km Skopje	a_{cc}	0.064	0.097	0.142	0.198	0.292	0.340	0.360
	I	6.19	6.79	7.34	7.82	8.38	8.60	8.68
Local foci R < 40 km Skopje and Kacanik	a_{cc}	0.089	0.117	0.146	0.198	0.292	0.340	0.360
	I	6.66	7.06	7.36	7.82	8.38	8.60	8.68
Adjacent foci R > 40 km	a_{cc}	0.060	0.076	0.86	0.090	0.097	0.100	0.100
	I	6.09	6.43	6.61	6.68	6.79	6.83	6.83
All foci	a_{cc}	0.093	0.117	0.146	0.198	0.292	0.340	0.360
	I	6.73	7.07	7.36	7.82	8.38	8.60	8.68

Source: Stojkovic et al. Volume 7 (1992: 55)

Table 5.5 Maximum ground acceleration (a_{cc}) and seismic intensities (I) for return period of fifty, two hundred and five hundred years for the selected structures

Name of the church	Seismic influence exerted by	a_{cc} I	Return period of t_p (years)		
			50	200	500
St. Bogorodica v. Matejce	Local foci R < 40 km Skopje	a_{cc} I	0.107 6.93	0.233 8.05	0.293 8.38
	Local foci R < 40 km Skoje and Kacanik	a_{cc} I	0.133 7.24	0.233 8.05	0.293 8.38
	Adjacent foci R > 40 km	a_{cc} I	0.103 6.87	0.137 7.28	0.140 7.32
	All foci	a_{cc} I	0.140 7.32	0.233 8.05	0.293 8.38
St. Nikola, v. Psaca	All adjacent foci	a_{cc} I	0.143 7.35	0.191 7.76	0.204 7.86
St. Bogorodica Zahumska	Local foci R < 40 km	a_{cc} I	0.202 7.84	0.268 8.25	0.320 8.51
	Adjacent foci R > 40 km	a_{cc} I	0.202 7.84	0.268 8.25	0.320 8.51
	All foci	a_{cc} I	0.202 7.84	0.268 8.25	0.320 8.51

Source: Stojkovic et al. Volume 7 (1992: 56-57)

Table 5.6 Dynamic characteristics obtained by using ambient vibration techniques for the selected structures

Direction	St. Nikita		St. Bogorodica Zaumska		St. Nikola		St. Bogorodica Matejce	
	Natural frequency (Hz)	Damping %	Natural frequency (Hz)	Damping %	Natural frequency (Hz)	Damping %	Natural frequency (Hz)	Damping %
E-W	6.0	3.2	6.0	1.5	5.4	6.5	4.4	2.7
N-S	4.0	4.0	4.6	2.2	4.0	8.3	3.4	4.9
Torsion	8.0	2.1	8.2	2.5	6.4	5.2	5.8	1.5

Table 5.7 *Ductility ($m = s_{max}/s_y$) for different earthquakes and different input accelerations*

Earthquake	$a_{max} = 12 \%$	$a_{max} = 20 \%$	$a_{max} = 29 \%$	$a_{max} = 36 \%$
Petrovac	1.04	1.64	2.49	4.80
El Centro	1.01	1.53	2.22	2.58

Source: Gavrilovic, Volume 10 (1992: 33)

Table 5.8 *Physical - chemical characteristics of masonry mortar for building and filling the joints*

	Characteristics	sample 1	sample 2
1.	Loss on burning	22.01 %	26.25 %
2.	Undissolved residue	39.90 %	54.02 %
3.	CaO	22.24 %	16.64 %
4.	MgO	11.88 %	11.08 %
5.	R2O3	1.72 %	2.06 %
6.	Crushed brick	(+)	(+)
7.	Straw	(-)	(-)
8.	Proteins	(+)	(+)
9.	Binder-filler ratio	1 : 1.80	1 : 3

Source: Staniseva, Volume 10 (1992:10)

Table 5.9 *Mechanical characteristics of the built - in materials*

Material	Specific gravity KN/m ³	Compressive strength fc(MPa)	Shear strength fs(MPa)	Bending strength fb(MPa)
Tuff	19.00	13.95	0.145	-
Brick	15.30	31.00	-	5.0
Mortar	18.10	1.34	0.102	-

Source: Institute Macedonia, Volume 10 (1992: 13)

Table 5.10 *Physical quantities in model analysis of problems related to dynamics of structure*

Physical quantity	Indication	Dimensions
1. Length, displacement	l, x	L
2. Velocity	v	LT^{-1}
3. Acceleration	a, g	LT^{-2}
4. Time	t	T
5. Frequency	f	T^{-1}
6. Mass	m	M
7. Force, weight	P, G	MLT^{-2}
8. Moment of force	M	ML^2T^{-2}
9. Mass density	r	ML^{-3}
10. Stress	s, t	$ML^{-1}T^{-2}$
11. Deformation	e, g	
12. Modulus of elasticity, shear modulus	E, G	$ML^{-1}T^{-2}$
13. Poisson's coefficient	n	
14. Damping coefficient	m	
15. Moment of inertia	I, F	L^4, L^2

Source: (Gavrilovic - Volume 10)

Table 5.11 *Mechanical characteristics of the materials used for the construction of the model*

Materials used for the model	g $kN m^3$	Compressive strength f_c (MPa)	Bending capacity f_b (Mpa)	Shear strength f_s (MPa)
Mortar	17.00	0.11	0.09	-
Tuff stone	16.50	7.30	-	0.075
Brick	18.50	21.30	4.70	-

Source: Institute Macedonia - Volume 10 (1992)

Table 5.12 Main characteristics of the model and the prototype

No.	Characteristic	Unit of measurement	Prototype X_p	Model X_m	X_p / X_m	Designed scale
1.	Proportion at plan total length/total width	m	11.4x7.40	4.15x2.80	2.75	2.75
2.	Total height	m	12.46	4.50	2.76	2.75
3.	Total volume	m ³	270	11.60	23.2	2.75 ³ =20.8
4.	Bulk density	kN/m ³	17.29	17.80	0.97	1
5.	Total weight	kN	4,670	2.02	23.1	2.75 ² =7.56
6.	Tambour area	m ²	5.56	0.76	7.31	2.75 ² =7.56
	Wall area at plan	m ²	30.30	3.90	7.76	2.75 ² =7.56
7.	-Average s_o at the tambour level	kN/m ²	87.00	89.00	0.98	1
	-Average s_o for the walls	kN/m ²	116.00	110.00	1.05	1
8.	Total mass	kN.s ² /m	476	20.2	23.2	2.75 ³ =20.8
9.	Elasticity modulus E	kN/m ²	680,000	650,000	1.05	1
10.	Compressive strength f_c					
	- Mortar	Mpa	1.34	0.55	2.40	1
	- Tuff stone	Mpa	13.95	7.30	1.90	1
	- Brick	MPa	31.00	21.30	1.45	1
11.	Shear strength					
	- Tuff stone	Mpa	0.54	0.075	1.90	1
	- Mortar	MPa	0.102	-	-	1
12.	Bending capacity					
	- Brick	Mpa	5.0	4.70	1.06	1
	- Mortar	Mpa	-	0.30	-	1
13.	Frequency content in N-S direction	Hz	4.8	11.2	0.42	1/2.75=0.36

Source: Gavrilovic/Sumanov Volume 10 (1992: 55)

Table 5.13 Characteristics of injection grouts emulsions

Mass type	Components	% per kg. mixture	Press. in %	v/c	7 days g	7 days bs	7 days bp	14 days g	14 days bs	14 days bp
Mixture in belt	- Usjema	100.00	58.70	/	/	/	/	/	/	/
	- Filler Banjani	30.00	17.60	/	1700	/	3.66	1680	1.69	5.73
	- Superfluid	0.40	0.24	0.40	/	/	/	/	/	/
	- Water	40.00	23.46	/	/	/	/	/	/	/
Mixture for cracks	- Usjema	125.00	44.30	/	/	/	/	/	/	/
	- Filler Banjani	17.00	6.00	/	/	/	/	/	/	/
	- Super plasticisers	0.40	0.14	/	/	/	/	/	/	/
	- Lime fluid	90.00	/	0.94	/	/	/	/	/	/
	- Lime:water 1 : 3	22.5:67.5	8.00	/	1367	/	/	1074	0.39	0.78
	- Water	50.00	41.60	/	/	/	/	/	/	/

Source: Trajkovska, Volume (1992)

Table 5.14 Grouts

Label	Date of preparation	Dose	W/ lime with H ₂ O	W/ lime	P Flow l/sec	P Flow after 50'	Crushed on 8.06.94			Crushed on 12.09.94		Crushed on 12.10.94.		τ after 5 m. MPa
							γ g/cm ³	β_s MPa	β_p MPa	γ g/cm ³	β_p MPa	γ g/cm ³	β_p MPa	
If1 F.M = 1:1	31.03.94	2-10	0.20	1.40	10"	13"	1.34	0.68	22.5	1.34	22.4	1.30	22.40	/
If2 T F = 1:1	31.03.94	2-10	0.38	1.77	10"	12"	0.78	0.13	1.88	/	2.5	0.80	3.58	/
If3 F L = 1:1	31.03.94	2-10	0.07	1.13	9"	10"	1.25	1.76	3.25	1.21	4.1	1.20	6.81	/
If4 F.M = 1:1	18.04.94	2-10	0.02	1.04	/	/	1.64	2.38	34.4	1.60	38.8	1.54	38.50	0.117
If5 F.M = 7.3	20.04.94	2-10	0.04	1.08	/	/	1.66	2.33	32.08	/	30.4	1.65	31.90	0.106
If6 F:M = 8.5 1.5	18.04.94	2-10	0.14	1.28	/	/	1.53	/	21.3	1.56	20.	1.56	22.15	0.192
If7 F L = 1:1	18.04.94	2-10	0.005	1.01	/	/	1.55	/	4.06	/	7.8	1.56	7.86	0.465
Ik1 F M = 1:1	31.03.94	2-k	0.73	2.46	11"	12"	/	/	/	/	/	/	/	/
Ik2 F.L = 1:1	31.03.94	2-k	0.17	1.33	12"	12"	1.53	1.80	3.25	1.23	7.8	/	/	/
Ik3 F.L = 1:1	20.04.94	2-k	0.05	1.10	/	/	1.26	1.45	3.28	1.27	8.3	/	/	0.487

τ - adhesion force

p - flow of mass per unit time

Source: Volume 11, Trajkovska et. al. 1994

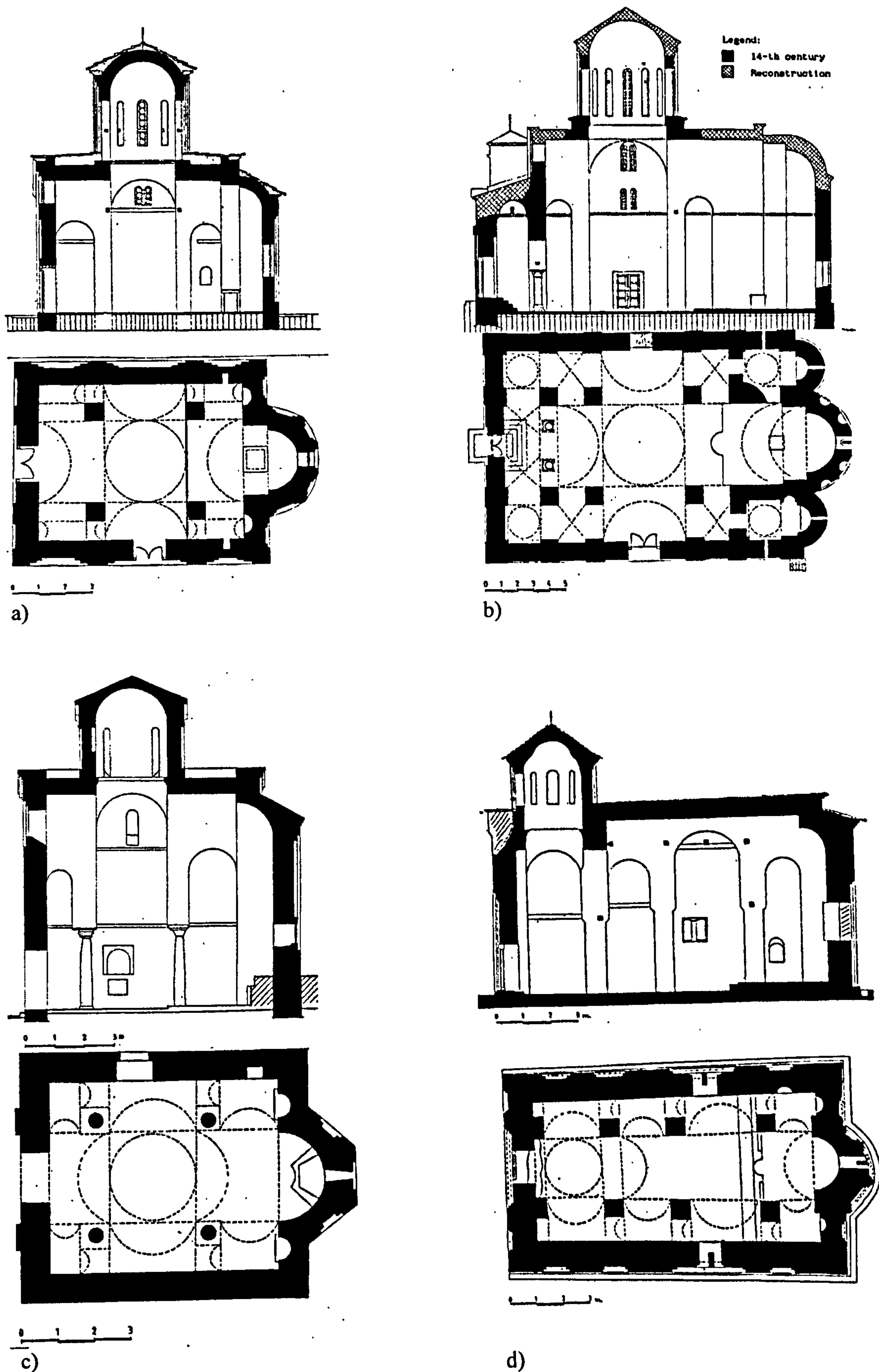

Figure 5.1 a) - *St. Nikita, v. Banjani*; b) - *St. Bogorodica, v. Matejce*;
 c) - *St. Bogorodica Zaumska, v. Trpejca*; d) - *St. Nikola, v. Psaca*



a)



b)

Figure 5.2 a) - St. Nikita, v. Banjani; b) - St. Bogorodica, v. Matejce;

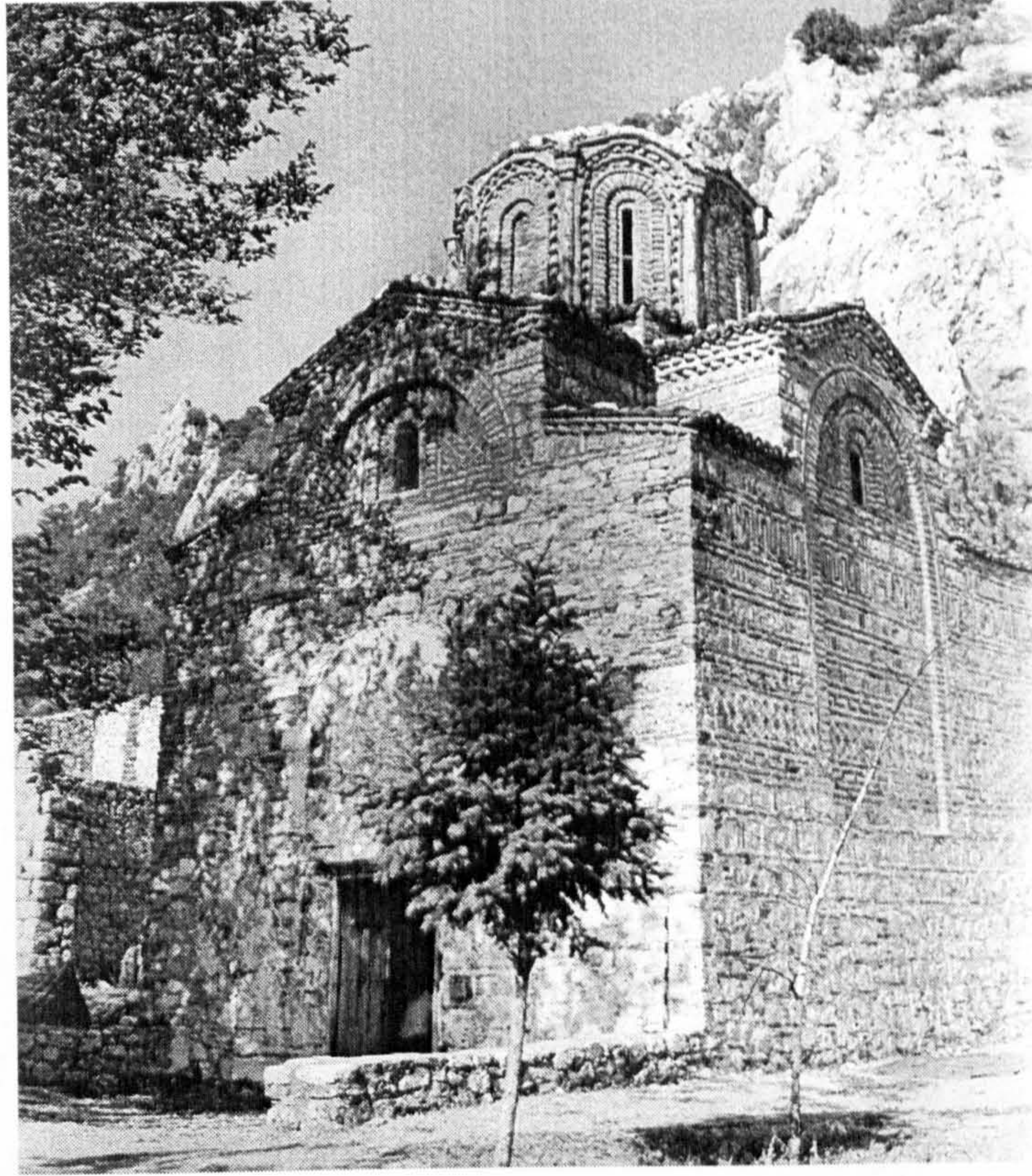

c)

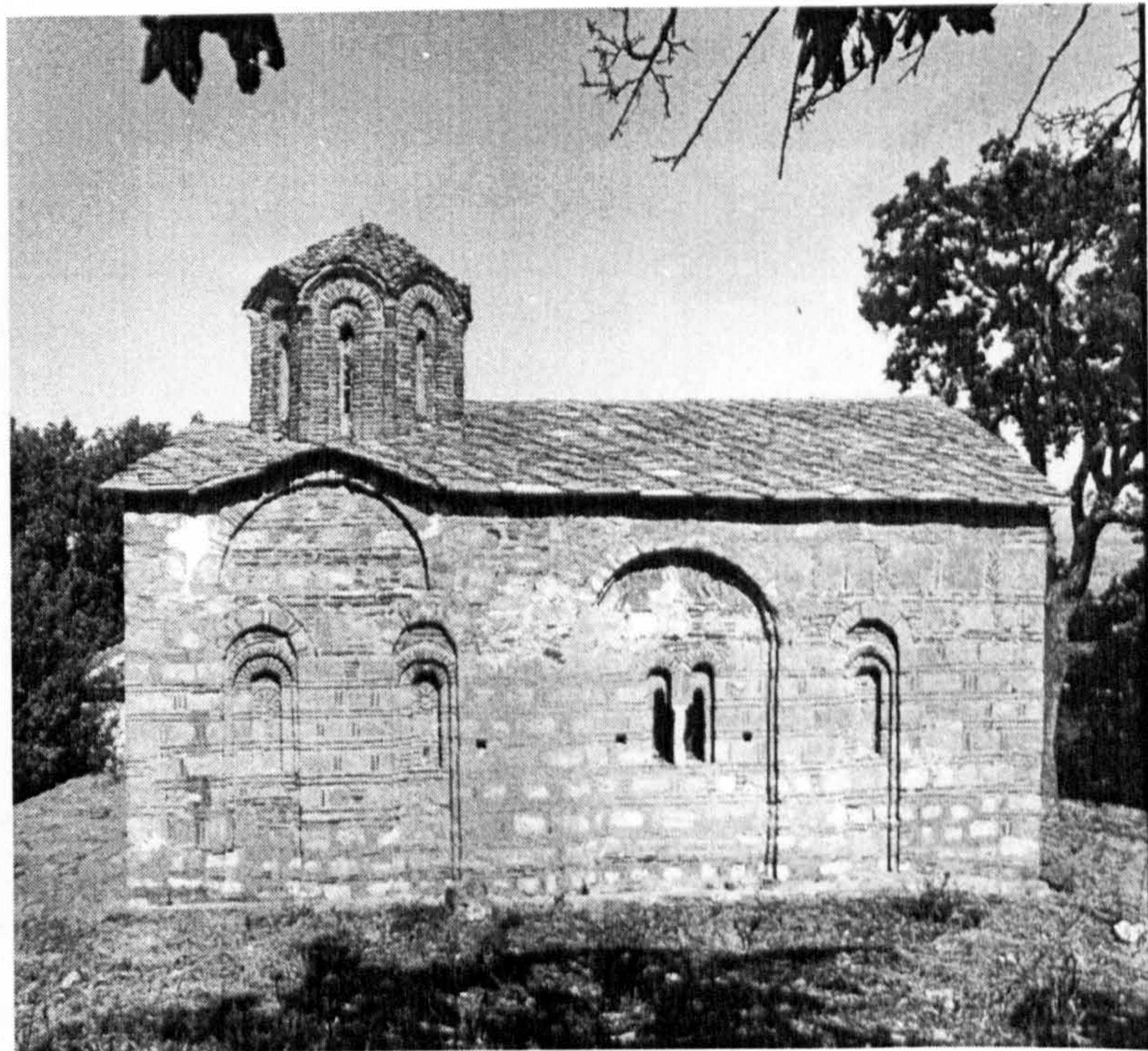

d)

Figure 5.2 c) St. Bogorodica Zahumska; d) - St. Nikola, v. Psaca.

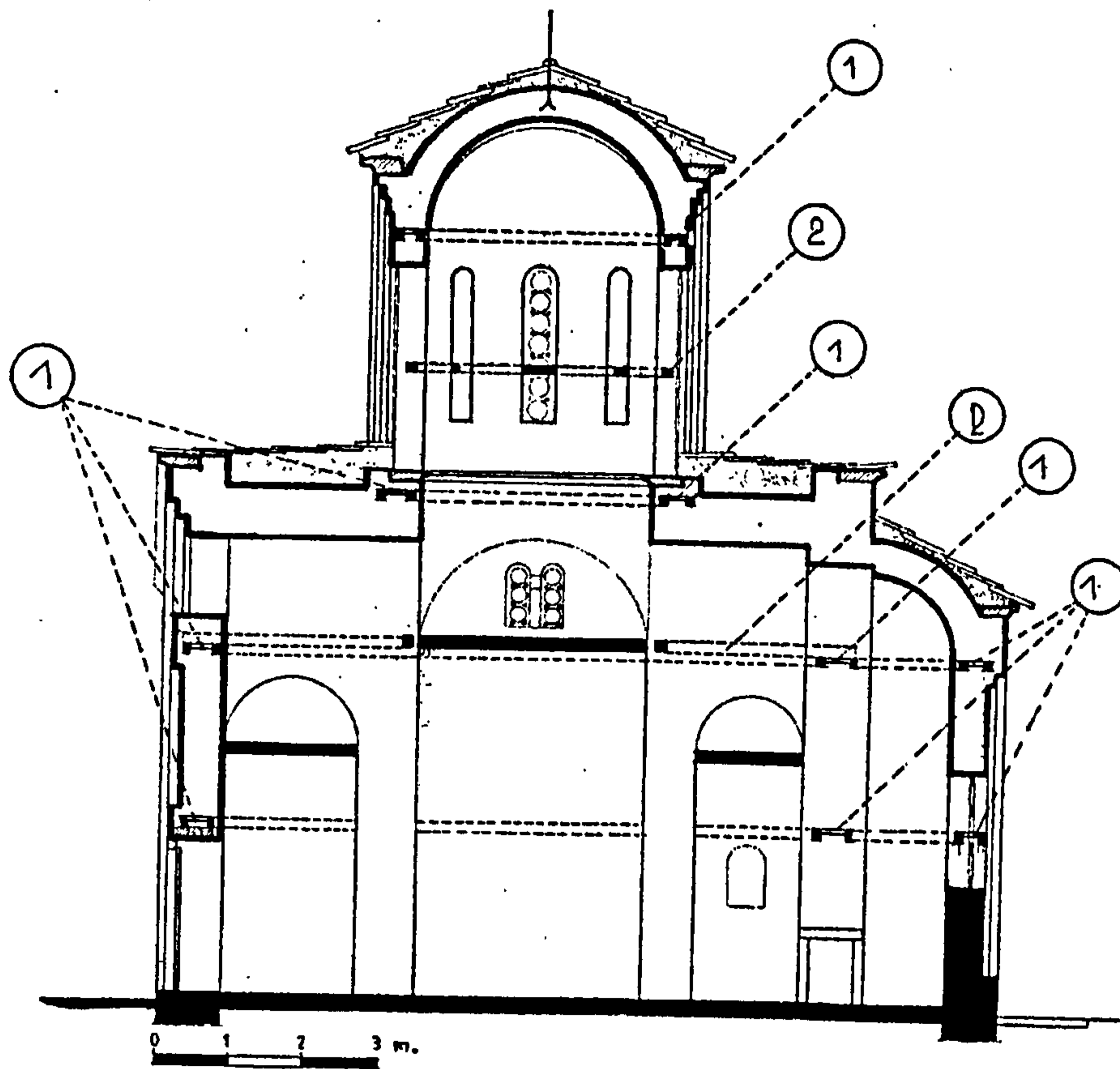

a)

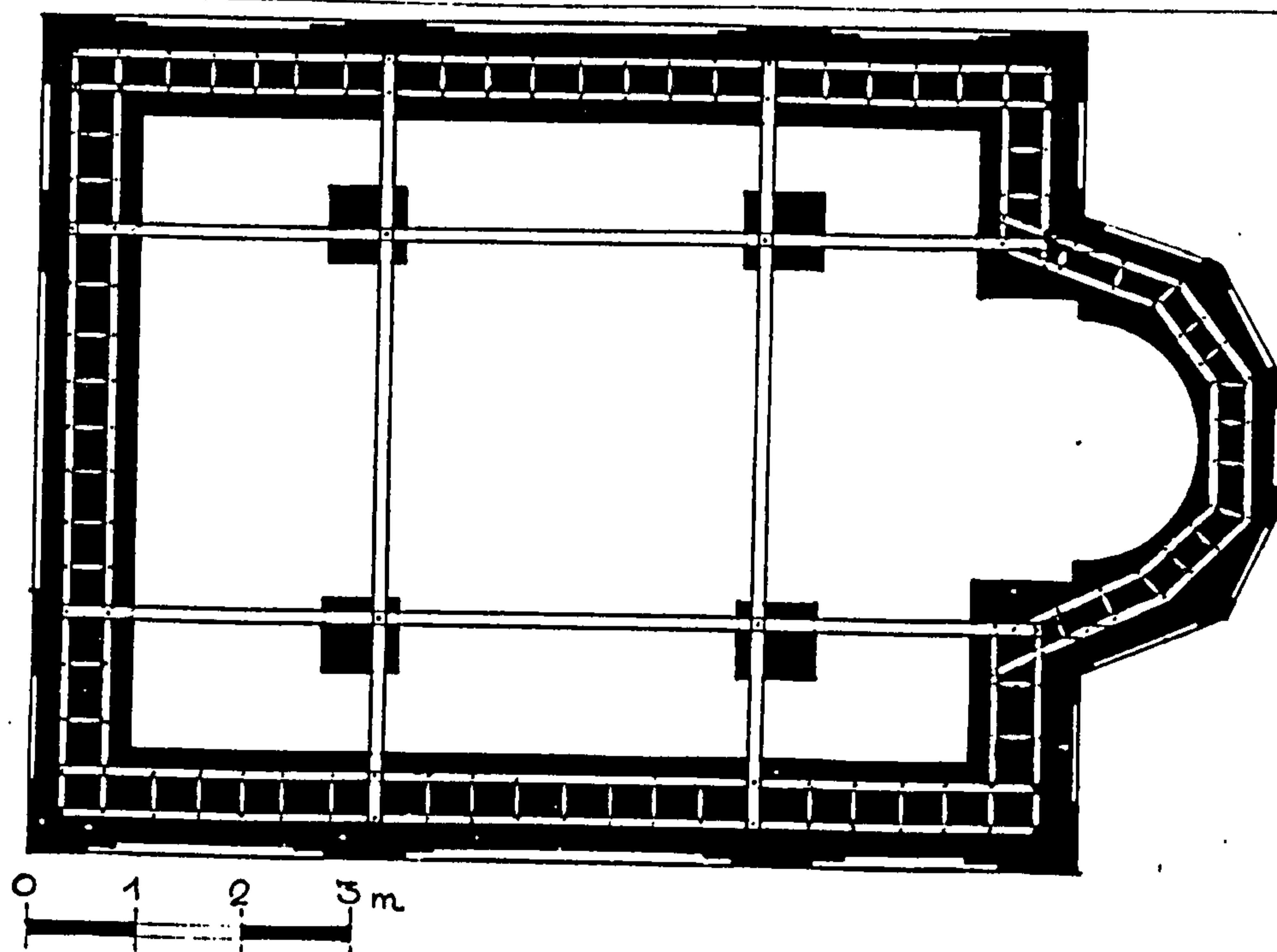

b)

Figure 5.3 *St. Nikita, v. Banjani;*
 a) Cross section; b) Horizontal timber belts.

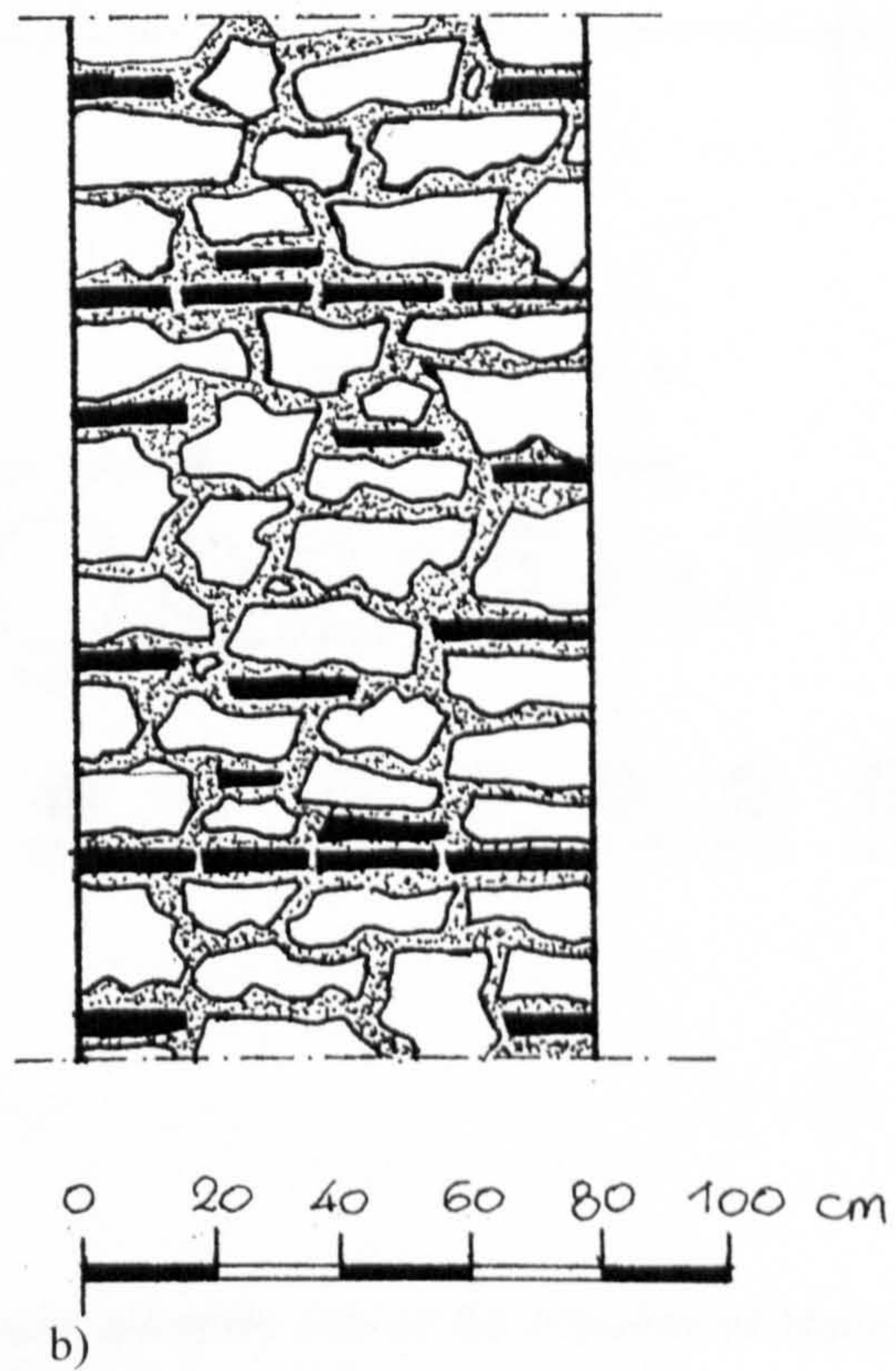
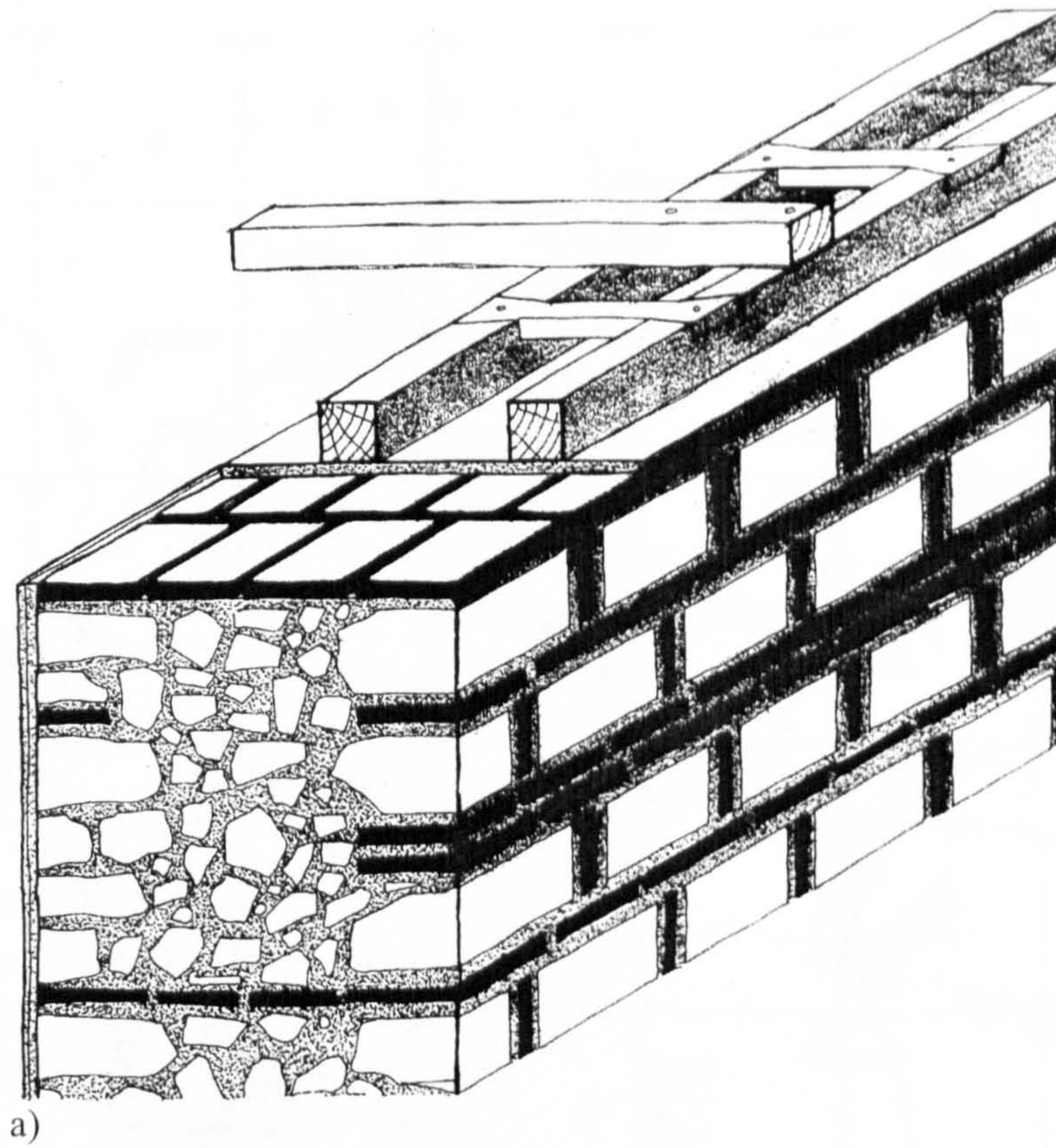
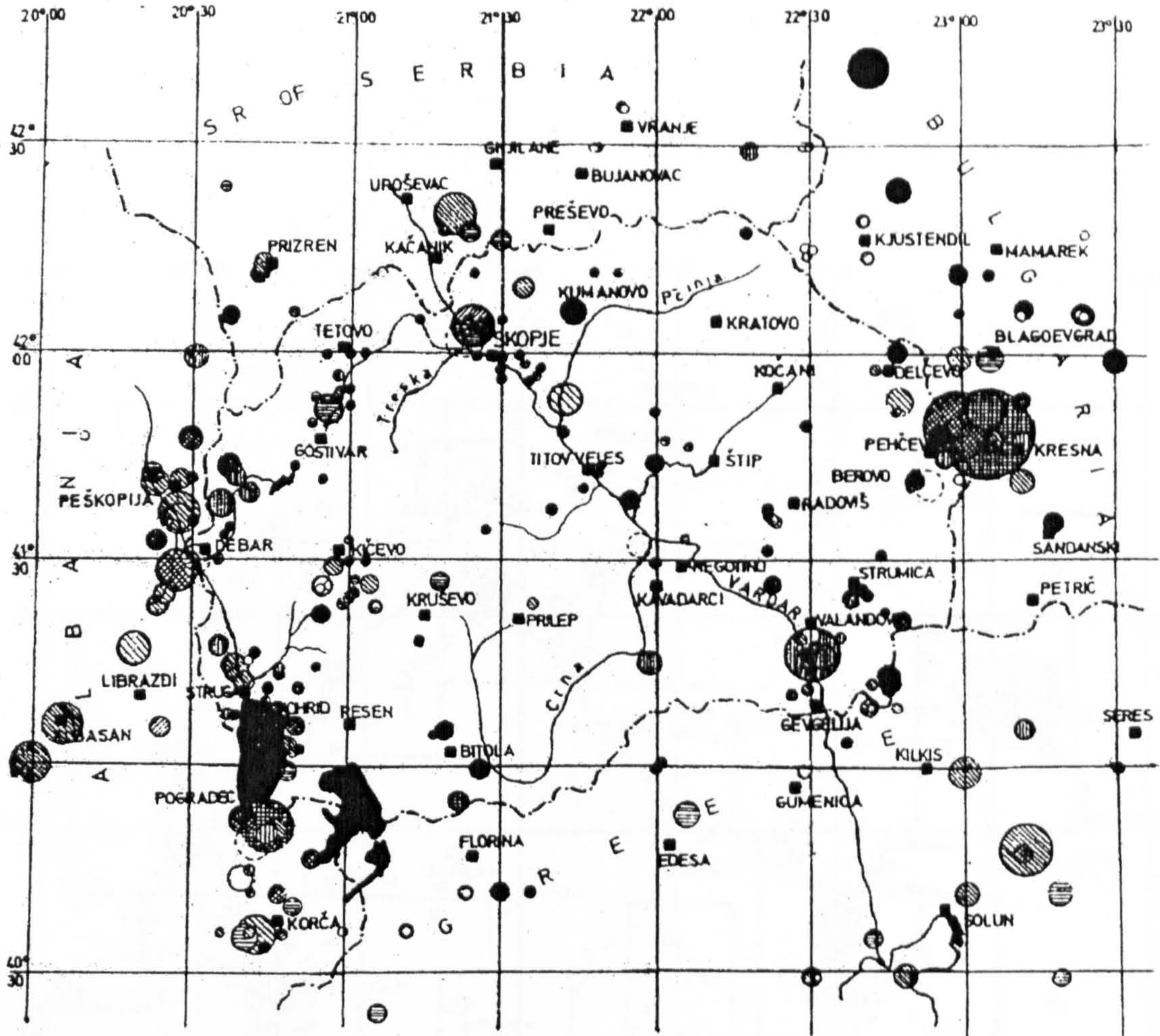

Figure 5.4 a) Horizontal timber belts and masonry structure;
b) Vertical cross section of church piers.



10 0 10 20 30km

L E G E N D

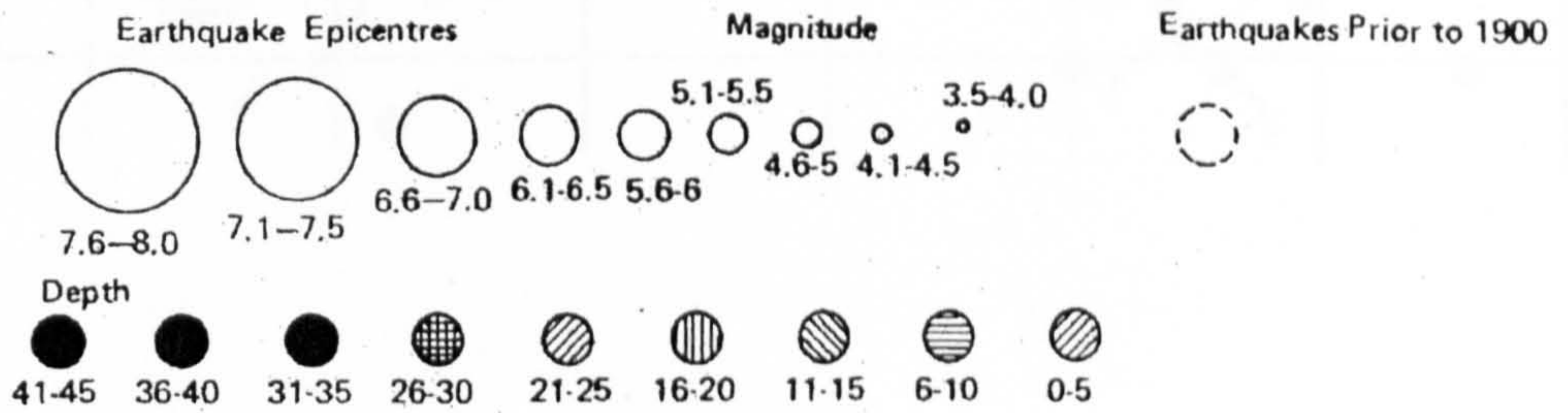

Figure 5.5 Earthquake epicentre map of the Republic of Macedonia
 Source: Volume 7, Stojkovic et. al. 1992

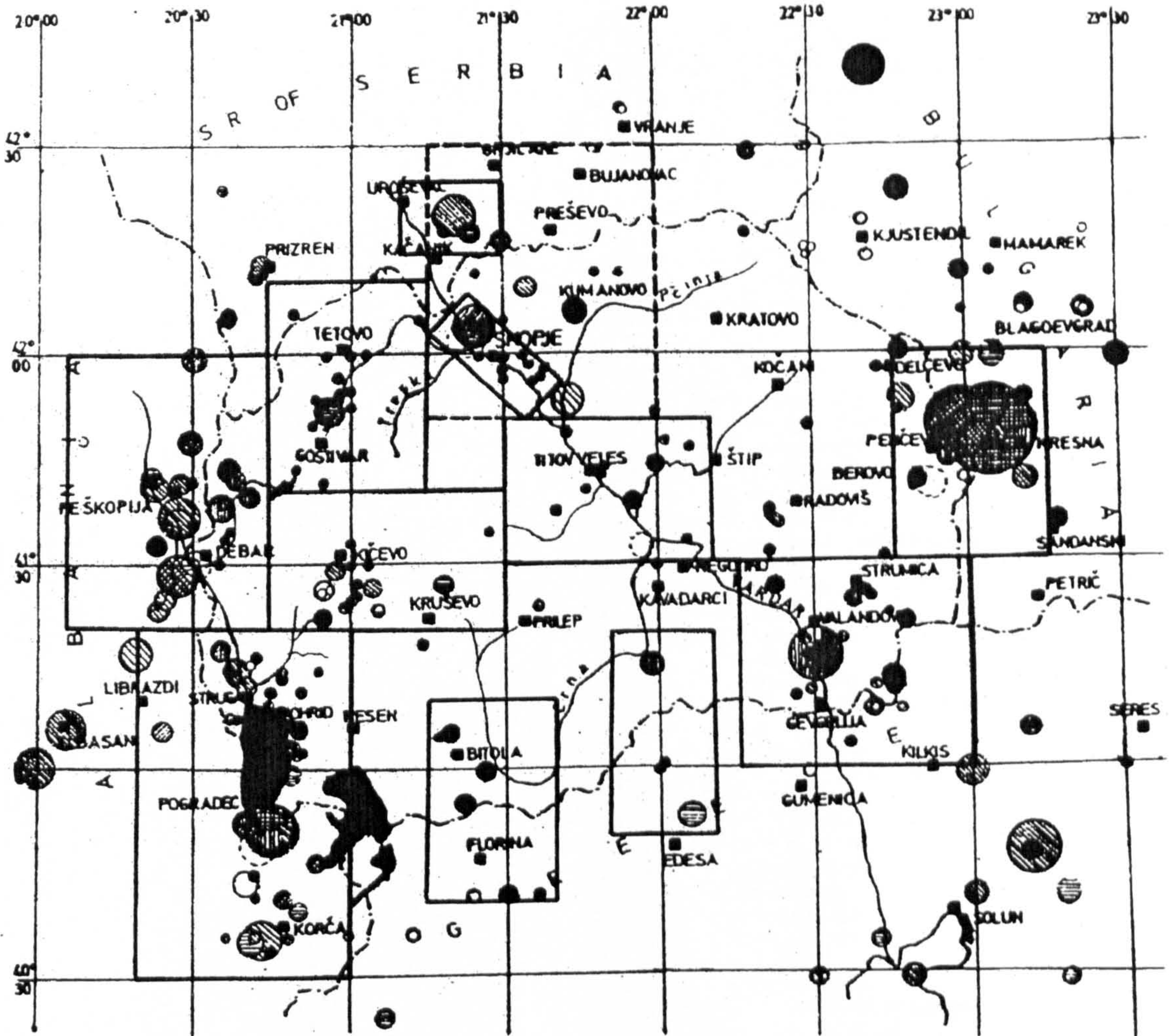
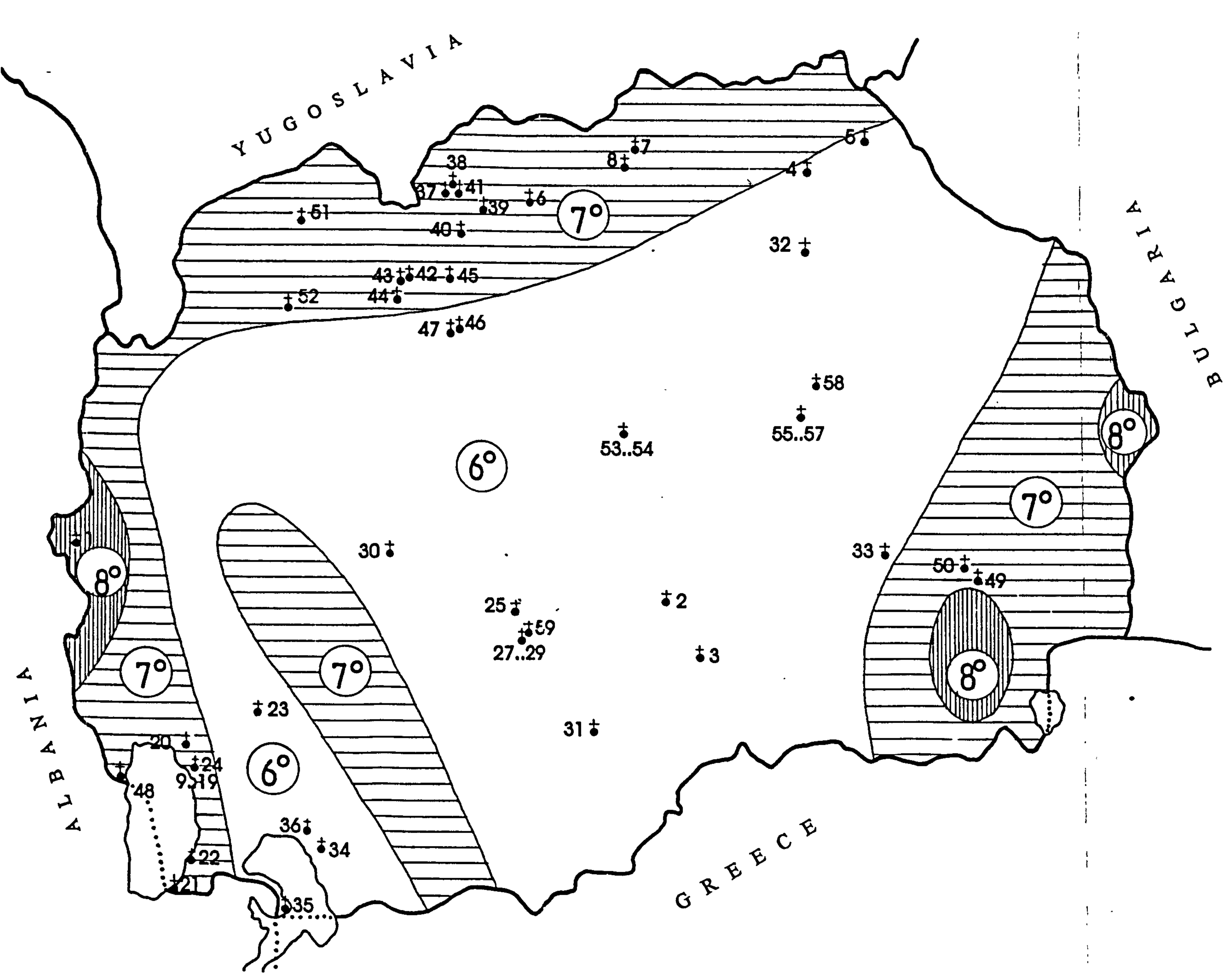
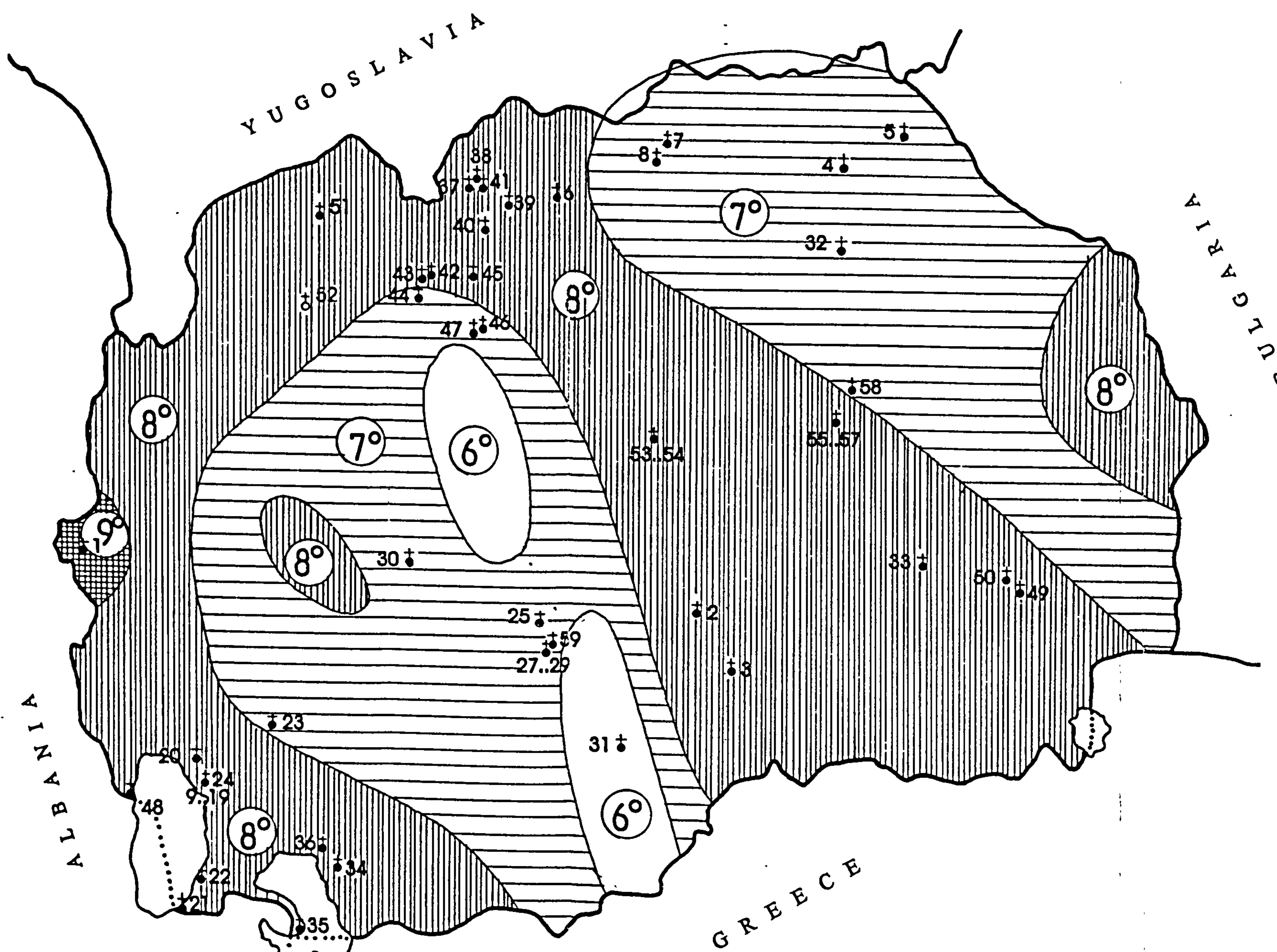

Figure 5.6 *Earthquake foci map of the Republic of Macedonia*
 Source: Volume 7, Stojkovic et. al. 1992



1. *St. Petka* - Debar
2. *St. Bogorodica* - v. Drenovo, Kavadarci
3. *St. Gorgi* - (Pološki monastery), Kavadarci
4. *St. Nikola* - v. Pasca, Kriva Palanka
5. *St. Bogorodica* - (Osogovski monastery), Kriva Palanka
6. *St. Bogorodica* - v. Matejce, Kumanovo
7. *St. Gorgy* - v. Staro Nagoricane, Kumanovo
8. *St. Gorgy* - v. Mlado Nagoricane, Kumanovo
9. *St. Pantelejmon* - Ohrid
10. *St. Sofija* - Ohrid
11. *St. Nikola Cudotvorec* - Ohrid
12. *St. Jovan* - Kameo, Ohrid
13. *St. Bogorodica* - Perivlepta, Ohrid
14. *St. Kliment Star* - Ohrid
15. *St. Bogorodica Celnica* - Ohrid
16. *St. Vracl Mal* - Ohrid
17. *St. Dimitrija* - Ohrid
18. *St. Nikola Bolnicki* - Ohrid
19. *St. Bogorodica Bolnicka* - Ohrid
20. *St. Erasmio* - v. Lakocerej, Ohrid
21. *St. Naum* - v. Lubanista, Ohrid
22. *St. Bogorodica Zahumska* - Ohrid
23. *St. Gorgy* - v. Ratica, Ohrid
24. *St. Elena and Kostadin* - Ohrid
25. *St. Bogorodica* - (monastery Treskavec), Prilep
26. *St. Nikola* - Varos, Prilep
27. *St. Dimitrija* - Varos, Prilep
28. *St. Atanasie* - Varos, Prilep
29. *St. Bogorodica* - Varos, Prilep
30. *St. Spas* - v. Zrze, Prilep
31. *St. Nikola* - v. Manastir, Prilep
32. *St. Gavril Laznovski* - v. Lesnovo, Probistip
33. *St. Stefan* - v. Konce
34. *St. Gorgy* - v. Kurbinovo, Resen
35. *St. Gorgy* - Ostrovo Golem Grad, Resen
36. *St. Ilja* - v. Grcari, Resen
37. *St. Nikita* - v. Banjani, Skopje
38. *St. Ilja Gorni* - v. Banjani, Skopje
39. *St. Nikola* - v. Ljuboten, Skopje
40. *St. Nikola* - Radisani, Skopje
41. *St. Spas* - v. Kuceviste, Skopje
42. *St. Nikola* - v. Sisovo, Skopje
43. *St. Atanasie* - v. Sisovo
44. *St. Andreja* - v. Matka, Skopje
45. *St. Pantelejmon* - v. Gorno Nerezi, Skopje
46. *St. Bogorodica* - v. Susica, Skopje
47. *St. Dimitrija* - v. Susica, Skopje
48. *St. Arkangel and Mihael* - v. Radozda, Struga
49. *St. Leontie* - v. Vodoca, Strumica
50. *St. Bogorodica* - v. Veljusa, Strumica
51. *St. Atanasie* - v. Lesok, Tetovo
52. *St. Nikola* - v. Celopok, Tetovo
53. *St. Dimitria* - Veles
54. *St. Nikola* - Veles
55. *St. Arkangel* - Stip
56. *St. Spas* - Stip
57. *St. Jovan* - Stip
58. *St. Gorgy* - v. Gorni Kozjak, Stip
59. *St. Arkangel* - Varos Prilep

Figure 5.7 Seismological map of the return period - 50 years. The Republic of Macedonia.
Source: IZZIS Indok Centre



1. *St. Paks* - Dober
2. *St. Bogorodica* - v. Drenovo, Kavadarci
3. *St. Gorgi* - (Poloski monastery), Kavadarci
4. *St. Nikola* - v. Psaca, Kriva Palanka
5. *St. Bogorodica* - (Osogovski monastery), Kriva Palanka
6. *St. Bogorodica* - v. Matejce, Kumanovo
7. *St. Gorgy* - v. Staro Nagoricane, Kumanovo
8. *St. Gorgy* - v. Mlado Nagoricane, Kumanovo
9. *St. Pantelajmon* - Ohrid
10. *St. Sofija* - Ohrid
11. *St. Nikola Cudotvorac* - Ohrid
12. *St. Jovan* - Kameo, Ohrid
13. *St. Bogorodica* - Perivlepta, Ohrid
14. *St. Klement Star* - Ohrid
15. *St. Bogorodica Celnica* - Ohrid
16. *St. Vraci Matii* - Ohrid
17. *St. Dimitrija* - Ohrid
18. *St. Nikola Bobicki* - Ohrid
19. *St. Bogorodica Bobicka* - Ohrid
20. *St. Erzno* - v. Lakocerej, Ohrid
21. *St. Nezum* - v. Lubanista, Ohrid
22. *St. Bogorodica Zahumska* - Ohrid
23. *St. Gorgy* - v. Resica, Ohrid
24. *St. Elena and Kostadin* - Ohrid
25. *St. Bogorodica* - (monastery Treskavec), Prilep
26. *St. Nikola* - Varos, Prilep
27. *St. Dimitrija* - Varos, Prilep
28. *St. Atanasie* - Varos, Prilep
29. *St. Bogorodica* - Varos, Prilep
30. *St. Spas* - v. Zrze, Prilep
31. *St. Nikola* - v. Manastir, Prilep
32. *St. Gavril Lesnovski* - v. Lesnovo, Probistip
33. *St. Stefan* - v. Konco
34. *St. Gorgy* - v. Kurbinovo, Resen
35. *St. Gorgy* - Ostrovo Golem Grad, Resen
36. *St. Ilja* - v. Grcari, Resen
37. *St. Nikita* - v. Banjani, Skopje
38. *St. Ilja Gorni* - v. Banjani, Skopje
39. *St. Nikola* - v. Ljuboten, Skopje
40. *St. Nikola* - Radisani, Skopje
41. *St. Spas* - v. Knevista, Skopje
42. *St. Nikola* - v. Sisovo, Skopje
43. *St. Atanasie* - v. Sisovo
44. *St. Andreja* - v. Matka, Skopje
45. *St. Pantelajmon* - v. Gorno Nerezi, Skopje
46. *St. Bogorodica* - v. Sunica, Skopje
47. *St. Dimitrija* - v. Sunica, Skopje
48. *St. Arhangel and Mihael* - v. Radozda, Struga
49. *St. Leontie* - v. Vodoca, Strumica
50. *St. Bogorodica* - v. Veljusa, Strumica
51. *St. Atanasie* - v. Lesok, Tetovo
52. *St. Nikola* - v. Celopek, Tetovo
53. *St. Dimitria* - Veles
54. *St. Nikola* - Veles
55. *St. Arhangel* - Stip
56. *St. Spas* - Stip
57. *St. Jovan* - Stip
58. *St. Gorgy* - v. Gorni Kozjak, Stip
59. *St. Arhangel* - Varos, Prilep

Figure 5.8 Seismological map of the return period - 200 years. The Republic of Macedonia.
Source: IZZIS Indok Centre

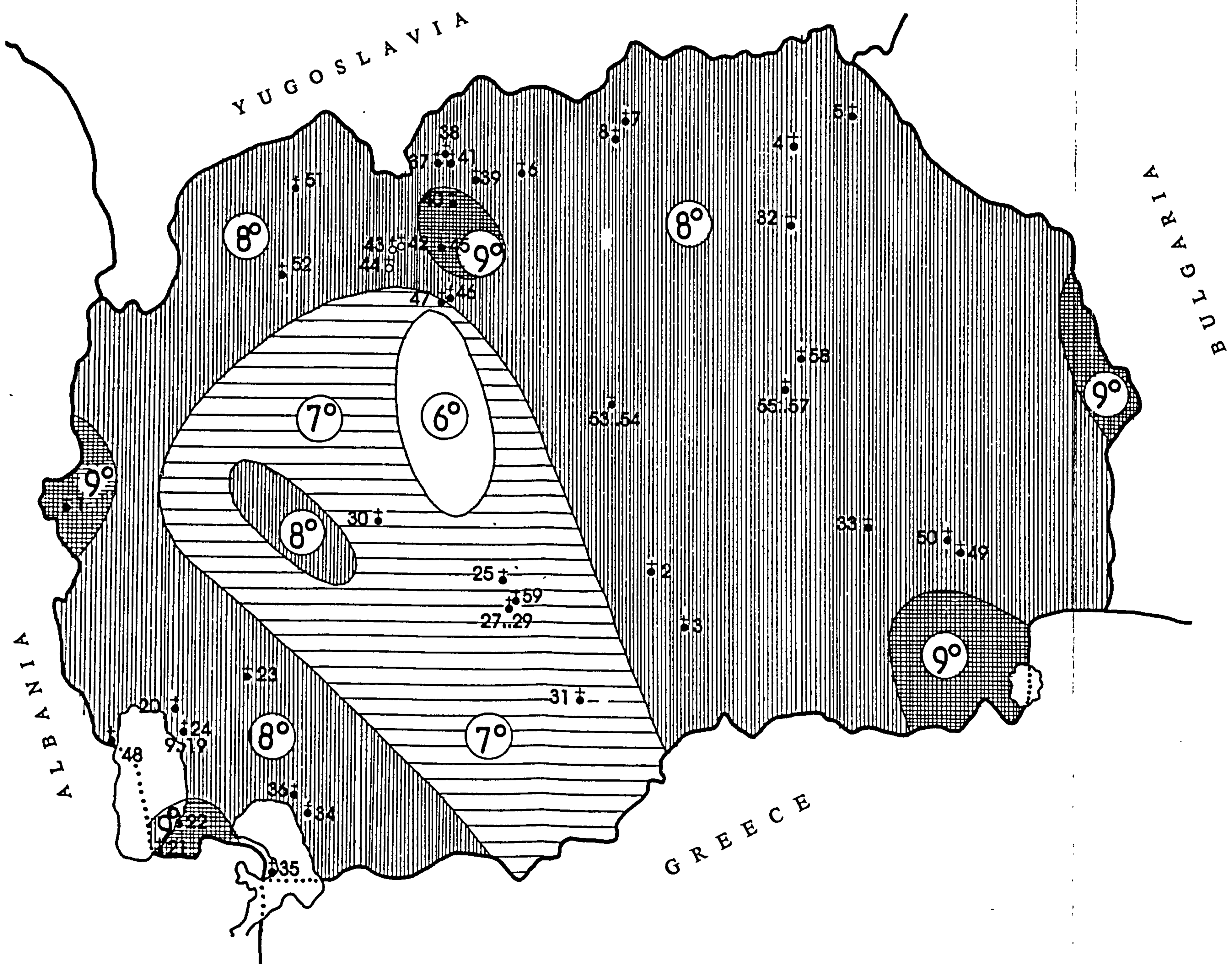

1. *St. Petka* - Debar
2. *St. Bogorodica* - v. Drenovo, Kavadarci
3. *St. Gorgi* - (Poloski monastery), Kavadarci
4. *St. Nikola* - v. Praca, Kriva Palanka
5. *St. Bogorodica* - (Osogovski monastery), Kriva Palanka
6. *St. Bogorodica* - v. Matejce, Kumanovo
7. *St. Gorgy* - v. Staro Nagoricane, Kumanovo
8. *St. Gorgy* - v. Mlado Nagoricane, Kumanovo
9. *St. Pantalejmon* - Ohrid
10. *St. Sofija* - Ohrid
11. *St. Nikola Cudotvorac* - Ohrid
12. *St. Jovan* - Kameo, Ohrid
13. *St. Bogorodica* - Perivlepta, Ohrid
14. *St. Kliment Star* - Ohrid
15. *St. Bogorodica Celnica* - Ohrid
16. *St. Vraci Mali* - Ohrid
17. *St. Dimitrija* - Ohrid
18. *St. Nikola Bolnicki* - Ohrid
19. *St. Bogorodica Bolnicka* - Ohrid
20. *St. Erazmo* - v. Lakocerej, Ohrid
21. *St. Naum* - v. Lubanista, Ohrid
22. *St. Bogorodica Zahumaka* - Ohrid
23. *St. Gorgy* - v. Recica, Ohrid
24. *St. Elena and Kostadin* - Ohrid
25. *St. Bogorodica* - (monastery Trezakvec), Prilep
26. *St. Nikola* - Varos, Prilep
27. *St. Dimitrija* - Varos, Prilep
28. *St. Atanasie* - Varos, Prilep
29. *St. Bogorodica* - Varos, Prilep
30. *St. Spas* - v. Zrze, Prilep
31. *St. Nikola* - v. Manastir, Prilep
32. *St. Gavril Lesnovski* - v. Lesnovo, Probistip
33. *St. Stefan* - v. Konce
34. *St. Gorgy* - v. Kurbinovo, Resen
35. *St. Gorgy* - Ostrovo Golem Grad, Resen
36. *St. Ilija* - v. Gmrcari, Resen
37. *St. Nikita* - v. Banjani, Skopje
38. *St. Ilija Gorni* - v. Banjani, Skopje
39. *St. Nikola* - v. Ljuboten, Skopje
40. *St. Nikola* - Radisani, Skopje
41. *St. Spas* - v. Knoeviste, Skopje
42. *St. Nikola* - v. Sisovo, Skopje
43. *St. Atanasie* - v. Sisevo
44. *St. Andreja* - v. Matka, Skopje
45. *St. Pantalejmon* - v. Gorno Nerezi, Skopje
46. *St. Bogorodica* - v. Suzica, Skopje
47. *St. Dimitrija* - v. Suzica, Skopje
48. *St. Arhangel and Mikael* - v. Radozda, Struga
49. *St. Leontie* - v. Vodoca, Strumica
50. *St. Bogorodica* - v. Veljusa, Strumica
51. *St. Atanasie* - v. Lesok, Tetovo
52. *St. Nikola* - v. Celopek, Tetovo
53. *St. Dimitria* - Veles
54. *St. Nikola* - Veles
55. *St. Arhangel* - Stip
56. *St. Spas* - Stip
57. *St. Jovan* - Stip
58. *St. Gorgy* - v. Gorni Kozjak, Stip
59. *St. Arhangel* - Varos Prilep

Figure 5.9 Seismological map of the return period - 500 years. The Republic of Macedonia.
Source: IZZIS Indok Centre

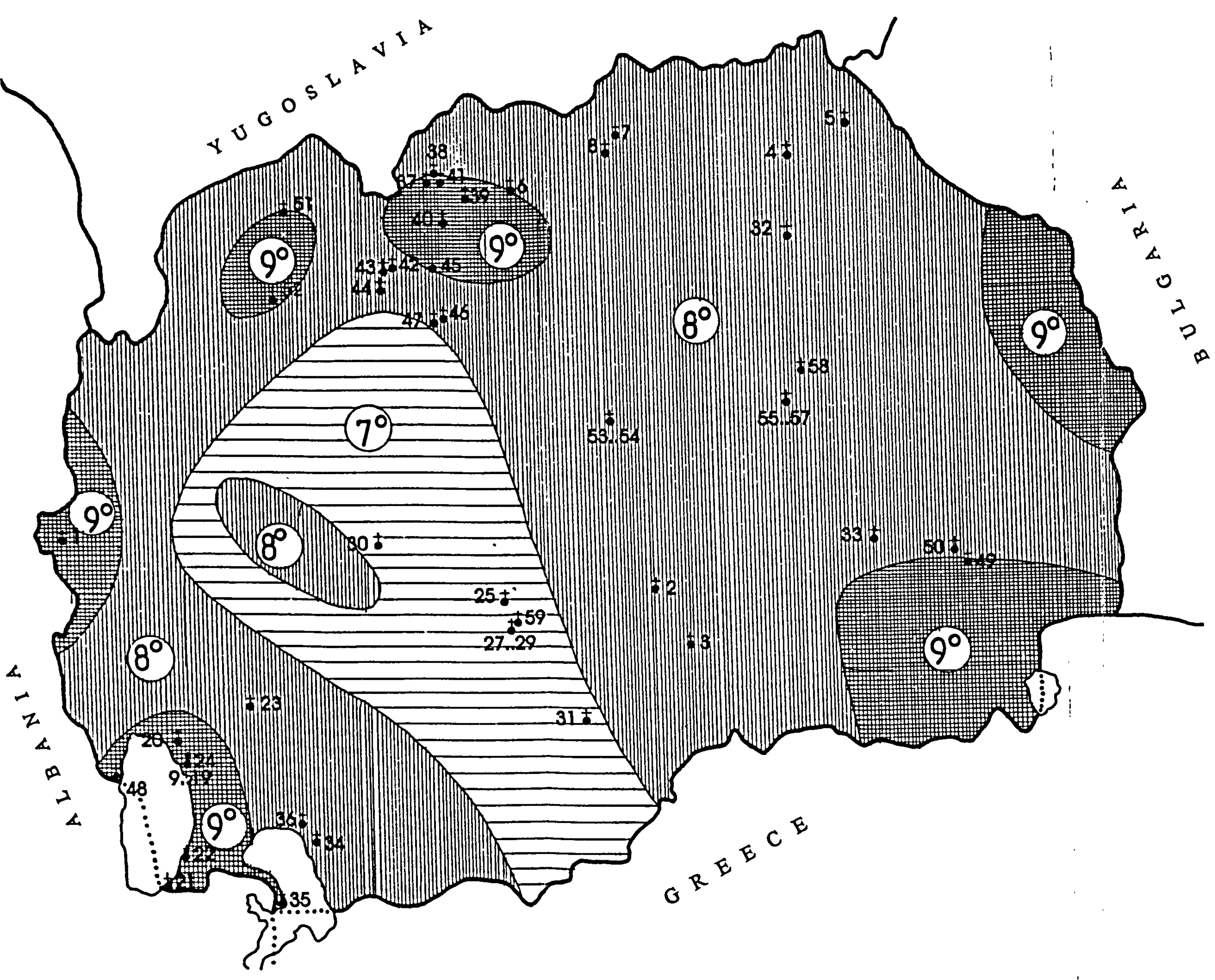

1. *St. Petka* - Debar
2. *St. Bogorodica* - v. Drenovo, Kavadarci
3. *St. Gorgi* - (Pološki monastery), Kavadarci
4. *St. Nikola* - v. Pasca, Kriva Palanka
5. *St. Bogorodica* - (Osogovski monastery), Kriva Palanka
6. *St. Bogorodica* - v. Matejce, Kumanovo
7. *St. Gorgy* - v. Staro Nagoricane, Kumanovo
8. *St. Gorgy* - v. Mlado Nagoricane, Kumanovo
9. *St. Pantelejmon* - Ohrid
10. *St. Sofija* - Ohrid
11. *St. Nikola Čudotvorec* - Ohrid
12. *St. Jovan* - Kameo, Ohrid
13. *St. Bogorodica* - Perivlepta, Ohrid
14. *St. Kliment Star* - Ohrid
15. *St. Bogorodica Celnica* - Ohrid
16. *St. Vraci Mali* - Ohrid
17. *St. Dimitrija* - Ohrid
18. *St. Nikola Bobicki* - Ohrid
19. *St. Bogorodica Bobicka* - Ohrid
20. *St. Erazmo* - v. Lakocerej, Ohrid
21. *St. Naum* - v. Lubenista, Ohrid
22. *St. Bogorodica Zahumska* - Ohrid
23. *St. Gorgy* - v. Recica, Ohrid
24. *St. Elena and Kostadin* - Ohrid
25. *St. Bogorodica* - (monastery Treskavec), Prilep
26. *St. Nikola* - Varos, Prilep
27. *St. Dimitrija* - Varos, Prilep
28. *St. Atanasie* - Varos, Prilep
29. *St. Bogorodica* - Varos, Prilep
30. *St. Spas* - v. Zrze, Prilep
31. *St. Nikola* - v. Manastir, Prilep
32. *St. Gavril Lesnovski* - v. Lesnovo, Probistip
33. *St. Stefan* - v. Konce
34. *St. Gorgy* - v. Kurbinovo, Resen
35. *St. Gorgy* - Ostrovo Golem Grad, Resen
36. *St. Ilija* - v. Grncari, Resen
37. *St. Nikita* - v. Banjani, Skopje
38. *St. Ilija Gorni* - v. Banjani, Skopje
39. *St. Nikola* - v. Ljuboten, Skopje
40. *St. Nikola* - Radisani, Skopje
41. *St. Spas* - v. Kucoviste, Skopje
42. *St. Nikola* - v. Sisevo, Skopje
43. *St. Atanasie* - v. Sisevo
44. *St. Andreja* - v. Matka, Skopje
45. *St. Pantelejmon* - v. Gorno Nerezi, Skopje
46. *St. Bogorodica* - v. Susica, Skopje
47. *St. Dimitrija* - v. Susica, Skopje
48. *St. Arhangel and Mihael* - v. Radozda, Struga
49. *St. Leonie* - v. Vodoca, Strumica
50. *St. Bogorodica* - v. Veljusa, Strumica
51. *St. Atanasie* - v. Lesok, Tetovo
52. *St. Nikola* - v. Celopek, Tetovo
53. *St. Dimitria* - Veles
54. *St. Nikola* - Veles
55. *St. Arhangel* - Stip
56. *St. Spas* - Stip
57. *St. Jovan* - Stip
58. *St. Gorgy* - v. Gorni Kozjak, Stip
59. *St. Arhangel* - Varos Prilep

Figure 5.10 Seismological map of the return period - 1,000 years. The Republic of Macedonia.
Source: IZZIS Indok Centre

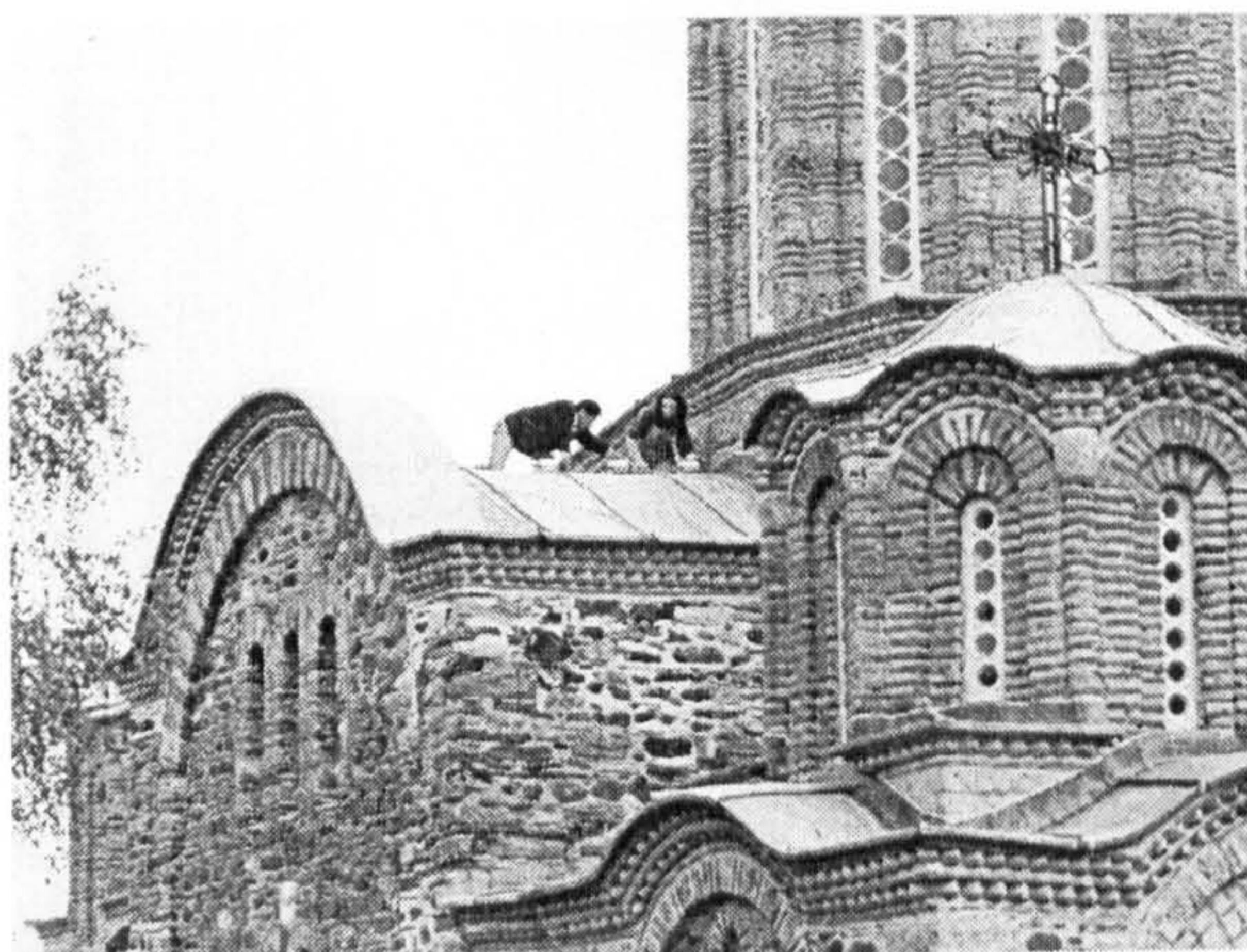

a)

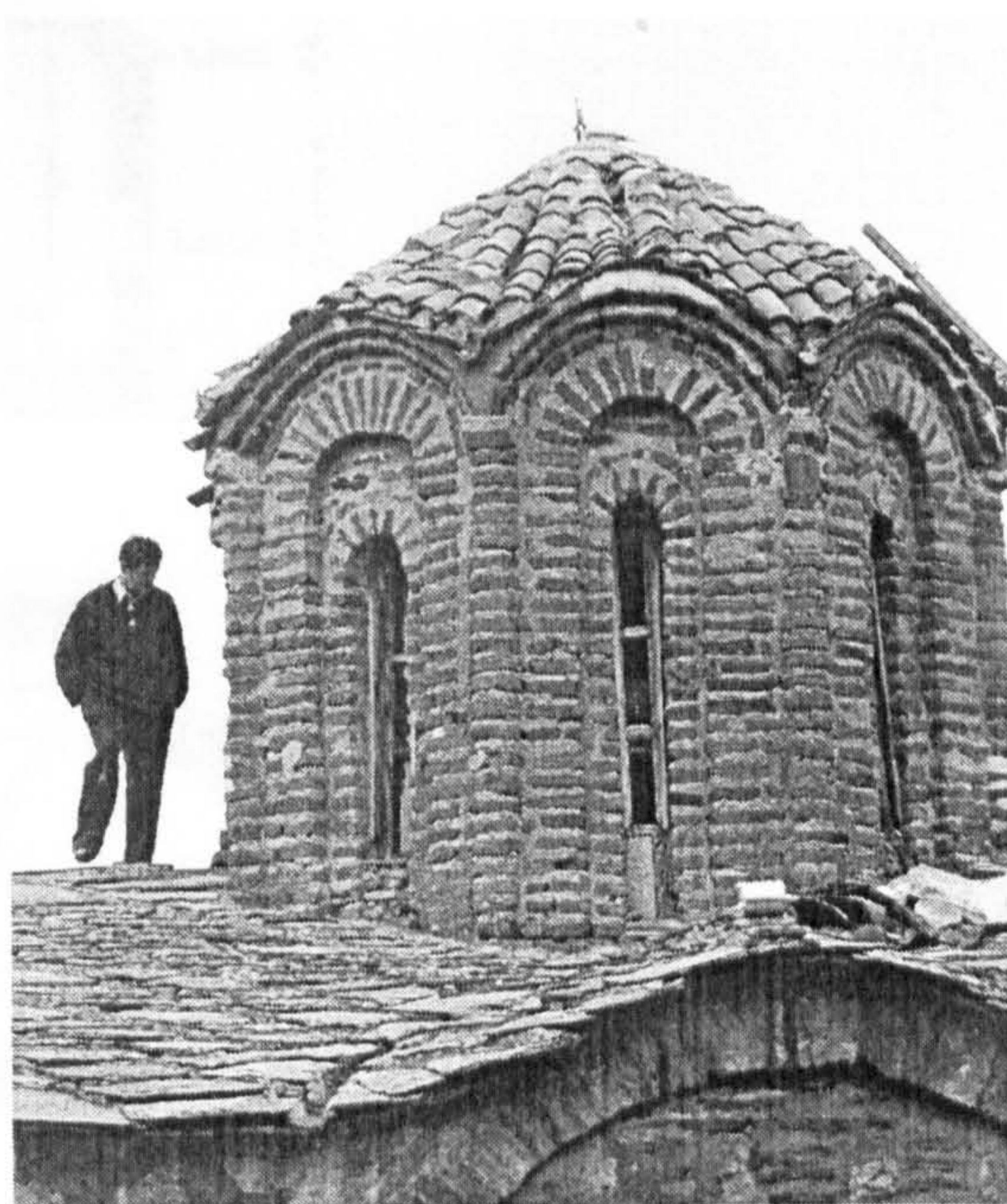

b)



c)

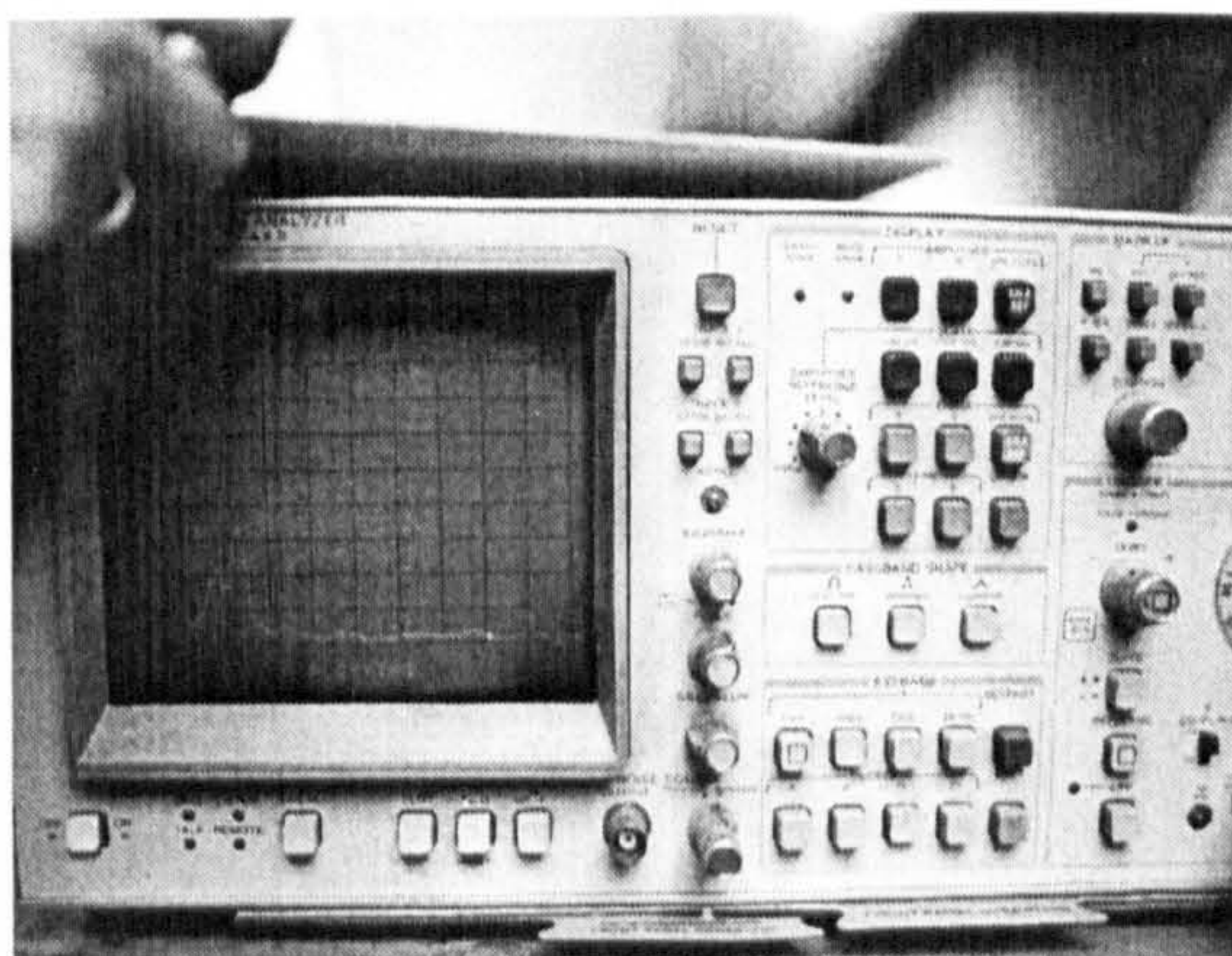

d)

Figure 5.11 *Installation of seismometers.*
 a) - St. Bogorodica, v. Matejce; b) - St. Nikola, v. Psaca; c) and d) - Equipment.

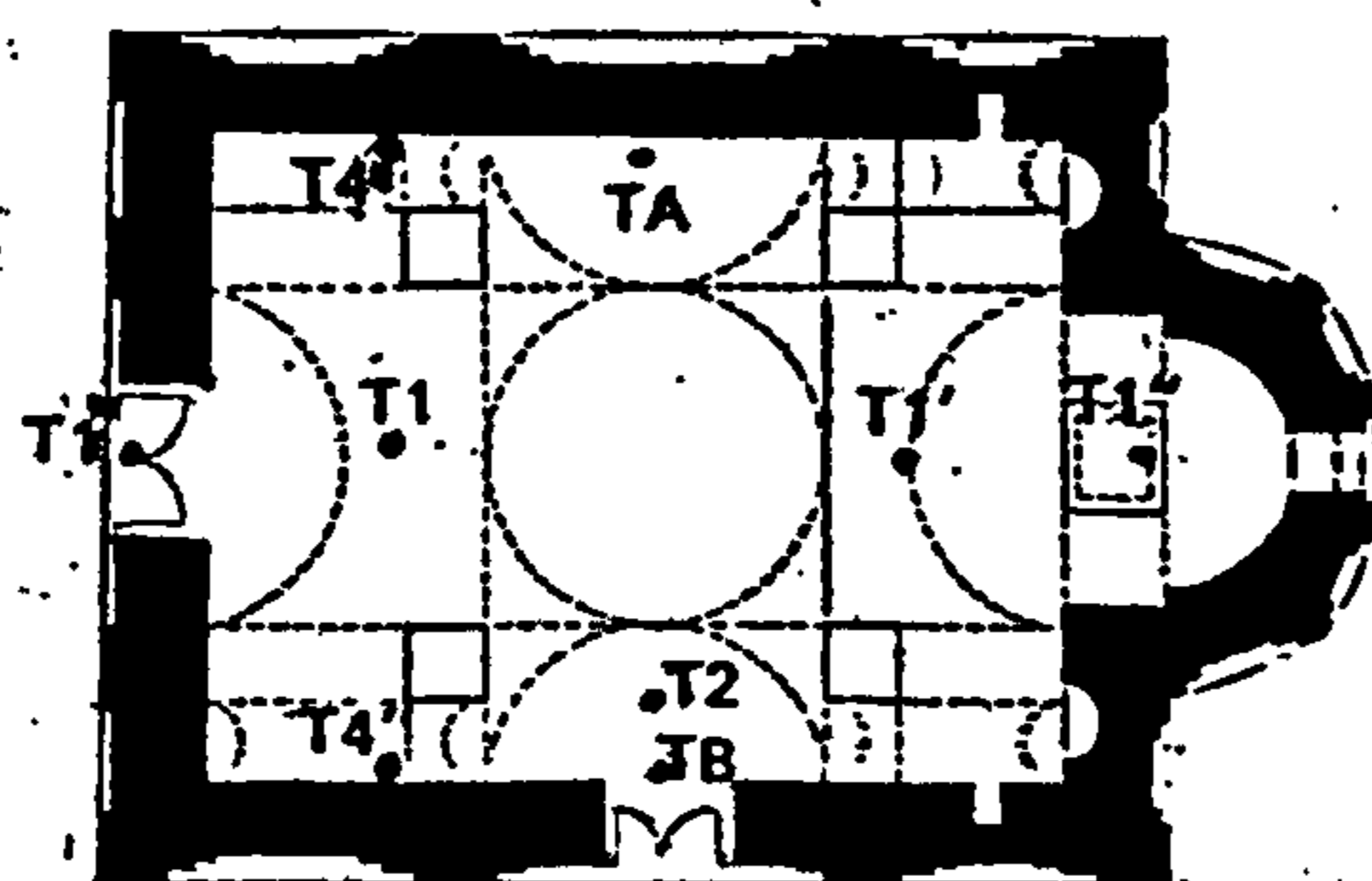
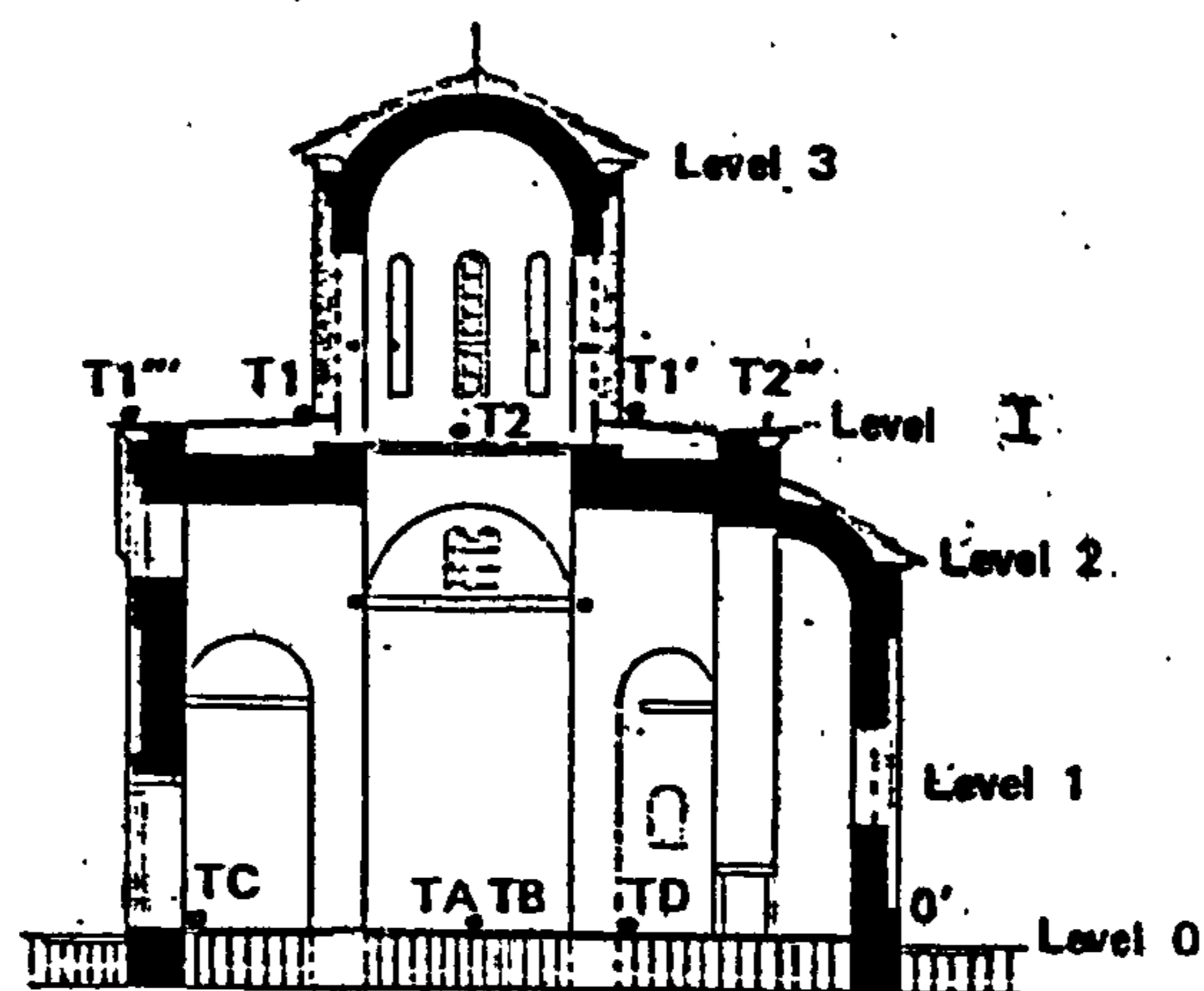

a)

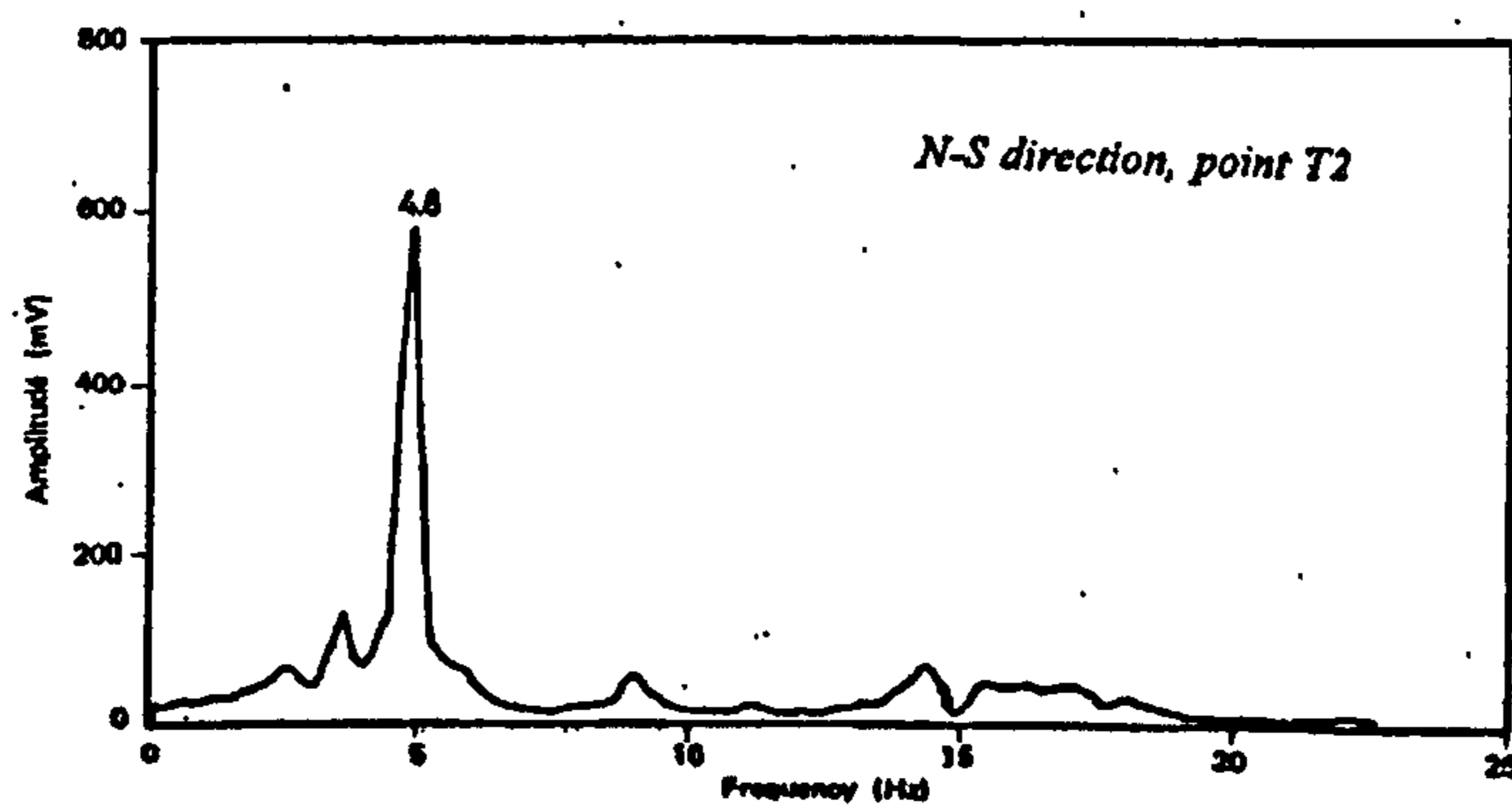
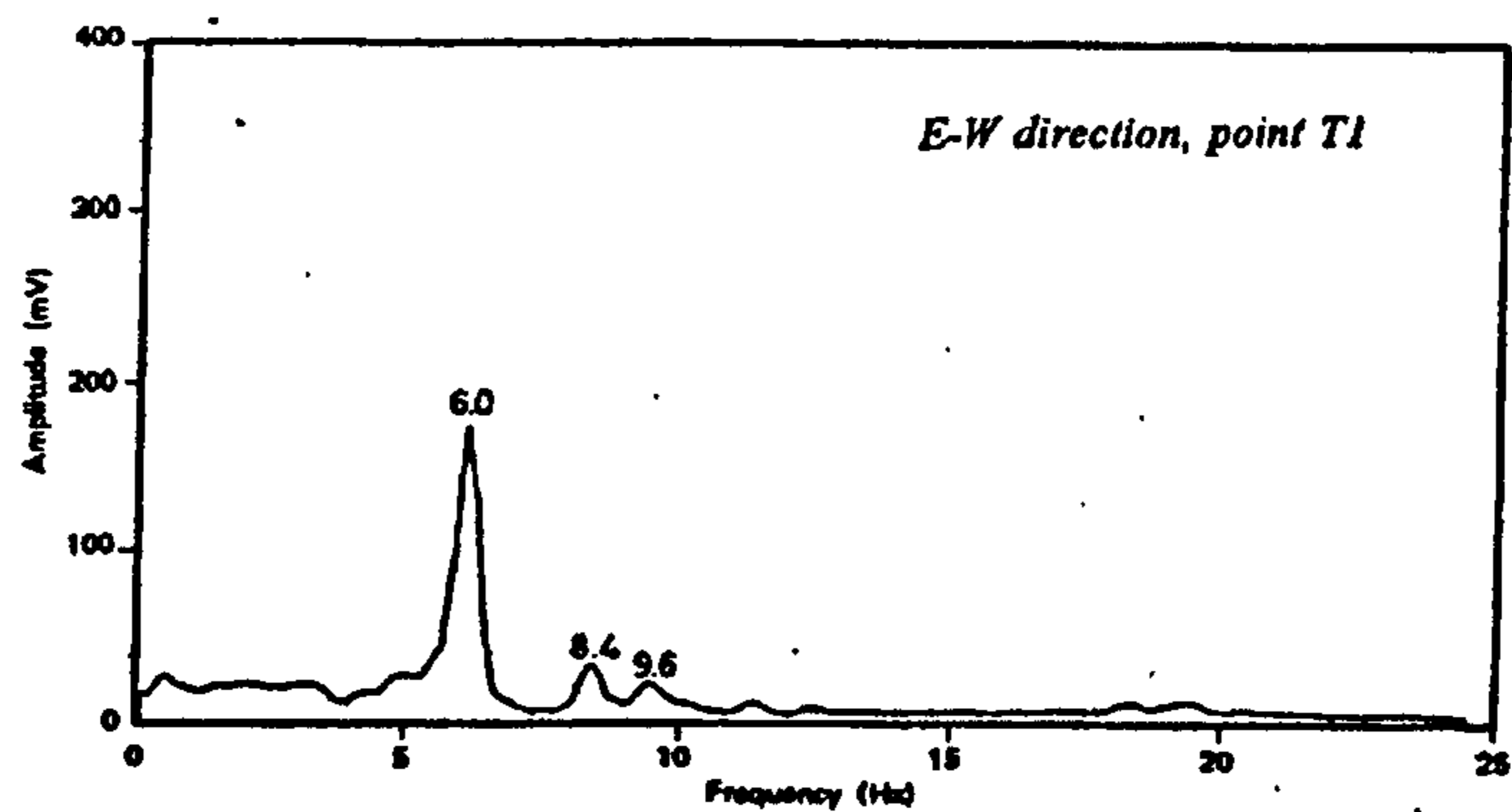

b)

Figure 5.12 *St. Nikita, v. Banjani*
 a) - Position of the seismometers; b) - Fourier diagram.
 Source: Volume 7

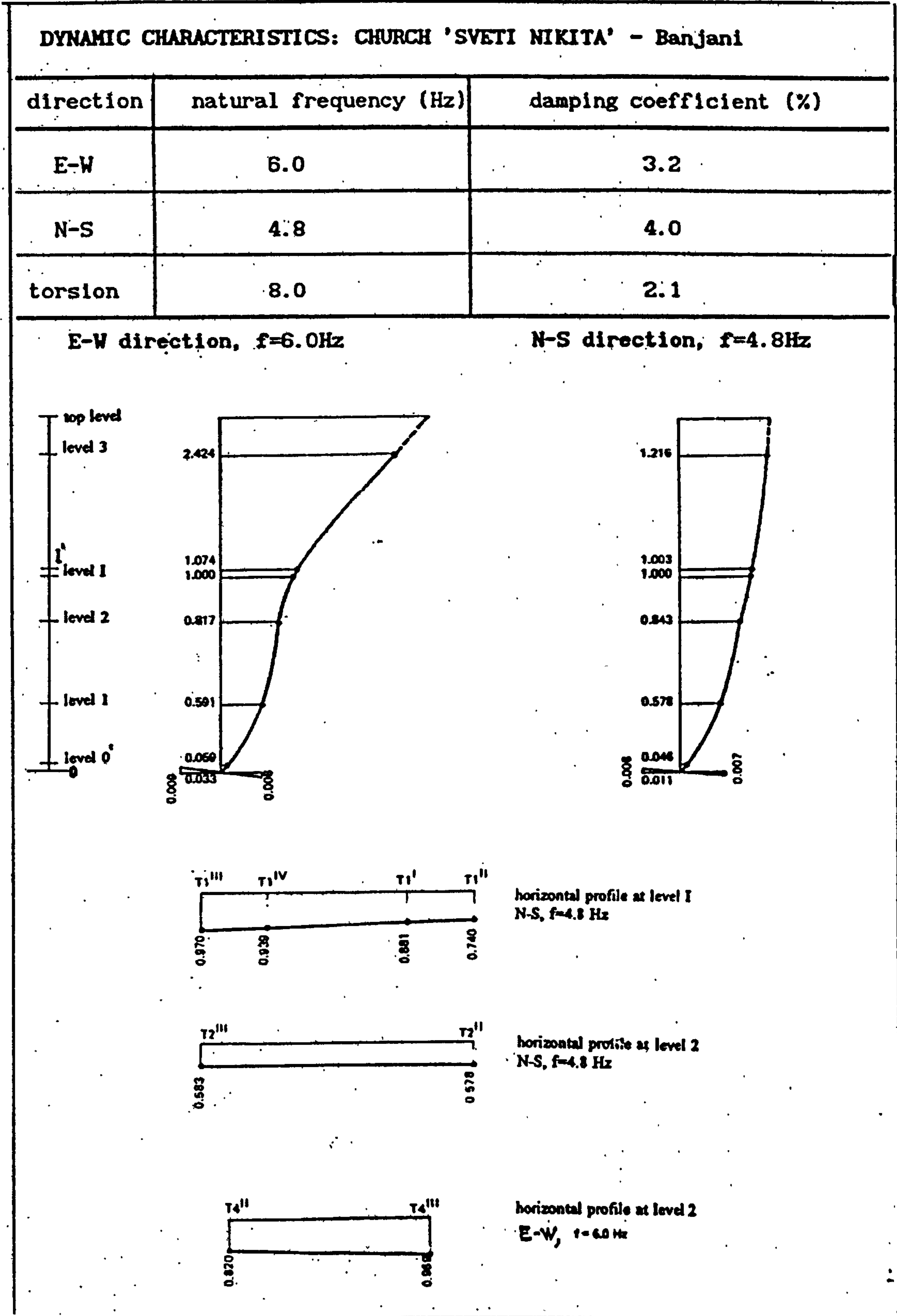

Figure 5.13 *St. Nikita, v. Banjani*
 Dynamic characteristics
 Source: Volume 8 Krstevska et. al. 1992

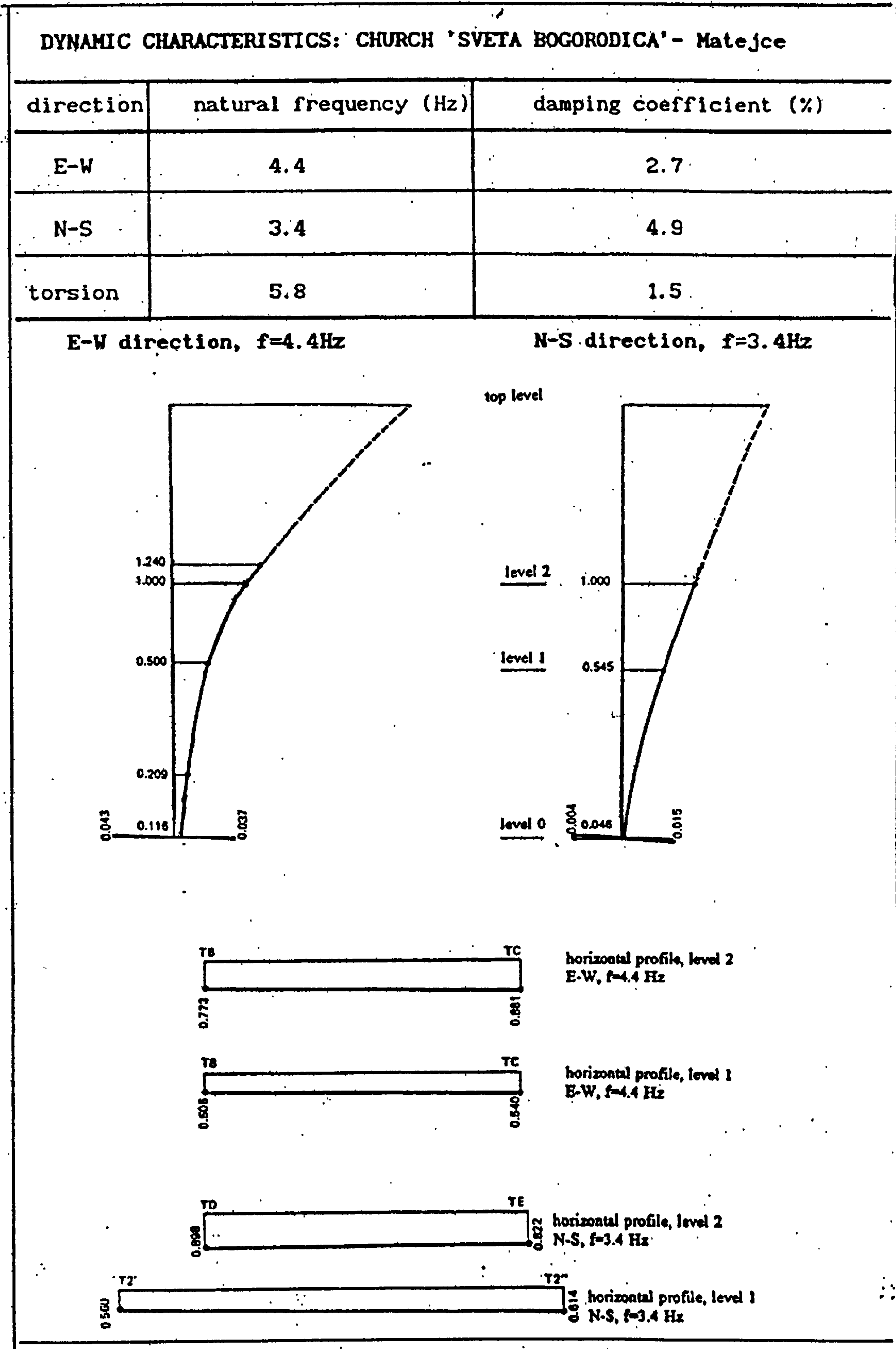
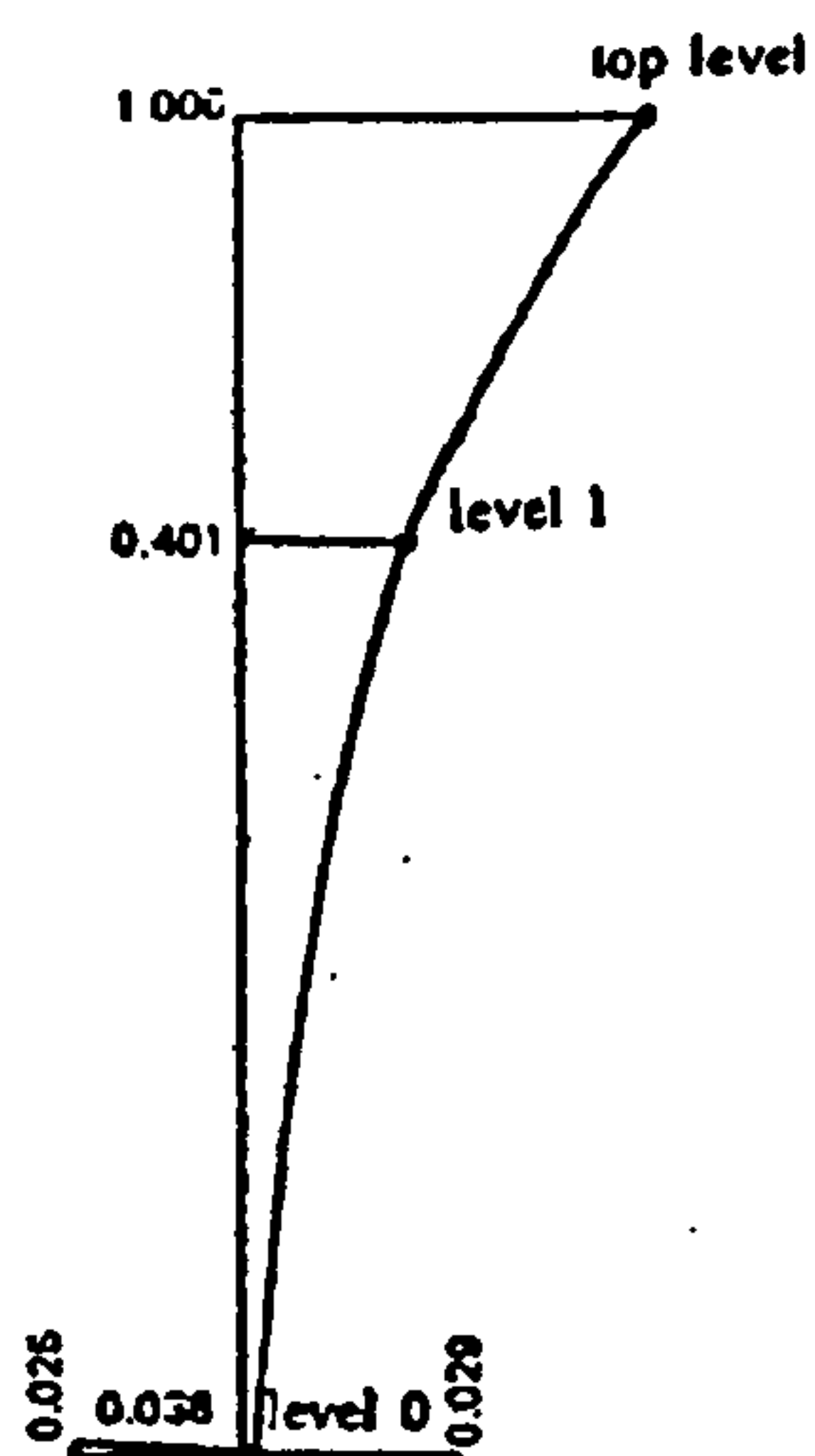

Figure 5.14 *St. Bogorodica, v. Matejce*
 Dynamic characteristics
 Source: Volume 8 Krstevska et. al. 1992

DYNAMIC CHARACTERISTICS: CHURCH 'SVETI NIKOLA' - Psaca

direction	natural frequency (Hz)	damping coefficient (%)
E-W	5.4	6.5
N-S	4.0	8.3
torsion	6.4	5.2

E-W direction, $f=5.4\text{Hz}$



N-S direction, $f=4.0\text{Hz}$

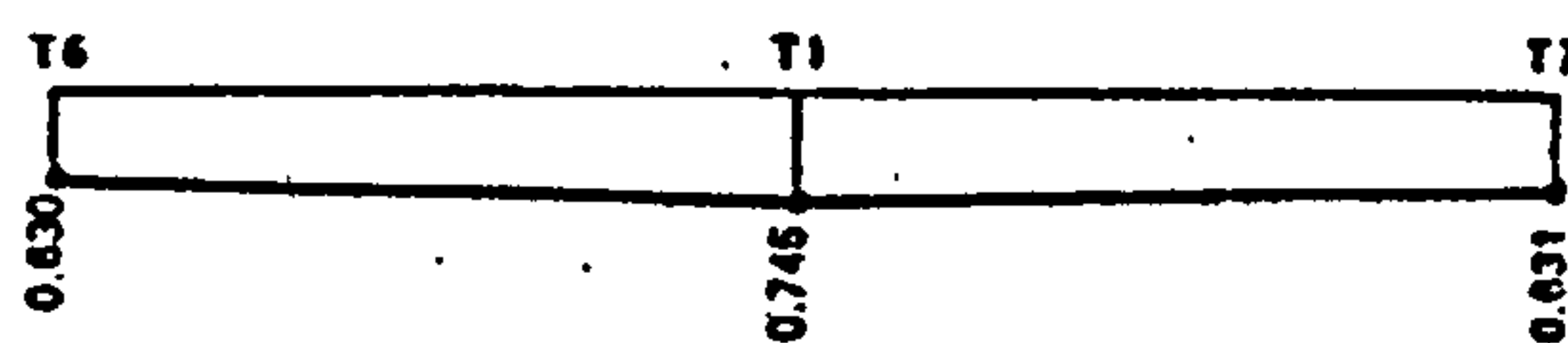
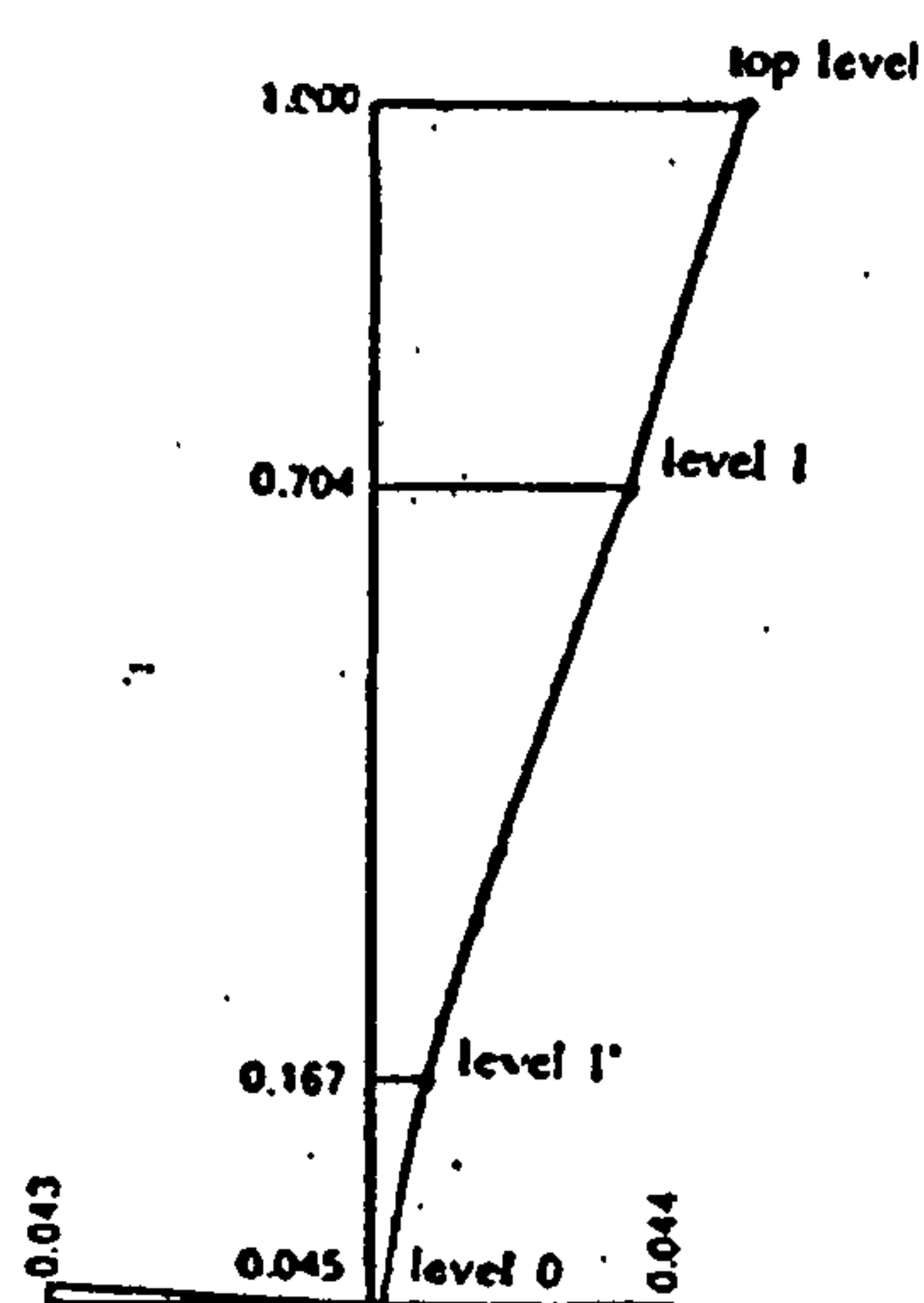

horizontal profile, level 1
N-S, $f=4.0\text{ Hz}$

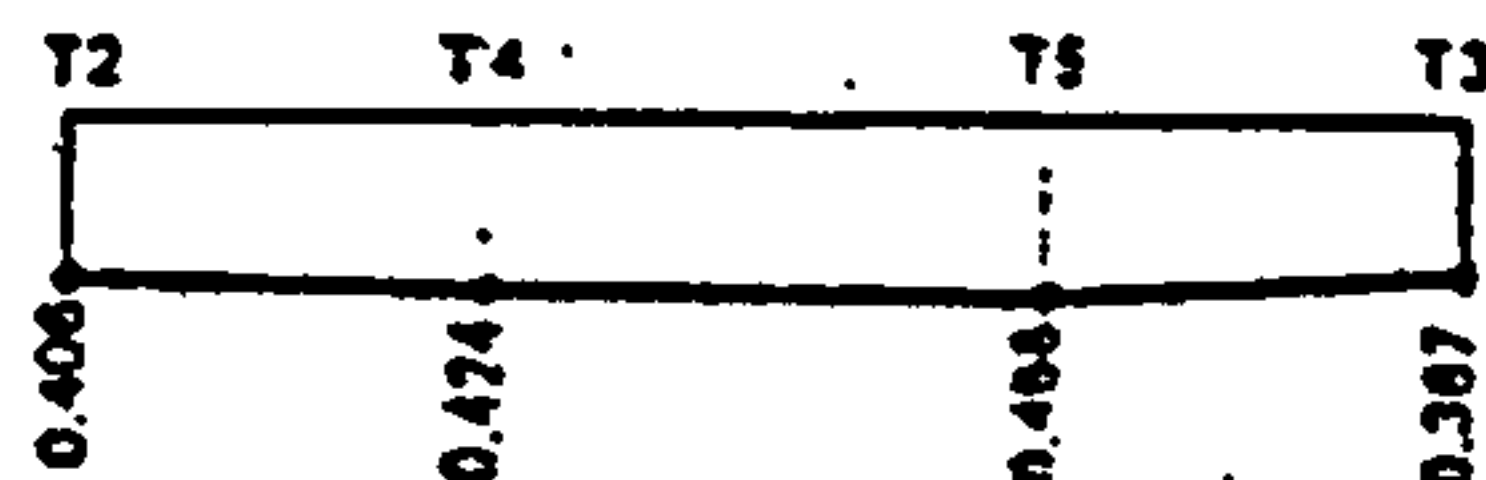

horizontal profile, level 1
E-W, $f=5.4\text{ Hz}$

Figure 5.15 *St. Nikola, v. Psaca*
Dynamic characteristics
Source: Volume 8 Krstevska et. al. 1992

DYNAMIC CHARACTERISTICS: CHURCH 'SV. BOGORODICA ZAHUMSKA' - Trpejca

direction	natural frequency (Hz)	damping coefficient (%)
E-W	6.0	1.5
N-S	4.6	2.2
torsion	8.2	2.5

E-W direction, $f=6.0\text{Hz}$

N-S direction, $f=4.6\text{Hz}$

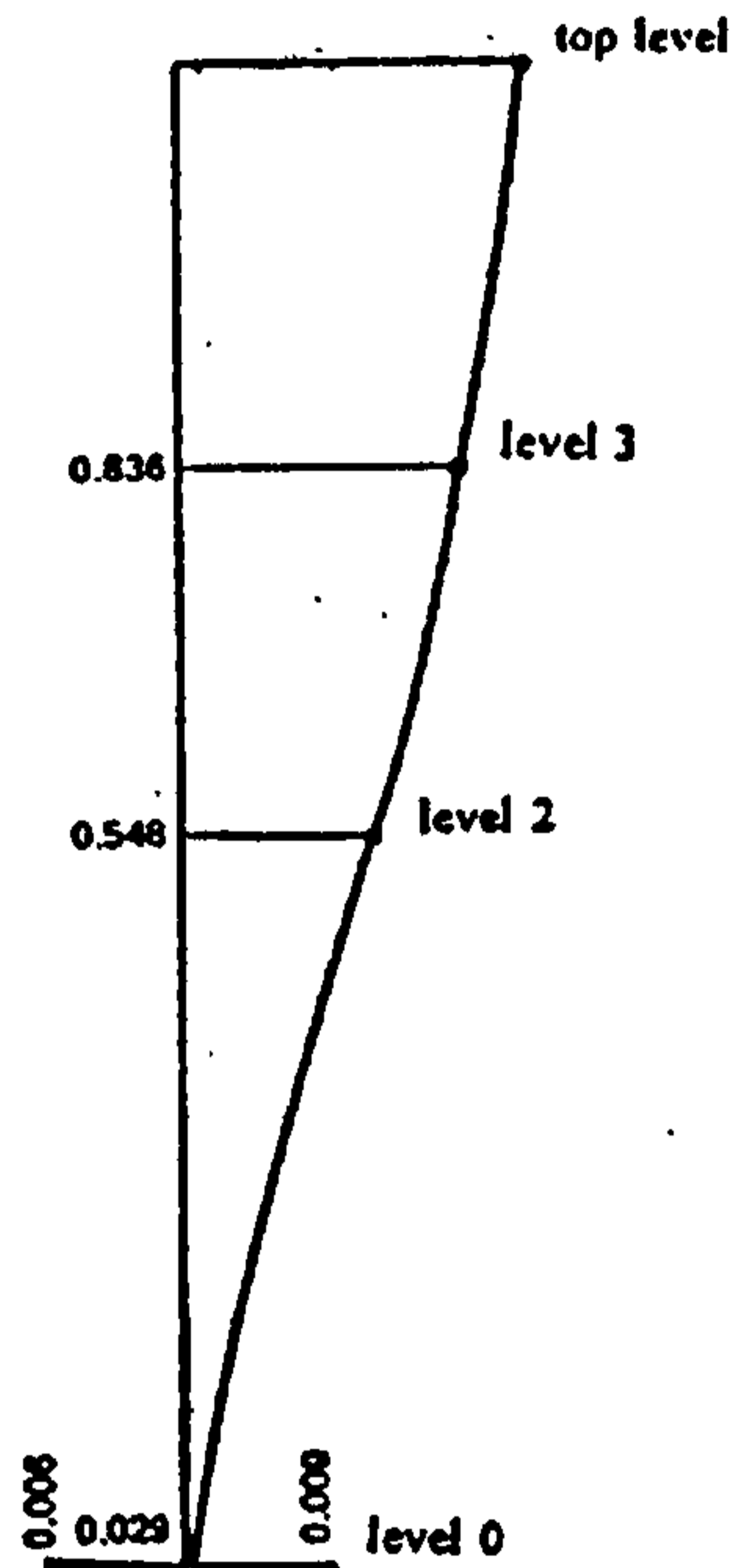
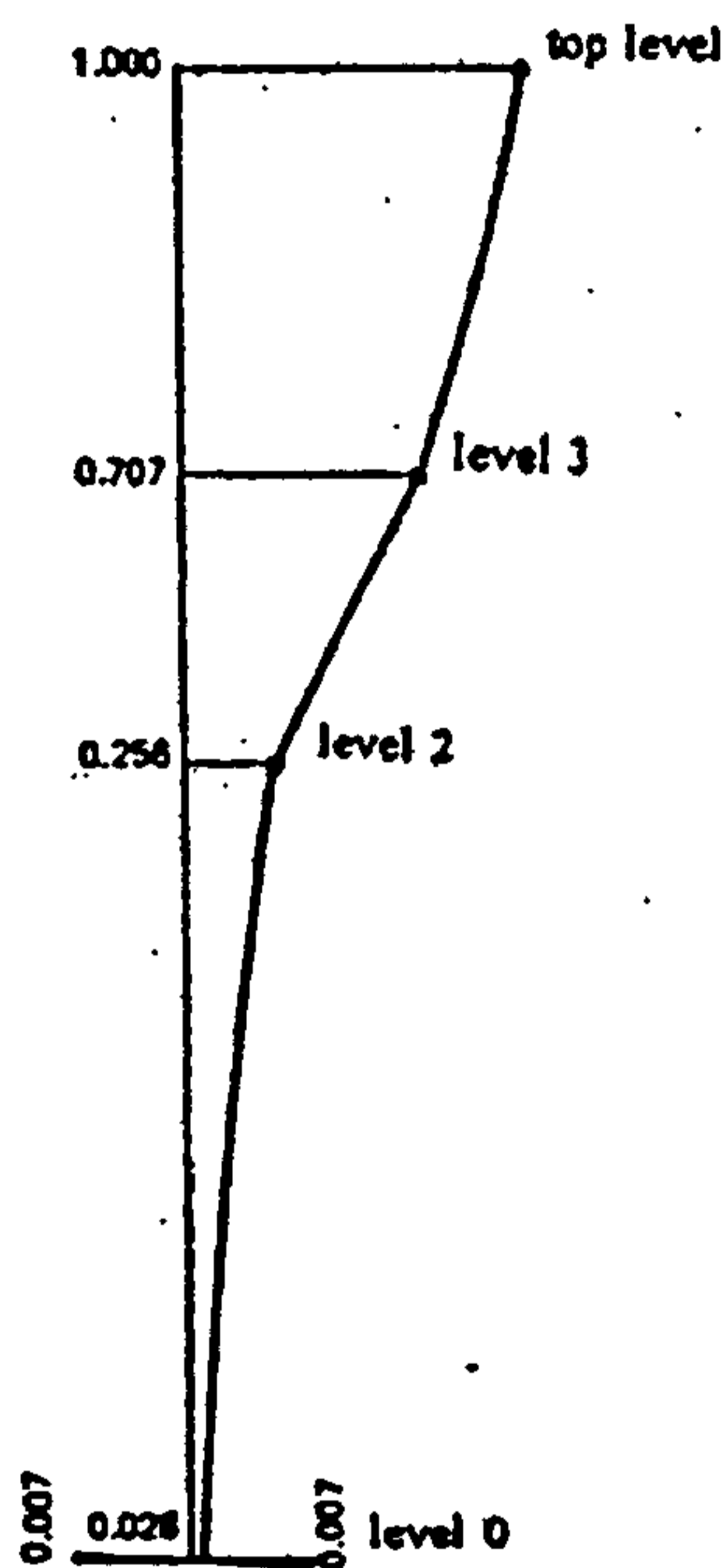

horizontal profile, level 3, $f=6.0\text{ Hz}$

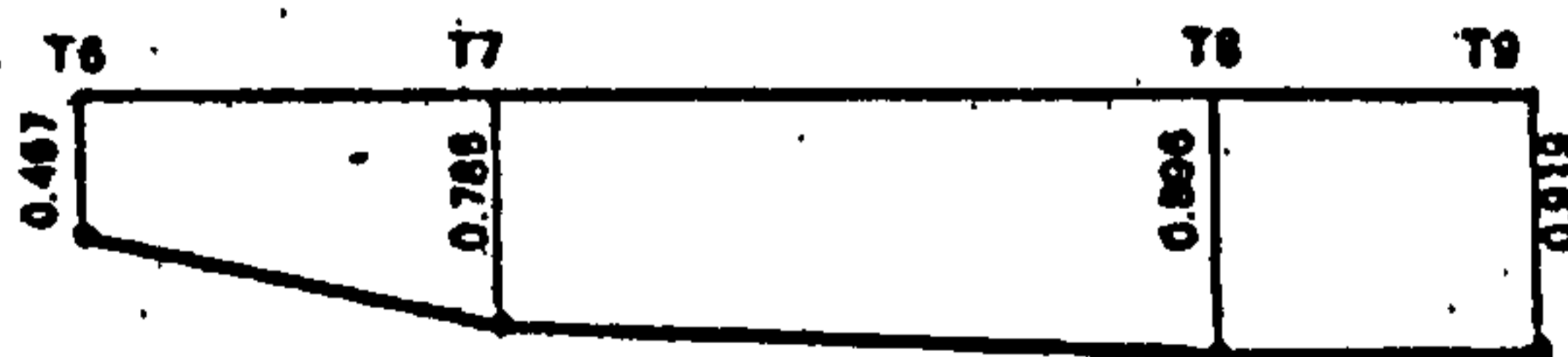

horizontal profile, level 3, $f=4.6\text{ Hz}$

Figure 5.16 *St. Bogorodica Zahumska*
 Dynamic characteristics
 Source: Volume 8 Krstevska et. al. 1992



a)

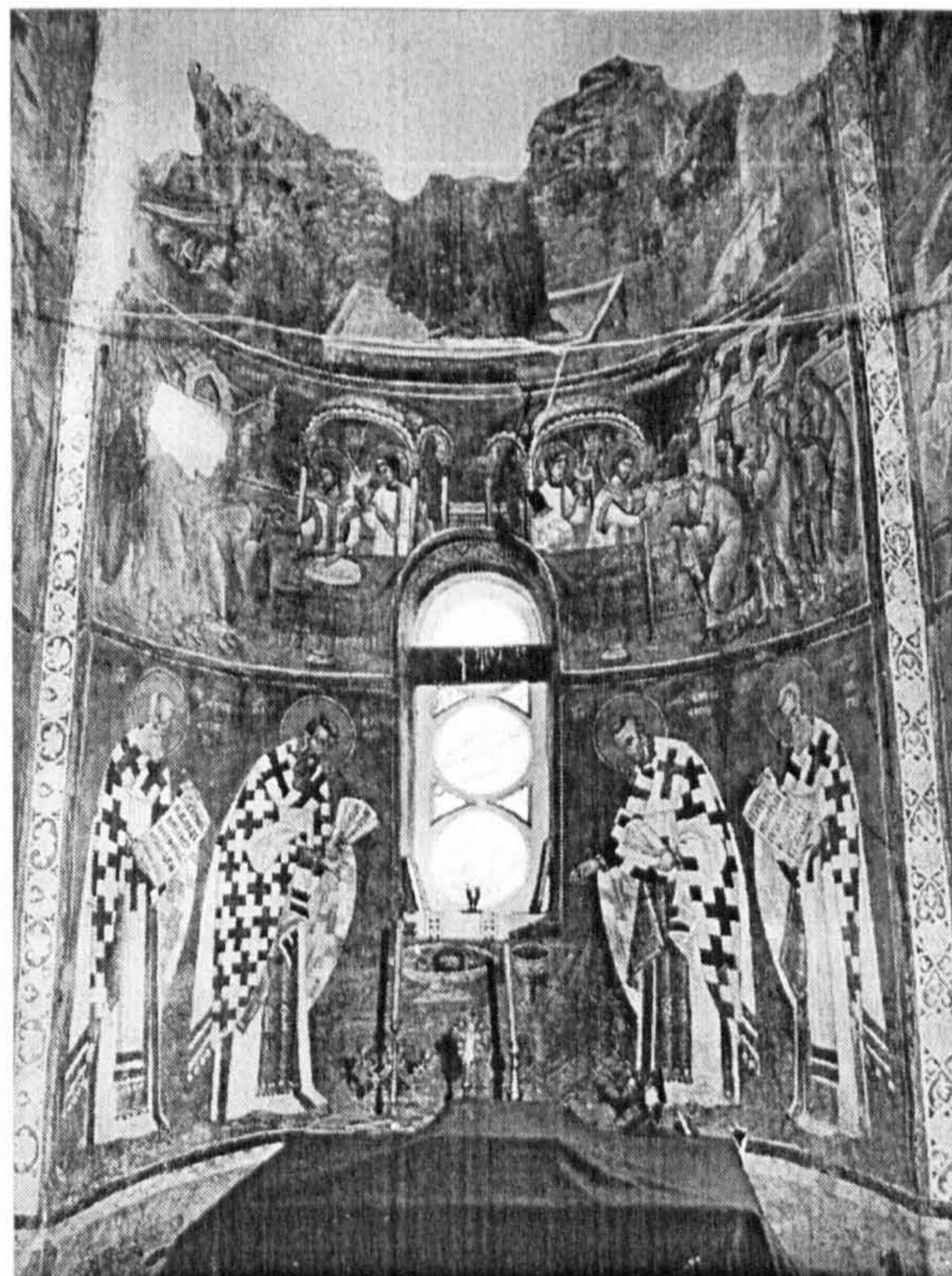

b)

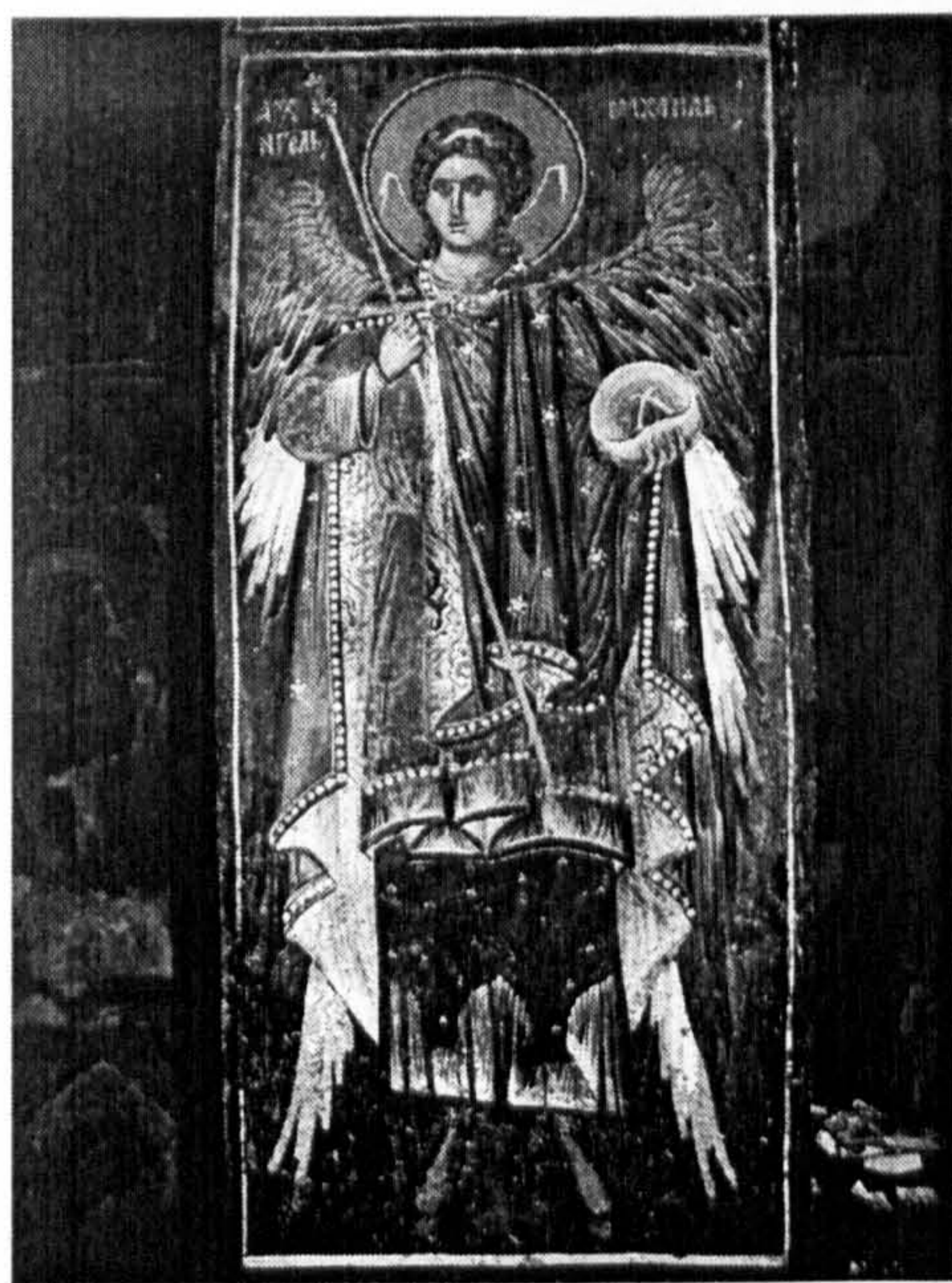

c)



d)

Figure 5.17. a) , b) and c) - St. Nikita, v. Banjani. Mural paintings.
d) - St. Georgi, v. Staro Nagoricane. Mural paintings.

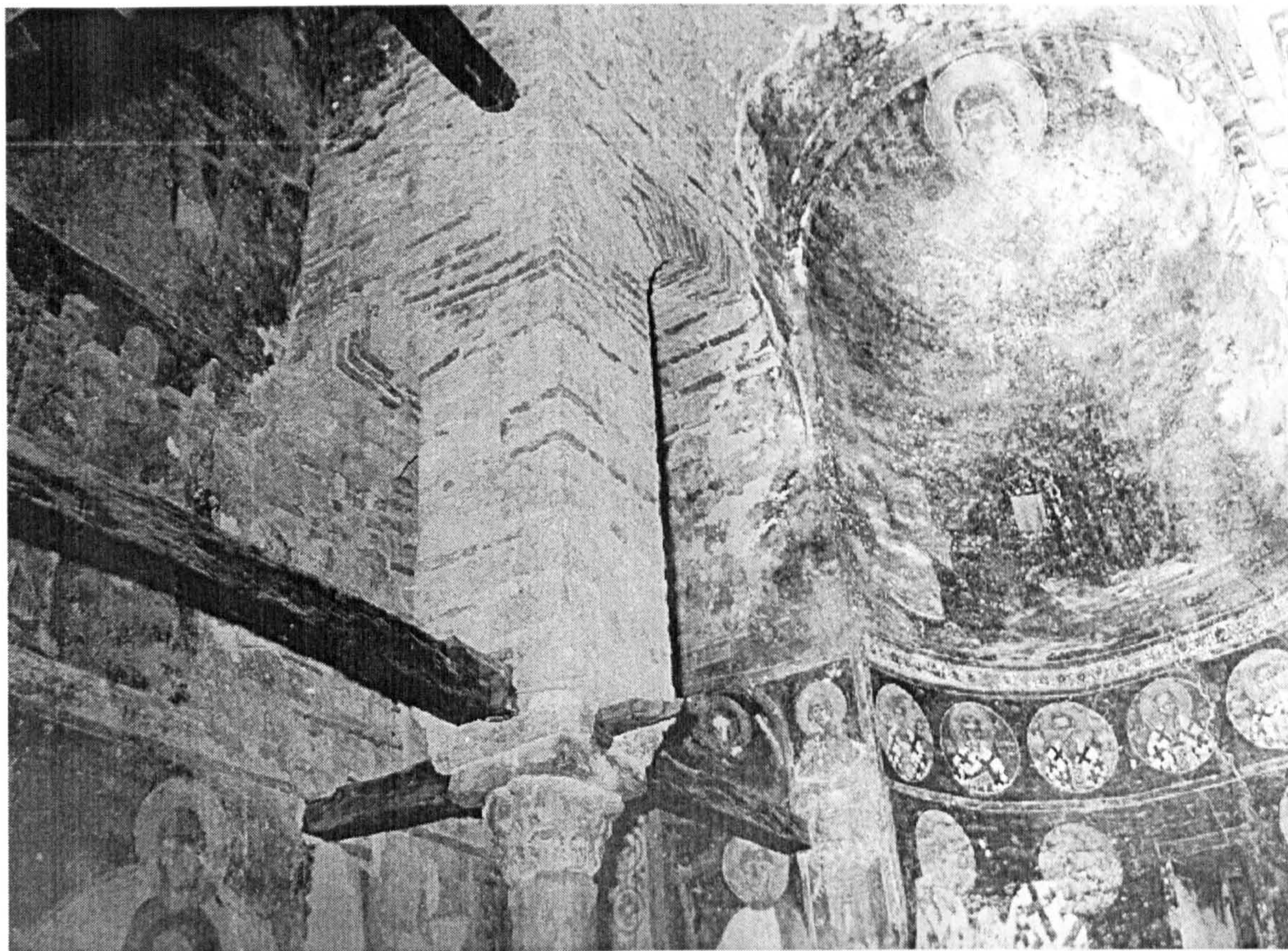

a)



b)

Figure 5.18 *St. Bogorodica Zaumska, v. Trpejca.*
 a) - Column, pier and timber ties. b) - Marble column with base and capital.

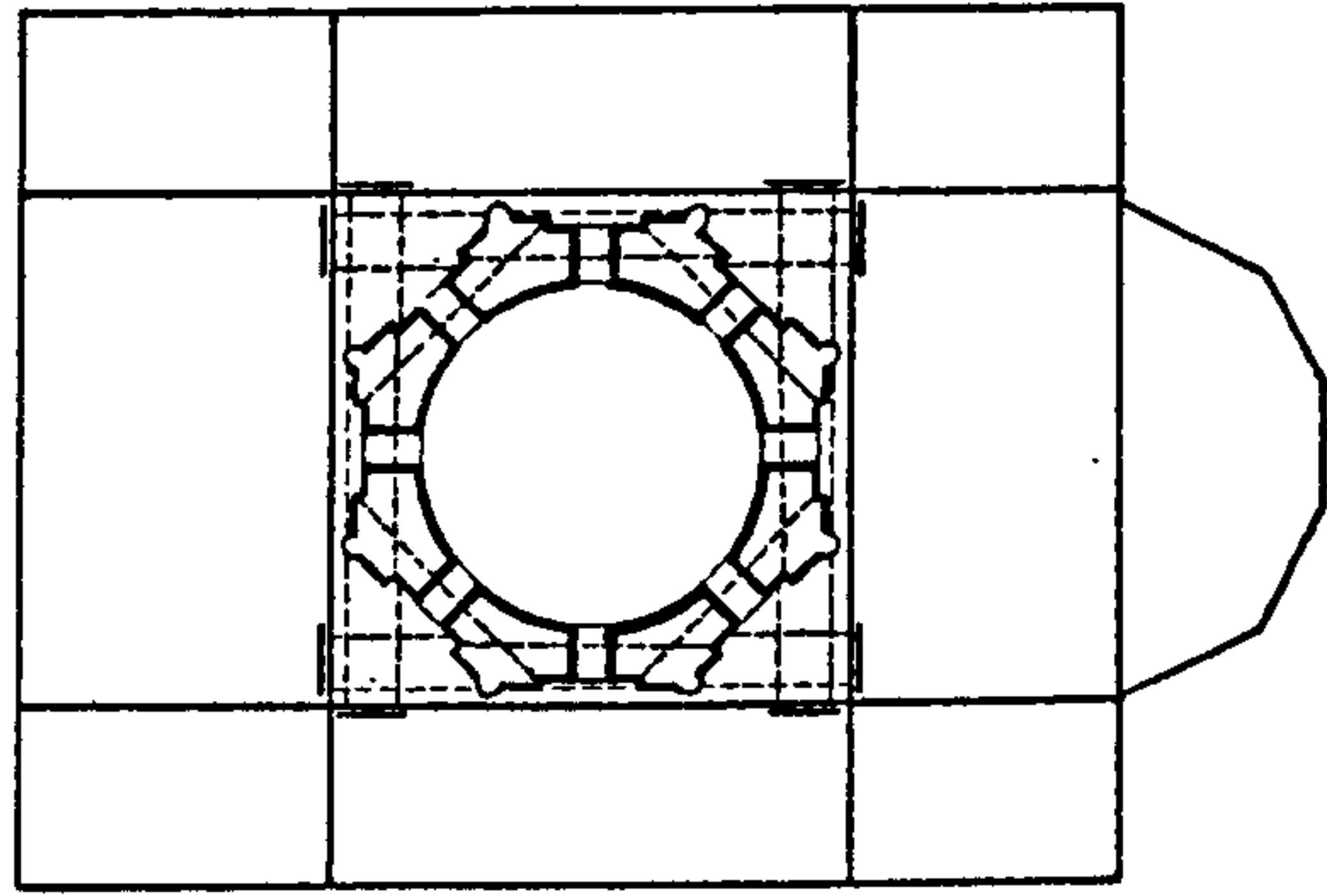

a)

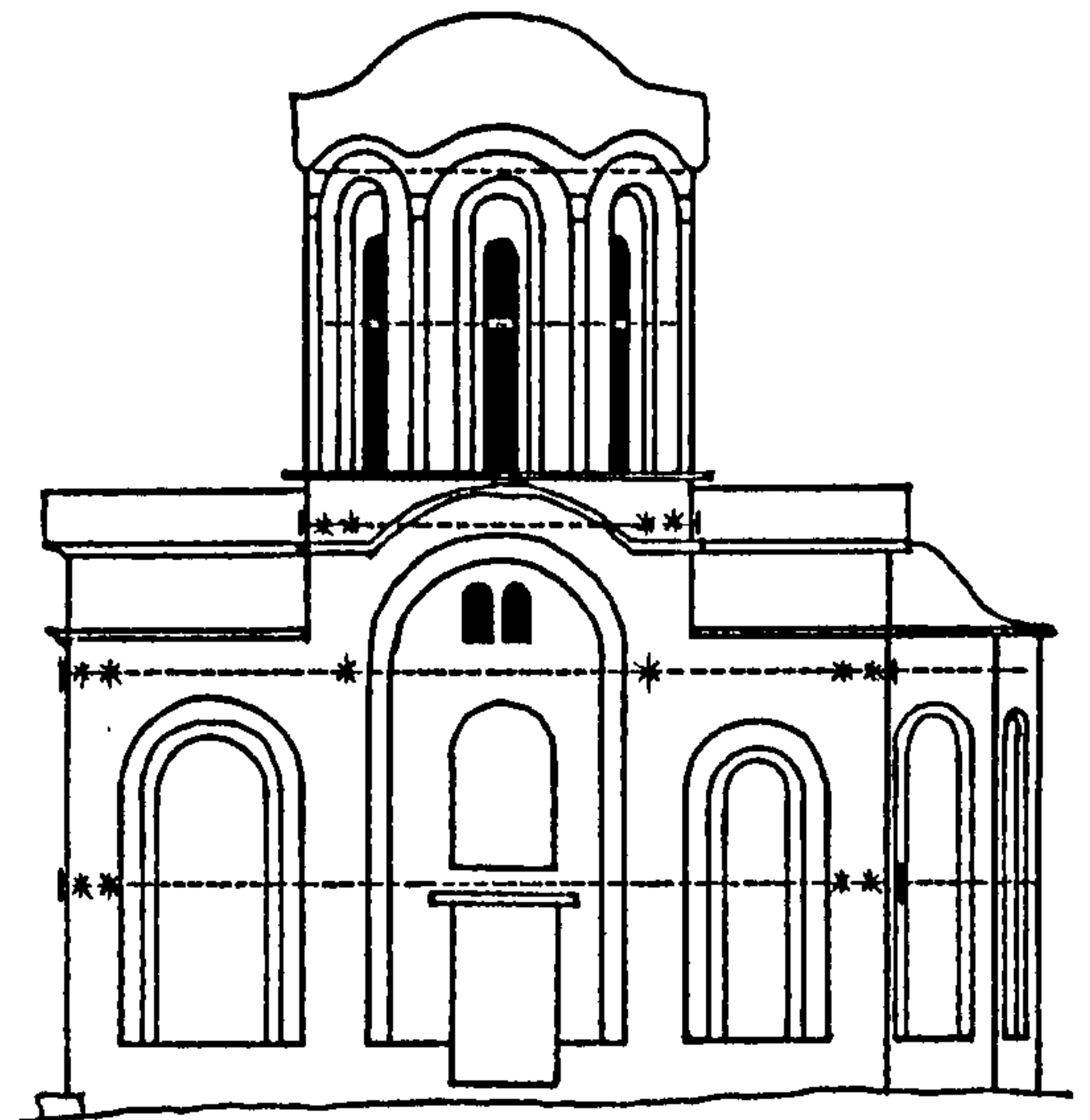

b)

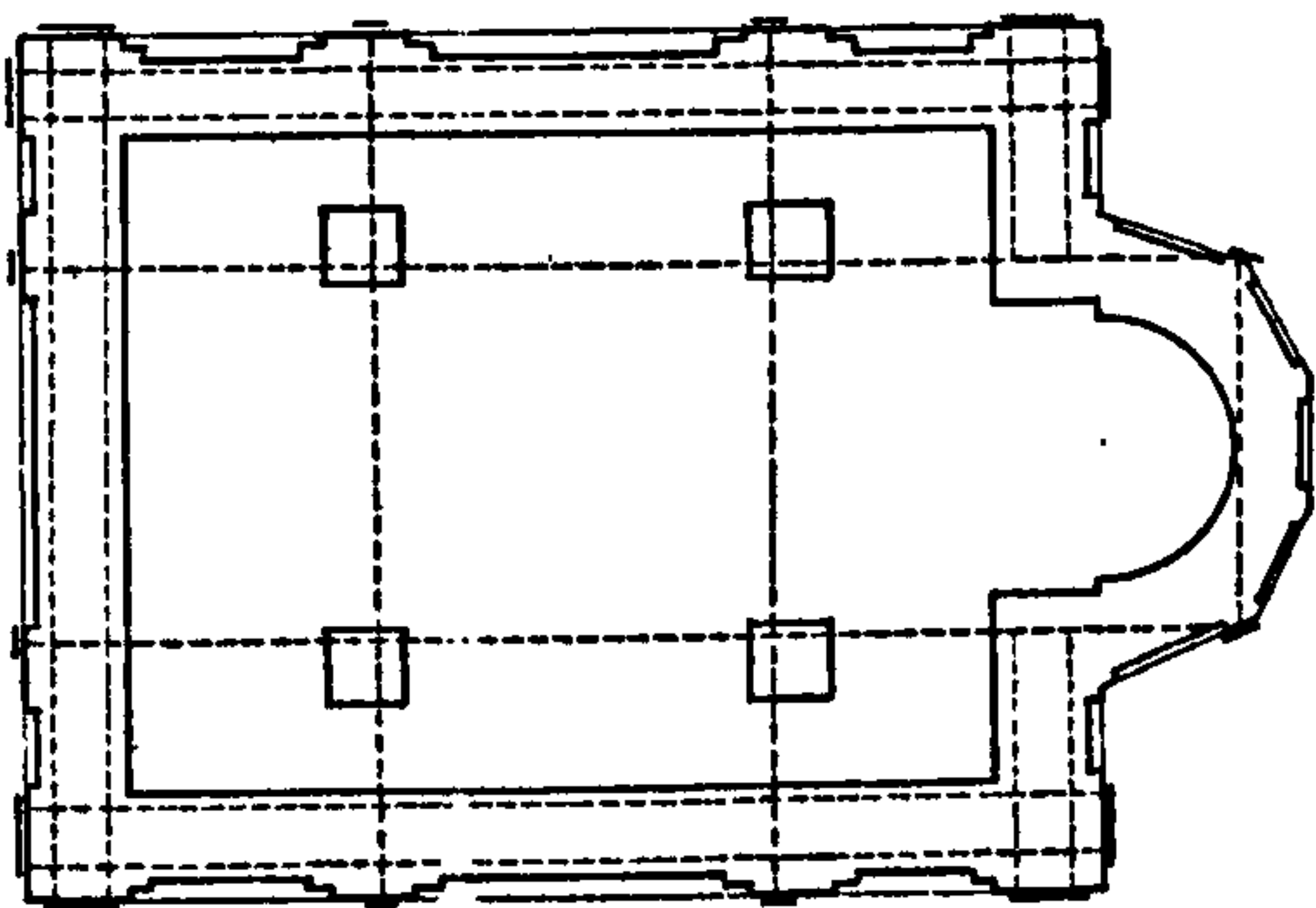

c)

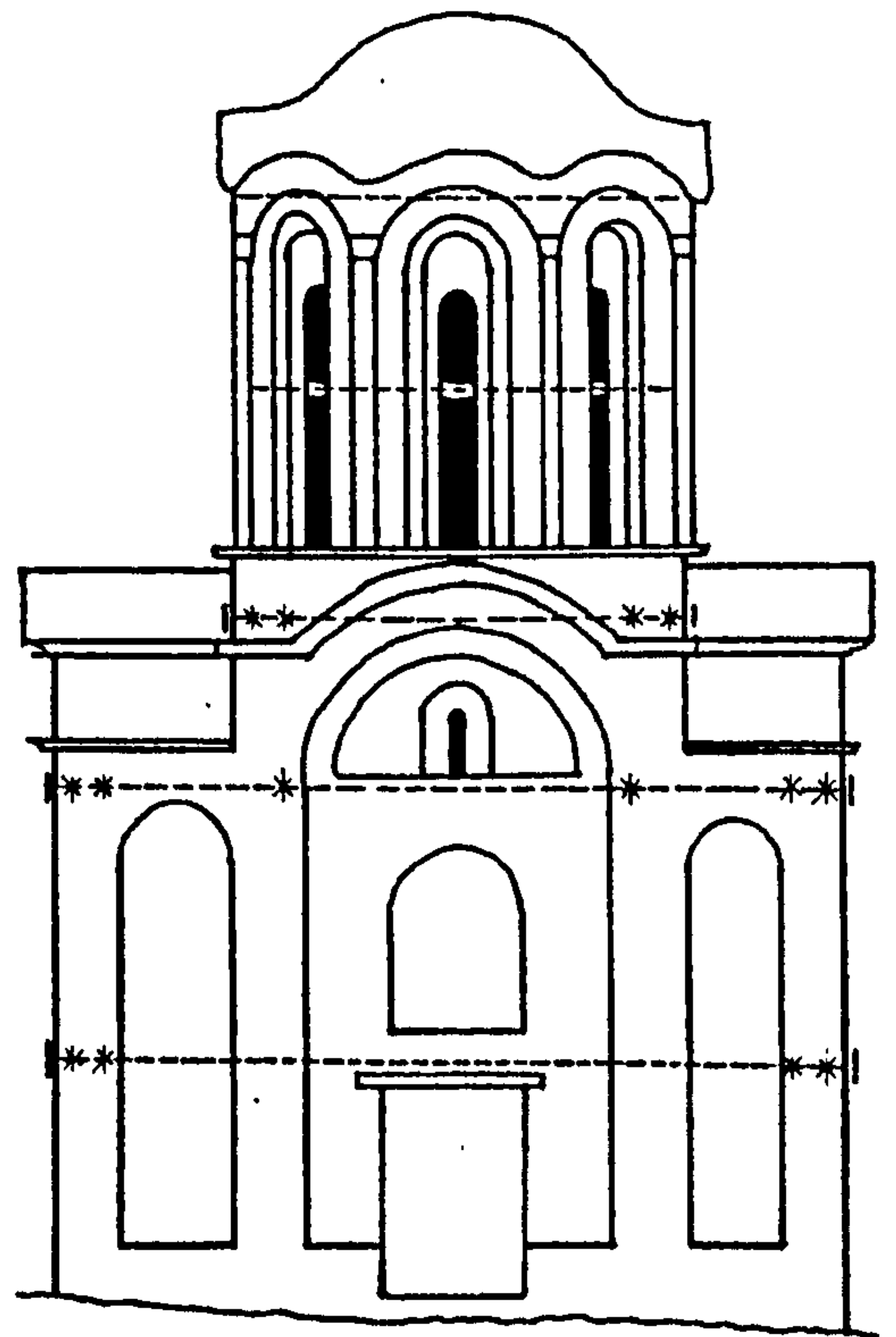

d)

Figure 5.19 *Proposed strengthening method - Variant A.*
 a) - Drum section; b) - Southern facade; c) - Ground plan; d) - Western facade.

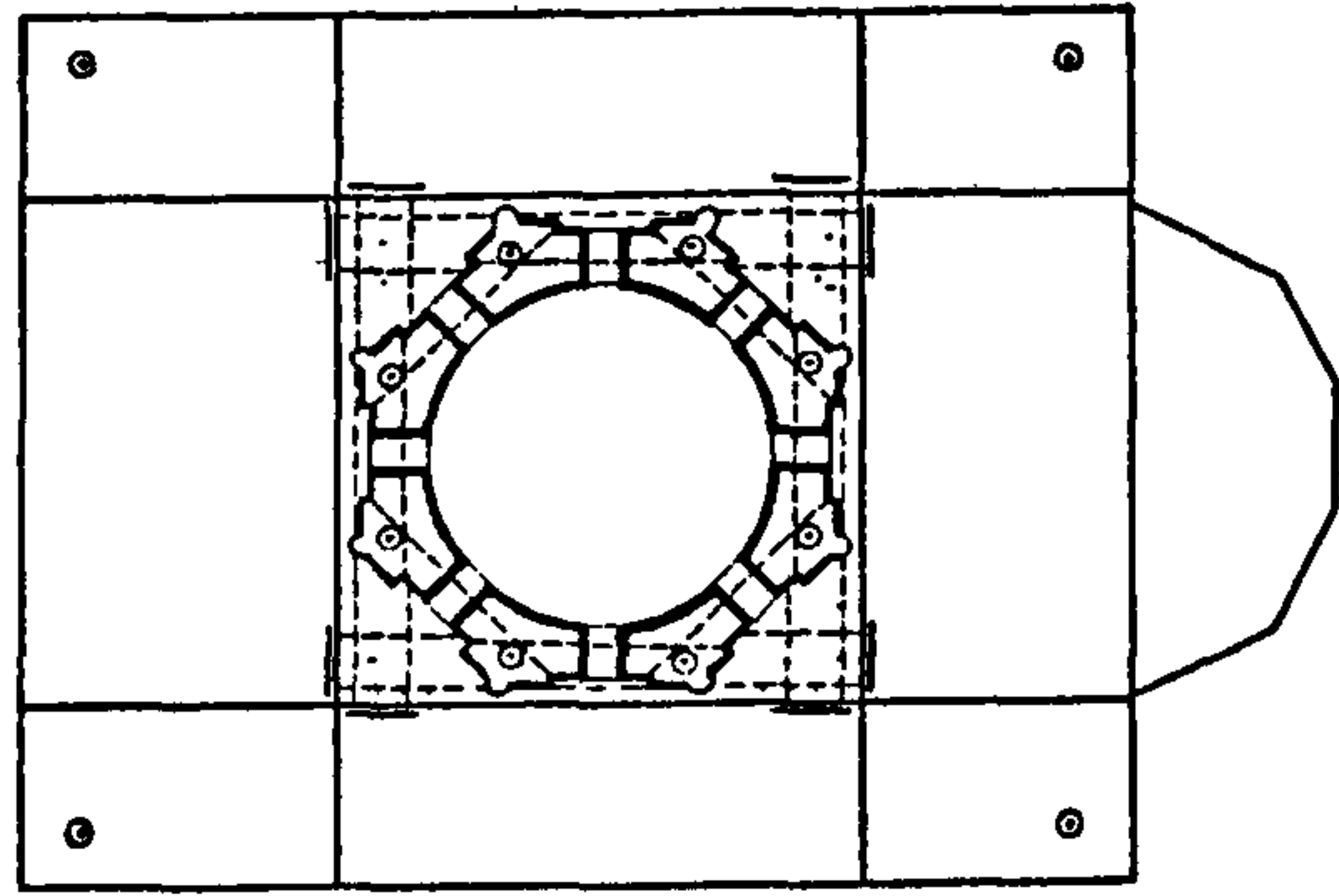

a)

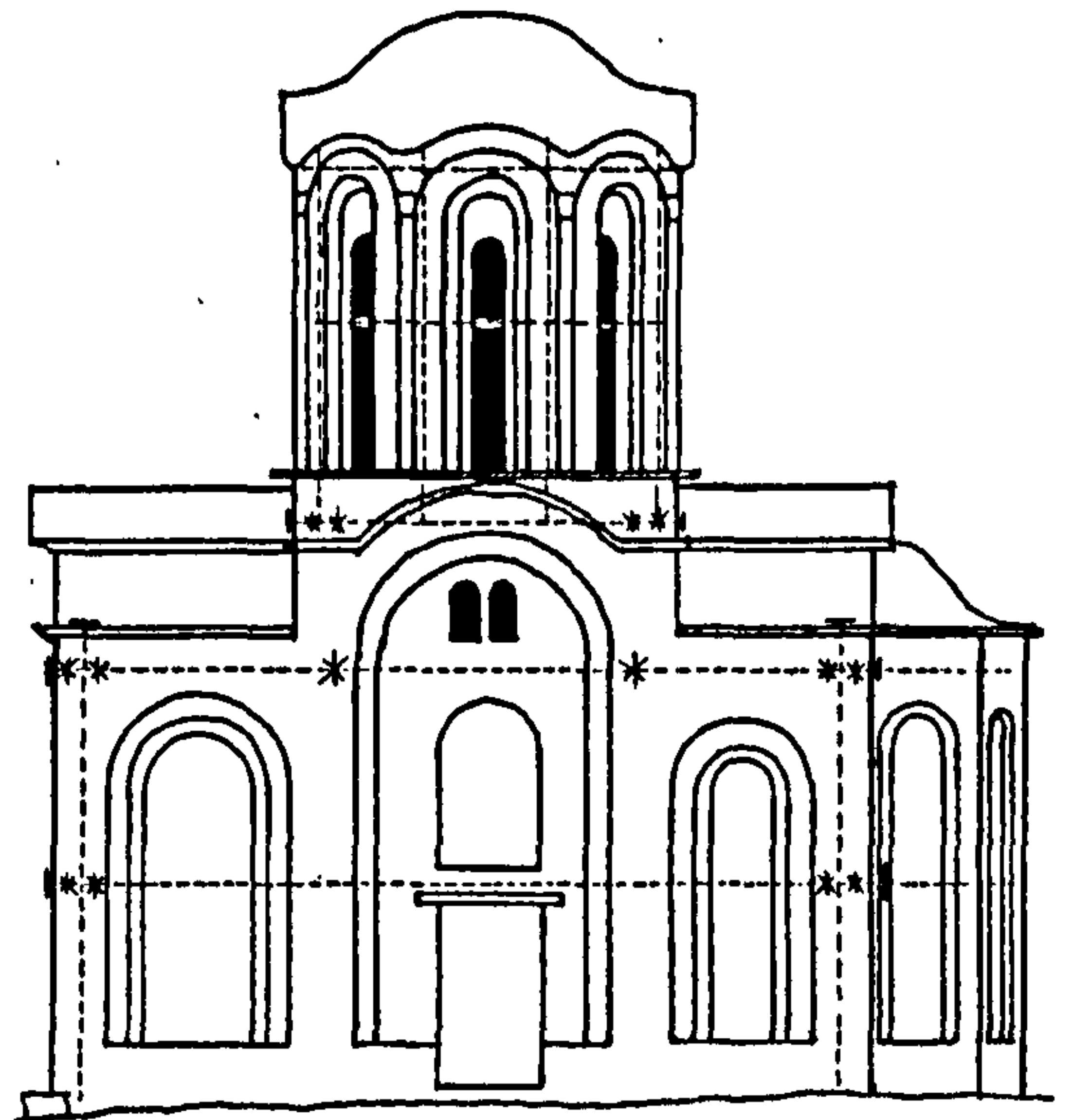

b)

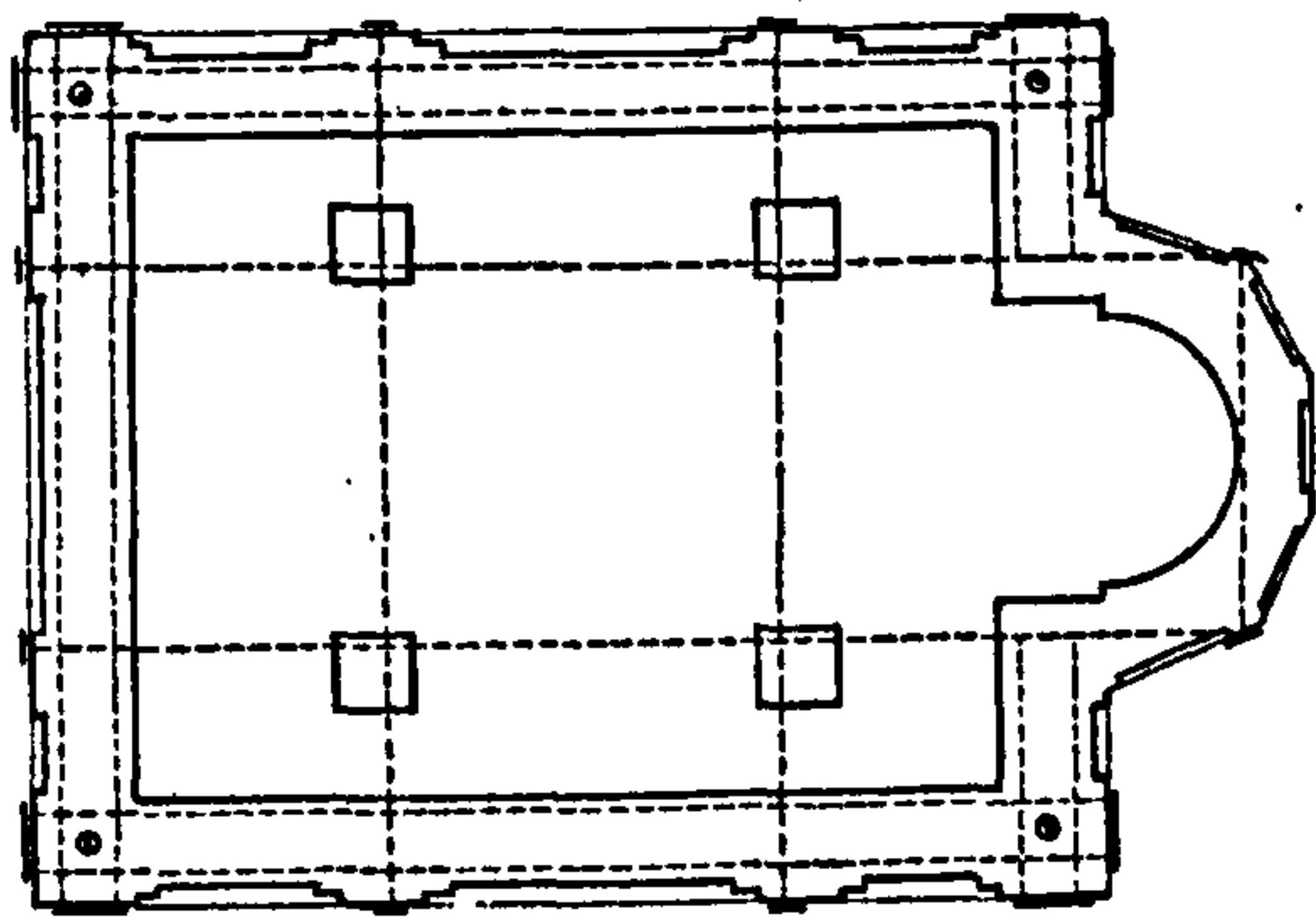

c)

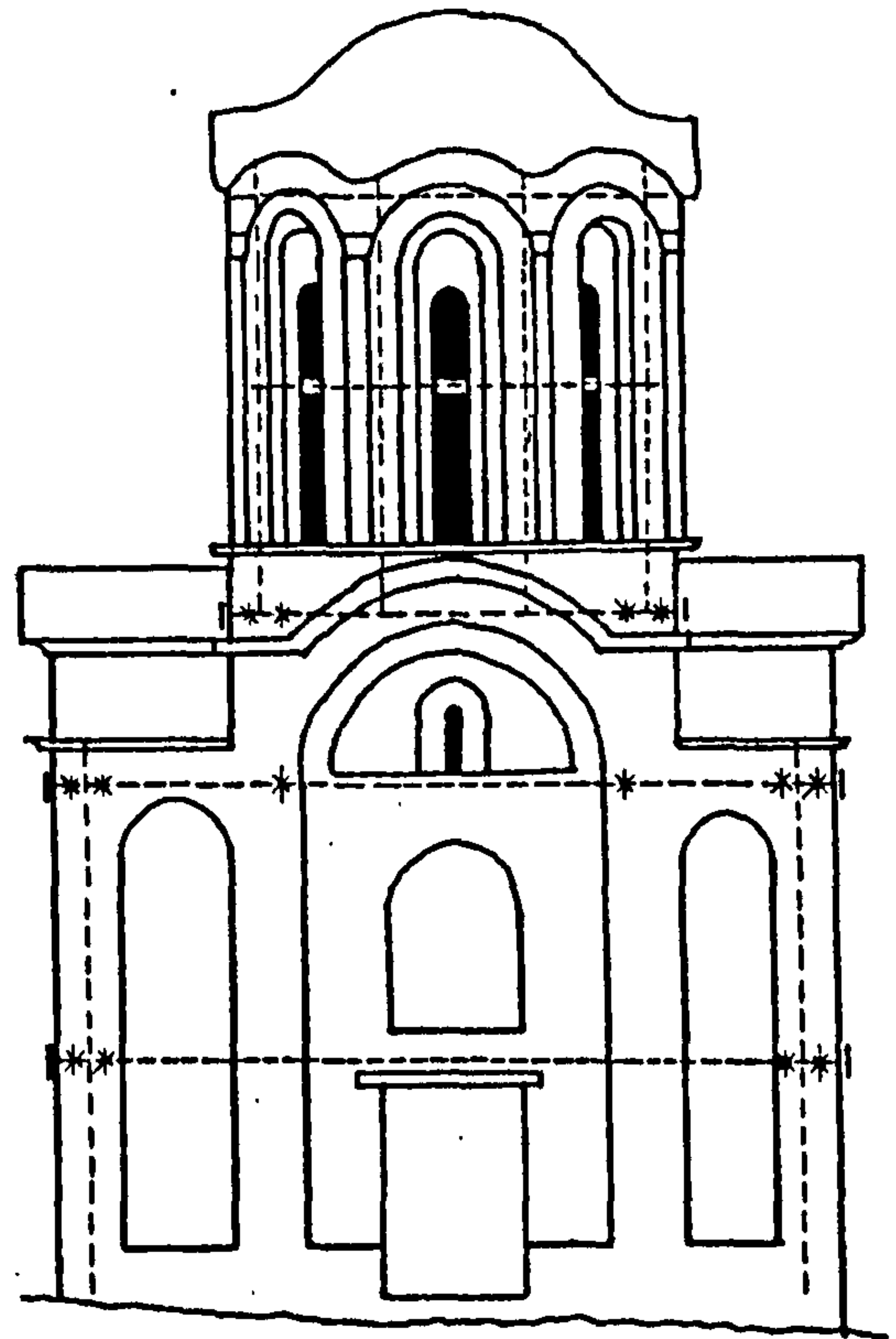

d)

Figure 5.20 *Proposed strengthening method - Variant B*
 a) - Drum section; b) - Southern facade; c) - Ground plan; d) - Western facade.

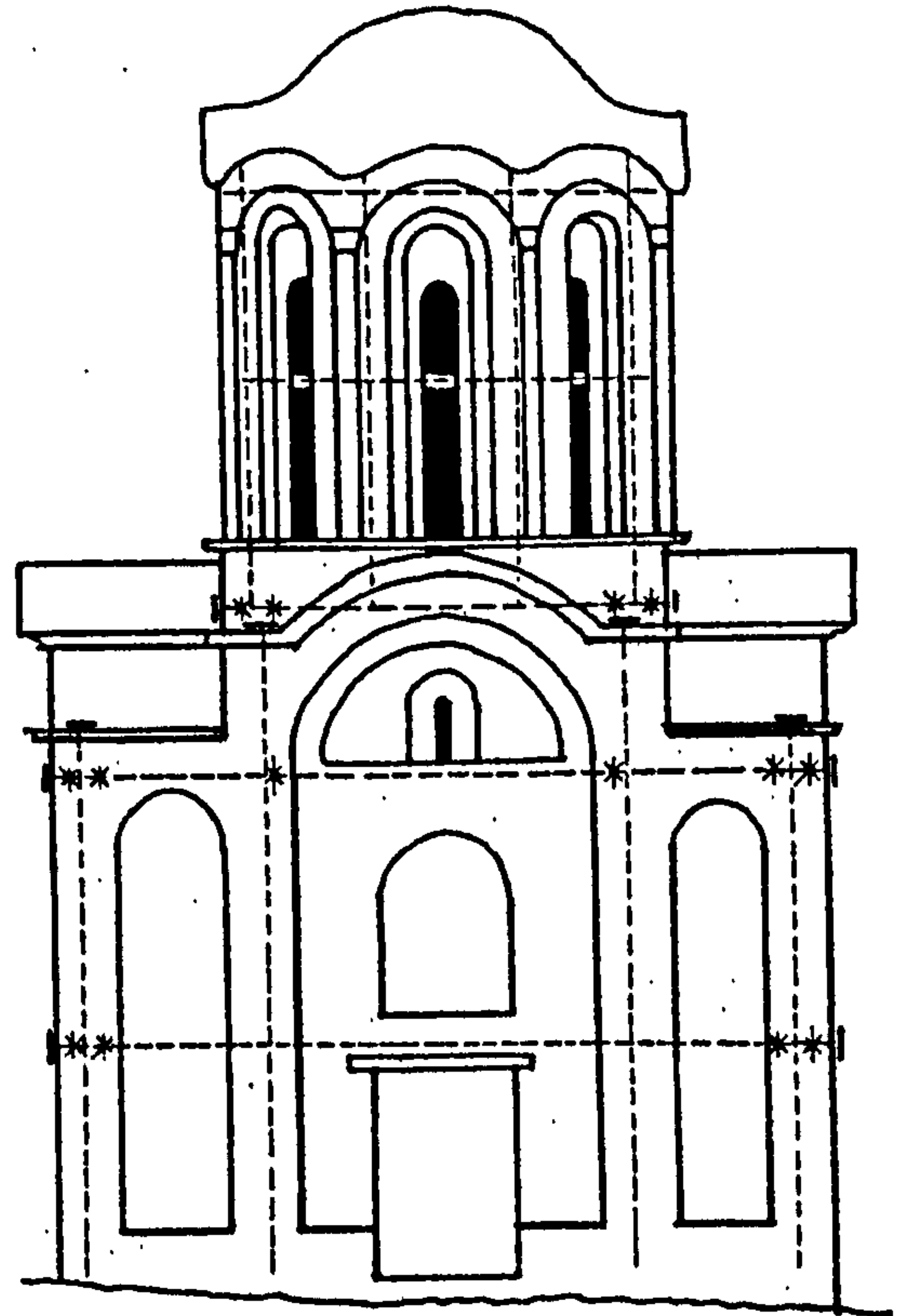
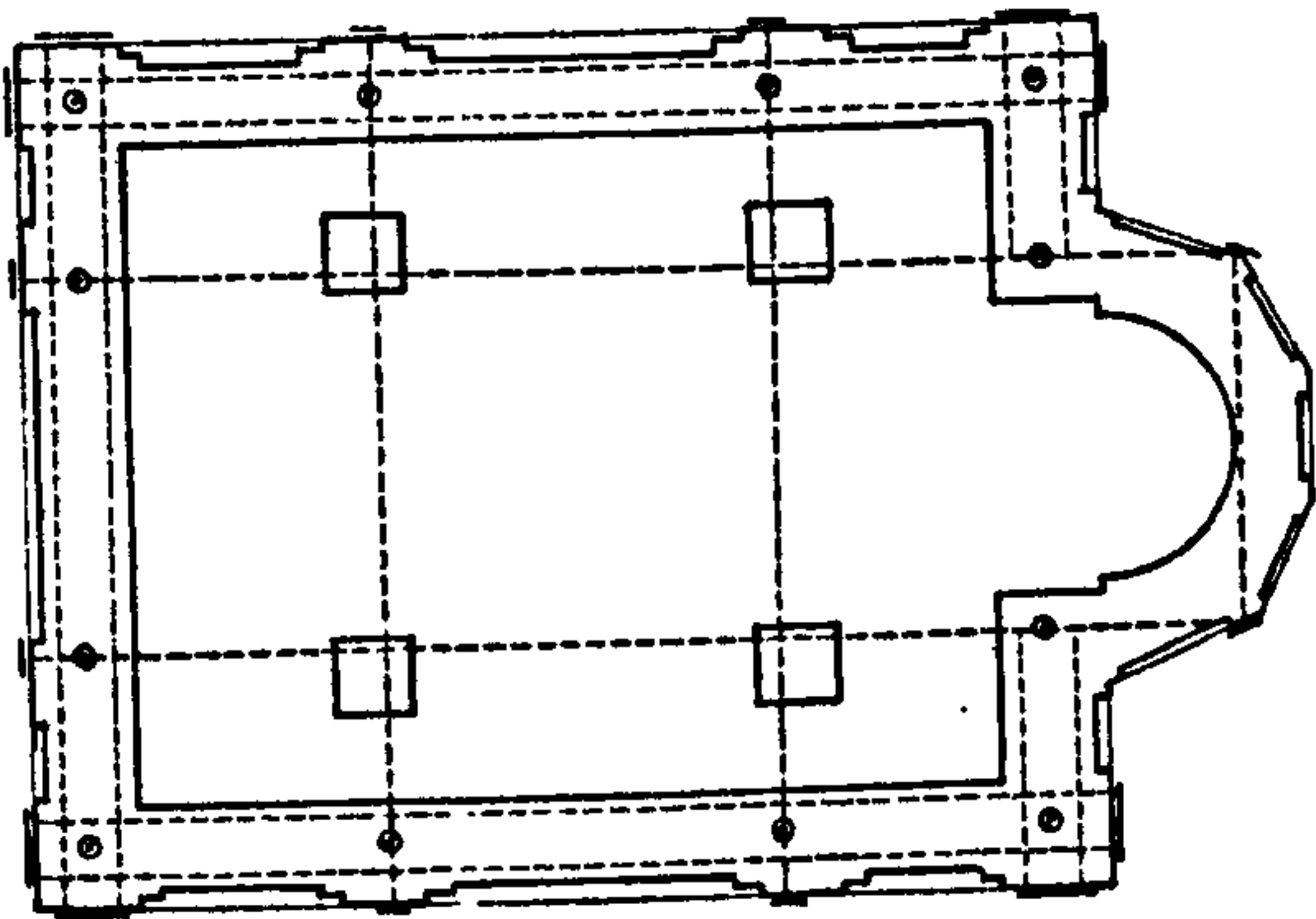
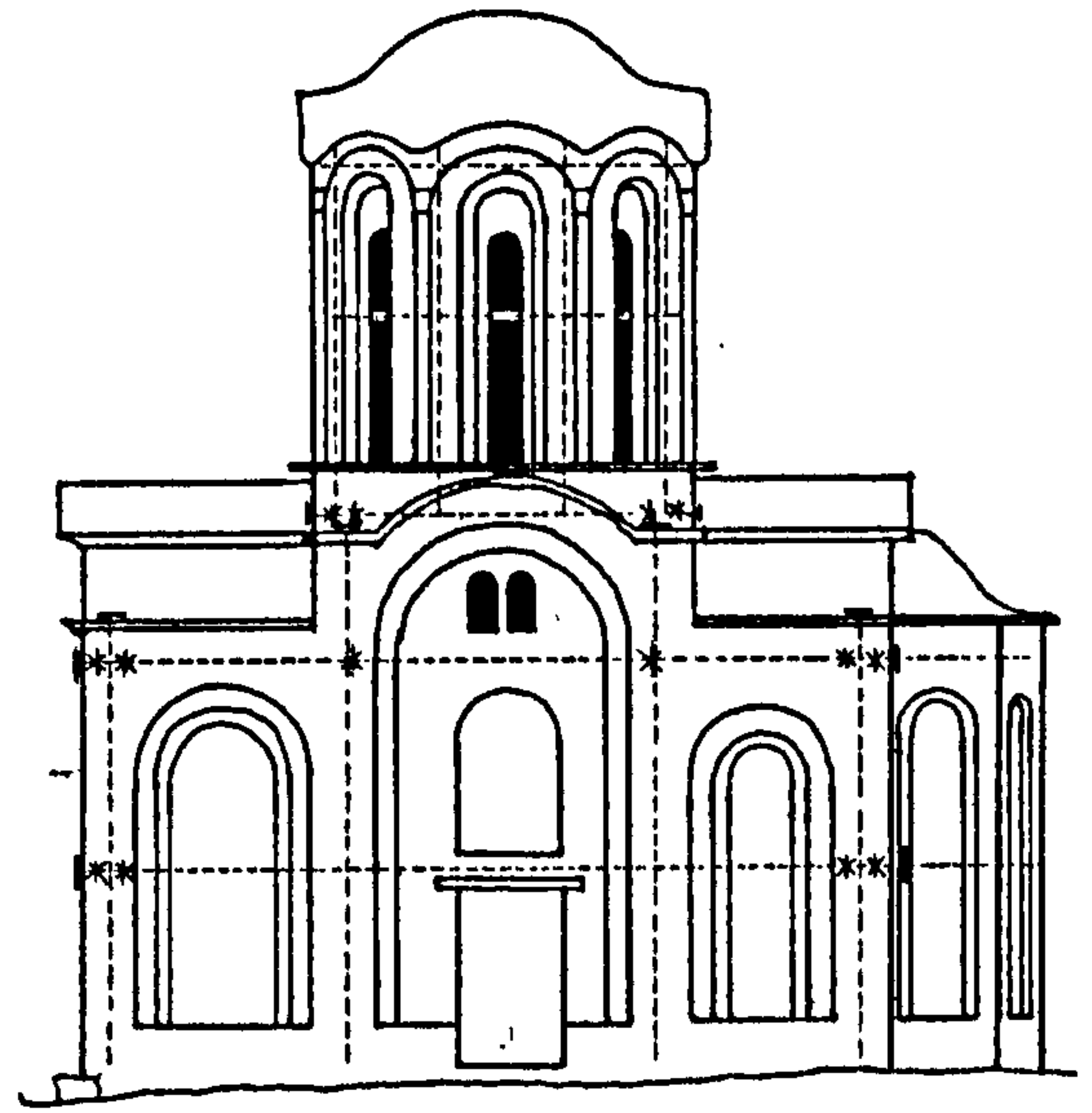
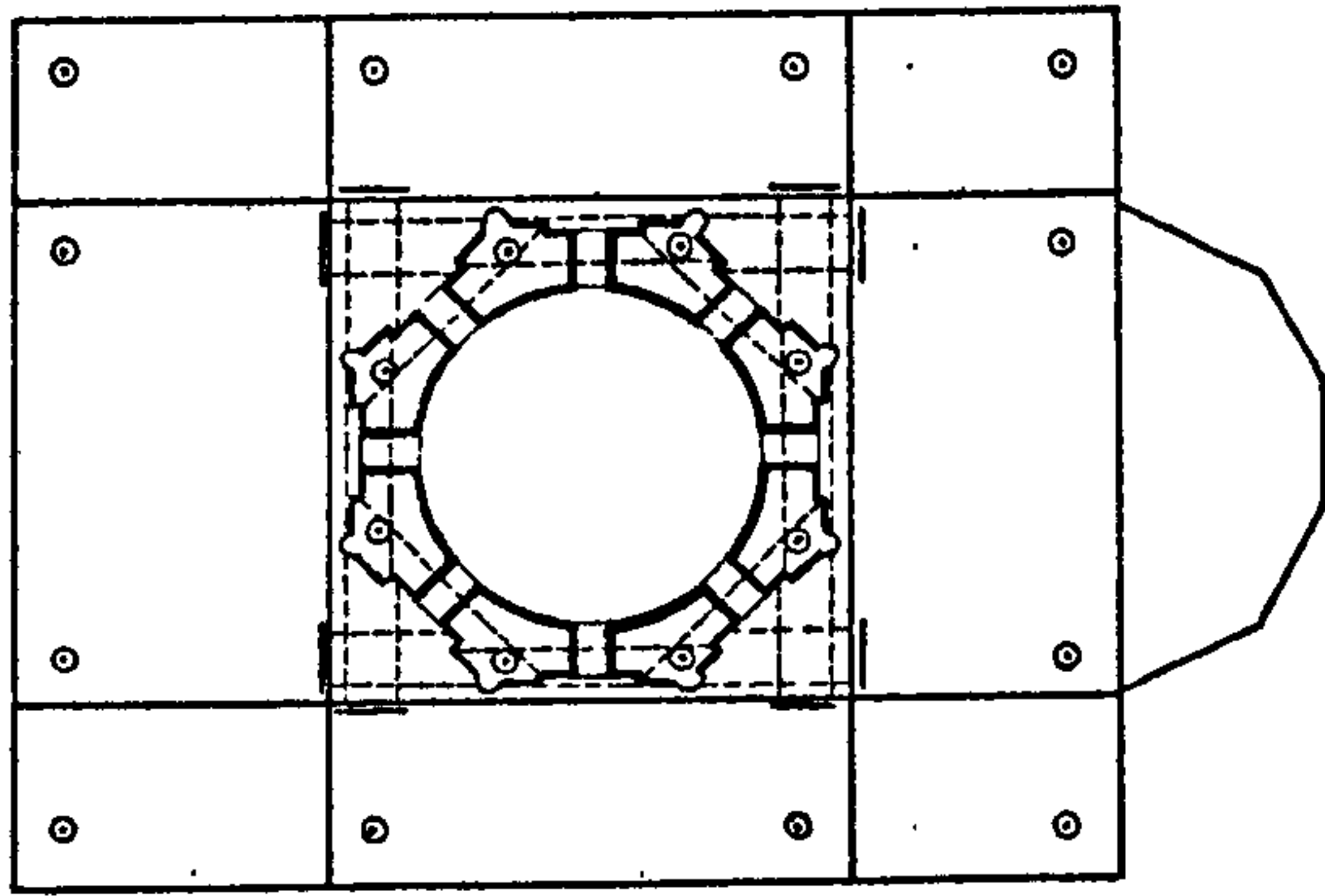
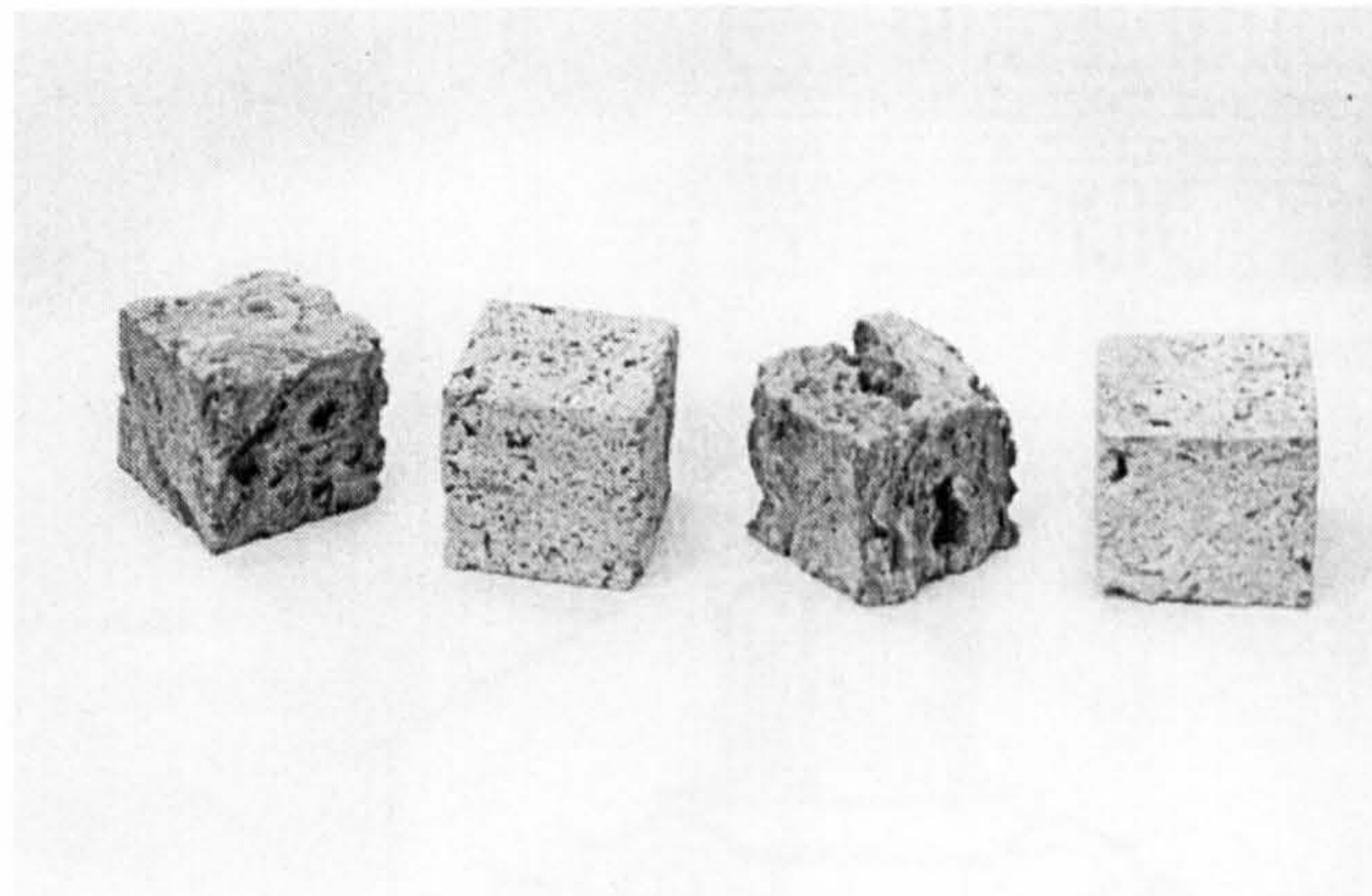

Figure 5.21 *Proposed strengthening method - Variant C*
 a) - Drum section; b) - Southern facade; c) - Ground plan; d) - Western facade.



a)



b)

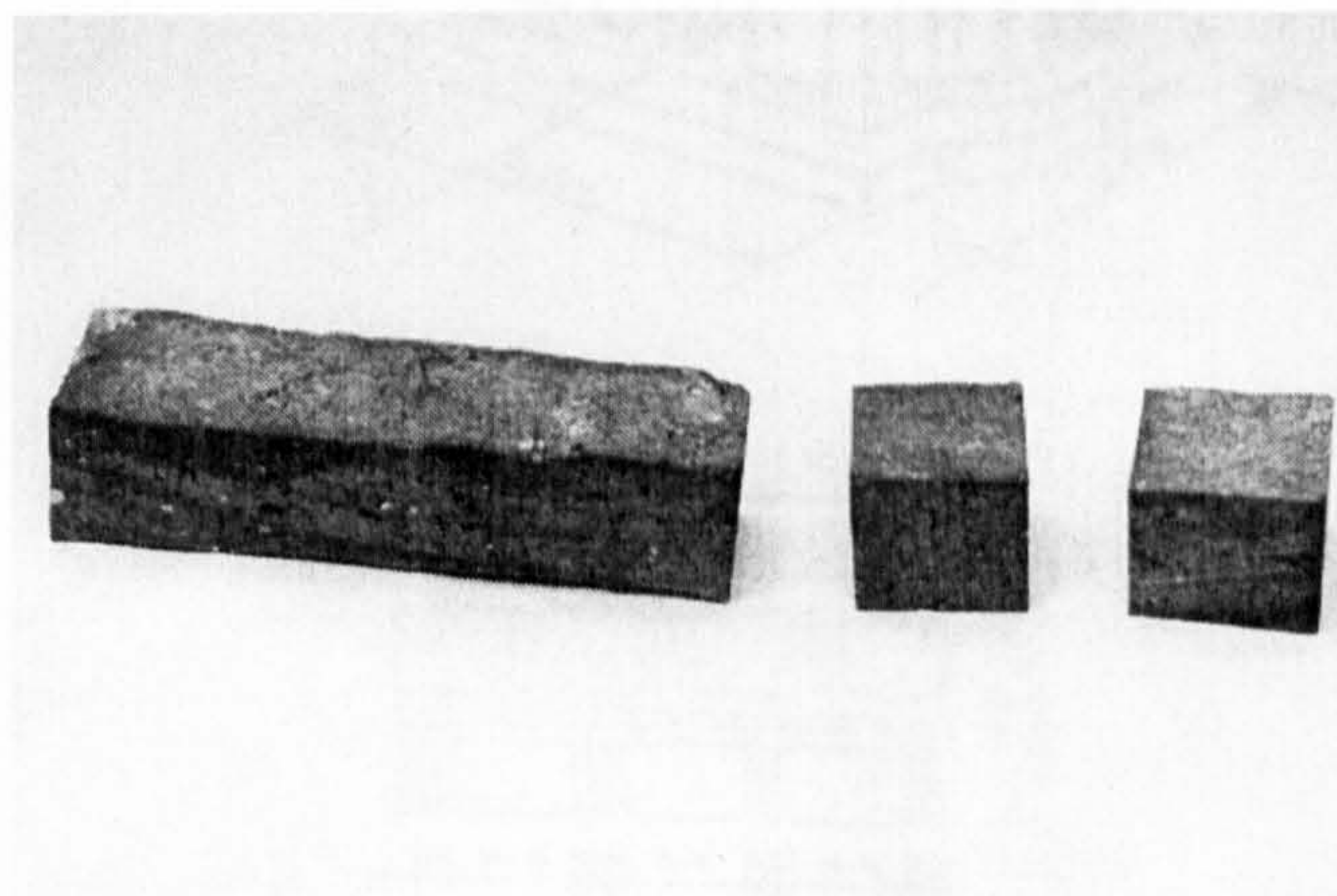

c)

Figure 5.22 *St. Nikita, v. Banjani.*
a) - Samples of mortar; b) - Samples of tuff stone; c) - Samples of bricks, prepared for experimental investigation.

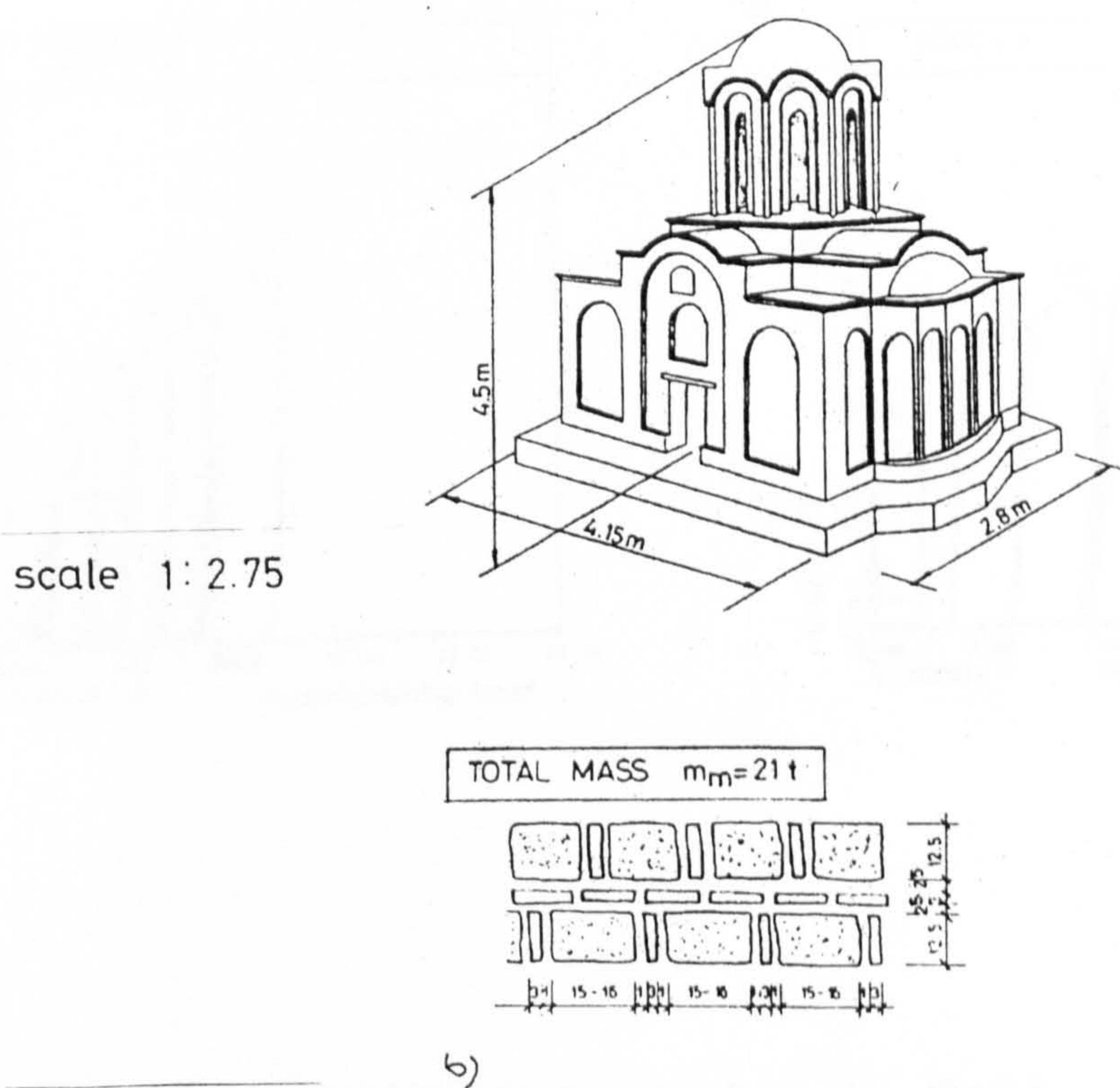
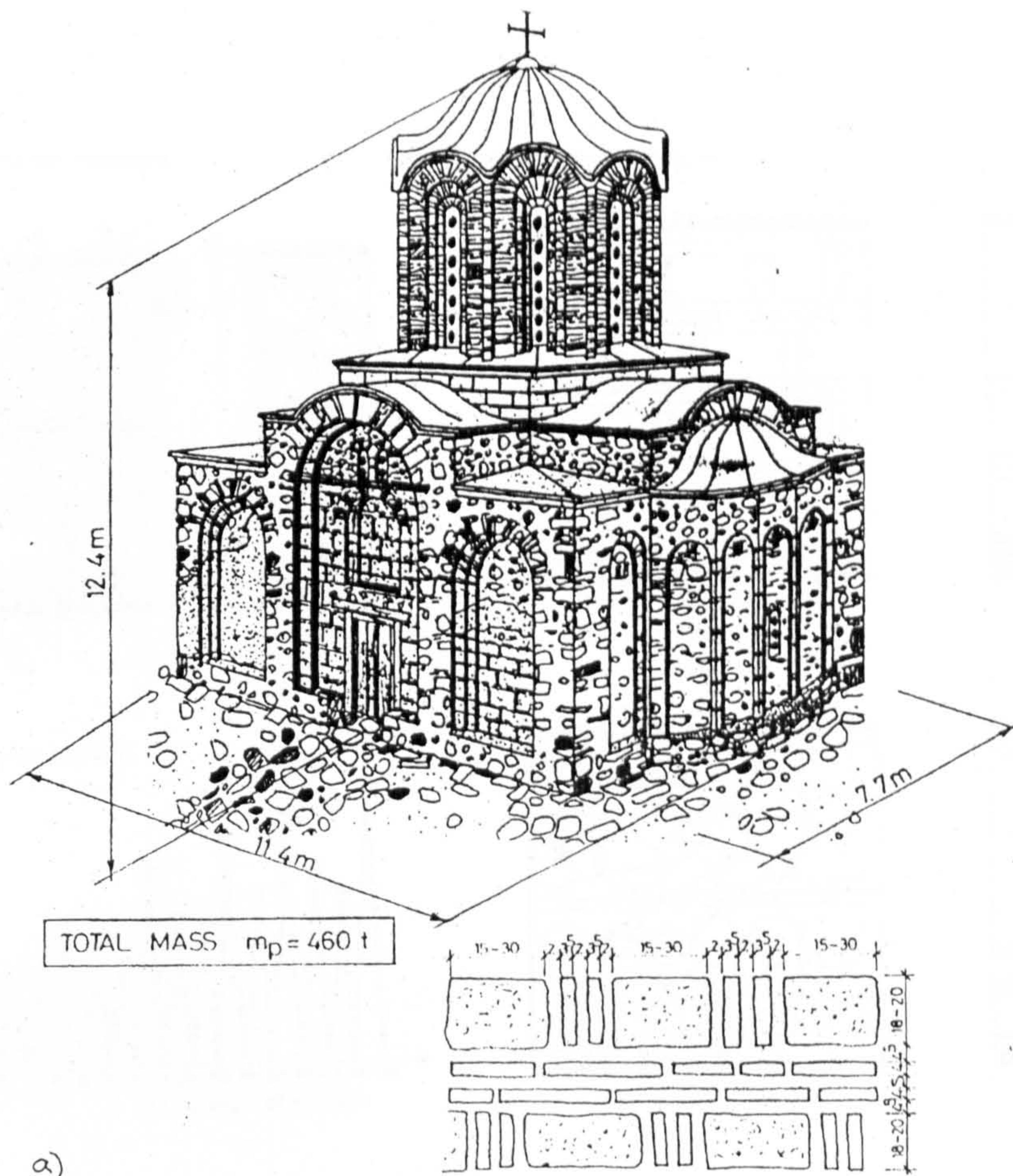

Figure 5.23 Comparison between the original church and the model.

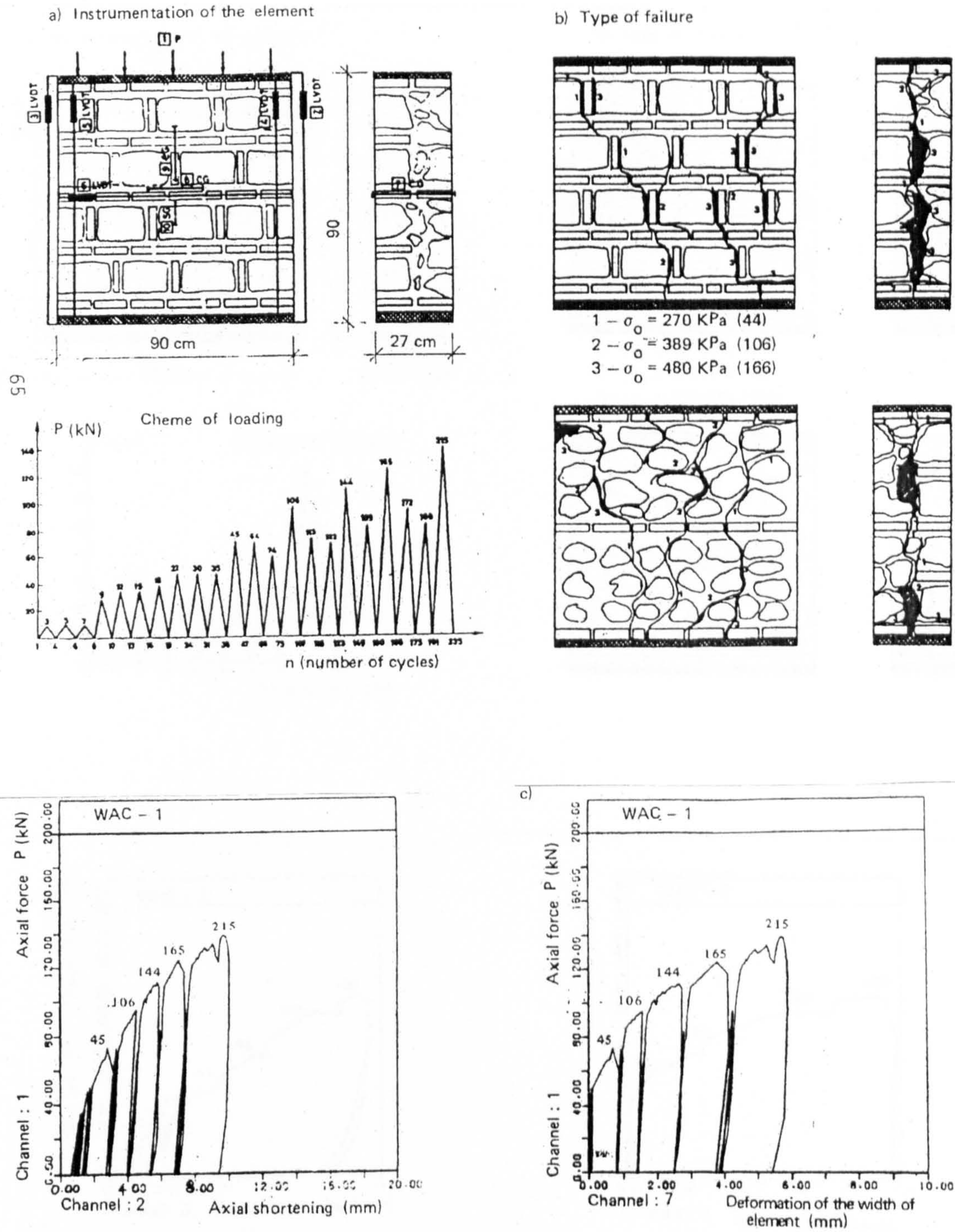

Figure 5.24 Experimental investigation of wall samples - WAC 1.
 Source: Volume 10.

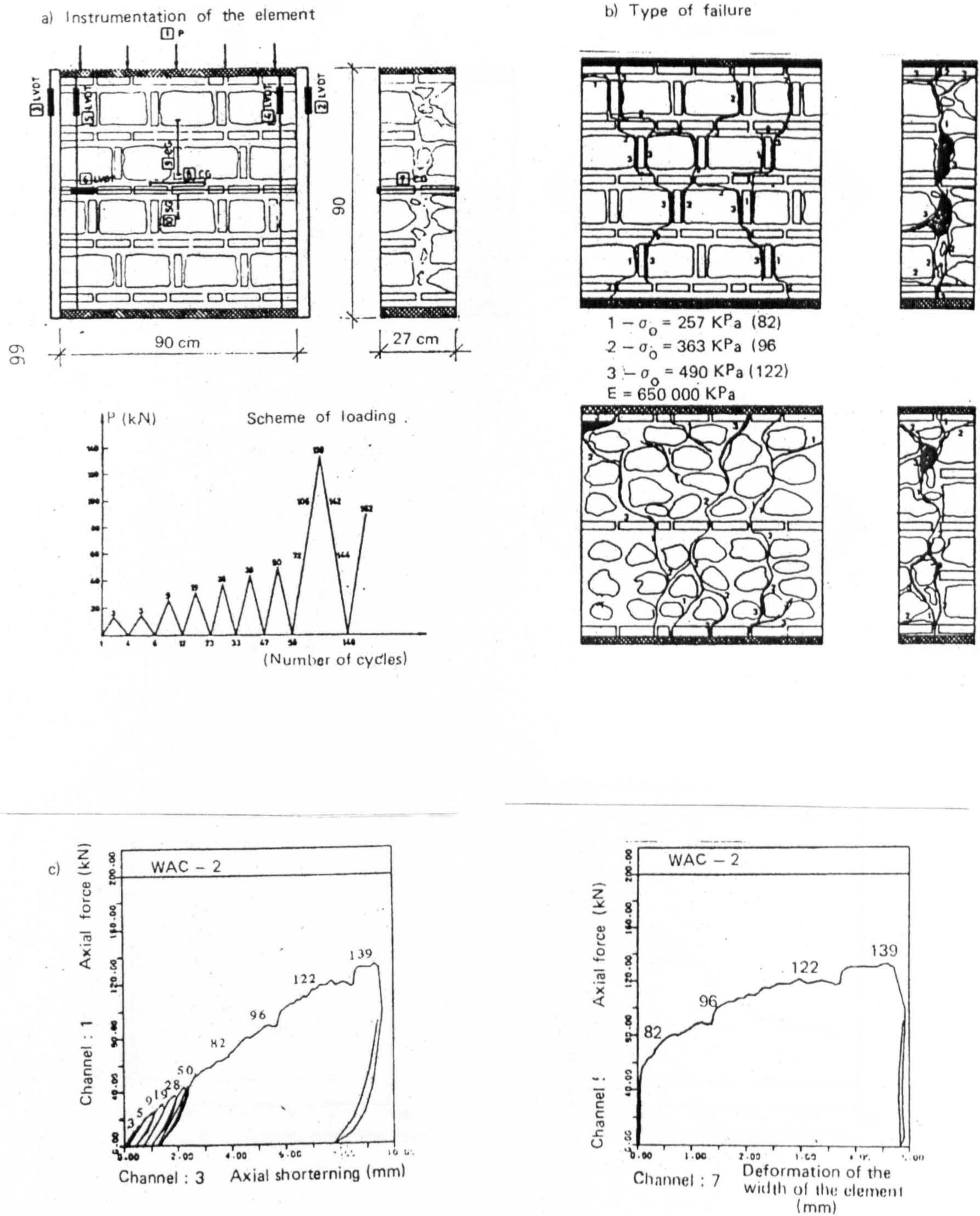

Figure 5.25 Experimental investigation of wall samples - WAC 2.
 Source: Volume 10.

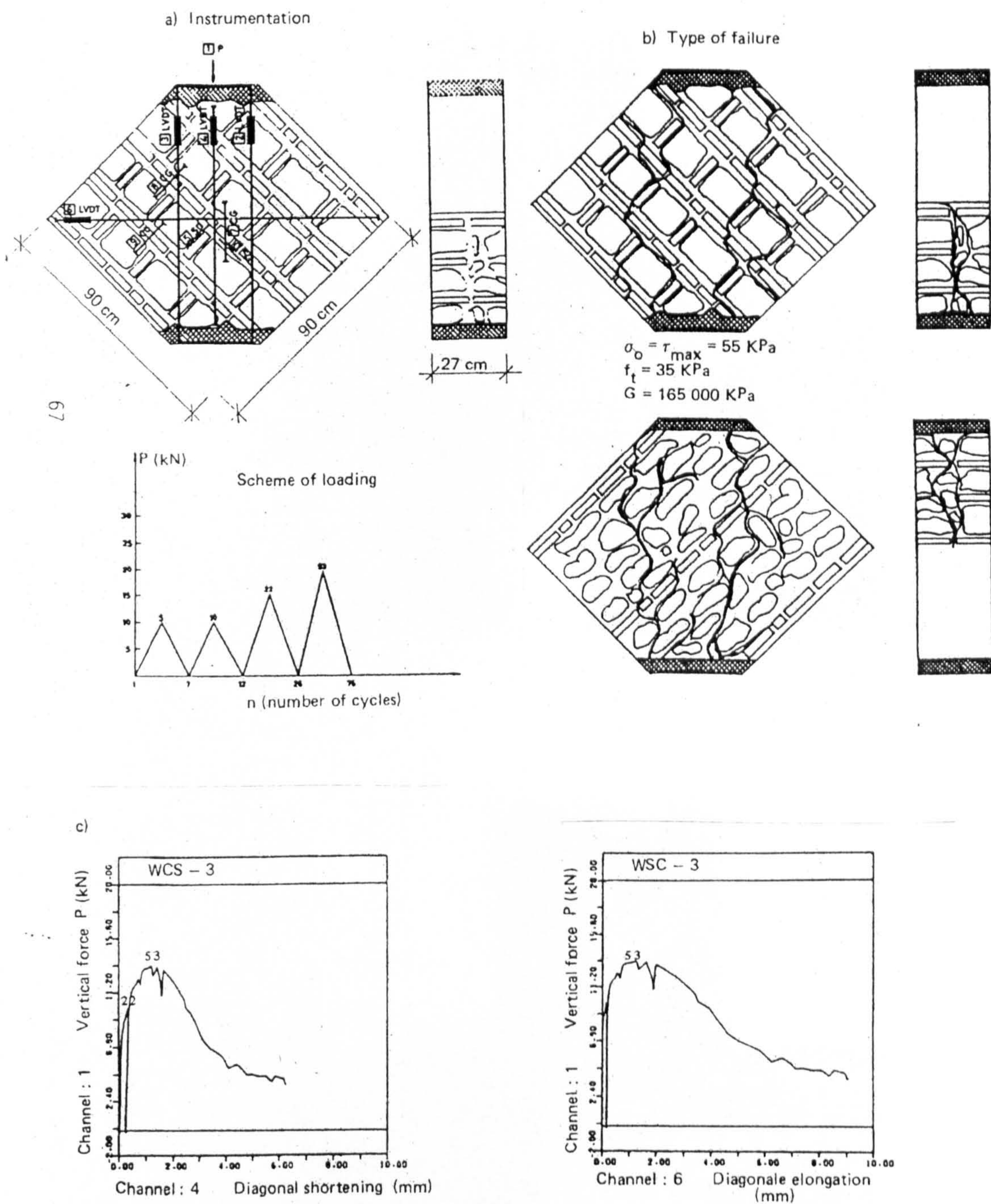
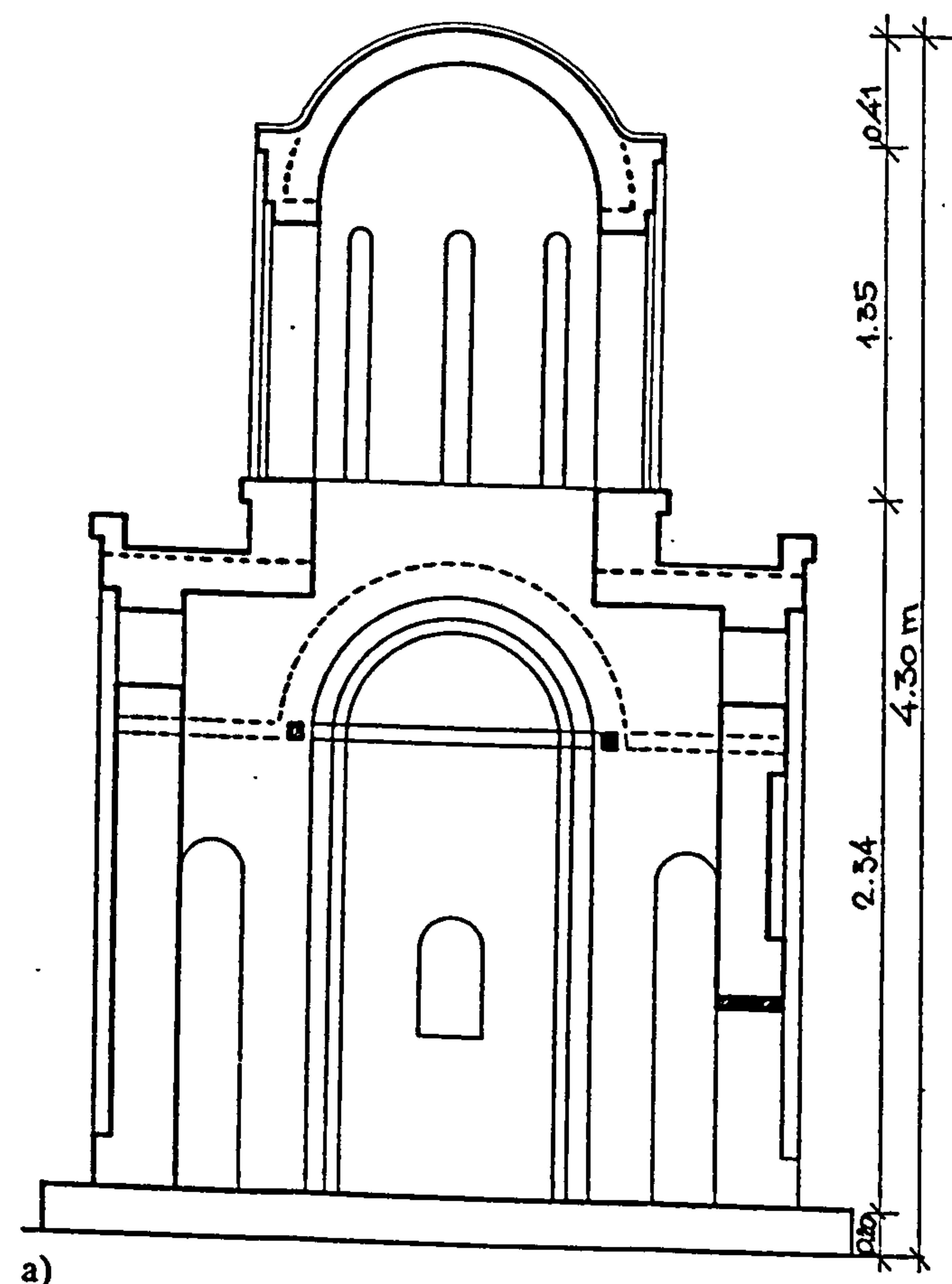
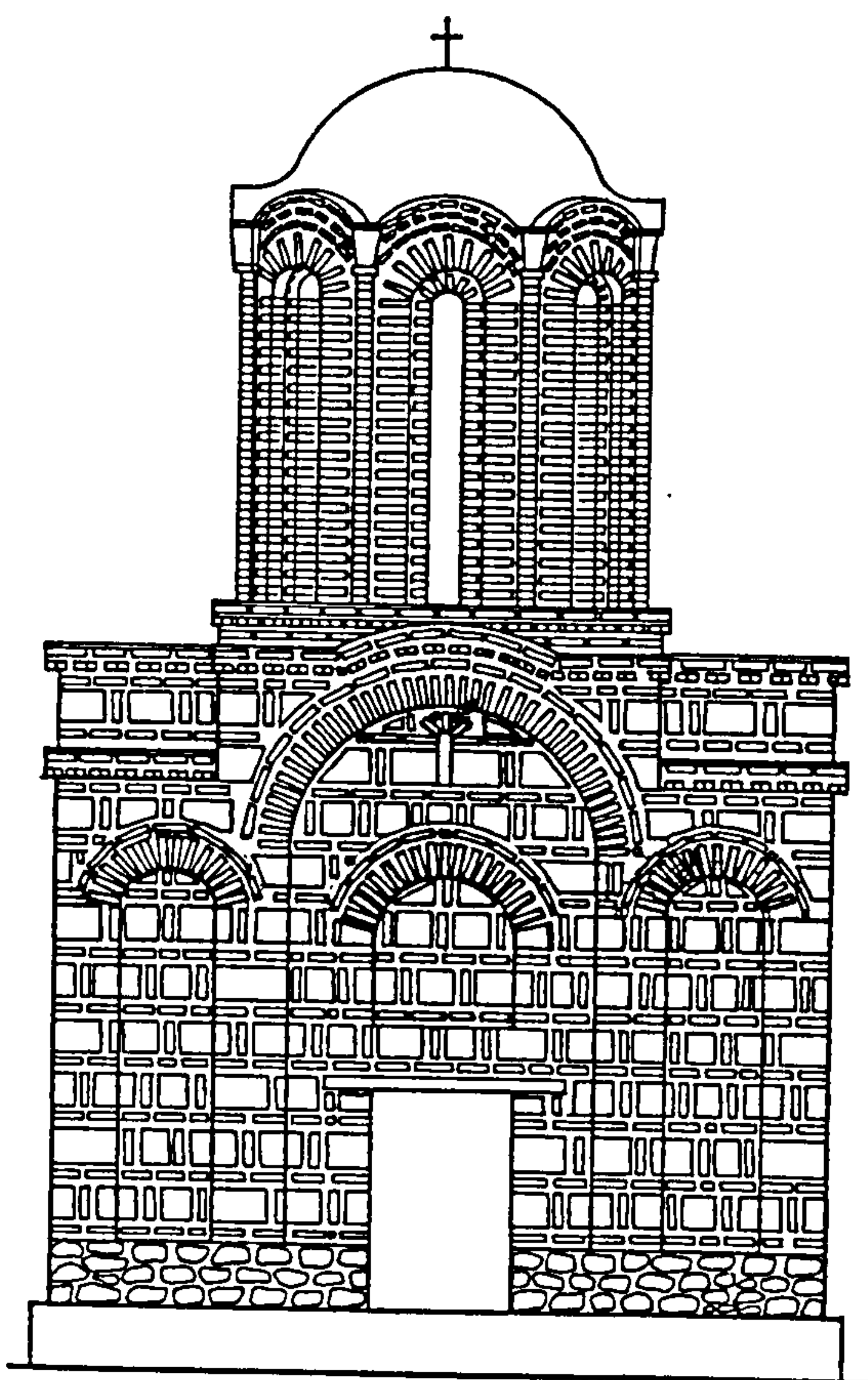

Figure 5.26 Experimental investigation of wall samples - WSC 3.
 Source: Volume 10.



a)



b)

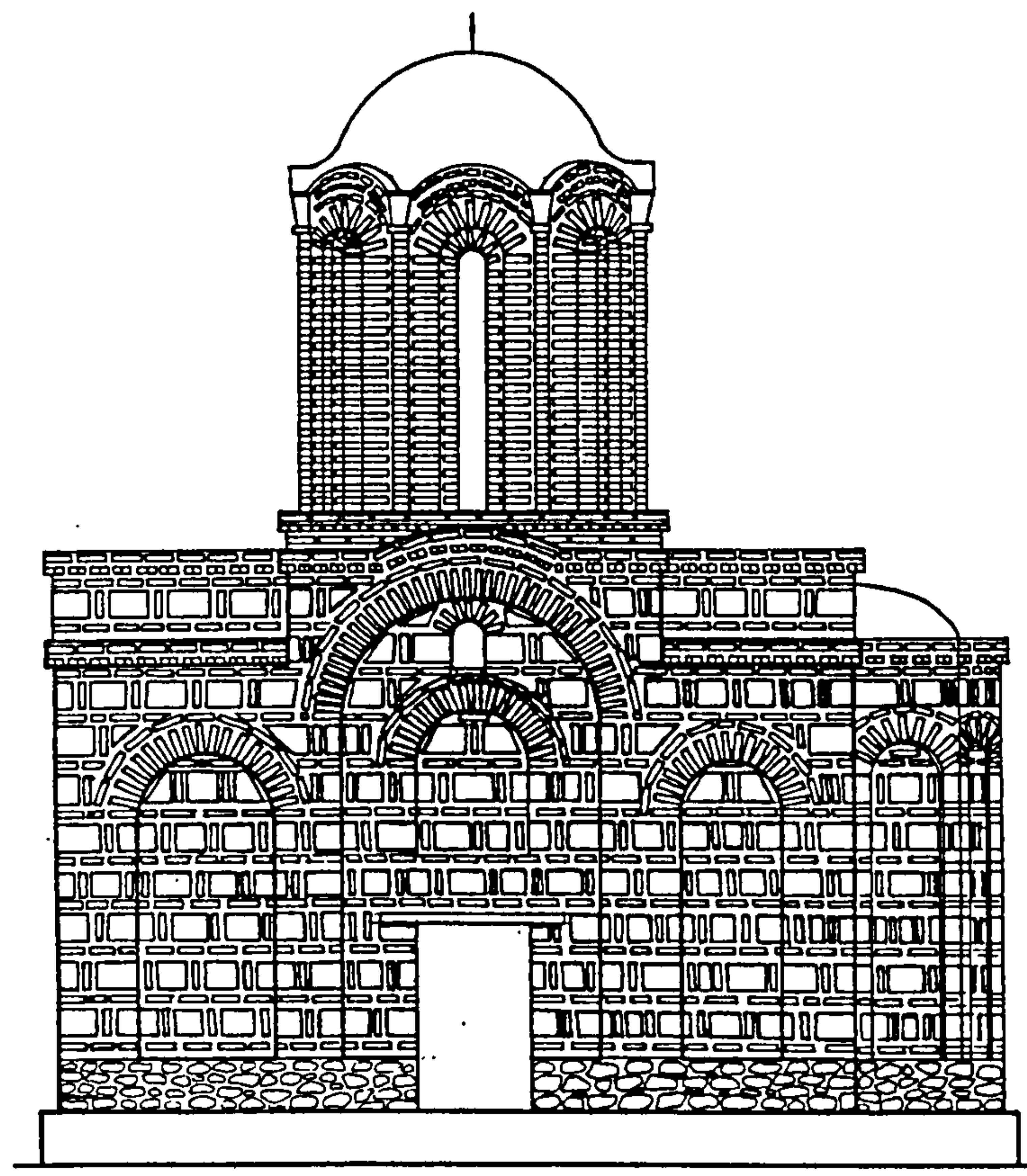

c)

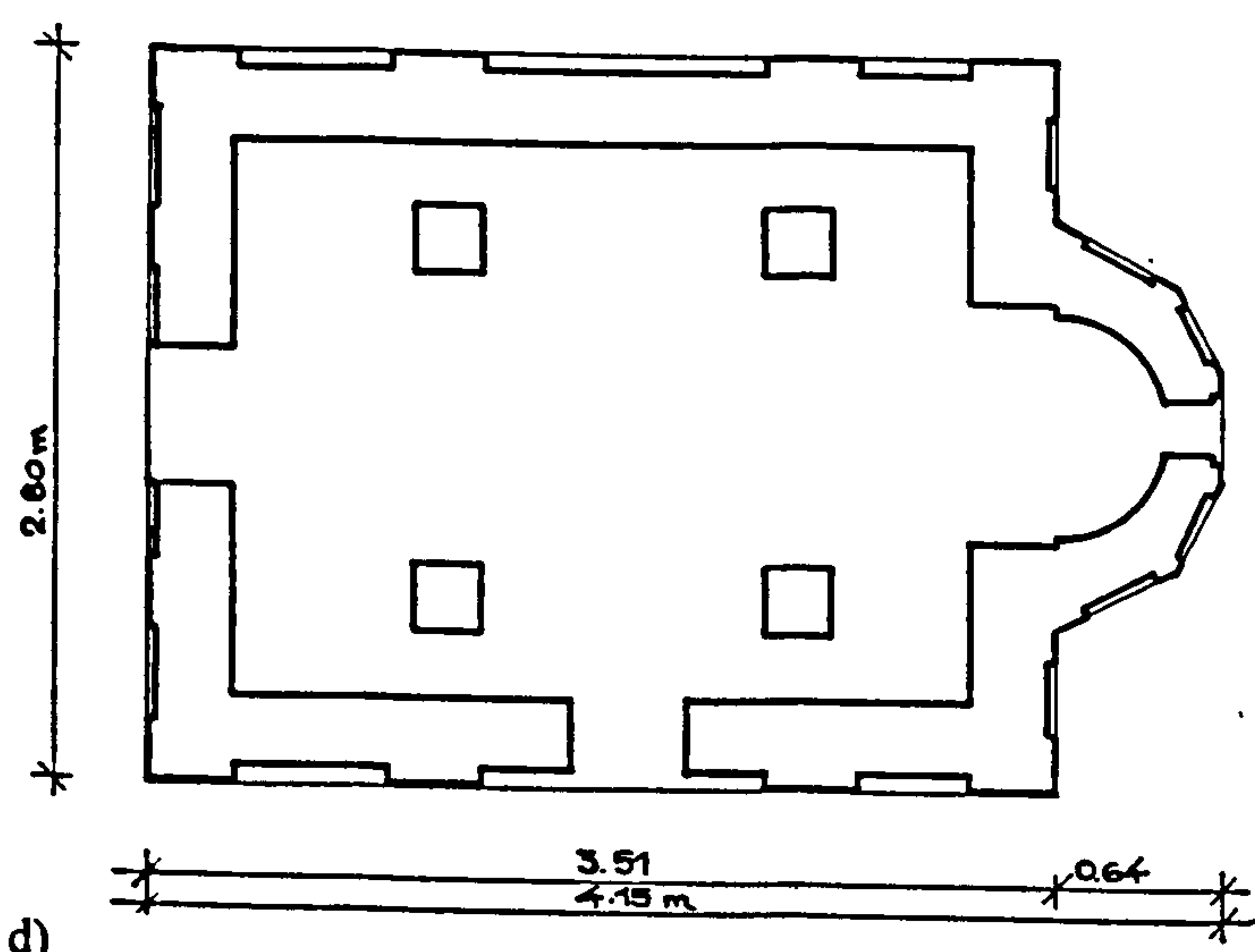

d)

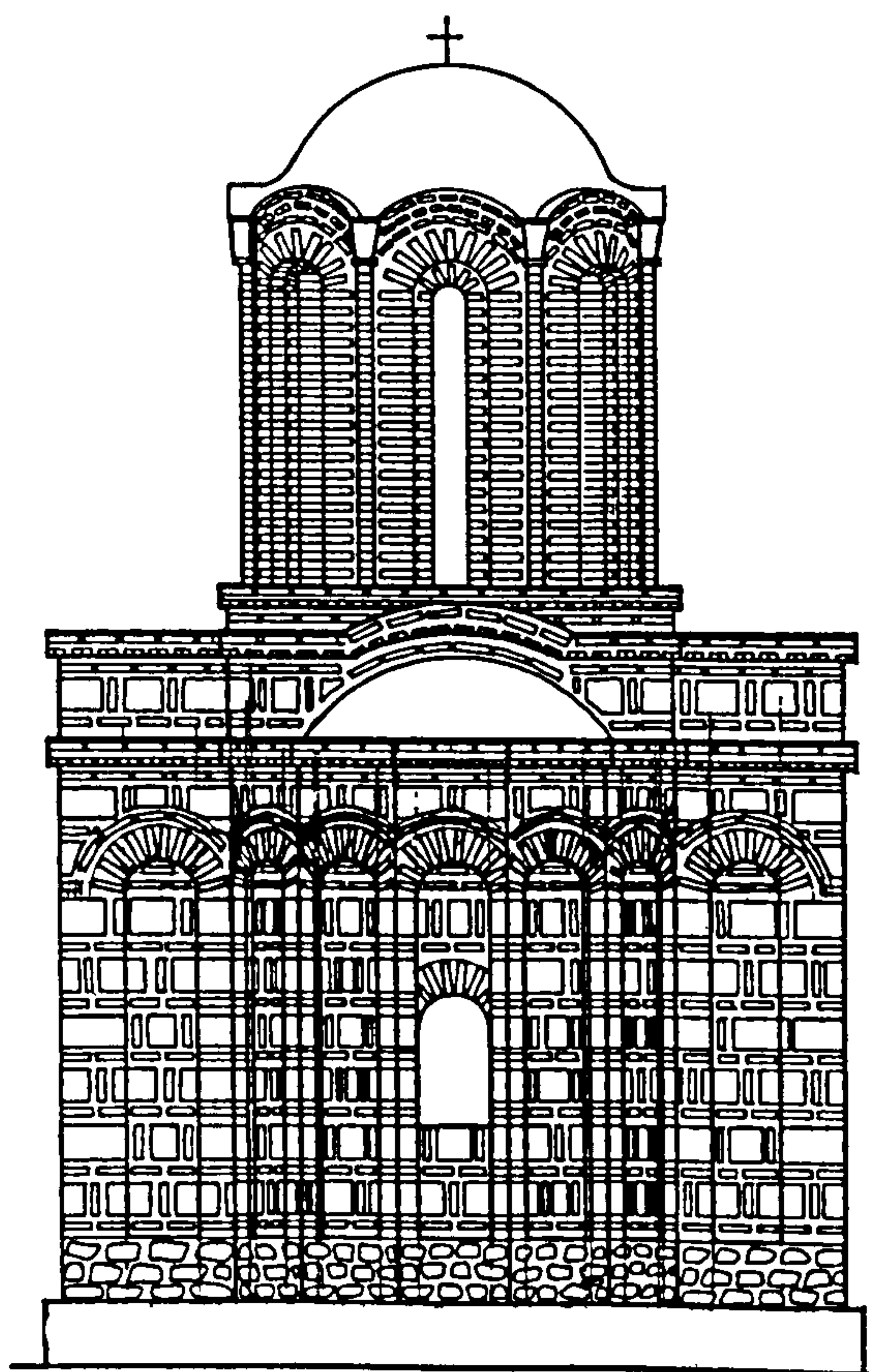

e)

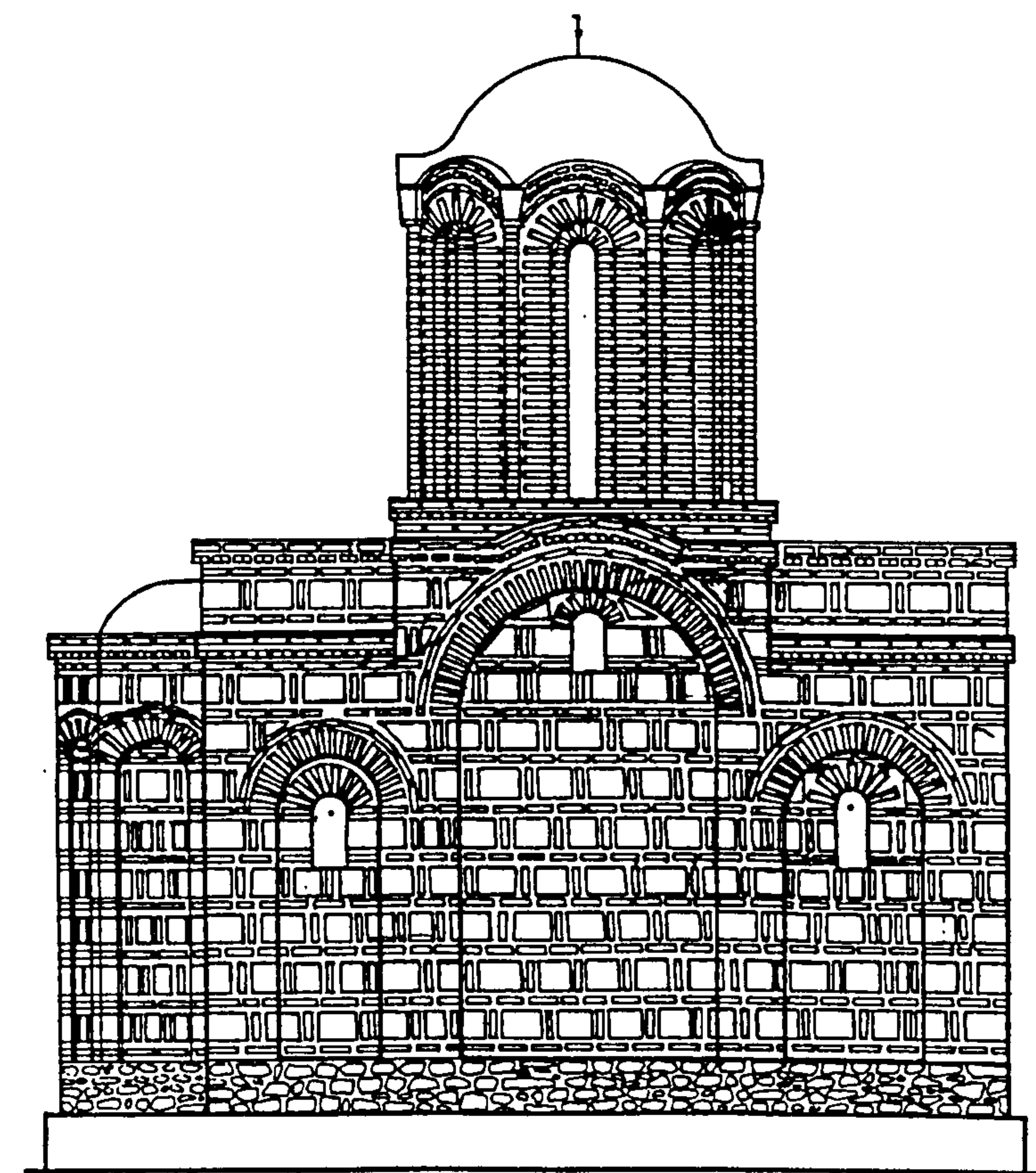

f)

Figure 5.27 Design of church model.
a) - Cross section; b) - West facade; c) - South facade; d) - Ground floor;
e) - East facade; f) - North facade.

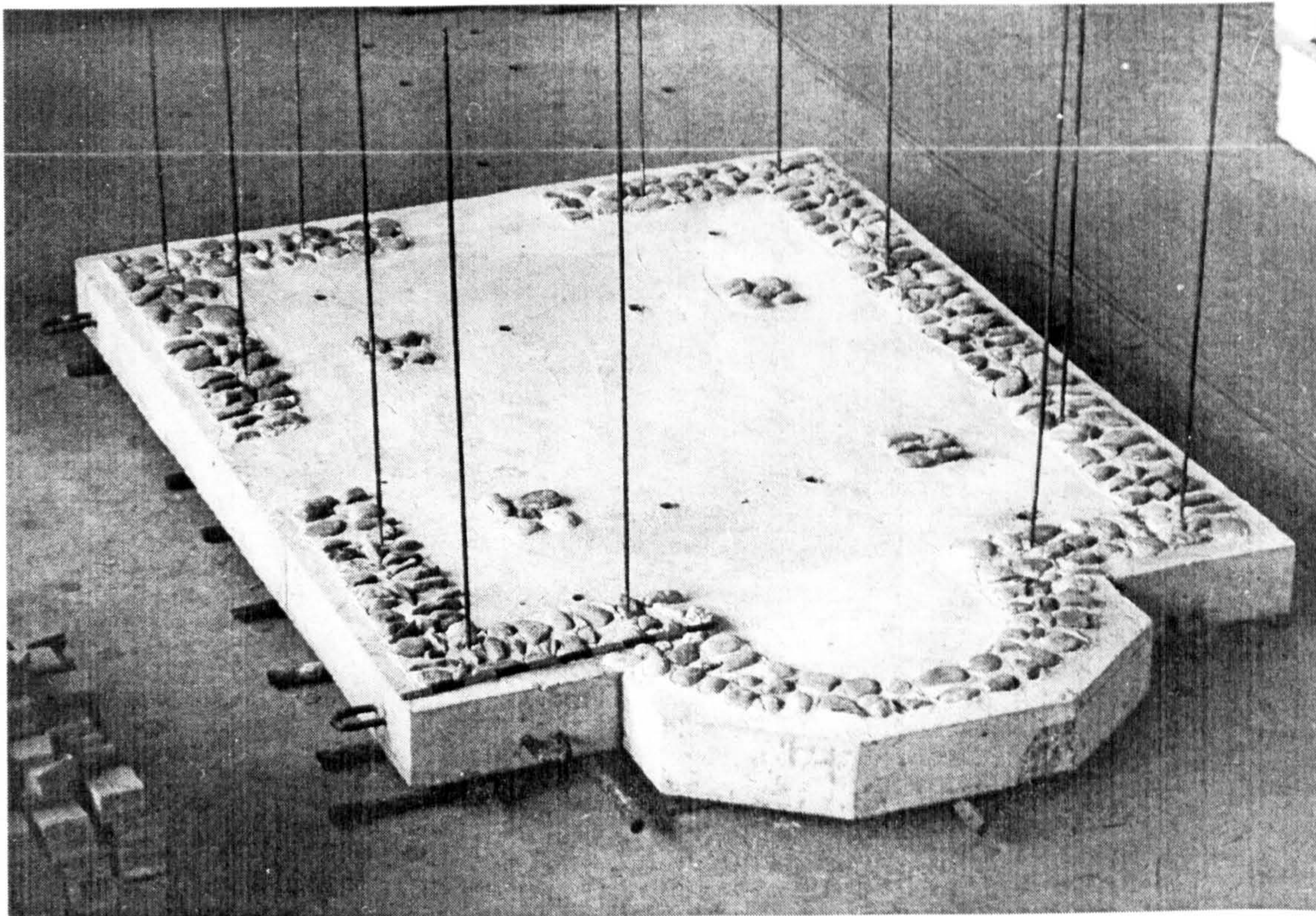

a)

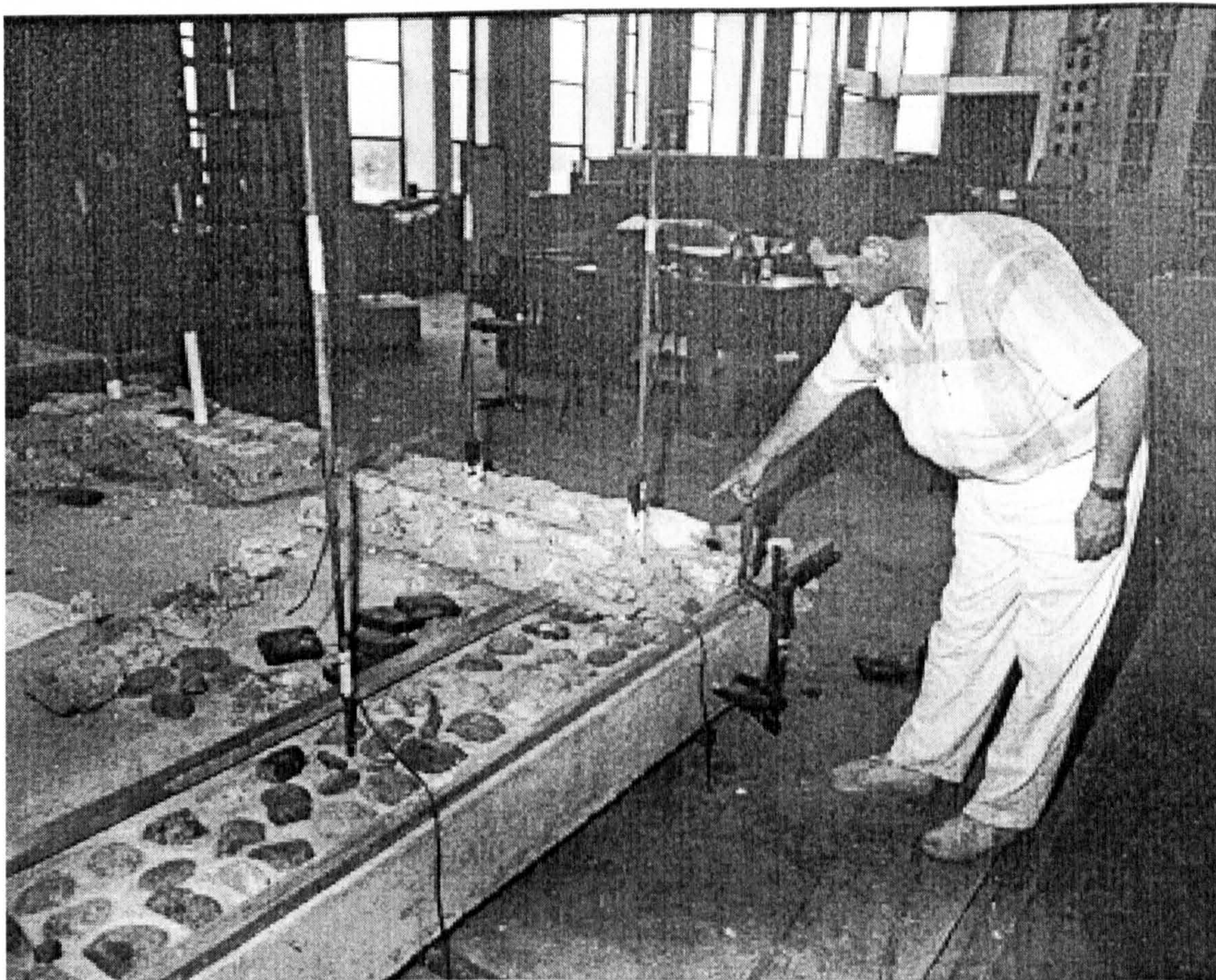

b)

Figure 5.28 *Building of the church mode in the scale 1 : 2.75. Platform and foundation of the model.*

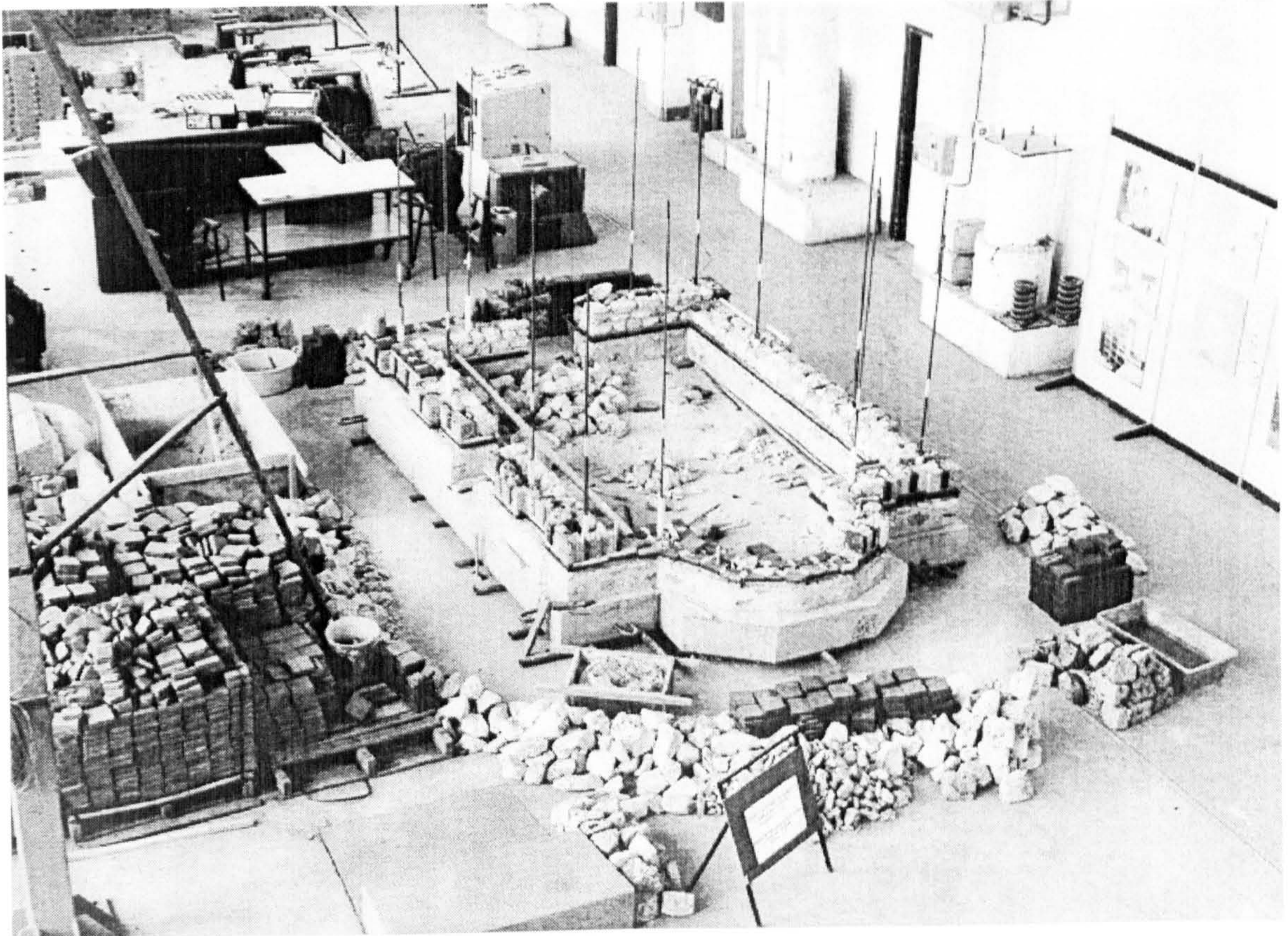

a)

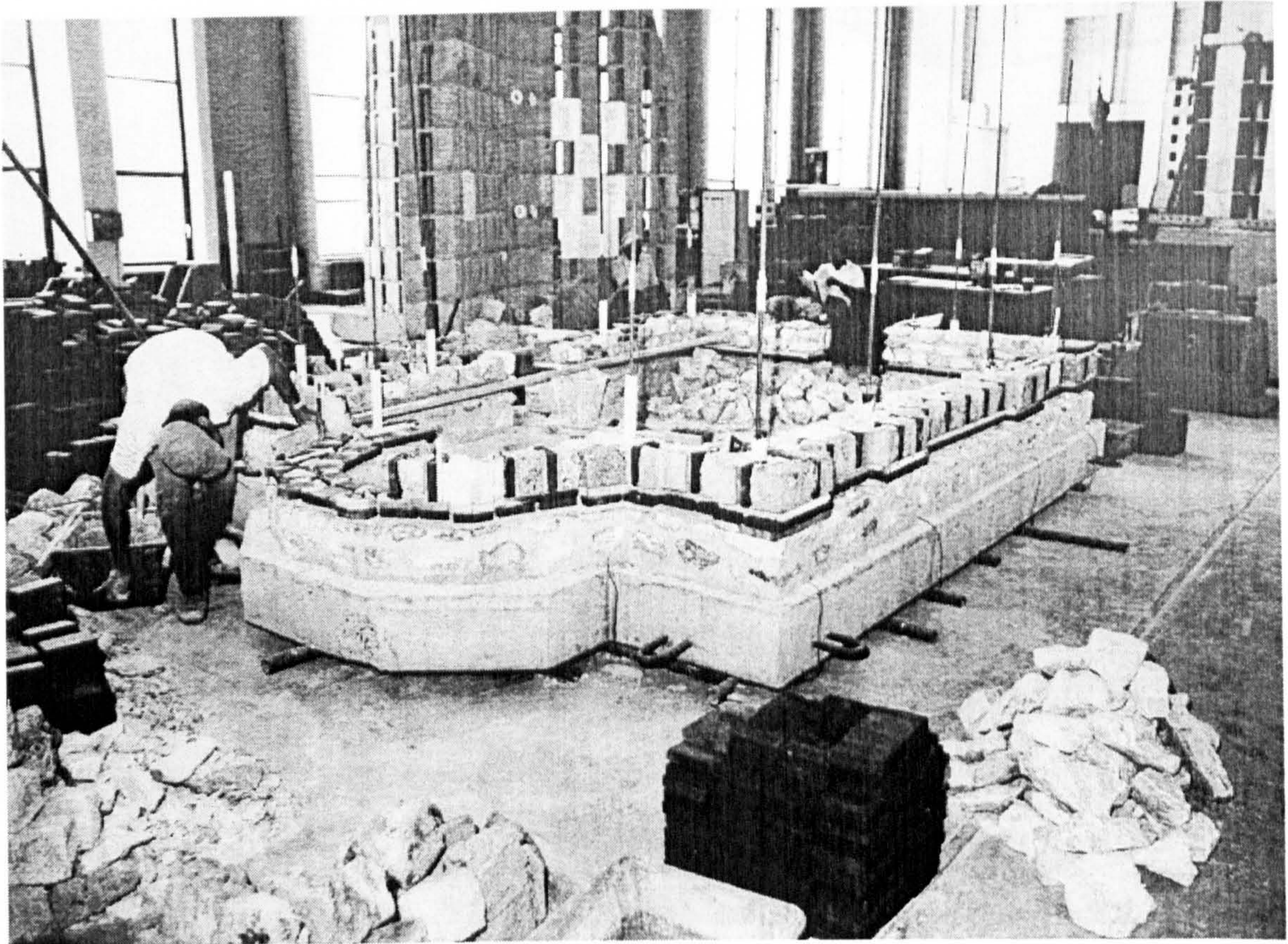

b)

Figure 5.29 *Building of the model.*
a) and b) - Perimetric walls.

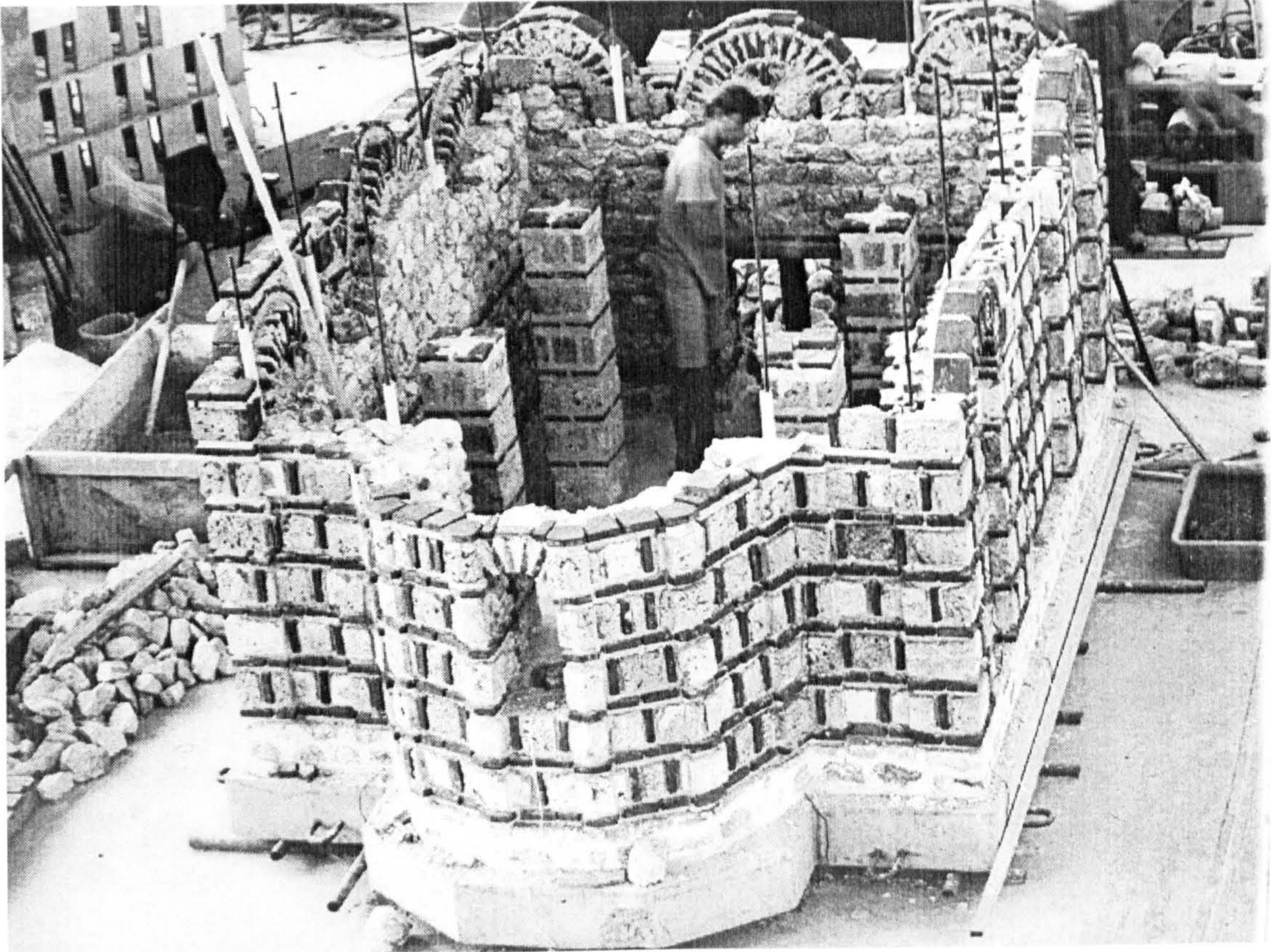

a)

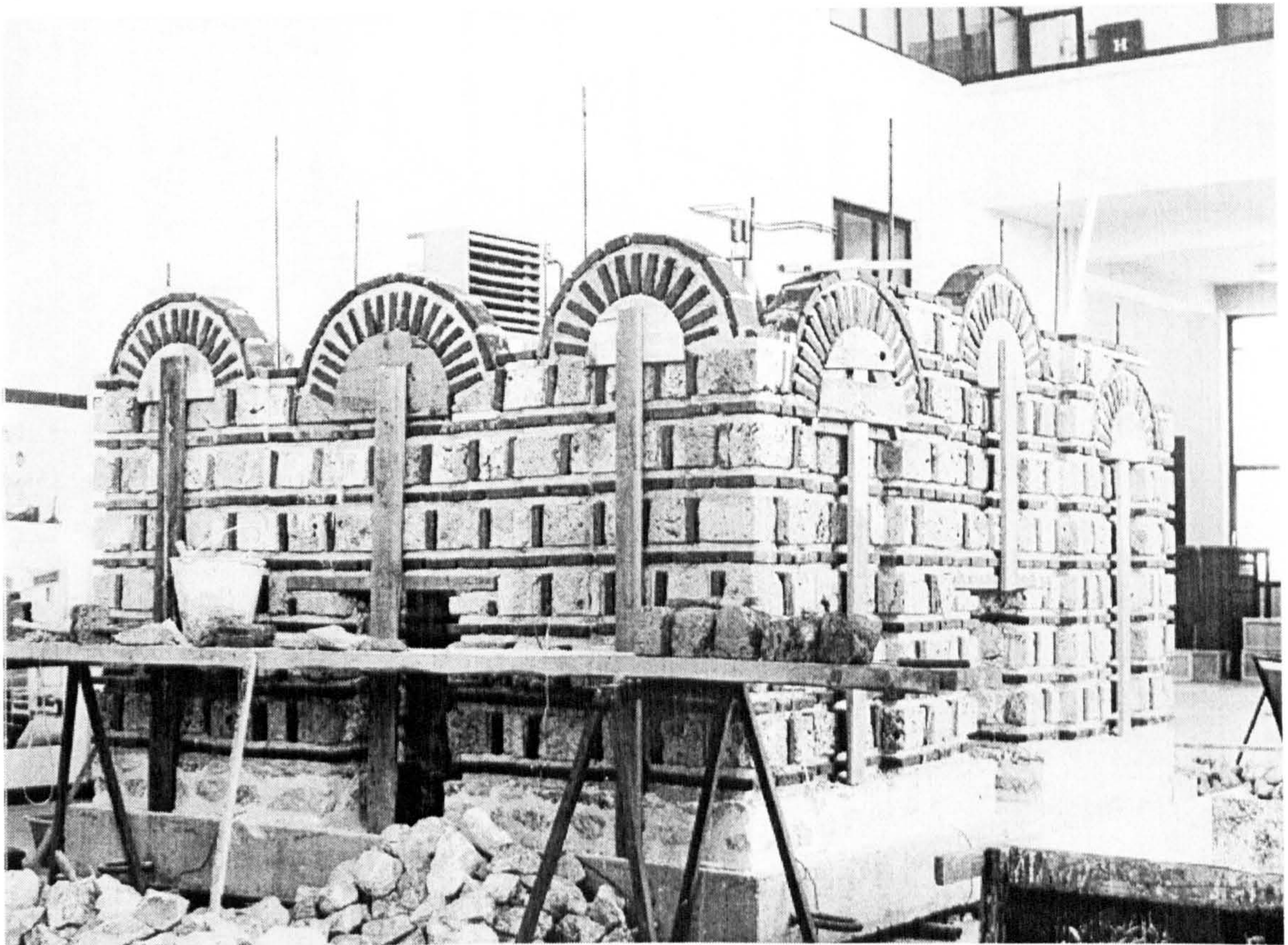

b)

Figure 5.30 *Building of the model.*
a) - Perimetric walls and piers; b) - Perimetric walls and arches.



a)



b)

Figure 5.31 *Building of the model.*
 a) - Vaults; b) - Vaults and apse semi - dome.

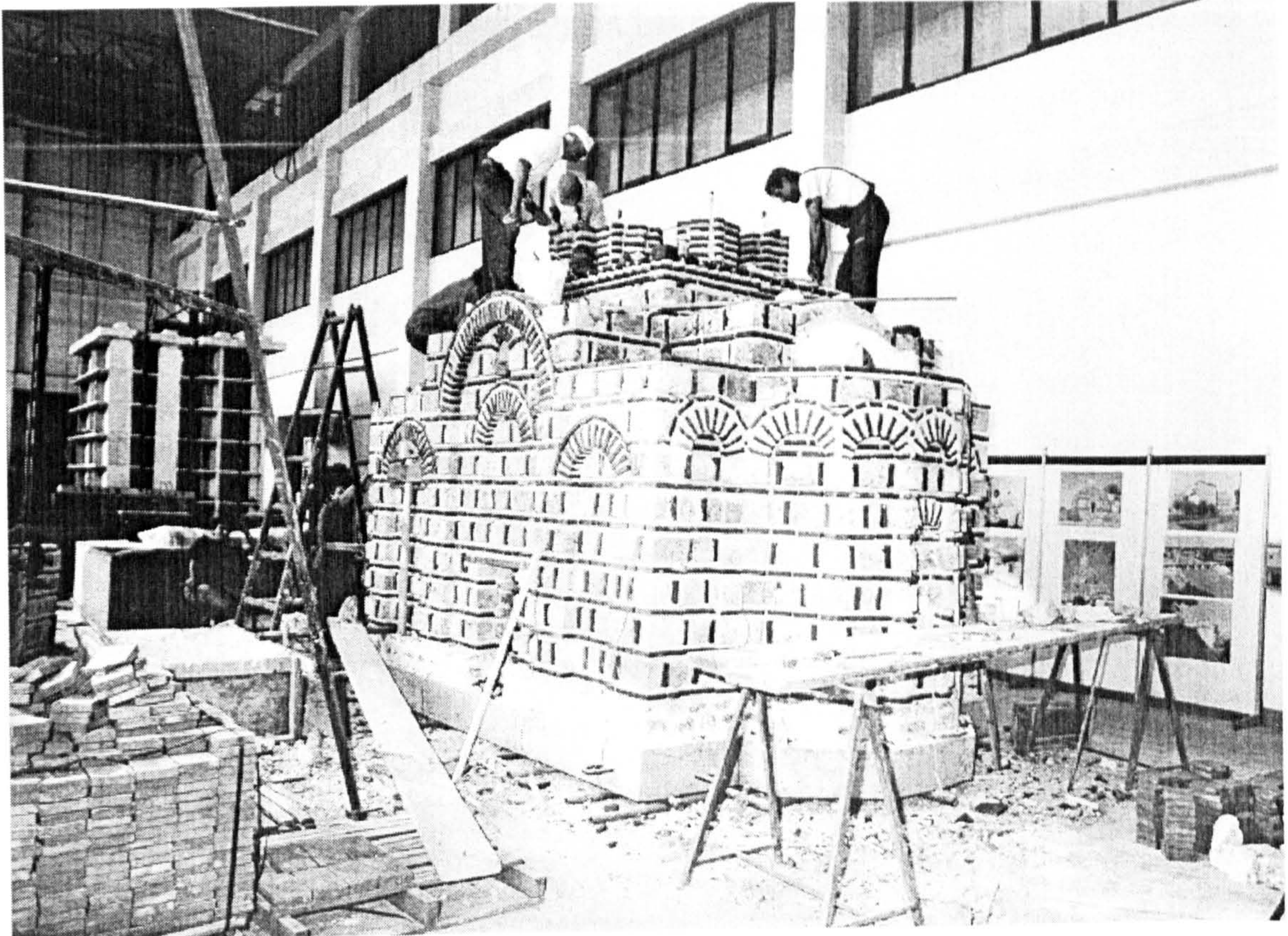

a)



b)

Figure 5.32 *Building of the model.*
a) - Base of the drum; b) - Drum 'piers'.

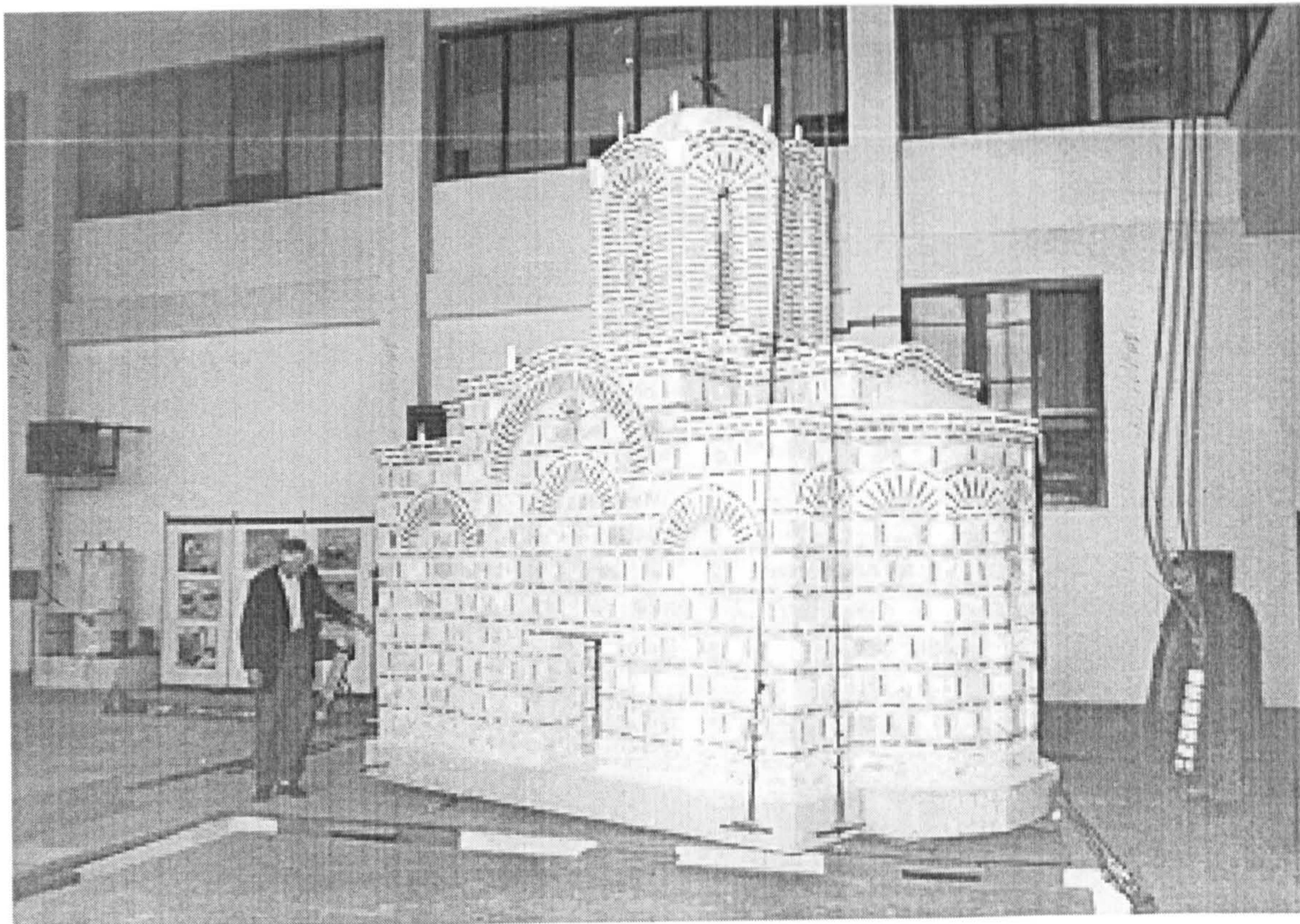

a)

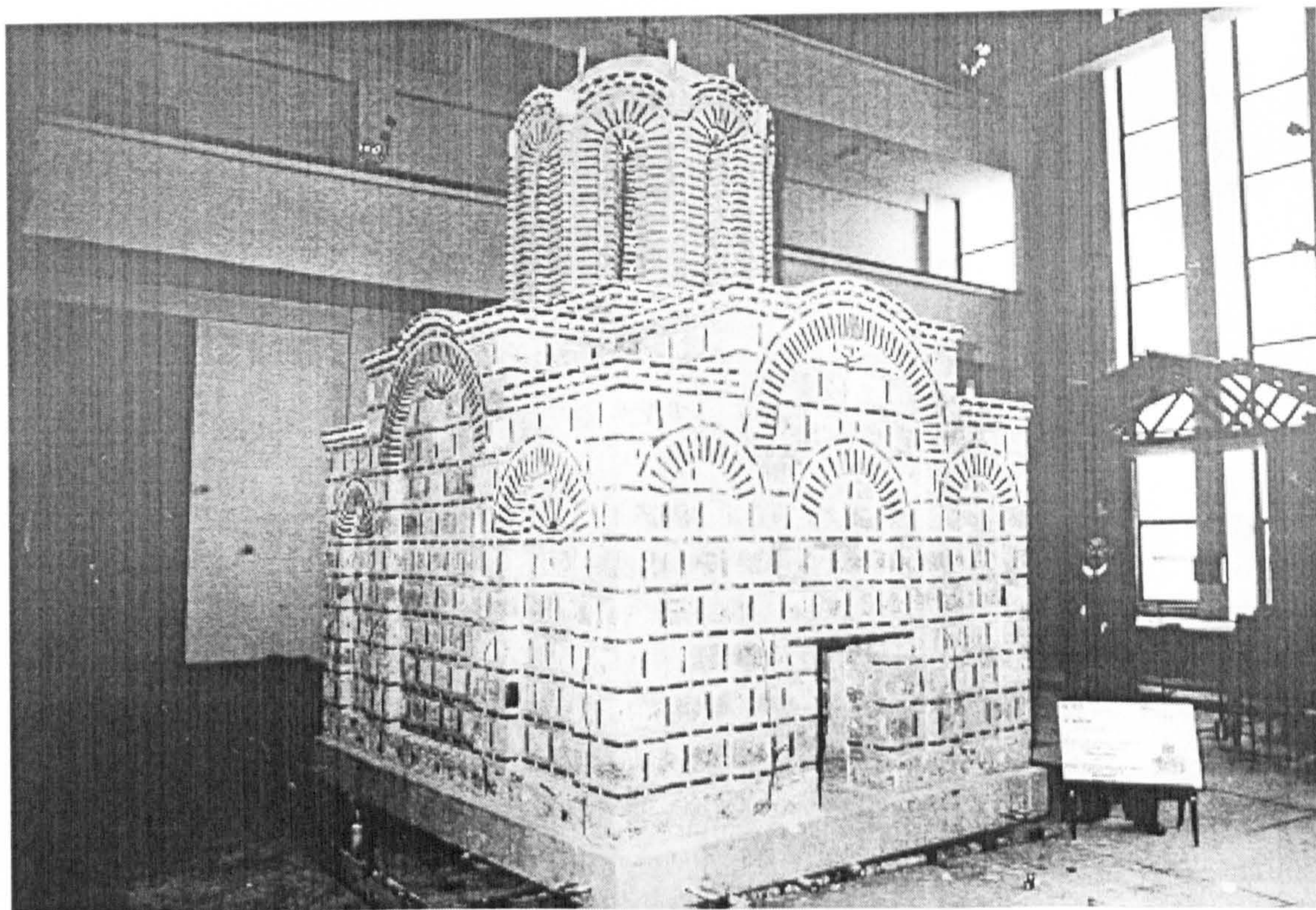

b)

Figure 5.33 *Completed model of the church in scale 1 : 2.75.
a) - South and East facade; b) - North and West facade.*



a)



b)

Figure 5.34 *Completed model of the church in scale 1 : 2.75.*
 a) - Interior. Pier, vaults, timber ties and pendentive (with the author);
 b) - Interior. Apse - half plastered and timber tie (with the author)

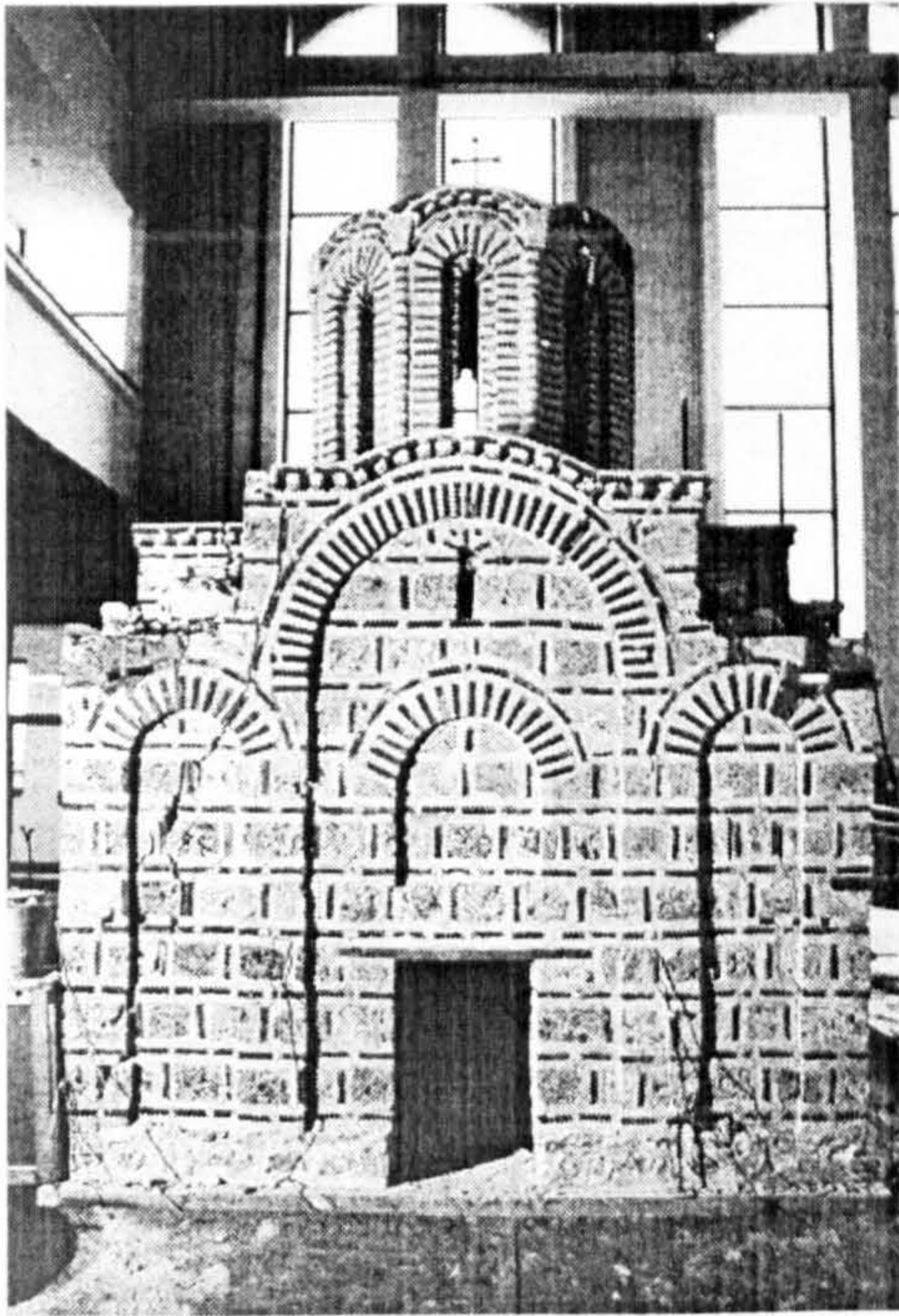

a)

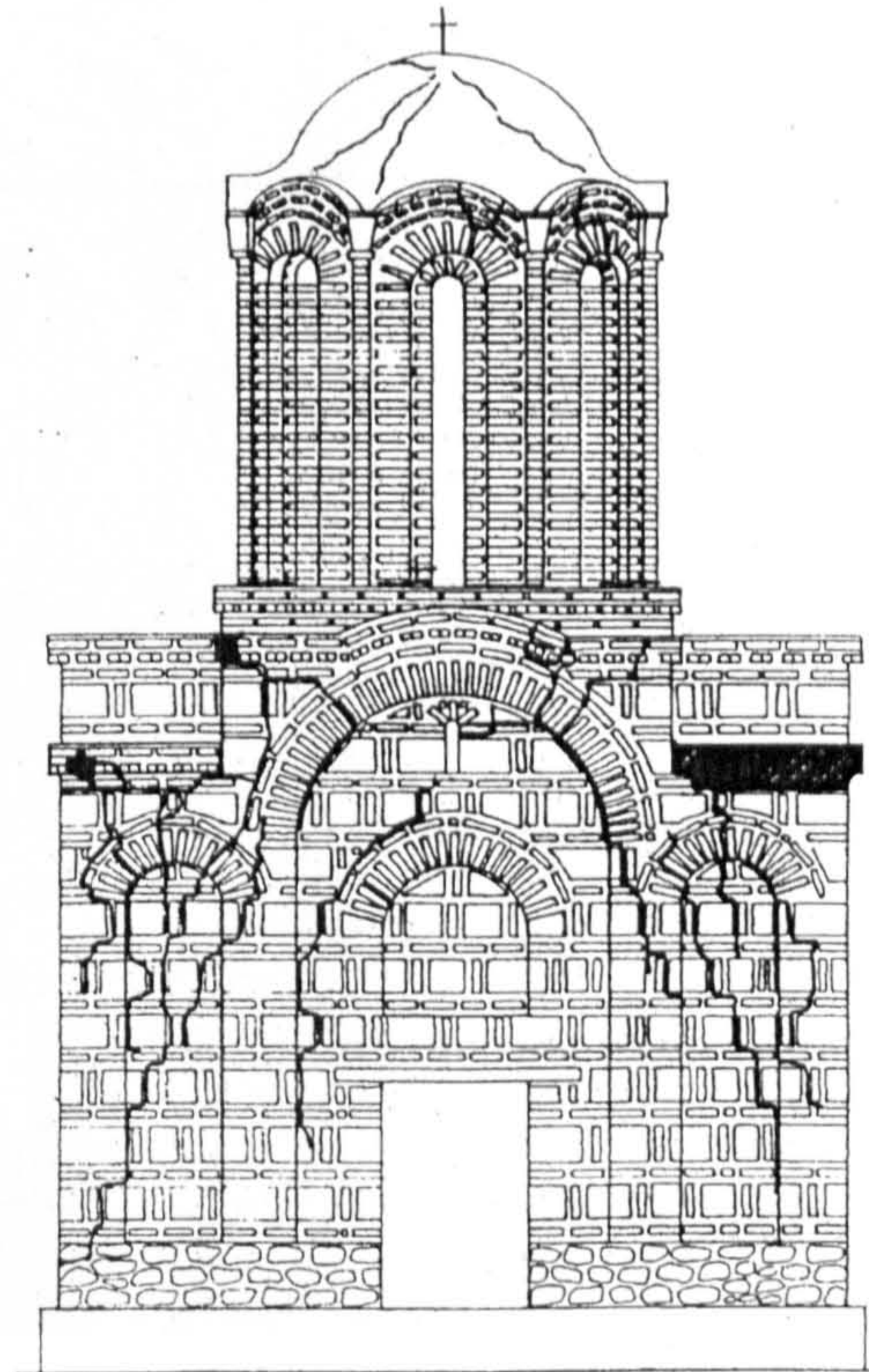

b)



c)

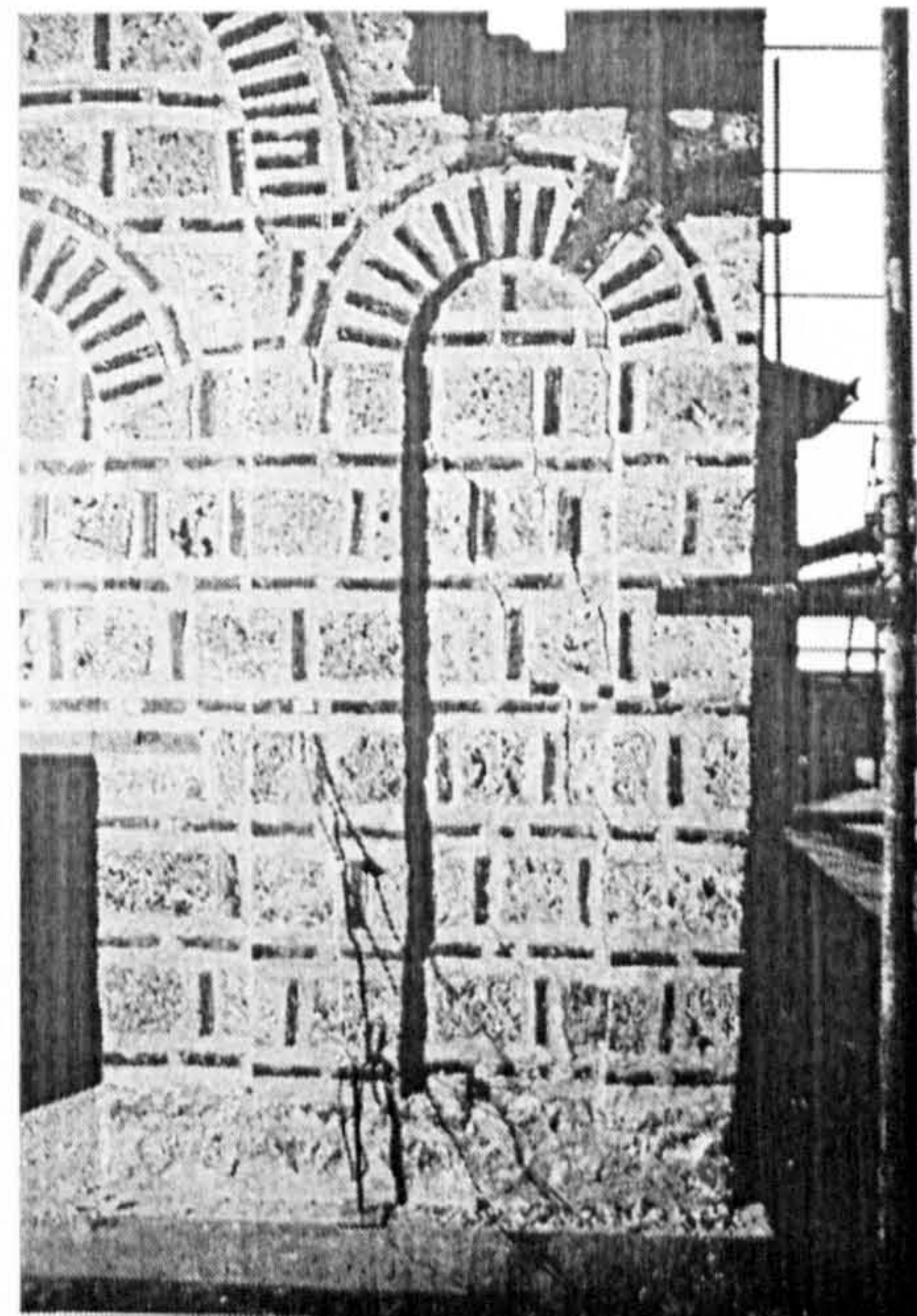

d)

Figure 5.35 *Damage pattern of non - strengthened model after the final shaking table test. a) and b) - West facade-total; c) - Detail of the Northern wing; d) - Detail of the Southern wing.*

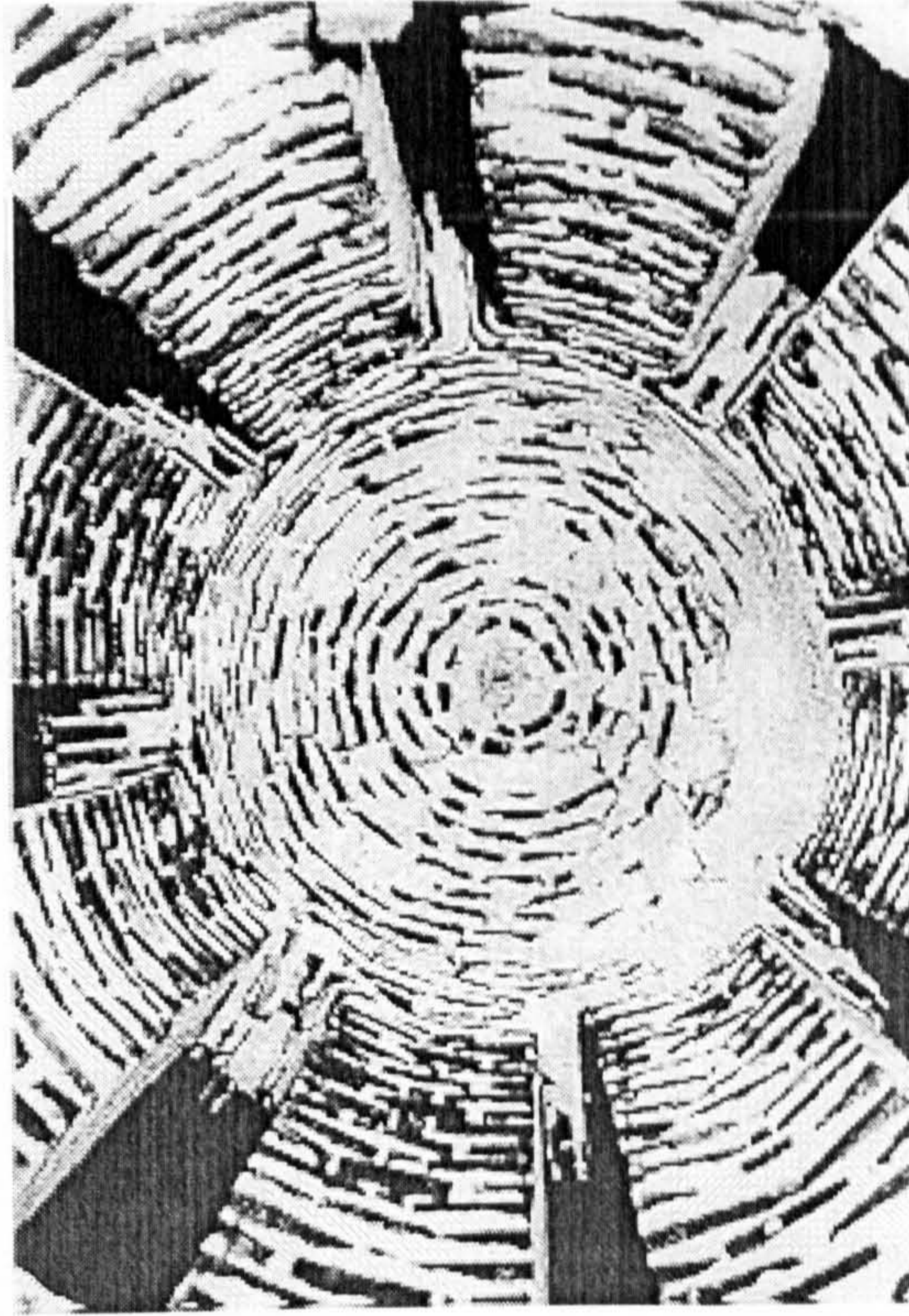

a)



b)

Figure 5.36 *Damage pattern of non - strengthened model after the final shaking table test.*
a) - Interior. Dome; b) - Interior. Western wall of the naos.

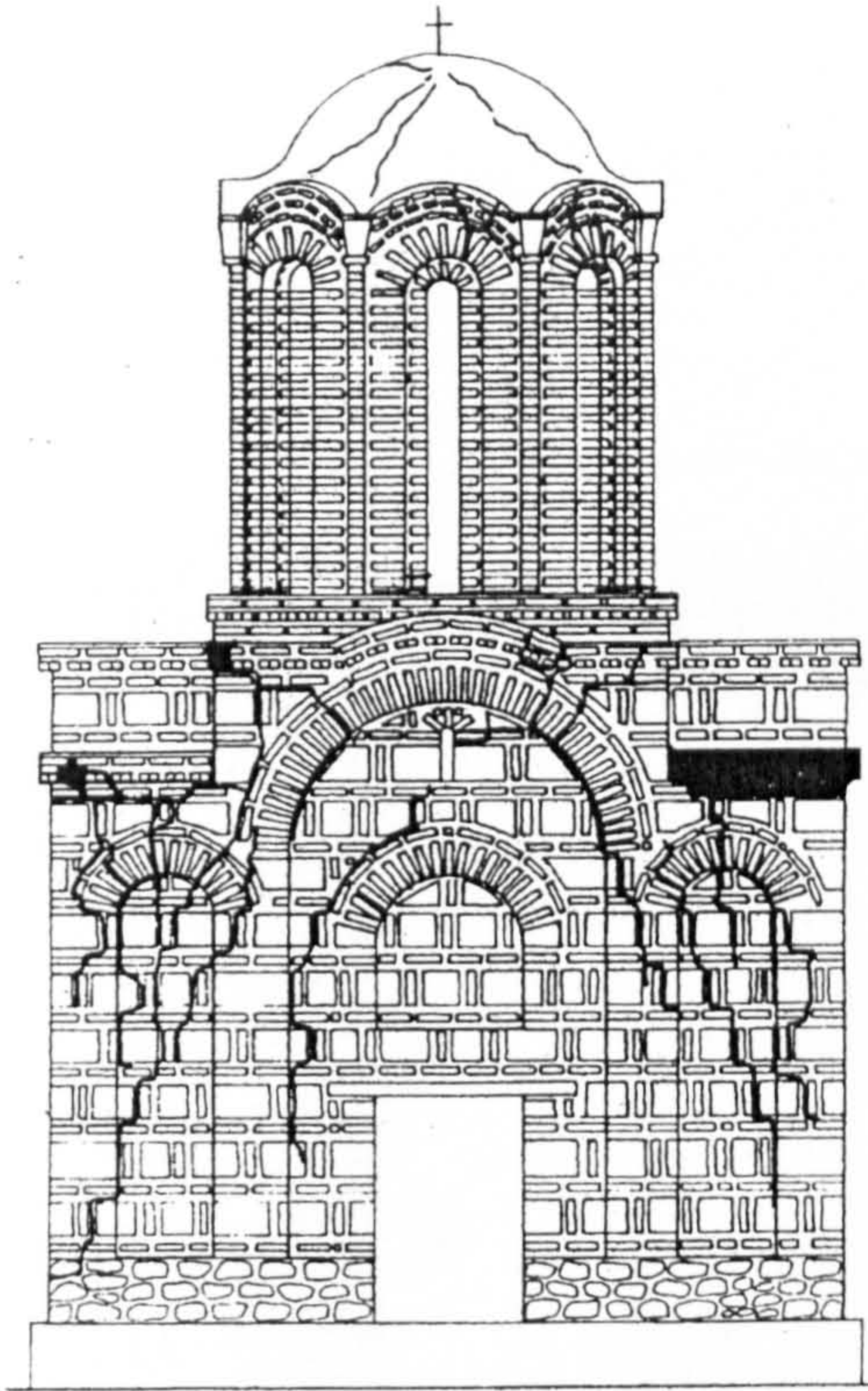

a)

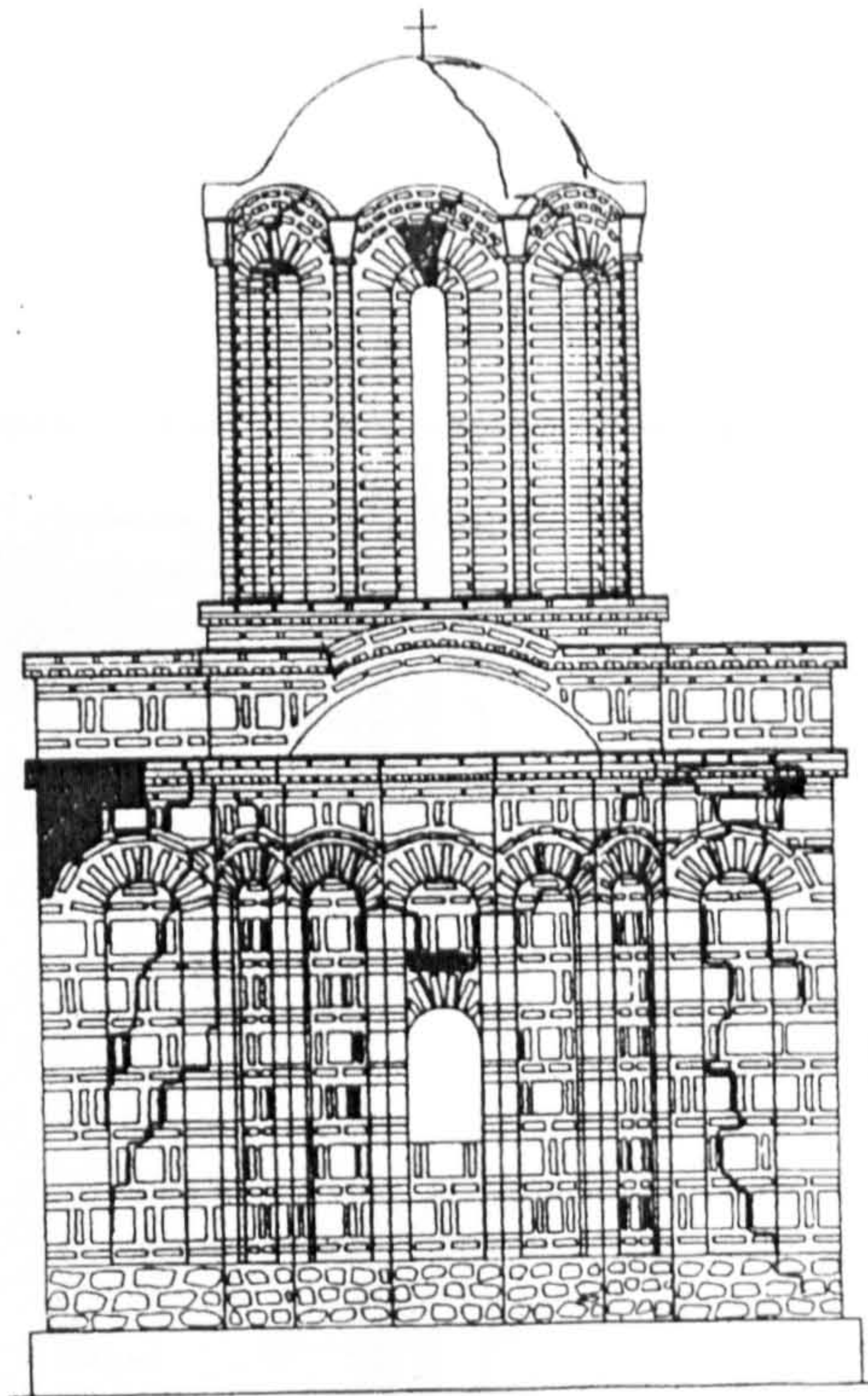

b)

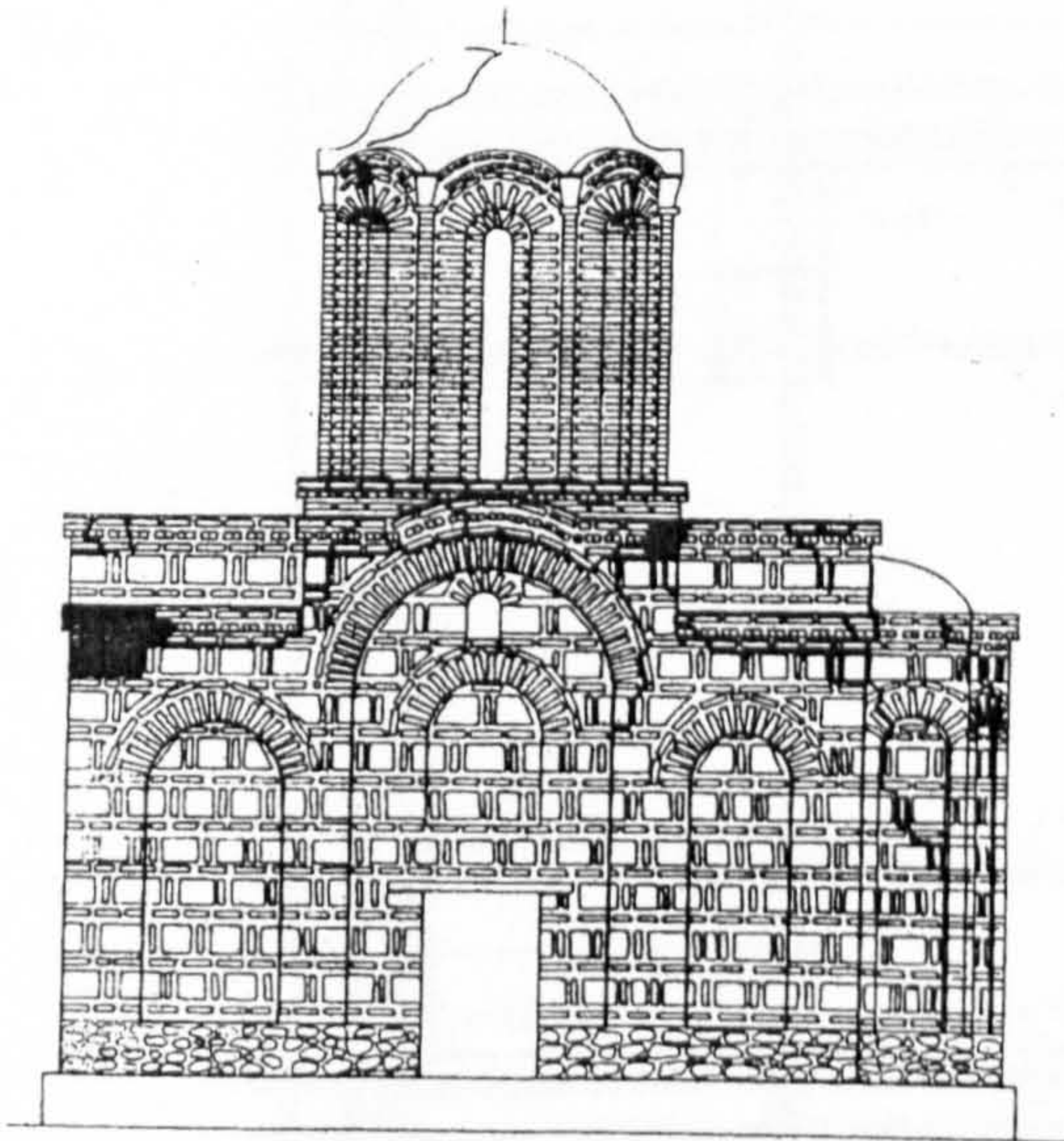

c)

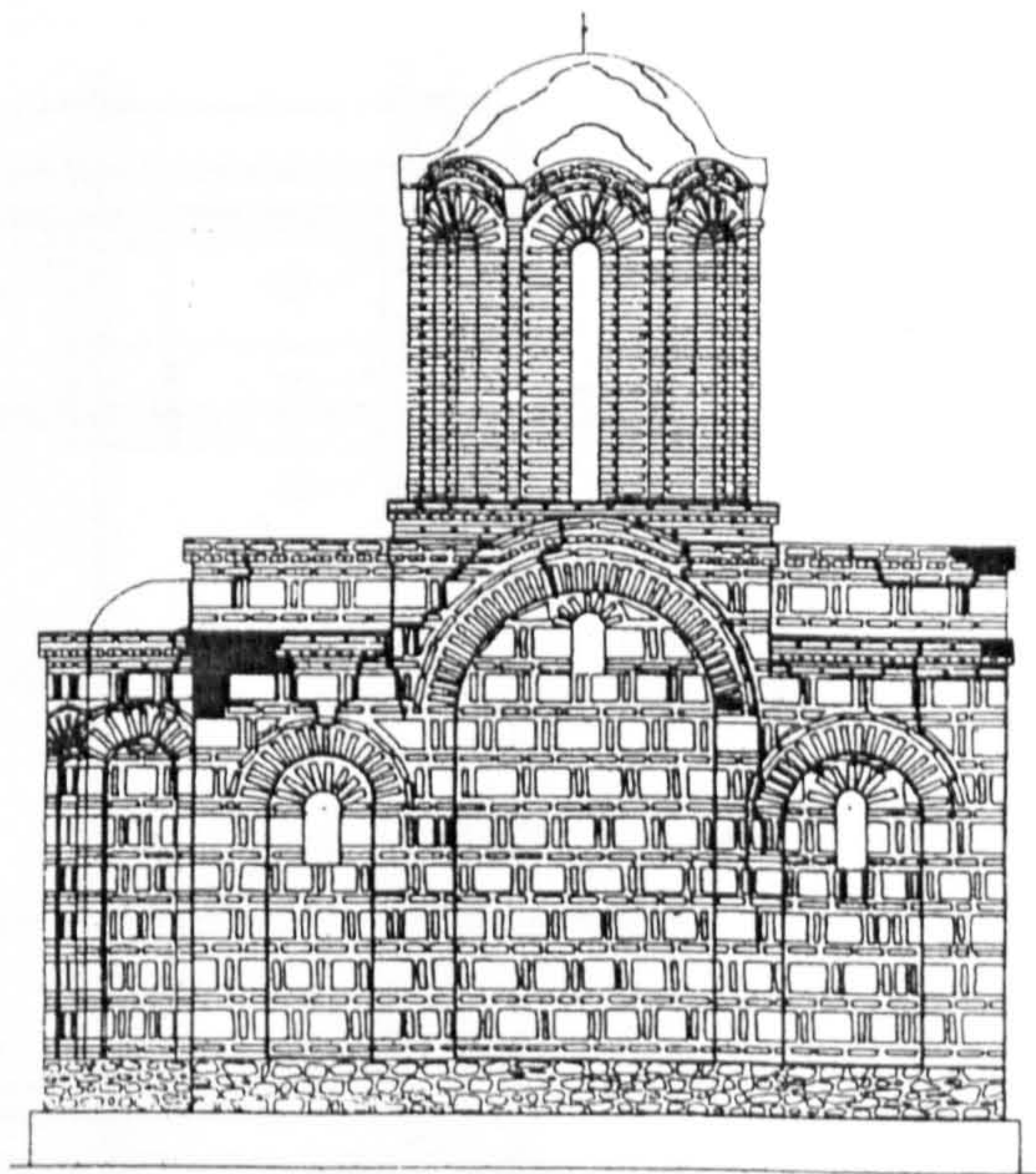

d)

Figure 5.37 Damage pattern of non-strengthened model after the final shaking table test.
 a) - West facade; b) - East facade; c) - South facade; d) - North facade.

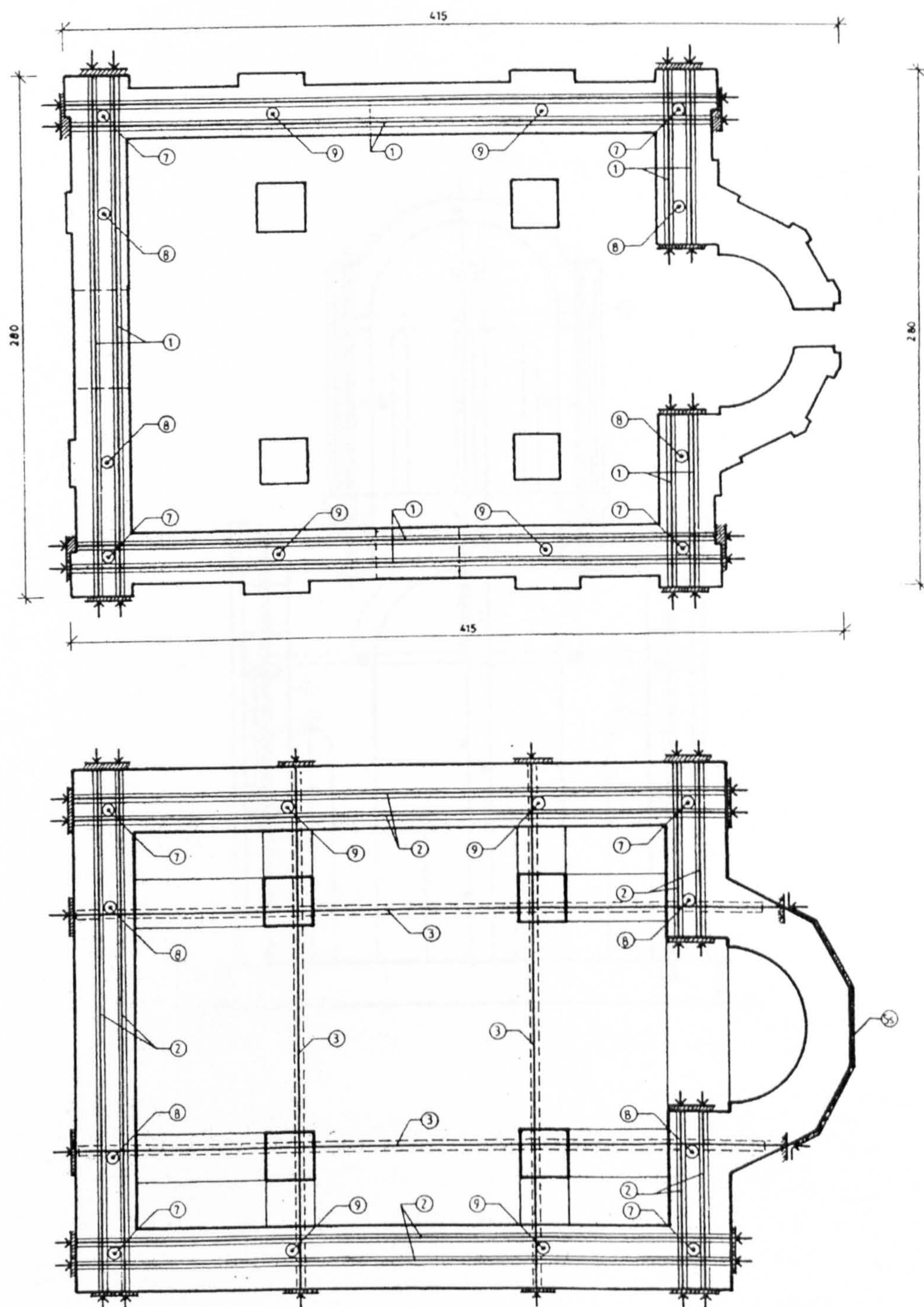

Figure 5.38. *Strengthening of damaged church model. Design. Ground floor on different levels.*

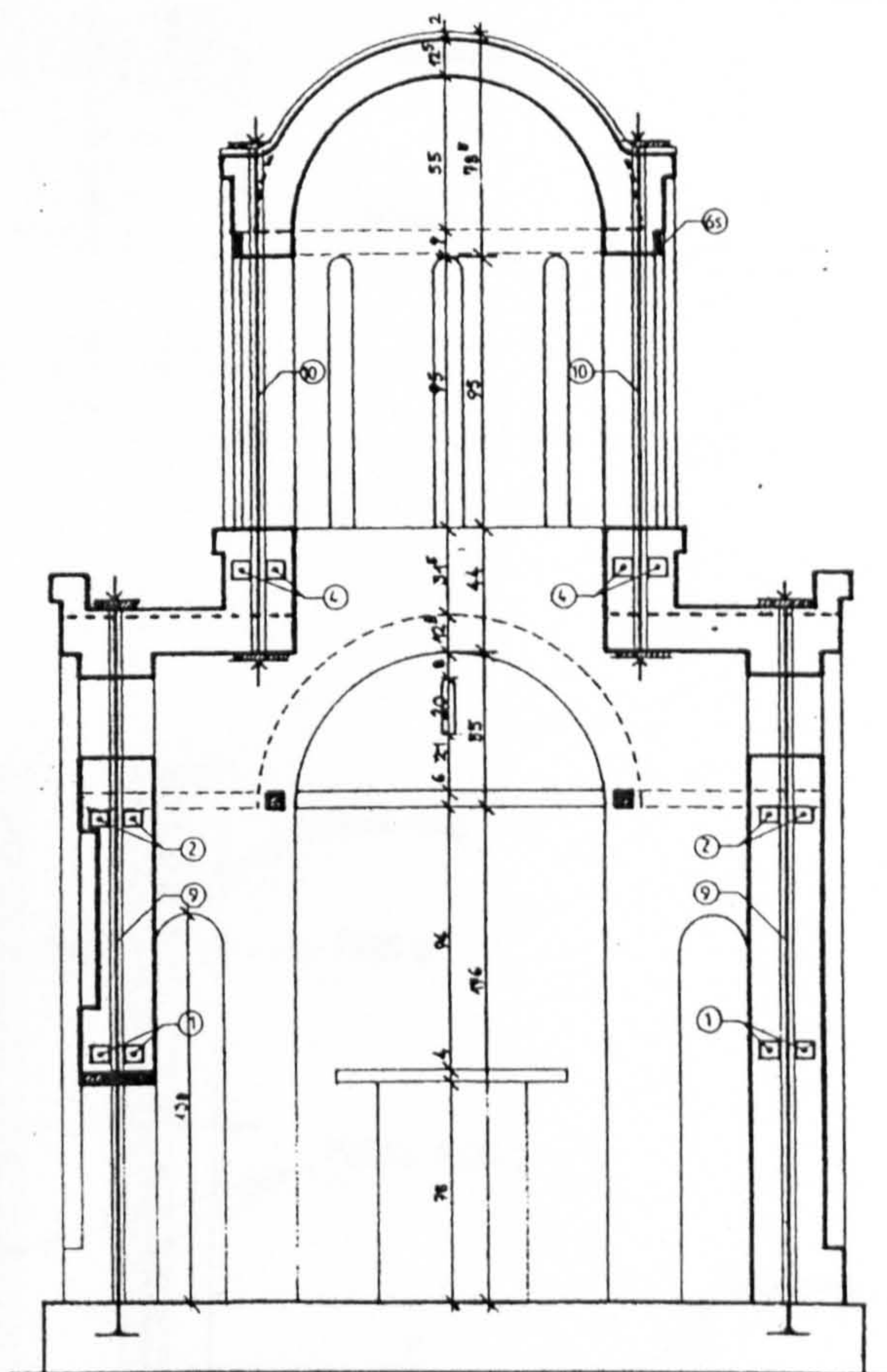

Figure 5.39 *Strengthening of damaged church model. Design.
Cross - section.*

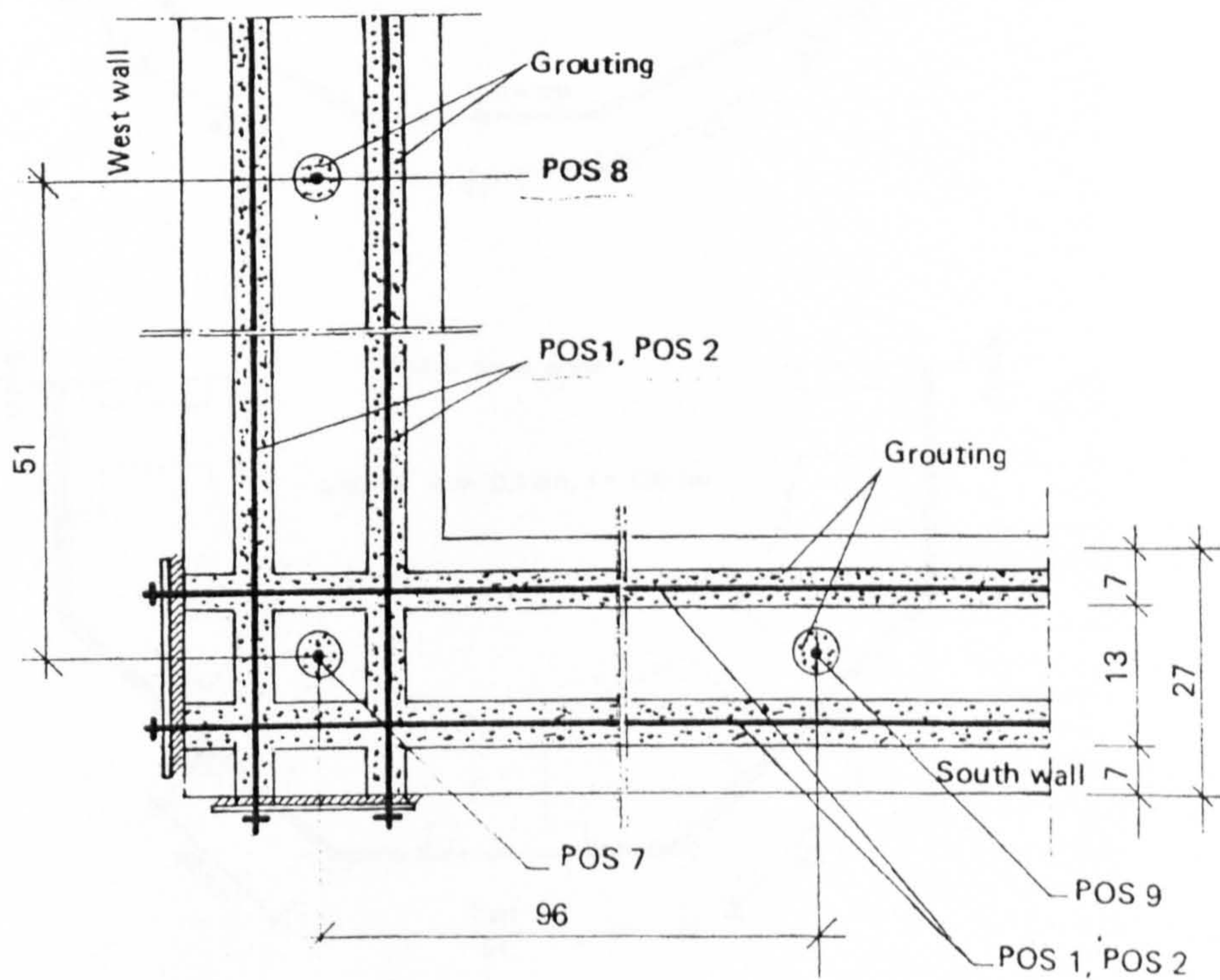
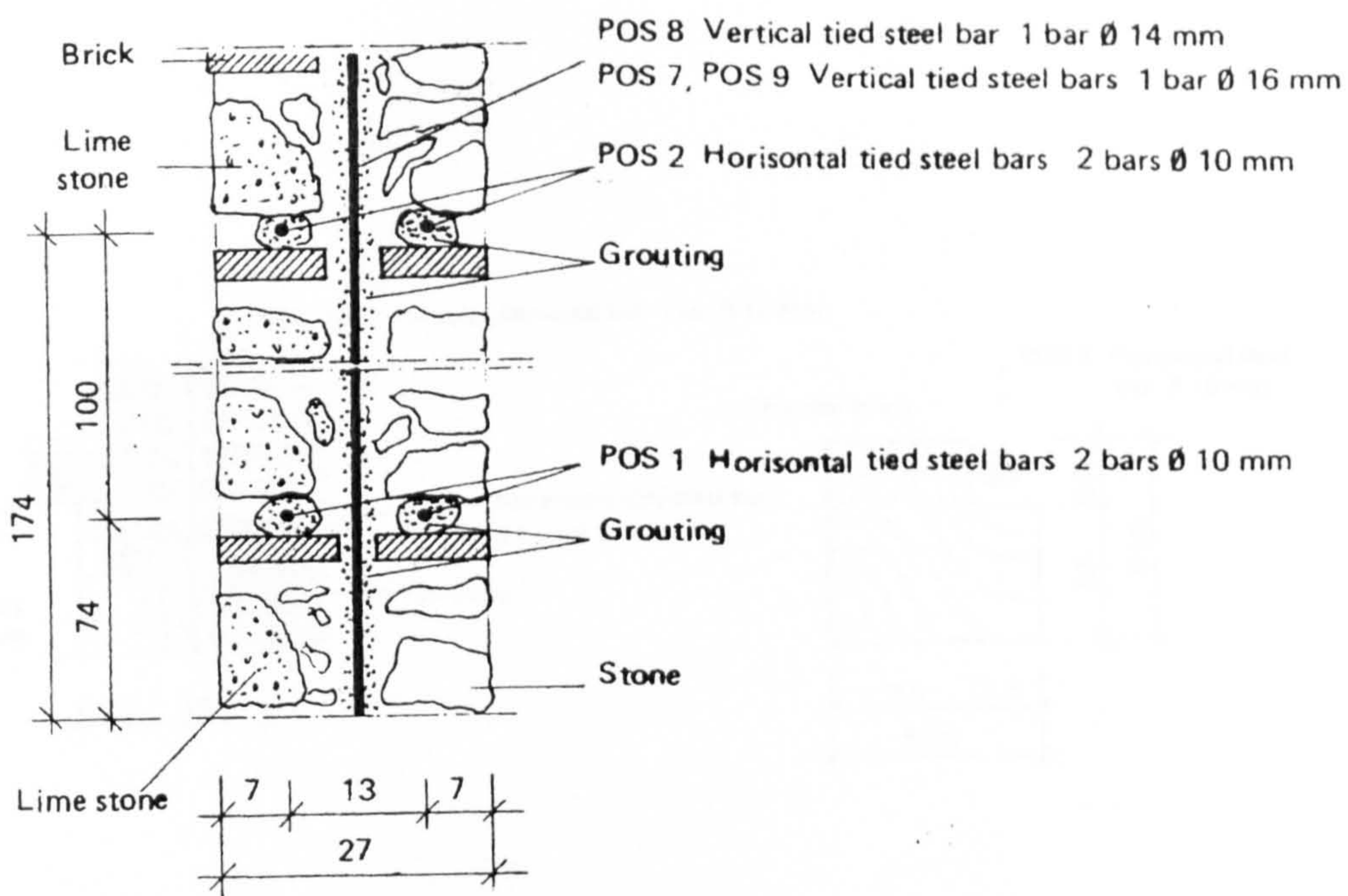

Figure 5.40 Strengthening of damaged church model. Design. Details of the perimetric walls.

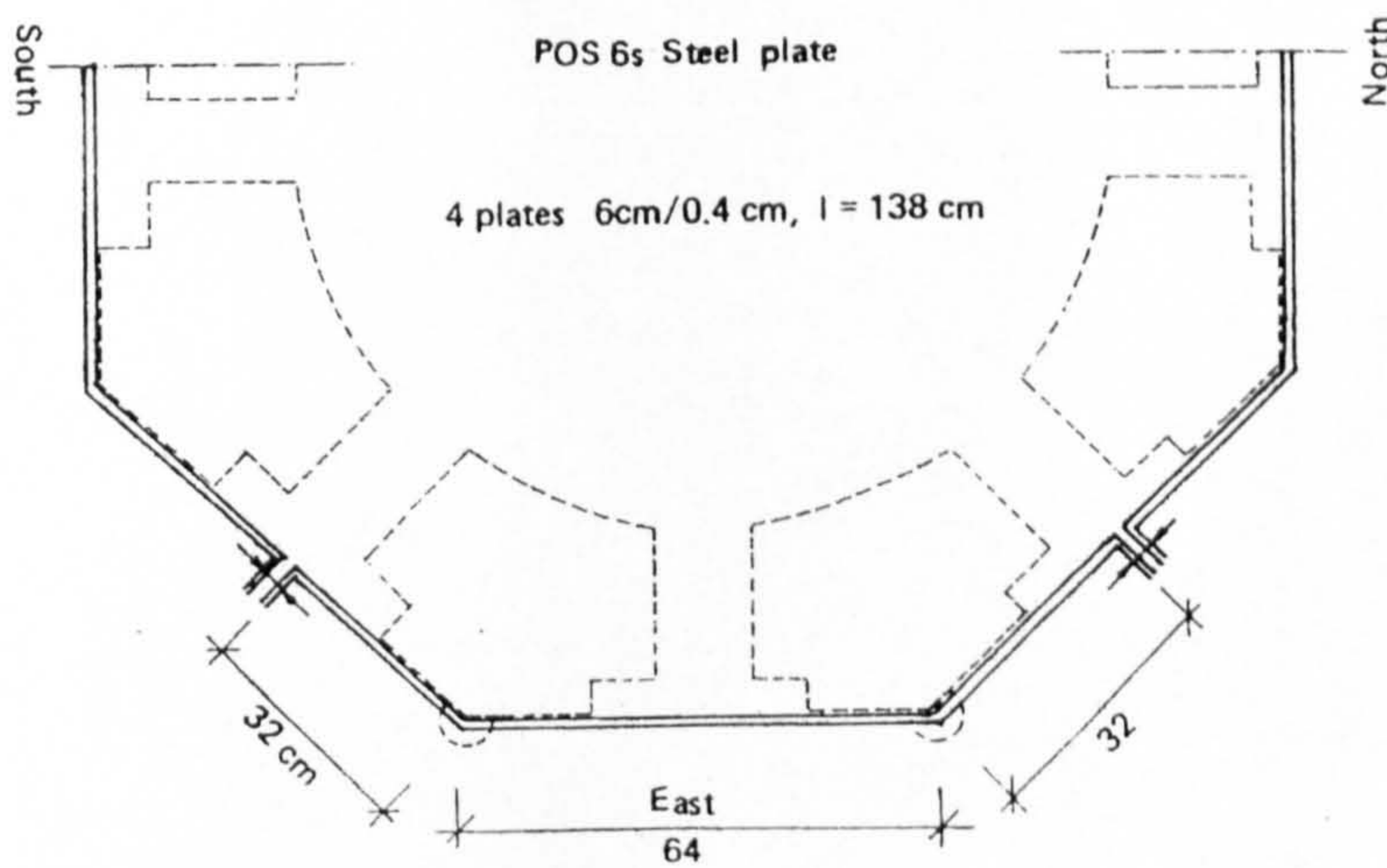
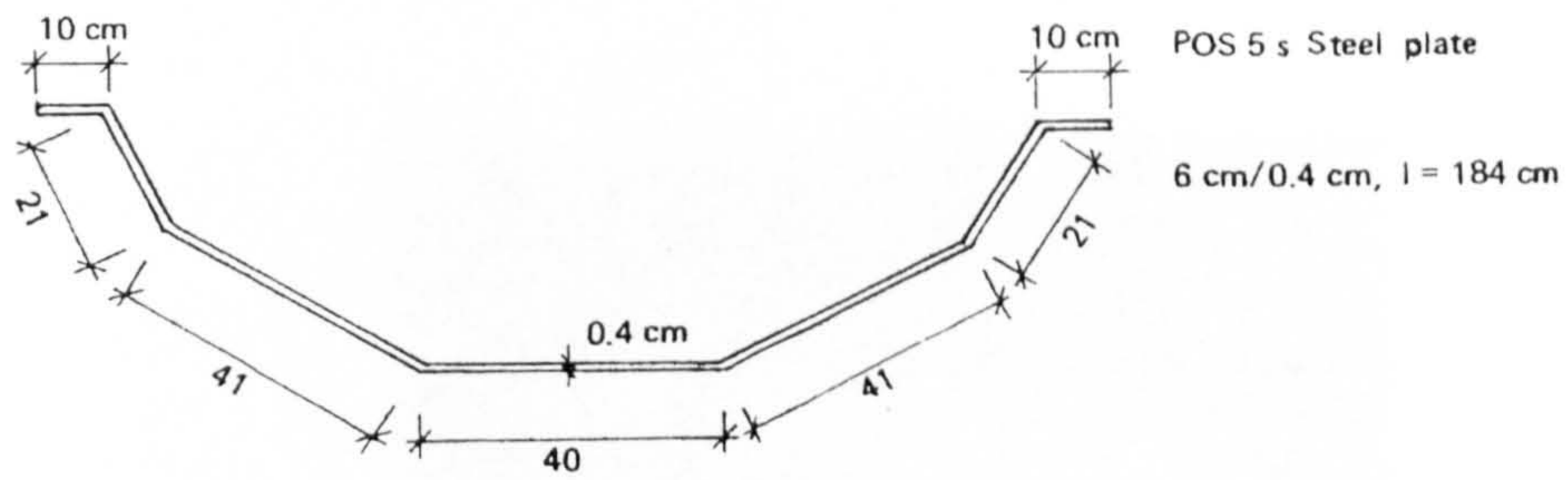
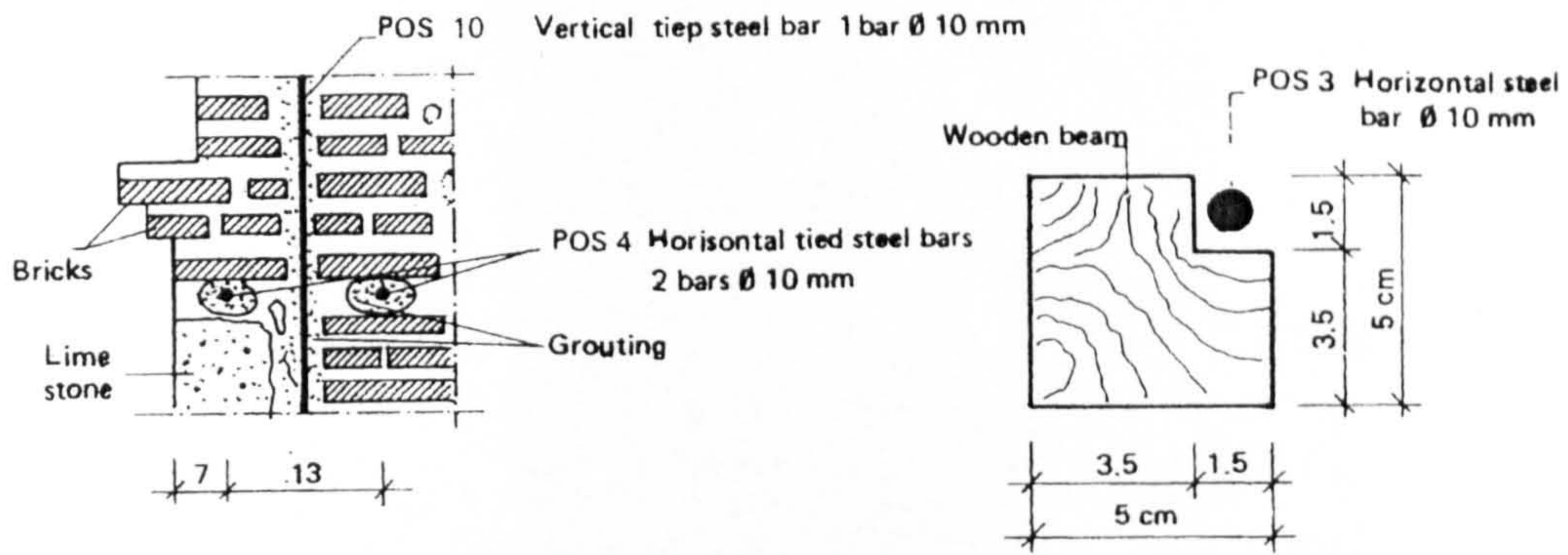
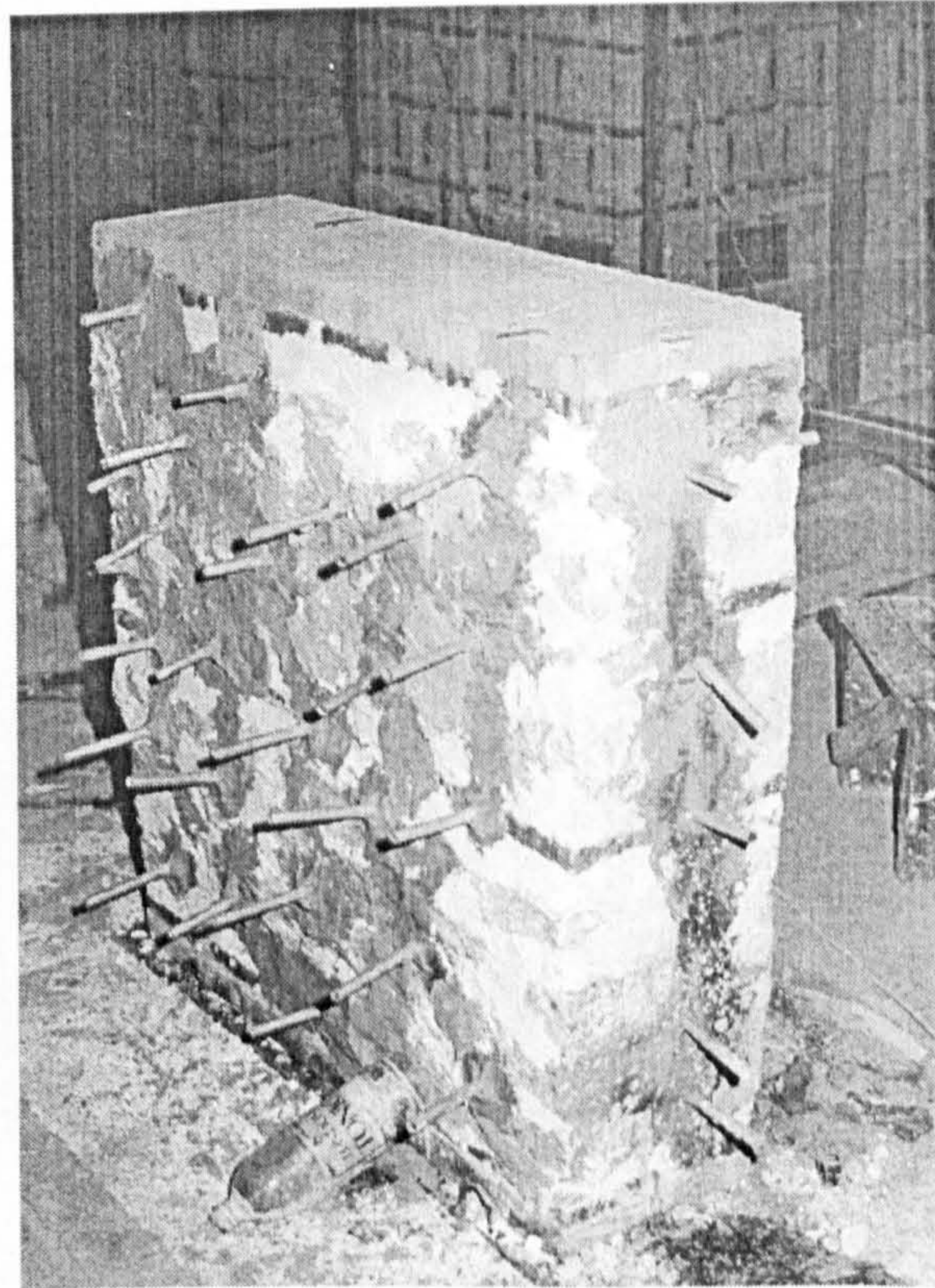

Figure 5.41 Strengthening of damaged church model. Design. Horizontal steel elements on apse and drum.



a)



b)

Figure 5.42 *Repair of damaged a) - wall sample (WAC 1) and b) - damaged model. Prepared for injection.*

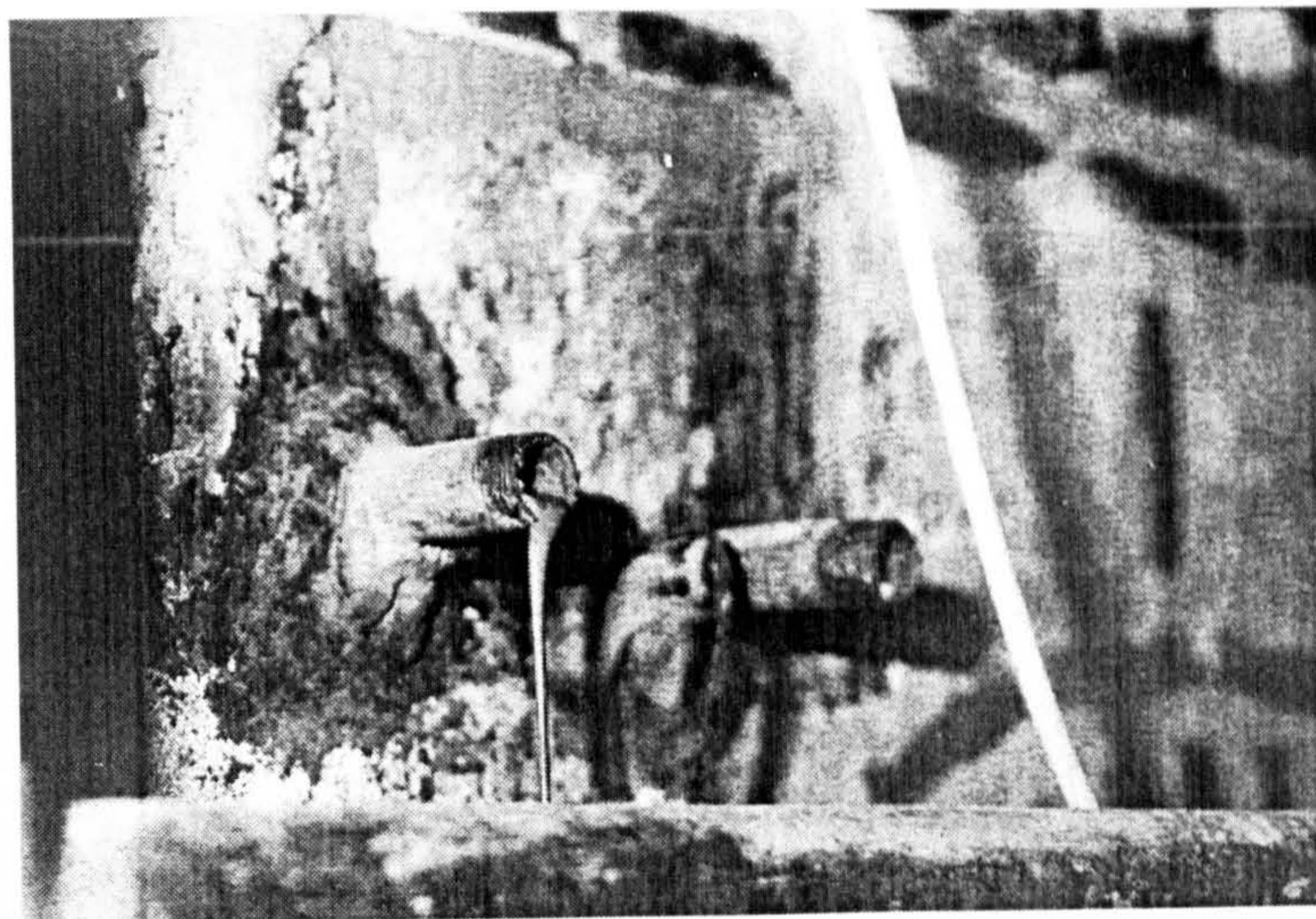

a)

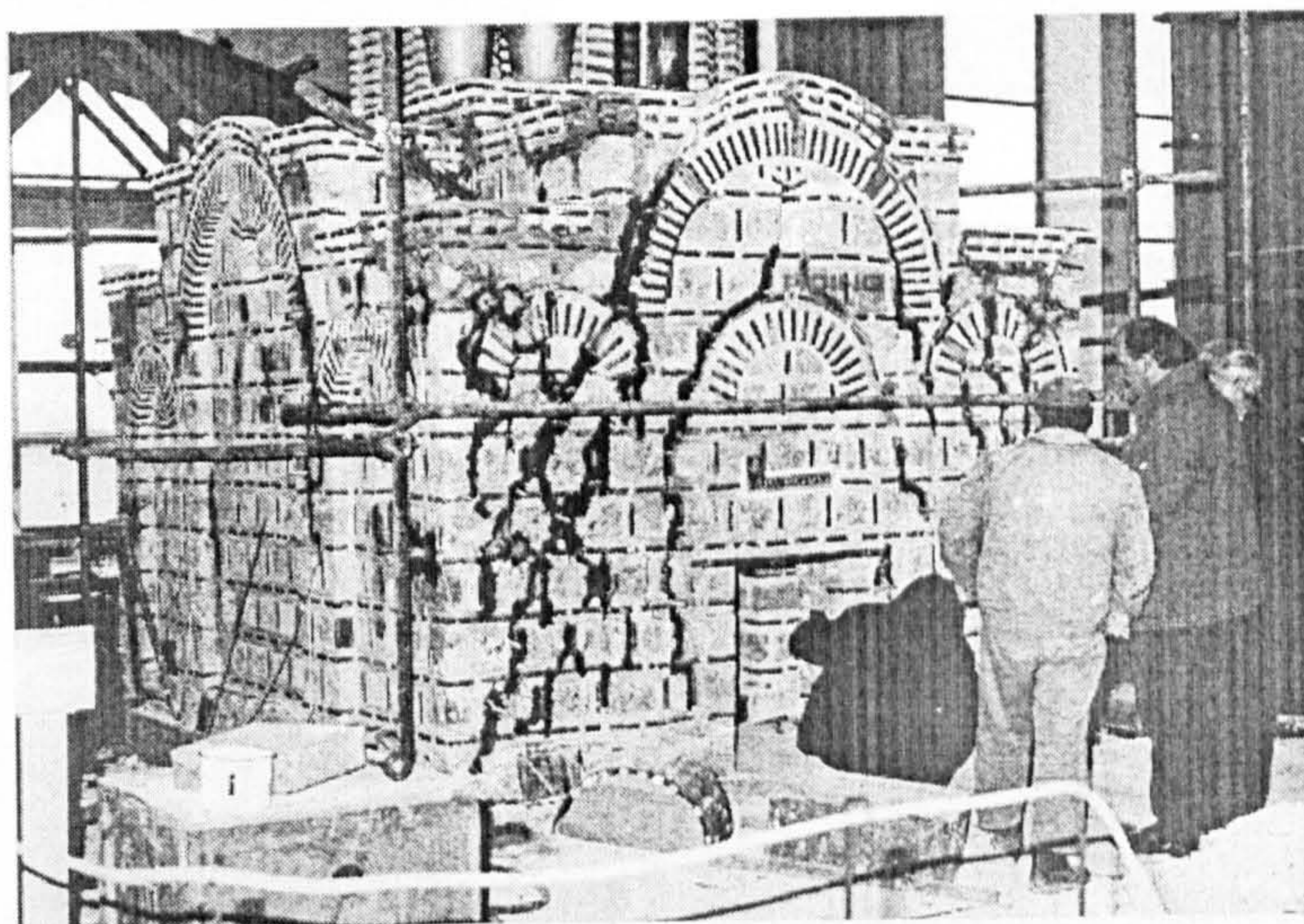

b)

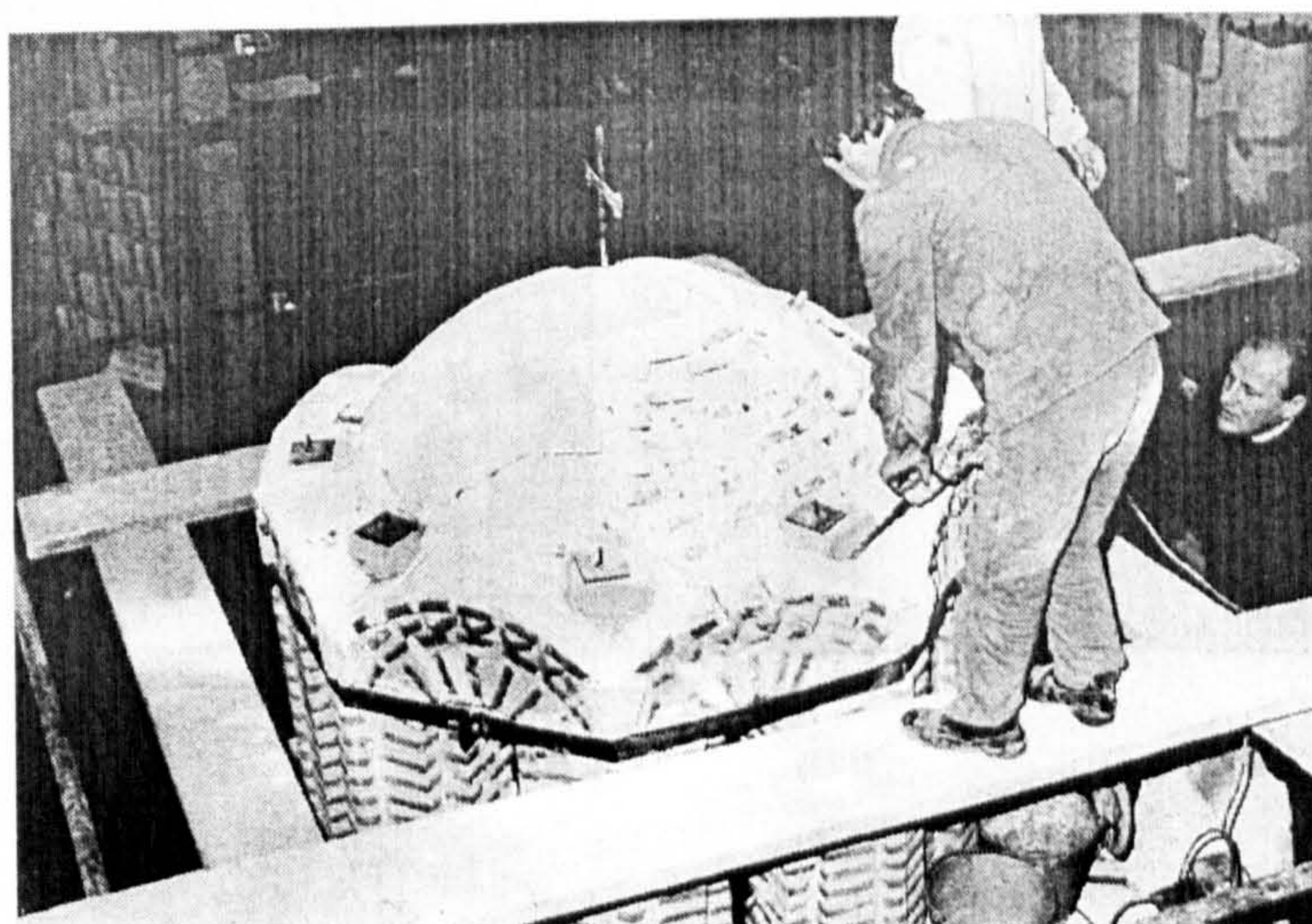

c)

Figure 5.43 *Repair and strengthening of the damaged model.*
 a) - Injection of the horizontal belts; b) - West facade;
 c) - East facade.



a)



b)

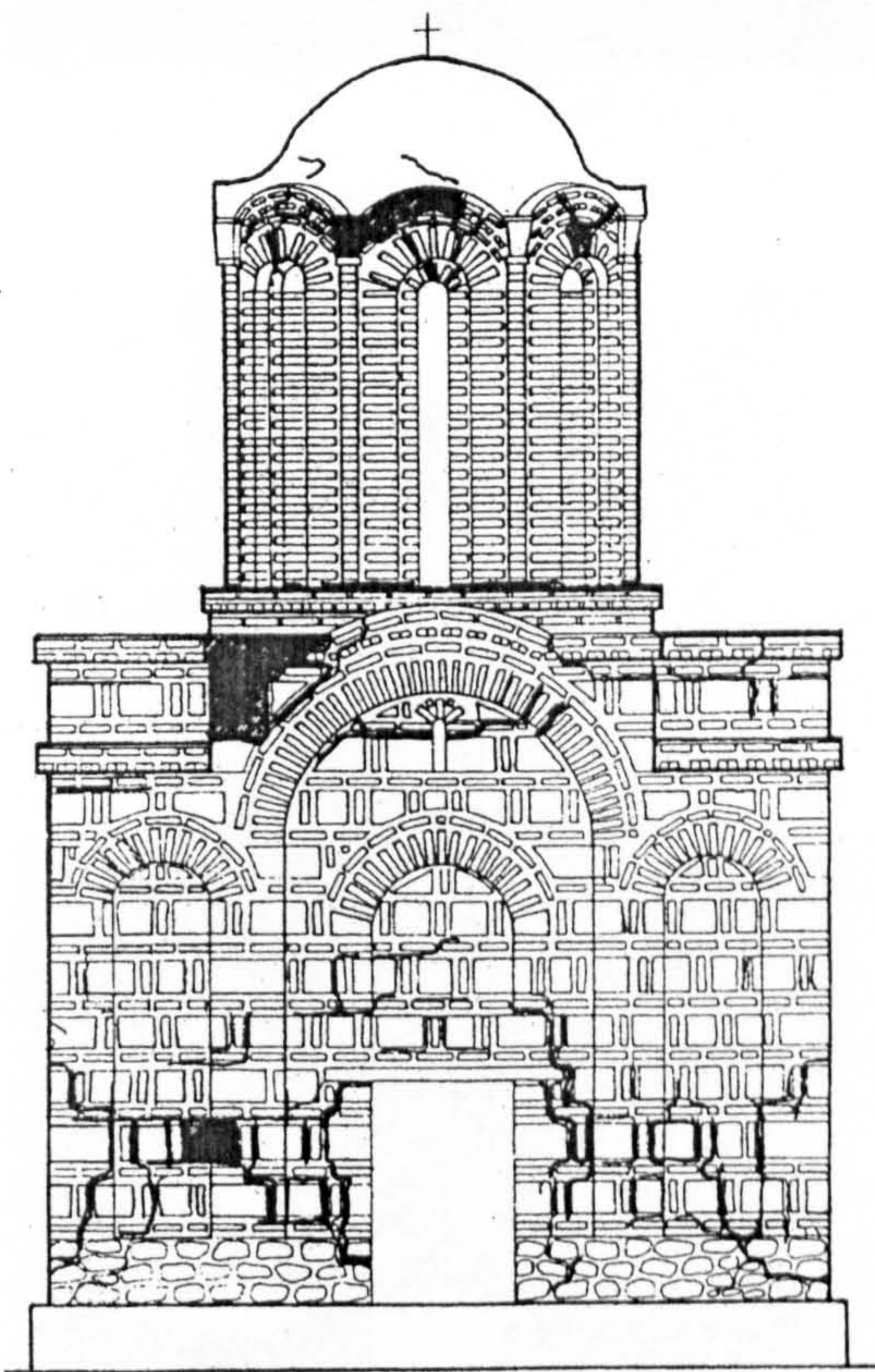

— After Petrovac $a_{max} = 0.40 g$
 — After Ci Centro $a_{max} = 0.49 g$
 — After El Centro $a_{max} = 0.54 g$

c)



d)

Figure 5.44 Completed repair and strengthening of damaged model.
 a) - East facade; b) - South and East facade; c) - North and West facade;
 d) - South and West facade.

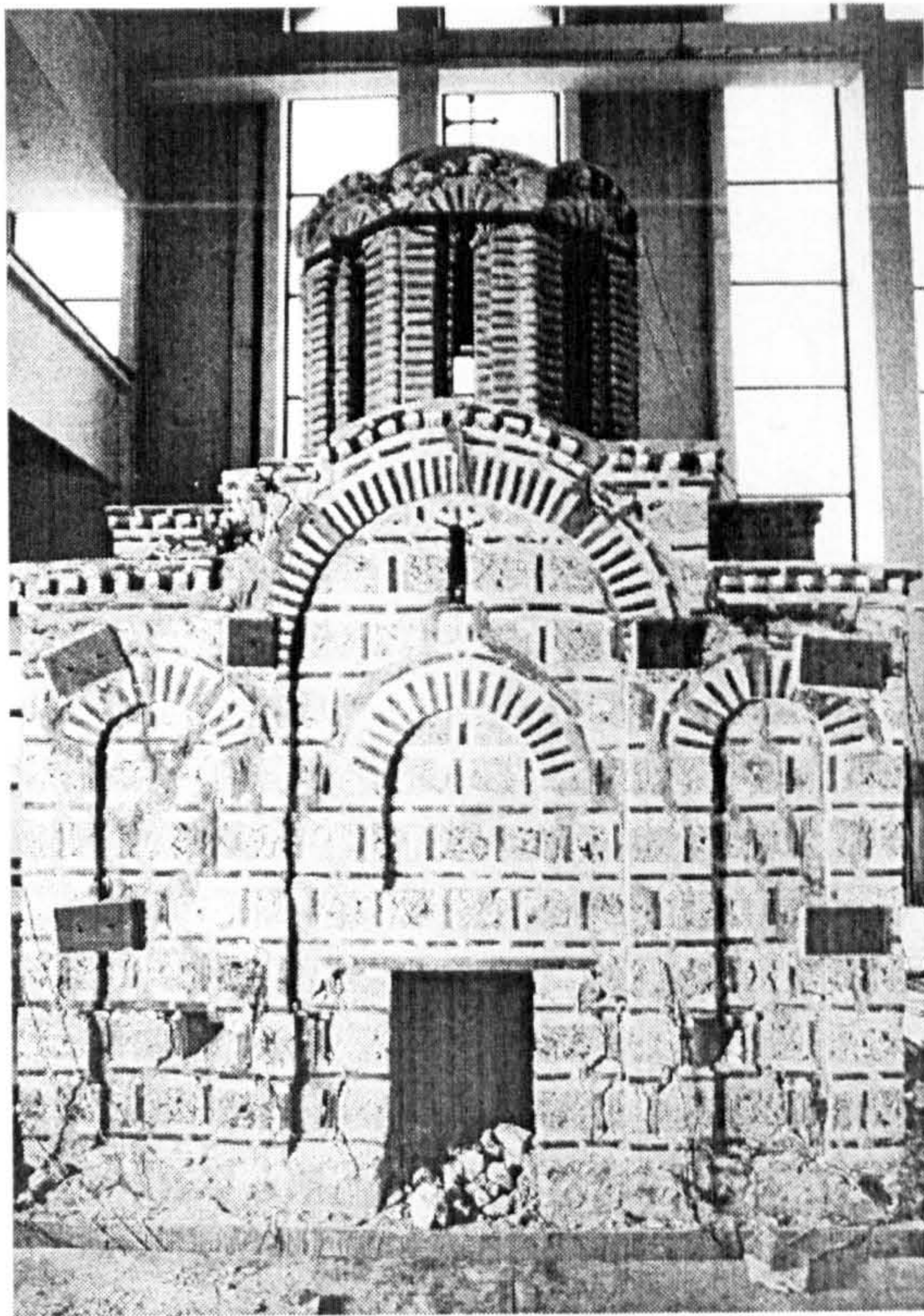

a)



b)

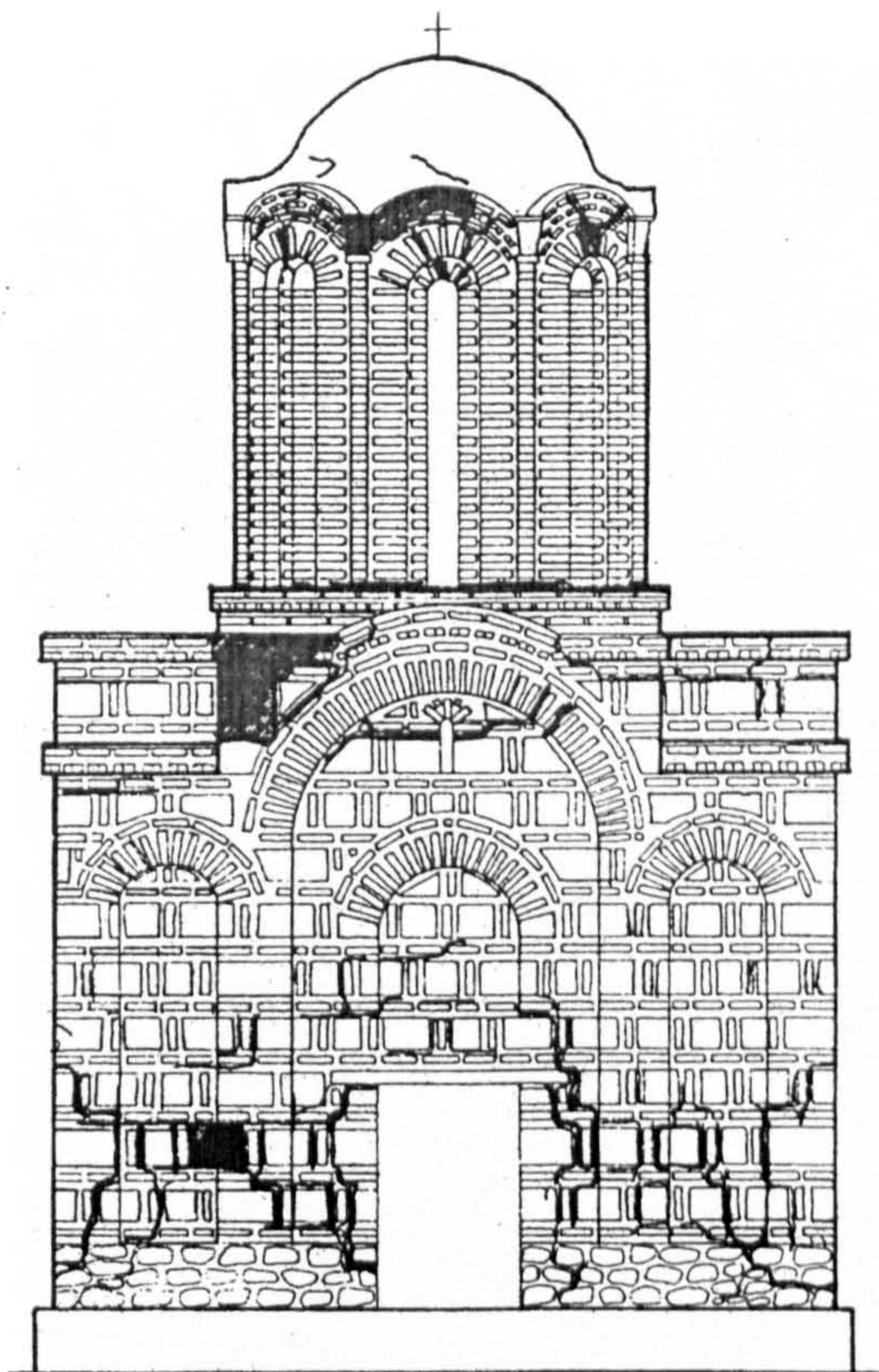

c)

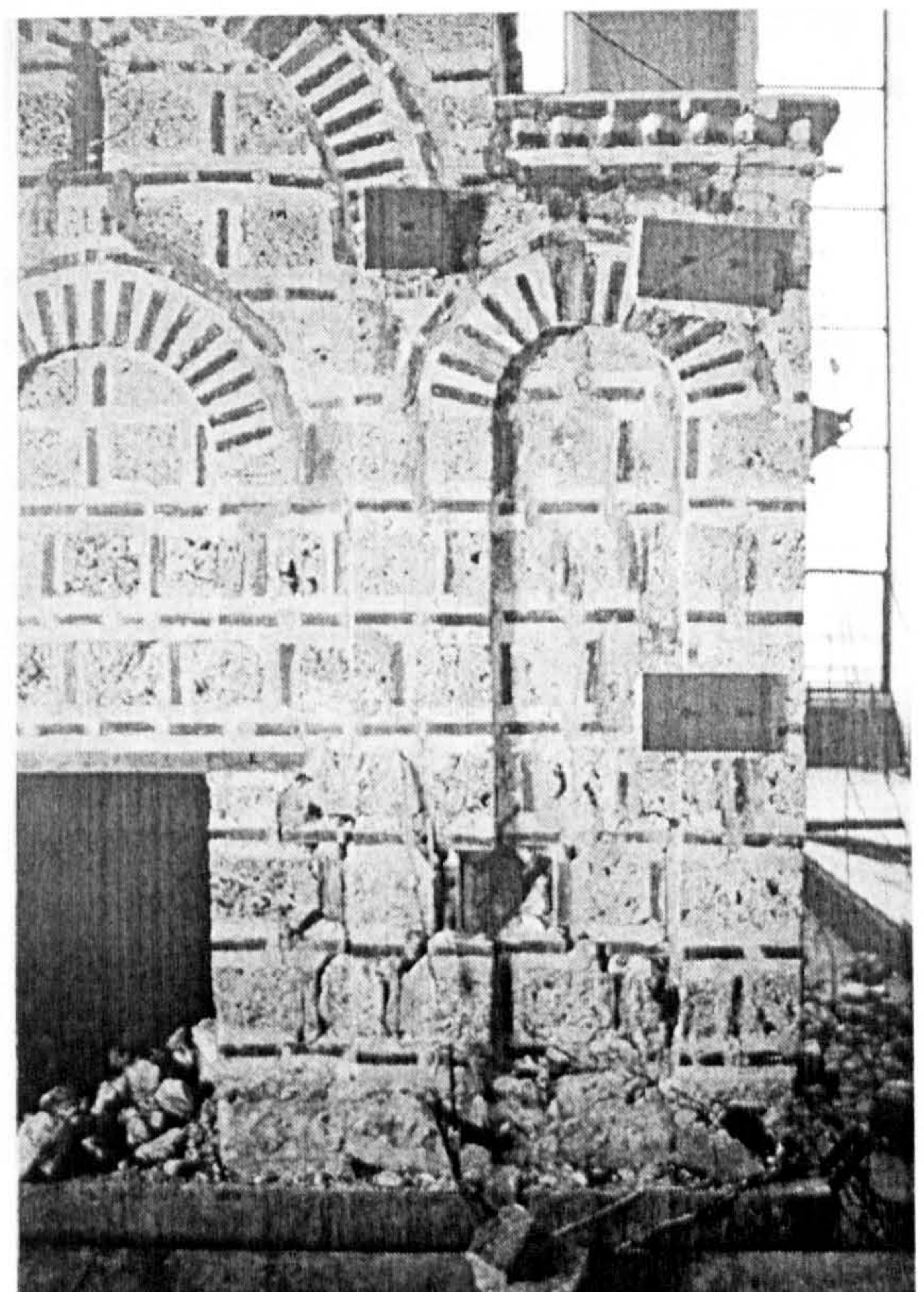

d)

Figure 5.45 Damage pattern of strengthened model after the final shaking table test. a) and b) - West facade; c) - Northern wing; d) - Southern wing.



a)

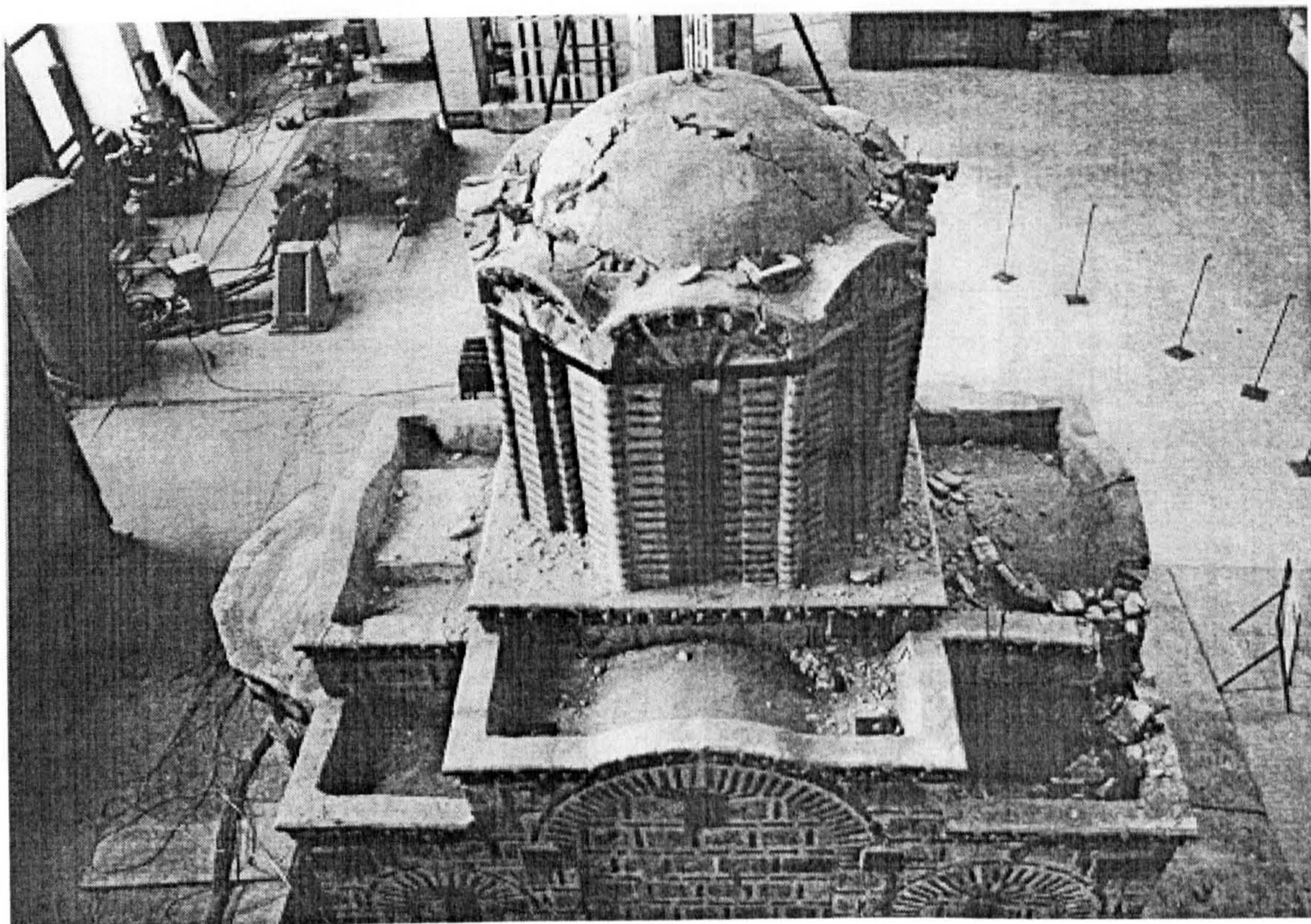

b)

Figure 5.46 *Damage pattern of strengthened model after the final shaking table test.*
a) - Interior. Western wall; b) - Dome and vaults.

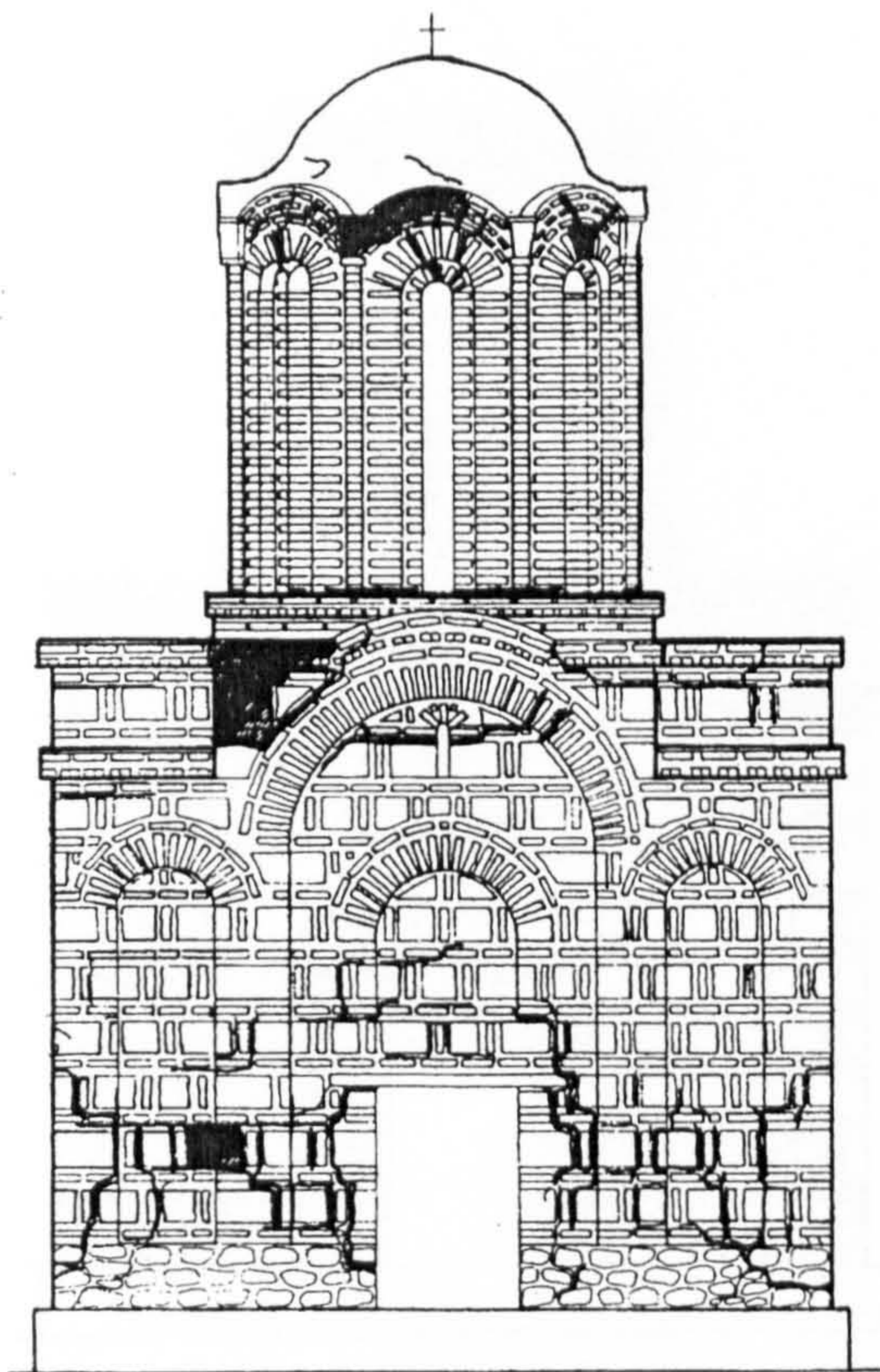

— After Petrovac $a_{max} = 0.40g$
 — After Ci Centro $a_{max} = 0.49g$
 — After El Centro $a_{max} = 0.54g$

a)

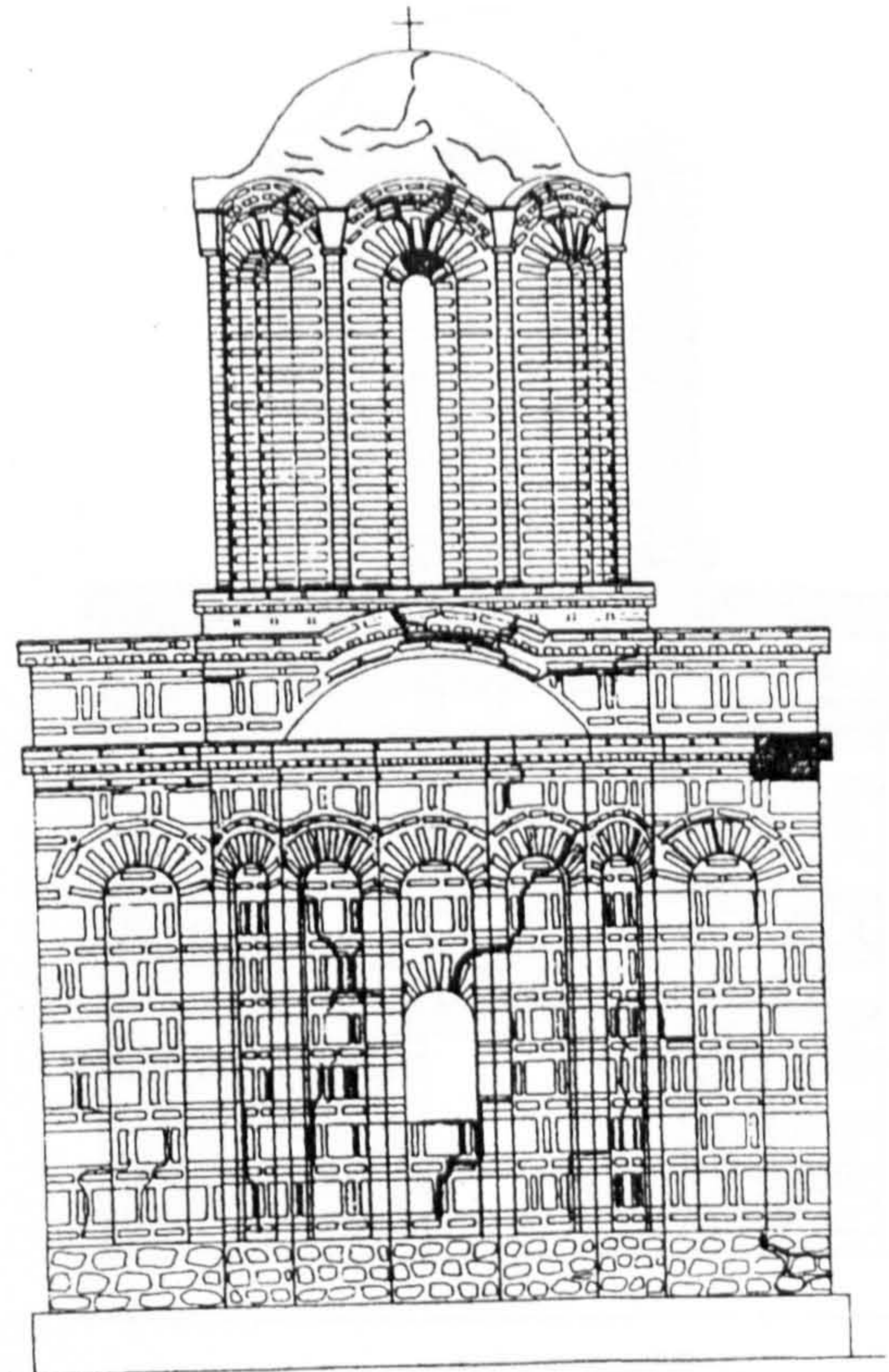

— After Petrovac $a_{max} = 0.40g$
 — After Ci Centro $a_{max} = 0.49g$
 — After El Centro $a_{max} = 0.54g$

b)

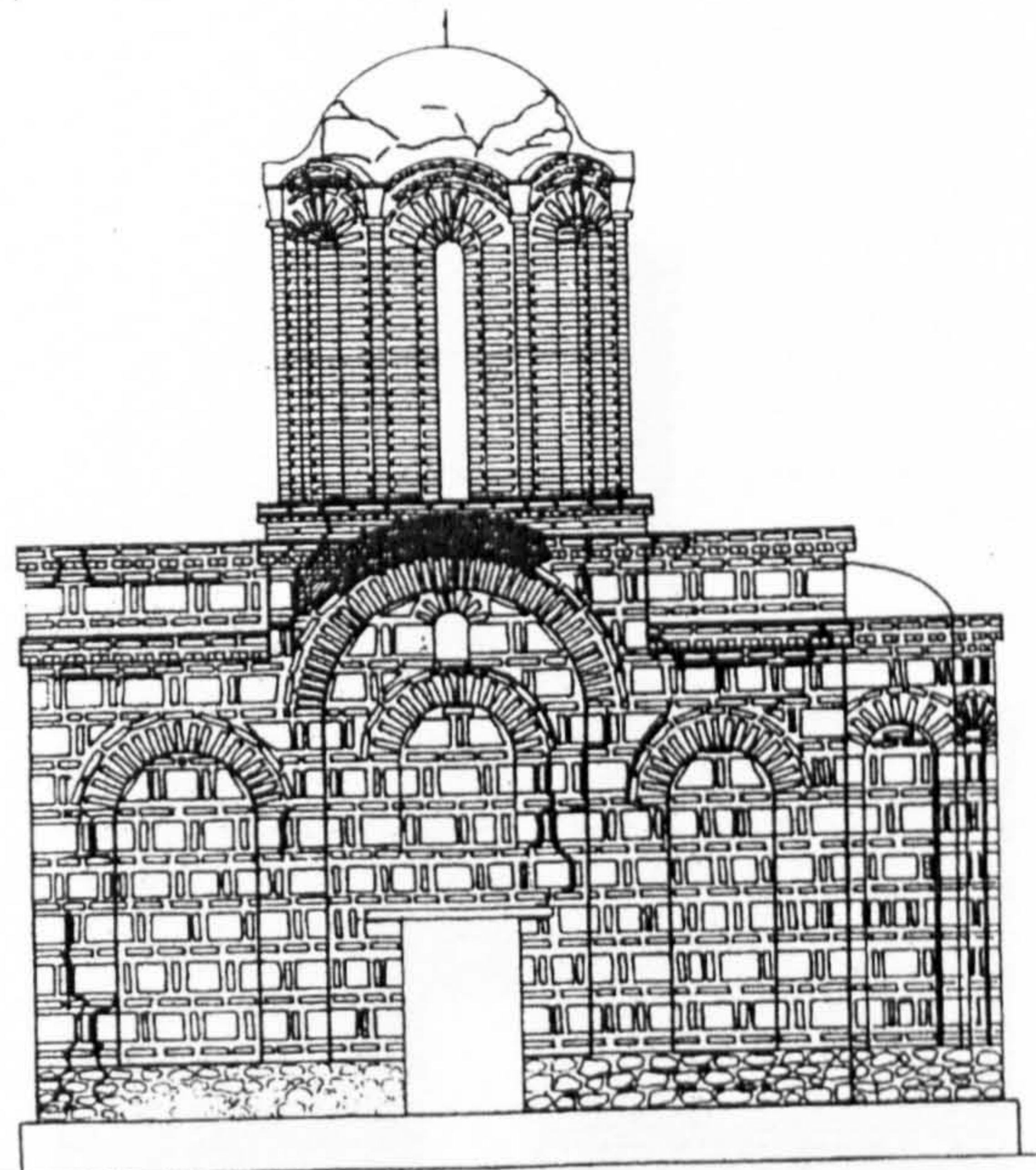

— After Petrovac $a_{max} = 0.40g$
 — After Ci Centro $a_{max} = 0.49g$
 — After El Centro $a_{max} = 0.54g$

c)

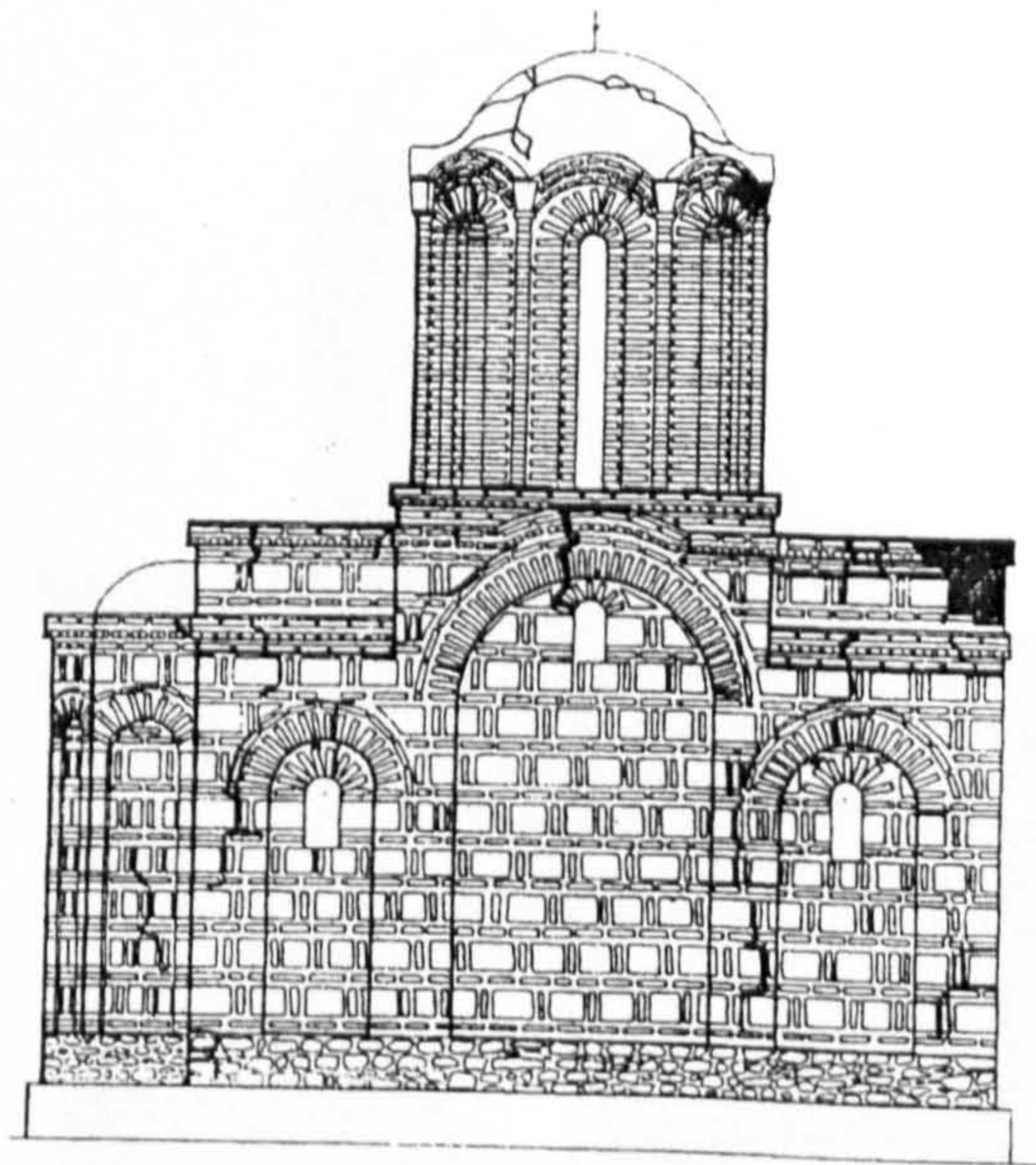

— After Petrovac $a_{max} = 0.40g$
 — After Ci Centro $a_{max} = 0.49g$
 — After El Centro $a_{max} = 0.54g$

d)

Figure 5.47 Damage pattern of strengthened model after the final shaking table test.
 a) - West facade; b) - East facade; c) - South facade; d) - North facade.

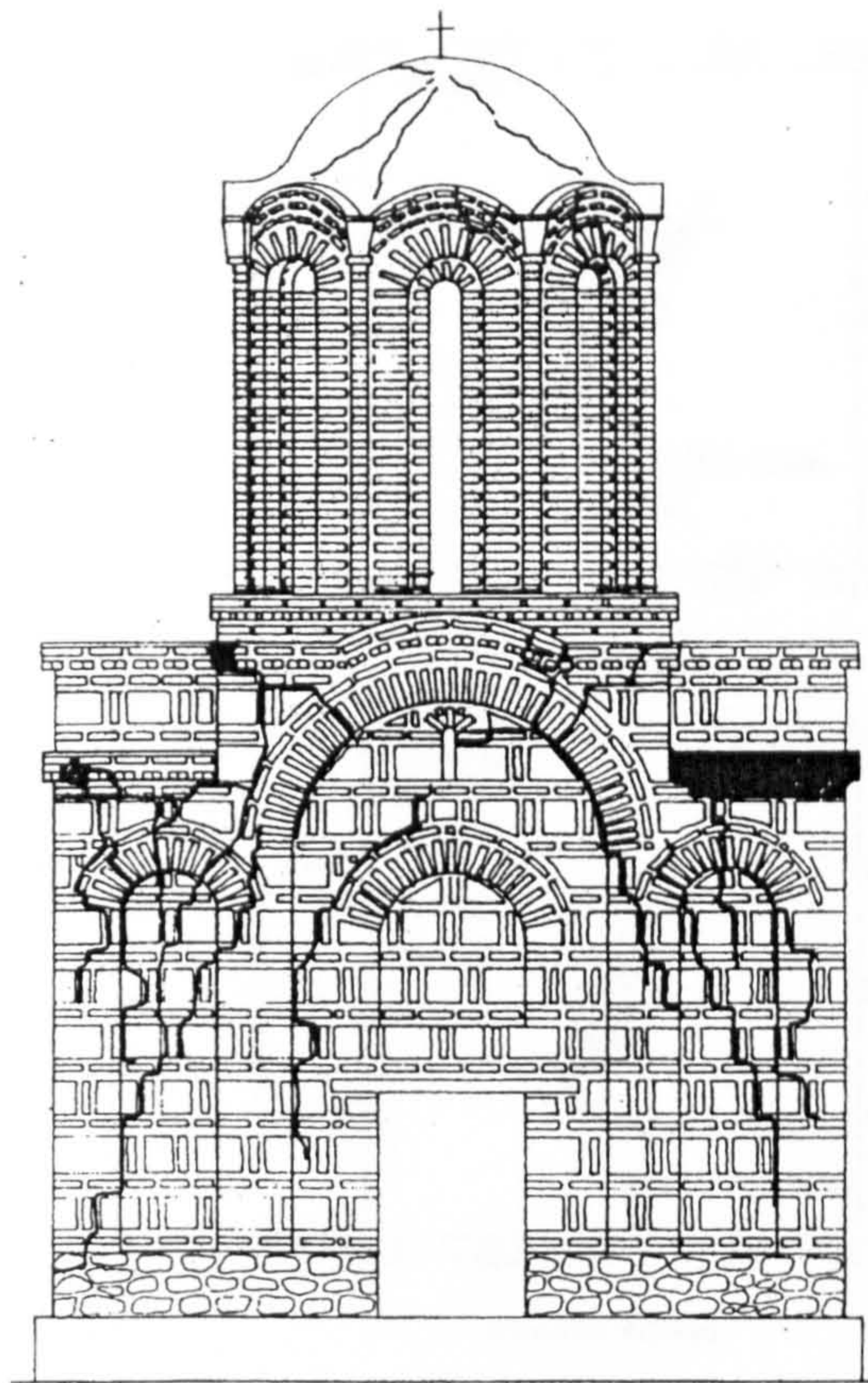

a)

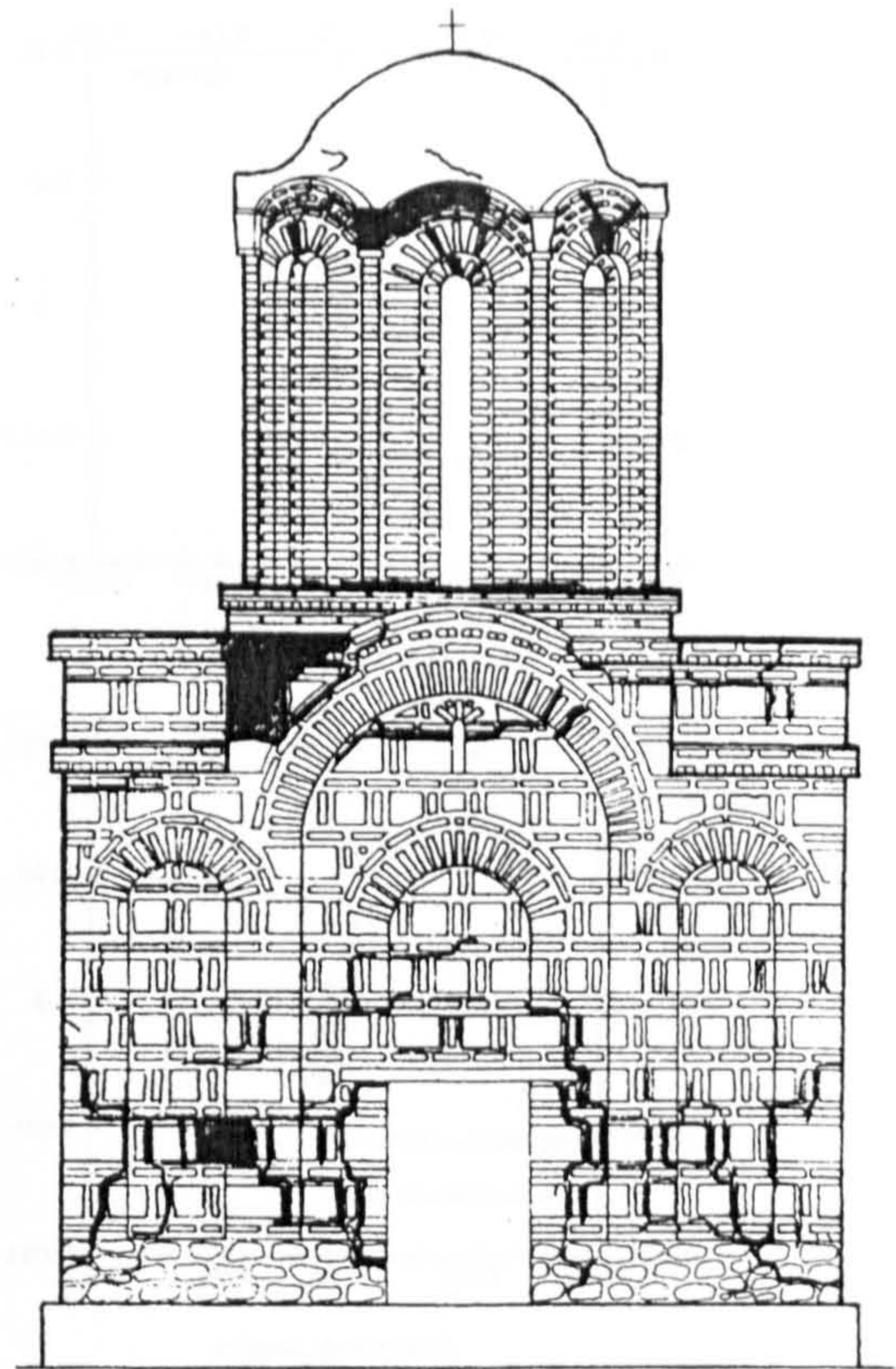

b)

— After Petrovac $a_{max} = 0.40 g$
 — After Ci Centro $a_{max} = 0.49 g$
 — After El Centro $a_{max} = 0.54 g$

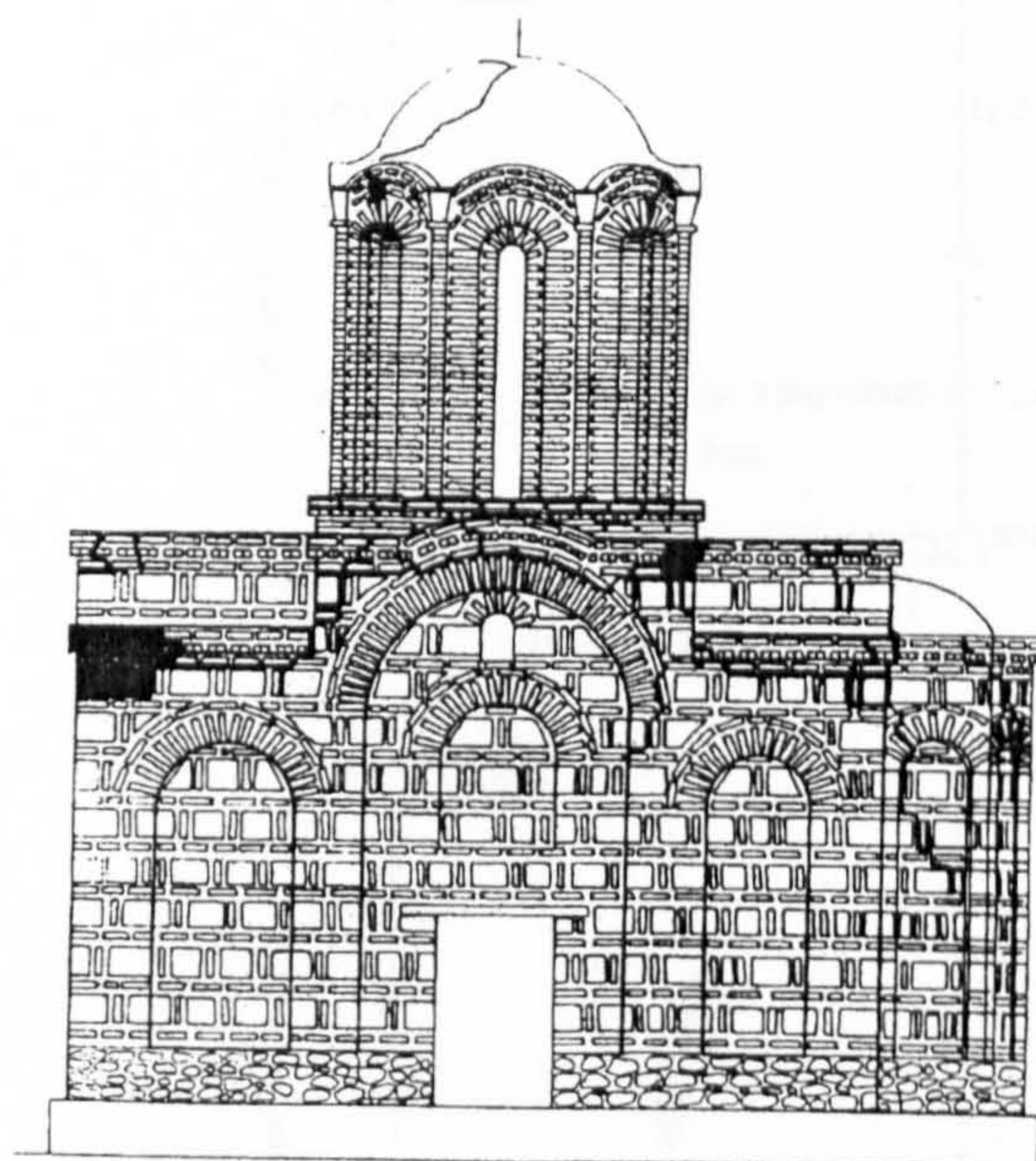

c)

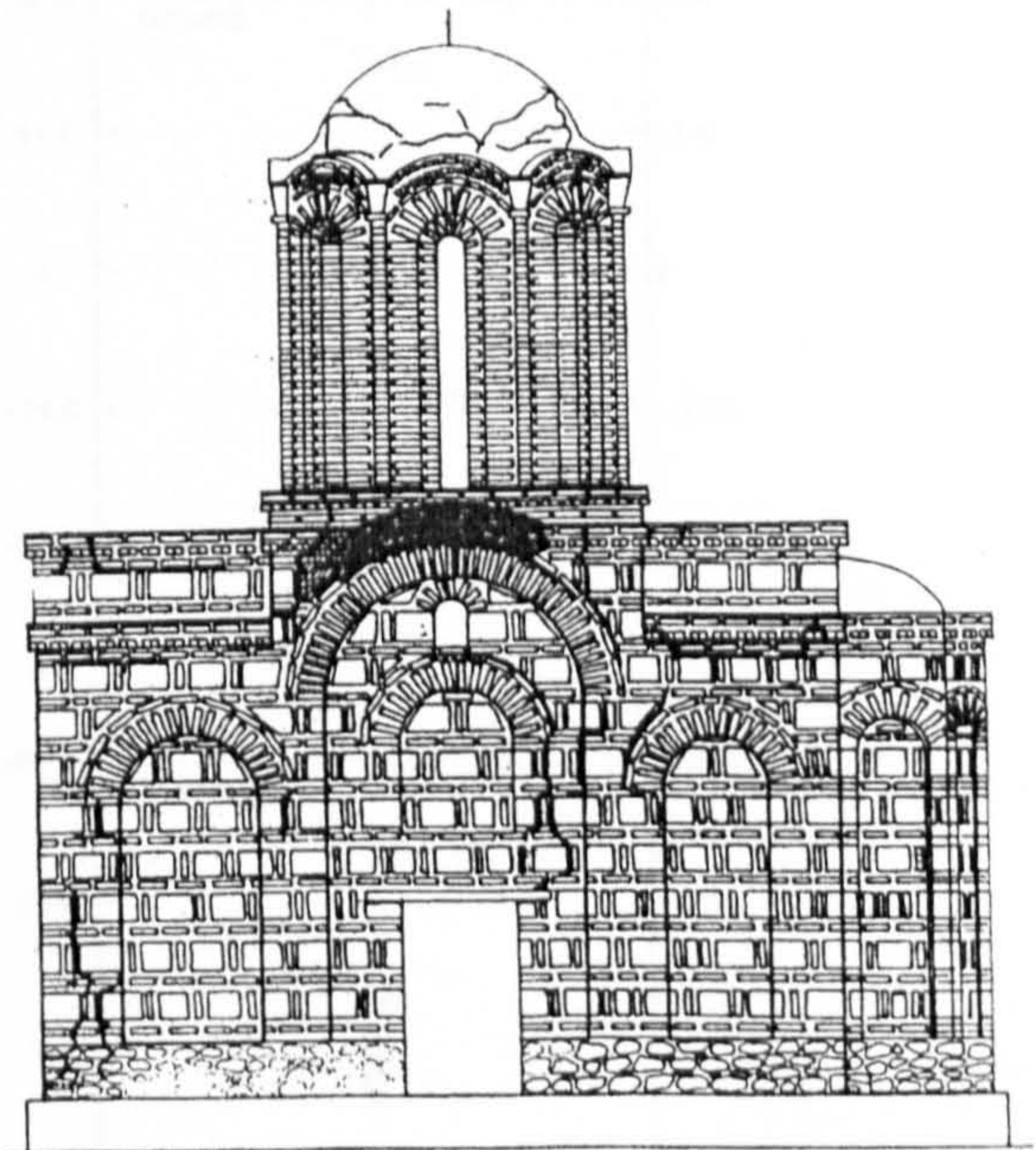

d)

— After Petrovac $a_{max} = 0.40 g$
 — After Ci Centro $a_{max} = 0.49 g$
 — After El Centro $a_{max} = 0.54 g$

Figure 5.48 Comparison of damage pattern of non - strengthened and strengthened model.

a) - West facade, non - strengthened model; b) - West facade, strengthened model; c) - South facade, non - strengthened model; d) - South facade, strengthened model.

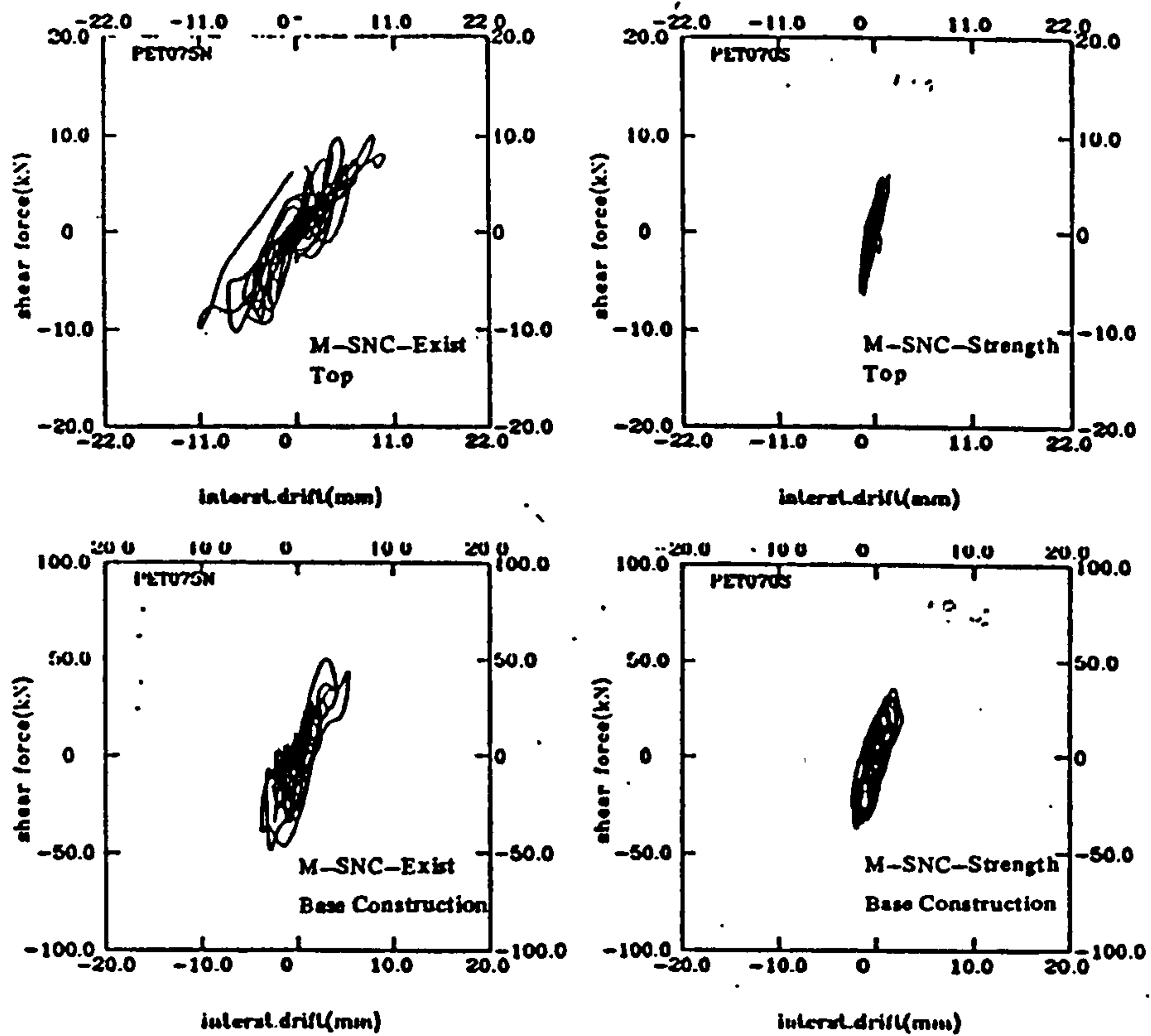

Figure 5.49 Comparison between $P - \delta$ diagrams of non-strengthened and strengthened model. (Petrovac $a_{max} = 0.20g$); Source: Volume 10.

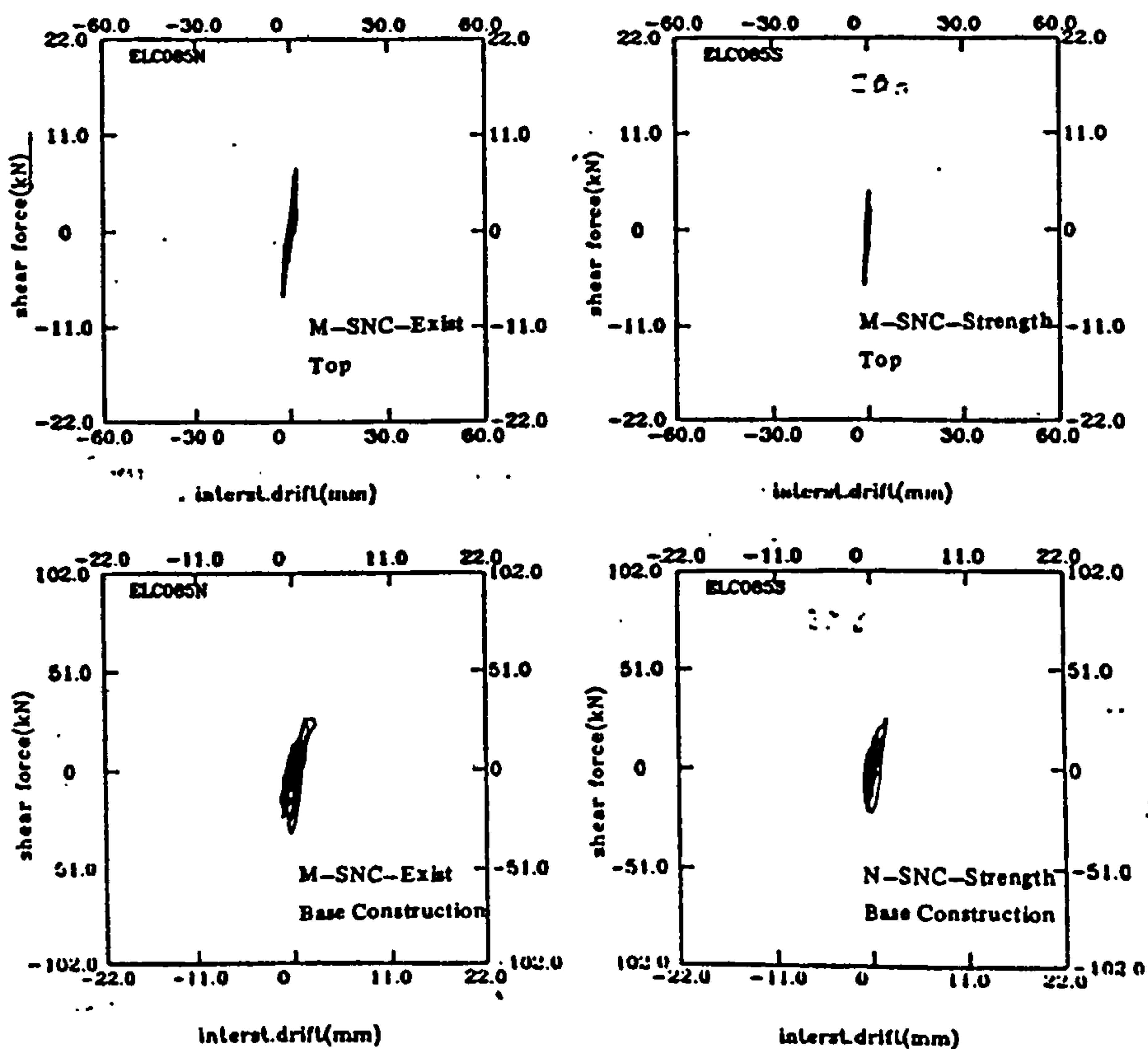

Figure 5.50 Comparison between $P - \delta$ diagrams of non-strengthened and strengthened model; (El Centro $a_{max} = 0.17g$); Source: Volume 10.

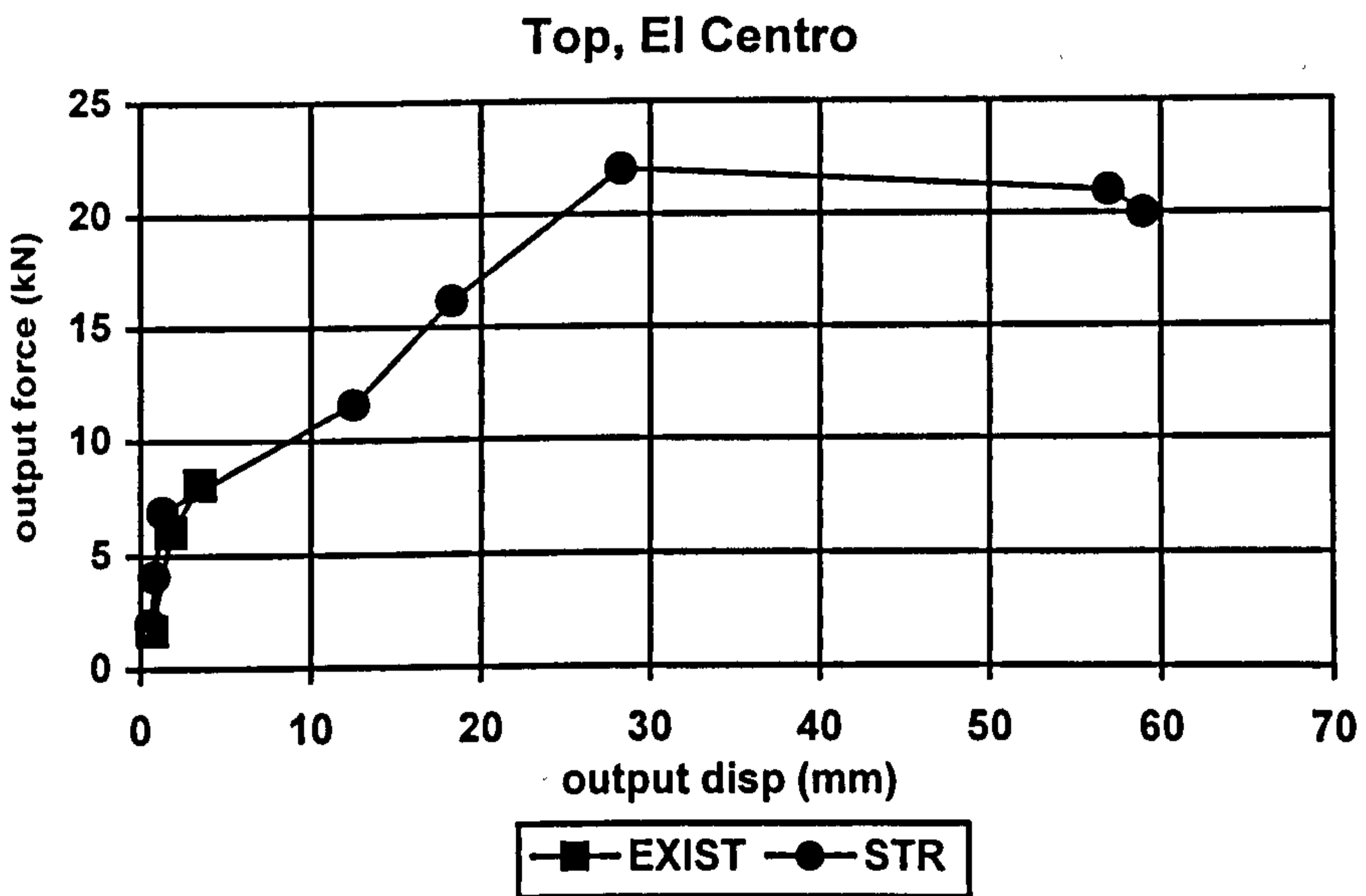
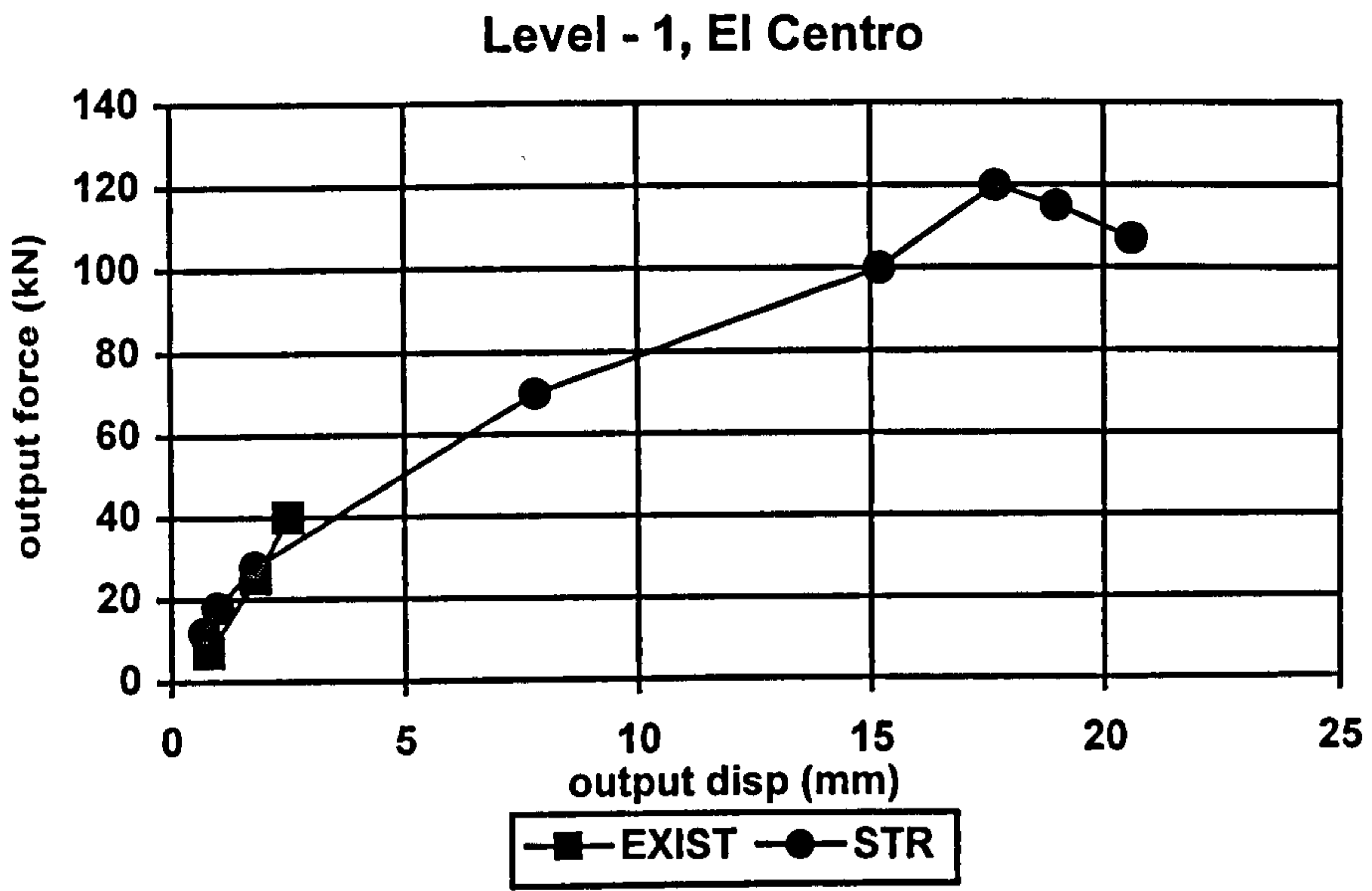

Figure 5.51 Comparison of the shear - force relative deformation on two characteristic levels (level 1 and top) of original (EXIST) and strengthened (STR) model for different intensities of El Centro earthquake.

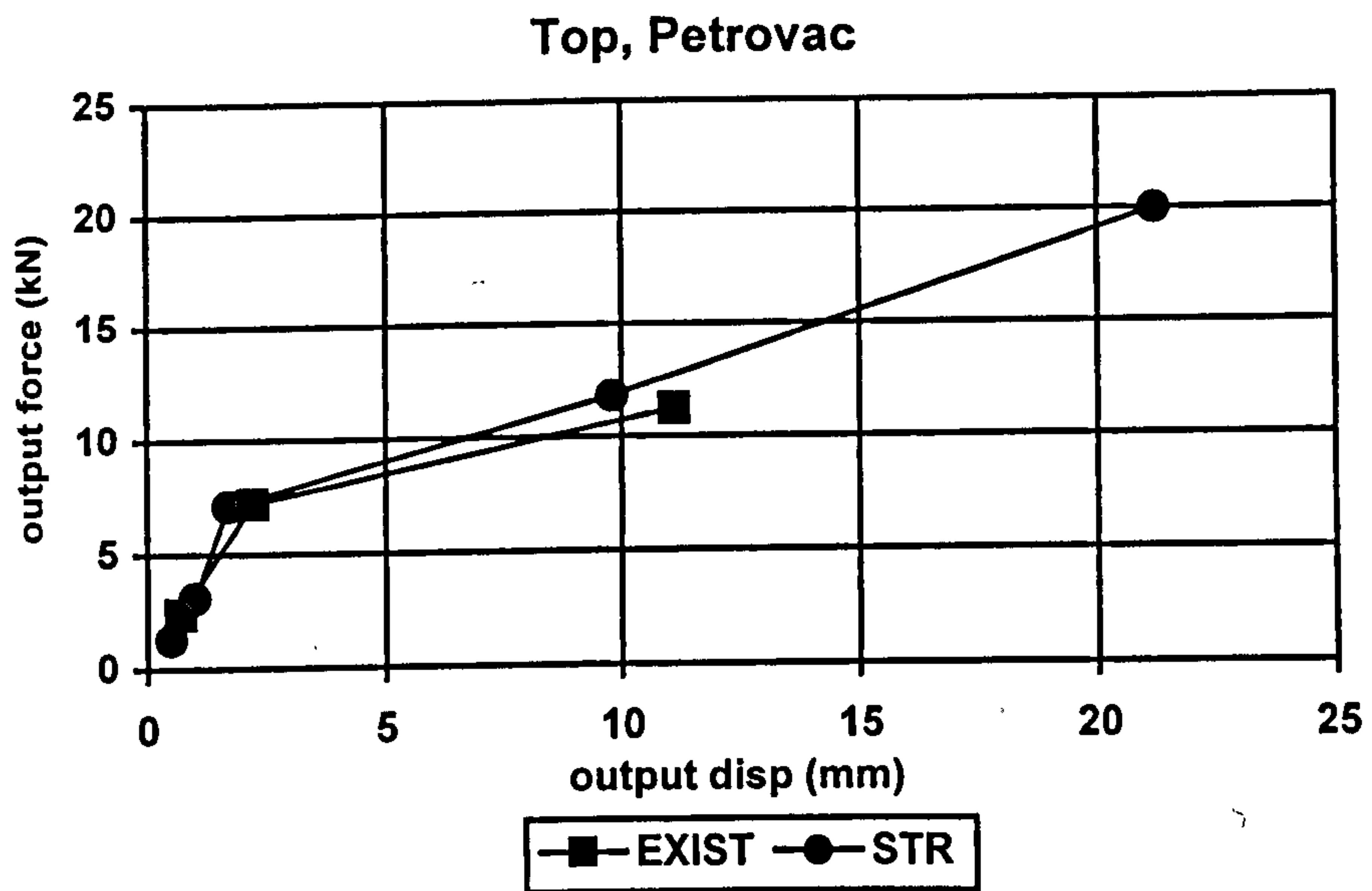
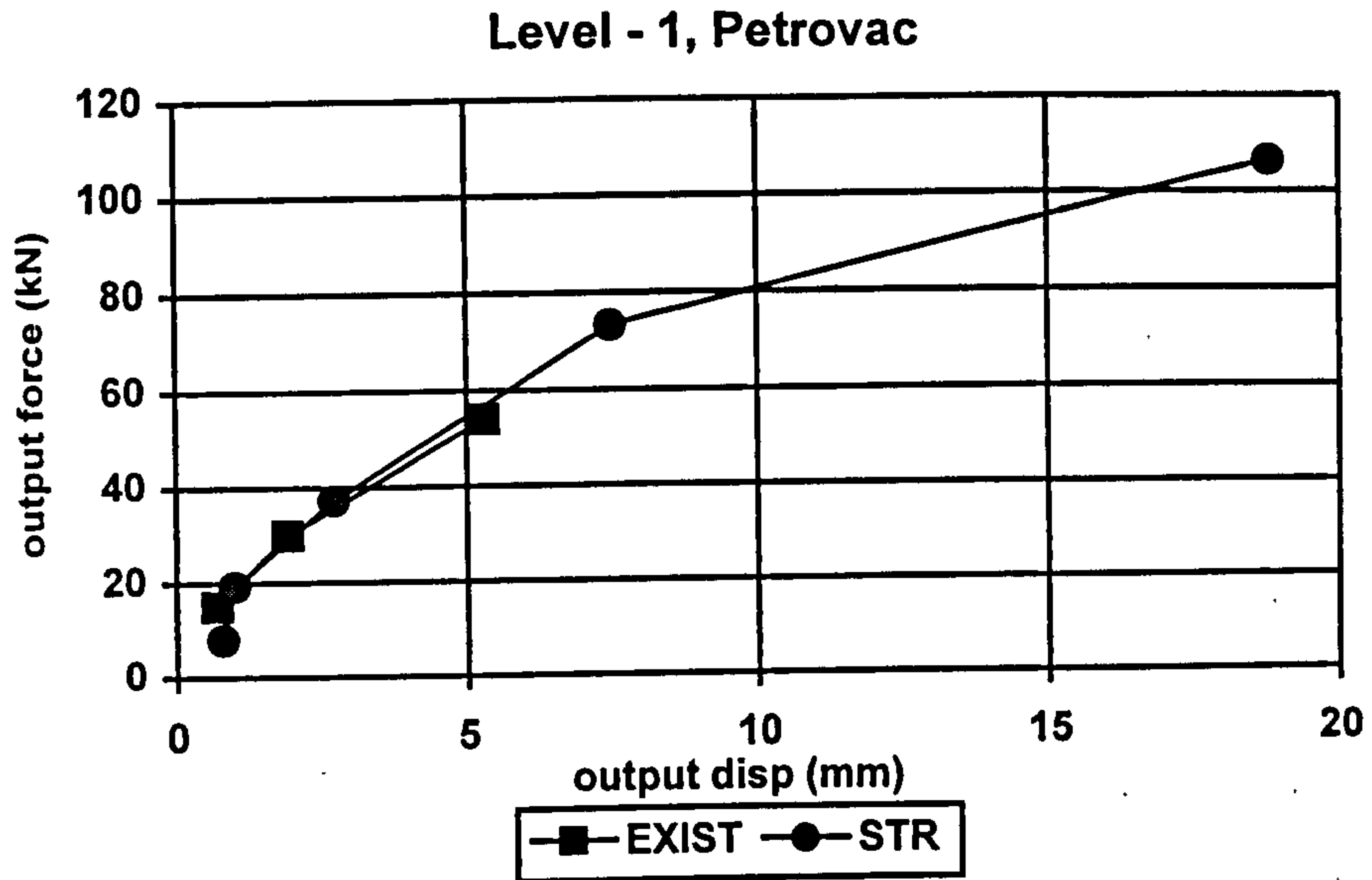

Figure 5.52 Comparison of the shear - force relative deformation on two characteristic levels (level 1 and top) of original (EXIST) and strengthened (STR) model for different intensities of Petrovac earthquake.

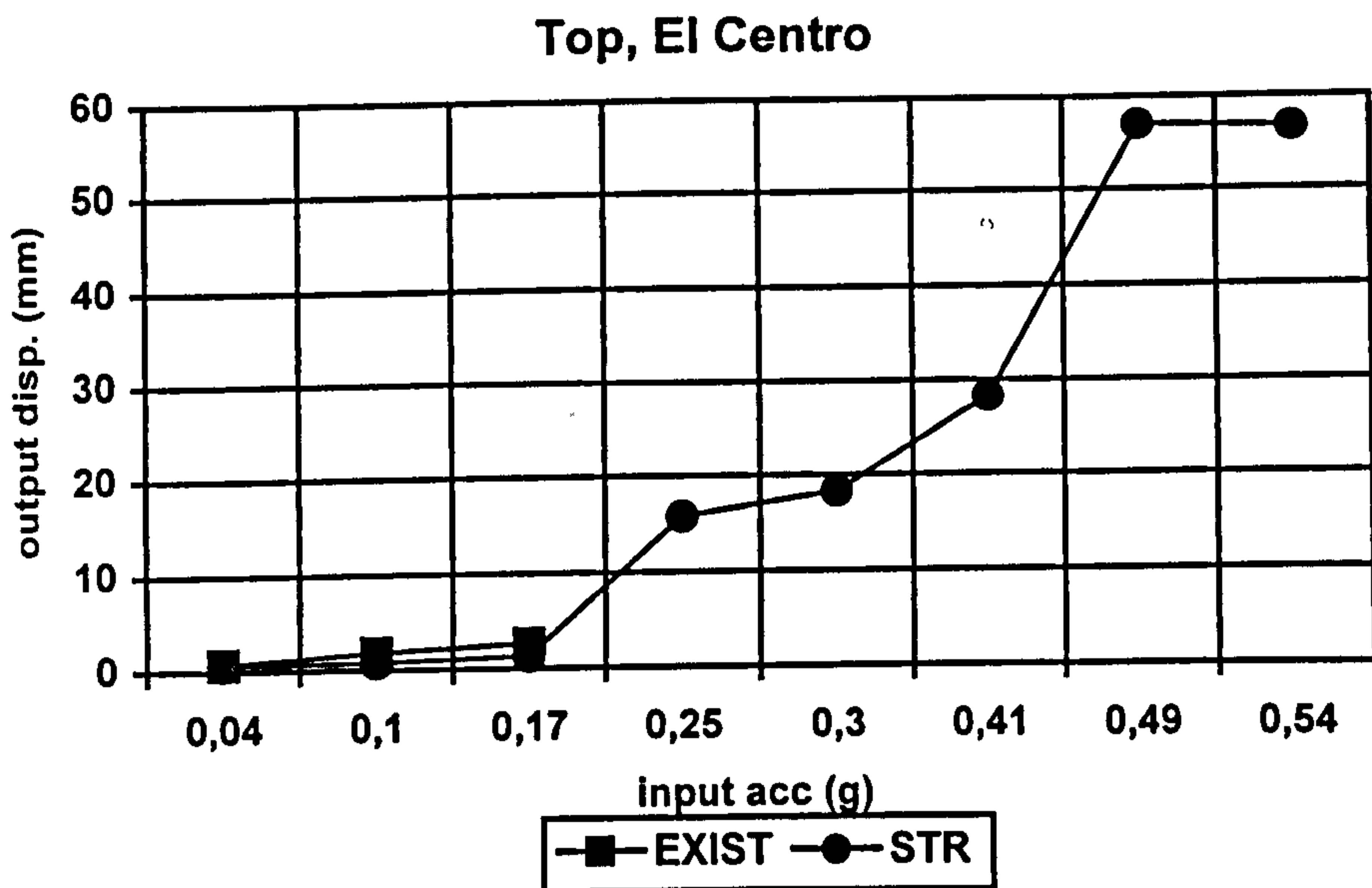
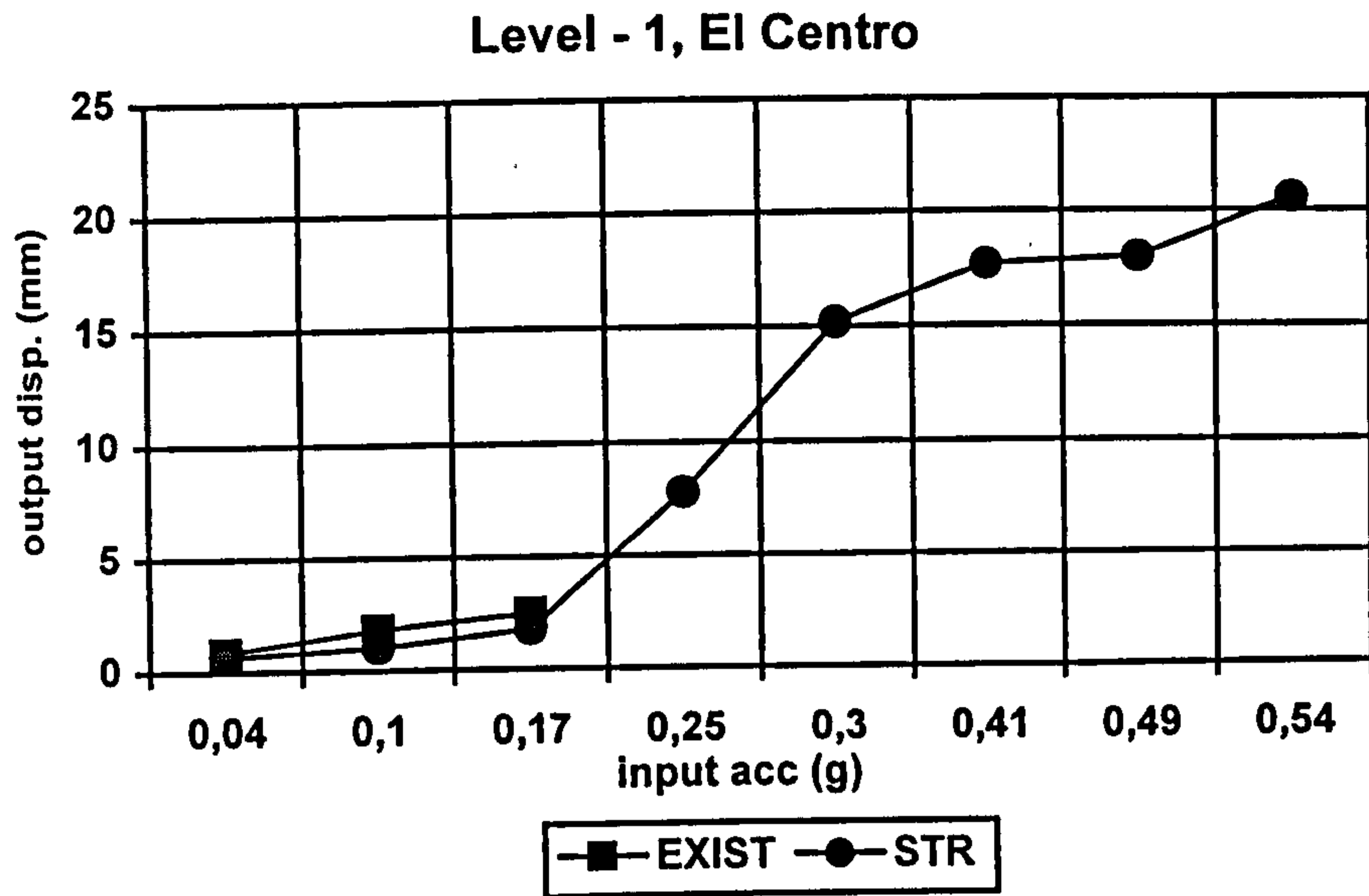

Figure 5.53 *The relationship between the values of the input acceleration and output displacement on two characteristic levels (level 1 and top) of original (EXIST) and strengthened (STR) model for different intensities of El Centro earthquake.*

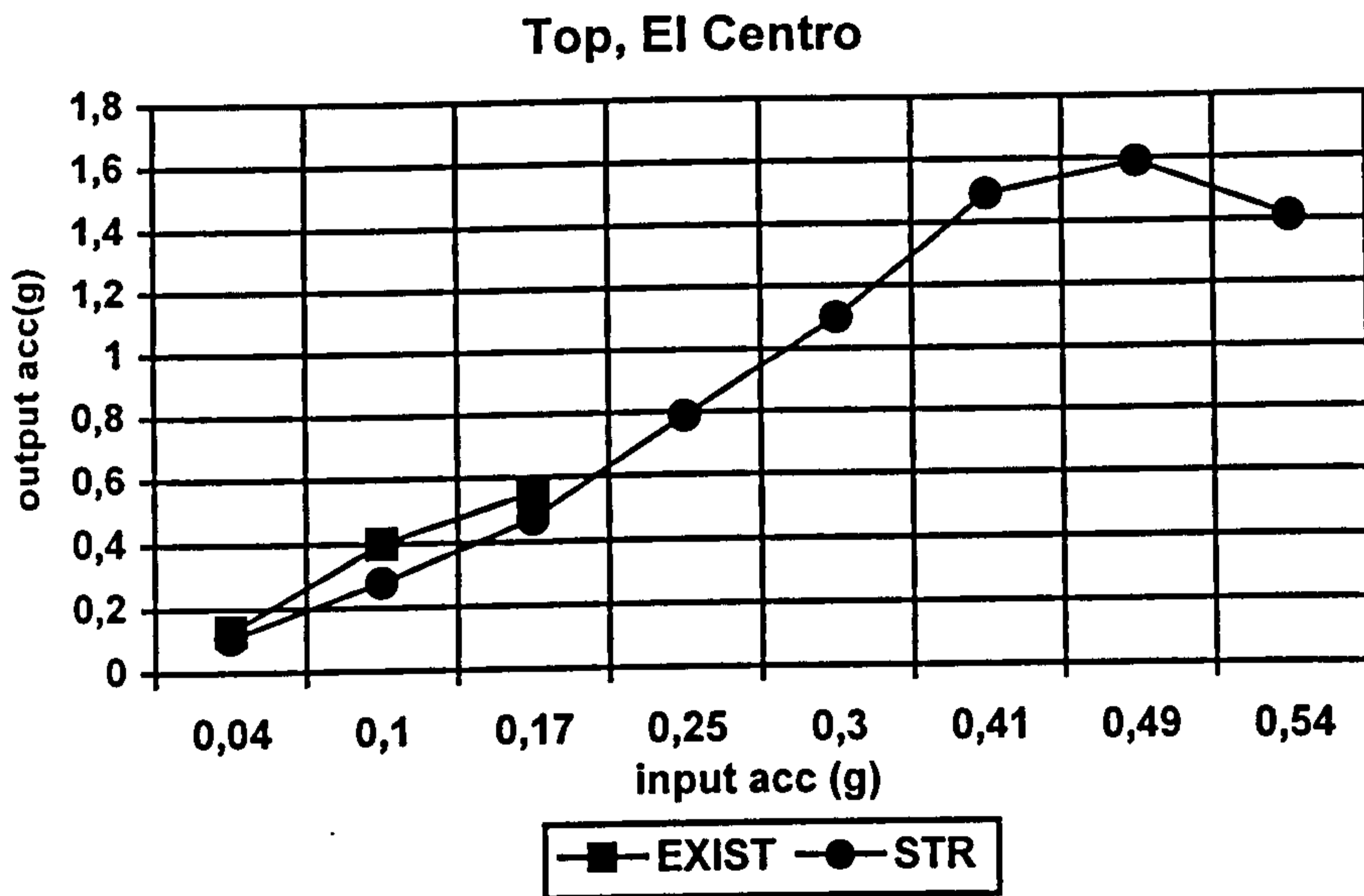
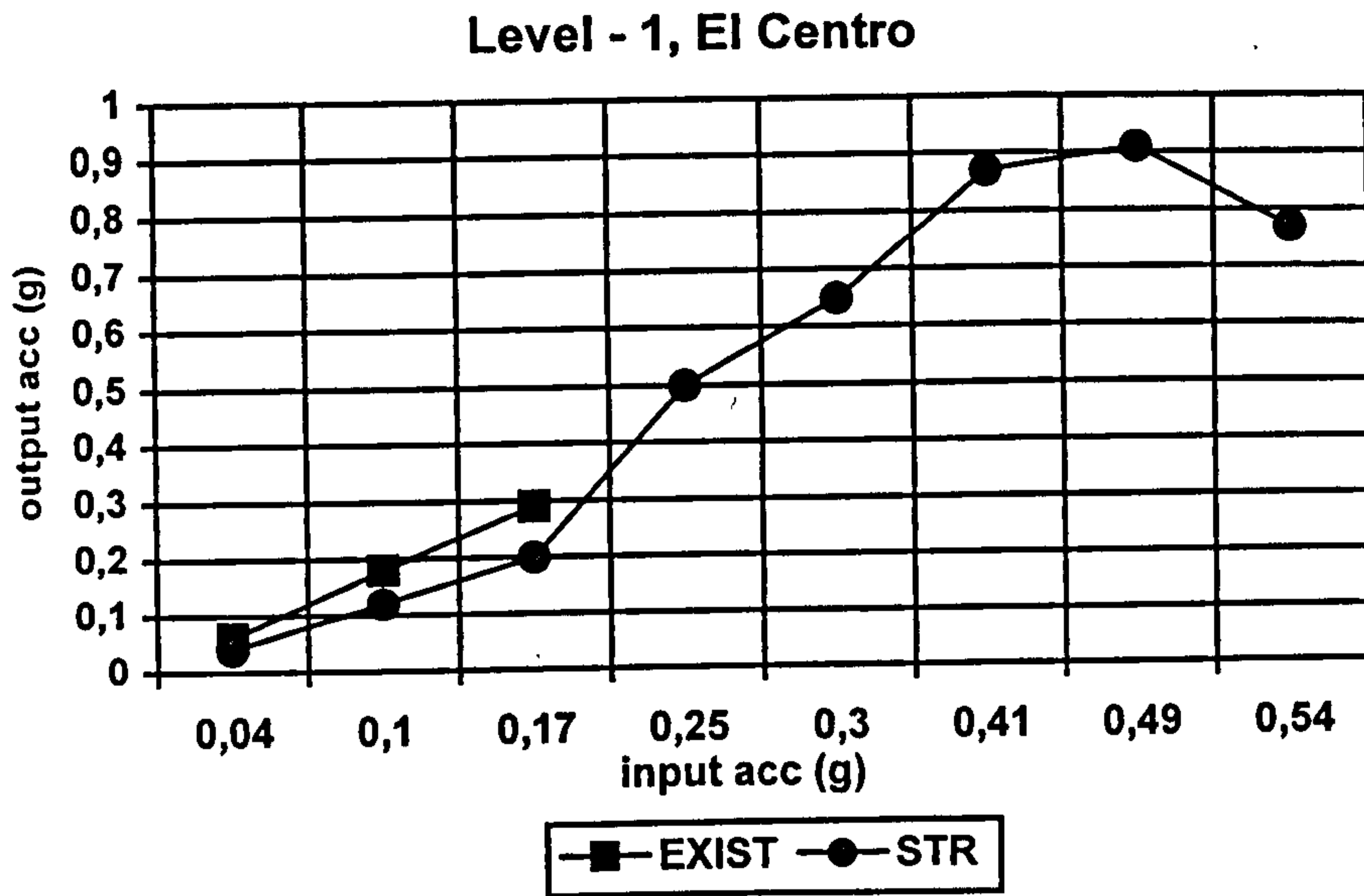

Figure 5.54 *The relationship between the values of the input acceleration and output acceleration on two characteristic levels (level 1 and top) of original (EXIST) and strengthened (STR) model for different intensities of El Centro earthquake.*

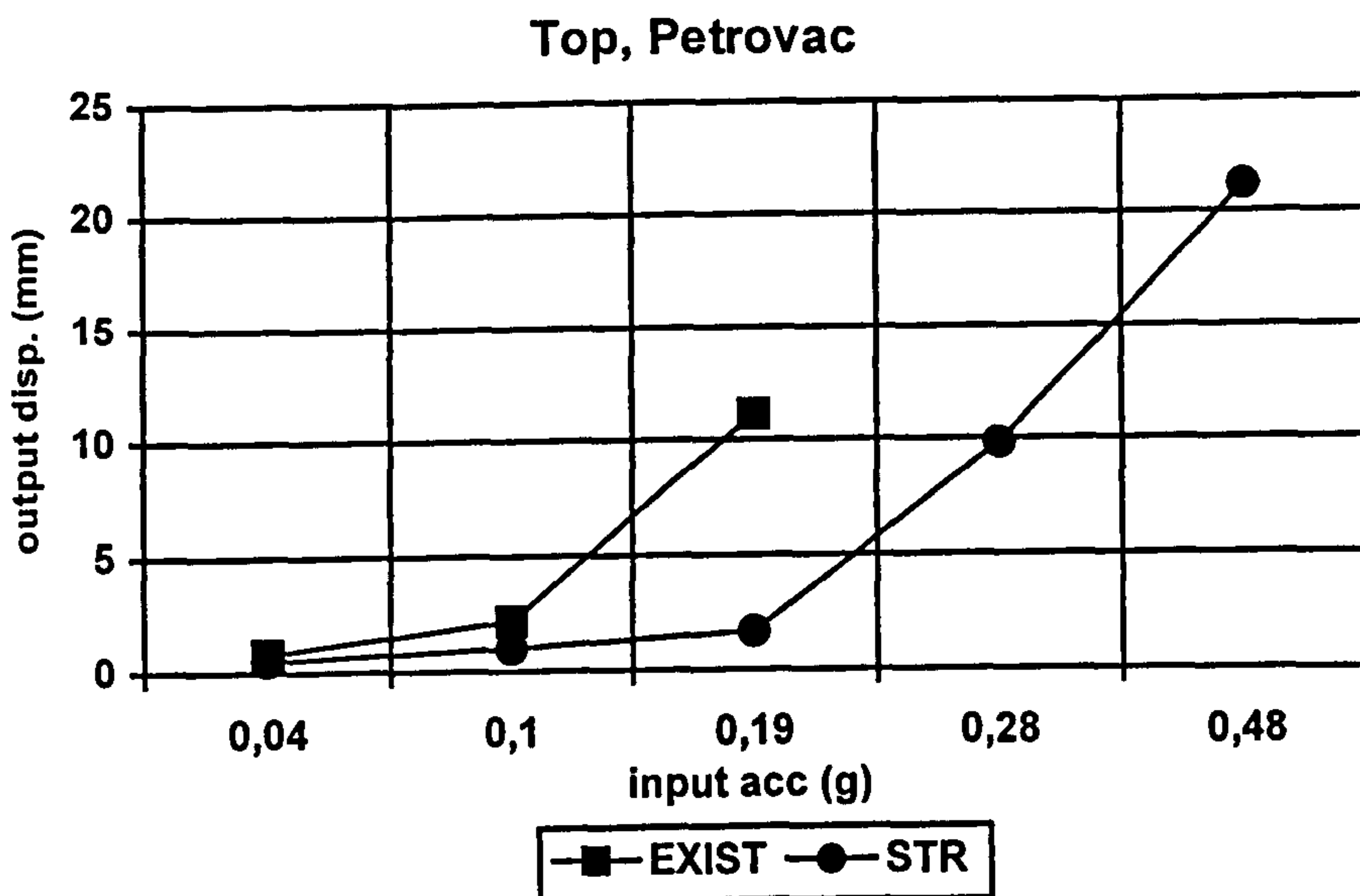
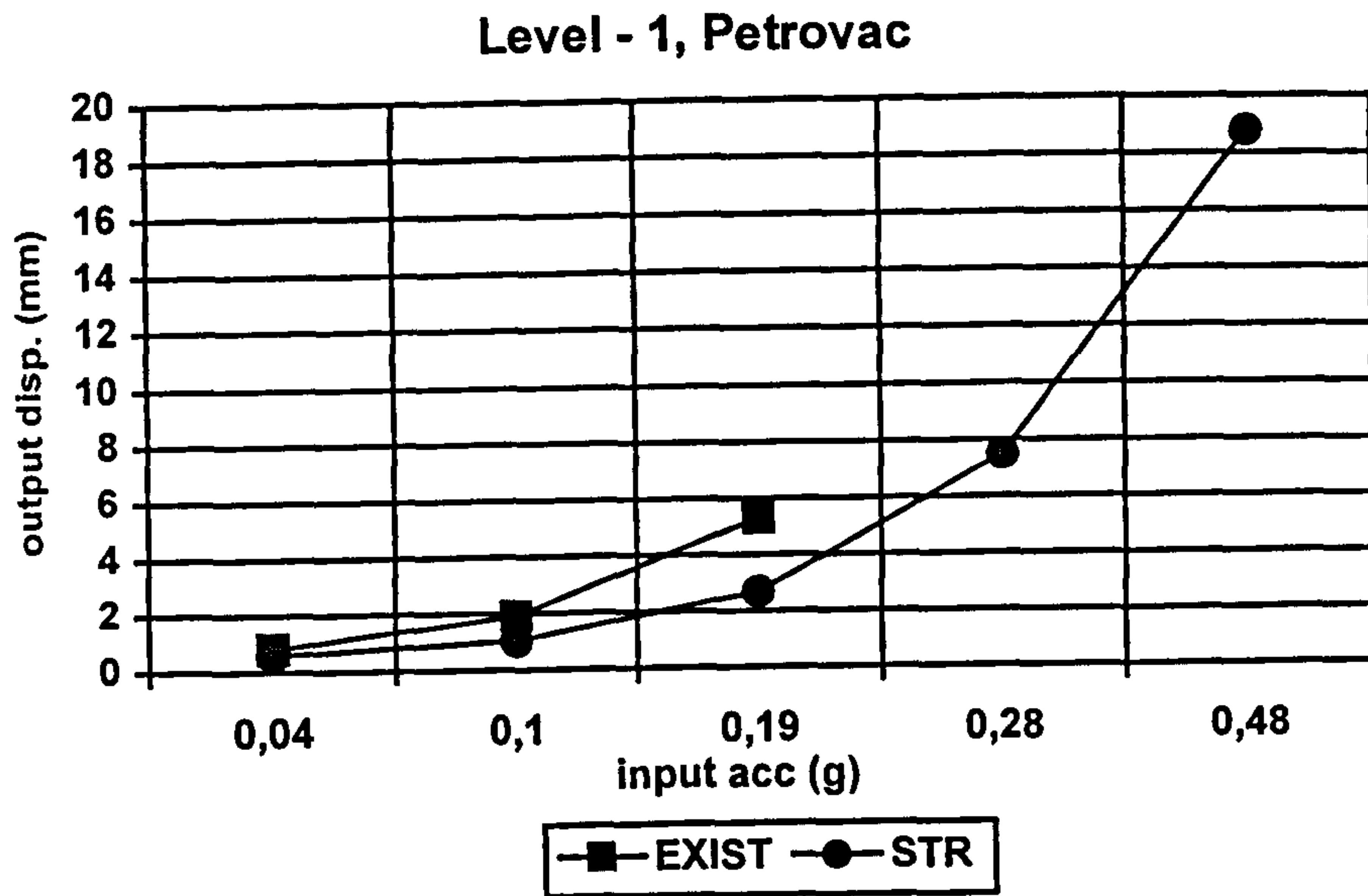

Figure 5.55 *The relationship between the values of the input acceleration and output displacement on two characteristic levels (level 1 and top) of original (EXIST) and strengthened (STR) model for different intensities of Petrovac earthquake.*

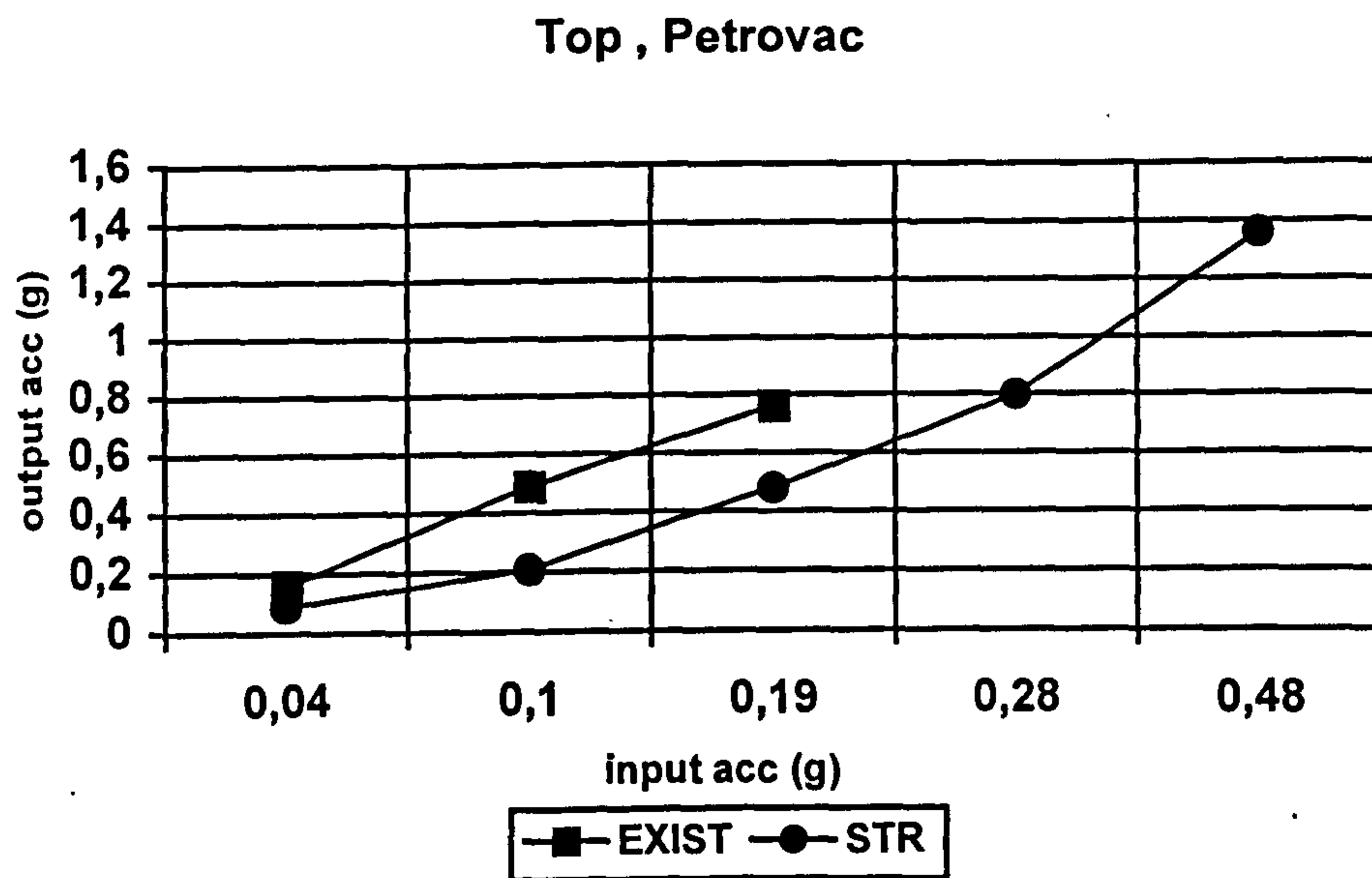
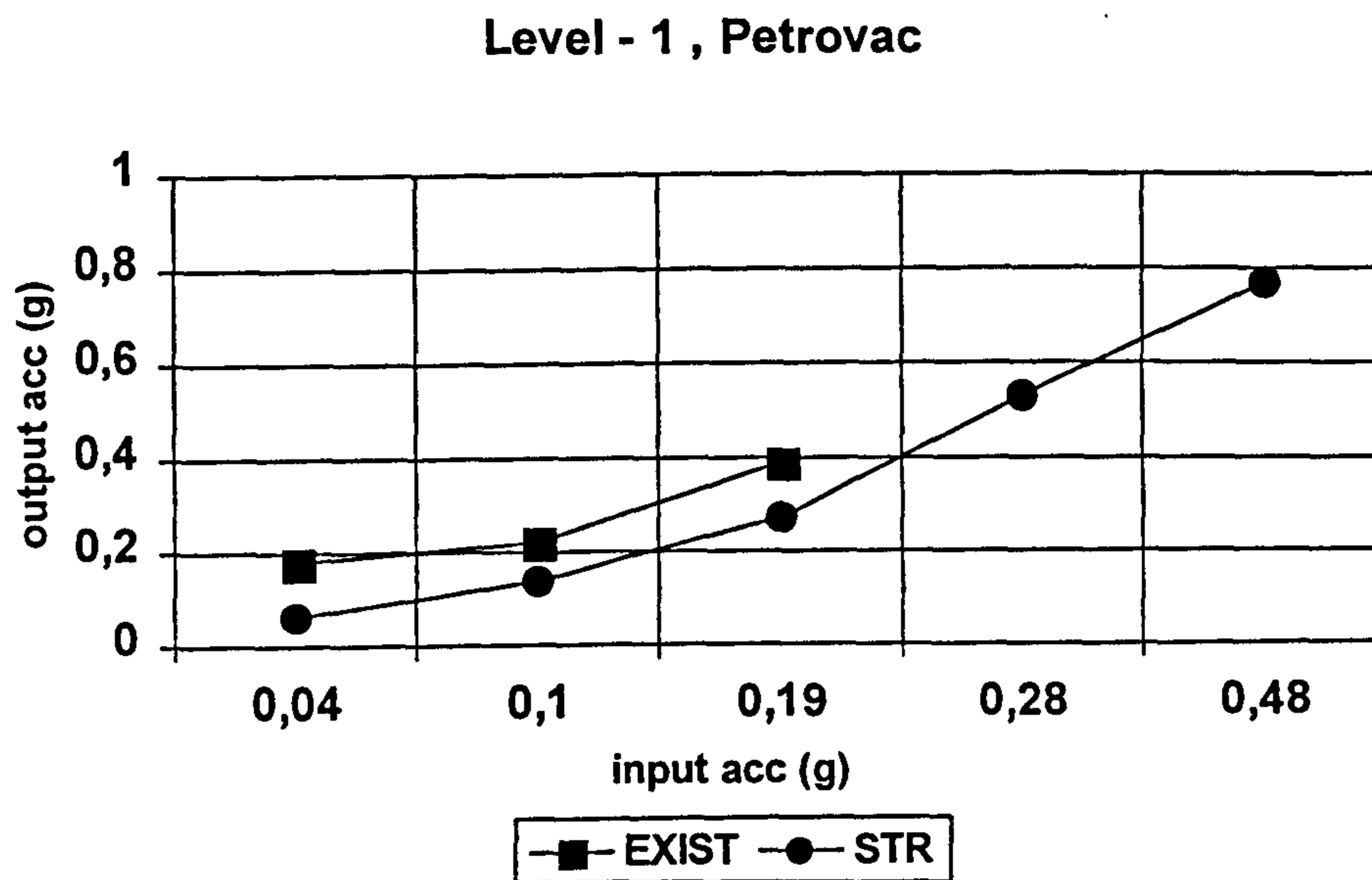

Figure 5.56 *The relationship between the values of the input acceleration and output acceleration on two characteristic levels (level 1 and top) of original (EXIST) and strengthened (STR) model for different intensities of Petrovac earthquake.*

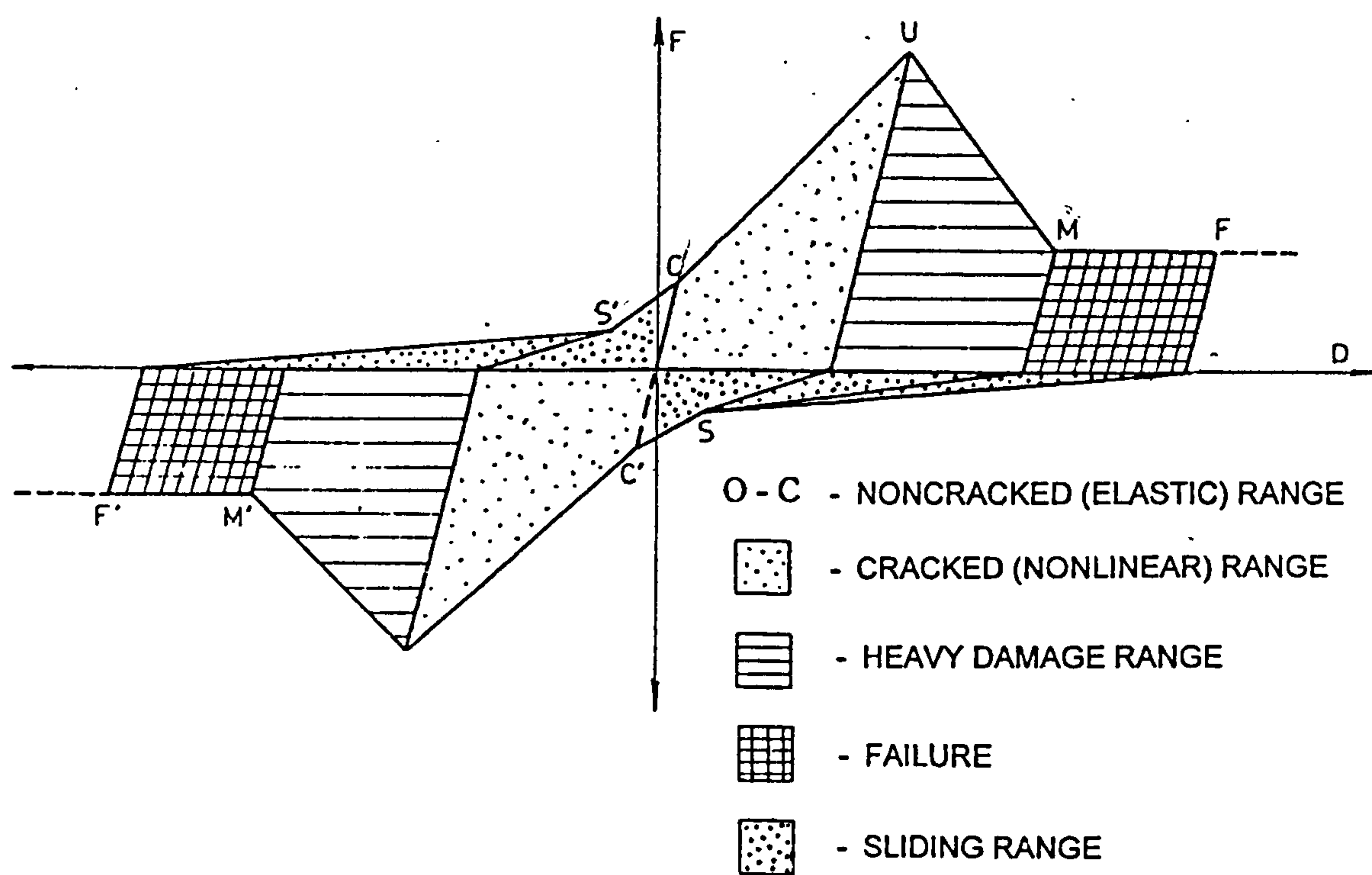

Figure 5.57 *Hysteretic model (description of the behaviour of the church model in phases: elastic (no cracks); nonlinear (occurrence of the cracks) and the range of large deformations.*

CHAPTER SIX

VERIFICATION AND IMPLEMENTATION OF METHODOLOGY FOR SEISMIC STRENGTHENING OF BYZANTINE CHURCHES IN MACEDONIA

After performing theoretical and experimental investigations and obtaining results, we should continue with verification of the actions and their future implementation on Byzantine churches of Macedonia.

Based on the results obtained, particularly those obtained from the performed experiments, it is possible to define clear methods for conservation, repair and strengthening that can be applied in the future.

The proposal should confirm to the existing, valid and international recommendations and they might even upgrading of these with regard to certain elements. This should be accepted since has obtained from experimental investigations which gives it greater value and applicability.

6.1. Revision of safety criteria

The assumptions as to the safety criteria (discussed in 5.4.2), after the experimental investigations performed on both materials and the church model, may again be checked and defined as appropriate.

The factors that govern the safety criteria factors can generally be classified into two main groups:

- A group of factors which have an indirect (non - physical) influence, and;
- A group of factors which have a direct (physical) influence.

The group of factors which have indirect (non - physical) influence includes: historic, cultural, existential and development a values of the structures and their functions, i.e. the purpose of the structures. These have been defined and deserve maximum respect. This particularly holds through the function of the structure, though both elements play an important role in defining the safety coefficient. To these, the following should be added: local soil conditions, climatic parameters - these do have a physical influence, level of development of science and social relationships, in general, as well as attitude toward cultural monuments.

In our case, the structures that are the subject of this investigation, possess the attributes of the most important cultural monuments in Macedonia. Their original function (performance of religious service) has not altered. The soil and climatic conditions as well as the social relationships are known and defined, the latter being in a phase of transition, which means that an improved and more positive attitude toward cultural heritage can be expected.

The second group of elements that have a direct (physical) influence involves: architectural shape and plan of the structure, the characteristics (physical, chemical and mechanical) of the buildings materials; the buildings technology and the workmanship used; the characteristics of the structural elements and systems; the extent and character of interventions.

The architectural plan of the structure is given and unchangeable. The plan and its characteristics are important for definition of safety criteria through the elements of the main proportions of the organised area.

The physical - chemical and mechanical characteristics of the materials (stone, brick, timber, lime mortar) have survived the test of time. Some of these materials (as for example the wood) have lost a high proportions of their original properties. This loss is much less for the lime mortar and is least in the brick and stone, used.

The present physical - chemical and mechanical characteristics of the main binding material - lime mortar - are of particular importance. The existence of such a large number of well preserved structures, shows that, despite the loss of some of the original properties of the lime mortar, the properties that have still remained, have ensured the durability and further existence of these structures.

Attention should therefore be paid to the contribution to the safety of this material - lime mortar - because of its low strength and deformability characteristics.

The construction of the structural elements and systems utilised, a technology based on long - term experience acquiring the characteristics of a "tradition".

The mass and the stiffness of the structures have been defined. These have a great influence upon the earthquake effects (stronger or slighter). The mass per unit volume and the stiffness may vary from one point in the structure to another. The mass is generally constant in time, apart from rotting of timber and washing out of fines from mortar; the stiffness may reduce with age, because of these losses.

Particular emphasis should be put on structural continuity that allows adequate transfer of loads from the superstructure to the foundation and vice versa: transfer of forces from the soil through the foundation to the superstructure. This determines the response of the structure to dynamic loads.

The use of horizontal "bonding timbers" played an important role in providing a kind of a continuity of structural elements. Although, because of decay, most belts no longer fulfil their original function, they should be re - created in order to increase the resistance of the structure.

The physical treatment of the structures is also an important factor in defining the safety criteria. Special importance should be given to the process of adequate preventive maintenance. The next step of intervention involves conservation -repair and strengthening works that can be divided into two basic categories: hard or 'aggressive' and modest and 'conservative' treatment. (5.4.2)

- A. The following should also be considered when defining the safety criteria:
- a. Complete research of documentation of actions that were previously taken on the structure, where such documentation exists. Oral evidence may be helpful, when not accepted un - critically.
 - b. Maximum respect for authenticity and originality in all areas, which means that attention should be paid to the history, cultural value and the physical integrity of the building;
 - c. The planned interventions should be reduced to minimum;
 - d. Any material to be used for repair and strengthening should have identical or very similar physical, mechanical and deformability characteristics to those used for the original structure in order to achieve a good interaction. They should have slightly higher strength characteristics (which particularly refers to the binder) in order to be able to sustain possible dynamic effects without additional damage to the original binding material;
 - e. The existing tying elements - "bonding timbers" - of the structure should be used as much as possible. However, considering the fact that the timber belts are decayed in most cases, the space left after them, can be used for insertion of new strengthening elements without any destruction;
 - f. All the interventions should be replaceable so that they are not treated as final;

In accordance with the above, the safety criteria proposed in 5.4.2 can be confirmed. These are the following:

- Under slight earthquakes, the dynamic structural behaviour should be such that no damage should occur on either the structural or the non - structural elements of the building;
- Under stronger earthquakes (expected earthquakes), the principal structure should not suffer any damage, (it would be acceptable if some cracks, e.g. in masonry bed - joints, opened during the seismic movements, as long as they closed again with

no permanent displacement, i.e. 'temporary damage') while slight deformations of the non - structural elements are allowable;

- The maximum expected earthquakes should not affect the stability or strength of the main structural system. Larger deformations of structural and non - structural elements are allowable if the elements and the entire structure are not damaged beyond physical repair.

Due to their importance and as a definite requirements , we will put an emphasis on proper physical treatment of the structures. Particular attention will be paid to maximum respect for the built - in materials and structural elements.

When making decisions about physical intervention on a structure, the level of safety provided will not be such that it requires such a scope and character of interventions would destroy the character and the authenticity of the existing structure. Experimental results point to the fact that an adequate and acceptable levels of resistance can be achieved by use of the same building original materials and technology used for the structure.

6.2. Recommended methods and details for repair and strengthening in accordance with developed and experimentally verified methodology

Generally speaking, depending on the level of vulnerability of the structure, the repair and strengthening measures proposed enable an increase of the strength of the existing structures and an increase in their ductility. In some cases, the measures for repair and strengthening have combined effects.

The experimental results obtained for the non - strengthened model of the church (*Fig 5.35*) have proved the assumptions regarding the extent and zones of vulnerability of the structure, insofar as it has been shown that the most vulnerable zones and elements are the upper zone of the perimeter walls and the upper zone of the drum walls, i.e. has been proved that the initial types of failure are wall separation and loss of structural integrity due to the inability of wall elements incapable of resisting tension and the roofs enable to prevent distortion of upper parts of the building.

Accordingly, the main concept for repair and strengthening must be to provide safety of these vulnerable elements - structural integrity, i.e. enable the structure to behave as an entity.

This is achieved by incorporation of the new tie - roads in place of the formerly existing horizontal timber beams.

Analysing the failure mechanism of certain walls, it is clear that they need to have an adequate resistance against shear forces and moments as well as capacity for ductile deformation.

It is known that the moment resistance of the walls depends on their capacity to withstand tensile forces. The measures proposed which were carried out on the model provide an increase in tensile capacity of the masonry by grouting and insertion of vertical steel bars at the wall junctions.

The load carrying capacity of masonry in traditional structures is increased by incorporation of "bonding timbers" at different levels (starting from the dome base level, middle of the drum, the drum base, the ends of the vaults, above the openings, etc.).

In accordance with the above, at least two possible methods for repair and strengthening could be proposed:

A) Strengthening of the main structural system by horizontal elements (steel ties - bars) with partial injection. Also, replacement of the traditional wooden ties by steel ties, filling the space around them with a corresponding material and grouting the cracks.

This method is applicable for structures of minor proportions, with masonry bearing structures, located in zones of low seismicity. Structural horizontal connection of the perimeter walls in the north - south and east - west directions is also anticipated at the level where the vaults rest on the wall and on the masonry columns in the naos. This will further increase the capacity for synchronous behaviour of all the bearing walls.

B) In a greater number of cases, apart from the incorporation of horizontal elements to provide greater seismic stability and sustaining tensile forces due to overturning moments, vertical strengthening elements are also to be inserted at the junctions of the perimeter walls and in the masonry of drum structure. This should be completed by partial injection of the zones of insertion. Here also, spatial connection of perimeter walls in north - south and east - west direction is recommended.

To realise the above strengthening actions, mainly traditional (first under B) or the so called 'conservative' methods are used.

To these conservative methods, one could add a method of seismic isolation of buildings that could be acceptable since relatively small structures are considered.

The application of this method will however require of future theoretical and experimental investigations. Any future theoretical and experimental investigations, should certainly be required to consider this practice.

6.2.1 Horizontal tie courses in perimeter walls

To provide integrity and synchronous behaviour of all the perimeter bearing walls, stainless steel ties are incorporated in place of the former wooden belt courses. These steel ties are activated when cracks occur (due to an earthquake effect), i.e. if in the state of exceeding of the tensile capacity of masonry is exceeded and enable further vibration of the structure.

The existing documentation, visual inspection and experimental tests all have proved the existence of original timber belt courses.¹ If these are decayed, the holes should be used for incorporation of steel ties with a 16 mm.² diameter of minimum.

From the authenticity aspect of such interventions, it is anticipated that the interventions should be immediately recognisable.

The steel ties, whose number depends on the needs, are anchored on a steel plate visible on the facade. These enable the application of prestress forces in the ties. After that, the space around should be filled with lime based admixtures with special additives for better fluidity, early strength gain, protection against rusting of the steel ties and good connection with the existing masonry structure.

If, as is quite rare, it happens that the timber horizontal elements still exist in the wall mass, systematic injection is recommended to be done in such a way that a kind of an enlarged - combined belt course is formed (timber - lime mortar admixture with special additives for better contact with the wood and the existing masonry).

In both cases, it is necessary to achieve horizontal spatial connection of the perimeter walls in the zone and in the directions discussed under A and B. The anchorage of elements would also be done with stainless steel plates that should be visible on the facade for immediate recognition.

6.2.2 Vertical tie courses in perimeter walls

In addition to the horizontal strengthening elements incorporated, a vertical steel ties should, if necessary, be installed at the junctions of the perimeter walls in order to increase the moment resistance and ductility of the structure.

These can also be incorporated near the openings (the entrances and the wider windows), if necessary. It should be noted that the installation of such vertical elements means an introduction of new structural elements for which certain minor destructive works have to be done. What is required are holes with a diameter of 4 - 6 cm, made by using special drilling machines.³ A steel tie is then inserted in this hole and the empty space is filled with the same lime mixture as that recommended for the horizontal elements.

This operation is very delicate and will require maximum care in order to not disturb the good quality of the masonry which is often found at this part of historic buildings. The steel ties are anchored into stainless steel plates. Due to the fact that incorporation of new elements (steel plates and ties) is envisaged, a few facing stones will be carefully removed. A groove is made into the wall mass and a steel plate is incorporated.

It must however be said that this measure involving incorporation of vertical elements is envisaged only for those structures that do not possess a sufficient capacity to sustain the overturning moment, particularly slender walls ($H > D$) where the bending effects are dominant.

If there are walls with large cross-sections and small height, these vertical ties will not be necessary.

6.2.3 Details of strengthening of the drum and dome structures

Since Chapter four contains a detailed description of the extent and type of damages to structures, it will only be repeated here that the drum and the dome, along with the vaulted areas are the structural elements most frequently have been heavily damaged and have completely failed. The investigations showed that the most extensive reconstruction works were carried out on these elements.

The behaviour of the drum and dome during the tests carried out on the model showed that their relative displacements are much greater than those of the basic structural element - the central area with the perimeter walls.

It is proposed that horizontal ties should be placed at three levels: in the square base of the drum, in the middle height of the walls and in the supporting base of the dome, i.e. at places where formerly existed horizontal "bonding timbers". The method of incorporation is the same as for the perimeter walls. We would like to emphasise again that the steel plates should be visible on the facade.

It is recommended to use vertical ties, where needed. The number will range from 4 to 8, depending on the geometry and the proportions of the drum elements. The method of incorporation is the same as those for the central unit.

6.2.4 Injection, grouting and repair

It is not only the incorporation of the new horizontal and vertical elements that will be important for a thorough increase of the resistance of the structure. Injection and rebuilding, when applied on existing masonry, will also contribute to the increase of the resistance of these structures. Rebuilding of certain parts of severely damaged masonry walls and elements must be expected.

For all those actions an adequate lime - based mixture, to improve the mechanical characteristics and eliminate the damage to the existing materials and structural elements, should be used.

Injection mixtures for building and repair should satisfy the maximum requirements for the specific application.

Particular importance should be given to injection of the core of external walls in the zone of the horizontal and vertical elements, by which a kind of an invisible horizontal and vertical belt course is formed, which satisfies, to the best possible extent, the need for an increased and adequate safety of each structure.

6.3 Implementation on representative Byzantine monuments

Based on the results from the experimental investigations and the safety criteria defined, schemes of implementation of the recommended methods for repair and strengthening were drawn up. In this phase, three structures were chosen (out of the four selected ones - St. Nikita, v. Banjani; St. Bogorodica Zaumska, v. Trpejca and St. Nikola, v. Psaca).⁴

It should be noted that these schemes were theoretical, using the values and characteristics of the structures obtained in the phase of investigation (mathematical - engineering) and after the application of the anticipated parameters (based on the proposed methods). Satisfying results were obtained even for the maximum anticipated earthquake intensity (return period of 1000 years), Table 6.1.

For the final application, the author plans to reduce the return period to 200 years. Why? One of the author's reason is that if strengthening against a once - in -

1000 - years earthquake involves interventions that may damage irreplaceable items of cultural heritage, such as wall paintings, then we are better off only strengthening against a once - in - 200 - years quake, because 'the big one' may never happen. The second is from the point of view that the analyses of the events that have taken place so far, show that this is a practical approach which leads to:

- Lower earthquake intensities being predicted which reduces the extent and severity of the damage to the structures and hence a correspondingly lower level of resistance;
- The need for extensive physical interventions on the structures is reduced and the reversibility increased;
- There is a possibility of the actual implementation being carried out as part of conservation works, considering, *inter alia*, the economic aspect;
- It gives a possibility for realistic natural testing of the works undertaken under future earthquakes of lower than the anticipated or the anticipated intensity (return period of 200 years);
- It enables future generations to apply new and perhaps better solutions, as a result of development of science and its application in protection of heritage.

The theoretical interventions in these chosen structures were based on the above considerations. For each structure , two scheme are shown: first the result of applying the methods for an earthquake with a return period of 1000 years (A); the second being the author's proposal which assumes a return period of 200 years (B).

For variant A an earthquake capacity analysis⁵ for a shear base coefficient corresponding to an earthquake with a return period of 1000 years was carried out for the designed strengthening of each of the three structures.

Dynamic response analysis⁶ was also performed by defining previously the parameters for the IZIIS hysteretic models in compliance with the results from the performed analytical modelling of the strengthened model (M - SNC - Strength). The test was done for two main directions: east - west and north - south, for two types of earthquakes: local - Petrovac - and distant - El Centro, for both the existing and the strengthened structure.

Table 6.1. shows the comparison of the characteristics of the integral structures in their existing state and after repair and strengthening works. It clearly shows out that the activities taken contributed to a drastic increase in stiffness of the structure (K) and safety factor against failure (F), which is of a particular importance for the stability and the resistance of the treated structures.

St. Nikita, v. Banjani

In accordance with the needs, a system of horizontal and vertical strengthening was designed.

Variant A (*Fig. 6.1a-e*)

As presented in the figures, a horizontal strengthening is envisaged at two levels - 2.5 and 4.75 m (*Fig. 6.1a*) from ground level and vertical strengthening of the perimeter walls at the corners (*Fig. 6.1a*); horizontal ties between of the perimeter walls at the level of 4.75 m, i.e. the level of the existing timber ties in north - south and east - west direction (this is the zone of support of the arches and the vaults of the roof structure).

The base of the drum, at the level of 6.40 m (*Fig. 6.1b*) as well as its walls and the dome at two levels (10.5 and 10.9 m) are to be strengthened horizontally. Each column of the drum, in the vicinity of the openings, is to be strengthened vertically.

The vertical strengthening of the perimeter walls is anchored into the wall mass at the level of 4.75 m at the top, while their lower end is anchored into the mass of the foundation wall.

The vertical strengthening of the drum walls is anchored at the top at the level of the dome ring on the upper side. (*Fig. 6.e*) and the bottom plate in wall core of the drum base..

For such a strengthened structure, mathematical - computer analyses were performed for the bearing capacity of the structure in both directions (east - west and north - south).

As is clear from Table 6.1, the whole structure has a satisfying bearing capacity ($F > 1$) under the maximum expected effects ($g = 0.38$), which represents a considerable improvement in respect to the values obtained for the non - strengthened structure ($F < 1$) in both east - west and north - south directions.

After the dynamic response analysis performed by using the IZIIS hysteretic model, in both orthogonal directions and under input acceleration levels corresponding to return periods of 100, 200 and 1,000 years, an analysis of this structure was performed under the maximum earthquake with a return period of 10,000 years for the purpose of exploring the applicability of the IZIIS model also for the range of extreme nonlinearity. (*Gavrilovic et.al. Volume 12, 1994*)

Variant B (*Fig. 6.4.a-e*)

In accordance with my decision to consider a return period of 200 years and its parameter $\alpha_{max} = 0.20 g$ as the basis for it is envisaged that the strengthening should be carried as follows:

a) Horizontal strengthening

Horizontal strengthening of the structure should be done at five levels: at two levels of the core of perimeter walls (1-2), at the second level two pairs of horizontal ties that will connect the perimeter walls in two orthogonal directions (2a); one at the base of the tambour (3), half way up of the drum walls (4) and in the dome base (5). The space of formerly existing timber belts should be used. The anchoring of the steel bars should be made with stainless steel plates, visible on the outside. The installation of these plates requires drilling of masonry, with proportions necessary for incorporation of the steel elements and the infill of injection mixture. (*Fig. 6.4.a-c*)

b) Vertical strengthening

Author anticipated vertical strengthening of the basic area (naos) only at the corners of the perimeter walls (6) and connection of the east wall with the apse (6) - one bore - hole only. (*Fig.6.4.a*) Because of non existence of vertical drilling practice of such kind of masonry walls substantial practical trials are required.

The walls of the drum should be vertically strengthened at eight positions (8) as shown in the drawing. Vertical strengthening position would be such that all the horizontal elements are connected along a vertical line. These are located at each column. Their anchorage on the lower side would be made into a stainless steel plate incorporated into the wall mass of the drum base, while on the upper side, they will be anchored into a steel plate in the plane of the roof covering. (*Fig.6.7*)

In addition to such a strengthening, injection of the existing empty spaces with adequate materials (described in 6.2) is envisaged. The immediate zone of this infill would be systematically injected by lime compounds in order to form para - belt courses with somewhat higher strength characteristics of binding material that those of the existing one.

St. Bogorodica Zaumska, v. Trpejca

Variant A (Fig. 6.2.a-d)

Variant A involves horizontal strengthening at four levels as follows: the first level is at 2.92 m from the ground of the naos and the strengthening elements are incorporated into the perimeter walls; the second level is at 5.28 m, the third is at a height of 7.35 m and the fourth level is at a height of 9.64 m.

At the first and the second level, in addition to the horizontal elements into the perimeter walls, there should be spatial connections of perimeter walls in north - south and east - west direction. (Fig. 6.2.a)

Vertical strengthening is envisaged to be done at the corners of the perimeter walls. All the eight drum columns are connected to the drum base by two vertical elements each.

All the elements are incorporated in a way described for the church of St. Nikita in the village of Banjani.

Variant B (Fig. 6.5.a-e)

The parameters for a return period of 200 years are used as the basis for the strengthening, author anticipated the following:

a) Horizontal strengthening

Horizontal strengthening should be done at five levels:

The first, at the level of 2.42 m in the perimeter walls (1) and spatial connection by ties (1a).

At the second level of 5.28 m ties are (2) in the perimeter walls, (2a) spatial connection in both directions and (2e) in the apse wall. (Fig. 6.5.a)

The third level, at the height of 7.35 m (3) should be installed in the base of the drum, while the fourth level, at the height of 8.57m (4) should pass through the middle height of the columns of the drum. The last horizontal element is anticipated at level 9.64 m (5) - where the dome rest on the drum columns. (Fig. 6.5.b -c)

In all these cases the voids left after the former horizontal timber belts are used with additional holes drilled through the external faces of he walls.

b) Vertical strengthening

Vertical strengthening is anticipated at the corners of the perimeter walls (6) and the connection of the east wall with the apse walls (6) in the lower zone, while in the zone of the drum, vertical strengthening is anticipated at eight positions (7) and into the tissue of the drum columns. The ends of the vertical steel bars should be anchored with stainless steel plates: those at the bottom embedded in the foundation masonry, those at the top, bearing on the top of the masonry.

The anchorage of strengthening of the drum zone should be made in the tissue of the wall mass of the drum pedestal in the lower zone, while in the upper zone, this should be done above the bearing masonry.

The details regarding the infill and the injection are the same as those for the church of St. Nikita.

St. Nikola, v. Psaca

Variant A (Fig. 6.3.a-c)

Horizontal strengthening to be done at four levels, while vertical strengthening is planned only for the upper zone - the drum. This simplified strengthening is envisaged because of the lower values of expected earthquake intensity in the future.

Variant B (6.6.a-d)

It is envisaged that horizontal strengthening be done at four levels. In addition to the first level (1) at a height of 3.0 m and the second level (2) at the height of 5.92 m, there should be horizontal spatial connection of the perimeter walls in two orthogonal directions (2a). (Fig. 6.6.a)

The third level (3), incorporated in the base of the drum, is at a height of 6.2 m from the floor level. (Fig. 6.6.b)

The fourth horizontal level is located at a height of 8.92 m, in the zone of the dome base. (Fig. 6.6.c)

Vertical strengthening is not anticipated for the perimeter walls. It is planned only for the drum (4). (Fig. 6.6.d)

The filling of the empty spaces and injection is the same as those for the church of St. Nikita, v. Banjani.

The details of performance represent a routine and a task that can easily be performed in practice. Therefore, they are not presented as definite, but are left to the choice of the designer. Still the following should be noted:

- a) The steel ties will have diameter of minimum 16 mm and maximum 28 mm;
- b) The steel plates will have the proportions of minimum 100 x 100 x 10 mm to 600 x 300 x 30 mm at the most.

The injection mixtures should be adequately applied in accordance with the existing state of the structures.

To realise the envisaged works, only the most recent technical tools should be used, particularly for the drilling of the masonry mass. This should be done in such a way that no damage will occur particularly on valuable fresco paintings.

It is to be hoped that these new methods will be applied in the Republic of Macedonia and beyond in the near future.

Chapter six - Notes

1. This was proved by use of Ultrasonic Pulse Velocity that recorded the difference in the values of time of passage of sound waves through the masonry, depending on the media through which they passed (masonry, timber or empty space).
2. The proportions of the steel elements can be defined by an exact computation, but practical reasons, the minimum diameter should not be less than 16 mm.
3. Special drilling machines characterised by low vibration shall be used. These are based on dry drilling, preventing penetration of water that could adversely affect the wall paintings.
4. In this phase, the church of St. Bogorodica, v. Matejce was not the subject of implementation due to the fact that, prior to the investigation, definite repair-strengthening works were done on this church.
5. The following elements were considered in computing the wall geometry: wall type/material; wall restraining; effective wall length (m); wall height (m); thickness of the masonry portion (cm); thickness of the concrete portion (cm); centre of gravity of the wall (m) in respect to a referent point.
6. The elements taken for computation of the wall strength parameters were: shear modulus of the wall (kPa); elastic modulus of the wall (kPa); ultimate tensile stress (kPa); ultimate compressive stress (kPa); reinforcement at the end of the masonry wall (cm*cm); vertical reinforcement (cm*cm/m); horizontal reinforcement (cm*cm/m).

Table 6.1 Earthquake capacity analysis of the representative structures performed for the existing state and the defined strengthened state (Variant A)

Church	Weight G(kN)	Height H (m)	Max. seismic force S (kN)	State	Direction	stiffness K (kN/cm)	Q (kN)	F Q/S
St. Nikita v. Banjani	3378	7.20	1284 Cbs=0.38	existing	e-w	1991	1084	0.84
					n-s	1425	843	0.66
				strengthened	e-w	2938	2354	1.82
					n-s	2367	2124	1.65
St. Bogorodica Zaumska v. Trpejca	2400	7.70	912 Cbs=0.38	existing	e-w	1263	787	0.86
					n-s	968	624	0.68
				strengthened	e-w	2068	2036	2.23
					n-s	1722	1763	1.93
St. Nikola v. Psaca	4230	7.25	973 Cbs=0.23	existing	e-w	4860	1794	1.84
					n-s	1435	1011	1.04
				strengthened	e-w	5980	1926	1.98
					n-s	2541	1535	1.58
St. Bogorodica v. Matejce	11000	11.80	3960 Cbs=0.36	existing	e-w	12573	7517	1.90
					n-s	9636	4492	1.13

Source: Gavrilovic - Volume 12 (1994)

Glossary to Table 6.1

$C_b s$ = Coefficient of seismicity

Q = Force at failure

F = Safety factor against failure

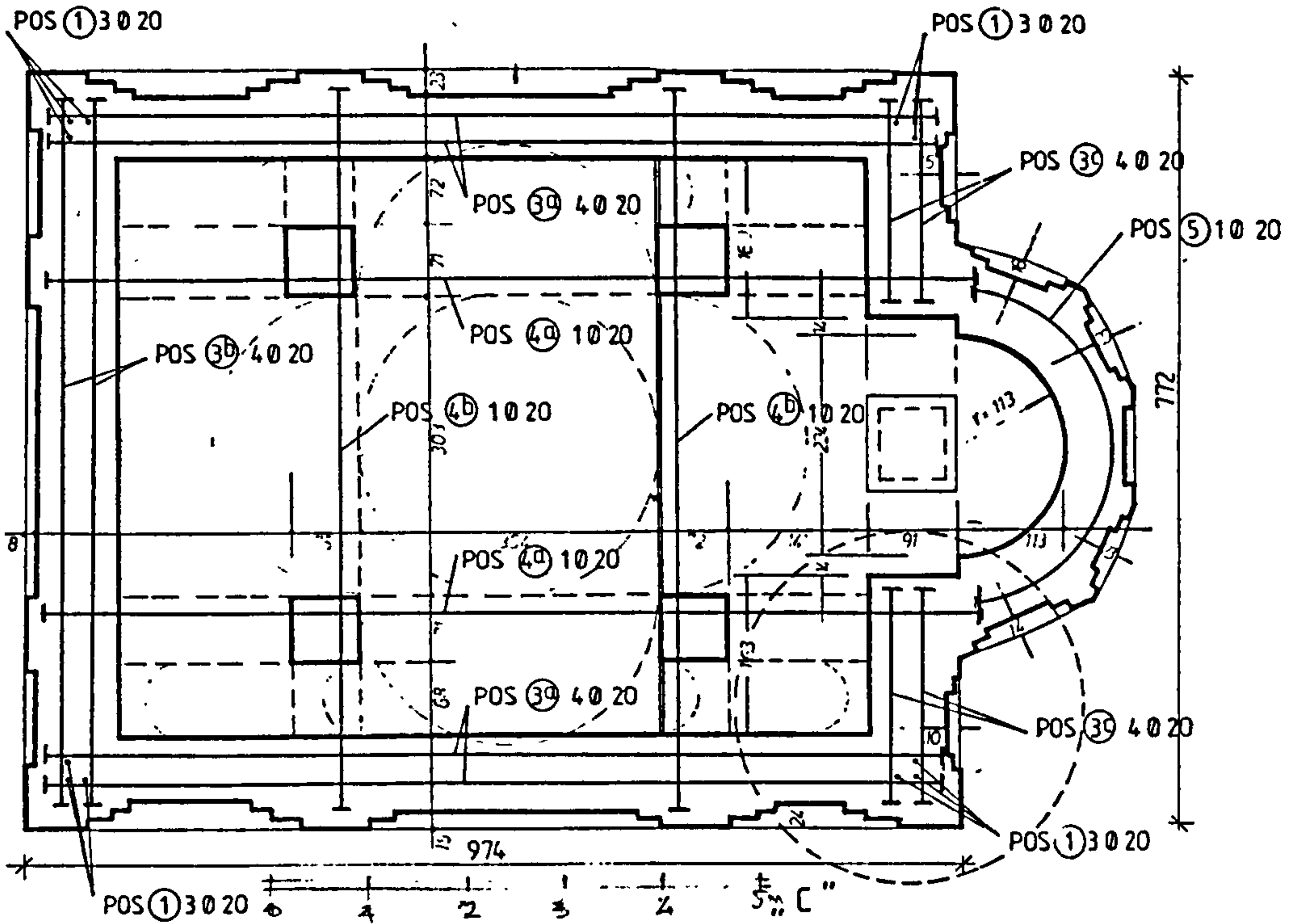

Fig. 6.1.a *St. Nikita, v. Banjani (Variant A)*
 Section at timber ties level $H = 4.75$
 Source: Volume 12

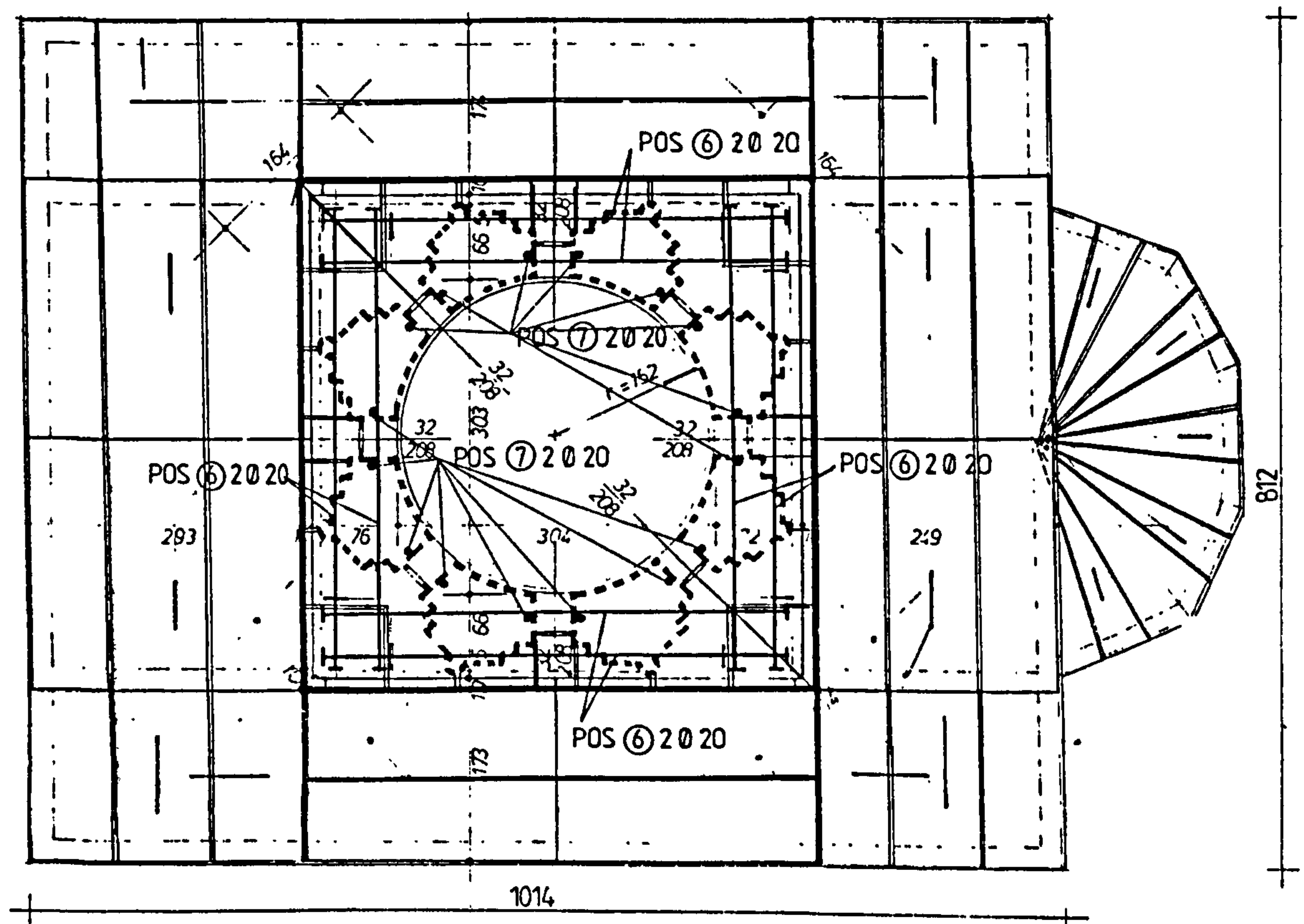

Fig. 6.1b *St. Nikita, v. Banjani (Variant A)*
 Section at level $H = 6.40m$
 Source: Volume 12

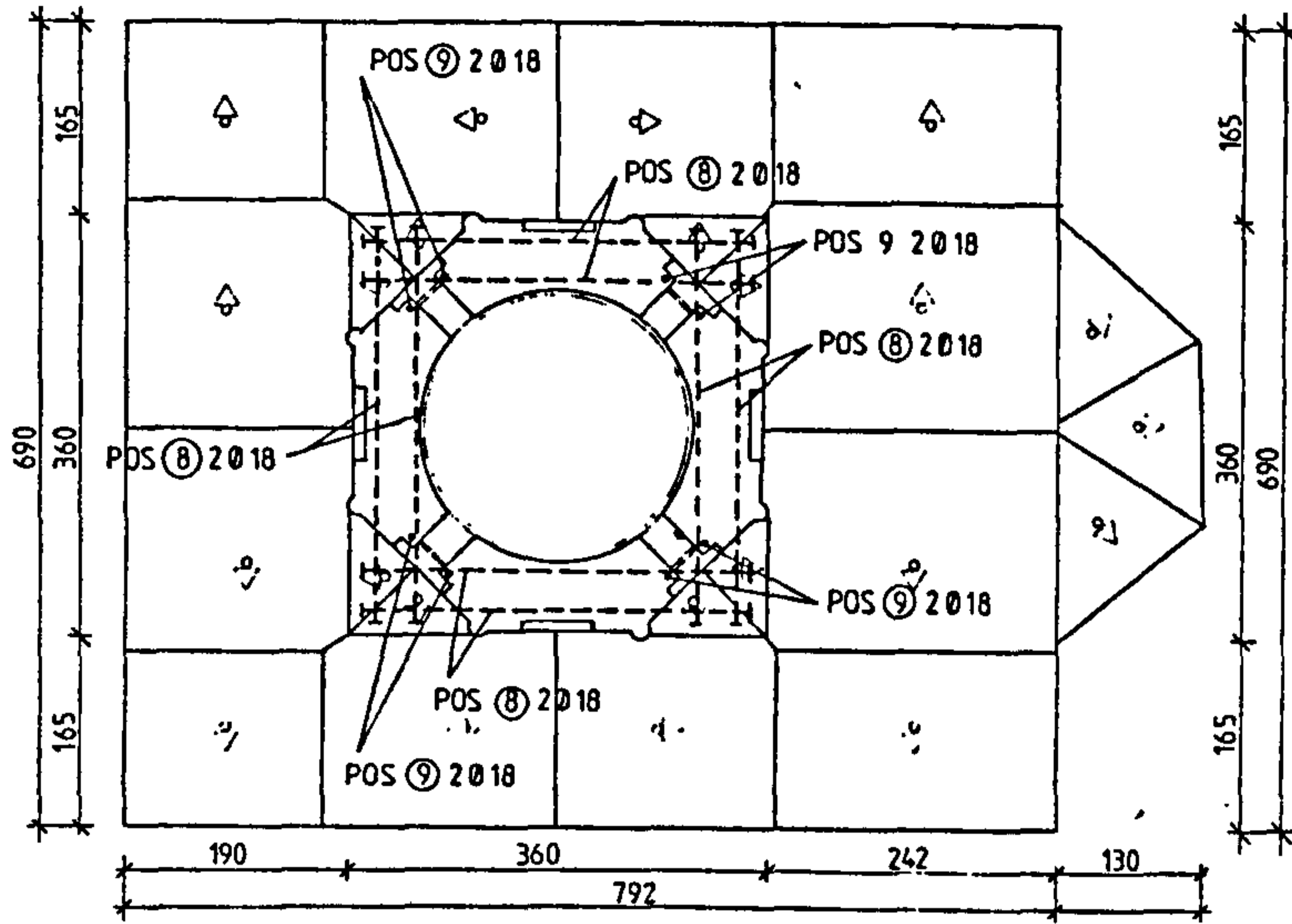
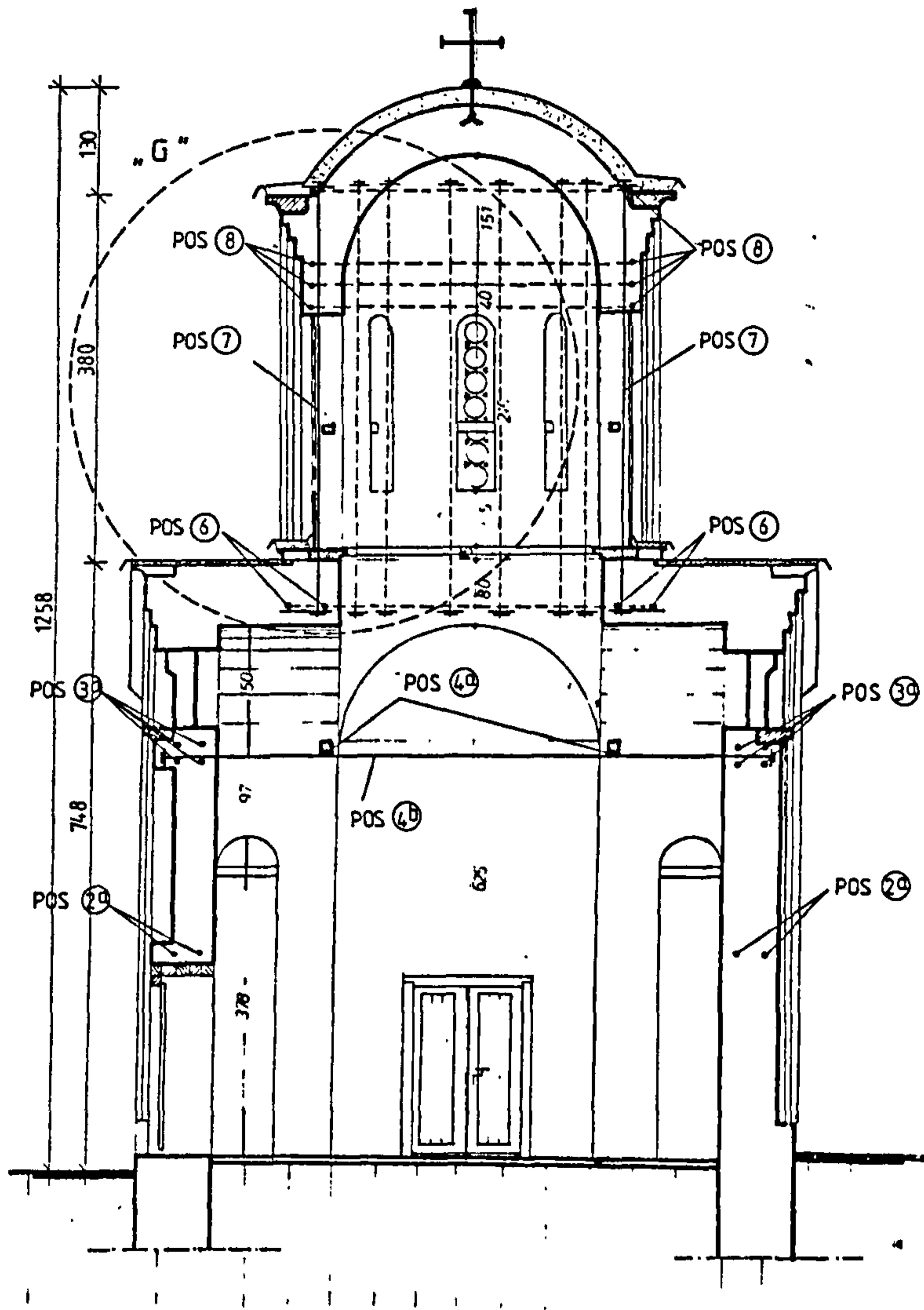

Fig. 6.1.c

St. Nikita, v. Banjani (Variant A)
 Section at level $H = 8.70m$
 Source: Volume 12



SECTION 2-2 M = 1:50

Fig. 6.1.d

St. Nikita, v. Banjani (Variant A)
 Cross section N-S direction
 Source: Volume 12

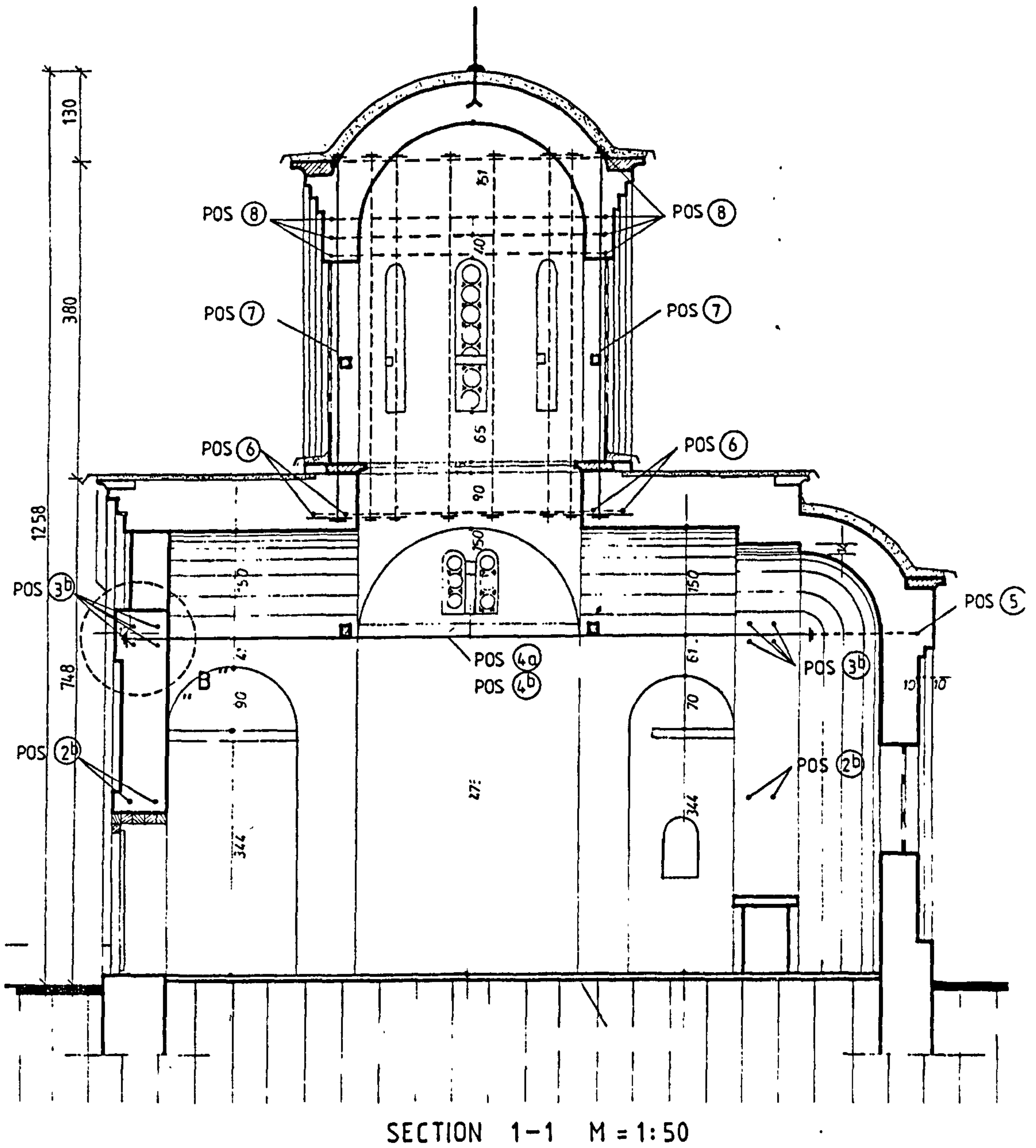
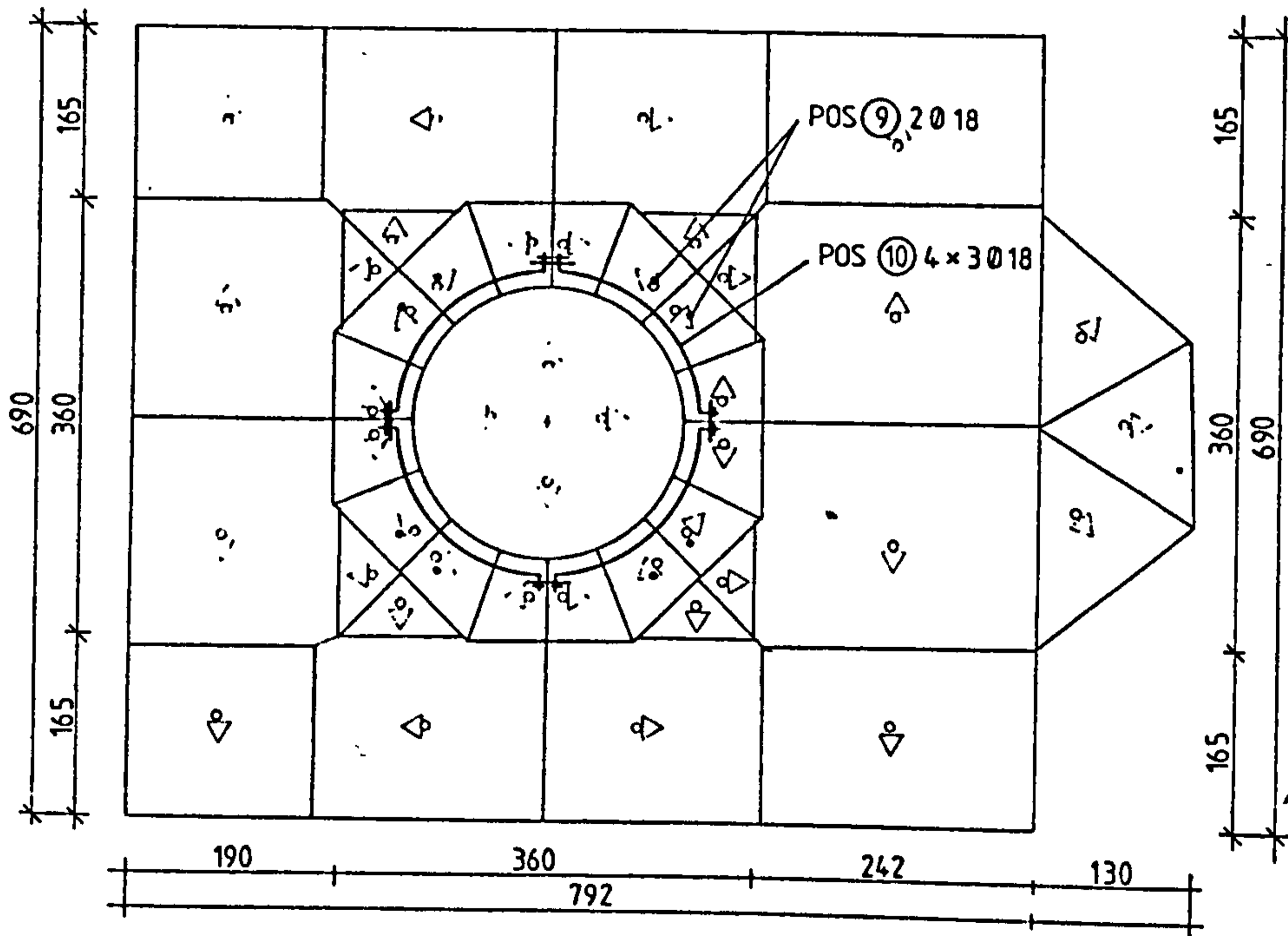
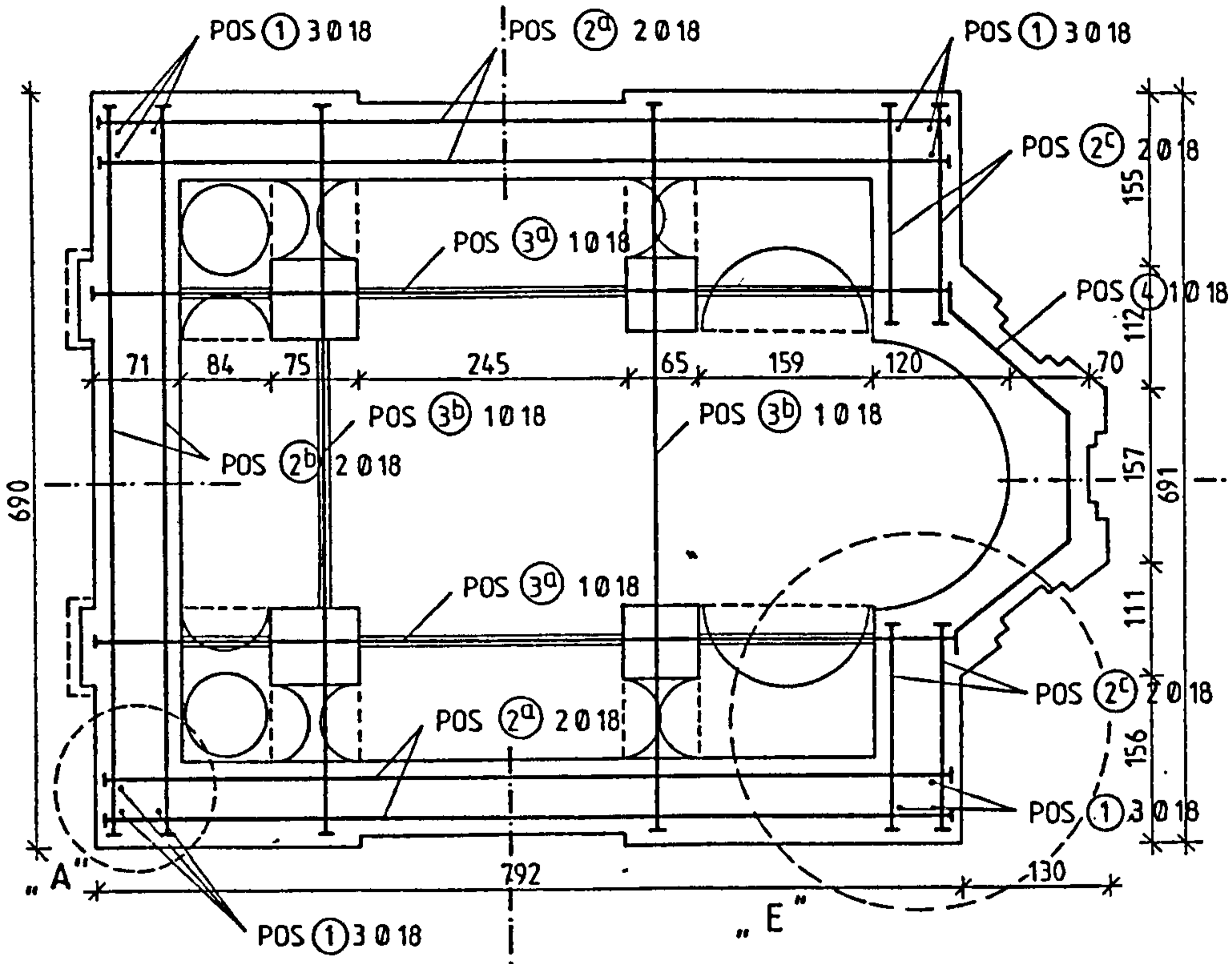

Fig. 6.1.e *St. Nikita, v. Banjani (Variant A)*
Cross section W-E direction
Source: Volume 12



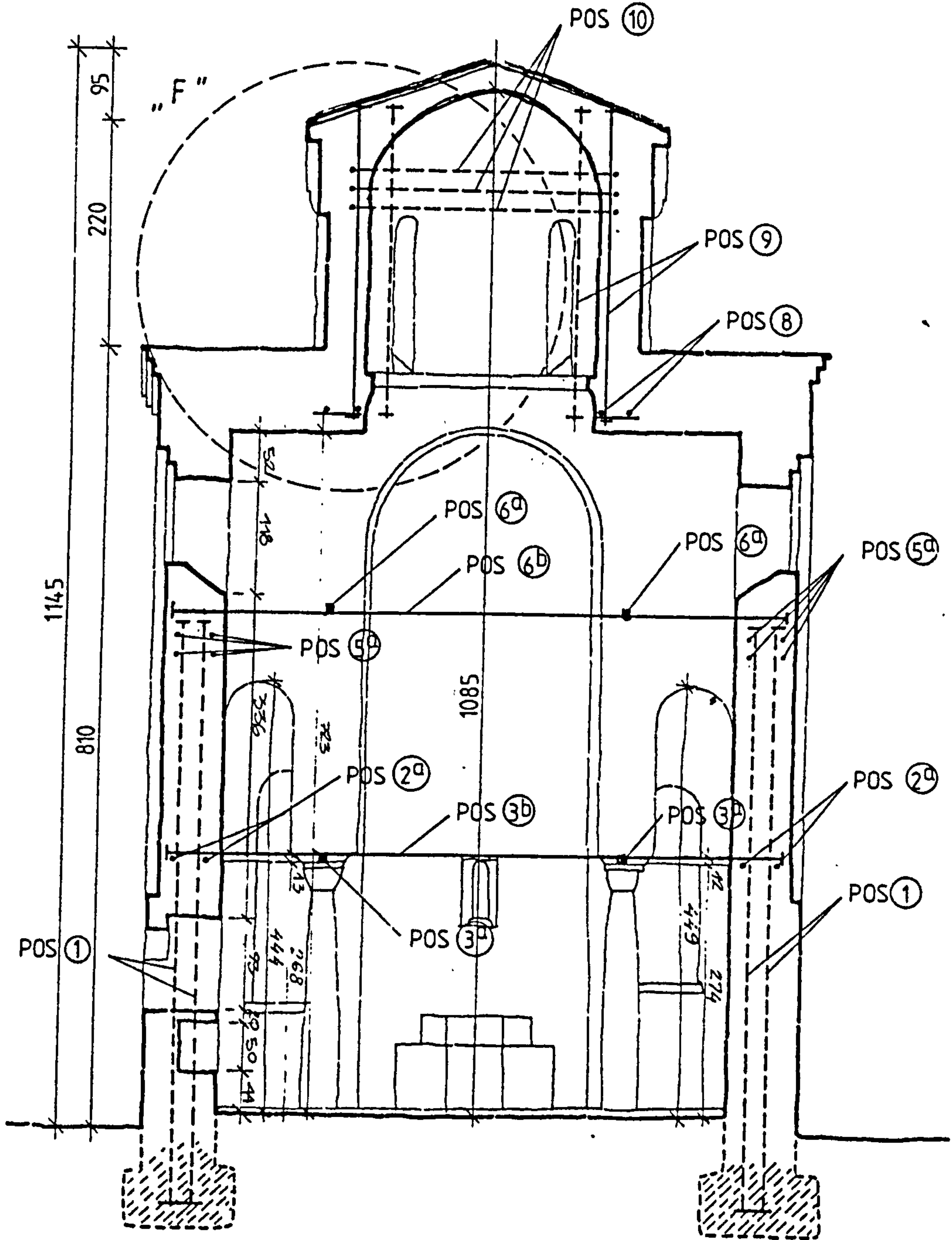

Fig. 6.2.c

St. Bogorodica Zaumska, v. Trpejca (Variant A)
 Cross section N-S direction
 Source: Volume 12

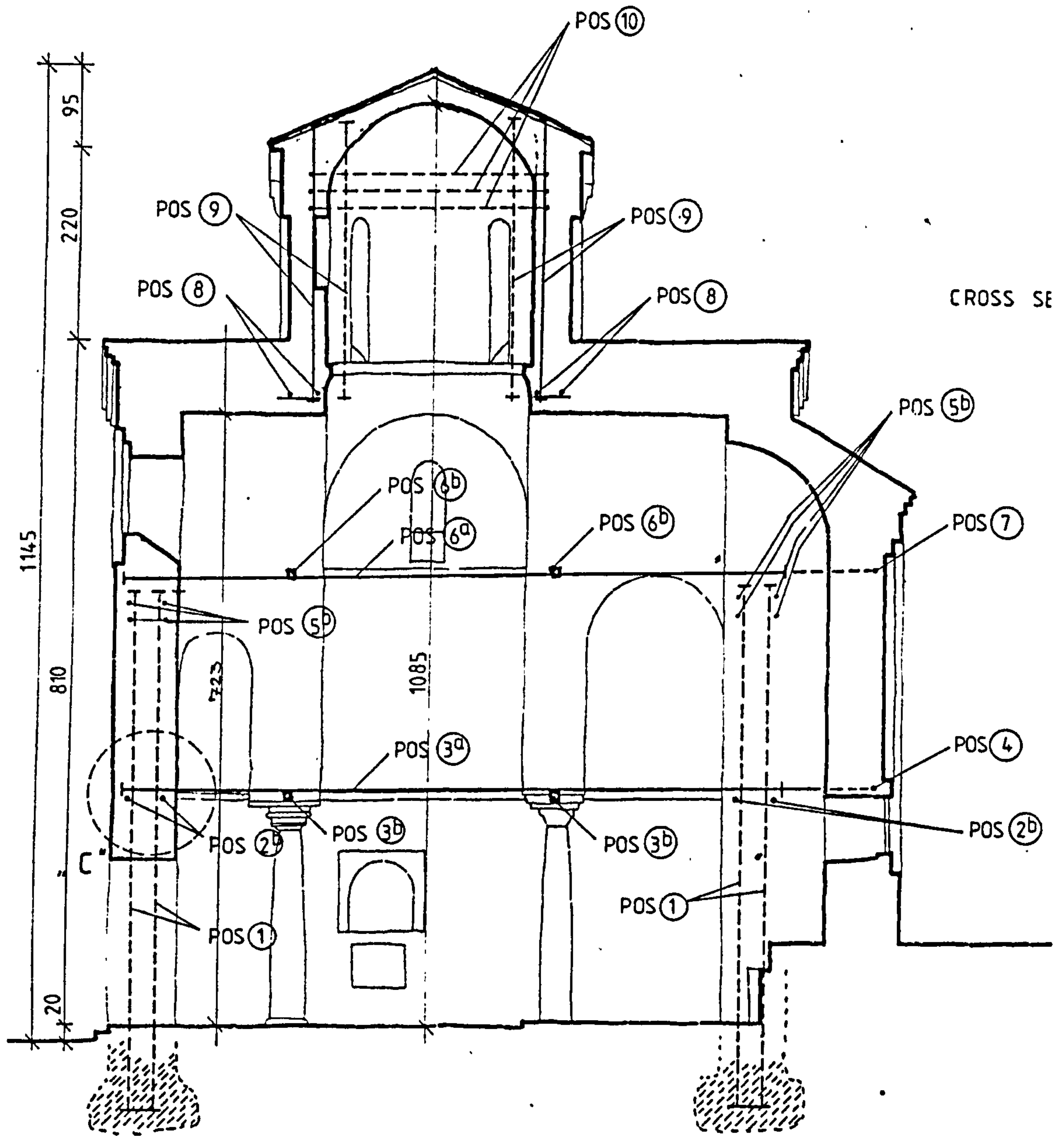

Fig. 6.2.d

St. Bogorodica Zaumska, v. Trpejca (Variant A)

Cross section W-E direction

Source: Volume 12

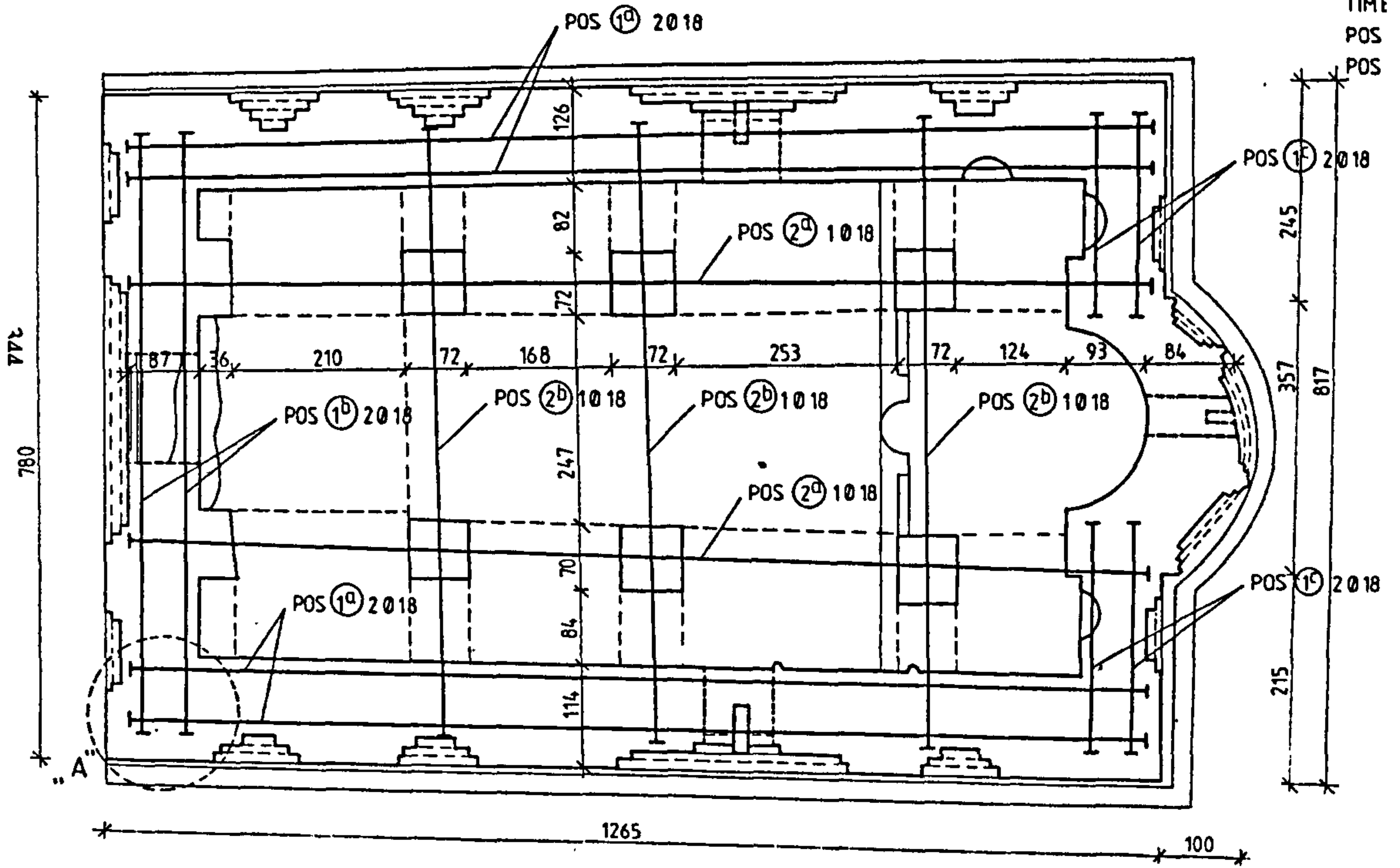

Fig. 6.3.a *St. Nikola, v. Psaca (Variant A)*
Section at timber ties level $H = 2.90m$
Source: Volume 12

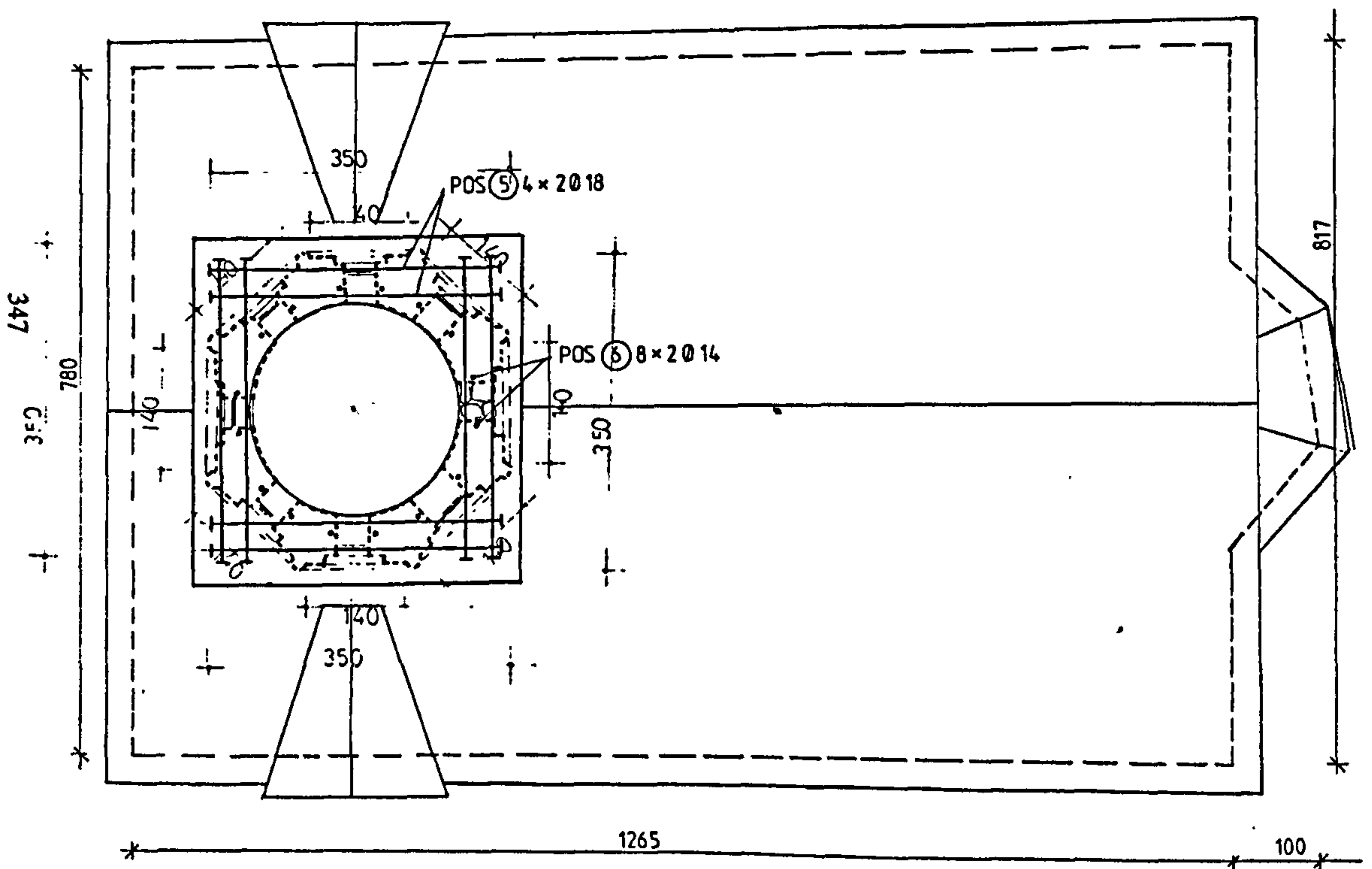
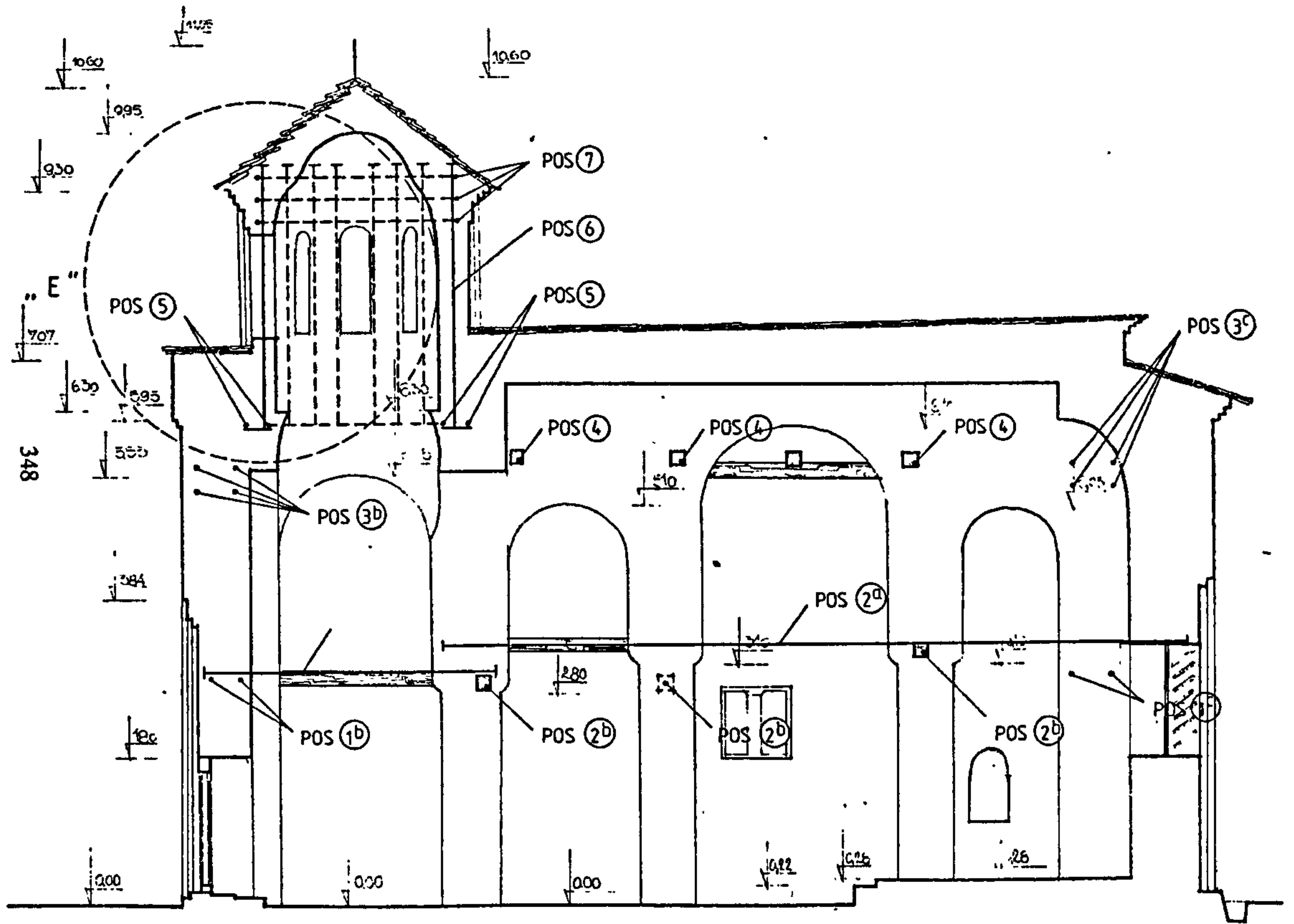

Fig. 6.3.b *St. Nikola, v. Psaca (Variant A)*
Section at level $H - 4.15m$
Source: Volume 12



SECTION 1-1 M = 1:50

Fig. 6.3.c *St. Nikola, v. Psaca (Variant A)*
Cross section W-E direction
Source: Volume 12

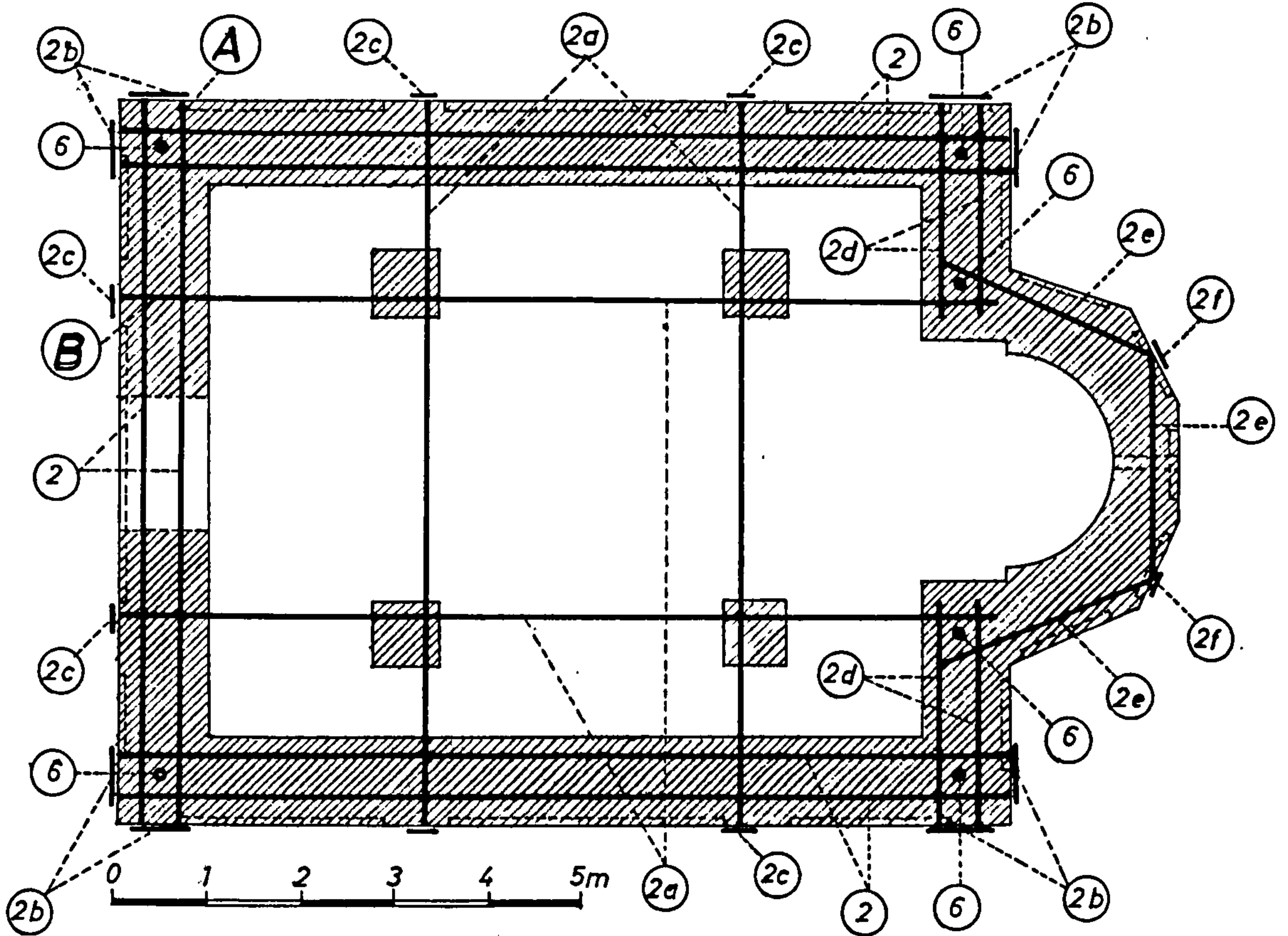

Fig. 6.4.a *St. Nikita, v. Banjani (Variant B)*
Section at timber ties level $H = 4.75m$

Legend:

Horizontal belts

1. 2 \varnothing 18 mm (in the walls)
2. 2 \varnothing 18 mm (in the walls)
- 2.a 1 \varnothing 18 mm (ties - connection of perimetral walls in N-S and W-E direction)
- 2.b Steel plate 600x250x10 mm
- 2.c Steel plate 200x150x10 mm
- 2.d 2 \varnothing 18 mm (horizontal elements in East perimetral wall)
- 2.e 1 \varnothing 18 mm
- 2.f Steel plate 150x120x10 mm
3. 2 \varnothing 18 mm
- 3.a Steel plate 200x150x10 mm
4. 1 \varnothing 18 mm
- 4.a Steel plate 120x120x10 mm
5. 1 \varnothing 18 mm
- 5.a Steel plate 120x120x10 mm

Vertical belts

6. 1 \varnothing 20 mm (In the perimetral walls)
- 6.a Steel plate 150x150x10 mm
7. 1 \varnothing 18 mm
- 7.a Steel plate 120x120x10 mm

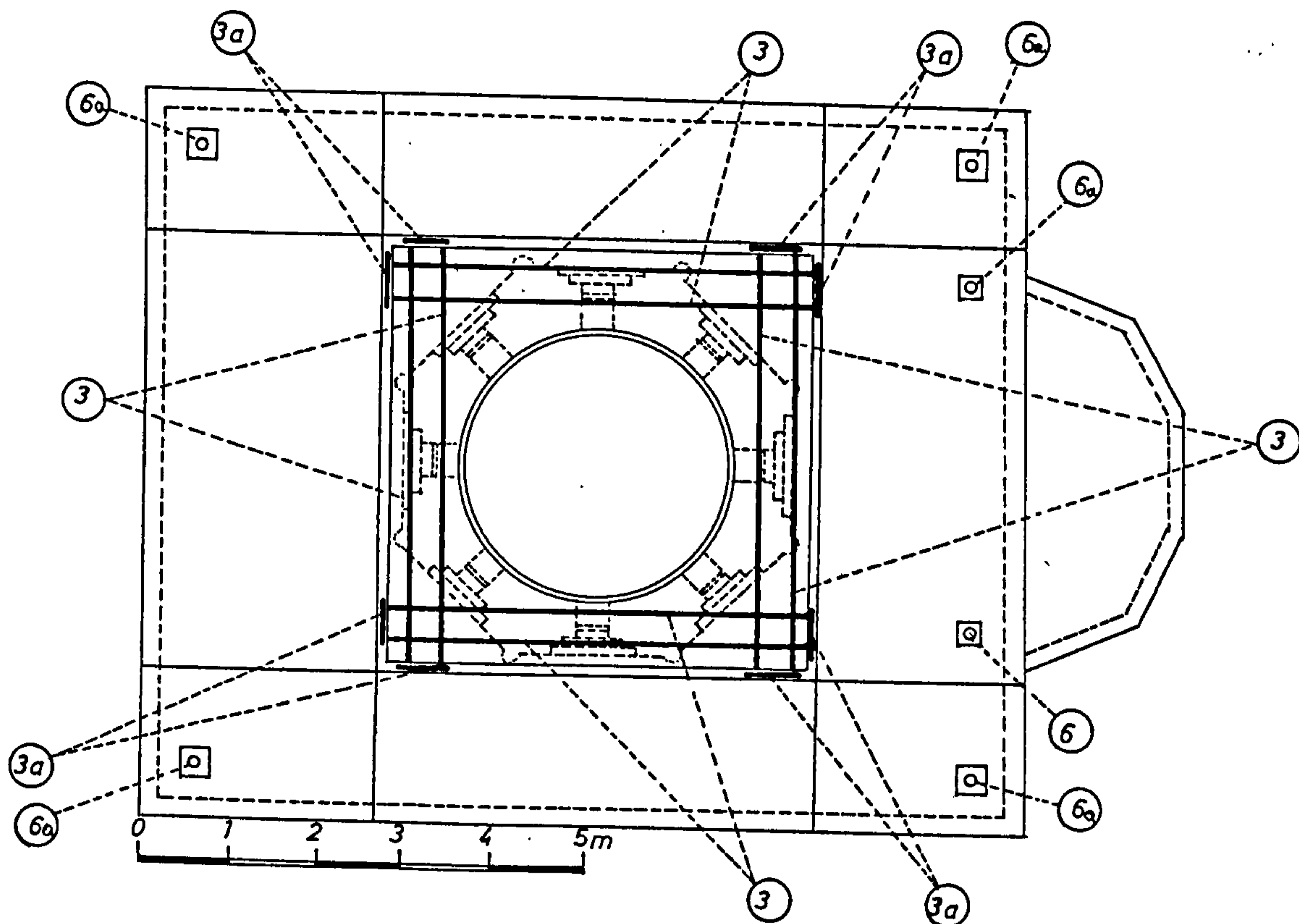

Fig. 6.4.b *St. Nikita, v. Banjani (Variant B)*
Section at level $H = 6.64m$

Legend:

Horizontal belts

- 1. 2 \emptyset 18 mm (in the walls)
- 2. 2 \emptyset 18 mm (in the walls)
- 2.a 1 \emptyset 18 mm (ties - connection of perimetral walls in N-S and W-E direction)
- 2.b Steel plate 600x250x10 mm
- 2.c Steel plate 200x150x10 mm
- 2.d 2 \emptyset 18 mm (horizontal elements in East perimetral wall)
- 2.e 1 \emptyset 18 mm
- 2.f Steel plate 150x120x10 mm
- 3. 2 \emptyset 18 mm
- 3.a Steel plate 200x150x10 mm
- 4. 1 \emptyset 18 mm
- 4.a Steel plate 120x120x10 mm
- 5. 1 \emptyset 18 mm
- 5.a Steel plate 120x120x10 mm

Vertical belts

- 6. 1 \emptyset 20 mm (In the perimetral walls)
- 6.a Steel plate 150x150x10 mm
- 7. 1 \emptyset 18 mm
- 7.a Steel plate 120x120x10 mm

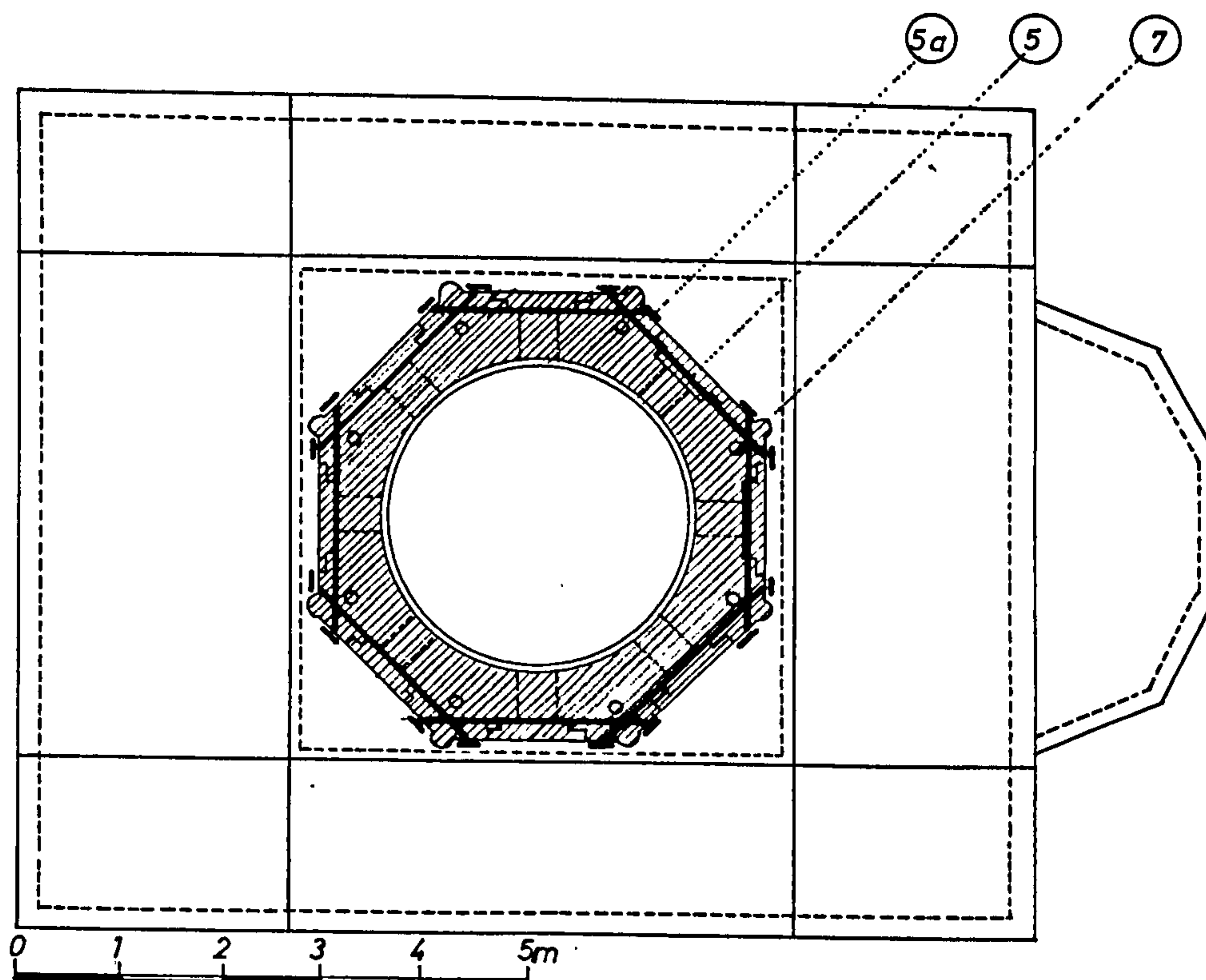

Fig. 6.4.c *St. Nikita, v. Banjani (Variant B)*
Section at level H = 10.25m

Legend:

Horizontal belts

- 1. 2 Ø 18 mm (in the walls)
- 2. 2 Ø 18 mm (in the walls)
- 2.a 1 Ø 18 mm (ties - connection of perimetral walls in N-S and W-E direction)
- 2.b Steel plate 600x250x10 mm
- 2.c Steel plate 200x150x10 mm
- 2.d 2 Ø 18 mm (horizontal elements in East perimetral wall)
- 2.e 1 Ø 18 mm
- 2.f Steel plate 150x120x10 mm
- 3. 2 Ø 18 mm
- 3.a Steel plate 200x150x10 mm
- 4. 1 Ø 18 mm
- 4.a Steel plate 120x120x10 mm
- 5. 1 Ø 18 mm
- 5.a Steel plate 120x120x10 mm

Vertical belts

- 6. 1 Ø 20 mm (In the perimetral walls)
- 6.a Steel plate 150x150x10 mm
- 7. 1 Ø 18 mm
- 7.a Steel plate 120x120x10 mm

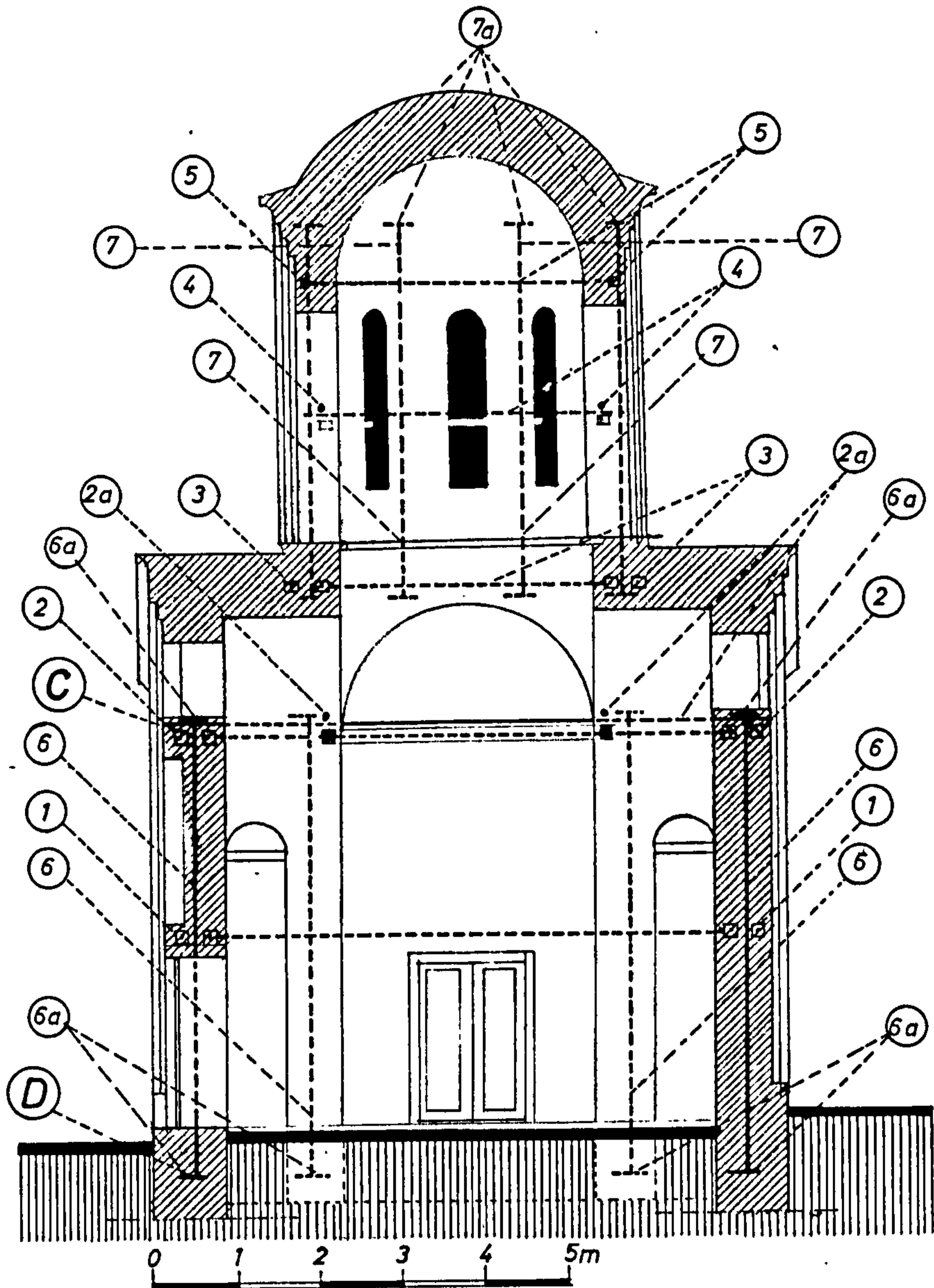

Fig. 6.4.d

St. Nikita, v. Banjani (Variant B)
Cross section N-S direction

Legend:

Horizontal belts

- 1. 2 Ø 18 mm (in the walls)
- 2. 2 Ø 18 mm (in the walls)
- 2.a 1 Ø 18 mm (ties - connection of perimetral walls in N-S and W-E direction)
- 2.b Steel plate 600x250x10 mm
- 2.c Steel plate 200x150x10 mm
- 2.d 2 Ø 18 mm (horizontal elements in East perimetral wall)
- 2.e 1 Ø 18 mm
- 2.f Steel plate 150x120x10 mm
- 3. 2 Ø 18 mm
- 3.a Steel plate 200x150x10 mm
- 4. 1 Ø 18 mm
- 4.a Steel plate 120x120x10 mm
- 5. 1 Ø 18 mm
- 5.a Steel plate 120x120x10 mm

Vertical belts

- 6. 1 Ø 20 mm (In the perimetral walls)
- 6.a Steel plate 150x150x10 mm
- 7. 1 Ø 18 mm
- 7.a Steel plate 120x120x10 mm

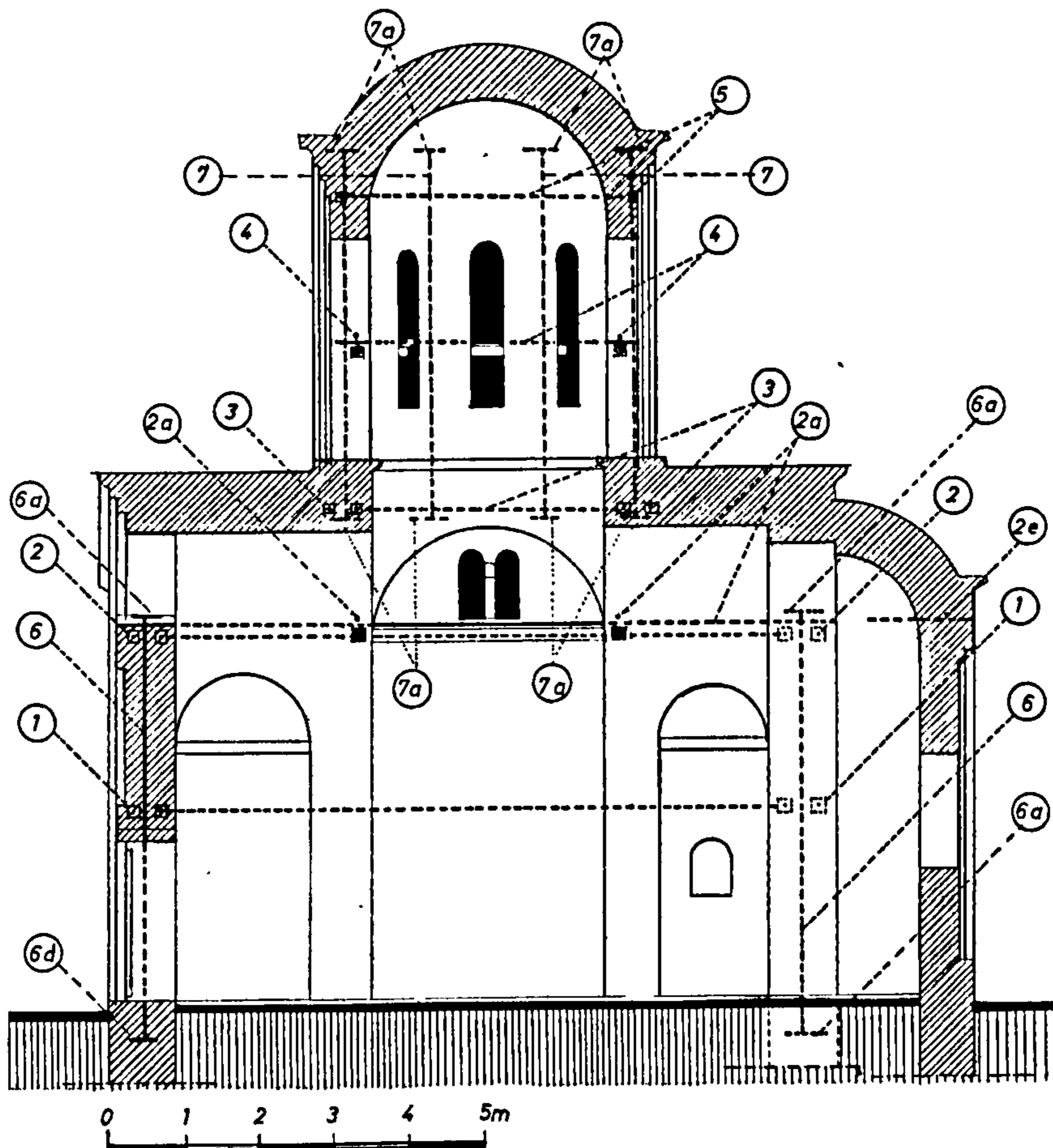

Fig. 6.4.e

St. Nikita, v. Banjani (Variant B)
Cross section W-E direction

Legend:

Horizontal belts

- 1. 2 Ø 18 mm (in the walls)
- 2. 2 Ø 18 mm (in the walls)
- 2.a 1 Ø 18 mm (ties - connection of perimetral walls in N-S and W-E direction)
- 2.b Steel plate 600x250x10 mm
- 2.c Steel plate 200x150x10 mm
- 2.d 2 Ø 18 mm (horizontal elements in East perimetral wall)
- 2.e 1 Ø 18 mm
- 2.f Steel plate 150x120x10 mm
- 3. 2 Ø 18 mm
- 3.a Steel plate 200x150x10 mm
- 4. 1 Ø 18 mm
- 4.a Steel plate 120x120x10 mm
- 5. 1 Ø 18 mm
- 5.a Steel plate 120x120x10 mm

Vertical belts

- 6. 1 Ø 20 mm (In the perimetral walls)
- 6.a Steel plate 150x150x10 mm
- 7. 1 Ø 18 mm
- 7.a Steel plate 120x120x10 mm

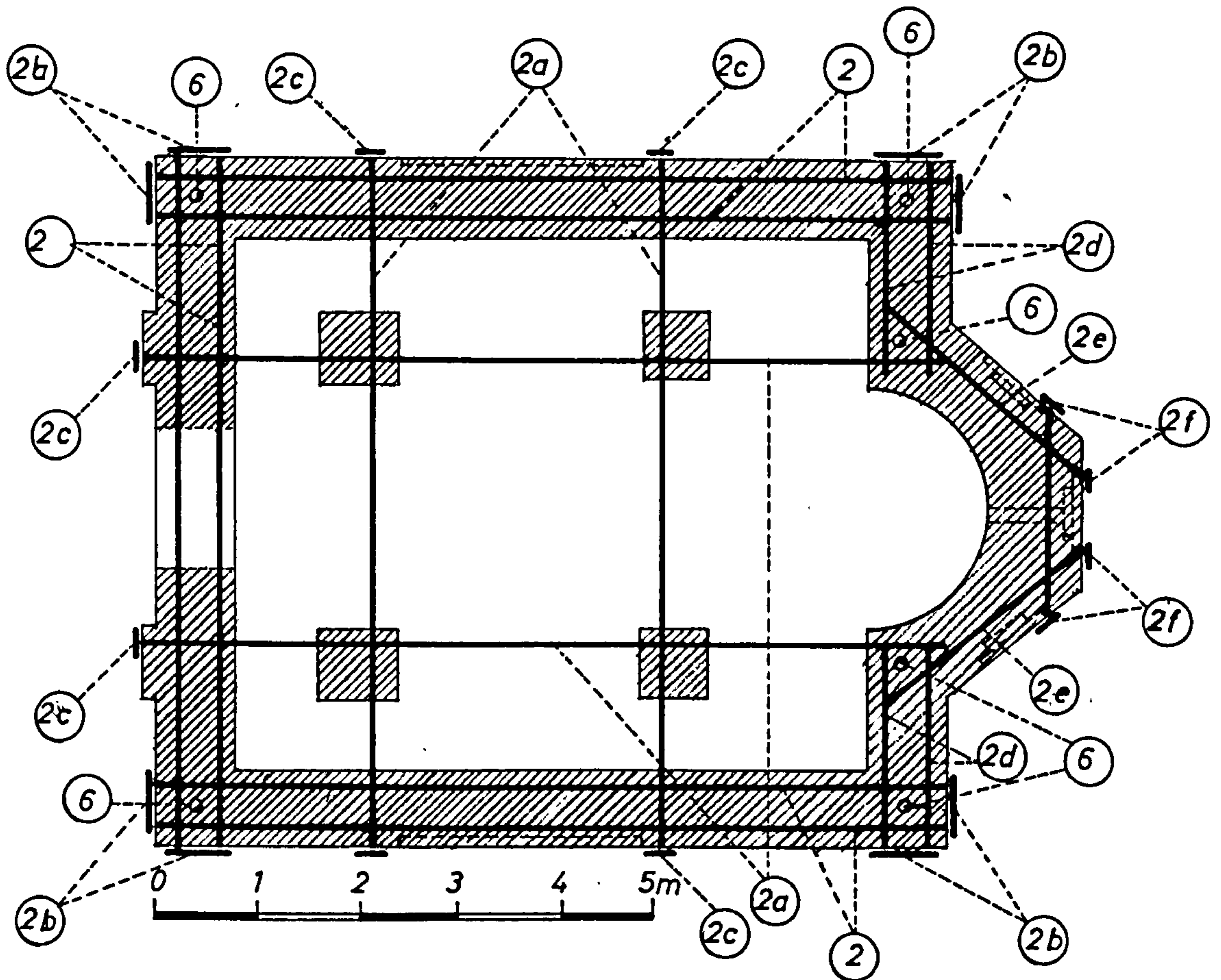

Fig. 6.5.a *St. Bogorodica Zaumska, v. Trpejca (Variant B)*
 Section at timber ties level $H = 5.28$

Legend:

Horizontal belts

- 1. 2 \varnothing 18 mm (in the walls)
- 1.a 1 \varnothing 18 mm (ties - connection of perimetral walls in N-S and W-E direction)
- 1.b Steel plate 200x150x10 mm
- 2. 2 \varnothing 18 mm (in the walls)
- 2.a 1 \varnothing 18 mm (ties - connection of perimetral walls in N-S and W-E direction)
- 2.b Steel plate 600x250x10 mm
- 2.c Steel plate 200x150x10 mm
- 2.d 2 \varnothing 18 mm (horizontal elements in East perimetral wall)
- 2.e 1 \varnothing 18 mm
- 2.f Steel plate 120x120x10 mm
- 3. 2 \varnothing 18 mm
- 3.a Steel plate 200x120x10 mm
- 4. 1 \varnothing 18 mm
- 4.a Steel plate 120x120x10 mm
- 5. 1 \varnothing 18 mm
- 5.a Steel plate 120x120x10 mm

Vertical belts

- 6. 1 \varnothing 20 mm (In the perimetral walls)
- 6.a Steel plate 150x150x10 mm
- 7. 1 \varnothing 18 mm
- 7.a Steel plate 120x120x10 mm

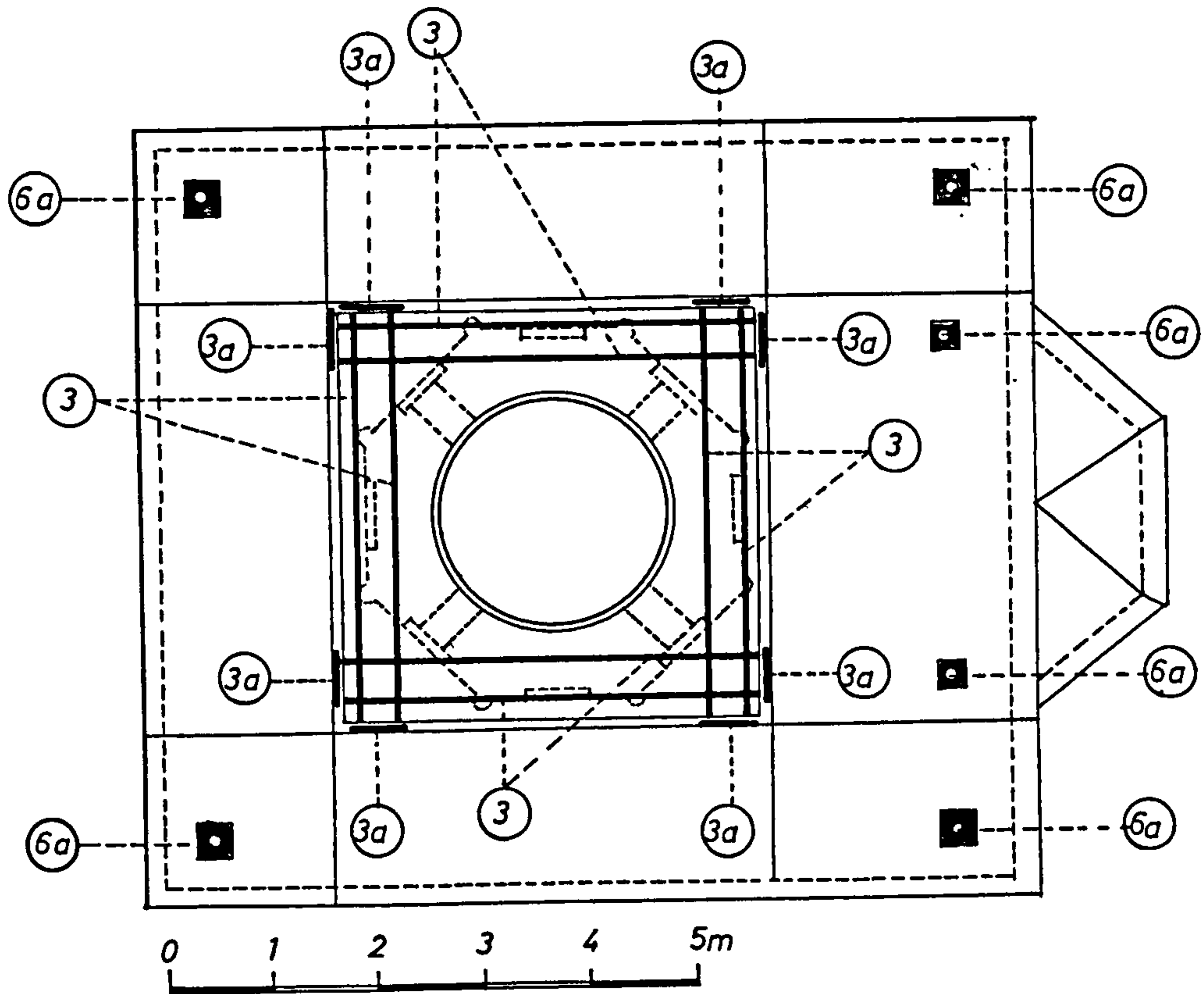

Fig. 6.5.b

St. Bogorodica Zaumska, v. Trpejca (Variant B)
 Section at level $H = 7.71\text{ m}$

Legend:

Horizontal belts

- 1. 2 $\varnothing 18\text{ mm}$ (in the walls)
- 1.a 1 $\varnothing 18\text{ mm}$ (ties - connection of perimetral walls in N-S and W-E direction)
- 1.b Steel plate 200x150x10 mm
- 2. 2 $\varnothing 18\text{ mm}$ (in the walls)
- 2.a 1 $\varnothing 18\text{ mm}$ (ties - connection of perimetral walls in N-S and W-E direction)
- 2.b Steel plate 600x250x10 mm
- 2.c Steel plate 200x150x10 mm
- 2.d 2 $\varnothing 18\text{ mm}$ (horizontal elements in East perimetral wall)
- 2.e 1 $\varnothing 18\text{ mm}$
- 2.f Steel plate 120x120x10 mm
- 3. 2 $\varnothing 18\text{ mm}$
- 3.a Steel plate 200x120x10 mm
- 4. 1 $\varnothing 18\text{ mm}$
- 4.a Steel plate 120x120x10 mm
- 5. 1 $\varnothing 18\text{ mm}$
- 5.a Steel plate 120x120x10 mm

Vertical belts

- 6. 1 $\varnothing 20\text{ mm}$ (In the perimetral walls)
- 6.a Steel plate 150x150x10 mm
- 7. 1 $\varnothing 18\text{ mm}$
- 7.a Steel plate 120x120x10 mm

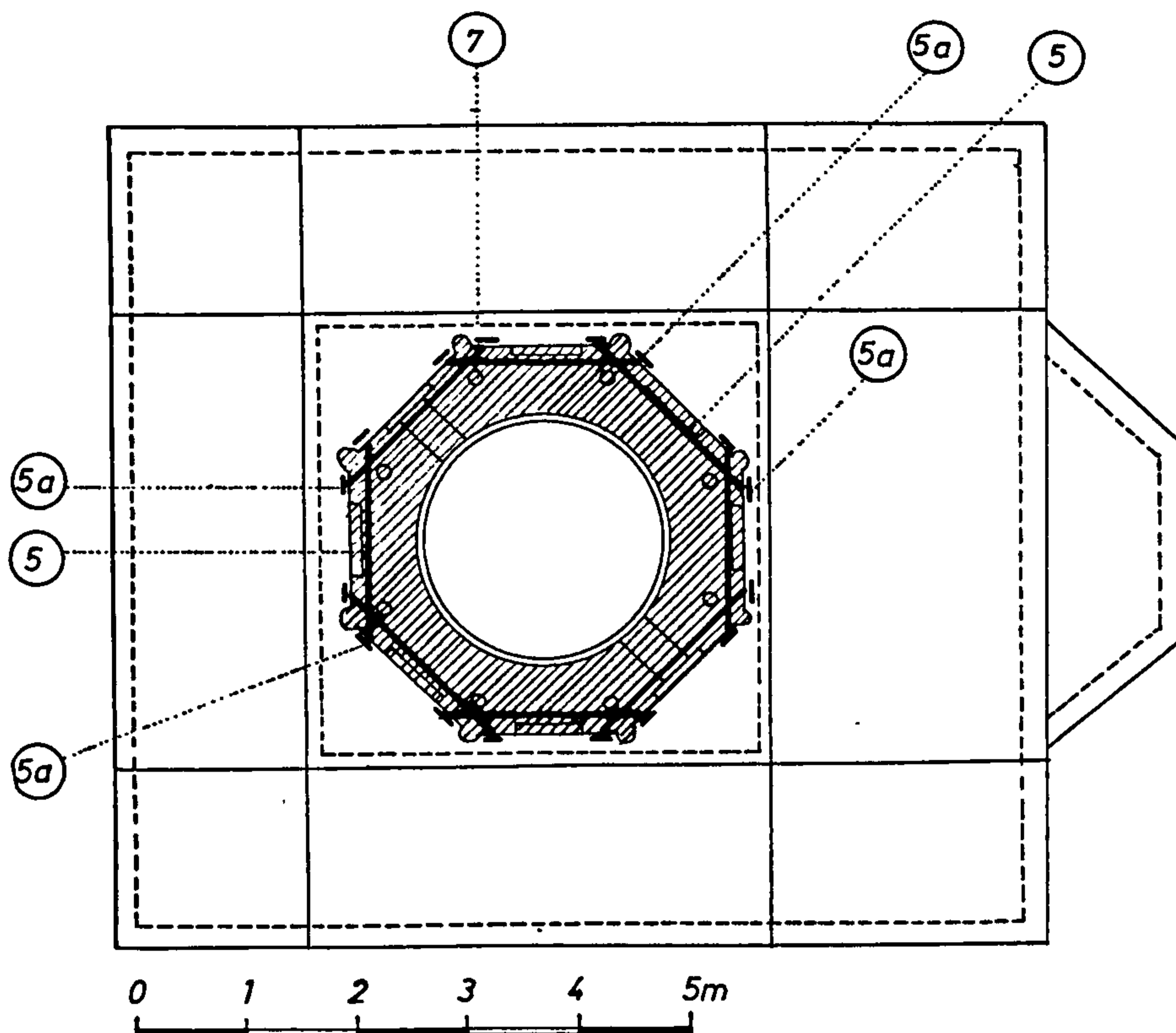

Fig. 6.5.c

St. Bogorodica Zaumska, v. Trpejca (Variant B)
 Section at level $H = 9.78$ m

Legend:

Horizontal belts

- 1. 2 \varnothing 18 mm (in the walls)
- 1.a 1 \varnothing 18 mm (ties - connection of perimetral walls in N-S and W-E direction)
- 1.b Steel plate 200x150x10 mm
- 2. 2 \varnothing 18 mm (in the walls)
- 2.a 1 \varnothing 18 mm (ties - connection of perimetral walls in N-S and W-E direction)
- 2.b Steel plate 600x250x10 mm
- 2.c Steel plate 200x150x10 mm
- 2.d 2 \varnothing 18 mm (horizontal elements in East perimetral wall)
- 2.e 1 \varnothing 18 mm
- 2.f Steel plate 120x120x10 mm
- 3. 2 \varnothing 18 mm
- 3.a Steel plate 200x120x10 mm
- 4. 1 \varnothing 18 mm
- 4.a Steel plate 120x120x10 mm
- 5. 1 \varnothing 18 mm
- 5.a Steel plate 120x120x10 mm

Vertical belts

- 6. 1 \varnothing 20 mm (In the perimetral walls)
- 6.a Steel plate 150x150x10 mm
- 7. 1 \varnothing 18 mm
- 7.a Steel plate 120x120x10 mm

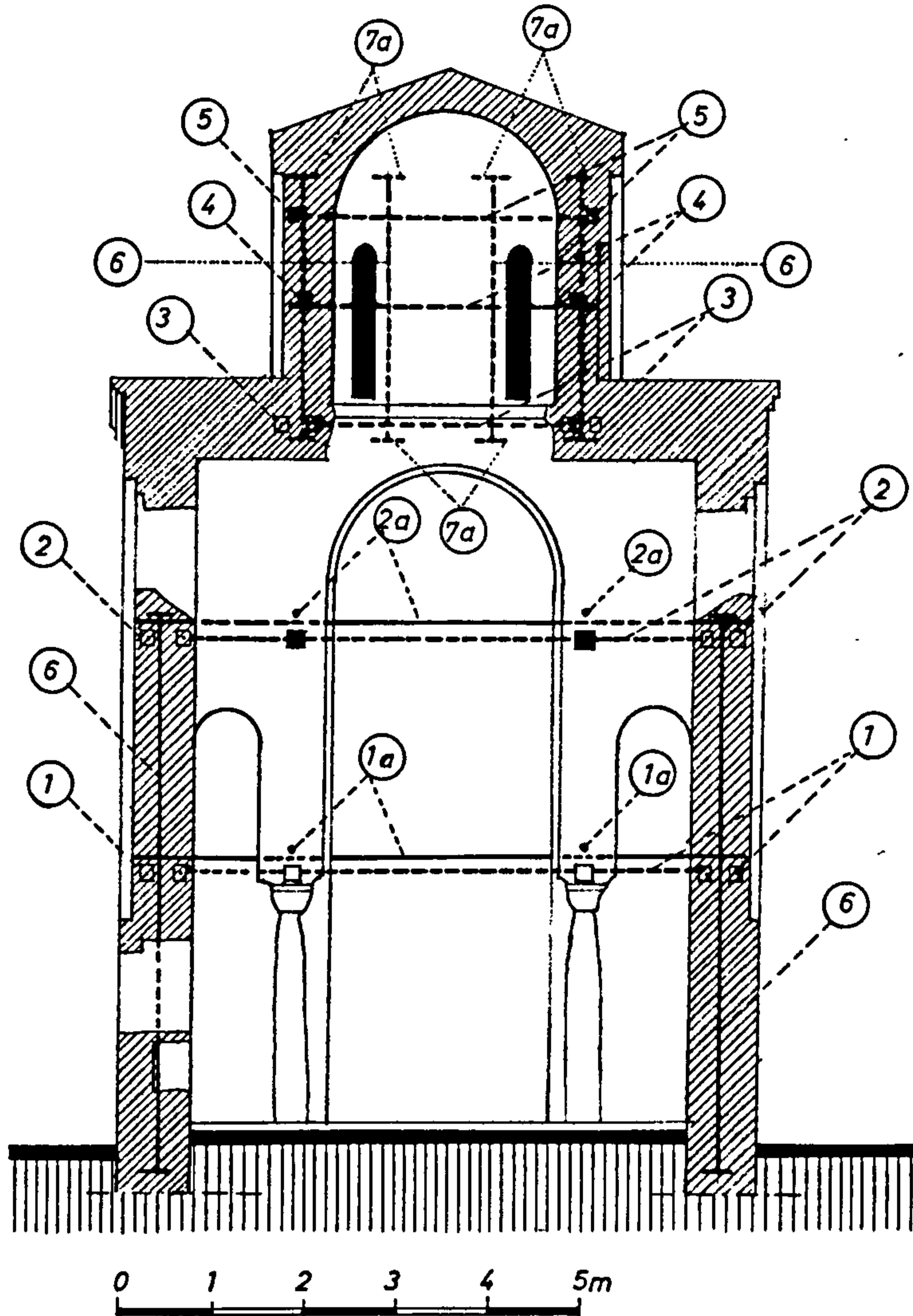

Fig. 6.5.d

St. Bogorodica Zaumska, v. Trpejca (Variant B)
Cross section N-S direction

Legend:

Horizontal belts

- 1. 2 Ø 18 mm (in the walls)
- 1.a 1 Ø 18 mm (ties - connection of perimetral walls in N-S and W-E direction)
- 1.b Steel plate 200x150x10 mm
- 2. 2 Ø 18 mm (in the walls)
- 2.a 1 Ø 18 mm (ties - connection of perimetral walls in N-S and W-E direction)
- 2.b Steel plate 600x250x10 mm
- 2.c Steel plate 200x150x10 mm
- 2.d 2 Ø 18 mm (horizontal elements in East perimetral wall)
- 2.e 1 Ø 18 mm
- 2.f Steel plate 120x120x10 mm
- 3. 2 Ø 18 mm
- 3.a Steel plate 200x120x10 mm
- 4. 1 Ø 18 mm
- 4.a Steel plate 120x120x10 mm
- 5. 1 Ø 18 mm
- 5.a Steel plate 120x120x10 mm

Vertical belts

- 6. 1 Ø 20 mm (In the perimetral walls)
- 6.a Steel plate 150x150x10 mm
- 7. 1 Ø 18 mm
- 7.a Steel plate 120x120x10 mm

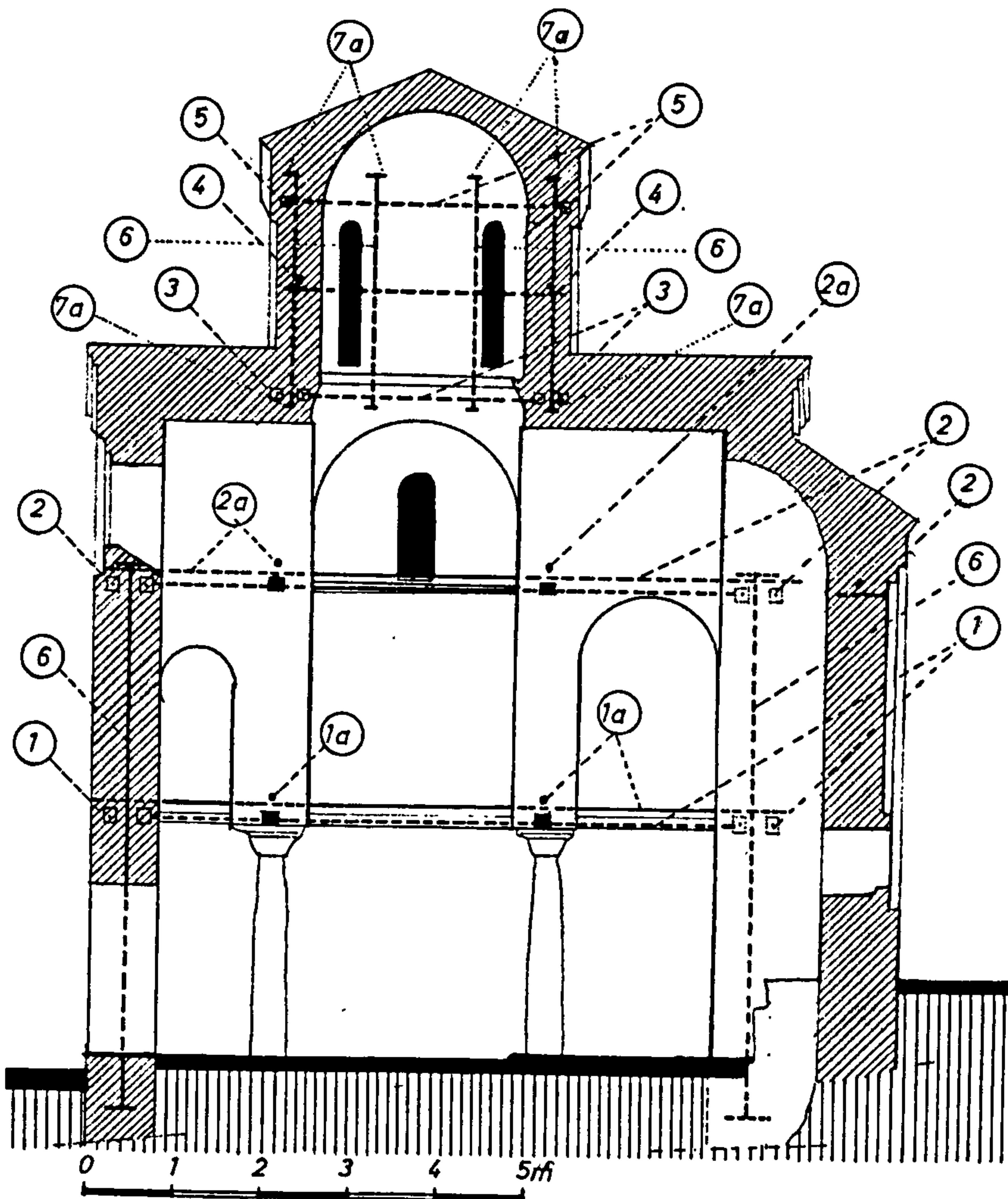

Fig. 6.5.e

St. Bogorodica Zaumska, v. Trpejca (Variant B)
Cross section W-E direction

Legend:

Horizontal belts

- 1. 2 Ø 18 mm (in the walls)
- 1.a 1 Ø 18 mm (ties - connection of perimetral walls in N-S and W-E direction)
- 1.b Steel plate 200x150x10 mm
- 2. 2 Ø 18 mm (in the walls)
- 2.a 1 Ø 18 mm (ties - connection of perimetral walls in N-S and W-E direction)
- 2.b Steel plate 600x250x10 mm
- 2.c Steel plate 200x150x10 mm
- 2.d 2 Ø 18 mm (horizontal elements in East perimetral wall)
- 2.e 1 Ø 18 mm
- 2.f Steel plate 120x120x10 mm
- 3. 2 Ø 18 mm
- 3.a Steel plate 200x120x10 mm
- 4. 1 Ø 18 mm
- 4.a Steel plate 120x120x10 mm
- 5. 1 Ø 18 mm
- 5.a Steel plate 120x120x10 mm

Vertical belts

- 6. 1 Ø 20 mm (In the perimetral walls)
- 6.a Steel plate 150x150x10 mm
- 7. 1 Ø 18 mm
- 7.a Steel plate 120x120x10 mm

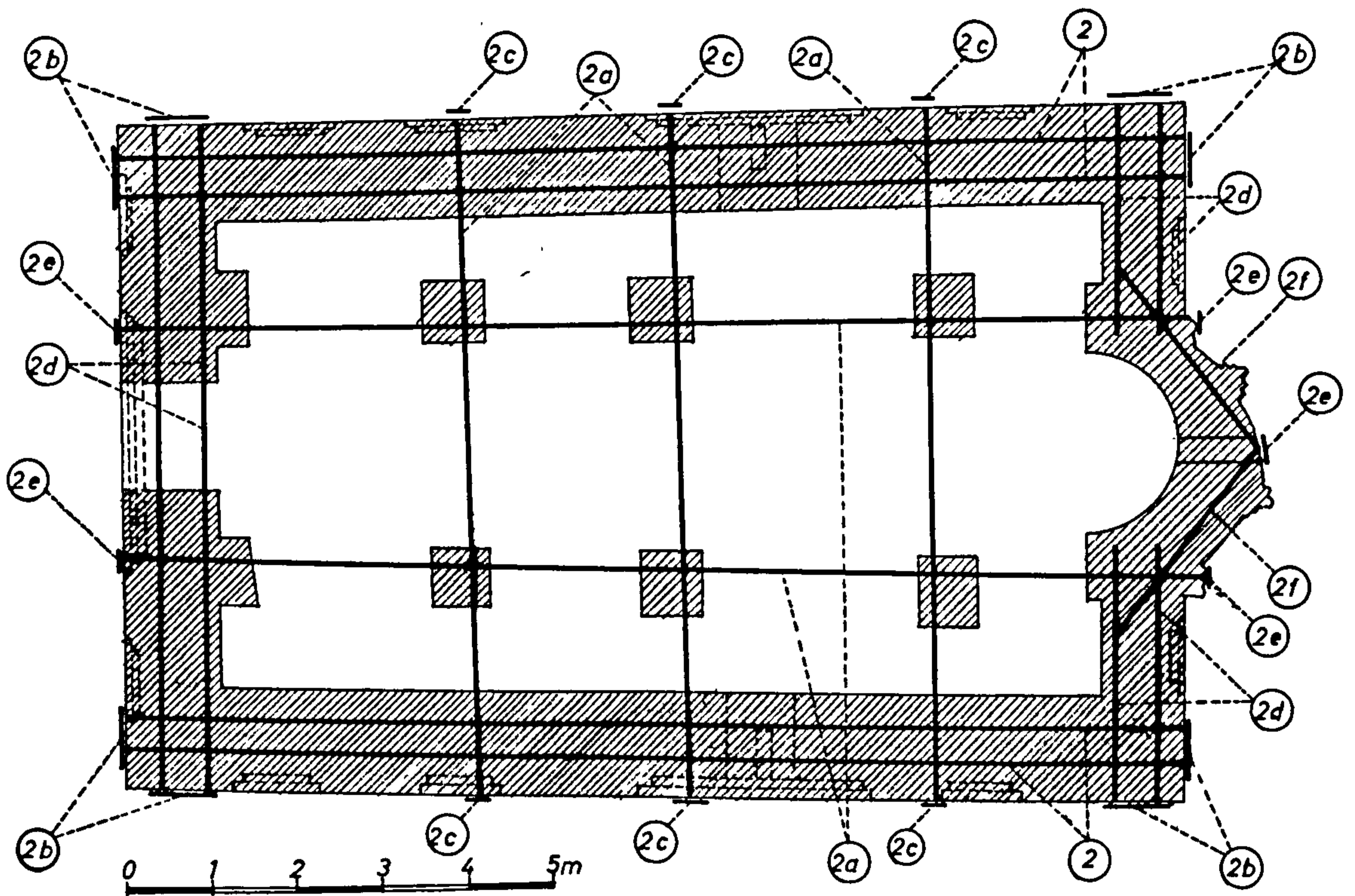

Fig. 6.6.a *St. Nikola, v. Psaca (Variant B)*
Section at timber ties level $H = 5.71$ m

Legend:

Horizontal belts

- 1. $2 \text{ } \varnothing 18 \text{ mm}$ (in the walls)
- 1.a $1 \text{ } \varnothing 18 \text{ mm}$ (ties - connection of perimetral walls in N-S and W-E direction)
- 1.b Steel plate $200 \times 150 \times 10 \text{ mm}$
- 2. $2 \text{ } \varnothing 18 \text{ mm}$ (in the walls)
- 2.a $1 \text{ } \varnothing 18 \text{ mm}$ (ties - connection of perimetral walls in N-S and W-E direction)
- 2.b Steel plate $600 \times 250 \times 10 \text{ mm}$
- 2.c Steel plate $200 \times 150 \times 10 \text{ mm}$
- 2.d $2 \text{ } \varnothing 18 \text{ mm}$ (horizontal elements in East perimetral wall)
- 2.e $1 \text{ } \varnothing 18 \text{ mm}$
- 2.f Steel plate $120 \times 120 \times 10 \text{ mm}$
- 3. $2 \text{ } \varnothing 18 \text{ mm}$
- 3.a Steel plate $200 \times 150 \times 10 \text{ mm}$
- 4. $1 \text{ } \varnothing 18 \text{ mm}$
- 4.a Steel plate $120 \times 120 \times 10 \text{ mm}$
- 5. $1 \text{ } \varnothing 18 \text{ mm}$
- 5.a Steel plate $120 \times 120 \times 10 \text{ mm}$

Vertical belts

- 6. $1 \text{ } \varnothing 18 \text{ mm}$
- 6.a Steel plate $120 \times 120 \times 10 \text{ mm}$

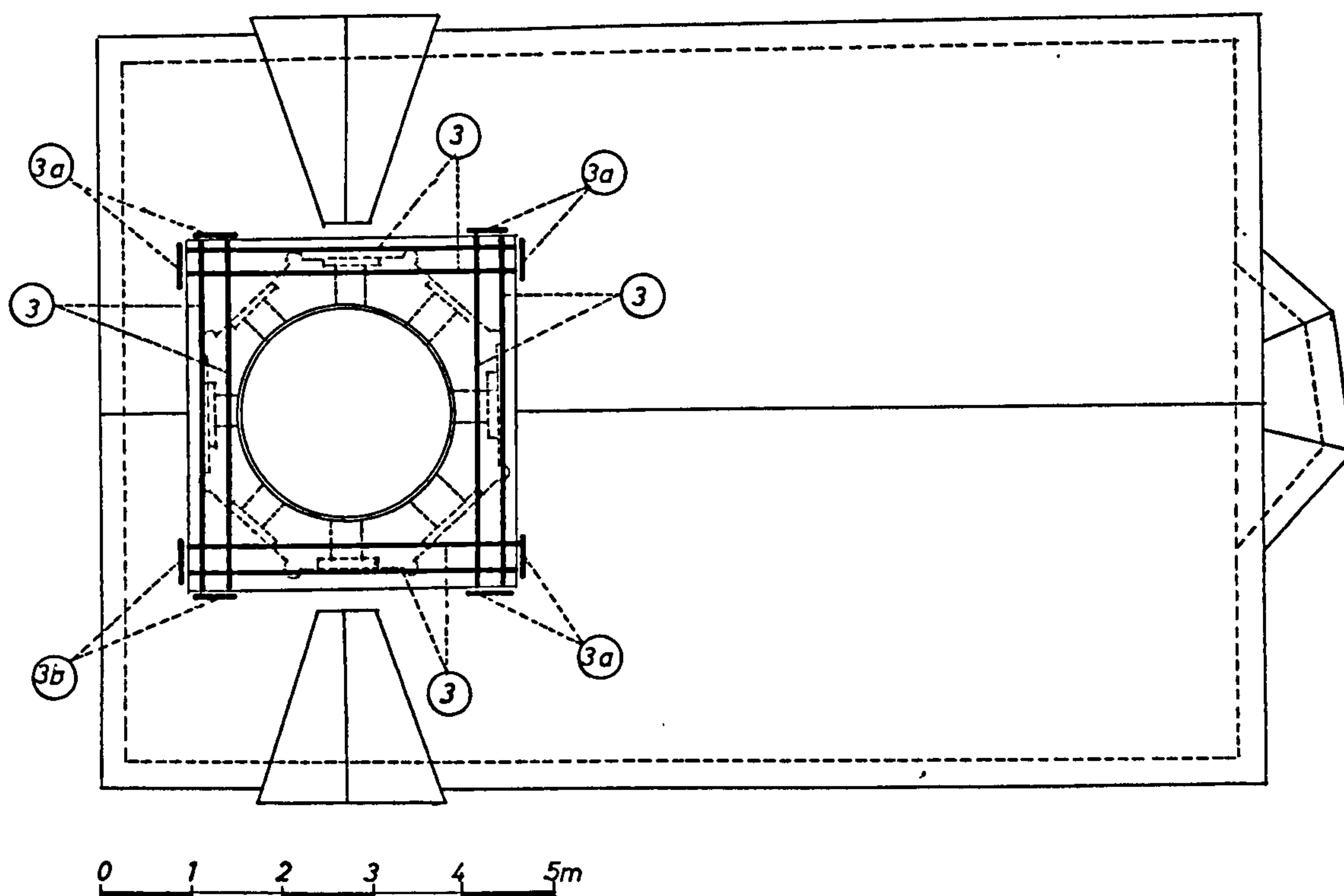

Fig. 6.6.b *St. Nikola, v. Psaca (Variant B)*
Section at level $H = 6.85\text{ m}$

Legend:

Horizontal belts

- 1. $2\ \varnothing\ 18\text{ mm}$ (in the walls)
- 1.a $1\ \varnothing\ 18\text{ mm}$ (ties - connection of perimetral walls in N-S and W-E direction)
- 1.b Steel plate $200 \times 150 \times 10\text{ mm}$
- 2. $2\ \varnothing\ 18\text{ mm}$ (in the walls)
- 2.a $1\ \varnothing\ 18\text{ mm}$ (ties - connection of perimetral walls in N-S and W-E direction)
- 2.b Steel plate $600 \times 250 \times 10\text{ mm}$
- 2.c Steel plate $200 \times 150 \times 10\text{ mm}$
- 2.d $2\ \varnothing\ 18\text{ mm}$ (horizontal elements in East perimetral wall)
- 2.e $1\ \varnothing\ 18\text{ mm}$
- 2.f Steel plate $120 \times 120 \times 10\text{ mm}$
- 3. $2\ \varnothing\ 18\text{ mm}$
- 3.a Steel plate $200 \times 150 \times 10\text{ mm}$
- 4. $1\ \varnothing\ 18\text{ mm}$
- 4.a Steel plate $120 \times 120 \times 10\text{ mm}$
- 5. $1\ \varnothing\ 18\text{ mm}$
- 5.a Steel plate $120 \times 120 \times 10\text{ mm}$

Vertical belts

- 6. $1\ \varnothing\ 18\text{ mm}$
- 6.a Steel plate $120 \times 120 \times 10\text{ mm}$

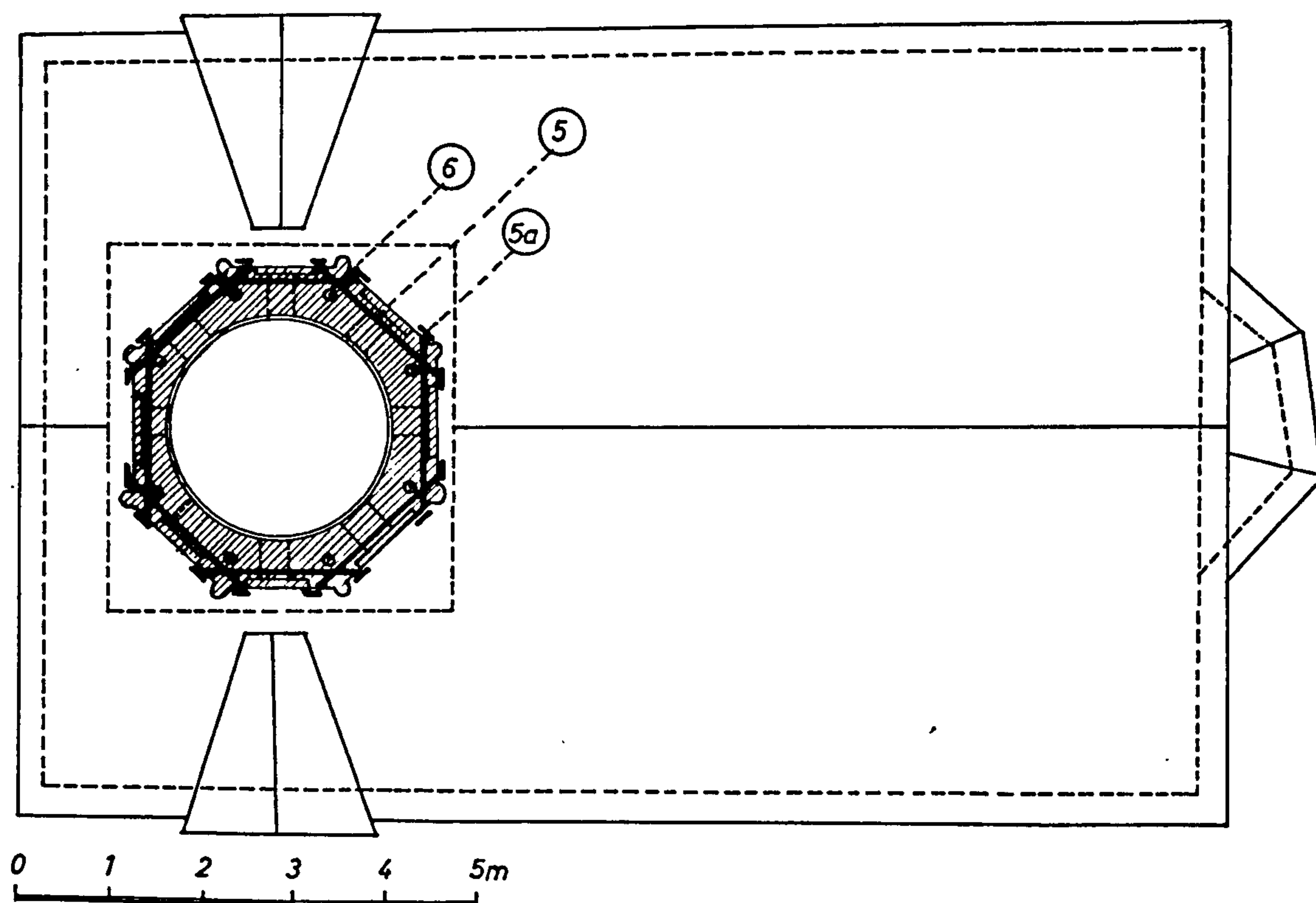

Fig. 6.6.c *St. Nikola, v. Psaca (Variant B)*
Section at level $H = 8.92\text{ m}$

Legend:

Horizontal belts

- 1. $2\ \varnothing\ 18\text{ mm}$ (in the walls)
- 1.a $1\ \varnothing\ 18\text{ mm}$ (ties - connection of perimetral walls in N-S and W-E direction)
- 1.b Steel plate $200 \times 150 \times 10\text{ mm}$
- 2. $2\ \varnothing\ 18\text{ mm}$ (in the walls)
- 2.a $1\ \varnothing\ 18\text{ mm}$ (ties - connection of perimetral walls in N-S and W-E direction)
- 2.b Steel plate $600 \times 250 \times 10\text{ mm}$
- 2.c Steel plate $200 \times 150 \times 10\text{ mm}$
- 2.d $2\ \varnothing\ 18\text{ mm}$ (horizontal elements in East perimetral wall)
- 2.e $1\ \varnothing\ 18\text{ mm}$
- 2.f Steel plate $120 \times 120 \times 10\text{ mm}$
- 3. $2\ \varnothing\ 18\text{ mm}$
- 3.a Steel plate $200 \times 150 \times 10\text{ mm}$
- 4. $1\ \varnothing\ 18\text{ mm}$
- 4.a Steel plate $120 \times 120 \times 10\text{ mm}$
- 5. $1\ \varnothing\ 18\text{ mm}$
- 5.a Steel plate $120 \times 120 \times 10\text{ mm}$

Vertical belts

- 6. $1\ \varnothing\ 18\text{ mm}$
- 6.a Steel plate $120 \times 120 \times 10\text{ mm}$

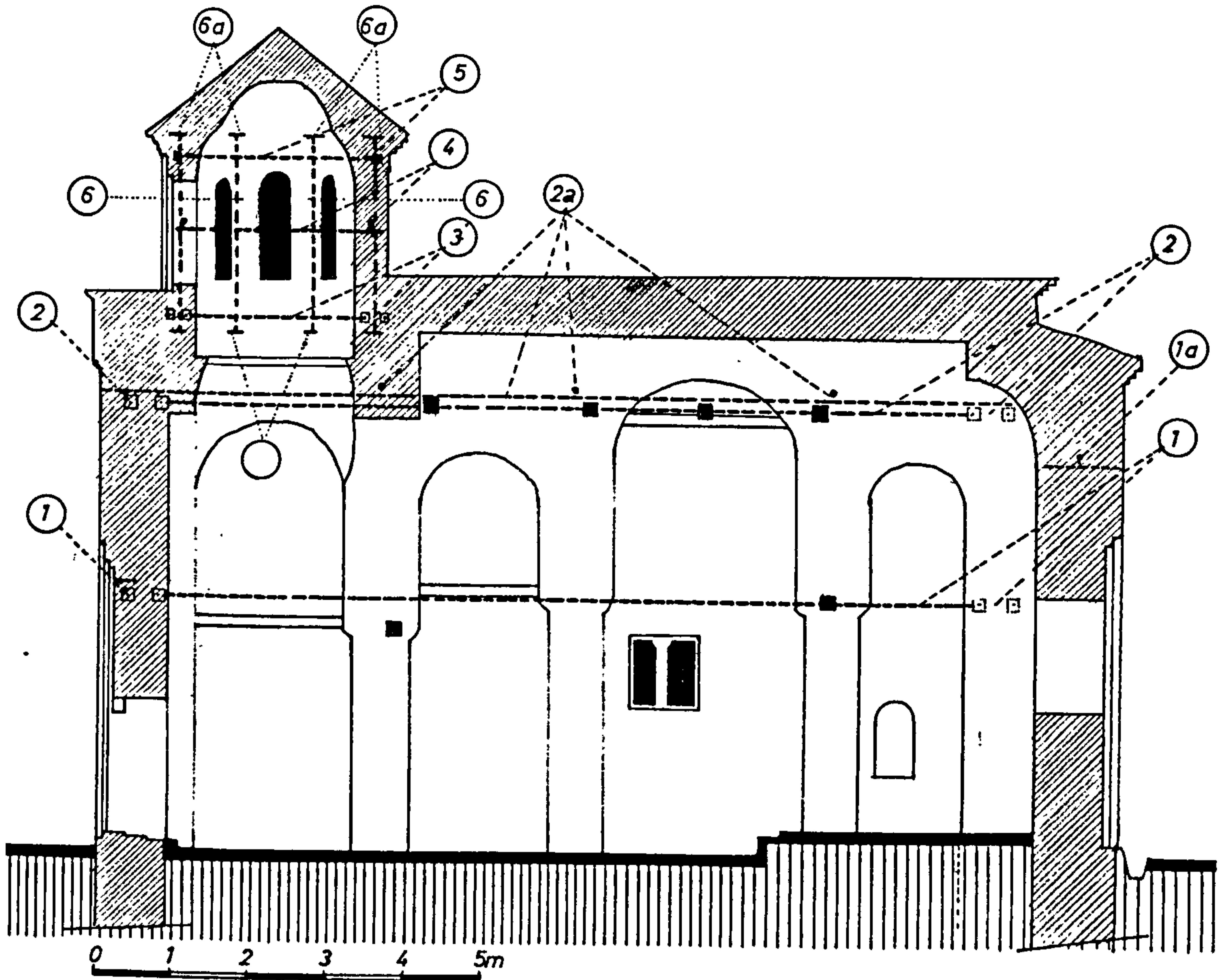

Fig. 6.6.d *St. Nikola, v. Psaca (Variant B)*
Cross section W-E direction

Legend:

Horizontal belts

- 1. 2 Ø 18 mm (in the walls)
- 1.a 1 Ø 18 mm (ties - connection of perimetral walls in N-S and W-E direction)
- 1.b Steel plate 200x150x10 mm
- 2. 2 Ø 18 mm (in the walls)
- 2.a 1 Ø 18 mm (ties - connection of perimetral walls in N-S and W-E direction)
- 2.b Steel plate 600x250x10 mm
- 2.c Steel plate 200x150x10 mm
- 2.d 2 Ø 18 mm (horizontal elements in East perimetral wall)
- 2.e 1 Ø 18 mm
- 2.f Steel plate 120x120x10 mm
- 3. 2 Ø 18 mm
- 3.a Steel plate 200x150x10 mm
- 4. 1 Ø 18 mm
- 4.a Steel plate 120x120x10 mm
- 5. 1 Ø 18 mm
- 5.a Steel plate 120x120x10 mm

Vertical belts

- 6. 1 Ø 18 mm
- 6.a Steel plate 120x120x10 mm

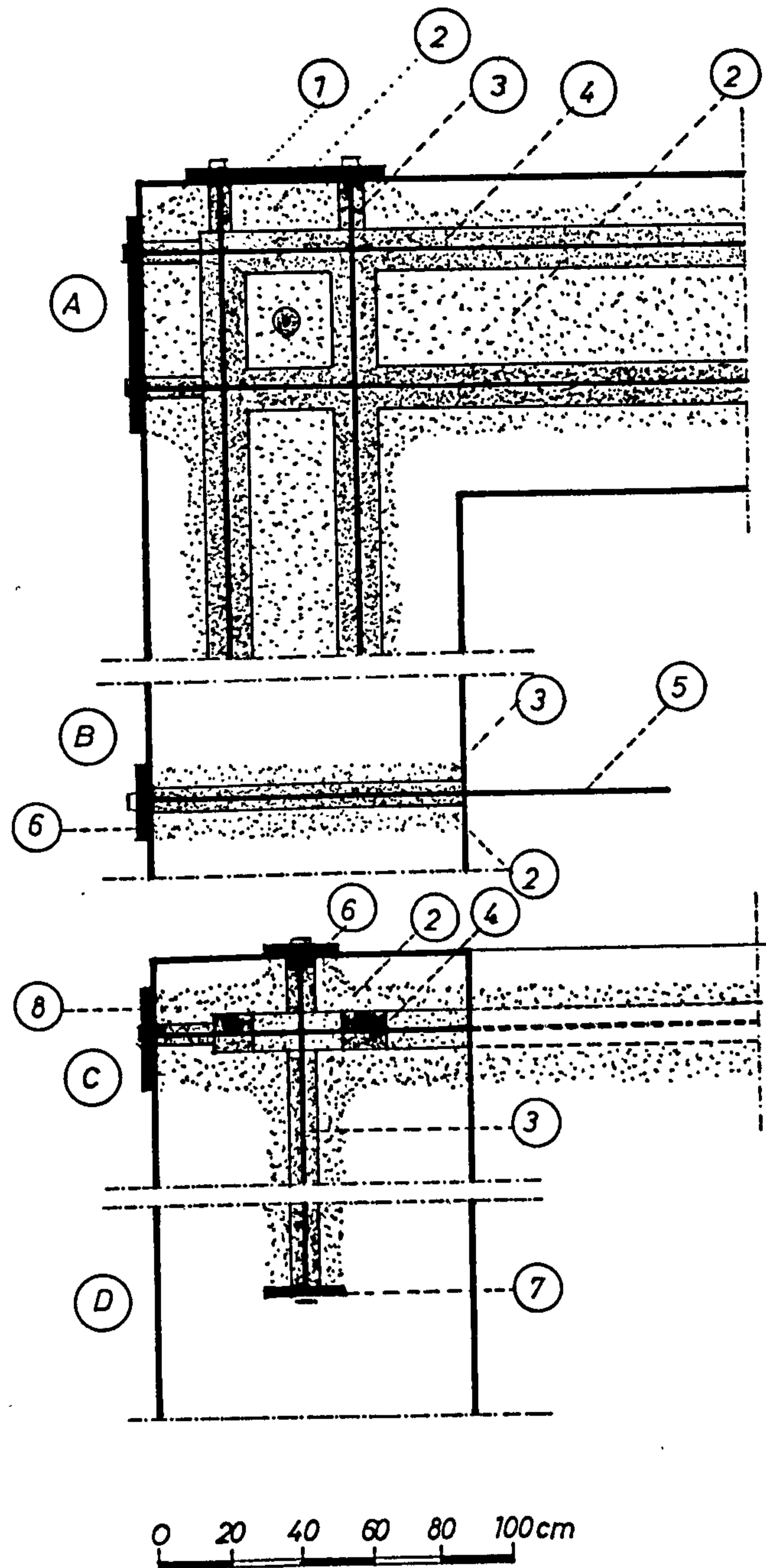

Fig. 6.7 *Details of strengthening*

1. *Steel plate 600 x 300 x 10 mm in which horizontal steel ties are anchored.*
2. *Systematic injection of masonry by which a kind of a "belt course" with somewhat higher mechanical properties than those of the original is formed.*
3. *Filling of new bores with grouting mixture*
4. *Filling of existing empty spaces of formerly existing horizontal timber belts with a grouting mixture.*
5. *Steel tie \varnothing 18 mm, horizontal steel tie connecting the perimetric walls in N-S and W-E direction.*
6. *Steel plate 150 x 150 x 10 mm in which vertical ties are anchored.*
7. *Steel plate 200 x 200 x 10 mm in incorporated into the wall mass, for anchorage of the lower end of the vertical tie.*
8. *Steel plate 300 x 200 x 10 mm in which horizontal steel ties connecting the perimetric walls in N-S and W-E direction are anchored.*

Note:

The same details are used in strengthening of the tambour and dome elements

CHAPTER SEVEN

CONCLUSIONS AND RECOMMENDATIONS

7.1. Conclusions

The results from the theoretical and experimental investigations carried out within the framework of this dissertation completely satisfy the theses set in Chapter one - that it is possible to make certain structures (in this case, Byzantine structures dating from the period of the ninth till the fourteenth centuries) - capable of sustaining future movements of the earth's crust.

The earthquakes that were the main reason for the writing of this dissertation, will occur also in the future, with the same or similar intensity, and the structures treated by applying the new methods, will be able to survive these and exist further as evidence of the sound~~s~~ and quality of the construction genius of the past.

The experimentally obtained results (test^{ed} on materials and structural elements are considered to be an important contribution, particularly the construction of the model of the church of St. Nikita in the designed scale of 1 : 2.75. This is thought to be a unique case in the domain of protection and conservation of architectural heritage, particularly in the domain of Byzantine churches in general should be considered as an important contribution.

Also, the materials used are the products and achievements of the present development of technology of construction materials, and their application thoroughly satisfies the requirements for complete interaction with the existing ones that are incorporated in the structures.

The results obtained thoroughly justify and confirm the appropriateness of the methodological approach, applied.

With the use of the new, originally designed methods, the following goals are achieved:

- The envisaged interventions and strengthening are minimal and economically justified, and are in accordance with decision to maximum respect of the original historic, aesthetic, architectonic and structural values to the greatest degree;
- Complete justification of the rehabilitation of the original 'idea' for structural strengthening, i.e., application of horizontal "bonding timber" courses, and use of traditional materials and technologies;

- The newly designed lime admixtures 'co - operate' well with the original mortar of the structures;
- Maximum satisfaction of the defined criteria for seismic stability of the structures, with the allowance of certain 'repairable damage.'

As a final conclusion, it may be said that a first step has been made among several successive ones that will lead to implementation of that which has been achieved in practice. The implementation will be relevant not only for the territory of the Republic of Macedonia, but also for the wider region of the Balkans and the Mediterranean where many identical or very similar Byzantine structures exist.

This fact contributes even more to the justification of the theme used for this doctoral thesis.

The steps taken through experiments and research for ~~the~~ and their implementation in practice should be conceived but as a 'little stone' in the permanent process of completing the huge 'mosaic of conservation and restoration of cultural heritage.'

7.2. Recommendations

This last section is the recommendations for further activities defined as possible and necessary. The realisation of these activities, in the shortest period possible, would contribute to the realisation of realistic assumptions that the Byzantine churches of Macedonia would, first of all, acquire scientifically verified qualities that would enable them to sustain more adequately and successfully the effect of future earthquakes.

The realisation of the recommendations will mean a qualitative contribution to preventive activities to be realised by society, the owners and the other involved in ^{their} for better and more sustainable protection of the cultural heritage located in Macedonia.

Their accomplishment would also stimulate their possible application in the neighbouring countries of the region, on structures dating from the same period of time and pertaining to the same style, whereby the objectives for their wider implementation will be fulfilled.

Certain recommendations that refer, in this case, to a certain type of structures, should be accepted as recommendations also for the total remaining *corpus* of heritage structures existing in this territory. By their application, a satisfying level of preventive activities will be achieved, leading to a decrease in the extent of damage induced, first of all, by natural catastrophes.

7.2.1 Recommendations indirectly affecting the Byzantine churches and the entire building heritage in the Republic of Macedonia

- Incorporation of the Eurocode 8 recommendations for treatment of cultural heritage situated in seismically active regions in an amendment to Macedonian law.. This will create the legal basis and also an obligation all the relevant authorities involved in protection of the cultural heritage in the state to treat this heritage adequately, in a scientifically verified way.
- Ratification of the international recommendations regarding treatment of the immovable cultural heritage in seismically active regions and application of their principles.
- A study on the seismic risk, hazard and vulnerability level of the entire *corpus* of architectural heritage in the Republic of Macedonia should be carried out.
- Creation of a data bank on cultural monuments located in seismically active regions that will contribute to fast and adequate contact with relevant authorities for presentation of the present state as well as for short and long - term planning of activities, prior, during and after the earthquakes;
- A study on the physical state of the construction heritage in the country should be carried out.
- A priority list of activities based on defined states and criteria should be drawn up.
- Programmes for short - term, medium - term and long - term activities for regular professional inspection of the construction heritage and its regular maintenance should be drawn up and implemented.
- A methodology and theoretically and experimentally verified methods of conservation and strengthening of the remaining types of heritage buildings should be developed and applied.

- A short and mid - term programme for education and advanced training of staff for the realisation of the above stated recommended activities at national and regional level should be drawn up and implemented.
- This dissertation should be published.

7.2.2 Recommendations directly affecting the Byzantine churches and the structures from the *corpus* of immovable heritage in the Republic of Macedonia

- Application of the designed and recommended methods of strengthening on Byzantine churches in Macedonia, in the phase of their conservation, but in compliance with a previously elaborated complete study of each structure, according to the defined criteria;
- Application of the defined and verified methods of strengthening and conservation on real structures, to a scale of 1 : 1, i.e., the churches of St. Nikita, v. Banjani, St. Nikola, v. Psaca and St. Bogorodica Zaumska, v. Trpejca. *The church of St. Atanasie, Varos - Prilep (Fig 5.4.Af) is recommended for experiment to a scale of 1 : 1. Namely, its reconstruction (arches, vaults, pendentives, drum and dome - missing parts) is recommended to be done by use of traditional materials and technology and complete application of the verified methods of strengthening;*
- Providing the conditions to encourage use of natural and traditional construction materials (stone, brick, wood, lime mortar), should be safeguarded by preserving the centuries long traditions for their preparation and production;
- The characteristics of the new materials (steel, brick, lime mixtures) used in the realisation of the methods should be improved in respect of mechanical - strength and chemical characteristics, increased interaction with the original materials and increased level of reversibility;
- The application of base isolation methods as a method for safeguarding these structures should be studied, particularly because the dimensions and proportions of Byzantine churches in Macedonia are such that this method may be practical;

- Instrumentation of the structures that are the subject of this investigation. Instruments should be installed for measuring the real behaviour of the structures under earthquake effects. These permanent observations will enable comparison with the theoretically established parameters and their possible correction;
- In accordance with the values, a start should be made on dynamic studies for each structure that will serve as an element of proper planning for taking of adequate precautions.

In the territory of Republic of Macedonia there exist extraordinary sacred structures pertaining to Islamic architecture (14th - 19th century). Since the structural systems and elements of these buildings are the same or very similar to those of the Byzantine churches, it is recommended that a scientific - research project for development of a methodology for their repair and strengthening be elaborated. One more reason for the elaboration of this project is that the results obtained could be applied to Islamic sacred structures that exist throughout the Balkans in great numbers. It is assumed that this project would be carried out with participation of experts from Turkey by which it should acquire a status of a regional project.

7.2.3 Recommendations at a wider regional level

- Organisation of a Regional Workshop on: The possible application of strengthening methods on Byzantine churches located in the Balkans and Mediterranean Region;
- Preparation of a programme for permanent advanced training at regional level (Mediterranean region and Near East) of experts for the protection of cultural heritage in seismic regions with a seat in Skopje and in co - operation with UNESCO and co-ordinated by ICCROM.

It is highly desirable to achieve the step realisation of these recommendations in the shortest possible time since, as Sir Bernard Feilden once said, 'we are living between two earthquake'

ABBREVIATIONS

app.	Appendix
Fig.	Figure
GCI	Getty Conservation Institute, Los Angeles, USA
GEPA	General Emergency Plan of Actions
ICCROM	International Centre for the Study of the Preservation and Restoration of Cultural Property, Rome, Italy.
ICOM	International Council of Museums
ICOMOS	International Council of Monuments and Sites
IDNDR	International Decade for Natural Disaster Reduction
INDOK	Information and Documentation Centre at RZZSK, Skopje, The Republic of Macedonia.
IZIIS	Institute for Earthquake Engineering and Engineering Seismology, The University of 'St. Cyril and Methodius', Skopje, The Republic of Macedonia.
RC	Reinforced concrete
RZZSK	Republic Institute for the Protection of Cultural Monuments, Skopje, The Republics of Macedonia.
v.	village
Volume 1-12 (1991-94)	"Study for seismic strengthening, conservation and restoration of churches from the Byzantine period (9th - 14th centuries) in Macedonia". Unpublished report. Gavrilovic / Sumanov, principal investigators. Skopje: RZZSK, IZIIS, GCI.
UNESCO	United Nations Educational, Scientific and Cultural Organisation
UNDP	United Nation Development Programme

**PAGE
MISSING
IN
ORIGINAL**

REFERENCES & BIBLIOGRAPHYCHAPTER ONE

- Barakat, S. (1993) 'Reviving war - damaged settlements: Towards an International charter for reconstruction after war', unpublished DPhil thesis, York: the University of York.
- Eurocode 8 (1996) *Design provisions for earthquake resistance of structures - Part 1-4: General rules - Strengthening and repair of buildings (Draft)*, Brussels: European Committee for Standardisation.
- Feilden, B. (1987) *Between two earthquakes: Cultural Property in Seismic Zones*, Rome: ICCROM, and Los Angeles: GCI.
- Pichard, P. (1984) *Emergency measures and damage assessment after an earthquake*, UNESCO - Studies and documents on the cultural heritage - 6 (CLT/84/WS/14).
- Pichard, P. (1984) *Emergency measures and damage assessment after an earthquake*, UNESCO - Studies and documents on the cultural heritage - 6 (CLT/84/WS/14)
- Skopje (1985) 'Recommendations - Skopje, Yugoslavia 1985', adopted at the International course on preventive measures for the protection of cultural property in earthquake - prone regions, Skopje 25 June - 5 July 1995.
- Skopje (1988) 'Recommendations Skopje '88' in the Proceedings of the 1st International seminar on modern principles in conservation and restoration of urban and rural cultural heritage in seismic prone regions, Skopje: IZIIS and RZZSK, Rome: ICCROM.

CHAPTER TWO

- Beckmann, P. (1995) *Structural aspects of building conservation*, London: McGraw - Hill Book Company
- Berkley, J. (1984) 'Cultural Heritage in Peril from Natural Disasters' ed. Jones. Washington DC: Architectural Research Centers Consortium.
- Bowman, I. (1985) 'Conservation in seismic prone regions', unpublished M.A. thesis, University of York
- Coburn, A. and Spence, R. (1992) *Earthquake protection*, Chichester: John Wiley.
- Key, D. (1995) 'Structures to withstand disasters, ed., London: Thomas Telford, London
- Milutinovic, Z. (1985) 'Nature of the earthquake and earthquakes intensity', paper in *Proceedings of the 1st International seminar on modern principles in conservation and restoration of urban and rural cultural heritage in seismic - prone regions*, Skopje, IZIIS; RZZSK; Rome: ICCROM.
- Sumanov, L. (1990) 'A possible outline for both to increase the strengthening and to keep the value of cultural property' in *La protection du bati ancien dans les zones a risque sismique*, Ravello: PACT 28, P. de Maisonneuve, F. Ferigny, Br. Helly (eds) (Journal of the European Study Group on Physical, Chemical, Mathematical and Biological Techniques Applied to Archaeology).

- Sumanov, L. (1988) 'Draft - thesis for the model for preventive seismic protection of the World cultural - historic heritage of Ohrid and Ohrid region', paper in *Proceedings of the 1st International seminar on modern principles in conservation and restoration of urban and rural cultural heritage in seismic - prone regions*, Skopje, IZIIS; RZZSK; Rome: ICCROM.
- Volume 1-12 (1991-94) 'Study for aseismic strengthening, conservation and restoration of churches dating from the Byzantine period (9th - 14th century) in Macedonia', Gavriloviic, P. Sumanov, L. - principal investigators, unpublished report, Skopje: RZZSK, IZIIS and GCI.
- UNIDO / UNDP (1984) '*Repair and strengthening of historical monuments and buildings in urban nuclei*', in 'Building construction under seismic conditions in the Balkan region', Volume 6, Vienna: UNDP / UNIDO Project RER /79/ 015.

CHAPTER THREE

- Aleksova, B. (1989) '*Episcopi on Bregalnica - the first Slav religious and cultural center in Macedonia*', Prilep, Institute for Research of Old Slav Culture.
- Antoljak, S. (1969) 'Primitive Society, Establishment and Development of the Ancient Macedonian State' (in Macedonian), paper published in '*History of the Macedonian People*', Volume 1, Skopje: Institute of National History.
- Causidis, N. (1995) 'Prehistory', in '*MACEDONIA cultural heritage*', Skopje: Mislа.
- Garasanin, M. (1982) '*Praistorija*' (in Serbian), Beograd, Zagreb: Edition Umetnost na tlu Jugoslavije.
- Lazarevski, A. (1971) 'Le climat da la Macedoine. Les precipitation dans la R. Macedoine', (original in Macedonian language), in *Revue geographique*, Volume 8 - 9, Skopje: Societe de geographie da la R.S. Macedoine.
- Lilcic, V. (1995) 'Antiquity' in '*MACEDONIA cultural heritage*', Skopje: Mislа.
- Serafimova, A. (1995) 'The middle age' in '*MACEDONIA cultural heritage*', Skopje: Mislа.
- Taskovski, D. (1970) '*Samuel's Kingdom*', (in Macedonian - Самуиловото Царство) Skopje: Наша книга.
- Todorovski, G. (1995) 'Macedonia - eternal and undeniable' in '*MACEDONIA cultural heritage*', Skopje: Mislа.

CHAPTER FOUR

- Boskovic, G. (1961) Tomovski, K. 'Средновековна архитектура во Охрид' (In Macedonian), (The Medieval Architecture in Ohrid), Ohrid: Anthology.
- Beckmann, P. (1982) 'Report on earthquake damage to buildings in Kotor, Montenegro, and Recommendations for remedial works', paper in un published report *Technical Mission during 1981 and 1982 - Kotor, SR Montenegro, Yugoslavia - UNESCO Contract BOC Ref. 652179*, Rome: ICCROM.

- Djurovski, V and Popovski, G. (1988) 'Solution for renewal - structural system reinforcement of the Monastery St. Bogorodica at the village Matejce' in *Proceedings of the 1st International seminar on modern principles in conservation and restoration of urban and rural cultural heritage in seismic - prone regions*, Skopje: IZIIS;RZZSK; Rome: ICCROM.
- Feilden, B. (1982) 'Principles of Structural Intervention to Historic Buildings in Earthquake Zones', paper in unpublished report *Technical Mission during 1981 and 1982 - Kotor, SR Montenegro, Yugoslavia - UNESCO Contract BOC Ref. 652179*, Rome: ICCROM.
- Mano Zisi, Gj.(1931) 'Crkve u okolini Ohrida', (In Serbian), (Churches in the Ohrid surroundings), Volume 6, Belgrade: Starinar.
- Mesesnel, F. (1930) 'Живопис цркве Св. Никите у Скопској Црној Гори', (In Serbian) (Fresco paintings of the Church St. Nikita on Skopska Crna Gora), Skopje: Bulletin of the Faculty of Philosophy.
- Nikolovski, A. (1961) 'Spomenicite na kulturata vo SR Makedonija', (In Macedonian) Skopje: RZZSK.
- Penelis, G. (1986)
Stylianidis, K.A.
Karaveziroglou, M.
Leontaridis, D. 'Restoration of Byzantine and post - Byzantine monuments', in the Proceedings of International Symposium (11 - 13 December 1985), Thessaloniki: 9th Ephorate of Byzantine Antiquities.
- Popovic, P.J. (1923) 'Prilog za studiju stare srpske crkvene arhitekture' ('A Study on the Old Serbian Church Architecture'), (In Serbian), Belgrade: Starinar I.
- Radojic, G. (1954) 'Ko je podигао манастир Заум', (In Serbian) (Who was the Founder of the Monastery Zaum), Belgrade: Historical Review.
- Stylla, V. (1988) 'Intervention in restoration of the cultural monuments damaged by earthquakes' in *Proceedings of the 1st International seminar on modern principles in conservation and restoration of urban and rural cultural heritage in seismic - prone regions*, Skopje: IZIIS;RZZSK; Rome: ICCROM.
- Theoharidou, T. (1980) 'Byzantine vaulted churches', unpublished M.A. thesis, York: The University of York.
- Vogiatzis, S. (1990)
Floros, K. 'Conservation of the church of the Holy Apostles in Kalamata' in the Proceedings of International Technical Conference (31 October - 3 November 1989 Athens, Greece), Rome: ICCROM.
- Zlokovic, M. (1925) 'Stare crkve u oblastima Prespe i Ohrida' ('Old churches in Prespa and Ohrid', (In Serbian), Volume 3, Belgrade: Starinar I.
- CHAPTER FIVE**
- Bardjieva, D. (1991) 'Historic - artistic characteristics of St. Nikita, v. Banjani', in Volume 2, Existing state of representative selected monuments, Skopje: IZIIS, RZZSK, GCI.
- Clough, W.R.,
Pezien, J., (1975) 'Dynamics of structures', Mc Graw Hill Inc.

- Hadjievski, D. (1976) *'Seismicity of the territory of Macedonia'*, Skopje: The University of St. Cyril and Methodius. (in Macedonian).
- Gavrilovic, P
Sumanov, L.
(1992) *'Study for repair and strengthening of St. Nikita church on the base of the existing state, experimental field works and shaking table test'*, Volume 10, unpublished report. Skopje: IZIIS, RZZSK, GCI.
- Jurukovski, D. (1978) *'Research in the field of seismic design of masonry structures'*, (version in Macedonian and English), Annual report, IZIIS 78-62.
- Krstevska, L. (1992)
Taskov, Lj. *'Ambient vibration testing of selected structures'*, Volume 8, unpublished report, Skopje; IZIIS, RZZSK, GCI.
- Maroevic, I. (1988) *'Material structure and authenticity of the architectural heritage in view of possible interventions for seismic protection'* in *Proceedings of the 1st International seminar on modern principles in conservation and restoration of urban and rural cultural heritage in seismic - prone regions*, Skopje: IZIIS; RZZSK; Rome: ICCROM.
- Nikolic, J. (1991) *'Historic - artistic characteristics of St. Nikola, v. Psaca'*, in Volume 2, Existing state of representative selected monuments, Skopje: IZIIS, RZZSK, GCI.
- Shebalin, N.V. (1974)
Karnik, v.
Hadjievski, D. *'Catalogue of Earthquakes'*, Skopje: UNDP / UNESCO, Edition 'Survey of the Balkan Region'.
- Skoko, D.,
Hadzievski, D.,
Jordanovski., (1989), *'Catalogue of Isoseismal Maps of Earthquakes that Occurred in Yugoslavia in the period 1971-1985 (M>4)'*, (in Serbocroatian), paper presented at the II Meeting of Task Group 1 of the Co-ordinating Committee for Earthquake Risk Reduction in the Balkan Region, Tirana, Albania.
- Skoko, D. Arsovski, M.
Hadzievski, D. (1976) *'Determination of Possible Earthquake Origin Zones on the Territory of Yugoslavia'* (1976), paper in UNDP/UNESCO Survey of the Seismicity of the Balkan Region, Vol. 1, UNESCO, Skopje.
- Stojkovic, (1992)
Milutinovic, Z.
Aleksovski, D. *'Determination of seismic hazard parameters for the sites of the selected monuments, Volume 7, unpublished report, Skopje: IZIIS, RZZSK, GCI.*
- Stojkovic, M. (1986) *'Estimation of Attenuation Functions and Effective Ground Accelerations of Strong Earthquakes of the Basis of Macroseismic Field Functions'*, paper presented at the VIII European Conference on Earthquake Engineering, Lisbon, Portugal.
- Stojkovic, M., (1987) *'Engineering Seismology'*, (in Macedonian), Unpublished lecture for Post-Graduate Studies in Earthquake Engineering and Earthquake Seismology at IZIIS, University 'St. Cyril and Methodius', Skopje.
- Trajkovska, V. (1994)
Sumanov, L.
Staniseva, T.
Danilov, D. Study of lime mortars and lime based mixtures for repair, grouting and injection of churches dating from the Byzantine period in Macedonia', Volume 11 unpublished report. Skopje: IZIIS, RZZSK, GCI.

APPENDIX A) - LIST OF FIGURES**CHAPTER ONE**

Figure 1.1 ***World earthquake zones, historic cities and monuments***
Source: Pichard (1984: 35)

CHAPTER TWO

Figure 2.1 ***The Earth's plates***
Source: Bowman, I. (1985:39)

Figure 2.2 ***Earthquake transmission***
Source: Key (1988 and 1995: 8)

Figure 2.3 ***Risk is a product of hazard and vulnerability: typical curve shape***
Source: Coburn et al. (1992: 258)

Figure 2.4 ***A typical strong motion earthquake record***
Source: Coburn et al. (1992: 219)

Figure 2.5 ***Typical response spectra and the building types they affect***
Source: Coburn et al. (1992: 222)

Figure 2.6 ***Damage pattern***
Source: Volume 1 (1992)

Figure 2.7 ***Plan of typical Byzantine church (St. Stefan, v. Konce - 14th century)***

Figure 2.8 ***Typical damage of Byzantine church, dome and vaults***
(St. Nikita, v. Banjani - 14th century)

Figure 2.9 ***Damage of Baths of Trajan, Rome***
Source: UNDP / UNIDO (1984: 45)

Figure 2.10 ***Damage of western dome and pendentives (St. Irene, Istanbul)***
Source: UNDP / UNIDO (1984: 45)

Figure 2.11 ***Typical damage of perimetral walls and vaults***
Source: Budva - Petrovac seminar (1982)

Figure 2.12 ***Typical damage of out - of - plane walls***
Source: Budva - Petrovac seminar (1982)

CHAPTER THREE

Figure 3.1 ***The Republic of Macedonia***

Figure 3.2 ***Climate map of the Republic of Macedonia***
Source: According the text of Lazarevski, A. 1971

Figure 3.3 ***Map of Ancient Macedonia***
Source: Archive of the Republic of Macedonia

- Figure 3.4** *St. Sophia, Ohrid. Wall conservation*
Source: Cipan, B. 1952
- Figure 3.5** *Stobi, Map of the Site*
Source: Stobi documentation centre
- Figure 3.6** *Classification*
- Figure 3.7** *Mustafa Pasha Mosque, Skopje. Plan.*
Source: Archive of Macedonia
- Figure 3.8** *Mustafa Pasha Mosque, Skopje*
Cross - section
Source: Archive of Macedonia
- Figure 3.9** *Isa Bey Mosque, Skopje*
Source: Archive of Macedonia
- Figure 3.10** *Turbeh in the yard of Aladja Mosque, Skopje*
- Figure 3.11** *Kale Fortress, Skopje*
- Figure 3.12** *The Aqueduct, near Skopje*
- Figure 3.13** *Gorenicki Bridge, River Radika near Debar*
Source: INDOK Centre, RZZSK
- Figure 3.14** *Bezisten, Covered Market, Stip*
- Figure 3.15** *Clock Tower, Skopje*
- Figure 3.16** *Theodosius Palace, Stobi*
- Figure 3.17** *House in Ohrid*
- Figure 3.18** *Robev's House, Ohrid*
- Figure 3.19** *Martinovski House, Krusevo*
- Figure 3.20** *Street in Veles Town*
- Figure 3.21** *Adobe House in Cucer village near Skopje*
- Figure 3.22** *Rural House, Krkornica village*
- Figure 3.23** *St. Joakim Osogovski Monastery - Inn, near Kriva Palanka*
a) South facade; b) Second floor
- Figure 3.24** *St. Jovan Bigorski Monastery - Inn, Rostusa village*
- Figure 3.25** *Kursumli An - Caravan Saraj, Skopje*
a) Ground Floor; b) South facade
Source: Archive of Macedonia

- Figure 3.26** *Rural house in Djepiste village, Debar*
- Figure 3.27** *St. Elena and Konstantine, Ohrid*
- Figure 3.28** *Rural house in Zeleznec village, Demir Hisar region*
- Figure 3.29** *St. Jovan Kaneo, Ohrid*
- Figure 3.30** *St. Georgi, Gorni Kozjak village near Stip. Tribelium*
Source: INDOK Centre, RZZSK-Skopje
- Figure 3.31** *St. Nikola, v. Manastirec, Prilep region - Piers*
Source: INDOK Centre, RZZSK-Skopje
- Figure 3.32** *Inn, St. Joakim Osogovski Monastery - Wooden post*
- Figure 3.33** *Inn, St. Joakim Osogovski Monastery - Timber frame structure*
- Figure 3.34** *Rural store for straw - Zeleznec village, Demir Hisar*
- Figure 3.35** *Rural house - Gari village, Rostusa*
- Figure 3.36** *Rural house - Galicnik village, Mavrovo*
- Figure 3.37** *Rural house, village Cucer, Skopje*
- Figure 3.38** *Rural house - village Brodec, Mavrovo*
- Figure 3.39** *St. Georgi, Staro Nagoricane village*
- Figure 3.40** *Isa Bey Mosque, Skopje - arches*
Source: INDOK Centre, Skopje Institute
- Figure 3.41** *St. Bogorodica Zaum, Trpejca village, Ohrid - Ties, pier, vaults, pendentive, drum and dome*
Source: INDOK Centre, RZZSK-Skopje
- Figure 3.42** *Isa Bey Mosque, Skopje - Squinches*
Source: INDOK Centre, Skopje Institute
- Figure 3.43** *St. Bogorodica Zaum, Trpejca village, Ohrid. Semidome*
Source: INDOK Centre, RZZSK-Skopje
- Figure 3.44** *St. Clement Mal, Ohrid - Buttresses*
- Figure 3.45** *Reconstructed elevation of the Grand Staircase, Knossos*
Source: Evans, The Palace of Minos, I, fig. 247)
- Figure 3.46** *Basilica, Nicea (Iznik-Turkey), wall between the nave and the southern aisle*
- Figure 3.47** *City wall near the sea, Istanbul*
- Figure 3.48-50** *Fortress walls, Isar -Stip*
- Figure 3.51** *St. Atanasie, Varos-Prilep, Southern facade*

- Figure 3.52** *St. Atanasie, Varos-Prilep, Interior*
- Figure 3.53** *Dukandjik Mosque, Skopje*
- Figure 3.54** *Turkish bath, near the Kursumli Caravanserai, Skopje*
- Figure 3.55** *Rural dwelling, Maloviste village, Bitola Region*
- Figure 3.56** *Rural dwelling, Kicinica village, Mavrovo region*
- Figure 3.57** *Rural dwelling, Gornjani village, Skopje region*
- Figure 3.58** *Rural dwelling, Cucer village, Skopje region*
- Figure 3.59** *Rural dwelling, Konjari village, Debar region*
- Figure 3.60** *Dwelling, Struga*
- Figure 3.61** *Rural dwelling, Djepiste village, Debar region*
- Figure 3.62** *Rural dwelling, Ljubanci village, Skopje region*
- Figure 3.63** *New dwelling building 1996, Skopje*
- Figure 3.64** *Stobi, the Episcopal basilica - around 525*
Source: Hamans, F. / Aleksova, B. 1989
- Figure 3.65** *St. Erasmus, Ohrid. An early Christian basilica.*
Source: INDOK Centre, RZZSK-Skopje
- Figure 3.66** *Basilica, Archaeological site - Bargala, Gorni Kozjak village, Stip region*
Source: INDOK Centre, RZZSK-Skopje
- Figure 3.67** *Cathedral church, Krupiste village, Stip region*
Source: Aleksova, B. (1989: 277)
- Figure 3.68** *St. Clement, Ohrid. 9th-10th century*
Source: INDOK centre, Ohrid Institute
- Figure 3.69** *St. Naum, Ljubanista village, Ohrid Lake*
Source: INDOK centre, Ohrid Institute
- Figure 3.70** *St. Georgi, Staro Nagoricane village, Western facade*
- Figure 3.71** *The face of St. Simeon the receiver of God, Fresco-St. Panteleimon*
Gorno Nerezi village
Source: INDOK centre, RZZSK - Skopje
- Figure 3.72** *The lamentation of the Christ. St. Panteleimon, Gorno Nerezi village, Skopje*
region
Source: INDOK centre, Skopje Institute
- Figure 3.73** *Fresco. Western wall . St. Georgi, Staro Nagoricane village*

- Figure 3.74** *Iconostasis. St. Panteleimon, Gorno Nerezi village, Skopje region*
Source: INDOK centre, Skopje Institute
- Figure 3.75** *Iconostasis. St. Naum 1711, Ljubanista village, Ohrid Lake*
Source: INDOK centre. RZZSK - Skopje
- Figure 3.76** *Portrait of the wood-carvers. Iconostasis. St. Jovan Bigorski Monastery church. Rostusa village*
Source: INDOK centre. RZZSK - Skopje
- Figure 3.77** *Icon of St. Matthew the Evangelist. Ohrid icon gallery. (1295)*
Source: INDOK centre. RZZSK - Skopje
- Figure 3.78** *Icon of Christ the Saviour and Giver of Life. (1394) St. Spas, Zrze village Prilep region*
Source: INDOK centre. RZZSK-Skopje
- Figure 3.79** *Mosaics at the baptistery. The Episcopal basilica - Stobi*
Source: INDOK centre. RZZSK - Skopje
- Figure 3.80** *Mosaics at large basilica. Heraclea Lyncestis, Bitola*
Source: INDOK centre. RZZSK - Skopje

CHAPTER FOUR

- Figure 4.1** *Churches as basilica with or without a cupola and transept*
a) St. Nikola, Manastir village
b) St. Sophia, Ohrid
c) St. Bogorodica, Drenovo village
d) St. Georgi, Staro Nagoricane village
- Figure 4.2** *Churches of triconchal and tetraconchal conceptual solutions*
a) St. Naum (St. Archangel Mihail) Ljubaniste village
b) St. Panteleimon, Ohrid
c) St. Andrea, Matka village
d) St. Bogorodica Eleusa, Veljusa village
- Figure 4.3A** *Churches as single or five dome cross - in - square structures*
a) St. Nikita, Banjani village
b) St. Jovan Kaneo, Ohrid
c) St. Bogorodica Zaum, Trpejca village
d) St. Stefan, Konce village
e) St. Archangel Mihail, Stip
f) St. Atanasie, Varos - Prilep
g) St. Nikola, Ljuboten village
h) St. Dimitrija, Varos - Prilep.

- Figure 4.3B** *Churches as single or five dome cross-in-square structures*
- a) *St. Bogorodica Perivlepta, Ohrid*
 - b) *St. Archangel Mihail, Lesново village*
 - c) *St. Spas, Kuceviste village*
 - d) *St. Dimitrija, Susica village*
 - e) *St. Atanasie, Lesok village*
 - f) *St. Bogorodica, Gorno Varoviste village*
 - g) *St. Bogorodica, Matejce village*
 - h) *St. Panteleimon, Gorno Nerezi village*
- Figure 4.4** *Churches as single nave building*
- a) *St. Dimitrija, Ohrid*
 - b) *St. Kliment Mal, Ohrid*
 - c) *St. Nikola Bolnicki, Ohrid*
 - d) *St. Nikola, Varos-Prilep*
 - e) *St. Georgi, Kurbinovo village*
 - f) *St. Bogorodica Bolnicka, Ohrid*
 - g) *St. Elena and Konstantin, Ohrid*
 - h) *St. Georgi Poloski, Begniste village*
- Figure 4.5** *Church complex of St. Leontie, Vodoca village*
- Figure 4.6** *St. Bogorodica Perivlepta, Ohrid. South facade*
- Figure 4.7** *St. Sophia, Ohrid. Western facade of the exonarthex*
- Figure 4.8** *St. Panteleimon, Gorno Nerezi village. Southern facade*
- Figure 4.9** *St. Georgi, Gorni Kozjak village. Southern facade*
- Figure 4.10** *St. Leontie, Vodoca village. Detail of vaults, pendentives and dome*
- Figure 4.11** *St. Leontie, Vodoca village. Detail of apse semi-dome structure*
Source: Indok centre - RZZSK
- Figure 4.12** *St. Sophia, Ohrid. Eastern facade - monophoria*
- Figure 4.13** *St. Jovan Kaneo, Ohrid. Eastern facade - biphora*
- Figure 4.14** *St. Georgi, Staro Nagoricane village. Northern facade - trephora*
- Figure 4.15** *Pieta. Fresco painting. St. Panteleimon 1164, Gorno Nerezi village*
- Figure 4.16** *Angel. Fresco painting. St. Georgi 1191, Kurbinovo village*
- Figure 4.17** *Dormition. Fresco painting. St. Bogorodica Perivlepta 1295, Ohrid*
- Figure 4.18** *The communion of the Apostles. Fresco painting.*
St. Georgi, Staro Nagoricane village
- Figure 4.19** *The Holy Virgin. Icon. (1108-1120) Ohrid Icon Gallery*
Source: Icon gallery - Ohrid

- Figure 4.20** *St. Matthew. Icon, 1295. Ohrid Icon Gallery*
Source: Icon gallery - Ohrid
- Figure 4.21** *St. Bogorodica Eleusa, v. Veljusa*
- Figure 4.22** *St. Nikita, Banjani village. Eastern and Northern facades*
- Figure 4.23** *St. Stefan, Konce village. Northern facade*
- Figure 4.24** *St. Archangel Michail, Stip. Southern and Eastern facades*
- Figure 4.25** *St. Bogorodica Zaum, Trpejca village. Detail of the facade opus*
- Figure 4.26** *St. Dimitrija, Varos. Eastern facade*
- Figure 4.27** *St. Leontie, Vodoca village. Eastern facade*
- Figure 4.28** *St. Nikola, Psaca village. Eastern facade*
- Figure 4.29** *St. Georgi, Staro Nagoricane village. Southern facade*
- Figure 4.30** *St. Archangel Mihail, Lesново village. Western facade*
- Figure 4.31** *St. Archangel Mihail, Lesново village. Central dome*
- Figure 4.32** *St. Andrea, Matka village. Southern and Eastern facades*
- Figure 4.33** *St. Andrea, Matka village. Detail - central dome*
- Figure 4.34** *St. Dimitrija, Susica village. Eastern facade*
- Figure 4.35** *St. Dimitrija, Susica village. Detail of the drum*
- Figure 4.36** *St. Bogorodica, Osogovski Monastery*
- Figure 4.37** *St. Bogorodica Perivlepta, Ohrid. Eastern facade*
- Figure 4.38** *St. Dimitrija, Varos. Northern facade*
- Figure 4.39** *St. Bogorodica Zaum, Trpejca village. Southern facade*
- Figure 4.40** *St. Bogorodica Zaum, Trpejca village. Northern facade*
- Figure 4.41** *St. Georgi Poloski. Southern and Eastern facades*
- Figure 4.42** *St. Georgi Poloski. Eastern facade*
- Figure 4.43** *St. Nikola, Varos. Western facade*
- Figure 4.44** *St. Dimitrija, Susica village. Blind niches - Eastern facade*
- Figure 4.45** *St. Spas, Kuceviste village. Blind niches on Eastern facade*
- Figure 4.46** *St. Bogorodica, Matejce village. Eastern facade*
- Figure 4.47** *St. Jovan Kaneo, Ohrid. Detail of drum*

- Figure 4.48** *St. Archangel Mihail, Stip. Northern facade*
- Figure 4.49** *St. Archangel Mihail, Stip. Northern facade*
- Figure 4.50** *St. Bogorodica, Matejce village. Southern facade*
- Figure 4.51** *St. Sophia, Ohrid. Intervention on South wall*
- Figure 4.52** *St. Sophia, Ohrid. Intervention on South wall.*
- Figure 4.53** *St. Bogorodica, Drenovo village. Eastern facade - before repair and strengthening*
- Figure 4.54** *St. Bogorodica., Drenovo village. After partial intervention*
Source: Indok centre - RZZSK
- Figure 4.55** *St. Bogorodica Eleusa, Veljusa village*
- Figure 4.56** *St. Bogorodica Treskavec, Dabniste village*
- Figure 4.57** *St. Jovan Kaneo, Ohrid. Before the restoration*
Source: Indok centre - RZZSK
- Figure 4.58** *St. Nikola, Psaca village. Before restoration*
- Figure 4.59** *St. Nikola, Psaca village. After restoration*
- Figure 4.60** *St. Stefan, Konce village. Before restoration and reconstruction*
- Figure 4.61** *St. Stefan, Konce village. After restoration and reconstruction*
- Figure 4.62** *St. Panteleimon, Gorno Nerezi village. Before restoration*
- Figure 4.63** *St. Panteleimon, Gorno Nerezi village. After restoration*
- Figure 4.64** *St. Nikita, Banjani village. Before restoration*
- Figure 4.65** *St. Nikita, Banjani village. After restoration*
- Figure 4.66** *St. Leontie, Vodoca village. North facade - before reconstruction*
Source: Indok centre - RZZSK
- Figure 4.67** *St. Leontie, Vodoca village. North facade - after reconstruction*
- Figure 4.68** *St. Leontie, Vodoca village. East facade - before reconstruction*
- Figure 4.69** *St. Leontie, v. Vodoca. East facade - after reconstruction*
- Figure 4.70** *St. Bogorodica, Matejce village. Western and Southern facades - before reconstruction*
Source: Indok centre - RZZSK
- Figure 4.71** *St. Bogorodica, Matejce village. Western and Southern facade - after reconstruction*

- Figure 4.72** *St. Spas, Stip*
- Figure 4.73** *St. Nikola, Sisevo village*
- Figure 4.74** *a) St. Georgi, Staro Nagoricane village; b) St. Bogorodica Ljeviska, Prizren (Serbia)*
- Figure 4.75** *a) St. Bogorodica, Drenovo village; b) St. Bogorodica (Nicea - Iznik), Turkey; c) St. Mary Deaconess (Kalender Mosque), Istanbul; d) St. Sophia, Thessaloiniki; e) Church in Recafa, Syria*
- Figure 4.76** *a) Church in Kulata, Petricko region, Bulgaria; b) Kalenic (Serbia); c) Kozia, Romania*
- Figure 4.77** *a) St. Panteleimon, Gorno Nerezi village; b) Sulidje Mosque, Thessaloniki*
- Figure 4.78** *a) Incorporation of horizontal and vertical reinforced concrete belts by cutting existing wall from the facade
b) Same by cutting the wall from inside.
Source: Nicota 1983*
- Figure 4.79** *Reinforcement of foundation
Source: Nicota 1983*
- Figure 7.80** *a) Reinforcement of drum base element by insertion of reinforced concrete belt
b) Reinforcement of the cupola by insertion of circular reinforced concrete belt
Source: Nicota 1983*
- Figure 4.81** *St. Bogorodica, Matejce village. New reinforcement concrete belts, vaults and dome
Source: Djurovski et. al 1988:351*
- Figure 4.82** *Ducal Palace, Dubrovnik. New reinforced concrete floor structure
Source: Exhibition in Skopje by Dubrovnik Institute 1988*
- Figure 4.83** *Ducal Palace, Dubrovnik. New reinforced concrete columns
Source: Exhibition in Skopje by Dubrovnik Institute 1998*
- Figure 4.84** *Ducal Palace, Dubrovnik. Reinforcement of original stone masonry with reinforced concrete layer
Source: Exhibition in Skopje by Dubrovnik Institute 1998*
- Figure 4.85** *St. Christ, Mborje village near Korca, Albania. Preventive measures after earthquake
Source: Stylla 1988: 150*
- Figure 4.86** *St. Christ, Mborje village near Korca, Albania. After restoration*
- Figure 4.87** *St. Christ, Mborje village near Korca, Albania. North facade after restoration*
- Figure 4.88** *St. Panteleimon, Thessaloniki. Damage pattern of the vaults.
Source: Theoharidou 1980*
- Figure 4.89** *Rotunda, Thessaloniki. Cracking of the dome base from the Southwest.
Source: Penelis et.al. - 1986: 39*

- Figure 4.90** *The church of the Holy Apostles, Kalamata-Greece. Damage pattern.*
Source: Vogiatzis et. al. 1990: 485
- Figure 4.91** *Rotunda, Thessaloniki. Temporary supporting of damaged structure.*
Source: Penelis et. al. 1985
- Figure 4.92** *St. Panteleimon, Thessaloniki. Temporary supporting of Northern wall.*
- Figure 4.93** *Holy Apostles, Kalamata. Grouting of the drum wall of the Byzantine part of the church.*
Source: Vogiatzis et.al. 1990: 493
- Figure 4.94** *Rotunda, Thessaloniki. Permanent prestressed tie rings.*
Source: Penelis et.al. 1985
- Figure 4.95** *Holy Apostles, Kalmata. Newer part - reconstruction of the dome. Reinforced concrete beam on pendentives.*
Source: Vogiatzis et.al. 1990: 492
- Figure 4.96** *Christ Saviour's Chapel, Thessaloniki.*
Source: Theoharidou 1980
- Figure 4.97** *Christ Saviour's Chapel, Thessaloniki. Proposal A (Reinforced concrete frame) and B (Reinforced concrete ring - beam with vertical steel rods).*
Source: Theoharidou 1980
- Figure 4.98** *Christ Saviour's Chapel, Thessaloniki. Proposal C (Consolidation of the main arch).*
Source: Theoharidou 1980
- Figure 4.99** *Christ Saviour's Chapel, Thessaloniki.*
Source: Theoharidou 1980

CHAPTER FIVE

- Figure 5.1** a) - St. Nikita, Banjani village; b) - St. Bogorodica, Matejce village;
c) - St. Bogorodica Zaumska, Trpejca village; d) - St. Nikola, Psaca village
- Figure 5.2** a) - St. Nikita, Banjani village; b) - St. Bogorodica, Matejce village
- Figure 5.2** c) St. Bogorodica Zaumska, Trpejca village; d) - St. Nikola, Psaca village
- Figure 5.3** *St. Nikita, Banjani village*
a) cross section; b) Horizontal timber belts
- Figure 5.4** a) Horizontal timber belts and masonry structure;
b) Vertical cross section of church piers.
- Figure 5.5** *Earthquake epicentre map of the Republic of Macedonia*
Source: Volume 7, Stojkovic et.al. 1992

- Figure 5.6** *Earthquake foci map of the Republic of Macedonia*
Source: Stojkovic Volume 7 1992
- Figure 5.7** *Seismological map of the return period - 50 years. The Republic of Macedonia.*
Source: IZZIS Indok Centre
- Figure 5.8** *Seismological map of the return period - 200 years. The Republic of Macedonia.*
Source: IZZIS Indok Centre
- Figure 5.9** *Seismological map of the return period - 500 years. The Republic of Macedonia.*
Source: IZZIS Indok Centre
- Figure 5.10** *Seismological map of the return period - 1,000 years. The Republic of Macedonia.*
Source: IZZIS Indok Centre
- Figure 5.11** *Installation of seismometers.*
a) - St. Bogorodica, Matejce village; b) - St. Nikola, Psaca village;
c) and d) - Equipment.
- Figure 5.12** *St. Nikita, Banjani village*
a) - Position of the seismometers; b) - Fourier diagram.
Source: Volume 7, Stojkovic et al. 1992
- Figure 5.13** *St. Nikita, Banjani village*
Dynamic characteristics
Source: Volume 8, Krstevska et.al. 1992
- Figure 5.14** *St. Bogorodica, Matejce village*
Dynamic characteristics
Source: Volume 8, Krstevska et.al. 1992
- Figure 5.15** *St. Nikola, Psaca village*
Dynamic characteristics
Source: Volume 8, Krstevska et.al. 1992
- Figure 5.16** *St. Bogorodica Zaumska, Trpejca village*
Dynamic characteristics
Source: Volume 8, Krstevska et.al. 1992
- Figure 5.17.** a) , b) and c) - St. Nikita, Banjani village. Mural paintings
d) - St. Georgi, Staro Nagoricane village. Mural paintings
- Figure 5.18** *St. Bogorodica Zaumska, Trpejca village*
a) - Column, pier and timber ties. b). - Marble column with base and capitel
- Figure 5.19** *Proposed strengthening method - Variant A.*
a) - Drum section; b) - Southern facade; c) - Ground plan; d) - Western facade.
- Figure 5.20** *Proposed strengthening method - Variant B*
a) - Drum section; b) - Southern facade; c) - Ground plan; d) - Western facade.

- Figure 5.21** *Proposed strengthening method - Variant C*
a) - Drum section; b) - Southern facade; c) - Ground plan; d) - Western facade.
- Figure 5.22** *St. Nikita, v. Banjani.*
a) - Samples of mortar; b) - Samples of tuff stone; c) - Samples of bricks, prepared for experimental investigation.
- Figure 5.23** *Comparison between the original church and the model.*
- Figure 5.24** *Experimental investigation of wall samples - WAC 1.*
Source: Gavriovic Volume 10, 1992.
- Figure 5.25** *Experimental investigation of wall samples - WAC 2.*
Source: Gavriovic Volume 10, 1992..
- Figure 5.26** *Experimental investigation of wall samples - WSC 3.*
Source: Gavriovic Volume 10, 1992.
- Figure 5.27** *Design of church model.*
a) - Cross section; b) - West facade; c) - South facade; d) - Ground floor; e) - East facade; f) - North facade.
- Figure 5.28** *Building of the church model in the scale 1 : 2.75. Platform and foundation of the model.*
- Figure 5.29** *Building of the model.*
a) and b) - Perimeter walls.
- Figure 5.30** *Building of the model.*
a) - Perimeter walls and piers; b) - Perimeter walls and arches.
- Figure 5.31** *Building of the model.*
a) - Vaults; b) - Vaults and apse semi - dome.
- Figure 5.32** *Building of the model.*
a) - Base of the drum; b) - Drum 'piers'.
- Figure 5.33** *Completed model of the church in scale 1 : 2.75.*
a) - South and East facade; b) - North and West facade.
- Figure 5.34** *Completed model of the church in scale 1 : 2.75.*
a) - Interior. Pier, vaults, timber ties and pendentive (with the author);
b) - Interior. Apse - half plastered and timber tie (with the author)
- Figure 5.35** *Damage pattern of non - strengthened model after the final shaking table test.*
a) and b) - West facade-total; c) - Detail of the Northern wing; d) - Detail of the Southern wing.
- Figure 5.36** *Damage pattern of non - strengthened model after the final shaking table test.*
a) - Interior. Dome; b) - Interior. Western wall of the naos.
- Figure 5.37** *Damage pattern of non - strengthened model after the final shaking table test.*
a) - West facade; b) - East facade; c) - South facade; d) - North facade.

- Figure 5.38.** *Strengthening of damaged church model. Design. Ground floor on different levels.*
- Figure 5.39** *Strengthening of damaged church model. Design. Cross - section.*
- Figure 5.40** *Strengthening of damaged church model. Design. Details of the perimeter walls.
Source: Gavrilovic/Sumanov Volume 10 1992*
- Figure 5.41** *Strengthening of damaged church model. Design. Horizontal steel elements on apse and drum.
Source: Gavrilovic/Sumanov Volume 10 1992*
- Figure 5.42** *Repair of damage a) - wall sample (WAC 1) and b) - damaged model. Prepared for injection.*
- Figure 5.43** *Repair and strengthening of the damaged model. a) - Injection of the horizontal belts; b) - West facade; d) - East facade.*
- Figure 5.44** *Completed repair and strengthening of damaged model. a) - East facade; b) - South and East facade; c) - North and West facade; d) - South and West facade.*
- Figure 5.45** *Damage pattern of strengthened model after the final shaking table test. a) and b) - West facade; c) - Northern wing; d) - Southern wing.*
- Figure 5.46** *Damage pattern of strengthened model after the final shaking table test. a) - Interior. Western wall; b) - Dome and vaults.*
- Figure 5.47** *Damage pattern of strengthened model after the final shaking table test. a) - West facade; b) - East facade; c) - South facade; d) - North facade.*
- Figure 5.48** *Comparison of damage pattern of non - strengthened and strengthened model. a) - West facade, non - strengthened model; b) - West facade, strengthened model; c) - South facade, non - strengthened model; d) - South facade, strengthened model.*
- Figure 5.49** *Comparison between $P - \delta$ diagrams of non - strengthened and strengthened model. (Petrovac $a_{max} = 0.20g$); Source: Gavrilovic Volume 10, 1992..*
- Figure 5.50** *Comparison between $P - \delta$ diagrams of non - strengthened and strengthened model; (El Centro $a_{max} = 0.17g$); Source: Gavrilovic Volume 10, 1992.*
- Figure 5.51** *Comparison of the shear - force relative deformation on two characteristic levels (level 1 and top) of original (EXIST) and strengthened (STR) model for different intensities of El Centro earthquake.*
- Figure 5.52** *Comparison of the shear - force relative deformation on two characteristic levels (level 1 and top) of original (EXIST) and strengthened (STR) model for different intensities of Petrovac earthquake.*

- Figure 5.53** *The relationship between the values of the input acceleration and output displacement on two characteristic levels (level 1 and top) of original (EXIST) and strengthened (STR) model for different intensities of El Centro earthquake.*
- Figure 5.54** *The relationship between the values of the input acceleration and output acceleration on two characteristic levels (level 1 and top) of original (EXIST) and strengthened (STR) model for different intensities of El Centro earthquake.*
- Figure 5.55** *The relationship between the values of the input acceleration and output displacement on two characteristic levels (level 1 and top) of original (EXIST) and strengthened (STR) model for different intensities of Petrovac earthquake.*
- Figure 5.56** *The relationship between the values of the input acceleration and output acceleration on two characteristic levels (level 1 and top) of original (EXIST) and strengthened (STR) model for different intensities of Petrovac earthquake.*
- Figure 5.57** *Histeretic model (description of the behaviour of the church model in phases: elastic (no cracks); nonlinear (occurrence of the cracks) and the range of large deformations.*

CHAPTER SIX

- Fig. 6.1.a** *St. Nikita, Banjani village (Variant A)
Section at timber ties level $H = 4.75$
Source: Gavrilovic/Sumanov Volume 12, 1994*
- Fig. 6.1.b** *St. Nikita, Banjani village (Variant A)
Section at level $H = 6.40m$
Source: Gavrilovic/Sumanov Volume 12, 1994*
- Fig. 6.1.c** *St. Nikita, Banjani village (Variant A)
Section at level $H = 8.70m$
Source: Gavrilovic/Sumanov Volume 12, 1994*
- Fig. 6.1.d** *St. Nikita, Banjani village (Variant A)
Cross section N-S direction
Source: Gavrilovic/Sumanov Volume 12, 1994*
- Fig. 6.1.e** *St. Nikita, Banjani village (Variant A)
Cross section W-E direction
Source: Gavrilovic/Sumanov Volume 12, 1994*
- Fig. 6.2.a** *St. Bogorodica Zaum, Trpejca village (Variant A)
Section at first timber ties level $H = 2.95m$
Source: Gavrilovic/Sumanov Volume 12, 1994*
- Fig. 6.2.b** *St. Bogorodica Zaum, Trpejca village (Variant A)
Section at level $H = 10.0m$
Source: Gavrilovic/Sumanov Volume 12, 1994*
- Fig. 6.2.c** *St. Bogorodica Zaum, Trpejca village (Variant A)
Cross section N-S direction
Source: Gavrilovic/Sumanov Volume 12, 1994*

- Fig. 6.2.d** *St. Bogorodica Zaum, Trpejca village (Variant A)*
Cross section W-E direction
Source: Gavrilovic/Sumanov Volume 12, 1994
- Fig. 6.3.a** *St. Nikola, Psaca village (Variant A)*
Section at timber ties level $H = 2.90m$
Source: Gavrilovic/Sumanov Volume 12, 1994
- Fig. 6.3.b** *St. Nikola, Psaca village (Variant A)*
Section at level $H = 4.15m$
Source: Gavrilovic/Sumanov Volume 12, 1994
- Fig. 6.3.c** *St. Nikola, Psaca village (Variant A)*
Cross section W-E direction
Source: Gavrilovic/Sumanov Volume 12, 1994
- Fig. 6.4.a** *St. Nikita, Banjani village (Variant B)*
Section at timber ties level $H = 4.75m$
- Fig. 6.4.b** *St. Nikita, Banjani village (Variant B)*
Section at level $H = 6.64m$
- Fig. 6.4.c** *St. Nikita, Banjani village (Variant B)*
Section at level $H = 10.25m$
- Fig. 6.4.d** *St. Nikita, Banjani village (Variant B)*
Cross section N-S direction
- Fig. 6.4.e** *St. Nikita, Banjani village (Variant B)*
Cross section W-E direction
- Fig. 6.5.a** *St. Bogorodica Zaum, Trpejca village (Variant B)*
Section at timber ties level $H = 5.28$
- Fig. 6.5.b** *St. Bogorodica Zaum, Trpejca village (Variant B)*
Section at level $H = 7.71 m$
- Fig. 6.5.c** *St. Bogorodica Zaum, Trpejca village (Variant B)*
Section at level $H = 9.78 m$
- Fig. 6.5.d** *St. Bogorodica Zaum, Trpejca village (Variant B)*
Cross section N-S direction
- Fig. 6.5.e** *St. Bogorodica Zaum, Trpejca village (Variant B)*
Cross section W-E direction
- Fig. 6.6.a** *St. Nikola, Psaca village (Variant B)*
a) - Section at timber ties level $H = 5.71 m$
- Fig. 6.6.b** *St. Nikola, Psaca village (Variant B)*
b) - Section at level $H = 6.85 m$
- Fig. 6.6.c** *St. Nikola, Psaca village (Variant B)*
c) - Section at level $H = 8.92 m$

Fig. 6.6.d **St. Nikola, Psaca village (Variant B)**
d) - Cross section W-E direction

Fig. 6.7 **Detail of strengthening**

Legend: (For Figures 6.4a-e; 6.5a-e and 6.6a-d)

Horizontal belts

- 1. 2 Ø 18 mm (in the walls)
- 2. 2 Ø 18 mm (in the walls)
- 2.a 1 Ø 18 mm (ties - connection of perimetral walls in N-S and W-E direction)
- 2.b Stainless steel plate 600x250x30 mm
- 2.c Stainless steel plate 200x150x20 mm
- 2.d 2 Ø 18 mm (horizontal elements in East perimetral wall)
- 2.e 1 Ø 18 mm
- 2.f Stainless steel plate 150x120x10 mm
- 3. 2 Ø 18 mm
- 3.a Stainless steel plate 200x150x15 mm
- 4. 1 Ø 18 mm
- 4.a Stainless steel plate 120x120x10 mm
- 5. 1 Ø 18 mm
- 5.a Stainless steel plate 120x120x10 mm

Vertical belts

- 6. 1 Ø 20 mm (In the perimetral walls)
- 6.a Stainless steel plate 150x150x10 mm
- 7. 1 Ø 18 mm
- 7.a Stainless steel plate 120x120x10 mm

APPENDIX B) - LIST OF TABLES**CHAPTER TWO**

- Table 2.1** **General schedule of 'A possible outline for both to increase the strengthening and to keep the value of cultural property'**
Source: Sumanov (1990: 185)
- Table 2.2** **Converting table for seismic scales of intensity**
Source: Z. Milutinovic, 1985
- Table 2.3** **The Mediterranean's earthquake countries: their loss of life in this century**
Source: Martin Centre Database of destructive earthquakes 1900-1990 (Coburn et al.: 1992)
- Table 2.4** **Economic losses inflicted by major recent earthquakes.**
Source: Martin Centre earthquake database
Note: GNP's and Loss percentage for Montenegro* and Loma Prieta** refer to the whole Yugoslavia and the whole of the USA, respectively.

CHAPTER THREE

- Table 3.1** **Climatic characteristics of Skopje, Prilep and Ohrid regions**
Source: Lazarevski (1971)
- Legend:
1. Region and object
 2. North latitude
 3. East longitude
 4. Altitude
- Air parameters
5. The lowest average monthly temperature
 6. The highest average monthly temperature
 7. Annual air amplitude in C°
 8. Absolute minimum
 9. Absolute maximum
 10. Average duration of frosty periods per year (in days)
 11. Actual number of frosty days (per year)
- Rainfall parameters
12. Minimum average monthly rainfall
 13. Maximum average monthly rainfall
 14. Average annual rainfall
 15. Snow percentage included in the average annual rainfall
- Table 3.2** **Average monthly and yearly air temperature and rainfalls at Skopje, Prilep and Ohrid region. (1931-1960 period)**
- Table 3.3** **Listed and identified monuments in Macedonia**
Source: INDOK Centre at the Republic Institute for the protection of Cultural Monuments (1997)

CHAPTER FIVE

- Table 5.1** *Review of intensities of earthquake effect at the sites of the selected churches in the period 1900-1990*
Source: Stojkovic et al. Volume 7 (1992: 6)
- Table 5.2** *Review of more significant sources and the strongest past earthquakes related to these sources*
Source: Stojkovic et al. Volume 7 (1992: 7)
- Table 5.3** *Selected information about the dynamic physical-mechanical characteristic of the geotechnical media*
Sources: Stojkovic et al. Volume 7 (1992: 17, 19, 21, 23)
- Table 5.4** *Maximum ground accelerations (a_{ce}) and seismic intensities (I) for the St. Nikita church, v. Banjani*
Source: Stojkovic et al. Volume 7 (1992: 55)
- Table 5.5** *Maximum ground acceleration (a_{ce}) and seismic intensities (I) for return period of fifty, two hundred and five hundred years for the selected structures*
Source: Stojkovic et al. Volume 7 (1992: 56-57)
- Table 5.6** *Dynamic characteristics obtained by using ambient vibration techniques for the selected structures*
- Table 5.7** *Ductility ($m = s_{max}/s_y$) for different earthquakes and different input accelerations*
Source: Gavrilovic, Volume 10 (1992: 33)
- Table 5.8** *Physical - chemical characteristics of masonry mortar for building and filling the joints*
Source: Staniseva, Volume 10 (1992:10)
- Table 5.9** *Mechanical characteristics of the built - in materials*
Source: Institute Macedonia, Volume 10 (1992: 13)
- Table 5.10** *Physical quantities in model analysis of problems related to dynamics of structure*
Source: Gavrilovic - Volume 10 (1992)
- Table 5.11** *Mechanical characteristics of the materials used for the construction of the model*
Source: Institute Macedonia - Volume 10 (1992)
- Table 5.12** *Main characteristics of the model and the prototype*
Source: Gavrilovic/Sumanov Volume 10 (1992: 55)
- Table 5.13** *Characteristics of injection grouts emulsions*
Source: Trajkovska, Volume (1992)
- Table 5.14** *Grouts*
Source: Trajkovska Volume 11 (1994: 70)

CHAPTER SIX

Table 6.1 *Earthquake capacity analysis of the representative structures performed for the existing state and the defined strengthened state (Variant A)*

APPENDIX ONE -GLOSSARY OF TERMS

- Accelerometer.*** *A seismograph for measuring ground acceleration as a function of time*
- Aftershocks.*** *Smaller earthquakes following the largest earthquake of a series concentrated in a restricted crust volume.*
- Aisle.*** *Part of a longitudinally - planned building such as a Roman basilica or later church.*
- Amplitude.*** *The maximum height of a wave crest or dept of a trough.*
- Apse.*** *A semicircular or polygonal projection from a larger rectangular space, particularly opposite the entrance of a church.*
- Arcade.*** *A sequence of arches spanning between the columns / piers of a colonnade or between a series of piers.*
- Arch.*** *A structural element capable of spanning a horizontal gap and carrying its own weight and other loads wholly or largely by internal compression.*
- Barrel - vault*** *A half - cylindrical vault, as in continuous arch; also, a tunnel - vault*
- Basilica*** *An assembly room; in Christian parlance, a church; as a rule longitudinal and composed of nave and aisles.*
- Beam.*** *A structural element capable, like an arch or catenary, of spanning a horizontal gap, acting structurally as combination of the two.*
- Bearing wall.*** *A wall that fulfils a primary structural role as a vertical support for loads other than its own - weight.*
- Biforia.*** *Greek word for a window or an opening divided in two parts by one column.*
- Bending.*** *A type in which initially parallel section of a structural element become inclined towards one another; and type of structural action that leads to this deformation.*
- Buttress.*** *A mass of masonry designed to bear a thrust by using its weight to deflect the action downwards within its outline, so giving a wall added resistance.*
- Catechumen.*** *In the early church, a convert to Christianity, under instruction but not yet baptised.*
- Cloisonné.*** *A decorative use of masonry in which small stone blocks are framed by bricks placed vertically and horizontally in single or double courses.*
- Column.*** *A vertical structural element of relatively small cross - section capable of serving as a support and acting wholly or primarily in compression.*
- Compression.*** *Contraction and the type of structural action that leads directly to it.*

- Compressive strength.** *The ability to resist compression or crushing loads. It is measured by weight per unit area.*
- Conch.** *A semicircular niche surmounted by a half dome.*
- Chrystobulls.** *Gold - sealed decrees, given by the Emperor*
- Crack.** *To respond to tension in the ultimate manner by either a local or a more extensive cleavage.*
- Cross church.** *See Greek cross plan.*
- Cross - domed church.** *A church plan whose core, enveloped on three sides by aisles and galleries, form a cross; the core is surmounted by a dome in the centre and four barrel - vaults resting on four strong corner piers:*
- Cross - in - square.
(cross inscribed)** *See Quincunx.*
- Damping.** *Dissipation of the energy of disturbing forces, particularly periodic ones, by turning it into a form of energy that is not associated with structural deformation or displacement.*
- Density.** *The mass per unit volume of a substance, commonly expressed in grams per cubic centimetre.*
- Diaconocon.** *A room attached to or enclosed in the church; in Early Christian times, utilised for the reception of the congregation's offerings and serving as archive, vestry and library.*
- Deformation.** *Change in shape or dimensions as a result of or as part of structural action.*
- Dome.** *A hemispherical vault supported by either a circular wall or, over a square space, by squinches or pendentives placed in the corners, the former transforming the square into an octagon, the latter into a circle (see: squinch, pendentive).*
- Drum.** *The circular or polygonal structure on which a dome is raised.*
- Ductile.** *Capable of carrying loads at or near the ultimate strength over a wide range of deformation rather than failing in a brittle manner.*
- Dynamic load.** *A load that is applied or changes sufficiently rapidly to bring into play significant inertial resistance and thus frequently to have an effect markedly different from that of an otherwise identical load applied more slowly and acting more continuously.*
- Earthquake.** *The vibration of the Earth caused by the passage of seismic waves radiating from some source of elastic energy.*
- Elastic, elasticity.** *Capable of returning to the original shape and dimensions when a load is removed. A property well exemplified by a spring provided that it is not overloaded.*

Elastic deformation.	<i>The part of the total deformation under load that disappears when the load is removed.</i>
Epicentre.	<i>The point on the Earth's surface directly above the focus (or hypocenter) of an earthquake.</i>
Exonarthex.	<i>See Narthex.</i>
Focus.	<i>The place at which rupture commences in an earthquake (Hypocentre).</i>
Foundation.	<i>That part of a structure that meets the ground and through which all loads transferred to it.</i>
Groin - vault.	<i>The vault formed over a square bay by the interpenetrating of two barrel - vaults of equal diameter and height, the lines of intersection (the groins) forming a diagonal cross; also known as a cross - vault.</i>
Grout.	<i>To fill interstices and voids with a liquid mixture.</i>
Grouting.	<i>The process by which grout is injected, i.e. hand grouting, gravity grouting, mechanical grouting by pump or air pressure, and vacuum grouting.</i>
Hazard.	<i>The probability that a disastrous event of given intensity will occur in a particular place.</i>
Hypocentre.	<i>See focus.</i>
Iconostasis.	<i>In a Byzantine church, the screen wall covered with icons which separates nave from the chancel.</i>
Intensity.	<i>A measure of ground shaking obtained from the damage done to structures built by man, changes in the Earth's surface and felt reports.</i>
Lime mortar.	<i>Mortar made from slaked lime.</i>
Lime putty.	<i>Lime putty is the result of slaking quicklime and tempering it by keeping it covered with water.</i>
Lintel.	<i>The horizontal beam resting on two supports (jambs) to form the opening.</i>
Natural frequency.	<i>The number of cycles of a free oscillation or vibration in unit time (usually per second).</i>
Magnitude.	<i>A measure of earthquake size, determined by taking the common logarithm (base 10) of the largest ground motion recorded during arrival of a seismic wave type and applying a standard correction for distance to the epicentre. (Richter scale)</i>
Monastery.	<i>A residence for a community of monks.</i>
Monoforia.	<i>Greek word for one single space of a window or an opening.</i>

- Naos.** *In modern Greek, a church; architecturally and liturgical, the core and sanctuary of a Byzantine centrally - planned church; i.e. the parts reserved for the performance of the liturgy.*
- Narthex.** *In Greek, a cane; architecturally, the transverse vestibule of a church either preceding nave and aisles as an inner narthex (esonarthex), or preceding the facade as an outer narthex (exonarthex).*
- Natural period of vibration.** *The time interval between successive crests in a sinusoidal wave train; the period is the inverse of the frequency of a cyclic event.*
- Nave.** *The main central body of a longitudinally - planned building such as a Roman basilica or later church.*
- Niche.** *A recess in a wall.*
- Pantokrator.** *Christ as ruler of the world.*
- Pendentive.** *A triangular spherical section of vaulting that springs from a corner of a rectangular ground plan to allow the area to be covered by a dome.*
- Pier.** *A vertical structural element like a column, but more massive in proportion and made of masonry.*
- Pilaster.** *A shallow pier - like projection from a wall, usually built integrally with the wall.*
- Plastic, plasticity.** *Descriptive of the deformational behaviour of a ductile material after the limit of elastic behaviour or elasticity has been passed. In perfectly plastic behaviour, deformation continues to increase with load, and the increase remains as a permanent set when the load is removed.*
- Plastic deformation.** *Continued deformation of a ductile material under a constant or near - constant load close to the ultimate strength.*
- Prestressing.** *A structural engineering technique of inducing compressive stresses before loadings are applied.*
- Prothesis.** *A rectangular chamber adjoin the sanctuary and in line with one of the side aisles in an Early Christian or Byzantine church. Contained an altar and served for the preparation of the Host.*
- Quincunx.** *A structure divided into nine bays, the centre bay a large square, the corner bays small squares, the remaining four bays rectangular; the centre bay, resting on four columns / piers, is domed, the corner bays are either domed or groin - vaulted, the rectangular bays are, as a rule, barrel - vaulted; also referred to as cross - in square, cross - inscribed, croix - inscrite.*
- Reinforcement.** *A general term denoting some kind of addition to a structural element, usually in another material, for the purpose of improving its strength or stiffness.*

Rendering.	<i>1. In external plastering, coats of mortar or stucco applied to a wall in order to produce a smooth surface and prevent the penetration of rain. 2. In internal plastering the first thick coarse coat of plaster on a wall, usually followed by a scrim coat and finishing coat.</i>
Resonance.	<i>A state when the frequency of the ground vibrations is equal to the natural frequency of the building.</i>
Risk.	<i>The probable loss, combining the hazards of location and the vulnerability of buildings and their contents. Risk can be removed, transferred, shared, accepted or accommodated.</i>
Rotunda.	<i>A building that is circular in plan.</i>
Shear strength.	<i>Resistance to shear forces which act at 45° in the ends of a beam. Shear forces are a form of transverse compression acting in opposite parallel directions.</i>
Sclavenes.	<i>The areas settled by the Slavs with no organised state, which only formally recognised the supreme rule of the Empire.</i>
Stability.	<i>Another name for the state of stable equilibrium, though sometimes used more loosely to denote little more than a state of equilibrium under static loads.</i>
Stiffness.	<i>Resistance to a deformation.</i>
Strength.	<i>Ability to carry load. More specifically the maximum load that can be carried before a chosen limit of behaviour is reached.</i>
Stress.	<i>The local intensity of an internal force measured as the force acting perpendicularly (in the case of tension or compression) or tangential (the case of shear) to a unit area of a given cross - sectional plane.</i>
Tensile strength.	<i>Strength per unit area in resisting the pull forces of tension.</i>
Tie.	<i>A straight slender structural element acting wholly or almost wholly in tension either as a hanger or as a part of a triangulated space frame or truss.</i>
Timber.	<i>Sawn or cleft timbers used for the frames or roof of a building.</i>
Thermae.	<i>In the Roman Empire, a bathing establishment for public or private use.</i>
Torsion.	<i>Twisting and the type of structural action that leads directly to it.</i>
Tribelium.	<i>Entrance from the narthex to the naos divided by two column in three parts.</i>
Triforia.	<i>Greek word for a window or an opening divided in three parts by two columns.</i>
Tufa.	<i>A calcareous porous stone, light in weight, deposited around mineral springs.</i>

- Tuff.** *A volcanic light - weight stone used for partitions and, in stronger heavier grades, for walls.*
- Vault.** *A single curve of continuous arch of brick or stone covering part, or whole, of a building, e.g. a barrel vault.*
- Triconch.** *A building composed of three conchs. (also trefoil) (See Conch)*
- Tetraconch.** *A building composed of four conchs. (also quatrefoil) (See Conch)*
- Tribelon.** *The triple arcade connecting the esonarthex with the nave.*
- Vulnerability.** *The degree of loss that will be sustained by an element from an earthquake of given intensity.*

APPENDIX TWO - Chapter two

Section 2.1

(1) geological studies, (2) seismic studies for defining the hazard, risk and return periods of earthquakes of various intensities, (3) vulnerability studies for earthquakes of different magnitudes. These also involve elaboration of seismic maps for different return periods of 50, 100, 200, 500 and 1000 years with locations of all registered cultural monuments⁴, (4) climatic studies. It is certain that the application of these parameters will lead to correction of the already established and defined existing plans for conservation works, (5) List of the buildings according to their cultural importance, so that technical and financial resources for strengthening and / or post - earthquake repairs can be properly prioritised.

Section 2.2

- B.2.a Temporary protection of the monuments. In relation to the importance and value of the monument, it is enclosed and a watchmen service organised for its protection against thefts in accordance with the recommendations of the expert team.
- B.2.b Clearing of debris. The expert team¹⁶ for providing first aid to the stricken or ruined structure must participate, from the very first moment of contact with the monument, in the clearing of the debris since their presence and advice are essential.¹⁷ After each earthquakes a 'shock syndrome' occur. (Feilden 1987:36).¹⁸
- B.2.c Providing temporary safety for the structure. There follows the phase in which actions are taken for temporary¹⁹ support and making the structure safe against aftershocks, i.e., a safe access to the phase of investigation for elaboration of a project for its repair and seismic strengthening. Particular importance is given to temporary shelter and protection against collapse of all structures particularly those that possess valuable works of fine arts, sculptures and others art treasure.

- B.2.d Post - disaster inspection. After all conditions for further treatment²⁰ are provided, it is of an extraordinary importance to evaluate properly the intensity and the level of actual damage to the heritage.²¹ This will be the basis for elaboration of a priority list of activities as a groundwork for further activities.²²
- B.2.e Priority list of activities. For the purpose of proper direction and use of experts and financial resources allocated for elimination of the consequences, depending on the level of damage at national or international level, this list should contain details on all the activities with their importance and the order in which they are to be performed in the next phase.

Section 2.3

Neglect. This negative 'activity' of man has an important impact for decay of heritage. This cause of damage should be eliminated, or its effect would at least be decreased by two, very important, processes - regular inspection and maintenance.

War. As already mentioned, wars often cause greater permanent damage and destruction of heritage than do natural damaging factors.

It is a planned damaging factor that can, but very rarely, be reduced or eliminated³³ as is the case with my country - the Republic of Macedonia. The major point here is prevention before the occurrence of a catastrophe.³⁴

Environmental pollution. This cause, due to lack of care or forethought can be eliminated or its effect reduced. In almost all countries of the region, with a very few exceptions, even at national level, this factor should be treated seriously in the longer period to come.

Planning and traffic schemes. This is a human factor with a lasting damaging effect. Its effect is different depending on the level of development of the community, the economic and human potentials.

The increased tendency for fast and dynamic progress of society has frequently been accompanied by 'the most destructive damaging activities.' These activities inflicted lasting damage to the architectural cultural heritage. There are numerous examples of towns in Macedonia that after the Second World War, in the name of

progress and modern times, lost their original appearance created through hundreds of years.

This factor will continue to be present in future.

Vandalism. As a result of the too intensive utilisation of the cultural heritage by one of the most powerful world industries - tourism and the tourists as the centre of the world - this factor has become increasingly damaging wherefore it must be suppressed at both national and international levels.

The effect of this factor is long - term and cyclic, with a tendency to become permanent.

Section 2.4

When an earthquake takes place, potential energy accumulated during a period of time is suddenly released as kinetic energy. The kinetic energy is consumed in three ways: by the breaking of the rocks within the focus, by transformation into heat and by elastic waves. These elastic waves propagate rapidly, advancing as wave fronts that, reaching the earth's surface, are manifested as earthquakes. An earthquake also has its own characteristics. Its first phase is a slight trembling which is called the initial tremor or foreshocks. The next phase is characterised by wide amplitudes and is called "the main tremor". The last portion is the tail tremor or is referred to as 'aftershocks.' (*Milutinovic 1985*).

There is ample literature on this phenomenon. Detailed discussion is therefore not within the scope of this thesis.

Section 2.5

Intensity

General requirements for a workable intensity scale will be:

- Every grade of the seismic intensity scale should represent approximately equal increments in the amount of damage;
- The more reliable gauge of intensity to be used in a scale would be the mechanical manifestation effects of an earthquake rather than personal sensation and impressions;
- Too many alternative manifestations for each grade should be excluded. Those included should be commonly observable; and
- The grades should be well enough separable in order to make it possible for an observer of ordinary intelligence to distinguish clearly between tests for each grade.

The history of establishment of the intensity scale dates back from the end of the nineteenth century in Italy. (Rossi - Forel Intensity scale)

The modified Mercalli Seismic Intensity Scale (1931). This scale represents an improvement of the existing Wood and Neumann (1931) scale which is referred to as the Modified Mercalli scale (MM).

This scale was further improved by Richter (1958). For its application, from the aspect of engineering and architectural design, a certain categorisation of the construction stock has been made, irrespective of whether it has the attribute of cultural heritage or not. This is as follows:

- Masonry A. Good workmanship, mortar and design; reinforced especially laterally, and bound together by using steel and other appropriate building materials and elements, designed to resist lateral forces.
- Masonry B. Good workmanship and mortar; reinforced but not designed in detail to resist material forces.
- Masonry C. Ordinary workmanship and mortar; no extreme weakness like failure of ties at corner, but neither reinforced not designed against horizontal forces;
- Masonry D. Weak materials such as adobe; poor mortar; low standards of workmanship; weak horizontal ties. (*Milutinovic 1985: 33*)

Modified Mercally Intensity Scale (1983) abridged and rewritten by C.F. Richter.

- I. Not felt. Marginal and long-period of large earthquakes.
- II. Felt by persons at rest, on upper floors, or favourable placed;
- III. Felt indoors. Hendon objects swing. Vibrations like passing of light trucks. Duration estimated. May not be recognised as an earthquake.
- IV. Hanging object swing. Vibration like passing of heavy trucks; sensation as a jolt like a heavy ball striking the walls. Standing motor car rock. Windows, dishes, doors, rattle. Glasses clink. Crockery glasses. In the upper range of IV, wooden walls and frame crack.
- V. Felt outdoors; direction estimated; Slippers weakened; Liquids disturbed, some spilled; Small unstable objects displaced or upset. Doors swing, close and open. Shutters, pictures move. Pendulum cocks stop, start, change ratio.
- VI. Felt by all. Many frightened and run out doors. Persons walk unsteadily. Windows, dishes, glassware broken. Knickknacks, books, and so on, of shelves. Pictures off walls. Furniture moved or overturned. Weak plaster of masonry D cracked. Small bells ring (churches, school). Trees, bushes shaken visibly, or heard to rustle.
- VII. Difficult to stand. Noticed by drivers of motor cars. Hanging objects quiver. Furniture broken. Damage to masonry D including cracks. Weak chimneys broken at roof line. Fall of plaster, loose bricks, stones, tiles, cornices, unbarred parapets, and architectural ornaments. Some cracks in masonry C. Waves on ponds; water turbid with mud. Small slides and caving in along sand or gravel banks. Large bells ring. Concrete irrigation ditches damaged.
- VIII. Steering of motor cars, Damage to masonry C; partial collapse. Some damage to masonry B; none to masonry A. Fall to stucco and some masonry walls. Twisting, fall of chimneys, factory stacks, monuments, towers, elevated tanks. Frame houses moved on foundations if not bolted down; loose panel walls thrown out. Decayed pilling broken off.

Branches broken from trees. Changes in flow or temperature of springs and wells. Cracks in wet ground and on steep slopes.

- IX. General panic. Masonry D destroyed; masonry C heavily damaged, sometimes with complete collapse; masonry B seriously damaged; General damage to foundations. Frame structure, if not bolted, shifted of foundations. Frames racked. Conspicuous cracks in ground. In alluviated areas sand and mud ejected, earthquake fountains, sand craters.
- X. Most masonry and frame structures destroyed with their foundations. Some well-built wooden structures and bridges destroyed. Serious damage to dams, dikes, embankments. Large landslides. Water thrown on banks of canals, rivers, lakes, etc. Sand and mud shifted horizontally on beaches and flat land. Rails bent slightly.
- XI. Rails bent greatly. Underground pipelines completely out of services.
- XII. Damage near total. Large rock masses displaced. Lines of sight and level distorted. Objects thrown into the air. (Z. Milutinovic, 1985)

MSK 1964 Seismic Intensity Scale (1981). Recently, a new classification known as the MSK Intensity Scale, has been suggested by S.V. Medvedev, W. Sponheuer and V. Karnik. In this scale, the classification of the effects of an earthquake is based on three distinct criteria:

- perception by human beings and effects on everyday surroundings;
- effects on buildings of any type; and
- effects on underground and variation of the underground water level and surface water systems.

This triple structure distinguishes the MSK from the other scales. It is also divided into twelve categories but is otherwise roughly similar to MM scale. Such structure makes the MSK- 64 different from all others scales.

Section 2.6

Classification of the scale.

I Types of structures (non - seismic buildings)

- A. Buildings constructed of field stone, adobe houses, clay houses
- B: Ordinary brick buildings, buildings of large blocks and prefabricated type, half - timbered structures, constructed in non - dressed stone.
- C. Reinforced buildings, well - built wooden structures.

II. Definition of quantity

Single, few:	about 5%
Many:	about 50%
Most:	about 75%

III. Classification of damage to buildings

Grade 1:	<i>Slight damage:</i> fine cracks in plaster; failure of small pieces of plaster.
Grade 2:	<i>Moderate damage:</i> Small cracks in walls; fall of fairly large pieces of plaster; tiles slip off; cracks in chimneys; part of chimneys fallen down.
Grade 3:	<i>Heavy damage:</i> Large and deep cracks in walls; falling of chimneys.
Grade 4:	<i>Destruction:</i> Gaps in walls; parts of buildings may collapse; separate parts of the building lose their cohesion; inner walls and filled-in walls of the frame collapse
Grade 5:	<i>Total damage:</i> total collapse of buildings

IV. Arrangement of the scale

- a) Persons and surroundings
- b) Structures of all kinds
- c) Nature

This intensity scale has twelve degrees. To focus on damages, we will focus on levels of damage according to types of structures (3) and the classification given above.

Damage level of buildings according to the level of intensity (V - XII) is:

V. Awakening

- b) Slight damage of grade 1 in buildings of type A are possible.
- c) Sometimes, a change in flow of springs.

VI. Frightening

- b) Damage of grade 1 is sustained in single buildings of type B and in many of type A and damage in a few buildings of type A is of grade 2.

VII. Damage to buildings

- a) Most people are frightened and run outdoors. Many find it difficult to stand. The vibration is felt by persons driving motor cars. Big bells ring.
- b) Damage of grade 1 is caused in many buildings of type C ; in many buildings of type B the damage is of grade 2. Many buildings of type A suffer damage of grade 3, few of grade 4. In certain instances, landslides of roadway take place on steep slopes; cracks in roads; seams of pipelines damaged; cracks in stone walls.

VIII. Destruction of buildings

- b) Many buildings of type C suffer damage of grade 2, a few of grade 3. Many buildings of type B suffer damage of grade 3 and a few of grade 4, and many buildings of type A suffer damage of grade 4 and a few of grade 5. Occasional breakage of pipe seams. Memorials and monuments move in twist. Tombstones overturn. Stone walls collapse.

IX. General damage to building.

- b) Many buildings of type C suffer damage of grade 3, a few of grade 4. Many buildings of type B show damage of grade 4; a few of grade 5. Many buildings of type A suffer damage of grade 5. Monuments and columns fall.

X. General destruction of buildings

- b) Many buildings of type C suffer damage of grade 4, a few of grade 5. Many buildings of type B show damage of grade 5; most of buildings of type A experience destruction category 5.

XI. Catastrophe

- b) Severe damage even to well-built buildings, bridges, dams and railway lines; highways become useless; underground pipes destroyed.

XII. Landscape changes

- b) Practically, all structures above and below ground are greatly damaged or destroyed.

APPENDIX THREE - Chapter three

Section 3.1

Geographical and geological characteristics

With its central geographical position in the Balkan Peninsula and being widely open to the Aegean Sea and to Thessaloniki, Macedonia early felt the economic and cultural influences from the East and the developed Mediterranean.

At the same time, it also felt the negative repercussions from multiple penetrations of numerous conquerors that used the favourable natural communication lines existing in this territory.

In the past, a communication line referred to as Via Egnatia passed through the territory of Macedonia connecting the Adriatic Sea, i.e., the town of Drach and Elbasan (both in Albania) through Ohrid and Bitola (Macedonia) with Thessaloniki (Greece) and Istanbul (Turkey).

The high mountains formed in the Tertiary are situated in the west part. The east part is characterised by the old Rhodopian masses with well-rounded tops.

About seventy percent of the territory of the Republic of Macedonia represents a mountainous terrain, while the remaining part is represented by deep spacious tectonic valleys such as the Skopje, Polog, Pelagonia and Gevgelija - Valandovo valleys.

As for the rocks, they are mainly represented by crystalline shells, magmatic and metamorphic rocks. The existence of construction material that was and is still used for construction purposes is considered of a particular importance. These are the various kinds of granite, basalt, limestone, travertine and marbles. The last three elements are particularly important since they were used with a great skill and a lot of knowledge.

Section 3.2

From the average meteorological elements observed for a longer period of time and the calculated average for certain time intervals (months, years), the so - called climatic elements are obtained.

In fact, climate is an average weather regime for a given place or zone, defined from measuring and observations through many years. In other words, climate is a sum

of weather phenomenon, i.e., atmospheric processes, which characterise the average physical state of the atmosphere over some place or over some regions of the Earth.

The configuration of the territory is such that it is opened to the penetration of influence from the Aegean basin, particularly through the Vardar river. Through the Crni Drim river, the Macedonian climate is influenced by the Mediterranean one. Generally, it may be said that the climate in the territory of the Republic of Macedonia is a transition between Mediterranean and continental climate by which it stands apart from the neighbouring countries.

Rainfalls

As to the amount and intensity of precipitation in Macedonia, these meteorological elements have been studied and data have been collected since 1900.

For studying of this meteorological element data, over 100 meteorological stations distributed in valleys, plains and hilly terrain in Macedonia and different altitudes from 59 m in Gevgelija to 1750 m on Popova Sapka (Sar Planina) were used.

The Mediterranean climatic regime is characterised by increased rainfalls in winter seasons, especially in late autumn. The rainfall maximum is in March or April while summers are dry with the least rainfall in the hottest months of July and August.

The continental and the modified continental climate are characterised by long, dry summers and long cold winters, with rainfalls mainly in early autumn.

Section 3.3

The above stated and studied three zones in Macedonia (Skopje, Prilep and Ohrid), have the following characteristics:

Skopje Region

Skopje and the Skopje region belong to the disturbed pluviometric regime. The main maximum of rainfall is in October and November and the minimum is in May. The annual quantity of rainfalls is about 500 mm.

Prilep Region

Prilep and Prilep region is within the disturbed Mediterranean pluviometric

regime with slightly less rainfall in the south part of the Pelagonia valley (Bitola). The annual quantity of rainfall is about 550 mm.

Ohrid Region

Ohrid and the Ohrid region are characterised by the Mediterranean pluviometric regime. Most rainfalls are during autumn and winter with the maximum in November and March. The average annual rainfall quantities are about 670 mm.

Section 3.4

Pre - history

Here, two great cultural spheres were connected: the Aegean - Anatolian as the centre of the earliest high agricultural settlements and the interior of the Balkans and Central Europe whose importance became greater in the later epochs, particularly the Iron Age.

Two factors are important to define the characteristics of development of prehistoric Macedonia:

- The position of the important natural communication lines in the Balkans on one hand, and,
- The relative isolation of certain areas conditioned by the relief on the other.

This has led to specific forms of cultural development.

At this point, we should point out the importance of the Vardar – Morava communication line as one of the main Balkan communication lines in South-North direction. Noteworthy is also the existence of the natural communication line in East - West direction, along the Struma river.

The great Aegean Migrations affected considerably the interior of the Balkans and to some extent the regions along the main communication lines.

Section 3.5

The Neolithic Age

According to data, it is an epoch of primitive agriculture and the beginning of cattle breeding. It represents, in fact, a transition from the primitive society, i.e., the

phase of savagery to the somewhat more developed phase – the barbarity.

The main elements of activities were: agriculture and manufacture of earthenware. The weapons used were: stone axes and spears (influence from Anatolia). More important localities are: Tumba, Madzari near present Skopje, Porodinska Tumba and Porodin house in Pelagonia (Southwest part of Macedonia).

At Porodin and some other sites in Pelagonia, outstanding models of clay houses with chimneys have been discovered.

Section 3.6

The Bronze Age

The danger of invasion by hostile tribes became even greater with the improvement in production and usage of metals.

Particular characteristics of this age are:

- Use of various kinds of ceramics (grey or brown);
- Beginning of intensive development of cattle breeding and particularly the use of the horse, probably for labour, waging of wars and hunting;
- Migrations from the East (Pontian steppes) toward the Balkans and Central Europe;

This is a period of symbiosis with the aboriginal population and the creation of the Indo - European languages.

According to the time period, the early epoch lasted until 1,900, the middle one until 1,500 and the late one until 1,200 BC.

This is the period when groups of peoples – Illyrians and Thracians were differentiated.

Noteworthy among the valuable remains found in Macedonia are those that bear the characteristics of the Mycenaean culture (a sword found in the surroundings of Tetovo) and the findings at localities in Crnobuki, Baresani and Kravari (Pelagonia).

Section 3.7

The Iron Age

About 1,300 – 1,200 BC, Macedonia and the whole Balkan Peninsula, were involved in a wave of riots, displacement of tribes and demolishing of settlements. This process lasted for centuries. It is an epoch of destruction of the old Mycenaean culture

in Greece, the fall of Troy, the fall of the Hittite state in Asia, the appearance of the Philistines in Palestine and the barbarian attacks on Egypt.

- The first phase (from 1,300 to 1,200 BC) is characterised by the great Aegean Migration, the end of the Mycenaean culture and the beginning of the Greek one. Known archaeological localities are: graves in Prilep, Demir Kapija and the surrounding of Bitola.
- The second phase starting from the 700 BC is characterised by a stabilisation of culture and the ethnic groups after the great Aegean Migration. Known localities are: Radanje, Orlovi Cuki, Gorno Pole on Karaorman Mt. and grave findings in the surroundings of Orizari near Kocani and Vucidol near Skopje. This period is also marked by construction of fortified settlements and the use of dry masonry (construction without mortar).
- The third phase that covered the period from the sixth until the fourth century BC is characterised by domination of the tribal aristocracy. Evidence: intensified importation of luxurious goods from Greece, i.e., a great cultural influence from Greece. Known localities: necropolis in Pelagonia, Trebeniste culture (near Ohrid), Demir Kapija and Gorno Pole near Karaorman.
- The fourth iron phase is characterised by a great Hellenistic influence.

Section 3.8

The ancient Macedonian State (King Philip)

During the reign of king Philip II, (359 - 336 BC) the Macedonian state became the strongest in the Balkans as a centralised monarchy. The rise of Macedonia was based on its social - economic development and the favourable political situation – the crisis of the Greek city states.

During his rule, the most important activities in the sphere of interior politics were: the military and the financial reforms.

- **Military reform:** reorganisation of the army and creation of a heavily armed infantry called the Macedonian phalanx. Introducing of permanent staff, permanent training, new military techniques and tactics.
- **Financial reform:** introducing of the gold coin – stater.

Philip II planned to gain an exit to the sea. After long clashes with the Greek city states, the Macedonian citizens and warriors became known as 'Macedonian barbarians.' Demosthenes who strongly opposed the Macedonians and even

established his own party against them is known for his 'Philippic' – orations against Philip and the Macedonians.

Should be mentioned that during the reign of Philip II, the town Heraclea Lyncestis was established. This town is located in the area of the present town of Bitola and had a great military - strategic role in the ancient Macedonian state. Lately, some new structures and artefacts dating from the time of king Philip have been found in the surrounding of Gevgelija which is in the south region of the Republic of Macedonia as a material evidence that the history of the ancient Macedonian state developed on the territory of present Macedonia.

Section 3.9

The ancient Macedonian State (Alexander the Great)

The Alexander's attempt to create a united world state was unsuccessful because there were not the necessary economic - political prerequisites. Namely, the differences between the countries to be united were too great. The state extended from the west coast of the Balkan peninsula up to India to the east, from the Danube and the Black Sea in the north to Egypt, Libya and Cyrenaica to the south. It included vast territories on which there were highly developed Slav owning countries parallel to the existence of countries going through the final stage of primitive society. The economic and cultural connections between certain areas could not be retained despite all measures that Alexander took to unite them. His campaigns spread and made famous the name of Macedonia to such an extent that it was imposed on the entire cultural heritage .

After Alexander's death, the Hellenistic states were established in the Balkans and all the subdued countries were liberated from the Macedonian hegemony. The power of the state declined fast with the establishment of the new world power - the Roman Empire.

Section 3.10

Macedonia under the rule of the Roman Empire

The emperor Diocletian divided the empire into two parts: the Eastern and the Western Empire. Each part was ruled by an emperor - a Caesar. This division became

permanent. Each of these parts of the empire consisted of two parts - prefectures. The East Empire consisted of the Illyrian Prefecture, which covered most of the Balkans, and the Prefecture of the Orient, which included the east part of Asia Minor and the other eastern regions. Each prefecture was further divided into two dioceses.

The Illyrian Prefecture consisted of the Dacian and Macedonian dioceses.

The first Macedonian province (Macedonia Prima), or Southern Macedonia covered the areas of Thessaloniki and Edessa, while most of the present Republic of Macedonia was encompassed by Macedonia Salutaris.

The capitals of some provinces were: Stobi as the capital of Macedonia Secunda, Scupi as the capital of Dardania, Skodra as the capital of Prevalitana, Dyrrachium as the capital of Epirus Nova; Serdica (Sofia) as the capital of Mediterranean Dacia and Thessaloniki as the capital of Macedonia Prima.

The Diocese of Dacia consisted of the following six provinces:

- 1) The Mediterranean Dacia, including Nis, Pirot, Sofia, Kustendil, Blagoevgrad, Kratovo, Kocani, Delcevo, Berovo and Stip;
- 2) The coastal Dacia - present northern Bulgaria up to the right bank of the Danube;
- 3) Moesia Prima;
- 4) Dardania, i.e., the Skopje and Kosovo areas;
- 5) Prevalitana, covering the Polog region (Gostivar and Tetovo) and a large part of Northern Albania, and
- 6) Part of Macedonia Salutaris.

The Diocese of Macedonia consisted of seven provinces:

- 1) Achaea;
- 2) Macedonia Prima;
- 3) Crete;
- 4) Thessaly
- 5) Old Epirus;
- 6) New Epirus, present - southern and central Albania, Debar, Struga and Ohrid, and,
- 7) Part of Macedonia Salutaris.

In the third and the fourth century, there began the intrusion of the barbarian tribes from the north. That was the period of more active christianisation of the population and the division of the Roman Empire into West - Rome and East - with the establishment of Constantinople in 324. The consolidation and the spreading of Christianity became increasingly important particularly for the construction activities through the whole history of the West and particularly the East Roman Empire.

Section 3,11

Macedonia in the period of the Late Roman and Early Byzantine Rule and the settlement of the Slavs

The history of the spreading of Christianity is well known. About 58 AD, Apostle Paul undertook many missionary journeys to settlements in Asia Minor, Macedonia and Greece, during which many Christian communities were established. Out of these journeys, the one to Thessaloniki is of a particular interest for us, since it is possible that Apostle Paul may have got as far as Stobi while visiting Thessaloniki. From the latter, the Christian influence soon made its way to Stobi and Scupi along the route following the Vardar (Axios) river and to Heraclea via Lychnidos along the Via Egnatia.

It was in the year of 313 AD that Christianity was made equal with the other religions in the empire by the Edict of Mediolanum (Milan) passed by emperor Constantine I. By the end of the fourth century, emperor Theodosius proclaimed Christianity the state religion and prohibited all other sects and beliefs.

After this period of time, till the first invasion of Slavs (sixth century), some periods, actions and dates are important:

- Struggle for dominance between the West - Catholic Church - under the jurisdiction of the Pope in Rome and the East Church with a seat in Constantinople. Apart from Constantinople, Salonika (Thessaloniki) as a seat of the Vicariate of Thessaloniki established by Pope Innocent in 412 AD underwent a fast growth.
- In 535, the Byzantine emperor Justinian proclaimed the Archiepiscopal of Justiniana Prima an autocephalous church with a wide territory of influence. Justiniana Prima included the territories of Moesia and Dacia, Mediterranean Dacia, Pannonia Secunda, Moesia Prima, Prevalitana, Dardania and Macedonia Secunda.
- It should be noted however that due to the creation of favourable conditions, i.e., weakening of the Roman Empire, the attacks by the Nordic tribes, the Goths, the Sarmatians and others from the north became very frequent.

Section 3.12

From the Samuel's Empire until the Balkan Uprisings

The mission of Cyril and Methodius in Greater Moravia 863 (the first, however short-lived, Slavic state, established on the territory of present - day Czech and Slovak

Republics) was very important. By using the Slavic language, the ruler of Moravia, held back the influence of the Pope and the German language, which was unintelligible for the Slavic population.

It should be noted however, that almost all the Slavic peoples spoke the so - called Common Slavonic until 1100 AD.

Although the mission of Cyril and Methodius in Moravia was unsuccessful, it was an incentive to create the alphabet (at first called the Glagolitic according to the Slavonic word 'glagolati' which means 'to speak').

After the death of Cyril, his brother and their disciples Clement, Naum, Gorazd, Angelarius, and Sava continued his work since they were of equal learning and maturity as apostles.

Knowing the influence of religion, the Byzantine emperors succeeded in winning over to their side the neighbours - the Old Bulgarian Empire, who accepted the Byzantine Christianity as an official state religion, by which the tensions and the hostilities were decreased to some extent. The territory of Macedonia start to be part of this Old Bulgarian Kingdom.

The historic and religious circumstances on this territory, gave rise to the Bogumil movement. Like their ancestors from the East, the Bogumils, who interpreted the visible as a creation of the devil and repudiated all rituals, cults and churches, revered only the pure and spiritual, the stringent and ascetic as their own ladder to spiritual baptism.

The division of society into classes prolonged this movement up to the sixteenth century in Russia. The Bogumil movement exerted a particularly great effect in the Balkan Peninsula.

Section 3.13

Clement and the others went to the court of the Bulgarian prince Boris Michael in Pliska. After a few months, Clement was appointed to Ohrid, Devol and Glavenica to preach the gospel and introduce the Slavonic alphabet to the flock there.

Due to political reasons, instead of becoming Chief Counsellor of Car Boris, Clement again returned to Ohrid where he established the first Slavonic Literary School. Naum joined him in his activities. With their religious activities, they activated the construction activities in the region.

The surrounding of Ohrid and the Ohrid Lake are rich with structures dating from this period. Because here lived the Slavonic people, this century has been taken

as the referent one in defining the time period to be investigated. Their fruitful educational, religious and literary activities put Clement and Naum in the highest rank among the creators of the history of the Macedonian Orthodox Church. Their work and the work of Constantine and Methodius, have ranked Macedonian history equally among the histories of the other peoples in Europe.

Section 3.14

The Ohrid Patriarchate

However, due to the fact that the territory of Macedonia is of a strategic importance, it was often conquered and ruled by different states.

After the Byzantine Empire in the eleventh century, Macedonia was ruled by the Bulgarians at the beginning of the twelve century, then by the Despots of Epirus, then by the Bulgarians and by the Byzantine again. In the fourteenth century by the Serbs, before coming under the Turkish rule until the beginning of the twentieth century.

Briefly, it may be concluded that the Macedonian Slavs have their own place in the Roman and Slavonic culture. Its weft consists of the letters of the alphabet of Cyril and Methodius, the School of Clement and Naum, the heterodoxy of the Bogumils and their defiance, the State and that defiance tempered, and the Church and its godly defiance.

The warp of autonomy was completed by the alphabet and christianisation. The promotion of independence was achieved through the activities of the Church, the Ohrid Archbishopric. When the State ceased to exist, the Church continued its independence.

The Ohrid Archbishopric had its independence for a long time under the Turkish rule, until 1767 when it lost it and became subject to the Patriarchate of Constantinople which had a great autonomy granted by the Turkish sultans.

Section 3.15

Macedonia under the rule of Ottoman Empire

Ohrid, established on a road which since ancient times, under the name of Via Egnatia, connected Constantinople and Thessaloniki with the western coast of Balkan peninsula, was also affected. At the transition from the fourteenth to the fifteenth

century, the recent towns, virtually isolated, experienced economic and cultural stagnation.

The situation improved, at first with the significant privileges, which the Ohrid Archbishopric was granted by the Port, and then the new territorial expansion of the Ottoman Turkish Empire.

In the middle of the sixteenth century, the Empire reached its zenith. It was the time of the Sultan Suleyman the Great. For the Balkans, the grant for the re-establishment of the Pek Patriarchate (1557) (now in SR Yugoslavia) was an event which had considerable influence over the life of the Orthodox population under the Turks. This political move was a result of the desire to secure stability and peace in a region of strategic importance.

Section 3.16

Legislation and institutional organisation

II Rights and obligations of the owners of the cultural monuments

Article 20: 'Actions that may change the cultural monument or disturb its integrity may be taken only by previous approval by the authorised institution. Considered as such actions, according to Paragraph 1 of this Article are particularly: conservation, restoration, reconstruction, displacement, rebuilding, enlargement, transformation or painting of the monument'

III. Registration and public designation of the cultural monuments and other legislative measures

Article 33: 'Each cultural monument or object which has been designated as a cultural monument are registered in the Register of Cultural Monuments...'

Article 36: 'Entered in the Register of Cultural Monuments are the main data on the cultural monuments, particularly: the type of monument, description and date of creation, place of the monument and name of the owner of the monument...'

Article 40: 'Archaeological excavations and investigations can be carried out only on the basis of a permission issued by the Republic Institute, by previous approval of the Institute in whose area the excavations and the investigations are to be done...'

Article 43: 'While preparing and elaborating a regional and urban plan, i.e., making decisions by which plans of settlements or parts of settlements are to be

replaced..., the competent authority is obliged to obtain previously a statement containing the opinion of the competent institute...'

Article 45: 'Permission for works that might disturb the integrity of the cultural monument ... could be issued only in case an approval by the competent institute is given previously..'

IV Organisation of institutional protection of cultural monuments

Article 48: 'Protection of cultural monuments is performed by institutes, according to the provisions of this Law. Institutes are founded by the municipalities and the Republic....'

Article 51: 'The Institutes decide on the following:

- They consider issues related to protection of cultural monuments;
- They investigate, explore and use scientific methods in dealing with issues related to protection of cultural monuments;
- They elaborate projects on works for conservation and restoration of cultural monuments and take care of performance of these works...'

VII Penalty provisions

Article 76: "Anyone that shall damage or destroy a cultural monument shall be punished by a fine or put into prison for a criminal act.'

In addition to this Code, all the international conventions treating cultural heritage are obligatory in the treatment of the cultural heritage of Macedonia.

In the course of 1996, the Republic of Macedonia ratified all international conventions by succession (which have been formerly signed by SFR Yugoslavia).

In 1949, the Central Institute for Protection of Cultural Monuments and Natural Rarities was established. Presently, there are seven institutes in the Republic of Macedonia: one State institute, one institute for protection of cultural monuments of City of Skopje and five institutes for protection of cultural monuments and the museum in the cities of Bitola, Ohrid, Prilep, Strumica and Stip.

The last ones have been established as a transitional solution. Namely, sections for protection of cultural monuments were formed in already existing museum organisations. However, practice has shown that these cannot yield satisfying results.

Section 3.17

It should be noted however, that experts from scientific and educational institutions like the Faculty of Philosophy, the Faculty of Architecture, the Academy of

Fine Arts and the institutes of the University of Skopje and the University of Bitola take active participation in all the processes.

Despite the practice of the Code, institutions and experts, the non - existence of planned and organised professional training of staff is a handicap for the achievement of better protection of the cultural heritage. The solution of this problem should be one of the priority tasks in future.

Section 3.18

Conservation and restoration activities

The staff of the then existing Central Institute for Protection consisted of an engineer - architect, who also performed the duties of a director, one senior technician - conservator, one craftsman and three painter - conservators.

Although small, the staff of this Institute undertook complex activities on the above - mentioned structures in Skopje and Ohrid (St. Sophia).

Due to the extreme importance of the monument, experts from UNESCO (Mr. Ferdinando Forlatti, Mr. Cesare Brandi both from Italy and Mr. Iv Broadveau from Paris, France) were involved in the investigations and the performance of conservation works on architecture and fresco - paintings.

The works were carried out in the period 1951 - 1958. This activity is important not only because it is a pioneering work on conservation and restoration in Macedonia, but also for another two important achievements.

The architecture and the fresco - paintings of later one important medieval cultural monument in Macedonia were treated. Because of the high values of the monument, Yugoslav Council for Science and Culture appointed a Federal Commission to propose adequate treatment of the monument.

The second one is the conservation - restoration activities of the church mural paintings. It was carried out in the period of eight years. It was the greatest and the longest conservation - restoration work in that time in former Yugoslavia. Namely, in this period of eight years, many experts from all over the country were involved and acquired valuable experience. They later became the core of conservation experts network in Macedonia and Yugoslavia.

It is even today that in these areas, the Ohrid conservation school is highly esteemed.

Section 3.19

This important and valuable fund of movable heritage was the reason for establishment of the well - known Ohrid Gallery of Icons, as one of the most valuable galleries at a European level. The icons were conserved by Macedonian conservators.

The conservation - restoration works were carried out based on the states of the structures and their values, as main factors that designed the list of priority tasks. With the establishment of the city institutes, these activities were increased not according to needs, but according to the possibilities of the state.

Section 3.20

To those activities importance was given by establishing the Republic Institute for Conservation. But, unfortunately it existed only three years. The reasons for this have still not been explained.

As a result of the unique values and the efforts of the community in the course of 1979 and 1980, based on a submitted application, Ohrid and its heritage (both natural and cultural) was listed by UNESCO as a world natural and cultural heritage.

In 1993 and 1994, the Macedonian national committees of ICOM and ICOMOS were established as associations of experts whose endeavours are to bring the protection and conservation of cultural heritage to a higher level.

Section 3.21

We are afraid that this enthusiasm will not be long lasting and this should alert all those that are directly or indirectly involved in protection and conservation of our cultural heritage.

Since their beginning, the conservation and restoration works carried out on the architectural heritage have not always been in full compliance with the recommendations, but according to their number and scope, they still deserve respect.

Why?

According to the number of staff, the technical equipment and particularly due to the great deficit of professional craftsmen, the number of activities is impressive for respect.

Since its foundation, the Service for Protection of Cultural Monuments in Macedonia can be proud of itself for the following activities (expressed by numbers):

- Preventive works carried out on over than 300 structures;
- Partial or complete conservation works carried out on more than 100 structures of medieval churches and monasteries; over 30 monuments of Islamic architecture and art, more than 15 towers, bridges and market places;
- Works on over 100 other kinds of immovable cultural heritage.

Section 3.22

I. General provisions

Article 2: In accordance with the provisions of this Book of Regulations, the high-rise buildings should be designed in such a way that the strongest earthquakes may induce damage to their bearing structures, but no failure. The churches of the Byzantine period in Macedonia should be excluded due to the reason since they are not high rise buildings.

II. Categorisation of high - rise buildings

Article 4: 'Buildings of the first category are those that are intended for larger public gatherings (churches, mosques, inns and museum buildings - adapted cultural monuments). For these buildings, coefficient $K_o = 1.5$ is considered.'

For the second category buildings - residential buildings,(all the buildings of the urban and rural architecture) ..., the coefficient $K_o = 1.0$ (K_o = coefficient used for computation of seismic effects upon the structural elements) is considered.

III. Methods of computation, allowable stresses and displacements

Article 15: 'If computation of the bearing structure is done according to the ultimate states method, the following safety coefficients are applied: a) for reinforced and prestressed concrete = 1.30; b) for steel structures = 1.15 and c) for masonry structures = 1.50.

The above stated data clearly show that, in the Republic of Macedonia, the possibility for some treatment of the heritage from the aspects of earthquakes is only indirectly mentioned.

Section 3.23

Architectural heritage, basic information - Prehistory

As previously stated , there exists material evidence on construction activities that have been carried out since the Neolithic period. Each prehistoric or historic epoch, in accordance with the existing constellations, more or less successfully responded to its construction needs.

The beginning of construction activities is associated, first, with the need for sheltering and then the need for a place for temporary or permanent residence.

If in the Paleolithic Age, man found and used natural space for his own needs, in the Neolithic Age he was already a creator in making adequate living spaces for his needs, using, first of all, natural construction material in the beginning and later in this age, processing this material according to his needs.

The oldest traces of construction activities in Macedonia dating from this period are found in the region of Sveti Nikole (Barutnica near the village of Anzabegovo); over Stip (Vrsnik near the village of Tarinci), and in the Bitola region (Tumba near the village of Porodin and Veluska Tumba near the village of Velusino).

Wood and earth (mud) were the main construction materials for the structures in this period.

The new possibilities introduced with the discovery of metals lead to more sophisticated construction activities. The advance made can be briefly summarised as follows: 'In the Copper Age, the man struck the blade of the moulded copper axe with a stone hammer over and over again so that, once he had tempered it, he could use it to cut down a tree or overcome his enemy.' (*Causidis 1995: 19-20*) This means that in this age, man acquired a tool - an implement that rapidly changed the then existing world.

Due to the geographic position of Macedonia and the historic conditions, the main construction activity was directed toward houses, but also fortresses as elements of the ruling class, at the beginning of the class society.

The local, natural material, now well processed, was the main element used for the creation of the structure. Known structures from this period are: Visoki Rid near the village of Buki; Tumba near the village of Radobor; Karamani and Kaino, Gradiste near the village of Pelince and Pribovce near Lopate, Kumanovo region.

Antiquity

Antiquity and the Classical period constitute an epoch in which the development of Macedonian's material and spiritual culture reached its climax. All this was based on a phenomenon known as civilisation.

The first millennium BC is the time of the Paeonian State on the territory of Macedonia. This region was exposed to the influence of strong cultural currents from the superior south - eastern civilisations at an extremely early stage.

The construction activity during the rulers, whose capital was near Demir Kapija, was to a very high level, which is proved by the remains of their residences. Stone masonry, well - dressed limestone and no lime mortar were the dominant walling patterns of these settlements.

Towns, as places for living in groups, were characteristic for this period. Developed with these towns was the first urbanism - simple and practical. Unfortunately, there are only remains from fortifications, very rarely from residential structures.

Religion, as a constituent part of the social life of the community played a great role in the interpretation of the space necessary for exercising and consuming of these needs, but not with the quality of those in the Aegean world.

Section 3.24

Roman period

These are found as archaeological localities, individual and complex structures, irrespective of whether they are private - residential, public, religious or defensive, and structures intended for certain purposes. When talking about construction activities, certain urban agglomerations, whose remains are one of the most valuable in Macedonia from this period, should be discussed in more details.

Stobi

Stobi, an urban settlement whose beginnings date back from the end of the fourth century BC, had an important role during the Roman reign. In this period, there was an extensive building activity. Secular structures (theatres and like), private residences - palaces, and religious structures (eight early Christian basilicas), (Fig. 3.5 and 3.64)

Scupi (Skopje area)

The city of Scupi (present Skopje) developed from an early Roman Legionary

camp on the western slope of Zlokukansko Kale.

Noteworthy among structures from this period are: the Roman theatre and the basilicas - both Roman and early Christian (3). This was the period of conversion of the local pagan population to Christianity.

Heraclea Lyncaestis (Bitola area)

Heraclea Lyncaestis (near Bitola) got its name from Hercules, the legendary hero and father of the Macedonian royal dynasty of the Argeadae. There are remains of a stronghold erected during the reign of King Philip V of Macedon.

There are also remains of several basilicas (7) and the theatre - small in proportions but well preserved, as well as remains from the clerical residential complex (the Episcopal ensemble). This was also the Christian Episcopal Centre of southern Pelagonia.

Lychnidos (today Ohrid)

Lychnidos, by the lake of Ohrid (present city of Ohrid) had many structures of private, public, sacral-religious and defensive character during the Roman period.

Christianity spread by St. Erasmo in the beginning of the fourth century was the reason for the erection of several early Christian structures - basilicas (Imaret; St. Erasmo; Studencica). (Fig. 3.65)

Section 3.25

Byzantine period

This was the period when this territory was not under the rule of the Byzantine Empire. However, it is a fact that the new religion - Christianity -, played an enormous role in all spheres of social and cultural life of this area.

The settlement of the Macedonian Slavs in the Balkans is of a great importance for the culture of the Macedonian people since a contact was made between two worlds - the barbarian and the pagan world - with the Byzantine one, with the highest accomplishments of civilisation in that period.

The first contacts were destructive for the advanced culture. There was a terrible Slavonic destruction of the Roman culture and the rising Byzantine one. A struggle

between pagans and believers, a struggle between 'culture' and 'uncultured' - a struggle against the unknown.

However, the Slav population that settled in these areas in a great number, with their own traditional values brought from their homeland, abandoned soon this destructive instinct.

The period from the beginning of the seventh and the end of the ninth century in Macedonia, is not marked by extensive construction activity since it was a period of permanent settlement of Slavonic tribes.

Section 3.26

Ottoman Empire - the post Byzantine period

The Islamic temples - the mosques - with heavy domes and high minarets, were erected in prominent places by prominent people (sultans, pashas, beys). Skopje and Bitola were towns of political and economic importance. Therefore, the most important samples of Islamic architecture (religious or secular) in Macedonia are found in these towns.

With the decline of the Ottoman Empire, there were conditions for a modest increase of the economic power of the new class - the Macedonian middle class. This was the end of the eighteenth and the beginning of the nineteenth century.

In accordance with the circumstances, a fast construction activity began in both spheres - religious and secular. New donators of Christian origin, supported the construction of religious and vernacular structures. This was the time of the Macedonian renaissance that is seen in the intensive construction of residential structures and churches in towns.

Towards the mid - century, began the construction of imposing three - nave basilicas, enveloped by wide porches at the west end and the sides, covered by domes, with high bell towers over the western galleries.

Section 3.27

Typology and chronology

The living activities and the development of Macedonia from this period until the beginning of the twentieth century and after, have been marked by, sometimes

decreased, but permanent and noteworthy building activities.

Namely, it was then that imposing sacral three - nave or five - nave basilica - like structures characteristic for the fifth till ninth century were created. It is usually thought that these are replicas of the basilicas in Constantinople and Thessaloniki, but constructed of other materials and with different church furniture.

The continuity of each type of a structure will be considered from its beginning to its end.

Section 3.28

Islamic architecture

The Turks used, sometimes, to turn the existing churches into mosques, as was the case with St. Sophia church in Ohrid. (Fifteenth century)

The oldest and the most valuable Islamic sacral structures were constructed in Skopje and Bitola. Noteworthy among these are Hadji Kasm Mosque (1420) in Skopje and Sungur Crier Mosque (1434) in Bitola. Unfortunately, both have been ruined.

Some of the better preserved and still functioning structures in Skopje are: Sultan Murat II's Mosque called Hunkar Mosque (1436 and later restored), , Mustafa Pasha's Mosque (1492) (Fig. 3.7 - 8), Isac Bey's Mosque called Aladja Mosque (1438), Isa Bey's Mosque (1475) (Fig. 3.9) with two domes that remind us of the mosques in Bursa (Turkey), Jaja Pasha's Mosque (1506) with a richly ornamented portal, etc.

Noteworthy among those in Bitola are: Isac Bey's Mosque (1508), Hajdar Kadija Mosque (1561), Jeni Mosque (1558).

It should be mentioned that there is a very rare mosque in Tetovo. It is called Sarena Djamija (Coloured Mosque).

Section 3.29

Christian tombs

It is frequently the case that the cemeteries are located near the sacral structures. They exist, often slightly removed, but still within the area of the churches.

Often, the graves of eminent priests are immediately next to the church in which they worked.

Sometimes, in larger town agglomerations where space is valuable, town cemeteries are formed at the peripheral parts of the towns. For functional needs, the so called 'cemetery churches' are built within the frames of these cemeteries. Such dislocated cemeteries are found in almost all larger towns in Macedonia.

Islamic tombs

The same is the case with the Islamic tomb architecture. There are valuable samples of marble tombstone elements of certain historic and aesthetic values.

They are square or polygonal and are usually covered by a cupola.

There are only a few turbehs that have been preserved (some of them were destroyed during the disastrous earthquake of 1963). Noteworthy among these are those in the courtyard of Mustapha Pasha and Aladja mosques (*Fig. 3.10*) in Skopje and in the courtyard of Aladja Mosque in Tetovo.

Section 3.30

Ohrid

Ohrid's fortification architecture dates from long ago. According to some historic data, the first fortification walls date from the fourth century AD. These were very skilfully incorporated into the steep terrain, as an organic part of the configuration of the terrain, whereby they were very efficient. Upon the remains of these fortification walls, there was constructed a new citadel at the time of king Samuel.

Skopje

It is assumed that the beginnings of the Skopje fortress date back to the Neolithic period (based on archaeological findings - ceramics). This continuity did not stop until the midst of the nineteenth century.

There was a fortified settlement in the beginning of the tenth century. It existed throughout the whole Middle Ages. Today, there are remains of the fortification walls and either towers with either square or circular cross - section.

As is the case with each fortification, the Skopje fortress has a dominant location in the town. This fortress represents, in fact, the core of medieval Skopje. (*Fig. 3.11*)

Other towns

In Kratovo, Stip and Prilep as well as in the Polog valley (Tetovo - Gostivar), there are remains (walls and towers) of medieval fortified cities that were enlarged in the Middle Ages.

The remains of fortresses, although in ruins, look majestic. Although they were built only for military purposes, the aesthetic principles were not neglected. They are part of the functional concept of the citadel itself. Both the volume of the towers, which reinforced the walls, and the concept of their sculptural forms helped the citadel become part of the landscape.

Markovi Kuli in Prilep is a typical example of this. Here the walls and the towers of the citadel are incorporated with unusual forms of natural rocks and create a unique work in which nature and man's creation have become an indissoluble unity.

During the Ottoman rule and the decline of power of the Turkish rulers, towers with two functions (defensive and residential) were built in some towns or larger rural settlements that the Turks they owned. Their owners moved into these towers in case of danger and stayed there until the situation had calmed down. These towers possess the functional characteristics of defence and residence.

The greatest number of preserved structures of this type are found in Kratovo as well as Skopje, Negotino and Kavadarci.

Section 3.31

Economic architecture

A.4.a Communication structures (bridges)

Bridges are very important architectural and engineering structures. From the Roman period in Macedonia, there are remains of abutment footings of a bridge in Stobi (third - fourth century AD). The building of bridges flourished in Macedonia during the Turkish period. (*Fig. 3.13*).

Existing structures in Macedonia dating from this period are: the Stone Bridge in Skopje, the bridges in the town of Kratovo as well as the bridge over Babuna river in the village of Bogomila - Central Macedonia.

A.4.b Water supply structures

Water is one of the basic needs for development and living activities in populated areas.

In Skopje, there are remains of the old aqueduct (15 - 16th century) through which water was transported from Skopska Crna Gora mountain to the city. This is a unique example of an aqueduct in Macedonia. (*Fig. 3.12*)

A.4.c Production - trade architecture

The oldest example of a structure pertaining to this type (from which only the walls are preserved) and used for production purposes is the so called 'Textile Workshop' in Stobi dating back to the fourth century AD.

A much larger number of these (conditionally speaking) serving for production and trade functions date back the Turkish period (after the fifteenth century). Such structures in Macedonia referred to as 'bezisten' (covered market places) exist in Skopje, Bitola and Stip. (*Fig. 3.14*)

These structures in Skopje and Bitola have preserved their original function - trade - until nowadays. That in Stip has been converted into an art gallery.

A.4.d Clock - Towers

As everywhere in the world, measuring of time was of importance also in Macedonia, in town settlements, particularly after the eighteenth century. The clock - towers were therefore important places in the cities. They were built in the middle or at some landmark place of the city. Preserved clock - towers are found in Skopje (*Fig. 3.15*), Bitola, Prilep, Ohrid, Kratovo and Veles.

A much larger number of these (conditionally speaking) serving for production and trade functions date back the Turkish period (after the fifteenth century). Such structures in Macedonia referred to as 'bezisten' (covered market places) exist in Skopje, Bitola and Stip. (*Figure 3.14*)

These structures in Skopje and Bitola have preserved their original function - trade - until nowadays. That in Stip has been converted into an art gallery.

Section 3.32

This was a very functional architectonic complex. Namely, after the long journey, the merchants used to go to the mosque to thank Allah for the happily ended journey of the caravan. Then they used to take a bath in the Turkish bath and go to sleep in the caravan sarai.

Section 3.33

- *Baths*

These were most frequently constructed on locations of hot springs and served not only for maintenance of body hygiene and also for curing purposes. Structures of this type are found in Debar, Kezovica near Stip, Negorski Banji near Gevgelija and Banja BANSKO (Strumica).

The Turkish baths were usually built as big (double) or smaller baths consisting of only one part. The double baths had two separate parts for men and women.

As to the plans and the heating of the baths, the Turkish baths are similar to the Roman *thermae*. They were also built of stone and bricks and were covered by domes. Each big bath had the following rooms: *shadrvan* (wardrobe), *kapalak* (rest room), *halvati* (bathing room), *hazna* (water reservoir) and *kulhan* (resting room).

The most important Turkish baths in Macedonia are: Daut Pasha Bath in Skopje - 15th century (now converted into an art gallery) and Deboj (Bitola - now converted into covered market).

Section 3.34

- *Earth*

- Earth floor areas in residential premises, and particularly accessory premises as are stables, pantries and the like; infill for floor structures, etc.;
- Different types of masonry mortar (depending on additives) for construction of structural elements of different kinds;
- Earth mixture for plastering of walls and ceilings constructed of stone, bricks, sun-baked bricks and timber partition and bearing elements, i.e., infill for different kinds of partition walls;

- As a main element for production of sun - baked bricks of different proportions and with different additives (sand, gravel, cut straw, animal hair). The brick is the main element for construction of different kinds of bearing and partition walls;
- Special kinds of earth - clay with characteristic properties is used for manufacturing of different kinds of baked bricks and covering elements - tiles.

Section 3.35

- *Stone*

In its dressed form has been used for:

- Construction of almost all kinds of foundations in earth or lime mortar;
- Infill in lime mortar, for the formation of the core of many kinds of bearing walls (with two faces) in different types of structures;
- Infill in earth mortar, for different bearing and partition timber structures, floors, floor structures and attics;

In its dressed form, the stone is used for:

- Construction of all kinds of bearing and non-bearing structural elements, systems and forms, with or without the usage of a bonding material - mortar and baked brick, as are: foundations, columns, walls, piers, beams, lintels, arches, vaults, domes, semi - domes, pendentives, squinches and buttresses;
- Construction of different kinds of elements as are: capitals, parapets, paved floor areas, mosaic walls and floor areas, preparation of different kinds of earth and lime mortar;
- Preparation of lime mixtures according to known procedures - baking and hydrating of limestone in special ovens - a tradition which is still active in Macedonia.

Section 3.36

They have the property sustaining the loads from the arches, the vaulted and dome structures through the capitals or the arch.

Sometimes, they were used in smaller proportions (both regarding length and cross - section) as bearing elements, often decorative - with a relief structure, in biforia or triforia of the facade walls of the churches from the Byzantine and the post - Byzantine period.

Section 3.37

- Timber non - structural wall / partition structures with different kinds of infill;
- Masonry, bearing structural walls constructed of sun - baked bricks, stones, bricks or a combination of the stated elements, with or without a binding material, mainly two -skin and with an irregular core. Exceptions are masonry bearing structures constructed of bricks (sun - baked or baked) in mud mortar or lime mortar, where horizontal continuous brick rows are found in both directions along the whole cross - section of the structure.

Section 3.38

Being born as a town religion against the paganism, the Christianity built its hierarchy parallel to the civil one, and the bishops in towns represented the supreme authority of the late antique civitas.

When talking about the beginning of the church architecture in Macedonia, its continuity was enabled by the development and the flourishing of the Byzantine Empire and culture that greatly affected the thorough development of all the countries in its vicinity (Macedonia, Serbia, Bulgaria) and even beyond (Romania, Russia, Syria, Armenia).

The Christianity, that was organised and reinforced by the emperors, was a bearer of great building activity of sacral character. The great public and private edifices from the old antique towns regained new usage and they served as Christian temples, while the luxurious niphons and pools were used as baptisteries. Here, in Macedonia we have a good example in Stobi, where Early Christian Basilicas represent the old Roman palaces and synagogues converted into Christian churches.

This meant rearrangement of the town areas and of the buildings in them and forming of new town quarters with objects of the Christian cult and edifices which formed the Early Christian complexes. So, the Christianity as one of the leading factors in the state and the towns, contributed to the change of their urban organisation.

However, this influence was the most intense in Macedonia and Serbia inhabited mainly by Slavic tribes. Both at the time of their independence and under the rule of Byzantium, the most beautiful examples of architectural heritage and examples of Byzantine fine arts were created in these states, which were beyond the centres of the Byzantine Empire - Constantinople and Thessaloniki.

However, in the course of time, the Slavic Macedonian population adopted the Christian religion (end of the ninth and beginning of the tenth century) and they started to express their cultural entity thoroughly in the spirit of the Orthodox Byzantine Empire.

However, construction activities did not end at that time, but have been continued until nowadays.

A particular transition was made with the fall of the territory of Macedonia (as a constituent part of the Medieval Serbian State) under the Ottoman rule by the end of the fourteenth century.

After the fall, the construction of churches continued in Macedonia but with a drastically lower intensity, with specific characteristics, in accordance with the new state, which can be the subject of some other investigations and another dissertation.

Section 3.39

B. General characteristics

In accordance with the organisation of the service in the Christian church, large premises were needed for the increasing number of believers. The most appropriate for this purpose were the basilicas, samples of which (now as archaeological remains) are found in the above stated town agglomerations.

After the settlement of the Slavic tribes in the Balkan and their first frightful reaction - destruction of all that is new and unknown to them - there was a period of stagnation of construction. This was the state of construction until the mass conversion of the Macedonian Slavs which took place at the end of the ninth century.

Activities for construction of such large churches were dominant until the fall of the Samuel's Empire under the jurisdiction of the Byzantine Empire at the beginning of the eleventh century. The church in this period played a great role in supporting the fight for independence of the Macedonian people within the frames of their own Macedonian state.

This was the period of Macedonian renaissance, which although late, has all the characteristics of the European one which took place several centuries before. Large buildings - basilica-like structures were constructed according to the basilica structures from the tenth and the eleventh century, i.e., the time of the Samuel's Macedonian Empire. From this period, there are structures that, according to their proportions, correspond completely to the old basilicas but have different interior and church furniture. Such are the churches in Veles, Prilep, Bitola, Kriva Palanka.

The construction of sacral Christian buildings in Macedonia still continues.

Section 3.40

According to chronology, the basilicas are the creations that were mostly built from the beginning of this period until the beginning of the eleventh century when central type of structures - trefoil or tetra - foil and cross -in - square structures began to be built.

Churches dating from the fourth until the ninth century are found only as archaeological remains or bases upon which new - adapted structures were constructed.

Structures that were constructed after this period still exist, more or less, in their original form and structure, which was one of the decisive factors for elaboration of this dissertation aimed at their preservation for the future generations.

A classical example is the church of St. Georgi, v. Staro Nagoricane which represents an original basilica transformed into an elongated cross - like church with five cupolas. (*Fig. 3.70 and 4.1d*)

From this period until the end of the fourteenth century, the dominant plan of structures was the classical and the most recognisable type of structures: cross - in - square structure with one or five domes.

APPENDIX FOUR - Chapter four

Section 4.1

Churches of triconchal and tetraconchal design

Another concept was used for the construction of churches of smaller dimensions as part of monastic complexes. These churches belonged to a single monastic order of monks or nuns and were intended for a smaller number of worshippers.

The central area of these churches is surmounted by a dome (which is always semicircular) resting on an octagonal drum which is constructed over the circular spatial architectonic element formed, with no exception, by the construction of spatial triangular elements - pendentives. Most commonly, the drum is octagonal seen from outside and circular from inside.

Section 4.2

Churches as single or five dome cross - in - square structures

The plan of these structures is covered by four main vaults over the cross-arms and a dome space. Sometimes the corners between the spatial cross - arms are lower and are covered either by vaults or by smaller domes which are lower than the central one.

The development of the quincunx churches of this type was a specific characteristic until the erection of St. Bogorodica, v. Matejce. The church of St. Georgi, v. Staro Nagoricane was formed by renovation of an older Byzantine basilica with the introduction of a five - domed plan.

The large proportions of the St. Bogorodica, v. Matejce central dome and the low narthex which is only distinguished by separation from the naos with two columns and two new columns instead of a wall, give an overwhelming beauty to the interior.

The central drums are most commonly *octagonal* or *dodecangular* (St. Bogorodica, v. Matejce - unique example in Macedonia).

Section 4.3

Chronological development of the church buildings

The development of this church architecture and its construction throughout this period may be considered with regard to its continuity starting from the fourth century when there were many people that did not yet accept Christianity. At this time a large space was needed in order to make possible the division between believers and non-believers and, later on, division between the sexes.

The concept of the Roman three - aisle basilica (with or without a cupola and transept) was used for many purposes such as public meetings, justice courts, shopping, while later on, it was used or adapted for congregational purposes. There was a clear division between the clergy, worshippers and the non - believers.

Saint Clement of Ohrid made a good and clever move. He decided, for the new purposes, to restore an older triconchal building, suitable for a school and a monastery. The edifice created was an architectural model which was intended to be followed.

The most renowned structures pertaining to this type are the following: St. Achileus on the island bearing the same name on Lesser Prespa Lake, and St. Sophia in Ohrid, which was the seat of the Ohrid Archiepiscopacy for a long period.

Section 4.4

It is possible that, in the beginning, the old part of St. Georgi in v. Staro Nagoricane was a basilica as well.

According to a legend, the old structure was erected by Romanus IV Diogenes (1068-71), who became emperor inspired by a vision that he had there. The massive walls, using no bricks, were built of dressed trachite. The lintels of the doors and the windows were flat cornices and the niches on the lateral facade were deep. It is said that the church 'resembled those to the East.' Later, in the course of the fourteenth century, this church was transformed into a cross -in - square structure.

The old basilica structure obtained a new architectonic shape within the frames of the existing outline. Formed within the basilica was a five - domed cross elongated precisely because of the shape of the old building. The adapted part of the church bears all the characteristics of the Byzantine churches from the fourteenth century, particularly the facade.

In the same century, due to the decreased construction of such large and spacious structures as are the basilicas, there started the construction of smaller cross-like structures. This represents a step forward in construction of cruciform - domed structures, as opposed to those of the central planned edifices in Constantinople.

Section 4.5

St. Atanasie, v. Lesok

Although the structure is in ruins, its contours can be defined. It consists of a central dome resting on four pilasters that mean continuation of the walls on the north and the south arm of the spatial cross. To the west, there is the narthex with the dome supported by the east - west perimeter walls, and the arches in the north and the south wall. Inside the structure, there are capitals with the presentations of human, animal and floral elements, a unique example of the Romanesque influence in Macedonia.

Section 4.6

• Basilicas - in total (Figure 4.1)	4
- without dome	1
<i>St. Nikola, v. Manastir</i>	
- with dome on central nave	2
<i>St. Sophia, Ohrid; St. Bogorodica, v. Drenovo</i>	
- converted basilica into quincunx	1
<i>St. Georgi, v. Staro Nagoricane</i>	
• Triconchs and tetraconchs - in total (Fig. 4.2)	4
- triconchs	3
<i>St. Naum, v. Ljubanista (complex of churches, the oldest one and only in traces); St. Panteleimon, Ohrid; St. Andrea, v. Matka</i>	
- tetraconchs	1
<i>St. Bogorodica Eleusa, v. Veljusa</i>	
• One or five dome cross - in - square (Quincunx) - in total	25
<i>(Fig. 4.3A - B)</i>	

- one dome cross-in-square (on free standing piers or columns and cantilevers) 14

St. Panteleimon, Ohrid (second church-archaeological site);
St. Jovan Kaneo, Ohrid; *St. Bogorodica Zaumska*, v. Trpejca;
St. Atanasie, v. Varos; *St. Stefan*, v. Konce; *St. Nikita*, v. Banjani;
St. Nikola, v. Ljuboten; *St. Nikola*, v. Celopek (dome on cantilevers);
St. Archangel Mihail, Stip; *Complex of Churches St. Leontie*,
v. Vodoca (Church from the end of the tenth century-reconstructed
in 1975/85; Church from the twelfth century-reconstructed in 1975/85;
Church from the fourteenth century-reconstructed 1975/85; *St. Georgi*,
v. Gorni Kozjak; *St. Bogorodica Treskavec*, v. Dabniste (the oldest
part of the church); *St. Dimitrija*, Varos; *St. Petka*, Debar

- one dome cross-in-square with narthex 4

St. Bogorodica Perivlepta, Ohrid; *St. Arhangel Mihail*, v. Lesново;
St. Spas, v. Kuceviste; *St. Dimitrija-Marko's Monastery*, v. Susica

- two domes cross-in-square 1

St. Nikola, v. Psaca;

- free cross 2

St. Atanasie, v. Lesok; *St. Bogorodica*, St. Joakim Osogovski Monastery,
v. Gorno Varoviste

- five dome cross in square (quincuncx) 3

St. Bogorodica, v. Matejce; *St. Georgi*, v. Staro Nagoricane
(converted from basilica); *St. Panteleimon*, v. Gorno Nerezi

• **Single nave - in total (Fig. 4.4)** 27

- single nave 24

St. Vraci Mali, Ohrid; *St. Dimitrija*, Ohrid; *St. Kliment Mal*, Ohrid;
St. Georgi, v. Recica; *St. Bogorodica Celnica*, Ohrid; *St. Nikola Bolnicki*, Ohrid;
St. Nikola Cudotvorec Celnicki, Ohrid; *St. Nikola*, Varos; *St. Bogorodica*,
Varos; *St. Spas*, v. Zrze; *St. Arhangel Mihail*, Varos; *St. Georgi*,
v. Kurbinovo; *St. Nikola*, v. Radisani; *St. Nikola*, v. Sisevo;
St. Bogorodica, v. Susica; *St. Arhangel Mihail*, v. Radozda (cave church);
St. Dimitrija, Veles; *St. Spas*, Stip; *St. Jovan*, Stip; *St. Nikola*, Veles;
St. Erazmo, v. Lakocerej-Ohrid (cave church); *St. Petar*, Island

Golem Grad, Prespa Lake; *St. Atanasie*, v. Sisevo; *St. Ilija*, v. Banjani;

St. Ilija, v. Grncari;

- single nave with opposite vault 2

St. Bogorodica Bolnicka, Ohrid; St. Elena and Constantine, Ohrid;

- single nave with one dome 1

St. Georgi Poloski, v. Begniste;

Section 4.7

¹ In this group are: *St. Panteleimon*, v. G. Nerezi; *St. Naum*, *St. Leontie*, v. Vodoca and *St. Sophia*.

² Part of *St. Leontie*, *St. Bogorodica*, v. Veljusa; *St. Sophia*, *St. Georgi*, v. Staro Nagorcane - the old part - basilica and *St. Nikola*, v. Manastir.

³ *St. Bogorodica*, v. Veljusa - the south chapel; *St. Panteleimon*, v. Gorno Nerezi; *St. Gorgi*, v. Kurbinovo and *St. Gorgi*, v. Gorni Kozjak.

⁴ *St. Jovan Bogoslov -Kaneo*, Ohrid; *St. Nikola*, v. Varos-Prilep and *St. Bogorodica Perivlepta*, Ohrid

⁵ *St. Petka*, *St. Gorgi*, Poloski Manastir, v. Begniste; *St. Nikola*, v. Psaca; *St. Bogorodica*, Osogovski Monastery; *St. Bogorodica*, v. Matejce; *St. Gorgi*, v. Staro Nagoricane, *St. Nikola Cudotvorec*, *St. Kliment Mal.* *St. Bogorodica Celnica*; *St. Vraci Mali*, *St. Nikola Bolnicki*, *St. Bogorodica Bolnicka*, *St. Erazmo*, *St. Naum*, *St. Bogorodica Zaum*, v. Trpejca-Lake Ohrid; *St. Georgi*, v. Recica; *St. Elaena and Konstantine*, *St. Bogorodica Treskavec*, *St. Dimitrija*, Varos-Prilep; *St. Atanasie*, Varos-Prilep; *St. Spas*, *St. Archangel Michael*, Varos - Prilep; *St. Archangel Michael*, v. Lesnovo; *St. Stefan*, *St. Georgi*, Golem Grad-Prespa Lake; *St. Nkita*, *St. Ilija Gorni*, *St. Nikola*, v. Ljuboten; *St. Nikola*, v. Radisani; *St. Spas*, v. Kuceviste; *S. Nikola*, Sisevo; *St. Atanasie*, v. Sisevo; *St. Andrea*, *St. Bogorodica*, v. Susica; *St. Dimitrija*, v. Susica; *St. Georgi*, v. Radozda; *St. Atanasie*, v. Lesok; *St. Nikola*, v. Celopek; *St. Dimitrija*, Veles; *St. Nikola*, Veles; *St. Archangel Michael*, Stip; *St. Spas*, Stip; *St. Nikola*, Stip; *St. Jovan*.

Section 4.8

Churches as basilicas with or without a cupola and transept (Fig. 4.1)

All the piers represent massive masonry structures with a square or rectangular cross - section with similar dimensions to those of the perimeter walls. This refers to the churches of *St. Sophia*, Ohrid (*Fig. 4.1b*) and *St. Nikola*, v. Manastir (*Fig. 4.1a*) which represent original authentic creations. This form is changed and has larger and irregular proportions in the case of the church of *St. Bogorodica*, v. Drenovo (*Fig. 4.1c*).

The arches as structural elements of the wall structures which are used to span the openings (doors, windows or the span between the columns) are always of the proportion of the wall or the column. They are always semi - circular.

The vaults, as main structural elements for the horizontal spans between the vertical bearing structures (the walls and the columns) are most frequently of a semi-circular form. Two structures (St. Sophia and St. Georgi, v. Staro Nagoricane (*Fig. 4.1d*)) are characterised by the use of groined vaults in the narthex of the first structure and the central part of the second structure.

The pendentives as spatial structural elements are present in all structures with the exception of the church of St. Nikola, v. Manastir, which has a classical basilica-like structural form without a dome.

The dome as a structural element is an existing element (in its original form) in two structures (St. Sophia – exonarthex from the fourteenth century and St. Georgi). In the case of the church of St. Bogorodica which does not have any masonry roof structure (now ruined), there are some remains in the central dome area and in the west part.

Section 4.9

Churches of triconchal and tetraconchal design (Fig. 4.2)

The perimeter walls of these churches consist of shorter lengths which outwards to form rectilinear 'transepts' externally, with their internal faces are concavely curved. In fact, these curved forms basically represent the cross – the symbol of the Christian faith – transcribed in a material form. These deviations of the straight line from both inside and outside are characteristic of this group.

It is characteristic that only two structures are complete and in their original form – St. Andreja, v. Matka (*Fig. 4.2c*) and St. Bogorodica Eleusa, while the other two exist only as archaeological remains, which are however sufficient to assume their spatial structural elements and structural system.

The dome – the main spatial element that is found in all the structures of this group rests, via the pendentives, on the half of the hemisphere that vaults the semi-circular form of the cross arms. There is only one structure (the church of St. Bogorodica Eleusa, v. Veljusa, *Fig. 4.2d*) representing a tetraconch, where all the arms of the cross have a semi-circular form from the inside. As to the three remaining structures, the west arm of the cross has a rectangular shape from the inside. It has a different covering structural element – barrel vault instead of a hemisphere as is the case with the remaining three arms.

Section 4.10

Churches as single or five dome cross-in-square structures (Fig. 4.3A-B)

In the second case, the placement of the corner domes does not have the attribute of contributing to structural stability as is the case with the first variant, but contributes to the visual and aesthetic effect.

A particular characteristic of all the examples is that the form of the cross is visible not only at plan but also as a spatial structural form. This is particularly evident on the fifth facade of these structures (roof seen from above).

The apse structural form is always semi - circular from the inside and, as a rule, polygonal from the outside.

Section 4.11

The structural elements enable that all the loads from the highest point of the structure the dome, to be transferred through the shortest way, i.e., through the tambour, the pendentives, the arches, the vaults, the columns and the walls to the foundation and hence to the soil. Each individual element contributes to the stability of the structure as a whole.

Their existence today after so many centuries is a sufficient proof that their structural system has the ability to sustain all kinds of external damaging factors, both static and dynamic.

The dome as a structural element which differentiates this and the previous type of structures from the other two types, is situated on the topmost point of the structure. This emphasizes its symbolism and the importance of Christ Pantocrator since his presentation is always found inside the dome.

An emphasis will be put on the use of timber structural elements because of their great importance.

In almost all the buildings, there are timber ties placed at several levels in the interior. They are most frequently placed at the foundation level of the vaults of the cross-arms, at the level of the side vaults and the capitals of the piers. These ties sustain the tensile stresses occurring in the structure due to the secondary effects like differential settlement, wind and seismic effects. Placed in the walls they represent timber belts. These timber horizontal belts stretch all through the perimeter walls, at several levels. It is very important to say that they are placed at the level of the timber

ties. In this way, a system of timber beams and belts is formed that stiffens the whole structure and increases its stability under dynamic, i.e., seismic loads. In this way a synchronous behaviour of the individual wall elements is made possible with several lines of defence of the structure. (*Fig. 4.3Bd and 3.41*)

There are examples of apses being semi - circular from the outside (St. Bogorodica, v. Matejce and St. Sophia, Ohrid. The church of St. Dimitrija, Varos (*Fig. 4.3Ah*) has two apse forms, which are semicircular also from the outside. As to the side naves and the area of the diaconicon and the proskomide, they are always vaulted by a semi - dome.

Usually, the octangular tambour on the facade always has a side at the main axes with the exception of the churches of St. Arhangel Mihail, Stip (*Fig. 4.3A/e*) and St. Arhangel Mihail, v. Lesnovo (*Fig. 4.3Bb*) where there is an edge in the form of a semi - circular column at the axes.

Section 4.12

- by a couple flat roof as is the case with the churches of St. Dimitrija, Ohrid (*Fig. 4.4a*) and St. Georgi, v. Kurbinovo; (*Fig. 4.4e*)
- by barrel vaults – St. Kliment Mal, Ohrid (*Fig. 4.4c*), St. Nikola, Varos (*Fig. 4.4d*) and others.
- by barrel vaults and one dome – St. Georgi Poloski, v. Begniste as a sole example of a single - nave structures with a dome in Macedonia; (*Fig. 4.41-42*)
- by a system of barrel vaults crossed at different level, the lower being always the one in the east-west direction, while that in the north - south direction being always perpendicularly placed upon the lower one. In fact, they represent a spatial cross in which the spaces merge one into another (St. Bogorodica Bolnicka, Ohrid (*Fig. 4.4f*) and St. Elena and Konstantin, Ohrid (*Fig. 4.4 g*).

Here also, the timber ties are used in vaulting the area. These and the horizontal timber belts incorporated into the wall mass at the level of the ties, represent a traditionally high quality structural element.

Most frequently, the apse is semi - circular from the inside and vaulted by a semi - dome, while its form is polygonal from the outside. Almost always, blind niches – conches - are incorporated in the wall mass of the east wall. These represent the diaconicon and the proskomide.

Section 4.13

The foundations of the structures that represent the base of the superstructure, but also an element for contact with soil on which the structures are erected, have had little attention paid to them in the investigations that have so far been carried out in Macedonia. Based on scarce data, these represent massive walls composed of natural or semi - dressed stone of a lower quality and good lime mortar.

It is assumed that, due to their importance, they have a somewhat different morphology. Namely they have two faces, a somewhat higher quality of constructed core which is more compact than that of the superstructure and has much more stone aggregate and less of mortar. More details on all the characteristics of materials (chemical - physical and mechanical) will be given in Chapter five, noting that the information is general for all the materials found in Macedonia.

To form the vertical bearing structures of the superstructure – the perimeter - and the inner partition or bearing walls, the piers and the drum walls, the builder used a combination of four types of construction material:

- Local stone of poor technical properties. This is most frequently limestone, tuff and sometimes sandstone. These all have the common characteristics of being light, but with a possibility of being easily processed and cut into the desired dimension and form;
- brick which was produced in different proportions (width and length), but with a constant thickness ranging from three to four and half centimetres. It is well baked and its form is adapted to the special needs. More details on its mechanical properties are given in chapter five;
- lime mortar as a binding material, with or without additives whose main chemical-physical and mechanical characteristics are given in Chapter 5, and,
- wood, mainly high quality oak wood, used for construction of the horizontal timber belts incorporated into the wall mass.

It must be mentioned however that, in the course of the first epochs of Byzantine construction, the builders used material from older structures "in situ" or they brought them from the immediate surroundings. Certain elements (particularly columns,

capitals, bases, parapet slabs from iconostasis, etc.) were incorporated into the new structures. They sometimes contributed to modification of the planned proportions of the plan so that these were adapted to the dimensions of the taken elements. There are many of examples, noteworthy among which are those in the church of St. Bogorodica, v. Drenovo (*Fig. 4.1c*) where marble columns and capitals from the archaeological site of Stobi, which is in the immediate surroundings, were used for the creation of the biforia in the north, the west and the south wall of the central area.

To form the covering structures (vaults, pendentives, domes, semi - domes and the flat coupled timber roofs) closing the structure from above, the previously mentioned construction materials were used. This completes the structural system of the buildings.

Each of these structural elements was constructed of a certain type of construction material.

The arches, the vaults, the pendentives, the domes and the semi - domes are most frequently constructed of high quality baked brick placed radial , with a smaller joint at the entrados than at the extrados. (*Fig. 4.10-11*).

However, there are cases when the vaults are constructed of dressed stone (mainly tuff) particularly in the first (St. Sophia, Ohrid) and the fourth typological group.

Worthy of to mention is the quality of the lime used with or without additives that has contributed to the long existence of these structures on this soil.

Section 4.14

In the service of Christianity, paintings became visual interpreters of a network of abstract theological ideas about the Scriptures, the relationship between the Old and New Testaments, baptism as a witness to the incarnation of God, the ascension of Christ and the Mother of God, suffering as a way to salvation, the power of faith, its deeds, its miracles, all the mystery of the Eucharist.

Section 4.15

The iconostasis, formally a parapet, represents an essential bond between the two natures of reality embodied in Christ, the spiritual and the physical, and gives meaning to the living rather than the 'deceased', the vital rather than the mechanical function performed by icons.

The iconostasis not only represents a screen, but is the bearer of another element of Byzantine fine arts and culture – the icon. The Ohrid gallery of medieval icons contains some of most important and most renowned such as those originating from Sinai, Mount Athos, Moscow.

Section 4.16

What are the characteristics of this system? It is a combination of horizontally and at a certain distance vertically, placed bricks that form square, or frequently rectangular fields. Incorporated in these fields are semi - and well - dressed stones. The bricks are horizontally applied in one, two or rarely three rows, while one or two parallel bricks are placed vertically (*Fig. 4.25-26*). Sometimes, vertical placement of bricks is not used as a separating element, but several horizontally placed (one onto another) narrower bricks are used instead. Such a walling pattern is characteristic for the church of St. Leontie, v. Vodoca. (*Fig. 4.27*)

Sometimes, well - dressed stone, most frequently sandstone or stone of volcanic origin, was used as the dominating element in forming the facade walls, while bricks are used only to break the monotony of the stone colour (grey) by single or double horizontal lines, with one or two vertically placed bricks. (*Fig. 4.28*)

Sometimes, in combination with well - dressed stone, the brick enables extraordinary combinations particularly in construction of the openings, the arches, the tambours and the ordinary or dented cornices. Some structures really represent galleries of these presentations. Such is the church of St. Georgi, v. Staro Nagoricane (*Fig. 4.29*) where the brick still dominates. This figure shows almost all the characteristic forms of this period. This is repeated also in the case of the church of St. Arhangel Mihail, v. Lesnovo. (*Fig. 4.30 – 31*)

Section 4.17

Of course, there are some forms that represent an exception or are elements that occur quite rarely.

One of these peculiarities occurs on some east facades. These are the shallow and deep semicircular blind niches formed into the wall mass on the sides of the polygon apse. The semicircular ones are vaulted by a semi - dome. These are decoratively dressed in combination with brick in different positions. Such examples

are found in the churches of St. Dimitrija, v. Susica (Fig. 4.44), St. Spas, v. Kuceviste (Fig. 4.45) and St. Bogorodica, v. Matejce. (Fig. 4.46)

Section 4.18

The period and natural location of the structure certainly contribute to the definition of the general conditions in which the building is constructed. Following its erection, the structure has been observed in time. Its location in contemporary conditions, after six, seven or eight centuries, has been changed only in respect to the social development, which is more dynamic and can affect its values much more in both a positive and a negative sense.

The natural conditions are assumed to have undergone very little change, with the exception of such factors as the pollution of soil and air as well as other natural destructive elements.

Section 4.19

Why is the knowledge of the location of the churches in the living environment given such an importance? There are several reasons. For example, what has been done in the past regarding their treatment within the framework of social developments may be only slightly corrected or improved. From the aspect of their present and future existence, the level to which they are threatened is different and depends on the location.

Here, we should note the fact that it is the result of the multi - disciplinary action of many factors.

Structures located in urban settlements

Possible positive elements are the following: easy access; regular functioning for the purpose for which they are constructed (this creates conditions for increase of income from donations by believers)¹⁵; easy access for domestic and foreign tourists; possibility for regular inspection and monitoring; control and guarding of valuable items; less expensive transportation of materials for maintenance; use of public utilities.

Possible negative elements are the following: increased pollution of air; change of the micro - climate; uncontrolled and increased access of individuals or groups of

tourists; effect of ever - increasing motor traffic; non - appropriate treatment in general and detailed urban plans that change the immediate surrounding of these monuments.¹⁶

Structures located in rural settlements

Certain elements that are negative for the first group do not exist or are of a lesser intensity.

Positive elements can be considered: regular , but with a drastically decreased intensity, use of the structures; periodical inspection by owners¹⁷ and professional services; while visiting these structures, the visitor (individual or group of individuals) travel through the state; lesser pollution of air and damage; their values contribute to faster development of the surrounding and the microstructure of the commune in which they are located (roads, public services).

The negative parameters are: non-regular use of the structure, aggravated and more expensive control and guarding of the structure (personnel and technical); the inspection by owners, i.e., the professional services for protection because more expensive and less frequent (transport); increased expenses for their maintenance.

Structures located outside populated areas

This group comprises the smallest number of structures. It is characteristic that some of these are at a distance of several tens of kilometres from inhabited places. Some can only be reached by boat (St. Bogorodica Zaumska, St. Georgi, Golem Grad, St. Georgi Poloski) which can be considered both as negative and positive components in their existence.

Based on the analysis carried out, positive elements are: almost negligible degree of pollution; non - existence of traffic; decreased non - controlled access; their values can contribute to the construction of the infrastructure in their surrounding.

Negative influences is greater: difficult or non - existent access (lack of modern roads); irregular usage of the structure; difficult and expensive safeguarding; increased expenses for inspection and monitoring; non - existence of necessary infrastructure.

Section 4.20

The transformation of the church of St. Georgi was less extensive. In this church, two new pairs of piers were constructed to support the corner domes. The church represents a combination of a basilica and cross - form solution. This adaptation was in compliance with the proportions of the older structures.

The transformation of the church of St. Bogorodica Ljeviska was somewhat more complex. Namely, the side naves were left in their original form. All the interventions were carried out in the central nave. Namely, the rectangular area was transformed into a five nave area of an inscribed cross by construction of two rows of piers with a square cross - section. There is a certain difference in the forms of the arches of the gables of the cross arm on the facade. Those in St. Georgi are semi - circular, while those in St. Bogorodica are pointed (which is quite unusual).

The first church has only one, while the second has three apses. In the first one, there are only traces of the narthex, while in the second there is a narthex and a big bell tower - belfry - which gives the impression of an influence from the west as regards the form but not the finishing of the facade wall.

Section 4.21

The west part is assumed to have represented a kind of a narthex divided into three parts by a centrally placed dome that rests, via pendentives, on the arches of the north, the east and the south vault²⁵ and the pendentives incorporated into the original west wall. It is assumed that the division of the west entrance by a column (similar to those in the south and north area) was created in a later intervention stimulated by the above mentioned older elements.

On the east side, there are three apses, with a biforia and a monoforia in the central one and monoforiums in the side ones.

If the architectonic plan of the church is compared to those of older ones in the near and farther surroundings, we may talk about compilation of the structure as a whole, i.e., from design elements found in many nearby churches.

Section 4.22

The contact between the central and the side areas and the entrance on the west side is realised via a tribelium (with two cylindrical columns) in the church in

Istanbul, which is not the case with the church in Drenovo where there is only one column.

In the older structure, there is not a dome in the so called "narthex", while there is one²⁴ in the church in Drenovo.

In the church in Drenovo, there is an entrance on the south side, while in the church / mosque in Istanbul, there are entrances on both the south and the north side.²⁵

Section 4.23

If we analyse the plan of St. Panteleimon (Ohrid) and compare it to similar plans in the Balkans, no match can be found. Namely, smaller conches are formed in the wall mass of the north and south conches that take the role of the proskomide and the diaconicon which is a unique example in these areas.

Investigations have shown that the buildings of this type in Macedonia represent a unique local variant, with detail which are not repeated anywhere else in churches of a similar age and general design.

It may be concluded that the chronological characteristics are preserved in the spatial shaping, particularly the outline and the height of the structure as well as the central area - the dome. Namely, the older the structure (the dome structure) the smaller is the height of the tambour when compared to that of structures constructed later, which is the main characteristic marking the local identity of the structures existing in Macedonia.

Section 4.24

The east part is identical in both structures. Namely, the corner premises represent the proskomide and diaconicon with an entrance from the cross arms, the difference being that St. Panteleimon has three apses, while the other church has only one (central).

The difference between these two structures is that the first has a narthex, while the other has not. This is the reason why there is an entrance in the corner areas of the west part on the side of the narthex of the first structure. In the second structure, there is an entrance at the central area.

These are placed according to the traditional Byzantine principle - at the places where the roof elements run pyramidal toward the central area and the central dome.

Section 4.25

The facts speak for themselves that from that date on, there have begun serious considerations in Europe and the Mediterranean region and even beyond, about improving the treatment of the total construction heritage.

The Macedonian experience forms the basis for reflection. It should be the starting point for analysing the 'learning tools.'

It is known that the Skopje earthquake affected a large number of cultural monuments, mainly from the Islamic period. Why? All those objects were located in the city area where intensity of the earthquake was the highest. Inter alia, a large number of older town buildings failed or were extensively damaged.

Section 4.26

Injection of masonry structures as a single process was very used applied only on a few damaged structures. It was usually combined with other methods. The basic materials used were cement mixtures. Incorporation was done under pressure of 4 - 5 atmospheres. All the applied injection types are irreversible.

Rebuilding was applied for ruined minor parts of building. Particularly positive is the approach in which restoration is done only on the basis of existing information (documentation) on the individual ruined parts. It was endeavoured to reproduce the same walling pattern, by use of same the materials and technology as of in the existing one.

Reinforcement as a method was applied extensively in the domain of total or partial reconstruction. It was particularly used in structures that suffered extensive structural elements and systems damage. Such a reconstruction, almost without exception, was carried out by changing the original, existing structural system. The most frequently used new structural element was the reinforced concrete belt, often in combination with vertical reinforced concrete columns. These reinforced concrete elements, as new ones, were most frequently incorporated into the core of the masonry structure which was restored in compliance with the existing one (applied on Isa Bey Mosque and Mustafa Pasha Mosque).

Section 4.27

Reinforced concrete panels represent elements that were mainly applied for

repair and reconstruction of structures of minor architectural and historic - artistic values. They were used for reconstruction of plastered and coloured wall structures, so that the new structure is invisible on the facade (the old City Assembly building, the old Turkish Post - Office).

For reconstruction of the minaret of the Sultan Murat's Mosque, a special type of a wall panel in the form of a spiral was used. It should be noted that the project is the work of experts from IZIIIS - Skopje.

The reinforced - concrete columns and belts in the form of a frame system were adopted for reconstruction and strengthening of structural systems which have been totally ruined. In this case also, the new reinforced concrete structure was incorporated into the wall mass, which was reconstructed according to the model of the existing masonry elements (Kursumli Caravan Sarai, Double Turkish Bath, St. Panteleimon, v. Gorno Nerezi). All these interventions as well as those previously mentioned in this section are of an irreversible character.

Section 4.28

If the structure had valuable fresco - paintings in the interior, the drilling of holes in the wall was carried out from external side (a), whereas in cases where there were no fresco - paintings, the drilling of holes was done from the inside (b). This mode of 'strengthening' proved to be inappropriate and adverse during the catastrophic Montenegro earthquake of 1979. All the buildings strengthened in this way, prior to the earthquake, suffered severe damage and even complete failure. Why?

Because the original walling pattern of the important structural element - the corner - was disrupted. It is a wall section of the highest importance - the perpendicular connection of two perimeter walls. That is the reason for its original high building quality. The old masters paid the greatest attention to these structural elements. By drilling of holes and incorporation of horizontal and vertical reinforced concrete elements, this quality is disturbed and a combination of two bearing systems is obtained. One is the old flexible one, which represents a bearing wall of stone in lime mortar and the other is the new and rigid one, representing by reinforced concrete skeleton system.

Section 4.29

At the meeting of the Committee for World Heritage Convention of UNESCO, held in Cairo and Luxor (Egypt), the natural and cultural heritage of Kotor was added to the List of World Natural and Cultural Heritage and the List of Endangered World Cultural Heritage.

Section 4.30

This, first of all, refers to the better organisation and systematic approach of the first activities: visit to all the damaged structures; sheltering of important movable property; protection against precipitation; systematic survey and assessment of inflicted damage (a photogrammetric documentation was prepared for some more important structures).

The establishment and practical realisation of a multidisciplinary approach in investigation and the proposal of necessary activities was of a particular importance.

The activities taken were not planned and realised at random but were based on the following criteria: category of values, level of damage; social - economic justification of investment; place of the structure / structures in all urban development plans.

During realisation, there were some obstacles. For example, all projects for realisation, except the obligatory re - conservation inspection, had to be subjected to technical and financial review. This administrative procedure proved to be a hindrance for fast realisation of the project and the reason for loss of value of accumulated resources (due to the slowness of the realisation). Another difficulty was the lack of masters in specialised crafts that had withered away in the course of time: stonecutters, woodcarvers, plasterers and so forth.

Section 4.31

The above mentioned methods were applied in the repair of St. Basileus in Stoliv (fifteenth century), St. George in Orahovac (sixteenth century) and St. Lucas (twelfth century - church in Roman style) and others. The most significant work was done on the repair and strengthening of St. Triphun church in Kotor (twelfth century).³²

Section 4.32

The report also gives some recommendations regarding the proposed measures in the sense of their improvement or their abandoning.

However, much more important are the recommendations of what to be done. Regarding the interventions on roof structures, the traditional timber structure must be preserved because massive and heavy structures have to be avoided in the topmost zones of the structure.

As to the walls, the corners should not be treated at all since they are important structural elements.

Regarding the treatment of structures in the Praskavica monastery, i.e., the church of the Holy Trinity and the recommended treatment, the following recommendations should be noted: minimum measures for stabilisation (in order not to disturb the authenticity of the original structure - our remark), use incorporation of new ring beams at three levels in the perimeter walls. Their formation at the level of the vault reinforcement is of particular importance.

To consolidate the vault, the use of a light reinforced mass (with a mesh of 50 x 50 mm in a layer of mortar with a high percentage of aggregate - crushed bricks) was recommended.

It may be concluded that the recommended and performed methods for repair and strengthening of damaged structures in Montenegro represent a more acceptable treatment than that undertaken after the Skopje earthquake.

Section 4.33

However, in the period immediately after the earthquake and in the activities undertaken, particularly the activities undertaken for the most important monuments, there was not good co-operation between the professions involved: architects, art historians and engineers on one hand and the civil engineers on the other. Such discordance gave rise to certain activities that were very contradictive as to what was necessary and acceptable.³³

As was the case in Kotor, some positive activities were also carried out. The Institute for Renovation of Dubrovnik was established (10th October 1979). This Institute played an important role in the complete reconstruction of the total damaged constructed area (including also the cultural monuments).

Section 4.34

It is a legal obligation (Article 32), *inter alia*, to elaborate directions for conservation, i.e., renovation, investigate structural systems and elaborate programmes for repair. Further, in the domain of composition of the teams, it is obligatory that they involve an urbanist, a conservator, an architect - conservator and a civil engineer - specialised in statics.

Article 40 stated that if a structure cannot be repaired to the necessary level, without disturbing its authentic structural, archaeological, artistic and aesthetic values, it will be repaired in such a way that its safety coefficient is decreased. This is right, in principle. However, in practice, we consider that this was not consistently applied.

Section 4.35

Noteworthy among these was the application of certain high - quality and appropriate methods for repair and strengthening. An example of such an intervention is the repair of the wall mass of the Kruja fortress that was damaged by an earthquake in the beginning of 1988.

The repair and strengthening were carried out by incorporation of steel cables with a diameter of 42 mm and anchorage into metal plates. This was accompanied by injection of the wall mass and achieved a greater stability of the stone blocks of the wall.

Section 4.36

The incorporation of a reinforced concrete belt course at the level of the cornice of the perimeter walls was also anticipated for another church (Bukal church dating from the eleventh century).

Anticipated for another church (Bukal church dating from the eleventh century) was incorporation of a reinforced concrete belt course at the level of the cornice of the perimeter walls. However, we have still no information whether the planned works have so far been realised.

In the case of the church of St. Nicholas in Moskopole dating from the eighteenth century, steel ties were incorporated to replace the original timber ones for the purpose of repair and strengthening of the porch arcade damaged by an earthquake.

Another old but good method that did not affect the authenticity of the wall mass, which was displaced from the vertical position due to an earthquake, was applied for stabilising the new position of the wall of the church in Sopi by construction of masonry buttresses.

Section 4.37

These experts and the experts from the Thessaloniki University and other public services jointly prepared the bases for a long - term programme for repair and strengthening of the damaged structures.³⁵

Although their own experience in treating structures after catastrophes was modest, the activities taken point to a well thought - out systematic approach, particularly in the phase of documentation, investigation and evaluation of damage. These activities enabled a proper and adequate approach in the proposals for repair and strengthening. The proposal were carried out and subsequent strikes tested the results.

Section 4.38

Presented further in the text will be Types and degrees of damage to structural elements and systems will be presented further in the text. as will also the proposed and executed activities.

The centre of Thessaloniki contain a large number of buildings of various types dating from the Byzantine period. The 1978 earthquake affected especially the most vulnerable parts: arches, vaults and domes. With a somewhat less intensity, it affected also the vertical structural elements - the walls and the columns. The concentration of so many Byzantine buildings this earthquake makes Thessaloniki a particular valuable study centre for the subject of this thesis.

Section 4.39

Namely, the stricken parts of the vertical perimeter wall masses were temporarily supported by a flexible timber structure, while in the zone of the dome, the tambour and the cornice of the main structure, steel ties were incorporated on the facade. These steel ties and the vertical steel elements over the whole tambour provided a certain possibility of prevention of further damage (*Fig. 4.91*). A similar

element for temporary support was used for the church of St. Panteleimon in Thessaloniki (*Fig. 4.92*).

Here, we should point out how right the decision was to flexible construction material (wood and coated steel) which is reversible. Certain works of temporary character that were done for the Rotunda in Thessaloniki twenty years ago, are still performing their original function.

Section 4.40

Recommended as long - term measures were the following: full scale documentation of monuments; extension of possible photogrammetric survey; microfilming of records (and their storing in a safe place); regular inspection and maintenance; and one piece of practical advice: ensuring enabling that the equipment and materials for emergency repair and restoration be easily accessible.

A particularly important decision, in the sense of direct treatment of structures is that the standard building codes cannot be automatically applied on monuments.

The objective of the meeting was to give recommendations as an instrument for the General Assembly of UNESCO in formulation of principles and norms for the international regulations to be accepted and adapted individually by each country member. These principles were adopted by the GA of UNESCO in 1985.

Section 4.41

Particular attention was paid to experimental investigation of methods for repair and strengthening. To that effect, the following was recommended:

'... the number of experiments and investigations of the seismic resistance should be increased paying special attention to historic construction techniques including studies on old concepts of structures and seismic protection; research and testing of alternative grout mixtures and evaluation of their direct effect on masonry should initiate study and testing of mortar mixtures which are compatible with the very nature of the historic buildings; the efficiency of the reinforcement technique should be evaluated on the basis of the behaviour of the strengthened buildings during earthquakes". (*Recommendation - Skopje 1985*)

Section 4.42

We could focus on some of the important recommendations that are known as Recommendations - Skopje 1985, particularly those referring to direct treatment of the structures.⁴⁰

Inter alia, it was emphasised that:

'... the structural system of each historic building must be respected as it has already withstood a number of earthquakes; any new material used for repair and strengthening must be compatible and durable, while the use of reinforced concrete is restricted.'

Section 4.43

We would like to focus on the recommendations at the technical level. In these recommendations, an emphasis is put on the prompt acquisition knowledge on the degree of vulnerability of monuments exposed to earthquakes, intensification of training of technical and specialised personnel, systematic verification of the effect of the application of modern building technologies on buildings with traditional materials and systems and permanent exchange of knowledge and experience in the subject.

Section 4.44

Among other things, noteworthy is the decision conceived as a preparation measure of special scientific interest, that a data bank on cultural heritage in seismic prone regions and a methodology for uniform and systematic processing of data be created.

Although the recommendations contained the decision that this seminar becomes a biennial or triennial meeting, the war in former Yugoslavia prevented the realisation of this idea and recommendation.

Section 4.45

This decade represents the main framework for many activities aimed at the realisation of many activities aimed at bringing about a reduction of the global risk related to natural hazards through application of science and technology. In fact, the notion of "hazard reduction" refers to the process of lessening the impacts of a

potential event on the social and the built environment. The first step of that is hazard and risk assessment, the second is disaster preparedness and the third is disaster mitigation.

APPENDIX FIVE - Chapter five

Section 5.1

It should be mentioned again that these horizontal timber belts (*Fig. 5.3a-b and 5.4a*) consists of two long parallel timber elements with dimension 10 x 10 - 12 x 12 cm connected, perpendicularly at each 60-70 cm, by smaller wooden elements of 5 - 7 / 5 - 7 cm. All the connections between the elements of the timber belt and smaller elements are by carpenter joints.

Another important matter is that in the interior of the structures, at precisely defined places in the walls and the piers, in the lower area of the church and the drum, there are timber ties of a larger cross - section ranging from 12 x 12 to 18 x 18 cm. The importance of these elements has been elaborated thoroughly in section 3.4.4. (*Fig. 5.3.a*)

Section 5.2

It is also evident from the epicentral map (*Fig. 5.5*) that there is a tendency for the formation of seismic zones transverse to the above mentioned principal zones of longitudinal stretch. These are the seismic zones from Debar via Gostivar and Tetovo to Skopje and further towards Vranje (Yugoslavia), then from Debar via Kicevo and Krusevo to Veles and further to Berovo and Pehcevo, and finally from Ohrid via Bitola to Valandovo.

Based of the epicentral map the high seismic risk of the territory of Macedonia has been defined. (*Stojkovic et all. 1992*)

Section 5.3

It contains isoseismal maps for almost all destructive earthquakes which can be used as a basis for evaluation of intensity of their effects upon the sites of the selected four churches. Table 5.1 gives a review of intensities of earthquakes that were felt on these sites with the smallest intensity of 6 (MCS) degrees - which is an intensity at which non - structural damage starts to occur in masonry structures.

Section 5.4

The St. Nikola church is affected by the Pehcevo - Kresna seismic focus with the following parameters: M_{\max} (occurred) = 7.8 and M_{\max} (possible) is 7.9 with hypocentral depth of 15 - 25 km.

The church of Bogorodica Zahumska is mainly affected by the Ohrid - Korca focus with the following parameters: M_{\max} (occurred) = 6.7 and M_{\max} (possible) = 6.9 with hypocentral depth of 15 - 20 km.

These data are important from the point of view that they can serve as a basis for prediction and definition of the seismic intensity attenuation.

Section 5.5

Detailed investigations (*Stojkovic et al. 1992: 13-53*) have proved that from geological aspects, the composition and numbers of the layers varies from two (St. Nikita and St. Bogorodica Zaumska) to three (St. Nikola and St. Bogorodica). The thickness of the layers ranges from two to twenty eight metres. From the stability point of view of the terrain, the situation is almost identical - there are no signs of instability.

From the structural - tectonic aspect, the situation is different. The distance from the fault structures varies from ten to twenty metres (St. Bogorodica Zaumska), fifty metres (St. Nikola) and 500 metres (St. Nikita).

Section 5.6

From the geological point of view, the considered terrain is composed of Palaeozoic, sericite and phylite shells. The surface of the terrain is covered with a diluvial layer with a thickness of 10 - 15 metres, composed of clayey material and detritus.

Section 5.7

The surface of the terrain is covered with a diluvial layer composed of clayey silt material and detritus with a thickness of up to ten metres. From the aspect of stability, the church is located on a potentially unstable mild slope. However, signs of instability of the terrain have not been observed.

Section 5.8

The terrain is composed of Triassic massive limestone, that on the very spot of the church, are covered with lacustrine 'marshy' sediments consisting of gravel, sand and mud with clay intercalation, with a total thickness of two to five metres.

At a distance of about ten metres from this church to the lake, faults stretching in North - South and Northwest - Southwest direction intersect wherefore the surface limestone is disintegrated and loose up to a depth of ten to twenty metres.

Section 5.9

Equipment

For measurement of the wind excited vibrations, three 'Ranger' type seismometers, SS-1 model, manufactured by Kinometrics, USA were used.

The natural frequency of the seismometer is 1 Hz. The signal conditioner model SC - 1 is also manufactured by Kinometrics and it was used both for amplification and simultaneous control of the seismometers. The three outputs are capable of simultaneous or independent recording. Each channel has a nominal magnification of 100,000 times. The system has a low pass filter which can select frequencies in the range from 1 to 100 Hz for each channel. (*Krstevska et al. 1992*)

Section 5.10

The natural frequencies of the St. Nikita Church, as can be seen from the presented spectra, were clearly selected; $f = 6.0$ Hz for the E - W direction, $f = 4.8$ Hz for the N - S direction and $f = 8.0$ Hz for torsion. Damping coefficients were 3.2, 4.0 and 2.1%, respectively. (*Fig. 5.13*)

Section 5.11

It should be repeated that the church was under extensive reconstruction in 1923 and 1985. During the last activities reinforced - concrete belt courses were placed in the perimeter walls, while the vertical belt courses and new steel ties were placed in the central part, at the level of the pier capitals. Over the existing vaults and the central dome, reinforced - concrete vaults and a dome have been built.

Section 5.12

These walls and two rows of piers (three per row) support the vaults and the dome above the exonarthex defining in this way the very physiognomy of the church. The proportions of the church are 13 x 8 meters.

At the level of the support of the vaults and the arches inside the church, placed at two levels are timber ties which sustain the tensile stress and contribute to the total stability of the church structure.

Section 5.13

The structural system of the building taken as a whole consists of massive perimeter walls built of roughly dressed stones, dressed stones and fired bricks in lime mortar. The walls have a thickness of about 90 cm at the foundation level. These walls and two rows of symmetrically placed marble columns support the vaulted roof elements and the central dome, a typical cross - in - square Byzantine church plan. This is the best example of Byzantine type of a church plan in Macedonia.

Section 5.14

1983 31 January - 2 February:

*International Meeting on Technical and Legal Aspects of the Preservation of the Cultural Heritage Against Disasters and Other Major Calamities.*¹¹

1985 24 June - 5 July:

*International Course on Preventive Measures for the Protection of Cultural Property in Earthquake -Prone Regions.*¹²

1985 5 - 9 November:

*International Conference on Reconstruction, Restoration and Urban Planning of Towns and Regions in Seismic Prone Regions.*¹³

1988 17 - 22 October:

*1st International Seminar on Modern Principles in Conservation and Restoration of Urban and Rural Cultural Heritage in Seismic-Prone Regions.*¹⁴

Section 5.15

These were carried out by the conservation team of the Republic Institute for Protection of Cultural monuments in the middle sixties of this century.

Section 5.16

Historic - artistic values of selected structures

St. Nikita, v. Banjani

The St. Nikita church in the village of Banjani was founded by the Serbian king Milutin in the fourteenth century. As noted in many documents, the fresco-paintings in this church are works of the medieval painters Michael and Eutybios. These works of art were created when the Serbian kingdom was at the peak of its power and after its invasion and occupation of Macedonia.

However, the whole church was not thoroughly painted by these artists in the period of 1313-15. According to some authors, they worked together on the north half of the church a difference was detected in the produced fresco technique) on two very important compositions: "The Communion of the Apostles" (in the conch) and "Dormition of the Holy Virgin" (north wall).

The concept of the fresco painting programme of the church is based on the Byzantine and Balkan principle (regarding the dome structures) established during the previous centuries. Presented in the lowest zone are the full - size figures of saints, while the fresco - cycles "The Great Feasts", "The Passion" and "The Miracles and Parables of Christ" are presented in the upper zones. (Bardjieva 1991: 44).

According to the author's own observations of the decoration of the dome and the vaulted areas, it may be concluded that there are no fresco-paintings in these areas, while those that exist in the lower zones of the dome and the tambour walls and the lower zones of the vaults date back from the fifteenth century and were done by several authors.

This gives the right to the author to conclude that the structure suffered extensive damage not only in the fourteenth and the fifteenth century but even in the period after.

The characteristic damages to the dome and vaulted structures inflicted by earthquakes show that it is exactly the zone where these spatial bearing structures rest

on the perimeter walls of the tambour and the structure (representing the most vulnerable elements under dynamic loads) that non-homogeneous behaviour of the vertical bearing elements and their "opening" takes place that contributes to the collapse of the dome and vault apexes in case of earthquakes.

St. Nikola, v. Psaca

There is no document on the exact date of construction and fresco-painting of the church. According to Nikolic (1991:6) and based on an old document dating from 1358 and signed by czar Stefan Uros, the church was built by landowner Vlatko and the czar donated it to Chilandar. The document and the portraits of czar Uros and king Volkasin on the north wall of the narthex lead to the conclusion that the painting of the church was done in the period between 1366 (coinciding with the time when Volkasin became king) and 1371.

The same author writes about the fresco-paintings characterised by academic classicism, with an extraordinary plasticity of the forms and figures with rosy and white accents standing out from the dark background.

From the artistic view point, the fresco-paintings of the church are similar to those in the church of St. Georgi in the village of Recica, Prizren (SR Yugoslavia) dating back to 1370 that are of a lower value than those in the church of Psaca. Some similarities with the fresco-paintings of the church of St. Bogorodica Manastir Treskavec are also found (Nikolic 1991:8).

Here also, there are no fresco-paintings in the vaulted areas as a consequence of frequent damage inflicted by earthquakes.

St. Bogorodica Zaumska, v. Trpejca

The church was constructed in 1361 during the reign of czar Uros. In the past, the whole church and the porch were covered with frescos. It is characteristic that the church possessed extraordinarily valuable fresco-paintings in the porch. There are traces of: the monumental presentation of the Deity with Jesus Christ - Czar, the Holy Virgin -Empress and St. John the Forerunner. Recognisable are the Old Man Zosimus and St. Maria from Egypt, St. George and St. Demetrius as well as St. Peter and St. Paul.

In the church interior, there is a large number of scenes and portraits of saints and holy warriors. However, the bad condition of the fresco-paintings aggravates

proper evaluation of their quality. However, according to some authors, these are not of great value.

St. Bogorodica, v. Matejce

There are no documents about the exact date of the foundation of the church. However, according to the remains from the fresco-paintings, some authors date it back to the beginning of the second half of the fourteenth century.

This can be concluded based on some data found in Karlovac according to which the founders of the church were Queen Elena and her son Uros. This is supported by the composition in the first zone of the south wall presenting the founders of the church.

With its huge proportions and a total number of 13 preserved cycles of fresco-paintings in the interior, the church of St. Bogorodica in the village of Matejce represents a unique structure in Macedonia.

Three of the preserved cycles are dedicated to Jesus Christ and three to the Holy Virgin. Another three cycles are dedicated to the hagiography of some saints and apostles. The main concept of the iconographic programme of Matejce has some special properties regarding the selection of presentations and fresco-cycles as well as their artistic shaping. Some of them bear witness to the old traditions of the thirteenth century.

Section 5.17

Architectural and structural characteristics

St. Nikita, v. Banjani

The church St. Nikita is a representative of the classical type of monastery Byzantine churches. It represent a rectangular space with inscribed cross-in-square and four free - standing rectangular masonry piers supporting the dome. (Figure 5.16a)

Clearly defined in this church are two areas: the altar and the central part of the church - the naos.

The central part of the church is formed by two rows of rectangular piers in which space it is possible to enter from two sides - west (main) entrance and south

(additional) entrance. Remains on the latter one and traces of wall paintings on the south facade provide evidence of the existence of a former open porch.

The central area is covered with a semi - circular dome resting on an octagonal drum which is placed perpendicularly, i.e., with its sides towards the main cardinal directions. A narrow and high monoforia exists on each side of the tambour. The tambour structure is supported by the arches and the pendentives by which a transition is made from a square form at plan to a circular form at the height of the apexes of the arches of the four vaults of the cross arms.

Unlike the smooth surfaces of the interior walls, facade walls are typically decorated with shallow blind niches (double or triple) and pilasters, as decoration. With the virtuoso use of brick, dressed tuff stone in lime mortar and classical 'cloisonné' walling they provide a perfect picturesque polychromy. (Photo 5.8.b)

The position of the pilasters and blind niches reflect completely the interior of the church as a very logical and significant element of the aesthetics and especially of the structural stability of the church. Looking at the facades (the south, the west and the north one) it can be noticed that the position of the pilasters and niches is the disposition of structural elements such as piers, barrel vaults, arches. They contribute to the stability of the building, ribs for stiffening acting as the long and high perimeter walls.

The structural system of the church consists of massive perimeter composite walls which have a thickness of 85 cm at the base, massive masonry columns and arches, vaults, pendentives and a dome. During the construction of the church, horizontal timber belt courses were incorporated at the level of the door lintels, the level of support of vaults by the perimeter walls, at the tambour base, in the middle of the tambour walls and at the base of the dome (Fig. 5.2.a). These were connected by timber ties placed at the level where the arches and the vaults end.

The vaulted elements of the roof and the dome over the square base of the naos rest on the perimeter walls and the two rows of freely and symmetrically placed masonry columns in the naos. The large cross - section of the walls and columns enable the structure to withstand the compressive stresses occurring in the structure due to gravity loads.

The timber ties that are located at the level of the capitals of the columns and the side vaults have the role of sustaining tensile forces occurring as a result of secondary effects: uneven settlement of soil, winds and particularly earthquakes.

The main materials used for construction are: limestone in different modifications, dressed tuff stone, well burned bricks, lime mortar and timber as visible or invisible construction elements.

The massive perimeter walls have the classical characteristics of Byzantine composite masonry. They have two faces and a core in-between formed by randomly placed stone, bricks and a large quantity of lime mortar in irregular connections. The two faces of the wall do not have the same characteristics. The facade was constructed with much more care, with a definite pattern in usage of hewn stone and brick and elaboration of regular well-proportioned joints of high quality lime mortar in the characteristic "cloisonné walling" style. It is formed of dressed tuff stone in the shape of a parallelogram framed by double horizontal brick rows, i.e., one or two vertically alternatively placed bricks.

Because it is thoroughly covered with two layers of fresco-mortar, the interior wall face is of a much lower quality both in the usage of hewn stone and elaboration of regular joints.

Almost everywhere the cross-section of the wall face is much smaller than the cross-section of the wall core which contributes to the decrease of the mechanical strength of this type of composite masonry (Fig. 5.3).

It is sure that the builders in the past knew the importance of connecting the two very thin faces of the wall by layers of horizontally placed bricks up to the end of connect and strengthen them. In these walls, they are located at a regular distances certain distance and, as a rule, they are constructed as a base for placement of two parallel timber beams connected by timber cross-bars placed perpendicularly to their direction, at distance of sixty to seventy centimetres.

It is important to say, once again, that the invisible timber belt courses incorporated into the wall along with the visible timber ties had the role of connecting the wall elements in both directions, increasing thus the stability of the structure under dynamic, i.e., seismic effects.

This contributes to synchronous behaviour of the individual wall elements, at several lines of defence of the structure. Such walls and the building as a whole have a greater deformation capacity, i.e., they are characterised by a "ductile behaviour" under excessive damages inflicted by strong earthquakes. The structure is thus made capable of sustaining seismic effects without total failure.

The piers were constructed by a somewhat higher quality and have a more compact structure because of their cross-section. Their structure is different from that of the perimeter walls which is the reason why these elements did not suffer any heavier damage although they seem to be quite vulnerable structural elements (Fig. 5.3.a)

The arches, the vaults, the pendentives and the dome are constructed of bricks in lime mortar. These are of a higher quality and may be considered as a "monolith structure" different from that of the perimeter walls and the columns. Their proportions depend on the proportions of the bricks used ranging from 25 to 30 centimetres.

Section 5.18

Tuff stone has mainly been used for the construction of the facade. This stone is also of a local origin. It is important to note that it is light dressed, particularly when still wet. It is light and porous and is not characterised by continuity of cavities. It represents a carboniferous calcium carbonate.

As components of the composite masonry, it is used in the form of:

- Undressed natural stone - limestone
- Dressed stone - tuff - limestone

Smaller quantities of natural stone of the type of travertine, dolomite and granite were also used for the construction of the building.

Section 5.19

In general, size and widths of the bricks used on the monument but they always have constant thickness of 3 to 3.2 cm.

From the performed chemical analysis, the brick is defined as a well baked clay product having the following components: Aluminium oxide, Iron, Magnesium, Sodium, Carbon, Calcium, Chromium. (*Staniseva: Volume 10, 1992*)

Section 5.20

If we comment the results presented in Table 5.8 regarding the characteristics of lime mortar used for building and pointing, it is clear that the loss on ignition varies from 22 to 27% representing a sum of carbon dioxide and organic admixtures. Presence of proteins is observed. The burning residue representing the sand or the filler in mortar preparation of two samples varies from forty to fifty four per cent. Dolomite lime was used as a binder in which the percentage of calcium oxide varies from sixteen to twenty two per cent while the percentage of magnesium oxide is eleven per cent in both samples. (*Staniseva: Volume 10, 1992*)

Section 5.21

The last (coloured) layer contains the following pigments: azurite; malachite; yellow ochre; sienna; hematite; green earth; lime and charcoal. In the two layers lime

is used as a binder while tempera is a binder of the upper layers (and calcium caseinate as a variant). By stratigraphic investigations it has been discovered that layers of green and blue colour are placed over a black one. Three samples were tested.

Section 5.22

All samples contain more or less straw. In all samples, the process of carbonisation was over, that is, there was neither free calcium hydroxide nor hydroaluminates or hydrosilicates. By testing of soluble salts, the presence of chlorides and nitrates was detected.

Section 5.23

The following notations apply:

- β_p and β_s are given in Mpa
- γ is given in kgr/m^3
- in mixture under II the additional water and water in the lime solution are taken as a sum value
- Lime solution (milk) is prepared as a mixture of slaked lime, dry matters and water in ratio 1:1.

The admixture used for injection called "USJEMAL" contained a certain quantity of cement used only to obtain certain strength characteristics of the admixture and to shorten the hardening time only for the needs of the experiment. However, in an actual structure, this will not be the case since a lime binder and carboniferous filler will be used to achieve adequate interaction between the original and the new material. In this admixture, a superplasticiser was added to achieve a good fluidity.

Section 5.24

In order to define the percentage of microsilica and obtain an insight into the accelerating effect, mixtures were made with a filler - lime paste ratio as that used for the grouts but with a standard consistency of mortar (as for plastering - building).

These were combinations If4, If5 and If6 where the dose of microsilica was 50 per cent, 30 per cent and 15 per cent in respect to the amount of lime paste. If the strengths are compared, it may be noticed that they are decreased with the decreasing of the microsilica dose.

All the grouts were prepared by using plasticizers since it is difficult to obtain a lime-based mixture for injection without using a plastiziser. The reason for this is that mortar remains stiff regardless the quantity of water.

Two types of additives were used as plasticizers - Additive - K and Additive - 10 which enabled obtaining of a fluid mass suitable for injection and improving, at the same time, the strength characteristics. This was the reason why these additives were used in practical trials performed for the walls.