

Intelligent Vehicle Motion Control

by

Mark Albert Selby, BEng(Hons).

**Submitted in accordance with the requirements for the degree of
Doctor of Philosophy**

**University of Leeds
School of Mechanical Engineering**

February, 2003

The candidate confirms that the work submitted is his/her own and that appropriate credit has been given where reference has been made to the work of others.

Abstract

This thesis investigates the principle of co-ordination of chassis subsystems by proposing a new control structure for co-ordinating active steering technologies and a brake based directional stability controller.

A non-linear vehicle handling model was developed for this study using the MatLab and Simulink tools. This consists of a 4 degree of freedom (d.o.f) lumped-parameter model that includes longitudinal, lateral, yaw and roll motions with quasi-static longitudinal load transfer effects including non-linear suspension and tyre descriptions. The non-linear vehicle dynamics are discussed for the whole operating regime and two specific driving tasks are identified, steerability and stability. In the context of the vehicle states these are yaw rate control and side slip angle bounding respectively.

Linear active steering controllers for front, rear and four wheel steering are designed and evaluated in the context of the vehicle handling problem throughout the non-linear operating regime to assist the driver in the two driving tasks previously defined. It is shown through the analysis of the vehicle dynamics in the Chapter 3 that linear controllers can be used to significantly improve the handling behaviour of a non-linear vehicle when only one active input is considered, however when controlling two active inputs, non-linear multivariable approach is required to deal with the strongly coupled nature of the vehicle handling with respect to front and rear steering inputs.

A brake based stability system that reflects the state of the art is implemented.

The work then proposes a novel co-ordination controller structure for co-ordination of an active steering controllers and a brake based stability controller for improving to vehicle handling control. The controller was assessed both in steady state and transient tests selected to simulate real world driving manoeuvres over the whole non-linear vehicle handling regime.

The co-ordination controller is found to lead to a trade-off between stability and limit cornering performance. The proposed structure improves vehicle stability and reduces interactions in the longitudinal vehicle motion.

A detailed discussion of the implications of a coordinated control approach showing it to be a powerful tool providing, the interactions can be conveniently related vehicle handling task and that an appropriate measure of vehicle performance is available. The limitations of the approach are discussed. The most significant limitations being a) the difficulty in proving the optimality of a heuristic control structure, b) the difficult in assessing the controller behaviour and its interaction with a real driver and c) the likely complexity of the rule base for coordinating more than 2 or 3 systems or describing more complex interactions than were observed here.

Acknowledgements

This thesis would not have been completed without the help of my various supervisors, Andrew Plummer, Michael Brown, and Professor David Crolla in particular and for this, I thank them. Thanks must also go to Warren Manning who has also been heavily involved with the direction of this research, and also to Richard King and Andrew Deakin for their time and insight into all aspects of vehicle dynamics behaviour.

In addition, other members of the vehicle dynamics group, staff and assorted hangers-on have made it a pleasure to work and play in Leeds, especially Geoff, Scott, Andrew, Ray, Howard, Blake and Adrian.

Another reason for the eventual completion of this work has been the unwavering support of my friends and family, in particular my Mother and Father, Toby and especially, Hannah.

Publications

“Intelligent Vehicle Motion Control, Sub-system Co-ordination”, M. A. Selby, W. J. Manning, M. D. Brown and D. A. Crolla. FISITA World Youth Congress, Seoul, 2000

“A Co-ordination Approach For DYC And Active Front Steering”, M. A. Selby, W. J. Manning, M. D. Brown and D. A. Crolla. SAE2000-01-1275, Selected for SAE 2001 Transactions Journal of Passenger Cars - Mechanical Systems.

“Co-ordination Of Chassis Control Systems For Vehicle Motion Control Vehicle”, W. J. Manning, M. D. Brown, D. A. Crolla and M. A. Selby, International Symposium on Advanced Vehicle Control, Ann Arbor, Michigan, 2000

“A Comparison Of The Relative Benefits Of Active Front Steering And Active Rear Steering When Co-ordinated With Direct Yaw Moment Control”, M. A. Selby, W. J. Manning, M. D. Brown and D. A. Crolla. ASME International Mechanical Engineering Congress and Exposition, New York 2001

“Intelligent Vehicle Motion Control - A Generic Design Methodology For Integrating Chassis Control Systems”, W. J. Manning, M. D. Brown, D. A. Crolla and M. A. Selby, European Automotive Conference, Bratislava 2001.

“IVMC: Intelligent Vehicle Motion Control”, W. J. Manning, M. A. Selby, M. D. Brown and D. A. Crolla. 2002-01-0821, Selected for SAE 2002 Transactions Journal of Passenger Cars - Mechanical Systems.

Contents

| | |
|--|-------------|
| ABSTRACT | I |
| ACKNOWLEDGEMENTS | III |
| PUBLICATIONS | IV |
| CONTENTS | V |
| TABLE OF FIGURES | VIII |
| ABBREVIATIONS | XII |
| 1 INTRODUCTION | 1 |
| 1.1 VEHICLE RIDE AND HANDLING CONTROL | 1 |
| 1.2 BENEFITS OF SYSTEM INTEGRATION..... | 2 |
| 1.3 THIS THESIS..... | 3 |
| 2 REVIEW OF ACTIVE VEHICLE HANDLING SYSTEMS | 5 |
| 2.1 CHASSIS SUB-SYSTEM CONTROL | 7 |
| 2.1.1 <i>Steering based active control systems</i> | 7 |
| 2.1.2 <i>Brake-based handling systems</i> | 28 |
| 2.1.3 <i>Driveline-based handling systems</i> | 37 |
| 2.1.4 <i>Suspension-based handling systems</i> | 41 |
| 2.1.5 <i>Comparative studies</i> | 50 |
| 2.2 CO-ORDINATION APPROACHES..... | 52 |
| 2.3 GENERIC MOTION CONTROL(GMC)..... | 54 |
| 2.4 DISCUSSION | 58 |
| 2.5 AIMS AND OBJECTIVES | 62 |
| 2.6 CONCLUSION | 63 |

| | | |
|----------|---|------------|
| 3 | VEHICLE MODELLING AND CONTROL OBJECTIVE FORMULATION | 65 |
| 3.1 | VEHICLE MODELLING | 65 |
| 3.1.1 | <i>Linear 2 D.O.F. model.</i> | 66 |
| 3.1.2 | <i>Non-linear 4 D.O.F. vehicle model</i> | 69 |
| 3.1.3 | <i>Using the vehicle models for controller development</i> | 79 |
| 3.2 | CONTROL OBJECTIVES FOR IMPROVEMENT OF VEHICLE HANDLING BEHAVIOUR | 83 |
| 3.2.1 | <i>Steerability as a control objective</i> | 84 |
| 3.2.2 | <i>Stability as a control objective</i> | 85 |
| 3.2.3 | <i>Co-ordination of objectives over complete vehicle handling regime</i> | 86 |
| 3.3 | CONCLUSION | 87 |
| 4 | STEERING SUB-SYSTEM CONTROLLER DESIGN..... | 88 |
| 4.1 | CONTROL OBJECTIVES | 89 |
| 4.1.1 | <i>Yaw Rate Tracking</i> | 90 |
| 4.1.2 | <i>Lateral Velocity Tracking</i> | 90 |
| 4.2 | CONTROL ALGORITHM SELECTION..... | 90 |
| 4.3 | INTERNAL MODEL CONTROL (IMC) | 91 |
| 4.4 | DESCRIPTION OF STEERING SUB-SYSTEMS..... | 94 |
| 4.4.1 | <i>Active Front Steering (AFS)</i> | 94 |
| 4.4.2 | <i>Active Rear Steering (ARS)</i> | 97 |
| 4.4.3 | <i>Active Four Wheel Steering (A4S)</i> | 99 |
| 4.5 | EXAMPLE OF IMC APPLIED TO LATERAL VELOCITY TRACKING USING AFS..... | 102 |
| 4.6 | MULTIVARIABLE CONTROLLER FOR ACTIVE FOUR WHEEL STEERING. | 109 |
| 4.6.1 | <i>Vehicle Dynamics for Multivariable Control</i> | 110 |
| 4.6.2 | <i>Multi-loop Internal Model Control, MIMC, for lateral velocity tracking</i> | 111 |
| 4.6.3 | <i>Simplified Sliding Mode Control for Active four wheel steering</i> | 114 |
| 4.7 | COMPARISON OF STEERING CONTROLLERS | 117 |
| 4.8 | CONCLUSIONS..... | 124 |
| 5 | BRAKE-BASED SUB-SYSTEM CONTROLLER DESIGN | 127 |
| 5.1 | USING LONGITUDINAL TYRE FORCE TO AFFECT VEHICLE HANDLING..... | 127 |
| 5.2 | STABILITY ALGORITHM DESIGN | 133 |
| 5.2.1 | <i>DYC Results</i> | 140 |
| 5.3 | CONCLUSION | 144 |

| | | |
|-----------|--|------------|
| 6 | DEVELOPMENT OF A SUB SYSTEM CO-ORDINATION (SSC) APPROACH | 146 |
| 6.1 | GENERIC RULE BASED APPROACH..... | 146 |
| 6.2 | IMPLEMENTATION..... | 149 |
| 6.2.1 | <i>Rule tuning through numerical optimisation.....</i> | <i>154</i> |
| 6.3 | RESULTS | 156 |
| 6.3.1 | <i>AFS with DYC.....</i> | <i>156</i> |
| 6.4 | COMPARISON OF STEERING SYSTEMS CO-ORDINATED WITH DYC..... | 164 |
| 6.5 | CONCLUSIONS..... | 170 |
| 7 | CONCLUSIONS..... | 173 |
| 7.1 | FURTHER WORK | 177 |
| | REFERENCES..... | 179 |
| A. | APPENDIX – TYRE MODEL AND PARAMETERS | 197 |
| B. | APPENDIX – SUB-SYSTEM COORDINATION TIME HISTORIES FOR AFS-C AND ARS-C | 204 |

Table of Figures

| | |
|---|----|
| FIGURE 2-1 STRUCTURE OF A GENERIC MOTION CONTROLLER WITH THE MULTIVARIABLE CONTROLLER RESPONDING TO VEHICLE STATES AND DRIVER COMMANDS..... | 6 |
| FIGURE 2-2 STRUCTURE OF CO-ORDINATION APPROACH SHOWING THE CO-ORDINATION BLOCK AS AN INTERFACE BETWEEN CONTROLLERS AND VEHICLE..... | 7 |
| FIGURE 2-3 FRONT WHEEL STEERING INTERVENTION SYSTEM..... | 11 |
| FIGURE 3-1 SINGLE TRACK VEHICLE MODEL..... | 66 |
| FIGURE 3-2 PLAN VIEW OF NLVM SHOWING TRANSNATIONAL AND ROTATIONAL STATES, TYRE FORCES AND DIMENSIONS IN THE X-Y PLANE. NOMENCLATURE IS DEFINED IN TABLE 3 3..... | 71 |
| FIGURE 3-3 SIDE VIEW OF NLVM SHOWING LONGITUDINAL STATE, TYRE FORCES AND DIMENSIONS IN THE X-Z PLANE. THE TYRE VERTICAL FORCE, $F(z_{Re}, z_F)$ ARE SHOWN AS A FUNCTION OF LONGITUDINAL ACCELERATION AND LOAD TRANSFER RATIO(LTR)..... | 71 |
| FIGURE 3-4 REAR VIEW OF NLVM SHOWING ROLL AND LATERAL STATES, TYRE FORCES AND DIMENSIONS IN THE Y-Z PLANE..... | 72 |
| FIGURE 3-5 TOTAL ROLL MOMENT AS A FUNCTION ROLL ANGLE..... | 74 |
| FIGURE 3-6 TOTAL ROLL MOMENT AS A FUNCTION OF ROLL RATE. | 75 |
| FIGURE 3-7 LATERAL LOAD TRANSFER DISTRIBUTION. 1 INDICATES ALL LOAD TRANSFER IS REACTED AT THE FRONT, 0.5 INDICATES EQUAL DISTRIBUTION FRONT AND REAR, 0 INDICATES ALL LOAD TRANSFER REACTED AT THE REAR WHEELS. | 76 |
| FIGURE 3-8 UNDERSTEER PARAMETER PLOT FOR TYPICAL GENERIC LARGE SALOON CAR DESCRIBED.. | 78 |
| FIGURE 3-9 CROSS COUPLING EFFECTS IN A MIMO SYSTEM..... | 80 |
| FIGURE 3-10 TYRE CORNERING STIFFNESS EXTRACTED FROM A NON-LINEAR VEHICLE MODEL..... | 82 |
| FIGURE 4-1 CONTROL STRUCTURE..... | 89 |
| FIGURE 4-2 INTERNAL MODEL CONTROL STRUCTURE AND REFERENCE MODEL..... | 92 |
| FIGURE 4-3 POLE ZERO POSITIONS FOR LATERAL VELOCITY AND YAW RATE IN RESPONSE TO FRONT STEERING FOR INCREASING LATERAL ACCELERATION(BLUE LEAST, CYAN GREATEST). ROOT LOCUS DRAWN AS A FUNCTION $C_f(A_\gamma)$ AND $C_r(A_\gamma)$ GIVEN IN FIGURE 3-10..... | 95 |
| FIGURE 4-4 BODE MAGNITUDE PLOTS FOR LATERAL VELOCITY AND YAW RATE IN RESPONSE TO FRONT STEERING FOR INCREASING LATERAL ACCELERATION. | 97 |
| FIGURE 4-5 POLE ZERO POSITIONS FOR LATERAL VELOCITY AND YAW RATE IN RESPONSE TO REAR STEERING. | 98 |
| FIGURE 4-6 BODE MAGNITUDE PLOTS FOR LATERAL VELOCITY AND YAW RATE IN RESPONSE TO REAR STEERING. | 99 |

| | |
|--|-----|
| FIGURE 4-7 STEP RESPONSES OF LATERAL VELOCITY AND YAW RATE W.R.T. FRONT AND REAR STEER INPUTS, SHOWN DOTTED FOR BOTH THE NLVM AND STVM. THE INPUTS LEAD TO AN APPROXIMATE PEAK LATERAL ACCELERATION OF 0.3G..... | 100 |
| FIGURE 4-8 BODE MAGNITUDE PLOTS OF FRONT STEER TO LATERAL VELOCITY TRANSFER FUNCTION FOR OPERATING POINTS THROUGHOUT THE VEHICLE HANDLING REGIME | 103 |
| FIGURE 4-9 DAMPING FACTOR(BLUE) AND DC GAIN(GREEN) AS VERSES LATERAL ACCELERATION .. | 103 |
| FIGURE 4-10 POSITION OF THE SINGLE REAL ZERO OF THE TRANSFER FUNCTION BETWEEN FRONT STEER ANGLE AND LATERAL VELOCITY FOR STRAIGHT AHEAD DRIVING. POSITION DERIVED IN EQUATION 4-5..... | 105 |
| FIGURE 4-11 EFFECTS OF REFLECTING AND DISCARDING ZEROS ON THE FRONT STEERING TO LATERAL VELOCITY TRANSFER FUNCTION INVERSE..... | 106 |
| FIGURE 4-12 COMPLIMENTARY SENSITIVITY AND SENSITIVITY FUNCTIONS FOR AFSLV COMPARING METHODS OF DEALING WITH NMP ZEROS IN THE INTERNAL MODEL, IE INSTABILITIES IN THE INVERSE MODEL BASED CONTROLLER. | 108 |
| FIGURE 4-13 AGGRESSIVE LANE CHANGE MANEUVER USING AFSLV, PEAK LATERAL ACCELERATION 0.7G | 109 |
| FIGURE 4-14 PIECE-WISE TYRE DESCRIPTION | 117 |
| FIGURE 4-15 OPEN LOOP REPRESENTATION OF A SINGLE LANE CHANGE. INPUT 1 LEADS TO PEAK LATERAL ACCELERATION APPROX. 0.7G, INPUT 2 LEADS TO PEAK LATERAL ACCELERATION APPROX. 0.3G..... | 118 |
| FIGURE 4-16 LATERAL VELOCITY TRACKING, ALL CONTROLLERS. SOLID LINES, STATE HISTORY, DOTTED LINES, TRACKING ERROR. | 119 |
| FIGURE 4-17 STEER INPUT AT WHEELS FOR LATERAL VELOCITY TRACKING, ALL CONTROLLERS..... | 120 |
| FIGURE 4-18 TRACKING PERFORMANCE FOR LATERAL VELOCITY SHOWN AS TRACKING ERROR, SMALLER = BETTER..... | 121 |
| FIGURE 4-19 YAW RATE TRACKING PERFORMANCE, ALL CONTROLLERS. SOLID LINES, STATE HISTORY, DOTTED LINES, TRACKING ERROR. | 122 |
| FIGURE 4-20 STEER INPUT AT WHEELS FOR YAW RATE TRACKING, ALL CONTROLLERS..... | 123 |
| FIGURE 4-21 TRACKING PERFORMANCE FOR YAW SHOWN AS TRACKING ERROR, SMALLER = BETTER | 124 |
| FIGURE 5-1 DEPICTION OF AN OVERSTEERING CAR, CORNERING AT THE LIMIT | 128 |
| FIGURE 5-2 EXPANSION OF THE WHEEL SHADED BLUE IN FIGURE 5-1 SHOWING VEHICLE LONGITUDINAL AND LATERAL VELOCITYS, U AND V AND SIDE SLIP ANGLE..... | 129 |
| FIGURE 5-3 EFFECT ON TYRE FORCE DUE TO SINGLE WHEEL BRAKING AS IN FIGURE 5-2 | 130 |

| | |
|--|-----|
| FIGURE 5-4 YAW MOMENTS GENERATED BY BRAKING THE REAR AND FRONT OUTER WHEELS OF AN OVERSTEERING VEHICLE AT THE LIMIT, SOLID AND DOTTED LINES RESPECTIVELY. | 131 |
| FIGURE 5-5 GENERATED YAW MOMENTS AS A FUNCTION OF LATERAL ACCELERATION FOR FOUR DIFFERENT VALUES OF WHEEL SLIP AT EACH WHEEL..... | 132 |
| FIGURE 5-6 A PHASE PLANE SHOWING REGIONS WHERE THE STATE WILL CONVERGE(BLUE) OR DIVERGE(RED). THE APPROXIMATION OF A STABLE REGION TYPICALLY USED IN VEHICLE DYNAMICS IS SHOWN BOUNDED GREEN..... | 134 |
| FIGURE 5-7 PHASE PLANE PLOT OF VEHICLE SIDE SLIP ANGLE AND RATE, SHOWING A STABLE TRAJECTORY(BLUE), AN UNSTABLE TRAJECTORY(RED) AND A BOUNDARY DISTINGUISHING STABLE AND UNSTABLE REGIONS(GREEN)..... | 135 |
| FIGURE 5-8 PHASE PLANE PLOT OF VEHICLE SIDE SLIP ANGLE SHOWING MULTIPLE TRAJECTORIES. ... | 136 |
| FIGURE 5-9 STABLE REGIONS USING PHASE PLANE ANALYSIS FOR VARYING μ | 137 |
| FIGURE 5-10 BRAKE INTERVENTION MAP..... | 139 |
| FIGURE 5-11 BLOCK DIAGRAM OF DYC IMPLEMENTATION | 139 |
| FIGURE 5-12 STEERING INPUT AT THE WHEELS FOR AN AGGRESSIVE OPEN LOOP MANEUVER AT 30M/S OR 70MPH..... | 140 |
| FIGURE 5-13 VEHICLE PATH AND HEADING IN RESPONSE TO THE INPUT SHOWN IN FIGURE 5-12..... | 141 |
| FIGURE 5-14 β -PHASE PLANE FOR STEER INPUT SHOWN IN FIGURE 5-12..... | 142 |
| FIGURE 5-15 SIDE SLIP ANGLE AND CONTROL ACTION FOR STEER INPUT IN FIGURE 5-12..... | 143 |
| FIGURE 5-16 DYC CONTROLLED VEHICLE FORWARD SPEED FOR INPUT IN FIGURE 5-12..... | 144 |
| FIGURE 6-1 DESCRIPTION OF CONTROL TASK AS A FUNCTION LATERAL ACCELERATION..... | 147 |
| FIGURE 6-2 PHASE PLANE APPROACH TO OPERATING POINT METRIC | 149 |
| FIGURE 6-3 CHARACTERISTICS OF A FUZZY SWITCH..... | 150 |
| FIGURE 6-4 SIDE SLIP ANGLE PHASE PLANE SHOWING TYPICAL TRANSITIONS BETWEEN CONTROL TASKS THE OPERATING POINT MEASURE (BLACK ARROW) ALIGNED PERPENDICULAR TO THE DYC STABILITY BOUNDARIES..... | 151 |
| FIGURE 6-5 STRUCTURE OF PROPOSED CO-ORDINATION STRATEGY, REGION SHADED BLUE IS THE EXISTING DYC SYSTEM DESCRIBED IN CHAPTER 5 AND SHOWS THE REUSE OF THE INFORMATION FROM THE STABILITY CALCULATION IN THE FUZZY SCHEDULING CONTROLLER. | 152 |
| FIGURE 6-6 SOFT SATURATION OR SQUASHING FUNCTION..... | 153 |
| FIGURE 6-7 FUZZY SWITCH PARAMTERS FOR CO-ORDINATION OF AFS, ARS WITH DYC IDENTIFIED USING NUMERICAL OPTIMISATION ON A HIGH SPEED AGGRESSIVE OPEN LOOP LANE CHANGE MANOEUVRE USING THE NLVM. | 156 |
| FIGURE 6-8 STEER ANGLES FOR STAND ALONE AND CO-ORDINATED AFS AND DYC, ALSO SHOWN SINGLE CYCLE SINE STEER INPUT AT 1HZ AND 3° AMPLITUDE..... | 158 |

| | |
|---|-----|
| FIGURE 6-9 CONTROL TASK OR FUZZY SWITCH STATE | 158 |
| FIGURE 6-10 VEHICLE YAW RATE..... | 159 |
| FIGURE 6-11 VEHICLE LATERAL ACCELERATION..... | 160 |
| FIGURE 6-12 VEHICLE SIDE SLIP ANGLE | 160 |
| FIGURE 6-13 VEHICLE SIDE SLIP ANGLE PHASE PLANE | 161 |
| FIGURE 6-14 VEHICLE TRAJECTORY | 162 |
| FIGURE 6-15 VEHICLE FORWARD SPEED..... | 163 |
| FIGURE 6-16 RAMP STEER INPUT AT CONSTANT FORWARD SPEED TO EVALUATE STEADY STATE CHARACTERISTICS OF CO-ORDINATION TECHNIQUE AND RESULTANT CONTROLLED STEER ANGLES. | 165 |
| FIGURE 6-17 VEHICLE YAW RATE STEADY STATE IN RESPONSE TO RAMP STEER INPUT..... | 166 |
| FIGURE 6-18 VEHICLE STEADY STATE SIDE SLIP ANGLE IN RESPONSE TO A RAMP STEER INPUT..... | 166 |
| FIGURE 6-19 VEHICLE STEADY STATE LATERAL ACCELERATION IN RESPONSE TO A RAMP STEER INPUT | 167 |
| FIGURE 6-20 PERCENTAGE CHANGE IN STEADY STATE VEHICLE BEHAVIOUR AT TWO CONSTANT STEER INPUTS CORRESPONDING TO 0.5G AND 0.7G WHEN COMPARED TO THE VEHICLE WITH UNCO- ORDINATED CONTROLLERS..... | 168 |
| FIGURE 6-21 CONTROL TASK, 1=STEERABILITY, 0=STABILITY, IN RESPONSE TO RAMP STEER INPUT. | 169 |
| FIGURE 6-22 DYC CONTROLLER DEMANDED WHEEL SLIP AT FRONT OUTER WHEEL IN RESPONSE TO RAMP STEER INPUT | 169 |
| FIGURE 6-23 COMPARISON OF ALL SYSTEMS FOR VEHICLE STATE TRACKING PERFORMANCE IN THE PRESENCE OF STAND ALONE AND CO-ORDINATED CONTROLLERS, (TOP), INTEGRAL OVER TIME OF ERROR SIGNAL DRIVING THE DYC CONTROLLER, (MIDDLE), AND INTERACTION WITH THE LONGITUDINAL DYNAMICS, (BOTTOM). COMPARISON REFERS TO LANE CHANGE MANOEUVRE IN PREVIOUS SECTION..... | 170 |
| FIGURE B-1 | 204 |
| FIGURE B-2 | 204 |
| FIGURE B-3 | 205 |
| FIGURE B-4 | 205 |
| FIGURE B-5 | 206 |
| FIGURE B-6 | 206 |
| FIGURE B-7 | 207 |

Abbreviations

| Abbreviation | Definition |
|---------------------|--|
| 4WD | 4 Wheel Drive |
| 4WS | Four Wheel Steering |
| A4S | Active 4 Wheel Steering |
| ABS | Antilock Braking System |
| ACC | Automatic Cruise Control |
| ACE | Active Cornering Enhancement |
| AFS | Active Front Steering |
| AFS-C | Active Front Steering co-ordinated with DYC using the SSC proposed in chapter 6 |
| AFS-D | Active Front Steering and DYC with out |
| AFSLV | Active Front Steering- Lateral Velocity (Controller) |
| AFSYR | Active Front Steering- Yaw Rate (Controller) |
| AHS | Autonomous Highway System |
| ARC | Active Roll Control |
| ARK | Active Rear-Axle Kinematics |

| | |
|---------------|---|
| ARS | Active Rear Steering |
| ARS-C | Active Rear Steering co-ordinated with DYC using the SSC proposed in chapter 6 |
| ARS-D | Active Rear Steering and DYC with out co-ordination |
| ARSLV | Active Rear Steering- Lateral Velocity (Controller) |
| ARSYR | Active Rear Steering- Yaw Rate(Controller) |
| ATTS | Automatic Torque Transfer System |
| AWD | All Wheel Drive |
| BDC | Brake Distribution Control |
| C.o.G | Centre of Gravity |
| CVT | Continuously Variable Transmission |
| d.o.f. | Degrees of Freedom |
| DSC | Dynamic Stability Controller |
| DYC | Direct Yaw Moment Control |
| EBM | Electronic Brake Management |
| ECU | Electronic Control Unit |
| EPAS | Electrically Power Assisted Steering |

| | |
|---------------|---|
| EV | Electric Vehicle |
| FWS | Front Wheel Steering |
| FWSI | Front Wheel Steer Intervention |
| GA | Genetic Algorithm |
| GMC | Generic Motion Control |
| HILS | Hardware In The Loop Simulation |
| HPAS | Hydraulic Power Assisted Steering |
| IHS | Intelligent Highway System |
| IMC | Internal Model Control |
| IVMC | Intelligent Vehicle Motion Control |
| l.h.p. | Left half plane |
| LQG | Linear Quadratic Gaussian |
| LQR | Linear Quadratic Regulator |
| LSD | Limited Slip Differential |
| LTI | Linear Time Invariant |
| LTR | Load Transfer Ratio |
| MIMC | Multi-loop Internal Model Control |

| | |
|---------------|--|
| MIMO | Multi-input Multi-Output (Controller) |
| MISO | Multiple Input Single Output (Controller) |
| MPC | Model Predictive Control |
| NLMPC | Non-Linear Model Predictive Control |
| NLVM | Non-linear Vehicle Model |
| NMP | Non-minimum Phase |
| NN | Neural Network |
| PD | Proportional – Derivative |
| PID | Proportional-Integral-Derivative |
| r.h.p. | Right half plane |
| RGA | Relative Gain Array |
| RMD | Roll Moment Distribution |
| SbW | Steer By Wire |
| SISO | Single Input Single Output (Controller) |
| SMC | Sliding Mode Control |
| SSC | Sub-system Co-ordination |
| STVM | Single Track (Linear) Vehicle Model |

| | |
|------------|-----------------------------------|
| SUV | Sports Utility Vehicle |
| TCS | Traction Control System |
| TDS | Torque Distribution System |
| VDC | Vehicle Dynamics Control |
| VRS | Variable Ratio Steering |
| VSC | Vehicle Stability Control |

1 Introduction

The use of electronic controllers for affecting the ride and handling properties of passenger vehicles has been ongoing since the late 1970's. Considerable advances in performance have been achieved through control of individual aspects of vehicle behaviour. Early studies have reported improved ride through reduction of body vertical accelerations, improved handling through reductions in dynamic tyre load using active suspension and improved vehicle stability during braking through wheel slip control using the, now common place, anti lock braking systems (ABS). In fact, the development of individual controllers for many aspects of vehicle behaviour relating steering, braking, transmission and suspension have all been widely researched and investigated. Though these advanced control systems first appeared commercially on luxury passenger cars, they are now becoming more widespread in usage and even mid market saloons are now available, for example, with yaw stability systems that have been developed from ABS technology.

1.1 Vehicle Ride and Handling Control

Many of the currently available systems are designed to improve or control a single aspect of vehicle behaviour but rarely are the effects limited to just a single aspect, i.e. active suspension improves body control and ride comfort and dynamic tyre load through controlling the vertical forces at each corner of the vehicle. This improvement in dynamic tyre load improves the ability of the tyres to generate both lateral and longitudinal forces, and also influences the handling and acceleration/braking of the vehicle.

The next logical step is to consider using more than one of these systems to exploit these interactions, for instance, braking and suspension controllers and indeed literature exists to suggest that this is the current vogue, for example (Smakman 2000a; Brennan and Alleyne 2001a).

One of the key benefits of this proliferation of automotive control systems is the potential to increase vehicle safety as dynamic stability and predictability are improved in severe manoeuvres.

There are two immediately apparent approaches to integrating vehicle controllers with these interactions in mind, a) take two or more of the previously well understood handling controllers and apply them to a vehicle or b) design a single controller that explicitly describes the interactions between the inputs and outputs of the system. These can be considered from a design point of view to be “bottom - up” or “top - down”, respectively.

These two methods have specific strengths and weaknesses. The top-down approach is a complex task requiring a detailed description of the system to be controlled, however it provides the most analytic and quantitative approach. The bottom-up approach is comparatively simple as it can make use of previously designed and well understood systems. It does, however, require a careful study of the systems in question as interactions between them may exist. If this is the case, an additional level of knowledge based control is required to prevent interactions detrimental to vehicle performance, in much the same way as advanced drivers understand the interactions between braking and steering.

1.2 Benefits of System Integration

Aside from the potential to improve the vehicle behaviour as described above, two other additional and attractive benefits exist

- a) Controllers attempting to improve a specific aspect are likely to use the same sensors, for instance with respect to handling a steering system improving vehicle yaw rate response requires a measure of yaw rate to implement feedback control, a brake based stability controller also requires a measure of yaw in order to assess vehicle stability and estimate side slip angle. If these two systems were implemented separately, two yaw rate sensors would be required. Stand alone systems generally require a set of sensors per system. The co-

ordination of controllers allows the use of information from one sensor in many systems. A second aspect of this sharing of information is improved robustness or virtual redundancy that can be achieved through communication between different systems.

- b) The increased scope for affecting vehicle handling properties and a reduction in traditional trade-offs allows a degree of tuning to occur through software. This can be exploited in two ways, a reduction in the length of the development cycle as the need for mechanical tuning is reduced and secondly, to improve the potential market. For example, one vehicle can have selectable ride and handling characteristic to appeal to a broader range of people, a sporty setting as well as a more leisurely behaviour but still be able to respond appropriately in critical driving situations.

The potential for these improvements is limited by the level of integration and the number of different systems available. Since this linked to cost, it is almost inevitable that this potential for greater flexibility will be explored on the expensive, luxury class of passenger cars in the first instance.

1.3 This Thesis

In order to investigate some of the implications of the trends described above, this thesis is arranged as follows

Chapter 2 will present a review of the many techniques that have been studied for improving vehicle handling performance. In the context of this broad review, a detailed set of aims and objective for thesis will be defined.

Chapter 3 describes the necessary level of vehicle modelling required for a simulation study into the effects of vehicle control system co-ordination. In particular, a detailed discussion of the practical vehicle dynamics is presented. The outcome of this discussion is a clear understanding between the control problem and the vehicle dynamics problem.

Chapter 4 presents the development of active steering controllers for the vehicle dynamics problem described in Chapter 3. Importantly, it is found through a proper understanding of what is required, linear controllers can be used to improve the vehicle handling behaviour throughout the vehicle handling regime when only one actuator is used, i.e. active front or rear wheel steering. However when both front and rear steering is used to improve vehicle handling, a non-linear approach must be applied in order to tackle the strong coupling between steer inputs and vehicle states.

Chapter 5 documents the development of active steering controllers and brake based stability systems for use in a co-ordination strategy.

Chapter 6 details the design and implementation of a co-ordination strategy for the controllers developed in chapters 4 and 5. Predicted simulation results for this approach are presented. The implications for vehicle handling control involving multiple systems in general and specifically, for braking and steering are identified. The proposed controller successfully coordinates active steering and active braking controllers. The power and the limitations of this heuristic control approach are discussed in the context of solving the problem of improving the vehicle handling using existing “off the shelf” handling controllers.

Chapter 7 presents an overview of the work and identifies the key conclusions to be drawn in the context of the aims and objectives defined in chapter 2. Future areas of research are also highlighted based on the outcomes of the thesis.

2 Review of active vehicle handling systems

This chapter presents a review of the literature relating to active control systems for vehicle handling behaviour. In this thesis, handling specifically relates to the lateral vehicle behaviour, and does not include systems such as antilock braking system (ABS) and traction control (TCS) as these relate to longitudinal handling. It does include systems such as differential braking and active suspension as these systems exploit longitudinal or vertical forces to affect vehicle handling behaviour.

The development of systems for affecting vehicle handling has been ongoing since the mid 1980's, (Wright and Williams 1984; Roppenecker and Wallentowitz 1993), with active rear steering(ARS) being the first to receive considerable attention (Sano, Furukawa et al. 1986; Whitehead 1988). At the start of the 1990's active braking systems and low cost suspension systems such as active roll control (ARC) began to attract more interest. At this point, ARS had received little commercial interest except in expensive luxury and sport cars like the BMW 8-series and the Honda Prelude, (Donges and Wimberger 1993; Donges 1995). This lack of commercial interest reflects the cost of packaging the new system and the fact that ARS fails to come out favourably in a detailed cost/benefit analysis. However around this time, ABS was starting to achieve penetration in to mid range cars, despite the fact it had been commercially available since the late 1970's. In order to add value to this system, interest began to focus on developing new systems to improve vehicle lateral handling that exploits the existing ABS hardware. The modern direct yaw moment control (DYC) is the result. In addition to this, the increase in popularity of large off-road vehicles or sports utility vehicles(SUV) has lead to interest in active roll control(ARC) and roll moment distribution(RMD), (Everett, Brown et al. 2000a; Smakman 2000a), to address the suspension design trade-offs inherent in that particular class of vehicle. Significant current interest is also focused on active front steering(AFS) or steer-by-wire (SbW) as new ways to improve vehicle handling continue to be sought, (Mammar and Koenig 2002).

The advanced state of development of all these systems is reflected through their appearance in the market place, for example, BMW with RMD, DYC and ARS,

(Donges 1995; Konik, Bartz et al. 2000), and Landrover with ARC,(Everett, Brown et al. 2000b). The next challenge in vehicle dynamics is to seek to integrate the

functionality of each of these systems in various combinations such that the greatest cost/benefit is achieved.

Two approaches to this problem have appeared in the literature, the analytic, top-down approach and, by contrast, the more pragmatic bottom-up co-ordination approach. The former will be referred to as Generic Motion Control (GMC) in this thesis and is characterised by the use of modern multivariable control techniques. Figure 2-1 shows a typical structure of a such a system.

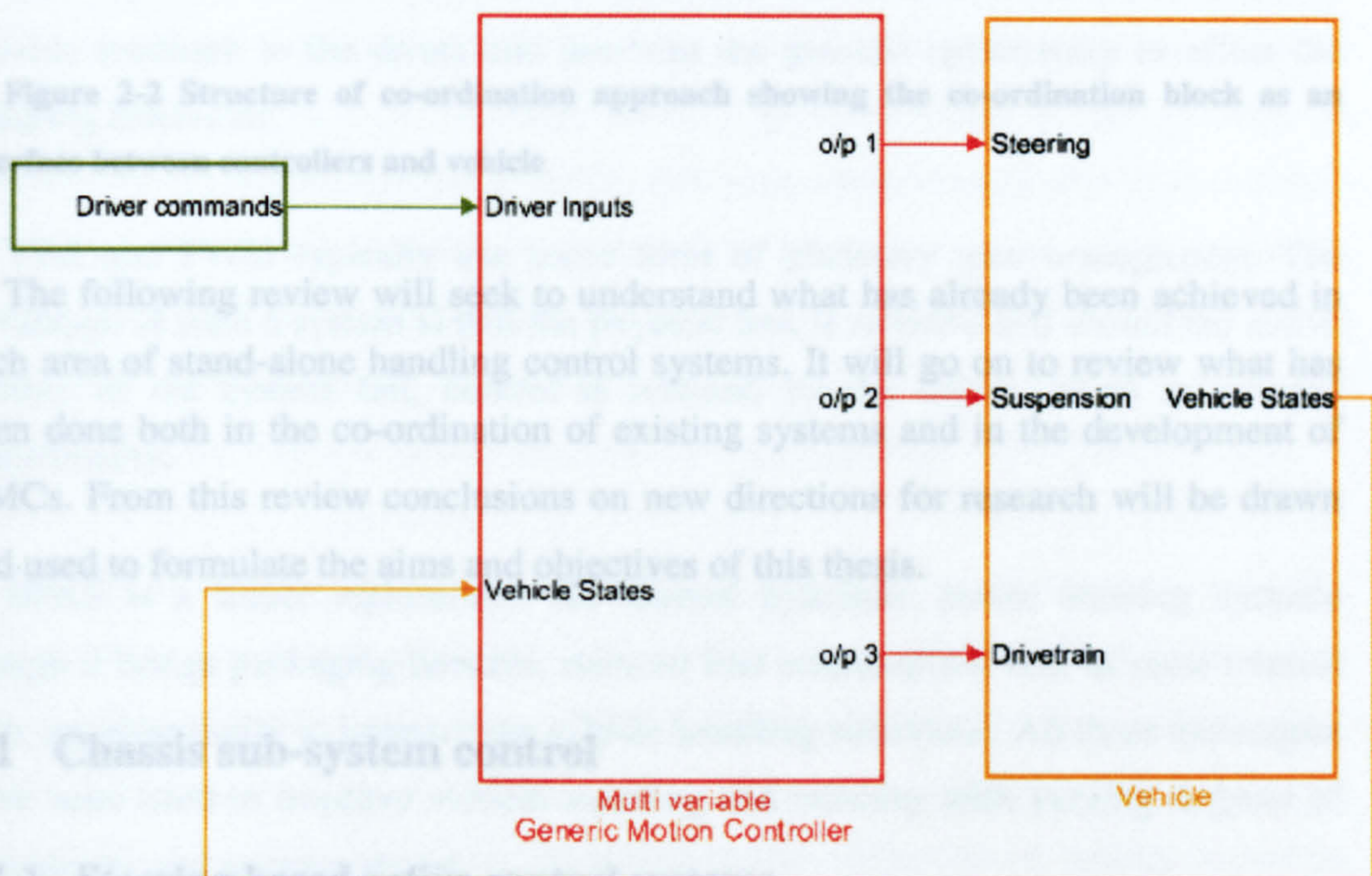

Figure 2-1 Structure of a generic motion controller with the multivariable controller responding to vehicle states and driver commands.

The latter, i.e. bottom-up approach, applies what is commonly referred to as expert knowledge, to develop handling controllers. These rule based controllers typically arbitrate between two or more stand-alone systems, Figure 2-2 shows a typical structure of this type controller.

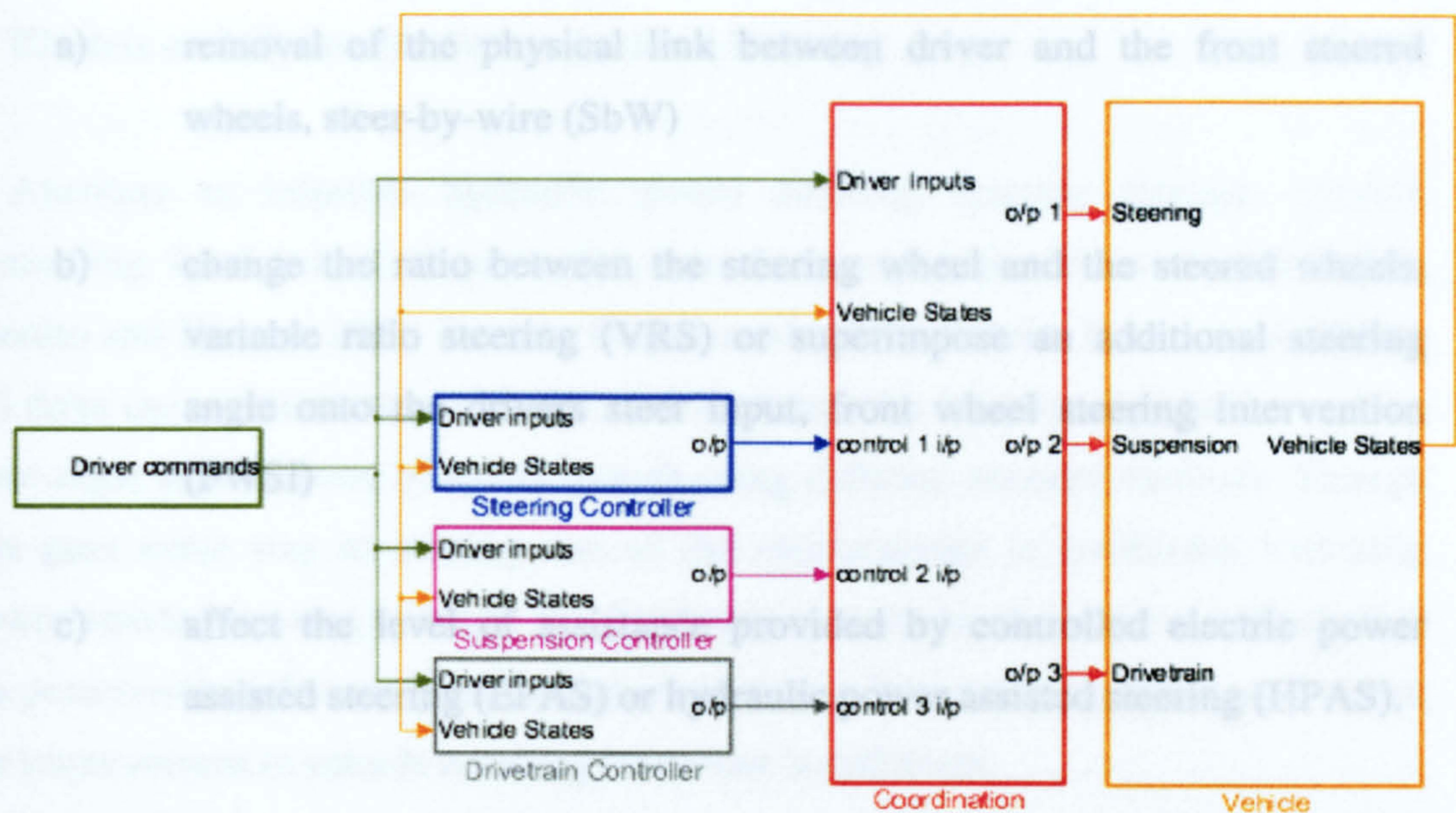

Figure 2-2 Structure of co-ordination approach showing the co-ordination block as an interface between controllers and vehicle

The following review will seek to understand what has already been achieved in each area of stand-alone handling control systems. It will go on to review what has been done both in the co-ordination of existing systems and in the development of GMCs. From this review conclusions on new directions for research will be drawn and used to formulate the aims and objectives of this thesis.

2.1 Chassis sub-system control

2.1.1 Steering based active control systems

Active vehicle steering systems present the most obvious opportunity for affecting vehicle handling as they are traditionally the primary vehicle input, steering is also the most direct form as it is the only input that directly controls the amount of generated lateral force rather than manipulating it through affecting the amount of vertical or longitudinal force. The introduction of active controllers to the steering system has been investigated since the early 80s.

The techniques associated with active front steering fall into three distinct categories,

- a) removal of the physical link between driver and the front steered wheels, steer-by-wire (SbW)
- b) change the ratio between the steering wheel and the steered wheels, variable ratio steering (VRS) or superimpose an additional steering angle onto the drivers steer input, front wheel steering intervention (FWSI)
- c) affect the level of assistance provided by controlled electric power assisted steering (EPAS) or hydraulic power assisted steering (HPAS).

Steer by wire uses an actuator to steer the wheels and a second actuator to provide feedback to the driver and provides the greatest opportunity to affect the handling behaviour.

VRS and FWSI typically use some form of planetary gear arrangement. The advantage of such a system is that the physical link is retained and should the active portion of the system fail, control is retained by the driver, albeit at reduced functionality.

EPAS is a direct replacement for current hydraulic power steering systems though it brings packaging benefits, reduced fuel consumption and, of most interest here, an opportunity to improve the vehicle handling behaviour. All three techniques have been used to improve vehicle handling and stability with varying degrees of complexity and associated cost.

Finally, vehicles which have active steering front and rear have also been investigated, active four wheel steering (A4S or 4WS, though the latter abbreviation is also commonly used for vehicles where only the rear wheels are actively steered and will not be used again in this thesis).

2.1.1.1 Active Front Wheel Steering (AFS)

This section will consider all the variants of AFS discussed i.e. HPAS, EPAS, FWSI, VRS and Steer by wire.

Electric and Hydraulic Power Assisted Steering

Attempts to improve hydraulic power steering systems through actively controlling the level of torque assist have been reported and two are found in (Bonito and Herrera 1993; Pawlak, Graber et al. 1994; Suzuki, Harara et al. 1994). All three use an electronic controller, and to change the amount of assist for a given steer angle as a function of speed, though using different actuator methods. Though this goes some way to solving one of the shortcomings in traditional hydraulic power assisted steering systems, the fixed torque assist level, it seems unlikely that the perceived benefits are great enough compared to the increased complexity or that the improvement in vehicle handling behaviour is sufficient.

Power assisted steering systems based on electrical actuators have been studied from the point of view of implementation, a good overview of the problem is provided by (Dominke and Ruck 1999). The main advantage of electrical actuator approach with respect to handling is that it becomes simple to affect the assist characteristic with driving condition. The paper concludes that it is a matter of time before such systems replace current hydraulic and electro-hydraulic approaches due to potential improvements in steering feel, fuel economy and reduced complexity.

The actual control of an EPAS system also receives much attention with H_{∞} control being a common approach (Badawy, Bolourchi et al. 1997; Chabaan and Wang 2000a; Chabaan and Wang 2000b; Kohno, Takeuchi et al. 2000). Two practical implementations are discussed in (Shimuzu and Kawai 1991; Badawy, Zurafski et al. 1999). The work presented in this collection of papers serves to demonstrate that issues regarding implementation, control, and safety are well understood though little attention is given to the ideal steering characteristic.

An approach by (McCann 2000) similarly claims to improve transmissibility of the steering system through the use of yaw rate feedback. Yaw rate feedback improves the steering characteristic by reducing assist levels as the manoeuvre becomes more severe, hence providing greater levels of road feedback when it is most needed. It does imply that this is beneficial on surfaces with a low coefficient of friction, μ , however it does not address the fact that high yaw rates are unachievable on low μ surfaces and therefore the associated reduction in assist is

small. A well discussed work is marred due to the simple linear modelling and insufficient results to appropriately evidence the arguments made. Intuitively however, the conclusions of the work are sound. A more detailed study with appropriate modelling and an investigation of parameter variations, such as μ is needed.

(Yuhara, Horiuchi et al. 1992) provides a theoretical and experimental study of the driver-vehicle system during on-centre handling. The work proposes that the torque feedback to the steering wheel is proportional to either lateral acceleration or yaw rate and compares the effects of these two different controllers. The theoretical analysis of this suggests that the gain between disturbance and lateral deviation is reduced and so the driver will find tracking a straight line easier. An experimental study using fixed base simulators as well as an experimental vehicle validates the assumptions: drivers do find it easier to track a straight line in the presence of external disturbances due to cross winds and that driver workload is reduced. The work load results are based on a secondary task method . The greatest improvements are found using lateral acceleration rather than yaw rate. Though the reasons for this are not discussed, it is unsurprising because lateral acceleration is the second derivative of lateral error and therefore the torque generated artificially produces a steering torque to reduce the increase of lateral error. While this work is an interesting study, it does not address driver-vehicle interaction during anything other than straight ahead driving, it is not clear if the results would be the same if some low lateral acceleration course following manoeuvres were examined, i.e. a lane change. The strategy suggested probably has its greatest potential during motorway driving but the speeds involved in the study are too low (only 30mph) to draw conclusions.

The papers reviewed so far have concentrated on EPAS systems and the effect on handling. The literature available is sparse though the work here suggests that improvements to driving quality are possible and that this leads to an improvement in vehicle stability at the limit and a reduction in driver work load away from the limit of vehicle handling. The following section will review work based on the second approach, VRS and FWSI.

Variable ratio Steering and front wheel steering intervention

These two approaches are closely linked as the hardware tends to be very similar; the typical method is to use an epicyclic planetary gear arrangement as described in (Kramer and Hackl 1996; Millsap and Law 1996). One shaft to the steering wheel, the other to the steering rack, and the carrier velocity or position is controlled by a worm drive. It appears the main advantage of this arrangement suggested in the literature is one of safety. If the electronic control or actuator fails, the physical link is retained by locking the position of the carrier, hence the vehicle is still controllable although with a deteriorated steering characteristic. A further benefit is a low power consumption compared to fully active steering or Steer by Wire. In a fully active system, additional power is needed for torque feedback to the driver. Using this type of gear arrangement, all torque is still reacted, by the driver, at the steering wheel.

The difference between a VRS or FWSI is the way in which the problem is posed. In VRS, for given steer input, there is a computed steer angle that is also a function of vehicle speed or some other state. With FWSI, an ideal steer angle is calculated, based on some control scheme, and the actuator is moved to superimpose the difference between the controllers desired steer angle and drivers commanded steer angle, Figure 2-3.

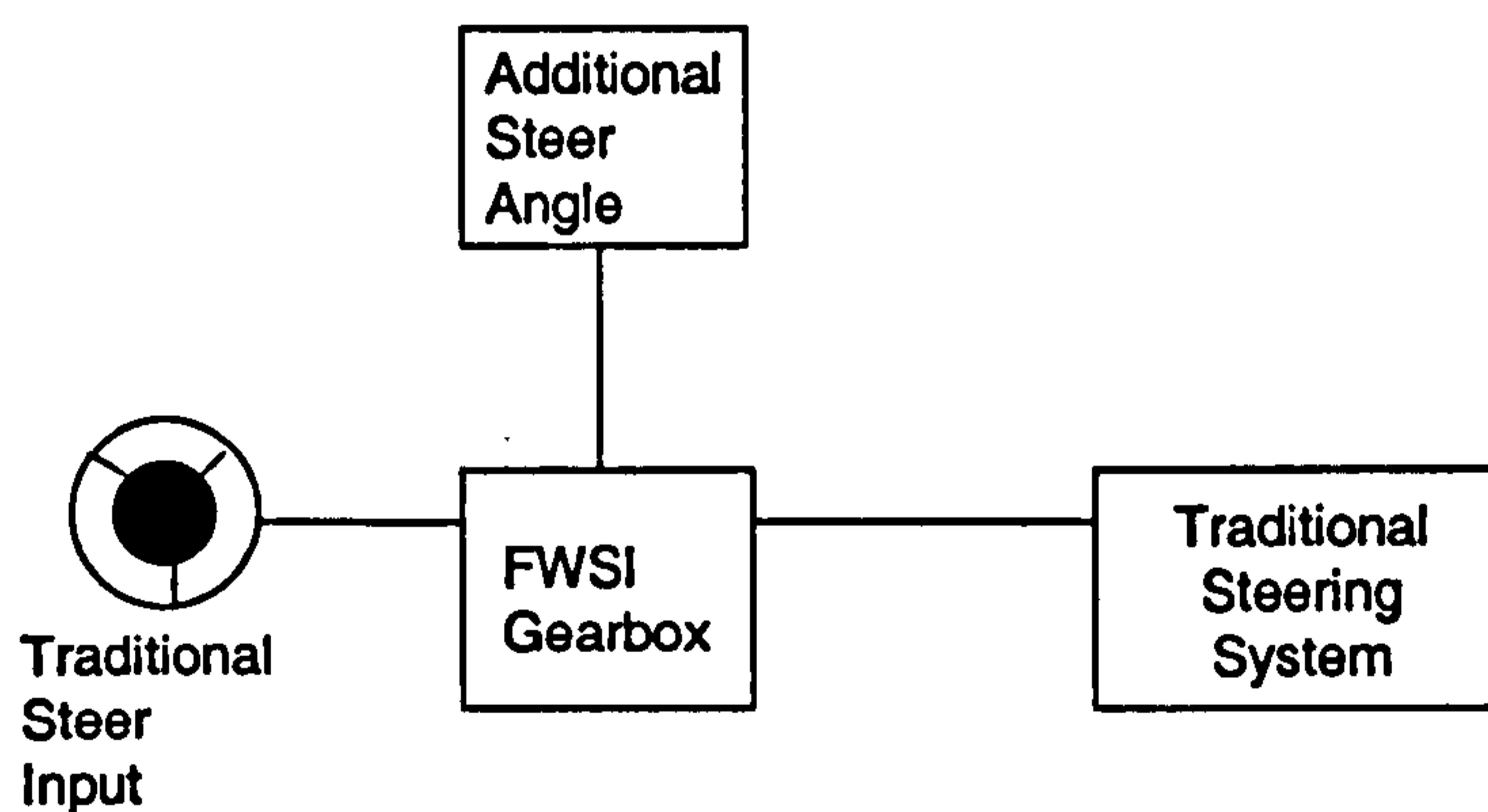

Figure 2-3 Front wheel steering intervention system

In essence, VRS is a feedforward system, and FWSI is a feedback system. In this respect, FWSI is more closely allied to fully active steering than a VRS system. With FWSI however, if the driver does not provide the necessary reaction torque no control is possible. The following section will discuss work based on VRS and then finally FWSI and Steer by wire together.

(Kramer and Hackl 1996) present four simple control strategies to investigate the effectiveness of a the epicyclic gear arrangement described above. These strategies are

- a) A power assisted steering
- b) A phase lead compensator
- c) Yaw rate tracking controller
- d) Yaw rate compensation strategy for yaw disturbances induced by braking on split- μ surfaces.

The power assisted steering system is found to fall short of conventional hydraulic systems and is not discussed in detail. The phase lead and yaw rate tracking are both found to improve handling characteristics, showing reductions in peak lateral accelerations and steering effort with improved driver subjective ratings during a double lane change manoeuvre at 90kph on a dry road. The yaw torque compensation improves braking behaviour on a split- μ surface, a 70% reduction in driver steer angle and 25% reduction in peak yaw rate. The work was performed on an experimental vehicle. A clear discussion of 4 strategies shows the potential of this system to improve vehicle handling behaviour through improved yaw response and improved rejection of external disturbances such as crosswinds and also suggests that significant benefits can be achieved through co-ordination with a brake based system manifested as reduced deviation from the desired course and reduced stopping distance.

(Yoshimoto, Tanaka et al. 1999; Hayama, Nishizaki et al. 2000) present two strategies based on qualitative analysis of two specific situations, i) spin out during oversteer instability and ii) split μ braking respectively using an idealised AFS system. The main problem with these approaches is the lack of generality required by a steering system as the main form of vehicle control, i.e. these two specific situations will not be the only two encountered in typical driving. The conclusions of the work themselves offer little to the field AFS control. (Hayama, Nishizaki et al. 2000) claims that AFS has a greater ability to stabilise the vehicle than a brake based

stability system which contradicts the rest of the literature and most analysis on the situation, it does seem to concur with (Kramer and Hackl 1996) in that a co-ordinated AFS and brake based system potentially offer significant benefits over such brake based systems alone.

(Abe, Shibahata et al. 2000) provide a much more detailed discussion of the effect of steering gain on driver behaviour utilising the implementation described in (Shimuzu, Kawai et al. 1999), an alternative to the more common planetary gear train. The method is less versatile but less complicated and is a genuine variable gear ratio system. The work is evidenced using a mixture of simulation, fixed base simulator and experimental results. The study is well reasoned and suggests that there is an upper and lower ideal limit on steering gain and that the most important scheduling parameters are lateral acceleration and speed as these relate the vehicle operating point to that of the tyre. It also suggests that the handling performance is most sensitive to the upper bound at high lateral accelerations and speed. It clearly shows that dynamically changing the steering gain can mitigate the deterioration of vehicle handling characteristic using a plot of yaw rate gain and effective yaw rate time constant. This approach for presenting information about the quality of the vehicle handling characteristic was first presented in (Weir and DiMarco 1978) and is commonly referred to as Weir-DiMarco plot. The work does not discuss the robustness of the approach, particularly with respect to μ , as this will affect the relationship between tyre characteristic and lateral acceleration.

A human factors study on the VRS system is presented in (Akita, Satoh et al. 2000). The work use a mixture of linear vehicle and driver model simulations and an experimental vehicle. The work looks at various driving situations but does not discuss the severity of the manoeuvres. It does concur with (Abe, Shibahata et al. 2000) that there is an upper and lower bound on steering gain. The most interesting aspect is the investigation on system failure, concluding that providing the manoeuvre at the time of failure is not extreme, most drivers will cope well providing the system reverts to a reasonable passive steering gain. Also studied is the maximum permitted time delay for the additional steer angle, this is approximately 100ms.

(Tajima, Yuhara et al. 1998; 1999; Yuhara, Tajima et al. 1999) also study the use of steer by wire to improve the performance of the driver-vehicle system. Gain scheduling between steering wheels and steered wheel is studied as is the introduction of an additional torque to the driver to provide information about tracking error measured from road markers. A technique for calculating an ideal gain and two gain scheduling strategies are proposed; one favouring heading angle, the other lateral error. A fixed based simulator study finds that the benefits of each strategy are inherently linked to driver task, continuous lane following or a discrete lane change. It is also found that the calculated ideal gain is ineffective if driver measurements are poor, introducing a torque feedback to the driver is found to allow the gain to be set closer to ideal. A more complete and improved description of the work is found in (Yuhara and Tajima 2001). This work proposes a number of extensions. The conclusion in the previous work that the ideal gain is related to task is reaffirmed and augmented in that it is also related to driving mood. Strategies for determining task and mood are proposed using neural networks for mood and autoregressive moving average technique for driving situation, lane change or lane-following. A H_{∞} based yaw rate controller is also used to extend the earlier gain scheduling concept. The advanced steering system proposed addresses a far broader range of the man-machine interface issues than the other work and suggests solutions to a number of them. Whilst the motivation for some of the approaches is poorly justified, a working system that is found to be subjectively preferable to a conventional system using an experimental vehicle is proposed, though the subjective results presented are too narrow to be conclusive. The task identification is also shown to be effective through measured data, though the influence of mood on the control system is not discussed beyond its use in the controller and its identification, it is unclear whether it brings any benefit in the final system or not.

The following papers use the same actuation principle but treat the relationship between steering wheel and steered wheels as dynamic, usually in response to some measured vehicle state, i.e. yaw.

(Wang and Nagai 1992) present an adaptive AFS system for tracking yaw rate and lateral acceleration reference models on a 14 tonne commercial vehicle but the study uses the 2 D.O.F. single track vehicle model (STVM) description of vehicle handling and hence is applicable to passenger vehicles. A self tuning pole placement

controller is designed in discrete time and found to improve vehicle response in the presence of step changes of cornering stiffness for both under and neutral steering vehicles. The main weakness of the simulation results is that no description is given of the model.

LQR control is developed for AFS in (Smith, Benton et al. 2000). The work suggests that the controller is a non-linear optimal controller. However what is described in the text is gain scheduled a linear state feedback controller using forward velocity as the scheduling parameter. This neglects the important non-linearities due to suspension and tyre characteristics that would be observed in a real vehicle at the high lateral accelerations discussed. The gains are calculated using a 2 D.O.F. STVM to minimise an LQR-type cost function. This is tested, through simulation on non-linear vehicle model with Dugoff tyre model, (Dugoff 1970), in a number of aggressive handling manoeuvres (0.5-0.6g peak) and shown to be effective and robust to changes in cornering stiffness, μ , and mass. The results indicate steer angles at the wheel of 25° which seems excessive as peak force is generated at somewhere less than 3° in the tyre model plots presented, no discussion of this feature is included.

(Zhang, Xu et al. 2001) presents a sliding mode controller for a three degree of freedom vehicle model. The paper claims the model used for controller development includes the important vehicle non-linearities. The model actually only includes cross coupling terms between the longitudinal, lateral and yaw velocities and some linear approximation of aerodynamic effects. A further assumption, "most roads are straight" reduces the applicability of the controller to the handling problem. The same model is used for development and assessment of controller performance. Simulation results for the rejection of a step lateral velocity error and longitudinal acceleration are presented. Sliding mode control can clearly be applied to this system, however the link to the real vehicle dynamics problem is not discussed.

(Feng, Tan et al. 2000) propose a decoupling controller to decouple the lateral dynamics with the roll degree of freedom. The work suggests that interactions between yaw and roll are significant between 1 and 4Hz, but only for softly sprung vehicles. The controller is based on a look ahead scheme for use in an autonomous highway system (AHS). This frequency range would appear to be above the

frequencies of interest for the handling of a softly sprung vehicle particularly if used in a look ahead scheme. Active steering is a prerequisite for such an AHS. The work fails to describe the model used for simulation. The controller is derived using H_∞ and μ -synthesis techniques including a description of the structured uncertainties. However, it is not clear how this description is arrived at nor is its effect on controller performance or robustness.

Three papers on the same study, (Ono, Hosoe et al. 1996; 1998a; 1998b), present a new analysis of non-linear vehicle instability using bifurcation theory and an AFS H_∞ controller to prevent instability; the most detailed of which is (Ono, Hosoe et al. 1998a). The analysis of stability is performed through a study of the trajectories of a yaw-side slip angle plot for various steer angles, the work identifies a number of previously well understood features of vehicle dynamics such as the effect of rear tyre force saturation on stability. An adaptive H_∞ controller is shown to effectively stabilise a vehicle in simulation through not only controlling front steer angle but also through identifying the peak lateral force of a tyre and limiting the steer angle so that cornering stiffness' remain greater than zero front and rear. The work is clear and well argued but is let down by the use of an inappropriately simple model for demonstrating the effectiveness of the control strategy.

A body of work, (Guldner, Utkin et al. 1994; Sienel and Ackermann 1994; Ackermann 1996aa; 1996bb; 1997; Guldner, Ackermann et al. 1999; Akita, Satoh et al. 2000), develop a mixture of linear and nonlinear controllers for pathway following in an AHS. Whilst the work is largely theoretical and not directly applicable to the handling problem considered here, it does provide a framework in which to solve the problem, including a technique for solving the trade-off between good tracking with harsh variations in lateral acceleration and passenger comfort. The main value of the work however comes from (Ackermann, Guldner et al. 1995), it shows through simulation that very little difference is observed in terms of performance between linear and nonlinear control formulations for path tracking though this is only tested in the linear region of vehicle handling; it remains to be seen if this assertion is still valid in wider operating regimes including tyre non-linearities. Whilst the work is thorough in its analysis as far as it goes, the controller performance is not characterised over a wide enough operating regime to draw useful conclusions.

(Ackermann and Bunte 1997), discuss the effect of actuator rate limits. The theoretical study based on a STVM was performed in response to earlier experimental work where limit cycles were observed for some speeds and surfaces. Hence the limit cycle behaviour was examined with respect to H_{∞} and speed. A technique is presented that reduces the required actuator bandwidth and removes the limit cycle behaviour. The limit cycle behaviour is unreported in other studies and it is likely a property of the particular robust control approach applied. No simulation results are presented. Whilst it does provide a technique for reducing actuator requirements, it is of little practical value, particularly as it is restricted to the linear range of vehicle motion.

(Sienel 1997) presents a study of the effect of front tyre cornering stiffness on the robust control strategy described (Ackermann 1996a; Ackermann and Bunte 1997) for AFS. The motivation for this study is that near the limit of vehicle handling, the robust controller causes vehicle instability. An estimation technique for cornering stiffness is presented and used to detect the point when it approaches zero. At this condition, an expert driver is mimicked, the steer angle is reduced by some integral of the driver's steer angle. Simulation results present an extreme cornering manoeuvre to demonstrate the effectiveness. Whilst the new strategy is an improvement over the original one, unusually, it does not appear to be a substantial improvement over the passive vehicle. Further weaknesses are the lack of an appropriate model, whilst it does include tyre non-linearities in the form of a Dugoff tyre model, (Dugoff 1970), it does not include load transfer or dynamic roll effects in a transient manoeuvre resulting in a peak lateral acceleration of 0.6g.

(Huh, Seo et al. 1999) propose a technique for estimating lateral tyre force at the individual wheels using Kalman filtering. A fuzzy logic controller is then developed to compensate the lack of tyre lateral force experienced on low μ surfaces by controlling the actual front steer angle. The work is demonstrated using hardware in the loop simulation (HIL). Though the technique is found to be effective, its effect on vehicle handling is not demonstrated. It appears from the results presented that the combined estimation and control algorithm introduces some high frequency dynamics that a driver, might potentially, find irritating or lead to unnecessary actuator usage.

(Wang and Ackermann 1998), present a study of PID controllers for AFS; through an analysis of the STVM, it is shown that an oversteering car cannot be destabilised by any collection of positive PID gains, but an understeering car can. The application of this result is unclear.

(Tagawa, Ogata et al. 1996) also use AFS in the context of AHS. They propose to design robust model matching controller using H_{∞} control to achieve a vehicle characteristic invariant to speed, mass, geometry, surface coefficient, and acceleration. Simulation results are presented using a mixture of linear and non-linear models using open loop and closed loop tests, as well as frequency domain results. As far as it goes, the work successfully achieves its yaw rate tracking aims up to 0.6g lateral acceleration, but at the expense of large side slip angles, 4deg at 0.6g. This suggests that the vehicle is approaching its handling limit, and it is not discussed how the controller copes with the impending tyre force saturation.

Whilst much of the reviewed work has considered a number of robust or optimal control strategies, by far the most convincing and complete discussion of the control problem can be found in (Mammar and Baghdasarian 2000; Mammar and Koenig 2002), the latter in particular. The earlier work presents a highly idealised H_{∞} controller for the two degree of freedom control problem, i.e. good disturbance rejection and good state tracking, in this case, yaw rate. The later work deals with most of the earlier assumptions. In particular, out of the many papers on this subject, an appropriate description of the parameter uncertainty is presented. The work is evidenced using simulation on a non-linear model with a Pacejka tyre model; it does not include changes in tyre vertical force however. The results presented include a wide range of handling only manoeuvres on various surfaces and at various speeds, however, the lateral accelerations achieved are too low allow proper evaluation of the robustness properties of the developed controller, even on the low μ surfaces.

2.1.1.2 Active Rear Wheel Steering (ARS)

Active rear steering was one of the first active controllers considered for improving vehicle handling and as such has received a considerable amount of interest. Further work has considered the effect controlling both front and rear steer angles actively. Much of this literature considers both ARS and A4S. This section

will consider only ARS variants. And the following section will consider A4S and A4S and ARS comparisons.

(Irie and Kuroki 1990) details Nissan's early strategies for improving vehicle dynamic behaviour using feedforward control, from Nissan's earliest attempts dating back to 1977. The first production system was released by Nissan in 1985. A similar discussion, this time for commercial vehicles, comes from Mitsubishi, (Susuki, Matsuda et al. 1994). These papers discuss the same three control strategies, i) proportional to front steer angle, ii) first order delay, and iii) a non-minimum phase controller (called phase reversal control). The first order delay strategy is found to have the greatest effect on stability and is improved further by scheduling gain time constant with vehicle payload. The phase reversal controller provides most improvement to the vehicles yaw rate response. Both these studies are carried out using experimental vehicles.

A simulation study is found in (Lee 1995) which compares the feedforward proportional strategy with one feeding back yaw rate through a phase lead-lag compensator, showing improved transient response of yaw rate. An experimental study by (Inoue and Sugasawa 1993) comparing linear feedforward and feedback control shows that a combination of both can improve yaw dynamics whilst reducing the effect of external disturbances. BMW provide a description of the feedforward strategy Active Rear Axle Kinematics (ARK), (Donges and Wimberger 1993). These works are representative of much of the early literature.

A detailed study of the benefit of ARS is performed on a single track vehicle model by (Whitehead 1988). A passive front wheel steered vehicle, a proportional feedforward and a zero side slip angle ARS are compared both with and without the effects of the steering system at low and high speeds. The zero side slip angle strategy is derived from the equations of motion and is a yaw rate feedback and steer feedforward control. The author argues that many papers have reported transient and subjective improvements in vehicle behaviour but none have been able to explain why with respect to the vehicle dynamics. A number of important conclusions are made. 1. ARS is not necessarily a good thing at low speeds, an analysis of parallel parking shows it is most favourable to steer only at one end of the vehicle. 2.

Improvements from zero side slip angle strategy that are at the expense of excessive understeer, result from three distinct features:

- a) yaw damping is improved at high speeds because it effectively reduces the trade-off between short chassis for manoeuvrability and long chassis for stability
- b) it improves the balance between front and rear tyre force with respect to high frequency steer inputs as it increases the rate at which rear tyre slip is generated
- c) a complex interaction exists at high frequencies between steer input torque and a free resonance of the vehicle called the weave mode. The study demonstrates that the zero side slip strategy totally removes the weave mode which is suggested to be responsible for drivers losing control at the end of extreme obstacle avoidance manoeuvres. This improvement allows a driver to “feel more secure” when driving ARS vehicles.

The work importantly points out that the improvements, for the zero side slip strategy, in vehicle handling are slight and only correspond to high frequency excitation at high speeds. This may explain the lack of sustained interest by vehicle makers; benefits are only tangible in rarely occurring situations and also the improvements at low speed are questionable when considered from the point of view parking in a confined space. The work concludes that much more study is required for many different strategies and the effect on the driver control task. It can be inferred that a reduction in side slip is good if the vehicle is in an extreme manoeuvre likely to lead to instability. In other situations benefits are much less tangible. The use of the side slip angle reduction is commonly cited, e.g. (Sato, Kawai et al. 1991; Kleine and van Niekerk 1998), but none provide the level analysis found in Whitehead’s study.

(Xia and Law 1990) compare Whitehead’s closed loop zero side slip control with and an open loop version proposed by (Sano, Furukawa et al. 1986). The controllers are applied to a vehicle using combined steering and braking for collision

avoidance. Whilst the work is well argued and shows an appropriate selection of results, the modelling only includes the interaction between longitudinal and lateral forces, other factors affecting vehicle non-linearities such as load transfer are not considered. A 15% decrease in the distance required to miss a 10 ft wide obstacle is demonstrated.

Side slip control is again considered in (Sutantra and Kaelani 2000). In this study, three different control algorithms, either zero side slip, side slip control or control of instantaneous centre of turning are compared. The work notes that the control strategy is linked with driving task which concurs with (Whitehead 1988) but the analysis of the vehicle dynamics is less detailed than that work.

In addition to more classical control techniques described above, two papers have implemented a fuzzy logic technique for controlling ARS. (Szosland 2000) presents an open loop algorithm which reduces side slip angle. The technique is shown to be highly effective on a non-linear vehicle model. It would appear that the success however is dependent on the controller being tuned to a particular vehicle as no feedback exists. As such a discussion of sensitivity of the controller parameters on an objective measure of handling performance would allow more confidence in the presented conclusions. Further the main value in using a fuzzy technique is to describe the vehicle dynamics in terms of linguistic variables, and though a description of these variables is given, no discussion of how the rules were tuned is presented. This would appear to be key to both implementation and eventual performance and robustness analysis.

An implementation with more value to the real vehicle dynamics problem is presented in (Will, Teixeira et al. 1997). A local model technique is presented based on the 2 D.O.F. STVM where two LQR based controllers for yaw and side slip are designed and scheduled against slip angle. The simplicity of the technique presented makes it an attractive solution to this non-linear problem, one linguistic variable with two sets, BIG and SMALL. This is compared with the 196 rules of the approach in (Szosland 2000). The accuracy of the fuzzy model is compared against a non-linear model and found to be good though the presentation fails to include a description of the model, a tyre characteristic is all that is included. The fuzzy controller performance is also shown to be good compared with a linear LQR

version. More appropriate modelling and a broader selection of results is required to confirm the effectiveness of the technique.

Much of the work has focused on classical control techniques for yaw rate and side slip control. Few works include a detailed vehicle dynamics analysis of the effects of the controller. An exception to this is the work by (Whitehead 1988) where it is shown that the benefits of ARS are closely linked with driving task and the benefits of approaches controlling purely to side slip or yaw rate are questionable.

2.1.1.3 Active Four Wheel Steering (A4S)

This section will consider the problem of controlling front and rear steer angles actively, it also includes works where ARS and A4S have been compared.

The simplest approach to controlling vehicle motion is through the use of feedforward control. A muddled discussion of the “Dynamics of four-wheel-steering vehicles” by (Spentzas, Alkhazali et al. 2001) compares two feed forward ARS and one feedforward A4S algorithm on 3 different models; one model for each controller. In the ARS case, a zero side slip angle control is proposed. In the A4S case, rear steer angles are calculated as a function of front steer angle and its derivative with gains selected using a numeric optimisation technique to again minimise side slip. The model used for the A4S case is a non-linear model and includes roll and load transfer effects and a Pacejka tyre model. It is unclear what the author set out to achieve, the conclusions are therefore impossible to interpret. No base vehicle is shown for comparison, controller objectives are inconsistent as is the model used for each controller. It may well be that simple feedforward control is effective, but it can not be assessed on the basis of this work.

(Tran 1994) compares the principle of feedforward ARS and A4S control to reduce the effect of wind disturbances produced by wind disturbances. The need for disturbance rejection is linked to the improved aerodynamic characteristics with respect to drag. Improving the fuel economy in this way has caused vehicles to be more susceptible to side winds. The discussion of the controllers is based on an analysis of the way external forces and moments are produced on the body by

external wind. Proposed feed forward controllers for AFS,ARS A4S are evaluated in simulation with a STVM and ARS on an experimental vehicle. Simulation results suggest that significant improvements are found with A4S and ARS being the best and worst respectively. AFS is very close in performance to A4S. The predicted effectiveness was not confirmed during experimental trails; in fact the driver rated the vehicle subjectively worse. The work is an interesting study and the author suggests it as an alternative to yaw rate feedback; a comparison of yaw rate feedback and cross wind feedforward may have proved more insightful.

(Kleine and van Niekerk 1998) discusses the ARS controller developed by (Whitehead 1988) which leads to zero side slip angle, the controller is derived analytically based on the single track vehicle model(STVM) equations. This particular algorithm creates an increase in the understeer behaviour of the vehicle and therefore increased driver work load though with increased stability at high speed. The algorithm proposed in this paper is an extension of Whitehead's and shows the ability to decouple yaw and side slip behaviour. The work fails to recognise that the improvements reported by Whitehead result from improving the drivers ability to control the steering wheel in response to torques generated by the road, hence a different strategy can used if the front steer angle is to be controlled in addition to the rear. The work is demonstrated on an appropriate non-linear vehicle model and result for an aggressive lane change manoeuvre are presented. The controller improves yaw damping and decreases the response time, the strong understeer characteristic evident in Whitehead's algorithm is also removed. The work is clear well argued and well evidenced. Though improvements are shown to vehicle handling response in terms of transient behaviour it is unclear what is actually an ideal steering characteristic. In addition, as the author points out, much work is required to asses robustness to parameter variations and also in order to implement the algorithm.

Four companion works, (Ackermann 1990; 1992; 1993; 1994), provide a theoretical discussion of robust handling controller development. They describe a technique for controlling lateral acceleration at the front axle using AFS, allowing the driver to track a given path, though it remains to be seen if this control is desirable by a driver. The control is then improved by introducing a second loop affecting the rear wheel steer angle, this is done to improve yaw damping which is

degraded by the first control loop. Whilst the work provides interesting insight into the vehicle dynamics problem, it is not sufficiently practical to be of much interest. These works propose controllers to change the vehicle dynamics in ways different to the rest of the literature but provide not evidence or even analysis on why these techniques are an improvement. Further, it fails to demonstrate improvements to vehicle handling away from the linear regime despite claims that the controllers are robust. Although some simulation results are presented, none use a realistic vehicle model and although the controllers are claimed robust, no study of parameter variation is presented in the simulation work.

A similar robust approach drawing from Ackermann's work is found in (Koumboulis and Skarpetis 2002). The work is again a theoretical derivation of a robust control strategy for zero side slip and yaw and lateral acceleration decoupling. The results are attractive as the final implementation relies on the tuning of single gain to affect behaviour. The work suffers from many of the same problems however: lack of appropriate models, assumptions and handling manoeuvres; in this respect it adds little though it at least acknowledges the need for a study of the inherent non-linearities.

Robust control has received a substantial amount of interest with respect to A4S and ARS; probably the most insightful and most clearly explained is by (Gianone, Palkovics et al. 1995). The work compares a conventional LQR controller for ARS and A4S with a robust LQR/ H_∞ approach with a structured description of the parametric uncertainties for state tracking a yaw rate and side slip angle. In this study, only cornering stiffness is considered variable but the approach is readily extendible to include mass etc. The work is performed through simulation on a linear model. Performance is assessed both with respect to a lane change manoeuvre and a side wind disturbance. The robust strategy is shown to have equal performance to the nominal LQR system with 35% variation in cornering stiffness, no discussion is given of variations greater than this. Though the work is clear and well argued, a broader range of simulation results and the use of a non-linear model would provide further insight in to the features of the proposed controller.

(Mitschke and Ahring 1994) address the problem of parameter variations by attempting to develop a controller to provide an "Invariable vehicle characteristic",

i.e. one with characteristics that do not vary in response to parameters changes such as mass, inertia of surface coefficient of friction. It is shown through the manipulation of ideal and actual vehicle transfer functions that this characteristic can not be achieved, even if it is possible to measure all vehicle parameters, by the use of only one extra input; only one state can be made invariant. It is demonstrated on a STVM, using seven different parameter sets to represent load and surface variations that a 2 D.O.F. controller(feedforward and feedback) can make the vehicle largely invariant in handling behaviour in open-loop tests. When a driver-model and a handling manoeuvre is performed however, the controlled vehicle behaviour is found to be unstable on low- μ surfaces such as an ice coated road. The analysis suggests that estimation of parameters is required to mitigate changes in vehicle handling behaviour due to large parameter variations such as iced roads. It is not clear whether this analysis remains valid using a non-linear vehicle model though it is likely to be representative.

A further implementation of the feedforward and feedback control approach is found in (Aga, Kusunoki et al. 1990). Of particular interest here is the discussion of reference model. The work is performed in both simulation on a linear vehicle model and with the use of an experimental vehicle. A simple linear frequency domain controller is developed for yaw rate and side slip angle tracking. Subjective evaluation of this strategy found that the vehicle experienced increase roll rates and this was found to be unpleasant, this is unreported elsewhere in the literature. To deal with this problem, the states tracking problem was redesigned as one of yaw rate and roll angle. Simulation and experimental results show effective yaw rate tracking and the work also reports on an improved subjective rating due to the smoother roll response. Improved stability is claimed but a insufficiently complete set of results is presented. In the final analysis, comparisons and results are only included for ARS as a function of steer angle, ARS for yaw rate tracking and A4S for yaw and roll tracking, hence it is difficult interpret this result with respect to the more common yaw and side slip tracking strategy.

(Shiotsuka, Nagamatsu et al. 1994) present two Neural Network(NN) techniques for state tracking of yaw and zero-side slip behaviour using A4S. The first technique uses a NN to capture the tyre non-linearities and is then used in to vary the gains in a control loop. The second uses a NN to capture the full vehicle model and a second to

implement a non-linear controller. Both are compared to a fixed gain controller based on optimal control theory. The work is performed in simulation and validated on an experimental vehicle. Whilst both NN controllers show an improvement over the fixed gain approach, there is the commitment of a significant NN teaching task and the need to re-teach the controller if the tyres are changed. It is also assumed in the controller that surface coefficient of friction, μ , can be measured. Though improvements are clearly available through the use of adaptive non-linear techniques, there is no discussion of issues such as robustness to parameter variation, time for adaptation to take place, i.e. the time to teach the NN or the required computational power required to make these techniques feasible on production cars.

2.1.1.4 Conclusion

This foregoing section has reviewed the body of work pertaining to active steering controllers for vehicle handling.

AFS systems have received attention both in terms of the practicalities of implementing the system and also in terms of the benefits of various robust and optimal control strategies. The overriding weight of study has been aimed at complex control strategies to simple situations rather than a realistic and general discussion of the vehicle dynamics problem. The studies reviewed either solve very specific problems, i.e. split- μ braking or crosswind rejection or the implementation of a control strategy. Specifically relating to control, out of a very large number of publications, only one attempted a description of the uncertainty to the parameters of the vehicle.

The resulting work largely fails to address the problems of designing controllers to work over the full range of the vehicle non-linear handling regime which must be a prerequisite for a realistic implementation. Particular failings of this area of study are i) the use of inappropriately simple models for testing complex controllers and ii) the lack of realistic and wide enough ranging handling manoeuvres to fully investigate the performance and limits of proposed controllers. Further, only one study investigated the behaviour of the steering controller at the point where tyre

force saturates with respect to steer angle and this study implemented an ad-hoc strategy to mitigate its effects.

Similarly, the ARS and A4S literature suffers many of the same problems. A lack of generality being the main one.

In the ARS case, the most common aim seems to be a reduction in side slip angle and a decoupling of side slip and yaw behaviour, this however has been shown to induce understeer. Whilst Whitehead demonstrated that ARS control aims are different depending on speed and driving task, few authors seem to have studied anything other

than the high speed driving task. In fact, many of the works considered revisit Whitehead's work without addressing many of the issues that Whitehead raises, excessive understeer in particular. Further it is clear that logic that dictates which control aims are appropriate will be key to an effective implementation and this appears to have been given no consideration with respect to ARS. The modelling practices also seem to fall short of what is required to fully investigate the controllers developed. Though the STVM is appropriate for high speed lane change manoeuvres, providing side slip is small, a few works have considered combined manoeuvres where this model is not valid.

The A4S approach allows two vehicle states to be controlled and yaw and side slip or lateral acceleration and side slip are most common. A4S is again viewed as a control problem with little analysis of the vehicle dynamics problem.

The development of handling control systems using steering systems needs to be pursued in the light of clear and well defined objectives for improving vehicle handling over the whole lateral acceleration range. It is not suggested that steering can eliminate effects such as tyre force saturation or low- μ surfaces, but the effect of such uncontrollable parameters needs to be clearly identified and addressed.

The presentation of advanced robust or optimal control algorithms for active steering systems can not be said to be advantageous unless the studies consider an appropriately broad range of handling manoeuvres on a vehicle model containing

with appropriate degree of complexity. A clear discussion of what is required and why when formulating control objectives is lacking in this area of the literature. It is recognised that this is difficult as it involves many subjective as well as objective factors but control solutions that neglect to consider the tasks required are of little value.

2.1.2 Brake-based handling systems

Brake-based handling systems, e.g. direct yaw moment control (DYC), are well developed in the literature and are also now common place options on the mid to high end cars from most manufacturers. A significant reason for this is the lack of additional hardware required for implementation on vehicles already equipped with ABS. The literature in this section is broadly split into: (I) studies of simple, typically affecting only one wheel, algorithms for modulating the yaw moment acting on the vehicle during severe manoeuvring, studies of advanced control algorithms for controlling a particular vehicle state, side-slip or yaw rate through the use of differential braking and (II), studies investigating the problems of implementing brake based stability systems ready for use by the automotive industry, this final section also includes papers dealing with the prerequisite parameter and state estimation techniques.

In order to affect the lateral behaviour of a vehicle, brake based systems exploit the fact that modulating wheel slip has the effect of rotating the tyre force vector on the braked wheel. This can be used to control the lateral forces and yaw moment to affect vehicle handling behaviour. A detailed analysis of the effects of differential braking is presented in Chapter 6, and will be referred to DYC.

An early and important contribution to the analysis of vehicle stability is presented in (Inagaki, Kshiro et al. 1994), by Toyota. The work presents a series of results utilising the side-slip angle, β , phase plane to analyse the stability of the vehicle. Side slip angle rate instead of yaw rate (commonly used in vehicle dynamics studies) ensures the phase plane characteristics are largely invariant with respect to speed. The method is a natural extension to the study by (Shibahata, Shimada et al. 1992) (discussed in section 2.1.3) where the name β -method is coined. The outcome of the analysis is a control algorithm where the primary task is

to confine the vehicle state in a region of the phase plane. If the vehicle states exceed this region a braking action at one wheel is generated. Experimental tests carried out with a novice driver show this control strategy is effective and robust to rapid changes in surface coefficient of friction, μ .

(Yasui, Tozu et al. 1996a) presents a qualitative analysis of how a yaw moment can be created by steering, braking or traction systems. The conclusion is that braking is the best solution as it can stabilise the yaw behaviour and reduce the vehicle speed. The weakest feature of the analysis is the assertion that the tyres stay within their friction limit. In reality it is the ability to balance the front and rear lateral tyre forces, whether or not lateral tyre saturation is reached, that make this system effective. The work exploits the β -phase plane method for assessing vehicle stability. An analysis of the yaw moment generated by controlling individual wheel slips is given leading to the conclusion that front outer and rear inner wheels are most effective for generating stabilising yaw moments. It is suggested that only the front wheel needs to be braked, however this assumption is not related to the fact that their test vehicle has an oversteering tendency and that using just the front wheels allows this directional instability to be compensated for. The paper also examines the required actuator characteristics for the implementation of the β -phase plane stability algorithm and empirical bounds for transport delay and first order lag are proposed, again these are not related to vehicle characteristics and therefore lack generality. The work is validated through actual vehicle tests. A closed loop test result shows a clear reduction in high frequency driver corrections at the expense of larger low frequency inputs. Through out the work, no analysis is presented on the inevitable interactions with the longitudinal vehicle motion. The attractiveness of the technique presented is its simplicity.

The importance of the characteristic of hydraulic brake actuators is further suggested in the work by (Nishimaki, Yuhara et al. 1998). A robust H_{∞} two degree of freedom controller is designed. The work is validated experimentally. It is shown that the requirements for DYC with respect to actuator transport delay and rise time can be satisfied for all reasonable situations even in the presence of extreme environmental conditions providing an appropriate controller is designed. A substantial improvement in DYC performance is demonstrated in the presence of the new actuator control strategy.

A further work by (Yasui, Tozu et al. 1996b), compares the above algorithm for a braking in turn manoeuvre with Brake force Distribution Control (BDC). BDC moderates the amount of rear brake force such that it is maximised but limited such that the rear tyres do not reach lateral force saturation, and hence ensure stability when braking and cornering. The presented results show that in the combined manoeuvres, BDC performs as well as DYC with respect to lateral behaviour, but that DYC has the added ability to improve behaviour when the no braking is taking place, i.e. a lane change. The commercial advantage of BDC is that on a vehicle fitted with ABS, no addition hardware is required. Despite the fact that BDC is only active during a braking manoeuvre, no comment as to which system provided the greatest deceleration whilst maintaining stability is given, though the DYC system allows greater brake pressure to be applied at the rear wheels implying shorter stopping distances.

Toyota present a similar approach in (Koibuchi, Yamamoto et al. 1996). The work is based on the same principle as the previous work but extends the single wheel algorithm to include braking of all four wheels in fixed proportion. The simulation work is evaluated on the basis of minimum achievable steady state cornering radius at various speeds. It is shown that the braking of more than one wheel increases the generated yaw moment and the system therefore has a greater ability to either stabilise the vehicle in the β phase plane or for yaw rate tracking. However this greater actuation ability is only applied to yaw rate tracking, referred to as course trace, the one wheel algorithm is still used in stability control. The selection of which control mode is used is not described, though it is implied that stability has priority.

Again the work is validated experimentally through a closed loop lane change and a J-turn manoeuvre with deceleration, i.e. braking and steering. The lateral behaviour is as predicted and the very large braking forces suggest large deceleration, but no results are presented. Again, no discussion of the longitudinal dynamics are presented.

Work exploiting hardware in the loop simulation(HILS) is presented by (Ryu, Lee et al. 1998). The work clearly explains the HILS technique with respect to evaluating the performance of a single wheel DYC system. The work confirms the

effectiveness of the braking algorithm whilst adding little to what has already been done. However the real value of the work is the analytic description of generated yaw moments through controlling wheel slip based on the Dugoff tyre model (Dugoff 1970) and more importantly, the fact the technique is highly robust to variations in surface coefficient of friction, μ .

(Cheng 1998) proposes a single wheel braking algorithm that is substantially more complicated than any of those already reviewed. The paper presents an ad-hoc collection of “modification factors” and fuzzy rules designed to allow the system to be easy to implement. A rule based arbitration technique for ABS controller and DYC is presented. Also of interest is the assertion that DYC should be used to control yaw rate away from the limit but when this is no longer feasible, side slip angle should be controlled. In common with the papers reviewed, the implications on the longitudinal dynamics of yaw rate tracking through differential braking are not discussed. Whilst both simulation and experimental results suggest the technique is successful; justification of the complexity of this “simple” approach is weak.

The most structured approach to the simple one wheel DYC algorithm is by (Bang, Lee et al. 2001). The work starts by developing a SMC wheel slip controller for a quarter car model with an effective friction force estimation technique and hence optimises braking distance. The approach suffers due to a lack of robustness to external disturbances yaw disturbances and the stability benefits are small. As is the case in BDC systems. A simple PID algorithm is introduced to moderate the reference wheel slip in order to generate a yaw moment from the front wheels. This algorithm is only active during braking but the structured approach lends itself to extensions to a full DYC. The work is demonstrated on a full non-linear vehicle model in an extensive set of severe combined braking and handling manoeuvres.

The forgoing papers demonstrated the development of DYC algorithms based on qualitative analysis of the influence of the non-linear tyre characteristic under braking and steering. The single wheel braking algorithm based on β phase plane method was found to be effective at controlling vehicle directional stability in severe steering only and combined steering and braking manoeuvres. The following papers predominantly use modern control theory to develop controllers based on mathematical descriptions of vehicle handling behaviour.

The work presented in (Kimbrough 1994) optimises vehicle deceleration through the use of a Linear Program. Posing this vehicle dynamics problem in the framework of a linear program allows the author to gain insight into this high coupled non-linear dynamic system. The author uses the technique to quantitatively compare what is essentially a DYC system using differential braking with a BDC. The results concur with (Yasui, Tozu et al. 1996b). Namely, that BDC works well in preventing instability in the vehicle behaviour during braking but not in steering only manoeuvres, however during combined and steering only manoeuvres, DYC is more effective. This work explicitly shows, that stopping distances can be optimised through the use of differential braking when compared with BDC. The highly idealised description of the vehicle is claimed to be effective in capturing the important interaction between longitudinal and lateral forces when braking and steering through the use of bilinear tyre model. However, the controller performance is not validated on a vehicle model with non-linear tyre characteristic and hence the work remains highly academic in nature.

Another paper which concentrates on the more theoretical control aspects is by (Draknov, Ashrafi et al. 2000). The controller is based on left to right distribution of brake torque. The real benefit in the proposed formulation is that it is shown that no knowledge of the tyre characteristic is needed. However the work falls far short of being practically useful due the highly idealised analysis of vehicle handling.

A more practical approach is given in (Kwak and Park 2000) which attempts to address some of the implementations issues with SMC for vehicle dynamics, namely the need to differentiate estimated states. The results presented from a full non-linear vehicle model only show that state tracking is good and no discussion is presented with respect to actuator usage or the effect on longitudinal vehicle behaviour.

A sliding mode control(SMC) approach is presented by (Yoshioka, Adachi et al. 1998; Yoshioka, Adachi et al. 1999). Both papers present identical controllers and simulation results, and the latter adds a brief description of the state and parameter estimation techniques used. A simple tyre model is presented for use in the controller development. In the work, PD, SMC and adaptive SMC systems are presented with standard SMC technique being found most effective, though there is

little explanation of the failure of the adaptive version to improve on the basic system. The work is validated with a real vehicle.

It is of note that a control system developed from a model of the vehicle performs in exactly the same fashion

as the strategies developed qualitatively, i.e. the control action is to brake only one wheel; either the front outer or rear inner. This confirms the validity of the simpler strategies.

Another description of the SMC technique is from (Abe, Kano et al. 1999). A clear and well reasoned discussion of the use of side-slip control as an improvement over yaw rate control is presented and the work is experimentally validated. The results are clear and comprehensive. The most practically important fact to be asserted is that accurate estimation of road coefficient of friction is not necessary for good control performance in the vehicles side slip behaviour.

So far, two basic approaches have been presented: control design based on expert knowledge and control design based on mathematical models of vehicle dynamics. The first approach lends itself to fast practical implementations and this is reflected by the fact that much of the work done is commercially driven. The second more analytical approach is useful in two respects. Firstly, it allows the control objectives to be formulated in ways which provide insight into the nature of the vehicle dynamics problem being tackled and the importance of different aspect of the implementation, i.e. state and parameter estimation. Secondly, it is frequently found that the control action from the first expert knowledge algorithms closely mimics the control action from the model based controllers. This gives confidence in both approaches. So the analytic approach allows engineers to be much more quantitative in their formulation of control algorithms for complicated systems.

In addition to investigations of the effects of brake control on vehicle handling dynamics and the development of control algorithms, much work has been published on the practical implementations and a smaller body of work on the human factors. Again many of these publications have been commercially driven. Due to the nature

of this study, this review will not be comprehensive but will include the most important papers in this category.

Bosch have been a major protagonist in advancing the development of brake-based safety systems, which they name VDC, and released their first commercial system in 1995. Bosch have documented much of their work in (van Zanten, Erhardt et al. 1995; 1997; 1998) and most recently presented an overview of their efforts in (van Zanten 2000). The first publication details the first generation of VDC available for rear wheel drive cars. The detail relates to the formulation of control objectives, controller and software structure. The conclusions of which are:

1. Vehicle behaviour should be linearised so the drivers have experience of the vehicle characteristics up to the limit.
2. Interventions from the system should be minimal and smart so the driver is unaware of the action. This is achieved using optimal control.
3. Software structure is critical to the safety of the system. The ability to recognise a failure in any system component is prerequisite.

The second publication is devoted to modifications made to VDC to (I) allow it to be used on vehicles other than rear wheel drive, (II) improvements to sensor and actuation technologies, and (III) the extensive restructuring of the software such that some VDC functions are available even in the event of sensor or actuator failure. This reduced availability is a substantial improvement over the earlier strategy. The third paper is predominantly an overview of the system. The main interest in this publication is the qualitative analysis of the performance requirements in relation to driver perception in different driving modes, i.e. cruising, sporty handling or panic braking and robustness characteristics with respect to changes in vehicle parameters i.e. snow tyres in cold countries.

BMW present a description of the development of their third generation stability system in (Leffler, Auffhammer et al. 1998; Leffler, Krusche et al. 1998). Both papers discuss rationalisations in hardware requirements and software development and implementation in order to reduce cost. In addition, the second paper presents an

electronic brake management(EBM) system to facilitate the DSC actuator demands. The advantage of this hierarchical approach is that brake actuation technology can be changed, i.e. Electro-hydraulic or Electromechanical brakes without change to the DSC algorithm. Also additional brake functionality such as brake assist and/or functions for Automatic Cruise control(ACC) can be included here. A complete discussion of the benefits of EBM as an enabling technology is given in (Leffler 1996).

The main driving factor behind this cost reduction exercise is to achieve penetration into the medium sized and compact car market. This implies that the automotive industry, or least BMW, have decided that brake based stability systems have an important role to play with regard to safety and product differentiation in cars other than top end luxury models.

The importance of the software structure and robustness is further reinforced in the publication by (Fennel and Ding 2000) who introduce a model based technique including many redundant sub-models of the various actuators and sensors. The conclusions from the work are that through appropriate use of measured and estimated signals, that sensor redundancy is unnecessary.

Modern active chassis control systems have the ability to significantly change the typical vehicle handling characteristics. This change in behaviour requires that the effect of these systems on the driver is investigated. (Sharp 2000) discusses the problem in the context of the man machine interface. The drivers control task is discussed with respect to eleven aspects of vehicle dynamics including stability, steerability, behavioural consistency, control quality and performance envelope amongst others. As evidence of the need for study in this area, the work highlights a number of anecdotal situations where vehicle behaviour as influenced by active chassis control systems such as active roll control, is changed in such a way as to contradict the idea that vehicle handling characteristics should be. The main conclusion is that there is little known about the subject. And that which is known requires further analysis before it is useful.

A similar work is presented by (Donges 1995), comparing the hierarchy of the human control behaviour and the nature of the vehicle driving task. It then goes on

to show how BMW control systems, active rear axle kinematics(ARK) and the first three generations of dynamic stability control(DSC), have reduced the drivers workload. The conclusions contrast the functional pros and cons of both approaches and show the commercial reasons for pursuing brake based systems. A dominant factor is much of the required hardware and sensor technology is already well developed and produced in large volumes, where as ARK has is expensive to implement and is relatively low volume.

2.1.2.1 Conclusion

The above review of brake based stability systems has concentrated on the development of algorithms, implementation issues and briefly considered human factors and commercial reasons for pursuing this approach to chassis control. The literature presented above is targeted at the passenger car sector, however much of it is general. This technology is not limited to this sector and a number of publications have been presented on commercial vehicles, articulated vehicles and car-caravan combinations, (Kageyama 1992; Palkovics and Boker 1994; Gerum, Palkovics et al. 1998; Harada, Shinjyou et al. 1998; Sakakura, Shimosaka et al. 1998; O'Brien and Piper 2000). This work will not be reviewed here.

Brake based stability systems have reached acceptance as a commercially viable technique for improving limit handling. Two broad approaches to the control problem have been suggested: model based and knowledge based control. Both techniques have been demonstrated to be effective in improving the limit handling behaviour of vehicles and assisting drivers in a wide range severe cornering, braking and combined cornering and braking manoeuvres. Both approaches, reassuringly, yield a similar algorithm, i.e. most or all braking occurs at the front outer or rear inner wheel depending on the required stabilising yaw moment. A number of problems regarding the implementation of brake based stability systems were raised, particularly that of state and parameter estimation, however this has not hindered Bosch or BMW amongst others from releasing systems in to the market. Further, the effect of surface coefficient of friction has been shown to have little effect on the performance of DYC systems.

2.1.3 Driveline-based handling systems

Driveline based systems again exploit the interactions between longitudinal and lateral tyre forces. The advantage of driveline based systems is that the interferences in longitudinal vehicle motion present in brake based systems are removed in an ideal system. In order to transfer torque from left to right or front to rear, there are essentially four basic techniques.

1. **Control using braking:** Braking one wheel on a traditional differential cause torque to be increased on the opposite side.
2. **Control of a limited slip differential(LSD):** This approach reduces the speed difference between the left and right sides of the vehicle. The level at which a speed difference cause locking is variable.
3. **Drive torque control:** Two clutches at either wheel are controlled to vary torque at each wheel.
4. **Torque Bypass:** An extra gearbox is arranged across the existing differential so that torque can be transferred between outputs. This can be done using either a continuously variable transmission (CVT) or a fixed ratio gearbox with controlled clutches.

These approaches can be used for both left/right torque transfer and front/rear torque transfer. Whilst it is recognised that the implementation method is crucial to the commercial success of driveline control, the intricacies of the transmission will not be discussed further in this study. The following will review will concern itself with systems effect on the handling dynamics and on the control strategies applied.

The following literature falls into three broad groups, theoretical and experimental handling studies and implementation studies. Finally, a discussion of the studies investigating handling of electric vehicles(EV) with individual wheel motors is given. The work in this group is interesting as the results from EVs can be generalised to other approaches and in particular make ideal platforms for investigating different control approaches.

The work by (Shibahata, Shimada et al. 1992) demonstrates a new technique, the β -method, for analysing the vehicle dynamic behaviour throughout the non-linear handling regime and the effects of longitudinal acceleration or deceleration on handling. The excellent analysis allows the authors to relate side-slip angle to vehicle stability. The relationship is then used to successfully predict the required amount of external yaw moment to compensate for changes in vehicle handling behaviour due to lateral longitudinal acceleration. The unfeasibility of generating an external yaw moment is then dealt with by generating the yaw moment through distributing torque between left and right sides of the vehicle. The technique is found to significantly increase the vehicle performance envelope in combined cornering and braking/acceleration manoeuvres. The analysis and control design is validated experimentally. The commercial product, Honda's Active Torque Transfer System(ATTS), is presented in (Kuriki and Shibahata 1998), the main outcome of this implementation study is that implementing ATTS on a front wheel steer vehicle requires the suspension to be modified to ensure zero torque steer due to the ATTS system.

A study on the relative merits of front/rear and left/right torque distribution is given in (Motoyama, Uki et al. 1993). The work examines the potential of both approaches in simulation. The conclusions are that the ability to control the left /right torque distribution has the greatest potential to affect vehicle handling limit due the ideal use of tyre lateral and longitudinal forces. This concurs with the previous studies by Shibahata. The work is validated on an experimental vehicle.

(Doniselli, Mastinu et al. 1994) investigate left/right torque distribution. An theoretical analysis of different mechanical approaches is presented. A control scheme, assuming the differential to be a ideal, is presented and shown to improve the steady state and transient properties of vehicle handling. It is also suggested that a vehicle with a controller differential has the potential to be more efficient though this is not substantiated. The work is carried out on a non-linear vehicle model including tyres, elasto-kinematics, dampers, engine and transmission characteristics.

Mitsubishi present an implementation of an active torque control system, Active Yaw Control(AYC) in (Sawase and Sano 1999). A discussion of different approach to torque distribution is presented. A control strategy, with a μ estimation technique

is included. The system is then integrated with a brake based DYC system. The integrated system is shown to control yaw more effectively than the brake based DYC alone. The author draws attention to the fact that most drivers find brake based DYC systems unpleasant in normal or sporty driving, however, no discussion of the improvement, or otherwise, of this human aspect is discussed in the conclusions. However, size and frequency of driver corrections during acceleration in a curve are shown to be reduced.

Another experimental study is given in (Matsuno, Nitta et al. 2000). The work presents a $\dot{\theta}$ -estimation technique on which a control strategy is based. The work does not detail the control strategy, but suggests it is largely based on detecting driver intention and scheduling with respect to μ and throttle and is co-ordinated with a brake based stability system. The structure of the system is unclear. Though experimental results show the system is an improvement on fixed torque distribution systems when limit handling is concerned.

In contrast to the controlled differential techniques described previously, Electric vehicles present an ideal platform for investigations of such strategies, particularly with the use of in-wheel motors due to the fast torque generating properties of electric motors. (Sakai and Hori 2000) presents a description of such an experimental vehicle and some simple controllers that demonstrate the potential of such an approach.

Three papers have been presented (Shino, Miyamoto et al. 2000; Shino, Wang et al. 2000; Shino and Nagai 2001) concerning the use optimal control theory to control two electric motors used for drive on an electric vehicle. The nature of this vehicle means it is ideally suited for studies into torque transfer control strategies. However the others only present variations on a Linear Quadratic Gaussian(LQG) feed-forward feed-back approach. Simulation results are presented for a model with a non-linear brush tyre model, however the manoeuvres are only at low levels of lateral acceleration and are therefore presumably in the linear regime of the vehicle.

A similar LQG based study is presented in (Park and Heo 2000). This study also includes the development of μ and side-slip angle estimation. Using the estimated values, the linear controller design is found to work well on a vehicle model with

non-linear tyres on a low μ surface. A simulation of a combined steering-acceleration manoeuvre is presented.

2.1.3.1 Conclusion

The studies considered show the potential of driveline torque distribution system for affecting vehicle handling. They show these systems are only less able to affect the vehicle handling at the limit compared with brake based systems as the drive torque involved has a lower limit than braking torque and although torque transfer devices may have very fast responses, engines generally do not in comparison to brake based systems. The characteristics of the devices with regard to the amount and rate at which torque can be applied to a given wheel has not been fully presented in the literature, nor have these requirements been clearly related to the vehicle dynamics behaviour. In fact, it can be implied from (Sawase and Sano 1999; Matsuno, Nitta et al. 2000) that during transient limit manoeuvring, a co-ordinated brake and driveline approach is required. The benefits of a torque transfer system therefore need to be investigated further with respect to transient manoeuvring in the context of actuator limits.

Whilst the general principles with respect to handling are identical, control theory has not been so rigorously applied compared with the brake based approaches. As a result the insight provided and the diversity of control approaches is not apparent. The early papers are excellent and many of the conclusions are general and have formed the basis of the studies on brake based systems in the previous sections, (Shibahata, Shimada et al. 1992) in particular. However many of the later papers are concerned with the implementation of the system and the discussion of controllers is largely qualitative, and so, consequently is the discussion of the improvements in handling behaviour.

The technique of torque transfer across the vehicle has obvious value with respect to handling, (Motoyama, Uki et al. 1993), however scope for refinement of the control strategies and understanding of actuator limitations still exists.

2.1.4 Suspension-based handling systems

Active suspension systems have been under investigation for affecting both handling and ride since the early 80's. There are four main types of active suspension:-

1. **Fully Active, High Bandwidth** A force generating actuator, usually hydraulic, replaces passive spring and damper components.
2. **Fully Active, Low Bandwidth** A force generating actuator, usually hydraulic, is included with passive spring and damper components.
3. **Semi Active** Only the damping rates are modified through controllable dampers. These switch or constantly vary orifice sizes within the damper to achieve different rates. More recently they have used Electro or Magneto Rheological fluids; this fluid changes its viscosity in the presence of a electrical or magnetic field.
4. **Active roll systems** Only the roll stiffness of the suspension is actively controlled using either a linear or rotary actuator to affect the roll bar properties.

High and Low bandwidth fully and semi-active system based on actuators at each wheel station however, have failed to become commercially attractive due to the complexity of implementation, problems with harshness in ride and with large power consumption though research is ongoing. A specific example of an implementation of fully active suspension for ride and handling is presented in (Williams and Haddad 1997); the result only show improvements in passenger discomfort, handling improvements are claimed and a technique for dynamically controlling the roll moment is included within the strategy. A review of the control aspects of the problem is presented by (Hrovat 1997) or (Gordon, Palkovics et al. 1994) and a discussion of the different approaches and practical problems can found in (Williams 1997a; Williams 1997b). The conclusion is that semi-active systems (controllable dampers) combined with some form of roll control system is the most likely to be considered viable by vehicle manufacturers due to its low degree of

complexity, low cost, and simple packaging compared to other approaches. Systems that affect the roll properties of the suspension in particular have received considerable interest recently. A significant benefit of these systems is that handling benefits are not only achievable through an “ideal” suspension characteristic but handling characteristics can be actively control through the use of roll moment distribution(RMD). Although semi-active suspension has been investigated with respect to actively control the handling characteristic, (Murata and Ikeda 2000), little has been published. The bulk of this section is concerned with techniques for affecting vehicle handling through controlling the roll properties of a suspension.

The ability to affect the roll properties of a suspension is attractive as it allows the designer to reduce the ride/handling trade-offs associated with passive suspension, more specifically, ride properties can be improved with sacrificing body roll control and without the complexity or power consumption issues. A further potential benefit of active suspension systems is that the ability to affect the vertical forces at a tyre directly influences the ability of that tyre to generate longitudinal and lateral forces. This ability to affect the vertical force of the tyre has been studied with a view a control the lateral handling behaviour of vehicles and is commonly referred to as RMD. Specifically, the greater the difference in vertical tyre forces at an axle, the smaller the sum of lateral forces produced. A sensitivity study on the effects of lateral load transfer distribution on vehicle handling can be found in (Clover and Bernard 1993). The ability to control where the roll moment is reacted affects the understeer or oversteer characteristic of the vehicle and in passive vehicles is an important tool for affecting vehicle handling at mid to high ($>0.4g$) lateral acceleration.

A number of papers have been published that detail the development of active roll control systems. The largest portion of these is concerned with improvement of roll characteristics and the implementation of systems to achieve this; although a number of these point to improvements in handling characteristics. A brief review of the most interesting of these will be given along with the main conclusions. The remainder of this section will review the lesser number of papers that specifically investigate roll control or roll moment distribution to affect the lateral handling properties of the vehicle and potential control approaches to achieve this.

A paper by (Shuttlewood, Crolla et al. 1993) details a roll control algorithm utilising a limited bandwidth fully active suspension system. The roll algorithm is in addition to a ride and handling controller. The study includes detailed modelling of the actuators. The main value of the work is that it demonstrates that the non-linearities involved with actuators significantly affect the control performance and that studies on this type of system must include these characteristics. Secondly, that the longitudinal position of the lateral acceleration sensor used in the control algorithm affects the control performance; if the sensor is a long way forward of the C.o.G, then although control over the largest frequency range is possible, and therefore a good transient response, undesirable oscillations in roll occur.

Another work that considers active suspension at each wheel station is by (Murata and Ikeda 2000) where a semi active technique is used. As it is only possible to affect the damping rates using switchable dampers, only transient characteristics are considered. The author states that roll in a passive vehicle is undesirable as is the associated heave; two roll control strategies that promote squat are therefore proposed. Both are claimed to offer subjective improvements in both handling and “driver security” through the use of an experimental vehicle. Only one control algorithm is described however (the better one) and no comparisons with a passive vehicle are presented. The control algorithm presented involves the use of a virtual damper at the inside of the corner, some distance from the vehicle. The paper however offers little value without a more comprehensive set of results, and detailed objective and subjective comparisons with other strategies.

(Cech 2000) compares the more common active roll bar strategy with an active suspension approach and a passive vehicle. Whilst the work shows that the active suspension approach is between 10% and 50% more effective at reducing lateral, longitudinal and vertical seat accelerations than the active roll bar system, the tests, measuring disturbance rejection, only generate accelerations of about 0.15g. It is difficult to extrapolate the results presented in the context of handling and is therefore of little value.

A low cost, low power roll control system utilising a Hydragas suspension is presented in (Rosam and Darling 1997). Whilst the system presented is an improvement to the passive system at only modest cost and power consumption, it is

unlikely to receive much interest due to the associated proprietary suspension system. The simulation work is validated experimentally and demonstrates an improvement in body roll angles and vehicle acquires an increasingly neutral steer characteristic.

A simulation study by (Lang and Walz 1991) considering a large rear wheel drive car using actively controlled anti roll bars with a rotary type actuator at the front and rear. According to this paper, the first description of a technique for modifying roll bar properties is in a German patent, (van Winsen and Schumacher 1961).

Few details of control, implementation, or the vehicle parameters are given though control is based on lateral acceleration. For a step steer input leading to a max lateral acceleration of 0.45g, peak power is expected to be in the region of 220w although this is doubled if the lateral acceleration derivative is included in the control algorithm. During a sinusoidal input, roll angles are reduced by a factor of 10 with peak lateral accelerations of about 0.35g though power consumption is not discussed for this input. The work hints at the ability to affect understeer/oversteer behaviour.

A paper by (Reusing, Ochs et al. 1992), presents some experimental results for Renault Espace fitted with a rotary type actuator on the front and rear roll bars, in much the same way as the previous work. The controller uses lateral acceleration and its derivative, calculated from steer angle and speed rather than measured, to calculate the required extra roll moment. The distribution of this moment from front to rear appears also to be a function of lateral acceleration and is used to promote a more neutral steer characteristic except when a critical driving situation is detected, in which case, an understeer characteristic is induced. The levels of roll are reduced to zero up to 0.45g and then increase linearly, this increase in roll serves to alert the driver that the vehicle limit is approaching. The fuel consumption of the system is predicted to be 0.11 per 100km of normal driving, though this increases linearly as more time is spent at higher lateral accelerations. The results are well presented and the value of the system is well argued. The discussion of the controller is very brief and does not discuss how the system copes with different surfaces, this is of particular importance if the system bases control action on speed and steer angle. Using full the full stroke of the actuator, the system bandwidth is

approximately 2Hz and consumes 1800w, though for typical driving conditions, a bandwidth or power consumption is not suggested where the control signals are smaller.

(Sharp and Pan 1992) perform a simulation based study with detailed models of the hydraulic configuration of an active roll bar system. The work investigates the various effects of flow rate limitations, sensor positioning, lateral acceleration derivative feedback gains and control valve bandwidth for a typical rotary actuator and suggests bounds a number of these. The issue of sensor position is again discussed, the main conclusion is that the further forward, the better initial transient response but at the expense of roll oscillations; concurring with (Shuttlewood, Crolla et al. 1993). It is also stated that the sensor should be placed lower than the body C.o.G. but this is not demonstrated with results or justified qualitatively. Also, the use of lateral acceleration derivative is found to be beneficial in small amounts; large derivative gains induce a counter roll at the start of transient manoeuvres which, it is argued, would be found subjectively bad. A companion work, (Sharp and Pan 1993) investigate the effect of controller sampling time performance and similarly suggests bounds for a large saloon car. This second work also discusses energy usage and, in contrast to the suggested 220W peak in (Lang and Walz 1991), suggests a more realistic figure is 4kW peak. A very brief, qualitative discussion of this work is given in (Sharp 1994).

Evidence of the importance of the characteristics of the hydraulic system is further found in (George, Burdock et al. 2000). A genetic algorithm technique is presented for optimising the electrical and mechanical characteristics of the pressure control valve used in Landrover's Active Cornering Enhancement(ACE), now available on the Discovery 2.

These three works by Sharp and Pan do not discuss in detail the effect on handling but do present some lateral acceleration responses without conclusion. The work is the most comprehensive discussion of the design and implementation issues for such roll control system.

Though there are a number of other papers relating to passenger cars, (Darling, Dorey et al. 1992; Darling and Ross-Martin 1997; Darling and Hickson 1998;

Darling, Tilley et al. 1999; Everett, Brown et al. 2000a; Parsons, Pask et al. 2000), which cover similar ground, both experimentally and in simulation, but add little. In addition, commercial vehicles have also been considered as a potential platform for roll control systems (Lin, Cebon et al. 1993; Kushahara, Li et al. 1994; Lin and Cebon 1996; Sampson and Cebon 1998; Sampson, McKeivitt et al. 1999). The main aim here however, is an improvement in roll over stability. Secondly, the implementation and control strategies are significantly different due to the structural flexibility of large vehicles as noted in Kushahara. These papers will not be reviewed here as they offer little useful information when considering how to affect handling of passenger car.

The remainder of this section will be devoted to studies of systems affecting handling through distribution of roll moment, RMD.

(Abe 1992) presents a RMD strategy for use with an active suspension which is not described, though the results are general. Actual roll moments are assumed to be a first order lag of the demand roll moments. The work proposes a series of rules based on the side-slip yaw rate phase plane to assess the vehicles stability; the vehicles tendency to spin or drift. An amount of roll moment is calculated to achieve zero roll. A base roll moment distribution is then calculated to match weight distribution, this is first modified with respect to changes in longitudinal load transfer due to longitudinal acceleration and then with respect to driver intention and state point in the phase plane. The effectiveness of the technique is demonstrated in simulation on a non-linear vehicle model; stability is preserved at high speed in aggressive combined manoeuvring. The strategy is aimed at limit stability control and only affects handling if the vehicle is close to a drift out or spin out situation. The main weakness is the lack of robustness to surface variations due the use of yaw in the phase plane; though the strategy could easily be transferred to the β phase plane which would go some way to alleviating this. Further, the RMD has the potential to affect handling away from the limit and this is not discussed.

Two more studies confined to limit handling are proposed in (Constantine and Law 1994; Kahrs and Law 1995). Both works lack the structure and the clear objectives of work by Abe. The control algorithms are largely rule based, developed from qualitative analysis with the aims to promote low roll and lateral stability under

handling, though the later paper includes a yaw rate tracking controller utilising RMD. The simulation results do suggest some improvements in yaw rate tracking but the lack of clear objectives undermines the conclusions and comparisons between algorithms. The rule based algorithms are likely to be largely invariant to surface variations though no discussion is given to robustness issues.

Most of the implementation work suggests that simple P or PD lateral acceleration feedback control provides adequate performance of for roll control systems, though some feedforward of steer angle was also reported with good effect. (Hwang and Park 1994; Hwang and Park 1995) present a model predictive control(MPC) for roll and roll moment distribution with aim of dealing with the inherent limitations of the slow hydraulic actuators.

Whilst predictive control would appear to be appropriate control algorithm for this type of problem, the work falls short of providing a convincing argument on a number of counts. The work is highly idealised and it is assumed that a roll moment can be generated and it possesses the characteristic of a first order lag with a 300ms time constant. Whilst this concurs with results in (Sharp and Pan 1992), it appears too idealised to provide genuine insight into the effect of actuator characteristics and therefore, ways to reduce their effect on controller and handling performance; in fact it fails to demonstrate there is actually a real problem associated with this delay. The model used for controller design is a linear model including yaw, lateral velocity and roll. This model may well be sufficient if the controller is suitably robust however no comment is given on robustness problems associated with mismatch between predictor model and non-linear vehicle plant. The robustness characteristics of MPC are difficult to demonstrate for non-linear plants and are closely associated with the correct selection of design parameters such as control and prediction horizons, (Camacho and Bordons 1999). No discussion of the selection of these parameters is given. The latter paper includes the effects of actuator saturation, the demand and saturated values only differ by less than 10%, the robustness claims are therefore unconvincing.

The work contrasts feedforward and MPC for ARC and RMD. Whilst the predictive control shows improvement over feedforward control and the passive vehicle for both body control and a combined cornering-braking manoeuvre. The

feed forward algorithms for ARC and RMD are developed from descriptions of steady state handling leading to zero roll or a constant understeer gradient, it is therefore unsurprising that model based controller is an improvement. MPC predictive control may however be a useful tool for this control problem, particularly with respect to power consumption and the oscillations associated lateral acceleration sensor positioning, it remains to be seen.

The other significant contribution with respect to alternative control approaches for RMD is from (Williams and Haddad 1995). A non-linear sliding mode controller is developed using a simple non-linear empirical tyre model. In addition a simple proportional yaw rate tracking strategy is employed for comparison. Both controllers were designed to achieve neutral steer behaviour. The work is demonstrated both in simulation and experimentally, though only the proportional controller is tested experimentally. The simulation study is weakened by using the same model for plant and controller development. The work concludes that the simple strategy approaches the performance of the SMC version and is preferred as the requirements for state and parameter estimation are much reduced. Whilst improvements were shown, subjective issues relating to the high yaw rate accelerations were apparent, and had to be addressed by filtering the steer angle input to the controller, slowing down the vehicle's dynamic response. The effects of low μ surfaces were not addressed, though control signals do saturate on high μ surfaces and both performance and stability are demonstrated; it is likely to be similar on low μ surfaces.

More recently, (Konik, Bartz et al. 2000) published a description of BMW's latest driver aid, Dynamic Drive; a combination of roll control and their proprietary DSC, a brake based stability algorithm. The paper provides no description of the control algorithm, though it is likely to be based on yaw and side slip angle as the system shares information with DSC. This assumption is based on other BMW publications, (Smakman 2000a; Smakman 2000b) which will be reviewed in more detail in the section 2.1.5. A description of the hardware and associated development cycle is included. Significant reductions in roll angle and in steer angle, 80% and 15% at 0.6g respectively during steady state cornering. This behaviour converges to the passive vehicle handling characteristic above 0.6g to warn the driver of the approaching vehicle limit. During a double lane change manoeuvre including peak lateral accelerations of 0.8g, the yaw rate during the second phase was reduced by

50% suggesting increased linearity between steer input and yaw rate and lateral acceleration responses. The impact of these changes is judged to be subjectively good. It was also noticed that system encouraged drivers to driver in excess of 0.5g for 0.4% of driver time, this is a five fold increase on the passive vehicle but it is unclear whether this was due to experienced test drivers or typical untrained drivers. The praise for this system is glowing, however the results and details are sparse. The system is available on the latest 7 series as standard.

2.1.4.1 Conclusion

The early interest in fully active suspension systems has eventually led to the commercial interest in comparatively simple semi active and active roll control systems. The latter have been shown to have a strong ability to affect vehicle handling properties and have already been accepted by manufactures of expensive luxury cars and of SUVs where the high centre of gravity means that roll is a significant problem.

From the literature, the largest body of work is concerned with implementation of roll control. Most studies utilising lateral acceleration and its derivative for feedback controllers or steer angle and forward velocity for feed forward controllers. These predominantly aim to reduce body roll while cornering and most studies report an associated improvement in handling, this has been attributed to a reduction in camber effects at the tyre contact patch and more effective use of the suspension working space.

Little consideration has been given to the robustness of these control algorithms with regard to variations in load, C.o.G. or surface variations, though (Everett, Brown et al. 2000a) shows that feedback of roll angle improves performance with respect to the first two. Unlike the brake based systems where it was found that controller performance was largely invariant to surface variation, no similar analysis has been performed with respect to roll control systems.

Roll moment distribution systems have also been considered and a mixture of general strategies based on yaw rate tracking or on measures of understeer parameter have been proposed along with limit manoeuvring strategies aimed at maintaining

stability during critical situations like high lateral acceleration combine braking and steering. Similarly to the roll control work, robustness has not been largely studied; BMW have a commercially available system and the problems are clearly not insurmountable and are likely to be of a practical nature.

The control algorithms for RMD are more varied with the introduction of MPC and SMC, the latter being used to bench mark a proportional controller for yaw rate tracking, again, variations in parameters are not investigated. Whilst the justification of the use of advanced control algorithms is not convincing and the studies are inclusive, there may be the potential to improve some aspects of performance like power consumption or the roll oscillations associated with lateral acceleration sensor positioning through a proper application of these model based techniques; further research is required.

2.1.5 Comparative studies

An excellent paper by (Shimada and Shibahata 1994) of Honda presents an analytic study of torque transfer, roll moment distribution, and active rear wheel steering through an analysis of the vehicle dynamics. The study also serves to demonstrate the power of the β -method, developed in (Shibahata, Shimada et al. 1992). The analysis details the ability of each system to generate a stabilising yaw moment, and hence the ability to improve the vehicle behaviour in steady state combined cornering and acceleration and deceleration, i.e. on a vehicle with constrained forward speed. It is therefore a study detailing the ability of the systems to mitigate changes in vehicle handling due to longitudinal load transfer and tyre operating point. The conclusions are summarised in Table 1.

| | Scope of operation | Acceleration | Deceleration |
|-------------|---|--|--|
| ARS | Effective at only low side slip angles. | Effective in maintaining cornering characteristic and effect declines in a progressive way. | Less effective and handling behaviour changes in a very abrupt way as effect declines. |
| RMD | Effective only at slip angles approaching 6°. The effectiveness of this system is highly dependent on the weight distribution of the vehicle. | Moderately effective in maintaining cornering characteristic and effect declines in a progressive way. | |
| ATTS | Effective throughout the vehicle handling regime. | Highly Effective in maintaining cornering characteristic throughout the vehicle handling regime. | |

Table 2-1 Summary of (Shimada and Shibahata 1994)

The work does not include actuator characteristics. However, by analysing the control action in acceleration and deceleration it is shown that torque transfer has the greatest power to affect the vehicle in changes from acceleration to deceleration and large lateral accelerations.

(Motoyama, Isoda et al. 1998) of Mitsubishi present a practical technique utilising a flat belt chassis dynamometer to perform a similar analysis to that by (Shimada and Shibahata 1994). In addition a study of the effect of front/rear torque distribution. The work includes simulation and road tests. Whilst similar conclusions are reached, the analysis with respect to the vehicle dynamics is less rigorous and interpretation of the results is much more qualitative.

(Hac and Bodie 2002) attempt a comparison of ARS, AFS, DYC, and RMD by active roll bar and by magneto-rheological(MR) dampers. Initially, an analysis of the reason for vehicle instability is performed on 2 D.O.F. STVM with non-linear tyres. Stability criteria are identified and it is stated that changes in the yaw moment on the vehicle can promote stability. The ability of each system to generate a yaw moment is presented though little conclusion is drawn about the relative merits. Results are presented which show that MR dampers when integrated with DYC significantly reduce the brake usage compared with only DYC in a transient manoeuvre.

2.2 Co-ordination approaches

The review so far has looked at the many systems that have been developed, utilising different aspects of the vehicle dynamic to affect lateral vehicle handling. More specifically the systems have been stand-alone. This means that potential synergies are not exploited and more importantly, from a safety point of view, conflicts are not mitigated. Studies of the potential for improving vehicle handling through the use of two or more systems will be reviewed in this section. The advantages of system co-ordination are not only aimed at handling performance but also have commercial implications, as discussed in (Roppenecker and Wallentowitz 1993; Wallentowitz 1995). The ability to exploit the information contained in one vehicle control system in another can be used to reduce the number sensors, improve robustness or simply to reduce computational overheads by not duplicating controller computations. The benefits may involve cost reduction and almost certainly, a space saving by reducing the number of ECUs distributed throughout the vehicle and a discussion of this is found in (Wallentowitz 1990). This section will review only a selection of studies that best reflect the ideas behind a co-ordination approach: the combination of stand-alone systems to exploit information and reduce interferences.

The combined use of two systems for affecting vehicle handling is becoming increasingly popular and has already found its way in to the top end of the market place, BMW's 7-series being one example that includes RMD and a brake-based stability program.

An early, if somewhat vague, discussion of the co-ordination of a fully active suspension and an open loop ARS system is presented in (Yokoya, Kizu et al. 1990) by Toyota. Most of the work is dedicated to a discussion of the implementation of both systems, it emerges that a few rules are included in the control strategy to improve handling. It is this introduction of rules to improve the combined behaviour that is typical in co-ordination approaches. In this case, the suspension control gains are scheduled as a function of the ARS steer angle to improve lateral handling. The effect of this is to react more roll gain to the rear of the vehicle to generate a pro cornering moment. This experimental study demonstrates a 5% improvement of maximum achievable speed in a slalom compared with the vehicle with only ARS and 8% with conventional uncontrolled vehicle. Unfortunately, the results presented do not allow the effects of introducing rules to control systems to be appreciated. A further work by Toyota is presented in (Kawakami, Sato et al. 1992). Similar conclusions are reached with the only extension being the addition of a yaw rate sensor allowing closed loop control of yaw rate.

Braking and ARS are co-ordinated in (Plochl and Lugner 1996) but only for braking on split- μ surfaces where the ability to steer the rear wheels allows braking forces to be increased much more rapidly with out generating a yaw that the driver cannot control, this leads to reduced stopping distance and reduced lateral deviations due to the induced yaw moment.

(Everett, Brown et al. 2000b) describe a vehicle with TDS, ARC and RMD. It is suggested that although RMD has a significant ability to affect steady state handling and reduce the effects of large mass variations on handling characteristics, it does not significantly improve transient behaviour. A scaling factor schedules the TDS system based on yaw acceleration; this is the only description of the control system. Although it is noted that RMD has the ability to affect the sizes of forces generated by TDS it is not discussed whether this feature is exploited. Good yaw rate tracking is demonstrated on a non-linear vehicle model; results for the controller are limited, it is therefore difficult to draw conclusions about the quality of the control strategy.

A study by (Alleyne 1997) integrating active suspension with ABS attempts to demonstrate reductions in stopping distance by modulating the normal force at each wheel as a function of brake torque. The work uses a static tyre model and therefore

fails to include the transient properties of the tyre which are shown to have an effect on the ability to produce a longitudinal and lateral force in (Pacejka and Besselink 1997; Zegelaar and Pacejka 1997).

The most detailed example of a co-ordination or bottom up technique is found in (Smakman 2000a; 2000b) of BMW. A thorough vehicle dynamics analysis of brake based and suspension based stability systems is provided. An internal model control(IMC) scheme for RMD and a simple gain scheduled one wheel DYC system are proposed. These systems are found to interfere with out co-ordination. The work investigates the interactions and proposes a simple rule that prevents this interaction. In addition, the longitudinal interactions observed with DYC are reduced through proper selection of these rules. This work demonstrates the ability to improve the behaviour of two control systems by understanding the interactions between them.

2.2.1.1 Conclusion

The reviewed work aims to co-ordinate different chassis control systems. Although many authors claim to integrate systems, it is rarely through a detailed understanding of the vehicle dynamics. In contrast to much of the literature, Smakman provides a detailed discussion of the technique and the need for integration from the point of view of the vehicle dynamics. Though it seems likely that this co-ordination approach is the one actually followed in industry (much of the work reviewed here is by vehicle manufacturers such as Toyota and BMW), a detailed description of methodologies are not available. The value or otherwise of the approach has yet to be fully understood.

2.3 Generic Motion Control(GMC)

The term Generic Motion Controller(GMC) is applied to studies that investigate multivariable control approaches to vehicle motion. This differs from the co-ordination

described earlier in that the controller is explicitly designed to integrate control of many vehicle motions. Typically model based, GMC possesses the greatest potential for significant improvements in vehicle dynamics control through mathematically

describing the interactions between motions such as braking, steering and induced vertical motions (pitch, roll and bounce). This design process can be considered a "Top Down" approach and is attractive due to its analytic nature and the fact that a quantitative framework for controller evaluation is inherent. This potential improvement is tempered by the substantial increase in complexity of the design process and the need for expensive state and parameter estimation and reliable sensors in the implementation. The following section will review work that has applied multivariable techniques to the vehicle handling problem. This review will not be exhaustive but will serve to identify the important issues in this field of vehicle handling control.

A strategy proposed in (Hirano, Harada et al. 1993) uses H_{∞} based technique to design a 2 D.O.F. yaw rate tracking controller for a vehicle with rear steering and a front-rear torque distribution system. The strategy does not explicitly describe the interactions between longitudinal and lateral tyre forces but is shown to be robust to them suggesting further improvements are possible. The authors observe that at the limit of handling, large yaw rates are limited by the road surface and as such the desired reference model is no longer realistic. This problem is addressed through the use of an adaptive gain that reduces the demanded yaw rate when an estimated side slip angle is high. This suggests that interactions with yaw and side slip need to be addressed in limit handling and concurs with other literature already reviewed. The advantage of the technique proposed here is that side slip is not used directly in the control algorithm, and provided that any estimation of slip is an over estimate, the system is stable. An extension of this work is found in (Hirano and Ono 1994) where a NN tyre model is introduced to remove the need for this adaptive strategy by estimating the tyre characteristic online, though similar performance is shown. The controller is demonstrated through simulation and on an experimental vehicle.

(Salmon 1990) presents an LQR approach to controlling combined AFS and braking. A simple approach demonstrating marginal improvements using a linear controller on a non-linear model through simulation. The work only augments the drivers actions, i.e. moderates brake pedal pressure and front steer angle; though simple it shows that an understanding of the interactions between the two can lead to improvements in much the same way as an experienced driver can control a vehicle in difficult situations. A comparison of the previous approach with control of

individual wheel torques and rear steering is found in (Venkataraman and Waldron 1993), both are compared to a passive vehicle and a vehicle with brake proportioning and a stand alone steering controller. This time pole placement is used to design the controller. The system with individual wheel torque and steering control shows only marginal improvements in lateral acceleration and yaw rate though side slip angle is reduced by 50% compared with the Salmon's work. It is unclear from the study why the improvements suggested by other studies on individual brake torque control are not observed here. It is claimed the main advantage is a reduced sensitivity to parameter variations though no evidence for this is provided.

A model based technique, Non-linear Model Predictive Control(NLMPC), is proposed in (Horiuchi, Okada et al. 1998; 1999aa; 1999bb). A 7 D.O.F. vehicle model(longitudinal, lateral, yaw and four wheel speeds) and simplified Dugoff tyre model is used to for controller development and evaluation. The controller is designed for yaw rate tracking, longitudinal velocity tracking and zero side slip angle by integrating control of torque at each wheel and of steer angle front and rear. The simulation results presented show excellent performance and good robustness to surface variations and split- μ conditions, particularly in comparison to a ARS system with zero side slip control. Excellent results are to be expected when the design model is used for evaluation in model based controllers, though the results with large changes in μ provide some reassurance as to the robustness of the controller. Whilst the work demonstrates the power of model based control techniques to this problem, the work assumes all states and tyre normal forces are available. This is either expensive in terms of sensors or computationally expensive in terms of state estimation, or more probably both. Though the controller was shown to be robust to changes in surface friction, no discussions of the required accuracy or upper limits on noise for such sensors and estimators is provided.

(Yu and Moskwa 1994) again use a model based technique. Using input-output linearisation and applying sliding model control to longitudinal and lateral body forces which are calculated based on driver inputs. The controller model in this case uses the Dugoff tyre model and includes lateral, longitudinal and yaw D.O.F. The validation model is an eighteen D.O.F model including suspension and load transfer effects with the same tyre model. Though a different approach to that used by

Horiuchi, the use of model based control is again shown to be highly effective. The main draw back to this specific work is demonstrated in (Manning, Selby et al. 2002). The use of the Dugoff tyre model limits performance at the limit of vehicle handling as it does not accurately represent tyre behaviour at this operating point. The implication of this to all model based controllers is that control is only as good as the model used. This model based approach is shown to be largely robust to the limitations of the Dugoff tyre model in the work (Manning, Selby et al. 2002) through the use of Pacejka tyre model for controller testing. This robustness is not demonstrated through appropriate modelling in the work by (Yu and Moskwa 1994) as the same Dugoff model is used for controller testing. Controller performance is seen to be excellent, partially because there is no consideration to the mismatch between the model used for controller development and the real world plant.

A further paper, (Manning, Crolla et al. 2000), discuss how the same SMC is extended to control roll and bounce. Though good set point tracking is shown in aggressive braking and handling manoeuvre, the work does not investigate whether the controller integrates the vertical tyre forces into the control of handling motions in the same way that RMD systems do. There is clearly a control trade-off to be investigated, whether set point tracking of body motions are dominant or whether handling is dominant.

A number of other papers exist that integrate the control of vehicle motions (Abe, Ohkubo et al. 1994; Abe 1998; You and Chai 1999; Abe, Kano et al. 2001; Brennan and Alleyne 2001a; Nagai, Shino et al. 2002), however the work reviewed here reflects the studies which most encompass the idea of “Top Down” design.

2.3.1.1 Conclusion

The literature reviewed in this section presents an overview of the work in the field of multivariable vehicle handling controllers. Most of the papers presented demonstrate excellent control of vehicle handling, and in some cases body control, through describing, mathematically, the interactions between vehicle control inputs (steering, braking and suspension) and vehicle states. The analytic nature of the proposed methods has two distinct advantages, a) a great deal of insight can be gained, as can confidence in the more heuristic approaches reviewed elsewhere in

this thesis, and b) the top down approach provides a benchmark for other control approaches as it allows a quantitative study of what is achievable through combined control of vehicle inputs.

Many of the papers reviewed here assume state and parameter information is available rather than actually implementing such schemes. Although many of the schemes presented here have inherent robustness properties, i.e. SMC, a detailed investigation of what is required in terms of maximum noise and minimum accuracy on estimated variables is not presented. Further, the ability to implement complex, computationally expensive control algorithms is not discussed in the context of the typical embedded computer systems which would be required to perform in real time.

Most of the works reviewed use simple tyre models for the models and the effect of the difference between these simple tyre models and more accurate descriptions such as Pacejka's is not discussed except in (Manning, Selby et al. 2002).

The applicability of the work presented here is unclear at present though excellent performance is clearly achieved. These complex multivariable controls are expensive in terms of required information; many publications concerning state and parameter estimation exist though it is conceded that the computational requirements are high and many of the algorithms perform complex optimisation functions at each control step to determine the required control action.

2.4 Discussion

This literature review has covered all the individual systems for affecting vehicle handling, both for steerability and stability and also comparative studies of those systems. In addition, two distinct areas have been reviewed that contrast the likely approaches to a combined control strategy exploiting the interactions in vehicle motion, "Top-Down" and "Bottom-up". A detailed conclusion of each individual approach is included with the relevant section. The desire to influence vehicle handling properties is clearly very important to academics and industrial engineers

alike, as can be seen from the volume of the literature here and over one hundred papers on the subject in the last 2 years.

The above review covered all the potential areas that have been applied to affecting the handling behaviour of modern passenger cars. The system that currently finds most favour in the market place is the brake based system. The literature suggests a number of important reasons for this. Not least is the apparent robustness of the approach to road surface variations and other parameter variations. A second reason is that heuristic control strategies, which are simple to implement and have shown excellent and robust dynamic performance.

The field of brake based stability systems also has other interesting features that can be applied to other vehicle handling control problems. The use of advanced optimal and robust control techniques such as sliding mode control have also been applied with great success. The use of the model based approaches have confirmed the validity of the earlier heuristic approaches and to some degree can be used to benchmark the performance of earlier approaches as the controller performance and robustness is defined quantitatively. Despite the difficulties in applying advanced multivariable control techniques to vehicle handling problems in a "real world" situation, it appears this approach has an important role to play in allowing a proper evaluation of the potential performance of many individual systems.

The brake-based system can be seen to be a subset of the more general torque distribution systems(TDS), and the underlying analysis is identical. The use of these TDS seems likely to be limited to niche markets aimed at sporty drivers due to the high cost of implementation. Most of the open literature reflects this trend and is done largely by vehicle manufacturers. The problems limiting a more widespread application seems to be the cost of the hardware involved rather than anything more fundamental. The advantage of the brake based systems is that they make use of largely existing ABS hardware and only require the addition of a small number of sensors. One of the main disadvantages of brake based systems cited in the literature is the interaction with the longitudinal dynamics which does not exist with the TDS approach and it can therefore be applied over wider range of vehicle operating conditions.

The problem of brake based systems only being subjectively acceptable at the limit can be solved by the introduction of a second (or indeed, a third) handling system. Active steering and RMD systems have been extensively studied in this respect. RMD is limited in its effect as a roll moment needs to exist before it can be distributed and hence the system cannot be used at low lateral accelerations. However, vehicle manufacturers have become highly proficient in making cars behave in subjectively favourable ways in this region. The system looks to be particularly appropriate in large SUVs where large roll angles are problematic, an ARC system can be simply extended to provide RMD functionality. This is unlikely to be the case in passenger cars in all except the most expensive luxury cars and the BMW 7-series is the only car that currently uses such a system. Control theory has not been so rigorously applied to RMD systems as in the area of braking and steering and most systems described rely on simple P and PD feedback schemes based on lateral acceleration or feed forward of steer angle and speed. The ability to improve performance or reduce energy consumption through more advanced approaches has not been quantified.

In contrast active steering controllers have received a large amount of attention from control theorists and have had the broadest range of control techniques applied. This however has not meant that the field is the most developed with respect to practical solutions to the vehicle handling problem. Though a vast amount of literature has been published on techniques for improving the vehicle dynamic response, it is as yet unclear what a driver finds subjectively an improvement and it appears there are three distinct approaches favoured in the literature: decoupling of yaw and side slip motions, yaw rate tracking and zero side slip angle. The advantages of each these approaches has yet to be fully quantified and it actually appears the benefit of each approach is closely linked to the driving task. In fact, this is one of the great shortfalls of the literature pertaining to steering systems: authors have generally failed to consider an broad enough spectrum of handling situations in assessing the benefit of the system. It is clear that steering is a highly effective system for affecting vehicle handling behaviour providing tyre slip angles are small and the tyre is away from the saturation region, however, few papers consider this situation which is in fact the most critical region for drivers. The ability to control steer angle in the way expert drivers do at the limit of vehicle handling has received only a very small amount of attention. The concept of active steering was first

studied with respect to ARS, more recently though AFS has received renewed commercial interest.

It seems likely that vehicle manufacturers will continue the trend of increasing the number of active handling systems on cars and a considered methodology is required

to ensure that interferences are mitigated and possible synergies exploited. The systems discussed above are all powerful tools for defining the behaviour of the vehicle and it may be that in combination they become more powerful than the sum of their individual effects.

Two approaches to this have become apparent. The “bottom up” approach of adding systems with some supervisory action to deal with the interactions heuristically and the “top down” approach to quantitatively describe system interactions with respect to vehicle handling behaviour. The parallel development of these two approaches can, potentially be likened to the situation in the development of brake based controllers where both heuristic and model based approaches have used.

The model based approach is likely to be unfavourable from an industrial perspective as it comparatively difficult develop and is computationally expensive. There also remain a number of state and parameter estimation or measurement problems to be solved. However this approach is useful for providing insight.

Co-ordination based approaches, in contrast, make use of previously developed and well understood vehicle handling controllers to improve behaviour. This modular approach allows control and development work to broken down into sub-tasks with the associated reduction in complexity. From a commercial point of view, it allows the subsystems to be developed by tier-1 suppliers in much the same way as ABS and DYC currently are but to retain control of the high level algorithm which will ultimately vehicle behaviour.

The approaches to co-ordination in the literature are not based on a detailed analysis of the vehicle dynamics. This suggests that the interactions between

systems have not been fully understood. In order to apply a structured approach to co-ordination, this analysis is required. Without a detailed understanding of the problem, the full benefits of a co-ordination approach are unlikely to be achieved.

The above discussion has led to an understanding of the control for vehicle handling problem. In order to answer some of the questions raised, it is required to specify the details of the following investigation. It seems clear that most vehicles in the future will have some brake based stability system. In addition a system is required to affect the vehicle away from the limit. Active steering is to be co-ordinated with a brake based system. This is because steering systems are well understood and therefore likely to find favour in early commercial interest. Steering systems are also the most general system considered in this review as steering is the dominant control input by drivers and therefore clearly very powerful. A number of works have selected these systems and have implemented multivariable control for vehicle handling. This allows the co-ordination approach to be validated and its effect quantified. The development of a co-ordination strategy for any two systems would allow this to be done but the development of both a multivariable controller and a co-ordination approach is considered to be beyond the scope of this project. Further, the insight gained from this study should be applicable to any two, or more, systems.

2.5 Aims and Objectives

The following aims and objectives will define the nature of the work in this thesis and follow directly from the above review.

2.5.1.1 AIMS

1. Through an analysis of the vehicle dynamics and, in particular, its non-linear behaviour, a definition of driving task will be proposed. This will allow an objective definition of the control task to be solved in the development of vehicle handling controllers.
2. Again through study of the vehicle dynamics, a controller structure will be proposed to co-ordinate different vehicle handling controllers. It is

desired that this controller structure will allow vehicle handling systems to interact more effectively to improve vehicle handling behaviour of the full range of non-linearities.

3. Through the use of a non-linear model of vehicle handling, the value of co-ordinated approaches to vehicle handling will be comprehensively assessed over the complete range of vehicle handling motions.

2.5.1.2 OBJECTIVES

In order to achieve these aims, the following specific objectives will be met.

1. A vehicle model which allows a study of handling over the entire range of vehicle non-linearities will be developed.
2. A discussion of vehicle handling behaviour will allow an objective definition of the control task.
3. Simple linear controllers will be developed for AFS, ARS and A4S in the context of the definition of handling control task. This will allow the relative merits of these three systems assessed in the context of a co-ordination approach. These three systems have not been compared effectively in the literature and it is necessary to establish what is required in terms of the vehicle handling problem.
4. A brake based handling system from the literature will be implemented
5. A structured approach to a co-ordinated control system will be developed for the above two systems to gain understanding and to propose a methodology for future development.

2.6 Conclusion

The chapter has presented a detailed and broad review of the literature relating to vehicle handling controllers. The specific trends and features with respect to each

vehicle handling system have been discussed and possible directions for improvement in each field have been suggested. Finally, a discussion of the integration of vehicle handling systems has allowed the aims and objectives of this thesis to be specified. The following chapter will present a discussion of vehicle modelling and a discussion of the non-linear vehicle handling regime.

3 Vehicle Modelling and Control Objective Formulation

The following chapter will discuss the development of linear and non-linear vehicle models based on data provided by a vehicle manufacturer for a generic large modern saloon car. It will develop the relationship between the formulation of control objectives for affecting the lateral handling behaviour throughout the vehicle operating regime and practical vehicle dynamics.

A discussion of the vehicle handling for which controllers will be developed will justify the features the model describes.

Terms used to relate the practical vehicle dynamics handling behaviour to the formulation of control objectives will be defined. The discussion will break down the vehicle handling regime into three distinct regions of low, mid and high lateral acceleration. This characterisation of the handling behaviour will be used to illustrate the difficulties of designing control systems to improve all aspects of vehicle handling behaviour over the entire range of possible operating conditions.

3.1 Vehicle modelling

In order to investigate the interactions of different subsystem controllers for lateral handling, the vehicle operating regime and its associated non-linearities must be considered. For low levels of lateral acceleration, a simple linear description, the 2 D.O.F single track vehicle model(STVM), serves as a useful tool in gaining insight in to the properties of the vehicle system, (Dixon 1991).

Beyond these low lateral accelerations, the vehicle's non-linearities become important. In order to investigate the vehicle and controller behaviour, a 4 D.O.F model using non-linear tyre and suspension descriptions is developed; this model will be referred to as the non-linear vehicle model(NLVM). The data required to populate this model is provided by a vehicle manufacturer. Though this study is confined purely to lateral handling controllers, the NLVM includes a quasi-static

description of longitudinal load transfer to account for the effects of using braking systems to affect lateral handling behaviour.

Finally, a technique that allows the 2 D.O.F model to be used to investigate the effect of vehicle non-linearities observed in the 4 D.O.F. non-linear vehicle model is described.

3.1.1 Linear 2 D.O.F. model.

The STVM model has been described extensively in the literature. The derivation of the STVM by (Dixon 1991) is particularly good. The model describes the lateral handling behaviour, lateral velocity and yaw modes, at low lateral accelerations; the linear range. The linear range of the vehicle is considered to be $0 \rightarrow 0.3g$. Throughout this chapter, this range will be referred to as the low lateral acceleration regime. This description of vehicle behaviour is not used for predicting performance of developed controllers in this study. However, it is commonly referred to clarify details of vehicle behaviour. It is also used directly for controller development. Its use as a design tool is described in more detail in Section 3.1.3.

A schematic of the STVM model is shown in Figure 3-1, variable names are defined in Table 3-1.

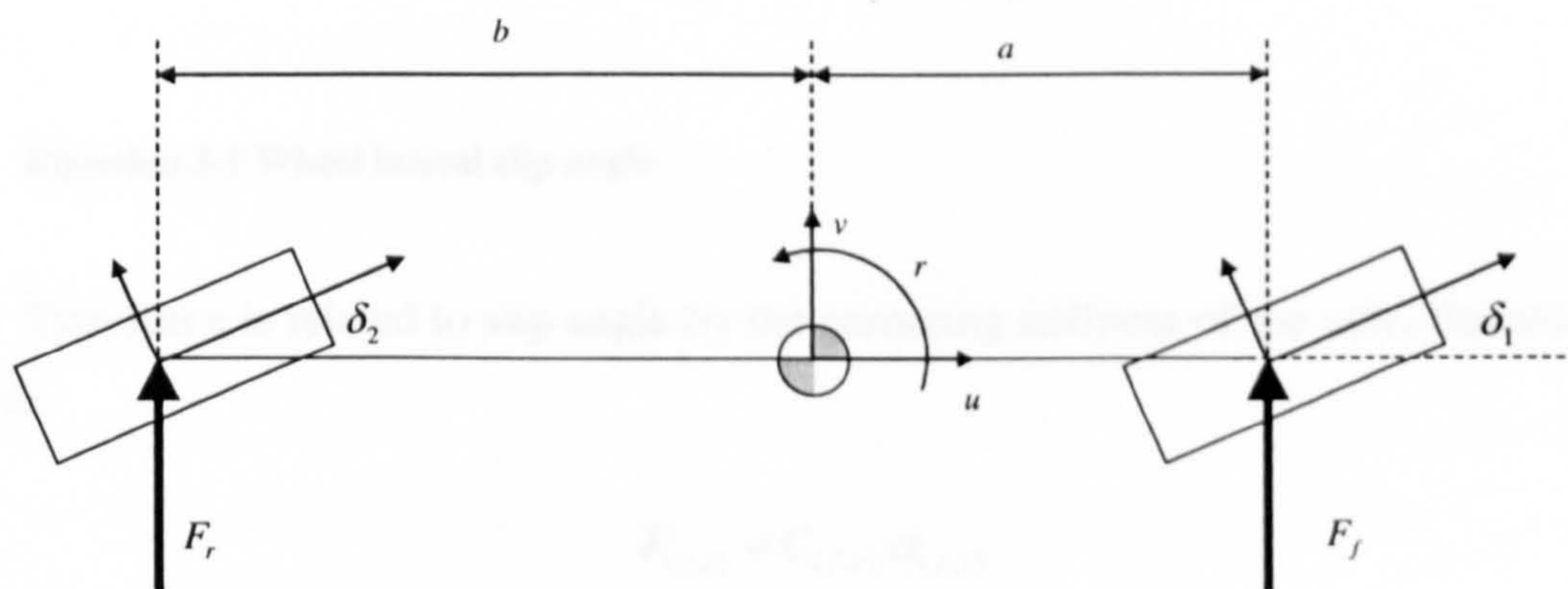

Figure 3-1 Single track vehicle model

Where:-

| Name/State | Symbol | Units |
|--------------------------|------------|-------|
| Lateral velocity | v | m/s |
| Yaw rate | r | rad/s |
| Front steer angle | δ_1 | rad |
| Rear steer angle | δ_2 | rad |
| Front axle lateral force | F_f | N |
| Rear axle lateral force | F_r | N |

Table 3-1 State Variable, Actuator and Force Naming

The forces shown acting at the front and rear of the vehicle, shown as F_f and F_r , are generated by the tyres. The force generated is proportional to the slip angle at the wheel. Lateral slip angle, α , is the angle between the plane of the tire and the tyre's direction of travel. If the wheel is steered, then lateral slip is a function of the wheels lateral and longitudinal wheel velocities and steer angle Equation 3-1.

$$\alpha_f = \frac{v + ar}{u} \text{ and } \alpha_r = \frac{v - br}{u}$$

Equation 3-1 Wheel lateral slip angle

Tyre force is related to slip angle by the cornering stiffness of the axle, Equation 3-2.

$$F_{(f,r)} = C_{(f,r)} \cdot \alpha_{(f,r)}$$

Equation 3-2 Tyre force

Assuming constant forward velocity, Equation 3-3 describes the vehicle dynamic response to tyre forces.

$$\begin{aligned}m(\dot{v} + ur) &= F_f + F_r \\ I_z \dot{r} &= aF_f - bF_r\end{aligned}$$

Equation 3-3 Newtonian description of single track model

Using Equation 3-1, Equation 3-2 and Equation 3-3, the vehicle response to a steer input at front or rear is described by Equation 3-4.

$$\begin{aligned}\dot{v} &= \frac{1}{m} \left\{ -\frac{C_f + C_r}{u} + \left(\frac{aC_f + bC_r}{u} - u \right) r + C_f \delta_1 + C_r \delta_2 \right\} \\ \dot{r} &= \frac{1}{I_z} \left\{ -\frac{C_f + C_r}{u} - \left(\frac{a^2 C_f + b^2 C_r}{u} - u \right) r + aC_f \delta_1 + bC_r \delta_2 \right\}\end{aligned}$$

Equation 3-4 Equations of motion for single track vehicle model

3.1.1.1 Parameter set

The parameter set for the linear 2 D.O.F. vehicle model used in this study is as follows.

| Parameter | Symbol | Value | Units |
|----------------------------------|--------|---------|------------------|
| Vehicle forward velocity | u | 30 (67) | m/s (mph) |
| Distance of front axle to C.o.G. | a | 1.544 | m |
| Distance of rear axle to C.o.G. | b | 1.364 | m |
| Vehicle mass | m | 1712 | kg |
| Vehicle yaw inertia | I_z | 3344 | kgm ² |
| Front axle cornering stiffness | C_f | 111 | kN/rad |
| Rear axle cornering stiffness | C_r | 121 | kN/rad |

Table 3-2 Parameter Naming and Nominal Values used in this study

3.1.2 Non-linear 4 D.O.F. vehicle model

A simple description of the vehicle dynamics described above is a useful tool for understanding the key features of vehicle handling behaviour. However, beyond the low lateral acceleration region, described earlier, it cannot capture the vehicle behaviour. The following section will describe and justify the features included in the NLVM to be used in this study.

The cause of these non-linearities can be accounted for through a study of individual systems, i.e. tyres or suspension, of the vehicle. A number of these non-linearities are 'designed in' to improve the driver experience. The dominant non-linearities that affect the vehicle are to be found within the suspension and tyres. Therefore by implementing a non-linear suspension and tyre model, a good representation of vehicle behaviour can be produced.

The dominant effect of the suspension with respect to the lateral handling behaviour is the roll mode as this affects the lateral transfer of vertical tyre load, which in turn affects the available tyre force. The vehicle is assumed to run on a flat, smooth road surface, consequently, vehicle bounce can be ignored. In additional

longitudinal decelerations are assumed to be small, therefore pitch is also ignored. However, in order to account for the longitudinal load transfer during the use of brake based handling systems, a quasi-static description of longitudinal load transfer is include. Hence, to capture the vehicle dynamics for this study a 4 D.O.F. vehicle model with non-linear tyres and suspension is adequate. The vehicle model therefore has longitudinal, lateral, yaw and roll degrees of freedom represented by respectively.

Figure 3-2 shows the vehicle from above with the states described in the single track model. Figure 3-3 shows the effect on vertical tyre forces due to changes in longitudinal motion. Figure 3-4 shows the vehicle unsprung mass with the vehicle body free to roll about the roll axis shown.

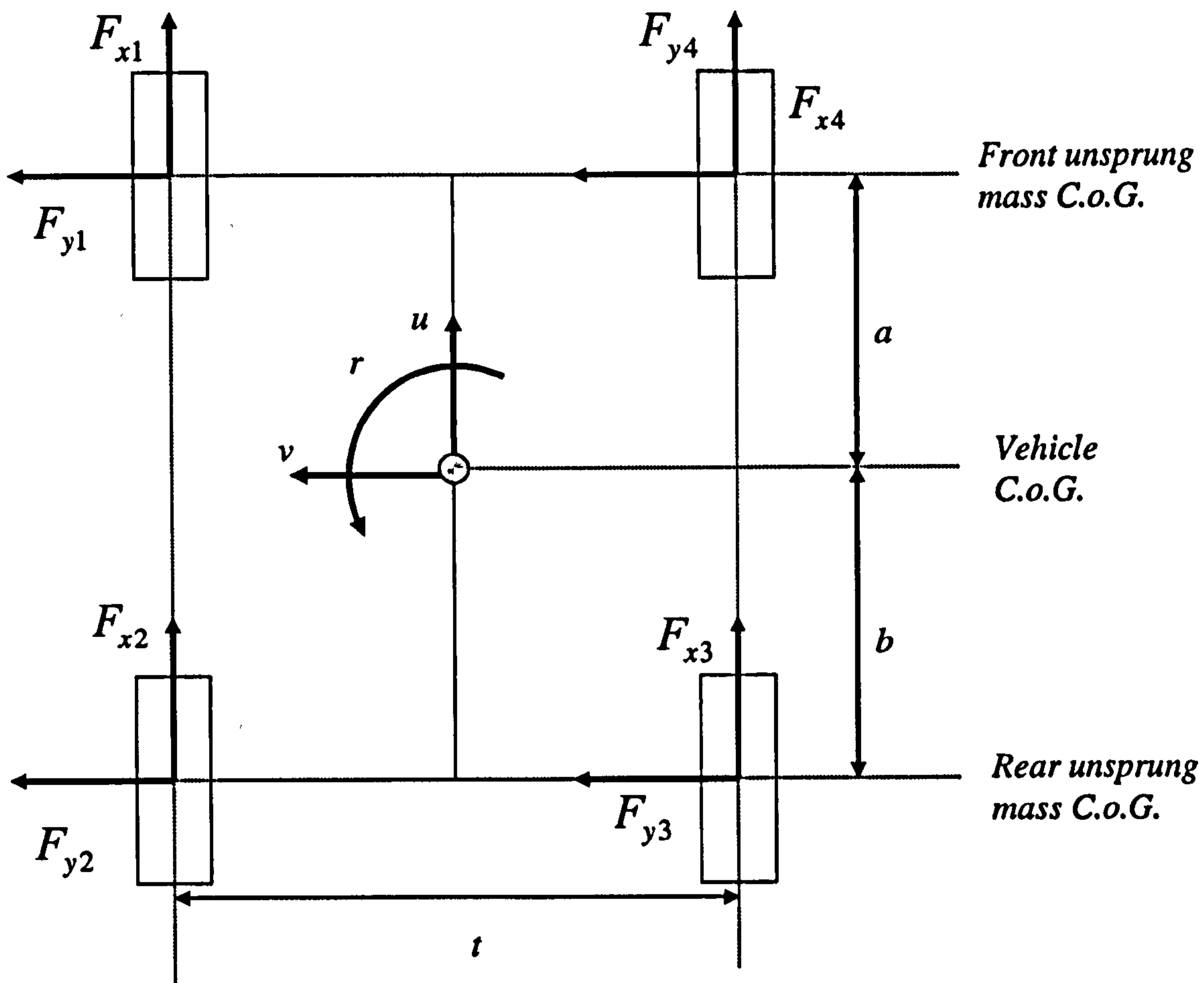

Figure 3-2 Plan view of NLVM showing transnational and rotational states, tyre forces and dimensions in the x-y plane. Nomenclature is defined in Table 3-3.

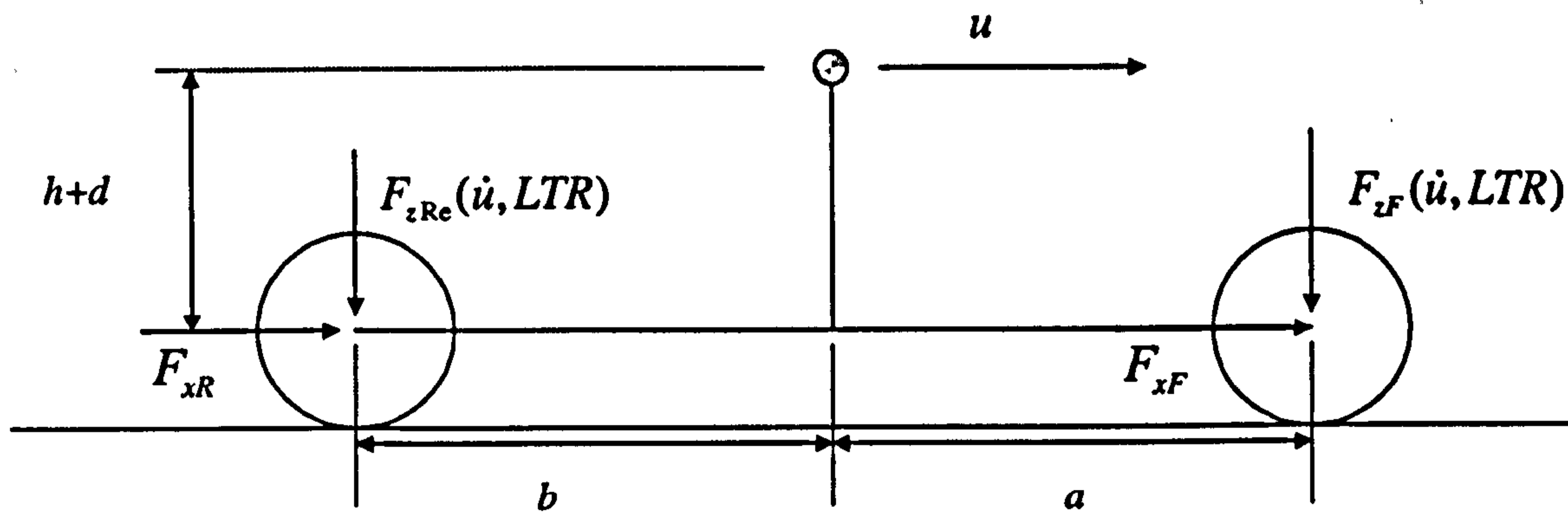

Figure 3-3 Side view of NLVM showing longitudinal state, tyre forces and dimensions in the x-z plane. The tyre vertical force, $F(zRe, zF)$ are shown as a function of longitudinal acceleration and load transfer ratio(LTR).

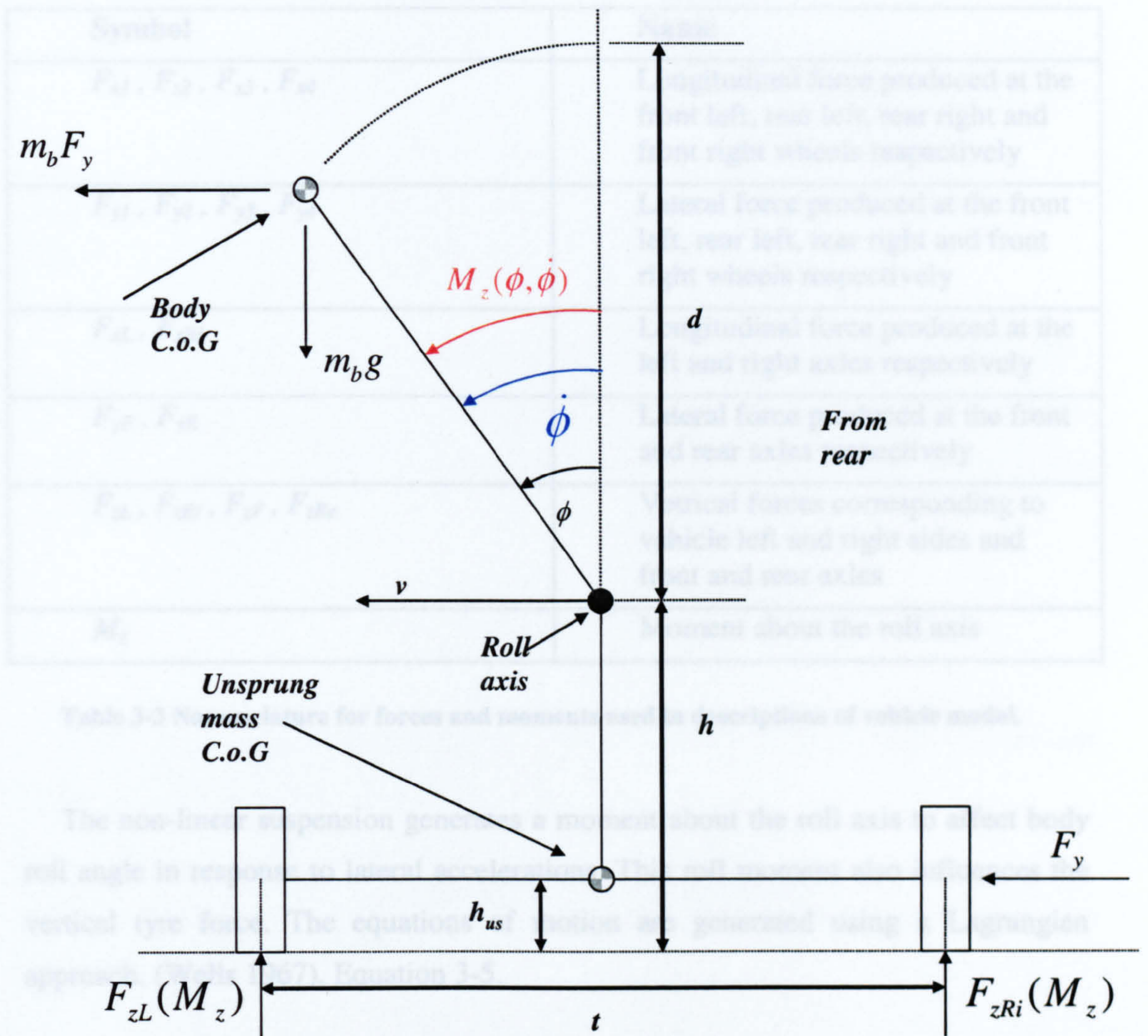

Figure 3-4 Rear view of NLVM showing roll and lateral states, tyre forces and dimensions in the y-z plane.

Equations of motion

$$Q_1 = m_b (\ddot{y} - \dot{\psi} v) + (a m_{f1} - b m_{f2}) \dot{\psi}^2$$

$$Q_2 = m_b (\dot{y} + \dot{\psi} u) + (a m_{f1} - b m_{f2} - m_b h) \dot{\psi}$$

$$Q_3 = (a m_{f1} - b m_{f2}) \dot{y} + (a m_{f1} - b m_{f2}) \dot{\psi}^2 + \dot{\phi} I_r$$

$$Q_4 = -m_b g h \dot{\phi} + (\dot{\psi} u - \dot{y} v) m_b h + \dot{\phi} I_r$$

and generalised forces

$$Q_1 = F_{yf} + F_{yr}$$

$$Q_2 = F_{yf} + F_{yr}$$

$$Q_3 = a F_{yf} - b F_{yr} + t (F_{zL} - F_{zR})$$

$$Q_4 = M_z(\phi, \dot{\phi})$$

Equation 3-5 Lagrangian equations of motion and generalised forces for 4 D.O.F model

| Symbol | Name |
|------------------------------------|--|
| $F_{x1}, F_{x2}, F_{x3}, F_{x4}$ | Longitudinal force produced at the front left, rear left, rear right and front right wheels respectively |
| $F_{y1}, F_{y2}, F_{y3}, F_{y4}$ | Lateral force produced at the front left, rear left, rear right and front right wheels respectively |
| F_{xL}, F_{xRi} | Longitudinal force produced at the left and right axles respectively |
| F_{yF}, F_{yR} | Lateral force produced at the front and rear axles respectively |
| $F_{zL}, F_{zRi}, F_{zF}, F_{zRe}$ | Vertical forces corresponding to vehicle left and right sides and front and rear axles |
| M_z | Moment about the roll axis |

Table 3-3 Nomenclature for forces and moments used in descriptions of vehicle model.

The non-linear suspension generates a moment about the roll axis to affect body roll angle in response to lateral accelerations. This roll moment also influences the vertical tyre force. The equations of motion are generated using a Lagrangian approach, (Wells 1967), Equation 3-5.

Equations of motion

$$Q_x = m_t (\ddot{u} - \dot{\psi}v) + (am_f - bm_r)\dot{\psi}^2$$

$$Q_y = m_t (\ddot{v} + \dot{\psi}u) + (am_f - bm_r - m_b h)\dot{\psi}$$

$$Q_\psi = (am_f - bm_r)\dot{v} + (am_f - bm_r)u\dot{\psi} + \dot{\psi}I_x$$

$$Q_\phi = -m_b gh\phi + (\dot{\psi}u - \dot{v} + \ddot{\phi})m_b h + \ddot{\phi}I_x$$

and generalised forces

$$Q_x = F_{yF} + F_{yR}$$

$$Q_y = F_{xL} + F_{xR}$$

$$Q_\psi = aF_{yF} - bF_{yR} + t(F_{yF} - F_{yR})$$

$$Q_\phi = M_z(\phi, \dot{\phi})$$

Equation 3-5 Lagrangian equations of motion and generalised forces for 4 D.O.F model

The non-linear suspension description comprises a non-linear spring and damper elements and an anti roll bar to affect lateral load transfer distribution from front to rear. The description comes from data provided by a vehicle manufacturer for a typical large European saloon car. Data for roll moment due to the springs and dampers respectively is shown Figure 3-5 and Figure 3-6.

Data in Figure 3-5 and Figure 3-6 is used to calculate the term, Q_ϕ in Equation 3-5 and corresponds to the combined suspension moments generated by all sprung elements and the combined damping effects generated by all damping elements, shown in Equation 3-6.

$$M_Z(\phi, \dot{\phi}) = M_{z_{Spring}}(\phi) + M_{z_{damp}}(\dot{\phi})$$

Equation 3-6 Separation of vehicle roll moment in effects from damping elements and effects due to stiffness elements.

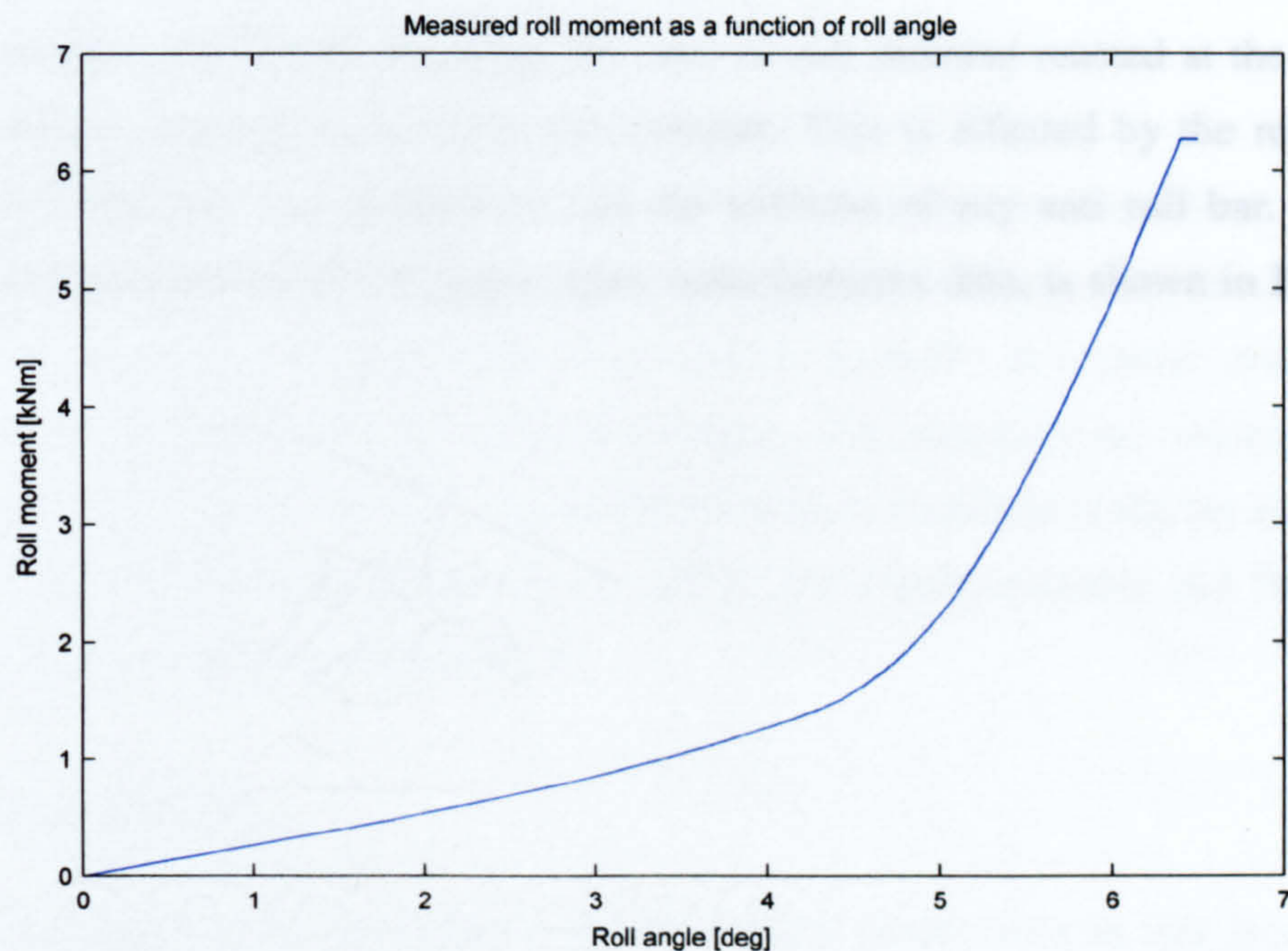

Figure 3-5 Total roll moment as a function roll angle.

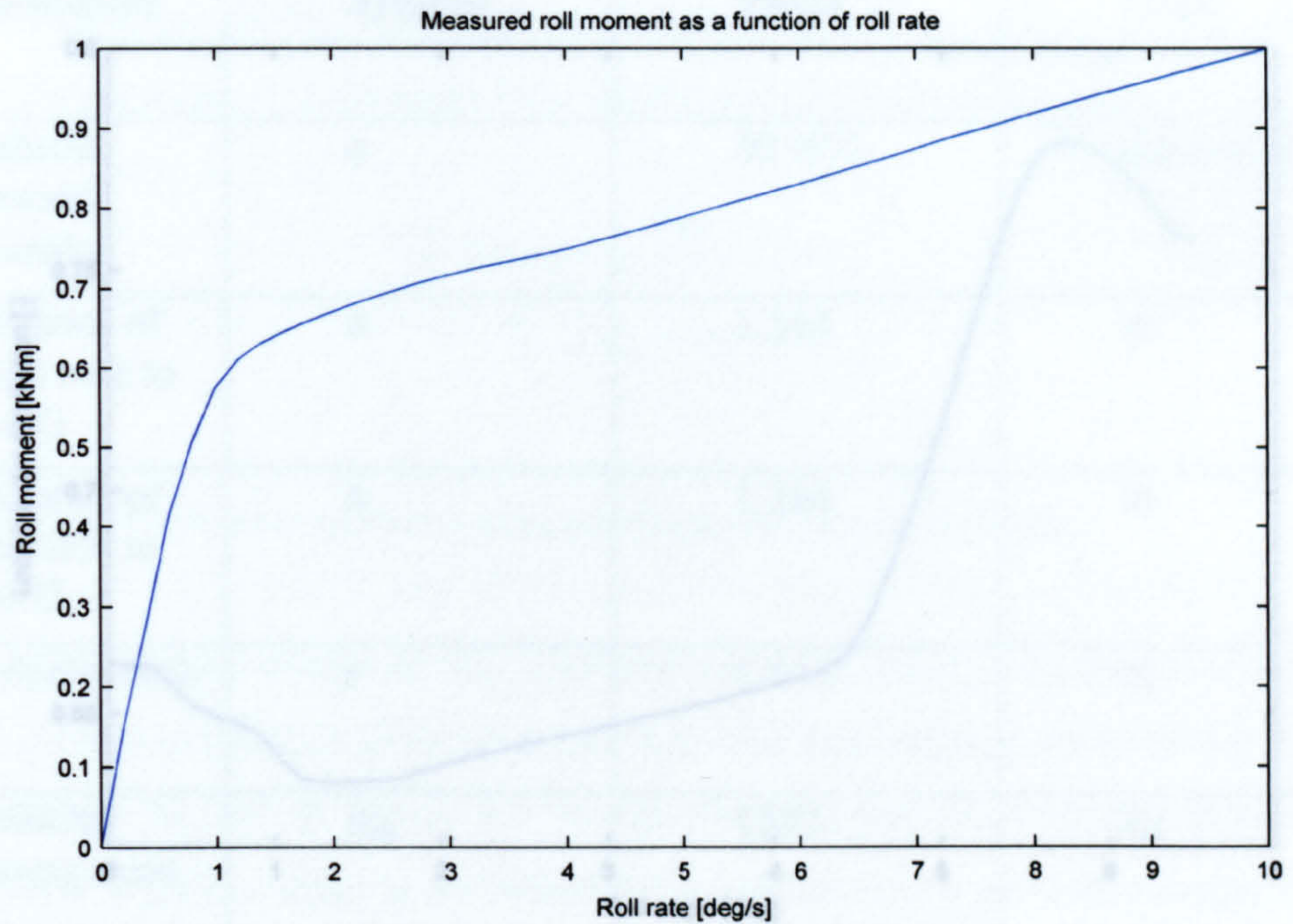

Figure 3-6 Total roll moment as a function of roll rate.

Load transfer distribution describes the ratio of roll moment reacted at the front of the vehicle compared to the total roll moment. This is affected by the relative stiffness of front and rear suspension and the stiffness of any anti roll bar. Load transfer ratio as function of roll angle, again manufacturers data, is shown in Figure 3-7.

3.1.2.1 Parameter Set

The parameter set for the linear 4-D.O.F. vehicle model used in this study, in addition to the non-linear suspension parameters presented in the previous section is given Table 3-4.

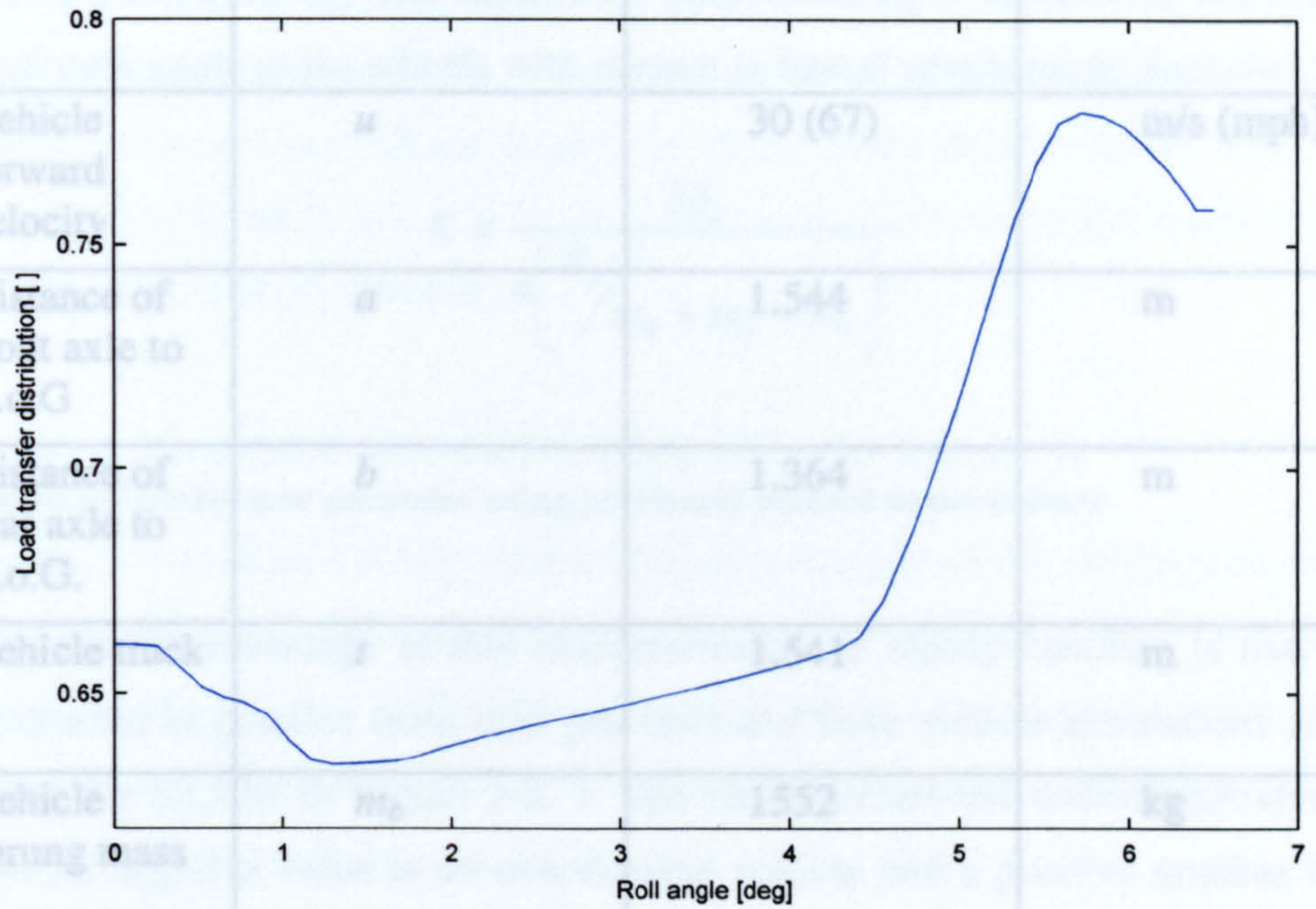

Figure 3-7 Lateral load transfer distribution. 1 indicates all load transfer is reacted at the front, 0.5 indicates equal distribution front and rear, 0 indicates all load transfer reacted at the rear wheels.

The tyre forces are functions of the longitudinal and lateral wheel slips. Longitudinal slip ratio is the deviation from a state of pure rolling. The tires are the dominant force-generating component of a vehicle. As such, an accurate model of the non-linear behaviour of the tyres is essential. The characteristic relating tire force, slip angle, slip rate and tire vertical load has been modelled using the Pacejka "Magic Formula" (Bakker, Nyborg et al. 1987). The implementation and Pacejka coefficients are included in Appendix A.

3.1.2.1 Parameter Set

The parameter set for the linear 4 D.O.F. vehicle model used in this study, in addition to the non-linear suspension parameters presented in the previous section is given Table 3-4.

3.1.2.2 Vehicle handling behaviour results

The steady behaviour of a car is typically described through the use of the understeer parameter, a definition and discussion of the usefulness of this parameter is provided in Appendix B.

| Parameter | Symbol | Value | Units |
|------------------------------------|----------|---------|------------------|
| Vehicle forward velocity | u | 30 (67) | m/s (mph) |
| Distance of front axle to C.o.G | a | 1.544 | m |
| Distance of rear axle to C.o.G. | b | 1.364 | m |
| Vehicle track | t | 1.541 | m |
| Vehicle sprung mass | m_b | 1552 | kg |
| Vehicle unsprung mass front | m_f | 80 | kg |
| Vehicle unsprung mass rear | m_r | 80 | kg |
| Roll axis height at C.o.G | h | 0.59 | m |
| Sprung mass height above roll axis | d | 0.2 | m |
| Unsprung mass height | h_{us} | 0.3 | m |
| Vehicle yaw inertia | I_z | 3344 | kgm ² |
| Vehicle roll inertia | I_x | 563 | kgm ² |

Table 3-4 Vehicle geometry, masses and inertias used for non-linear vehicle model

3.1.2.2 Vehicle handling behaviour results

The steady behaviour of a car is typically described through the use of the understeer parameter, a definition and discussion of the usefulness of this parameter

is found in (Dixon 1991). The understeer parameter, K , is defined as the rate of change of steer angle at the wheels with respect to lateral acceleration, Equation 3-7.

$$K = \frac{\partial \delta_1}{\partial \left(\frac{F_y}{m_b + m_f + m_r} \right)}$$

Equation 3-7 Understeer paramter using previously defined nomenclature

One particular advantage of this characterisation of steady handling is that it is easily extracted in practice from skid pan tests and from vehicle simulations and is plotted for the NLVM in Figure 3-8. It also characterises the understeer/oversteer behaviour, a negative value is an oversteering vehicle and a positive number is an understeering vehicle, a value of zero means the vehicle has a neutral steer characteristic.

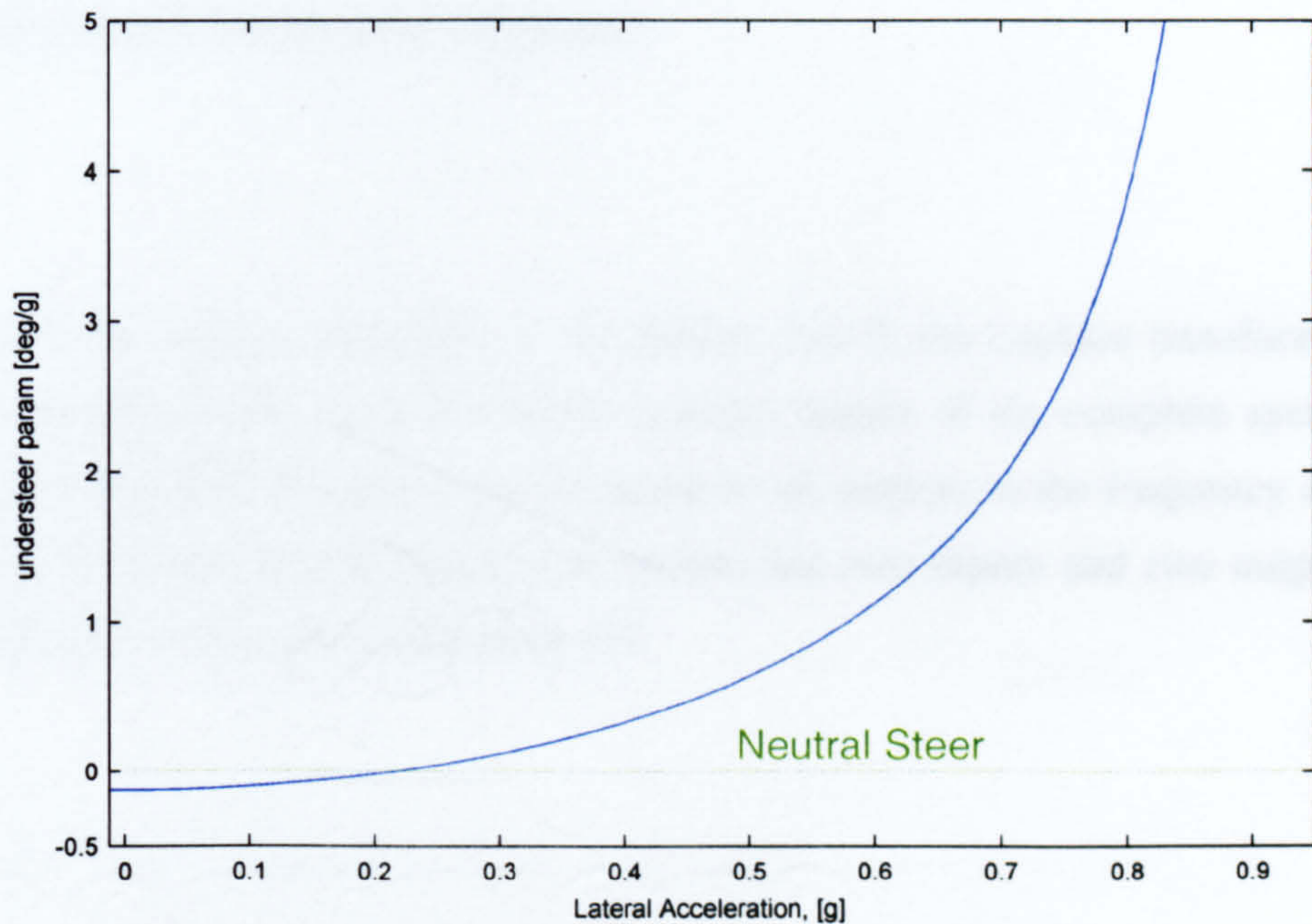

Figure 3-8 Understeer parameter plot for typical generic large saloon car described.

The vehicle in question can be seen to be slightly oversteering at low lateral accelerations, changing to understeering at around 0.2g and become progressively

more understeering up to the vehicle steady state limit. This is referred as limit understeer, any increase in steer angle has progressively less effect on lateral acceleration. Also the idea of the vehicle having a linear regime can be seen. The curve is locally flat up to about 0.3g; it is this region that the single track vehicle model is typically used to describe.

3.1.3 Using the vehicle models for controller development

Designing controllers for any system requires an appropriate description of the plant. In this study, two plant descriptions, a linear model and a non linear mode, have been proposed. The 2 D.O.F linear model is easily converted to a form useful for controller development. In this case, the frequency domain description of the 2 D.O.F model will be used; the transfer function matrix, Equation 3-8.

$$\frac{Y(s)}{X(s)} = H(s)$$

Equation 3-8 Transfer function description

$Y(s)$ is the Laplace transform of the output, $X(s)$ is the Laplace transform of the input, and $H(s)$ is the Laplace transfer function matrix of the complete system. As such $H(s)$ describes the path from all inputs to all outputs in the frequency domain. In the case of the bicycle model, the system has two inputs and two outputs and hence $H(s)$ is a 2x2 matrix, Equation 3-9.

$$H(s) = \begin{bmatrix} H_{1,1}(s) & H_{1,2}(s) \\ H_{2,1}(s) & H_{2,2}(s) \end{bmatrix}$$

where

$$H_{1,1}(s) = \frac{uC_f(sI_z u + bC_r(a+b) - m_{total}u^2 a)}{den(s)}$$

$$H_{1,2}(s) = \frac{uC_r(sI_z u + aC_f(a-b) + 2b^2 C_r - m_{total}u^2 a)}{den(s)}$$

$$H_{2,1}(s) = \frac{uC_f(sm_{total}ua + C_r(a+b))}{den(s)}$$

$$H_{2,2}(s) = \frac{uC_r(sm_{total}ub + C_f(a-b) - 2bC_f C_r)}{den(s)}$$

where $den(s) = s^2 I_z m_{total} u + su(ma^2 C_f + mb^2 C_r + I_z(C_f + C_r)) + \dots$
 $C_f C_r(a+b) + m_{total} ub C_f + 2C_f C_r ab$

and $m_{total} = m_b + m_f + m_r$

Equation 3-9 Transfer function matrix elements where s is the Laplace variable.

Figure 3-9 shows the physical meaning of each of the above components of the transfer function matrix.

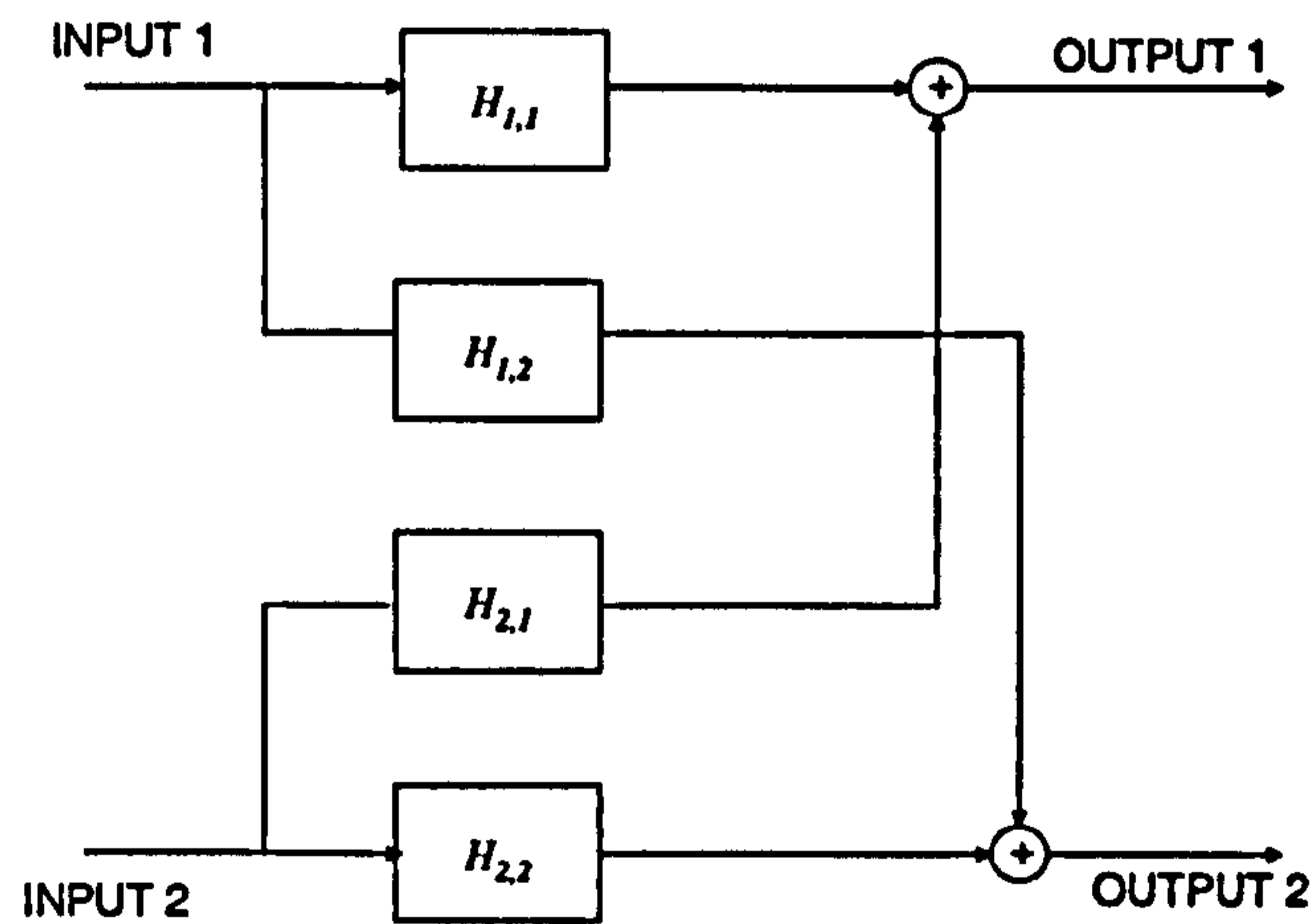

Figure 3-9 Cross coupling effects in a MIMO system

With reference to the STVM description, the inputs are front and rear steering and outputs are lateral velocity and yaw rate. By inspection of the transfer function matrix, if either the terms on the diagonal or the terms off the diagonal are small, then it can be seen that one input predominantly affects one output, and hence the control of one state can be assigned to one input; called input-output pairing. In the

case of a vehicle, this is not the case. The relevance of this strong coupling to the control task studied here will be quantified and discussed in section 4.4.3.

This expression of the system behaviour is found to be very useful for gaining insight into the nature of the control problem to be solved. Whilst the NLVM provides a complete description of the vehicle dynamics of interest for handling studies, it is cumbersome to use when trying understand how vehicle handling changes as a function of operating point. By populating the STVM with values of cornering stiffness at different operating points, insight in to the change in handling behaviour can be gained by viewing these changes as different linear systems.

The dominant non-linearities in vehicle handling arise from the highly non-linear relationship between tyre force, lateral slip angle, longitudinal slip ratio and tyre vertical force. The vehicle can be described over any small operating regime using the STVM. Tyre forces are related to steer angle by the cornering stiffness, Equation 3-2. The cornering stiffness describes the change in tyre force for a unit change in steer angle. This property can be used to describe the vehicles behaviour at any operating point for small deviations from that operating point. The cornering stiffness can be extracted from the NLVM as it is the gradient of tyre force with respect to wheel steer angle. This technique allows the vehicle to be described using a simple linear description for perturbations about any fixed operating point. Figure 3-10 shows cornering stiffness plotted against steady state lateral acceleration.

This ability to describe the full non-linear system in terms of many simple linear models is very useful in understanding vehicle behaviour at different operating points.

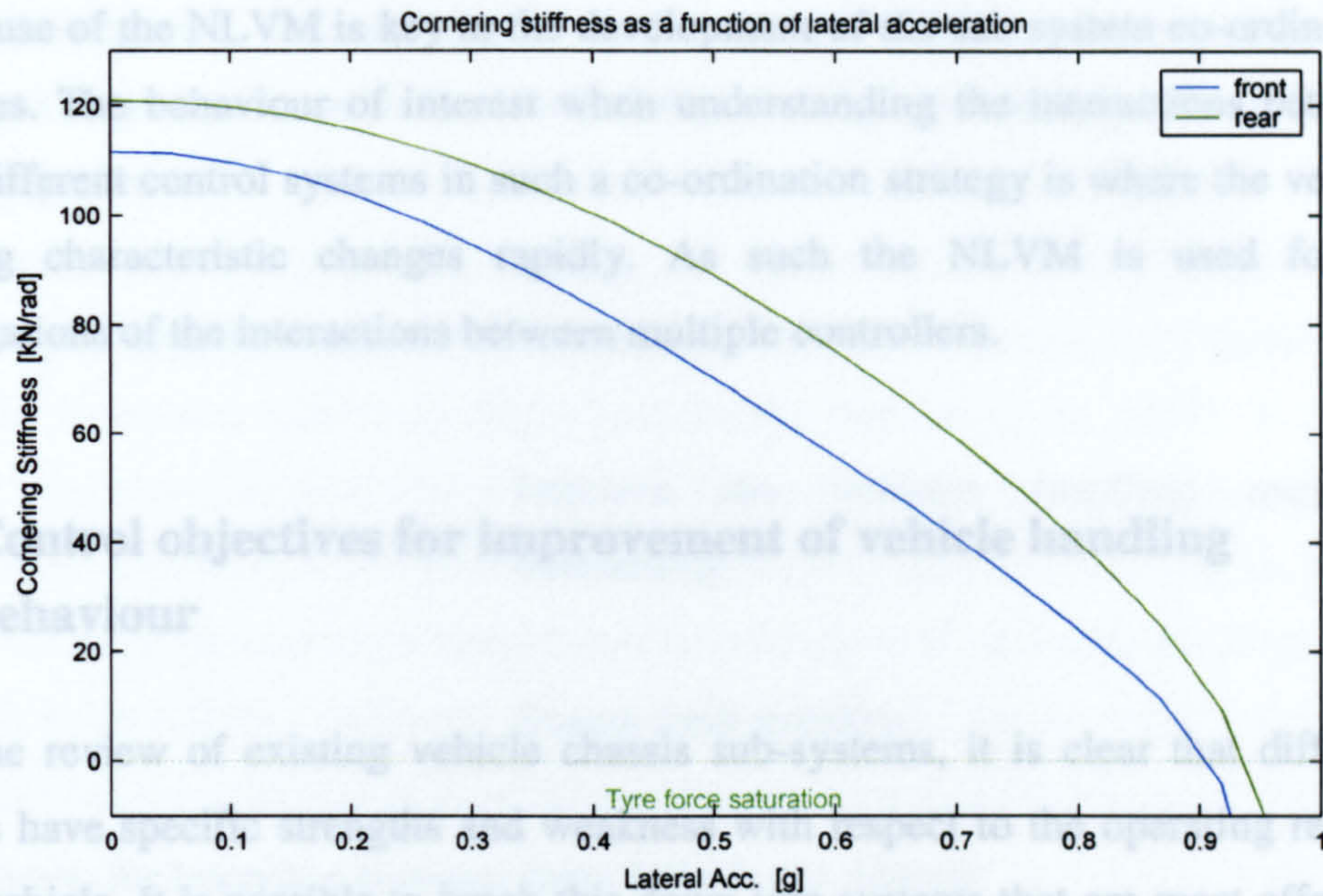

Figure 3-10 Tyre cornering stiffness extracted from a non-linear vehicle model.

It can be seen that cornering stiffness remains largely unchanged up to 0.5g, this is commonly referred to as the linear region of vehicle handling.

The limit of vehicle handling is determined by the saturation of tyre force. Modern vehicles are designed such that the front tyre force saturates before the rear so that at the limit of handling, the vehicle understeers. Figure 3-10 shows the front cornering stiffness at zero before the rear. This is considered to be safer than the oversteer which would occur if rear tyre force saturated before the front. At this operating point a small change in front steer angle will have virtually no effect on the tyre force generated because the tyre cornering stiffness is zero. From this it can be seen that active steering has little effect at the limit. However, away from the limit, where cornering stiffness is still large, the effect of additional steer angles generated by an active steering system have a significant effect on vehicle handling response.

This example of the insight that can be gained using this technique also highlights the need to validate controller design on a realistic vehicle model.

It can therefore be stated that the control task is closely related to the vehicle operating point.

The use of the NLVM is key to the development of the sub system co-ordination strategies. The behaviour of interest when understanding the interactions between many different control systems in such a co-ordination strategy is where the vehicle handling characteristic changes rapidly. As such the NLVM is used for all investigations of the interactions between multiple controllers.

3.2 Control objectives for improvement of vehicle handling behaviour

In the review of existing vehicle chassis sub-systems, it is clear that different systems have specific strengths and weakness with respect to the operating regime of the vehicle. It is possible to break this down into systems that are most effective in the low, mid, and high lateral acceleration regimes of a car. These operating regimes have been identified as :-

| | | | | |
|---|-----|---|-------|---------------------------|
| A | 0 | → | 0.3g | Low lateral acceleration |
| B | 0.3 | → | 0.7g | Mid lateral acceleration |
| C | 0.7 | → | Limit | High lateral acceleration |

Examples of systems which work in a particular regime would be active steering in A and B, roll moment distribution in B and C, and Direct Yaw Moment in C.

That fact that a system is particularly effective in one of these three regions does not entirely preclude its use away from this region to support another system. For instance, (Smakman 2000b), uses RMD to improve vehicle handling in the mid lateral acceleration region. In addition to this, RMD is used to maximise the effect of DYC in the high lateral acceleration region.

It can therefore be stated that the control task is closely related to the vehicle operating point.

Establishing that different control tasks are dominant in different operating regimes is important in order to clearly define the objective task for the individual control algorithms.

In this problem, there are two clear tasks:-

1. Improve the vehicles handling response:
Steerability
2. Ensure limit stability.

However, the boundary between these tasks is not distinct.

The rest of this section will discuss the meaning of these tasks and the interface between them with respect to the practical vehicle dynamics problem.

These two tasks need clearly defining from the point of view of the practical vehicle system and then from the point of view of controller development.

3.2.1 Steerability as a control objective

The vehicle handling response, is related to the ability of the vehicle to track commands from the driver. It is however important to recognise that handling quality (or otherwise) of a vehicle is ultimately a subjective decision. Much work has been published on the link between subjective and objective measures of vehicle handling (Bisimis et Al. 1977, Weir and Dimarco, 1978, Ash et al, 2001), the application of these metrics to determine the 'ideal' vehicle response is beyond the scope of this work. However, the ability to alter the characteristics of the vehicle in a beneficial way according to classical metrics will be demonstrated. Weir and DiMarco suggest that a vehicle can be evaluated with respect to its yaw rate response. The work suggests a range of values for yaw rate steady state gain and equivalent time constant which a typical driver will regard as good. The work by (Salmon 1990), suggests that during most closed loop driving manoeuvres, i.e. moderate cornering, mid lateral acceleration region, the driver is attempting to

control the yaw rate of the vehicle. This concurs with the work by (Weir and DiMarco 1978).

A typical driver spends the majority of time operating in the low-lateral acceleration region of the vehicle, i.e. the linear region (Mitschke, Wallentowitz et al. 1991; Shibahata, Abe et al. 1994; van Zanten, Erhardt et al. 1995). A typical driver is therefore inexperienced at controlling a vehicle in the non-linear region of its handling behaviour. It can therefore be considered a favourable objective for the vehicle response to remain unchanged over a wide range of operating conditions, i.e. the vehicle should be predictable, regardless of changes due to vehicle operating point, external disturbances or parameter variations such as mass or yaw inertia.

Hence it can be stated that a specific objective for a steerability controller is to track a reference yaw rate behaviour. This link between the general description of good vehicle handling dynamics and the exact definition of the control problem is important.

For the purposes of this study, the reference model will be based on the bicycle model, described in 3.1.1, populated with vehicle data for the unladen vehicle during straight ahead driving.

3.2.2 Stability as a control objective

The second task to ensure limit stability, also needs the link between practical vehicle dynamics and the specific control problem establishing. The vehicle limit is based purely on the ability of the tyres to generate a force. Further the behaviour at the limit of vehicle handling is determined by whether it is the front or rear tyres which saturate first. These two modes at the vehicle limit are referred to as limit understeer and limit oversteer respectively. A controller designed to operate at the vehicle limit will be required to deal with both these situations.

Stability analysis with respect to linear dynamic systems and controller development is related to eigenvalue analysis. However, this technique is not directly applicable to the highly non-linear vehicle considered here. Limit understeer, or ploughing, is not unstable in a strict mathematical context. However,

at this limit, a driver has no ability to control the directional behaviour of the vehicle; in fact small changes in front steer angle will have no effect on the vehicle due to the nature of the tyre characteristic. Limit oversteer, or spinning, on the other hand is unstable in the mathematical sense. Again control of vehicle direction is also lost. Thus, the second control task, ensure limit stability is related to controlling the directional behaviour of the vehicle at the limit.

(Shibahata, Abe et al. 1994) showed that directional stability of the vehicle can be determined on the sideslip or lateral velocity phase plane, and that bounding side slip behaviour on the phase plane can ensure vehicle stability. In the definition of the vehicle model presented here, the states are lateral velocity and yaw rate rather than side slip angle and yaw rate. Lateral velocity and side slip are easily related and Shibahata's analysis is still appropriate. Hence a controller will also be designed to control the lateral velocity behaviour. The problem in this case, however, is not to maintain a predictable behaviour for the lateral velocity state as was the case for steerability. However, the problem can still be posed in this way, and a modified reference behaviour will be discussed in Section 6.2.

3.2.3 Co-ordination of objectives over complete vehicle handling regime

The previous discussion has broken down the vehicle handling regime and the associated control tasks into steerability and stability. These two tasks were then related to the mathematical description of vehicle handling. It was established that a subjective improvement in handling quality is related to the vehicle yaw state and that a reference model tracking controller provides a framework to achieve an improvement. Also, it was shown that stability is related to the ability to fix bounds on the vehicle side slip angle and vehicle side slip angle velocity. By inspection of Equation 3-9, it can be seen that the vehicle states, yaw and side slip, are strongly coupled. In addition to this, directional stability is not in question away from the vehicle limit; yaw rate tracking and handling quality are unimportant at the vehicle limit as safety is the dominant concern. The nature of this boundary is indistinct and becomes a feature for the designer to tune.

Through a detailed understanding of the vehicle dynamics relating these two tasks, it is proposed to develop a rule based strategy to co-ordinate active steering

and brake based handling systems. The study aims to identify the key features required for such an approach and assesses the suitability of the studied systems for use in a co-ordinated chassis system. It is desired that the synergies and conflicts between the systems can be exploited and mitigated respectively through the use of a rule base to schedule both control task and actuation system.

3.3 Conclusion

This chapter has demonstrated the development of two vehicle models, a linear single track model and a 4 D.O.F. non-linear model. The features of each model have been discussed and justified with respect to the study to be performed. The uses of these models for controller development tools as well as for testing developed controllers has been discussed. A technique for using the linear model to understand the non-linear features of vehicle behaviour has been proposed.

The relationship between practical vehicle dynamics and the development of controllers to affect the handling has been exposed. In particular, the task of improving the drivers control of the vehicle has been termed steerability. This steerability task has been linked to yaw rate tracking. The ability to control the vehicles limit understeer/oversteer behaviour has been related to directional stability. These two different tasks have been shown to be conflicting and the nature of the interface between them discussed.

In addition, the language relating to driving tasks, controller design objectives and vehicle handling terminology has been clarified in relation to this study. These terms will be used throughout this thesis.

4 Steering sub-system controller design

Active steering algorithms have been widely developed in the literature. The review in chapter 2 concluded that whilst a wide variety of control algorithms have been applied to achieve different vehicle responses, i.e. yaw rate tracking or zero side slip angle, no consensus has yet been achieved on what is desirable. Furthermore, few have tackled the problem from the practical vehicle dynamics point of view with an aim to control the vehicle outside its linear operating regime. This lack of consistency throughout the literature makes it difficult to draw conclusions about the suitability of a particular approach for a particular control objective using either front, rear or four wheel steering. Initial results of a number of the control algorithms presented in the literature were compared on a linear vehicle model using a lane change manoeuvre and a side wind disturbance using seven metrics covering driver workload, path tracking, tyre workload and vehicle states when compared on a linear driver and vehicle model. This work is found in (Selby, Brown et al. 2000).

The aim of this study is to investigate the benefits of different active steering systems as part of a co-ordinated strategy to affect the vehicle handling dynamics. In this study, the situation of high speed driving is considered on a constant or homogeneous μ surface.

This section will show the development of controllers for each of active front steering (AFS), active rear steering (ARS) and active four wheel steering (A4S). In order to compare the suitability of these three systems for use in a co-ordinated approach with a brake based handling system, controllers will be designed to address both control objectives discussed in section 3.2. In order to aid this comparison of the effectiveness of AFS, ARS and A4S, a consistent approach to controller design will be applied, i.e. the control design algorithm will be applied to all steering variations for both state tracking problems.

4.1 Control objectives

The control objectives discussed in section 3.2 linked the development of handling controllers to a state-tracking problem, Figure 4-1. A classical control approach will be applied to solve this problem.

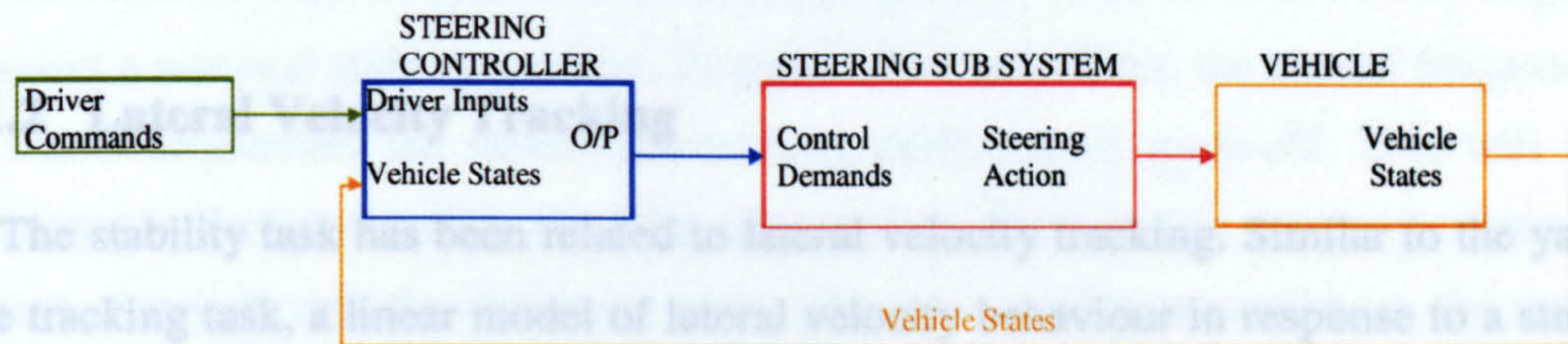

Figure 4-1 Control Structure

The following controllers will be developed, Table 4-1.

| System | Control task | Referred to as |
|----------------------------|-----------------------------------|----------------------|
| Active front steering | Yaw rate tracking | AFSYR ₁ |
| Active front steering | Lateral velocity tracking | AFSLV ₁ |
| Active rear steering | Yaw rate tracking | ARSYR ₁ |
| Active rear steering | Lateral velocity tracking | ARSLV ₁ |
| Active four wheel steering | Lateral velocity tracking | A4SLV ₁ |
| Active four wheel steering | Yaw and Lateral velocity tracking | A4SYRLV ₁ |

Table 4-1 Steer controllers to be designed

The characteristics of the reference models selected will be briefly discussed in the following section. Stability control has been related to lateral velocity bounding, it is appropriate, however to design a state-tracking controller, and bound the reference behaviour as will be discussed in the co-ordination section.

4.1.1 Yaw Rate Tracking

As has been discussed earlier, the aim for the steerability controllers is to extend the linear range of the vehicle and maintain the handling characteristic in the presence of parameter variations. This is to be achieved through the use of reference following controller. The reference model selected is the bicycle model, described in 3.1.1, for yaw rate response to a steer input at the front axle, $H_{21}(s)$ in Equation 3-9.

4.1.2 Lateral Velocity Tracking

The stability task has been related to lateral velocity tracking. Similar to the yaw rate tracking task, a linear model of lateral velocity behaviour in response to a steer input at the front axle has been selected as the reference model, $H_{11}(s)$ in Equation 3-9. However in relation to the overall problem, the goal is to bound the lateral velocity behaviour and hence ensure directional stability of the vehicle. The bounds for this vehicle state are predetermined as it is directly related to the stability of the vehicle. The process for determining these bounds is discussed in Chapter 5 and the application of these bounds to the steering controllers will be discussed in Chapter 6.

4.2 Control Algorithm Selection

As mentioned earlier, the literature is difficult to interpret with respect to the most appropriate actuation system and control algorithm for a given task. This makes the comparison of different approaches to affect the vehicle dynamic response difficult.

In this study, the same control algorithm will be applied to AFS and ARS. A4S is a substantially more complicated problem due to its multivariable nature and will require a different approach. However all three systems will be designed in the context of a reference model tracking approach in order that the actuators themselves can be compared in the context of a co-ordination approach.

This requirement to implement a number of different controllers quickly suggests the use of a simple well understood classical approach. The task here is to develop a tracking controller that has good disturbance rejection and robustness characteristics.

This problem is generally solved using a combination of feed forward and feedback control. The technique selected in this case is internal model control, sometimes referred to as “Q-” or “Youla-” parameterisation. (Morari and Zafiriou 1989) provide an excellent text on the technique. This approach allows the control design engineer to select a controller based upon knowledge of the plant to be controlled. Rearranging the classical feedback problem in terms of all stabilising controllers, (Morari and Zafiriou 1989), allows the design process to be reduced to two stages, 1) select a nominal stable controller, 2) apply a low pass filter, the cut-off frequency of which determines the robustness-tracking performance trade-off. This will be discussed in further detail in the following section. Further, this approach allows a degree of insight into the dynamics of the plant, not readily accessible in the more classical formulations. The technique has been successfully applied in other fields of vehicle dynamics, an example is found in the work by (Smakman 2000b).

The selection of an algorithm for A4S is discussed in section 4.6.

4.3 Internal model control (IMC)

Internal model control is a two degree of freedom (feedforward and feedback) control technique which has traditionally been used in situations where good servo tracking performance is required and good robustness to disturbances (either external or due to unmodelled nonlinearities), (Glad and Ljung 2000). The desire, in this case, is for the vehicle to track a reference behaviour and be robust to disturbances. IMC is an attractive technique due to the simplicity of its application. A further advantage is that closed loop stability is easy to demonstrate if both the controller and the plant are open loop stable, (Glad and Ljung 2000).

Internal model control is a control technique commonly used with model reference schemes. It allows controllers to be developed simply provided that a good approximation of the plant and its inverse can be found.

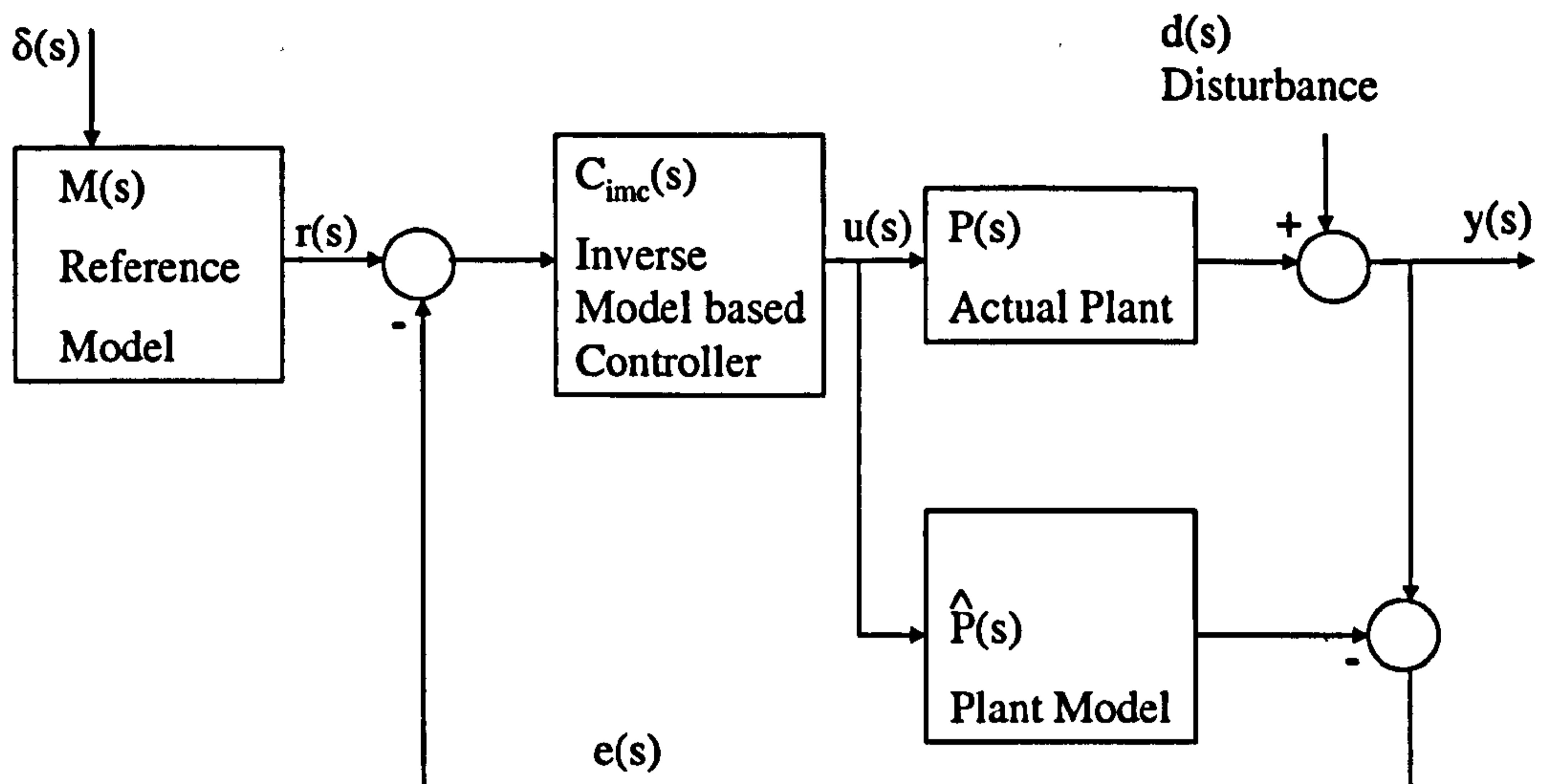

Figure 4-2 Internal Model Control Structure and Reference model

| Term | Description |
|--------------|--|
| $\hat{P}(s)$ | Internal Plant Model |
| $C_{imc}(s)$ | Inverse Model Based Controller |
| $d(s)$ | External Disturbance Signal |
| $e(s)$ | Feedback Error Signal |
| $M(s)$ | Reference Model, either $H_{11}(s)$ or $H_{21}(s)$. |
| $P(s)$ | Actual Plant |
| $r(s)$ | Desired Reference State |
| $u(s)$ | Control Signal |
| $y(s)$ | Controlled State |

Table 4-2 Nomenclature used in Figure 4-2

The controller $C_{imc}(s)$ in Figure 4-2 can be any stable system; a further practical requirement is that the system be realisable. The IMC approach allows the concept of “perfect” control to be introduced. If $C_{imc}(s)$ is selected as the inverse of the plant model and all modelling is assumed to be perfect then the controller is open loop as the feedback path is reduced to zero. It can be seen that $C_{imc}(s).P(s)$ is unity in the idealised case; perfect tracking, the system output perfectly tracks the reference. The closed loop system is guaranteed to be stable in this formulation providing the internal model is close enough to the real plant. Bounds on tolerable levels of plant

and model mismatch can be found using the small gain theorem, (Glad and Ljung 2000), Equation 4-1, the loop gain of the IMC structure is found from the left hand side.

$$\left| C_{imc}(j\omega)(P(j\omega) - \hat{P}(j\omega)) \right| < 1$$

Equation 4-1 Small gain theorem stability criteria for IMC, where ω is frequency in rad/s and $j = \sqrt{-1}$, (Glad and Ljung 2000).

A first requirement for perfect control is that the plant has a stable inverse i.e. that the plant be minimum phase. The implications for a system that is non-minimum phase (NMP) or has an unstable inverse, is that control performance is inherently limited by the dynamics of the plant rather than the control strategy. It can be seen that a plant having NMP zeroes will have an unstable inverse. However an approximation of the plant excluding or reflecting the NMP zeroes is often a sufficient approximation. In the idealised situation where a NMP plant is inverted, “perfect” control clearly requires that the actuators have no saturation or bandwidth limitations as the control output from the inverse is unstable. The implication is that NMP zeroes severely restrict controller performance, (Morari and Zafiriou 1989). A study of the zeros for the lateral velocity dynamics of the STVM will show that this is the case, performance is restricted by NMP behaviour, for the transfer function of front and rear steer angle and lateral velocity. It can be predicted that tracking performance of lateral velocity will be poor in light of this conclusion. A second feature of this technique is that a stable inverse will not be realisable as it will generally not be strictly proper and causal. A system must have at least more poles than zeros for this condition to be met. This second point is solved by adding to the plant model inverse, an appropriate number of extra poles, ie placing the inverse in series a low pass filter of order such that the controller becomes strictly causal and proper, (Morari and Zafiriou 1989).

The above features of this arrangement lead to a simple controller design procedure, though the design is not optimal, excellent performance and robustness is usually achieved in the SISO case.

The control design procedure is

1. Select $C_{imc}(s)$ as a good stable approximation of the system inverse. This controller will provide good nominal performance. The requirement that $C_{imc}(s)$ must be causal can be neglected at this stage.

2. Make the system realisable. $C_{imc}(s)$ must be augmented by another system. This is usually selected to be a unity gain low pass filter of sufficient order that $C_{imc}(s)$ becomes strictly proper. It can be shown that the effect of this filter is to improve the robustness characteristics of the closed loop system at the expense of closed loop bandwidth. The cut-off frequency is thus selected such that the closed loop systems bandwidth is the maximum that will satisfy the small gain theorem for all expected plant variations. This reduces the tuning process of the control system to the selection of an appropriate filter time constant.

Step 2 affects the performance and robustness of the closed loop system. The values selected in step 2 provide a generally good first guess for the controller. The performance is then investigated on the NLVM and the controller is tuned if necessary.

4.4 Description of Steering Sub-systems

The following section will discuss the nature of the plant dynamics for AFS, ARS and A4S.

In light of the insight gained from the above controller design methodology, a brief discussion of the plant dynamics for each of the steering subsystems will follow.

4.4.1 Active Front Steering (AFS)

The relationships between the front steer input and the vehicle lateral velocity and yaw rate are described by the linear vehicle model in Equation 3-9 by elements $H_{11}(s)$ and $H_{21}(s)$. Plotting the poles and zeroes of these two functions for different operating points allows a number of predictions to be made about controller

performance, Figure 4-3. It should be remembered that it is only the zero positions in the individual input-output paths that are unique for the coupled description of plant dynamics.

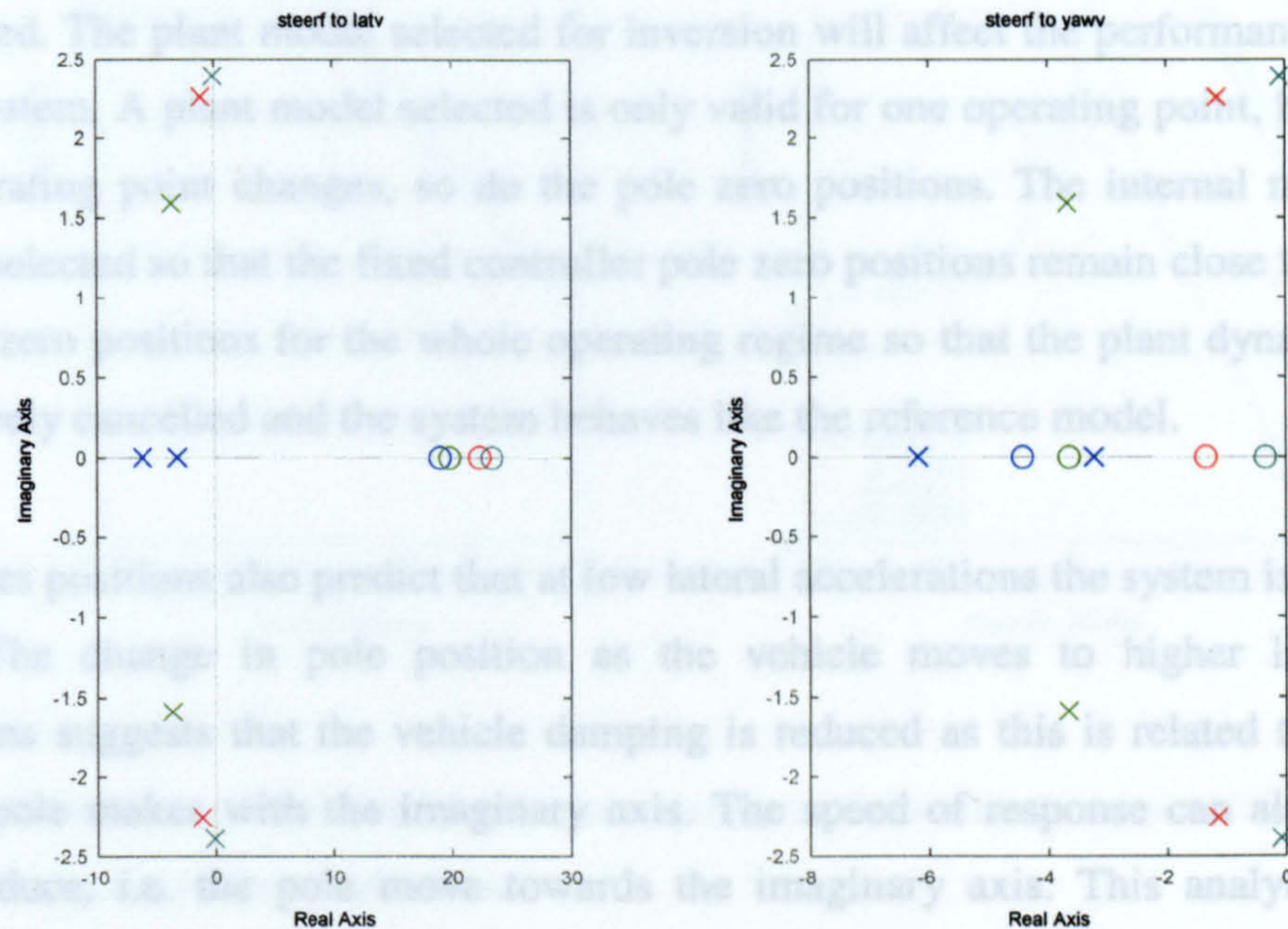

Figure 4-3 Pole zero positions for lateral velocity and yaw rate in response to front steering for increasing lateral acceleration(blue least, cyan greatest). Root locus drawn as a function $C_f(A_y)$ and $C_r(A_y)$ given in Figure 3-10.

The lateral velocity response in high speed driving is NMP. As stated in Section 4.3, this suggests that active front steering lateral velocity controller performance is inherently limited by the plant dynamics as this control technique cannot be used to cancel the NMP dynamics associated with the r.h.p zero. An alternative control technique, that deals explicitly with NMP systems could be selected for further investigation. However this study is aimed at understanding the interactions between a steering system to yaw behaviour and a brake based system to improve directional stability at the vehicle handling limit. As such, it is expected that even a poor, but stable, state tracking controller for lateral velocity will show improvements in vehicle handling behaviour in the context of this study. For this reason alternative control design techniques were not investigated at this point.

However, the zero positions for the yaw mode are in the left hand plane. This suggests that the yaw rate controller formed by inverting the plant model will cancel the plant dynamics effectively; leading to good control performance.

The plant model and its inverse are selected such that the plant poles and zeroes are cancelled. The plant model selected for inversion will affect the performance of the final system. A plant model selected is only valid for one operating point, hence as the operating point changes, so do the pole zero positions. The internal model should be selected so that the fixed controller pole zero positions remain close to the plant pole zero positions for the whole operating regime so that the plant dynamics are effectively cancelled and the system behaves like the reference model.

The poles positions also predict that at low lateral accelerations the system is well damped. The change in pole position as the vehicle moves to higher lateral accelerations suggests that the vehicle damping is reduced as this is related to the angle the pole makes with the imaginary axis. The speed of response can also be seen to reduce, i.e. the pole move towards the imaginary axis. This analysis is confirmed in the bode plots for this steering system, Figure 4-4. The bandwidth can be seen to reduce, and the emergence of a peak in the magnitude plot suggests a resonant response.

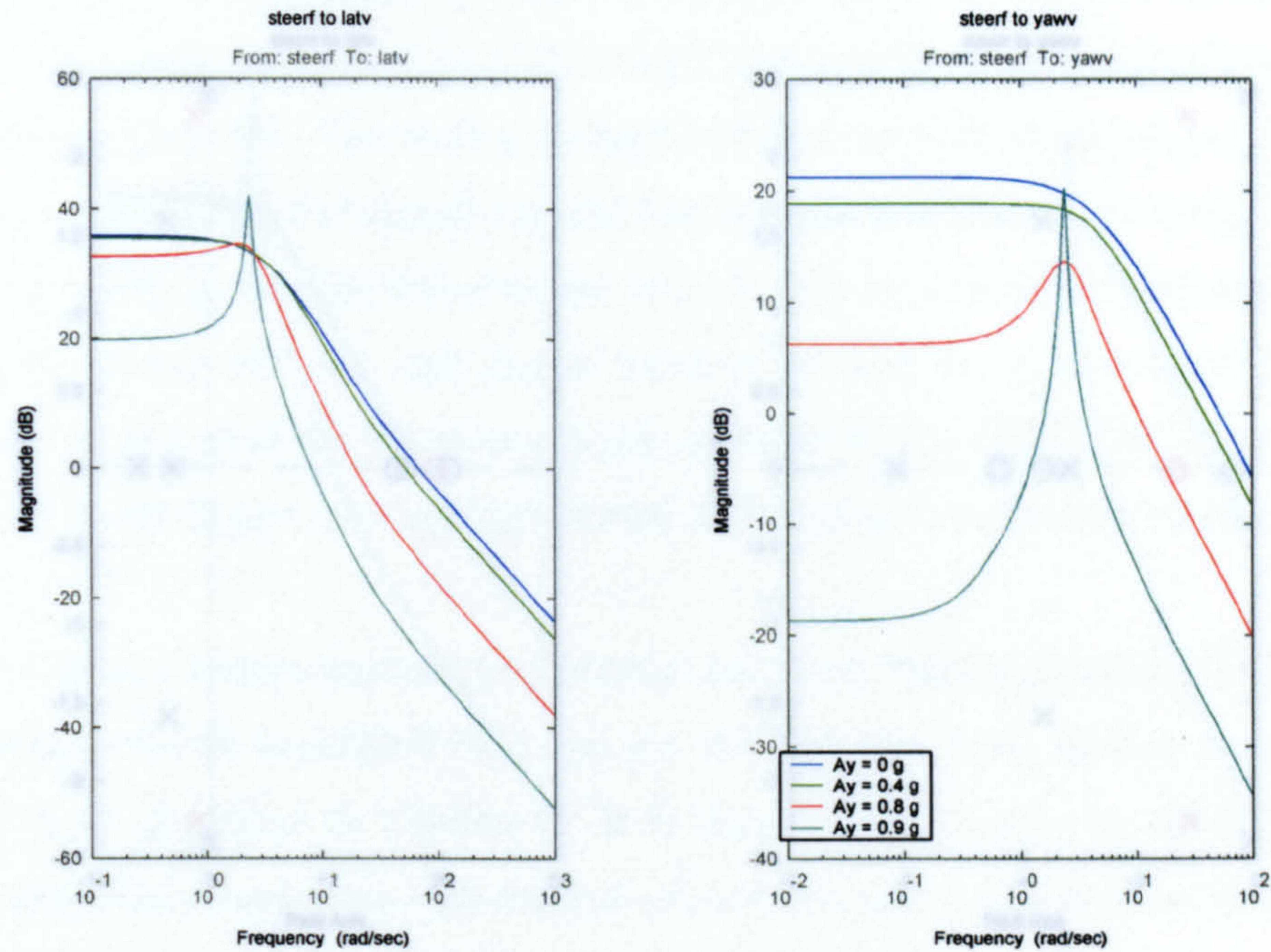

Figure 4-4 Bode magnitude plots for lateral velocity and yaw rate in response to front steering for increasing lateral acceleration.

However previous work, (Whitchhead 1988), has shown that ARS is effective at
 The conclusions from this simple inspection are that the vehicle response becomes slower and less damped, more oscillatory, as the vehicle operating point moves towards the vehicle limit. It is this change in vehicle response that the steerability controllers aim to mitigate. Although the system behaviour is dictated by the interactions between the pole and zero positions, it is seen in Equation 3-9 that the pole positions are the same for each system at a given operating point, in this case lateral acceleration. This qualitative analysis of the pole positions is the same for all systems for which controllers are to be designed and will not be repeated.

4.4.2 Active Rear Steering (ARS)

The relationships between the rear steer input and the vehicle lateral velocity and yaw rate are described by the linear vehicle model in Equation 3-9 by elements $H_{12}(s)$ and $H_{22}(s)$. As in the previous discussion, the lateral velocity behaviour is NMP; hence performance is limited by the plant dynamics, Figure 4-5.

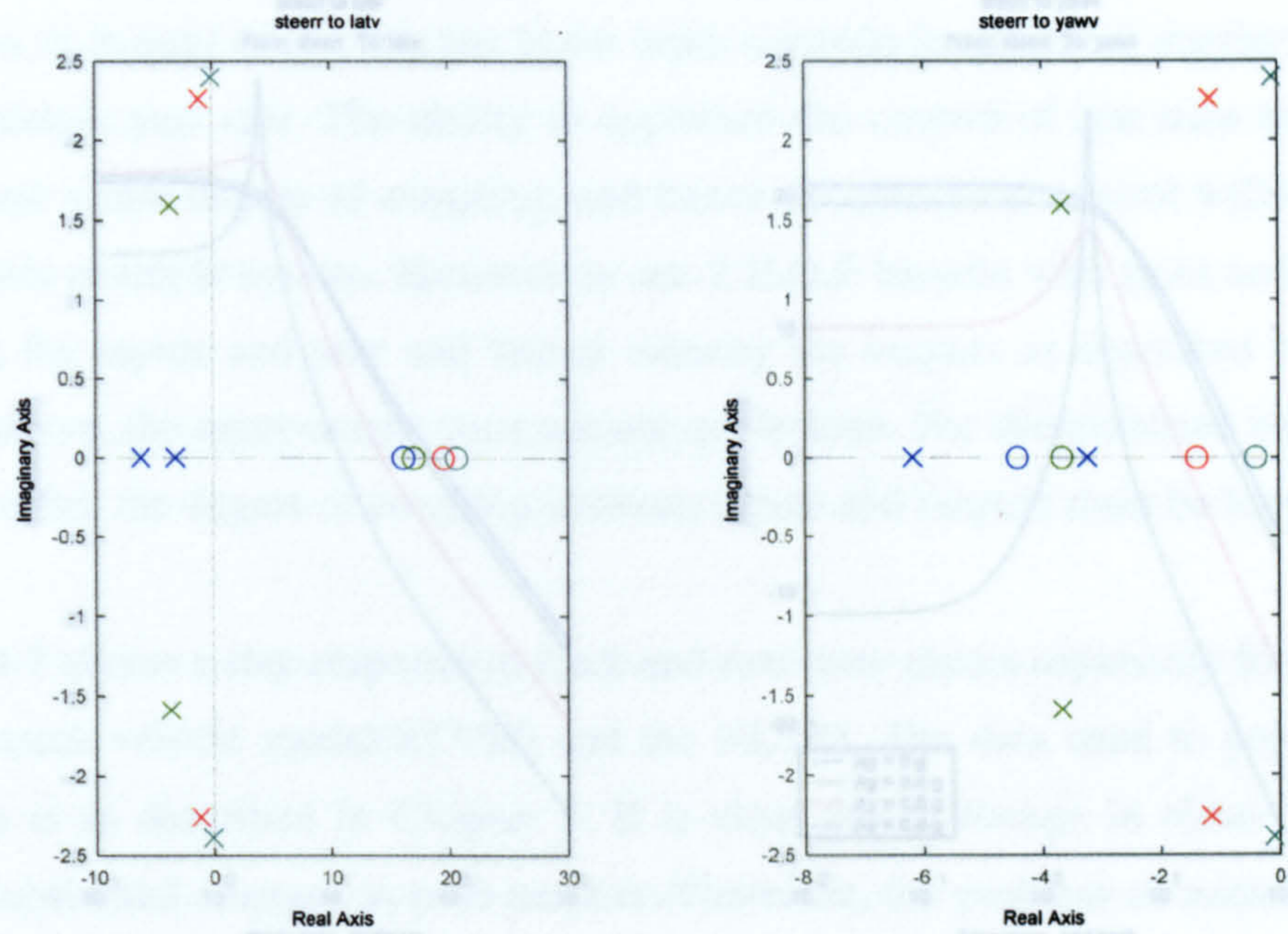

Figure 4-5 Pole zero positions for lateral velocity and yaw rate in response to rear steering.

However previous work, (Whitehead 1988), has shown that ARS is effective at promoting zero side slip behaviour during vehicle manoeuvring at the expense of yaw rate behaviour.

The analysis of the multivariable plant differs from the above. The plant derivation in Equation 3-9 is used in its entirety. The plant poles of a transfer function matrix are the lowest common denominator of all matrix elements. The plant transmission zeros are the poles of the inverse of system transfer function matrix. It is found that the multivariable system is minimum phase, which suggests that good controller performance can be achieved. However, the nature of the coupled dynamics means that this is not the only consideration. The coupling between states and inputs must now also be considered. The states cannot necessarily be considered in isolation. In some special cases where this is possible, the multivariable control task is reduced to one of decentralised control.

Decentralised control, often called multi-loop control, attempts to reduce the single MIMO control problem to one of many SISO problems. This approach consists of arranging the plant into the set of input-output pairs that have the greatest effect on each other. For example, in a 2 input 2 output case of a vehicle where the

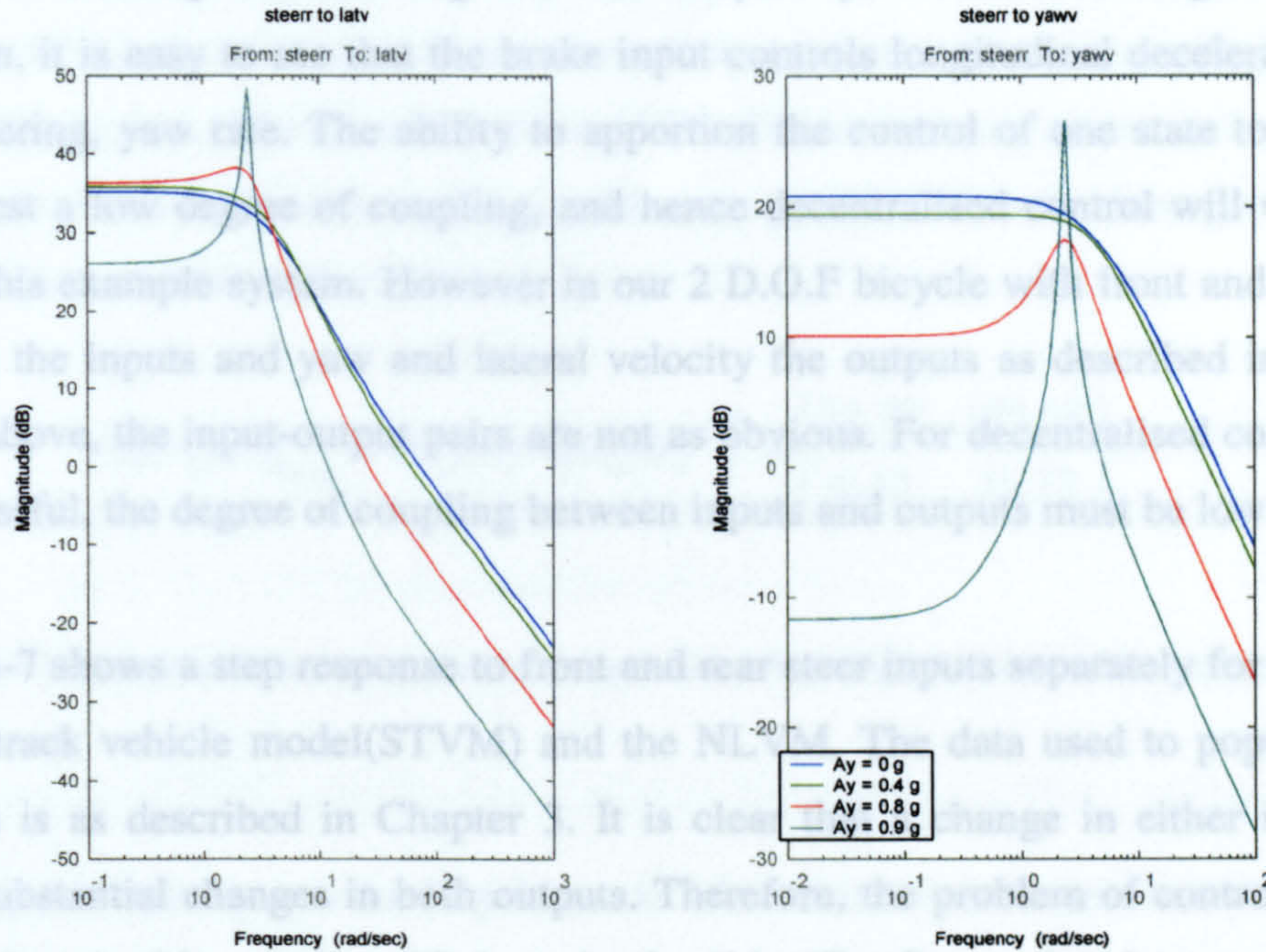

Figure 4-6 Bode magnitude plots for lateral velocity and yaw rate in response to rear steering.

4.4.3 Active Four Wheel Steering (A4S)

The analysis of the multivariable plant differs from the above. The plant description in Equation 3-9 is used in its entirety. The plant poles of a transfer function matrix are the lowest common denominator of all matrix elements. The plants transmission zeroes are the poles of the inverse of system transfer function matrix. It is found that the multivariable system is minimum phase, which suggests that good controller performance can be achieved. However, the nature of the coupled dynamics means that this is not the only consideration. The coupling between states and inputs must now also be considered. The states cannot necessarily be considered in isolation. In some special cases where this is possible, the multivariable control task is reduced to one of decentralised control.

Decentralised control, often called multi-loop control, attempts to reduce the single MIMO control problem to one of many SISO problems. This approach consists of arranging the plant into the set of input-output pairs that have the greatest effect on each other. For example, in a 2 input 2 output case of a vehicle where the

inputs where braking and steering and the outputs yaw rate and longitudinal deceleration, it is easy to see that the brake input controls longitudinal deceleration and the steering, yaw rate. The ability to apportion the control of one state to one input suggest a low degree of coupling, and hence decentralised control will work well with this example system. However in our 2 D.O.F bicycle with front and rear steer being the inputs and yaw and lateral velocity the outputs as described in the equations above, the input-output pairs are not as obvious. For decentralised control to be successful, the degree of coupling between inputs and outputs must be low.

Figure 4-7 shows a step response to front and rear steer inputs separately for both the single track vehicle model(STVM) and the NLVM. The data used to populate the models is as described in Chapter 3. It is clear that a change in either input produces substantial changes in both outputs. Therefore, the problem of controlling an A4S system in this way is unlikely to be feasible. The figure also demonstrates the effectiveness of the STVM in capturing the vehicle dynamics in the low lateral acceleration region.

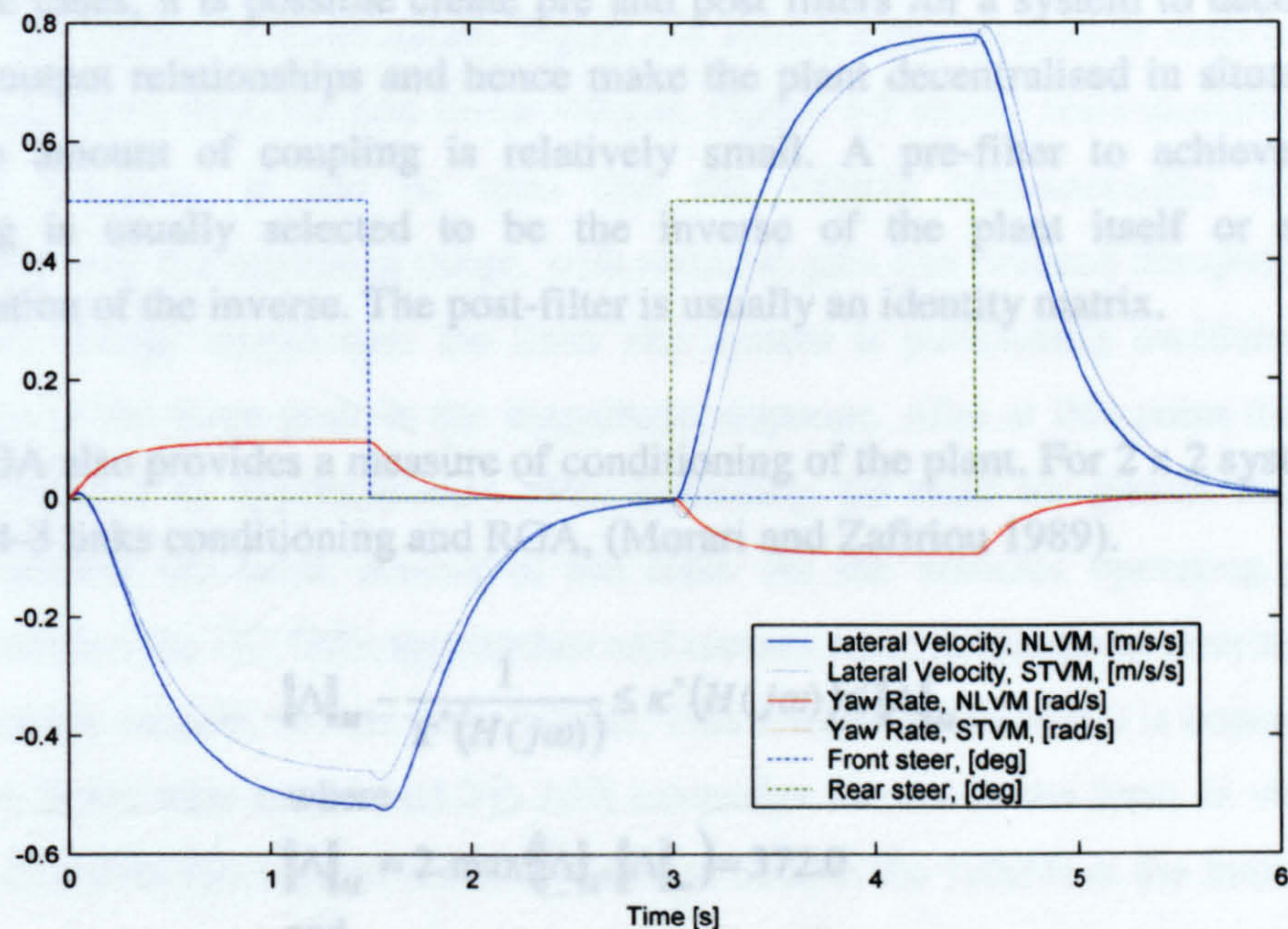

Figure 4-7 Step responses of lateral velocity and yaw rate w.r.t. front and rear steer inputs, shown dotted for both the NLVM and STVM. The inputs lead to an approximate peak lateral acceleration of 0.3g.

In order to extract the degree of coupling, it is possible to construct a Relative Gain Array (RGA), Λ , which provides a conservative measure of cross coupling as a function of frequency, (Morari and Zafiriou 1989). For an arbitrary system, where A is the transfer function matrix and $*$ signifies the product of each corresponding element in the matrix, the Schur product.

$$\Lambda(H(j\omega))_{\omega=0} = H(j\omega) * (H(j\omega)^{-1})^T = \begin{bmatrix} 31.77 & 153.98 \\ 6.15 & 31.77 \end{bmatrix}$$

Equation 4-2 Relative Gain Array definition and value for single track model evaluated at steady state, $\omega=0$

Applying this technique to the bicycle model of a vehicle it becomes clear that no such input-output pairs exist that allow for decentralised control, i.e. the norm of the RGA is large. This analysis confirms what is expected from the step responses in Figure 4-7.

In some cases, it is possible create pre and post filters for a system to decouple the input output relationships and hence make the plant decentralised in situations where the amount of coupling is relatively small. A pre-filter to achieve the decoupling is usually selected to be the inverse of the plant itself or some approximation of the inverse. The post-filter is usually an identity matrix.

The RGA also provides a measure of conditioning of the plant. For 2 x 2 systems, Equation 4-3 links conditioning and RGA, (Morari and Zafiriou 1989).

$$\|\Lambda\|_M - \frac{1}{\kappa^*(H(j\omega))} \leq \kappa^*(H(j\omega)) \leq \|\Lambda\|_M$$

where

$$\|\Lambda\|_M = 2 \cdot \max(\|\Lambda\|_1, \|\Lambda\|_\infty) = 372.0$$

and

$\|\Lambda\|_1$ and $\|\Lambda\|_\infty$ are the largest column and row sum, respectively of the matrix Λ

Equation 4-3 Relationship between RGA and minimised plant condition number and evaluated for the single track model, where κ^* is the minimised condition number.

If some norm of the RGA is large, it is implied that the system will be ill-conditioned. The relevance of this with respect to a decoupling pre-filter is that it suggests a small change in the plant will lead to a large change in the true inverse. Hence the required decoupling action, and the decentralised controller, will only work well over a small range of plant perturbations.

Due to the nature of this system, the decentralised approach is not appropriate. A technique that explicitly deals with the multivariable nature and high degree of coupling is needed. This will be discussed in section 4.6.

4.5 Example of IMC applied to Lateral Velocity tracking using AFS.

In order to illustrate the previous discussions the AFS controller for lateral velocity tracking will be designed and appropriate results presented.

Applying the IMC approach is a straightforward procedure, but first it is worth looking at the system in more detail. Figure 4-8 shows a the magnitude response of all operating points from the non-linear vehicle. Figure 4-9 shows corresponding DC Gain and damping. It can be seen that the vehicle characteristics change considerably over the operating range, with reduced gain and reduced damping, but most of the change occurs near the limit. The system is particularly oscillatory at 0.9g shown as the large peak in the magnitude response. Also at this point the DC Gain has reduced by approximately 35%; indicating the need for greater steering effort to achieve the same control of the state. As the vehicles operating point increases further, the DC Gain approaches and crosses zero; at this point steering has no effect on the vehicle, i.e. the vehicle limit. This feature shows that it is impossible to design a linear time invariant(LTI) AFS controller for use at the limit of vehicle handling. However this system is not expected to control the vehicle at the limit.

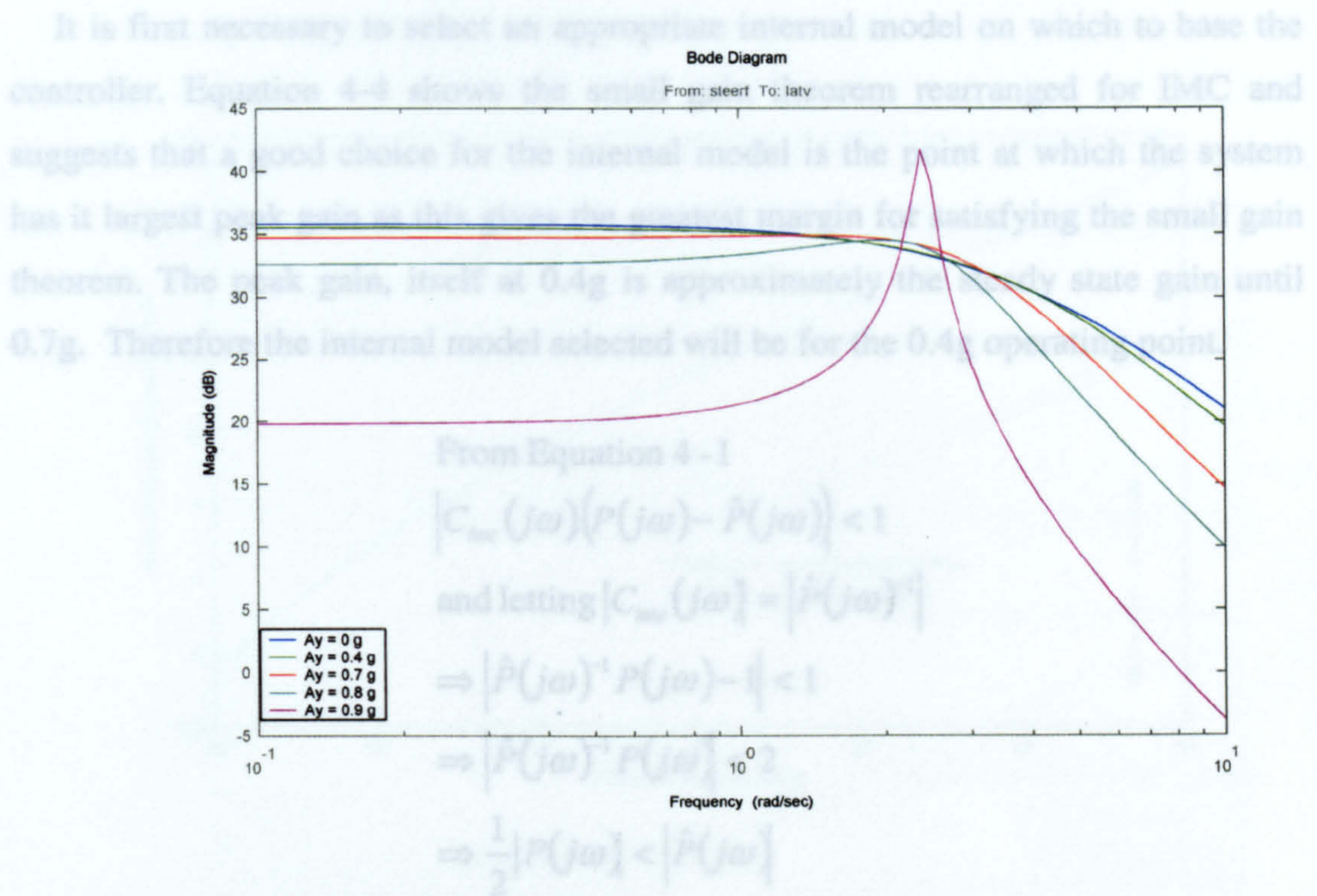

Figure 4-8 Bode magnitude plots of front steer to lateral velocity transfer function for operating points throughout the vehicle handling regime

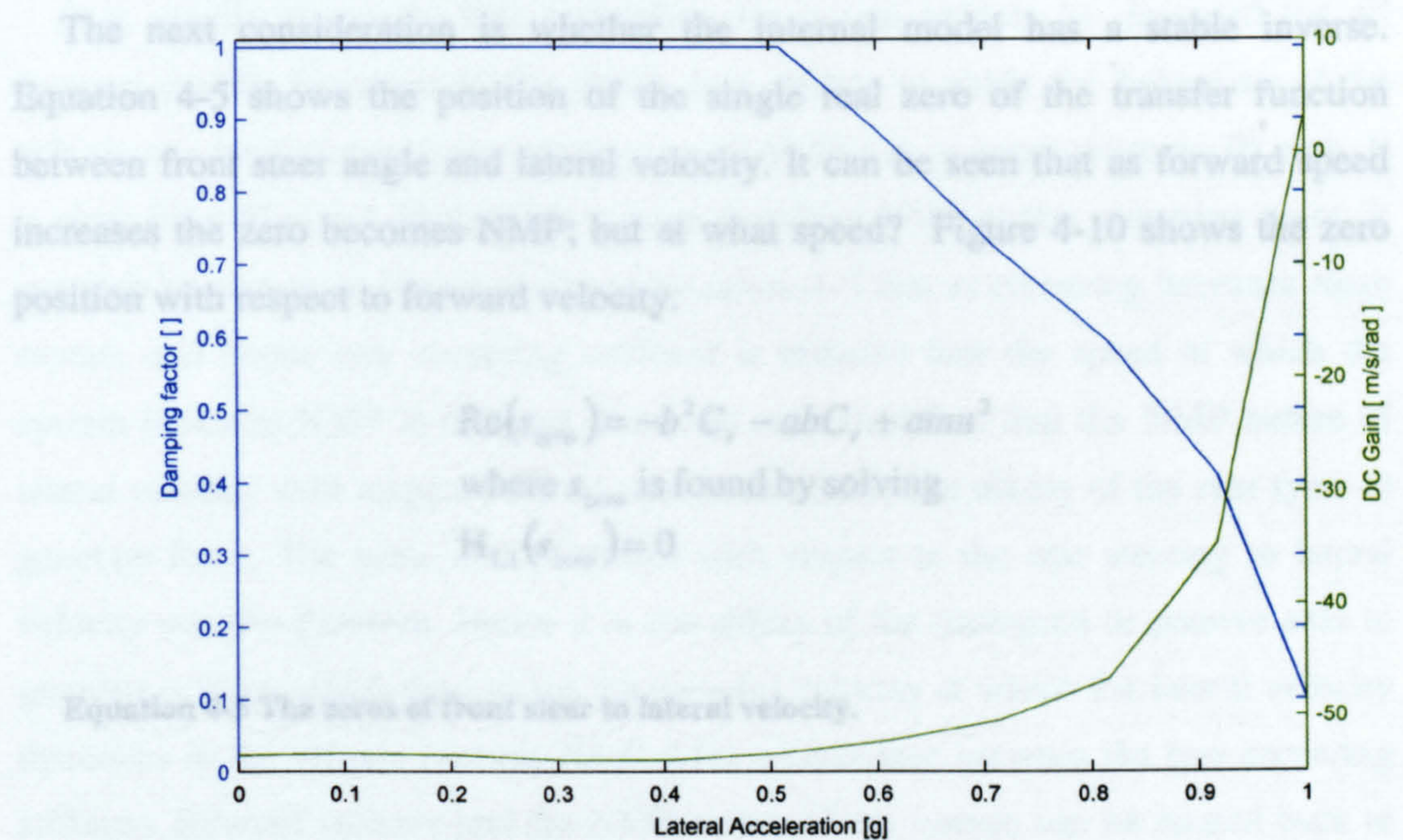

Figure 4-9 Damping factor(blue) and DC gain(green) as verses lateral acceleration

It is first necessary to select an appropriate internal model on which to base the controller. Equation 4-4 shows the small gain theorem rearranged for IMC and suggests that a good choice for the internal model is the point at which the system has its largest peak gain as this gives the greatest margin for satisfying the small gain theorem. The peak gain, itself at 0.4g is approximately the steady state gain until 0.7g. Therefore the internal model selected will be for the 0.4g operating point.

From Equation 4-1

$$|C_{imc}(j\omega)(P(j\omega) - \hat{P}(j\omega))| < 1$$

$$\text{and letting } |C_{imc}(j\omega)| = |\hat{P}(j\omega)^{-1}|$$

$$\Rightarrow |\hat{P}(j\omega)^{-1}P(j\omega) - 1| < 1$$

$$\Rightarrow |\hat{P}(j\omega)^{-1}P(j\omega)| < 2$$

$$\Rightarrow \frac{1}{2}|P(j\omega)| < |\hat{P}(j\omega)|$$

Equation 4-4 Small gain theorem for IMC

The next consideration is whether the internal model has a stable inverse. Equation 4-5 shows the position of the single real zero of the transfer function between front steer angle and lateral velocity. It can be seen that as forward speed increases the zero becomes NMP; but at what speed? Figure 4-10 shows the zero position with respect to forward velocity.

$$\text{Re}(s_{zero}) = -b^2C_r - abu^2$$

where s_{zero} is found by solving

$$H_{1,1}(s_{zero}) = 0$$

Equation 4-5 The zeros of front steer to lateral velocity.

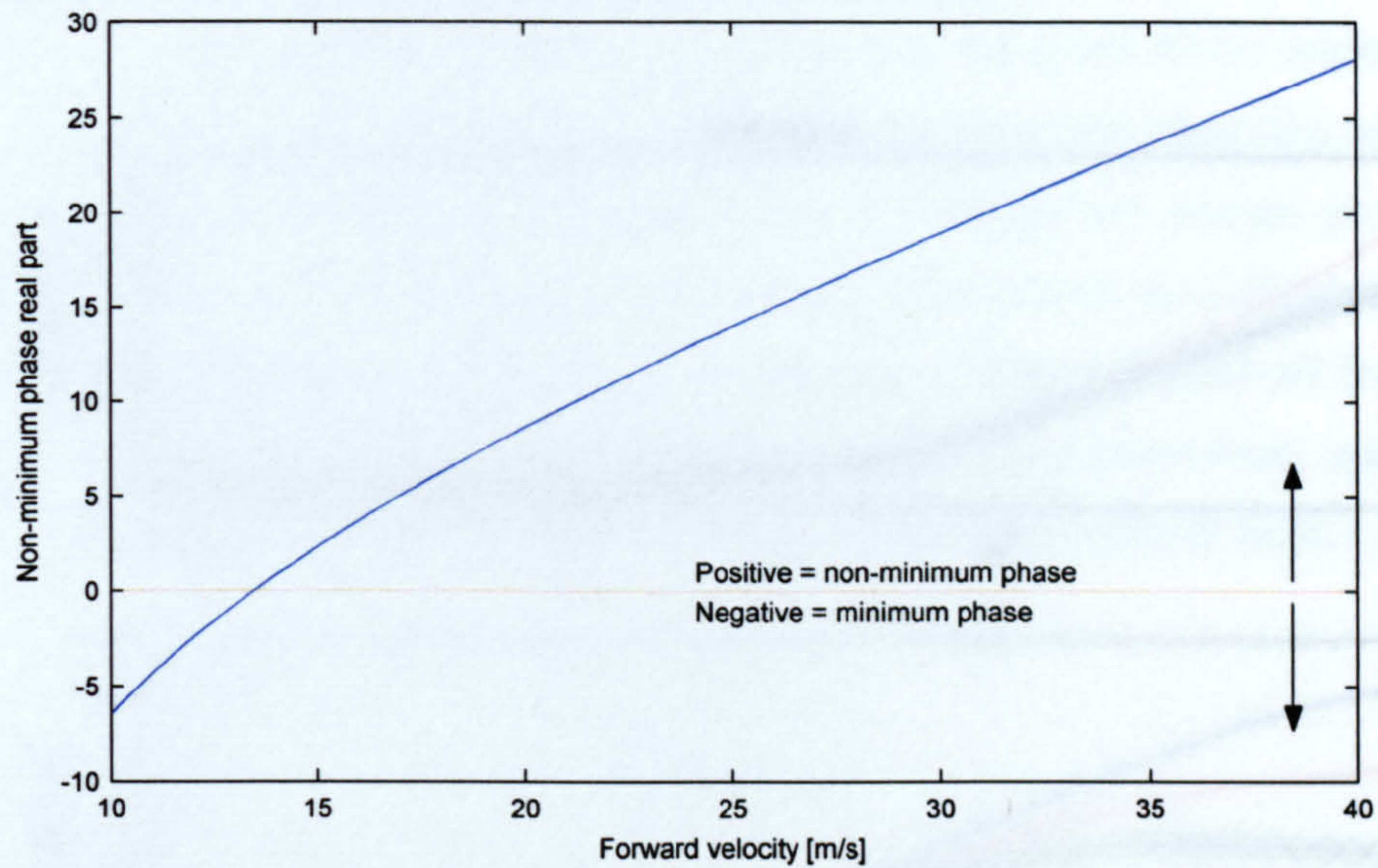

Figure 4-10 Position of the single real zero of the transfer function between front steer angle and lateral velocity for straight ahead driving. Position derived in Equation 4-5.

It is clearly necessary that controllers for a real vehicle be designed for all forward speeds. However in this study, it is chosen to study the behaviour of the vehicle at a typical motorway cruising speed of 30 m/s or approximately 70 mph. It is clear from Figure 4-10 that this system is indeed NMP at this operating point. It can also be seen from Figure 4-10 and Equation 4-5 that as cornering becomes more severe, and hence rear cornering stiffness is reduced that the speed at which the system becomes NMP is reduced. It can be seen therefore that the NMP nature of lateral velocity with respect to front steer is related to the ability of the rear tyres to generate force. The same can be shown with respect to the rear steering to lateral velocity transfer function. Hence it is the ability of the unsteered or passive axle to generate a force which determines the forward velocity at which the lateral velocity dynamics of the vehicle become NMP. This relationship between the tyre cornering stiffness, forward velocity and the NMP nature of the system can be related back to the idea of perfect control. At high speeds, or lateral accelerations, (or on low μ surfaces), no stable inverse exists, therefore control performance of the lateral velocity dynamic is severely restricted in the SISO case.

There are two possible options, a) reflect the zero in the imaginary axis, b) discard the zero. The effect of each is shown in Figure 4-11.

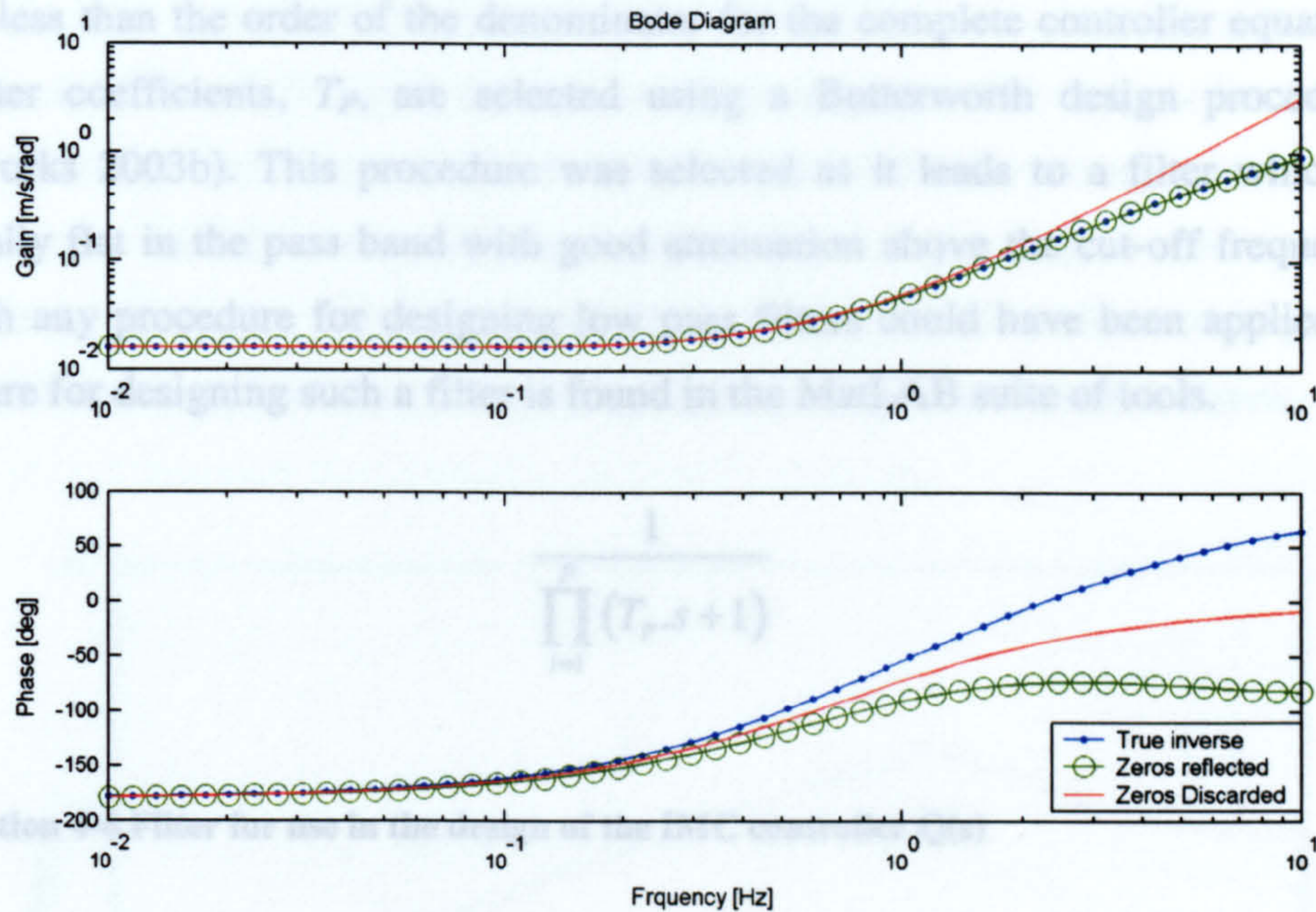

Figure 4-11 Effects of reflecting and discarding zeros on the front steering to lateral velocity transfer function inverse.

The effect of reflecting the zero is to preserve all magnitude information at the expense of phase information. The effect of discarding a zero is to partially preserve the magnitude information but to more closely preserve the phase information than in the case where a zero is reflected.

In this case, discarding the zero location makes it more likely to satisfy the small gain theorem as it leads to lower gain at higher frequencies. However, from a study of the plant, it can be seen that the damping factor is low at higher operating points. A large phase margin at the open loop cross over frequency corresponds to good damping. This requires that the technique which gives the controller the most phase lead be selected, hence in the following design, unstable zeros will be discarded.

Once the nominal controller has been selected based on the internal model, a filter must be added to make the inverse realisable. A filter of the form of Equation 4-6 was used with selected cut-off frequency of 15Hz. This value was found

experimentally such that the filter cut-off was high enough not to interfere with nominal performance but low enough so that robustness was preserved. $\hat{P}(s)$ was selected so that the system was strictly realisable, i.e. the order of the numerator is strictly less than the order of the denominator for the complete controller equation. The filter coefficients, T_p , are selected using a Butterworth design procedure, (Mathworks 2003b). This procedure was selected as it leads to a filter which is maximally flat in the pass band with good attenuation above the cut-off frequency although any procedure for designing low pass filters could have been applied. A procedure for designing such a filter is found in the MatLAB suite of tools.

$$\frac{1}{\prod_{i=1}^P (T_p \cdot s + 1)}$$

Equation 4-6 Filter for use in the design of the IMC controller Q(s)

The previous discussion has allowed the internal model to be selected at 4m/s/s lateral acceleration and established that the NMP zeroes be discarded. An analysis of the closed loop system will now follow.

Two functions which provide insight into the performance–robustness trade-off are the Sensitivity and Complimentary sensitivity functions. For the IMC scheme, they are shown in Equation 4-7.

$$S(s) = \frac{1 - C_{imc} \hat{P}}{1 + C_{imc} (P - \hat{P})}$$

$$T(s) = \frac{C_{imc} P}{1 + C_{imc} (P - \hat{P})}$$

$$S(s) + T(s) = 1$$

Equation 4-7 Sensitivity and Complimentary Sensitivity functions where $s=j\omega$

Referring back to the principal of perfect control, if the controller is the perfect inverse then $S(j\omega) = 0$ and $T(j\omega) = 1$, however for real systems $T(j\omega)$ approaches 0 and $S(j\omega)$ approaches 1 for high frequencies. The implication is that good disturbance rejection is only possible over a finite bandwidth. The highest frequency

where $S(j\omega) < 1/\sqrt{2}$ is the system bandwidth. Also it can be shown that either measurement noise or modelling error place an upper bound on $T(s)$; therefore a small $T(s)$ implies a high degree of robustness.

Figure 4-12 shows S and T for the two nominal controller designs for lateral velocity tracking. The first discards the NMP zero, whilst the second mirrors it. It can be seen that the two techniques have little direct impact on tracking performance. However, the reflection technique was found to lead to a poorly damped control signal, related to the reduced phase margin as discussed above.

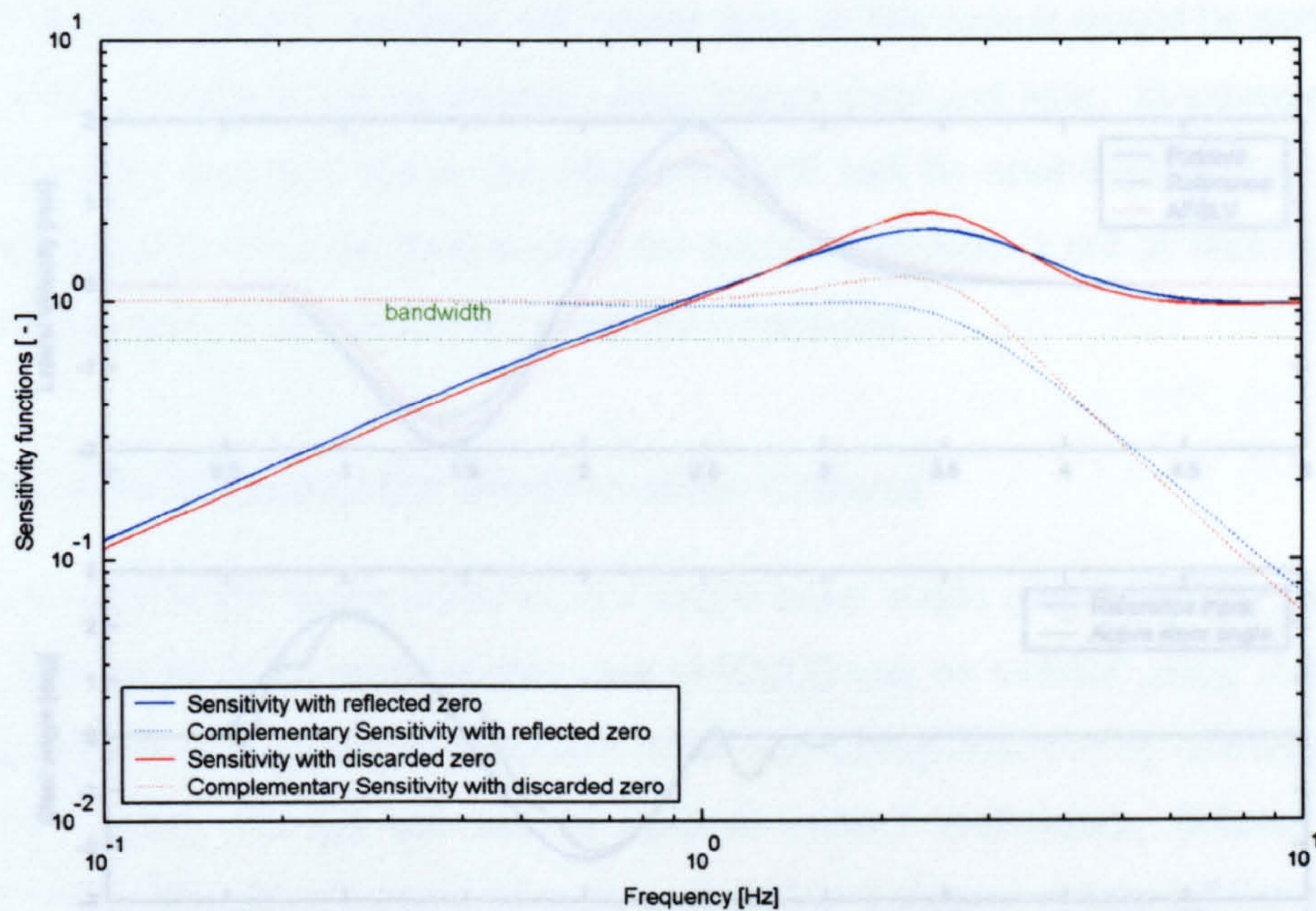

Figure 4-12 Complimentary Sensitivity and Sensitivity functions for AFSLV comparing methods of dealing with NMP zeros in the internal model, ie instabilities in the inverse model based controller.

Whilst firstly considering the sensitivity functions, it can be seen that the system with a mirrored zero has an improved bandwidth for disturbance rejection. The larger peak value for the mirror case suggests that the system will deal less effectively with disturbances above the systems bandwidth compared to discard case.

Before closing the loop on the controller, the stability can be tested by applying the small gain theorem to the loop function with different plant models, $P(s)$, Equation 4-1. This predicted that the controller developed will be stable for all operating points up to the vehicle handling limit or where $C_f(A_y)=0$, ie steering the front wheels has no effect on the vehicle dynamic response.

This controller has been developed under the assumption that the non-linear system can be modelled using the simple linear technique described above. The results must however be confirmed on the full non-linear vehicle. Figure 4-13 shows the simulation results using the developed controller.

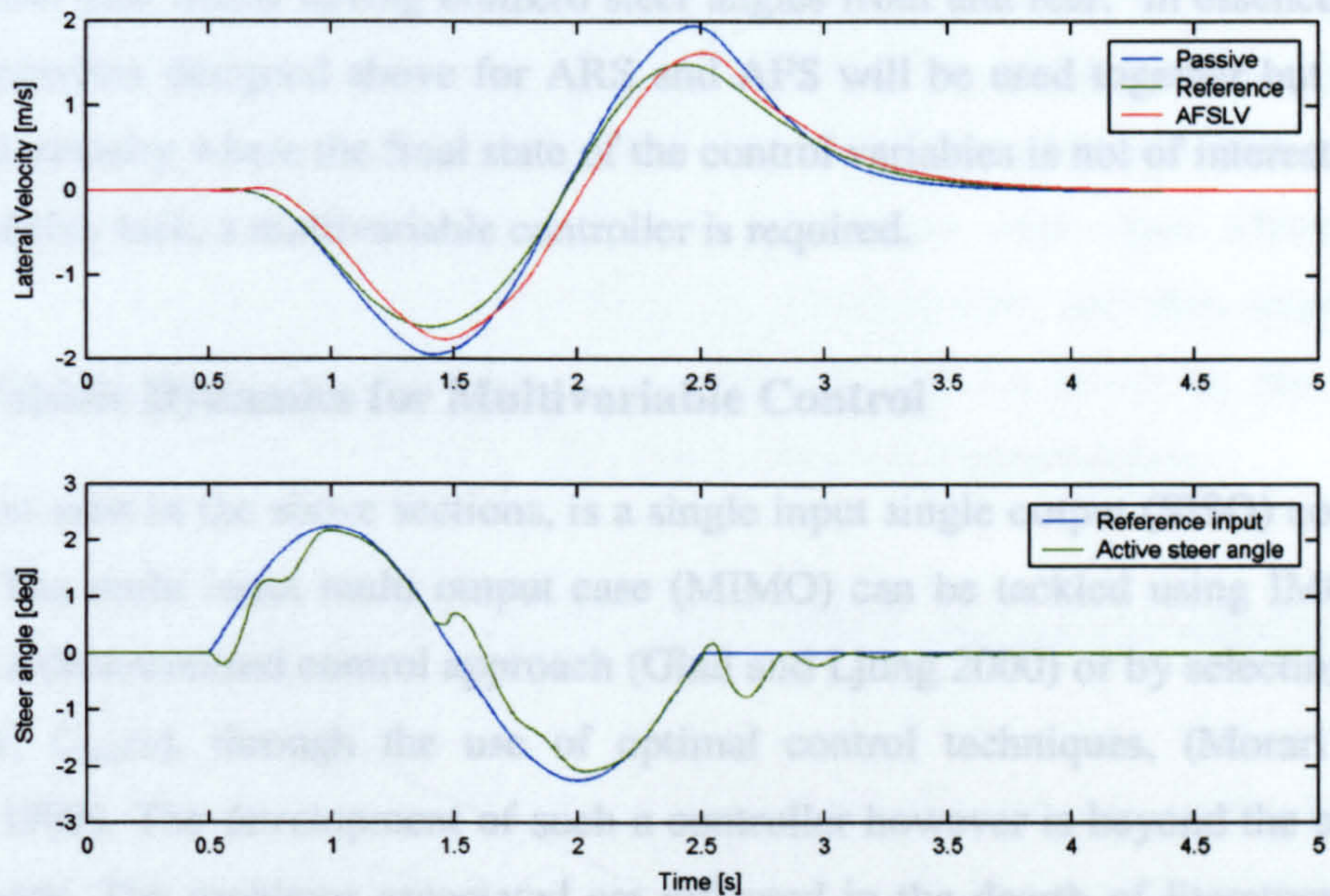

Figure 4-13 Aggressive lane change maneuver using AFSLV, peak lateral acceleration 0.7g

4.6 Multivariable Controller for Active four wheel steering.

A4S provides the opportunity to achieve improved performance over approaches where only one set of wheels is actively steered. In the previous sections, the tracking of lateral velocity and yaw rate have been considered as separate control objectives. If this approach is followed with A4S, the system is over-determined, i.e. more inputs exist than control objectives. This fact can be exploited in two ways. A

controller can be designed such that both control objectives are met. Alternatively, both inputs can be used to control just one objective.

The first approach initially seems to be the most favourable. Many techniques exist for developing such controllers. A number of these multiobjective multivariable techniques are discussed in the following sections. It can be seen that applying these approaches to vehicle dynamics is problematic.

The second approach however can be used to provide improved tracking performance of a single objective. This is problematic however as it does not guarantee that the control variables will return zero, in this case it would be possible to have zero yaw whilst having nonzero steer angles front and rear. In essence, the SISO controllers designed above for ARS and AFS will be used together but only for lateral velocity where the final state of the control variables is not of interest. For the steerability task, a multivariable controller is required.

4.6.1 Vehicle Dynamics for Multivariable Control

IMC, as seen in the above sections, is a single input single output (SISO) control scheme. The multi input multi output case (MIMO) can be tackled using IMC by adopting a decentralised control approach (Glad and Ljung 2000) or by selecting the controller, $C_{imc}(s)$, through the use of optimal control techniques, (Morari and Zafiriou 1989). The development of such a controller however is beyond the scope of this work. The problems associated are reflected in the dearth of literature that deals explicitly with active front and rear steering based handling controllers at any operating point other than the linear regime. The problem lies in an inherent trade-off between robustness and performance. Linear multivariable control techniques when applied to the vehicle dynamics problem must be designed such that they include the wide range over which parameters, particularly cornering stiffness', vehicle mass and vehicle inertia, can vary. Explicitly describing these plant variations is possible using techniques such as H_∞ -control (Morari and Zafiriou 1989). Much work has been published for steering controllers using this technique but is predominantly restricted to vehicles operating in the linear regime, and has little application to the more realistic situation considered here. A technique that takes account of the interaction between states is required. One such approach is a

model based technique called sliding mode control. This has been applied with great success (Yu and Moskwa 1994; Abe, Ohkubo et al. 1996; Manning, Crolla et al. 2000) over the complete range of vehicle handling. However these approaches are not yet to be considered viable due to the requirement for reliable state and parameter estimation, particularly for the road surface coefficient of friction. These approaches commonly extend the problem to include torque control at each wheel to further improve control performance. A simplified version of sliding mode control is proposed by (Yoshioka, Adachi et al. 1999) and will be used in this case for the steerability controller.

Finally, the simplest approach, is to use all inputs to affect only one state and disregard the other state in the control problem. This can be justified in the scope of this problem as the control task is to be scheduled against vehicle operating point. As discussed earlier, controllers designed in this way do not guarantee that control variables, or indeed other state are zero for zero driver steer input which is a requirement. Two controllers will be designed for each state and then scheduled through the co-ordination approach. Each controller will be based on the SISO control developed earlier with only small modifications discussed below.

4.6.2 Multi-loop Internal Model Control, MIMC, for lateral velocity tracking

MIMC is a simple extension to the IMC principle. The diagram in Figure 4-2 remains the same except that $C_{imc2x1}(s)$, $P_{1x2}(s)$, $\hat{P}_{1x2}(s)$, the controller, plant and internal model respectively are now transfer function matrices, with sizes denoted by the superscripts. Again $C_{imc}(s)$ includes the filters to set robustness and loop gain properties. The small gain theorem still applies as a test for stability. The link between the, now four, tuning parameters and system behaviour is much less clear. This is apparent in Equation 4-8, selecting either k_1 or k_2 to be zero reduces to the SISO controller. The Sensitivity and Complimentary Sensitivity functions can also be derived in a similar way. The robustness of the two channels can be different by selecting different filter cut-off frequencies.

The loop transfer function of the multiloop IMC is

$$\begin{aligned}
 X(s) &= C_{imc}(j\omega)(P(j\omega) - \hat{P}(j\omega)) \\
 &= Q_1(G_1 - \hat{G}_1) + Q_2(G_2 - \hat{G}_2) \\
 &= \frac{\hat{G}_1^{-1}k_1}{\prod_{i=1}^{P_1}(T_i s + 1)}(G_1 - \hat{G}_1) + \frac{\hat{G}_2^{-1}k_2}{\prod_{i=1}^{P_2}(T_i s + 1)}(G_2 - \hat{G}_2) \\
 &= \frac{k_1}{\prod_{i=1}^{P_1}(T_i s + 1)}(\hat{G}_1^{-1}G_1 - 1) + \frac{k_2}{\prod_{i=1}^{P_2}(T_i s + 1)}(\hat{G}_2^{-1}G_2 - 1)
 \end{aligned}$$

Applying the small gain theorem gives

$$1 \geq R > \sigma_{\max}(X(s))$$

Equation 4-8 Small gain theorem for two input - single output controller where R is selected arbitrarily to make the stability test conservative and σ_{\max} is the largest singular value.

In using this approach, it can be seen that a static gain is associated with each control path, $k_{(1,2)}$. These two gains affect the influence of each actuator on the plant, i.e. front and rear steering.

The selection of the four parameters is done using a numeric optimisation routine. A cost function is to be minimised. This can be done using the small gain theorem as a constraint to guarantee stability and the Sensitivity function to infer tracking performance. The value R is selected to be some number less than one selected arbitrarily to increase the robustness of the controller derived during the optimisation process. An alternative approach is to tune the controllers from approximate initial guess of a good solution using the full non-linear model. The multi input single output control design steps are now:-

1. Select the controller as in the SISO case based on the plant model
2. Select initial values for $k_{(1,2)}$ and for filter cut-offs.
3. Tune $k_{(1,2)}$ and for filter cut-offs using NLVM and optimisation routine.

The optimisation routine used was gradient descent technique found in the MatLAB suite of tools (Mathworks 2003a).

The performance of the controller is determined purely on the basis of tracking performance, though other factors such as actuator usage could be included.

Using this technique, the following values were found.

| | k_1 | k_2 | Filter cut-off front(Hz) | Filter cut-off rear(Hz) |
|-------|-------|-------|--------------------------|-------------------------|
| A4SLV | 0.03 | 0.2 | 22.5 | 17.5 |

The simulation selected to tune the controllers was a single sine steer, such that peak lateral accelerations were in the region of 0.7g.

The results suggest, with respect to AFSLV, that ARS is best used in isolation for this task. This is suggested by the small value for k_1 . It was also found that the effect of filter cut-off frequency on tracking performance was very small above about 10Hz. This is to be expected as the reference model bandwidth is less than 1Hz for both states. The filter cut-offs found using this technique produced excellent tracking but the control signal was found contain a large noise component. Reducing the filter cut-offs to 15Hz for both front and rear removed this problem and tracking performance was only marginally degraded, less than 1%. Hence, the following values were used.

| | k_1 | k_2 | Filter cut-off front(Hz) | Filter cut-off rear(Hz) |
|-------|-------|-------|--------------------------|-------------------------|
| A4SLV | 0.03 | 0.2 | 15 | 15 |

This result however suggests that a the SISO control approach performs better or at least as well as this multivariable approach. An unexpected result. The reasons for this can be explained by referring back to the RGA and the minimised condition number presented in Equation 4-3 and Equation 4-4 earlier. The implications of a large condition number is that plant is highly singular, or in the context of this inverse model based controller is that a small change in the plant leads to a very large change in the plants inverse. Hence as the real plant moves away slightly from

the design operating point, the plant controller mismatch leads to very poor performance and instability. The numeric optimisation technique therefore found a solution that reduced the controller to the SISO variant. The following section will discuss an alternative linear model based multivariable technique.

4.6.3 Simplified Sliding Mode Control for Active four wheel steering

A technique commonly referred in the literature relating to vehicle handling is sliding mode control (SMC). The main reasons claimed for this are its inherent robustness to unmodelled nonlinearities, shown in (Manning, Selby et al. 2002) for the vehicle dynamics problem. One such example of this technique, particularly relevant to the problem here is proposed in (Yoshioka, Adachi et al. 1999). The work applies a simplified sliding mode controller for DYC based on the STVM. It can be applied to vehicle steering with a very simple modification to the design process. It is based on the idea of using the current error between desired state and observed state and the time derivatives of this error to calculate the required change in force and yaw moment acting on the vehicle, Equation 4-9 and Equation 4-10 show this procedure, Table 4-3 describes the nomenclature used.

| Term | Description |
|--------------------------|--|
| $S_{(v,r)}$ | Tracking error for (lateral velocity, yaw rate) |
| $\lambda_{(v,r)}$ | Tuning variables |
| $v_{(ref, obs, target)}$ | Lateral velocity (reference model, measured state, target value) |
| $r_{(ref, obs, target)}$ | Yaw rate (reference model, measured state, target value) |
| ΔFy | Change in Vehicle Lateral Force |
| ΔMz | Change in Vehicle Yaw Moment |
| $\delta_{(f,r)}$ | Steer angle (front, rear) |

Table 4-3 Nomenclature for following derivation, all other variables retain their existing meaning.

$$\begin{aligned}
 S_v &= v_{ref} - v_{obs} \\
 \dot{S}_v &= -\lambda_v S_v \\
 \dot{v}_{target} &= \dot{v}_{ref} + \lambda_v S_v \\
 \Delta F_y &= m_{total} (\dot{v}_{target} - \dot{v}_{obs})
 \end{aligned}$$

Equation 4-9 Desired change in vehicle lateral force required to drive vehicle state to the desired reference state

$$\begin{aligned}
 S_r &= r_{ref} - r_{obs} \\
 \dot{S}_r &= -\lambda_r S_r \\
 \dot{r}_{target} &= \dot{r}_{ref} + \lambda_r S_r \\
 \Delta M_z &= I_z (\dot{r}_{target} - \dot{r}_{obs})
 \end{aligned}$$

Equation 4-10 Desired change in vehicle yaw moment required to drive vehicle state to the desired reference state

Where $S_{(v,r)}$ are the tracking errors for the states in question and $\lambda_{(v,r)}$ are tuning parameters selected to weight the control effort on each state. These are used to calculate a target rate of change for each state which in turn is used to calculate the required moment and force changes, ΔM_z and ΔF_y .

Once these required force and moment changes are calculated, it is required to relate them to a change in the steer angles which is shown in Equation 4-11.

$$\begin{bmatrix} \Delta M_z \\ \Delta F_y \end{bmatrix} = \begin{bmatrix} a.C_f & -b.C_r \\ C_f & C_r \end{bmatrix} \begin{bmatrix} \dot{\delta}_f \\ \dot{\delta}_r \end{bmatrix}$$

Equation 4-11 Relationship between desired change in force and moment to change of steer angle.

This set of two linear equations is solved directly to give Equation 4-12, which is then integrated to give actual steer angle.

$$\begin{bmatrix} \dot{\delta}_f \\ \dot{\delta}_r \end{bmatrix} = \begin{bmatrix} \frac{\Delta M_z + \Delta F_y \cdot b}{C_f (a+b)} \\ \frac{\Delta M_z - \Delta F_y \cdot b}{C_r (a+b)} \end{bmatrix}$$

Equation 4-12 Controller output, steer angle rates

It can be seen by inspection that the control variables change only slightly for relatively large changes in tyre cornering stiffness'. However, as cornering stiffness approaches zero, which happens with increasing lateral acceleration, the control variable calculated will no longer produce the required moment and force changes; in particular the internal model no longer adequately matches the real plant.

This technique was found to perform well in the linear regime where the cornering stiffness' in Equation 4-12 reflect the values of the actual tyre, however at high slip angle and as the tyre saturation is approached, the controller is found to be unstable. To solve this problem, the cornering stiffness' are described by a piece-wise function shown in Equation 4-13 and Figure 4-14.

$$\begin{aligned} C_{(f,r)} &= C_{(f,r)} & \text{if } \delta_{(f,r)} < (5^\circ, 2^\circ) \\ C_{(f,r)} &= C_{sat} & \text{if } \delta_{(f,r)} \geq (5^\circ, 2^\circ) \end{aligned}$$

Equation 4-13 Piece wise description of tyre cornering stiffness

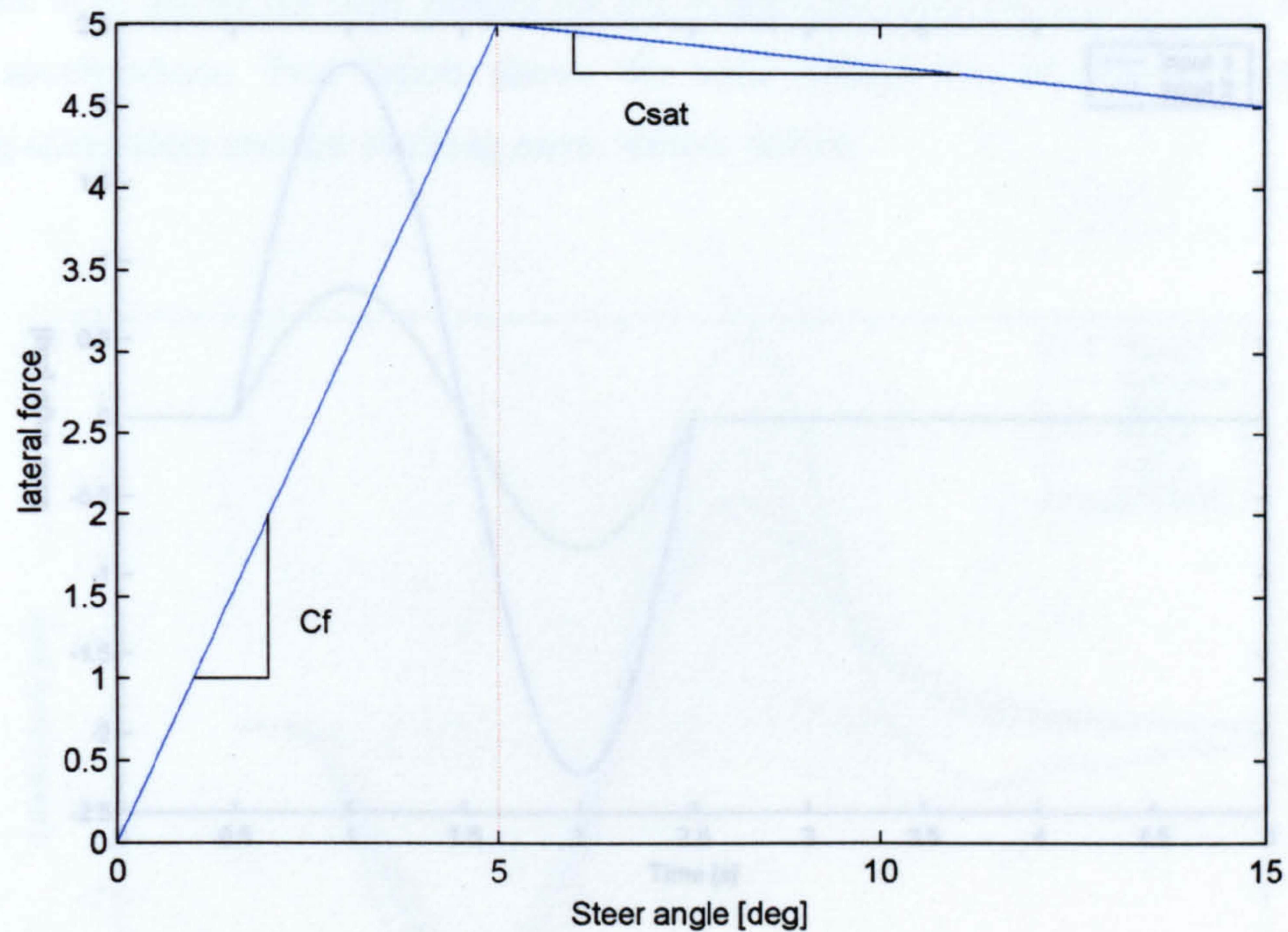

Figure 4-14 Piece-wise tyre description

The point at which the tyre is considered to saturate is low compared to a real tyre but at the front wheels this level of steering was found not to be reached in transient manoeuvres and at the rear 2° was selected to be the level of actuator saturation. C_{sat} was selected to be 10kN/rad.

4.7 Comparison of steering controllers

The following section will present results for all six controllers developed in this chapter. The results are presented in two forms for one manoeuvre. The manoeuvre selected is an open loop representation of an aggressive single lane change at 30m/s on a high μ surface; producing peak lateral accelerations in the region of 0.7g. This is simulated on the NLVM using a single cycle sine input.

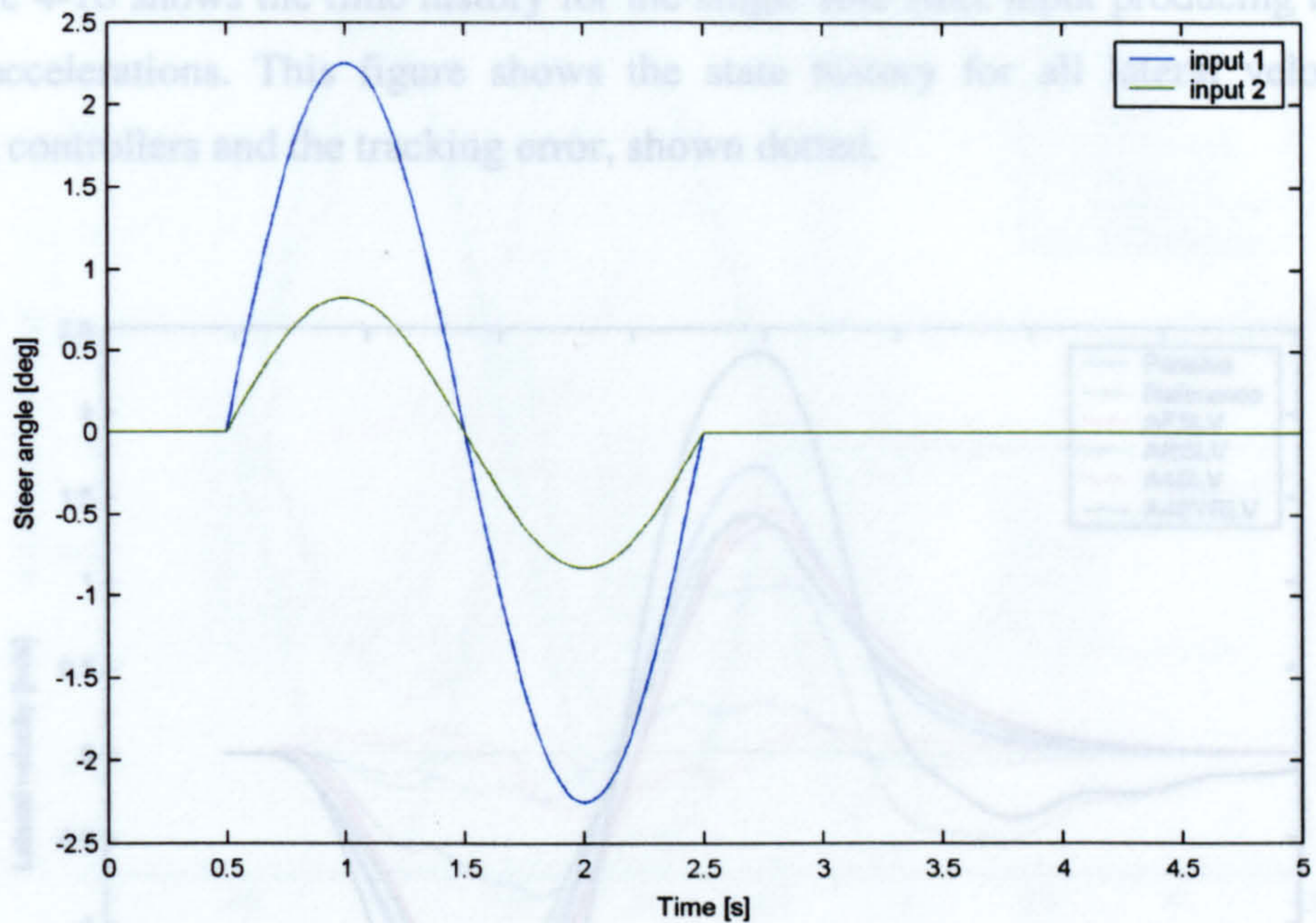

Figure 4-15 Open loop representation of a single lane change. Input 1 leads to peak lateral acceleration approx. 0.7g, input 2 leads to peak lateral acceleration approx. 0.3g.

This is the most extreme situation that the steering controllers have been designed to cope with. The results are presented firstly as a time history of the state and tracking error for input 1 and secondly as a single metric of performance; integral squared error (ISE) of tracking for inputs 1 and 2, Equation 4-14.

Figure 4-17 shows the control signal for system. This is steer angle at the wheel.

$$ISE = \int_{t=0}^{t=5} \left[(v, r)_{obs} - (v, r)_{ref} \right]^2 .dt$$

Equation 4-14 Tracking metric, integral squared error for the single sine steer input for all lateral velocity, v , and yaw, r .

This single metric is normalised to the benchmark, 'best' controller designed. In both cases the ARS system was found to produce the best tracking performance and as such has an ISE of 1. In addition to the high lateral acceleration case, the ISE is presented for the same manoeuvre but with a smaller input amplitude leading to lateral accelerations of around 0.3g. For all results, the behaviour of the passive vehicle is presented for comparison.

Figure 4-16 shows the time history for the single sine steer input producing high lateral accelerations. This figure shows the state history for all lateral velocity tracking controllers and the tracking error, shown dotted.

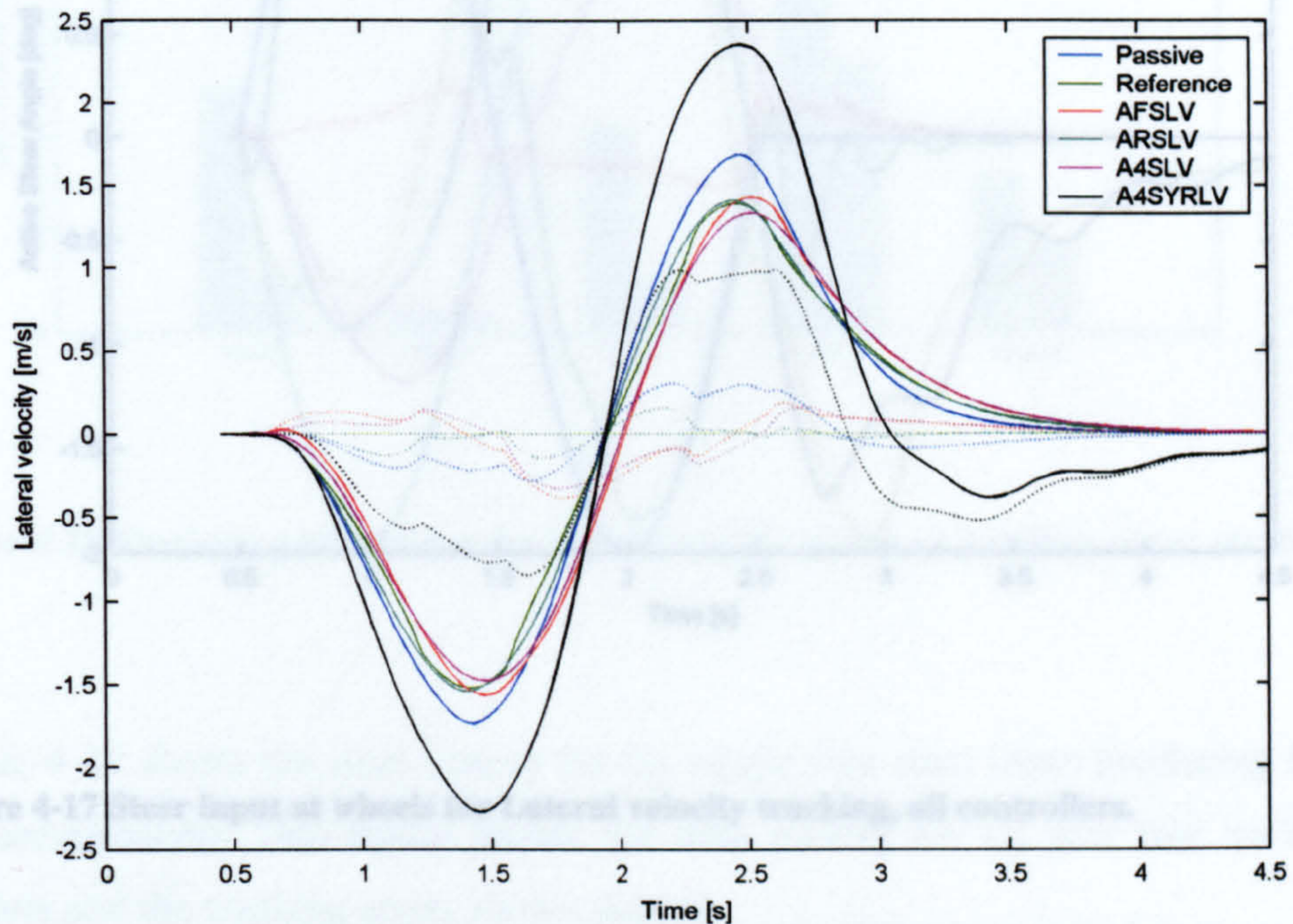

Figure 4-16 Lateral velocity tracking, all controllers. Solid lines, state history, dotted lines, tracking error.

Figure 4-17 shows the control signal for system. This is steer angle at the wheel. is highly oscillatory and takes over two seconds for oscillations to decay. The comparatively high frequency oscillations do not, however, substantially affect the state behaviour as they are strongly attenuated through the plant.

ARS is by far the most effective at tracking lateral velocity behaviour. The state history shows the smallest tracking errors and the control signal does not show the oscillations evident with AFS.

The relative performance of these three controllers is shown in Figure 4-18. Tracking performance for lateral velocity normalised to best controller, ARSLV. These single value metrics confirm the observations noted with regard to the time

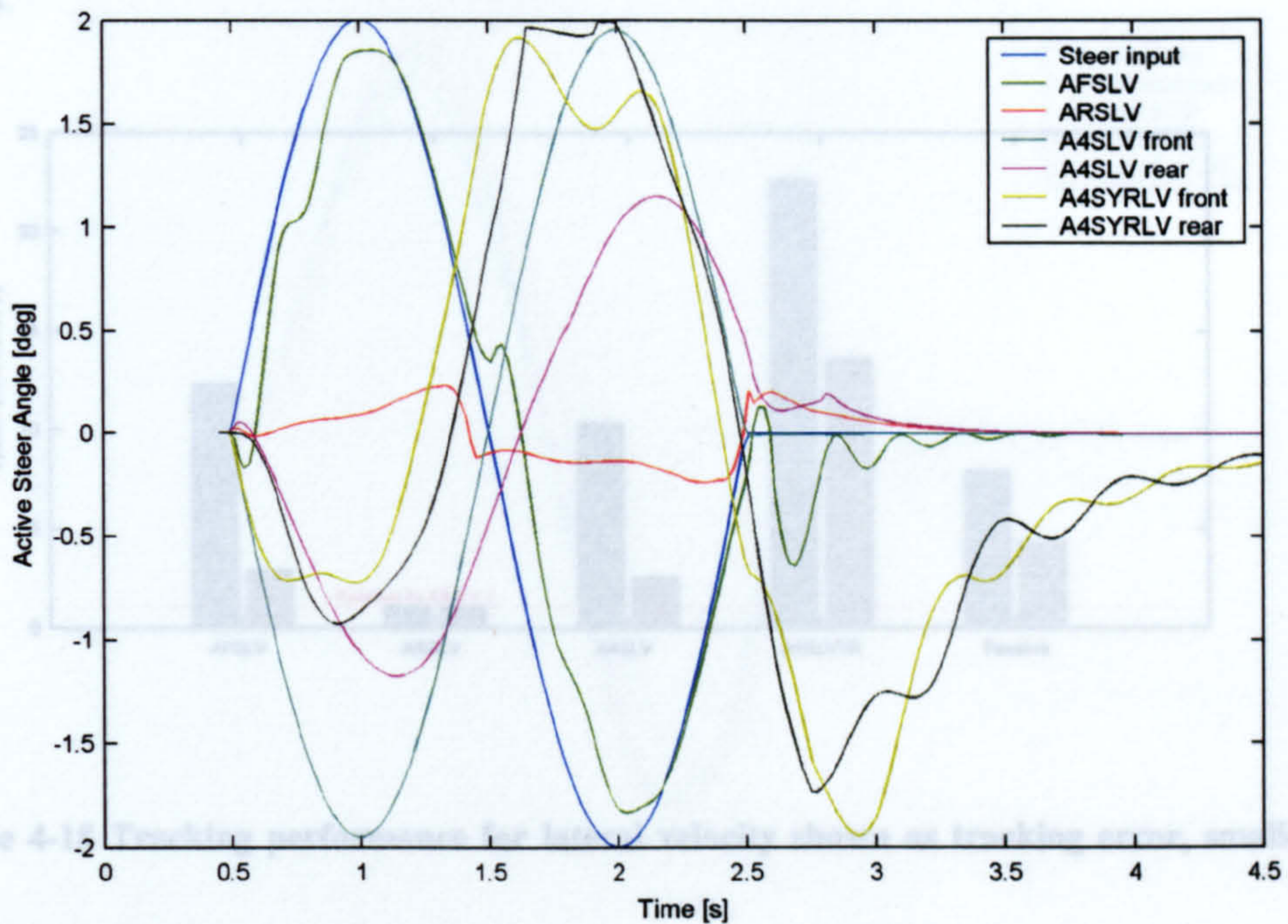

Figure 4-17 Steer input at wheels for Lateral velocity tracking, all controllers.

The above state histories show that despite the NMP characteristics, lateral velocity can be controlled through active steering. However, the performance is poor, exhibiting significant delay in tracking the reference and showing large overshoots, seen as the large peaks in the state error.

AFS is particularly poor in tracking lateral velocity. The control signal for AFS is highly oscillatory and takes over two seconds for oscillations to decay. The comparatively high frequency oscillations do not, however, substantially affect the state behaviour as they are strongly attenuated through the plant.

ARS is by far the most effective at tracking lateral velocity behaviour. The state history shows the smallest tracking errors and the control signal does not show the oscillations evident with AFS.

The relative performance of these three controllers is shown in Figure 4-18. Tracking performance for lateral velocity normalised to best controller, ARSLV. These single value metrics confirm the observations noted with regard to the time

histories.

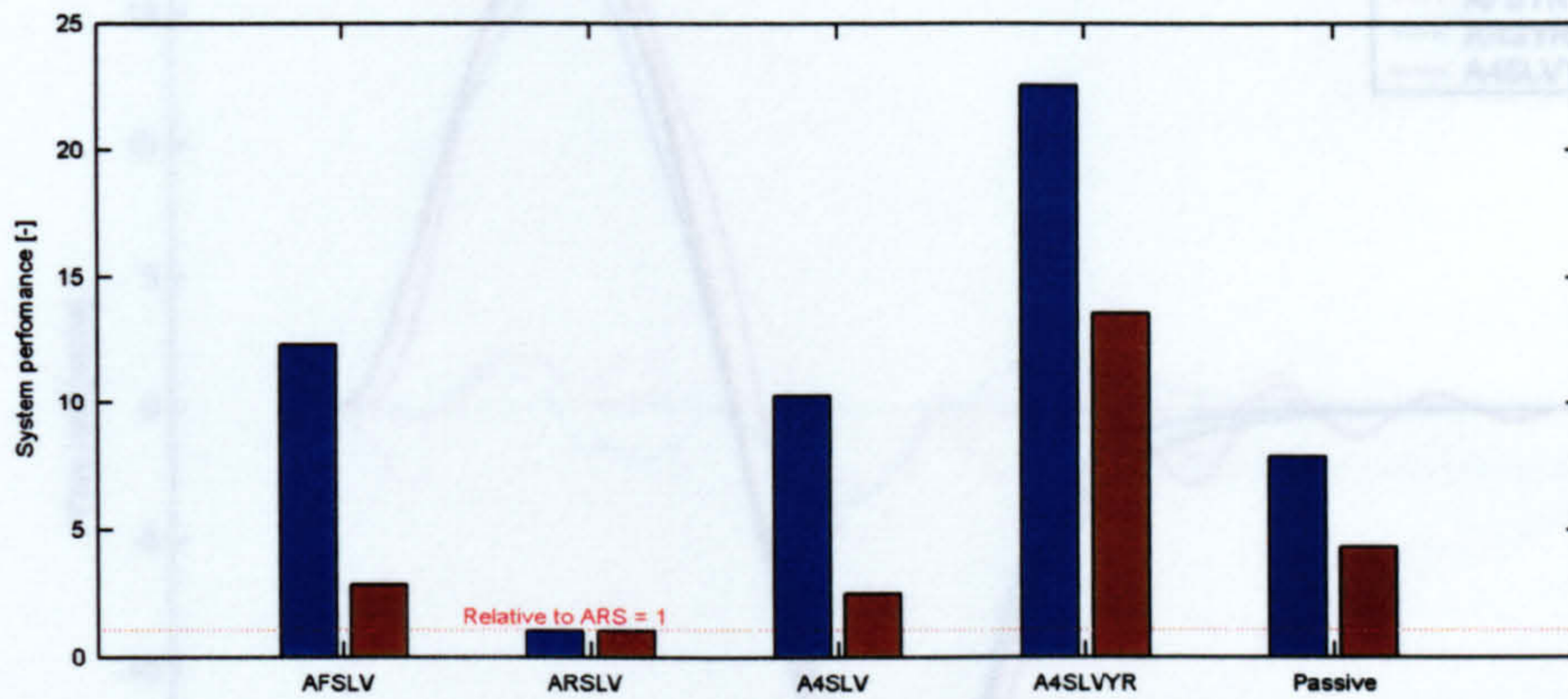

Figure 4-18 Tracking performance for lateral velocity shown as tracking error, smaller = better

Figure 4-19 shows the time history for the single sine steer input producing high lateral accelerations. This figure shows the state history for all yaw rate tracking controllers and the tracking error, shown dotted.

Figure 4-20 shows the control signal for system. This is steer angle at the wheel.

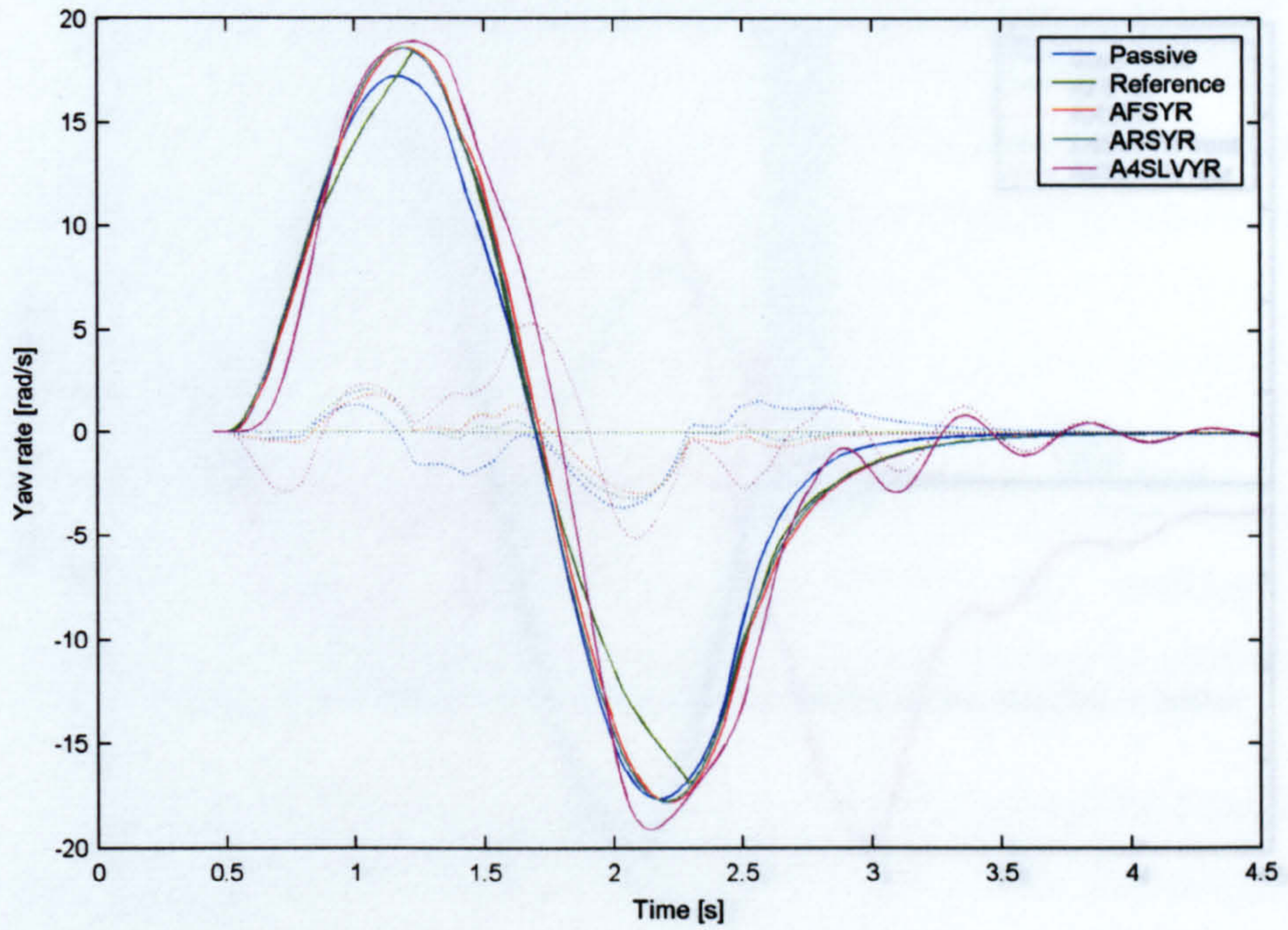

Figure 4-19 Yaw rate tracking performance, all controllers. Solid lines, state history, dotted lines, tracking error.

Figure 4-20 shows the control signal for system. This is steer angle at the wheel.

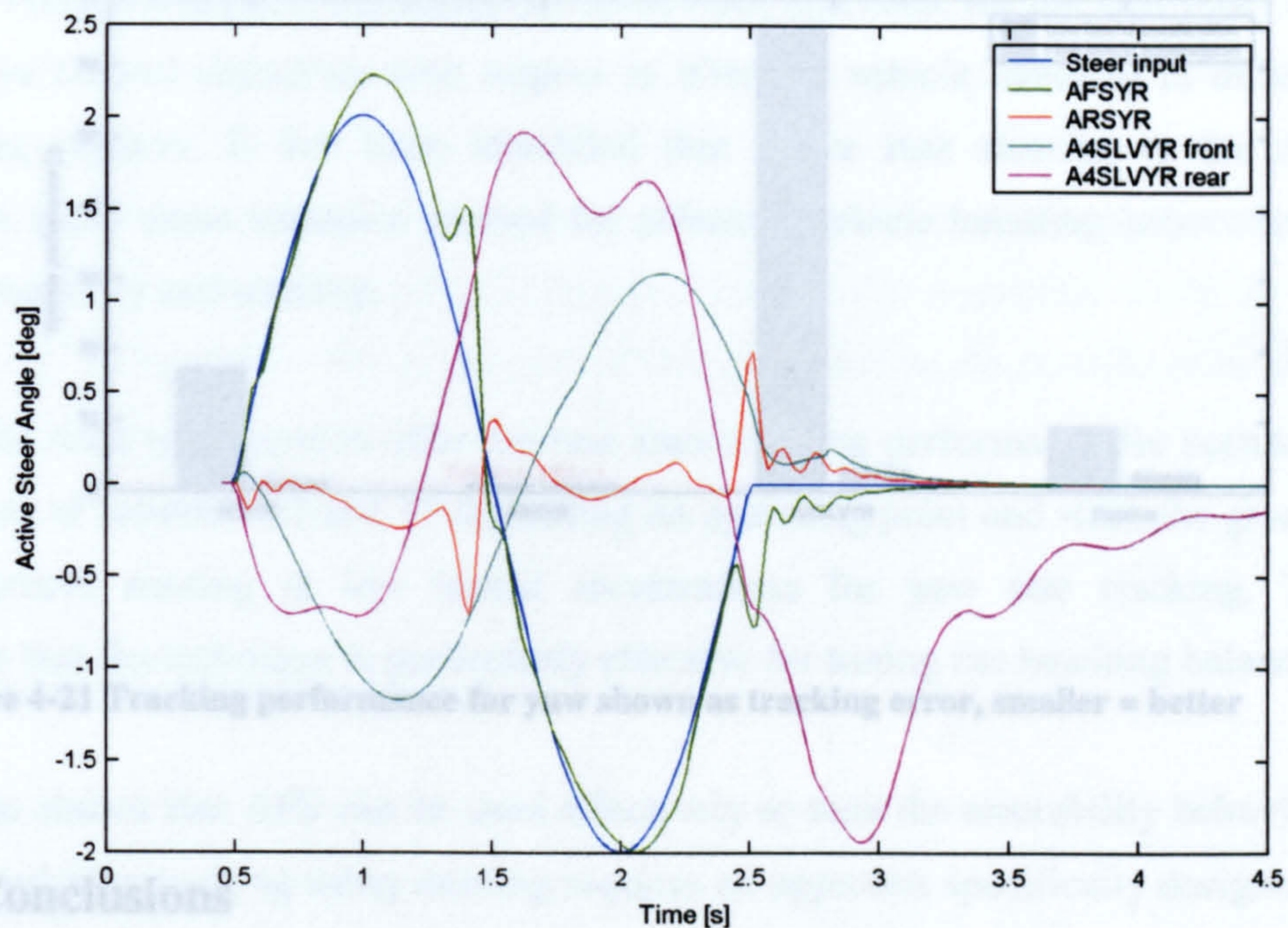

Figure 4-20 Steer input at wheels for yaw rate tracking, all controllers.

The performance of the yaw rate controllers is substantially better than corresponding lateral velocity controllers. Peak errors are a factor of three smaller for all controllers. The performance spread between controllers is also much smaller. Showing all three options have good potential to affect the handling behaviour with respect to steerability.

The controllers as presented here produce highly oscillatory control signals but, again, this does not significantly affect the state behaviour due to the relatively high frequency. This behaviour can be reduced at the expense of absolute tracking performance.

The A4S again failed to improve on the SISO systems. Tracking performance for yaw rate normalised to best controller, ARSYR and relative performance is shown in Figure 4-21.

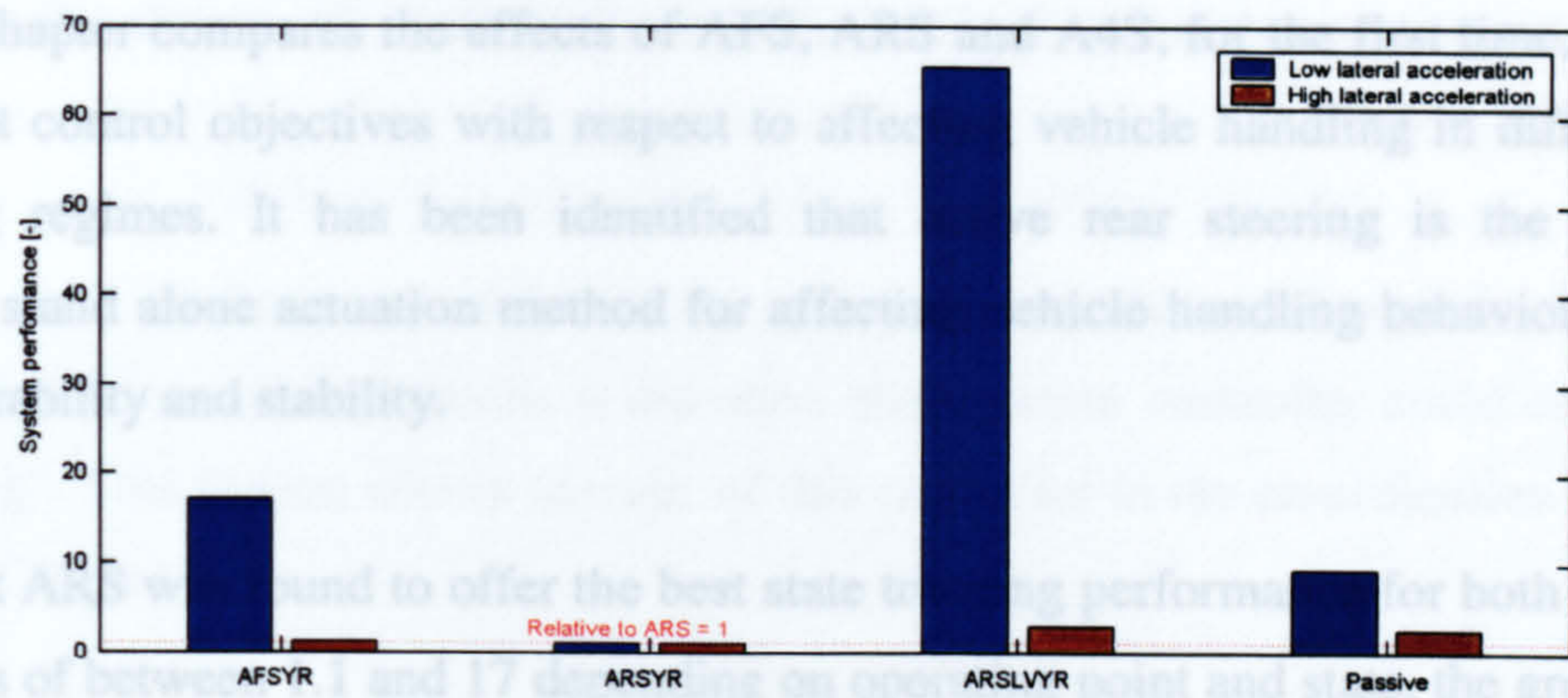

Figure 4-21 Tracking performance for yaw shown as tracking error, smaller = better

4.8 Conclusions

This chapter has presented a very simple classical design technique, IMC, and shown that it is applicable to the active steering vehicle handling problem. The IMC technique was applied to the state-tracking problem for lateral velocity and yaw rate behaviour of a non-linear vehicle. A novel technique of characterising the vehicle behaviour in terms of many linear plants describing the vehicle response to small perturbations was used to allow the linear control technique to be applied.

The plant dynamics were discussed with respect to the state-tracking problem for lateral velocity and yaw rate with respect to front, rear and four wheel steering. The discussion identified that state-tracking of lateral velocity was likely to be difficult due to the NMP nature of the state. Further, the problems of developing a multivariable linear controller for A4S were identified; particularly the high degree of cross coupling and the high condition number of the plant. A MISO technique was suggested and justified in the context of the co-ordination approach and the concept of task scheduling discussed in Chapter 6, but only for the stability task. The steerability task for A4S was addressed using a simplified linear SMC approach.

The complete control design procedure was demonstrated for the tracking of lateral velocity using active front steering. The performance of the developed linear controllers was then validated on the NLVM.

This chapter compares the effects of AFS, ARS and A4S, for the first time, with consistent control objectives with respect to affecting vehicle handling in different operating regimes. It has been identified that active rear steering is the most effective stand alone actuation method for affecting vehicle handling behaviour for both steerability and stability.

Whilst ARS was found to offer the best state tracking performance for both tasks by factors of between 1.1 and 17 depending on operating point and state, the greatest improvement coming at low lateral accelerations for yaw rate tracking. This suggests that the technique is particularly effective for tuning the handling balance.

It has shown that AFS can be used effectively to tune the steerability behaviour. Lateral velocity tracking using steering requires an approach specifically designed to deal with the NMP behaviour of the state. It has shown that A4S cannot effectively be achieved by combining two stand alone controllers and the discussion of the multivariable system identified that a non-linear model based approach was required to achieve an effective A4S system.

The poor performance of the linear multivariable controller is not thought to accurately reflect the potential of this approach and the controller designed here will not be used in the study of a co-ordination approach. The AFS and ARS controllers developed here will be used to investigate the interaction between a steering based handling system and a brake based limit stability system. The understanding gained here will allow the interactions to be studied effectively.

In particular this study has shown that linear SISO controllers for AFS and ARS can be used to good effect when combined with a realistic vehicle model to improve the yaw rate behaviour of passenger cars. The use of a realistic vehicle model and high lateral acceleration manoeuvres when assessing the performance of linear controllers addresses a number of the shortcomings referred to in Chapter 2 in the open literature. Further, the attempt here to apply a linear multivariable controller to the nonlinear vehicle was found to be unsuccessful at any operating point. This was related to the highly singular (high condition number) nature of the passenger vehicle which precludes the application of a technique which does not explicitly

deal with the degree of nonlinearity and the cross-coupling between inputs and outputs.

While poor tracking was observed for a linear controller to change the lateral velocity behaviour of the vehicle, it did show that a linear controller could do “the right thing”. This feature allows the use of this controller in the co-ordination study found in Chapter 6.

5 Brake-based sub-system controller design

This chapter will discuss the use of a brake based control systems to affect vehicle handling. The concept of exploiting the longitudinal force generating properties of the tyres to affect the lateral handling behaviour is a well documented technique. The following section will describe, both qualitatively and quantitatively, the effect of individual wheel braking to affect the vehicle handling behaviour throughout the vehicle handling regime. A simple system that reflects the current commercial state-of-the-art system will be described and results presented.

In the previous chapters it has been shown how that steering is unable to influence the vehicle at the limit due to tyre force saturation. Direct Yaw Moment Control, **DYC**, is found to be highly effective at controlling the vehicle at this operating point but the control action is often reported to be very aggressive. The following chapter will describe a technique that allows this brake based stability system to be supported by the steering controllers developed in the previous one.

5.1 Using longitudinal tyre force to affect vehicle handling.

Vehicle tyres behave in a highly non-linear way. The ability to generate a force in one direction is limited by the force being generated in another; i.e. the total available force is limited. Techniques have been developed which allow a designer to exploit this interaction between forces generated due to applied torque, wheel slip ratio, and forces generated due to wheel steer angle, wheel slip angle. This section will discuss the effect of this interaction with respect to vehicle handling behaviour. Specifically, a brake based system will be considered, though the analysis is equally valid for a drive train based system.

This is achieved by varying torque applied at individual wheels. The effect of this torque modulation is to affect the longitudinal slip of a wheel and hence the size and direction of the force vector produced at the tyre contact patch. This in turn affects the total yaw moment acting on the vehicle.

The following qualitative analysis is applied to an oversteering vehicle though the approach holds for an understeering vehicle. All results presented are from the NLVM.

Consider the typically oversteering vehicle in Figure 5-1. At the limit of vehicle cornering, the ability of the rear tyres to generate a lateral force is saturated before the front wheels and this leads to the vehicle spinning, ie a loss of directional stability.

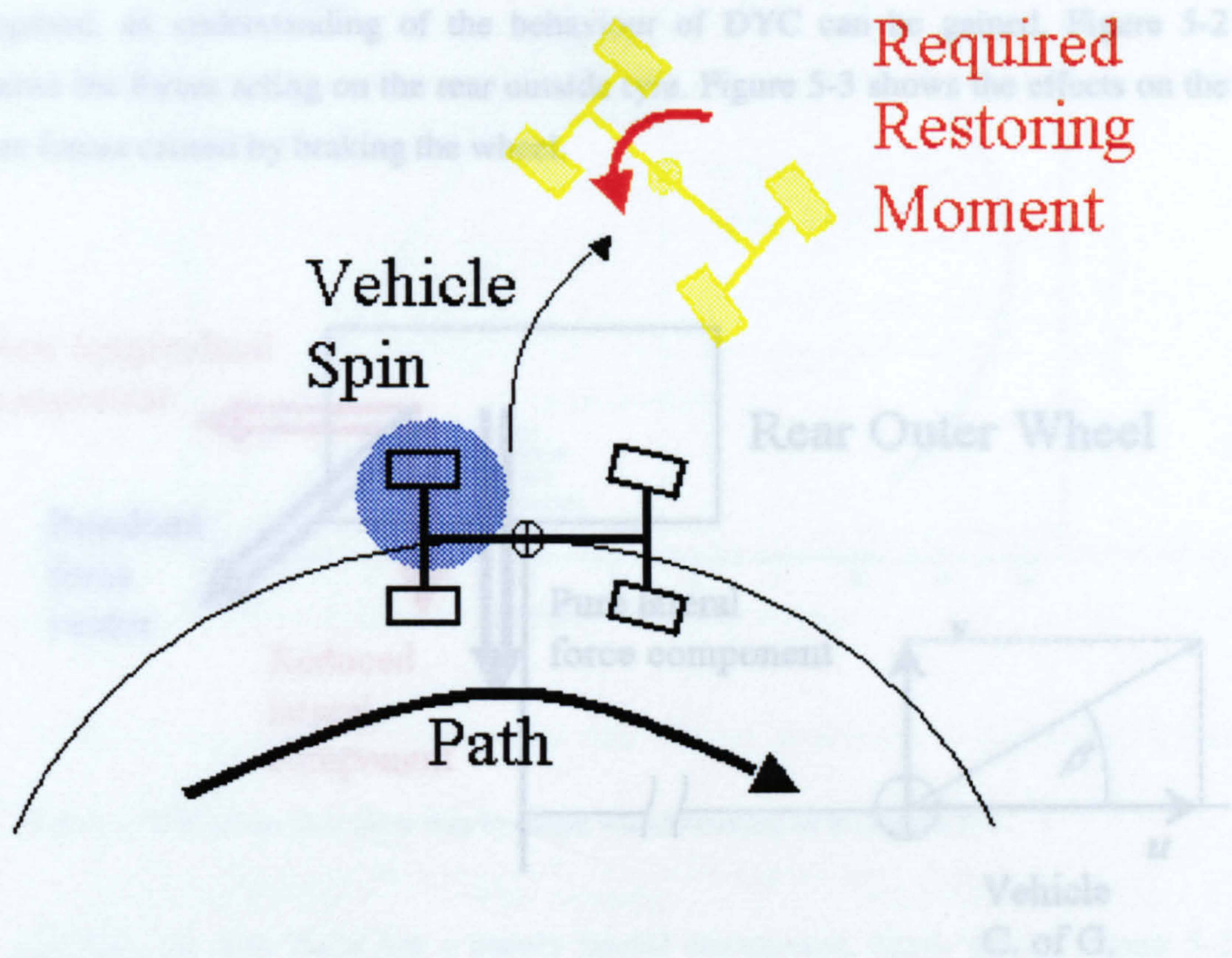

Figure 5-1 Depiction of an oversteering car, cornering at the limit

In order to control this situation, a yaw moment must be generated to counter the impending spin, or the balance of lateral force must be restored. Although a yaw moment can be generated by either braking or accelerating a given wheel, the term **DYC** is generally reserved for brake based systems and that convention is adopted here.

The DYC control system can be understood by considering the tyre operating point in this situation. It can be seen that lateral force of the rear tyres has been saturated, however no longitudinal force is being used. This unused longitudinal tyre force can be exploited, to generate the required restoring moment through braking at an individual wheel. Considering, Figure 5-1, it can be seen that braking either or both of the wheels on the outside of the turn will generate the appropriate restoring yaw moment, shown red; this is a contra-cornering moment.

The effect of braking the rear outer wheel will be considered, shaded blue. By looking at the forces acting on the tyre at a the instant when control action is required, an understanding of the behaviour of DYC can be gained. Figure 5-2 shows the forces acting on the rear outside tyre. Figure 5-3 shows the effects on the tyre forces caused by braking the wheel.

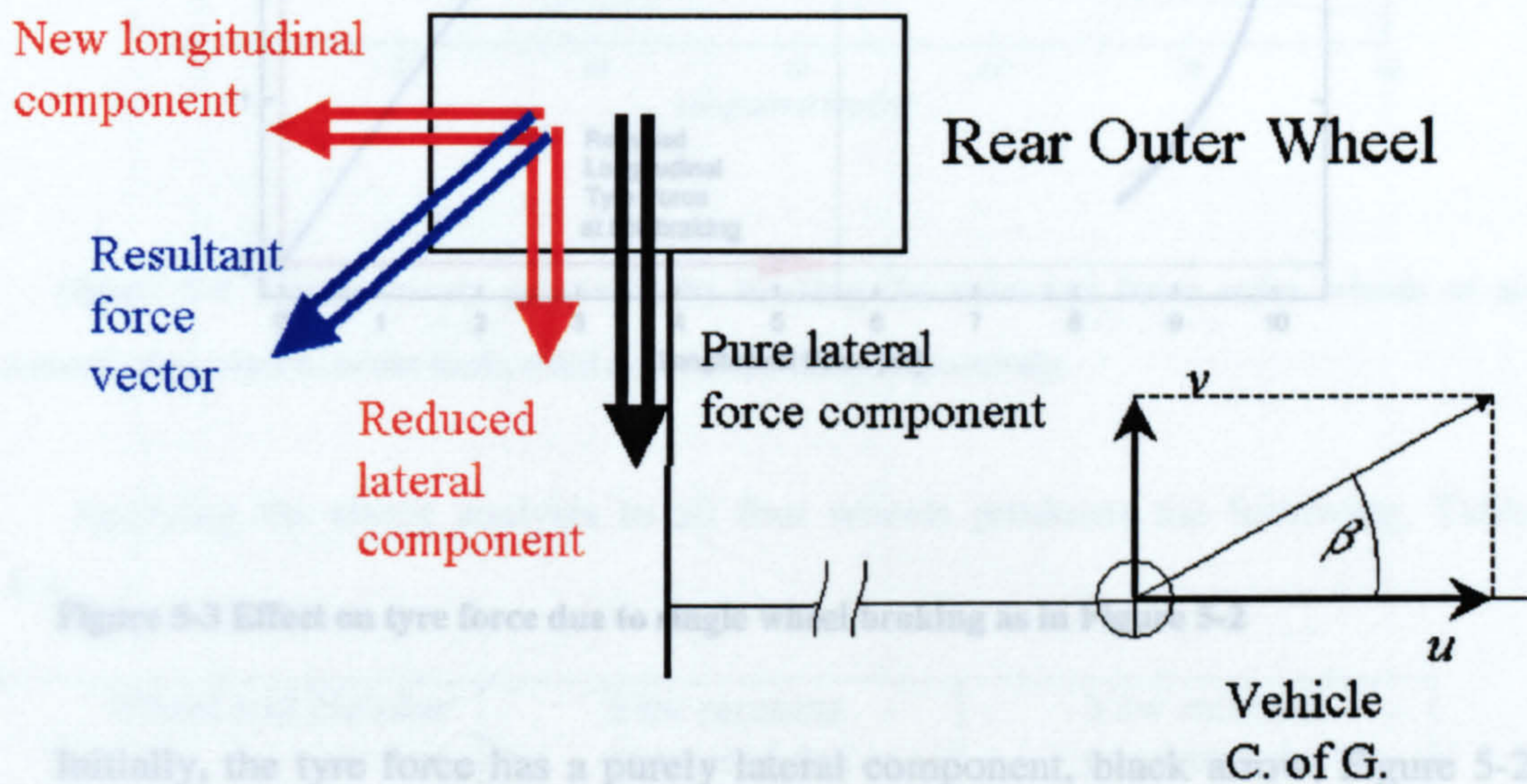

Figure 5-2 Expansion of the wheel shaded blue in Figure 5-1 showing vehicle longitudinal and lateral velocities, u and v and side slip angle, β .

magnitude of the yaw moments is due to the differing vertical forces at the two wheels. The rear outer wheel, as discussed above, is capable of producing a restoring effect however the front outer wheel is clearly more effective.

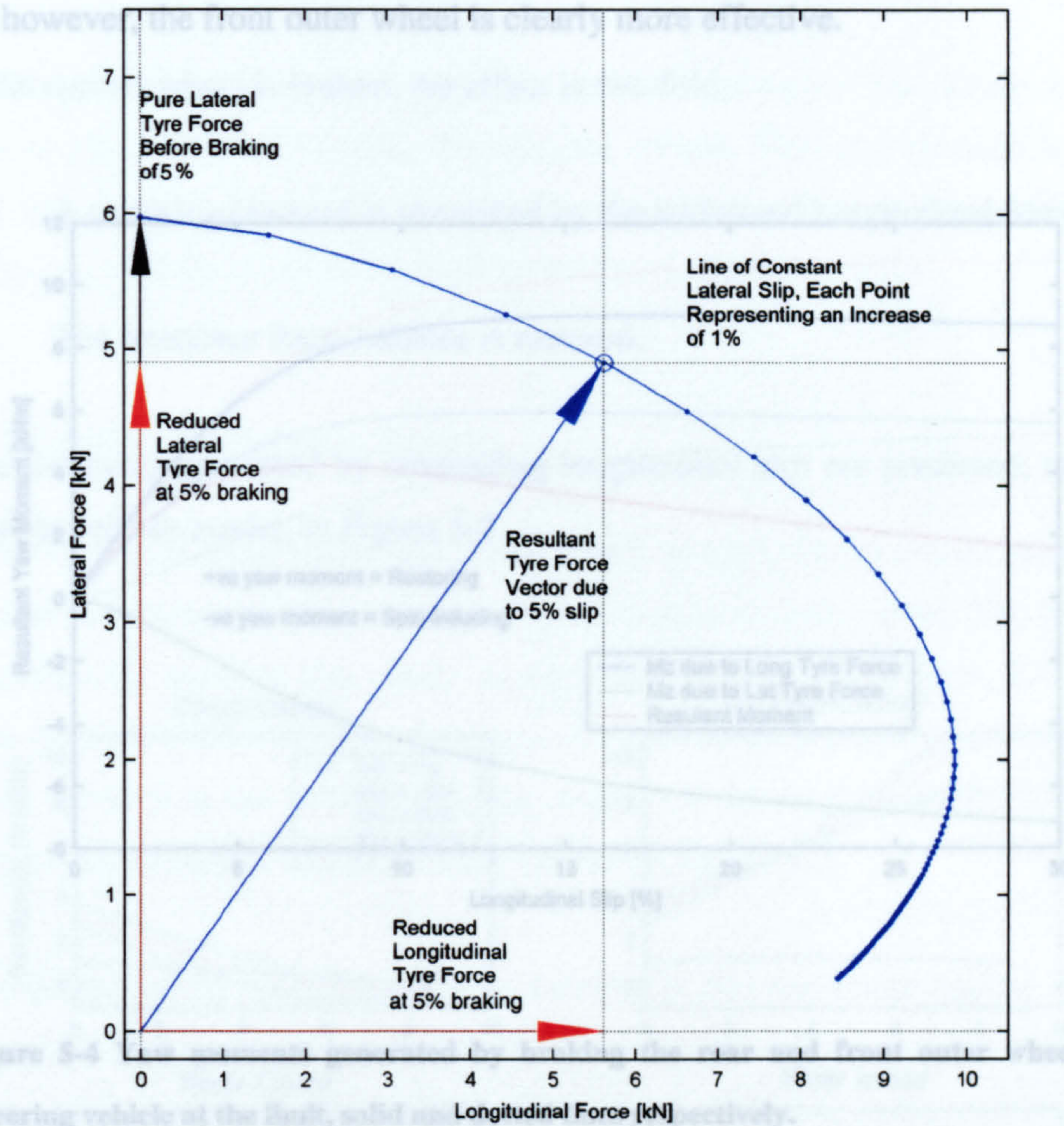

Figure 5-4 shows the relative magnitude of these two effects; a comparison is made of the effects of braking either the front outer wheel and rear outer wheel. The difference in absolute

Applying the above analysis to all four wheels produces the following. Table

5-1
Figure 5-3 Effect on tyre force due to single wheel braking as in Figure 5-2

| Wheel and Number | Yaw moment | Yaw moment |
|---|------------|------------|
| Initially, the tyre force has a purely lateral component, black arrow, Figure 5-2 and Figure 5-3. Braking this wheel generates a longitudinal force component and a reduction in lateral force, red arrows, Figure 5-2 and Figure 5-3. The effect of braking the wheel can be seen to rotate the resulting force vector, blue arrow, Figure 5-2 and Figure 5-3. With respect to the vehicle dynamics, the increase in longitudinal force at the rear outer wheel provides a restoring moment, however the reduction in lateral force aggravates the original problem of rear lateral tyre force saturation and produces a moment to further worsen the spin. Figure 5-4 shows the relative magnitude of these two effects; a comparison is made of the effects of braking either the front outer wheel and rear outer wheel. The difference in absolute | | |

magnitude of the yaw moments is due to the differing vertical forces at the two wheels. The rear outer wheel, as discussed above, is capable of producing a restoring effect however, the front outer wheel is clearly more effective.

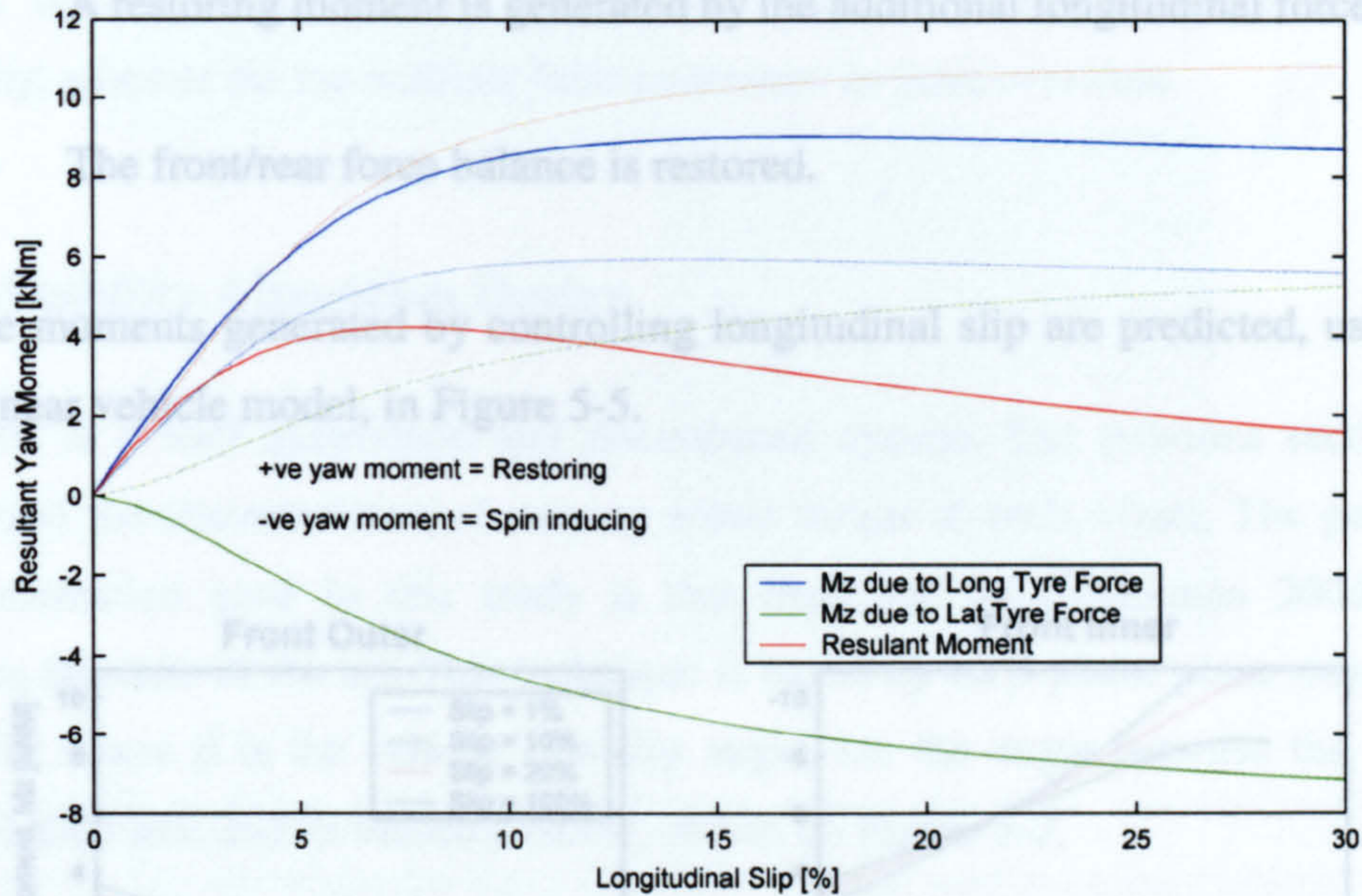

Figure 5-4 Yaw moments generated by braking the rear and front outer wheels of an oversteering vehicle at the limit, solid and dotted lines respectively.

Applying the above analysis to all four wheels produces the following, Table 5-1.

| Wheel and Number | Yaw moment generated due to change in longitudinal tyre force. | Yaw moment generated due to change in lateral tyre force. |
|------------------|--|---|
| FRONT INNER | Pro-cornering | Contra-cornering |
| FRONT OUTER | Contra-cornering | Contra-cornering |
| REAR INNER | Pro-cornering | Pro-cornering |
| REAR OUTER | Contra-cornering | Pro-cornering |

Table 5-1 Effects of single wheel braking

Hence the most logical wheel to brake to control an oversteering unstable vehicle is the front outer, and the for an understeering vehicle is the rear inner.

If the correct wheel is braked, the effect is two fold,

- 1.) A restoring moment is generated by the additional longitudinal force
- 2.) The front/rear force balance is restored.

The moments generated by controlling longitudinal slip are predicted, using the non-linear vehicle model, in Figure 5-5.

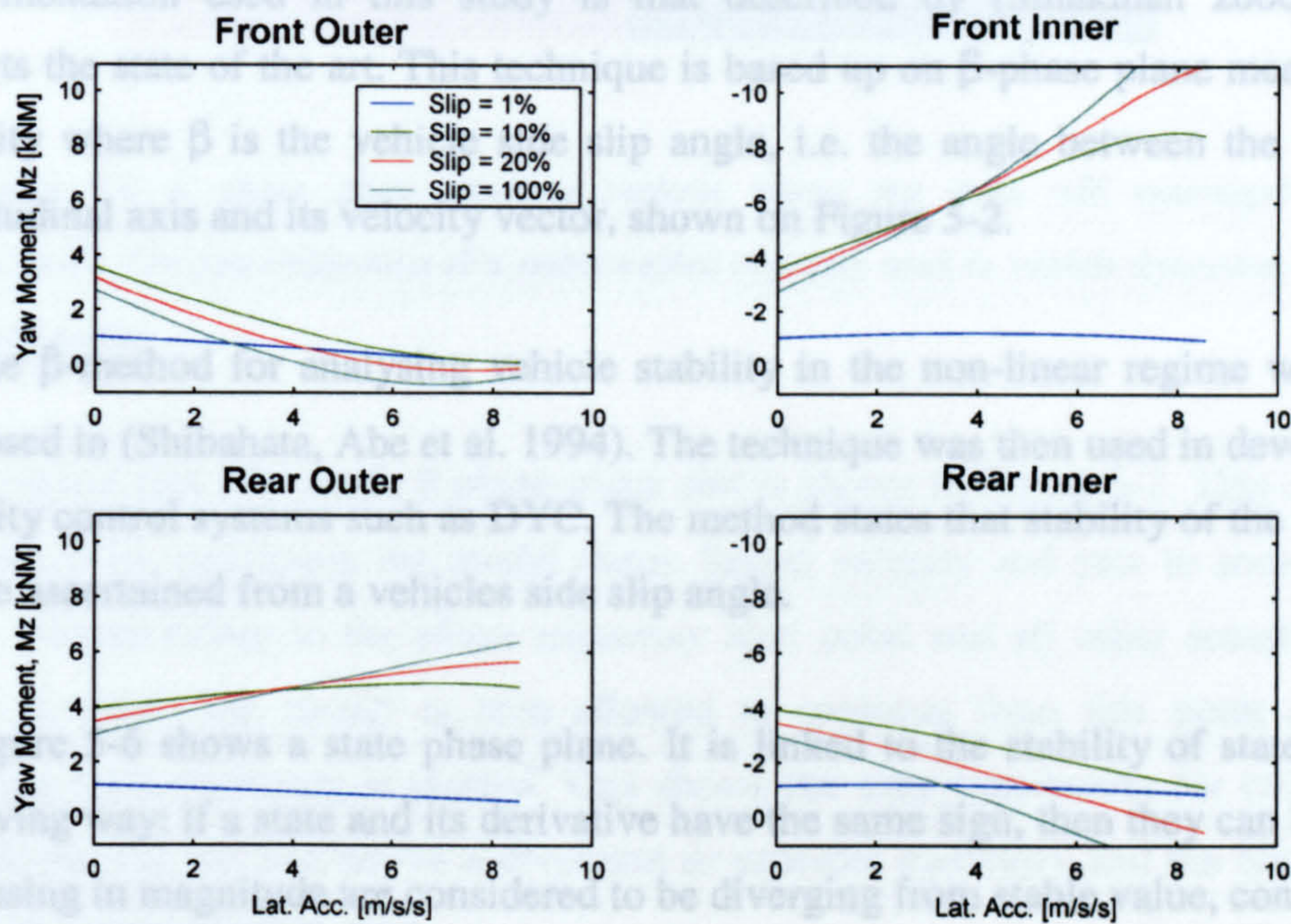

Figure 5-5 Generated yaw moments as a function of lateral acceleration for four different values of wheel slip at each wheel.

It can be seen that as predicted, the moments generated by the rear inner wheel to generate a pro-cornering moment are much larger than the front inner wheel. It is clear, however, that DYC strategies can make use of braking of the front inner wheel as well, though care must be taken at high lateral accelerations to ensure that commanded slips remain low, otherwise the stability problem is aggravated.

Commercial systems often implement strategies that brake multiple wheels in order to enlarge the available moments.

In the previous discussion, a technique has been presented that allows a control system to affect the yaw moment affecting the vehicle. That yaw moment is used to bound vehicle lateral velocity or side slip angle and hence maintain directional stability, whether the car exhibits limit understeer or limit oversteer.

5.2 Stability Algorithm Design

DYC is a well understood and documented system. The previous section has discussed the characteristics of varying wheel torque at each wheel. The particular implementation used in this study is that described by (Smakman 2000b) and reflects the state of the art. This technique is based up on β -phase plane measure of stability where β is the vehicle side slip angle, i.e. the angle between the vehicle longitudinal axis and its velocity vector, shown on Figure 5-2.

The β -method for analysing vehicle stability in the non-linear regime was first proposed in (Shibahata, Abe et al. 1994). The technique was then used in developing stability control systems such as DYC. The method states that stability of the vehicle can be ascertained from a vehicles side slip angle.

Figure 5-6 shows a state phase plane. It is linked to the stability of state in the following way: if a state and its derivative have the same sign, then they can be seen increasing in magnitude are considered to be diverging from stable value, conversely if there signs differ then they are converging. In vehicle dynamics, this region is commonly approximated with the two green lines shown. A state with in these bounds is considered stable.

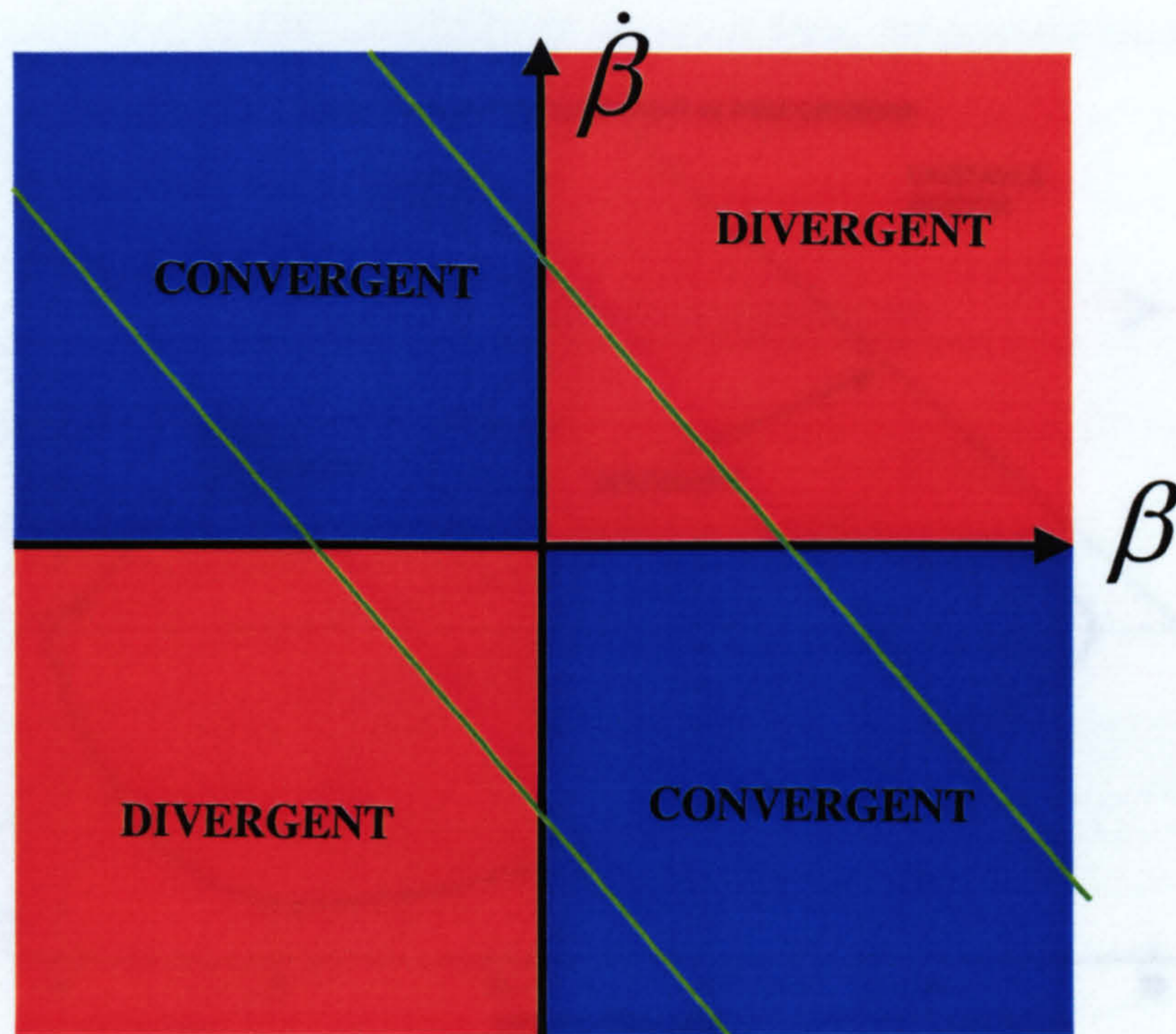

Figure 5-6 A phase plane showing regions where the state will converge(blue) or diverge(red). The approximation of a stable region typically used in vehicle dynamics is shown bounded green.

A typical side slip angle, β phase plane plot is shown in Figure 5-7. This diagram is produced by initialising the model states, lateral velocity and yaw to some initial value corresponding to the phase trajectory start point and all other actuators and states to zero. The model is then allowed to continue from this point and the resulting state trajectory is plotted. This shows the state trajectories for two initial conditions, the red line shows a divergent or unstable trajectory and the blue line a trajectory converging to zero.

Figure 5-7 illustrates the phase plane plot for the model used within this study. The plot is generated by initialising the model conditions of the yaw and lateral velocity states to some initial value and allowing the model to return to its equilibrium state (Koenig 2002). However in this study the phase plane plot is plotted to provide information about the system's stability against yaw rate is not a phase plane plot and

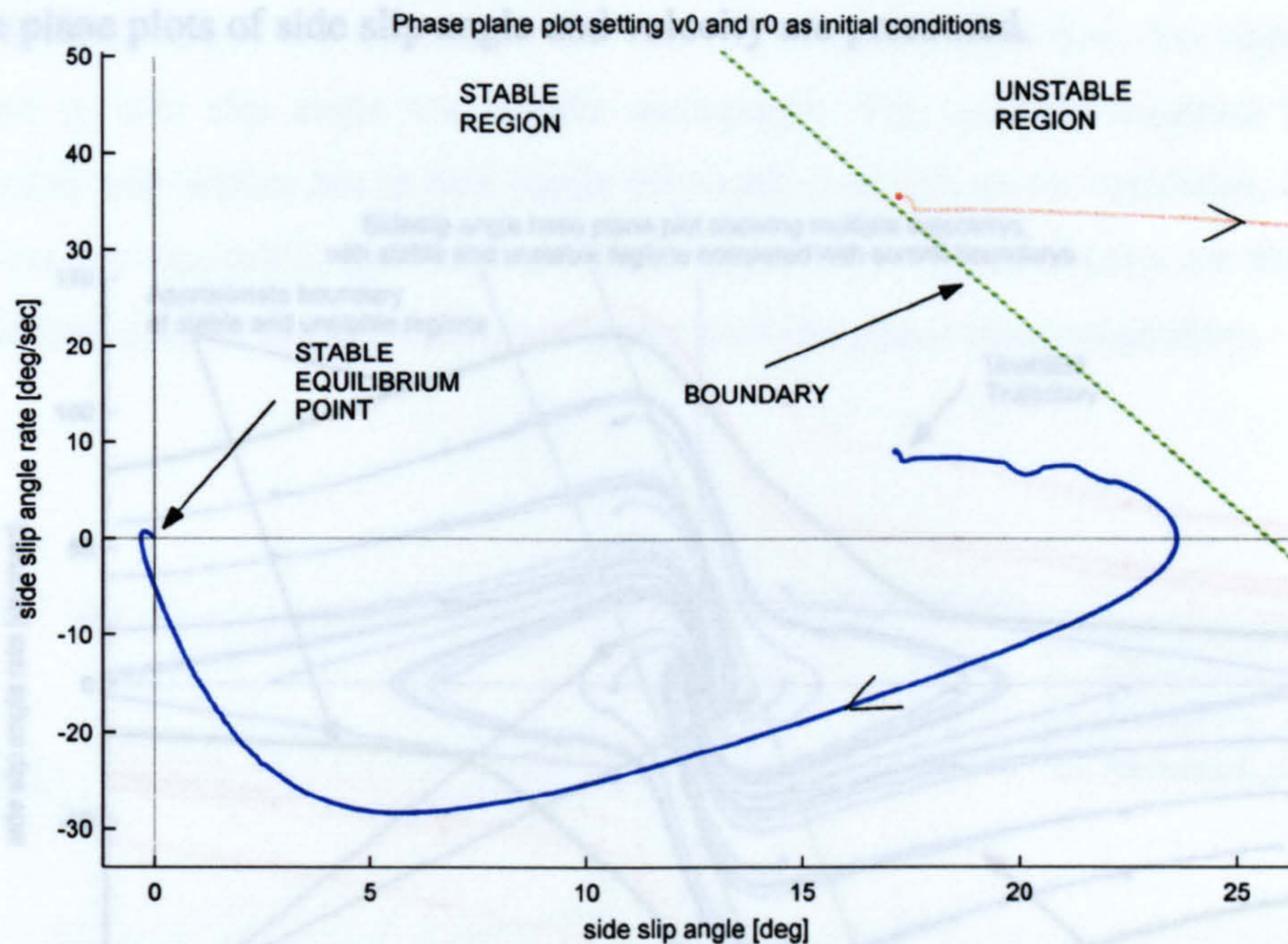

Figure 5-7 Phase plane plot of vehicle side slip angle and rate, showing a stable trajectory(blue), an unstable trajectory(red) and a boundary distinguishing stable and unstable regions(green).

Figure 5-8 Phase plane plot of vehicle side slip angle showing multiple trajectories.

Many publications, (Smakman 2000b), (van Zanten, Erhardt et al. 1997), have used Shibahatas work to propose vehicle stability systems.

The approach followed here includes the effect of side slip velocity in order to improve the characteristics of the control action. This DYC system is used purely to ensure vehicle stability by bounding the vehicle side slip state to be within arbitrarily selected boundaries.

Figure 5-8 shows the phase plane plot for the model used with in this study. The plot is constructed by setting the initial conditions of the yaw and lateral velocity states and then plotting the calculated states as the model returns to its equilibrium for a given input, in this case zero, as in (Mammar and Koenig 2002). However in their work, it is side slip and yaw rate that is plotted to provide information about stability. In the strictest sense side slip against yaw rate is not a phase plane plot and

as such physical interpretation is difficult. However from these initial conditions the phase plane plots of side slip angle and velocity are presented.

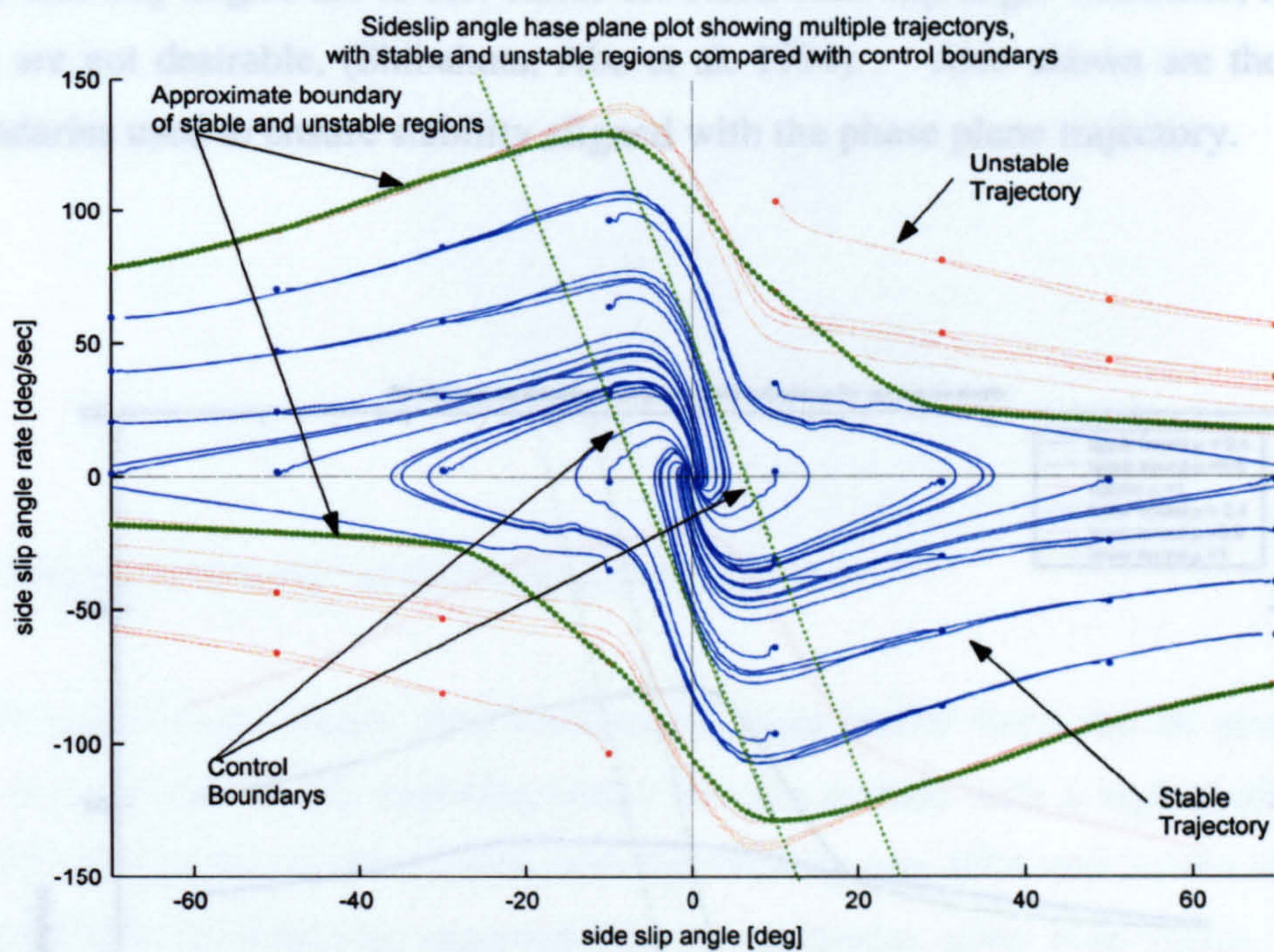

Figure 5-8 Phase plane plot of vehicle side slip angle showing multiple trajectories.

It can be seen in Figure 5-8 that a distinct boundary can be approximately inferred with respect to the stability of the vehicle. In Shibahatas quasi-static analysis, it is only the side slip angle that is considered. It is shown that the side slip angle at which instability occurs is largely invariant to road surface. Smakman introduced the idea of aligning the boundaries on which the control action is based with the phase plane trajectories in order to limit the rates of change of the control signals and hence perceived harshness by the vehicle occupants.

One of the significant benefits of this approach is that it is largely invariant to road surface and hence μ estimation is not required and only one state and its derivative need be estimated. Sides slip angle is assumed to be measurable in this study, though in reality much work has been done on reliable estimations of this vehicle state and is now available commercially, μ -estimation is not yet commercially viable though much work is ongoing.

Figure 5-9 shows the predicted stable regions using phase plane analysis. Though substantial changes are evident in the side slip velocity direction, the regions with respect to side slip angle are largely unchanged. The analysis suggests that very large side slip angles are in fact stable for small side slip angle velocities, however, they are not desirable, (Shibahata, Abe et al. 1994). Also shown are the control boundaries used to ensure stability aligned with the phase plane trajectory.

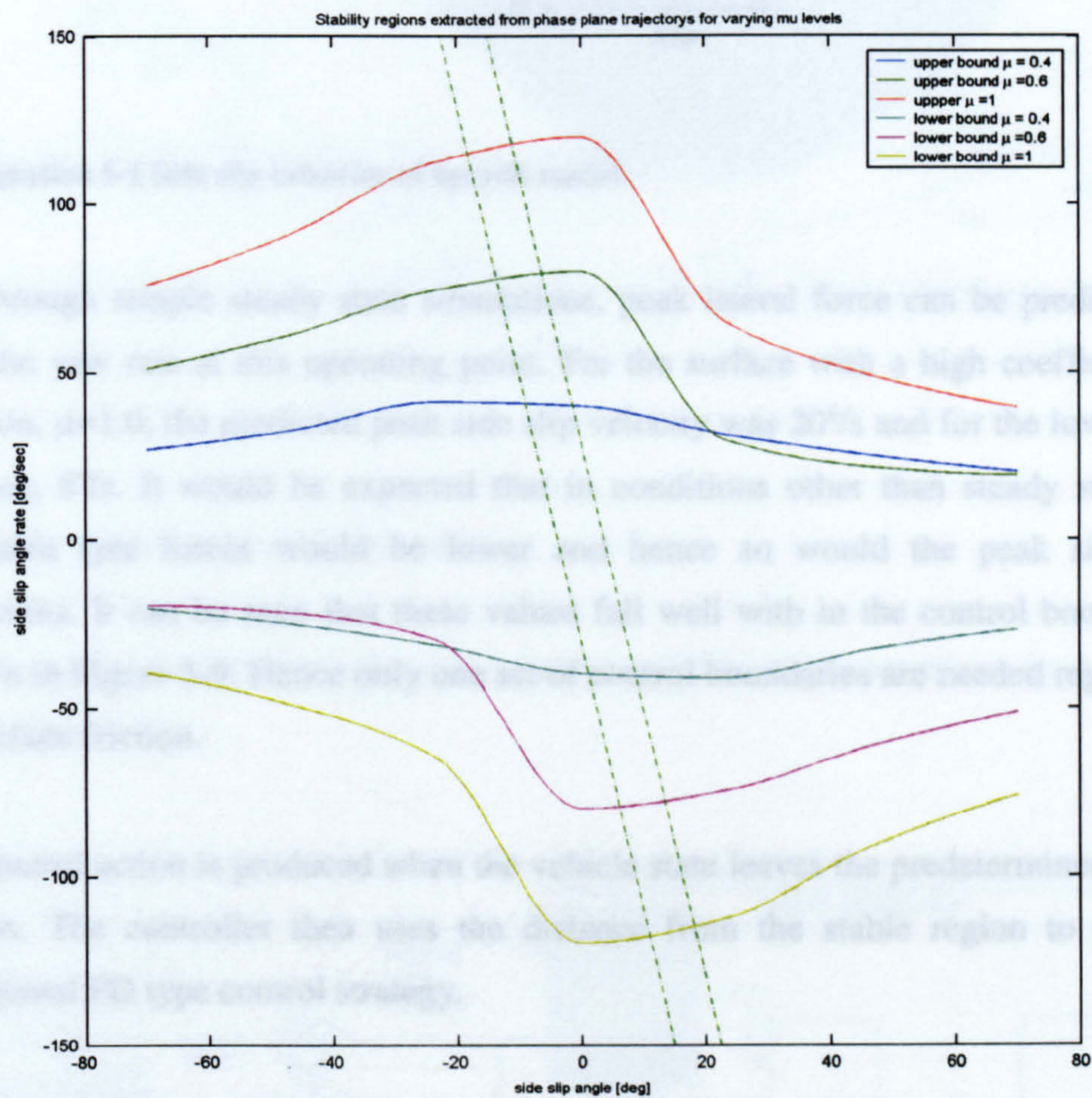

Figure 5-9 Stable regions using phase plane analysis for varying μ .

Through simple analysis of the phase plane it can be seen that if a states rate of change is zero it is, by definition stable. Further to this bounds of expected maximum side slip velocities can be predicted using a two degree of freedom

description of the vehicle behaviour using side slip and yaw as the vehicle states, Equation 5-1.

$$\begin{aligned}
 m(\dot{v} + ur) &= F_f + F_r \\
 \dot{v} &= \frac{F_f + F_r}{m} - ur \\
 \beta &= \tan^{-1}\left(\frac{v}{u}\right) \\
 \dot{\beta} &\approx \dot{v}/u \\
 \dot{\beta} &\approx \frac{F_f + F_r - mur}{mu}
 \end{aligned}$$

Equation 5-1 Side slip behavior of bicycle model.

Through simple steady state simulations, peak lateral force can be predicted as can the yaw rate at this operating point. For the surface with a high coefficient of friction, $\mu=1.0$, the predicted peak side slip velocity was $20^\circ/s$ and for the low $\mu=0.2$ surface, $6^\circ/s$. It would be expected that in conditions other than steady state the available tyre forces would be lower and hence so would the peak side slip velocities. It can be seen that these values fall well within the control boundaries shown in Figure 5-9. Hence only one set of control boundaries are needed regardless of surface friction.

Control action is produced when the vehicle state leaves the predetermined stable region. The controller then uses the distance from the stable region to drive a traditional PD type control strategy.

The nature of the control problem is highly non-linear due to the tyre characteristic. This characteristic is static with respect to the tyre operating point and the size of the required restoring moment. This non-linearity can be captured in what Smakman calls a Brake Intervention Map; shown in Figure 5-10. The use of this technique leads to a gain scheduled controller using the phase plane to calculate the error signal.

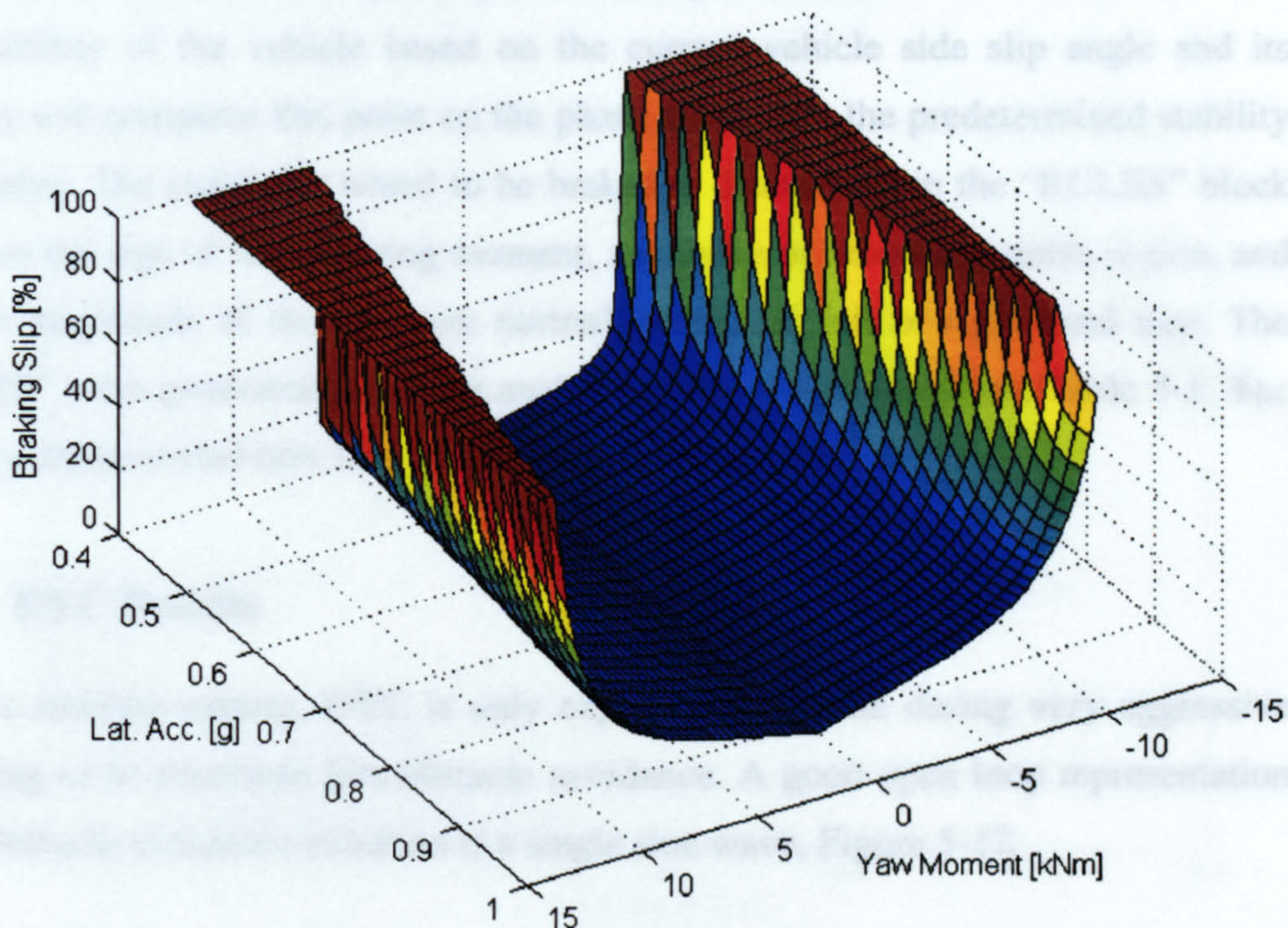

Figure 5-10 Brake intervention map

The controller structure for this particular DYC implementation is shown in Figure 5-11.

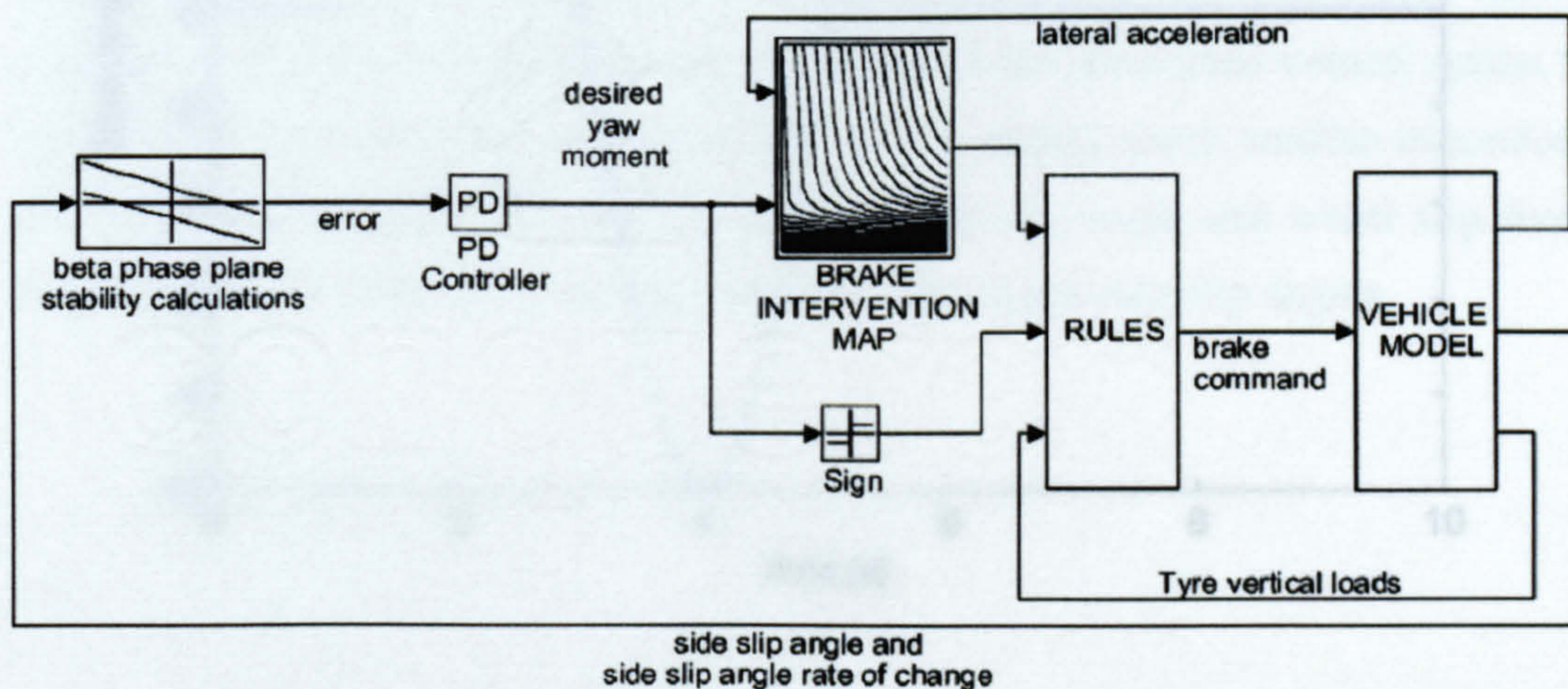

Figure 5-11 Block diagram of DYC implementation

The Block labelled “beta phase plane stability calculations” determines the level of instability of the vehicle based on the current vehicle side slip angle and its velocity and compares this point on the phase plane with the predetermined stability boundaries. The particular wheel to be braked is determined in the “RULES” block based on the sign of the restoring moment, i.e. above or below the stable region, and relative magnitude of the rear tyre normal forces, i.e. left or right hand turn. The “RULES” were generated using the analysis in the previous section, Table 5-1. The strategy implemented here brakes only one wheel at once.

5.2.1 DYC Results

As a stability system, DYC is only expected to operate during very aggressive cornering or in situations like obstacle avoidance. A good open loop representation of an obstacle avoidance situation is a single sine wave, Figure 5-12.

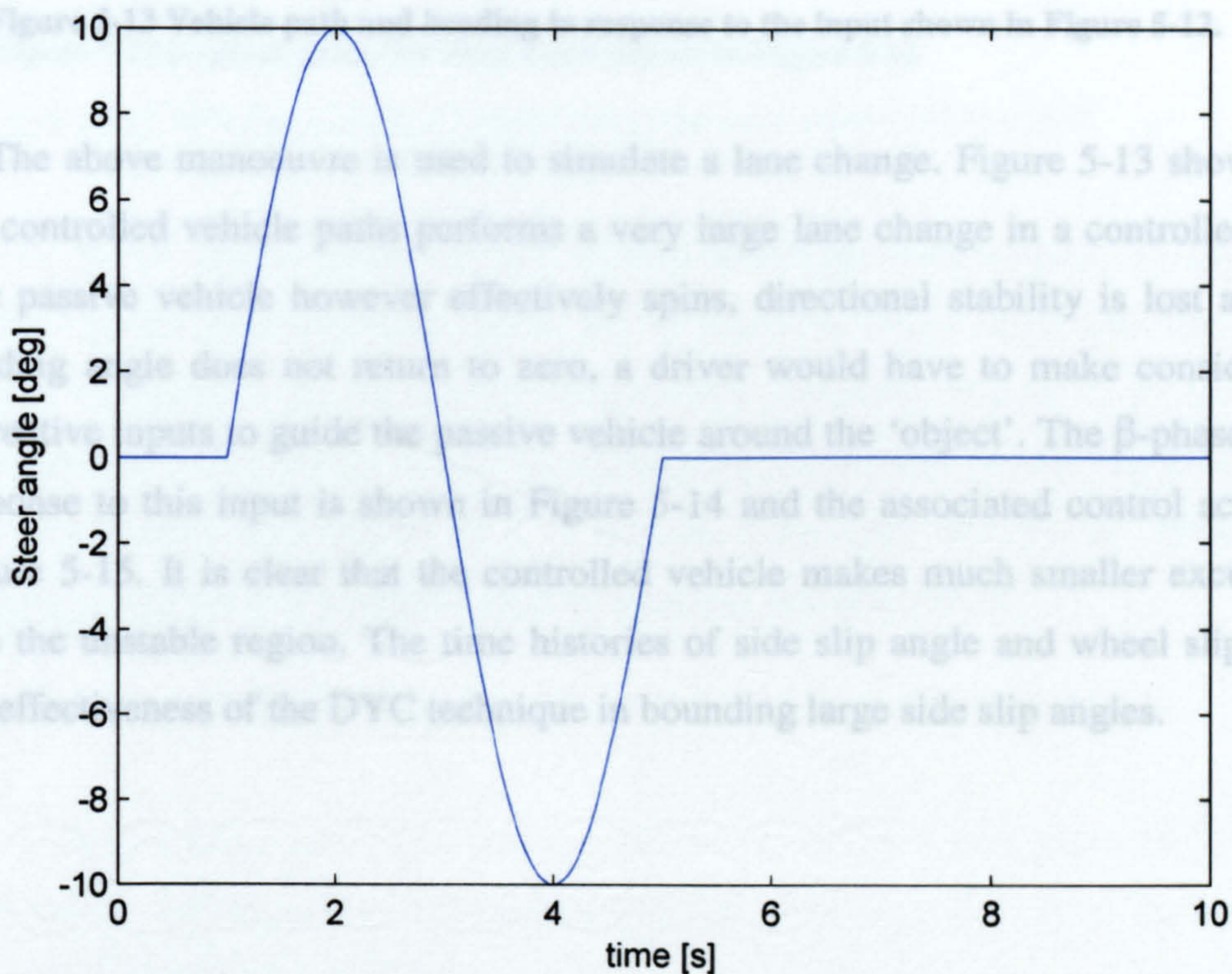

Figure 5-12 Steering input at the wheels for an aggressive open loop maneuver at 30m/s or 70mph

Figure 5-13 shows the vehicle path and heading in response to this input.

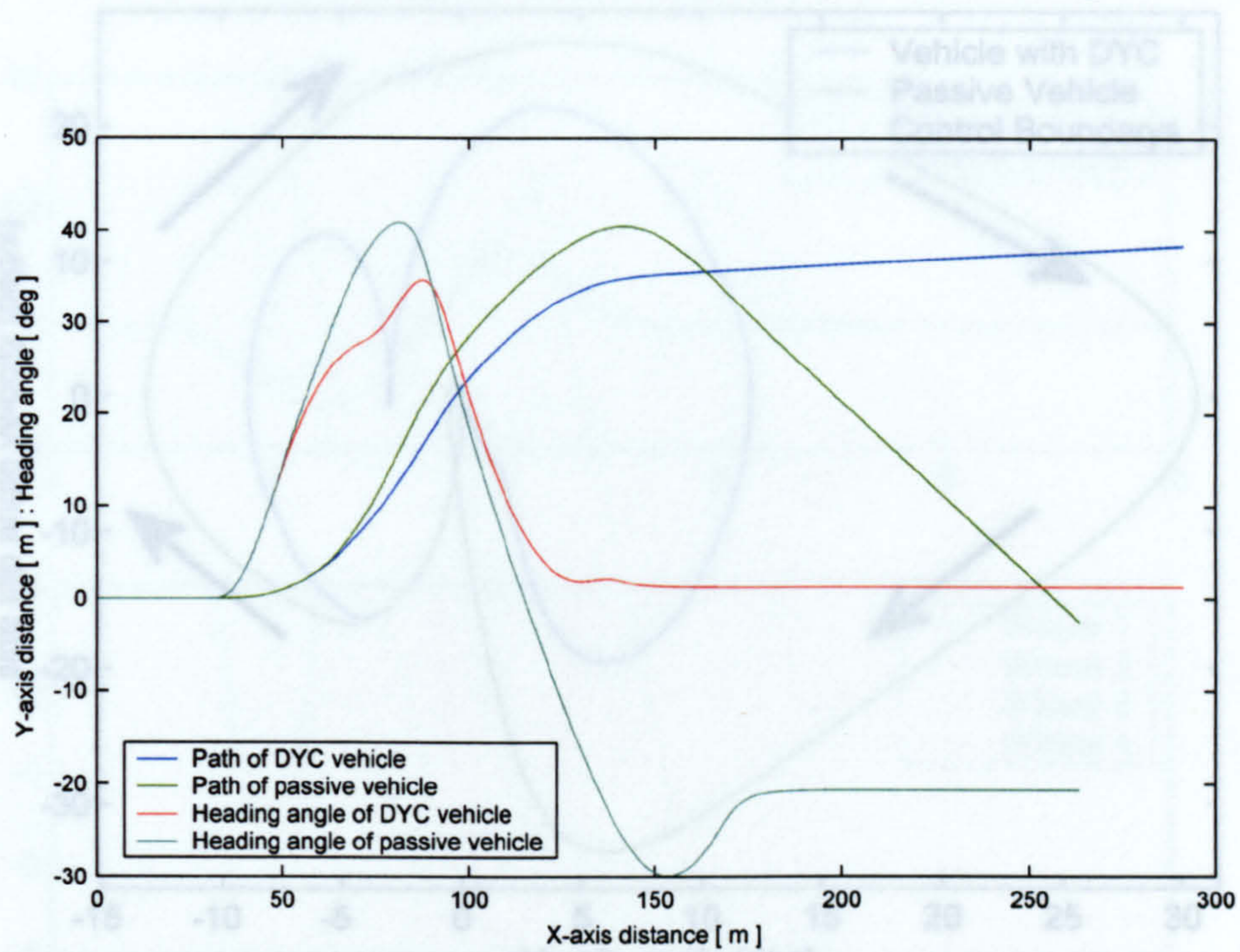

Figure 5-13 Vehicle path and heading in response to the input shown in Figure 5-12.

The above manoeuvre is used to simulate a lane change. Figure 5-13 shows that the controlled vehicle paths performs a very large lane change in a controlled way. The passive vehicle however effectively spins, directional stability is lost and the heading angle does not return to zero, a driver would have to make considerable corrective inputs to guide the passive vehicle around the 'object'. The β -phase plane response to this input is shown in Figure 5-14 and the associated control action in Figure 5-15. It is clear that the controlled vehicle makes much smaller excursions into the unstable region. The time histories of side slip angle and wheel slip show the effectiveness of the DYC technique in bounding large side slip angles.

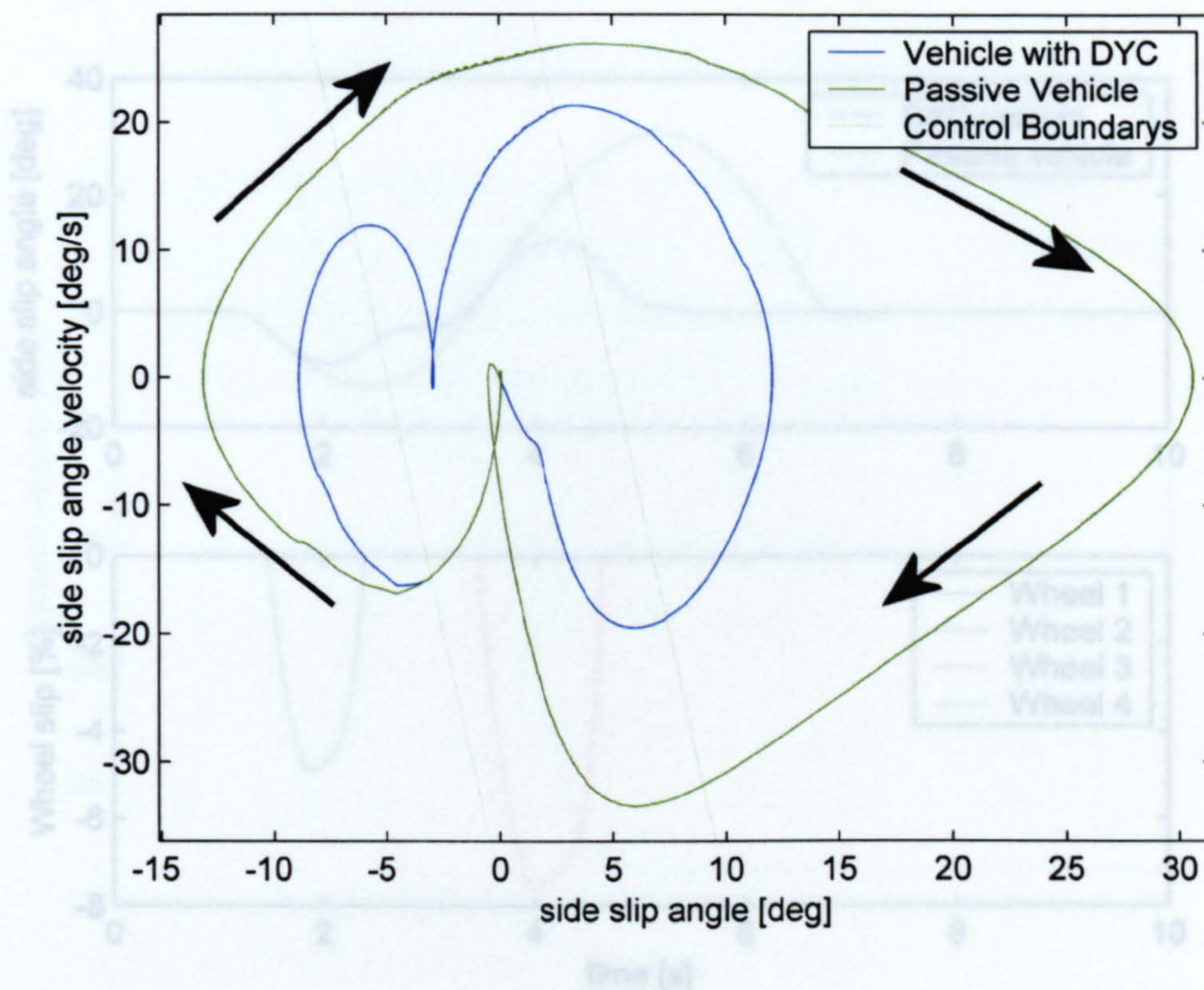

Figure 5-14 β -phase plane for steer input shown in Figure 5-12

Figure 5-15 Side slip angle and control action for steer input in Figure 5-12

The DYC's improvement of the vehicle behaviour with respect to aggressive inputs and side slip behaviour makes use of available longitudinal tyre forces. This in turn interferes with the vehicle longitudinal dynamics. Figure 5-16 shows the deceleration of the vehicle during the manoeuvre. It has been shown that drivers find this interference undesirable as it is unusual behaviour, (Smakman 2000b). The following chapter will consider ways of reducing this interaction.

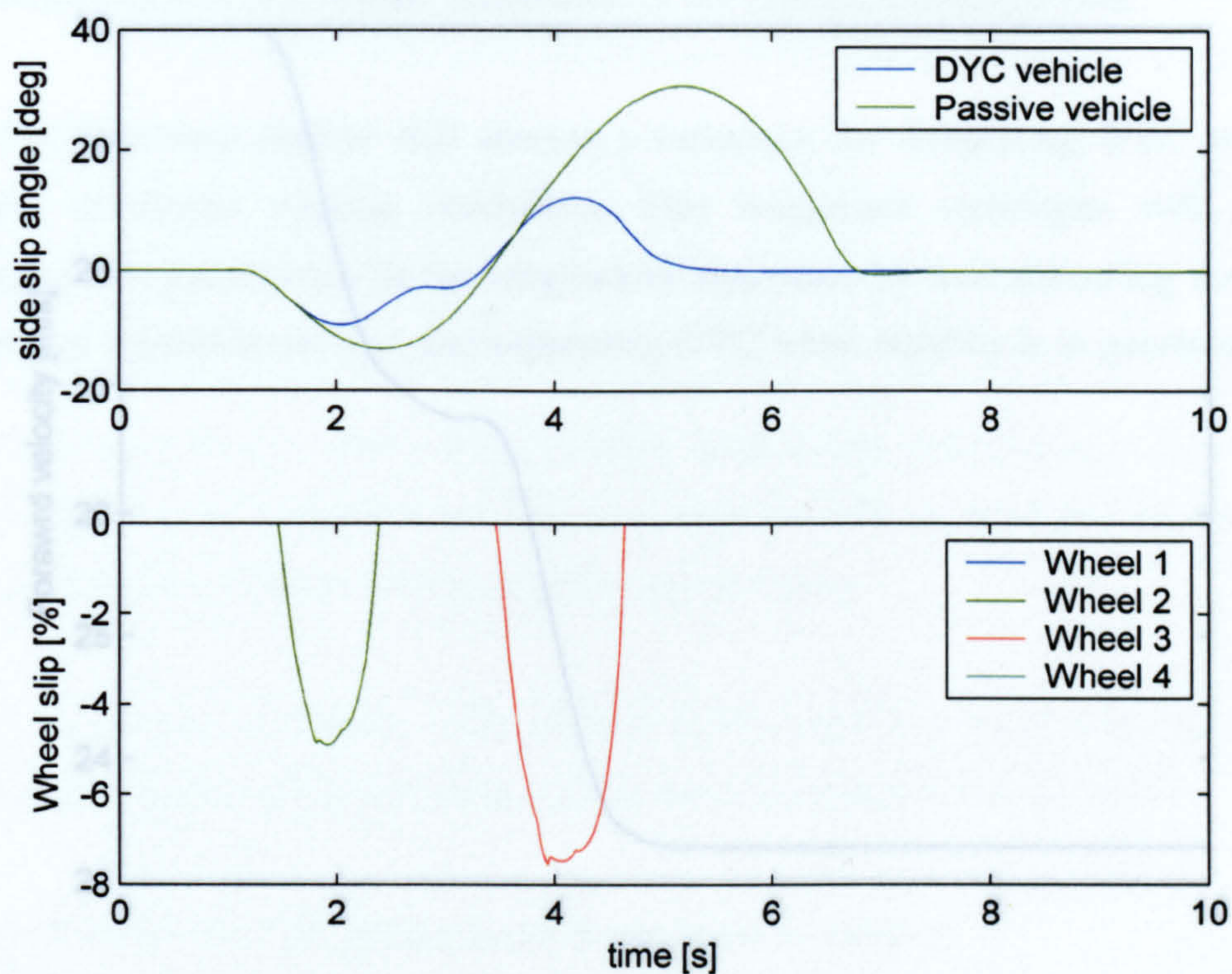

Figure 5-15 Side slip angle and control action for steer input in Figure 5-12

The DYC's improvement of the vehicle behaviour with respect to aggressive inputs and side slip behaviour makes use of available longitudinal tyre forces. This in turn interferes with the vehicle longitudinal dynamics. Figure 5-16 shows the deceleration of the vehicle during the manoeuvre. It has been shown that drivers find this interference undesirable as it is unusual behaviour, (Smakman 2000b). The following chapter will consider ways of reducing this interaction.

Results for this implementation on a non-linear vehicle model show the technique to be highly effective in maintaining directional stability at the vehicle limit through control of individual wheel slips.

It has also highlighted that the use of the brakes to affect vehicle stability interferes with the longitudinal motion of the vehicle. Whilst it can be argued that this may be a good thing in a critical situation, it has also been suggested that this

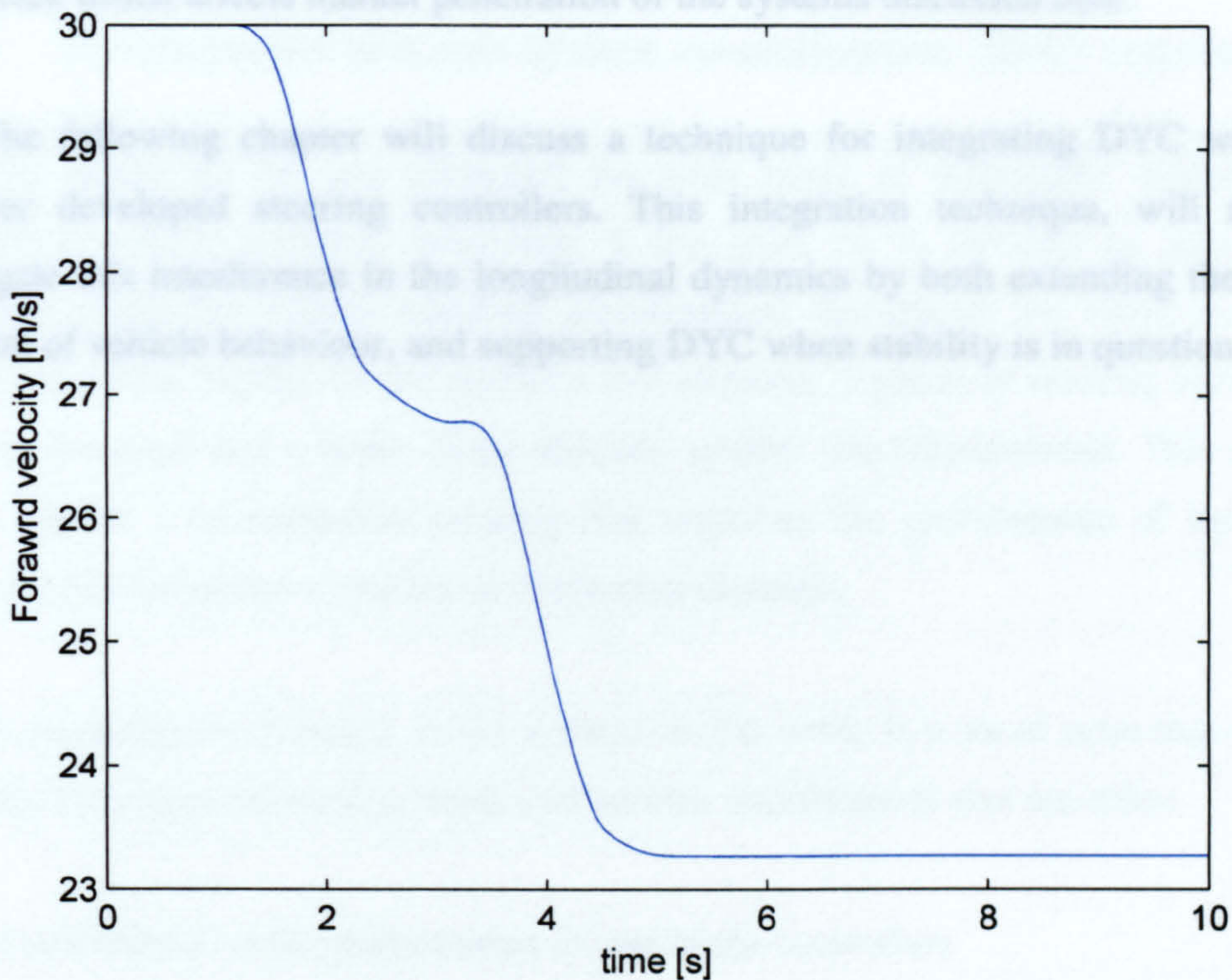

Figure 5-16 DYC controlled vehicle forward speed for input in Figure 5-12

5.3 Conclusion

This chapter has discussed a technique for controlling the vehicle lateral handling behaviour using the ability to control longitudinal tyre force through individual wheel braking. The system is commonly referred to as direct yaw moment control, DYC. It has further gone to show the implementation of a simple DYC system, typical of that used commercially and described elsewhere in the literature.

Results for this implementation on a non-linear vehicle model show the technique to be highly effective in maintaining directional stability at the vehicle limit through control of individual wheel slips.

It has also highlighted that the use of the brakes to affect vehicle stability interferes with the longitudinal motion of the vehicle. Whilst it can be argued that this may be a good thing in a critical situation, it has also been suggested that this

interaction is found to lead to poor subjective evaluations particularly for sporty vehicles which affects market penetration of the systems discussed here.

The following chapter will discuss a technique for integrating DYC with the earlier developed steering controllers. This integration technique, will aim to mitigate this interference in the longitudinal dynamics by both extending the linear region of vehicle behaviour, and supporting DYC when stability is in question.

6 Development of a sub system co-ordination (SSC) approach

The thesis, so far, has discussed the wide range of techniques available for affecting vehicle handling behaviour. It has gone on to develop an appropriate vehicle model for vehicle handling investigations throughout the linear and non-linear handling regime. In the previous two chapters, a group of steering controllers were designed and a brake based stability system was implemented. This chapter will discuss a co-ordination strategy that improves the performance of these two approaches compared to the no co-ordination situation.

A co-ordination strategy, in the context of this work, is a set of rules that aims to exploit synergies between systems and prevent interferences that are either

a) detrimental to the performance of one of the controllers

or

b) detrimental to the vehicle handling behaviour.

An example of the first might be that steering is ineffective if both wheels on an axle are being braked, an example of the second might be the interference of brake based systems with the longitudinal motion of the vehicle.

The aim of this chapter is to present a strategy for co-ordinating handling systems. The strategy to be proposed is based upon the concept of the handling task, steerability or stability, as defined in Chapter 3.

6.1 Generic rule based approach

As discussed in the literature review, Chapter 2, co-ordination strategies allow well developed and understood handling controllers to be combined. It was noted that few of the examples of these approaches describe the strategy used in any great

detail. It is therefore difficult to exploit work that has already been done, in this Chapter.

In order to exploit the insight gained in the discussion of vehicle handling in Chapter 3, a fuzzy approach has been selected. This technique allows the engineer to capture features of the system to be controlled in terms of membership functions.

Figure 6-1 shows two possible membership functions that relate the control task, 1 is steerability and 2 is stability control, to the vehicle operating point; in this case lateral acceleration. An early product of this work using the idea handling task scheduled against lateral acceleration for AFS and DYC work is found in (Selby, Manning et al. 2000), and using this approach a comparison of AFS and ARS is found in (Selby, Manning et al. 2000). The problems of using lateral acceleration as the scheduling variable is discussed below.

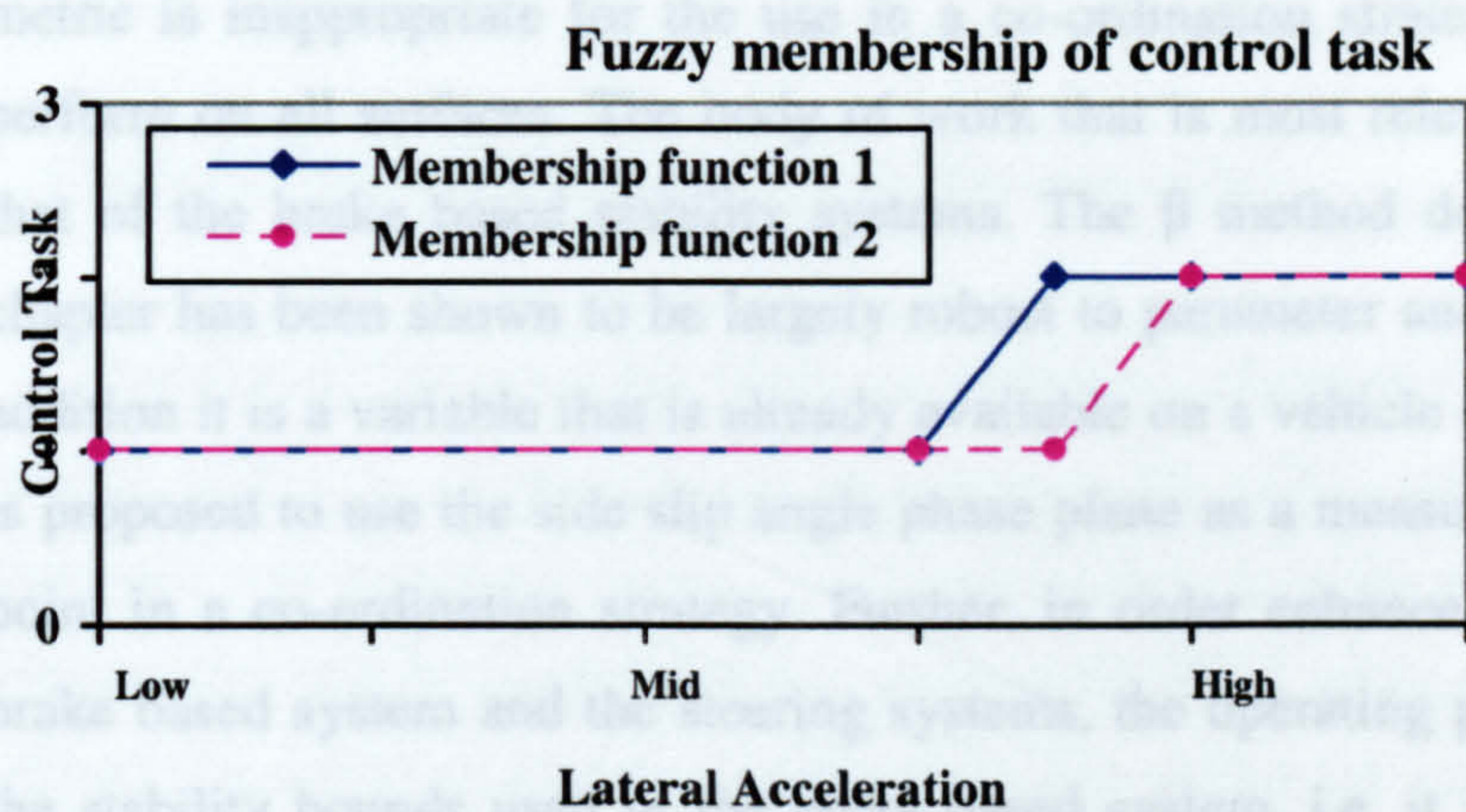

Figure 6-1 Description of control task as a function lateral acceleration

Two possible membership functions are shown. The membership function 1 changes the control task from steerability to stability at a lower operating point than membership function 2. This can be seen to offer a more conservative coordination of the conflicting control tasks.

Through a detailed understanding of the vehicle dynamics relating these two tasks, it is proposed to develop a rule based strategy to co-ordinate active steering and brake based handling systems. The study aims to identify the key features required for such an approach and assess the suitability of the studied systems for use in a co-ordinated chassis system. It is desired that the synergies and conflicts between the systems can be exploited and mitigated respectively through the use of a rule base to schedule both control task and actuation system.

Figure 6-1 proposed a fuzzy membership function to distinguish the current task, steerability or stability and it is this approach that will be followed. It is therefore necessary to measure the operating point of the vehicle. The operating point of the vehicle, in linguistic terms, ranges from on-centre handling or straight ahead driving to limit manoeuvring. A quantitative measure of this is lateral acceleration and is commonly used as it is the most easily measured variable. However, the relationship between operating point and lateral acceleration is, itself a function of the road surface coefficient of friction. As the latter is difficult to measure or estimate, this metric is inappropriate for the use in a co-ordination strategy that is expected to perform on all surfaces. The body of work that is most relevant to this problem is that of the brake based stability systems. The β method detailed in the previous chapter has been shown to be largely robust to parameter and surface variations. In addition it is a variable that is already available on a vehicle equipped with DYC. It is proposed to use the side slip angle phase plane as a measure of vehicle operating point in a co-ordination strategy. Further, in order to enhance the integration of the brake based system and the steering systems, the operating point will be related to the stability bounds used in the brake based system, i.e. it includes both side-slip angle and side slip angle velocity, as shown Figure 6-1.

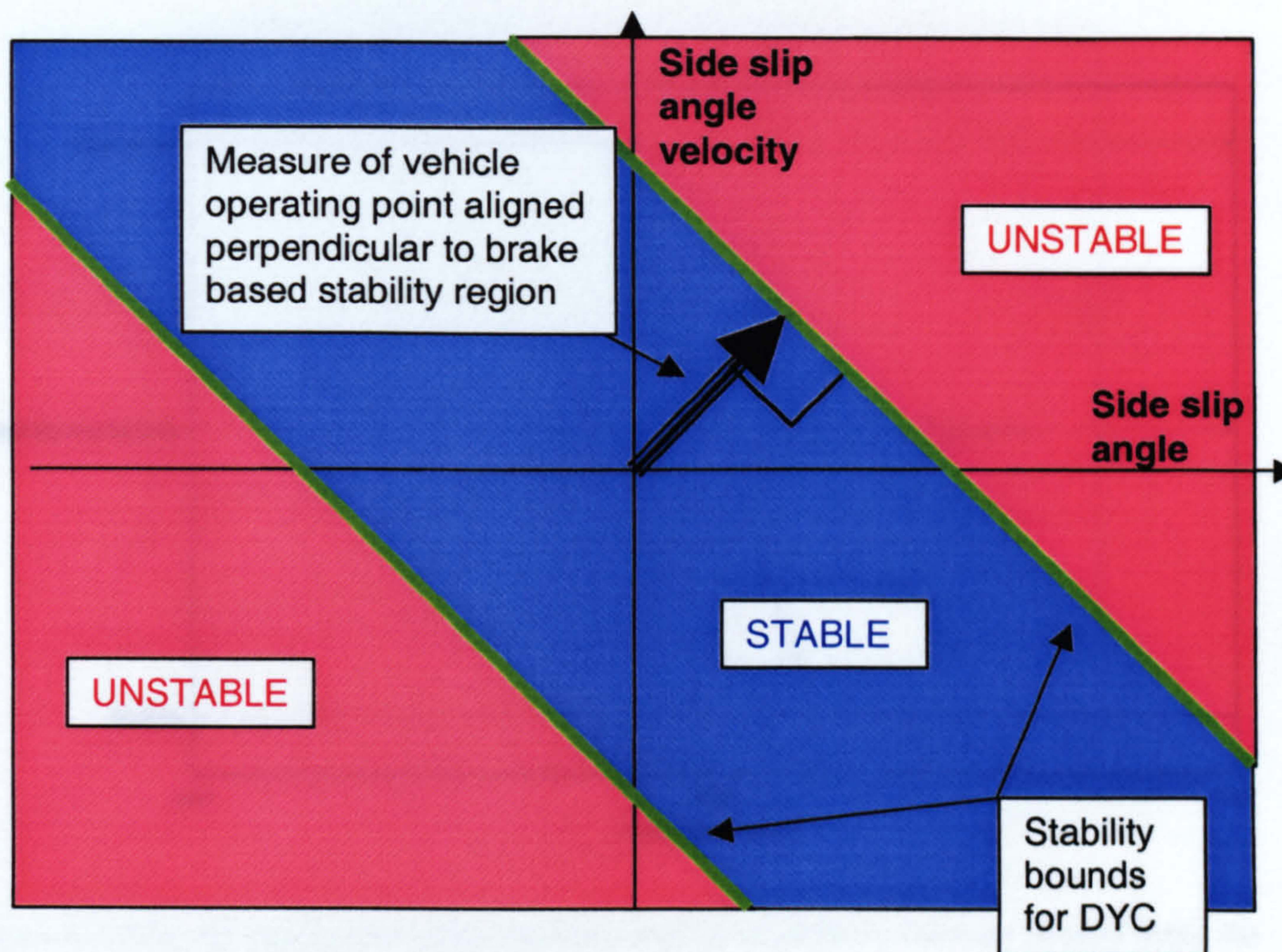

Figure 6-2 Phase plane approach to operating point metric

Considering this approach from an industrial perspective, it is imperative that vehicle safety is preserved, for this reason the DYC stability system will be dominant and its control action will be unchanged. It is the steering based handling systems that will be co-ordinated to support the DYC when required and otherwise support the driver in the steerability task. The difference between these tasks was established in chapter 3. Steerability implies yaw rate tracking and Stability implies lateral velocity bounding which has been posed a tracking controller by bounding the reference in this approach.

6.2 Implementation

The controllers will be scheduled using the fuzzy switch in Figure 6-3. The reason for this fuzzy relationship is to ensure the transition between controllers is smooth.

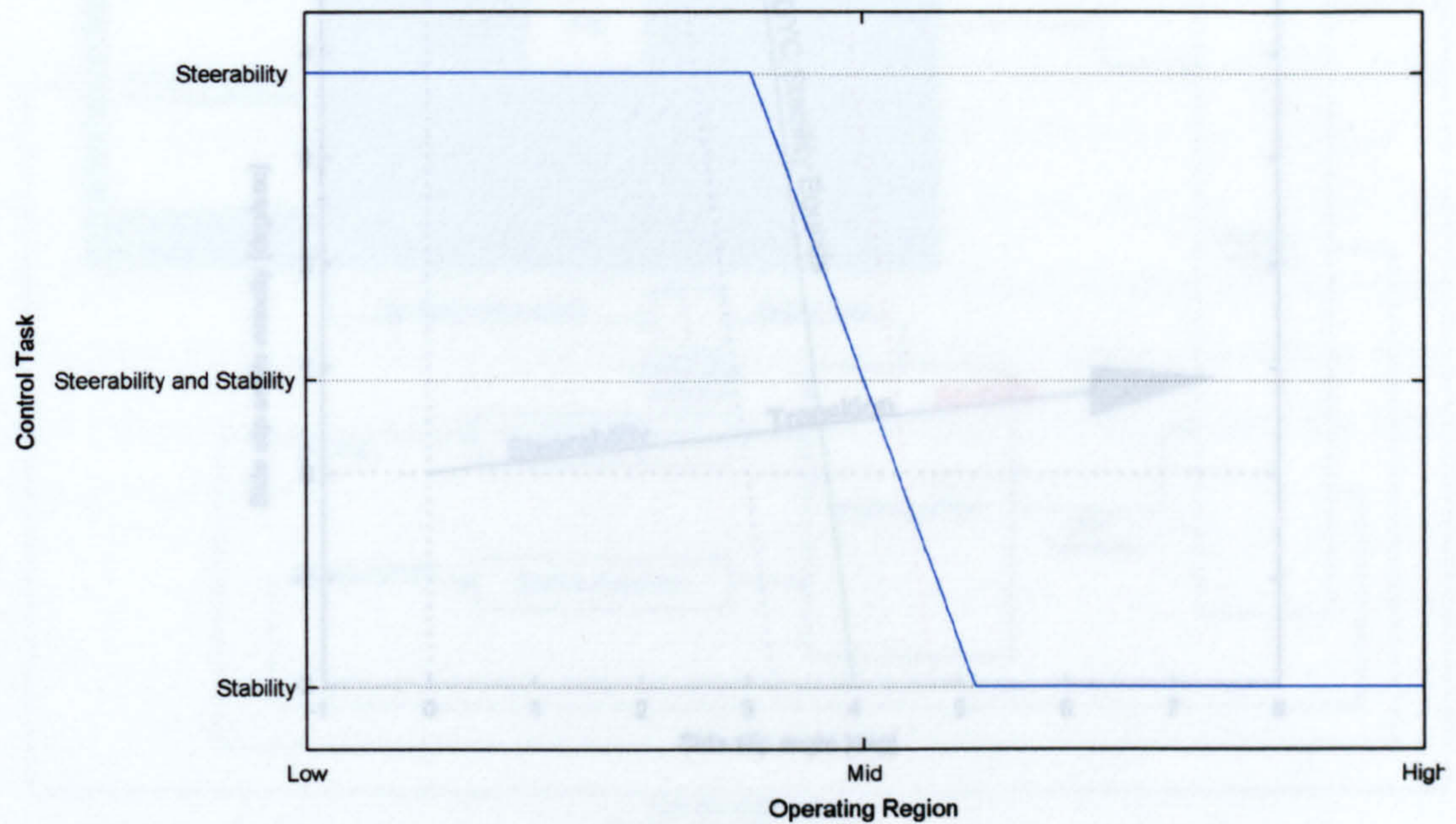

Figure 6-4 Side slip angle phase plane showing typical transitions between control tasks the perpendicular to the DYC stability boundaries.

Figure 6-3 Characteristics of a fuzzy switch

The points on the operating region that correspond to fully on or fully off are selected using a numerical optimisation technique for each combination, AFS-C or AFS-D in order to achieve optimal performance.

The implementation of this switch is described in Equation 6-1.

$$\delta_{vehicle} = (\text{control task}) \cdot \delta_{steerability} + (1 - \text{control task}) \cdot \delta_{stability}$$

Equation 6-1 Implementation of fuzzy switch for selection of steering controllers where $\delta_{steerability}$ is the control variable from the yaw rate tracking controller and $\delta_{stability}$ is the control variable from the lateral velocity tracking controller and $\delta_{vehicle}$ is the weighted sum of these two control variables.

Figure 6-4 relates the fuzzy switch to the side slip angle phase plane.

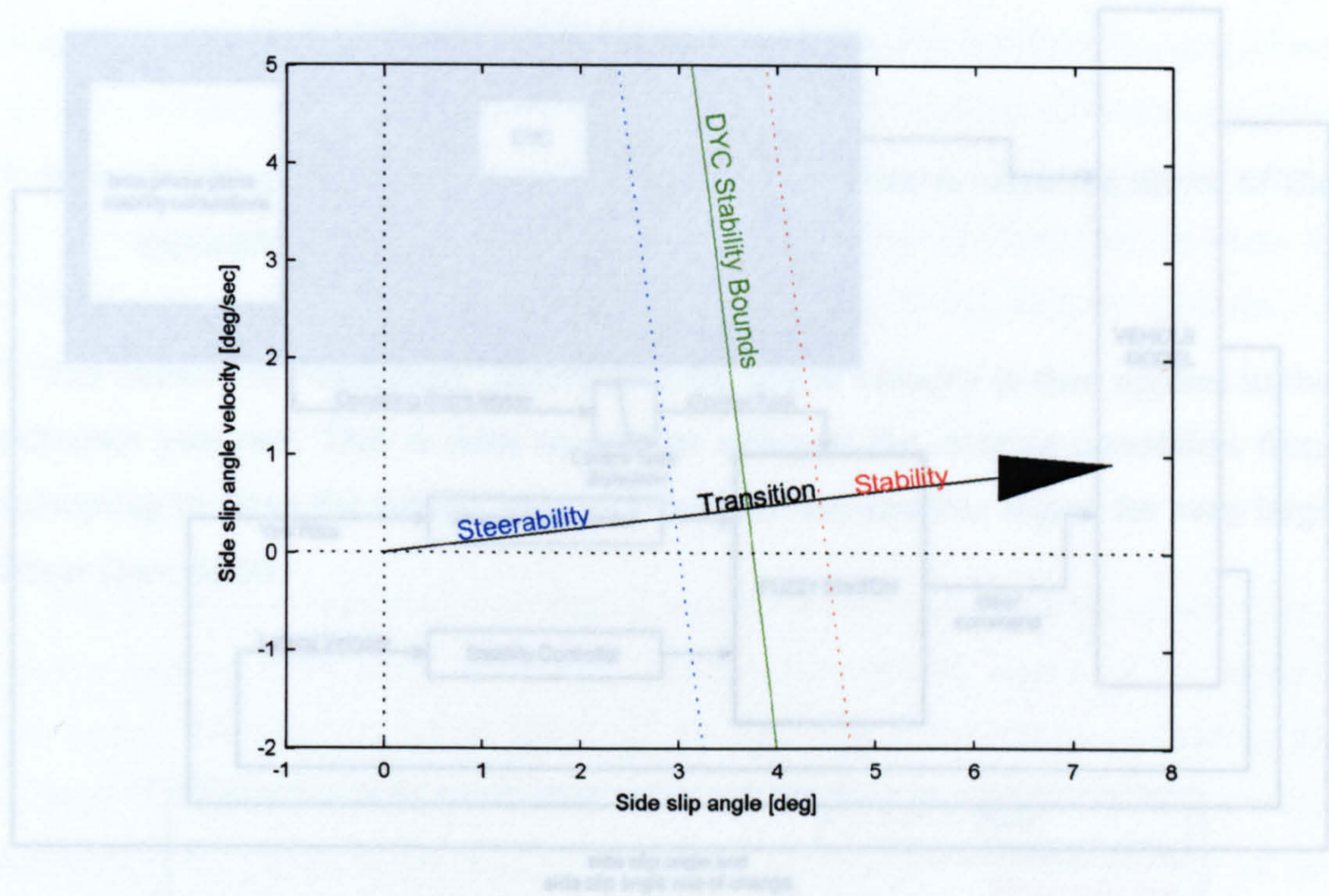

Figure 6-4 Side slip angle phase plane showing typical transitions between control tasks the operating point measure (Black Arrow) aligned perpendicular to the DYC stability boundaries.

DYC system described in Chapter 5 and shows the route of the information from the stability

The block diagram in Figure 6-5 describes the complete co-ordination structure. The blue shading represents an existing DYC controller being used to drive the fuzzy coordination switch for the steering controllers.

5-5, a squashing function was applied to the reference lateral velocity. The squashing function, shown in Figure 6-6, is used in preference to a hard saturation to promote a gradual and progressive change in vehicle behaviour. This squashing function is described by hyperbolic tangent which has the property of being approximately linear for small input values and saturates asymptotically at 1 for large input values. The attractiveness of this is that it allows a steady progressive change from state tracking to state bounding. This progress change is important for two reasons,

The squashing function has two advantages over a hard saturation function:

- a) the hard saturation function introduces a discontinuity which introduces unwanted high frequency components into the control signal and is likely to be viewed poorly in subjective ratings as drivers are known to dislike harsh changes in vehicle behaviour.

Figure 6-6: Squashing function plot. The x-axis is 'Input' ranging from -1 to 1. The y-axis is 'Output' ranging from 0 to 1. The curve is a hyperbolic tangent function, starting at 0 for negative inputs and approaching 1 for positive inputs.

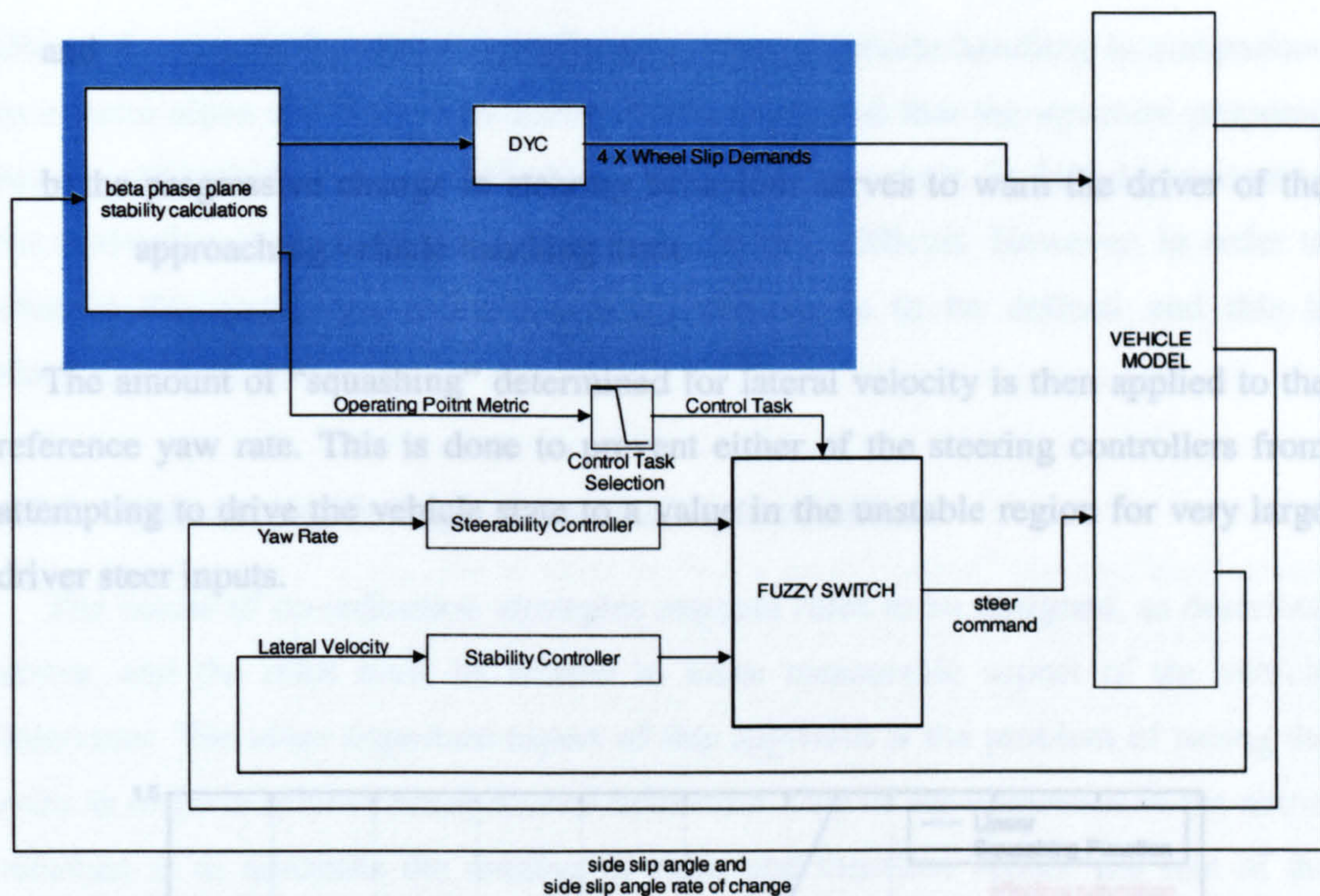

Figure 6-5 Structure of proposed co-ordination strategy, region shaded blue is the existing DYC system described in Chapter 5 and shows the reuse of the information from the stability calculation in the fuzzy scheduling controller.

In addition to the above description in Figure 6-5, a squashing function was applied to the reference lateral velocity. The squashing function, shown in Figure 6-6, is used in preference to a hard saturation to promote a gradual and progressive change in vehicle behaviour. This squashing function is described by hyperbolic tangent which has the property of being approximately linear for small input values and saturates asymptotically at 1 for large input values. The attractiveness of this is that it allows a steady progressive change from state tracking to state bounding. This progress change is important for two reasons,

- a) the hard saturation function introduces a discontinuity which introduces unwanted high frequency components into the control signal and is likely to be viewed poorly in subjective ratings as drivers are known to dislike harsh changes in vehicle behaviour

and

- b) the progressive change in steering behaviour serves to warn the driver of the approaching vehicle handling limit.

The amount of “squashing” determined for lateral velocity is then applied to the reference yaw rate. This is done to prevent either of the steering controllers from attempting to drive the vehicle state to a value in the unstable region for very large driver steer inputs.

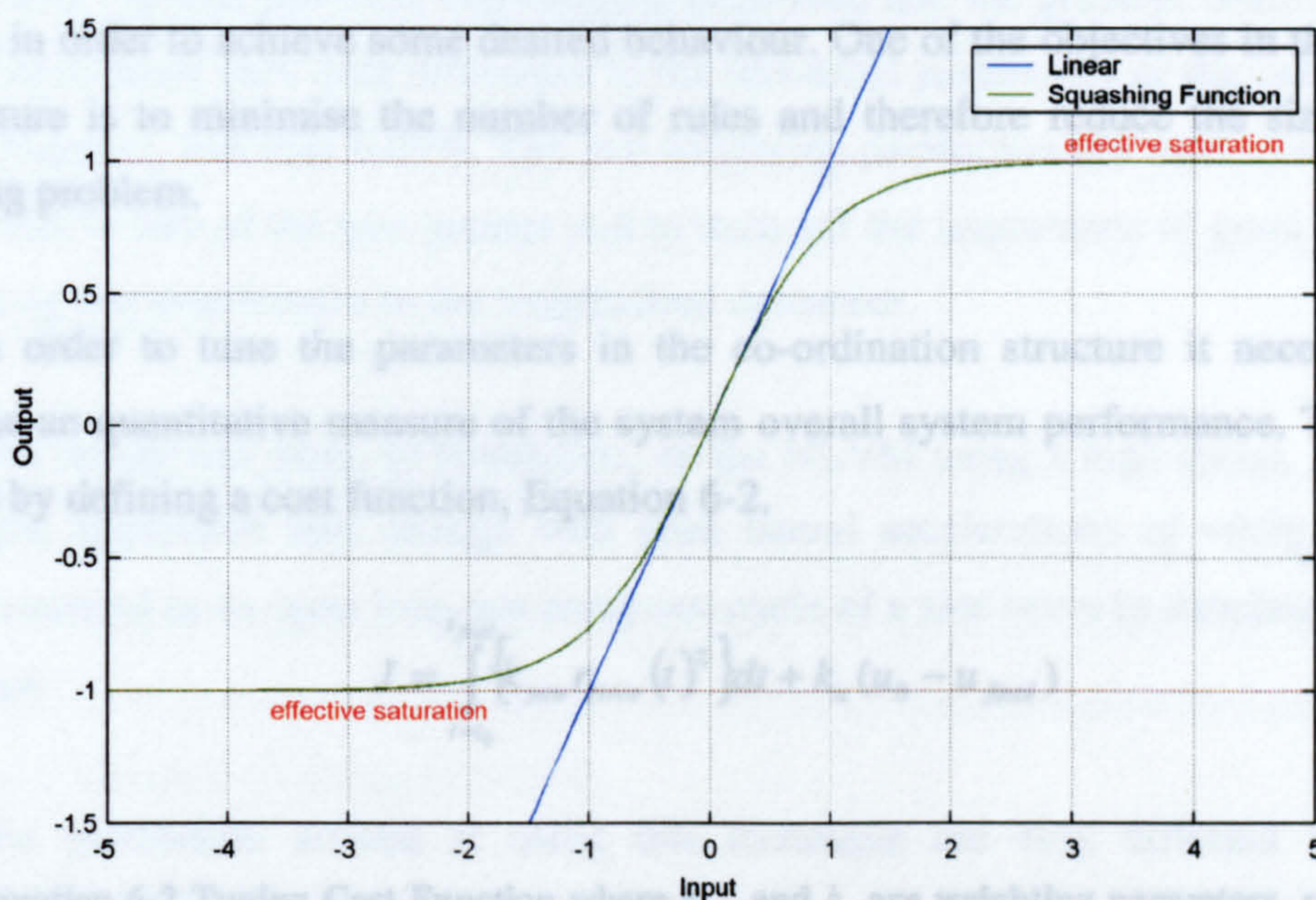

Figure 6-6 Soft saturation or squashing function

The structure proposed above attempts to co-ordinate a DYC system and a steering controller. The idea of stability bounds on the side slip angle phase plane is well understood and has been used extensively in the literature and this structure is proposed to extend that idea. An attractive feature of the strategy proposed here is the small number of rules, and therefore parameters, making tuning simple.

A particular problem with SSC approaches to vehicle handling control is that it is particularly difficult to define an appropriate performance index. Although it will be

shown that this SSC improve specific properties of vehicle handling in comparison to a stand-alone approach, it is therefore not suggested that the structure proposed here is optimal in all aspects of vehicle handling behaviour. In fact demonstrating the optimality of such rule based strategies is very difficult. However, in order to identify the parameters a performance index needs to be defined and this is discussed in the next section.

6.2.1 Rule tuning through numerical optimisation

The nature of co-ordination strategies requires rules to be designed, as described above, and the rules must be related to some measurable aspect of the vehicle behaviour. The other important aspect of this approach is the problem of tuning the rules in order to achieve some desired behaviour. One of the objectives in the above structure is to minimise the number of rules and therefore reduce the size of the tuning problem.

In order to tune the parameters in the co-ordination structure it necessary to define an quantitative measure of the system overall system performance. This was done by defining a cost function, Equation 6-2.

$$J = \int_{t=t_0}^{t_{final}} \{k_{yaw} r_{error}(t)^2\} dt + k_u (u_0 - u_{final})$$

Equation 6-2 Tuning Cost Function where k_{yaw} and k_u are weighting paramters, r_{error} is the difference between the measured and reference yaw rate and u is the forward velocity and t_0 and t_{final} are simulation start and end times.

This cost function consists of two elements, yaw rate and forward speed, again the simplicity reduces the number of parameters for the designer to influence the behaviour of the final system.

Other variables could have been selected, brake usage, steering usage, lateral velocity tracking error. The reason yaw and forward speed were selected over these others is that they most closely encompass the trade-off between the stability and cornering performance of a vehicle. The reduction in forward speed suggests that the

DYC controller has been active and therefore, stability has been in question. Low yaw rate tracking error suggest that steerability characteristics are good but this may be achieved at the expense of stability.

The tuning was performed in two stages using a global search optimisation algorithm initially. Firstly the box-bounded 'Direct' algorithm proposed by (Jones, Perttunen et al. 1993) and implemented by (Bjorkman and Holmstrom 1999) is used. Then a gradient search algorithm, (Mathworks 2003a), for fine tuning is applied. The a global search algorithm is used to find a good "guess" the and local search technique is required to approach the optimum more closely as many global search algorithms are in efficient in as a minimum is approached. In this case, the 'Direct' algorithm showed excellent convergence properties and the gradient descent search algorithm made very little difference to the identified parameters or the value of the cost function, less than 0.01%. The two weighting parameters are used to normalise the relative size of the two metrics and to trade off the importance of good yaw rate tracking and interference in the longitudinal dynamics.

The tuning was done, in simulation, on the NLVM using a high speed, 30m/s or 70mph, aggressive lane change with peak lateral accelerations of $\approx 0.9g$. This is implemented as on open loop test using one cycle of a sine wave to simulate the lane change.

The parameters arrived at using this technique are very different for each combination, AFS or ARS with DYC. The fuzzy switch properties are shown in Figure 6-7.

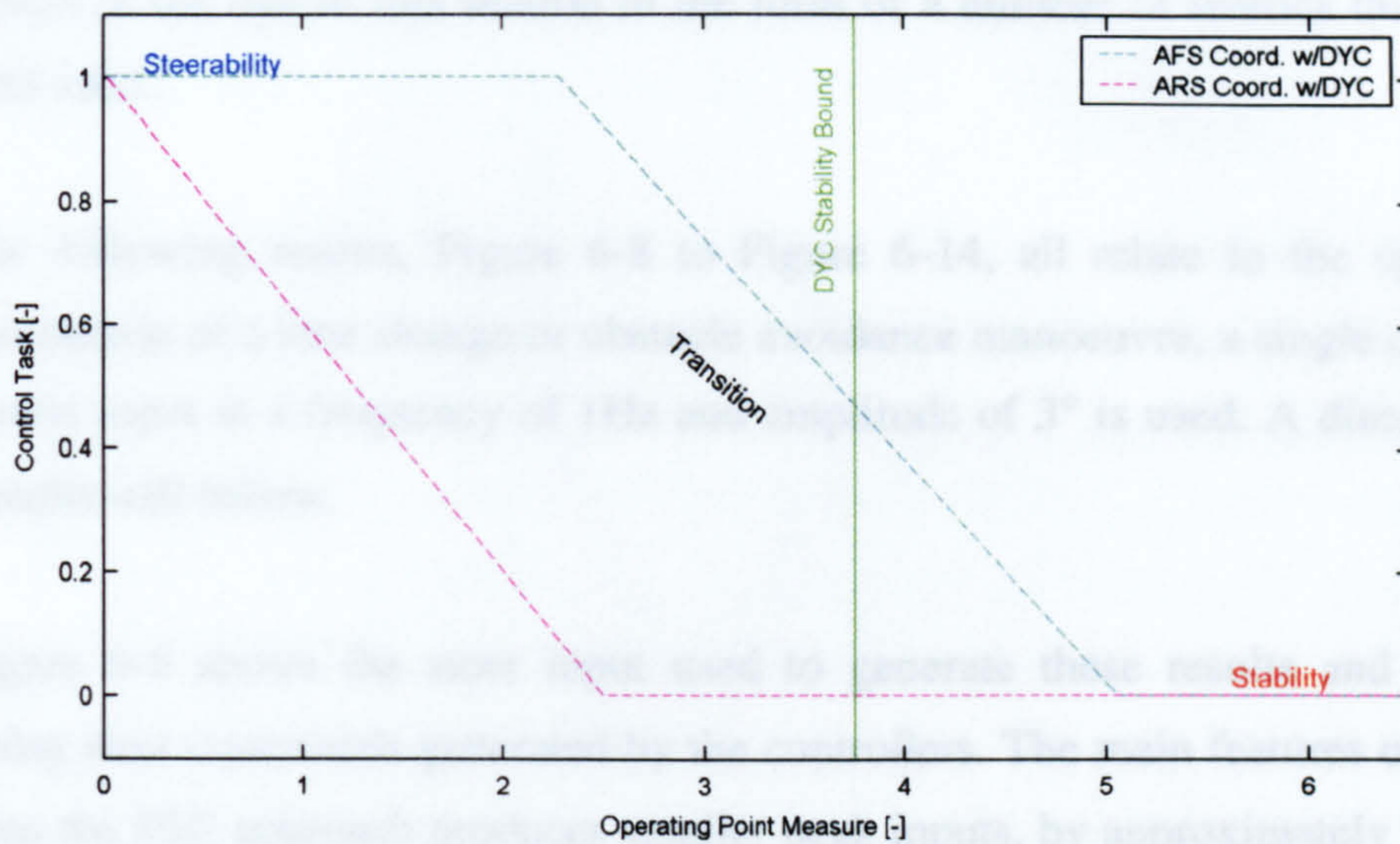

Figure 6-7 Fuzzy switch parameters for co-ordination of AFS, ARS with DYC identified using numerical optimisation on a high speed aggressive open loop lane change manoeuvre using the NLVM.

The identified parameters can be used to infer the following difference between the two steering controllers in the SSC. The change from steerability, Control Task =1, to Stability, Control Task =0 is very early for ARS compared with AFS. This suggests that stability is aggravated by the ARS yaw rate controller and needs to be effectively disabled earlier than AFS.

6.3 Results

6.3.1 AFS with DYC

In order to investigate the behaviour of the co-ordination system described above, results will be presented for the high speed aggressive lane change manoeuvre for AFS co-ordinated with DYC and for AFS and DYC as stand-alone controllers. Results here take the form of time histories of states and control variables. Complete time history results for all controller combinations can be found in Appendix A and are not presented here for clarity.

A comparison of all co-ordination and stand-alone combinations will be presented at the end of this section in the form of a number of metrics that will be defined later.

The following results, Figure 6-8 to Figure 6-14, all relate to the open loop representation of a lane change or obstacle avoidance manoeuvre, a single cycle of a sine steer input at a frequency of 1Hz and amplitude of 3° is used. A discussion of the results will follow.

Figure 6-8 shows the steer input used to generate these results and also the resulting steer commands generated by the controllers. The main features of interest are that the SSC approach produces smaller peak inputs, by approximately 25% and with much higher frequency content, up to 4Hz in contrast to about 1.5Hz for the unco-ordinated system. The smaller peak amplitudes can be accounted for by the saturation of the reference input. Whilst the higher frequency content relates primarily to the change in control task, Figure 6-9. As the control task changes from steerability to stability the controller applies short burst of opposite lock, which can be seen to mimic the behaviour of a skilled driver.

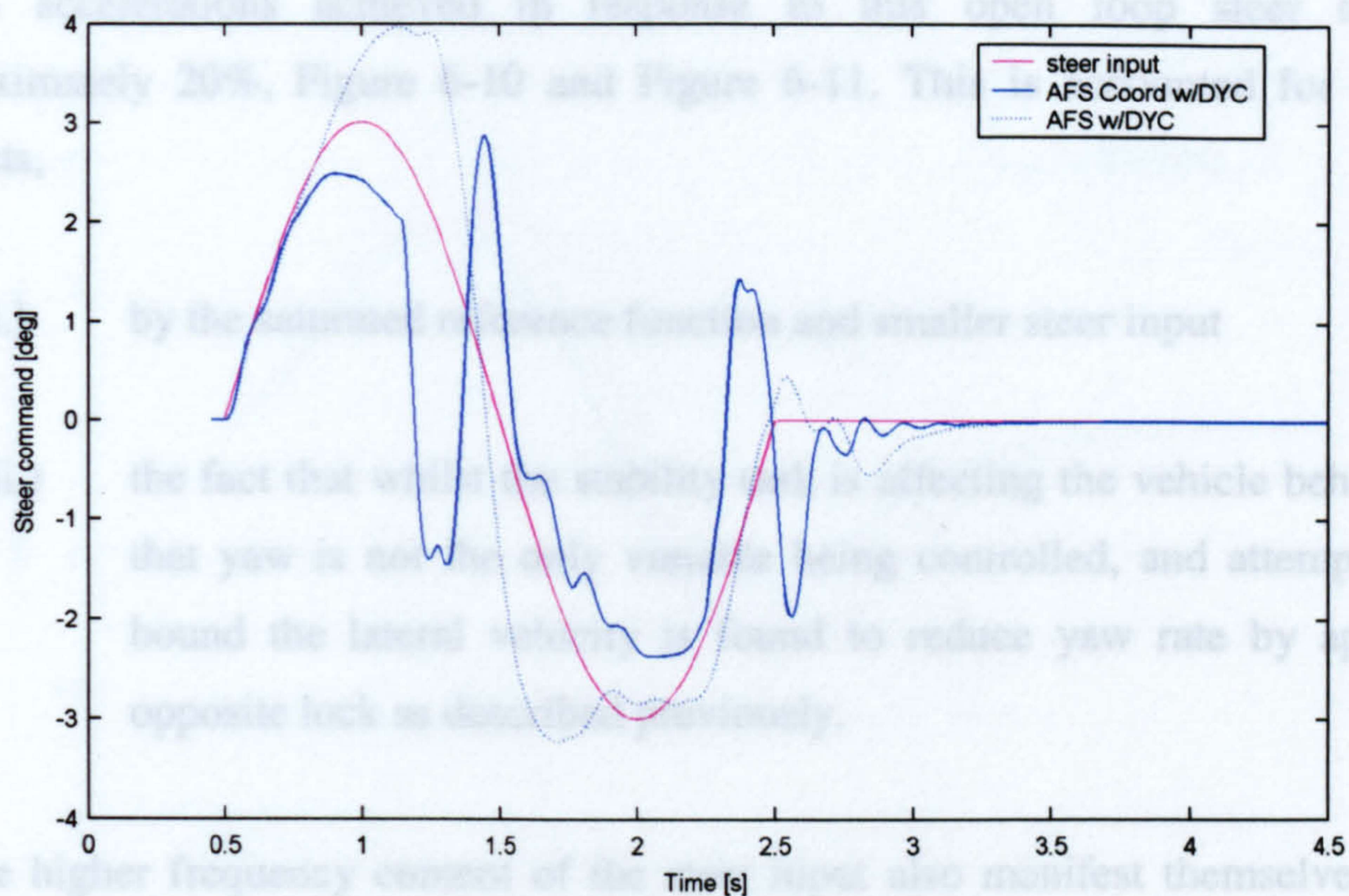

Figure 6-8 Steer angles for stand alone and co-ordinated AFS and DYC, also shown single cycle sine steer input at 1Hz and 3° amplitude

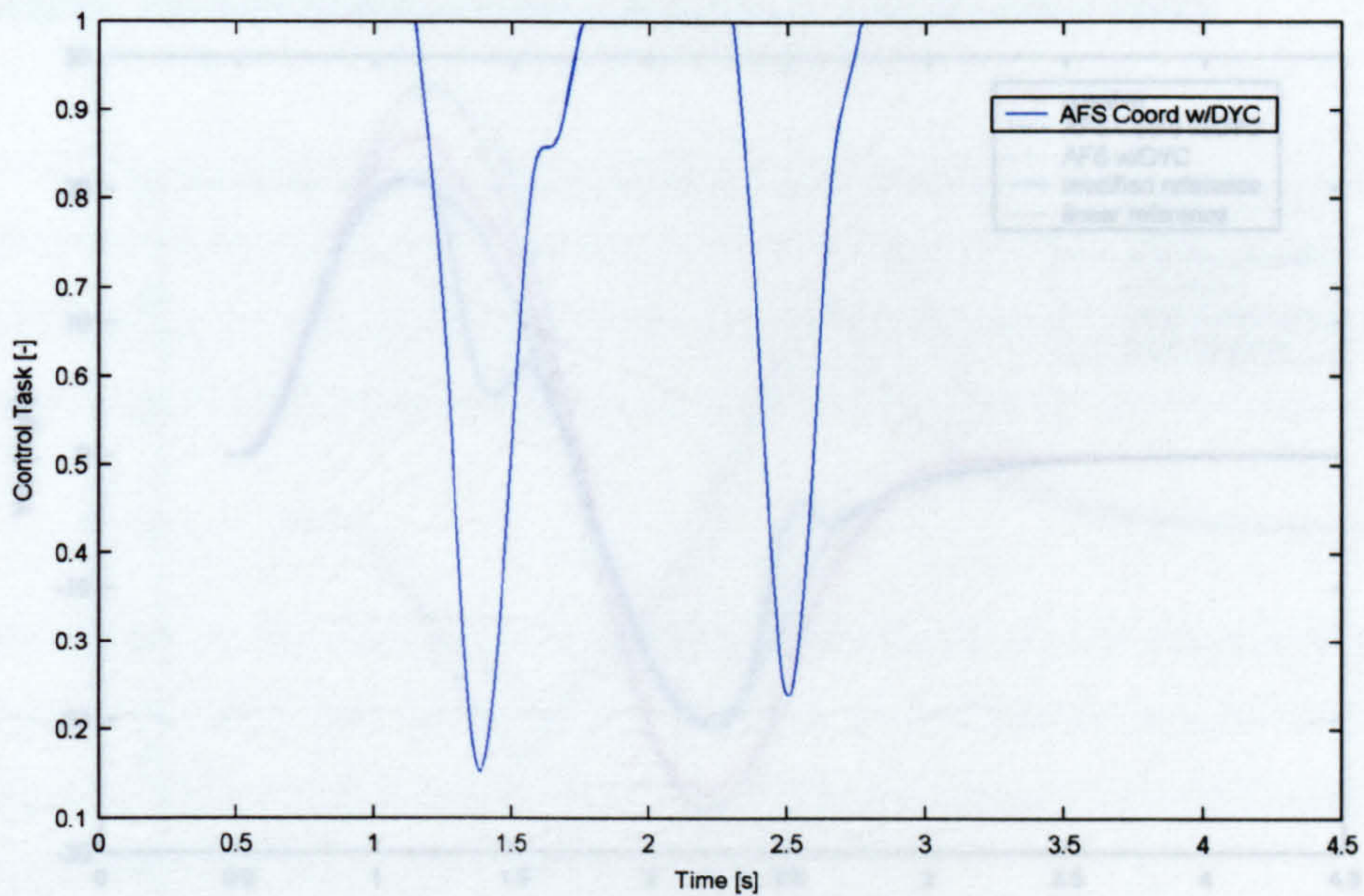

Figure 6-9 Control task or Fuzzy switch state

The use of the SSC in this case can be seen to reduce the peak yaw rates and lateral accelerations achieved in response to this open loop steer test by approximately 20%, Figure 6-10 and Figure 6-11. This is accounted for in two respects,

- i.) by the saturated reference function and smaller steer input
- ii.) the fact that whilst the stability task is affecting the vehicle behaviour, that yaw is not the only variable being controlled, and attempting to bound the lateral velocity is found to reduce yaw rate by applying opposite lock as described previously.

The higher frequency content of the steer input also manifest themselves here. The yaw rate differs significantly from the passive and reference whilst the stability task is dominant. This is likely to be found unusual and potentially disconcerting. It is however beyond the scope of the work to investigate the human-machine-interactions of these systems.

The side slip behaviour is presented here both as a time history and as a phase plane plot, Figure 6-12 and Figure 6-13, though the phase plane is probably most informative, the time history allows comparisons with the other cases.

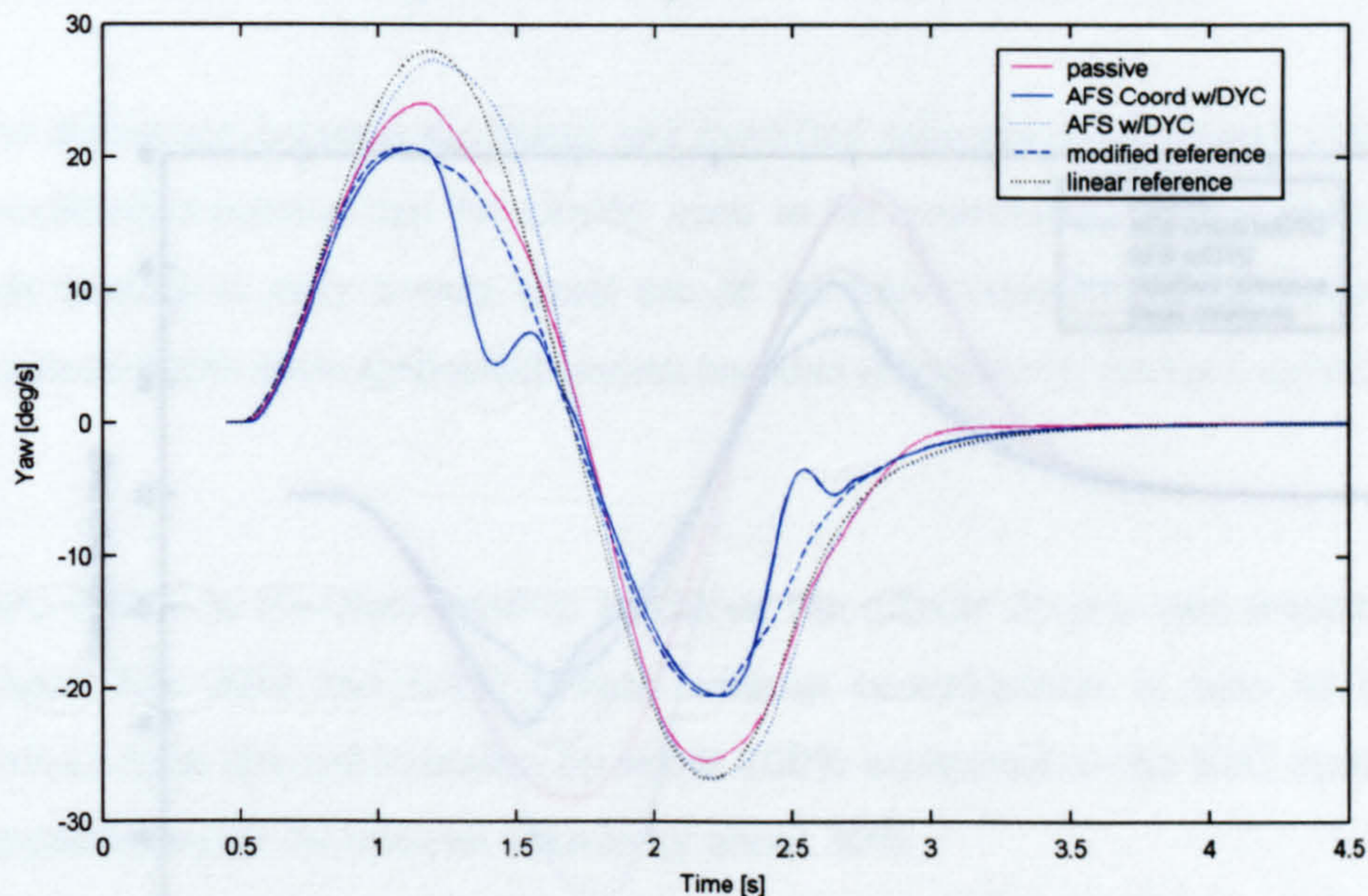

Figure 6-10 Vehicle yaw rate

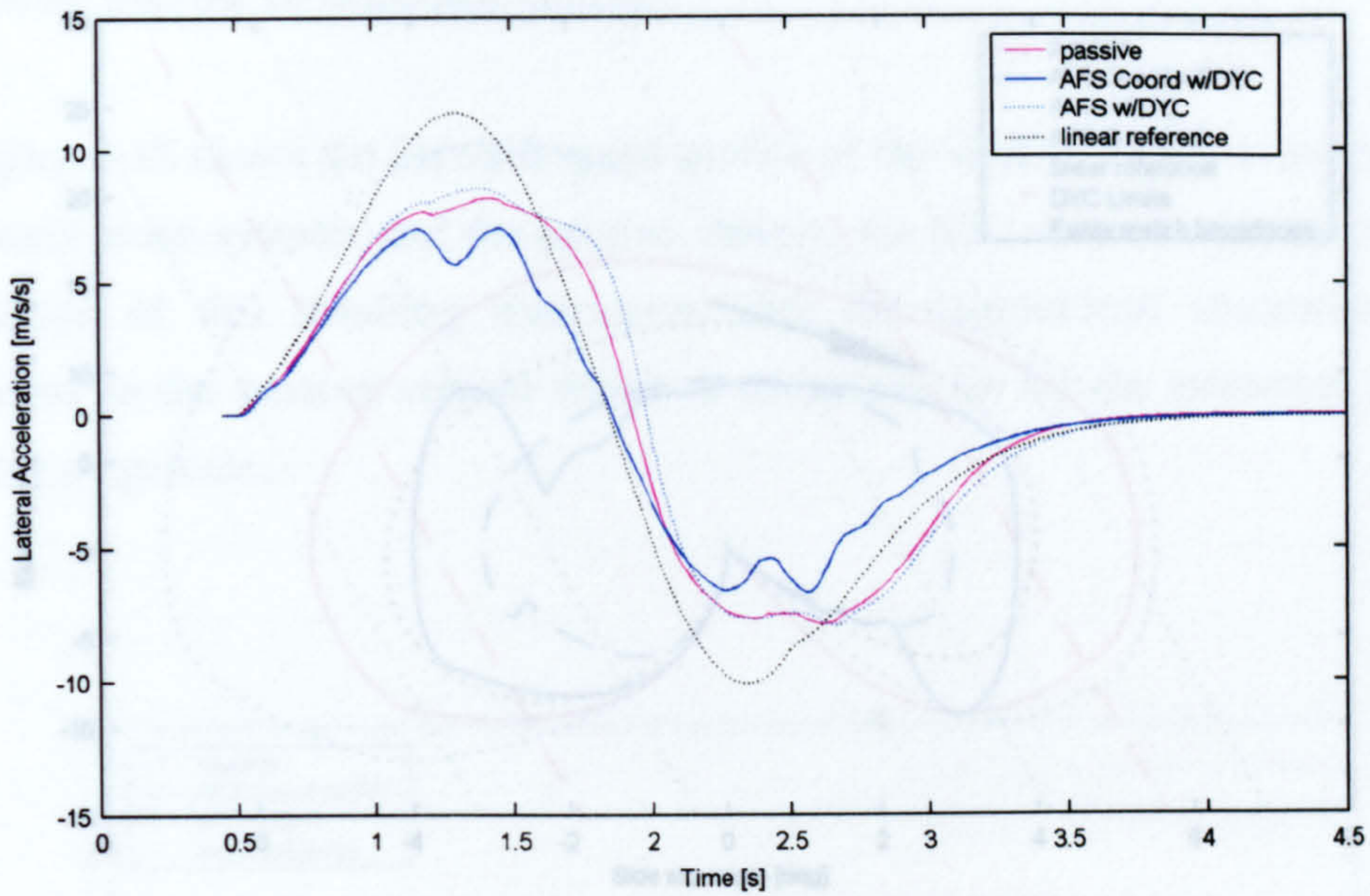

Figure 6-11 Vehicle lateral acceleration

The side slip behaviour is presented here both as a time history and as a phase plane plot, Figure 6-12 and Figure 6-13, though the phase plane is probably most informative, the time history allows comparisons with the other states.

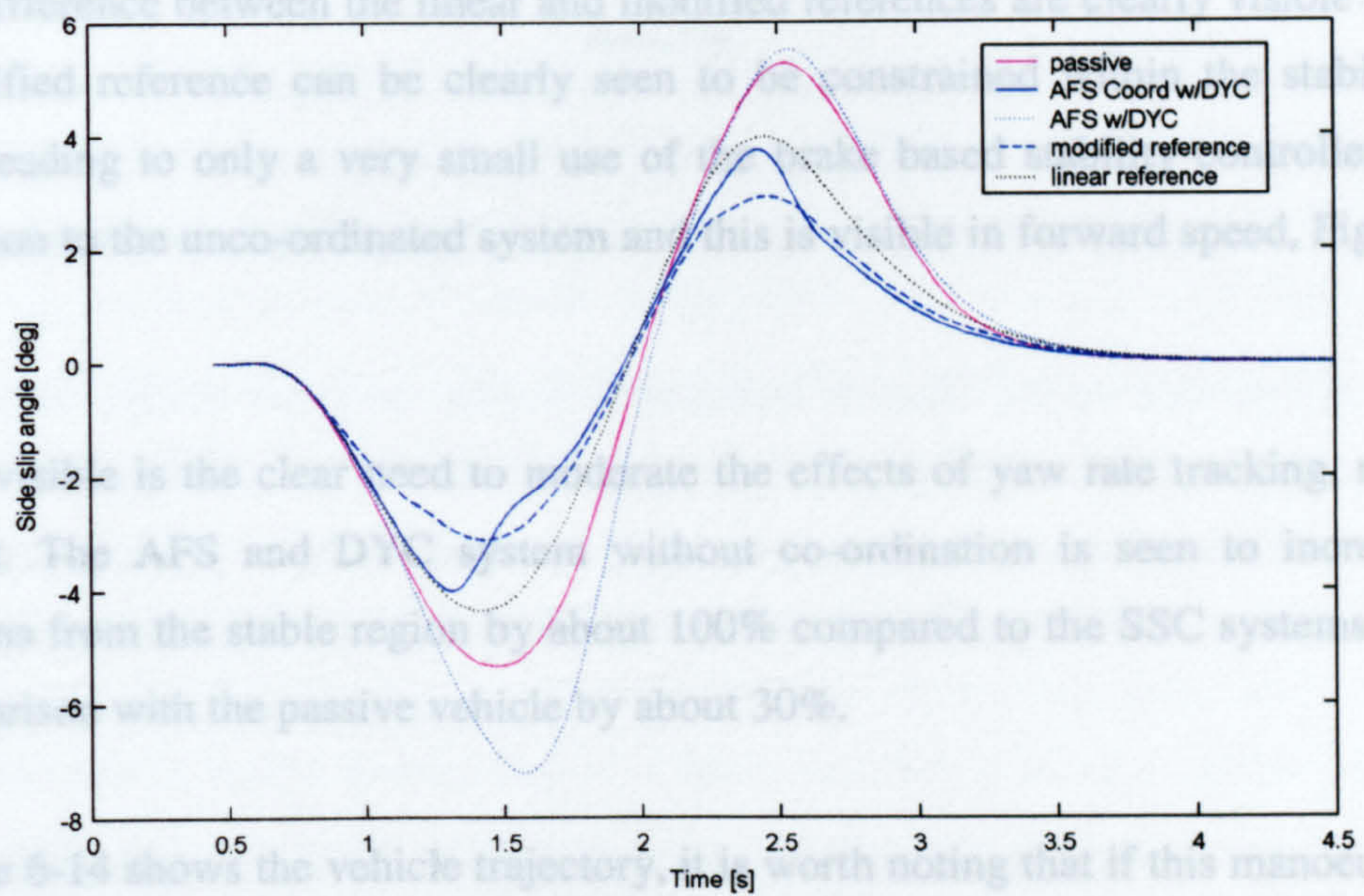

Figure 6-12 Vehicle side slip angle

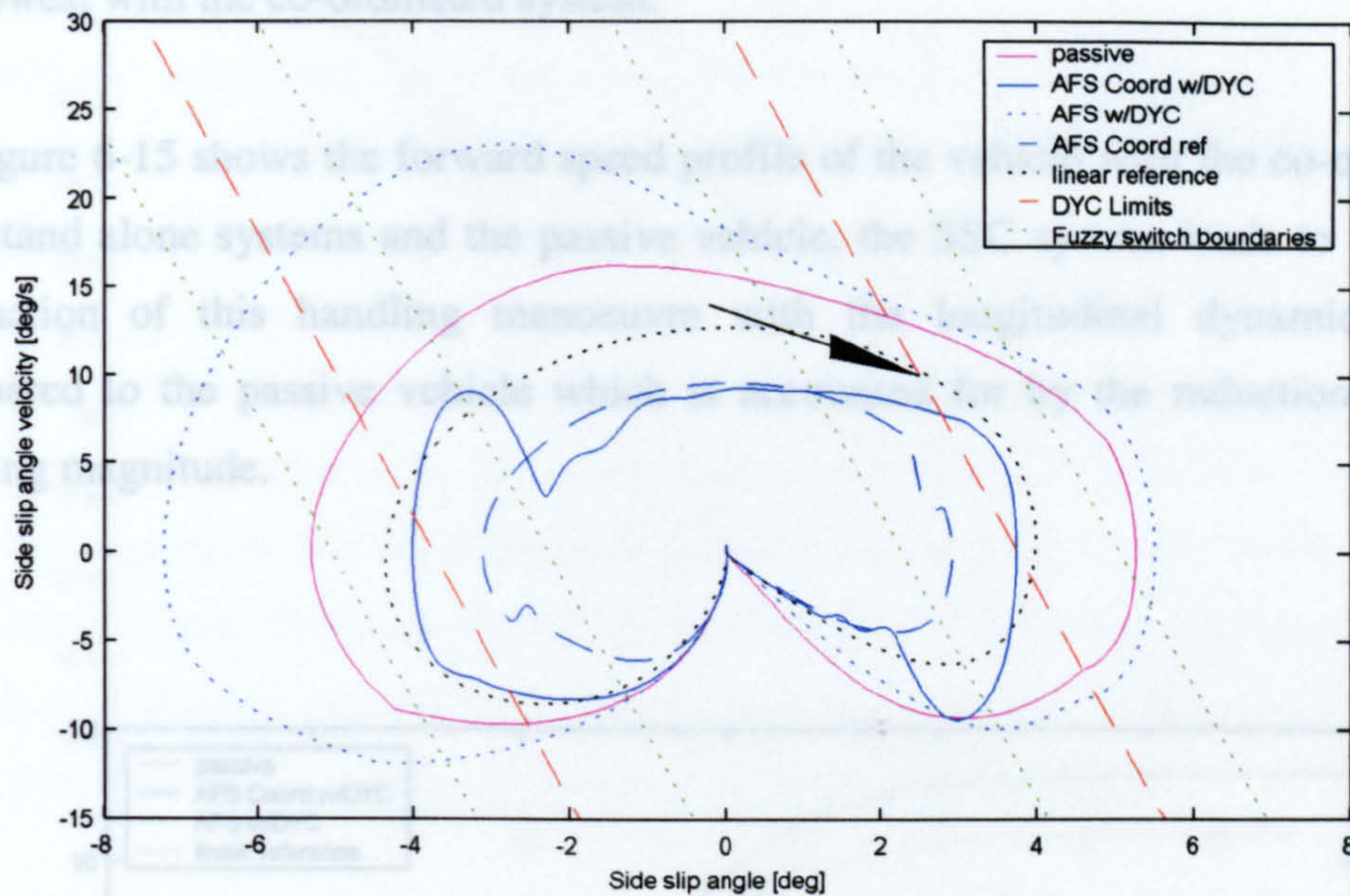

Figure 6-13 Vehicle side slip angle phase plane

The main features of the SSC can be observed in the side slip angle phase plane. Shown in red and green respectively are the DYC stability limits and the fuzzy boundaries used to assess control task.

The difference between the linear and modified references are clearly visible and the modified reference can be clearly seen to be constrained within the stability bounds leading to only a very small use of the brake based stability controller in comparison to the unco-ordinated system and this is visible in forward speed, Figure 6-15.

Also visible is the clear need to moderate the effects of yaw rate tracking, near the limit. The AFS and DYC system without co-ordination is seen to increase excursions from the stable region by about 100% compared to the SSC systems, an in comparison with the passive vehicle by about 30%.

Figure 6-14 shows the vehicle trajectory, it is worth noting that if this manoeuvre were an obstacle avoidance manoeuvre, then the co-ordinated system would require

the earliest reaction by the driver as the achievable yaw and lateral acceleration are the lowest with the co-ordinated system.

Figure 6-15 shows the forward speed profile of the vehicle with the co-ordinated and stand alone systems and the passive vehicle, the SSC system leads to the least interaction of this handling manoeuvre with the longitudinal dynamics, even compared to the passive vehicle which is accounted for by the reduction vehicle steering magnitude.

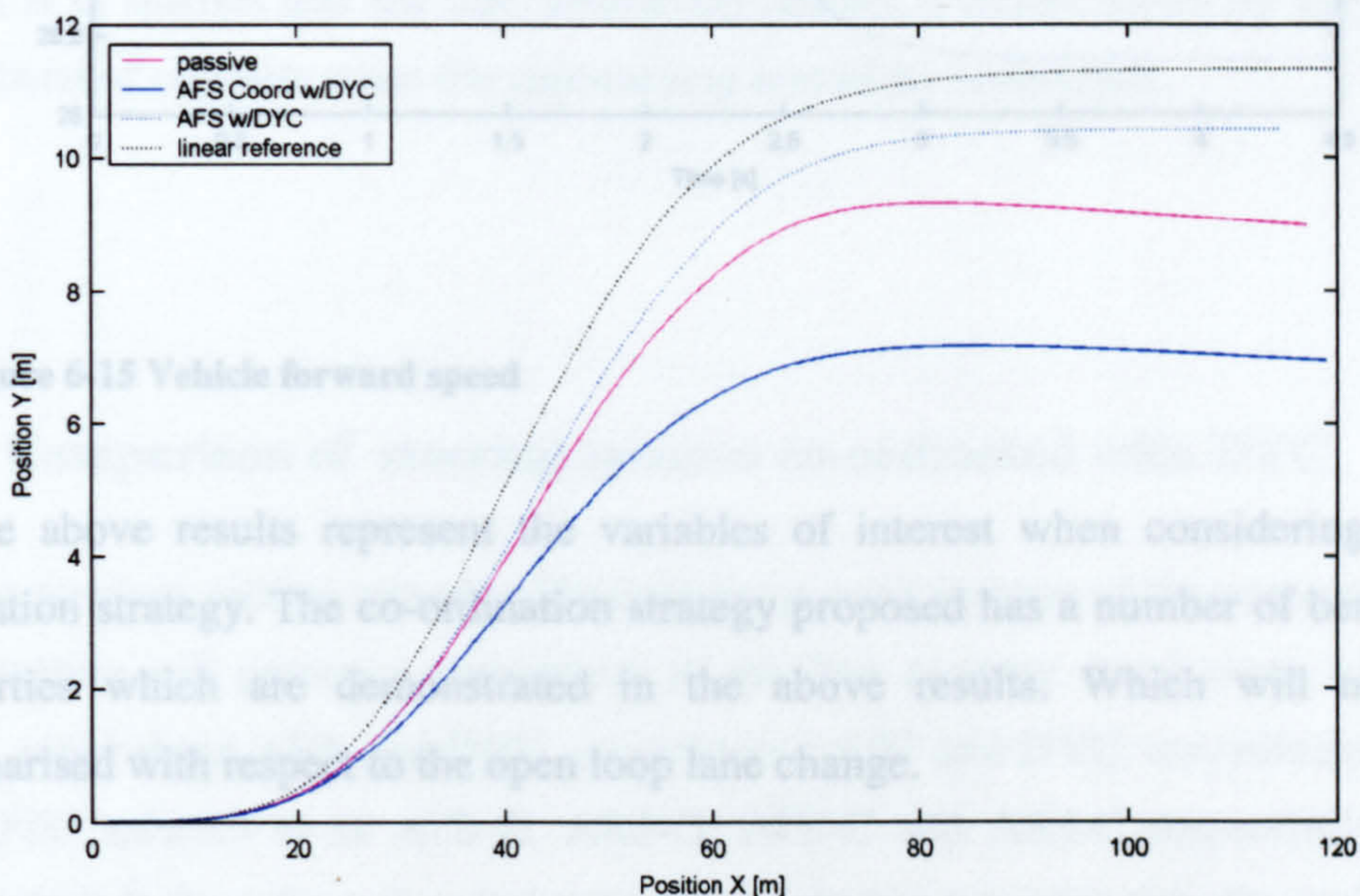

Figure 6-15 Vehicle forward speed

Figure 6-14 Vehicle trajectory

The other effects observed include a reduction in peak lateral acceleration and yaw rate which can be viewed as a reduction in limit performance. The implication of this that stability of the vehicle in aggressive manoeuvres is in conflict with ultimate cornering performance, in the context of this strategy where stability and steerability are considered separately.

This reduction in ultimate cornering potential could be viewed as subjectively undesirable though is unlikely that a typical driver spends much time at this operating point. A further potential problem in any subjective assessment are the

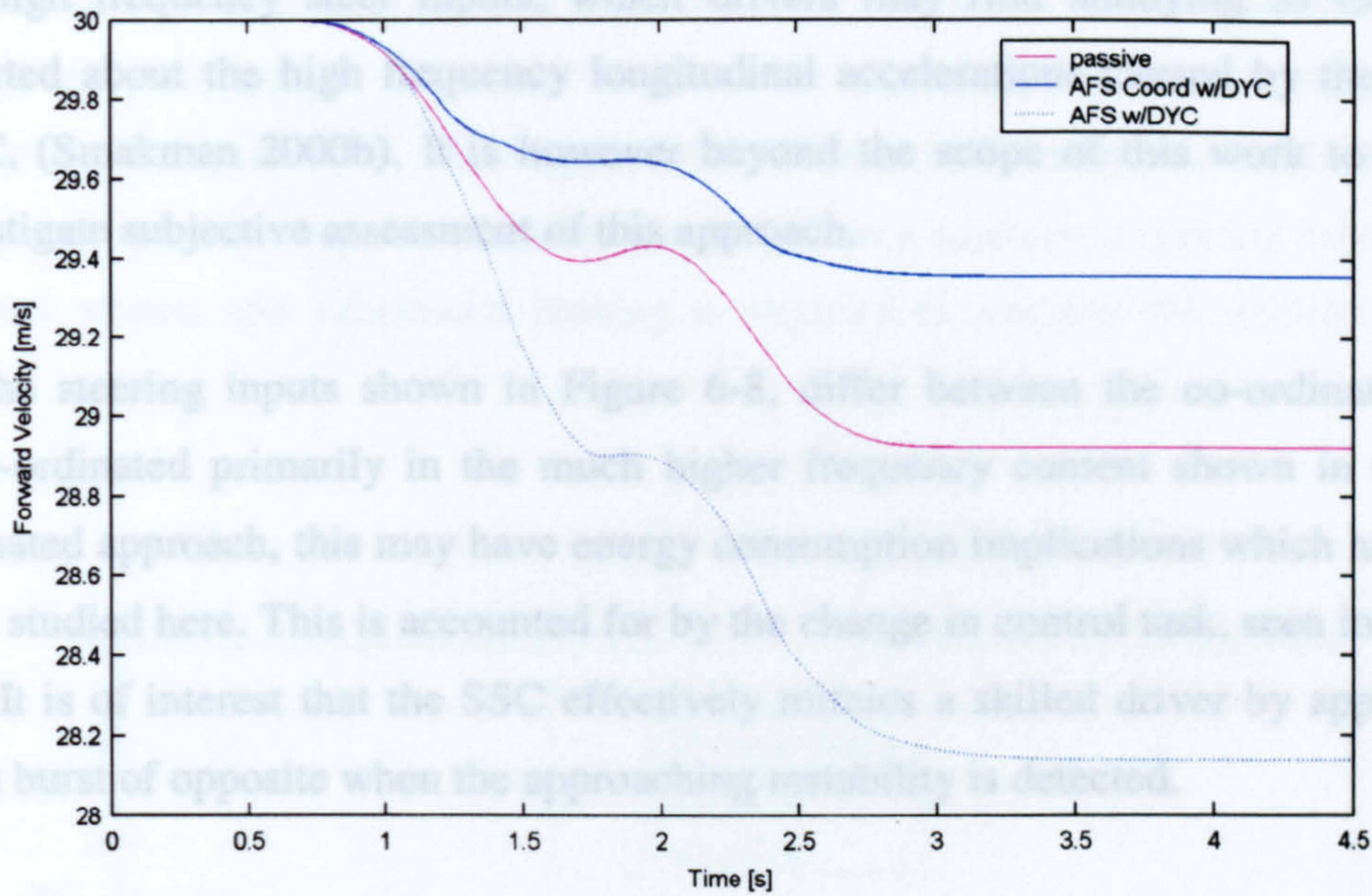

Figure 6-15 Vehicle forward speed

6.4 Comparison of steering systems co-ordinated with DYC

The above results represent the variables of interest when considering a co-ordination strategy. The co-ordination strategy proposed has a number of beneficial properties which are demonstrated in the above results. Which will now be summarised with respect to the open loop lane change.

As discussed earlier, with respect to AFS-C, side slip angle behaviour is constrained to the stable region on the β - phase plane. This, in turn, leads to reduced DYC intervention and reduced interference with the longitudinal dynamics.

The other effects observed include a reduction in peak lateral acceleration and yaw rate which can be viewed as a reduction in limit performance. The implication of this that stability of the vehicle in aggressive manoeuvres is in conflict with ultimate cornering performance, in the context of this strategy where stability and steerability are considered separately.

This reduction in ultimate cornering potential could be viewed as subjectively undesirable though is unlikely that a typical driver spends much time at this operating point. A further potential problem in any subjective assessment are the

increase of high frequency components in lateral acceleration and yaw rate due to the high frequency steer inputs, which drivers may find annoying as has been reported about the high frequency longitudinal accelerations caused by the action DYC, (Smakman 2000b). It is however beyond the scope of this work to further investigate subjective assessment of this approach.

The steering inputs shown in Figure 6-8, differ between the co-ordinated and unco-ordinated primarily in the much higher frequency content shown in the co-ordinated approach, this may have energy consumption implications which have not been studied here. This is accounted for by the change in control task, seen in Figure 6-9. It is of interest that the SSC effectively mimics a skilled driver by applying a short burst of opposite when the approaching instability is detected.

6.4 Comparison of steering systems co-ordinated with DYC

The previous section served to illustrate the general features of the proposed SSC. This section will present a comparison of the four systems: stand alone AFS and DYC, stand alone ARS and DYC, co-ordinated AFS and DYC, co-ordinated ARS and DYC referred to as AFS-D, ARS-D, AFS-C and ARS-C respectively. This comparison is done through a discussion of steady responses for side slip angle, yaw rate, lateral acceleration, demand brake slip, controller steer angles and control task measure. In addition, a comparison of the transient behaviour is performed through three single number metrics of vehicle performance, yaw and side slip angle ISE tracking error as defined in chapter 4 and reduction in forward speed for the sine steer input used in the previous section.

Figure 6-16 shows the resultant steady control outputs for the steering controllers. It can be seen that the two unco-ordinated systems generate very large steady steer angle demands for inputs greater than 1° . This is due to fact that the desired yaw is unachievable but the linear controller does not include this saturation effect. However, in the SSC, the reference function is squashed as a function of operating point so this does not occur.

It can be seen that the rear steer angle remains virtually zero, suggesting that the ARS system is most beneficial in transient manoeuvres. With ARS-C, the vehicle has virtually unchanged behaviour in yaw, side slip angle and lateral acceleration, Figure 6-17, Figure 6-18, and Figure 6-19. This is to be expected for such small additional rear steer inputs, where as the stand alone equivalent quickly saturates at the rear wheels and substantial braking is required to stabilise the vehicle, Figure 6-22.

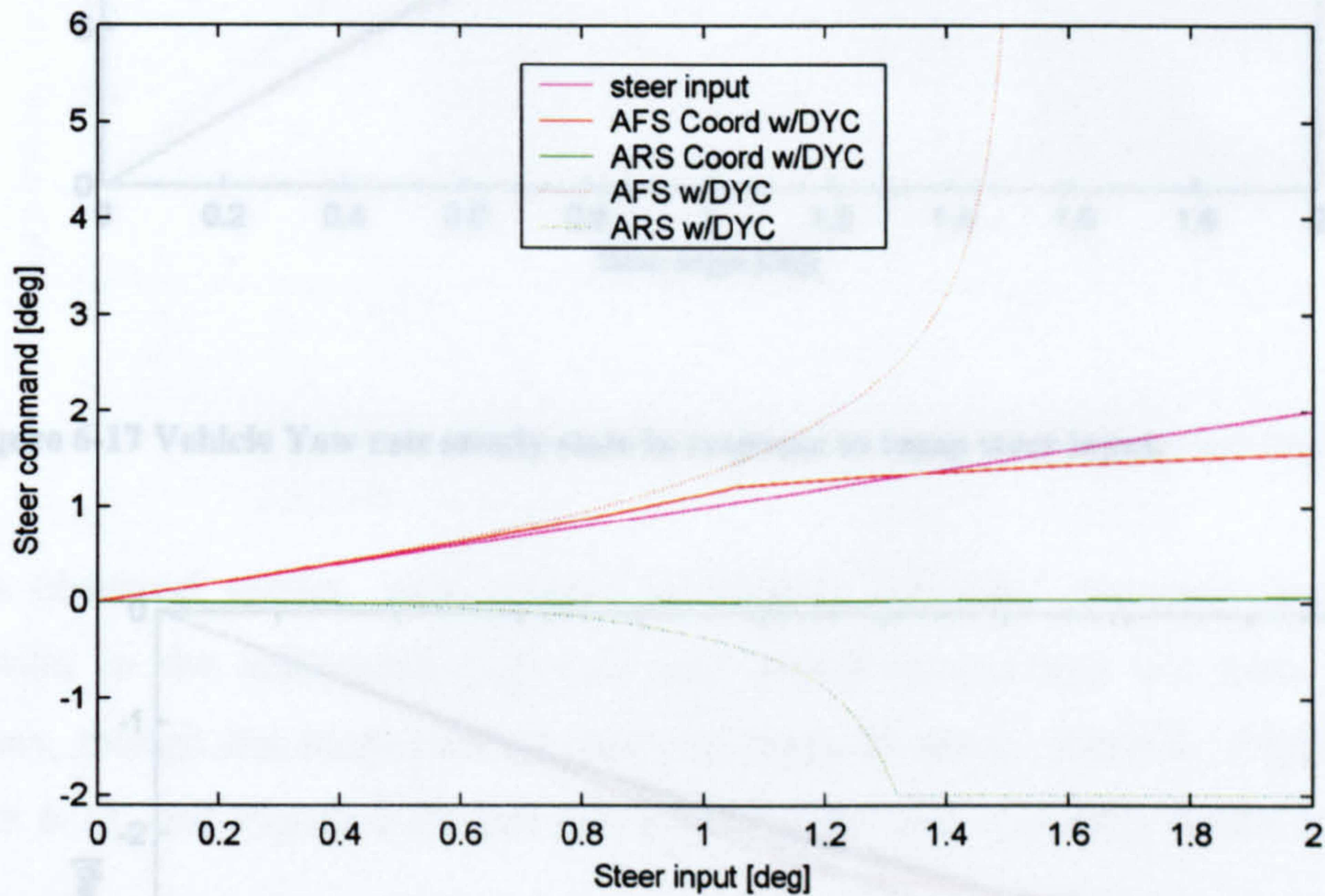

Figure 6-16 Ramp steer input at constant forward speed to evaluate steady state characteristics of co-ordination technique and resultant controlled steer angles.

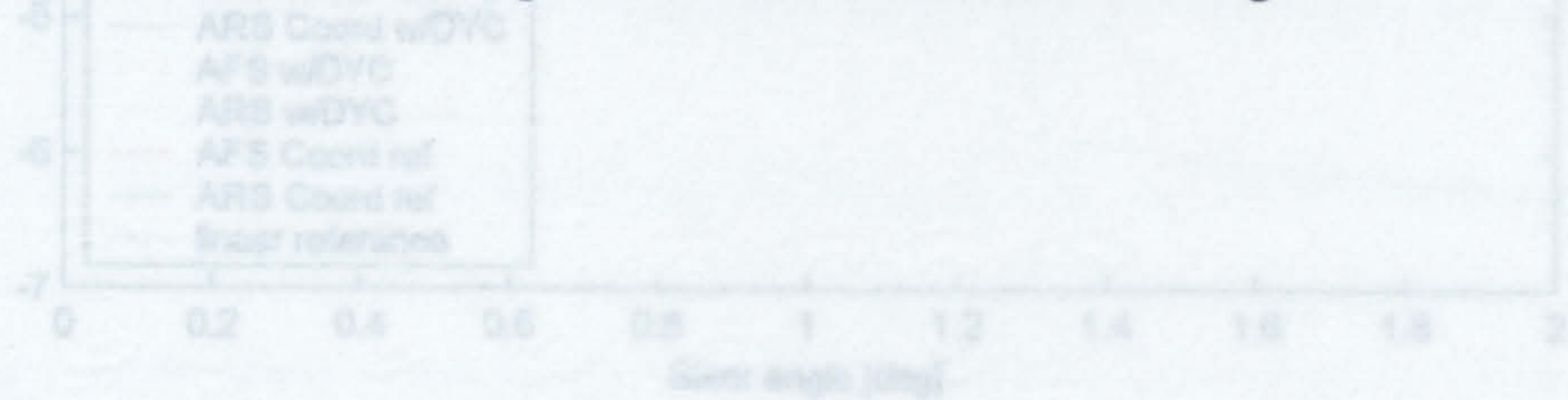

Figure 6-18 Vehicle steady state side slip angle in response to a ramp steer input

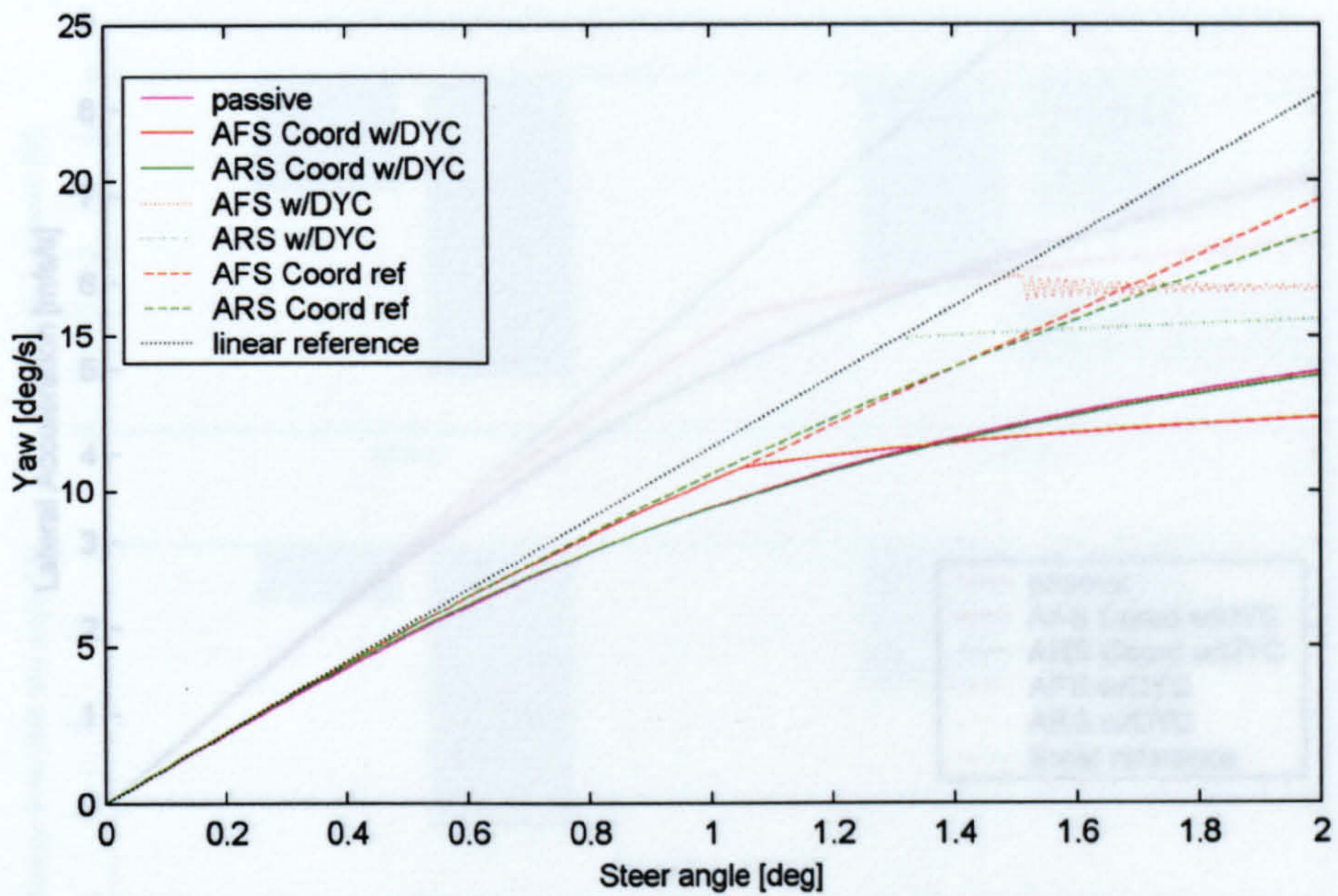

Figure 6-17 Vehicle Yaw rate steady state in response to ramp steer input.

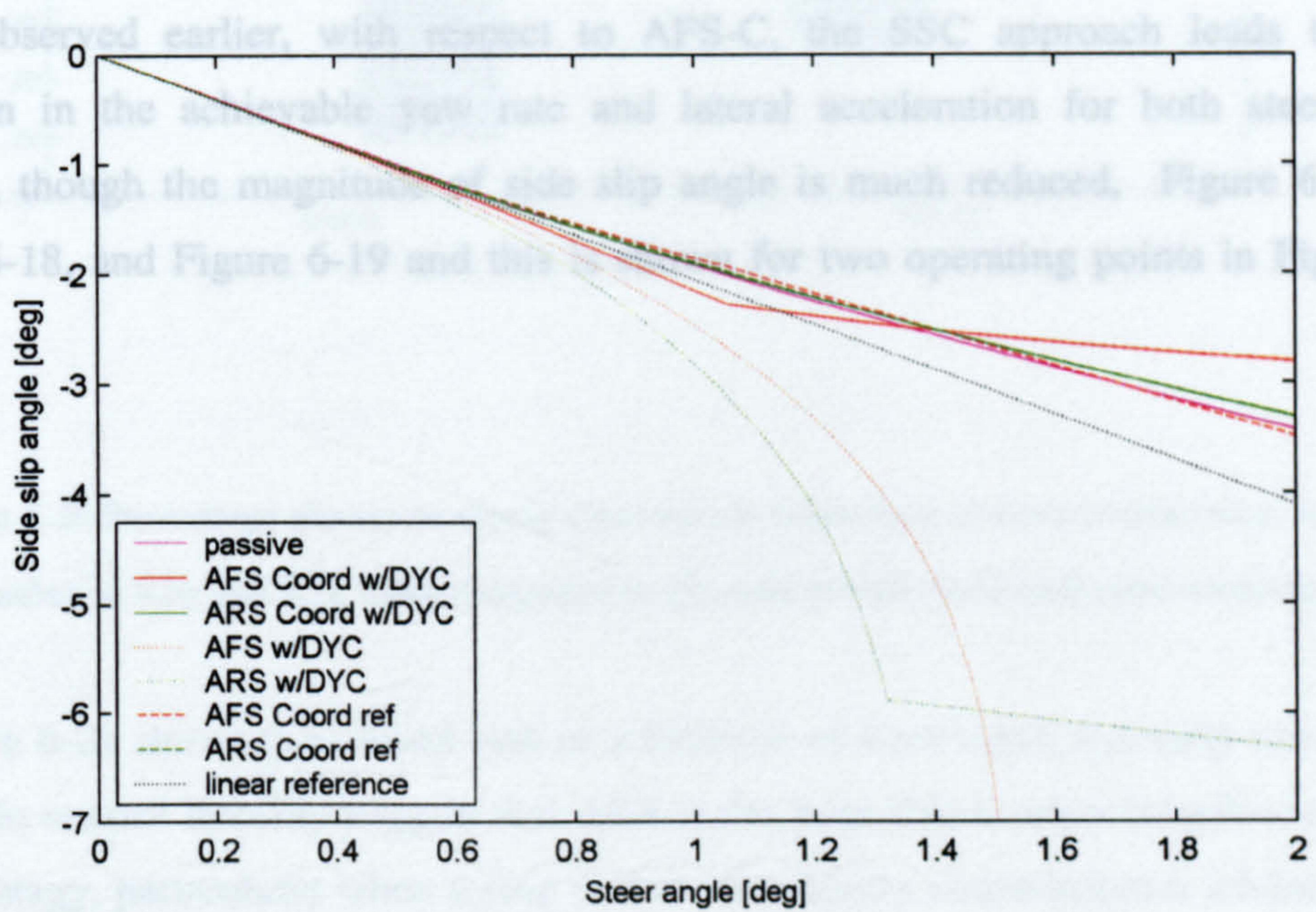

Figure 6-18 Vehicle steady state side slip angle in response to a ramp steer input

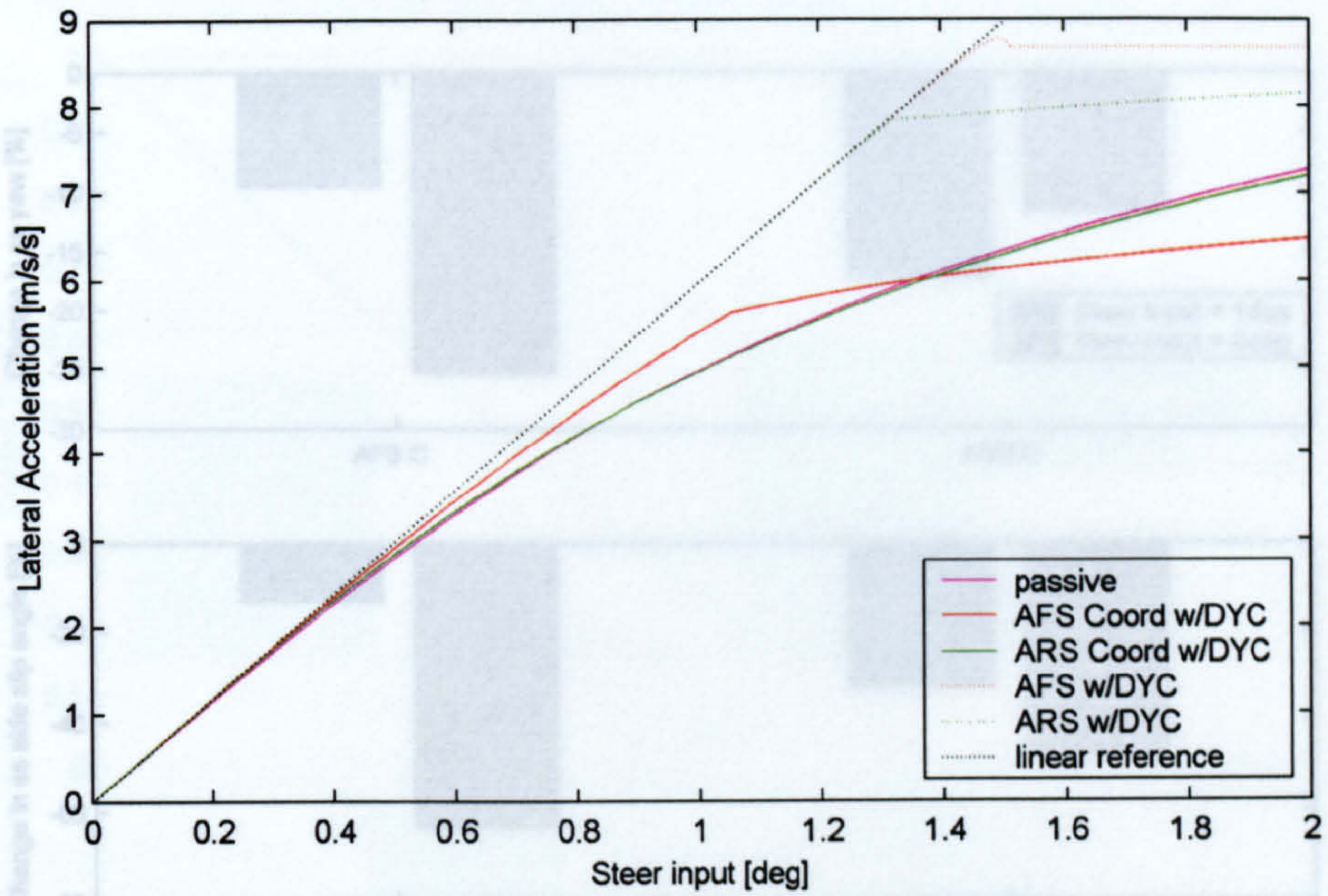

Figure 6-19 Vehicle steady state lateral acceleration in response to a ramp steer input

As observed earlier, with respect to AFS-C, the SSC approach leads to a reduction in the achievable yaw rate and lateral acceleration for both steering systems, though the magnitude of side slip angle is much reduced, Figure 6-17, Figure 6-18, and Figure 6-19 and this is shown for two operating points in Figure 6-20.

Figure 6-20 Percentage change in steady state vehicle behaviour at two constant steer inputs corresponding to 0.5g and 0.7g when compared to the vehicle with non-coordinated controllers.

Figure 6-21 shows the control task as a function of steer input, the early onset of actions to control stability suggest that ARS is the best way to offer benefits in this SSC strategy, particularly when trying to limit oversteer characteristics whilst still improving limit directional stability.

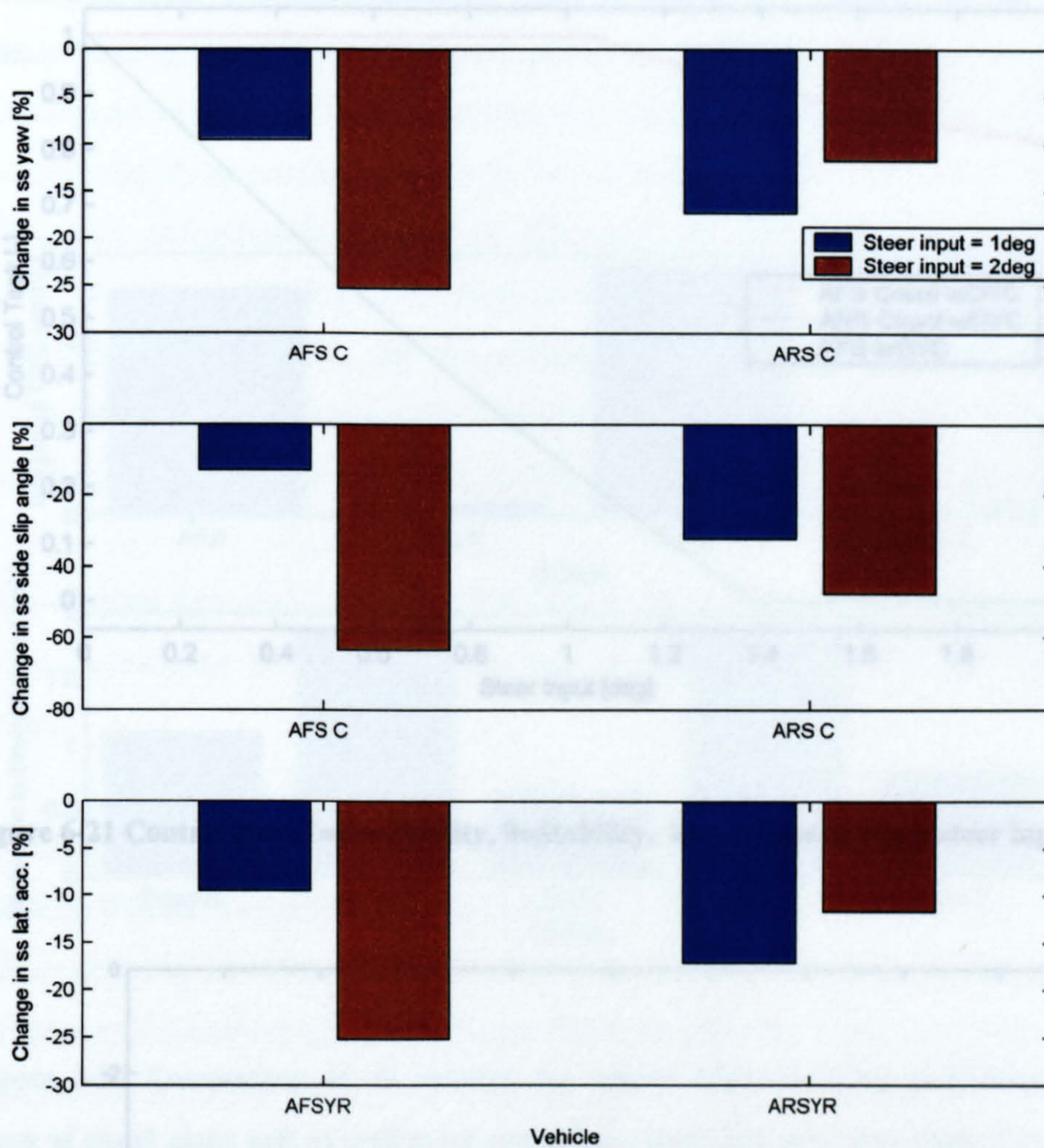

Figure 6-20 Percentage change in steady state vehicle behaviour at two constant steer inputs corresponding to 0.5g and 0.7g when compared to the vehicle with unco-ordinated controllers.

Figure 6-21 shows the control task as a function of steer input, the early onset of actions to control stability suggest that ARS is the least able to offer benefits in this SSC strategy, particularly when trying to tune steerability characteristics whilst still improving limit directional stability.

Figure 6-22 *DYC controller demanded wheel slip at front outer wheel in response to ramp steer input*

The three bar graphs Figure 6-23 summarise the differences between systems for the transient tests described through time histories for AFS-C in the previous section.

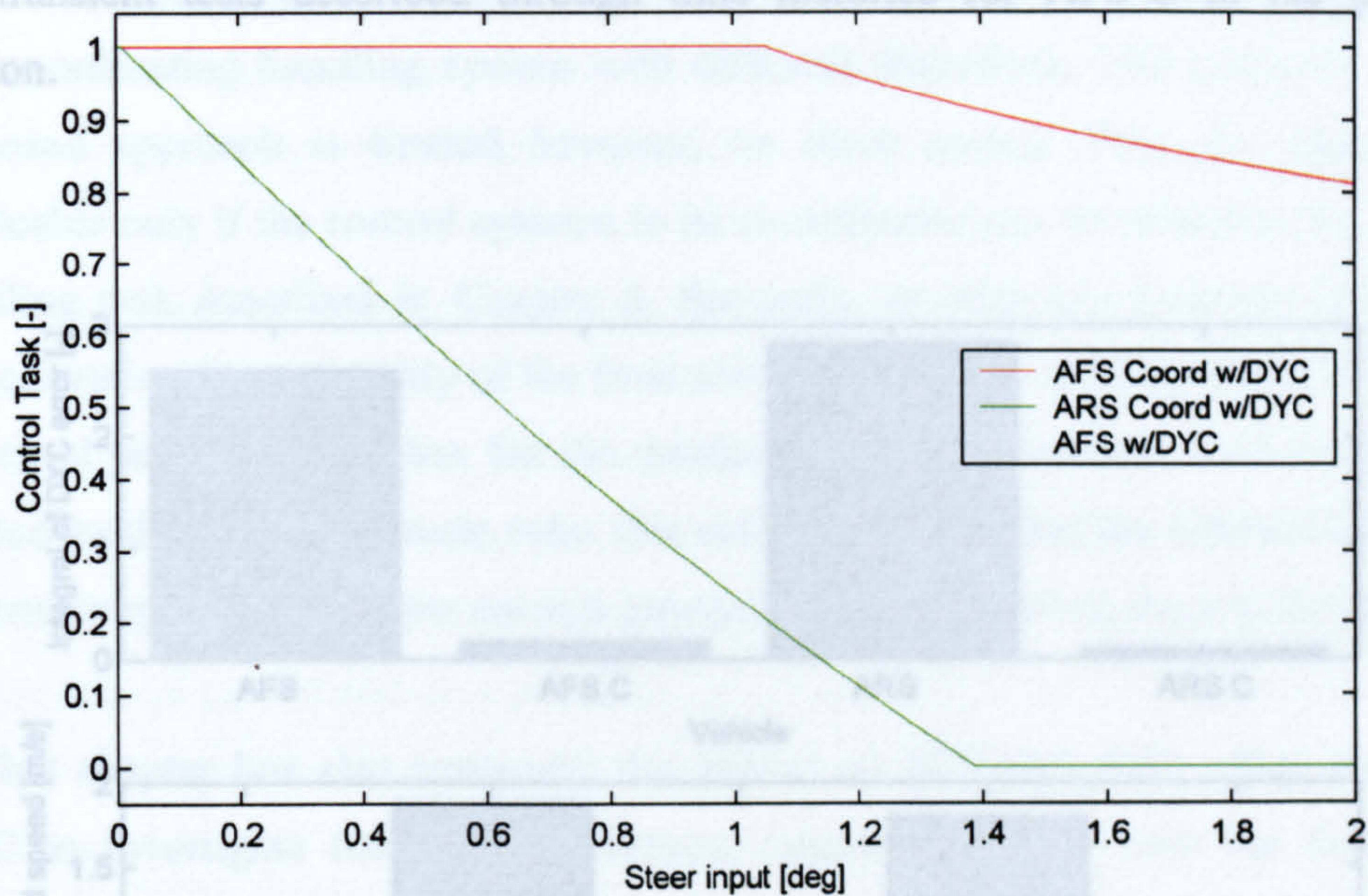

Figure 6-21 Control task, 1=Steerability, 0=Stability, in response to ramp steer input.

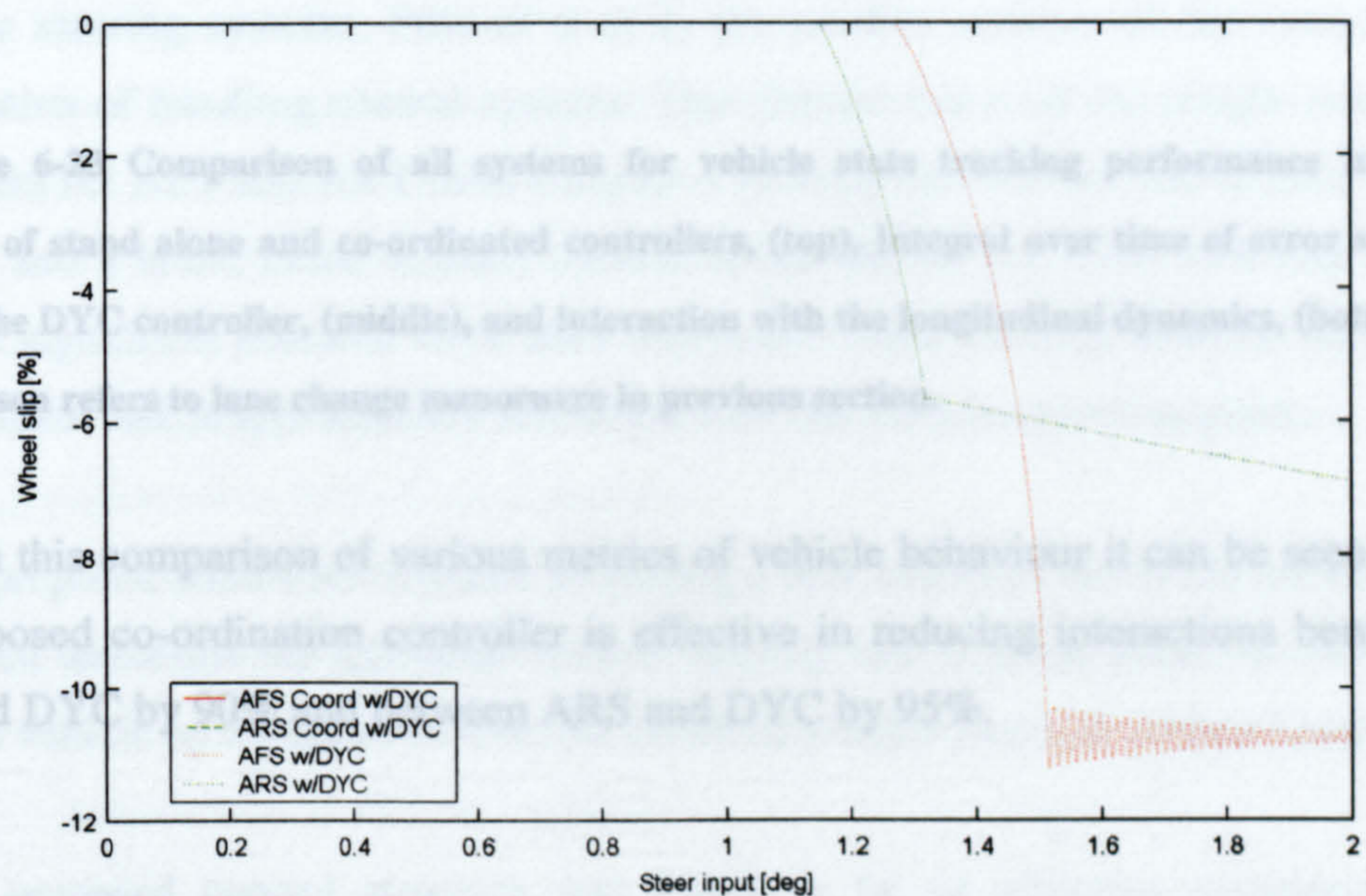

Figure 6-22 DYC controller demanded wheel slip at front outer wheel in response to ramp steer input

6.5 Conclusions

The proposed sub system co-ordination (SSC) problem. The SSC controller proposed was designed with the specific aims of reducing interactions and exploiting synergies between a steering controller and a brake based controller. This was achieved through the detailed understanding of the problem gained in Chapter 3. It

The three bar graphs Figure 6-23 summarise the differences between systems for the transient tests described through time histories for AFS-C in the previous section.

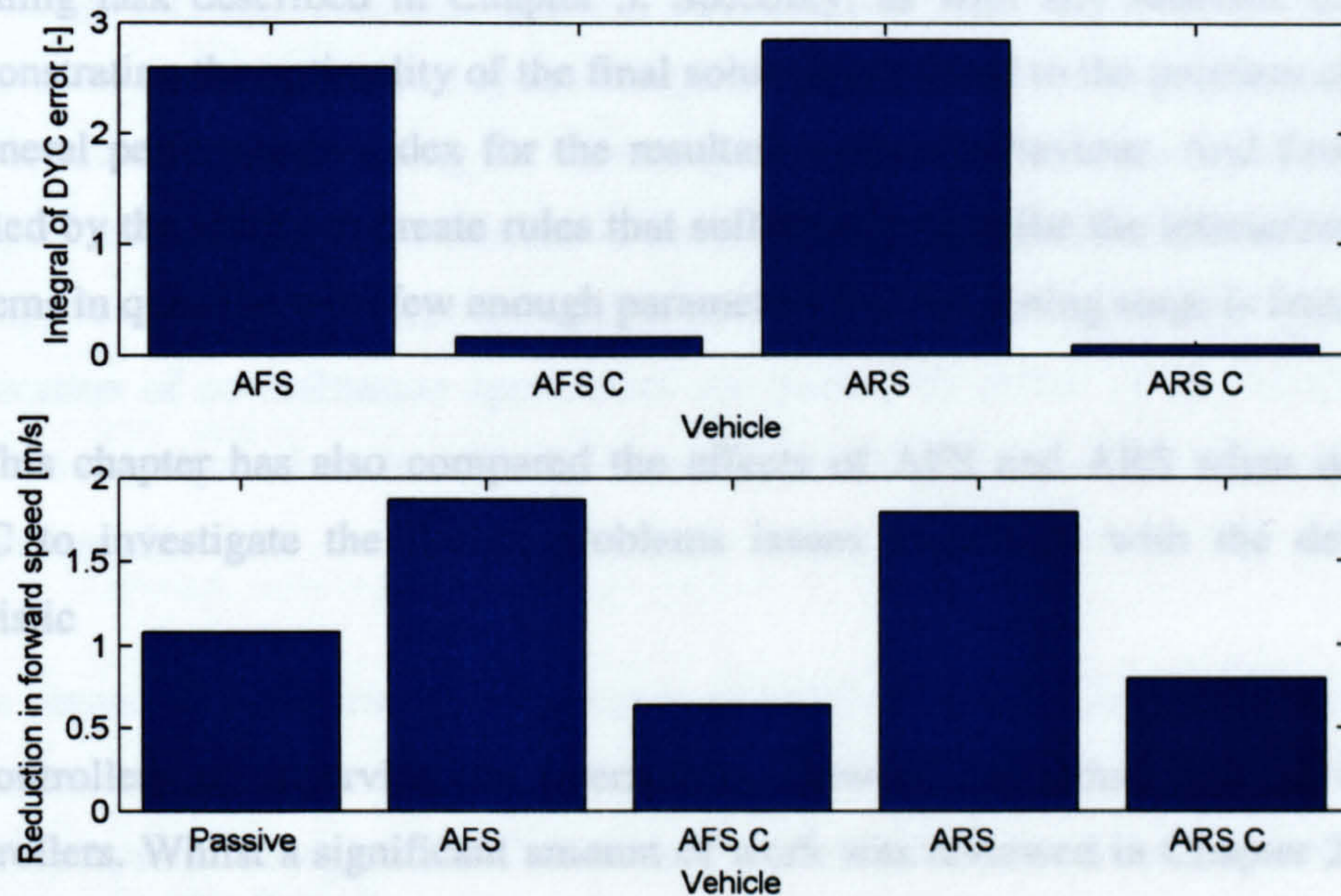

Figure 6-23 Comparison of all systems for vehicle state tracking performance in the presence of stand alone and co-ordinated controllers, (top), Integral over time of error signal driving the DYC controller, (middle), and interaction with the longitudinal dynamics, (bottom). Comparison refers to lane change manoeuvre in previous section.

From this comparison of various metrics of vehicle behaviour it can be seen that the proposed co-ordination controller is effective in reducing interactions between AFS and DYC by 90% and between ARS and DYC by 95%.

6.5 Conclusions

This chapter has proposed new approach applying a simple fuzzy scheduling controller sub system co-ordination (SSC) problem. The SSC controller proposed was designed with the specific aims of reducing interactions and exploiting synergies between a steering controller and a brake based controller. This was achieved through the detailed understanding of the problem gained in Chapter 3. It

goes further than much of the work reviewed in Chapter 2 as the approach is not limited to steering and braking examined here but provides a general methodology for co-ordinating handling system with different objectives. The generality of the proposed approach is limited however, on three counts. First the approach is applicable only if the control systems to be co-ordinated can be related to the vehicle handling task described in Chapter 3. Secondly, as with any heuristic controller, demonstrating the optimality of the final solution is related to the problem of finding a general performance index for the resultant vehicle behaviour. And finally, it is limited by the ability to create rules that sufficiently describe the interactions of the systems in question with few enough parameters that the tuning stage is feasible.

This chapter has also compared the effects of AFS and ARS when used with **DYC** to investigate the design problems issues associated with the developing heuristic

controllers to supervise the interactions between individual vehicle handling controllers. Whilst a significant amount of work was reviewed in Chapter 2 relating to active steering systems, little of it is in the modern context of the increasing proliferation of handling control systems. This chapter has used the simple steering controllers for AFS and ARS from Chapter 4 to study the interactions of these two systems and a brake based stability system. It has shown that both AFS and ARS have the significant potential to be used with brake based stability systems but only if the control task is appropriately scheduled with the vehicle operating point.

The proposed controller structure proposing a new extended use of the previously developed technique for assessing vehicle stability, the β phase plane, in order to measure vehicle operating point over the entire non-linear range of vehicle handling.

The proposed control structure was found to be an effective technique for scheduling steering controllers between steerability and stability tasks. Further, it was shown that handling regime could be effectively described through the use of one fuzzy rule which leads to simple tuning as only two parameters need to be identified.

The main draw back of these heuristic approaches is the difficulty in proving the optimality of the approach based on any general performance index. It is also going to be problematic to tune these systems, particularly considering subjective assessment will play such a significant role in their eventual acceptance.

Though this approach had only one rule and two parameters, there are potential gains to be made by increasing the complexity of the rule set in improving the yaw rate behaviour and extending the cornering limit. As such approaches become more complex it is likely that the number of parameters to tune will become prohibitive in the application of this approach. This leads to the conclusion that the practical application of co-ordination approaches are limited by either, a) the complexity of the rule set required to describe the interactions or b) the number of systems to be co-ordinated.

In terms of comparing the potential of ARS-C and AFS-C in this controller structure, both were found to perform similarly in supporting the role of DYC as a stability system though AFS-C was the more effective in tuning the steerability handling behaviour of the vehicle. The handling results and the fuzzy parameters identified for ARS-C implies that supporting a brake based stability system should reduce side slip throughout the vehicle operating regime. Though this suggests that ARS is less flexible for affecting vehicle handling behaviour over the entire range of vehicle handling. In terms of vehicle handling, the co-ordination controller is found to constrain side slip behaviour to the stable region, whilst trading off limit cornering performance in both combinations.

The approach proposed has been shown to be a powerful tool for controlling the interactions between handling controllers as it relates control functions to practical linguistics descriptions of vehicle handling .

7 Conclusions

At the outset of this thesis, the value and potential of vehicle handling controllers in terms of increased safety, performance and flexibility in handling behaviour were explained. It was further noted that, improving the interactions between controllers could result in increased performance and reduced cost. In order to investigate this potential a detailed review of the literature relating to systems for affecting vehicle handling was performed. The review allowed a clear direction for this work to be established and specific aims and objectives to be stated. These conclusions will describe how, and to what extent, those objectives have been satisfied.

The literature relating to handling systems is vast, but a structure was extracted relating to the actuation method systems used to affect vehicle handling behaviour, namely steering, braking, driveline and suspension. Each field was reviewed and in addition, literature on the interactions between systems which is comparatively limited, was also studied.

It was identified that the proliferation of control systems on passenger cars is likely to take an evolutionary approach and that the system which has recently attracted most commercial exploitation is the brake based stability system, DYC. This is due to the fact that there are already a large number of cars equipped with ABS and that DYC is a relatively simple extension to ABS functionality. In addition, it was decided to consider the use of active steering in conjunction with DYC as this system has the greatest ability to change the vehicle handling behaviour over the greatest range of the vehicle operating regime but not at the limit, where DYC tends to be employed. Interestingly, BMW has now announced the first commercial application of active front steering on the BMW 5 Series some time in 2003.

In order to investigate the interactions that exist between these two systems, active steering and DYC, a discussion of the required modelling complexity was formulated in chapter 2. It was concluded that the dominant non-linear effects result from the highly non-linear tyre properties and from the non-linear suspension

characteristic. A 4 D.O.F. vehicle model, including lateral velocity, yaw and roll with non-linear suspension and tyre characteristics of a large luxury saloon car was implemented in simulation.

In light of the literature review and a study of the vehicle dynamics, different aspects of vehicle handling defined as falling into two distinct areas of the complete non-linear handling regime were identified. The first, called steerability, is characterised by fact that it is the vehicle response to driver inputs that is most important, i.e. that it should be “easy” and predictable. This corresponds to what is referred to as the low – mid lateral acceleration region of vehicle handling. However, it is recognised that defining vehicle handling is not straight forward because it is influenced by the surface coefficient of friction. The second, called stability, is the region in which directional stability (rather than the more analytic mathematical stability) is the most important characteristic and corresponds to the high lateral acceleration manoeuvres. These two regions were related to the vehicle states and it was shown that steerability corresponds to yaw rate control and stability corresponds to side slip angle bounding. Although the terms steerability and stability have been previously applied to yaw rate tracking and side slip angle bounding, there has not been an objective relationship established in the context of the complete non-linear handling regime. The relationship established here for the first time allows a new a controller structure to be proposed in which the control task, yaw rate tracking and side slip angle bounding, is scheduled as a function of handling task, steerability and stability.

In order to fully assess the performance of steering controllers in the context of co-ordination, the ability of these systems to affect vehicle handling over a wide range of vehicle motions needed to be considered. This is something which is not apparent in the literature, which in general was characterised by a lack of appropriate modelling and a lack of generality in the objectives posed. For this reason, linear controllers were designed for AFS, ARS and A4S for yaw rate and lateral velocity tracking and evaluated on the non-linear model discussed. This study showed that, linear AFS and ARS controllers were highly effective at controlling the vehicle handling motion in the context of the driving tasks identified, steerability and stability. ARS was also found to be between 3 and 12 times better than AFS for performing the stability task and 1.1 and 17 times better for performing the

steerability task when used in isolation as the only vehicle handling controller. This assessment is based on the performance as tracking controllers for the states identified for the two tasks, steerability and stability.

However, a linear A4S controller was found to perform poorly and this was related to the high condition number of the plant implying, that the designed linear controllers are highly sensitive to parameter changes and to coupling between input output pairs. A simplified SMC, based on a linear vehicle model was found not to improve the situation and it was concluded that in contrast to AFS and ARS, non-linear model based methods must be used to achieve the potential benefits of A4S. The A4S controller was not considered further in this study.

A DYC controller typical of many proposed in the literature was implemented and found to be capable of performing the stability task at operating points where the active steering systems could not. This controller was based on the, now common, β phase plane method for assessing vehicle directional stability. The effectiveness and robustness of this approach has been demonstrated extensively in the literature for brake based stability systems.

The use of β phase plane has been extended from describing purely vehicle stability to quantitatively measure vehicle operating point. Through the use of a fuzzy membership function with parameters identified on the NLVM using numerical optimisation, the β phase plane was used to establish whether the dominant handling task was one of steerability or stability.

Based on this measure of vehicle operating point, a new controller structure for the co-ordination of vehicle handling controllers was proposed. This controller structure is characterised by a hierarchical heuristic controller to arbitrate between two steering controllers.

The controller structure, importantly does not interfere with the DYC safety system but was shown to support its operation. This was demonstrated through a 55-65% reduction in interference in the longitudinal vehicle motions in an aggressive transient manoeuvre and 15% reduction in the use of the brakes to control stability in steady state and a 15% reduction in steady state slip angle. This however was at

the expense of 9% reduction in steady state yaw rate and lateral acceleration. Also similar restrictions in cornering performance were observed in transient tests.

As has been stated, a reduction in side slip angle implies improved stability. The controller structure proposed here reduces side slip angle in both transient and steady state handling through appropriately scheduling controllers as a function of vehicle operating point. These improvements in vehicle safety were observed to limit cornering performance in terms of peak yaw rate and lateral acceleration which suggests an inherent trade-off between ensuring safety, or stability, and maximising cornering performance.

In order to identify the parameters of the heuristic controller, a practical performance index is required. The one used here explicitly describes the trade-off between vehicle stability and vehicle cornering performance. The optimality with respect to all aspects of vehicle handling is difficult to show as the definition of an all encompassing metric of vehicle behaviour is elusive as it inextricably linked to driver subjective assessments. A particularly attractive feature of the controller structure proposed here is that only two parameters are required to be identified. Further these are related through the cost function by two designer selectable parameters to describe the relative importance of steerability and stability.

Specifically, the aims and objective of this thesis, set out in Chapter 2, have been met.

From an analysis of vehicle handling over the full operating spectrum, an objective definition of the control task has been developed. This involved separating the overall handling requirements into two distinct areas, termed steerability and stability. This new characterisation of the vehicle handling performance into distinct regimes was then used in the proposal of a new controller structure, involving a combination of active steering and DYC.

Based on an extension to the β phase plane stability technique, a metric was proposed that links the practical linguistic description of vehicle handling tasks to a quantitative measure of vehicle operating point. In the new controller structure, this

metric was used, through a fuzzy membership function, to arbitrate between a steerability controller and a stability controller.

The proposed controller was assessed by comparing it to a vehicle equipped with stand-alone controllers. The improvements through co-ordination were quantified, through steady state tests and an aggressive transient manoeuvre, in three ways:-

Interactions with the vehicle longitudinal motions were quantified by the reduction in vehicle forward speed. This was found to reduce by 65% for AFS co-ordinated with DYC(AFS-C) and 56% for ARS co-ordinated with DYC(ARS-C) for an aggressive transient manoeuvre of approximately 0.7g. For the steady state manoeuvre, this was quantified by the steering controllers removing the need for brake based stability control altogether for all operating points.

Steerability performance was quantified by comparing the yaw behaviour of the co-ordinated vehicle in the same transient and steady state tests. Peak yaw rates reduced by 23% for both AFS-C and ARS-C. However, AFS-C had an additional high frequency component, about 25% amplitude of the peak, that is not found in the ARS-C case. During steady state cornering, with a 2° steer input (which corresponds to approximately 0.7g at 30m/s on a high μ surface), a 20% and 12% reduction in yaw rate was observed for AFS-C and ARS-C, respectively.

The ability of the controller structure to improve stability performance was quantified by comparing the side slip behaviour in the same transient and steady state tests. Peak side slip angles were reduced by 50% and 43% for AFS-C and ARS-C respectively. During steady state cornering, with a 2° steer input, a 64% and 47% reduction in side slip angle was observed for AFS-C and ARS-C, respectively.

7.1 Further Work

This section will propose areas, that in the light of this thesis, are considered to require further investigation.

The literature review at the start of this thesis noted that although much work has been presented on active steering controllers and that simple implementations have found their way in to the market, the potential of these systems has yet to be fully understood or realised, particularly in the area of four wheel steering. Any future work must be performed through a detailed understanding of vehicle non-linearities and the fact that as the primary control input of current steering controllers are required to perform a wide range of tasks from manoeuvring in car parks to high speed, high lateral acceleration manoeuvring.

One of the main areas where it is difficult to be entirely objective in this work is the evaluation of the final SSC system optimality with respect to vehicle handling. In addition to this, the question of optimality with respect to the human-machine interactions also exists. The fact that these advanced control systems can significantly affect vehicle behaviour poses interesting questions about how drivers respond to these changes. A further potential opportunity exists to redefine the human machine interface between cars and drivers to reduce work loads or to support the physically impaired.

Work in the field of multivariable controllers for all aspects of vehicle dynamics is currently ongoing. There exists a potential for these systems to be valuable even before they become practically viable. This is suggested by the trend that was observed in the field of brake based stability controllers. The initial heuristic approaches were mirrored by the more analytic model based approaches where the optimality can be assessed quantitatively. A similar benchmarking of approach would give valuable insight into the vehicle handling problem and confirm the validity, or otherwise of heuristic approach suggested here and in other works.

References

- Abe, M. (1992). "Roll moment distribution control in active suspension for improvement of limit performance of vehicle handling." (SAE923068).
- Abe, M. (1998). "Vehicle Dynamics and Control for improving handling and active safety: from 4WS to DYC." Proc. Institute of Mechanical Engineers: Part D: 229-248.
- Abe, M., Y. Kano, Y. Shibahata and Y. Furukawa (1999). "Improvement of vehicle handling safety with vehicle side-slip control by direct yaw moment." *Vehicle System Dynamics* 33: 665-679.
- Abe, M., Y. Kano, K. Suzuki, Y. Shibahata and Y. Furukawa (2001). "Side-slip control to stabilize vehicle lateral motion by direct yaw moment." *Jsaec Review* 22(4): 413-419.
- Abe, M., N. Ohkubo and Y. Kano (1994). "Comparison of 4WS and Direct Yaw Moment Control for Improvement of Vehicle Handling Performance." (SAE9438196).
- Abe, M., N. Ohkubo and Y. Kano (1996). "A direct yaw moment control for improving limit performance of vehicle handling - Comparison and cooperation with 4WS." *Vehicle System Dynamics* 25: 3-23.
- Abe, M., Y. Shibahata and Y. Shimuzu (2000). Analysis on Steering Gain and Vehicle Handling Performance with Variable Gear-ratio Steering System(VGS). FISITA World automotive congress, Seoul, Korea.
- Ackermann, J. (1990). "Robust Car Steering by Yaw Rate Control." Proceedings of the 29th Conference on Decision and Control(TP-2-3:50): 2033-2034.
- Ackermann, J. (1992). "Robust yaw damping of cars with front and rear wheel steering." Proceedings of the 31st Conference on Decision and Control: 2586-2590.
- Ackermann, J. (1993). "Robust Yaw Damping of Cars with Front and Rear Steering." *Ieee Transactions on Control Systems Technology* 1(1): 15-20.

- Ackermann, J. (1994). Robust Decoupling of Car Steering Dynamics with Arbitrary Mass Distribution. Proceedings of the American Control Conference, Baltimore, Maryland.
- Ackermann, J. (1996a). Robust Control Prevents Car Skidding. IEEE Control Systems. June: 23-31.
- Ackermann, J. (1996b). Safer Car Driving by Robust Steering Control. UKACC International Conference on CONTROL 96.
- Ackermann, J. and T. Bunte (1997). Actuator Rate Limits in Robust Car Steering Control. Proceedings of the 36th conference on Decision and Control, San Diego, California.
- Ackermann, J., J. Guldner, W. Sienel, R. Steinhauser and V. I. Utkin (1995). "Linear and Nonlinear Controller Design for Robust Automatic Steering." Ieee Transactions on Control Systems Technology 3(1): 132-143.
- Aga, M., H. Kusunoki, Y. Satoh, R. Saitoh and M. Ito (1990). "Design of 2-Degree-of-Freedom Control System for Active Front-and-Rear-Wheel Steering." (SAE901746).
- Akita, T., K. Satoh, M. Kurimoto and T. Yoshida (2000). Development of the Active Front Steering Control System. FISITA World automotive congress, Seoul, Korea.
- Alleyne, A. (1997). "Improved vehicle performance using combined suspension and braking forces." Vehicle System Dynamics 27(4): 235-265.
- Badawy, A., F. Bolourchi and S. K. Gaut (1997). "The Design and Benefits of Electric Power Steering." (SAE973041).
- Badawy, A., J. Zurafski, F. Bolourchi and A. Chnady (1999). "Modelling and Analysis of an Electric Power Steering System." (SAE1999-01-0399).
- Bakker, E., L. Nyborg and H. B. Pacejka (1987). "Tyre Modelling for use in Vehicle Dynamics Studies." (SAE870421).
- Bang, M. S., S. H. Lee, C. S. Han, D. B. Maciuca and J. K. Hedrick (2001). "Performance enhancement of a sliding mode wheel slip controller by the

- yaw moment control." Proceedings of the Institution of Mechanical Engineers Part D- Journal of Automobile Engineering 215(D4): 455-468.
- Bjorkman, M. and K. Holmstrom (1999). "Global Optimization using the DIRECT Algorithm in MatLAB." Advanced Modelling and Optimization 1(2): 17-37.
- Bonito, M. M. and F. Herrera (1993). "Steering Systems with Speed Related Variable Forces." (SAE931617).
- Brennan, S. and A. Alleyne (2001a). Integrated Vehicle Control via Coordinated Steering and Wheel Torque Inputs. Proceedings of the American Control Conference, Arlington, VA.
- Brennan, S. and A. Alleyne (2001b). Integrated vehicle control via coordinated steering and wheel torque inputs. Proceedings of the 2001 American Control Conference, Vols 1-6. New York, I E E E: 7-12.
- Camacho, E. F. and C. Bordons (1999). Model predictive control, Springer.
- Cech, I. (2000). "Anti-Roll and Active Roll Suspensions." Vehicle System Dynamics 33: 91-106.
- Chabaan, R. C. and L. Y. Wang (2000a). H infinity Control of Electrical Power Assist Systems. International Symposium on Advanced Vehicle Control, Ann Arbor, Michigan.
- Chabaan, R. C. and L. Y. Wang (2000b). Torque Estimation in Electrical Power Assist Systems. International Symposium on Advanced Vehicle Control, Ann Arbor, Michigan.
- Cheng, J. (1998). "The Simulation Study of Vehicle Interactive Control." (SAE9837201).
- Clover, C. L. and J. E. Bernard (1993). "The influence of Lateral Load Transfer Distribution on Directional Response." (SAE930763).
- Constantine, J., C. and E. H. Law (1994). "The effects of roll control for passenger Cars during Emergency Maneuvers." (SAE940224).

- Darling, J., R. E. Dorey and T. J. Ross-Martin (1992). "A Low Cost Anti-Roll Suspension for passenger cars." *Journal of Dynamics systems, measurement and control*. 114: 599-605.
- Darling, J. and L. R. Hickson (1998). "An Experimental Study of a Prototype Anti-Roll Suspension System." *Vehicle System Dynamics* 29(5): 309-330.
- Darling, J. and T. J. Ross-Martin (1997). "A Theoretical investigation of a prototype active roll control system." *Proc. Institute of Mechanical Engineers: Part D* 211: 3-12.
- Darling, J., D. G. Tilley and L. R. Hickson (1999). "A centralized hydraulic system for passenger cars." *Proc. Institute of Mechanical Engineers: Part D* 213: 425-434.
- Dixon, J. C. (1991). *Tyres, suspension and handling*. Cambridge, Cambridge Universtiy Press.
- Dominke, P. and G. Ruck (1999). "Electric Power Steering - The First step on the Way to "Steer by Wire"." (SAE1999-01-0401).
- Donges, E. (1995). *Supporting drivers by chassis control systems. Smart Vehicles*. H. B. Pacejka and J. P. Pauwelussen: 276-296.
- Donges, E. and J. Wimberger (1993). "Performance and Safety Requirements for Auxilliary Steering Equipment by means of the example of BMW's Active Rear-Axle Kinematics(ARK)." *Vehicle System Dynamics* 22: 437-454.
- Doniselli, C., G. Mastinu and R. Cal (1994). "Traction control for front wheel drive vehicles." *Vehicle System Dynamics* 23(SUPPL): 87-104.
- Draknov, S. V., B. Ashrafi and A. Rosiglioni (2000). *Yaw Control Algorithm via Sliding Mode Control*. American Control Conference, Chicagio, Illinois.
- Dugoff, H., et AL (1970). "An Analysis of tyre traction properties and their influence on vehicle dynamic performance." (SAE700377).
- Everett, N. R., M. D. Brown and D. A. Crolla (2000a). "Investigation of a roll control system for an off-road vehicle." (SAE2000-01-1646).

- Everett, N. R., M. D. Brown and D. A. Crolla (2000b). Investigation of the integration of a roll control system and a traction force distribution system for an off-road vehicle. International Symposium on Advanced Vehicle Control, Ann Arbor, Michigan.
- Feng, K.-T., H.-S. Tan and M. Tomizuka (2000). Decoupling Steering Control For Vehicle Using Dynamic Look-Ahead Scheme. International Symposium on Advanced Vehicle Control., Ann Arbour, Michigan.
- Fennel, H. and E. L. Ding (2000). "A Model-Based Failsafe System for the Continental TEVES Electronic Stability Program (ESP)." (SAE2000-01-1635).
- George, S. C., W. Burdock, K. J. Burnham, M. Campbell and J. L. Mahtani (2000). Genetic Algorithms for model optimisation of pressure control valves automotive applications. UKACC International Conference on Control, Cambridge, UK.
- Gerum, E., L. Palkovics and A. Semsey (1998). Drive Stability Control System for Commercial Vehicles. FISITA World Automotive congress.
- Gianone, L., L. Palkovics and J. Bokor (1995). "Design of an active 4WS system with physical uncertainties." Control Engineering Practice 3(8): 1075-1083.
- Glad and Ljung (2000). Control theory multivariable and nonlinear methods. London, Taylor & Francis.
- Gordon, T. J., L. Palkovics, C. Pilbeam and R. S. Sharp (1994). "Second Generation Approaches to Active and Semiactive Suspension Control-System Design." Vehicle System Dynamics 23: 158-171.
- Guldner, J., J. Ackermann, W. Sienel and H.-S. Tan (1999). "Robust Automatic Steering Control for Look-Down Reference Systems with Front and Rear sensors." Ieee Transactions on Control Systems Technology 7(1): 2-11.
- Guldner, J., V. I. Utkin and J. Ackermann (1994). A Sliding Mode Control Approach to Automatic Car Steering. Proceedings of the American Control Conference, Baltimore, Maryland.

- Hac, A. and M. O. Bodie (2002). "Improvements in vehicle handling through integrated control of chassis systems." *International Journal of Vehicle Design* 29(1-2): 23-50.
- Harada, M., H. Shinjyou, K. Matsuda, K. Oophata and K. Sakata (1998). *Vehicle Behaviour Stabilization technique for truck by Control of Braking Force. FISITA World Automotive Congress.*
- Hayama, R., K. Nishizaki, S. Nakano and K. Katou (2000). *The vehicle stability control responsibility improvement using steer-by-wire. Proceedings of the IEEE Intelligent Vehicles Symposium, Dearborn, Michigan.*
- Hirano, Y., H. Harada, E. Ono and K. Takanami (1993). "Development of an Integrated System of 4WS and 4WD by Hinf Control." (SAE930267).
- Hirano, Y. and E. Ono (1994). "Non-linear Robust Control for an Integrated System of 4WS and 4WD." (SAE9438178).
- Horiuchi, S., K. Okada and S. Nohtomi (1998). "Integrated Control of Four Wheel Steering and Wheel Torques using Nonlinear Predictive Controller." (SAE9836464).
- Horiuchi, S., K. Okada and S. Nohtomi (1999a). "Effects of integrated control of active four wheel steering and individual wheel torque on vehicle handling and stability - A comparison of alternative control strategies." *Vehicle System Dynamics* 33: 680-691.
- Horiuchi, S., K. Okada and S. Nohtomi (1999b). "Improvement of vehicle handling by nonlinear integrated control of four wheel steering and four wheel torque." *JSAE Review* 20(4): 459-464.
- Hrovat, D. (1997). "Survey of advanced suspension developments and related optimal control applications." *Automatica* 33(10): 1781-1817.
- Huh, K., C. Seo, J. Kim and D. Hong (1999). *Active Steering Control Based on the Estimated Tire Forces. Proceedings of the American Control Conference, San Diego, California.*
- Hwang, S.-M. and Y. Park (1994). "Active Roll Control and Roll Distribution Control for Ground Vehicle." (SAE9438493).

- Hwang, S.-M. and Y. Park (1995). "Active roll moment distribution based on predictive control." *International Journal of Vehicle Design* 16(1): 15-28.
- Inagaki, S., I. Kshiro and M. Yamamoto (1994). "Analysis on Vehicle Stability in Critical Cornering using Phase-Plane Method." (SAE9438411).
- Inoue, H. and F. Sugawara (1993). "Comparison of Feedforward and Feedback Control for 4WS." *Vehicle System Dynamics* 22: 425-436.
- Irie, N. and J. Kuroki (1990). "4WS Technology and the Prospects for Improvement of Vehicle Dynamics." (SAE901167).
- Jones, D. R., C. D. Perttunen and B. E. Stuckman (1993). "Lipschitzian optimization without the Lipschitz constant." *Journal of Optimization Theory and Applications* 79(1): 157-181.
- Kageyama, I. (1992). "A stability control method for Articulated Vehicle at Braking." (SAE923060).
- Kahrs, J. J. and E. H. Law (1995). "An investigation of the Effects of Roll Control on Handling and Stability of passenger vehicles during severe Lane Change Maneuvers." (SAE950305).
- Kawakami, H., H. Sato, M. Tabata, H. Inoue and H. Itimaru (1992). "Development of Intergrated System Between Active Control Suspension, Active 4WS, TRC and ABS." (SAE920271).
- Kimbrough, S. (1994). "A computer investigation of the performance of an advanced brake controller." (SAE940836).
- Kleine, S. and L. van Niekerk (1998). "Modelling and Control of a Steer-By-Wire Vehicle." *Vehicle System Dynamics* 28: 114-142.
- Kohno, T., S. Takeuchi, M. Momiyama, H. Nimura, E. Ono and S. Asai (2000). "Development of Electrical Power Steer(EPS) System with H infinity control." (SAE2000-01-0813).
- Koibuchi, K., M. Yamamoto, Y. Fukada and S. Inagaki (1996). "Vehicle Stability Control in Limit Cornering by Active Brake." (SAE960487).

- Konik, D., R. Bartz, F. Barnthol, H. Bruns and M. Wimmer (2000). Dynamic Drive - the New Active Roll Stabilization System from the BMW Group - System Description and Fundamental Improvements. International Symposium on Advanced Vehicle Control, Ann Arbor, Michigan.
- Koumboulis, F. N. and M. G. Skarpetis (2002). "Robust control of cars with front and rear wheel steering." Control Theory and Applications, IEE Proceedings 149(5): 394-404.
- Kramer, W. and M. Hackl (1996). Potential Functions and benefits of Electronic Steerin Assistance. FISITA World automotive congress.
- Kuriki, N. and Y. Shibahata (1998). Development of Active Torque Transfer System. FISITA World Automotive Congress.
- Kusahara, Y., X. Li, N. Hata and Y. Watanabe (1994). "Feasibility Study of Active Roll Stabilizer for reducing Roll Angle of an Experimental Medium Duty Truck." (SAE9438501).
- Kwak, B. and Y. Park (2000). Robust Vehicle Stability Controller by Multiple Sliding Mode Control. International Symposium on Advanced Vehicle Control, Ann Arbor, Michigan.
- Lang, R. and U. G. Walz (1991). Active Roll Reduction. European Automobile Engineers Cooperation, 3rd International Congress, Strasbourg.
- Lee, A. Y. (1995). "Performance of Four-Wheel-Steering Vehicles in Lane Change Maneuvres." (SAE950316).
- Leffler, H. (1996). Electronic brake management EBM - a possible approach for brake and control system integration. FISITA World automotive congress, Czech Republic.
- Leffler, H., R. Auffhammer, R. Heyken and H. Roth (1998). "New Driving Stability Control System with Reduced Technical Effort for Compact and Medium Class Passenger Cars." (SAE980234).
- Leffler, H., H. Krusche, R. Auffhammer, H. Roth and H. Vieler (1998). Accident prevention by driving stability control for compact passenger cars. FISITA World automotive congress.

- Lin, R. C. and D. Cebon (1996). "Optimal roll control of a single-unit lorry." Proc. Institute of Mechanical Engineers: Part D 210: 45-55.
- Lin, R. C., D. Cebon and D. J. Cole (1993). An Investigation of Active Roll Control of Heavy Road Vehicles. Proceeding of IAVSD symposium, 13th, China.
- Mammar, S. and V. B. Baghdasarian (2000). Two-degree-of-freedom Formulation of Vehicle Handling Improvement by Active Steering. Proceedings of the American Control Conference, Chicago, Illinois.
- Mammar, S. and D. Koenig (2002). "Vehicle handling improvement by active steering." *Vehicle System Dynamics* 38(3): 211-242.
- Manning, W. J., D. A. Crolla, M. D. Brown and M. A. Selby (2000). Co-ordination of Chassis Control Systems for Vehicle Motion Control. International Symposium on Advanced Vehicle Control, Ann Arbor, Michigan.
- Selby, M. A., W. J. Manning, M. D. Brown and D. A. Crolla. "A Comparison Of The Relative Benefits Of Active Front Steering And Active Rear Steering When Co-ordinated With Direct Yaw Moment Control", ASME International Mechanical Engineering Congress and Exposition, New York 2001
- Manning, W. J., M. A. Selby, D. A. Crolla and M. D. Brown (2002). "IVMC: Intelligent Vehicle Motion Control." (SAE2002-01-0821).
- Mathworks, I. (2003a). MatLAB R13 "The optimization toolbox".
- Mathworks, I. (2003b). MatLAB R13 "User Manual".
- Matsuno, K., R. Nitta, K. Inoue, K. Ichikawa and Y. Hiwatashi (2000). Development of a New All-Wheel Drive Control System. FISITA World Automotive Congress, Seoul, Korea.
- McCann, R. (2000). "Variable Effort Steering for Vehicle Stability Enhancement Using an Electric Power Steering System." (SAE2000-01-0817).

- Millsap, S. A. and E. H. Law (1996). "Handling Enhancement Due to an Automotive Variable Ratio Electric Power Steering System Using Model Reference Robust Tracking Control." (SAE960931).
- Mitschke, M. and E. Ahring (1994). "Control Loop for Driver-Vehicle with Four Wheel Steering." (SAE947980).
- Mitschke, M., H. Wallentowitz and R. Schwarze (1991). ""Avoidance of critical lateral dynamic situations through dynamic behaviour monitoring" (Vermeiden querdynamisch kritischer Fahrzustände durch Fahrzustandssüberwachung)."
- Morari, M. and E. Zafiriou (1989). Robust process control. Englewood Cliffs, N.J, Prentice Hall.
- Motoyama, S., K. Isoda and T. Mimuro (1998). "Quantatative Evaluation for Yaw Control Ability." (SAE9837058).
- Motoyama, S., H. Uki, K. Isoda and H. Yuasa (1993). "Effect of Traction Force Distribution Control on Vehicle Dynamics." *Vehicle System Dynamics* 22: 455-464.
- Murata, M. and S. Ikeda (2000). Development of a Roll Attitude Control Theory for Semi Active Suspension Systems. FISITA World automotive congress, Seoul, Korea.
- Nagai, M., M. Shino and F. Gao (2002). "Study on integrated control of active front steer angle and direct yaw moment." *Jsaec Review* 23(3): 309-315.
- Nishimaki, T., N. Yuhara, Y. Shibahata and N. Kuriki (1998). "Hydraulic Pressure Controller Design for Direct Yaw Moment Control System." (SAE9836067).
- O'Brien, R. T. and G. E. Piper (2000). Steering Control of an Articulated Vehicle using Differential Braking. International Symposium on Advanced Vehicle Control, Ann Arbor, Michigan.
- Ono, E., S. Hosoe, S. Doi, K. Asano and Y. Hayashi (1998). "Theoretical Approach for improving the vehicle robust stability and maneuverability by active front wheel steering." *Vehicle System Dynamics* 28: 748-753.

- Ono, E., S. Hosoe, D. Hoang and S. Doi (1998). "Bifurcation in Vehicle Dynamics for Robust Front Wheel Steering Control." *Ieee Transactions on Control Systems Technology* 6(3): 412-420.
- Ono, E., S. Hosoe, H. D. Tuan and S. Doi (1996). Robust Stabilization of Vehicle Dynamics by Active Front Wheel Steering Control. Proceedings of 35th conference on Decision and Control, Kobe, Japan.
- Pacejka, H. B. and I. J. M. Besselink (1997). "Magic formula tyre model with transient properties." *Vehicle System Dynamics* 27: 234-249.
- Palkovics, L. and J. Boker (1994). "Stabilization of a Car-Caravan Combination using Active Unilateral Brake Control." (SAE9438169).
- Park, K. and S.-J. Heo (2000). Design of a control logic for improving vehicle dynamic stability. International Symposium on Advanced Vehicle Control, Ann Arbor, Michigan.
- Parsons, K. G. R., M. Pask and W. Burdock (2000). "The development of ACE for Discovery 2." (SAE2000-01-0091).
- Pawlak, A. M., D. W. Graber and D. C. Eckhardt (1994). "Magnetic Power Steering System - Magnasteer." (SAE942388).
- Plochl, M. and P. Lugner (1996). "Braking Behaviour of 4-Wheel-Steered Automobile with an Antilock Braking System." *Vehicle System Dynamics Supplement No. 25*: 547-558.
- Reusing, G., M. Ochs, U. G. Walz and J. Bungeler (1992). "Low-Cost Active Suspension." (SAE923033).
- Roppenecker, G. and H. Wallentowitz (1993). "Integration of chassis and Traction control systems, What is possible, what makes sense, what is under development." *Vehicle System Dynamics* 22: 283-298.
- Rosam, N. and J. Darling (1997). "Development and Simulation of a Novel Roll Control System for the interconnected Hydragas Suspension." *Vehicle System Dynamics* 27: 1-18.
- Ryu, J., J. Lee and H. Kim (1998). "Evaluation of a Direct Yaw Moment Control Algorithm by Brake Hardware-in-the-Loop Simulation." (SAE9836671).

- Sakai, S. and Y. Hori (2000). Advanced vehicle motion control of electric vehicle based on the fast motor torque response. International Symposium on Advanced Vehicle Control, Ann Arbor, Michigan.
- Sakakura, T., H. Shimosaka, N. Ehara and Y. Kuroda (1998). "A study on the braking stability of an articulated vehicle by controlling brake force." (SAE9837391).
- Salmon, M. (1990). Coordinated control of braking and steering. ASME symposium on Advanced Automotive Technologies.
- Sampson, D. J. M. and D. Cebon (1998). An Investigation of Roll Control System Design for Articulated heavy Vehicles. International Symposium on Advanced Vehicle Control, Ann Arbor, Michigan.
- Sampson, D. J. M., G. McKeivitt and D. Cebon (1999). "Development of Active Roll Control System for Heavy Vehicles." Vehicle System Dynamics Supplement No. 33: 704-715.
- Sano, S., Y. Furukawa and S. Shiraishi (1986). "Four Wheel Steering System with Rear Wheel Steer Angle Controlled as a Function of Steering Wheel Angle." (SAE860625).
- Sato, H., H. Kawai, M. Isikawa, H. Iwata and S. Koike (1991). "Development of four wheel steering system using yaw rate feedback control." (SAE911922).
- Sawase, K. and Y. Sano (1999). "Application of active yaw control to vehicle dynamics by utilising driving/braking force." Jsaе Review 20: 289-295.
- Selby, M. A., W.J. Manning, M. D. Brown and D. A. Crolla , "A Co-ordination Approach For DYC And Active Front Steering",. SAE2000-01-1275, SAE 2001 Transactions Journal of Passenger Cars - Mechanical Systems.
- Selby, M. A., M. D. Brown, W. J. Manning and D. A. Crolla (2000). Intelligent Vehicle Motion Control, Sub-system Coordination. FISITIA, Seoul.

- Sharp, R. S. (1994). Design concepts and details for an active roll control systems. Automotive Applications of Advanced Modelling and Control, IEE Colloquium on.
- Sharp, R. S. (2000). "Some contemporary problems in road vehicle dynamics." Proceedings of the Institution of Mechanical Engineers Part C - Journal of Mechanical Engineering Science 214: 137-147.
- Sharp, R. S. and D. Pan (1992). "On Active Roll Control for Automobiles." Vehicle System Dynamics 20: 566-583.
- Sharp, R. S. and D. Pan (1993). "On the design of an active roll control system for a luxury car." Proc. Institue of Mechanical Engineers: Part D 207: 275-284.
- Shibahata, Y., M. Abe, K. Shimada and Y. Furukawa (1994). "Improvement on Limit Performance of Vehicle Motion by Chassis Control." Vehicle System Dynamics 23: 449-468.
- Shibahata, Y., K. Shimada and T. Tomari (1992). "Improvement of Vehicle Maneuverability by Direct Yaw Moment Control." (SAE923081).
- Shimada, K. and Y. Shibahata (1994). "Comparison of Three Active Chassis Control Methods for Stabilizing Yaw Moments." (SAE940870).
- Shimuzu, Y. and T. Kawai (1991). "Development of Electric Power Steering." (SAE910014).
- Shimuzu, Y., T. Kawai and J. Yuzuriha (1999). "Improvement in Driver-Vehicle System Performance vy Varying Steer Gain with Vehicle Speed and Steering Angle: VGS (Variable Gear-Ratio Steering System." (SAE1999-01-0395).
- Shino, M., N. Miyamoto, Y. Wang and M. Nagai (2000). Traction control of electric vehicles considering vehicle stability. Advanced Motion Control, 2000. Proceedings. 6th International Workshop on.
- Shino, M. and M. Nagai (2001). "Yaw-moment control of electric vehicle for improving handling and stability." Jsae Review 22(4): 473-480.

- Shino, M., Y. Wang and M. Nagai (2000). **Motion Control of Electric Vehicles Considering Vehicle Stability. International Symposium on Advanced Vehicle Control, Ann Arbor, Michigan.**
- Shiotsuka, T., A. Nagamatsu, K. Yoshida and M. Nagaoka (1994). **"Active Control of Drive Motion of Four Wheel Steering Car with Neural Network." (SAE940229).**
- Shuttlewood, D. W., D. A. Crolla, R. S. Sharp and I. L. Crawford (1993). **"Active Roll Control for Passenger Cars." Vehicle System Dynamics 22(5-6): 383-396.**
- Sienel, W. (1997). **Estimation of the Tire Cornering Stiffness and its application to Active Car Steering. Proceedings of the 36th Conference on Decision and Control, San Diego, California.**
- Sienel, W. and J. Ackermann (1994). **"Automatic Steering of Vehicles with Reference Angular Velocity Feedback." Proceedings of the American Control Conference(TP1-4:20): 1957-1958.**
- Smakman, H. (2000a). **Functional Integration of Active Suspension with Slip Control for Improved Lateral Vehicle Dynamics. International Symposium on Advanced Vehicle Control, Ann Arbor, Michigan.**
- Smakman, H. (2000b). **Functional Integration of Slip Control with Active Suspension for Improved Lateral Vehicle Dynamics. Engineering. Delft, Technical University.**
- Smith, D., R. Benton and J. Starkey (2000). **"Non-linear-gain-optimized controller development and evaluation for automated emergency vehicle steering." International Journal of Vehicle Design 24(1): 79-99.**
- Spentzas, K. N., I. Alkhalili and M. Deric (2001). **"Dynamics of four-wheel-steering vehicles." Forschung Im Ingenieurwesen-Engineering Research 66(6): 260-266.**
- Susuki, Y., K. Matsuda and S. Sasaki (1994). **"Four wheel Steering System for Medium-Duty Trucks." (SAE942310).**

- Sutantra, I. N. and Y. Kaelani (2000). **Dynamic Characteristics of Multifunction Four wheel Steering System. FISITA World automotive congress, Seoul, Korea.**
- Suzuki, H., M. Harara and H. Kumakura (1994). **"Study on suitable steering feeling for various driving conditions by controlling power steering assist characteristics." (SAE9438024).**
- Szosland, A. (2000). **"Fuzzy logic approach to four-wheel steering of motor vehicle." International Journal of Vehicle Design 24(4): 350-359.**
- Tagawa, Y., H. Ogata, K. Morita, M. Nagai and H. Mori (1996). **"Robust Active Steering System Taking Account of Nonlinear dynamics." Vehicle System Dynamics 25: 668-681.**
- Tajima, J., N. Yuhara, S. Sano and S. Takimoto (1999). **"Effects of Steering system characteristics on control performance from the view point of steer-by-wire system design." (SAE1999-01-0821).**
- Tajima, J., N. Yuhara, S. Takimoto, T. Kawai and Y. Shimuzu (1998). **"Research on effect of Steering Characteristics on Control Performance of a driver-vehicle system from a view point of steer by wire system design." (SAE9837238).**
- Tran, V. T. (1994). **"Crosswind Feedforward Control - a Measure to Improve Vehicle Crosswind Behavior." Vehicle System Dynamics 23(3): 165-209.**
- van Winsen, F. and E. Schumacher (1961). **Cornering stabilization of motor vehicles with pneumatic cushioning. Germany.**
- van Zanten, A. T. (2000). **"Bosch ESP Systems: 5 Years of Experience." (SAE 2000-01-1633).**
- van Zanten, A. T., R. Erhardt, H. Bartels, J. Hesselbarth, A. Lutz and W. Neuwald (1997). **Simulation for the development of the Bosch-VDC. System Engineering in Automotive Design. 1374: 89-114.**
- van Zanten, A. T., R. Erhardt, K. Landesfeind and G. Pfaff (1998). **"VDC Systems Development and perspective." (SAE980235).**

- van Zanten, A. T., R. Erhardt and G. Pfaff (1995). "VDC, The Vehicle Dynamics Control System of Bosch." (SAE950759).
- Venkataraman, S. C. and K. J. Waldron (1993). "Performance Improvement with Active Control of Steering Angles and Wheel Torques during a combined Braking and Steering Maneuver." *Journal of Dynamic Systems Measurement and Control-Transactions of the Asme* 52: 39-49.
- Wallentowitz, H. (1990). "Scope for the Intergration of Powertrain and Chassis Control Systems:Traction Control - All-Wheel-Drive - Active Suspension." (SAE901168).
- Wallentowitz, H. (1995). Longitudinal Control and Interaction with other systems. *Smart Vehicles*. H. B. Pacejka and J. P. Pauwelussen, Swets & Zeitlinger: 252-275.
- Wang, L. and J. Ackermann (1998). Robustly stabilizing PID controllers for car steering systems. *Proceedings of the American Control Conference*.
- Wang, Y. and M. Nagai (1992). "Intelligent vehicle Motion Control by Adaptive Front Steering System." (SAE923070).
- Weir, D. H. and R. J. DiMarco (1978). "Correlation And Evaluation Of Driver/Vehicle Directional Handling Data." (SAE780010).
- Wells, D. A. (1967). *Theory and Problems of Lagrangian Dynamics*, McGraw-Hill Book Company.
- Whitehead, J. C. (1988). "Four-Wheel Steering: Maneuvrability and High Speed Stabilization." (SAE880642).
- Will, A. B., M. C. M. Teixeira and H. Z. Stanislaw (1997). "Four Wheel Steering Control System Design Using Fuzzy Models." *Proceedings of the IEEE International Conference on Control Applications*: 73-78.
- Williams, D. E. and W. M. Haddad (1995). "Nonlinear Control of Roll Moment Distribution to Influence Vehicle Yaw Characteristics." *Ieee Transactions on Control Systems Technology* 3(1): 110-116.
- Williams, D. E. and W. M. Haddad (1997). "Active suspension control to improve vehicle ride and handling." *Vehicle System Dynamics* 28: 1-24.

- Williams, R. A. (1997a). "Automotive active suspensions - Part 1: basic principles." Proceedings of the Institution of Mechanical Engineers Part D- Journal of Automobile Engineering 211(6): 415-426.
- Williams, R. A. (1997b). "Automotive active suspensions Part 2: Practical considerations." Proceedings of the Institution of Mechanical Engineers Part D- Journal of Automobile Engineering 211(6): 427-444.
- Wright, P. G. and D. A. Williams (1984). "The application of Active Suspension to High Performance Road Vehicles." Institute of Mechanical Engineers C239/84.
- Xia, X. and E. H. Law (1990). "Nonlinear Dynamic Response of Four Wheel Steering Automobiles to Combined Braking and Steering Commands in Collision Avoidance Maneuvers." (SAE901731).
- Yasui, K., K. Tozu, N. Hattori and M. Nishii (1996a). "Improvement of Vehicle Directional Stability for Transient Steering Maneuvers Using Active Brake Control." (SAE960485).
- Yasui, Y., K. Tozu, N. Hattori and M. Nishii (1996b). "Vehicle Stability Enhancement System using Brake Control." FISITA World automotive congress(F1996B1631).
- Yokoya, Y., R. Kizu, H. Kawaguchi, K. Ohashi and H. Ohno (1990). "Integrated Control System Between Active Control Suspension and Four Wheel Steering for the 1989 CELICA." (SAE901748).
- Yoshimoto, K., H. Tanaka and S. Kawakami (1999). "Proposal of Driver Assistance System for Recovering Vehicle Stability from Unstable States by Automatic Steering." Proceedings of the IEEE International Vehicle Electronics Conference.: 514 -519.
- Yoshioka, T., T. Adachi, T. Butsuen, H. Okazaki and H. Mochizuki (1998). "Application of sliding mode control to control vehicle stability." (SAE9837076).
- Yoshioka, T., T. Adachi, T. Butsuen, H. Okazaki and H. Mochizuki (1999). "Application of sliding mode theory to direct yaw-moment control." Jsaе Review(20): 523-529.

- You, S.-S. and Y.-H. Chai (1999). "Multi-objective control synthesis: an application to 4WS passenger vehicles." *Mechatronics*: 363-390.
- Yu, S.-H. and J. K. Moskwa (1994). "A Global approach to vehicle control: coordination of four wheel steering and wheel torques." *Journal of Dynamics systems, measurement and control*. 27: 235-265.
- Yuhara, N., S. Horiuchi, N. Asanuma, Y. Nishi and T. Kohata (1992). "Improvement of Vehicle Handling Through Active Control of Steering Reaction Torque." (SAE923073).
- Yuhara, N. and J. Tajima (2001). "Advanced steering system adaptable to lateral control task and driver's intention." *Vehicle System Dynamics* 36(2-3): 119-158.
- Yuhara, N., J. Tajima, S. Sano and S. Takimoto (1999). "Steer-by-wire-oriented steering system design: concept and examination." *Vehicle System Dynamics* 33: 692-703.
- Zegelaar, P. W. A. and H. B. Pacejka (1997). "Dynamic tyre responses to brake torque variations." *Vehicle System Dynamics* 27: 65-79.
- Zhang, J. R., S. J. Xu and A. Rachid (2001). Sliding Mode Controller fo Automatic Steering of Vehicles. IECON'01: The 27th IEEE Industrial Electronics Society Conference.

A. Appendix – Tyre Model and Parameters

| Lateral Force | |
|--|-------------|
| Coefficient Number | Coefficient |
| 1 | -4.095e+001 |
| 2 | -1.261e+003 |
| 3 | -1.484e+003 |
| 4 | -9.086e+000 |
| 5 | +7.913e-003 |
| 6 | +9.518e-002 |
| 7 | +2.311e-002 |
| 8 | +7.813e-003 |
| 9 | +3.799e-002 |
| 10 | -4.065e-002 |
| 11 | +6.036e+000 |
| 12 | +8.858e+000 |
| 13 | -5.950e-001 |
| 14 | -1.487e+001 |
| 15 | -9.212e-005 |
| 16 | +1.736e-001 |
| 17 | -1.485e-004 |
| 18 | +1.430e+000 |
| <p>Implementation of lateral force pacejka model utilising lateral force coefficients.</p> | |
| <pre> /* x = lateral slip angle, gam = castor angle z = normal force, P = lateral coefficient *FORCE = pointer to result */ void fy_94(real_T x, real_T gam, real_T z, real_T P[], real_T *FORCE) { real_T sign(real_T x); /* sign function */ </pre> | |

```

real_T D1;          /* */
real_T C1;          /* */
real_T B1;          /* */
real_T E1;          /* */
real_T SHS;         /* */
real_T SVS;         /* */
real_T ASUB;        /* */

D1=P[0]*pow(z,2)+P[1]*z;
D1=(1-P[14]*pow(gam,2))*D1;
C1=P[17];
B1=(P[2]*sin(2*atan(z/P[3]))*(1-P[4]*fabs(gam)))/(C1*D1);
E1=P[5]*z+P[6];
SHS=P[7]*z+P[8]+P[9]*gam;
SVS=P[10]*z+P[11]+(P[12]*z+P[13])*gam*z;
ASUB=x+SHS;
E1=(1-(P[15]*gam+P[16])*sign(ASUB))*E1;
*FORCE=D1*sin(C1*atan(B1*(1-E1)*ASUB+E1*atan(B1*ASUB)))+SVS;

) /* end of fy_94 */

```

| Longitudinal Force | |
|--------------------|-------------|
| Coefficient Number | Coefficient |
| 1 | -4.504e+001 |
| 2 | -1.387e+003 |
| 3 | +0.000e+000 |
| 4 | -3.775e+002 |
| 5 | -2.000e-002 |
| 6 | +0.000e+000 |
| 7 | +1.000e-001 |
| 8 | -5.000e-001 |
| 9 | +0.000e+000 |
| 10 | +0.000e+000 |
| 11 | +0.000e+000 |
| 12 | +0.000e+000 |
| 13 | +0.000e+000 |
| 14 | +1.500e+000 |

Implementation of longitudinal force pacejka model utilising longitudinal

```

force coefficients.

/* x = slip ratio,
   z = normal force,
   P = longitudinal coefficient
   *FORCE = pointer to result
*/

void fx_94(real_T x, real_T z, real_T P[], real_T *FORCE)
{
    real_T sign(real_T x);          /* sign function */

    real_T D2;                      /* */
    real_T C2;                      /* */
    real_T B2;                      /* */
    real_T E2;                      /* */
    real_T SHL;                    /* */
    real_T SVL;                    /* */
    real_T KSUB;                   /* */

    D2=P[0] * pow(z,2) + P[1]*z;
    C2=P[13];
    B2=(P[2]*pow(z,2)+P[3]*z)*exp(-P[4]*z)/(C2*D2);
    E2=P[5]*pow(z,2)+P[6]*z+P[7];
    SHL=P[8]*z+P[9];
    SVL=P[10]*z+P[11];
    KSUB=x+SHL;
    E2=(1-P[12]*sign(KSUB))*E2;

    *FORCE=D2*sin(C2*atan(B2*(1 - E2) *KSUB+E2*atan(B2*KSUB)))+SVL;
} /* end of fx_94 */

```

| Self Aligning Moment | |
|----------------------|-------------|
| Coefficient Number | Coefficient |
| 1 | +3.649e+000 |
| 2 | -2.927e+000 |
| 3 | +1.463e+000 |
| 4 | -4.177e+000 |
| 5 | -2.225e-002 |
| 6 | +2.632e-003 |
| 7 | +1.759e-002 |

| | |
|----|-------------|
| 8 | +4.354e-001 |
| 9 | +3.085e-001 |
| 10 | +1.404e-003 |
| 11 | -6.058e-002 |
| 12 | -3.435e-001 |
| 13 | -3.557e-002 |
| 14 | +6.479e-001 |
| 15 | +3.423e+000 |
| 16 | +9.610e-002 |
| 17 | -3.669e-001 |
| 18 | -9.986e-004 |
| 19 | -5.777e-002 |
| 20 | +3.834e-002 |
| 21 | +2.340e+000 |

Implementation of self aligning moment pacejka model utilising self aligning moment coefficients.

```
/* x = slip ratio,
   gam = castor angle,
   z = normal force,
   P = longitudinal coefficient
   *FORCE = pointer to result
*/
void mz_94(real_T x, real_T gam, real_T z, real_T P[], real_T *FORCE)
(
   real_T sign(real_T x);           /* sign function */

   real_T D4;                       /* */
   real_T C4;                       /* */
   real_T B4;                       /* */
   real_T E4;                       /* */
   real_T SHT;                      /* */
   real_T SVT;                      /* */
   real_T ASUB;                     /* */

   D4 = P[0]*pow(z,2)+P[1]*z;
   D4 = (1-P[17]*pow(gam,2))*D4;
   C4 = P[20];
```

```

B4 = ((P[2]*pow(z,2)+P[3]*z)*exp(-P[4]*z) * (1-P[5]*fabs(gam)))/(C4*D4);
E4 = P[6]*pow(z,2)+P[7]*z+P[8];
E4 = E4/(1-P[9]*fabs(gam));
SHT = P[10]*z+P[11]+P[12]*gam;
SVT = (P[15]*pow(z,2)+P[16]*z)*gam+P[13]*z+P[14];
ASUB = x+SHT;
E4 = (1-(P[18]*gam+P[19]))*sign(ASUB)*E4;
*FORCE = D4*sin(C4*atan(B4*(1 - E4)*ASUB+E4*atan(B4*ASUB)))+SVT;

) /* end of mz_94 */

```

Combined Coefficients

Coefficient Number

Coefficient

| | |
|----|-------------|
| 1 | +9.000e-001 |
| 2 | +2.400e-001 |
| 3 | +3.600e-001 |
| 4 | +2.400e-001 |
| 5 | +1.000e+000 |
| 6 | +4.900e-001 |
| 7 | +2.500e-001 |
| 8 | +2.500e-001 |
| 9 | +0.000e+000 |
| 10 | +0.000e+000 |
| 11 | +0.000e+000 |
| 12 | +0.000e+000 |
| 13 | +0.000e+000 |
| 14 | +0.000e+000 |
| 15 | +2.500e-006 |
| 16 | +0.000e+000 |
| 17 | +0.000e+000 |
| 18 | +2.900e-003 |

Implementation of combined slip pacejka model utilising combined coefficients.

```
static void mdlOutputs(SimStruct *S, int_T tid)
```

```
{
```

```
    real_T
```

```
    *y
```

```
    = ssGetOutputPortRealSignal(S,0);
```

```
InputRealPtrsType  uPtrs      = ssGetInputPortRealSignalPtrs(S,0);

real_T

                                *comcoeff_pr    = mxGetPr(COMCOEFF_PARAM(S));
real_T

                                *fxcoeff_pr     = mxGetPr(FXCOEFF_PARAM(S));
real_T

                                *fycoeff_pr     = mxGetPr(FYCOEFF_PARAM(S));
real_T

                                *mzcoeff_pr     = mxGetPr(MZCOEFF_PARAM(S));

real_T fx0, bxy, dxy, fx;
real_T fy0, g0, dvyx, svyx, fy;
real_T BCD, BCDx, shs, svs, sht, svt, alp0, angle1, xteq;
real_T mzc, mzc1, mzc0, mz1, fyl, mzc, mz;

fx_94(RSLIP,FZ,fxcoeff_pr,&fx0);
bxy = comcoeff_pr[2]*cos(atan(comcoeff_pr[3]*RSLIP));
dxy = fx0/cos(comcoeff_pr[0]*atan(bxy*comcoeff_pr[1]));
fx = dxy*cos(comcoeff_pr[0]*atan(bxy*(SLIP + comcoeff_pr[1])));

fy_94(SLIP,CAMBER,FZ,fycoeff_pr,&fy0);
bxy = comcoeff_pr[6]*cos(atan(comcoeff_pr[7]*(SLIP-comcoeff_pr[8])));
dxy = fy0/cos(comcoeff_pr[4]*atan(bxy*comcoeff_pr[5]));
g0 = comcoeff_pr[10]*FZ + comcoeff_pr[11];
dvyx = comcoeff_pr[9]*FZ*(CAMBER-g0)*cos(atan(comcoeff_pr[13]*SLIP));

/*The 'svyx' term calculated here is zero when using the default combining
*coefficient set, the term was mysteriously missing from an old version of this
*code. But has been reintroduced now.
*
*WARNING: If the combining coefficients used come from a .cof file which has
not
*been optimised for the 'svyx' part of the combining equations then goofy
results
*are likely. Such a set of coefficients can be found in the standard X200 tyre
data
*file: pip22555r16_23_X200A_1.cof
*/
```

```
svyx = dvyx*sin(1.9*atan(comcoeff_pr[12]*RSLIP));
fy = dxy*cos(comcoeff_pr[4]*atan(bxy*(RSLIP + comcoeff_pr[5]))) + svyx;

BCD = fycoeff_pr[2]*sin(2.0*atan(FZ/fycoeff_pr[3]));
BCDx = (fxcoeff_pr[2]*pow(FZ,2) + fxcoeff_pr[3]*FZ)*exp(-fxcoeff_pr[4]*FZ);
shs = fycoeff_pr[7]*FZ + fycoeff_pr[8];
svs = fycoeff_pr[10]*FZ + fycoeff_pr[11];
sht = mzcoeff_pr[10]*FZ + mzcoeff_pr[11];
svt = mzcoeff_pr[13]*FZ + mzcoeff_pr[14];

alp0 = -shs-svs/(BCD+1e-6);

angle1 = DEGTORADS*(SLIP + sht);
xteq = sqrt(pow(tan(angle1),2) + pow(BCDx/((BCD+1e-6)/DEGTORADS),2)*pow(RSLIP,2));
xteq = atan(xteq)/DEGTORADS;

mz_94(alp0,0.0,FZ,mzcoeff_pr,&mzr);
mz_94(SLIP,CAMBER,FZ,mzcoeff_pr,&mzc1);
mz_94(SLIP,0.0,FZ,mzcoeff_pr,&mzc0);
xteq = xteq-sht;
mz_94(xteq,0.0,FZ,mzcoeff_pr,&mz1);
mz1 = mz1-svt;
xteq = xteq + sht-shs;
fy_94(xteq,0.0,FZ,fycoeff_pr,&fy1);
fy1 = fy1-svs;

mzc = fy*(mz1/(fy1+1e-6)) + (mzr + mzc1-mzc0)*exp(-0.005*pow(RSLIP,2));
mz = mzc + (comcoeff_pr[14]*fy + (comcoeff_pr[15] +
comcoeff_pr[16]*FZ)*CAMBER +
comcoeff_pr[17])*fx;

y[0] = fx;
y[1] = fy;
y[2] = mz;
}
```

B. Appendix – Sub-system Coordination time histories for AFS-C and ARS-C

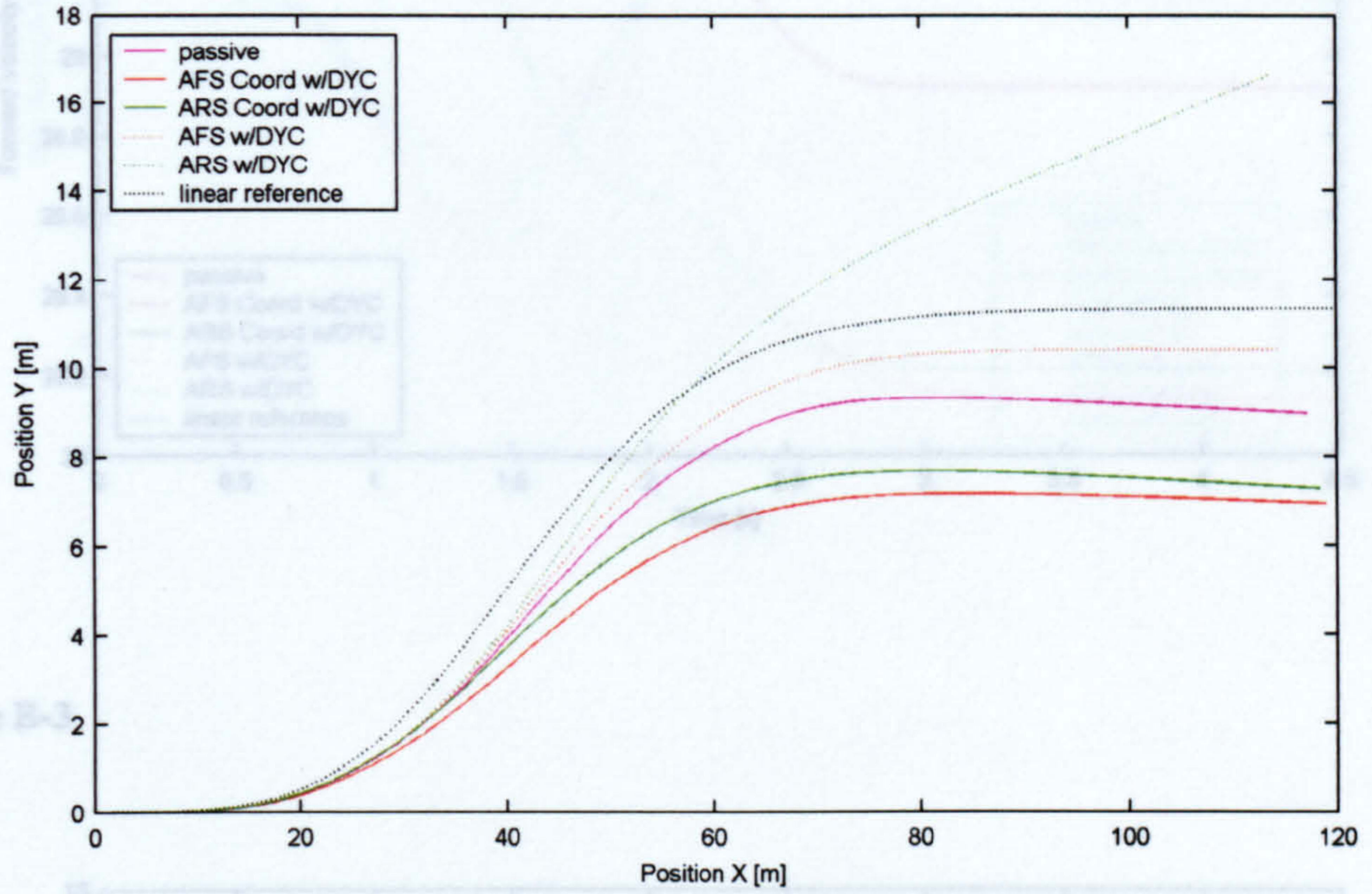

Figure B-1

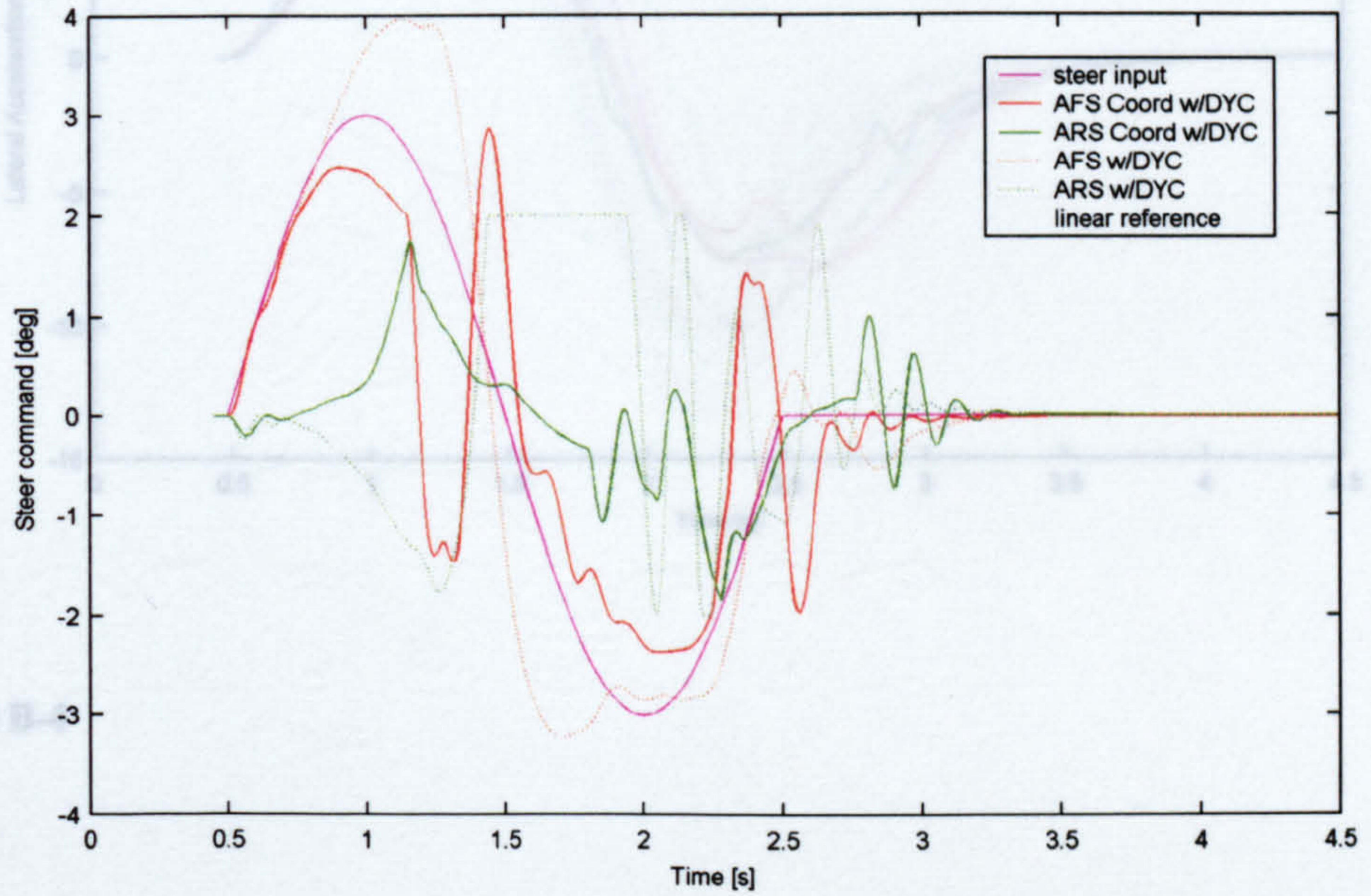

Figure B-2

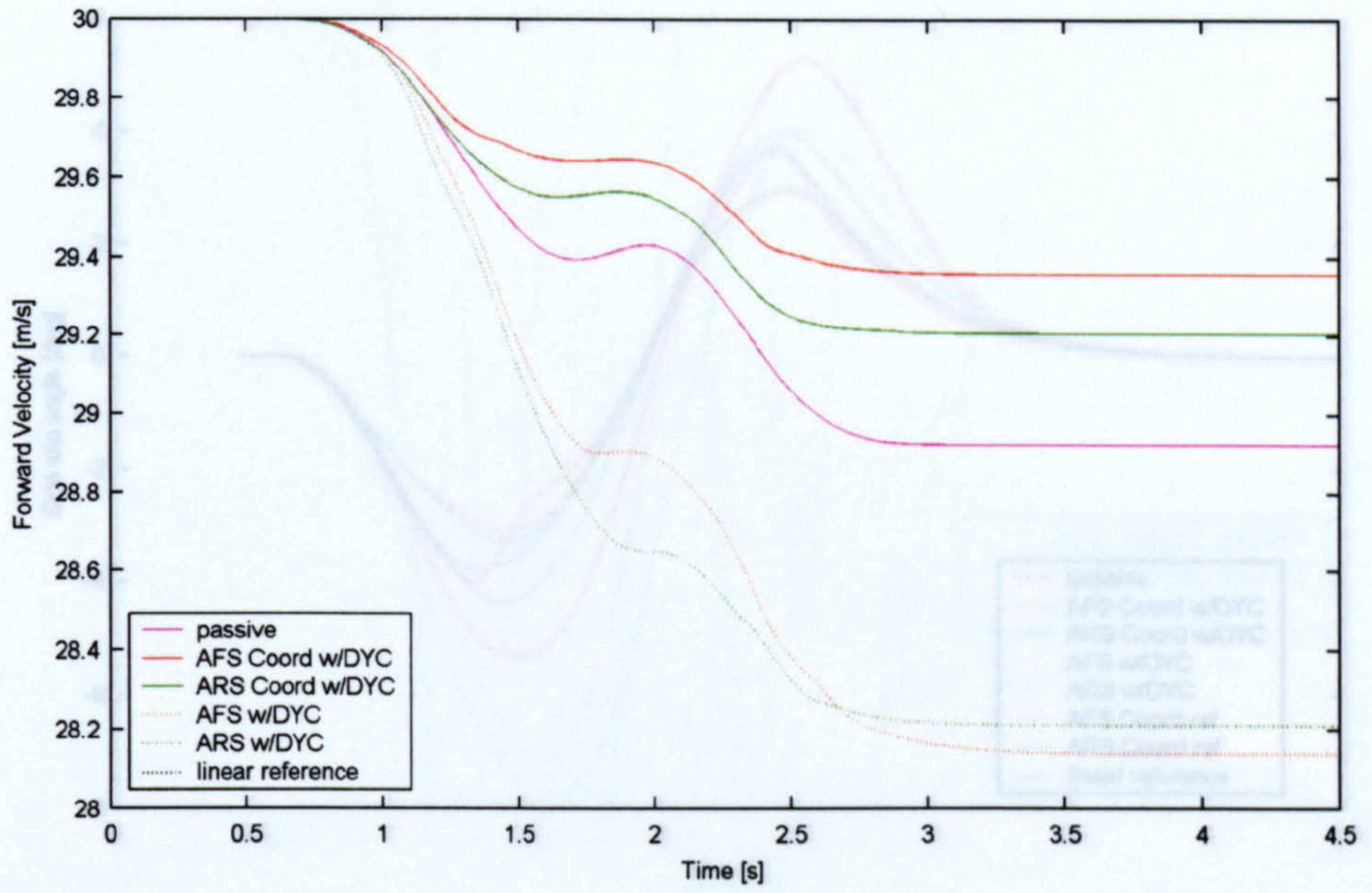

Figure B-3

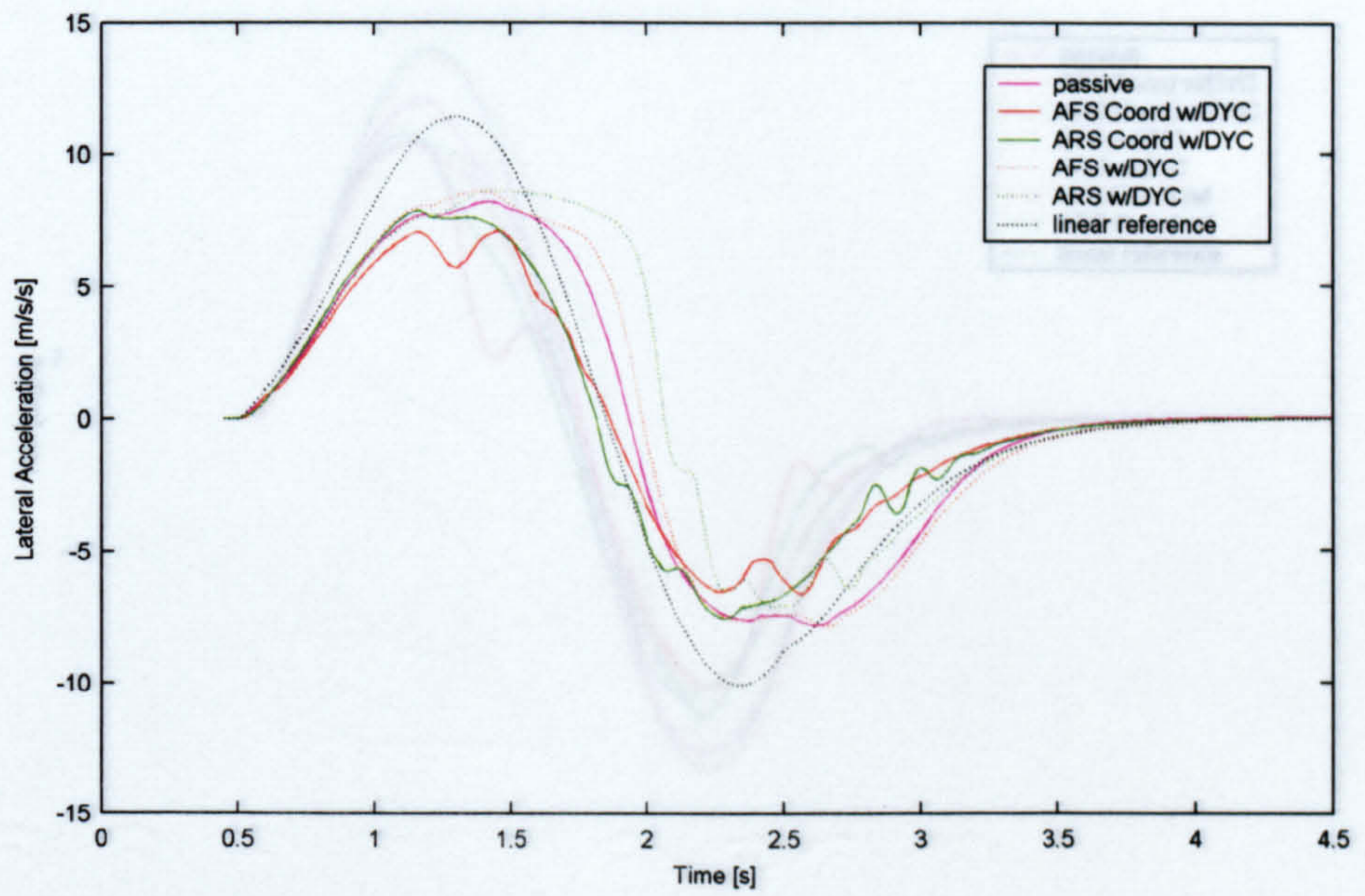

Figure B-4

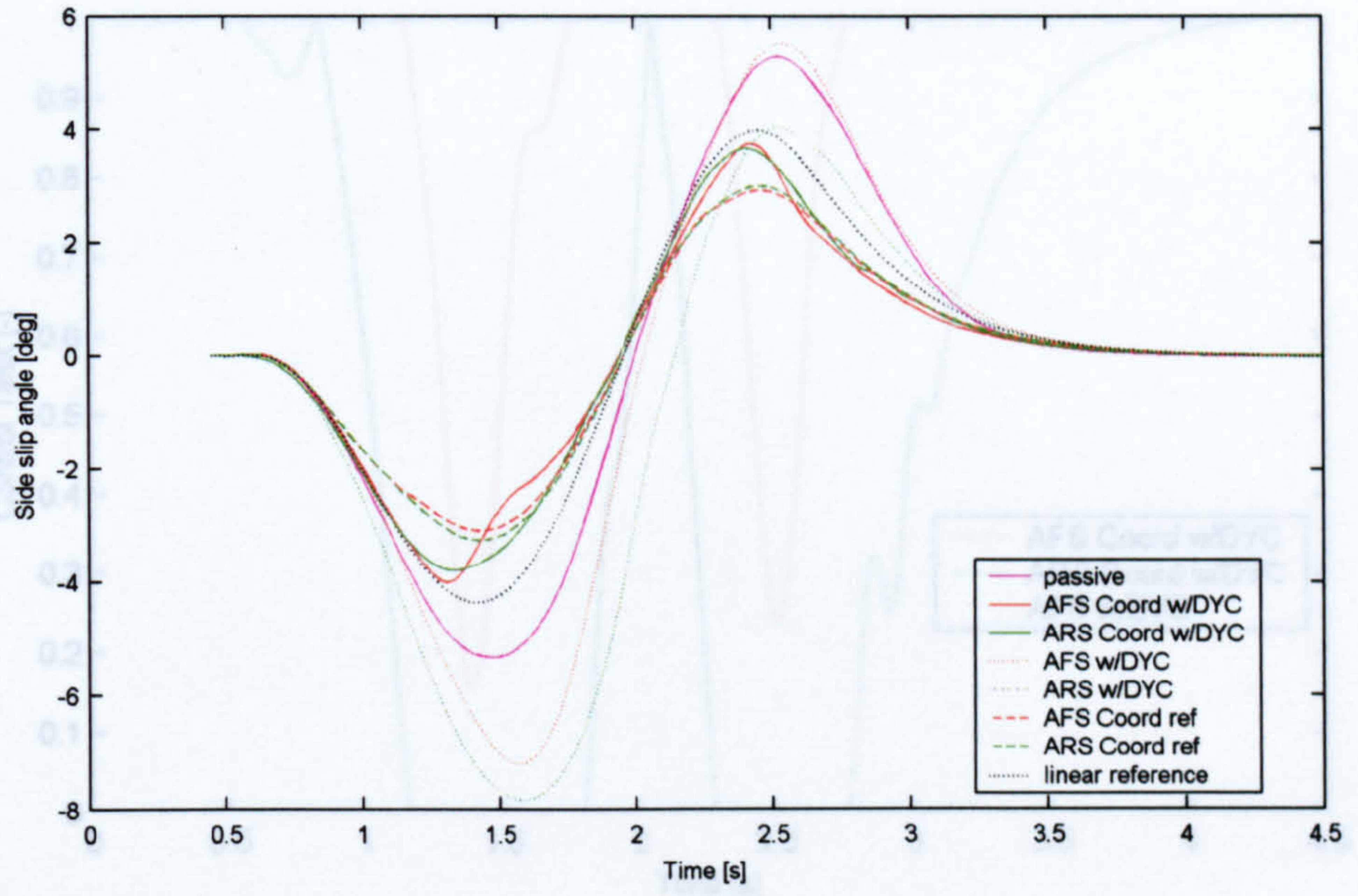

Figure B-5

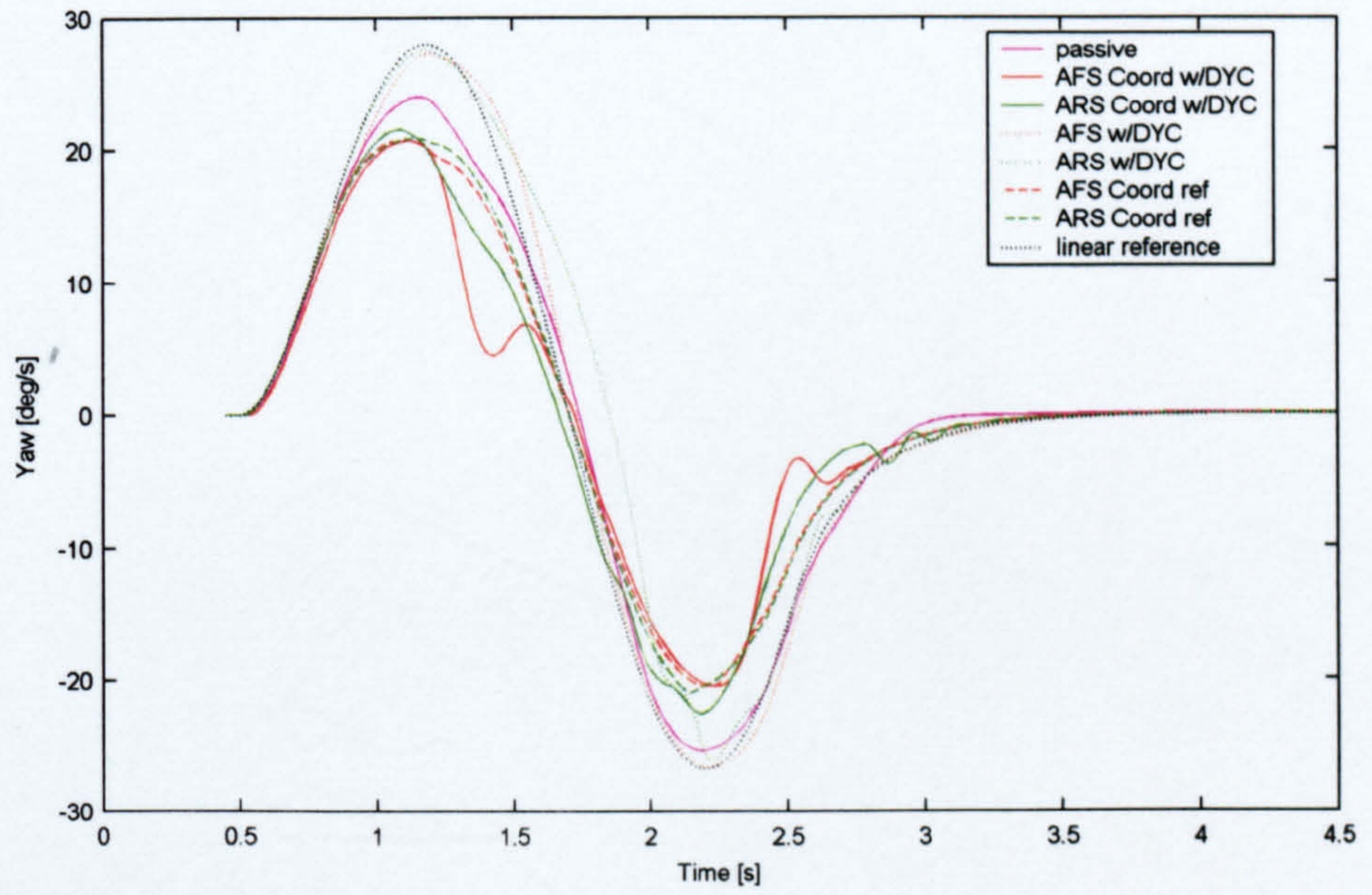

Figure B-6

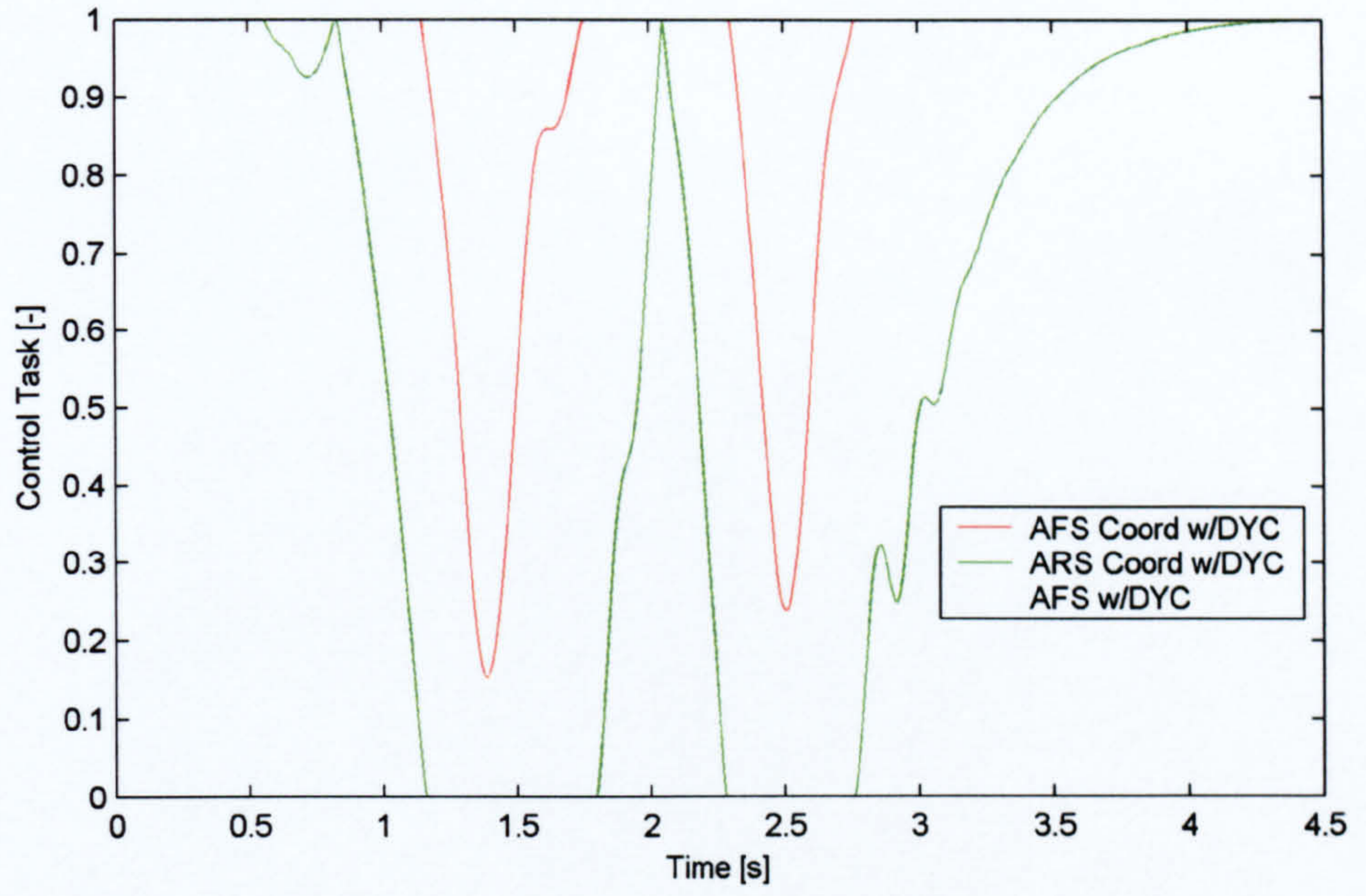

Figure B-7